

OCTOBER

25 CENTS

# POPULAR MECHANICS

## MAGAZINE

WRITTEN SO YOU CAN UNDERSTAND IT

REG'D. TRADE MARK, GREAT BRITAIN, NO. 410426

U.S. PAT. OFF.

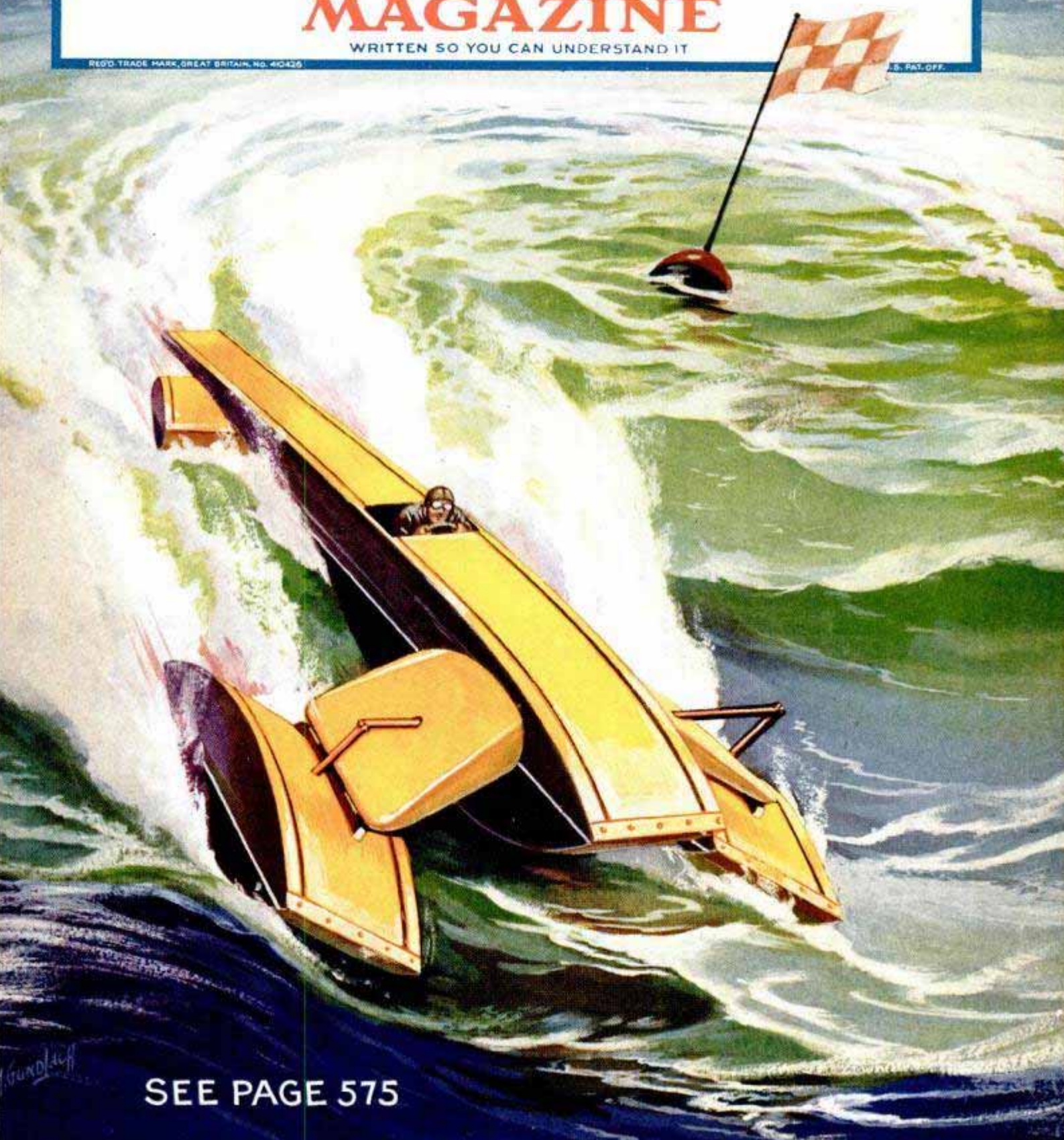

SEE PAGE 575



WHY FAMOUS MEN OF THE DAY USE BARBASOL

# Barbasol is the Headliner Shave

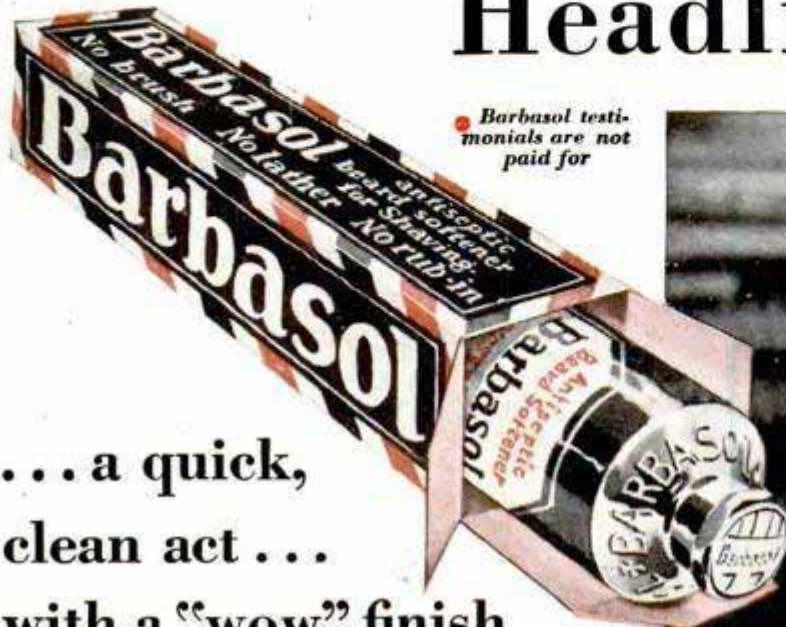

• Barbasol testimonials are not paid for

... a quick,  
clean act ...  
with a "wow" finish

\* "We're all showmen—behind the lights or on the stage of life—and that's why the Barbasol shave is best for the boys who have to take the spotlight, whether in big business or in the show business. Barbasol's a real trouper—no fuss, no trouble, no brush, no rub, or lather. And how quick and clean the razor gets through its routine. And, man, what a fine finish! I give it a big hand."

*Jesse Crawford*

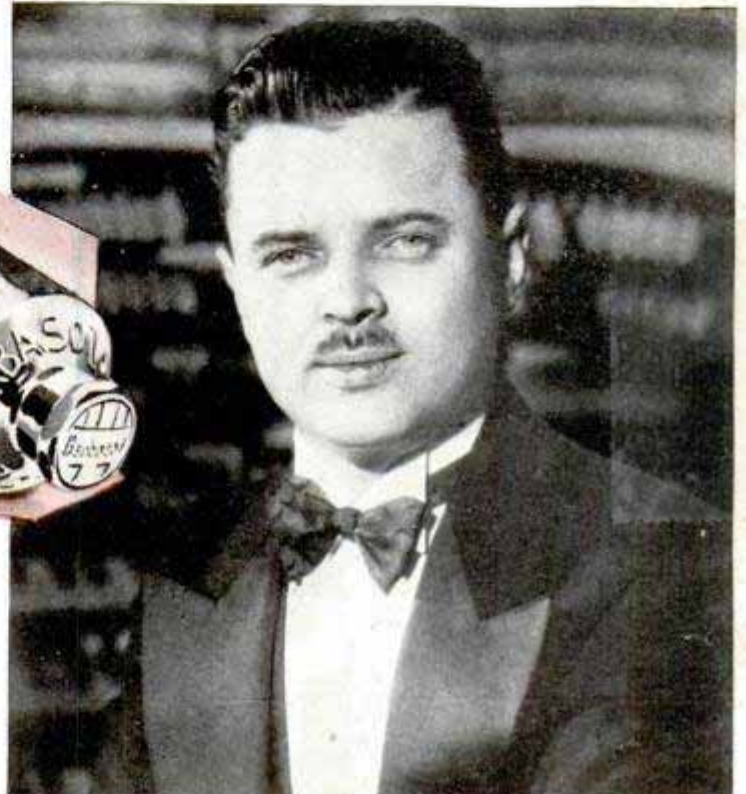

Jesse Crawford, musician extraordinary; wizard of the motion picture pipe organ; creator of musical novelties and "effects." He's a featured artist at the great Paramount Theatre on Broadway these days, where he is charming thousands daily.

IT'S the comfort, speed, ease and almost magical beard-softening of the Barbasol shave that turns so many men into Barbasol Believers.

Follow these directions and you'll be following the crowd—

1. Wet your face thoroughly. Leave it wet.
2. Spread on Barbasol. Don't rub it in.
3. Wet a good blade and—Shave.

If you're going to be a Barbasol Believer, don't look for a lather. No brush needed; and, man, how clean and crisp the razor glides along. How refreshed and soft and COMFORTABLE your face feels afterward. Blades last longer, too. Get Barbasol from the drug store today; generous tubes 35¢ and 65¢. The Barbasol Company, Indianapolis, Indiana.



## BARBASOL SKIN FRESHENER

Here's a new kind of "bracer." Slap it on face or neck, morning, noon or night, for a quick pick-up. It t-i-n-g-l-e-s; rejuvenates.

# Barbasol

For Modern Shaving

No brushing — No lathering — No rubbing



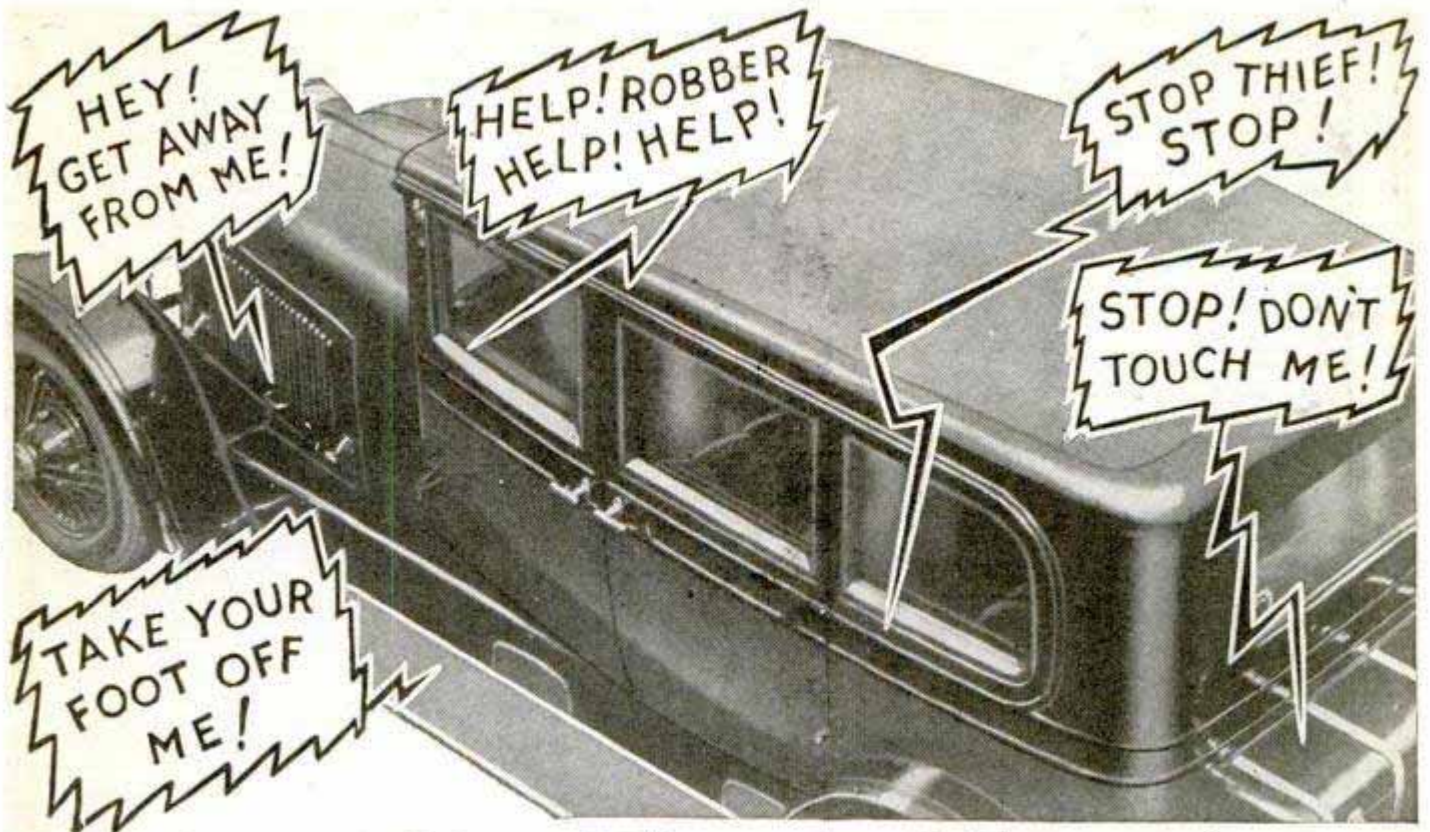

# Astonishing Electrical Invention Protects Your Car from Thieves ...Automatically!

This unquestionably is the queerest, most incredible invention since the first discoveries of radio! A magical, shouting, automatic watchman that actually is far more than human! Never sleeps, rests or gets

tired! Stands guard over your entire car from spare tire to headligns and steering wheel! Endorsed by police! Approved by Motor Associations! Now offered on generous 5-day test basis! The coupon brings full details.

## A Startling, Uncanny Money Maker For Agents

"WHAT makes it work?" "Where on earth did you get it?" "Bet you five dollars he's got someone hiding in there!" "It simply can't be true." A running fire of comment like this breaks out whenever and wherever this new invention is exhibited. And why not? When no one ever heard of such a startling, uncanny device before! In fact few people would even dare to dream there could be such a thing! So this, men, is something really NEW, something to grip the imagination of everyone, something that sells to every autoist on sheer novelty alone. Distributors, "star" salesmen, every man who wants to double and triple his present income should note carefully the following facts.

### The Secret Of A Theft-Proof Car

Now in this amazing new way, every car can be protected from theft for 24 full hours a day. In the garage or parked on the street, if any thief so much as pulls at your spare tire or touches his foot to your running board—ZOWIE! A riot of noise starts instantly! And your car never shuts up till the thief leaves. And listen to this. Even if the thief is wise to what's up, you alone place the secret control button anywhere you want it around the car. The thief can't possibly find it. If he wastes time looking for it—Bingo! He's caught and on his way to jail! This astonishing invention guards your spare tire, head-lights and spot-lights as well as the car itself.

### Installed In 10 Minutes—Costs Nothing To Operate

The inventor has asked the U. S. Government to protect his patent rights in this revolutionary discovery. Because of its uncanny powers and to distinguish it from everything else on earth this queer discovery is now

called "Devil Dog." Among its amazing features is the fact that it can be installed by anyone in 10 minutes or less. There is absolutely no cost for operation. It will last as long as the car. Fits any car from Ford to Rolls Royce without adjustment or fussing.

For introductory purposes a special 5-day test offer is now being made. If you are interested in learning about the most astonishing invention since the radio first came in, use the coupon at once. If your present income is less than \$50 a week, the profit possibilities as our agent may astonish you. The coupon brings details of all offers. Mail it now.

**NORTHWEST ELECTRIC CORP.,**

Dept. P-10.

Pukwana, So. Dakota

AUTOMATIC  
**DEVIL DOG**



This One



KP2C-LQ6-W426

Northwest Dept. P-1  
Rush det for agent

Name.....

Address.....

Town.....State.....

Check here if interested only in one for your own car and not in agents' money-making offer.





THE AMERICAN TELEPHONE AND TELEGRAPH COMPANY PAYS ONLY A REGULAR, REASONABLE DIVIDEND TO THE 500,000 OWNERS OF ITS STOCK

## They use it, they believe in it, they own it

*An Advertisement of the American Telephone and Telegraph Company*

THE Bell Telephone System is representative of the new type of ownership in American business, and of the responsibility to further the nation's welfare and prosperity which such an institution accepts.

Some 500,000 men and women, in nearly every town and city in the country, own the stock of the American Telephone and Telegraph Company. The average number of shares per stockholder is thirty. No single individual owns as much as one per cent of the total capital stock. The company pays only a regular, reasonable dividend, which it has not missed paying since its incorporation. Earnings beyond that go into the extension and improvement of the telephone service.

The Bell System is an American institution which consistently builds ahead of the communication needs of the day and year. Its construction program for 1930 requires the expenditure of approximately 700 million dollars.

The scope, speed and accuracy of its service is dependent on the constant research of more than 5000 scientific workers, new methods of operation and construction, and the co-ordinated efforts of more than 450,000 widely scattered employees. All its efforts are centered on giving the public a steadily improving telephone service at the lowest possible cost. This is the accepted responsibility of the Bell System.





# Popular Mechanics Magazine

200 E. Ontario Street, Chicago, U. S. A.

H. H. WINDSOR, Founder

H. H. WINDSOR, Jr., Editor and Publisher

London: Hachette & Cie.,  
3 La Belle Sauvage, Ludgate Hill, W. C. 2

Paris: Hachette & Cie.,  
111 Rue Reaumur

Melbourne: Gordon & Gotch  
509-513 Little Collins St.

ISSUED MONTHLY

SUBSCRIPTION:

SINGLE COPY, 25 CENTS

In United States and its possessions, Canada, Cuba, Mexico, and all }  
countries in the Pan-American Postal Union, per year, postpaid } . . . . \$2.50

To all other countries in the Postal Union . . . . . 3.00

All subscriptions are discontinued at expiration. Please examine the date printed on your wrapper.

Entered as Second Class Matter Sept. 15, 1903, at the Post Office at Chicago, Illinois, under Act of March 3rd, 1879.

Entered as Second Class Matter at the Post Office Department, Canada.

Published monthly by POPULAR MECHANICS CO.

Copyright, 1930, by Popular Mechanics Co.

Copyright in Australia. Copyright in France

Vol. 54

Contents for October, 1930

No. 4

## Special Features

<u>Super-Farm Runs Day and Night</u> . . . . .	555
<u>The Truth about Snakes</u> . . . . .	571
<u>Three Hundred Fathoms beneath the Sea</u> . . . . .	577
<u>Treasures from the Air</u> . . . . .	588
<u>The Lamps of the Modern Aladdin</u> . . . . .	596
<u>The Fishermen's Race</u> . . . . .	610
<u>I Solo in Seven Hours</u> . . . . .	618
<u>Junking Old Warships</u> . . . . .	627

<u>Airplanes</u> <i>gun mounting 629</i>		<u>Bridge—many miles of wire carry</u> . . . . .	603
carrier pigeons on, for aid in emergency	593	<u>Building Construction—windowless offices to end dirt</u>	
built like giant box kite	601	and noise	642
motor vibration detected with egg	569	<u>Building Material—brick veneer helps rebuilding home.</u>	642
resembling vulture to soar like a bird	561	<u>Butterfly Wings—photograph themselves</u> . . . . .	553
slashed shoe shows power of propeller	640	<u>Chemistry—touches all life making living easier</u> . . . . .	636
telling a plane by its silhouette	552	<u>Children</u>	
wind motors prevent nose dives	626	penny golf links like miniature course for	631
<u>Airships</u>		rack for clothes develops neatness	595
balancing in flight is big problem	551	<u>China—attacks by pirates call for extra guard</u> . . . . .	563
blimp lands on liner's deck to take off passenger	615	<u>Clock—keeps tab on universe in measuring time</u> . . . . .	606
latest type of mooring mast for dirigibles	600	<u>Desert—comes back to life</u> . . . . .	643
<u>Air Traffic—giant air yacht will carry eight passengers</u>	550	<u>Dishes—that will not break made of cotton</u> . . . . .	617
<u>Animals—muskox herds for Alaska</u> . . . . .	609	<u>Earthquake—Italian, is recorded in America</u> . . . . .	624
<u>Archery—miniature field vies with small golf course</u> . . . . .	616	<u>Eggs—soaked in mineral oils lose less weight</u> . . . . .	637
<u>Atoms—models of</u> . . . . .	551	<u>Electrical Appliances</u>	
<u>Automobiles, Accessories</u>		miniature dry-steam plant in electric iron	558
car starter, lights and horn operated by one button	615	neon tubes run by direct current	570
chair for baby has adjustable legs	637	<u>Exposition—Liege fair reflects latest building trends</u>	607
<u>Automobiles, Design</u>		<u>Farming—arid farming is a return to ancient customs</u> . . . . .	551
built from old parts of a score of cars	616	<u>Fire Alarm—towns use worn-out saws as</u> . . . . .	629
latest improvements give more comfort	594	<u>Fire Extinguisher—boy's invention saves home</u> . . . . .	559
<u>Automobiles, Repairing—grit remover saves time in</u>		<u>Fish and Fishing—salmon swims 1,300 miles</u> . . . . .	545
valve grinding	647	<u>Garden—drawing room arranged from hedge</u> . . . . .	558
<u>Automobiles, Trailer—expanding, gives home comforts</u>	623	<u>Gases—add offensive odor to warn of leaks</u> . . . . .	647
<u>Aviation</u>		<u>Gasoline—chemical detective</u> <i>559</i>	
air-law violations are increasing	629	carried in pipelines	569
loss of airmen is blamed on ore deposits	609	made from tar	576
training in cycloplane helps student flyers	608	<u>Golf</u>	
<u>Awning—for business street protects shoppers</u> . . . . .	569	automatic tee operated by pedal	554
<u>Balloons</u>		highest-speed movie camera helps teach	615
candles in, banned as forest-fire hazard	576	hog bristles for grass on miniature courses	575
to go up ten miles with two passengers	637	<u>Gorilla—hunter tells how to capture</u> . . . . .	646
<u>Bees—go thousands of miles for one pound of honey</u> . . . . .	606	<u>Guns</u>	
<u>Binoculars—dime-in-slot, give view of city</u> . . . . .	574	"mercy" bullet brings sleep	631
<u>Boats and Boating</u>		naval biggest, have twelve-mile range	624
cruiser goes over mountain on trailer	576	<u>Head Net—has window for clear vision</u> . . . . .	642
guide block for anchor rope has automatic grip	561	<u>Household Devices</u> . . . . .	638
pontoon-hydroplane promises higher speed	575	<u>Infants—name tanned on new babies for identification</u>	640
yacht's speed increased by air science	574		

[Continued on Page 4]

*Wings for all you 534*  
*Sanagee Blue Streak motor silencer 594*  
*Head Net with window 642*  
*Gasoline chemical detective 559*  
*Gasoline engine 595*  
*Fireproofing 641*  
*Blame 646*

640  
 get marking  
 Ultra. Used camp  
 Baby.  
 Bottle for  
 north  
 04



Lake Thomas 8 575

[Contents—Continued]

Insects  
 fair for collectors from all over world . . . 560  
 now you can buy . . . 640  
 Leaves—in lye solution bath become like gauze . . . 616  
 Life—secret of, sought in mystery ray . . . 564  
 Life Saving—knapsack holds user's valuables . . . 568  
 Light—artificial sunshine speeds up night workers . . . 559  
 Locks—removable cores for, operated by master key . . . 568  
 Locomotive—four men pull, on roller bearings . . . 554  
 Model—hand-carved, takes two years to finish . . . 602  
 Motor—tiny cycle runs many miles to the gallon . . . 560  
 Motor Bus—giant inter-city carries fifty-three passengers . . . 626  
 Moving Pictures  
 movie-film cleaner fits on the projector . . . 609  
 to show easiest way of doing things . . . 553  
 Musical Instruments  
 silent violin for beginners has no sounding board . . . 575  
 violin made of match sticks work of school boy . . . 595  
 Navy, U. S.  
 latest treaty cruiser "Northampton" . . . 604  
 sixty navy planes "battle" with mother ship . . . 545  
 Needle—threader, saves time of busy housewife . . . 576  
 Ocean—unseen fence across Pacific is barrier to sea life . . . 601  
 Paints and Painting—air brush that does not clog works under pressure . . . 641  
 Perfume—smells are put to work . . . 632  
 Pests  
 garden, killed by electricity . . . 568  
 insect police force at war with harmful . . . 554  
 Plastering—done by air cuts down hard work . . . 635  
 Porcelain—cast, aids dentists and repair work . . . 574  
 Power—of future from soil, air and sun . . . 631  
 Power Lines—portable lightning factory tests . . . 563  
 Printing—matrix with white lettering is more easily read . . . 646  
 Radio Apparatus—A.C. DX tuner highly selective . . . 648  
 Radio Applications  
 locating metals . . . 651  
 radio from plane goes half around the world . . . 558  
 Radio Broadcasting—voice from sky carried by horns on plane . . . 632  
 Radio, Helpful hints from laboratory . . . 652  
 Radio, Loud Speakers—radio heard twenty miles with giant speaker . . . 642  
 Radio Receivers—from 15 to 195 meters without plug-in coils . . . 654  
 Radio Reception—thunder converted to music in radio experiments . . . 608  
 Radio Tubes—with metal coat has grid on outside . . . 563  
 Radium—an ounce of, in eight years . . . 567  
 Railroad  
 car lunch counter for hungry passengers . . . 609  
 gymnasium on car . . . 561  
 "Sherlock Holmes" builds miniature . . . 636  
 steam engine, high-pressure, halves fuel cost . . . 593  
 suspended rail cars driven by air propellers . . . 641  
 Rayon—silk's principal rival to undersell cotton . . . 626  
 Rivers—low water mark set by drouth . . . 617  
 Rockets—tests aided by grant from Guggenheim Fund . . . 625  
 Rubber Plating—of concrete, wood and metals . . . 602  
 Sacks—twin screws replace belts in moving . . . 635  
 Safety Devices and Measures—chemical acts as detective of deadly gases . . . 559  
 Sea—bed of Zuyder Zee revealed as pumps clear water . . . 617  
 Searchlight—giant lens for, to go in light house . . . 559  
 Ships and Shipping  
 interior decoration of liner needs "international" art . . . 640  
 oil driving steam from sea . . . 617  
 peace ship's steering wheel is museum exhibit . . . 570  
 secrets of Davy Jones' cupboard . . . 546  
 ship cut in three sections to make it longer . . . 595  
 Shoe Peddlers—go barefoot to save their wares . . . 632  
 Sponges—tanned like leather . . . 601  
 Sprinkler—street, high speed operated by one man . . . 608  
 Steam—how man came to know wonders of . . . 562  
 Submarine  
 carrier for, takes boat through France . . . 560  
 famous "S-51" makes last trip to junk pile . . . 645  
 Sun—sunniest spot on continent scene of ten-year test . . . 637  
 Table—card, automatic folds all legs at once . . . 602  
 Telephone—world's exchange . . . 624  
 Telescope—search for new stars aided by mirror . . . 603  
 Temperature—lawn sprinkler on roof keeps building cool . . . 632  
 Tennis—ball visible in dark has luminous coating . . . 631  
 Trees—sap often freezes . . . 570  
 Turtle—caught with lasso weighs third of ton . . . 647  
 Warfare, Aerial  
 better plane-gun mounting sought by Uncle Sam . . . 629  
 rear-view mirrors aid pilot sight tail-firing gun . . . 568

Water, Lithia—served free at public fountains . . . 602  
 Weather  
 low humidity is fire hazard of forest . . . 633  
 varying names of same wind lead to confusion . . . 606  
 Welding—better jobs assured with gas regulator . . . 574

AMATEUR MECHANICS

Aquarium—food trap for . . . 686  
 Automobiles—pulling out of mud . . . 679  
 Automobiles, Accessories  
 flag waver for auto . . . 665  
 propeller makes ornamental bumper . . . 687  
 Automobiles, Repairing  
 toolbox under driver's seat . . . 673  
 wrench for removing headlamp rims . . . 673  
 Boats and Boating  
 carrying folding boat in auto . . . 680  
 "Roamer"—a speedy outboard cruiser . . . 666  
 Book Ends—monogram . . . 674  
 Bridge—auto frame used as . . . 685  
 Camping—quick boiling for . . . 675  
 Cleaning—generator commutator . . . 665  
 Clothes Closet—ventilating . . . 682  
 Dogs—stick cures of chasing cars . . . 682  
 Draftsmen's Kinks—preventing ink blotches . . . 675  
 Drying Cabinet—for baby's clothes . . . 673  
 Dyeing—bleaching dark clothes before . . . 681  
 Fruit—comb for cleaning red currants . . . 679  
 Garden—making a miniature Japanese . . . 660  
 Garden Hose—getting on tight fitting . . . 682  
 Gardening—banana crate protects young shrub . . . 676  
 Guns—rubber band, for boy's arsenal . . . 674  
 Hammer—reverse . . . 685  
 Heater—improved water . . . 682  
 Kitchen Table—folds into wall . . . 681  
 Lathe—feeding iron work to drill in . . . 681  
 Mail Box—rural covered with stones . . . 676  
 Mirror—transforming an old . . . 683  
 Motor, Outboard—using two on speedboat . . . 676  
 Paintbrushes—battery box for storing . . . 665  
 Painting—Roman crystalotype . . . 684  
 Playthings—how to build a "wobble-go-round" . . . 657  
 Porch—delivery box for screened . . . 675  
 Razor—how to strop safety blade at angle . . . 665  
 Screen Door—curtain rods for guard . . . 665  
 Shellac  
 for insulating wire . . . 659  
 removing from brushes . . . 686  
 Shooting—painted revolver sights aid vision . . . 685  
 Soap Dispenser—liquid, from tin can and air valve . . . 675  
 Telephone Cabinet—built-in . . . 676  
 Water—disinfecting with iodine . . . 681  
 Water Marks—removing from table top . . . 665  
 Weather Vanes—novelty . . . 677

SHOP NOTES

Automobiles, Repairing  
 tool for removing broken axle . . . 698  
 tool for removing valve guides . . . 700  
 Babbitt—improved pinion of . . . 704  
 Barrel—detachable shelf for . . . 690  
 Belt—joining ends of . . . 691  
 Boxes—packing, skid for heavy . . . 691  
 Cabinetmaking—a small drum table . . . 692  
 Crane—blacksmith's, for heating tires . . . 699  
 Crowbar—old driveshaft makes good . . . 696  
 Electric Meters—installing outdoors . . . 689  
 Fireplace—building a portable . . . 687  
 Garden Poles—inexpensive . . . 704  
 Lathe—double-purpose cuttings pan for . . . 696  
 Logging—horse plane with broadax bit squares logs . . . 697  
 Maps—road, prolonging life of . . . 696  
 Motor Bus—cleaning exhaust heater pipes . . . 700  
 Nails, Floor—driving down projecting . . . 700  
 Paints and Painting—fireproof . . . 699  
 Paint Shop—auto trucks for small . . . 698  
 Pipe—wooden cores strengthen nipples . . . 690  
 Poultry—ranch for city lot . . . 701  
 Saws and Sawing—bandsawing inside diameters of rings . . . 691  
 Soldering—tin roof, flux for . . . 689  
 Truck—for storage batteries . . . 704  
 Wheelbarrow—track on cleated incline . . . 690  
 Woodworking  
 cutter for . . . 691  
 homemade router . . . 699

Solarium 644

Battleships sunk 629



# "Hard times" didn't touch these men\*

*They had LaSalle Job Insurance*

**WE'VE** been going through one of those periods when men outnumber available jobs.

Lots of fellows riding along on the crest of the wave, thinking things would last forever, have found out differently.

But wherever an individual has had something worth while to offer—so called "hard times" haven't touched him. Many men have increased their earnings—bettered their positions when other fellows found themselves on the street.

And it hasn't been luck—or chance—or circumstance.

The trained man—like the rock in a storm—isn't affected by times or conditions.

Listen to these facts:

*"When most of our old men were laid off, I was promoted"*

For instance, there was our Industrial Management student in a Middle West aircraft plant who found that his training and his use of it in his daily work paid quickly. He writes, "During these bad times when most of our old men were laid off, I was promoted. Now whenever I meet one of the old gang and he asks me about my 'pull,' I simply show him my LaSalle membership card."

And our Higher Accountancy member in Philadelphia who, employed as a temporary man by one of the nation's outstanding firms of accountants, did so well that a month later his job was made permanent. In telling us of it, he adds, "This I consider quite a boost for LaSalle training, since the firm was letting other men go."

Another man cashed in on his training even more quickly, for, broke and unable to get a job, he enrolled for our

Traffic Management course and then went to the employment department of the largest firm in his Southern city, told them he was enrolled with us and wanted work in their shipping department. He was given the job over a long line of applicants—largely, as they told him, because he was studying with LaSalle.

*His LaSalle button won the job and at a higher salary than he expected!*

A LaSalle lapel button turned the trick for another Accountancy member. It showed the employer that he had successfully completed six months training with us. That carries weight and our student got the job—over 100 other applicants—at a salary higher than he had expected!

One company—a national leader in its line—after watching five of its major executives come up from lesser jobs and twenty-eight of its rank and file increase their efficiency with the aid of LaSalle training, has worked out with LaSalle a cooperative plan under which fifty-three of its most promising employes in shop and office and salesforce are training for executive positions—and their opinion after this thorough testing is best evidenced by the words of the president, "As I see it, LaSalle training makes a man worth

more not only to himself but to the firm he works for."

*"If we've got a man that ambitious—"*

There's no magic, nothing mysterious about this advantage enjoyed by our members. It's just plain common sense.

Alert employers know that it takes ambition and perseverance to study in the hours which others give to rest or pleasure—and they prefer men with those same qualities, especially when those men also have the added efficiency of the trained man.

One executive expressed this attitude forcefully when we told him that a minor employe in his warehouse was studying with us. "If we've got a man who is that ambitious down there, we'll bring him up here and give him a real job."

And another nationally known manager sums up the almost universal feeling of employers, "When we find a man with sufficient faith in himself to spend his own time, energy and money to complete a home study course, we consider him as being in that group from whom our future leaders will be drawn."

*You can have this same job insurance*

The remarkable thing about this LaSalle job insurance is that it is available to every normal, ambitious adult—and in nearly every major business field—at low cost and on easy terms. If you are really in earnest about protecting yourself in the present and making ready for even larger success when prosperity returns, this outstanding twentieth century development in building business success is at your service. And your first step is simple—

Send the coupon for full and free information.

The booklets which that coupon will bring may be priceless to you—if you read and act on the facts contained in them.

Fill out and mail the coupon now. "Later" means never.

\*Names and Addresses gladly given on request.

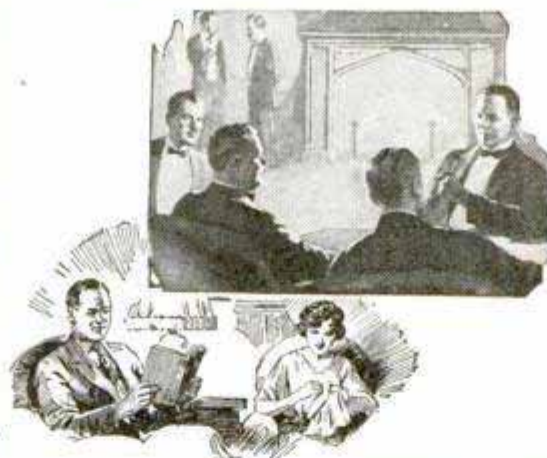

## LaSalle Extension University

THE WORLD'S LARGEST BUSINESS TRAINING INSTITUTION

----- Find Yourself Through LaSalle! -----

LA SALLE EXTENSION UNIVERSITY Dept. 1064-R CHICAGO Michigan Ave. at Forty-first

Please tell me about LaSalle job insurance in the field I have checked below:

- |   |  |  |
|---|--|--|
| <input type="checkbox"/> Business Management        | <input type="checkbox"/> Modern Salesmanship       | <input type="checkbox"/> Railway Accounting                |
| <input type="checkbox"/> Higher Accountancy         | <input type="checkbox"/> Paper Salesman's Training | <input type="checkbox"/> Credit and Collection             |
| <input type="checkbox"/> Expert Bookkeeping         | <input type="checkbox"/> Law: LL.B. Degree         | <input type="checkbox"/> Correspondence                    |
| <input type="checkbox"/> C. P. A. Coaching          | <input type="checkbox"/> Commercial Law            | <input type="checkbox"/> Business English                  |
| <input type="checkbox"/> Modern Business Corres.    | <input type="checkbox"/> Industrial Management     | <input type="checkbox"/> Effective Speaking                |
| <input type="checkbox"/> Traffic Management         | <input type="checkbox"/> Modern Foremanship        | <input type="checkbox"/> Commercial Spanish                |
| <input type="checkbox"/> Railway Station Management | <input type="checkbox"/> Personnel Management      | <input type="checkbox"/> Telegraphy—Railway and Commercial |
|   | <input type="checkbox"/> Banking and Finance       |  |



Name \_\_\_\_\_ Present Position \_\_\_\_\_ Address \_\_\_\_\_



# Opportunity for Boys in the United States

## University Scholarships . . . Industrial Recognition . . . National, State and General Awards valued at \$50,000

# FISHER BODY

*Open to Boys 12 to 19 inclusive.*

**Boys!** In founding the Fisher Body Craftsman's Guild, Fisher Body Corporation opens to boys in the United States literally a new world of opportunity. ¶ For those who demonstrate surpassing skill for fine craftsmanship, a series of valuable awards is planned to open the doors to higher education in your choice of the leading colleges and universities in the land—to industrial recognition—and to other benefits and honors. ¶ To many a boy, membership in this Guild thus will mean the deciding influence in life—an education, a career, and the rewards that come with success. ¶ The Fisher Body Craftsman's Guild is established to advance and honor the art of fine craftsmanship. ¶ The memorable spirit of the old crafts guilds, where every artisan, designer, and artist engaged in friendly rivalry to outdo his fellows in the perfection of his handiwork is likewise the guiding spirit of this modern Guild. ¶ To encourage this rivalry along practical and constructive lines, the Fisher Body Craftsman's Guild has decided on a means of demonstrating and judging the craftsmanship of modern youth.

## AWARDS

valued at \$50,000

### *Four Grand National Awards*

Two 4-year University scholarships, valued at \$5,000 each, are established in the name of the Guild, and will be the grand national awards for the two winning Guild members in the Senior group.

Winners in the Senior group may choose their colleges and courses of study as soon as the awards are made.

Two 4-year University scholarships, valued at \$5,000 each, are established in the name of the Guild, and will be the grand national awards for the two winning Guild members in the Junior group.

Winning members in the Junior group will have their scholarships held in trust for them, by the Guild, until graduation, or otherwise ready to enter college.

*96 State Awards—48 Senior Awards and 48 Junior Awards* which include a trip to Detroit as guests of the Fisher Body Craftsman's Guild.

### *Many other General Awards*

These awards will be made on the basis of excellence in various phases of craftsmanship, such as decorating, upholstery, metal work, wood work, etc.



HONORARY BOARD of JUDGES			
THOMAS S. BAKER President Carnegie Institute of Technology	W. F. DURAND Professor Emeritus, Mechanical Engineering Stanford University	M. L. BRITTAIN President Georgia Institute of Technology	E. A. HITCHCOCK Dean College of Engineering The Ohio State University
P. R. KOLBE President The Polytechnic Institute of Brooklyn	R. L. SACKETT Dean of Engineering Pennsylvania State College	D. S. KIMBALL Dean College of Engineering Cornell University	GEO. J. DAVIS, JR. Dean College of Engineering University of Alabama
S. W. STRATTON President Massachusetts Institute of Technology	REV. T. A. STEINER, C. S. C. Dean College of Engineering University of Notre Dame	M. E. COOLEY ENG. D. Dean Emeritus, College of Engineering and Architecture University of Michigan	R. A. MILLIKAN Chairman, Executive Council California Institute of Technology

# CRAFTSMAN'S GUILD

*No Entrance Fees or Dues*



W. A. FISHER  
President  
Fisher Body Corporation  
President of the Guild



D. C. BEARD  
National Boy Scout  
Commissioner  
Honorary President  
of The Guild

## A COACH MODELING CONTEST IS ANNOUNCED

The entrants in this contest will compete for awards on the basis of their craftsmanship in fashioning a model of the Napoleonic coaches.

A jury of able, learned and impartial educators will pass on the models submitted, and present the awards. This honorary Board of Judges will be headed by Daniel Carter Beard, America's loved National Boy Scout Commissioner, as Honorary President of the Guild.

Every boy in the United States between the ages of 12 to 19 inclusive, is welcomed into the Guild and the Coach Modeling Competition.

## ENROLL NOW WITH ANY GENERAL MOTORS DEALER

Every boy in either the Junior Group (12 to 15 inclusive) or the Senior Group (16 to 19 inclusive) has only to go to a General Motors Dealer in his community and enroll in order to be eligible to the Competition and all awards offered in his class or locality.

Dealers in Cadillac-La Salle, Buick, Oldsmobile, Oakland-Pontiac, and Chevrolet cars are all General Motors Dealers. There is one in your community.

The General Motors Dealer will welcome you, give you complete information about the Guild, and enroll you. When your enrollment is registered by the Guild, you will receive the official emblem of the Fisher Body Craftsman's Guild, certificate of membership, and full particulars about the Coach Modeling Competition, with complete working drawings of the model you are to reproduce.

*Enroll today with any General Motors Dealer in your Community. They will welcome you.*

Watch future issues of this magazine for further comment and news of the Guild.

## FISHER BODY CRAFTSMAN'S GUILD

Sponsored by FISHER BODY CORPORATION, DETROIT *Division of General Motors*



# Answer This Ad!

## If You Want Quick Success and Big Pay In AUTOS

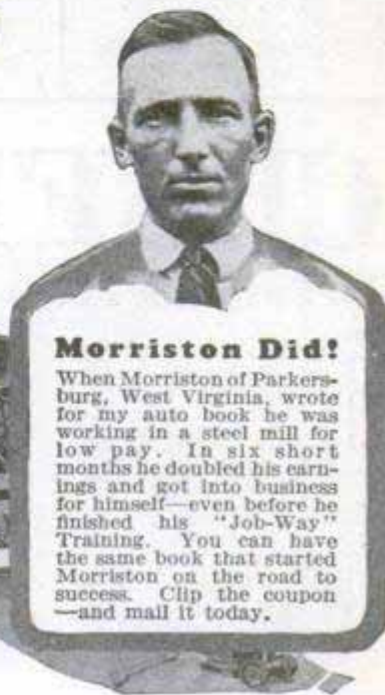
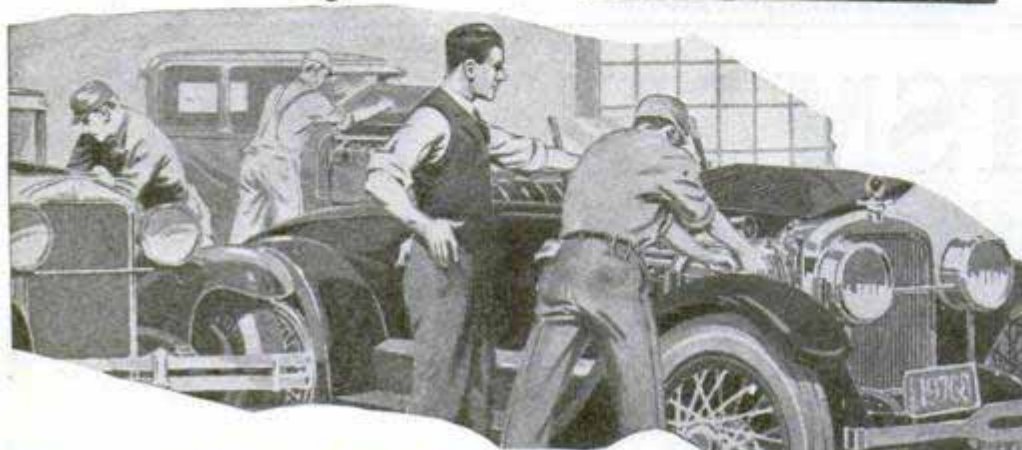

### Morriston Did!

When Morriston of Parkersburg, West Virginia, wrote for my auto book he was working in a steel mill for low pay. In six short months he doubled his earnings and got into business for himself—even before he finished his "Job-Way" Training. You can have the same book that started Morriston on the road to success. Clip the coupon—and mail it today.

## Earn Up to \$100 a Week

Get YOUR share of the \$7,000,000,000 spent every year on auto upkeep. **Just think of it**—more than 25,000,000 autos in the U. S. No wonder there are so many big pay jobs! Get into this fascinating game, now. Don't put it off another day. Get the facts. Mail coupon for big, FREE auto book. Learn of the countless opportunities in the World's Biggest Business where real jobs and big pay come quick. See how \$50—\$75—\$100 a week is possible for you now. Learn how "Job-Way" Training has brought big money—promotion—shops of their own to scores of men. Find out about my Employment Department—how it helps you get a good job in the auto business.

**3 WORKING OUTFITS**  
also included **FREE** of extra charge if you act quick!

## Learn at Home in Spare Time

"Job-Way" Training is the short cut to Auto Success. No need to quit your present job—no need to leave home—just use your spare time to prepare for a brilliant future—a real job paying up to \$100 a week. All you need is common schooling. I don't care if you never touched an auto before, I can train you at home. You should be able to make extra money quick—a few weeks after starting. Men from all walks of life who worked

long, hard hours for low pay are becoming garage owners, foremen and superintendents. If you like autos—if you're between 15 and 55—get the facts now. "Job-Way" Training covers everything about autos—Mechanical and Electrical Work, Starting, Lighting, Ignition, Welding, Vulcanizing, etc.—Everything you need to get in line for a big money job as an Electrical and Mechanical Auto Expert.

It's the trained man who gets the good jobs and "Job-Way" Training is COMPLETE, yet so simple, so easy that you get it quick.

## Send Coupon for FREE Auto Book

Get my FREE Auto Book. Learn how "Job-Way" Training has brought success to hundreds. See what it can do for you. Find out how my Employment Department helps you get a good job—about the three big outfits you get. Read my money-back agreement, my aviation course offer and many other features.

**B. W. Cooke, Directing Engineer**  
**Motor Institute of America**  
Motor Institute Bldg. Dept. 3167  
EVANSTON, ILLINOIS  
(Chicago's Largest Suburb)



**Do It NOW!**

Don't delay another day. Clip the coupon before you turn this page. Take the first step to a big-pay auto job. Now.

**B. W. Cooke, Directing Engineer,**  
**MOTOR INSTITUTE OF AMERICA,**  
Motor Institute Bldg., Dept. 3167, Evanston, Ill.

Send me your free auto book. I want to succeed in the auto business. Tell me about "Job-Way" Training—about your Employment Department and your 3 testing and repair outfits offer. No obligation on my part whatever.

Name.....  
Address.....  
Town..... State.....  
Age..... Occupation.....



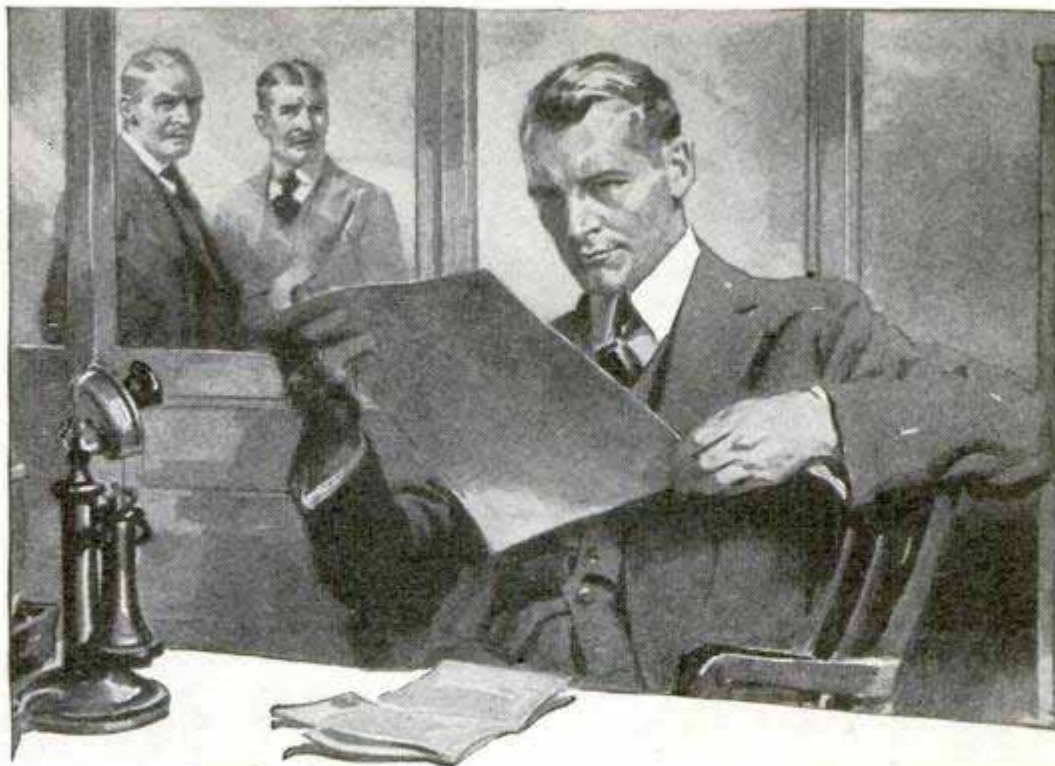

## “We pay him \$100 a week”

**A**ND he's worth every cent of it. Came here several years ago asking for a job. He got just that—a small job at a small salary.

“Then I forgot about him—hardly knew he was on the payroll until one day I got a letter from the International Correspondence Schools telling me that Thomas A. Andrews had enrolled for a course and had received a mark of 98 for his first lesson.

“‘There's a man worth watching,’ I said to myself, so I began to keep tabs on his work. Pretty soon he began coming to me with suggestions. I could almost see him growing.

“Somehow, he was the first man I thought of whenever there was a position open. And he always made good because he was always preparing himself for the job ahead. We pay him \$100 a week now and he's going to be earning even a larger salary some day. I wish we had more men like him.”

**H**OW do you stand when your employer checks up his men for promotion? Does he think of you? Is there really any reason why you should be selected?

Ask yourself these questions fairly. You must face them if you expect advancement and more money. For now, more than ever, the big jobs are going to men with special training.

There is an easy, fascinating way for you to get this special training right at home in spare time. One hour a day, spent with the I. C. S. in the quiet of your own home, will bring you more money, more comforts, more pleasure, all that success means.

Don't let another priceless hour of spare time go to waste! Without cost or obligation, let us prove that we can help you. Mark and mail this coupon now.

### INTERNATIONAL CORRESPONDENCE SCHOOLS

*“The Universal University”*

Box 5504-G, Scranton, Penna.

Without cost or obligation, please send me a copy of your booklet, “Who Wins and Why,” and full particulars about the subject before which I have marked X in the list below:

#### TECHNICAL AND INDUSTRIAL COURSES

- |  |   |  |  |
|--|---|--|--|
| <input type="checkbox"/> Electrical Engineering            | <input type="checkbox"/> Lighting       | <input type="checkbox"/> Architect               | <input type="checkbox"/> Draftsman               |
| <input type="checkbox"/> Machinist                         | <input type="checkbox"/> Toolmaker      | <input type="checkbox"/> Architects' Blueprints  | <input type="checkbox"/> Contractor and Builder  |
| <input type="checkbox"/> Patternmaker                      | <input type="checkbox"/> Automobiles    | <input type="checkbox"/> Reading Shop Blueprints | <input type="checkbox"/> Architectural Draftsman |
| <input type="checkbox"/> R. R. Section Foreman             |   | <input type="checkbox"/> Structural Draftsman    | <input type="checkbox"/> Concrete Construction   |
| <input type="checkbox"/> R. R. Bridge and Building Foreman |   | <input type="checkbox"/> Engineering             | <input type="checkbox"/> Mechanical Engineer     |
| <input type="checkbox"/> Gas Engines                       | <input type="checkbox"/> Diesel Engines | <input type="checkbox"/> Steam Engineering       | <input type="checkbox"/> Structural Engineer     |
| <input type="checkbox"/> Aviation Engines                  |   | <input type="checkbox"/> Chemistry               | <input type="checkbox"/> Pharmacy                |
| <input type="checkbox"/> Highway Engineering               |   | <input type="checkbox"/> Agriculture             | <input type="checkbox"/> Poultry                 |
| <input type="checkbox"/> Civil Engineer                    | <input type="checkbox"/> Coal Mining    | <input type="checkbox"/> Navigation              | <input type="checkbox"/> Radio                   |
| <input type="checkbox"/> Surveying and Mapping             |   |  |  |
| <input type="checkbox"/> Plumbing                          | <input type="checkbox"/> Steam Fitting  |  |  |
| <input type="checkbox"/> Heating                           | <input type="checkbox"/> Ventilation    |  |  |

#### BUSINESS TRAINING COURSES

- |  |   |   |
|--|---|---|
| <input type="checkbox"/> Business Management     | <input type="checkbox"/> Advertising            | <input type="checkbox"/> Signs                |
| <input type="checkbox"/> Industrial Management   | <input type="checkbox"/> Salesmanship           | <input type="checkbox"/> Lettering Show Cards |
| <input type="checkbox"/> Personnel Management    | <input type="checkbox"/> Stenography and Typing | <input type="checkbox"/> Civil Service        |
| <input type="checkbox"/> Traffic Management      | <input type="checkbox"/> Railway Mail Clerk     | <input type="checkbox"/> Mail Carrier         |
| <input type="checkbox"/> Accountancy             | <input type="checkbox"/> Grade School Subjects  | <input type="checkbox"/> High School Subjects |
| <input type="checkbox"/> Cost Accounting         | <input type="checkbox"/> C. P. Accountant       | <input type="checkbox"/> Secretarial Work     |
| <input type="checkbox"/> Business Correspondence | <input type="checkbox"/> Spanish                | <input type="checkbox"/> French               |
|  | <input type="checkbox"/> Designing              | <input type="checkbox"/> Illustrating         |
|  |   | <input type="checkbox"/> Cartooning           |

Name.....

Street Address.....

City..... State.....

Occupation.....

Persons residing in Canada should send this coupon to the International Correspondence Schools Canadian, Limited, Montreal, Canada





## ARTISTS EARN MORE

**W**HILE you are dreaming of making money . . . enjoying life . . . why not train your talent for drawing? A fortune may be at your finger tips if you train them now. Many people do not realize they have artistic ability. Through art, you may find the way to a famous name and a large income.

Artists are paid more today than ever before. Since the war, rates for art work have increased tremendously. Advertisers and publishers are paying millions of dollars annually to those who are trained in Modern Art.

Think of the money paid to artists for the illustrations in this magazine alone. Many successful students of the Federal School of Illustrating are now making from \$2500 to \$6000 a year and others are making even larger incomes.

More than fifty famous artists . . . earning big money themselves . . . have contributed their drawing secrets to the Federal Course. The Federal Course teaches you their methods of Illustrating, Cartooning, Lettering, Poster Designing, Window Card Illustrating, etc. Through this course you can learn at home during your spare time.

### TEST YOUR TALENT FREE

Why be content with a small income at routine work when art training offers such possibilities? Write your name, age and address on the coupon and get the Free Book, "A Road To Bigger Things" illustrated below. It gives details about how famous artists of today started their careers and shows examples of our students' drawings. With it, you will receive our Free Vocational Art Test. Clip and sign this coupon now. It may be the beginning of an art career which will enable you to clip bond coupons and sign big checks later.

# FEDERAL SCHOOL OF ILLUSTRATING

10130 Federal Schools Building



Minneapolis, Minnesota



Federal School of Illustrating,  
10130 Federal Schools Building,  
Minneapolis, Minnesota.

Please send me free book "A Road to Bigger Things" and Standard Art Test.

Name \_\_\_\_\_ Age \_\_\_\_\_ Occupation \_\_\_\_\_

Address \_\_\_\_\_



# Get Into One Of These BIG PAY FIELDS



All practical work on real  
Electrical machinery

## Amazingly Easy Way to Get Into ELECTRICITY

Don't spend your life waiting for \$5 raises in a dull, hopeless job! Let me show you how to make up to \$60, \$70 and even \$200 a week, in Electricity — NOT BY CORRESPONDENCE, but by an amazing way to teach that makes you a practical Electrician in 90 days!

### LEARN WITHOUT BOOKS IN 90 DAYS

No Books! No Lessons! You learn by doing actual electrical work right here in the Coyne Shops. You are trained on huge motors, generators, switchboards, transmitting stations, power plants, auto and airplane engines, etc. You don't need advanced education or previous experience. You qualify for real electrical work in 90 days!

#### Earn While You Learn

Don't worry about a job! You get FREE life-time Employment Service. And don't let lack of money stop you. If you need part-time work to help pay living expenses, I'll help you get it. Coyne is 31 years old. Coyne Training is tested. You can find out everything FREE. Just mail coupon below and I'll send you my BIG FREE ELECTRICAL BOOK, telling all about jobs—salaries, etc. This does not obligate you. Just send the coupon below!

### MAIL THIS COUPON FOR BIG FREE ELECTRICAL BOOK..

H. C. LEWIS, PRESIDENT  
COYNE ELECTRICAL SCHOOL, Dept. 70-72  
500 S. Paulina Street, Chicago, Illinois

Gentlemen: Please send me your big Free Electrical Book, with 151 illustrations. This does not obligate me.

Name .....

Address .....

City.....State.....



Student working on Television  
transmitter in  
Coyne Radio Shops

## Learn RADIO TELEVISION TALKING PICTURES

Every branch of Radio is calling for trained men! 5,000 Service Men needed at once. Big call for Wireless Operators, both at Sea and in the Air. Many jobs open in Broadcasting Stations. Talking Picture and Sound Experts in great demand. And now Television is on the way! Soon there'll be a demand for thousands of Trained Men in this one branch alone.

Say "good-bye" to \$25 and \$35 a week—get into Radio, where thousands of jobs are open, paying \$60 a week and up.

### Not By Correspondence By Actual Work—in 8 Weeks

Come to Coyne and learn Radio in 8 weeks! NOT BY BOOKS OR CORRESPONDENCE, but by actual Radio work on actual Radio equipment — on scores of Radio receivers, huge Broadcasting equipment, the very latest Television transmitters, Code Practice apparatus, Talking Picture and Sound equipment, etc. No experience needed. You learn all branches of Radio in 8 weeks.

#### FREE EMPLOYMENT SERVICE

After you graduate, I'll help you get the Radio Job you want — and if you need part-time work while at school, I'll help you get that, too. Coyne has been training men since 1899. Let Coyne train you for a Big Pay Radio job! Mail coupon below for a copy of my BIG FREE RADIO BOOK, telling all about Radio, Television, Talking Pictures, Wireless, etc. This costs you nothing. Just mail coupon below.

### MAIL THIS COUPON FOR BIG FREE RADIO AND TELEVISION BOOK

H. C. LEWIS, PRESIDENT  
RADIO DIVISION, COYNE ELECTRICAL SCHOOL  
500 S. Paulina St., Dept. 70-1B, Chicago, Ill.

Gentlemen: Send me your Big Free Radio Book and all details of your Special Introductory Offer. This does not obligate me in any way.

Name .....

Address .....

City.....State.....



# It's amazing what

★ 35,000,000 words (equals 500 books)

★ 15,000 illustrations

★ 500 maps—a complete atlas

★ all the world's knowledge

★ written by 3,500 expert contributors

Completely

NEW

## ENCYCLOPAEDIA

## BRITANNICA

### at the Lowest Price in 60 Years

**H**ERE beyond question is your money's worth, and more, actually the most profitable investment you could make. That fact, and that fact alone, explains the tremendous success of the new Encyclopaedia Britannica. *It explains why 50,000 families have already purchased this greatest knowledge book of all times.*

**The value is really amazing.** Just consider what you get! Twenty-four thousand pages of text, fifteen thousand illustrations, hundreds of maps—all in 24 compact volumes. Five hundred books would not give as much, and they would cost you many times more.

#### **Greatest Knowledge Book of All Times**

Here is all the knowledge of all the world—the most complete, authentic and up-to-date summary of all man's achievements anywhere in existence.

Better still, this is knowledge you can rely upon, because it is *written throughout by authorities*—by 3,500 experts from fifty countries.

"It is the best evidence of the great

prestige of this encyclopaedia," says Carl Van Doren, "that its editors have been able to include among their contributors so many of the busiest as well as the most expert men and women now or recently alive. *The list is overwhelming.*"

This "new model" encyclopaedia brings you illustrations on a scale

---

**SEND FOR ILLUSTRATED 56-PAGE FREE**



# you get

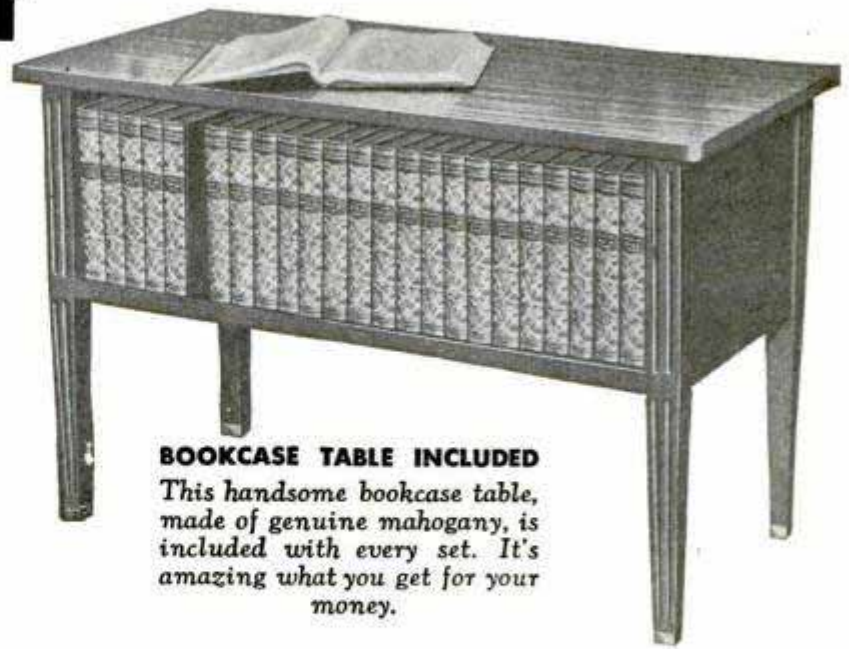

never equaled—15,000 of them. Gorgeous color plates, superb half-tones, skilful line drawings enable you to see as well as read.

## Fascinating—Practical

**M**ERELY to browse in this new Britannica is an adventure. You can spend fascinated hours poring over the illustrations alone. But you can consult it for profit, too.

"It has more practical value than had any preceding work intended to present a summary of human learning," says the president of Northwestern University, Dr. Walter Dill Scott.

## For All The Family

**M**EN eager to get ahead find it a real aid to greater earning power. Women use it as a guide in all the activities of the home and in their outside interests. Children revel in it. "It satisfies the needs of curious readers, whether eight or eighty years old," says James Harvey Robinson.

Your children especially will benefit by having all knowledge at hand and easy to look up as it is in this "new model" encyclopaedia. It will make their school work easier, more interesting and more profitable. It will teach them to use their minds, think accurately

## BOOKCASE TABLE INCLUDED

This handsome bookcase table, made of genuine mahogany, is included with every set. It's amazing what you get for your money.

and reason keenly. It is the one book they will never outgrow.

## New Low Price—\$5 Down

And it is not expensive. This new Britannica represents a triumph in lower encyclopaedia prices. You can buy it today at a new low price—a price lower, in fact, than that of any completely new Britannica in 60 years. Under our time-payment plan, an initial investment of only \$5 brings the full 24 volumes to your home.

## 56-PAGE BOOKLET FREE

Brought to you by your postman

Act now! Send for our free illustrated booklet. It contains numerous specimen maps, color plates, etc., and gives full information. Before you spend a dollar you can see exactly what you get for your money. Just fill out the coupon and mail today.



## RAY LYMAN WILBUR says:

"There is a rare pleasure in consulting these volumes. I cannot help but feel that the editors of the fourteenth edition have rendered a real service to all English-speaking peoples."

—Ray Lyman Wilbur, Secretary of the Interior

**BOOKLET TODAY**

ENCYCLOPAEDIA BRITANNICA  
342 Madison Avenue, New York City

3P.M.—B1

WITHOUT OBLIGATION—

Please send me, by return mail, your 56-page illustrated booklet with color plates and maps from the new Britannica, together with low price offer, etc.

Name.....

Address.....





**Before Kenneth McCarty  
Mailed that Coupon  
He was an  
\$18<sup>00</sup> Clerk~**

**Today  
His  
Income  
is  
\$85<sup>00</sup>  
a Week**

After completing the course he wrote us: "Yours is the finest course ever presented for the Tenor Banjo. Before I enrolled with you, I knew nothing whatever about music. I was earning \$18.00 weekly clerking in a store. **Little did I realize the opportunity that had come.** I took up the course just for fun. But here I am playing in one of the best orchestras in Western Michigan and **making \$85.00 a week.** Your course and your kind co-operation have made me a professional Tenor Banjoist."—*Kenneth McCarty, Parkview Hotel, South Haven, Mich.*

### You Get Phonograph Records, Too

Every selection of the course, fifty-five in all—comes to you on a phonograph record. You hear the instructor's playing just as though he were right at your side. The Play-Way is different, interesting, **FOOLPROOF.** Get the good news the coupon brings. **SEND FOR IT NOW!**

### FREE Book Tells How

Send at once for "The Play-Way to Popularity and Big Pay." Learn all about our unique method of training you at home, about the big, professional size Tenor Banjo, Phonograph Records and complete Outfit that we send you along with your very first lesson. Undreamed of possibilities for pleasure, popularity and big pay are open to you the minute you "become good." The book below is your first step. Take it now. Clip the coupon while it's here before your eyes.

### Clip-Sign-Send

**A. F. Bloch, President,  
NEW YORK ACADEMY OF MUSIC,  
Studio 1100, 100 Fifth Avenue,  
New York City.**

Send me the book that started McCarty. No obligation whatsoever on my part, understand.

Name.....

Address.....

### Play for Fun or \$5,000 a Year

Whether a salary of \$65 to \$100 a week—or spare time playing at \$5, \$10, \$15 or more a night—interests you or not—think of the fun in store for you. In one to three months we can train you at home to play this marvelous, melodious instrument with a fine easy skill that will make you the envy of all other eyes. Think, too, of the pleasure of being able to express yourself musically when alone! You're passing up the **best times** of your life if you pass up an opportunity like this to learn at slight cost and with no inconvenience at all the world's most popular instrument. **DON'T DO IT!** Decide NOW to learn more about The Play-Way—the quickest, surest short-cut ever devised to social and professional success.

**Big Tenor Banjo  
and Outfit  
comes with  
1st Lesson**



## Learn AVIATION

WHERE LINDBERGH LEARNED!

You, too, learn at Lincoln. Come to the Lincoln School. Get thorough, practical training for a pilot's or mechanic's license. Approved by U. S. Dept. of Commerce as Transport, Limited Commercial and Private; both Ground and Flying School.

**Extraordinary Facilities . . .** \$250,000 ground and mechanics school. Modern airport equipped for night flying and all weather runways. Fleet of modern training planes. Connected with airplane factory. Write for details today, stating age.

**LINCOLN AIRPLANE & FLYING SCHOOL**  
204 Aircraft Bldg. Lincoln, Nebr.

## Electrical Engineering

Training for men of ambition and limited time. Concise, comprehensive course in Theoretical and Practical Electrical Engineering including the closely related subjects of Mathematics and Mechanical Drawing. Students construct motors, install wiring,

test electrical machinery. Course designed to be completed in **one college year** by eliminating non-essentials. **THIRTY-SEVEN YEARS'** successful experience assures you maximum training in minimum time.

Send for free catalog.

## Bliss Electrical School

120 TAKOMA AVE., WASHINGTON, D. C.

## YOUR FUTURE ASSURED



Now is the time to safeguard yourself against such periods of depression as we have been having. Many good, profitable trades are not subject to hard times or slack seasons—trades meeting everyday human needs, such as Mechanical Dentistry. Your age, circumstances, or lack of experience need not stop you. The way is open to you. A helpful booklet, "Choosing a Trade," will be sent you without cost. Your copy is waiting. Simply ask for Bulletin 2.

**BODEE INSTITUTE, 1755 Broadway, N. Y.**  
1305 N. Broad St., Philadelphia 85 Court St., Brooklyn

## COLLEGE COURSES

### AT HOME

Carry on your education. Develop power to initiate and achieve. Earn credit toward a Bachelor degree or Teaching Certificate *by correspondence.* Select from 450 courses in 45 subjects, including English, Mathematics, History, Education, Psychology, Economics, the Languages, etc. Write for catalog.

## The University of Chicago

527 ELLIS HALL

CHICAGO, ILL.

## STAMMER

IF YOU

Write for my free book "Millard's Advanced Natural Corrective Course" and a free copy of my speech magazine. 10,000 cases successfully treated. Est. 24 years. Largest school for stammerers in world. Millard Inst. of Normal Speech, 2317 Millard Bldg., Milwaukee, Wis.



Wonderful new device, guides your hand; corrects your writing in a few days. Big improvement in three hours. No failures. **Complete outline FREE.** Write C. J. Ozment, Dept. 34, St. Louis, Mo.



# 100,000 Strong Men CAN'T Be Wrong!

**I**F YOU WANT TO KNOW what muscle is worth, ask the man who has plenty. Don't ask him for even so much as one ounce of his strength, for he won't part with it, but you can find out what he thinks about strength and vitality. Ask any strong man what muscle has done for him. Then ask yourself what you would give to be strong. (You bet your life you'd give plenty! But you don't have to.) Think of the healthy, happy lives of these men who have tasted the success made possible to them through strength and vitality. These men know now what real, live muscle can do for them. Ask them what they think of Earle Liederman, **THE MUSCLE BUILDER**. Ask any one of the 100,000 strong men built by Earle Liederman what they think of **THE MUSCLE BUILDER'S** marvelous system.

## THEY CAN'T BE WRONG!

Think of this army of finished athletes. What a record that is! Over 100,000 real men guided to strength and sound, physical perfection by **THE MUSCLE BUILDER'S** scientific short-cut to bulging muscles and unbounded vitality. 100,000 strong men can't be wrong!

## EARLE LIEDERMAN'S RECORD

Twenty years of muscle building—college training—world-wide experience in physical culture—a deep-felt enthusiasm for his life work—a sincere desire to help the poor weaklings who don't know how, and can't, enjoy life—his own splendidly proportioned and perfectly muscled body—the knowledge that his system cannot fail—all these make up Earle Liederman's record, and give him the right to *guarantee* to show results in the quickest time. That's why 100,000 strong men call him **THE MUSCLE BUILDER**.

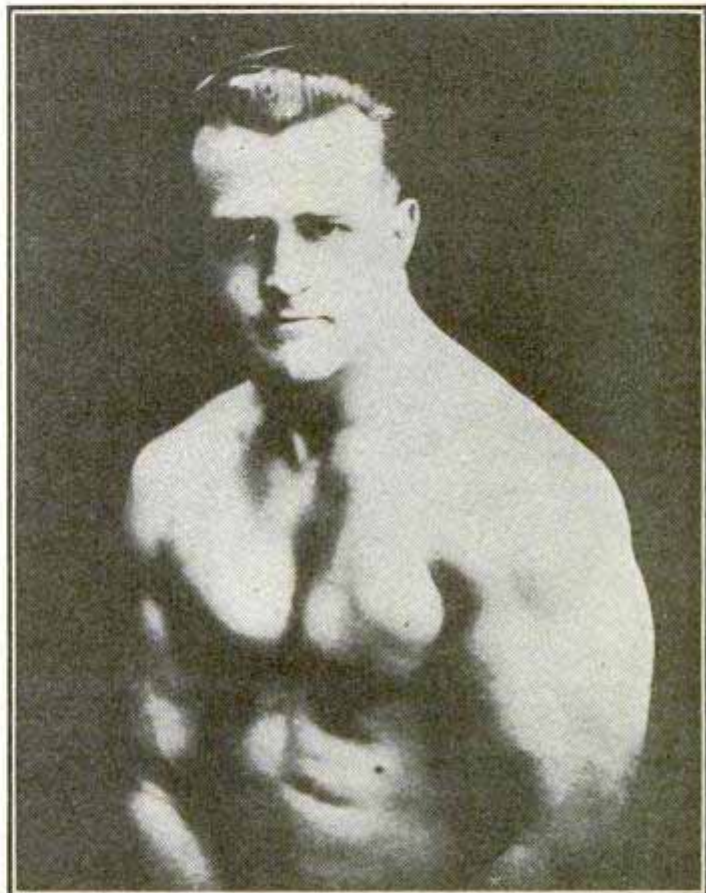

**EARLE LIEDERMAN, The Muscle Builder**

*Author of "Muscle Building," "Science of Wrestling," "Secrets of Strength," "Here's Health," "Endurance," Etc.*

## WHAT EARLE LIEDERMAN WILL DO FOR YOU

If you've got thirty days, and want a new body, get into this institution! "**THE MUSCLE BUILDER**" will put you among those hundred thousand strong men in double quick time. You can have a deep, massive chest, arms with muscles like steel, a panther-tread, a solid trunk that hurts the other fellow's fist, a mighty back, a quick, powerful body that shouts health and vitality at every move. When your friends admire and envy your physique, then you too will join the army of he-men who thank Earle Liederman, and who, by their very force of numbers, prove that 100,000 strong men can't be wrong.

SEND FOR  
HIS NEW  
64-PAGE BOOK

*"Muscular Development"*

IT IS  
FREE

What do you think of that? He doesn't ask one cent. And it's the peppiest piece of reading you ever laid your eyes on. You'll never blink an eyelash till you've turned the last cover. And there's 48 full-page photos of himself and some of his prize-winning pupils. This is the finest art gallery of strong men ever assembled. And every last one of them is shouting his praises. Look them over. If you don't get a kick out of this book, you had better roll over—you're dead. Come on, then. Take out the old pen or pencil and sign your name and address to the coupon. If you haven't a stamp, a postal will do. But snap into it. Do it now. Tomorrow you may forget. Remember, it's something for nothing and no strings attached, no obligation. **GRAB IT!**

**EARLE LIEDERMAN**

DEPT. 2010

305 BROADWAY, NEW YORK

**EARLE LIEDERMAN,**

Dept. 2010, 305 Broadway, New York City

Dear Sir:—Please send me, absolutely FREE and without any obligation on my part whatever, a copy of your latest book, "Muscular Development."

Name..... Age.....

Street.....

City..... State.....

(Please write or print plainly.)



# Do You Make these Mistakes in ENGLISH?

MANY persons say "Did you hear from him today?" They should say "Have you heard from him today?" Some spell calendar "calender" or "calander." Still others say "between you and I" instead of "between you and me." It is astonishing how often "who" is used for "whom," and how frequently the simplest words are mispronounced. Few know whether to spell certain words with one or two "c's" or "m's" or "r's" or with "ie" or "ei." Most persons use only common words—colorless, flat, ordinary. Their speech and their letters are lifeless, monotonous, humdrum.



Sherwin Cody

## Wonderful New Invention

For many years Mr. Cody studied the problem of creating instinctive habits of using good English. After countless experiments he finally invented a simple method by which you can acquire a better command of the English language in only 15 minutes a day.

Under old methods rules are memorized, but correct habits are not formed. Finally the rules themselves are forgotten. The new Sherwin Cody method provides for the formation of correct habits by calling to your attention constantly only the mistakes you make—and then showing you the right way without asking you to memorize any rules.

One of the wonderful things about Mr. Cody's course is the speed with which these habit-forming practice drills can be carried out. You can write the answers to fifty questions in 15 minutes and correct your work in 5 minutes more. The drudgery and work of copying have been ended by Mr. Cody! You concentrate always on your own mistakes until it becomes "second nature" to speak and write correctly.

## FREE—Booklet on English

A new booklet explaining Mr. Cody's remarkable method is ready. If you are ever embarrassed by mistakes in grammar, spelling, punctuation, pronunciation, or if you can not instantly command the exact words with which to express your ideas, this new free booklet, "How You Can Master Good English—in 15 Minutes a Day," will prove a revelation to you. Send the coupon or a letter or postal card for it now. SHERWIN CODY SCHOOL OF ENGLISH, 510 Searle Building, Rochester, N. Y.

SHERWIN CODY SCHOOL OF ENGLISH  
510 Searle Building, Rochester, N. Y.

Please send me your free booklet, "How You Can Master Good English—in 15 Minutes a Day."

Name.....

Address.....

This valuable booklet can not be sent to children.

## NEW FREE BOOK

On How to Raise Poultry for Profit will be sent postpaid, on request to readers of Popular Mechanics. It tells how we help you start a highly profitable spare-time or full-time business of your own or get a good job at good pay. One of our students, J. L. Mosher, of Buffalo, N. Y., for example, started at \$35 a week after tenth Lesson.

Read of the International Poultry work done by Harry M. Lamon, whose famous home study Course gives methods of increasing egg production, culling out non-layers, saving on feed, raising fat broilers quick, etc., methods that have doubled poultry profits—have raised salaries—have brought good jobs to men and women all over the country. You need this Book. It shows how you too can make poultry pay, make big money quick. Write for your FREE copy—today. Address,

National Poultry Institute, Dept. 411-B, Washington, D.C.

## BEDFORD YMCA TRADE SCHOOL

Aviation Mechanic  
Flying  
Airplane Welding  
Airplane Drafting  
Air Navigation  
Aero Starting, Lighting, Ignition  
Auto Mechanic  
Machine Shop. Electric Welding  
Oxy-Acetylene Welding  
Radio Mechanic. Battery Repair  
Mechanical, Architectural Drawing  
Sign Painting. Show Card Writing  
Window Dressing  
Commercial Art. Fine Art  
DAY AND EVENING SESSIONS  
Write for Catalog 50  
Brooklyn Engineering Institute  
(Operated by Bedford Y. M. C. A.)  
1125 Bedford Avenue, Brooklyn  
New York City

## LAW

STUDY AT HOME  
Legally trained men win high positions and big success in business and public life. Be independent. Greater opportunities now than ever before. Big corporations are headed by men with legal training. Earn \$5,000 to \$10,000 Annually

We guide you step by step. You can train at home during spare time. Degree of LL. B. conferred. Successful graduates in every section of the United States. We furnish all text material, including fourteen-volume Law Library. Low cost, easy terms. Get our valuable 64-page "Law Guide" and "Evidence" books FREE. Send for them NOW.  
LaSalle Extension University, Dept. 1084-L, Chicago  
The World's Largest Business Training Institution



## TRAVEL ON "UNCLE SAM'S" PAYROLL

New Bandit Proof Railway Mail Car  
**U. S. GOVERNMENT JOBS**  
\$1260 TO \$3400 YEAR

Men—Boys, 18 Up  
Steady Work  
Paid Vacations  
Common Education  
Usually Sufficient  
Mail Coupon  
—Today  
SURE

FRANKLIN INSTITUTE  
(Dept. P172, Rochester, N. Y.)  
Gentlemen: Rush to me without charge 32-page book with list of U. S. Government big paid positions. Tell me regarding salaries, hours, duties, vacations and full particulars.  
Name.....  
Address.....

COUPON





# They Told Him Salesmen Were "Born" But Now He Makes \$10,000 a Year ...Thanks to This Little Book

IT was just a little free book that made the difference between Ed Pinkham and the rest of the men in our shop. Nobody ever imagined that Ed would land, even in the \$5,000-a-year class, let alone be making \$10,000 before he was thirty. Ed didn't know himself the abilities he had in him as a money-maker.

But one day, a strange occurrence changed his whole life. During his lunch hour Ed started to read a little book he had brought to work with him.

"It's a book called 'The Key To Master Salesmanship,' Bill," he told me. "It's the most amazing thing I ever read. I never dreamed there was so much in salesmanship. You ought to send for a copy yourself. It's free."

"Huh!" said Luke Jones. "Does that book tell you how to become a salesman?"

"It sure does," replied Ed, enthusiastically.

"Don't waste your time," advised Luke. "You can't learn how to be a salesman. A fellow has to be 'born' that way to be a good salesman."

Ed just smiled at that, but he said nothing. Soon afterward he quit the shop, and we forgot about him. And then last night, I met Ed again—driving a snappy new sedan and dressed like a million dollars.

"For Pete's sake," I said. "What are you doing nowadays, Ed?" He smiled. "City salesmanager for the Steel Castings Company," he told me. "What are you doing?"

"Still at the shop," I replied. "But what I want to know is, how do you come to be salesmanager for Steel Castings? They're one of the biggest firms in the business."

Ed smiled again. "Remember that book on Salesmanship that Luke Jones was kidding me about one day? Well, when I finished my Salesmanship training the Association I took it from gave me a choice of twenty-one jobs through their Free Employment Department. I got a wonderful job, and I had wonderful training, so I've had a pretty successful time of it. They made me City Sales Manager three months ago at ten thousand dollars a year."

"Good night!" I said. "And Luke and I are still punching the old time clock!"

Ed looked at me seriously. "See here, Bill," he said. "Are you sport enough to risk two cents that you can do as well as I

did? Then spend the two cents to write to the National Salesmen's Training Association tonight and get their free book. Then take their course. When you have your diploma, their Free Employment Department will help you get a good sales job—every year they have calls for over 50,000 salesmen. Not only will they help you get the job, but they give you an iron-clad money-back guarantee that you must be satisfied with the training received—or they refund your tuition!"

## FREE—TO EVERY MAN

A book—but what a book! Just seven ounces of paper and printers' ink—but it reveals facts and secrets that have led hundreds of men to success beyond their fondest expectations! See for yourself—FREE—why "The Key To Master Salesmanship" has increased the earning capacities of thousands, as a direct result of their reading it! You'll know then, how J. H. Huppert of Michigan, learned from its pages the secrets that enabled him to make \$525 in one week. You can understand how it helped A. A. Fidler of Alabama to raise his pay 700%. Learn for yourself the REAL TRUTH about salesmanship. You do not risk one penny or incur the slightest obligation. And since it may prove the turning point in your career it is certainly worth your while to fill out and mail the coupon below. Do it now!

## NATIONAL SALESMEN'S TRAINING ASSOCIATION,

Dept. R - 103, N. S. T. A. Bldg.,  
[Chicago, Ill.]

## Now Sent FREE



National Salesmen's Training Association,  
Dept. R-103, N. S. T. A. Bldg., Chicago, Ill.

Without cost or obligation please send me my free copy of "The Key To Master Salesmanship," including details of your FREE EMPLOYMENT Service.

Name.....

Address.....

City..... State.....

Age..... Occupation.....



**Prepare  
for Success**  
... IN ONE OF THE  
WORLD'S THREE  
BIGGEST  
BUSINESSES!

**COME  
IN LOS**

**RA**

**RADIO CALLS**  
NATIONAL GRADUATES either hold fine Radio positions or own prosperous businesses. Chas. Freshman Co., Also California Victor Distributing Co., and scores of other leading Radio concerns prefer National trained men. Coupon below brings you **FREE RADIO CATALOG.**

**I Pledge You**

finest training of its kind in America, plus our deep and sincere interest in your progress and success. J. A. Rosenkranz, Pres.



**NATIONAL Qualifies YOU to MAKE GOOD**

Actual experience on our great shop equipment (not correspondence) makes it easy, fascinating to learn quickly and properly in only 4 to 7 months. Lifetime Scholarship no extra charge. NATIONAL FITS YOU to MAKE GOOD as a COMPETENT, WELL PAID, PRACTICAL SPECIALIST and won't let you risk a "fall down" on a good job, as is the danger with inferior, too short training on poor equipment.

**AUTO Opportunities**

NATIONAL offers you more than \$25,000 worth of new cars to learn on, plus a world of other Auto shops equipment so you can become Expert. Astonishing opportunities for fine salaried positions or a prosperous business of your own. Twenty eight million motor vehicles in use, are your good fortune—all need repairing, overhauling—kept moving. You will find NATIONAL training COMPLETE, EASY, FASCINATING and QUICK.

**NATIONAL—Best Equipped Trade School in America**

NATIONAL the twenty-five year old, Million Dollar Institution specializes in ELECTRICITY, AUTOS, RADIO—outstanding for high pay oppor-

tunities. Choose one of these professions today, but INSIST ON NATIONAL TRAINING. IT'S BEST and YOU NEED IT TO handle any of the many desirable jobs.

**MORE MEN NEEDED IN ELECTRICITY**

NATIONAL TRAINING is REAL Shop work—winding REAL armatures, WORK on REAL dynamos, REAL motors, REAL generators—everything REAL. It's thorough, too, yet easily mastered. Ours is complete, man size training for man size jobs at man size pay. Boulder Dam is only one of many West Coast projects involving millions of dollars now under way. Clip coupon for **FREE ELECTRICAL CATALOG.**

**AUTOMOBILES**

**NATIONAL ELECTRICAL, RADIO & AUTO SCHOOLS**



# TO FAMOUS "NATIONAL" ANGELES, *the City Beautiful* ... **INCOMPARABLE!**

## The Heart of The Progressive West Coast

The West Coast is growing faster than any other part of the United States. Los Angeles leads the West Coast. It is the heart of Electrical, Automotive and Radio development. Moreover it is truly the **ONE IDEAL PLACE TO ENJOY LIFE.** Living expenses more reasonable than in any of the country's large centers.

## Indescribable Los Angeles

Words can hardly express the ideal living conditions in Los Angeles. The comfortable year round climate, the nearby beaches, the encircling mountains, reasonable living expenses. Here indeed is the perfect place to prepare for success.



## National's Training In Every Man's Reach

If you are really ambitious and want to make a success in life National will be glad to help you. Send coupon for free catalog today. Let me tell you how we have trained over 22,000 men for success.



**Los Angeles alone needs more trained men than we can supply.**

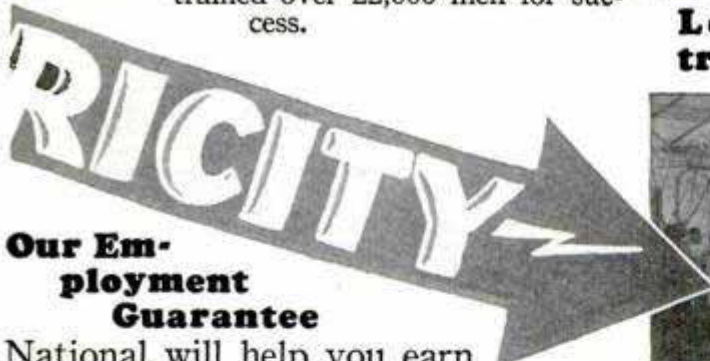

## Our Em- ployment Guarantee

National will help you earn living expenses while learning, also free, efficient employment service after you graduate.

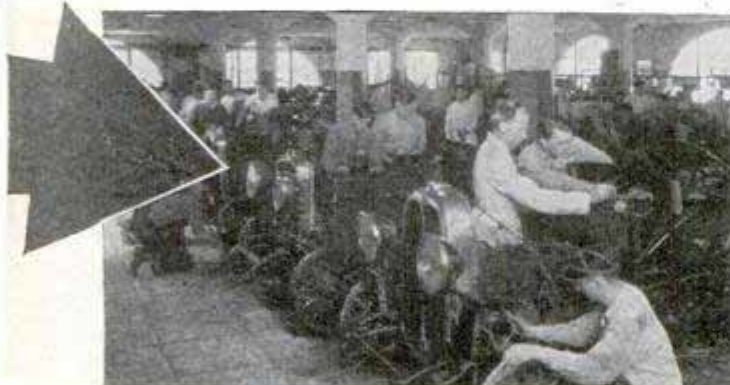

**22,000 Successful Graduates**

**MAIL COUPON FOR FREE CATALOG**

## NATIONAL ELECTRICAL RADIO & AUTO SCHOOLS

Dept. 74  
Figueroa at Santa Barbara Sts.  
Los Angeles, California  
Please rush **FREE CATALOG** checked below without obligation on my part.  
 Electrical       Radio       Autos

NAME.....

ADDRESS.....CITY.....

**FOR AMBITIOUS MEN, YOUNG AND OLD!**





## "I had to make more money—for her"

"THREE weeks after I met Ann we were engaged. It was when we began talking about rents and furniture and such things that I woke up.

"I'd been drifting along in a routine office job for years. I knew I didn't deserve a raise. And yet I had to make more money—a lot of it—and quick. It was Ann herself who suggested the International Correspondence Schools. She believed in me so thoroughly that she made me believe in myself, and I started studying the I. C. S. course in Accounting in my spare time.

"That was a year and a half ago. We've been married six months and I just got my third promotion. I'm head of the cost accounting department now. My I. C. S. course was the finest investment I ever made."

Are you one of the thousands of young men who need a bigger salary and a better job? In an hour a day of your spare time you can secure the training that will bring you advancement. Without cost, without obligation, find out what the I. C. S. can do for you. Mark and mail this coupon now!

### INTERNATIONAL CORRESPONDENCE SCHOOLS

"The Universal University"  
Box 5507-G, Scranton, Penna.

Without cost or obligation, please send me a copy of your booklet, "Who Wins and Why," and full particulars about the subject before which I have marked X:

#### TECHNICAL AND INDUSTRIAL COURSES

- |  |  |
|--|--|
| <input type="checkbox"/> Architect   | <input type="checkbox"/> Automobile Mechanic                                 |
| <input type="checkbox"/> Architectural Draftsman                             | <input type="checkbox"/> Plumbing <input type="checkbox"/> Steam Fitting     |
| <input type="checkbox"/> Building Estimating                                 | <input type="checkbox"/> Heating <input type="checkbox"/> Ventilation        |
| <input type="checkbox"/> Wood Millworking                                    | <input type="checkbox"/> Sheet Metal Worker                                  |
| <input type="checkbox"/> Contractor and Builder                              | <input type="checkbox"/> Steam Engineer                                      |
| <input type="checkbox"/> Structural Draftsman                                | <input type="checkbox"/> Steam Electric Engineer                             |
| <input type="checkbox"/> Structural Engineer                                 | <input type="checkbox"/> Civil Engineer                                      |
| <input type="checkbox"/> Electric Wiring                                     | <input type="checkbox"/> Surveying and Mapping                               |
| <input type="checkbox"/> Electrical Engineer                                 | <input type="checkbox"/> Refrigeration                                       |
| <input type="checkbox"/> Electric Lighting                                   | <input type="checkbox"/> R. R. Locomotives                                   |
| <input type="checkbox"/> Welding, Electric and Gas                           | <input type="checkbox"/> R. R. Section Foreman                               |
| <input type="checkbox"/> Reading Shop Blueprints                             | <input type="checkbox"/> R. R. Bridge and Building Foreman                   |
| <input type="checkbox"/> Telegraph Engineer                                  | <input type="checkbox"/> Air Brakes <input type="checkbox"/> Train Operation |
| <input type="checkbox"/> Telephone Work                                      | <input type="checkbox"/> Highway Engineering                                 |
| <input type="checkbox"/> Mechanical Engineer                                 | <input type="checkbox"/> Chemistry <input type="checkbox"/> Pharmacy         |
| <input type="checkbox"/> Mechanical Draftsman                                | <input type="checkbox"/> Coal Mining Engineer                                |
| <input type="checkbox"/> Machinist <input type="checkbox"/> Toolmaker        | <input type="checkbox"/> Navigation <input type="checkbox"/> Boilermaker     |
| <input type="checkbox"/> Patternmaker  | <input type="checkbox"/> Textile Overseer or Supt.                           |
| <input type="checkbox"/> Pipefitter <input type="checkbox"/> Tinsmith        | <input type="checkbox"/> Cotton Manufacturing                                |
| <input type="checkbox"/> Bridge Engineer                                     | <input type="checkbox"/> Woolen Manufacturing                                |
| <input type="checkbox"/> Bridge and Building Foreman                         | <input type="checkbox"/> Agriculture <input type="checkbox"/> Fruit Growing  |
| <input type="checkbox"/> Gas Engines <input type="checkbox"/> Diesel Engines | <input type="checkbox"/> Poultry Farming <input type="checkbox"/> Radio      |
| <input type="checkbox"/> Aviation Engines                                    | <input type="checkbox"/> Marine Engineer                                     |

#### BUSINESS TRAINING COURSES

- |   |  |
|---|--|
| <input type="checkbox"/> Business Management                                  | <input type="checkbox"/> Business Correspondence                             |
| <input type="checkbox"/> Office Management                                    | <input type="checkbox"/> Lettering Show Cards <input type="checkbox"/> Signs |
| <input type="checkbox"/> Industrial Management                                | <input type="checkbox"/> Stenography and Typing                              |
| <input type="checkbox"/> Personnel Management                                 | <input type="checkbox"/> Complete Commercial                                 |
| <input type="checkbox"/> Traffic Management                                   | <input type="checkbox"/> Civil Service <input type="checkbox"/> Mail Carrier |
| <input type="checkbox"/> Accountancy <input type="checkbox"/> Cost Accountant | <input type="checkbox"/> Railway Mail Clerk                                  |
| <input type="checkbox"/> C. P. Accountant                                     | <input type="checkbox"/> Grade School Subjects                               |
| <input type="checkbox"/> Bookkeeping  | <input type="checkbox"/> High School Subjects                                |
| <input type="checkbox"/> Secretarial Work                                     | <input type="checkbox"/> College Preparatory                                 |
| <input type="checkbox"/> Spanish <input type="checkbox"/> French              | <input type="checkbox"/> Illustrating <input type="checkbox"/> Cartooning    |
| <input type="checkbox"/> Salesmanship <input type="checkbox"/> Advertising    | <input type="checkbox"/> Lumber Dealer                                       |

Name.....

Address.....

City..... State.....

Occupation.....

If you reside in Canada, send this coupon to the International Correspondence Schools, Canadian, Limited, Montreal, Canada

# Increase Your Earning Power

Apply time and labor-saving kinks to your work. Your efficiency will soon be recognized and you will be in line for advancement.

If you do machine shop work of any kind, sheet-metal work, painting, carpentry, auto repairing, farming, concrete work, plumbing, electrical work, welding, building, glass work, general repairing, tool-making, poultry raising, masonry or home repair work, get this

## LIBRARY OF 6000 TIME AND LABOR SAVING IDEAS FOR SHOPMEN AND HANDYMEN

### JUST PUBLISHED

## SHOP NOTES for 1930

192 Pages  
415 Articles  
377 Illustrations

See partial list  
of  
contents below

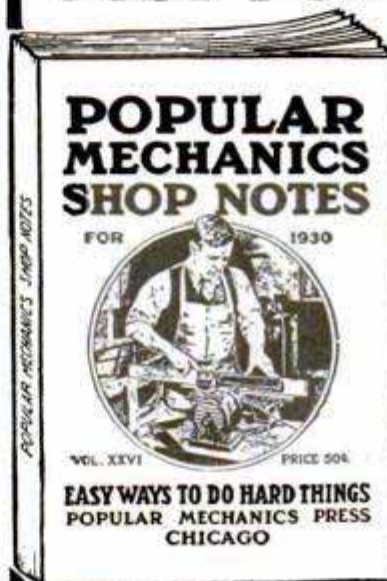

Including the new 1930 issue illustrated above, there are now 13 volumes in the Shop Notes Library of 6,000 easily understood short cuts to every-day jobs. Here are just a few of the subjects taken from the 415 articles in the latest issue.

- |  |                                     |   |
|--|-------------------------------------|---|
| Animal Traps, Care of  | Concrete Fountain Water, Cooler for | Sanding on the Lathe                                    |
| Barrel Method of Stringing                                     | Furniture, Refinishing Old          | Saw Mount for Home Shop                                 |
| Bench Light, Convenient  | Furniture, Restoring Damaged        | Saws, Keeping Fit                                       |
| Bench Saw, Getting Most Out of                                 | Hacksaw, Power, for Small Shops     | Scrollsaw, Ball-Bearing                                 |
| Boatwain's Chair Rigging                                       | Hoist, Light and Strong             | Speedboats, Automatic                                   |
| Bookcase, Modern   | Household Shortcuts                 | Switch for Stainless Steel, Soldering                   |
| Brass Fixtures, Cleaning                                       | Ice Cutter, Engine-Driven           | "Sugi" Finish, How to Apply                             |
| Builders' and Contractors' Kinks                               | Outboard Motor, Super-charger for   | Summer House, Japanese                                  |
| Cams Jig for Layout of Conveyor, Portable                      | Package Sealer, Home-made           | Templates, Making Accurate                              |
| Speeds Loading   | Pipe Holder, Hammered-Copper        | Tinners, Paint Scraper for                              |
| Doing on Small Power Saws                                      | Power Saw Made from Buffing Head    | Toolrest, Sliding, for Emery Wheel                      |
| Decorating with Pastry Gun                                     | Power Shears Made in Small Shop     | Tools for Home Mechanics                                |
| Disk Sander Making Ellipse, How to Lay Out "Exercise" Electric | Sand Disk for Small Lathe           | Towed Car Steered by Tow Bar                            |
| Farmers, Labor-Saving Kinks for "Fingertones", Making          |                                     | Wood, Plastic Filler for Workshop, Homemade Combination |

Each volume contains approximately 500 articles and 400 illustrations and has 224 Pages. At the regular price of 50 cents per single volume this library costs \$6.50, but for a limited period we will supply the 13 vols. when ordered at one time at the special reduced price of only \$4.00.

### SPECIAL OFFER COUPON

POPULAR MECHANICS PRESS,  
200 E. Ontario St., Room P10, Chicago, Ill.

Send me, as per your special offer, the following books. I will pay postman price and small amount of postage. My money will be refunded if I am not satisfied. (Check what you want.)

- 1930 Shop Notes and Lathe Handbook, both for 98c.  
 Complete Shop Notes Library (13 vols.) \$4.00.

Name.....

Street and No.....

City..... State.....



# Who else wants to learn to play....

at home without  
a teacher, in 1/2 the usual  
time and 1/3 the usual cost?

**O**VER half a million men and women have learned to play their favorite instruments the U. S. School of Music way!

That's a record of which we're mighty proud! A record that proves, better than any words, how *thorough*, how *easy*, how *modern* this famous method is.

Just think! You can quickly learn to play any instrument—directly from the notes—and at an average cost of only a few cents a day.

You study in your own home, practice as much or as little as you please. Yet almost before you realize it you are playing real tunes and melodies—not dull scales, as with old-fashioned methods.

## Like Playing a Game

The lessons come to you by mail. They consist of complete printed instructions, diagrams, and all the music you need. You simply can't go wrong. First you are *told* what to do. Then a picture *shows* you how to do it. Then you do it yourself and *hear* it. No private teacher could make it any clearer.

As the lessons continue they become easier and easier. For instead of just scales you learn to play by *actual notes* the favorites that formerly you've only *listened* to. You can't imagine what fun it is, until you've started!

Truly, the U. S.

School method has removed all the difficulty, boredom, and extravagance from music lessons.

## Fun—Popularity

You'll never know what real fun and good times are until you've learned to play some musical instrument. For music is a joy-building tonic—a sure cure for the "blues." If you can play, you are always in demand, sought after, sure of a good time. Many invitations come to you. Amateur orchestras offer you wonderful afternoons and evenings. And you meet the kind of people you have always wanted to know.

Never before have you had such a chance as this to become a musician—a really good player on your favorite instrument—without the deadly drudging and prohibitive expense that were such drawbacks before. At last you can start right in and *get somewhere*, quickly, cheaply, thoroughly.

## Here's Proof!

"I am making excellent progress on the 'cello—and owe it all to your *easy lessons*," writes George C. Lauer of Belfast, Maine.

"I am now on my 12th lesson and can already play simple pieces," says Ethel Harnishfeger, Fort Wayne, Ind. "I *never* nothing about music when I started."

"I have completed only 20 lessons and can play almost any kind of music I wish. My friends are astonished," writes Turner B. Blake, of Harrisburg, Ill.

And C. C. Mittlestadt, of Mora, Minn., says, "I have been playing in the brass band for several months now. I learned to play from your *easy lessons*."



You, too, can learn to master the piano, violin, 'cello, saxophone—any instrument you prefer—this quick, easy way! For every single thing you need to know is explained in detail. And the explanation is always *practical*. Little theory—plenty of *accomplishment*. That's why students of the U. S. School course get ahead *twice as fast* as those who study by old-fashioned, plodding methods.

## Booklet and Demonstration Lesson—FREE!

The whole interesting story about the U. S. School course cannot be told on this page. A booklet has been printed, "Music Lessons in Your Own Home," that explains this famous method in detail, and is yours free for the asking. With it will be sent a Free Demonstration Lesson, which *proves* how delightfully quick and easy—how *thorough*—this modern method is.

If you really want to learn to play at home—without a teacher—in one-half the usual time—and at one-third the usual cost—by all means send for the Free Booklet and Free Demonstration Lesson AT ONCE. No obligation. (Instruments supplied if desired—cash or credit.) U. S. SCHOOL OF MUSIC, 710 Brunswick Bldg., New York.

U. S. SCHOOL OF MUSIC,  
710 Brunswick Bldg., New York City

Please send me your free book, "Music Lessons in Your Own Home," with introduction by Dr. Frank Crane, Free Demonstration Lesson and particulars of your easy payment plan. I am interested in the following course:

Have You

.....Instrument?.....

Name.....

Address.....

City.....State.....

### Pick Your Instrument

Piano	Violin
Organ	Clarinet
Ukulele	Flute
Cornet	Saxophone
Trombone	Harp
Piccolo	Mandolin
Guitar	'Cello
Hawaiian Steel Guitar	
Sight Singing	
Piano Accordion	
Italian and German Accordion	
Voice and Speech Culture	
Harmony and Composition	
Drums and Traps.	
Automatic Finger Control	
Banjo (Plectrum, 5-String or Tenor)	



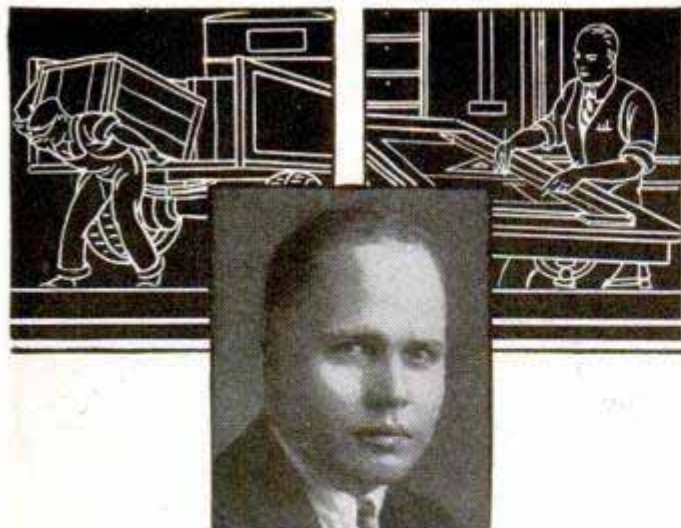

**"Pleasantly Surprised"**  
at starting salary

**\$150**

Writes James Gebhart, of 5134 Camden St., Oakland, Calif. "I report for work tomorrow morning in the Drafting room of Thebo, Start and Anderton, engineering firm in Frisco. I was pleasantly surprised at the starting salary, which is \$150 per month."

Compare that with \$110 a month Gebhart earned when he came to us and it's easy to see that a year's training which cost him \$72 has already increased his earning capacity \$480 a year.

Gebhart used to be a truck driver. Not much future to that. Now, as architectural draftsman—he has a wonderful future ahead of him. And Gebhart is just one of THOUSANDS of men that have found American School courses a good investment. Why don't you find out what we can do for you?

**— American School —**  
Dept. G-747, Drexel Ave. and 58th St., Chicago, Ill.



**AMERICAN SCHOOL**  
Chartered in 1897, as an Educational Institution, NOT FOR PROFIT. Over 200 noted engineers, business executives and educators have helped us prepare our instruction *ser vice*.

Without cost or obligation please tell me how I can win a better position and increased pay in line marked X below. Also explain your employment plan.

**BUILDING CONSTRUCTION**

- Architecture
- Building Contracting
- DRAFTING and DESIGN**
- Machine Drafting and Design
- Architectural Drafting
- Electrical Drafting
- Structural Drafting
- Automotive Drafting

**ENGINEERING**

- Mechanical Engineering
- Civil Engineering
- Electrical Engineering
- Automotive Engineering
- Machine Shop Practice

**BUSINESS**

- Accounting, Auditing
- Business Management (Finance, Sales, Production, Accounting)
- HIGH SCHOOL IN 2 YEARS**

Name.....

Occupation.....

St. No. .... City ..... State .....

**Why Good Dancers Are Popular**

Everyone wants to dance with the person who knows the smart new steps!

Through my new method you can learn the latest, most popular steps in *one evening*—right in your own home, without music, partner, teacher. Simple as taking one step after another.

Thorough—takes you from the very beginning to this season's newest dances and all their variations.

Regular **Now Only \$1.98**  
**\$5.00 Course**

**5 Day Trial—Free** Would cost you \$24.00 if taken at a Studio. Practice in your spare time—surprise your friends—with your new-found popularity.

400,000 have already become accomplished, versatile dancers this easy way. Your success is guaranteed! To prove it I will send you my dancing course *without one penny in advance*. Just send your name and address and when the package arrives give postman only \$1.98 plus delivery charges, and this famous course is yours. Try for 5 days—*money back if not delighted!* Don't delay—act now and be a good dancer soon.

**ARTHUR MURRAY** Studio 152, 7 East 43rd Street  
NEW YORK, N. Y.



*Learn to Write*

**I Teach by Mail**

Begin Today—Write for My FREE Book, I can make a good penman of you at home during spare time. Write for my FREE BOOK, "How to Become a good Penman." It contains specimens and tells how others mastered penmanship by the Tamblin System. Your name will be elegantly written on a card if you enclose stamp to pay postage. Write today for book. F. W. Tamblin, 418 Ridge Bldg., Kansas City, U.S.A.

**WORLD NEEDS PLUMBERS**

Old style plumbers are fading like the horse and buggy. The world demands modern Plumbing and Skilled Trained Mechanics to do it. Unlimited, swift growing field. Make \$50 to \$100 a week or start own shop. We train you quick. Learn in 8 to 12 WEEKS to do any job with skill and science. Need no previous experience. Strictly tool using system. Opportunity knocks. Investigate today—amazing offer—low tuition. World's greatest school.

Write—**UNIVERSAL PLUMBING SCHOOL**  
2130 Troost Ave. Kansas City, Mo.



Learn to **PAINT SIGNS and SHOW CARDS**

We quickly teach you by mail, or at school, in spare time. Encourages demand. Big future. Interesting work. Oldest and foremost school. **EARN \$50 TO \$200 WEEKLY**

Otto Wiegand, Md., home-study graduate, made \$12,000 from his business in one year. John Vassos, N.Y., sets \$25 for a show card. Crawford, B. C., writes: "Earned \$200 while taking course." Write for complete information.

**DETROIT SCHOOL OF LETTERING**  
154 Stinson Ave. Est. 1899 Detroit, Mich.

**WHY STAMMER?**

Don't be a failure. Master perfect speech. Live a healthy, normal and happy life. Send for free book which tells you how. **THE LEWIS INSTITUTE, 12962 Woodward Ave., Detroit, Mich.**

**LEARN WATCH REPAIRING**



You can learn by our modern and original system of instruction every part of the **Watch Repairing Trade** at home as good or better than at a shop. You can earn money while learning and secure a well paying position or start in business after completing our course of instruction. Good watch repairers are always in demand and earn from \$50 to \$75 per week. For particulars apply to the **Wisconsin School of Watch Repairing**  
166 Mason St., MILWAUKEE, WIS.



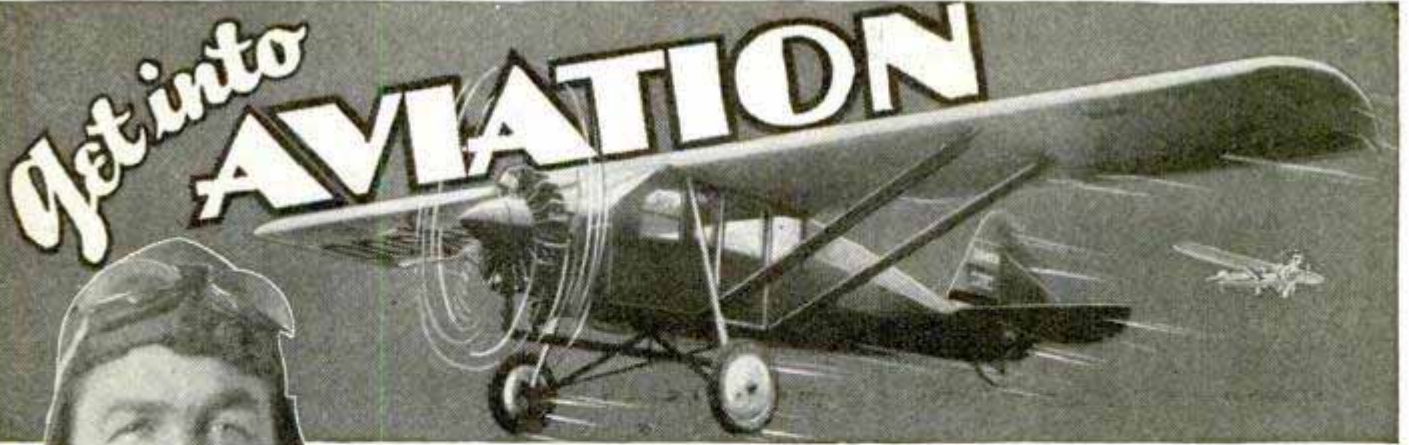

**Major Rockwell  
World War Flyer  
Who Will Teach You**

Major Rockwell is a famous World War Flyer, decorated with the Legion of Honor and the War Cross. He is now devoting himself to teaching Aviation, and he will train you for a position in this great new industry as only a Veteran World War Flyer can train you. Under Major Rockwell's guidance your future in Aviation is assured.

**"I Will Train You in Your Spare Time  
Learn to Earn  
\$300 to \$400 a Month"**

I make this amazing offer, for a short time and to a limited number, to supply the crying need for trained men. Here is your opportunity to get into this uncrowded, fascinating field with a definite certainty of your future.

**In a Few Short Months**

Just devote about an hour a day to my Home Study Course, and in a few short months you can master the principles of Ground Training, which are necessary before you

**take your place in any branch of Aviation.**

In a few short months I will give you practical aviation training and prepare you for one of the big pay, thrilling jobs open only to men thoroughly trained in Aviation.

**No Advance Education Necessary or Experience Needed**

You don't need to have a high school or college education to master my course. You do not even need to know anything about airplanes, motors or mechanics. My home course is thorough and complete. Everything is so clearly explained, with easy-to-understand text and pictures, that in a few short months you will be

able to grasp every fundamental principle of Aviation ground work and you will be well on the road to qualify for any important aviation job paying \$300 to \$400 a month. My Home Study Course will give you all the knowledge necessary to pass the government's written examinations for mechanics' or pilots' licenses.

**Glider Course  
No Extra Cost**

To all students who enroll now we will include a Glider Course without extra charge. This course has been prepared in accordance with the correct principles of glider construction and operation and is a very valuable addition to your knowledge of Aviation. Enroll at once and get the Glider Course.

**You Learn Principles of Aviation at Home  
Then Choose Any One of 40 Ground Jobs.  
If You Want Actual Flying, My Home Study Course**

teaches you the principles of flight. When you have completed the ground training I will arrange for you to take your flying instruction at any licensed airport near your home at special reduced rates. Or if you want you can come here to Dayton and get training at one of the finest and best equipped airports in America. No matter where you learn to fly you can qualify for a pilot's license and a high pay flying job in passenger lines, mail service, and other important branches of flying.

**Employment  
Service**

After you graduate I assist you in getting a job without any cost to you. Right now the demand for trained men is greater than the supply. A place is ready for you!

**Only Trained Men Can Qualify in Aviation**

The big money in Aviation does not go to the novice or apprentice. Only TRAINED men can command the high salaries. Employers are glad to pay big money for men who know Aviation—builders, mechanics, service and maintenance men, and flyers. Let me prepare you for one of the many high salaried Aviation jobs open to the trained man. I will prepare you to take your place in the most fascinating, fastest growing industry in the world. Act now while my special offer lasts. Rush this coupon to me for a copy of my famous free book.

**MONEY BACK AGREEMENT**

I am so sure that you can learn Aviation with my help and step into a big aviation job that if you are not satisfied when you have finished my course, I agree to return every penny of your tuition.

**MAJOR ROB'T L. ROCKWELL**

**THE DAYTON SCHOOL OF AVIATION**  
Desk X-1 DAYTON, OHIO

**Get My No-Risk Plan  
My Big Book  
Explains ALL  
I'll send it FREE**



**Major Rob't L. Rockwell  
The Dayton School of Aviation  
Desk X-1, Dayton, Ohio.**

Dear Major:—Please send me FREE and without obligation a copy of your famous book on Aviation; also your special tuition and position offer.

Name.....

Address.....

Town..... State..... Age.....



# There's A Better Living For Any Man of Limited Means and Education IN BARBERING



## SHORT—PRACTICAL COURSE

*Protecting Laws Make It the Best Profession  
in the Universe*

RALPH KUHLMAN has a Barber job on the Santa Fe running from Chicago to Los Angeles paying as high as \$60 a single trip. ARTHUR BAKER runs a shop in the exclusive great money district of Wall Street. He has accumulated a fortune. BOTH of these boys are MOLER GRADUATES. (Names of other graduates furnished on request.)

## GOODNESS!!! GRACIOUS!!!

Why not learn a profession by enrolling in a school whose method of teaching and course of instruction is approved by all State Boards? **There is a school near you.** Write to the nearest one and see.

## Standardized Branches Moler System of Colleges

139 E. 23rd St., New York City  
512 N. State St., Chicago, Ill.  
810 N. 6th St., St. Louis, Mo.  
801 Main St., Kansas City, Mo.  
206 E. 4th St., Cincinnati, Ohio  
215 Huron Road, Cleveland, Ohio  
559 Michigan Ave., Detroit, Mich.  
1229-17th St., Denver, Colo.

1302 Douglass St., Omaha, Neb.  
501 E. Water St., Milwaukee, Wis.  
81 Forsyth St., N. W., Atlanta, Ga.  
81 S. Second St., Memphis, Tenn.  
1713 Commerce St., Dallas, Texas

## Address Nearest Branch

Please send me without obligation on my part your Booklet B

Name.....

Address.....

City.....State.....

# Play the Drums

## IT'S EASY TO LEARN!

If you can "keep step" to music, you can learn to play the drums. Then you'll be popular. In demand everywhere. Chances to play in bands and orchestras. Fun playing at home with radio accompaniment. New, easy method. Instruction course free with every Leedy outfit. Leedy drums are best in tone, finish and construction. Endorsed by leading professionals. Yet you can own a genuine Leedy outfit; snare drum, bass drum and traps, for as little as \$35.

**HOME TRIAL—EASY PAYMENTS**  
Easy terms. Home trial. You risk nothing. Write today for free literature and special offer.

**LEEDY MANUFACTURING COMPANY**  
1008 LEEDY BLDG.,  
ELKHART, IND.

# Leedy



Mechanical and flying instruction under Government licensed experts. Training for all types of licenses. Day or evening. Work out part of your tuition.

2000 Allegheny Ave., Phila., Pa.

## WM. PENN AIRCRAFT SCHOOL

## TRI-STATE COLLEGE

B. S. degree in 2 years in Aeronautical, Civil, Electrical, Mechanical, Chemical, Administrative Engineering. Students who left H. S. can make up work. Tuition low. *Catalog.*

4100 College Street  
Angola, Indiana

## Learn Watchwork, Jewelrywork and Engraving

A fine trade commanding a good salary, and your services always in demand. Address **Horological**, Dept. P, Bradley Institute, PEORIA, ILLINOIS, for our latest catalog.

## Now! Ruined NECKTIES

### Look Like NEW!

NEVER BE THROWN AWAY! Newly invented Electric "Nek-Tie" Iron keeps them like new indefinitely. Smooths, restores, reshapes, old wrinkled ties in less than a minute.

**AGENTS! PROFIT!** 100%  
Great Profits for agents. 10 Easy Sales a Day nets \$20.00. Reserve territory NOW. Write TODAY for Free Offer. Don't wait minute.

**Ser-Val Products Corp.**  
1060 Broad St.  
Dept. K-14 Newark, N. J.

Works smoothly, easily, effortlessly. Plug into electric socket. Slip tie over iron. That's all! Now, tie looks new, crisp and retains all the original gloss and luster.

**OLD TIES LOOK GOOD again**



# 1000 Hotel Positions! Open!



**H**OTELS, Restaurants, Clubs, Apartment Hotels, Institutions, Schools, Colleges, Hospitals, etc., everywhere need trained men. Over 70,000 high-class positions as Manager, Assistant Manager, Steward, Room Clerk, Purchasing Agent, Sports Director and scores of other executive positions, paying from \$2,500 to \$10,000 a year, are open each year in the hotels of the United States alone. Nearly two billion dollars' worth of new hotels, apartment hotels, clubs, restaurants and institutions being built this year will need over 200,000 trained men and women.

## I WILL TRAIN YOU IN YOUR SPARE TIME

Through my spare-time study course you can qualify for a well-paid position. At any time there are over 1,000 positions open in this industry. I put my students in touch with positions. All over the United States they are eagerly sought by the biggest and best hotels. Hotels start you at salaries up to \$2,500 a year with your living usually included. If you want a steady, permanent position, with quick advancement, fascinating work, big pay, fine living, with meals and luxurious apartment usually furnished FREE—you can find it in hotel work.

## Opportunity Coupon 1000 Hotel Positions Open!

Lewis Hotel Training Schools,  
Room CS-310, Washington, D. C.  
Send me without obligation the FREE BOOK,  
"Your Big Opportunity," with details about  
Registration in the Lewis National Employment Bureau.

Name.....

Address.....

City.....State.....

### NO PREVIOUS EXPERIENCE NECESSARY

We train you by mail in your spare time at home with the Lewis Simplified Home Study Plan and put you in touch with big opportunities. All of your training under the personal supervision of Clifford Lewis, former U. S. Government Hotel and Restaurant Expert, who has been appointed Managing Consultant by over 300 hotels throughout the United States.

Through Lewis Training, Leroy L. Saunders became Assistant Manager of an \$8,000,000 Athletic Club. Frank Schrath, through the Lewis Course, became Steward of a large Restaurant, at **double** his previous salary! C. W. Ryder was appointed Purchasing Agent of a chain of hotels a few weeks after he received his diploma from the Lewis Schools.

### FREE BOOK GIVES FULL DETAILS

No matter what your present occupation is—there are opportunities for you in the big-paying hotel and institutional field. Many students have obtained splendid hotel positions paying as high as \$2,500 a year, even before they had finished the course. My Free Book—"Your Big Opportunity"—shows how you can do as well and explains how you are registered in our National Employment Bureau.

Mail the coupon at once for your free copy of "Your Big Opportunity," explaining our Money-Back Agreement and showing how we can train you for one of these splendid positions. Send for it today—NOW—before you forget.

## LEWIS HOTEL TRAINING SCHOOLS

Room CS-310

CLIFFORD LEWIS, Pres.

Washington, D. C.

The Original and Only School of Its Kind in the World



**"When All Other Methods of VOICE**

**Training Have Failed—**

*I urge you to try this NEW Silent Method of Voice Training . . . it saved—restored my voice after other methods failed."*

*Pompeo Tommasini*

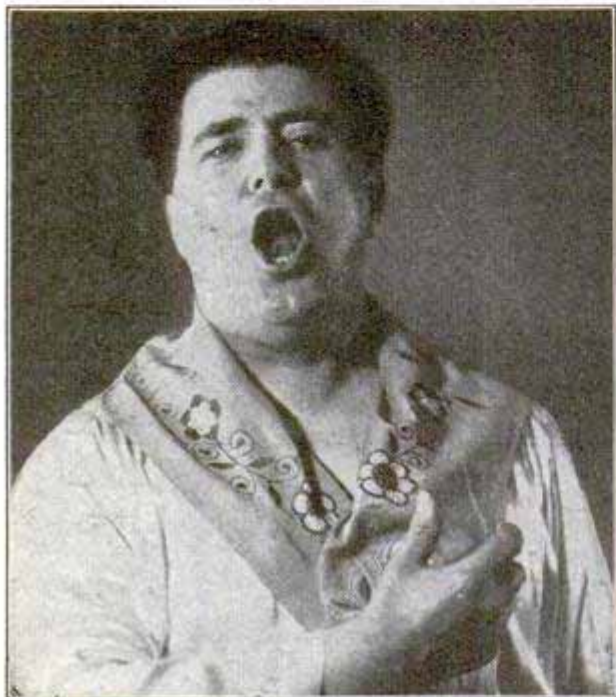

*Famous Italian Tenor*

**100% Improvement Guaranteed!**

If you, too, have found other methods failed to develop or improve your voice—don't be discouraged!—Write for free voice booklet telling all about this tried and proved Silent Method of Voice Training that has worked seeming miracles for this famous Italian tenor and scores of other men and women. Take the first step toward the voice you've longed for—**mail coupon!**

**Perfect Voice Institute, Dept. 13-57  
1922 Sunnyside Ave., Chicago**

**Mail Coupon for Free Voice Book**

**Perfect Voice Institute, Dept. 13-57  
1922 Sunnyside Ave., Chicago**

Please send me FREE and without obligation, Prof. Feuchtinger's new book, "Physical Voice Culture." I have checked subject in which I am most interested.

Weak Voice  Singing  Stammering  Speaking

Name \_\_\_\_\_

Address \_\_\_\_\_

City \_\_\_\_\_ State \_\_\_\_\_

**ENGINEERING — ELECTRICITY  
ARCHITECTURE — DRAFTING**

Save time—enroll at this old established school of engineering. Enter any time, days or evenings. 1, 2 and 3 year courses. Diplomas and B. S. Degrees.



Special 4 months' practical course in Drafting. Others short courses. Low tuition—easy terms. Earn while you learn. Free employment bureau. Athletics. Successful graduates everywhere. Write for our free, illustrated 80 page "Blue Book." It gives you all the facts. Address the President, Charles W. Morey, B. S., M. E.

**CHICAGO TECHNICAL COLLEGE**  
Dept. N-78 118 East 26th Street, Chicago, Ill.

**BE A JAZZ MUSIC MASTER**



**Play Piano By Ear**

Play popular song hits perfectly. Hum the tune, play it by ear. No teacher—self-instruction. No tedious ding-dong daily practice—just 20 brief, entertaining lessons, easily mastered.

**At Home in Your Spare Time**

Send for FREE BOOK. Learn many styles of bass and syncopation—trick endings. If 10c (coin or stamp) is enclosed, you also receive wonderful booklet "How to Entertain at Piano"—and many new tricks, stunts, etc.

**Niagara School of Music**  
Dept. 402 Niagara Falls, N.Y.

Send for this Free Book

You can be quickly cured, if you

**STAMMER**

Send 10 cents for 288-page book on Stammering and Stuttering. "Its Cause and Cure." It tells how I cured myself after stammering 20 yrs. B. N. Bogue, 11134 Bogue Bldg., 1147 N. Illinois St., Indianapolis.



**"BECOME A LIGHTNING TRICK CARTOONIST"**

Send \$1.00 for Laugh Producing Program of 23 Trick Drawings with Instructions. Catalog of Chalk Talk Supplies Free. BALDA ART SERVICE, Dept. 1, Oshkosh, Wis.

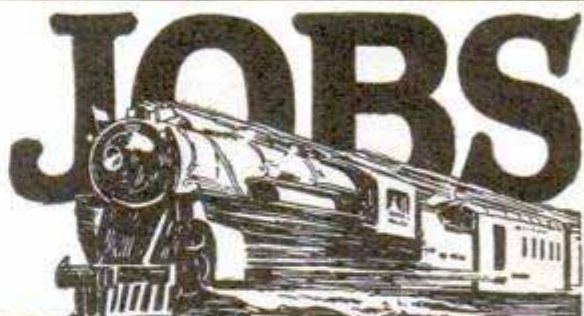

**U.S. GOV'T TRAVELING OR LOCAL \$110 TO \$250 MONTH**

<b>MAIL TODAY</b>	<input type="checkbox"/> Railway Mail Clerk	<input type="checkbox"/> Meat Inspector
	<input type="checkbox"/> P. O. Clerk	<input type="checkbox"/> Special Agent
	<input type="checkbox"/> P. O. Laborer	<input type="checkbox"/> [Investigator]
	<input type="checkbox"/> File Clerk	<input type="checkbox"/> Stenographer-Typist
	<input type="checkbox"/> Matron	<input type="checkbox"/> Immigrant Inspector
	<input type="checkbox"/> General Clerk	<input type="checkbox"/> City Mail Carrier
	<input type="checkbox"/> Custom's Inspector	<input type="checkbox"/> U. S. Border Patrol
	<input type="checkbox"/> Skilled Laborer	<input type="checkbox"/> Typist
	<input type="checkbox"/> Watchman	<input type="checkbox"/> Seamstress
	<input type="checkbox"/> Postmaster	<input type="checkbox"/> Steno-Secretary
<input type="checkbox"/> RFD carrier	<input type="checkbox"/> Auditor	

**Ozment Instruction Bureau, 111-A, St. Louis, Mo.**  
Send me particulars about positions marked "x"; salaries, locations "How to Qualify" opportunities, etc.

Name \_\_\_\_\_  
Address \_\_\_\_\_



# Prutzman made \$16 the very first night . . .

**H**ERE are seven sentences taken from a letter written to us by Ralph A. Prutzman, Leighton, Pennsylvania. They tell a short, simple story—yet a story that is brimming with Opportunity for YOU. Read them:

"I saw your advertisement and decided to try to learn the Hawaiian Guitar. I'm getting along splendidly—for the lessons are easy and interesting. I was asked to play at a dance and though it was my first professional engagement—I made \$16.00 that very first night! That money certainly looked good to me—and I see lots more good money-making opportunities ahead. But that's not all! I have more friends and more good times than ever before. I wish I had taken your Course ten years sooner!"

Now before you read another word of this message, understand that it has been written for YOU—not for someone with special "talent," or knowledge of music, or any particular training whatsoever. . . .



## Hawkins is Earning \$10.00 an Evening

Perry Hawkins of 218 Warner Road, Canton, Ohio, is another go-getter who is climbing the ladder of Success two steps at a time! Like all the others, he credits everything he has now, everything he is going to have in the bright future, to the training we have given him. He writes:

"I am getting along fine with my Hawaiian Guitar lessons and am invited to many parties and dances, where I have made as high as \$10.00 in one night with my playing. I have made many new friends, too, and am sorry I didn't take your Course sooner than I did. The instrument you sent me is beautiful and has a wonderful tone."

## Now YOU Can Learn the Real Hawaiian Way— Right at Home—and Cash In Just as BIG

The New York Academy of Music trained Hawkins, Prutzman and hundreds of others. Every lesson is an adventure—a fascinating game! You don't need to know one thing about Music. It doesn't make a bit of difference if you've never touched a string or played a note on any kind of instrument whatsoever. We start you at the very beginning, right at home, to learn to play the real Hawaiian Way. With your very first lesson we send you the Big Outfit shown below—a handsome, professional-size Hawaiian Guitar, complete accessories, demonstration Phonograph Records—everything you need to learn—and earn.

Investigate this opportunity! Get the facts, weigh them—then decide whether YOU will ACT on them!

## Get Your FREE Copy of this Big Book

A copy of "The Hawaiian Way to Popularity and Big Pay" is ready for you. It will bring you all the facts, all the proof. Prutzman and Hawkins both wish now that they had started sooner. Don't let one day's delay make you regretful later on. Use the coupon NOW.

Genuine  
**HAWAIIAN  
GUITAR**  
and  
Complete Outfit  
come with  
first lesson



## Friends, Fun and Man-Size MONEY Are Waiting for YOU;

Make them Yours in 3 Short Months

Ralph Prutzman has proved that the opportunity we offer you can be quickly, easily, PROFITABLY capitalized. And he is only one of hundreds—who have found the New York Academy of Music's amazingly simple Hawaiian Guitar method all and more than we claim for it.

Give yourself this chance to get ahead—socially and financially—this new, proved, practical way. "The Hawaiian Way" is the quick way, too,—1 to 3 short months is all you need. Read the BIG FREE BOOK that meant the starting-point to so many others. The coupon brings it without obligation; send it to us at once!

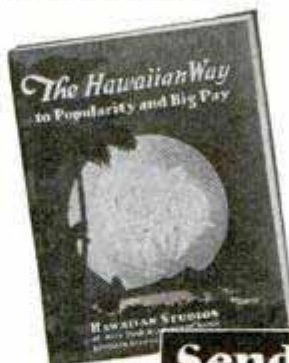

## LOOK at the wonderful outfit you get

With very first lesson we send genuine, full-size, Hawaiian Guitar worth \$20—complete set of picks, strings, tuner, etc.—famous "Know-All" and "Master" Charts that make notes easy as the alphabet—easy, clearly illustrated lessons, and demonstration Phonograph Records, played by Robert Yap, the famous Hawaiian Guitarist.

## Make Every Hour Pay You— Spare-Time or Full-Time

No matter how much or how little time you can give—you profit by every hour, every minute you devote to "The Hawaiian Way." Many of our students make \$15 to \$50 a week spare-time before they finish the Course, playing at dances, entertainments, over the radio, etc. Others play full-time with orchestras.

## Send Coupon by next Mail

A. F. BLOCH, President  
Hawaiian Studios No. 52100 of  
NEW YORK ACADEMY OF MUSIC  
100 Fifth Avenue, New York City

I want more friends—I can use more money. Without obligation send my FREE copy of "The Hawaiian Way to Popularity and Big Pay."

Name.....Age.....

Street.....

City.....State.....



# if-

**you pledge**

yourself to secrecy we will  
teach you the secrets of

**Real Professional**

# Magic



*Dr. Harlan Tarbell, internationally known magician and teacher of some of the world's greatest magicians.*

## Be a Magician!

**No Salesman Will Bother You!**

For the first time in the history of Magic the age-old, sacredly guarded secrets of Mystic Art are being revealed. Now at last you can learn to be a Real Professional Magician. Yes, and you can learn this wonderful art *easily and quickly* AT HOME. You are taught the mysterious *Principles* by which the Professional Magician works. But before you can study, you must sign the Magician's Solemn Pledge of Secrecy. This means you are getting the *guarded secrets* of the Magic Profession.

**Tarbell System, Inc., Studio 13-57**  
1926 Sunnyside Avenue Chicago, Illinois

**Tarbell System, Inc., Studio 13-57**  
1926 Sunnyside Avenue, Chicago, Ill.

Gentlemen: Without any obligation send me your free literature and information all about your wonderful "Tarbell Course in Magic." Also tell me about your Low Price Offer and Easy Payment Plan.

Name .....

Address .....

Age .....

## OPPORTUNITIES IN Traffic Management

### Become a Traffic Expert

The opportunities in traffic management are limited only by the boundaries of the business world. The trained traffic man is in demand by transportation systems and by industrial organizations.

**Three Detroit Firms  
Pay Their Traffic Managers  
Over \$20,000 a Year**

Prepare for this growing, profitable profession at home in your spare time under supervision of traffic experts. Low cost; easy terms. Thru the LaSalle Problem Method you learn by doing. Valuable 64-page booklet free. Send for it Now.

**LaSalle Extension University, Dept. 1064-T, Chicago**



**This Book  
FREE!**

## A Card Case Any MASON Would Be Proud To Own



Protects your lodge cards, \$1 auto license, passes, etc. **1** under isinglass windows, ready to be seen at a glance. A genuine leather, 5-window sturdy card case, extra pocket—snap button—gold corners, for only \$1. Stamped with Masonic Emblem in heavy gold FREE—Same price without emblem. Name and other stamping 35c a line extra. Larger cases, 9 windows \$1.50, 13 windows \$2. Send for Catalogue.

Masonic Books, Monitors, Jewelry.  
 Lodge Supplies. [Check Choice]

**REDDING MASONIC SUPPLY CO.**  
200 Fifth Ave., Dept. P.M., New York

## WELDING ELECTRIC ARC OXY-ACETYLENE

**Taught by Actual Welding Practice.**

No Finer Equipment Anywhere at Any Price. Pipe-Line, Sheet Steel, Structural Steel, Cast Iron, Aircraft and Commercial Welding, Cutting and Brazing. **LOW RATES FOR SUMMER COURSES—ENROLL AT ONCE**

Also Courses in Radio, Electricity and Automobiles

Full Information Free on Request.

**Coleman Electrical School, 1628-X Main St., Kansas City, Mo.**

## BASHFUL?

"Shame on you!" Are you nervous, embarrassed in company of the other sex? Stop being shy of strangers. Conquer the terrible fear of your superiors. Be cheerful and confident of your future! Your faults easily overcome so you can enjoy life to the fullest. Send 25¢ for this amazing book.

**RICHARD BLACKSTONE, B-4710 Flatiron Bldg., N. Y.**

## New Type Door Closer

**Ends SLAM**  
**Saves Nerves**  
**Banishes Flies!**



A SIMPLE yet astonishing little invention that millions of people have always needed now opens an utterly new profit field to agents. It's a new-type, inexpensive, "pneumatic" door closer. Needed for every screen door, all outside doors, bathroom door, etc. Ends slamming and banging. Banishes flies and mosquitoes. Saves fuel in winter. So simple that any boy who can handle a screw driver can attach it. Every home needs and can afford several. Stores, offices, factories, also need and may buy dozens at a time. That's where agents make \$10, \$15, \$20, even more, on just one order! Rich unworked territories now open everywhere for full-time and spare-time workers who act promptly. Write today for introductory sample offer and details.

**Close-A-Door Co., Dept. M-10, 1531 Washington Ave., St. Louis, Mo.**





Radio Me-  
chanic and In-  
spector \$1800  
to \$4000 a Year

# The only course in Radio sponsored by RCA

LET THIS SHORT-CUT HELP YOU INTO

## SUCCESS *in* RADIO

**T**HOUSANDS of men are making good money at Radio—and so can you!

Commercial training is all you need to give you the professional confidence and ability. You can secure this training in your spare time... through a marvelous home-laboratory course sponsored by the Radio Corporation of America. Our big FREE Radio book tells all about it.

### Round out your knowledge with this home-laboratory training

Put the finishing touch to your Radio experience. Get the "How" as well as the "Why" of Radio with this commercial training. Only an hour or so a day—in spare time—is all you need. As part of your course, you receive absolutely free of extra charge—a magnificent outlay of fine apparatus. With this outfit you learn to build fine sets and solve the radio problems that bring good pay. You acquire not only the ability but the confidence to succeed in a real commercial way.

### Training backed by Radio Corporation of America

Our graduates are in demand everywhere. They enjoy greater success be-

cause they're posted right up-to-the-minute in *everything* in Radio. Radio's progress each year is measured by the accomplishment of the great engineers at work in the research laboratories of Radio Corporation of America. This Radio organization sets the standards for the industry.

### Money back if not satisfied

The lessons prepare you for success in all phases of Radio—manufacturing, servicing, selling, ship and shore broadcasting and all types of Radio equipment. A signed agreement backed by RCA assures you of complete satisfaction upon completion of the training—or your money will be promptly refunded.

### Read this thrilling free book

It may mean the turning point in your life. It gives you the real "dope" about Radio and it describes in detail the famous training that has enabled us to place thousands of our students in fine positions, usually from 3 to 10 days after graduation! It tells in 40 fascinating pages and photos all about Radio's brilliant opportunities for adventure and success. Mail the coupon now—the book is absolutely free! RCA Institutes, Inc., 75 Varick Street, New York, N. Y.



Land Station  
Operator \$1800  
to \$4000 a Year



Broadcast Oper-  
ator \$1800 to  
\$4000 a Year



Broadcast Sta-  
tion Mechanic  
\$1800 to \$3600  
a Year



## RCA INSTITUTES

INC.

{A Division of Radio Corporation of America}

RCA INSTITUTES, Inc.  
75 Varick Street, New York, N.Y.

PM-10

Gentlemen: Please send me your big free 40-page book which tells about the great opportunities in radio and about your famous laboratory-method of radio instruction at home.

Name.....

Address.....

Occupation.....



**"He used to work at a machine"**



"That man is head of our engineering department. He worked at a machine for a long time. One day he told me he didn't want to do that kind of work all his life and that he had enrolled for an International Correspondence Schools course to get the training he figured he needed.

"In less than a year the superintendent had chosen him as his assistant. And when the superintendent left he stepped right into his shoes. That course was certainly what he needed to get going and to help put him where he is today."

Spare-time study has helped many men advance from routine jobs to executive positions. Their promotions do not come by luck—they are the rewards of practical training and hard work. You, too, can get ahead—can earn more money! Find out what an hour or two of spare-time study each week will do for you.

**Mark and mail the coupon today**

**INTERNATIONAL CORRESPONDENCE SCHOOLS**  
 "The Universal University"  
 Box 5505-G, Scranton, Penna.

Without cost or obligation, please send me a copy of your booklet, "Who Wins and Why," and full particulars about the subject before which I have marked X:

**TECHNICAL AND INDUSTRIAL COURSES**

- |  |  |
|--|--|
| <input type="checkbox"/> Architect   | <input type="checkbox"/> Automobile Mechanic                                 |
| <input type="checkbox"/> Architectural Draftsman                             | <input type="checkbox"/> Plumbing <input type="checkbox"/> Steam Fitting     |
| <input type="checkbox"/> Building Estimating                                 | <input type="checkbox"/> Heating <input type="checkbox"/> Ventilation        |
| <input type="checkbox"/> Wood Millworking                                    | <input type="checkbox"/> Sheet Metal Worker                                  |
| <input type="checkbox"/> Contractor and Builder                              | <input type="checkbox"/> Steam Engineer                                      |
| <input type="checkbox"/> Structural Draftsman                                | <input type="checkbox"/> Steam Electric Engineer                             |
| <input type="checkbox"/> Structural Engineer                                 | <input type="checkbox"/> Civil Engineer                                      |
| <input type="checkbox"/> Electrical Wiring                                   | <input type="checkbox"/> Surveying and Mapping                               |
| <input type="checkbox"/> Electrical Engineer                                 | <input type="checkbox"/> Refrigeration                                       |
| <input type="checkbox"/> Electric Lighting                                   | <input type="checkbox"/> R. R. Locomotives                                   |
| <input type="checkbox"/> Welding, Electric and Gas                           | <input type="checkbox"/> R. R. Section Foreman                               |
| <input type="checkbox"/> Reading Shop Blueprints                             | <input type="checkbox"/> R. R. Bridge and Building Foreman                   |
| <input type="checkbox"/> Telegraph Engineer                                  | <input type="checkbox"/> Air Brakes <input type="checkbox"/> Train Operation |
| <input type="checkbox"/> Telephone Work                                      | <input type="checkbox"/> Highway Engineering                                 |
| <input type="checkbox"/> Mechanical Engineer                                 | <input type="checkbox"/> Chemistry <input type="checkbox"/> Pharmacy         |
| <input type="checkbox"/> Mechanical Draftsman                                | <input type="checkbox"/> Coal Mining Engineer                                |
| <input type="checkbox"/> Machinist <input type="checkbox"/> Toolmaker        | <input type="checkbox"/> Navigation <input type="checkbox"/> Boilermaker     |
| <input type="checkbox"/> Patternmaker  | <input type="checkbox"/> Textile Overseer or Supt.                           |
| <input type="checkbox"/> Pipefitter <input type="checkbox"/> Tinsmith        | <input type="checkbox"/> Cotton Manufacturing                                |
| <input type="checkbox"/> Bridge Engineer                                     | <input type="checkbox"/> Woolen Manufacturing                                |
| <input type="checkbox"/> Bridge and Building Foreman                         | <input type="checkbox"/> Agriculture <input type="checkbox"/> Fruit Growing  |
| <input type="checkbox"/> Gas Engines <input type="checkbox"/> Diesel Engines | <input type="checkbox"/> Poultry Farming <input type="checkbox"/> Radio      |
| <input type="checkbox"/> Aviation Engines                                    | <input type="checkbox"/> Marine Engineer                                     |

**BUSINESS TRAINING COURSES**

- |   |  |
|---|--|
| <input type="checkbox"/> Business Management                                  | <input type="checkbox"/> Business Correspondence                             |
| <input type="checkbox"/> Office Management                                    | <input type="checkbox"/> Lettering Show Cards <input type="checkbox"/> Signs |
| <input type="checkbox"/> Industrial Management                                | <input type="checkbox"/> Stenography and Typing                              |
| <input type="checkbox"/> Personnel Management                                 | <input type="checkbox"/> Complete Commercial                                 |
| <input type="checkbox"/> Traffic Management                                   | <input type="checkbox"/> Civil Service <input type="checkbox"/> Mail Carrier |
| <input type="checkbox"/> Accountancy <input type="checkbox"/> Cost Accountant | <input type="checkbox"/> Railway Mail Clerk                                  |
| <input type="checkbox"/> C. P. Accountant                                     | <input type="checkbox"/> Grade School Subjects                               |
| <input type="checkbox"/> Bookkeeping  | <input type="checkbox"/> High School Subjects                                |
| <input type="checkbox"/> Secretarial Work                                     | <input type="checkbox"/> College Preparatory                                 |
| <input type="checkbox"/> Spanish <input type="checkbox"/> French              | <input type="checkbox"/> Illustrating <input type="checkbox"/> Cartooning    |
| <input type="checkbox"/> Salesmanship <input type="checkbox"/> Advertising    | <input type="checkbox"/> Lumber Dealer                                       |

Name.....  
 Address.....  
 City..... State.....

Occupation.....  
 If you reside in Canada, send this coupon to the International Correspondence Schools, Canadian, Limited, Montreal, Canada

**Learn SIGN and SHOW-CARD WRITING**  
*In spare time, few hours weekly*

**FREE "Book of Facts" — Write For It**

Fascinating profession. Big opportunity in this fast-growing trade. Earn while you learn the sign arts. No talent or experience required. Be your own boss or obtain a good position. Learn show cards, posters, bulletins, signs, advertising layouts and allied subjects. We teach by mail or at our school. Quick results—easy to learn.

**EARN \$50 TO \$200 WEEKLY**

Otto C. Wiegand, Md., home-study graduate, made \$12,000 from his business in one year. Many successful graduates. Oldest and foremost school. Don't delay. Write for complete information.

**DETROIT SCHOOL OF LETTERING**

193 Stimson Ave. Est. 1899 DETROIT, MICH.

**Learn Advertising at HOME**

Send your name and address for free booklet giving interesting information and vital facts about Advertising. Find out how we prepare you at home, in your spare time, for the opportunities open in this fascinating business. Practical work. No text books. Old established school. Successful graduates everywhere. Just the plan you have always wanted. Write today. No obligation.

**PAGE-DAVIS SCHOOL OF ADVERTISING**

Dept. 1357, 3601 Michigan Ave. Chicago, U. S. A.

**Learn Photography at HOME**

Make money taking pictures. Prepare quickly during spare time. Also earn while you learn. No experience necessary. New easy method. Nothing else like it. Send at once for free book, OPPORTUNITIES IN MODERN PHOTOGRAPHY and full particulars.

**AMERICAN SCHOOL OF PHOTOGRAPHY**

Dept. 1357 3601 Michigan Ave. Chicago, U. S. A.

**MUSIC LESSONS IN YOUR HOME**



You can play music like this quickly

Write today for our FREE BOOKLET AND SAMPLE LESSON. It tells how to learn to play Piano, Organ, Violin, Mandolin, Guitar, Banjo, etc. Beginners or advanced players. You pay as you learn. Costs you only a few cents a day. Thousands of satisfied students. AMERICAN SCHOOL of MUSIC, 51 Manhattan Bldg., CHICAGO

**ENGINEERING ELECTRICAL · MECHANICAL · STRUCTURAL and ARCHITECTURE**

INTENSIVE PRACTICAL TECHNICAL COURSES. Degree in 2 years. Diploma in 1 year. Special short courses 6 Weeks to 4 Months in Electricity, Radio, Power Plant, Electric Refrigeration, Armature Winding, Wiring, Testing, Drafting, Welding. LOW TUITION. Expert instructors. Extensively equipped laboratories. Free life-time employment service for graduates. Part-time work while attending. Write for new free illustrated catalog giving all facts. 29th year.



**FINLAY ENGINEERING COLLEGE**

1001 A Indiana Avenue Kansas City, Missouri

**Wireless (Radio)**

and Morse telegraphy taught thoroughly. School, oldest and largest; endorsed by Telegraph, Radio, Railway and Government officials. Unusual opportunities. Expenses low—can earn part. Catalog free. DODGE INSTITUTE, Jones St., Valparaiso, Indiana.

**HIGH SCHOOL EDUCATION at HOME**

Easy, fascinating question and answer method. Used in 12,000 High Schools. Every subject covered. Certificate awarded. Amazing low cost. Write for FREE booklet

**HIGH SCHOOL HOME-STUDY BUREAU,**

31 Union Square Dept. 3377 New York, N. Y.





# Railway Postal Clerks

**\$158 Month First Year**

**Raise to Maximum of \$225 Month**

**Many Other U. S. Government Jobs Open to Men and Boys 18 to 45**  
**POST OFFICE CLERKS RURAL MAIL CARRIERS CITY MAIL CARRIERS**  
**PROHIBITION AGENTS CUSTOMS INSPECTORS**

These are steady positions. Strikes, poor business conditions, lockouts or politics do not affect them. U. S. Government employees get their pay for full twelve months every year. There is no such thing as "HARD TIMES" in the U. S. Government Service.

### ALLOWANCE FOR HOTEL EXPENSES

Railway Postal Clerks now get \$1900 the first year regular, being paid on the first and fifteenth of each month. \$79.16 each pay day. Their pay is increased \$100 and \$150 a year. The maximum is \$2700 a year. \$112.50 each pay day. They get extra allowance for hotel expenses when away from home.

### PAID VACATIONS

Railway Postal Clerks, like all Government employees, are given a yearly vacation of 15 working days (about 18 days). When on runs they usually work 3 days and have 3 days off duty or in the same proportion. During this off duty and vacation, their pay continues just as though they were working. When they grow old, they are retired with a pension. As Railway Postal Clerks are continually traveling, they have an excellent chance to see the country.

### CITY MAIL CARRIERS—POST OFFICE CLERKS

Clerks and Carriers get \$1700 the first year regular and automatically increase \$100 a year to \$2100 with further special increase to \$2300. They also have 15 days' vacation. City residence is unnecessary.

### What Will You Earn 5 Years From Now?

Compare these conditions with your present or your prospective condition, perhaps changing positions frequently, kicking around from post to pillar, no chance in sight for PERMANENT employment; frequently out of a position and the year's average salary very low. **DO YOU EARN \$1900 EVERY YEAR? HAVE YOU ANY ASSURANCE THAT A FEW YEARS FROM NOW YOU WILL GET \$2700 OR MORE A YEAR, EVERY YEAR?**



### Get FREE List of Positions

Fill out the coupon. Tear it off and mail it today—now, at once. **DO IT NOW**—This investment of two cents for a postage stamp may result in you getting a U. S. Government Job.



**FRANKLIN INSTITUTE**  
 Dept. P174  
**ROCHESTER, N. Y.**

Rush to me entirely free of charge 32 page book with (1) a full description of the position checked below; (2) a list of U. S. Government jobs now obtainable; (3) tell me how to get the position checked.

- Railway Postal Clerk.. (\$1900-\$2700)
- Post Office Clerk..... (\$1700-\$2300)
- City Mail Carrier..... (\$1700-\$2100)
- Rural Mail Carrier..... (\$2100-\$3300)
- General Clerk and File Clerk..... (\$1260-\$2500)
- Inspector of Customs..... ( \$2100 up )
- Prohibition Agent..... (\$2300-\$2800)
- Immigrant Inspector..... ( \$2100 up )

Name.....

Address.....

**Use This Coupon Before You Mislaid It—Write or Print Plainly**

**MAIL COUPON TODAY**



# Easy home method quickly teaches HAWAIIAN GUITAR



Play all the latest hits  
just as the Hawaiians do!  
Have good times aplenty!

Win fame—  
friends—fortune! Play the  
Hawaiian  
Guitar!

## Native Hawaiian expert directs you

You get expert instruction directed by a world-famous player and teacher, Prof. Walter Kolomoku. He quickly reveals to you the secrets of this fascinating instrument.

**Only 4 Motions** to learn. Then you can play any music—popular songs, classical, old-time melodies, native Hawaiian airs—or real jazz. You'll never be lonesome after you learn the Hawaiian Guitar.

## Complete Course

52 lessons. Nothing omitted. Pictures explain every move. You are sure to learn—what we can do for others we can do for you. Over 50,000 successful students.

## Payasyouplay

We make it easy for you. Start with small first payment—then pay while learning. Costs only few cents per lesson. You only pay the cost of instruction—we furnish everything.

## Learn at home in spare time

Study in spare time at home. Even if you don't know a note our method is so simple, plain and easy, you begin a piece your first lesson. In half an hour you can play it!

## Sweet Toned HAWAIIAN GUITAR

# GIVEN when you enroll

—with genuine seal grain Fabrikoid Cover and complete playing outfit. Reliable retailers ask \$18 to \$20 for a similar instrument and outfit without the fine Fabrikoid Case, which alone is valued at \$3.50.

## TENOR BANJO and other courses

The same thorough instruction on the Tenor Banjo, Violin, Tiple, Tenor Guitar, Ukulele, Banjo Ukulele—well known instructors. Write for full information.

**FIRST HAWAIIAN  
CONSERVATORY OF MUSIC, Inc.**  
9th Floor, Woolworth Bldg.  
Dept. 748, New York

Approved as a Correspondence School Under  
the Laws of the State of New York

Member National Home Study Council

## Send This Coupon for Liberal Offer!

**FIRST HAWAIIAN CONSERVATORY OF MUSIC, Inc.**  
9th Floor, Woolworth Bldg., Dept. 748, New York, N.Y.  
Please mail full information about your 52-lesson Hawaiian  
Guitar Course. I am not obliged to enroll unless I want to.

Name \_\_\_\_\_

Address \_\_\_\_\_

City \_\_\_\_\_ State \_\_\_\_\_

# Books on 65 Practical Subjects

Popular Mechanics Press specializes in supplying the outstanding best books on many subjects. As new books of merit appear, we will revise the list accordingly.

- AERODYNAMICS**  
Simplified. Just out... \$3.50
- AIRCRAFT ENGINES**  
Dyke's New Instructor  
Best Engine Book... \$5.00
- ARCHERY**  
Bows and Arrows for Boys \$0.75
- ARCHITECTURAL**  
Design and Lettering... \$2.00
- ARMATURE WINDING**  
Excellent new book... \$2.00
- AUTO ENCYCLOPEDIA**  
Dyke's. (Covers New  
Model A Ford)... \$6.00
- AVIATION**  
Practical new book on flight  
training... \$5.00
- BIRD HOUSES**  
How to Make... \$1.00
- BLUE PRINTS**  
How to Read... \$2.00
- BOAT BUILDING**  
35 Popular Types, Out-  
board Motor, Sail,  
Row, etc... \$3.00
- BOY MECHANIC**  
Famous 4 Vol. Library,  
4000 Things to Make... \$7.00
- BUILT-IN FURNITURE**  
Complete Instructions... \$2.50
- CARBURETORS**  
Excellent book on all  
makes... \$2.00
- CARPENTRY**  
Hand book of 336 Kinks... \$1.50
- CHALK TALK**  
How to... \$1.00
- COLOR SIMPLIFIED**  
Practical new Book (for  
Color Users)... \$3.50
- CONCRETE**  
173 Ways of Using  
New Edition (Cloth)... \$1.00
- CONTRACTOR**  
Building Cost Estimator... \$2.00
- DIESEL ENGINES**  
(New Work). Best Au-  
thority... \$5.00
- DOGS**  
Care and Raising... \$2.00
- ELECTRICITY**  
Practical—all branches... \$2.00
- ELECTROPLATING**  
Practical Results Easily  
Obtained... \$1.00
- ENGLISH**  
Self-Improvement In... \$2.50
- ETIQUETTE**  
New 560-Page Book.  
Only... \$1.00
- FARMER'S BOOK**  
of 861 Kinks and Book  
for Farmers' Wives... \$1.00
- FLYING**  
Stunt Flying... \$2.50
- FORMULAS**  
10,000 Money Making... \$4.00
- FURNITURE (Mission)**  
Homemade (3 vols.)... \$3.00
- GARDENS**  
1001 Questions An-  
swered... \$2.00
- HOME REPAIRS**  
Practical Book of... \$2.50
- HOME WORKSHOP**  
900 Different Things  
to Make... \$3.00
- INVENTIONS (American)**  
Popular History of  
2 vols. Reduced to... \$5.00
- INVESTMENT**  
Policies that pay  
By Ray Vance... \$4.00
- JOINT WIPING**  
(New Edition)... \$1.00
- KITES THAT FLY**  
How to Make... \$1.25
- LANDSCAPING**  
Practical... \$2.50
- LATHE WORK (METAL)**  
and Drilling and Thread  
Cutting... \$1.00
- LETTER WRITING**  
Social and Business  
Only... \$1.00
- MACHINIST**  
Complete, Practical... \$3.00
- MAGIC**  
200 New Tricks for Am-  
ateurs... \$1.00
- MASONS and BUILDERS**  
Guides (4 vols.)... \$6.00
- MATHEMATICS**  
Made Easy for the Pra-  
ctical Man... \$1.50
- MECHANICAL DRAWING**  
Practical Course In... \$1.00
- MODEL AIRCRAFT**  
Building and Flying... \$2.25
- OUTDOOR OPPOR-  
TUNITIES**  
for Making a Living... \$2.00
- OUTDOOR SPORTS**  
for All Year 'Round... \$1.50
- PAINTING**  
House (Best Methods)... \$2.00
- PLUMBING**  
500 Plain Facts for  
Every Homeowner... \$1.50
- POULTRY RAISING**  
for Profit... \$2.00
- PUZZLES**  
Amusing Mathematical... \$1.50
- RABBITS**  
For Food and Fur... \$2.00
- RADIO**  
Trouble Shooting. Covers  
All-Electric Sets and  
Television... \$3.00
- SHOP NOTES**  
13 Vols. of 6000 Valu-  
able Kinks... \$4.00
- STAMP ALBUM (Modern)**  
12,000 Varieties... \$2.00
- STEEL SQUARE**  
Pocket Book, Practical... \$1.00
- STENCILS**  
How to Use... \$1.25
- TOY MAKING**  
Complete Instructions... \$1.50
- TREASURES**  
Hunting Hidden... \$2.50
- WALL DECORATION**  
(Interior) Newest  
Methods... \$4.00
- WHITTLING**  
The Art of... \$1.35
- WIRING**  
House (New Book)... \$2.50
- WOOD TURNING (LATHE)**  
Practical Course In... \$1.50
- WOODCRAFT**  
590 Page Book on  
Forestry, Campcraft,  
Scouting, etc., by  
Seton... \$1.00

## Books sent C. O. D. anywhere in U.S.

Just check the books you want, write your name and address below, and mail the advertisement. It is your order blank. When post-man hands you books, pay him the price and few cents postage. If outside the U. S. remit when ordering and include 10 cents per book extra for postage. We have many other books on these and 2,000 other subjects. Catalog free.

Name.....

City..... State.....

Address.....

Mail to Popular Mechanics Press,  
Room P10—200 East Ontario St., Chicago, Ill.





# FREE BLUE PRINTS

AND FREE BOOK "HOW TO READ BLUE PRINTS"

## SHOW YOU THE WAY TO

# 9 BIG PAY JOBS

- |   |  |
|---|--|
| 1 Building Superintendent—\$5,000 to \$12,000 | 6 Building Estimator—\$6,000 to \$10,000                               |
| 2 Building Inspector—\$4,800 to \$8,000       | 7 Real Estate Expert—\$5,500 to \$12,000                               |
| 3 Appraiser—\$6,000 to \$10,000               | 8 Construction Foreman—\$4,500 to \$8,500                              |
| 4 Material Buyer—\$5,000 to \$7,500           | 9 CONTRACTOR AND BUILDER IN A BUSINESS OF YOUR OWN—\$5,000 to \$12,000 |
| 5 Material Salesman—\$5,000 to \$12,000       |  |

**FIND OUT HOW**  
**Easy it is to Make**  
**Up to \$12,000 in a Year**

Learn to read Blue Prints this amazing new way! Get into the world's richest industry—Building! See how quickly and easily you can train to make up to \$12,000 a year! My FREE Book "How to Read Blue Prints" discloses all the so-called "mysteries" of Blue Print Reading—also gives some startling facts about the nine best jobs in America. Don't send one penny—just mail the coupon!

NO longer need you spend years trying to pick up the "mysteries" of Blue Print Plan Reading. For now a quick, sure, practical method has been perfected that has made thousands of men Blue Print Experts in a surprisingly short time.

This is no ordinary "school course." It is practical from start to finish. It is based on many sets of real Blue Prints—plans that would cost thousands of dollars if purchased from architects. Twenty famous experts in all lines of construction work talk over these Blue Prints with you in plain, simple language. Show you every detail. Explain every short cut. Tell you the "secrets" of quick, accurate estimating. Explain Superintending. Give you for the first time many inside facts and money-making methods used by the "Giants" of the Building Industry.

This is the kind of training that quickly puts men into high-salaried jobs—or into profitable contracting businesses of their own. Yet now you get it right at home in only 2 or 3 months. It requires no extensive education. If you can read and understand what is written here you can easily master it. See what this training has done for others: Bartholomew, Calif., became a contractor at an increase of over 300% his first year; Blair, Okla.,

stepped up to Superintendent at 100% increase; Dickerson, R. I., increased his salary 700% in 12 months; Marchand, La., says: "My income has increased 200% and I now have more contracting work than I can do."

Over seven billion dollars will be spent this year in new construction! No wonder, then, such tremendous opportunities are open to you when you have this "head-work" training in Blue Prints.

If you want more money—real big money! Then choose a "Blue Print" job in Building. Clerk or Salesman, Carpenter or Bricklayer, here is the one field where there are unlimited opportunities for advancement.

So accept my FREE gift of a complete set of real working Blue Prints, and my fascinating Book "How to Read Blue Prints" that tells all the interesting and instructive facts about Blue Print Plans. Don't send one penny—pay no C. O. D.—It's all FREE. Just fill out and mail the coupon today—NOW!

**TWO BOOKS also**

**FREE**



#### IF YOU LIVE NEARBY

Visit our big day or evening school attended by over 1000 Builders. You can get the same training at home by mail—same plans, lessons and instructors. Your spare time is enough.

Chicago Technical School for Builders—Dept. N-143, Chicago Tech. Building, 118 East 26th Street, Chicago, Ill.

Please send me your free book, "How to Read Blue Prints," and complete set of real Blue Prints. I understand these are mine to keep without obligation. It is also understood that no salesman will call on me.

Name .....

Address .....

City..... State.....

Age..... Occupation.....

**Chicago Technical**  
**SCHOOL for BUILDERS**

Dept. N-143, 118 East 26th St., Chicago, Ill.





# Now! Automatic



## WONDERFUL Invention Burns Oil NEW WAY

Here, at last! An automatic oil burner that really challenges coal . . . AT A FRACTION OF PRESENT COSTS . . . on the easiest terms imaginable . . . at the lowest prices ever offered! Think! No more cold wintry mornings. No ashes to shovel. No dirt. No responsibility. Get rid of coal forever! Install America's Wonder Burner and enjoy its time and money saving advantages every winter! Do it now—while you're thinking about it.



### MINERAL WICK Smashes Fuel Costs Eliminates Smoke, Soot, Grease

The Laco, by means of the new indestructible Mineral Wick BURNS OIL WITH AIR, and ELIMINATES FUEL WASTE. As the oil rises in the Mineral Wick, it is converted into hydro-carbon gas—the most perfect fuel known to man—because all of it burns, giving intense heat, without smoke, soot, or grease. WITHOUT WASTE. This is the exclusive, U. S. Patented Laco feature—found on no other burner—and it saves you money all winter long! FULL AUTOMATIC CONTROL! Standard thermostat with every burner. Absolutely SAFE—safer even than the ordinary kitchen range. Complies with all city ordinances. Won't interfere with radio. No noise. No vibration. GUARANTEED, AND PROVEN BY SEVEN YEARS' ACTUAL PERFORMANCE.

#### Fits any Stove or Furnace Instantly

No matter where you live—what kind of heating system you have—hot water, air, steam, vapor—whether parlor furnace or small stove . . . or the tallest skyscraper . . . LACO FITS INSTANTLY without bricking the firebowl or injuring your furnace. Any plumber can do it. So simple many users put in their own! Do it in just an hour.

### Sensational Low Price

Laco costs so little and operates so cheaply, it just doesn't pay to fuss with coal. Send now for SENSATIONAL LOW PRICE introductory offer, easy terms, and full information.

### Griswold Model

A complete line of amazingly low priced, cheap to operate power burners for the modern home. Burns oil with air (through the use of Patented Crystal Wick) and saves one-half the fuel costs. Siphonic gravity feed. Absolutely SAFE. EASY TO OPERATE. Easy to install. COMPLETELY AUTOMATIC. Quiet. Guaranteed. Send for complete specifications and amazing low price.

#### AGENTS WANTED NOW

Make as much as \$10,000 to \$50,000 selling Laco's Complete Line in your community. This is the peak season. GET IN RIGHT NOW with America's fastest growing industry. BIG ENOUGH OPPORTUNITY for any man! Particularly big chance for jobbers who want large territories. Write for Sensational Offer.

**SPECIAL LOW PRICE**



# OIL HEAT

## AT AMAZING LOW COST

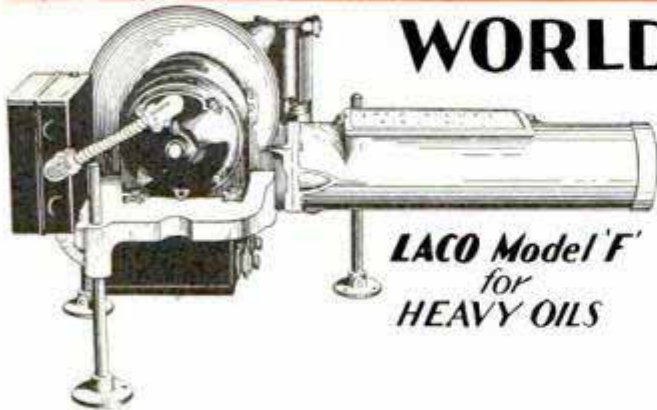

**LACO Model 'F'**  
for  
**HEAVY OILS**

## WORLD'S LOWEST PRICED Fuel Oil Burner

Now—after years of scientific study and research—Laco Model F solves the fuel waste problem on atomizing power oil burners. **BURNS ORDINARY, CHEAP FUEL OIL and 24 West Coast Diesel Oil WITHOUT WASTE. SAVES FUEL. AND PRICED ASTONISHINGLY LOW—**lower than any other atomizing power burner in the world. Specially designed combustion chamber scientifically extracts every degree of heat from every drop of oil by metering it drop by drop. Burns slow, low pressure flame in spiral direction, not a shooting flame that blows heat and oil out chimney. **CATCHES EVERY PARTICLE OF OIL AND BURNS IT!** Fully equipped with electric ignition, automatic controls, room thermostat, safety lock-out system, stack switch. Several rich color patterns. So simple, so inexpensive, doesn't pay you to bother longer with coal. Special prices if you write now!

## Sales Jump Into Millions as Fuel Costs Drop to a Fraction ...

There's no more sales resistance to oil heat now! Laco—America's Wonder Burner—has revolutionized the industry. Sales last year jumped INTO the MILLION DOLLAR Class, as Laco cut fuel costs for owners everywhere. That's why Laco dealers are cleaning up! Think what a sensational chance this is for you! Every home, commercial building, apartment, etc., a prospect. Any ambitious man with small investment can make a killing.

## Astounding Offer

IF YOU ACT NOW we're ready to make you a proposition **BIG ENOUGH** for any man. **SPECIAL Sensational Offer** for promptness.

Listed as Standard by Underwriters' Laboratories

**LACO OIL BURNER CO.**  
136 UNION ST.  
GRISWOLD IOWA U.S.A

## HEAT for the Smallest Home



**LACO 'Jr'**

Heats 2 to 8 rooms, Arcolas, Heatrolas, small furnaces, and parlor furnaces. Operates on as little as one-half pint of oil an hour. Sells to the mass market because low price puts it within the moderate income and for even the smallest home. Three Models. Send for Sensational Low Price!

### Laco Cook Stove Burner

For all wood or coal burning stoves. Brings new happiness and convenience in cooking. Simple to install and sold at amazingly low price. Write today!

### EASY TERMS

Install Laco Automatic Oil Heat before cold weather gets here. Payments later. Send the coupon now for special offer with a letter telling us the size of home you want to heat and the type of heating system.

Attach This Coupon to Your Letterhead

Laco Oil Burner Co.  
136 Union Street  
Griswold, Iowa, U. S. A.

Gentlemen: Send me your sensational low price offer on Laco, the Wonder Burner ( ) Dealer Offer ( )

Name.....

Address.....

City.....State.....

**OFFER! MAIL**





# You Can Learn HYPNOTISM

## ... or No Cost

### Try FREE 5 Days!

**DON'T** be unpopular, lonesome, or unhappy a minute longer. Now you can make your life what you want it to be—now you can win admiration, success and big money—through the strange power of hypnotism. I'll show you how to use this great force to help you master every situation or *The Five Day Trial is FREE!*

In just a few hours I'll teach you the hidden secrets of Hypnotism—the methods used by the great operators—the amazing things you can accomplish once you understand this mighty power. You can use it to overcome obstacles, achieve your fondest ambitions and become **MASTER** of yourself, friends and acquaintances—either sex. See for yourself how Hypnotism can banish fear, worry and opposition—improve your memory—**increase your earnings—and force others to give you the good things in life you deserve!**

In his startling **NEW** book, *The Science of Hypnotism*, the world famous hypnotist—Prof. L. E. Young—reveals the most carefully guarded secrets of this fascinating subject. He not only explains the methods of noted hypnotists, step by step—but tells clearly all about the nine stages of hypnotism, the Hypnotic Mirror, Mental Telepathy, how to select your subjects, magnetic healing, methods of hypnotizing, how to waken the subject, how to make money out of hypnotism!

**Try 5 Days FREE—  
Send No Money**

So confident are we that Prof. Young and his great book will quickly teach you the science of hypnotism, that we will send you a copy without one cent in advance! Simply clip and mail the coupon below. When the book arrives pay the postman the special low price of \$2.50 plus few cents postage. Then test the powers of Hypnotism 5 days! If not amazed and delighted return the book and money will be refunded at once! Mail the coupon now.

**FRANKLIN PUBLISHING CO.**  
800 N. Clark St., Dept. M-70, Chicago

#### Mysteries of Hypnotism Revealed

- How to Hypnotize at a Glance
- Susceptible Subjects
- How to Hypnotize by Telephone
- How to Give an Entertainment
- How to Make Others Obey You
- Overcoming Bad Habits
- How to do Dozens of Hypnotic Feats
- Use of Hypnotism in Operations

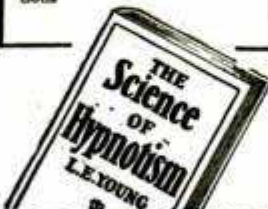

Franklin Publishing Co., Dept. M-70,  
800 N. Clark St., Chicago, Illinois

Please send me your amazing new book—*The Science of Hypnotism*—by Prof. Young. When the book arrives I'll pay the postman only \$2.50 plus postage. If I am not satisfied after 5 days' trial, I may return the book and you are to refund my money.

Name.....

Street and No.....

Town..... State.....

If you are likely to be out when postman calls, send \$2.50 with coupon and we'll pay delivery charges. Customers outside U. S. must send cash with order.



## SOARING TO SUPREMACY!

The Rhon Ranger is making Glider history; it is here portrayed at the start of its remarkable flight on which it floated aloft over level ground for more than seventy-five seconds from an altitude of only 250 feet. Spectators who had only seen ordinary gliders were amazed at the performance of the Rhon Ranger. **\$89.50**

And you can **BUILD IT YOURSELF** for only **\$89.50**

The Rhon Ranger Kit contains every item used on the glider, from the finest nail to the last coat of dope; every part is numbered; you can't make a mistake. Send 10c today for illustrated literature describing this

*Superb Training Glider!*

## MEAD GLIDERS

Dept. B.5. 12 S. Market St. Chicago, Ill.

# "The TRUTH about VOICE"

**Sent FREE—No Obligation to Buy!**

**NO MONEY DOWN**

If you act quick!—we will send you, post-paid—for 30 days free reading—new Voice Book disclosing startling VOICE FACTS that may save hundreds of dollars to every man or woman seeking a stronger, rich voice for either singing or speaking. A REVELATION! Know the truth about YOUR voice. Remember—sent for 30 days' FREE reading. Then, if you keep it, send only \$1.00. Otherwise, just return it—that's all!

PROF. E. FEUCHTINGER Dept. 13-57  
Suite 29, 1810 Wilson Ave., Chicago, Ill.



## HOT PIANO Ultra-modern Piano

Jazz taught by mail. Note or ear. Easy rapid lessons for adult beginners. Also Self-instruction system for advanced pianists. Learn 358 Bass Styles, 976 Jazz Breaks, hundreds of Trick Endings, Hot Rhythms, Soek, Stomp and Dirt Effects; Symphonic and Wicked Harmony in latest Radio and Record Style. Write for Free Booklet.

WATERMAN PIANO SCHOOL, 1826 W. Adams St., Los Angeles, Calif.

## Anyone CAN LEARN

No talent or experience necessary. Fascinating work. Pays big money. Complete instruction book tells about: Alphabets, Colors, How to Mix Paints, Show Cards, Window Board and Wall Signs, Ready-made letters, Gliding, Tricks of the Trade, also gives 100 Alphabets and Designs. Book bound in flexible lmt. leather-gold edges, and four ball bearing Show Card Pens. Sent postpaid \$3.00. (C.O.D.) 10c extra.

Ogilvie Pub. Co., 57 Rose St., Dept. 20, N.Y. City

**EARN MONEY IMMEDIATELY—  
WE FURNISH EQUIPMENT TO START!!**

## SHORTHAND IN 30 DAYS

Boyd, the wonderful easy system, 150 words a minute guaranteed. Send today for Catalog and sample lesson.

**CHICAGO HOME STUDY SCHOOLS**  
801 Reaper Block Chicago, Ill.

## LAW Free Book

Write today for FREE 64-page book, "THE LAW-TRAINED MAN", which shows how to learn law in spare time through the Blackstone home-study course prepared by 80 prominent legal authorities, including law school deans, and U. S. Supreme Court Justices. Combination text and case method of instruction used. All material necessary furnished with the course, including elaborate 25-volume law library, delivered immediately upon enrollment. Many successful attorneys among our graduates. LL. B. degree conferred. Moderate tuition, low monthly terms. Money-Back Agreement.

Write for free book today.

**BLACKSTONE INSTITUTE**, 307 N. Michigan Ave. Dept. 57 Chicago





# I will train you at home



## to fill a **BIG PAY** Radio Job!

**Here's Proof**



**\$100 a week**

"My earnings in Radio are many times greater than I ever expected they would be when I enrolled. They seldom fall under \$100 a week."  
**E. E. WINBORNE,**  
 1414 W. 48th St.,  
 Norfolk, Va.



**Jumped from \$35 to \$100 a week**

"Before I entered Radio I was making \$35 a week. Last week I earned \$110 servicing and selling Radios. I owe my success to N. R. I."  
**J. A. VAUGHN**  
 3715 S. Kingshighway,  
 St. Louis, Mo.



**\$500 extra in 6 months**

"I find I made \$500 from January to May in my spare time. My best week brought me \$107. I should have taken it long ago."  
**HOYT MOORE**  
 R. R. 3, Box 919,  
 Indianapolis, Ind.

If you are earning a penny less than \$50 a week, send for my book of information on the opportunities in Radio. It is free. Clip the coupon NOW. Why be satisfied with \$25, \$30 or \$40 a week for longer than the short time it takes to get ready for Radio.

**Radio's growth opening hundreds of \$50, \$75, \$100 a week jobs every year**

In about ten years Radio has grown from a \$2,000,000 to a \$1,000,000,000 industry. Over 800,000 jobs have been created. Hundreds more are being opened every year by its continued growth. Men and young men with the right training—the kind of training I give you—are needed continually.

**You have many jobs to choose from**

Broadcasting stations use engineers, operators, station managers and pay \$1,800 to \$5,000 a year. Manufacturers continually need testers, inspectors, foremen, engineers, service men, buyers, for jobs paying up to \$15,000 a year. Shipping companies use hundreds of Radio operators, give them world wide travel at practically no expense and a salary of \$85 to \$200 a month. Dealers and jobbers employ service men, salesmen, buyers, managers, and pay \$30 to \$100 a week. There are many other opportunities too.

**So many opportunities many N. R. I. men make \$5 to \$25 a week extra while learning**

The day you enroll with me I'll show you how to do 10 jobs, common in most every neighborhood, for spare time money. Throughout your course I send you information on servicing popular makes of sets; I give you the plans and ideas that are making \$200 to \$1,000 for hundreds of N. R. I. students in their spare time while studying.

**Talking Movies, Television, Wired Radio are also included**

Radio principles as used in Talking Movies, Television and home Television experiments, Wired Radio, Radio's use in Aviation, are all given. I am so sure that I can train you satisfactorily that I will agree in writing to refund every penny of your tuition if you are not satisfied with my Lessons and Instruction Service upon completing.

**64-page book of information FREE**

Get your copy today. It tells you where Radio's good jobs are, what they pay, tells you about my course, what others who have taken it are doing and making. Find out what Radio offers you, without the slightest obligation. ACT NOW.

**J. E. SMITH, President**  
 National Radio Institute Dept. OLP  
 Washington, D. C.



I will give you my new **8 OUTFITS** of **RADIO PARTS** for a home Experimental Laboratory

You can build over 100 circuits with these outfits. You build and experiment with the circuits used in Crosley, Atwater-Kent, Eveready, Majestic, Zenith, and other popular sets. You learn how these sets work, why they work, how to make them work. This makes learning at home easy, fascinating, practical.



Back view of 5 tube Screen Grid A. C. set—only one of many circuits you can build.

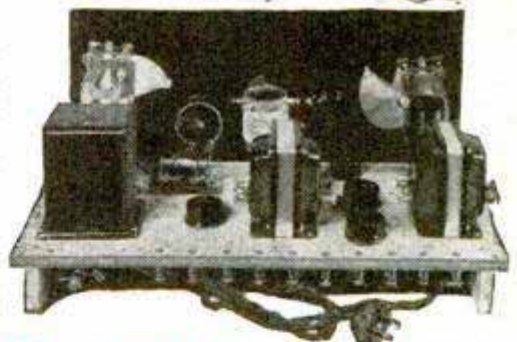

I am doubling and tripling the salaries of many in one year and less Find out about this quick way to



**BIGGER PAY**

**FILL OUT AND MAIL THIS COUPON TODAY**



J. E. SMITH, President,  
 National Radio Institute, Dept. OLP  
 Washington, D. C.  
 Dear Mr. Smith: Send me your book.  
 This request does not obligate me.

Name .....

Address .....

City ..... State .....

**Lifetime Employment Service to all Graduates**



# Send for this Gripping Secret Service BOOK

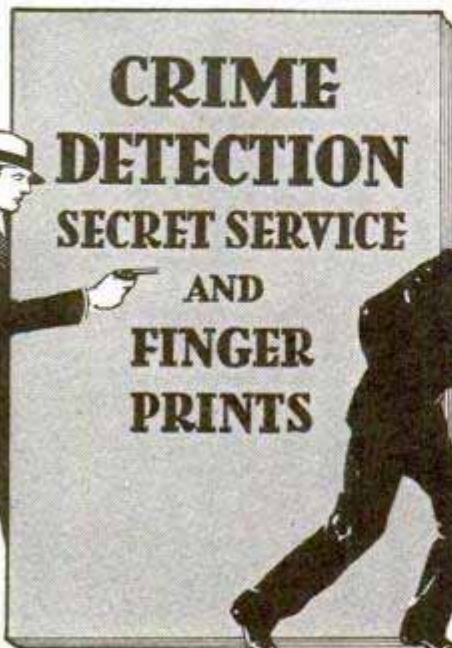

## 30 Days FREE Reading No Money Down

Here is one of the greatest books that has ever been written on Crime Detection, Secret Service and Finger Print Identification Work. Written by a well-known authority. Scores of gripping mystery cases. Actual crime cases — not fiction. You follow the operator straight through as he unravels some of the most baffling crime cases that have ever confronted officials. Nothing like it ever before.

Send for this unusual book TODAY. All you have to do now is merely mail the coupon below. Send no money. The book comes to you postpaid—for 30 Days Free Reading. Then, if you decide to keep it, you send me only \$1.00. If not—return it. That's all. You are not obligated to buy anything. Fill in, mail coupon now—before present limited supply is exhausted.

**T. G. COOKE, Book Dept. 13-57**  
1920 Sunnyside Ave. Chicago, Illinois

**T. G. COOKE, Book Dept. 13-57**  
1920 Sunnyside Ave., Chicago, Ill.

Send me at once—for 30 days free reading—with no obligation to buy, your "Crime Detection—Secret Service—Finger Print" Book. If after the free reading period I desire to keep the book I am to send you \$1.00. Otherwise I have the liberty to return it with no further obligation. Book will NOT be sent to boys under 17 years.

Name \_\_\_\_\_  
Address \_\_\_\_\_ Age \_\_\_\_\_  
City \_\_\_\_\_ State \_\_\_\_\_

# Play a Gibson GUITAR

Nick Lucas

MAKE everyone love you as they love Lucas, his Guitar and singing. Learn to play your own accompaniment on a Guitar, Banjo, Mandolin or Ukulele. Be popular among your friends.

**FREE TRIAL EASY PAYMENTS**

*this FREE BOOK*

Gives Valuable Facts—Send for it Now!

**Gibson Inc.**

1003 Parsons St., Kalamazoo, Mich.



## 1000 WONDERS 10c

**Be Popular—Learn to Entertain!**  
Amaze and Mystify your friends. Our famous "Book of 1000 Wonders" tells how. Explains many startling Tricks with Cards, Coins, etc., you can do. No skill required. Also complete Catalog Tricks, Jokes, Puzzles, Novelties. Postpaid 10c. Send today!

**LYLE DOUGLAS**  
Station A-10 Dallas, Texas

## AVIATION Information FREE

Send us your name and address for full information regarding the Aviation and Airplane business. Find out about the many great opportunities now open and how we prepare you at home, during spare time, to qualify. Our new book "Opportunities in the Airplane Industry" also sent free if you answer at once.

**AMERICAN SCHOOL OF AVIATION**  
3601 Michigan Ave. Dept. 1357 CHICAGO



Send for my Book  
**STRONG ARMS And BROAD SHOULDERS**  
for 25c coin or 30c stamps

Illustrated with 20 full-page half-tone cuts, showing exercises that will quickly develop, beautify and gain great strength in your shoulders, arms and hands, without any apparatus.

Equal to a \$20.00 Course  
**Prof. ANTHONY BARKER**  
1235 6th Avenue Studio K New York City

# How To Secure A Government Position

Why worry about strikes, layoffs, hard times? Get a Government job! Increased salaries, steady work, travel, good pay. I'll help you become a Custom House Clerk, Railway Postal Clerk, Post Office Clerk, City Mail Carrier, Rural Carrier—or get into any other Government job you want. I was a Secretary Examiner of Civil Service Commission for 8 years. Have helped thousands. **Railway Postal Clerk examination coming.**

**Now FREE** My 32-page book tells about the jobs open—and how I can help you get one. Send the coupon for your copy TODAY.

**A. R. Patterson, Civil Service Expert,**  
**PATTERSON SCHOOL, 810 Wisner Bldg., Rochester, N. Y.**  
Please send me, without obligation, your free book "How to Secure a Government Position."

Name \_\_\_\_\_  
Address \_\_\_\_\_





# Money Making Tools

**ALL**  
are Regular  
Draftsman's  
Tools  
**SENT AT**  
**ONCE**



Sent to  
**YOU**  
Become a  
**BIG PAY MAN**  
with My Help

**Earn as You Learn**  
I tell you how to start earning extra money a few weeks after beginning my training.



**Copy this Jack and Get this Draftsman's Rule**

# FREE



Automobiles—Electricity—Motor Busses—Aviation—Building Construction. There are jobs for Draftsmen in all of these industries and in hundreds of others. Aviation is expanding to enormous proportions. Electricity is getting bigger every day. Motor Bus Building is becoming a leading world industry. Building of stores, homes, factories and office buildings is going on all the time. No structure can be erected without plans drawn by a draftsman. No machinery can be built without plans drawn by a draftsman. I train you at home, in Drafting. Keep the job you have now while learning drafting. I will train you in drafting right where you are in your spare time. I have trained men who are making from \$3,500 to \$9,000 a year. There is a big future for draftsmen because you plan and supervise the work of others, or you go into business for yourself. Get started now toward a better position, paying a good, straight salary, the year around. Comfortable surroundings. Inside work.

**Employment Service** After training you I help you to get a job without charging you a cent for this service. Employers of Draftsmen come to me for men because they know that Dobe Trained Men make good as they have learned drafting by actually doing the work themselves, in a practical way. Employers know they are not taking chances on men trained by me.

**Money-Back Agreement**  
I train you at home under a positive Money-Back Agreement. If my training does not satisfy you after you have finished, you get every penny back.

**Age or Lack of Education No Drawback**

Previous experience is not necessary. You do not need to be a college man or high school graduate.

**Get My Pay-Raising Plan —also FREE**

*If you will mail sketch at once I'll send you also FREE "My Pay-Raising Plan"*



**If You Earn Less Than \$70 a Week—Write Me Today!**

I'll train you at home.  
—Engineer Dobe

Mail this coupon, at once with copy of Jack. Get "My Pay Raising Plan" and "Successful Draftsmanship". Both of them point the way to Success. You owe it to yourself to find out what a big opportunity there is in practically all industries, for Draftsmen. These two books are Free. They come to you post-paid. Mail the Coupon for them TODAY.

**Engineer Dobe, 1951 Lawrence Ave., Div. 13-57 Chicago**

## MONEY-MAKING TOOLS COUPON

**ENGINEER DOBE, 1951 Lawrence Ave., Div. 13-57 Chicago**

Here's my copy of Jack. Send me free of all cost your book, "Successful Draftsmanship", also plan to earn money while learning and proof of big money paying positions. Also your new book "My Pay-Raising Plan." Also tell me about your Money-Making Tools which you furnish. Send the free Pocket Rule.

Name..... Age.....

Address.....

Post Office..... State.....



# 20 Years of Shirt Sleeve Practice In ELECTRICITY

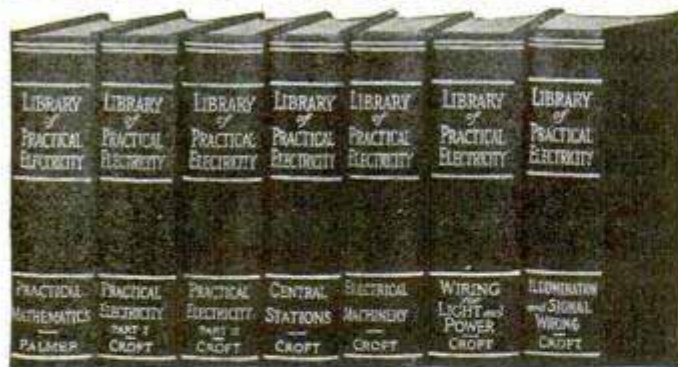

## The Croft Library of Practical Electricity

**NEW EDITION**  
Revised and Enlarged

**T**HIS is the electrical age, with unlimited opportunities for the man who has educated himself in the finer points of electrical practice. Fit yourself for a big-pay job by knowing electrical practice complete, including inside and outside work, central stations, and the whole subject. With the aid of the Croft books you can know electricity as experts know it and put yourself in line for an expert's pay.

### Standard Electrical Training

The Croft Library is a complete electrical educator. It is founded on practice—on work as it is actually done. It is jammed from cover to cover with the kind of hard-headed facts you want. Written so that the beginner can easily understand it, yet so sound, so thorough, that it is the daily guide of 59,000 highly paid electrical workers and engineers. Croft tells you the things you need to know about motors, generators, armatures, commutators, transformers, circuits, switchboards, distribution systems—electrical machinery of every type—wiring for light and power—wiring of finished buildings—underwriters and municipal requirements—illumination in its every phase—the latest and most improved methods of lighting—lamps and lamp effects, etc.—how to do a complete job, from estimating it, to completion. Make no mistake about it—there are big jobs in electricity ready for you when you're ready for them. Thousands of men who have the Croft Library know that to be a fact. The Library itself, on a FREE TRIAL BASIS, will prove it to your own absolute satisfaction.

### 3000 Pages, 2100 Illustrations

In these volumes Croft teaches you electrical practice complete. He takes you in quick, easy steps from the simplest principles to the complete and economical operation of a great central station. He tells you all that he has learned in twenty years of shirt-sleeve practice. With these books at his elbow a man can learn as much about electricity in six months—good practical "bread and butter" stuff—as he would ordinarily learn in a lifetime of practice.

### NO MONEY DOWN SMALL MONTHLY PAYMENTS

Fill in and mail the coupon attached and we will send you the entire set of seven volumes for ten days' Free Examination. We take all the risk—pay all the charges. You assume no obligation—you pay nothing unless you decide to keep the books. Then \$1.50 in ten days and the balance at the rate of \$2.00 a month. Send the coupon NOW and see the books for yourself.



### FREE EXAMINATION COUPON

McGraw-Hill Book Co., Inc., 370 Seventh Ave., New York.

Send me for 10 days' free examination the Croft Library of Practical Electricity. If satisfactory I will send you \$1.50 in 10 days and \$2.00 monthly until the special price of \$19.50 is paid. If not wanted, I will return the books at your expense. (To insure prompt shipment write plainly and fill in all lines.)

Name.....  
Address.....  
City and State.....  
Position.....  
Company..... P. M. 10-30

## NEW KIND OF PROPOSITION LETS YOU MAKE MONEY WHILE YOU SLEEP

**NO "SELLING"—NO "CANVASSING"—**

customers come to you. Just turn on a switch and go to bed. Can make \$50 in a week in spare time. Proessel, Ill., has built a full time business paying up to \$150 a week. Operate at home—in basement, spare room, garage or barn. Chicago engineer has amazing way to charge auto and radio batteries for a few cents each—you can do tremendous business among motorists and garages. Can make 90c profit on a battery—up to 1500% clear. Generous new offer puts you into this quick-money, rapidly growing battery charging business on our credit. We trust you for machine—pay us out of profits. Full or spare time.



C. F. HOLMES

**WRITE FOR FREE BOOK**

WRITE quick to C. F. Holmes, Chief Engineer, Dept. 1357, Independent Electric Works, 4912 N. Clark St., Chicago, Ill.

## BEAUTIFUL UKULELE \$2.95



**T**HIS Beautiful Ukulele, Artistic color finish—wonderful tone—regular retail price \$5.00 for only \$2.95. Included with this offer Pick Tuner and Extra set of strings; also easy instruction method. SEND NO MONEY—pay postman on delivery, plus postage. Money back if not satisfactory.

**MUSICAL SUPPLY CO.**

Madison Square Station, P. O. Box 78

New York City

## LEARN WATCHMAKING

and become independent. We help you secure a position.

Easy to learn. Send for FREE CATALOG.

ST. LOUIS WATCHMAKING SCHOOL

Dept. 5,

ST. LOUIS, MO.



## A Career in Aviation

AVIATION is the great career of the future! Get into it now, by practical, proved routes—study International Correspondence Schools Courses in Aviation Engines and Ocean Navigation!

Captain Lewis A. Yancey, hero of the recent New York-Bermuda flight, says: "The I. C. S. books on Navigation are about as fine as have ever been prepared on the subject, and are to be highly recommended to the aviator who is desirous of learning the navigational side of his calling."

The Aviation Engines Course includes necessary study of Mathematics, Mechanical Principles, Combustion and Fuels, Principles of Gas Engines, Construction, Carburetion, Ignition, Lubrication and Cooling, Pumps, Propellers, etc. You can start at once. Study at home in spare time. Mark and mail the coupon!

### INTERNATIONAL CORRESPONDENCE SCHOOLS

"The Universal University"

Box 5509-G., Scranton, Penna.

Without cost or obligation on my part, tell me how I can qualify for the position or in the subject before which I have marked X:

- AVIATION ENGINES  OCEAN NAVIGATION  
 DEAD RECKONING

Name.....  
Street Address.....  
City..... State.....



# Has the World Suddenly Stumbled onto the True Secrets *that Brought these Men* Wealth...Power... Success?

Forty-three poor men—using methods described in this amazing new book—became millionaires. A Milwaukee man, fired from 20 jobs, discovered one of the secrets, and quickly rose to wealth and fame. A certain obscure man, using similar methods, secretly controlled the actions of a President of the United States. How hundreds of other men have forged their way to the top to achieve power, wealth, success—all using the same secrets of handling people, is brought to light in a revolutionary new book.



**JOHN D. ROCKEFELLER**—As a young man he bluffed with his check book. The methods he used for removing obstacles can be just as well used by anyone once they are known.

**D**URING the past two and one-half years a most remarkable research has been carried to a successful conclusion. Two men, one a Professor of Psychology at Northwestern University—the other a business man well known for his part in the success of many of the country's leading business concerns, working with a corps of assistants, have made an intensive study of the lives of hundreds of the world's most successful men. Many of

these were such prominent men as John D. Rockefeller, Henry Ford, Theodore Roosevelt, Charles Schwab and Mark Hanna. Others were men less commonly known but who had achieved unusual wealth or success in their particular field. One by one all of these men contributed their bit to the story—and at last the final results are ready for you.

The title of the revolutionary book, which brings you the results of these findings, is the key to what it contains. It is called "Strategy in Handling People" because it has been found that invariably the man who achieves success learns or knows instinctively how to get along with people, how to deal with them, how to influence them. Never before has the true significance of the ability to handle people, for those who expect to achieve success, been brought to light.

Applied by the average individual, the secrets unfolded in this book have an immediate, positive effect that is almost unbelievable. Whether you are a business executive, a young man or woman, a teacher, lawyer, laborer or clerk, your path to advancement is unalterably influenced by your every-day contact with people.

When you read the pages of this astonishing book, you will realize at once that here is the greatest stimulus for success that you have ever found. Do you want a raise in pay? Do you want to win the good will of a certain person? Do you want to learn how to impress people—how to win arguments—how to sell yourself and your ideas—how to make people work for you—how to insure your popularity both in business and social



**HENRY FORD**—Who started out as a mechanic. Methods he used in handling people are now put within the reach of everyone who reads this remarkable book.

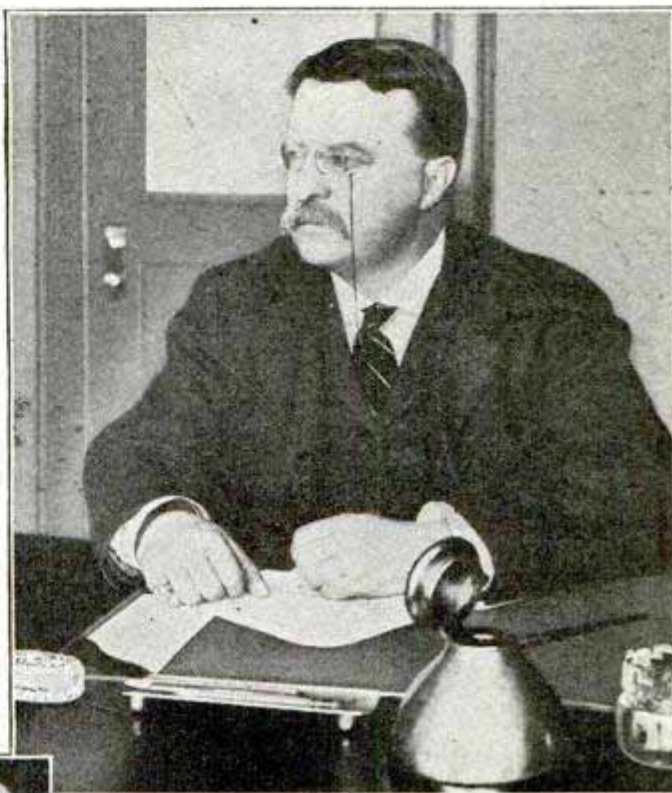

**THEODORE ROOSEVELT**—He had an uncanny knack of making people want to work for him—turning enemies into friends. The strategies he used are explained in this remarkable new book. They can be used by you to help win the things you want most.

life? These are problems that confront you every day, perhaps up to this time the most trying and perplexing problems of your life. But now you will learn how to solve these problems—solve them easily—with definite examples of how great and successful men have met each situation.

## Yours for 5 Days FREE

Already this history-making book has brought a new power of success to thousands of men. George W. Hodges, prominent New York financier, says: "This is the sort of book which should be in the hands of every young man who is earning his own living." The authors are so confident that you will never be without it once you have opened its illuminating pages that they are now making a special introductory offer to send it for 5 days' Free use. You do not have to send a cent—simply mail the coupon below. If you decide to keep the book send the publisher \$3.00, otherwise send the book back and it costs you nothing. Mail the coupon now while this introductory offer is being made.

**BOULTON, PIERCE  
& COMPANY**  
232 East Erie Street  
Dept. M-20 CHICAGO, ILL.



Boulton, Pierce & Co., Dept. M-20,  
232 East Erie St., Chicago, Ill.

Please send me a copy of "Strategy in Handling People" for 5 days' free examination. It is understood that at the end of 5 days I will either return the book without cost or obligation—or keep it as my own and send you \$3.00 in full payment.

Name.....  
Address.....  
City.....State.....



# Is there a Job and a Future for Me in AVIATION?



*"My answer is YES!"*  
Walter Hinton



## Walter Hinton

first to pilot a plane across the Atlantic, first in other deeds of the air, and today a recognized leader in the industry, is the world-famous aviator to offer you the training and backing you need for success in ANY branch of Commercial Aviation.

### Get His FREE Book

Perhaps the reason Hinton is not training YOU right now—is because you haven't begun to appreciate what a tremendous opportunity Aviation offers you. So, if you are over 18, get a copy of his FREE book "Wings of Opportunity." It's crammed with FACTS that are vital to YOUR FUTURE. Mail the coupon now.



**T**HERE'S more than that! There's a BETTER job and a BETTER future for YOU in Aviation than in ANY other industry because Aviation is just beginning its period of BIG GROWTH.

A few years ago a lot of fellows saw their opportunity when the automobile and radio industries were young. They got in early and literally "cleaned up." Today thousands of those "early-birds" are wealthy.

That's the kind of a chance YOU HAVE in Aviation today. During the next few years Aviation is going to pick its bosses, its high-priced specialists, its leaders and executives. And YOU—by LOOKING AHEAD and ACTING AHEAD—can be one of them.

What is more, to fit yourself for an important place in AVIATION—it isn't necessary for you to leave your home, give up your present job or spend a lot of money. Instead, give me just a part of your spare time during the next few months, and I'll give you the kind of training that employers need and are paying REAL CASH to get.

I'll do even more! I'll actually help you get a job. You will receive the free assistance of my Employment Department. This department is called upon for trained men to fill "ground jobs" and "flying jobs" that pay REAL MONEY and offer REAL FUTURES.

**MAIL NOW!**

Walter Hinton, President  
Aviation Institute of U. S. A.  
1115 Connecticut Avenue, Washington, D. C.  
Send my FREE copy of "Wings of Opportunity."

301-P

Name.....  
Address..... Age.....  
(Must be over 18)  
City..... State.....

# NEW YORK Electrical SCHOOL

The Quick Road to Electrical Knowledge. No wasted apprenticeship or drudgery. Here you work with your hands and in a few months' time you are competent to handle a paying position. Day and evening classes. Open all year. Write for catalog.

44 West 17th Street  
NEW YORK



*"Learn by Doing"*



## AN EASY WAY TO SHAPE your NOSE

Anita Nose Adjuster shapes flesh and cartilage—quickly, safely, painlessly, while you sleep or work. Lasting results. Gold Medal Winner. Doctors praise it. 78,000 users. Write today for FREE BOOKLET.

ANITA INSTITUTE, 1012 Anita Bldg., Newark, N. J.

# TRUSS USERS

STUART'S ADHESIF PLAPAO-PADS are patentably different—being mechanico-chemico applicators—made self-adhesive purposely to keep the muscle-tonic called "PLAPAO" continuously applied to the affected parts, and to minimize danger of slipping and painful friction. The fabric is soft as velvet, and being adhesive—

—clings closely to the body—



—without straps, buckles or springs.

Easy to apply, comparatively inexpensive and comfortable

For almost a quarter century stacks of sworn testimonials from many different countries report success, without delay from work. Process of recovery natural, after which no further use for a mechanical support. Test of the remedial herbal factor "PLAPAO" sent you **FREE** No charge for it now or ever. Write name on coupon NOW, and mail TODAY.

Plapao Co., 2621 Stuart Bldg., St. Louis, Mo.

Name.....  
Address.....

**FREE—Trial Plapao—FREE**





# THERE'S MONEY TODAY IN ART

**T**HIS is the day of the artist. His skill is sought wherever design and color are important factors in the sale of merchandise.

Furniture, rugs, wall hangings, household utensils, wearing apparel, jewelry, art gifts, lamps, automobiles, — nearly everything sold today depends on design and color to attract the eye of the purchaser. Drawings for advertisements in newspapers, magazines, catalogs, folders, posters, display cards and many other media call for the skill of the modern artist. Consider the number of drawings in this magazine alone! Art is a necessity in modern business.

If you like to draw, train this talent of yours and put it to work in a field offering rich reward. You can learn Commercial Art at home in your spare time. Many leading artists have contributed exclusive illustrated lessons to our courses.

Many of our students and graduates now earn \$2500.00 to \$6000.00 a year, some a great deal more.

## Send For Our Free Art Test

It brings out your sense of proportion, design and color. Our instructors will

give you frank advice as to your talent and probable chance of success. It costs you nothing. Just fill in the coupon below and we will send you this test together with our book "Your Future," outlining possibilities and showing examples of our students' work.

**FEDERAL SCHOOL OF  
COMMERCIAL DESIGNING**  
DEPT. PM, FEDERAL SCHOOLS BUILDING  
Minneapolis, Minn.

— COUPON —  
Federal School of Commercial  
Designing

Dept. PM, Federal Schools Bldg.  
Minneapolis, Minn.

Please send me free Art Test  
and book "Your Future."



Name.....

Age.....Occupation .....

Address .....



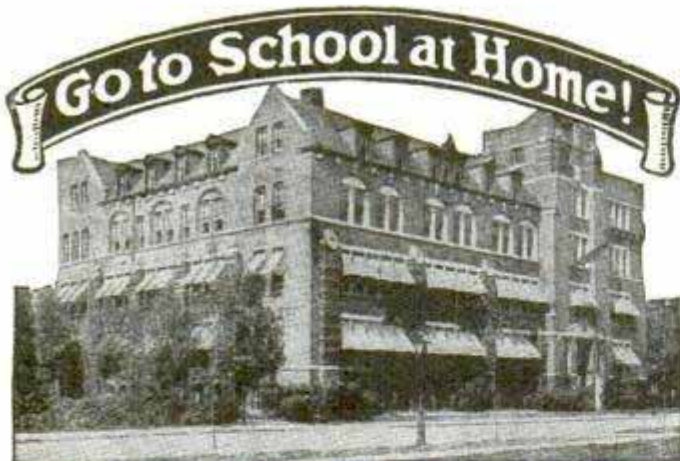

# High School Course in Two Years!

## You Want to Earn Big Money!

And you will not be satisfied unless you earn steady promotion. But are you prepared for the job ahead of you? Do you measure up to the standard that insures success? For a more responsible position a fairly good education is necessary. To write a sensible business letter, to prepare estimates, to figure cost and to compute interest, you must have a certain amount of preparation. All this you must be able to do before you will earn promotion. Many business houses hire no men whose general knowledge is not equal to a high school course. Why? Because big business refuses to burden itself with men who are barred from promotion by the lack of elementary education.

### Can You Qualify for a Better Position

We have a plan whereby you can. We can give you a complete but simplified high school course in two years, giving you all the essentials that form the foundation of practical business. It will prepare you to hold your own where competition is keen and exacting. Do not doubt your ability, but make up your mind to it and you will soon have the requirements that will bring you success and big money. YOU CAN DO IT.

Let us show you how to get on the road to success. It will not cost you a single working hour. Write today. It costs you nothing but a stamp.

### American School

Dept. H-747 Drexel Ave. and 58th St., Chicago

### American School

Dept. H-747 Drexel Ave. and 58th St., Chicago

Send me full information on the subject checked and how you will help me win success.

- |                             |                           |
|-----------------------------|---------------------------|
| ....Architect               | ....Business Law          |
| ....Building Contractor     | ....Lawyer                |
| ....Automobile Engineer     | ....Machine Shop Practice |
| ....Automobile Repairman    | ....Mechanical Engineer   |
| ....Civil Engineer          | ....Shop Superintendent   |
| ....Structural Engineer     | ....Employment Manager    |
| ....Business Manager        | ....Steam Engineer        |
| ....Cert. Public Accountant | ....Foremanship           |
| ....Accountant and Auditor  | ....Sanitary Engineer     |
| ....Bookkeeper              | ....Surveyor (& Mapping)  |
| ....Draftsman and Designer  | ....Telephone Engineer    |
| ....Electrical Engineer     | ....Telegraph Engineer    |
| ....Electric Light & Power  | ....High School Graduate  |
| ....General Education       | ....Wireless Radio        |
| ....Vocational Guidance     | ....Undecided             |

Name.....

Address .....

# Play Piano BY EAR

—IN 90 DAYS!



Play anything — jazz to classical! Even if you know nothing about piano music — I'll have your fingers dancing over the keyboard with confidence in 90 days. If you can hum or whistle a tune you can play it! My students are broadcasting — making money. **MAKE ME PROVE IT!** Without puzzling notes! Without practicing tedious scales! I've found the way to bring out your musical instinct. New and original system does away with years of work. **YOU WANT THE PROOF?** I'll send it. Write me now.  
D. M. SUTLE, Director  
ILLINOIS SCHOOL OF MUSIC  
1801 Byron, Dept. 1315, Chicago, Ill.

Send NOW for PROOF!

# HEALTH for YOU

Suffering Relieved Work Made Easy!



Overcomes weakness and organic ailments; develops lungs, chest; erect, strong figure. Replaces and supports misplaced organs. Supports enlarged abdomen. Strengthens and straightens the back—corrects stooping shoulders. Relieves backache, nervousness, curvatures, constipation, after effects of Flu. A wonderful proved aid for ruptures!

## THE NATURAL BODY BRACE

**COSTS YOU NOTHING TO TRY 30 DAYS**  
If Not Satisfactory At End of Trial, Write now for free illustrated booklet, "Health, Strength and Perfect Figure," and liberal trial proposition.  
**THE NATURAL BODY BRACE CO.,** Howard C. Rash, President  
1005 Rash Bldg., SALINA, KANSAS

# LUCKY TIGER

FOR HAIR AND SCALP!



A single application stops that miserable itching. A single bottle corrects scalp irritations. A Proven Germicide, delicately perfumed, safe for adults and children. World's largest seller at Druggists, Barbers, Beauty Parlors.

**GUARANTEED**

# NO JOKE TO BE DEAF

—EVERY DEAF PERSON KNOWS THAT



George P. Way made himself hear, after being deaf for 25 years, with Artificial Ear Drums — his own invention. He wore them day and night. They stopped head noises and ringing ears. They are invisible and perfectly comfortable. No one sees them. Write for his true story, "How I Got Deaf and Made Myself Hear." Also booklet on Deafness. Address  
**George P. Way, Inc.,** 610 Hofmann Building, Detroit, Michigan



Artificial Ear Drum

# QUIT TOBACCO



No man or woman can escape the harmful effects of tobacco. Don't try to banish unaided the hold tobacco has upon you. Join the thousands of inveterate tobacco users that have found it easy to quit with the aid of the Keeley Treatment.

# KEELEY Treatment For Tobacco Habit Successful For Over 50 Years

Quickly banishes all craving for tobacco. Write today for Free Book telling how to quickly Free yourself from the tobacco habit and our Money Back Guarantee.

Home of the famous Keeley Treatment for Liquor and Drugs. Booklet Sent on Request. Correspondence Strictly Confidential.  
**THE KEELEY INSTITUTE** Dept. A-938 Dwight, Illinois



# Genuine *Refinished and Guaranteed* UNDERWOOD

Late Model No. 5

**Yours for full  
10 Days Trial**

Yes—this world-famous Underwood No. 5 is yours for full 10 days' trial. (Positively the lowest price and easiest terms ever offered.) See how beautiful and new it looks—compare its neat, perfect work with any typewriter costing twice as much.

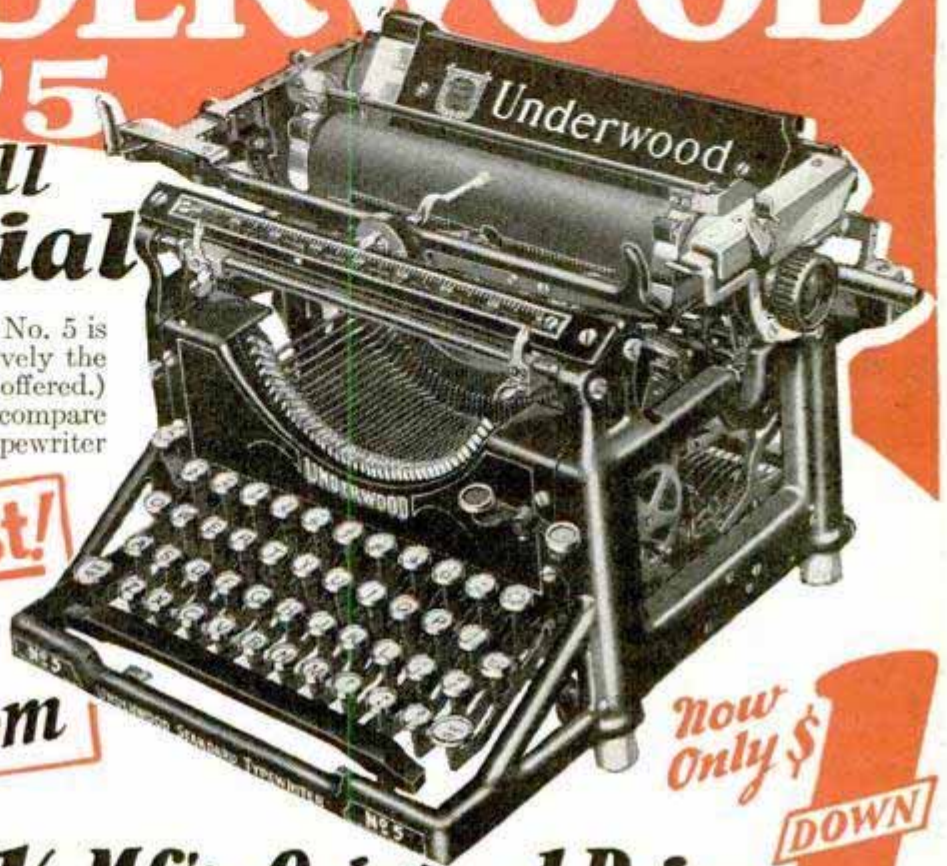

**While They Last!**  
**Prices Smashed  
to Rock Bottom**

Now Only \$**1**  
**DOWN**



**Save over 1/2 Mfg's. Original Price**

Only by an exceedingly fortunate purchase direct from the manufacturers am I able to offer this amazing low price. While they last—less than half (1/2) the manufacturer's original price—and easy terms besides. (Do not confuse this genuine late model Underwood with inferior or frail machines worth only one-half as much.) This is the full-sized late model Underwood with standard universal 4-row keyboard of 84 characters and has all late improvements. Manufactured to sell originally for \$102.50. Fully Guaranteed in writing.

**Easy Terms** Only 12c a Day

Think of it—a genuine late model Underwood No. 5 reduced to \$44.90 (Cash).

Send only \$1 deposit for a 10-day Trial. Then only 12c a day on my easy year-to-pay plan. Use and enjoy your typewriter all the time. Remember this famous No. 5 Underwood all renewed and refinished is without question one of the greatest values ever offered at this rock-bottom price. (See column to left for its many outstanding features and improvements.)

**Money Back Guarantee!**

Accept my liberal 10-day trial offer. See for yourself the wonderful bargain this famous Underwood really is. Your deposit returned at once if you are not perfectly satisfied. Send now.

**International Typewriter Exchange**  
231 W. Monroe St. Chicago

**Complete Course in Speed Touch  
Typewriting Given During This Offer**

**Also Office Supply Set**

Learn Speed Touch typewriting. Complete Home Study Course of the Famous Van Sant Speed Typewriting System, fully illustrated, given during this offer. Easily learned. Used in schools, business offices everywhere. We also give complete office supply set during this sensational sale.



**Late Model  
No. 5  
Underwood  
With Modern  
Improvements**

1. Genuine Underwood No. 5.
2. Standard 4-row Keyboard (84 characters)
3. 2-color Ribbon—Rising Scale
4. Back Spacer
5. Ribbon Reverse
6. Tabulator
7. Automatic Release
8. Shift Lock Key
9. Lowest Price
10. Easiest Terms
11. 10-Day Trial
12. Fully Guaranteed

**International Typewriter Exchange,  
231 West Monroe St., Chicago, Ill., Dept. 1001.**

Please send the Underwood No. 5, F. O. B. Chicago, at the special reduced price for 10-day Trial. I am enclosing \$1.00 deposit with the understanding that if I am not perfectly satisfied I can return it Express Collect and get my deposit back. If I keep it I will pay \$3.50 a month until I have paid \$49.90 (term price) in full.

Name.....Age.....

Address.....

Town.....State.....





## RADIO NEEDS YOU

*Learn at home!*

THOUSANDS of positions are opening up in the field of radio. It seems certain that for the next five years there will be more jobs than there are trained men to fill them.

This is your opportunity! Study radio now, at home. Train yourself for a position as radio operator on a ship or in one of the many new land communication stations. Get the knowledge you need to become a radio expert on installations or service.

Radio has only begun to grow. Get in now, and rise with this fascinating business.

You don't have to give up your present job, or spend your savings on tuition. The International Correspondence Schools plan lets you learn while you earn—at home, in spare time.

Famous radio authorities have prepared the great I. C. S. Radio Course. It is complete—up to the minute. Even the latest developments, such as television, are covered. Many graduates of this course are already earning big salaries in the various branches of radio.

Find out *today* just how the I. C. S. can train you for a radio position. There is no obligation in asking. Just mark and mail the coupon.

INTERNATIONAL CORRESPONDENCE SCHOOLS  
Box 5508-G, Scranton, Pa.

Without cost or obligation, please tell me all about the  
**NEW RADIO COURSE**

Name \_\_\_\_\_

Street Address \_\_\_\_\_

City \_\_\_\_\_ State \_\_\_\_\_

If you reside in Canada, send this coupon to the International Correspondence Schools of Canada, Ltd., Montreal.

## Light As A Feather... Yet.. Holds Rupture!

AT last—an invention to supplant old obsolete trusses that press and gouge cruelly. This amazing device actually buttons rupture. Soft as a pillow, light as a feather. Breathes air. Washes itself. These and many other astounding features are in this newest invention that ends cruel gouging cushions and bulky unsanitary pads. Many now say the protrusion has disappeared. Others say — "My rupture never comes down." The Inventor, John G. Homan, says—"I'll send you a free sample of its flesh-soft material and let you wear the Efficiency Model for 10 days at my risk." Simply write



NEW SCIENCE INSTITUTE  
2177 Clay Street Steubenville, Ohio

**Learn Watchwork, Jewelrywork and Engraving** A fine trade commanding a good salary, and your services always in demand. Address **Horological**, Dept. P, Bradley Institute, PEORIA, ILLINOIS, for our latest catalog.



How to Obtain **A Better Looking Nose!**

Improve your personal appearance My new Model 25 Nose Shaper is designed to improve the shape of the nose by remoulding the cartilage and fleshy parts, safely and painlessly. This is accomplished thru the very fine and precise adjustments which only my patented Model 25 possesses. Results are lasting. Can be worn at night, or during the day. Money refunded if not satisfied after thirty days' trial. Write for free booklet to

M. TRILETY, Pioneer Nose Shaping Specialist  
Dept. 61 BINGHAMTON, N. Y.

## NERVES?

Are You Always Excited? Fatigued? Worried? Gloomy? Pessimistic? Constipation, indigestion, acid sweats, dizzy spells and bashfulness are caused by NERVE EXHAUSTION. Drugs, tonics and medicines cannot help weak, sick nerves! Learn how to regain Vigor, Calmness and Self Confidence. Send 25c for this amazing book. RICHARD BLACKSTONE, N-4710 FLATIRON BUILDING, N. Y.

## RUPTURE

### Appliance Praised by Athletes



Scores of ruptured runners, athletes, golfers and sportsmen wear the Brooks made-to-measure sanitary, automatic air cushion appliance for its lightness and superior comfort. Holds rupture correctly with a firm, gentle support that does not interfere with body freedom. Over 3,000,000 Brooks appliances sold. A vast improvement over old-style devices. Wear one 10 days on trial. Don't suffer all your life. Investigate. Free 28-page Rupture Booklet sent in plain sealed envelope.

Brooks Appliance Co., 107D State Street, Marshall, Mich.





You get proof in  
the first **7 DAYS**

(New photo—  
Charles Atlas  
TODAY)

# YOU

can be this  
**new man**

By **CHARLES ATLAS**

*"The World's Most Perfectly Developed Man"*

I'VE helped thousands of men—young and old—underweight and overweight—weaklings and even "strong men" and other physical directors who wanted *my kind* of Muscle Power. Now I'll show YOU my quick, sure way to build yourself a new body and make "a new man" of yourself.

It's easy my way—my secret of Dynamic-Tension *does the work!* You get the PROOF in your first seven days—in one week you begin to SEE and FEEL the difference in your bodily condition and physical appearance. Spending just a few minutes a day, doing what I tell you, without tricky apparatus, starving or gorging—using only my natural methods of Dynamic-Tension—you build up or tone-down to reach the fighting trim that I am always in myself.

And besides getting this new muscle power and the strength and energy of an "Atlas Champion," my Dynamic-Tension method digs down into your system, banishing such ailments as constipation, pimples, skin blotches and the others that do you out of the good things and good times of life. Your new health, pep and vigor show even in your eyes, your hair, and the way you carry yourself. If you're timid and bashful, you lose all that—you have a new, more forceful personality—you become a NEW MAN!

## Gamble a 2c Stamp

It's a shame if you are being held back by a below-par body—now that you can so easily and quickly make this new man of yourself. Do what my thousands of other pupils did—send for a free copy of my 48-page book "*Everlasting Health and Strength.*" You'll get the stories of scores of other fellows and learn how I built myself up from a weak, no-muscle, always-tired "runt" to the powerful, evenly-balanced figure that you see in my new photos and that won for me my title "*The World's Most Perfectly Developed Man.*"

Where shall I send YOUR FREE COPY? Don't put off. Tear out my coupon, put it in an envelope and gamble a 2c stamp for the biggest prize that anyone can win—a handsome, healthy, husky body. I'm waiting to help you. Address CHARLES ATLAS, (Dept. 810,) 133 East 23rd Street, New York City.



## FREE

The coupon below entitles you to a free copy of my 48-page book, full of photos of myself and pupils. Supply is limited—mail coupon at once for YOUR free copy.

**CHARLES ATLAS (Dept. 810)**  
133 East 23rd Street, N. Y. C.

I want the proof that your system of Dynamic-Tension will make a New Man of me—give me a healthy, husky body and big muscle development. Send me your free book, "*Everlasting Health and Strength.*"

Name.....

Address.....

City & State.....

(Please print or write plainly)



**R. T. I.** R. T. I. QUALIFIES YOU TO MAKE MONEY AND ITS SERVICE KEEPS YOU UP-TO-THE-MINUTE ON THE **R. T. I.** -  
NEWEST DEVELOPMENTS IN RADIO, TELEVISION AND TALKING PICTURES

# OPPORTUNITY

IS KNOCKING AT YOUR DOOR

**RIGHT NOW**  
from this GREAT FIELD of

# RADIO

TELEVISION  
TALKING PICTURES

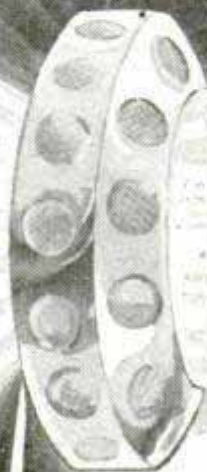

## BIG MONEY STEADY JOBS OFFERED and the Definite Way to Get Them

Good Jobs at Good Pay! Steady, Interesting Work! Fine Profits for your Spare Hours! Big Money as Your Own Boss! That's The Opportunity for you in Radio right Now!

Why? Because the great, fast-growing Radio industry has reached the stage where it must have many more trained men. Most of those now employed are untrained—they just "picked up" what they know about radio, and even many of them get good pay. But the *Big Pay Steady* jobs go to the *Trained Man*, and R. T. I. offers you the definite way to prepare for them. R. T. I. training is endorsed by Leading Radio Men and Radio Trade Associations.

## R. T. I. TRAINS YOU AT HOME FOR THE BETTER PAID RADIO JOBS

Do you want to get into some branch of Radio where trained men can easily make \$40 to \$50 weekly—where some earn \$75 to \$100 per week—where trained, experienced men are selected for executive positions paying up to \$5,000 and \$10,000 yearly and more? Then, send for the R. T. I. Radio Opportunity Book. Find out how R. T. I. trains you at home for this well-paid work—you don't have to give up your present job—you learn quickly and thoroughly—just a little time needed at home—earn an extra \$10 to \$20 per week in spare hours while learning—Then step into radio and go steadily on up to the Big Money. No experience needed to start—R. T. I. starts you right.

## LEARN TELEVISION and Talking Pictures TOO

Be prepared for Television! Learn Talking Picture Apparatus installation, adjustment, etc. Both of these great branches of Radio are included in the R. T. I. practical training.

### LEARN FROM LEADERS

Why does the radio industry want men trained the R. T. I. way? Because you learn under experts—leading men in different branches of Radio—well-known specialists of high standing.

### FREE OPPORTUNITY BOOK

Remember you need no experience to start in Radio—R. T. I. starts you right—and helps you on to success. The big R. T. I. Radio Opportunity book explains everything. If you are interested, send for it now. Don't wait. Use the coupon, or write, or telegraph to

**RADIO & TELEVISION INSTITUTE**  
Dept. 17, 4806 St. Anthony Court, Chicago, Ill.

**BROADCASTING**  
Stations demand better trained men.

**SERVICE**  
Where R. T. I. training brings quick money.



**TALKIES**  
Studio and theatre apparatus requires trained men.

**AUTO-RADIO**  
Great field for men with R. T. I. training.



**AVIATION**  
Trained radio men needed more and more.



**TELEVISION**  
Great new branch of radio soon to call for many trained men.

R. T. I. HOME TRAINING includes all these and the other branches of Radio. You learn under F. H. Schuell, "The Ace of Radio," and the R. T. I. Advisory Board of prominent radio men.

**R. T. I. R. T. I. TRAINS YOU AT HOME FOR A GOOD JOB OR A PROFITABLE PART TIME OR FULL TIME BUSINESS OF YOUR OWN**



**RADIO & TELEVISION INSTITUTE**  
Dept. 17, 4806 St. Anthony Court, Chicago

Send me Free and prepaid your **BIG RADIO OPPORTUNITY BOOK**, "Tune In On Big Pay" and full details of your three-in-one Home Training (without obligating me in any way).

Name.....

Address.....

City..... State.....



# Classified Advertisements

WORLD'S BEST WANT AD MEDIUM

Advertisements in this section, 35 cents per word, each insertion, minimum 10 words, payable in advance. To be printed under proper classification in November issue, copy should be in our office September 18th.

## ADVERTISING AGENCIES

**ADVERTISE**—24 Leading Sunday newspapers, 24 words \$15.00. Excellent for obtaining help, salesmen, or business opportunities. Information 1,000 best paying dailies, mail-order weeklies, monthlies, mailing lists, everything. Free. Wade Agency, Great Northern Bldg., Chicago.

**GET** into advertising. Learn quickly at home. Experience unnecessary. New easy plan. No text books used. Practical work. Old established school. Send name and address for interesting free booklet. Page-Davis School of Advertising, Dept. 343-C, 3601 Michigan, Chicago.

**ADVERTISERS:** Complete lists Southern Negro Newspapers now ready! R. L. Stricklen, Jr., Box 661, Staunton, Va.

**ADVERTISING:** 24 words 20 newspapers \$9; fifty weeklies \$5. Free list magazines, farm. LeGrand Agency, M34 West 33rd Street, New York.

**ADVERTISE** 50 Magazines, old and reliable syndicate; 3c word; \$3.00 inch. List free. Evans King Co., Box 672P, Wilmington, Delaware.

**OBTAIN** canvassers, distributors through publication advertising. Martin, 276B West 43d, New York.

**BEFORE** Advertising get our catalog. No charge. 25 years in business. The largest classified agency in the world. Ankrum Advertising Agency, 100 No. LaSalle St., Chicago, Ill.

**FREE**—New 1930 Advertisers Rate Guide, 44 pages. Includes everything. Lowest rates. E. H. Brown Advertising Agency, 140 S. Dearborn, Chicago.

**TIME** Counts in applying for patents. See pages 134 and 135. Clarence A. O'Brien, Registered Patent Attorney, Washington, D. C.

**INCH** Display advertisement 50 magazines year \$24. Wood's Popular Services, Atlantic City, N. J.

**ADVERTISE** in rural weeklies. Lists free. Meyer Agency, 4112 Hartford, St. Louis, Mo.

## FOR ADVERTISERS

**ADVERTISING:** 20 Words, 50 magazines 60c; three insertions, \$1.20. Malling Bureau, Lawndale, Calif.

**OILCLOTH** Signs painted. Reasonable. Also other signs. Comic cartoons drawn. Henry Kost, Liberty, N. Y.

**SUNDAY** Newspapers—1c rates. Send 10c. Art-Ad, 1338 S' Olive, Los Angeles.

**ADVERTISE** in country papers; low rates; lists free. Keator, Hartford Bldg., Chicago.

## SALES PROMOTION

**WRITE** Any sales letter or advertisement, one dollar. Advertising specialist; national experience. Komaroff, 931 Pine, Long Beach, Calif.

**FOR** Analysis of your sales problem—send dollar. Banning, Times Building, Watertown, New York.

**ADVERTISING** Specialist analyzes sales literature, one dollar. Constructive criticism. Mail to Komaroff, 931 Pine, Long Beach, California.

## AGENCIES WANTED

**MANUFACTURERS**—Established firm wants New Zealand agencies any saleable line—hustlers—particulars, prices, to Stay-on, Box 718, P. O. Dunedin, New Zealand.

## INFORMATION

**GARDENING.** There are many books on this subject but if you want the latest and most complete work covering flowers, vegetables, shrubs, trees, landscaping, the rock garden, the water garden, etc., for the average American home, you will send for Everybody's Garden by Frank A. Waugh. Sent C. O. D. 300 pages. Profusely illustrated. Cloth. Pay postman price, \$3.50 and small amount of postage upon delivery. Popular Mechanics Press, Room 806, 200 E. Ontario St., Chicago, Ill.

## MAILING LISTS

**NAMES** Of persons with incomes of \$3,000 to \$5,000, \$1.50 per thousand, also others. Stamp Sales Co., Not Inc., 736 West 24th Street, Milwaukee, Wis.

**CANADA**—Manufacturers, jobbers, retailers. Classified in trades. Any city or province separate if required. Freedman's Mailing Lists, 4485 Marcell, Montreal, Canada.

## AUTOMOBILES

**TIME** Counts in applying for patents. See pages 134 and 135. Clarence A. O'Brien, Registered Patent Attorney, Washington, D. C.

**CARBURETOR** Information every auto service man needs will be found in special carburetor supplement to the famous Dyke Auto Encyclopedia. Deals with every make of carburetor. 106 pages. 246 illustrations. Price \$2. Sent C. O. D. if you prefer. Popular Mechanics Press, Room 801, 200 E. Ontario St., Chicago, Ill.

## AUTO SUPPLIES

**"SPRINGS** of Silence"—Inexpensive Sets—Ford Chevrolet, Hudson, Essex, all cars—Ask automobile dealer—"Safety" mirror-hinge attached—chromium, \$2.00. Seat springs \$1.00 set, guaranteed. Catalog sent on request. Universal Spring Co., 550 Bond Ave., Grand Rapids, Mich.

**CHROMIUM** Plating powder plates iron, steel, brass, copper and silver, without electricity or machinery. Guaranteed not to tarnish; ½ pint can \$1.50 prepaid. Gunmetal Co., Ave. J, Decatur, Ill.

**PROFITABLE** Electric trouble shooting with new and reconditioned, attractively priced test benches. Easy terms, trial. Mitchell Company, Box M-1004, Troy, Ohio.

**HOTWATER** Automobile heaters \$5.00 C. O. D. Box 1116, Charleston, West Va.

**ELECTRIC** Arc welding proving profitable automotive shops. Easy payments on gasoline or electric. Hobart Brothers Welding Division, Box M-1003, Troy, Ohio.

**NEW** Auto parts 25-50%. Motors, rear-ends, radiators, wheels, generators, carburetors, brakelining 50%. Used parts 40-80% off. Brightman, 2065 Main St., Hartford, Conn.

**RADIATORS:** All standard makes at wholesale. Guaranteed. Send for prices. State make, model. Independent Radiator Co., 1119 So. Wabash, Chicago.

**SHOP** Notes for 1930. Get your copy now. Only a limited edition. Contains all the articles published in the Shop Notes department of Popular Mechanics Magazine during 1929. Send 50 cents. If you want the entire set of Shop Notes books consisting of 15 volumes including the 1930 number and 14 others issued previously we will send them C. O. D. at a special reduced price of \$4.50. Popular Mechanics Press, Room 802, 200 E. Ontario St., Chicago, Ill.

## AUTO SERVICE AND EQUIPMENT

**"FIFTEEN** Capacity battery charger, direct from factory; guaranteed; 110 volts; money maker for owner \$27.34. Adams Barr Corporation, Columbus, Ohio.

**COMPRESSORS,** Twin automatic, 8 hour battery chargers, 20-minute car washers, test benches, paint sprays, \$20 monthly. Pays for itself without investment. Guaranteed. Write Ken's Service, Box M-1005, Troy, Ohio.

**RECONDITIONED** Bargains in car washers, battery chargers, compressors, test benches, many only used few months. Easy terms and trial, guaranteed. Mitchell Electric, Box M-1006, Troy, Ohio.

**DYKE'S** Famous Automobile Encyclopedia—Latest edition. Fully revised to cover all latest facts regarding newest developments in automobile field, including new Model A Ford. Popular Mechanics Press, 200 E. Ontario St., Chicago.

## FOR FORD OWNERS

**AURORA** Underlugs parts and 3.1 racing gears. Speedster bodies, headlights hi compression head. See Sport Factories ad page 122.

## MOTORCYCLES

**LARGEST** Stock Harley-Davidson new and used parts in southwest.—Buy direct from factory authorized distributor. One day service. Closing out parts on all other makes at tremendous reduction, everything for the Motorcyclist. Send 12c in stamps for two big catalogs and magazine, Tulsa Motor & Cycle Co., Distributor, Tulsa, Oklahoma.

**REBUILT** Motor cycles, \$25 to \$100, terms. Tires \$2.50. New tires \$4.50, new automobile tires \$2, wheels-\$2, frames \$3, forks \$3, handle bars \$3, tanks \$3, bells \$5, 3 speeds clutches, cylinders, side cars, airplane motorcycle, engine \$25, bicycle \$9.50, tires \$1. Save your dollar prices. Send 25c for catalogue. Price Cutter Deninger, Rochester, N. Y.

**WANTED** Indian twin opposed motor, R. Watt, 77 W. Milton, Hazel Park, Mich.

**HENDERSON,** Excelsior, Harley, Indian used parts, engines, cheap. Conversion parts, Catalogue free. Ballak, 100 N. 12th St. Louis, Mo.

**MOTORCYCLE** Bargains, lowest prices, bargain sheets for stamp, special aviators supplies, motorcycle accessories largest line in America, lowest prices. Largest motorcycle mail order house in the United States. Rochester Harley Davidson Corporation, 129 West Main St., Rochester, N. Y.

**HEADQUARTERS** For Henderson and other motorcycles, parts and accessory bargains. Largest stock, lowest prices. Good machines as low as \$100. Send for list. Wiedeman, 3517 North Avenue, Chicago.

**HARLEY** Davidson bargains at a tremendous sacrifice. All models and prices. Guaranteed. Send 4 cents in stamps for our catalog. "Money Saving Motorcycle Bargains." The Knuth Co., 2525 Fond du Lac Ave., Milwaukee, Wis.

## AVIATION

**HEATH** Parasol—Now you can purchase America's most popular sport plane in eleven conveniently progressive groups for only \$199.00. Practically no upkeep expense. Hundreds of enthusiastic builders declare Heath plans clear and easy to follow. Highest quality parts used. \$12.00 will bring you the first shipment of parts. Send 10 cents today for large illustrated booklet. Heath Aircraft Corp. Dept. CL7P., Chicago, Illinois.

**BUILD** The Russell monoplane. The Sportplane Constructor book with full page blueprints, drawings, photographs, gives sizes, weights, materials, balance diagram, motors, flight instruction, etc., sent postpaid \$1.00. Russell Aircraft Co., Box 455, Toledo, Ohio.

**OX5** SPORTPLANE Two seater, uncovered, less motor, \$250. New 9 cylinder air cooled motor, 80 horsepower, complete \$80. Flying instruction, 7 hours for \$100. Bargain circular free. Allison Airplane Co., Lawrence, Kansas.

**BLUE** Print for building speedy ice sled \$2.00. Blue print for installing thrust bearing in Harley motors, \$1.00. Sensesich Brothers, Litz, Pa.

**HEATH** Henderson aircraft motors—are America's only successful light plane motors. Won 1st and 2nd prize in National Air Races. Guaranteed to give performances that will please. Weigh only 115 lbs. and consume 50% less fuel than any aircraft motor in country. Prices as low as \$190 remanufactured or \$325 brand new. 10 cents for large illustrated booklet. Heath Aircraft Corp., Dept. CL8P., Chicago, Illinois.

**AIRCRAFT** Supplies, propellers, 4', \$8.75; 5', \$13.25; 6', \$16.50; "Aerodrive," boat and sled blueprints, special, 25c each. Five different types blueprints only \$1.00. Primary glider blueprints, complete set only \$2.50. Ostergaard Aircraft, 4305 North Naragansett, Chicago.

**CITY** Of Chicago World's duration plane, 30' plan 20c. Model Aviator, Dept. PM, 601 Washington, Chicago.

**HENDERSON** And big V motors, metal tipped propellers \$9.95 each. Hibbs, Ft. Worth, Texas.



**BUILD** Your sport plane from the plans of the famous Heath Parasol, 4 years winner at the National Air Races. Don't take chances with plans of unproven value. Heath blueprints declared clear and easy to follow by enthusiastic builders everywhere. Price only \$5.00 for complete set of large detailed shop prints. 10 cents in coin or stamps for large illustrated booklet. Heath Aircraft Corp., Dept. CL9P., Chicago, Illinois.

**DECORATE** Your club or den with real airplane propellers. 8 feet long, beautiful new ones, highly polished, \$8.00; used ones \$5.00. Air Transport Equipment, Garden City, N. Y.

**STUNT Flying**—A new book of flight instruction that is different. The author, Capt. Richard Duncan, has developed in this book a unique system of practicing and working out your flight maneuvers on the ground. Use it and learn as other great flyers have done. Will save you hours of costly flying practice. 185 pages, 32 illustrations, cloth. Sent C. O. D. Pay postman price \$2.50 and small amount of postage upon delivery. Popular Mechanics Press, Room 806, 200 E. Ontario St., Chicago, Ill.

**AIRPLANES**, Monoplanes, biplanes; all types, lowest prices. Motors 30 to 300 hp., new and used; at big discounts. State your needs. Aviation Service, 925 Broadway, New York.

**WHERE** To buy. Hundreds used, new engines. Airplanes \$250. Sport engines \$25. Power-gliders. Balloons. Gas. Parachutes. Supplies. Wheels \$3.50. Hubs \$1. Directory-catalog 50c. Midwest Co., 603-5 Sec-Mutual Bldg., Lincoln, Nebr.

**AVIATION Books**—Send for our 24-page illustrated catalog, the most complete published, describing the latest and best books of all publishers on every phase of flying. Sent free upon request. Popular Mechanics Press, Room 807, 200 E. Ontario St., Chicago.

**WANT** To get in aviation? Write, Grover Chaffin, Route 5, Winters, Texas.

**LEARN** Aviation engines. New handbook complete instruction, maintenance, operation, whirlwind, wasp, Ox 5, cirrus, scarab. Mail money order \$2.50. Aviation Publishing Company, 280 Broadway, New York.

**"IF** You want to fly" let Alexander Klein, brilliant engineer, teach you. With great skill whole course of training has been simplified and made crystal clear. Remarkable book teaches in most practical and easily understood fashion. Recommended by skilled flyers. Sent C.O.D. anywhere in U. S. Simply pay postman \$2.50 and postage when delivered. Sent postpaid to any address upon receipt of price. Popular Mechanics Press, Room 801, 200 E. Ontario St., Chicago.

**WHITE** Helmet, wing emblem, both \$1.00. Box 89, G. P. O. N. Y. C.

**HENDERSON** & Harley motors converted. All work guaranteed. Let us quote on converting your motor. Satisfaction assured. Write, Sensenich Bros., Lititz, Pa.

**LEARN** How aircraft engines work. Latest and most complete information is found in "Dyke's New Aircraft Engine Instructor." We unhesitatingly recommend this valuable book. Money refunded if not satisfied. Pay postman \$5.00 plus postage when delivered. Popular Mechanics Press, Room 801, 200 E. Ontario St., Chicago, Ill.

**GUARANTEED** Re-manufactured Henderson engines \$175.00 up. New deep cases at additional cost. One new 1930 Henderson converted guaranteed \$275.00. Ten cents in stamps brings you the catalog. Sensenich Brothers, Lititz, Pa.

**BOYS**, Girls, 10-weeks' aviation course \$2 or send 25 cents for first lesson. Money back guarantee. Details free. NYFL, Box 40, Syracuse, N. Y.

**DECORATE** Your club or den with real airplane propellers. 8 feet long, beautiful new ones, highly polished, \$8.00; used ones \$5.00. Air Transport Equipment, Garden City, N. Y.

**PRACTICAL** Flight Training is a splendid, thorough instruction book written by Lieut. Barrett Studley of the Naval Air Station at Pensacola. It is the official text book from which all U. S. naval flyers are trained. You can double the value of expensive instruction time in the air by a preliminary study of the subject from this book. Pay postman \$5 and postage when he delivers it to your door. Popular Mechanics Press, Room 802, 200 E. Ontario St., Chicago.

**EFFICIENT** Propellers, 4 ft. \$8.00 4½ ft. \$10.00, 5 ft. \$12.00. Special Henderson propeller \$15.00. Ten cents brings you the catalog. Sensenich Brothers, Lititz, Pa.

**SEND** 5c For bundle of balsa, reeds and price list on supplies. Aero Shop, 3050 Huribut Ave., Detroit, Mich.

**BIGGEST**, Best catalog model airplanes; parts, supplies; 5c postpaid. Ideal Company, 19 West 18th St., New York.

**TIME** Counts in applying for patents. See pages 134 and 135. Clarence A. O'Brien, Registered Patent Attorney, Washington, D. C.

**FLYING** Simplified—Just out. Here is a remarkable non-technical book for beginners, prospective or advanced students that teaches in an easily understood manner all you can need to know to master the art of flying. Will save you many dollars when you learn to fly. Pay postman only \$1 and postage when book is delivered at your door C. O. D. Popular Mechanics Press, Room 802, 200 E. Ontario St., Chicago.

#### MODEL AIRPLANES

**BIG** New catalog. Championship compressed air equipment, record kits, quality supplies, lowest postpaid prices. Send 10c today! Peru Model Aero Shop, Peru, Ind.

**4, 6, 8, CYLINDER** Compressed air motors and tanks, most powerful made. 5 foot Lockheed Sirius and 32" rubber driven. 10c for catalogue. Miniature Aircraft Corp., 83 Low Terrace, New Brighton, N. Y.

#### BOOKS AND PERIODICALS

**"SOLOMON'S** Proverbs Book," San Jose, California. Million samples free.

**YOU** Need a better grip on mathematics? Ask us to send you a copy of "Mathematics for the Practical Man," only \$1.50. By common sense methods it removes the mystery and difficulties so algebra and calculus are made simple. Assuming your knowledge is limited to arithmetic you quickly and easily gain a working knowledge of algebra, geometry, trigonometry and calculus. Simply pay postman when he hands you the package. Address Popular Mechanics Press, Room 802, 200 E. Ontario St., Chicago, Ill.

**INDUSTRIAL** Alcohol. Complete directions for making. Fully illustrated. \$2.50. Spon & Chamberlin, 120 P.M. Liberty St., New York.

**ANOTHER** Famous \$5 book now \$1. The Story of Philosophy, by Will Durant, is the latest popular book of modern times to be placed within the reach of everyone. You will want to add this to your library. The author has the knack of making the lives and opinions of great philosophers as interesting as dramas. 592 pages. Illustrated. Cloth. Sent C. O. D. Pay postman price \$1 and small amount of postage upon delivery. Popular Mechanics Press, Room 806, 200 E. Ontario St., Chicago, Ill.

#### GAME ENTERTAINMENTS AND PLAYS

**PLAYS**, Operettas, musical comedies and minstrels, comedy and talking songs, black-face skits, vaudeville acts, monologs, dialogues, recitations, juvenile plays and songs, musical readings, entertainments, make-up goods. Catalog free. T. S. Denison & Co., 623 So. Wabash, Dept. 11, Chicago.

**READ** Sealed Messages in Dark; messages retained by audience; burned message appears on black slate; spirit message appears on slate in sitter's presence; spirit rappings; spirits appear in the dark; answer questions written on folded papers while blindfolded. All this you can do with directions in "Behind the Scenes with The Mediums." 69 best secrets of mediums fully exposed. The best because most baffling, yet all easy to do. Send no money. Just write a postal. Pay postman \$1.50 and postal charges. Popular Mechanics Press, Room 801, 200 E. Ontario St., Chicago, Ill.

#### MAGIC TRICKS, BOOKS AND JOKER NOVELTIES

**MAGIC** Tricks, entertainments, various objects, easily learned. Illustrated. 35c. Goldmans, 424 So. Dearborn, Chicago.

**MAGIC** Catalog 20c. Lynn, 105 Beach, Dept. 3, Jersey City, N. J.

**MAGIC**—Tricks, Books and Supplies. For amateurs as well as the great professionals. Anyone can learn through our instructions. Feature Acts in Mind-Reading, Spiritualism, Rope Ties, etc. Large illustrated professional catalog. 20c. Chicago Magic Co., 140 So. Dearborn St., Dept. B, Chicago, Ill.

**A FLASH** And it's gone. What? "Flas" card trick of the century. You can do it anywhere, anytime 25c. Marshall's, 5518 So. Loomis, Chicago.

**TRICK** Catalogue, 10c stage money, 50 bills, 20c; black art, 30c; 10 card tricks, 50c. Oaks Magical Co., Dept. 548, Oshkosh, Wis.

**CARD** Tricks, coin tricks, hypnotism, ventriloquism. 4-instructive, 64 page books, 10c each. Geo. Fenner, 2401 Jefferson, Louisville, Ky.

**200 TRICKS** You can do—Mystify your friends; have loads of fun. This collection of tricks has been selected by Thurston for the average person. Neither unusual skill nor elaborate apparatus are required. Send for this 200-page illustrated book. Pay postman \$1 plus postage when delivered. If outside U. S. remit when ordering. Popular Mechanics Press, Room 801, 200 E. Ontario St., Chicago.

**BECOME** A handcuff king and mystery man. Escape from locked handcuffs, trunks, safes, etc. Full instructions 50c coin. J. Parr, 501 Harrison, Harrison, N. J.

**ELECTRIC** Fun! 200 stunts, 110 volts, \$1. Kutting Sona, Campbell, Calif.

**CARTOONING**. Complete course in. New book on How to Draw Funny Pictures with over 200 original illustrations by "Zim" has student begin with simple studies and work up to most difficult cartoon compositions. Delivered to your door C. O. D. Simply pay postman \$3 and postage. Popular Mechanics Press, Room 801, 200 E. Ontario St., Chicago.

#### RADIO SETS AND SUPPLIES

**THE** 1931 Neotone automobile radio designed for circuit, volume, clarity, using screen grid distance. Five tubes in all. Fits any car. Easily installed. Includes remote control and seven spark suppressors, \$39.50. Parts for the above unassembled with diagrams, \$29.50. Fully guaranteed. Enclose \$5.00 with order. Schissmann Bros., 3840 N. Ashland Ave., Chicago.

**NO** Batteries, no tubes! New scientific crystal radio brings endless enjoyment. Introductory price \$1.00. Agents proposition included. Music Sales Co., Dept. AA, Independence, Mo.

**TIME** Counts in applying for patents. See pages 134 and 135. Clarence A. O'Brien, Registered Patent Attorney, Washington, D. C.

**NEW** 300-Mile "pocket" radio, \$3.85. Complete with special loud receiver. No tubes or batteries required. Order direct. Spencer Laboratories, 116 Atlas, Akron, Ohio.

**BEST** Radio Book—Latest revised edition—Radio Theory and Operating by M. T. Loomis of the Loomis Radio College is America's Standard Radio Text-Book. Used by the various government departments and leading radio schools. 900 pages, 700 illus., flexible kraft leather binding. Sent C. O. D. Pay postman \$3.50 and the postage when package is delivered. Popular Mechanics Press, Room 801, 200 E. Ontario St., Chicago.

**TRANSFORMERS** Everything you want to know about the design and making of transformers is given in Prof. F. E. Austin's two well known books, "How to Make Low-Pressure Transformers" and "How to Make High-Pressure Transformers." Sent C. O. D. Pay postman price \$1.70 and small amount of postage for both books upon delivery. Popular Mechanics Press, Room 806, 200 E. Ontario St., Chicago, Ill.

#### CHALK TALKS

**LAUGH** Producing program, \$1.00. Catalog free. Balda, The Cartoonist, Oshkosh, Wis.

**CHALK-TALK** Your way to popularity. Audiences at your feet if you learn how to entertain with a few simple pictures. Little artistic ability needed. "How to Chalk Talk" tells what to say and what to draw. Profusely illustrated. Make money giving chalk talks. Just order on a postal. Pay postman \$1.00 and postage when delivered. Popular Mechanics Press, Room 801, 200 E. Ontario St., Chicago, Ill.

#### STAMP COLLECTING

**FREE**—The entire complete set of 8 values of the Famous Russian occupation stamps of Latvia, to approval applicants who send 10c for our unique small country package, which contains 10 selected stamps from only very small countries, cataloguing well over \$2.00; also free 2 genuine Prussia—Our approvals are "different" and famous. We always offer unheard of bargains in sets and singles of all countries, all issues of United States, airmails, old classics, rarities etc. Our stock is one of the largest in the world. Don't wait. Write today. It will pay you. Globus Stamp Co., 214 Third Ave., New York City.

**GET** Good stamps! Fine set Yugoslavia (catalogued \$1.81) 5c, with choice approvals. Rosedale Stamp Company, Box 1733, Winnipeg, Canada.



**MYSTIC "Queer Country" Packet!** Contains scarce stamps from the following strange lands: San Marino, Antioquia, Congo, Cyprus, Fiji Islands, Gwalior Hyderabad, Iceland, Jhind, Kenya, Uganda, Lebanon, Monaco, North Borneo, Nyassa, St. Thomas Prince, Eastern Roumelia, Siam, Sierra Leone, Tanganyika, Trinidad Tobago, Ubangi, Upper Volta, Wallis Futuna, Al-mouties. Get this wonderful packet of "freak countries" and make your friends envious! Price only 10c to approval applicants! Write today. Mystic Stamp Company, (Dept. 8), Camden, N. Y.

**THRILLING War scenes.** A packet of all different stamps showing exciting scenes and records of nations at war. Include siege guns; firing squad; mounted troops; prisoners of war; fire-pot hurlers; hand-to-hand bayonet struggle; bloody battle scenes; troop transport; red cross stamp; dying soldier; victory stamps, etc. Send for this thrilling "Big Parade" packet at once—limited supply. Only 10c to approval applicants. W. A. Rowell 58 Cornhill Boston Mass.

**ANCHERS \$\$\$ Outfit—only 12c!** Fine triangle stamp; set German stamps with (pre-war) value forty million dollars (interesting!); perforation gauge, mm scale; airmail set; scarce stamp from smallest republic on earth; newspaper set packet good stamps and Transvaire, Malay, Dutch Indies, etc. Entire outfit for 12c to approval applicants! (Nice pocket stock book, value 25c, with every order!) Ancher Stamp Co., Box 47, Rutherford, N. J.

**INCOMPARABLE Bargain!** U. S. \$5.00 stamp, Liberia Triangles and others including Abyssinia, Benadir, South Africa, British Colonial packet, etc. All for only 10c to approval applicants. Elliott, 6103 Brynhurst Ave., Los Angeles, Calif.

**300 DIFFERENT** 20c, 60c, 50c; 1100, \$1.00; 2000, \$3. Fred Onken, 630 79th Street, Brooklyn, N. Y.

**ON October 27th, the 1931 edition** Scott's Standard Postage Stamp catalogue will be on sale. This edition will contain a large number of price changes with many reductions. Order your copy now—bound in cloth \$2.00; cloth with thumb index \$2.50. Shipping weight 3 lbs. Postage extra. Scott Stamp and Coin Co., 1 West 47th Street, New York.

**WORLD'S Largest stamp catalogs** 75c. 5c to applicants for approvals at 60% discount. Charles Cleveland, 808 N. Humphrey Ave., Oak Park, Ill.

**28 FRENCH Colonial** 3c to approval applicants. Sterling, 367 S. Broadway, Lexington, Ky.

**DANDY Packet** free with approvals. William Moniar, 1553 Knox, Cincinnati, Ohio.

**BEAUTIFUL Stamps** on approval. Free premium. Makovsky, 11221 Dale Ave., Cleveland, Ohio.

**UNITED States \$5 No. 524** good copies \$1. Bargain lists free. Nagy, 8 South 18th, Philadelphia.

**SEND 2c** And reference for approvals. Furner, 39 Merlin St., Rochester, N. Y.

**FRENCH—Packet** of stamps. China, Chile, etc. Send postage. H. C. Buchholz, Norwood, Ohio.

**ILLUSTRATED United States** list price 50c; large complete U. S. price list 1930 free. Stanley Gibbons, 38P, Park Row.

**SAVE Money.** Stamps 1/2c up. Many sets. Josiah Babcock, Saint Joseph, Mich.

**120 DIFFERENT**, including U. S. commemoratives, to approval applicants sending 4c postage. Thousand different \$1.35. We buy stamps. Tricity Stampco, Rock Island, Ill.

**SPECIAL—U. S. packet,** 100 different, \$1.00. 20 U. S. commemoratives and airmail, 40c. Alvin Good, 455 Arcade, Cleveland, Ohio.

**100 DIFFERENT Foreign** stamps from 100 different foreign countries, including Africa, Asia, Australia, Europe, West Indies, etc., for only 20c. Free with each order, our pamphlet telling "How to Make a Stamp Collection Properly," together with our price list of albums, supplies and hundreds of bargains in sets, packets, etc. Queen City Stamp Co., Room 36, 604 Race St., Cincinnati, Ohio.

**111 STAMPS.** Price list, approvals, for 2c postage. Hollister, 3523 N. Seeley, Chicago, Ill.

**UNITED States stamps** only on approval. Stamp House, 5 Franklin Gardens, Roxbury, Mass.

**75 DIFFERENT** From 75 different countries—10 cents to applicants for 75% discount approvals and list of 5 cent packets. Beverly Stamp Co., 9337 Vanderpoel Ave., Chicago, Ill.

**BEAUTIFUL Picture stamps** sent free. Paul Cornish, Schenectady, N. Y.

**AIRMAILS—25 Different** 10c famous dime list free. Splendid approvals 50%. Webster, Box 11, Tremont Sta., New York.

**TO Introduce** our unbeatable approvals, we will send you, upon receipt of 10c, a beautiful bi-colored Belgium Charity set, Scott's No. 361-66, six values cataloging \$2.83. Genuine Baden free with each order! Viking Stamp Co., Sheepshead Bay Station, Brooklyn, N. Y.

**FREE Surprise** packet with 14 different unused gold and silver bordered Persian stamps, catalog value \$5.01 for only 40c. Drexel Stamp Shop, 5726 Drexel, Chicago.

**57 VARIETIES** unused stamps 10c. Chas. Townsend, Akron, O.

**12,000 VARIETIES—100** Approval books, alphabetically arranged—averaging 3c. less than half catalog. References necessary. Iole Dione, 1429 33rd Avenue South, Seattle, Washington.

**100 GOOD Stamps** from 5 parts of the world, 5 cents. Luffbery Stamp, Branford, Conn.

**UNITED States** mission gathered stamps. Unpicked two pounds \$1.00. Claud Denney, Box 315, Dallas, Texas.

**FINE U. S. collection.** How to organize stamp club 10 cents. Approval applicants. Baltimore Stamp Co., 623 Sewell, Baltimore, Md.

**DIME Wonder** 100 fine stamps 10c. Imperial, Box 1089, Vancouver, Canada.

**PLANOGRAPH Approvals** make stamp collecting more interesting. Send for selection. No reference necessary. M. Grosser, 1721 North Harding, Chicago, Ill.

**100,000 STAMPS 1c Each—**catalog values disregarded. Star, 210 Wright-Callender Building, Los Angeles, California.

**65 DIFFERENT Stamps** only 5c. Nassau Stamp Co., 4182 Paul St., Philadelphia, Penna.

**\$50.00 catalogue** value free, particulars with approvals. Reid, 608 Yonge Street, Toronto.

**25 DIFFERENT Air mails** 17c. Approvals, Cat. 10c up. Reference. Mark West, West Hartford, Conn.

**FREE! Curious** set Azerbaijan, big illustrated lists, air mail, commemorative, pictorial. Premiums galore. 2c postage. Penna. Stamp Co., Greensburg, Penna.

**CAYMAN Islands—**astounding packet from Cayman Islands, thirty other unique, interesting, beautiful distant land stamps (richly colored unusual designs). Hurry! Rush! Get yours now! Free for 5c postage. Empire Stamp, Toronto, Can.

**STAMP Collector's** magazine, America's favorite stamp monthly. Sample copy free. Philatelic Publishing Co., 15 John, New York.

**MAURITIUS Set** catalog 53c. Free to approval applicants sending 10c. Richmond, Box 273, Staten Island, N. Y.

**CANADA Jubilee,** catalogue over \$63.00. Absolutely free. Particulars and approvals. The Canuck, Box 471, Station F., Toronto, Canada.

**COMPLETE U. S.** set up to one dollar 27c. World Packet 5c. Billek, 644 Cass, Chicago.

**FREE—108 Different** with approvals. Victoria Stamp Shop, 1458 Victoria, Chicago.

**1,000 NICELY Mixed** stamps, 25c postage; 1,000 hinges 10c; 2,000 17c. Approvals. Price lists. Sunshine Stamp Co., 549 East Maryland St., St. Paul, Minn.

**120 STAMPS** 30 different countries 10c. Luffbery, Port Orange, Florida.

**COLE'S Approvals** will satisfy. Cole, 2215 North Rockwell St., Chicago.

**UNITED States \$2** present issue (catalogs 50c) for ten cents to approval buyers. State size of collection. United States price list free. Leduc, Redlon, Penna.

**FREE Borneo, Honkong** etc., with approvals. Essee, 3808 12th Avenue, Brooklyn, New York.

**LEBANON: 5 Varieties** free to approval applicants. Allison, Angola, Ind.

**MAMMOTH Bargain:** 8 different packets 10c to approval applicants. Goldwater, 1827 Amethyst St., Bronx, New York.

**300 DIFFERENT Foreign** stamps, 10c to approval applicants. Fulmen, Columbia, Missouri.

**UNITED States \$2** present issue (catalogs 50c) for ten cents to approval buyers. State size of collection. Leduc, Redlon, Penna.

**WHEN You compare** our 1c approvals with someone else's it is like comparing champagne with water! Introductory special. Soruth, Turkestan, Liberia, Labuan, Carinthia, Madeira, Abyssinia, Azerbaijan, Tanno Tauva, Kelantan, only 10c to approval applicants. (25c without approvals). Julius Goldin, 926 Southern Boulevard, New York.

**FREE—1,000 Mixed U. S. Stamps.** Particulars 2c. Weatherby, Willoughby, Ohio.

**ACME Price list** and special bargain list free upon request. Approvals against references. Filling want lists our specialty. Acme Stamp Company, 1480 B'way, New York.

**200 EXCELLENT,** 25c. Sunset, 5254 St. Charles Ave., Baltimore, Md.

**CONGO.** Five fine free to approval applicants. Bernard Karch, Middle River, Maryland.

**AIRMAIL Free.** 20 different if approvals requested only. Postage 4c. The Trinity Co., Box 97, Washington Bridge, New York, N. Y.

**MORE Stamps** for less money, write for free plan. P. W. Mansfield, Jr., Canton, Mass.

**FREE Stamps** with approvals. 2c postage. Harvey Teepie, Decatur, Ind.

**40 DIFFERENT United States** 12c. 60% approvals. Seldenberg, Baroda, Mich.

**100 FOREIGN Stamps.** Nicaragua, Peru, Siam, Turkey, etc., 10 cents. Luffbery Stamp Co., Branford, Conn.

**FREE—\$1.00 U. S. postage** Lincoln memorial free, if you write for our 56 page price-list of U. S. and foreign stamps. 2,000 illustrations and fine stamps on approval. Hussman Stamp Co., 620-3 Olive St., St. Louis, Mo.

**WHOLESALE Catalog** for dealers; 4c postage. Grossman, 102 W. 42nd, New York.

**ONLY 5c.** 33 different stamps including scarce Latvian triangular airmail stamps, 10 airmail, 12 United States (early issues, commemoratives, etc.) and 10 Canada. Approvals and illustrated pricelist sent with each order. Curhan Stamp Company, Gloucester, Mass.

**24 VARIETIES** Cuban stamps, 10 cents. List of 6,000 low-priced stamps free. Address Chambers Stamp Co., 111P, Nassau St., New York City, N. Y.

**110 NEW Europe** All Different, a wonderful collection cataloging several dollars, free to collectors requesting our Net Approvals. Postage 2 cents. Badger Stamp Co., Milwaukee, Wis.

**CANADA Airmail** stamp free if you ask for approvals and send 15c for 25 different airmails or 30 different Canada and Newfoundland; both packets only 25c. We list 329 countries in our dime packets. Lists free. Special bargains, 500 different, 25c; 1,000 different, 75c; 2,000 different \$2.50. Victoria Stamp Co., London, 4, Canada.

**110 DIFFERENT Stamps,** many unused, high values, free to collectors requesting our net approvals. Postage 2 cents Christensen, Milwaukee, Wis.

**STAMPS—100 Varieties,** Africa, Brazil, Peru, Cuba, Mexico, etc., 10c; 25 different U. S. 25c; 1,000 mixed, 40c; 1,000 hinges, 15c. C. Stegman, 5941 Cote Brillante, St. Louis, Mo.

**FREE—Canada (15 Var.)** for new applicant of my 1c, 2c and 3c approval, and also my 50% discount. Chas. W. Schmidt, P. O. Box No. 4832, Frankford Sta., Phila, Penna.

**203 DIFFERENT Catalog** \$4.25 only 7c with approvals. L. W. Hudson, Plainfield, N. J.

**BEST One cent** approvals in America. F. Hand, 1117 So. 60th St., Philadelphia, Pa.

**STAMP Bulletin.** Published monthly. Fine stamp offerings. Profusely illustrated. Authoritative information. Sent free to advanced collectors. Reimers Co. 30 N. LaSalle St. Chicago.

**STAMPS, 100 All different.** Postage 2c. Lists free. P. M. Quaker Stamp Co., Toledo, Ohio.

**105 CHINA, Etc.,** 2c. Album (500 illustrations) 3c. Bullard, 446 Tremont, Boston.

**FREE! Triangles,** airmail, Iceland and 50 others to approval applicants, including 3c postage. Hawkeye Stamp Co., Cedar Rapids, 39, Iowa.

**200 DIFFERENT** 10 cents. 25 airmail 10 cents. 60% discount approvals. Covert Stamp, 39 State, Rochester, N. Y.

**301 DIFFERENT** 10c To approval applicants only. Free list of bargain packets. Kansas City Stamp Co., Lee Bldg., Kansas City, Mo.



**STAMPS** On approvals, 1/4c up. Dandy premium. Kelgwin Stampco, 214 A Lurie Bldg., Oakland, Calif.

**PENNY** Approvals that satisfy. Neil Gronberg, Box 5441, Philadelphia, Pa.

**STAMPS** Sent on approval at 70% discount. Reference required. Emory Renoll, Hanover, Pa.

**ALBUM**, 1,000 Hinges, 200 foreign, 25 Cuba, 25 Japan, 35c. Postpaid. Burtiss Company, Saratoga, N. Y.

**ATTRACTIVE** Approvals at 50% discount and 25% discount. Noemus Stamp Co., 312 East 23rd St., New York.

**SPECIAL**—500 Different stamps 25c to approval applicants. Ohio Stamp Co., Box 249, Cleveland, Ohio.

**FREE** Stamp collection to approval applicants. Contains Iceland, Hamburg, Turkey, etc., 2c postage. 15 Confederate essays, 5c. Tatham Stampco, Mitteneague, Mass.

**STAMP** Album—The Modern Album is unsurpassed in usefulness. Spaces for 12,000 illustrations, 350 pages. Large size 9 1/2 x 11 inches. Cloth bound. Price only \$2. Either pay postman when delivered or if outside U. S. remit when ordering. Popular Mechanics Press, Room 801, 200 E. Ontario St., Chicago.

### RARE COINS

**ROMANO'S** Greatest sale United States coins. 7 dates half cents \$1.00; 25 dates large cents \$1.00; 35 nickel cents \$1.00; 25 eagle cents \$1.00; 25 1922 cents \$1.00; 30 2c pieces \$1.00; 18 dates 3c nickel \$1.00; 10 dates 3c silver \$1.00; 18 dates half dimes \$1.00; 5 20c pieces \$2.00; 3 trade dollars \$2.50; 5 half dollars before 1837 \$3.00; 3 gold dollars \$5.00; 25 different civil war cents \$1.00; 12 different Jackson cents \$1.00; 12 different broken bank bills \$1.00; 20 different Confederate bills \$1.00; 100 different foreign coins \$1.00; 6 ancient Roman coins \$1.00. Romancoinshop, Springfield, Mass.

**SPECIAL** Prices on United States commemorative half dollars in uncirculated condition. Columbian 69c; Lincoln \$1.19; Pilgrim 99c; Grant \$1.27; Monroe 99c; Lexington \$1.17; Oregon \$1.29; Bennington \$1.29; Trade dollars \$1.15; bargain price list and old coin 10c. Arcey, Box 483, Muskogee, Okla.

**OLD** Money wanted. Will pay \$100.00 for 1894 dime, S. Mint, \$50.00 for 1913 Liberty head nickel (not buffalo). Big premiums paid for all rare coins. Send 4c for large coin folder. May mean much profit to you. Numismatic Co., Dept. H, Ft. Worth, Tex.

**25 DIFFERENT** Fine foreign coins, 50c; 15 different 25c. California Gold quarter size 26c. Willbert Bishoff, Ottawa, Kansas.

**40 OLD** Coins all different \$1.00. 100 different coins \$3.00. 100 mixed foreign coins \$1.00. Panama Pacific gold dollar uncirculated \$3.50. Claud Denney, Box 315, Dallas, Texas.

**60 DIFFERENT** Coins \$1.00. 15 different 25c. Oddehon, Box 681, Kansas City, Mo.

**CALIFORNIA** Gold quarter 27c. Half 52c. 1793 cent \$6, 1855 1/2 cent 50c, Confederate \$100 25c. A. Wylie, 365, Wheaton, Ill.

**CALIFORNIA** Gold—Quarter size, 27c; 3/4 size, 53c; 3c piece and catalog, 10c. Norman Shultz, Box 746, Salt Lake, Utah.

**RARE** United States and foreign coins, war medals and decorations. Indian Cent and catalogue 10c. Alexis Mengelle, Colorado Springs, Colorado.

**GET** Profit and pleasure in collecting old coins. Send 10c for large illustrated coin catalog. You'll be delighted with it. Send for it right now. B. Max Mehl, Numismatist, Mehl Bldg., Dept. P, Fort Worth, Tex. Largest Rare Coin Firm in the U. S.

**UNITED** States. Large cent, two-cent bronze, three-cent nickel and bargain list, 25c. Thirteen dates large cents, \$1.00. George Coffin, Greenwood Mountain, Me.

**\$2 TO \$500** Each paid for hundreds of old coins. Keep all old money, it may be very valuable. Send 10 cents for illustrated coin value book, 4x6. Prices guaranteed. Get posted. We buy and sell. Clarke's Coin Office, Box 5, Le Roy, N. Y.

**OLD** Coins, large fall selling catalog of coins for sale, free to collectors only. Catalog quoting prices paid for coins, ten cents. William Hesselein, 101A Tremont St., Boston, Mass.

**3 DIFFERENT** Fine bronze or nickel coin, 2 large crisp bank notes and catalog, 10c. Geo. Best, Box 283, Cedar Rapids, Iowa.

### CAMERAS AND PHOTO SUPPLIES

**MINIATURE** Prints for less than 1c each. Brilliant, clear, fascinating. Make charming gifts either for album, watch case or locket. Send six negatives and we will make five prints of each, thirty in all, for 25c. No stamps. Miniature Photo Laboratory, R. 5, Box 651-A, Jacksonville, Fla.

**GERMAN** Cameras, lenses, Baritro, 6436 La Riba Way, Los Angeles, Calif.

**TRIAL** Offer 11"x14" hand colored enlargement 85c C. O. D. Send photo or film. Williams, 827 Newall, Flint, Mich.

**FILM** 35 MM. (new) technicolor 50-ft. Send \$1.00 worth \$12.50 action subjects (no lists) Hemenway Film Co., 37 Church St., Boston, Mass.

**KODAK** Film developed 5c roll, prints 3c each. Trial offer. Photo Christmas greeting card from any negative 10c. 8x10 mounted enlargement 40c. Young Photo Service, 405 Bertha St., Albany, N. Y.

**FREE**—Our bargain book and catalog No. 40 listing practically used and new cameras, lenses and supplies at great savings. Send for your copy now. Central Camera Co., 230 South Wabash Ave., PM-10D, Chicago, Ill.

**FILM** And six prints developed 25c. Reprints 3c. Satisfaction guaranteed. Skrudlan, 4118 Overhill, Chicago.

**TIME** Counts in applying for patents. See pages 134 and 135. Clarence A. O'Brien, Registered Patent Attorney, Washington, D. C.

**KODAK** Prints, 3c each; pocket mirrors free. Jenkins Studio, Denison, Tex.

**YOUR** Favorite kodak picture enlarged, size 5x7, 10c. Three for quarter, coin. Send best negative (film) today. Address Darmer Photo Lab., 221 Securities Bldg., Des Moines, Iowa.

**LEARN** "Transgraphy." Photograph without films. Instructions \$1.00, guaranteed. Sample 10c. Koch's Studio, Collbran, Colo.

**MAKE** Money in photography. Learn quickly at home. Spare or full time. New plan. Nothing like it. Experience unnecessary. American School of Photography, Dept. 3431, 3601 Michigan Ave., Chicago.

**HAVE** You a camera? Write for free sample of our big magazine, showing how to make better pictures and earn money. American Photography, 116 Camera House, Boston, 17, Mass.

**FILMS** Developed. Special trial offer. Any size kodak film developed 5c, prints 3c each. Trial 6x10 enlargement in handsome folder 40c. Overnight service. Roanoke Photo Finishing Co., 209 Bell Ave., Roanoke, Va.

**GERMAN** Cameras, lenses, Baritro, 237 1/2 S. Spring St., Los Angeles, Calif.

**SAMPLE** Enlargement—dime, and negative (returned). Trial roll, glossy prints, 25c silver. Brown, Warsaw, N. C.

### MOTION PICTURES

**SOUND** Motion pictures! You must order this great and only authoritative text book on the subject by James Cameron, world's foremost authority. 400 pages crammed full of information on photo cells, Vitaphone, Movietone, Phonophone, methods of recording maintenance. We are selling thousands of copies. Price, \$5.00 postpaid anywhere. Bass Bargaingram No. 199 just off the press. Red hot bargains in standard and 16 mm. motion picture cameras, projectors and accessories. Send 4c in stamps. Bass Camera Company, Motion Picture Headquarters, 179 West Madison St., Chicago, Ill.

**\$1,250** FOR Original photoplay story. Our sales department sold unknown author's first story for above amount. We revise, copyright and submit to studios stories for both silent and talking pictures. Being located in the heart of motion picture industry we know production requirements. Established 1917. Free booklet. Universal Scenario Company, 206 Western and Santa Monica Bldg., Hollywood, Calif.

**TALKIE** And movie producers are clamoring for new short story ideas, plots, etc. Perhaps you can write one that we can shape and sell for you. One writer (V. M.) received \$3,000. New York best market. Write for full particulars. Daniel O'Malley Company, Suite P, 1776 Broadway, New York.

**BE** A movie exhibitor. Big opportunity. Only moderate capital required. Complete equipment at remarkably low prices. Write Atlas Moving Picture Company, 825 South Wabash Ave., Chicago, Ill.

**COMEDIES**, Westerns, dramas, odd reels, \$2.50 each. Bell Pictures Inc., 630 Ninth Avenue, New York.

**FREE**, Our latest bargain list listing hundreds of bargains in motion picture cameras at great savings. Send for your copy now. Central Camera Co., 230 South Wabash Ave., Dept. PM-10Dx, Chicago, Ill.

**MOVIE** Cameras, projectors, film, accessories, professional and amateur. Catalog free. Universal Photographers, 10 W. 33rd St., New York.

**COMEDIES**, Action, western and sensational subjects at lowest prices. Perfect condition film. List. Address Colonial Film & Supply Co., 630 Ninth Ave., New York, N. Y.

**BARGAINS** Machines, films, cameras, stereopticons. National Equipment Company, Duluth, Minn.

**EARN** Big money. Operate your own movie theatre. Small capital needed. Complete equipment at low prices. Catalog free. Monarch Theatre Supply Co., Box 2042 Memphis, Tenn.

**LEARN** The motion picture theatre business at home. Big opportunities for trained men as business or profession. Free catalog. Theatre Managers Institute, Elmira, New York.

**300 FEET** Western 90c. Reels \$2.50. Lowell Films, Allentown, Pa.

**325 FEET** \$1.10. Odd reels \$2.25. Bargain lists. Hoffman Film Service, 57 Broad, Albany, N. Y.

**MOVIE** Films, 1,000 ft. reels, \$2.50 each; shipped anywhere on receipt of remittance. Particulars on request. Independent Films, 177 Golden Gate Ave., San Francisco, Calif.

**SAVE** Money. Movie cameras, \$25; projectors, \$35; Pathex camera, \$20; stereopticon, \$25; printing machine, \$75; 35m negative stock, 2 cents foot; 100 foot Eastman 16m negative, \$4.50; kodak, \$5. Typewriter, \$16. Cameras and films bought and exchanged. Ray, 266 W. 46th, New York.

**TIME** Counts in applying for patents. See pages 134 and 135. Clarence A. O'Brien, Registered Patent Attorney, Washington, D. C.

**SOUVENIR** Strips movietone, photophone talkie film; big list film bargains and samples all for dime. Eastin Feature Films, Galesburg, Ill.

### TRADE AND TECHNICAL SCHOOLS

**LEARN** Watch repairing. Hiles School, 5330 Mission St., San Francisco.

**BE** A blue print reader. Men in your trade have succeeded. Write for facts. What's your trade? Carroll Rumsay, Drexel Bldg., Philadelphia.

### TELEGRAPHY

**LEARN** Wireless (Radio) and Morse telegraphy. School, oldest and largest; endorsed by telegraph, radio, railway and government officials. Expenses low—can earn part. Catalog free. Dodge's Institute, H Street, Valparaiso, Ind.

### BUSINESS OPPORTUNITIES

**IF** You are really looking for a real, sure-enough, money-making opportunity, in a good paying business of your own, in your own community, ask us to write you what there is in store for you in the clean, money-making business of sharpening all makes of safety razor blades and cutlery with Helmerdinger Automatic Sharpener. Same as used by big razor blade manufacturers and by many wide-awake, money-making men, the world over, who are "cleaning up" with it. Address, W. C. Helmerdinger, 116 W. Market St., Louisville, Ky.

**BUILD** A Business of your own. Subscribe to The Income Increaser the only magazine edited by Edward C. Barroll, the well known advertising man and mail order writer. This 36 page magazine filled with the latest ideas, plans, schemes, pointers and suggestions comes to you monthly for only one dollar per year. Sample copy 10c. Income Increaser, 88 Pearl St., Boston, Mass.

**CERTAINLY!** Free information may be had pertaining to the opening of a profitable mail order business. Julius Goldin, 926 Southern Boulevard, New York.

**RAISE** Rabbits, pigeons, guinea pigs for us. Stock supplied on credit terms. catalogue, contract 10c. Houck's, Tiffin, Ohio.

**BUSINESS** Profession of your own and earn income in service fees. See Stephenson Laboratories, display ad page 138.

**SOUTHERN** U. S. new profitable industry revealed. Girard, 210 E. 25 St., New York.



**MULZOL:** New discovery. Wonderful external remedy. Money for you introducing it. Write at once for offer. Exclusive territory. Fenway Laboratories, Box 2402, Boston, Mass.

**MAKE** Your own products, employ agents yourself. Toilet articles, soap, extracts. We furnish everything. Valuable book free. National Scientific Laboratories, 1935W Broad, Richmond, Va.

**CANDIES,** Home-made, sell 4 times material cost. Same course teaches men and women for own business, also for positions. Only occupation where loss of job, with almost no cash, enables you to start business from home kitchen, selling to agencies. Free book explains. Capitol Candy School, Dept. G-5973, Washington, D. C.

**WE Start** you in business, furnishing everything. Men and women, earn \$40 to \$100 weekly operating our original "New System Specialty Candy Factories." Begin home spare time. Unlimited opportunity. Valuable booklet free. W. Hillyer Ragsdale, Drawer 4, East Orange, N. J.

**250,000 ARTICLES** Wholesale—directory 10c. W. Patterson Co., 4111 University, Des Moines, Iowa.

**LEARN** Marbleizing; with cement. Make garden furniture, artificial marble. Statues etc. Inexpensive sanitary floors. Veneer any concrete products and wood. Enamel walls or anything. Glossy flintlike hardness. Unlimited uses for this new industry. Dime brings sample. Cowell Institute, Grayling, Mich.

**MAIL Dealers' Wholesale Directory**, where to buy thousands of articles, and 68 page copyrighted book containing 72 money making plans, 25c. Lester-Marie Co., Box 1244, Chicago, Ill.

**EXCLUSIVE Territory** offer for a New Auto Wonder. Beacon-lite 4 in 1 Spark plugs. Saves gas, repairs. 30,000 mile guarantee. Opalite core. Shows firing inside of engine. Fires in oil or water. Yale Specialty Co., Box O-777, Phila., Pa.

**OWN** Your business—our plans show you how to build a profitable, spare-time business. W. and H. Distributing Co., 400 West Sixth, Anderson, Ind.

**SECURE** Capital for your business. We incorporate companies in any state, bond the stock and put on stock selling campaigns. Complete financial service. Western Security, 319 W. W. Wilson Building, Huntington Park, Calif.

**CONVERT** Old clocks into electric. We furnish chassis completely assembled. You can make hook-up in 30 minutes. Average profit \$4 to \$5 on each sale. You can easily earn \$100 a week. Send for one chassis \$5.85. That gets you started. Money refunded if not satisfactory. Write for particulars. Midland Appliance Corporation, 223 No. Michigan Avenue, Chicago.

**FOR** Real opportunities, offers, ideas, formulas, read "Acid Test Magazine." Sample 10c. Teycer, Publisher, Box 1275P, Chicago.

**LEARN** Watchmaking at home. Make money while learning. Free book U. S. School of watchmaking, 1107 N. Mayfield, Chicago, Ill.

**MINIATURE** Golf course plans complete for \$30 J. W. Trotter, Landscape Architect, Camden, S. C.

**1,000% PROFIT** Manufacturing perfumes. Sample 10c. George Ross, 6521 Kenwood Ave., Chicago.

**SELL** "Money Making" books by mail System. Rolling Prairie, Ind.

**CLEARED** 500 Dollars on one order. New sign process. No brush skill. Particulars, Merritt Signs, South Berkeley, Calif.

**BIG** Proposition; no canvassing. Asco, Box 1081, Washington, D. C.

**MONEY** in "Fixit" service. Instructions \$1.00. Houlgate's "Fixit" Service, 1305 N. El Molino, Pasadena, Calif.

**RUBBER** Flooring. Wholesale. 1000 uses. Send three dimes formula and sample David Brown Co., 429 Wayne, Detroit.

**POLISHING** Cloth formula 25c. Raymond Bertrand, South Schuyler, Kankakee, Ill.

**START** That business. Distribute advertising samples, etc. Good pay, all-year, pleasant healthy outdoor work. No selling or experience. Advertising Service, 1032 Market, Oakland, Calif.

**OPERATE** Chain of vending and amusement machines. Be independent for life. Start small, grow big. P. Goodbody, 72 VanBergh, Rochester, N. Y.

**DRY** Cleaning business of your own. Cleaning hats, clothing, dyeing, pressing. Particulars free. Dry Cleaner, 408 Grand St., Buffalo, N. Y.

**AMATEUR** Cartoonists: Sell your work. Write Smith's Service, PX1194, Wenatchee, Wash.

**GET** Copyrights yourself. Blanks, directions, \$1. Cutting Sons, Campbell, Calif.

**BIG** Profits operating "chain" of peanut, chewing gum, candy vending machines. Start small capital. Write Robbins Corp., Dodworth Street, Brooklyn, N. Y.

**MIRRORS** Resilvered at home. Costs near 5 cents per square foot; you charge 75 cents. Profitable business plating like new, brassy, worn-off autoparts, reflectors, tableware, stoves, etc. Outfits furnished. Details free. Sprinkle, Plater, 127, Marion, Ind.

**MONEY** Seekers! Start business at home—grow. Real opportunities. Not mere schemes. Send for descriptive list of plans. R. M. Shanks, 3128 Dale St., San Diego, Calif.

**BIG** Money at home plating auto parts, reflectors, mirrors, chandeliers; by new method; experience unnecessary. Outfits furnished. Gunmetal Co., Ave. N, Decatur, Ill.

**CAPITAL**—For copy, the "Promoters' Hand Book," a leaflet on financing; an eye opener for capital seekers. Send \$1.00 to Amster Leonard, East Orange, N. J.

**A REAL** Successful Mailorder Proposition. Details 10c. K. Home, 3949 Metropolitan, Chicago.

**"WHY** Not a business of your own" Cleaning hats, clothes, dyeing and pressing. Particulars free. Scientific American Cleaner, 432 Tenth St., New Kensington, Pa.

**CLEARED** \$4,000 two months. Gordon. Tested food—confection business. Men or women. Legitimate—pleasing. Experience unnecessary. Equipment furnished. Eakins, 2160 High St., Springfield, Ohio.

**MAKE** Money manufacturing building material, Marble, Granite, Fireproof Paint, Flooring, Roofing. No machinery, cheap; big profits; formulas, latest methods, Wm. Lang, 443 Washington, Portland, Ore.

**LEARN** The collection business. Good income, quick results. Interesting booklet, "Skillful Collecting" free. National Collectors Assn., Long St., Newark, Ohio.

**"LIBERTY** Bell" contains valuable information; copy and interesting mail 10c. Geo. Bell, Murfreesboro, Tenn.

**CHEMICAL** Expert furnishes manufacturing formulas and processes with complete working directions. Reliable individual service only. No lists. Charges reasonable. Correspondence invited. Dr. Arthur VanHeeden, 7051 Bennett, Chicago.

**PUBLISH** Your own magazine. We issue a syndicate magazine. Sample and particulars 10c. Tasam Publishing Company, P. O. Box 3594, Washington, D. C.

**I MADE** \$30 a week home. French breadmaking. 15 years' experience; free booklet tells. Ashbrook 67, Marengo, Ohio.

**CHARTERS:** Delaware; best, cheapest; free forms. Colonial Charter Co., Wilmington, Del.

**SIGNS** And showcards easily painted. If you use Letter Patterns. Write for free samples. John Rahn, B2120 Neva Ave., Chicago.

**LEARN** To correct automobile shimmy, hard steering, tire scuffing. Capable men in demand everywhere. Complete course offered at cost (\$2) by gauge manufacturer. Send quick. Bear School, Rock Island, Ill.

**SCHEMER**, Alliance, Ohio, 32p. monthly, prints big \$—getters. Subscriber reports \$25,000 from three; another \$10,000 from one. Try your luck! Year, \$1.00; 3 months, 25c.

**DELAWARE** Charters; fees small; free forms. Chas. G. Guyer, Wilmington, Del.

**TIME** Counts in applying for patents. See pages 134 and 135. Clarence A. O'Brien, Registered Patent Attorney, Washington, D. C.

**FREE** Book. Start your own little business anywhere, selling novelties by mail. My beginner's outfit contains everything required, novelties, circulars, instructions, etc. Descriptive book free. Hadwil, 33A-74 Cortlandt St., New York.

**CHEMICAL** Expert will furnish formulas and trade secrets. All lines. Lists free. W. L. Cummings, Ph. D., 228 Gordon Ave., Syracuse, N. Y.

**SUCCEED** With your own products. Make them yourself. Formulas, processes, trade-secrets. Expert analytical service. Catalog, circulars free. B. Thaxly Co., Washington, D. C.

**ARTIFICIAL** Marble sanitary flooring, instructions covering wood or cement flooring ½ inch thick, fireproof, all colors, low cost. Ornamental casting, concrete, plaster, papier-mache decorations, garden furniture, statuary, flexible molds, particulars and illustrations free. Chris. Mahler, Huntington, N. Y.

**SELL** By mail. Books, novelties, bargains! Large profits. Particulars free. B. Ellico, 525 S. Dearborn, Chicago.

**A BUSINESS** Of your own making—Sparkling Glass Name and Number plates. Checkerboards, signs. Big book and sample free. E. Palmer, 540, Wooster, Ohio.

**UNUSUAL**—Uncommon specialties always sell best. Make these yourself from Miller's guaranteed formulas. Why work for others when others can be working for you? Latest eye-opening literature brings you many specialty propositions for you an independent business. Miller Chemist, 706-K Chemical Bldg., Tampa, Fla.

**FREE** Booklet describes 67 plans for making \$20-\$100 weekly in home or office business of your own. Elite Co., 84 Elizabeth St., New York.

**"ODD-THINGS"**—Money making ideas; tips; plans; opportunities! New, different! Three months' trial, 25c. Year \$1.00. "Odd-Things Magazine," 720 Advance Bldg., Cleveland, Ohio.

**AMATEUR** Cartoonists earn \$25.00 week, spare time, copying or tracing cartoons for advertisers. 3-Em Syndicate, Argyle, Wis.

**THAXLY** Formulas produce perfect products. All lines. Catalog free. B. Thaxly Co., Washington, D. C.

**15,000 PROFIT** Making formulas. Following and many others: Accidents and emergencies, agriculture, alloys and amalgams, artist's materials, beverages, cements, glues, pastes, mucilages, bleaching, renovating, coloring metals, dyeing, glass, heat treatment of metals, household formulas, ice cream, confectionery, chewing gum, lapidary work, exterminating vermin, lubricants, paints, varnishes, photography, condiments, canning formulas, rubber, soap, candles, soldering, toilet preparations, perfumes, waterproofing, fireproofing, writing materials. Just write for "Scientific American Encyclopedia of Formulas." When postman hands you book pay \$5.50 and postal charges. Popular Mechanics Press, Room 801, 200 E. Ontario St., Chicago, Ill.

## CHEMISTRY

**CHEMICAL** Digest, thoroughly American in ideas, chock full of money making opportunities through formulas, chemical talks. Headed by Dr. Lucien Royer, recognized authority. Particulars regarding subscription, membership, free. Copy 15c. Box 2616 St. Petersburg, Florida.

**"HANDBOOK** For Chemical Experimenters." Hundreds of interesting experiments; illustrated, 50c. Booklet of experiments, 15c. Pricelist, 5c. General Chemical Company, Box 397, Reading, Penna.

**YOUR** Chemical problem solved and formula or process furnished for Five dollars. Write me. W. Stedman Richards, Industrial Chemist, Box 2402, Boston, Mass.

**CHEMICAL** Analysis, processes, technical information. Robert Henderson, Laboratory, Madison, Maine.

**EXPERT** Chemical advice on manufacturing problems. Analysis. Ideas developed. Formulas. Write, Associated Chemists, Industrial Chemists, Indianapolis, Indiana.

## FORMULAS AND TRADE SECRETS

**ICE-Making** formula, 50c. Elastic, waterproof, cement formula, 25c. Ten guaranteed original formulas, \$1.00. Neil Tasker, Shamokin, Pa.

**MAKE** Your own products, employ agents yourself. Toilet articles, soap, extracts. We furnish everything. Valuable book free. National Scientific Laboratories, 1935W Broad, Richmond, Va.

**MODERN** Formulas. Guaranteed, tested. Catalog free. Imperial Laboratories, Edwardsville, Ill.

**MAKE** Money. 15 formulas \$1.00. Premium free. Address "Asco," P. O. Box 1404, Paterson, N. J.

**FREE** Formula catalog, latest money makers. Western Chemical, Salem, Oregon.

**500 FORMULAS** And big illustrated catalog 25c. Ideal Book Shop, Park Ridge, Ill.



**GUARANTEED** Formulas, best science can produce for making popular, biggest-selling specialties all lines. Don't buy formulas till you've received valuable eye-opening literature. Miller, Chemist, 706-F Jetton, Tampa, Fla.

**FORMULAS** All kinds. Catalog free. Clover Laboratories (P), Park Ridge, Ill.

**SUCCEED** With your own products. Make them yourself. Formulas, processes, trade-secrets. Expert analytical service. Catalog, circulars free. B. Thaxly Co., Washington, D. C.

**PRACTICALLY** Any formula, 50c. Just send 50c and name it. Catalog free. Industrial Institute, Dept. 206, 64 West Randolph, Chicago.

**10,000 MONEY-MAKING** Formulas. Tells you how to make and sell almost everything under the sun; cosmetics, mucilage, anti-freeze solutions, battery solutions, beverages, cheese, chewing gum, cleaning preparations, extracts, hair preparations, inks, bluing, leather polish, mirrors, perfumes, polishes, typewriter ribbons, carbon paper, washing powders, liquid soap, and hundreds of other profitable articles. Send no money. Just write a postal for "Hentley's 20th Century Book of Formulas." Pay postman postage and \$4. Popular Mechanics Press, 200 E. Ontario St., Room 802, Chicago.

### AGENTS WANTED

**STOP** Working for small pay; own and operate a Rawleigh home service business; good anywhere, anytime the year around; you supply 200 home necessities; guarantee satisfaction or no sale; over 42 million sold 1929; thousands doing \$4,000 to \$6,000 annual business in Medicines, Food, Soaps, Toilet Preparations, Stock-Poultry Supplies, all backed by \$17,000,000 industry; established 40 years; largest of its kind with 17 great factories and branches; selling experience unnecessary; practically no capital; credit if deserving; first send for full particulars—then decide. Rawleigh Co., Dept. J-N-PPM, Freeport, Ill.

**I START** Men in a grocery business a new easy way. You use my money. Don't need to put up a penny of your own cash for stock. Expansion program now opens up many desirable opportunities, also established trade. Hustlers make good money from the start, increasing rapidly as they learn the business. Not a "chain" proposition, but your own business. Buy on credit. Give credit if you wish. If honest and need more money, write at once for application and details to McConnon & Company, Room L-6610, Winona, Minn.

**EARN** More pay the Quaker way. Take orders, complete line men's shirts, ties, hosiery, underwear. Remarkable values. All quick sellers. Big commissions. We furnish everything, deliver and collect. Satisfaction guaranteed. Complete outfit free. Write today. Dept. Z-1000, Quaker, 1107 Broadway, New York.

**MAKE** \$5.00 A sale, selling suits for \$19.95. Big profits with this quick selling line. Suits, topcoats, overcoats direct to wearer; marvelous values. Union made. Big repeats. Outfit free. Mastercraft, Dept. G1000, 873 Broadway, New York.

**STRANGE** New ironing cord! Prevents scorching. Saves electricity. Cannot kink or snarl. For telephones also. Up to \$25 daily. Samples furnished. Neverknot, Dept. 10-A, 4503 Ravenswood, Chicago.

**AGENTS:** Free catalog 200 household specialties, toilet preparations, food products, remedies, portraits, frames, photo pillows, medallions, religious goods, pictures, Christmas Cards. Credit. James C. Bailey Co., Station C-10, Chicago.

**AMAZING** New invention. Electric water heater. Sells for \$3.75. Heats water almost instantly. Make big money. Write today. Lux-Visel Company, Dept. 73, Elkhart, Ind.

**STEADY** Permanent income assured by selling biggest, finest line shirts, ties, underwear, guaranteed full year. No substitutions. Free silk monogram. Postage prepaid. Big advance commissions. Earn your shirts, ties; cash bonuses. Free outfit. Write today. Dept. PM, Rosecliff, 1237 Broadway, New York.

**MAKE** Your own products, employ agents yourself. Toilet articles, soap, extracts. We furnish everything. Valuable book free. National Scientific Laboratories, 1935W Broad, Richmond, Va.

**AGENTS—100% Profit.** Fast selling easy working finer razor strop. Sharpens any make blade. A. Victor, 201 No. Wells, Chicago.

**LOOKING** For something that sells fast, and so satisfies that customers repeat time and again? Something with a worth while profit and excellent future, then you are looking for Reid Cream Metal Polish. (In tubes, also in bulk.) Write for sample today. P. M. Reid Manufacturing Co., 1914 Chouteau Ave., St. Louis, Mo.

**BIG Money** applying gold initials on automobiles. Easiest thing today. No experience needed. \$1.45 profit every \$1.50 job. Free samples. "Balco," X-1043 Washington, Boston, Mass.

**FLAVORING** Extracts—bottle yourself! Concentrated, labels furnished. Amazing 600% profitmakers! Steady repeaters! Free offer! Thomas Manufacturing Company, Indianapolis, Indiana.

**100% PROFIT—Christmas box.** 21 greeting cards with sample tags, stamps, catalog, pricelists 60c postpaid. Catalog, pricelists 4c. Klees Co., 1710 Undercliff Ave., New York.

**WANT** Distributing agent for Hansitck, powdered handsoap; removes anything from the hands without injury to skin; everybody a customer; great opportunity for hustler to get in business; sample free. Solar Products Co., 32144 So. Troy, Chicago.

**\$60-200 A WEEK.** Genuine gold letters for store windows. Easily applied. Free samples. Liberal offer to general agents. Metallic Letter Co., 438-B North Clark, Chicago.

**BIG Proposition;** no canvassing. Asco, Box 1081, Washington, D. C.

**STATE** And county agents or distributors for "quick trick," the quality automobile dry cleaning and polishing cloth. Popular price. Exclusive rights offer most unusual opportunity. Sample free. Walter S. Doe, & Co., Kent, Ohio.

**LARGE** Earnings selling best value 21 cards, Christmas box assortment \$1; cost you 49c prepaid. Details free. Edmo Studio, 509 Fifth Ave., New York.

**NEW** Revolutionary idea changing men's shaving habits! Guarantees quicker, cleaner, better shaves! 125% clear profit, no competition. Pays \$6 to \$14 a day, exclusive territory. Send for free details. Shave King Company, Dept. 91-R, 1800 Olive Street, St. Louis, Mo.

**SELL** Good business cards \$2.40 thousand. Profit \$1.00. Send 25c for outfit, refunded first order. Wm. Richards, 411 Mass., Indianapolis.

**FINEST** Grade face powder. \$1.00 dozen boxes \$40.00 gross. Sample box 50c. Bonnie Brier Laboratories, 198 Stoakes, San Leandro, Calif.

**AGENTS—New shirt proposition.** No capital or experience needed. Commissions in advance. Samples free. Madison Company, 566 Broadway, New York.

**NEW** Imported changeable price tickets, instant seller, every store needs them, big commissions. Tiara, 160 5th Ave., New York.

**AMAZING** Raincoat line pays up to \$75.00 weekly in advance. New materials, smashing sales records. New styles capture attention. Free outfit. Amazon, 1515J Milwaukee, Chicago.

**BRAND** New union label printing line. Largest assortment cuts and specialty items in country at half price. 72 hour delivery. Big commissions advanced. Sensational bonus offer. Experience unnecessary. Outfit free. Northwestern, 625C Jackson, Chicago.

**AGENTS—Can openers, new improved hand, wall, table models.** Safety Products Co., 315 American Bank, Kansas City, Mo.

**FASTEST** Selling household specialties. Sample 25c. Matz Specialties, Reading, Pennsylvania.

**AGENTS** Buy direct guaranteed hosiery at lowest mill prices. Men's latest fancy hose doz. \$1.45-\$1.85. Ladies' Pointex Silk Hosiery doz. \$4.25-\$6.50. Catalog free. Superior Knitting Co., Dept. 34, New Haven, Conn.

**AGENTS** Making big money putting non-chain store emblems on independent merchants' windows. Consolidated, 69-LC, West Van Buren, Chicago.

**FACTORY** Sales agents wanted to introduce quick selling Vantor double ventilators for all closed cars; 10 minutes to install. Sample set for your car at factory price. Dept. C. Vantor Mfg. Co., 1623 Broadway, Toledo, Ohio.

**100% PROFIT** in new mystery cigar lighter. No flint or friction. What makes it light? No wind can blow it out. Retail 50c. Sample and sales plan 25c. New Method Manufacturing Co., Box PM-10, Bradford, Pa.

**GET** Our free sample case. Toilet articles, flavorings and specialties. Wonderfully profitable. LaDerma Co., Dept. A, St. Louis, Mo.

**946 FIRMS** Seeking distributors are listed in new 104 page Directory. Write, Pruitt System, Brookfield, Ill.

**AGENTS—Sell** tube flavors and food colors. Thos. J. Ferguson, 7426 Richmond, Maplewood, Mo.

**OUR** Luminous crucifix and new luminous St. Therese statue shine brilliantly in the dark. Sell on first demonstration. Write for prices. W. G. Hannan Co., 2543 So. State, Chicago.

**AGENTS** And distributors: Amazing new home invention for extracting orange and lemon juices. No competition. Large cash profits. Protected territories for producers. Get demonstrator at once. Will earn \$100 weekly. Kwikway Products, 1415 Pine St., Dept. P-120, St. Louis, Mo.

**1000 AGENTS** Wanted, to sell our new invention, sewing outfit with needle threader attached; send 50c for sample. The Needle Threader Co., Thomasville, Ga.

**AGENTS** 150% Profit. Dri-Kleanit makes any car like new. Removes mud, grease, road oil, all one operation. No soap or water used. Cleans car for about 10c. Wonderful seller. Send three 2c stamps for sample. American Accessories Co., Desk 7031, Cincinnati, Ohio.

**200% PROFIT:** \$12 day easy; beautiful pocket calculator, retails 50c. Other items. Write. Sparks Novelty Co., 2822 Woodward, Detroit, Mich.

**IT'S** A winner. Patented cigarette case. Holds package cigarettes and box safety matches. Beautiful, compact, flexible container. Large profits. Write for liberal proposition. All-In-One, 4648 R. Grand Ave., Minneapolis, Minn.

**REMNANT** Store, 1512 Vine St., Cincinnati, O. World's greatest dry goods bargains; fine silk dress lengths. Agents wanted.

**AMAZING** New money-maker. Resoles old shoes in 3 minutes for only 9c. Sensational seller. Good for \$10 profit a day. Investigate this sure. Albert Mills, 5369 Monmouth, Cincinnati, O.

**ATTENTION—\$5.00 to \$12.00** advance commission selling suits, overcoats, water-proofed topcoats for \$17.95, plus bonuses. Large double swatches. Other unusual features. Restricted territory. Outfit free. Write today. Dept. E100, Beecher, 58 W. 21 St., New York.

**OLDEST** And largest manufacturer rubber specialties offers men and women equal opportunity to clear \$75 weekly with every day necessities. Write B. & G. Rubber Co., Dept. 463, Pittsburgh, Pa.

**ARE** You satisfied with your present earnings? You can increase your income by selling Colonial articles. Sells on sight. Write, Colonial Chemical Co., Pittsburgh, Pa.

**'XMAS** Card agents"—Something new—Engravo ink, greatest Christmas card sales stimulus on market. Produces signature or handwriting in beautiful engraved effect, matches engraved cards perfectly. Great for box assortments. Big profits. Sample free. Greeting Card Co., A-13, Boulder, Montana.

**MIRRORS** Resilvered at home. Costs near 5 cents per square foot. You charge 75 cents. Profitable business plating autoparts, reflectors, tableware, stoves, refinishing metalware, etc. Outfits furnished. Details free. Write, Sprinkle, Plater, 128, Marion, Ind.

**MAKE** \$28 Daily demonstrating automatic gaslighters. Cost you \$8 gross, doz. \$1. Rapid Mfg., 2772 Pitkin Ave., Brooklyn, N. Y.

**MAKE** Your own products, employ agents yourself. Toilet articles, soap, extracts. We furnish everything. Valuable book free. National Scientific Laboratories, 1935W Broad, Richmond, Va.

**NO** Dull times selling food! People must eat. Federal distributors make big money; up to \$3,000 yearly or more. No capital or experience needed; unsold goods may be returned. We furnish free sample case, license and free samples for customers—sure repeat orders. Exclusive territory. Ask now. Federal Pure Food Co., A2307 Archer, Chicago.

**OLIVER** Cleared \$700 in 30 days with our line of books and Bibles. Outfit free! Exclusive territory. Nichols Co., Dept. B30, Naperville, Ill.

**PORTRAIT** Men, you can make money anywhere selling our guaranteed portraits. Send for free frame catalog. Portrait Agents' Supply Co., Dept. F, LaPorte, Ind.



**MAKE** Big money with fast selling line of food products. Prize motor and tractor oils, paints. Sure repeat orders. Write for free sample case. Loverin & Browne, 1602-D So. State, Chicago.

**NEW** Electric Hashing sign, just out—changeable letters. Beautiful Neon color effect. Three sizes and styles. Unbreakable. Guaranteed. Every merchant buys on sight. 100% profit. Protected territory. Preston Mfg. Co., Dept. S-355, St. Louis, Mo.

**EARN** More pay the Quaker way. Take orders, complete line men's shirts, ties, hosiery, underwear. Remarkable values. All quick sellers. Big commissions. We furnish everything, deliver and collect. Satisfaction guaranteed. Complete outfit free. Write today. Dept. Z-10, Quaker, 1107 Broadway, New York.

**STEADY** Permanent income assured by selling biggest, finest line shirts, ties, underwear, guaranteed full year. No substitutions. Free silk monogram. Postage prepaid. Big advance commissions. Earn your shirts, ties; cash bonuses. Free outfit. Write today. Dept. PC, Rosecliff, 1237 Broadway, New York.

**ELEVEN** Piece toilet goods assortment at \$2.00, with self-sharpening dressmakers shears free to your customers. 100% profit. Davis Products Co., 238 North Ave., Dept. 630, Chicago.

**ARE** You old at forty? See our advertisement on page 143 of this issue. The Electro Thermal Company, 2134 Morris Ave., Steubenville, Ohio.

**PRACTICALLY** Any formula, 50c. Just send 50c and name it. Catalog free. Industrial Institute, Dept. 208, 64 West Randolph, Chicago.

**250% PROFIT.** Amazing new stove polish, in tubes. Cleans, polishes stove and nickel trimmings, one operation. Easily demonstrated. Tremendous demand. Housewives buy on sight. Enormous repeater. Outfit free. No deposit. MacDonald Company, Dept. 16, Vineyard Haven, Massachusetts.

**DOES** 300% Profit interest you? World's best polishing cloth. Everybody buys. Sample free. Magicloth, 3317 Summit, Kansas City, Mo.

**YES!** Two of the biggest money making propositions ever put on the market. \$150 to \$250 per week. Manager, 6137 So. Park Avenue, Chicago.

**CHRISTMAS** Card salespeople—Why pay more? Get our prices on attractive twenty-one card \$1.00 assortments. John McLaughlin, Box 302P, Torrington, Conn.

**WANT** Something different—something sells easily? Then sell razor blades, all makes, under your own name, retail, wholesale, through agents and by mail. 40 page booklet free. The Ann Arbor Blade Co., Ann Arbor, Mich.

**AGENTS**—Klear vue windshield cloth sells to every automobile owner on demonstration. Big profits. 75c sample mailed for 35c. Money back if not as represented. Write: Beacon Chemical Company, 3732 63rd St., Woodside, N. Y.

**AGENTS**—Build your own business—clean, profitable, dignified—taking orders from pocket samples for outstanding line made to measure shirts, neckwear and underwear for men. \$50 weekly to workers. Get details now. Superior Textile Mills, Dept. P, 18 East 12th Street, New York.

**FULL** Time—spare time—side line—Amazing profits the year 'round selling washable aprons and uniforms to business and professional men! Over 425 different kinds of prospects. Write quick for details. Dura Style, Dept. P-100, 318 N. 15th St., St. Louis, Mo.

**CLEVER** New invention closes door automatically and keeps them from slamming. Needed in every home, store, office factory. Saves glass, nerves, fuel, doors. Costs less, get introductory sample demonstrator and big money plans. Write quick! Close-A-Door Company, Dept. M-170, 1531 Washington Avenue, St. Louis, Mo.

**AGENTS** Chance to make \$250 month. Sell new line hosiery. Latest shades. Big fall sellers. Extra commission. Earn your own silk hose. Write quick. State size hose worn. Silknet Hosiery Co., Dept. 2431, Dayton, Ohio.

**JUST** Invented—new washing machine. No motors or moving parts. Automatically cleans entire washing. Fully guaranteed. Retail price \$9.50. Your profit 100%. Protected territory. Preston Mfg. Co., Dept. CP-10, St. Louis, Mo.

**SELL** Personal Christmas cards. Names embossed in gold. Lowest prices, highest commission. Sample free. Also box assortments. H. Dunbar Co., New Brunswick, N. J.

**BIG** Money daily selling shirts, ties, underwear, socks, raincoats, lumberjacks, sweaters, leather coats, mackinaws, coveralls, pants, children's play suits. Outfit free! Experience unnecessary. Nimrod Co., Dept. S, 4922-28 Lincoln Ave., Chicago.

**MAKE** Your own products, employ agents yourself. Toilet articles, soap, extracts. We furnish everything. Valuable book free. National Scientific Laboratories, 1935W Broad, Richmond, Va.

**BIG** Money selling the Yale Pocket Advers. Used in U. S. Post Offices over quarter century. New model "A" \$1.50. Model "B" for keeping golf scores \$2.00. Yale Mfg. Co., Box P-777 Phila., Pa.

**BIG** Profits—100%. Agents for beautifully designed Christmas cards with rich double lined envelope and exclusive steel engravings. Full particulars, Park Specialty Co., Dept. P., 219 Park Place, Brooklyn, N. Y.

**NEW.** Profitable—Sell auto step mats. Quality rubber with owner's name molded white. Details free. Ebonite Products, Dept. P-40, 895 Main, Akron, Ohio.

**BIG** Profits! Permanent business. Sign letters for stores, offices, trucks. Easy to apply. Samples free. Printasign, Akron, O.

**EMBOSSSED** Signs. Guaranteed permanent. New low prices. Samples and lists, ten cents. Superior, 4646 Telegraph, Oakland, Calif.

**BRISKO** Polishing cloth, shines silverware like magic. Fastest 25c seller out. Amazing profits! Sample free. Brisko Company, South Shaftsbury, Vermont.

**SELL** Stores salted nut meats, sundries, etc., cellophane packed. Big profits; repeat orders; exclusive territory. Sunshine Products, 4411 Lisbon Ave., Milwaukee, Wis.

**ANTI-Rust** removes automobile radiator rust. Sensational 25c seller. Specialty Mfg., 127 N. South Broadway, Los Angeles, Calif.

**NEW** Automatic clothes washer. Washes quickly and thoroughly. No rubbing. No electricity. Retail \$9.75. Guaranteed. Write Sales Manager, 3612 Enright, St. Louis, Mo.

**SELL** Runproof Hosiery, written guarantee with every pair. Most remarkable invention. Silktext Mills, Phila., Pa.

**\$100 WEEK** Distributing heatless liquid solder. Sample 50c. No stamps. Hamlin, 262 Olive, Ventura, Calif.

**AGENTS** Wanted for fastest selling, newly patented salt and pepper containers. Send one dollar for samples, Pasnik Co., Norwich, Conn.

**250,000 ARTICLES** Wholesale. Directory 10c. W-Patterson, 4111 University, Des Moines, Iowa.

**AGENTS**—Something new. 100% profit. 4 sales daily nets you \$150.00 per week. Write for particulars. Aladdin Service Company, P. O. Box 1404, Paterson, N. J.

**ALL** Good agents with bad feet, get free Kleen-Foot Balm. If it cures, sell the world. Eastern Laboratory, Mather Bldg., Washington, D. C.

**SELL** New signs embossed price tickets and changeable signs. Wonderful selection for Christmas and all year. Used in all business; \$1.00 samples 25c. P. Franklin Co., 3322 3rd Ave., New York.

**MAKE** Money—your own business. Valuable information and formulas free. Arthur Terry, 1964 West 7th St., Brooklyn, N. Y.

**JUST** Out—Electric clock. No winding—No springs. Accurate timekeeper. Low price. Sells fast. Tremendous profit. Take orders. We deliver. Edward-Walfrid Co., 511 Irving Park Station, Chicago.

**ONE** Demonstration sells this new product for every home. Large profits. Particulars free. General Floor Corporation, 4010 W. Madison St., Chicago. Dept. P10.

**MAKE** And sell imitation maple syrup. Big profits. Instructions and sample 25c coin. Cozart, 2815 Main, Louisville, Ky.

**SELL** Koehler's blue signs. Start now! \$3.50 will bring 100 wonderful 20c sellers. Koehler's, 717 N. Fourth, St. Louis, Mo.

**\$2.98 RAINCOAT** Line pays record-breaking profits. Flashy new numbers. Season on. Experience unnecessary. Outfit free. American, 3908AA Lincoln Ave., Chicago.

**NEW** Electric flasher signs—just out. Dazzling colors. Changeable letters. Merchants buy on sight. Retail \$13.50. Storm Royalty Co., Dept. 10, St. Louis, Mo.

**ENGRAVED** Nameplates, signs, numbers, initial, desk, city nameplates. Big profits. Hilton Specialty, 90 Stewart, Providence, R. I.

**BIG** Money easy, simply showing new Polly Wrench. 10 wrenches in one. Guaranteed fast seller. Sample furnished. Gellman Mfg. Co., Dept. 6-X, Rock Island, Ill.

**WONDERFUL** New sideline; astonishes everyone; repeat sales. The new Gem can opener for all cans. Agents sample 25c. Allneeds Mfg. Co., Box 26, Oak Park, Ill.

**MAKE** Big money showing our hand-colored Christmas card box assortment. 100% clear profit. Samples postpaid 50c. Bertin Jones Studios, Superior, Nebr.

**BEAUTIFUL** Christmas greeting cards. Sample boxes, 40c. Matz Novelties, Reading, Pennsylvania.

**ARVEO** Polishing cloths offer large commissions to our distributors. Every home needs them. Sample and particulars free. Arveo Industries, 3230 Helen Ave., Detroit, Mich.

**AGENTS**—A whirlwind seller for agents and dealers; needed in every club, lodge, room, ice cream parlors and restaurant; essential in every home; liberal offer to general agents. H. E. Junler Co., 117 Pleasant St., Fairhaven, Mass.

**IN** All parts of country sell Drip Coffee Pots, tested and approved "Good House-keeping" and leading physicians. Build your own business with weekly repeat on a high grade coffee. Liberal profits, exclusive territory; no investment. Write Dripco Sales Organization, 25 Willoughby St., Brooklyn, N. Y.

**CHINESE** Parasol ceiling shades with attachments. Sample and terms \$1.00. Act quick. Weston Co. of Hongkong, 4th St., Long Beach, Calif.

**AGENTS**—No hard times. Earn up to \$12 daily wearing fine felt hats and showing friends. Smartest styles. Latest shades. \$2 to \$5 saving. Samples free. Taylor Hat and Cap Mfrs., Dept. GC-135, Cincinnati, Ohio.

**SHORTHAND.** Remarkably simple Spanish and English systems. Teachers, agents wanted. McKwan, 224 E. Huron, Chicago.

**SALESMEN**—Take orders for America's finest ties, shirts, hosiery, underwear. Generous commissions. Master Sales Outfit loaned free. Write Public Service, Dept. KC-17, West New York, N. J.

**AGENTS**—Mosco corn and callous remover will build you a steady repeat business. Send today for pocket-size trial outfit. The Moss Company, 504 Searle Bldg., Rochester, N. Y.

**SELL** Housewives something they want. They are bound to be interested. A signed guarantee to reduce gas bills 25%. No competition. 400% profit. Box 18E, East San Diego, Calif.

**OUR** New card of 5c aspirin sells fast to stores. Over 100% profit. DeVore Mfg. Co., Desk C, Columbus, Ohio.

**YOU** Make 300% profit selling changeable signs to stores; six lines, three colors, cost 35c, sells \$1.50. Robinson sold 18 signs in four hours. Particulars free. National Sign System, St. Louis, Mo.

**PORTRAIT** Agents—Highest quality enlargements, medallions, frames. Reasonable prices. Write for catalog. Adam J. Kroll Co., 2543 South State, Chicago.

**AGENTS:** "Clear-O" pays large profits, great repeater. Bloom Products, 307 E. 22nd, Baltimore, Md.

**"HOW** To Secure Agents," a specially prepared booklet, tells of one of the most inexpensive methods in which to secure good live producing agents. It is free; write for your copy today! M. L. Rund, Mgr. Classified Advertising, Popular Mechanics Magazine, 200 E. Ontario St., Chicago, Ill.

**AGENTS** Everywhere making money with our line of kitchen specialties, demanded in all homes. Big earnings possible. Write today for details. P. Seed Filter Co., 353 Broadway, New York.

**BESTEVER** Powdered Hand Cleaner. Removes Grease—Paint—Ink instantly. Sells fast. Sample Free. Bestever Co., 400 Irving Park Station, Chicago.

**NEW** Line Counter Displays, Aspirin, Flints, Chewing Laxative, Breath Gum, No-tartar, Silkstone, etc. Steady Repeats. Over 100% Profit. Superba Co., W5, Baltimore, Md.

**RE-DYE** Rugs on Floor. Fibertint the dye applied with a brush. Red, Blue, Green, Brown, Purple. Does quick work. \$15 to \$20 daily. Sample outfit dyes 9x12 rug \$1. Texply Co., Inc., Somerville, N. J.



**BRAND New Idea.** 1930 Christmas Card line. Amazing seller. Experience unnecessary. Full-part time. Samples free. Windermere, (Established 1900) 6702 Dorchester, Chicago.

**AGENTS—\$30 Day easy placing Stypko Counter Displays with dealers.** Globe Chemical Works, Bay City, Mich.

**CHICAGO Expert valued \$3 stone at \$900.** The diamond's only guaranteed rival. Greatest spare time, side-line article ever known! Amazing profits. \$5 pocket sample case free. Write quick. Mexican Gem Company, Dept. P.M. Monterey, Calif.

**AGENTS—Make 80c profit on \$1.00 sales.** Wonderful cleaner for automobiles, furniture, metal and glass. Your name on labels—fast repeater—exclusive territory. Free sample. Minute Kleen Laboratories, Evansville, Ind.

**BIG Money and fast sales.** Every owner buys gold initials for his auto. You charge \$1.50; make \$1.45. Ten orders daily easy. Write for particulars and free samples. American Monogram Co., Dept. 40, East Orange, N. J.

**THAXLY Formulas produce perfect products.** All lines. Catalog free. B. Thaxly Co., Washington, D. C.

**MANUFACTURER Wants distributor for new "Pocket" Radio, \$3.85 complete.** "Sells itself with music." Pays 100%. Write Spencer Radio, Akron, Ohio.

**UNUSUAL Income.** Every community. Sell home, shops, theaters, stores, banks, schools, etc., the new Fugo world's simplest fire protection. No sales experience necessary; we teach you. Part or full time. Act quick! The National Formetal Co., 6547 Metta Ave., Cleveland.

**SELL Men's neckwear—wonderful proposition.** Astor-M, 39 East 28th, New York.

**FREE "Booklet of money making opportunities."** new ideas, original plans, money making secrets and other valuable information. None require peddling or outfits. Elite Co., 84 Elizabeth St., New York.

**TIME Counts in applying for patents.** See pages 134 and 135. Clarence A. O'Brien, Registered Patent Attorney, Washington, D. C.

**SELL Stores 5c carded breathlets, etc.** Lorræ Products, Albany, N. Y.

**POLMET Polishing Cloth removes tarnish from metals without the use of liquid, paste or powder.** Our agents say it sells like "hot cakes." Retail 25c; sample free. Gale & Co., Inc., 15 Edinboro St., Boston, Mass.

**ENGRAVED Name plates, signs, numbers, desk plates, store window signs, etc.;** profits large. Brett Bros., Winthrop, Mass.

**AGENTS Wanted everywhere.** Write for further particulars. Snow & Parker, Inc., 41 Fish Pier, Boston, Mass.

**SUCCEED With your own products.** Make them yourself. Formulas, processes, trade-secrets. Expert analytical service. Catalog, circulars free. B. Thaxly Co., Washington, D. C.

**AMAZING Profits showing new table cloth.** Looks like linen. Wash like oilcloth. No laundering. You just take orders. We deliver. Pay daily. Sample free. Bestever, 231 Irving Park Station, Chicago.

**\$50,000 PICTURE Man Friedman made canvassing.** Get free circular "Profits in Portraits." Samples free. Picture Man Friedman, 109 West Austin Ave., Chicago.

**\$200 MONTHLY Selling amazing new automobile trouble light.** Electro magnetic. Sticks anywhere on car. It's an Everlasting Flashlight. Sells on sight. Send for demonstrator and prices. National Electric Corporation, 222 High St., Newark, N. J.

**SELL 3A Garage door holders, simple, automatic, quickly installed.** Interests garage owners, builders, everybody. Exclusive territory proposition. Knowlson-Stevenson Co., Ann Arbor, Mich.

**MAN In each town to plate auto parts, reflectors, bathroom fixtures, refinish beds, mirrors, chandeliers;** by new method. No capital or experience required. Simple plan of manufacturing at home starts you in big money-making business. Outfit furnished. Free particulars and proofs. Gun Metal Co., Ave. H. Decatur, Ill.

**AGENTS—Make a dollar an hour.** Sell Mendets, a patented patch for instantly mending leaks in all utensils. Sample package free. Collette Mfg. Co., Dept. 404, Amsterdam, N. Y.

**BIG Profit putting our gold sign letters on store windows, without experience.** Samples. Consolidated, 69-T West VanBuren, Chicago.

**A BUSINESS Of your own—Making sparkling glass name and number plates, checkerboard signs.** Big book and sample free. E. Palmer, 512, Wooster, Ohio.

**WANTED: District manager to appoint agents.** Unlimited opportunity. No canvassing. Mother Hubbard Products, 654U Congress, Chicago.

**CALIFORNIA Perfumed beads selling like hot cakes.** Agents coinng money. Big profits. Catalog free. Mission Factory P, 2328 W. Pico, Los Angeles, Calif.

**THIS Advertisement may make you thousands of dollars, if you write immediately for my "Eye-Opening" literature describing guaranteed formulas;** valuable trade processes, money-making information how to easily make the world's best-selling specialties. All lines. Investment small. Profits immense! Start in your home, room or office. Make the good money you're entitled to. Dr. Liscombe Miller, Chemist, Tampa, Fla.

**GENUINE Gold Leaf Letters anyone can put on store windows.** Guaranteed to never tarnish. Large profits. Enormous demand. Free samples. Write today. Metallic Letter Co., 438-D North Clark, Chicago.

**AGENTS: Stamping names on pocket-key protectors.** Sample check with your name and address, 25c. Stamping outfits. Emblem checks, check-fobs, name plates. Hart Mfg. Co., Desk 2, 303 Degraw St., Brooklyn, N. Y.

**PHOTO Medallion men and women, the largest line of photo novelties in the world.** Lowest prices, quickest service. Send for catalog showing over 200 money makers. Gibson Photo Jewelry Co., Inc., 833-837 Gravesend Ave., Brooklyn, N. Y.

**GREATEST Opportunity; newest proposition.** Build continually paying business in your own name. Household, industrial, brushes, brooms, mops, dusters, fully guaranteed. New catalog, all net prices, no discount to bother with. Make as high as 300 per cent and over. Write today. Wire Grip Sanitary Brush Corp., 41 East 11th St., New York.

**BIG Profits! Fast sales! \$9.75 automatic washing machine.** Guaranteed. Write Storm Royalty Co., 3601 Enright, St. Louis, Mo.

**AGENTS — Clever Invention! Inkspoon makes every pen a fountain pen.** Fast office seller; big profit, demand increasing everywhere. Exclusive territory offered. Sample free. H. Marul Company, Tribune Bldg., New York, N. Y.

**WE Start you without a dollar.** Soaps, extracts, perfumes, toilet goods. Experience unnecessary. Carnation Co., 641, St. Louis, Mo.

**AVIATION—Every person seriously interested in this subject should make full use of the opportunity to learn aerodynamics with Alexander Klemin as his instructor, through his timely new book, "Simplified Aerodynamics."** Heretofore this subject has been rather difficult for the thousands who need it but Klemin's method enables all to master it. Every pilot, mechanic, student needs this book. Pay postman price, \$3.50, and few cents postage when he delivers it. Order from Popular Mechanics Press, Room 807, 200 E. Ontario St., Chicago.

#### HIGH-GRADE SALESMEN WANTED

**40%-55% PROFITS.** Be independent with America's greatest printing line. Sensational new "Endless Chain" selling plan guarantees repeat sales and extra profits even during business depressions. We set you up in business and send you all this free: (1) Great new 138-page catalog of 1000 printed forms for every business; (2) New line of personal stationery; (3) New line pictorial parcel post and shipping stickers; (4) New line graphic advertising stickers; (5) New and different collection sticker system. Thousands of free cuts. Lowest prices. Highest qualities. Main or side-line. Experience unnecessary. Write quick for Big New Outfit free and greatest money-making proposition ever offered keen salesmen. Kaiser-Blair, Inc., Dept. 231, Cincinnati, Ohio.

**BIG Money daily selling shirts, ties, underwear, Sox, raincoats, lumberjacks, sweaters, leather coats, mackinaws, coveralls, pants, children's playsuits.** Outfit free! Experience unnecessary. Nimrod Co., Dept. 65 4922-28 Lincoln Ave., Chicago.

**PUNCHBOARD—Hurray.** New protection plan opens "closed" territory creating tremendous demand. Dealers jubilant. Business booming. Commissions enormous. Outfit free. Puritan Co., 1407 Jackson Blvd., Chicago.

**SALESMEN—Wonderful sideline.** 40% commission paid daily. Sells all merchants. Pocket outfit free. David Lionel Press, 312 So. Hamilton, Dept. 171, Chicago.

**BIGGEST Cash commissions ever.** Marvelous complete line raincoats, sportswear, jackets. Latest styles. Complete sales outfit free! \$1.00 bag given. Dunco, 19 Williams St., Boston.

**SALESMEN—Hava-Rexa 5c cigars repeat everywhere.** Superior quality! Big money! Special selling plan. Rex Cigars, Shelby, N. C.

**SALESMEN—Easy selling Die-U-Rat thru jobbers.** 20% commission. Kills nothing but rats and mice. Rick Drug Co., Gallon, Ohio.

**SELL Brand new flashing sign, all businesses.** Unheard of profits. D. Williams Sign Co., 30 North LaSalle, Chicago.

**PLACE Punchboards, vending machines, in stores;** free kit. Badger Bay Company, Green Bay, Wisconsin.

**MARVEL Siphons start, stop, sell themselves.** Big cash commissions. Sample 30c. Marvel Mfg. Co., Box 1066, Long Beach, Calif.

**DO You want a snap? Sell our effective premium business building plans to merchants everywhere.** Big front money and 100% repeats. Write today and you'll be with us to stay. Western Premium Co., Dept. D., 118 So. Wells, Chicago.

**NEW Line of tools selling direct to the automotive and general trade.** Priced from \$1.80 to \$15.00. The potential earnings of this line will attract the highest type of salesmen. Write for details. Huhn Mfg. Co., 23 West 100 St., New York City.

**NEW And plenty different—Fast selling 5c-10c merchandise on attractive counter cards.** 100% commission for you and dealers. Advertised by radio. No capital required. Catalog free. World's Products (Estab. 1921), 99 Central, Spencer, Ind.

**EARN \$20.00 a day up taking orders for Goodwear clothes.** Build an established business with assured income. Selling outfit supplied free offers powerful display Pure Virgin Wool Fabrics and everything else required to start you making real money at once. Address Dept. 934, Goodwear, Inc., 844 West Adams, Chicago.

**\$18 To \$25 Daily; biggest selling line of men's suits, \$11.95, \$14.50, \$16.95, \$19.95.** Amazing values. Pure virgin wool overcoats, \$18.95. Also raincoats, slickers, topcoats and boys' suits. Biggest commission paid in advance. Liberal bonus. Free outfit. "Jim" Foster, Inc., Dept. 210, 2250 S. Snoulding Ave., Chicago, Ill.

**SELL Nothing, earn up to \$170 weekly empty handed.** No sample case to tote. Oldest and largest punchboard firm, established 20 years, rated \$500,000, announces amazing new plan. Salesmen cleaning up! No one invests a penny. We even pay express charges. Unsaleable merchandise returnable. Big season now here. Full commission repeat business. Grab this quick! K. & S. Sales Co., 4302 Ravenswood, Chicago.

**SALESMEN—No hard times.** Earn up to \$12 daily wearing fine felt hats and showing friends. Smartest styles. Latest shades. \$3 to \$5 saving. Samples free. Taylor Hat and Cap Mfrs., Dept. GC-135-A, Cincinnati, Ohio.

**NEW—Fast selling specialty to merchants.** Commissions paid daily with weekly salary guaranty. Enormous opportunity, worth \$150 weekly. Drawer 1029, Cedar Rapids, Iowa.

**NEW Specialty all retailers.** Pleasant, permanent, profitable. Good income. Repeats. Commissions daily. \$40.00 weekly expense guaranty. Splendid opportunity. Manager, Drawer 602, Cedar Rapids, Iowa.

**MANUFACTURER And distributor of Shoes and Leather goods wants salesmen.** Big money opportunity. No experience necessary. No investment. Consolidated Shoe System, Dept. C-9, Eau Claire, Wis.

**SPECIALTY Salesmen, part and full time, cleaning up with Jiffy Lubricator and Grease Gun.** Room for many more. Sell truck fleets, service stations, garages. Light, compact hand pump, new hydraulic principle; clean fast, more powerful than larger, higher priced units. Sold on money back guarantee. Write for attractive proposition. Jiffy Lubricator Co., Fargo, N. D.

**UNHEARD-OF Profits.** Live-wire sales people coinng money daily with our new sales plan for hosiery, lingerie, ties, etc. Buy direct. Small lots at quantity prices. Make up to 200% profit. Catalog and plan free. New Ideal Knitting Co., 183C Legion Ave., New Haven, Conn.



**SALESMEN:** Our men earning \$15-\$40 daily selling to stores. Sayers Systems, Est. 1895, 2813 Sheffield, Chicago.

**WONDERFUL** invention. Seals fifty envelopes minute. Sells on sight at \$2.25. Attractive trial offer. Square deal. Bank references. Kendall Sealer Co., Dept. C-23, East Jaffrey, N. H.

**SELL** Business printing. Hundreds of standardized items with illustrations, complete selling outfit for real workers, full repeat. A national service. All Trade Printing Service, 1110 N. Second St., Rockford, Ill.

**CHRISTMAS** Cards, 50% commission. Large line, low prices. 6 box assortments, 4 for imprinting. Buckeye Thermographers, 1108 Adams, Toledo, Ohio.

**PUNCHBOARD** Salesmen: New plan sells every merchant. Better terms, bigger commissions. Sure repeat orders with full commission. Experience unnecessary; outfit free. A. J. Novelty Co., 161 W. Washington, Chicago.

**NEW** Electric flashing sign, just out—changeable letters. Beautiful Neon color effect. Three sizes and styles. Unbreakable. Guaranteed. Every merchant buys on sight. 100% profit. Protected territory. Preston Mfg. Co., Dept. S-356, St. Louis, Mo.

**CLEAN** Up now till Xmas. New holiday advertising plan for every business. Quick action money-maker for hustlers. Free outfit. Chicago Graphite, 130 S. Clinton, Chicago.

**SELL** Goodyear raincoats, \$2.95 up. Good-year Rainwear, 682 Sixth Avenue, New York.

**ARE** You old at forty? See our advertisement on page 143 of this issue. The Electro Thermal Company, 2134 Morris Ave., Steubenville, Ohio.

**ADVERTISING** Novelty or book match salesmen for new items. Gits Co., 1M5419 Chicago Ave., Chicago, Ill.

**SELL** Brohard-Rainer "Good Shirts." Everybody buys. They repeat, too. Good pay. Act quick! Brohard-Rainer, 400 Pike, Cincinnati.

**BIG** Profit putting our gold sign letters on store windows, without experience. Samples. Consolidated, 69-V West Van Buren, Chicago.

**SALESMEN**—Become independent. Own your business; experience unnecessary, selling our \$10,000 accidental death; \$50 accident; \$25 sick weekly benefits—\$10.00 yearly. Other amounts proportionate. Guaranteed steady income from renewals. \$250,000 deposited insurance department. Universal Policy, Dept. A, 716 Lefcourt Bldg., Newark, N. J.

**BIG** Pay every day. Bonus every week. Adelite sells everywhere. New spectacular electric window display. Ever-changing colors, original posters, patented changeable letters defy imitation or competition. Special models for merchants, banks, etc. Instant seller. Big repeats, full commission. Write for thirty day demonstration offer. Display Products Co., 409A East 31st, Kansas City, Mo.

**\$60-\$200 A WEEK.** Genuine gold letters for store windows. Easily applied. Free samples. Liberal offer to general agents. Metallic Letter Co., 438-A North Clark, Chicago.

**PUNCHBOARD** Salesmen make big commissions, selling punchboards and vending machines. Reliable concern, established 20 years. Largest most complete catalog in colors, free. Best season now. Write today! Lincoln Sales, 116 S. Wells, Chicago, Dept. D.

**PUNCHBOARD** Salesman—Most gigantic line ever featured. Vending machines, all kinds. Make high as \$28.00 on single order. Repeat commissions. Beautiful colored catalog free. Lion Mfg., Dept. 8, 308 W. Erie, Chicago.

**WANTED** District managers. Oldest organization of its kind in accident and health insurance. Write today for information. Dept. 18, Inter-State Business Men's Accident Ass'n, Des Moines, Iowa.

**SALESMEN** Sell tires and auto accessories to garages, tire stores, filling stations, etc. Established line repeats everywhere. Liberal commission. Write for particulars. Economy Rubber Prod. Co., 606 Burkhardt, Dayton, Ohio.

**SALESMEN**—Make 80c profit on \$1.00 sales. Wonderful cleaner for automobiles, furniture, metal and glass. Your name on labels; fast repeater; exclusive territory; free sample. Minute Kleen Laboratories, Evansville, Ind.

**DAILY** Cash! Merchants can't refuse this amazing introductory offer! Sells everywhere. Big commissions. Big quick repeats—prompt checks. Pocket kit free. Sales Stimulators, Inc., 339 W. Madison, Chicago.

#### DEMONSTRATOR SALESMEN

**DEMONSTRATOR** Salesmen. New auto necessity, every motorist buys. Our demonstrators average \$20 daily. Wholesale supply, 1604 Morse, Chicago.

#### HELP WANTED

**IF** You want to get your groceries and household supplies at wholesale, and a wonderful chance to make \$15 cash profit a day besides, send me your name immediately. No experience necessary. Albert Mills, 5370 Monmouth, Cincinnati, O.

**MEN**—Sideline; photos, 20, \$1.00. Cartoon books. Samples. GPO, Bx471, New York.

#### EDUCATIONAL AND INSTRUCTION

**\$105.00 TO \$250.00** Month. Men, women, 18 up. Want a government job? Steady work. Short hours. Paid summer vacation. Common education usually sufficient. Experience usually unnecessary. We coach you without leaving home. 32 page book with full particulars and sample coaching free. Write today. Franklin Institute, Dept. P3, Rochester, N. Y.

**FIREMEN**, Brakemen, baggagemen; colored train or sleeping car porters, \$150—\$250 monthly. Experience not necessary. 810 Railway Instruction Bureau, East St. Louis, Ill.

**PIANISTS**—New course by QRS Roll artist includes demonstration rolls, special arrangements song hits. Harmony, improvising, hot rhythm instruction for instrumentalists. Questionnaire free. Sparks Music School, Norwich, Conn.

**DON'T** Spend a dollar for civil service instruction without consulting Seaboard Service Co., Baltimore, Md.

**U. S. GOVERNMENT** Wants men, \$1,700—\$1,900 and up at start. Railway mail clerk examination coming. Let our expert (former government examiner) prepare you for this and also rural carrier, post office, customs, internal revenue, and other branches. Write today for free booklet. Dept. 8, Patterson School, Rochester, N. Y.

**CARTOONING**—Let the world's most successful cartoonist tell you how to draw cartoons. Briggs in his new book gives every step in cartoon work and answers every question a beginner might ask. Elaborately illustrated. Pay postman price of book, \$3, and small amount of postage when he delivers the package C. O. D. Popular Mechanics Co., Room 801, 200 E. Ontario St., Chicago, Ill.

**WANTED** Immediately, men-women, 18-55, qualify for permanent government positions, \$105-250 month; no government experience required. Paid vacations. Common education. Many needed soon. Write Ozment Inst., 101, St. Louis, Mo.

**LEARN** Rapid figuring from "Higher Arithmetic." Write for prospectus. F. A. Smith, 608 S. Dearborn St., Chicago.

**BECOME** A landscape architect. Uncrowded profession; wonderful opportunity for money-making. Easily mastered by mail. Earn while you learn. Est. 1916. Write for details. American Landscape School, 29 Plymouth Bldg., Des Moines, Iowa.

**LEARN** Lacquer system of sign painting. Valuable new book gives complete description of methods, materials and equipment with hints and helps for sign shops. Covers latest in electric, neon tube, and daylight reflector signs, etc. Delivered to your door C. O. D. Simply pay postman \$3 and postage. Popular Mechanics Press, Room 801, 200 East Ontario St., Chicago.

**DON'T** Prepare for any civil service examination without seeing our catalog. Free. Columbian Correspondence College, Washington, D. C.

**DOUBLE** Entry bookkeeping 60 hours with 8 keys guaranteed. (Diplomas.) International Bookkeeping Inst., 8 Springfield, Mo.

**A BILLION** Ideas. This is the title of our remarkable catalog of books along practical lines. Arranged alphabetically by subjects for easy reference. If you have not received it, send for a copy. You will find hundreds of subjects you cannot usually locate in book stores or public libraries. Sent free upon request. Popular Mechanics Press, Room 807, 200 E. Ontario St., Chicago.

**BOYS!** Here's fun galore. Four large profusely illustrated books tell how to make almost everything you could want. Nearly 4,000 different articles are described (Think of it). Now \$2 per book or \$7 for the four if ordered at once. Just write a postal saying, "Send the Boy Mechanic Library." Pay postman \$7 and postage. For single books, specify either Book 1, 2, 3 or 4. Popular Mechanics Press, Room 801, 200 E. Ontario St., Chicago, Ill.

#### TYPEWRITERS AND SUPPLIES

**TYPEWRITERS**—All makes, guaranteed, \$6 to \$34. Free catalog. Typewriter Exchange, Ada, Okla.

**TYPEWRITERS**—All standard makes \$10 up. Catalog free. Northwestern Typewriter Exchange, 121 N. Francisco Ave., Chicago.

#### ADDING MACHINES

**NEW** \$3.50 Automatic adding machine. Adds, subtracts, multiplies, absolutely accurate. Capacity 999,999.99. Fully guaranteed. 75,000 pleased users. Makes adding easy, positive, quick. Eliminates mistakes. Saves time. Postpaid \$3.50. Bassett Co., 1458-J, Hollywood Ave., Chicago.

#### PRINTING, ENGRAVING AND MULTIGRAPHING

**LETTERHEADS** (8½x11) Envelopes, 500 each \$2.75; C.O.D. plus postage. Free samples. Universal Printing, 1111 Smith St., Bay City, Mich.

**500 LETTERHEADS** And envelopes \$2.95. Billheads, circulars, labels, tags. Samples. Ware, Box 357, Ft. Madison, Iowa.

**5,000 TINTED** Enamel folders, \$13.75; 5,000 6x9 circulars, \$7.50. (5,000 elegant envelope slips, \$5.00 prepaid). Samples. Goodprint, Harrisonburg, Va.

**PARTICULAR?** "Near Gravure"—500 8½x11 letterheads, 250 envelopes \$4.44, postpaid. Solldays, Knox, Indiana.

**200 LETTERHEADS** And 100 envelopes, \$1.00; 200 letterheads, 8¼x11, 150 envelopes, \$2.00; 250 cards, \$1.00. Hoosier Print Shop, Portland, Ind.

**OUR** Standardized plan makes it possible to print house organs and magazines at one-third ordinary prices. We print more than 1,100 different publications. Samples and particulars free. National Publishers Press, Grand Rapids, Mich.

**1000 BUSINESS** Cards \$2.75 postpaid. Samples free. Miller, Printer, Narberth, Pa.

**LETTERHEADS**, Envelopes, 500, \$1.10; 1,000, \$2.00; 5,000, \$8.00, plus postage. Samples. Coyle & Kimballs, Newport, N. Y.

**QUALITY** Printing! Reasonable prices! Send for free standardized samples and prices. Folders, Circulars, Catalogs our specialty. Earnest Fantus, 525 South Dearborn, Chicago.

**250 BOND** Letterheads, envelopes, billheads, cards, \$1.35 each. Economic Press, Leonia, N. J.

**WE** Print stationery, booklets, catalogs, circulars. Samples. Commercial Press, Batavia, Ohio.

**SOCIAL** And business printing. Specializing in raised letter work. Samples free. LaClyde Service, Westfield, Mass.

**PUBLICATIONS**, Catalogs, stationery. Prices reasonable. Annville Printing Company, Annville, Penna.

**BEST** Printing prices. Battlefield Press, Gettysburg, Penna. Free battlefield souvenir.

**BUSINESS** Cards \$1.55, letterheads \$1.90 per 1,000, in 5,000 lots. Wilson's 2922 Victor, Kansas City, Mo.

**500 BUSINESS** Cards \$1.00. Attractive samples free. Hanzer's, Magnolia, N. J.

**250 LETTERHEADS** And envelopes, bond, \$2.49. Newman & Son, Auburn, Nebraska.

**200 PERSONAL** Letterheads, 100 envelopes, best bond, white or tints, \$1.50. 250 best vellum bristol cards, business or personal, \$1.50. Gapeo Print Shop, 25 Garfield Avenue, New London, Conn.

#### PRINTING OUTFITS AND SUPPLIES

**COMPLETE** Printing outfits, presses, type, ink, paper, supplies. Write for free catalog. Kelsey Co., B-11, Meriden, Conn.

**PREUSED** Printing presses and supplies. Lists 2c stamp. Popular Bargains, Richland, Pa.

**PRINTING** Outfits—Presses, type supplies, type novelties. Send stamp for catalog. Model Press, York, Penna.



**GUMMED LABELS**

1,000 PRINTED: Name, business, address 50c. JBS Company, Box 93, Holyoke, Mass.

**DUPLICATORS AND DEVICES**

G. S. W. STENCIL Duplicator duplicates typewriting handwriting, drawings etc. in one or more colors. Notesize \$14.50. Letter-size \$19.50 complete. General Stamping Works, 238 E. 24th St., New York.

YOU Can make 50 to 100 copies of a letter, notice, etc., at a cost of three cents on a Heyer Quality Duplicator. Write for free trial offer. The Heyer Duplicator Co., 909 Jackson Blvd., Chicago, Ill.

"EXCELLOGRAPH" Rotary stencil duplicator \$39.00. "Two-Faced" film duplicator \$6.00. Booklet free. Pittsburgh Typewriter Supply, Dept. 601, Pittsburgh, Pa.

**FOR MEN**

SOMETHING New—Plain tie painted to order. Your name or initials with flowers \$1.00. Money order or cash. Binder's Tie Shop, 909 Vine St., Cincinnati, Ohio.

**RUBBER STAMPS**

SEND For catalogue 50c. Mansfield Rubber Stamp Works, Mansfield, Ohio.

RUBBER Stamps; name, address 35c. Newman & Son, Auburn, Nebr.

**FOR THE HOME**

CEDAR Chests only \$11.65—"Red-I-Kut" complete with rich copper trim—you assemble and save half—send for pictures. Kuempel Furniture Company, Guttenburg Iowa.

N-U-HEAT Fireplace. Information available. 2623 Exposition Place, Los Angeles, California.

**FOR SMOKERS**

GOLD Leaf tobacco; mild, mellow, like rare old wine. Smoking, 4 pounds \$1; Chewing, 4 pounds \$1.25, postpaid. Belmont Farms, Box 9, Chatham, Virginia.

**GUNS, FISHING TACKLE AND SPORTING GOODS**

SHOTGUNS Restocked, checked complete, \$8.00. Bradley Gunsmith Savannah, Ga.

**FIELD GLASSES, TELESCOPES AND MICROSCOPES**

IMPORTED Eight mile binoculars. Only \$7.50. Free trial. Literature. M. Tarres, 4732 Griscom, Philadelphia.

\$5.00 GOVERNMENT Used field and marine glasses, powerful, with leather case, cost \$20.00. Send free list, field glasses, binoculars, aeroplane cameras and lenses, also musical instruments. Weil's Curiosity Shop, 20 South Second Street, Philadelphia, Pa.

**BOATS AND LAUNCHES**

BUILD Your own boat using ready cut semi-assembled materials furnished by originators of this system of building. Save two-thirds. 55 designs—outboard speedsters, runabouts, cruisers, sail, row, etc. Send 10c for catalog. Brooks Boat Co., etc., Box M.M., Saginaw, Mich.

MAKE 16' Rowboat. Blueprint. 30c. Weesho-Uco, 31st Office, Detroit, Mich.

REMARKABLE Pictures of the Cup Yachts in breeze shown in September Rudder. 25c copy. Send for catalog boat books free. The Rudder, 15 Murray, New York City.

16' CANVAS Canoe. Easily made. Blueprint. 30c. Weesho-Uco, 31st Office, Detroit, Mich.

BUILD Your own boat—Complete directions make it comparatively easy. 14 different types for all purposes including row, motor, sail, canoe, out-board motor boats, etc. With this book is included "Outdoor Sports the Year 'Round" on making all sorts of devices for outdoor recreation. Pay postman \$1.98 plus postage when delivered. Popular Mechanics Press, Room 801, 200 E. Ontario St., Chicago.

MAKE 12' Rowboat. Blueprint 30c. Weesho-Uco, 31st Office, Detroit, Mich.

**DIAMONDS, WATCHES AND JEWELRY**

REBUILT Watches—Elgins, Walthams, etc., cheap. Send for price list. Crescent City Smelting Co., 508 Chestnut St., St. Louis, Mo.

**RAZORS AND BLADES**

GILLETTE Blades honed, stropped, 1c each. Petter Wetterquist, Rockford, Ill.

GILLETTE Blades sharpened 2c. V. Swedberg, Harris, Minn., R. 1.

**ANTIQUES, WAR RELICS AND INDIAN GOODS**

SEND 5c For fine new list Indian relics, antique firearms. F. E. Ellis, Webster Groves, Missouri.

INDIAN Relics. Beadwork. Coins. Curios. Catalog free. Vernon Lemley, Osborne, Kans.

**PHONOGRAPHS AND RECORDS**

BUILD Your own phonograph radio. Catalog mailed for 10c. American Phonograph Co., 3602 Wesley, Berwyn, Ill.

**MUSIC AND MUSICAL INSTRUMENTS**

COMPOSERS—Verse or music. Brilliant opportunity. Write VanBuren, 2149 McClurg Bldg., Chicago.

DUO-Flex reeds for clarinets and saxophones eliminate your reed troubles. Write for circular, Duo-Flex Reeds, 1204 1st Ave., Evansville, Ind.

SONG Poems wanted, marketing proposition, if suitable. Clifford Studio, 4562 Hollywood Blvd., Hollywood, Calif.

ADVANCE Royalty payments, talking pictures song requirements, etc., fully explained in free booklet. Write today. Newcomer Associates, 1674-DD, Broadway, New York.

SONG Poems from the Hearts of The People, set to music by real composer. Complete publication service. Write now. C. Isabel Mayer, Okobaji, Iowa.

SEND Song poems, 50-50 plan. Indiana Song Bureau. (Brookside), Salem, Ind.

PIANISTS, Instrumentalists: Read our ad under Educational-Instruction. Sparks, Norwich, Conn.

WRITERS—Poems, melodies, wonderful opportunity, legitimate. Tommie Mallo, PM4215 North Ave., Chicago.

GIVE Your songs the right start. Free information. Tucker, 330 Wadsworth, New York.

PIANO-Accordian Groff's wonder book "Jazz" teaches you. Send \$3.00 today. Money back guarantee. Groff, 2828 Madison Street, P. Chicago, Illinois.

SONG Writers. Send for our "Publishing Agreement." McKinley Music Printers, 1501 E. 55th St., Chicago.

SONG Poems solicited. A different proposition. Richard Broughton, Sioux Falls, S. Dak.

WRITE Songs. Big money and reputation. Write for information. J. Gordon Pub. Co., 201 N. Hoyne Ave., Chicago.

POEMS Wanted. Work guaranteed. We publish. Great Eastern Song Bureau, Dept. 27, Thomaston, Me.

CORNETISTS—Trumpetists—Saxophonists—Clarinetists. Get "Free Pointers." Name instrument. Virtuosi School, Buffalo, N. Y.

"MUSIC Composed" to words. Bauer Bros. (formerly of Sousa's Band), Oshkosh, Wis.

SONG Poem writers. "Real" proposition. Hibbeler, DL 2104 Keystone, Chicago.

GUARANTEED Results. Write Sequoia Songwriters Service, Sherman Branch, Los Angeles, Calif.

**PATENT ATTORNEYS**

INVENTORS Service Bureau will send booklet and give you free advice concerning the proper procedure for obtaining patents on easy payment plan and at least expense. Dept. B, Union Trust Bldg., Washington, D. C. Chicago representative, N. E. Hewitt, 1853 Conway Bldg.

PATENTS Procured. Prompt, careful efficient service. Highest references. Moderate fees. Send sketch or model for actual search and advice. George P. Kimmel, Master of Patent Law, 54-J, Legal Bldg., Washington, D. C.

PATENTS Obtained. Frederick J. Larson, Registered Patent Attorney, St. Louis, Mo.

PATENTS. Send sketch or model for advice. Free book, "How to Obtain a Patent." Established thirty years. Highest references. Prompt service. Reasonable charges. Chandler & Chandler, 908 F Street, Washington, D. C.

INVENTIONS Patented and Exploited. Former patent office examiner; Master patent law. Benj. Webster, Esq., No. 15 East 26 Street, New York.

INVENTORS—Write for our Guide Book, "How to Get Your Patent," and Evidence of Invention Blank. Send model or sketch of your invention for our prompt examination and instructions free. Randolph & Co., Dept. 439, Washington, D. C.

PATENTS. Booklet free. Highest references. Best results. Promptness assured. Watson E. Coleman, Patent Lawyer, 724 Ninth St., Washington, D. C.

LANCASTER, Allwine & Rommel, 221 Ouray Bldg., Washington, D. C. "Originators of the Form Evidence of Conception." Before disclosing your invention to anyone send for blank form to be signed and witnessed. Form and patent information bulletin free.

INVENTOR'S Adviser with mechanical movements sent free. Labiner, 15 Parkrow, New York.

"INVENTOR'S Guide," valuable information, free. Frank Ledermann, Registered Attorney-Engineer, 1712 Woolworth Bldg., New York.

PATENTS. Prompt personal service. Write for information. Albert E. Dieterich, Registered Patent Lawyer, 621½ Ouray Bldg., Washington, D. C.

PATENTS Procured: trade marks registered—preliminary advice furnished without charge. Booklet and form for disclosing idea free. Irving L. McCathran, 704 International Bldg., Washington, D. C.

PATENTS—Write for free instructions. Send drawing or model for examination. Miller & Miller, Registered Patent Attorneys (former Patent Office Examiners), 259 McGill Bldg., Washington, D. C.

TIME Counts in applying for patents. See pages 134 and 135. Clarence A. O'Brien, Registered Patent Attorney, Washington, D. C.

PATENTS—Write for our free book, "How to Obtain a Patent" and Record of Invention Blank. Send model or sketch of invention for inspection and instructions free. Terms reasonable. See advertisement on pages 136 and 137. Victor J. Evans & Co., 934 Ninth, Washington, D. C.

LACEY'S Patent Sense. Valuable book free. See ad page 138.

INVENTORS: Send for booklet telling how to patent and sell your inventions at lowest cost. Ralph Burch, Patent Lawyer, 900 F St., Washington, D. C.

PERCY S. WEBSTER, 203 Saving and Loan Bldg., Stockton, Calif. Patent booklet free.

ESTABLISHED 1864. Milo B. Stevens Company. Free booklet. Patents. Trade marks. Copyrights. Offices. Monadnock Block, Chicago; Barrister Bldg., Washington, D. C.

INVENTORS—Cash in on your invention now. Don't delay the sale any longer! Send for a free copy of our specially prepared booklet, "Turn Your Patent Into Money," today! It contains helpful information for all inventors. M. L. Rund, Mgr. Classified Advertising, Popular Mechanics Magazine, 200 E. Ontario St., Chicago, Ill.

**FOR INVENTORS**

WANTED Patents and ideas to manufacture on royalty basis or outright purchase. Big Ten factories, 1220 West Sixth Street, Cleveland, Ohio.

WE Are interested in any new invention or improvement on locks, safes, electric protection or any device for the prevention of burglary daylight holdup or fire resisting protection of records or valuables. Do not send models unless asked for. Room "D", % Popular Mechanics Magazine, 200 E. Ontario St., Chicago, Ill.

TIME Counts in applying for patents. See pages 134 and 135. Clarence A. O'Brien, Registered Patent Attorney, Washington, D. C.

AUTOMOBILE Parts or accessories for winter or summer use. New ideas or patents wanted by metal goods manufacturer of International reputation. Royalty paid. Box 549 Middletown, Conn.

EXPERIMENTAL Models—Small electrical and mechanical devices. Lewis Scriven, 60 Ann St., N. Y. C.

INVENTIONS And new patents of commercial value are wanted for manufacture by prominent company. Mechanical equipment preferred but will consider any article having big sales possibilities. Do not send model until asked. Address: Room 30, % Popular Mechanics Magazine, giving full details.

INVENTIONS Patented and Exploited. Former patent office examiner; Master patent law. Benj. Webster, Esq., No. 15 East 26 Street, New York.

LOW Cost manufacturing. Large plant completely equipped for blanking, drawing, stamping and wire forming in any finish. Can save you money on your product. Our figures will convince. Eastern States Products, Box 721, New Haven, Conn.



**INVENTOR'S Universal Educator:** contains 900 mechanical movements; 50 perpetual motions; instruction on procuring and selling patents and selecting an attorney, etc. Suggests new ideas. Price \$1.00 post-paid in U. S. A. Address Dieterich Co., publishers, 602B Ouray Bldg., Washington, D. C.

**INVENTIONS—Write for our free book "How to Obtain a Patent" and Record of Invention Blank.** Send model or sketch of invention for inspection and instructions free. Terms reasonable. See advertisement on pages 136 and 137. Victor J. Evans & Co., 157 Ninth, Washington, D. C.

**LACEY'S Patent Sense.** Valuable book free. See ad page 138.

#### PATENTS FOR SALE

**CONTAINER Cap.** Thomas Trull, 5254 St. Charles Avenue, Baltimore, Maryland.

**OUTRIGHT Or royalty.** Water faucet with lever shutoff for repacking. O. B. Wright, 715 Sullivan St., Miami, Arizona.

**FOR Sale—Patent on positive nut lock.** Address C. C. Rich, No. 8 Horace St., Bridgeport, Conn. This lock is not a joke.

**WILL Sell sketch of valuable unbreakable, underground fort.** Smoke goes underground. Oscar Abate, 1295 William St., Baltimore, Md.

**FOR Sale—Hair-clasp or pin.** U. S. Patent 1767720. Canadian patent pending. Particulars, Daniel Treloar, 1716 West 56, Seattle, Wash.

**OUTRIGHT Or royalty, patent 1,762,419,** issued June, 10, 1930. Appliance for household sewage disposal plant. Walter D. Pettis, Oxford, Mississippi.

**FOR Sale or royalty.** My patent anti-glare safety device, for automobile lights. Roy Zigler, Plymouth, Ohio.

**OUTRIGHT Or royalty, up to minute mechanical toy.** Patent pending. C. B. Jordan, Myrtlewood, Ala.

**INVENTION, Game, latest fad.** Manufacture cheap 25 cent article, financial backing or sale. E. E. Stuphin, Chicago, Ill., 8029 Colfax Ave.

**SHOP Ticket holders.** Patent for sale; investigate. Andrew T. Larson, Boyceville, Wis.

**A HOUSEHOLD closet fixture.** Rotary. All or part metal. Space saving device. Georgia Johnston, 1039 West 22nd Street, Los Angeles, California.

**FOR Sale—Design patent for tire tread.** Unique nature. B. Omoto, Box 532, Green River, Wyo.

**MUST Sell outright combination square.** Very useful tool for carpenters and mechanics. O. S. Greene, 1301 Main Street, Dallas, Texas.

**VALUABLE Invention, practical and useful self closing umbrella.** Patent No. 1,282,387. Royalty or outright. Jos. Delre, 507 No. Halsted, St., Chicago, Ill.

**FOR Sale—Outright, simple, weeder attachment for harrows.** Otto Koller, Pomeroy, Wash.

**MERITORIOUS Labor saving invention.** Victor J. Giampolini, 162 29th St., San Francisco, Calif.

**PATENT—Household article; \$5,000, a bargain.** H. Sanders, 538 S. Clark St., Chicago.

**OUTRIGHT Or Royalty basis, improved Chiropractic Table.** Do your own adjusting. Manufactured at very low cost. Edw. Rosenquist, 1448, 44th Ave., Oakland, Calif.

**FOR Sale—Patents, improved flour sifter and improved snare.** Outright or royalty. Harry Nakagawa, Tanana, Alaska.

**TIME Counts in applying for patents.** See pages 134 and 135. Clarence A. O'Brien, Registered Patent Attorney, Washington, D. C.

**INVENTORS—Cash in on your invention now!** Don't delay the sale any longer! Send for a free copy of our specially prepared booklet, "Turn Your Patent Into Money," today! It contains helpful information for all inventors. M. L. Rund, Mgr. Classified Advertising, Popular Mechanics Magazine, 200 E. Ontario St., Chicago, Ill.

#### MODELS AND MODEL SUPPLIES

**INVENTORS:** Send us sketch or crude model of your idea. Crescent craftsmen will develop it into a practical working model. 30 years of successful experience and thousands of satisfied clients. Confidential service guaranteed. Bank references furnished. Free illustrated book: "Making Inventions Pay." Crescent Tool Co., Dept. 8-10, Cincinnati, Ohio.

**KIRK Hardware Co.** A business devoted to supplying light machine parts, gears, bearings, pulleys, hangers, supplies etc. for use of mechanics, amateurs, experimenters, modelmakers and home workshops. Folder on request. P. O. Box 365, Madison Sq. Sta., New York City.

**BIG Catalog 20c steam and gasoline engines, motors, model makers' supplies.** Howard Engine & Mfg. Co., 2417 N. Ashland Ave., Chicago.

**YOUR Ideas developed.** Models made to exact specifications, also light manufacturing our specialty. Howell Machine Works, 128 N. Jefferson St., Chicago.

**MODEL Builders.** Handy man supplies—gears, motors, materials, books, 3,000 price listings. Illustrated catalog No. 28, 25c coin. Amalgamated Corp., 601 Washington, Chicago.

**THE Modelmaker.** An illustrated magazine devoted to practical model making. Sample 10c. Modelmaker, 122 P.M. Liberty St., New York.

**MODEL Making.** Inventions developed. Write for estimate. Stearns, Paxton, Ill.

**SHIP And yacht model fittings.** Send dime for illustrated catalog No. 6. A. J. Fisher, 1002 Etowah Ave., Royal Oak, Mich.

**WE Make working models for inventors and do experimental work and carry a complete stock of brass gears and model supplies.** Send for catalog. The Pierce Model Works, Tinley Park, Ill.

**LET Our experience be your guide.** Models that are models; tools and equipment for economic manufg. Patterns of all types; manufacturing in all branches. Satisfaction guaranteed. United Machinery Company, Cincinnati, U. S. A.

**TIME Counts in applying for patents.** See pages 134 and 135. Clarence A. O'Brien, Registered Patent Attorney, Washington, D. C.

**MODEL Steam engines and boilers for miniature power boats.** Boat and boiler fittings. New catalog 15c. Model Machine Shop, 212 Price St., Rahway, N. J.

#### DRAFTING

**LEARN Drafting at home.** Scholar or tradesman. Write Canadian Drafting School, Toronto, 5 Ont.

#### MANUFACTURING

**WIRE Goods made to order.** Cooley Mfg. Co., 530 N. Western Ave., Chicago.

**SPECIALIZE Complete manufacture, dies, tools, special machinery.** Models made. Atlas Indicator Works, 817 W. Washington, Chicago, Ill.

**ECONOMICAL Manufacturing from sheet, bar, wire or tubing.** Models, dies, special machinery. Swanberg, 5124 N. Kildare Ave., Chicago.

**MANUFACTURING Models, dies, stampings, brassworks, one or thousands.** Circular free. Baum's Metal Specialties, Kansas City, Mo.

**SPECIAL Machinery or parts, dies, tools, metal specialties, models, special gears, stock gears and model supplies.** Send for catalog. The Pierce Model Works, Tinley Park, Ill.

**LOW Cost manufacturing.** Large plant completely equipped for blanking, drawing, stamping and wire forming in any finish. Can save you money on your product. Our figures will convince. Eastern States Products, Box 721, New Haven, Conn.

#### MACHINERY, TOOLS AND SUPPLIES

**16"x8" SEBASTIAN Lathe.** \$150.00; No. 1 Brown & Sharpe univ. milling machine, \$185.00; No. 60 Hand grinder, \$500.00; 24" Hedy shaper, \$250.00; 36"x18" Fifield lathe, \$750.00; 36" Cordesman band saw, \$95.00; 18" Fay pony planer, \$100.00; Crescent universal woodworker, six machines in one, \$300.00; Quincy air compressor, \$65.00; 10" new drill press, \$21.00. Write for catalog. Terms to suit. Cincinnati Machinery & Supply Co., 27 West Second St., Cincinnati, Ohio.

**START Business of your own, small investment required, doing nickel, copper and silver plating.** This work in big demand. Information free. Electro Platers Supply Co., 28 W. Second St., Cincinnati, Ohio.

**LATHE Castings.** Many satisfied owners. We supply them to students, amateurs and shop owners. Keneipp & Son, Mt. Carmel, Ill.

**BARGAINS New and reconditioned equipment.** Chromium platers, grinders, compressors, all ball bearing. Payment terms. Write Hobart Platers, Box M-1008, Troy, Ohio.

**FLEXIBLE Shafts new 1/2" core 5' long \$13.50 each.** Roberts Mfg., 1829 Otto, Chicago.

**FOR Sale: Ten thousand drills, taps, gears and milling cutters, set screws, gauges and machinery.** Send stamps for list. Address "Tool Crib," 47 Whittier St., Bridgeport, Conn.

#### ENGINES, MOTORS AND DYNAMOS

**BRAND New motors, 1/4 hp. a.c. \$6.50; 1/2 hp. repulsion induction 3450 rpm. \$16.00; 1/2 hp. Universal \$5.00. 32v. motors, 1/4 hp. \$8.50; converters 32v. d.c.-110v. a.c. \$35.00. Large stock motors, generators and engines.** Queen City Electric, 1736 Grand Avenue, Chicago.

**NEW 1/4 Horse, 110 volt alternating motors, \$6.50; some used, \$4.50. New 1-12 horse, 110 volt universal, \$2.75. New 1/2 horse, 110 volt 3,450 speed alternating, \$16.50 Other bargains.** Electrical Surplus Company, Dept. 12, 1911 Chicago Ave., Chicago.

**FEW Bodine motors, 1-50 hp., 110 volts, with thrust bearing.** Excellent condition, almost new. \$3.75, delivered, cash with order. John D. Gray, 2222 Diversey Blvd., Chicago, Ill.

**COMPRESSORS, Twin cylinder, for small tire shops.** Duco spraying. J. Trockman & Sons, Inc., 110-112 Lincoln Ave., Evansville, Ind.

**CHEAP Gas power, from auto engines, but they need governing.** We make the governors—all engines. Easily installed. \$10.00. Circulars. Candee-Smith Governor Co., 215 No. Los Angeles St., Los Angeles.

**TIME Counts in applying for patents.** See pages 134 and 135. Clarence A. O'Brien, Registered Patent Attorney, Washington, D. C.

#### BENDING MACHINES

**THE Famous Hossfeld "Wrenches" Universal Iron Bender is the last word in bending machines.** Bends metal, cold or hot, into most any conceivable shape, including Eye Bolts and Automobile Spring Eyes. Bends up to 1" bars or 1 1/2" pipe cold. Also bends "Angle Iron." Thousands in use by all classes of trade, from the smallest shops to the largest railway systems. Write for circular and prices. Hossfeld Mfg. Co., Winona, Minn.

#### WELDING AND SOLDERING

**ELECTRIC Arc welders—new and used.** Terms and trial. Tell needs to Hobart Welders, Box M-1007, Troy, Ohio.

#### SURVEYING INSTRUMENTS

**BARGAINS—Rebuilt transits and levels.** All types and makes. Absolutely guaranteed. Terms if desired. Write today for descriptive list M-410. Warren-Knight Company (Makers of "Sterling" Transits and Levels), 136 N. 12th St., Phila., Pa.

#### FARMS AND FARM LANDS

**PROSPERITY—Independence—For You On A Western Dakota Farm.** A dairy, grain, or diversified farm or stock ranch in Western North or South Dakota, when selected on good advice, offers you real opportunity for independence—in these days of uncertainty. There's more contentment on the farm today than ever before—and you're your own boss. Prices are low, terms easy on rich farm lands, improved or unimproved. The Milwaukee Road is interested only in aiding new settlers to get best land values for their money; in protecting them against false claims about climate, soils, crop production. Our Agricultural Agents have carefully investigated these farm lands. We will gladly advise you the kind of farming suited to each locality. Only a successful farmer is an asset to The Milwaukee Road. These lands vary from level to slightly rolling, suitable for tractor or horse farming, to rough or hilly land good for grazing. Prices vary with location and quality, ranging from \$5. to \$25. per acre, unimproved; from \$15. to \$40. per acre, improved. On lands we recommend, corn, wheat, flax, oats, barley, alfalfa, alfalfa seed, sweet clover, vegetables, small fruits grow profitably. Stock raising is a proven success. Poultry hog and dairy industries increasingly successful. Good roads, railroad markets, good schools and churches, good neighbors. Ask questions. Write now for free, illustrated booklet. Tell us the kind of farm you wish, the crops or stock you want to raise. All your questions carefully and reliably answered. No obligation. Low Homeseekers Fares. Write R. W. Reynolds, Commissioner, The Milwaukee Road, 942-M Union Station, Chicago, Illinois.



**LAND** Openings along the Great Northern Railway. Fertile productive improved farms, new land or rich cutover land. Opportunities in many kinds of farming; grain, livestock, dairying, fruit, poultry, small tracts or general farms in Minnesota, North Dakota, Montana, Idaho, Washington, and Oregon. Renters and owners get benefit of low prices, low interest, low taxes. We have free books on each state, can give accurate detailed information and help to find kind of location desired. Write E. C. Leedy, Dept. 557, Great Northern Railway, St. Paul, Minnesota. Low Homeseekers' rates.

**SELL** Your property quick for cash. William Selsor, Blanca, Colo.

**NEVER-DEAD "B"** batteries last a lifetime and save their cost. Charles Horton, Ridgefield Park, N. J.

**OLD** Grist mill \$700, 10 acres land, pond, old mill, turbine wheel, ready to run. L. P. Simonson, Bonded Strout agent, Rm. 17 Law Bldgs., Fredericksburg, Va.

**EASTERN** Pennsylvania farms near Philadelphia. Write for bulletin giving prices, sizes and descriptions. Wilson George, Quakertown, Pa.

**SELL** Your property for cash. No matter where located. Information free. Established 26 years. Black's Realty Co., Dept. B-11, Chippenwa Falls, Wis.

**MONEY** Made in Michigan potatoes. \$10 down now and easy terms buys land near markets, lakes, streams. Write today. Swigart & Co., P-601, 32 N. State St. Bldg., Chicago, Ill.

**TUNG** Oil varnish tree groves. Suburban Orchards Co., Bloxi, Miss.

**SELL** Your property quickly for cash, no matter where located. Don't pay big commission. Particulars free. Real Estate Salesmen Co., Desk B, Lincoln, Nebr.

**OZARKS:** Fishing cabin, river frontage, boating, bathing, hunting, \$200, \$10 monthly. Hubbard, 218 Grossman Bldg., Kansas City, Kans.

**REDUCE** Labor on your farm and increase income. One farmer writes he would not part with the information for \$100 if it could not be duplicated. Send today for our valuable "Farmers' Handbook" and get ready to put some of the 861 practical ideas into operation for your own benefit. Pay postman only 98 cents plus postage when delivered. Popular Mechanics Press, Room 808, 200 E. Ontario St., Chicago.

#### ELECTRICAL

**KINKS** For machinists, 419 discoveries. For mechanic, machinist or the man who tinkers at home. 287 illustrations. Send no money. Just write a postal asking for "Machinist's Kinks." When postman hands you book pay postage and price of book, \$1.50. Popular Mechanics Press, Room 801, 200 E. Ontario St., Chicago, Ill.

#### FOR MECHANICS

**WOODTURNING** For amateurs. Excellent new course just published for the amateur and home work shop owner. Contains all the needed information and is well illustrated yet published to sell at the low price of 25 cents postpaid. Send for your copy today. Mail remittance with your order. Popular Mechanics Press, Room 807, 200 E. Ontario St., Chicago.

**BATTERY** Shop—How to run. Most complete and authoritative information ever compiled on tools needed, shop equipment, charging methods, opening batteries, work on plates, jars, case, etc. Covers auto, radio and farm lighting batteries. Send for big 550-page book and pay postman \$5.00 plus postage when he delivers same. If outside U. S. remit when ordering. Popular Mechanics Press, Room 801, 200 E. Ontario St., Chicago.

#### RABBITS

**BIG** Profits in Rabbits if properly raised. Complete course of instruction by former Government expert. Descriptive book free. National Rabbit Institute, Box 635-M, Monrovia, Calif.

**MONEY** Making rabbits on easy terms. A small deposit—pay balance out of stock shipped us on contract. Write Stahl, Dept. 216, Holmes Park, Mo.

#### MUSKRATS

**TRAPPERS**—"Eleven Box Traps." Complete blueprints, 50c. Weesho-Uco, 31st Office, Detroit, Mich.

**MUSKRAT** Farming—The greatest book on one of the greatest opportunities today. Tells of the opportunity in this business and how to do everything in connection with the raising and marketing of muskrats. Pay postman only \$2.25 and postage when delivered or, outside U. S., remit when ordering. Popular Mechanics Press, Room 809, 200 E. Ontario St., Chicago.

#### DOGS AND PETS

**REGISTERED** Doberman-Pincher puppies. Show stock. Prices reasonable. Satisfaction guaranteed. H. Glasmann, Station B., Omaha.

**COONHOUNDS.** Combination fur hunters, still trailers, Foxhounds, beagles, dog supplies. Free catalogue. Riverview Kennels, Ramsey, Ill.

**PUPPIES**—Spitz, snow white, dandies, \$11.00 paid. National Pet Shops, St. Louis, Mo.

**\$35.00 BUYS** a Coonhound that must please you on long trial. Kevil Kentucky Kennel, Kevil, Ky.

**COONHOUNDS.** Foxhounds, rabbit-hounds. Blue-ticks, redbones, black-tans. Cash fur catchers. Dog supplies. Sporting goods. Big catalogue. Kaskaskia Incorporated, E-67, Herrick, Illinois.

**ST. BERNARDS!** Rare, beautiful thoroughbred puppies. Photos submitted, delivery guaranteed. Helvetia Kennels, 181-P McKenna Ave., Montreal, Que.

**DOG** Lovers—Every fact regarding every phase of dog training (all breeds) including psychology, obedience, guarding, swimming, rescue work, hunting, herding flocks, teaching tricks, finding lost articles, racing, war service, police dogs, sled dogs, etc., will be found in "Training the Dog," by Will Judy. Price only \$1.50. Pay postman when delivered or, if outside U. S., remit when ordering. Popular Mechanics Press, Room 809, 200 E. Ontario St., Chicago, Ill.

#### POULTRY

**TURKEY** Sale—Closing out 1,000 large mammoth bronze at farmers prices. Raised in confinement. Only require small space. Schadt's Turkey Farm, Goshen, Indiana.

#### WANTED—MISCELLANEOUS

**MAIL** Us your discarded jewelry, gold crowns and bridges, watches, diamonds, silver, platinum. Money promptly mailed. Goods returned if offer refused. United States Smelting Works (The Old Reliable), Dept. 71, Chicago.

**SCRAP**—Gold and silver refined. Returns made on actual recovery with refining charge only 5%. Universal Refining and Research Corporation, 1291 19th St., Denver Colo.

#### FOR SALE—MISCELLANEOUS

**ADDRESSOGRAPHS.** Letter folders, multigraphs, envelope sealers, duplicators, less than half price. Guaranteed. Pruitt Co., Suite 108, 190 N. LaSalle St., Chicago.

**"ONE-HAND** Telephone." Investigate. J. F. Parker, 104 Congress St., Portland, Maine.

**WATCHMAKERS** Lathe for sale at a bargain. R. Jaegermann, 5815 Easton Ave., St. Louis, Mo.

**INTERIOR** Wall decoration in a valuable new book covering all the modern methods of artistic wall treatments. Practical working instructions for both plain and decorative finishes are given. 451 pages, illustrated. Delivered to your door C. O. D. Simply pay postman \$4 and postage. Popular Mechanics Press, Room 801, 200 E. Ontario St., Chicago.

#### PERSONAL

**QUIT** Tobacco. Send for free nicotine test or \$1.00 for treatment. Campbell Products, 3625 Whittier Blvd., Los Angeles.

**ASTROLOGER** Can read your life. Test predictions for one year 20c, dimes or stamps. Send year and birthdate. G. Niemeyer, Box 228, Mays Landing, N. J.

**INGROWING** Nails, painless correction folder free. Eugene Eaton, Bandon, Oregon.

**MAGIC** Incense Occult books, catalogue 10c. Hindu Publishers, Garrick Building, Chicago.

**TOBACCO** Habit overcome or no pay. 500,000 used Superba to help stop cigarettes, cigars, chewing, pipe, snuff. Treatment sent on trial. Costs \$2.00 if successful. Superba Co., L84, Baltimore, Md.

**FREE!** Herbalist almanac. Over 500 herb medicine recipes for home use. Write for details. Botanica, 145 West 112th St., Chicago.

**BEST** Books for \$1. All formerly sold for \$2.50 to \$5 each. Select from the following list of guaranteed bargains. All brand new books: Woodcraft by Seton. Book of Letter Writing by Crowther, Etiquette by Eichler, Creative Chemistry by Slosson, Lawn Tennis by Tilden, also Revolt in the Desert by Lawrence, Trader Horn, White Shadows in South Seas by O'Brien, Count Luckner (The Sea Devil) and Outline of History by Wells. Delivered at your door C. O. D. Simply pay postman \$1 each and postage. Popular Mechanics Press, Room 801, 200 E. Ontario St., Chicago.

#### MISCELLANEOUS

**AMATEUR** Cartoonists: Sell your work. Write Smith's Service, PW1194, Wenatchee, Wash.

**MIRRORS** Resilvered at home. Costs near 5 cents per square foot; you charge 75 cents. Profitable business plating autoparts, reflectors, tableware, stoves, refinishing metal-ware, etc. Outfits furnished. Details free. Write Sprinkle, Plater, 288, Marion, Ind.

**FOR** Sale—One inch ratchet micrometers. New and perfect \$3.00. J. B. Witmer, 19 Clement St., Worcester, Mass.

**QUIT** Tobacco, easy, pleasant, harmless. The Ni-Ko System, Ojai, California.

**TIME** Counts in applying for patents. See pages 134 and 135. Clarence A. O'Brien, Registered Patent Attorney, Washington, D. C.

**STAMP** Album—The Modern Album is unsurpassed in usefulness. Spaces for 12,000 illustrations, 330 pages. Large size 9 1/4 x 11 inches. Cloth bound. Price only \$2. Either pay postman when delivered or if outside U. S. remit when ordering. Popular Mechanics Press, Room 801, 200 E. Ontario St., Chicago.

**HOMEOPATHIC** And biochemic preparations sent postpaid to all parts of the world. Booklets free. Halsey Bros. Co., 5547 Ravenswood Ave., Chicago. Established 1855.

**THE** Outdoor season is here. Send for a copy of our book entitled "Outdoor Sports the Year Round." It is on making all sorts of devices for outdoor recreation. Pay postman price, \$1.50, and few cents postage when delivered. Popular Mechanics Press, Room 807, 200 E. Ontario St., Chicago.

**TATTOOING** Outfits, supplies. Illustrated list free. "Waters," 965 Put-nam, Detroit.

**AMATEUR** Cartoonists earn \$25.00 week, spare time, copying or tracing cartoons for advertisers. S-M Syndicate, Argyle, Wis.

**TELL** An army of 3,000,000 live readers all about your offer! If you have anything to sell, buy or exchange, or if you have any reasonable proposition, tell our readers all about it—they'll respond quickly. Our booklet "How to Create More Business" contains some very interesting, helpful facts. Write today for your copy—it's free. M. L. Rund, Manager Classified Advertising, Popular Mechanics Magazine, 200 E. Ontario St., Chicago, Ill.

## BEFORE YOU INVEST — INVESTIGATE

In order that there be no mistake made in selecting a school to train you in Engineering, Drafting and Tool Designing, either at home or in a resident school, it would be wise to investigate the school owned and operated by Col. Jesse G. Vincent, famous designer of the Liberty Aircraft motor, "Eddie" Stinson, Pres., Stinson Aircraft Corp., Harold H. Emmons, former Chairman of the Board, Detroit Aircraft Corp., Prof. John Younger, Vice-Pres., Society Automotive Engineers, three of whom were decorated by the U. S. Govt., for outstanding Engineering Achievements. For particulars write to the Detroit School of Applied Science, 8213 Woodward Ave., Detroit, Michigan.



# Now... You Can Weatherstrip Your Own Home at 1/3 the Cost!



**MADE OF REAL S-P-R-I-N-G BRONZE**



## AGENTS BIG MONEY!

This great new development gives you an amazing chance to get into a business of your own. Up to \$200 in a week is possible even in small cities. Even Spare Time may pay from \$3 to \$6 in an hour. Sales outfit furnished. Mail coupon for territory.

This short message contains facts of almost startling significance to both home owners and renters. Read them and then use the coupon below for detailed proof including generous free sample.

### INVENTOR'S DISCOVERY BANISHES ALL OLD-STYLE EXPENSIVE METHODS

**N**O more costly "make-shifts"! No more inefficient zinc, rubber, felt or composition "strips"! Now a new-type material used to weather-proof the great city skyscrapers is available to householders in a new form. The mechanical wizardry of a St. Louis genius brings this super-insulating material to you ready to use right in your home. If you can handle a yardstick and a pair of scissors you can now weatherstrip every door and window in your home in just a few minutes.

#### Cuts Fuel Bills in Half . . . Ends Drafts

This new weatherstrip is guaranteed to pay for itself in fuel savings alone in less

**Red D Ply**  
THE RED-D-PLY COMPANY

Dept. P-11,  
1531 Washington Avenue, St. Louis, Mo.

than two years . . . otherwise it doesn't cost you one penny. It banishes drafts . . . ends "colds" and doctor bills. Keeps out all the soot, dust and dirt that now sifts in around doors and windows. Curtains, rugs, drapes, clothing stay clean twice as long.

For advertising purposes a sample of this revolutionary new weatherstrip is being sent to interested people. With it are included the many astonishing details that there is naturally not room to print in this limited space. Get the facts along with our low-cost introductory offer. Mail the coupon at once.

### FREE SAMPLE!

The Red-D-Ply Co., Dept. P-11,  
1531 Washington Ave., St. Louis, Mo.

Without obligation to me, rush sample of weatherstrip invention, also low-cost introductory offer.

Name.....

Address.....

Town.....State.....

Put check mark here if you want to make money as our agent.

# Boys a Bicycle for You

*You can earn it easily in YOUR spare time*



Do you want this beautiful bicycle? This is just one of the many prizes Crowell Junior Salesmen are given. They are a group of peppy go-getters who deliver The American Magazine, Woman's Home Companion and Collier's, The National Weekly.

You need no experience to start. We tell you how to locate readers of our magazines and furnish all material. Hundreds of boys are winning prizes and earning their own spending money. You can do the same—just mail the coupon now.

*Mail this*

Mr. Jim Thayer's Dept. 167,  
The Crowell Publishing Company,  
Springfield, Ohio.

Dear Mr. Jim:  
I sure want one of your bicycles. Start me off as a salesman and send me full instructions.

My Name.....

Address.....

Town.....State.....



# NOW FIX ANY MAKE OF AUTO



## SIX BIG AUTO BOOKS ALL SHIPPED FREE

on approval; whether you want to qualify as garage owner, auto repair expert or merely wish to know how to keep your own car 100% efficient, look at these books—they are sent to you for free examination. This brand new 1930 edition has been prepared by a large group of America's greatest automotive engineers. Anybody who can read will understand them, for this great automobile encyclopedia is a veritable gold mine of valuable facts. Take advantage of this great opportunity now; send in the coupon for FREE examination. You don't pay us a penny, you don't obligate yourself to pay anything unless you decide to keep the books. Just tell us you want to see them and the full set of 6 great volumes, just off the press, will be sent to you. Read them, look them over and prove to your own satisfaction that one fact alone, which you will find in them, may save you an expensive repair, or help you to a better job.

### Aviation Motors

In addition to being a complete encyclopedia of automobile engineering, these books contain over 100 pages on Aviation Motors, and as they are just off the press they bring to you the newest and latest information obtainable. This alone makes these books invaluable to anyone.

## New 1930 Edition

Imagine books which are so new that every page is right up to date—wiring diagrams, construction details, service problems—are all right up to the minute. Nowhere else that we know of can you get as complete and up to date information. Over a million dollars of resources have enabled us to give you the most up to date books on the subject ever published. You will find nearly 26 pages on front wheel drives alone. Everybody interested in automobiles in any way will welcome these books, especially on our no money offer.



## CAN YOU FIX IT?

Can you take out "play" in differential? Can you kill the "shimmy" in steering? Can you reset TIMING? Can you put your finger on engine trouble without guessing or tinkering? Can you pull the starter off and fix it? Can you adjust and repair transmission, engine, rear axle, bearing?

### These Books Tell How

and they tell you how to do any and every auto job right, the first time.

#### 6 Big Volumes

Nearly 3,000 pages, over 2,000 illustrations, wiring diagrams, equipment charts, etc. De Luxe edition with gold-stamped flexible binding. Sent FREE for 10 days' use. If not wanted return express collect. If kept, send only \$2 after 10 days, then \$3 a month until special advertising price, \$24.80, is paid.

### A Year's Consulting Membership FREE!

Privilege of consulting engineers of million-dollar American Technical Society on any automotive problem for one year without charge, if you mail coupon immediately.

## SEND NO MONEY

American Technical Society, Dept. A-719, Drexel Ave. at 58th St., Chicago, Illinois.

I would like to see the new 6 volume 1930 edition of your automobile books but without any obligation to buy. I will pay the few cents delivery charges only and will examine the books and return them at your expense in 10 days unless I like them, in which case I will send you \$2.00 then and only \$3.00 per month until the special price of only \$24.80 is paid. You are to include free consulting membership certificate in the American Technical Society. Send brand new 1930 edition.

Name.....  
 Street.....  
 City.....State.....  
 Employer's Name.....  
 Employer's Address.....



# Get Strong! Eight Improved Muscle Builders All for \$3.75



Easily master feats which now seem difficult. If you want physical culture for health this equipment is what you need. **SAVE AT LEAST HALF!** We furnish ten cable chest expander adjustable to 200 lbs. resistance. Made of new live extra strength rubber to give resistance needed for sure muscle development. Pair of patented hand grips develop powerful grip and arm. Wall exercising parts develop back, arms and legs. Head strap permits exercise of neck muscles. Develop leg muscles with foot strap—gives speed, endurance. Illustrated course shows how to develop any part of body.

**GUARANTEE**  
Entire satisfaction guaranteed or money back.

### Send No Money

Send name and address. We send all by return mail. Pay postman \$3.75 plus postage.

### MUSCLE POWER CO.

Dept. PM-10  
150 Nassau Street  
New York

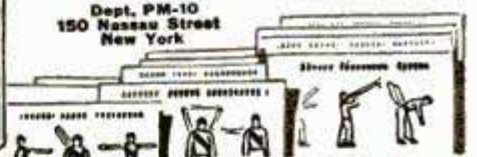

## LAW HIGH-GRADE INSTRUCTION BY CORRESPONDENCE

College, Post Grad. and Bar Ex. Rev. Courses. Law has attracted more keen, braloy men than any other calling. Send today for catalog. Low cost, easy terms. Standard texts. Degrees. Dept. 801, Reaper Block CHICAGO, ILL.

### BUCHSTEIN'S FIBRE LIMB



is soothing to your stump—strong, cool, neat, light. Easy payments. Braces for all deformities. BUCHSTEIN CO. 610 3rd Ave. So. MINNEAPOLIS, MINN.

Send for Catalog Today

## PLAY DRUMS •• Easily Quickly ••



With easy-playing Ludwig drums you develop a fine roll quickly. Brilliant tone that snaps out wins instant admiration. Leading professionals use Ludwigs. Complete outfits from \$34.50 up.

**FREE TRIAL; Easy Payments.** Self-Instructor free with every outfit. Write now for catalog and details.

## LUDWIG & LUDWIG

1002 Ludwig Building  
1611-27 N. Lincoln St., Chicago, Ill.



# Be A Commercial Photographer

Earn \$2,000 to \$12,000 a Year!

THERE'S big money—fascinating work for YOU in photography. Many photographers receive as much as \$50-\$100-\$200 and even more for only one photograph. Photography today is one of the nation's most profitable professions—one that offers unequalled opportunities to the man or woman looking for interesting work, big pay and unlimited future.

### IT'S ALL IN KNOWING HOW!

Now, at last, you can quickly qualify yourself for this well-paid profession—in which you come in daily contact with society people, prominent business executives, theatrical stars and athletic luminaries. Be your own boss or secure a well-paid position. Many photographers have incomes ranging from \$2,000 to \$12,000 a year or more!

### SUCCESS IS WITHIN YOUR GRASP!

Now it is up to you—if you want your share of this lucrative profession! Through our Simplified Plan you can quickly master every phase of modern photography. Many of our students earn many times their tuition fee even while learning.

Thousands are winning quick success in "Still" and News Photography; Portrait Photography; Motion Picture Photography or Projection; Photo-Finishing—these are but a few of the many fascinating branches of photography in which you are thoroughly trained by our simplified method.

### FREE Book Gives Full Details!

Let us show you how in a few weeks you can qualify for a well-paid position or to open a business of your own. Send now for our BIG FREE BOOK giving full details.



N. Y. Institute of Photography,  
Dept. S-1414, 10 West 33rd Street,  
New York, N. Y.

Please send me your FREE Book, "The Modern Art of Photography," and details as to how I can qualify as:

- ( ) Motion Picture Cameraman.
- ( ) Motion Picture Projectionist.
- ( ) "Still" Photographer.
- ( ) Photo-finisher.

Name.....

Address.....

City..... State.....

## YOUR SUCCESS COUPON

## Government Positions

Clerk Carriers, Rural Carriers, Railway Mail Clerks, Postmasters, Department Clerks, and many others. Splendid salaries, easy work, vacation with pay. Only common school education required. Examinations often. 44,817 appointed last year. Send for our Civil Service Catalog No. 6. **COLUMBIAN CORRESPONDENCE COLLEGE, Washington, D. C.**

## FREE Radio Handbook

Write today for your copy of the new Radio Association handbook. Shows you easy ways to make money in Radio. Tells you how our members are cleaning up \$3.00 an hour spare time. Write for Membership Plan which need not cost you a cent and **FREE RADIO HANDBOOK.**  
RADIO TRAINING ASSOCIATION OF AMERICA  
Dept. PM-10 4513 Ravenswood Ave., Chicago

## LEARN CARTOONING

### AT HOME DURING SPARE TIME

with the course that has trained HUNDREDS of beginners successfully. The Landon Picture Chart Method of teaching ORIGINAL drawing by mail makes cartooning easy to learn. This school is a Member of The National Home Study Council. Write today for sample picture chart to TEST YOUR ABILITY and examples of the work of successful students now earning from \$50 to \$200 and more per week. Enclose 6c in stamps and STATE YOUR AGE.

**THE LANDON SCHOOL, 2838 National Bldg., Cleveland, Ohio**



## Men's Extra Money Quick

**Here's An Easy Way!**  
—to bring you a fine cash income! Without taking any time away from your job. Pleasant easy work at home. Decorate beautiful giftwares the Fireside way. You can do it — in spare moments. No previous training required. No special ability needed. No tedious study. No memorizing. With the Three Simple Steps sent you by Monsieur Petit the great artist — Director of Fireside Industries, it is just fun! We want men in every community. Be the first!  
Fireside Industries, Dept. 66-P, Adrian, Mich.

**Begin Right Now!**  
Thousands are making Fireside decorations—making from hundreds to thousands of dollars and doing their own work besides. We supply you with everything you need. Big Generous Complete Kit WITHOUT EXTRA COST. It's a cinch! We absolutely guarantee your success.  
**FREE!**  
Fill out and mail coupon at once. Without any obligation it brings you wonderful Fireside Book in colors. Explains everything.  
**Act now!**



Fireside Industries,  
Dept. 66-P, Adrian, Mich.  
Send me your wonderful Free Book in colors. This does not put me under any obligation.  
Name.....  
Address.....



# "It's Easy to Fly"

## Master the Air With CURTISS-WRIGHT



**A**RE you looking for a future in aviation? Regardless of your vocation, air training will help you to succeed in business.

It's easy to fly the Curtiss-Wright way. Whether you train for a position on the ground or in the air your education will be thorough and complete. Curtiss-Wright is the greatest name in aviation—the largest manufacturer of aircraft and engines and the largest operator of planes and owner of airports.

You will find a Curtiss-Wright Flying School near you. Each school is a university of the air completely fitted with the latest and best equipment.

When you graduate from the Curtiss-Wright Flying School you will be respected as a capable pilot wherever you go and you will find no trouble in turning your flying ability into profit.

Write for complete details of Curtiss-Wright Flying School courses. Mail this coupon! An illustrated booklet giving full information will be sent to you without cost or obligation. Act now!

**MAIL THE COUPON TODAY!**

PM-10  
**CURTISS-WRIGHT FLYING SERVICE, 27 W. 57th St., N.Y.**  
 Gentlemen: I am interested in Aviation and would appreciate more information on the subjects I have marked X.

- |   |  |
|---|--|
| <input type="checkbox"/> Flight Instruction | <input type="checkbox"/> Opportunities in Aviation   |
| <input type="checkbox"/> \$50 Ground Course | <input type="checkbox"/> Aerial Charter Trips        |
| <input type="checkbox"/> New Payment Plan   | <input type="checkbox"/> Free Curtiss-Wright Booklet |

NAME.....AGE.....  
 STREET.....  
 CITY.....STATE.....

# FREE BOOKS of BUSINESS HELPS

We publish over 200 Home Study Books, each a complete treatise of its subject. We have one or more for you. Books on

- |  |   |
|--|---|
| <input type="checkbox"/> Commercial Art      | <input type="checkbox"/> Decoration       |
| <input type="checkbox"/> Lettering           | <input type="checkbox"/> Automobiles      |
| <input type="checkbox"/> Advertising         | <input type="checkbox"/> Battery Work     |
| <input type="checkbox"/> Sign Making         | <input type="checkbox"/> Electricity      |
| <input type="checkbox"/> Radio               | <input type="checkbox"/> Carpentry        |
| <input type="checkbox"/> Aviation            | <input type="checkbox"/> Building         |
| <input type="checkbox"/> Painting            | <input type="checkbox"/> Contracting      |
| <input type="checkbox"/> Silk Screen Process | <input type="checkbox"/> Sheet Metal Work |

and many other subjects. All fully described in our FREE CATALOG. Check the subjects in which you are interested and write today.

**FREDERICK J. DRAKE & CO., Publishers**  
 Room 508—179 No. Michigan Blvd., Chicago  
 Drake books are for sale in all book stores.

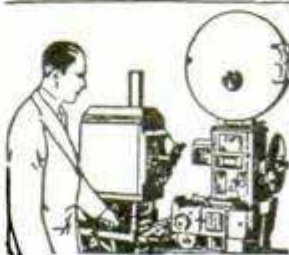

## LEARN MOTION PICTURE OPERATING

**Complete Home Study Course**  
 With the privilege of attending our school, for free practical training on Western Electric Sound Equipment.

WRITE FOR FREE BOOKLET  
**CALIF. OPERATORS SCHOOL**  
 103 N. Rowan Ave., Los Angeles, Cal.

# WAKE UP!

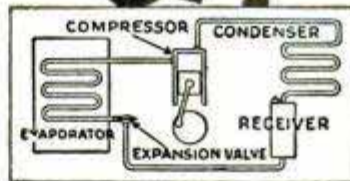

## Amazing Opportunities in ELECTRIC REFRIGERATION

**W**HY look for big pay in crowded industries? Get into the newest and fastest growing industry in America—**Electric Refrigeration**. Millions of dollars being invested by Wall Street in factories and advertising. Urgent need for technically trained men in manufacture, installation, sales and service. Jobs pay \$200 to \$1,000 a month. And now a new easy method trains you at home to fill a big pay job. Learning Electric Refrigeration simplified amazingly. This course sponsored by Kelvinator and Copeland, praised by General Electric, Zerozone, Fervel and other leading manufacturers. Our Employment Department helps you find big jobs, FREE.

### BIG BOOK FREE

Mail coupon now for big free book "Rich Rewards in Electric Refrigeration." See how easy it is to quickly become a highly paid refrigeration expert. No obligation. **Utilities Engineering Institute, Dept. 1100, 4403 Sheridan Road, Chicago, Ill.**

"Your Institute should be of great interest to young men wishing to get into the service and sales end of this business. It will be a pleasure to co-operate with you."  
 Col. F. E. Smith,  
 President, Fervel, Inc.

**Utilities Engineering Institute,**  
 Dept. 1100, 4403 Sheridan Road, Chicago, Ill.  
 Without obligating me, send free book "Rich Rewards in Electric Refrigeration."

Name.....  
 Address.....  
 City.....State.....



# Opportunities

were never so great for technically trained men!

You Can  
Learn  
Practical

## DRAFTING

At Home By Mail

UNDER EXPERT  
COLLEGE INSTRUCTORS

No other calling open to young men of limited schooling, leads so quickly and surely as drafting to big-pay jobs. The field is enormous—world wide. Wake up! Look around you! This is a mechanical and engineering age. Consider our amazing inventions, sky-scrapers, ocean liners, air ships, aeroplanes, automobiles, industrial plants, bridges, dams, power houses, etc. Every-

thing planned or built comes first through the hands of expert draftsmen. What creative work could be more fascinating—a greater inspiration and guide to worthwhile careers? Scores of our noted architects, engineers and builders won their way to fame and leadership with a common school education and a self acquired knowledge of drafting.

## \$100 a Week Paid Expert Draftsmen

Let the facts about Chicago TECH successes prove that you, too, can train in spare time. Send the coupon below. Investigate! You'll be amazed when you learn how easily young men have mastered drafting through our practical home-study plan. Nothing difficult about it—the simplest, shortest, step-by-step method you can imagine . . . the result of years of successful experience in teaching by mail and in our resident classes. Read the stories of Chicago TECH successes in our big catalog. Hundreds of our graduates are now engineers, architects, designers, builders, contractors, chief draftsmen, superintendents. Drafting was the ladder on which they climbed to big incomes. Chicago TECH is

famed everywhere for its successful graduates. Don't delay another minute. Send for all the interesting facts at once. Our low cost and easy terms place this training within the reach of every ambitious man. The first small tuition payment brings everything needed to start the course. Draftsman's table, all drawing instruments, tools, etc.—a complete, high-grade outfit is furnished each student free of extra cost.

Send For  
Proof Today!

Let the success  
of others be your  
guide to a big-  
pay job.

### DRAFTING OUTFIT

furnished FREE  
of extra cost

This exceptionally high-grade outfit, a \$25 value, complete in every respect, the same as used by expert draftsmen, is furnished without extra charge. Enrollment includes full equipment. No extras to buy. A small first payment under our easy installment plan brings at once everything needed to begin the course and assure rapid progress.

## Big FREE Book on Drafting

Send coupon now for your copy. Tells everything you want to know—what to do and how to do it—to succeed quickly in practical drafting work. Opportunity is calling. This is the big chance you've long wanted. Grasp it today.

## Chicago TECHNICAL College

Architecture—Engineering—Drafting—Electricity—Building

We also offer complete resident day and evening classes in above subjects. Founded 1904, our College-Training-At-Home Plan is the result of 26 years experience in training men both in our Chicago College and at their homes by mail.

Chicago Technical College  
Dept. N-203, 118 E. 26th St., Chicago, Ill.

Please send me postpaid, your big Free Book on Drafting, telling about opportunities and your College-Training-At-Home Plan. I have checked below the field in which I am particularly interested.

Architectural  Mechanical  Electrical  
 Structural

Name..... Age.....

Address.....

City..... State.....

Check here if you prefer coming to Chicago to take our short resident day or evening course in Drafting.



# BRAND NEW GENUINE Model 3 CORONA

LOWEST PRICE EVER OFFERED



E. C. Smith & Corona Typewriter Co. Inc.

**\$2.00**  
DOWN  
BALANCE  
EASY  
TERMS

**H**ERE'S your chance to own that brand new Genuine Model 3 Corona you've wanted—on the easiest terms ever offered—at **LOWEST PRICE** ever offered! Complete in every detail; back spacer, etc., **MANUFACTURER'S GUARANTEE**. Recognized the world over as the finest, strongest, sturdiest, portable built. Try this wonderful portable typewriter—the same machine that has satisfied 500,000 users.

**Yours for 10 Days' TRIAL  
—Send No Money**

Experience the joy this personal writing portable typewriter can give you! Use it 10 days! See how easy it is to run and the splendidly typed letters it turns out. Ideal for the office desk, home, traveling. Small, compact, light, convenient. Don't send out letters, reports, bills in poor handwriting when you can have this Corona at such a low price or on such easy terms. Remember these are brand new machines right out of the Corona factory.

**Carrying Case Included  
—If You Act Now**

Leatheroid carrying case, oiler, instructions, free on this offer. Send no money—just the coupon. Without delay or red tape we will send you the Corona. Try it 10 days. If you decide to keep it, send us only \$2, then \$3 a month until our special price of \$39.90 is paid. Now is the time to buy. Mail coupon today!



**MONEY SAVED  
By Using This Coupon**

**Smith Typewriter Sales Corp.  
[Corona Division]  
469 E. Ohio St., Chicago, Dept. A-3**

Ship me the Corona, F.O.B. Chicago. On arrival I'll deposit \$2 with express agent. If I keep machine, I'll send you \$3 a month until the \$37.90 balance of \$39.90 price is paid; the title to remain with you until then. I am to have 10 days to try the typewriter. If I decide not to keep it, I will repack and return to express agent and get my money back. You are to give your standard guarantee.

Name .....

Address .....

Employed by .....

## MAKE MUCH MONEY

Making and Selling Your Own Products. Formulas, Processes, Trade-Secrets. All lines. Automobile Specialties. Cleaning, Polishing Compounds. Food Products. Toilet Preparations, etc. Expert Analytical Service. Catalog, circulars free.

**B. THAXLY CO., Washington, D. C.**

## SONG WRITERS!



**SUBSTANTIAL ADVANCE ROYALTIES** are paid on work found acceptable for publication. Anyone wishing to write *either the words or music* for songs may submit work for free examination and advice. *Past experience unnecessary.* New demand created by "Talking Pictures" fully described in our free book. Write for it Today. **NEWCOMER ASSOCIATES**

759 Earle Building, New York, N. Y.

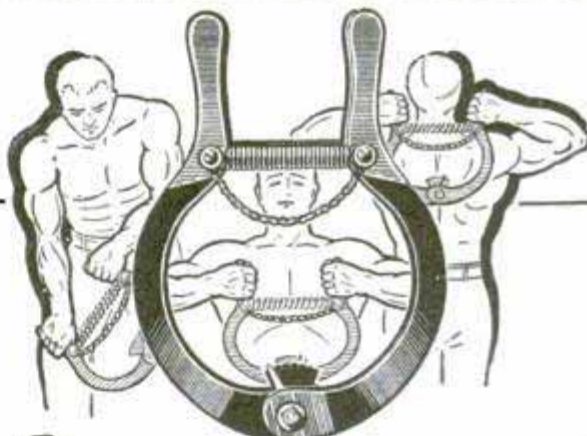

### Build Muscles and Strength With This Iron Shoe

The Germans invented the Iron Shoe because they realized it enabled them to achieve physical perfection. We have brought it to America and improved it. It is offered you at a ridiculously low price. Every strong man uses one to build back muscles, tremendous chest and powerful giant-like arms. We show you how to develop abdomen and legs so that you will be a top-notch in 30 days. We don't just ship the apparatus and let you work out your muscle building problems for yourself. We include with our

### Free Special Offer

the **IRON MAN'S FAMOUS 60-DAY ILLUSTRATED PICTURE COURSE** of exercise instruction. **SPECIAL STRENGTH RECORDER** and **STRENGTH RESISTER** thereby making this the greatest body-building offer presented to you in a lifetime. It is the greatest muscle-building apparatus you ever saw. Write for particulars today and start getting strong at once. Follow the choice of champions and get that grip of steel. Ring in now on our special offer and learn all about the lowest priced and biggest result getting exerciser under the sun.



**THE AMERICAN ATHLETIC APPLIANCE CO.,  
4341 Frankford Ave., Dept. PM-10, Philadelphia, Pa.**

Without any obligation send me free illustrated information on the Iron Shoe Strength Builder and Special Offer.

Name .....

Address .....



# Test This Amazing Money Making Invention **FREE**



Men, here's the most remarkable money maker of the age! A little automatic machine that makes old-style can-openers obsolete! Now just a twist of the wrist makes the dollars hum for you. So mail the coupon today for liberal **FREE TEST OFFER**.

## UP TO \$6 and \$8 IN AN HOUR Just Offering This \$1,000,000 Can Opening Machine

**N**O more awkward stabbing and hacking with old-style can openers. No more danger of blood poisoning from gashed and lacerated fingers. For now a remarkable new invention banishes every old-style can opener to the scrap heap. Now a simple twist of the wrist opens any can in a couple of seconds. No wonder they all simply go wild over it. No wonder salesmen have sold to every house in the block and have made up to \$8 in an hour.

### WORKS LIKE A CHARM

This queer little device doesn't just chop a ragged hole in the top of the can. It cuts the entire top completely out, not off, clean as a whistle. The machine takes hold of the can—opens it—flips up the lid so you can grab it—and gives it back without any sharp edges to snag your fingers. You just put the can in the machine—turn the handle—and almost instantly the job is done.

### SELLS ITSELF IN SECONDS

Everyone knows how women detest the dangerous old-style can opener. Imagine then, how they welcome this startling new

method—this automatic way of doing their most distasteful kitchen task. Men, honestly I'm not exaggerating one bit when I tell you that not ten words are necessary to sell many of them. All you do is hand your demonstrator to your prospect and let her try it. She often sells herself in seconds—and you pocket a nice, fat profit. Yes really, it's just that simple and easy. That's why salesmen have made \$75 to \$150 in a week.

### OPENS ANY CAN IN A JIFFY

You just slip the can in the holder and turn the handle. Nothing complicated, nothing to get out of order. Opens any can, square, round or oval, in a few seconds. And, men, **IT'S TRIPLE PATENTED**, so there is no competition.



### ACT QUICK FOR FREE TEST OFFER

I don't care whether you're an "old-timer" or just breaking in, some of the quickest, easiest money of your life is waiting for you now, right here. That's a mighty strong statement. But all I ask is a chance to prove it at my risk. I know this

proposition will coin money for you with such speed that it will make your head swim. Territories are closing fast. The Free Test costs you nothing. Just mail me the coupon and I'll shoot you the most sensational dollar making plan you ever heard of. Mail it today. Right now!

## CENTRAL STATES MANUFACTURING CO.

Dept. M-704

4500 Mary Ave., St. Louis, Mo.

### OH BOY! HOW THE DOLLARS ROLL IN! \$208 IN 24 HOURS



"Speedo products do everything that is claimed for them. I went to a small railroad town and sold 24 Speedo products in about 3 hours. In another instance I sold 30 Speedos on one street in 1 1/2 hours. In 24 hours of selling I have made exactly \$208."  
John Neighbors, O.

### 1,000 SALES IN 90 DAYS

"I have now made 1,000 Speedo sales in 90 days, which is pretty good to start. The other day I sold 21 Speedos in less than 5 hours. Anyone can work up a nice business with Speedo; my earnings are now almost \$1,000."  
R. W. Graffe, Ind.



**REVOLUTIONARY NEW SHARPENER**  
Works like magic. Puts a razor edge on any knife or tool in a few seconds. Anyone can use it. Sharpens scissors, too. The coupon brings full details.

Central States Manufacturing Co.,  
Dept. M-704, 4500 Mary Ave.,  
St. Louis, Mo.

Rush me your Free Test offer.

Name.....

Address.....

Town..... State.....

( ) Check here if interested only in one for your own home.



# Learn to make more money



*Be a*

# Radio Expert

Hundreds of fine jobs paying \$50, \$60, \$75 a week and plenty of them paying \$100 a week are opening every year in Radio. No wonder. In the short period of a few years Radio has taken its place among the world's greatest industries. Its amazing growth has astounded the world. You can't enjoy the good things of life—a home, an automobile, money in the bank—on \$25, \$35 or \$40 a week. Why be satisfied with that for more than the short time it takes to get ready for Radio.

**I will show you how to make \$10 to \$25 a week extra on the side while learning**

One month from today you can be making more money. The day you enroll I will show you how to do Radio jobs in your neighborhood. G. W. Page, 1807 21st Ave., S., Nashville, Tenn., made \$935 in his spare time while taking his course.

**I will train you at home in your spare time. You must be satisfied**

Hold your job. Give me only part of your spare time. I'll bring my training to you. I give you the parts for a home experimental laboratory, six big outfits, without extra charge. Further, I will refund every penny of your money if you are not satisfied upon completion with the lessons and instruction service I give you.

**Act NOW. Get "Rich Rewards in Radio"**

This 64-page book points out the money-making opportunities in the different branches of Radio such as broadcasting, operating on board ship which gives you world-wide travel without expense, how to start a spare-time or full-time Radio business of your own, Radio in Aviation, openings with dealers and manufacturers and many others. Clip the coupon.

J. E. SMITH, President,  
Dept. OLPPP

National Radio Institute, Washington, D. C.

**Mail this Coupon at Once**

J. E. Smith, Pres.,  
National Radio Institute, Dept. OLPPP  
Washington, D. C.

Dear Mr. Smith: Without obligating me, send "Rich Rewards in Radio" explaining your training and Radio's opportunities for bigger success.

Name..... Age.....

Address .....

City..... State.....

## BE A RAILWAY TRAFFIC INSPECTOR



### RAILWAYS AND BUS Earn up to \$250 Monthly

Active men—19 to 55—needed at once in Railways and Bus Traffic Inspection. This steady, profitable work pays up to \$250 per month plus expenses. Interesting outdoor work. Travel or remain near home. We'll train you for this uncrowded profession and on completion of a few months spare time home instruction will assist you to a

position paying from \$120 up or refund your tuition. Our free booklet tells what Traffic Inspection can do for you. Write for it today. Don't delay. Write

**Standard Business Training Institute**

Div. 2

Buffalo, N. Y.

## LEARN WATCHMAKING AND ENGRAVING

### BY OUR PROFIT-SHARING PLAN OUR GRADUATES SUCCEED

One of our Iowa students started in a very small way—now doing over \$30,500 a year. Another in Wisconsin, over \$10,000 the first year. Day or night classes. Call or write for FREE BOOK.

Chicago School of Watchmaking, Dept. 8501, 549 W. Randolph St., CHICAGO

## Save Your Feet



When all else fails end your suffering with the flexible "no metal"

**Heefner ARCH SUPPORT**

WRITE FOR FREE BOOKLET

HEEFNER ARCH SUPPORT CO., 877 M. E. TAYLOR BUILDING, LOUISVILLE, KY.



# DRAFTING

**BOOKS SENT FREE!**  
ON APPROVAL

### For Beginners

Written so you can understand every word, by 18 famous Engineers and Architects. Deluxe, flexible binding, 1750 pages, 1050 blue prints, charts and diagrams. Prepares you for a good Drafting job in mechanical or architectural lines. Sent for 10 days' free use, if you mail coupon immediately.

Only fifteen minutes a day with these WONDER BOOKS will prepare you for a good Drafting job in less than a year! Mechanical and Architectural Drafting from simple straight lines to important, complex plans, a step at a time! Built especially for beginners, for men with only grammar schooling. Drafting room practice plus engineering made easy and clear!

### Big Field—Big Demand—Big Pay!

Competent Draftsmen are urgently needed right now in all building and manufacturing lines at \$50 to \$100 a week. That's just the beginning—for draftsmen have the best chances for advancement! Pleasant, fascinating work, easy to learn and do. Learn quick with these books—send coupon for a set FREE, and see for yourself!

*A year's Consulting Membership in the American Technical Society now given free to all readers of this famous Cyclopaedia of Drafting. Many say that's worth more than cost of books.*

**American Technical Society  
Dept. D-719, 58th & Drexel Ave., Chicago**

**FREE** If you send for these great Drafting Books NOW we will include without cost a complete volume "Blueprint Reading" containing 120 pages durably bound in cloth, and also a complete portfolio of 58 plates covering the basic orders of architecture. These plates are drawn to scale and are very valuable.

**American Technical Society  
Dept. D-719, 58th & Drexel Ave., Chicago**

Send for 10 days' free use 4-volume set of DRAFTING. In return for mailing this coupon promptly send absolutely FREE "Blueprint Reading" (Building) 120 pages, 69 illustrations, also a complete portfolio of 58 plates. I will pay the few cents delivery charges. If I wish I may return books in 10 days and owe you nothing. But if I prefer to keep them I will send \$1.50 after 10 days, then \$2.00 a month until \$14.50 (special reduced price) is paid.

Name.....

Address.....

Employed by.....

Address.....



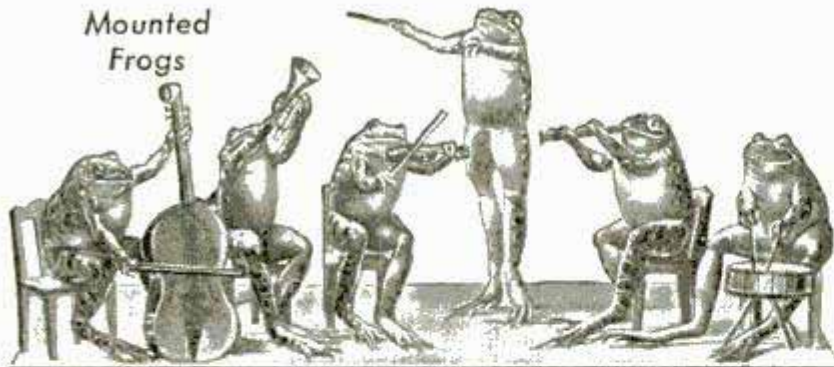

# Mount Birds and Animals Be a TAXIDERMIST!

Mount and preserve PERMANENTLY just like LIFE, all kinds of BIRDS AND ANIMALS—both wild game and common and domestic specimens. **Quickly Learned by Mail!**

## Amazing Profits and Pleasure in This Art

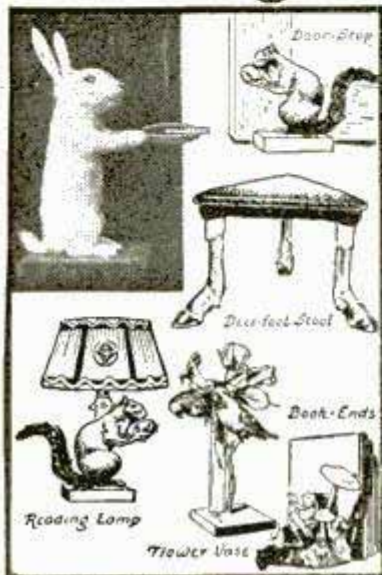

Learn easily and quickly in spare time AT HOME, from our reliable school—Taxidermy *only* taught for 27 years, over 100,000 graduates. Your success guaranteed.

Men, boys, women, be a taxidermy artist. It brings splendid profits, popularity, and simply wonderful fascination, fun, and entertainment for your lifetime. You will be *delighted*—send NOW for our unique FREE BOOK!

### Need Money? Sportsmen

You can make BIG PROFITS in spare time, in Taxidermy. Mount and SELL all kinds of specimens. Merchants eagerly buy groups for window display like the frogs above, or rabbits "getting married", squirrels in "barber shop", and hundreds of HUMANIZED common things your alert imagination suggests.

Mount your trophies—BIRDS, ANIMALS, GAME-HEADS, FISH. Tan skins and furs. Decorate your home and den with nature's finest art. Have your own MUSEUM. Mount for others. Sell your mounted game. EARN extra money for things you want—guns, boats, autos, radios, hunting trips, travel. Your GUN and ROD can earn you a fine income. Sportsmen soon know you and flood you with jobs.

### FREE BOOK

Tells all about Taxidermy. Get your FREE copy today. 48 pages, 100 alluring pictures. Tells all about Taxidermy with its PLEASURE and PROFIT. Tells how YOU can be an EXPERT easily, quickly, and at small cost.

Taxidermy is marvelous for BOTH WILD GAME AND DOMESTIC SPECIMENS. Suitable specimens are on every hand, easily secured. Sportsmen, do not throw away the finest parts of your trophies. Save them. Mount them. Have a delightful hobby. Be famous as a TAXIDERMIST. Earn a lot of EXTRA MONEY from your spare time.

The sketches above show merely a few of HUNDREDS of splendid useful articles you can make with Taxidermy. The commonest specimens can be HUMANIZED and become real art. Use squirrels, frogs, rabbits, cats, pigeons, sparrows, mice, guinea pigs, etc.; also wild game. These alluring and HUMAN-POSING art-gems win praise from everyone. EASILY SOLD AT FINE PROFITS.

### FREE BOOK Send Coupon!

Mail this coupon, or a postal or letter and this BOOK will be rushed to you by return mail POST-PAID—Free! No obligation on your part. Grasp this OPPORTUNITY. It MAY mean your financial independence, and a life-time profitable business for you. Nothing like it. You will SURELY send at once for the FREE BOOK and INVESTIGATE. (State age).

**NORTHWESTERN SCHOOL OF TAXIDERMISTRY,**  
3377 Elwood Bldg. Omaha, Neb.

Send me your free illustrated book "How to Mount Game." Also tell me how I may learn this fascinating art easily and quickly by mail. No obligation.

Name \_\_\_\_\_ Age \_\_\_\_\_

Address \_\_\_\_\_

## BE AN OIL EXPERT!

New, easy, practical way to learn at home in spare time. Geology, Drilling Methods, Pipe Line Transportation, Refining and Marketing. Write Today! FREE Book!

PETROLEUM ENGINEERING UNIVERSITY, Dept. 220-A, FORT WAYNE, IND.

\$10.00 PER MONTH BUYS Fibre-Life Limbs



NEXT TO NATURE. BRACES MADE TO ORDER. AGENTS WANTED. FREE FIBRE SAMPLE. WORMAN CO. 252-P HENNEPIN AVE. MINNEAPOLIS, MINN.

## Learn MECHANICAL DENTISTRY



**EARN BIG MONEY —STEADY WORK**

WHY spend the best years of your life at uncertain jobs at small pay? YOU can earn while learning this modern, money making business and become your own boss. School is highly endorsed. BIG DEMAND. You learn by doing in day or night school. Individual instruction. Easy terms. Send for free book NOW. Address SECRETARY:

N. Y. SCHOOL OF MECHANICAL DENTISTRY

125 W. 31st Street, New York, N. Y.

—CLIP COUPON AND MAIL—

Name \_\_\_\_\_  
Street \_\_\_\_\_  
City \_\_\_\_\_ State \_\_\_\_\_

## Instant Hot Water from any COLD WATER faucet

Simply attach a Hot Shot Electric Water Heater as shown in picture, plug cord in electrical outlet, turn switch and get an unlimited supply of pure, hot water instantly, at any desired temperature. A "Hot Shot" fits all faucets, can be moved from one faucet to another in a jiffy. A REAL necessity for homes, shops, garages, or anywhere hot water is desired. Sold at a price anyone can afford, a "Hot Shot" gives



Has Auto-matic Shut-off — uses minimum amount of electricity; comes complete with Adapter for all faucets and water-proof, insulated cord. Fully Guaranteed. Write for low price.

### Unlimited Hot Water Service

Desirable Territory Open To Responsible Agents

Write at once for full information, descriptive literature, and low introductory price — less than one-fifth the cost of a small unit tank system. Write now—address:

Hot Shot Electric Water Heater Corp. Dept. 500, 360 N. Michigan Ave. Chicago, Ill.



# Oh! You Misfit

## Sailing Under the Name of Man!



LIONEL STRONGFORT  
Man Builder

You know the truth if no one else does—you know what you lack—what you need. You may hide it from others, in a way, but you can't hide it from yourself! Are you a victim of any habit that you want to get rid of? Have you a spark of ambition left to be the man you once were, to be the man you ought to be? Are you an easy victim to every little ailment that comes along; going around without snap or ginger; losing ground when you ought to gain it? *Wake up and be a man, not a misfit!*

*Deserve the name of man; be vigorous!* Come to me if you are a physical wreck. Join hands with me and I'll make you the kind of man that's wanted, the kind of man looked for, sought for, bid for all the time—and it will be done *without drugs, or tonics or stimulants.*

## STRONGFORTISM

### Science of Health and Strength

Through my system of Strongfortism, I can build your body up to the symmetrical proportions Nature intended you to possess. You will gain in vim and vigor; your muscular power will increase in flexibility and strength, your nervous system will be fortified to renew its energy—not bolstered up for the time being, to fall back below the level it was, as it does when you resort to drugs or medicine.

ity and strength, your nervous system will be fortified to renew its energy—not bolstered up for the time being, to fall back below the level it was, as it does when you resort to drugs or medicine.

## Think of Your Future

How about it? Are you fit?—are you qualified?—do you feel it in your soul? Are others getting by you, doing more,—getting more than you are? I know what is dragging you down, what is keeping you down. I have helped thousands; physically, mentally, morally. I will help you; will make you the kind of young man that is a credit to any community. I will make you so that your progress in any undertaking will be easier at your job, in business, socially. Just be frank and above board. Tell me your troubles.

## SEND FOR MY FREE BOOK

To know what Strongfortism can do for you, send for a FREE copy of my book, "*Promotion and Conservation of Health, Strength and Mental Energy.*" See that coupon—check what interests you—*mail it*, and I will send you helpful personal information. It will not cost you anything and it will surely help you to broader, bigger, better things and a great deal more happiness.

## STRONGFORT INSTITUTE

LIONEL STRONGFORT, DIRECTOR.

Physical and Health Specialist for Over 30 Years

Dept. 70, NEWARK, NEW JERSEY, U. S. A.

— Send This Coupon —  
FREE CONFIDENTIAL CONSULTATION

Mr. Lionel Strongfort, Strongfort Institute, Dept. 70, Newark, N. J.—Please send me absolutely free my copy of your book, "*Promotion and Conservation of Health, Strength and Mental Energy.*" I have marked (x) before the subjects in which I am interested.

.. Catarrh	.. Constipation	.. Blood Pressure
.. Colds	.. Rheumatism	.. Lung Troubles
.. Asthma	.. Nervousness	.. Round Shoulders
.. Headache	.. Overweight	.. Stomach Disorders
.. Rupture	.. Weak Back	.. Increased Height
.. Thinness	.. Weak Eyes	.. Muscular
.. Pimples	.. Short Breath	.. Development
.. Insomnia	.. Weak Heart	.. Great Strength

Other Ailments.....

Name.....

Age..... Occupation.....

Street.....

City..... State.....

## FREE BOOK CATALOG

Send today, without obligation, for our new 72 page catalog, describing books on more than one hundred and fifty practical and scientific subjects, including books on Aviation, Automobiles, Air Brakes, Alloys, Electricity, Horology, Heating, Hydraulics, Model Making, Metallurgy, Radio, Ship Models, Soaps, Perfumes, Recipes, Plumbing, Inventions, Tanning, Television, etc.

Norman V. Henley Publishing Co., Dept. 410, 2 W. 45th St., New York, N. Y.

## ELECTRICITY RADIO WELDING AUTOMOBILES

PRACTICAL TRAINING ON MASSIVE LAY-OUT OF UP-TO-DATE EQUIPMENT  
Oxy-acetylene and Electric Welding, Armature Winding, Power Plants, Switchboards, Transformers, Motors, Generators, Batteries, Radios and Automobiles. Write now for Free Catalog.

Coleman Electrical School, 1628 Main St., Kansas City, Mo.

## Mysterious Power of Pelmanism

Let us send you a free copy of "Scientific Mind Training." An instructive book which explains an amazing system of mind training already used by more than 650,000 people. It will show you how and why Pelmanism is the *only* system of teaching for developing *all* the mental powers at the same time. Endorsed by such distinguished men as Judge Ben B. Lindsey, Sir Harry Lauder, Jerome K. Jerome, Prince Charles of Sweden and hundreds of others. Write TODAY to

THE PELMAN INSTITUTE OF AMERICA

71 WEST 45th STREET DEPT. 610 NEW YORK CITY

## LEARN TO EARN \$50 to \$150 PER WEEK Write for Free Booklet SWEENEY Automotive Electrical SCHOOL

1615E Grand Ave.

KANSAS CITY MO.

The man who studies gets ahead. Popular Mechanics Press will advise you what books to read to advance in your trade. 200 East Ontario Street, Chicago, Illinois.

## FOR THE RADIO BUILDER

The blueprints below include the best of Popular Mechanics tested circuits. When ordering, simply quote the numbers of blueprints desired and inclose proper amount addressed to Popular Mechanics Magazine, Radio Dept., 200 E. Ontario St., Chicago, Ill. Magazines containing full descriptions of the circuits can be obtained. Send 25 cents for each magazine desired, giving date of publication.

No. 134, Edison Type B-Battery..... July 1928.. 25c

No. 138, Screen-Grid Perfect-Tone Six Receiver..... Nov. 1928.. 25c

No. 139, Simple Television Receiver..... Dec. 1928.. 25c

No. 140, Power Amplifier and B-Supply for Television..... Jan. 1929.. 25c

No. 142, Two-Tube Screen-Grid Short-Wave Adapter..... Mar. 1929.. 25c

No. 143, Four-Tube Screen-Grid Receiver..... May 1929.. 25c

No. 144, Three-Tube Self-Contained A.C. Receiver..... Oct. 1929.. 25c

No. 145, One-Tube S-G Set for Beginners..... Nov. 1929.. 25c

No. 146, Adjustable B-Eliminator..... Nov. 1929.. 25c

No. 147, A-Eliminator for Set and Dynamic Speaker..... Dec. 1929.. 25c

No. 148, Adding Audio Stages to S. G. Receiver..... Dec. 1929.. 25c

No. 149, Plug-In Power Amplifier for use with any Broadcast Receiver. June 1930.. 25c

No. 150, Short-Wave Receiver Without Plug-In Coils..... Sept. 1930.. 25c

No. 151, Beginners Low Power S - W Transmitter..... June 1930.. 25c

No. 152, Portable Radio Amplifier for the Deaf..... July 1930.. 25c

No. 153, Low Cost Code and Phone Transmitter..... Sept. 1930.. 25c

No. 154, A. C. Screen-Grid DX Tuner..... Oct. 1930.. 25c

Material Lists for any of the above instruments will be mailed free upon application.



# ACCOUNTING

The ACCOUNTANT  
Who he is  
What he does  
How to become one

THOUSANDS of ambitious men are earning more money today because they know Accounting. Send for our new book, "The Accountant—Who he is, What he does, How to become one," and the first lesson. Both will be sent free. In reply please state age and position.

International Accountants Society, Inc.  
A Division of the  
ALEXANDER HAMILTON INSTITUTE  
Dept. 151, 3411 So. Michigan Ave., Chicago, Ill.



## Learn Watch Repairing

by correspondence in a few weeks, in your own home, by the DeSelms Chart System. You can earn money while learning, secure a well paying position, or go in business for yourself. For complete details, address DeSelms Watch School, 37 S. Wabash Ave., Chicago, Ill.



## "I Won't Be Clerk Any Longer!"

### How Higher Accountancy Helped P. S. Blessing Increase His Salary 250%

For four years Philip S. Blessing worked hard as a clerk and got nowhere. He learned what every successful man knows—opportunity without trained ability means nothing. He decided to get that trained ability!  
Within fifteen months after he started with LaSalle in Higher Accountancy, Mr. Blessing was made Assistant Treasurer of the Lancaster Brick Company, Lancaster, Pa., and his salary was increased 137 per cent. Since then it has increased even more, until now it is 250 per cent larger than when he enrolled. His employer, Clarence B. Horning, General Manager, adds the vital point: "We believe he has many successful years ahead of him. His business progress has only begun."

### Send for This Book—It's Free

Are you ambitious to make a real success in business—to fit yourself for positions paying \$3,000, \$5,000, \$10,000 a year and even better? Then you will find LaSalle's 64-page book, "Accountancy, the Profession that Pays," of the greatest help and inspiration—and—LaSalle will send it to you FREE. For the sake of a brighter future, clip and mail the coupon NOW.

— — — Find Yourself Through LaSalle! — — —

### LaSalle Extension University Dept. 1064-HR Chicago

I should be glad to have details of your salary-increasing plan and a copy of "Ten Years Promotion in One," all without obligation.

- |   |   |
|---|---|
| <input type="checkbox"/> Higher Accountancy             | <input type="checkbox"/> Telegraphy                           |
| <input type="checkbox"/> Business Management            | <input type="checkbox"/> Modern Foremanship                   |
| <input type="checkbox"/> Modern Salesmanship            | <input type="checkbox"/> Expert Bookkeeping                   |
| <input type="checkbox"/> Traffic Management             | <input type="checkbox"/> C. P. A. Coaching                    |
| <input type="checkbox"/> Railway Station Management     | <input type="checkbox"/> Business English                     |
| <input type="checkbox"/> Law—Degree of LL.B.            | <input type="checkbox"/> Commercial Spanish                   |
| <input type="checkbox"/> Commercial Law                 | <input type="checkbox"/> Effective Speaking                   |
| <input type="checkbox"/> Industrial Management          | <input type="checkbox"/> Stenotypy—Stenography                |
| <input type="checkbox"/> Banking and Finance            | <input type="checkbox"/> Credit and Collection Correspondence |
| <input type="checkbox"/> Personnel Management           |   |
| <input type="checkbox"/> Modern Business Correspondence |   |



Name .....

Present Position .....

Address .....



1—Von Hoffmann Student Flight Hangar.  
2—Von Hoffmann Storage and Service Hangar.  
3—Von Hoffmann Ground School and Office.  
4—Von Hoffmann Student Home.  
5—Present Site of Army and Navy Hangars.  
6—Air Mail Hangar.

## There Is a Future for YOU in AVIATION

A practical method of easy payments is available for those who desire it.

Located on the famous \$2,000,000 Lambert-St. Louis Airport.

Aviation is a sound, big business—a business full of opportunities for men with foresight. Many young men, such as you, have already fitted themselves. Today they are holding good paying positions of importance. The need for more trained men is constantly increasing. Government figures show that the Aviation business is growing at the average rate of 60% a year. This means that both pilots and ground men are needed. You can be one of them if you prepare yourself now.

### Proper Training Can Be Had Easily and Quickly

U. S. Department of Commerce approved School for Transport, Limited Commercial and Private—Ground and Flying courses.

Compared with any other business, Aviation training takes but a very short time. In the Von Hoffmann School the training you get exceeds government requirements. It is thorough and practical. This school is a leader. Late types of planes and modern and complete ground equipment only are used. Because of the reputation of the school, Von Hoffmann graduates find ready employment.



"Red" Jackson — twice holder of the World's Endurance Record — a Von Hoffmann graduate

### Write for Illustrated Catalog

It gives detailed information about the opportunities in Aviation—about the school—about the courses—about the low cost—and it tells you how to make your start in this great business. No obligation involved. Use the coupon below for convenience.

## Von Hoffmann Aircraft School 134 Lambert - St. Louis Flying Field — St. Louis, Mo.

VON HOFFMANN AIRCRAFT SCHOOL  
134 Lambert-St. Louis Flying Field  
St. Louis, Missouri, MAIL TODAY

Name .....

Address .....

City .....

State .....

Age .....

I am interested in  
 FLYING COURSE     MECHANICS COURSE  
 WELDING COURSE     HOME STUDY



# Let Slamming Doors Pay You \$15 a Day

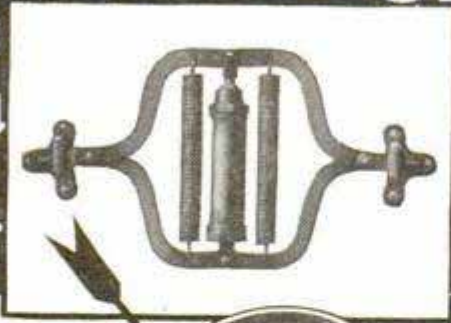

Amazing invention that ends all trouble, annoyance and expense of slamming doors, and brings fortunes to agents. Just one look at this clever device and the sale is made. Easily installed in a few minutes with just a screw driver. Can be adjusted to close any door at any speed by turning a handy little screw at the top of the check. Saves nerves, besides enormous loss through broken glass and wasted fuel. Every office, factory, store, institution, or public building needs one for every noisy door.

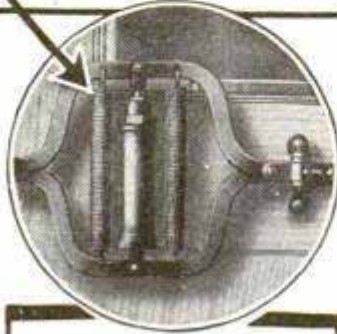

## Clever Demonstrator Offered FREE!

LOOK! A FULL SIZED SAMPLE ON MINIATURE DOOR FURNISHED EVERY ACTIVE AGENT! Can I offer you more than that? An actual working sample mounted on an easy-to-carry, light weight miniature door. With this clever demonstrator you can't fail. Sales pour in, and in just a few minutes time. Demonstrate this clever device—tell how it saves thousands of dollars each year in fuel and broken glass, and you're bound to make good. Mail the coupon for AMAZING FREE OFFER.

## Entirely New Principle— Works in Oil

Kant-Slam is different from any other door control. It's not pneumatic, but is built on new oil principle, that controls door like human hand. Gives lifetime service without adjustments. Always efficient in any weather.

## Amazingly Low in Price!

Kant-Slam is neat, compact, light in weight and is lowest priced control ever offered with a factory guarantee. Pays big commission that makes agents up to \$15 a day and more, easily. Just showing it. Simple demonstrator does all the work. Just take orders and collect the big commissions in ADVANCE!

## Mail Coupon for FREE OFFER

NOW—TODAY! Is the time to mail the coupon for TREMENDOUS FREE OFFER. Get in on the ground floor and clean up the profits being distributed among my representatives. Just open and shut your demonstrator 5 or 6 times a day and you'll be making up to \$30, \$40, and \$50 a week just as easy as singing a song. If you can't afford to wait, because territories are being taken as fast as we can hand them out—mail your name and address on coupon below, and I'll reserve your territory for you.

**Kant-Slam Door Check Co.**  
Dept. G-7 BLOOMFIELD, IND.

## "Sold 6 in 2 Hours"

This enthusiastic report comes from R. F. Culver of Michigan.

"One installation sold 6 more," says J. C. Adams, Ohio.

"Fourteen orders in one day," Outcast, of Ohio.

J. C. Woodruff, Minn., sold 7 in one afternoon.

"Four calls—three orders," F. E. McDaniel, Indiana.

**KANT-SLAM DOOR CHECK CO.**  
DEPT. G-7, BLOOMFIELD, IND.

GENTLEMEN: Please reserve my territory, and send me full details of your AMAZING FREE OFFER. I am not obligated.

Name.....  
Address.....  
Town.....State.....



# BOYS! Here's Fun Galore



**Zip!** Here they come! Around a turn and down the home stretch to cross the finish line with a last furious burst of speed!

You want things that will "GO"—things you can race with—scooters, pushmobiles, small autos with motorcycle engines, wind wagons, etc.—Whether on spinning wheels or glistening runners—fast ice yachts, skis, toboggans, bobsleds, motor driven sleds and snow speedsters.

You air-minded boys enjoy gliders and model airplanes. Turn your back yard into a regular amusement park with all these thrillers—ferris wheels, roller coasters, merry-go-round swings, etc.

How fascinating to imitate the big engineers and make small water wheels, pile drivers, aerial cableways and other things that "work."

When at camp or on the water you need plenty of ideas for new ways of having fun. Here are dozens such as water bicycles, push boats, water coasting toboggans, water games, etc.

On rainy days and other times when working in your home shop you have the hardest time finding interesting things to make. Here are any number such as electric locomotives, motion picture cameras, wood turning lathes, etc.

All in this great

## Boy Mechanic Library

YES—ACTUALLY  
4000 Worth While Things to Make and Do

Don't envy the other boys on account of the things they have. Be the boy in your neighborhood to make the others wonder where you get all your ideas.

Get the thrill of having "Made It Yourself." Everything is pictured out and made easy. Don't try to get along without these books. Send for them right away.

The complete library of 4 volumes, each book 7x10x1 1/2 inches and with 460 Pages.

## Price \$7.00

or single volumes at \$2 each. Each volume complete in itself.

Books are numbered: 1, 2, 3 and 4. State the ones you want when ordering. Sent postpaid when remittance is sent with your order, or will be sent C. O. D. anywhere in the U. S. Pay postman price plus extra postage for this service.

**POPULAR MECHANICS PRESS**  
200 E. Ontario St. Room P 10 Chicago, Ill.



# If You Are Suffering

From Colds, Coughs, Catarrh, Bronchitis, Asthma,  
Rheumatism, Neuralgia, Arthritis, Neuritis

## READ

# The Strange Story of JOHN F. CLASS

*Who cured himself of an "incurable disease"  
—and in doing so discovered a marvelous new  
system of treatment which those who use it say  
"gives almost miraculous results."*

**J**OHN F. CLASS suffered agonies for 15 years—at the age of 50 was judged a hopeless case by doctors. Now, at 71, he is robust, active, healthy, never knowing a minute of ache or pain. He cured himself by his own discovery. Since then this has been used to treat over thousands of sufferers who have thronged to him for relief after other methods had brought them nothing but pain, misery, loss of time and waste of money, discouragement and despair.

**No Medicine — No Drugs — No Diet**

The discovery of John F. Class was based on his own knowledge of the body and reveals an entirely new and astonishing system of treating disease. Thousands say of it "Miraculous." Mr. Class himself says, "I have gone to Nature, the one and only Great Healer. Nature never intended man to burn out his stomach with medicine, tear down nerves with drugs, or wreck the body with diets. Nature makes the body its own physician.

"My principle is founded upon a scientific fact: **that no disease can exist in a healthy body.** The simple device I invented for the application of my Therapeutic principle is designed for removing the cause of disease by putting back into the body the vital elements that it has lost through unnatural living. Not by electricity—not by injection—not by medicine—not by yeast or vitamins—but with a pleasant, harmless, painless, exhilarating, **natural** method that is so absolutely positive. And you can derive the full benefit of this treatment in your own living room.

### POSITIVE PROOF TEST

If you suffer, take the hand I offer you—the hand that has lifted others from misery. Make my Positive Proof Test in your own home **At my risk.**



JOHN F.  
CLASS

Now brings to homes of sufferers the amazing discovery which restored him, after 15 years of agony, and which has brought relief to thousands who came to his famous institutions for treatment.

### Find Relief—At My Risk In Your Own Home

I don't care how bad your case is; I don't care how deep-seated or long standing; or how many other treatments you have tried. **Don't give up hope!** I am so anxious to help men and women who suffer that I will send my device to you for 30 DAYS' TRIAL IN YOUR OWN HOME AT MY RISK.

## SEND NO MONEY

Just send coupon. Don't take my word. Don't even take the word of thousands of others who say my method has brought permanent relief. **Try it yourself at my risk!** If my method fails, the trial costs you nothing. If it brings you the relief I expect, you will be grateful all your life. Send the coupon—get my FREE book that has led thousands of sufferers to enjoyment of life. Don't delay the revelation that awaits you. Mail the coupon at once—today!"



### \$17,800 IN A YEAR

Performing a Pleasant Service  
to Humanity

This is the income of T. W. Dougherty who is directing a local John F. Class Institution in Indiana. Because of the spreading fame of this treatment, Mr. Class has started 200 local

institutions throughout the country. The directors of these institutions are realizing most unusual incomes.

More institutions will be opened in the near future. There is a tremendous opportunity for ONE man or woman in each locality. A moderate capital is required. Experience is not necessary—we give full training. If you are interested in having an ethical, respected, dignified business in which you can render an appreciated service to your community and earn an exceptional income, send coupon for full details.

## POSITIVE PROOF COUPON

John F. Class, President,  
John F. Class Health Fume System,  
210 Monument Avenue, Dayton, Ohio

Please send full information about your remarkable discovery, your FREE book, details of POSITIVE PROOF Test and Trial **In My Own Home At Your Risk.** I desire relief from

Name.....

Address.....

Check here if interested in John F. Class Institution franchise in your locality.



# MOULDING MIGHTY LEGS



## The Greatest Yet! Complete Course on Leg Building ONLY 25c

Don't be a half built man. Don't let your legs spoil your physique. Get a 24 inch thigh, a 16 inch calf with 16 inch biceps. Your legs can be made props of power. Never again will the world "tell" "skinny legs" when you walk the beach in a bathing suit. Let your legs proclaim you a fully developed man no matter whether you are on the beach, in the gym or paddling your canoe. No matter what the physical problem of your legs may be this book course will solve it.

Do your knees fold like a weak clasp knife when you carry a load? Have you trembly legs, weak knees or ankles, or cold, aching feet? Blood stagnation or low nerve vibration? This remarkable book course provides numerous new exercises with priceless information on leg building and foot correction that will quickly remedy these conditions. Tells how knock knees and bow legs can be effectively corrected. Vigorous legs make a vigorous heart, increase virility, dynamize the nerve forces and fill the body with vital life.

Let the small investment of 25c get you a pair of powerful, shapely legs. Let the spring in your heel and the swing of your stride proclaim a new existence of health and strength within you. Get this marvelous new book course hot off the press. The most remarkable illustrated course on the legs and leg exercises ever published. Contains thousands of dollars' worth of health, strength and happiness for you. Yours for only 25c.

### RUSH THE COUPON TODAY

With each copy will be given *THE THRILL OF BEING STRONG*—a priceless book to the strength fan and muscle builder. Full of pictures of marvelous bodied men who tell you decisively how you can build symmetry and strength the equal of theirs.

### REACH OUT--GRASP THIS SPECIAL OFFER

### JOWETT INSTITUTE of PHYSICAL CULTURE

422 Poplar Street, Dept. 4Ka, Scranton, Penna.

Dear Mr. Jowett: I am enclosing 25c. Please send me the course "MOULDING MIGHTY LEGS" and a free copy of "THE THRILL OF BEING STRONG."

Name \_\_\_\_\_

Address \_\_\_\_\_

# Wrestling

## Expert Secrets Learn at Home



Men, Boys be perfect physically. Learn right in your own home from *World's Champions*

how to be an expert WRESTLER. Learn secret trick holds, blocks, breaks and pinning holds. Learn how to defend yourself against bigger, stronger men. Learn Jiu-jitsu. Also most wonderful course in PHYSICAL CULTURE ever discovered. The world renowned **Farmer Burns** and **Frank Gotch** are authors of these splendid lessons. Learn to be a real athlete. You can if you'll try. Have a beautiful attractive body that all will admire. Surprise your friends, and the "bully" with your great ability. Learn to protect yourself, your mother, sister or sweetheart. Have perfect health, ability.

**Send Only 10c** in coin or stamps for 32-page ILLUSTRATED prospectus. Tells HOW you can quickly learn the secrets of the big Champions; their many tricks and holds. Highly interesting and full of valuable information. A costly book which we send for only 10c—the cost of packing and postage. Don't miss it! Don't delay. **Send today—this moment.** State your age.  
**Farmer Burns School, 3377 Courtney Bldg., Omaha, Neb.**



## HAND-FORGING AND WROUGHT-IRON ORNAMENTAL WORK

Complete instructions, with photographs and drawings, for making the most attractive styles of ornamental iron work.

Andirons	Grilles	Rosettes
Scroll Work	Leaf Work	Hinges
Bulbs	Drawer Pulls	Door Plates
Window	Door Keeps	Spiral Deco-
Fasteners	Fire Sets	rations
Lamps	Candle Sticks	Picture
Coat Racks	Chains	Frames

Thomas F. Googerty, the author, is one of the best-known makers of this type of metal work. The illustrations are all of work made by the author. Almost every page has one or more illustrations either made from drawings or from photographs. Anyone

interested in this type of work can soon develop his ability so that he can make these articles for his own use or for sale. There is a growing demand for articles of this type.

**Send No Money** Simply write a postal for this book of Instructions. When postman hands you the book, pay him the postal charges and \$2.00.  
**POPULAR MECHANICS PRESS, Room 710, 200 East Ontario St., Chicago, Illinois**

### 34 Lesson

## Drawing Course \$2.98

The biggest value you ever saw **2.98**  
advertised anywhere . . . . .



Haven't you often wished that you could draw cartoons, illustrate some idea, sketch some pretty face, etc.? You can do all of these things. One of America's most famous Cartoonists and Illustrators has developed a great, simple system for success in all branches of Commercial Art. This system has revolutionized the entire theory of drawing. It means that drawing can be as easy for you as writing—much simpler than learning shorthand, bookkeeping or typewriting. We are now placing this original system for learning Drawing, Art and Cartooning, consisting of 34 lessons with over 500 illustrations, within reach of every one. If you will devote a few hours each week to the Course **WE ABSOLUTELY GUARANTEE** that you will learn to draw and draw well before you have half finished the Course. If we fail to make this claim good, we will refund every cent paid us. By eliminating a large office force for answering correspondence, expensive catalogs, etc., we are enabled to make a price of \$2.98, the cheapest price ever known for a high-grade, home study course. Learn to draw. It is a big asset, no matter what field you are in.

### Send No Money

Just order the course and on arrival **\$2.98** pay postman plus a few cents postage. payment in full for the entire Course and Drawing Outfit. If not entirely satisfied, return within five days and we will Refund Money. Address: **LEDERER SCHOOL of DRAWING, Dept. 674-F, Chattanooga, Tenn.** Orders from outside the U. S. A. are payable \$3.28 cash with order.

If you order the course at once, we will include a drawing outfit, consisting of artist's pencils, pens, paper, erasers, thumb tacks, etc., enabling you to go to work without any additional cost.



# How I MADE UP for JOHN'S Shrunken PAY CHECK



## How a Little Home Business Brought Independence

"They've cut our piece rate again," John said bitterly as he gloomily ate his supper. "I've been working at top speed and then only making a bare living, but now—"

It had been hard enough before but now—with John's pay check even

smaller—I feared it would be impossible to make ends meet.

Idly I fingered through the pages of a magazine and saw an advertisement telling how women at home were making \$15.00 to \$50.00 a week supplying Brown Bobby greaseless doughnuts.

"Why can't you do the same?" I asked myself. "Why can't you do what others have done. In-

vestigate!" I did. In a few days I received details of the Brown Bobby plan. It seemed too good to be true because it showed how I, without neglecting my housework or little Jimmy could easily make money.

Well to make the story short, I went into the business without telling John. I passed out sample Brown Bobbys to my friends, gave out a few samples around restaurants, lined up a couple of grocery stores. In my first week, I sold 238 dozen Brown Bobbys at an average profit of 15c a dozen.

When John brought home his next pay check, he threw it down on the table and said gloomily, "I'm sorry, honey, but it's the best I can do."

"It's not the best you can do, darling," and I almost cried when I told him of the money I had made selling Brown Bobbys. It was the happiest moment of my life.

Inside of three weeks John quit his job at the factory to devote all his time to Brown Bobbys. Now we are dissatisfied at less than \$150.00 a week. Women interested in making \$15.00 to \$50.00 in their spare time are invited to write for details of the Brown Bobby plan to FOOD DISPLAY MACHINE CORP., Dept. 310, Chicago, Ill.

### Men—Make Up To \$1,000 a Month

Men, here is a real, red hot money-making opportunity! It's a chance to jump into business for yourself and make more money every week than the average man makes in a month. Surprising as it may sound, we actually put you in a business, with the first day's income often running from \$18 to \$55. \$350 to \$600 the first month is not unusual for ambitious men.

#### CUT IN ON THE BIG MONEY

All you need is the ambition to make real money. We supply you with complete equipment to make and sell that famous new food specialty—Brown Bobby—a greaseless doughnut baked by electricity!

#### Goodwin Sells \$157.00 Worth in One Day

BROWN BOBBYS going big. Sold \$157.00 worth today. Last Saturday, our sales amounted to \$150.00, and the Saturday previous \$112.00. This certainly indicates that our business is rapidly increasing, and unquestionably will grow to great proportions.—William Goodwin

#### Stephens Clears \$20.00 Profit First Day

BROWN BOBBYS a sensation. Selling like wildfire. Keeping me busy night and day to supply demand. My first day's sales from one machine netted me \$20.00 clear profit. In the short time I have been operating I have sold over five thousand dozen BROWN BOBBYS. Selling all four machines can produce.—Stephens

#### Start At Once ANYWHERE!

Men and women everywhere are starting in this business daily! YOU cannot afford to delay. Send the coupon at once! TODAY!

**FOOD DISPLAY MACHINE CORP.,**  
Dept. 310, 500-510 N. Dearborn St., Chicago, Ill.

Without cost send me details of your Brown Bobby plan.

Name.....

Address.....

City..... State.....





# Which Job do YOU Want

Lawyer



Auto Expert

## Try for it This



Civil Engineer



Business Manager way

Men don't just fall into easy jobs of big pay positions—they prepare for the big chance before it comes. Make up your mind today what you want to be, then take the first step at once. You don't have to go to college to get ahead. Other men have gone there for you and have put the things they learned there and through years of practical experience into easily understood books which give you a short cut to a better and a bigger job. We have picked 10 of the best paying professions and have published for your benefit new editions of the most practical, the most valuable books we have ever printed on the subjects covered.

### JIFFY INDEX

Our new Jiffy Index makes each book a quick reference work—no time need be wasted in search or study—put your finger on the facts you want instantly.

### SHIPPED FREE

Words alone cannot describe the full value these books may be to you, so we ship Free for Examination. Pick the set you want, the price is plainly shown, but **Send No Money**; just your name and address, and the books will be sent promptly. Take ten full days to read, test and examine them. You'll realize at once what a tremendous force for a better future they can be. After ten days you send only \$2.00; then \$3.00 per month until the balance is paid. **There Are No Interest Charges of Any Kind**; the price shown is the total cost.

### Special Price List of Pay-Raising Books

- Automobile Engineering, 6 volumes, over 2,500 pages, brand new 1930 edition. . . . . **\$24.80**
- Practical Business Administration, 12 volumes, 3,400 pages. (Extra volume containing self quiz reading course of 80 lessons included free.) This is a complete business guide. . . . . **39.80**
- Electrical Engineering, 8 volumes, 4,300 pages, 3,200 illustrations. . . . . **34.80**
- Modern Shop Practice, 7 volumes, 2,600 pages, 2,670 pictures. . . . . **29.80**
- American Law and Practice (with reading course), 13 volumes, 6,000 pages, illustrated. . . . . **49.80**
- Telephony, 925 pages, 682 illustrations. . . . . **6.00**
- Sanitation, Heating and Ventilating, 4 volumes, 1,436 pages, 1,000 pictures. . . . . **14.80**
- Drawing, 4 volumes, 1,750 pages, 1,000 pictures, blue prints, etc. . . . . **14.80**
- Employment Management and Safety Engineering, 7 volumes, 1,800 pages, 450 illustrations, charts and diagrams. . . . . **24.80**
- Architecture, Carpentry and Building, 5 volumes, includes 120-page book "Blueprint Reading" free, Special price—reduced from \$24.80. . . . . **19.80**

### MEMBERSHIP FREE

Anyone who takes advantage now of this opportunity to "Raise his Pay" will be given absolutely free, a certificate of membership in the American Technical Society, which entitles him to full consultation privileges with our experts in his chosen field. This is good for a whole year and is of tremendous value in solving special problems.

**American Technical Society, Dept. X-719, Drexel Ave. at 58th St., Chicago, U. S. A.**

Please send me set of. . . . .

for **Ten Days'** examination. I will examine the books thoroughly and, if satisfied, will send \$2.00 within 10 days and \$3.00 each month (\$2.00 on telephony) until I have paid the special price of \$ . . . . . If I decide not to keep the books I will return them at your expense at end of 10 days and will owe you nothing.

Name. . . . .  
 Address. . . . .  
 Employed by. . . . .  
 Address. . . . .



## Young outdoor men wanted

Interesting, vigorous outdoor work in a growing organization where merit wins advancement. Good starting wages. Permanent positions and a real future for men who make good. Expansion to meet increasing need for this unique service creates additional openings. So we are selecting now, to enter our employ, a number of sturdy, clean young men, thorough Americans, single, between 20 and 30, free to travel, industrious, with good practical education, able to give good references, and to pass a thorough physical examination. Write The Davey Tree Expert Co., Inc., 507 Federal Bldg., Kent, Ohio.

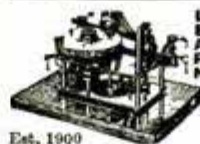

### LEARN CODE TELEGRAPH Morse or Radio AT HOME WITH THE AUTOMATIC Omnigraph

Leads quickly to big money jobs of Aviation, Ships and Railroads. Your Future is SECURE. Many Young Men Holding Important Jobs. Models \$15 to \$35. Catalog. Now. Omnigraph Mfg. Co., 810 E. 39th St., P. 9, Brooklyn, N. Y.

**WANTED MECHANICS, SHOPMEN DRAFTSMEN AND TOOL MAKERS**

to MAKE BIGGER MONEY AND BECOME INDEPENDENT OF PRESENT JOB. Become Apprentice with us and gradually develop into a Practical Tool and Die Designer. Learn how to design Tools, Jigs, Fixtures, Punches, Dies, etc., at home in spare time.

**TOOL ENGINEERING SERVICE BUREAU**  
 P. O. Box 503 Chicago, Ill.

**WASHES CARS in A JIFFY!**

Here's the cleverest invention of the age! GY-RO washes cars CLEAN, without *chamols, soap* or spray! Water pressure from garden hose makes it operate. And in the *easiest, simplest* manner ever! Whirling brush cuts right through dirt and road film—car becomes spotlessly clean in a jiffy. Saves autoists valuable time and a nasty job. They buy GY-RO on sight, **USEFUL IN EVERY HOME**—Cleans screens, walls, etc., like new.

**100% PROFIT FOR AGENTS!**

AGENTS WANTED AT ONCE. Valuable territories still open. No experience needed. Exceptionally large profits for hustlers. Car owners, garages, service stations, etc., are prospects. **COSTS NOTHING TO START.** Send name and address for full particulars.

**GY-RO BRUSH COMPANY, Dept. K-14, Ampere, N. J.**



## Painting—Decorating Sign Making Art Work

Whatever help you may need along these lines, here is a list of books to choose from. They will enable you to do better work.

House Painting Methods.....	\$2.00
Mixing of Colors and Paints.....	2.00
Graining and Marbling.....	.75
Automobile Painting.....	1.50
Interior Wall Decoration.....	4.00
New Stencils and Their Use.....	1.25
Furniture, Furniture Finishing, Decoration and Patching.....	5.00
Wood Finishing, Plain and Decorative.....	2.00
The Ross Crane Book of Home Furnishing and Decoration.....	3.00
New Hardwood Finishing.....	1.50
The Lacquer System of Sign Painting.....	3.00
Art of Show Card Writing.....	4.00
Studio Handbook—Letter and Design.....	3.00
How to Draw Funny Pictures.....	3.00
Layouts for Advertising.....	3.00
Chalk Talk and Crayon Presentation.....	1.25

### NO RISK ORDER PLAN

Pick out any of the above books you want and send us your order with remittance. We will mail the books postpaid. If, for any reason, you are not satisfied with your purchase, return to us and your money will be refunded. Address:

**POPULAR MECHANICS PRESS**

Room P7—200 E. Ontario St., Chicago, Ill.

## Dentists Need Men



Experts  
Earn up  
to

**\$125<sup>00</sup>**  
a week

### Make Crowns, Plates, Bridgework, etc. for Dentists

We teach you to make rubber plates, crowns, bridge work, metal base dentures, etc., for dentists. After graduating you are ready for a job or can open your own laboratory. We assist you.

### Demand for Men

Thousands of dentists everywhere send work to mechanical dentists. We train you quickly in day or night school for this uncrowded field. No classes—no books—no mechanical experience necessary. Work your way thru school. We help you find a job to meet your expenses while taking our training. Railroad fare allowed to nearest school.

### MAIL COUPON FOR FREE BOOK

McCARRIE SCHOOL OF MECHANICAL DENTISTRY,  
1338 S. Michigan Ave., Dept. 416, Chicago.

Without cost or obligation, send me your illustrated book on Mechanical Dentistry, and complete information as to my opportunities in dental laboratory work.

Name.....

Address.....

## Self-Teaching Books on DRAFTING That Will Help You to MORE MONEY

### 1. ARCHITECTURAL DRAFTING

by C. L. Svensen, M. E., and E. G. Shelton, B. S. A text-book of all the fundamentals of drafting carried right through to house planning. 500 problems with diagram layouts. 472 illustrations. **\$2.00**

### 2. DRAFTING FOR ENGINEERS

by C. L. Svensen. A complete course in elementary engineering drawing up to machine design. 325 problems with layouts. 583 illustrations. **\$2.75**

### 3. MACHINE DRAWING

by C. L. Svensen. A text and problem book for technical students and draftsmen. 200 problems with layouts. 338 illustrations. **\$2.25**

### 4. ESSENTIALS OF DRAFTING

by C. L. Svensen. An elementary text-book on mechanical drawing—simple, thorough, practical. 250 problems with layouts. 450 illustrations. **\$2.50**

### 5. PERSPECTIVE

by B. J. Lubschez. A text-book for beginners, especially prepared for home study. With 38 illustrations. **\$2.00**

### 6. FREEHAND DRAFTING

by A. E. Zipprich. A course covering the sketching of industrial objects and the fundamentals of mechanical drawing. 170 problems and exercises. 71 pages of illustrations. **\$1.60**

### 7. ARCHITECTURAL IRON DESIGN

by D. M. Driscoll. Teaches the design and construction of all metal units entering into building construction—and building laws involved. 53 plates and 12 valuable tables. **\$4.00**

### 8. CONSTRUCTION DRAWING

by Brahdry and Landsman. A splendid beginner's book on architectural drawing. 129 sections, profusely illustrated. **\$2.50**

### 9. ART OF LETTERING

by C. L. Svensen. Letter forms, the methods of executing them, guidance in appropriate use. 96 full page plates—alphabets and samples of use. **\$3.50**

## FREE EXAMINATION

The coupon below brings any titles you choose for free examination. Pay or return in five days. ORDER BY NUMBER.

D. Van Nostrand Co.

250 Fourth Ave., New York, N. Y.

Send me for free examination the books marked below. (Draw a circle around the number of each book you want.)

1 2 3 4 5 6 7 8 9

Within five days I will either return the books, or remit the price as shown in the list above. (P. M. 10-30)

Name.....

Address.....

City.....State.....

Business Connection.....



# ORANGE JUICE

*Amazing New Easy Way!*

**NO  
SQUEEZING,  
STRAINING,  
SEEDING OR WASTE**  
*The Money Making Opportunity  
Of a Lifetime For*  
**AGENTS!**

**B**YOND question, Orange juice is now the national drink. It is served daily in almost every home and thousands of gallons are served every day in restaurants, hotels, and soft drink parlors. This has created a tremendous demand for a simple, really efficient juice extracting machine—one that would *get all the juice*, save all the valuable nutritive elements, be easily used, easily cleaned and still sell low enough so that everybody could afford to buy. Now comes an entirely new, revolutionary machine called KWIKWAY which meets all these requirements and more. Works on an entirely new principle which eliminates tedious, tiresome squeezing, straining and seeding.

## Sells Like Wildfire Everywhere

Every housewife wants one. Big demand in hotels, restaurants, etc. Actually replaces expensive electrical machines in some cases. Agents reap a golden harvest without half trying. If you want to make money as never before in all your life—spare time or full time—get your name and address on the coupon below and mail it at once to

**KWIKWAY PRODUCTS, Inc., Dept. P-530**  
**1415 Pine St. ST. LOUIS, MO.**

KWIKWAY PRODUCTS, Inc., Dept. P-530  
1415 Pine Street, St. Louis, Missouri.

Gentlemen: Please rush me full information about your new type Orange Juicer, also details of your No-risk Offer to prove that I can make more money with KWIKWAY.

Name.....

Address.....

City.....State.....



## OUTDOOR SPORTS

*The Year 'Round*

POPULAR MECHANICS PRESS  
CHICAGO

## Thrills Galore IN OUTDOOR SPORTS

THE YEAR ROUND

Have you ever heard of Water "Bug Ball" played with round motorboats or Angling for Human "Fishes"

or the "Tumbling Barrel" popular at bathing beaches?

Do you know how to try "Solo" batting practice in baseball or improve your accuracy in tennis by trying to place the ball in numbered squares? Have you tried webfoot attachments in swimming or played Human "Checkers" on the beach?

There are 226 ideas for new and popular sports in this interesting book

### Take A Copy On Your Summer Outing

Although winter sports are thoroughly covered, the following are of most interest at this time of the year:

Baseball	Golf	Outdoor summer games	Photography
Boats	Handball	Overhead trolley coaster	Swimming
Camping	Model air-planes	Pets	Tennis
Fishing	Motor boats		Track work
Glders			Trapping
			Water sports

152 Pages Fully Illustrated, Cloth Binding

Sent C.O.D. anywhere in U.S. Pay postman price, \$1.50, plus few cents postage upon delivery. If outside U.S., remit with order.

**POPULAR MECHANICS PRESS**  
Room P10 200 E. Ontario St. CHICAGO

## AUTO REPAIRMEN EARN GREATER PROFITS

Get your share of the big money being spent on automobile upkeep.

Put improved time, labor and money-saving ideas to work in your shop to-day. Take advantage of our special bargain offer and secure 3 valuable kink books at a reduced price.

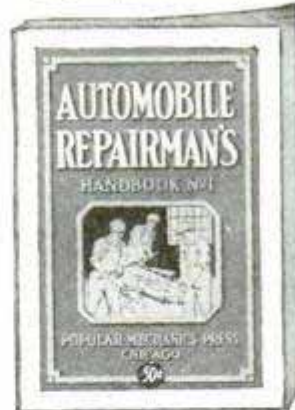

1. 334 Valuable Discoveries made by auto mechanics in our **Automobile Repairman's Handbook**. 337 Illustrations.

2. 301 Ways to use drills, drill presses, taps and dies more effectively in our **Drilling and Thread Cutting Handbook**. 298 Illustrations.

3. 259 Kinks furnished by the most expert Lathe Operators in our **Lathe Handbook**. 212 Illustrations.

**Special Offer**—These 3 books (regular price 50 cents each, \$1.50 value) are offered for a limited time for only 98 cents plus postage. Pay postman C. O. D. when he delivers or if outside U.S. send 98 cents and 15 cents extra for postage.

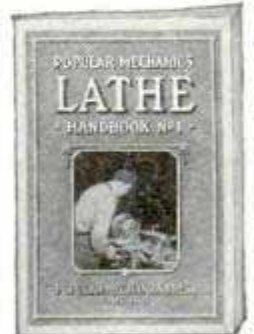

**POPULAR MECHANICS PRESS**  
Room P10  
200 E. Ontario St. CHICAGO



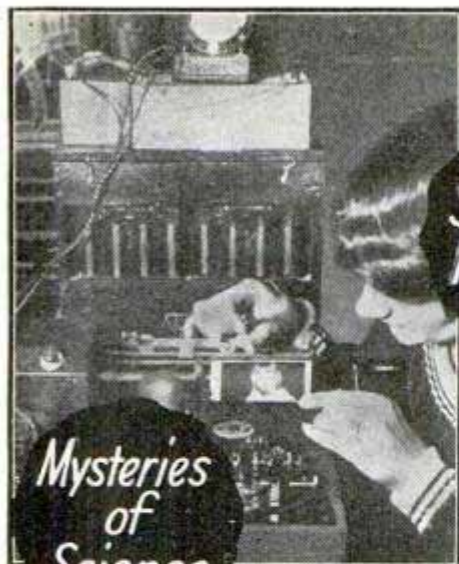

**Mysteries  
of  
Science**

Transmitting photos by radio, fully explained—and all other branches of Science and Invention—in simple, non-technical language.



**Strange  
Peoples**

South Sea Islanders in one of their wild tribal dances. Strange lands—famous people—meet them all in this new-type encyclopedia.

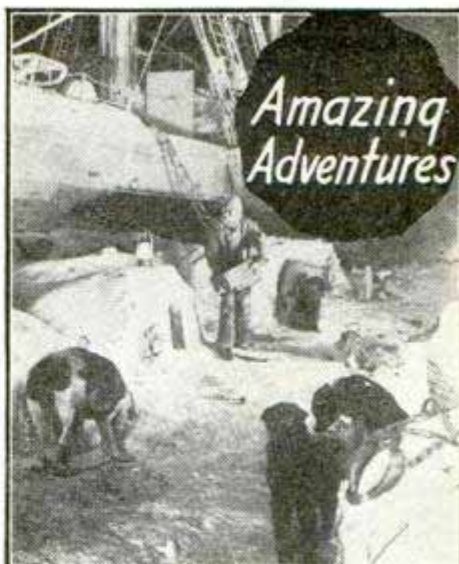

**Amazing  
Adventures**

Shackleton stopped by hunger a few miles from the Pole. Man's most thrilling adventures on land, sea, in the air—illustrated with wonderful pictures.

# He judges men by their books



**Now 12 Volumes (and  
Study Guide)**

**9,002 Pages, 14,000 Illustrations**

New edition just off the press—prepared under the editorship of Dr. O'Shea, Professor, Department of Education, University of Wisconsin and over 200 noted educators, scientists and business men.

The paper, printing, binding and text-matter set a new standard for encyclopedias. As easy to use as a dictionary, because all topics are in their alphabetical place, abolishing the old-fashioned "index in the back."



**13th Volume "Makes Your  
Easy Chair a University"**

In preparation over 2 years, off the press this month. Contains outlines and page references of all the material in the other 12 volumes, grouped under 38 department heads, such as Science, History, Biography, Travel, Music, Art, etc. Under Civics alone there are over 2,000 topics listed. With THE NEW WORLD BOOK and the Study Guide—you have an inexhaustive supply of pleasure-giving, dollar-making information.

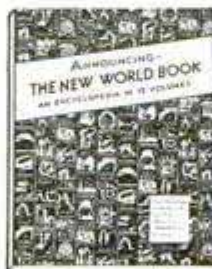

**FREE!**

Portfolio of specimen pages, showing the wonderful new-type maps, examples of leading articles on Science, Travel, Biography, etc.

**Just Mail the Coupon**

**W. F. Quarrie & Company  
Dept. 159-A, 154 E. Erie St.  
Chicago.**

Please send FREE and without obligation portfolio of sample pages from THE NEW WORLD BOOK.

**THE NEW WORLD BOOK  
ENCYCLOPEDIA**

W. F. Quarrie & Company, Dept. 159-A, 154 East Erie Street, Chicago

Name.....

Address.....

City..... State.....



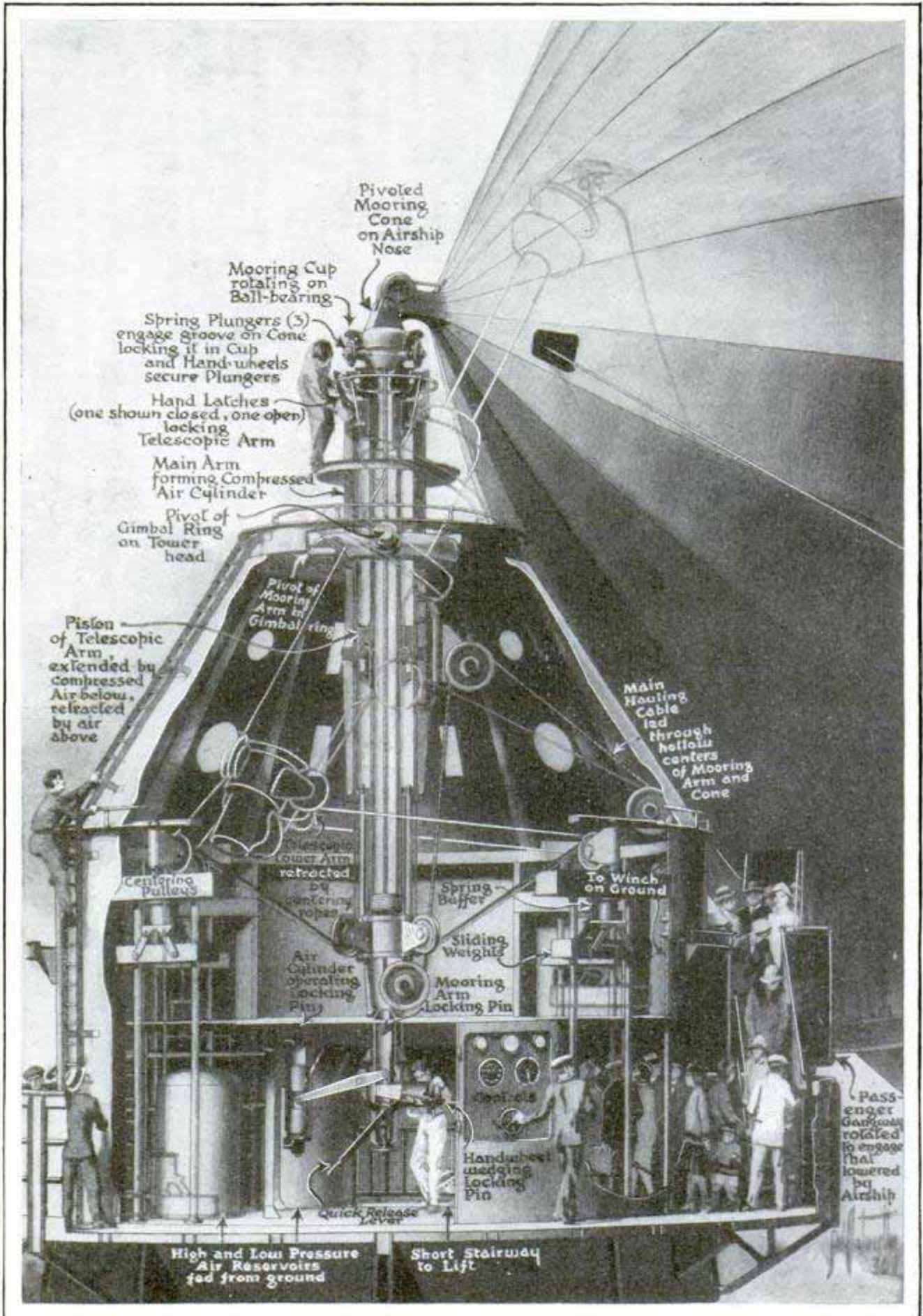

Where the "R-100" Rested When in Montreal; Artist's Drawing of the Mooring Tower Head at St. Hubert; the Mechanism Is Operated by Compressed Air—See Page 630

Copyright, S. W. Clatworthy, *leg*  
 54, Ribblesdale Road  
 London, S.W. 16



# Popular Mechanics Magazine

REGISTERED IN U. S. PATENT OFFICE

WRITTEN SO YOU CAN UNDERSTAND IT

Vol. 54

OCTOBER, 1930

No. 4

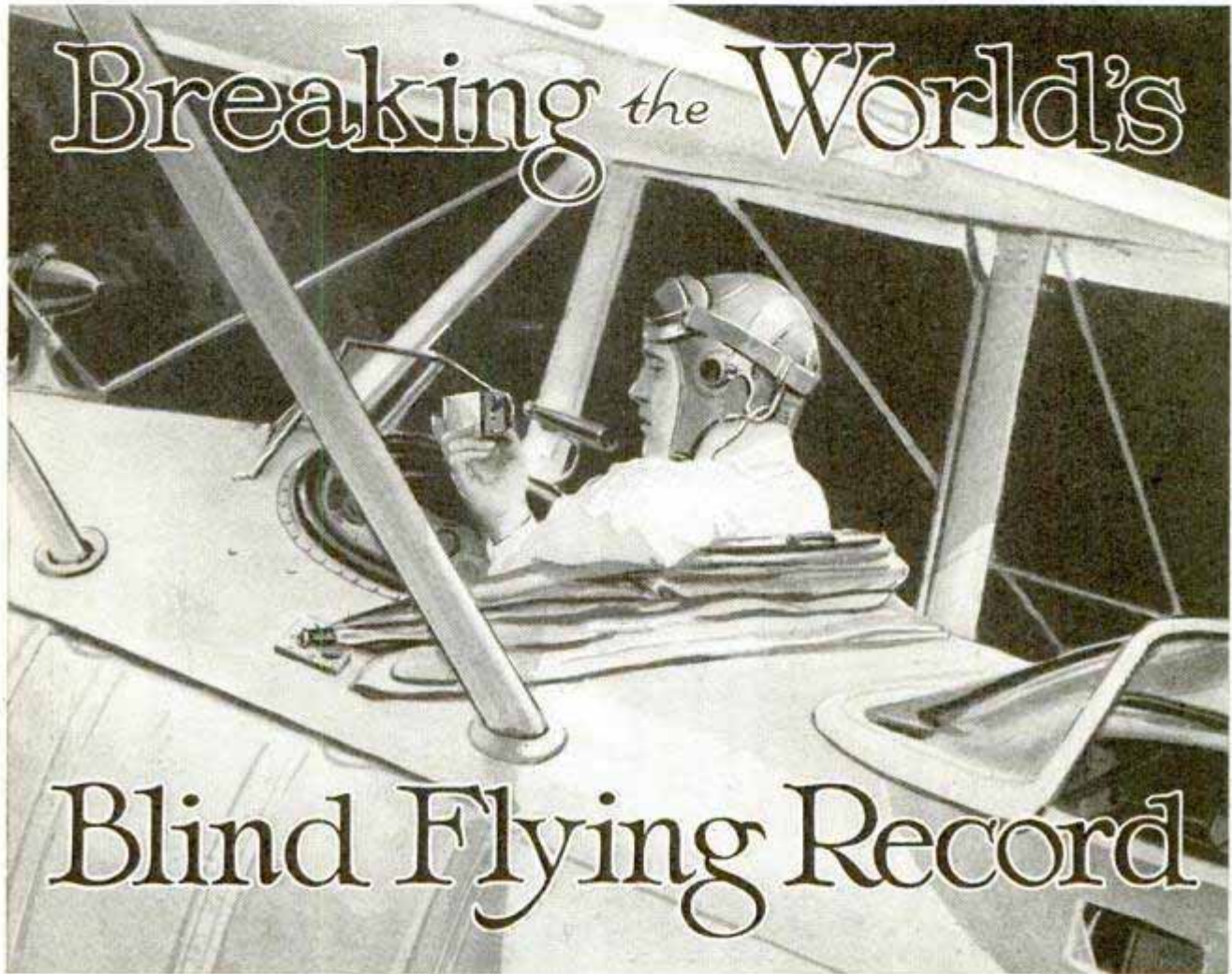

Captain Page Wearing Headphones Which May Be Plugged into Radio Receiver, and Holding Reed Visual Indicator Which Is Also Connected to Receiver and Gives Light Signals to Aid in Keeping on Course

By CAPTAIN ARTHUR PAGE, U. S. M. C.

**H**OW does it feel to fly blind for over a thousand miles on a blistering-hot day, when your life depends entirely on your familiarity with directional instruments and radio equipment?

This is the question many of my friends have been asking me ever since I broke the world's record the other day by flying blind in a hooded-in cockpit over the radio-controlled airways from Omaha, Nebr., to Washington, D. C.

Such a trip involves its share of drama and, perhaps, a surprise or two. Imagine, for instance, my feelings when, after flying safely over the treacherous Allegheny

*Belle Haven Alexandria Va*  
mountains and finally feeling the welcome sod of the naval air station in Washington under my feet, I was informed that I had flown over a terrific storm shortly after passing Cleveland. My companion, Lieut. V. M. Guymon, also of the marine corps, who rode behind me in an open cockpit, tells me that the visibility was reduced to zero and that probably only a radio control brought us through.

The major aim of the flight was to test out the value of a new type of radio apparatus, designed to help keep a pilot on his course during the worst conditions of black night, fog, rain or snowstorm. De-

*Killed at Chicago Air Show Sept 1 1930.*





Cleveland, I was able to try out the new visual radio system and direct my course all the way to the Capital City thereby.

A rugged little box mounted on the instrument board and electrically connected with the receiving set, replaced the aural system.

The picture conveyed to the flyer by this indicator consists of two white vertical ribbons, varying from an eighth of an inch to a quarter of an inch in length. When the two lines are equal in length, the plane is on its course. A deviation to the left increases the vibration of the left reed or white line and reduces the other

reed. A deviation to the right increases the vibration of the right white line, meantime reducing the other line. In a word, the longest reed, or the deepest white line, shows the side of the course on which the airplane is traveling.

This reed system works admirably, far better, I believe, than the standard, or aural system and promises much for safety of aviation.

veloped after many months' research by experts of the department of commerce, this is known as the reed type of visual indicator.

I also carried the standard type of radio apparatus, consisting of a six-tube receiver to which I could plug in a pair of lightweight earphones. This is called the "aural type" and indicates the flyer's

position by means of two coded signals, an N (dash-dot), and an A (dot-dash), which the earphones readily pick up. When on one side of the course, the N is louder; on the other side the A is louder, while, when the pilot is on his true course, the two signals merge into an easily recognizable long dash.

My take-off from Omaha was made while I was sealed in the cockpit at 6:00 a.m. and exactly at 6:45 that night I arrived at the Anacostia air station. Lieutenant Guymon's only maneuvers were the landings at Chicago, Cleveland and Anacostia.

After we had refueled, I made my final blind take-off from Cleveland and began the last lap of my journey. And now the fun began! Since there is no radio beacon pointed toward Washington from

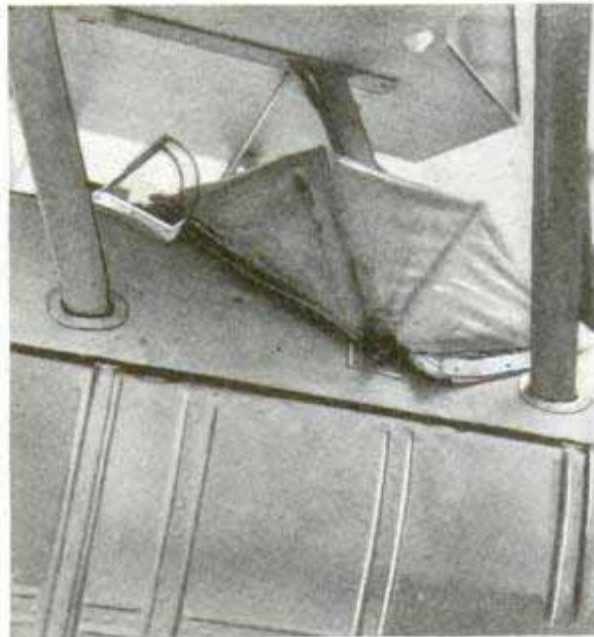

Captain Page and Lieut. V. M. Guymon; Hooded-In Cockpit, and Captain Page after Finishing His Flight



# MILLIONS OF CANDLEPOWER FOR NIGHT BASEBALL



Wrigley Field, Los Angeles, during a Night Baseball Game; the Diamond Is Lighted by 144 Floodlights Yielding 40,000,000 Candlepower, Making the Field Almost as Light as Day

Night baseball is increasing in popularity since the innovation was introduced, and Wrigley field, Los Angeles, now has a night baseball plant that outshines Broadway in illuminating brilliance. The field is equipped with the most complete lighting installation of its kind in the country, the spectators being afforded a view almost as good as in daylight. The field is lighted by 144 floodlights, yielding more than 40,000,000 candlepower.

## FINGER NAILS SHOW STAGES OF SERIOUS DISEASE 1270

The condition of the finger nails of tubercular patients is an index to the progress of the disease, according to a well-known physician. Pitted nails were found in every one of fifty cases of the disease, while the same number of ex-patients and normal persons had smooth nails, and only three cases of pitted nails were found among those having inactive tuberculosis. Downward curving of the nails and extreme blueness are also symptoms of the malady, the doctor asserts.

*Dr. A. L. Habin  
Boulevard Sanitarium*

This correspondence between the appearance of the nails and the condition of the lungs is said to have been recognized first by the ancient Greek physician Hippocrates, the "Father of Medicine."

## POTATO PEELER LIKE A GRATER REMOVES SKINS EASILY 1265

Operating on the principle of a grater, a potato peeler which quickly and easily removes the skins is now available as an aid to the busy housewife. It consists of a bowl with grated sides in which the potatoes are placed and a mechanical arrangement operated by a crank, the turning of which causes the grated sides to rub off the skins.



*cannot locate*



Mr. John S. Coggeswell,

1166  
532

POPULAR MECHANICS

16 Edgemoor Road, Belmont, Mass

BRINGING THE TROPICS TO CONNECTICUT VALLEY

Tobacco farms located along Connecticut River Valley from above Westfield, Mass to New Haven, Conn.

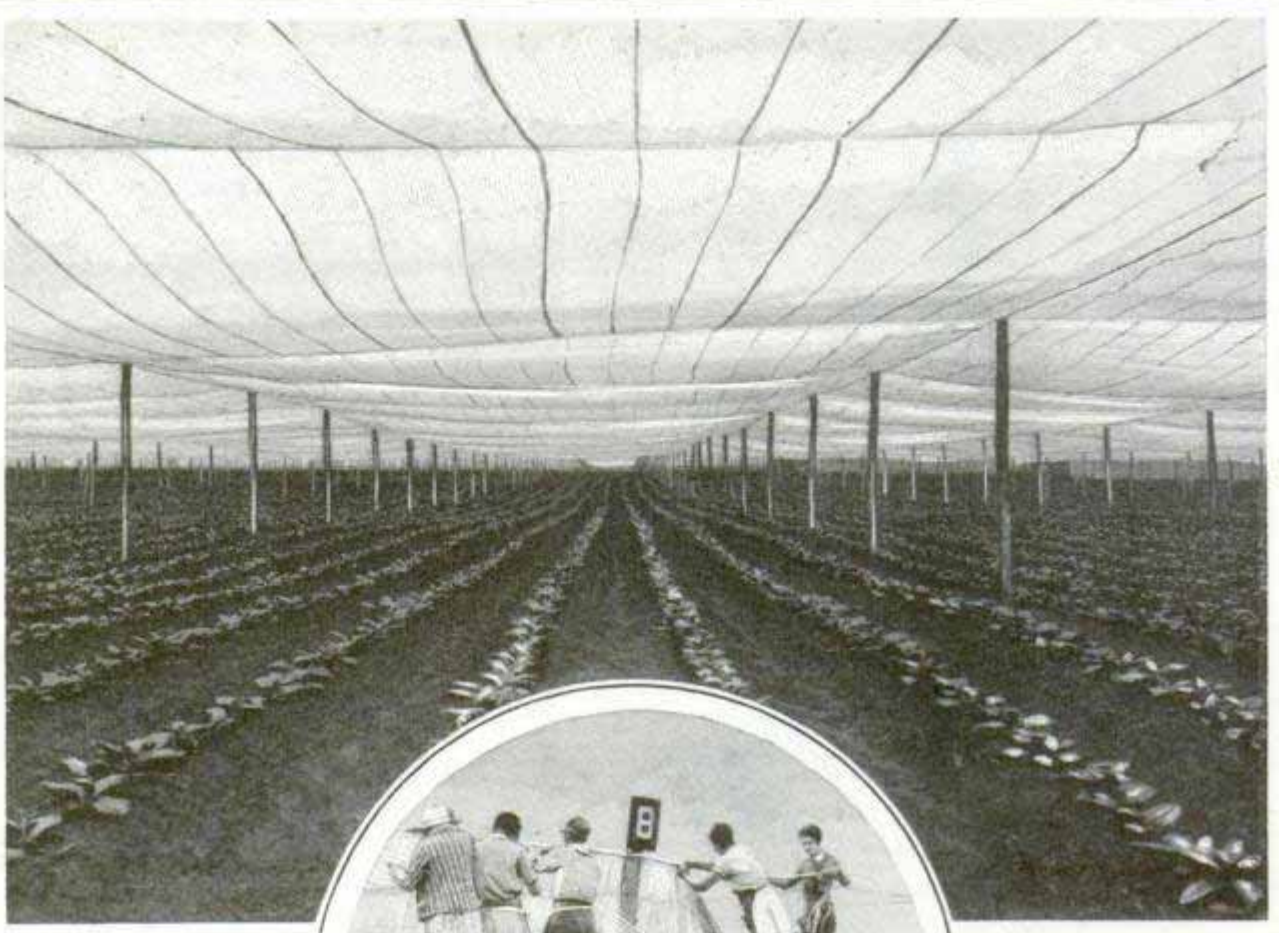

Tent, over a Connecticut Tobacco Field to Increase Humidity; Below, Placing One of the Tents in Position

A few years ago, a New England tobacco raiser stepped into a tent to seek relief from the burning rays of a hot summer sun. In the tent, he found an idea of how to bring the climate of the tropics—and many million dollars—to the Connecticut valley. For, as he wiped his brow, he realized that under the tent canvas was the sort of heat he'd been wanting for years, to enable him to raise the quality of tobacco that would bring the highest prices on the market—the dripping, moisture-laden heat of an equatorial jungle. The valley, he knew, had most of the requisites to producing a high-grade wrapping and binding leaf. The soil was just right, the summer temperature ran high enough and the season was of ample length. Just one item was lacking—high

humidity—without which the finer leaves would burn and be valueless. He was certain that if he could reproduce the atmospheric condition obtaining under the tent canvas over a large area of tobacco land, he could raise the highest-

grade leaf. That fall he ordered a supply of seeds of the finest Sumatra wrapper tobacco plants. The next spring he planted the seeds in hotbeds and, while they were sprouting, built a ten-acre tent. Instead of canvas, he used a loose-meshed fabric like cheesecloth, but heavier, the idea being to have a covering that would hold the humidity within and at the same time allow the moisture from rains to drip through. As soon as the first warm days arrived, the farmer set his young tobacco plants out under the big tent. It had cost

American Sumatra Tobacco Co  
Westfield,



*218 N. 7th St  
St Louis, Mo*

*1234*

him a lot of money, but the idea worked out and he was well repaid. That winter he sold the tobacco raised under cloth for \$3 per pound, while the remainder of the Connecticut valley outdoor crop brought 35 cents a pound. Since that day—and using the same method as that pioneer—the New England valley has become an important factor in the high-grade market. The tents are ten feet high and the fields covered vary from five to twenty-five acres. This season about 4,000 acres have been under cloth, a considerable increase over the area covered last year.

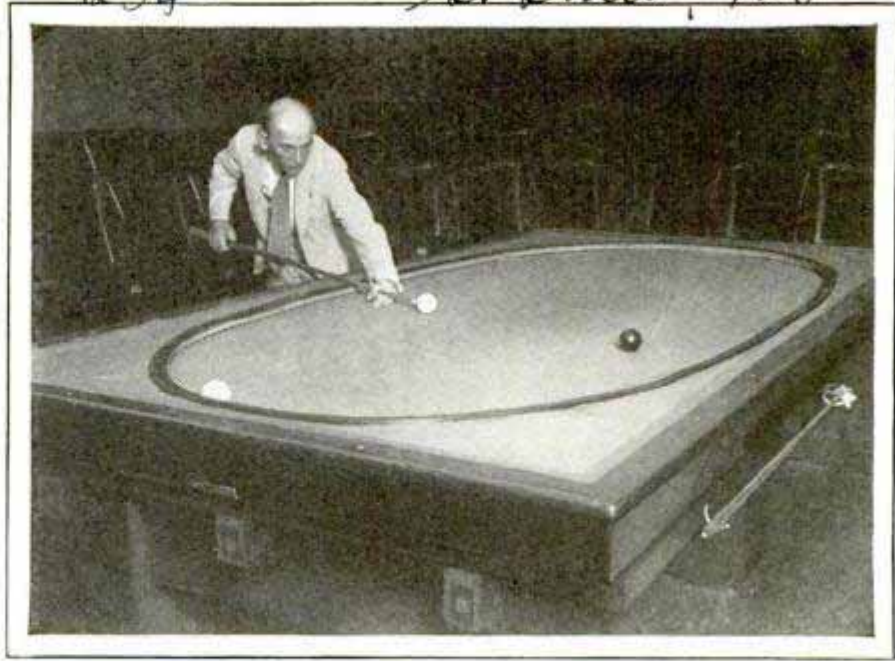

Oval Billiard Table Whose Rounded Ends Add to the Number of Possible Angles and Hence to the Number of Shots That Are Possible

**OVAL BILLIARD TABLE OFFERS DIFFICULT SHOTS**

Offering many more angles to be conquered than the rectangular table, an oval billiard table has been introduced by Charles Peterson, fancy-shot expert. The play on the oval table is the same as on a rectangular one, but it is more difficult because of the shape.

**WATERPLANE AND SPEEDBOAT OFFER AQUATIC THRILLS**

To give added thrills to aquatic sports, a waterplane has been made for towing behind a speedboat. The waterplane resembles a small amphibian and rests on pontoons. When pulled at high speed, the craft rises several feet above the water, but is designed to prevent the passenger being catapulted out in case of trouble.

**PHONE VOCABULARIES USED BY THE WORLD**

*1251*

Telephone vocabularies vary throughout the world. In London it is, "Are you there?" while Paris says, "J'ecoute." China says, "Day huey bin she ah?" Berlin says, "Bitte, nummer," and America, "Number, please." In London the hello-girl is a telephonist, in Paris she is just made-moiselle. China calls her "hom sin luey" and Berlin and New York refer to her as an operator. The proper term for operator in China is "Din wax sin gay sum," which means "someone who takes care of connecting."



Waterplane with Stubby Wings Which Is Towed behind a Speedboat; When Sufficient Momentum Is Gained, the Craft Rises from the Water

*Adm. Bert Longworth Publicity  
Lept. 1st National Studios*

*Cont Dwight Lloyd  
Capitol Hill Station*







Amv. Dr. H. Edwards, 9520 Wainwright  
Phila

1041



# WINGS for ALL of US

© The Chicago Daily News

*Bellanca Aircraft Co., Newcastle, Del.*

"The Blue Streak," Mighty Bellanca Tandem Plane with Pusher and Puller Propellers; Its Engines Develop 1,398 Horsepower, It Carries 2,150 Gallons of Gasoline and Has a Top Speed of 160 Miles an Hour

By CORLEY McDARMENT

**T**HE time has come—almost—when you may say:

"I'd buy that baby with the robin's-egg-blue wings if I only knew how to fly," and the salesman will say:

"If you have an hour to spare we'll teach you to fly it and you can fly it home, just like driving a new automobile home."

This is not a fanciful idea. It is something which has been slowly developing since the Wright brothers made their first flight. All of the old heads in the aviation game have known, and all big business men have known, that, unless airplanes became safe enough for the average person to fly them, their commercial use will be greatly limited.

It has been said that the war set aviation ahead forty years in performance but back twenty years in safety. Figures compiled by the government disclosed that human errors of judgment in the fine art of flying caused most of the fatalities. And then, in simmering down the human-error business, it was found that the errors were mostly around tail spins resulting from stalls in the air. It takes a "crack" pilot to fly one of the conventional type of air-

planes which the lessons of the war have brought out. Any person who could not tell exactly when his speed dropped from sixty miles an hour to forty when he was inclosed within a cockpit, was just a "gone gosling." But this thing has changed.

Inventors have long known that a safe airplane must be produced if the average person is going to buy it. It has been the hope of airplane makers to produce a vast market like the automobile industry. So, after finding the cause of so many accidents, an intensive study started which not only included charts and wind-tunnel experiments but extended to the birds in the air. And from the birds the greatest lessons in flying have been learned.

At first the shape of the wings of birds was studied, but with careful copying of these wings, the same results that birds get could not be produced. Slow-motion pictures were studied, and long hours of observation in other ways were spent in trying to solve the secret of safety which birds possess. It was found that certain feathers in the wings play as important a part as the entire wing. The reason birds were studied so carefully was that



*McDonnell monoplane. J. S. McDonnell Jr & Associates, Tribune Tower, Chicago 1041*

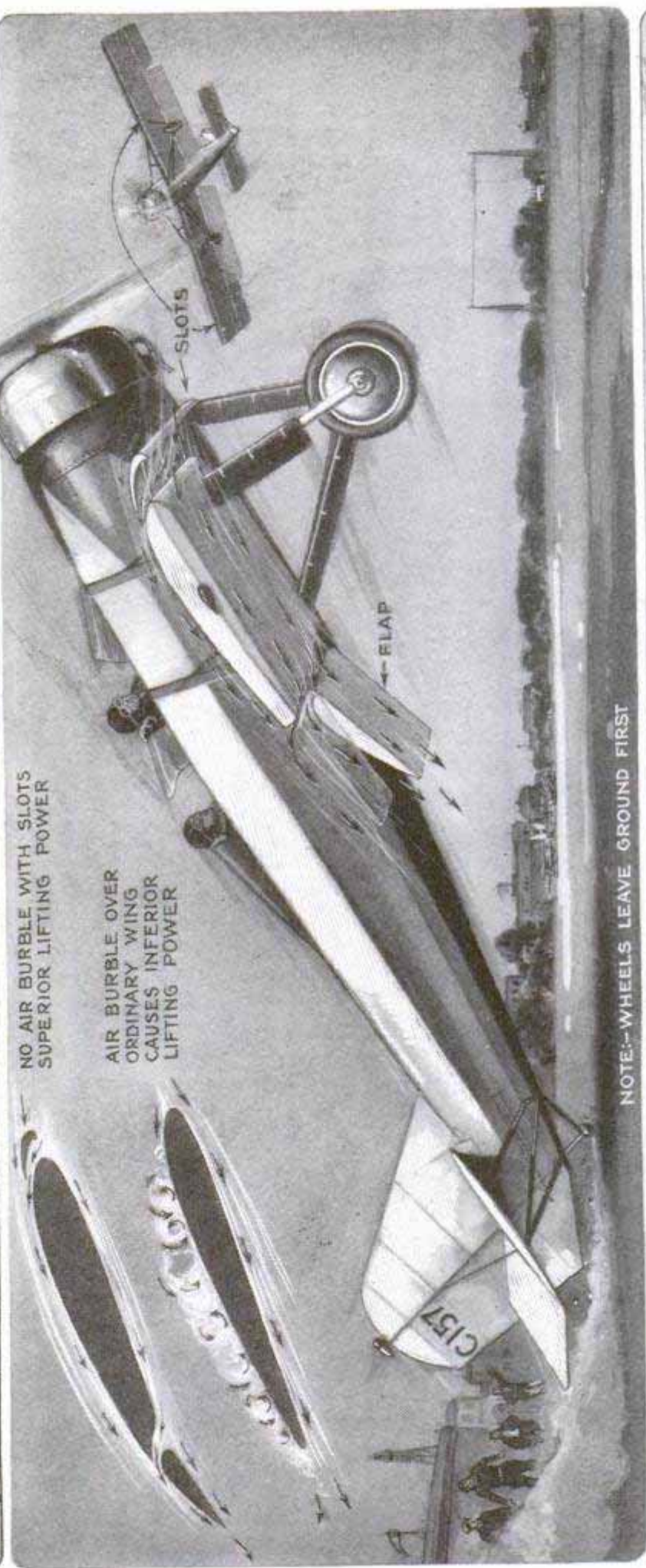

NOTE:--WHEELS LEAVE GROUND FIRST

"The Doodle Bug," an Experimental Plane, Promises Wide Usefulness Because of Its Remarkable Flight Performances; It Combines Slots and Flaps and Has Been Flown Out of and Landed in a 150-Foot Circle; It Was Designed by J. S. McDonnell, Jr., and C. L. Zakh, Assisted by J. G. Cowling, Jr.



they do not often get into tail spins and can land very slowly.

Finally, somebody came out with wing slots on the leading edge of airplane wings, then somebody else brought out flaps for the rear or trailing edge, and later came forth the floating aileron. The combination of these three things so nearly approximates the feather action in birds' wings that almost birdlike accomplishments became possible. Today the aviation world is standing aghast at the safety performances of airplanes built with these devices. Almost overnight they have revolutionized the industry, and planes are being brought out which almost anybody can fly. The dreaded tail spin has been removed from the realm of probability, and an unskilled pilot may level off for a landing 200 feet in the air and, with the automatic slots and float-

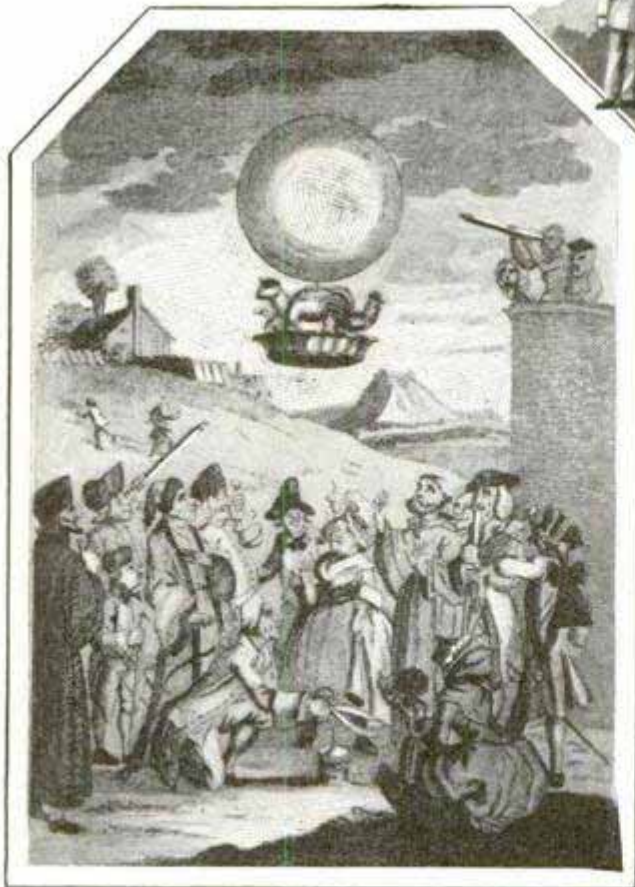
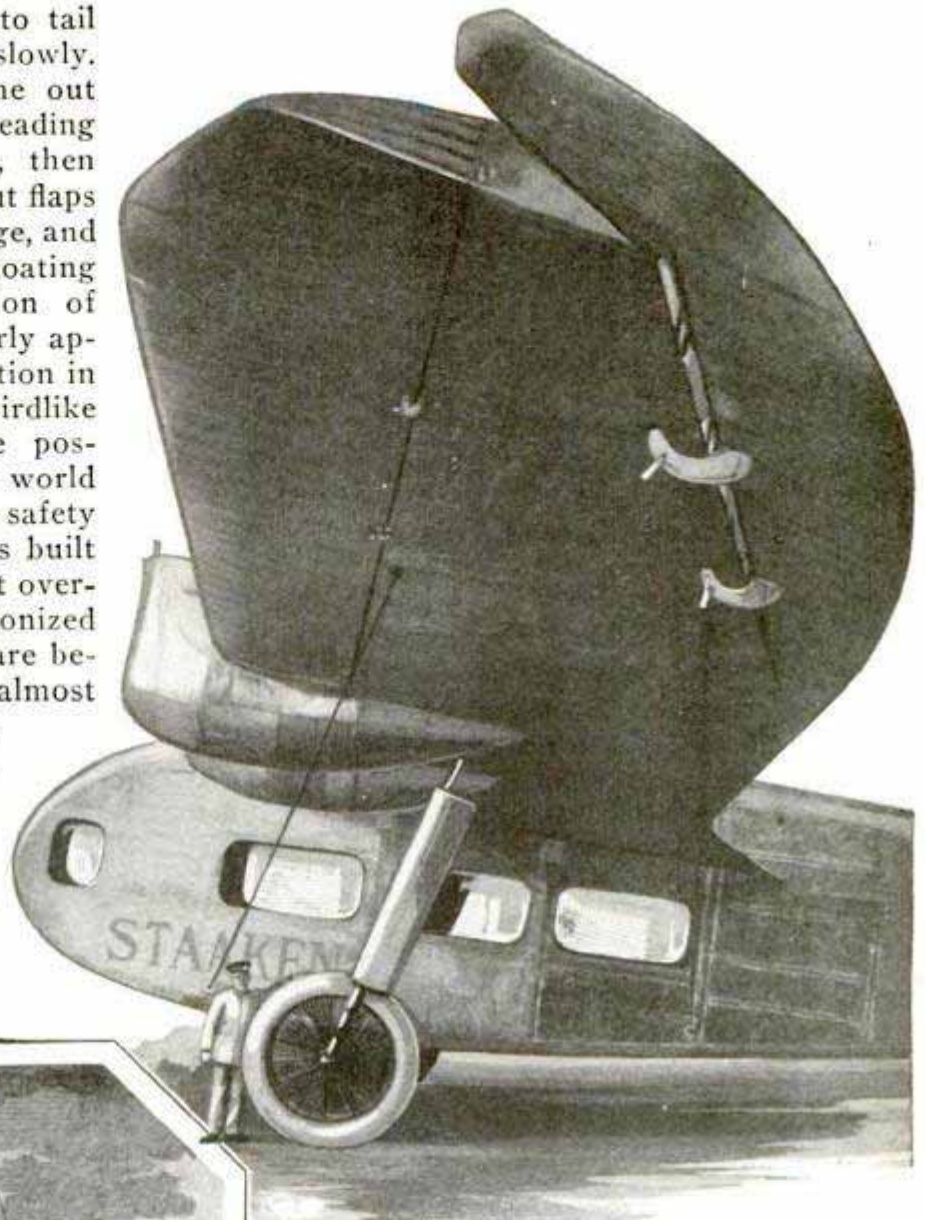

Peculiar Aileron Control of German Thick-Wing Plane, and Sketch of Early Test with Balloon.

ing ailerons, come in safely. A plane with a top speed of 112 miles an hour, landing speed of thirty miles, and aileron control at all speeds over ten miles, is a monument in aviation history.

Such an airplane makes its appearance, and it is only the beginning of safety and performance in flying. Wing slots, flaps and floating ailerons are the only safety devices made for airplanes since the first ailerons of the ordinary type were put on planes. Veteran pilots who have forgot their training days often wonder why more people cannot learn to fly. The trick seems so simple after once learned. The fact is that straight flying is simple and is easy to learn. The catch comes in the few little mistakes which may be so fatal. These mistakes occur when flying speed is lost in glides, climbs or turns. That



it takes a master to know exactly the right climbing and gliding angles is shown by the number of experienced flyers who have been killed each year by slight errors of judgment in this simple maneuver.

Most old pilots prefer to fly in an open cockpit where they can feel the rush of air upon their faces and thereby estimate the speed. When the rush of air gets less than the pilot knows from experience it should be, he quickly senses danger and pushes the nose of the plane downward to pick up extra speed. It takes a good man to tell when the air speed has dropped from sixty miles an hour, where an airplane may be controlled, to fifty miles an hour where the controls may be useless.

The new airplanes coming out make all fine distinctions of speed unnecessary. Airplanes will probably never become foolproof any more than locomotives or steamships are, and there will always be an element of danger. They will never be quite as safe as automobiles. Whenever a person is up in the air in a craft which has a motor and gasoline and wings, he will be subject to certain apparent

dangers. The new safety planes cannot be exactly parachuted down. They land at about thirty miles an hour. In an airplane one can hit most anything at this slow speed and survive.

The parachute is the safest of all aerial vehicles. A parachute with a motor would be ideal for safety, but would have little performance. The new airplanes, however, are using the parachute principle. The parachute owes its efficiency to the big inside curvature of silk. The greater the curvature up to a certain limit, the greater the efficiency. Slots and flaps increase this curve.

The trouble with too much curvature in a wing is that it cuts down the speed. If it were not for this, all planes would have highly curved wings. The wing flaps on the trailing edge of wings, however, fit into the streamlining in normal flight and do not retard motion through the air. The flaps may be depressed by a handle or lever when needed for a landing.

The floating aileron is a new idea of the manufacturer who builds a plane using them. These ailerons look awkward, but they appear to be highly efficient. They

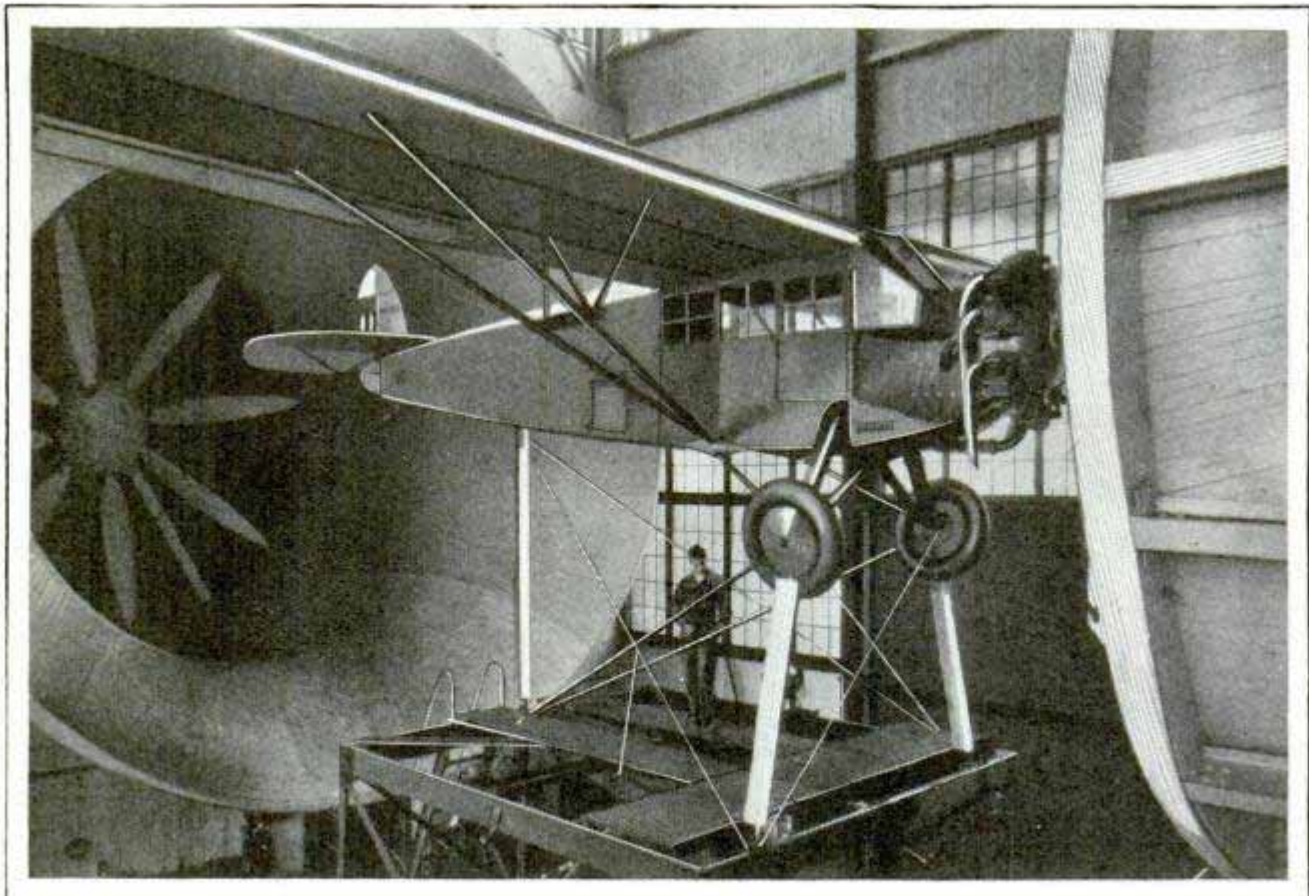

Accurate Tests of a Plane's Performance Are Obtained before Flights in the Wind Tunnel, Where Flying Conditions Are Simulated; Experiments Here Have Done Much to Develop Streamlining







Cont. H. J. Kauffman, 1975 Am M

Lerner, Cole

1139

# MANY NEW USES FOUND IN INDUSTRY FOR X-RAYS

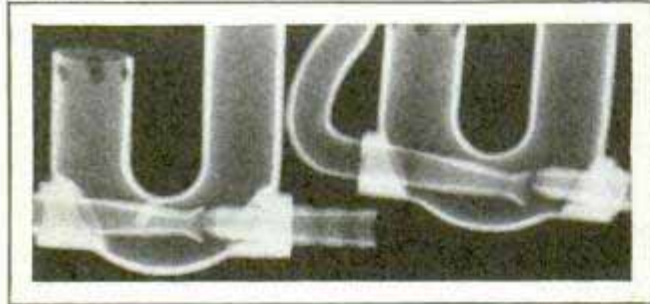
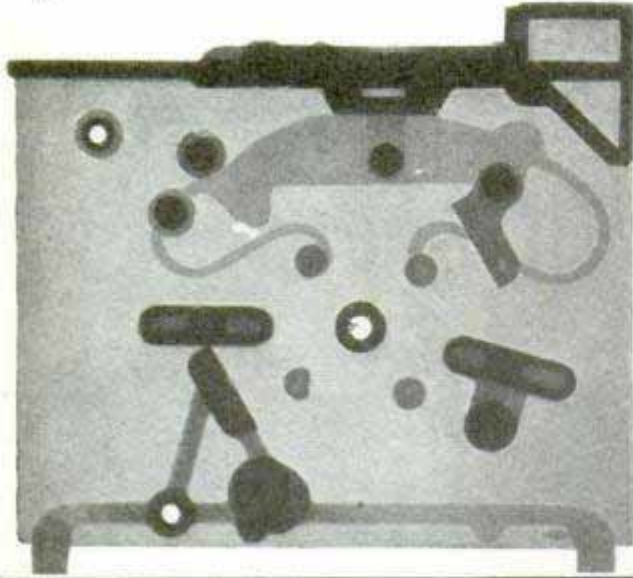

X-Ray of a Die Casting, and Incorrect Assembly of Hard-Rubber Siphons Shown by X-Ray; Right, X-Raying a Camera

ing an important part in adding to our safety. In the rubber industry, golf balls are being X-rayed to determine the symmetry and correct positioning of the hard-rubber core. One of the rubber companies has made examinations of its tires to determine the union between the rubber and the cord. This is done by filling the cord with some lead salts which make them



In the construction of a large Massachusetts power plant, it was decided to have X-ray examinations made of all the pipe and fittings for the high-pressure steam line. As a result, some of the parts, which would have been accepted under any other test, were found to be defective and were rejected. Thus the power company obtained definite assurance that the equipment was safe and could be operated continuously, without the possibility of an early shut-down for repairs. Industry is finding that there is as much need for X-ray examination of the interior of metal castings, essential parts of automobiles, airplanes, welds, munitions, etc., as of the human body, for they are equally susceptible to internal ills that might lead to serious results. Welding of materials is now practiced extensively in all fields of industry, and is an art where the skill of the workman has much to do with the effectiveness of the weld. The X-ray is now being employed to locate defective welds, and thus is play-

opaque to X-rays. A large eastern manufacturing company is using the rays to examine its metal radio-transmission tubes. Each tube is X-rayed twice, the positions differing by ninety degrees to assure that there is correct spacing between the grid and the filament. The presence of metallic particles in electric insulators often causes trouble on high-voltage lines and the X-ray is proving a big aid in its detection. Cables, heavily insulated wire, and all hidden and concealed wiring often require examination, and the X-rays offer the easiest way to do it; they also are used to determine the diameter of capillary metal tubing. Much information is being gained about any abnormalities in the structure and grain of high-grade wood by means of X-ray ex-



aminations. The detection of knots, resin pockets, grubholes, etc., is very important if the wood is to be used in fine furniture. The late discovery of these spots, after much labor had been done, would mean a distinct loss, for the piece would have to be discarded. Such examination is also very important if the wood is to be subjected to strain. Fire brick is being examined with the X-ray to detect hidden cracks and flaws and metallic particles.

VACUUM HELPS CLEAN MOTORS AND SWITCHBOARDS 1246

Blower and vacuum cleaner have been combined in a single unit that not only provides powerful suction for cleaning autos, bins or other restricted interiors, but also furnishes a blast of air for blowing dust and dirt from places ordinarily inaccessible, including parts of automobiles and electrical equipment. The apparatus is changed from vacuum cleaner to blower by removing the dust bag and changing the location of the hose. By hanging motor, fan and dust bag from the shoulder or a convenient hook, the operator gains access to spaces that otherwise could not be reached without handling of materials. The body of the cleaner is of aluminum, thus making it light in weight.

The United States Electrical Tool Co. Chicago  
2482 W. 6th St.



Portable Vacuum Cleaner Slung from the Shoulder; It Also Can Be Employed as a Blower

United State Electrical  
Tool Co. 2482 W. 6th

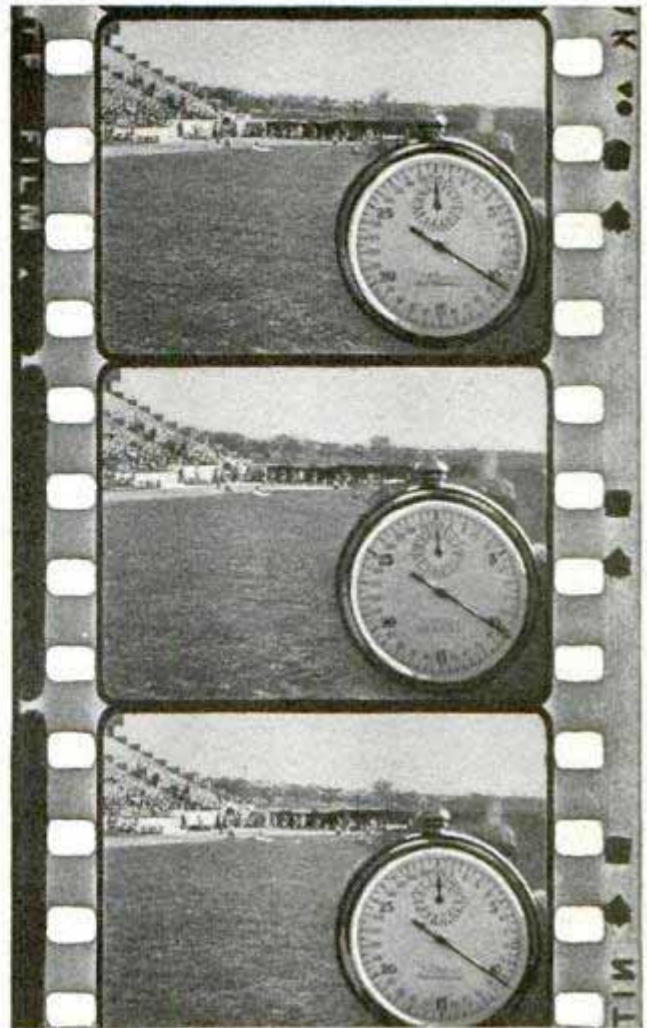

Movie Film of Sporting Event, and Split-Second Watch Used with Camera to Time the Race

RACE TIMED BY MOVIE CAMERA FOCUSED ON WATCH

Eliminating the human element from the accurate timing of races, a movie camera and split-second watch were used together recently in timing relay races at Ohio State University. The movie camera was mounted on a board and focused, by means of a special lens, on both the runners and the watch, the special lens being situated between camera and watch. The camera is trained toward the start of the race and the smoke puff from the starter's gun is shown on the film, the time of starting being recorded simultaneously by the watch. The camera then follows the runners down the course, taking a picture of the finish with the watch recording the time. The difference in time shown between that indicated on the picture with the puff of smoke and that on the picture of the finish is the correct time for the race, and a complete picture of the event also has been taken.

Emb. Tool Refacer, 1101  
Av. Columbus Ohio

Developed by W. L. Smith and L. A.



Refer my George H. Holden. Windy neck



Copyright, G. H. Holden

Ice Frozen in Thin Sheets and Segregated in Small Blocks So It Can Be Broken with Fingers

**ICE FROZEN IN SMALL BLOCKS IS BROKEN WITH FINGERS**

Ice, segregated in small sheets like a cake of chocolate, can be broken as easily with the fingers as the confection, thus eliminating the need for a mallet and containing bag. For such freezing, a special tray is used, the bottom containing grids and the ice being frozen in quarter-inch sheets. This makes it very easy to handle, as there is no splintering.

**SPONGE DIVERS FIND MILLION DOLLARS ANNUALLY IN SEA**

Greek divers with headquarters at Tarpon Springs on the west coast of Florida annually bring from the bottom of the Gulf of Mexico sponges worth about \$1,000,000. The work is hazardous, since a shark may foul the air lines or a barracuda attack a diver. In addition, those who remain long at the task are subject to the "bends," a paralytic condition occasioned by air and water pressure. The boats often stay out for two or three months before coming in with their foul-smelling cargo. The diver plies his trade with a three-pronged hook attached to a stick. He hooks the sponges and places them in a net which is raised and another

Emb Maurice Elfer no address

Highfield Wash. Dept. of Geology

Chicago - Midland Div. 20 N. Wacker Drive

lowered when he has filled it. The commercial sponge is the skeleton of an animal which has adhered to the bottom of the sea or to submerged surfaces. When brought from the sea, it is hard and covered with a tenacious black skin, while gelatinous gray matter fills the pores. This gray matter is allowed to decay and is pressed out, after which the sponges are soaked in permanganate of potash to give them the tan color. A sponge's age is reckoned by its breadth, one one-eighth of an inch in diameter being about eighteen months old. Four varieties are found in the Gulf of Mexico, the best quality being the sheep's-wool sponge which is more durable. Twice weekly auctions are held, one day's sale often amounting to \$50,000.

**ELECTRIC PHOTO FLASH LAMP ENDS SMOKE AND NOISE**

A fireless, smokeless, odorless and noiseless photographic flash lamp has been developed by the General Electric company.



Requiring only a one-hundredth of a second to act, and being without hazard, it will make possible the taking of flashlight photographs in places heretofore practically impossible to "shoot," as in trains, airships and theaters, under water, and by insurance companies requiring night photographs under all weather conditions. The lamp consists of a clear bulb of standard design, with the flashlight filament coated with a special preparation and with a quantity of very thin aluminum foil in crumpled sheet form within the bulb. The bulb is oxygen-filled. When the circuit is closed, the filament is lighted and this, in turn, lights the foil. The lamp operates on any 115-volt house supply, or with dry, storage or flashlight batteries. A new lamp is needed for each flash, and a suitable reflector equipment should be used with it.

National Lamp Works General Electric Co



# SCENES ON BOARD AN AMERICAN CUP DEFENDER

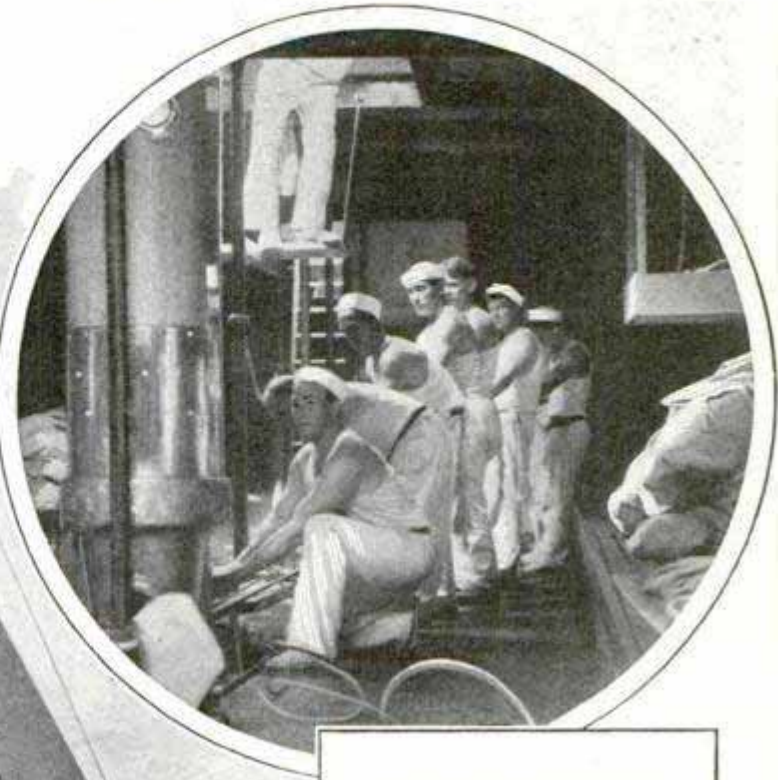
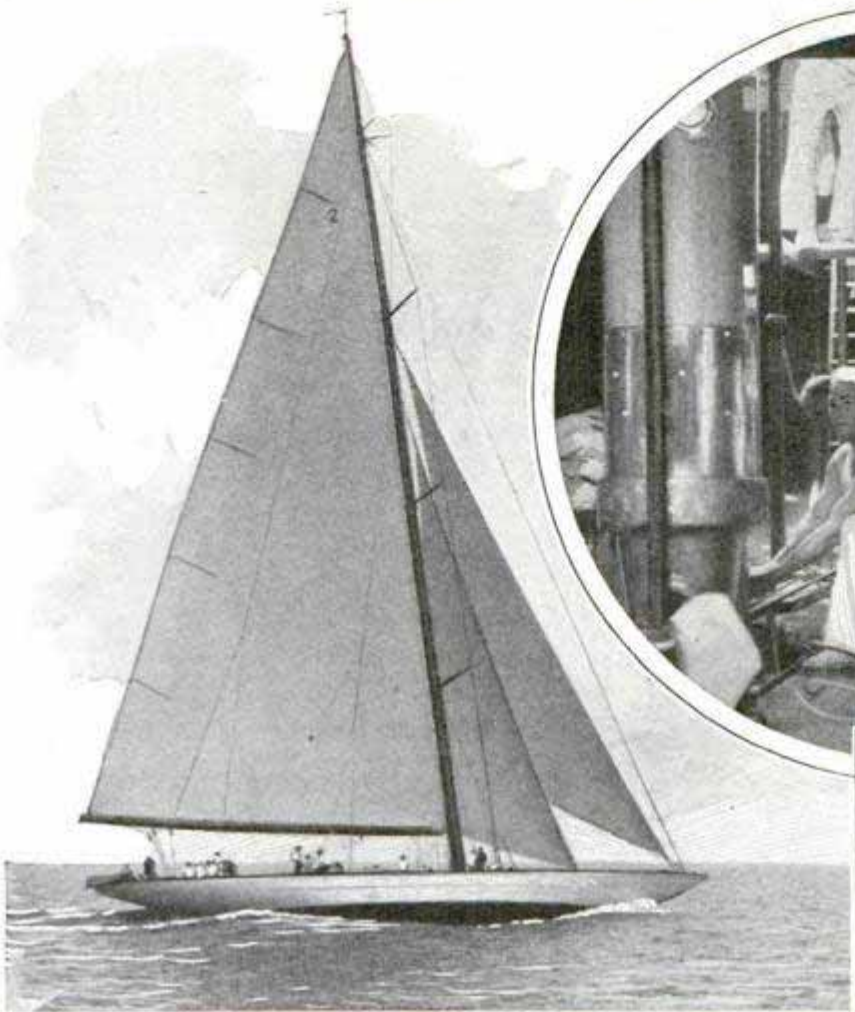

The "Yankee" on a Test Run off Oyster Bay, Long Island; Above, Crew Hoisting the Mainsail by Means of Halliards Run through the Hollow Mast and below Deck; Below, a Deck Scene during the Run; the "Yankee" Is the Boston Syndicate Entry in the America Cup Race, and Made Creditable Showing on Its Trial Performance under Exacting Conditions

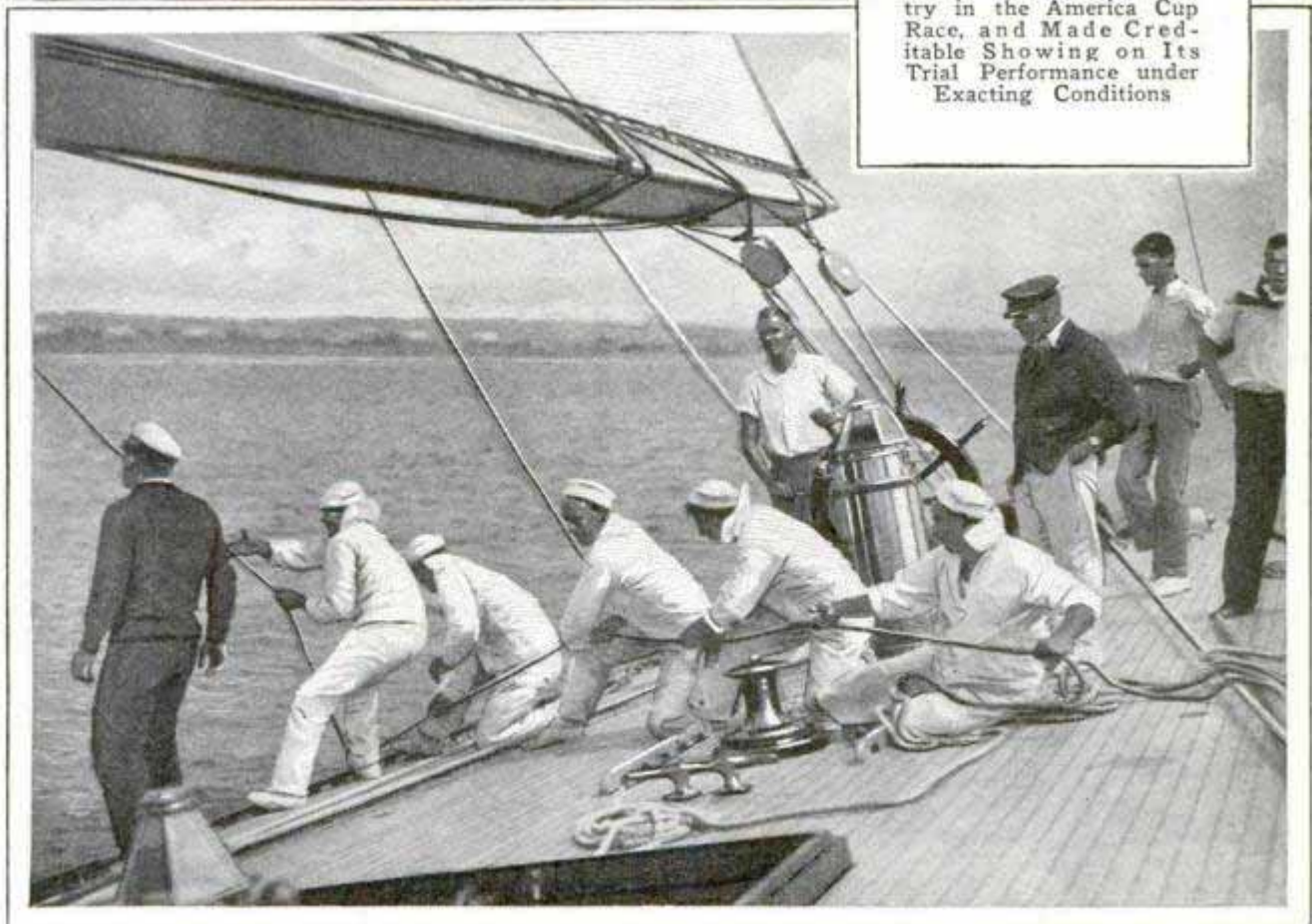

*Osca*



1254 155 Sixth Ave. New York



Microphone in Top of Bank Vault Which Sets Off a Police Alarm at Any Slight Noise

### MICROPHONE IN A BANK VAULT SOUNDS POLICE ALARM

As a burglar alarm, a microphone has been installed in a Chicago bank vault and connected to police stations. The microphone is smaller than those used in broadcasting, but so sensitive that the slightest noise causes it to function. It is expected to prove useful in case someone is accidentally locked in the vault, as well as in the event of attempted robbery.

### CASEMENT-WINDOW ADJUSTER WORKS THROUGH SCREEN

Operating through a screen without catching or binding, a casement-window



Casement-Window Adjuster Which Operates through the Screen

attachment adjusts the window at any desired angle and holds it firmly in that position. A small curved metal rod extends through a notch at the bottom of the screen. To the window sill is attached a clamp in which the rod is held by a thumbscrew. The curved rod is jointed, and when the window is closed, a hinge allows it to fold down against the wall out of the way.

Solar Violet Ray Corp Ltd. 1241 Los Angeles, Calif. *Antarctica*

### CLAM-SHELL SOLARIUM ADMITS ULTRAVIOLET RAYS.

Clam shells are being used to construct roofs, solariums, greenhouses, canopies and porches since it has been discovered that the underside of the clam's shell, which is translucent, freely admits the ultraviolet and infra-red rays of sunlight. From the shells, canopies for the baby's sun bath are being made, to allow exposure to the ultraviolet rays without at

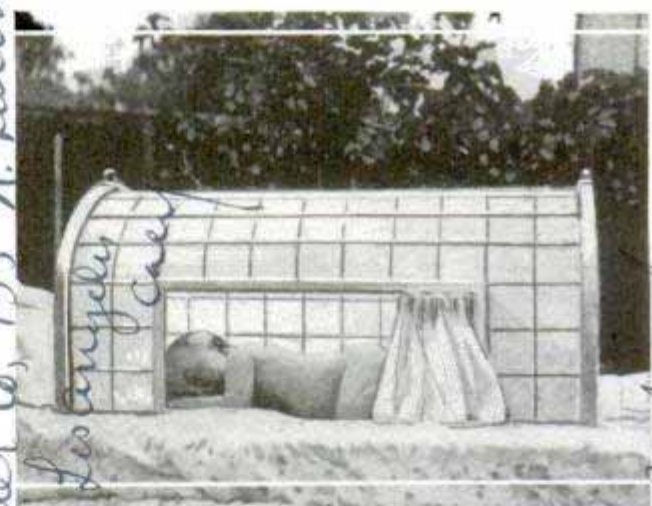

Solarium for the Baby, Made from Clamshells Which Admit the Sun's Ultraviolet Rays

the same time exposing the infant to wind and other discomforts. The material is non-shatterable, and it is claimed that it is stronger than window glass, although no more expensive. It is light in weight and resists the deteriorating effects of sun, rain and weather over a long period. Being opaque, it is of value in making covers for hospital beds, thus allowing patients to enjoy sun baths in private, and this quality also makes it adaptable for greenhouses, since it cuts out the glare.

CA world's record of 49.7 miles per hour for outboard motorboats was made recently at Fox Lake, Ill., by Ray Pregenzer.

Antioch, Ill.

(Survived Hurricane)

1244

Electrol W. Fuller Co, 135 N. Los Angeles

Los Angeles *Antarctica* Milwaukee *Antarctica* Outboard Motors Corp

John Belanger, 2954 Crestmore Place



## SIXTY NAVY PLANES "BATTLE" WITH MOTHER SHIP



© Henry Miller

Two Views of Navy Planes on the Deck of the Airplane Carrier "Lexington" during Maneuvers

More than sixty navy planes participated in large-scale aerial maneuvers off the Virginia coast, staging a mimic battle with the "Lexington," the airplane carrier that serves as mother ship for the war birds. Sixty-nine planes were sent off the deck of the "Lexington" at intervals of ten seconds, and, when all were in the air, they staged an attack on the boat, the "battle" lasting for three hours before hostilities were called off and the fighting planes settled back on the deck.

### SALMON SWIMS 1,300 MILES <sup>123</sup> 7

Evidence that an Alaskan salmon swam 1,300 miles in forty-four days indicates the distance that certain species of fish travel, according to the bureau of fisheries. This individual fish, which had been tagged with a metal marker by the bureau in Alaska, was caught in a Siberian stream 1,300 miles away.

*U.S. Navy 8/1/30*

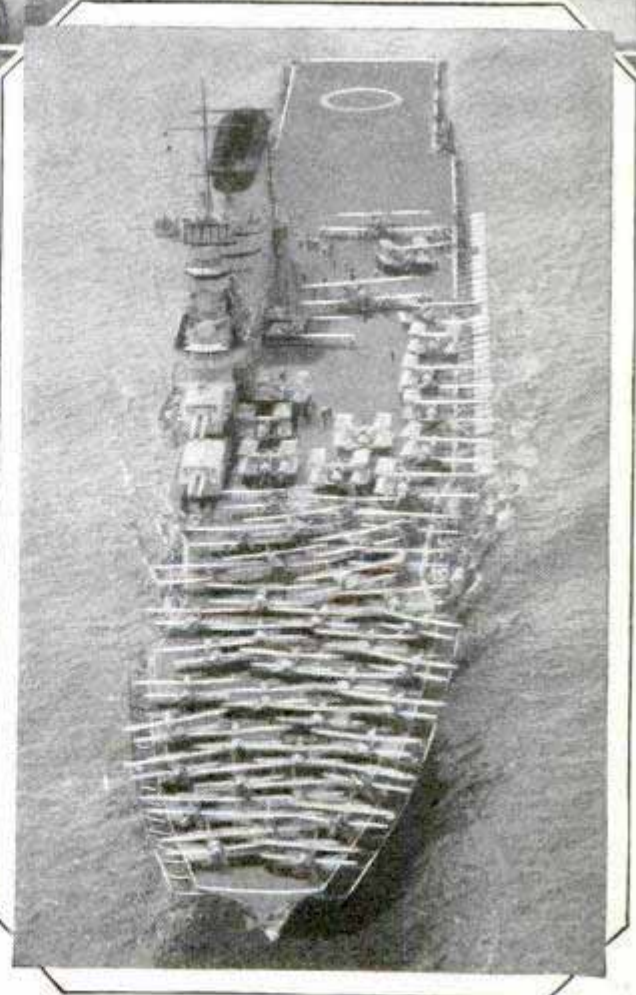



948

Cap. Colombari 29 Bean Lloyd  
Bisley head in London

# The Secrets of Davy

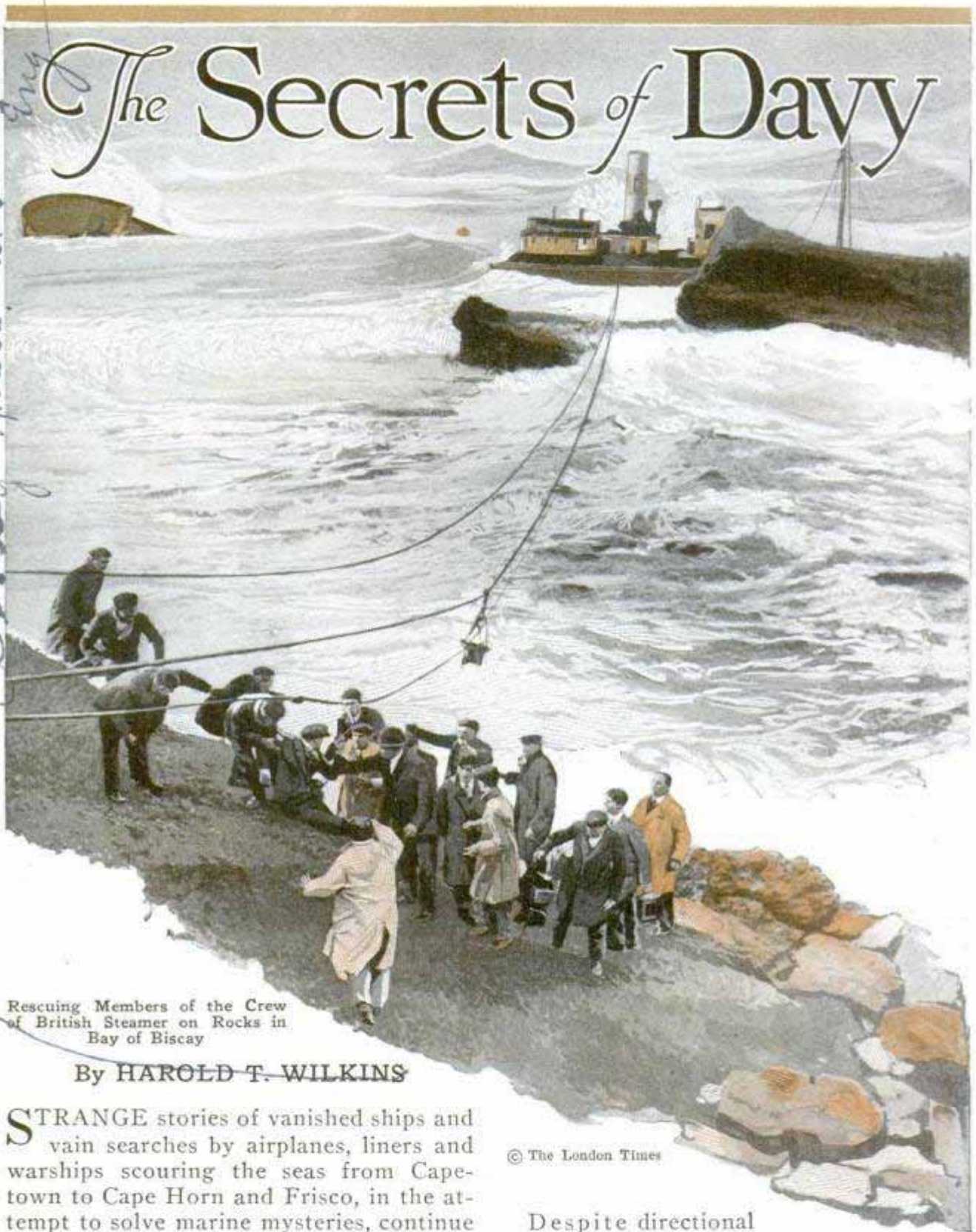

Rescuing Members of the Crew of British Steamer on Rocks in Bay of Biscay

By HAROLD T. WILKINS

STRANGE stories of vanished ships and vain searches by airplanes, liners and warships scouring the seas from Capetown to Cape Horn and Frisco, in the attempt to solve marine mysteries, continue to puzzle the sleuths of Lloyd's, the famous shipping corporation of the Royal Exchange, London.

Not a month goes by without the name of some missing boat being added to the files in Lloyd's ships' "graveyard." At the present moment, there are half a dozen first-class mysteries of missing ships of European ownership alone which have vanished on the high seas in 1929 to 1930.

© The London Times

Despite directional wireless, radio light-houses and compasses, and beam-radio navigation, the sea retains all its elements of mystery and danger. The red-robed caller still mounts the rostrum at Lloyd's and rings the bell of the lost "Lutine," tolling the unknown fate of some good ship of which no news has reached any of the world's ports for many months since she left her home port. Yet, of all



# Jones' Cupboard

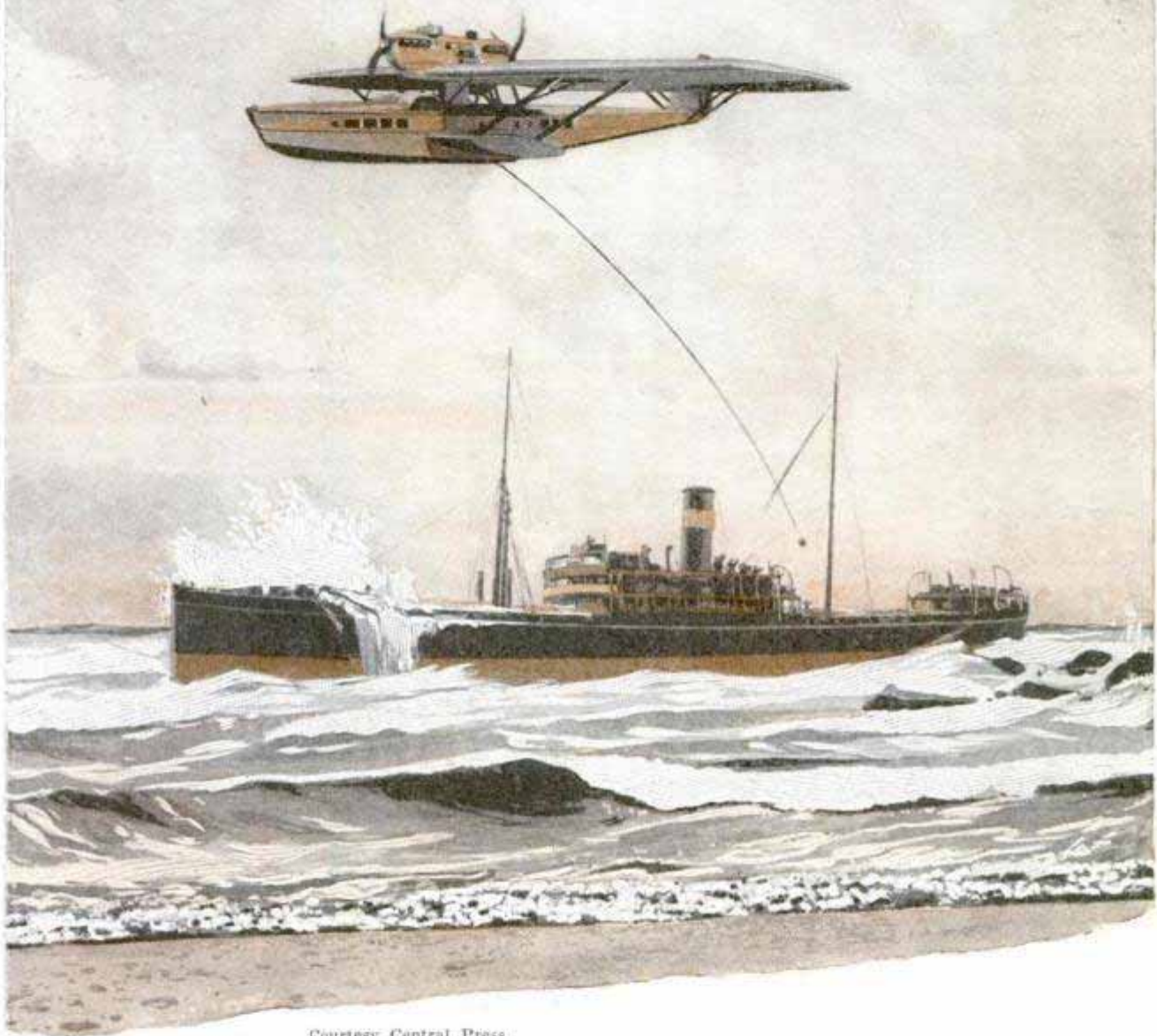

Courtesy Central Press

**Rescue Plane Flying over Stranded Steamer with Life Line Being Lowered to the Crew; Aircraft, Summoned by Radio, Frequently Have Given Aid to Vessels in Distress**

the skeletons in Davy Jones' locker, nothing is stranger than the mystery of the fate of the crew of the "Mary Celeste." Fifty-eight years ago, this stanch ship was found derelict in the North Atlantic, and today, in ports of the eastern seaboard of the United States, there are yet living descendants of the captain who are hoping that the mystery will be cleared up. They complain of sea writers weaving legends about the captain and crew of a ship which has become as weird in reputation as the mythical Flying Dutchman. Where-

as, in fact, the truth about the "Mary Celeste" is stranger than any fiction.

What are the facts about this famous derelict? The "Mary Celeste," a brigantine of 282 tons, left New York for Genoa, Italy, on Nov. 7, 1872, freighted with alcohol. The captain, Benjamin S. Briggs, an American citizen, was part owner of the ship with James H. Winchester, a New York shipowner, and aboard on the last fateful voyage were the captain's wife and child. Besides the mate, Albert C. Richardson, the second mate, Andrew Gilling,



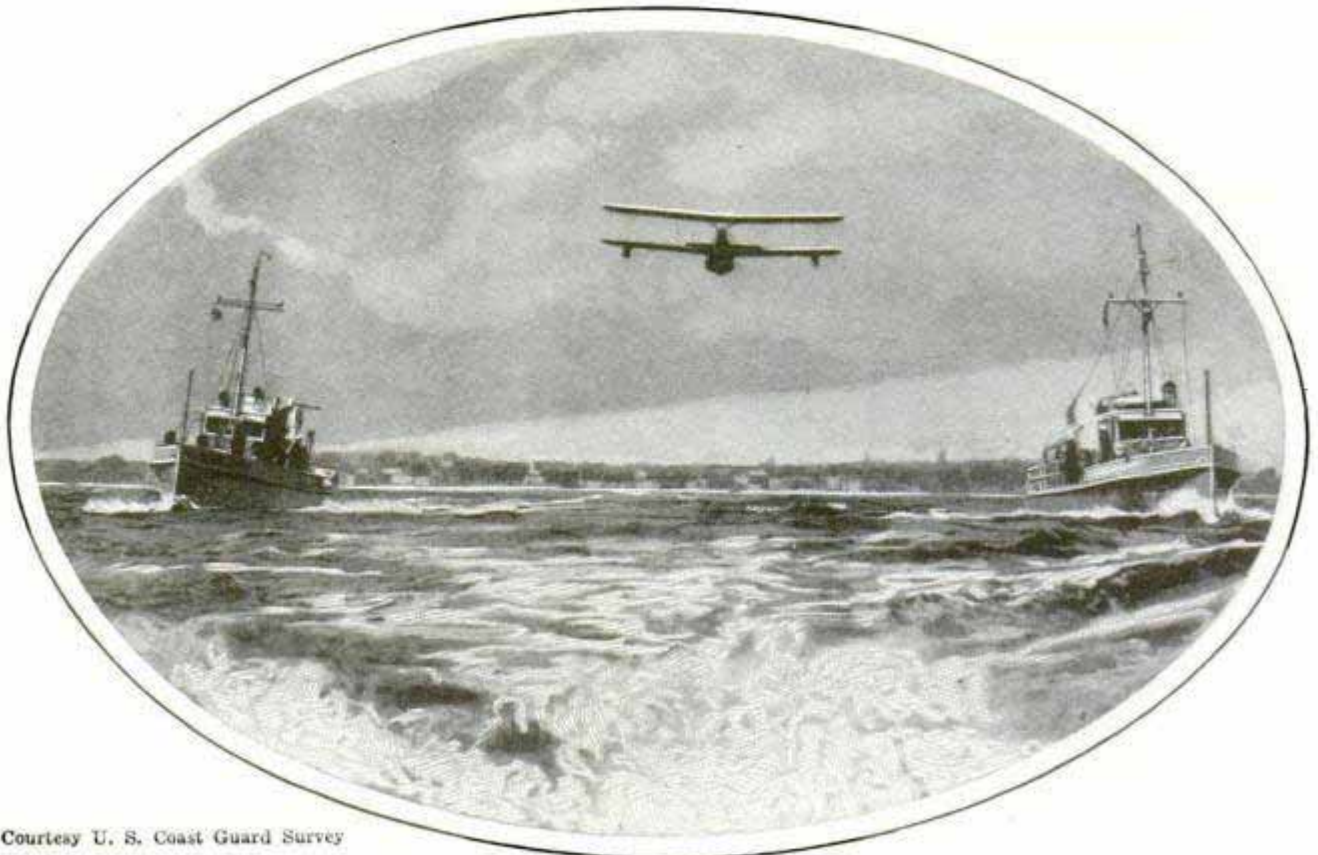

Courtesy U. S. Coast Guard Survey

Speeding by Air to the Help of Steamers in a Heavy Storm; an Airplane of the United States Coast Guard Survey Going Out to Sea

and the steward, Edward W. Head, were a crew of four seamen—Germans or Scandinavians—Walkert Lorenzen, Arian Hardene, Boy Lorenzen, and Gallhib Gondschatt.

For about seventeen days, the ship held on her course across the Atlantic till, at 8:00 a.m. on November 25, somebody wrote on the deck slate log that she sighted the island of Santa Maria, in the Azores. Twelve days after this last entry ever made on the ship's records, the British Nova Scotian brig "Dei Gratia," Captain Morehouse, bound from New York to Gibraltar for orders, sighted a strange ship, with jib and foremast staysail set, running on the starboard tack, but in so erratic a way that Morehouse decided to investigate. The ship was searched thoroughly, but not a soul was found. In the cabin a table was set for breakfast, but the meal had been only half eaten. In the foc's'le, the seamen's chests of clothes were quite dry, and the razors left behind showed no trace of rust. There wasn't a crack in the paint or planks of the deck, and if the "Mary Celeste" had met bad weather, why was it that a small phial of sewing-machine oil stood upright by a

reel of cotton and thimble? Surely, rough seas would have upset that phial.

The captain of the "Dei Gratia" ordered the mate and two of the crew to take the "Mary Celeste" into Gibraltar, which they reached on December 13. "There were no boats aboard the 'Mary Celeste,'" said U. S. Consul Horatio J. Sprague, in reporting to Washington. "The vessel is said to leak some, but her new crew had no difficulty in bringing her into this port."

The cargo of alcohol was all in good order, except for one cask that had started; the exterior of the hull below the waterline showed not the least sign of damage; the ship herself was in excellent order. However, the sleuths noted one apparently sinister feature: Marks, seemingly of blood, stained the "Mary Celeste's" top-gallant rail, and both bows had been "intentionally slashed." The ship's bill of lading and manifest were missing. They examined and compared the logs of the "Mary Celeste" and the "Dei Gratia," and noted a strange circumstance.

Between November 25 and December 5 when the "Mary Celeste" was apparently abandoned, and actually sighted by the "Dei Gratia," the derelict ship seemed to



have held on her course with the wheel loose and no one at the helm. Now, the distance of the longitude of the place where the derelict was found by the "Dei Gratia" from that of the island of Santa Maria is about 527 miles, and, says the admiralty experts, "It appears almost impossible that the derelict should have compassed within that time such a distance at all events on the starboard tack, upon which she was met by the 'Dei Gratia,' when the log of the latter shows that the wind was blowing from the north all that time, and that she was on the port tack all the time."

This, in non-technical language, means that during the ten days the position of the sails of the "Mary Celeste" must have been altered by someone, "and the obvious inference is that the 'Mary Celeste' was not abandoned till some days after the last entry in her log."

When the marshal of the vice-admiralty court entered the cabin of the "Mary Celeste," he found on the floor a curious sword. "I have examined it," reports Consul Sprague to Washington, "and it is evidently of Italian make, and bears a cross of Savoy on the hilt; it remains in the custody of the court. The chronometer and ship's papers cannot be found."

Capt. R. W. Shufeldt, of the U. S. warship "Plymouth," chanced at this time to call at Gibraltar, and went aboard the "Mary Celeste," at the request of the U. S. consul. "I reject the idea of a mutiny," said he; "there is no evidence of violence about the deck or in the cabins." And so this mystery remains unsolved.

West Australian airplanes, a liner from Capetown, a motorship, a steamer, and

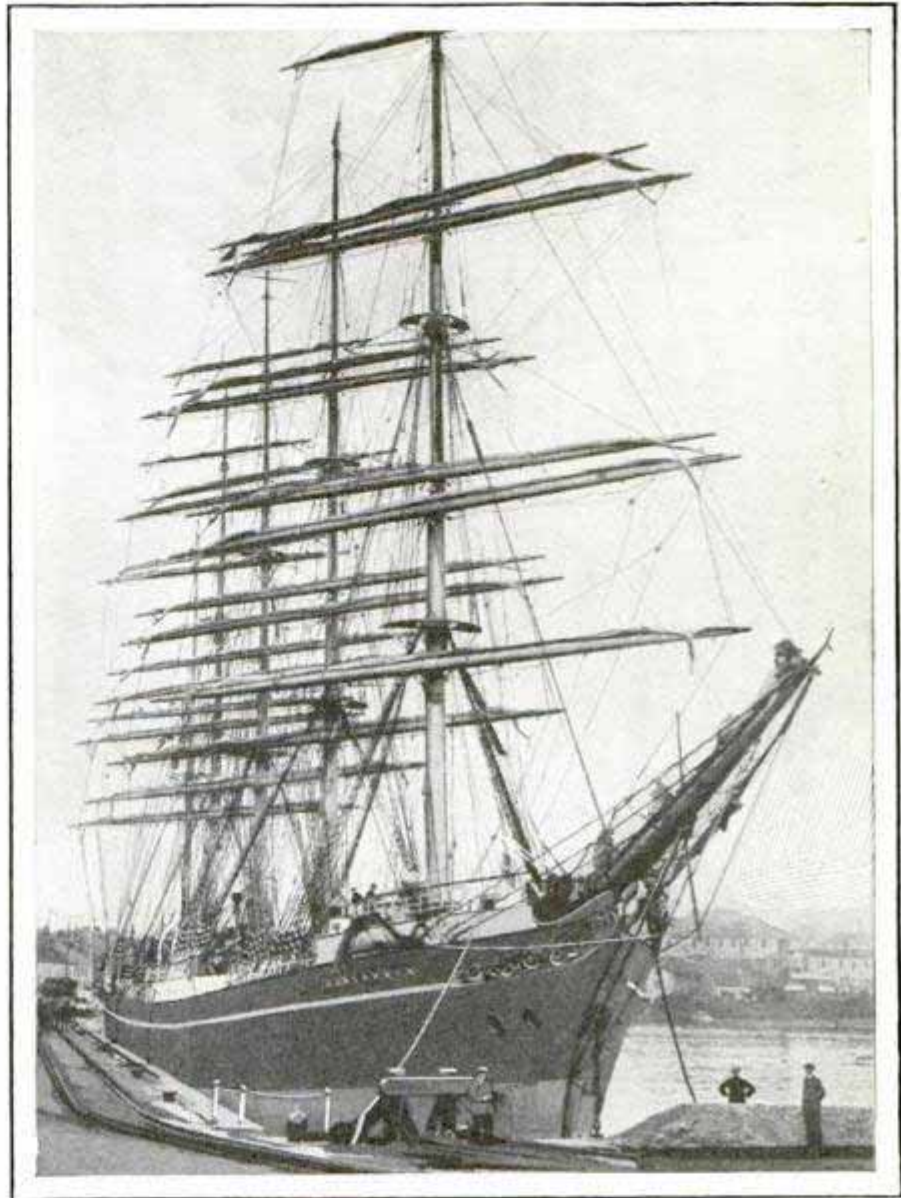

© Topical Press

Lost Five-Master "Kobenhavn" at Her Moorings Before She Left Port; a "Phantom Ship" like Her Was Sighted off Tristan da Cunha

a fleet of Danish vessels have recently been unable to solve another mystery of the sea. A nearly new and well-found five-master sailing ship, the "Kobenhavn" left Montevideo, on Dec. 14, 1928, on a voyage to Melbourne, Australia, where she was to load wheat. Eight days out of port, in the South Atlantic, she signaled "all's well" to a passing Norwegian steamer, and then she vanished into the regions of the "Roaring Forties." Aboard were seventy Danish naval cadets and an experienced crew, and she was fitted with radio and auxiliary engines.

Those wishing further information on anything described in the editorial pages can obtain it by addressing Bureau of Information, Popular Mechanics Magazine.



1182  
**GIANT AIR YACHT WILL CARRY EIGHT PASSENGERS**

Amphibian planes that can alight on the water as well as on the ground, have been in demand for some time for sport and private use, and now this type of craft is making a bid for wider recognition in the commercial field. An

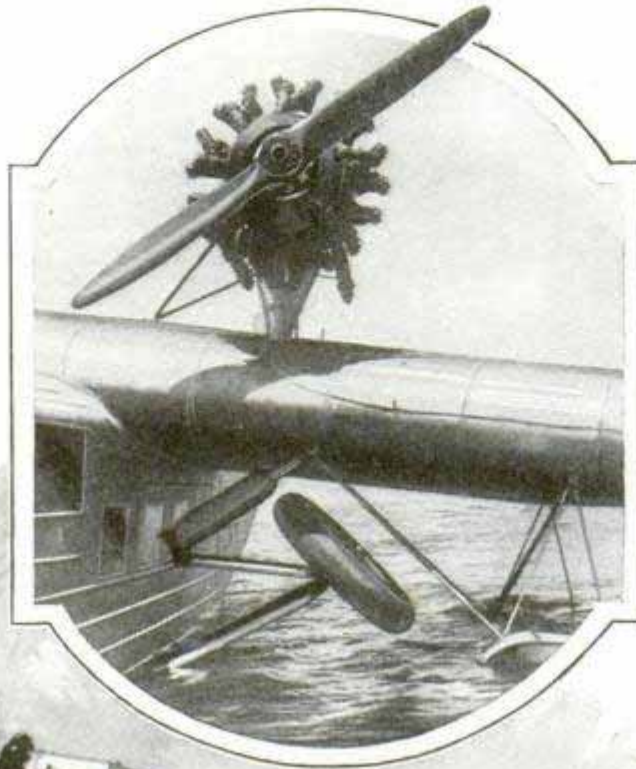

prevent too much tipping when landing upon the water. Success of the amphibian plane is partly due to the development of lightweight metal alloys for the construction of the hulls, so as to decrease the load. A popular amphibian



Two Views of Eight-Passenger Air Yacht Recently Completed in England for Service in Canada; Note the Design of the Hull and How the Wheels Are Folded Up under the Wings

amphibian that can carry eight passengers, besides a crew of pilot, navigator and wireless operator, has been built in England for a Canadian air line. It is said to be the largest in the world. Flying over a lake and river country, it can be brought to rest upon the water as well as on the land, for its fuselage is designed like a boat on the bottom and its landing wheels, as shown in the accompanying illustration, can be folded up to decrease wind resistance when the plane is in the air, and to be out of the way when descents are made upon the water. Pontoons under the wings help keep the craft afloat and

made in this country utilizes aluminum-alloy sheets, one-sixteenth of an inch thick, for the bottom of the hull and side sheets of the same material only one-thirty-second of an inch thick. Machine screws are used instead of rivets to assemble the members. As in boat construction, water-tight bulkheads are built into the hull fore and aft. A padded buffer is installed in the nose. Amphibians are being used widely for commuting and cross-country flying in regions where there are many lakes and rivers, and are finding a special place as carriers in large harbors. An example of this is San Fran-



cisco, where amphibians fly between that city and Oakland in a fraction of the time required to make the trip by boat. Docking the amphibian is a simple matter, as it can climb out of the water on a ramp or floating dock and can be managed in much smaller space than a ferryboat.

**BALANCING THE AIRSHIP IN FLIGHT IS BIG PROBLEM** 1226

Maintaining the balance of a dirigible without sacrificing too much of the hydrogen gas which provides the lifting power is the big problem on a long airship flight. It was this problem that the crew of the British dirigible "R-100" faced as the ship set a record of seventy-eight hours and fifty-one minutes crossing the Atlantic from east to west. The commander of a dirigible must calculate constantly to keep his craft from soaring upward or plunging downward as hydrogen gas is allowed to escape. Unless the temperature of the hydrogen in the gas bags is kept the same as the outer air, the lift will vary. Moreover, as the ship rises into less dense atmosphere, the hydrogen expands accordingly, and if the gas bags are full, the captain must sacrifice the reserve lift by letting hydrogen escape if he rises above what is known as the pressure height, which, for the "R-100," is about 2,000 feet, the altitude at which it travels most conveniently. False lift is another phenomenon that must be watched for. It is caused by action of the sun's rays which heat the interior of the ship, giving it a higher temperature than the outside air. This tends to send the ship up and force the blowing off of the gas. Likewise, at night, the ship which has been subjected to false lift tends to become heavier as the craft cools and the gas shrinks in volume. The "R-100" is not entirely at the mercy of such variations, because its surfaces are so curved as to provide a dynamic lift of their own when necessary, this being accomplished by the simple operation of pointing the bow upward.

*New York Times 7/31/30*



Models of Atom Formations of Various Substances Such as Might Be Seen through a Powerful Microscope

**MODELS OF ATOM FORMATIONS SHOWN WITH BALLS**

Models of atom formations as they group themselves into various elements or chemical substances can be illustrated with small balls placed on frames. Each ball represents an atom and the frame the formation as it might appear under a powerful microscope.

**ARID FARMING IS A RETURN TO ANCIENT CUSTOMS** 1232

Present-day irrigation and dry farming constitute, in a way, a return to methods practiced centuries ago. Civilization originated in the semi-arid lands of the world, and only after the lapse of ages did agriculture leave such places and reach its greatest development in the temperate regions. Today attention is again paid to lands of little water, but with the improved methods derived from modern science, according to Sir John Russell, head of the oldest agricultural experiment station in England.

*Head Agricultural Experiment Station*

*869*

*presented at Second International Soil Engrg. Cong.*

*Science Service News Bulletin 488 Fi 8/2/30*



HOW YOU CAN TELL A PLANE BY ITS SILHOUETTE

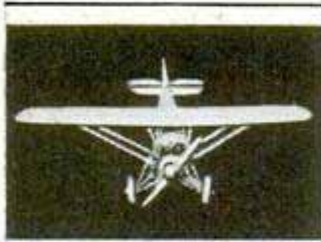

**MONOPLANE**

A monoplane is an airplane which derives its lifting power from one main supporting surface. It is distinguished from other planes by this feature.



**LOW-WING MONOPLANE**

A low-wing monoplane is not unlike a high-wing type monoplane with the exception that its main supporting surface is placed below fuselage.



**BIPLANE**

You will have little difficulty in identifying a biplane by its two sets of wings, one set placed above the other.

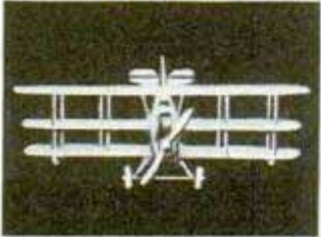

**TRIPLANE**

A triplane boasts three sets of wings, one set placed above the other. The triplane, however, has lost favor with the modern designers.



**SESQUIPLANE**

A sesquiplane is a cross between a monoplane and a biplane. It is a wing and a half design with a main and a supplementary supporting surface.



**PONTOON PLANE**

A pontoon seaplane is an airplane whose landing gear is fitted with pontoons. Frequently the pontoons are interchangeable with wheels or snow skis.



**FLYING BOAT**

A flying boat is a seaplane with a fuselage like a boat hull. The passengers sit in the hull as they do in a boat. For use over water only.



**AMPHIBIAN**

An amphibian is a new type of airplane, capable of landing on or taking off from either land or water. The landing wheels are retractable.

**AUTOGIRO**

An autogiro is a new type of plane which can ascend or descend almost vertically, in addition to horizontal flight. It is a newcomer to aviation.



**ORNITHOPTER**

An ornithopter is a machine with flapping wings like a bird. Although countless attempts have been made, no ornithopter design has flown.



**GLIDER**

A glider is usually a monoplane without a form of motive power. A glider soars like a bird and depends upon upward currents for sustained flight.

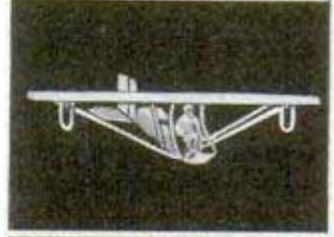

**BI-MOTOR**

Some airplanes are powered with two motors which are mounted on each side of the fuselage. These may be pushers or tractors. This is a tractor type.



**TRI-MOTOR**

The majority of tri-motored airplanes are tractor types. The airplane illustrated is the new Stanolind 3rd—a modern three-motored monoplane.

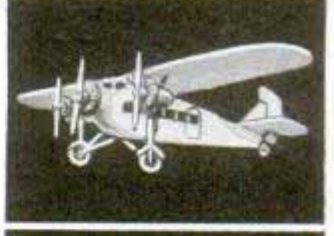

**TRACTOR**

To be termed a tractor, an airplane must be pulled through the air by its propeller. In a tractor type, the propeller is placed in front of the wings.



**PUSHER**

A pusher type airplane is pushed through the air by the propeller. In a pusher type, the propeller is always mounted in the rear of the wings.



**PUSHER-TRACTOR**

In some multi-motored airplanes, the designers favor the pusher-tractor principle. One motor pushes and the other pulls.





19/30/30

**BUTTERFLY WINGS PHOTOGRAPH SELVES**

1229

Butterfly wings give off something—either invisible light waves or a gas—that enables them to photograph themselves in the dark, Austin Clark, of the National Museum, has discovered, and he is now trying to find what the emanation is. He mounted the wings on paper which was put in the bottom of a plate box to give a flat surface. A fresh plate, emulsion-side down, was placed on it, and the box, with light excluded, was laid away for a week. When taken out, the plate had a clear picture of the wings, complete as to detail and relative intensity of the color pattern, except that on the print black areas came out white and white patches as black. Specimens that had been dead as long as thirty years were subjected to the same tests and likewise took their own pictures, but not as clearly. It was found that, the agent, whatever it may be, does not pass through glass or quartz, but will go through cellophane.

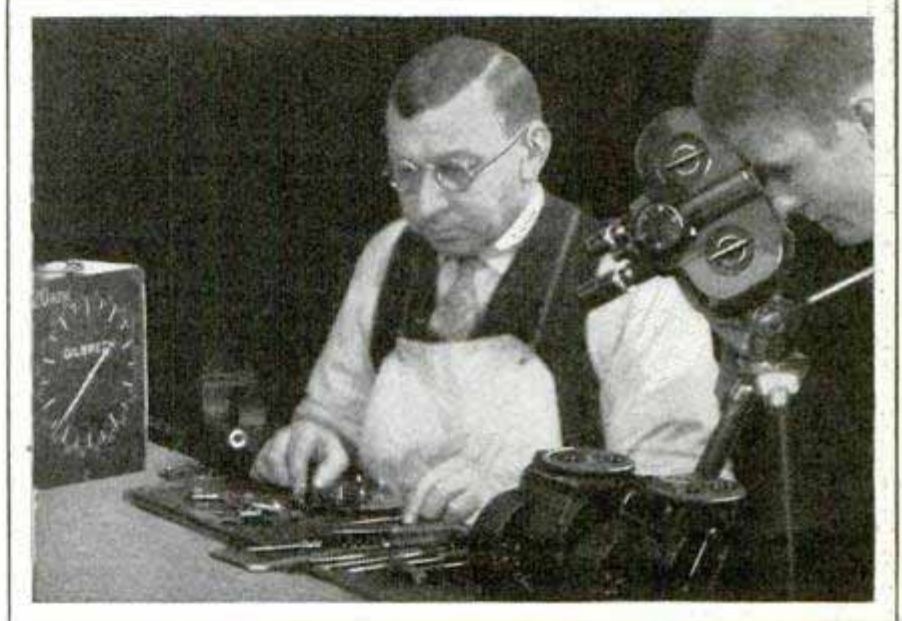
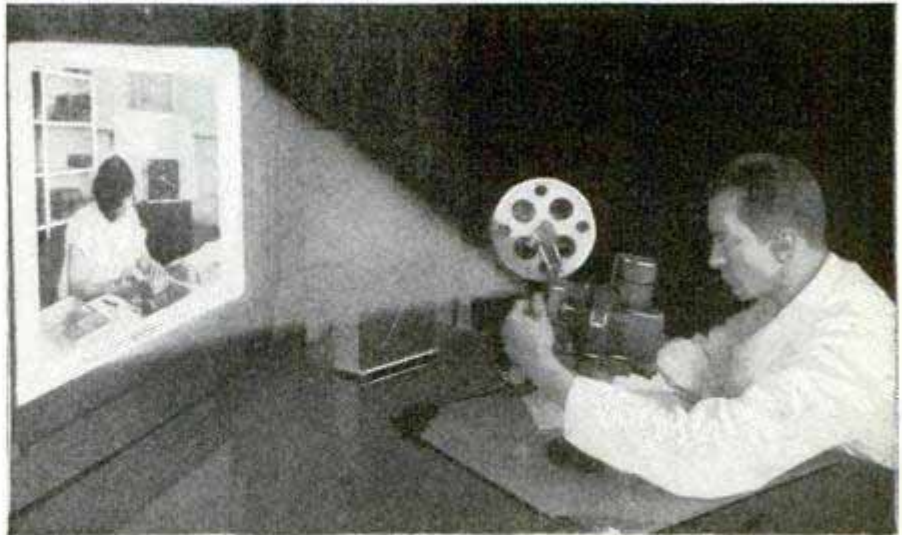

Above, Studying Movie of an Industrial Process; Below, Taking Picture of Industrial Operation to Find Easier Way of Doing It

**MOVIES TO SHOW EASIEST WAY OF DOING THINGS 1192**

To find the one best way of performing a task in industry without wasteful motions, the movie camera is being used to record the operation for study. The study of motions necessary in completing an operation is not a speeding-up process, but an effort to find the best, and usually the easiest, way of performing a task. Moving pictures of the performance to be studied are made, a fast-moving clock, known as a micro-chronometer, being included in the picture field and timing the various

motions to one-thirtieth of a second. The picture then is analyzed by projection on a screen, one frame at a time, and by this slow and laborious process, the analyst draws up a simultaneous motion-cycle chart on which the motion of each part of the hands, wrists and arms is plotted against time. By this process all motions are broken down into seventeen fundamental ones, represented on the chart by colors and symbols. Study of the completed chart reveals violation of the laws of motion, and a new and better method of doing the job can be constructed synthetically. The operator then is taught this method, making possible increased production with the same, or less, effort. Lately an attempt has been made to eliminate the clock arrangement.

Carl Allari H. Mogensen  
 c/o Osell + Hobell 180 3  
 One Cheard



121  
Timber Roller Bearing Co  
Canton, Ohio

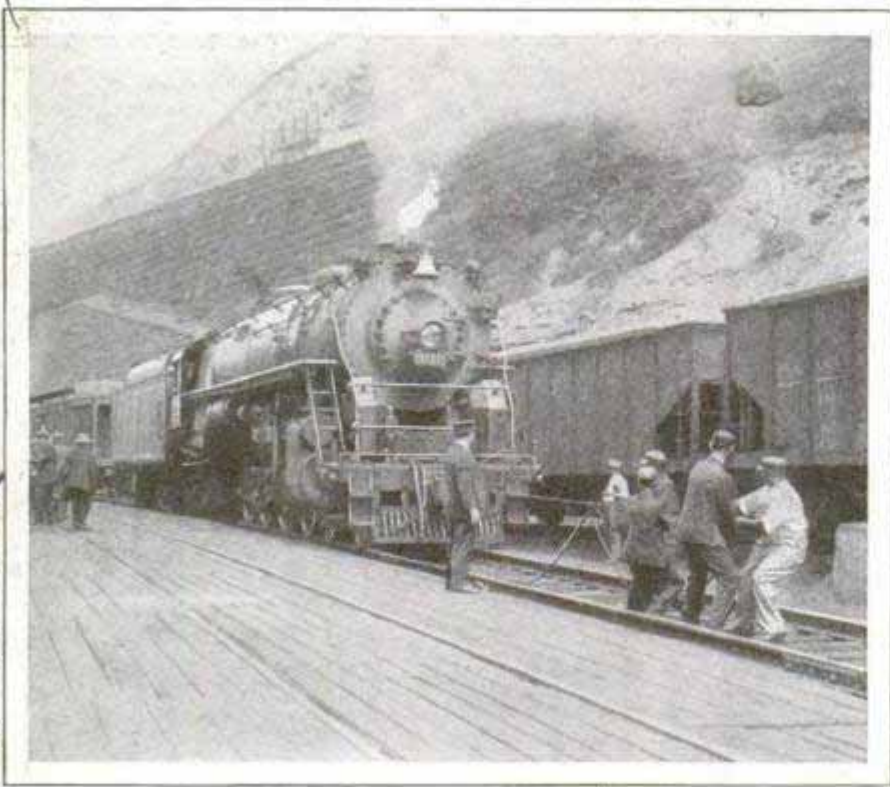

Four Men Pulling a Locomotive Weighing 711,500 Pounds; the Engine Is Equipped Throughout with Roller Bearings, Making Feat Possible

### FOUR MEN PULL LOCOMOTIVE ON ROLLER BEARINGS

Four men recently pulled a locomotive weighing 711,500 pounds for a distance of 150 feet, starting the engine from a dead stop by hauling on a rope tied to the front. With an ordinary locomotive such a feat would have been impossible, but the test was performed with an engine equipped throughout with roller bearings. Friction had been reduced to a minimum by using such bearings for every part.

### INSECT POLICE FORCE AT WAR WITH HARMFUL PESTS

In its fight against insect pests, which annually destroy about ten per cent of the world's crops, science has enlisted an insect police force as one of its most potent weapons. It has been found that there is hardly an insect that is not preyed on by some other, and science has turned this fact to its own advantage in dealing with the harmful bugs and flies. The greenfly, for instance, which damages roses, has a powerful foe in the larva of the ladybird, and ichneumon flies keep the devastations of caterpillars within bounds. Whenever a plague of obnoxious insects is reported, flying squads are imported to

battle them. These are insects which are known to prey on the pests and are bred in large numbers in Europe in order always to be in readiness for such an emergency. Such policemen insects have been sent to Australia, New Zealand, Canada, India, Africa and the West Indies, and each year are traveling farther and farther in relentless battle on their natural enemies.

### AUTOMATIC GOLF TEE OPERATED BY PEDAL

1174

Enabling the golfer to practice shots without stooping to tee the ball,

an automatic teeing device is operated with a pedal. Pressure on the pedal releases a hinged arm with a spoonlike cup which snaps over and places the ball on the tee. The arm then returns to a horizontal position with the cup under a rack which holds thirty balls. The golfer thus can make one shot after another without changing his stance.

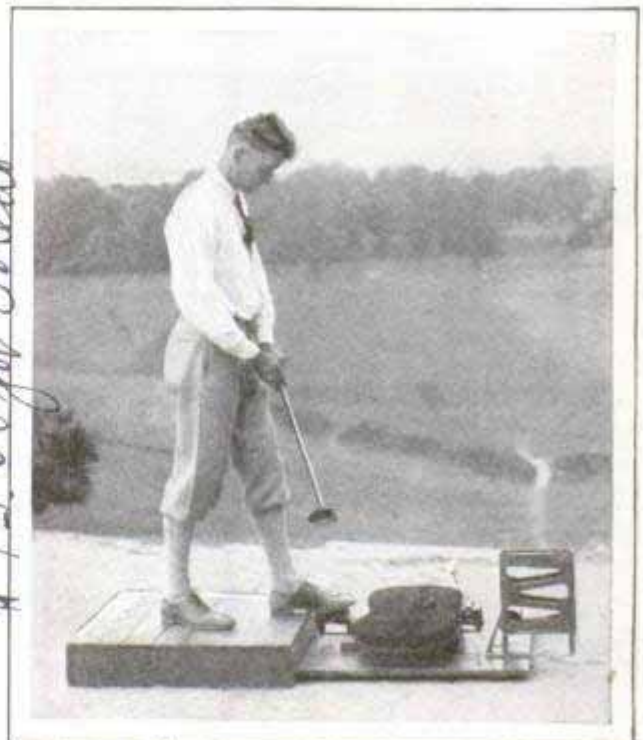

Automatic Tee for the Golf Ball; Pressure on the Pedal Places a Ball Ready for a Shot

1219

\$75.00 per Toledo

John Bets  
8/1/30

International Golf  
Equipment Co. Inc.



1070

Hickman Price  
Lawrence Park Wash.  
Bromville Wash.

# Super-Farm Runs Day and Night



With the Aid of Powerful Headlights on the Tractors, Plowing Proceeds at Night as Well as by Day, and the Workers Enjoy the Benefits of Comparative Coolness

**I**N THE VICINITY of Amarillo, Tex., a stupendous enterprise is in progress. An outfit of ten sixty-horsepower tractors, going day and night, are converting thousands of acres of prairie into plowed ground. This outfit belongs to Hickman Price, whose farming operations are as startling in magnitude as they are unusual in method.

There was a time when the popular conception of a farmer was a weathered toiler of the sun, struggling for existence under trying conditions, the pawn of politics, climatic conditions and his own poor judgment. But the shifting scenes have brought another picture: agricultural engineers trained in the best universities are directing their efforts toward farming. In Hickman Price, farmer, we find a Columbia graduate, a business executive of high standing and a cultured man of the world.

Even in the Texas Panhandle, 30,000 acres, or fifty sections of land, have always been regarded as a tract too large to utilize in any way except for cattle raising.

Had anyone, even so late as two years ago, suggested to the owner of such a tract that it be put under cultivation, the idea would have registered as the wildest on record. Yet, that is the extent of land that Mr. Price has in cultivation, to say nothing of an additional 25,000 acres of virgin prairie he has plowed the last few months.

It was in 1902 that Mr. Price made his initial venture in farming. This was also the year that he first visited the land he is now cultivating, the land his grandfather purchased somewhere back in the seventies and then forgot about. He amused the seasoned cowmen when, after graduation from college, he started plowing with a steam tractor out there on the wild plains of a cattle empire.

"One objection to superfarming," said Mr. Price, "has been that as the capital for it increases, so do the hazards. The answer to this has been found by such concerns as the United Fruit company. It distributes its vast acreage over large areas, in

Hickman Price Lawrence Park Wash. - Bromville Wash.

summer -

Cont. Mrs. Anne Elyer 515  
702 Jackson Hill



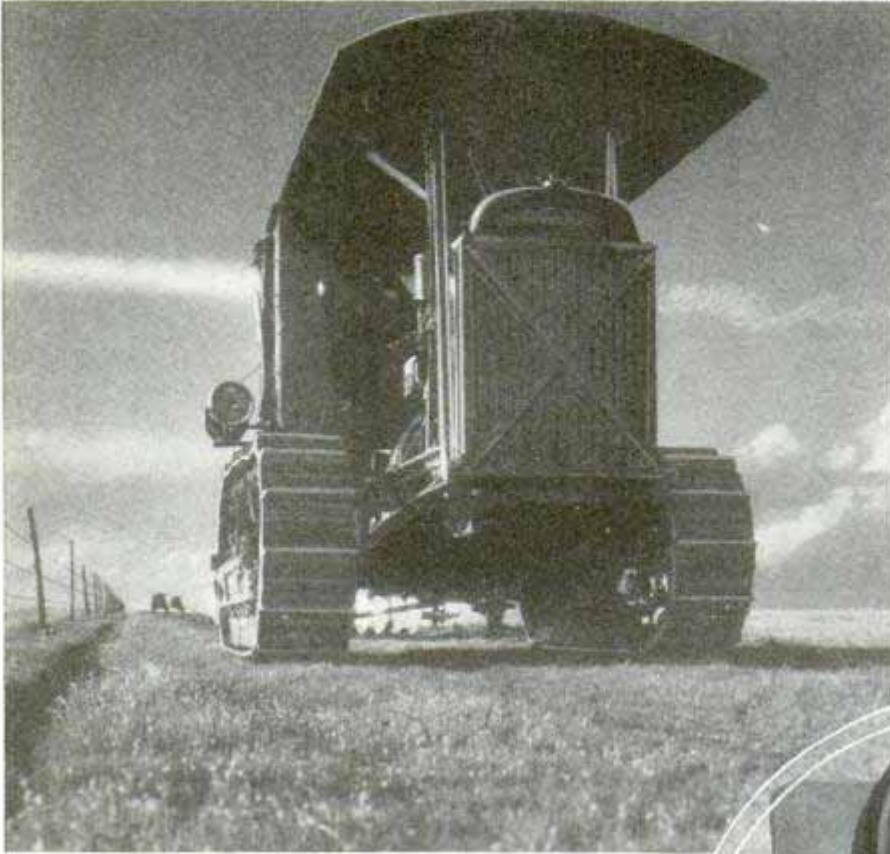

handle to use sixty-horsepower tractors—"and by operating on a factory basis of continuous operation, the cost of growing wheat can be slashed far below the cost to the small farmer. Thus we can make a fair profit from prices that would embarrass him.

"In Montana it is estimated that on 800 to 1,400-acre farms with thirty-horsepower tractors, the cost per acre can be reduced to \$8.70. Our tests, here in the Panhandle, where twen-

ten or more tropical countries. The effects of vagaries of the weather are correspondingly distributed."

Hickman Price's operations embrace four tracts in four counties of northwest Texas. It is seven miles between the two closest farms and 120 miles between the two that are farthest apart.

"With the seasons varying from year to year," he declares, "the surest air-tight defense against unfavorable weather conditions—the proverbial bugaboo of farming—is found in an ample supply of power and equipment. Having machinery sufficient to cover the entire acreage in a short time, it is possible to avail oneself to the utmost of all the important element of timeliness, making or saving crops otherwise lost. Thus, in large measure, mechanized agriculture effectively combats that which, up to now, has been the bane of farming."

"How about the fluctuation in the price of grain?" I asked. "How do you take care of that side of the problem?"

"Our recent studies of wheat costs," Mr. Price returned, "show that merely by using standard tractor power double that of the largest commonly used tractor"—Mr. Price is the first farmer in the Pan-

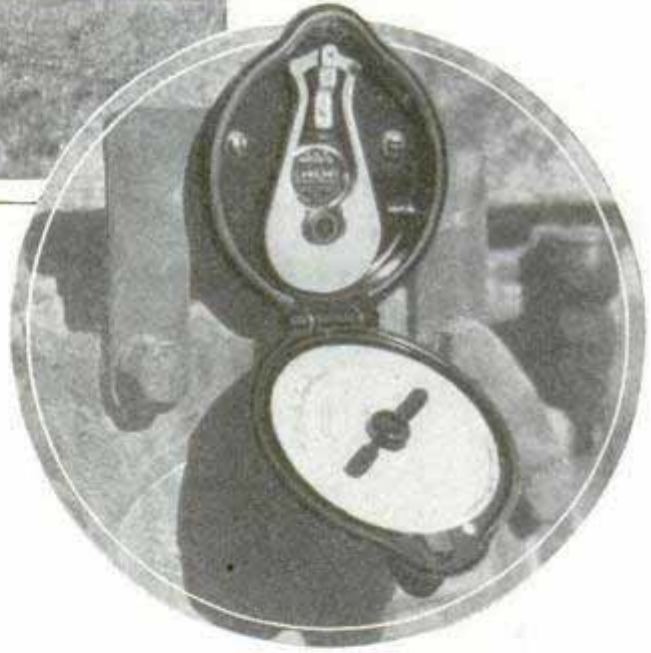

Close View of One of the Huge Tractors and Clock Used to Record "Bonus" Time

ty-four-hour tractor operation is practical, indicate that with the biggest tractors and correspondingly larger implements, the cost can be reduced to \$6. We believe that even larger types of machinery and more extensive unit areas will result in greater reductions in production costs. We hope that the time is near when manufacturers, aided by agricultural engineers, will make it possible to farm at constantly lowering prices through the use of superpower machinery with tractors of, say, 500, 800 or 1,000 horsepower.

"Our tractors run continuously day and night," he continued, "stopping only for

*Service Recorder Co.  
Lansing, Michigan*





Some of the Tractors That Turn 200,000,000 Tons of Soil Per Year, and Big Derrick Used for Repairs

servicing or when the ground is frozen or too wet. There is always work ahead for a successful, expanding farm organization as it takes over new acreage to put into wheat. This means that our tractors operate from 5,000 to 6,000 hours a year. In intermediate gear, at about three miles an hour on most of the jobs, each tractor travels approximately 18,000 miles.

"The new assumption is that scientific farming has one goal, that of producing foodstuffs and other commercial products as cheaply as possible and without injury to farm workers.

"The old method of getting low production prices was through exploited or underpaid labor. The producer has been made to suffer for the sake of the consumer. That was unjust. The new ideal is to be equally fair to all concerned."

This is not a mere theory with Mr. Price, and it is fully demonstrated in the way his men are managed. Each worker is made to feel that he is a definite part in the scheme of superfarming. He has set a new standard of wages for farm hands which is the most generous ever paid in this country; he has set a new standard of home life for farm hands, enabling them

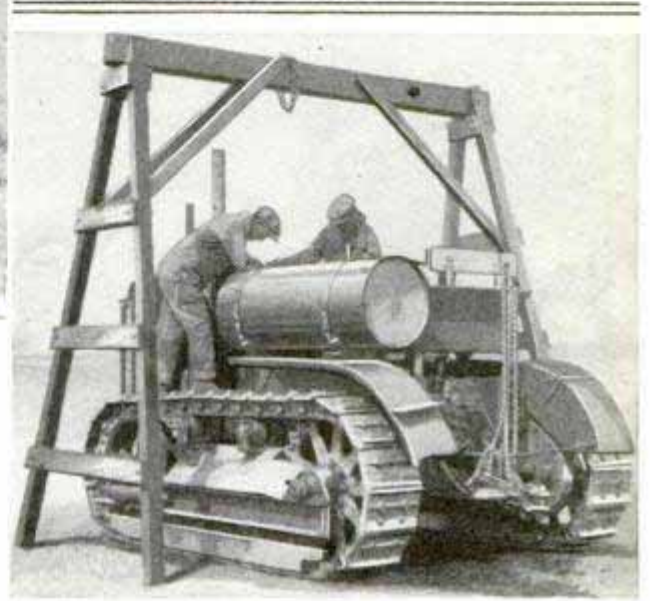

to enjoy every necessary comfort and convenience.

His tractor drivers receive a base wage of \$90 per month and a ten-cent bonus for every hour they run their machines. Workers in other departments—he employs twenty-five to about a hundred men—receive correspondingly generous salaries. For it must be remembered that agricultural labor is about the poorest paid in any industry.

Mr. Price's employes live on a train which is moved overland from one large farm to another. It consists of sleeping, dining and club cars with complete repair and shop equipment. The club car is equipped with shower bath, hot and cold water, a lounging room with comfortable chairs, desks, radio and magazines.

All this "fuss" over hired help has caused much comment among farmers in northwest Texas, but Mr. Price contends that better living standards for farm workers must find adjustment to this new era of superfarming.



163 GARDEN DRAWING ROOM ARRANGED FROM HEDGE

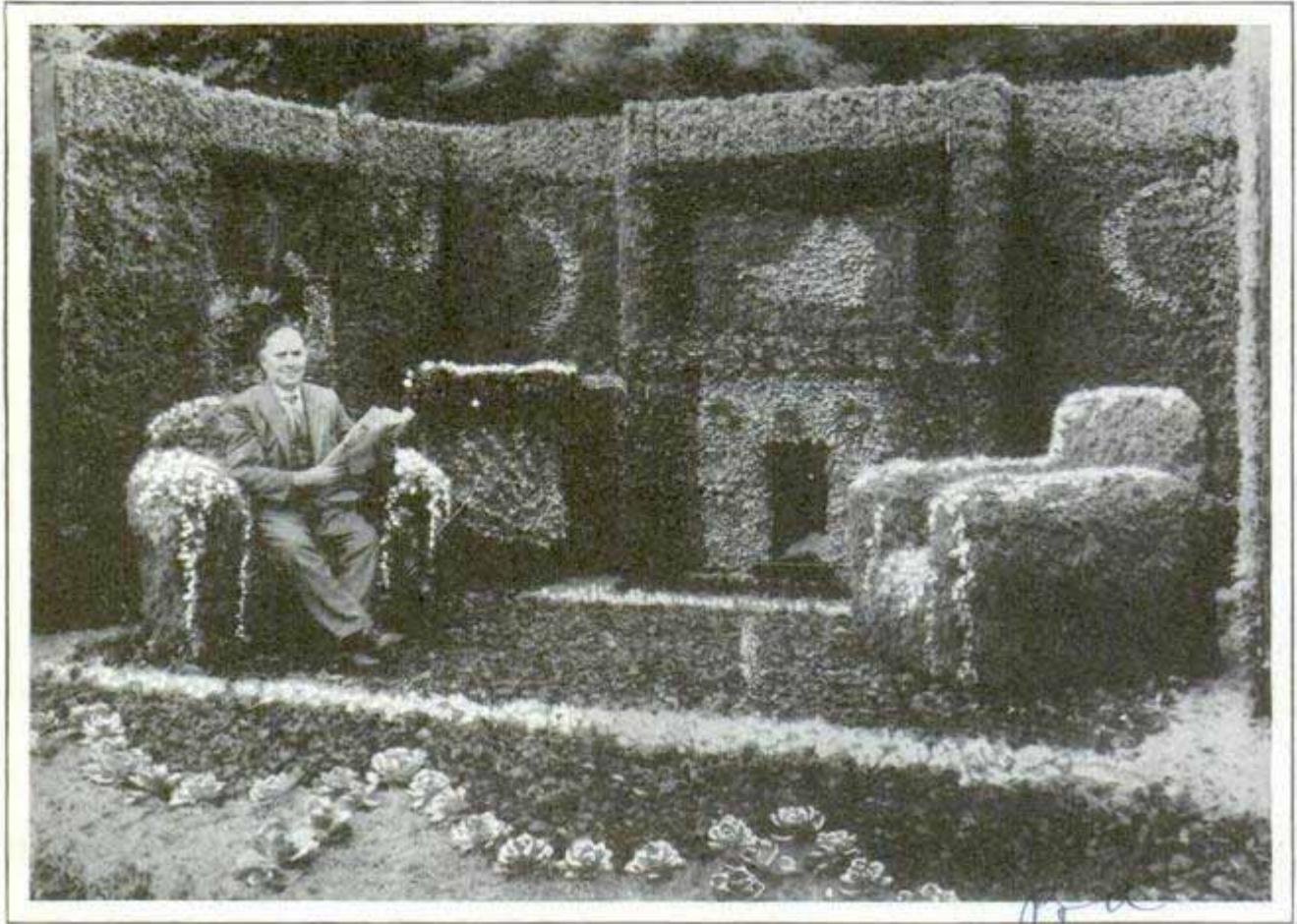

A Summer Drawing Room in a Garden; an English Gardener Designed This Arrangement of Carefully Nurtured and Clipped Hedge, Plants and Flowers; Note Chairs and Fireplace

As a model for those who entertain extensively in the summer, a British gardener has arranged a garden drawing room. It is made from carefully nurtured and clipped hedge, plants and flowers, and besides its green walls, the appointments include a fireplace, chairs and a phonograph.

fits may be obtained with a larger boiler for continuous operation, or with an attachment for a steam line.

RADIO FROM PLANE GOES HALF AROUND THE WORLD 120

From an airplane 5,000 feet over Buenos Aires, Capt. Lewis Yancey recently talked by radiophone with Sydney, Australia, thus telephoning from an airplane in flight over a distance of 14,000 miles. His conversation went by radio to a radiotelephone station in Buenos Aires, then by radio to Madrid. At Madrid the conversation was transferred to land lines of a telephone company which took it to the French border, where it was transferred again to other land lines and carried to the English channel. A submarine cable took it to England, then other land lines carried the words to a radiotelephone station at Rugby. From Rugby the beam wireless carried the words to Sydney. The conversation was quite distinct.

MINIATURE DRY-STEAM PLANT IN AN ELECTRIC IRON

Weighing only three pounds, a small dry-steam outfit is contained in an appliance resembling and operating like an electric flatiron. It plugs into any light socket, the heating element converting water into dry steam which is evenly distributed over the pressing surface. Similar out-



Dry Steam Appliance Co.  
130 N. State

Ref James  
7/29/30

Factory, 766 Johnson St  
San Francisco, Calif  
194



9/31/30

### ARTIFICIAL SUNSHINE SPEEDS UP NIGHT WORKERS

1231

Imitation sunlight, shining through fake windows to approximate further the effect of real daylight, has been found to speed up the production of night workers. Experiments in London by the national physical laboratory showed that the eyes are more at home under conditions as nearly as possible like natural daylight, and that better vision resulted in better work. A comparison of the hourly output of night clerks in offices working under ordinary artificial lights and under artificial sunshine showed a distinct balance in favor of the latter. Coloring of the light to approximate the sun's rays was found to be the most essential condition.

1200

### BOY'S INVENTION SAVES HOME WHEN FIRE THREATENS

In his homemade laboratory, a sixteen-year-old Philadelphia school boy made a fire extinguisher out of odds and ends about the house, and loaded it with proper chemicals, awaiting only a good chance to test it. The opportunity came when fire broke out in the home of the family. The homemade apparatus put out the blaze before serious damage was done.

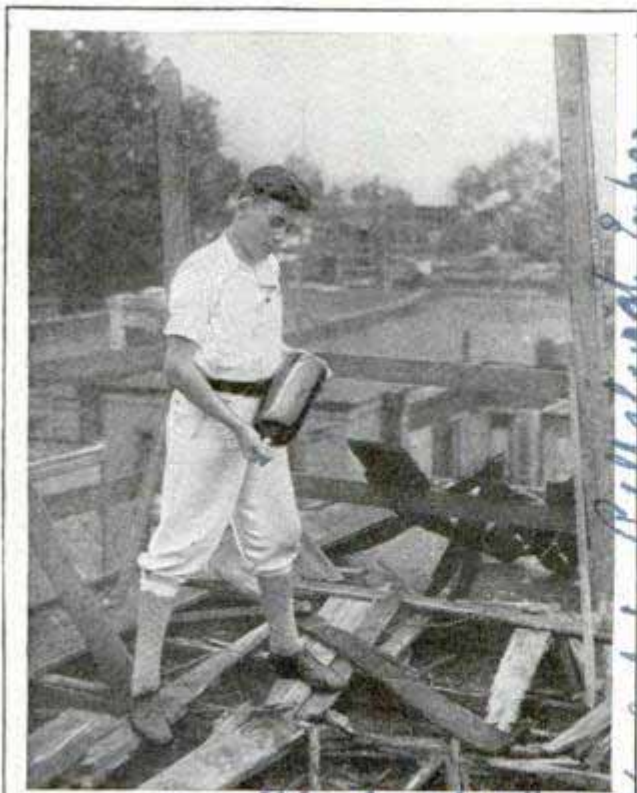

Philadelphia School Boy and His Homemade Fire Extinguisher Which Saved the Family Residence

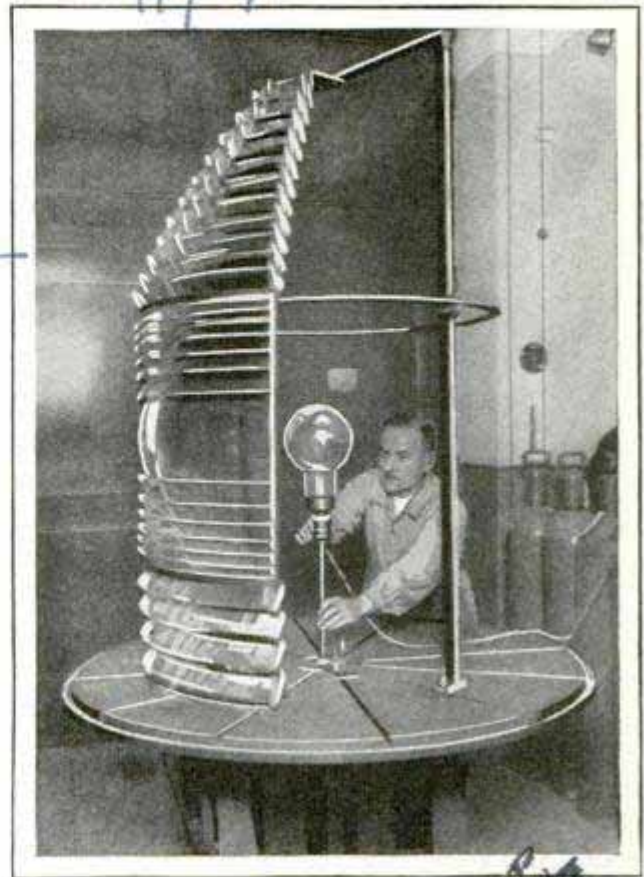

Four-Foot Searchlight Lens for a Lighthouse, and the 3,000-Watt Bulb Used with It

### GIANT LENS FOR SEARCHLIGHT TO GO IN LIGHTHOUSE

Lighthouses and searchlights are constantly studied and improved by the state institution for sea marks and navigation, near Berlin, where much research work is done in experimenting with equipment which will prove more efficient in warning ships of danger. One of the recent pieces of equipment that underwent tests was a giant searchlight lens four feet in diameter. The light source to be used with it is a 3,000-watt bulb.

### CHEMICAL ACTS AS DETECTIVE OF DEADLY GASES

123.

Warning of the presence in the air of carbon monoxide and other deadly gases may now be given by a chemical in a handy little container which can be carried by workmen going into suspected garages, sewers or mines. When the outer covering of the packet is crushed, a white filter paper or piece of cotton, soaked in palladium chloride, is exposed to the air. When this chemical meets carbon monoxide, the palladium is freed and the cotton turns gray or black.

tested by Pillsbury & Co. of Minneapolis  
 and Meade St. also Pillsbury St. also

Bullard, Davis, Huntington  
 67 Wall, Huntington

Ampules } Mines Safety  
 Pillsbury Co.



1212

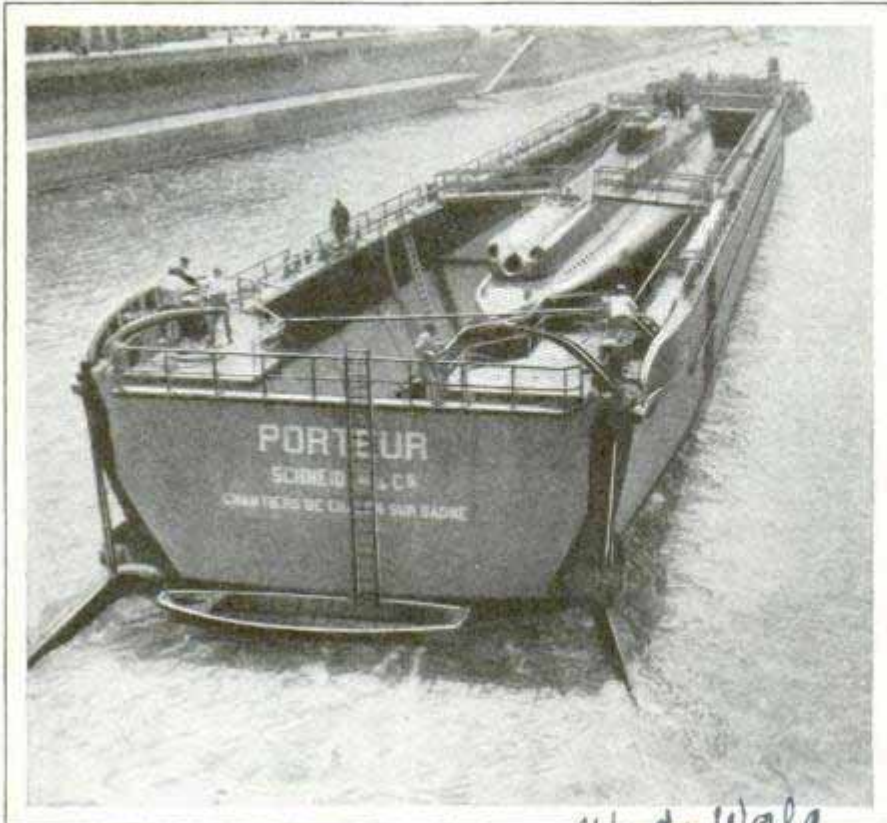

Submarine Carrier Which Was Used to Transport the Undersea Craft from the Ocean across France to the Mediterranean Sea

1209  
**TINY CYCLE MOTOR RUNS MANY MILES TO THE GALLON**

One hundred and fifty miles to a gallon of gasoline is the average performance of a lightweight motorcycle, the power plant of which, with magneto, weighs but twenty-five pounds and may be used for sawing, grinding, pumping, generating current, and many other purposes where a portable unit is needed. Attaching the motor to an ordinary bicycle frame is not successful, as a special frame, built to withstand the strain of operation and shaped to fit the motor, is necessary. The motorcycle has been run as far as 225 miles on a

**CARRIER FOR SUBMARINE TAKES BOAT THROUGH FRANCE**

When the French submarine "Argonaut" recently was ordered to proceed from the coast to its base in the Mediterranean, its officers faced the task of taking the craft across the heart of France. The problem was solved by building a submarine carrier in the form of a large scow in which the sub was placed.

single gallon of fuel. The motor develops one and one-half horsepower, is a valveless, two-stroke affair of the simplest design, and drives the cycle through a chain-and-belt transmission. A special feature of the cycle is that its lights are supplied with current in ordinary bulbs directly from the magneto. The complete cycle weighs eighty-four pounds and runs at from three to thirty miles an hour.

**INSECT FAIR FOR COLLECTORS FROM ALL OVER WORLD**

One of the strangest fairs in the world is held annually at Frankfurt, Germany, in the form of an insect exhibition. Here collectors from everywhere gather to meet the sellers of rare butterflies, moths, beetles, flies, grasshoppers and crickets. Some rare specimens bring large sums of money. Most of the vendors bring their stock with them, but others come empty-handed and merely take orders for rare insects as yet unborn, because they know where these tiny creatures may be found. While the insect fair probably is the strangest of all, another city has a goose fair and still other towns have mop and fur fairs.



Midget Motor for Motorcycle Which Makes About 150 Miles to One Gallon of Gas

*Wido Wala*  
 used \$20.00  
 \$50.00 to \$85.00  
 \$44.50  
 due in 3 or more  
 \$110.00 - used  
 Mr. Morley  
 Mr. Madry  
 Rochester  
 NY  
 Mr. Whipple  
 1227 W Jackson Blvd

1220

Int Bits 7/26/30

Mr. Whipple  
1227 W Jackson Blvd



PLANE RESEMBLING VULTURE TO SOAR LIKE A BIRD

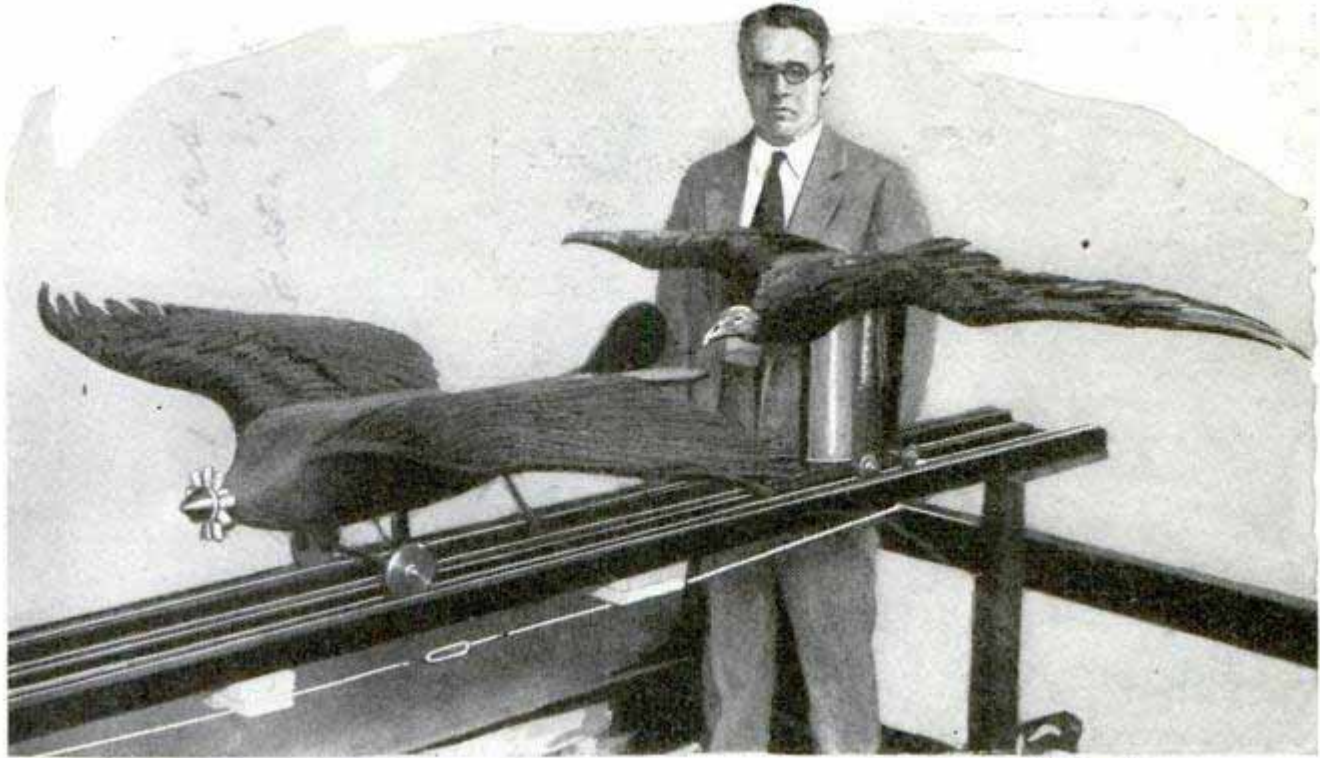

Comparison of Model of Plane Shaped Like a Bird and the Vulture It Resembles; the Makers Expect to Apply the Principles of Aerodynamics Used by Birds to Enable the Ship to Soar

Construction has been started in Los Angeles on an all-metal airplane wing that is expected to embody the intricate aerodynamical system that nature bestowed on the eagle, vulture and albatross—a system that requires no flapping of wings or artificial power plant to sustain flight. The wing is not an invention, but merely the application of the heretofore unknown principle of the bird's flight. Experts long have studied the natural phenomenon that allowed the vulture or eagle to soar without apparent effort, and now are attempting to apply this principle to man's advantage. It is claimed the vulture-type plane will be superior to present aircraft by tripling the lifting power, cutting the motor horsepower in half, increasing the pay load 150 per cent, reducing the landing speed by sixty per cent, shortening the take-off ninety per cent and decreasing both fuel consumption and dead weight.

GYMNASIUM ON RAILROAD CAR

One Canadian railroad has added to one of its principal trains a combination lounge car containing a small gymnasium, as well as a soda fountain, baths, barber shop and radio-reception room. The exer-

cise room contains various kinds of massage apparatus as well as foot and hand-exercising devices. Next to it is a shower. The windows are of glass which permits the passage of the ultraviolet rays of light.

GUIDE BLOCK FOR ANCHOR ROPE HAS AUTOMATIC GRIP

Operated from the seat of the boat, and without any springs to get out of repair, an anchor-rope guide block has a grip that takes hold automatically when the line is released. It consists essentially of a pulley with a spiral groove which throws the rope between the pulley and the guide when the line is allowed to run free, thus jamming it, and holding the anchor at any height desired. It operates as simply as a window-shade roller, gripping the line instantly as soon as the rope is released after the anchor is raised.



no further information

Milwaukee, Wis

The Confederation Aero Boat Co, 1031 Milwaukee Ave



1018  
562

# HOW MAN CAME TO KNOW THE WONDERS OF STEAM

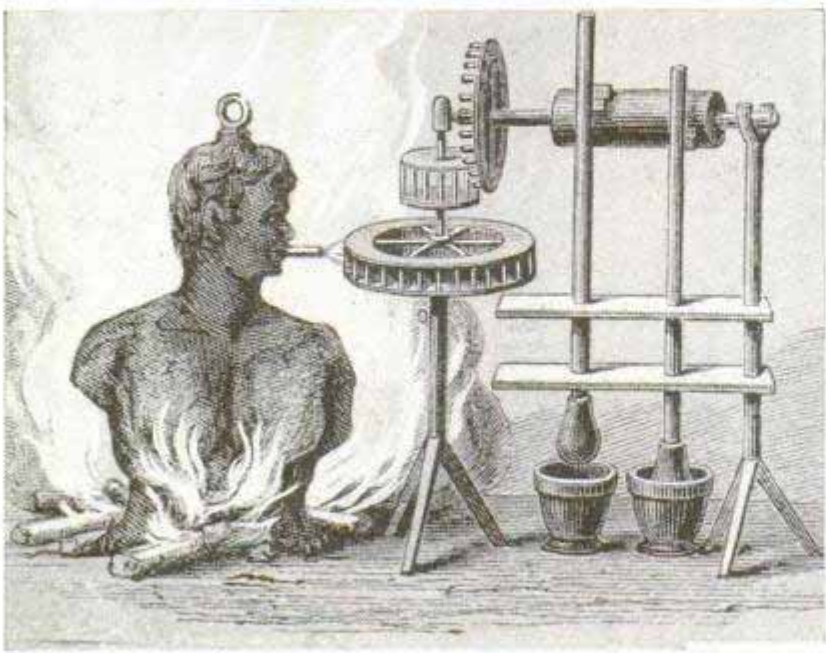

Above, Forerunner of the Modern Steam Turbine; Right, Model of First Steam Engine; Below, a Steam Engine Invented in 1712

*The ENGINE for Raising Water (with a power made) by FIRE*

The National Museum in Washington has placed on view an exhibit to show "How Man Came to Know Steam." It begins with a steam toy, invented by an engineer named Hero, of Alexandria, in Egypt, about 150 B. C. Not until the middle of the sixteenth century was anything more heard of the uses of steam. But in 1629, an Italian chemist, Giovanni Branca, invented a steam engine to generate power, and his design, later modified, developed into the modern steam turbine. In 1690, a French engineer named Papin invented the safety valve, and suggested the use of steam to drain water from mines, etc. The rudiments of a power-generating steam engine having been contributed by Branca, Papin, and others, it only awaited the touch of a mechanical magician to become a complete achievement. That touch was given in 1698 by Thomas Savery, an English coal-mine operator, who built an engine, with cylinder and piston, for lifting water out of his mines. Fourteen years later, an English blacksmith, Thomas Newcomen, constructed a steam engine which was one of the most remarkable inventions of any age or time. From it grew the modern steam engine. An engine of the Newcomen type (imported from England, and the first

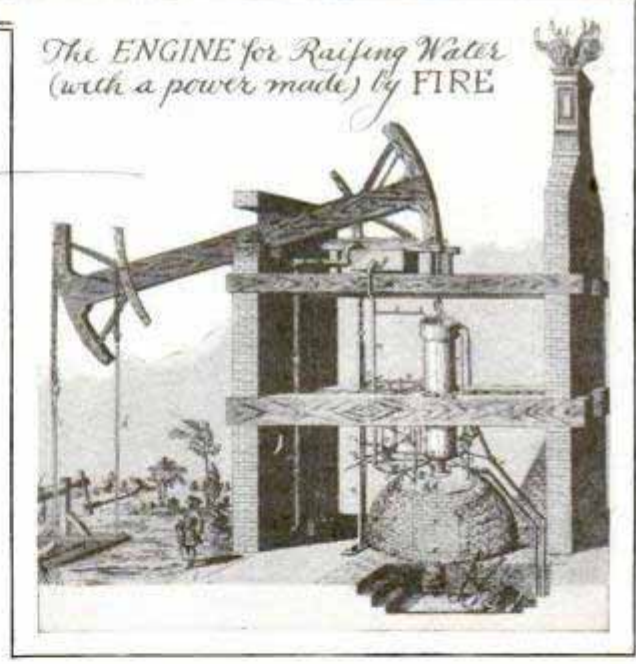

steam engine ever seen in America) was set up near Newark, N. J., in 1754, to drain a copper mine. The first person in the United States to apply steam for propelling a boat was William Henry, gunsmith and famous patriot, who, in 1763, built a small stern-wheel craft and launched it on Conestoga creek, at Lancaster, Pa. It carried no passengers, but was designed to prove that a steam-driven boat could travel upstream, against the current. Twenty-four years later, with the first passenger-carrying steamboat, John Fitch made a successful trial trip on the Delaware river. Fitch died in 1798. Nine



years later the reward which he had sought came to Robert Fulton, whose steamboat, the "Clermont," made its first trial trip up the Hudson, Aug. 7, 1807. In 1805, Oliver Evans built in Philadelphia the first steam-driven wagon seen in the United States. It was a dredge, designed for work along the river docks, but could run on land under its own power. Evans made definite prediction of carriages running on railways. "The time will come," he said, "when people will travel in stages moved by steam engines almost as fast as birds can fly, fifteen to twenty miles an hour." Indeed, by that time railways of some kind were plainly seen to be a necessity for commerce. The

question was, what motive power could be used? A treadmill car operated by horses, carrying twenty-four passengers, won a \$500 prize. Cars equipped with masts and sails were tried. Evans' prediction was ridiculed. But when, in 1829, news came from England of the wonderful performances of George Stephenson's locomotive "Rocket," all doubt about the use of steam for power was removed.

**RADIO TUBE WITH METAL COAT HAS GRID ON OUTSIDE**

In Germany a type of radio tube in the form of a flat container, somewhat resembling a tube of tooth paste, is being produced. The grid is not inside the tube, but is in the form of a metal layer on the outside of the glass. It is made at lower cost than the ordinary tubes and operates as efficiently.



do not sell nor advertise

Telefunken  
Telefunken

Telefunken Gesellschaft  
Berlin S W 11 Hallesches Ufer 12

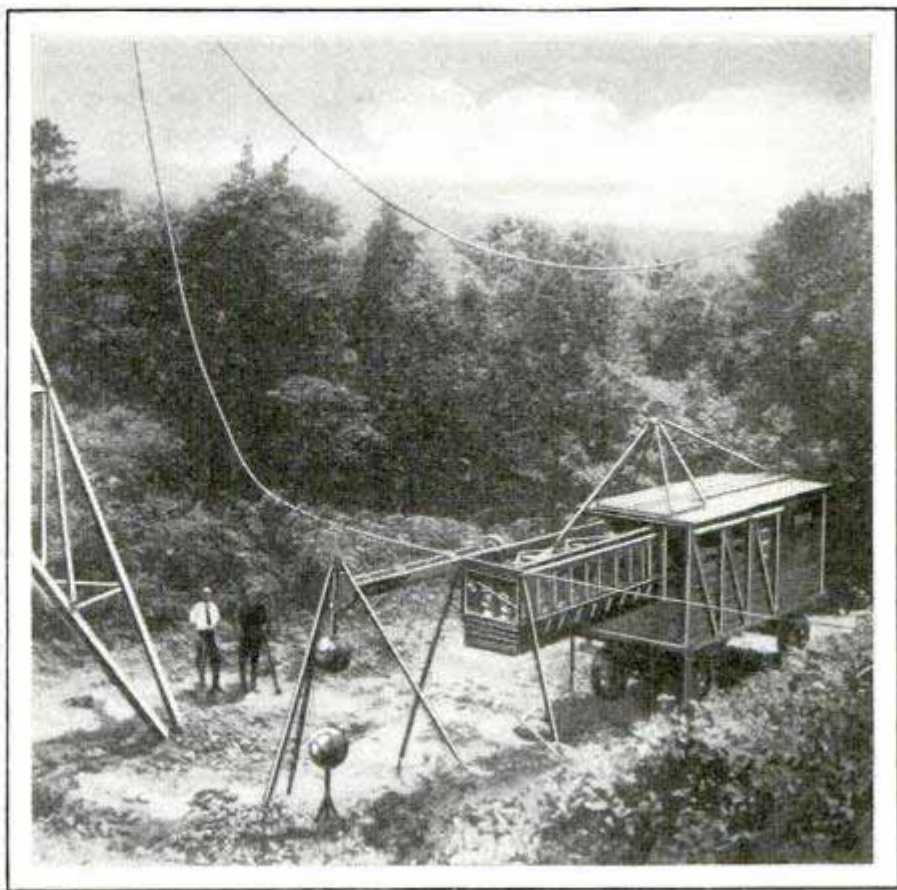

Portable Lightning Generator Capable of Developing 1,000,000 Volts, Used to Determine Effects of Lightning on Power Lines

**PORTABLE LIGHTNING FACTORY TESTS POWER LINES**

To determine the effects of lightning on overhead transmission lines and power-station equipment, a portable lightning factory, capable of generating 1,000,000 volts, has been made in compact form so that experiments can be conducted from different locations. The generator is being used extensively in the mountains of Tennessee, where the man-made bolts are released near the electric-power lines in an effort to approximate the effect of Nature's much more powerful bolts.

**ATTACKS BY CHINESE PIRATES CALL FOR EXTRA GUARD**

Shipping companies have formed special guards to protect their passengers and property from attacks by Chinese pirates, according to reports from England. During the past year, two British ships were attacked. The third officer of one of the vessels was killed. Temporary arrangements were made for military guards, and a police organization is now functioning.

Shipping World  
6/11/30

107  
100  
Wetengrause



761

Edmonton St.  
Winnipeg Canada

# Secret of Life Sought

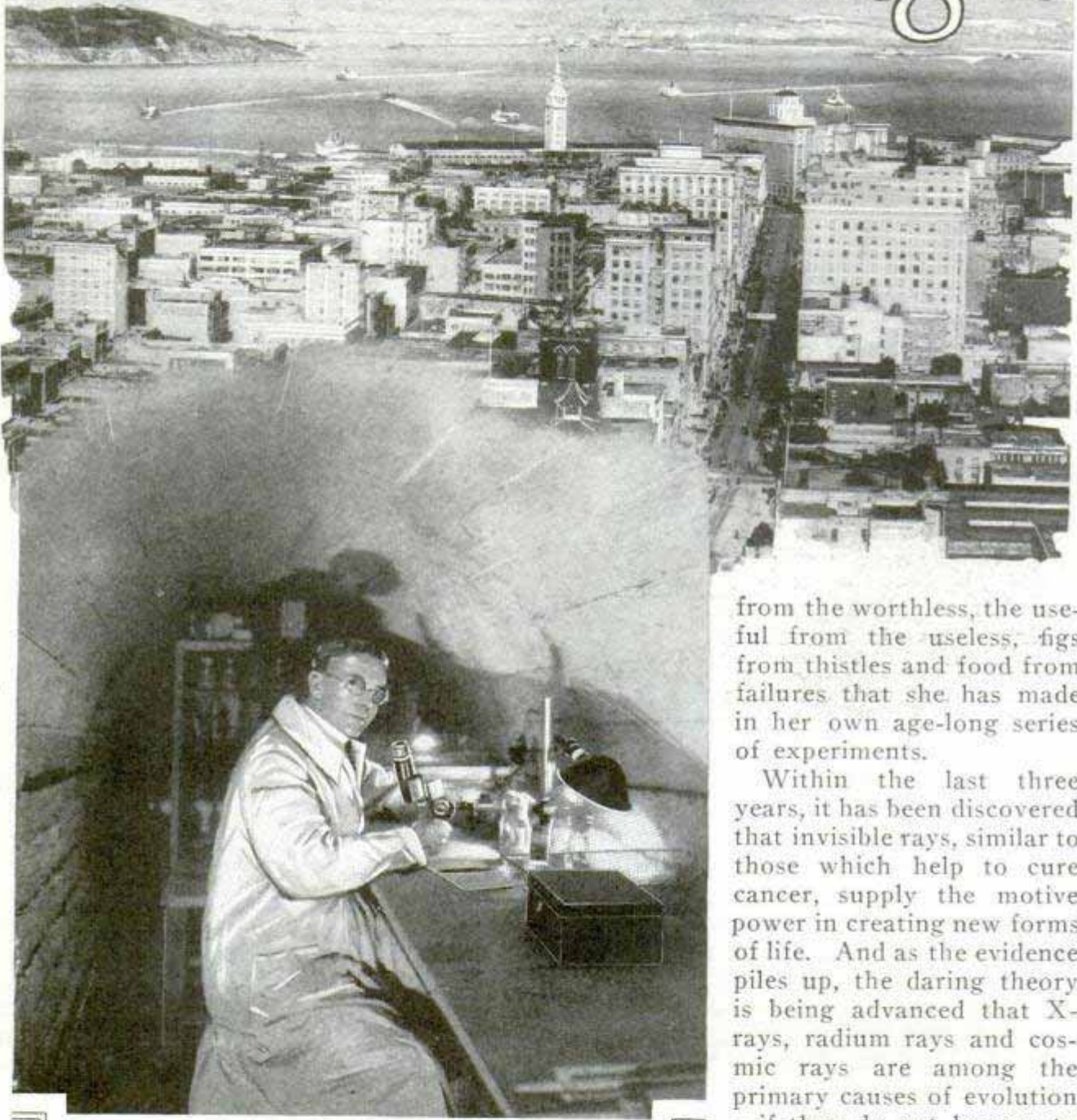

from the worthless, the useful from the useless, figs from thistles and food from failures that she has made in her own age-long series of experiments.

Within the last three years, it has been discovered that invisible rays, similar to those which help to cure cancer, supply the motive power in creating new forms of life. And as the evidence piles up, the daring theory is being advanced that X-rays, radium rays and cosmic rays are among the primary causes of evolution—if they do not happen to be the sole cause.

Three years or so ago, Prof. H. J. Muller, of the University of Texas, startled the world by his discovery that fruit flies, given a dose of X-rays, produce offspring radically different from themselves. "They were a motley throng," reported this scientist. "There were big flies and little ones; dark ones and light ones; fertile and sterile ones; long-lived and short-lived ones. What had been done? The root of

Prof. E. B. Babcock, of the University of California, in His Laboratory Deep beneath the City of San Francisco

**W**HY the difference between the mouse and the mastodon? What makes one tree produce apples and another oranges? What entered into plant life to develop poppies on one and sweet peas on another?

Following this line of questioning, scientists now are seeking to unearth Nature's secrets so they can produce the worthy



# in Mystery Ray

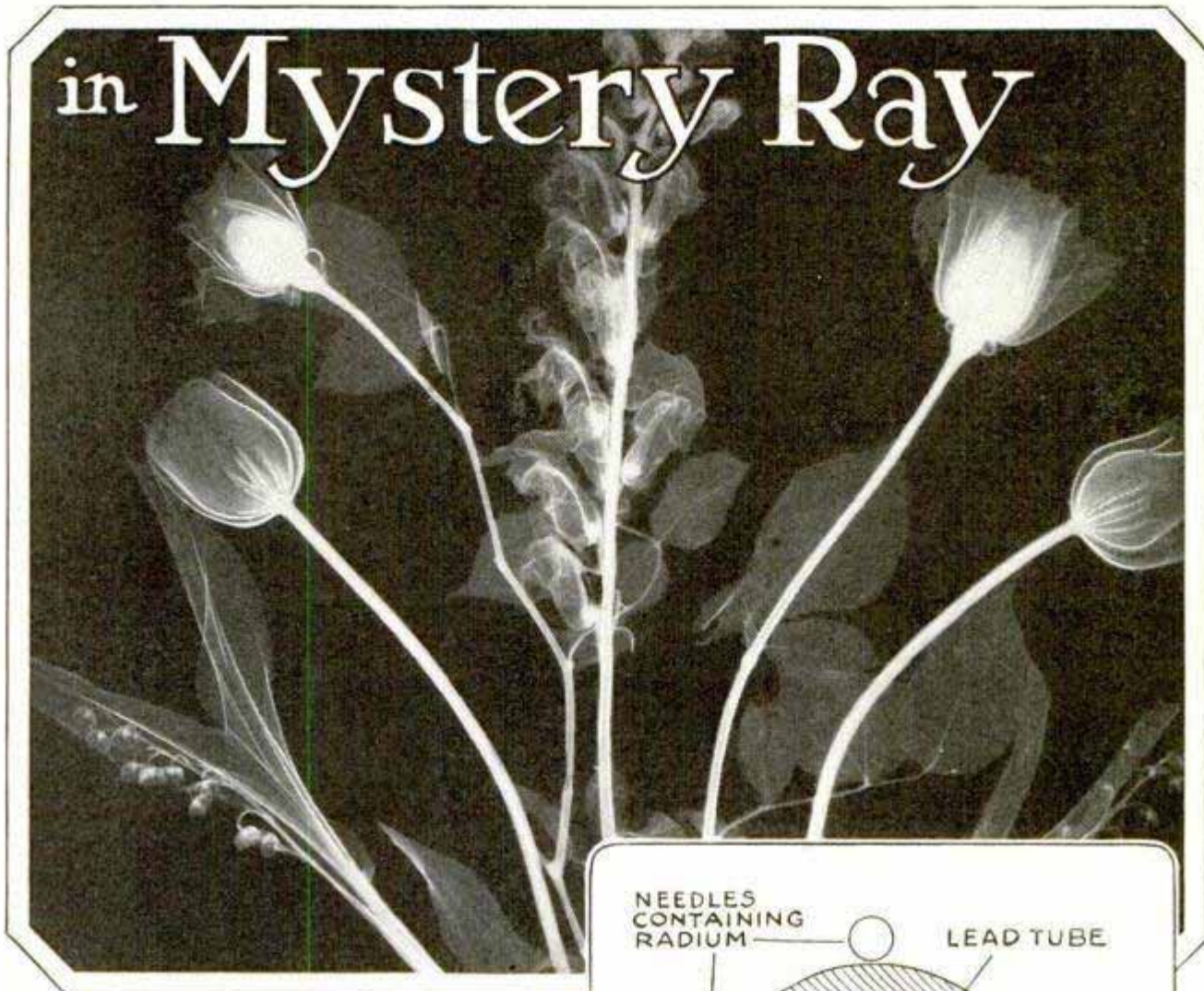

life had indeed been struck and yielded."

About a year later, Prof. T. H. Goodspeed, of the University of California, created new types of tobacco plants with the aid of X-rays. Flowers, leaves and stems produced by the treated seeds differed radically from those grown from untreated seeds. Contrary to expectation, it was found that the X-rays possessed no power to kill the seeds of the plant, but that early growth was slightly retarded. Further experiments with radium rays produced similar results.

Prof. E. B. Babcock, of the same institution, has supplied further evidence. In a tunnel through 150 feet of solid rock beneath a portion of the city of San Francisco, a laboratory had been fully equipped, it having been shown that the natural radioactivity of the rocks in the tunnel was exceptionally high. Exposed to this unusual intensity of radium rays, the offspring of fruit flies have displayed marked

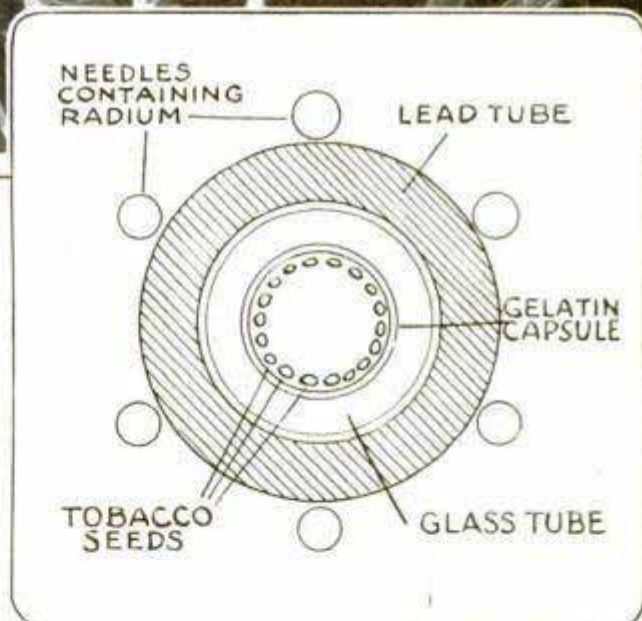

How Flowers Look under X-Rays, and Diagram Showing How Rays Are Applied to Tobacco Seeds

evolutionary changes, new kinds of flies being produced in much the same manner as in the laboratory of the University of Texas.

In these experiments, the effect of cosmic rays from the realms of space have been taken into consideration. Where they come from no one knows. Prof. Robert A. Millikan, of the California Institute of Technology, has proved their existence and suggests that possibly the



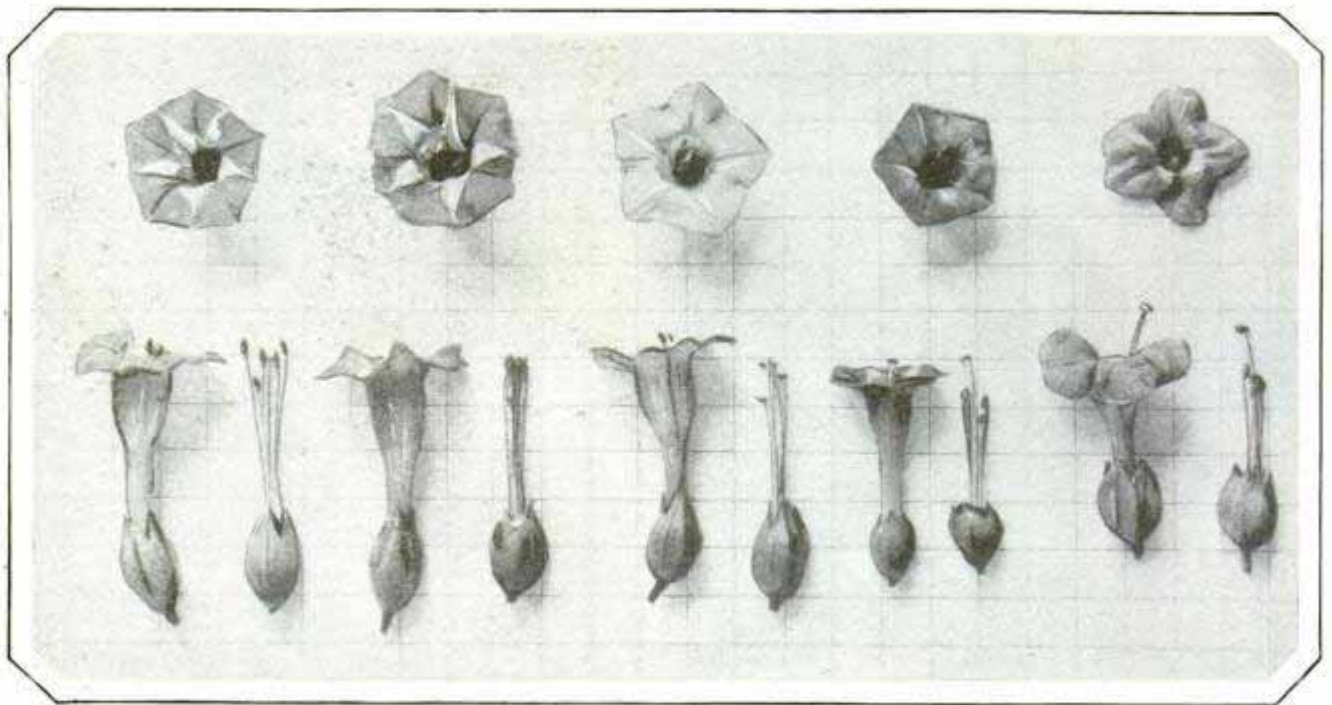

How Generations of Plants Change through Effects of X-Ray Treatment; Top and Side Views, Below, with Tubes Removed; Note Marked Changes from Extreme Left to Right

distant stars may send forth this energy which is continually reaching our earth both day and night. Possibly cosmic rays have played a most important part in the production of the strange prehistoric creatures that once roamed the world.

"Below the wavelengths of visible light," says Doctor Goodspeed, "are the radiations of increasingly high frequency, that is, shorter waves—the ultraviolet, the X-rays, the gamma radiations of radium and, finally, the cosmic rays. Waves visible to us as light vary from .00028 to .00014 of an inch, while the cosmic rays, for example, show distances from one wave to another, of approximately four-trillionths of an inch. Possibly these lengths will be better understood when it is said that, if visible light waves could be so magnified that they were fifty to 100 miles long, the cosmic ray would have a maximum length of one-half inch."

The cosmic rays, charging down from interstellar space with power to pierce twelve feet of lead or more than 100 feet of solid rock, were shut out of the tunnel used by Doctor Babcock as a fly laboratory. A similar control and experiment station was established at the University of California, in Berkeley, from which the cosmic rays were not excluded. It was found, also, that earth radiation in the tunnel is more than twice as strong as it is in the laboratory at Berkeley. Then

the fruit flies were subjected in the one place to the earth-made rays to which all life apparently has been subjected since time began, and in the other to man-made rays of exactly the same kind. This was an excellent test of the actual effect of the natural radiation of the earth on life changes.

All living substances are now known to be radioactive and, in regions of rapid growth, the emanation is strong enough to affect a photographic plate. When actively growing tissue is artificially treated with X-rays, or radium, very remarkable changes in the processes of growth take place. This is the secret of the fight against cancer by the use of X-rays as well as the changes produced upon metals, in industry, in plants, in animals. This field of research is very new, but in the words of Dr. C. Judson Herrick, of the University of Chicago, it gives promise of opening up secrets of vital mechanisms which ten years ago no one could have dreamed of.

Professor Muller produced life changes 150 times as fast by the use of these invisible rays as is possible by the ordinary processes of nature. This means that man may be able to force the production of new and desirable plant and animal varieties far more rapidly than he has hitherto been able to do.

Professor Goodspeed points out that, under right conditions, a fruit tree could



be given a dosage of the rays and certain branches would bear a different kind of product, the cuttings, being planted, would go on producing that new variety, possibly totally different from any ever known.

New laws of nature are being discovered. It is not impossible that what we have believed to be natural laws are really not "natural," but rather the results of "accidents" such as great sweeping of cosmic rays upon the earth. Something of this sort is suggested in the work of a Russian scientist of note, Doctor Vassilief, who is working to make animal life and human life transparent. He has been able to make the cells of inanimate bodies transparent or invisible and believes that, by the use of radium rays, he may ultimately succeed upon living cells.

"If the bones and organs themselves be-

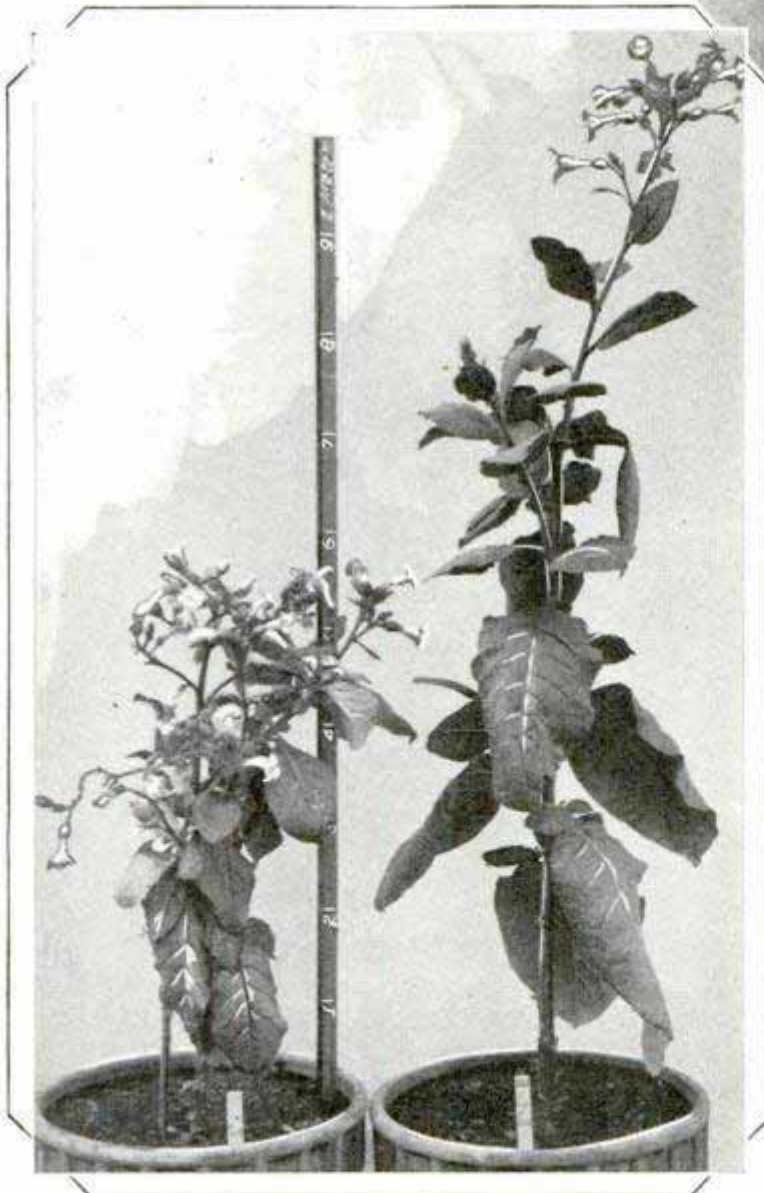
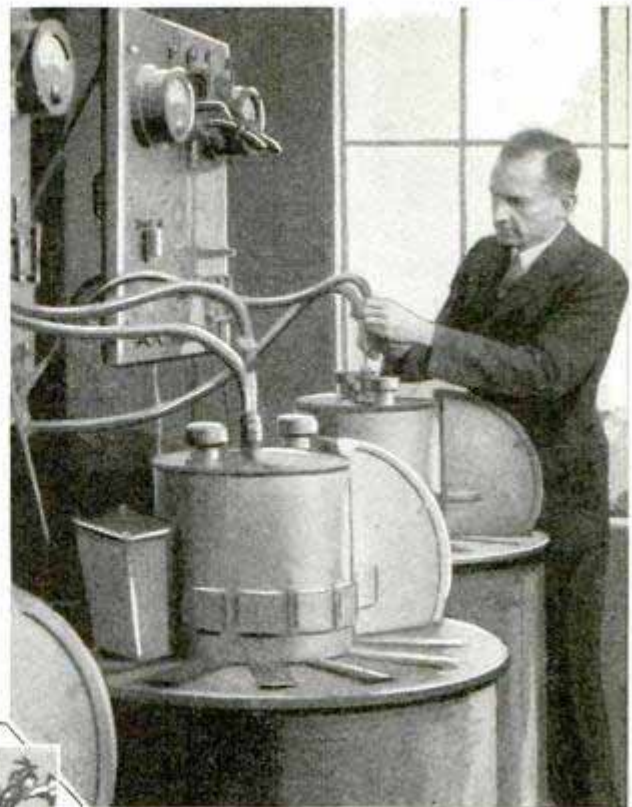

Dr. T. A. Wilson with X-Ray Apparatus, and, Below at Left, X-Ray-Treated Plant Compared with Natural One of Same Kind

come so nearly invisible, they can be slightly colored, and at one glance by a physician it will be possible to see if a person has a cancer or merely a stomach ache."

Animal life would be made to appear like the photograph taken of a pistol or automatic, showing instantly all its parts. Other effects of the rays may change the very organs in unknown ways.

Man, put together by bits of tissue and cells operating as the parts of a machine, may be changed to operate in an entirely different way by the application of X-rays. As shifting of wheels, nuts, screws and bolts changes a machine, so the X-ray changes the life form and there is a new creation.

#### AN OUNCE OF RADIUM IN EIGHT YEARS / 065

In Czechoslovakia is a chemical plant where 300 workmen have labored for eight years to produce one ounce of radium, which it is making at the rate of about three and one-half grams a year, equivalent to one-eighth ounce, and valued at about \$2,500,000.

J. A. B. to 6/28/30



35  
568

Sportakademie Sand  
Cuxhavenstrasse 17A,  
Berlin NW 23  
Germany

# LIFE-SAVING KNAPSACK HOLDS USER'S VALUABLES

retail price about 30 mark



Life-Saving Knapsacks Which Not Only Keep the Wearers Afloat, but Also Provide a Dry Place for Clothing and Other Valuables; the Buoyant Apparatus Is Worn About the Neck

Not only enabling the victim of a boat accident to remain afloat, but also allowing him to keep his valuables dry, a life-saving knapsack was recently tested successfully in Berlin. Clothing and other valuables are placed in the knapsack, which is specially treated and water-tight. The sack is worn about the neck and is so buoyant that it sustains the weight of the wearer and the contents of the bag.

abling one set to be operated with one key, and the second with another. This, for instance, enables one key to open all the locks in one section or suite of offices without operating those in other parts.

## REMOVABLE CORES FOR LOCKS OPERATED BY MASTER KEY

Door locks and padlocks with removable cores have the advantage over ordinary locks of adjustable combinations in the cores, thus enabling the owner to set all his locks on the same combination and operate locks for house, garage and even his automobile with one master key. To all outward appearances the locks resemble the usual kind, the cores containing the lock mechanism being removed with a special key. All cores are interchangeable, and if desirable, some locks can be set at one combination and others at another, thus en-

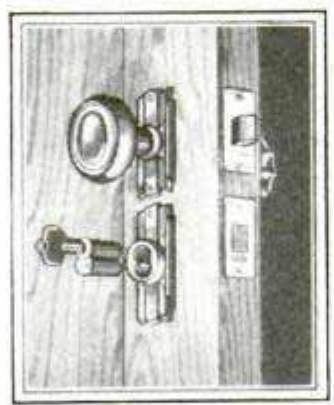

## PESTS KILLED BY ELECTRICITY

Garden pests, such as caterpillars and green flies, are being successfully electrocuted instead of poisoned by one English gardener. He has made a "death wand," an arrow-shaped copper plate connected with a simple arrangement of batteries, insulated leads and switches, the entire apparatus somewhat resembling a small radio set. There is a voltage-control switch to supply current in varying strength to different classes of plants, and, in use, the wand is flicked over leaves and stems of the infested plants, killing insects on or inside the plants without injuring the vegetation.

## REAR-VIEW MIRRORS AID PILOT SIGHT TAIL-FIRING GUN

Rear-view mirrors have been installed in one single-seater British fighting plane to enable the pilot to fire "blind" but accurately at a target behind his ship. Reflex mirror sights have been connected with a gun trained to the rear of the plane, thus enabling the pilot to obtain an accurate aim on his target by looking into

Best Lock Corpen Wilmington 908 Aranged. Th. Cal. 124

Wm. J. Neale,  
Smithborough, Tunbridge



7/10/30

London Daily Mail

B. de, Holywell, Orford, England

1130

a mirror on his instrument board. By this means he will be able to dive down at a target, sending out a hail of lead from guns trained forward, then, zooming upward, he can bring the tail gun into play. The mirrors are so arranged that, when the target is reflected in the instrument-board glass, the gun is trained on it. The sighting mirrors are electrically heated and wiped so as to give clear vision despite varying atmospheric conditions.

**MOTOR VIBRATION IS DETECTED BY USE OF EGG**

1136

As a vibration detector, an ordinary hen's egg is quite commonly used to test an airplane motor. A spoon is clamped to the motor and the egg placed in it. With a cylinder disconnected, the engine is revolved at high speed, and any vibration in the engine is at once transmitted to the spoon and the egg. Lack of vibra-



Awning Containing 6,000 Square Yards of Canvas Stretched over a Business Street to Protect Shoppers from Sun and Rain

**AWNING FOR BUSINESS STREET PROTECTS SHOPPERS**

To protect shoppers from rain and sun, merchants of Darby, Pa., purchased a vari-colored awning which was placed above the principal business street. It entirely covered the street from building line to building line.

**GASOLINE CARRIED IN PIPELINES**

1141

Gasoline shortly will be transported by underground pipelines from refineries to marketing centers. One oil company is planning a 550-mile line costing \$5,000,000 and capable of moving 15,000 barrels daily from its plant in Pennsylvania to Lake Erie shore cities, and eventually into New York state. Another company is rehabilitating an old Pennsylvania oil pipeline to move fuel westward from its New Jersey refineries, and a third plans a gasoline pipeline from the mid-continent area to St. Louis and Chicago.



Testing the Vibration of an Airplane Motor with an Egg in a Spoon Clamped to the Engine

tion allows the egg to remain perfectly still in the spoon.

Lawn Motors Ltd, 940 N. Claude Drive

Auto Topics 7/19/30



1184



in winter as in summer, but in the Canadian woods, when the temperature is forty or fifty degrees below zero, the rupture of tissues in trees caused by freezing can often be heard in the form of sharp reports. As a rule, such freezing results in vertical cracks up and down the trunk. In succeeding seasons, the tree attempts to heal over these ruptures, but layers of scar tissue remain as evidence of the freezing.

**NEON TUBES NOW RUN BY DIRECT CURRENT**

Luminous tubes, such as those used for illuminated signs, now may be operated from direct current of 110 to 120 volts with a special transformer, thus making direct-current operation as simple as has been possible heretofore only with alternating current. Previously in direct-current districts, it has been necessary to add a motor generator to the alternating-current transformer. Now, however, it is only necessary to plug the new device into the direct-current socket, substituting it for the other apparatus. It will also operate on alternating current, but the output will be only half that for direct-current work, so the brilliancy of the tubes will be cut in two. It does not interfere with radio sets, and as it has no moving or vibrating parts, does not get out of order and requires no attention. Special bulbs are used in conjunction with its operation.

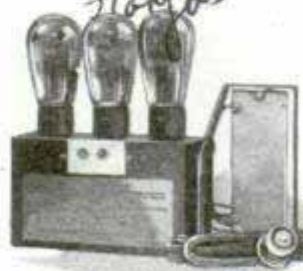

Steering Wheel of the "Powhatan," in Which Commodore Perry Visited Japan, the Trip Resulting in the Treaty Opening the Island's Ports

**PEACE SHIP'S STEERING WHEEL IS MUSEUM EXHIBIT**

One of the prized possessions of the Chicago historical society is the steering wheel of the "Powhatan," the ship in which Commodore Matthew Perry made his visit to Japan seventy-seven years ago. The visit resulted in negotiations leading to the treaty that opened the island's ports to the world and gave Japan a position among the great nations.

**SAP IN TREES OFTEN FREEZES**

Sap in trees frequently freezes during the winter, although its freezing point is considerably below thirty-two degrees, since the water in sap also contains various other substances. Trees are further protected by the fact that the moisture content near the surface is not so great

ously in direct-current districts, it has been necessary to add a motor generator to the alternating-current transformer. Now, however, it is only necessary to plug the new device into the direct-current socket, substituting it for the other apparatus. It will also operate on alternating current, but the output will be only half that for direct-current work, so the brilliancy of the tubes will be cut in two. It does not interfere with radio sets, and as it has no moving or vibrating parts, does not get out of order and requires no attention. Special bulbs are used in conjunction with its operation.

Accident-insurance policies are being dispensed by slot machines in Germany.

U. S. Forest Service

Motorless U.C. Signals  
1898 P3 id H...

1148  
1.50 7.416, 017  
see forest patents  
see forest patents  
see forest patents



# The Truth about Snakes



By DON GLASSMAN

*55 W. 86th St. New York City*

THE GREAT order of snakes—more than 1,700 recognized species—sleep with eyes wide open and hear with their tongues.

The average man will find that hard to believe. People revolt at the word "snake," and everybody is willing to whack a serpent if it can be done with impunity. Yet a reptile expert not only finds endless fascination in the lives of serpents, but claims that many species are highly beneficial to mankind, especially those that subsist on rats and frogs.

The curator of reptiles at the New York Zoological Park, Raymond L. Ditmars, staunchly opposes clubbing to death harmless snakes. "In India," says Ditmars, "the death toll from snakes exceeds 20,000 per year, largely because the natives walk barefooted; but serious injury or death from snake bite is very rare in the United States."

A student of snakes all his life, Ditmars has handled venomous and innocuous kinds, large and small. But a long acquaintance with serpents increases his appreciation of their wonder and causes him to speak of his pets sympathetically. Out of his full experience, Ditmars hopes to explode a long train of erroneous theories



Unloading a Twenty-Three-Foot Python, and Wearing a King Snake as a Bracelet

about snakes. The various rattlesnake species are confined to the New World. Yet the "pit vipers," to which the rattlesnakes belong, are found in both hemispheres. All ten species of the cobra are found in the Old World and not all of them spread a hood. The Elapidæ snakes



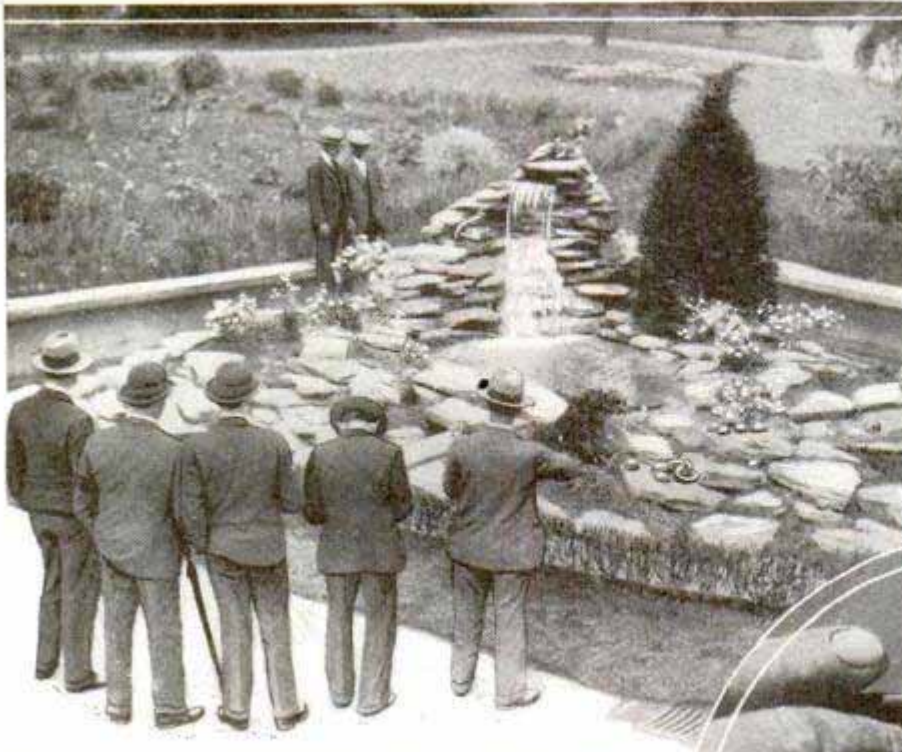

Reptile Garden in Philadelphia Zoo, and Close View of the Fangs of a Rattlesnake

swarm in Australia, which is one of the few parts of the world where poisonous snakes exceed non-poisonous ones. Madagascar is the only large country in warm climate that is entirely free from dangerous serpents.

What distinguishes snakes from most animals is the absence of eyelids. The eyes are ever open, and they can be awakened by "seeing" motion in sleep. Also, snakes have no sign of an external ear. A snake can tune his highly sensitive tongue to receive the faintest sound waves, just as a radio set receives electric waves.

But the snake's expansive jaws are most wonderful. Aside from being able to swallow relatively immense animals, certain species have poisonous teeth, or fangs. Essentially, the snake's fangs are hypodermic needles, and they operate exactly as do those needles used by doctors. When the mouth is closed, the fangs of viperine teeth fold back against the roof; as the jaws open, these dangerous weapons spring out, ready to inject deadly poison.

Although without developed limbs, the snakes can move swiftly and directly. The broad plates on the abdomen are the real organs of locomotion. In crawling, a snake walks upon these plates by bringing them forward in series along the body, then pulling them back again. Most snakes

are good swimmers. The tree-dwelling snakes are usually elongated like whips. The subterranean snakes bore their way through earth like worms.

Ditmars believes the regal python is the largest species of serpent, actually reaching a length of thirty feet.

Wherever snakes are found in North Amer-



ica, the garter snake will be among them. It is easily the most abundant species in America. Frogs, toads and earthworms are its principal foods. Water snakes are harmless and should not be confused with poisonous moccasin snakes.

The black snake is also familiar to Americans. It is very agile and skims over rocky surfaces in search of rodents, birds, frogs and the young of other snakes. It will dart away from a man, but when cornered will fight savagely. The black snake is highly beneficial to the farmer.

Ditmars considers "spectacled" cobras the most vicious snakes to be seen in captivity. King cobra is the lion among the serpents. Ditmars considers it the most dangerous of poison-secreting snakes.

The United States is rich in the relative proportion of reptile life within its boundaries. Of the 111 species in the country, seventeen are poisonous. In addition, we have ninety-seven species of lizards, only



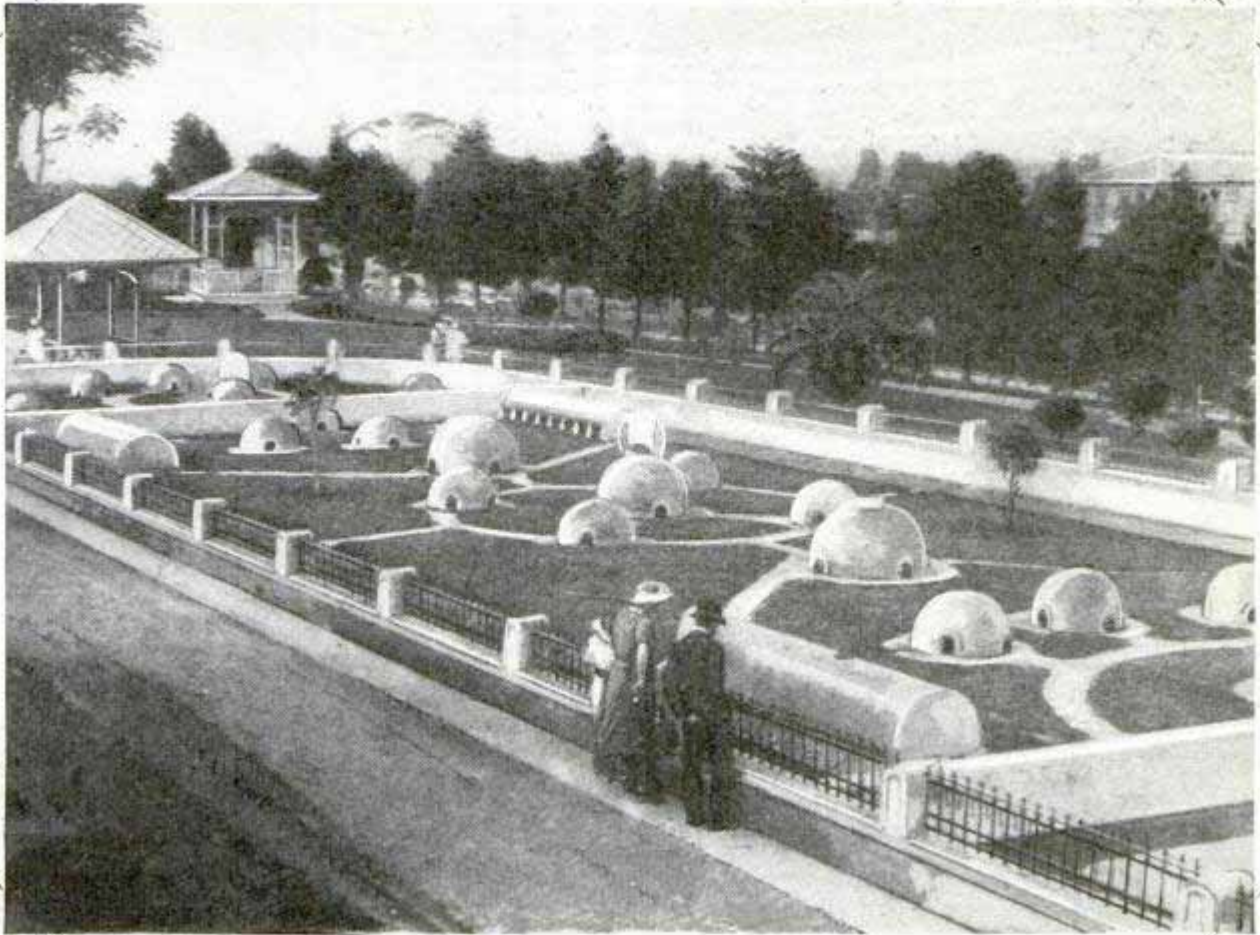

Where Poisonous Snakes Are Raised for the Preparation of Serums to Counteract Their Bites; Reptile Gardens and "Bungalows" at Butantan, near Sao Paulo, Brazil

one of which, the gila monster of the southwest, is poisonous.

The coral snake is the most difficult venomous species to distinguish from innocuous varieties. Its skin pattern consists of alternating rings of red and black, the latter bordered by very narrow rings of yellow. Any snake having a rattle is poisonous.

The two North American moccasins, the water moccasin and copperhead, belong to the same subfamily as the rattlesnakes, namely, the pit vipers. On each side of the head, between the ear and eye, they have a deep pit, by which they may be distinguished. Our harmless snakes have round eye pupils; the water moccasin and copperhead have an elliptical—catlike—pupil.

"It is quite wrong to believe," says Ditmars, "that a poisonous snake springs at its enemy. It never jumps from the ground and seldom strikes more than one-third of its length. Poisonous snakes never chase an enemy. Their attitude toward man is entirely that of self-defense.

It is impossible to render a venomous snake permanently harmless by extracting the fangs."

Usually a person is bitten on the arm or leg. His safety depends upon how promptly he is treated. A ligature—tight bandage—should be applied directly above the bite. Next, enlarge the punctures, at least as deep as they are. The flow of poisoned blood should be quickened in every way possible. If there are no fresh cuts or abrasions in the mouth, it is harmless to suck venom from the wound. Wash the cuts thoroughly, then bathe in permanganate of potash, dissolved in water until its color resembles deep-red wine.

If a doctor is not available, an anti-toxin called anti-venine, should be injected, preferably under the skin of the abdomen. This antitoxin can be obtained from agencies of the Pasteur institute.

After the wounds have been bled and washed with permanganate, the bandage may be removed, but not before all possible venom has been extracted from the bitten flesh, both by suction and massage.







PONTOON-HYDROPLANE PROMISES HIGHER SPEED

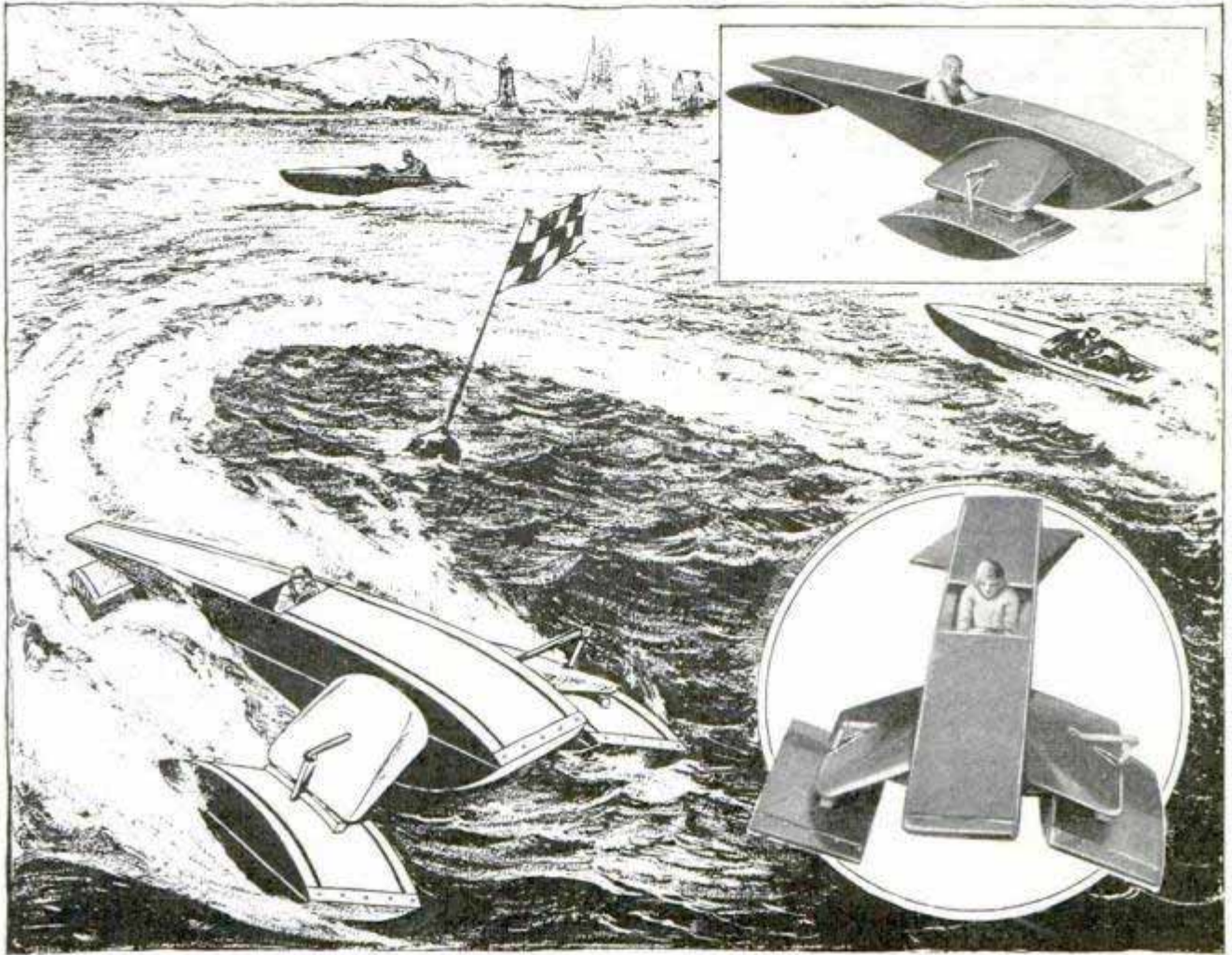

Model of a Hydroplane, Which in Reality Consists of Three Small Hydroplanes Operating as a Unit; Drawing Shows How the Forward Pontoon Can Be Banked to Prevent Skidding

Greater safety and stability and steep turns at high speed, without skidding or capsizing, are hoped for in a hydroplane designed by Thomas A. Edison Lake. The accompanying illustrations of a model show some of the chief features. The boat is really three small hydroplanes, joined by a framework. There is three-point contact with the water, to help keep the craft on an even keel. Steering is done with the rear hull and, on quick turns, the two forward pontoons can be banked at an angle, in order to counteract any tendency to skidding.

or cottonseed hulls, it lasts longer and requires no upkeep. High heels will not cut it, and the hog-bristle grass comes in light layers easily handled.

SILENT VIOLIN FOR BEGINNERS HAS NO SOUNDING BOARD



Intended particularly for beginners, a "silent violin" has been so constructed that only the player can hear the notes. It is built along conventional lines without any sounding boards. Since there is no amplification, the notes produced are faint.

HOG BRISTLES FOR GRASS

Hog bristles set in rubber and tinted green are now being used as a green for portable miniature golf courses, the bristles slowing up the ball almost like real grass turf. While the first cost is greater than for the artificial greens of flax straw

*Carrie-Soudie Co.*  
 26th & Penn  
 37 - Ma

*1138 Prof. Beche*  
*1134*  
 by Institute for Acoustics  
 Berlin, Germany



Rev. H. Barker  
H. Boomer

1129

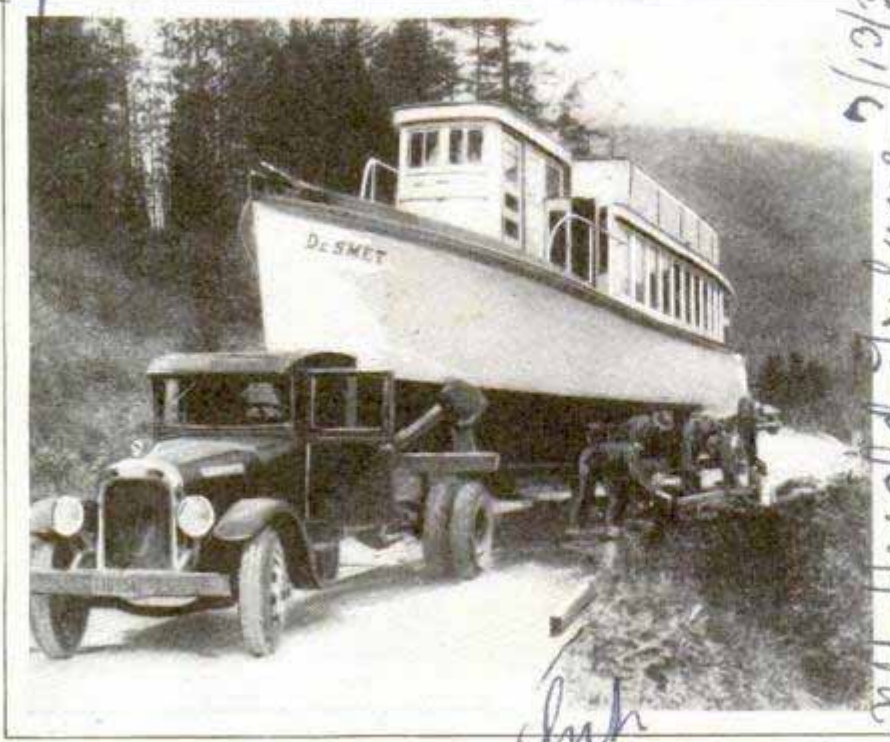

A Sixty-Foot Cabin Cruiser, with Room for 125 Passengers, Being Taken over the Continental Divide on a Motor Truck

### GASOLINE MADE FROM TAR

Gasoline can be produced from natural tar sands found in western Canada, chemists of the University of Alberta report. The sands lie in strata, similar to the beds of oil fields except that the compounds do not contain so much liquid material as would be necessary for it to flow out of the sands and be useful. It is possible, however, to extract the oils by a chemical process known as "hydrogenation," now employed in Germany to make oils from low-grade brown coal. It requires enormous

My Herald Tribune 7/13/30 1110

### CRUISER GOES OVER MOUNTAIN ON A TRUCK TRAILER

Transporting a sixty-foot cabin cruiser from the point in Montana where it was built to a mountain lake in Glacier national park recently offered a difficult problem for the owners until a motor truck and trailer was pressed into service. The truck hauled the boat, capable of carrying 125 passengers, through the mountains without mishap to the point where it was to be placed in its native element. During the trip the craft was taken across the continental divide.

quantities of hydrogen gas which is combined with the tar so that it is converted into the constituents of fluid oils or gasoline, the atoms of hydrogen combining with the molecules of the tarlike substance to produce the change. A source of the hydrogen has been found in the natural gas wells of the same region.

### NEEDLE THREADER SAVES TIME OF BUSY HOUSEWIFE

To save the time and patience of the busy housewife, a simple needle threader is available with which needles having even the finest eyes are quickly threaded. It consists of a round piece of metal to which is attached a fine steel wire, bent to diamond-shape with the long end tapering to a point. The point is pushed through in the eye beyond the diamond-shaped section. The thread end is then pushed between the spread wires and the threader withdrawn, pulling the thread with it through the eye.



### CANDLES IN BALLOONS BANNED AS FOREST-FIRE HAZARD

Weathermen in California, who have been accustomed to finding the direction and velocity of winds aloft by sending up small balloons equipped with little lanterns carrying tallow candles to make them visible at night, have been ordered to stop this practice because of the danger of starting forest fires. The balloons used for this night-observation work burst and the protected candle falls, often burning until it reaches the ground. Airmen will be deprived of the reports until a safe light is found.

Warman

New York

cannot locate maker

Scene Service News  
Bulletin 486 a  
7/11/30

Sold by A. G. Nester  
Sewing Machine Co.



# Three Hundred Fathoms Beneath *the* Sea



Two-Ton Steel Chamber, Six Feet in Diameter, in Which William Beebe and Otis Barton, His Assistant, Descended to a Depth of 1,426 Feet below the Surface of the Sea

*Wide World*  
Book kept can furnish  
"Beneath Tropic Seas"



991  
578

POPULAR MECHANICS

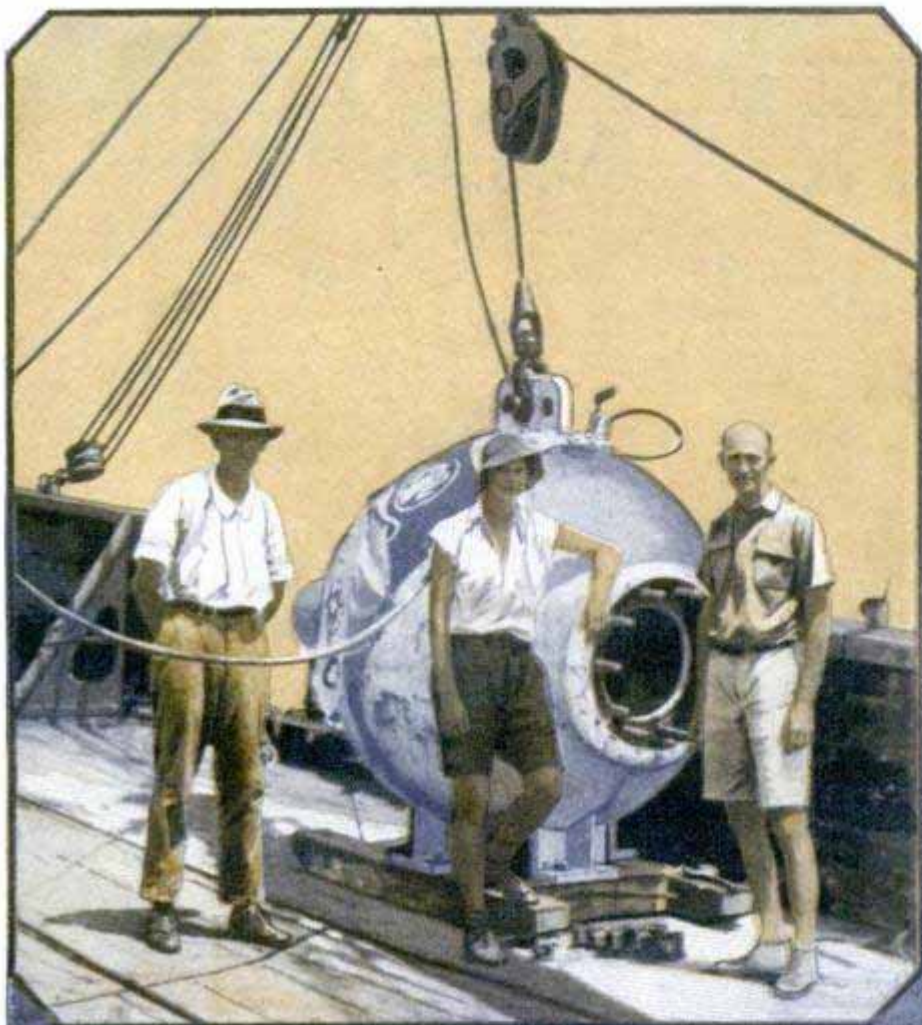

Left to Right, John Lee Van, Gloria Hollister and William Beebe, Standing beside the Diving Sphere, and, Below, an Underwater Torch Bearer, a Creature Found 800 Fathoms Deep; the Projecting Tentacle on Its Head Carries a Glowing Luminous "Lamp" That Lights the Way; the Portholes of the Diving Chamber Are Fitted with Strong Fused-Quartz Glass; the Interior of the Sphere Is Kept at Sea-Level Pressure, While the Exterior Is Subjected to a Pressure of About 20,000 Pounds to the Square Inch at a Depth of 1,400 Feet; an Oxygen Reserve Is Depended Upon for the Air Supply inside the Chamber, and Communication Is Carried on with the Ship by Telephone; Mr. Beebe Remained Down Half an Hour at a Depth of 1,400 Feet



© William Beebe

33 W 67 St.





The Diving Chamber Being Lowered from the Ship by Its Strong Steel Hawser; Electric Cables Are Connected to Provide Current for the Lamps inside the Ball and to Illuminate the Submarine Darkness Outside; at Right, Pilot Joseph Millet and William Beebe at the Wheel of the "Ready," the Service Ship; Explorer Beebe's Submarine Adventures Are Doing Much to Give the World Authentic Information about the Ocean Depths; He Has Obtained Many New and Interesting Forms of Submarine Life for Other Scientists to Study; How Animals Adapt Themselves to the Depths Is One of the Interesting Sidelights of Deep-Sea Study





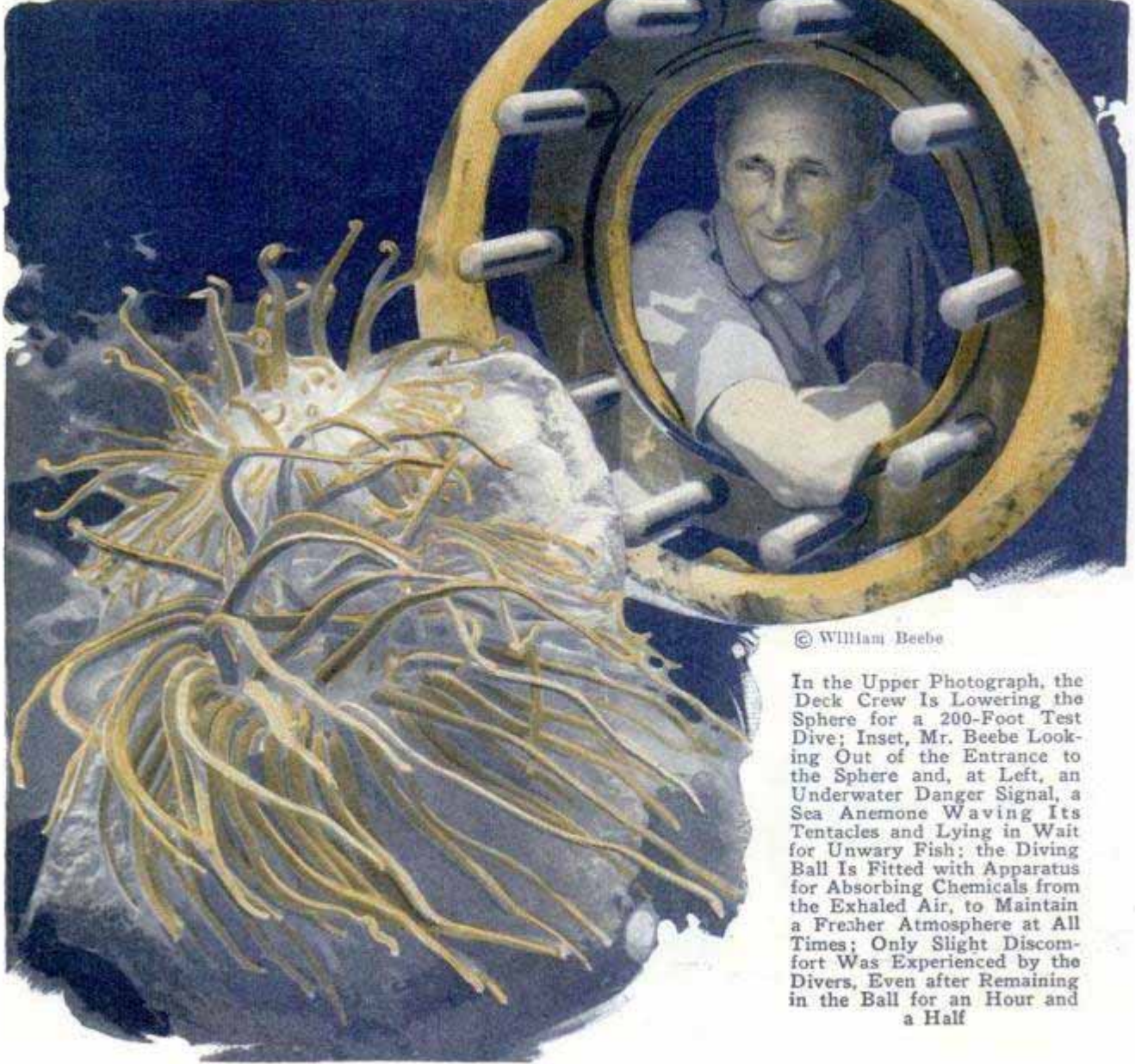
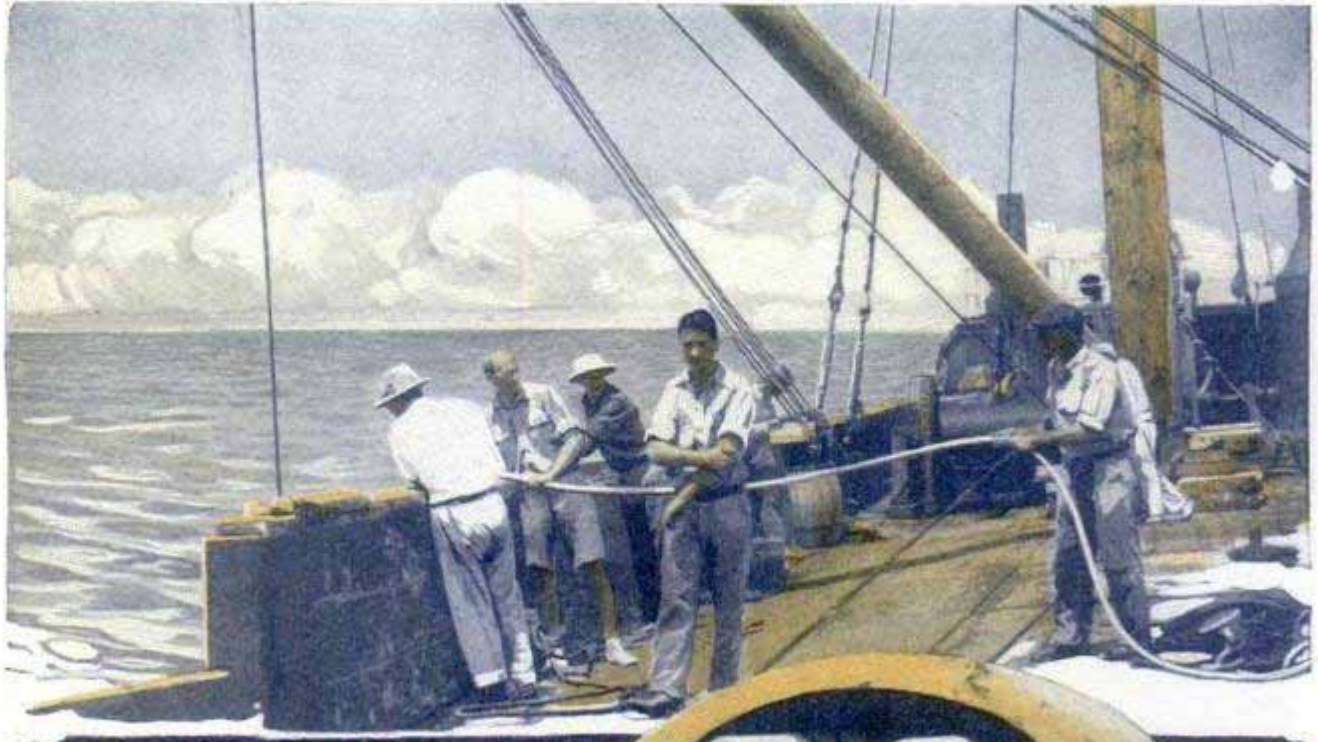

© William Beebe

In the Upper Photograph, the Deck Crew Is Lowering the Sphere for a 200-Foot Test Dive; Inset, Mr. Beebe Looking Out of the Entrance to the Sphere and, at Left, an Underwater Danger Signal, a Sea Anemone Waving Its Tentacles and Lying in Wait for Unwary Fish; the Diving Ball Is Fitted with Apparatus for Absorbing Chemicals from the Exhaled Air, to Maintain a Fresher Atmosphere at All Times; Only Slight Discomfort Was Experienced by the Divers, Even after Remaining in the Ball for an Hour and a Half



At Right, Mr. Beebe Attaching a Clamp on the Cable; Below, Spotted Ray of Bermuda Whose Spine Is Poisonous and, at Bottom, an Illuminated White Fish Found at Depths of One Mile; the Cluster at the Left Is Sea "Lettuce," a Growth Somewhat Similar to Kelp; Until Comparatively Recent Years, It Was Thought That Vegetation Covered the Bottom of the Sea at Practically All Depths, but It Is Now Known That Plants Do Not Grow below the Level That Sunlight Penetrates, a Depth of Not More than 500 or 600 Fathoms; below This Level, However, Animal Life in Many Forms Abounds; the Specimens Vary According to the Layer or Zone of Pressure and Temperature in Which They Live; the Greatest Variety of Marine Life Is Found at Depths between 500 and 2,000 Feet, While Only the Rarer Forms of Fishes Are Known to Thrive between 1,500 and 3,000 Feet; How Far Does Life Extend in the Ocean Depths? That Is One of the Questions Scientists like William Beebe May Answer; the Extreme Depths Are Cold, Absolutely Dark, and the Pressures There Are Enormous; Sponges and Mollusks Have Been Dragged Up from Depths of Over 4,000 Fathoms

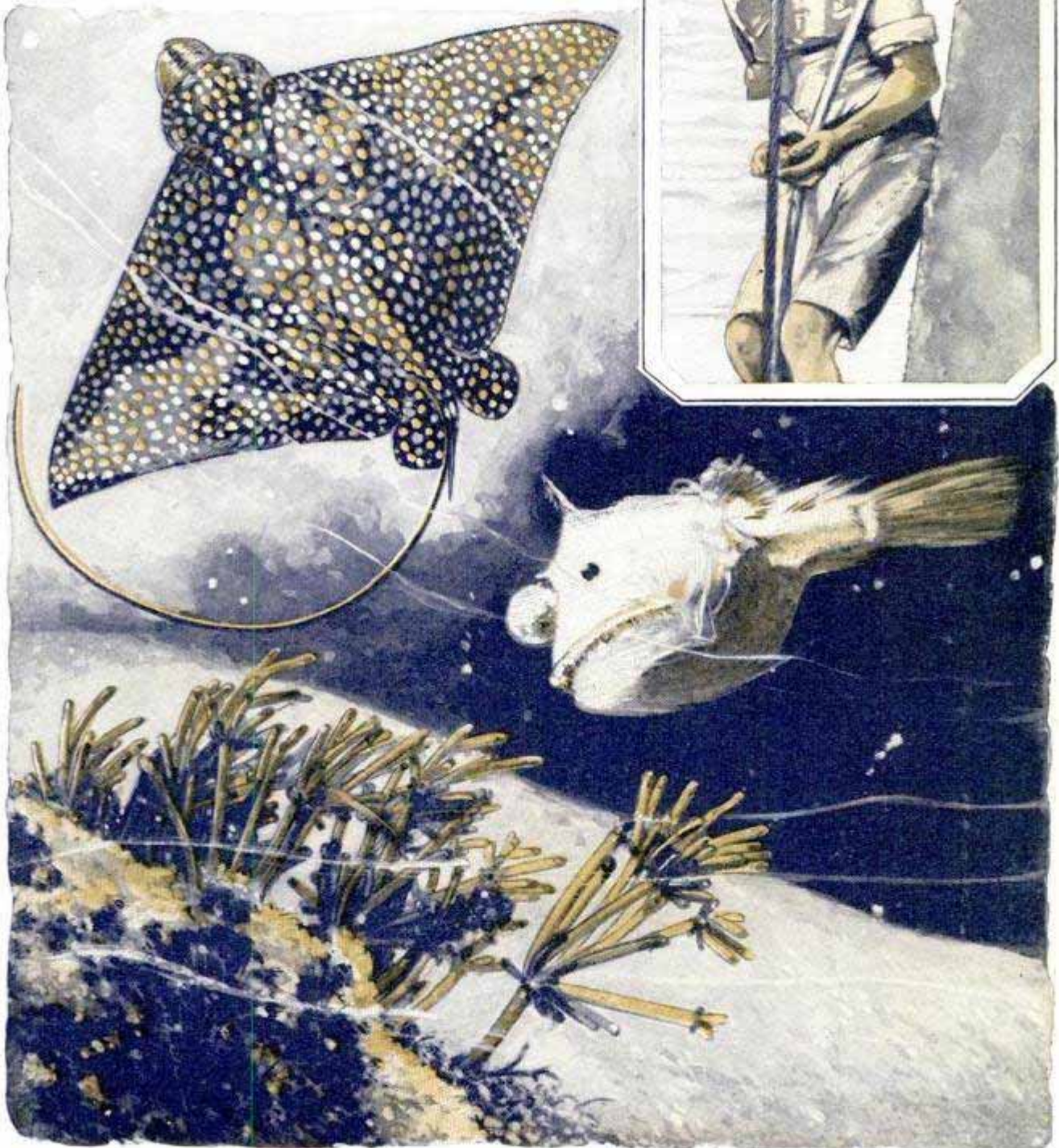
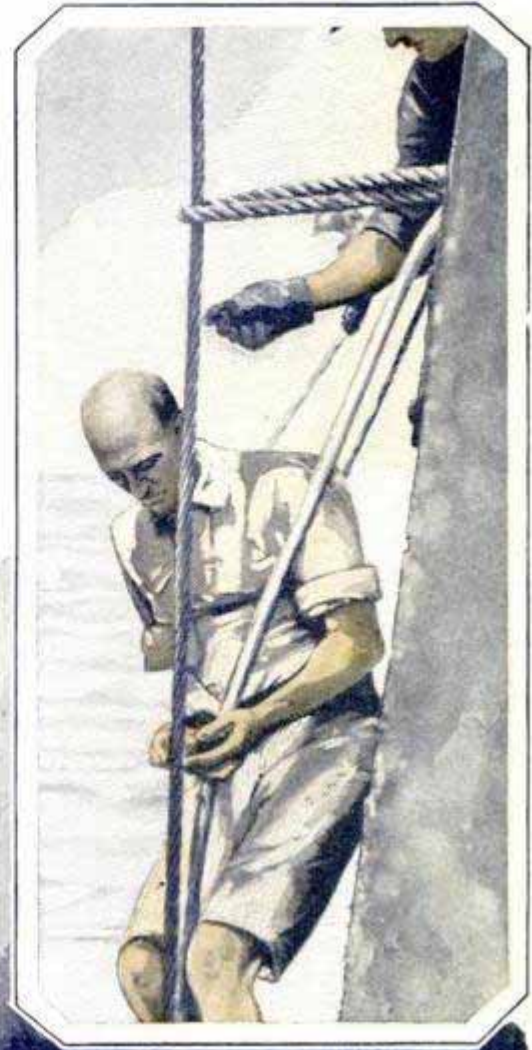



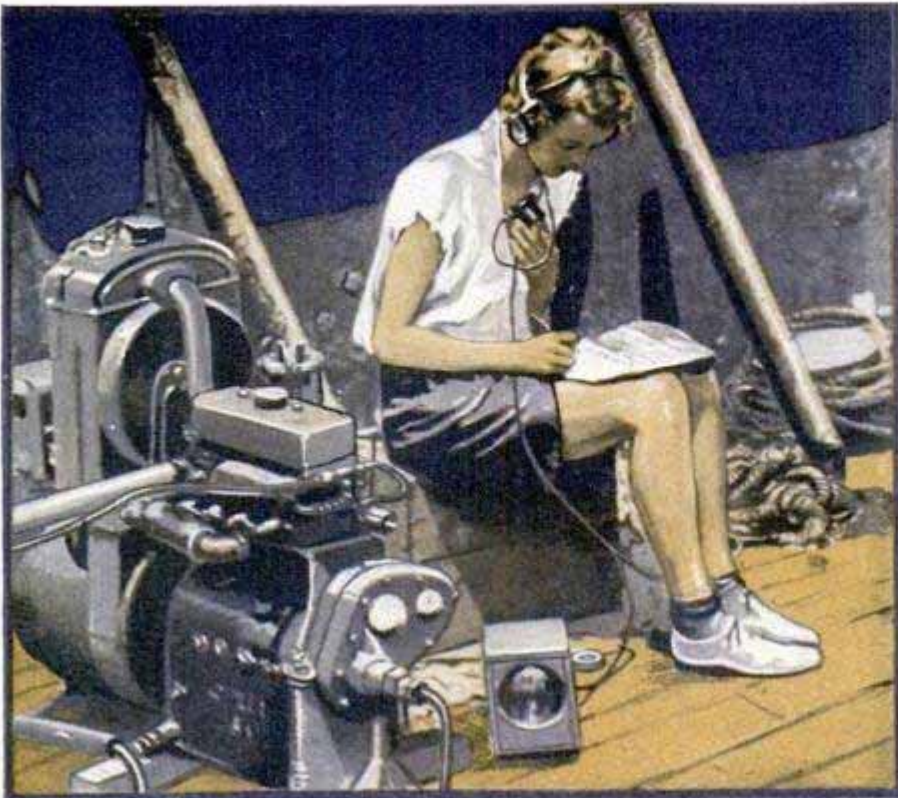

Gloria Hollister at the Telephone Connected to the Diving Sphere, and, Below, the "Eater of the Stars," a Black Fish of Voracious Appetite, Pursuing Its Luminous Prey on the Surface of the Ocean at Night; Mr. Beebe Plans Dives to Greater Depths Than He Has Yet Reached; Engineers Believe That a Ball Can Be Built to Go Down to Depths of Half a Mile without Difficulty; with Every Fathom, the Pressure Increases Until, at 5,000 Fathoms, About the Greatest Known, It Becomes Approximately Six Tons to the Square Inch

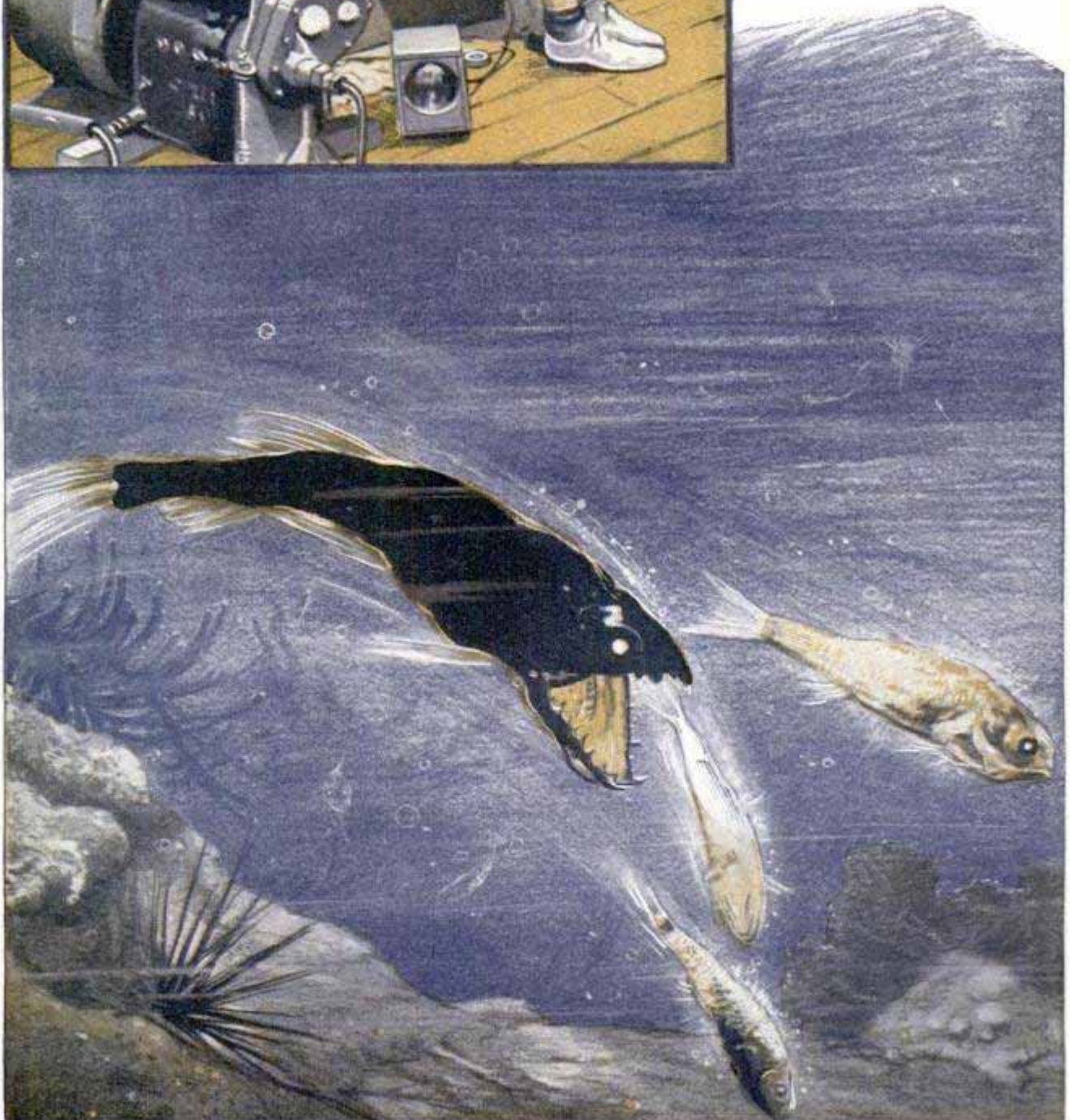



Full View of the Diving Bell, Showing Entrance Door; Below, a Silver Hatchet Fish with Violet Lights That Point Downward While Its Eyes Look Upward, and a Deep-Sea Fish That Has Swallowed Another Almost as Large as Itself; More Than Half of the Area of the Globe Is Covered with Water, but Little Is Known of the Life under the Seas; Animal Life Is Found at Submarine Levels Far below Those at Which Vegetation Ceases to Appear; Possibly Some Form of Living Thing Exists to the Greatest Depths, Estimated to Be More than 25,000 Feet; Sea Life Is More Abundant in Tropical than in Polar Waters; Mr. Beebe's Observations, Here Recorded, Were Made off the Coast of Bermuda under the Auspices of the New York Zoological Society, and Further Explorations at Much Greater Depths Are Being Planned with Apparatus like That Used on This Venture like That Used on This Venture

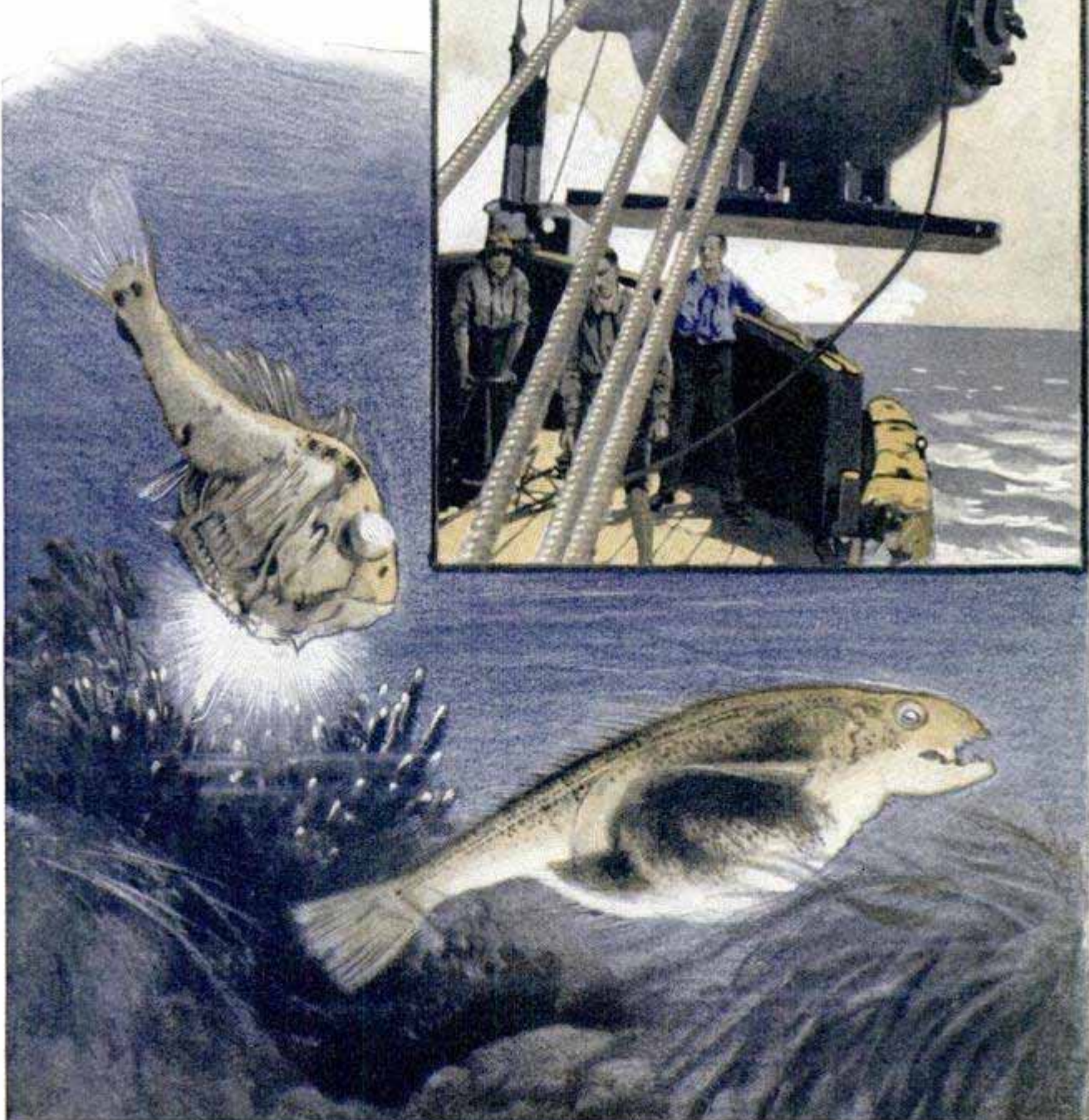
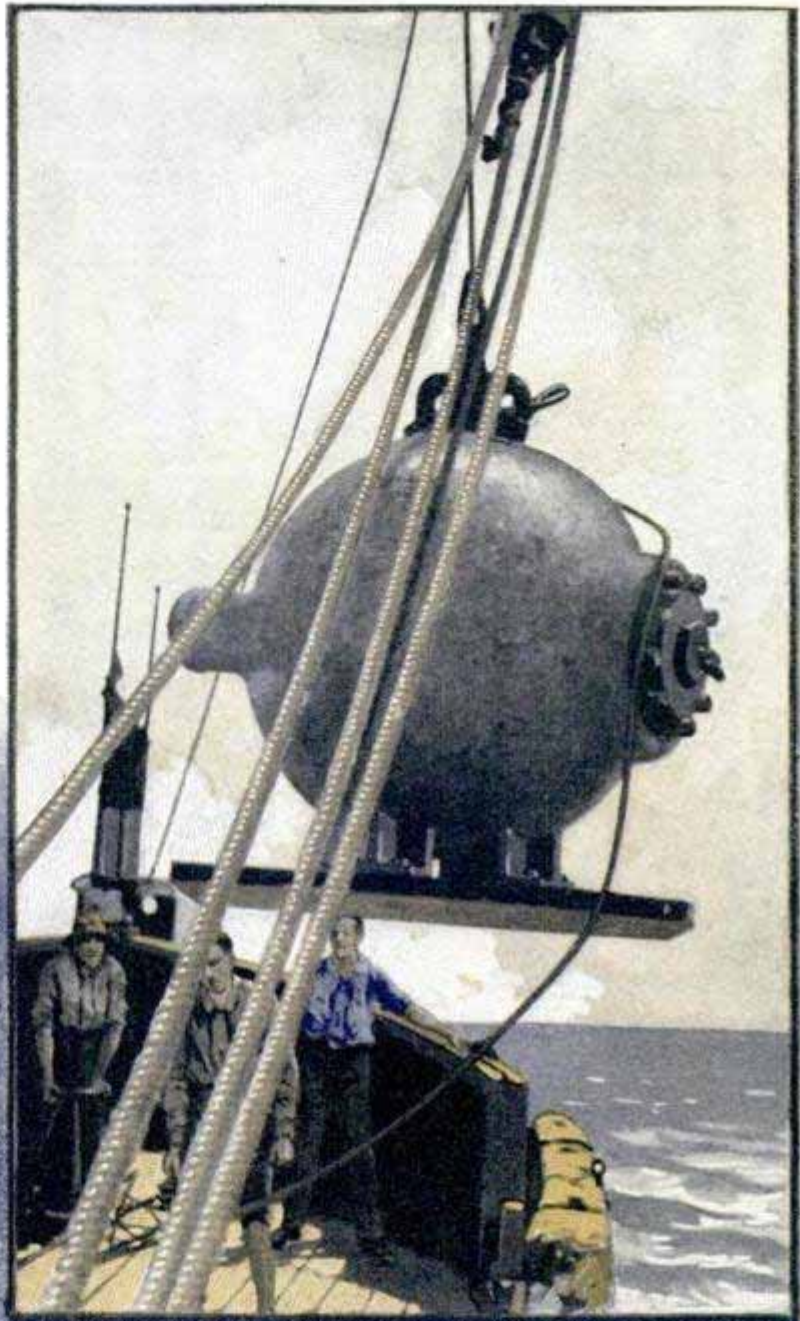



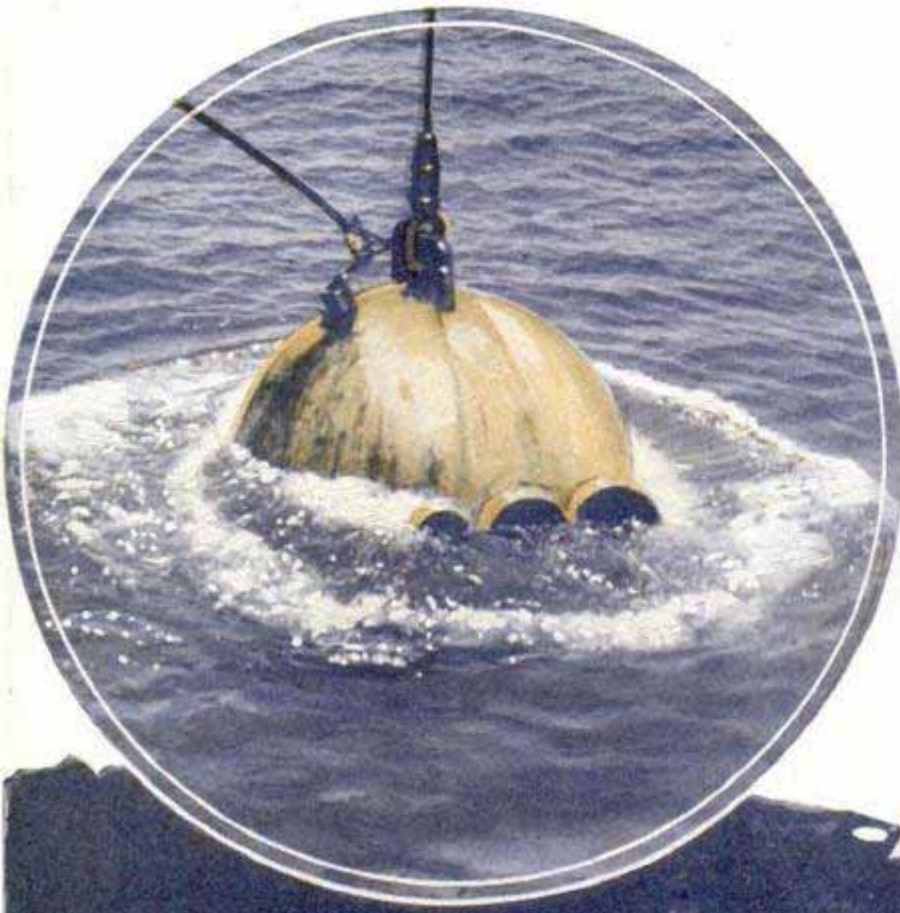

Lowering the Diving Sphere for a Test Dive, and Odd Specimens of Sea Life Dragged Up in Nets from Great Depths; the Curious Little Creatures Fought and Devoured Each Other Until the Very Last and Were Aglow with White, Yellow and Pink Lights; Until Recently, Scientists Were Dependent upon Hooks and Nets to Obtain Specimens from the Deep, but Today, with the Diving Bell, the Submarine Camera, Powerful Lights and Telephones, Observers Are Able to Visit the Depths and There Study and Record the Life Discovered in Its Natural Habitat; Besides the Wide Interest in the Strange Forms of Life from the Deep, There Is an Economic Appeal Also for the Ocean Depths May Yield Hitherto Un-suspected Riches in Foods and Chemicals





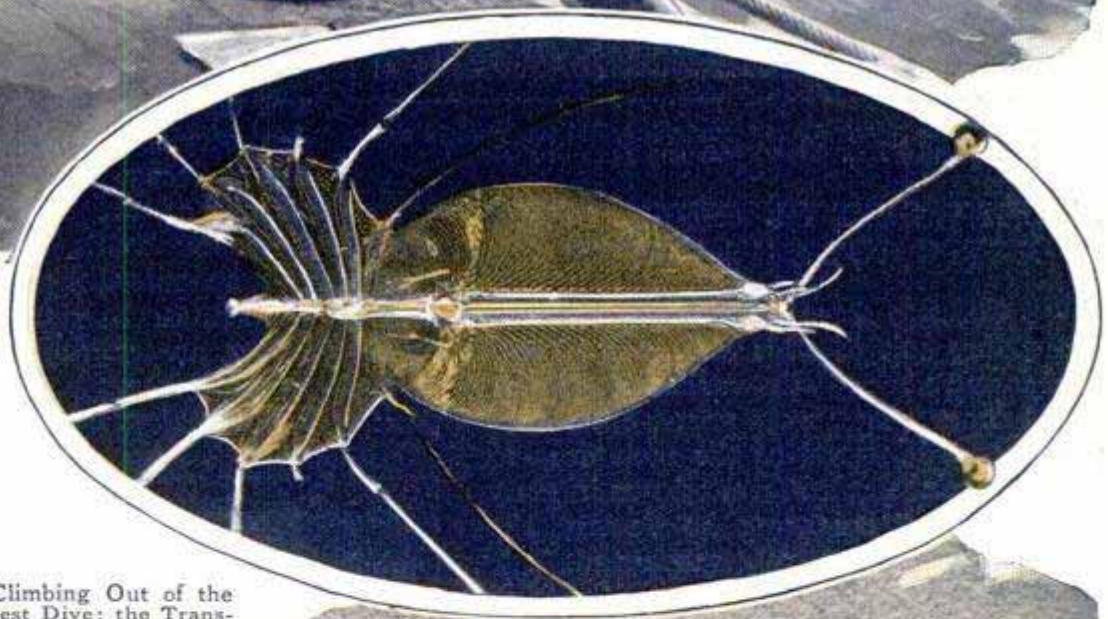
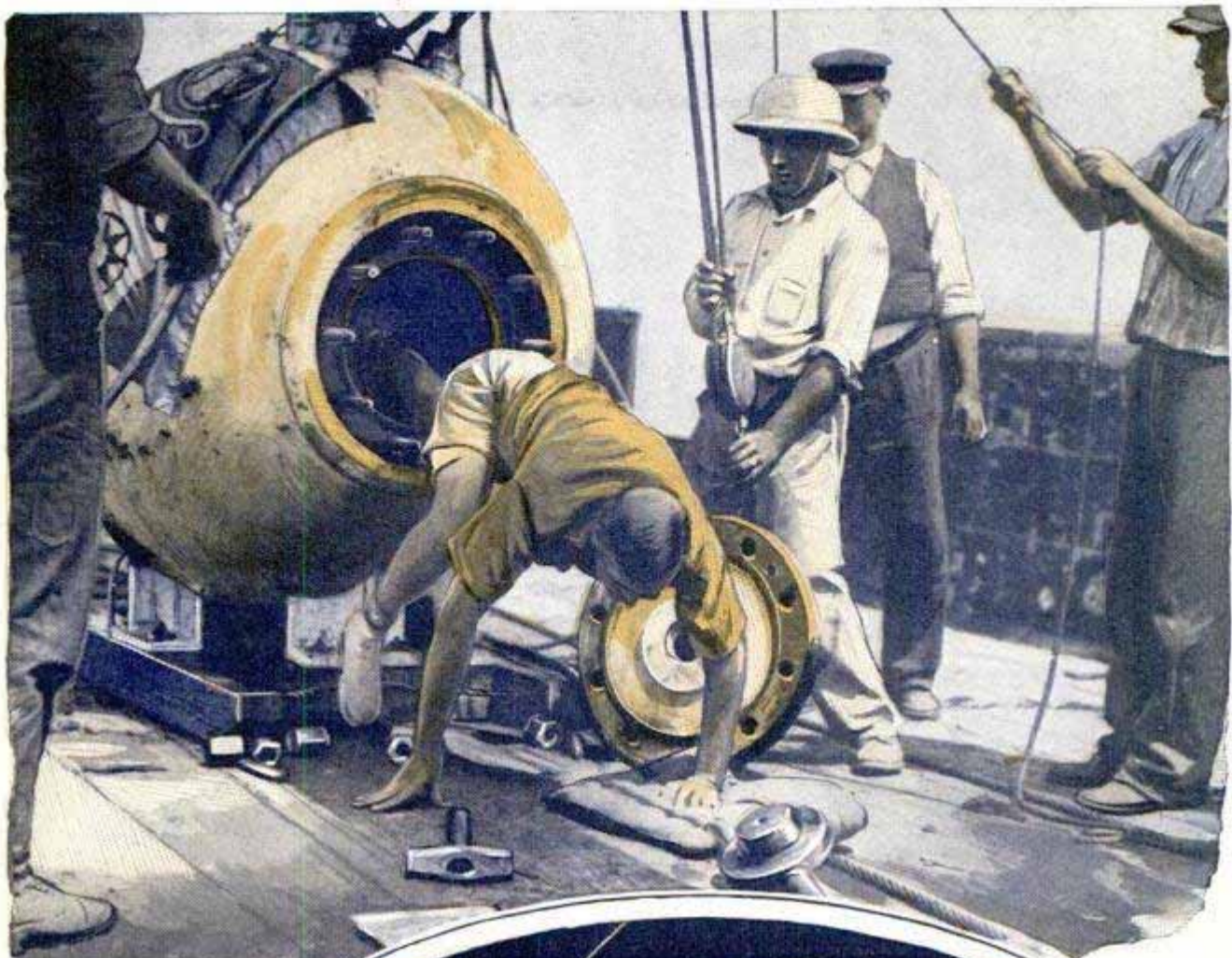

William Beebe Climbing Out of the Sphere after a Test Dive; the Transparent Larva of the Giant Bermuda Lobster as Pictured by the Camera, and, Below, Volonia, a Specimen of Sea Weed; These Cells are the Largest in the World, Each Being Complete within Itself; Note How Thick the Walls of the Diving Sphere are and How Firmly the Door or Lid Can Be Clamped Down; the Occupants Felt a Slight Discomfort Due to a Change in Air Pressure after Being Released; the Pressure inside the Ball Increased a Bit When the Oxygen Was Let Out of the Reserve Tanks; Part of the Increase Was Canceled, However, as Chemicals Absorbed the Carbon Monoxide Exhaled by the Divers





1239

196  
no information available  
9/15/38

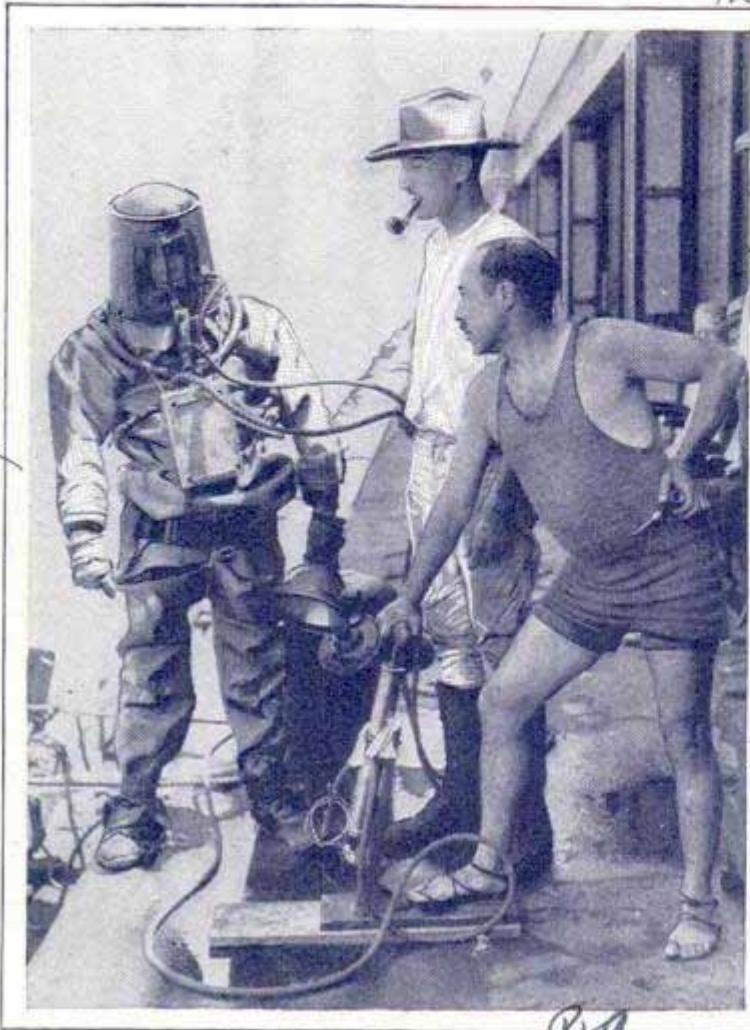

Homemade Diving Suit Constructed from Old Automobile Inner Tubes and a Few Other Odds and Ends of Material

### A DIVING SUIT OF INNER TUBES KEEPS OUT THE WATER

Two Chicago divers recently constructed a diving suit of odds and ends of material found about their workshop, relying on old inner tubes from automobile tires for most of it. One of the men donned the completed suit and went down in sixty feet of water, emerging to declare the homemade outfit entirely successful.

### TREES USE BARREL OF WATER A DAY IN SUMMER

1249

Trees need large quantities of water to keep them in healthy condition. An apple tree thirty years old gives off about a barrel of water a day in summer, and a good-sized birch gives off twice that much on a hot day. A single oak is known to have given off into the air in the form of vapor more than 100 tons of water in one growing season.

Comr Slurghit Lloyd  
Capitol Hill Sta Box 96

### PLANT DISEASES COST BILLIONS A YEAR

Plant diseases are responsible for a loss amounting to about \$1,500,000,000 annually in the United States, according to estimates of Dr. R. J. Haskell, in charge of the plant-disease survey. In Canada, the loss is estimated at \$45,000,000 and England's loss is calculated at one-tenth the value of its plant products. The American wheat crop is reduced by about 97,000,000 bushels a year through rusts, root rots, smuts and other infections, while the corn crop is curtailed approximately 271,000,000 bushels and potatoes by about 95,000,000 bushels. The banana industry also is threatened by a fungus known as the Panama disease.

1239  
Derald Inbume 9/30

### ANIMAL DENTISTRY AIDS IN FINDING CAUSES OF TOOTH DECAY

1218

Experiments with cows, hogs and monkeys aid the scientists of dentistry to discover the causes of tooth decay, find defects in the bony structure of the body and develop special diets for tooth building. Nose clamps and speculum spreaders, instruments very similar to smaller ones used on the human, are employed to force the animals to keep their mouths in proper position for dental examination.



Examining a Cow's Teeth for Defects; Studying the Teeth of Animals Aids Dental Science



## WORLD IN MINIATURE SHOWN IN BUILDING LOBBY



Two Views of a 4,000-Pound Globe, Twelve Feet in Diameter, in the Rotunda of a New York Building; It Revolves Once Every Ten Minutes

One of the most elaborate geographical, astronomical and meteorological exhibitions from a practical standpoint is contained in the lobby and rotunda of the New York Daily News building, recently opened. In the center, revolving in a lighted pit, is a 4,000-pound globe, twelve feet in diameter. From the top of the rotunda, rising four stories, with walls of black glass separated by silver bands, a sun shines down on the miniature world, while reflections in the glass give a definite impression of vast space. The globe makes a complete rotation each ten minutes. Around the rotunda are panel exhibits including a thirty-inch mechanical glass globe, utilizing internal illumination to show the daily, seasonal and annual aspects of the earth and sun, a calendar arrangement showing moon rise and set in all phases and at all altitudes, a map of the United States, Mexico, West Indies and portions of Canada, showing railways, time-zone boundaries, air-mail routes, passenger and express air routes and lighted

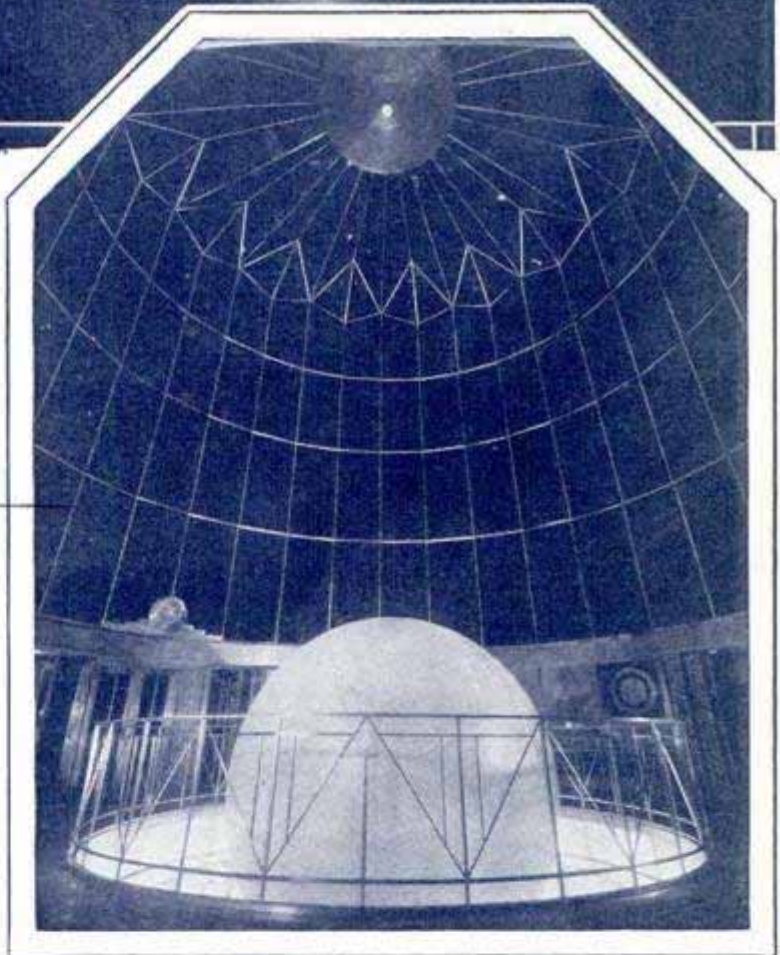

airways. In addition there is also a standard time-zone clock, showing simultaneous times in all zones, the principal cities in each zone, and denoting, by shading, dawn, dusk, night and day throughout the world. A weather map of the entire northern hemisphere shows average weather conditions for the United States, Europe and the Atlantic ocean.



1020

Mr. C. C. ...  
Pictogram Co. Box 49  
Washington, D.C.

# Treasures *from*

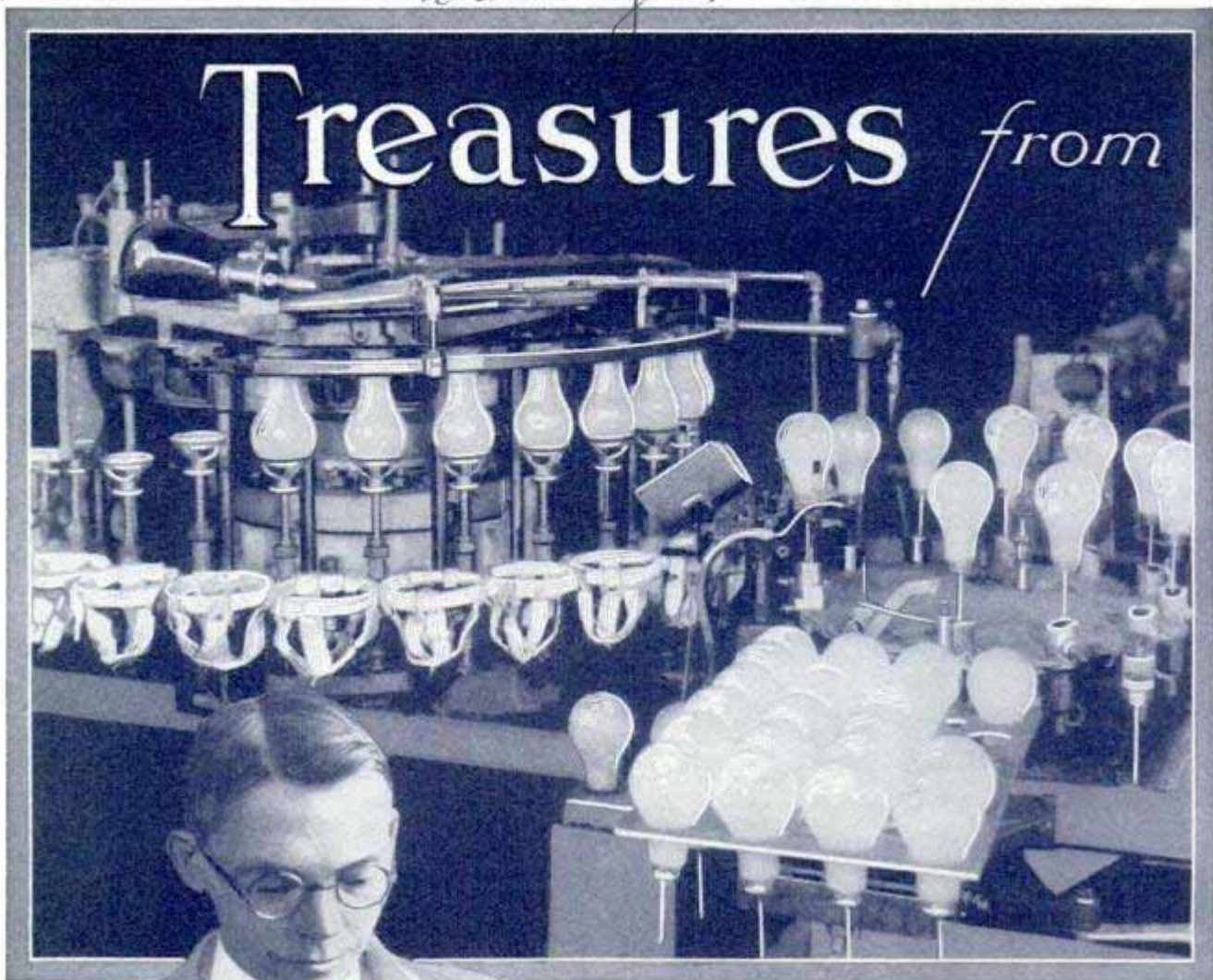

Filling Electric-Light Bulbs with Argon and Nitrogen, and, Left, Quartz Hot-Cathode Neon Lamp for Aircraft Beacon

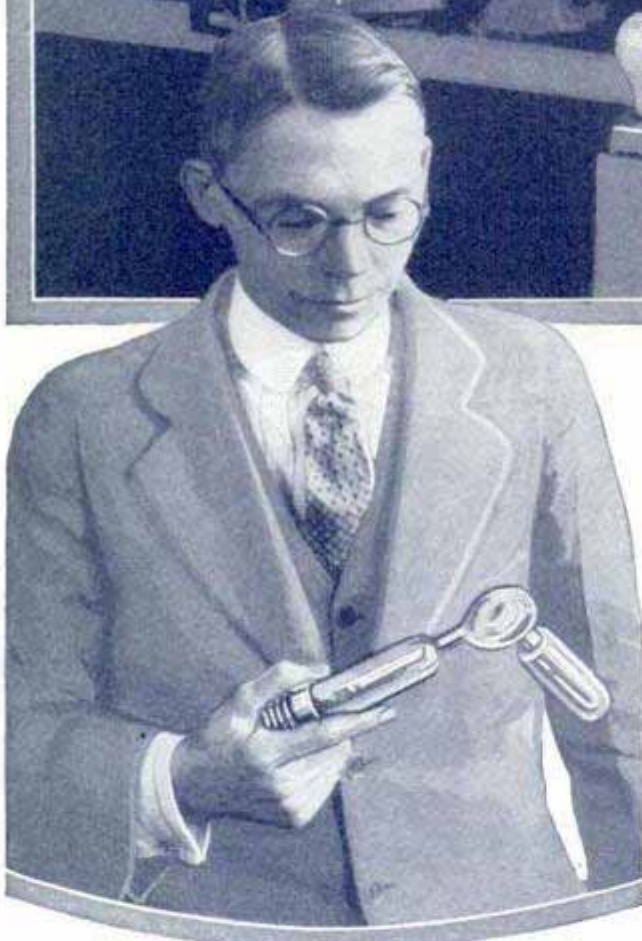

**M**AN'S dependence upon the atmosphere as a source of things necessary to his existence and conducive to his comfort is an old story. From this source he has always obtained oxygen for breathing and for the combustion of fuel; carbon, gleaned from the air by plants and used by man as fuel and food; his entire water

supply, fed from the clouds to the streams as rain and snow, and compounds of nitrogen, essential to the fertility of the soil, formed from the free nitrogen of the air partly through the action of lightning and partly through minute organisms.

Only recently, however, has he begun to draw upon the air for blessings not supplied by the spontaneous processes of nature. Today he looks upon the air as a mine of precious substances obtainable, like the metals and minerals under his feet, by artificial methods of extraction. Some of these substances were not even known to exist until about a generation ago.

The discovery of the so-called "rare" gases of the atmosphere, made in the last decade of the nineteenth century, was a startling scientific event, though its important practical bearings were not realized at the time. Argon, the most abundant of these gases, forms nearly one per



# the Air

cent of the air by volume—while the mass, or weight, of all the argon in the atmosphere is about five times that of all the water vapor—so that the fact that it escaped detection until the year 1894 seems astonishing. The other rare atmospheric gases discovered at the same period—helium, neon, krypton and xenon—form very minute fractions of the atmosphere, but their rarity is only relative. Xenon, the rarest of all, is present in a sample of air only to the trifling extent of nine parts in a hundred

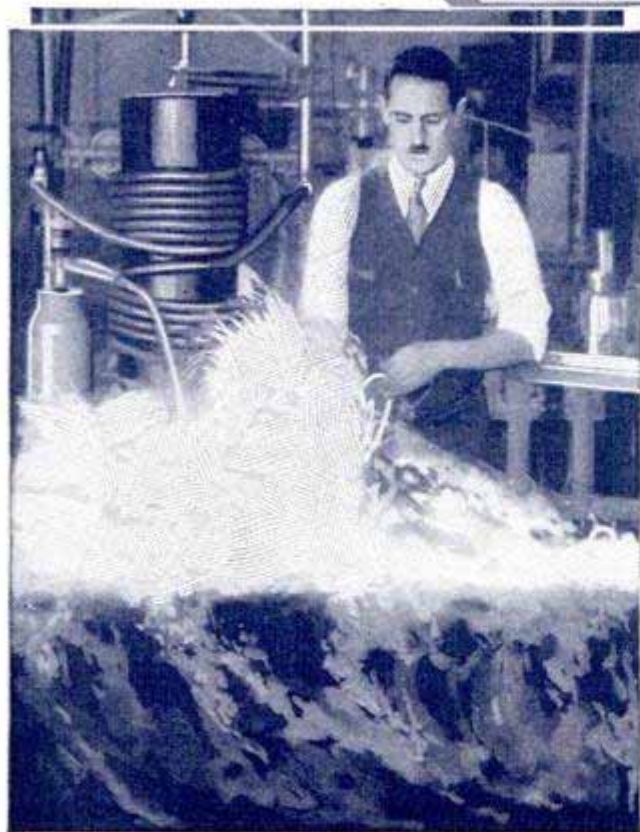
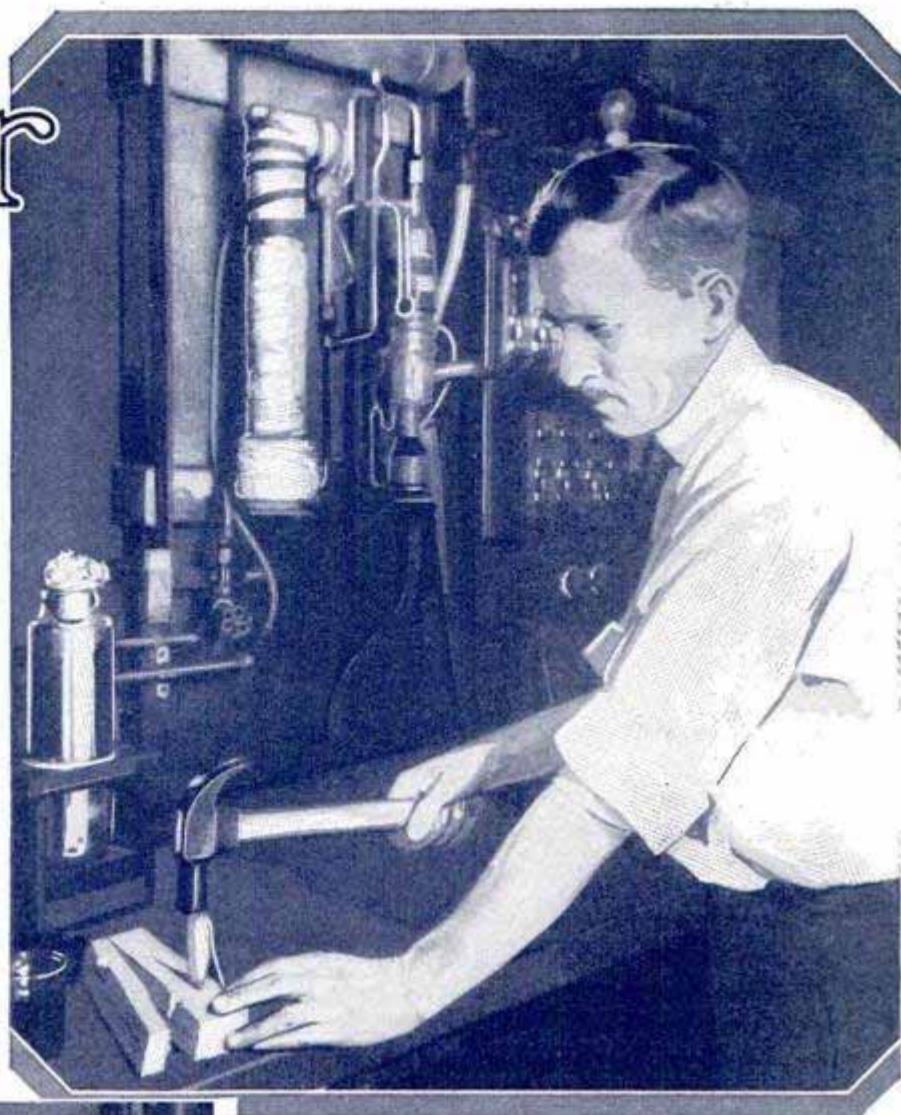

Splitting Piece of Wood with Tung Oil Frozen in Liquid Air, and a Cloud of Liquid Air

million, by volume, but the total amount of this gas in the atmosphere is something like 1,874,000,000 tons.

For some years after their discovery, the five gases mentioned were mere chemical curiosities. Argon was the only one that could then be obtained in appreciable quantities except at enormous cost, and no important industrial uses were foreseen for any of them. At present, through methods since devised, argon, neon and helium are obtained on a large scale and valuable applications have been found for them. Argon and neon are extracted entirely from the air and a small amount of helium is also obtained from that source, though the principal supply comes from certain grades of natural gas.

The chief means of mining the air for both common and rare gases is the liquid-air process. Air is, in one respect, much like petroleum. It is a mixture of several substances, which are not chemically combined with one another, and which, on





account of boiling or vaporizing at different temperatures, can be separated by the procedure known as "fractional distillation." The chemist runs petroleum through a still and thus obtains gasoline, kerosene, heavy oils, paraffin and other distillates. In order to treat air in a similar way, he must first liquefy it by subjecting it to high pressure and an extremely low temperature.

Liquid air had ceased to be a novelty at the beginning of the present century, but although it was then one of the most interesting substances known to mankind on account of the remarkable experiments that could be performed with it, there seemed to be little prospect of turning it to account in a commercial way. In fact, the men who had lately perfected methods of liquefying air in quantity at low cost were trying in vain to find profitable markets for their product.

Finally, in 1901, Linde invented a process of distilling liquid air as a means of separating it into its constituents, and this was the foundation of the great liquid-air industry that now exists. Liquid air itself has never become an important article of commerce, but billions of cubic feet of it are now prepared every year at plants where it is immediately distilled and thus made to yield products of commercial value.

The main product of this industry is oxygen. This gas is needed for a variety of purposes, but by far the largest part of the commercial output, amounting at

present to more than 5,000,000,000 cubic feet a year, is employed for the welding and cutting of metals by means of the oxyacetylene torch.

A use of more recent origin is for blasting. In this case the oxygen is employed in liquid form. Cartridges filled with



Reviving Drowning Victim with Oxygen, and Testing Textile Fibers with Ozone in Westinghouse Laboratories by Newly Introduced Process

lampblack, powdered charcoal or carbon in some other form, are soaked in the liquid shortly before use, and the mixture is known as "liquid-oxygen explosive"—alias L.O.X. This blasting material is far more effective than dynamite and the other older explosives, owing to the fact that the oxygen, being in an uncombined form, is ready to unite instantaneously with carbon or other elements present. It is also exceptionally safe, as, because of the rapid evaporation of the oxygen, a cartridge automatically becomes dead within an hour or so after it is made.

Nitrogen, which forms nearly four-fifths of the atmosphere, is separated in corresponding proportion by the liquid-air process, but most of it is allowed to escape, though some is saved and used industrially. The bulk of the atmospheric nitrogen needed for fixation processes is obtained by other methods.

Pure nitrogen was used for a time in filling tungsten-filament electric lamps. The pressure of an inert gas permits the filament to be operated at a high temperature, and thus to give a brilliant light,



without disintegrating, but a mixture consisting of argon with a small percentage of nitrogen has now been found to be best for this purpose and is used in about half of all the electric lamps at present manufactured. Gas-filled lamps are more economical of current and much longer-lived than vacuum lamps, and it is estimated that the use of argon in this connection saves the American people \$300,000,000 a year in electric-light bills. Argon is also employed to some extent for filling radio tubes, though not so widely

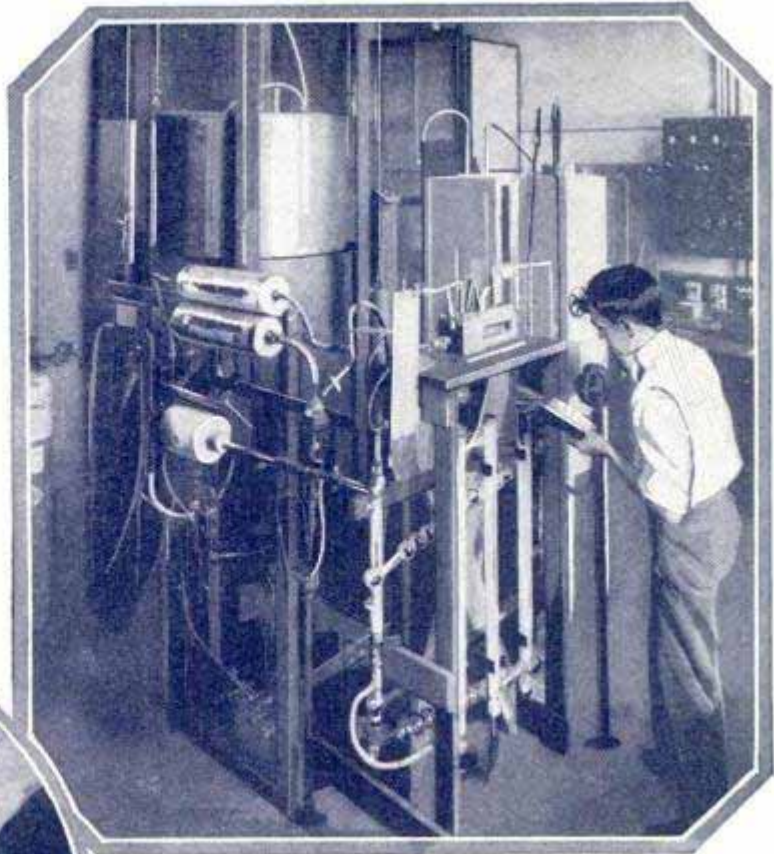

Above, Right, Purifying Argon for Electric Lamps, and Pouring Liquid Air to Freeze Rubber Tubing

as helium or neon. All the argon used industrially is obtained from liquid air.

Neon has become very familiar in this country through the thousands of neon tubes that have recently been installed for advertising and other display purposes. These tubes contain neon and glow with a vivid orange-red light when an electric current is sent through them. A wide range of colors is now secured through the addition of other gases and chemicals and the use of special kinds of glass.

Krypton and xenon possess properties that make them superior to argon for filling electric-light bulbs, but the difficulty of obtaining them in quantity has hitherto prevented their use for this or any other industrial purpose.

Nitrogen, as we have already stated, is

easily extracted from the atmosphere—which contains upward of 20,000,000 tons of it over every square mile of the earth's surface—but a more difficult problem is to make this relatively inert gas enter into chemical combinations, forming substances, such as ammonia and nitrates.

One more substance that mankind obtains by artificial means from the atmosphere is ozone. This modification of oxygen is valuable for sterilizing water and for a wide range of industrial purposes requiring a powerful oxidizing agent. Practically none of it is present naturally and permanently in the lower atmosphere (though a wonderful "ozone blanket" has been discovered many miles above the earth), but it is produced from atmospheric oxygen by sending a brush discharge of electricity through dry air.

The business of mining the atmosphere is in its infancy. As compared with many other natural resources that may fail in the near future, the supply of the atmospheric gases is practically inexhaustible. New methods of tapping the supply will undoubtedly be found.

More and more, in the years to come, will man gather wealth from the air. He may even, some day, solve the perennial problem of rain making!



592  
 1217 2006 Temple St  
 Los Angeles Calif



Used at Wilshire Golf Fairway  
 5864 Wilshire Blvd  
 Los Angeles, Calif

Wire Suit of Armor for the Protection of Boys Retrieving Golf Balls on a Driving Range

**WIRE SUIT OF ARMOR SHIELDS GOLF-BALL RETRIEVER**

Boys who retrieve golf balls on a Los Angeles driving range are protected from injury by a wire framework somewhat resembling a suit of armor. The wire covers head, shoulders and the entire upper part of the body, leaving only arms and legs exposed.

**OVERSHOES GO HUNDRED MILES BEFORE WEARING OUT**

Walking tests conducted by a rubber company reveal that the average pair of overshoes is good for about 100 miles of walking before being consigned to the junk box, and some zipper and shower boot types worn by women have gone 400 miles before breaking down. Mileage tests for rubbers and galoshes are conducted along lines similar to the experiments with auto-

1240

\$5.00 to \$8.50

B. L. Woodruff Co.  
 Chicago, Ill.

mobile tires. Four young women, each wearing a different type of rubber shoe, walk eighteen miles a day over brick, concrete, cinders and gravel, the course being over a measured circuit two miles long. The girls make the first trip in about half an hour, but the last journey takes nearly twice that time. Often a girl is wearing a black shoe on one foot and a gray one on the other. Each time a new compound or new construction feature is incorporated in the shoes, rigid walking tests reveal the exact degree of success before they are placed on the market.

1250

**OWLS FIGHT RANCHERS' ENEMY**

Sixteen species of owls inhabit North America, the great horned owl being the most powerful. This bird is a friend of the western rancher, since it preys on pocket gophers, one of the rancher's worst enemies. It also is a terror to the varying hare, aiding the lynx and other predatory animals in keeping this little animal in check.

**WAIST AND ANKLE CLIPS HOLD AUTO ROBE IN PLACE**

For the particular comfort of the driver, an auto robe is provided with steel clips for both the waist and ankles. The spring fits snugly around the waist, keeping the robe from slipping or falling from the driver's lap, and the ankle clips keep it from becoming tangled with the pedals of the car.

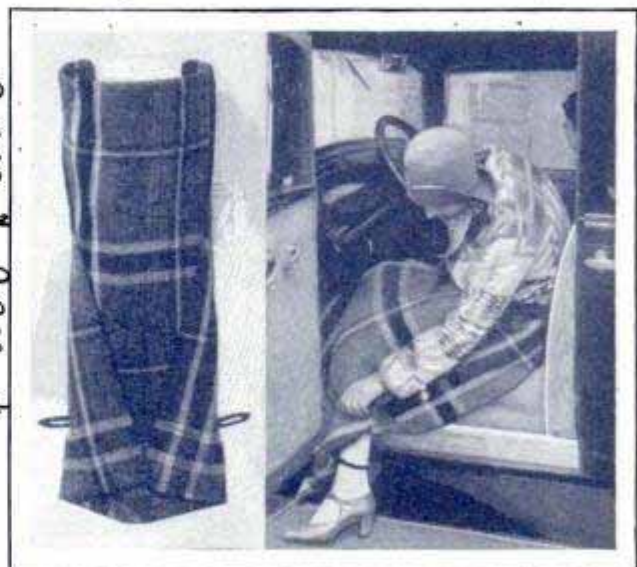

Auto Robe Provided with Steel Clips for Waist and Ankles, to Hold It in Place

Perfection Mfg Co  
 Manufacturers, Lowell, Mass.



see June 1930  
8PC

AGTengesellschaft 593  
Lato E. Schwarzkopf

# HIGH-PRESSURE STEAM ENGINE HALVES FUEL COST

Differing radically both in appearance and performance from the ordinary engine, a super-pressure steam locomotive recently was demonstrated in Germany. The engine develops 2,500 horsepower, and uses a steam pressure of 120 atmospheres at a temperature of 500 degrees centigrade. Through its high-pressure steam system, the locomotive saves about forty-five per cent in heating material as compared with the ordinary type of engine. In appearance the locomotive is higher than the ordinary engine and its more powerful boiler has a greater streamlined effect than is usually evident. Aside from the economical aspect, the fuel saving of this super-pressure locomotive

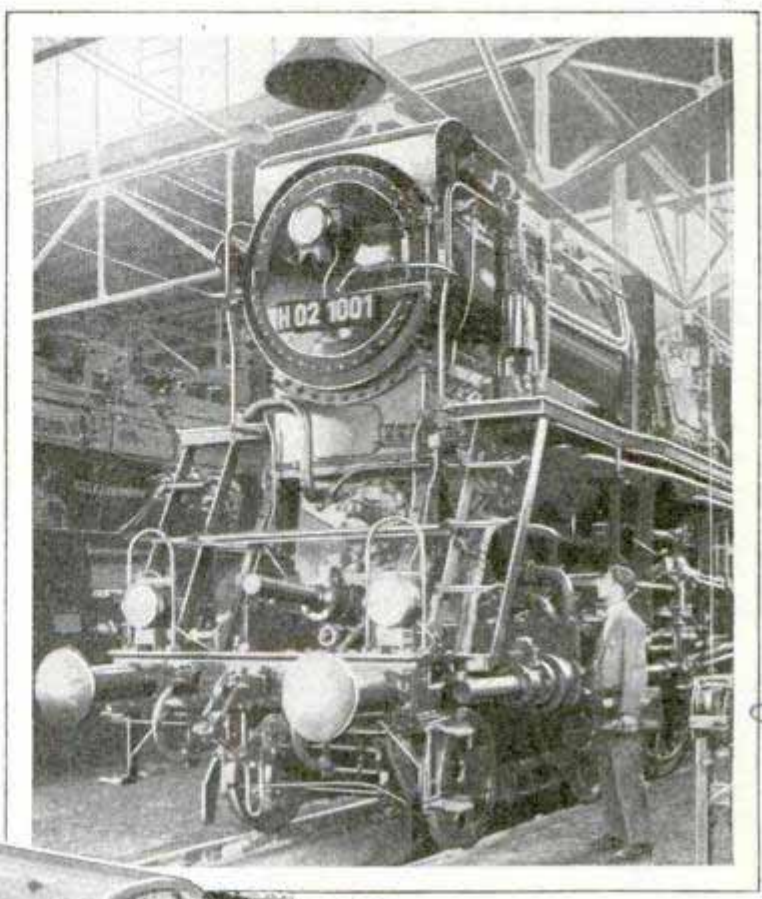

Boiler. n. 4, Germany.

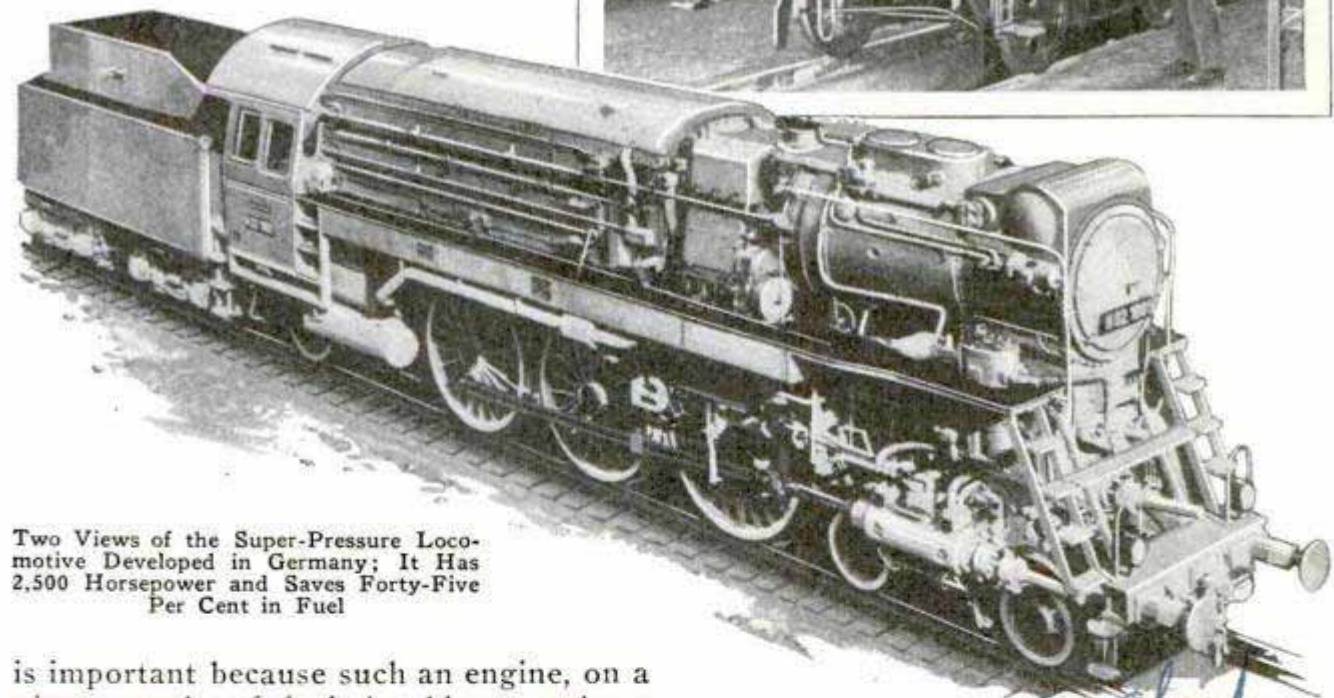

Two Views of the Super-Pressure Locomotive Developed in Germany; It Has 2,500 Horsepower and Saves Forty-Five Per Cent in Fuel

is important because such an engine, on a given supply of fuel, is able to make a longer trip without a stop than is the case with the conventional type of engine.

## CARRIER PIGEONS ON AIRPLANE FOR AID IN EMERGENCY 1175

Although the plan has not been entirely successful, homing pigeons are being used by the Royal Canadian air forces on forestry patrol to summon help when a ship meets with a mishap. If, for instance, a pilot is forced down, he releases one of the

birds which is expected to return to the home airport to summon aid. One bird, sent on such a mission, returned to the base, but had lost its message on the way. The pilot who sent it returned after three days of travel. Birds released more than 500 miles from home ran into an electrical storm and only one out of eighty finally completed the flight. However, the work is carried on in the expectation that eventually they may prove a valuable part of a pilot's safety equipment.

cont. J. A. M. Cook, 26 Canada  
P.O. Box 100 Regina Sask. Can.



*Quick*

# LATEST AUTO IMPROVEMENTS GIVE MORE COMFORT

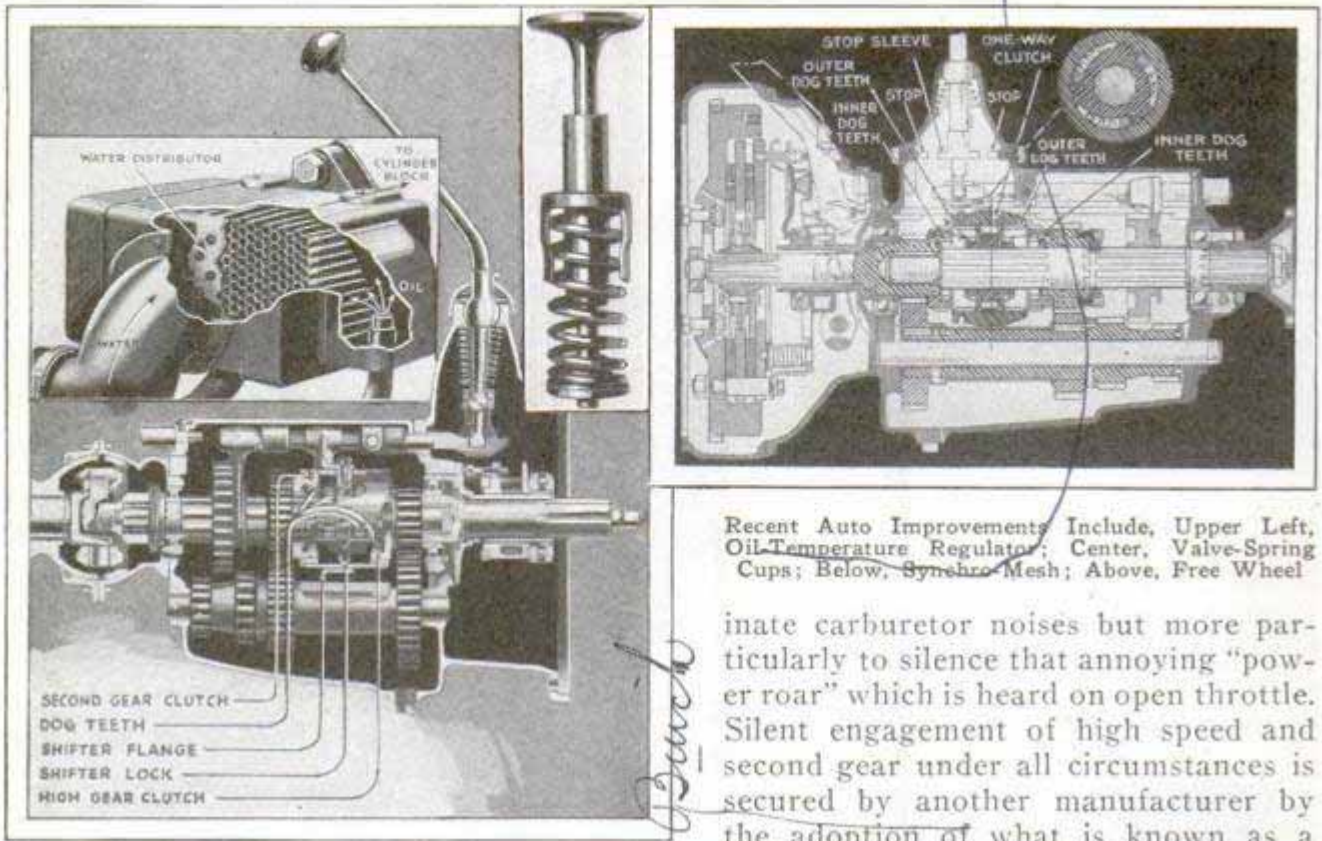

Recent Auto Improvements Include, Upper Left, Oil-Temperature Regulator; Center, Valve-Spring Cups; Below, Synchro-Mesh; Above, Free Wheel

After more than twenty-five years of intensive development, it hardly seems possible that anything of importance could be added to the automobile. Nevertheless, there are some unusual new features on the new model cars recently announced. Heading the list of innovations is a coasting device called a free wheel, adopted by one of the leading companies. Whenever the throttle is closed, the engine idles and the car coasts. Fuel economy is improved twelve to twenty-five per cent, depending on driving conditions and, particularly, on how hilly and winding the roads are. Wear and tear on the complete driving mechanism is proportionately reduced. But most important of all, the free wheel enables gear-shifting to high or second without touching the clutch pedal, and yet the shift is absolutely silent whether the lever is manipulated by novice or expert. So that the engine may be used as a brake in descending a long mountain grade, the free wheel may be "locked out" either in high or second, by depressing a button on the top of the gear-shift lever. Another outstanding device on the same make of car is an intake silencer. In plain language it is a muffler applied to the carburetor, not only to elim-

inate carburetor noises but more particularly to silence that annoying "power roar" which is heard on open throttle. Silent engagement of high speed and second gear under all circumstances is secured by another manufacturer by the adoption of what is known as a synchro-mesh transmission. Gear-shifting is silent regardless of how unskillfully the shift is made, or how slow or fast the lever is moved, and regardless of the speed of the car. Silent engagement is gained by means of two frictional metal cones, one for each gear, which bring the teeth to the same speed just an instant before they actually mesh. The same manufacturer has introduced another innovation, an oil-temperature regulator which cools the oil in summer and warms it in winter. Another improvement is the extra spring shackle recently adopted by a large producer. Shackles of this type are also used by other manufacturers. The shackle is attached to the front end of the left front spring, and it is kept in neutral or normal position by four coil springs. Both front springs, of course, are shackled at the rear as usual. This device not only yields to absorb road shocks which would otherwise be transmitted to the steering wheel but also prevents shimmying. Valve springs and piston rings are also subject to shimmy—as well as front wheels, crankshaft and intake gases. When a valve spring shimmies, ripples or waves run up and down its coils, often overstressing them to the point of breakage. The shim-

*Studebaker*

*Studebaker*

*Studebaker*



my also reduces the effectiveness of the spring with the result that the valves do not close properly and "valve bounce" results. There are various remedies including the use of two concentric valve springs, a single conical spring or a frictional cup in contact with one end of the spring. Piston rings also are subject to shimmy. In fact, they may shimmy so violently at some certain speed, say, 3,200 revolutions per minute, as to cause a marked reduction in power. In the case of one new model, shimmy-proof piston rings, developed after long research, resulted in an increase of six horsepower at 3,200. This new ring is ground slightly oval, so that, in the round cylinder, its pressure against the wall is highest at the ring tips and diminishes gradually from this point. This slight variation in tension prevents shimmy.

**RACK FOR CHILDREN'S CLOTHES DEVELOPS NEATNESS** 1197

To develop the habit of neatness, a metal rack for children's clothes is intended for the child's room, playroom or nursery. It consists of a metal base in which shoes, stockings and other apparel may be placed, and an upright frame on which garments may be hung. It can be obtained in different colors.

*\$3.00*



Metal Clothes Rack for Children Which Is an Aid in Developing Habits of Neatness

*Baby Aids Inc.  
5124 Kenwood Ave*

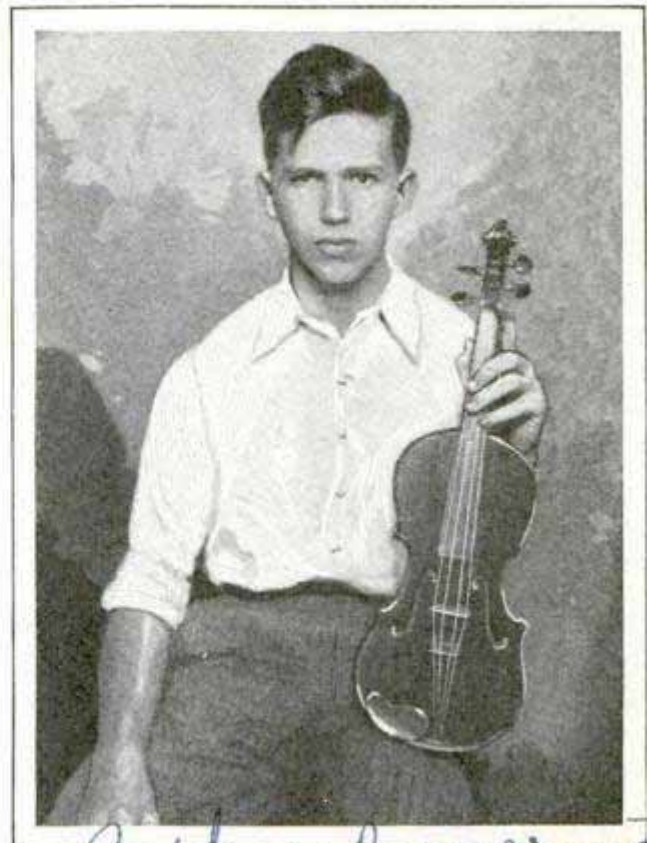

*Arthur Liverman*  
High-School Boy and His Violin Which He Made by Gluing Together 2,500 Safety Matches

**VIOLIN MADE OF MATCH STICKS WORK OF HIGH-SCHOOL BOY**

More than 2,500 safety matches of the ordinary variety were used by a Washington high-school boy in making a full-size violin which is complete in every detail. He spent six weeks constructing and gluing together his musical instrument. When finished, it was found to have a good tone.

**SHIP CUT IN THREE SECTIONS TO MAKE IT LONGER** 1070

*Cadillac* Unusual speed was made recently in rebuilding a 12,000-ton oil tanker in a British shipyard. The vessel was cut in three sections and a midship section 300 feet long and containing 4,000 tons of steel was floated in and joined up in seven weeks. Under ordinary methods, the work would have required at least four months.

The Popular Mechanics' Bureau of Information offers its free service to all readers of our magazine. Names and addresses of manufacturers and dealers in articles described, will be promptly furnished by the bureau.

*Palmer's Yard  
Hoboken, N.J.  
Syne*

*Shipping World  
6/11/30*



967

Chas. Elm. Massman,  
55 W. 86 St.,  
New York

# The Lamps of the



One Type of Photo-Electric Cell, Used in Sun-Illumination Studies by the United States Public Health Service

Electric company—conducts an institution which is engaged in nothing else but making truth stranger than fiction.

Little unobtrusive glass tubes, each inclosing one of these curious areas of "nothing-something," now measure the heat and light of far distant stars; sort, grade and count quantities of small articles; safeguard premises from burglary and fire; turn on lights when darkness approaches; operate train signals, control electric motors and actuate compasses for ships and airplanes. Man has succeeded in utilizing the vacuum for transmitting

WHEN the front page of a San Francisco newspaper is read in New York shortly after it is printed; when a popular lecturer makes a ray of light produce music and transmit his voice across the room; when Australia chats with America, and engineers talk of bringing water power from Pacific slopes to industrial markets in the northeast—even this ultra-modern world begins to inquire, "Wherefore?" And the answer has more than a touch of the mysterious, for it is: "It's the vacuum—it's all in the vacuum!"

In the vacuum! But can there be anything whatever in a vacuum—defined as mere empty space, devoid even of air? Emphatically, yes! Truth, in the twentieth century, is more than ever stranger than fiction, for this is truth; and the man who first uttered the paradoxical statement, "The vacuum—there's something in it"—Dr. Willis R. Whitney, director of the research laboratory of the General

entertainment programs great distances through space without connecting wires, for sending his messages to isolated spots, for aiding materially in alleviating his physical ailments. Every time he even switches on electric lights in his home, he relies implicitly upon vacuum, and millions of cubic feet of such light-giving "emptiness" are in nightly use throughout the world.

Otto von Guericke, burgomaster of Magdeburg, was a pioneer in electrical science. His accomplishments included the invention of an air pump with which he obtained a partial vacuum—not a high vacuum, such as is common today, but still one in which the air content was pretty thin. One day, in 1654, he called by appointment on Emperor Ferdinand III, accompanied by two teams of eight horses each, with their drivers and various queer paraphernalia. He showed the emperor two copper bowls which, when



# Modern Aladdin

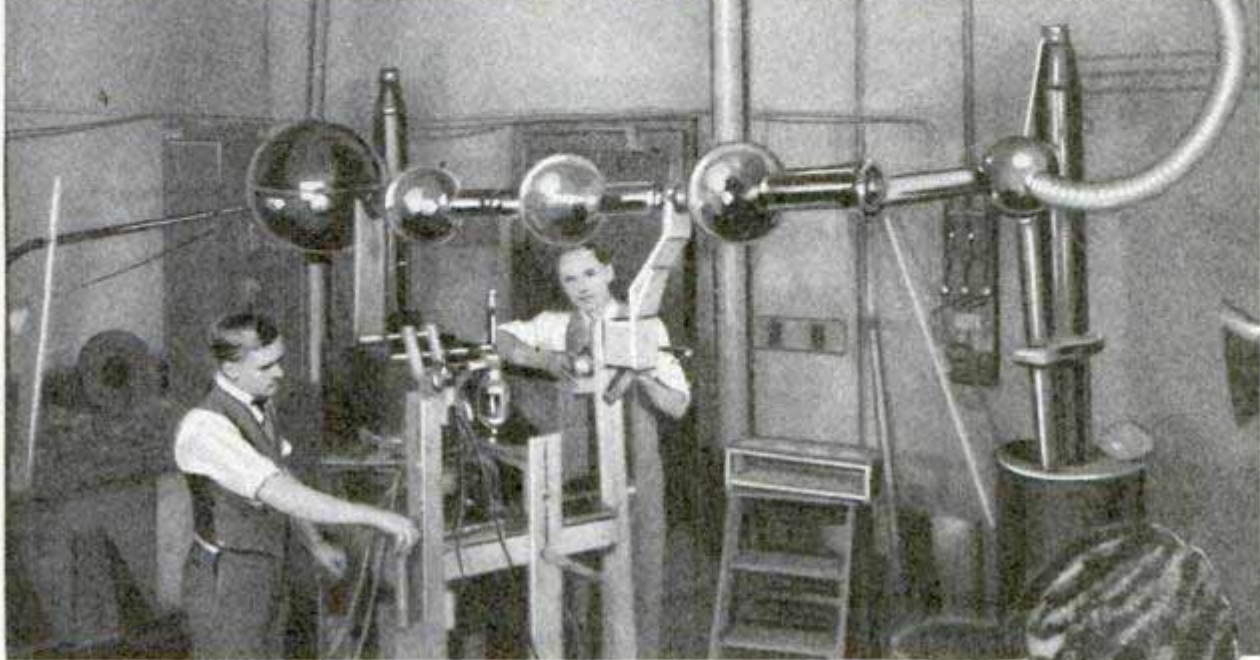

placed together, formed a hollow sphere. Between them von Guericke inserted a ring of leather soaked in wax and oil, making an air-tight joint, but there was no mechanical connection whatever. With his air pump he drew off a great deal of the air from the sphere through a hole which was closed by a tap.

The teams of horses were then brought up, one being hitched to each of the copper bowls or hemispheres. At the signal to go, the sixteen horses pulled and strained but their utmost exertions could not drag the hemispheres apart. The emperor, amazed, found it impossible to believe that the bowls were locked together merely by the difference in pressure between the atmosphere outside and the partial vacuum within.

This was the vacuum doing tricks. The vacuum universally at work did not come until two centuries later, and Edison was the scientific "magician" of this later affair. By that time men knew much more about electricity, and there is a close working



Three-Section High-Voltage Cathode Tube, and, Below, Placing Rough Sapphires under Cathode Rays for Test

relation between electricity and the vacuum. Edison hit on a relatively minor aspect of it when he placed a hairlike carbon filament within a vacuum and then connected the filament to an electrical circuit. The resistance of the filament to the passage of the electric current made it glow with light, while the vacuum pre-



967

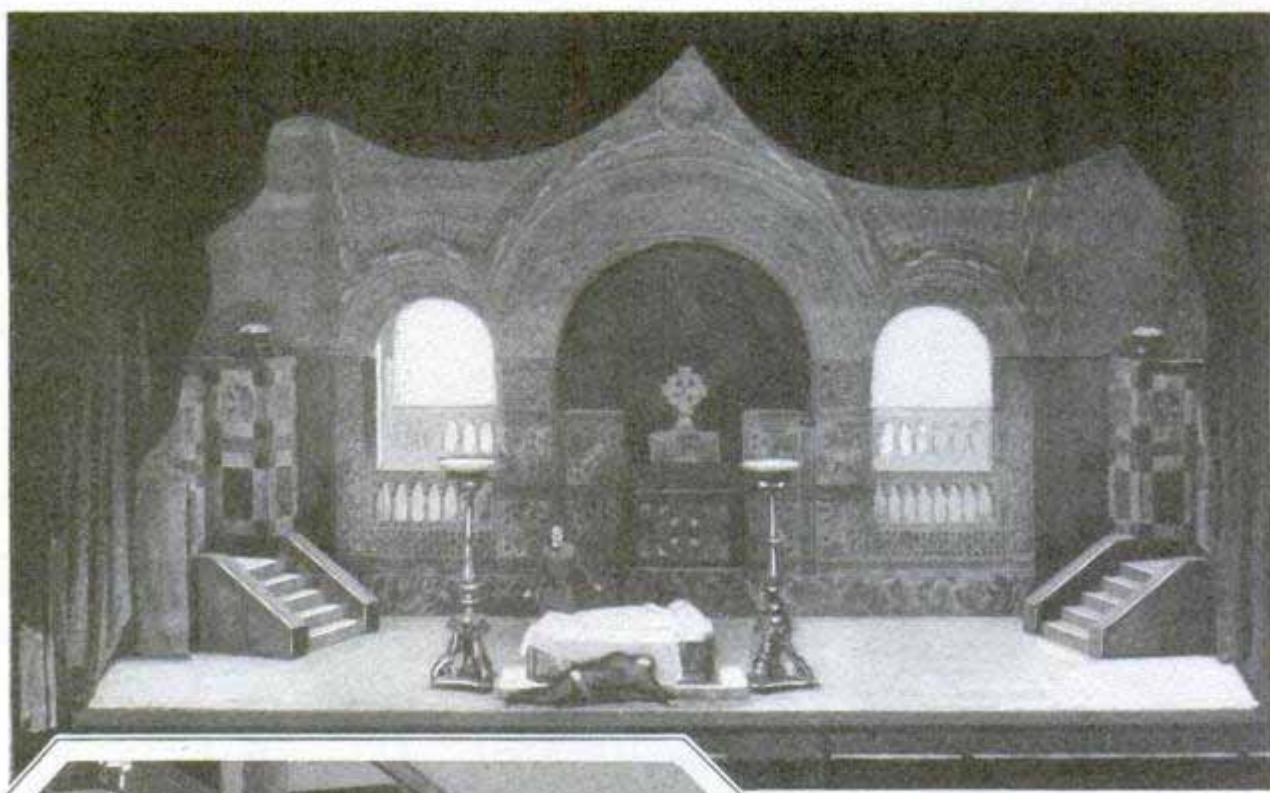

Scene from "Love of Three Kings," and Thyatron Rack for Chicago Civic Opera Installed Eleven Floors above Stage

vented it from burning up—and lo! the incandescent electric lamp was born, essentially a vacuum device.

Had Sir Walter Scott seen this he might have paraphrased his own incredulous comment on the experiments of William Murdock, the pioneer of gas lighting. When he heard of Murdock's work he exclaimed: "There is a mad man who proposes to light London with—what do you think?—smoke!" If he had known of Edison's lamp, he would probably have scoffed: "There is a mad man who expects to illuminate the world with—what do you suppose?—nothing! A vacuum!"

As it was, Edison's idea of an electric lamp was considerably ridiculed at the time. Among other criticisms, doubts were heard of the possibility of producing with facility such a high vacuum as was necessary. Sir William Crookes, the English scientist, who was then studying the subject, was asked if a vacuum as high as Edison required could be created in quantity. He replied, promptly and succinctly,



"Why, such vacua can be produced by the ton!" And so they have been, ever since.

Edison, as fate would have it, did more than construct a practical and popular electric lamp depending on a vacuum. He was the first to observe a peculiar electric current originating with the hot filament inside the vacuum and known at the time as the Edison effect. It was thirty years before scientists, working principally with Crookes' tubes, fully understood what this meant—that a hot filament in a vacuum gives off a stream of electrons (an electric current, but not usually a powerful one) capable of being manipulated in many remarkable ways.

In the successive brilliant discoveries that occurred in this great field, Millikan, J. J. Thomson, Fleming, DeForest, Langmuir—all of them laboratory experimenters of the great line—participated. This

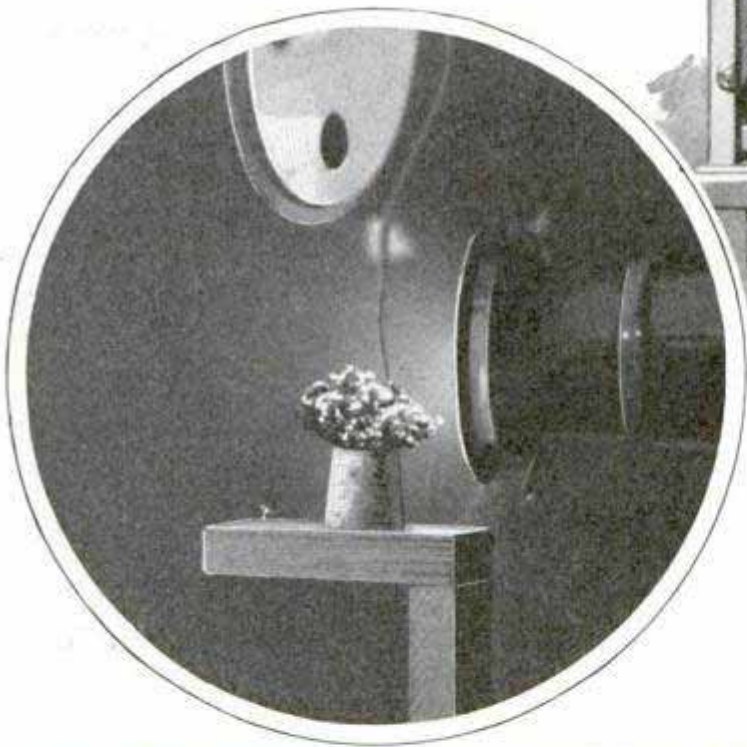
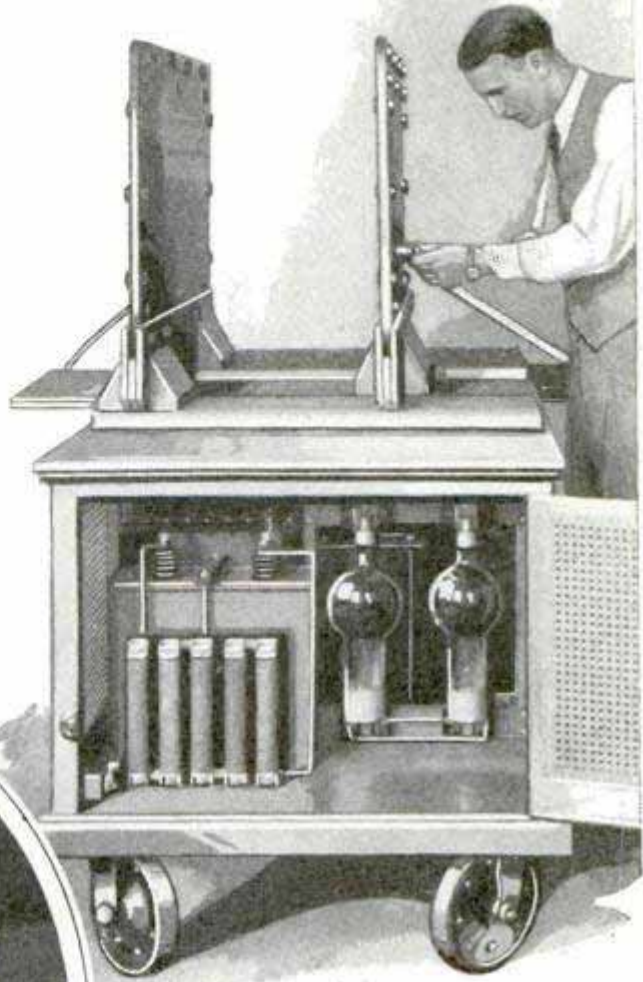

General Electric High-Frequency Heater with Rectifier End Open, and Precious Stone under Cathode Rays

work culminated at length in the modern vacuum tube with its boundless possibilities, already numerous and by no means even approaching finality. Radio broadcasting, one of the most spectacular and best understood of modern feats with vacua, was one of the earliest, following that of radio telegraphy.

Great numbers of these modern tubes are at present in world-wide use, each with

its vacuum, and each vacuum more nearly perfect than ever before produced by man. So completely are these tubes and bulbs "exhausted" (that is, evacuated of air) that out of every seven hundred million molecules originally in each tube only one remains. Yet in every cubic inch of space in each tube there are still to be found, after the pumps have done their best, more molecules than there are people in the world! Thus it is far

from empty, although a living creature in such an inclosure would instantly suffocate, if he did not literally explode before he was smothered.

The latest magician in the ever-growing family of tubes is the thyatron. In its common form it resembles the ordinary tube. However, it is not a vacuum tube, for it contains either a small quantity of a chemically inert gas at a known pres-



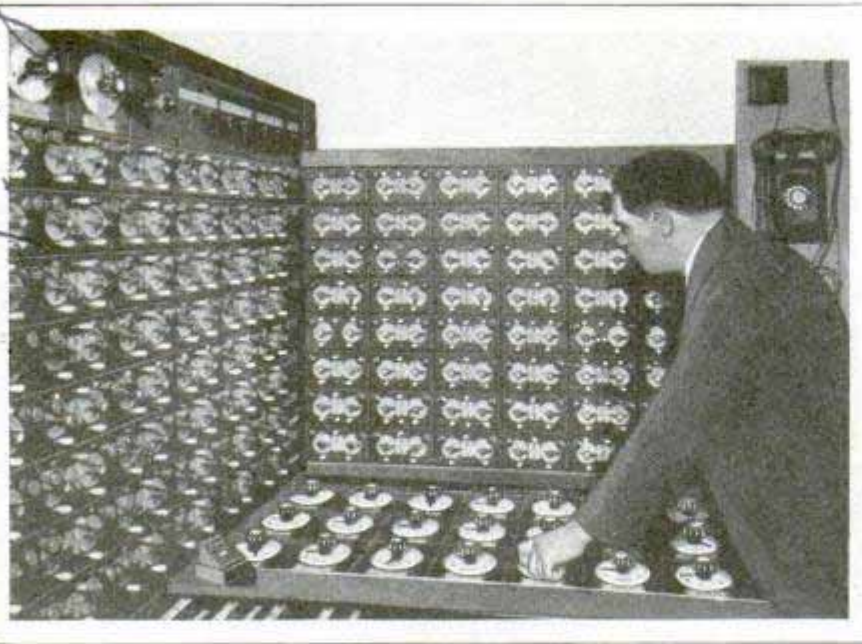

Part of Stage-Lighting Control Board, Used in Chicago Civic Opera House; It Is beneath and in Front of Stage

sure, or a drop of mercury which produces a low pressure of mercury vapor in the open space.

The currents which can be controlled by thyratrons are immense compared with those of high-vacuum tubes under similar conditions. The new tube also has the advantage of fineness of control, absence of wear, and silence.

The first use of the thyatron outside a laboratory was in the stage-lighting equipment of the new Chicago Opera House. This institution undoubtedly has the most advanced system of theater lighting found anywhere in the world. Henceforth, a "lighting director" will control the illumination of a large auditorium, not an electrician. Instead of throwing his weight on those immense switches commonly found backstage, he merely moves a dial with the turn of a wrist. One of these dials can do the work of ten ordinary switches.

At the Museum of Peaceful Arts in New York, I was startled on entering. I came off the elevator and made a step forward, when from some mysterious corner came a voice saying, "Thank you!"

For what? I turned about. Not a man in sight. I asked an attendant who had thanked me, and he answered, "Meet Mr. Thyatron, the robot greeter."

Well, the thyatron cast in the role of a greeter. It turned out that I had interrupted a light beam in stepping off

the elevator. The eagle eye of a photo-electric cell caught the shadow. It told the thyatron tube, which turned on a phonograph record, which said politely, "Thank you."

Again, at the House of Magic in Schenectady, I was shown a heavily bolted door, and asked, "Can you open that?" I shook my head, "Not without the proper keys." My guide waved his hand as a hypnotizer would do before his subject. Lo! the door was hypnotized, for it swung open. "You see," explained the guide,

"the thyatron makes homes safe. You can't forget your key. The combination to this door is the way in which you wave your hand. If you forget how to do that, you'll be locked out of your own home."

Now just inside the magic door is a sign asking the visitor to say "hello" into a telephone mouthpiece. I did. This set into operation another thyatron which started a phonograph to playing an orchestral composition.

Among other recent applications of electron tubes is a fire-prevention system. By placing photo-electric cells around an industrial plant, it is possible to detect the first puff of smoke and have an alarm turned in automatically.

The light cell has also been found useful in automatically bringing elevators to a level stop. In the paper industry, photo cells are now used to determine the correct proportion of wood fiber in raw pulp.

In short, the electron tube has such universal applications that, without it, civilization would surely stagnate. So far as we know, television would be impossible; likewise, talking moving pictures and long-distance telephony. Were electron tubes suddenly prohibited by law, every major industry in the world would suffer a collapse. But the end is not yet. The most conservative scientists foresee such a tube development that everything one hears, sees or buys will be controlled in some important aspect by tubes.

So I believe in Thyatron System  
General Electric Co., Schenectady, N.Y.







*any. have no need*

184



Hand-Carved Wooden Model of Cleveland Union Terminal; It Contains 50,000 Pieces of Wood

**HAND-CARVED MODEL TAKES TWO YEARS TO FINISH**

*Charles Hlinka*

Working five hours a day for two and one-half years, a Cleveland barber has completed a hand-carved wooden model of the \$160,000,000 union terminal tower in that city. It is composed of 50,000 pieces of wood, all carefully glued together, and is an exact duplicate from the street lamp at the bottom to the flagpole at the top. More than 3,000 illuminated windows are contained in the structure. Having no plans to work from, the barber made more than 100 trips to the building itself to obtain his ideas.

**LITHIA WATER SERVED FREE AT PUBLIC FOUNTAINS**

115

Carbonated mineral water flows from drinking fountains in Ashland, Ore., where the water is served free to the public after passing through an electric refrigerating process. It comes from natural mineral

*Cont. Emerson Esterling  
391 Liberty Ashland, Ore.*

*Announced by Dept. of Commerce*

springs, and the gas from the springs is used to operate the town's fire whistle, and also as free air in some garages.

**RUBBER PLATING OF CONCRETE 1173 WOOD AND METALS**

Rubber plating of wood, metals and concrete is being attempted to encourage the vending of perishable goods by automatic coin-operated machines. By a process recently developed, such materials can be coated with a film of rubber, thus eliminating one of the difficulties in vending dairy products. Heretofore the sweating of the packages caused them to freeze to the metal parts of the vending machine, but the rubber plating obviates this difficulty. The rubber plating also is expected to facilitate the use of dry ice.

**AUTOMATIC CARD TABLE FOLDS 1179 ALL LEGS AT ONCE**

All the legs of an automatic card table may be opened or folded simultaneously in one operation. One leg is folded in the usual manner, this action manipulating a folding device beneath the table top which also causes all the other legs to collapse. The folding mechanism is simple and positive in action, there being no complicated parts to get out of order.

*Automatic Acme*

*The Carron Co. Folding Table*



All the Legs of This Card Table Are Opened or Folded Simultaneously in One Operation



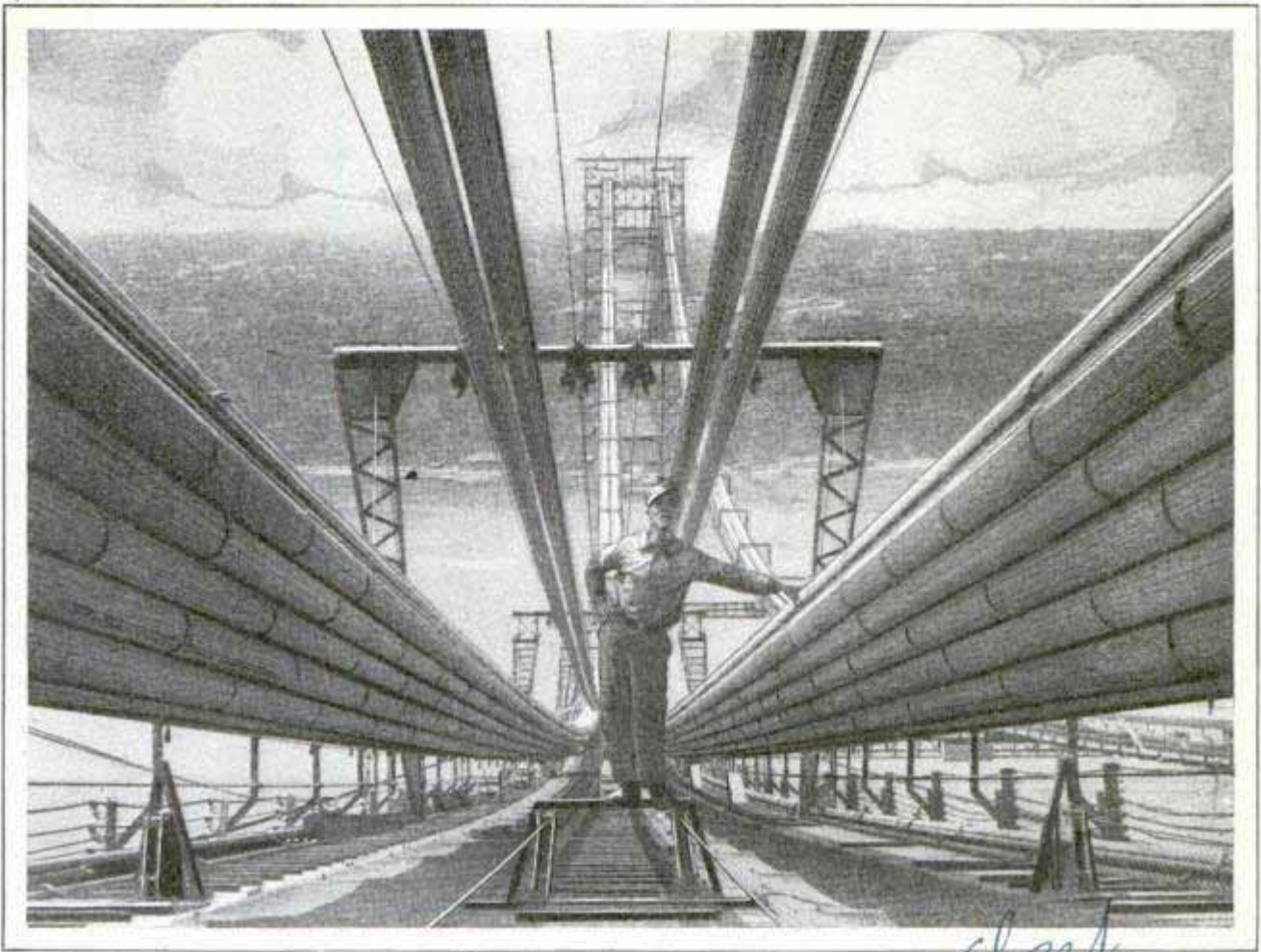

Two of the Great Cables That Will Support the Hudson River Bridge at New York, the World's Longest Suspension Span; More Than 107,000 Miles of Wire Are Spun into These Cables

**MANY MILES OF WIRE CARRY WEIGHT OF BRIDGE**

Gigantic wire cables will support the enormous weight of the new Hudson river bridge at New York, the world's longest suspension span. About 107,000 miles of wire will go into the cables, spanning 3,500 feet of space. The 26,000 wires of each of the four cables are grouped into bundles of 434 wires each, the bundles being known as strands.

**SEARCH FOR NEW STARS AIDED BY MIRROR TELESCOPE 1193**

For bringing new invisible stars into the field of observation, Prof. C. W. Woodworth, of the University of California, has made a composite mirror telescope representing only one-thousandth the cost of a large modern telescope. The instrument may aid in determining whether there is a possible limit to the number of stars in the universe. It has for its underlying principle the bringing of many

rays together and focusing these upon a single spot for magnification. To such an extent can the process be carried, that the light from an ordinary star of no great magnitude can be made unbearable to the human eye. Four hundred mirrors are contained in a frame about ten feet square, these mirrors being larger at the center and decreasing in size toward the sides. Every mirror surface represents the segment of a sphere, and they are ground so that the images of all will be the same size. The mirrors may be adjusted to the proper angles and are supported by a metal framework constructed so that its form is affected by changes in temperature. They all are focused on a single spot where the reflected light from a star is thrown. At the focal point this reflected light may be magnified and studied. To increase the size and efficiency of the instrument, it is only necessary to enlarge the frame and add more mirrors. With the apparatus it is possible to gain a reflected glimpse of stars that have never been visible through any telescope.

*Berkeley, Calif*

*Emb. Mrs. Elizabeth M. Stearn  
R. R. W. Box 146, Berkeley, Calif.*



# UNCLE SAM'S LATEST TREATY CRUISER IN "ACTION"

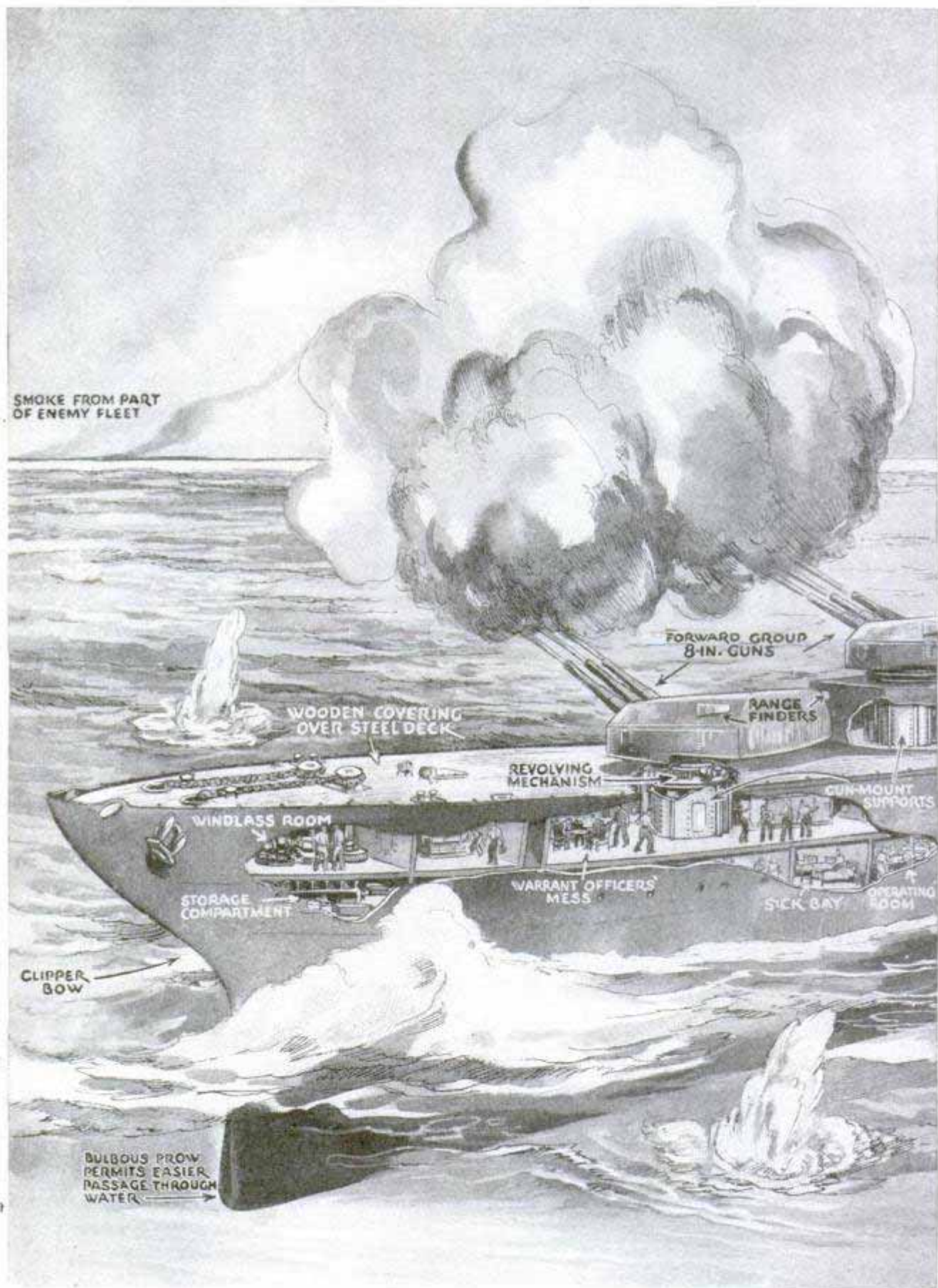

Artist's Drawing of Recently Completed Cruiser "Northampton," Showing Inner Details and How It Would Look in Battle; Note the Two Smokestacks Instead of the Usual Four



TEN-THOUSAND TON WARSHIP IS BUILT FOR SPEED

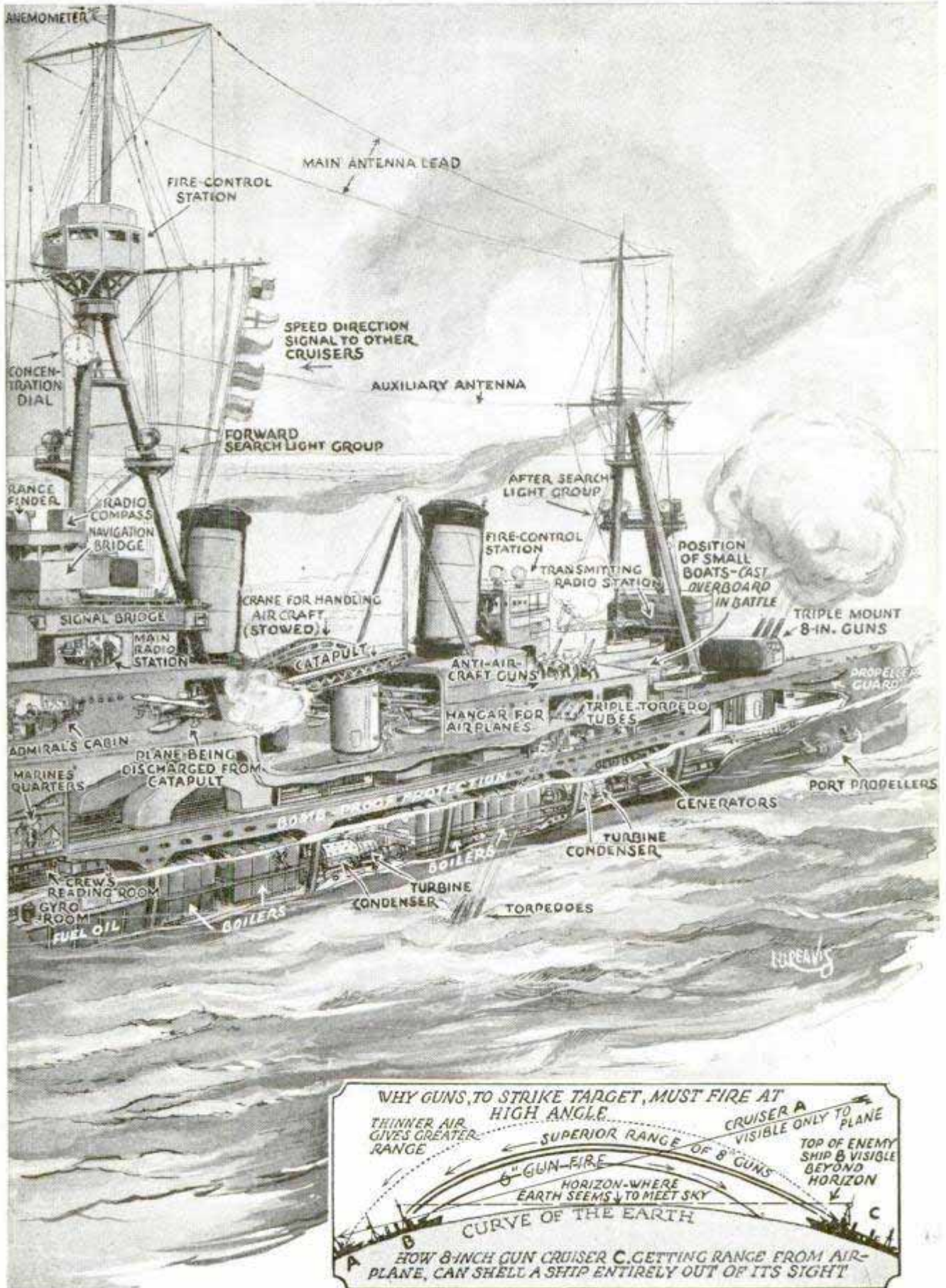

This Cruiser Develops in Excess of Thirty-Five Miles an Hour; It Is Longer and Has a Broader Beam than Other Ships of Its Type; the Diagram Explains the Effectiveness of Its Eight-Inch Guns



1180

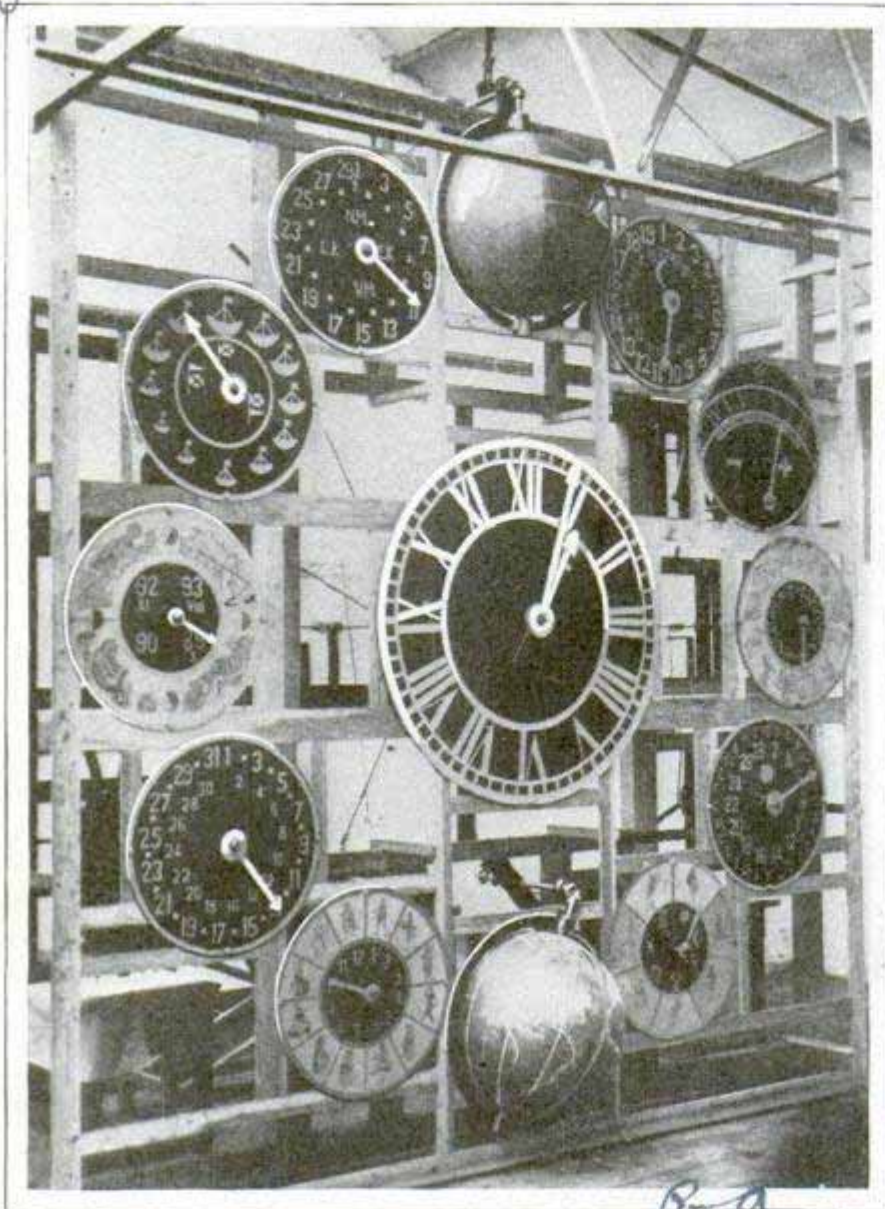

Super-Clock. Built in Belgium, Which Tells the Time of Day, and Gives Signs of Zodiac, the Solar System and Days of the Week

### CLOCK KEEPS TAB ON UNIVERSE IN MEASURING TIME

One of the most intricate clocks in the world recently was unveiled in the old tower of Cornelius at Lierre, Belgium. Besides indicating the time from Greenwich, this super-clock virtually keeps track of the universe, giving the signs of the Zodiac, the solar system, days of the week, phases of the moon and the tides.

### BEEES GO THOUSANDS OF MILES FOR ONE POUND OF HONEY

One pound of honey sometimes represents about 300,000 miles of travel by the bees that produce it, tests by the department of agriculture indicate. The depart-

ment learned that bees will often fly eight miles or more and return with their minute loads. Thus a pound of honey would represent approximately 18,000 trips of sixteen miles each. Hives were placed eight miles from the nearest nectar supply, and the bees made regular daily trips from the hives to the supply and back. Some of them, however, were impeded by sand storms or head winds. Laden with honey, they were forced to rest and sometimes reached the hives exhausted.

### 1205 VARYING NAMES OF SAME WIND LEAD TO CONFUSION

Each country has its favorite names for its distinctive winds although fewer than a dozen different winds are recognized by meteorologists, and the many names applied to the same wind often lead to confusion. Blizzards are known as burans, poorgas or pamperos and the Central

American chubasco season is a small-scale copy of India's monsoon, while an Australian in Texas would soon learn that a Texas norther corresponded to his own southern burster. America's hot wave from the south is a sirocco in Italy and a solano or leveche in Spain. Australia probably bestows more curious nicknames on its winds than any other country. There the north winds are brickfielders, hurricanes are willy-willies, a cooling breeze from the sea is the Fremantle doctor and Cockeyed Bob is a thunderstorm. The soft, dry, warm breeze that sweeps the Rockies in early spring is called a chinook by natives. The Swiss who sniffed it would call it a foehn wind, a South African a berg wind, a Sumatran a bohorok and a Earoe islander a glave wind.

1204  
N.Y. Herald Tribune  
7/28/38

Geographie hand  
Bulletin 1897  
National Geographic Society  
Washington D.C.



# LIEGE FAIR REFLECTS LATEST BUILDING TRENDS



Night and Daytime Views of Liege Exposition Buildings; the Palace of Electricity with Its Facade Is a Dominant Feature

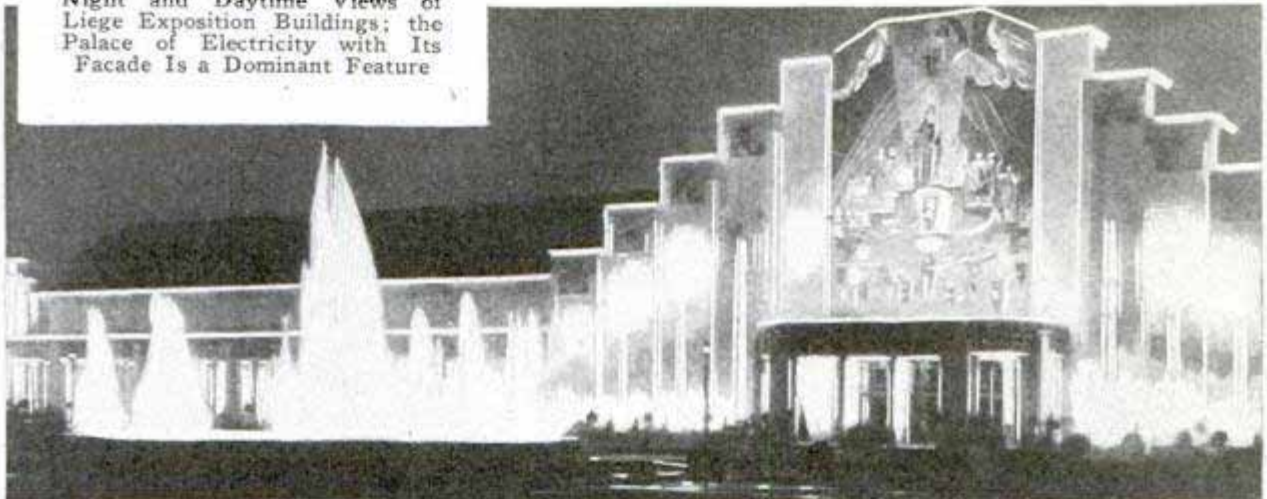

Modern Adaptation of Columns with Angular Designs on Capitals and "Step-Back" Towers



11/15  
25 hp Cyclomotor

SAS News, Tages-Bldg  
New York

3781 Angeles mesa Drive  
**TRAINING IN CYCLOPLANE HELPS STUDENT FLYERS**

Los Angeles, Calif.



The Cycloplane, a Small Ship with Little Wings, Goes through Maneuvers of a Real Ship without Leaving Ground; the Fuselage Is Hinged on the Landing Gear

J. W. H. S. Hughes

Capable of performing most of the stunts of a real airplane in the air, although it does not leave the ground, the "cycloplane" is being employed to train student aviators. The ship is in reality a baby plane with a low-powered motor and wings of relatively small surface. The fuselage is cleverly hinged on the landing gear, and joints are so placed that the ship can bank or turn on the ground with the same effect as though it were in flight. An additional set of wings, with sufficient surface to take the student up, are attached after the ground work has been mastered.

motor sprinklers, it is very speedy, and also has the advantage of being maneuvered easily, while the cost of operation is reduced by about forty per cent.

**THUNDER CONVERTED TO MUSIC IN RADIO EXPERIMENTS**

1170

Musical thunder, accompanied by a vivid electrical display, was encountered by radio engineers recently in experiments with high-powered short-wave broadcasting. The thunder, created artificially, was converted into music corresponding to the input at the radio microphone. In handling powers above fifteen kilowatts on the short waves, the engineers found that vivid coronas flashed when attempts were made to modulate. Since the power supplying the arc was modulated with music, the arc alternately collapsed and built up according to the modulation, this action setting up air-wave vibrations similar to thunder. Instead of the roar and roll of real thunder, however, it was a musical sound similar to the music being broadcast, and persons 400 feet away thought they were hearing the output of a giant loud speaker. The arc finally melted the copper and caused the antenna to drop. The trouble was solved when larger antenna wire was used, and a large corona plate was placed at each end, making it possible to obtain thirty-five kilowatts, perfectly modulated in the antenna, without coronas.

**HIGH-SPEED STREET SPRINKLER OPERATED BY ONE MAN**

On the streets of Berlin a small sprinkler that is operated by one man is being used successfully in cleaning and flushing the pavement. In comparison with the heavy



Small Street Sprinkler Operated by One Man

Whenever you find that you wish to know more about any article in this magazine, write our Bureau of Information.

General Electric Co  
Schenectady NY



Akron, Ohio

LOSS OF AIRMEN IS BLAMED ON ORE DEPOSITS 1222

Deposits of magnetic ore in the north Atlantic may possibly have caused the death of several transatlantic flyers in the opinion of Lieut. Col. Charles Kingsford-Smith, in charge of the flight of the "Southern Cross." He said that, in crossing from England to America, all three of his compasses failed to function when about 400 miles off Nova Scotia. Later he found that every other successful ocean flyer with whom he talked encountered similar difficulty at about the same place. He believes that there must be some extraordinary deposit of ore or other strong magnetic attraction in that section, and that the unsuccessful flyers lost their way there. The "Southern Cross" had radio equipment which served while the compasses were useless. Rear Admiral W. R. Gherardi, of the U. S. Navy hydrographic office, said there have been instances in which ship compasses have been deviated by magnetic influences from ore in shallower waters, but off Nova Scotia, where the water is two miles deep, such sources of disturbance would be too far removed to affect the magnetic needle. In any case, a non-magnetic compass has been suggested for safety.

MOVIE-FILM CLEANER FITS ON THE PROJECTOR 1208

Extremely simple and practical to operate, a motion-picture film cleaner can be connected with the projector and removes grease, oil spots and dirt as the film runs through the projection machine. It weighs less than a pound and consists of an upright frame, through which the film runs between two layers of tape moistened with a cleaning fluid. Under regulated pressure, the dirt and grease are wiped off, then, in passing through the projector mechanism, the film becomes dry before reaching the take-off reel.

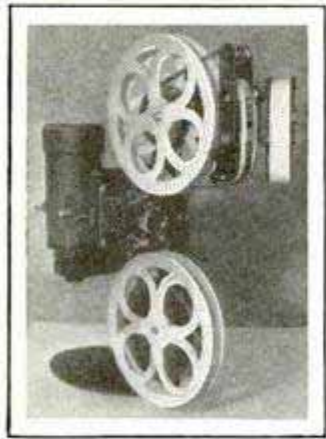

runs through the projection machine. It weighs less than a pound and consists of an upright frame, through which the film runs between two layers of tape moistened with a cleaning fluid. Under regulated pressure, the dirt and grease are wiped

off, then, in passing through the projector mechanism, the film becomes dry before reaching the take-off reel.

Bell & Howell Co  
1803 Larchmont Ave

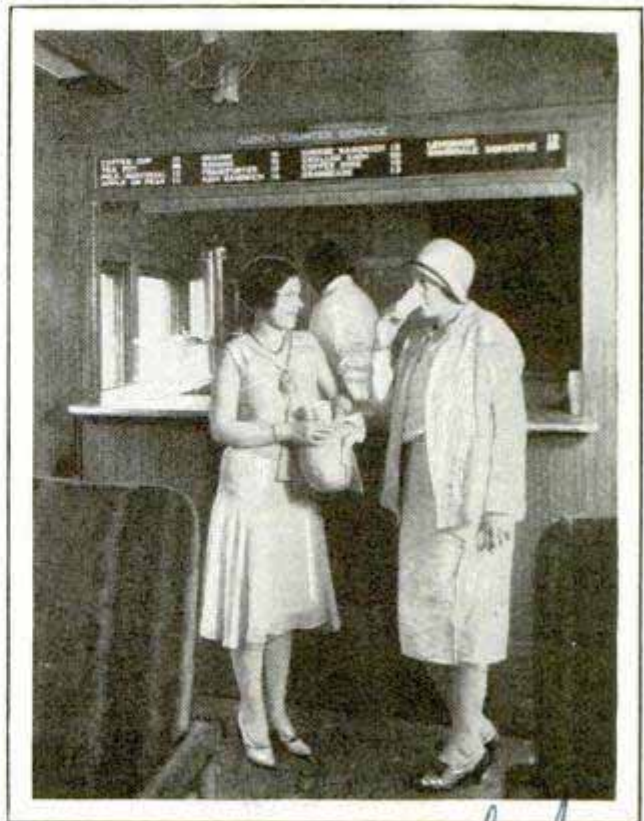

Lunch Counter on Washington-New York Train Where Passengers May Eat at All Hours

RAILWAY-CAR LUNCH COUNTER FOR HUNGRY PASSENGERS

Railroad passengers who like to eat between meals now may have their wants satisfied on one of the fast trains between Washington and New York. A sandwich and lunch counter has been installed in one of the cars, which has as an added feature reclining chairs inducive to rest and comfort during the night journey.

MUSKOX HERDS FOR ALASKA 1228

In an effort to replace the lost muskox herds of northern Alaska, the department of agriculture is importing thirty of these animals from Greenland. The little herd will be expensive, for it will cost \$40,000 before it finally is established in its new home. However, it is expected the animals eventually may pay for themselves many times over, as the reindeer have done, by becoming the basis of a new meat-producing industry, utilizing food plants that now go to waste. Zoologically the muskox stands in the missing-link position between cattle and sheep. The imported herd will travel from Greenland to New York, then by rail to Seattle, and by boat and rail to Fairbanks.

Science Service  
Washington 20 D.C.



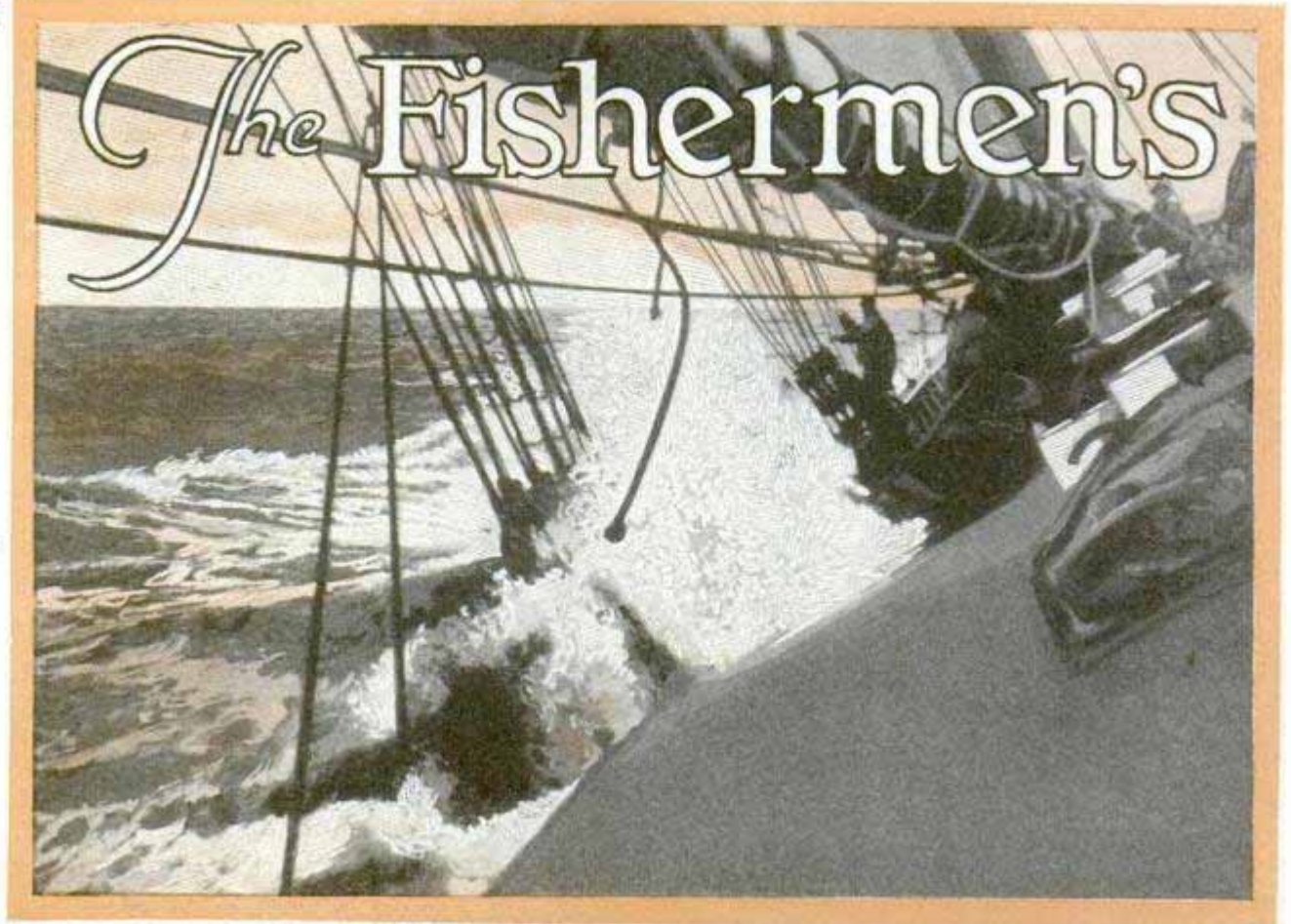

Scene on Board the "Columbia" during a Trip to the Grand Banks; This Boat Was One of the Fastest Fishing Schooners Ever Built; She Was Lost during a Voyage Four Years Ago

By JOHN F. COGGSWELL, 16 Edgmoor Road  
Belmont, Mass.

SIR THOMAS LIPTON'S "Shamrock V" and America's "Whirlwind," "Enterprise," "Weetamoe" and "Yankee"—they and their \$5,000,000 yacht race for the America cup aren't causing even a ruffle of excitement among the men of Gloucester, Mass., whence sail the fishing schooners to the Grand Banks. Nor among the fishing folks of Nova Scotia, either.

Any other year, these peerless sailors of the rough waters might find time to argue over the big sporting event. But just now they have a race of their own to worry over. For, after seven long years, the Gloucestermen have added to the fishing fleet a schooner, the "Gertrude L. Thebaud," that seems to have more than a chance to wrest the International Fishermen's Cup from the "Bluenose," the pride of the Canadian fleet, hailing from Lunenburg, Nova Scotia.

Furthermore, the fishermen of both Lunenburg and Gloucester have declared themselves eager for the contest, and all that remains is for the international committee to get together and arrange course

and dates. The race will be off Halifax and the dates likely will fall late in October.

Until ten years ago, these fishermen's races were local affairs. The pick of the Gloucester fleet raced off their home town, and Canada's fastest fishing schooners met off Halifax. Each fleet found its champion, pulled off a big celebration in honor of ship and crew and then went back to their fishing.

In 1920, a Canadian editor—inspired doubtless by the fact that in that year Sir Thomas sent over the "Shamrock IV" to race the "Resolute"—promoted a race between the champion schooners of the two fleets. He put up a big cup—almost as ornate as the one that the America brought home from England in 1851—as emblematic of the speed championship of all the schooners that fished the Banks.

Immediately, the Nova Scotians sent down a challenge for the Gloucestermen to come up and take the cup if they could. The Bay State fishermen accepted with enthusiasm, and the race was on. The



# Race

time was too short to hold elimination contests, so Gloucester picked the "Esperanto" and Capt. Marty Welsh and sent them to Halifax to race the "Delawana," of Lunenburg, best two out of three.

Cap'n Marty turned the trick. With light winds, he sailed his ship over the course and brought her home well in the lead to take the first race. The next day, with a full gale roaring out of the north, he repeated the performance, finishing so far in the lead, that there was no doubt of the superiority of the Yankee craft. So the cup came to Gloucester, in two straight races, but it stayed only one year at the New England fishing headquarters. During the winter of 1920-21, the Canadians built a new schooner. She was big—capable of carrying more sail than any schooner in the American fleet. In these fishermen's races, the bigger ship suffers no time penalty—the schooners race "boat for boat" regardless of size, sails or tonnage. They called the new ship "Bluenose," and on her trips to the Banks she proved as swift as they had hoped.

Gloucester stood pat on the "Esperanto." But during the summer of 1921, the swift little ship, homeward bound from the fishing grounds, piled up on a reef off Sable island. After elimination races, the Gloucestermen sent the "Elsie"—a little craft much smaller than the Canadian entry—into a race against the "Bluenose." She went down to defeat in two races, and the cup went back to its Canadian home.

The next year, the Yankees entered the "Henry Ford," a new ship from which they expected great performances, but she shared the "Elsie's" fate—the "Bluenose" chalked up two more victories. Then the Gloucestermen built a real ship, the "Columbia." She had everything but luck. In the elimination races off Gloucester, she sailed away from the best of the American fleet. Then she set out for another trip to the Banks before meeting

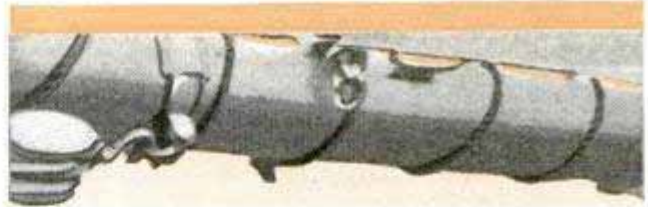

Above, Captain Clayton Morrissey Who May Command American Entry, and, Below, the Prize Cup



the "Bluenose," and was run down by a steam trawler. By heroic efforts, the crew kept her afloat while the trawler towed her to the island St. Pierre, off Newfoundland. Just one thing, they said, kept them from abandoning her—they knew she could beat the "Bluenose."

Repairs made at the island port, they sailed back to the Banks, caught a full cargo of fish and made for Gloucester, two men at the wheel in anything more than a light breeze on account of a split rudder post. There was just time to discharge the fish and make Halifax in time for the race—not time enough to repair the rudder post. So to Halifax, split post and all, she sailed.

The "Columbia" didn't lose. But her hard luck prevailed and prevented her from bringing home the cup. For the full forty sea miles (about forty-seven land miles) of the triangular course of the first race, it was nip and tuck; first one schooner and then the other nosed ahead, but never did either have any great advantage. But the "Bluenose" crossed the finish line fifty seconds ahead of the "Columbia"—compare that finish with any in the big yacht race.

Again, in the second race, the "Bluenose" breezed home one and a half minutes ahead of the "Columbia," but the race committee awarded the contest to the American ship as the Canadian had failed to round one of the buoys, which made the contest stand one race apiece, but the skipper and crew of the "Bluenose" decided they wouldn't sail the third, and deciding, race.

"Sail your schooner over the course, by herself, and take home the cup," the committee told Captain Pine.

"I came here to race the 'Bluenose' not to go for a sail," answered the Gloucesterman and sailed home without the prize.

During the next two years, conditions in the fishing industry were such that neither Canadians nor Yankees cared to take the time or go to the expense of holding a race. In the fall of 1926,

the "Columbia" joined the ghostly legion of ships that have sailed out of Gloucester and never come back. Ship and crew vanished into the waters with never a trace save only a battered dory that came ashore on Sable island, hard by the spot where the "Esperanto" crashed to pieces.

Then there was the "Puritan." A noble ship and a fast one, built especially to bring the cup again to Gloucester, but she never came back from her second trip. Flying before a northeast gale, loaded deep with her catch, she, too, was piled up on a bar off that same Sable island that claimed the "Esperanto" and the "Columbia."

Still the list isn't finished. For the "Henry Ford," even now claimed by the fishermen to have been able to beat the "Bluenose" with anywhere near an even break, and the "Elizabeth Howard," that

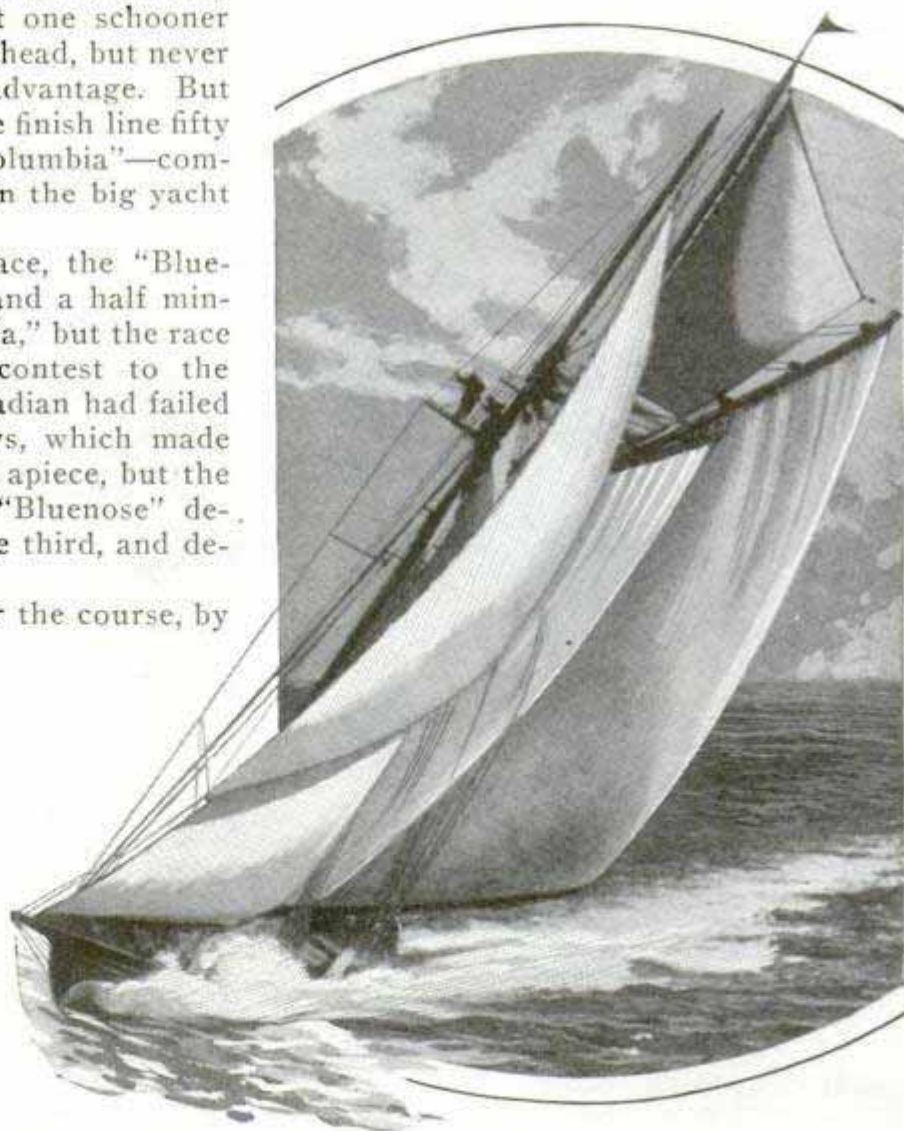

The "Columbia" Showing Her Gait with Her Lee Rail Awash; the Topsail Men Ride Their High Perches during the Entire Race



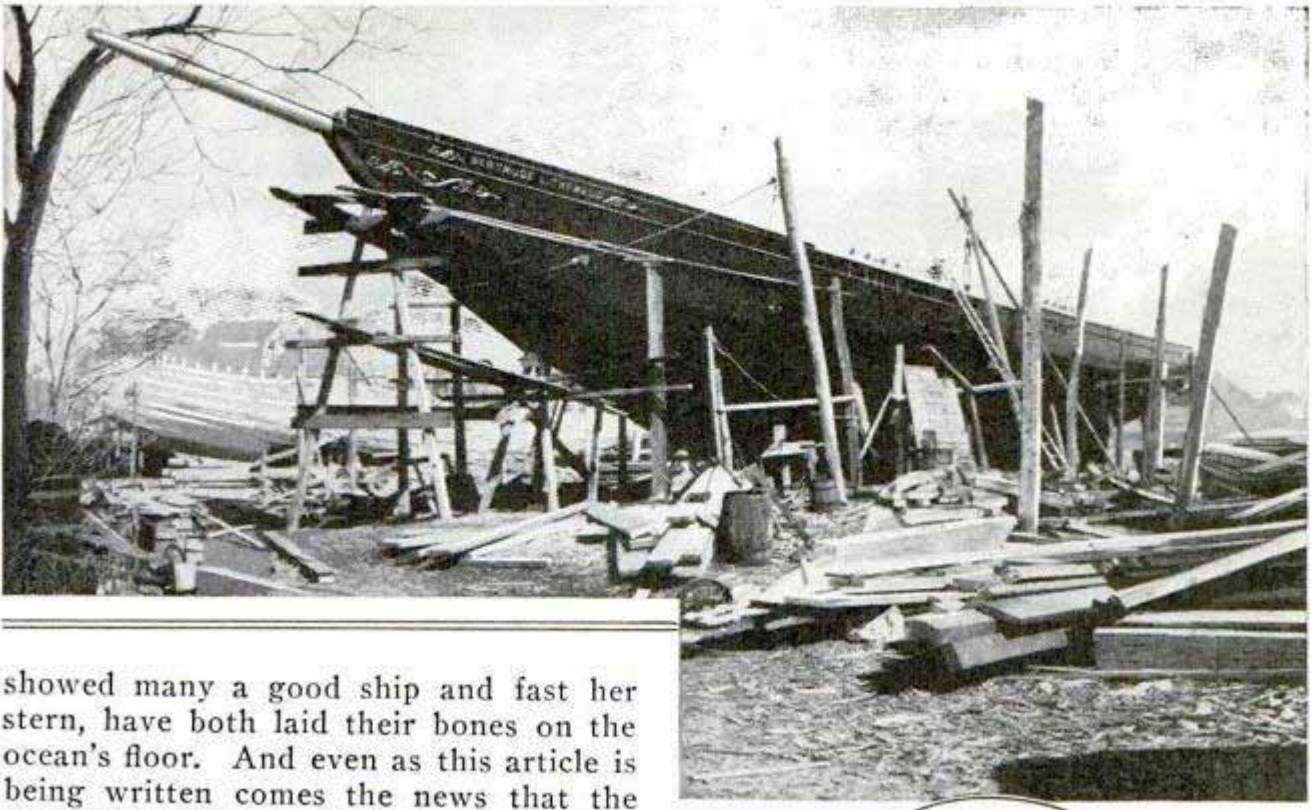

showed many a good ship and fast her stern, have both laid their bones on the ocean's floor. And even as this article is being written comes the news that the brave little "Progress"—that last year beat the best of the Gloucester fleet, even though a full twenty-five feet shorter than the smallest of her rivals—has burned and sunk at sea.

But the men of Gloucester are betting that the new schooner, the "Gertrude L. Thebaud," will outsail both the "Bluenose" and the jinx. For she is backed by Louis A. Thebaud, millionaire of Morristown, N. J., who has a summer residence near the fishing port, and Louis Thebaud is counted a harbinger of good fortune. Never has another fishing schooner just like the "Thebaud" sailed out of Gloucester. She was planned by Frank Paine, noted marine architect of Boston, who designed the America-cup defender, "Yankee." She cost nearly \$80,000, the most money ever laid out for a New England fishing schooner.

Her every line denotes speed. She has the same long overhang that is noted in the yacht racers and her masts tower nearly as high as theirs, with mainmast of ninety feet and topmast of forty feet. Having two sticks, she will carry more canvas than any of the yachts. The latter have a waterline length of seventy-four to eighty-six feet and are 115 to 125 feet over-all. The "Thebaud" is 135 feet over-all and ninety-eight feet on waterline.

In the big race, the schooners are sel-



The "Gertrude L. Thebaud," New American Entry, on the Stocks; Below, The "Bluenose" and "Columbia" Racing Nearly Neck and Neck



dom sailed by the captains and crews that man them on the fishing voyages. Every one aboard is a picked man, the best for his particular job among all the fishermen of the fleet. Capt. Angus Walters, a veritable sailing wizard, hard to beat under any conditions and a veteran of the Halifax course, will undoubtedly be at the wheel of the "Bluenose."

Gloucester has three skippers who are considered about on a par in handling a schooner in a race—Ben Pine, Marty Welsh and Clayton Morrissey. Long ago, all three of these became vessel owners in their own right and now spend most of their time ashore. But they're still rated the best in Gloucester, when it comes to getting all there is out of a fishing schooner in either a light breeze or a howling gale. Captain Pine, being a part owner of the "Gertrude Thebaud," will probably sail her in the international race.

The rules of the fishermen's race are

few. Each contestant is allowed a crew of twenty-five men, including the captain, and two invited guests, one a pilot, if desired. A representative of the opposing schooner is also carried. There are no time allowances on account of a ship's length, tonnage or sail area.

The approximately triangular course of forty sea miles—of course, on account of tacking, the boats sail much more than this distance—must be covered within nine hours, or it is no race. The competing schooners are allowed to carry only the number and size of sails ordinarily used in their fishing cruises, but the captains may use their own judgment regarding removal of part of the usual ballast.

The men of Gloucester believe that the "Thebaud" will beat the "Bluenose." But they are taking no chances. They are completing another schooner, as speedy, in case something should happen to the new contender.

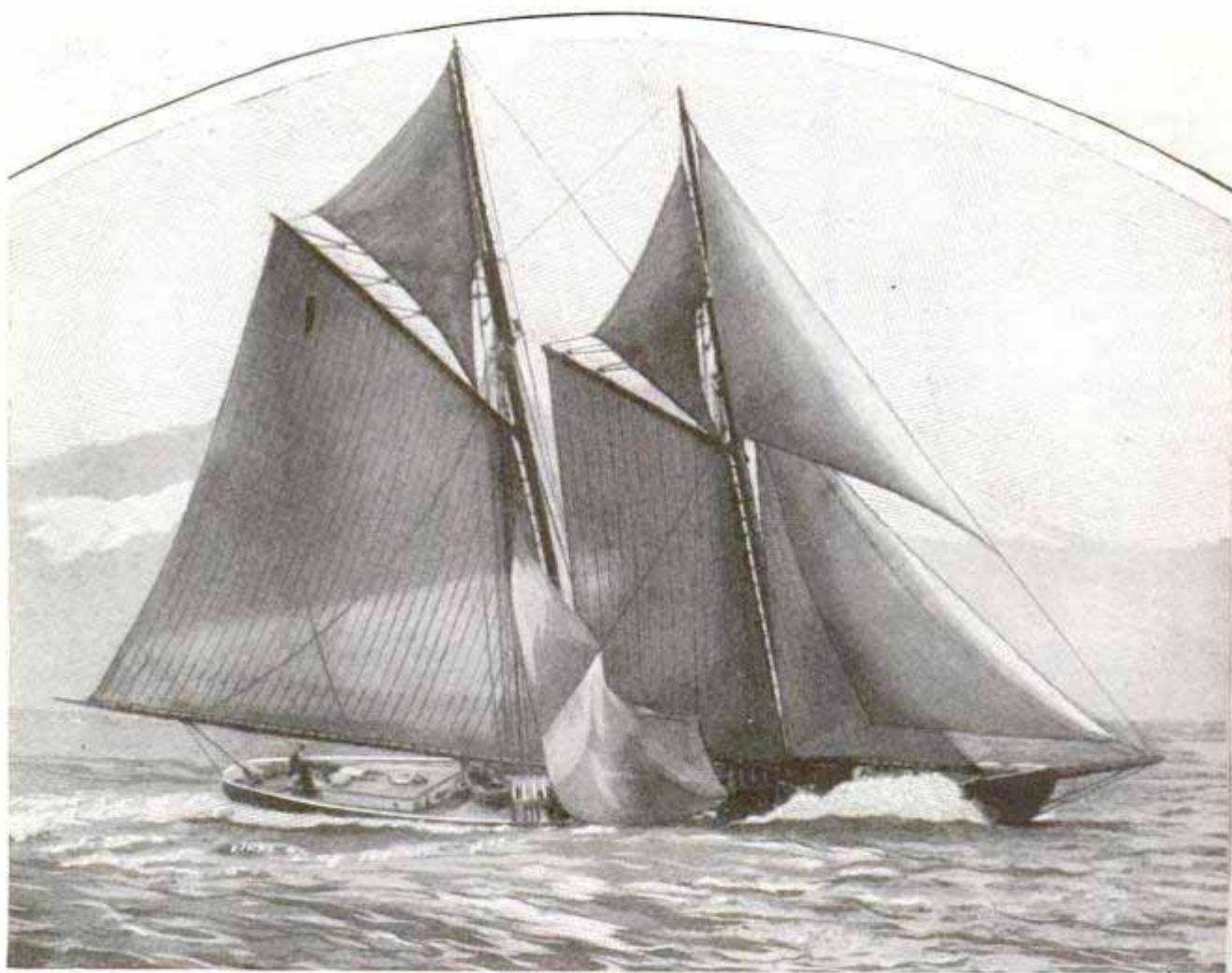

Typical View of a Racing Fishing Schooner in Action; This Is the "Bluenose," the Canadian Vessel That Has Several Times Beaten American Boats and Will Compete in the Coming Race



HIGHEST-SPEED MOVIE CAMERA HELPS TEACH GOLF

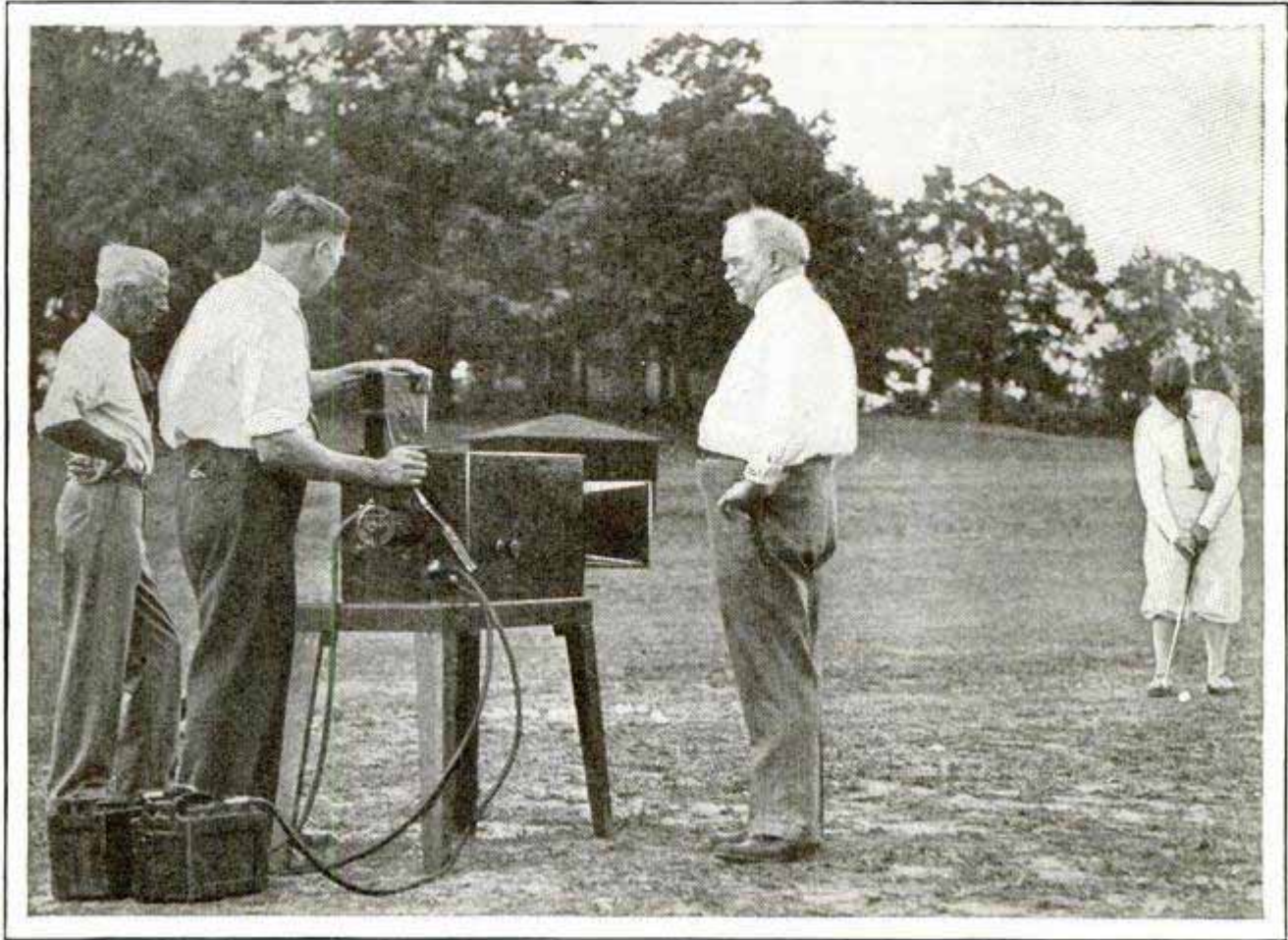

Using the Fastest Motion-Picture Camera to Improve the Golfer's Game; Pictures of the Play of Experts Are Taken with the High-Speed Camera to Show Every Motion of the Stroke

To acquaint golfers with the exact methods of play used by the top-notchers, pictures of the play of prize winners recently were taken with the world's fastest movie camera, for display throughout the country. The high-speed camera catches many of the fine points of the golfer's movements that would be missed by the ordinary camera.

ates parking, driving and bright lights, and pulling up on the button starts the motor.

BLIMP LANDS ON LINER'S DECK TO TAKE OFF PASSENGER 12 16

For the first time a non-rigid airship has landed and taken off from the deck of an ocean liner, the feat having been successfully performed recently when the "Mayflower," a blimp of the Goodyear fleet, came to momentary rest on the deck of the German liner "Bremen" as the ship reached New York. The airship paused long enough to pick up a passenger. An experienced ground crew was aboard the liner, on the deck of which a space eighty-five feet long and thirty-six feet wide had been cleared, the railings being lined with mattresses to prevent puncturing the gas bag. The "Mayflower" is 128 feet long and thirty-seven feet wide, so a slight miscalculation would have plunged the blimp into the ship's superstructure.

CAR STARTER, LIGHTS AND HORN OPERATED BY ONE BUTTON

One control switch, which operates the starting motor, the lights and the horn, now may be installed on any standard automobile. The finger-tip switch is a single button in the center of the steering wheel. Pressing down on the button sounds the horn, turning it oper-



*Pinet Wenterfront Co,  
26 36*

*Chicago Tribune  
8/1/30*



1201  
616  
*Evansville Ind*

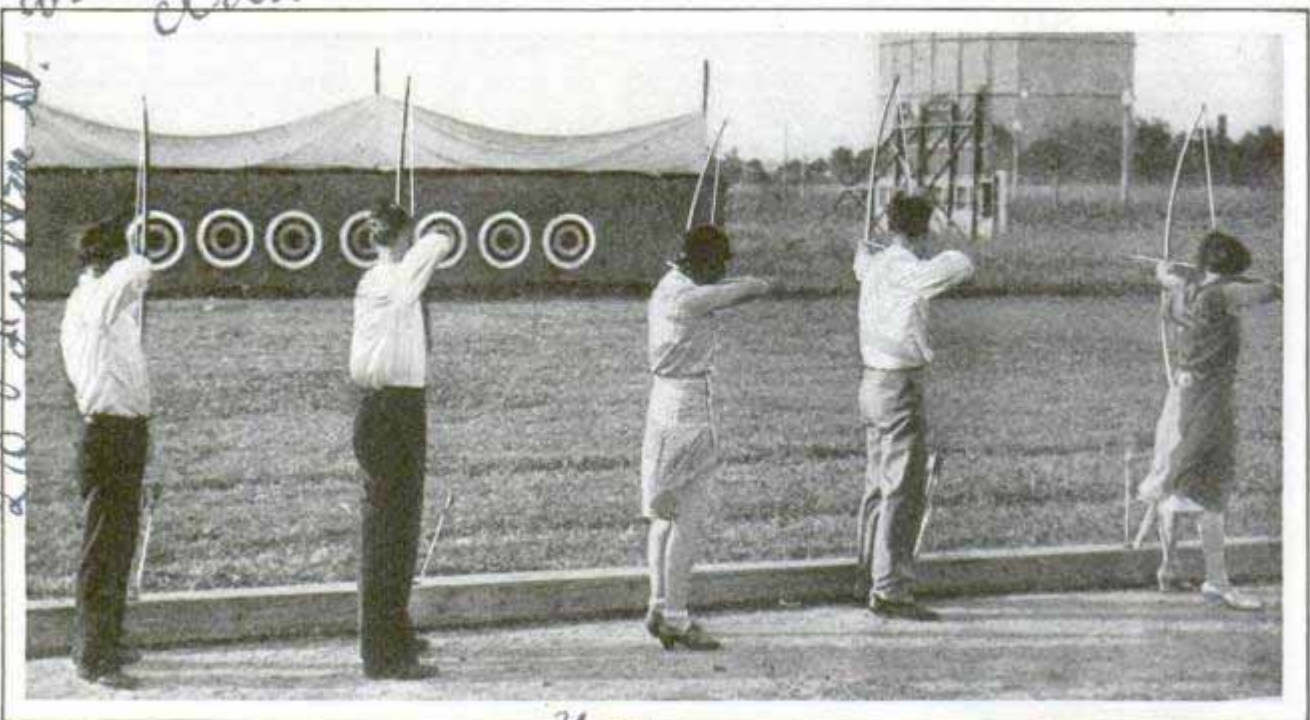

Small Archery Field Like the Miniature Golf Course; Several Targets on a Single Strip of Canvas Allow a Half Dozen or More Persons to Shoot at Bull's-Eyes Simultaneously

**MINIATURE ARCHERY FIELD VIES WITH SMALL GOLF COURSE**

Those who are tiring of the small golf course on a vacant lot now may take up archery on a similar scale. In Chicago, a miniature archery field has been constructed with several bull's-eyes on a single strip of canvas, thus allowing half a dozen or more persons to shoot at once.

**AUTO IS BUILT FROM OLD PARTS OF A SCORE OF CARS**

What might be termed a composite of most of the standard automobiles of the

United States is contained in a car built by a Racine, Wis., youth, mostly from old parts. More than a score of different kinds of automobiles contributed to the composite machine, some of the parts being from models of fifteen years ago. Other parts are from current makes and a few are new or made specially for the composite automobile. For a few pieces, the maker went outside the automotive field, having obtained his door and rumble-seat hinges from an ice box. Assembling the auto required a year and a half of spare time. The hybrid car had its inception in an old 1919 chassis that the youth found abandoned on the lake beach.

**LEAVES IN LYE-SOLUTION BATH BECOME LIKE GAUZE**

Certain kinds of leaves in Honduras are placed in a lye-solution bath to separate the veiny structure from the rest of the leaf, the result being a gauzy, silky coherent fabric used for making wreaths and corsage bouquets. The lemongilla leaf lends itself best to this treatment. A half teaspoonful of lye is added to three quarts of water and the leaves are soaked for twenty-two days. They are then rinsed in clean water and dried. The gauzelike leaf can be dyed and can be stiffened by adding a starch preparation to the dye.

*Built by. Reginald Eugene Freeman, 1433 Michigan Blvd. Racine, Wis*



Auto Made of Old Parts of Twenty Cars

*Capt. Russell P. Voorhes c/o American Consul*



Washington, D.C.  
7/30/30

**LOW-WATER MARK SET IN RIVERS BY DROUTH, 122**

Rivers which were breaking records for height a year or so ago set new marks for low water during the drouth of the past summer. All along the Mississippi river system, low records were established, readings being three and four feet, while the normal for the season is eleven or twelve feet. During the summer, many sections reported only a third or a fifth of the normal rainfall for the months, and in widespread sections the drouth was characterized as the worst ever recorded by local weather bureaus.

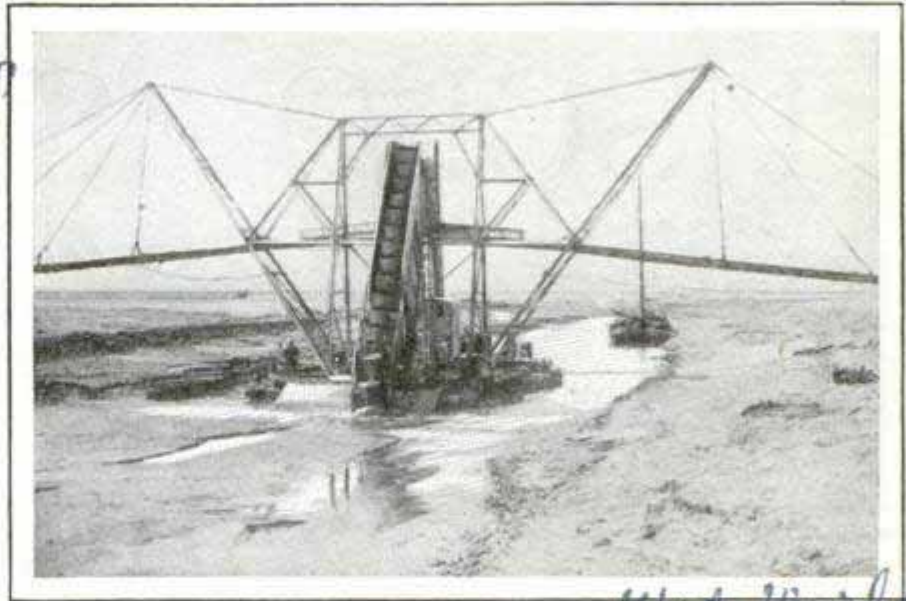

One of the Dredges at Work on the Bed of the Zuyder Zee; This Dutch Sea Is Being Drained to Provide More Farm Land

*Wide World*

**BED OF ZUYDER ZEE REVEALED AS PUMPS CLEAR WATER**

Drainage of the Zuyder Zee in Holland, a project undertaken to convert the area into farmland, has progressed until the sea bed is visible. Two pumping stations were used, drawing off 4,000,000 tons of water a day from the historic Dutch sea, which has been completely diked in. There is an area of more than 45,000 acres lying just inside the island of Wieringen which is expected to be dry before winter. More than seventy-seven square miles of new land, most of it of the same rich, heavy clay as the adjacent province of North Holland, will then have been won back from the sea.

**DISHES THAT WILL NOT BREAK MADE OF COTTON, 1210**

After experimenting for several years, a British inventor has succeeded in treating cotton in such a way that it can be made into serviceable dinner plates and other light articles usually made of some material that is easily broken. Aside from being unbreakable when dropped, the cotton dishes and other articles also are light in weight as compared with the materials used ordinarily for such purposes.



Samples of Lightweight Unbreakable Plates, Which Have Been Made Entirely from Cotton

**OIL DRIVING STEAM FROM SEA, 1203**

Oil is gradually driving steam from the sea, according to shipping reports. In Great Britain, the tonnage of motorships now building is 831,159 tons, compared with 556,804 tons of steamships, while elsewhere the motorship tonnage is ninety-four per cent greater than steamship tonnage under construction. There are now being built in the world ninety-one motorships over 8,000 tons, but only thirty steamers, including ten motorships and eleven steamers, 15,000 tons and upward.

■ A fireproof cargo pouch of asbestos for air express and mail recently underwent successful tests.

*London Daily Mail 7/16/30*

*Dr. J. Samuel, London, Inc.*

*Designed by Johns.*



# I SOLO *in* SEVEN

By PAUL D. PADDOCK

off on one wing, I'll kick rudder to keep it approximately level."

The nose of the plane was rising gently into the blue. Higher it climbed. Then an instant's pause. The wings trembled as the plane halted at the top of the climb. Then it shot down like an arrow that has reached the peak of its flight. As the nose fell, one wing started to drop lower. Myers corrected the movement with a quick kick on the rudder. We darted down, nose first, with a sensation like that in the dip of a roller coaster, only this was faster and smoother.

As we started the stall, the stick was clear back against the seat. To stop the dive, Myers pushed the stick forward to neutral position, then pulled it back slightly, and we shot out in level flight. Nothing hard about it. More fun

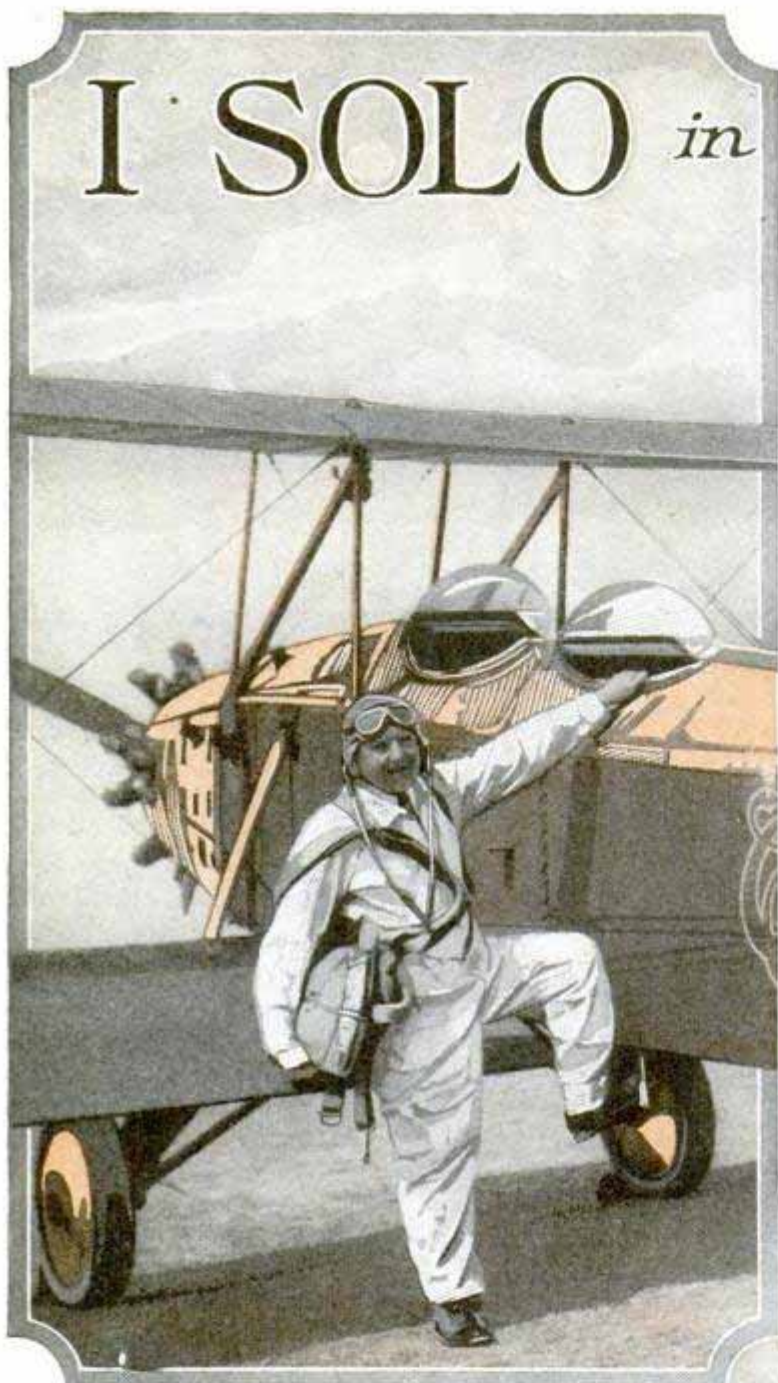

OUR altimeter needle was trembling around the 2,500-foot mark. The air was growing cool, and quiet too, as we were high above the disturbed currents nearer the ground. Myers throttled the engine to idling speed and pulled back gently on the stick.

"We'll do stalls first," he said. "Follow through and watch the position of the nose of the plane. To keep the ship from falling



Ready for a Flight Lesson, and Scene at Department of Commerce Test, Where Student Pilots Attempt to Qualify for License Papers



# HOURS

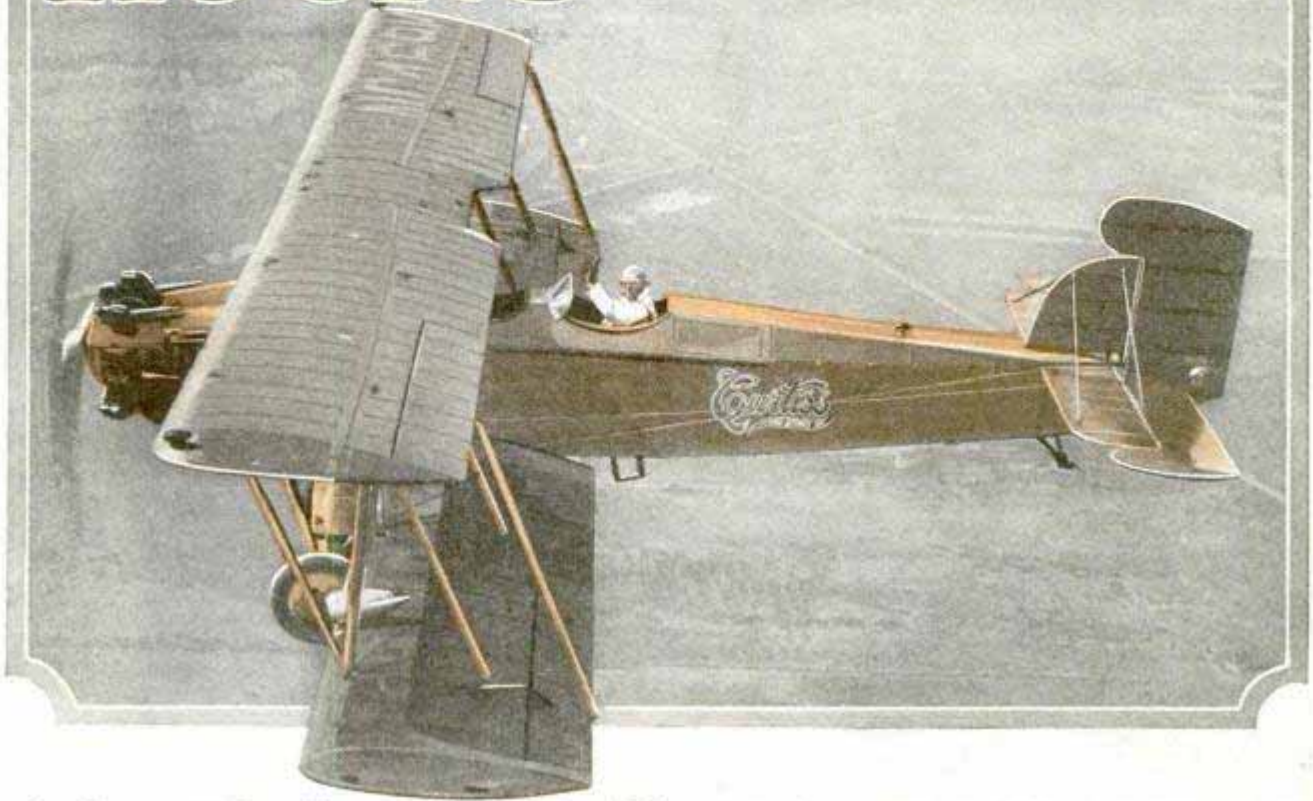

On Solo at 2,000 Feet, Where the Air Is Cool and Quiet and the Steady "Fledgling" Practically Flies Itself with Almost No Need of Stick or Rudder Control

than anything else. We did another after climbing back to our former altitude.

"Now we'll do a spin," said Myers. "We start it just as we did a stall, but in order to spin, we apply full rudder on the side we wish to spin. We'll do one to the left. The stick will be far back against the seat and as we fall, I'll give full left rudder and hold both controls in that position. To come out of the spin, I'll neutralize both rudder and stick, leaving us in a dive. To get out of that, I'll simply pull back on the stick and we'll fly level again. Here we go!"

As the nose of the plane dropped, Myers kicked full left rudder. Instead of shooting straight down as we had done before, the plane started spinning with amazing speed. It was as though we were suddenly caught in some gigantic whirlpool that was sucking us down to the earth with greedy speed. It seemed incredible that our sturdy ship could cut such a dizzy pattern through the skies. Around we went, the motion throwing us against the right side of the cockpits.

"Notice that I have the stick clear back against the seat and am holding it there with the rudder fully forward at the same time," said Myers calmly. "As long as I hold the controls in this position, we'll spin. Normally, to stop a dive, you push back on the stick. That is just what you don't want to do to stop a spin. Now we'll come out."

He pushed the stick forward to neutral, at the same time the right rudder pedal went forward and the left came back until both were opposite, the neutral condition, and the whirling motion stopped. A slight backward pull on the stick to stop the dive, and we shot out in level flight. To my surprise, we had fallen little more than 400 feet. Myers repeated the spin and then directed me as I went through the same maneuvers. Simple, nothing to fear and the sensation was more pleasant than anything else. I shall never fear a stall or a spin, for I know how to get out of them. Only, and here is the chief reason why the much talked of and little understood spin is a menace, you must



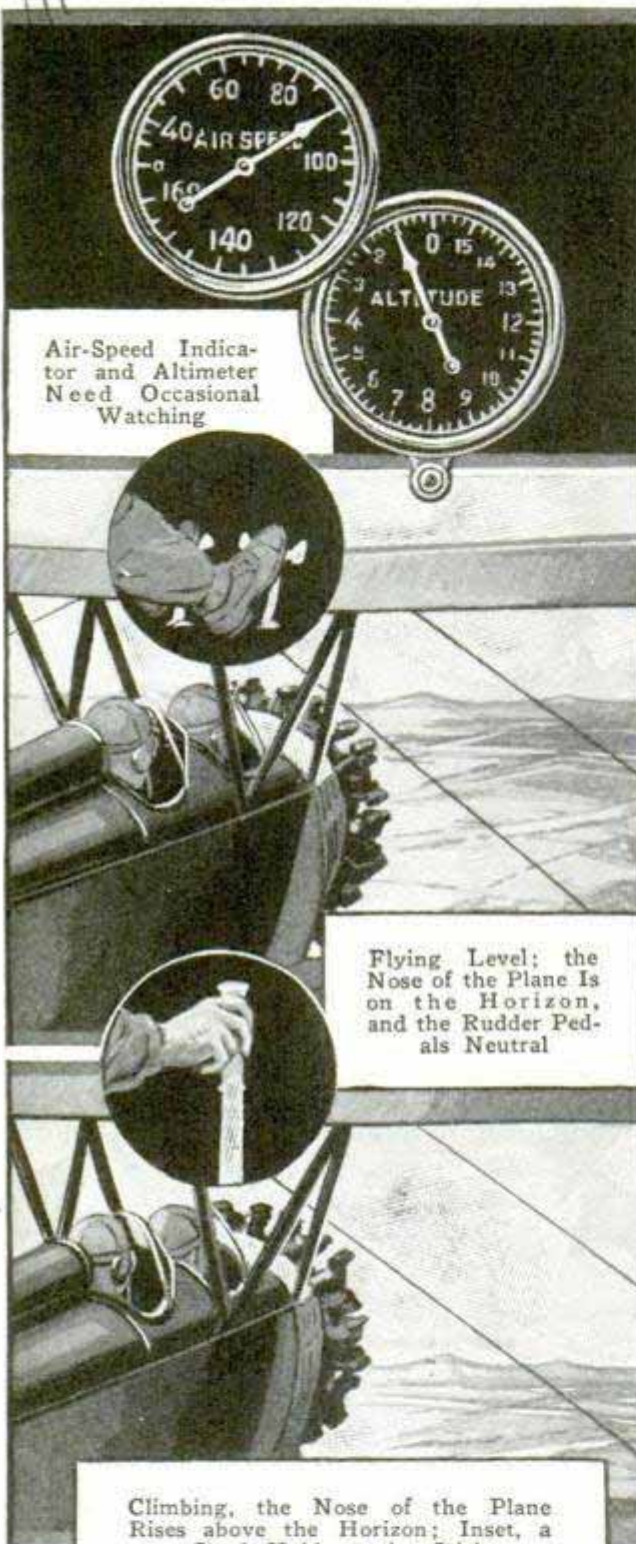

have plenty of altitude. A spin near the ground would be serious. A stall at low altitude might be equally disastrous.

After stalls and spins, which took but one lesson, the hardest part of the flight instruction proceeded anew—practice on take-offs and landings. The former gave me more trouble than I had anticipated. I had the wrong impression that all one had to do was to give the engine the gun and the ship would fly itself off the ground. That is partly true, but the part that is left out is the rudder, the most important feature of the take-off controls.

Skimming along in the air, a plane steers easily at the slightest pressure on either rudder pedal, but in taxiing or taking off, before flying speed has been attained, the rudder response is much slower and the rudder therefore has to be applied much more vigorously. As the wheels run along, they strike slightly uneven places in the ground, or currents of air swerve the plane. Therefore, unless the ship is steered carefully, it will head crossways into the wind, or, perhaps, turning too sharply, it will touch one wing and a crash will result. To counteract these tendencies, the rudder must be used vigorously and correctly.

Get squarely into the wind. That's the first essential. Have plenty of room ahead of you and be sure the way is clear and that no ships are coming to land behind. Give the engine the gun and, as soon as the ship moves, shove the stick all the way forward. Hold it there just long enough for the nose to come down on the horizon. Don't hold the stick longer. The full forward position is the one for a dive. If you keep the stick there too long, the ship will start a downward course just as it would in the air, the propeller blade will

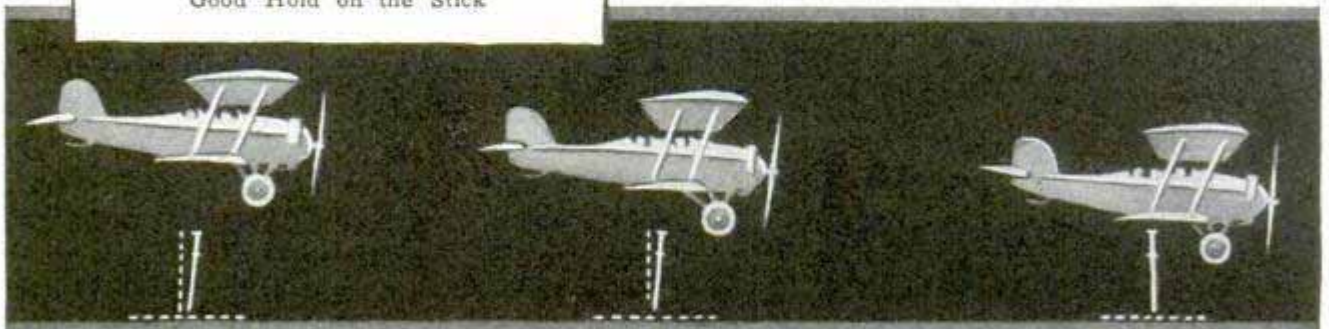

Critical Stages of a Landing; Gliding Down to a Height of Thirty Feet, Then Leveling Off by Pulling Back Slightly on the Stick

Copyright



hit the ground and there probably will be no more take-offs in that ship that day. But the stick control is easy compared with the rudder.

Try to steer a straight course toward a tree or some object across the landing field. If the nose of the plane swerves to the right, apply left rudder quickly and vigorously. Don't hold the left rudder as that would overcontrol. Neutralize the action as soon as the nose is back on the course by a quick application of right rudder. Nose to the left, hit right rudder, nose to the right, hit left rudder; that is the thing to remember. The action is comparatively rapid and must be done correctly. Pressing the wrong rudder exaggerates the swerve of the ship and might result in a spill. As flying speed is gained, the stick drifts back of its own accord.

We were gliding down for the field one afternoon when Myers said, "You land the ship this time. It's all yours. Handle it just as though I were not here." He had cut the gun, the plane was headed straight into the wind and the big brown field was coming up to meet us. I tried to do exactly as I had been told. Glide down to a height of about thirty feet, level off by pulling back slightly on the stick. That slows up the speed. The ship settles a bit in a few seconds. Pull back farther on the stick. The nose lifts a bit higher and, just before you strike the ground, the stick is all the way back against the seat. Easy to describe but not so easy to do.

One of the big moments in the student flyer's life is when the instructor climbs out, stays on the field to watch, and his pupil goes up and lands alone. When my time came to solo, Myers waved me off. I gave the engine the gun and No. 6

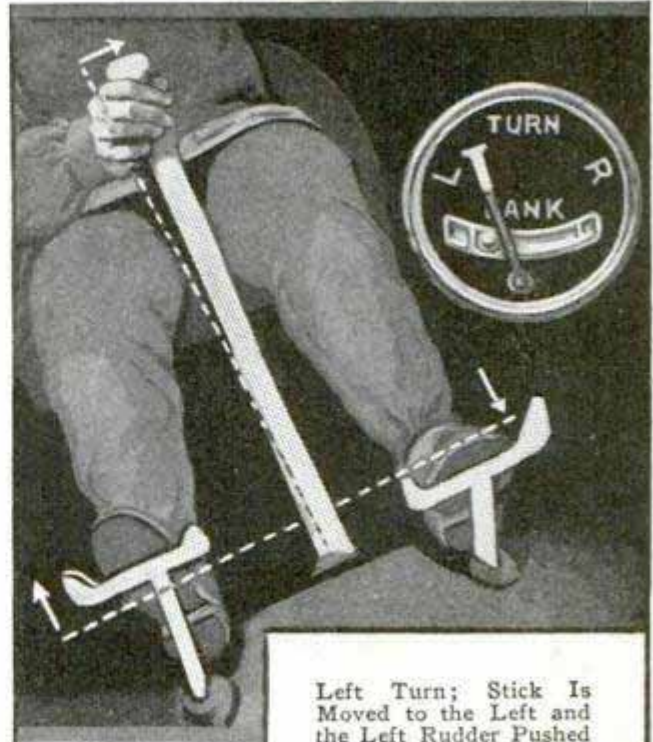

Left Turn; Stick Is Moved to the Left and the Left Rudder Pushed Forward

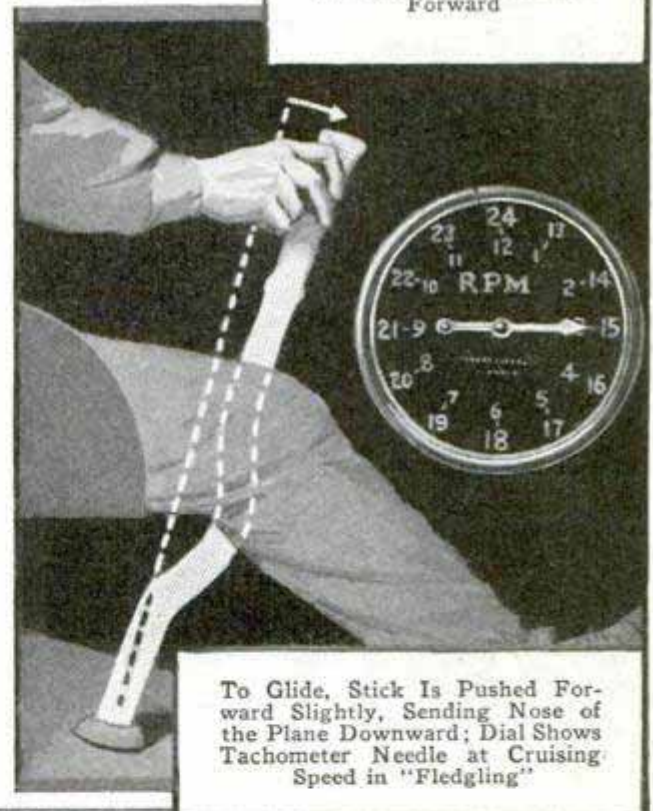

To Glide, Stick Is Pushed Forward Slightly, Sending Nose of the Plane Downward; Dial Shows Tachometer Needle at Cruising Speed in "Fledgling"

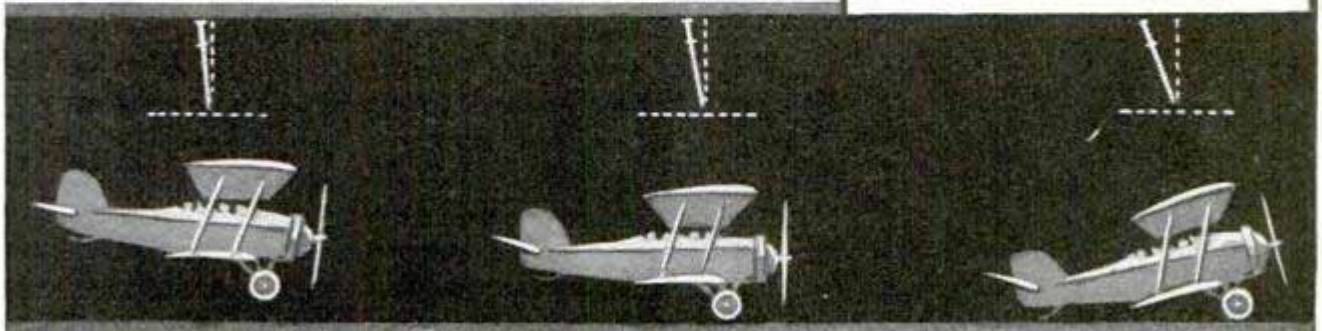

Standard Oil Co.

As Plane Sinks, Stick Is Pulled Back Farther, Raising the Nose Until Ship Is in Position to Land on Three Points, Both Wheels and Tail Skid, Simultaneously



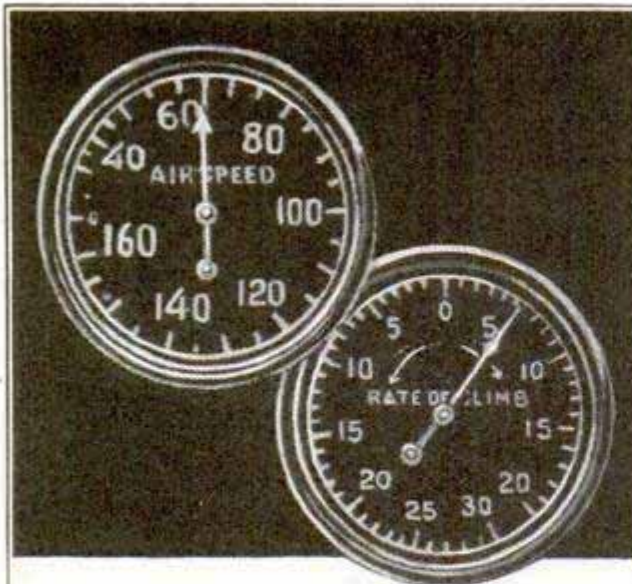

Air Speed and Rate of Climb Are Indicated on These Dials

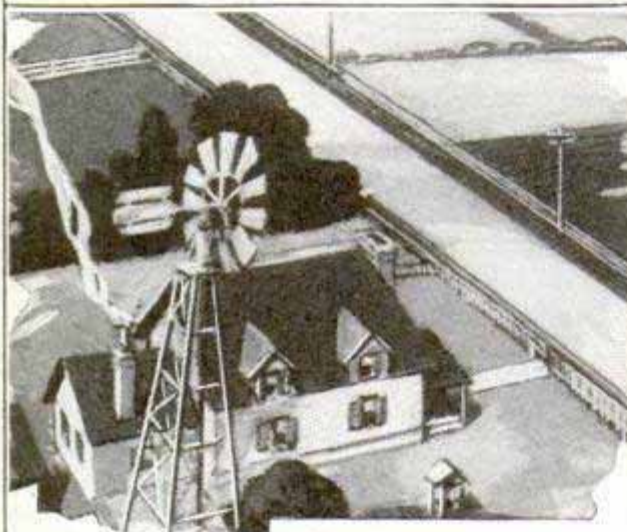

Smoke, Windmills, Dust and Other Objects Indicate Wind Direction and the Velocity

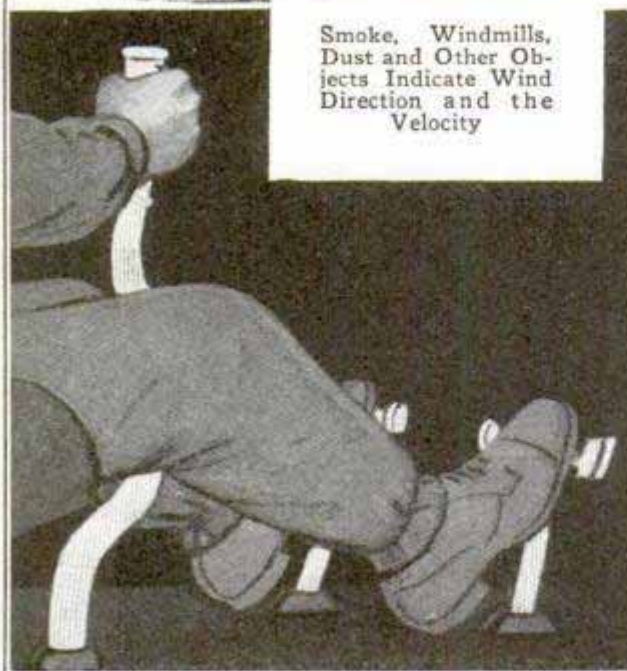

A Poor Stick Hold; Grasping It This Way Encourages Squeezing or "Freezing," and Prevents Pilot from Feeling the Stick's Natural Movements

moved ahead. Far forward with the stick, watch the nose, kick rudder as the plane swerves, let the stick come back after the nose is on the horizon. Faster the brown dirt goes blurring by. I'm off the ground and climbing. Full throttle to about 500 feet. Ease it back until the tachometer shows 1,500. Bank and turn for the first side of the field. I eased back in the seat, let the stick rest gently between my thumb and first two fingers and enjoyed things.

A splendid, sturdy plane, 170 horses in the motor ahead, all under the leash of your throttle hand, cool air sweeping past, the instant response of the wings, the thrill of doing everything yourself and the knowledge that for the first time in your life, you're flying alone!

Here's the western edge of the field. Now for the glide and the landing. I cut the gun and lowered the plane's nose. Out there was Myers, the first time I had seen a human being on the landing field from the air. How small he looked! Gliding down. Something like sliding on greased velvet, perhaps, only much smoother. A rush of wind through the wing wires—good music for it tells you have speed and are not stalling. There's the wind cone. You're headed too far north. Steer straight into the wind. That's better. Over the trees now and right ahead is the field proper. Down gently, no cause for steepening the glide. The wings are shaking a little but a movement or two of the stick levels them up.

This is about thirty feet! Back on the stick just a trifle. Flying level. The plane sinks. Back again on the stick. A little too much that time and the nose rises too high. Don't stall. Getting closer now, here comes the ground and, with a final pull, I moved the stick all the way back against the seat. Just a trifle too soon. I nosed up a bit but landed without too much of a bounce. Not as good a landing as I had hoped for, but the next one would be better.

In taxiing back to Myers who had been watching carefully, I learned another valuable lesson. I tried to turn too soon, applying rudder before the ship had stopped rolling after the landing. Myers warned me against this as there is danger of turning over. Let the plane come to a



halt or nearly stop, unless there is an emergency, and keep it rolling straight after it touches the ground.

"That wasn't so bad," said Myers in commenting on the landing, "but it might have been better. Be sure you have the stick all the way back and don't let your wheels touch first. Try it again and make everything perfect this time."

Away I roared once more, resolved to score a three-pointer. I glided down to a good start but estimated my altitude wrongly. Wheels hit first, rather hard this time, and in pulling back on the stick, something I should not have done, I pulled too hard and too fast and the plane rose fifteen or twenty feet. Remembering orders, I quickly advanced full throttle and shot around again for a third attempt.

This time it was better. I kept a step ahead of the plane, that is, tried to anticipate the movements and be in time with the settling with a movement on the stick. I looked farther ahead this time, watched both sides and kept special check of the nose position. I didn't hit wheels first and No. 6 stayed firmly on the ground. I rolled nearly to a stop and then turned to taxi back to Myers.

"Seven minutes solo and six hours and forty-five minutes dual instruction before soloing," reported the timekeeper at the office. I tried not to show my elation too much, but a great joy took command of me as I journeyed back to the city. I had soloed!

To my surprise, I had not felt nervous when Myers climbed out of the cockpit and let me go alone. Looking back, I ascribe my calmness to two things. First, for some time, Myers had been letting me operate the ship practically alone. Repeatedly, he had told me to manage things just as though he were not there. By careful, logical training he had built up my confidence until it seemed only natural to be starting out alone. Second, before the lesson that day, I resolved to relax and take things more easily than I had ever done before. Again, I repeat, much of the ease in learning to fly lies in that magic word "relax."

"Don't get too cocky now that you've soloed," cautioned the school chief the next day. "You will have a few things to learn!" His prophecy proved correct.

(To Be Continued)

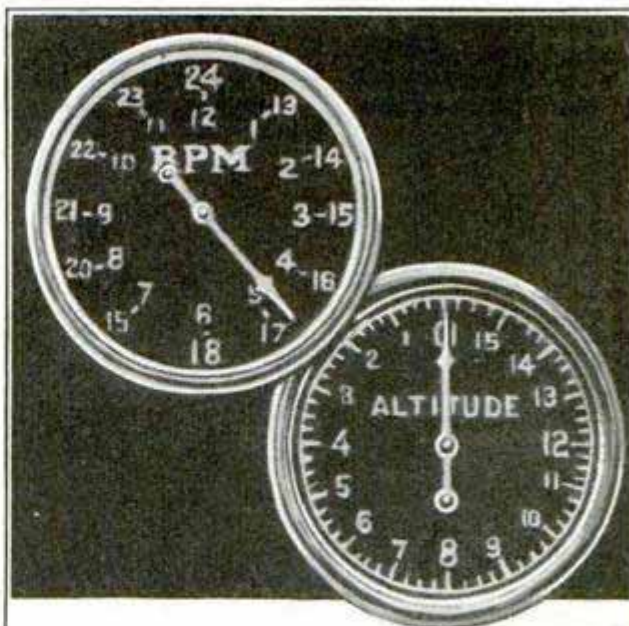

In Warming Up, a Few Seconds of High Speed Indicate if Engine "Revs" Up Properly before Taking Off

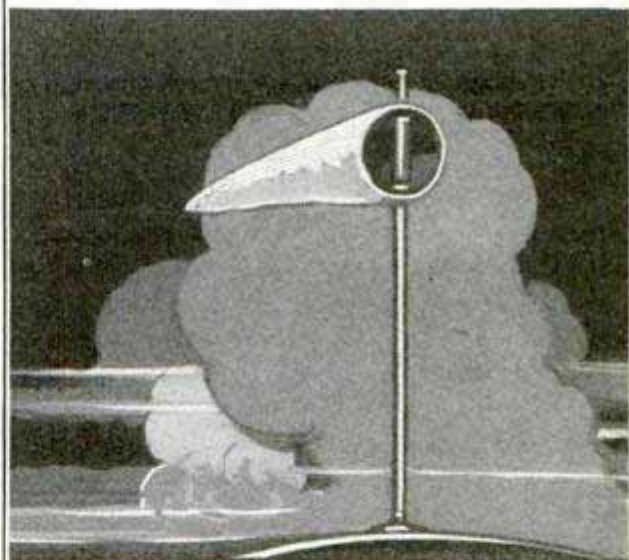

The Friendly Finger That Directs the Airman; the Wind Cone Giving Wind Direction

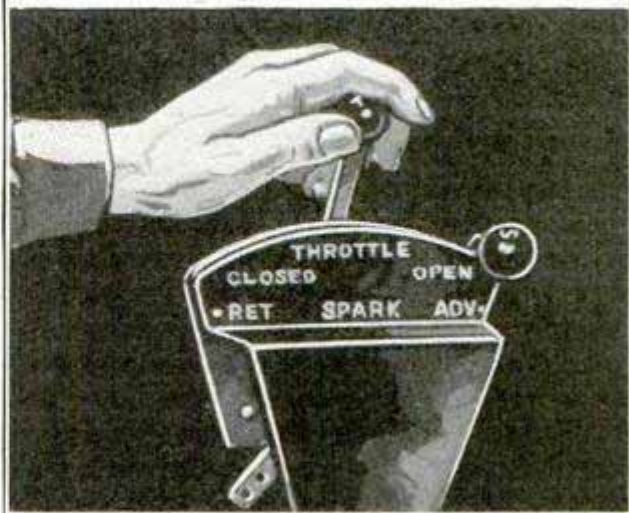

Throttle in "Fledgling" Is Operated with the Left Hand; Here It Is Shown at Cruising Position; the Spark Is Fully Advanced for Flying



# BIGGEST NAVAL GUNS HAVE TWELVE-MILE RANGE

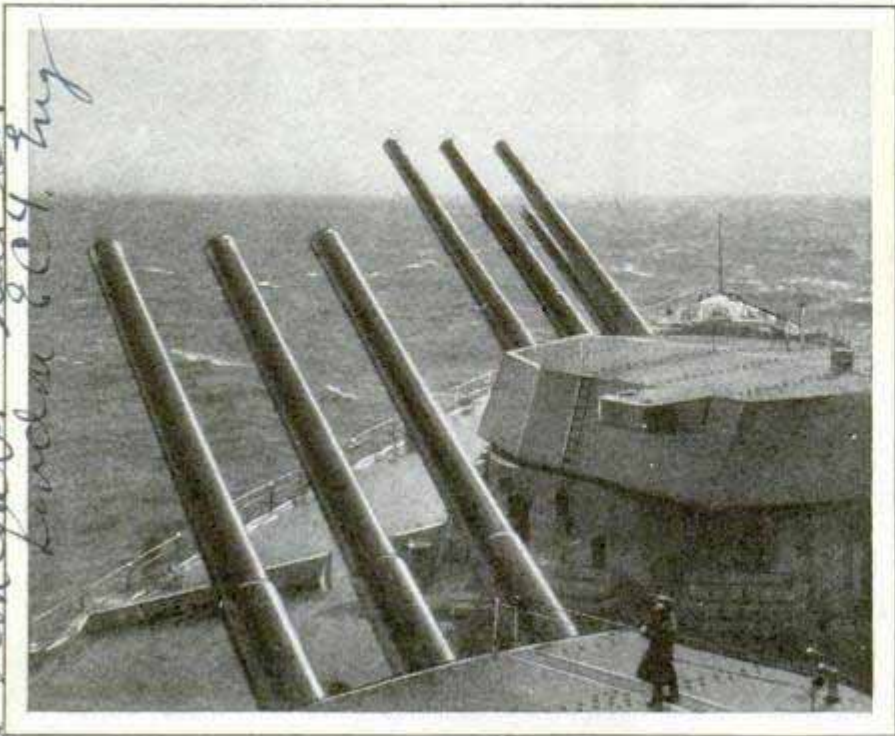

Giant Sixteen-Inch Guns on the British Battleship "Nelson"; Note the Elevation Which Is Necessary Because of the Guns' Long Range

York and passed over land wires here to its destination. Besides all points in Canada and the United States where there are telephone lines, London likewise is connected with Australia, South America, Cuba and Mexico.

## ITALIAN QUAKE IS RECORDED IN AMERICA

When the recent disastrous earthquake shook Italy, the tremors were recorded accurately by the seismograph at Georgetown University. It was estimated that forty minutes were required for the tremors to

travel the 4,500 miles from the scene of the quake to the recording apparatus. There are five of these instruments at the Georgetown observatory.

Some of the most powerful weapons in existence today are the giant guns on modern battleships. One of the most effective of the larger weapons is the sixteen-inch gun used on some of the fighting ships of both Great Britain and the United States. These guns, weighing hundreds of tons, are mounted in units of three. They have a range of 20,000 yards and are capable of piercing seventeen-inch armor at half this distance. The cost of firing a triple-turret salvo is about \$3,500, and the total weight of a broadside is 18,500 pounds. The high elevation is necessary because of the long range.

## WORLD'S TELEPHONE EXCHANGE

London has become the telephone exchange for the world's long-distance calls. Through that city now pass most of the transatlantic telephone messages as well as all the messages to Australia and to most other parts of Europe. A call from Rome to Oklahoma, for instance, comes over land lines from Italy to northern France, then by submarine cable under the English channel and so to the foreign exchange in London. There it is switched to the giant station at Rugby from which it is transmitted across the ocean to New

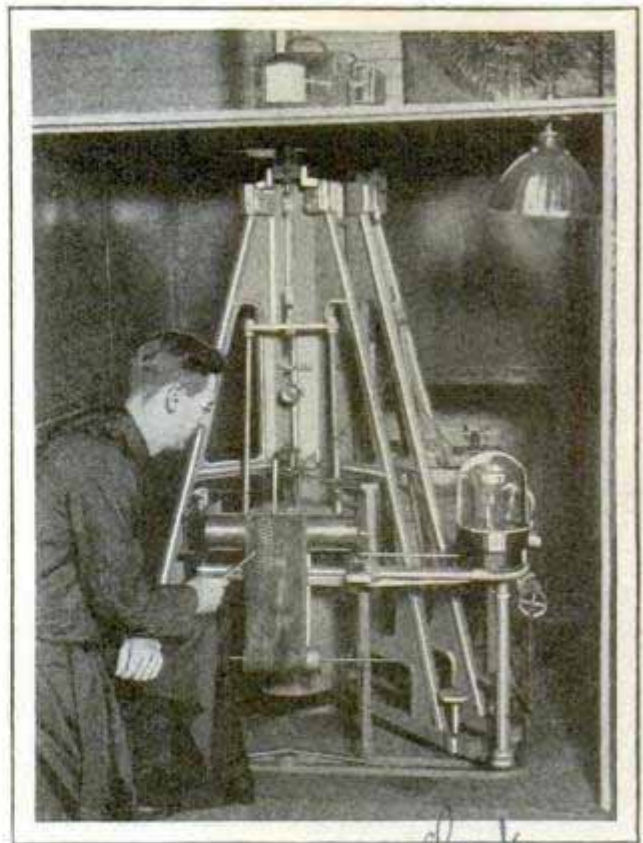

Seismograph at Georgetown University, and Chart Showing the Record of an Earthquake

*Topical Press Agency, 10+11  
Red Sea Coast, 7th Feb. St.  
London 204, Eng*

*1221*

*Int. Obs. 6/14/30*



## EXPANDING AUTO TRAILER GIVES HOME COMFORTS

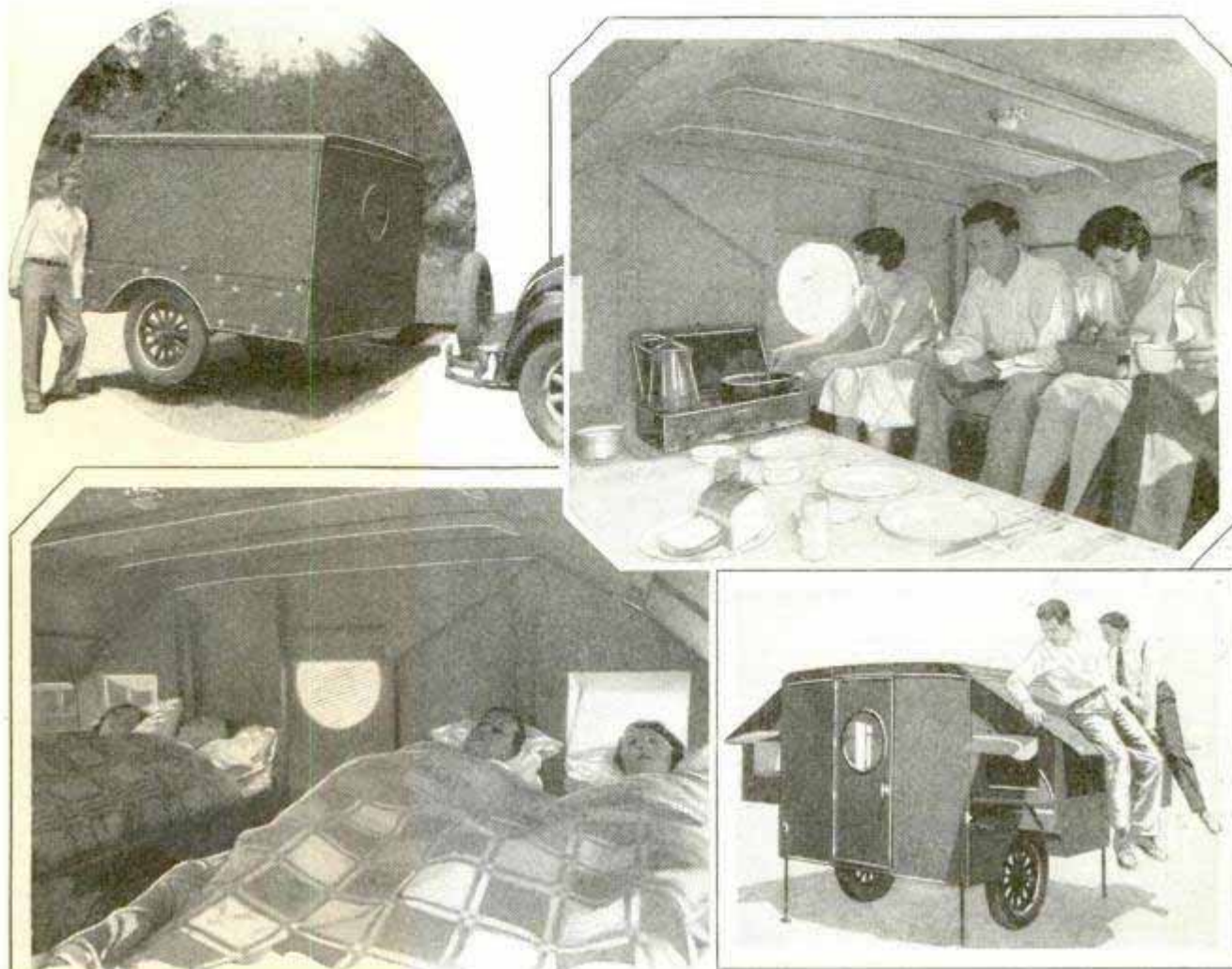

Interior and Exterior Views of an Auto Trailer Which Expands into Commodious Living Quarters; Compact Equipment Transforms the Trailer into Kitchen, Dining Room or Bedroom

Some of the comforts of home are offered in a compact auto trailer which, when expanded, may be used successively as kitchen, dining room, living quarters and bedroom. On the highway, the trailer is no wider than an automobile, but when parked, its sides may be extended by a crank inserted in sockets at the rear. It is provided with extension legs for use

when the 800-pound trailer is detached from the car, and has its own lighting plant. On each side of the car is a double bed, half of each folding back to make seats as required, while lockers and closets carry all necessary camping equipment. The trailer is dustproof when closed, and is so designed that making camp is a matter of little more than a minute.

*Worcester, Mass*

### ROCKET TESTS AIDED BY GRANT FROM GUGGENHEIM FUND

So important do scientists consider the experiments with high-altitude rockets designed to explore the upper reaches of atmosphere, that Daniel Guggenheim recently made a grant to Dr. Robert H. Goddard, of Clark University, who is carrying on his experiments at Camp Devens, Mass. Here he has constructed a tower inside of which is a track to direct

the path of the rockets at the start of their flight. He has been carrying on research work for several years, and while, thus far, the rockets have only been sent a few hundred feet into the air, the work has reached a stage where it is predicted that they may eventually ascend for fifty or seventy-five miles, carrying instruments to record conditions, and even bringing back samples of the atmosphere from these heights. The rockets used are propelled by the recoil from the discharge of gases.

*Professor of Physics*



O'ckurck

El Segundo, Calif

626

1064

POPULAR MECHANICS

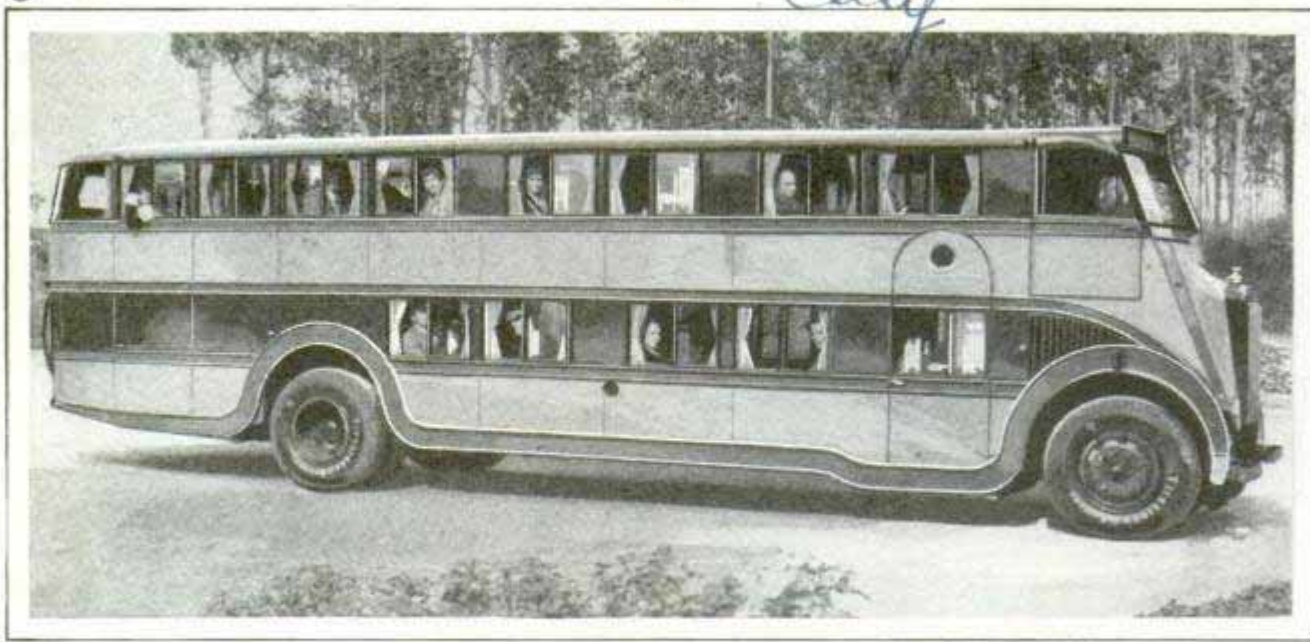

All the Comforts of the Parlor Car Are Contained in Big Double-Decked Motor Buses Like the One Shown Above; It Accommodates Fifty-Three Passengers on Long Inter-City Runs

GIANT INTER-CITY MOTOR BUS CARRIES FIFTY-THREE

Capable of accommodating fifty-three passengers each, giant double-deck motor coaches are being turned out by a Pacific coast coach works to be used in inter-city travel and long cross-country runs. The palatial busses have all the comforts of the modern parlor railroad car and from the upper deck offer a splendid view of the scenery along the highways.

WIND MOTORS FOR AIRPLANES PREVENT NOSE DIVES

To prevent a nose dive when the engine of a single-motored airplane goes dead, an aeronautical expert has made two auxiliary wind motors, placed in the position on the wings of the two outboard motors of a tri-motored ship. The wind motors consist of two-bladed propellers geared to four-bladed propellers in a ratio of two to one, the four-bladed propellers being in

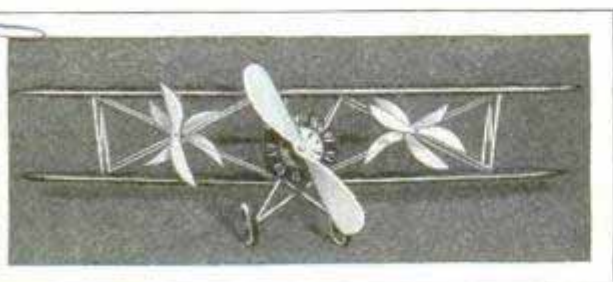

Single-Motored Plane Equipped with Two Auxiliary Wind Motors for Use When the Engine Fails

the rear. When the main motor dies, the "back wash" drives the wind motors in such a way that the front two propellers of the auxiliary develop a lifting power. Thus the plane rises from the motion given the rear propellers and transferred to the two-bladed ones.

RAYON, SILK'S PRINCIPAL RIVAL, 1080 TO UNDERSELL COTTON

Rayon, the principal rival of silk, and other synthetic cellulose fabrics, will soon be underselling cotton goods just as they now are priced under silk. This is the prediction of Prof. Charles E. Mullin, head of the division of textile chemistry at Clemson College in South Carolina. One company already can produce viscose yarn at a lower price than that of medium or fine grades of cotton yarns. As soon as the prices of the synthetic yarns drop to near that of cotton yarns generally, the same result will be apparent in the case of cotton goods, Professor Mullin says. He has found that synthetic silks are competing with real silks not only in price but in quality, since it is now possible to produce filaments more than twice as fine as those of true silk. It requires more than 4,225 miles of one of these filaments to weigh a pound, and six pounds would encircle the world.

Iodine has been found in coal by German scientists.

Science Service News Bulletin, No. 484-B.

Alexander Altieri, 1625 S Broad St Philadelphia Pa

Clemson College S.C.



Am. N. G. Union  
Box 407, Route 4,  
Hayward, Calif

7067  
Letter recd 4/2/37

# Junking Old Warships

WHAT becomes of the fighting ships of yesterday—ships such as those with which, thirty-two years ago, in the harbor of Manila, Commodore George Dewey destroyed the Spanish fleet? Though they were formidable fighting craft in their day, it is significant of the rapid progress that has been made in naval construction, that Dewey's entire squadron, consisting of six warships, representing a total of

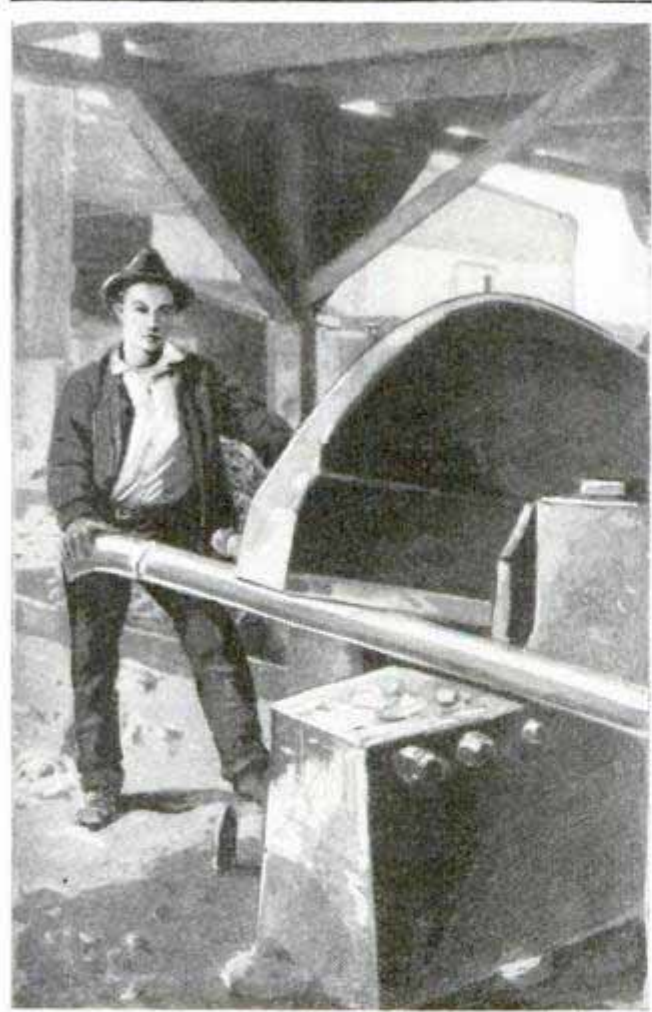
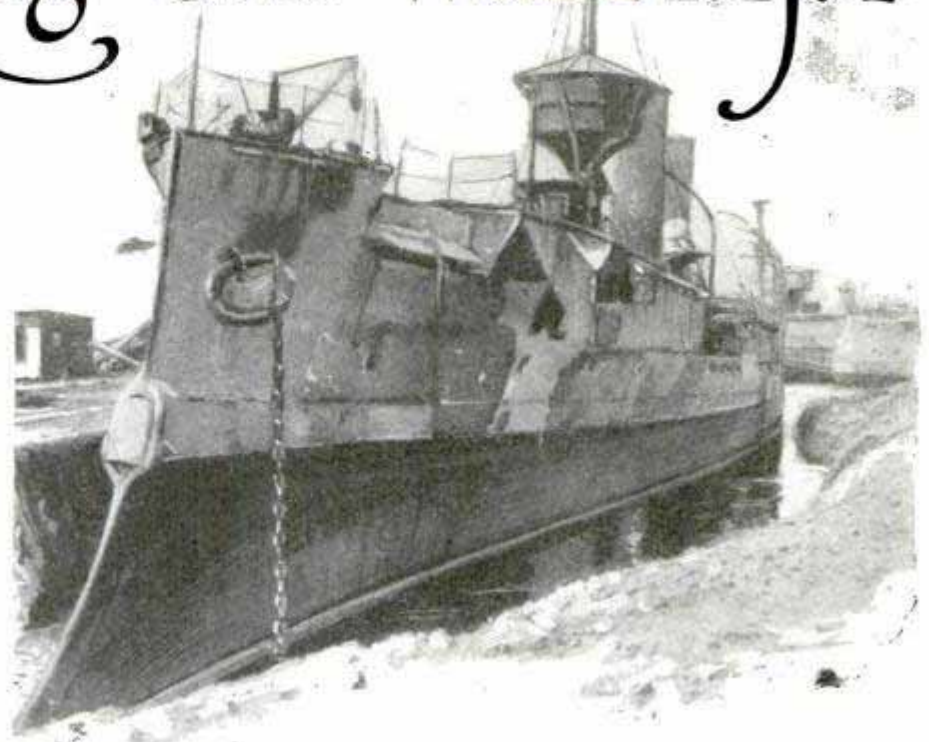

Salvaged Vessel Ready for Cutting with Acetylene Torches, and Shearing Steel Pipe and Copper Tubing

19,000 tons, was less in tonnage than one modern battleship.

The buyers of these condemned warships, in most instances, are firms which specialize in breaking up old vessels for their steel, copper, brass and marketable fittings. The steel is eventually manufactured into nails, bolts, wire, tin plate and other hardware. Ship fitters purchase most of the salvaged fittings, and the copper and brass are sold to manufacturers in the United States and Europe, to find their way back into the world in various commodities.

With the hull of a partially scrapped battleship high in the water alongside a wharf; busy workmen on the ship and ashore; on its track of steel an electric crane towering high above the ship, a view of a ship-breaking yard from a distance suggests a shipbuilding scene. But closer inspection and the junk-strewn yard tell another story. Here are the spoils from many scrapped ships, both merchantmen and men-of-war.

In one end of the cluttered yard, amid a mass of steel wreckage, varying from huge smokestacks to sections of thick armor plate, workmen, grotesquely masked, are at work with cutting torches; and here, like wheat separated from chaff, are



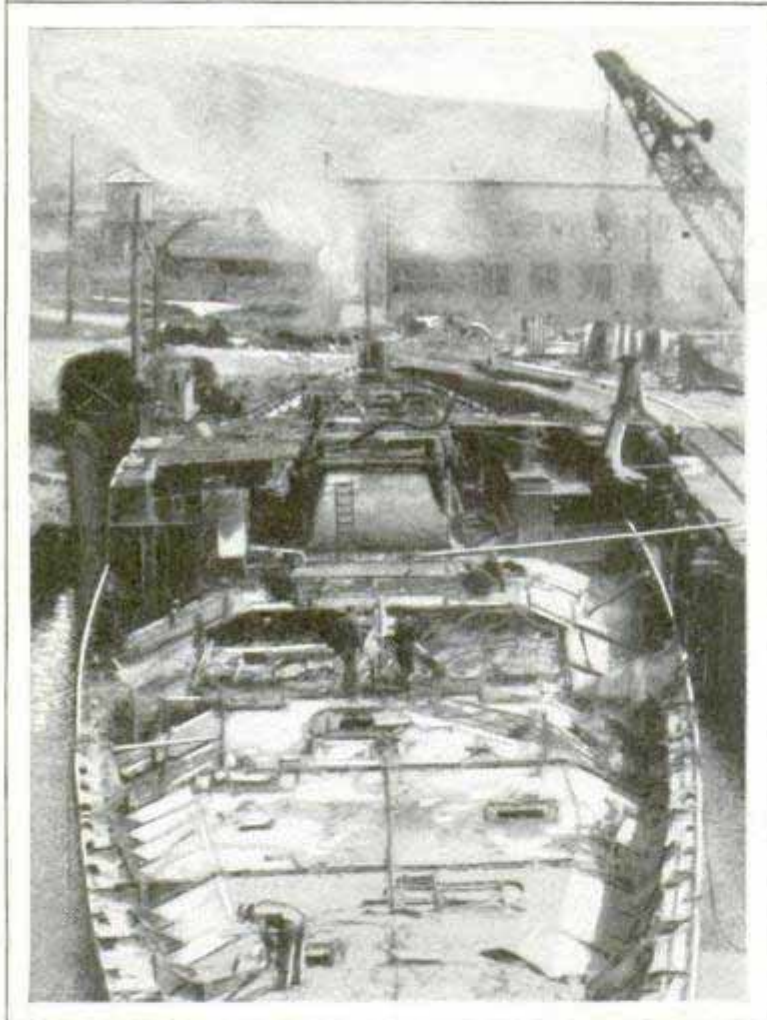
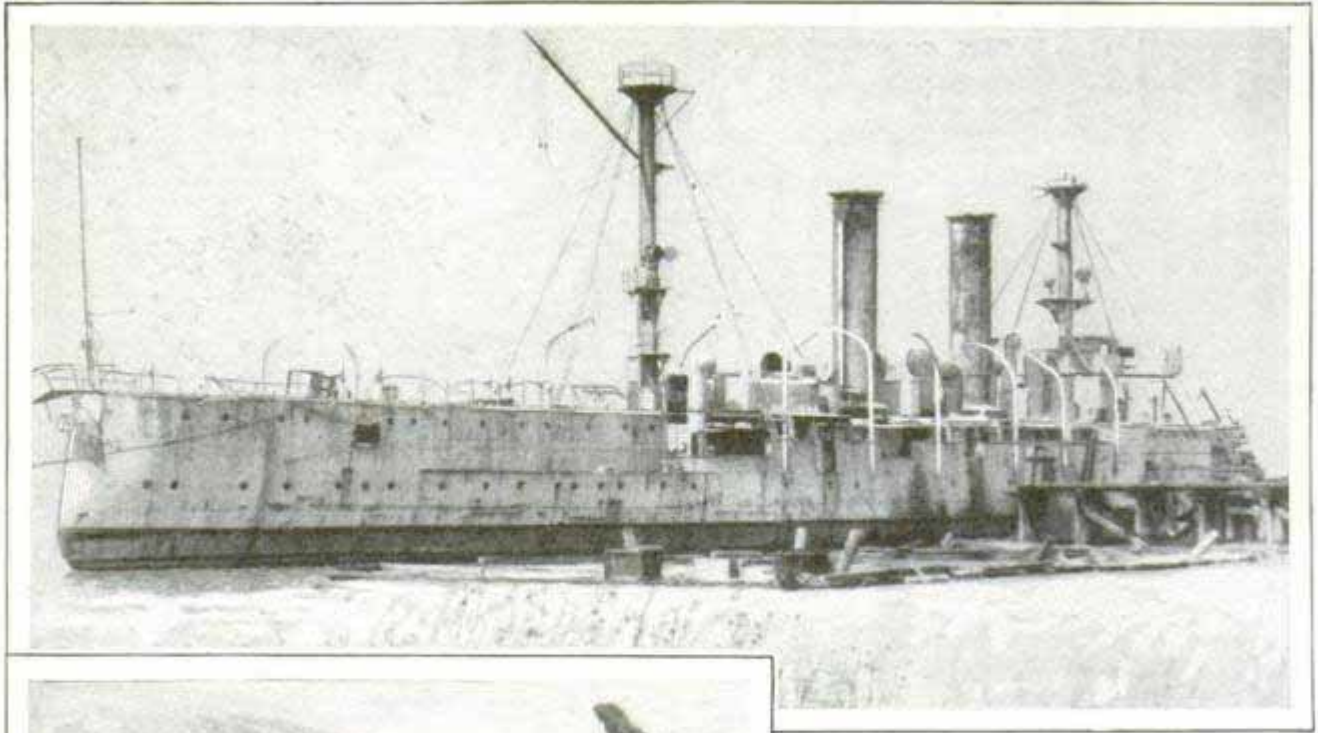

Obsolete Battleship Ready for Firing to Destroy All Woodwork, and, Below, Cutting Up a Metal Hull; Not a Pound Is Wasted

and the latter for cutting the steel decks and other parts into sections which can be handled by crane, are the principal tools of the ship breaker. Equipped with cutting torches, a comparatively small force of workmen in less than a year can scrap a battleship which required several years and scores of skilled workers to build.

The first step in the junking process is the removal of the more valuable machinery and fittings, such as pumps, dynamos and searchlights, following which the ship is made ready for burning. To prevent undue damage, the ship is fired a deck at a time. This is accomplished by laying oil-soaked kindling over the deck planking and igniting it. The burning usually is done with the ship anchored offshore, and with flames leaping from the hatches and portholes, and smoke rolling high above the ship, the effect is spectacular. When the burning, requiring several days, has been completed, the ship is reduced to

anchors, ship wheels, gratings, fathoms of rusty chain, blocks, wire rope, spars, and a miscellany of other salvaged fittings.

Primitive fire and the cutting torch, the former to rid the ship of deck planking and other woodwork not worth salvaging,

a heat-buckled, fire-blackened hulk. The vessel next is moved alongside the wharf, where are crane, rail and other facilities.

Torch men then attack the steel deck, cutting it into sections. As rapidly as the sections are cut, they are hoisted, amid



a cloud of smokelike dust, and swung to shore. Not a pound of convertible metal is wasted by the ship breaker. When the hull has been scrapped to a few inches above the water, it is towed into a specially constructed basin resembling a drydock. The gates of the basin are closed and the water pumped out. As the water drops, the keel comes to rest on timbers, and the breaking up is continued until the last scrap of steel has been reclaimed.

**BETTER PLANE-GUN MOUNTING SOUGHT BY UNCLE SAM** *1168*

Wanted! A better way for doing this. This picture shows an airplane gun mounting which is the same kind used during the war and which has not been improved since. But now, with airplanes flying 175 miles an hour, the gunner in the rear seat cannot swing these heavy and cumbersome mounts against the terrific wind blast and centrifugal force which is set up. The latest attempt in developing a better mount was made by putting a wind vane beneath the fuselage which would help move it, but when tests were made the vane, small as it was, tended to act as a rudder and steered the plane off at an angle. The ideal mount would be one that is not in the way of the gunner or passenger, yet is flexible enough to work easily. No country has developed a satisfactory machine-gun mount for movable guns.

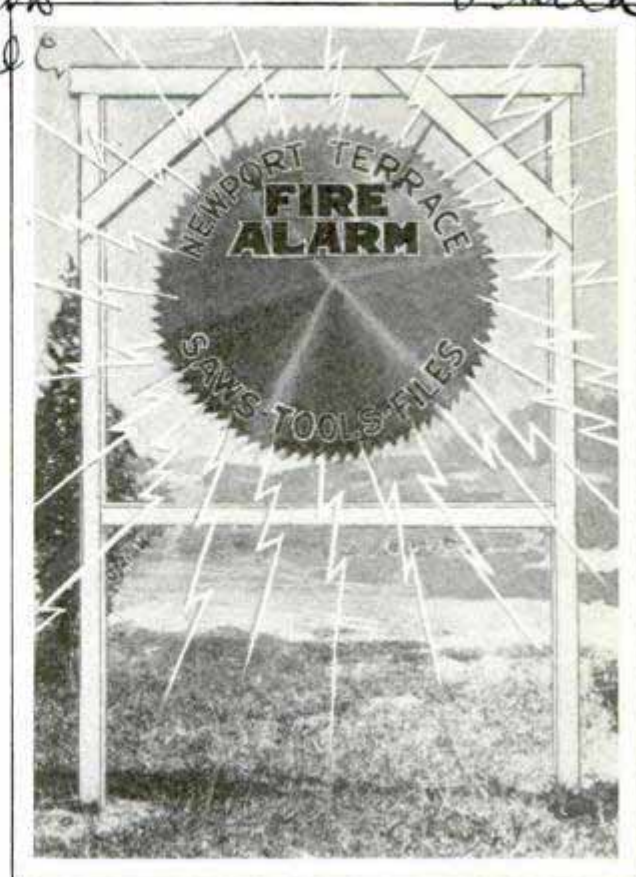

Old Circular Saw Suspended from a Frame, Where It Serves as a Fire Alarm for a Small Town

**TOWNS USE WORN-OUT SAWS AS FIRE ALARMS**

Small towns and communities are besieging a saw factory for worn-out circular saws which are being employed as fire alarms. The saws are mounted on wooden frames, so suspended that when struck, a gonglike sound is produced that can be heard for great distances.



Airplane Gun Mount of Type Used Since the World War; a More Efficient Mounting Is Sought

**AIR-LAW VIOLATIONS ARE INCREASING** *1160*

During the second quarter of 1930, the aeronautics branch of the department of commerce heard 177 cases of violations of air-commerce regulations, representing an increase of fifty-five over the first quarter. Fifty-three persons were fined a total of \$900 while sixty-three licenses were suspended, twelve revoked and five denied. Of the violations, thirty-two were committed on account of acrobatics, thirty-one by low flying, fifteen for an unlicensed pilot flying a licensed plane, and others for minor offenses.

*air travel news 7/21/30*

*Col. L. Corley McHarmant*



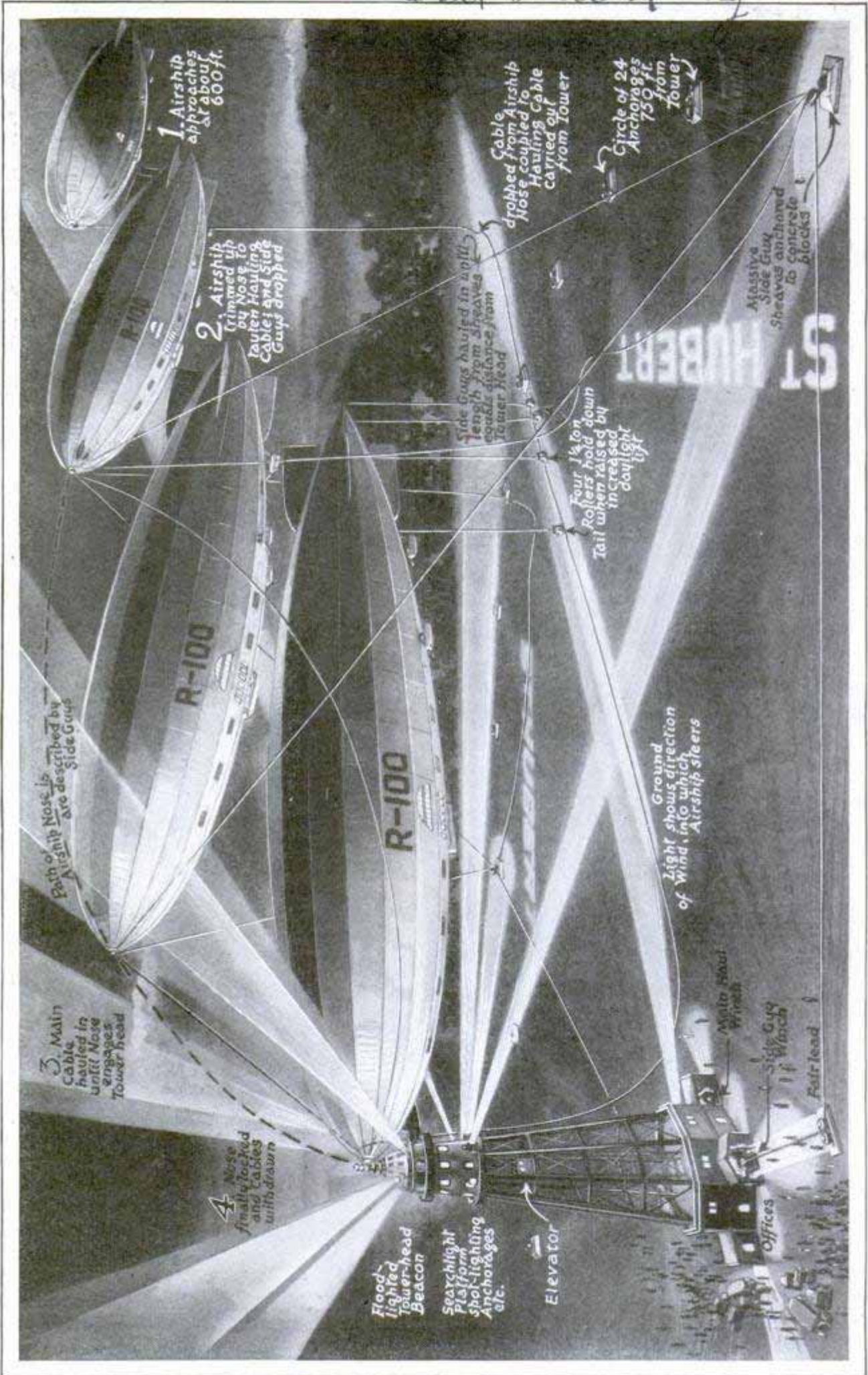

Sketch of Latest Type of Mooring Mast for Dirigibles, Showing the Lights, Tackle and Winches Used in Bringing a Big Airship to Anchor; Note the Ground Light That Indicates the Direction of the Wind for the Guidance of the Airship Crew



minutes  
7/19/30

1162

**POWER OF FUTURE FROM SOIL, AIR AND SUN**

1133

Water, soil, the air and the sun may be expected to furnish the power for future generations in the opinion of Dr. Herbert Levinstein, president of the Society of Chemical Industry. He estimated that the world's principal coal deposits will be exhausted in about fifteen more generations. Chemical science has already reached a stage where it can obtain direct access to new sources of coal-tar products by a synthetic process. A complete reduction of carbonic acid, obtained from the air, to methane or coal gas, has been accomplished, and this, in turn, can be converted, in an arc oven, into acetylene or changed into tar, half of which consists of benzine. The supply of carbonic acid in the air is inexhaustible.



Penny Golf Course for Children Modeled after Miniature Courses Popular with Grown-Ups; It Has Sea-Shell Hills and Coffee-Can Hazards

**CHILDREN'S PENNY GOLF LINKS LIKE MINIATURE COURSE**

Taking advantage of the miniature golf-course fad, four Cleveland girls recently opened a penny course for children, the nine-hole homemade course being laid out on a narrow plot of ground between two houses. Hills on the course are banked with sea shells, while tunnels built of lacquered coffee cans form difficult hazards. Children under seven pay a penny to play, while those from eight to fourteen are charged two cents.

**"MERCY" BULLET BRINGS SLEEP INSTEAD OF DEATH**

1153

Capturing wild animals alive after administering a long-distance anesthetic now is possible by using the "mercy" bullet, which is similar to a hypodermic needle in construction, except that it can be fired from a gun. The missile renders an animal helpless within two minutes

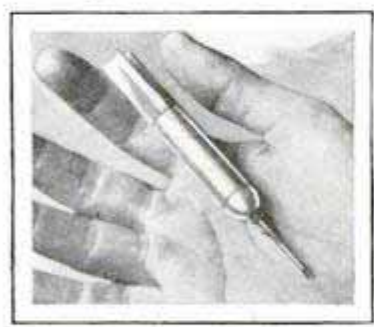

by producing a deep slumber, but the effects disappear completely after an hour or so. It is believed the bullets will make possible the capture of wild animals in the jungle without resorting to traps.

**TENNIS BALL VISIBLE IN DARK HAS LUMINOUS COATING**

1121

For those who like to play tennis at dawn or dusk, a ball that is visible in the dark is being introduced in England. The luminous balls are given a coat of phosphorescence by treating them with sulphur in a special process. The luminous quality does not tend to slow the balls during play nor damage the racquet.

d no Capt. B. W. Harris  
635 Sherman Ave

referring to.

new Highfield View, Lakemore  
New Abund. Cheltenham



212 N. 11th St  
Lincoln, Neb

1181

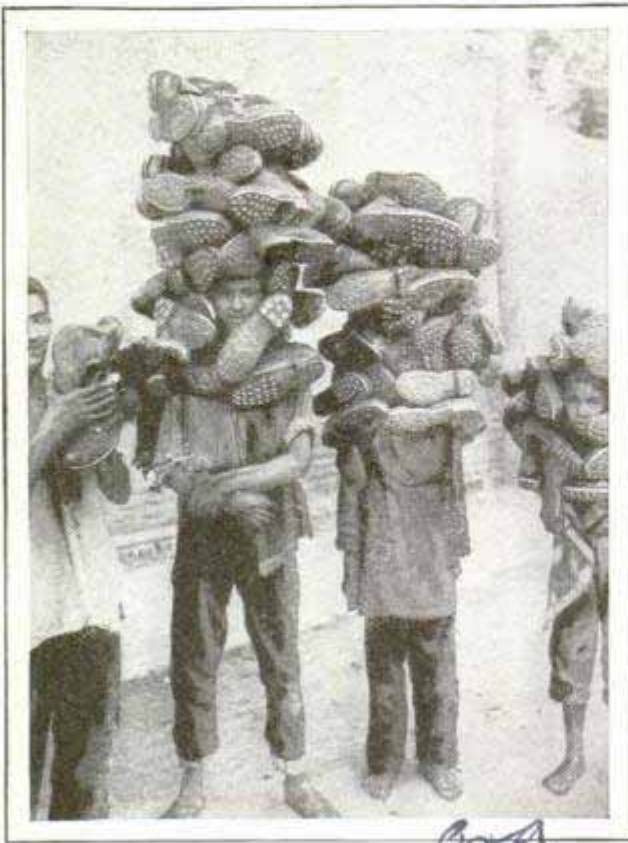

Barefoot Shoe Peddlers in Persia Who Would Rather Carry Their Wares Than Wear Them

### SHOE PEDDLERS GO BAREFOOT TO SAVE THEIR WARES

Shoe peddlers from Teheran, Persia, walk hundreds of miles to their market, carrying their stock about their necks and traveling barefoot rather than wear out any of their merchandise. Often these itinerant merchants walk for months before disposing of their goods, but never do they consider using the shoes and boots themselves.

*Gora*

### LAWN SPRINKLER ON THE ROOF 1176 KEEPS BUILDING COOL

Lawn sprinklers have been installed on the roof of an Omaha apartment building to lower the temperature during extremely hot weather. With the mercury at 107 degrees, the manager of the building succeeded in bringing down the temperature ten degrees by keeping the sprinklers in operation.

*By Montreal Light & Aeroplane Club*

### 1188 VOICE FROM THE SKY CARRIED BY HORNS ON PLANE

From an airplane in flight words and music were broadcast recently for the first time in Canada through eight loud-speaker units extending from the sides of the ship. When attempted in this country, the loud speakers have been placed under the plane instead of projecting from its sides. The broadcasting equipment, magnifying the microphone input several million times, consists of eight loud-speaker units, such as used in theaters, mounted at the end of a large horn projecting through the cabin wall and carefully streamlined. Each pair of loud speakers is fed by one of four amplifiers. The entire apparatus weighs only 600 pounds and was clearly audible on the ground when the ship was at an altitude of 4,000 feet.

*Winged Whorlwind*



*Winged Whorlwind*

Airplane Used for Broadcasting in Flight; Note the Streamlined Horn Containing Loud Speakers

### 1089 SMELLS ARE PUT TO WORK

One of the secrets of the perfumers' art is being applied by manufacturers of linoleum, glue, textiles, rubber goods and other products which have an unpleasant odor. The perfumer puts unpleasant smells to work to blend the more pleasant odors he adds to produce a pleasing scent, and manufacturers are using the unpleasant smells as a base to which to add industrial aromatics, which either neutralize the offensive odor or blend with it to form a pleasant smell. It has been found that goods which ordinarily smell worst are the ones which, by these applications, can be made to smell the best, but without being perfumed.

*Leading Chemich in this field*

*Mr. Eric C. King*

*Montclair N.J.*

*fitted up by Northern Electric Co. Montreal*



# Fire Weather!

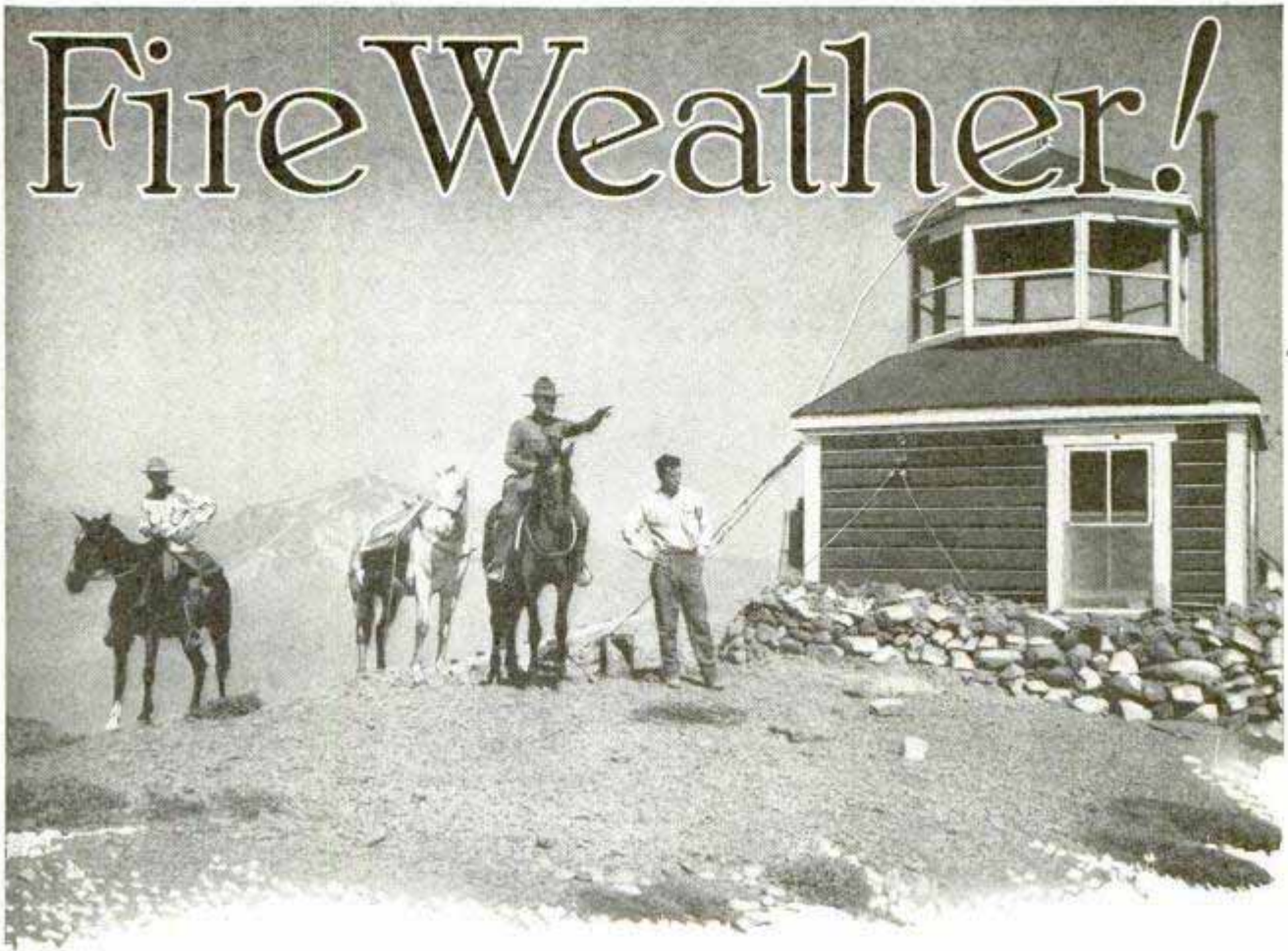

Rangers Watching Progress of Forest Fire from Lookout Station on Top of Mt. Eddy, California; Mt. Shasta Is Seen in the Background

By CHARLES FITZHUGH TALMAN,

*Box 840  
Washington C.*

THE WORD "humidity" is familiar to the man in the street as the name of something that adds to weather discomforts in the dog days. "It's not the heat, it's the humidity," is a classic explanation of sensations too well known to all Americans. To loggers and lumbermen the word has, in recent years, become equally familiar in another connection.

Striking relations have been found to exist between certain types of weather and the prevalence of forest fires. Some states of the atmosphere are conducive to fires; others check or prevent them. In both cases, the weather element that plays the leading part is humidity. High humidity is a safeguard against forest fires. Low humidity is the worst fire hazard of the forest.

Weather that promotes the spread of forest fires is called "fire weather." In its extreme forms it leads, when other con-

ditions are favorable, to such startling performance of the "red demon" as the veritable epidemic of fires witnessed early last May in the northeastern states. Woods and fields were ablaze at scores of different places at the same time; several towns, including Nashua, N. H., were damaged by the flames, and the toll of losses mounted up to sixteen million dollars.

Little rain had fallen for weeks before these fires and they were attended by high winds, but the principal atmospheric cause of the disaster was the excessive dryness of the air.

"It's not," explained the forestry experts, "the drouth or the wind, it's the low humidity." And the same diagnosis is passed nowadays on the majority of big forest fires.

Low humidity means little moisture in the air, and high humidity means much. The moisture is not a liquid, but an invis-





ible gas called water vapor. It is not directly perceptible to the human senses, though in an indirect way it affects comfort in both hot and cold weather.

The capacity of the air for water vapor varies with the temperature; the warmer the air, the more it can hold. The actual amount present at any time in a unit volume of air is called the absolute humidity, but this has little to do with forest fires. The thing in which foresters and fire fighters are interested is the relative humidity—the ratio between the amount of water vapor present and the greatest amount the air can contain at the prevailing temperature. This is expressed in percentage. One-hundred per-cent relative humidity means that the air is fully charged with water vapor, so that any lowering of its temperature would cause some of the vapor to condense.

Measuring the relative humidity of the air as a test of the fire hazard is rapidly becoming a routine practice among American woodsmen. In the Douglas fir region of Washington and Oregon, humidity in-

struments are found universally in logging camps, because a logger cannot get insurance on his equipment and felled timber, except at prohibitive rates, unless he agrees to maintain such instruments on his operation and to suspend work whenever the humidity falls below thirty per cent. In the Pacific northwest this value has become a somewhat arbitrary deadline between safe and unsafe weather for logging.

The explanation of why relative humidity is so important in connection with forest fires begins with the fact that both the start and the spread of a fire depend

upon a certain degree of dryness in the forest fuels. The living vegetation of a forest contains, of course, a supply of moisture that is independent of weather and varies chiefly with the season of the year, but the principal fuels of the forest fire are the litter, logs and dead trees, the moisture content of which is controlled by atmospheric influences.

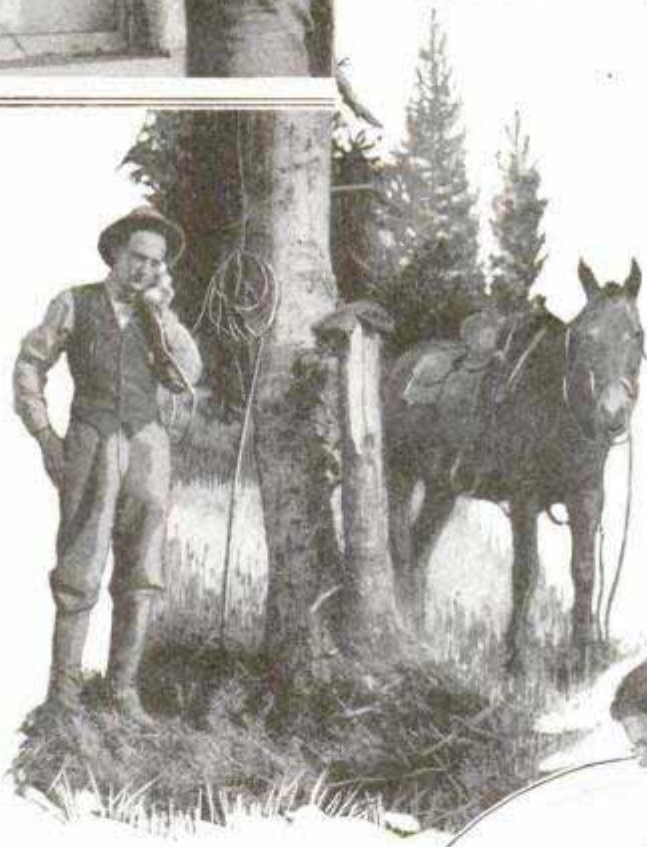

Rangers Receiving Radio Weather Report; Using Portable Phone, and Measuring Dryness of the Air



1094 Clark & Bradstreet  
Battle Creek Mich

These dead materials of the forest are all more or less hygroscopic. This means that they readily absorb moisture from the air when the latter is well supplied with water vapor and lose moisture rapidly by evaporation when the air contains little water vapor. Hot weather and wind both tend to increase the rate of evaporation, but they are less effective in this respect than low humidity.

The study and prediction of fire weather have been added to the manifold jobs of official meteorologists in the United States and Canada. Special fire-weather services have been organized in the principal forested areas of both countries for the purpose of keeping watch of weather conditions affecting forest fires and issuing timely bulletins and warnings on the subject. As an aid in protecting the forests from fire these services are now recognized to be second in importance only to the vast system of patrols and lookouts that has been maintained in the forests for many years. The latest adjunct of this service is the fire-weather truck, which takes instruments, a radio outfit and two men directly to the scene of a fire, where observations are taken, weather maps drawn and forecasts issued with due regard to local conditions that would, as a rule, be unknown to a distant forecaster.

**PLASTERING DONE BY AIR CUTS DOWN HARD WORK**

Operated by compressed air, a plastering machine which mixes and applies plaster to the walls has been made by a California inventor. The familiar trowel with which plaster has been applied for centuries, is used only to spread the material. The machine works effectively over all plaster bases, including wood and metal lath, plasterboard, wire, paper, concrete or brick. It handles both interior and exterior coats.

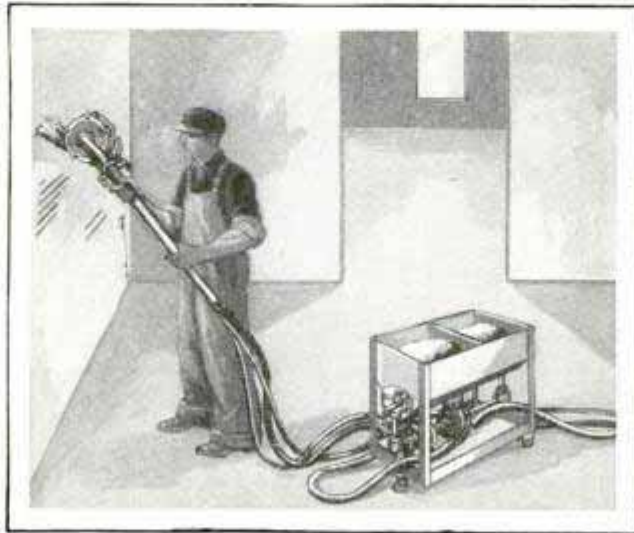

Plastering Machine Operated by Compressed Air, Which Mixes and Applies the Coating

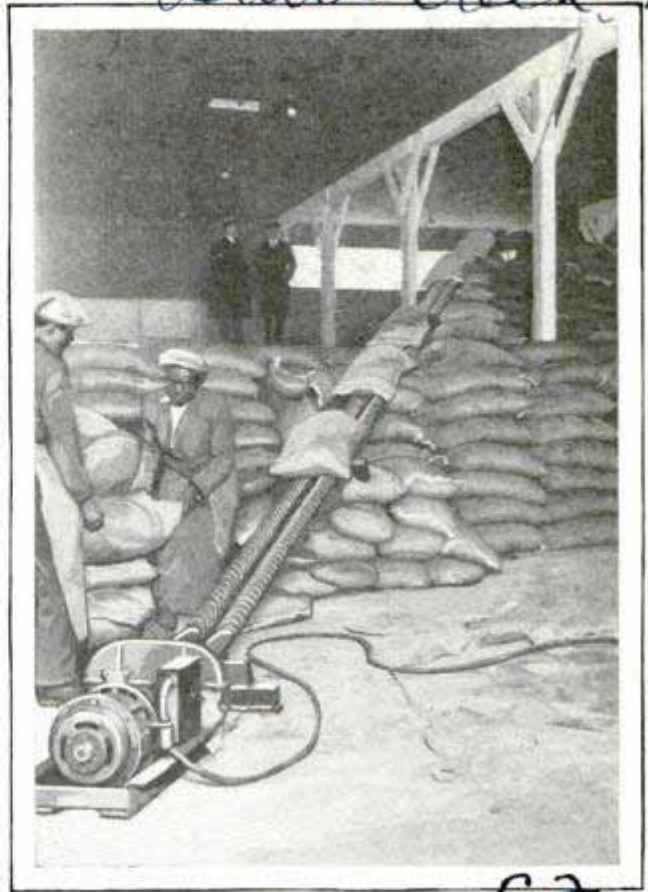

Twin-Screw Electric Conveyor Whose Revolving Spiral Tubes Move Bulky Articles Quickly

**TWIN SCREWS REPLACE BELTS IN MOVING SACKS**

Combining the advantages of a tiering machine, escalator and belt conveyor, a twin-screw electric conveyor has the additional features of being both flexible and portable. It was first used in sugar warehouses where it moved sacks up a thirty-per-cent grade at the rate of ninety feet a minute, handling 1,800 bags an hour. Aside from the motor, the machine consists of parallel screws turning toward each other. Additional sections may be connected to provide any desired length, and since the system is both flexible and portable on a hand-truck, commodities may be routed to any part of a factory or warehouse.

3200 N. Alameda St. Compton, Calif.

Conley Plastering Machine Co.  
3554  
Hesperia, Calif.



## "SHERLOCK HOLMES" BUILDS MINIATURE RAILWAY

1150

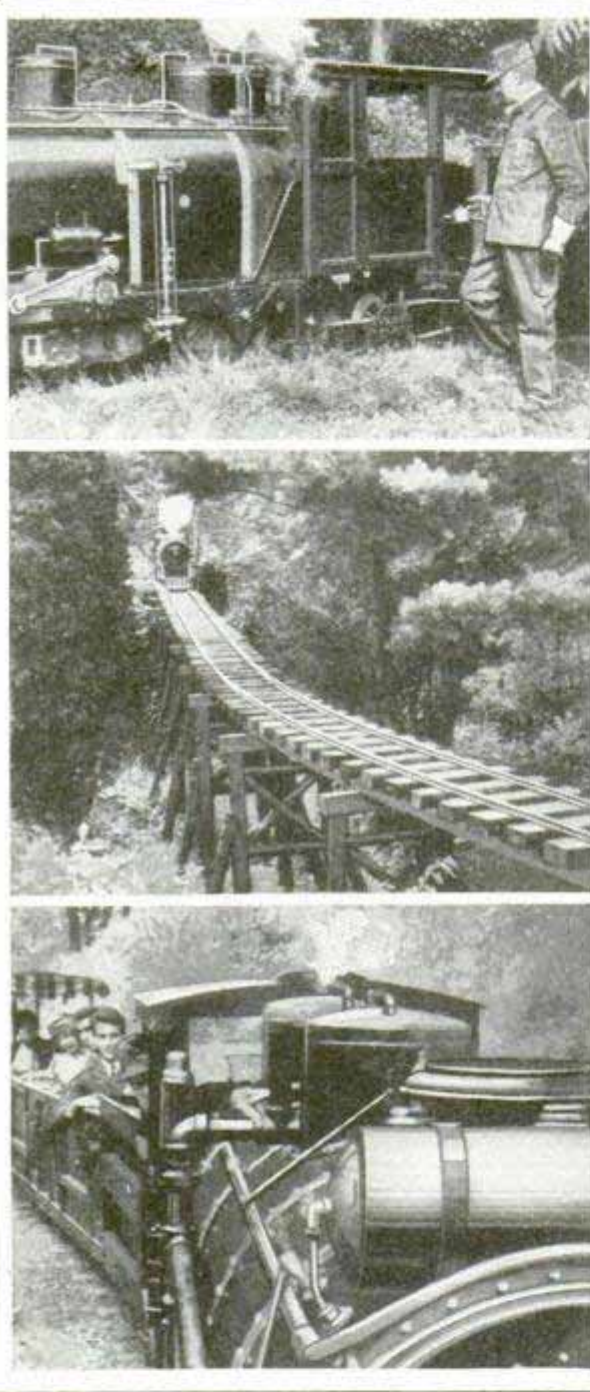

Views of Homemade Locomotive and Railroad That Winds through Grounds of a Private Estate

In order to realize in part his boyhood dream of becoming a railroad engineer, William Gillette, the actor, has built a private railroad on his estate near Hartford, Conn., with which to entertain himself and his friends. The little engine, built to scale, pulls a train of cars over tracks which run through tunnels, over trestles and beside beautiful gardens and wooded sections. From the train, the passenger gains a view of most of the estate during a round trip over the system.

Mr. Gillette, famous for his portrayal of Sherlock Holmes, built his cars without tops, to make them better for sight-seeing purposes.

### CHEMISTRY TOUCHES ALL LIFE 1085 MAKING LIVING EASIER

A chemist recently addressed an audience of business men. "I will talk a half hour on the chemistry of anything in this room," he challenged. Up spoke one of his hearers. "Take my watch," he offered with a knowing smile. "You can have all the chemistry you can prove is in it." The chemist jumped at the chance. He described the chemistry of an ordinary gold watch, the chemically controlled baking that makes its dial from rare zirconium, the cyanide process of gold extraction, the wonderful alloys immune to temperature changes, crystal glass and steel spring, luminous dials of mysterious radium. The chemist could just as well have talked about a plate, a spoon, the chairman's cigar or the paint and paper on the walls, for all about him was chemistry, as it is all about us every day, waiting only to be revealed by the initiate. The chemist is one of the most indispensable of scientists, adventurer into unknown realms, servant of progress. In the midst of life we are in—chemistry. A chemically made spring sets off the alarm that wakens us in the morning; at night we slip between chemically bleached sheets. While we sleep, the chemical process of respiration goes on. Chemistry supplies also most of the things used to prepare your breakfast. Utensils of aluminum, chemically extracted from clay or enameled with chemical compounds, are first to strike the eye. Besides the rustless knives, the table holds glasses of soda, lime and sand. Your office desk may be covered with plate glass. Upon it are appliances made of another marvelous product of chemistry, rubber. Your telephone and its insulated wires, your typewriter, fountain pen, eraser, rubber bands and stamps, even the galoshes and raincoat behind the door, are due to chemistry. Then you drive home from the office in an automobile that is almost a traveling chemical exhibit, with gasoline engine, rubber tires and many parts

Carl Thomas M. Johnson  
420 W. 116 St.



Experiment by J. L. Swenson and H. A. Molteni

POPULAR MECHANICS

made by chemical process. Arrived home, you may walk in your garden, that is another chemical factory, where plants build up complex compounds from simple materials. Soluble chemical compounds are brought from the soil by the sap. The cleverest chemists have not yet duplicated nature's work in the garden.

EGGS SOAKED IN MINERAL OILS LOSE LESS WEIGHT 1169

Eggs with oil-soaked shells have been found by the department of agriculture to lose less weight from shrinkage and evaporation than untreated eggs. In experiments, eggs were treated with two different kinds of oil, both at ordinary atmospheric pressure and in a vacuum. They were kept for ten days at a temperature of ninety-eight degrees and weighed at regular intervals. It was found that untreated eggs lost about thirteen per cent in weight, those dipped in mineral oil at atmospheric pressure lost two per cent, and eggs dipped in aluminum soap oil under vacuum lost only one-half of one per cent.

SUNNIEST SPOT ON CONTINENT SCENE OF TEN-YEAR TEST 1183

Scientists of the Smithsonian Institution have selected Table mountain, 100 miles from Los Angeles, as the location of their solar observatory because the mountain is believed to be the sunniest spot in North America, although not the hottest. From this mountain a constant watch is to be kept on the sun for the next ten years.

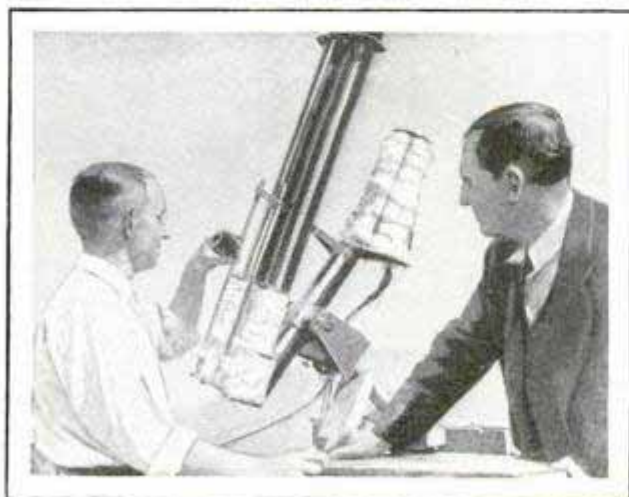

Pyrheliometer, an Apparatus with Which Scientists Measure the Intensity of Solar Radiation

Table Mountain, Big Bear Camp

Perfection Montgomery + 637  
Lefebvre, St. Louis, Mo

AUTOMOBILE CHAIR FOR BABY HAS ADJUSTABLE LEGS 1178



An Auto Chair for the Baby; Insert Shows How It Can Be Folded When It Is Not in Use

For the comfort and safety of the baby, an auto seat for the car with removable cushions is available. The feet of the back frame are adjustable and are placed under the car cushion, holding the baby chair firmly. The front legs also are adjustable to conform to the thickness of the cushion on which they rest. When not in use, the seat folds against the back of the car.

BALLOON TO GO UP TEN MILES WITH TWO PASSENGERS 1206

For scientific exploration of the upper atmosphere, a Brussels scientist is preparing for a balloon ascent of 50,000 feet to be attempted at Augsburg, Bavaria. As the air pressure at this height is too low to maintain human life, the gondola of the balloon will be constructed on the diving-bell principle. It will consist of a hollow aluminum sphere, about six feet in diameter, hermetically closed and fitted with oxygen supply and breathing apparatus. It will be provided with outlook windows for the scientist and an assistant.

Professor Picard  
Brussels, Belgium



28

# New Conveniences



Above Is a Wall Mop of Special Material to Remove Dust, Smoke and Stains from Walls with a Minimum of Labor and Trouble; It Is Virtually an Eraser and May Be Attached to a Broom Handle

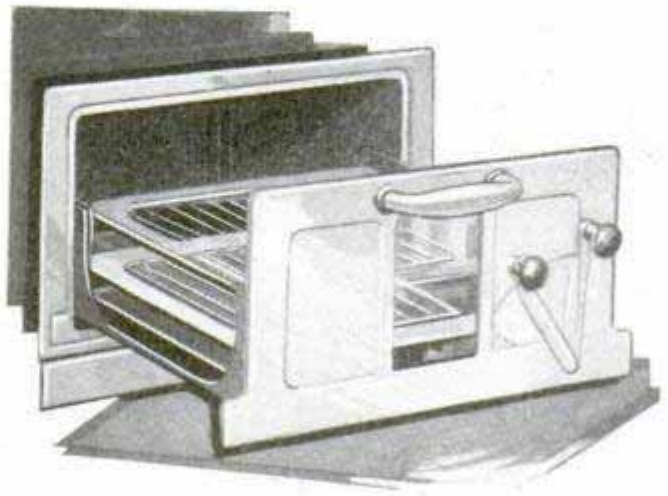

This Broiler Compartment for the Stove Has Window through Which Foods Can Be Watched, and the Pan May Be Raised or Lowered as Desired Simply by Moving the Lever at Side; the Drawer Is on Roller Bearings for Smooth Operation



At Left, an Electric Lamp, the Base of Which Conceals a Grill That Is Used as Illustrated Below; Toast Browned on the Grill May Be Kept Warm by Placing It under the Bulb as Shown



*corn popper*  
This Electric Cooker with Strainer Top Has Handy Base to Protect Table and Operates from Lighting Socket; Can Be Used for Many Purposes and Is of Convenient Size





# for your Home

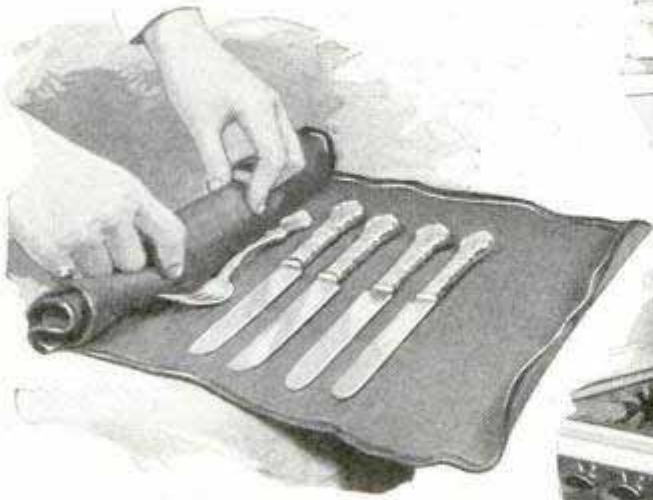

Wrapper for Silverware Is Chemically Treated to Prevent Tarnish When Articles Are Covered; It Absorbs the Substances That Usually Cause Discoloration; Slips into Drawer or May Be Left on Top of Buffet



Four-Compartment Steamer May Be Used on Gas, Coal, Wood, Oil or Electric Ranges; Keeps Foods Hot After They Are Cooked, Prevents Burning and Insures Proper Preparation



Vacuum for the House-Cleaning Outfit Is Created by the Water System and Carries off Waste and Dust through Tubes to the Sewage; No Bag Is Used and Operation Cost Is Low

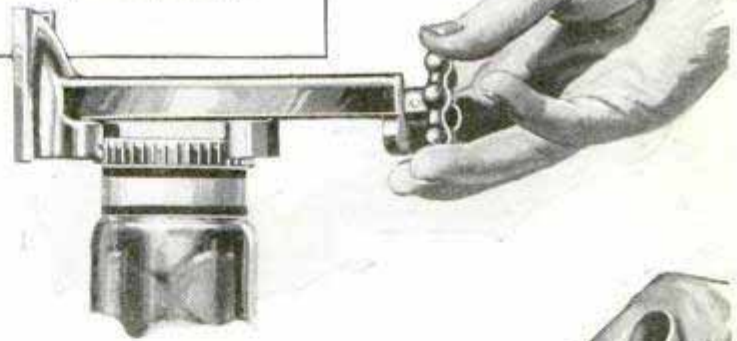

Opener Safely Removes Tops from All Types and Sizes of Screw-Cap Jars, Bottles and Sealed Glass Containers

At Right, Below, Two-Prong Fork Removes Seeds from Grape Fruit without Wasting the Meat; Takes Two Seeds at a Time





*University of California  
Citrus Experiment Station  
Riverside Cal*

**NAME TANNED ON NEW BABIES FOR IDENTIFICATION**

*1164  
Hanovia  
Chemical & Mfg. Co.  
30 N. Michigan Ave.  
Chicago*



Water-Cooled Violet-Ray Lamp Used with Stencil to Tan Names on Backs of New-Born Babies

Following a dispute between parents as to the ownership of two babies born on the same day in a Chicago hospital, the city health department is considering a plan to brand the names of all new-born babes on their backs with an ultraviolet-ray lamp. The lamp is used with a stencil to brand the name of the infant in sun tan on its skin. The name would disappear in about six months.

**INTERIOR DECORATION OF LINER NEEDS "INTERNATIONAL" ART**

*1072*

Decorating the interiors of the "hotels within hulls," the modern ocean liners, has been one of the most difficult problems of the owners and has given rise to a sort of international movement in art, since the steamers are international in character. Some companies have successfully broken away from the strictly ship idea in the decorations and have followed hotel designs and furnishings. This is said to be particularly true of the German, Dutch and French liners. In recent years, decorating the big steamers' interiors has been

*Rafayette*

taken out of the hands of the shipyard men and placed under the direction of specialists who realize that an unusual style of decoration must be adopted to appeal to the mixed passenger lists made up of persons from many nations.

**NOW YOU CAN BUY INSECTS**

Insects are being raised and marketed in California for \$10 a million, or a penny a thousand. The insects that have a cash value are the almost microscopic wasps, known as "trichogramma," which prey on the eggs of other insects, thereby preventing an increase in the numbers of the harmful kind. An entomologist has been rearing them, and has improved his methods until he can produce a thousand of them for a cent. They are sent in great numbers to orchardists who release them to assist in warfare on insects preying on fruit.

**SLASHED SHOE SHOWS POWER OF AIRPLANE PROPELLER**

No better illustration of the deadly menace of a whirling airplane propeller is afforded than the accompanying picture of the slashed shoe which was cut in four places in one-seventh of a second when the pilot's foot came in contact with the blades. The co-pilot of an army bomber was thrown from the front cockpit as the ship dropped suddenly, but almost miraculously saved his life when he fell into the falling plane. As he grasped the ship, however, his foot came in contact with the steel propeller, which was turning at 1,750 revolutions per minute, or thirty per second. So intent was the aviator on getting back into his ship that he did not know his foot had been injured until he was seated in the cockpit again.

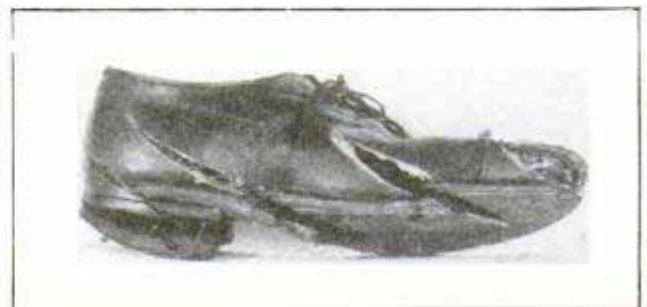

An Airplane Propeller Slashed This Pilot's Shoe Four Times in One-Seventh of a Second

*1167  
Capt. Lt. Corley  
Muller...*



near Glasgow 641

SUSPENDED RAIL CARS DRIVEN BY AIR PROPELLERS

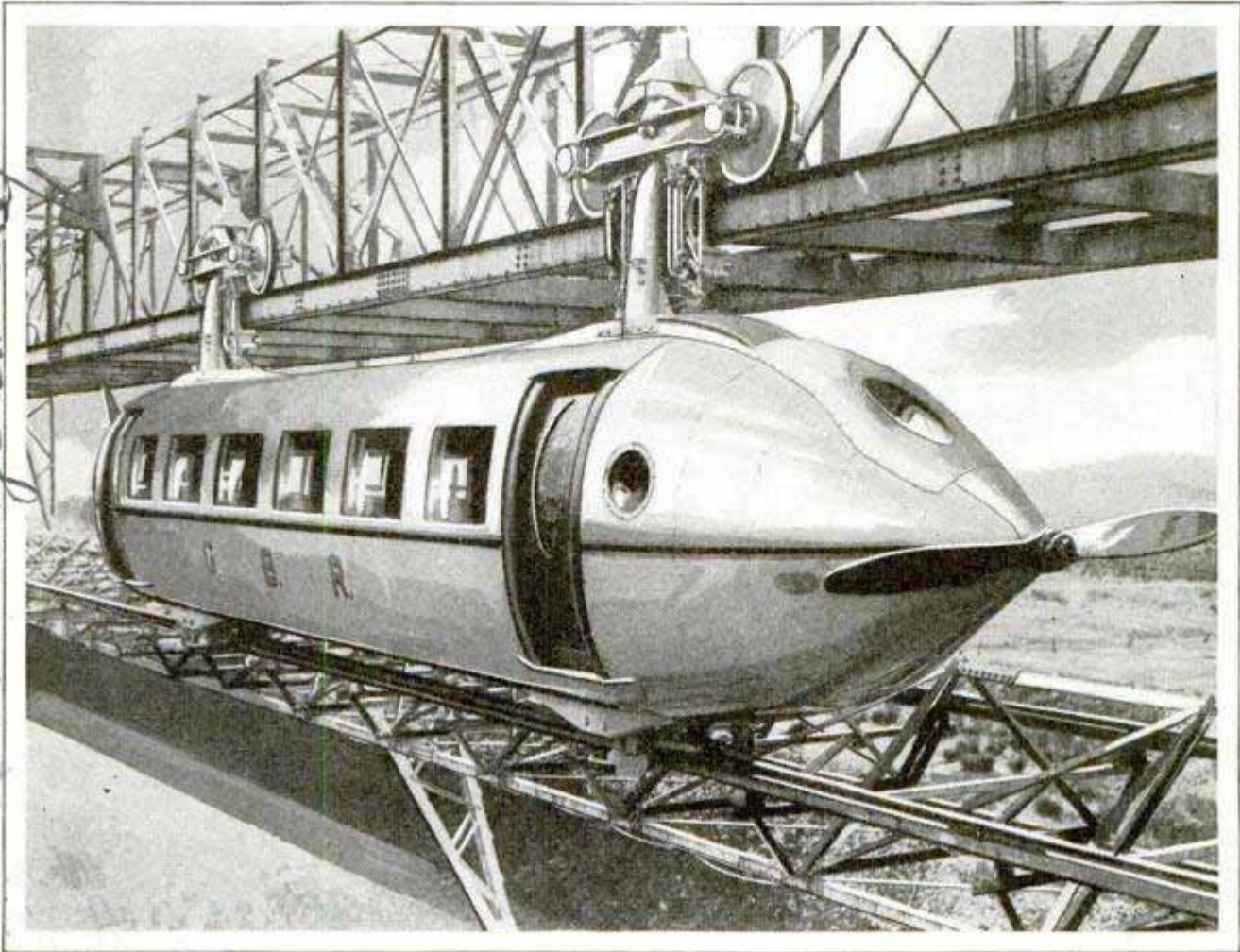

Railplanes, Combining Railroad and Airplane Transportation; the Cabin Car Is Suspended from an Overhead Steel Girder and Air Screws, Front and Rear, Provide the Power

Railplanes, streamlined railroad cars suspended from an overhead rail and driven by airplane propellers fore and aft, are undergoing successful tests in Scotland as a means of providing fast passenger service. Routes for the railplanes would be built along existing railways, thus involving a relatively small expense. The cabin cars are suspended from a steel girder and air screws provide the power.

and also forms the pressure that forces the paint through another tube and out the nozzle. The paint tube is screened so that particles cannot get through and clog the nozzle, and the air tube is in a position to wash the screen itself to keep it from clogging. It contains an air-pressure release which instantly stops the spray, and, since it is a pressure sprayer, will paint with heavier materials than is possible with the ordinary spray outfit. When not in use for painting, the equipment makes a handy fire extinguisher if it is filled with the proper solution.

AIR BRUSH THAT DOES NOT CLOG WORKS UNDER PRESSURE

Spraying all kinds of liquids and paint without clogging, a hand-operated air brush that is exceedingly simple in construction has a variable nozzle for the different adjustments or materials, thus avoiding interchanging. All the air used in the system is forced down a tube to the bottom of the jar containing the paint, where it agitates the spraying material,



1101  
Paid 3/12/29  
170,539

Flamex  
Mixed with water, a chemical now on the market is used to make curtains, draperies and like articles flame-proof without changing their colors.

West. Stone + Crawford 443 S. San Pedro. Los Angeles Calif.

Foster Mfg Co.  
Paramount Mfg Co.



*Ans. H. G. Anderson  
15000 Linwood Ave  
Detroit Mich*

offices providing quiet and comfort for the occupants.

**"BRICK" VENEER HELPS IN REBUILDING HOME**

*1126*  
Owners of old frame dwellings who desire to remodel them to resemble brick without the cost of this building material, now may obtain a brick veneer for the purpose. The veneer is produced at one-fifth the weight of ordinary brick and comes in units of twelve burned-clay bricklets one-half inch thick, made fast to a backing of insulating board with cement, making a total thickness of one inch. The units are nailed to the existing wall surface, and when pointed up, the veneer appears like real brick construction.

**HEAD NET HAS WINDOW FOR CLEAR VISION**

For the fisherman or other outdoor sportsman harassed by flies and mosquitoes, a head net now is available that has the additional advantage of offering clear vision because it is fitted with a window. The net, which will fit any hat, contains a section of transparent, non-breakable material.

*Clear View \$3.00*



Head Net Fitted with a Window, to Provide Protection without Obstructing the Vision

*The Wahacraft Co., 272 40 St., New York*

*Pat. as for*

*1137*

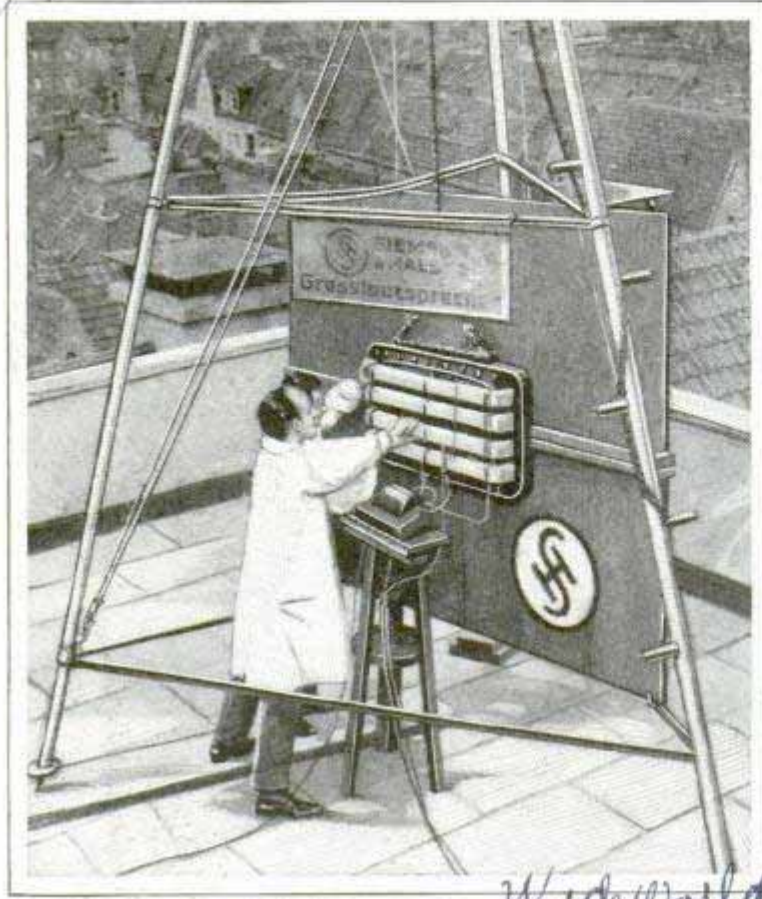

Big Loud Speaker Which Provides Entertainment for an Entire Town; It Is Audible for About Twenty Miles

**RADIO HEARD TWENTY MILES WITH GIANT SPEAKER**

Audible for a distance of twenty miles, a giant loud speaker, installed on the roof of a building in a suburb of Berlin, provides entertainment for the entire town. The speaker produces a sound strength equal to an orchestra of 2,000 players.

**WINDOWLESS OFFICES TO END DIRT AND NOISE**

*1132*  
Windowless office buildings probably will result as a natural development of metropolitan life, according to Robert D. Kohn, president of the American Institute of Architects. The dirt and noise of the city have become almost unbearable, and, with modern lighting and ventilating systems, it is entirely feasible to eliminate windows to exclude the outside interference. In one New York building, a series of administration offices is being built in the interior of the structure, the windowless section being completely isolated from the outdoors by sound-proof walls. Artificial lighting and ventilation take the place of the conventional windows, the

*quoting Rudolph Meler's talk before American Society of Architects*



4351 Georgia St  
San Diego, Calif

# The Desert Comes Back to Life

MAN'S machinery is conquering the desert. Heat, hunger and thirst have yielded to steam, gasoline and electricity; barren wastes have become beauty spots; a month's trip in a creaking wagon has become an hour's flight in a roaring plane; the most remote mine and the loneliest ranch in the sandhills of the west talk at will with the cities; poisonous snakes and even more deadly Indians and halfbreeds have laid down the rifle for the shovel, and what was once a barrier to American advancement has become a winter resort for the tourists of the world.

From the high and wind-swept plateaus of the New Mexican desert to the depths of Death valley, 300 feet below sea level, modern hotels, well-equipped bungalow courts, homes filled with every improvement civilization has to offer are spread from the western slopes of the Rocky Mountains to the western edge of California's Sahara. In less than a quarter of a century, mechanical science has made

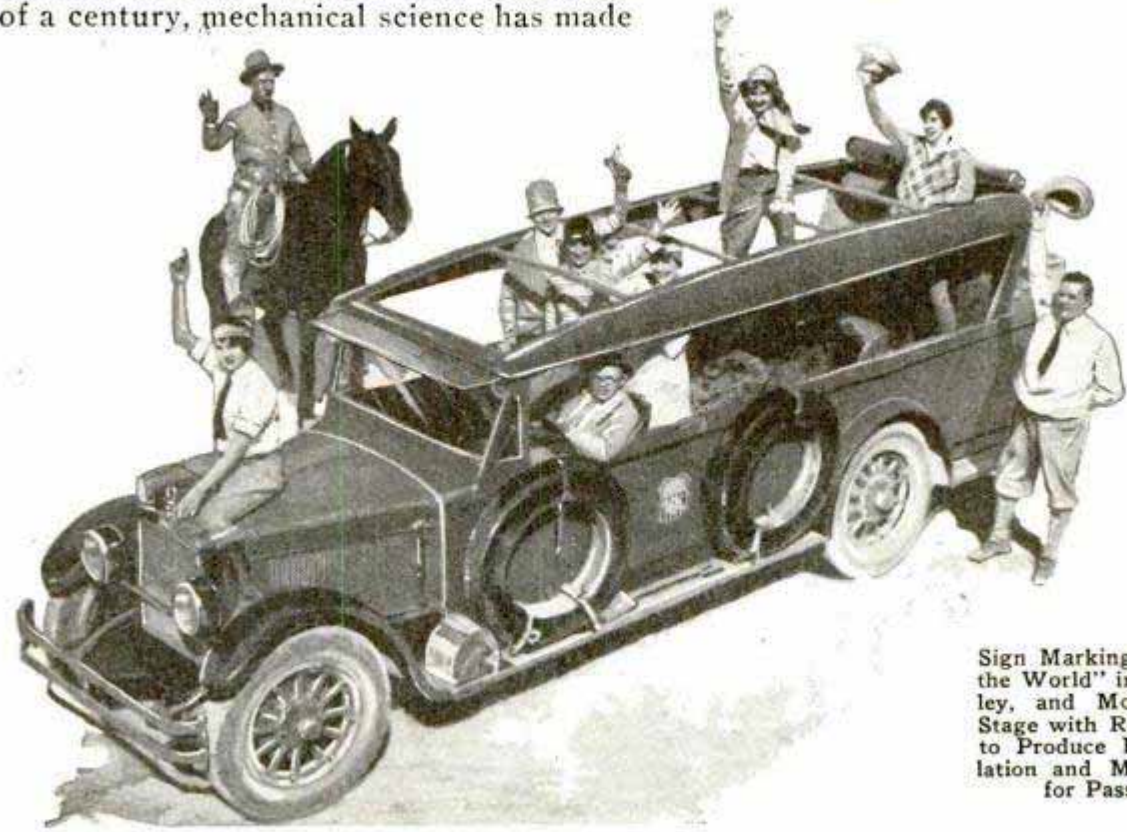
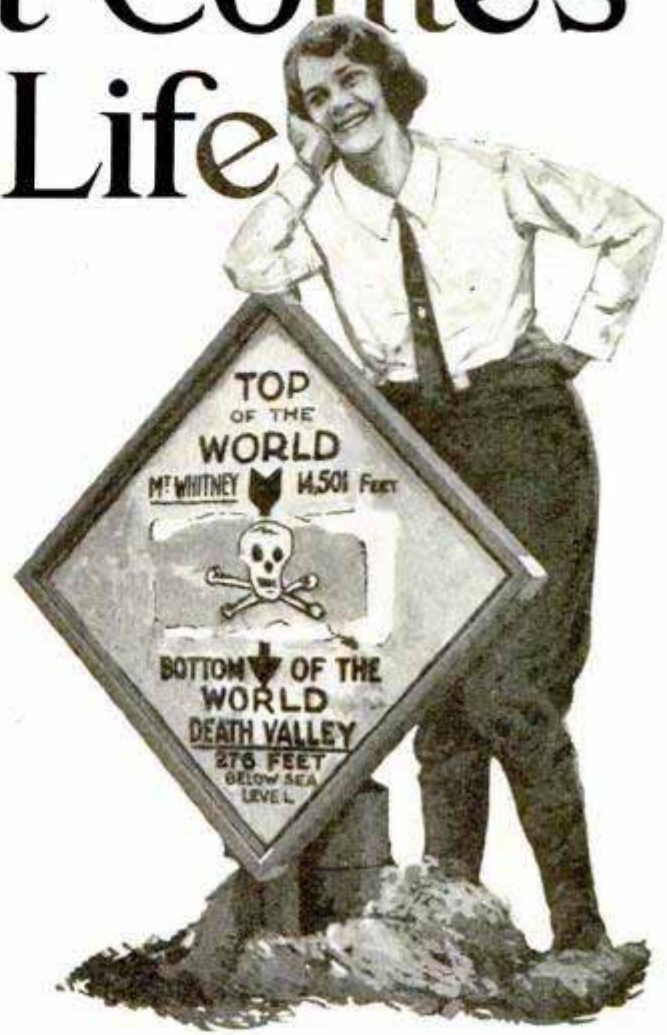

Sign Marking "Bottom of the World" in Death Valley, and Modern Desert Stage with Roll-Back Top to Produce Better Ventilation and More Comfort for Passengers



the desert as safe, as comfortable, and as productive as any other area in the world—even safer than the streets of some of our large cities after nightfall.

The two principal barriers nature raised to the civilization of the desert were lack of water and difficulty of transportation. Gasoline engines and electricity have overcome both. When drills were mounted on trucks propelled by gasoline motors, and driven into desert sands or rocks, it was found that the lack of water was merely superficial. A few feet under ground was abundant water, much of it artesian, the rest rising to a short distance from the top of the drilled hole, so that pumping became comparatively easy.

But power for the pumps was needed, so the trucks went out, drilled long lines of holes, carried wood and steel posts to the holes, set them up, and, presently, electric transmission lines appeared as if by magic, running like cobwebs across the barren lands. It is estimated that there are more than 100,000 producing wells on the American desert, at least ninety per cent of them drilled within the last fifteen years, and all contributing to the great and growing production of minerals and food-stuffs the so-called waste lands are making.

Hotels with all modern equipment, even to large swimming pools, bungalow courts, and winter resorts of every description,

have followed the stages and the paved highways into the heart of the desert. Two of the most interesting hotels of this kind are in Death valley, and if you wish to spend a day or week in either of them, between November of one year and May of the next, you have to make your reservation weeks in advance. Diesel railroad cars, with a gasoline-engined branch line and large through stages, connect them with the outside world, and there is a large and well-equipped airplane landing field for flyers who care to see the hottest, deadliest bit of the American desert.

But the most phenomenal development man's mechanical ingenuity has brought to the desert is in southeastern California, where the total annual rainfall is about an inch and a half. In 1900, the white population of this Imperial valley was none, the assessed valuation of its present 526,000 irrigable acres, nothing. Today, there are more than 65,000 persons living in the valley; the assessed valuation is more than \$55,000,000, while its agricultural, dairy and poultry products sold, in 1929, for \$62,000,000. Machine-dug canals bring water from the Colorado river by gravity to these lands. Tractor cultivation has converted the sand and clay and silt into 4,769 farms, whose crops are hauled by trucks to packing houses, where they are sorted, classified, cleaned and packed

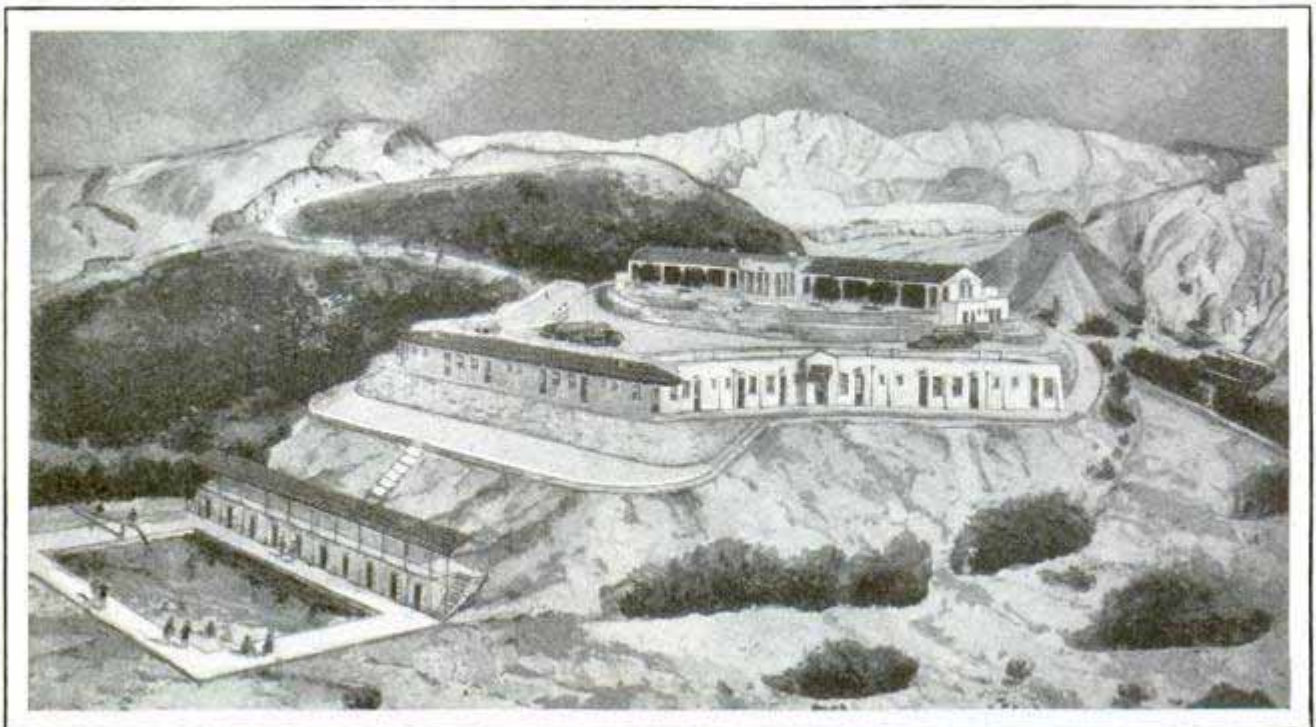

This Comfortable Hotel Offers Travelers Luxuries of a City Inn, Although It Stands in Death Valley Desert at the Mouth of Skull Canyon



by machinery, and sent in refrigerated express cars and motor trucks to markets all over the United States.

New and valuable mineral and agricultural products are coming from the desert under the reign of the machine there. Borax, which, in the days of the twenty-mule teams, cost nearly ten cents a pound to produce and deliver to market, is now being mined with shovels and transported in tractor and truck-drawn trailers, so that it can be retailed for less. Pottery clays are being shoveled out by Diesel-driven scoops, and hauled by truck to manufacturing on the Pacific coast. Cost of mining and transporting these clays was prohibitive until the oil and gasoline engine entered the desert.

Semi-precious gems—turquoise, tourmaline rock crystal, topaz, beryl, and the like—hidden in the great burned-over wastes of volcanic rock, are being found by prospectors driving "flivvers." These men cover so much greater areas than they could do with burros or mules that the difference in cost between gasoline and hay is more than balanced by the discoveries made. Not less than four parties of gem experts are motoring in as many sections of the American desert in the belief that there are diamond deposits.

From seats in cabin planes, other prospectors search the desert hills for more visible deposits of copper, gypsum, and other ores and salines, with cameras to record for them the terrain over which they pass. With such planes, more territory can be prospected in a week than could be covered in six months by the old-time prospector on foot or on mule back, while hidden deposits are more easily seen.

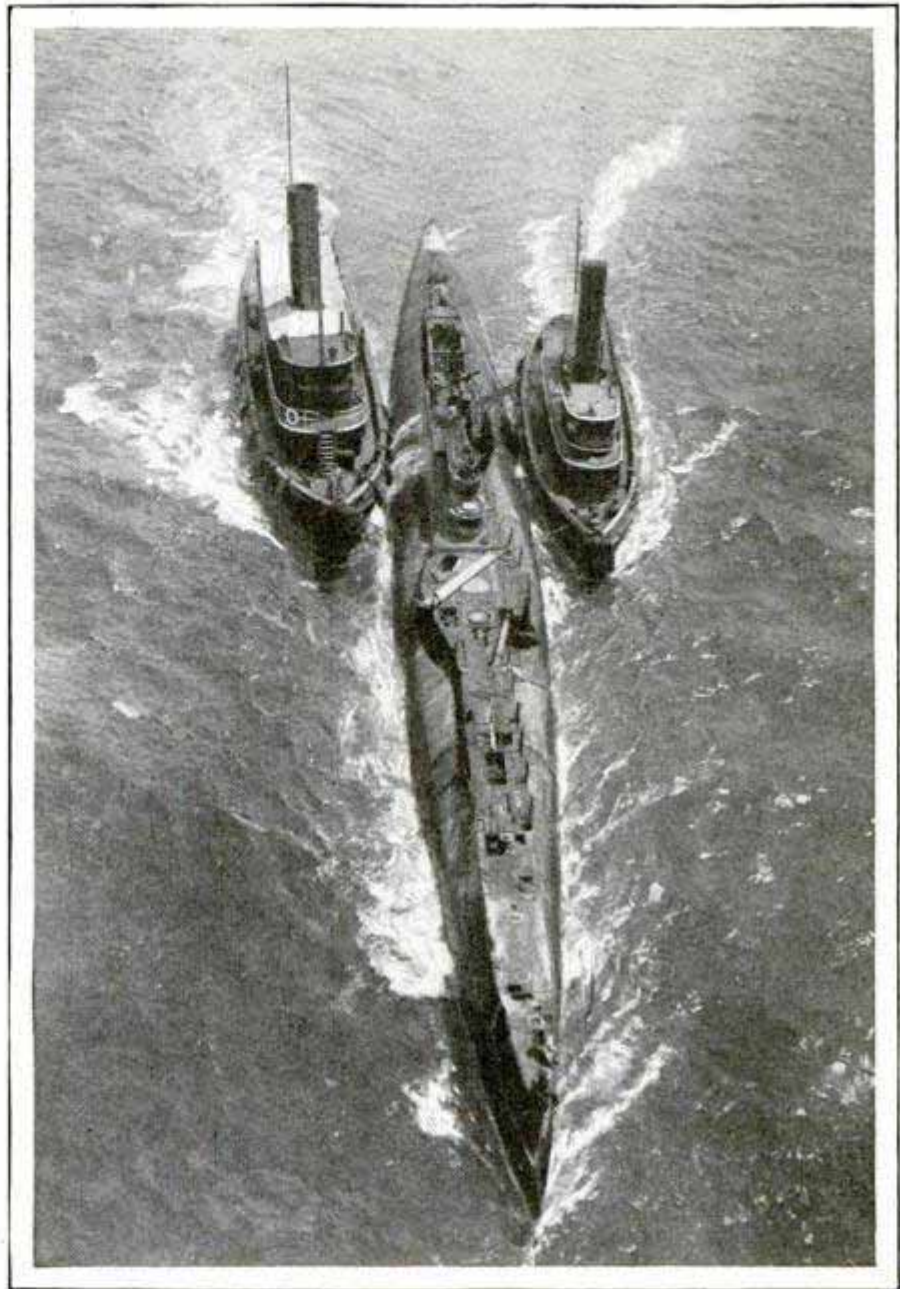

The Submarine "S-51" on Way to the Junk Pile; a Crew of Over Thirty Perished When the Boat Sank off the Rhode Island Coast

### FAMOUS SUB MAKES LAST TRIP TO THE JUNK PILE

Two tugs and a battered submarine formed a water funeral procession under the Brooklyn bridge recently, when the undersea craft, the famous "S-51," was taken on its last journey with its destination the junk pile. The "S-51" is the ill-fated boat that carried more than thirty of her crew to their death when she sank off Block island, R. I., five years ago. She was raised after a long period of suspense.

☛ Luminous programs, readable in the dark, have been introduced by a London theater.

*From Je Sais Tout  
Girls 1930*



1053 Mr. Iseo. H. Ickerman  
4528 Walnut St  
646 POPULAR MECHANICS  
Phila.

## HUNTER TELLS HOW GORILLAS ARE CAPTURED

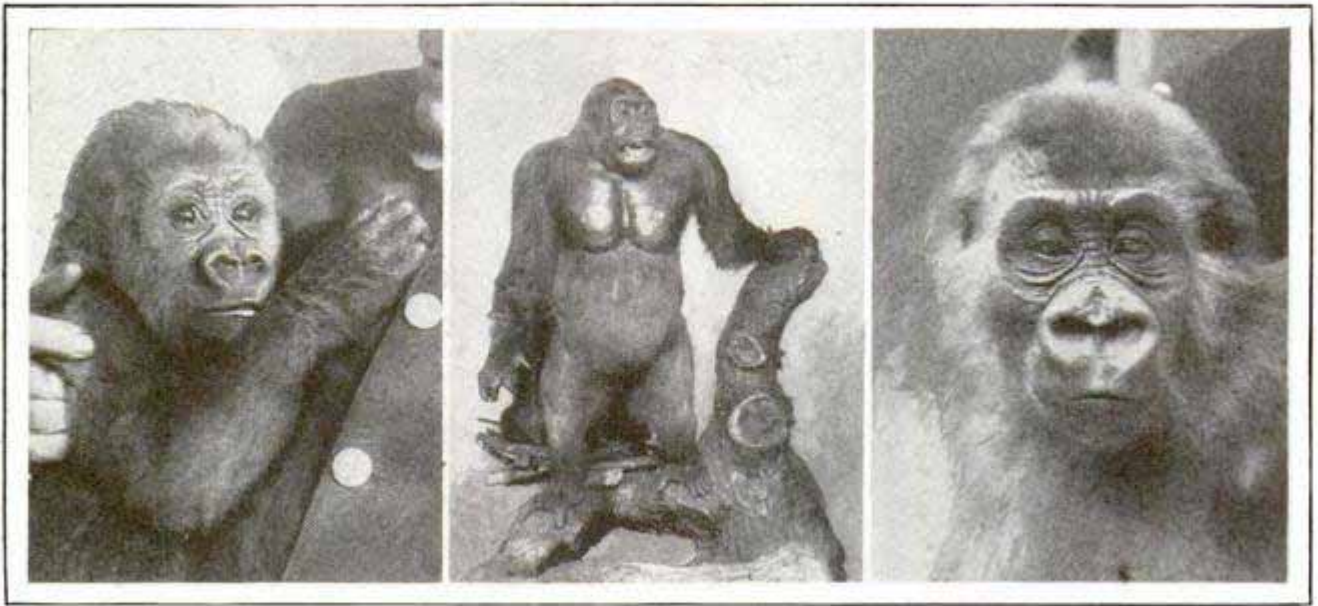

Specimens of Gorillas That Have Been Taken Captive, the Center One Being a Mounted Museum Exhibit; These Animals Are Unable to Survive Captivity More Than Four Years

While a good lion cub, in perfect health, may be purchased for as little as \$150, a two-year-old gorilla is still worth more than \$5,000. For the first time there are five strapping young gorillas in captivity, Julius Buck, wild animal collector and veteran of thirty-five expeditions into the jungles for rare beasts and birds, recently having returned with a new specimen. To be sure, a rhinoceros may be worth as high as \$9,000, but when it is realized that no gorilla has lived more than four years in captivity, and that the hay eaters, such as the rhino, are long-lived, it will be seen that the gorilla is a particularly expensive beast for the menagerie. No animal has been more misunderstood, and none has suffered more at the hands of fiction writers than the gorilla. It has ever been an animal of mystery and little is known of its habits—in fact, until 1903, only one live specimen had been seen in the United States. No less an authority than Carl Akeley, the scientist and explorer, stated that the gorilla is not vicious, and not being wary, has been the prey of hunters. The method of capturing them alive is most interesting. A mother with a baby is singled out of a herd and followed from a distance for days. Finally the mother is wounded by a poison arrow shot by a native—care being taken that she is not instantly killed, but merely wounded. The herd is then followed, and the mother, becoming weaker from her wound, falls

farther behind until finally she drops from exhaustion and the baby is then taken from her. Now the real troubles of the animal collector begin, because, like as not, the baby will refuse to eat and will die. No full-grown gorilla has ever been raised, or captured alive, and guesses can only be made of its strength. Compared with man, the animal is much stronger and heavier.

### MATRIX WITH WHITE LETTERING IS MORE EASILY READ

1055

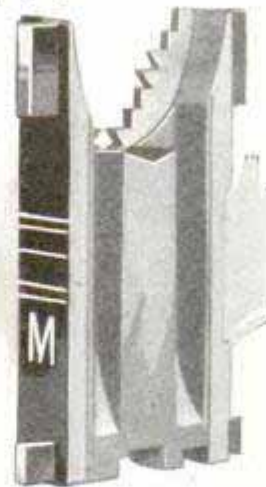

Through a special process of chemical treatment, white lettering now is being used on matrices to aid the linotype operator or compositor in spacing and to give better visibility. The matrix, or piece of brass which stamps the letter impression in type

metal in printing, ordinarily has the letter stamped in its face, but this is not easily seen when the matrix becomes dirty. By a chemical process the brass face has been turned black and the lettering in contrasting color set in it.

Matrix Contract Corp.  
326 W. Madison



6500 Lancaster St.

POPULAR MECHANICS

1111 St. Louis, Mo

116 2647

### VACUUM CLEANER FOR GRIT SPEEDS VALVE GRINDING

To facilitate the difficult task of cleaning up an automobile engine after a valve-grinding job, a grit remover, somewhat like a vacuum cleaner, now is being employed. It fits over and around the grinder body and is moved from one cylinder to another with the grinder. With this equipment, the motor is clean and ready for the fitting of pistons when the grinding is finished, thus saving an hour or more on each job. Particles of dirt and grit are collected in a bag which, with a small electric motor, is mounted on two rubber-covered brackets, hanging on the car door. With the addition of a few attachments, the apparatus can be adapted to cleaning car interiors and rugs.

\$48.00

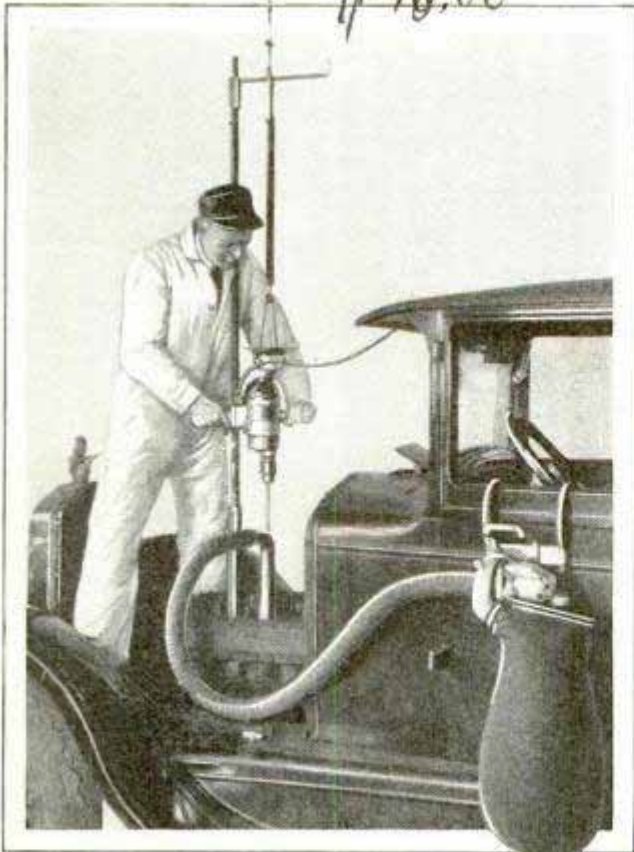

Portable Cylinder Grinder and Grit Remover, the Latter Operating Also as a Vacuum Cleaner

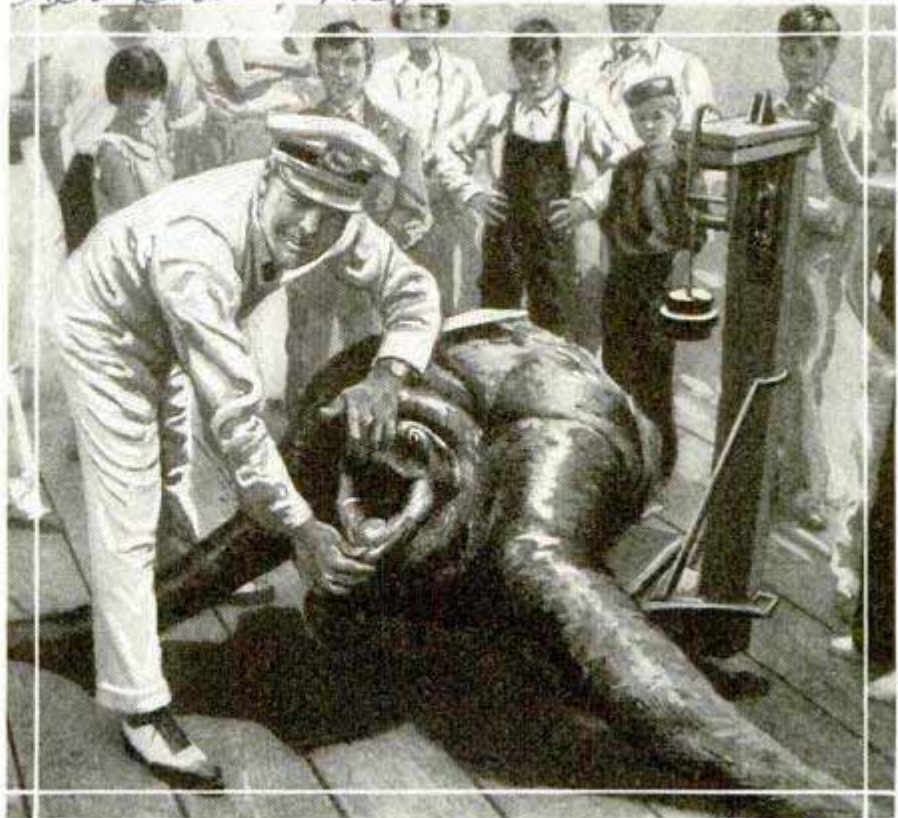

Sea Turtle Weighing 750 Pounds, Which Was Lassoed as It Plunged through the Water, and Landed with Rope after Struggle

### TURTLE CAUGHT WITH A LASSO WEIGHS THIRD OF TON

Capt. Lurch

Catching a sea turtle with a lasso was the difficult feat performed recently by the skipper of a vessel on the Pacific coast. The turtle, which weighed 750 pounds, was roped as it plunged through the waves, and was landed with the lasso after it had worn itself out in struggling.

### ADD OFFENSIVE ODOR TO GAS TO WARN OF LEAKS 1155

Engineers of the bureau of mines have developed a chemical of very offensive odor which they urge be added in small quantities to odorless illuminating and fuel gases so that leaks in pipes can be detected instantly. The substance is ethyl mercaptan, an organic sulphur compound, which has such a disagreeable odor that only one-hundredth pound in a million cubic feet of gas is necessary to warn. Eight pounds per million feet of gas would warn of slow leaks in homes, and forty pounds would allow inspectors to detect leaks in mains. Most manufactured gas has an odor that can be detected, but natural gas is virtually odorless.

Daily Science News Bulletin Service



# This A.C. DX Tuner

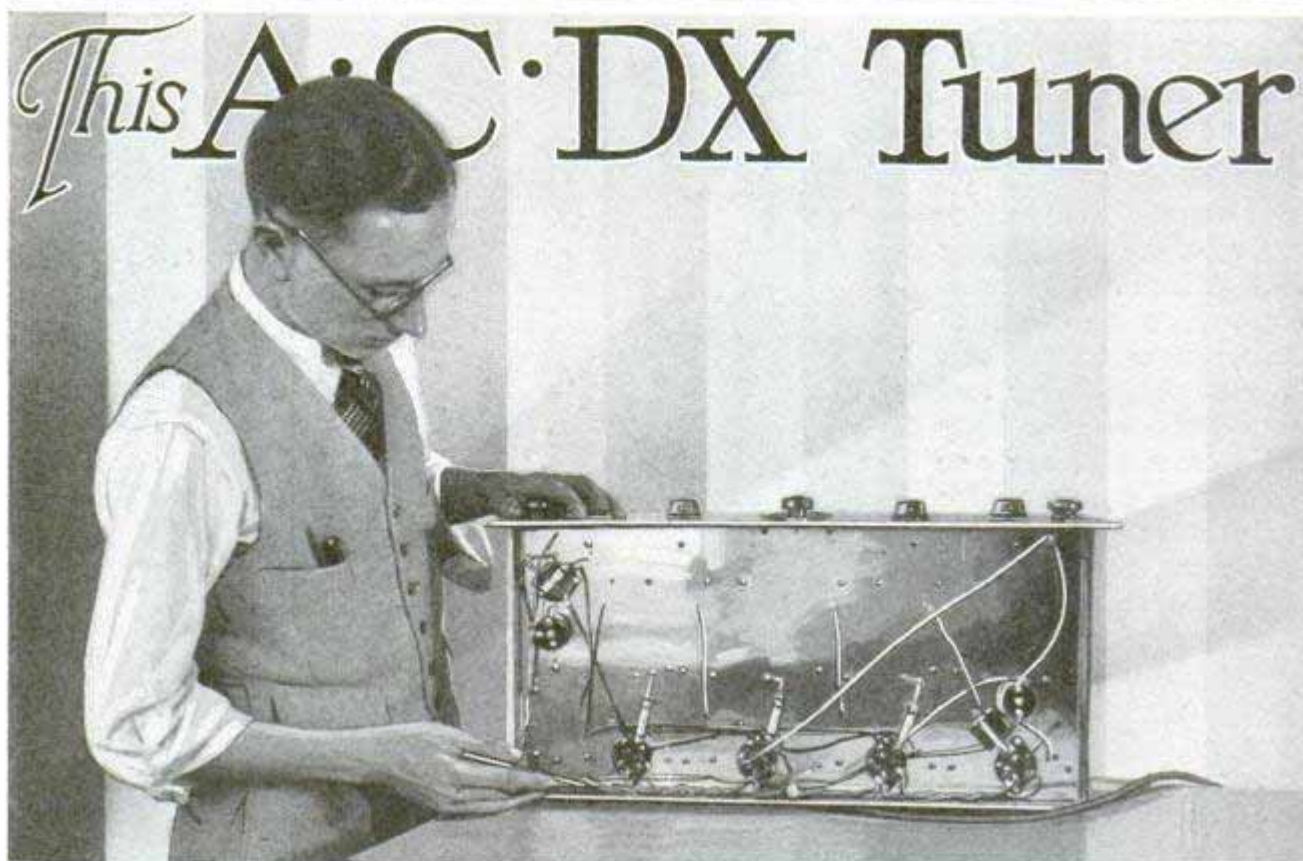

**T**HE RECEIVER described in this article has been designed for a very high order of selectivity and sensitivity, with a minimum number of controls to do the job correctly. The circuit, shown in Fig. 2, gives maximum gain without introducing any of the more common losses, and an antenna of almost any length may be used, without changing the tuning.

The chassis is made of 20-oz. burnished and lacquered copper, and each stage is individually shielded by a copper can. Templates for building the chassis and cans are shown in Figs. 2 and 3. The base

layout, Fig. 2, gives the location of the holes drilled in the top, as measured from the edge of the base, and the over-all size is for the top only. The metal sheet from which the base is made is actually  $1\frac{1}{2}$  in. larger all around, a  $1\frac{1}{2}$ -in. square being cut out of each corner and the ends and sides bent down to raise the base  $1\frac{1}{2}$  in.

The tuning condensers are mounted on brass bushings,  $2\frac{3}{32}$  in. high and  $\frac{1}{2}$  in. in diameter. These condensers are furnished with two mounting holes on the base, which are tapped to take 8-32 brass machine screws,  $1\frac{1}{4}$  in. long. When mounted

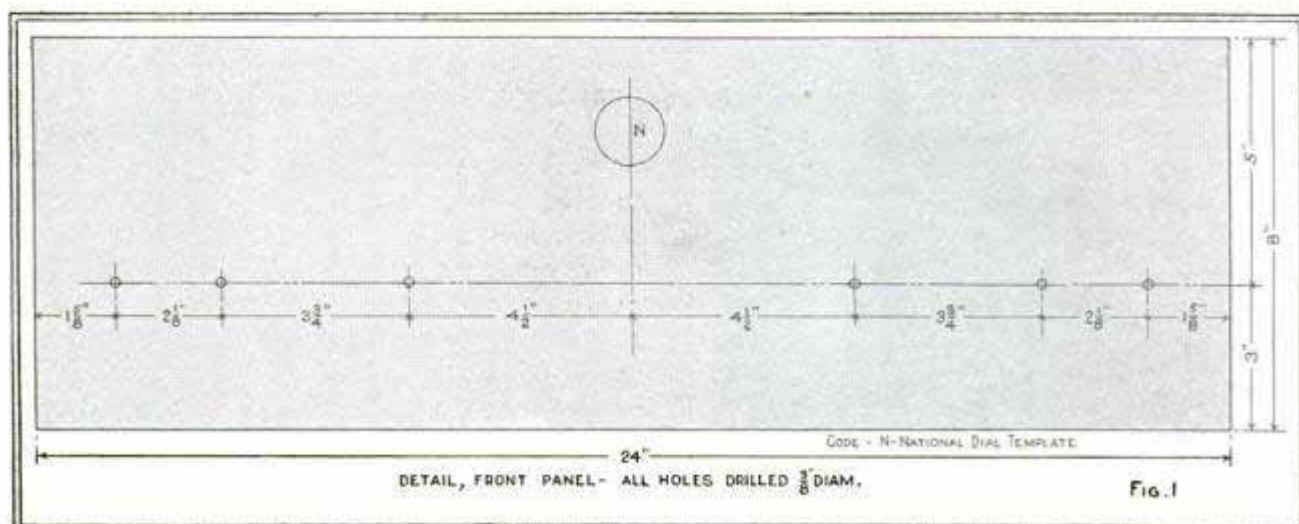



# is Highly Selective

by J.O. Barnes

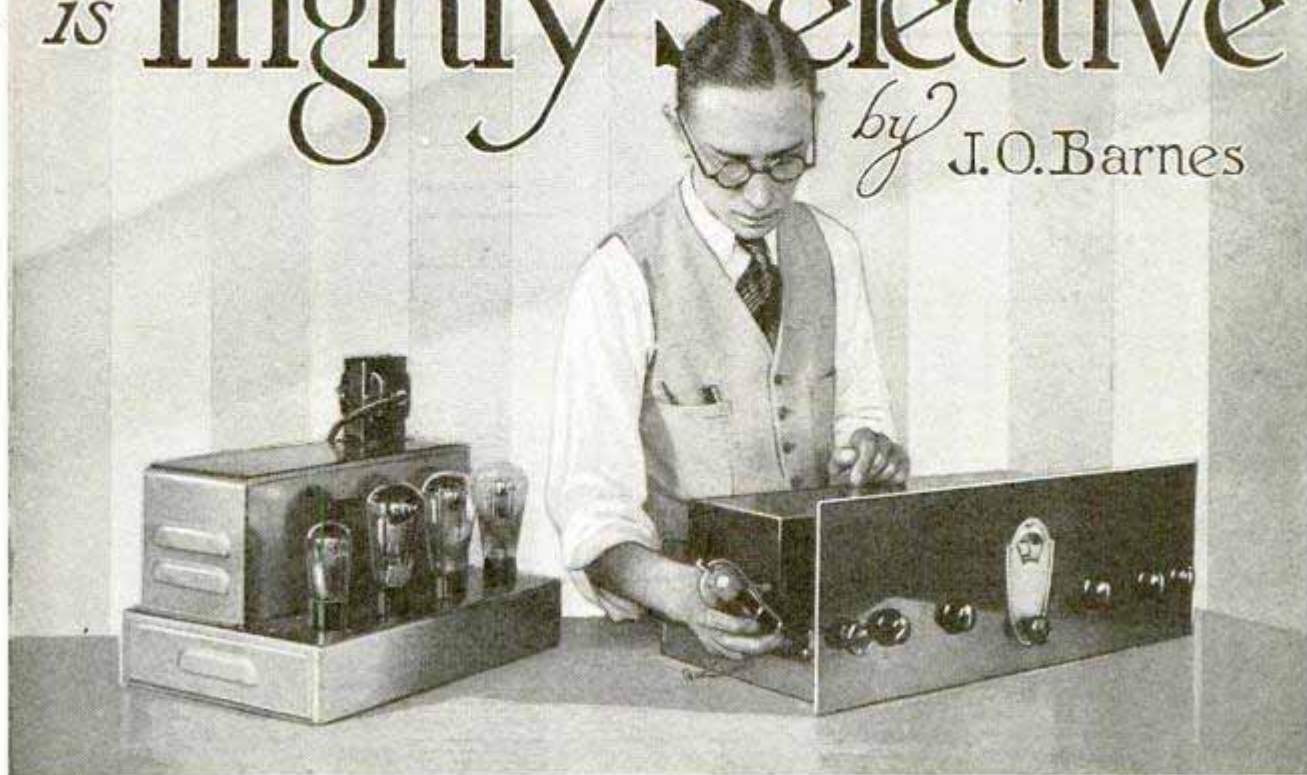

in this manner, the metal base panel serves as the connection to ground and negative B, which are common to all the variable condenser rotors, both tuning and trimmer types. The latter are mounted on a standard 1 by 1-in. brass bracket, and are screwed directly to the metal base.

The battery cable has seven conductors, four being used to supply the filament of the heater-type tubes, two in parallel for each side; see lower photo on page 650. The three remaining leads furnish the plate voltages to the tuner.

Leads for varying the coil taps are made

of insulated flexible wires, with a split lug on the coil end to be inserted under the various machine screws on the coil bases. The entire metal base and the shields must be kept at ground potential. This makes it necessary to guard against short circuits when running the wires through the metal base, as shown in upper photo on page 650. Fig. 1 shows the template for drilling the front panel; this panel is of  $\frac{1}{8}$ -in. bakelite, and the template for the dial holes, indicated at N, comes with the dial.

The filament transformer, which supplies all the tubes in the tuner at the neces-

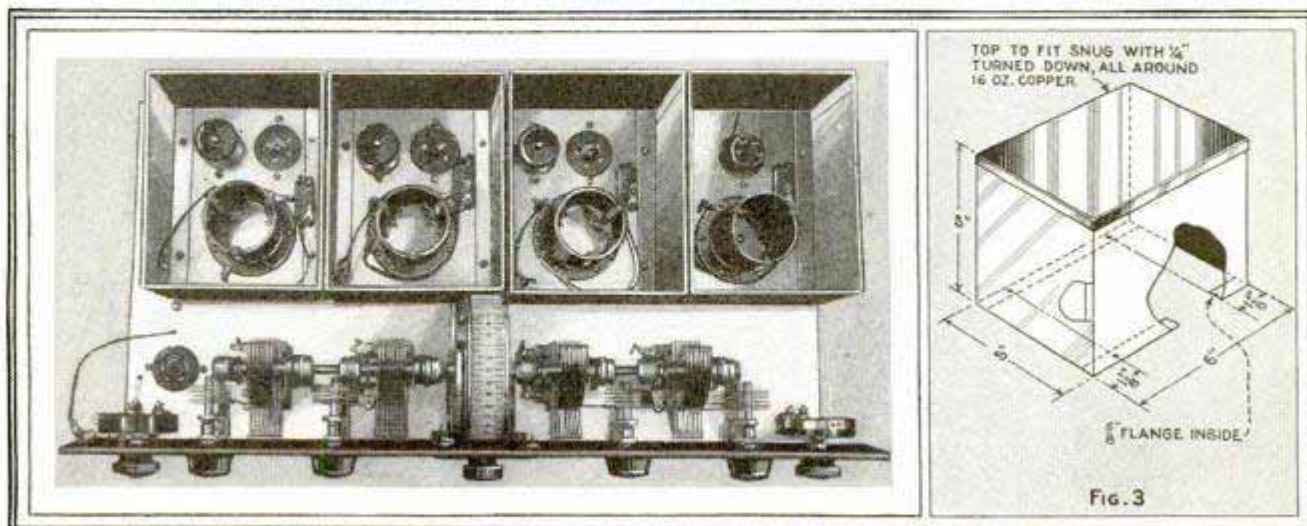



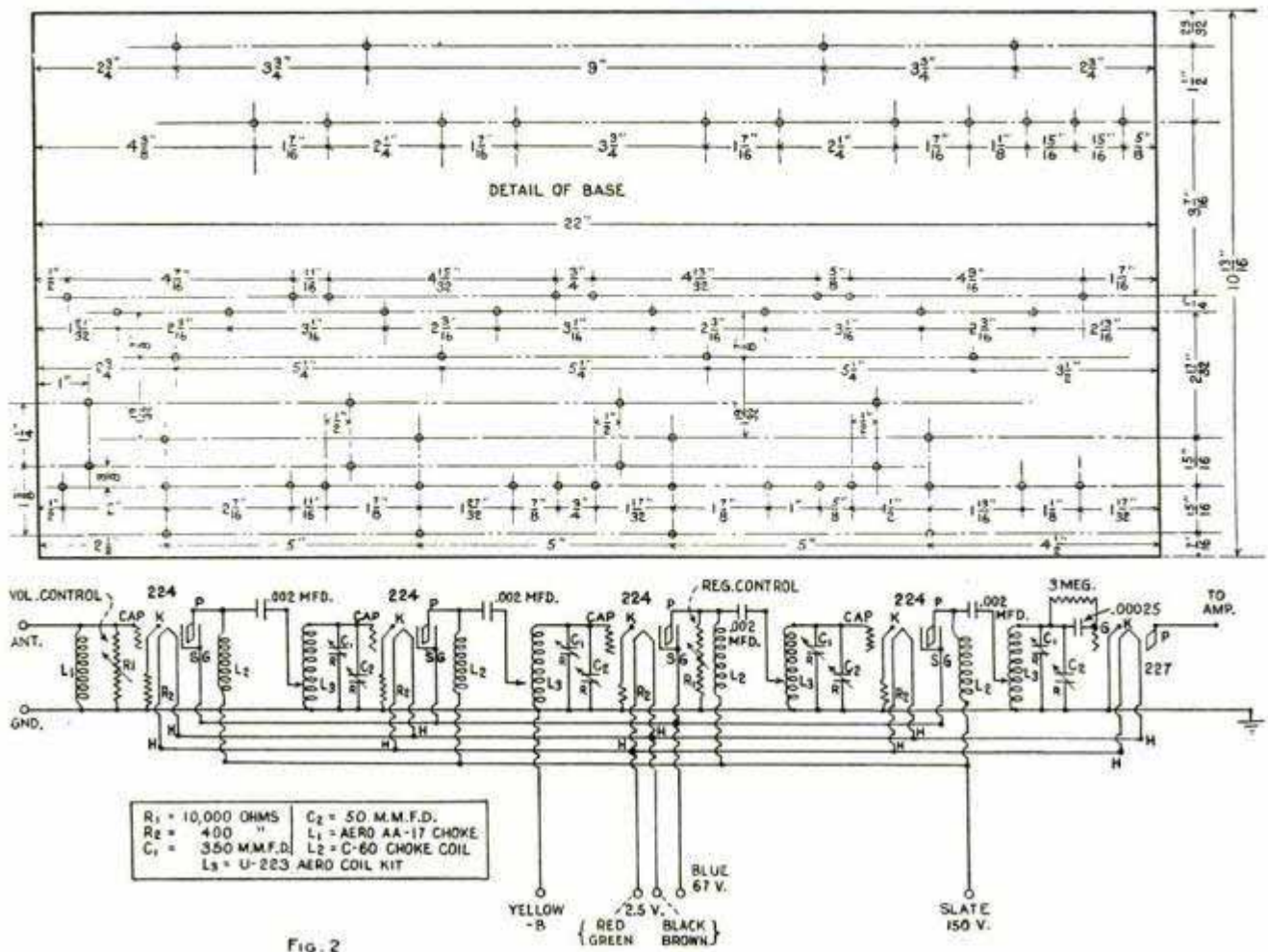
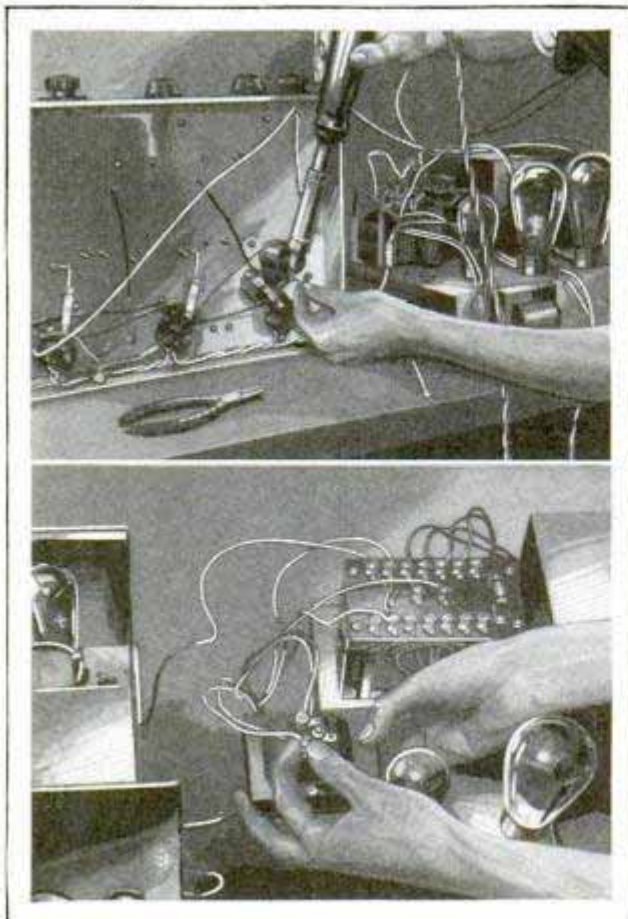

Fig. 2



sary 2.5 volts a.c. and required amperage, is used separately, making it possible to employ any type of power amplifier desired with this independent tuner unit. The output from the plate of the detector tube to the input of the audio amplifier may be taken from an adapter, as shown at the left in Fig. 4, or a lead may be soldered directly to the plate terminal of the detector socket and taken to an insulated binding post mounted at a convenient point on the base panel. The antenna post must be carefully insulated from the base, but the ground post is mounted directly.

The power amplifier shown in the head of the article is a type that furnishes all the B-voltage for the tuner as well as for the audio system. It contains a stage of 227-audio which feeds into a stage of 250.

Dynamic speakers of the d.c. type or magnetic speakers can be used with this amplifier. A sketch of the terminal board connected to supply this tuner and the field winding of a 90-volt d.c. dynamic speaker is shown. Directions for other combinations are available as well as enlarged set layouts, material list and circuit diagrams.



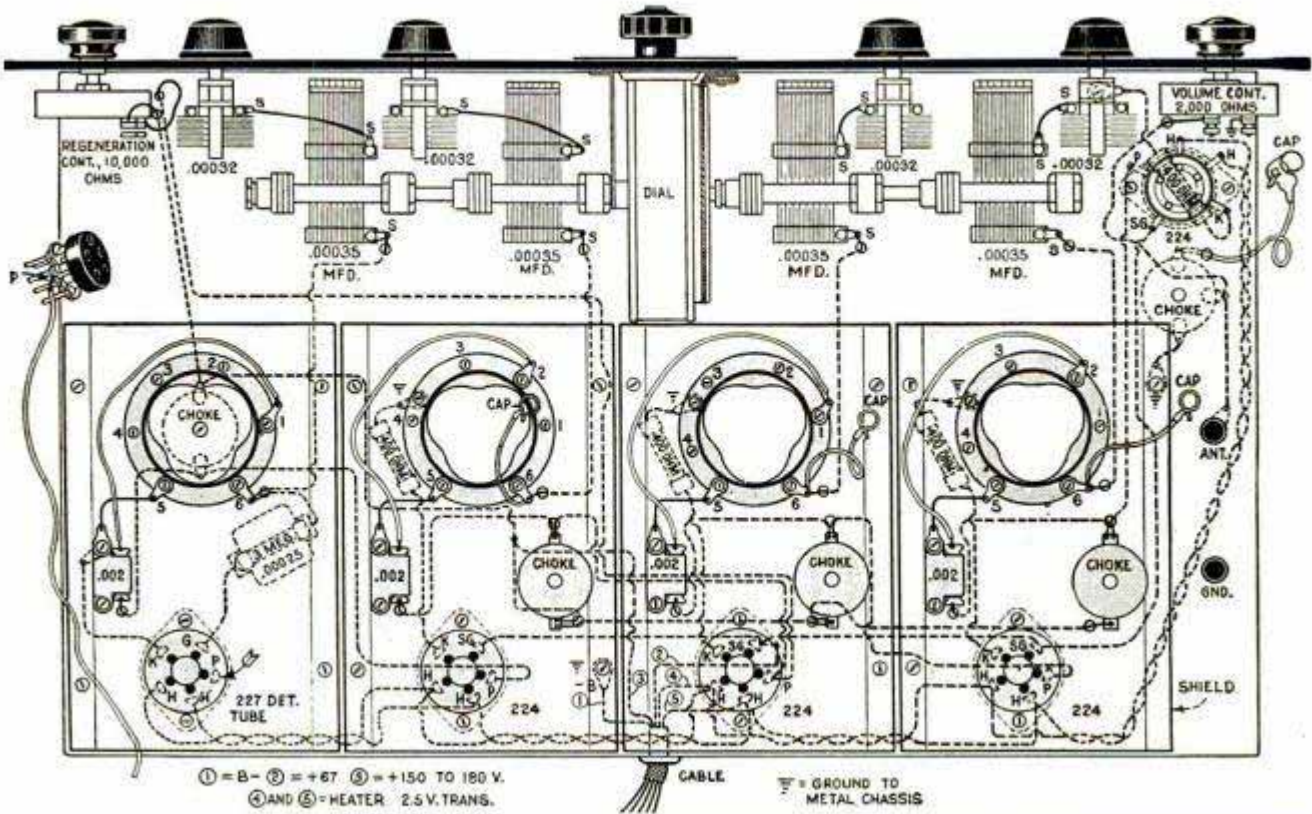
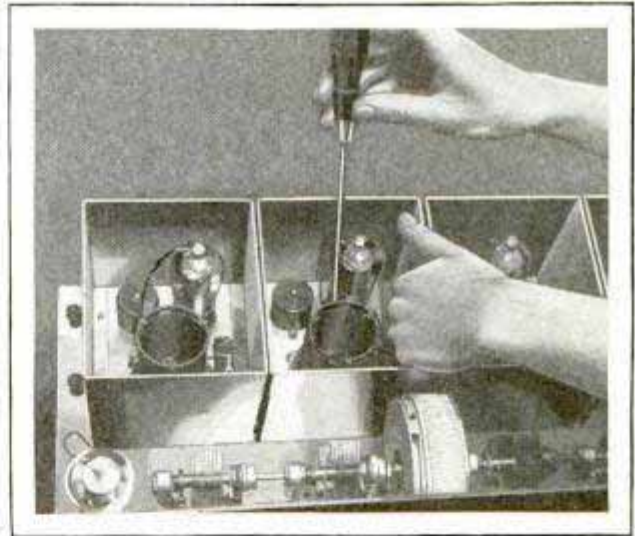

FIG 4

To adjust and tune the set, connect all coils on tap No. 2, and tune in a fairly weak signal, then, when the set is oscillating, adjust the trimming condensers on the front panel until maximum volume is obtained. Next work the regeneration control until the set is brought out of oscillation. If the set does not oscillate freely, change the tap on the detector coil to No. 3. If, after tuning in several stations, the set is too broad, move the taps on the r.f. coils down to No. 1. See photo on this page. The use of care in adjusting the taps on the coils and lining up the trimming condensers is important. When they are once lined up, the operator can control sensitivity with the trimmers, to suit either local or distant reception.



**Further Data on Locating Hidden Metals**

Owing to the interest of our readers in the article, entitled "It's Easy to Locate Hidden Metals," which appeared in the May, 1930, issue, further experiments were conducted with the exploring device in an effort to make it more sensitive. It was found that the oscillator was too stable, or limited as to sensitivity. This was easily remedied by substituting a .00035-mfd. variable condenser for the .001-mfd.

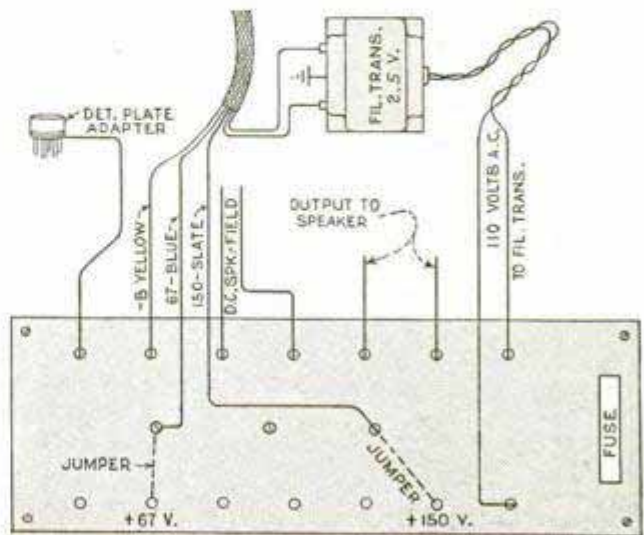

AMPLIFIER TERMINAL BOARD



# Helpful Hints from the



A Piece of Cardboard under the Radio Console will Compensate for Floor-Level Imperfections; Right, a Homemade Phonograph Pick-Up for the Radio Amplifier Made from a 1,500-Ohm Headphone and an Old Phonograph Stylus; the Sketches Are Self-Explanatory

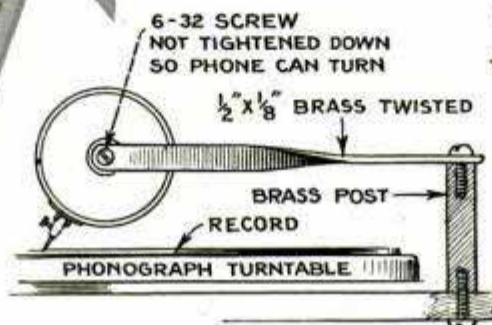
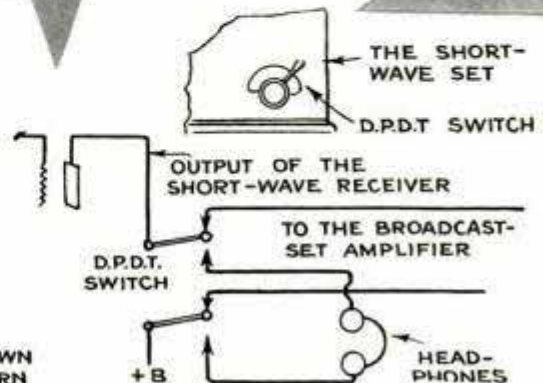

Owners of Short-Wave Sets Usually Wish to Use the Amplifier of the Broadcast Receiver to Obtain Volume on Short-Wave Programs; When Tuning in These Short-Wave Stations Squeals Are Rather Difficult to Avoid, So One Experimenter Solved the Problem with a D.P.D.T. Switch Used to Connect a Pair of Headphones to the Output of the Short-Wave Set for Tuning Purposes, and When the Short-Wave Station Is Properly Tuned In, It Is Easy to Switch to the Broadcast Amplifier and Speaker

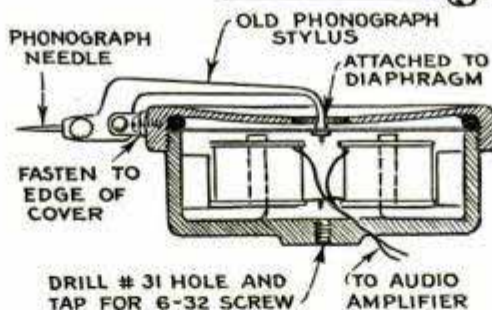
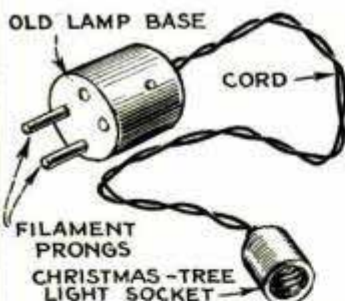

Left, Handy Plug-In Test Lamp for the Experimenter; the Lamp Used Must Correspond to the Voltage Employed in the Set Socket into Which It Is to Be Plugged

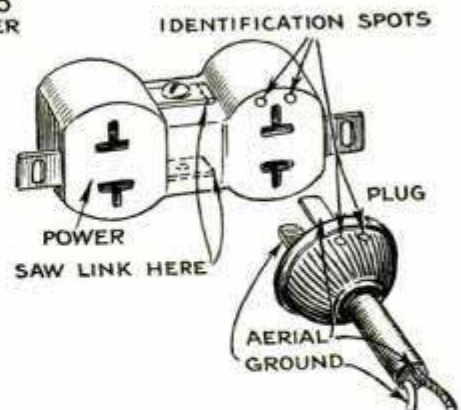

Above, Combination for Power, Antenna and Ground Connections, Made from an Ordinary Double Baseboard Receptacle; Mark Plug and Outlet so as Not to Confuse Antenna Connections When Removed; Left, When Tightening Nuts on Transformer Terminals, Use Pliers to Hold the Screw While Turning the Nut; This Prevents Breaking Soldered Wire Connections

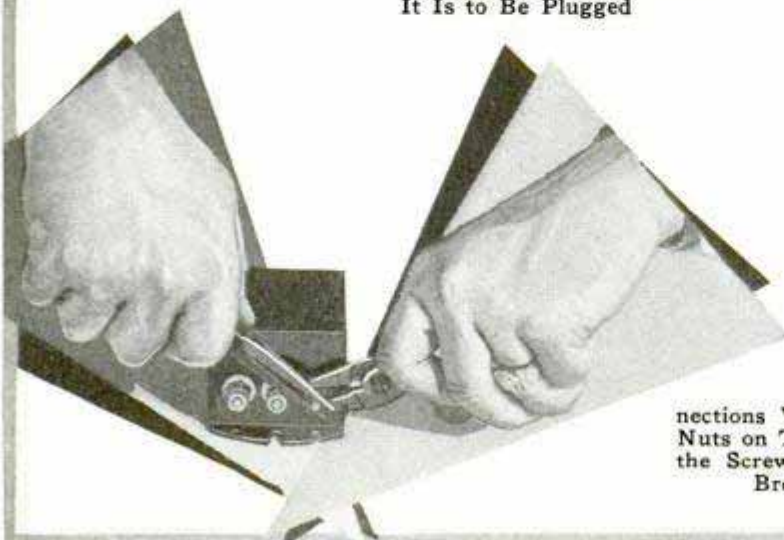



# and Kinks Radio Lab.

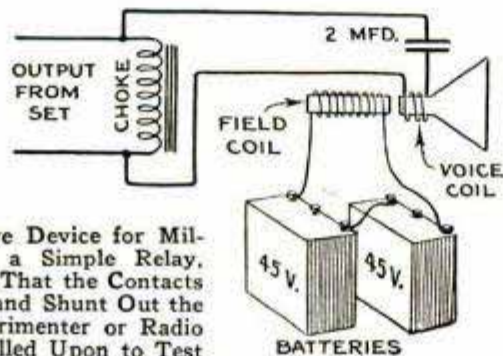
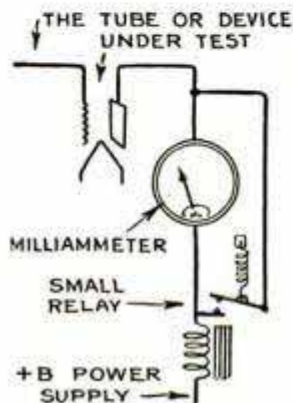
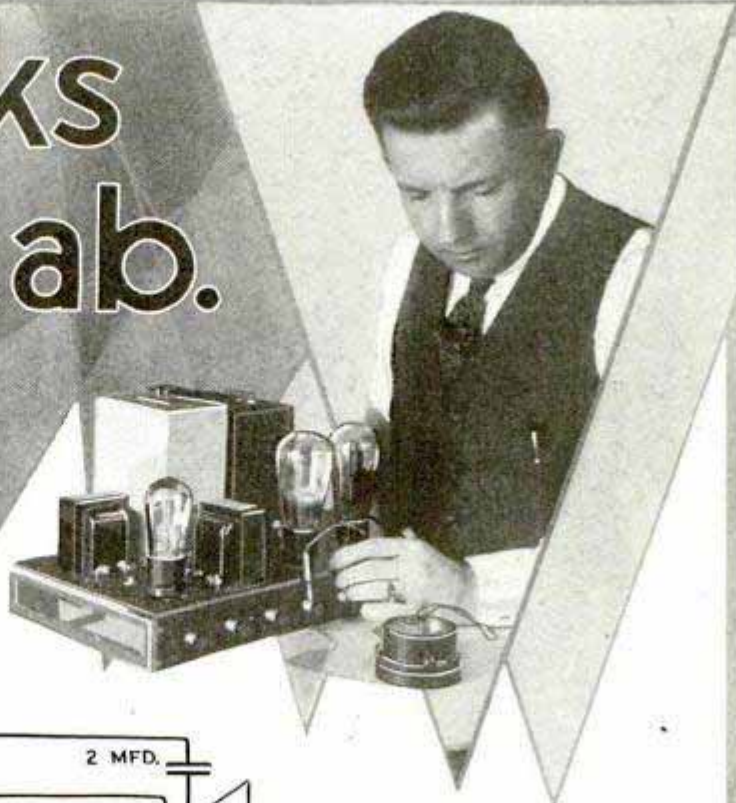

A Voltmeter, Reading 0-150, May Be Used to Measure High-Voltage Outputs; Add Readings, Negative to 90; 90 to 180 and 180 to Maximum, and Total Will Be Maximum Voltage; Below, Simple Homemade Metal Chassis

Upper Left, a Protective Device for Milliammeters Consists of a Simple Relay, Connected as Shown, so That the Contacts Will Close on Overload and Shunt Out the Meter; Right, the Experimenter or Radio Handy Man Who Is Called Upon to Test a D.C. Dynamic Speaker May Not Have a Receiver Using That Particular Type of Speaker; in Such Cases the Speaker May Be Operated by Using B-Batteries, Connected to Supply 90 Volts to the Field Winding

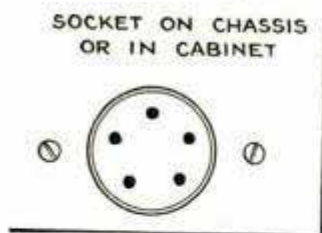
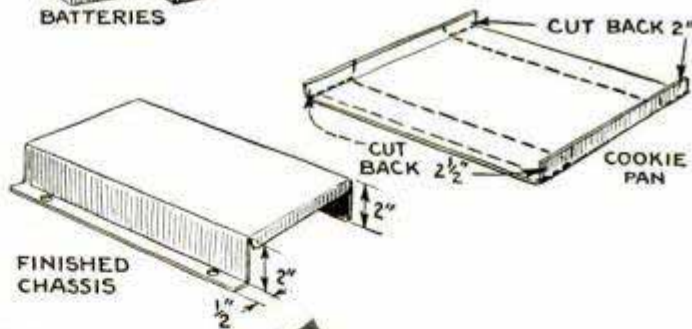

Above, a Convenient Method of Bringing Leads to Receivers; an Old 5-Prong Tube Base and Socket, Prepared and Mounted as Shown, Make Quick Connections; Right, Soldering Lug of a By-Pass Condenser to the Metal Container, to Make a Short and Efficient Ground Connection to the Metal Chassis upon Which It Is Mounted

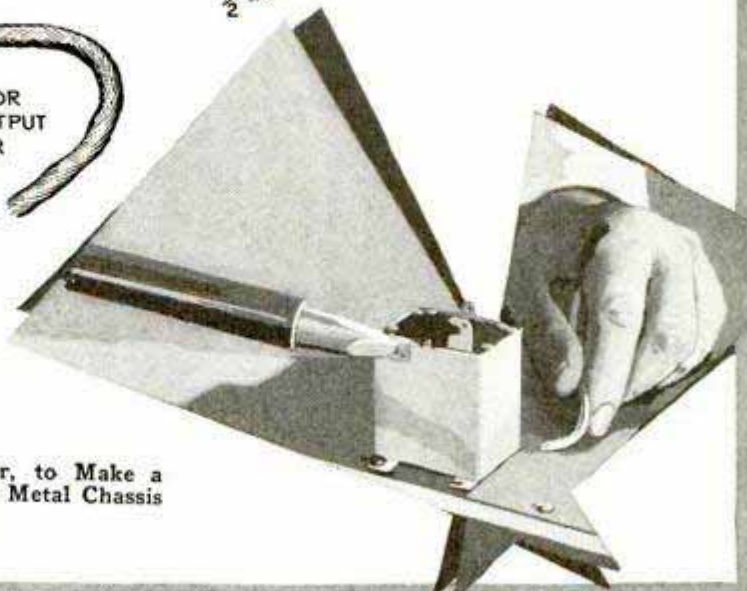



# From 15 to 195 Plug-In



condition. This method is only to be employed on weak signals that cannot be otherwise received. Frequently weak signals brought in by the zero-beat method will gradually increase in strength to a point where the detector

## PART II

**T**UNING instructions help the beginner in the operation of a short-wave receiver, but skillful tuning comes only with practice. A short-wave receiver is not tuned like a broadcast receiver, for example; the most important control knob on the panel is the one that controls the regenerative action of the detector. The detector should be kept in a continual state of oscillation by turning the "volume" or regeneration-control knob back and forth as the tuning dial is turned a fraction of a degree at a time. When the carrier wave of a short-wave station is picked up, there is a characteristic whistle. If the signal is fairly strong, you can back off the regeneration control until the whistle disappears. In case the signal is weak, keep the circuit in oscillation, but move the tuning dial so that the set oscillates at exactly the same frequency as the incoming signal. This is known as zero-beat tuning, and the whistle disappears, owing to the fact that there is no heterodyning action when the receiver is in this

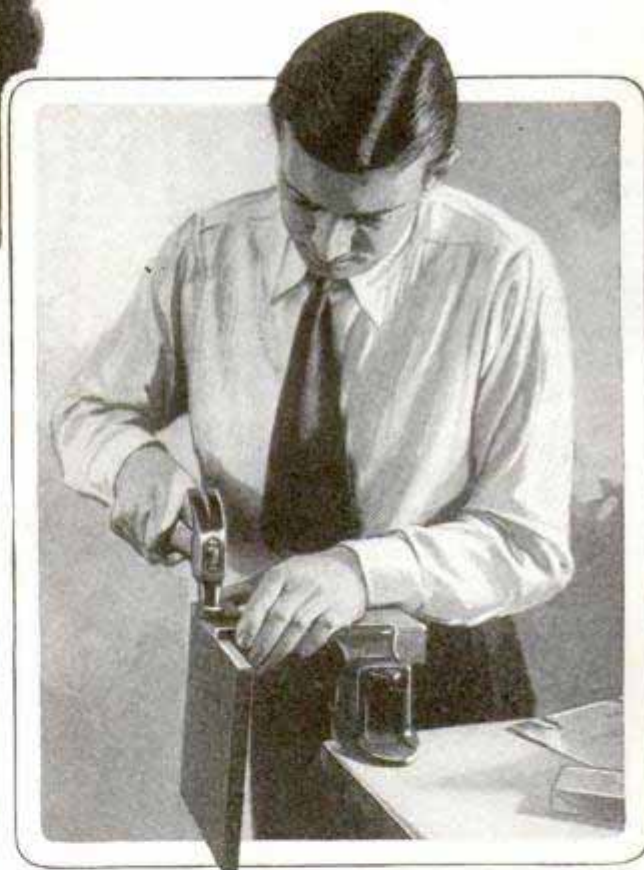

can be thrown out of oscillation to advantage.

The 20, 40, 80 and 160-meter coils can be thrown in and out of the circuit by turning the knob at the left while the receiver is in operation. It will be found that the 20-meter coil is the best choice for morning and early afternoon, its efficiency dropping off at about 5:00 p. m., whereupon the 40-meter coil is good until about 9:30 and the 80-meter coil from then until daybreak, when again the 20-



# Meters Without Coils

by  
Frank L. Brittin

meter coil will be the most effective. This schedule refers to DX-reception and, of course, is not intended to be a set rule, as stations will be picked up at almost any time with either of the three coils. The 160-meter coil will be found most useful for receiving television signals; all of these coils overlap so that the wave bands from 15 to 195 meters are thoroughly covered by them.

Complete lists of short-wave stations all over the world are available and many of these stations are broadcasting on voice as well as code. Short-wave receiving conditions change quickly without apparent reason; therefore, if you pick up a foreign station one night and fail to get it again for several nights, do not feel discouraged.

The following short-wave stations were logged with this set within a few hours, at our testing laboratory in Chicago.

Four stations in the seventh district, four in the fourth, two in the fifth, six in the sixth, one in the second, four in the first, and four in the ninth district; in addition, one eighth-district station on phone and WGY on trans-oceanic phone. Two of the ninth-district stations were also on phone, but no effort was made to tune in foreign stations owing to unfavorable atmospheric conditions during this test.

The homemade metal cabinet with the bakelite front panel, illustrated herewith by photos and templates, is very simple to construct. The material used for this

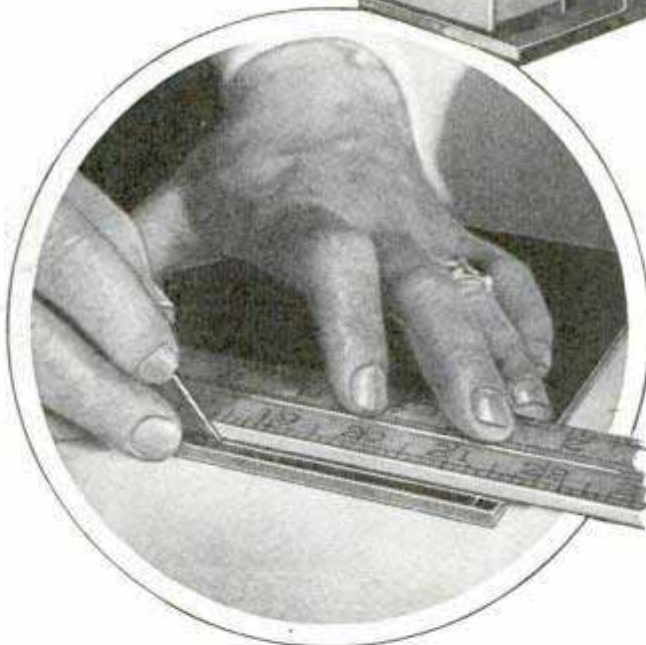
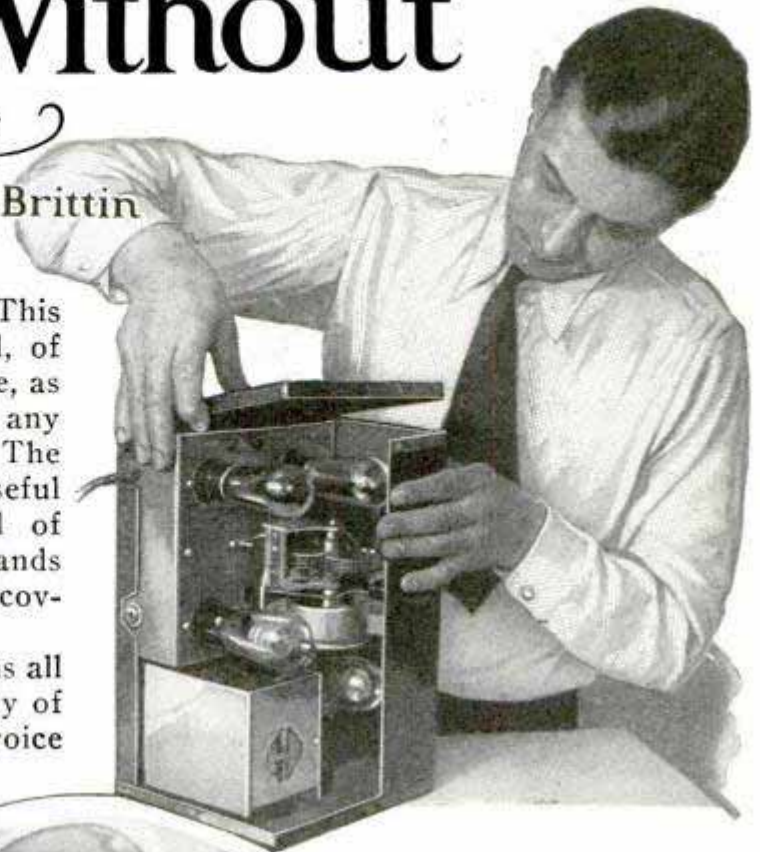

box and removable cover is  $\frac{1}{32}$ -in. sheet aluminum. Fig. 1 shows the template for the front and bottom with the overlapping back and top strips all in one piece. Make the large cut-out with an expansion cutter, and drill all holes before attempting to make the bends on the dotted lines. This also applies to Figs.

2 and 3, and if the phone jack is to be mounted at the rear of the set chassis, an additional cut-out must be made in the back strip of Fig. 1, to accommodate the phone plug, which must not touch the metal chassis or the metal cabinet. Full-size working templates are available for those who wish them.

When the instrument controls on the front panel are in position, they hold the panel in place and no further machine screws are necessary. The sketch in the upper right-hand corner on page 656 shows the simple method used for bending



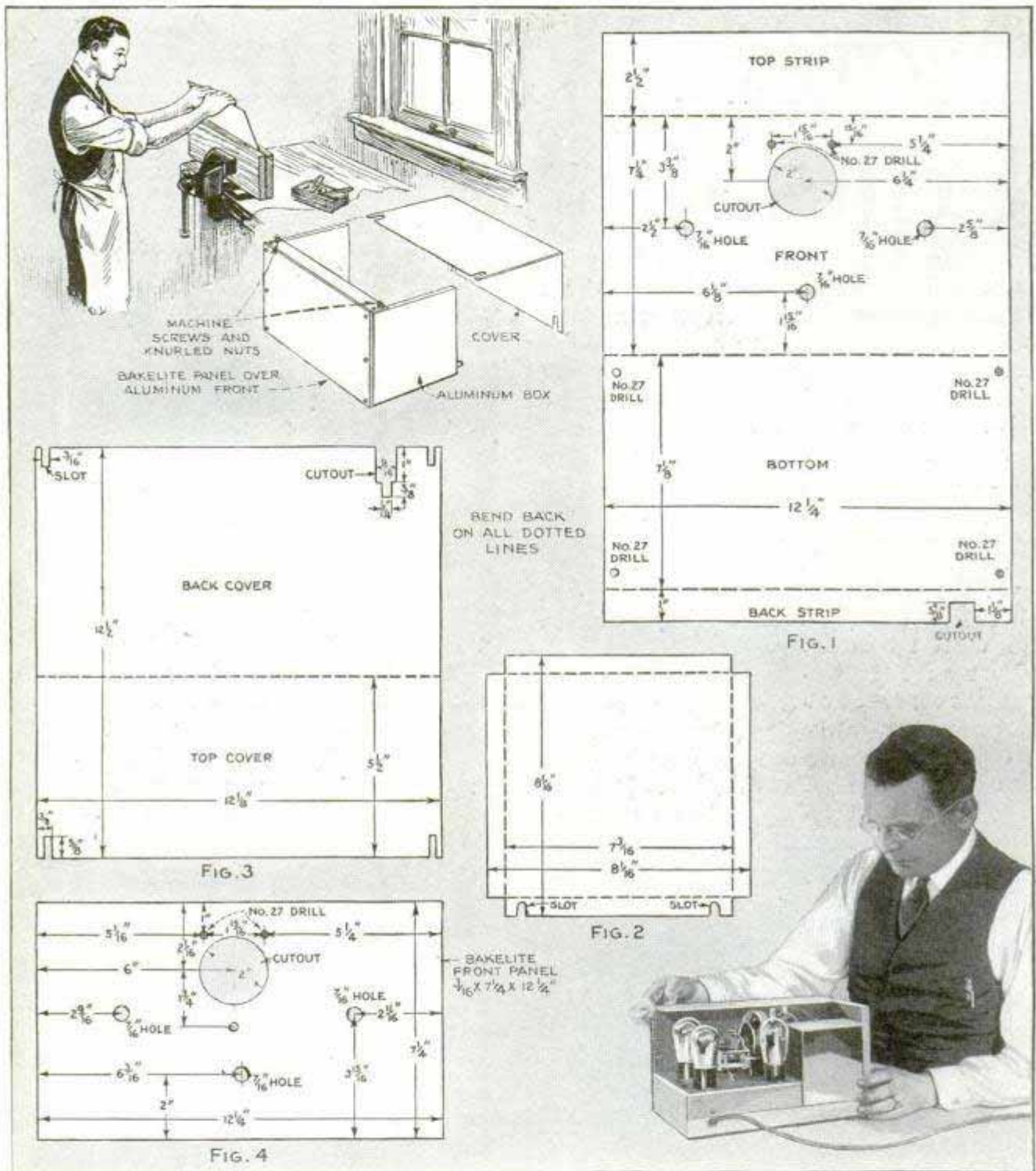

the aluminum sheets to form the cabinet. The lower photo on page 654 shows the method of bending and shaping the edges of the end covers. This is done by clamping a short piece of 2 by 4-in. wood in a vise and bending the edges over with another short piece of wood, after which a few light taps with a hammer, as shown, will make a neat sharp bend. The completed cabinet may be given an attractive finish with one of the quick air-drying black crackle lacquers, as shown.

The cabinet is now ready for the bakelite front panel and this panel may be engraved and decorated to suit the builder; the engraved border was done with a ruler and icepick, as shown in the insert photo on page 655. Wet the engraved lines and rub in white chalk. Mount the bakelite panel on the front of the cabinet by means of bushings and locknuts that come with the coil unit and variable resistance, then mount the escutcheon for the drum dial.



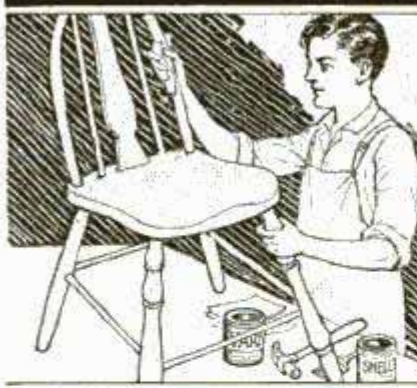

# AMATEUR MECHANICS

## How to Build a "Wobble-Go-Round"

By RICHARD COLE

HERE is a novel amusement device which can be made easily and cheaply by any handy man or boy—a "Wobble-Go-Round." The operation of this novel device can be visualized by referring to the illustration on this page. The wobble-go-round is similar to a merry-go-round, ex-

cept that its axis is tilted 15°, so that the riders are alternately raised and lowered as the device turns. This makes possible a very simple means of auto-operation. When one of the arms reaches the top of its swing, the rider quickly forces his weight back by pushing against the foot-rests, while the rider at the opposite end draws his weight forward by pulling on

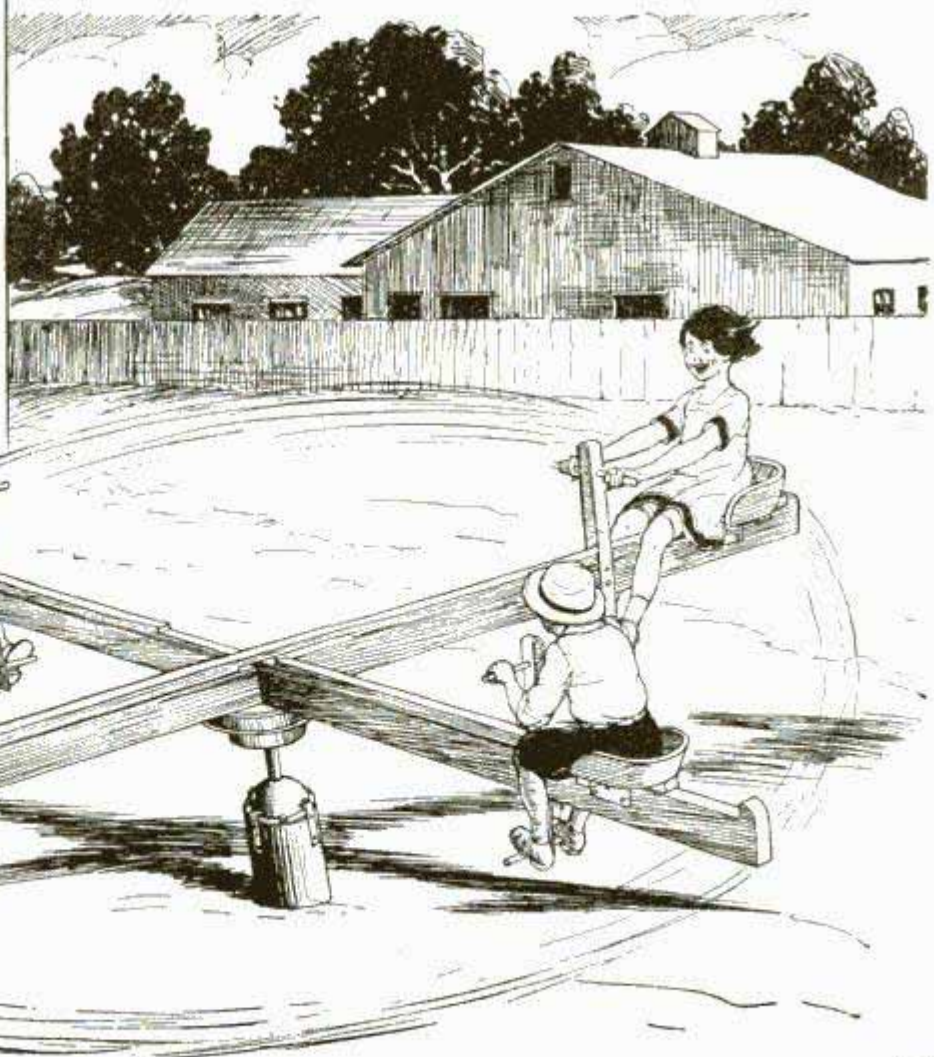
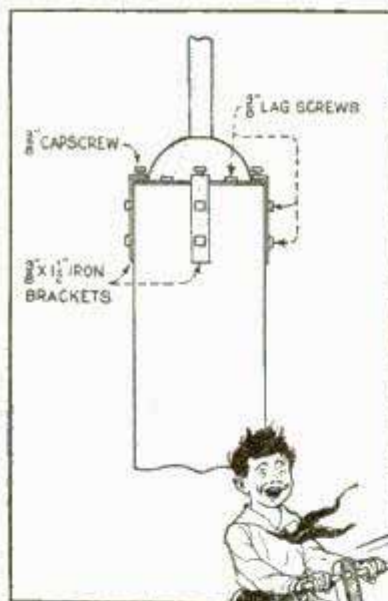



the handholds. This brings the center of gravity above the center line of the axis of revolution, and the rider at the top swings down to the bottom. Again, the weight of the riders is shifted, and the wobble-go-round is kept turning continuously.

The device is free from all mechanical complications, and all the material for its building can usually be bought for less than \$5. The chief requisite is one-half of a full-floating-type rear-axle assembly from a junked car. This type was used extensively on heavy cars and trucks a few years back, and many of them can be picked up for a song at an auto "graveyard." The differential gears—even the driving axle itself—are not needed in building the wobble-go-round; only the housing, wheel and wheel bearings. There is little "used-part" demand for housing and wheels, and they can be found in the junk pile and can be bought at junk price. It might be well to mention that a full-floating axle assembly is one in which the wheel is supported and turns on the housing; it is not rigid on the driving axle.

After the axle assembly has been obtained, the next operation is to prepare

and mount the rigid radial members. Two 16-ft. lengths of 2 by 6-in. wood of good quality are notched at the middle and interlocked at right angles. They are then fastened to the side of the wheel with long bolts through the rim. The bolt heads must be countersunk so as to leave no projection on the top face of the 2 by 6-in. pieces.

Brackets for the footrests and handholds are made of 3/16 by 1 1/2-in. iron or steel, the footrests and handholds themselves being made of 1/2-in. round rod. A hole for a 5/32-in. cotter pin is drilled in the middle of the rod, to prevent it from coming out. Three or more holes are drilled through the bracket at the bottom, so that the footrests can be adjusted for different leg lengths.

Movable radial members slide on the top surface of the rigid members; so, to make the movement as frictionless as possible, old ball bearings, obtained from the auto junk yard, are set into the rigid members, with the outer face of the bearings projecting 1/8 in. above the surface. The detail drawing will make the installation of these bearings quite obvious. Stop blocks are screwed to the extreme ends

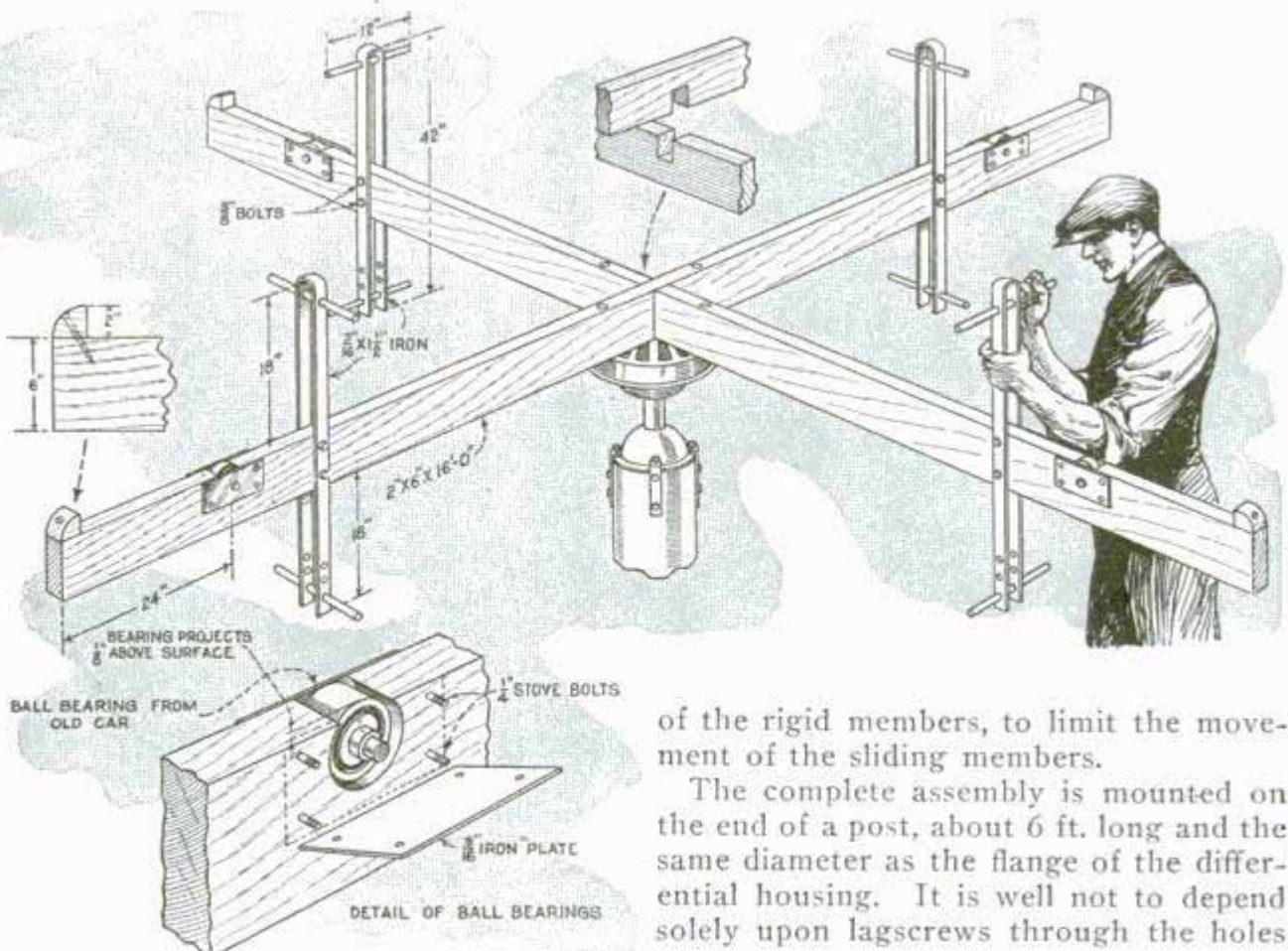

of the rigid members, to limit the movement of the sliding members.

The complete assembly is mounted on the end of a post, about 6 ft. long and the same diameter as the flange of the differential housing. It is well not to depend solely upon lagscrews through the holes



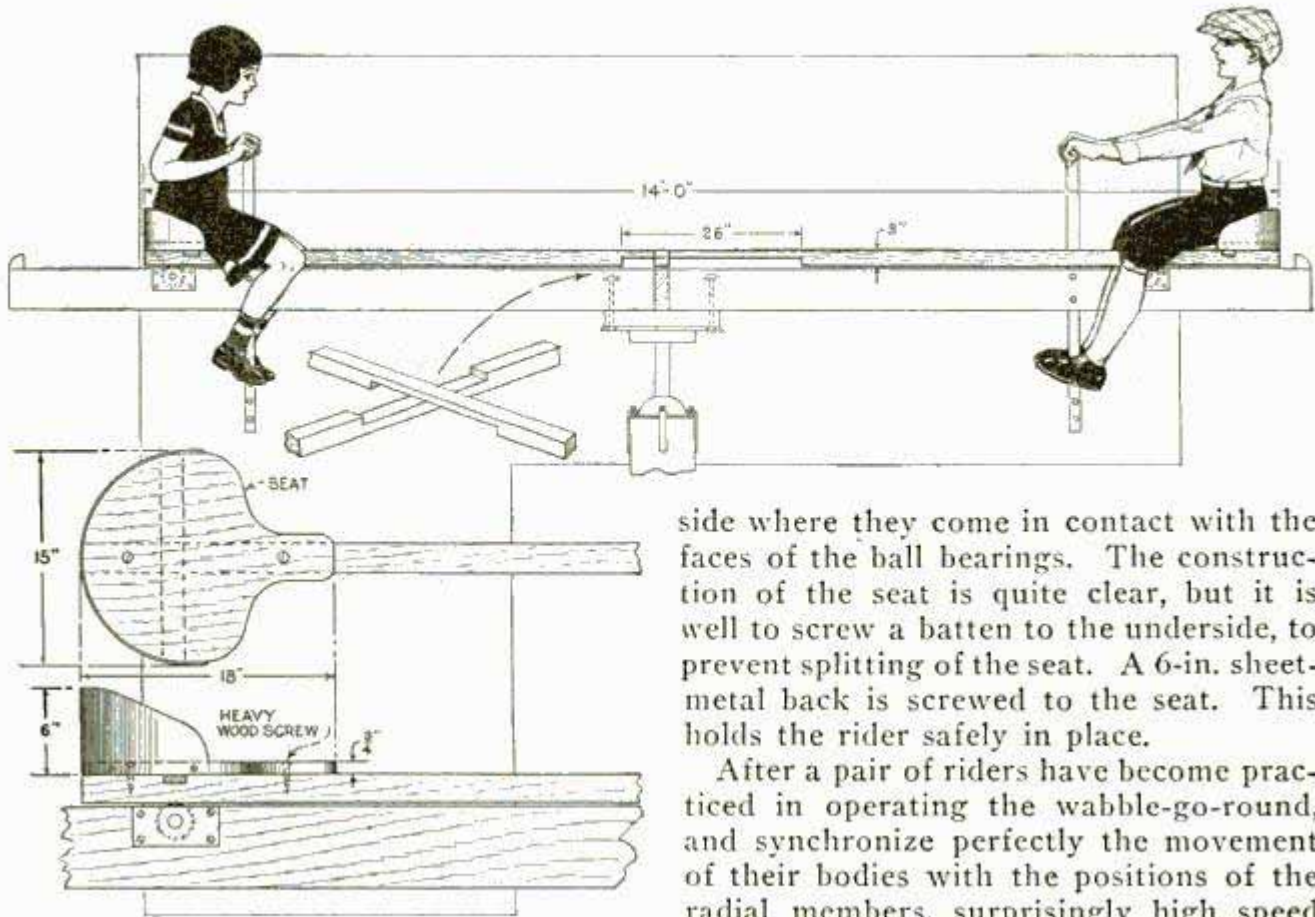

in the flange, as these must be driven into the end wood, so four angle brackets of  $\frac{3}{8}$  by  $1\frac{1}{4}$ -in. iron are lagscrewed to the side of the post, and the flange is clamped with  $\frac{3}{8}$ -in. capscrews at the top. If a cylindrical post is not readily available, although a section of an old telephone pole can usually be procured, a square box can be made of 1-in. lumber and filled with sand or concrete, when it will serve equally well.

The post must be set very firmly in the ground at an angle of  $15^\circ$ , and care should be taken that the arms, at the lowest point of their swing, clear the ground amply. As a safety precaution, this clearance should be sufficient for the moving parts to pass freely over anyone lying on the ground, otherwise, if a rider were to fall off, he might be severely pinched. It is well also to set the post in concrete, but if this is not readily at hand, old bricks, rocks and soil should be tamped firmly around the post.

The final operation is to make the sliding radial members. It is recommended that these be made of hardwood, oak preferred. If soft wood is used, sheet-metal plates should be fastened to the under-

side where they come in contact with the faces of the ball bearings. The construction of the seat is quite clear, but it is well to screw a batten to the underside, to prevent splitting of the seat. A 6-in. sheet-metal back is screwed to the seat. This holds the rider safely in place.

After a pair of riders have become practiced in operating the wobble-go-round, and synchronize perfectly the movement of their bodies with the positions of the radial members, surprisingly high speed can be obtained, and the riders experience some thrilling sensations, not only the ordinary merry-go-round reaction, but the sensation of the quick starting and stopping of an elevator as well. Too prolonged a ride should not be taken, for fear of dizziness that might result in an accident. To stop the wobble-go-round, it is necessary only to relax and let the bodily weight shift of itself with the rotation of the device.

### Shellac for Insulating Wire

When the experimenter needs a length of wire with thin insulation and has no enameled wire on hand, a temporary substitute can be made by using shellac. If the wire is not too long, it can be coiled and dipped. If it is of considerable length, it should be wound on a spool and drawn through the shellac, the surplus being wiped off with a cloth. It is usually best to give the wire three or four applications, permitting each coat to dry thoroughly before putting on the next. In this way, the wire will be sufficiently insulated, but it should not be used for carrying an excessive amount of current.—Cecil Metzger, Lincoln, Nebr.



Figures - Vaughan's *et al* of Core  
10W. Randolph Chicago

# MAKING A MINIATURE



Saijo Trading Co. Inc. 327 W. Madison, Chicago  
 101-5th Ave New York

IN OLD JAPAN land is so valuable that the nature-loving Japanese have developed a style of garden especially adapted to limited space. Many of them, complete in every detail, with pool, arched

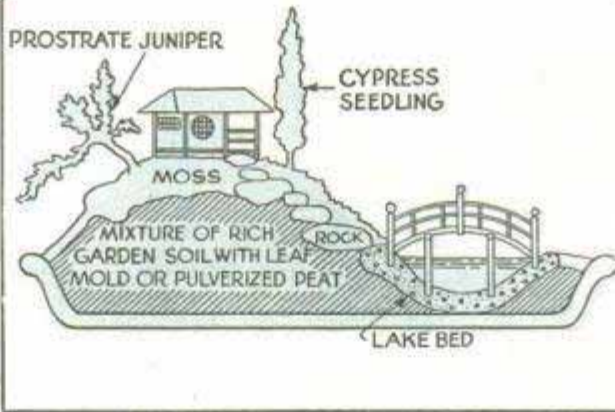

bridge, stone lamps and shrubs, would scarcely cover an average kitchen table, yet they constitute the entire backyard.

The picturesque features of these little gardens lend themselves admirably to construction

in miniature, and can be built up on trays or bowls from 6 to 24 in. in diameter. All the necessary materials are available in practically every section of the country, with the possible exception of moss in the

Fig. 1. Above, Shows a Section of the Garden, and How the Soil Is Banked; Fig. 2, Left, Gives Details of the Arched Bridge

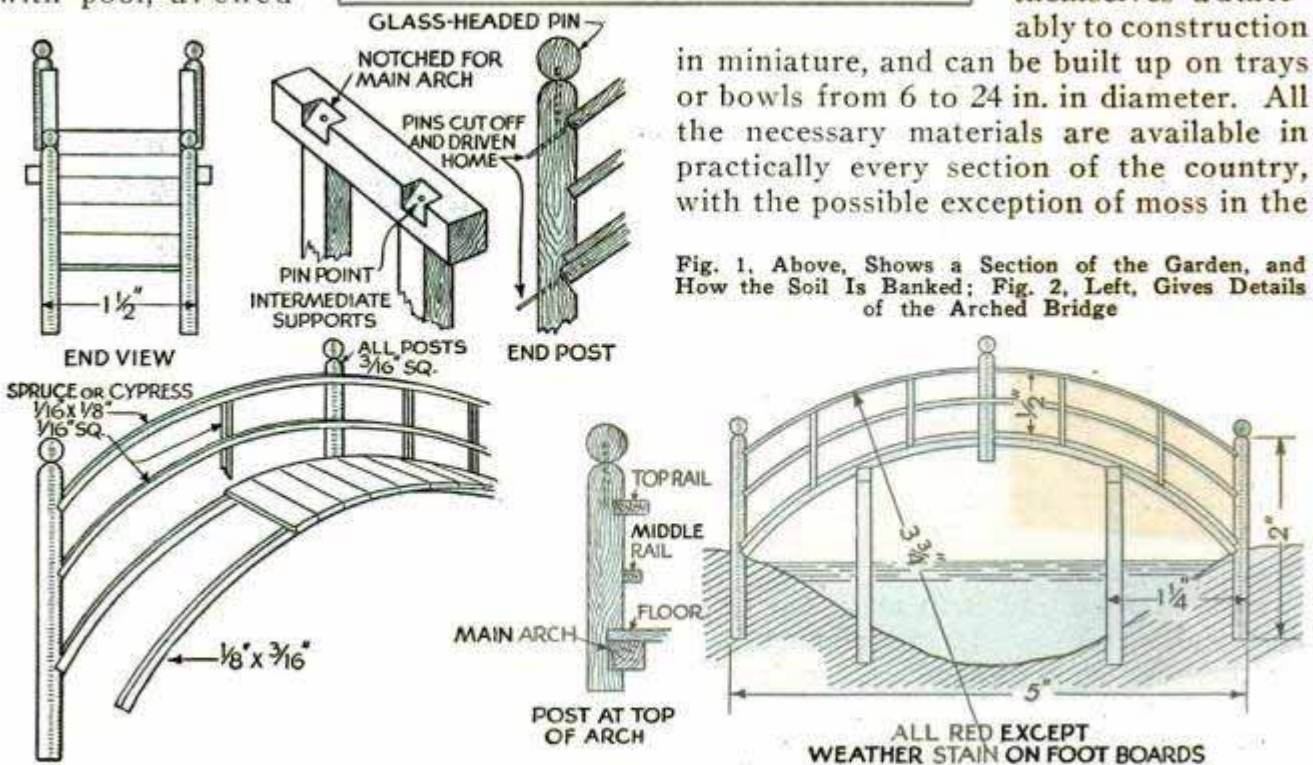



# JAPANESE GARDEN

by Bob Hartley

southwestern states, and model-airplane cement in rural communities. However, the latter can be purchased by mail from model-supply houses. It is excellent for the purpose, as it is waterproof, and will not loosen from the moisture of the garden as glue might. Besides, it takes the place of pins or nails in very thin wood, and has a grip like a snapping turtle.

To start with your garden, first select the size of base you wish. A 20-in. diameter is good for a table centerpiece and offers ample space for the many features of the "landscape." Japanned serving trays can be bought for about 60 cents and are entirely satisfactory, although a vitrified bird bath is more ornamental. The original shown in the photos was built up on one which cost \$3. It is of a lettuce-green tint and is exceptionally attractive.

Sift a thin layer of rich garden soil over the bottom, bank it up around

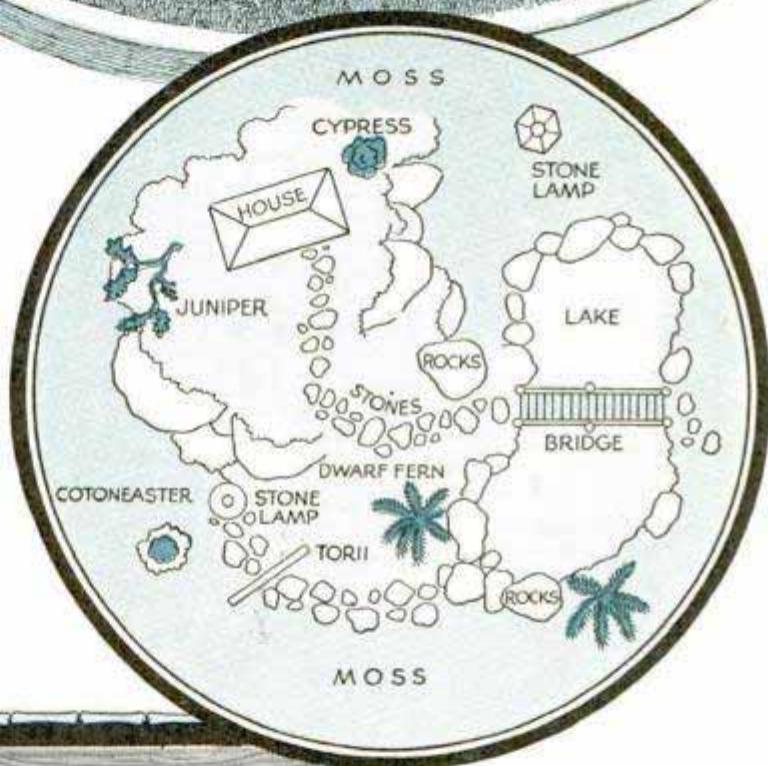
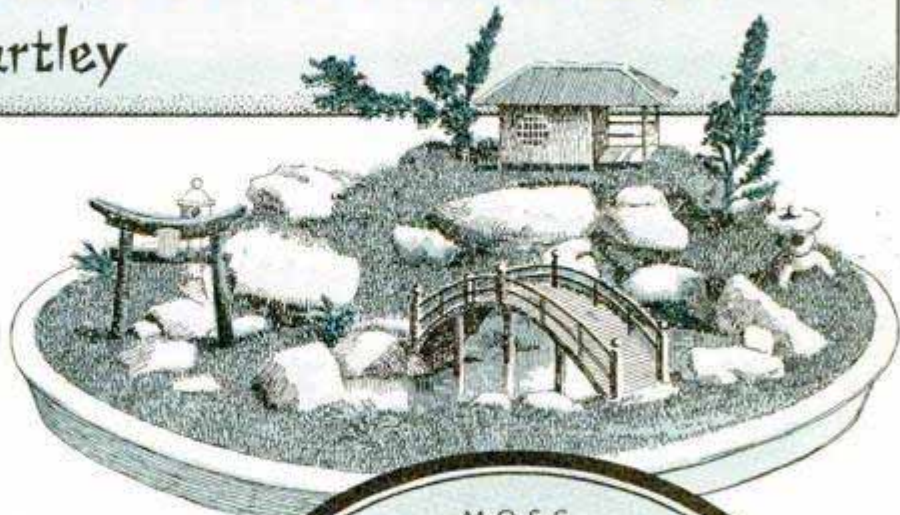

the site for the lake and fill around this, to the level of the rim, with a mixture of soil and leaf mold, or pulverized peat, as in Fig. 1. Any other potting soil suited to shrubs will be satisfactory.

Fig. 3. Above, Plan of Layout: Left, Form for Bending Bridge Stringers; Below, Laying Bridge Boardwalk

It is necessary to build the arched bridge, Fig. 2, before completing the lake, since the former must be set in the cement bottom. This bridge, typical of Japan, is really the keynote of the entire garden, and you must gear your mind to working on a very small scale, for oversize timbers will give it a

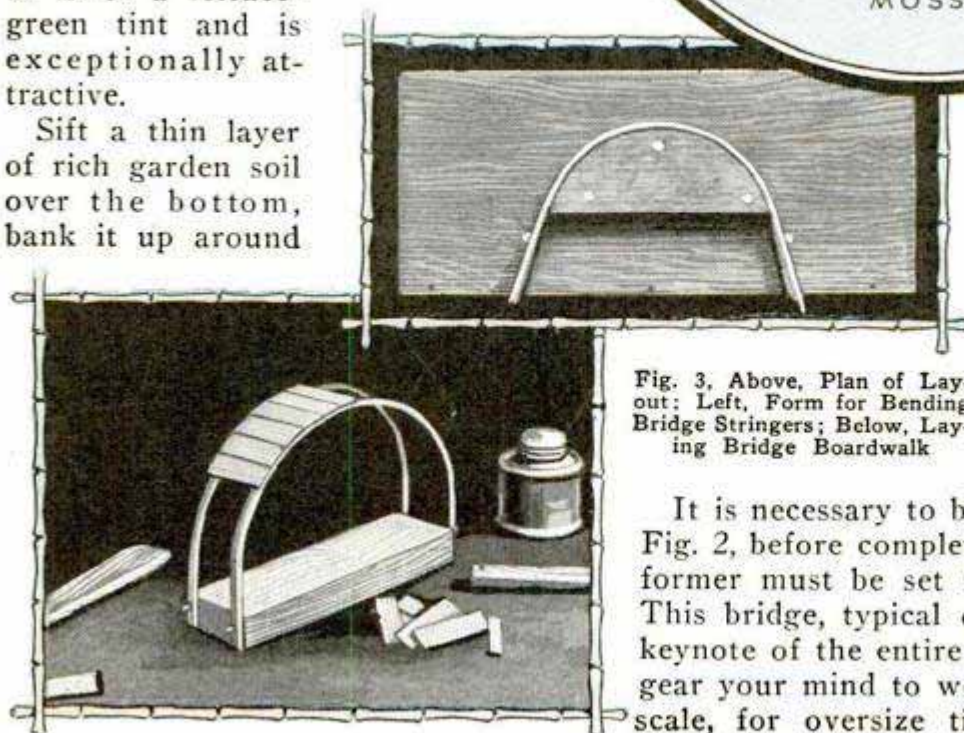



clumsy appearance. Spruce or cypress will do for the curved pieces. Soak the straight sticks in water for an hour and then bend them over a form, as shown in one of the photos, to dry thoroughly in the sun. When they have set to shape, tack the two main arches to a block of wood, about 6 in. long, with small brads, and put on the footboards. These can be cut from berry boxes or other thin wood. Apply cement liberally on the underside, but keep the top sides of the boards clean, as these are to be stained a weathered tone. You will note that the bridge is 5 in. long at the base of the arch, so carry the footboards down to these points. When the cement has set—half an hour is sufficient time—saw off the ends of the arches with a fine-tooth hacksaw.

Install the four end posts next. These are made of  $\frac{3}{16}$ -in. square white pine, notched as shown, to receive the ends of the curved pieces, and rounded on the top end. Large glass-headed pins, with most of the points cut off, are pushed into the tops of all the posts. Save the pin points and use them to secure the posts to the ends of the main arches and top rails, and reinforce the joints with cement. Install the short

sembling the rails and intermediate posts. Cement the pair of timber supports under the arch, and bridge is complete. Give the entire job two coats of brushing lacquer in a Chinese red, with the exception of the footboards, which are to have a weathered tone. Oil stain should be used for these.

Now you can go ahead with the lake bed. A pint can full of portland or waterproof cement will be enough for the job. You can get this small quantity from some contractor who has

a construction job in the neighborhood. In a bucket or large pan, mix about three parts sifted, dry sand with one part of the cement. Mix them dry, and then add enough water to make it about the consistency of the mud pies of your childhood. With a small trowel, spread it around in the lake depression to a depth of  $\frac{1}{2}$  or  $\frac{3}{4}$  in., and bank it up around the sides. Have a quantity of clean, small stones of odd shapes and

sizes on hand to set in the cement at the edges, and press the cement up into all crevices with the fingers. See that the lake level will be high enough and then push the bridge supports down into the concrete. Cement, by the way, should be kept fairly moist while hardening. Don't set it

out in the hot sun. Half an hour after it has been laid, spread cloths over it and sprinkle a little water over them from time to time, just enough to keep them damp.

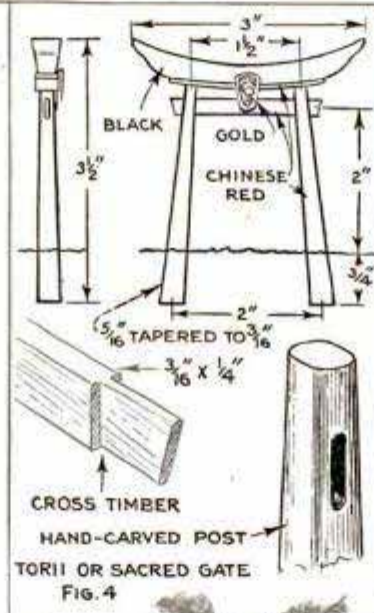

Completed Bridge, View of Lagoon with Bridge in Place, Details of Torii, and View of Finished Garden

posts at the top of the arch before putting on the top and middle rail. It may be necessary to lay the bridge on its side on a board, with large nails against the end posts, to keep it in shape while as-



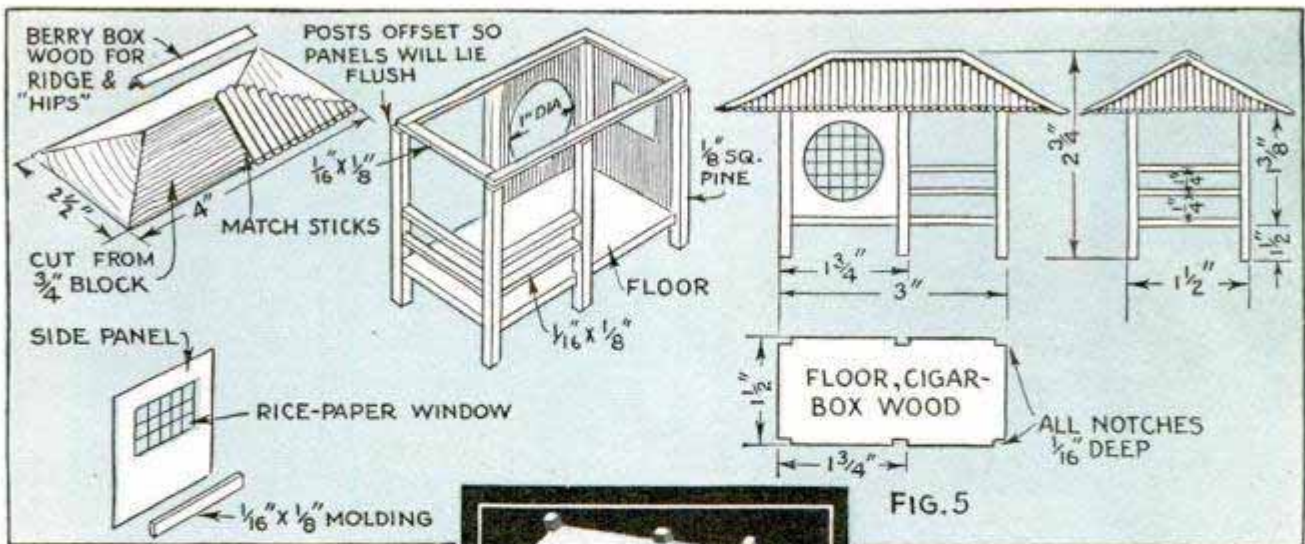

Complete the soil arrangement, something after the layout shown in the plan, Fig. 3. Keep the soil moist and well packed down. Here and there between the rocks, imbed tiny rock plants. There is a seemingly endless variety of these, and if your local nurseryman cannot supply them, he will advise where to send for some. Many of them have very small leaves and are particularly suitable for this type of garden.

Build up the rock work and soil to a little eminence, about 5 or 6 in. high, where the summer house is to be set. A dwarf pine, with its twisted branches, is almost indispensable to this type of garden, and if you are unable to procure the genuine Japanese variety, or what is commonly known as a prostrate juniper, a cypress seedling can be trained into an odd shape by twisting a stiff wire around it and bending it to the desired

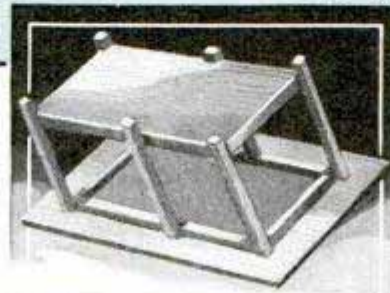

position. In a few weeks, it will retain the shape and the wire can be removed. Dwarf ferns are very attractive along the edge of

the lake, and one especially suitable is the polystichum angulare. As the garden should be kept inside, or at least in the shade, common forest moss is satisfactory for "sod," and on the Pacific coast

helixine and arenaria are available for this purpose. If you have no other choice, any small-leaved shrub seedlings such as Cotoneaster thymifolia can be used for trees, and kept down to proper proportions by occasional pruning. A very tiny water plant, called duckweed, and another slightly larger, known as salvinia, are very attractive in the lake. The water should be changed several times at first to remove all cement and other solubles.

Construction of the torii, or so-called sacred

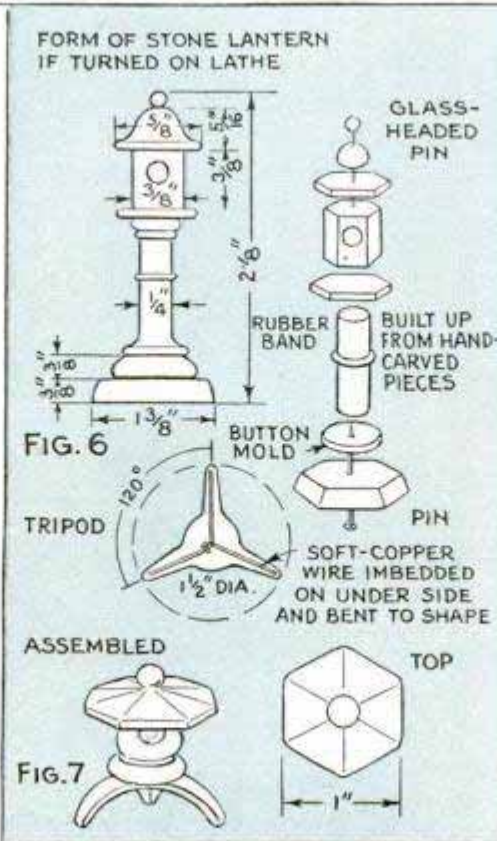
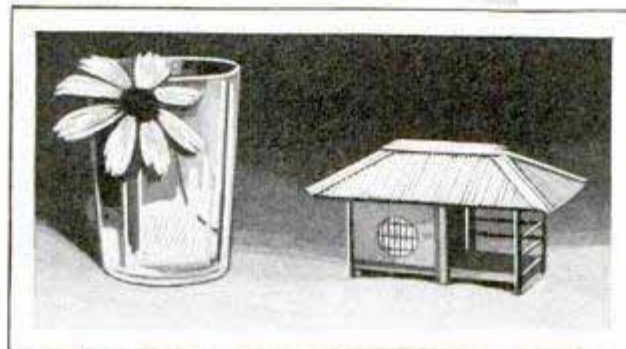

FIG. 6

FIG. 7



arch, Fig. 4, is extremely simple, consisting of two hand-carved uprights (to



View of the Garden Taken from the Rear of the Summer House; Note the "Stone" Lantern at the Left

imitate hand-hewn logs) with a mortised cross timber, and two curved pieces above it. A small plaque or shield is cemented at the center of the cross timbers. Paint the entire job Chinese red, with the curved top piece black, and gold or bronze on the shield. If you know how to apply such delicate material, gold leaf is very effective on the shield, shellacked over and having some Japanese character painted in black waterproof ink. Press the arch in the soil at about the location indicated in the plan drawing.

The little summer house, shown in Fig. 5, is a very important feature, and is quite easily built of  $\frac{1}{8}$ -in. square white-pine posts,  $\frac{1}{16}$  by  $\frac{1}{8}$ -in. plates and porch rails, and a roof whittled or planed from a piece of  $\frac{3}{4}$ -in. white pine. Siding is made of berry-box wood, cut with a safety-razor blade and cemented in place. Japanese rice paper is used for the windows, or "shojii." Mark out the little squares in black waterproof ink with a ruling pen, and cement the paper on the insides of the window openings before installing the panels. The paper should be treated with model-airplane dope to render them tight as well as waterproof.

A thatched roof is very difficult to make, and a much more effective job is achieved with match sticks or small applicator sticks, cemented in place, with strips of berry boxes placed over the ridge and hips. Give the entire house an application of oil stain in a light-brown or weathered tone. You will note that the floor is made from a clean cigar-box lid.

For a true Japanese effect, the floor should be shellacked or waxed to a fine polish. And remove your shoes before you enter!

The tall lamp, Fig. 6, is built up of small pieces of white pine, and the more rotund design of clay. The former can be turned on a lathe and the hexagonal portions whittled with a jackknife. Pins and airplane cement are used on the wooden models.

The clay lamp, Fig. 7, requires a little more skill and care. For the tripod or base, roll or spread the clay on a dry board to about  $\frac{1}{8}$ -in. thickness and with a moist knife cut the legs to shape. Then press small copper wires into each leg, on the underside, and bend them to the required shape. Allow them to set half an hour or so before putting on the weight of the other pieces. Push a pin up through the bottom to hold the lamp together. Don't let the clay dry too fast, and while it is still moderately soft, give it a coat of shellac and immediately dust it with a mixture of very fine dry sand and portland cement. The sand should be sifted through a tea strainer, as well as the cement. Treat the wood model the same way. Enough sand and cement adheres to give the lamps a very convincing old-stone effect.

As a miniature garden of this size is rather heavy to move around frequently, it should have a permanent stand of its own, preferably near a window where it will get a little sunlight at some time during the day. Keep the moss and plants well watered, but do not sprinkle directly on any of the little structures.

The original proved so attractive that I have accorded it a place of honor in our dining room, and have even added two tiny live minnows to the life of the pool.

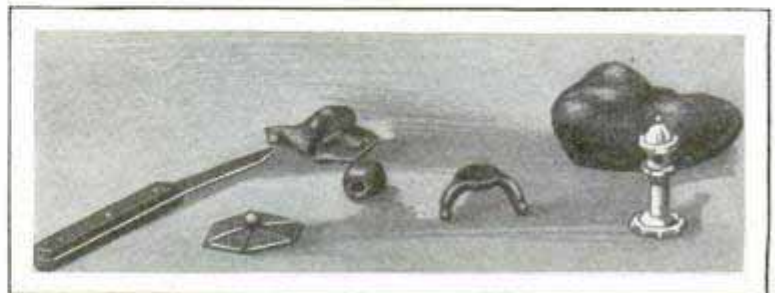

The Lanterns, Showing the Clay Parts for the Smaller One Before Assembling, and the Taller Lantern at the Right



### Cleaning Generator Commutator

Frequently auto generators stop charging owing to oil and dirt on the commutator. In such cases a rag, moistened with a cleaning fluid that is not inflammable, can be used to clean off the oil and dirt. It is highly important that a non-inflammable cleaning fluid be used for the purpose so that a spark from one of the brushes will not set it afire.—E. T. Gunderson, Jr., Humboldt, Iowa.

### Removing Water Marks from Polished Table Tops

It is not necessary to refinish a whole table top just because it is marred with a water mark. Place a small quantity of olive oil in a pan and shave off a little white wax into the oil. Apply a small amount to the spot and rub well. Use any old linen rag but rub in one direction only, as rubbing in a circle will injure the polished surface.

### How to Strop Razor at an Angle

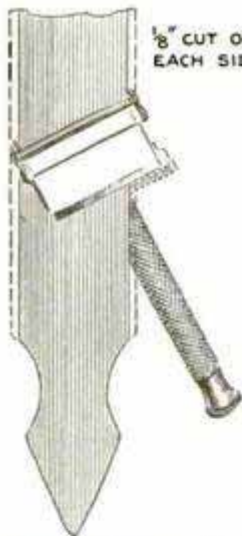

While the blades of the self-stropping type of safety razor may be used over and over, it is seldom possible to give them the keen edge of a straight-edge razor blade, owing to the fact that it is usually impossible to strop the blade at an angle. This trouble can, however, be overcome by taking a pair of shears and cutting a narrow strip off each

side of the strop, which allows the razor to be held at an angle when stropping, as shown in the drawing.—Floyd A. Meek, Rockbridge, Ill.

### Curtain Rods for Screen-Door Guard

Children are likely to push and kick against the screen door without thinking of the consequences. To prevent a broken screen, get three or four small curtain rods from the 5 and 10-cent store, and attach them across the door at the proper height.

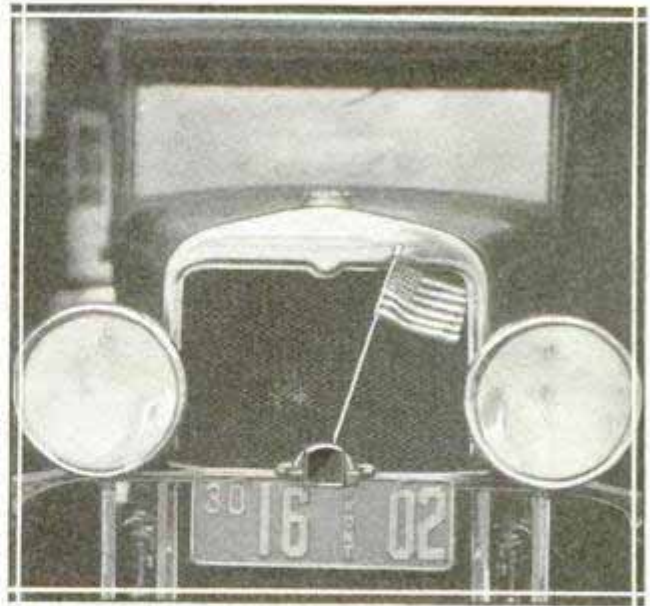

Old Windshield Wiper of the Suction Type Makes Automatic Flag Waver

### Automatic Flag Waver for the Auto

An old windshield wiper of the suction-operated type makes an excellent flag waver for holidays. It can be mounted in almost any position where the flag will be conspicuous, although the cross brace between the lamps has been found especially suitable. It is not advisable to mount it on the radiator cap, as it is likely to work loose. Substitute a rattan stick, about 18 in. long, for the wire holding the wiper.

### Battery Box for Storing Paintbrushes

For cleaning and storing paintbrushes, a rubber battery box, having compartments as shown in the drawing, will be found highly convenient. Fill one of the compartments with gasoline for cleaning purposes. The

ridges on the bottom assist in cleaning the brush if the bristles are rubbed back and forth over them. After a brush has been cleaned thoroughly, rinse it in the second

section, also containing gasoline, and then place it in another containing linseed oil.

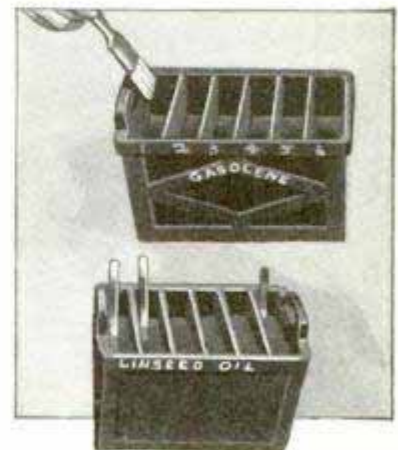



*Distance from center of  
Keel slot to outside line of chine*

*31 inches*

# "ROAMER"-A Outboard

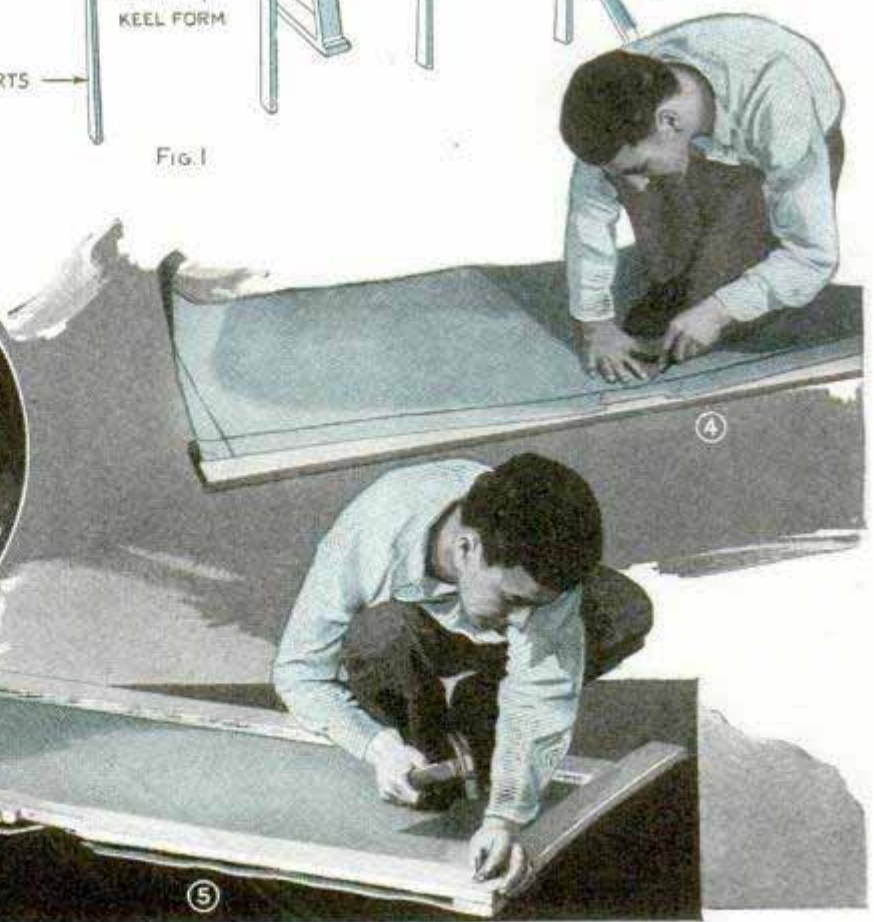
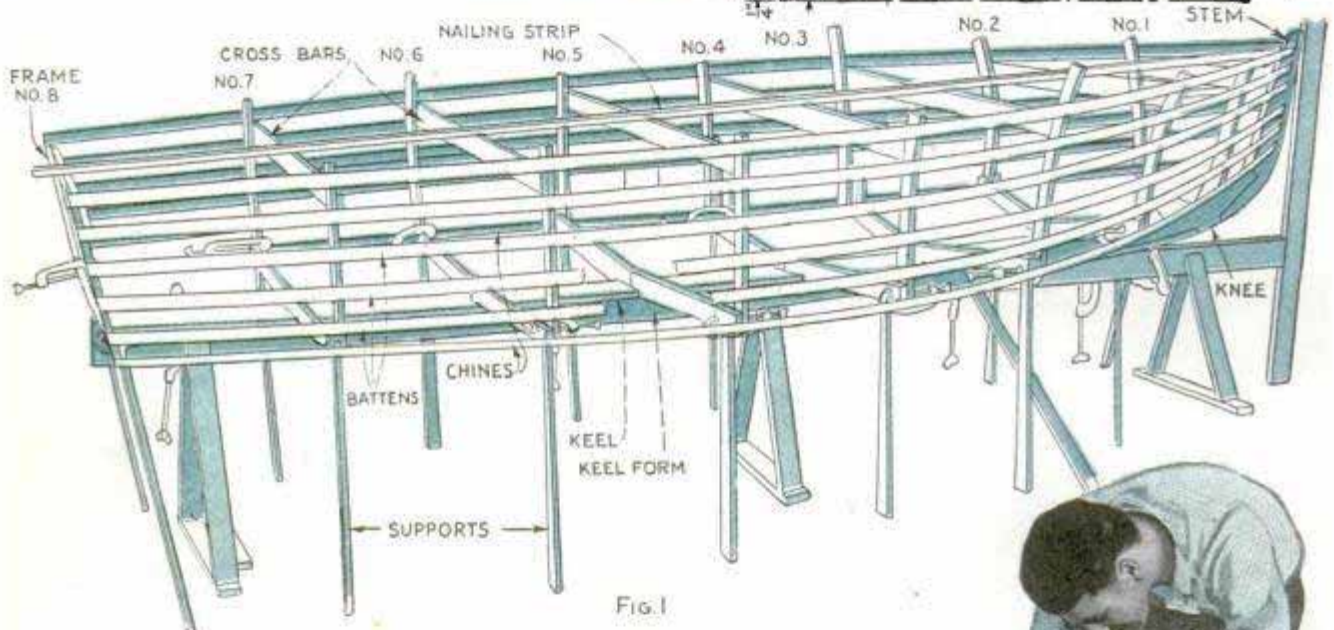
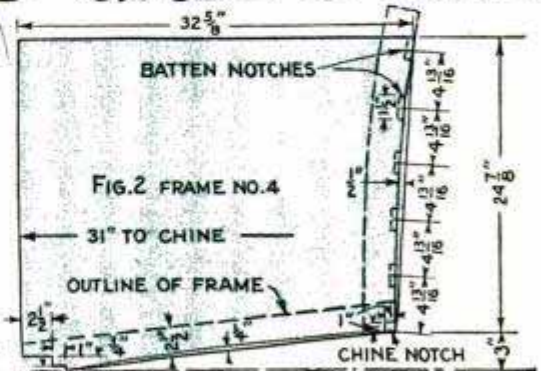







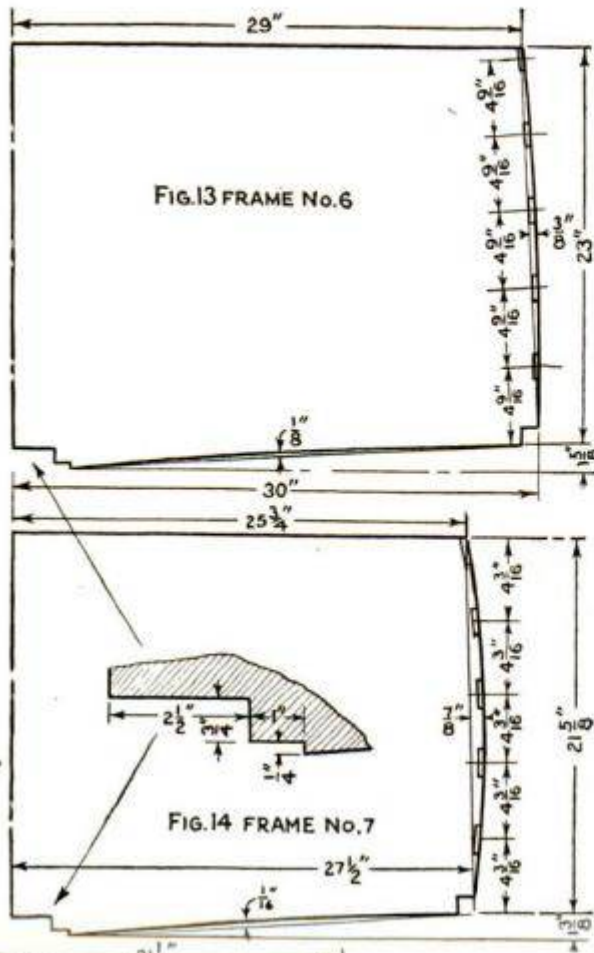

2 1/2 in. apart, and, keeping the steel point over the edge of the paper pattern, run in a line with the marking end, as shown in Fig. 3. The section of paper between this line and the outer edge of the paper is an actual outline of frame No. 4.

All frames are to be cut from 3/4-in. material. White oak is an excellent wood to use, but red elm is really the best frame lumber for a boat of this size, as it is considerably lighter than oak. Almost any durable wood will serve. Slip a 6-in. width of the wood selected under the paper pattern, and pencil off the long V-section. A pencil can be used only around the outside of the paper. In making the inside line, use a toothed wheel, as shown in Fig. 4. By running this firmly over the line, the sharp teeth will pierce the paper and leave a perfect impression.

The next job is to cut the V-section out, and then to outline and cut the two shorter pieces which form the sides of the frame. In cutting these, allow about 2 in. more wood at the top than the paper pattern shows.

Mark the positions of the chine and batten notches, as indicated in Fig. 2.

The three pieces, when cut, are placed just where they belong over the paper pattern, and lightly fastened together with nails, as in Fig. 5. In ad-

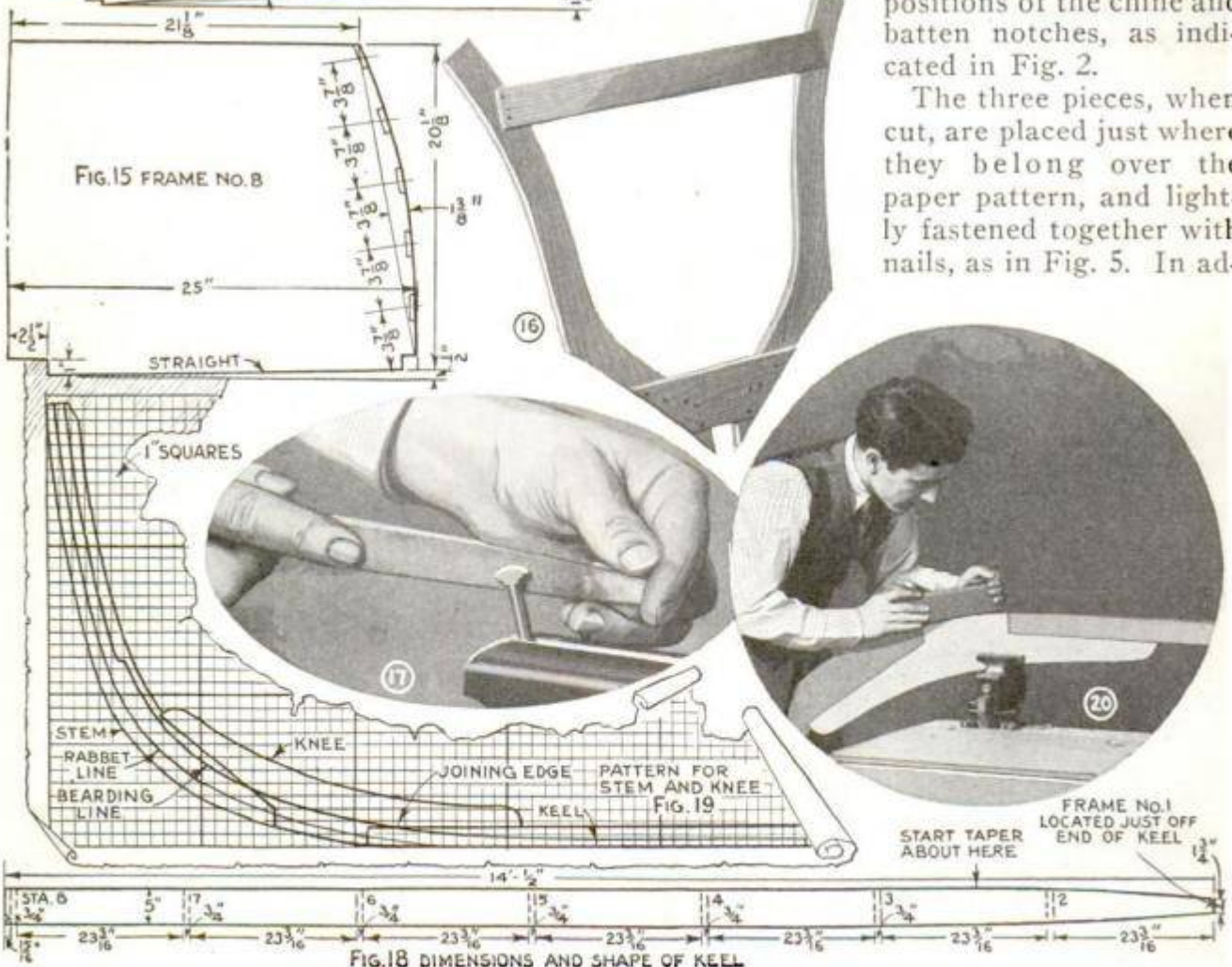

FIG. 18 DIMENSIONS AND SHAPE OF KEEL



dition to the three pieces which make the frame, nail a temporary crossbar from side to side, parallel to and 1 in. below the top of the paper pattern. Mark this piece with a centerline. When the frame is trued up to your satisfaction, the two short pieces are fastened to the V-section with copper rivets, three to each joint, as in Fig. 6. Notice that the rivets are placed outside the chine-notch markings. Coat the joining edges of the wood with heavy paint before fastening. This rule applies throughout the construction—no bare wood in the joints.

Frames 1 to 8, Figs 7 to 15, are drawn on paper, cut, and fastened in a similar manner. Frame 8 varies from the others in that the joints are half-lapped, as in Fig. 11. Frame 1 is different in that it is made from two sidepieces only, fastened together with a short crossbrace, as in Fig. 16.

Now for the keel. Fig. 18 gives the dimensions. The rear end of this piece is straight, so, by using a plank of the proper width, it is only necessary to taper the forward end. Use white oak, 1 3/4 in. thick. Do not forget to mark the places where the frames will be stationed, indicated in the diagram.

Both stem and knee are cut from pieces of 1 3/4-in. white oak. The shapes of these two pieces and the manner in which they fit together are shown in Fig. 19. No dimensions are given, but each square in the diagram represents 1 in. This means another drawing on the building paper, making each square the full 1 in. and then drawing the shapes of the stem and knee accordingly. Also, mark the position of the rabbet line and the bearding line. Transfer the drawing to the wood, and cut out the two pieces.

Next, bolt stem, knee and keel

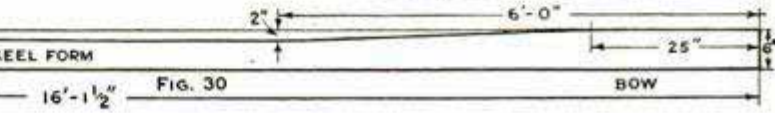
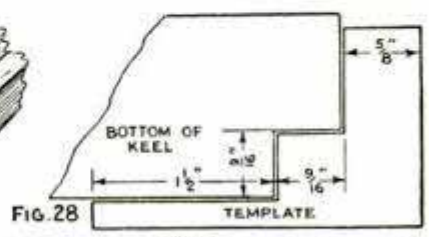
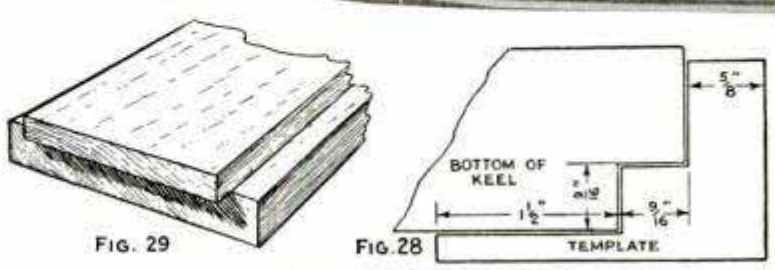
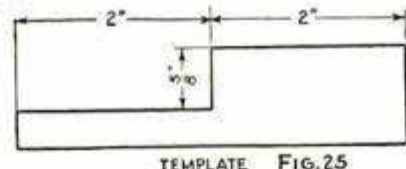
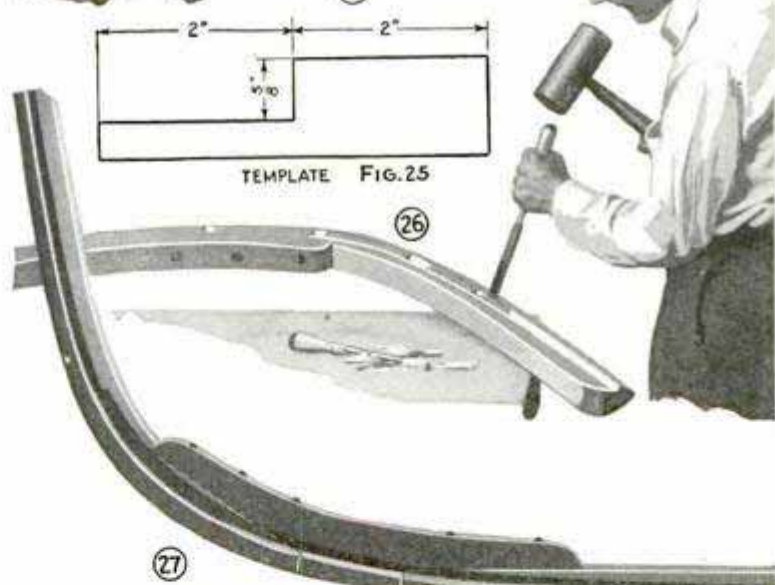
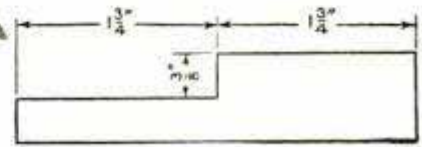
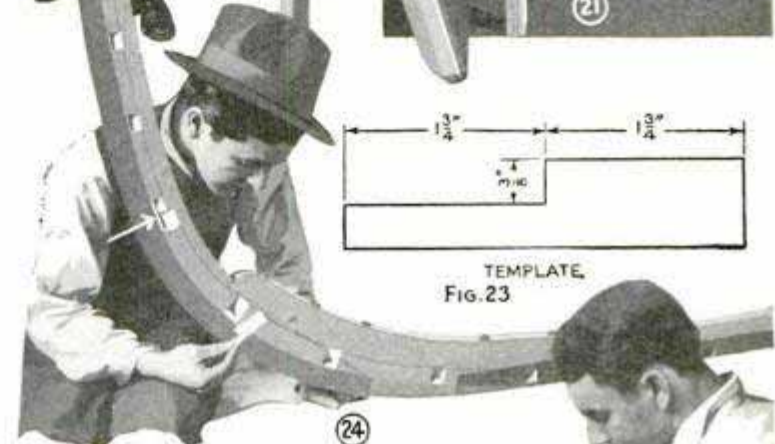
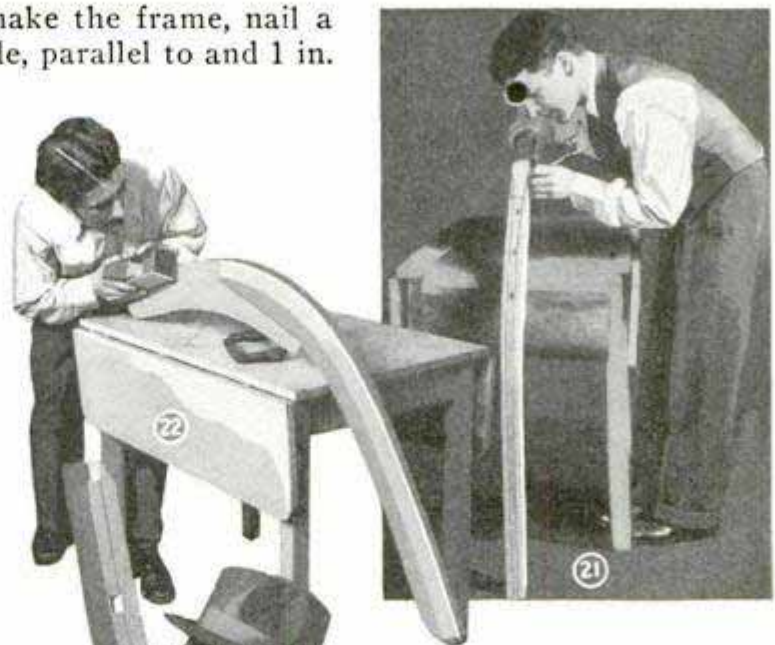



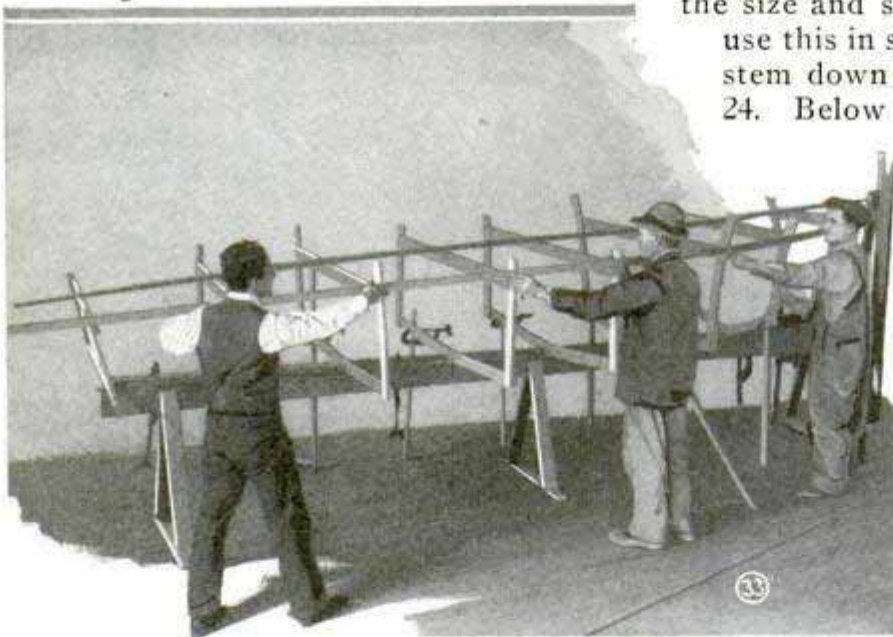
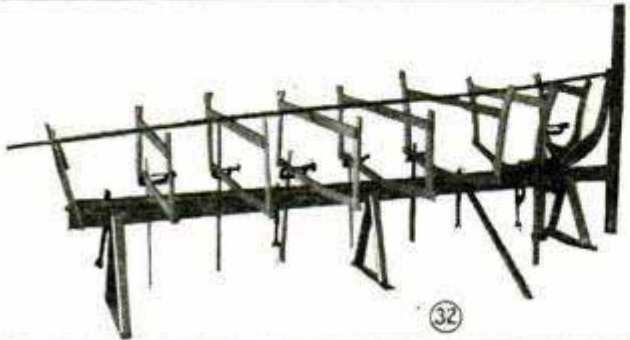
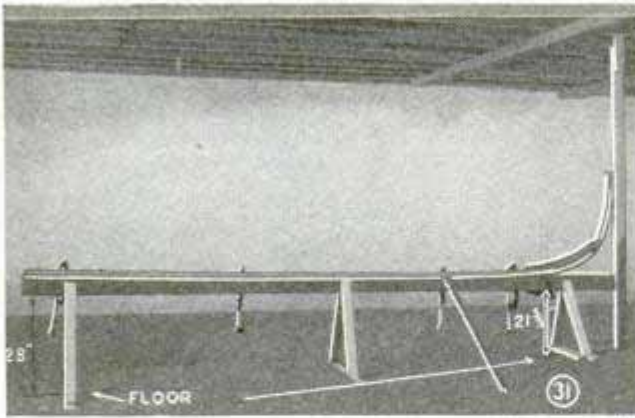

together. Five  $\frac{1}{4}$ -in. galvanized or brass carriage bolts are used for this purpose, and their placing can be readily determined from Fig. 12. The heads of bolts, A, B and C are filed flat, as in Fig. 17, so that they will not interfere with the later shaping of the stem. All bolts must be countersunk neatly. After bolting, you will find that the keel projects a trifle beyond the knee. Round off this projection to a gradual sweep, as in Fig. 20.



The rabbet comes next. This is a long, running notch in the stem and keel, so cut as to permit the planking to fit into place. You already have a rabbet line and a bearding line marked on one side of the sawed-out stem, these marks taken from Fig. 19. These lines should be duplicated on the other side. Draw a centerline down the front of the stem, and continue this mark along the full length of the keel on the underside. Two other lines, parallel to this centerline and at a distance of  $\frac{3}{16}$  in. on either side of it, must be drawn as shown in Fig. 21. Notice that these lines gradually widen at the bottom to merge into the keel.

Use a plane to bevel away both forward corners of the stem from the rabbet line on either side to the off-center line on the same side, as shown in Fig. 22. Cut a template from thin wood or cardboard of the size and shape shown in Fig. 23, and use this in shaping the rabbet along the stem down to the arrow mark in Fig. 24. Below the arrow mark, the rabbet

is cut  $\frac{5}{8}$  in. deep instead of  $\frac{3}{8}$  in., in order to take in the heavier, double planking which is to go on the bottom of the boat, and another template, of the size shown in Fig. 25, should be cut for this. The manner of using these templates is shown in Fig. 24, small sections being cut out to the templates every 6 in. or so, and the intervening wood then cut away as in Fig. 26.

Cutting the rabbet along the stem and knee is no picnic. Unless you





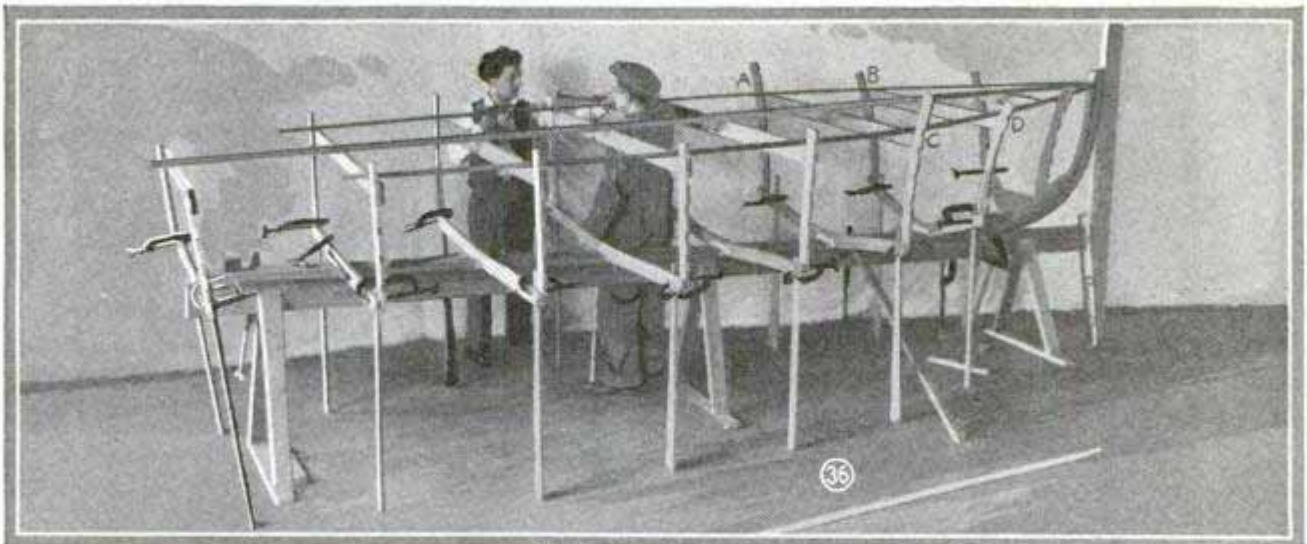

are skilled at this business, it is best to leave a little extra wood to work on instead of at once cutting the rabbet to the full depth. Fig. 27 shows the stem, knee, and forward part of the keel fully rabbeted. The rabbet along the rear of the keel is almost a square cut—use the template shown in Fig. 28, and then trim the line to shape after the frames are set in place. The cutting-away process also continues around the rear, the wood being cut as pictured in Fig. 29.

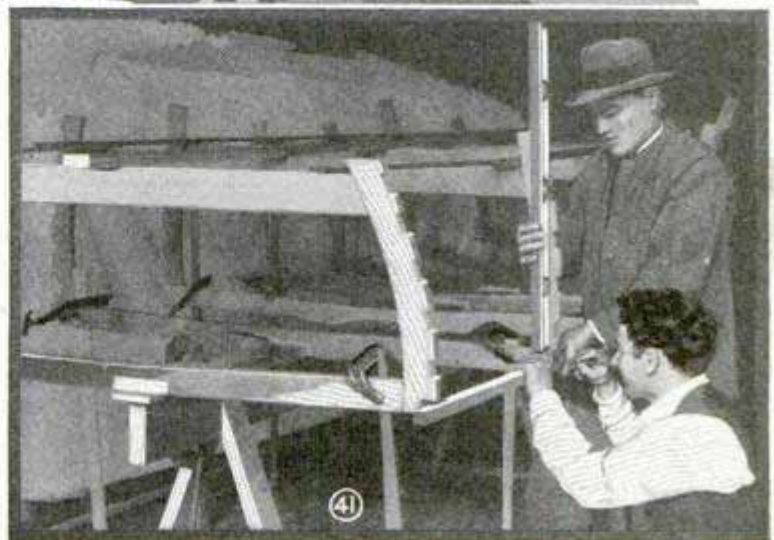

Commence assembling by cutting a plank of the shape shown in Fig. 30. This plank is the "bench" upon which the boat is built. It is supported at the distances from the floor shown in Fig. 31. This picture also shows how the keel and stem assembly is placed upon this curved plank and held in position with clamps. The upright timber against the stem should be plumbed true, and anchored to a rafter. The top of the stem should be toenailed to this timber. The sawhorses should be nailed down.

The best way to fit the frames calls for a preliminary assembly and truing-up of the frames, then a removal of the frames for beveling and notch-cutting, and the final assembling.

The frames are set in position and lightly toe-nailed to the keel. Now, look at Fig. 32. The long



strip of wood across the tops of the frames is first toe-nailed to the stem, so that the edge of the wood lines up with the stem centerline. The centerline on each frame crosspiece is then lined up with the edge of the strip and nailed. Before nailing, make certain that the distance between frames at the top is the same as at the bottom— $23\frac{3}{16}$  in. Test by using a plumb bob on each frame. No. 8 frame is not plumb, but is set  $2\frac{1}{2}$  in. out of plumb, as can be seen in the picture.

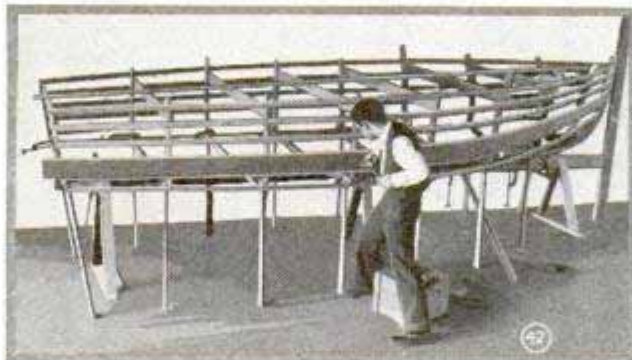

Each frame is then leveled horizontally, and light pieces of wood from the corners of the frames to the floor, as in Fig. 32, are used to maintain this balance. These two leveling processes do not completely true up the frames, but they are sufficient to enable you to do fairly accurate frame beveling. For this, take a long strip of thin wood and spring it across the frames from end to end, as in Fig. 33. The curve of this stick is the curve which the planking will take. Notice, however, that the stick does not run flat across the frames; it rides only on the forward edge of the forward frames, and the rear edge of the after frames. The remedy consists in marking the proper amount of bevel on each frame at various levels; then removing the frames, one by one, for the beveling. Fig. 34 shows the bevel being cut on frame 3. Once the sides and bottoms of all frames are correctly beveled, the chine and batten notches can be cut out. The bottoms of these notches must be cut on the same angle as the frame in which each one is cut.

Now the final assembling can be done. Two No. 10 galvanized or brass screws of suitable length are used to attach each frame to the keel, as shown in Fig. 35. Both the leveling-up processes described before are checked over carefully and the frames readjusted if necessary. A third truing-up step calls for two light pieces of wood nailed to the crosspieces immediately inside each frame, as shown in Fig. 36. These are not fastened until the distances between frames are equalized.

For example, the distance AB, Fig. 36, should be the same as the distance CD, etc.

That completes the set-up. Since much depends on this part of the building, check the whole thing over again to make certain that you are absolutely correct. This applies especially to the horizontal balance, controlled by the wood pieces which extend from the frame corners to the floor. Use a level or plumb in testing these again, as in Fig. 37, tapping down one stick or the other until perfect horizontal balance results. You will notice that quite a number of clamps have been used on these sticks. They can be nailed equally well, and then adjusted by thin pieces of wood slipped under them.

The 1 by 1-in. white-oak chine pieces are fastened into place with 2-in. No. 10 flat-headed brass screws, one to each frame, as shown in Fig. 38. Drill holes for these screws, and countersink so that the screw heads will be flush or slightly below the wood surface. The front end of the chine is notched to fit onto the stem immediately behind the rabbet, Fig. 39, and fastened with a galvanized nail from the top and a brass screw from the side, as in Fig. 40. It is advisable to fit this joint first, and then work along the frames. No exact mark where the chine should meet the stem can be given—merely line it up, with clamps, in the frame notches and let the natural sweep determine its position. Before fastening each frame to the chine, be certain about the "uprightness" of each frame, testing with a level or plumb bob in the manner shown in Fig. 41.

The battens, which are long slips of  $\frac{5}{16}$  by  $1\frac{1}{2}$  in. spruce, are merely slipped into their proper notches and fastened at each frame with a single  $1\frac{1}{4}$ -in. No. 6 brass screw. Each batten is centerlined before being fastened into place, and the screw inserted on this line. The forward ends are beveled to lie snug against the stem immediately behind the rabbet.



Figure 42 shows what you will be doing next month—putting on the planking. This is  $\frac{3}{8}$ -in. thick mahogany, white cedar or white pine. You will need 22 pieces, 6 in. wide and 17 or 18 feet long, so have it on the job, all set for next month's installment.

### Packing Box and Electric Lamp Make Drying Cabinet for Baby's Clothes

For drying the baby's clothes when the weather does not permit hanging them outside, get a clean packing box of suitable size and fit an electric light in the inside. A wire shelf is hung directly over the light, the heat of which soon dries out the clothes laid on the shelf.—Miss Durfe Rockwell, Hollywood, Calif.

### Wrench for Removing Rims of Auto Headlamps

When you find it difficult to remove your auto headlamp rims, try the home-made wrench shown in the drawing. It consists of a length of leather belting with both ends bolted to a hardwood handle of the shape shown. The loop of the belting must be large enough to be slipped over the rim, and the handle is brought back to the position indicated so that considerable leverage can be exerted. You will find that this wrench saves much time and trouble.—Chas. H. Willey, West Concord, N. H.

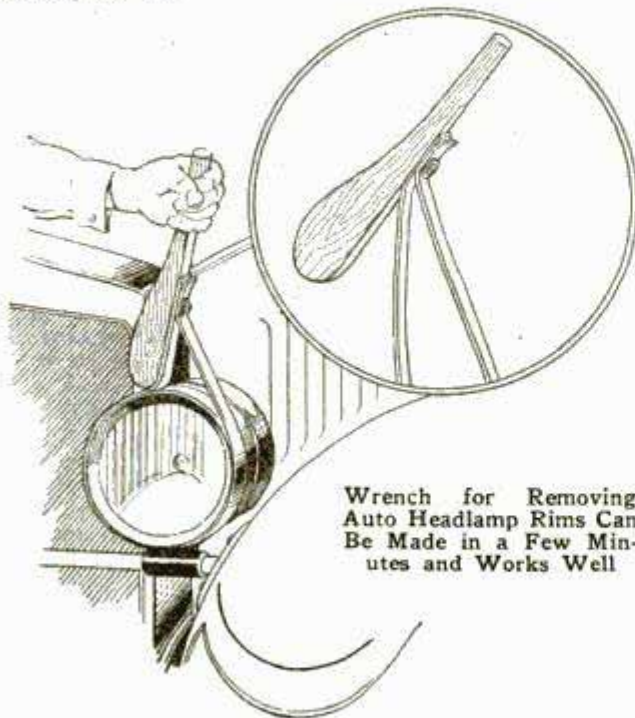

Wrench for Removing Auto Headlamp Rims Can Be Made in a Few Minutes and Works Well

### Auto Toolbox under Driver's Seat

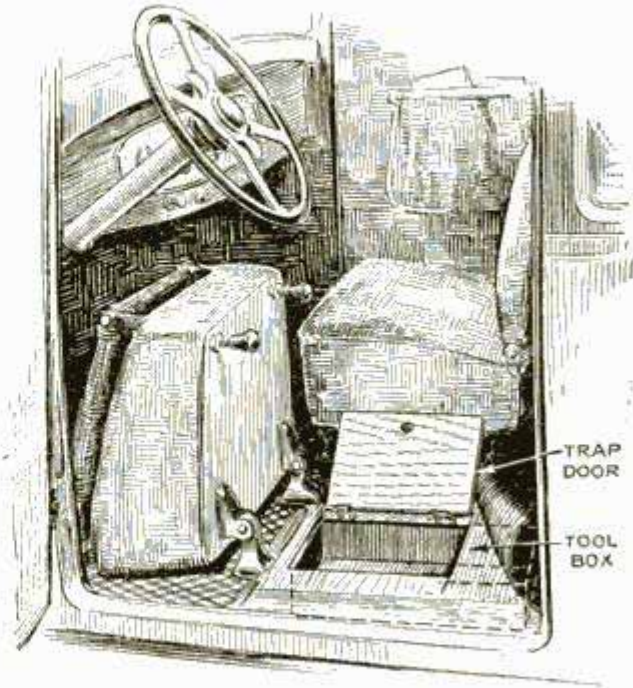

Handy Toolbox under Driver's Seat Eliminates Inconvenience to Other Occupants

Getting at the toolbox under the rear seat of a car is usually rather inconvenient in the case of two-door sedans, especially if the occupants must get out. As the driver is the one who must get out when repairs and adjustments are made, he can avoid unnecessary bother by having a toolbox arranged under the floorboards, directly under his seat, which swings forward as shown. A square hole is cut in the floor and a hinged trapdoor, fitting flush, is provided. A strong, wooden box, a trifle larger than the hole, is attached to the underside of the floorboard by means of small angle brackets. Of course, the available space underneath the floorboards should be measured and a box of suitable size obtained, before the hole is cut.

### Checking the Work of Ants

To keep ants off the dining table, it is not necessary to place the table legs in cups of water. The following method will be found to be much better: Dip some string in kerosene and wind it around the feet, tying it securely. This will prevent the ants from passing.—L. H. Georger, Buffalo, N. Y.

Gasoline feed pipes should not be allowed to vibrate; tie them with rawhide thongs.



## RUBBER-BAND GUNS FOR THE BOY'S ARSENAL

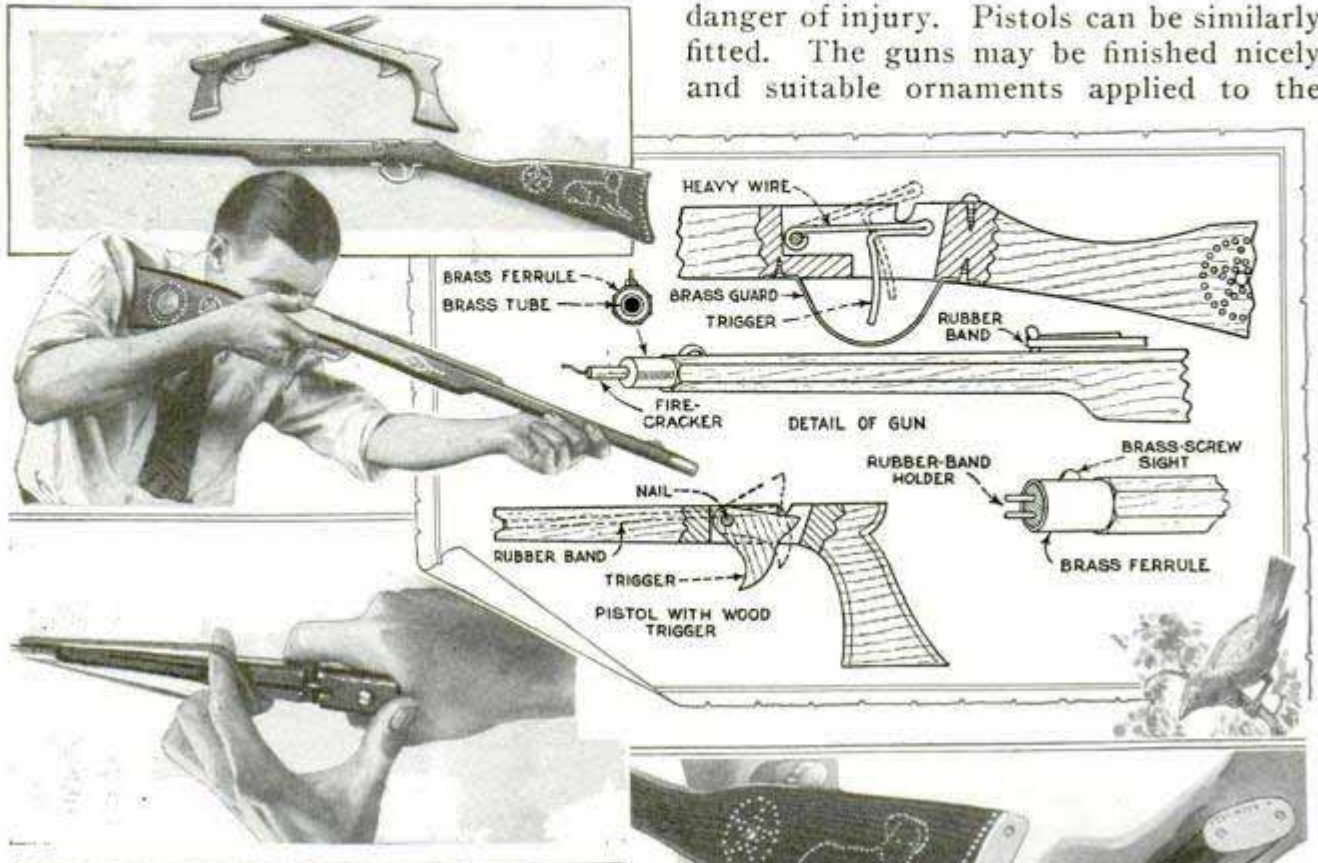

Rubber-Band Guns That Resemble Real Weapons Are Harmless to Use and Greatly Appreciated by the Youngsters; They Are Easily Made of Simple Material Available Anywhere

Although rubber-band guns and pistols are in themselves rather common, they can be greatly refined and made to resemble real guns, as indicated in the drawing. One end of the rubber bands, which are  $\frac{1}{4}$ -in. strips of inner tube cut crosswise, is slipped between two pins at the muzzle of the pistol, while the other end is brought back and slipped into a notch cut across the gun directly over the trigger. To release the band from the notch it is only necessary to pull the trigger, which is pivoted in a slot. Either heavy wire or thin wood can be used for the trigger. In the case of a rifle, a single pin, driven into the top side of the barrel, halfway between the muzzle and trigger, serves to hold the rubber band. If desired, provision can be made for shooting off firecrackers from the end of the gun. A brass ferrule is first driven on the end of the barrel and a tube of the same material is then driven into the end, a hole being drilled for the purpose. Firecrackers can be inserted in the tube, and, as the barrel is held away from the user, there is practically no

danger of injury. Pistols can be similarly fitted. The guns may be finished nicely and suitable ornaments applied to the

stock. In the examples shown, small brass brads were used to decorate the weapons with a starlike figure and a hunting dog. —Addison Bain, Marion, Ohio.

## Monogram Book Ends

Cut out of 1-in. wood with a bandsaw, the monogram book ends shown in the drawing represent an interesting departure from the usual block type. Both

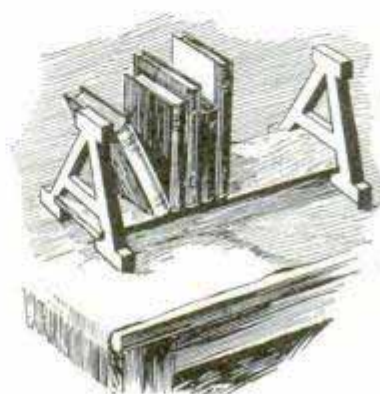

ends are made at the same time, slots being cut to fit over the edge of a horizontal board on which the books are set. The snugness of these slots determines the ri-



gidity of the assembly as the ends are not permanently fastened but are designed to slide along the board to accommodate any number of books. Hardwood is best suited to the purpose.—Herbert Pike, Ames, Iowa.

### Preventing Blotches with French Curve

Often beginners experience difficulty with the use of a French curve in that the ink adheres to its edge when the line is made too close, and when the curve is pulled away, a blotch results. To avoid this trouble, get two ordinary paper clips and slip them over the edge of the curve on each side of the portion where the line is to be drawn. The clips will hold the curve away from the paper so that there will be no possibility of the ink getting on it.—Ralph A. Muth, Catasauqua, Pa.

### Quick Boiling for Campers

Although rather odd in shape, the boiler shown in the drawing has been found highly efficient, and especially useful to campers. A hole is cut in the bottom of an ordinary copper or iron boiler and an inverted can is soldered to the edges of the hole as indicated. The can must be



large enough to give room inside it for a small heater, burning solidified alcohol. A number of rivets are soldered to the bottom to extend underneath, so that air will reach the flame when the boiler is

placed on a flat surface, such as the top of a stove. It has been found that  $\frac{1}{2}$  gal. of water can be brought to the boiling point in a short time with this boiler. All the heat from the flame is caught in the can, which conducts it directly to the liquid. In this way a relatively large heating surface is obtained over a small flame.—James E. Noble, Toronto, Can.

### Delivery Box for the Screened Porch



Delivery Box, Having Doors on Either Side, Prevents Excessive Use of Door

As delivery men do not like to leave parcels on the steps, we seldom closed the door of the screened porch. This made it easy for the dog to get in and out, and the result was that we had many more flies than would be the case if the door could have been kept closed. The trouble was, however, readily overcome by providing a special delivery box as shown in the drawing, to which access is possible from either side.—H. Mercereau Geer, Binghamton, N. Y.

### Tin Can and Air Valve Used for Liquid-Soap Dispenser

It takes only a few minutes to make the liquid-soap dispenser shown in the drawing. Get a tin can and solder a tire valve in the bottom. Then make a bracket to hold the dispenser on the wall. Pressing the core of the valve

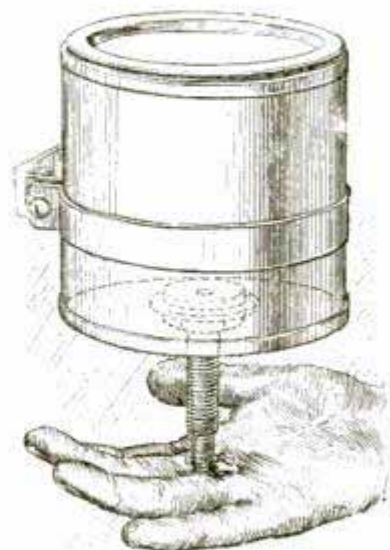

upward causes the soap to flow out.—Hayes J. Wilson, North Platte, Nebr.



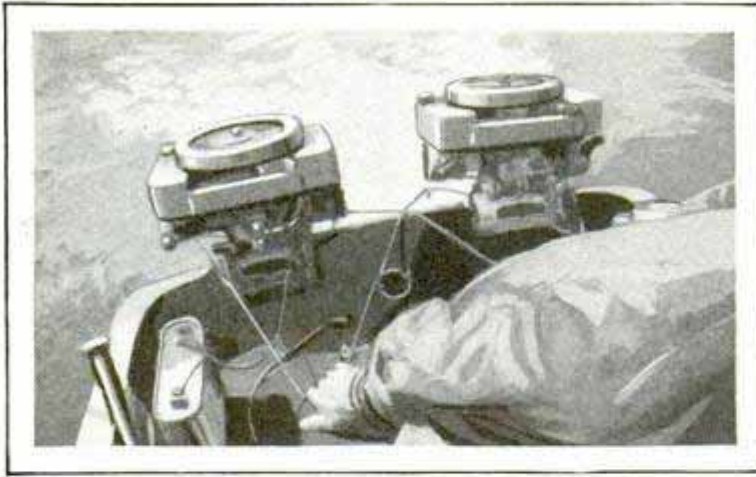

Hooking Up Two Outboard Engines So That They May Be Turned, for Steering, at the Same Time and to the Same Degree

### Steering Two Outboards on Speedboat

A simple rig for steering a speedboat which is run by two outboard engines, is shown in the photo. Two pieces of rope are used; one piece is tied to the left-hand motor steering arms on both motors, and the other to the right-hand arms. A pull on one rope will then swing both motors in the same direction. In the photo the pilot's right hand is seen pulling the right-hand steering arms forward. The loops of the ropes are held so that as the right hand is pulled forward the left is allowed to go back, and vice versa.

### Banana Crate Protects Young Shrub

The efficiency of burlap, heavy paper and other material commonly used to cover young shrubs during the winter months, can be greatly increased by the use of banana crates as shown in the photo. In



accordance with the usual practice, the shrubs are wrapped more or less tightly, but with such a crate, a softer wrapping is made possible so that there is less chance of injuring the shrub.—F. Bentley, Jr., Missouri Valley, Iowa.

### Built-In Telephone Cabinet

Where to place the telephone is a problem frequently encountered. When building a home, this problem can be solved by providing a built-in cabinet between the dining room and the kitchen. A box of proper size is set in the wall before the plastering is done, and a door on each side is provided, using butt hinges that will not show. The door on the dining-room side should be flush with the wall so that a picture can be mounted on it to hide it. On the kitchen side, the box may extend a little, and the wood be painted to match the rest of the woodwork. The telephone is accessible from both rooms.—Edgar C. Hanford, Springfield, Ohio.

### Attractive Rural Mail Box Covered with Stones

Differing from the common type of mail box, the one shown in the photo is quite attractive. A

wooden box with a hinged top is set on a post, and the surfaces of both post and box are covered with metal lath to hold mortar, into which stones are imbedded. The lid is also covered with mortar and stones and is therefore quite heavy. As one might drop the lid,

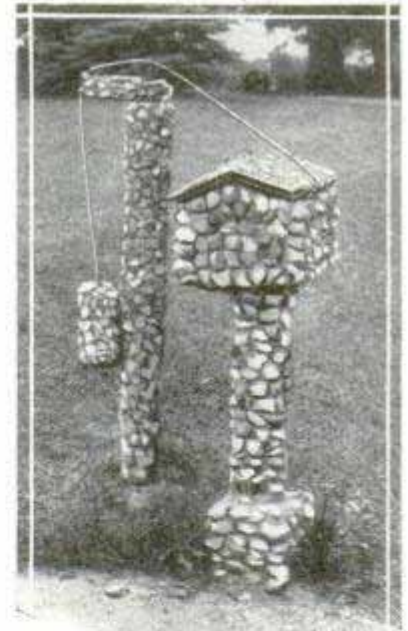

which would cause the mortar to crack in a short time, a suitable counterweight is provided. The wire connecting the lid and counterweight runs over a pulley which is held on a separate post. This post and the counterweight are similarly studded with stones.—H. Rossiter Snyder, Guilford, Conn.





# NOVELTY WEATHER VANES



By DALE R.

VAN HORN

WEATHER vanes are back in style again. Not the regular arrow type, but novelty vanes; weather vanes that tell a story or depict an interesting idea, silhouette fashion. With a little thought, you can work out a vane story that will stand for your hobby, business or favorite sport. All you need to make these vanes is a few cents' worth of sheet iron, some pipe and strap iron, a few rivets and a rod, then a little paint to finish them. A simple and effective vane is the one shown in Fig. 2. This represents a farmer planting seeds. He is in old clothes, big shoes and the familiar broad-brimmed hat. He must be placed at one end of the vane. Too offset this relatively large area, one of much smaller size is needed for the upwind end. A hen garnering the seeds just planted is suitable for this purpose.

First, the pattern for both the hen and the planter is laid out on paper in pencil and spaced to give an over-all length of 30 in. Then the two figures are cut out and laid on a piece of sheet iron of reasonable thickness, 1 in. above the lower edge, and are traced on the metal with a pencil, as shown in

Fig. 1. For the average weather vane, sheet iron a trifle too thick to cut easily with a pair of tin snips should be used, especially when the objects are large.

The best method of cutting the metal is by means of a cold chisel. A piece of railroad track or some other heavy flat bar iron should be used for an anvil, as shown in Fig. 3. Note that a continuous strip of the sheet metal connects the two, and the top edge can be cut in any irregular fashion to resemble plowed

ground. Grass can be shown by cutting thin triangular pieces from the top edge. Waves can best be shown by a series of rather even scallops. To strengthen the silhouette, get two pieces of strap iron, say  $\frac{1}{16}$  in. thick and  $\frac{3}{4}$  in. wide. Rivet the sheet iron between them with the bottom edges of the three pieces in line. A break must occur, as shown, for the upright rod, which is of  $\frac{3}{16}$ -in. steel. This is slightly flattened for 1 in. and is then clamped tightly between the strap irons a little upwind from the center, with a rivet on each side. Also be sure that the rod is at right angles to the bottom edge of the silhouette.

For the supporting

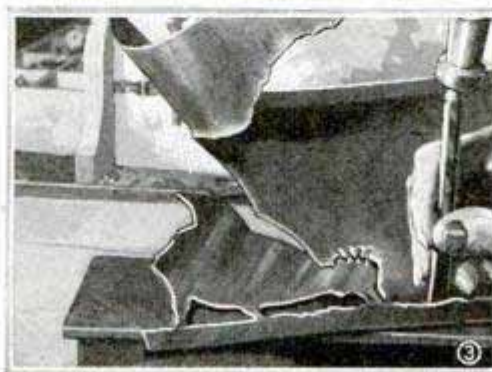
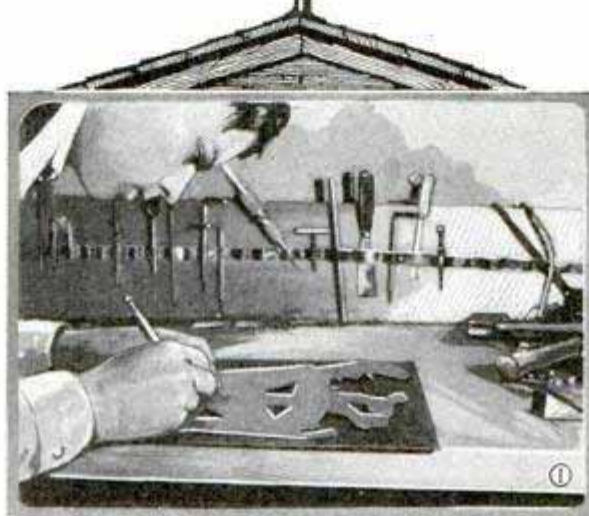



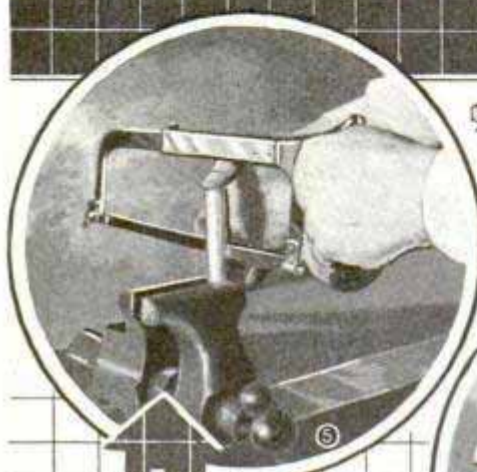
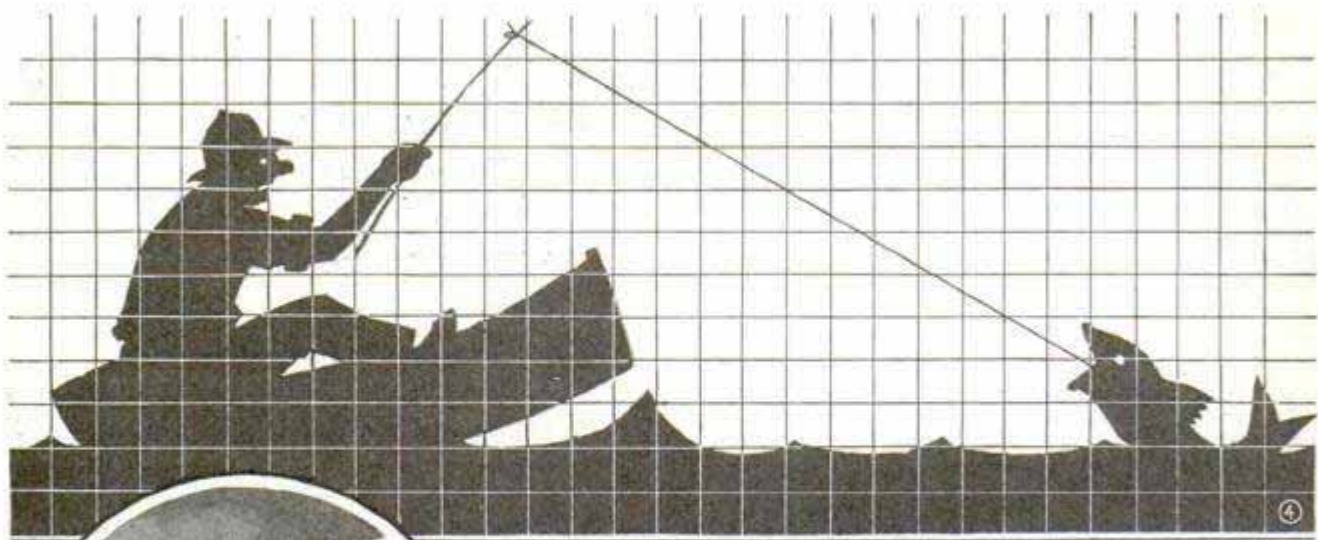

$\frac{3}{4}$ " X  $\frac{1}{16}$ " STRAP IRON 30" LONG, 2 REQUIRED  
 $\frac{3}{16}$ " STEEL ROD 22" LONG  
 $\frac{1}{4}$ " GALVANIZED-IRON PIPE 20" LONG

$\frac{1}{2}$ " GALVANIZED PIPE 12" LONG

20-GAUGE SHEET IRON  
 30" X 12"

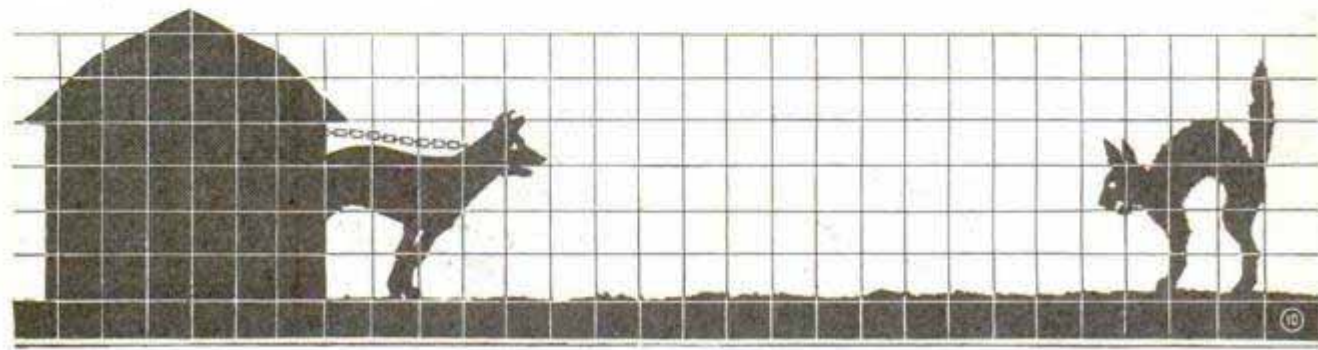
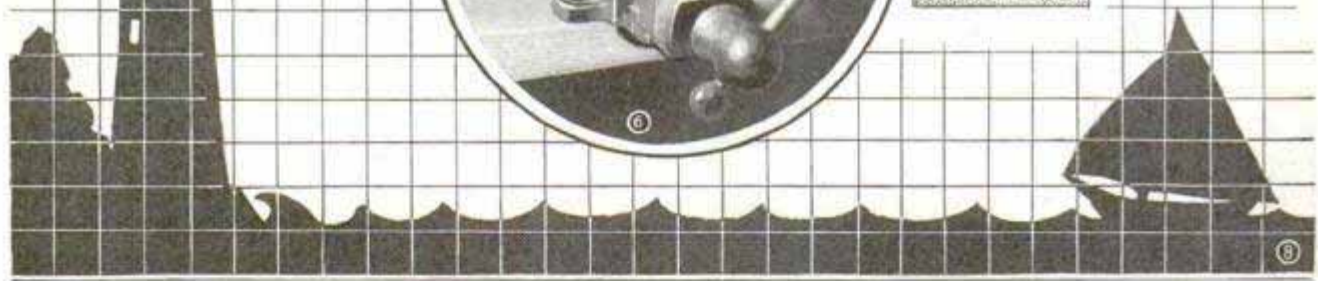
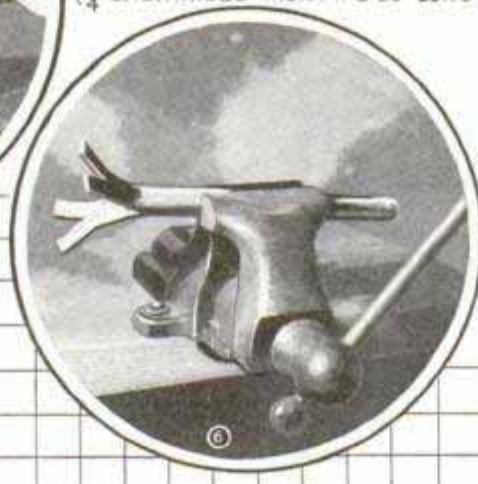
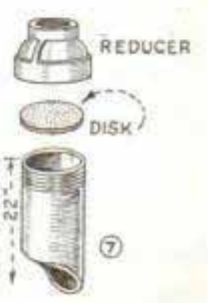



housing, get a piece of  $\frac{3}{4}$ -in. galvanized iron, 12 in. long and threaded at one end. Provide a reducer for this to take a  $\frac{1}{4}$ -in. pipe, 20 in. long and also threaded at one end. Set the lower end of the larger pipe upright in a vise and make two cuts with a hacksaw at right angles to each other, one 1 in. deep and the other 3 in. deep. Then spread these to form two feet to fit the ridge. See Figs. 5 and 6. If you are to install the vane on a flat roof, make both hacksaw cuts 3 in. deep and spread the four feet evenly. Drill the feet for  $\frac{3}{16}$ -in. lagscrews.

The parts for making the vane are shown in Fig. 7. Sharpen the bottom of the upright rod slightly, and place a metal disk on the top of the lower pipe to take the end of the rod, as shown in the detail, Fig. 7. Assemble the pipes, and drop the vertical rod in place. You can apply a little hard grease on the disk to insure easy turning for a long time. When completed, the horizontal piece should clear the top of the pipe by about  $\frac{1}{2}$  in. Before installing the vane on the house or garage roof, give all the metal parts a liberal coat

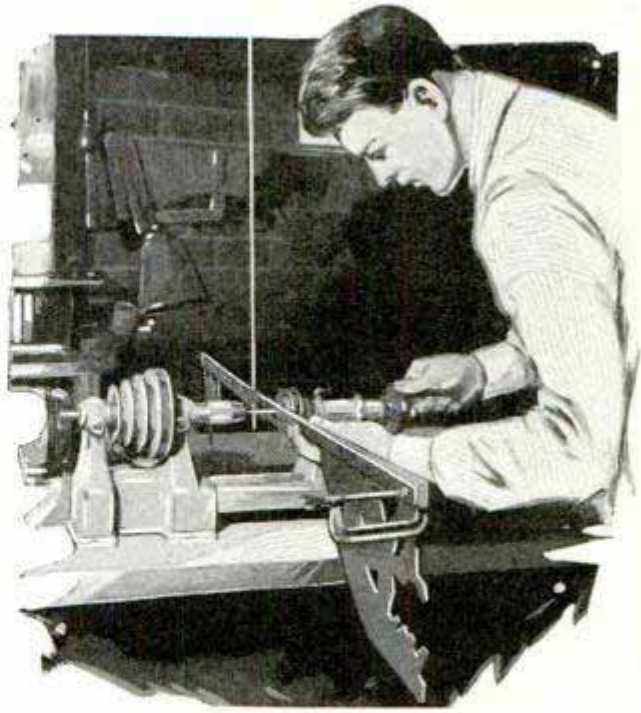

Drilling Holes through the Silhouette and Strengthening Bars for Rivets

of paint. While the color for the upright is optional, black should invariably be used for the silhouette. Four suggestions are shown in Figs. 4, 8, 9 and 10, but these are only a few of the possibilities.

### Pulling Car Out of Mud

When my auto seemed hopelessly sunk in a mud hole and the only salvation to get a near-by farmer to pull me out with a team, I remembered that I had an old pair of skid chains under the back seat, which I then proceeded to use to advantage. Two fence posts, found beside the road, were laid under the running board on each side and the chains fastened over the forward end, as indicated in the illustration, leaving the chain hooks extending toward the rear wheel. My regular chains were already on the rear wheels, and the hooks of the first chains were attached to them, where the posts touched the tires. Putting the car in low gear raised the wheel ver-

tically, and then it came forward on the posts. In doing this, of course, the pressure on the back part of the posts threw the forward ends up against the underside of the running boards. This method has saved me quite a sum of money so far, as I have used it time and again.—Bernard McManus, East Moline, Ill.

### Comb for Cleaning Red Currants

Preparing red currants for stewing or jam making is always a slow job as it takes some time and care to remove the berries from the stems by hand. This work can be done more quickly by using a coarse comb. Draw the stem through the comb and the currants will come off.—D. Leechman, Ottawa, Can.

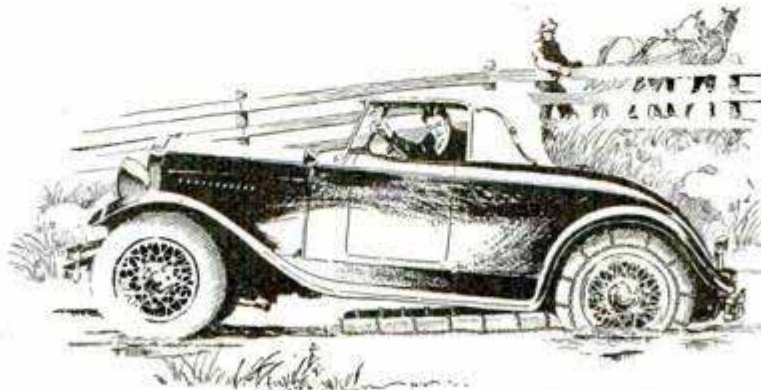

Effective Method of Getting Car Out of Mud



## CARRYING FOLDING BOAT AND MOTOR IN YOUR AUTO

For those who are going camping to a secluded spot at a lake where boats are not obtainable, a folding boat, which can easily be carried along, will be found satisfactory. Besides, a light-weight outboard motor can be car-

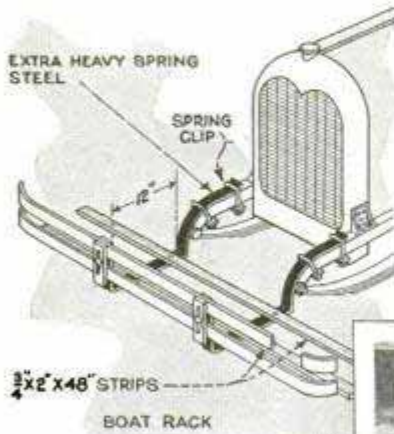

ried along if desired, thus literally providing the camper with a portable motorboat. The photo shows a 14-ft. portable canvas boat folded and stored in its carrying bag on a special cradle made for it. The writer has carried such a boat nearly 30,000 miles in this way and it is still in good condition. Contrary to general belief, a bundle carried in front of the radiator, but separated from it by a sufficient space to permit circulation of air, will not cause the motor to overheat. Although it cuts off the air rushing through the radiator due to the forward movement of the car, the fan nevertheless draws enough air through to prevent overheating. The drawing shows the construction of the

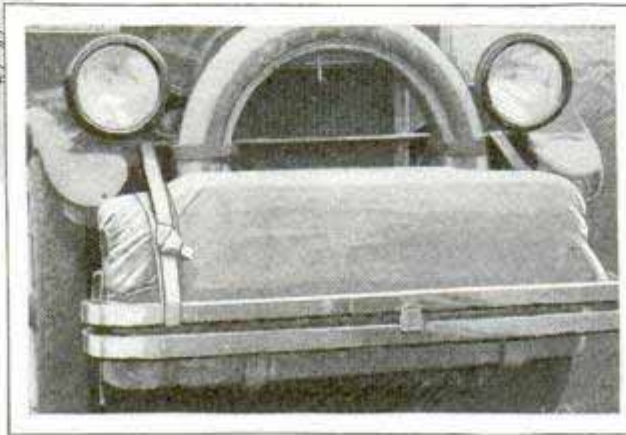

Camper's Portable Boat and Motor Can Easily Be Transported on the Car to Secluded Lakes

brackets, the exact dimensions of which depend on the particular make of car on which the installation is being made. It is best to take the car to a blacksmith's shop or auto-spring shop, where the main arms can be shaped to fit the car. Extra-heavy spring-steel stock should be used for the purpose and the arms should be fastened to the frame with spring clips instead of bolts, which would weaken the frame. The bottom of the bracket should be on a level with the bottom of the front axle. A convenient method of carrying an outboard motor is also shown. Two angle-

iron brackets are bolted to the running board of the car and both are bolted to a short piece of 1-in. oak, on which the motor is clamped.

The dimensions of this bracket depend on the particular kind of motor it is to hold.—Dick Cole, Los Angeles, Calif.

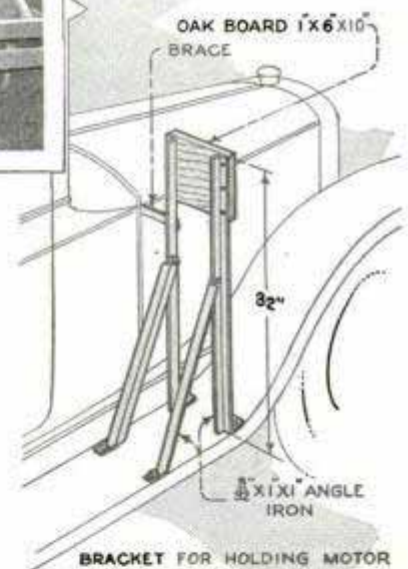

### Homemade Varnish Remover

Here is an effective homemade varnish remover: Mix 1 cupful of flour in twice that amount of water. Dissolve  $\frac{1}{2}$  cupful of lye in an equal amount of water and add this to the flour mixture. Apply the paste with a cotton swab or cloth tied to a stick. Allow the paste to remain on the surface for just about one minute, after which the softened varnish can be removed with a spatula. If all the varnish

does not come off, repeat the operation. However, you must be careful not to let the paste remain on the wood too long, as it will darken the latter, and for this reason it is best practice to apply the paste to small sections at a time. In case you do get some dark spots on the wood, the natural color can be restored by rubbing with a cloth dipped in vinegar. Another method of bleaching out the wood is to use a solution of oxalic acid, obtainable at any drug store.



### Bleaching Dark Clothes

Before dyeing clothes, it is sometimes necessary to remove a darker color. This can be done easily with a solution of ordinary chloride of lime, which is a bleaching powder and can be obtained at any drug store. Make a solution consisting of about 1 oz. of the powder to 1 gal. of water. If there is plenty of time, simply soak the garment in this solution. The bleaching process can, however, be speeded up by heating the solution or by adding a few drops of sulphuric acid.—Ralph W. McPherson, Omaha, Nebr.

### Feeding Iron Work to Drill in Lathe

Amateurs who are working small lathes without a screw-operated tailstock, often experience difficulty in feeding iron work to the drill when the set is used as a drill-press. To minimize this trouble, the following device has been found efficient. A piece of scrap iron of appropriate length is bent at right angles and the arms are drilled, one to accommodate the lock screw of the tail center, and the other to permit the easy passage of a bolt, as indicated. The nut of the bolt is centered and welded in position over the large hole. A 4-in. bolt is used for the feeding element, and the head is drilled to permit the insertion of a steel rod, which is bent to form a crank. Because of the variation in size of machines, it is useless to give specific dimensions. With care in forming the angle of the crank and in laying out the piece before drilling, however, no trouble should be experienced in adapting

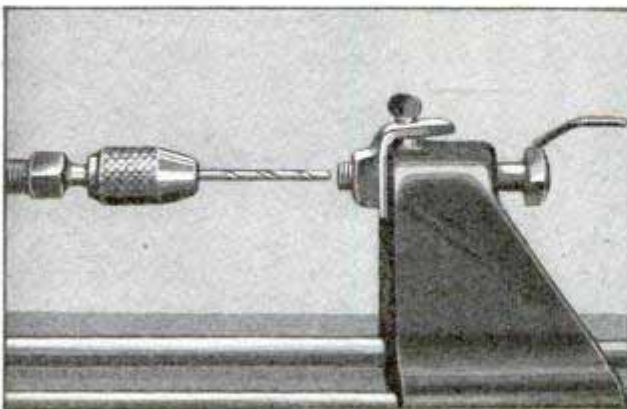

Improved Screw-Feed Attachment on Small Lathe for Feeding Work to Drill

it to any lathe.—Robert L. Swanson, Minneapolis, Minn.



Unused Ironing Board of the Built-In Type Converted into a Small Table

### This Kitchen Table Folds into the Wall

As we preferred to have an ironing board in the laundry instead of the kitchen, where one was built in the wall, we converted it into a small table as shown. It was sawed off to a convenient length and an extra leaf hinged to it on one side. This leaf was made as wide as the ironing board and could therefore be folded back in the cabinet. A pivoted cleat under the ironing board was used to hold up the leaf when in use, and the cleat did not interfere when the assembly was folded. Most housewives will find such an extra table extremely handy.—Ralph Erskine, Washington, D. C.

### Disinfecting Water with Iodine

One drop of ordinary tincture of iodine, of 7-per-cent strength, is sufficient to thoroughly disinfect a quart of water, according to federal chemists. Water treated in this way is safe for drinking purposes in most cases. After the iodine has been added and mixed, the water should be set aside at least 30 minutes before it is used. For a pailful of water, which equals  $2\frac{3}{4}$  gal., add 11 drops of iodine.

☐ Kerosene is a good lubricant for reamers used in aluminum.





Stick Suspended Across Dog's Legs Breaks the Habit of Chasing Cars

### Stick Cures Dogs That Chase Cars

One of the most annoying habits of dogs is to chase cars. To effectively cure them of doing this, suspend a light spruce stick from the collar as shown in the illustration. When the dog is running, the stick hits against its knees so that it soon will stop. This remedy has been used with success, is no cruelty to the dog, and will, in fact, prevent many accidents into which the habit may lead it.—William F. Porter, Red Deer, Can.

### Improved Hot-Water Heater

When small quantities of hot water are required, and the furnace is not in operation, an effective water heater can be improvised. Wrap 10 turns of  $\frac{1}{2}$ -in. asbestos cord around the vertical section of hot-water pipe leading from the furnace, the lowest coil of the wrapping being just above the elbow of the pipe, as shown in the illustration. Continue the wrapping for about 30 in. and then slip a 36-in. length of asbestos pipe covering over it, the latter being a snug fit over the

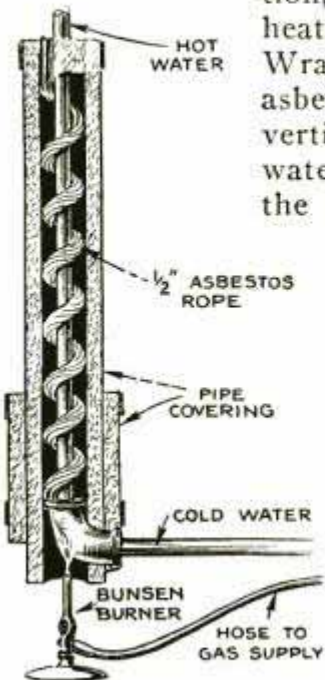

wrapping so that heat applied at the bottom will rise spirally and therefore be more effective in heating the pipe. One coil of the rope plugs the space at the top between pipe and covering and a clamp is then used to hold the covering in place. Flutes through the upper coil allow the escape of warm air. A Bunsen burner is set in a convenient position under the elbow to furnish heat.—Otto Emmert, Denver, Colo.

### Ventilating the Closet

Proper ventilation of clothes closets is often a problem, especially in older houses. It is usually impractical to provide a vent in the ceiling, and this method also has certain disadvantages in cold weather. However, ventilation can readily be obtained by providing grillwork in the closet door as shown in the drawing. Get some plywood and cut it to the size of the top and bottom door panels so that it can be substituted for these as indicated. The plywood panels can be cut out according to any suitable design with a jig-saw or fretsaw. In addition to the ventilation obtained in this way, the appearance of the door is greatly improved, and the grills may be removed any time.—Hi Sibley, Pasadena, Calif.

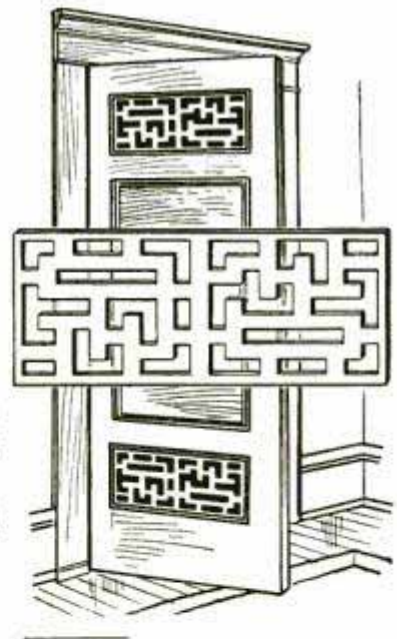

### How to Get Hose on a Tight Fitting

When it is difficult to get the end of a garden hose on a coupling, dipping the hose in gasoline will help considerably. The gasoline reduces the friction and also causes the rubber to swell slightly. As the gasoline dries out quickly, no harm will be done to the hose. The same method can be followed when installing automobile radiator hose.—C. E. Packer, Chicago.



# TRANSFORMING AN OLD MIRROR

by TUD KEMPF

**B**EFORE throwing away that old mirror look at the accompanying photos and illustrations to see some novel homemade and hand-carved frames, which are not only interesting to make but also help to give your home that touch of individuality that cannot be duplicated by any commercial product. Any mirror will do for the purpose, provided the silvered surface is still in good condition. Do not use a glass with tarnished, flecked and spotted silver, or you will run the risk of having a better frame than glass, which would, of course, not do justice to your workmanship. Plate glass is preferable to ordinary thin glass, as it is free from many imperfections found in the latter.

Although any desired design can be used, the ship-and-fish design shown here is rather easy to work out and makes an attractive job. For your convenience, the fish is laid off on squares, which you can duplicate in larger proportions. A single  $\frac{3}{4}$ -in. piece of wood of the required size to cover the mirror is obtained. In this case, sugar pine was used, because it is easy to work and does not split readily. However, mahogany is an excellent wood to carve and there are many other varieties which are equally suitable. Pick out



a piece that is free from knots and is nicely grained, although a knot hole, as shown in the photo, may appeal to some as being more artistic in this particular kind of ornament. Use a piece of carbon paper for tracing the design, which is first laid out on paper. Then proceed with the cutting of the holes, using a drill and a keyhole saw. The edges are scraped smooth and then sanded, after which the carving is done. Any handy knife can be used for this purpose, but most workers will find an ordinary jackknife convenient. Care must be taken not to cut cross lines too deep, or the in-

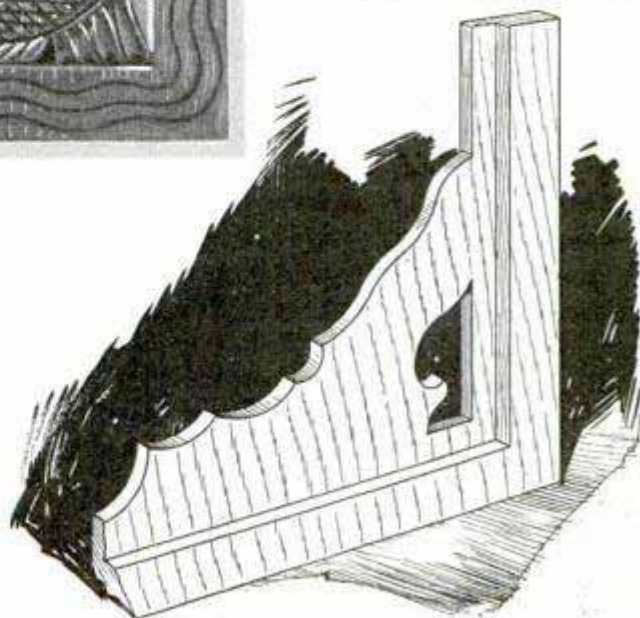



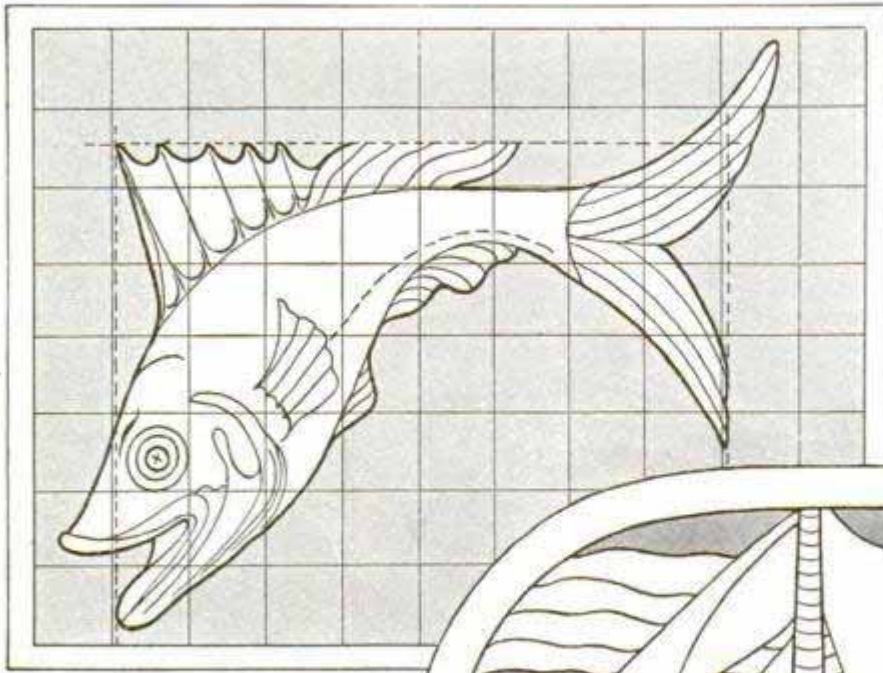

Lay Out the Designs on Paper in Any Size and Trace Them on the Wooden Frame

terstices of wood are likely to crack loose and fall out. Round off the fish designs near the edges, to give them a realistic effect. When finished with the carving, go over the surface carefully with sandpaper and then stain the wood any desired color and shade, after which shellac or varnish can be applied. Rub the finish down with powdered rottenstone and oil in order to eliminate the luster, as a dull satin finish is preferable for work of this kind.

### Roman Crystallotype Painting

You can produce some really attractive imitation Roman crystallotype paintings by following the instructions given in this article. First get a picture, choosing the cheapest sort of colored print, and cut the margin down to the colors. A magazine cover will do nicely for the purpose. Next, get a piece of common window glass. It should be clear and free from blemishes. Cut it down to the size of the picture desired. See that the glass is clean, and then give one side a smooth coat of crystallotype varnish, which is composed of 1 oz. of fir balsam and  $\frac{1}{2}$  oz. of spirits of turpentine. A flat camel's-

hair brush is used for applying it. After this has been done, the glass is set away to dry for 24 hours in a place where it will be free from dust. When you are ready to continue the work, get a pan, or any clean vessel of fair size, and fill it with finishing solution, which consists of 1 tablespoon-

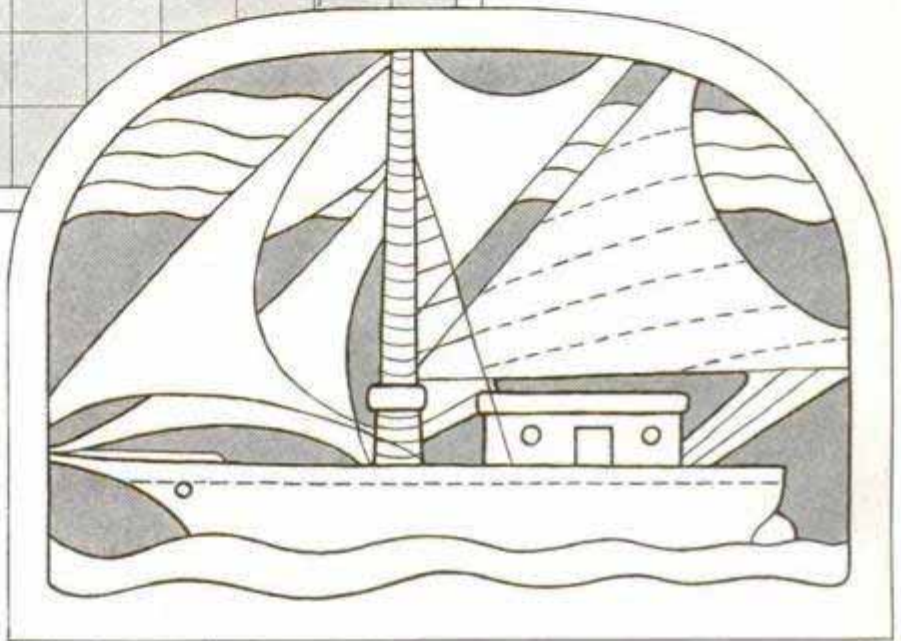

ful of vinegar, 1 teaspoonful of common salt and 1 qt. of water. This liquid serves to set the colors. Varnish the glass the second time on the same side, with the same varnish as before, and then dip the picture in the finishing solution, being careful to see that it is entirely submerged. Keep the picture face up, and let it remain that way for a moment or two, until it is thoroughly saturated. Then remove it carefully and place it, face up, on a newspaper. Left in this manner for a short time, the top side will soon dry off, but the underside will still remain damp. As soon as the solution disappears from the face of the picture, you are ready to proceed. Place the picture, face down, on the varnished side of the glass, being careful to get it on evenly. Press it down firmly to exclude all wrinkles and bubbles. This is quite important, for any air between the picture and the glass will mar the finished product. While the picture is still damp, rub the paper from the back



side until you get it sufficiently thin to see the outlines of the print, taking care not to rub through into the glass. Get the surface of the paper as even as possible and smooth it off with a piece of very fine sandpaper. Finally, give the back a heavy coating of varnish and place the picture away to dry in a dustless, airy place. If any white spots show up, just give the surface another coat of varnish, and they will disappear. When the picture is absolutely dry, take a sheet of colored paper—any color you desire—and use it as a background. Exposing one face of the picture will give you an imitation oil painting, while the other side will give the effect of a crayon sketch. You can experiment with backgrounds and pictures until you get what you like best. Properly framed, these pictures make highly attractive wall decorations for the home.—Geo. Pommer, Jr., Minneapolis, Minn.

### Old Auto Frames Used as Bridges

Old auto frames, which cost very little, make sturdy stock bridges over small creeks on the farm. Cement blocks on either side provide the footing for the bridge, and 2-in. planks, laid crosswise, form the floor. The floorboards are bound together by 2 by 4-in. stringers along the edges, as shown, nailed down securely. Holes are drilled through the planking over the holes in the frame so that bolts can be used to bind the assembly together. These bridges have been found heavy enough to withstand ordinary pasture



Improved Pasture Bridges Made from Old Auto Frames Are Cheap and Sturdy

floods.—George R. Harrison, Council Bluffs, Iowa.

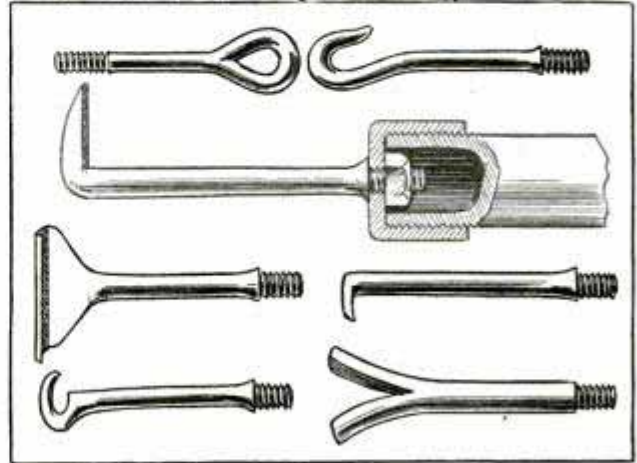

Reverse Hammer, Made from Pipe Fittings, Will Be Found Useful for Many Purposes

### Reverse Hammer Has Many Uses

Many workmen often feel the need of a reverse hammer, that is, one that exerts a pull by jarring it backward. The one shown in the drawing is made up almost entirely of pipe fittings and is equipped with a number of interchangeable hooks adaptable to all kinds of work. The body of the tool consists of a pipe nipple, 12 or 18 in. in length, fitted at each end with a cap. A 6-in. sleeve, fitting rather loosely on this nipple, but restrained from coming off by the caps, provides the driving power by being struck sharply against the rear cap. The front cap is drilled, the hole is tapped to receive the threaded ends of the hooks, and a nut is provided on the inside to prevent stripping the thread in the cap. Modifications in the size of this tool depend on the use for which it is desired. Uses for such reverse hammers extend from the watchmaker's trade to the heaviest kind of engine work in ships and power houses.—J. E. Hoag, Alhambra, Calif.

### Painted Revolver Sights Aid Vision

Skill at target shooting with pistols is materially increased by improving the visibility of the sights. This can be done by painting the front one white and the rear one red, according to a champion pistol marksman of the police force at Ogden, Utah.—Glen Perrins, Ogden, Utah.



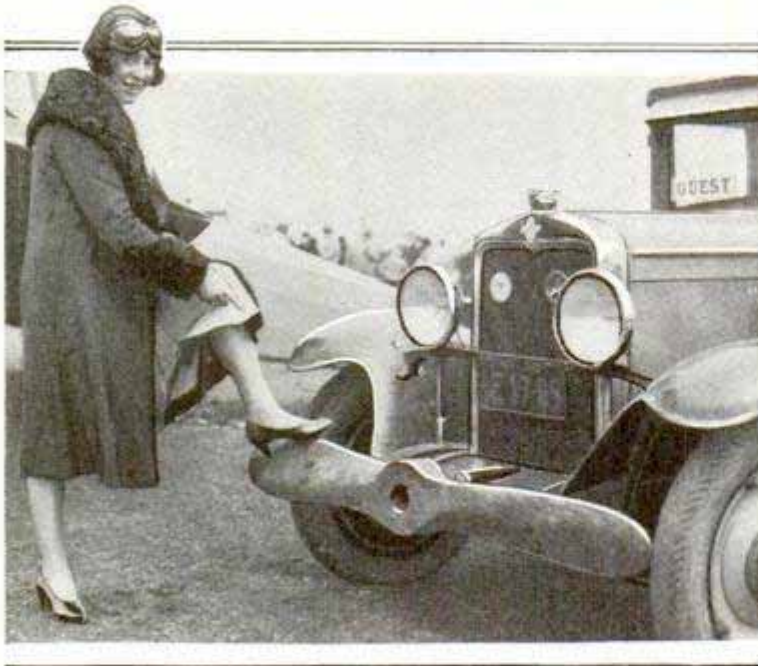

This Ornamental Bumper for Car Is Made from Old Airplane Propeller and Serves the Purpose Well

### Old Propeller Makes Ornamental Bumper

Being thoroughly "air-minded," this young aviatrix even installs airplane fittings on her car. An old propeller, no longer useful for its original purpose, was substituted for the front bumper, bolts being used to attach the blades to the extending brackets.—Edwin G. Stephan, Detroit, Mich.

### Food Trap for the Aquarium

In aquaria, whether of the balanced or unbalanced kind, great care must be taken that the water does not become sour, acid or otherwise unfit for the fish. The main cause of polluted water is the uneaten fish food, which, settling to the bottom of the tank, drops between the pebbles or mixes with the sand. This unconsumed food, even though it remains in the water only a few hours, decays and endangers the health of the fish. Glass-tube rings,

which float on the water, are good for keeping the food from floating all over the water, but do not prevent the food from settling to the bottom. In order to keep the food out of the pebbles and sand, a food trap of the kind shown in the drawing should be used. The trap is made simply by taking a strip of glass, about  $\frac{1}{2}$  in. longer than the short side of the tank and as wide as the depth of the pebbles and sand. The strip is placed edge up so that one end of it rests in one corner of the bottom and the other end butts against the opposite side, as indicated. This arrangement divides the bottom into two sections, the smaller one of which is the trap. The strip is held in place by the pebbles and

sand against one side. It may also be bent to a right angle as shown in the right-hand sketch. The floating food ring must always be directly over the food trap, when food is dropped into it. Usually the ring will remain in its position due to the cohesion between it and the side. All the food that settles to the bottom of the trap and is not eaten, can be siphoned out without any trouble. It is also a good idea to round off the upper edges of the glass strip on an emery wheel so the fish will not get hurt by bumping against it. This food trap has been used by a breeder and seller of fancy fish.—Walter C. Michel, Jersey City, N. J.

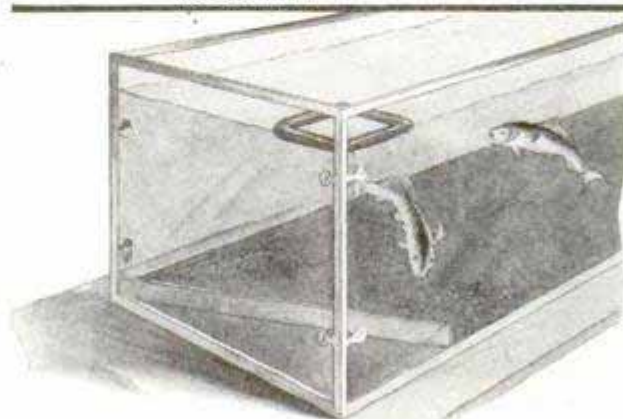
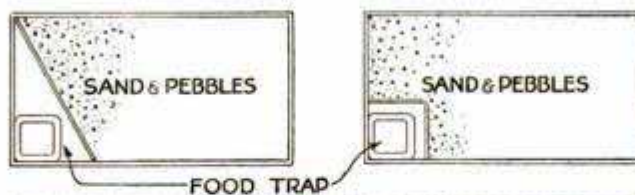

This Arrangement Provides a Food Trap Which Prevents Polluted Water

### Removing Shellac from Brushes

Shellac can be removed from brushes without trouble in the following way: Immediately after finishing the job, clean the brush out in ammonia, lye water, sal-soda solution or even borax. The main thing is to clean the brush well before the shellac dries hard.



# SHOP NOTES



## How to Build a Portable Fireplace

By E. E. SCOTT

**F**IREPLACES are usually considered a luxury, and the high cost of brickwork and ashpit foundations has forced many a home builder to reluctantly omit this much desired feature from his plans. However, a substitute, which closely resembles a real fireplace, is the portable one shown in the photos and drawings. It

even includes the "brickwork" and it can be moved from room to room or house to house without any difficulty. Furthermore, it is easy to make, which puts it within the reach of nearly everyone.

It consists of a mantel made of pine or other soft wood and a gas heater of either the radiant or imitation-log type. Al-

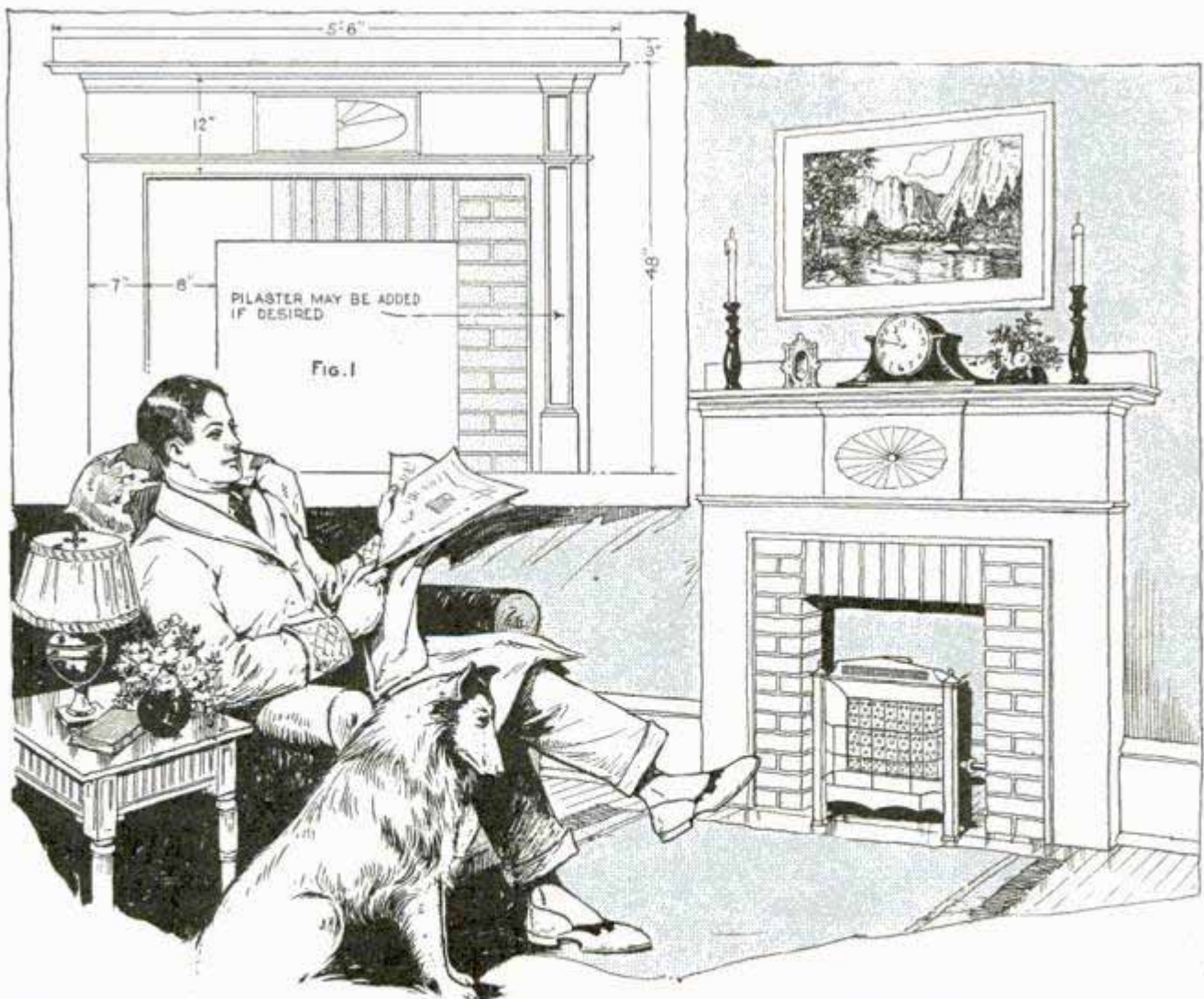

If You Must Have a Fireplace in Your Apartment or House, Here Is One That Is Easily Built and That You Can Take with You When You Move



though preferable, a flue connection is not necessary.

The mantel should be of approximately the dimensions given in Fig. 1, but may be proportionately larger if it is to be installed against a large wall space. About 25 feet of 8 by  $\frac{3}{4}$ -in. stock and 12 ft. each of several kinds of fire-place molding

The brickwork consists of pieces of wallboard, some cut  $2\frac{1}{2}$  by 8 in. and some  $2\frac{1}{2}$  by 4 in., to correspond to the long and short sides of tapestry brick. The bricks are laid out on a base of  $\frac{3}{4}$ -in. stock, which is securely attached to the back of the mantel and projects 8 in. on all sides, as indicated in the cross section Fig. 2. Hold the bricks in place with brads, arranging them like regular brickwork and allowing  $\frac{3}{8}$  in. for mortar. Fill in these joints with patching plaster, preferably using a molder's slick, although an old spoon flattened and filed to a rounded point will do.

No plaster should be used until all hammering is finished, otherwise it is likely to crack. Sandpaper off the surplus plaster after it is well set and countersink and putty all nails in the woodwork.

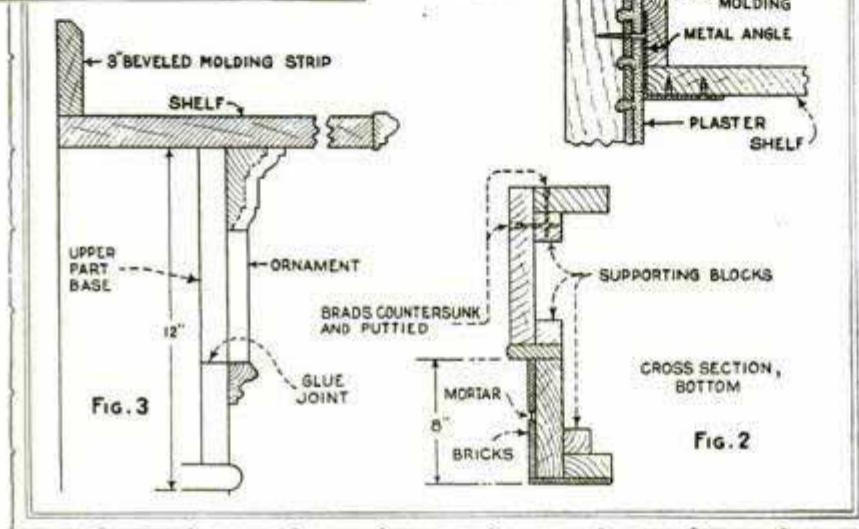
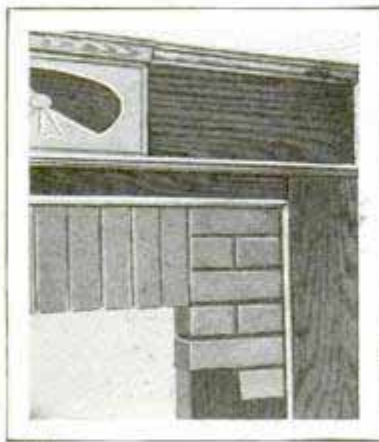

Above, Photo Showing How the "Bricks" Are Laid on the Backing; Right, the Fireplace in Winter, with Heater in Place

should be obtained from a building-supply house. First make a U-shaped piece to serve as a base for the built-up design. Attach sidepieces of approximately the depth of the heater which is usually about 6 in., reinforcing them with supporting blocks at the corners, as shown in Fig. 2. Lay out the design of the central motif and build it up with individual pieces, first outlining it with cove molding. Separate parts of the design should be filed and sanded smooth, then bradded and glued in place. The various moldings should also be fastened with glue and brads. If a more elaborate design than that shown is desired, pilasters may be added but accurate mitering is required to run the molding up over them. The fire opening is boxed in with a 1-in. strip, rounded on the outer edge.

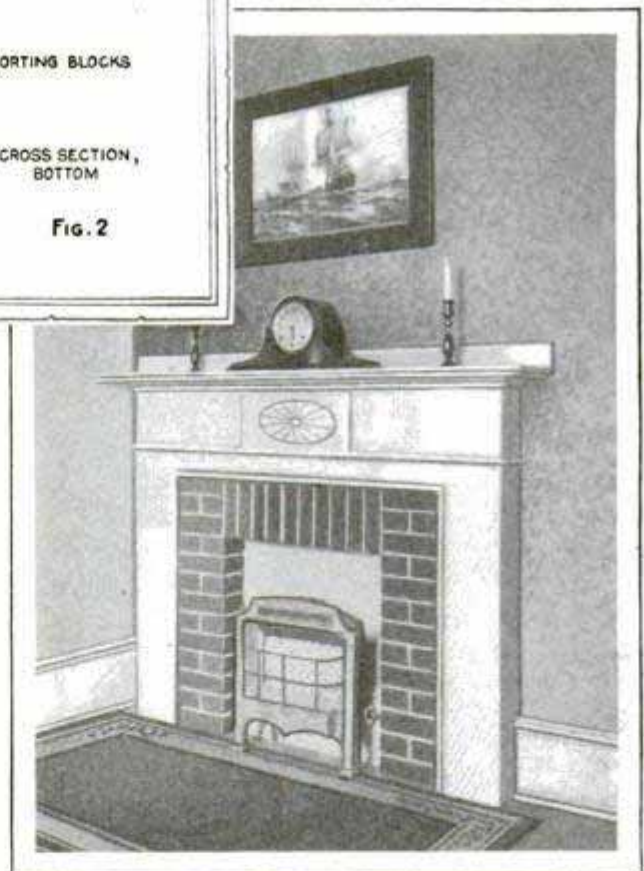

Two coats of flat white, followed by a finish coat of eggshell gloss enamel, to match the woodwork of the house, should then be applied, sanding lightly between each coat. The bricks should be painted with dark-red iron-oxide roofing paint,



which will dry perfectly flat and lusterless like real brickwork. A very pleasing effect may be obtained by mixing some blue with the roof paint and some lighter red with another batch and alternating the three shades obtained. The finished brickwork can then hardly be told from tapestry brick. The mortar should be painted a steel-gray, to resemble the mortar ordinarily used for fireplaces, which consists of the usual white variety into which has been stirred a quantity of lamp-black.

To attach the finished mantel to the wall, use three angles as shown in Fig. 2. It is not necessary that the screws enter the stud under the plaster, as a lath will give sufficient support. The metal angles are concealed by the beveled molding at the back edge of the mantel shelf. This molding is added after the mantel is in place. The wall space within the line of the brickwork should be covered with a piece of wallboard to give a more finished effect. Around the base of the mantel should be placed the usual quarter-round to match that at the baseboard of the room.

If no gas lines are in place, a plumber can deftly run the required  $\frac{1}{4}$ -in. pipe between the partitions and under the floors as required.

During the summer, while no heat is

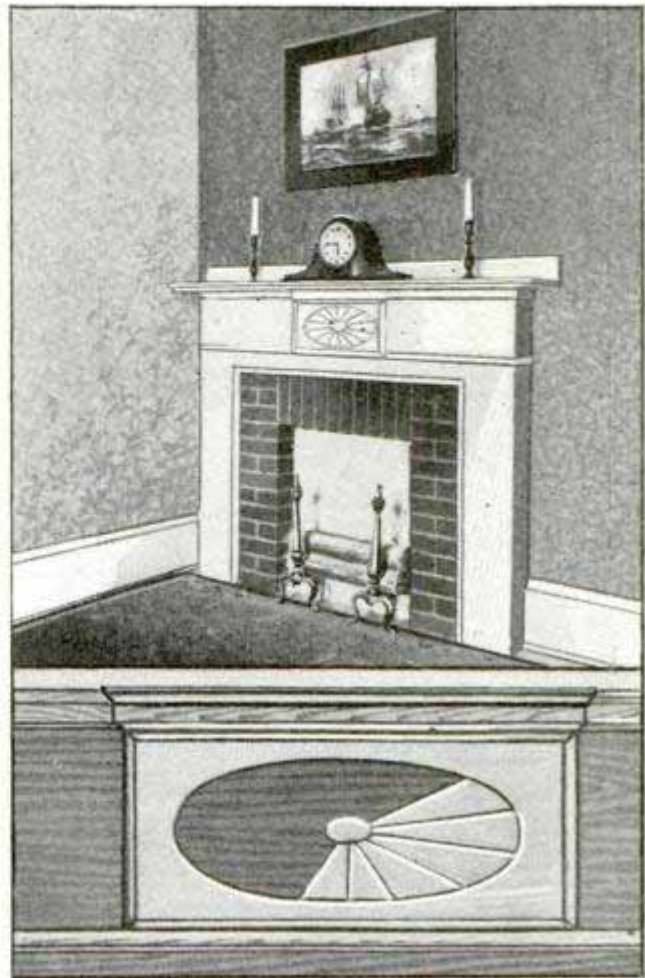

The Fireplace in Summer, with Logs and Andirons, and How the Ornament Is Built Up

required, a pair of andirons with short fuel supports may be set in place to carry a few birch logs.

### Installing Electric Meters Outdoors

At San Diego, many residences have the electric meters installed outdoors, in suitable boxes to protect them from the weather, so that meter readers need not bother the occupants, and never have to make a second trip. The boxes have a

round opening fitted with glass, directly over the meter, and are attached to the wall by means of angle brackets, or they may be built right onto the wall and provided

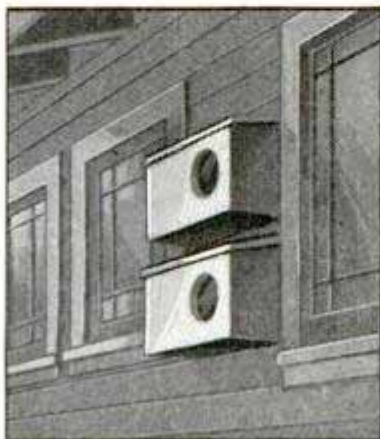

with a hinged front. It is an easy job to make an installation of this kind, even in an old house.—Dale R. Van Horn, Lincoln, Nebr.

### Flux for Soldering Tin Roof

When rosin is used as a flux for soldering a tin roof, some of it flows out of the seam and onto the surface of the tin which is to be painted. In a short time, the paint will peel off this spot, leaving the metal exposed. If acid flux is used, such as chloride of zinc, it will corrode the tin in places and rusty spots will appear. Both of these objections can be overcome by using ordinary boiled linseed oil as a flux. It is very easy to apply and excessive oil on the surface of the tin will protect it instead of injuring it.—James H. Beebe, Rochester, New York.



### Portable Shelf Attached to Barrel

For grocers, and others who occasionally have to fill bags from barrels, the



Small Shelf Hooked to Edge of Barrel Saves Effort in Filling Bags

portable shelf shown in the drawing is highly convenient. It consists of two lengths of flat iron, bent at right angles and attached to a small board. The upper ends of the brackets are bent over to form hooks which are slipped over the edge of the barrel. The use of the shelf is apparent as well as the amount of stooping that it eliminates.

### Cementing Glass to Metal

For cementing glass to metal, a mixture of sodium silicate and quartz meal, baked 12 to 24 hours to set hard, is recommended. If the color is unimportant, a useful preparation may be obtained by soaking leather-scrap glue in water, melting it by heat and then mixing it with 11 lb. of pitch, 4½ lb. of asphaltum and 4½ lb. of rosin to each 1¾ lb. of glue solution. The mass may be loaded with powdered slate, etc., without losing its adhesive properties. Casein cement for immediate use is made by mixing fresh curds with one-fourth its weight of powdered chalk; while a second preparation, which will keep, consists of a solution of casein in ammonia, or of a solution of the same material in a 5-per-

cent solution of caustic soda or borax, with the addition of a very small proportion of hexamethylene-tetramine. This cement is impervious to water. Rosin adhesives are also used, the "amber" cement employed by jewelers being composed of three parts of mastic and two to four parts of shellac, dissolved to a "sirup" in 90-per-cent alcohol.

### Wooden Core Strengthens Pipe Nipples

Old pipe nipples, particularly those used for steam and water, are often very thin and should be protected by means of a wooden core when it is necessary to remove them with a pipe wrench. Whittle down a long tapering plug and drive it into the nipple. The wrench is applied at the point where the plug fits snugly. In this way, one can easily prevent the pipe from being crushed and bent.

### Wheelbarrow Track on Cleated Incline

When running heavily loaded wheelbarrows up or down steep inclines, it is often necessary to provide cleats on the incline in order to prevent the workmen from slipping. A plank is laid over the cleats to serve as the barrow track, but difficulty is sometimes experienced in the barrow slipping off. To prevent this, use a length of channel iron instead of a plank. The barrow can then be pushed up without even looking at the track.—Jos. C. Coyle, Englewood, Colo.



Length of Channel Iron Laid on Cleated Runway Guides Wheelbarrow



### Bandsawing Inside Diameters of Rings

With the ordinary use of a bandsaw, it is impossible to saw out an inside diameter without cutting a path from the outside, which is usually not desired. In the case of large rings used in pattern shops, it was found convenient to slip the entire ring over the top of a small bandsaw and it was then an easy matter to saw the inside diameter without making a cut through the ring.—Alexander Forsyth, Hartford, Conn.

### Cutter for the Woodworking Shop

Wherever there is need for a quick and accurate cutter for lining up internal and external members on a curved or warped surface, the marker illustrated will be a distinct advantage. It can be used in boat building for trimming down stringers, etc., to line up with the keel and chine; in automobile-body work; in furniture work, and, in fact, it will be found useful in practically any shop. Without it, the worker must keep lining up with a straightedge and planing off a little on the interior members, checking back with the straight-



edge, and then planing some more. This cutter will actually plane off the wood along the top of each stringer or internal member in turn, producing an absolutely accurate and true surface, with no interruptions to the operation for lining up. It is made by mounting a small electric motor, such as is used for drills, on a straight piece of wood of convenient length. A router bit is recessed in a notch in the under side of the straightedge so that it comes flush with the bottom. The hole through the straightedge should be bushed with a free-fitting metal tube. Knobs may be added in the ends for convenience.

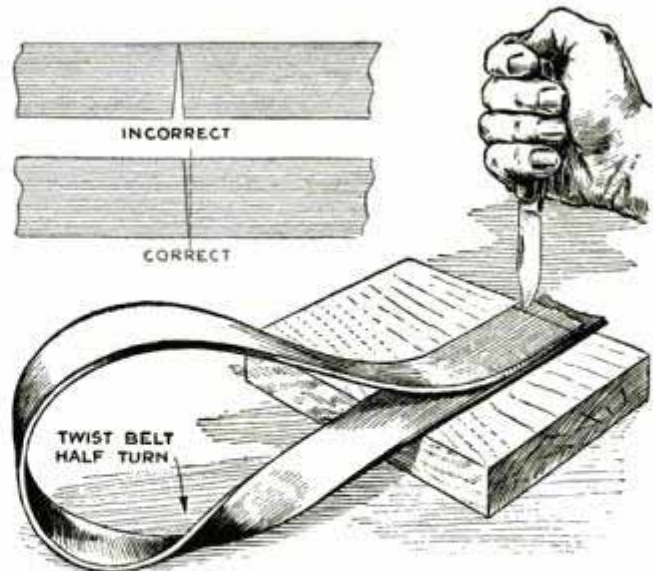

Cutting Both Ends of a Belt at the Same Time Insures Accuracy of Joining Line

### Joining the Ends of Belting

Although it is not absolutely essential to have the joining ends of belting cut perfectly square to the sides, as shown by the dotted line in the drawing, they must butt together all the way across. If they do not, the belt will not run straight. A good method of insuring accuracy is to give the belt a half twist, bringing the ends together over a block, after which a knife is used to make a clean cut through both ends at the same time. In doing this, care must be taken not to shift the belt.

### Skid for Heavy Boxes

In a manufacturing plant where the goods were packed in smooth boxes of uniform size, and the handling of these boxes was rather awkward, owing to their weight, the skid shown in the illustration was found useful. It consists of two U-shaped pieces, with the outsides rounded, the gaps of which fit the boxes. These pieces are riveted to a strip of  $\frac{1}{4}$ -in. flat iron used as a handle. The skid is slipped over the box and the whole is turned over by means of the handle, so that the skid can be dragged over the floor. The underside of the runners are rounded to make this easier.—Harry Moore, Hamilton, Canada.

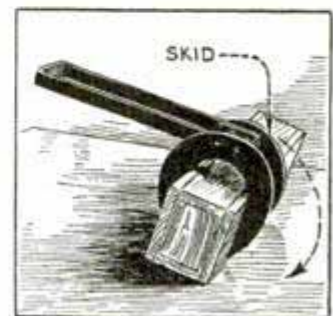



7153

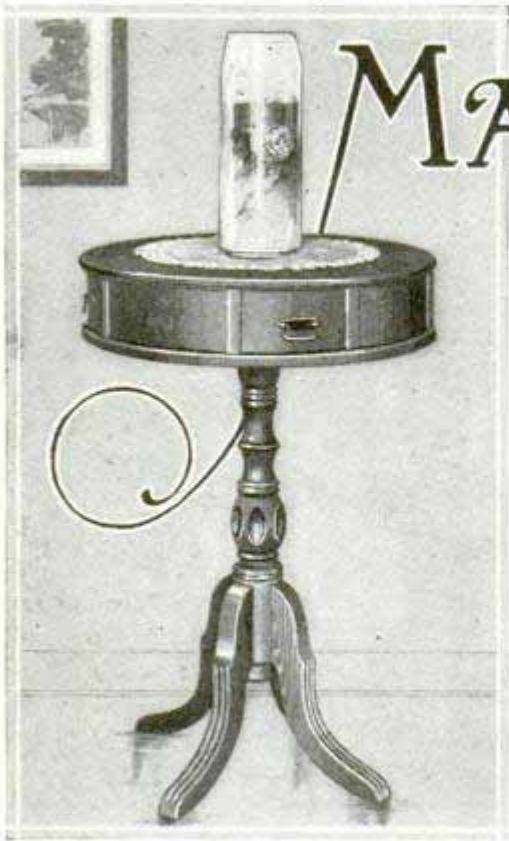

# MAKING A SMALL

*by Clyde Lamme*

THE DRUM TABLE shown in the accompanying illustrations offers an excellent exercise in wood bending, one kind of woodworking seldom attempted in the home shop. In this instance, the top and bent parts were of quartered oak and the base of plain sawed stock, although walnut or mahogany may be used equally well.

The column, Fig. 1, is built up of three pieces of  $1\frac{3}{16}$ -in. stock,  $3\frac{1}{4}$  by 20 in., glued to form a square piece. Square the ends and turn to a 3-in. cylinder, then turn the dowel at the top 1 in. in diameter and  $\frac{7}{8}$  in. long. Lay off the divisions with a pencil and turn to the shape and dimensions given in Fig. 1. Lay out the legs on plain  $1\frac{1}{4}$ -in. oak, saw to shape and sand the edges well. Note particularly the direction of the grain in Fig. 1.

The top is glued up from three pieces,  $\frac{1}{2}$  by 8 by 20 in. On both long edges of one piece, a  $\frac{1}{8}$  by  $\frac{5}{8}$ -in. groove is run, and on one edge of each of the other two, a  $\frac{1}{8}$  by  $\frac{9}{16}$ -in. tongue. Make the joints an easy fit, then glue and clamp. Make up a bottom framework, as shown at the left in Fig. 2, from two pieces  $\frac{1}{2}$  by 6 by 20 in. and two pieces  $\frac{1}{2}$  by 6 by 13 in. Cut tongues on the ends of the short pieces,  $\frac{1}{8}$  by  $\frac{7}{16}$  in., and glue into  $\frac{1}{8}$  by  $\frac{1}{2}$ -in. grooves in the longer pieces, to make a frame 20 in. square.

The curved pieces forming the drum are set into grooves cut in the top of the bottom frame and the underside of the table top. To mark the groove in the bottom frame, make up the rig shown in Fig. 2. Nail a scrap piece of wood across the bottom of the frame and on top of this a  $\frac{1}{2}$ -in. block. Piece A, which forms the trammel for striking the circles, has a small nail driven through one end, and,  $9\frac{1}{4}$  in. from this, a  $\frac{1}{8}$ -in. hole is drilled, at C. Mark the center of the frame on the block, drive

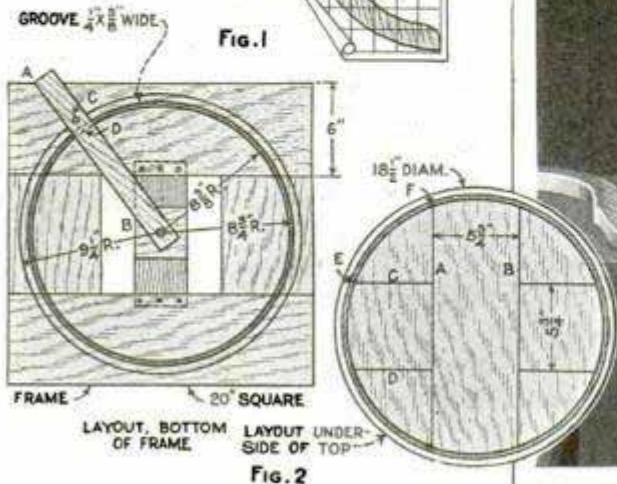
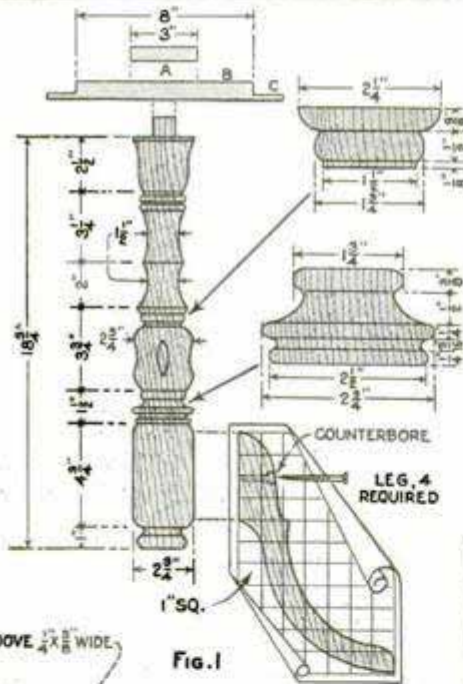

Top, the Completed Table, with Fluted Column and Reeded Legs; Bottom, Screwing a Leg to the Column



# DRUM TABLE

the nail into this mark, and, with a pencil through the hole in the bar, strike the circle which marks the edge of the top. Make two marks on the bar,  $8\frac{3}{8}$  and  $8\frac{3}{4}$  in. from the center, stick the point of a sharp knife through the bar exactly on one mark and swing the bar around so that the knife point will scribe a circle on the wood. Do the same on the other mark, and the two knife cuts mark the groove in the frame. Mark out the underside of the table top in exactly the same manner, using the same trammel. Before sawing out, clamp the work on the bench and rout out the grooves. Take cuts only  $\frac{1}{16}$  in. deep at one time and work entirely around the groove before taking another  $\frac{1}{16}$ -in. cut. The grooves are cut  $\frac{1}{4}$  in. deep. Saw the two pieces to the circle marking the outside diameter and sand the edges thoroughly, rounding them slightly.

For the bent work, use two pieces  $\frac{3}{8}$  by  $3\frac{1}{2}$  by 36 in. Measuring  $\frac{1}{4}$  in. from the edge, rout a  $\frac{1}{4}$  by  $\frac{1}{4}$ -in. groove on the face of one of the pieces. In this bending job, no steaming is necessary, and the work may be done over a gas plate or similar flame. The wood must be heated to a point just short of scorching before it will bend readily.

The preliminary bending of the two pieces is done by simply taking hold of the piece at both ends, holding the center of the piece over the heat and applying a bending pressure by slowly pulling the ends together. Remember that the wood bends only at that point where the heat strikes, so that, when held in this manner, it must be moved back and forth over the heat in order to make the curve uniform.

This simple method will serve to start the bend, but it must be brought to a uniform arc by a more positive means. Fig. 3 shows a caul made from four thicknesses of pine stock nailed together. The arc of the caul is sawed to a slightly smaller radius than the arc required. Triangular

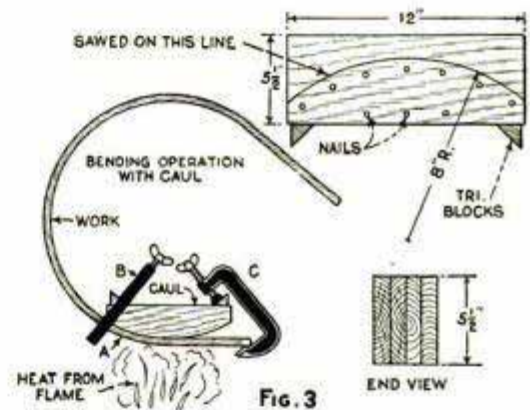

Top. Scribing the Groove; Bottom, Right, Cutting Groove with Router; Left, Clamping the Wood to the Caul



blocks are nailed securely at the ends as shown. Place this caul with the curved face next to the inside of the work and at the point A in Fig. 3. By the first preliminary operation the piece can only be bent to approximately the form shown, and to make the required number of pieces with as little waste as possible, the arc must be made uniform clear to the ends.

The single clamp at B, Fig. 3, is placed first and drawn tight; those at C are only drawn sufficiently tight to stay in place. It is better to use two small clamps at C. Hold over the stove, allowing the heat to strike only the portion to be bent. Draw the two clamps up slowly and uniformly until the wood is tight against the caul. It is necessary to be very careful in this operation for, owing to the short arc, the wood may splinter if drawn too tightly against the caul before it is thoroughly heated. When the wood has been bent to the arc of the caul, allow it to cool before releasing the clamps. Continue the operation to the end, moving the caul about two-thirds its length each time. Do the same with both pieces. Once bent to the required arc, the pieces will retain their shape indefinitely provided they are not exposed to excessive moisture or heat.

Strike the line AB, CD on the underside of the table top, Fig. 2, equidistant from center lines drawn at right angles. Lay aside the curved piece which was grooved, to be used later for the drawer fronts, and cut the other into four segments, each of the length EF, Fig. 2. Be careful to cut each segment individually to fit, and cut the ends at an angle parallel

with the lines AB and CD. Spread glue in the groove and clamp the four curved pieces in place, making sure that each piece is forced into the bottom of the groove before allowing to dry. For the drawer guides, first cut two pieces from

$\frac{5}{8}$ -in. stock to 16-in. length and rip to exactly 3-in. width. Set these along the lines A and B, Fig. 2, mark for length and cut the ends at an angle to fit the ends of the segments with the outer edge of the piece on the line A; the second piece along the line B. Counter-bore, glue, and fasten the pieces with short screws. The four shorter guides are ripped to the same width and fitted in the same manner along the

lines C and D. The position of these guides will be readily seen from one of the photos.

Spread glue in the groove on the bottom framework. Set the drawer guides square with the opening in the lower frame and clamp the parts together, making sure that the segments are forced tightly into the groove. Drive screws through from the bottom into the guides. Fill the exposed portions of the groove with plastic wood level with the surface and, when dry, smooth with a fine rasp.

Rip the drawer sides from  $\frac{3}{8}$ -in. plywood to 3-in. width and cut to 6-in. length. Cut the bottoms to  $5\frac{1}{2}$ -in. width and  $5\frac{3}{4}$ -in. length, and round one end of each to the same curve as the drawer front. Run grooves,  $\frac{1}{4}$  in. wide and  $\frac{1}{8}$  in. deep, in the sides, to take the bottom and back. Cut the curved drawer fronts from the bent and grooved piece, allowing about  $\frac{1}{4}$  in. over the actual measurement of the opening it is to fit, as in Fig. 4. Set the dado head to cut

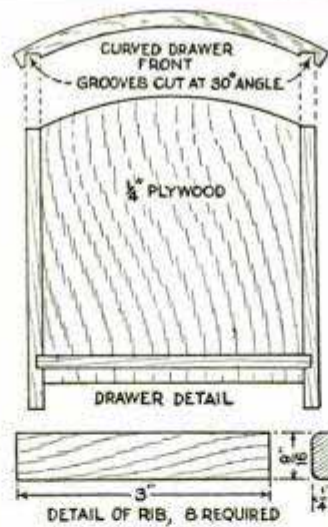
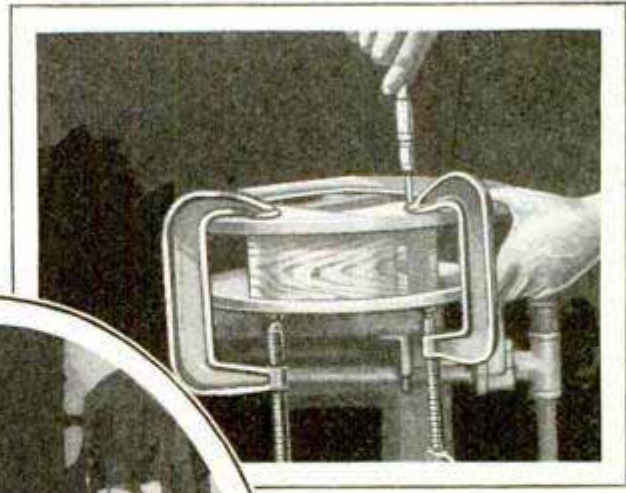
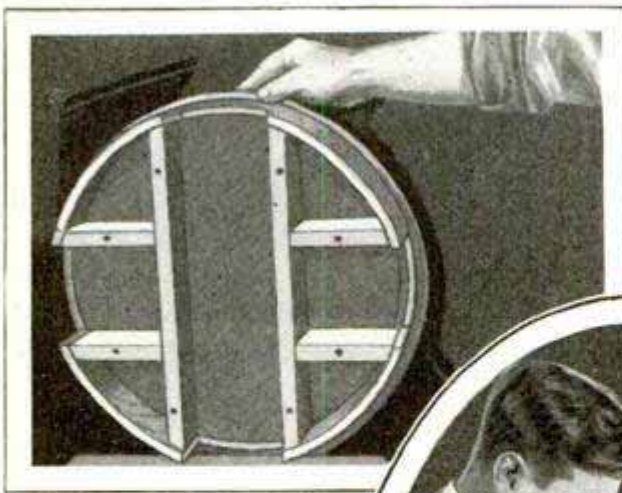

Fig. 4  
Table Top with Segments  
Glued and Clamped in Place  
in the Groove in the Under-  
side





a groove,  $\frac{3}{8}$  in. wide and about  $\frac{1}{2}$  in. deep. Mark the outer edges of the grooves the same as the width of the drawer, or  $5\frac{3}{4}$  in., and then set the piece against the crosscut guide with the convex side up. Bring the outside cutter of the dado exactly to the line. In this way the groove is cut to the correct angle. Hold

the piece firmly against the guide when running the grooves. Assemble the drawers with glue and clamps. When dry trim the front and sides to fit in the individual openings. Tack a strip to the side of the two long guides to act as a stop for the two drawers fitting in these openings.

The beading and hollow fluting on the column and legs, as shown in the photo of the finished piece, is optional. The base looks very well when left plain, with the edges of the legs simply rounded and sanded very smooth. However, this work is easily done with a gouge, should it be desired.

Counterbore each leg for a single large screw, as shown in Fig. 1. Hollow the joining end of each leg on the sand drum or with a wide sweep gouge to fit the column. Lock each leg in place with a large screw, using glue on the joining surfaces and being careful to get the legs equidistant around the column. Fill the holes with plastic wood, and, when dry, sand smooth. The legs may be doweled

Left, Underside of Top with Drawer Guides in Place;  
Right, Screwing the Bottom Frame to the Guides

and clamped over glue where time is not a consideration, though the method described defaces the work so very little that the saving in time is worth while.

Cut the piece B in Fig. 1 to 10-in. length and rip to 8-in. width. Locate the exact center and bore a 1-in. hole. Saw the piece A to 3-in. diameter.

Cut rabbets at the ends of piece B 1 in. wide and  $\frac{5}{8}$  in. deep, as shown at C. Set this over the column dowel and drive down tight on shoulder; then trim the projecting end of the dowel flush with the surface. Bore a small hole at the center of the circular piece C, and screw it to the end of the dowel. Set the table top in place, with the inner edges of the lower frame set on the rabbets in the ends of the piece B. Drive small screws into the lower frame at the rabbets. This assembly allows the table top to be turned on the column. Round off the edge of a length of  $\frac{3}{16}$ -in. stock and rip off a strip  $\frac{1}{4}$  in. thick. Cut this into eight pieces, each 3 in. long, and nail these at each side of each drawer to form the "ribs" of the drum top. Use small brads and set in the heads.

If quartered oak is the wood used, first stain the wood lightly with silver-gray stain. Sand lightly and fill with white lead, reducing the lead to a paste with turpentine. Rub off with a coarse cloth until only the grain shows light. Allow



to dry and give two coats of flat varnish. Rub with rottenstone and oil to a smooth finish. If walnut, sand and fill the wood, stain and allow to dry, then sand lightly and give the two coats of flat varnish. Polish in the same manner as described above. Fasten small brass or bronze pulls on each of the drawer fronts.

### Double-Purpose Cutting Pan

Only the larger shops possess magnetic machines for separating brass and cast-

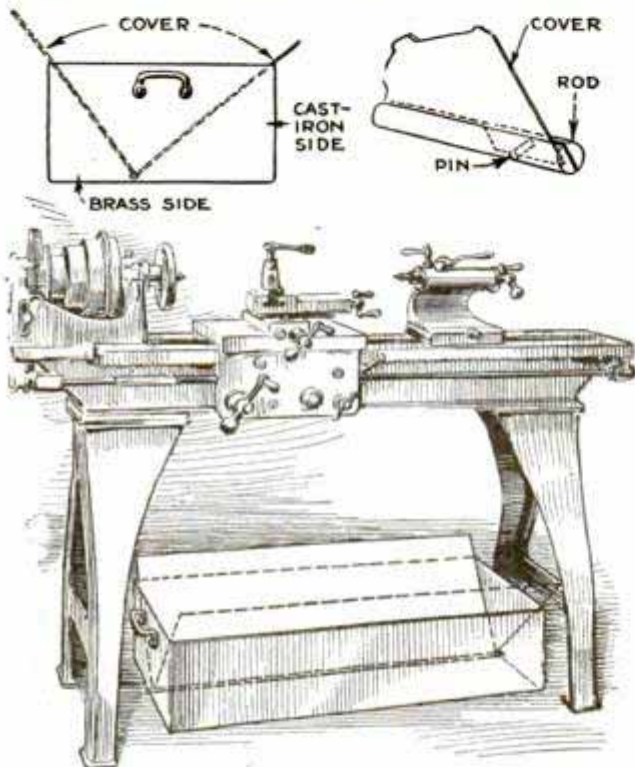

Cover of Cutting Pan, Pivoted at the Bottom, Separates Brass and Cast-Iron Cuttings

iron cuttings and consequently, when a lathe is used for working both materials in a small shop, the space beneath the lathe, and the pan or box used to catch the cuttings, must be cleaned each time a change is made. The time consumed in doing this can be saved by using the novel pan shown in the drawing, the cover of which, being hinged at the bottom, forms two compartments, one of which is open when the other is closed. The cover is made of a length of rod slightly longer than the pan, and a piece of sheet metal the same length as the inside. A slot is sawed in the bar at each end, and the sheet metal is cut to leave two projecting pieces to fit into these slots. The ends of the rod are drilled for pins and a hole is drilled through each end of the pan,

close to the bottom, to take the rod. The parts are then assembled and the pins are driven in when the rod is in the holes in the pan. In this particular case, the rod is off center so that more space is left for cast-iron cuttings, which is the metal mostly used. The cover is tipped to one side or the other to keep the brass cuttings in one compartment and the cast-iron in the other.—Harry Moore, Hamilton, Can.

### Prolonging Life of Road Maps

Paper road maps, subjected to frequent use and exposed to moisture, soon become worn out. This trouble can be remedied by mounting them on oilcloth or any rubberized fabric. Paint the back of the map and the cloth side of the oilcloth with ordinary rubber cement. Scrape all the surplus cement off, allowing only a thin film to remain. Let this dry thoroughly and then apply a second coat of cement to both surfaces. When this is dry, press the map firmly against the backing material. Starting from the center, use a short, smooth piece of wood, or preferably a roller, for pressing the map down evenly to eliminate all the wrinkles and blisters. This method is particularly useful for aviators' flight maps, which are often exposed to wind and rain. In the case of aerial strip maps, which are cut into 6½-in. strips, each covering 50 miles of ground, place them on the backing in the way just described, but separated about  $\frac{3}{16}$  in., to provide space for folding. The army air corps uses hundreds of square feet of old balloon cloth for this purpose each year.

### Old Driveshaft Makes Good Crowbar

A strong crowbar, which cannot be bent by the combined efforts of two men, may be made from a discarded driveshaft of a model-T Ford. The threaded end is cut off and the rough spot filed or ground down so that it will be easy on the hands, while the other end is cut off at an angle as shown.—J. A. Blaker, West Auburn, Mass.

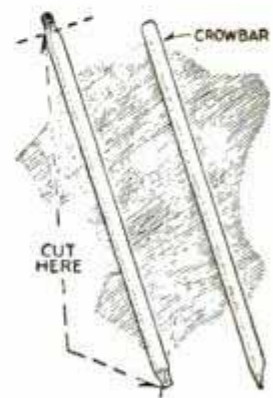



## HORSE PLANE WITH BROADAX BIT SQUARES LOGS

When we want to hew logs to shape, we save labor by making our horses provide the power for our "planing mill." The plane consists of a 4 by 8-in. by 12-ft. plank, sawn in two to make a block 6 ft. long. Each piece has a slot cut in it as shown in the drawings, and back of the slot a seat is cut to form a bed for the plane bit, which is a common broadax. The slope of the bed is made to suit the bevel of the ax, the lower bevel being almost parallel with the bottom. The planks are fastened together with three 1-in. dowels and a piece of pipe, the latter being used as a dowel at the front end. Two runners are nailed to the sides of the block to keep the "bit" off the ground when drawing the plane from one log to another.

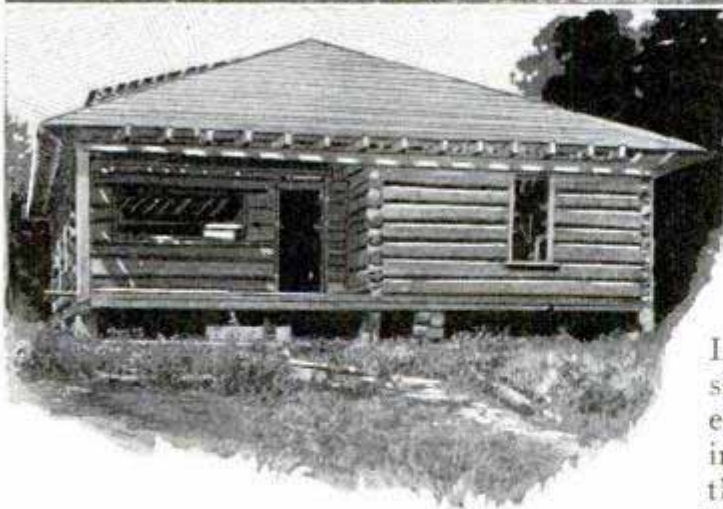
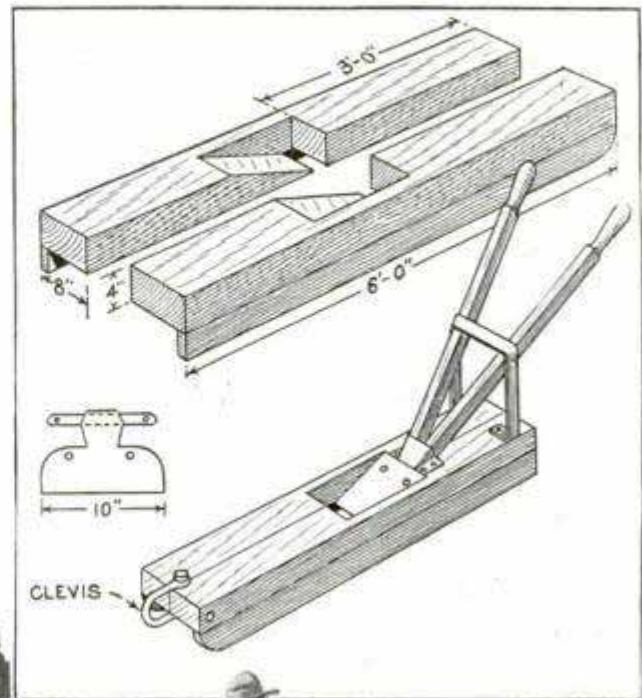

Log Plane Uses Horses as Power and Broadax as Bit; Left, Canadian Ranch House Built of Logs Hewn with the Plane

We hew two logs at a time, running the plane down one log and then back on the other, to save time. In most cases it is necessary to set a short post in the ground in front of each log to take the thrust. The shavings should not be more than  $\frac{3}{8}$ -in. thick, and, of course, the wider the blade of the ax the bigger the logs that can be handled.

The ax is held in place with four bolts, two holes being drilled in the shoulder of the ax and a piece of  $\frac{3}{8}$  by 1-in. flat iron driven through the eye for the other two bolts. The nuts and washers are counter-bored into the underside of the block.

Shakes can easily be made by sawing across the log. We hew from twenty to thirty logs a day, and the shavings, when dried, make excellent kindling.—Eden W. Robinson, Bear Flats, B. C.



## HANDY AUTO TRUCKS FOR THE SMALL PAINT SHOP

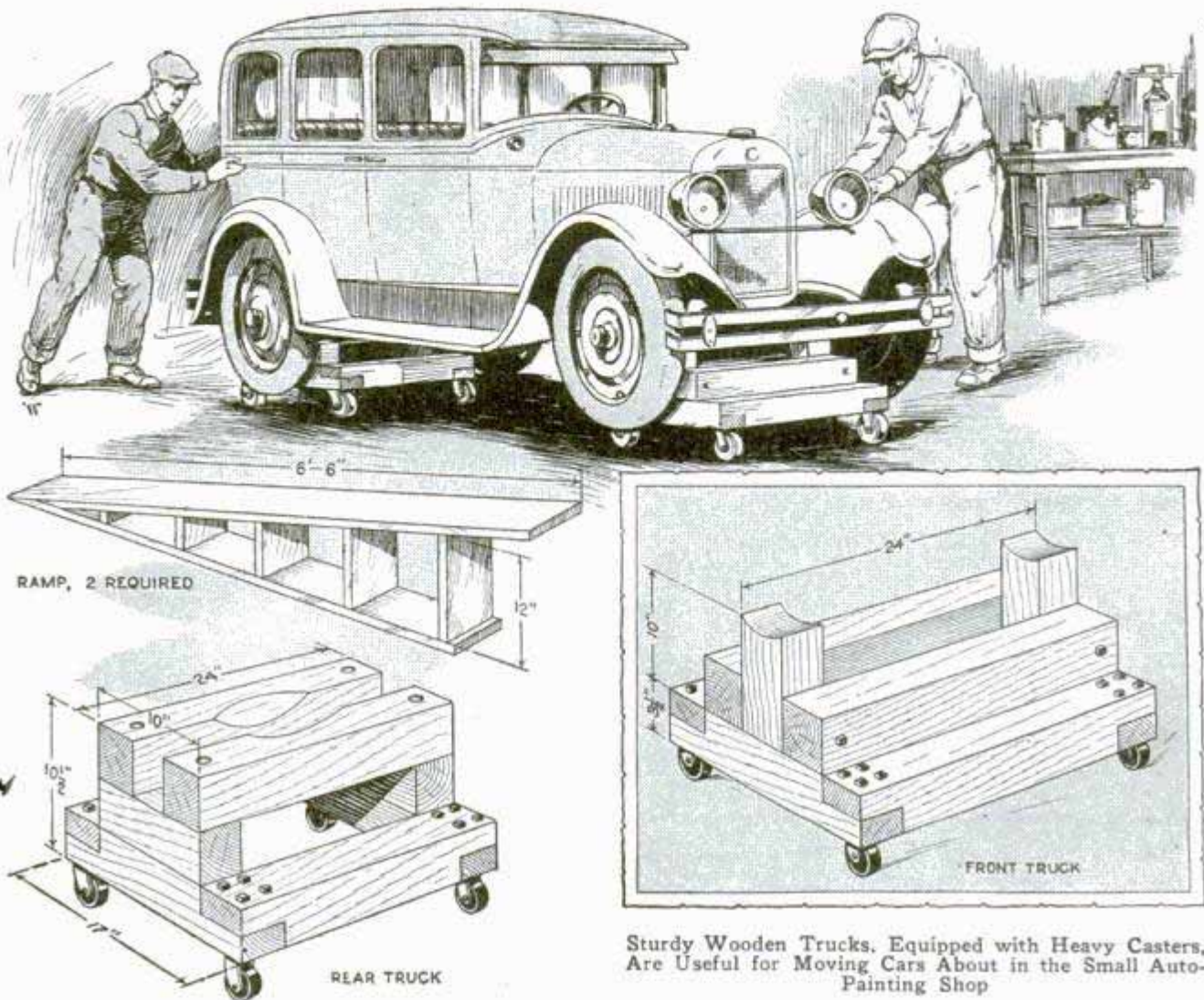

Sturdy Wooden Trucks, Equipped with Heavy Casters, Are Useful for Moving Cars About in the Small Auto-Painting Shop

In small auto-painting shops where space is rather limited, the couple of trucks shown in the illustration will be found a great convenience. They were specially designed to move the cars about as required, when stripped of wheels and accessories, which, according to customary practice, is the first thing done before cleaning and painting the cars. After being mounted on the trucks, the cars can be moved to the wash rack, rubbing room, color-varnish room and finishing room. The constructional details of the front and rear trucks are shown in the drawing and no difficulty should be met in making them. Two ramps are also provided, as shown in the detail, so that the cars can be run on the trucks under their own power, which eliminates the necessity of using jacks. First the front wheels are partly run up the ramp until the axle is elevated far enough to permit the front truck to be placed directly under it, and then the same

procedure is followed in mounting the rear axle on the other truck. Large swivel casters allow the trucks to be moved about in any direction.—E. E. Moffat, Pasadena, California.

#### Tool for Removing Broken Axle

For removing a piece of broken rear axle from the housing, a handy tool can be made from a piece of broomstick and a 5-in. pipe nipple. The latter is slipped over the end of the broomstick so that 2 or 3 in. projects, and a hole is drilled through both to take a pin or screw to hold the assembly together. In use, the pipe end of the tool is inserted into the housing to fit over the piece of broken axle. Then the handle is brought over toward one side, which will bind the nipple on the broken piece, after which it is an easy matter to remove it. This method has been used for some time in a large



garage and has been found entirely satisfactory in practice.—Carlton Groat, The Dalles, Ore.

**Blacksmiths' Crane for Heating Heavy Tires**

Blacksmiths will find the illustrated crane of considerable utility for holding heavy tires in the fire. It consists of a standard and arm of 4 by 4-in. stock, mortised and fastened together at the desired height by means of a strap bolt screwed to the top of the arm and passed through the standard. A shouldered pin of 7/8-in. stock was driven into each end of the standard to provide pivots. The ends of the standard were also banded to prevent splitting. A lever for handling the crane was made of 1/2 by 2 by 2 1/2-in. soft steel. A loop, to serve as a guide for the lever, was bolted to the arm, leaving a little vertical and horizontal play, to prevent the handle of the lever from catching behind the pins, which are driven into the standard for the purpose of holding the lever in place when not in use. A hook for lifting and carrying the tire is fitted to the end of the lever as indicated. The work can be moved from the fire

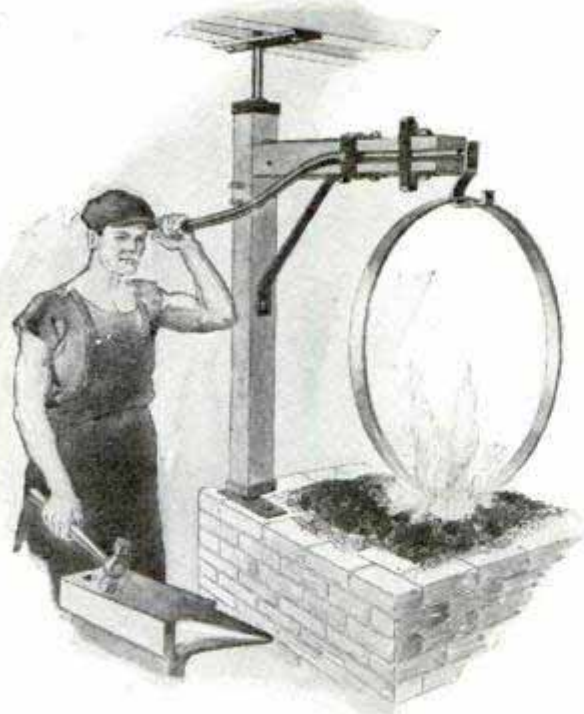

Blacksmiths' Crane Transfers Heavy Tires from Fire to Anvil

to the anvil and vice versa without any trouble.—Roy McLalan, Lexington, Mass.

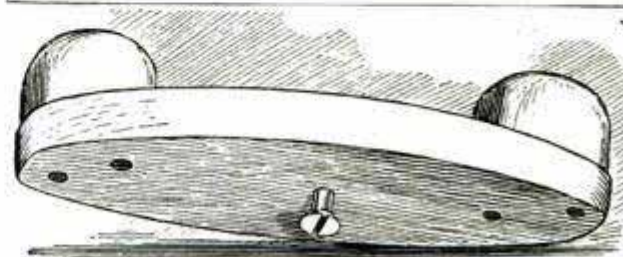

Block of Wood Fitted with Two Handles and a Sharp-Edged Screw Makes a Good Router

**Simple Homemade Router**

For the home mechanic who has only a few tools, the router illustrated herewith will be found convenient. It consists of a suitable oblong block of proper length, fitted with a handhold at each end and a screw on the underside, projecting the same distance as the depth of the routing. The screw head is filed to a sharp edge so that it will cut through the wood readily.—E. K. Wehry, Cedar Rapids, Iowa.

**Fireproof Paint**

To make a good fireproof paint, slack stone lime by putting it into a tub, covering the tub to keep in the steam. When it is slacked, pass the powder through a fine sieve and to each 6 qt. add 1 qt. of rock salt and 1 gal. of water. Then boil the mixture and skim it clean. Next, to each 5 gal. of this mixture add 1 lb. of pulverized alum, 1/2 lb. of pulverized copperas or copper sulphate, and after these ingredients have been mixed, add 3/4 lb. of powdered potash, and 4 lb. of either very fine sand or hickory ashes. Now give it any desired color and apply it with a large brush. This paint is as durable as slate. It will stop small leaks in roofs, prevent moss growth, make bricks impervious to moisture and make any surface fireproof.—Louis Andrews, St. Louis, Mo.

5918 Highland Ave

*A. Slaughter & Co. 159 W. Kenzie, Chicago*



### Redriving Projecting Floor Nails

A nail projecting, however little, above the surface of the floor, is always danger-



This Tool Detects and Hammers Down Dangerous Projecting Nails in the Floor

ous. Machine shops and warehouses using trucks are often troubled in this way, the vibration working up nails here and there. In one plant, a man was detailed to go around periodically to knock down any projecting nails. Accumulation of dirt around the floor joints often makes it difficult to see such nails, and for this reason a special tool was devised to locate them. It is a combination floor scraper and driver, a cross section being shown in the illustration. A projecting nail stops the scraper and one blow on the driver will send it home again. The tool consists of a vertical tube, one end of which is cut away to about half its diameter. The driver is a piece of shafting fitting loosely in the tube. A hole is drilled in the top end of the driver to take the end of a spring lifter, the coiled end of which fits snugly on the handle, which is brazed or welded to the tube. The driver is held about  $\frac{1}{8}$  in. above the floor by means of the spring.—Harry Moore, Hamilton, Can.

### Cleaning Bus Exhaust-Heater Pipes

Exhaust pipes and exhaust-heater pipes often have right-angle bends, which make it impossible to clean them by means of rods and scrapers. The cleaning can be quickly done in the following way: The heater pipes are removed from the bus and filled with kerosene, which is allowed

to stand in them for a short time, so that the oil may penetrate the carbon. Some wood chips are then saturated with kerosene, set on fire and inserted in one end of the pipe, after which a moderate air blast is applied to the burning wood. The carbon takes fire and the pipe will get red-hot. If there are any brazed joints, they should be kept cool with water to prevent them from loosening. It is a good idea to make an iron plug to fit the pipe and to screw the air-hose connection to this in order to force the air through the pipe. A 10-ft. pipe, badly sooted, can be cleaned in from 20 to 30 minutes in this way.—Ernest Romkee, Colorado Springs, Colorado.

### Tool for Removing Valve Guides

Removal of valve guides is an easy matter with the tool illustrated. It consists of a rod with an offset at the bottom, to be slipped under the valve guide as indicated, and a suitable head at the top end under which the claws of a pinch bar are pushed. A small wooden block is pushed under the bar to serve as a fulcrum and downward pressure on the bar causes the pulling rod to lift the valve guide.—G. A. Luers, Washington, D. C.

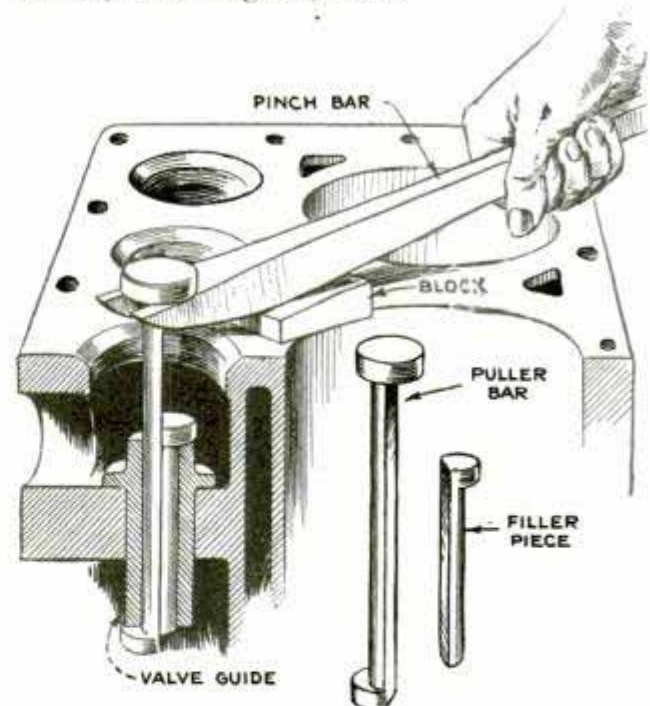

Pulling Rod and Pinch Bar Are Effective in Removing Valve Guides

Do not heat the work above a bare red heat when casehardening for colors, using cyanide.



# Poultry Ranch Designed for the City Lot

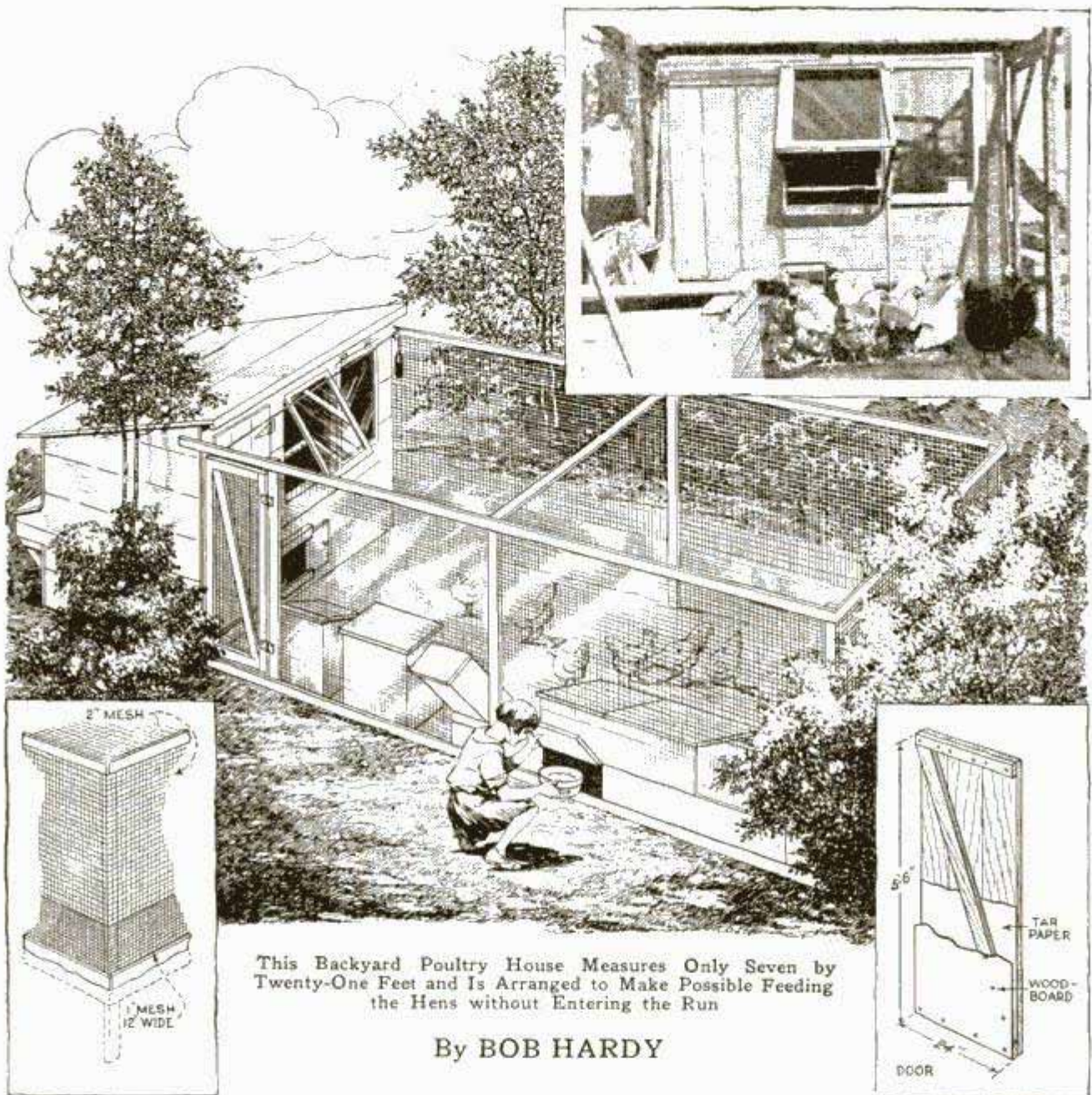

This Backyard Poultry House Measures Only Seven by Twenty-One Feet and Is Arranged to Make Possible Feeding the Hens without Entering the Run

By BOB HARDY

**R**AISING poultry on a small scale in the backyard is a very interesting diversion and keeps the table supplied with fresh eggs and tasty young fryers and broilers. The hens also solve the problem of disposal of most of the kitchen refuse, especially in the summer when there are so many melon rinds, vegetable parings, etc., turning this waste into eggs and meat. Lawn cuttings, weeds and the like are also valuable additions to the hen-house menu. At the same time the plant produces fertilizer which the home gardener will appreciate.

The construction of the hen house is clearly shown in the drawings. Although

2 by 4-in. stock is specified for all timbers, lighter stock can safely be used, as the framework is well braced. The bracing is important, for in high winds great havoc is wrought among poorly constructed hen houses. Build up the entire framework before laying the floor, and see that all studs are vertical, by using an improvised plumb line, consisting simply of a cord with a weight, nailed at the top of the stud or corner post so that it hangs about 1 in. from the timber. Corners of the floor frame should rest on large rocks or concrete blocks and must be absolutely level. If you have no level, a pan of water will do the trick. The siding specified is



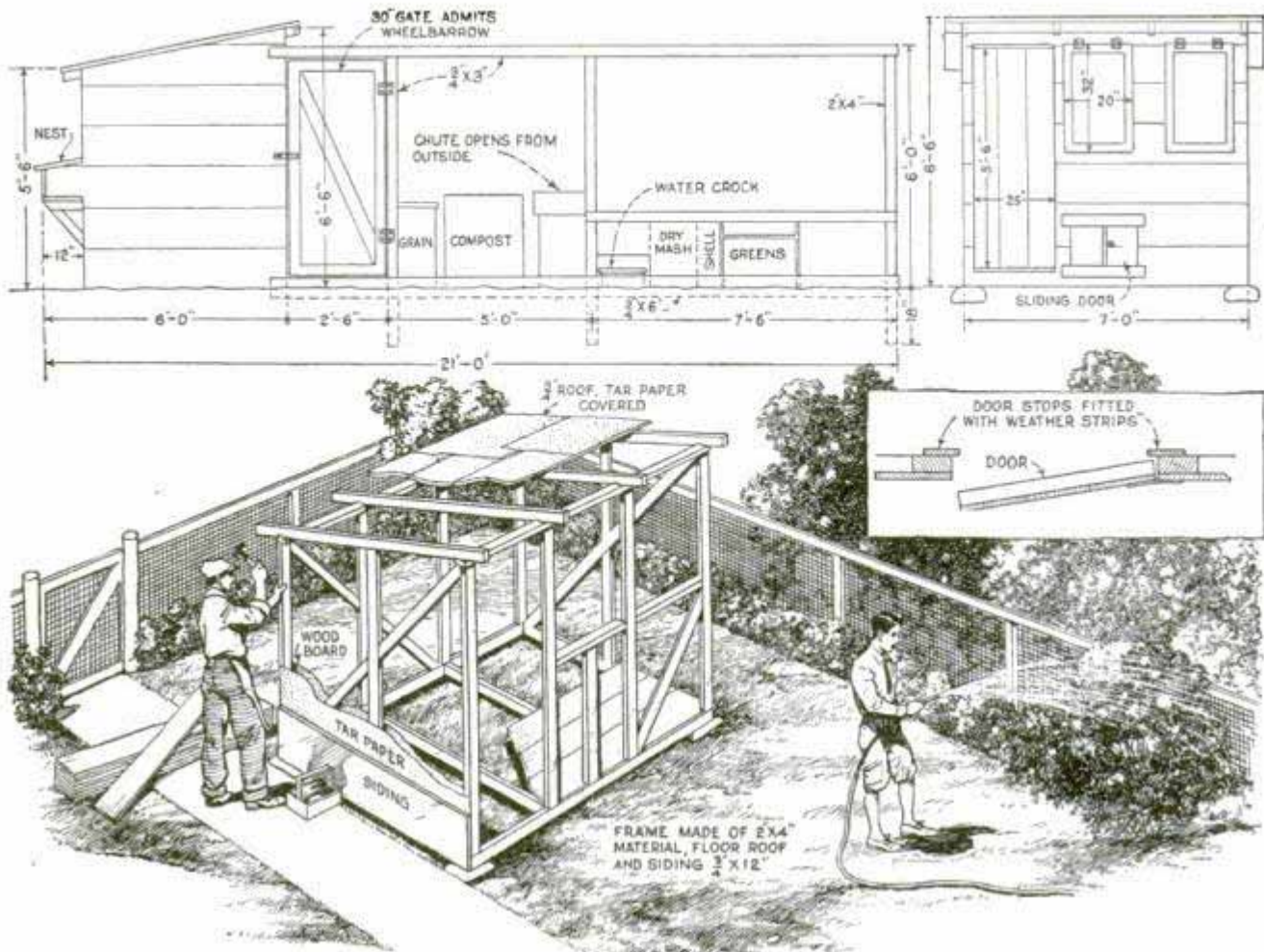

Constructional Details and Dimensions of the Hen House and Run, Showing How Easy It Is to Build One; Vines and Shrubbyery Can Be Used to Conceal It and Provide Shade

$\frac{3}{4}$  by 12-in. yellow pine. The wood should be well seasoned, so that it will not shrink under the summer sun and leave cracks for rain to enter during the wet season. Tack tar paper, or building paper, to the framework before putting on the siding. The floor is of the same material as the siding. Woodboard, laid beneath it, will help to insulate the house against cold. Lay standard roofing paper over the roof boards, lapped as shown in the drawing, and cemented with roofing tar. Note that there is an extension on the rear side for the nests, which eliminates the necessity of entering the hen house to gather eggs. The extension is divided into five compartments, each about 12 in. square, for the laying nests, and the remainder of the space is partitioned off for tools, insect powder and other accessories. Install a woodboard lining before the partitions are set. A strip, about 3 in. wide, is nailed along the studs in front of the nests, to prevent straw from being spilled out. A shelf, about 8 in. wide, is also provided for the hens to alight on when hopping up

to the nests. Seal the walls and ceiling tightly with woodboard. It makes a smooth interior which is easy to keep free of cobwebs and insects. A slot, about 3 in. wide and extending between two rafters, should be cut in the ceiling woodboard at the left rear corner and also the right front corner, for air circulation. Just below the intake slot, install an 8-in. board, as shown, to serve as a draft deflector, so that the cold air will not flow down directly on the hens. The roost frame consists of two 2 by 4-in. side members, supporting four roosting poles spaced about 12 in. apart. Round poles, about  $1\frac{1}{4}$  in. in diameter, make very good roosts, but either square or rectangular poles will do, provided the corners are rounded. They should be fairly smooth and must be sprinkled occasionally with insect powder. The roost frame is hinged to the wall, as shown, and it should extend from one side of the house to the other with just enough clearance of the end members to allow their swinging up out of the way by means of cables.

Windows, about 20 by 32 in. in dimen-



sions, admit plenty of sunlight, but other sizes will do as well, provided you alter the framework to fit them. They should be arranged to swing out in the daytime during fair weather, and should fit snugly against stops when closed with a dependable fastener. A notched stick, attached as shown, enables adjustment. In hot weather, they can be removed entirely or fitted with a cloth shade or standard window shade that can be pulled down over them. Weather strips along the stops of the door will keep out all drafts. A sliding door is provided for the poultry and should be kept closed on cold winter nights. The opening should be about 8 in. wide and 10 in. high. Building the outdoor run is a very simple job. The framework is built up of 2 by 4-in. posts with a 3-in. strip at the top and a 6-in. strip at the bottom. The latter is set halfway into the soil to prevent the hens from digging underneath. It is also a good idea to have the level of the poultry run 2 or 3 in. above the surrounding ground, so that it will drain off in wet weather. Fine wire mesh, 1 ft. wide, should be used at the bottom of the frame to keep the baby chicks in, and the remainder, as well as the top, should be covered with 2-in. screen mesh. The top really is covered to keep out prowling cats and also to keep in certain breeds, such as white leghorns, which otherwise could fly out easily. Make the gate about 30 in. wide, to admit a wheelbarrow for hauling out the compost. A weight on a cord over a pulley keeps the door closed.

The feed box has compartments for a water pan, dry mash, oyster shell and grit, and lawn cuttings. By having a roof over the box, feed and water are less likely to become fouled. One filling of shell serves a month or more. Lawn cuttings and other green food so necessary to egg production are supplied by a hopper made of 2-in. wire mesh, which can be filled from the outside of the pen. Grain is kept in a separate bin near the gate. This is built with the bottom a few inches above the ground and is lined with wire screen as a protection against mice and rats. The whole occupies only 7 by 21 ft. and can be concealed from view with vines.

Caring for the hens is a very simple matter and averages less than half an hour

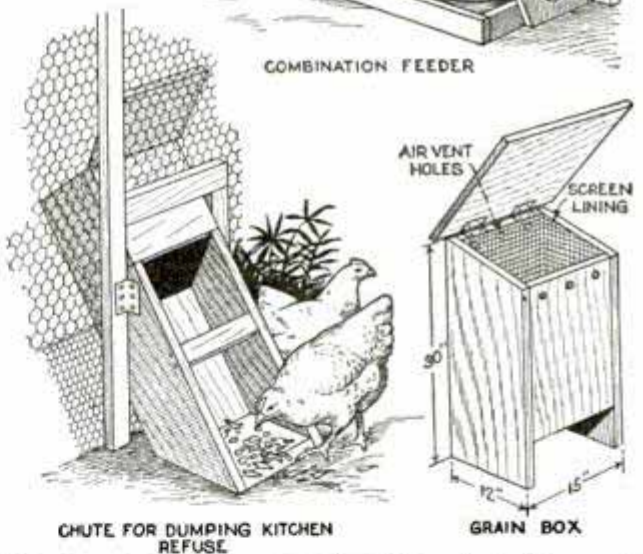
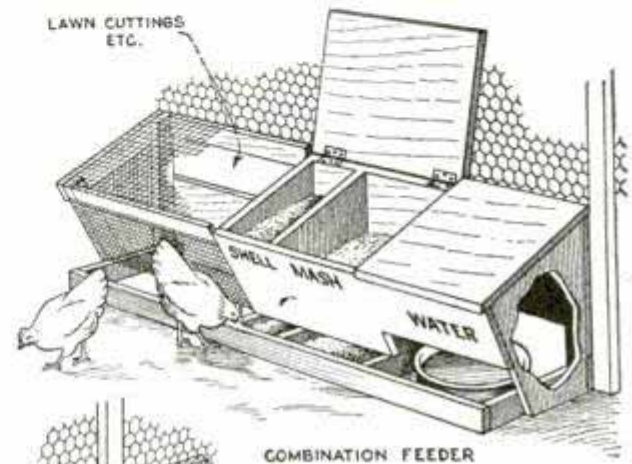
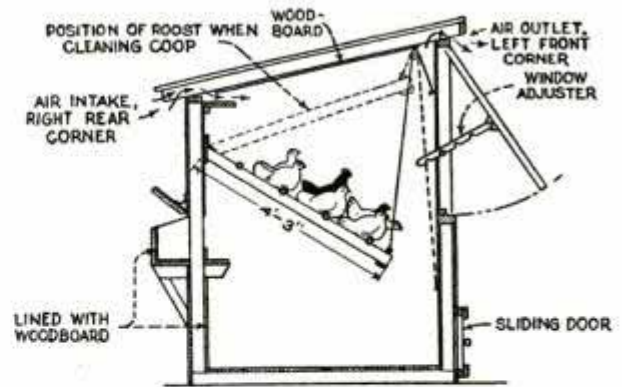

The Roost Board Can Be Raised Out of the Way, and the Hoppers Are of the Self-Feeding Type

daily. Feeding costs are nominal; one handful of grain per fowl each day, and two other meals of table leavings, with grass or other green food added when available. A quarter's worth of cracked oyster shells will last two or three months. A hundred pounds of dry or laying mash, and 100 lb. of scratch grain will last about five weeks for 24 hens. Thus the total feed expense is less than \$5 per month, while, on the other hand, the writer's hens produce close to four dozen eggs weekly the year around, and also provide meat for the table when desired, the older hens being replaced with younger ones.





A Battery-and-Tool Truck for the Service Station Is Highly Convenient

### Handtruck Carries Storage Batteries

Instead of carrying storage batteries from his customers' cars to his shop for inspection or charging, the owner of a battery-service station uses a small hand-truck. It is made from an ordinary cart axle fitted with wheels, and the handle, extending upward at an angle, can be made of wood or pipe. Two boxes are permanently attached to the truck, as shown, the lower one to hold batteries, and the upper one carrying all the tools necessary to remove, install and test batteries in the car. A suitable leg is provided so that the truck can be left standing without risk of tipping over while the battery is in a horizontal position. As the battery tools are at hand, the service man does not waste time on frequent trips to the shop for tools he has forgotten, which favorably impresses the customers.—K. M. Coggeshall, Webster Groves, Mo.

### Improved Pinion Made of Babbitt Metal

While doing some repair work in a remote mining camp, it was necessary to cut some threads on a lathe, and the only one available was in very poor condition. Some of the change gears had been lost, and among those was one that I needed for the job at hand. There was no milling machine so I could not cut a new pinion.

The difficulty was overcome by improvising a pinion of babbitt metal. Setting up some change gears on their studs, I ran a strip of tin between them, the tin taking the shape of the teeth. I then turned a piece of wood to the right diameter and wrapped the tin around it leaving quite a portion projecting over the edge. The butting ends of the tin were carefully matched and it was then tied on, making a mold into which melted babbitt was poured. The resulting casting was drilled and a keyway cut. Although the teeth of this pinion were not exactly the shape desired, it did the work and saved the time it would have taken to send for another pinion.—M. L. Lowrey, Livermore, Calif.

### Inexpensive Garden Poles

The problem of providing inexpensive yet satisfactory garden poles for pruned tomato vines, beans and the like, may be quickly solved by using a secondhand building lath. The upper part of the pole consists of a single lath, the lower 6 in. of it being straddled by two lath, which form the other half of the pole. The length will be about 6½ ft. The end where the two

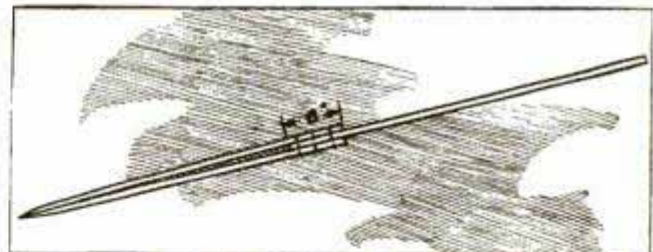

Three Lath Nailed Together at the Center Make a Good Garden Pole

outside lath come together is planed to a point and the whole nailed together as shown, so that the pole can easily be driven into the ground.

### Helps for Home and Shop

**YOU CAN MAKE IT**—One hundred illustrated articles telling how to make toys, furniture and dozens of other things from old boxes and odd pieces of lumber. Price Ten Cents.

**POPULAR WOODTURNING**—Especially written for the amateur, this book should be in the kit of every home workshop owner. Price Twenty-Five Cents.

**MODERN HOME INTERIORS**—Crammed full of suggestions for the home owner who likes to make his own built-in conveniences. Price Ten Cents

Order any of the above from the Librarian, Popular Mechanics Magazine, 200 E. Ontario St., Chicago, inclosing the proper amount in stamps or coin.



# Finger-touch CONTROL

*gives you*

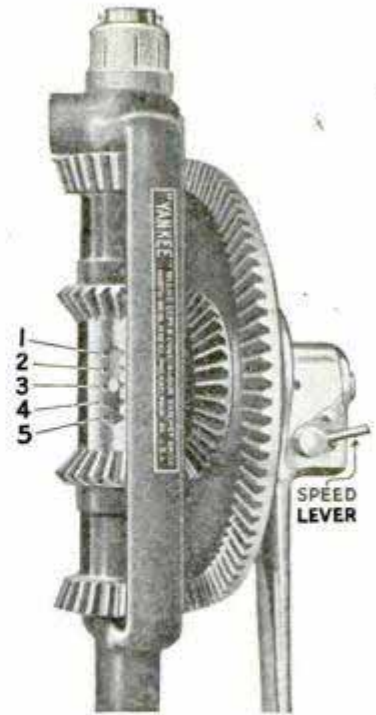

"Yankee" Ratchet Breast Drill No. 1555, in use on airplane motor. (Photograph by permission Pitcairn Aircraft, Inc.)



"Yankee" Ratchet adjustments bring awkward jobs out into the open.

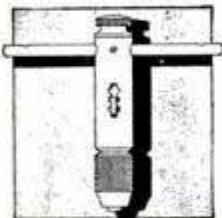

Use "Yankee" Tap Wrench No. 250. Ratchet adjustments and sliding crossbar make awkward jobs easy. Price...\$1.85



- Plain Drill (1)
- Left-hand Ratchet (2)
- Right-hand Ratchet (3)
- Double Ratchet (4)
- Gears Locked (5)
- Two Speeds

WHEN accuracy depends on the "feel" of the work, and you must know every instant where your drill is going and how it is cutting, the tool to use is a "Yankee" Ratchet Drill.

With a "Yankee," you drill fast or slow . . . change gears, high power or low . . . change ratchet adjustments. . . . All at a finger-touch and without removing drill from work.

In tight places, "Yankee" Double Ratchet drives drill continuously, on any slight forward-and-back motion of crank.



Any movement of crank, forward and back, no matter how slight, causes drill to cut continuously.



Drilling out broken studs, and the like, calls for control such as only a "Yankee" Ratchet Drill gives.

No. 1555.—Breast Drill. Length, 17 in. 3-jaw; $\frac{1}{2}$ in. Double speed. Also, 2-jaw. Price.....\$11.00	No. 1545.—Hand Drill. Length, 16 in. 3-jaw; $\frac{3}{8}$ -in. Double speed. Also, 2-jaw. Price.....\$10.00	No. 1530.—Hand Drill. Only $10\frac{1}{2}$ in., but has the five ratchet adjust- ments, 3-jaw; $\frac{1}{4}$ -in. Single speed. Price.....\$5.25
--	---	---

# "YANKEE" TOOLS

MAKE BETTER MECHANICS

NORTH BROS. MFG. CO., Lehigh Avenue, Philadelphia, U. S. A.

I know the economy of good tools: Send me "Yankee" Tool Book, showing Bit Braces with famous "Yankee" Ratchet, Quick-Return Spiral Screwdrivers, Automatic Push Drills, Ratchet Chain Drills, Removable-base Vises, etc.

Name.....

Address..... (pm)





# Drive this car five days to prove your purchase!

*If it does not come up to your expectations, return it. This is the way the Studebaker pledge protects your investment.*

**U**NDER the terms of the famous Studebaker Pledge, you may drive the used car you buy *five days* before you decide. If it does not please you, you may return the car and apply your payment on any car in your Studebaker dealer's stock, new or used.

More than 150,000 thrifty motorists bought Pledge-backed used cars last year. They got good appearance, good performance, and good value with the cars they bought. You will, too, if you buy a pledge-backed used car. And you'll get a 30-day guarantee on Certi-

fied cars — plus plainly marked prices on all cars sold on this plan.

See your Studebaker dealer *first*—get Studebaker Pledge protection when you buy *your* used car—your assurance of satisfaction.

**PLEDGE**  
to the Public on  
**USED CAR SALES**

1. 5 days' driving trial.
2. 30-day guarantee on certified cars.
3. Lowest price marked in plain figures.

**INVEST 2c . . . . .**  
**YOU MAY SAVE \$200**

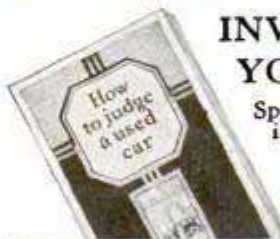

Spend 2c now for your copy of this interesting and instructive booklet, "How to Judge a Used Car"—it may save you as much as \$200 on the used car you buy. Mail the coupon now!

**STUDEBAKER**  
*Builder of Champions*

THE STUDEBAKER CORP. OF AMERICA  
Div. 1510, South Bend, Indiana

Please send me copy of "How to Judge a Used Car."

Name .....

Street .....

City.....State.....



# 24 JOINTS

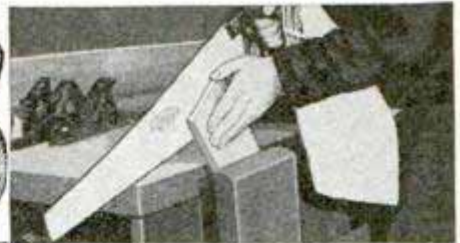

BUTT JOINT

END HALF LAP JOINT

HALF LAP SPLICE

CROSS HALF LAP JOINT

DADO JOINT

MITRED JOINT

MORTISE & TENON JOINT

DOWELED JOINT

DOVE TAIL JOINT

GLUED JOINT

MATCHED JOINT

COPE JOINT

**THE**  
**ATKINS**  
**SAW BOOK**  
*for Home Craftsmen*

**TELLS HOW TO**

- Start a Home Shop
- Select the Correct Saws & Tools
- CUT and FIT the 24 Most-Used WOOD JOINTS**
- Build a Work Bench, Tool Box, etc.
- Suggests 200 Things to Make

**10c**  
• Copy

Issued by the Makers of "SILVER STEEL" Saws

## .....How to CUT and FIT them Correctly

*Shown in This NEW ATKINS 32-Page Book!*

**T**HIS is the book thousands have always wanted—a complete guide to home workshop activities, condensed into 32 pages! It tells how to start your own shop and select the proper tools . . . describes 20 types of saws and their uses . . . shows how to make 24 joints most widely used in wood-working . . . tells how to build saw-horses, work-benches, tool box and wall cabinet . . . suggests 200 other articles for you to construct . . . tells where you can get plans to build them . . . and gives helpful information on sharpening saws.

### Written by an Expert

Prepared by a veteran craftsman, this new book is packed with practical instruction on wood-working and metal-cutting. And on the final pages are shown the leading ATKINS Silver Steel Saws and Saw Tools, which are aiding home craftsmen everywhere to do all their cutting jobs faster, easier and better.

An indispensable book for the beginner, and mighty helpful for the expert! Costs only 10c, but worth dollars to every home worker! Send the coupon with a dime, and get a copy.

### Mail Coupon for Your Book

E. C. ATKINS & COMPANY  
426 S. Ills. St., Indianapolis, Ind.  
I enclose 10c for a copy of "The New ATKINS SAW BOOK for Home Craftsmen."

Name.....

Address.....

My dealer is.....

## WOOD JOINTS and How to Make Them!

With this new book, you can quickly learn the secrets of making strong, accurate joints. Easily-followed drawings, photos and explanations show you the best way to mark, cut and fit all these joints—butt, halved, lap, dado, rabbet, miter, mortise-tenon, dowel, glued, coped, matched, splined, dovetail, etc. Tells where each type of joint should be used. This section on JOINTS alone is worth many times the price of the book. Write for your copy NOW.





# LePage's Waterproof Glue

*High Strength and Weather-Resisting*

**Now Offered in Convenient Packages**

**for Home Use**

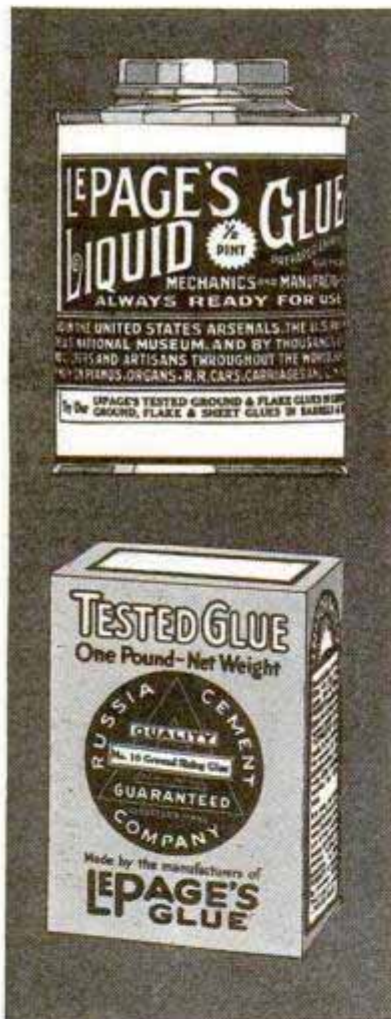

### *LePage's Tested Hard Glue*

If you prefer to use a hard glue, ask for LePage's Tested Hard Glue. Tested for uniform quality. No experimenting with each new lot to see how much water to add, or how long to cook.

### *LePage's Liquid Glue*

Always ready for immediate use. No bother of preparation. Easy to work with because it sets slowly enough to give you plenty of time to adjust joints. Makes lasting joints of tremendous strength.

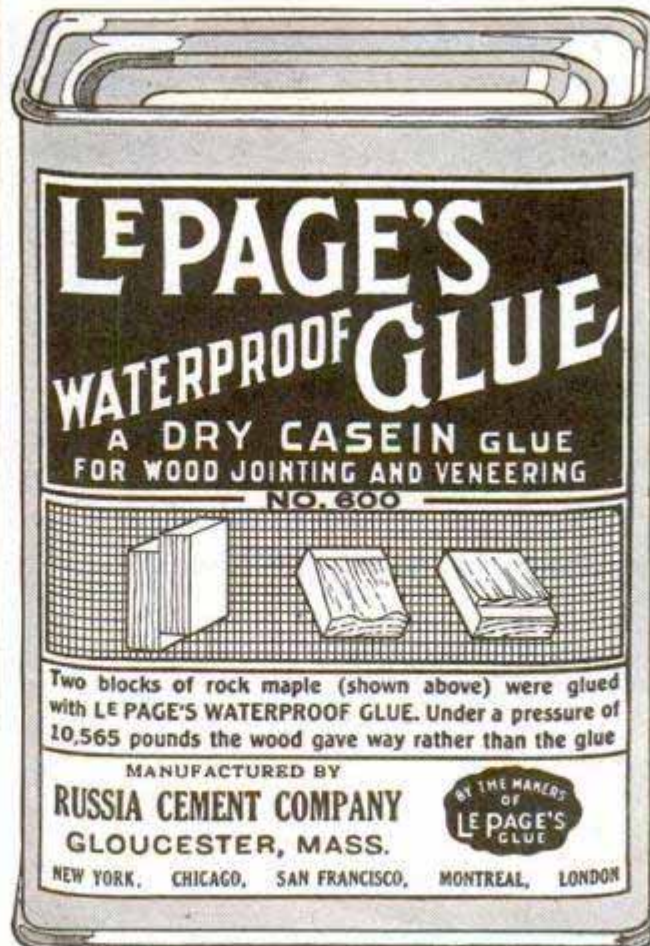

You've seen cans of LePage's Liquid Glue wherever things are made. You've probably used it yourself. But do you realize that LePage's also makes a waterproof glue? Often you have need for it in making joints that must stand up, impervious to moisture, indoors or outdoors.

Glue makes all joints stronger even though you also use nails or screws. Any cabinet-maker will tell you that the quality of your finished work depends upon the strength and permanency of joints.

Whatever kind of glue you like or need to use, LePage's makes it—Liquid, hard or waterproof. Stronger than the fibers of the wood they join. Every batch tested to stand 3000 lbs. shearing strain per square inch.





# PRECISE MACHINES SERVE DIAL TELEPHONES

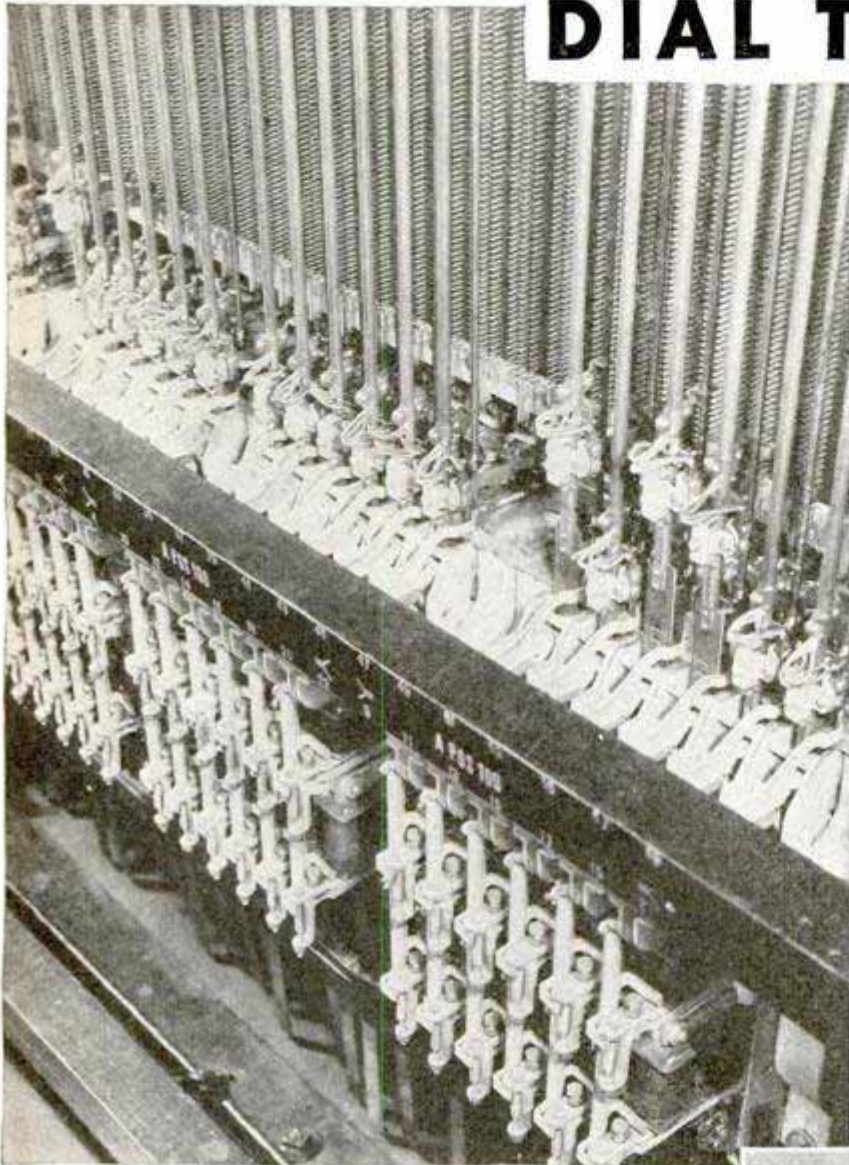

In the switch rooms of the big exchanges, complicated mechanism snaps smoothly into action when you lift the receiver of your dial telephone.

On most calls, your finger, dialing the number, is the only human touch. Machines do the rest . . . machines so complicated and so delicate that almost every part must be held within the most rigid limits of accuracy. A mis-adjustment of a thousandth or two in the terminal selectors at the left, for example, would give you a wrong number.

The precision of telephone switching equipment is a matter of scrupulous care . . . and fine tools. Tools like Starretts.

When you use Starretts, you use the same tools that are responsible for the faultless performance of most of the intricate machines which serve our age. In your home shop, or at your serious work, Starretts will bring surer precision to your hands, a new pride in craftsmanship.

In the new Starrett Catalog No. 25 "AP" appear over 2500 Starrett Tools, almost all of them designed for wood and metal-working shops. The coupon will bring your copy.

Above: Western Electric Selector Frame, the mechanism which selects the exchange trunk over which your call is routed. Photo, courtesy New England Telephone and Telegraph Company. Right: Starrett Micrometer Depth Gage No. 440, typical of the precision tools which skilled machinists prefer; Starrett Steel Tape No. 530 and Starrett Pocket Slide Calipers No. 425, two of the many Starrett Tools which belong in every kit. Below: the coupon. Send it for your copy of Starrett Catalog No. 25 "AP."

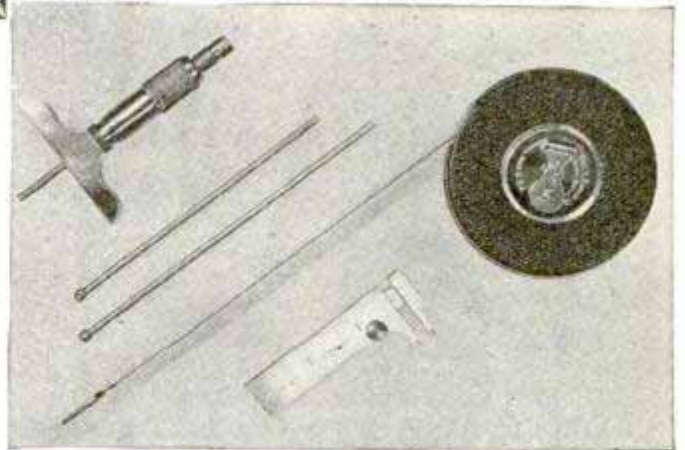

THE L. S. STARRETT COMPANY  
ATHOL, MASSACHUSETTS

Please send me Starrett Catalog No. 25 "AP."

Name .....

Street .....

City ..... State .....



50th Anniversary of Starrett  
Tools 1880-1930

# Use Starrett Tools





## Twist the Throttle and the Roads Are Yours

Ride away—over the Thrill Trail—on your Harley-Davidson! Where away? Out to the lake—fish strike hard in the Fall. Over to the marshes for some shooting. Or just out over the roads for a lungful of keen Autumn air, and the thousand thrills of motorcycling, Greatest Sport on Wheels.

### THE 1931 MODELS ARE OUT

—new Twins, Single, and Sidecars. Many big improvements—better looks and performance than ever. See your dealer.

All roads are yours when you open up the amazing power and speed of a Harley-Davidson. You don't need concrete highways—let the auto parades have them, while you whirl away over the roads and trails that wind through Sportland.

Have you seen the 1931 Harley-Davidsons? A dealer near you wants to show them to you, tell you about his easy Pay-As-You-Ride Plan. Drop in on him today.

Send the Coupon to us for free literature

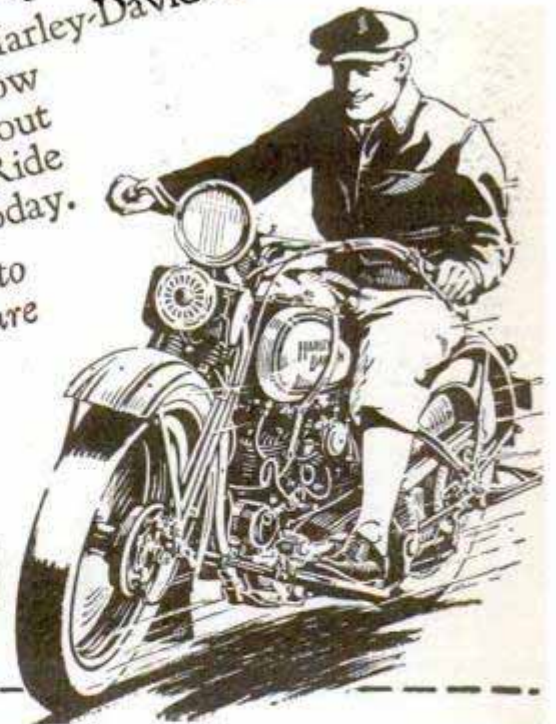

Ride a  
**HARLEY-DAVIDSON**

Mail this Coupon

HARLEY-DAVIDSON MOTOR COMPANY, Dept. P. Milwaukee, Wis.

Interested in your motorcycles.  
Send literature.

Name.....

Address.....

My age is  16-19 years,  20-30 years,  31 years and up,  under 16 years. Check your age group.





Montgomery Ward & Co. Retail Store, Denver, Colorado. Presdwood used for lining forms (Rocky Mountain Photo Co.)

Cincinnati Bell Telephone Building. 140,000 sq. ft.  $\frac{1}{8}$ " Presdwood used for lining concrete forms.

Ohio Bell Telephone Co., Dayton, Ohio. Interior showing slab, beam and column construction. Presdwood used to line all forms.

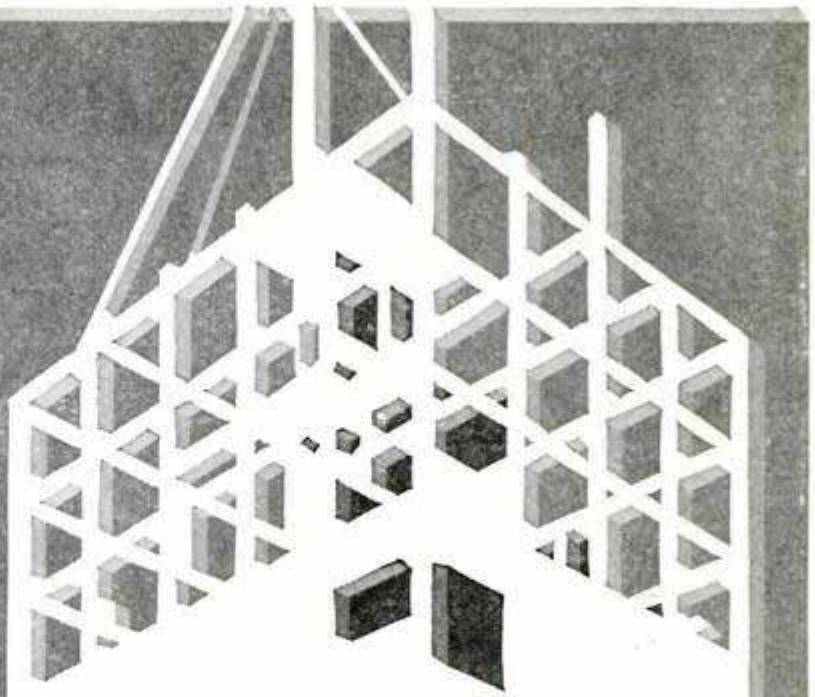

When great industries build  
**PRESDWOOD**  
speeds concrete construction

Modern engineers have discovered that with Masonite Presdwood forms they are producing concrete of maximum density, uniformity and strength—concrete so perfect, so glass-smooth, that expensive hand finishing is practically eliminated.

In addition to these advantages, Masonite Presdwood's amazing durability permits the boards to be used over and over again. They are easily and quickly erected, easily torn down, and easily moved. Handling costs are low, there is no waste in cutting, and breakage is reduced to a minimum.

The American Bell Telephone Company and Montgomery Ward & Company are two of the many great industrial institutions that have repeatedly specified Presdwood for concrete construction.

In factories and in homes, under punch press, drill or saw, and in the hands of home mechanics, this remarkable grainless wood is daily demonstrating its strength and versatility. It takes any finish beautifully, is highly resistive to moisture, and will not warp, split or crack. The FREE Presdwood booklet lists eighty of its many uses. Write for your copy today.

MASONITE CORPORATION, 111 W. Washington St., Chicago, Ill.

Send for Free Booklet  
Mail the coupon today. It will bring you the interesting story of Presdwood.

MASONITE CORPORATION, Dept. L-10,  
111 W. Washington St., Chicago  
Please send your free illustrated booklet that describes Masonite Presdwood and its many uses.

Name .....

Street .....

City.....State.....

If interested in Masonite Insulation, check here.

**Masonite**  
STRUCTURAL INSULATION • INSULATING LATH  
PRESDWOOD • QUARTRBOARD



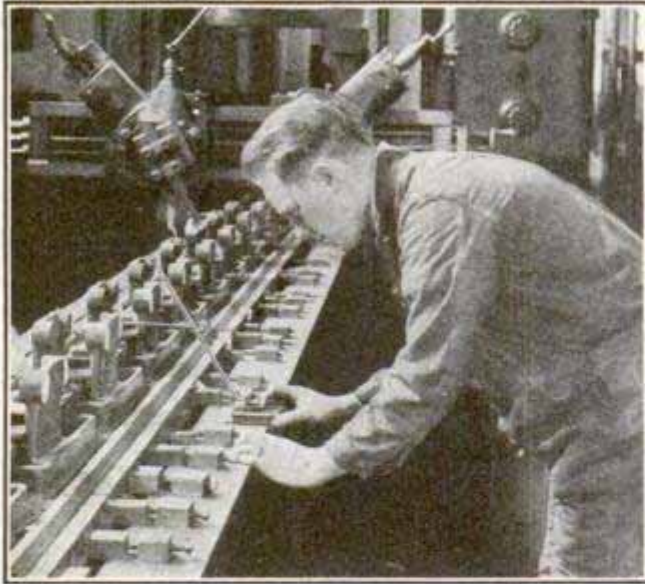

# Brown & Sharpe Gauges

-- a type for every class  
of work

**I**N the daily work of skilled mechanics, from manufacturing control to repair work, Brown & Sharpe Gauges are in constant use. It may be to measure the accuracy of finished parts, to check important clearances, or to select the proper size of tools or materials for the job.

Whatever the requirements, there is a Brown & Sharpe Gauge which will simplify the work—standard plug and ring gauges, standard caliper gauges, vernier height and depth gauges and many special gauges designed for some particular job. Below are described several Brown & Sharpe Gauges which occupy an important place in the kits of skilled mechanics.

American Standard Wire Gauge  
No. 688



A particularly useful tool for gauging sheets, plates and wire of non-ferrous metals. Decimal equivalents are stamped on the reverse side.

Screw Pitch  
Gauge  
No. 630



For quickly determining the pitch of threads of bolts and nuts.

For "V" Threads. 22 pitches—9 to 40 including Pipe Thread Pitches. Shape of blades permits their use on nuts as well as screws.

Universal Surface Gauge  
No. 621

A particularly handy tool for set-up work.

Knurled adjusting screw permits a wide range of adjustments. V-shaped bottom adapts it for cylindrical work.



Thickness Gauge  
No. 644

For checking clearances accurately.

Nine tempered blades—.0015, .002, .003, .004, .006, .008, .010, .012 and .015 of an inch. Blades 3" long, 1/2" wide.



Twist Drill and Machine Screw  
Tap Gauge  
No. 707

Gauge tells the correct drill to use with any common size of machine screw tap.



Planer and  
Shaper Gauge  
No. 625

With this gauge the cutting tool can be adjusted in a minimum of time. Can be used either on its base or its side.



The full line of Brown & Sharpe Gauges is included in Small Tool Catalog No. 31 which describes over 2300 useful tools. Ask your dealer for a copy or send to us for one. Dept. P. M., Brown & Sharpe Mfg. Co., Providence, R. I., U. S. A.

# Brown & Sharpe Tools

"WORLD'S STANDARD OF ACCURACY"





50¢  
QUALITY  
**LISTERINE**  
Shaving Cream  
NOW **25¢**

A big hit at 50¢; now you pay only half as much for this famous luxury shaving cream.

# Mobiloil

**ELECTRIC LIGHTS ANYWHERE**

Complete 110-volt Electric Light Plant. Ideal for Farms, Camps and Summer Homes.

**\$139.00**

Runs household appliances, Install it yourself, Wiring, Fixtures and Lamps for 7 rooms, \$17.50. Also larger models D. C. or A. C. Write for circular—D. W. ONAN & SONS, 38 Royalston Ave., Minneapolis, Minn.



Learn to **PAINT SIGNS and SHOW CARDS**

We quickly teach you by mail, or at school, in spare time. Big demand. Big future. Interesting work. Oldest, foremost school.

**EARN \$50 TO \$200 WEEKLY**

Otto Wiegand, Md., home-study graduate, made \$12,000 from his business in one year. John Vasson, N. Y., gets \$25 for a show card. Crawford, B. C., writes: "Earned \$200 while taking course." Write for complete information.

**DETROIT SCHOOL OF LETTERING**  
150 Stimson Ave. Est. 1899 DETROIT, MICH.

**FREE "Book of Facts"**

Write For It

**Auto Seat Covers \$2.95**

Special Price Offer

**AGENTS Make \$20 a Day**

Write orders fast for this excellent Quality line Auto Seat Covers. Amazing value—quick sales. Cash daily. We deliver. Write for handsome, Free Leatherette Sample Outfit. Quality Sales, 1834-36 W. North Ave., Dept. 1018, Chicago

**Send for SAMPLE PACKAGE**

**The Strongest GLUE Known**

**Use CASCO** for every gluing need—it glues practically everything—and permanently. CASCO is an all-glue dry powder—simply mix in cold water and apply.

**NO HEATING—NO ODOR—NO WASTE**



This interesting and helpful folder of CASCO uses—as a Glue—as a Size—as a Binder—will be sent with your sample. CASCO will be found at your hardware, paint or lumber dealers in convenient sizes.

Trial Box 10c  
1/2 lb. Can 40c  
1 lb. Can 65c  
Also 5 and 10 lb. Bags

Dealers—Write for Sales Plan. Manufacturers—Consult us on your glue problems.

**THE CASEIN MANUFACTURING COMPANY OF AMERICA, INC.**  
205 East 42nd Street New York

**You can Glue it Better with CASCO**

A CASCO glued job will stand up in any climate because

**CASCO GLUE IS WATERPROOF**

**THE CASEIN MANUFACTURING COMPANY of America, Inc.**  
205 East 42nd Street, New York.

Enclosed find 10c (stamps only) for which send me your Trial Package of CASCO WATERPROOF GLUE.

Name.....  
Street.....  
City..... State.....  
Hardware, Paint or Lumber Dealer's Name (Please include)





## Will you risk a stamp

to gain new shaving ease?

*Note the coupon, please*

**G**ENTLEMEN: We have a product that you will want to know about. But we find difficulty in advertising it, for the truth would sound extravagant to many.

Yet we are confident of its many superiorities. For we find that 86% of those who try it use it and discard all other ways. They have made it the largest selling shaving cream in the world.

This product is Palmolive Shaving Cream, different in action and effect from any you have ever known. To introduce it, we offer a free 7-day test. We take the risk of convincing you. Fair-minded men by the million have tried it at our invitation.

If you do not know Palmolive Shaving Cream, will you test it, please? A coupon is printed below for your convenience. Simply mail it, and make the trial to convince yourself.

**PALMOLIVE RADIO HOUR**—Broadcast every Wednesday night—over WEAJ and 39 stations associated with The National Broadcasting Co.



### 7 SHAVES FREE

and a can of Palmolive After Shaving Tale

Simply insert your name and address and mail to Palmolive, Dept. M-842, P. O. Box 375, Grand Central Post Office, New York City.

(Please print your name and address)

## When your eyes BURN!

Does exposure to sun, wind and dust make your eyes bloodshot and cause a burning sensation? Then you should use *Murine!* A few drops of this harmless lotion speedily ends the burning feeling and soon clears up the bloodshot condition.

Always apply *Murine* after motor-ing or outdoor sports to soothe and refresh your eyes. And also after reading or working to relieve eye strain. Write the Murine Co., 9E. Ohio St., Chicago, for valuable free book on the care of the eyes.

# MURINE

FOR YOUR EYES

### Make Your FORD Into The "ACE"

GET READY FOR SPRING—BUILD YOUR ACE NOW—

**\$599** Red-i-Kut life size patterns  
Class—Snap



38-inch Easy Riding Seat

Famous sure-fit RED-I-KUT life-size patterns and picture instructions show how you can easily convert your Ford into this **Fast, Saucy, Sport-Car** as thousands have done with easily obtained materials. No need to lay up the car. Makes wonderful 4-passenger car. Send 10c coin for actual photo of sport car and new manual of distinctive sport car patterns from \$5.80 up—“EKO” Steel “Swing-Lo” Irons, Tops, Windshields and many speed necessities. **ORDER RIGHT NOW** and get a real thrill.

**KUEMPEL COMPANY, 125 Kuempel Bldg., GUTTENBERG, IOWA**

### Every Coo-Coo \$1.75 For You!

A “knock-out” instant selling hit! The Coo-Coo Auto Horn (Patented) sells itself at \$4.00. Costs you \$2.25. Going like wildfire in Hollywood and Los Angeles. 1 dealer sold 3,000 in short time. Some Agents making as high as \$25 an hour. 1 horn sells 5 others. **No house to house selling**—just stand around garages and service stations—coo-coo and clean up. Installed by anyone in 3 minutes. Not an exhaust or motor horn. Certain in action—never fails to create a musical note that cleverly sings “Hello.”

Send \$2.25 for sample horn or write for further information



**PACIFIC COAST PRODUCTS CO., LTD.**  
1616 Cahuenga Blvd. Dept. 62 Hollywood, Calif.

### ALL BALSAs!

A realistic scale model of a one-place low-wing sport plane. Wing spread 15 in., weight only 3/8 oz. Takes off under own power. Flies 140 feet consistently.

New all-balsa construction makes this model lighter, stronger, better-looking and far easier to build. Everything marked. Nothing to draw or measure. No tools or skill required. Set includes die-stamped aluminum propeller, disc wheels, rubber motor, quick-drying cement, balsa, clear directions and all other material. Nothing else to buy. Complete set, postpaid in U. S. and Canada, \$1.00. Satisfaction or money back. Order now.

**The Midland Model Works, Dept. E, Chillicothe, Ohio**  
(We cannot accept stamps or C. O. D.'s.  
No catalogue except with set.)



# New Model SOUTH BEND LATHES

BACK GEARED SCREW CUTTING PRECISION LATHES

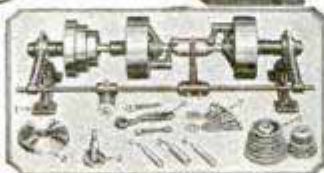
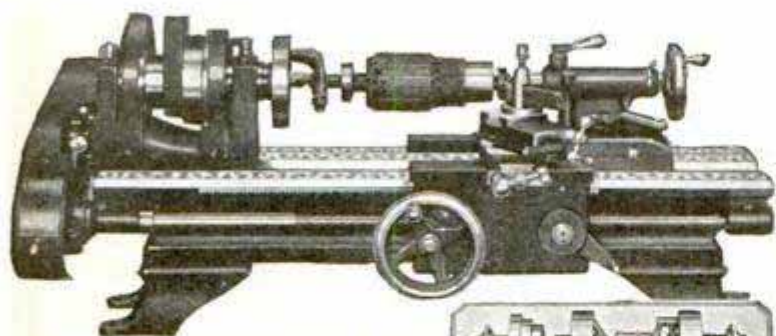

9' x 3' New Model South Bend Jr. Back Geared Screw Cutting Lathe (weight 375 lbs.). A precision Lathe for the Tool Room, Machine Shop, Electrical Shop, Repair Shop, Service Station and for quantity production of small parts in manufacturing plants. Complete with countershaft and equipment..... **\$169**

### Other Sizes of this Lathe

Size	Shipping weight	Countershaft Drive	Horizontal Motor Drive
9' x 2½' Jr.	350 lbs.	\$163	\$248
9' x 3½' Jr.	400 lbs.	175	260
9' x 4' Jr.	425 lbs.	182	267
9' x 4½' Jr.	555 lbs.	190	275

Easy payments as low as \$11.41 a month, if desired

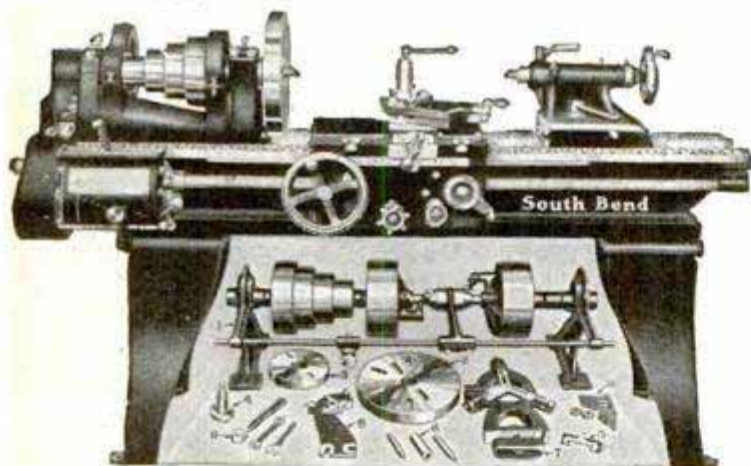

16' x 8' New Model South Bend Lathe—back geared, screw cutting, quick change gear. Most practical lathe for Tool Room, Repair Shop and Service Station. Size enables you to handle 90% of all Lathe work. Suitable for heavy production work in manufacturing. Contains all latest South Bend improvements. Weighs 2035 lbs. Complete with countershaft and equipment, price..... **\$638**

### Prices of Other Popular Sizes

Size	Shipping weight	Countershaft Drive	Silent Chain Motor Drive
11' x 4' Quick Change	725 lbs.	\$359	\$498
13' x 5' Quick Change	1110 lbs.	443	602
15' x 6' Quick Change	1550 lbs.	543	720

All sold on easy payments if desired

Write for Free Catalog No. 91-A

### Write for these Books



**"How to Run a Lathe"**  
—a 144-page book telling in detail how to handle all classes of work on the back geared screw cutting engine Lathe. Price, postpaid, **25c.**



**Auto Mechanics' Service Book No. 66—**  
96 pages illustrates and tells how to do 150 automobile service jobs on one machine. Price, **25c.**



**Catalog No. 91-A**  
—the 104-page catalog illustrating and describing 96 different sizes and types of New Model South Bend Lathes. Sent free.

**SOUTH BEND LATHE WORKS,**  
626 E. Madison St., South Bend, Ind., U.S.A.  
Gentlemen: Please send me books checked  
( ) Catalog No. 91-A (Free)  
( ) Auto Mechanics' Service Book No. 66 (25c)  
( ) "How to Run a Lathe" (25c)

Name.....  
Address.....  
City..... State.....

**SOUTH BEND LATHE WORKS**

626 E. Madison St., South Bend, Ind., U.S.A.

Lathe Builders for 24 Years



"Oh, I say... is there  
no end to this?"



SOME months ago Sir Walter Raleigh offered pipe lovers a *free* booklet on "How to take care of your pipe." And the poor chap's been buried under requests ever since.

However, we've engaged two of Queen Elizabeth's ladies-in-waiting to help the old boy out with his mail—so don't hesitate to send for your copy. It tells you how to break in a new pipe—how to keep it sweet and mellow—the proper way to clean a pipe—and many other hints on pipe hygiene.

You'll want to read this booklet. It's *free*. Just write to the Brown & Williamson Tobacco Corporation, Louisville, Ky. Dept. 83.

## SIR WALTER RALEIGH Smoking Tobacco

*It's 15¢ — and it's milder*

# Popular!

**YOU** will be doubly welcome everywhere when you learn to play a Conn. Chances to join a band or orchestra, to travel, to make extra money. Conns are the choice of Sousa and the world's greatest artists. Easiest to play. Recommended to beginners for quicker progress.

**FREE TRIAL, EASY PAYMENTS** on any Conn. No matter which band or orchestra instrument interests you most, Conn will send you a special booklet on that instrument giving valuable facts.

C. G. CONN, Ltd., 1031 Conn Bldg., Elkhart, Ind.

## CONN

World's Largest  
Manufacturers of  
BAND INSTRUMENTS

**Write for FREE BOOK**  
▶ Mention Instrument ◀

## MOVIES In Your Home

Our marvelous, practical Movie Machines sell as low as \$3.75 postpaid, and use same size film as big theatres. We also have wonderful films at lowest prices—with a new film exchange service.

**Don't Miss This! Write NOW for Free Catalogue.**

**PARAMOUNT MANUFACTURING CO.**  
Dept. G-32, BOSTON, MASS.

## Factory to Rider

Save \$10 to \$25 on the Mead Bicycle you select from 44 Styles, colors and sizes.

### 30 Days' Free Trial

We ship on approval. If not satisfied after trial return the bicycle. **EASY PAYMENTS.** \$5 down on RANGER Bicycles.

**Tires** lamps, wheels, equipment at half usual prices. Write for marvelous new prices, wonderful 30 day trial offer and terms.

**Mead Cycle Company** Write us today for free catalog  
Dept. R110 Chicago

## Fly the NEW IDEAL "ROBIN"

Construction Outfit \$350

Wing Span, 24 in.; Weight 2 1/2 oz. A beautiful "job" and a wonderful flyer. Demountable, adjustable wings, balsa propeller, large landing wheels, dummy motor, tremendous power for long, fast flights. Construction is easy, quick. Ask your dealer or order direct from us.

*Big Catalog Models and Supplies — Five (5) Cents.*

**IDEAL AEROPLANE & SUPPLY CO., Inc.**  
26 West 19th Street New York City



FACTORY TO YOU—SAVE to 50%—COMPARE WITH COSTLIEST OUTFITS BEFORE YOU BUY

# Enjoy a powerful new Miraco 30 DAYS FREE

Latest 1931 SUPER Screen Grid Outfit (No obligation to buy)

**NEWEST IN RADIO!** 1931 Miraco "Easy-Chair" Model with magazine racks, each end. Place it anywhere in any room. Easily moved about. Contains a complete full-size radio and Super-Dynamic speaker! No outside aerial or ground required. Many other new, clever models, obtainable nowhere else, shown in free literature.

**Get Our "SEND NO MONEY" 11th Anniversary Offer!**

Latest 1931 **Super Screen Grid** FULL YEAR'S GUAR.  
lighted dial steel chassis  
Vari-Tone and Automatic Sensitivity Control  
Also latest PUSH-PULL Amplification

*Built like—looks like—performs like newest radios in many outfits much more costly.* Latest, finest, heavy duty construction. Skillfully engineered to super-utilize a battery of "224" SCREEN GRID tubes—in addition to "245" PUSH-PULL POWER, "224" HUM-FREE long-lived POWER DETECTOR and AMPLIFIER and "280" A-C TUBES. Vari-tone feature gives any tone-pitch your ears prefer. Automatic Sensitivity Control reduces "fading," protects tubes. Phonograph pick-up connection. Built-in house wiring aerial and ground. Built-in plug for electric clock, lighter, lamp, etc. Super-sturdy power section. Razor-edge selectivity; Super-Dynamic Cathedral tone quality; marvelous distance-getter. Solid one-year guarantee if you buy! Wide choice of cabinets.

**Easy Chair Model**

(as illustrated less tubes)

Only \$49.<sup>88</sup> COMPLETELY ASSEMBLED

Values possible because you deal direct with big factory

# MIRACO

TRADE MARK REGISTERED

**CATHEDRAL TONED, SUPER SELECTIVE, POWERFUL DISTANCE GETTERS**

You need not send us a cent! For its 11th successful year, America's big, old, reliable Radio Factory again sets the pace in high-grade, latest guaranteed radios *direct to you*. And

**Don't Confuse with Cheap Radios**

With Miraco's rich, clear Cathedral Tone, quiet operation, razor-sharp separation of nearby stations, tremendous "kick" on distant stations, Vari-Tone and automatic sensitivity control, and other latest features—be the envy of many who pay 2 or 3 times as much!

**EASY TERMS** to reliable persons only

**USER-AGENTS WANTED**

**Exclusive Territory—Try it at Our Risk!**

**Spare or full time. No contract, no experience required. Big money! Send coupon now!**

Send for proof that delighted thousands of Miraco users cut through locals, get coast to coast, with tone and power of costly sets.

Miraco's are built of finest parts—approved by Radio's highest authorities. Our 11th successful year!

**Deal Direct with Big Factory**

Miraco outfits arrive splendidly packed, rigidly tested, to plug in like a lamp and enjoy at once. No experience needed. Entertain yourself 30 days—then decide. Liberal year's guarantee if you buy. Play safe, save lots of money, insure satisfaction—deal direct with Radio's big, reliable, pioneer builders of fine sets—successful since 1920. SEND POSTAL OR COUPON NOW for Amazing Offer!



**MIDWEST RADIO CORP., 807-EO Miraco Dept., Cincinnati, Ohio**

**BEAUTIFULLY ILLUSTRATED LITERATURE, TESTIMONY OF NEARBY USERS, PROOF OF OUR RELIABILITY—**

All the proof you want—of our honesty, fairness, size, financial integrity, radio experience and the performance of our sets—including Amazing Factory Offer—sent without obligation!



**Free!**

**MIDWEST RADIO CORPORATION**  
Pioneer Builders of Sets—11th Successful Year  
807-EO Miraco Dept., Cincinnati, Ohio

**THIS COUPON IS NOT AN ORDER**

- WITHOUT OBLIGATION, send latest literature, Amazing Special Free Trial Send-No-Money Offer, testimony of nearby users and all Proof.  User.  Agent.  Dealer
- Check here if interested in an **EXCLUSIVE TERRITORY PROPOSITION**
- NAME \_\_\_\_\_ ADDRESS \_\_\_\_\_

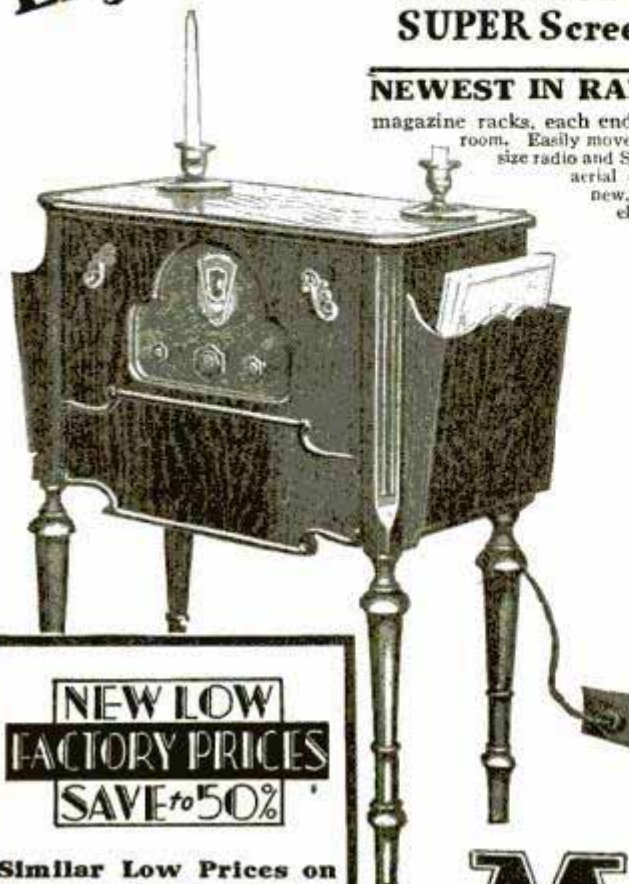

**NEW LOW FACTORY PRICES SAVE to 50%**

Similar Low Prices on Beautiful Variety of Latest Fine Consoles. Send Coupon!



Medium-size "Hi-Boy." Rich design, fine woods, fine finish.

Stylish small console takes very little space. Bargain factory price to you.



Full-size wall console with latest 1931 features.





## For Model Making PLASTIC WOOD

Reg. U. S. Pat. Off.

In model ships, model coaches, model airplanes, Plastic Wood permits the most delicate refinements, made to scale, and enhancing the value and accuracy of the model. In the Sea Witch, shown above, even the hull is modeled from Plastic Wood—that handles like putty, hardens into wood, and adheres lastingly to any clean dry surface.

When hard, it is wood without grain, that can be carved to the most delicate design. Much skill can be shown in making hand carved figures from Plastic Wood. See the elephant one man has done.

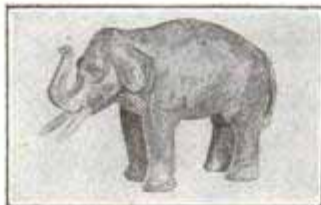

### "Things to do with Plastic Wood"

In this 48-page illustrated book on Plastic Wood and its uses—for the home, automobile, boat, sports equipment, etc.—there are sections devoted to model ships and model making. It is a book of practical value to every man who likes to work. By mail 10 cents.



Tube 25 cts. — 1/4 lb. 35 cts.

1 lb. \$1.00

Solvent — 25 cents

At Hardware and Paint Stores

ADDISON LESLIE CO.,  
432 Bolivar St., Canton, Mass.

Please send "Things to do with Plastic Wood." I enclose 10 cents.

Name.....

Address.....



## See It Go!!! See It Bank!!

Propellers spinning and flashing! Bright red wings, glistening metal body! Just like the big, new, trimotored passenger-liner planes. Brand new model of latest type. Strong, all-steel body. Big balloon tires. Long running spring motor sends it swiftly round and round the floor. Wing spread 21 inches. Model No. 367. Price \$3. (West of Miss. or in Canada \$3.30.) Other models, racing and cabin that actually fly, \$1 to \$3.50. If your dealer cannot supply you, send your order to us.

KINGSBURY MFG. CO. 83-J, Myrtle St.  
Keene, N. H.

## KINGSBURY MOTOR DRIVEN TOYS

FREE! Send for novelty moviescope; shows motion picture of Silver Arrow flight. Also complete toy catalog.

Send 10c for Kingsbury Disc Wheel Balloon Tire Eraser. Set of 4, 35c.



Build your own outboard hydroplane motor or sail boat. Use our plans or knock-down frames and machined parts. Many models to select from. Write for new catalog. Please enclose postage for catalog. J. B. WELCH, Inc., Dept. B, 1351 41st St., Milwaukee, Wis.

## MOTORCYCLES

Wonderful Bargains



Small Deposit—Liberal Terms  
Indians Harley-Davidsons Ace and Henderson

Send 10 cents for Bulletin A.  
Motorcycles shipped to all parts of the world

WALKER-INDIAN CO., 1309 Boylston St., Boston, Mass.

## GAS HEAT

ANYWHERE

1 1/2¢ an hour



38 Below Zero is not too cold when you have a **Sunshine Radiant Heater**. Makes and burns its own gas. Gives you clean, safe, healthful heat in 60 seconds from cold start. No piping, no installation costs. Easy to carry from room to room while in operation.

### 15-Day Trial

We'll send you the **SUNSHINE** on 15-day trial. Use it in your own home or store. Prove to yourself how easy it does away with dirt, ashes, smoke and odor. **Sunshine** is bringing cheery comfort to thousands of homes, now.

**FREE** Startling low offer on new, beautiful 1929 Model—and book, how new heater brings comfort and ease. Get your copy. Write today. **SUNSHINE SAFETY LAMP CO.** 339 Factory Bldg., Kansas City, Mo.

**AGENTS**  
**BIG MONEY—**  
easy sales on part or full time. WRITE!



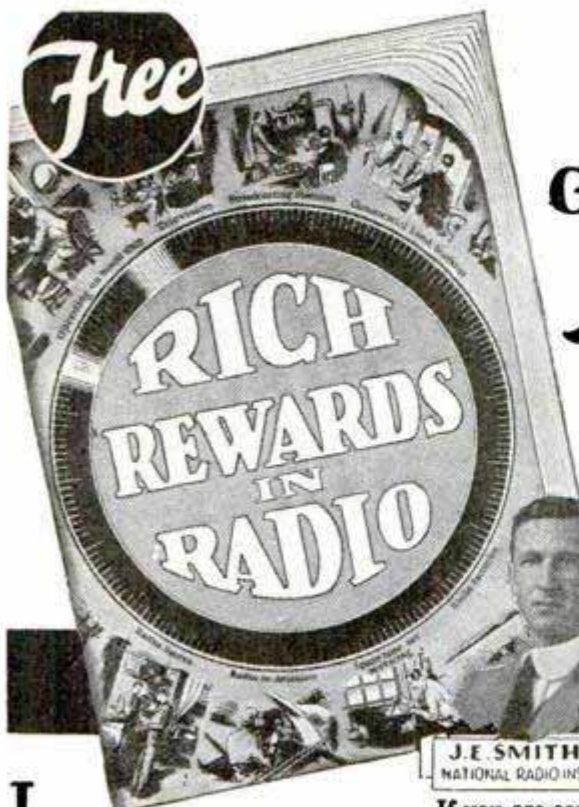

# MEN!

Get Your Copy of My *New* Book

*It shows you*

## How to get a good job in the Radio Industry

**Hundreds of Jobs paying \$50, \$60, \$75, \$100 a week are opening in Radio every year.**

J. E. SMITH, Pres.  
NATIONAL RADIO INSTITUTE

**I showed these men how to get Big Pay jobs like these**



**Seldom under \$100 a Week**

"My earnings in Radio are many times bigger than I ever expected they would be when I enrolled. In November I made \$577, December \$645, January \$465. My earnings seldom fall under \$100 a week. I merely mention this to give you some idea of what a Radio man can do who has the training."

E. E. WINBORNE,  
1414 W. 48th St., Norfolk, Va.



**\$3000 a Year in Own Business**

"I cannot give N. R. I. too much credit for what I have been able to do in Radio. I can safely say that I averaged \$3000 a year for the past three years. I am in the Radio business here. Any man who really wants to advance cannot go wrong in Radio. There is certainly a lack of trained men."

FRED A. NICHOLS,  
P. O. Box 207, Eaton, Colo.

If you are earning a penny less than \$50 a week, send for my book of information on opportunities in Radio. It is free. Radio's amazing growth is making hundreds of fine jobs every year. My book shows you where these jobs are, what they pay, how I can train you at home in your spare time to be a Radio Expert.

**You have many jobs to choose from**

Broadcasting stations use engineers, operators, station managers and pay \$1,800 to \$5,000 a year. Manufacturers continually need testers, inspectors, foremen, engineers, service men, buyers for jobs paying up to \$15,000 a year. Shipping companies use hundreds of operators, give them world-wide travel with practically no expense and \$85 to \$200 a month besides. Dealers and jobbers are always on the lookout for good service men, salesmen, buyers, managers and pay \$30 to \$100 a week for good men. Talking Movies pay as much as \$75 to \$200 a week to men with Radio training. There are openings almost everywhere to have a spare time or full time Radio business of your own—to be your own boss. Radio offers many other opportunities. My book tells you about them.

**New 8 Outfits give you Extensive Practical Radio Experience**

With me you not only get the theory of Radio—you also get practical Radio experience while learning. You can build over 100 circuits—build and experiment with the circuits used in Atwater-Kent, Majestic, Crosley, Eveready, Stewart-Warner, Philco, and many other sets. These experiments include A. C. and screen grid sets, push pull amplification and other late features. When you finish my course you won't need to take "any old job" just to get experience—you will be trained and experienced ready to take your place alongside men who have been in the field for years.

Back view of 5-tube A. C. screen grid tuned Radio frequency set—only one of many circuits you can build with the parts I give without extra charge.



**I Will Train You at Home in your Spare Time**

Hold your job until you are ready for another. No need to leave home. All I ask is part of your spare time. I have doubled and tripled the salaries of hundreds through my practical home-study training. You don't have to be a high school or college graduate. My course is written in easy, simple terms that most anyone can understand.

**My Course Includes Talking Movies, Wired Radio, Television**

My course is up-to-date with Radio's latest uses and improvements. It includes Radio's application to Talking Movies, Television and home Television experiments, Wired Radio, Radio's use in Aviation, in addition to fitting you for many other lines.

**Money Back If Not Satisfied**

I will agree in writing to refund every penny of your tuition if you are not satisfied with my Lesson Texts and Instruction Service when you have finished my course. This agreement is backed by the Pioneer and World's Largest organization devoted entirely to training men and young men by mail, for good jobs in the Radio industry.

**Find out what Radio offers you Get My Book**

This book gives the facts on Radio's opportunities and the many features and services of N.R.I. training. It gives 100 letters from students who have proved that my methods are successful. Get your copy today. There is no obligation.

J. E. SMITH, President  
National Radio Institute, Dept. OLPP  
Washington, D. C.

**THIS COUPON IS GOOD FOR ONE FREE COPY OF MY NEW BOOK**

**mail it NOW**

J. E. SMITH, President,  
National Radio Institute, Dept. OLPP  
Washington, D. C.  
DEAR MR. SMITH:—Send me your book. I want to see what Radio offers and what you offer in Radio training. This request does not obligate me in any way.

Name.....

Address.....

City..... State.....

**Lifetime Employment Service to all Graduates**



# One oil does 3 jobs

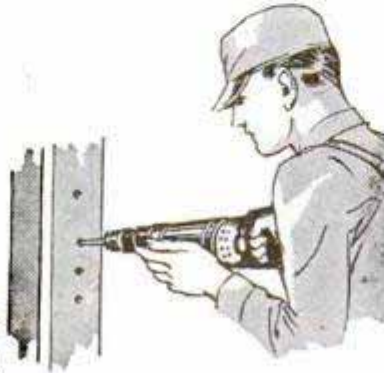

**Y**OU have to be mighty careful in choosing oil for workshop use. Almost any oil will provide a certain amount of lubrication—but that's not enough to keep tools, motors and other equipment in perfect condition, ready for every job.

With 3-in-One Oil, you're safe! Because this oil does *three* important things. It *works out* old, gummy oil from bearings and moving parts; leaves them bright and clean. It "stays put," so it provides lasting *lubrication*. And it *prevents* rust.

Three-in-One does all of these necessary jobs at once. And does them better than any ordinary oil ever can, for 3-in-One is a scientific blend of three different oils—*animal, mineral and vegetable*.

Handy cans and bottles; all good stores. Sample and "Dictionary of Uses" sent free.

THREE-IN-ONE OIL CO., Dept. 124  
130 William Street, New York  
Factories: Rahway, N. J. - Montreal, Que.



# 3-in-One Oil

CLEANS - LUBRICATES - PREVENTS RUST

## Is Proven Protection Against Fire Worth \$2.95 ?

**FLAME - X**  
is the most economical flame  
extinguisher ever invented

ITS action being so simple, yet so effective, makes it nothing short of wonderful. Prevention of fire—its elimination—are the two most important things to consider. **FLAME - X DOES BOTH.**

**FLAME - X** is not a liquid that you may find evaporated when needed. It will not lose its effectiveness, regardless of the length of time you keep it. Just a handful thrown with force at the base of flame or one properly directed spray when used with spray gun will extinguish flames immediately. If you would prevent the serious effects of fire, if you would safeguard your home—car—factory—office—store or garage against the danger of fire, order your **FLAME - X** today—NOW—while it is on your mind.

**Price \$2.95**

Complete with Spray Gun

Send Money or Express Order, Check or Stamps  
We pay postage

**GOVERNOR PRODUCTS, DEPT. F**  
519 EIGHTH AVENUE, NEW YORK CITY

**Note**—If you are interested in making big money, write at once for our special agent offer to men and women. Exclusive territory now open.

**BABY CALCULATOR**  
CHICAGO U.S.A.  
PATENT APPLIED FOR

**ADDITION  
SUBTRACTION  
MULTIPLICATION  
DIVISION**

**VEST POCKET ADDING MACHINE**  
Adds, Subtracts, Multiplies, Divides. Does work of \$300 machine. Not a toy. Million dollar capacity. Simple and accurate. Guaranteed 5 years.

**FREE TRIAL**  
—SEND NO MONEY—

**\$2.50**  
Total Cost

Just name and address. We will ship Calculator immediately. On delivery pay postman \$2.50 (plus few cents postage). (If outside U. S. send cash.) 10c additional in Leatherette Case. If not satisfied after 10 days' trial you get your money back. **THOUSANDS OF SATISFIED USERS.** Write for Agents' Proposition. **BABY CALCULATOR MACHINE CO.,** (Mfrs.) P. O. Box 1118, Dept. 41, CHICAGO, ILLINOIS

**Build a CLOCK** for *Pleasure* or *PROFIT!*

**FREE BOOK**  
of Clock Making,  
*Money Making*  
ideas. Gives details,  
prices of move-  
ments, parts.  
Write NOW for  
copy!

**Shows How YOU Can Make Fine  
Clocks Right at Home**  
—for yourself, or to sell at Big Profits. We  
furnish instructions, parts. Works \$1.65  
up; others with chimes, all prices. Make  
case or assemble parts. Cash-in on demand  
for Mantel, Banjo, Grandfather's Clocks.  
Write for Special Blue Print Offer, FREE  
Catalog.

**AMERICAN CHIME CLOCK COMPANY**  
1670-C Ruffner St. Philadelphia, Pa.

Only 8 Sales a Day Nets You \$116 a Week

Profits on larger size  
run higher. Unusual earning oppor-  
tunity for ambitious men. No experience  
necessary; we teach. Part or full time.

**FUGO** *World's Simplest*  
*Fire Extinguisher*

Automatic and instantaneous action. Within  
reach of every home, shop, store, theatre,  
garage, car owner, etc. Even smallest  
place needs two or more. Exclusive terri-  
tory to producers. You get your pay  
every day. Write for full details.

**The National Formetal Co.**  
6535 Metta Ave. Cleveland, O.



# New FREE BOOK

New Styles - New Colors

Now only \$5.00 DOWN ON ANY RANGE, HEATER OR FURNACE

SAVE 1/3 to 1/2

New FREE book quotes **Factory Prices**. Now only \$5 Down on any stove, range or furnace. Year to pay. Choice of 5 colors in New Porcelain Enamel Ranges. New Cabinet Heaters—\$38.25 up. 200 styles and sizes. Cash or easy terms. 24-hour shipments. 30-day FREE trial. 360-day test. Satisfaction guaranteed. 30 years in business. 750,000 customers. Write today for FREE book.



Cabinet Heaters \$38.25 up

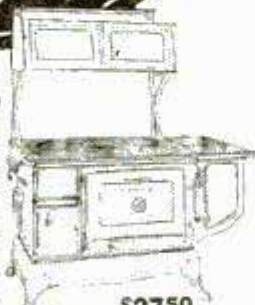

Ranges \$37.50 up

**KALAMAZOO STOVE CO.**  
391 Rochester Avenue  
Kalamazoo, Mich.

**"A Kalamazoo Direct to You"**

## This Modern Woodworker \$45.00



**Belt Sander—Saw—Grinder—Drill**

Has 1/2 H. P. Motor, switch, cord and plug. 3x24 in. sander for strips any length. 6-in. adjustable saw. 5x1/2 in. grinder for any tool or drill. Chuck takes up to 1/2 in. drills. Operates many other tools. Bronze bearings, endless belt, polished table, guards and trimmings lacquered. Size 20x20. Weight 60 lbs. Lowest price known for high grade tool. Satisfactory or money back. Order now or write for circular P.

**Steiner-Fulton Products Corporation**  
5751 Easton Ave. St. Louis, Mo.

## AGENTS 500% PROFIT GENUINE GOLD LEAF LETTERS

**S** guaranteed to never tarnish. Anyone can put them on stores and office windows. Enormous demand, large profits. Paul Clark says: Smallest day \$28.70. R. L. Reel made \$920 in two months. Write today for free sample and liberal offer to general agents.

**METALLIC LETTER CO. 433-B N. Clark St., CHICAGO**

### THIS LITTLE BOOK IS A GOLD MINE OF "NEW JOY FROM YOUR RADIO"

Enables you to correctly dial every station in the U. S., Canada, Mexico and Cuba. Gives timetable of every chain program on the air. Brimful of current, non-technical information you'll revel in knowing.

**Users Logging Scores of New Stations** So will you. Ask your Kresge store radio dealer, or newsstand today for Radex—or send a quarter direct for your copy.

**Radex Press, 1307 E. Sixth, Cleveland, O.**



## SAWS FILED

FOLEY FILER SERVICE



**Add \$25 A Week To Your Present Earnings**

## Free Plan Helps You Start!

Many men are earning \$10 to \$25 a week extra money in their spare time—some even more—filing saws on the Foley **Automatic Saw Filer**. Walter S. Thompson writes, "In 6 months I made an average of \$26 per week in spare time." You can quickly develop a fine paying, cash business of your own too, by starting in spare time at home.

### FOLEY <sup>ALTO</sup> <sup>MATIC</sup> SAW FILER

**Files Hand, Band and Circular Saws**

One machine **automatically** files all hand saws, band saws and circular saws with such mechanical precision that they cut better and stay sharp longer. Easy and simple to operate—no experience necessary.



### Steady, Cash Business

**No Canvassing.** Saw users want their saws filed the Foley way because they are so much better than hand filed saws. **Free Plan** shows you how to get the business, and the excellent work you can do on the Foley makes steady, repeat customers. Don't delay—investigate now.

## Mail Coupon for FREE PLAN

### Foley Manufacturing Co.

206 Foley Bldg., 11 Main St. N. E., Minneapolis, Minn. Please send me Free Plan and tell me how I can make extra money in my own business with the Foley Saw Filer.

Name.....  
Address.....  
City & State.....



# PROFITS for YOU!

**\$247**  
without  
power

## CABINET SHOP SPECIAL



Includes 16" band saw, 6" jointer and 8" circular rip and crosscut saw.

Why give someone else the profits that your skill and knowledge bring in? Open a shop of your own and get all the profits for yourself. The Parks Cabinet Shop Special is a compact, accurate woodworker with full-size units and is priced for the man with small capital who wants a shop of his own.

Send coupon today for complete catalog.

The Parks Woodworking Machine Company,  
Dept. P-10, 1530 Knowlton St., Cincinnati, Ohio.  
Canadian Factory: 338 Notre Dame East, Montreal.

Name..... City.....  
Address..... State.....



Every Parks guaranteed 10 years.

## GUARANTEED CORNWELL TOOLS

THE KIND TO USE - AND OWN



SKILLED mechanics have discovered they save time and effort with a Cornwell tool for two reasons: it is built, balanced and designed to handle its particular job in the most efficient way known to tool making—and is made by a special process of Swedish Chrome Molybdenum steel to withstand any shock or pressure.

### Sensational Tests Prove Their Strength

Hundreds of tests have proven their superiority over other tools. Placed jaw to jaw or using one as a lever against the other, the Cornwell always breaks or strains the other tool.

### Hand-Made by a Special Process

Cornwell tools are hand forged, heat treated and tempered in oil—made by tool makers who, for ten years, have been designing and manufacturing the stoutest mechanics' tools on the market. Cornwell guarantees that if you have ever seen a better tool for the job your money will be returned.

## Get This Catalog.. FREE

Send for this illustrated catalog that describes every Cornwell tool—showing you the famous super-service tools that last a lifetime under the most severe usage.

THE CORNWELL QUALITY TOOLS CO.  
Dept. Z, Mogadore, Ohio. (Formerly at Cuyahoga Falls, O.)  
Send me new illustrated catalog with prices on full line of CORNWELL Hand-Made Tools.

..... Where Employed  
Name.....  
Address.....  
City..... State.....

# ALL STEEL HACKSAW

An all steel, unbreakable hacksaw with perfect balance. The newly designed pistol grip fits the hand comfortably. A rugged fast cutting tool handsomely finished in heavy nickel plate. Sold with a money-back guarantee by hardware dealers.

Crescent Tool Co.  
Jamestown,  
N. Y.



**\$1.25**

Other saws, with wood, steel and composition handles. 60c to \$1.25.

## CRESCENT and Smith & Hemenway TOOLS

Write for Catalog



Systematic and Orderly Arrangement of Tools assured by GERSTNER Tool Chests for Machinists and Tool-makers. No more worry about loss or damage when you use one of these fine chests. Free Catalog

*Gerstner & Sons*

482 Columbia St. Dayton, Ohio

## BURN YOUR NAME ON TOOLS WITH THE ARKOGRAF

PROTECT YOUR TOOLS FROM THEFT Write with electricity any name or design on the hardest and finest tools and instruments, or any metal, like writing on paper with pen or pencil. Complete Outfit \$3.50—Prepaid Anywhere Interesting illustrated circular free. Write today. Agents wanted. ARKOGRAF PEN CO., 1171 E. Stark St., Portland, Oregon

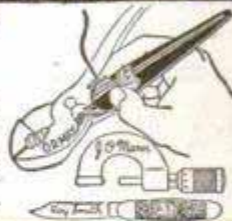

FREE TOOL BOOK "The Disston Saw, Tool and File Book" tells how to choose, use, and care for tools, file and set saws, etc. Every tool user needs it. Henry Disston & Sons, Inc., Dept. M, Philadelphia. Canadian Factory, Toronto

# ENGINES

Lifetime Guarantee  
All Sizes and Styles

**300,000 In World-Wide Use**

The WITTE (Magneto Equipped) provides cheapest reliable power for farm and ranch. Does more work in less time at less cost. Put one to work—will pay for itself. Send for Big Free Catalog.

**WITTE ENGINE WORKS**  
1747 Oakland Avenue, KANSAS CITY, MO.



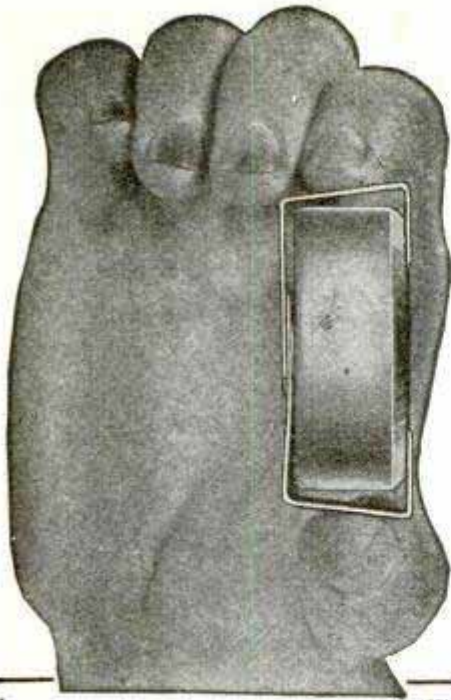

Diam. 2" Wt. 2 1/4 oz.

**IN THIS SMALL CUP IS COILED A SIX-FOOT STEEL RULE!**

Sounds unbelievable, doesn't it? But your hardware dealer will gladly demonstrate other unique qualities of this most remarkable of all modern tool inventions.

**The FARRAND RAPID RULE**

Patented in U. S. Nos. 1,402,589 & 1,730,199  
Write to factory for booklet and six-inch sample

**HIRAM A. FARRAND, Inc. Second St., Berlin, N. H.**

**SALESMEN WANTED!**

**SELL COX HOLDFAST SCREW DRIVERS**



Sells on sight to mechanics for Auto, Radio and Electrical Work. Self Holding, Self Releasing.

Send 50c for sample and ask how to get Salesman's Outfit Free. S. J. COX Dept. F, FRANKLIN, PA.

**Makes Old Ford a Tractor**

Now you can convert that old Ford car into a useful farm tractor without altering any Ford parts. We furnish the traction wheels, drive gears and auxiliary axle and mountings, ready to clamp on to the Ford frame. Pulls 16" plow.



We supply a Belt Pulley also

Write for Free Particulars. Shaw Mfg. Co., Dept. FM10, Galesburg, Kan.

The TOOL the World has been waiting for

**\$19<sup>95</sup>**

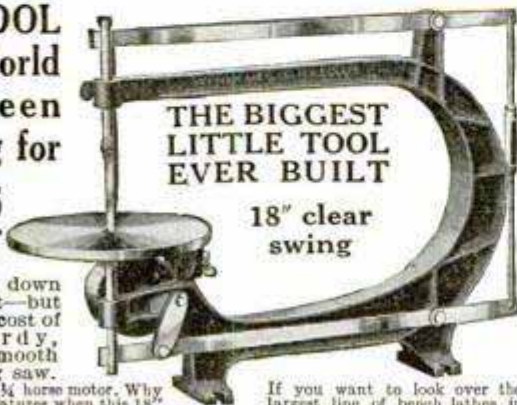

**THE BIGGEST LITTLE TOOL EVER BUILT**

18" clear swing

Not just a down payment—but the whole cost of this sturdy, powerful, smooth running jig saw. Requires only 1/4 horse motor. Why fool with miniatures when this 18" job with 9" tilting table and strong one piece frame costs no more.

If you want to look over the largest line of bench lathes in the world send 10c for the Sypher D10 catalog.

**SYIPHER MFG. CO., Dept. D10, 1524 Fernwood Av., Toledo, O.**

**Amazing New Tool Value**

An Automatic Push Drill Carrying in the Handle Eight Sizes of Drill Points

EVERY HOUSEHOLD NEEDS ONE USEFUL ON HUNDREDS OF REPAIR JOBS



Pick out the size drill you want from the separate numbered compartment. Insert it in the steel jaws. Place drill point where you want hole. Push—push—and presto, you have a smooth clean hole in any wood. It can also be used in plaster. The handiest tool ever invented for household use. Made by one of America's leading makers of fine tools.



Show this ad to your dealer and secure a drill for \$1.25 or mail coupon to us and drill will be sent postpaid C. O. D. \$1.40. Hundreds of household jobs formerly postponed will now be done neatly and easily.

**USE THE COUPON TODAY!**

GOODELL-PRATT COMPANY, Greenfield, Mass.

Please send me a No. 138 Automatic Drill. I will pay postman \$1.40.

Name .....

Street .....

City ..... State .....

Nothing under \$2.00 ever bought such a good tool.



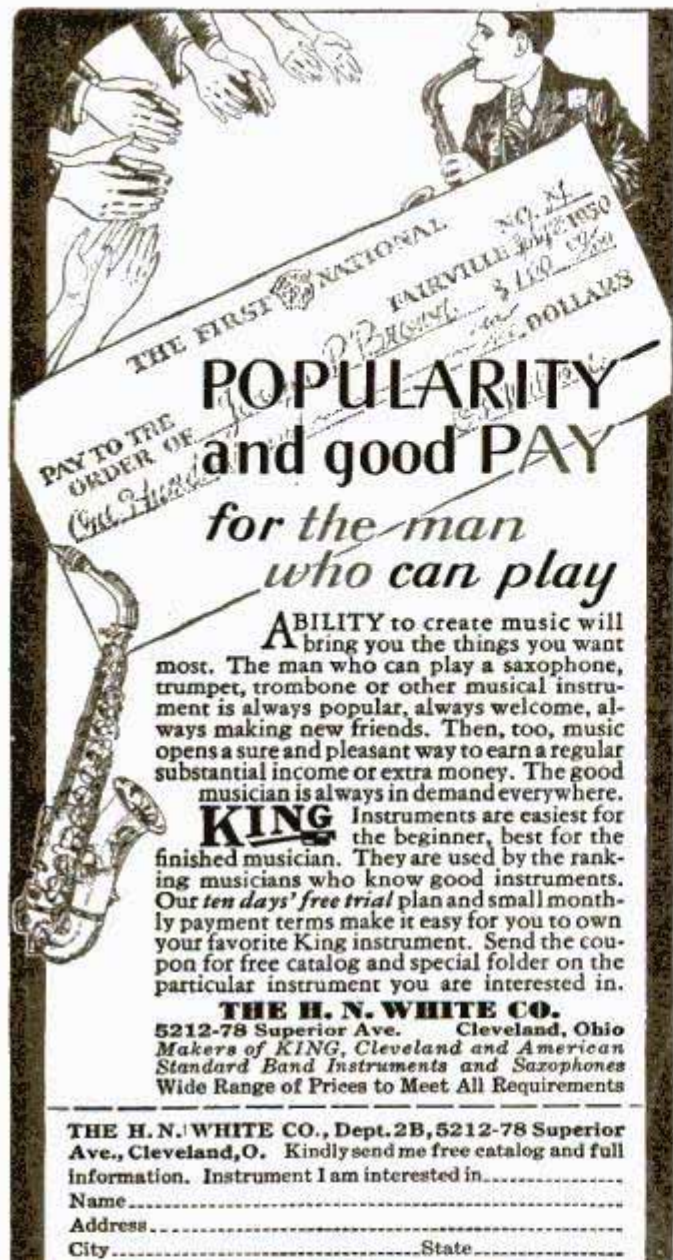

THE FIRST NATIONAL FAIRVILLE, ILL. 1930  
 NO. 24  
 \$1.00  
 \$1.00  
 DOLLARS

PAY TO THE ORDER OF  
 C. H. KING

## POPULARITY and good PAY

for the man who can play

**ABILITY** to create music will bring you the things you want most. The man who can play a saxophone, trumpet, trombone or other musical instrument is always popular, always welcome, always making new friends. Then, too, music opens a sure and pleasant way to earn a regular substantial income or extra money. The good musician is always in demand everywhere.

**KING** Instruments are easiest for the beginner, best for the finished musician. They are used by the ranking musicians who know good instruments. Our ten days' free trial plan and small monthly payment terms make it easy for you to own your favorite King instrument. Send the coupon for free catalog and special folder on the particular instrument you are interested in.

**THE H. N. WHITE CO.**  
 5212-78 Superior Ave. Cleveland, Ohio  
 Makers of KING, Cleveland and American Standard Band Instruments and Saxophones  
 Wide Range of Prices to Meet All Requirements

THE H. N. WHITE CO., Dept. 2B, 5212-78 Superior Ave., Cleveland, O. Kindly send me free catalog and full information. Instrument I am interested in.....

Name.....  
 Address.....  
 City.....State.....



**CRESCENT**  
 20" Band Saw

A high grade, moderately priced band saw for light work; affords all the accuracy, convenience and efficiency of large band saws. Ball bearing. Self contained motor operates from light socket; or may be driven from line shaft. Machine finished table, with graduated scale, tilts any angle to 45 degrees. Quick locking device. Saw, with spring tension, is fully guarded. We make wide line of light machines for cabinet makers, schools, and amateurs, also heavy machines for factories.

**THE CRESCENT MACHINE CO.**  
 93 Columbia St. Leontonia, Ohio

Send for **FREE BULLETINS**

# SUPER OIL BURNER

BOILS 100 GALLONS OR MORE IN LESS THAN HOUR

**TERRIFIC HEAT**



**MOST REMARKABLE GIANT BLUE FLAME BURNER BUILT.**  
 Ideal for gas fired boilers, heating large vats and tanks for factory, farm, agricultural and many other uses. (Burns outdoors as well as indoors.) Develops heat for 20 Horsepower gas fired boiler. Easy to install and operate.

**NO SOOT NOISE SMELL SMOKE**

### DOUBLE HEAT AT HALF COST

Improved generators convert ordinary kerosene oil into rarefied superheated gas, producing intensely hot blue flame capable of boiling from 100 to 500 gallons of water or other liquid. Double generators assure continuous performance without shut downs. 150 lava flame discs intensely heat. Equipped with all accessories. Nothing to buy.

### QUICK STARTING—PERFECT FLAME CONTROL

Equipped with pilot light for quick starting. Improved valve control regulates heat to any degree desired same as city or natural gas. For heavy or light duty this super-pressure oil burner gives entire satisfaction. Write for Catalog of Giant Therm-o-gas Burners, also smaller general utility burners for cook stoves, heaters, pressing machines, etc.

**HOME MFG. CO., Dept. 4813, 20 E. Kinzie St., Chicago, Ill.**

**Ogness Earned \$97.50**

... IN SIX DAYS

I'll give you the same chance. Show my samples of super-value tailored-to-measure all-wool suits at \$23.50. Cash commissions in advance and liberal bonus. Astounding values, guaranteed fit. No experience needed. FREE outfit, over 100 all-wool fabrics. Write.

**W. Z. GIBSON, Inc., Dept. X-516, 500 Throop St., Chicago, Ill.**



## Agents Wanted!

**Salesmen—Distributors**  
 to use and introduce attachment that gives 20% to 50% more mileage per gallon of gasoline. Automatically adjusts proportion of air to gas—giving correct mixture in accordance with changes in all weather and motor temperatures.

**Blancke Mixture Control**  
 An Automatic Thermostatic Carburetor Control for all cars and trucks. Saves gas—reduces crank case oil dilution—makes starting easier winter or summer—cuts repair bills—reduces carbon formation. Better lubrication. Motor runs smoother. Easily and quickly installed. Experience not necessary to sell this wonderful proven device. Blancke will start you without capital in a business of your own that is your opportunity to make from \$250 to \$2,000 a month profit. Get plan and free circulars. Write NOW!

**A. C. BLANCKE & CO., Dept. 805-N**  
 217 N. Desplaines Street Chicago, Illinois

**Cadillac, La Salle, Type W, Yellow Coaches and Delco Light**  
 now use as standard equipment Thermostatic Carburetor Control under Blancke License.

**30 Day Sales Guarantee**

# LOFTIS BROS. & CO. 1328

## DIAMONDS WATCHES

### CASH or CREDIT

### Send for FREE Catalog!

Write today for your free copy of our big Catalog showing over 2000 illustrations of Diamond-set Jewelry. Watches, Fancy Jewelry of all kinds, Silverware, Gifts, etc. All goods delivered on first payment.

**RAILROAD WATCHES—Guaranteed to Pass Inspection**  
 Hamilton No. 992—21 Jewels, Elgin's B. W. Raymond—21 Adjusted to 6 Positions. Gold Jewels, 8 Adjustments, Nickel Filled; 20-year Quality Case. \$60 Down; \$6.00 a Month. \$60 Down; \$6.00 a Month.

**LOFTIS BROS. & CO. National Jewelers**  
 Dept. E-894 108 North State Street, Chicago, Illinois

Stores in Leading Cities

No. 923—Three gorgeous blue white Diamonds; solid 18-K white gold ring. \$100.00.  
**\$250 a Wk.**

No. 947—Fiery blue white Diamond; solid 18-K white gold ring. \$50.00.  
**\$125 a Week**

No. 962—Balboa Wrist Watch, "Miss America." Watch and bracelet set with six synthetic sapphires. \$37.50—\$3.75 Down; \$3.75 a Mo.  
**MONEY BACK IF NOT SATISFIED**

No. 964—Sparkling blue white Diamond; solid 18-K white gold ring. \$75.00.  
**\$175 a Week**

No. 951—Three magnificent blue white Diamonds; solid 18-K white gold ring. \$150.00.  
**\$375 a Wk.**

No. 965—Elgin's B. W. Raymond, 21 Jewels. Yellow gold filled case, 20-year quality. \$60.00—\$6.00 Down; \$6.00 a Month.  
**ORDER DIRECT FROM THIS AD**





It's the powdered Italian pumice in Lava Soap that cuts the dirt without hurting the skin. Makes the dirtiest, greasiest hands spotless in 58 seconds



Takes the dirt, but leaves the skin

**AGENTS AND SIGN MEN**

Earn up to \$100 Weekly, and over, Putting up OUR GENUINE GOLD LEAF SIGN LETTERS



—on store and office windows, board signs, trucks and glass signs. We also make to order script signs and business emblems singly or by the thousands. A permanent business. No capital or experience required. Big demand in every City. Samples and Literature Free.

CONSOLIDATED SIGN LETTER CO. 71-X W. Van Buren CHICAGO, ILLINOIS

**OPEN Your SEARS Catalog to the . . .**

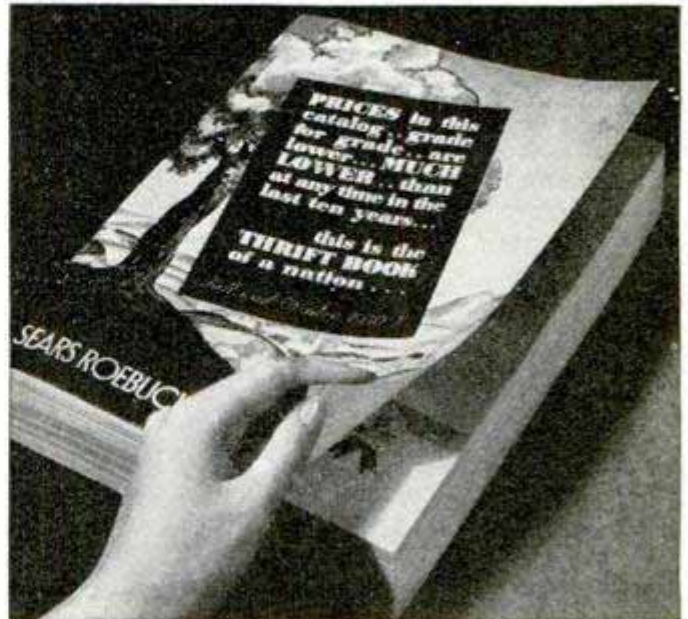

**LOWEST PRICES . . . in 10 YEARS**

The World's Largest Store is ready to serve you, at the lowest prices in ten years. Not alone the lowest prices we have quoted in ten years, but the lowest prices offered by any reputable organization.

You will be thinking more and more of thrift this Fall. And when you do, reach for your Sears catalog to find the lowest prices for whatever you want to buy.

**Leadership in Style, Too!**

While our buyers were securing these low prices for you, they were also alert to the new style influences in wearing apparel and in home furnishings.

The wanted styles this Fall are all prominently displayed in our new catalog. No matter what you need, we have it for you, of guaranteed quality, at a lower price.

**Send the Coupon**

If you have not received your copy of this 1100-page new "Thrift Book of a Nation," send for it today. It is free, of course. It quotes lowest prices on 46,000 articles for the family, the home, the shop, the auto and the farm.

**Send Now for Your Copy**

**SEARS, ROEBUCK AND CO.**

Chicago, Philadelphia, Boston, Minneapolis, Kansas City, Atlanta, Memphis, Dallas, Los Angeles, Seattle

(Mail Coupon to Store Nearest You)

Send me your Latest General Catalog.

80P29

Name.....

Postoffice.....State.....

Rural Route.....Box No.....  
(Please give both Route and Box Numbers if on a Rural Route)

Street Address.....

**68° SAVE FUEL 72°**  
 Enjoy health and comfort. Install M. & M. Moisture valve on your furnace. Automatic, nothing to get out of order.  
**M. & M. MFG. CO., Box 554, DAYTON, OHIO**  
 Representatives Wanted



# PATENT

## Protect Your Ideas

### Take the First Step Today

If you have a useful, practical, novel idea for any new article or for an improvement on an old one, you should communicate with a competent Registered Patent Attorney AT ONCE. Every year thousands of applications for patents are filed in the U. S. Patent Office. Frequently two or more applications are made for the same or substantially the same idea (even though the inventors may live in different sections of the country and be entirely unknown to one another). In such a case, the burden of proof rests upon the last application filed. Delays of even a few days in filing the application sometimes mean the loss of a patent. So lose no time. Get in touch with me at once by mailing the coupon on the opposite page.

### Prompt, Careful, Efficient Service

This large, experienced organization devotes its entire time and attention to patent and trade mark cases. Our offices are directly across the street from the U. S. Patent Office. We understand the technicalities of patent law. We know the rules and requirements of the Patent Office. We can proceed in the quickest, safest and best ways in preparing an application for a patent covering your idea. Our success has been built on the strength of careful, efficient, satisfactory service to inventors and trademark owners located in every state in the Union.

### NO CHARGE for Information On How to Proceed

The booklet shown here contains valuable information relating to patent procedure that every inventor should have. And with it I will also send you my "Record of Invention" form on which you can sketch your idea and establish its date before a witness. Such evidence may later prove valuable to you. Simply mail the coupon and I will send you the booklet, and the "Record of Invention" form, together with detailed information on how to proceed and the costs involved. Do this NOW. No need to lose a minute's time. The coupon will bring you complete information entirely without charge or obligation.



My Offices  
Just Across  
Street From  
U.S. Pat. Office



Above is a view of my drafting and specification offices where a large staff of experienced experts are in my constant employ. All drawings and specifications are prepared in my offices.

# NEWS

*Inventors*  
*Write for these*

**Free Books**

**Strict Secrecy Preserved**

All communications, sketches, drawings, etc., are held in strictest confidence in strong, steel, fireproof files, which are accessible only to authorized members of my staff. Feel free to write me fully and frankly. It is probable that I can help you. Highest references. But **FIRST**—clip the coupon and get my free book. Do **THAT** right now.

**Clarence A. O'Brien**

*Registered Patent Attorney*

Member of Bar of: Supreme Court of the United States; Court of Appeals, District of Columbia; Supreme Court, District of Columbia; United States Court of Claims.

Practice confined exclusively to Patents, Trademarks and Copyrights

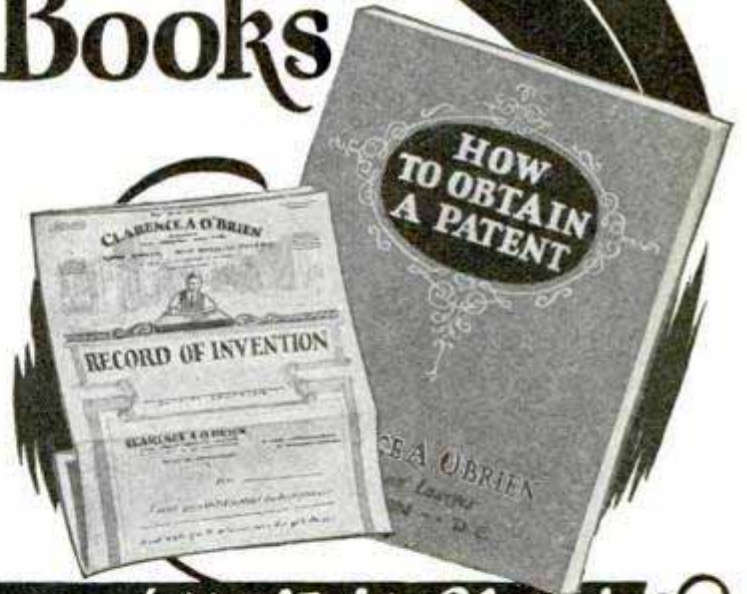

**Clip this Coupon and Mail it Now!**

**CLARENCE A. O'BRIEN, Registered Patent Attorney**  
709 Security Savings and Commercial Bank Bldg.  
Washington, D. C.

(Or, Suite 1106, Dept. A-4, Woolworth Bldg., New York City)

Please send me your free book, "How to Obtain a Patent," and your "Record of Invention" form without any cost or obligation on my part.

Name.....

Address.....

(Important—Write or print name plainly and address office nearest you)



# PATENTS TRADE MARKS COPYRIGHTS



Our New York Office  
Suite 1007 Woolworth Bldg.



Our Philadelphia Office  
828 Fidelity Phila. Trust Bldg.



VICTOR BUILDING  
Our New Building Nearly Opposite U. S. Patent  
Office Specially Erected by Us for Our Own Use

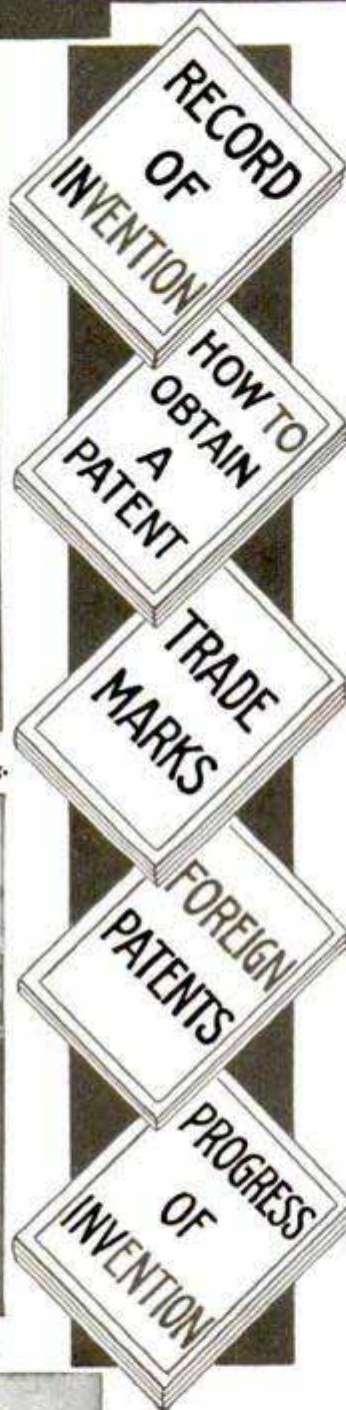

## Have You An Idea?

**Our Offer:** FOR THE PROTECTION OF YOUR INVENTION

**YOUR FIRST STEP**—The Inventor should write for our blank form "RECORD OF INVENTION." A sketch and description should be made on this Blank, signed, witnessed, then returned to us. **We also give our opinion** as to whether the invention comes within the Patent Office definition of a patentable invention. This "Record of Invention" will serve as "proof of conception." *There is no charge or obligation for this service.*

## Our Five Books Mailed Free to Inventors

*Our Illustrated Guide BOOK*

## How to Obtain a Patent

Contains full instructions regarding U. S. Patents. Our Methods, Terms, and 100 Mechanical Movements illustrated and described.

## Our Trade Mark Book

Shows value and necessity of Trade Mark Protection. Information regarding *Trade Marks and unfair competition in trade.*

## Our Foreign Book

We have Direct Agencies in Foreign Countries, and secure Foreign Patents in shortest time and lowest cost.

## Progress of Invention

Description of World's Most Pressing Problems by Leading Scientists and Inventors.

## Payment of Fees in Installments

It is not necessary that the total cost for the preparation and prosecution of a patent be paid in one payment. Our custom is to permit our clients to pay for their applications in three installments as the preparation of the application progresses in our office. This plan makes the payments easy for the inventor.

*We Regard a Satisfied Client* as our best advertisement, and furnish anyone, upon request, lists of clients in any state for whom we have secured patents.

*Highest References—Prompt Service  
—Reasonable Terms*

# VICTOR J. EVANS & CO.

Patent Attorneys, Established in 1898

Main Offices: 789 9th St., N. W., Washington, D. C.

*Nearly Opposite U. S. Patent Office*



# DELAYS ARE DANGEROUS IN PATENT MATTERS

## IMPORTANT! To Avoid Delay!

YOU SHOULD HAVE YOUR CASE MADE SPECIAL IN OUR OFFICE to save correspondence, secure protection and early filing date in the Patent Office. To secure **special preparation** of your case send \$25.00 on account with model or sketch and description of invention. If the invention is not patentable we will return fee less cost of search.

**We Assist our Clients to Sell their Inventions.**



MAIN OFFICE, VICTOR J. EVANS & CO.—VICTOR BUILDING, WASHINGTON, D. C.

Our Large, Comprehensive Organization has been established for 30 years and offers Prompt, Efficient and **Personal Service** by experienced Patent Lawyers and Draftsmen. Every case is in charge of a Specialist who has been selected for his knowledge and experience in certain lines of invention. Our Lawyers practice in all U. S. Courts and defend clients in suits involving Patents, Trademarks and Copyrights. All Communications, Sketches, Drawings, etc., preserved in fireproof Files, strictly **Secret and Confidential**. We shall be glad to have you consult us or to answer any questions in regard to Patents, Trademarks or Copyrights without charge or obligation.



Our Chicago Office  
Suite 1640-42 Conway Bldg.



Our Pittsburgh Office  
Suite 514 Empire Building



Our San Francisco Office  
Suite 1010 Hobart Building

**FREE  
COUPON**

**VICTOR J. EVANS & CO.**  
**PATENT ATTORNEYS** *Established  
in 1898*

NEW YORK OFFICES  
1007 Woolworth Bldg.

CHICAGO OFFICES  
Suite 1640-42 Conway Bldg.

PHILADELPHIA OFFICES  
828 Fidelity Phila. Trust Bldg.

PITTSBURGH OFFICES  
514 Empire Bldg.

SAN FRANCISCO OFFICES  
1010 Hobart Bldg.

**MAIN OFFICES: 789-9th Street, N. W., WASHINGTON, D. C.**

Gentlemen: Please send me *Free of Charge* your books as described on preceding page.

Name.....

Address.....



**MEN! NEW SHAVING  
IDEA PAYS...  
\$6 to \$14 AN HOUR**

**FREE SHAVES FOR LIFE!**

**Amazing Shaving Idea Bringing  
Fortunes to Agents!**

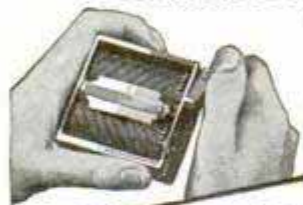

Surprising simplicity amazes everyone. New Merchandising Plan assures your success. We guarantee your sales—you take no risk. Mail coupon TODAY for FREE details.

**WE GUARANTEE SALES—NO RISK**  
**MAIL COUPON  
Send No Money**

Imagine! Revolutionary Shaving idea! More than 2,000,000 men use, recommend SHAVE KING principle. Old type stoppers now obsolete. No fussing, no reversing, simply turn handle. Blade lasts indefinitely. Big demand! Clear profit 125% on every sale.

Men needed to supply demand for world's greatest shaving device. \$6 to \$14 a day. Full or spare time. Big commissions! Easy, pleasant work. Send quick for FREE details!

Unlimited guarantee. Free shaves for life!

**MAIL THIS COUPON ... NOW!**

SHAVE KING CO.  
Dept. 9-R 1800 Olive St., St. Louis, Mo.  
Please rush details of SHAVE KING Revolutionary Shaving Idea! Also FREE 30-day Trial Offer.

Name.....  
Address.....  
City.....State.....

**PATENTS**

**PROTECT YOUR IDEAS**

Write today for FREE INSTRUCTIONS—or send Drawing or Model of your Invention for Examination.

Promptness Assured with Best Results

**MILLER & MILLER**  
**REGISTERED PATENT ATTORNEYS**

Former Members Examining Corps U. S. Patent Office  
255 McGill Building Washington, D. C.

**PATENTS**

**To the Man with an Idea**

PATENTS Procured. Trade Marks Registered. —A comprehensive, experienced, prompt service for the protection and development of your ideas. Preliminary advice gladly furnished without charge. Booklet of information and form for disclosing idea free on request.

IRVING L. McCATHRAN, Patent Lawyer  
Formerly with and successor to RICHARD B. OWEN  
704 International Bldg., Washington, D. C.  
41-E Park Row, New York City

**TRADE-MARKS  
REGISTERED**



**PATENTS  
TRADE-MARKS**

**Don't Lose Your Rights  
To Patent Protection**

Before disclosing your invention to anyone send for blank form "EVIDENCE OF CONCEPTION" to be signed and witnessed.

LANCASTER, ALLWINE & ROMMEL  
480 Ouray Bldg. WASHINGTON, D. C.  
*Originators of forms "Evidence of Conception."*

**PATENTS**

As one of the oldest patent firms in America we give inventors at lowest consistent charge, a service noted for results, evidenced by many well-known Patents of extraordinary value. Book, Patent-Sense, free, Lacey & Lacey, 635 F St. N. W., Dept. 5, Wash., D. C. Estab. 1869

**DO YOU**

WANT a new business profession of your own, with all the trade you can attend to? Then become a foot correctionist, and in a few weeks earn big income in service fees,—not medical nor chiropody—easy terms for home training, no further capital needed, no goods to buy, no agency. Address

Stephenson Laboratory, 1 Back Bay, Boston, Mass.

**PATENTS SECURED  
TRADE-MARKS REGISTERED**

High-class professional service for Inventors and Trade-Mark Users is necessary for PROPER PROTECTION. We Offer you our facilities on Reasonable Terms. If you have an invention send us a model or sketch and description and we will give you our OPINION whether your invention comes within the provisions of the Patent Laws. Our book, "HOW TO GET YOUR PATENT" and Record of Invention Certificate sent on request. DELAYS are DANGEROUS in Patent Matters.

Terms Reasonable.

Best References.

WRITE TODAY

**RANDOLPH & COMPANY, Patent Attorneys**  
301 VICTOR BUILDING, WASHINGTON, D. C.

Name.....

Address.....



# Boys-have fun with chemistry-25¢



Surprise your friends with magic chemical tricks: make ink; dye cloth; test water and soil; write secret letters with invisible ink; pour blue, brown and black liquids from a pitcher of water. All these and more chemical stunts can be done with Chemcraft Junior. It's the best box of fun you ever had; shows you useful things to do. Get yours now.



**FREE MAGAZINE** to every boy who writes now. Contains chemical information and new tricks and stunts with chemicals. Write for yours now.

**The Porter Chemical Company**  
54 East Washington St., Hagerstown, Md.

## AMAZING NEW GUN

Men all over the country are turning to this full size automatic high power rifle using round steel shot. Light, Speedy. Sporting arm balance and precision.

TRY THE **BENJAMIN** 25 SHOT AUTOMATIC "THE MYSTERY RIFLE"

OUTSHOOTS ALL OTHERS



Companion to the world famous Benjamin Single Shot. Same effective compressed air action with 25 shot automatic feed. 16 to 12 rapid fire shots on one pumping. Price \$10.00. Benjamin Single Shot Air Rifle \$5.00. Ask your dealer for demonstration or write for details and "BB MAGIC" FREE.



BENJAMIN AIR RIFLE CO., 605 North Broadway, St. Louis, Mo.

## PATENTS

Trade Marks, Copyrights, Patent Litigation Handbook with illustrations, 100 mechanical movements. Sent free on request.

**ALBERT E. DIETERICH**

Successor to Fred G. Dieterich & Co. formerly member Examining Corps, U. S. Patent Office

REGISTERED PATENT LAWYER and SOLICITOR  
621-A, Ouray Bldg.  
30 Years' Experience Washington, D. C.

The BLAIR TOOL AND MACHINE CORP.  
College Point, N. Y.  
Manufacturing Machinists Since 1895

## INVENTIONS

FINANCED DEVELOPED PATENTED MANUFACTURED MARKETED

Write for our free booklet.

Patent Dept. at Patent Law Offices of EDWARD GOTTLIEB 5 Beekman Street NEW YORK N. Y.

# Get Into The Shoe Business Without Investment!



We start you. Earn big money with our remarkable direct-to-wearer plan. Making profits is easy when you show splendid Tanners Line of Shoes and Hosiery for men, women and children.

**FOOTWEAR SERVICE** for

### Everybody Needs Shoes

Shoes are an absolute necessity—and Tanners Quality shoes at our low prices are a necessity that sells to the same customers again and again. Big advance commissions mean your profits come easy. We tell you how and where to sell.

### We Supply Everything

We furnish everything you need to do a big business in your territory—set you up in a big and profitable shoe business without investment. We furnish you a \$40.00 outfit containing actual shoes and hosiery—a larger variety of styles and sizes than any store can carry. Our patented measurement system insures perfect fit. Anyone can use this system correctly.

### No Experience Necessary.

Makes no difference what you have been doing—you can make a big success of this business if you will honestly try. Write for big FREE book "Getting Ahead" and \$10.00 Selling Outfit containing Actual Shoes and Hosiery.

### Mail This SUCCESS Coupon!

Tanners Shoe Co., 8710 C Street, Boston, Mass.

Without obligation on my part, send me my FREE copy of "Getting Ahead." Tell me how to secure \$40.00 Outfit of Shoes and Hosiery. I will take good care of this outfit.

Name \_\_\_\_\_  
No. \_\_\_\_\_ Street \_\_\_\_\_  
Town \_\_\_\_\_ State \_\_\_\_\_

## Do Your PRINTING

Cards, stationery, circulars, tags, labels, advertising, etc. Save money. Print for others, big profits; easy rules sent. Will do popular Raised Printing like Engraving. Junior Press, \$5.90. Job Presses \$11 up. Power \$149. Write for free catalog. THE KELSEY, CO., Y-37, Meriden, Conn.

Cal. 30-40 Six Shot Price \$9<sup>75</sup>

**KRAG CARBINE**  
All the qualities of a high price rifle. In fine used condition, all working parts guaranteed for one year. Send today for our Free 60-page illustrated catalog of money saving values; Guns, Ammunition, Cutlery, Sports and Gov't goods. Deposit required on all orders. Money refunded if not satisfactory. W. Stokes Kirk, Dept. P. M-10, 1627 N. 10th St., Phila., Pa.

# PATENTS

Booklet Free Highest References Promptness Assured Best Results Send drawing or model.

## ALL BUSINESS GIVEN PROMPT AND PROPER ATTENTION

Listed Patent Lawyer in the latest editions of the Rand-McNally Directory of Bankers and Bonded Attorneys, published by Rand-McNally & Co., Chicago, Ill.; The Baggott & Ryall Directory of Guaranteed Attorneys, published by Legal Directory Corporation, Boston, Mass.; Flugel's Law List, published by Legal Directory Publishing Co., St. Louis, Mo.; American Lawyers Annual, published in Cleveland, Ohio; Bankers Service Legal Directory, published by Bankers Service Co., Boston, Mass.; Eyre's Law List, 9 Park Place, New York City; Walters Legal Directory, Omaha, Nebraska, and the National Directory of Attorneys, Baltimore, Maryland.

**WATSON E. COLEMAN,**  
REGISTERED PATENT LAWYER

Victor Building, 724 Ninth Street, N. W.  
**WASHINGTON, D. C.**







# 1931 LOWEST WHOLESALE PRICES! FREE RADIO CATALOG

Everyone interested in RADIO should have this Catalog. Solid with "Specials" from cover to cover. Teeming with values . . . every item a feature. All latest sets and equipment. Screen Grid, A. C., Humless, all electric sets . . . also battery operated sets and direct current sets. Dynamic speakers, beautiful consoles, kits and parts. Wholesale prices. Astounding savings. Get this FREE bargain book today.

**Chicago Salvage Stock Store**  
509 S. State St. Dept. 565 Chicago

**\$12.75**



**SLIDING TOOL RESTS: \$12.75**  
For all lathes from 6" to 13" swing. Ways are milled and gibbed for take-up. Has 8" cross feed and 8" longitudinal feed. Shield lifts off for turning large diameters at extreme left. Sizes less than 7" have 1/2" H. S. Tool instead of tool holder as shown. Average weight 20 lbs.

State swing with order  
**GOODWIN MFG. CO.**  
OTTUMWA IOWA

**MCC** **CLASS PINS** **LABC**  
**FREE CATALOG**  
Either pin, silver plate . . . 35¢ ea.  
Sterling silver or gold plate . . . 50¢ ea.  
for 2 colors enamel, any 3 or 4 letters & dates

Lower Prices on Dozen Lots  
961 BASTIAN BLDG. ROCHESTER, N. Y.

BASTIAN BROS. CO. 3489 3499

## DEAFNESS IS MISERY

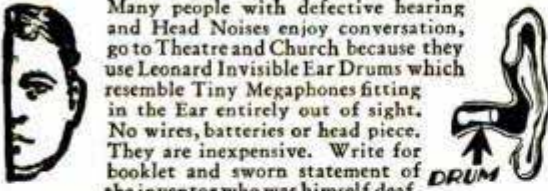

Many people with defective hearing and Head Noises enjoy conversation, go to Theatre and Church because they use Leonard Invisible Ear Drums which resemble Tiny Megaphones fitting in the Ear entirely out of sight. No wires, batteries or head piece. They are inexpensive. Write for booklet and sworn statement of the inventor who was himself deaf.

A. O. LEONARD, Inc., Suite 699, 70 5th Ave., New York

## A NEW CAR in 30 MINUTES



Get the BEAUTY and LUSTRE of a NEW PAINT JOB at a small fraction of the cost. Do it Yourself with NUKAR. NOT a Wax. NOT a Paint. NOT a Polish. This New Chemical discovery instantly restores Original Color to dull faded cars, and gives a Beautiful, Brilliant, Mirror-Like Lustre that lasts for months. Does not hold Dirt or Dust. Actually makes old Shabby Cars look NEW. No rubbing—No hard work. Flows on like water from a sponge. No Waiting—No Delay—Drive a NEW CAR the same day. Results Guaranteed.

**MEN! Amazing Cash Profits**  
Are being made by Agents, Distributors and Service Station operators. Get in on the biggest thing in the automobile business today. Earn up to \$50 a day. Full or part time. Millions of cars need NUKAR. Makes a Sensational sales compelling Demonstration. We back you to the limit with powerful Sales Co-operation and give you FREE—a Business Start that Money could not Buy. Let us send Prepaid and without charge a FREE SAMPLE and our Big Book in colors. Act NOW. Write TODAY.  
ATLAS SOLVENT CO. Morgan Park Sta. 33 CHICAGO, ILL.



## "Not Another Cent!"



"You're getting all you're worth—for the work you're doing. If you want a raise, you'll have to learn higher class work—on your own time—not mine."

Hard words from the boss. But I took it on the chin. That night at home, looking over my new Mechanics' magazine I read a little ad that promised a "soft" job; big pay; clean, honorable work—if I would get down and practice evenings for 3 months. I tore out that coupon, and today—

## I'm Doing Swell



Playing with a dance band is like getting paid for having fun. I've doubled my pay working 3 or 4 evenings a week. Good-by dirty overalls. Good-by grind. This is a cinch. And I thought I was musically dumb.

## What's the Matter with You?

Why don't you step out of the overalls and into a "white collar" job? You don't have to be talented. Learn any instrument in a few weeks' spare-time practice. Double your income, treble your social position. Make big money—big friends.

Mail coupon below for catalog of your favorite instrument, saxophone, trumpet, trombone, clarinet; then take an instrument home on six days' free trial. Test yourself before you buy. See what you can do. No obligation. Mail coupon NOW.



# BUESCHER

BUESCHER BAND INSTRUMENT COMPANY  
1010 Buescher Block, Elkhart, Indiana. B55

Gentlemen: Without obligating me in any way, please send complete catalog of (check which) trumpets  trombones  saxophones  clarinets . Mention any other

Name \_\_\_\_\_  
Address \_\_\_\_\_  
Town \_\_\_\_\_ State \_\_\_\_\_





**\$2,840 Earned  
By Clynic in His  
First Two  
Months**

4 to 6 Jobs a Day—One Man—Powerful—Light

**Big Profits—and Your Own Boss**

Furnace cleaning with a Super Suction Cleaner is an all-year money maker, and you can own this new, highly profitable business on easy terms.

In his first 2 months Clynic had 178 cleanings at \$1,424; 74 repair jobs and 15 complete overhauls bringing \$1,416. Total, gross: \$2,840. And he sold nine new furnaces besides.

You need not be an expert furnace man to get big profits. Our free Plan Book tells how to make money from the start. Send coupon for it today.

The National Super Service Co.  
1958 N. 13th St., Toledo, Ohio.

Please send Plan Book and easy terms.

Name.....

Street.....

City..... State.....

**NEW  
DISCOVERY ENDS  
PEELING POTATOES**



Imagine a tiny, automatic invention that peels potatoes at the turn of a little crank! Does the whole job in a few seconds! Banishes paring knives! Ends cut fingers! Stops waste!

**EVERY WOMAN WANTS IT**

AGENTS! Spare-time workers! Even beginners without selling experience! Here's a real chance for \$100 a week. Millions of women are eagerly waiting to see this amazing new discovery. Many will buy almost on sight! The demonstration is nothing short of startling. Take a potato of any size or shape, even an odd-shaped, crooked, "warted" one. Turn the crank and a little patented "goose-neck" travels like a flash across the surface, strips off a wafer-thin layer, does the whole paring job in just a few seconds! No mess, muss, fuss or work! No cut hands! No waste! Yet this magical little device is so inexpensive that it quickly pays for itself by saving potato wasted in hand paring with a knife! No wonder agents make almost incredible sums! Send quick for full details and sample offer to

GUARANTY PRODUCTS CO. Dept. P-80  
Francis Bldg., Washington at 16th Street St. Louis, Mo.

Guaranty Products Co., Dept. P-80, Francis Bldg., Washington at 16th Street, St. Louis, Mo.

Rush details and sample offer to

Name.....

Address.....

Town..... State.....

**It's a BULOVA—Sent with a Mesh Band! For \$1.00**

**TAKE 12 MONTHS TO PAY**

Send \$1.00 with order and tell us a little about yourself: (A) How long at present address, (B) Age, (C) Married or Single, (D) Name of Employer, (E) Position, (F) How long employed. All information held **strictly confidential**. We make no direct inquiries of anyone—not even from your employer.

**10 Days Free Trial—Satisfaction Guaranteed**  
This genuine Bulova watch comes to you postage paid—no C.O.D. to pay on arrival! You take no risk—satisfaction guaranteed or money back.

Estab. 1895

**\$2975 DGS-**  
15 jewel BULOVA gent's wrist watch, White Gold filled case; "dust-tite" protector; radium dial and hands; latest woven mesh wristband. Guaranteed. \$1 now, \$2.39 a mo. *Nationally advertised cash price, no extra charge for credit.*

**Catalog FREE** New catalog of genuine diamonds, standard nationally advertised watches, fine jewelry. Write for it now.

**ROYAL DIAMOND & WATCH CO.**  
ADDRESS DEPT. 11 K 170 BROADWAY, N.Y.

**MOTORCYCLES**

**WE WILL TRUST YOU  
Pay As Low As \$2.00 per Week**

Hendersons, Harley - Davidsons, Indians

Slightly used and rebuilt. Hundreds to select from.

Send 10c for list today.

**MYEROW BROS. CO., 15 Berkeley St., Boston, Mass., U. S. A.**

**Choo Choo—Another \$240 Profit!**

Another HOLLYWOOD knock-out selling hit—the CHOO-CHOO-AUTO HORN. (Pat. Pending) Closely resembles the sound of a roaring locomotive whistle. Not a toy, nor trick horn but a real motor car horn—preferable to most others. Hundreds being installed—from FORDS TO LINCOLNS!

Sells itself at \$4.90—costs you \$2.40. NO-HOUSE-TO-HOUSE SELLING. Sound it and collect the crowd—and then COLLECT THE MONEY! Agents are actually "cleaning up" on this new hit. Everybody wants one. Installed in 3 minutes by anyone. Be first in your locality with this clever horn.

SEND \$2.40 for sample horn or write for details.

**PACIFIC COAST PRODUCTS CO., LTD.**  
Dept. A20, 1616 Cahuenga Blvd., Hollywood, California

**8" Band Saw \$1395**

Only **\$1395**

**Here It Is. An Ace of An Up-To-Date Band Saw. Just What You Have Been Looking For!**

A Band Saw that is guaranteed to give the same results as the larger and more expensive machines now on the market.

Has hardened and ground shafts—saw guides made of tool steel— $\frac{1}{2}$ " Atkins Silver Steel Saw Blade—will cut wood up to 2  $\frac{1}{2}$ " thick and light metal. A real machine made to last a life time, and carries a guarantee of satisfaction or money refunded. With Endless "V" Belt and Motor Pulley \$15.00.

**Up-To-Date Machine Works**  
Dept. 100, 2909-15 So. Wabash Ave. CHICAGO, ILL.





# FREE To Men Past 40

## Amazing New Facts About The Misunderstood Subject of Rejuvenation

A well-known scientist's new book about old age reveals facts, which, to many men, will be amazing. Did you know that two-thirds of all men past middle age are said to have a certain seldom mentioned disorder. Do you know the frequent cause of this decline in health?

### Common Old-Age Symptoms

Medical men know this condition as hypertrophy of the prostate gland. Science now reveals that this swollen gland—painless in itself—not only often cheats men of health, but also bears on the bladder and is often directly responsible for sciatica, back ache, pains in the legs and feet, frequent nightly rising, and dizziness, denoting high blood pressure. When allowed to run on it is frequently the cause of the dreaded disease cystitis, a very severe bladder inflammation.

### 65% Have This Gland Disorder

Prostate trouble is now reached immediately by a new kind of home treatment—a new, safe hygiene that goes directly to the gland, itself, without drugs, medicine, massage, lessons, diet or the application of electricity. It is absolutely safe. 100,000 men have used it to restore the prostate gland to normal functioning. The principle involved in this treatment is recommended by practically all the physicians in America. Amazing recoveries are made in six days. Another grateful effect is usually the immediate disappearance of chronic constipation. Usually the entire body is toned up, as much

of your youthful vigor is restored. These results are guaranteed. Either you feel ten years younger in seven days or the treatment costs nothing.

### Send For Free Book

If you have this gland trouble or if you have any of the symptoms mentioned above, you should not lose a day in writing for the scientist's free Book, "Why Men Are Old at 40." It will enable you to ask yourself certain frank questions that reveal your true condition. Every man past 40 should make this test, as insidious prostate disorder often leads to surgery. This book is absolutely free, but mail coupon immediately, as the edition is limited. Address

**The ELECTRO THERMAL COMPANY**  
2134 MORRIS AVE. STEUBENVILLE, OHIO

If you live West of the Rockies, address The Electro Thermal Co., 303 Van Nuys Building, Dept. 21-L, Los Angeles, Calif. In Canada, address The Electro Thermal Co., Desk 21-L, 53 Yonge St., Toronto, Canada.

THE ELECTRO THERMAL COMPANY,  
2134 Morris Ave., Steubenville, Ohio.

Please send me Free, and without obligation, a copy of your booklet "Why Men Are Old at 40." Mail in plain wrapper.

Name.....

Address.....

City.....State.....

## MOTORCYCLES

Direct to you at wholesale prices

Send 10c today for the latest Illustrated Bulletin and Confidential Price List of Guaranteed Indians Harleys Hendersons SuperX etc. (Sold on easy terms if desired).

**CRANDALL CYCLE CO.** 826-28 State St. Shipments to all Motorcycles Since 1905 Springfield, Mass. parts of the world

## This is Easy Money!

Fast selling, big money-making line of Photo statuettes, Com-pacts, Medallions, Cigarette Cases, etc. \$50 to \$75 weekly profit from only 3 sales a day. Brand new—artistic—everybody wants. Write today for Free Sample Offer and catalog.

**200% TO 300% PROFIT**

Craver Manufacturing Co. Dept. 5100 2454 West Jackson Blvd., Chicago, Ill.

## Keds

At \$1.00, \$1.25, \$1.50, \$1.75 and up to \$4.00.

United States Rubber Company

## Catch Fish!

Eels, Mink, Muskrats with our new folding galvanized STEEL WIRE TRAP. Write for our FREE TRAP OFFER and Bargain Catalog. \$1 Box of our famous Fish Bait FREE to introduce our traps.

**WALTON SUPPLY CO., 3502 JUNIATA AVE., ST. LOUIS, MO.**

## ALL GIVEN

22 CAL. RIFLE

10 year guar. Watch with chain and ring, large Eastman Roll Film Camera or 22 cal. Hamilton Rifle, yours for introducing finest assorted liquid perfume at 15c a bottle. Send for 20 bottles and choose gifts as per offer in our catalog. We trust you—just write to **BELL PERFUME CO., Dept. 153A, Chicago, Ill.**



## Now Make Big Money! Give Away

**Delicious  
Confection**



Now the originators of one of America's most popular, widely advertised confections—has openings for more men to take care of the market among local stores—on a clever new plan that starts big money coming in even the first day just letting people taste it free. Already local men have taken in as high as \$200 to \$300 in a single day.

### NO SELLING TO DO

No house to house canvassing. Stores sell it for you. Generous new profit sharing plan gets it into nearly every store without need of high pressure selling. New "taste it first" plan brings enormous repeat orders. Now the market for this tempting confection is so tremendous that more men are needed quick to see that dealers are kept supplied. This opening means more to you than a mere job. It means big money quick—and the chance to build a permanent business of your own with a steady profit pouring in from local stores. Don't worry about big capital, business experience, or sales ability. We tell you just what to do to make big money at the start.

### \$365 IN ONE DAY

Ira Shook took in \$365 in a single day. Marine took in \$11,265 in three months. Gordon, \$4,000 profits in two months. Nazer, \$3,000 in three months. Hundreds more big profit records.

### RUSH APPLICATION

So many men will apply for these openings that we will probably be swamped. Therefore, we urge you to rush the application below if you are interested in up to \$50 even in a day. Address H. W. Eakins, President, 1028 High Street, Springfield, Ohio.

H. W. Eakins, President,  
1028 High St., Springfield, Ohio.

Consider me an applicant for opening as owner of one of your businesses on your new plan that starts me in big business without doing any high pressure selling or house to house canvassing.

Name.....

Address.....

City..... State.....



**Big 3 ft. Telescope** Five Sections. Brass bound. Powerful Lenses. 10-Mile range. Special Eye Piece for looking at the Sun, included FREE. Can be used as a Microscope. Guaranteed. Big value. Postpaid, \$1.75. C. O. D. 15c extra. **Benner & Company, T-48, Trenton, N. J.**

## STRANGE INVENTION! PAYS YOU IMMENSE PROFITS NEW FIELD for AGENTS

Sell only device in the world that prevents kinking, snarling and tangling of telephone and electric iron cords. Housewives and business men buy 1 to 50.

**NEW KIND OF CORD SET FREE**  
Every Neverknot Salesman is given FREE the complete Neverknot Switch Plug Cord Set pictured. This new kind of ironing cord automatically coils itself out of the way and a new kind of switch plug prevents scorching and saves electric bills. This set is a "gold mine" for house-to-house workers. It's different and it's yours if you work for us. Don't delay! Send now for free offer.

**NEVERKNOT CO. Dept. 10-V 4503 Ravenswood, Chicago**

The Plug That Saves Electric Bills.

## THIS PLANE IS DESIGNED FOR YOU TO FLY!



### BUILD IT NOW FOR ONLY \$199

Here's the famous Heath Parasol—the champion little plane that has been designed just for you to fly. For it is the most easily handled plane ever built—and brings you complete flying safety at the lowest cost in aviation history.

No other plane offers the marvelous convenience and economical features of the Heath Parasol. It requires no airport as it lands on any field or even a highway. With wings mounted on the sides—it takes no more room than a car, and costs even less to store.

Nor is any other plane as economical to own and operate. Consider that it costs only \$975.00 complete. That it can be built from clear easy plans for only \$199.00. Observe that its total upkeep cost, including gas, oil, storage, etc., is less than one cent a mile! Then you'll understand why the Heath Parasol is America's most popular sport plane.

### YOU TOO CAN BUILD IT

Hundreds of enthusiastic builders have completed their Heath Parasols in remarkably short time. Parts are sent in eleven convenient progressive groups. \$12.00 brings the first shipment.

Don't delay another day. Learn more about America's most popular sport plane. Ten cents in stamps or coin brings large illustrated booklet.



**AIRCRAFT CORP. CHICAGO**  
Dept. P 10—1721-9 Sedgwick Street, Chicago, Illinois



## PANTS MATCHED!

**Why Throw Away That Coat and Vest?**  
Save \$25 or more! Let us match your coat and vest with new trousers and save the price of a new suit. Each pair tailored to your measure. (Average price \$8.50). Over 100,000 patterns. Mail sample of suit, or your vest which will be returned together with

FREE Sample for your approval.  
**MATCH PANTS CO., Dept. 400**  
20 W. Jackson Blvd. CHICAGO



### BUILD "FLYING CLOUD"

Send for quality parts and clear blueprints of 20" model. Readily made in spare hours as hull fully shaped and sanded. Set includes anchor, bell, capstan, dead eyes, wheel, rigging line, etc. Complete for \$11. Postage 5 lbs. White metal figure-head 50c. Send 10c today for catalog.

**ROY HANCOCK**  
323 Douglas Ave. Portsmouth, Va.

SOLD ON EASY TERMS

## WORKACE Electric WOODWORKER

Complete Outfit Including Planer, Saw, Lathe, Electric Motor and Many Useful Attachments

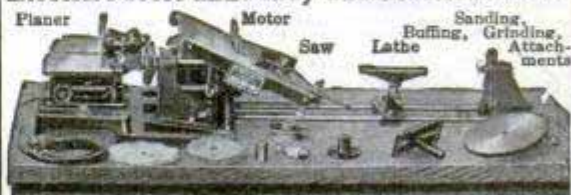

Fast—Accurate—Complete

Price complete, \$89.00. Easy Terms.  
Write for complete information.

**J. D. Wallace & Co.,** Adams St., Chicago  
11 W. 42nd St., New York. 268 Market St., San Francisco





# Is Tobacco Hurting You?

Look the facts square in the face, Mr. Tobacco User. You may think tobacco is not hurting you.

That is because you haven't as yet, perhaps, felt the effects of the nicotine poison in YOUR system. For you know that nicotine, as absorbed into the system through smoking and chewing tobacco, is a slow working poison. Slow, yes—but sure.

Tobacco lowers efficiency. It slows a man down. Makes it harder to concentrate the mind on work. Tobacco users seldom have the amount of "pep" and energy of those who do not use the weed. There's many a man older than you in years who is younger in energy, simply because he lets tobacco alone.

Some day, probably, you will realize to what an alarming extent tobacco does undermine the system.

When your hands begin to tremble—  
and your appetite begins to fail—  
and your heart seems to "skip a beat" now and then—  
and slight exertion makes you short of breath—  
then you have a right to suspect that  
TOBACCO is getting the upper hand.

Any well-informed doctor will tell you that these are only a few of many symptoms of tobacco poisoning.

And YOU know that the use of tobacco in any form is an expensive, utterly useless habit. You know you ought to quit.

## Tobacco Habit Banished In Many Cases—Let Us Help You

It doesn't make a particle of difference whether tobacco has been used for a single month or fifty years, or how much, or in what form—whether cigars, cigarettes, pipe, plug, fine cut, or snuff. In most cases, Tobacco Redeemer removes all craving for tobacco in any form in a very few days. Not the slightest shock to the nervous system. The tobacco craving will usually begin to decrease after the very first dose—there is no long waiting for results.

Tobacco Redeemer contains no habit-forming drugs of any kind and is quick, safe, pleasant and thoroughly reliable.

It is in no sense a substitute for tobacco. It helps to quiet the nerves and makes one feel better in every way.

**Our Guarantee** A single trial will convince you. Our legal, binding, money-back guarantee goes with each full treatment. We will refund every cent you pay for the treatment if, after taking it according to the easy-to-follow directions, it should fail to banish the tobacco habit completely.

**SEND Coupon for Free Proof** Let us send you our free booklet on the injurious effects of tobacco, together with testimonial letters from men all over the country telling how they have been absolutely freed from the tobacco habit by this simple home treatment. You could not ask for stronger proof than the evidence we will gladly send on request. Just mail the coupon—or a postal will do.

**NEWELL PHARMACAL CO.**

Dept. 300 Clayton Station St. Louis, Mo.



### Free Book Coupon

**NEWELL PHARMACAL CO.**

Dept. 300 Clayton Station St. Louis, Mo.

Please send, without obligating me in any way, your free booklet regarding the tobacco habit and proof that Tobacco Redeemer has relieved the tobacco habit in thousands of cases. If it fails my money will be refunded.

Name.....

Street and No.....

Town..... State.....



**20 MIN. CAR WASHER**

*Here's a \$250 Monthly Stream of Profits*



**30 Days' Trial Easy Terms**

Now is the season when power car washing pays biggest profits. HB 20-Minute Car Washer will do more work than others—extra profit easily pays for outfit. Get details now by checking No. 1 in coupon.



**8-Hour Charging**

With this outfit you charge batteries in one-third the time required by others. Costs less to operate—you make more profit on each battery charged. No special experience required. Will pay for itself on easy monthly payments. Check No. 2 in coupon below.



**Get 5 Men's Profits**

HB Portable Paint Spray lets you do work of five brush painters. Paint automobiles, houses, barns, garages, furniture, etc., quicker and better. A size for every need, easy payments lets it pay its own way. Check No. 3 in coupon for information.



**Profits in Air**

If in automotive business there's no easier way to get customers to your door than through dependable air service. HB automatic, upright air service is standard equipment of money-making shops. A size for every need. Trial and easy terms. Check No. 4 for details.



**HOBART BROS., Box M100, TROY, OHIO**

Send complete information on items checked with 30 days' trial offer, easy payment terms, and information on how HB will increase my earnings:

- 1. } 20-Minute Car Washer
- 2. } 8-Hour Charging
- 3. } Portable Paint Spray Business
- 4. } Better Automatic Air Service

**30 DAYS TRIAL** Name.....  
Address.....

**EASY TERMS**

*Only 3¢ Each for—*  
**HOT OIL TREATMENTS**

**LIKE MAGIC**

**NEW Electric OIL COMB**

**FOR FALLING HAIR, DANDRUFF, SCALP TROUBLES**

Remarkable invention applies electrically heated oil treatments for FALLING HAIR, DANDRUFF and various SCALP DISORDERS—quickly—easily—scientifically.

SAV-D-R-HAR Electric Oil Comb passes through and around the strands of hair, gently stimulating the scalp. Heated oil comes through hollow teeth of the comb.

Used by leading beauty and hair specialists—saves 15 to 45 minutes time—costs only 3 cts. per treatment. Anyone can use it at home. Write for low introductory price and full details free.

**BEAUTY AIDS, Inc., Suite 2009 K 307 N. Michigan Ave., CHICAGO**

**\$24.00 a Day**

We have a few good openings for live representatives that pay \$24.00 profit on only 5 sales per day. Write us.

**RAISE CHINCHILLA AND NEW ZEALAND WHITE FUR RABBITS** Make Big Money We Supply Stock and pay you following prices for all you raise:

Chinchillas average \$5 each—New Zealand Whites \$2 each. 32-page illustrated book, catalog and contract, also copy of Fur Farming magazine, tells how to raise rabbits for big profits, all for 10c. Address **OUTDOOR ENTERPRISE CO., Box 1021 Holmes Park, Missouri**



**SQUAB BOOK FREE**

Breed PR squabs for rich trade. Sold by millions for more than chickens. Write for free 48-page book telling how to do it and how to profit by new sales method.

**PLYMOUTH ROCK SQUAB CO. 634 H Street Melrose Highlands, Mass.**



**6 SHOT 22 Cal. Blank Automatic**

**NO PERMIT REQUIRED** You can own this 6-shot Automatic (for Blanks only) without a license. Get one for fun or real protection, to frighten off traps and thieves and scare dogs away. Identical in construction and appearance to genuine Automatic Pistol. Loud report. Full blue steel finish, rubberstock. **Send no money. Pay expressman \$4.89, plus express charges. 3 for only \$11.89. Address WINEHOLT MAIL ORDER, Box B-25, Woodbine, Pa.**

**WITH 100 CARTRIDGES FREE!**

**\$4.89**



**A CLIPPER SHIP FOR \$4.50**

We supply all the necessary parts, cut and numbered, ready to put together. Instructions show detail for detail how each numbered part fits into another. You can't go wrong. A few hours of pleasant pastime and you have a beautiful ship model. We also supply parts for the Santa Maria, the La Pinta and the Mayflower for \$4.50. Constitution (Old Ironsides) \$5.98. All models sent C. O. D. plus a few cents postage. Foreign orders must be accompanied by U. S. money order or check. Write for Illustrated Circular.

**C. J. BIERBOWER, Dept. P. M. "Originator of Build Your Own Ship Model"**

**3216 Baring Street PHILADELPHIA, PA.**



**Ideal Equipment for the Ideal Home Shop**

**Universal Handisaw**  
**Big, Powerful**

**\$30**

Saws, rips, dadoses, mitres, sands, bores, mortises, etc. Wonderful value.



**Buy Now Pay Later**

Each machine a complete, separate unit. Ready to go at the touch of the switch. Circular Saws plough through toughest wood. Jig Saws stout enough to cut steel. Band Saws fairly eat work. Lathes run true and accurate. Jointers plane smooth as satin. It's no wonder so many thriving home shops are completely BOICE-CRANE equipped.

This dependability, convenience, and capacity for work makes BOICE-CRANE Bench Machines ideal equipment for the ideal home shop. Get details of our annual Achievement Contests, low prices, easy terms, broad money-back guarantee, etc. Send for free catalog.

**W. B. & J. E. BOICE Dept. P. M.-10-F Toledo, Ohio**



# every home can NOW enjoy this New Noiseless Economical Heat

Try this wonderful burner right in your own home at our risk, on 30 Days' Trial under our money saving offer and with it you have the opportunity of filling other orders in that territory and making big money as our protected distributor. Modernize your home and enjoy the comfort of this new economical heat without the dirt and ashes of coal. You can have this modern heat at a cost that is within the reach of every pocket book. Thousands of satisfied users speak in high praise of the many benefits they enjoy for cooking, baking or heating. The New Silent International Oil Burner fits in the firebox of your furnace or stove. Installed in a few minutes. No pressure—no wicks—lights with a match. Approved by National Institutions and Engineers everywhere.

## new low cost Special Offer

Simply fill in the coupon below and we will mail you complete information and without obligation on your part. Also mark in the spaces showing your interest in making money. Remember, while that territory is open you have the advantage of a very special introductory price on 30 Days' Free Trial. Hurry!

**OVER 100,000 IN USE**

**BIG MONEY SAVING FREE TRIAL OFFER**

**International Oil Heating Co.  
Dept. 204-O, St. Louis, Mo.**

Please mail your free booklet and free burner offer on home heating for stove  furnace . This places me under no obligation.

Name .....

St. or R. F. D. ....

City ..... State .....

Check if interested in making money as International representative with protected territory.



No Wood No Coal

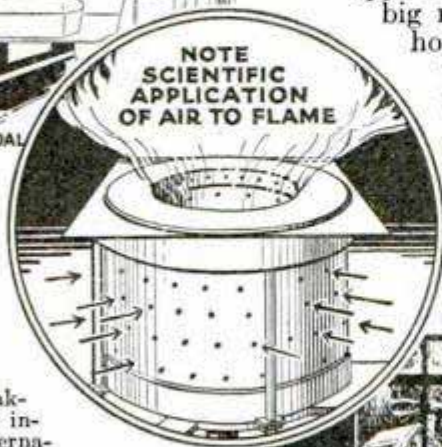

NOTE SCIENTIFIC APPLICATION OF AIR TO FLAME

**AGENTS EARN \$15-\$25 A DAY**

Our men are making big money introducing International Oil Burners. The demand is enormous! We want spare-time or full-time workers immediately. You can limit your income by the amount of time you can devote. If \$500 a month and more interests you, write or wire us for our protected territory offer.

**EASY TO INSTALL IN ANY STOVE FURNACE OR BOILER**

**International Oil Heating Co.  
Dept. 204-O ST. LOUIS, MO.**



Fits Any Stove

**\$3240 MADE BY CHAI SELLING OUR PENS**

No. 10, 3 in 1 fountain pen-pencil with compass. "I can honestly say that I have earned \$60 weekly for the last two years selling these pens."  
—Joe. Chai, Illinois.



**39¢** GUARANTEED TWO YEARS  
Writes like \$7 pen.  
FREE: Wholesale catalog showing over 500 fast sellers.  
**SPORTS IMPORTING CO.**  
830 Main St. Lesueur Center, Minn.

**NEW ZEP-LITES FOR YOUR AUTO!**

Install these beautiful chrome-plated lamps on your fenders for safer night driving. Racy lines. Red side lenses on left lamp, green on right. Adds class to any car. Complete with bulbs, switch and wiring; easily installed. Write today for FREE illustrated folder.  
**TORPEDO LIGHT CO., 581 St. Claire St., Detroit, Mich.**

WRITE FOR FREE FOLDER

SPECIAL AGENTS PROPOSITION

**AS NATIONALLY ADVERTISED RINGS O' ROMANCE**

Pay Only \$2.50 Monthly

Cat. No. 1450  
"Modern Bride" \$19.85

"Ring O' Rose" \$37.50

DIAMONDS DENOTE PROSPERITY

Cat. No. 1418

**YOURS WITHOUT CASH!**

Now you can wear a nationally advertised diamond Ring O' Romance—a beautiful 18Kt. white gold modern ring set with a genuine diamond of generous size, and a nationally advertised Bulova watch—your faithful timekeeper for years to come.

Send no cash!—Just mail coupon! Nationally Advertised Cash Price on Liberal Credit—and you can wear your jewelry without delay! The names Ring O' Romance inside the ring and Bulova on the Dial are your guarantees.

**BULOVA Watches**  
LONE EAGLE—\$37.50  
MISS AMERICA—\$37.50



Pay Only \$3.75 a Month

**SANTA FE WATCH CO. Dept. A-6 Thomas Bldg. TOPEKA, KANSAS**

ONLY \$5.00 A MONTH

Cat. No. 1429  
"Dress Parade" \$50.00

To SANTA FE WATCH CO.  
Dept. A-6, Thomas Bldg., Topeka, Kansas  
Gentlemen:  
Please send me:  
Diamond Ring O' Romance \_\_\_\_\_  
And Bulova Watch \_\_\_\_\_ as featured in your advertisement. Also send beautifully illustrated jewelry catalogue.

Name \_\_\_\_\_  
Address \_\_\_\_\_ City \_\_\_\_\_





## Bruises — sprains what makes them swell?

When you get a bruise the blood becomes congested, causing a swelling. This swelling feels hot and tender. What bruises need is healing white blood cells to rebuild injured tissue. You can bring white blood cells quickly by gently applying Sloan's Liniment. Rich blood rushes to the spot as soon as Sloan's is applied. This blood carries the white cells that rebuild injured tissue. Sharp pain quickly goes. Swelling is relieved. Get a *fresh* bottle of Sloan's Liniment from your druggist today. Only 35¢. Send for free sample to Dr. Earl S. Sloan, Dept. E-10, 113 W. 18th St., N. Y. C.

## SLOAN'S Liniment The Man Who Never Had a Chance

He doesn't exist any more. Like the Dodo and the Dinosaur, and a lot of other things, he has passed out. He is still with us but he doesn't rate, nobody listens to him because there are a lot of opportunities, and the successful man is busy tending to his own affairs. But the successful man is successful *only because he picked the right opportunity for him*, and did not fall into the rut and imitate what his neighbor was doing. He selected a line of work of his own and put his heart and soul into *specializing* in that work. SURE, YOU KNOW THAT. Well, then, where do you fit in? Are YOU going to see year after year pass by, with some men getting more and more secure and carefree as they get older? And YOU getting older too, but with a lower pay scale in sight every year?

HERE is an Opportunity WORTH YOUR WHILE. It's not salesmanship, it's not peddling, it's not commission. IT'S YOUR OWN BUSINESS, all the profits are yours, all the good will and reputation you build up are yours, all your efforts go to providing better living, luxuries, education for you and your family. And your FUTURE is under YOUR OWN CONTROL. No books, no tuition, no schooling, are necessary, and you don't need to be a mental giant to make \$25 to \$75 a day profit. We show you all you need to know, for nothing. The field is not crowded, there is business all around you, and it's year round work. Pleasant, easy, inside work. It's a CRAFT, a business on the same level as the Building business, the Electrical business, but with a greater scale of profits and more work in sight, and nowhere near the expense. About \$100 is all you need, and you are ready to go. Every day makes Your Future Safer, Your Bank Roll Bigger. DON'T SAY YOU NEVER HAD A CHANCE. Fill in the Coupon TODAY, it costs you nothing.

MAIL THE COUPON

A. A. CLARKE COMPANY  
Dept. T-310, Muskegon, Michigan

Gentlemen: If this is as good as you say, I want to get full particulars. Give me proof without obligation to me.

Name.....

Address.....

City..... State.....

Present Occupation or Trade.....

## Don't Be Afraid To Tackle That Concrete Job!

With the instructions found in the new, revised edition of Popular Mechanics Concrete Handbook you can make any of the following useful articles:



Garden Seats—Fountain and Basin—Flower Boxes and Vases—Pedestals and Bird Baths—Ornamental Pools—Sanitary Drinking Fountain—Gateposts—Auto Driveway—Sidewalks—Boat Landings and Docks—Entrance and Garden Walks—Sidewalk Flagging—Narrow Curb Walks—Curbs and Gutters—Wall Coping—Steps—Garage Floor—Basement Floor—Fence Posts—Lawn Roller—Cistern—Chimney Cap—Refuse Burner—Culvert—Benches for Greenhouses—Tile—Retaining Walls—Foundation Supports—Engine Foundations—Septic Tank—Toy Blocks—Forge—Fireproof Safe—Ice House—Watering Troughs—Milk House—Smokehouse—Silo—Horse Stalls—Hitching Post—Rural Mail Box Post—Cyclone Cellar

### Build With Ease for Permanence and Beauty

This is a book of practical plans for using concrete about the home, farm or shop. For amateurs as well as contractors. In addition to making all the articles mentioned above the making of good concrete mixtures for various classes of construction is given; mechanical mixers and homemade tools are dealt with. All necessary form and mold making are covered as well as many other valuable pointers too numerous to mention here.

Simply write and ask us to send you this book. When postman hands you the package pay him \$1.00 plus the postage. If outside U. S. remit when ordering and include 15 cents extra for mailing.

POPULAR MECHANICS PRESS  
Room P10 200 E. Ontario Street CHICAGO

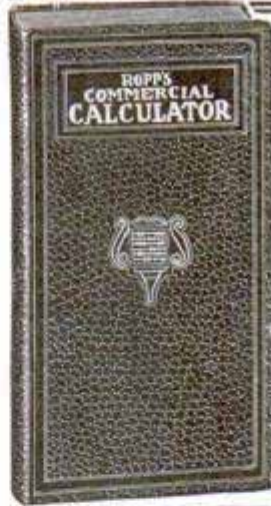

## Mathematics Made Easy by ROPP'S CALCULATOR AND SHORT-CUT ARITHMETIC

Shows the Answer as Quickly as a Watch shows the Time to all Problems likely to occur in the Office, Store, Shop, Bank, Farm, or Factory.

Over 2,000,000 Sold  
Explains and simplifies every principle in Arithmetic, Mechanics, and Mensuration.

PRICES POSTPAID  
Desk Size, Flexible Keratol Binding..... \$2.00  
Pocket Size, Art Leather Binding..... \$1.00  
Pocket Size, Cloth Binding, \$0.50

POPULAR MECHANICS PRESS  
Room P10 200 E. Ontario St. CHICAGO

## NEED A BETTER GRIP ON MATHEMATICS?



SEND for a copy of "Mathematics for the Practical Man," only \$1.50. By common sense methods it removes the mystery and difficulties so that algebra and even calculus are made simple.

Assuming your knowledge is limited to arithmetic you quickly and easily gain a working knowledge of Algebra, Geometry, Trigonometry and Calculus. Simply pay postman price of book plus the postage when he hands you the package.

Popular Mechanics Press  
Room P 10  
200 E. Ontario Street, Chicago



**1931 Radio Catalog** **RADIO BARGAINS**  
**WHOLESALE DISCOUNTS**  
**LOWEST PRICES**

Greatest bargains shown at a regular wholesale trade discounts.

Nationally-sold, guaranteed radio merchandise including the sensational **BONDED LAFAYETTE ALL ELECTRIC RADIO RECEIVER**, with tone control. Write at once for **FREE 1931 Radio Bargain Catalog** showing complete selection. Don't buy until you see this wonder catalog.

**WHOLESALE RADIO SERVICE CO.**  
 Dept. K-11,  
 36 Vesey St. New York

**RADIO CATALOG 1931**  
**WHOLESALE FREE!**

**BOY SCOUTS of AMERICA**



3 new complete Kits, designed by **SILVER ACE Engineers**, including a powered glider and two splendid duration cabin models with the latest of all improvements and real aircraft design. Prices from 50c to \$3.

Complete description, plus the 1930 Silver Ace Catalog for five cents.

**AERO MODEL COMPANY**  
 Dept. M-30 111 North Wacker Drive Chicago

**MOULDS**  
*For Making Toy Soldiers, Indians, Cowboys, Animals, etc.*

With one Mould you can make many **HUNDREDS OF CASTINGS**, whole Armies. Outfits, including material for casting, enamel paints and everything complete. \$5.00. Easy enough for any boy to make and great fun for grown-ups. Sport for the whole family. Write for illustrations of dozens of patterns you can make.

**MAKE-A-TOY COMPANY, Dept. E, 1696 Boston Road, N. Y. City**

**A MONEY MAKER**

FILL RESERVOIR WITH WATER. HOLDS ENOUGH TO CLEAN 40 WINDOWS.

REMOVABLE RUBBER SCRAPERS ONLY. CLEANS POLISHES WITH ONE STROKE.

WATER FEEDS THRU FELT TO WINDOW FRAME.

RUST PROOF. FOOL PROOF. LASTS FOR YEARS.

REMOVE CAP AND INSERT BRUSH HANDLE FOR HIGH WINDOWS.

New Improved window washer eliminates all fuss wherever there is glass to be cleaned. Approved by Good Housekeeping and Household Searchlight. Restricted territory. Write today.

**CARTER PRODUCTS CORPORATION, 998 Front Street, Cleveland, Ohio**

**COACH BUILDING MADE EASY**

You can build a beautiful coach model in a few hours. We supply all the parts, cut to fit and ready to put together, of the George Washington coach, the Tully-Ho, or the Deadwood coach (famous Western stage) for \$4.95. Full instructions for building included with each kit. Build coaches for pleasure or profit. Models sent C.O.D. plus a few cents postage. Foreign orders must be accompanied by U.S. check or money order.

**HISTORICAL COACH MODELS, INC.**  
 Dept. P. M. 5, 2206 Fairmount Ave., Philadelphia, Pa.

**Have you a Wet Cellar?**

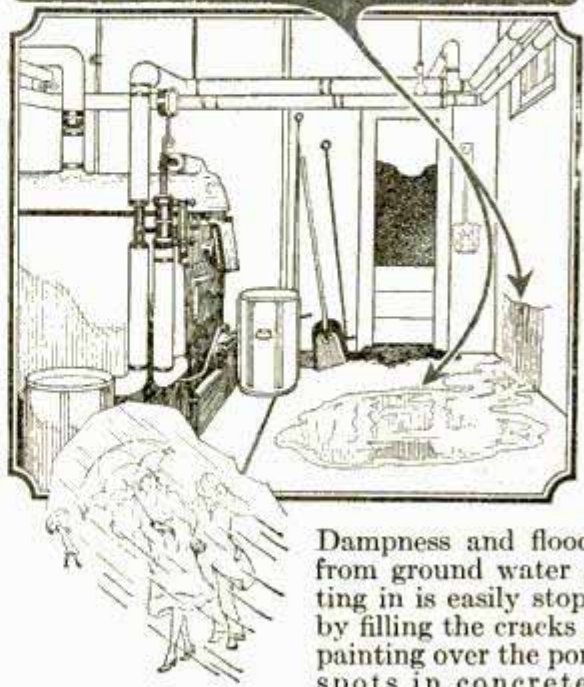

Dampness and flooding from ground water getting in is easily stopped by filling the cracks and painting over the porous spots in concrete or brick walls and floor with

**SMOOTH-ON NO. 7**

—the only effective waterproofing material that can be applied from inside and to wet or dry surface.

Excellent also for waterproofing boiler pits, cisterns, tanks, ponds, wash-room, garage and stable floors, etc. About 1.5 lbs. required for each 100 sq. ft. of surface.

*You should also know*  
**SMOOTH-ON NO. 1**

—The good old standby for stopping leaks in pressure joints, mending cracks, making loose handles, screws, etc., tight, stopping leaks in automobile radiators and hose connections, keeping lubricators, hub caps and nuts from loosening, etc.

**The Free Smooth-On Repair Book**

will show you how, and by doing the work yourself you make big savings. Mail the coupon for free copy.

Get Smooth-On No. 7 in 1 or 5-lb. can, or 25 or 100-lb. keg and Smooth-On No. 1 in 7-oz. or 1 or 5-lb. can. At any hardware store, or from us direct.



*Do it with* **SMOOTH-ON**

**SMOOTH-ON MFG. CO., Dept. 37,**  
 574 Communipaw Ave., Jersey City, N. J.  
 Please send the free Smooth-On Repair Book.

Name.....

Address.....  
 10-30



# New "DELTA" 1931 Units for HOME and SHOP WOODWORKERS

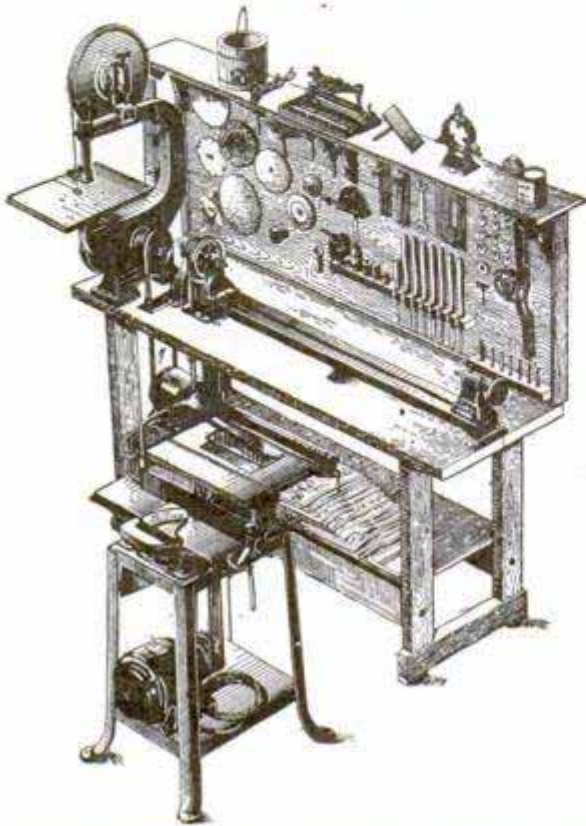

A COMPLETE line of low-priced, ruggedly built, practical woodworking machines for craftsmen, artisans, farmers, mechanics—that's what "Delta" is offering this year. Every "Delta" motor-driven unit embodies numerous exclusive constructional features that insure efficient work and many years of satisfactory service. The 1931 "Delta" line includes "Delta" Handi-Shop, De Luxe Workshop, Band Saw, Jointer, Circular Saw, Scroll Saw, Moulding Cutter, and many other woodworking items, all available for either electric or gasoline motor power.

## For Pleasure or Profits

"Delta" motor-driven units enable you to make things out of wood quickly and easily. They save time and labor and produce better work. For a hobby there is no greater thrill than working with Delta machines. For full or spare-time work, "Delta" units quickly pay for themselves.

## 10-Day Trial—Easy Terms

For complete details and full description of the complete 1931 Delta line, write for **Free** illustrated literature. Shows many items of interest to those who work with wood. You will learn, also, how you can try any Delta equipment for 10 days under actual working conditions **at our risk**. Choice of three convenient payment plans.

## DELTA SPECIALTY COMPANY

Division of DELTA MANUFACTURING CO.

1661-67 Holton St. Dept. A. 1020 Milwaukee



**FLY A CURTISS ARMY HAWK**

2-ft. Flying Scale Model; simple to build. Set complete with Blueprint and instructions \$3.00  
National Models guaranteed to fly.

29 North Avenue

Dept. C1

Here's ground work instruction for amateur aviators. Other interesting models for you to build.

2-ft. Vought Corsair... \$3.00  
2-ft. Lockheed Sirlus... 3.00  
2-ft. Boeing P. 12-B... 3.75  
2-ft. Sikorsky Amphibian... 2.75  
Full Size Blueprints... .50  
Illustrated 32-page Catalogue... .05

**NATIONAL MODEL AIRCRAFT & SUPPLY CO.**  
New Rochelle, N. Y.

# FOR YOUR HOME WORKSHOP

If you like to make things, you will enjoy this new book just published by Popular Mechanics entitled

## Make It Yourself



The home mechanic, whether young or old, amateur or professional, will take pride and delight in making many of the things described therein.

Both father and son will find fascination and an association of interest in making useful and ornamental articles for mother to admire upon their completion.

## 900 Articles All Different

There are attractive ship models, a great variety of toys that operate themselves by means of an ingenious application of mechanical principles, novel amusement devices for indoors and outdoors, for both water and land, unique designs in furniture for children, scores of useful appliances for the home, things of beauty and utility for lawn and garden, etc.

Special articles instruct the amateur mechanic in the care and use of tools, special tools for special purposes, how to read and use plans, how to solder, the making of a handy work bench, cuts, joints and methods in woodworking, automobile repairing, installing radio equipment, house wiring, fixture hanging, working in glass, leather, metal, celluloid, lathe work, utilizing parts of old machines to make equipment that would be expensive to buy, etc.

480 Pages—823 Illustrations.  
Size 7x10x1 1/2 in. Cloth Binding

Price \$3.00

Mailed Postpaid upon receipt of price anywhere in the world. If you reside in U. S., Hawaii, Porto Rico, Alaska or Mexico, we will send the book by mail C. O. D. if you prefer.

**POPULAR MECHANICS PRESS (ROOM P-110)**  
200 East Ontario St. Chicago, Ill.

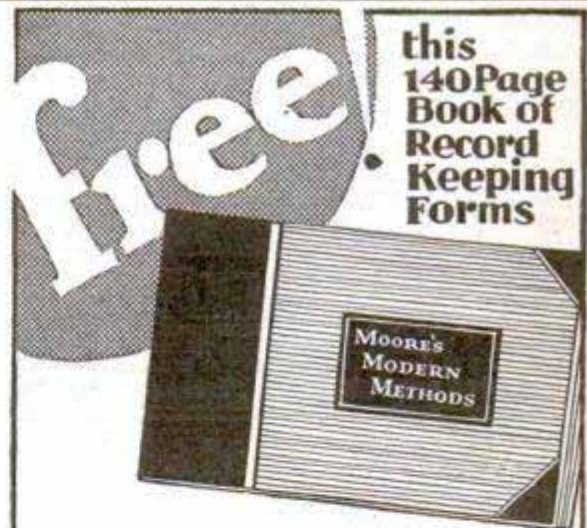

this 140 Page Book of Record Keeping Forms

HERE'S a book that will help you with your record-keeping problems. Contains wide variety of life-size Bookkeeping forms, completely filled in, illustrating uses. For office or factory—business or profession—it shows you simplest and most efficient methods of accounting now being used by 300,000 leading firms. Book sent FREE when requested on business stationery. No obligation!

JOHN C. MOORE CORP., Est. 1839  
6088 Stone Street, Rochester, N. Y.

Merely Fill in Coupon and 140-page Book Will be Sent you FREE

Name \_\_\_\_\_

Business \_\_\_\_\_

City \_\_\_\_\_ State \_\_\_\_\_



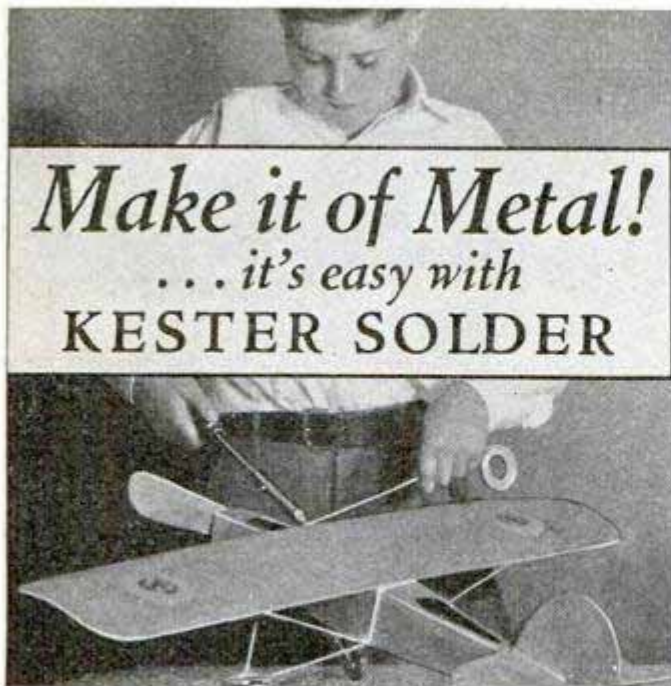

**Make it of Metal!**  
... it's easy with  
**KESTER SOLDER**

**B**UILD your models of metal with solder the modern way... airplanes, boats, trucks, toys and many useful articles! It's easy and lots of fun when you use KESTER Metal Mender. KESTER has made soldering simple and quick for everyone. The secret is in the flux right inside the solder itself. You can get KESTER Solder at any hardware dealer in handy Metal Mender tins for 25c, or on 1, 5 and 20 lb. spools or by the foot.



A new thrill awaits you. Be a member of the Metalcrafters of America and win a Metalcraft Merit Medal. Send for our new Book of Prize Projects with complete plans, instructions and sample of Metal Mender FREE! Start now! Write today!



**KESTER SOLDER COMPANY**  
Inc. 1899  
4210-04 Wrightwood Avenue  
CHICAGO, ILL.

**KESTER**  
FLUX-CORE  
**SOLDER**

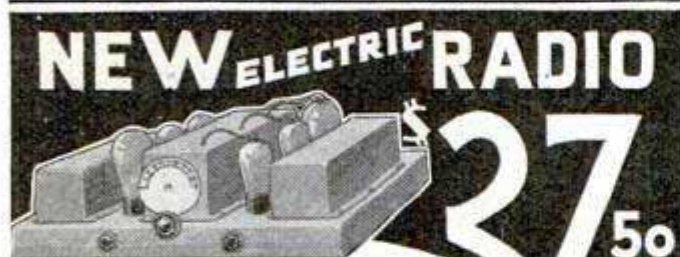

**6 Tubes—Screen Grid**

Amazing new long distance 6-tube A. C. screen grid radio at a price anybody can pay. Marvelous tone. Plenty of volume for dynamic speaker. Absolutely free from A. C. hum. The very latest in A. C. radio using three screen grid tubes and the price is only \$27.50. All ready to plug in the electric light socket and operate. This is the most startling radio bargain offer in history.

**AGENTS MAKE FORTUNES**  
Live agents everywhere are making big money selling this new set. Demonstration always means a sale. Add SIXTY DOLLARS A WEEK PROFIT to your present income in spare time evenings. This ultra-modern all-electric set replaces battery radios everywhere. Exclusive territory franchise worth fortune to right men but act quick as choice territory is going fast, and my company has asked me to place good men in all open territory QUICK. Write or wire immediately and be sure to give me the name of your county.  
**P. H. WILCOX, Secretary, 4903 N. Crawford Ave., Chicago, Ill.**

**\$500**

**GIVEN AWAY**

**W**E mean it. You have a chance to win a money prize of \$250! How? Simply by telling us what you think is the best possible use for our new product, Handi-Wood.

**23 cash prizes**

In addition to the big first prize of \$250 cash, we are offering 22 other prizes. Anybody can win. Nothing could be more useful in a hundred different ways than Handi-Wood. Imagine a paste that handles like putty—yet hardens quickly into strong wood! You can use it for practically everything from plugging a drafty window to repairing a boat. And the man, woman, or child who can think of the most unique use for this product gets the \$250 first prize!

Think a minute. Have you ever fixed anything—a chair or a table, perhaps—in some unusual way? A way that was perfectly practical—yet no one but you ever thought of it before? Just apply the experience you've already had—and try for the first prize. If you miss it, you have 22 other chances to win.

**It's easy—send for rules**

No work to this contest—it's all fun! Simply mail the coupon and we'll send you complete information. Then work out your best ideas, and send them in to us. You can count on the makers of Creo-Dipt Stained Shingles to give your entry a fair chance at first prize.

Handi-Wood is sold by leading lumber, paint and hardware dealers everywhere. Ask the one nearest you. Meanwhile, mail the coupon today.



**HANDI-WOOD**

**MAIL COUPON TODAY FOR DETAILS OF CONTEST**

**CREO-DIPT COMPANY,**

1652 Oliver Street, North Tonawanda, N. Y.

I'd like to win \$250. Please send me complete information about prize contest for best uses of Handi-Wood.

Name \_\_\_\_\_

Address \_\_\_\_\_



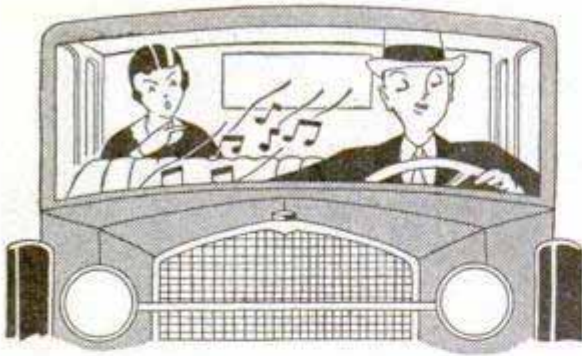

## When back seat driving interferes—start the Crosley ROAMIO

“Look out!” “Be careful!” “Ooh! We’re coming to a hill!” No longer need you grit your teeth and suffer such well-meant but irritating exclamations. Instead—just turn on your CROSLY ROAMIO Automobile Radio Receiving Set. All fear and irritability are forgotten as you spin along the smooth road enjoying concerts, symphonies, the latest dance hits, or the wit of world-famous humorists.

The CROSLY ROAMIO is extremely selective and sensitive. You’ll easily get your favorite programs. The automatic volume control maintains a practically uniform volume, even on distant stations. You lock the CROSLY ROAMIO just as you do your automobile. It uses Screen Grid tubes, Neutrodyne circuit, and employs the latest type Crosley dynamic-power speaker. Thousands are now in use.

The CROSLY ROAMIO can quickly and easily be installed in your car no matter what its make. It fits snugly and conveniently under the dash, entirely out of the way. It will give you hours of satisfying pleasure and delightful relaxation. Consider too, that the price of this marvelous set is amazingly low—only \$75.00, less accessories—installation extra. Go to your nearest Crosley dealer today—see the CROSLY ROAMIO—hear it—drive with it. Or write for circular and name of nearest Crosley distributor who will arrange for installation. The CROSLY ROAMIO is recommended for use in motor boats and cruisers.

**The CROSLY RADIO CORPORATION**  
 1300-B Arlington Street CINCINNATI  
 Home of “the Nation’s Station”—WLW  
 Also manufacturers of Crosley A. C., D. C. and Battery  
 Radio Receivers and the famous AMRAD RADIO

## YOU'RE THERE WITH A CROSLY CROSLY RADIO

**NEW No. 200 SERIES (DUPLX) MASTER SLIDE RULE**

Both sides for OUTSIDE MEASURE—figures run both ways. One side for INSIDE MEASURE by direct reading—figures, etc., printed in red. No guess work—accurate. At dealer or direct. 6 ft. Size \$1.50, 8 ft., \$2.00, 5 ft., \$1.00. Agents Wanted

**MASTER RULE MFG. CO., 821 E. 136th St., New York City**

## Earn Big Profits Making Keys

One girl took in \$98.30 her first week! Be independent. Let us show you how!

WRITE TODAY

**BUILD A PERMANENT BUSINESS OF YOUR OWN!**  
 Duplicate any type of key in one minute. Make new keys from lock number. New patented key cutting machine is simple, easily operated and fully guaranteed. No experience is needed. A boy or girl can cut perfect keys with it. Everyone needs keys. Be the one to fill the demand in your territory. Full information FREE, regarding machine and liberal time payment plan.

**Beisser Key Machine Co.**  
 3919 Woodward Ave.  
 Detroit Michigan

WRITE for FREE CIRCULAR

# WORLD-WIDE SHORT WAVE RECEIVER

ONLY \$6.45

Span the World with this Set!

A new radio thrill for you! Listen in DIRECT to London, Paris, Berlin, Buenos Aires and other broadcasting stations throughout the world via short waves. Enjoy unique foreign programs from strange lands. Your ordinary receiver cannot tune in these low wave stations. **WORLD-WIDE RECEIVER** gets 14 to 550 meter stations with surprising clarity. **SEND NO MONEY!** Just write your name and address on a postcard and ask us to send you this wonderful guaranteed short wave set. Pay postman \$6.45 plus a small delivery charge. All orders west of Rockies must be accompanied by \$1.00 deposit. Foreign countries \$2.00 extra, postpaid. Write today for our parts catalog.

CHAS. HOODWIN CO.

4240 Lincoln Ave., Dept. K-2

CHICAGO

# SOLDERALL

METAL IN PASTE FORM

The only convenient metal solder

Every Electrical Connection needs Solderall for perfect reception

25¢

The SOLDERALL CO., NEWARK, N.J.



## BOW LEGS?

THIS GARTER (Pat'd) Makes Trousers Hang Straight If Legs Bend In or Out

Free Booklet—Plain Sealed Envelope  
**THE T. GARTER CO., Dept. E**  
 South Bend, Ind.

## Books on 32 Subjects

Popular Mechanics Press specializes in supplying books on any subject. Look over this list. Check the books you want, and mail this advertisement as your order blank. Catalog with lists on 2,000 subjects free.

- |  |   |
|--|---|
| <b>AIRCRAFT (Modern)</b><br>Complete. Up-to-date. . . \$5.00       | <b>INVENTIONS</b><br>How to Make Pay . . . \$2.50                       |
| <b>ARTIST (Commercial)</b><br>Money-Making Art. . . \$5.00         | <b>LETTERING AND DESIGN</b><br>Studio Handbook of. . . \$3.00           |
| <b>ATLAS (of World)</b><br>Modern. New Boundaries. . . \$3.00      | <b>MAGIC</b><br>World's Best Book of. . . \$2.00                        |
| <b>AUTOMOBILE</b><br>Painting. . . \$1.50                          | <b>PAINTS AND COLORS</b><br>Mixing of. . . \$2.00                       |
| <b>BOOKKEEPING</b><br>Practical Handbook. . . \$1.00               | <b>PICTURES (FUNNY)</b><br>How to Draw. . . \$3.00                      |
| <b>BRICKLAYING</b><br>Plain and Fancy. . . \$1.50                  | <b>PLASTERING</b><br>Best Instruction Manual. . . \$1.25                |
| <b>CARBURETORS (All Makes)</b><br>Only Book Covering. . . \$2.00   | <b>RADIO ENCYCLOPEDIA</b><br>Very Complete. . . \$6.00                  |
| <b>CHALK TALK</b><br>and Crayon Presentation. . . \$1.25           | <b>REAL ESTATE</b><br>Educator. . . \$2.00                              |
| <b>DRAWING</b><br>Freehand and Perspective. . . \$1.50             | <b>SHOW CARDS</b><br>Artistic. . . \$3.50                               |
| <b>DRY CLEANING (Practical)</b><br>and Dyer. . . \$3.00            | <b>SIGN PAINTING</b><br>Laquer System of. . . \$3.00                    |
| <b>FLOWER RAISING</b><br>1001 Questions Answered. . . \$2.00       | <b>Steam Engineer's License</b><br>How to Obtain. . . \$2.00            |
| <b>FLYING</b><br>Simplified. . . \$1.00                            | <b>STEEL SQUARE</b><br>How to Use. . . \$1.00                           |
| <b>FUR RAISING</b><br>For Profit. . . \$4.00                       | <b>TELESCOPE (Amateur's)</b><br>How to Make. . . \$3.00                 |
| <b>FURNITURE REPAIRING</b><br>Finishing and Decoration. . . \$5.00 | <b>TOOLS (Using)</b><br>Tinkering with Tools. . . \$2.00                |
| <b>HOME FURNISHING</b><br>and Decoration. . . \$3.00               | <b>TRICKS (200)</b><br>For the Amateur. . . \$1.00                      |
|  | <b>WOOD FINISHING</b><br>Plain and Decorative. . . \$2.00               |
|  | <b>WOODWORKING (New)</b><br>Most Complete Book for Amateurs. . . \$2.00 |

SEND NO MONEY

Just check the books you want, and mail the whole advertisement. It is your order blank. When postman hands you books, pay him the price and few cents postage. If outside the U. S. remit when ordering and include 10 cents per book extra for postage.

**POPULAR MECHANICS PRESS, Room P10, 200 East Ontario St., Chicago, Ill.**



# GAS

## The Gloria Automatic Gas Machine

brings to the village and suburban districts beyond the reach of public service gas mains, a trouble-free, practical, safe, economical gas service. For installation in homes, hotels, restaurants, barbecue stands and for any purpose that artificial or natural gas is used.

### "At the Scratch of a Match"

No matter where you live—you can now have Gas! Gas for cooking, Gas for the hot water heater, Gas for any and every ordinary purpose—and all at an exceedingly low cost.

Gloria-Gas is made only as used. There is no stored up supply in the house at any time. It is a safe fuel for household and commercial uses.

Exclusive Districts open to responsible men to appoint dealers, salesmen and direct-to-consumer sales.

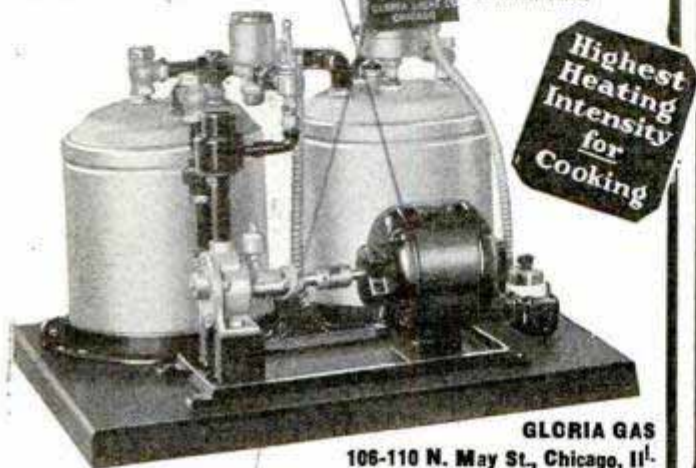

**GLORIA GAS**  
106-110 N. May St., Chicago, Ill.

## COMMERCIAL GLIDER

model—designed by Robt. Flury, Pres., Detroit Model Airplane Fliers' Club. Kit includes everything—Balsa wood, music wire, Ambroid glue, silk thread, sand paper, weights, plans. Eagle Scout John Lafferty, Austin, Minn., flew this model 1/2 mile. Send money order (no stamps) only 45c post paid.

COMPLETE

ONLY  
**45c**

**COLLINS PLOW COMPANY**  
Dept. 44 Quincy, Ill.

POST  
PAID

## ONE-MAN SAW MILL

Makes lumber, shingles, cross ties, fence posts, laths, fruit and vegetable crates and boxes, dimension blanks for furniture, etc. Splits blocks into firewood. Needed by farmers, timber owners, contractors. Pays for itself in a week, or on one job. Guaranteed. Sold direct from factory. Write today for Special Offer and Free Book "How To Make Lumber."  
**BELSAW MACHINERY CO.**  
704 AMBROSIA Bldg., Kansas City, Mo.

**\$39**  
BRINGS IT TO YOU

## AN INCOME BUILDER

Two distinct lines in one. For either salesmen or those mechanically inclined.

**\$50.00 Value for \$6.00**

with profits accordingly large. We can provide you with unlimited quantities of all leading makes of electric vacuum cleaners at sensationally low prices, each guaranteed perfect in action and appearance. Such extreme value and profit offers any man of average intelligence a splendid income even for spare time.

### FREE VAC COURSE

To our associates we give in bound book form, free expert advice and seldom disclosed instructions in building and servicing all vacs. Through this free training you may readily develop a permanent, well-paying business all your own. From our immense resources we supply all needs. At trifling cost and no risk you can prosper with us, the originators. Oldest and largest in the line. Literature tells all.

**URON ASSOCIATED INDUSTRIES**  
1302 ENGINEERS BUILDING, CLEVELAND, OHIO



## "I'm Getting Fed-Up with this Grind"

"I've been looking around and I don't like what I see. Look at Pop Clark and Butch—been on the job for ten and fifteen years—and they don't make as much as we do because they've slowed up.

"That doesn't look so good to yours truly. Me for the boss-job, and big pay and a real future. I don't know how I'm going to get there but I'll sure bust a leg trying."

If that's how you're fixed, you'll be interested to know that the way to promotion, a better position and increased earnings is no mystery. Thousands of men have gone from the mechanic's bench and the clerk's grind to positions as Superintendent, Manager, Draftsman, Engineer, Auditor—by American School home-study courses.

We'd like to tell you how we have taken the gamble out of home-training—how we undertake to increase your salary and help you get a better position, or no cost.

## American School

Dept. GA-747 Drexel Ave. and 58th St., Chicago, Ill.

Without cost or obligation please tell me how I can win a better position and increased pay in line marked X below. Also explain your employment plan.

**BUILDING CONSTRUCTION**

- Architecture
- Building Contracting

**DRAFTING and DESIGN**

- Machine Drafting and Design
- Architectural Drafting
- Electrical Drafting
- Structural Drafting
- Automotive Drafting

Mechanical Drawing for beginners

- ENGINEERING**
- Mechanical Engineering
  - Civil Engineering
  - Electrical Engineering
  - Automotive Engineering
  - Machine Shop Practice

- BUSINESS**
- Accounting, Auditing
  - Business Management (Finance, Sales, Production, Accounting)
  - HIGH SCHOOL IN 2 YEARS

Name.....

Occupation.....

St. No.....

City..... State.....





Designed by the  
**MASTER Firearms  
INVENTOR**

JOHN M. BROWNING

**BROWNING**  
AUTOMATIC SHOTGUNS

With a built-in Shock Absorber that works on the same principle as the French 75 Barrel recoils on slide, thus easing the jar, giving greater comfort in



shooting. Adjustable for heavy or light loads.

Every man who admires mechanical perfection and who wants greatest enjoyment in shooting, sooner or later gets a genuine Browning Automatic Shotgun, the neatest, smoothest-acting, easiest-handling shotgun you ever saw. And supremely comfortable to use, due to the marvelous Shock Absorber! Made in a world-famous Belgian factory. Unequaled for beauty of finish and accuracy of workmanship!

**A Work of Genius**

Browning Automatic Shotguns are designed by John M. Browning, the world's foremost firearms inventor. Many arms of Browning invention are standard equipment in the U. S. Army. Every genuine Browning arm is a work of genius!

**Be Sure You Get the Genuine**

The success of the Browning has invited many imitations. But only one automatic shotgun is made under our supervision, and contains the latest exclusive Browning features—and that is the genuine Browning, 12 or 16 gauge. Look for our name and "Made in Belgium" stamped on the gun—your assurance of the genuine. Mail the coupon today.

**BROWNING ARMS CO.**

Founded 1879 by John M. Browning  
St. Louis, Mo. Ogden, Utah

Send coupon to nearest office

**MAIL THE COUPON**

Please send your illustrated catalog on Browning Automatic Shotguns. No obligations on my part.

Name.....  
Address.....  
City..... State.....



HERE THEY ARE  
**Ship Models and  
Stage Coach Models**  
YOU CAN BUILD ONE



**FREE** Illustrated Catalog

We furnish the parts, all cut to fit and ready to put together. Also full instructions as to how it is done.

No tools required except a small hammer. When it is finished you will have a beautiful ornament for your radio cabinet or mantel.

**Write for Catalog**

Ship models \$4.98 and \$6.98 each  
Coach models \$4.98 each

All models sent C. O. D. plus a few cents postage by parcel post to anywhere in the United States.

All foreign orders must be accompanied by check or money order.

**MINIATURE SHIP MODELS, INC.**  
Dept. RT, Perkasio, Penna.

**BUILT-IN FURNITURE**

Adds Beauty and Convenience  
to Your Home



With the plans and directions given in this new book by Edwin M. Love any handy man will be able to build the various pieces of popular space-saving furniture.

These useful and ornamental cabinets are easily added to an old house and many are designed to be built into odd nooks and recesses. The construction is very simple as the walls offer support and no structural alteration of either floors or walls is necessary.

Stock sizes of material are specified in each instance. The home owner will be able to alter designs if necessary to suit available space.

That practically every adaptation of built-in furniture is covered by this book is shown by the following list of contents.

General Details of Construction—Portable Buffet—Recess Buffet—Corner China Closets—Clothes Closet Linen Cabinet—Furnishing a Clothes Closet—Bathroom Cabinet—Linen Closet—Mantel Shelves—Bookcases—Writing Desk—Seats—Indirect Lighting Fixtures—Sewing Cabinet—Corner Kitchen Cupboards—Breakfast Nook—Bathtubs—Laundry Porch Furnishings—Dining Table—Dressing Table—Radio Set—Phonograph—Safe—Shaving Cabinet—Cupboard and Drainboard Cabinet—Clothes Chute—Wood Box—Work Bench and Tool Cabinet—Mortise and Tenon and Dado Joints—Wood Dowels—Bending Small Moldings—Driving Nails and Screws—Care of Tools.

198 pages. Size 7x10 In. Fully illustrated. Price \$2.50 postpaid.

**Popular Mechanics Press**

Room P10

200 E. Ontario St.

CHICAGO, ILL.

**BLUEPRINT READING**

For the Building Trades



Every man who is ambitious to learn the last detail of blueprint reading will want this new book which is thorough, complete and up-to-the-minute. Written in a clear, non-technical manner. An ideal working tool for apprentices, teachers, students, carpenters, bricklayers, etc.

Over 100 pages—50 plans and illustrations.

Cloth—Price \$1.25 postpaid

**Popular Mechanics Press**

Room P10

200 E. Ontario St. Chicago

**366 SHORT CUTS FOR**

**CARPENTRY WORK**

**Popular Mechanics Carpenter's Handbook** is filled with illustrated short cuts and improved methods for doing all sorts of carpentry work and odd jobs. Each idea was discovered by a practical man in the course of his work. Each idea is practical, a time-saver, a money-saver. The 229 Pictures are so clear that in many cases, the picture itself explains the short cut. This new book is a book for professional carpenters, for amateurs, and for boys. It is destined to be just as popular as the many other handbooks published in recent months. This new book is beautifully bound in golden brown cloth, is a handy size, and sells for the remarkably low price of \$1.50.

**Send No Money** Simply write a postal saying that you want Popular Mechanics Carpenter's Handbook. It will be sent C. O. D. and you may pay the postman the price of the book and the few cents postage when he delivers the book to you. If you live outside the U. S. or if you are not at home when the postman delivers your mail, send \$1.50 with your order.

**POPULAR MECHANICS PRESS**

Room 710, Popular Mechanics Bldg., 200 E. Ontario Street, Chicago, Ill.



Save 1/2 at **FACTORY PRICES**  
Buy direct!

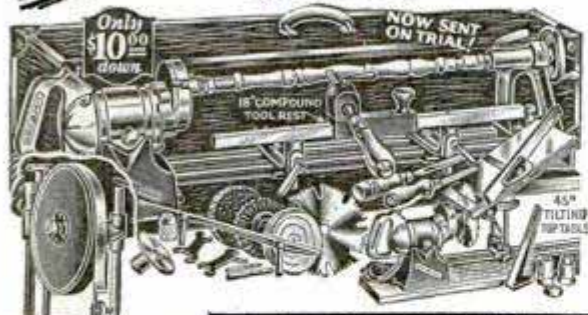

**BE A REAL CRAFTSMAN**

Enjoy the thrill of your new skill in making things this modern motorized way!

Now, you can do things you long have wanted to—at home in your own modern motorized work shop—with this new, improved Waco Red Jacket Wonder Shop. By buying direct from factory you save one-half or more. Complete shops or separate tools. Easy terms or liberal cash discount.

Free Craft Course  
Free Blue Prints

Make It Yourself!



**Complete Interchangeable Power Shop - Improved Features - Exclusive Advantages**

Powerful Red Jacket Master Drill Motor, Wood Turning Lathe (capacity 9"x36"). Compound and 18" Rests, Tilting Top Mitre Saw, Sander Disc, Scroll and Jig Saw, Band Saw, and all accessories. No installation problems. Small space required.

**The Waco Guarantee**  
If it is not what you want when you get it send it back.

TODAY! Send Coupon for Interesting Facts FREE!

WACO TOOL WORKS, Inc.  
5216 W. Kinzie St., Dept. 507, Chicago, Ill.  
Manager, Dept. 50A. Please send me all free information and literature on Red Jacket Assemblies and FREE Service.

Name.....  
Address.....



**His Salary Was Raised while others were reduced**

"Up to the time I enrolled for a course with the International Correspondence Schools, I had only a grade-school education. Since enrolling, I have advanced to a much better position, where my salary is nearly four times as much as I was making previously. I would not be able to hold my present position had I not taken your Course. Recently I received a nice increase in salary, while other men were being reduced."

There could be no better proof of the value of an I. C. S. course than that. It shows that the trained man is given preference over all others and paid more money, even in slack times, if his work deserves it. It shows that there are always bigger, better jobs open for men who have the foresight to prepare for them in spare time.

Why don't you study and get ready too? We'll be glad to help you if you will only make the start.

Choose the work you like best in the coupon below; then mark and mail it to the I. C. S. today. This doesn't obligate you in the least, but it will bring you information that will start you on a successful career. This is your opportunity.

**Mail the Coupon for Free Booklet**

**INTERNATIONAL CORRESPONDENCE SCHOOLS**

"The Universal Academy"  
Box 5506-G, Scranton, Penna.

Without cost or obligation, please send me a copy of your booklet, "Who Wins and Why," and full particulars about the subject before which I have marked X:

**TECHNICAL AND INDUSTRIAL COURSES**

- |  |  |
|--|--|
| <input type="checkbox"/> Architect   | <input type="checkbox"/> Automobile Mechanic                                 |
| <input type="checkbox"/> Architectural Draftsman                             | <input type="checkbox"/> Plumbing <input type="checkbox"/> Steam Fitting     |
| <input type="checkbox"/> Building Estimating                                 | <input type="checkbox"/> Heating <input type="checkbox"/> Ventilation        |
| <input type="checkbox"/> Wood Millworking                                    | <input type="checkbox"/> Sheet Metal Worker                                  |
| <input type="checkbox"/> Contractor and Builder                              | <input type="checkbox"/> Steam Engineer                                      |
| <input type="checkbox"/> Structural Draftsman                                | <input type="checkbox"/> Steam Electric Engineer                             |
| <input type="checkbox"/> Structural Engineer                                 | <input type="checkbox"/> Civil Engineer                                      |
| <input type="checkbox"/> Electric Wiring                                     | <input type="checkbox"/> Surveying and Mapping                               |
| <input type="checkbox"/> Electrical Engineer                                 | <input type="checkbox"/> Refrigeration                                       |
| <input type="checkbox"/> Electric Lighting                                   | <input type="checkbox"/> R. R. Locomotives                                   |
| <input type="checkbox"/> Welding, Electric and Gas                           | <input type="checkbox"/> R. R. Section Foreman                               |
| <input type="checkbox"/> Reading Shop Blueprints                             | <input type="checkbox"/> R. R. Bridge and Building Foreman                   |
| <input type="checkbox"/> Telegraph Engineer                                  | <input type="checkbox"/> Air Brakes <input type="checkbox"/> Train Operation |
| <input type="checkbox"/> Telephone Work                                      | <input type="checkbox"/> Highway Engineering                                 |
| <input type="checkbox"/> Mechanical Engineer                                 | <input type="checkbox"/> Chemistry <input type="checkbox"/> Pharmacy         |
| <input type="checkbox"/> Mechanical Draftsman                                | <input type="checkbox"/> Coal Mining Engineer                                |
| <input type="checkbox"/> Machinist <input type="checkbox"/> Toolmaker        | <input type="checkbox"/> Navigation <input type="checkbox"/> Boilermaker     |
| <input type="checkbox"/> Patternmaker  | <input type="checkbox"/> Textile Overseer or Supt.                           |
| <input type="checkbox"/> Pipefitter <input type="checkbox"/> Tinsmith        | <input type="checkbox"/> Cotton Manufacturing                                |
| <input type="checkbox"/> Bridge Engineer                                     | <input type="checkbox"/> Woolen Manufacturing                                |
| <input type="checkbox"/> Bridge and Building Foreman                         | <input type="checkbox"/> Agriculture <input type="checkbox"/> Fruit Growing  |
| <input type="checkbox"/> Gas Engines <input type="checkbox"/> Diesel Engines | <input type="checkbox"/> Poultry Farming <input type="checkbox"/> Radio      |
| <input type="checkbox"/> Aviation Engines                                    | <input type="checkbox"/> Marine Engineer                                     |

**BUSINESS TRAINING COURSES**

- |   |  |
|---|--|
| <input type="checkbox"/> Business Management                                  | <input type="checkbox"/> Business Correspondence                             |
| <input type="checkbox"/> Office Management                                    | <input type="checkbox"/> Lettering Show Cards <input type="checkbox"/> Signs |
| <input type="checkbox"/> Industrial Management                                | <input type="checkbox"/> Stenography and Typing                              |
| <input type="checkbox"/> Personnel Management                                 | <input type="checkbox"/> Complete Commercial                                 |
| <input type="checkbox"/> Traffic Management                                   | <input type="checkbox"/> Civil Service <input type="checkbox"/> Mail Carrier |
| <input type="checkbox"/> Accountancy <input type="checkbox"/> Cost Accountant | <input type="checkbox"/> Railway Mail Clerk                                  |
| <input type="checkbox"/> C. P. Accountant                                     | <input type="checkbox"/> Grade School Subjects                               |
| <input type="checkbox"/> Bookkeeping  | <input type="checkbox"/> High School Subjects                                |
| <input type="checkbox"/> Secretarial Work                                     | <input type="checkbox"/> College Preparatory                                 |
| <input type="checkbox"/> Spanish <input type="checkbox"/> French              | <input type="checkbox"/> Illustrating <input type="checkbox"/> Cartooning    |
| <input type="checkbox"/> Salesmanship <input type="checkbox"/> Advertising    | <input type="checkbox"/> Lumber Dealer                                       |

Name.....  
Address.....  
City.....State.....  
Occupation.....

If you reside in Canada, send this coupon to the International Correspondence Schools, Canadian, Limited, Montreal, Canada

**MAKE BIG MONEY WITH OUR LIST PRICE BARGAIN CATALOG**

Filled with electric driven machines to sell to shops, stores, restaurants, homes, workshops, factories, farms, hotels. Filled with real items for agents. Write for free copy and wholesale prices to you.

**E. & A. CORP., 1424 So. Ridgeland BERWYN, ILLINOIS**

**\$\$\$ IN ARC WELDING**

Hobart Welder starts you on road to success. Anyone can easily get into this profitable business.  
**30 DAYS TRIAL—EASY MONTHLY TERMS**  
Easy to operate, does better job, uses less current. Write today for details, terms and trial to  
**HOBART BROTHERS, BOX M, 1001, TROY, OHIO**

**Newest THING IN RADIO**

**Vari-Tone**

**\$295**

MAKES A 1931 MODEL OF YOUR PRESENT RADIO

Gives you **TONE CONTROL!**

Connects in One Minute to any Electric or Battery Radio

**TRY IT A WEEK At Our Risk!**

Makes your set sound like a latest 1931 "tone control" model. **SATISFACTION or money back!** Vary tone and pitch to suit yourself. No need to buy a new \$200 radio. Send \$2.95 or order C. O. D. Free literature. Radio agents wanted.



**VARI-TONE LAB. Dept. 807**  
P. O. Box 700, Cincinnati, O.



# Get Your RADIO AND PARTS at Lowest Wholesale Prices

1931 Screen  
Grid All-  
Electric Sets.  
Beautiful  
Consoles,  
Battery  
Operated  
Sets



Accessories,  
Parts, Kits and  
Electric  
Appliances.  
Dynamic  
Speakers. At  
Wholesale

We have just issued our 1931 book of money-saving bargains in everything in radio. 168 pages full of the latest radio attractions . . . over 500 illustrations. The last minute improvements in sets, accessories, parts and kits. Remote control, public address, phono-combinations; also the latest slot machine sets.



THE MOST  
COMPLETE  
**RADIO  
CATALOG**  
IN AMERICA  
168 Pages  
**FREE**

## Lowest Wholesale Prices

Bed-rock prices and unusual values on all sets, parts and appliances, including the new 1931 screen grid, tone control A. C. humless all-electric sets, etc. Also battery operated sets. You must have this catalog to tune in on the newest and greatest values in radio merchandising, made possible by the tremendous buying power of this great three million dollar corporation. Money-saving values on every page at real wholesale prices. Send for it TODAY. It's FREE.

# ALLIED RADIO CORPORATION

711 W. LAKE ST. Dept. 166 CHICAGO

## ALADDIN PORTABLE ELECTRO-PLATER

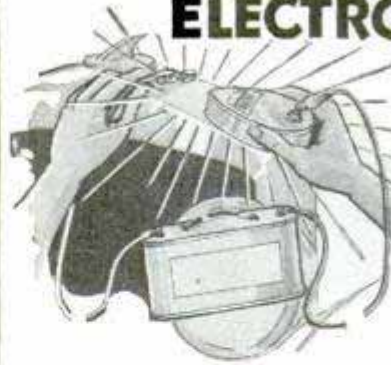

Introductory  
**AGENTS  
OFFER**  
**0.50**

### Instantly Applies Real Nickel

Also Electrically Plates Brass, Copper, Silver, Gold, Etc. With the inexpensive ALADDIN OUTFIT you can easily nickel plate the nickel on your car and do a good job of it. The ALADDIN OUTFIT is also a home necessity.

### MAKE BIG PROFITS WITH THE ALADDIN

Whether you are interested in the ALADDIN for yourself or should you wish to go into business putting real nickel on autos or doing metal plating in your neighborhood, or if you would like to act as our agent in your territory, write us immediately for free particulars.



**P. J. F. BATENBURG CO.**

Dept. 189

Racine, Wisconsin



## LAWN MOWER SHARPENER

WELLS MANUFACTURING COMPANY  
Box 613, Greenfield, Mass., U. S. A.

## \$\$\$ IN AUTO WASHING

Auto washing pays biggest profit right now. Hobart 20-Minute Car Washer does more work than others. Come on—**30 DAYS' TRIAL—EASY MONTHLY TERMS**—extra profit easily pays for outfit. Write today for complete details, terms and trial to **HOBART BROTHERS, Box M1002, TROY, OHIO**

## ELECTRIC MOTOR

winding models show winding and connections in plain sight. Make your own or rewind motors for your own use or for profit. In use all over the world. Quick, easy way. Write Dept. DPM, **Gaines Bros. Box 481 Gainesville, Texas** Send dime for circulars.

## BUILD MODEL SHIPS OF THE BETTER KIND

We can supply construction sets and all sorts of parts such as semi-finished hulls, blocks, deadeyes, special flags, anchors, steering wheels, capstans, figureheads, blue prints, books, etc., for building real fine scale models of the Flying Cloud, Constitution, Spanish Galleon, Mississippi River Steamboat, Sovereign of the Seas, Biscayne, Mayflower and many others. Also special construction sets for racing sail boats, power boats, model steam engines, propellers, etc., and fine tools for the model maker. Our large 48-page photographically illustrated booklet contains valuable information and hints for building ship models in addition to prices and full description of the above articles. Many people only slightly interested in models have become greatly enthused upon receiving this booklet. A copy will be sent postpaid upon receipt of 15 cts. (coin preferred).



**MODEL SHIP SUPPLY CO., Dept. L, Mineola, N. Y.**



# Bring on Your Repair Jobs!

**HERE'S THE CAN  
THAT MAKES YOU  
AN EXPERT . . .**



**W**HEN you are working with hammer and saw, plane and chisel, you'll find a can of Savogran Crack Filler a real life-saver.

When joints don't fit evenly, when corners don't square up—pieces cut too small or holes too large—just mix up a little Savogran Crack Filler, press it into place, and stop worrying. After it's smoothed and painted, the patch cannot be detected, and you've got a job that the best cabinet-maker in the country couldn't improve on.

With Savogran Crack Filler you can make permanent repairs to wood, stone, metal, and plaster, use in building toys, models, and furniture. Tools and finishes like wood. And best of all, Savogran Crack Filler *does not shrink!* Better get a can today at your hardware or paint store. Use it once and you'll always keep a can handy.

**← HERE'S THE BOOKLET THAT SHOWS HOW TO DO IT!**

Let George Boardman Perry, well-known decorator and writer, show you how to put new life in old furniture. In his booklet "How to Repair and Refinish Furniture," he explains every step by word and picture. Here's a valuable book worth real money to anyone who is ever called on to put a chair or table back into service. We send it **FREE** to those who mail the coupon. Supply is limited. Act promptly and be sure of your copy of this handy book.

**AND HERE'S THE COUPON THAT  
BRINGS IT TO YOU FREE!**

**↓ FREE**

Big 1-lb. can only 30c.; 5-lb. can, \$1.25; 35-lb. pressed steel pail (for large users), \$7.70. No solvents to buy—no hardening in the can—no waste. Safe—efficient—economical. Biggest value on the market.

**SAVOGRAN**  
REG. U.S. PAT. OFF.  
**CRACK FILLER**  
PAT. APP. FOR

SAVOGRAN COMPANY,  
India Wharf, Boston, Mass. M-10

Rush me my free copy of "How to Repair and Refinish Furniture." It's just what I've been looking for.

Name.....

Address.....

City.....State.....



# NOW

... THAT YOU'VE TRIED THEM ALL

# SETTLE DOWN

# TO DURHAM - DUPLEX



**DURHAM - DUPLEX**

THE RAZOR WITH THE  
BLADES MEN SWEAR BY—NOT AT

**T**RIED them all? Now get yourself a fresh package of Durham-Duplex blades and try something that's really *new*. Not in shape—not in name—not in finish—but new in the thing that really counts—*shaving efficiency*.

The hollow-ground edges on the latest output of blades are a pleasant surprise even to those who thought Durham-Duplex blades had already reached the peak!

Prove for yourself the merit of this wonderful blade. Secure a genuine razor complete with one blade ready for shaving from your dealer or send 25c. to cover cost to the Durham-Duplex Razor Company, Jersey City, N. J.



## Let These Books Help You Make More Money

The books listed below will perfect you in your chosen trade—pave the way to the big positions. Written in non-technical language—easy to read and understand. *Every book covers its subject completely. An entire course of instruction condensed into one volume.* Your choice sent postpaid—money refunded in full if not entirely satisfactory. Order direct from this list.

### AVIATION AND AUTO

Aviation From the Ground Up.....	\$3.50
Automobile Starting, Lighting and Ignition, by Manly. 700 pp.....	\$3.00
Brookes' Automobile Handbook.....	\$2.00
Ford Motor Car, Truck and Tractor, by Manly. Auto and Radio Battery, Care and Repair, by Manly.....	\$1.50
Motorcycle Handbook, by Manly.....	\$2.00
	\$1.50

### CARPENTRY

Modern Carpentry, 2 vols.....	\$3.00
The Steel Square, 2 vols.....	\$3.00
Modern Estimator.....	\$1.50
Timber Framing.....	\$2.00
Builders' Architectural Drawing.....	\$2.00
Concretes.....	\$1.50
Practical Bungalows.....	\$1.00
Roof Framing, by Van Gaasbeek.....	\$1.50

### PAINTING, DECORATING AND ART

Lettering, Modern and Foreign, Welo.....	\$5.00
Silk Screen Process of Reproduction.....	\$5.00
Modernistic Lettering and Design.....	\$2.00
Modern Illustration.....	\$3.50
The Lacquer System of Sign Painting.....	\$3.00
How to Draw Funny Pictures—a Complete Course in Cartooning.....	\$3.00
Layouts for Advertising.....	\$3.00
Furniture, Furniture Finishing, Decoration and Patching.....	\$5.00
Ross Crane Book of Home Furnishing and Decoration.....	\$3.00
House Painting Methods.....	\$2.00
Interior Wall Decoration, by Vanderwalker.....	\$4.00
The Mixing of Colors and Paints, by Vanderwalker.....	\$2.00
Automobile Painting.....	\$1.50
Wood Finishing, Plain and Decorative.....	\$2.00

### SHOP PRACTICE

Practical Heating Systems, Trouble Jobs and Ventilation.....	\$4.00
Sheet Metal Workers' Manual.....	\$2.00
Oxy-Acetylene Welding and Cutting.....	\$1.25
Slide Rule and Logarithmic Tables.....	\$2.00
Handbook for Millwrights.....	\$2.00
Machine Shop Practice.....	\$2.00
Mechanical Drawing and Machine Design.....	\$2.00

### STEAM ENGINEERING

Swingle's Handbook for Steam Engineers and Electricians.....	\$4.00
Examination Questions and Answers for Marine and Stationary Engineers.....	\$2.00
Steam Boilers.....	\$2.00
Swingle's Catechism of Steam, Gas and Electrical Engineering.....	\$1.50

### Order Direct--on Our Money-Back Plan

For quick action order direct from this list—cross name of each book wanted and send in with price quoted. We prepay postage and send the books on our money-back plan.

**POPULAR MECHANICS PRESS**  
Room P7—200 E. Ontario Street, Chicago, Ill.



# Auto Owners Now Save Millions of Gallons of Gas

A new invention called the Whirlwind is actually saving millions of gallons of gasoline for automobile owners. Those who have installed this amazing device on their cars report almost unbelievable gasoline savings. They also report more speed and power, quicker starting and reduction of carbon.

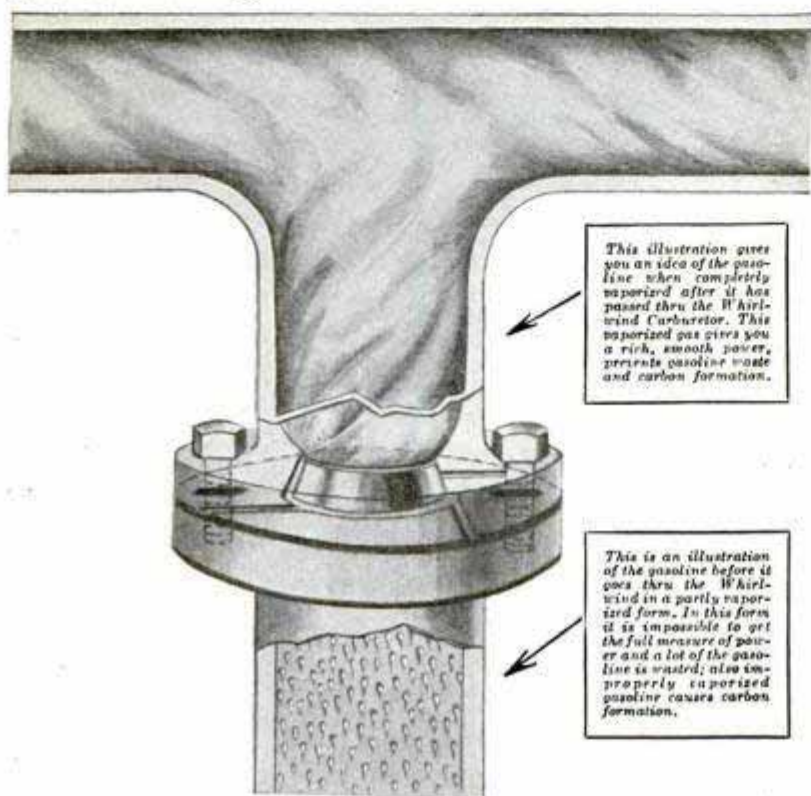

This illustration gives you an idea of the gasoline when completely vaporized after it has passed thru the Whirlwind Carburetor. This vaporized gas gives you a rich, smooth power, prevents gasoline waste and carbon formation.

This is an illustration of the gasoline before it goes thru the Whirlwind in a partly vaporized form. In this form it is impossible to get the full measure of power and a lot of the gasoline is wasted; also improperly vaporized gasoline causes carbon formation.

The marvelous thing about this Whirlwind is that it works as well on all makes of cars. Reports are received from owners of practically every known make of automobile from Fords to Lincolns and they are all equally enthusiastic in their praise.

## FITS ALL CARS

In just a few minutes the Whirlwind can be installed on any make of car, truck or tractor. It's actually less work than changing your oil or putting water in the battery. No drilling, tapping or changes of any kind necessary. It is guaranteed to work perfectly on any make of car, truck or tractor, large or small, new model or old model. The more you drive the more you will save.

## SALESMEN AND DISTRIBUTORS WANTED TO MAKE UP TO \$100.00 PER WEEK

Whirlwind men are making big profits supplying this fast selling device that car owners cannot afford to be without.

### GUARANTEE

No matter what kind of a car you have—no matter how big a gas eater it is—the Whirlwind will save you money. We absolutely guarantee that the Whirlwind will more than save its cost in gasoline alone within 30 days, or the trial will cost you nothing. We invite you to test it at our risk and expense. You are to be the sole judge.

## WHIRLWIND MFG. CO.

DEPT. 999-360-A THIRD ST.

MILWAUKEE, WISCONSIN

Good territory still open. Sample offer and full particulars sent on request. Just check the coupon.

### Free Trial Coupon

Whirlwind Mfg. Co.,  
999-360-A Third St., Milwaukee, Wis.

Gentlemen: You may send me full particulars of your Whirlwind Carbureting device and tell me how I can get one free. This does not obligate me in any way whatever.

NAME.....

ADDRESS.....

CITY.....

COUNTY..... STATE.....

Check here if you are interested in full or part time salesman position.



# Invisible "Cop"

## Protects Your Auto from Thieves

### and Offers Agents Up to \$40 a Day

What in the world IS this uncanny new discovery that so instantly terrifies auto thieves? Thieves fear it worse than poison. Its terrible power literally "petrifies" them. They cannot even remove a thing. Now your car can be absolutely safe, anywhere you leave it. Don't confuse this queer new invention with anything you ever saw. It is not a bell. Not a lock. Not an explosion. Not an electrical shocker. Not a poison gas. Yet the deadly fear it puts into thieves throws them into a panic. It works automatically the instant anyone even touches your car. Cannot injure innocent persons. Recommended by police and insurance companies. No bigger than your hand. Costs only one penny a year to operate. Almost never wears out. The cheapest, surest theft insurance you can buy. And that's not all. Excites and amuses everybody. Have lots of fun with your friends.



## We Pay You Just To Show It To Motorists

So startling, so absolutely new, so peculiar is this strange discovery that agents who have already taken it on are smashing daily profit records. The greatest crowd gatherer you ever saw. The minute you demonstrate this clever invention people are bewildered. They want to know how it "stiffens," "hypnotizes," "shell shocks" thieves. The need for this scientific protection is so great—the big profit possibilities are so almost unlimited and easy—that now we will actually pay you just to demonstrate this amazing thief chaser. You don't need to sell a single one to make this money. Just stand on the street by your car and make it perform its magic wonders that set your audience agog and bring quick profits. No use wasting your time any longer with "piker" propositions. \$40, \$50, \$75 a day is not too much to expect, is it? If we did not feel sure that you could make as much money as other men with this uncanny new discovery we certainly would not be willing to offer you pay just for demonstrating it. The protection it gives—its utter queerness—its strange power to put fear into thieves—and the fun it gives motorists make it the easiest, fastest selling, biggest money-making opportunity for you in many years.

The market is so tremendous—orders are pouring in so fast—that we can afford to do almost unheard of things for our local distributors. Not only will we pay you just for testing it, but we will actually send you a Free Sample offer for your own car so that your car and accessories will be protected and to start you demonstrating it. Yet that's not all. We actually offer to pay you cash for merely testing it on your car. Now we have territories for 1,600 more county distributors and 100 district managers on this generous pay plan. With our nation-wide advertising plans ready to start at once, distributors should be literally flooded with orders. We have worked out a new plan so that you don't have to do any selling or demonstrating to car owners to make big money.

The news of this startling discovery is traveling so fast that territories now open are being snapped up fast. So we urge you to rush the coupon for your Free Sample offer—offer to pay for demonstrating and plan that gets you big money without doing any selling or demonstrating to car owners.

### FREE SAMPLE OFFER We Pay You for Testing It

Send no money. Just coupon. This is not an order. Nothing will be sent C. O. D. This Sample Offer is yours free of all cost. Just mail coupon now.

**Allied Industries, Inc.,  
5297 Garver Bldg., Des Moines, Iowa.**

I accept your generous Free Sample offer of your amazing new thief "hypnotizer" with understanding that this offer costs me nothing now or ever. Nothing will be sent C. O. D. and I am not obliged in any way to buy anything or to become your distributor. You also offer to actually pay me for just testing it on my own car. Please send details of your offer of Pay for Demonstrating it, and also your plan that offers me big money even without demonstrating or selling to car owners. If I become your local distributor you agree to give me exclusive territory.

Name.....

Address.....

City.....State.....



# Start to Play Very First Day



## Xylophonists Thrill Audiences after 5½ Hours Practice

**Positive Proof That Here Is Easiest of All Instruments to Play. Free Lessons . . . . . Five Days' Trial . . . . . A Year to Pay**

**P**ICTURE in your mind this scene! The great Oriental Theater in Chicago. A "packed" house. A *super* stage presentation calling for thirteen Xylophones, played by charming misses, to accompany the world-renowned Deagan artist, Clair Musser.

The audience listens and bursts into raptures of applause. What would they have said had they realized that these Abbott dancing girls who produced such captivating music had never played a Xylophone before—that not one of them had more than 5½ hours' practice?

Can anything prove more conclusively that in the Xylophone you have the *easiest* road to musical happiness? Just think—on the very day you get your instrument, thanks to an amazingly simple method, you play a simple melody. Soon—guided by the free, easy les-

sons—you learn to play more difficult selections. Then an entirely new life—a happier, fuller, more joyful life—opens up to you.

The tantalizing music of the Xylophone is in demand everywhere. Master it and you are not only invited to all sorts of parties and gatherings, but you are the center of interest. Shoulders sway and feet begin to dance to the tinkling melody you provide. Hours and hours of delight. Pleasant duets with sweetheart, wife, sister or brother. The pride of every girl and the envy of every fellow!

### **\$5 to \$25 a Night For Work That Is "Play"**

Xylophonists command big pay; \$5 to \$25 a night is not unusual. Orchestra leaders, radio directors, entertainment bureaus are all seeking good Xylophonists. The Musical Hallmans (Reading, Pa.) averaged \$65 a week in spare time.

J. C. Deagan, Inc., world's leading Xylophone makers, now make it so

Money spent for entertainment gives, at the most, a few hours' pleasure. The Xylophone gives an entire lifetime of joy.

easy to play this remarkable instrument that nothing need stand in your way. Easy lessons. A bonafide 5-day trial in your own home that eliminates all risk. Such easy payments that you hardly miss them—can anything be fairer or more liberal?

### **BIG BOOK FREE**

In the interest of your own welfare, send today for the 1930 edition of the big Deagan Book. It describes Deagan Xylophones, the artists who use them, the pleasure they give, the opportunities they present, the trial offer, easy lessons and liberal payment plan. The coupon is such a simple thing to fill in; yet it may mean the turning point in your entire career. Isn't it a good idea to mail it NOW, before it slips your mind?

**Send Coupon for Big FREE BOOK**



**J. C. DEAGAN, Inc.**  
Dept. 3457, 1770 Berceau Av., Chicago

Send me, without obligation, full details of Free Trial offer and easy-payment plan on the Deagan Xylorimba.

Name \_\_\_\_\_

Address \_\_\_\_\_

*The same instrument that accompanied Admiral Byrd to the South Pole is now ready to provide fun and happiness for you.*





# Pleasure Ahoy!



CAMELS are companions for any occasion . . . mild, mellow, gloriously fragrant . . . enjoyable as the sparkle of sun and spray . . . a smoke that's *all* pleasure!



# Camels

© 1930, R. J. Reynolds Tobacco Company, Winston-Salem, N. C.