

SEPTEMBER

NSE.  
25 CENTS

# POPULAR MECHANICS

## MAGAZINE

WRITTEN SO YOU CAN UNDERSTAND IT

REG'D. TRADE MARK, GREAT BRITAIN, NO. 410426

REG. U.S. PAT. OFF.

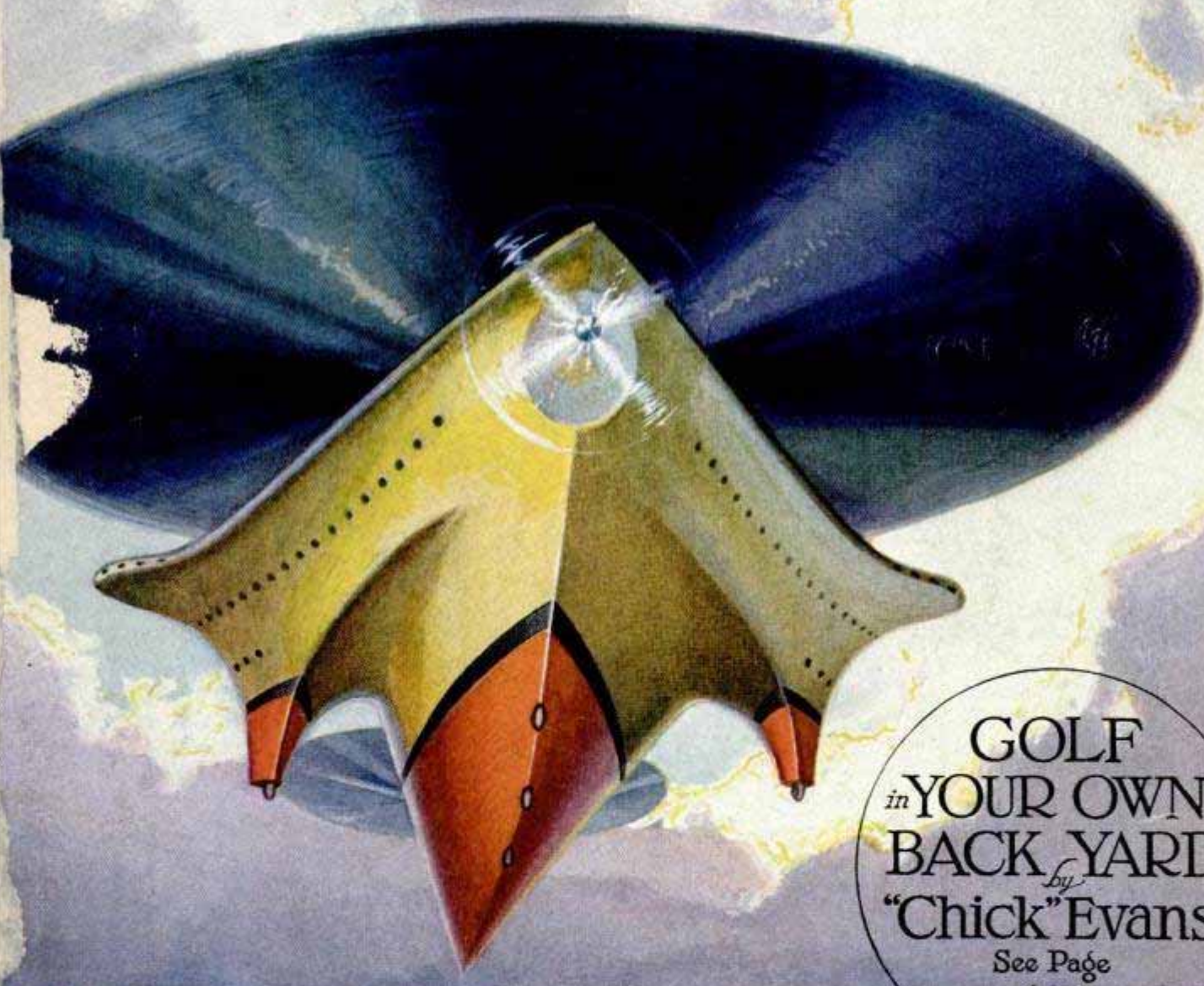

GOLF  
*in* YOUR OWN  
BACK YARD  
*by*  
"Chick" Evans  
See Page  
492

SEE PAGE 267



# Why



## did you pick the oil you now use?

**Because of the crude it was made from?  
Then it may be a deficient oil!**

Perhaps you picked an oil for your engine because it was made from some particular crude. But—did you know *this*? Oil scientists know that a dozen oils of widely different quality can come from the same crude!

### WHAT IS A DEFICIENT OIL?

To be a full-duty lubricant an oil must contain four essential properties to meet four definite needs in lubricating your engine. These properties must be blended in exactly the correct proportion for your particular engine. They are:

**Carbon Control**—keeps down carbon in your cylinders.

**Heat Resistance**—makes your oil last longer.

**Oily Character**—protects moving parts from wear.

**Oxidation Control**—prevents gumming and sticking of valves, and clogging of passages in oiling system.

If any of these properties are lacking in an oil—or present in incorrect proportions, that oil is a deficient oil.

Motor oil is made—not found. And the only way a *full-duty* oil can be made is to start with the needs of each type of engine, not with some particular crude. Engine study is the only foundation for a full-duty oil.

Twice as many automotive engineers use Mobiloil as any other oil—they know engines and they know the importance of correct lubrication. Twice as many motorists use Mobiloil as any other oil—they know that it gives better results. Ask for the grade of Mobiloil made especially for your engine as recommended by the Mobiloil Chart.

### VACUUM OIL COMPANY

Makers of high quality lubricants for all types of machinery

LOOK FOR THIS SIGN

Your Mobiloil dealer cordially invites you to hear the famous Mobiloil concerts each Wednesday evening... WEAJ and 29 associated N. B. C. stations.

# Mobiloil





# Start to Play Very First Day

Give Yourself  
Lifelong Fun  
Profit and  
Popularity



THINK of the best gift you have ever received. Multiply the pleasure it gave you by ten, and still you have only an idea of the joy you can give yourself right now if you act at once!

## PARENTS!

What greater gift can you confer on your children this year than lifelong fun and entertainment?

Love of music means love of home, an appreciation of the finer things in life. Here is a chance to give your boy or girl that love without the tedious practice that most instruments require. The Xylorimba is easy to play. No teacher is needed. Practice is actually a joy.

Remember, the Xylorimba is the guaranteed product of a company established nearly half a century ago—a company that stands back of every promise it makes.

## Start to Play the Very First Day!

Haven't you, like millions of others, envied the fellows who "bring down the house" with snappy xylophone or xylorimba numbers? Haven't you longed to create your own music, to be looked up to wherever you go, to be able to make real money in spare time? If you have, this ad spells O-p-p-o-r-t-u-n-i-t-y. The xylorimba—wonderful for home, in demand at dances and gatherings—is nevertheless the easiest of all instruments to play. In fact, on the very day you get yours you play simple melodies, even if you can't read a note of music right now. In a few weeks you astonish your friends and family. All your life you have the joy that comes to those who can entertain.

## Plays 20 Minutes; Gets \$20!

Ralph Smith, Chicago, played twenty minutes at wedding; his "pay" was \$20. Altho only 12, Turk McBee, Jr., plays big-time vaudeville exclusively. Harry Breuer, New York, has

made thousands of friends thru his xylophone selections on the radio. L. E. Hallman, Reading, Pa., writes: "Made \$300 in 5 weeks—spare time."

And now J. C. Deagan, Inc., (world's largest manufacturer of xylophonic instruments) has made it so easy to own a xylorimba that nothing stands in your way. Sizes and styles to fit every age and pocketbook. A five-day free trial that eliminates risk. Free, easy lessons that make teacher unnecessary—and, best of all, such easy payments that they are hardly noticed.

## Will You Investigate?

Everyone wants to be popular. Everyone wants to make extra money. Everyone wants to be center of attraction at gatherings. But these advantages don't come by themselves. Opportunities must be seized. This is your opportunity—will you pass it up without investigation? The accompanying coupon will bring our big FREE book to your door. It tells all about the Deagan line, the free trial, the easy payments. Remember, no cost or obligation! Simply fill in and mail the coupon—but do it before it slips your mind. Today is as good a day as any. Do it NOW!

J. C. DEAGAN, Inc.  
145, 170 Baitan Avenue, Chicago  
Free Trial offer and  
the Xylorimba.

YOUR  
MAGIC  
KEY

to Popularity

Mail  
Now!

Send for  
BIG FREE  
Book!

This One



JAPH-SFH-ZKAW

Please  
easy pay.

Name

Address

City

State





# Auto Owners Now Save Millions of Gallons of Gas

A new invention called the Whirlwind is actually saving millions of gallons of gasoline for automobile owners. Those who have installed this amazing device on their cars report almost unbelievable gasoline savings. They also report more speed and power, quicker starting and reduction of carbon.

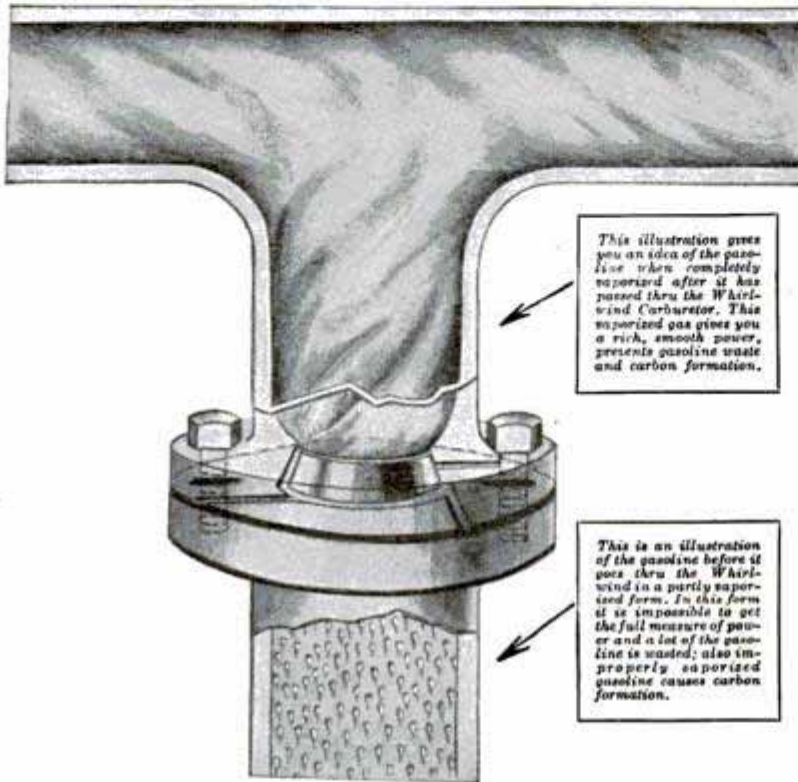

This illustration gives you an idea of the gasoline when completely vaporized after it has passed thru the Whirlwind Carburetor. This vaporized gas gives you a rich, smooth power, prevents gasoline waste and carbon formation.

This is an illustration of the gasoline before it goes thru the Whirlwind in a partly vaporized form. In this form it is impossible to get the full measure of power and a lot of the gasoline is wasted; also improperly vaporized gasoline causes carbon formation.

The marvelous thing about this Whirlwind is that it works as well on all makes of cars. Reports are received from owners of practically every known make of automobile from Fords to Lincolns and they are all equally enthusiastic in their praise.

## FITS ALL CARS

In just a few minutes the Whirlwind can be installed on any make of car, truck or tractor. It's actually less work than changing your oil or putting water in the battery. No drilling, tapping or changes of any kind necessary. It is guaranteed to work perfectly on any make of car, truck or tractor, large or small, new model or old model. The more you drive the more you will save.

## SALESMEN AND DISTRIBUTORS WANTED TO MAKE UP TO \$100.00 PER WEEK

Whirlwind men are making big profits supplying this fast selling device that car owners cannot afford to be without.

Good territory still open. Sample offer and full particulars sent on request. Just check the coupon.

### Free Trial Coupon

Whirlwind Mfg. Co.,  
999-336-A Third St., Milwaukee, Wis.

Gentlemen: You may send me full particulars of your Whirlwind Carbureting device and tell me how I can get one free. This does not obligate me in any way whatever.

NAME.....

ADDRESS.....

CITY.....

COUNTY.....STATE.....

Check here if you are interested in full or part time salesman position.

### GUARANTEE

No matter what kind of a car you have—no matter how big a gas eater it is—the Whirlwind will save you money. We absolutely guarantee that the Whirlwind will more than save its cost in gasoline alone within 30 days, or the trial will cost you nothing. We invite you to test it at our risk and expense. You are to be the sole judge.

## WHIRLWIND MFG. CO.

DEPT. 999-336-A THIRD ST.

## MILWAUKEE, WISCONSIN



# Popular Mechanics Magazine

200 E. Ontario Street, Chicago, U. S. A.

H. H. WINDSOR, Founder

H. H. WINDSOR, Jr., Editor and Publisher

London: Hachette & Cie.,  
3 La Belle Sauvage, Ludgate Hill, W. C. 2

Paris: Hachette & Cie.,  
111 Rue Reaumur

Melbourne: Gordon & Gotch  
509-513 Little Collins St.

ISSUED MONTHLY

SUBSCRIPTION:

SINGLE COPY, 25 CENTS

In United States and its possessions, Canada, Cuba, Mexico, and all }  
countries in the Pan-American Postal Union, per year, postpaid } . . . . . \$2.50

To all other countries in the Postal Union . . . . . 3.00

All subscriptions are discontinued at expiration. Please examine the date printed on your wrapper.

Entered as Second Class Matter Sept. 15, 1903, at the Post Office at Chicago, Illinois, under Act of March 3rd, 1879.

Entered as Second Class Matter at the Post Office Department, Canada.

Published monthly by POPULAR MECHANICS CO.

Copyright, 1930, by Popular Mechanics Co.

Copyright in Australia. Copyright in France

Vol. 54

Contents for September, 1930

No. 3

## Special Features

House Cleaning an Ocean Liner ✓	370
Dog Heroes of the White Hell ✓	378
What the Weather Man Can Tell You	390
It's Easy to Fly ✓	420
The World's Queerest Jobs ✓	434
A Modern Robin Hood ✓	443
Gunfighting Police Doom Gangsters ✓	452
Where do you Weigh the Most?	467

Air Mail—planes' total mileage twenty-four million . . . . .	464	Boll-Weevil—and weather data foretell cotton crops . . . . .	417
Airplanes		Bridges	
catapult for launching planes is engineering wonder . . . . .	389	giant of world's, rising in New York . . . . .	464
hooded cockpit helps pilots in blind flying . . . . .	469	memorial, stone-block eagles weigh two hundred tons each . . . . .	388
lights on wings show pilot height from ground . . . . .	426	world's longest arch span in Kill Van Kull . . . . .	471
Airship—portable mast for dirigible decreases ground crew . . . . .	451	Building—whole city under roof in new terminal . . . . .	383
Air Traffic—block system for airplanes run by radio telephone . . . . .	429	Cameras	
Archaeology		aimed like guns for air photography . . . . .	396
mystery veils old pyramids found in Mexico . . . . .	465	soundproof, weighs but thirty-seven pounds . . . . .	377
palace on top of Bible city to be excavated . . . . .	417	Chemistry—great opportunities of future seen in . . . . .	384
Arctic—was once temperate but never tropical . . . . .	377	Church—placed in steel cage for safe repairing . . . . .	466
Astronomy—how stars of the big dipper are breaking up . . . . .	394	Clock—boat-race starting, fires off cannon . . . . .	419
Automobiles		Coupling Device—powder serves as, instead of gear shift . . . . .	400
bullet-proof car for police has armored front . . . . .	432	Cradle—electric, for infant relieves mother . . . . .	396
gilded throne in, presented to Pope Pius . . . . .	460	Deafness—sounds heard through teeth instead of ears . . . . .	440
will steam, ever come back . . . . .	427	Dogs—onions give anemia . . . . .	459
Automobiles, Accessories		Doors—open automatically when approached . . . . .	387
coach converted into sedan with a movable seat . . . . .	469	Ear—shields on spectacles aid hard of hearing . . . . .	395
folding table also serves as footrest . . . . .	400	Electrical Appliances—vulcanized light extension free of fire dangers . . . . .	449
Automobiles, Design—body is free from rattles and squeaks . . . . .	442	Electricity—new jobs for, found on farms . . . . .	419
Automobiles, Driving		Eyeglasses	
electric brakes add safety to . . . . .	471	electric-light, aid night workers . . . . .	419
mirrors at street corners aid . . . . .	449	jewelers' lens on glasses saves wearing "barrel" . . . . .	387
Automobiles, Racing—light rays from auto lamp time cars . . . . .	375	Fan—to cool and dry air helps promote health . . . . .	449
Automobiles, Trailer—to prevent sidesway . . . . .	382	Fish and Fishing—game fish grown by government help anglers . . . . .	448
Automobile Truck—screen guards driver from balls on golf course . . . . .	445	Floodlights—beautify "biggest" building . . . . .	440
Aviation—flares as weather signals warn airplane pilots . . . . .	395	Fountain—of modern design features playground . . . . .	441
Blasting—steel net guards motorists from rocks in . . . . .	417	Gas—fuel, for rural use delivered in tanks . . . . .	433
Boats and Boating		Golf—robot aids amateurs in developing swing . . . . .	442
electric-powered towboat takes to the river . . . . .	417	Heating and Lighting—fixture combined in one unit . . . . .	448
glass-bottomed boat crawls on land . . . . .	426	Household Devices	
model of German battleship features boat show . . . . .	461	Humidifier—automatic, suits any furnace . . . . .	418
motorboat like torpedo will not sink . . . . .	457	Ice	
motorboats for self-use on park ponds . . . . .	388	dry, clouds sprayed with, made to yield rain . . . . .	418
outboard merry-go-round latest water sport . . . . .	450	"hot" made by high pressure . . . . .	429
		Ink—glowing offers guard against forgeries . . . . .	432
		Keys—automatic chain reel protects switchman . . . . .	450

[Continued on Page 4]

*Beery's Black Rocket*



## [Contents—Continued]

Knife—electric, hot blade helps clean game	385
Lawn Fertilizer—sprayed through garden hose	470
Lawn Mower—roller springs give smoother cut	461
Light	
speed of, checked through one-mile tube	385
weight of, from sun is many tons	458
Locomotive—roller-bearing, has living quarters	377
Magnetism—mystery of, laid to electron's spin	375
Meats—hand tester tells if tough or tender	460
Metals—cheapest of	442
Models—big engineering problems solved with	376
Mountain Climbing—to conquer Kanchanjanga	430
Moving Pictures	
cricket is master musician talking film reveals	460
fly plane about waterspout to make	466
talking film shown on train to entertain passengers	400
Nail—that seals hole makes roofing last longer	395
Ocean—power from, new effort to obtain	448
Oceanography—lands rise from the sea and disappear overnight	441
Overcoats—test warmth of, on refrigerating coils	419
Paints and Painting	
aluminum paint resists heat and keeps its color	385
fraudulent paintings found with electric rays	432
Parachutè	
attached to vest eliminates straps	386
for short jumps opens in few feet	470
safety of modern, proved in many tests	459
Passion Play—front and part of backstage of theater at Oberammergau	398
Peaches—"phony" disease of, to be studied	429
Pencils—clip on serves as letter opener	397
Rests—odors that lure corn borer to aid in war on	458
Petroleum—"black gold"	401
Phonograph—picture card has record	451
Photo-Electric Cell—textiles sorted by use of	470
Photography—self-portrait of mink shows photographer's skill	441
Piano—portable player for, fits in small case	390
Pile Driver—works as piston of gasoline engine	451
Plants	
blossoms three feet across found in Sumatra	468
sprout from plaster on building walls	461
Playground—checkerboard offers many games	387
Radio	
echoes, mystery perplexes scientists	449
helpful radio hints and kinks	475
short-wave radio current may fire big gun	426
Radio Broadcasting—microphone swung on shoulders aids sport	466
Radio Construction	
from 15 to 195 meters without plug-in coils	472
low cost is feature of simple radiophone	478
Radio Loud Speakers—eliminating rattle in dynamic speakers	475
Radio Receivers—auto radio on running board easily repaired	384
Radio Reception—long distance radio bottled on phonograph record	433
Railroad—has "navy" of many boats	433
Science—new source of power seen as next great discovery	395
Screen—adjustable, fits any size door or window	386
Seeds—pine, sprout on ice	433
Ships and Shipping	
climbing up "Jacob's Ladder" tests pilots' skill	399
development of shipping from ancient log dug-out	446
liner is cut in two to fit in bigger engines	369
Shoes	
detachable spiked sole prevents slipping	459
soles vulcanized like auto tires	384
Skiing—wings for, add thrills of flying	388
Skis—water, for policemen aid in saving lives	445
Skyscraper—house on top of, has two yards	433
Sports, Water—bicycle pedals on pontoons operate water craft	465
Steel—alloy of, resists effects of heat and corrosion	441
Street—sign with reflector visible night or day	383
Temperature—room at seventy may still be cold	399
Thermometers—gnats' wings help to record heat of the stars	386
Tractor—fitted with cradle speeds handling pipe	458
Traffic—rear-view mirror in goggles for officers	465
Travel—how you could circle the world in five minutes	383
Trees	
fertilizer helps most near tips of roots	397
secret of dwarf Jap pines lies in special diet	396
why leaves fall in autumn	450
Truck—refuse, self-filling eliminates dust	375

Ultraviolet Rays—invisible rays made visible shining on minerals	469
Walks—of colored concrete laid in fancy patterns	465
Warfare	
"Port Arms" through the ages feature of army show	428
rockets to displace cannon in future	389
Water Tower—tall, to fight fires in skyscrapers	418
Windows—closed by falling rain	451
Zoo— island home for monkeys at Cincinnati	397

## AMATEUR MECHANICS

Airplanes	
radial engine for model	498
stabilizer control for model stunt	505
Automobiles—filling the vacuum tank	506
Automobiles, Accessories	
dustpan ventilator	497
gasoline tank cap, quick opening	510
Baby Crib—"gym" provides exercise for baby	509
Boats and Boating	
rack for outboard motor boat	510
rigging a sailing canoe	500
Cigarets—unique holder "shoots"	481
Cleaning—removing grass stains from clothing	499
Clock—paper box on bedpost holds	483
Clothespin Box—travels on line	491
Copper—coloring, brown and black	499
Door—combination screen and storm	506
Drafting—dividers hold down tracing cloth when lettering	499
Drilling—improvised V-block for rod and tubing	491
File, Nail—handy cutter on end of	499
Garage—doors, ornamental windows for	483
Garden—adds beauty to wall	510
Gate—coil spring keeps closed	509
Golf—in your own backyard	492
Hydroplane—"Popular Flyer" a racing	484
Inkwell—old golf club makes novelty	505
Metals—"oxidizing" copper and brass	506
Mothproof—make your trunk	509
Photography—copying newspaper halftones	509
Pottèry—simple potters' wheel makes artistic jars	507
Radio Application—radio scarecrow saves garden	509
Silk—testing	497
Siphon—easy method of starting	490
Tank, Hot-Water—repair for rusted	491
Tools—staple holder saves your fingers	508
Toy—child's locomotive made from oil drum	506
Window Shelf—for potted plants	499

## SHOP NOTES

Airplanes	
aircraft streamlining	526
run-up blocks for the	527
Animals—"merry-go-round" exercises stock	525
Automobiles, Driving—air supply in Fords at high speeds	515
Automobiles, Repairing—tools for removing broken transmission keys	523
Camera—small, easy to convert for aerial use	521
Drafting	
draftsmen use file for crosshatching	514
drawing board surface restored by covering with "battleship" linoleum	524
keeping track of triangles	527
Drill Press—double handle for two-spindle	515
Electricity—device for indicating live power lines	520
Explosives—tamping	525
Foundry—pattern color indicates material	514
Glass—phonograph needle cuts	515
Grease Cups—"alemite" fitting on	513
Grinder—small emery, for home shop	528
Hoisting—convenient to single worker	523
Loading and Unloading—pit substituted for platform	525
Machine Shop—frame for individual motor drive straddles machine	515
Metals—tinning black iron	522
Micrometer—collar enables correct setting of dividers	524
Plating—effective, tricks easy to do	516
Punch Press—adjustable table for the	524
Road Grader—old tires aid	522
Sidewalks—cement reinforced with wire	514
Storage Bins—from empty cans	526
Vacuum Cleaner—removes machine chips	511
Vise—pipe, improvised made from cable clamp	520
Workshop	
handy stand for repair shops	526
self-aligning stamp holder	527

Ray Dinnubale, 469

Ray Dinnubale

Sodman 442

Sodman 442

Sodman 442





**STOP THIEF STOP**  
**GET AWAY FROM ME**  
**TAKE YOUR HANDS OFF ME**  
**LOOK OUT THIEF LOOK OUT**

# This Queer Little Automatic Device Protects My Car From Thieves

## ELECTRICALLY!

I have hit on something truly amazing. Since the first discoveries of radio, I know there has been nothing so startling and uncanny. My little secret device guards every part of your automobile from spare tire to headlights and steering wheel. In your garage or on the street it is on the job 24 hours a day. Never sleeps, rests or gets tired. Already approved by insurance companies and motor associations. Now offered on 5-day test.

### Puzzles Everyone!

THIS little, automatic "electric-watchman" invention is called "Devil-Dog." It is not only a new kind of device, it is an *entirely new idea!* Absolutely unique and utterly different than anything anyone ever saw before. So startling that it grips the imagination of everyone from the millionaire Rolls-Royce owner to the fellow who drives a second-hand Ford. Until he knows the secret every motorist will swear that you have some one hiding in your car. He just simply can't believe there can be such a device as this queer "electrical-watchman."

### INSTALLED IN 10 MINUTES— COSTS NOTHING TO OPERATE

Every man who owns a car can afford Devil-Dog. Actually, no man who owns a car can afford to be without this inexpensive protection. Last year over 116,000 automobiles were stolen in this country. Millions of dollars' worth of spare parts were pilfered by sneak thieves. Now Devil-Dog can be installed by

anyone in ten minutes or less. There is absolutely no cost for operation. No extra batteries to buy. It will last as long as the car. And you hide the secret switch button anywhere you want to around your car. It's nothing but common sense for a man to grab Devil-Dog the very first time he sees it demonstrated. No wonder distributors already are cleaning up young fortunes!

### 5-DAY FREE TEST

I invite readers of this magazine to send for the special 5-day test offer now being made on Devil-Dog. Test it. Show your friends. If your present income is less than about \$50 a week, profit opportunities as my spare-time or full-time representative may surprise you. My one condition is, I want men to help me quick! Write me today!



**NORTHWEST ELECTRIC CORP.**  
 Dept. M-10, Pukwana, So. Dak.



### RECORD EARNINGS — \$138 IN A DAY!

Every Devil-Dog sale brings you a real profit. No penny-ante little business! That's another reason Devil-Dog is a *real big money maker!* G. Oliver, Illinois representative, reports, "Made \$138 in a day. This is the easiest way to make money quick I ever heard of. My next order will be for 1,000." That's the top record so far. Who will beat it first?

### POLICE BUY FOR ARMORED CAR

Richard Jacques, Canada, just started, writes, "Here's our order for 24 Devil-Dogs. I have sold one to the police for their armored car. Am also getting letters from the Chief of Police and the Detective Department. Tomorrow we demonstrate to the motor league."

Northwest Electric Corp., Dept. M-10, Pukwana, S. Dak.

Rush territory details and your 5-day test offer without obligation.

Name.....

Address.....

Town..... State.....



1930 1931 1932 1933 1934 1935 1936 1937 1938 1939



## Will You Be Clerk or Manager Ten Years from Now?

**S**URELY, this could never happen to *me*," you say—"that I should be sitting at the same desk—be doing the same work, *for ten straight years!*"

But wait a minute—

Exactly the same thing is happening to thousands upon thousands of men thruout the country. It has probably happened to men right in the company you now are working for. *And—unless you deliberately fit yourself for a better job—there is a very good chance that it will happen to you!*

Unthinkable? That's what R. M. Whitney, of Rochester, N. Y., said to himself. Yet lack of training kept him slaving away at low wages for more than twenty years . . .

### Trebled His Salary in Three Years

—For more than twenty years, till finally, at the age of 47, and still receiving only thirty dollars a week, R. M. Whitney resolved to be a bookkeeper no longer. He enrolled with LaSalle for training in Higher Accountancy, and completed the course. Almost immediately came the offer of a bigger job.

Less than three years later, the Davenport Machine Tool Company—the very company he had worked for as a clerk—invited him to come back. He returned as Auditor, at a salary-increase of better than 300 per cent.

Today, he is Treasurer of this great company; and in a letter to LaSalle, after commenting on the opportunities LaSalle affords to men in their forties or early fifties, he adds, "And for the young man, who is just getting a foothold in the business world, LaSalle Extension University training is the most profitable investment he could make."

### Says Good-bye to Clerkship— Now Heads Successful Firm

We have told you about a man who *waited*—at a cost to himself of probably not less than \$100,000. Now consider the experience of a younger man—G. Roy Eshelman, of Decatur, Illinois—

Eshelman was occupying a subordinate position in the purchasing department of a manufacturing concern—salary \$16 a week. Visualizing the opportunities for skilled accountants, he enrolled with LaSalle for training in Higher Accountancy.

"Thru this training," writes Mr. Eshelman, "I became interested in the Auditing Department and often remained after working hours watching the Auditor at his work. Observing my interest, he soon placed me in his department at a 50% increase in pay, and as I progressed with my LaSalle work, I was shortly rewarded with an additional 40% increase.

"My studies rapidly equipped me to strike out for myself, and at present I have an extensive practice as a Public Accountant, employing four accountants. It is sufficient to say that my present income is *many, many times greater than when I enrolled.*"

### Send For These Two Books and Start Toward Real Success

Need you hear more before you investigate the opportunities in Accountancy? Shall we tell you about Pentland—or Gray—or McDuffie—all of them commanding incomes better than \$10,000 a year and all of them still in their thirties?

Or will you face the problem of your future NOW—and send to LaSalle and get further facts and particulars?

Without cost or obligation, the coupon will bring you two books—one a 64-page book entitled, "Accountancy, the Profession that Pays;" the other, "Ten Years' Promotion in One."

How about those next ten years—will you wait, or will you START TODAY to realize the opportunities that lie ahead of you thru sound and practical home-study business training?

Measure your grit and ambition by what you do with this coupon—NOW.

— — — — Find Yourself Through LaSalle — — — —

## LaSalle Extension University

The World's Largest Business Training Institution

Dept. 964-HR Chicago

Opportunities in Accountancy—Check below and we will send you copy of "Accountancy, the Profession that Pays," also copy of "Ten Years' Promotion in One," all without obligation.

### Higher Accountancy:

Other LaSalle Opportunities: If more interested in one of the other fields of business indicated below, check here:

- |   |  |
|---|--|
| <input type="checkbox"/> Business Management                  | <input type="checkbox"/> Personnel Management      |
| <input type="checkbox"/> Modern Salesmanship                  | <input type="checkbox"/> Expert Bookkeeping        |
| <input type="checkbox"/> Traffic Management                   | <input type="checkbox"/> C. P. A. Coaching         |
| <input type="checkbox"/> Railway Station Mgmt.                | <input type="checkbox"/> Business English          |
| <input type="checkbox"/> Law: Degree of LL. B.                | <input type="checkbox"/> Commercial Spanish        |
| <input type="checkbox"/> Commercial Law                       | <input type="checkbox"/> Effective Speaking        |
| <input type="checkbox"/> Industrial Management                | <input type="checkbox"/> Telegraphy                |
| <input type="checkbox"/> Business Correspondence              | <input type="checkbox"/> Stenotypy—Stenography     |
| <input type="checkbox"/> Credit and Collection Correspondence | <input type="checkbox"/> Railway Accounting        |
| <input type="checkbox"/> Banking and Finance                  | <input type="checkbox"/> Paper Salesman's Training |
| <input type="checkbox"/> Modern Foremanship                   |  |



Name.....

Present Position.....

Address.....



# 1000 Hotel Positions! Open!



**H**OTELS, Restaurants, Clubs, Apartment Hotels, Institutions, Schools, Colleges, Hospitals, etc., everywhere need trained men. Over 70,000 high-class positions as Manager, Assistant Manager, Steward, Room Clerk, Purchasing Agent, Sports Director and scores of other executive positions, paying from \$2,500 to \$10,000 a year, are open each year in the hotels of the United States alone. Nearly two billion dollars' worth of new hotels, apartment hotels, clubs, restaurants and institutions being built this year will need over 200,000 trained men and women.

## I WILL TRAIN YOU IN YOUR SPARE TIME

Through my spare-time study course on hotel work you can qualify for a well-paid position. At any time there are over 1,000 positions open in this industry. I put my students in touch with positions. All over the United States they are eagerly sought by the biggest and best hotels. Hotels start you at salaries up to \$2,500 a year with your living usually included. If you want a steady, permanent position, with quick advancement, fascinating work, big pay, fine living, with meals and luxurious apartment usually furnished FREE—you can find it in hotel work.

## Opportunity Coupon 1000 Hotel Positions Open!

Lewis Hotel Training Schools,  
Room CP-310, Washington, D. C.

Send me without obligation the FREE BOOK, "Your Big Opportunity," with details about Registration in the Lewis National Employment Bureau.

Name.....

Address.....

City..... State.....

### NO PREVIOUS EXPERIENCE NECESSARY

We train you by mail in your spare time at home with the Lewis Simplified Home Study Plan and put you in touch with big opportunities. All of your training under the personal supervision of Clifford Lewis, former U. S. Government Hotel and Restaurant Expert, who has been appointed Managing Consultant by over 300 hotels throughout the United States.

Through Lewis Training, Leroy L. Saunders became Assistant Manager of an \$8,000,000 Athletic Club. Frank Schrath, through the Lewis Course, became Steward of a large Restaurant, at **double** his previous salary! C. W. Ryder was appointed Purchasing Agent of a chain of hotels a few weeks after he received his diploma from the Lewis Schools.

### FREE BOOK GIVES FULL DETAILS

No matter what your present occupation is—there are opportunities for you in the big-paying hotel and institutional field. Many students have obtained splendid hotel positions paying as high as \$2,500 a year, even before they had finished the course. My Free Book—"Your Big Opportunity"—shows how you can do as well and explains how you are registered in our National Employment Bureau.

Mail the coupon at once for your free copy of "Your Big Opportunity," explaining our Money Back agreement and showing how we can train you for one of these splendid positions. Send for it today—NOW—before you forget.

## LEWIS HOTEL TRAINING SCHOOLS

Room CP-310

CLIFFORD LEWIS, Pres.

Washington, D. C.

The Original and Only School of Its Kind in the World



# BE AN AUTO EXPERT

## EARN up to \$5000 A YEAR

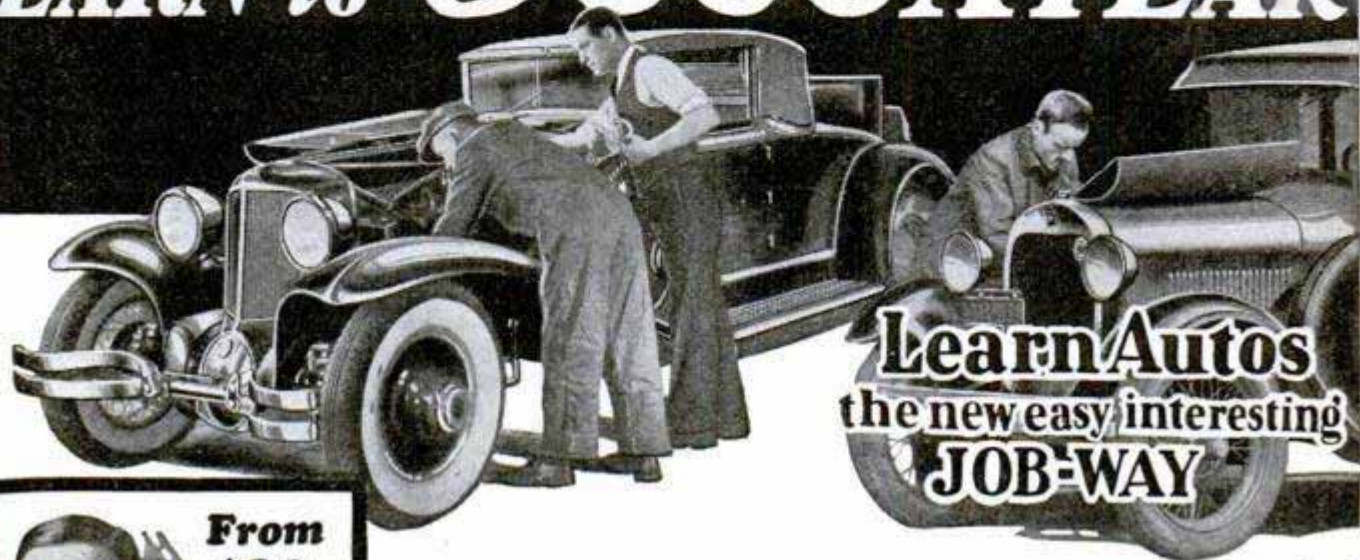

**Learn Autos**  
the new easy interesting  
**JOB-WAY**



**From \$30 a Week to \$90 a Week!**

W. S. Yancy, Perla, Arkansas, was making only \$30 a week when he wrote for my Book. Today he's earning \$90 a week! You can get the same book FREE! Just clip the coupon — and mail it today!

### Clip Coupon for Free Auto Book!

Say good-bye to low pay! Get into the Auto Business, where big pay — extra money — raises — come quick! A brilliant future awaits you in the World's Biggest Business.

### LEARN AT HOME In Spare Time

If you're earning a cent less than \$50 a week, clip that coupon now. Learn how \$50—\$75—even \$100 a week is now possible for you. See how I train you, right at home, in every branch of Auto Work, quickly and easily. Find out about this Training which boosted Yancy's salary from \$30 a week to \$90 a week!

### Experience, Education, Not Necessary!

All you need is common schooling—and it makes no difference if you never touched an auto before. Men from all walks of life who worked long, hard hours for low pay, are now becoming Garage Owners, Foremen and Superintendents. If you like autos, if you're between 15 and 66—get the facts now! "Job-

Way" Training covers everything about Autos — Mechanical and Electrical — everything you need to get in line for a Big Pay Job as an Auto Expert! It's the trained man who gets the good jobs and "Job-Way" is complete Training, yet so simple and so easy that you get it quick.

### 3 Testing and Repair Outfits also included FREE of extra cost — If You Act At Once!

Right now I am offering an Electrical Experimental Outfit, equipment for a Portable Electric Test Bench, and 381 Auto Wiring Diagram Charts to students. Send coupon now.

### Auto Book FREE!

Send for this big new book. Take the first step to a Big Pay Job!



### Read My Money-Back Agreement!

Learn about the 14 "Job-Way" Features shown in my big Free Auto Book. Also about my Money-Back Agreement. Be sure to get the book and see how easily you can get in line for a Job paying up to \$100 a week!

### MAIL THIS COUPON!

MOTOR INSTITUTE OF AMERICA, B. W. COOKE, Dir. Engineer  
Motor Institute Bldg., Dept. 3166, Evanston, Ill.

Send me your FREE Auto Book. Also proof that I can succeed in the Auto Business. Tell me about "Job-Way" Auto Training — about your Employment Department, and about your 3 Testing and Repair Outfits and Aviation Course Offer. No obligation on my part whatever.

Name.....  
Address.....  
Town..... State.....  
Age..... Occupation.....

### Get Full Particulars of AVIATION Course Offer

Find out how my Employment Department helps you get a Good Job — Raises in Pay — and Promotions. Get all the details of my offer of a complete, ground-school Aviation Course which I am making to men who enroll.

Address me **B. W. COOKE** Directing Personally **Engineer**

**MOTOR INSTITUTE OF AMERICA**

Motor Institute Bldg., Dept. 3166, Evanston, Ill.



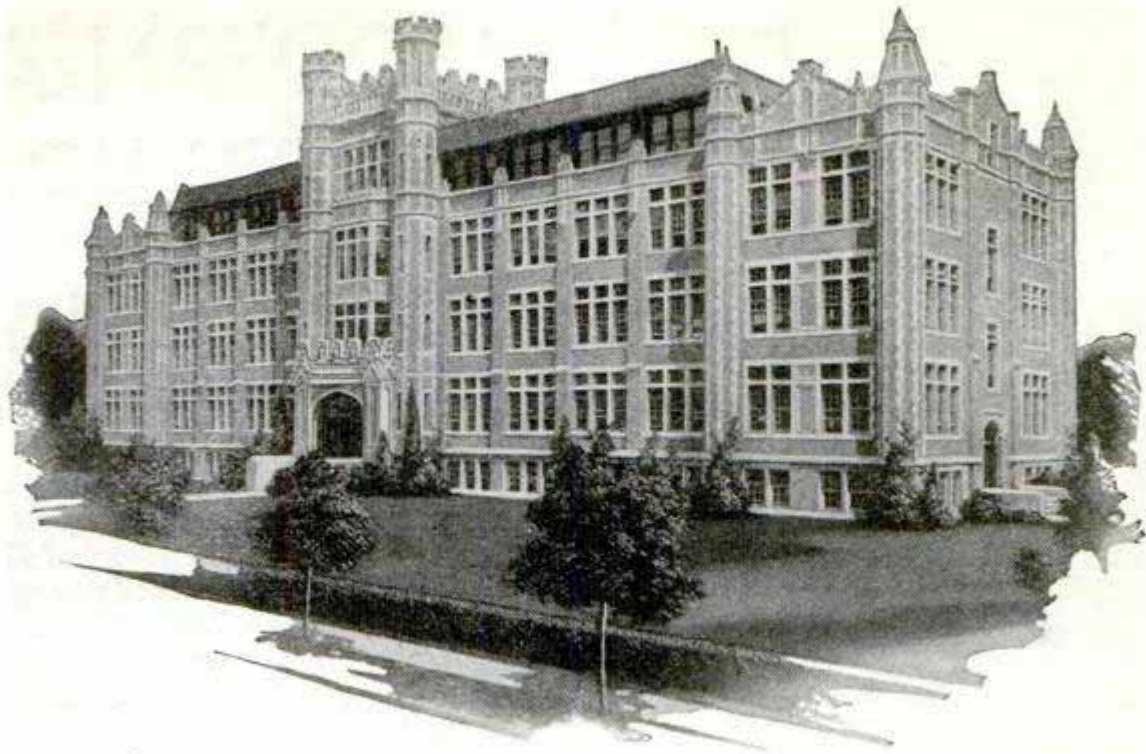

## Go to High School at Home

You can secure a high school education right at home by studying the splendid new courses recently prepared by the International Correspondence Schools.

These courses are equivalent to the courses given in resident high schools. They have been specially arranged for men and women who wish to meet college entrance examinations, to qualify for a business position, or to make up the education they missed when forced to leave school too soon.

The College Preparatory Course, the High School Commercial Course and the High School English Course include English, algebra, ancient, medieval, modern and U. S. History, physiology, literature, geography, Latin, book-keeping, drawing, geometry, shorthand, physics, chemistry, salesmanship, advertising, civics, trigonometry, economics, American business law, corporation finance, money and banking, business and trade economics, etc. A diploma is given at graduation.

The lessons are easy to understand and you will make rapid progress because you will be *in a class by yourself* and you will study under the guidance of instructors who are sincerely interested in helping you to get ahead and achieve the bigger things in life.

Just mark and mail the coupon and we will gladly send you interesting free booklets

describing the High School Courses of the International Correspondence Schools or any other subject in which you are interested.

### INTERNATIONAL CORRESPONDENCE SCHOOLS

"The Universal University"

Box 5698-F, Scranton, Penna.

Without cost or obligation, please send me a copy of your booklet, "Who Wins and Why," and full particulars about the subject before which I have marked X in the list below:

- College Preparatory Course
- High School Commercial Course
- High School English Course
- High School Vocational Course
- High School Agricultural Course

### BUSINESS TRAINING COURSES

- |  |   |
|--|---|
| <input type="checkbox"/> Industrial Management                   | <input type="checkbox"/> Advertising                                      |
| <input type="checkbox"/> Personnel Management                    | <input type="checkbox"/> Business Correspondence                          |
| <input type="checkbox"/> Traffic Management                      | <input type="checkbox"/> Show Card and Sign Lettering                     |
| <input type="checkbox"/> Accounting and C. P. A. Coaching        | <input type="checkbox"/> Stenography and Typing                           |
| <input type="checkbox"/> Cost Accounting                         | <input type="checkbox"/> English  |
| <input type="checkbox"/> Bookkeeping                             | <input type="checkbox"/> Civil Service                                    |
| <input type="checkbox"/> Secretarial Work                        | <input type="checkbox"/> Railway Mail Clerk                               |
| <input type="checkbox"/> Spanish <input type="checkbox"/> French | <input type="checkbox"/> Common School Subjects                           |
| <input type="checkbox"/> Salesmanship                            | <input type="checkbox"/> High School Subjects                             |
|  | <input type="checkbox"/> Illustrating <input type="checkbox"/> Cartooning |

### TECHNICAL AND INDUSTRIAL COURSES

- |   |  |
|---|--|
| <input type="checkbox"/> Electrical Engineering | <input type="checkbox"/> Architect                                       |
| <input type="checkbox"/> Electric Lighting      | <input type="checkbox"/> Architects' Blueprints                          |
| <input type="checkbox"/> Mechanical Engineer    | <input type="checkbox"/> Contractor and Builder                          |
| <input type="checkbox"/> Mechanical Draftsman   | <input type="checkbox"/> Architectural Draftsman                         |
| <input type="checkbox"/> Machine Shop Practice  | <input type="checkbox"/> Concrete Builder                                |
| <input type="checkbox"/> Railroad Positions     | <input type="checkbox"/> Structural Engineer                             |
| <input type="checkbox"/> Gas Engine Operating   | <input type="checkbox"/> Chemistry <input type="checkbox"/> Pharmacy     |
| <input type="checkbox"/> Civil Engineer         | <input type="checkbox"/> Automobile Work                                 |
| <input type="checkbox"/> Surveying and Mapping  | <input type="checkbox"/> Airplane Engines                                |
| <input type="checkbox"/> Metallurgy and Mining  | <input type="checkbox"/> Agriculture <input type="checkbox"/> Navigation |
| <input type="checkbox"/> Steam Engineering      | <input type="checkbox"/> Mathematics <input type="checkbox"/> Radio      |

Name.....

Street Address.....

City..... State.....

Occupation.....

Persons residing in Canada should send this coupon to the International Correspondence Schools Canadian, Limited, Montreal, Canada





# MODERN ART PAYS BIG MONEY

**T**he amazing demand for art work of all kinds is creating hundreds of big-pay opportunities every year. Trained artists are needed. This is the Age of Color . . . of Design . . . of Art in everything. Manufacturers, decorators, publishers . . . all are seeking men and women with art training.

Through the Federal School of Illustrating many who drudged at small pay have found fascinating careers . . . larger incomes. Many Federal students are now earning from \$2500 to \$6000 a year . . . others even more.

You can learn at home . . . in your spare time . . . the Federal way. Earn while you learn . . . most of our students do. The Federal Course is for practical artists who **MUST** make good. It aims at dollars and cents profit for every student.

More than fifty famous artists . . . masters of modern art . . . contribute exclusive lessons and drawings to the Federal Course. They tell you how they create new . . . striking . . . clever . . . art work. They give you their technical tricks in illustrating, cartooning, lettering, designing, etc.

## Test Your Talent Free

Send for our Free Vocational Test Chart. It's simple to fill out. Our artists judge it for you and give you a definite guide to your probable talent and earning power in art. We will also send you, without charge, "A Road To Bigger Things," giving names of the famous Federal instructors . . . showing where the big money in art is . . . what others are making. Get this Book and the Test Chart. Write now.

## THE FEDERAL SCHOOL of ILLUSTRATING

9130 FEDERAL SCHOOLS BUILDING

MINNEAPOLIS, MINNESOTA

Federal School of Illustrating

9130 Federal Schools Building, Minneapolis, Minnesota

Please send me free book, "A Road To Bigger Things," and Standard Art Test.

Name \_\_\_\_\_

Age \_\_\_\_\_ Occupation \_\_\_\_\_

Address \_\_\_\_\_





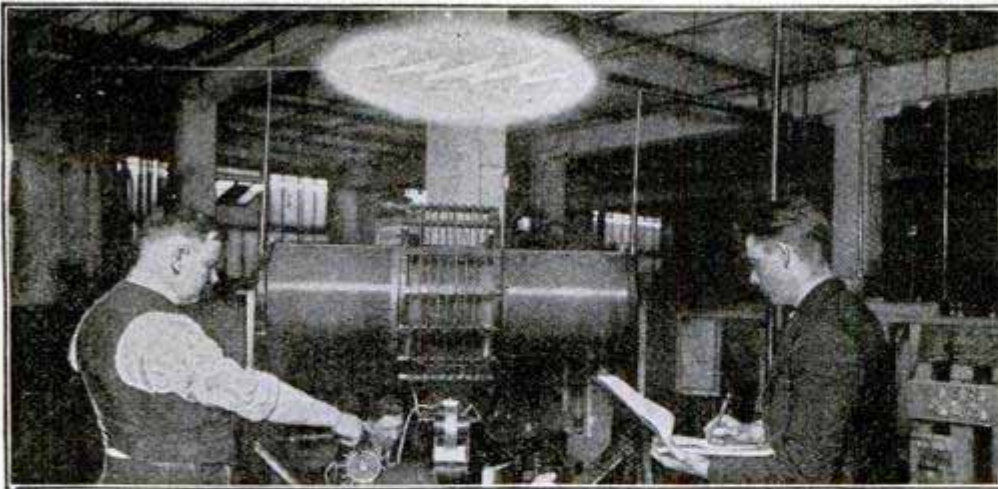

# 500,000 VOLTS

"Artificial lightning" being developed in Coyne School. Spark of 500,000 volts is shown jumping 30 inches. This gigantic Tesla Coil is the same as that used by Steinmetz, absolutely harmless, because of high frequency.

# Learn Electricity By Doing - Not Books in 12 Weeks!

By **ACTUAL WORK**—in the Great Shops of Coyne



ANYONE with common schooling who can see and understand the English language can learn electricity in 90 days. I teach you with as complete an outlay of electrical apparatus as was ever assembled in any institution—30-foot control board—transmitting stations—skeleton houses, huge motors—dynamos—sub-stations—automobiles—switchboards. In one department we generate enough electricity to supply a small city!

### No Books—No Classes

Enter anytime. Experts teach you on electrical machinery and *not books*. They guide you every step of the way with individual attention. You do the actual work on real full-size machinery in full operation. Take motors for instance. Instead of learning from books and charts—you actually build motors. You can't help but know all about them. Anyone can learn this fascinating way.

### No Experience Necessary

That's how my methods teach men electricity in 12 wonderful weeks. You don't need experience—Coyne training starts from the very beginning. You don't need advanced education—you learn by doing. Age is no handicap—Coyne students range from 16 to 45.

Not a Correspondence School

# COYNE Electrical SCHOOL

H. C. Lewis, President Dept. 60-72  
500 So. Paulina St., Chicago

### Triple Your Earning Power

I don't need to tell you about the opportunities in electricity. They are too many and too amazing to mention. Ordinary jobs run \$50—\$60 and up a week. And Coyne training leads to the biggest positions. Many Coyne men are making up to \$500 a month. Demand for Coyne men often exceeds the supply. Our employment bureau gives you lifetime service after graduation.

### Earn While You Learn

We help many students who haven't much money to secure part-time jobs to earn a good part or all of living expenses while training.

### All Details Sent Free

This school is 29 years old—Coyne training is tested—proven beyond all doubt—endorsed by electrical industry. You can find out everything absolutely free. Simply mail the coupon and let me send you the big, free Coyne book of 150 photographs—facts—jobs—salaries—opportunities. See what Coyne training can do for you in just 90 days! This does not obligate you. So act at once. Just mail the coupon.

### Get This FREE Book

**Fill In And Mail To Day**

Mr. H. C. Lewis, Pres. Dept. 60-72  
COYNE ELECTRICAL SCHOOL,  
500 S. Paulina St., Chicago, Ill.

Dear Mr. Lewis: Without obligation send me your big free catalog and all details of Free Employment Service, Radio, Aeroplanes and Automotive Electrical Courses, and how many "earn while learning." Also tell me about your offer of railroad fare to Chicago.

Name.....

Address.....

Town..... State.....



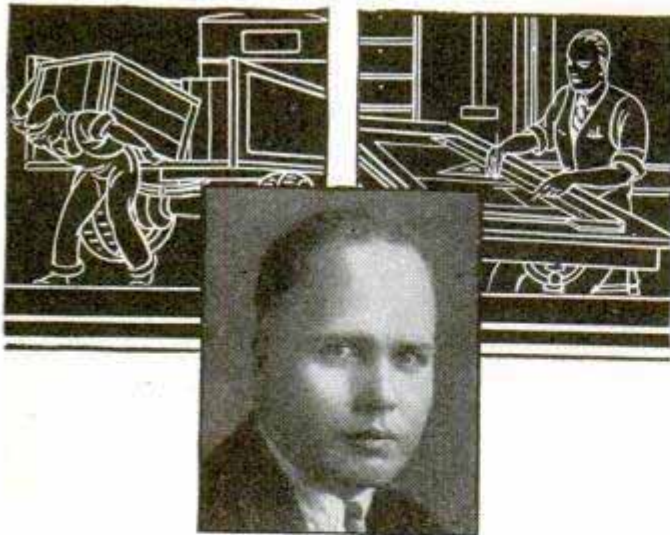

**"Pleasantly Surprised"**  
at starting salary

**\$150**

Writes James Gebhart, of 5134 Camden St., Oakland, Calif. "I report for work tomorrow morning in the Drafting room of Thebo, Start and Anderton, engineering firm in Frisco. I was pleasantly surprised at the starting salary, which is \$150 per month."

Compare that with \$110 a month Gebhart earned when he came to us and it's easy to see that a year's training which cost him \$72 has already increased his earning capacity \$480 a year.

Gebhart used to be a truck driver. Not much future to that. Now, as architectural draftsman—he has a wonderful future ahead of him. And Gebhart is just one of THOUSANDS of men that have found American School courses a good investment. Why don't you find out what we can do for you?

**— American School —**  
Dept. G-647A, Drexel Ave. and 58th St., Chicago, Ill.



**AMERICAN SCHOOL**  
Chartered in 1897 as an Educational institution, NOT FOR PROFIT. Over 200 noted engineers, business executives and educators have helped us prepare our instruction service.

Without cost or obligation please tell me how I can win a better position and increased pay in line marked X below. Also explain your employment plan.

**BUILDING CONSTRUCTION**

- Architecture
- Building Contracting

**DRAFTING and DESIGN**

- Machine Drafting and Design
- Architectural Drafting
- Electrical Drafting
- Structural Drafting
- Automotive Drafting

**MECHANICAL DRAWING for beginners**

**ENGINEERING**

- Mechanical Engineering
- Civil Engineering
- Electrical Engineering
- Automotive Engineering
- Machine Shop Practice

**BUSINESS**

- Accounting, Auditing
- Business Management (Finance, Sales, Production, Accounting)
- HIGH SCHOOL IN 2 YEARS

Name.....  
Occupation.....  
St. No..... City..... State.....

**ENGINEERING IN 2 YEARS**



B. S. degree in Aeronautical, Civil, Electrical, Mechanical, Chemical and Administrative Engineering. Intensive courses, half usual time. Students who left high-school can make up work. Living costs and tuition low. Enter classes Sept., Jan., March or June.

Ask for catalog.

490 College Street, ANGOLA, INDIANA

**TRI-STATE COLLEGE**

**OPPORTUNITIES IN TRAFFIC MANAGEMENT**

Conditions point to an unusual demand for trained traffic men, by transportation companies and industrial organizations. Men with scientific traffic training effect big savings for their firms—command big salaries.

**Three Detroit Firms Pay Their Traffic Managers Over \$20,000 a Year**

Prepare at home in your spare time, under supervision of traffic experts. Low cost; easy terms. "I would not take \$50,000 for my knowledge of traffic management," writes H. E. Stiffler, Traffic Manager, Marion Steam Shovel Co., Marion, Ohio. Send now for 64-page book—**FREE!** LaSalle Extension University, Dept. 964-T Chicago



**YOUR FUTURE ASSURED**



Now is the time to safeguard yourself against such periods of depression as we have been having. Many good, profitable trades are not subject to hard times or slack seasons—trades meeting everyday human needs, such as Mechanical Dentistry. Your age, circumstances, or lack of experience need not stop you. The way is open to you. A helpful booklet, "Choosing a Trade," will be sent you without cost. Your copy is waiting. Simply ask for Bulletin 2.

**BODEE INSTITUTE, 1755 Broadway, N. Y.**

1305 N. Broad St., Philadelphia

85 Court St., Brooklyn

**IF YOU STAMMER**

Write for my free book "Millard's Advanced Natural Corrective Course" and a free copy of my speech magazine. 10,000 cases successfully treated. Est. 24 years. Largest school for stammerers in world. Millard Inst. of Normal Speech, 2317 Millard Bldg., Milwaukee, Wis.

**GOV'T. POSITIONS**

\$35 TO \$75 WEEKLY

MEN - WOMEN

AGE 18 to 55

- |  |  |
|--|--|
| <input type="checkbox"/> Ry. Mail Clerk      | <input type="checkbox"/> Steno-Typist        |
| <input type="checkbox"/> Prohibition Agent   | <input type="checkbox"/> Immigrant Inspector |
| <input type="checkbox"/> R. F. D. Carrier    | <input type="checkbox"/> Seamstress          |
| <input type="checkbox"/> Special Agent       | <input type="checkbox"/> Auditor             |
| <input type="checkbox"/> (Customs Inspector) | <input type="checkbox"/> Steno-Secretary     |
| <input type="checkbox"/> City Mail Carrier   | <input type="checkbox"/> U. S. Border Patrol |
| <input type="checkbox"/> Meat Inspector      | <input type="checkbox"/> Chauffeur-Carrier   |
| <input type="checkbox"/> P. O. Clerk         | <input type="checkbox"/> Watchman            |
| <input type="checkbox"/> File Clerk          | <input type="checkbox"/> Skilled Laborer     |
| <input type="checkbox"/> General Clerk       | <input type="checkbox"/> Postmaster          |
| <input type="checkbox"/> Matron              | <input type="checkbox"/> Typist              |

GOVERNMENT INSTRUCTION BUREAU, 111 Arcade Bldg., St. Louis, Mo. Send me FREE particulars How To Qualify for positions marked "X". Salaries, locations, opportunities, etc. ALL SENT FREE.

NAME.....  
ADDRESS.....





# but when I started to play the laugh was on them!

"WELL, folks, I guess we'll have to lock up the piano and make faces at ourselves."

Helen Parker's party was starting out more like a funeral than a good time.

"Isn't Betty Knowles coming?" an anxious voice sang out.

"Unfortunately, Betty is quite ill tonight and Chet Nichols is late as usual," replied Helen gloomily.

"I know some brand new card tricks," volunteered Harry Walsh.

"Great!" said Helen. "I'll go and find some cards."

While she was gone I quietly stepped up to the piano bench, sat down, and started to fumble with the pedals underneath. Someone spotted me. Then the wise-cracks began.

## They Poke Fun at Me

"Ha! Ha! Ted thinks that's a player-piano," chuckled one of the boys.

"This is going to be a real musical comedy," added one of the fair sex.

I was glad I gave them that impression. So I kept fiddling around the pedals—making believe that I was hunting for the foot pumps.

"Come over to my house some night," said Harry. "I've got an electric player and you can play it to your heart's content. And I just bought a couple of new rolls. One is a medley of Victor Herbert's compositions—the other . . ."

Before he had a chance to finish I swung into the strains of the sentimental "Gypsy Love Song." The joking suddenly ceased. It was evident that I had taken them by surprise. What

a treat it was to have people listening to me perform. I continued with "Kiss Me Again" and other popular selections of Victor Herbert. Soon I had the crowd singing and dancing and finally they started to bombard me with questions . . . "How? . . . When? Where . . . did you ever learn to play?" came from all sides.

## I Taught Myself

Naturally, they didn't believe me when I told them I had learned to play at home and without a teacher. But I laughed myself when I first read about the U. S. School of Music and their unique method for learning music.

"Weren't you taking a big risk, Ted?" asked Helen.

"None at all," I replied. "For the very first thing I did was to send for a Free Demonstration Lesson. When it came and I saw how easy it was to learn without a teacher I sent for the complete course. What pleased me so was the fact that I was playing simple tunes by note from the very start. For I found it easy as ABC to follow the clear print and picture instructions that came with each lesson. Now I play several classics by note and most all of the popular music. Believe me there's a real thrill in being able to play a musical instrument."

### Which Instrument Do You Want to Play?

- |                                     |           |
|-------------------------------------|-----------|
| Piano                               | Saxophone |
| Violin                              | Trombone  |
| Organ                               | Harp      |
| Clarinet                            | Piccolo   |
| Ukulele                             | Mandolin  |
| Flute                               | Guitar    |
| Cornet                              | Cello     |
| Hawaiian Steel Guitar               |           |
| Sight Singing                       |           |
| Voice and Speech Culture            |           |
| Harmony and Composition             |           |
| Drums and Traps                     |           |
| Automatic Finger Control            |           |
| Banjo (Plectrum, 5-String or Tenor) |           |
| Piano Accordion                     |           |
| Italian and German Accordion        |           |

\*\*\*  
This story is typical. The amazing success of the men, women and children who take the U. S. School of Music course is largely due to a newly perfected method that makes reading and playing music — *actually simple!*

Even if you don't know one note from another now, you can easily grasp each clear, inspiring lesson of this surprising course. You can't go wrong. First you are *told* how a thing is done, then a picture *shows* you how, then you do it yourself and *hear* it.

## Free Book and Demonstration Lesson

Our wonderful illustrated Free Book and our Free Demonstration Lesson explain all about this remarkable method. They prove just how anyone can learn to play his favorite instrument by *note* in almost no time and for just a fraction of what old slow methods cost. The booklet will also tell you all about the amazing new *Automatic Finger Control*.

Forget the old-fashioned idea that "talent" means everything. Read the list of instruments to the left, decide which you want to play and the U. S. School of Music will do the rest. *At the average cost of only a few pennies a day!* Act NOW! Clip and mail this coupon today, and the fascinating Free Book and Free Demonstration Lesson will be sent to you at once. No obligation. Instruments supplied when needed, cash or credit. U. S. School of Music, 79 Brunswick Bldg., New York City.

## U. S. School of Music, 79 Brunswick Bldg., New York City

Please send me your free book "Music Lessons in Your Own Home," with introduction by Dr. Frank Crane, Free Demonstration Lesson and particulars of your easy payment plan. I am interested in the following course:

Have You  
.....Instr?.....  
Name.....  
(Please Write Plainly)  
Address.....  
City.....State.....



# FREE PROOF

*you can make real money*

in **RADIO**

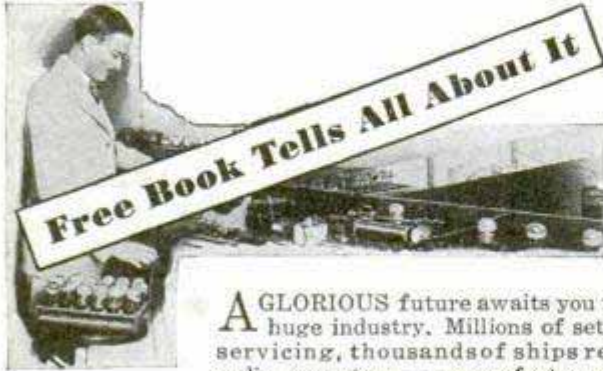

are eagerly seeking trained men . . . and now, nation-wide radio telegraph service, telephony, sound motion pictures, open up thousands of new and amazing opportunities.

### LEARN AT HOME

By means of this marvelous, simplified home-training course, sponsored by the Radio Corporation of America . . . you can now prepare for success in every phase of Radio. The remarkable outlay of apparatus given to you with this course enables you to learn by actual practice how to solve every problem in radio work. That's why you, too, upon graduation can have the confidence and ability to command good money.

### BACKED BY RCA

Graduates of this school are always posted in newest developments in Radio. That's why they are always in big demand. The progress of Radio is measured by the accomplishments of the Radio Corporation of America. This gigantic organization sponsors every lesson in the course.

### MONEY BACK IF NOT SATISFIED

As a student you will receive an agreement signed by the president of this school assuring you of complete satisfaction upon completion of your training—or your money instantly refunded.

### FREE!

This fascinating book on Radio's glorious opportunities . . . written by one of America's well-known radio experts.

## RCA INSTITUTES, Inc.

A Division of Radio Corporation of America



RCA INSTITUTES, Inc.  
Dept. PM-9, 75 Varick Street, New York

Gentlemen: Please send me your FREE 40-page book which illustrates the opportunities in Radio and describes your home laboratory method of instruction.

Name.....  
Address.....  
Occupation.....

Radio Operator \$90—\$200 per month with all expenses paid. Broadcast Operator \$1,800—\$4,800 a year. Radio Repair Mechanic \$1,800—\$4,000 a year. Radio Inspector \$2,000—\$4,500 a year.

# My \$5<sup>00</sup> Dancing Course

## ONLY \$1<sup>98</sup> Sent on 5 Days FREE TRIAL

EVERYONE wants to dance with the person who knows the smart new steps! No matter how poorly you dance now I'll make you a finished, versatile dancer—sought-after, popular, sure of a good time wherever you go! Think what that means! You can learn the fundamental steps—in just a few hours, right in your own room, without music or partner. Then, the very next time dancing starts you can surprise your friends by stepping right on the floor with the best dancers in your set—with as much ease and assurance as if you had been dancing for years! This instruction would cost you \$24.00 if taken at a Studio.



### Be Popular—Write TODAY

To prove it, I'll send you my complete \$5.00 course—through which over 400,000 people have already learned to dance—for five days' FREE trial. When it arrives give the post-man only \$1.98 (plus few cents delivery charges). Then practice the steps for five days. Remember—money back if not delighted. Don't delay—write for course NOW and be a good dancer soon!

**ARTHUR MURRAY** Studio 150, 7 East 43rd Street  
NEW YORK, N. Y.

## Electrical Engineering

Training for men of ambition and limited time. Concise, comprehensive course in Theoretical and Practical Electrical Engineering including the closely related subjects of Mathematics and Mechanical Drawing. Students construct motors, install wiring,

test electrical machinery. Course designed to be completed in one college year by eliminating non-essentials. **THIRTY-SEVEN YEARS'** successful experience assures you maximum training in minimum time.



Send for free catalog

## Bliss Electrical School

119 TAKOMA AVE., WASHINGTON, D. C.

## LEARN WATCH REPAIRING



You can learn by our modern and original system of instruction every part of the **Watch Repairing Trade** at home as good or better than at a shop. You can earn money while learning and secure a well paying position or start in business after completing our course of instruction. Good watch repairers are always in demand and earn from \$50 to \$75 per week. For particulars apply to the **Wisconsin School of Watch Repairing** 166 Mason St., MILWAUKEE, WIS.

## SONG WRITERS!



**SUBSTANTIAL ADVANCE ROYALTIES** are paid on work found acceptable for publication. Anyone wishing to write *either the words or music* for songs may submit work for free examination and advice. Past experience unnecessary. New demand created by "Talking Pictures" fully described in our free book. Write for it Today. **NEWCOMER ASSOCIATES**

759 Earle Building, New York, N. Y.



Wonderful, new device, guides your hand; corrects your writing in a few days. Big improvement in three hours. No failures. **Complete outline FREE.** Write C. J. Ozment, Dept. 34, St. Louis, Mo.

You can be quickly cured, if you

## STAMMER

Send 10 cents for 288-page book on Stammering and Stuttering. "Its Cause and Cure." It tells how I cured myself after stammering 20 yrs. B. N. Bogue, 11133 Bogue Bldg., 1147 N. Illinois St., Indianapolis.



# Where Do You Want NEXT WEEK'S MUSCLE?

**O**N YOUR biceps . . . across your chest? Do you want it added to your grip? In all seriousness . . . no kidding . . . all you've got to do is say the word, and Earle Liederman will shoot the works. Muscle after muscle that you never knew you had starts swelling and bulging and tightening up. Week after week for a couple of months, first thing you know, you're a steam engine in pants . . . all fired up and rarin' to go. Walls of muscle across your shoulders and back, a steel-banded waist, mighty arms, crushing grip, and filled to the brim with dynamite. Step out, man . . . you're strong! You've got the world by the tail . . . now twist.

No need to tell you how to do that. Any man knows what to do to enjoy himself. The big puzzle sometimes is how to begin. Here's the answer . . . get strong. Where do you want next week's muscle?

## Let Earle Liederman Decide

Earle Liederman's scientific shortcut to muscular development is the result of over twenty years experience in muscle building. That's why his army of over 100,000 finished athletes call him "THE MUSCLE BUILDER." If anyone can help you decide where you should have next week's muscle, he is the man. Don't think it's the easiest thing in the world! The science of muscular development is a science in every sense of the word. It requires years of study, college training, hard practical experience with every type of case, and a wide knowledge of conditions all over the world. The man you choose to guide you should first practice what he preaches (take a look at the photograph above) and he *must guarantee* what he preaches. The best proof in the world of that guarantee is Earle Liederman's 100,000 strong men now busily engaged in getting the most out of life. Isn't it time you began?

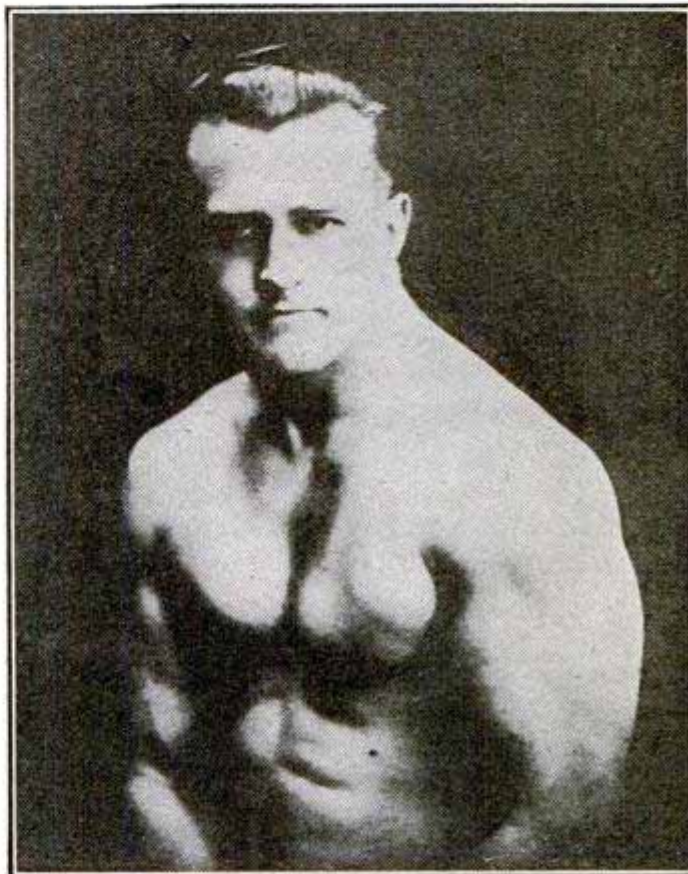

**EARLE LIEDERMAN—The Muscle Builder**  
Author of "Muscle Building," "Science of Wrestling," "Secrets of Strength," "Here's Health," "Endurance," Etc.

Send for My New  
64-Page Book

# "Muscular Development"

IT IS FREE

Take it and read it. It's the peppiest piece of literature you ever flashed your eyes on. And 48 full-page photos of himself and some of his numerous prize-winning pupils. This is the finest collection of strong men ever assembled into one book—look them over—doctors, lawyers, merchants, mechanics, and every line of trade you can think of. If you don't get a kick out of this book, you had better roll over—you're dead. Come on then. Take out the old pen or pencil and write your name and address on the coupon. If you haven't a stamp, a postal will do. But snap into it. Do it now. Tomorrow you may forget. Remember, it's something for nothing and no string attached—no obligation. GRAB IT!

**EARLE LIEDERMAN**

Dept. 2009, 305 Broadway, New York City

**It  
Is  
F  
R  
E  
E**

**DON'T  
SEND ONE  
PENNY**

**YOUR  
NAME AND  
ADDRESS  
ON A  
POSTAL  
WILL DO**

**EARLE LIEDERMAN**

Dept. 2009, 305 Broadway, New York City  
Dear Sir:—Please send me absolutely free and without any obligation on my part whatsoever, a copy of your latest book, "Muscular Development." (Please write or print plainly.)

Name.....Age.....

Street.....

City.....State.....  
(Please write or print plainly)



# Easy home method quickly teaches HAWAIIAN GUITAR



Play all the latest hits just as the Hawaiians do! Have good times aplenty!

Win fame—friends—fortune! Play the Hawaiian Guitar!

### Native Hawaiian expert directs you

You get expert instruction directed by a world-famous player and teacher, Prof. Walter Kolomoku. He quickly reveals to you the secrets of this fascinating instrument.

**Only 4 Motions** to learn. Then you can play any music—popular songs, classical, old-time melodies, native Hawaiian airs—or real jazz. You'll never be lonesome after you learn the Hawaiian Guitar.

**Complete Course** 52 lessons. Nothing omitted. Pictures explain every move. You are sure to learn—what we can do for others we can do for you. Over 50,000 successful students.

**Pay as you play** We make it easy for you. Start with small first payment—then pay while learning. Costs only few cents per lesson. You only pay the cost of instruction—we furnish everything.

### Learn at home in spare time

Study in spare time at home. Even if you don't know a note our method is so simple, plain and easy, you begin a piece your first lesson. In half an hour you can play it!

## Sweet Toned HAWAIIAN GUITAR GIVEN when you enroll

—with genuine seal grain Fabrikoid Cover and complete playing outfit. Reliable retailers ask \$18 to \$20 for a similar instrument and outfit without the fine Fabrikoid Case, which alone is valued at \$3.50.

### TENOR BANJO and other courses

The same thorough instruction on the Tenor Banjo, Violin, Tiple, Tenor Guitar, Ukulele, Banjo Ukulele—well known instructors. Write for full information.

**FIRST HAWAIIAN CONSERVATORY OF MUSIC, Inc.**  
9th Floor, Woolworth Bldg., Dept. 748, New York

Approved as a Correspondence School Under the Laws of the State of New York  
Member National Home Study Council

### Send This Coupon for Liberal Offer!

**FIRST HAWAIIAN CONSERVATORY OF MUSIC, Inc.**  
9th Floor, Woolworth Bldg., Dept. 748, New York, N.Y.  
Please mail full information about your 52-lesson Hawaiian Guitar Course. I am not obliged to enroll unless I want to.

Name \_\_\_\_\_  
Address \_\_\_\_\_  
City \_\_\_\_\_ State \_\_\_\_\_

# Learn SIGN and SHOW-CARD WRITING

In spare time few hours weekly

Fascinating profession. Big opportunity in this fast-growing trade. Earn while you learn the sign arts. No talent or experience required. Be your own boss or obtain a good position. Learn show cards, posters, bulletins, signs, advertising layouts and allied subjects. We teach by mail or at our school. Quick results—easy to learn.

### EARN \$50 TO \$200 WEEKLY

Otto C. Wiegand, Md., home-study graduate, made \$12,000 from his business in one year. Many successful graduates. Oldest and foremost school. Don't delay. Write for complete information.

### DETROIT SCHOOL OF LETTERING

193 Stimson Ave. Est. 1899 DETROIT, MICH.

**FREE**  
"Book of Facts"  
—  
Write For It

# Learn Photography at HOME

Make money taking pictures. Prepare quickly during spare time. Also earn while you learn. No experience necessary. Now easy method. Nothing else like it. Send at once for free book, OPPORTUNITIES IN MODERN PHOTOGRAPHY and full particulars.

**AMERICAN SCHOOL OF PHOTOGRAPHY**  
Dept. 1356 3601 Michigan Ave. Chicago, U. S. A.

## Learn Watchwork, Jewelrywork and Engraving

A fine trade commanding a good salary, and your services always in demand. Address **Horological**, Dept. P, Bradley Institute, PEORIA, ILLINOIS, for our latest catalog.



### 20 Years of Shirt Sleeve Practice in

# ELECTRICITY

Make no mistake about it—there are big jobs in electricity ready for you when you're ready for them. Thousands of men who have the Croft Library know that to be a fact. The Library itself, on a FREE TRIAL BASIS, can prove it to your absolute satisfaction.

## The New Croft Library of Practical Electricity

The Croft Library is a complete electrical educator. It is founded on practice—on 20 years of shirt-sleeve experience—on work as it is actually done. It is jammed from cover to cover with the kind of hard-headed facts you want. Written so that the beginner can easily understand it, yet so sound, so thorough, that it is the daily guide of 59,000 highly paid electrical workers and engineers. Croft tells you the things you need to know about motors, generators, armatures, commutators, transformers, circuits, switchboards, distribution systems—electrical machinery of every type—wiring for light and power—wiring of finished buildings—underwriters and municipal requirements—illumination in its every phase—the latest and most improved methods of lighting—lamps and lamp effects, etc.—how to do a complete job, from estimating it, to completion.

### No money down — easy payments

Fill in and mail the coupon attached and we will send you the entire set of seven volumes for ten days' Free Examination. We take all the risk—pay all the charges. You assume no obligation—you pay nothing unless you decide to keep the books. Then \$1.50 in ten days and the balance at the rate of \$2.00 a month. Send the coupon NOW and see the books for yourself.

### FREE EXAMINATION COUPON

**McGRAW-HILL BOOK CO., 370 Seventh Ave., New York**

Send me for 10 days' free examination the Croft Library of Practical Electricity. If satisfactory I will send you \$1.50 in 10 days and \$2.00 monthly until the special price of \$19.50 is paid. If not wanted, I will return the books post-paid. (To insure prompt shipment write plainly and fill in all lines)

Name \_\_\_\_\_  
Home Address \_\_\_\_\_  
City and State \_\_\_\_\_  
Position \_\_\_\_\_  
Name of Company \_\_\_\_\_ P.M. 9-30



# LOW PAY.. LONG HOURS.. ROUTINE.. NO FUTURE



Always worrying over money. Always skimping and economizing—going without the comforts and luxuries that every man **DESERVES** for his family and himself.



The Time Clock—a badge of hawk-like supervision and The Rut. A constant reminder that one is "just another name on the payroll."



Human cogs in a great machine. No chance to meet people, travel, or have interesting experiences. A long, slow, tiresome road that leads nowhere.



Always wondering what would happen in case of a "lay-off" or loss of job. No chance to express ability—no chance to get ahead. **COULD** there be a way out?

## I Said "Good-bye" to It All After Reading This Amazing Book—Raised My Pay 700%!



### Where Shall We Send Your Copy—Free?

**W**HEN a man who has been struggling along at a low-pay job suddenly steps out and commences to earn real money—\$5,000, \$7,500 or \$10,000 a year—he usually gives his friends quite a shock. It's hard for them to believe he is the same man they used to know—but such things happen much more frequently than most people realize. Not only one, but **HUNDREDS** have altered the whole course of their lives after reading the amazing book illustrated at the right.

True, it is only a book—just seven ounces of paper and printers' ink—but it contains the most vivid and inspiring message that any ambitious man can read! It reveals facts and secrets that will open almost any man's eyes to things he has never even dreamed of!

the rewards that this little volume placed within his reach. His salary runs well into the 5-figure class—actually exceeding \$10,000 a year!

Another man, Wm. Shore of Lake Hughes, California, was a cowboy when he sent for "The Key to Master Salesmanship." Now he is a star salesman making as high as \$525 in a single week. L. H. Lundstedt, Chicago, read this free book—and raised himself from a stenographer to the head of a business with 600% increase in earnings. C. V. Champion of Danville, Illinois, raised his salary to over \$10,000 a year and became President of his company in the bargain!

#### A Few Weeks—Then Bigger Pay

There was nothing "different" about any of these men when they started. None of them had any special advantages—although all of them realized that **SALESMANSHIP** offers bigger rewards than any other profession under the sun. But, like many other men, they subscribed to the foolish belief that successful salesmen are born with some sort of "magic gift." "The Key to Master Salesmanship" showed them that nothing could be farther from the truth! Salesmanship is just like any other profession. It has certain fundamental rules and laws—laws that you can master as easily as you learned the alphabet.

City and travelling sales positions are open in every line all over the country. For years, thousands of leading firms have called on

the N. S. T. A. to supply them with salesmen. Employment service is free to both employers and members, and thousands have secured positions this way.

#### Free to Every Man

See for yourself **WHY** "The Key to Master Salesmanship" has been the deciding factor in the careers of so many men who are now making \$10,000 a year. Learn for yourself the **REAL TRUTH** about the art of selling! You do not risk one penny or incur the slightest obligation. And since it may mean the turning point of your whole career, it certainly is worth your time to fill out and clip the blank below. Send it now!

**National Salesmen's Training Association**  
Dept. M-103, N.S.T.A. Bldg., CHICAGO, ILL.

National Salesmen's Training Assn. Dept. M-103, N.S.T.A. Bldg., Chicago, Ill.	
Without cost or obligation, you may send me your free book, "The Key to Master Salesmanship."	
Name.....	.....
Address.....	.....
City.....	State.....
Age.....	Occupation.....

#### Remarkable Salary Increases

For example, R. B. Hansen, of Akron, Ohio, is just one case. Not long ago he was a foreman in the rubber-curing room of a big factory at a salary of \$160 a month. One day this remarkable volume, "The Key to Master Salesmanship," fell into his hands. And from that day on, Mr. Hansen clearly saw the way to say "good-bye" forever to low pay, long hours, and tiresome routine! Today he has reaped





# High School Course in Two Years!

## You Want to Earn Big Money!

And you will not be satisfied unless you earn steady promotion. But are you prepared for the job ahead of you? Do you measure up to the standard that insures success? For a more responsible position a fairly good education is necessary. To write a sensible business letter, to prepare estimates, to figure cost and to compute interest, you must have a certain amount of preparation. All this you must be able to do before you will earn promotion. Many business houses hire no men whose general knowledge is not equal to a high school course. Why? Because big business refuses to burden itself with men who are barred from promotion by the lack of elementary education.

### Can You Qualify for a Better Position

We have a plan whereby you can. We can give you a complete but simplified high school course in two years, giving you all the essentials that form the foundation of practical business. It will prepare you to hold your own where competition is keen and exacting. Do not doubt your ability, but make up your mind to it and you will soon have the requirements that will bring you success and big money. **YOU CAN DO IT.**

Let us show you how to get on the road to success. It will not cost you a single working hour. Write today. It costs you nothing but a stamp.

## American School

Dept. H-917 Drexel Ave. and 58th St., Chicago

### American School

Dept. H-917 Drexel Ave. and 58th St., Chicago

Send me full information on the subject checked and how you will help me win success.

- |                              |                            |
|------------------------------|----------------------------|
| .... Architect               | .... Business Law          |
| .... Building Contractor     | .... Lawyer                |
| .... Automobile Engineer     | .... Machine Shop Practice |
| .... Automobile Repairman    | .... Mechanical Engineer   |
| .... Civil Engineer          | .... Shop Superintendent   |
| .... Structural Engineer     | .... Employment Manager    |
| .... Business Manager        | .... Steam Engineer        |
| .... Cert. Public Accountant | .... Foremanship           |
| .... Accountant and Auditor  | .... Sanitary Engineer     |
| .... Bookkeeper              | .... Surveyor (& Mapping)  |
| .... Draftsman and Designer  | .... Telephone Engineer    |
| .... Electrical Engineer     | .... Telegraph Engineer    |
| .... Electric Light & Power  | .... High School Graduate  |
| .... General Education       | .... Wireless Radio        |
| .... Vocational Guidance     | .... Undecided             |

Name.....

Address.....

# Increase Your Earning Power

Apply time and labor-saving kinks to your work. Your efficiency will soon be recognized and you will be in line for advancement.

If you do machine shop work of any kind, sheet-metal work, painting, carpentry, auto repairing, farming, concrete work, plumbing, electrical work, welding, building, glass work, general repairing, tool-making, poultry raising, masonry or home repair work, get this

## LIBRARY OF 6000 TIME AND LABOR SAVING IDEAS FOR SHOPMEN AND HANDYMEN

### JUST PUBLISHED

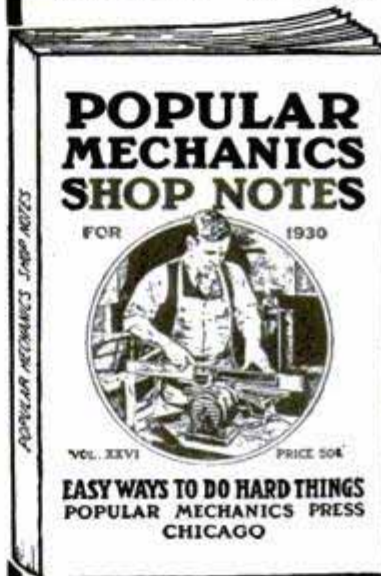

## SHOP NOTES for 1930

192 Pages  
415 Articles  
377 Illustrations  
See partial list of contents below

Including the new 1930 issue illustrated above, there are now 13 volumes in the Shop Notes Library of 6,000 easily understood short cuts to every-day jobs. Here are just a few of the subjects taken from the 415 articles in the latest issue.

- |  |                                     |   |
|--|-------------------------------------|---|
| Animal Traps, Care of  | Concrete Fountain Water, Cooler for | Sanding on the Lathe                                    |
| Barrel Method of Slings  | Furniture, Refinishing Old          | Saw Mount for Home Shop                                 |
| Bench Light, Convenient  | Furniture, Restoring Damaged        | Saws, Keeping Fit                                       |
| Bench Saw, Getting Most Out of                                   | Haakaw, Power, for Small Shops      | Scrollsaw, Ball-Bearing                                 |
| Bontswain's Chair Rigging  | Hoist, Light and Strong             | Speedboats, Automatic                                   |
| Bookcase, Modern   | Household Shortcuts                 | Switch for Stainless Steel, Soldering                   |
| Brass Fixtures, Cleaning   | Ice Cutter, Engine-Driven           | "Sugi" Finish, How to Apply                             |
| Builders' and Contractors' Kinks                                 | Onboard Motor, Super-charger for    | Summer House, Japanese                                  |
| Cams Jig for Layout of Conveyor, Portable                        | Package Sealer, Home-made           | Templates, Making Accurate                              |
| Speeds Lending   | Pipe Holder, Hammered-Copper        | Tinners, Paint Scraper for                              |
| Dadoing on Small Power Saws                                      | Power Saw Made from Buffing Head    | Toolrest, Sliding, for Emery Wheel                      |
| Decorating with Pastry Gun                                       | Power Shears Made in Small Shop     | Tools for Home Mechanics                                |
| Disk Sander Making Ellipse, How to Lay Out "Exerciser", Electric | Sand Disk for Small Lathe           | Towed Car Steered by Tow Bar                            |
| Farmers, Labor-Saving Kinks for "Flagstones", Making             |                                     | Wood, Plastic Filler for Workshop, Homemade Combination |

Each volume contains approximately 500 articles and 400 illustrations and has 224 Pages. At the regular price of 50 cents per single volume this library costs \$6.50, but for a limited period we will supply the 13 vols. when ordered at one time at the special reduced price of only \$4.00.

### SPECIAL OFFER COUPON

**POPULAR MECHANICS PRESS,**  
200 E. Ontario St., Room P9, Chicago, Ill.

Send me, as per your special offer, the following books. I will pay postman price and small amount of postage. My money will be refunded if I am not satisfied. (Check what you want.)

1930 Shop Notes and Lathe Handbook, both for 98c.  
 Complete Shop Notes Library (13 vols.) \$4.00.

Name.....

Street and No.....

City..... State.....



# AUTOS

**LEARN..**

**BY THE MOST PRACTICAL, SUCCESSFUL METHOD...**

**WE TRAIN YOU RIGHT!**

Be properly prepared for success in the great Automotive industry. Thousands of factories, garages, repair shops and service stations NOW demand the kind of men who graduate from this famous, practical Trade School.

**IN LOS ANGELES!**

**25 YEAR OLD INSTITUTION**

Learn Autos in this Million dollar School. Previous training or education unnecessary. Start any time...no age limit. The National practical system of training insures success.

**YOU DO ACTUAL SHOP-WORK HERE**

At National you learn EVERY branch of the Automotive trade by actually working on thousands of dollars worth of late model cars...four, six and eight cylinder types as well as truck, tractors and aviation motors...under the personal supervision of competent instructors.



**ALL PRACTICAL WORK!**

**PROVEN SHOP METHODS**

**NO DRY LESSONS**



**22,000 GRADUATES**

There is a steady demand for graduates of this "School of Shops"... because, National men make good! National training prepares you for success.

NOT a correspondence course...you learn here by doing the very things you will do when employed in this well paying profession. Interesting, likable training.

**FREE EMPLOYMENT SERVICE**

To graduates and part time work to pay student's living expenses. Big Auto Book of information sent FREE to men who act quickly! Fill in and mail this coupon—RIGHT NOW!

**SEND FREE FOR BOOK**



**NATIONAL AUTOMOTIVE SCHOOL**

4006 So. Figueroa St. . Dept. 738 Los Angeles, California

Please send your big FREE Book of Automobile opportunities and explain how I can quickly qualify for a big paying automobile position.

Name \_\_\_\_\_

Address \_\_\_\_\_

Age \_\_\_\_\_ City \_\_\_\_\_ State \_\_\_\_\_



# Chinese MAGIC



## Magic

**Learn at Home, By Mail!  
Easily! Quickly!**



NOW!—if you act quick!—you can learn *magic*, real professional magic, direct from the world-famous magic wizard, Dr. Harlan Tarbell, the man who has trained many of our most prominent magicians. He has developed a *new* simple course, that enables any man or woman

who can read or write to *learn magic*—easily and quickly, at home, by mail. Why envy others? Make them envy YOU! *Learn magic!*

**Write!** Mail coupon now for the free Magic circular telling all about the great Tarbell Course in Magic.

Learn how EASY it is going to be for you to LEARN REAL MAGIC!

**Tarbell System, Inc., Studio 13-56  
1926 Sunnyside Ave., Chicago, Ill.**

**Tarbell System, Inc., Studio 13-56  
1926 Sunnyside Avenue, Chicago, Ill.**

Gentlemen; Without any obligation send me your free literature and information all about your wonderful "Tarbell Course in Magic." Also tell me about your Low Price Offer and Easy Payment Plan.

Name .....

Address .....

Age .....

# Play Piano BY EAR



**—IN 90 DAYS!**

Play anything — jazz to classical! Even if you know nothing about piano music — I'll have your fingers dancing over the keyboard with confidence in 90 days. If you can hum or whistle a tune you can play it! My students are broadcasting — making money. **MAKE ME PROVE IT!** Without puzzling notes! Without practicing tedious scales! I've found the way to bring out your musical instinct. New and original system does away with years of work. **YOU WANT THE PROOF!**

I'll send it. Write me now.

D. M. SUTTLE, Director  
ILLINOIS SCHOOL OF MUSIC  
1801 Byron, Dept. 1215, Chicago, Ill.

**Send NOW for PROOF!**

# Pay Nothing! Earn Your Course in ADVERTISING

**Learn at Home!** Any ambitious man or woman, who is willing to do a little spare time work, can now learn Advertising at home without paying any money for complete course. Write for free catalog and information about this startling new plan of the Page-Davis School of Advertising (established 1896). Successful graduates everywhere. Find out how you can prepare yourself without cost for the big opportunities in the fascinating field of Advertising. Send name and address for details. No obligation.

**PAGE-DAVIS SCHOOL OF ADVERTISING  
3601 MICHIGAN AVENUE, DEPT. 1356, CHICAGO, ILLINOIS**

# WORLD NEEDS PLUMBERS

Old style plumbers are fading like the horse and buggy. The world demands modern Plumbing and Skilled Trained Mechanics to do it. Unlimited, swift growing field. Make \$50 to \$100 a week or start own shop. We train you quick. Learn in 8 to 12 WEEKS to do any job with skill and science. Need no previous experience. Strictly tool using system. Opportunity knocks. Investigate today — amazing offer — low tuition. World's greatest school.

Write—

**UNIVERSAL PLUMBING SCHOOL  
2130 Troost Ave. Kansas City, Mo.**



# Government Positions

Clerk Carriers, Rural Carriers, Railway Mail Clerks, Postmasters, Department Clerks, and many others. Splendid salaries, easy work, vacation with pay. Only common school education required. Examinations often. 44,817 appointed last year. Send for our Civil Service Catalog No. 6. **COLUMBIAN CORRESPONDENCE COLLEGE, Washington, D. C.**

# BE AN OIL EXPERT!

Trained geologists, drillers, refiners, salesmen are at a premium! New, easy, practical way to learn at home in spare time! Write Today! **FREE Book!**  
**PETROLEUM ENGINEERING UNIVERSITY, Dept. 229, FORT WAYNE, IND.**

# BE AN ARTIST

WE CAN TEACH YOU DRAWING in your own home during your spare time. Twenty-five years successful teaching proves our ability. Artists receive large salaries.

Write Today for Art Year Book

**SCHOOL OF APPLIED ART  
ROOM NO. 2 BATTLE CREEK MICH.**





**Here are a few examples of the kind of money I train "my boys" to make**

**Started with \$5. Now has Own Business**



"Can't tell you the feeling of independence N.R.I. has given me. I started in Radio with \$5. purchased a few necessary tools, circulated the business cards you gave me and business picked up to the point where my spare time earnings were my largest income. Now I am in business for myself. I have made a very profitable living in work that is play."

HOWARD HOUSTON,  
512 So. Sixth St., Laramie, Wyo.

**Made \$700 in 5 Months Spare Time**

"Although I have had little time to devote to Radio, my spare time earnings for five months after graduation were approximately \$700 on Radio sales, service and repairs. I owe this extra money to your help and interest. Thanks for the interest shown me during the time I studied and since graduation."



CHARLES W. LINSEY,  
537 Elati St., Denver, Colo.

**\$7396 Business in two and one-half Months**



"I have opened an exclusive Radio sales and repair shop. My receipts for September were \$2332.16—for October, \$2887.77 and for the first half of November, \$2176.32. My gross receipts for the two and one-half months I have been in business have been \$7396.25. If I can net about 20% this will mean a profit of about \$1500 to me."

JOHN F. KIRK,  
1514 No. Main St., Spencer, Iowa.

# I will show You too

how to start a spare time or full time

## Radio Business of Your Own without Capital



J. E. Smith, Pres.,  
National Radio Institute

The world-wide use of receiving sets for home entertainment and the lack of well trained men to sell, install and service them have opened many splendid chances for spare time and full time businesses. Besides Radio's growth is opening hundreds of fine jobs every year. "Rich Rewards in Radio" gives detailed information on these openings. It's FREE.

\$200 a week to the right men with Radio training. My book tells you of other opportunities in Radio.

**So many opportunities many make \$5 to \$30 a week extra while learning**

Many of the ten million sets now in use are only 25% to 40% efficient. The day you enroll I will show you how to do ten jobs common in most every neighborhood that you can do in your spare time for extra money. I will show you the plans and ideas that are making as high as \$200 to \$1,000 for others while taking my course. G. W. Page, 107 Raleigh Apts., Nashville, Tenn., writes: "I made \$935 in my spare time while taking your course."

**I will train you at home in your spare time**

Hold your job until you're ready for another. Give me only part of your spare time. Hundreds have won success through my course. J. A. Vaughn jumped from \$35 to \$100 a week. E. E. Winborne seldom makes under \$100 a week now. The National Radio Institute is the Pioneer and World's Largest organization devoted exclusively to training men and young men for good jobs in the Radio industry by correspondence.

**Many \$50, \$60 and \$75 a week jobs opening in Radio every year**

Broadcasting stations use engineers, operators, station managers, and pay \$1,800 to \$5,000 a year. Radio manufacturers continually need testers, inspectors, foremen, engineers, service men, and buyers for jobs paying up to \$15,000 a year. Shipping companies use hundreds of operators, give them world-wide travel at practically no expense and pay \$85 to \$200 a month. Radio dealers and jobbers are continually on the lookout for good service men, salesmen, buyers, managers, and pay \$30 to \$100 a week. Talking Movies pay as much as \$75 to

**You must be satisfied**

I will refund every penny of your money if you are not satisfied with my Lessons and Instruction Service when you complete. I'll not only give you thorough training in Radio principles, practical experience in building and servicing sets, but also train you in Talking Movies, give you home experiments in Television, cover thoroughly the latest features in sets such as A. C. and Screen Grid.

**64-page Book gives the Facts**

Clip and mail the coupon now for "Rich Rewards in Radio." It tells of the opportunities for a spare time or full time Radio business of your own; also of the many fine jobs for which my course trains you.

Get my new book It points out what Radio Offers You



J. E. SMITH, Pres.  
Dept. OKP  
National Radio Institute  
Washington, D. C.

**THIS COUPON IS GOOD FOR ONE FREE COPY OF MY NEW BOOK** mail it TODAY

J. E. SMITH, President,  
National Radio Institute, Dept. OKP  
Washington, D. C.

DEAR MR. SMITH:—Send me your book. I want to see what Radio offers. I understand this request does not obligate me and that no agent will call.

Name.....  
Address.....  
City..... State.....



**You'll get practical Radio Experience with my new 8 Outfits of Parts that I'll give you for a Home Experimental Laboratory!**

Rear view of 5-tube Screen Grid Tuned Radio frequency set—one of many circuits you can build

My course is not all theory. You use the 8 Outfits I'll give you, in easily working out the principles, diagrams and circuits used in modern sets and taught in my lesson books. This 50-50 method of home training makes learning easy, fascinating, interesting. You get as much practical experience in a few months as the average fellow who hasn't had this training gets in two to four years in the field. You can build over 100 circuits with these parts. You experiment with and build the fundamental circuits used in such sets as Crosley, Atwater-Kent, Eveready, Majestic, Zenith, and many others sold today. You learn how these circuits work, why they work, how they should work, how to make them work.

*Get the facts on my Lifetime Employment Service to all Graduates*



# Want More Fun?



DO YOU want more good times—more invitations? Would you like to be right "in the spotlight," entertaining the others and having a lion's share of the fun at all the parties? Would you? If your answer is "Yes"—then you can't afford to say anything but "Yes" to the offer I'm going to make you—right on this very page!

—I asked Basil Glaze, of Germantown, Md.: He answered "Yes!" and a few months later wrote me: "Though I started with no knowledge of music, your Course certainly taught me quickly. My playing has opened the doors to a new world of fun for me."

# Want More Friends?

More Invitations - Good Times?

DO YOU want more real pals to fill your spare hours with enjoyment? Do you? Then I'll show you how to make them—more than you've ever dreamed of having. How? Easy! By teaching you to play an instrument that everyone loves—the Hawaiian Guitar! Even if you think you have no "talent"—don't worry. You don't need any talent or previous experience whatsoever, to learn at home by this simple method!

—I asked Pauline Hamrick, of Matthews, N. C. She, too, answered "Yes!" and soon wrote: "The very day I received my Guitar and first Lessons I began to have fun. Now my lonesome days are over. I make new friends almost every day—everywhere I go, with my playing."

# Want More Money?

Extra Dollars Easily Earned

—I asked Ralph Prutzman of Lehigh, Pa. He also said "YES"—and I showed him the quickest, easiest way to make it. Now he writes: "I'm getting along fine. The Lessons are easy and interesting. Made \$16 the very first night I played professionally and I'm not even through the Course yet! I see lots of good money-making opportunities ahead and I'm making more friends and having a better time than ever before."

Big Hawaiian Guitar and Outfit Come with Very First Lesson! We send you this fine, full-size Hawaiian Guitar, Phonograph Records of 55 selections and Complete Outfit. These are yours to keep. The Free Book explains everything. Get it NOW.

## Learn the Hawaiian Guitar at Home—By Quick Easy Method

Ralph Prutzman didn't believe we could teach him—but he let us PROVE that we could! Never mind if you've never played a note in your life, either, this easy, simple method will teach you quick, just as it taught Ralph Prutzman, Basil Glaze, Pauline Hamrick and a thousand others. The Coupon below brings your copy of my big Free Book. It tells all about the Course and famous method. It tells, too, how I send you everything you need to learn. Get it quick! Clip and mail the Coupon today—right now—and I'll get your copy to you by return mail!

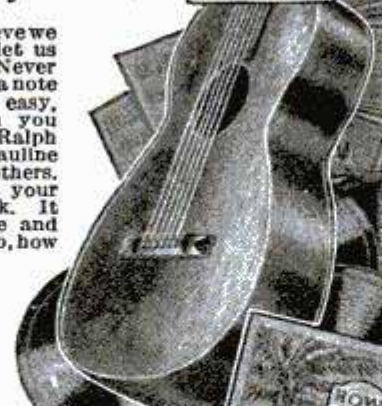

## This Brings FREE Book

A. F. BLOCH, President, Hawaiian Studios 52090 of New York Academy of Music, 100 Fifth Avenue, New York City.

Send me the book that tells more about getting more FUN—more FRIENDS—More MONEY. No obligation to me, of course.

Name.....  
 Address.....  
 City..... State.....



**GRISWOLD**  
OIL BURNER

**BURNS OIL and AIR**  
and SAVES 1/2 FUEL COST

Only \$216<sup>00</sup> Completely Installed

### Dealers Report Big Sales

Everywhere, men with or without oil heating experience, are cleaning up big money. Griswold meets instant approval, and sells because of low price and low cost to heat. Even the smallest home is your prospect.

### Amazing Offer

Get in right now. The BIG selling months are ahead. To help you start, we're ready to make an astounding offer. Write us today without fail!

### No More Shoveling Coal and Ashes

Goodbye winter worries. Here's automatic oil heat so cheap you can't afford coal. Amazing new way burns oil and air—patented crystal wick does it. Changes oil into hydro-carbon gas, and eliminates fuel waste. All the oil burns, and there's no soot, smoke, or odor. Cuts fuel costs. Fits any stove or furnace instantly, whether home, factory, apartment—hot water, air, steam, or vapor system. No complicated wiring—no ignition system. Anybody can install it in a few hours. Safe and easy to operate.

### Clean, Healthful Heat

Put it in and let the thermostat be your janitor. Enjoy clean, even heat at no extra cost. Fully automatic—fully safeproof, because you can't flood it. Oil fed by the siphonic level valve principle. Quiet. Guaranteed. Meets all city requirements. Send right now for our easy payment plan, FREE Descriptive Folder, and SPECIAL OFFER to dealers.

Manufactured by Griswold Division of **LACO OIL BURNER CO.**  
135 Union St., Griswold, Ia., U. S. A.

## LEARN MECHANICAL DENTISTRY



### Earn Big Money—Steady Work

Don't waste the best years of your life. Learn this money-making business in a few months in Day or Evening sessions. Big Demand. Practical training. Individual instruction. Easy terms. Railroad fare allowed—no extra cost. Write NOW for catalog and special tool offer.

NEW YORK SCHOOL OF MECHANICAL DENTISTRY  
125 WEST 31ST STREET NEW YORK

SEND FOR FREE BOOK



# BASHFUL?

"Shame on you!" Are you nervous, embarrassed in company of the other sex? Stop being shy of strangers. Conquer the terrible fear of your superiors. Be cheerful and confident of your future! Your faults easily overcome so you can enjoy life to the fullest. Send 25¢ for this amazing book.  
RICHARD BLACKSTONE, B-479 Flatiron Bldg., N. Y.

# "Pick YOUR Government Job"



Work for Uncle Sam. Get good pay, regular increases, vacations and sick leave with pay, steady advancement, pension. Send for my free book "How to Secure a Government Position"—tells about all jobs, near home or traveling, the money, what you need to know and how to get posted. Forget job hunting.

IMPORTANT NOTICE — Railway Postal Clerk examination coming. Yearly pay with allowances averages \$3759.00. Prepare yourself NOW. Send coupon at once.

A. R. Patterson, Civil Service Expert, PATTERSON SCHOOL, 89 Wisner Bldg., Rochester, N. Y.

Please send me, without obligation, your free book "How to Secure a Government Position."  
 Name.....  
 Address.....



*There is a* **JOB** *for You* **Here**

Get Into

**AVIATION**



MAJOR

*R.L. Rockwell*

**Will Train You AT HOME, and Until You Get a Job Paying You \$300 to \$400 a month**

Major Rockwell—famous world war flyer, is offering to train a limited number of ambitious men who want to get into aviation and get one of the big pay jobs that aviation offers.

**IN 12 SHORT WEEKS**

All you have to do is devote about an hour or two a day to my Home Study Extension Course and in 12 weeks you will be mastering the principles of Ground Training and be prepared to qualify for and accept a big pay job in this branch of Aviation. If you want to fly, my Home Study Course teaches you the principles of flight. When you have completed the ground training I will arrange for you to take

your flying instructions at any licensed airport near your home at special reduced rates. Or if you want you can come here to Dayton and get training at one of the finest and best equipped airports in America. No matter where you learn to fly you can qualify for a pilot's license and a high pay job in passenger lines, mail service, and other important branches of flying.

**Advance Education or Experience Unnecessary**

You don't need a high school education to master my course. My home course is thorough and complete. Everything is so clearly explained, with easy-to-understand text and pictures, that in a few short months you will be able to grasp every fundamental principle of Aviation ground work and get a start in Aviation qualifying for any important aviation job paying \$300 to \$400 a month. My Home Study Course will give you all the knowledge necessary to pass the government's written examination for a license.

**How I Help You Get Your Job**

Because of my experience in Aviation and knowledge of the work, I am in touch with large employers of trained aviation men who are constantly seeking help. Thus I am able to help my graduates get the aviation job they want at big pay. These employers prefer Rockwell Trained Men.

**Money-Back Agreement**

I am so sure that you can learn Aviation with my help and step into a big aviation job that if you are not satisfied when you have finished my course, I agree to return every penny of your tuition. Read my money-back agreement. Act now while my special offer lasts. Rush this coupon to me for a copy of my famous free book.

**MAJOR ROB'T L. ROCKWELL**  
**The Dayton School of Aviation**  
**Desk W-1 Dayton, Ohio**



**My Book Explains All ... Sent FREE ... MAIL COUPON**



**Major Rob't L. Rockwell**  
**The Dayton School of Aviation**  
**Desk W-1, Dayton, Ohio.**

Dear Major: Please send me FREE and without obligation a copy of your famous book on Aviation; the details of your no-risk plan; also your special tuition offer.

Name .....

Address .....

Town..... State..... Age.....



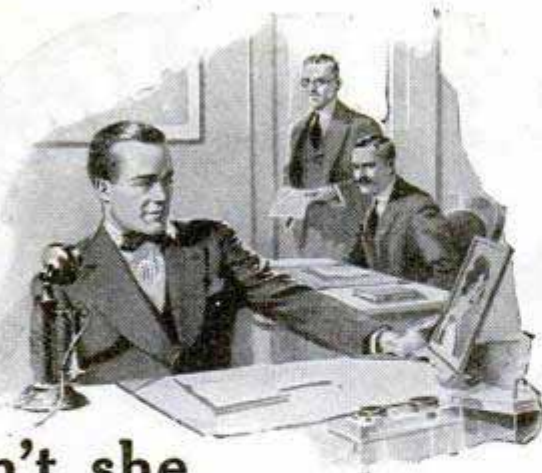

## Isn't she worth fighting for?

SHE believes in you and trusts you and she's depending on you to fight some of her battles for her.

As wife or mother, she can't go out in the world and earn the money necessary to support a family in comfort. That is your job.

Are you fair to her when you let the days drift by without making a real effort to get ahead? Is it right to ask her to scrimp and save and deny herself when with just a little grit and effort you could provide her with the comforts and luxuries she would like to have?

Think this over—then act! Decide today that you are going to get the special training that is becoming more and more necessary in every line of business.

There is an easy, fascinating way to do it. Right at home, in the spare time that now goes to waste, the International Correspondence Schools will prepare you for advancement and more money.

At least find out how by marking and mailing the same salary-raising coupon that has meant so much to so many other men in just your circumstances.

It doesn't cost you a penny or obligate you in any way to do this, but it may be the means of changing your entire life. Do it now. Do it for HER.

### Mail Coupon for Free Booklet

#### INTERNATIONAL CORRESPONDENCE SCHOOLS

"The Universal University"

Box 5501-G, Scranton, Penna.

Without cost or obligation, please send me a copy of your booklet, "Who Wins and Why," and full particulars about the subject before which I have marked X:

#### TECHNICAL AND INDUSTRIAL COURSES

- |  |  |
|--|--|
| <input type="checkbox"/> Architect   | <input type="checkbox"/> Automobile Mechanic                                 |
| <input type="checkbox"/> Architectural Draftsman                             | <input type="checkbox"/> Plumbing <input type="checkbox"/> Steam Fitting     |
| <input type="checkbox"/> Building Estimating                                 | <input type="checkbox"/> Heating <input type="checkbox"/> Ventilation        |
| <input type="checkbox"/> Wood Millworking                                    | <input type="checkbox"/> Sheet Metal Worker                                  |
| <input type="checkbox"/> Contractor and Builder                              | <input type="checkbox"/> Steam Engineer                                      |
| <input type="checkbox"/> Structural Draftsman                                | <input type="checkbox"/> Steam Electric Engineer                             |
| <input type="checkbox"/> Structural Engineer                                 | <input type="checkbox"/> Civil Engineer                                      |
| <input type="checkbox"/> Electric Wiring                                     | <input type="checkbox"/> Surveying and Mapping                               |
| <input type="checkbox"/> Electrical Engineer                                 | <input type="checkbox"/> Refrigeration                                       |
| <input type="checkbox"/> Electric Lighting                                   | <input type="checkbox"/> R. R. Locomotives                                   |
| <input type="checkbox"/> Welding, Electric and Gas                           | <input type="checkbox"/> R. R. Section Foreman                               |
| <input type="checkbox"/> Reading Shop Blueprints                             | <input type="checkbox"/> R. R. Bridge and Building Foreman                   |
| <input type="checkbox"/> Telegraph Engineer                                  | <input type="checkbox"/> Air Brakes <input type="checkbox"/> Train Operation |
| <input type="checkbox"/> Telephone Work                                      | <input type="checkbox"/> Highway Engineering                                 |
| <input type="checkbox"/> Mechanical Engineer                                 | <input type="checkbox"/> Chemistry <input type="checkbox"/> Pharmacy         |
| <input type="checkbox"/> Mechanical Draftsman                                | <input type="checkbox"/> Coal Mining Engineer                                |
| <input type="checkbox"/> Machinist <input type="checkbox"/> Toolmaker        | <input type="checkbox"/> Navigation <input type="checkbox"/> Boilermaker     |
| <input type="checkbox"/> Patternmaker  | <input type="checkbox"/> Textile Overseer or Supt.                           |
| <input type="checkbox"/> Pipefitter <input type="checkbox"/> Tinsmith        | <input type="checkbox"/> Cotton Manufacturing                                |
| <input type="checkbox"/> Bridge Engineer                                     | <input type="checkbox"/> Woolen Manufacturing                                |
| <input type="checkbox"/> Bridge and Building Foreman                         | <input type="checkbox"/> Agriculture <input type="checkbox"/> Fruit Growing  |
| <input type="checkbox"/> Gas Engines <input type="checkbox"/> Diesel Engines | <input type="checkbox"/> Poultry Farming <input type="checkbox"/> Radio      |
| <input type="checkbox"/> Aviation Engines                                    | <input type="checkbox"/> Marine Engineer                                     |

#### BUSINESS TRAINING COURSES

- |   |  |
|---|--|
| <input type="checkbox"/> Business Management                                  | <input type="checkbox"/> Business Correspondence                             |
| <input type="checkbox"/> Office Management                                    | <input type="checkbox"/> Lettering Show Cards <input type="checkbox"/> Signs |
| <input type="checkbox"/> Industrial Management                                | <input type="checkbox"/> Stenography and Typing                              |
| <input type="checkbox"/> Personnel Management                                 | <input type="checkbox"/> Complete Commercial                                 |
| <input type="checkbox"/> Traffic Management                                   | <input type="checkbox"/> Civil Service <input type="checkbox"/> Mail Carrier |
| <input type="checkbox"/> Accountancy <input type="checkbox"/> Cost Accountant | <input type="checkbox"/> Railway Mail Clerk                                  |
| <input type="checkbox"/> C. P. Accountant                                     | <input type="checkbox"/> Grade School Subjects                               |
| <input type="checkbox"/> Bookkeeping  | <input type="checkbox"/> High School Subjects                                |
| <input type="checkbox"/> Secretarial Work                                     | <input type="checkbox"/> College Preparatory                                 |
| <input type="checkbox"/> Spanish <input type="checkbox"/> French              | <input type="checkbox"/> Illustrating <input type="checkbox"/> Cartooning    |
| <input type="checkbox"/> Salesmanship <input type="checkbox"/> Advertising    | <input type="checkbox"/> Lumber Dealer                                       |

Name.....

Address.....

City..... State.....

Occupation.....

If you reside in Canada, send this coupon to the International Correspondence Schools, Canadian, Limited, Montreal, Canada.

## "Learn Electricity By Doing"



The Electrical World is continually seeking, and is willing to pay the price for, trained men. Enroll now, and in about six months' time you will be ready to enter this well-paying field. The

## NEW YORK ELECTRICAL SCHOOL

44 West 17th St., N. Y.

owns and occupies two seven-story buildings filled with every form of equipment devoted to the electrical profession. Here you learn how to do a thing by doing it. Day and evening classes open all year. Write or 'phone for catalog. CHELsea 2633.

## IMPROVE your ENGLISH

Through Sherwin Cody's new invention you will enjoy mastering English. Few rules—no drudgery. Only 15 fascinating minutes daily gives quick command of correct speech and writing. Send TODAY for free booklet "How You Can Master Good English in 15 Minutes a Day."

This EASY WAY

SHERWIN CODY SCHOOL OF ENGLISH  
59 Searle Bldg. Rochester, N. Y. FREE BOOK

## MUSIC LESSONS IN YOUR HOME



You can play music like this quickly. Write today for our FREE BOOKLET AND SAMPLE LESSON. It tells how to learn to play Piano, Organ, Violin, Mandolin, Guitar, Banjo, etc. Beginners or advanced players. You pay as you learn. Costs you only a few cents a day. Thousands of satisfied students.

AMERICAN SCHOOL of MUSIC, 51 Manhattan Bldg., CHICAGO

## This Great Book On VOICE

Cost a Fortune and took 30 Years to Prepare

Sent FREE



Postpaid—For 30 Days' Reading—if you act quick—we will send you postpaid—for 30 days' free reading—new Voice Book disclosing startling VOICE FACTS that may save hundreds of dollars to every man or woman seeking a strong, rich voice for either singing or speaking. A REVELATION! Remember—sent for 30 days' FREE reading. Then, if you keep it, send only \$1.00. Otherwise, just return it—That's all!

PROF. E. FEUCHTINGER, Suite 29  
1810 Wilson Avenue, Dept. 13-56, Chicago



# Be The Man Behind The Camera



**Earn \$2,000 to  
\$12,000 a Year**

**A**DVENTURE—thrills—more action in a week than the average man sees in a lifetime. When you're a motion picture cameraman the world is YOURS! You can travel, if you wish, or there are thrills galore close to home. As a news-cameraman you can be on the spot when things happen—there's no limit to the things you can see and do. Then, of course, there are the big picture studios where you come in daily contact with all the movie stars and actually take the pictures that millions of people see.

Adventure—sure—plenty of it—AND BIG PAY, TOO! Expert cameramen earn from \$60 to \$250 a week. Thousands of opportunities await the trained cameraman—opportunities offering fascinating work, big pay and unlimited chances for advancement. Best of all, you need no previous experience to qualify for one of these well-paid positions—to train for the position of your choice.

## **Billion Dollar Photographic Field Needs You!**

Motion picture photography is just one of the many big-paying branches of the billion dollar photographic industry. All over the country today there's a crying need for expert projectionists — for photo-finishers and trained "Still" photographers. No mat-

ter which branch of the work you select there are sure to be scores of positions awaiting you—positions paying \$2,000 to \$12,000 a year and offering unlimited opportunities for advancement.

## **We Train You In Spare Time**

Pick the branch of photographic work you like best—we'll train you for it, in your spare time. Previous experience unnecessary. Age or lack of education no obstacle. If you can read and write English we'll teach you, through our Simplified Study Method,

every phase of Motion Picture Photography, Projection, "Still" Photography or Photo-Finishing. Our Employment Bureau helps you secure the position of your choice FREE of extra charge.

## **SEND TODAY FOR FREE BOOK**

Let us tell you how you can quickly qualify as Motion Picture Cameraman, Projectionist, "Still" Photographer or Photo-Finisher. Our big FREE book gives details about this billion-dollar industry, and explains how you can easily step into a well-paid position. Fill in the coupon—check off the branch of photography you're most interested in, and mail it NOW! It means happiness—success for you!



## **NEW YORK INSTITUTE OF PHOTOGRAPHY**

Dept. R-1423

10 West 33rd Street

NEW YORK, N. Y.

New York Institute of Photography,  
Dept. R-1423, 10 West 33rd Street,  
New York, N. Y.

Without cost or obligation send me a copy of your FREE book and details about how I can qualify as:

- Motion Picture Cameraman  
 Motion Picture Projectionist  
 "Still" Photographer  
 Photo-Finisher

Name.....

Address.....

City..... State.....

**YOUR SUCCESS COUPON**





## BOY! What a Chance to Get into RADIO

"So you think I'm a Rad'io 'nut', do you?—well, I've been reading up on it, I'll admit. And it looks awful good to me—with millions of new sets manufactured every year and ten million sick ones to service.

"Say—I'll bet five million auto owners will buy Radios for their cars in the next couple of years! And look at Television coming in—and the way talking movies are spreading out—and the sweet jobs at Broadcasting Stations.

"While you sit here listening to the Radio—I wonder if you realize that thousands of men are paid big salaries to make it possible for you to enjoy programs put on the air all over the country—

"I'm through wishing I lived fifty years ago when Electricity was a baby—or thirty years ago when the auto game started. Me for the 'ground floor' in Radio and I'm not going to fool around much either.

"I see here where the American School is offering a real course in Radio Engineering—built by Duncan and Drew of R. C. A. and other big engineers—and they're cutting the price from \$127 to \$39 to the first 1000 students. And they promise to help find a good job when I'm half way through.

"Six bucks a month for a year does it, buddy. Then I can pay the rest out of 'velvet.' And if you think you can talk me out of it, you're a nut yourself.

"Here goes the coupon—and I'm sending it special delivery because I just can't wait to get the dope."

Here's the coupon that will bring you the reduced price offer of the American School. Mail it today and we'll send you complete information about the wonderful opportunities in Radio.

### -----American School-----

Dept. R-647, Drexel Ave. and 58th St., Chicago, Ill.



**AMERICAN SCHOOL**  
Chartered in 1897 as an Educational institution, NOT FOR PROFIT. Over 200 noted engineers, business executives and educators have helped us prepare our instruction service.

- RADIO ENGINEERING
- Mechanical Engineering
- Civil Engineering
- Electrical Engineering
- Automotive Engineering
- Machine Shop Practice
- DRAFTING and DESIGN
- Machine Drafting and Design
- Architectural Drafting
- Automotive Drafting
- Electrical Drafting
- Structural Drafting
- Mechanical Drawing for beginners
- BUILDING CONSTRUCTION
- Architecture
- Building Contracting
- BUSINESS
- Accounting, Auditing
- Business Management (Finance, Sales, Production, Accounting)
- HIGH SCHOOL IN 2 YEARS

Name.....  
Occupation.....  
St. No.....  
City.....State.....

## NEW FREE BOOK

On How to Raise Poultry for Profit will be sent postpaid, on request to readers of Popular Mechanics. It tells how we help you start a highly profitable spare-time or full-time business of your own or get a good job at good pay. One of our students, J. L. Mosher, of Buffalo, N. Y., for example, started at \$35 a week after tenth Lesson.

Read of the International Poultry work done by Harry M. Lamon, whose famous home study Course gives methods of increasing egg production, culling out non-layers, saving on feed, raising fat broilers quick, etc., methods that have doubled poultry profits—have raised salaries—have brought good jobs to men and women all over the country. You need this Book. It shows how you too can make poultry pay, make big money quick. Write for your FREE copy—today. Address,

National Poultry Institute, Dept. 411-P, Washington, D.C.

## Learn AVIATION WHERE LINDBERGH LEARNED!

**Big Opportunities for Lincoln-Trained Men**

Start at Lincoln—where "Lindy" began. Come to the Lincoln School. Here you get complete, thorough pilot and mechanics training on unusually elaborate equipment—at reasonable tuition charge. Approved by the U. S. Dept. of Commerce for Transport, Limited Commercial and Private.

Complete Mechanics' School connected with large production aircraft factory.

**LINCOLN AIRPLANE & FLYING SCHOOL**  
201 Aircraft Bldg. Lincoln, Nebr.

Catalog On Request Write Today!

**AVIATION Beckons You**

## WELDING ELECTRIC ARC OXY-ACETYLENE

**Taught by Actual Welding Practice.**  
No Finer Equipment Anywhere at Any Price. Pipe-Line, Sheet Steel, Structural Steel, Cast Iron, Aircraft and Commercial Welding, Cutting and Brazing. **LOW RATES FOR SUMMER COURSES—ENROLL AT ONCE.**  
Also Courses in Radio, Electricity and Automobiles.  
Full Information Free on Request.  
Coleman Electrical School, 1628-X Main St., Kansas City, Mo.

## AVIATION Information FREE

Send us your name and address for full information regarding the Aviation and Airplane business. Find out about the many great opportunities now open and how we prepare you at home, during spare time, to qualify. Our new book "Opportunities in the Airplane Industry" also sent free if you answer at once.

**AMERICAN SCHOOL OF AVIATION**  
3601 Michigan Ave. Dept. 1356 CHICAGO

Every Family should own this Newest, Greatest  
**ENCYCLOPAEDIA BRITANNICA**  
Write for FREE Booklet  
**THE ENCYCLOPAEDIA BRITANNICA, Inc.**  
342 Madison Ave., New York City

*Learn to Write*

**I Teach by Mail**

Begin Today—Write for My FREE Book, I can make a good penman of you at home during spare time. Write for my FREE BOOK, "How to Become a good Penman." It contains specimens and tells how others mastered penmanship by the Tambllyn System. Your name will be elegantly written on a card if you enclose stamp to pay postage. Write today for book.  
F. W. Tambllyn, 418 Ridge Bldg., Kansas City, U.S.A.



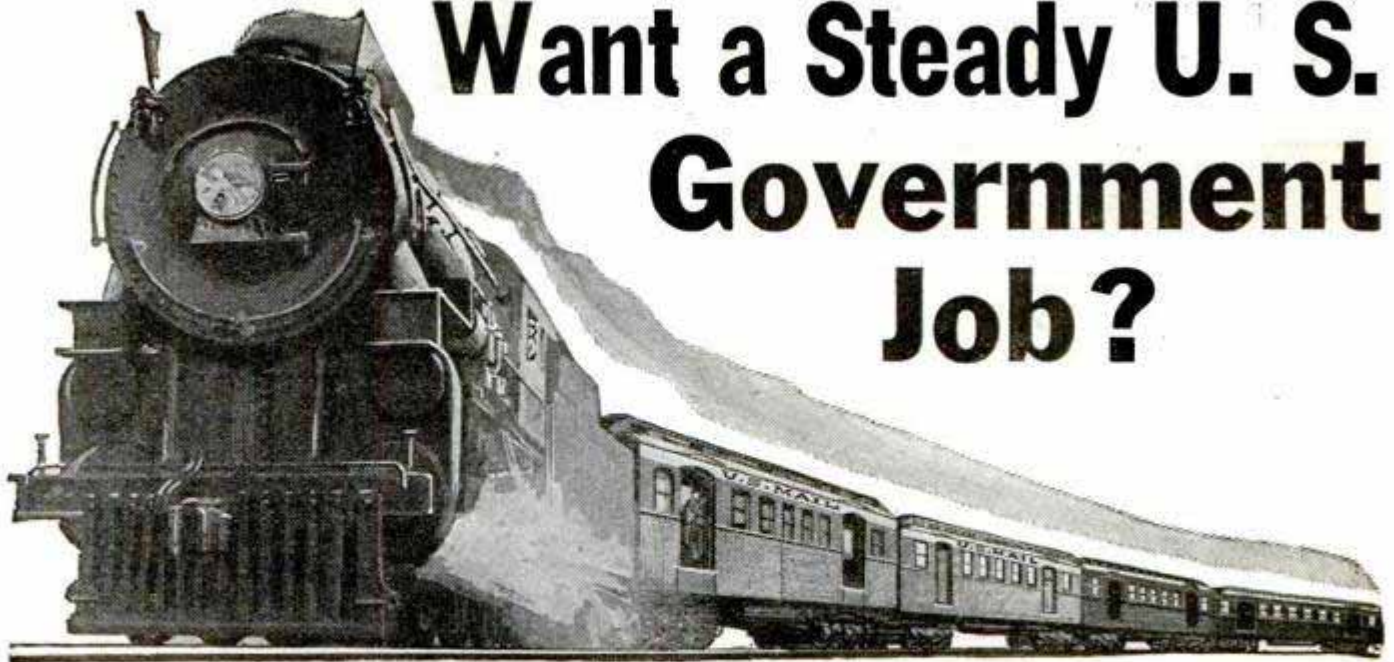

# Want a Steady U. S. Government Job?

## RAILWAY POSTAL CLERKS COMMENCE \$1900 YEAR

**Many U. S. Government Jobs Open to Men and Women 18 to 50**

POST OFFICE CLERKS—IMMIGRANT INSPECTORS  
 RURAL CARRIERS GENERAL OFFICE CLERKS  
 INSPECTORS OF CUSTOMS—CITY MAIL CARRIERS

These are steady positions. Strikes, poor business conditions, lockouts or politics will not affect them. U. S. Government employees get their pay for full twelve months every year. There is no such thing as "HARD TIMES" in the U. S. Government Service.

### RAILWAY POSTAL CLERKS

Railway Postal Clerks now get \$1900 the first year regular, being paid on the first and fifteenth of each month, \$79.16 each pay day. Their pay is quickly increased, the maximum being \$2700 a year, \$112.50 each pay day. They get extra allowance for hotel expenses when away from home.

### PAID VACATIONS

Railway Postal Clerks, like all Government employees, are given a yearly vacation of 15 working days (about 18 days). On runs they usually work three days and have three days off duty or in the same proportion. During this off duty and vacation, their pay continues just as though they were working. When they grow old, they are retired with a pension. As Railway Postal Clerks are continually traveling, they have an excellent chance to see the country.

### CITY MAIL CARRIERS—POST OFFICE CLERKS

Clerks and Carriers commence at \$1700 a year and automatically increase \$100 a year to \$2100 with further increase to \$2300. They also have 15 days vacation. City residence is unnecessary.

### GENERAL CLERKS—FILE CLERKS

(Open to men or women 18 to 50)  
 Salary \$1260 and \$1440 to \$2500 a year. Pleasant clerical work in the departments and offices at Washington, D. C., and throughout the country.

### WHAT WILL YOU EARN FIVE YEARS FROM NOW?

Compare these conditions with your present or your prospective condition, perhaps changing positions frequently, kicking around from post to pillar, no chance in sight for PERMANENT employment; frequently out of a position and the year's average salary very low. **DO YOU EARN \$1900 EVERY YEAR? HAVE YOU ANY ASSURANCE THAT A FEW YEARS FROM NOW YOU WILL GET \$2700 OR MORE A YEAR EVERY YEAR?**

### GET FREE LIST OF POSITIONS

Fill out the coupon. Tear it off and mail it today—now, at once. **DO IT NOW**—This investment of two cents for a postage stamp may result in your getting a U. S. Government Job.



**FRANKLIN INSTITUTE**  
 Dept. N174  
 ROCHESTER, N. Y.

Rush to me, entirely free of charge (1) a full description of the position checked below; (2) Free copy of illustrated 32-page book, "U. S. Government Positions and How to Get Them"; (3) Tell me how to get the Position checked.

MAIL COUPON TODAY

- Railway Postal Clerk.....(\$1900-\$2700)
- Post Office Clerk.....(\$1700-\$2300)
- City Mail Carrier.....(\$1700-\$2100)
- Rural Mail Carrier.....(\$2100-\$3300)
- General Clerk—File Clerk.....(\$1260-\$2500)
- Inspector of Customs.....(\$2100 Up)
- Immigrant Inspector.....(\$2100 Up)

Name.....

Address.....

Use This Coupon Before You Mislays it—Write or Print Plainly



# MOULDING A MIGHTY CHEST



**Get a 46 Inch Chest**  
**Complete Course on Chest Building**  
**ONLY 25c**

Learn the real secret of powerful chest building. Know all about the muscles that lift, widen and deepen the chest and broaden the shoulders. Practice the specialized exercises which will make YOUR chest massive and powerful. The greatest analysis of vital, vigorous chest development ever written. Learn the Hindoo religious system of exercises that makes their wrestlers and strong men invincible. A Hindoo strong man and wrestler threw Zybyso in two seconds. Many other methods unknown to the American body builder, are explained. Complete with anatomic illustrations on which are indicated the little known vital spots in creating vital internal strength. You can build for yourself a Herculean chest. The author, George F. Jowett, built his chest from 32 inches of weakness to 48 inches of colossal muscular strength. Develop your chest with straps of big steel muscle. Fill it full of unresisting vital strength energy.

**WORTH ITS WEIGHT IN GOLD—GET IT TODAY**

To each purchaser will be given a FREE COPY of *THE THRILL OF BEING STRONG*. It is a priceless book to the strength fan and muscle builder. Full of pictures of marvelous bodied men who tell you decisively how you can build symmetry and strength the equal of theirs.

**REACH OUT—GRASP THIS SPECIAL OFFER**

**JOWETT INSTITUTE of PHYSICAL CULTURE**  
 422 Poplar Street, Dept. 4Ja, Scranton, Penna.

Dear Mr. Jowett: I am enclosing 25c. Please send me the course "MOULDING A MIGHTY CHEST" and a free copy of "THE THRILL OF BEING STRONG."

Name \_\_\_\_\_

Address \_\_\_\_\_

# HOME OWNERS WANTED

**To Introduce World's Lowest Priced POWER OIL BURNER**

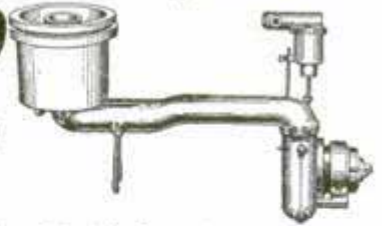

Make BIG MONEY selling World's Lowest Priced power oil burner, Laco Jr., the one and only mass market burner—on easiest terms—at lowest price. Heats 2 to 8 rooms! Fits Arcolas, Heatrolas, Stoves, and Small Furnaces. Can be attached to water heater. Operates on as little as 1/2 pint of cheap distillate an hour. Laco patented Mineral Wick—burns oil and air—stops fuel waste. Saves time, labor, and furnace drudgery. Comes complete, instantly installed. Anybody can do it. Simple to operate. Safer than gas or coal. Nothing to get out of order.

**Fast, Even, Safe Heat For As Little As \$70.00**

Sells fastest because of sensational low price and economical operation. Specially equipped with amazing safety features that prevent flooding. Gives quick heat, even temperature, and is safeproof against mistakes in turning on or off. Runs partially efficient even when electricity fails. Nationally advertised. Guaranteed. Easy payments. BIG OPPORTUNITY. Special Offer if you act now! Get low price, Free folder, and complete Laco money making agency plan.

**LACO OIL BURNER CO.**  
 135 Union Street Griswold, Iowa U. S. A.

**HOT WATER THE YEAR AROUND**

**HEATS 2 to 8 ROOM HOMES**

# HOT PIANO



Ultra-modern Piano  
 Jazz taught by mail. Note or ear. Easy rapid lessons for adult beginners. Also Self-instruction system for advanced pianists. Learn 358 Bass Styles, 976 Jazz Breaks, hundreds of Trick Endings, Hot Rhythms, Sock, Stomp and Dirt Effects; Symphonic and Wicked Harmony in latest Radio and Record Style. Write for Free Booklet.  
 WATERMAN PIANO SCHOOL, 1826 W. Adams St., Los Angeles, Calif.

# "BECOME A LIGHTNING TRICK CARTOONIST"



Send \$1.00 for Laugh Producing Program of 23 Trick Drawings with Instructions. Catalog of Chalk Talk Supplies Free.  
 BALDA ART SERVICE, Dept. 1, Oshkosh, Wis.

# LEARN WATCHMAKING

and become independent. We help you secure a position. Easy to learn. Send for FREE CATALOG.  
 ST. LOUIS WATCHMAKING SCHOOL Dept. 5, ST. LOUIS, MO.

# A Card Case Any MASON Would Be Proud To Own



Protects your lodge cards, \$1 auto license, passes, etc. under isinglass windows, ready to be seen at a glance. A genuine leather, 5-window sturdy card case, extra pocket—snap button—gold corners, for only \$1. Stamped with Masonic Emblem in heavy gold FREE—Same price without emblem. Name and other stamping 35c a line extra. Larger cases, 9 windows \$1.50. 13 windows \$2. Send for Catalogue.  
 Masonic Books, Monitors, Jewelry.  
 Lodge Supplies. [Check Choice]

**REDDING MASONIC SUPPLY CO.**  
 200 Fifth Ave., Dept. P.M., New York



# WHY *22,000 Ambitious Young Men* selected NATIONAL "THE SCHOOL OF SHOPS" to learn **ELECTRICITY**

## NATIONAL LOCATED IN LOS ANGELES

Come to the World's finest City and learn Electricity in the World's finest Trade school. Enjoy life in this fascinating garden-spot while learning a fascinating profession that will prepare you for steady, profitable employment.

## NATIONAL PERSONALIZED INSTRUCTION

Competent, experienced instructors teach you at National... not by correspondence or by dry lessons... but by actually showing you how to do electrical work on full sized electrical equipment of every modern type.

## NATIONAL ESTABLISHED 25 YEARS

This is a million dollar institution where 22,000 students have become graduates and entered the high salaried electrical industry, where there is a constant demand for the graduates of this approved "School of Shops."

## NATIONAL TEACHES YOU COMPLETELY

Here you learn EVERY branch of Electricity... to be properly and thoroughly equipped for practically any good paying position in the gigantic Electrical industry where millions of dollars are spent each year for new development.

Send **TODAY** for this big **ELECTRICAL BOOK**



## NATIONAL "THE SCHOOL OF SHOPS"

This practical, shop system enables you to start anytime... previous experience or advanced education are not necessary. You learn step by step working in the National shops under the personal direction of experienced instructors.

## NATIONAL NEWEST 1930 EQUIPMENT

Thousands of dollars worth of modern equipment for you to learn with... practically every standard type of motors, generators, transformers, power plant switch board equipment, meters, batteries. Every thing you need.

## NATIONAL PREPARES YOU FOR A POSITION

When you finish this complete course you are ready to accept a good paying position. You are fully equipped with a complete knowledge of electrical work... prepared to make good and start up the electrical ladder of success.

## NATIONAL LIFE EMPLOYMENT SERVICE FREE

Unlimited, guaranteed employment service to graduates... and part time work to cover student living expenses. Send today for free book of information... and for details about National's ELECTRICAL COURSE OUTFIT, FREE OF EXTRA COST.

*free*

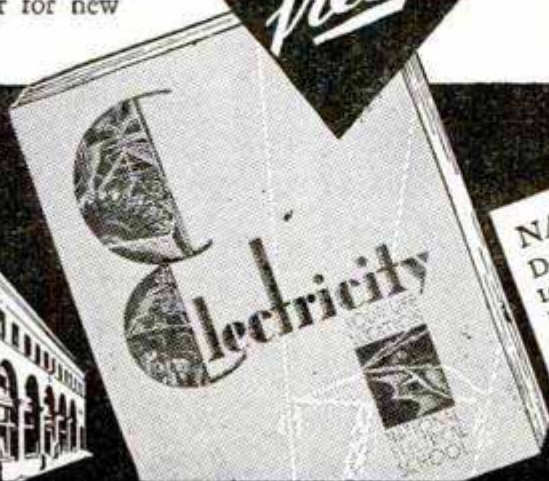

**NATIONAL ELECTRICAL SCHOOL**  
 Dept. 547 4006 Figueroa St.  
 LOS ANGELES, CALIFORNIA  
 Please send me your Big FREE illustrated Book of Electrical Opportunities, showing how I can get a FREE Electrical Course Outfit and quickly qualify for a Big Pay Electrical job.

Name \_\_\_\_\_  
 Address \_\_\_\_\_ City \_\_\_\_\_ State \_\_\_\_\_  
 Age \_\_\_\_\_

**NATIONAL--THE APPROVED "SCHOOL OF SHOPS"**



# How Fred Fisher Makes \$30 a Week in Spare Time with his TENOR BANJO



**Found Course Easy Right from Start; Now Enjoys More Friends, More Parties**  
 "Had no idea it was so easy! Nobody could go wrong with your clear, sure method. I now have more friends and never miss any parties. I have been earning \$30 a week in spare-time. There's always a job for a Tenor Banjoist."—Fred Fisher, 123 Ridge Street, Steelton, Pa.

**YOU Can Learn Quick Right at Home to Make Big Spare-Time Money**

Why "wish" for friends, fun and ready cash when you can have them—quick! Our tested, easy system will teach you—in 1 to 3 months—to make \$5 to \$15 an evening spare-time playing; \$65 to \$100 a week or even more playing in orchestras, etc. Be popular, have all the extra money you want. Find out NOW about "The Tenor Banjo Play-Way to Popularity and Big Pay."

**C. E. Samwell**  
 20 Devonshire Ave., Brantford, Ont., (shown above) writes: "Was only quarter-way through Course when playing in one of the best orchestras here. The Tenor Banjo is the sure, easy way to Big Money. My playing now paying for \$550 Banjo. Owe success to you."

**FREE BOOK tells how**  
 This inspiring book—that has shown countless others the short-cut to SUCCESS—will show you how to get the friends, popularity and money you want—QUICK! No obligation. Get the facts about the fascinating method that taught Fisher and Samwell and other prosperous Tenor Banjoists. No knowledge of music or notes necessary. No extras to buy. We teach everything—furnish everything—you need. Clip and mail coupon at once.

**Big Tenor Banjo Records and Outfit FREE When You Enroll**

**with First Lesson**  
 The same day we receive your enrollment for Course you are shipped a handsome, full-tone, professional-size Tenor Banjo worth \$20—lessons, Complete Outfit—and correct, fool-proof demonstration Phonograph Records of every selection in the Course!



**Mail Coupon Now**

A. F. Bloch, President,  
 New York Academy of Music,  
 Studio 1090,  
 100 Fifth Ave., New York City.  
 Dear Mr. Bloch: Please rush me your FREE Book telling how I too can make a Quick Success and Big Money with the Tenor Banjo.

Name.....

Address.....

## Earn up to \$250 per month

# Railways and Bus

Active men—19 to 55—needed at once in Railways and Bus Traffic Inspection. This steady, profitable work pays up to \$250 per month plus expenses. Interesting outdoor work. Travel or remain near home. We'll train you for this uncrowded profession, and on completion of a few months' spare time home instruction, immediately place you in a position paying from \$120 up or refund your tuition. Our free booklet tells what Traffic Inspection can do for you. Send for it today. Don't delay. Write

**STANDARD BUSINESS TRAINING INSTITUTE**  
 Div. 2 BUFFALO, N. Y.

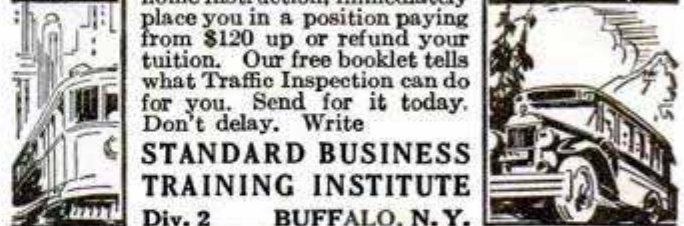

# BE A RAILWAY TRAFFIC INSPECTOR



# BEDFORD YMCA TRADE SCHOOL

Aviation Mechanic  
 Flying  
 Airplane Welding  
 Airplane Drafting  
 Air Navigation  
 Aero Starting, Lighting, Ignition  
 Auto Mechanic  
 Machine Shop. Electric Welding  
 Oxy-Acetylene Welding  
 Radio Mechanic. Battery Repair  
 Mechanical, Architectural Drawing  
 Sign Painting. Show Card Writing  
 Window Dressing  
 Commercial Art. Fine Art  
 DAY AND EVENING SESSIONS  
 Write for Catalog 50

Brooklyn Engineering Institute  
 (Operated by Bedford Y. M. C. A.)  
 1125 Bedford Avenue, Brooklyn  
 New York City

# ACCOUNTING

**The ACCOUNTANT**  
 Who he is  
 What he does  
 How to become one

THOUSANDS of ambitious men are earning more money today because they know Accounting. Send for our new book, "The Accountant—Who he is, What he does, How to become one," and the first lesson. Both will be sent free. In reply please state age and position.

International Accountants Society, Inc.  
 A Division of the  
 ALEXANDER HAMILTON INSTITUTE  
 Dept. 144, 3411 So. Michigan Ave., Chicago, Ill.

# LAW

**STUDY AT HOME**  
 Legally trained men win high positions and big success in business and public life. Be independent. Greater opportunities now than ever before. Big corporations are headed by men with legal training. Earn \$5,000 to \$10,000 Annually

We guide you step by step. You can train at home during spare time. Degree of LL. B. conferred. Successful graduates in every section of the United States. We furnish all text material, including fourteen-volume Law Library, Low cost, easy terms. Get our valuable 64-page "Law Guide" and "Evidence" books FREE. Send for them NOW.

LaSalle Extension University, Dept. 964-L, Chicago  
 The World's Largest Business Training Institution

# AN EASY WAY TO SHAPE your NOSE



Anita Nose Adjuster shapes flesh and cartilage—quickly, safely, painlessly, while you sleep or work. Lasting results. Gold Medal Winner. Doctors praise it. 78,000 users. Write today for **FREE BOOKLET**.

**30 DAYS HOME TRIAL**

ANITA INSTITUTE, 912 Anita Bldg., Newark, N. J.



# Raise Your Pay

with these  
**Tools** ↘

and with this

**FREE**  
Pay Raising Plan



These drawing instruments and 14 other tools furnished with my Training.

Make these tools help you to land a job leading to salaries of from **\$70.00 to \$175.00 a week**



# Jobs Waiting!

For Men Who Can Use These Tools In—

**Aviation** - **Building Construction**  
**Electricity** - **Auto and Bus Work**

There are jobs for Draftsmen in all of the above industries. Those industries are growing bigger every year. Industry cannot continue without draftsmen. All construction, all new machinery, all automobile and motor bus manufacturing, all electrical machinery building—and most important, **Aviation**, depend upon draftsmen.

## Earn While You Learn

I train you in drafting at home by mail. You keep your job while learning. I even show you how to earn extra money. I train you entirely in your spare time. No previous experience is necessary. You do not need to be a college man or high school graduate to learn by my quick, easy method, **My Practical Work Method**. After you have taken my training, I help you get a job without charging you a cent for this service. Employers of draftsmen come to me for men because they know they are not taking chances on men trained by me.

**\$3,500 to \$9,000 a Year**

Men I have trained are making from \$3500 to \$9000 a year. They lifted themselves from poor paying jobs to positions paying a good, straight salary, the year around, with comfortable surroundings and inside work.

## Get "My Pay-Raising Plan" —Not a Catalog

It points the way to success and opens up a road to salaries leading to from \$70.00 to \$175.00 a week. You owe it to yourself to send for this Pay-Raising Plan. Find out how I help you locate good paying opportunities in practically all the big industries. The book will come to you postpaid and free.



"I train you at home!"—  
Engineer Dobe

**FREE** This Genuine Ivoryne Pocket Rule

**Copy this Jack and Get this Rule.** Just copy Jack —that's all. That may tell me what kind of a draftsman you would be. If you are 16 years old or older and will mail me your sketch at once, I will send you free and prepaid a Draftsman's Ivoryne Pocket Rule shown here. **HURRY.** Send your sketch to me today. **Engineer Dobe, Chicago.**

Copy me and get Ivoryne Rule Free.—Jack

## Free "Pay-Raising Plan"

**ENGINEER DOBE, Div. 13-56**  
**1951 Lawrence Ave., Chicago**

Here is sketch. Send me Pocket Rule and "My Pay-Raising Plan" Free. Also how to earn money while learning and proof of big money paying positions in great industries.

Name \_\_\_\_\_ Age \_\_\_\_\_

Address \_\_\_\_\_

Post Office \_\_\_\_\_

State \_\_\_\_\_



# VOICE

**NOW! you can have the VOICE you want!**



## 100% Improvement Guaranteed!

No matter how hopeless your case may seem—send for free Voice Book. New SILENT Method of Voice Training. Increases Range. Improves quality. Banish huskiness—hoarseness. 100 per cent improvement *guaranteed*—or money back. Mail coupon *at once* for free booklet—the greatest voice booklet ever written—sent FREE with no obligation!

Perfect Voice Institute, Dept. 13-56  
1922 Sunnyside Ave., Chicago

### Mail Coupon for Free Voice Book

Perfect Voice Institute, Dept. 13-56  
1922 Sunnyside Ave., Chicago

Please send me FREE and without obligation, Prof. Feuchtinger's new book, "Physical Voice Culture." I have checked subject in which I am most interested.

Weak Voice  Singing  Stammering  Speaking

Name.....

Address.....

City..... State.....

## Books on 65 Practical Subjects

Popular Mechanics Press specializes in supplying the outstanding best books on many subjects. As new books of merit appear, we will revise the list accordingly.

- AERODYNAMICS**  
Simplified. Just out... \$3.50
- AIRCRAFT ENGINES**  
Dyke's New Instructor  
Best Engine Book... \$5.00
- ARCHERY**  
Bows and Arrows for Boys \$0.75
- ARCHITECTURAL**  
Design and Lettering... \$2.00
- ARMATURE WINDING**  
Excellent new book... \$2.00
- AUTO ENCYCLOPEDIA**  
Dyke's. (Covers New Model A Ford)... \$6.00
- AVIATION**  
Practical new book on flight training... \$5.00
- BIRD HOUSES**  
How to Make... \$1.00
- BLUE PRINTS**  
How to Read... \$2.00
- BOAT BUILDING**  
35 Popular Types, Outboard Motor, Sail, Row, etc... \$3.00
- BOY MECHANIC**  
Famous 4 Vol. Library, 4000 Things to Make... \$7.00
- BUILT-IN FURNITURE**  
Complete Instructions... \$2.50
- CARBURETORS**  
Excellent book on all makes... \$2.00
- CARPENTRY**  
Hand book of 336 Kinks... \$1.50
- CHALK TALK**  
How to... \$1.00
- COLOR SIMPLIFIED**  
Practical new Book (for Color Users)... \$3.50
- CONCRETE**  
173 Ways of Using New Edition (Cloth)... \$1.00
- CONTRACTOR**  
Building Cost Estimator... \$2.00
- DIESEL ENGINES**  
(New Work). Best Authority... \$5.00
- DOGS**  
Care and Raising... \$2.00
- ELECTRICITY**  
Practical—all branches... \$2.00
- ELECTROPLATING**  
Practical Results Easily Obtained... \$1.00
- ENGLISH**  
Self-Improvement in... \$2.50
- ETIQUETTE**  
New 560-Page Book. Only... \$1.00
- FARMER'S BOOK**  
of 861 Kinks and Book for Farmers' Wives... \$1.00
- FLYING**  
Stunt Flying... \$2.50
- FORMULAS**  
10,000 Money Making... \$4.00
- FURNITURE (Mission)**  
Homemade (3 vols.)... \$3.00
- GARDENS**  
1001 Questions Answered... \$2.00
- HOME REPAIRS**  
Practical Book of... \$2.50
- HOME WORKSHOP**  
900 Different Things to Make... \$3.00
- INVENTIONS (American)**  
Popular History of 2 vols. Reduced to... \$5.00
- INVESTMENT**  
Policies that pay By Ray Vance... \$4.00
- JOINT WIPING**  
(New Edition)... \$1.00
- KITES THAT FLY**  
How to Make... \$1.25
- LANDSCAPING**  
Practical... \$2.50
- LATHE WORK (METAL)**  
and Drilling and Thread Cutting... \$1.00
- LETTER WRITING**  
Social and Business Only... \$1.00
- MACHINIST**  
Complete, Practical... \$3.00
- MAGIC**  
200 New Tricks for Amateurs... \$1.00
- MASONS AND BUILDERS**  
Guides (4 vols.)... \$6.00
- MATHEMATICS**  
Made Easy for the Practical Man... \$1.50
- MECHANICAL DRAWING**  
Practical Course in... \$1.00
- MODEL AIRCRAFT**  
Building and Flying... \$2.25
- OUTDOOR OPPORTUNITIES**  
for Making a Living... \$2.00
- OUTDOOR SPORTS**  
for All Year 'Round... \$1.50
- PAINTING**  
House (Best Methods)... \$2.00
- PLUMBING**  
500 Plain Facts for Every Homeowner... \$1.50
- POULTRY RAISING**  
for Profit... \$2.00
- PUZZLES**  
Amusing Mathematical... \$1.50
- RABBITS**  
For Food and Fur... \$2.00
- RADIO**  
Trouble Shooting. Covers All-Electric Sets and Television... \$3.00
- SHOP NOTES**  
13 Vols. of 6000 Valuable Kinks... \$4.00
- STAMP ALBUM (Modern)**  
12,000 Varieties... \$2.00
- STEEL SQUARE**  
Pocket Book, Practical... \$1.00
- STENCILS**  
How to Use... \$1.25
- TOY MAKING**  
Complete Instructions... \$1.50
- TREASURES**  
Hunting Hidden... \$2.50
- WALL DECORATION**  
(Interior) Newest Methods... \$4.00
- WHITTLING**  
The Art of... \$1.35
- WIRING**  
House (New Book)... \$2.50
- WOOD TURNING (LATHE)**  
Practical Course in... \$1.50
- WOODCRAFT**  
590 Page Book on Forestry, Campercraft, Scouting, etc., by Seton... \$1.00

## Books sent C. O. D. anywhere in U.S.

Just check the books you want, write your name and address below, and mail the advertisement. It is your order blank. When post-man hands you books, pay him the price and few cents postage. If outside the U. S. remit when ordering and include 10 cents per book extra for postage. We have many other books on these and 2,000 other subjects. Catalog free.

Name.....

City..... State.....

Address.....

Mail to Popular Mechanics Press,  
Room P9—200 East Ontario St., Chicago, Ill.



# Wanted... Men To Read Blue Prints And Run Big Building Jobs!

Look, Men!  
Here's A Message Of  
Vital Importance To Every  
Ambitious Man In America!  
This Old Established College Now  
Offers Quick, Easy, Practical Train-  
ing In Blue Print Plan Reading—At  
Home In Spare Time. See How Easily  
You Can Take Your Choice Of Big Pay  
Jobs In Building At Salaries Up To \$75 And  
\$150 A Week And More! Coupon Below Brings  
You FREE Book, "How To Read Blue Prints."  
Also Free Set Of Actual Blue Prints. Mail It At  
Once!

**FIT YOURSELF AT HOME FOR  
A BIG PAY JOB**

## THIS EASY BLUE PRINT WAY

**B**UILDING is calling you!  
Building—the six billion dol-  
lar Industry—urgently needs  
practical, ambitious men who can  
read blue prints and run big build-  
ing jobs that only men with plan  
reading ability can fill!

And now, as the result of a  
amazing new method of training  
developed at Chicago Tech, you  
can in a surprisingly short time  
master plan reading right in your  
own home in spare time and fit  
yourself for "headwork" jobs pay-  
ing up to \$4,500 and \$12,000 a  
year. This announcement spells  
wonderful news for you if you  
are of the type that wants to  
escape from poor pay jobs, long  
hours, unemployment and limited  
future!

### Practical Blue Print Training

Think of it! No longer is it  
necessary for any man to spend  
years on the job in order to learn  
plan reading and qualify for  
leadership and big pay in Build-  
ing. For by this fascinating new  
blue print method you can grasp  
every money-making principle  
and practice of plan reading right  
while you are on your present job.  
This training is entirely different  
from ordinary schooling. You  
learn from actual blue prints  
under guidance of practical ex-  
perts. It doesn't matter what  
your age is. You don't even have  
to have previous education. If  
you can read what is written here,  
you can easily learn everything  
you need to know to become a

superintendent or building con-  
tractor!

### No Text Books—Fascinating Throughout

This training involves no study  
grind. No useless theory—prac-  
tical from start to finish. Based on  
many sets of real blue prints which  
we give you to examine and keep.  
Twenty famous experts go over  
them with you step by step and  
explain everything in plain, every-  
day language you easily under-  
stand. This is the kind of train-  
ing that has enabled practical,  
ambitious men like yourself to  
make the kind of money they  
want.

Samuel Schrier, Penn., reports  
he has been made foreman with  
an increase of \$72.50 per week.  
W. Fout, Va., was promoted from  
workman to superintendent as a  
result of this training. Percy F.  
Blair, Okla., writes: "When I  
started your training I received  
\$49.50 per week. Now I am  
superintendent and make \$100."  
And Clifford Scholl, a laborer,  
became assistant superintendent  
in 8 months!

### Mail Coupon for FREE Facts

It will pay you to investigate  
this short-cut blue print way to  
big pay and success in Building!  
Don't send one penny. Simply  
fill in and mail the coupon below.  
It brings you promptly a valuable  
book, "How To Read Blue Prints"  
and actual working blue prints,  
as well as proof that you can suc-  
ceed in this Wonderful Industry.  
No cost or obligation—so write  
**TODAY!**

### If You Live Nearby

Visit our big Day  
and Evening School  
attended by over 1,000  
You can get the same  
training at home in  
spare time—same les-  
sons, same plans and  
same instructions.

**Chicago Technical  
SCHOOL for BUILDERS**

Dept. M-143, Chicago Tech Building, 118 E. 26th St., Chicago, Ill.



**FREE!**  
**BOOK and BLUE PRINTS**

Without cost or obligation, you can now  
secure a copy of valuable book, "How To  
Read Blue Prints." Also, a set of actual  
working blue prints, as well as full facts  
about the practical home training that  
has made possible big pay jobs in  
Building for many men like you all  
over the country. Remember—it costs  
you nothing to investigate  
this opportunity—so mail  
coupon NOW!

Chicago Technical School For Builders,  
Dept. M-143, Chicago Technical Building,  
118 E. 26th Street, Chicago, Illinois.

Send me at once without obligation your FREE  
BOOK and complete set of FREE BLUE PRINTS  
which are mine to keep. It is understood that no  
salesman will call on me.

Name.....

Address.....

City..... State.....

Age..... Occupation.....



# There's A Better Living For Any Man of Limited Means and Education IN BARBERING



## SHORT—PRACTICAL COURSE

*Protecting Laws Make It the Best Profession  
in the Universe*

RALPH KUHLMAN has a Barber job on the Santa Fe running from Chicago to Los Angeles paying as high as \$60 a single trip. ARTHUR BAKER runs a shop in the exclusive great money district of Wall Street. He has accumulated a fortune. BOTH of these boys are MOLER GRADUATES. (Names of other graduates furnished on request.)

## GOODNESS!!! GRACIOUS!!!

Why not learn a profession by enrolling in a school whose method of teaching and course of instruction is approved by all State Boards? There is a school near you. Write to the nearest one and see.

## Standardized Branches Moler System of Colleges

139 E. 23rd St., New York City  
512 N. State St., Chicago, Ill.  
810 N. 6th St., St. Louis, Mo.  
801 Main St., Kansas City, Mo.  
206 E. 4th St., Cincinnati, Ohio  
215 Huron Road, Cleveland,  
Ohio  
559 Michigan Ave., Detroit,  
Mich.  
1229-17th St., Denver, Colo.

109 S. 15th St., Omaha, Nebr.  
501 E. Water St., Milwaukee,  
Wis.  
81 Forsyth St., N. W., Atlanta,  
Ga.  
81 S. Second St., Memphis,  
Tenn.  
1713 Commerce St., Dallas,  
Texas

## Address Nearest Branch

Please send me without obligation on my part your Booklet B.

Name.....

Address.....

City.....State.....

# FREE BOOKS of BUSINESS HELPS

We publish over 200 Home Study Books, each a complete treatise of its subject. We have one or more for you. Books on

- |  |   |
|--|---|
| <input type="checkbox"/> Commercial Art      | <input type="checkbox"/> Decoration       |
| <input type="checkbox"/> Lettering           | <input type="checkbox"/> Automobiles      |
| <input type="checkbox"/> Advertising         | <input type="checkbox"/> Battery Work     |
| <input type="checkbox"/> Sign Making         | <input type="checkbox"/> Electricity      |
| <input type="checkbox"/> Radio               | <input type="checkbox"/> Carpentry        |
| <input type="checkbox"/> Aviation            | <input type="checkbox"/> Building         |
| <input type="checkbox"/> Painting            | <input type="checkbox"/> Contracting      |
| <input type="checkbox"/> Silk Screen Process | <input type="checkbox"/> Sheet Metal Work |

and many other subjects. All fully described in our FREE CATALOG. Check the subjects in which you are interested and write today.

**FREDERICK J. DRAKE & CO., Publishers**  
Room 508—179 No. Michigan Blvd., Chicago  
Drake books are for sale in all book stores.

## ENGINEERING ELECTRICAL · MECHANICAL · STRUCTURAL and ARCHITECTURE

**INTENSIVE PRACTICAL TECHNICAL COURSES.** Degree in 2 years. Diploma in 1 year. Special short courses 6 Weeks to 4 Months in Electricity, Radio, Power Plant, Electric Refrigeration, Armature Winding, Wiring, Testing, Drafting, Welding. **LOW TUITION.** Expert instructors. Extensively equipped laboratories. Free life-time employment service for graduates. Part-time work while attending. Write for new free illustrated catalog giving all facts. 29th year.

**FINLAY ENGINEERING COLLEGE**  
1001 A Indiana Avenue Kansas City, Missouri



## Learn to PAINT SIGNS and SHOW CARDS

We quickly teach you by mail, or at school, in spare time. Enormous demand. Big future. Interesting work. Oldest and foremost school. **EARN \$90 TO \$200 WEEKLY**  
Otto Wiegand, Md., home-study graduate, made \$12,000 from his business in one year. John Varese, N.Y., gets \$25 for a show card. Crawford, B. C., writes: "Earned \$200 while taking course." Write for complete information.  
**DETROIT SCHOOL OF LETTERING**  
154 Stinson Ave. Est. 1899 Detroit, Mich.

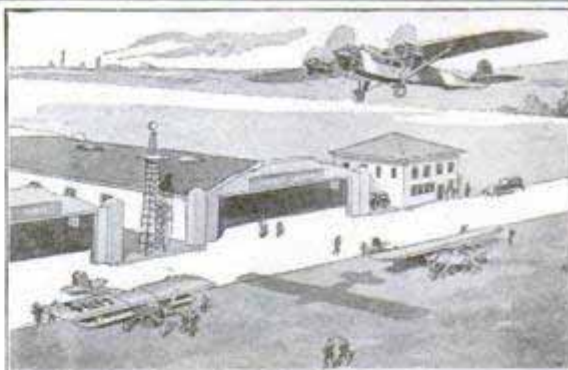

## A Career in Aviation

AVIATION is the great career of the future! Get into it now. Study International Correspondence Schools Courses in Aviation Engines and Ocean Navigation!

Captain Lewis A. Yancey, hero of the recent New York-Bermuda flight, says: "The I. C. S. books on Navigation are about as fine as have ever been prepared on the subject, and are to be highly recommended to the aviator who is desirous of learning navigation."

The Aviation Engines Course includes necessary study of Mathematics, Mechanical Principles, Combustion and Fuels, Principles of Gas Engines, Construction, Carburetion, Ignition, Lubrication, Pumps, Propellers, etc.

You can start at once. Study at home in spare time. Mark and mail the coupon today!

**INTERNATIONAL CORRESPONDENCE SCHOOLS**  
"The Universal University"  
Box 5503-G, Scranton, Penna.

Without cost or obligation on my part, tell me how I can qualify for the position or in the subject before which I have marked X:

- AVIATION ENGINES     OCEAN NAVIGATION  
 DEAD RECKONING

Name.....

Street Address.....

City.....State.....



**R. T. I.** R. T. I. QUALIFIES YOU TO MAKE MONEY AND ITS SERVICE KEEPS YOU UP-TO-THE-MINUTE ON THE R. T. I. NEWEST DEVELOPMENTS IN RADIO, TELEVISION AND TALKING PICTURES

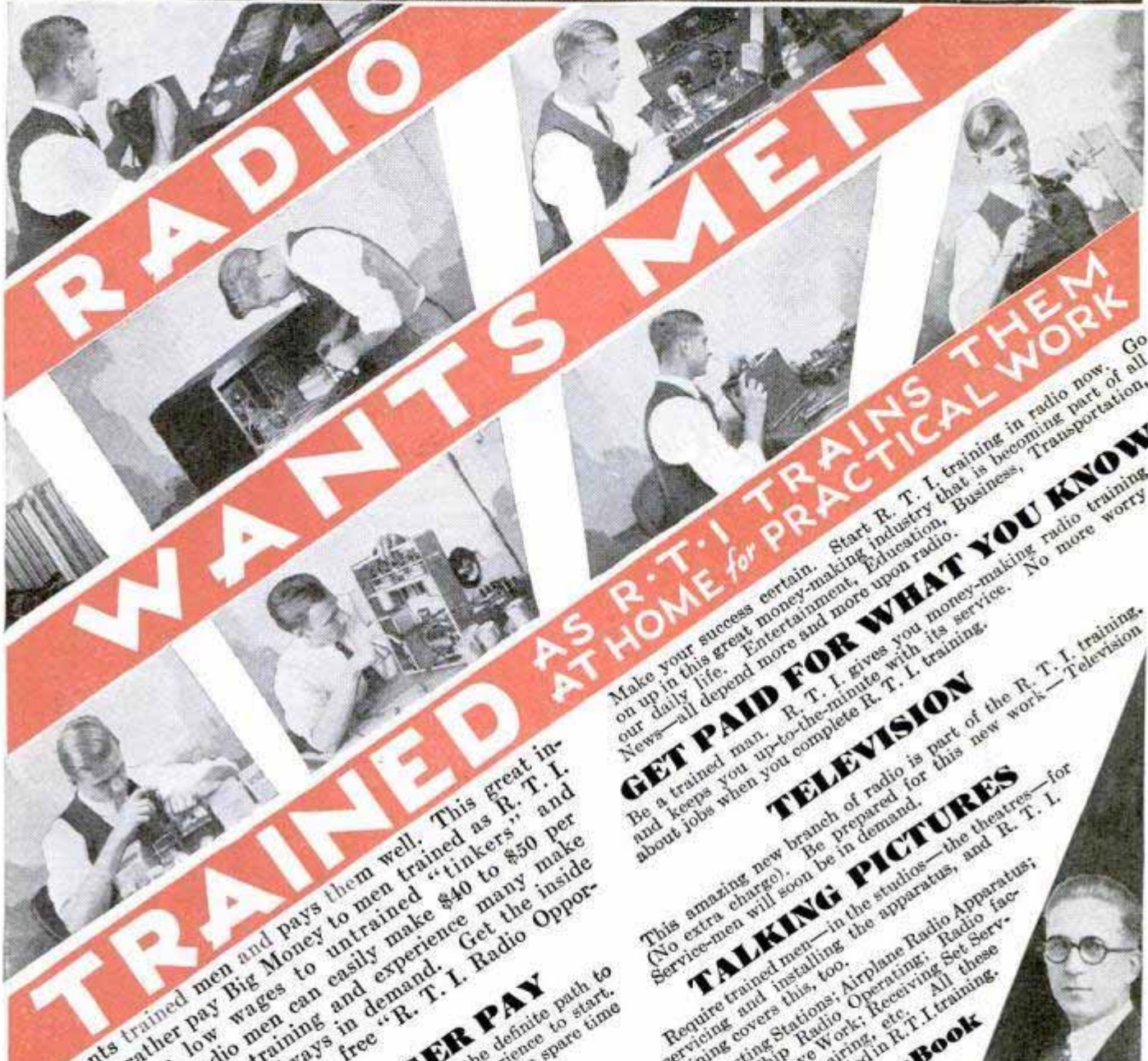

**RADIO WANTS MEN TRAINED AS R.T.I. TRAINS THEM AT HOME FOR PRACTICAL WORK**

Radio wants trained men and pays them well. This great industry would rather pay Big Money to men trained as R. T. I. "guessers." Trained radio men can easily make \$40 to \$50 per week and upwards. With training and experience many make \$75 to \$100 per week and are always in demand. Get the inside facts from leading radio men in the free "R. T. I. Radio Opportunity Book."

**BETTER JOBS—BIGGER PAY**  
R. T. I. offers you the way to get into Radio right, and the definite path to the Better Jobs and Bigger Pay. You need no experience to start. You can quickly make \$10 to \$20 per week Extra Money in spare time while learning.

**APPROVED TRAINING**  
R. T. I. training is endorsed by leading Radio Concerns and Radio Trade Associations. It is prepared and supervised by well known men in different branches of radio. You will find it interesting, practical, thorough and easy to understand.

**LEARN AT HOME**  
Why? Because the fellow who trains at home the R. T. I. way learns rapidly and makes a most valuable man. R. T. I. gives you the training the radio industry wants you to have for important, well-paid work.

Make your success certain. Start R. T. I. training in radio now. Go on up in this great money-making industry that is becoming part of our daily life. Entertainment, Education, Business, Transportation, News—all depend more and more upon radio.

**GET PAID FOR WHAT YOU KNOW**  
Be a trained man. R. T. I. gives you money-making radio training and keeps you up-to-the-minute with its service. No more worry about jobs when you complete R. T. I. training.

**TELEVISION**  
This amazing new branch of radio is part of the R. T. I. training. (No extra charge). Be prepared for this new work—Television Service-men will soon be in demand.

**TALKING PICTURES**  
Require trained men—in the studios—the theatres—for servicing and installing the apparatus, and R. T. I. training covers this, too.

Broadcasting Stations; Airplane Radio Apparatus; Sea-going Ship Radio Operating; Radio factoring; Selling; Repairing, etc. All these opportunities are included in R. T. I. training.

**Free Opportunity Book**  
Get the facts about the opportunities in Radio, Television and Talking Pictures in this wonderful book—it is free.

**MAIL COUPON FOR BIG FREE BOOK**



**Let F. H. SCHNELL** and the R. T. I. Advisory Board Help You

20 years' Radio Experience. First to establish 2-way amateur communication with Europe. Former traffic Mgr. of Am. Radio Relay League, Lieut. Com. U.S.N.R. Inventor and Designer. Cons. Radio Engineer.

Assisting him is the R. T. I. Advisory Board, composed of men prominent in the Radio Industry—manufacturing, broadcasting, engineering and servicing. All these men know Radio and will help you succeed in their field.

**RADIO & TELEVISION INSTITUTE**  
Dept. 16  
4806 St. Anthony Ct. Chicago



**THE R. T. I. ADVISORY BOARD.** These men are executives with important concerns in the radio industry—manufacturing, sales, service, broadcasting, engineering, etc., etc. They supervise R. T. I. Work Sheets, Job Tickets, and other training methods.

**R. T. I.** R. T. I. TRAINS YOU AT HOME FOR A GOOD JOB OR A PROFITABLE PART TIME OR FULL TIME BUSINESS OF YOUR OWN

**RADIO & TELEVISION INSTITUTE**  
Dept. 16, 4806 St. Anthony Court, Chicago

Send me Free and prepaid your **BIG RADIO OPPORTUNITY BOOK** "Tune in On Big Pay" and full details of your three-in-one Home Training (without obligating me in any way).

Name.....  
Address.....  
City..... State.....







If you're  
"On the  
outside  
looking in"

You need this  
**FREE Book**

ARE you standing on the sidelines, wishing you were in Aviation . . . envying those who are already making Aviation history while holding down good jobs with fine futures? If so, remember this:—Wishing won't get you into Aviation—but practical training will! Lt. Hinton's free book, "Wings of Opportunity," tells you a quick, sure, inexpensive way to get the necessary practical training—in your spare time, at home.

Hinton's personalized training and his free Employment Service are putting serious-minded, red-blooded men like you in good flying and ground jobs right along, at salaries of from \$40 to \$80 a week. Martin Co., Curtiss-Wright, Curtiss Flying Service, Alexander Aircraft, T. A. T., Fokker and scores of other leaders are employing Aviation Institute graduates. In one day alone, we had calls for more than forty men!

If you're 18 or over—and serious about wanting to get into Aviation, get a free copy of Lt. Hinton's book. It tells how he can give you the vital facts, the necessary knowledge of plane-construction, engine-design, rigging, repairing, servicing, airport management, navigating, theory of flight, etc. If you want to learn to fly, his course can save you many times its cost in cash. It's interesting and easy to understand from the start and packed with facts that mean success for you—no matter what branch of Aviation you choose to enter. Mail the coupon today—right NOW.

Aviation Institute of U. S. A., Inc.,  
1115 Connecticut Avenue, Washington, D. C.

Please send me a free copy of "Wings of Opportunity," telling how I can get into Aviation quickly. 301-M



"After completing your course I was engaged as Aeronautical Draftsman by a leading concern. I thoroughly recommend your training. It is complete in every detail."—Ira W. Bergen, Brooklyn, N. Y.

Another Hinton Graduate, John J. Morton of Bayport, L.I., writes that he secured a position with the Siekler Flying Service at \$50 a week, immediately after we recommended him for it.

Another graduate, Robt. N. Dobbins, was made Mechanic for Curtiss-Wright Flying Service at Valley Stream, L. I., at a salary of \$75 a week after he completed Lt. Hinton's course.



**FREE BOOK**

Name \_\_\_\_\_ Print Clearly

Address \_\_\_\_\_ Age \_\_\_\_\_  
(Must be over 18)

City \_\_\_\_\_ State \_\_\_\_\_

# No More Razor Blades to Buy!

KEEN, COOL shaves—and the end of razor blade expense. That's what this startling device offers shavers. Up to 365 shaves from one blade a common report. Unlike ordinary stoppers. Fits any blade including new Gillette. 11-second action, entirely automatic. Write for details and free razor offer. J. W. Diephouse, Dept. M-3715, 4330 Couzens Ave., St. Louis, Mo.



**AGENTS**—wonderful money-maker full or spare time. Loughren made \$5300 in one year. Hundreds cleaning up Big Money! Get liberal selling outfit offer.

## New Type Door Closer

Ends **SLAM**  
Saves Nerves...  
Banishes Flies!



A SIMPLE yet astonishing little invention that millions of people have always needed now opens an utterly new profit field to agents. It's a new-type, inexpensive, "pneumatic" door closer. Needed for every screen door, all outside doors, bathroom door, etc. Ends slamming and banging. Banishes flies and mosquitoes. Saves fuel in winter. So simple that any boy who can handle a screw driver can attach it. Every home needs and can afford several. Stores, offices, factories, also need and may buy dozens at a time. That's where agents make \$10, \$15, \$20, even more, on just one order! Rich unworked territories now open everywhere for full-time and spare-time workers who act promptly. Write today for introductory sample offer and details.

Close-A-Door Co., Dept. L-10, 1531 Washington Ave., St. Louis, Mo.



# DRAFTING

**BOOKS SENT FREE!**  
ON APPROVAL

### For Beginners

Written so you can understand every word, by 18 famous Engineers and Architects. Deluxe, flexible binding. 1750 pages, 1050 blue prints, charts and diagrams. Prepare you for a good Drafting job in mechanical or architectural lines. Sent for 10 days' free use, if you mail coupon immediately.

Only fifteen minutes a day with these WONDER BOOKS will prepare you for a good Drafting job in less than a year! Mechanical and Architectural Drafting from simple straight lines to important, complex plans, a step at a time! Built especially for beginners, for men with only grammar schooling. Drafting room practice plus engineering made easy and clear!

### Big Field—Big Demand—Big Pay!

Competent Draftsmen are urgently needed right now in all building and manufacturing lines at \$50 to \$100 a week. That's just the beginning—for draftsmen have the best chances for advancement! Pleasant, fascinating work, easy to learn and do. Learn quick with these books—send coupon for a set FREE, and see for yourself!

A year's Consulting Membership in the American Technical Society now given free to all readers of this famous Cyclo-pedia of Drafting. Many say that's worth more than cost of books.

**American Technical Society**  
Dept. D-619, 58th & Drexel Ave., Chicago

**FREE** If you send for these great Drafting Books NOW we will include without cost a complete volume "Blueprint Reading" containing 120 pages durably bound in cloth, and also a complete portfolio of 58 plates covering the basic orders of architecture. These plates are drawn to scale and are very valuable.

**American Technical Society**  
Dept. D-619, 58th & Drexel Ave., Chicago  
Send for 10 days' free use 4-volume set of DRAFTING. In return for mailing this coupon promptly send absolutely FREE "Blueprint Reading" (Building) 120 pages, 69 illustrations, also a complete portfolio of 58 plates. I will pay the few cents delivery charges. If I wish I may return books in 10 days and owe you nothing. But if I prefer to keep them I will send \$1.80 after 10 days, then \$2.00 a month until \$14.50 (special reduced price) is paid.

Name \_\_\_\_\_  
Address \_\_\_\_\_  
Employed by \_\_\_\_\_  
Address \_\_\_\_\_



# Now SLAMMING DOORS

## Pay up to \$15 a Day to Salesmen!

Fully  
Patented  
Fully  
Guaranteed

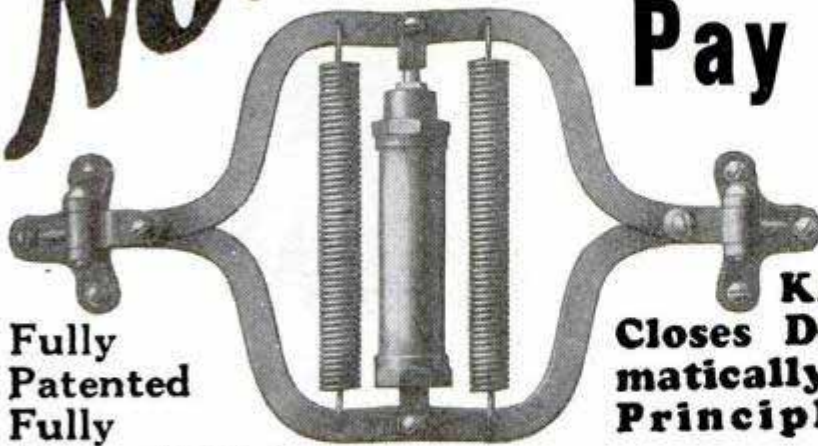

**Amazing New Invention  
KANT-SLAM DOOR CHECK**  
Closes Doors Silently and Auto-  
matically—Operates on New Oil  
Principle—Everlasting—Low  
Priced—NEW

Here is the greatest door silencer ever invented! Here is a fortune for men who act quick and grab the agency for this new patented invention. The Kant-Slam Door Check closes doors easily, quickly and noiselessly, with a touch of the finger. The Kant-Slam can easily be adjusted to close any door at any speed by turning the clever little screw at the top of the check. It is

the only low priced door check in the world that keeps a door open when you want it that way. It is built on new oil principle which assures a lifetime of perfect service. Works as well in cold weather as in hot weather. Takes only two minutes to install with a screw driver. Any boy can do it. It is the lowest priced practical door check on the market, and pays a big commission!

**"Sold 6  
in 2 Hours"**

This enthusiastic report comes from R. F. Culver, of Michigan.

"One installation sold 6 more," says J. C. Adams, Ohio.

"Fourteen orders in 1 day," Outcalt, Ohio.

J. C. Woodruff, Minn., sold 7 in one afternoon.

"Four calls — three orders," F. E. McDaniel, Indiana.

### Full Sized Sample on Miniature Door Furnished

Kant-Slam salesmen work with an actual sample of this amazing invention mounted on a light weight miniature door. You walk into any home, office, store, or factory building. In five minutes you convince the man by actual demonstration that the Kant-Slam will close his doors quietly. You explain that millions of dollars are lost every year by slamming doors which break the glass. You point out that tons of coal are wasted every winter by doors standing open. Show him that he can easily afford a Kant-Slam for every door. In a few minutes the man will order, one, two, three or more.

### At Last—A Specialty That Sells in Quantity

Usually you can take only one order from a customer for a specialty. But with the Kant-Slam you can take orders for as many doors as there are in any home, office, store or factory. Prospects everywhere! Four and five profits on every call where you otherwise make only one! Think that over! Slamming, banging, noisy doors are everywhere. Banish them, and banish the danger of broken glass by demonstrating this remarkable invention. No wonder you can make up to \$15 a day easily!

### Mail Coupon for Trial Offer

This proposition is new. You can easily get in on the ground floor and reserve a choice territory. Rush your name on the coupon below for complete details and FREE TRIAL OFFER. Or wire us for action.

**Kant-Slam Door Check Co.**

Dept. E-7

Bloomfield, Ind.

Kant-Slam Door Check Co.,  
Dept. E-7, Bloomfield, Ind.

STRAIGHTLINE

Gentlemen: Please rush details of FREE TRIAL OFFER—I am interested in agency for Kant-Slam Door Check.

Name.....

Address.....

Town..... State.....

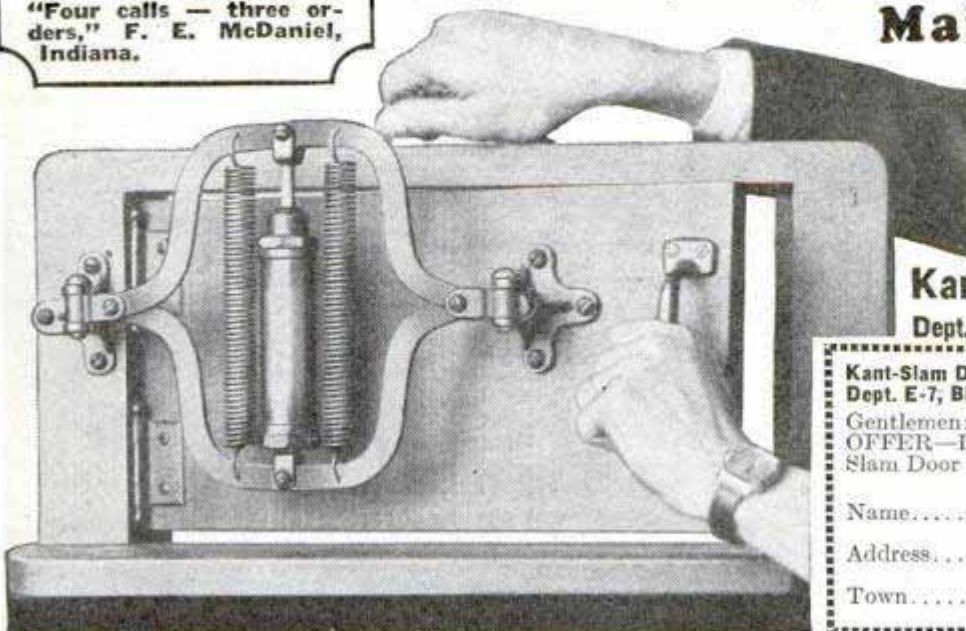





Pres. Lebeson  
instructing student.

## Cinch a \$60-week job

at easy, interesting work. While thousands of men have been out of work the past few months, there's one crowd working full time *every day at top pay*—because the wheels of industry simply *can't* turn without them. **MAN!** you can join them!

## BE A TOOL AND DIE MAKER

### A Machinist or Automatic Screw Machine Operator

### Thousands of Trained Men Needed

How can you learn these trades? Come to the ALLIED Schools—The Sure Short Cut to skilled trades and Big Pay. Better than a lifetime of apprenticeship. Man, you can work at your same job day after day for years and come out right where you started—just “one of the mob.” But give ALLIED training a chance and it will push you up ahead of the crowd—FAST!

You don't need to be educated or experienced. You learn by actual practice on REAL machines in the GREAT ALLIED SHOPS.

No books—No Written Lessons. No Time Wasted. *Everything practical.* Just a few short weeks of ALLIED training qualifies you. Easy Terms; Low Prices. Free employment service for life.

**Graduate Mucciatti Says:** “My salary is now exactly double” (after only two weeks' Allied Training).

**Get Ready NOW for a Steady “Top” Job INVESTIGATE!**



MAIL THIS COUPON FOR FREE CATALOG TODAY  
ALLIED SCREW MACHINE CO.  
School of Mechanical Trades  
524 W. Monroe St., Dept. 1009  
Chicago, Ill.

Without obligation on my part, send me free catalog “The SHORT CUT to BIG PAY JOBS.”

Name.....  
Address.....  
City..... State.....

**Learn how we pay your Railroad fare to Chicago! Every cent paid—a trip you've wished for.**

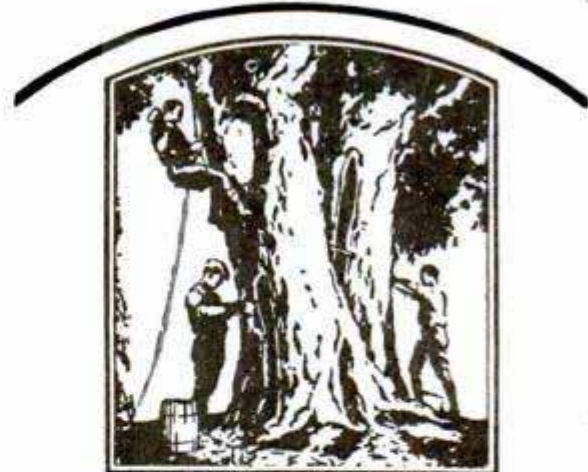

## Young outdoor men wanted

Interesting, vigorous outdoor work in a growing organization where merit wins advancement. Good starting wages. Permanent positions and a real future for men who make good. Expansion to meet increasing need for this unique service creates additional openings. So we are selecting now, to enter our employ, a number of sturdy, clean young men, thorough Americans, single, between 20 and 30 years old, free to travel, industrious, with good practical education, and able to give good references. Write for qualification blank to serve in place of personal interview. The Davey Tree Expert Co., Inc., 503 Federal Bldg., Kent, Ohio.

## COLLEGE COURSES

### AT HOME



Carry on your education. Develop power to initiate and achieve. Earn credit toward a Bachelor degree or Teaching Certificate by *correspondence*. Select from 450 courses in 45 subjects, including English, Mathematics, History, Education, Psychology, Economics, the Languages, etc. Write for catalog.

**The University of Chicago**  
527 ELLIS HALL CHICAGO, ILL.

## Learn Watch Repairing



by correspondence in a few weeks, in your own home, by the DeSels Chart System. You can earn money while learning, secure a well paying position, or go in business for yourself. For complete details, address DeSels Watch School, 37 S. Wabash Ave., Chicago, Ill.

## SHORTHAND IN 30 DAYS

Boyd, the wonderful easy system, 150 words a minute guaranteed. Send today for Catalog and sample lesson.  
**CHICAGO HOME STUDY SCHOOLS**  
801 Reaper Block Chicago, Ill.

## • • LUDWIG • •

### TIP TOP BANJO

ONLY \$19.85

A banjo with a big and snappy tone, built by the makers of the famous Ludwig Ace and other models chosen by leading professionals—a banjo you can master quickly; sturdily built and beautifully finished; at a price you can easily afford! Get into the fun, with a Ludwig banjo!



## FREE SELF INSTRUCTOR

Simple, easy to follow, you learn quickly at home. Write for catalog and details of easy payment plan

**LUDWIG AND LUDWIG**  
902 Ludwig Building, 1611-27 North Lincoln Street, CHICAGO, ILL.





**VALUABLE BOOK ON  
ELECTRIC REFRIGERATION**

Just off the press—an amazing new book, *Rich Rewards in Electric Refrigeration!* Sent absolutely free without obligation to ambitious men. Reveals unlimited opportunities in America's biggest new industry backed by General Motors and General Electric. Urgent need for trained experts—big pay positions waiting for trained men qualified for production, installation and service.

**NOW . . . QUICK TRAINING AT HOME**

By new, wonderfully simple spare time home training. Learn while you earn. Fascinating—simple as A.B.C. Endorsed by authorities—highly praised by Servel, Kelvinator and others. No textbooks—entirely practical throughout. Quickly prepares you for the "cream" positions in this uncrowded, fastest-growing field.

**INVESTIGATE AT ONCE**

Send no money. Simply write today. See for yourself without cost or obligation how marvelously easy it now is to become a highly paid refrigeration expert. Utilities Engineering Institute, Dept. 190, 4463 Sheridan Road, Chicago, Illinois.

**Amazing New Kind Of  
ORANGE JUICER**

*Pays Real Money to*  
**AGENTS**



WITHOUT doubt, here's the hottest item introduced in direct selling for the past ten years—KWIKWAY—an amazing little hand operated orange juicing machine that 9 out of every 10 housewives grab for the minute they see it. Fully patented. Remarkably efficient. Ten oranges with KWIKWAY equals a dozen with ordinary juicers. Saving actually pays for juicer in short time. Sells like wild-fire in homes, hotels, restaurants, hospitals, fountains. E. F. Johns sold 12 in 5 minutes in one hospital. Many other records as good or better. Selling Outfit without cost and protected territory to producers. Make income satisfactory to you or trial costs nothing. Write at once for full details of generous NO-RISK offer to agents. KWIKWAY PRODUCTS, Inc., Dept. M-120, 1415 Pine St., St. Louis, Mo.

*Play a Gibson*  
**BANJO**

Chief Eskimo  
**HARRY RESER**  
of the Clickquot  
Club  
Eskimos

Learn to play a Banjo, Guitar, Mandolin or Ukulele. It is easy to learn and makes you popular among your friends. If no teacher in your city, ask us about Reser's Correspondence Course.

**FREE TRIAL  
EASY PAYMENTS**

Write for this **FREE**  
**GIBSON BOOK**  
*Gibson Inc.*

903 Parsons St., Kalamazoo, Mich.

*"It's Easy to Fly"*  
Master the Air With  
**CURTISS-WRIGHT**



**A**RE you looking for a future in aviation? Regardless of your vocation, air training will help you to succeed in business.

It's easy to fly the Curtiss-Wright way. Whether you train for a position on the ground or in the air your education will be thorough and complete. Curtiss-Wright is the greatest name in aviation—the largest manufacturer of aircraft and engines and the largest operator of planes and owner of airports.

You will find a Curtiss-Wright Flying School near you. Each school is a university of the air completely fitted with the latest and best equipment.

When you graduate from the Curtiss-Wright Flying School you will be respected as a capable pilot wherever you go and you will find no trouble in turning your flying ability into profit.

Write for complete details of Curtiss-Wright Flying School courses. Mail this coupon! An illustrated booklet giving full information will be sent to you without cost or obligation. Act now!

**MAIL THE COUPON TODAY!**

PM-9  
CURTISS-WRIGHT FLYING SERVICE, 27 W. 57th St., N.Y.  
Gentlemen: I am interested in Aviation and would appreciate more information on the subjects I have marked X.

- |   |  |
|---|--|
| <input type="checkbox"/> Flight Instruction | <input type="checkbox"/> Opportunities in Aviation   |
| <input type="checkbox"/> \$50 Ground Course | <input type="checkbox"/> Aerial Charter Trips        |
| <input type="checkbox"/> New Payment Plan   | <input type="checkbox"/> Free Curtiss-Wright Booklet |

NAME.....AGE.....  
STREET.....  
CITY.....STATE.....





**Only \$2 DOWN**

and You **KEEP** These 6 **Big MONEY-MAKING Books**

Yes, money—big money, can be made with the help of good books—the right kind of books, books which teach you how to do things better and to make money doing it. These 6 big books on

# Auto-Engineering including Aviation Motors

are the greatest money makers that any man interested in automobile construction and repairs ever owned. Brimful of fascinating facts, designed to help anyone understand every detail of modern automobile construction. They become invaluable to you whether you own a garage, work for someone else, or are only interested in knowing how to keep your own car 100% efficient. These 6 big automobile books are published by the American Technical Society with over a million dollars of resources, enabling us to get the co-operation of the largest automobile manufacturing concerns who have supplied data sheets, specifications and the results of their own service experience. They are unquestionably the greatest automobile books we have ever published and include over 120 pages on **Aviation Motors**.

## FREE Examination

OVER **2500** PAGES Flexible Binding, 3000 Charts and Illustrations

Contains all the newest automotive developments, clearly and fully explained

**SEND NO MONEY NOW**

Engine Principles  
Four Wheel Brakes  
Front Wheel Drive  
Transmission  
Straight Eights  
Shop Kinks

1930 edition

All we want you to do before we ship these 6 big books is to give us your name and address. Just send the coupon and we will ship the books immediately. On delivery you deposit only \$2, plus the few cents delivery charges. Then keep the books for full 10 days before you decide whether or not you want them. If you decide to keep them you will immediately recognize the advantages of the Jiffy Index, which puts facts at your finger tips instantly. Then send \$3 in 30 days and \$3 a month until the special low price of only \$24.80 is paid. There is nothing more to pay and no obligation of any kind.

Note: Of course, if you prefer, you may enclose \$2 with the coupon, and the books will be sent to you with the same guarantee and the same promise of an immediate refund.

American Technical Society, Dept. A-619, Drexel Ave. at 58th St., Chicago.

You may send me the 6 big money-making books on automobile engineering, 1930 edition, with the understanding that I will deposit with the postman \$2 on delivery, which deposit is to be immediately returned to me if I return the books within 10 days, at your expense. If I decide to keep them, I will send you \$3 in 30 days and then \$3 a month until the special low price of only \$24.80 is paid.

Note: If you are enclosing \$2.00 please check here.....

Name.....  
Address.....  
City..... State.....

## 34 Lesson Drawing Course \$2.98

The biggest value you ever saw advertised anywhere.....



Haven't you often wished that you could draw cartoons, illustrate some idea, sketch some pretty face, etc.? You can do all of these things. One of America's most famous Cartoonists and illustrators has developed a great, simple system for success in all branches of Commercial Art. This system has revolutionized the entire theory of drawing. It means that drawing can be as easy for you as writing—much simpler than learning shorthand, bookkeeping or typewriting. We are now placing this original system for learning Drawing, Art and Cartooning, consisting of 34 lessons with over 500 illustrations within reach of every one. If you will devote a few hours each week to the Course **WE ABSOLUTELY GUARANTEE** that you will learn to draw and draw well before you have half finished the Course. If we fail to make this claim good, we will refund every cent paid us. By eliminating a large office force for answering correspondence, expensive catalogs, etc., we are enabled to make a price of \$2.98, the cheapest price ever known for a high-grade, home study course. Learn to draw. It is a big asset, no matter what field you are in.

**Send No Money**  
Just order the course and on arrival \$2.98 pay postman

If you order the course at once, we will include a drawing outfit, consisting of artist's pencils, pens, paper, erasers, thumb tacks, etc., enabling you to go to work without any additional cost.

plus a few cents postage, payment in full for the entire Course and Drawing Outfit. If not entirely satisfied, return within five days and we will Refund Money. Address: **LEDERER SCHOOL OF DRAWING, Dept. 648-C, Chattanooga, Tenn.** Orders from outside the U. S. A. are payable \$3.28 cash with order.

## LAW Free Book

Write today for FREE 64-page book, "THE LAW-TRAINED MAN", which shows how to learn law in spare time through the Blackstone home-study course prepared by 80 prominent legal authorities, including law school deans, and U. S. Supreme Court justices. Combination text and case method of instruction used. All material necessary furnished with the course, including elaborate 26-volume law library, delivered immediately upon enrollment. Many successful attorneys among our graduates. LL. B. degree conferred. Moderate tuition, low monthly terms. Money-Back Agreement.

Write for free book today.

**BLACKSTONE INSTITUTE, 807 N. Michigan Ave., Dept. 26 Chicago**

## FREE BOOK ON MIND TRAINING

An instructive book which explains an amazing system of mind training already used by more than 700,000 people.

Let us send you a free copy of "Scientific Mind Training." It will show you how and why Pelmanism is the *only* system of teaching for developing *all* the mental powers at the same time. Endorsed by such distinguished men as Edgar Wallace, Sir Harry Lauder, the late Jerome K. Jerome, Prince Charles of Sweden and hundreds of others. Write TODAY to

**THE PELMAN INSTITUTE OF AMERICA**  
71 West 45th Street Suite M-206 NEW YORK CITY

## LAW HIGH-GRADE INSTRUCTION BY CORRESPONDENCE

College, Post Grad. and Bar Ex. Rev. Courses. Law has attracted more keen, brainy men than any other calling. Send today for catalog. Low cost, easy terms. Standard texts. Degrees.

**Chicago School of Law Dept. 801, Reaser Block CHICAGO, ILL.**

# Telegraphy

PAYS WELL

—and you can thoroughly master it at home, quickly, in spare time, while holding present position. Training includes Morse, Automatic and Wireless. Complete sending and receiving outfits furnished. No instruments to buy. Our Sendograph enables you to receive and send in Morse and Continental codes at home without any outside assistance. Send for our Free Book, "Opportunities in Railway and Commercial Telegraphy." Tells about this attractive, well-paid vocation—how our easy home-study course qualifies for jobs with railways, stock exchange and brokerage houses, newspapers, press bureaus, etc.—how telegraphy has proved the first stepping-stone to executive positions for thousands of ambitious men and women. Write for this interesting book and complete free literature today. Address Dept. 964-Y.

**LaSalle Extension University Chicago, Ill**





"Give me your  
measure and  
I'll **PROVE**  
that you can have  
a body like mine"

## CHARLES ATLAS

twice proclaimed "The *WORLD'S Most Perfectly Developed Man.*" Now reveals his secret of health, strength and amazing muscular development.

**I**T'S easy my DYNAMIC-TENSION way. And quick! Just tell me what you NOW measure—and what you want to be. I'll give you PROOF in 10 DAYS that I can turn you, too, into a man of might and muscle. I'll put a solid inch of smooth, supple, powerful muscle all over your body.

If you are underweight, I'll add the pounds where they are needed and, if you are fat in any spots, I'll show you how to pare down to the fighting trim that I am always in myself.

And with the big muscles and powerful, evenly-developed body that my method so quickly gives you, I'll also give you *through-and-through* health—health that digs down into your system and banishes such things as constipation, pimples, skin blotches and the hundred-and-one other ailments that rob you of the good times and the good things of life.

First, do what my other prize-winning followers did. Send for a free copy of my 48-page book—"Everlasting Health and Strength," by Charles Atlas. Gamble a 2c stamp for the biggest prize that anyone can gain—a handsome, healthy, muscular body that commands the respect of anyone, any time, any place!

With my book I'll send you a chart so you can give me all your measurements. Then compare *your* biceps with *mine*. Measure your chest and put the figures beside mine. Do the same with your legs, arms, neck, wrist and all other parts of your body. Then get the proof of what my secret of *Dynamic-Tension* will do for you—in your home—spending as little as 15 minutes a day doing what I tell you—without apparatus—without special foods, pills, or baths—without any kind of fussy contrivance whatsoever! Give me 10 days and, I'll give you the proof!

## FREE—48-Page Book and Confidential Chart



Remember, it's easy my way! No apparatus — *Dynamic-Tension* does the work. You owe it to yourself to find out what my secret will do for you. Make sure of your free copy of my book—mail the coupon NOW. Address me personally—CHARLES ATLAS (Dept. 89A), 133 East 23rd St., New York City.

NECK

17 In.

CHEST  
[NORMAL]

46½ In.

BICEPS

17 In.

FOREARM

14½ In.

WAIST

32 In.

CALF

16¼ In.

HEIGHT

5 Ft. 10 In.

WEIGHT

178 Lbs.

Latest Photo

### CHARLES ATLAS

133 East 23rd St. (Dept. 89A), New York City  
Dear Mr. Atlas: I want the proof that your system of *Dynamic-Tension* will give me, too, a healthy, husky body and big muscle development. Send me your free book "Everlasting Health and Strength" and the confidential chart for my measurements.

Name.....

Address.....

City &amp; State.....

(Please print or write PLAINLY)



**BRAND NEW**  
**Genuine Model 3**  
**CORONA**  
**LOWEST PRICE EVER OFFERED**



**\$2.00**  
**DOWN**  
**BALANCE**  
**EASY**  
**TERMS**

**HERE'S your chance**  
**to own that brand**  
**new Genuine Model 3 Corona**  
**you've wanted—on the easiest**  
**terms ever offered—at LOWEST**  
**PRICE ever offered! Complete in**  
**every detail; back spacer, etc.,**  
**MANUFACTURER'S GUARAN-**  
**TEE. Recognized the world over**  
**as the finest, strongest, sturdiest,**  
**portable built. Try this wonderful**  
**portable typewriter—the same ma-**  
**chine that has satisfied 500,000 users.**

**Yours for 10 Days' TRIAL**  
**—Send No Money**

Experience the joy this personal writing portable typewriter can give you! Use it 10 days! See how easy it is to run and the splendidly typed letters it turns out. Ideal for the office desk, home, traveling. Small, compact, light, convenient. Don't send out letters, reports, bills in poor handwriting when you can have this Corona at such a low price or on such easy terms. Remember these are brand new machines right out of the Corona factory.

**Carrying Case Included**  
**—If You Act Now**

Leatheroid carrying case, offer, instructions, free on this offer. Send no money—just the coupon. Without delay or red tape we will send you the Corona. Try it 10 days. If you decide to keep it, send us only \$2, then \$3 a month until our special price of \$39.90 is paid. Now is the time to buy. Mail coupon today!



**MONEY SAVED**  
**By Using This Coupon**

**Smith Typewriter Sales Corp.**  
**(Corona Division)**  
**469 E. Ohio St., Chicago, Dept. 39**

Ship me the Corona, F.O.B. Chicago. On arrival I'll deposit \$2 with express agent. If I keep machine, I'll send you \$3 a month until the \$37.90 balance of \$39.90 price is paid; the title to remain with you until then. I am to have 10 days to try the typewriter. If I decide not to keep it, I will repack and return to express agent and get my money back. You are to give your standard guarantee.

Name \_\_\_\_\_  
 Address \_\_\_\_\_  
 Employed by \_\_\_\_\_



**SOARING TO SUPREMACY!**

The Rhon Ranger is making Glider history; it is here portrayed at the start of its remarkable flight on which it floated aloft over level ground for more than seventy-five seconds from an altitude of only 250 feet. Spectators who had only seen ordinary gliders were amazed at the performance of the Rhon Ranger.

And you can **BUILD IT YOURSELF** for only **\$89.50**

The Rhon Ranger Kit contains every item used on the glider, from the tiniest nail to the last coat of dope; every part is numbered; you can't make a mistake. Send 10c today for illustrated literature describing this

*Superb Training Glider!*

**MEAD GLIDERS**

Dept. B.3. 12 S. Market St. Chicago, Ill.

**RUPTURED**

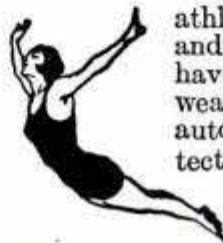

athletes, swimmers, dancers and men and women doing hard, tiring work have found new comfort and relief wearing the Brooks Appliance with automatic air cushion. Can't be detected under clothing. Retains rupture without gouging springs or hard pads. Each appliance made to measure and sold under absolute guar-

antee. A vast improvement over hard and unyielding rupture devices. Sent on 10 days' trial. Write for free rupture booklet sent in plain sealed envelope.

Brooks Appliance Co., 107D State Street, Marshall, Mich.

**NO JOKE TO BE DEAF**

**—EVERY DEAF PERSON KNOWS THAT**



George P. Way made himself hear, after being deaf for 25 years, with Artificial Ear Drums—his own invention. He wore them day and night. They stopped head noises and ringing ears. They are invisible and perfectly comfortable. No one sees them. Write for his true story, "How I Got Deaf and Made Myself Hear." Also booklet on Deafness. Address



Artificial Ear Drum

George P. Way, Inc., 609 Hofmann Building, Detroit, Michigan

**LUCKY TIGER**

**A PROVEN GERMICIDE**



For a clean, healthy scalp use Lucky Tiger. Destroys germs, and gives to thin, falling hair a new life and lustre. Delicately perfumed; world's largest seller at Druggists, Barbers, Beauty Parlors. **Try it Today!**

**QUIT TOBACCO**

No man or woman can escape the harmful effects of tobacco. Don't try to banish unaided the hold tobacco has upon you. Join the thousands of inveterate tobacco users that have found it easy to quit with the aid of the Keeley Treatment.



**KEELEY** Treatment For Tobacco Habit Successful For Over 50 Years

Quickly banishes all craving for tobacco. Write today for Free Book telling how to quickly Free yourself from the tobacco habit and our Money Back Guarantee.

Home of the famous Keeley Treatment for Liquor and Drugs. Booklet Sent on Request. Correspondence Strictly Confidential. **THE KEELEY INSTITUTE Dept. A-937 Dwight, Illinois**



# Men Past 40 MAKE THIS AMAZING TEST

Medical science claims that 65% of all men past middle age are victims of prostate trouble, either in a mild or severe form. Loss of health, sciatica, bladder weakness, nervousness, aches in back, legs and feet, frequent urination and chronic constipation are a few of the more common symptoms oftentimes mistaken as attributes of old age. A new drugless gland stimulant, perfected by a well-known American scientist, now offers victims of this devitalizing ailment a wholly advanced method that has shown startling results in many of the 100,000 cases where it has been used. Test it on our Gilt Edge Agreement, that **UNLESS YOU FEEL TEN YEARS YOUNGER IN ONE WEEK, YOU PAY NOTHING.** This bona fide guaranty accompanies each treatment. Send today for the intensely interesting booklet, "Why Many Men Are Old At Forty," written by the scientist who discovered this method. It contains information that every man should know and explains in a pleasantly frank manner all about this common ailment which oftentimes makes a man old before his time. It is absolutely FREE. Send for it today. Simply address:

**The Electro Thermal Company**  
2133 Morris Avenue, STEUBENVILLE, OHIO

Western Address:  
Dept. 21-K, 303 Van Nuys Bldg., Los Angeles, Calif.



## 1000 WONDERS 10c

**Be Popular—Learn to Entertain!**

Amaze and Mystify your friends. Our famous "Book of 1000 Wonders" tells how. Explains many startling Tricks with Cards, Coins, etc., you can do. No skill required. Also complete Catalog Tricks, Jokes, Puzzles, Novelties. Postpaid 10c. Send today!

**LYLE DOUGLAS**  
Station A-10 Dallas, Texas

# TRUSS USERS

**STUART'S ADHESIF PLAPAO-PADS** are patentably different—being mechanico-chemico applicators—made self-adhesive purposely to keep the muscle-tonic called "PLAPAO" continuously applied to the affected parts, and to minimize danger of slipping and painful friction. The fabric is soft as velvet, and being adhesive—

—clings closely to the body—



—without straps, buckles or springs.

Easy to apply, comparatively inexpensive and comfortable

For almost a quarter century stacks of sworn testimonials from many different countries report success, without delay from work. Process of recovery natural, after which no further use for a mechanical support. Test of the remedial herbal factor "PLAPAO" sent you **FREE** No charge for it now or ever. Write name on coupon **NOW**, and mail TODAY.

**Plapao Co., 2621 Stuart Bldg., St. Louis, Mo.**

Name.....  
Address.....

**FREE—Trial Plapao—FREE**

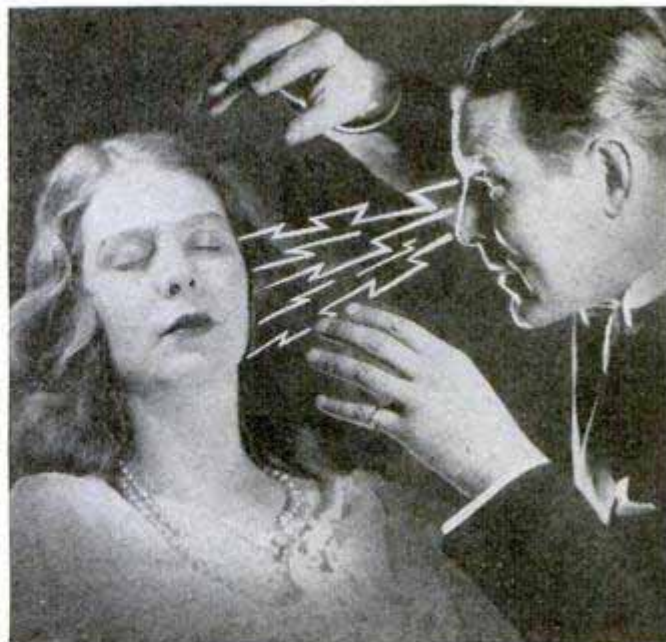

# See How Easy You Can Learn HYPNOTISM TRY FREE 5 DAYS!

**SEE** for yourself how easy it is to master the great science of Hypnotism—how quickly you can learn to bend people to your will—banish fear, worry and opposition— increase your earnings—and force others to give you the recognition, power, and admiration you deserve. I'll show you how to use this great force to help you master every situation or **The Five Day Trial is FREE!**

In just a few hours I'll teach you the hidden secrets of Hypnotism—the methods used by the great operators—the amazing things you can accomplish once you understand this mighty power. You can use it to overcome obstacles, achieve your fondest ambitions and become **MASTER** of yourself, friends and acquaintances—either sex. Now you can quit being just one of the crowd—now you need not be unpopular, lonesome or unhappy a minute longer. Through this strange power you can learn how to stand out—dominate—to make your life what you want it to be!

In his startling **NEW** book, *The Science of Hypnotism*, the world famous hypnotist—Prof. L. E. Young—reveals the most carefully guarded secrets of this fascinating subject. He not only explains the methods of noted hypnotists, step by step—but tells clearly all about the nine stages of Hypnotism, The Hypnotic Mirror, Mental Telegraphy, how to select your subjects, magnetic healing, methods of hypnotizing, how to wake the subject, how to make money out of hypnotism!

**Try 5 Days FREE—Send No Money**

So confident are we that Prof. Young and his great book will quickly teach you the science of Hypnotism, that we will send you a copy without one cent in advance! Simply clip and mail the coupon below. When the book arrives pay the postman the special low price of \$2.50 plus few cents postage. Then test the powers of Hypnotism 5 days! If not amazed and delighted, return the book and money will be refunded at once.

**FRANKLIN PUBLISHING CO.,**  
Dept. L-70, 800 No. Clark Street, Chicago, Illinois

## Mysteries of Hypnotism Revealed

- How to Hypnotize at a Glance
- Susceptible Subjects
- How to Hypnotize by Telephone
- How to Give an Entertainment
- How to Make Others Obey You
- Overcoming Bad Habits
- How to Do Dozens of Hypnotic Feats
- Use of Hypnotism in Operations

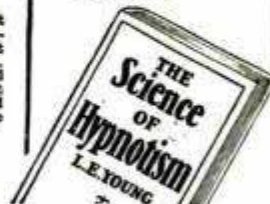

Franklin Pub. Co., Dept. L-70,  
800 No. Clark St., Chicago, Ill.

Please send me your amazing new book—*The Science of Hypnotism*—by Prof. Young. When book arrives, I'll pay the postman only \$2.50 plus postage. If I am not satisfied after 5 days' trial, I may return the book and you are to refund my money.

Name.....

Street and No.....

Town.....State.....

If you are likely to be out when postman calls, send \$2.50 with coupon and we'll pay delivery charges. Customers outside U. S. send cash with order.



# Swear Off Tobacco



Tobacco Tells on Nervous System



Tobacco Ruins Digestion



Tobacco Stunts Boy's Growth



Tobacco Robs Man of Vitality



Tobacco Steals from You the Pleasures, Comforts, Luxuries of Life

## Let Us Help You Banish the Tobacco Habit

### QUICK RESULTS

Trying to quit the tobacco habit unaided is often a losing fight against heavy odds, and may mean a distressing shock to the nervous system. So don't try it! Make the tobacco habit quit you.

It doesn't make a particle of difference whether tobacco has been used for a single month or fifty years, or how much, or in what form—whether it be cigars, cigarettes, pipe, plug, fine cut, or snuff. Tobacco craving usually begins to decrease after the very first dose—there's no long waiting for results.

Tobacco Redeemer contains no habit-forming drugs of any kind and is safe, quick, pleasant, and thoroughly reliable.

### Not a Substitute

Tobacco Redeemer is in no sense a substitute for tobacco, but is a radical, efficient treatment. It helps to quiet the nerves, and makes one feel better in every way. If you really want to quit the tobacco habit—get rid of it so completely that when you see others using it, it should not awaken the slightest desire in you—you should at once begin a course of Tobacco Redeemer treatment for the habit.

### Our Positive Guarantee

A single trial should convince the most skeptical. Our legal, binding, money back guarantee goes with each full treatment. If Tobacco Redeemer fails to banish the tobacco habit when taken according to the plain and easy directions, money will be cheerfully refunded upon request.

### Let Us Send You Convincing Proof

If you are a slave of the tobacco habit and want to find a sure quick way of quitting "for keeps," you owe it to yourself and to your family to mail the coupon today or send your name and address on a postal, and receive our free booklet on the injurious effects of tobacco on the human system and positive proof that Tobacco Redeemer does quickly relieve the habit for most users.

Newell Pharmacal Company  
Dept. 300, Clayton Station, St. Louis, Mo.



### Free Book Coupon

NEWELL PHARMACAL CO.

Dept. 300 Clayton Station St. Louis, Mo.

Please send, without obligating me in any way, your free booklet regarding the tobacco habit and proof that Tobacco Redeemer has relieved the tobacco habit in thousands of cases. If it fails my money will be refunded.

Name.....

Street and No.....

Town..... State.....



# Strange Rupture Discovery Ends Truss Torture!



## Ohio Scientist,

John G. Homan, whose discovery often ends truss torture overnight. His newest method weighs only four ounces, is soft as flesh and often gives nature a chance to actually heal. Mr. Homan will send a free sample of Airtex material to ruptured.



## Physicians Praise System

Among the many physicians who highly endorse Mr. Homan's invention is Dr. J. B. Walkinshaw, Wellsburg, W. Va. "I have never seen anything before that so sets the stage to help Nature heal a reducible rupture."

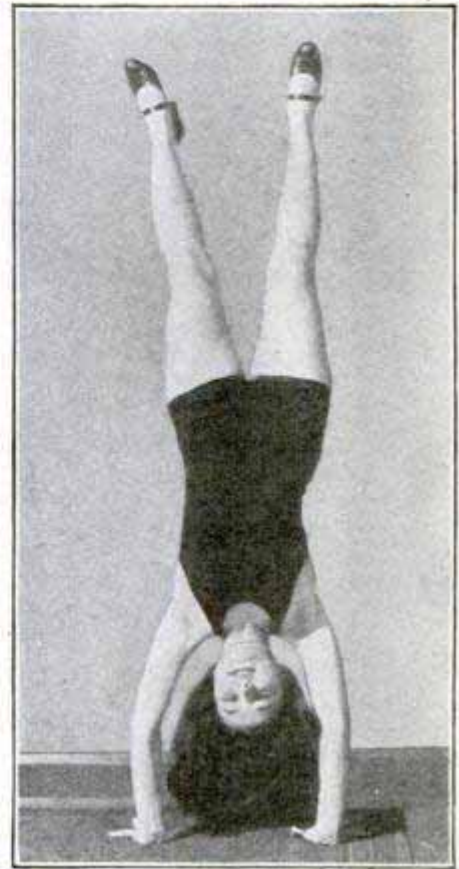

**Can't Slip!** Dancers, stage people, swimmers, athletes, people who engage in strenuous exercise, praise this new way to help retain and heal rupture. Many report they exercise freely and their ruptures never come out.



## "Breathes Air"

Mr. Homan's new system is really a twin invention. Airtex, the flesh-soft padlet, fits over the rupture. Above photo showing bubbles coming from Airtex submerged in water, demonstrating that it breathes with the movements of the body. It is washable and sanitary.



## Throws Away Old Trusses!

T. M. Cannon, California, is a splendid example that typifies the success which Mr. Homan's invention has met among ruptured people who test it rigidly. He tried many types of trusses previously. Now thanks to Magic Dot System he is able to teach boxing and wrestling.

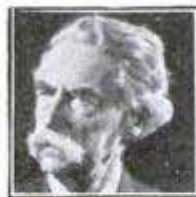

## For Old Or Young

One man, 80 years old, who has been ruptured for 32 years, reports relief at last from cruel trusses. He says: "I have been trimming the lawn, working on my knees. Magic Dot and Airtex are right in place."



**Rows Across Mississippi.** A ruptured St. Louis man, to prove his relief from any cruelty after 18 years, rowed a skiff across the Mississippi two miles upstream against wind and choppy water.



## Amazingly Tiny

Although the Homan invention makes it possible to secure and safely retain large and severe hernias, its most important part—Magic Dot—can be concealed by two fingers. It weighs less than 1/25 of an ounce.

### WORTH MONEY TO RUPTURED

New Science Institute,  
2176 Clay St., Steubenville, Ohio  
Send me the free sample of your Airtex material and full details of your 10-Day Trial Offer on the Efficiency Model.



Name.....

Address.....

City..... State.....

Print address and be sure of reply



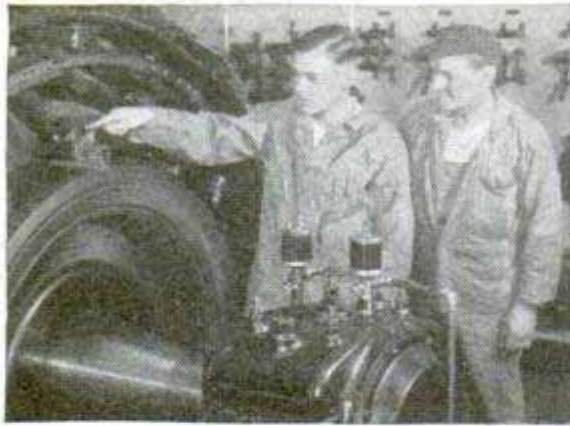

## Electrical Engineering Learn at Home

ONE of the best ways to prepare for a good position in the Electrical field or to have a business of your own is through the home-study courses of the International Correspondence Schools.

Nearly \$200,000 has been spent in the preparation of these courses and they have been endorsed by Thomas A. Edison and Charles P. Steinmetz—the late “electrical wizard” of the General Electric Co.

Here are some of the men who have prepared these courses:  
EDGAR KNOWLTON—Electrical Engineer, Alternating Current Engineering Department, General Electric Co.

J. LESTER WOODBRIDGE, E.D. and M.E.—Chief Engineer of the Electric Storage Battery Co.

S. A. FLETCHER—Electrical Engineer, Superintendent of Service, Alabama Power Co.

S. H. MORTENSON—Designer of Alternating Current Motors and Generators, Allis-Chalmers Manufacturing Co.

O. J. BUSHNELL—Supt. of the Meter Dept., Commonwealth Edison Co.

*Mail Coupon for Free Booklet*

INTERNATIONAL CORRESPONDENCE SCHOOLS  
Box 5700-F Scranton, Penna.

Without cost or obligation, please send me a copy of your booklet, “Who Wins and Why,” and full particulars about the course before which I have marked X in the list below:

- |  |   |
|--|---|
| <input type="checkbox"/> Electrical Engineer                             | <input type="checkbox"/> Electric Draftsman                                 |
| <input type="checkbox"/> Electrician                                     | <input type="checkbox"/> Electric Car Running                               |
| <input type="checkbox"/> Electric Wiring                                 | <input type="checkbox"/> Electric Machine Designer                          |
| <input type="checkbox"/> Electric Lighting                               | <input type="checkbox"/> Radio  |
| <input type="checkbox"/> Architect                                       | <input type="checkbox"/> Plumber and Steam Fitter                           |
| <input type="checkbox"/> Architectural Draftsman                         | <input type="checkbox"/> Plumbing Inspector                                 |
| <input type="checkbox"/> Building Foreman                                | <input type="checkbox"/> Foreman Plumber                                    |
| <input type="checkbox"/> Concrete Builder                                | <input type="checkbox"/> Heating and Ventilation                            |
| <input type="checkbox"/> Contractor and Builder                          | <input type="checkbox"/> Sheet-Metal Worker                                 |
| <input type="checkbox"/> Structural Draftsman                            | <input type="checkbox"/> Steam Engineer                                     |
| <input type="checkbox"/> Structural Engineer                             | <input type="checkbox"/> Marine Engineer                                    |
| <input type="checkbox"/> Reading Shop Blueprints                         | <input type="checkbox"/> Refrigeration Engineer                             |
| <input type="checkbox"/> Telegraph Engineer                              | <input type="checkbox"/> R. R. Positions                                    |
| <input type="checkbox"/> Telephone Work                                  | <input type="checkbox"/> Highway Engineer                                   |
| <input type="checkbox"/> Mechanical Engineer                             | <input type="checkbox"/> Chemistry <input type="checkbox"/> Pharmacy        |
| <input type="checkbox"/> Mechanical Draftsman                            | <input type="checkbox"/> Coal Mining Engineer                               |
| <input type="checkbox"/> Machine Shop Practice                           | <input type="checkbox"/> Navigation <input type="checkbox"/> Assayer        |
| <input type="checkbox"/> Toolmaker <input type="checkbox"/> Patternmaker | <input type="checkbox"/> Iron and Steel Worker                              |
| <input type="checkbox"/> Civil Engineer                                  | <input type="checkbox"/> Textile Overseer or Supt.                          |
| <input type="checkbox"/> Surveying and Mapping                           | <input type="checkbox"/> Cotton Manufacturing                               |
| <input type="checkbox"/> Bridge Engineer                                 | <input type="checkbox"/> Woolen Manufacturing                               |
| <input type="checkbox"/> Gas Engine Operating                            | <input type="checkbox"/> Agriculture <input type="checkbox"/> Fruit Growing |
| <input type="checkbox"/> Automobile Mechanic                             | <input type="checkbox"/> Poultry Farming                                    |
| <input type="checkbox"/> Aviation Engines                                | <input type="checkbox"/> Mathematics  |

### BUSINESS TRAINING COURSES

- |  |   |
|--|---|
| <input type="checkbox"/> Business Management                     | <input type="checkbox"/> Business Correspondence      |
| <input type="checkbox"/> Industrial Management                   | <input type="checkbox"/> Show Card and Sign Lettering |
| <input type="checkbox"/> Personnel Management                    | <input type="checkbox"/> Stenography and Typing       |
| <input type="checkbox"/> Traffic Management                      | <input type="checkbox"/> English                      |
| <input type="checkbox"/> Accounting and C. P. A. Coaching        | <input type="checkbox"/> Civil Service                |
| <input type="checkbox"/> Cost Accounting                         | <input type="checkbox"/> Railway Mail Clerk           |
| <input type="checkbox"/> Bookkeeping                             | <input type="checkbox"/> Mail Carrier                 |
| <input type="checkbox"/> Secretarial Work                        | <input type="checkbox"/> Grade School Subjects        |
| <input type="checkbox"/> Spanish <input type="checkbox"/> French | <input type="checkbox"/> High School Subjects         |
| <input type="checkbox"/> Salesmanship                            | <input type="checkbox"/> Cartooning                   |
| <input type="checkbox"/> Advertising                             | <input type="checkbox"/> Illustrating                 |
|  | <input type="checkbox"/> Lumber Dealer                |

Name.....

Address.....

City.....State.....

Occupation.....

*If you reside in Canada, send this coupon to the International Correspondence Schools Canadian, Limited, Montreal, Canada*



## Get Strong! Eight Improved Muscle Builders All for \$3.75



Easily master feats which now seem difficult. If you want physical culture for health this equipment is what you need. **SAVE AT LEAST HALF!** We furnish ten cable chest expander adjustable to 200 lbs. resistance. Made of new live extra strength rubber to give resistance needed for sure muscle development. Pair of patented hand grips develop powerful grip and arm. Wall exercising parts develop back, arms and legs. Head strap permits exercise of neck muscles. Develop leg muscles with foot strap—gives speed, endurance. Illustrated course shows how to develop any part of body.

**GUARANTEE**  
Entire satisfaction guaranteed or money back.

### Send No Money

Send name and address. We send all by return mail. Pay postman \$3.75 plus postage.

### MUSCLE POWER CO.

Dept. PM-9  
150 Nassau Street  
New York



## NERVES?

Are You Always Excited? Fatigued? Worried? Gloomy? Pessimistic? Constipation, indigestion, cold sweats, dizzy spells and bashfulness are caused by NERVE EXHAUSTION. Drugs, tonics and medicines cannot help weak, sick nerves! Learn how to regain Vigor, Calmness and Self-Confidence. Send 25c for this amazing book. RICHARD BLACKSTONE, N-479 FLATIRON BUILDING, N. Y.

## Great New Invention

For Seekers of Health — Power — Beauty

**ELCO ELECTRIC HEALTH GENERATOR**  
Generates High Frequency Violet Ray, Mechanical Vibration, Medical Electricity and Ozone. Four of Nature's Greatest Curative Agents. For Home Treatments at less than 50 cents per year.

**FREE BOOK** "Health, Power, Beauty" describing this Great New Invention. Re-vitalize yourself. Bring back energy. Be wholly alive. Write Today. Lindstrom & Co., 2322 Indiana Ave., Dept. 13-56, Chicago

## FREE Radio Handbook

Write today for your copy of the new Radio Association handbook. Shows you easy ways to make money in Radio. Tells you how our members are cleaning up \$3.00 an hour spare time. Write for Membership Plan which need not cost you a cent and **FREE RADIO HANDBOOK.**

**RADIO TRAINING ASSOCIATION OF AMERICA**  
Dept. PM-9  
4513 Ravenswood Ave., Chicago



# If I Send You a Suit



made to your measure in the latest style, would you keep and wear it, show it to your friends, let them see our beautiful samples and splendid new styles? Could you use \$3.00 an hour for a little spare time? Just write a letter or postal or fill out and mail coupon at side for my big new Swatch Line Sample Outfit and my new, special offer **FREE**. Even if you don't care to be agent, send anyway and learn how to get all your own clothes **FREE**. Fill out coupon and mail.

L. E. ASHER

**BANNER TAILORING CO.**  
Dept. 25 Chicago, Ill.

← Fill out coupon at side and mail →

Send me your special offer, **all FREE.**

Name.....

St. & No.....

Town..... State.....

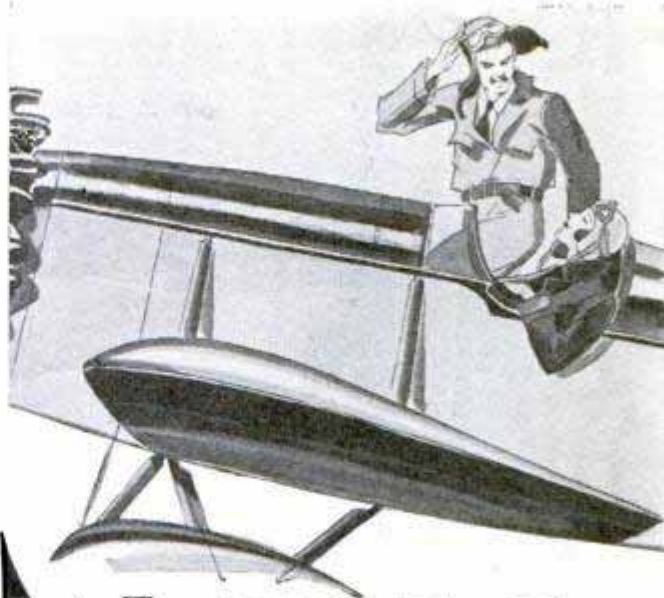

# WINGS! for you!

Get into the wide open spaces where no limits are placed on either speed or opportunity. Aviation is the fastest moving industry in this swift moving age. It is a young man's game and a young man's opportunity. This is the chance of a life time for fellows with ambition and determination to succeed, to enter a brand new business and grow with it to financial success and power. Without a doubt, aviation is just beginning its biggest development. It is high time for you to make a start in what is destined to become one of the world's most important industries.

Universal Aviation Schools will train you in any branch of aviation you wish to enter. If you wish to become a pilot, mechanic, welder, or enter the business end of aviation, this National System of Government Approved Aviation Schools has just the course you need and the highest type of equipment and personnel to train you. Send for a copy of the book, "Aviation—What It Means To You," which describes all that Universal Aviation Schools have to offer you and gives full information about training and tuition. Write for your copy of this free book today.

**Sent free** This interesting book about Aviation beautifully illustrated. Contains a wealth of information. Sent free to men interested in entering aviation. Clip the coupon below and mail.

011R1

## BIG SIX-TUBE RADIO GIVEN

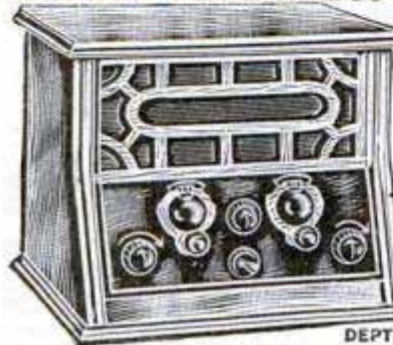

Big 17x22x13 inch radio set, licensed under R. C. A. Patents. Regular price \$50. Greatest premium offer ever made. Given for selling only 12 bottles Perfume at 25c each, giving Perfume Novelities free and remitting as per plan in catalog. Send no money. We trust you.

TREVAUX  
PERFUME CO.

DEPT. 5A78 CHICAGO

## Dentists Need Men



Experts  
Earn up  
to

**\$125<sup>00</sup>**  
a week

**Make Crowns, Plates, Bridgework, etc. for Dentists**

We teach you to make rubber plates, crowns, bridge work, metal base dentures, etc., for dentists. After graduating you are ready for a job or can open your own laboratory. We assist you.

### Demand for Men

Thousands of dentists everywhere send work to mechanical dentists. We train you quickly in day or night school for this uncrowded field. No classes—no books—no mechanical experience necessary.

Work your way thru school. We help you find a job to meet your expenses while taking our training. Railroad fare allowed to nearest school.

### MAIL COUPON FOR FREE BOOK

McCARRIE SCHOOL OF MECHANICAL DENTISTRY,  
1338 S. Michigan Ave., Dept. 412, Chicago.

Without cost or obligation, send me your illustrated book on Mechanical Dentistry, and complete information as to my opportunities in dental laboratory work.

Name.....

Address.....

MAIL this Coupon

## UNIVERSAL Aviation Schools

Division American Airways, Inc.

Box S-103, Lambert-St. Louis Field, Robertson, Mo.

Please send me, without obligation, a copy of "Aviation—What It Means to You," and advise me what training I need to become

Pilot  Mechanic  Welder  Office Executive

Name..... Age.....

Address..... Phone No.....

City..... State or province.....

My past experience other than aviation is



PLEASE PRINT CLEARLY



**- FOR STEADY WORK & BIG PAY-LEARN**

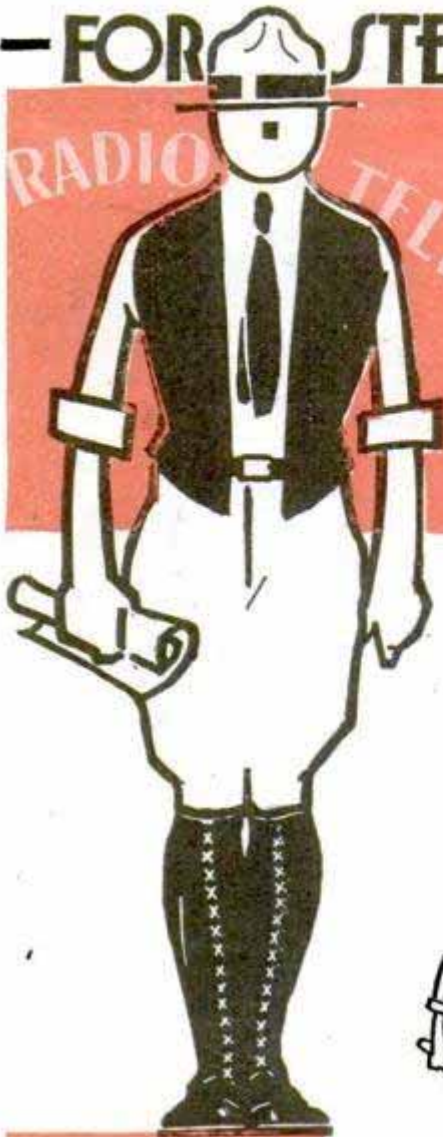

**ELECTRICITY**

The "DADDY" of THEM

ALL

Be wise—be foresighted—if it's good pay you want—a steady job with a real future — answer the call of **Electricity**—the "daddy" of them all —the giant of American industry—one of the world's greatest employers of well paid men.

Learn **Electricity** first—learn it easily and quickly in your spare time—the **L. L. Cooke way!** Prepare yourself to step into a steady job, where others easily earn **\$60 to \$100 a week** and more, in Radio and Television, Electrical Contracting, Power Plant Work, Aircraft and Automotive Electricity, or Talking Movie work.

Today as never before **Electricity**, on which all other industries depend, offers amazing opportunities! Get into this big pay field—**act now**—learn **Industrial Electricity!** It's the key to success in the most interesting, best paying work in the world—and it's remarkably easy to learn the **L. L. Cooke way.**

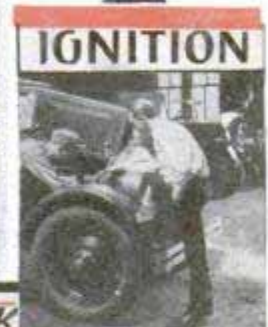
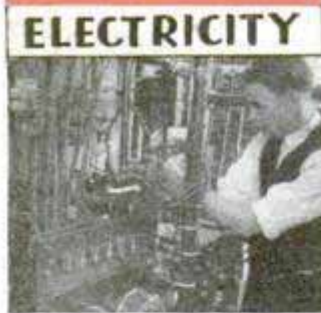

**Learn Electricity the Cooke Way and you learn them all . . . . .**

Practical Electricity, Radio, Television, Aircraft and Auto Electricity. It's the great **ALL-IN-ONE** Training—made easy by the famous **Work Sheet and Job Ticket Method.** You **learn by doing!** Six Big Outfits of Tools and Apparatus furnished **without extra cost.**

Write to "headquarters" for advice and information—investigate the school that is now preparing hundreds of men, and has prepared thousands, just like yourself, for big pay jobs in the world's greatest industries. **Don't wait** — mail the coupon for Big **FREE** Opportunity Book—**today!**

**L. L. COOKE SCHOOL OF ELECTRICITY**  
 Dept. 16                      2150 Lawrence Ave.                      CHICAGO



**FREE BOOK**

**L. L. Cooke School of Electricity, Dept. 16, 2150 Lawrence Ave., Chicago.**

Without obligation, send me your book "Secrets of Success in Electricity" and tell me about your **ALL-IN-ONE** Training—your **Money Back Agreement** and **Job Service.**

Name.....  
 Street.....  
 City..... State.....



# Classified Advertisements

## WORLD'S BEST WANT AD MEDIUM

Advertisements in this section, 35 cents per word, each insertion, minimum 10 words, payable in advance.

To be printed under proper classification in October issue, copy should be in our office August 18th.

### ADVERTISING AGENCIES

**ADVERTISE**—24 Leading Sunday newspapers, 24 words \$15.00. Excellent for obtaining help, salesmen, or business opportunities. Information 1,000 best paying dailies, mail-order weeklies, monthlies, mailing lists, everything. Free. Wade Agency, Great Northern Bldg., Chicago.

**GET** into advertising. Learn quickly at home. Experience unnecessary. New easy plan. No text books used. Practical work. Old established school. Send name and address for interesting free booklet. Page-Davis School of Advertising, Dept. 343-C, 3601 Michigan, Chicago.

**OBTAIN** canvassers, distributors through publication advertising. Martin, 276B West 43d, New York.

**BEFORE** advertising get our catalog. No charge. 25 years in business. The largest classified agency in the world. Ankrum Advertising Agency, 100 No. LaSalle St., Chicago, Ill.

**FREE**—New 1930 Advertisers Rate Guide, 44 pages. Includes everything. Lowest rates. E. H. Brown Advertising Agency, 140 S. Dearborn, Chicago.

**TIME** Counts in applying for patents. See pages 134 and 135. Clarence A. O'Brien, Registered Patent Attorney, Washington, D. C.

**INCH** Display advertisement 50 magazines year \$24. Wood's Popular Services, Atlantic City, N. J.

**ADVERTISE** in rural weeklies. Lists free. Meyer Agency, 4112 Hartford, St. Louis, Mo.

**REACH** Southern Negroes through their own newspapers. Write R. L. Stricklen, Jr., Box 661, Staunton, Va.

### FOR ADVERTISERS

**ADVERTISERS:** How are your results? Are you using the right media? Is your copy right? Send samples of your literature and outline of your advertising plan with \$10 for frank constructive criticism. Chicago-Union Advertising Agency, 20 W. Jackson Blvd., Chicago.

**ADVERTISING:** 20 Words, 50 magazines, 60c; three insertions, \$1.20; circulars mailed, 400, \$1.00. Mailing Bureau, Lawndale, Calif.

**ADVERTISE** in country papers: low rates; lists free. Keator, Hartford Bldg., Chicago.

### SALES PROMOTION

**WRITE** Any sales letter or advertisement, one dollar. Advertising specialist; national experience. Komarco, 931 Pine, Long Beach, Calif.

**SEND** Dollar bill for analysis of your sales plan. Banning, Times Building, Watertown, N. Y.

### INFORMATION SERVICE AND COUNSEL

**ANY** Information desired. Where to buy—where to sell. Expert advice on problems bothering you. Mail \$1 bill. Specialty Expert, Box 273, Saginaw, Michigan.

**MEN** And women, send for information on the great 1933 "Chicago's Worlds Fair," now under construction. Send \$1.25 to, Schulberg Co., Box 1194, Chicago, Ill.

**THE** Outdoor season is here. Send for a copy of our book entitled "Outdoor Sports the Year Round." It is on making all sorts of devices for outdoor recreation. Pay postman price, \$1.50, and few cents postage when delivered. Popular Mechanics Press, Room 807, 200 E. Ontario St., Chicago.

**REFRIGERATING** Machine, homemade. Inexpensive to build. Gives better service than ice. This and 328 other practical articles in our book "Home Mechanics." Just ask for this and "Handbook for Women," containing 394 valuable household helps and pay postman 98 cents and postage for the two books. Popular Mechanics Press, Room 801, 200 E. Ontario St., Chicago, Ill.

### AUTOMOBILES

**TIME** Counts in applying for patents. See pages 134 and 135. Clarence A. O'Brien, Registered Patent Attorney, Washington, D. C.

**ELECTRICAL** Trouble shooting on the motor car and airplane. Don't trust to luck or guess work. Learn to make every motion count in testing and repairing. Send for our standard 493-page book for electricians and mechanics. 300 diagrams. Hundreds of practical tests. Pay postman \$4.00 plus postage when delivered. If outside U. S. remit when ordering. Popular Mechanics Press, Room 801, 200 E. Ontario St., Chicago.

### AUTO-SUPPLIES

**INEXPENSIVE** Sets—Ford Chevrolet, Hudson, Essex, all cars—Ask automobile dealer—"Safety" mirror-hinge attached—chromium, \$2.00. Seat springs \$1.00 set, guaranteed. Catalog sent on request. Universal Spring Co., 550 Bond Ave., Grand Rapids, Mich.

**CHROMIUM** Plating powder plates iron, steel, brass, copper and silver, without electricity or machinery. Guaranteed not to tarnish; ½ pint can \$1.50 prepaid. Gunmetal Co., Ave. J, Decatur, Ill.

**CARBON** Remover, simple as filling your radiator. No burning or removing parts. Liberal supply 50c. prepaid. W. Mey, 3811 W. Grand Ave., Chicago.

**ELECTRIC** Arc welding proving profitable automotive shops. Easy payments on gasoline or electric. Hobart Brothers Welding Division, Box M-907, Troy, Ohio.

**NEW** Auto parts 25-50%. Motors, rear-ends, radiators, wheels, generators, carburetors, brakelining 50%. Used parts 40-80% off. Brightman, 2065 Main St., Hartford, Conn.

**PROFITABLE** Electric trouble shooting with new and reconditioned, attractively priced test benches. Easy terms, trial. Mitchell Company, Box M-906, Troy, Ohio.

**RADIATORS:** All standard makes at wholesale. Guaranteed. Send for prices. State make, model. Independent Radiator Co., 1119 So. Wabash, Chicago.

**CARBURETOR** Information every auto service man needs will be found in special carburetor supplement to the famous Dyke Auto Encyclopedia. Deals with every make of carburetor. 106 pages. 246 illustrations. Price \$2. Sent C. O. D. if you prefer. Popular Mechanics Press, Room 801, 200 E. Ontario St., Chicago, Ill.

### AUTO SERVICE EQUIPMENT

**COMPRESSORS,** Twin automatic, 8 hour battery chargers, 20-minute car washers, test benches, paint sprays, \$20 monthly. Pays for itself without investment. Guaranteed. Write Ken's Service, Box M-905, Troy, Ohio.

**BARGAINS** in new guaranteed battery chargers; direct from factory. Circulars free. Adams Barr Corporation, Columbus, Ohio.

**RECONDITIONED** Bargains in car washers, battery chargers, compressors, test benches, many only used few months. Easy terms and trial, guaranteed. Mitchell Electric, Box M-904, Troy, Ohio.

### FOR FORD OWNERS

**NEW** Model "A" Ford Textbook—Containing more than 350 mechanical questions and answers on the Model "A". Covering latest approved methods of Ford car repairing. Every detail explained in a non-technical manner. Handy pocket size. First volume of its kind ever published. Send \$1.00 today for "Questions and Answers on Ford Service" to Trade Press Publishing Company, 128 E. Michigan Street, Milwaukee, Wisconsin.

**USE** Shortcuts in Figures. Save valuable time. The quickest ways of working all problems. Instructions for drilling yourself to become rapid with figures. Complete, yet simplicity itself. Just write a postal for "Shortcuts in Figures." Pay postman \$1.25 and postage. Popular Mechanics Press, Room 801, 200 E. Ontario St., Chicago, Ill.

**AUBORA** Underlugs parts and 3.1 racing gears. Speedster bodies, headlights hi compression head. See Sport Factories ad page 122.

### MOTORCYCLES

**REBUILT** Motorcycles, \$25 to \$100. Easy terms. Used tires \$2.50. New tires \$5. Wheels \$2. New automobile tires \$3. Frames \$3. Forks \$3. Saddles \$3. Handle bars \$3. Chains \$2. Belts \$5. Transmissions \$12. Tanks \$3. Parts, Engines, Side cars. Save you dollars. Prices. Send 50c for catalogues. Price Cutter Deninger, Rochester, N. Y.

**MOTORCYCLE** Bargains, lowest prices, bargain sheets for stamp, special aviators supplies, motorcycle accessories largest line in America, lowest prices. Largest motorcycle mail order house in the United States. Rochester Harley Davidson Corporation, 129 West Main St., Rochester, N. Y.

**HENDERSON,** Excelsior, Indian, Harley used motorcycles, parts and engines cheap. Aircraft conversions and parts. Catalog free. Ballak & Co., 100 N. 12th, St. Louis, Mo.

**HEADQUARTERS** For Henderson and other motorcycles, parts and accessory bargains. Largest stock, lowest prices. Good machines as low as \$100. Send for list. Wiedeman, 3517 North Avenue, Chicago.

**HARLEY** Davidson bargains at a tremendous sacrifice. All models and prices. Guaranteed. Send 4 cents in stamps for our catalog. "Money Saving Motorcycle Bargains." The Knuth Co., 2525 Fond du Lac Ave., Milwaukee, Wis.

**REPAIR** With good used parts, save ½ or more, state parts needed, no lists. J. B. Dahl, 3661 Archer Ave., Chicago, Ill.

**MOTORCYCLE** Parts, new and used. Lists free. Tower Cycle Co., Pine Lawn, Mo.

### AVIATION

**BANKRUPT** Sale, lifetime opportunity, secure airplane parts at less than 10c on the dollar, extraordinary values. Glider seats \$1.95, 13 gallon gas tanks \$2.95, 25000 feet air service altimeter \$3.95, hand pressure pumps \$1.50, tachometers 2400 RPM \$4.95, 3" red or green lenses 50c, 6, 8, or 12 cylinder aircraft magnetos \$6.50, Stromberg carburetors, original cost \$375.00—given away \$4.95. No junk, everything brand new. Box 313, Mineola, N. Y.

**BUILD** Your sport plane from time-tested successful plans. Heath plans have 22 years experience behind them—and are endorsed by pilots everywhere. Large detailed shop prints of the famous Heath parasol at only \$5.00 per set clear and easy to follow. Don't take chances with plans of unproven value. 10 cents for large illustrated booklet. Heath Aircraft Corp. Dept. CL6P—Chicago, Illinois.

**AEROPLANE** Radio telegraph transmitters, with generator, airfan, casing and mounting bracket, \$10.50. Flying suits, helmets, portable telephones, set boxes, interphones, receiving sets, binoculars, telescopes. For descriptions, prices, etc., write, J. M. Siegel, Desk Three, 1440 So. Racine Ave., Chicago, Ill.

**AIRCRAFT** Supplies, propellers, 4', \$8.75; 5', \$13.25; 6', \$16.50; "Aerodrive" boat and sled blueprints, special, 25c each. Five different types blueprints only \$1.00. Primary glider blueprints, complete set only \$2.50. Ostergaard Aircraft, 4305 North Narragansett, Chicago.

**HEATH** Parasols—Now you can fly your own plane! Start building the famous Heath parasol, for only \$12. Highest quality parts sent you in 11 convenient progressive groups. Cost of parts complete only \$199. Heath plans declared clear and easy to follow by enthusiastic builders everywhere. Send 10 cents today for large illustrated booklet. Heath Aircraft Corp.—Dept. CL4P—Chicago, Illinois.

**AIRPLANE** Designer (calculation device) gives all dimensions and performances of your airplane you are building. Price \$1.00. Aerocalculator, Peru, Indiana.



**HEATH** Henderson Aircraft Motors—use 50% less fuel than any other aircraft motor in the country. The only successful light plane motors in America. Can be purchased as low as \$190 remanufactured or \$325 brand new. Completely guaranteed. Back by 22 years of constant improvements. 10 cents for large illustrated booklet. Heath Aircraft Corp. Dept. CL5P Chicago, Illinois.

**AVIATION** Books—Send for our 24 page illustrated catalog, the most complete published, describing the latest and best books of all publishers on every phase of flying. Sent free upon request. Popular Mechanics Press, Room 807, 200 E. Ontario St., Chicago.

**HENDERSON** And big V motors, metal tipped propellers \$9.95 each. Hibbs, Ft. Worth, Texas.

**BUILD** Our tapered low-wing monoplane for 2 passengers, large blueprints \$3.25. Brewold Lindahl Co., Box 19, Star Route, Medford, Ore.

One Pair new 18x3 wheels \$16.00 with tires etc., \$34.00. Latest 30 page catalog 10c. Kamm Aircraft Co., 524 12th, Oshkosh, Wis.

"If You want to fly" let Alexander Klein, brilliant engineer, teach you. With great skill whole course of training has been simplified and made crystal clear. Remarkable book teaches in most practical and easily understood fashion. Recommended by skilled flyers. Sent C.O.D. anywhere in U. S. Simply pay postman \$2.50 and postage when delivered. Sent postpaid to any address upon receipt of price. Popular Mechanics Press, Room 801, 200 E. Ontario St., Chicago.

**MEAD** Gliders are making glider history! For information about the complete knock-down construction kit at \$89.50 see our advertisement on page 42 or send 10c to Mead Gliders, Dept. B4, 12 S. Market St., Chicago.

**STUDENT** Flyers—You can easily earn more solo time by our plan. Artas Sales Co., 2219 Ohio Ave., Cincinnati, Ohio.

2c **POSTAGE** Stamp will bring you complete model airplane supplies price list. A. A. C. Model Aircrafters, 4719 Third Avenue, New York.

**AIR** Navigation and meteorology—A practical book for every flyer. Capt. R. Duncan, the author, has presented the subject in a simple, non-technical way. 243 pages. Illustrated. Delivered to your door C. O. D. Simply pay postman \$3 and postage. Popular Mechanics Press, Room 801, 200 E. Ontario St., Chicago.

**AIRPLANE** Magnetos. All types and makes. Also parts. Prices cut in half. Magneto Brokerage Company, 104 North Halsted St., Chicago, Illinois.

**FLYING** Simplified—Just out. Here is a remarkable non-technical book for beginners, prospective or advanced students that teaches in an easily understood manner all you can need to know to master the art of flying. Will save you many dollars when you learn to fly. Pay postman only \$1 and postage when book is delivered at your door C. O. D. Popular Mechanics Press, Room 802, 200 E. Ontario St., Chicago.

**BOYS, Girls, 10-weeks'** aviation course \$2 or send 25 cents for first lesson. Money back guarantee. Details free. NYFL, Box 40, Syracuse, N. Y.

**DECORATE** Your club or den with real airplane propellers. 8 feet long, beautiful new ones, highly polished, \$8.00; used ones \$5.00. Air Transport Equipment, Garden City, N. Y.

**BIGGEST.** Best catalog model airplanes; parts, supplies; 5c postpaid. Ideal Company, 19 West 18th St., New York.

**TIME** Counts in applying for patents. See pages 134 and 135. Clarence A. O'Brien, Registered Patent Attorney, Washington, D. C.

**AVIATION**—Every person seriously interested in this subject should make full use of the opportunity to learn aerodynamics with Alexander Klein as his instructor, through his timely new book, "Simplified Aerodynamics." Heretofore this subject has been rather difficult for the thousands who need it but Klein's method enables all to master it. Every pilot, mechanic, student needs this book. Pay postman price, \$3.50, and few cents postage when he delivers it. Order from Popular Mechanics Press, Room 807, 200 E. Ontario St., Chicago.

"CITY Of Chicago" World's Duration Plane 30" plan 10c. Model Aviator, Dept. PM, 605 Washington, Chicago.

**GLIDER** Scale model construction sets. Primary, 38" wing, \$1.15. Advanced, 42" wing, \$2.15. Send 25c for full size 38" wing airplane plan and catalog. Selley, 1371 Gates Ave., Brooklyn, N. Y.

SEND 5c For bundle of balsa, reeds and price list on supplies. Aero Shop, 3050 Hurbit Ave., Detroit, Mich.

**STUNT** Flying—A new book of flight instruction that is different. The author, Capt. Richard Duncan, has developed in this book a unique system of practicing and working out your flight maneuvers on the ground. Use it and learn as other great flyers have done. Will save you hours of costly flying practice. 185 pages, 32 illustrations, cloth. Sent C. O. D. Pay postman price \$2.50 and small amount of postage upon delivery. Popular Mechanics Press, Room 806, 200 E. Ontario St., Chicago, Ill.

### BOOKS AND PERIODICALS

**HYPNOTISM** Easily learned. Lessons guaranteed. Postpaid \$1.10. Smith Pub. Co. Dept. 3, Springfield, Mass.

**A BILLION** Ideas. This is the title of our remarkable catalog of books along practical lines. Arranged alphabetically by subjects for easy reference. If you have not received it, send for a copy. You will find hundreds of subjects you cannot usually locate in book stores or public libraries. Sent free upon request. Popular Mechanics Press, Room 807, 200 E. Ontario St., Chicago.

**INDUSTRIAL** Alcohol. Complete directions for making. Fully illustrated. \$2.50. Spon & Chamberlin, 120 Liberty St., New York.

**WELDING** Encyclopedia. The latest, completely revised 1930 edition of this famous book contains every known fact regarding every kind of welding. Covers such up-to-date subjects as aircraft welding. 542 pages. Illustrated. Flexibly bound. Sent C. O. D. Pay postman price, \$5 and small amount of postage upon delivery. Popular Mechanics Press, Room 806, 200 E. Ontario St., Chicago, Ill.

### PICTURES AND POSTCARDS

100 **PHOTOGRAPHIC** Postal cards from your negative \$3.00. From photo \$3.30. Samples. Tuculat Studio, Hillsdale, N. J.

### GAMES, ENTERTAINMENTS AND PLAYS

**PLAYS** Musical comedies and revues, minstrels, comedy and talking songs, black-face skits, vaudeville acts, monologs, dialogues, recitations, entertainments, juvenile plays and songs, musical readings, make-up goods. Catalog free. T. S. Denison & Co., 623 So. Wabash, Dept. 11, Chicago.

**READ** Sealed Messages in Dark; messages retained by audience; burned message appears on black slate; spirit message appears on slate in sitter's presence; spirit rappings; spirits appear in the dark; answer questions written on folded papers while blindfolded. All this you can do with directions in "Behind the Scenes with The Mediums." 69 best secrets of mediums fully exposed. The best because most baffling, yet all easy to do. Send no money. Just write a postal. Pay postman \$1.50 and postal charges. Popular Mechanics Press, Room 801, 200 E. Ontario St., Chicago, Ill.

### NOVELTIES AND CURIOS

**POCKET** Trick. Mystic match, elusive peg. 50c postpaid. Ridge Co., Box 202, Ridgewood, N. J.

### MAGIC TRICKS, BOOKS AND JOKER NOVELTIES

"THE Book of 1,000 Wonders" explains many mystifying tricks with coins, cards, handkerchiefs, etc. Also contains complete catalog magic tricks, jokes, puzzles, books, and imported novelties. Largest assortment, lowest prices. Amaze and mystify your friends. Send 10c today. Lyle Douglas, Station A-5, Dallas, Tex.

**THE** Three and one card mystery. Sensational. A real stage trick. Easy to perform. Special cards and instructions 50c. Our new magic catalogue, 10c. Halray Enterprises, Spitzer Bldg., Toledo, Ohio.

**IT'S** New—It's clever. Mystify your friends with a disappearing pencil. Easy to do. Send 15c (regular price 25c) for pencil and catalog of tricks, jokes, magic. Magic-Novelties Co., Hutchinson, Kansas.

**MAGIC**—Tricks, Books and Supplies. For amateurs as well as the great professionals. Anyone can learn through our instructions. Feature Acts in Mind-Reading, Spiritualism, Rope Ties, etc. Large illustrated professional catalog, 20c. Chicago Magic Co., 140 So. Dearborn St., Dept. B, Chicago, Ill.

**200 TRICKS** You can do—Mystify your friends; have loads of fun. This collection of tricks has been selected by Thurston for the average person. Neither unusual skill nor elaborate apparatus are required. Send for this 200-page illustrated book. Pay postman \$1 plus postage when delivered. If outside U. S. remit when ordering. Popular Mechanics Press, Room 801, 200 E. Ontario St., Chicago.

**MAGIC** Catalog 20c. Lynn, 103 Beach, Dept. 3, Jersey City, N. J.

**CARD** tricks, Coin Tricks, Hypnotism, Ventriloquism, 4 instructive 64 page books, 10 each. Geo. Fenner, 2401 Jefferson, Louisville, Ky.

**MEXICAN** Jumping Beans. Samples with game card. 35c, quantity prices with first order. Midwest Novelty, 1312 Main, Kansas City, Missouri.

**ELECTRIC** Fun! 200 stunts, 110 volts, \$1. Kutling Sons, Campbell, Calif.

**CARTOONING.** Complete course in. New book on How to Draw Funny Pictures with over 200 original illustrations by "Zim" has student begin with simple studies and work up to most difficult cartoon compositions. Delivered to your door C. O. D. Simply pay postman \$3 and postage. Popular Mechanics Press, Room 801, 200 E. Ontario St., Chicago.

### RADIO SETS AND SUPPLIES

**BIG** New radio catalog. Just off press. Lowest prices on standard radio parts, sets, accessories. Radiotron tubes, etc. Prompt service. Satisfaction guaranteed. Nelson Electric Company, 508A South Dearborn, Chicago, Illinois.

**TUNING** Fork—Piano. No more tuning; Silent practicing (earphones); or Loudspeaker performance. Pat. No. 1753069. Max Schumm, 94 Crouch St., Rochester, N. Y.

**TIME** Counts in applying for patents. See pages 134 and 135. Clarence A. O'Brien, Registered Patent Attorney, Washington, D. C.

**NEW** 300-Mile "pocket" radio, \$3.85. Complete with special loud receiver. No tubes or batteries required. Order direct. Spencer Laboratories, 116 Atlas, Akron, Ohio.

**BEST** Books for \$1. All formerly sold for \$2.50 to \$5 each. Select from the following list of guaranteed bargains. All brand new books: Woodcraft by Seton, Book of Letter Writing by Crowther, Etiquette by Eichler, Creative Chemistry by Slosson, Lawn Tennis by Tilden, also Revolt in the Desert by Lawrence, Trader Horn, White Shadows in South Seas by O'Brien, Count Luckner (The Sea Devil) and Outline of History by Wells. Delivered at your door C. O. D. Simply pay postman \$1 each and postage. Popular Mechanics Press, Room 801, 200 E. Ontario St., Chicago.

### CHALK TALKS

**AMAZING** Magical cartoons, \$1.00. Sample plates 10c. Fleishman Syndicate, 3333 Wilson Ave., Bronx, New York.

**LAUGH** Producing program, \$1.00. Catalog free. Balda, The Cartoonist, Oshkosh, Wis.

**CHALK-TALK** Your way to popularity. Audiences at your feet if you learn how to entertain with a few simple pictures. Little artistic ability needed. "How to Chalk Talk" tells what to say and what to draw. Profusely illustrated. Make money giving chalk talks. Just order on a postal. Pay postman \$1.00 and postage when delivered. Popular Mechanics Press, Room 801, 200 E. Ontario St., Chicago, Ill.

### STAMP COLLECTING

**MYSTIC** "Queer Country" Packet! Contains scarce stamps from the following strange lands: San Marino, Antioquia, Congo, Cyprus, Fiji Islands, Gwalior Hyderabad, Iceland, Jhnd, Kenya, Uganda, Lebanon, Monaco, North Borneo, Nyassa, St. Thomas Prince, Eastern Roumelia, Siam, Sierra Leone, Tanganyika, Trinidad Tobago, Ubangi, Upper Volta, Wallis Futuna, Alauites. Get this wonderful packet of "freak countries" and make your friends envious! Price only 10c to approval applicants! Write today. Mystic Stamp Company, (Dept. 8), Camden, N. Y.



**FREE!** Largest stamp in the world! Fine packet 65 different stamps from Cape Verde, Jamaica, Mozambique, Syria, etc., including dying soldier, beautiful women, ships, maps, savages, airplane scenes, bird and animal stamps, for only 5c to approval applicants. Largest Stamp in the World (Rare China Wild Goose Special Delivery) given absolutely free with each order. Supply limited! Send your 5c today! Western Philatelists, 6021 Harper Ave., M9, Chicago.

**THRILLING** War scenes. A packet of all different stamps showing exciting scenes and records of nations at war. Include siege guns; firing squad; mounted troops; prisoners of war; fire-pot hurlers; hand-to-hand bayonet struggle; bloody battle scenes; troop transport; red cross stamp; dying soldier; victory stamps, etc. Send for this thrilling "Big Parade" packet at once—limited supply. Only 10c to approval applicants. W. A. Rowell 58 Cornhill Boston Mass.

**ANCHEKS** \$\$\$ Outfit—only 12c! Fine triangle stamp; set German stamps with (pre-war) value forty million dollars (interesting!); perforation gauge, mm scale; airmail set; scarce stamp from smallest republic on earth; newspaper set packet good stamps and Tranvancore, Malay, Dutch Indies, etc. Entire outfit for 12c to approval applicants! (Nice pocket stock book, value 25c, with every order!) Ancher Stamp Co., Box 47, Rutherford, N. J.

**FREE**—Scarce Hawaii Scott Number 66, Catalog value 15 cents, perfect mint copy to approval applicants who send 10c for our 19th century "Classics" package. This package contains 10 different stamps from 10 different countries, which are the pride of all collectors. The youngest of the stamps is 50 years old, the oldest is 70. Don't wait, send your dime quick for this amazing offer before they are all sold out. Globus Stamp Co., 214 Third Ave., New York City.

**FREE** 100 Different with 50% approvals. Send 2c postage. Evanston Stamp Shop, 2412 Noyes, Evanston, Ill.

**RARE** Set of 4 Albania, 1914 issue (cataloguing \$1.27) and 52 other stamps from Alsouites, Lebanon, Quelimane, etc., total catalogue value about \$2.50. Price only 10c to approval applicants. Scarce Hawaii 1893 issue free with each order. Send today! Crown Stamp Co., 1120 Biltmore Ave., Pittsburgh, Pa.

**A SNAP**—300 Different foreign and 60 different U. S. stamps, including \$1 value, for only 25c. Free, with each order, our pamphlet telling "How To Make A Stamp Collection Properly," together with our price lists of albums, supplies and hundreds of bargains in sets, packets, etc., Queen City Stamp Co., Room 36, 604 Race St., Cincinnati, Ohio.

**ILLUSTRATED** Descriptive U. S. List, price 50c; large complete U. S. price list 1933 Free. Stanley Gibbons, 38P Park Row, New York.

**COLLECTORS!** For exchanging stamps, illustrated postcards with 2,500 collectors, ask American booklet 162, Zeller, 51 Passare, Bureau, Paris 362, France.

**ICELAND**—10 Different 4c to approval applicants. Frank Ewing, Box 693, Cleveland, Ohio.

**FREE** Surprise packet with unpeaked mixture 500 United States 35c. Drexel Stamp Shop, 5726 Drexel, Chicago.

**40 DIFFERENT** United States 12c. 60% approvals. Seidenberg, Baroda, Mich.

**50 GOOD** Foreign stamps 10c to approval applicants. Lester King, 3776 Isabella Ave., Cincinnati, Ohio.

**250 DIFFERENT** Stamps, only 10c, with approvals. Skillman, Titusville, N. J.

**ANNOUNCING** A new department! For the first time in the company's history all stamps, regardless of catalogue value, are being offered to the public at 1c each! Ask for approvals, you can't go wrong! Julius Goldin, 926 Southern Boulevard, New York.

**100 FOREIGN** Stamps. Nicaragua, Peru, St. Paul, Turkey, etc., 10 cents. Lufbery Stamp Co., Branford, Conn.

**BIG** One dollar summer bargain packet. 100 varieties of United States only, also a 2½ and 5 shilling British, all for \$1.00. Hub Stamp Co., 45 Bromfield, Boston, Mass.

**WESTERN AUSTRALIA**—4 varieties free with approvals. Allion, Angola, Ind.

**ICELAND** Millennial Jubilee airmail set of 5 values complete \$1.00. Approvals to applicants, DeLisle, 762 Harding, San Jose, Calif.

**120 DIFFERENT** including stamps marking history, U. S. Louisiana Purchase, Columbian, France Joan D'Arc, Portugal, Argentina, Italy, Chili and many more commemoratives. Intensely interesting packet. Price 20c. The Stamp Shop, Holland Bldg., St. Louis, Mo.

**FREE**—\$1.00 U. S. postage Lincoln memorial free, if you write for our 56 page price-list of U. S. and foreign stamps, 2,000 illustrations and fine stamps on approval. Hussman Stamp Co., 629-3 Olive St., St. Louis, Mo.

**FREE!** 150 Stamps with approvals. References: Aladdin, 1550 Carroll, St. Paul, Minn.

**25 AIR** Mail and 100 different British colonies .30 (coins) Roy Whipple, Ipswich, Mass.

**ALL** Different—100 United States 28c. 30 Canada 10c. 50 Scandinavia 10c. Al. VanDahl, Salem, Oreg.

**PERFECT** Stamps on low priced approvals. Waldes, 124 Congress St., Jersey City, N. J.

**ZANZIBAR!** Packet Queer freakish stamps from Zanzibar, Holkar, Antioquia, Congo, Hyderabad, Goldcoast, Newfoundland, British colonialia, Souamericans. Don't delay! Don't wait. This whopping packet free for 5c postage. Gray Stampco, Toronto, Can.

**WHOLESALE** Catalog for dealers; 4c postage. Grossman, 102 W. 42nd, New York.

**FREE** Montenegro—Approval applicants. Williams, 230 Fifteenth Avenue, San Francisco, California.

**50 DIFFERENT** Stamps, cataloguing over \$14.00, for 50c. Sunshine Stamp Co., 549 East Maryland St., St. Paul, Minn.

**TO** Introduce our unbeatable approvals, we will send you, upon receipt of 10c, a beautiful bi-colored Belgium charity set, Scott's No. 361-66, six values cataloguing \$2.83. This offer only good to those requesting approvals. Viking Stamp Co., Sheepshead Bay Station, Brooklyn, N. Y.

**FREE**—25 U. S. with approvals. Reynolds Stamp Co., Flint, Mich.

**TEN** Unused U. S. colonies 5c to approval applicants. Eastern Stamp Co., 3829 Veazey St., N. W., Washington, D. C.

**TANGANYIKA**, Zanzibar, Fiume, Greece, 100 others 15c to approval applicants. Rosen-schein, Lake Placid, N. Y.

**20 GOOD** Stamps free with approvals. F. Thorp, Norwich, N. Y.

**STAMP** Album—The Modern Album is unsurpassed in usefulness. Spaces for 12,000 illustrations, 330 pages. Large size 9¼x11 inches. Cloth bound. Price only \$2. Either pay postman when delivered or if outside U. S. remit when ordering. Popular Mechanics Press, Room 801, 200 E. Ontario St., Chicago.

**ONLY** 5c. 33 Different stamps including scarce Latvian triangular airmail stamps, 10 airmail, 12 United States (early issues, commemoratives, etc.) and 10 Canada. Approvals and illustrated pricelist sent with each order. Curhan Stamp Company, Gloucester, Mass.

**24 VARIETIES** Cuban stamps, 10 cents. List of 6,000 low-priced stamps free. Address Chambers Stamp Co., 111P, Nassau St., New York City, N. Y.

**110 NEW** Europe All Different, a wonderful collection cataloguing several dollars, free to collectors requesting our Net Approvals. Postage 2 cents. Badger Stamp Co., Milwaukee, Wis.

**CANADA** Airmail stamp free if you ask for approvals and send 15c for 25 different airmails or 30 different Canada and Newfoundland; both packets only 25c. We list 329 countries in our dime packets. Lists free. Special bargains, 500 different, 25c; 1,000 different, 75c; 2,000 different \$2.50. Victoria Stamp Co., London, 4, Canada.

**110 DIFFERENT** Stamps, many unused, high values, free to collectors requesting our net approvals. Postage 2 cents. Christensen, Milwaukee, Wis.

**STAMPS**—100 Varieties, Africa, Brazil, Peru, Cuba, Mexico, etc., 10c; 25 different U. S. 25c; 1,000 mixed, 40c; 1,000 hinges, 15c. C. Stegman, 5941 Cote Brillante, St. Louis, Mo.

**FREE**—Canada (15 Var.) for new applicant of my 1c, 2c and 3c approval, and also my 50% discount. Chas. W. Schmidt, P. O. Box No. 4832, Frankford Sta., Phila, Penna.

**203 DIFFERENT** Catalog \$4.25 only 7c with approvals. L. W. Hudson, Plainfield, N. J.

**BEST** One cent approvals in America. F. Hand, 1117 So. 60th St., Philadelphia, Pa.

**STAMP** Bulletin. Published monthly. Fine stamp offerings. Profusely illustrated. Authoritative information. Sent free to advanced collectors. Reimers Co. 30 N. La-Salle St. Chicago.

**STAMPS**, 100 All different. Postage 2c. Lists free. P. M. Quaker Stamp Co., Toledo, Ohio.

**105 CHINA**, Etc., 2c. Album (500 illustrations) 3c. Bullard, 446 Tremont, Boston.

**FREE** Stamps with approvals, 2c postage. Harvey Teeple, Decatur, Ind.

**FREE**, 6 Different Luxembourg to approval applicants. E. D. Stamp Co., 3905 Forest Park Ave., Baltimore, Md.

**STAMPS** On approvals, ¼c up. Dandy premium. Keigwin Stampco, 214 A Lurie Bldg., Oakland, Calif.

**PENNY** Approvals that satisfy. Neil Gronberg, Box 5441, Philadelphia, Pa.

**PENNY** Approvals, 5,000 Sudan, Congo, Nyassa, Liberia, etc. Also 14,000 averaging 1½c. Philatelic Exchange, Huntington, W. Va.

**FREE!** Triangles, airmail, Iceland and 50 others to approval applicants, including 3c postage. Hawkeye Stamp Co., Cedar Rapids, 39, Iowa.

**200 DIFFERENT** 10 cents. 25 airmail 10 cents. 60% discount approvals. Covert Stamp, 39 State, Rochester, N. Y.

**301 DIFFERENT** 10c To approval applicants only. Free list of bargain packets. Kansas City Stamp Co., Lee Bldg., Kansas City, Mo.

**U. S. STAMPS** Only on approval; give reference. Stamp House, 39 Torry, Dorchester, Mass.

**STAMPS** Sent on approval at 70% discount. Reference required. Emory Renoll, Hanover, Pa.

**ALBUM**, 1,000 Hinges, 200 foreign, 25 Cuba, 25 Japan, 35c. Postpaid. Burtiss Company, Saratoga, N. Y.

**ATTRACTIVE** Approvals at 50% discount and 25% discount. Noemus Stamp Co., 312 East 23rd St., New York.

**SPECIAL**—500 Different stamps 25c to approval applicants. Ohio Stamp Co., Box 249, Cleveland, Ohio.

**FREE** Stamp collection to approval applicants. Contains Iceland, Hamburg, Turkey, etc., 2c postage. 15 Confederate essays, 5c. Tatham Stampco, Mittencague, Mass.

**STAMP** Album—The Modern Album is unsurpassed in usefulness. Spaces for 12,000 illustrations, 330 pages. Large size 9¼x11 inches. Cloth bound. Price only \$2. Either pay postman when delivered or if outside U. S. remit when ordering. Popular Mechanics Press, Room 801, 200 E. Ontario St., Chicago.

#### RARE COINS

**SPECIAL** Prices on United States commemorative half dollars in uncirculated condition. Columbian 69c; Lincoln \$1.19; Pilgrim 97c; Grant \$1.23; Monroe 99c; Lexington \$1.17; Oregon \$1.27; Bennington \$1.23; trade dollars \$1.15; Bargain price list and old coin 10c; Arcy, Box 483, Muskogee, Okla.

**OLD** Money wanted. Do you know that coin collectors pay up to \$100.00 for certain U. S. cents? And high premiums for all rare coins? We buy all kinds. Send 4c for large coin folder. May mean much profit to you. Numismatic Co., Dept. H, Fort Worth, Tex.

**CALIFORNIA** Gold—Quarter size, 27c; ¾ size, 33c; 3c piece and catalog, 10c. Norman Shultz, Box 746, Salt Lake, Utah.

**RARE** United States and foreign coins, war medals and decorations. Indian Cent and catalogue 10c. Alexis Mengelle, Colorado Springs, Colorado.

**GET** Profit and pleasure in collecting old coins. Send 10c for large illustrated coin catalog. You'll be delighted with it. Send for it right now. B. Max Mehl, Numismatist, Mehl Bldg., Dept. P, Fort Worth, Tex. Largest Rare Coin Firm in the U. S.

**UNITED** States. Large cent, two-cent bronze, three-cent nickel and bargain list, 25c. Thirteen dates large cents, \$1.00. George Coffin, Greenwood Mountain, Me.

**\$2 TO \$500** Each paid for hundreds of old coins. Keep all old money, it may be very valuable. Send 10 cents for illustrated coin value book, 4x6. Prices guaranteed. Get posted. We buy and sell. Clarke's Coin Office, Box 5, Le Roy, N. Y.



**OLD Coins**, large fall selling catalog of coins for sale, free to collectors only. Catalog quoting prices paid for coins, ten cents. William Hesslein, 101A Tremont St., Boston, Mass.

**3 DIFFERENT** Fine bronze or nickel coin, 2 large crisp bank notes and catalog, 10c. Geo. Best, Box 283, Cedar Rapids, Iowa.

#### FOR BOYS

**PRACTICAL Flight Training** is a splendid, thorough instruction book written by Lieut. Barrett Studley of the Naval Air Station at Pensacola. It is the official text book from which all U. S. naval flyers are trained. You can double the value of expensive instruction time in the air by a preliminary study of the subject from this book. Pay postman \$5 and postage when he delivers it to your door. Popular Mechanics Press, Room 802, 200 E. Ontario St., Chicago.

**LEARN** How aircraft engines work. Latest and most complete information is found in "Dyke's New Aircraft Engine Instructor." We unhesitatingly recommend this valuable book. Money refunded if not satisfied. Pay postman \$5.00 plus postage when delivered. Popular Mechanics Press, Room 801, 200 E. Ontario St., Chicago, Ill.

#### CAMERAS AND PHOTO SUPPLIES

**BARGAINS**—A sample few, 2 1/4 x 3 1/4 R. B. Graflex Junior Camera, Kodak f:4.5 Lens, Film Pack Adapter \$62.50 1x1 1/4 Leica roll film camera, f:3.5 Anastigmat Lens Focal Plane Shutter 2 Magazines \$67.50. 2 1/4 x 3 1/4 Avus Roll film camera, Skopar f:4.5 Anastigmat Lens, Compur Shutter \$21.75, taken from our bargain book listing hundreds of slightly used equipments all guaranteed the same as new. Ten days trial allowed. Money refunded if not satisfied. Send for your copy now. Central Camera Co., 230 South Wabash Ave., Dept. PM-9D, Chicago, Ill.

**CAMERAS**—All makes—photographic supplies. Catalog free. Universal Photographers, 4 W. 33d St., New York.

**FIRST** Film developed six prints, 25c silver. Enlargement free. Three prizes monthly for three best prints. Superior Photo Service, Dept. F, Waterloo, Iowa.

**TIME** Counts in applying for patents. See pages 134 and 135. Clarence A. O'Brien, Registered Patent Attorney, Washington, D. C.

**KODAK** Prints, 3c each; pocket mirrors free. Jenkins Studio, Denison, Tex.

**YOUR** Favorite kodak picture enlarged, size 5x7, 10c. Three for quarter, coin. Send best negative (film) today. Address Darmer Photo Lab., 221 Securities Bldg., Des Moines, Iowa.

**MAKE** Money in photography. Learn quickly at home. Spare or full time. New plan. Nothing like it. Experience unnecessary. American School of Photography, Dept. 3431, 3601 Michigan Ave., Chicago.

**HAVE** You a camera? Write for free sample of our big magazine, showing how to make better pictures and earn money. American Photography, 116 Camera House, Boston, 17, Mass.

**FILMS** Developed. Special trial offer. Any size kodak film developed 5c, prints 3c each. Trial 6x10 enlargement in handsome folder 40c. Overnight service. Roanoke Photo Finishing Co., 209 Bell Ave., Roanoke, Va.

**GERMAN** Cameras, lenses. Barttro, 237 1/2 S. Spring St., Los Angeles, Calif.

**SAMPLE** Enlargement—dime, and negative (returned). Trial roll, glossy prints, 25c silver. Brown, Warsaw, N. C.

#### MOTION PICTURES

**SOUND** Motion pictures! You must order this great and only authoritative text book on the subject by James Cameron, world's foremost authority. 400 pages crammed full of information on photo cells, Vitaphone, Movietone, Photophone, methods of recording maintenance. We are selling thousands of copies. Price, \$5.00 postpaid anywhere. Bass Bargaingram No. 199 just off the press. Red hot bargains in standard and 16 mm. motion picture cameras, projectors and accessories. Send 4c in stamps. Bass Camera Company, Motion Picture Headquarters, 179 West Madison St., Chicago, Ill.

**CARTOON** Films \$2.00 reel. Holmes Film Supply Company, Box 63, Clifton, New Jersey.

**25 FEET** \$1.10. Odd reels \$2.25. Bargain lists. Hoffman Film Service, 57 Broad, Albany, N. Y.

**BARGAINS**, A sample few, 35mm., Devry Motion Picture Camera with f:3.5 Lens \$72.50, 16mm., Victor Cine Camera f:3.5 Lens \$81.50, 16mm., Model C Eastman Kodascope Projector \$39.50, taken from our latest bargain book listing hundreds of other bargains. All fully guaranteed and sold on ten days trial. Money refunded if not satisfied. Send for your copy now. Central Camera Co., Dept. P.M.-9D, 230 South Wabash Ave., Chicago, Ill.

**\$1,250** FOR Original photoplay story. Our sales department sold unknown author's first story for above amount. We revise, copyright and submit to studios stories for both silent and talking pictures. Being located in the heart of motion picture industry we know production requirements. Established 1917. Free booklet. Universal Scenario Company, 206 Western and Santa Monica Bldg., Hollywood, Calif.

**TALKIE** And movie producers are clamoring for new short story ideas, plots, etc. Perhaps you can write one that we can shape and sell for you. One writer (V. M.) received \$3,000. New York best market. Write for full particulars. Daniel O'Malley Company, Suite P, 1776 Broadway, New York.

**BE** A movie exhibitor. Big opportunity. Only moderate capital required. Complete equipment at remarkably low prices. Write Atlas Moving Picture Company, 825 South Wabash Ave., Chicago, Ill.

**1000** FOOT Odd reels \$2.00 each. Krazy Kat Cartoon—Complete \$5.00 reel. Roadshow Cinema Broker, Box 524, Cincinnati, Ohio.

**BARGAIN!** Perfect Power's 6A projector \$75.00. Stewart Marshall; Rome, Georgia.

**300 FEET** Film 90c. Reels \$2.50. Lowell Films, Allentown, Pa.

**SOUVENIR** Strips movietone, photophone talkie film; big list film bargains and samples all for dime. Eastin Feature Films, Galesburg, Ill.

**UNIVERSALS**, \$115.00 To \$325.00. Wilarts, DeVrys, Filmos, Patheux, films, list. F. W. Buchanan, Johnstown, Pa.

**MOVIE** Films, 1,000 ft. reels, \$2.50 each; shipped anywhere on receipt of remittance. Particulars on request. Independent Films, 177 Golden Gate Ave., San Francisco, Calif.

**SAVE** Money. Movie cameras, \$25; projectors, \$35; Patheux camera, \$20; stereopticon, \$25; printing machine, \$75; 35mm negative stock, 2 cents foot; 100 foot Eastman 16mm negative, \$4.50; kodak, \$5. Typewriter, \$16. Cameras and films bought and exchanged. Ray, 266 W. 46th, New York.

**TIME** Counts in applying for patents. See pages 134 and 135. Clarence A. O'Brien, Registered Patent Attorney, Washington, D. C.

#### TRADE AND TECHNICAL SCHOOLS

**LEARN** Watch repairing. Hiles School, 5330 Mission St., San Francisco.

**BE** A blue print reader. Men in your trade have succeeded. Write for facts. What's your trade? Carroll Rumsay, Drexel Bldg., Philadelphia.

#### TELEGRAPHY

**LEARN** Wireless (Radio) and Morse telegraphy. School, oldest and largest; endorsed by telegraph, radio, railway and government officials. Expenses low—can earn part. Catalog free. Dodge's Institute, H Street, Valparaiso, Ind.

#### BUSINESS OPPORTUNITIES

**DO** You want a fine hotel position? Then come to Washington! Here is the only school of its kind in the world—a nationally recognized training school which prepares men and women for positions paying \$2500 to \$7,500 in hotels, apt. hotels, resorts, clubs, schools, cafeterias and tea rooms. Come to Lewis—get ready for bigger earnings while enjoying delightful months in the beautiful, interesting capital city. Learn under practical experts; 14-year tested, time-saving, thorough training. National employment bureau for graduates, no extra cost. Write now for free book that brings your opportunity. Lewis Hotel Training Schools, Dept. 317-CP, Washington, D. C.

**DON'T** Slave all your life. We will start you in business. Thousands are making their living abroad by doing knitting at home. Others get large flat machines adapted to make all kinds of knitted goods, such as stockings, from an infant's size to the largest lady's or man's, children's knitted suits, sweaters, scarf, vest, cap, gloves, etc. Write for catalog. Ainslie Knitting Machine Co., Inc., 738-750 Grand Street, Brooklyn, N. Y.

**DISTRIBUTORS** Start a profitable business of your own. Sell to hotels, restaurants, office buildings, theatres, homes, factories, public institutions. Our attractive sample case is ready for immediate sales. We are manufacturing chemists producing the best grades of polish for furniture, automobiles, floors and metals. Fabric cleaners, deodorants, shampoo and liquid soaps, solvents, disinfectants and insecticides. Powders for cleaning, scouring and scrubbing. Goods packed in convenient sizes for fast selling. Protected territory. Write at once. Superior Brands Inc., 360 Furman St., Brooklyn, N. Y.

**WE** Start you in business, furnishing everything. Men and women, earn \$40 to \$100 weekly operating our original "New System Specialty Candy Factories." Begin home spare time. Unlimited opportunity. Valuable booklet free. W. Hillyer Ragsdale, Drawer 4, East Orange, N. J.

**MIRRORS** Resilvered at Home. Costs near 5 cents per square foot; you charge 75 cents. Profitable business plating like new, brassy worn-off autoparts, reflectors, tableware, stoves, etc., Outfits furnished. Details free. Sprinkle, Plater, 127 Marion, Indiana.

**CANDIES**, Home-Made, sell at 4 times their cost. Spare-time business from home kitchen. Profits while you learn. Same home-study course prepares men or women to fill demand in Candy Industry for "skilled" employees. Free Book explains. Capitol Candy School, Dept. F-5971, Washington, D. C.

**OWN** Your own business. Our successful business plans, which we sell at sensible prices, show you how to build a profitable spare-time business. M. Wahl Co., 4452 N. Melvina Ave., Chicago, Ill.

**A REAL** Successful Mailorder Proposition. Details 10c. K. Home, 3949 Metropolitan, Chicago.

**BIG** Profits operating "chain" of peanut, chewing gum, candy vending machines. Start small capital. Write Robbins Corp., Dodworth Street, Brooklyn, N. Y.

**REAL** Opportunities! Particulars for stamp. Walston Co., West Frankfort, Ill.

**"WHY** Not a business of your own? Cleaning hats, clothes, dyeing and pressing. Particulars free. Scientific American Cleaner, 432 Tenth St., New Kensington, Pa.

**WANTED** Backing for research work. Compressed Air Engine Piston Pressure to push cylinder in rotary. Substitute for Gas Engine. B. Berndt, 156 W. Huron, Chicago.

**CLEARED** \$4,000 two months, Gordon. Tested food—confection business. Men or women. Legitimate—pleasing. Experience unnecessary. Equipment furnished. Eakins, 2150 High St., Springfield, Ohio.

**\$10** WORTH For 50c. Fifteen nationally advertised Money Making Plans. Particulars 2c. Berg, A-439 Davidson, Bridgeport, Conn.

**EARN** Steady income making duplicate keys; stamping keychecks. Marvelous profits. No canvassing, easily learned. Instructions, sample check with name, address, 25c. Eagle Company, 223 West 116, Dept. D, New York.

**MONEY** Plus. Get free movie tickets and have cash income every week from local merchant advertisers. Particulars free. A. Benton, 914 Elsbeth, Dallas, Texas.

**MAKE** Money manufacturing building material, Marble, Granite, Fireproof Paint, Flooring, Roofing. No machinery, cheap; big profits; formulas, latest methods, Wm. Lang, 443 Washington, Portland, Ore.

**MAIL** Order business that actually brings results! For your benefit, and mine—write today! Julius Goldin, 926 Southern Boulevard, New York.

**OUR** Organization in Germany gets you any novelty. Box 485, City Hall Sta., New York.

**GET** Into the mail order business. Interesting literature free. Nagel, 1329 Olive, Indianapolis, Ind.

**CORPORATION** Organization, promotion, financing. Correspondence solicited, Curtis, 1109 Eighth Avenue, Fort Worth, Texas.

**LEARN** The collection business. Good income, quick results. Interesting booklet, "Skillful Collecting" free. National Collectors Assn., Long St., Newark, Ohio.

**"LIBERTY** Bell" contains valuable information; copy and interesting mail 10c. Geo. Bell, Murfreesboro, Tenn.

**THE** Best anti-freeze 20c per gal. Get particulars at once. Fred Herrick, Wahoo, Nebr.



**LEARN** The collection business. Conducted properly is very remunerative. Supplies and tuition at small initial cost. North West Protective Service, 500 Beatty St., Vancouver, B. C.

**HI GRADE;** Rabbits, Guinea Pigs, Pigeons. Money makers, Miller, Baltimore St., Hagerstown, Md.

**START** A chile parlor, candy kitchen, or cleaning, dyeing and pressing shop. Small capital. Details for stamp. H. Krause, 699 Hudson Ave., West New York, N. J.

**CHEMICAL** Expert furnishes manufacturing formulas and processes with complete working directions. Reliable individual service only. No lists. Charges reasonable. Correspondence invited. Dr. Arthur Van-Heeden, 7051 Bennett, Chicago.

**DRAFTSMEN,** Designers, plant executives, sales engineers seeking connection, write. E. S. Howard, Oswego, New York. "Letter and list service" confidential.

**INSURANCE** Against unemployment. Five hundred money making plans. Start a beauty parlor, candy kitchen, cleaning, pressing shop, chill parlor, resilver mirrors. All one dollar. Effie Wilson, Rotan, Tex.

**BUSINESS** Partner wanted. For particulars write, Eugene Pechota, Lawler, Iowa.

**PUBLISH** Your own magazine. We issue a syndicate magazine. Sample and particulars 10c. Tasam Publishing Company, P. O. Box 3594, Washington, D. C.

**BIG** Money at home plating auto parts, reflectors, mirrors, chandeliers; by new method; experience unnecessary. Outfits furnished. Gunmetal Co., Ave. N, Decatur, Illinois.

**LAUGH** At unemployment. Peanut machines will make you independent. Small capital. Novix, 1193 Broadway, New York.

**METHODS** Used by experts. If you can sketch letters, you can paint signs. Write for full details. Technical Department, Duffred Specialty Company, 6011 Mercedes St., Dallas, Texas.

**CONCRETE** Building block manufacturing is your home town opportunity. Particulars free. Concrete Machine Co., 5 Main St., St. Louis, Mo.

**BUSINESS** Profession of your own and earn income in service fees. See Stephenson Laboratories, display ad page 124.

**LEARN** Marbleizing, Art stone, casting, sanitary floor making, artificial marble all branches. How to cast solid, or veneer over concrete products, wood, etc. Trowel or spread on. Filinlike hardness, glossy, all colors and veining, inexpensive. Unlimited uses for this industry. Send dime for samples. Cowell Institute, Grayling, Mich.

**I MADE** \$30 a week home. French breadmaking. 15 years' experience; free booklet tells. Ashbrook 67, Marengo, Ohio.

**CHARTERS:** Delaware; best, cheapest; free forms. Colonial Charter Co., Wilmington, Del.

**SIGNS** And showcards easily painted. If you use Letter Patterns. Write for free samples. John Rahn, B2120 Neva Ave., Chicago.

**LEARN** To correct automobile shimmy, hard steering, tire scuffing. Capable men in demand everywhere. Complete course offered at cost (\$2) by gauge manufacturer. Send quick. Bear School, Rock Island, Ill.

**SCHEMER,** Alliance, Ohio, 32p. monthly, prints big \$-getters. Subscriber reports \$25,000 from three; another \$10,000 from one. Try your luck! Year, \$1.00; 3 months, 25c.

**DELAWARE** Charters; fees small; free forms. Chas. G. Guyer, Wilmington, Del.

**TIME** Counts in applying for patents. See pages 134 and 135. Clarence A. O'Brien, Registered Patent Attorney, Washington, D. C.

**FREE** Book. Start your own little business anywhere, selling novelties by mail. My beginner's outfit contains everything required, novelties, circulars, instructions, etc. Descriptive book free. Hadwil, 33A-74 Cortlandt St., New York.

**CHEMICAL** Expert will furnish formulas and trade secrets. All lines. Lists free. W. L. Cummings, Ph. D., 228 Gordon Ave., Syracuse, N. Y.

**THAXLY** Formulas produce perfect products. All lines. Catalog free. B. Thaxly Co., Washington, D. C.

**LOOK!** "The Rithmetic Kid" adds, subtracts, multiplies and divides sums accurately. Sent postpaid, 10c, 3 for 25c. Advertisers Service Co., Box 10, New Haven, Conn.

**SUCCEED** With your own products. Make them yourself. Formulas, processes, trade-secrets. Expert analytical service. Catalog, circulars free. B. Thaxly Co., Washington, D. C.

**ARTIFICIAL** Marble sanitary flooring, instructions covering wood or cement flooring 1/2 inch thick, fireproof, all colors, low cost. Ornamental casting, concrete, plaster, papier-mache decorations, garden furniture, statuary, flexible molds, particulars and illustrations free. Chris. Mahler, Huntington, N. Y.

**DON'T** Sell for others. Employ agents yourself. Make your own products. Toilet articles, soap, extracts. Valuable book free. National Scientific Laboratories, 1935W Broad, Richmond, Va.

**MECHANICS,** Painters, carpenters, start furniture refinishing, painting, handyman shop on nearly nothing; winning plan brings customers quickly. John Bracecland, 1439 So. Ninth, Philadelphia, Pa.

**SELL** By mail. Books, novelties, bargains! Large profits. Particulars free. B. Eifco, 525 S. Dearborn, Chicago.

**CAN** You draw? Spare time profits a plenty. Not a correspondence course. Samples and particulars 10c. Straco, 1013 Mulberry, Springfield, Ohio.

**A BUSINESS** of your own making—Sparkling Glass Name and Number plates. Checkerboards, signs. Big book and sample free. E. Palmer, 540, Wooster, Ohio.

**UNUSUAL**—Uncommon specialties always sell best. Make these yourself from Miller's guaranteed formulas. Why work for others when others can be working for you? Latest eye-opening literature brings you many specialty propositions for you an independent business. Miller Chemist, 706-K Chemical Bldg., Tampa, Fla.

**MAKE** Big profits with a fur farm in your backyard. Chinchilla rabbits, muskrat, mink. Write for facts. 252 Conrad's Ranch, Denver, Colo.

**FREE** Booklet describes 67 plans for making \$20-\$100 weekly in home or office business of your own. Elite Co., 81 Elizabeth St., New York.

**"ODD-THINGS"**—Money making ideas; tips; plans; opportunities! New, different! Three months' trial, 25c. Year \$1.00. "Odd-Things Magazine," 720 Advance Bldg., Cleveland, Ohio.

**1,000% PROFIT** Manufacturing Sachets. George Ross, 6521 Kenwood Ave., Chicago.

**AMATEUR** Cartoonists earn \$25.00 week, spare time, copying or tracing cartoons for advertisers. 3-Em Syndicate, Argyle, Wis.

**FREE** Sample money-making specialty. Write Superior Specialties, Springfield, Ill.

**15,000 PROFIT** Making formulas. Following and many others: Accidents and emergencies, agriculture, alloys and amalgams, artist's materials, beverages, cements, glues, pastes, muclages, bleaching, renovating, coloring metals, dyeing, glass, heat treatment of metals, household formulas, ice cream, confectionery, chewing gum, lapidary work, exterminating vermin, lubricants, paints, varnishes, photography, condiments, canning formulas, rubber, soap, candles, soldering, toilet preparations, perfumes, waterproofing, fireproofing, writing materials. Just write for "Scientific American Encyclopedia of Formulas." When postman hands you book pay \$3.50 and postal charges. Popular Mechanics Press, Room 801, 200 E. Ontario St., Chicago, Ill.

#### CHEMISTRY

**MUCH** Money can be made by resilvering mirrors. Full professional formula and process. Five Dollars. Richards, Chemist, Box 2402, Boston, Mass.

**YOUR** Chemical Problem solved and formula or process furnished. Five Dollars. Write me. W. Stedman Richards, Industrial Chemist, Box 2402, Boston, Mass.

**CATALOG** listing 2,500 illustrations chemists' supplies, 5,000 chemicals, 1,000 scientific books sent for 50c. Laboratory Materials Company, 643 E. 71st St., Chicago, Ill.

**EXPERT** Chemical advice on manufacturing problems. Analysis. Ideas developed. Formulas. Write, Associated Chemists, Industrial Chemists, Indianapolis, Indiana.

#### FORMULAS AND TRADE SECRETS

**FORMULAS,** All kinds, 3c each up—large list sent free. One stamp appreciated. Epneo Service, Box 748, Dayton, Ohio.

**3,000 VALUABLE** Formulas prepaid \$1.00 National Service, 3644 Tamarack, Cincinnati, Ohio.

**MODERN** Formulas. Guaranteed, tested. Catalog free. Imperial Laboratories, Edwardsville, Ill.

**500 MONEY** Making formulas and trade secrets 50c. Universal, 109 First Place, Brooklyn, New York.

**GUARANTEED** Formulas, analysis, lowest prices. Lloyd Laboratories, 5566 Jackson, Chicago.

**INEXPENSIVE** Ice-Making Formula, 50c. Machinery Unnecessary. Neil Tasker, Shamokin, Pa.

**WALLPAPER** Flooring. New process. Directions \$1.00. Universal Supply Co., 777 Boulevard, Bayonne, N. J.

**FORMULAS,** Chemical Services, Analysis, Free catalogue. Hertstein, Chemist, 46 Grand Ave., Grand Rapids, Mich.

**GUARANTEED** Formulas, best science can produce for making popular, biggest-selling specialties all lines. Don't buy formulas till you've received valuable eye-opening literature. Miller, Chemist, 706-F Jetton, Tampa, Fla.

**FORMULAS** All kinds. Catalog free. Clover Laboratories (P), Park Ridge, Ill.

**25 MONEY** Making formulas, premium, \$1. Arthur Lutz, York, Penna.

**SUCCEED** With your own products. Make them yourself. Formulas, processes, trade-secrets. Expert analytical service. Catalog, circulars free. B. Thaxly Co., Washington, D. C.

**DON'T** Sell for others. Employ agents yourself. Make your own products. Toilet articles, soap, extracts. Valuable book free. National Scientific Laboratories, 1935W Broad, Richmond, Va.

**PRACTICALLY** Any formula, 50c. Just send 50c and name it. Catalog free. Industrial Institute, Dept. 206, 64 West Randolph, Chicago.

**500 FORMULAS** And big illustrated catalog 25c. Ideal Book Shop, Park Ridge, Ill.

**10,000 MONEY-MAKING** Formulas. Tells you how to make and sell almost everything under the sun; cosmetics, muclage, anti-freeze solutions, battery solutions, beverages, cheese, chewing gum, cleaning preparations, extracts, hair preparations, inks, bluing, leather polish, mirrors, perfumes, polishes, typewriter ribbons, carbon paper, washing powders, liquid soap, and hundreds of other profitable articles. Send no money. Just write a postal for "Henley's 20th Century Book of Formulas." Pay postman postage and \$4. Popular Mechanics Press, 200 E. Ontario St., Room 802, Chicago.

#### AGENTS WANTED

**WANTED** At once: more good men to introduce and retail Rawleigh's Good Health Products. Town and Country. Wonderful opportunity. Get into business with backing of largest manufacturer of its kind. Capital over 15 million dollars. Quick freight, express, parcels post service from 10 great factories and branches—one near you. Nothing new—no experimenting. No experience required. You simply follow the same old time-tested Rawleigh Methods which secure the most business everywhere and have given consumers best values and satisfaction for 40 years. 170 necessities frequently needed every home. Enormous demand. Annual sales nearly 40 million products. Big free trial inducement. Quick easy sales. Repeat every 30-60 days. Enormous profits—\$100-\$400 month and more profits. Steady year around; no lay-off. No boss—you become sole owner and manager. Practically no capital required. We supply everything—stocks, outfit, sales and service methods. Big pay every day. Profits increase every month. "First come first served." For full particulars write W. T. Rawleigh Co., Dept. H-A-PPM, Freeport, Ill.

**STRANGE** New ironing cord! Prevents scorching. Saves electricity. Cannot kink or snarl. For telephones also. Up to \$25 daily. Samples furnished. Neverknot, Dept. 9-A, 4563 Ravenswood, Chicago.

**WANT** Distributing agent for Hanslek, powdered handsoap; removes anything from the hands without injury to skin; everybody a customer; great opportunity for hustler to get in business; sample free. Solar Products Co., J2144 So. Troy, Chicago.

**\$60-200 A WEEK.** Genuine gold letters for store windows. Easily applied. Free samples. Liberal offer to general agents. Metallic Letter Co., 438-B North Clark, Chicago.

**DON'T** Sell for others. Employ agents yourself. Make your own products. Toilet articles, soap, extracts. Valuable book free. National Scientific Laboratories, 1935W Broad, Richmond, Va.



**STOP** Working for small pay; own and operate a Rawleigh Home Service Business; good anywhere, anytime the year around; you supply 200 home necessities; guarantee satisfaction or no sale; over 42 million sold 1929; thousands doing \$4000 to \$6000 annual business in Medicines, Food, Soaps, Toilet Preparations, Stock-Poultry Supplies, all backed by \$17,000,000 industry; established 40 years; largest of its kind with 17 great factories and branches; selling experience unnecessary; practically no capital; credit if deserving; first send for full particulars—then decide. Rawleigh Co., Dept. H-N-PPM, Freeport, Ill.

**DISTRIBUTORS** And agents wanted for new internal sun and light visor for automobiles and buses. New invention. Fastens inside above windshield of any sedan or coupe. Shield 12 inches by 6 inches, instantly adjustable to any position—up, down, right, left. Retail \$3.75. Send \$2.50 for sample. Larger discount in quantities. Shipments prepaid in United States. Members Oakland Chamber of Commerce. Bank references. Very attractive proposition. Gresser Pacific Co., Ltd. Dept. 1. 371 Nineteenth St., Oakland, California.

**STEADY** Permanent income assured by selling biggest, finest line shirts, ties, underwear, guaranteed full year. No substitutions. Free silk monogram. Postage prepaid. Big advance commissions. Earn your shirts, ties; cash bonuses. Free outfit. Write today. Dept. P9, Rosecliff, 1237 Broadway, New York.

**EARN** More pay the Quaker way. Take orders, complete line men's shirts, ties, hosiery, underwear. Remarkable values. All quick sellers. Big commissions. We furnish everything, deliver and collect. Satisfaction guaranteed. Complete outfit free. Write today. Dept. Z900, Quaker, 1107 Broadway, New York.

**MAKE** \$5.00 A sale, selling suits for \$19.95. Big profits with this quick selling line. Suits, topcoats, overcoats direct to wearer; marvelous values. Union made. Big repeats. Outfit free. Mastercraft, Dept. G900, 873 Broadway, New York.

**AMAZING** New invention. Electric water heater. Sells for \$3.75. Heats water almost instantly. Make big money. Write today. Lux-Visel Company, Dept. 63, Elkhart, Ind.

**BIG** Money easy, simply showing new Polly Wrench, 10 wrenches in one. Guaranteed fast seller. Sample furnished. Gellman Mfg. Co., Dept. 6-W, Rock Island, Ill.

**GRAB** This quick! Astounding new plier wrench invention amazes tool users. Affords super-power grip. You take orders. We deliver. Kant-Slip Co., A-6036 Wentworth, Chicago.

**SALESMEN** And Agents. Information Bureau; Advertiser selling propositions; at your service. Best opportunities investigated. Advice. New inventions. Cooperative correspondence. Many other features, free to members. Join now. Agents' Cooperative Syndicate, 509 Fifth Avenue, New York.

**DON'T** Sell for others. Employ agents yourself. Make your own products. Toilet articles, soap, extracts. Valuable book free. National Scientific Laboratories, 1935W Broad, Richmond, Va.

**EASIEST** "Window" letters on the market. Big profits, 50 styles and colors. Free sample. Write quick. "Ralco," 1045 Washington, Boston, Mass.

**SELL**—Day and night combination house numbers. Particulars. Meritttype Signs, So. Berkeley, Calif.

**MAKE** Illuminating signs—Patent allowed. No brush skill required. One order cleared 500 dollars. Particulars. Meritttype Process, South Berkeley, Calif.

**EXCELLENT** Trouser presser. Retail \$1.50. Agents 85c. L. J. Winess, 461 Sumner Ave., Brooklyn, New York.

**MAGICLOTH.** The world's best metal polish; on market twenty years. Everybody buys. Unusual profits. Magic Mfg. Co., 3317 Summit, Kansas City, Mo.

**SELL** "Prevent Runs." Guaranteed to prevent runs in silk hosiery. Large profits. Particulars. Specialty Mfg., 127 S. Broadway, Los Angeles, Calif.

**FREE** Suit Offer to Hustlers. Opportunity to get free suit besides \$45 a week and up. Take orders for our high-grade, all-wool, union-made-to-measure suits at \$19.85 and up. New style outfit free. Write today. Progress Tailoring Company, Dept. W-217, Chicago.

**MIRRORS** Resilvered at Home. Cost near 5 cents per square foot; you charge 75 cents. Profitable business plating auto-parts, reflectors, tableware, stoves refinishing metalware, etc. Outfits furnished. Details Free. Write Sprinkle, Plater, 128, Marion, Indiana.

**BRING** Home the bacon selling Christy's Iron Rust and Stain Remover. Sells like blazes. -Write for free sample. Christy, Inc., 6567 Broadway, Newark, N. Y.

**GREATEST** Soap Discovery of the age! Made from South Sea Island plants. Produces 2 and 3 times more lather. Sensational seller. Good for \$10 profit a day. Wonderful repeater. Particulars free. Albert Mills, 5200 Monmouth, Cincinnati, O.

**AGENTS** Make \$75 weekly with extensive line of household specialties—sponge rubber mats, fairly damask tablecovers and 50 other fast sellers. Write B. & G. Rubber Co., Dept. 459, Pittsburgh, Pa.

**\$5.00** Including bonus every time you sell a tailored-to-order, all-wool suit for \$23.75. Extra fine values. If you want to try, write. Everything furnished free. Pioneer Tailoring Co., Congress and Throop Sts. Dept. W-1117, Chicago.

**SAMPLE** Free, our new style needle cases and threaders are fastest sellers on earth. Millions sold. Catalogue. Paty Needles, West Somerville, Mass.

**HAN-DEE** Cloth quickly polishes nickel—brass—copper—silver—gold—without paste, fluid or powder. Representatives enthusiastic over easy sales—quick profit. Retail 25c. Sample free. Ruskin Company, 1501 Euclid, Cleveland.

**AGENTS**—Sell Neway ratchet and T wrench, every factory, garage, auto owner interested. Nothing else like it. Big commission, write quick. Better Tool Co., 24 So. Clinton St., Chicago.

**NOBBY** Allows 300%. Sample and offer one dime. Ellmar, Muncy, Pa.

**DISTRIBUTORS**—Agents, grab exclusive territories for Silk. Sell stores, agents, wholesalers. Tremendous profits. Sets Colors any fabric, prevents runs in hosiery. Sells like wildfire. Silk Corporation, 209 Seneca, Seattle.

**"STRIKE** A gold mine" selling Nulustre Polishing Cloths at 25c; polishes all metals quickly—the duller the metal, brighter it shines. Instant sales, enormous profits. Agent sold 102 in 116 calls. Samples, terms free. Shef Mfg. Co., 20 Shef Bldg., Weehawken, N. J.

**AGENTS**—Mosco corn and callous remover will build you a steady repeat business. Send today for pocket-size trial outfit. The Moss Company, 504 Searle Bldg., Rochester, N. Y.

**REPLATE** Brass worn-off automobile parts, reflectors, bath room fixtures, worn spoons, forks, etc., with pure silver. Looks like new. Use U-Kan-Plate Polish. Positively no mercury; \$1.00 half pints. Postpaid. Satisfaction guaranteed. Agents wanted. Dept. A, U-Kan-Plate Co., Philadelphia.

**ALL** Good agents with bad feet, get free Kleen-Foot Balm. If it cures, sell the world. Eastern Laboratory, Mather Bldg., Washington, D. C.

**CALIFORNIA'S** Fastest seller. Only fountain brush for auto and household use selling for \$1.00. Large profits. Exclusive territory. Sample sixty cents. Western Commercial Company, 55 New Montgomery St., San Francisco, Calif.

**TWO** 50c Widely needed products. Shu-mend saves shoes. Sealex saves automobiles. Continuous repeat sales. Sample both 50c. Vaporet Corp., 655 6th Ave., N. Y.

**AGENTS**—New automotive service item. Commission one-third. Plews Oilier Company, Minneapolis, Minn.

**MAKE** \$4 Your first day. Marvelous device. Takes drudgery out of window cleaning. Sells on sight, every housewife, motorist, others. \$1 brings actual sample and outfit. Dept. P9, Wonder Corp., 313 W. 35th St., New York.

**KAKTUS** Kid is looking for energetic agents to sell his nationally known factory guaranteed line of tire boots, patches and auto sundries, to garage and service stations. Write for data. Cactus Manufacturing Company, 2702 San Fernando Road, Los Angeles, California.

**SELL** Business cards, \$1.90 thousand. Commission 60 cents. Richards, 411 Mass. Indianapolis.

**SOMETHING** New, needed in every home. \$2.00 per hour easy sample four cents. Clark Co., 505 Line Ave., Ellwood City, Pa.

**EARN** More pay the Quaker way. Take orders, complete line men's shirts, ties, hosiery, underwear. Remarkable values. All quick sellers. Big commissions. We furnish everything, deliver and collect. Satisfaction guaranteed. Complete outfit free. Write today. Dept. Z9, Quaker, 1107 Broadway, New York.

**STEADY** Permanent income assured by selling biggest, finest line shirts, ties, underwear, guaranteed full year. No substitutions. Free silk monogram. Postage prepaid. Big advance commissions. Earn your shirts, ties; cash bonuses. Free outfit. Write today. Dept. P900, Rosecliff, 1237 Broadway, New York.

**SELL** Housewives something they want. They are bound to be interested. A signed guarantee to reduce gas bills 25%. No competition. 400% profit. Box 18E, East San Diego, Calif.

**AGENTS**—No Hard Times. Earn up to \$12 daily wearing fine Felt Hats and showing friends. Smartest Styles. Latest shades. \$2 to \$5 saving. Samples Free. Taylor Hat and Cap Mfrs., Dept. EC-135, Cincinnati, Ohio.

**SELL** Personal Christmas Cards. Names embossed in gold. Lowest prices, highest commissions. Samples Free. Also Box Assortments. H. Dunbar Co., New Brunswick, N. J.

**AGENTS** Earn \$8 day. Sell Dri-Kleanit. Can't be beat for cleaning finest furniture, woodwork, hardwood floors, linoleums. Won't scratch. Removes greasy deposits on kitchen ranges. Cleans your auto for about 10c. Removes mud, grease, roadoil, in one operation. No soap or water used. Big seller. 100% profit. Send three 2c stamps for sample. American Accessories Co., Desk 6831, Cincinnati, Ohio.

**IMPORT** Your own goods. German export magazine published in English offers numerous bargains latest novelties; opportunity for obtaining profitable agencies. Copy 60c. Square Deal Supply, P-246 Fifth Ave., New York.

**OUR** New card of 5c aspirin sells fast to stores. Over 100% profit. DeVore Mfg. Co., Desk C, Columbus, Ohio.

**AGENTS:** Distributors: New safety glass device—household necessity. 25c seller; sample, particulars 10c. DeVann Corp., 303 Fifth Ave., New York.

**YOU** Make 300% profit selling changeable signs to stores; six lines, three colors, cost 35c, sells \$1.50. Robinson sold 18 signs in four hours. Particulars free. National Sign System, St. Louis, Mo.

**AGENTS**—Up to \$12 daily. Introducing hosiery guaranteed 6 months or replaced. 125 styles, color for men, women, children. Lowest prices. Auto and hose offered producers. Write for outfit. Wilknit Hosiery Co., Dept. P-1231, Greenfield, Ohio.

**PORTRAIT** Agents—Highest quality enlargements, medallions, frames. Reasonable prices. Write for catalog. Adam J. Kroll Co., 2543 South State, Chicago.

**OUR** Luminous Crucifix and new Luminous St. Therese statue shine brilliantly in the dark. Sell on first demonstration. Write for prices. W. G. Hannan Co., 2543 So. State, Chicago.

**NEW,** Profitable—Sell auto step mats. Quality rubber with owner's name molded white. Details free. Ebonite Products, Dept. N-40, 895 Main, Akron, Ohio.

**MAKE** And sell newly invented washable price ticket and glittering 2 colored glass sign. Write for samples and instructions. National Distributor, 396 Powell St., Vancouver, B. C., Canada.

**AGENTS:** "Clear-O" pays large profits, great repeater. Bloom Products, 307 E. 22nd, Baltimore, Md.

**AGENTS** Earn \$250 month. Sell new line Guaranteed Hosiery. Latest styles. Big sellers. Extra commission. Earn your own Silk hose. Write quick. State size hose worn. Silkknit Hosiery Co., Dept. 2231, Dayton, O.

**HEAVY** Profits Introducing New Type Mending Fluid! Amazing scientific development. Agents, part-time workers cleaning up. Details free. Karam-Smith Company, 6609 Bozan St., Fort Wayne, Ind.

**"HOW** To Secure Agents," a specially prepared booklet, tells of one of the most inexpensive methods in which to secure good live producing agents. It is free; write for your copy today! M. L. Rund, Mgr. Classified Advertising, Popular Mechanics Magazine, 200 E. Ontario St., Chicago, Ill.



**AGENTS** Everywhere making money with our line of kitchen specialties, demanded in all homes. Big earnings possible. Write today for details. P. Seed Filter Co., 353 Broadway, New York.

**BESTEVER** Powdered Hand Cleaner. Removes Grease—Paint—Ink instantly. Sells fast. Sample Free. Bestever Co., 400 Irving Park Station, Chicago.

**NEW** Line Counter Displays, Aspirin, Flints, Chewing Laxative, Breath Gum, Nattar, Silkstone, etc. Steady Repeats. Over 100% Profit. Superba Co., W5, Baltimore, Md.

**AGENTS** Buy direct at lowest mill prices. Men's latest fancy hosiery doz. \$1.45-\$1.85. Ladies' pointex silk hose doz. \$4.25-\$6.50. Catalog free. Superior Knitting Company, Dept. 34, New Haven, Conn.

**PORTRAIT** Men you can make money anywhere selling our guaranteed portraits. Send for Free Frame Catalog. Portrait Agents' Supply Co., Dept. F. LaPorte, Ind.

**OLIVER** Cleared \$700 in 30 days with our line of books and Bibles. Outfit Free! Exclusive territory! Nichols Co., Dept. B25, Naperville, Illinois.

**RE-DYE** Rugs on Floor. Fibertint the dye applied with a brush. Red, Blue, Green, Brown, Purple. Does quick work. \$15 to \$20 daily. Sample outfit dyes 9x12 rug \$1. Textply Co., Inc., Somerville, N. J.

**BRAND** New Idea. 1930 Christmas Card line. Amazing seller. Experience unnecessary. Full-part time. Samples free. Windermere, (Established 1900) 6702 Dorchester, Chicago.

**946 FIRMS** Seeking Distributors are listed in new 104 page Directory. Write: Pruitt System, Brookfield, Ill.

**AGENTS**—\$30 Day easy placing Stypro Counter Displays with dealers. Globe Chemical Works, Bay City, Mich.

**MEXICAN** Jumping Beans. Samples with game card 35c, quality prices with first order. Midwest Novelty, 1312 Main, Kansas City, Mo.

**NEW** Electric Flashing Sign Just Out—changeable letters. Beautiful Neon color effect. Three different sizes and styles. Unbreakable. Guaranteed. Every merchant buys on sight. 100% profit. Protected territory. Preston Mfg. Co., Dept. S-233, St. Louis, Mo.

**AGENTS:** Free catalog 200 household specialties, toilet preparations, food products, remedies, portraits, frames, photo pillows, medallions, religious goods, pictures, Christmas Cards. Credit. James C. Bailey Co., Station C-9, Chicago.

**JUST** Invented—New washing machine. No motors or moving parts. Automatically cleans entire washing. Fully guaranteed. Retail price \$9.50. Your profit 100%. Protected territory. Preston Mfg. Co., Dept. CP-9, St. Louis, Mo.

**CHICAGO** Expert valued \$3 stone at \$900. The diamond's only guaranteed rival. Greatest spare time, side-line article ever known! Amazing profits. \$5 pocket sample case free. Write quick. Mexican Gem Company, Dept. PM, Monterey, Calif.

**AGENTS**—Make 80c profit on \$1.00 sales. Wonderful cleaner for automobiles, furniture, metal and glass. Your name on labels—fast repeater—exclusive territory. Free sample. Minute Kleen Laboratories, Evansville, Ind.

**MAKE** Big money with fast selling line of food products, prize motor and tractor oils—paints. Sure repeat orders. Write for free sample case. Loverin & Browne, 1602-C So. State, Chicago.

**NEW** Discovery—Ultra Fuzon extreme heat resisting aluminum paint for Radiators, Exhaust Pipe, Ovens—Lustrous finish. Trial can 15c. Ultra Fuzon, 552 West Broadway, New York.

**BIG** Money daily selling shirts, ties, underwear, Sox, raincoats, lumberjacks, sweaters, leather coats, mackinaws, coveralls, pants, children's play suits. Outfit free. Experience unnecessary. Nimrod Co., Dept. 8, 4922-28 Lincoln Ave., Chicago.

**BIG** Money and fast sales. Every owner buys gold initials for his auto. You charge \$1.50; make \$1.45. Ten orders daily easy. Write for particulars and free samples. American Monogram Co., Dept. 40, East Orange, N. J.

**WINDOW** Letters in colors and gold. 500% profit! Giant temporary transfers. Complete line for stores, offices and trucks. No experience required. Samples free. Print-A-Sign, Akron, Ohio.

**BIG** Money made selling our Christmas box assortment 21 Christmas cards and folders with harmonizing envelopes. Costs you 50c. sells for \$1.00. We pay all shipping charges. Marvelous creations in parchment, deckle-edge, water color designs, engraving, embossing, tipped-on illustrations, raised gold metallic effects, etc. Write for particulars, free samples. Waltham Art Publishers, Dept. PS, 7 Water St., Boston, Mass.

**THAXLY** Formulas produce perfect products. All lines. Catalog free. B. Thaxly Co., Washington, D. C.

**MANUFACTURER** Wants distributor for new "Pocket" Radio, \$3.85 complete. "Sells itself with music." Pays 100%. Write Spencer Radio, Akron, Ohio.

**UNUSUAL** Income. Every community. Sell home, shops, theaters, stores, banks, schools, etc., the new Fugo world's simplest fire protection. No sales experience necessary; we teach you. Part or full time. Act quick! The National Formetal Co., 6547 Metta Ave., Cleveland.

**SELL** Men's neckwear—wonderful proposition. Astor-M, 39 East 28th, New York.

**FREE** "Booklet of money making opportunities," new ideas, original plans, money making secrets and other valuable information. None require peddling or outfits. Elite Co., 84 Elizabeth St., New York.

**SELL** Your brand. Food products, beverages, perfumes. Valizon Products Company, Geneva, N. Y.

**SELLING** Like blazes. Beautiful toilet goods assortment at \$1.75 with 24 inch pearl necklace free to your customers. 100% profit. Davis Products Co., 238 North Ave., Dept. 630, Chicago.

**TIME** Counts in applying for patents. See pages 134 and 135. Clarence A. O'Brien, Registered Patent Attorney, Washington, D. C.

**SELL** Stores 5c carded breathlets, etc. Lorrac Products, Albany, N. Y.

**POLMET** Polishing Cloth removes tarnish from metals without the use of liquid, paste or powder. Our agents say it sells like "hot cakes." Retail 25c; sample free. Gale & Co., Inc., 15 Edinboro St., Boston, Mass.

**ENGRAVED** Name plates, signs, numbers, desk plates, store window signs, etc.; profits large. Brett Bros., Winthrop, Mass.

**AGENTS** Wanted everywhere. Write for further particulars. Snow & Parker, Inc., 41 Fish Pier, Boston, Mass.

**SUCCEED** With your own products. Make them yourself. Formulas, processes, trade secrets. Expert analytical service. Catalog, circulars free. B. Thaxly Co., Washington, D. C.

**AUTO** Body polish. Get this eight dollar for one money maker. Shipped in powder form with labels. \$1.00 sample 25c. John Mickman, St. Paul, Minn.

**DON'T** Sell for others. Employ agents yourself. Make your own products. Toilet articles, soap, extracts. Valuable book free. National Scientific Laboratories, 1935W Broad, Richmond, Va.

**AMAZING** Profits showing new table cloth. Looks like linen. Wash like old cloth. No laundering. You just take orders. We deliver. Pay daily. Sample free. Bestever, 231 Irving Park Station, Chicago.

**\$50,000** PICTURE Man Friedman made canvassing. Get free circular "Profits in Portraits." Samples free. Picture Man Friedman, 109 West Austin Ave., Chicago.

**\$200** MONTHLY Selling amazing new automobile trouble light. Electro magnetic. Sticks anywhere on car. It's an Everlasting Flashlight. Sells on sight. Send for demonstrator and prices. National Electric Corporation, 222 High St., Newark, N. J.

**SELL** 3A Garage door holders, simple, automatic, quickly installed. Interests garage owners, builders, everybody. Exclusive territory proposition. Knowlson-Stevenson Co., Ann Arbor, Mich.

**GET** Our free sample case. Toilet articles, flavorings and specialties. Wonderfully profitable. LaDerma Co., Dept. A, St. Louis, Mo.

**MAN** In each town to plate auto parts, reflectors, bathroom fixtures, refinish beds, mirrors, chandeliers; by new method. No capital or experience required. Simple plan of manufacturing at home starts you in big money-making business. Outfit furnished. Free particulars and proofs. Gun Metal Co., Ave. H, Decatur, Ill.

**AGENTS:** Stamping names on pocket-key protectors. Sample check with your name and address, 25c. Stamping outfits. Emblem checks, check-fobs, name plates. Hart Mfg. Co., Desk 2, 303 Degraw St., Brooklyn, N. Y.

**PHOTO** Medallion men and women, the largest line of photo novelties in the world. Lowest prices, quickest service. Send for catalog showing over 200 money makers. Gibson Photo Jewelry Co., Inc., 833-837 Gravesend Ave., Brooklyn, N. Y.

**NO** Dull times selling food. People must eat. Federal distributors make big money; many over \$3,000 yearly. No capital or experience needed; guaranteed sales; unsold goods may be returned. We furnish you with license, sample case and free samples for customers. Repeat orders sure; exclusive territory. Ask now! Federal Pure Food Co., A2307 Archer, Chicago.

**AGENTS**—Clever Invention! Inkspoon makes every pen a fountain pen. Fast office seller; big profit, demand increasing everywhere. Exclusive territory offered. Sample free. H. Marul Company, Tribune Bldg., New York, N. Y.

**WE** Start you without a dollar. Soaps, extracts, perfumes, toilet goods. Experience unnecessary. Carnation Co., 641, St. Louis, Mo.

**GET** Out of the rut. Sell "11" flashy signs everywhere. Write. Free particulars. Koehler's, 717 N. Fourth, St. Louis, Mo.

**GREATEST** Opportunity; newest proposition. Build continually paying business in your own name. Household, industrial, brushes, brooms, mops, dusters, fully guaranteed. New catalog, all net prices, no discount to bother with. Make as high as 300 per cent and over. Write today. Wire Grip Sanitary Brush Corp., 41 East 11th St., New York.

**BIG** Profit putting our gold sign letters on store windows, without experience. Samples. Consolidated, 69-T West VanBuren, Chicago.

**FLAVORING** Extracts—Bottle yourself! Concentrated. Labels furnished. 600% profits! Whirlwind moneymakers! Free offer! Thomas Laboratories, Indianapolis, Ind.

**BIGGEST** Surprise offer ever made. Be sure to answer this ad. My line of soaps, coffee, tea, spices, toilet articles, household specialties, pays you bigger profits. M. G. Roth, President, 2872 Dodder, St. Louis, Mo.

**BIG** Profits! Fast sales! \$9.75 automatic washing machine. Guaranteed. Write Storm Royalty Co., 3601 Enright, St. Louis, Mo.

**A BUSINESS** Of your own—Making sparkling glass name and number plates, checkboard signs. Big book and sample free. E. Palmer, 512, Wooster, Ohio.

**WANTED:** District manager to appoint agents. Unlimited opportunity. No canvassing. Mother Hubbard Products, 554U Congress, Chicago.

**CALIFORNIA** Perfumed beads selling like hot cakes. Agents coining money. Big profits. Catalog free. Mission Factory P, 2328 W. Pico, Los Angeles, Calif.

**THIS** Advertisement may make you thousands of dollars, if you write immediately for my "Eye-Opening" literature describing guaranteed formulas; valuable trade processes, money-making information how to easily make the world's best-selling specialties. All lines. Investment small. Profits immense! Start in your home, room or office. Make the good money you're entitled to. Dr. Liscombe Miller, Chemist, Tampa, Fla.

**GENUINE** Gold Leaf Letters anyone can put on store windows. Guaranteed to never tarnish. Large profits. Enormous demand. Free samples. Write today. Metallic Letter Co., 438-D North Clark, Chicago.

**DON'T** Sell for others. Employ agents yourself. Make your own products. Toilet articles, soap, extracts. Valuable book free. National Scientific Laboratories, 1935W Broad, Richmond, Va.

**AGENTS**—Make a dollar an hour. Sell Mendets, a patented patch for instantly mending leaks in all utensils. Sample package free. Collette Mfg. Co., Dept. 404, Amsterdam, N. Y.

**100% PROFIT** In new mystery cigar lighter. No flint or friction. What makes it light? No wind can blow it out. Retail 50c. Sample and sales plan 25c to cover cost of mailing. New Method Manufacturing Co., Box PM-9, Bradford, Pa.



**HIGH-GRADE SALESMEN WANTED**

**SELL** Nothing, earn up to \$170 weekly empty handed. No sample case to tote. Oldest and largest punchboard firm, established 20 years, rated \$500,000, announces amazing new plan. Salesmen cleaning up! No one invests a penny. We even pay express charges. Unsaleable merchandise returnable. Big season now here. Full commission repeat business. Grab this quick! K. & S. Sales Co., 4349 Ravenswood, Chicago.

**YOU** Can sell business printing. Our big complete selling outfit makes it easy. Our quality and price positively beats competition. Thousands of prospective buyers. Free illustrations, big commissions daily; full repeats. Full time or part time. Write for details now. All-Trades Printing Service, 119 N. Second St., Rockford, Ill.

**\$18 TO \$25 Daily**; biggest selling line of men's suits, \$11.95, \$14.50, \$16.95, \$19.95. Amazing values. Pure virgin wool overcoats, \$18.95. Also raincoats, slickers, topcoats and boys' suits. Biggest commission paid in advance. Liberal bonus. Free outfit. "Jim" Foster, Inc., Dept. 29, 2250 S. Spaulding Ave., Chicago, Ill.

**300% PROFIT** Selling Mystery Gas Lighter. Retails 25c. Costs you \$1.00 doz. Sample free. Square Deal Mfg., Desk PM-11 Bradford, Pa.

**TAILORING** Salesmen, collect \$4.00 cash on every sale, representing old established manufacturer, men's fine tailored Suits, Topcoats, Overcoats, \$18.75, including All Wool fabrics. Expensive outfit free. Write fully. Dept. M-90, Leroy Tailoring, 892 Broadway, New York.

**EARN** Your own trousers—\$15.00 daily, writing orders for guaranteed tailored-to-fit trousers. Free outfit. Bigger commissions. World's greatest pants value at \$3.95. Dunlap Pants Co., Dept. 160, Cincinnati, Ohio.

**EARN** \$20.00 a day up taking orders for Goodwear clothes. Build an established business with assured income. Selling outfit supplied free offers powerful display Pure Virgin Wool Fabrics and everything else required to start you making real money at once. Address Dept. 917, Goodwear, Inc., 844 West Adams, Chicago.

**SELL** Brohard-Rainer "Good Shirts." Everybody buys. They repeat, too. Good pay. Act quick! Brohard-Rainer, 400 Pike, Cincinnati.

**NEW** And aplenty different—Fast selling 5c-10c merchandise on attractive counter cards. 100% commission for you and dealers. Advertised by radio. No capital required. Catalog free. World's Products (Estab. 1921), 94 Central, Spencer, Ind.

**NOVELTY** Styles, Radically Different, men's dress and work shoes and high boots, popular prices, exceptional quality. Real proposition for men with direct shoe, clothing, overall experience. Line sells and repeats. Free sample, protected territory. Canton Shoe Co., Boston, Massachusetts.

**MAGAZINE** Salesmen—Our contracts ranging from \$3.95 to \$7.80 are sold with exceptionally attractive premiums materially helping salesmen earn \$60.00 to \$100.00 weekly. Write for particulars. Geographical Publishing Co., 621 Plymouth Court, Chicago.

**SALESMEN** Big money maker—Sharpener for new Gillette Blades—sells on sight \$1.00. Satisfaction guaranteed—Send \$1.00 for two sample sharpeners and free selling plan, protected territory. Stanford Sharpener Corp., 220 Hearst Tower Bldg., Baltimore, Md.

**AMAZING** New "Honey-moon" trade builder coining money for salesmen. Siler made \$112.00 one week. You can too—Easy. Big, quick money-maker. Free outfit. "Honey-moon" Business Builders, 4016 Lewis, Toledo, Ohio.

**PLACE** Punchboards, vending machines, in stores; free kit. Badger Bay Company, Green Bay, Wis.

**AMAZING** Screw-holding screw driver! Remove, insert screws inaccessible places. Factories, garages, electricians, mechanics, auto, radio owners buy on sight! Exclusive territory. Free trial! Jiffy, 1665 Spring Lane, Boston.

**SALESMEN** \$22.00 Profit on nine \$3.00 sales. Only 1/2 days work with our beautiful metal Auto Monograms. Be the first in your locality to introduce this big number. Never before, never again such an opportunity. Stalder Mfg. Co., Dept. PM, 330 Venice Blvd., Los Angeles, Calif.

**TAILORING** Salesmen, collect \$4.00 cash on every sale, representing old established manufacturer, men's fine tailored Suits, Topcoats, Overcoats, \$18.75, including All Wool fabrics. Expensive outfit free. Write fully. Dept. M9, Leroy Tailoring, 892 Broadway, New York.

**EXTRA** Money—Easy! Sell Christmas Cards! Deal direct with Manufacturer of outstanding \$1 Box Assortment of 24 fine engraved designs; also personal name imprinted greetings. You'll be surprised at our prices and commission to you. Write for Samples and Details. Thistle Engraving & Pub. Co. Dept. O, 20 Vesey St., N. Y.

**DISTRICT** Managers to build own Accident and Health Insurance business. Particularly adapted for salesmen of mechanical and specialty temperament. Large immediate and continuous renewal income, with national organization having most liberal policy coverage. D. Coverley, 75 Fulton St. New York City, N. Y.

**SALESMEN**—No Hard Times. Earn up to \$12 daily wearing fine Felt Hats and showing friends. Smartest Styles. Latest shades. \$2 to \$5 saving. Samples Free. Taylor Hat and Cap Mfrs., Dept. EC-135-A, Cincinnati, Ohio.

**SIDELINE** Better than full time pay. New sales builder for every retail merchant only \$5.75 complete. Wrist Watch given. \$2.00 immediate cash commission. Several times that in repeats. Pocket outfit free. Business Builders, 303 W. Adams, Chicago.

**PUNCHBOARD**—Hurrah! New Protection Plan opens "closed" territory creating tremendous demand. Dealers jubilant, Business Booming, Commissions enormous. Outfit free. Puritan Novelty, 1407 Jackson Blvd., Chicago.

**BUSINESS** Stationery—Largest Line—Highest Quality—Quickest Delivery—Biggest Commissions—Liberal Bonuses—Free copy-righted Cuts every business—Experience unnecessary—Instructions and Outfit free. David Lionel Press, 312 So. Hamilton, Dept. 165, Chicago.

**SALESMEN** Wonderful Sideline. 40% Commission paid daily. Sells all merchants. Pocket outfit free. Willens Co., Dept. 317, 2130 Gladys Ave., Chicago.

**40%-55% PROFITS**, America's greatest printing line. Steady year round sales. 1000 styles every business uses daily. Lowest prices, highest qualities. Main or sideline. Experience unnecessary. Kaeser-Blair, Inc., Cincinnati.

**CHRISTMAS** Cards. 50% Commission. Large line, low prices. 6 Box assortments, 4 for imprinting. Buckeye Thermographers, 1108 Adams, Toledo, Ohio.

**SELL** Illustrated business printing. Experience unnecessary. Quickest service. 50% commission in advance. Full or part time. Union label. Cut catalog, sample book, instructions free. Interstate Printing Company, 5844Z Broadway, Chicago.

**CHRISTMAS** Greetings. The line that wins and holds customers. Genuine Steel engraved. 40% Commission. Portfolio of samples free. Your own cards given. Federal Art, Div. R1, 297 Congress, Boston, Mass.

**BIG** Profit putting our gold sign letters on store windows, without experience. Samples. Consolidated, 69-V West Van Buren, Chicago.

**ADVERTISING** Pencils sell fast to every line of business. New line. Quick cash commission plan. Main or sideline. Free pocket outfit to real salesmen. Chicago Graphite Co., 130 So. Clinton, Chicago.

**SALESMEN**—Become independent. Own your business; experience unnecessary. Selling our \$10,000 accidental death; \$50 accident; \$25 sick weekly benefits—\$10.00 yearly. Other amounts proportionate. Guaranteed steady income from renewals. \$250,000 deposited insurance department. Universal Policy, Dept. A, 716 Lefcourt Bldg., Newark, N. J.

**BIG** Pay every day. Bonus every week. Adelite sells everywhere. New spectacular electric window display. Ever-changing colors, original posters, patented changeable letters defy imitation or competition. Special models for merchants, banks, etc. Instant seller. Big repeats, full commission. Write for thirty day demonstration offer. Display Products Co., 409A East 31st, Kansas City, Mo.

**SALESMEN**—If you ever earned five figures a year then we want to hear from you. Radio Television Corp., Broad St., Detroit, Mich.

**SALESMEN** Sell tires and auto accessories to garages, tire stores, filling stations, etc. Established line repeats everywhere. Liberal commission. Write for particulars. Economy Rubber Prod. Co., 606 Burkhardt, Dayton, Ohio.

**SALESMEN**—Make 80c profit on \$1.00 sales. Wonderful cleaner for automobiles, furniture, metal and glass. Your name on labels; fast repeater; exclusive territory; free sample. Minute Kleen Laboratories, Evansville, Ind.

**DAILY** Cash! Merchants can't refuse this amazing introductory offer! Sells everywhere. Big commissions. Big quick repeats—prompt checks. Pocket kit free. Sales Stimulators, Inc., 339 W. Madison, Chicago.

**DON'T** Sell for others. Employ agents yourself. Make your own products. Toilet articles, soap, extracts. Valuable book free. National Scientific Laboratories, 1935W Broad, Richmond, Va.

**WANTED** District managers. Oldest organization of its kind in accident and health insurance. Write today for information. Dept. 18, Inter-State Business Men's Accident Ass'n, Des Moines, Iowa.

**COVERALL** Salesmen—Lettered garments, \$3.25. Commission 75c. Write for sample. Blue Bar Sales, 844 Dorr, Toledo, Ohio.

**PUNCHBOARD** Salesmen make big commissions, selling punchboards and vending machines. Reliable concern, established 20 years. Largest most complete catalog in colors, free. Best season now. Write today! Lincoln Sales, 116 S. Wells, Chicago, Dept. D.

**PUNCHBOARD** Salesman—Most gigantic line ever featured. Vending machines, all kinds. Make high as \$28.00 on single order. Repeat commissions. Beautiful colored catalog free. Lion Mfg., Dept. 8, 308 W. Erie, Chicago.

**SALESMEN**—Four \$15.00 sales to merchants net you \$40.00 daily. Sayers Systems, 2813 Sheffield, Chicago, Ill.

**\$60-\$200 A WEEK**. Genuine gold letters for store windows. Easily applied. Free samples. Liberal offer to general agents. Metallic Letter Co., 438-A North Clark, Chicago.

**CHOICE** Territories open to high class salesmen, to sell high grade lettered work garments. Write for free outfit. American Motor Suit Co., Winder, Ga.

**HELP WANTED**

**DON'T** Worry about the high cost of living! Here's a wonderful opportunity to get your groceries and household supplies at wholesale and make \$15 cash profit a day besides. Particulars free. Albert Mills, 5201 Monmouth, Cincinnati, O.

**ELECTRIC** Arc soldering. New, startling. Principle electric welding. Representatives. \$12.00 day easy. 100% profit. Sample \$2.00. Hubert Mfg. Co., Glendale, Calif.

**MEN**—Sideline; photos, 20, \$1.00. Cartoon books. Samples. GPO, Bx471, New York.

**EDUCATIONAL AND INSTRUCTION**

**DO** You want a fine hotel position? Then come to Washington! Here is the only school of its kind in the world—a nationally recognized training school which prepares men and women for positions paying \$2,500 to \$7,500 in hotels, apt. hotels, resorts, clubs, schools, cafeterias and tea rooms. Come to Lewis—get ready for bigger earnings while enjoying delightful months in the beautiful, interesting capital city. Learn under practical experts 14-year tested, time-saving, thorough training. National employment bureau for graduates, no extra cost. Write now for free book that brings your opportunity. Lewis Hotel Training Schools, Dept. 317-CP, Washington, D. C.

**U. S. GOVERNMENT** Steady Jobs. Men Women, 18 up. \$105.00 to \$280.00 month. Steady work. Short hours. Paid summer vacation. Common education usually sufficient. Experience usually unnecessary. We coach you without leaving home. 32 page book with full particulars and sample coaching free. Write—Today. Franklin Institute, Dept. N-3, Rochester, N. Y.

**FIREMEN**, Brakemen, Baggage-men; colored Train or Sleeping Car Porters, \$150—\$250 monthly. Experience not necessary. 810 Railway Instruction Bureau, East St. Louis, Ill.

**COMPLETE** Civil service course. Practical exercises, problems, answers. Over 200 pages \$2.50. Details free. Seaboard Service Co., Baltimore, Md.



**U. S. GOVERNMENT** Wants men, \$1,700-\$1,900 and up at start. Railway mail clerk examination coming. Let our expert (former government examiner) prepare you for this and also rural carrier, post office, customs, internal revenue, and other branches. Write today for free booklet. Dept. 8, Patterson School, Rochester, N. Y.

**WANTED** Immediately, men-women, 18-55, qualify for permanent government positions, \$105-250 month; no government experience required. Paid vacations. Common education. Many needed soon. Write Ozmest Inst., 101, St. Louis, Mo.

**WOODTURNING** For amateurs. Excellent new course just published for the amateur and home work shop owner. Contains all the needed information and is well illustrated yet published to sell at the low price of 25 cents postpaid. Send for your copy today. Mail remittance with your order. Popular Mechanics Press, Room 807, 200 E. Ontario St., Chicago.

**STUDY A Scientific** profession Microbiology, Bacteriology, Sanitation, Extension-residential course. Diplomas, degrees granted. Urinalysis outfit, prospectus free. Microbiology College Birchtree, Missouri.

**BATTERY Shop**—How to run. Most complete and authoritative information ever compiled on tools needed, shop equipment, charging methods, opening batteries, work on plates, jars, case, etc. Covers auto, radio and farm lighting batteries. Send for big 550-page book and pay postman \$5.00 plus postage when he delivers same. If outside U. S. remit when ordering. Popular Mechanics Press, Room 801, 200 E. Ontario St., Chicago.

**LEARN** Rapid figuring from "Higher Arithmetic." Write for prospectus. F. A. Smith, 608 S. Dearborn St., Chicago.

**BECOME A landscape architect.** Uncrowded profession; wonderful opportunity for money-making. Easily mastered by mail. Earn while you learn. Est. 1916. Write for details. American Landscape School, 29 Plymouth Bldg., Des Moines, Iowa.

**WELLS' Outline of History** now only \$1. The complete, illustrated, 1,200-page edition that originally sold for \$5.00. One of the most popular books ever published. Can be read with profit by young or old. Pay postman \$1.00 plus postage when delivered to your door C. O. D. Popular Mechanics Press, Room 802, 200 E. Ontario St., Chicago.

**DON'T** Prepare for any civil service examination without seeing our catalog. Free. Columbian Correspondence College, Washington, D. C.

**DYKE'S Famous Automobile Encyclopedia**—Latest edition. Fully revised to cover all latest facts regarding newest developments in automobile field, including new Model A Ford. Popular Mechanics Press, 200 E. Ontario St., Chicago.

**LEARN** Typewriting at home. Rational typewriting, brief course by Sorelle (a Gregg publication) enables you to become proficient at typing without the aid of an instructor. 96 pages. Illustrated Cloth. Sent C. O. D. Pay postman price, \$1 and small amount of postage upon delivery. Popular Mechanics Press, Room 806, 200 E. Ontario St., Chicago, Ill.

**PHOTOPLAY** Talking picture and magazine stories wanted for revision, development and copyright. Sell on commission. Established 1917. Booklet free. Universal Scenario Company, 406 Western and Santa Monica Bldg., Hollywood, Calif.

**DOUBLE** Entry bookkeeping 60 hours with 8 keys guaranteed. (Diplomas.) International Bookkeeping Inst., 8 Springfield, Mo.

**CASH** Paid for butterflies, insects. See Sinclair Display Advertisement on page 14.

**BUILD** Your own boat. Complete directions make it comparatively easy and you will not only save money but have lots of fun besides. The Outboard Motor Boat book covers 35 different types of the latest outboard motor, inboard motor, rowing, sailing boats, canoes, etc., with blueprints in addition to the instructions. Pay postman price, \$3, and few cents postage when delivered. Popular Mechanics Press, Room 807, 200 E. Ontario St., Chicago.

#### TYPEWRITERS AND SUPPLIES

**GUARANTEED** Typewriters, all makes, \$8 to \$34. Free catalog. Typewriter Exchange, Ada, Okla.

**TYPEWRITERS**—All standard makes \$10 up. Catalog free. Northwestern Typewriter Exchange, 121 N. Francisco Ave., Chicago.

#### ADDING MACHINES

**NEW \$3.50** Automatic adding machine. Adds, subtracts, multiplies, absolutely accurate. Capacity \$999,999.99. Fully guaranteed. 75,000 pleased users. Makes adding easy, positive, quick. Eliminates mistakes. Saves time. Postpaid \$3.50. Bassett Co., 1458-H, Hollywood Ave., Chicago.

#### PRINTING, ENGRAVING AND MULTIGRAPHING

**OUR** Standardized plan makes it possible to print house organs and magazines at one-third ordinary prices. We print more than 1,100 different publications. Samples and particulars free. National Publishers Press, Grand Rapids, Mich.

**NEARGRAVUREMBOSS** 250 Letterheads and envelopes \$6.75 postpaid. Solldays, Knox, Indiana.

**1000 BUSINESS** Cards \$2.75 postpaid. Samples free. Miller, Printer, Narberth, Pa.

**500 20 lb. BOND** Form letters \$1.50. Harrington, Lyons, Wis.

**LETTERHEADS,** Envelopes, 500, \$1.10; 1,000, \$2.00; 5,000, \$8.00, plus postage. Samples. Coyle & Kimballs, Newport, N. Y.

**5,000 6x9 CIRCULARS,** \$7.50; 25,000, \$25.00; Folders, circulars, stationery low prices. Elegant Samples free. Goodprint, Harrisonburg, Va.

**250 BOND** Letterheads, envelopes, billheads, cards, \$1.35 each. Midland Press, Arlington, N. J.

**QUALITY** Printing! Reasonable prices! Send for free standardized samples and prices. Folders, Circulars. Catalogs our specialty. Earnest Fantus, 525 South Dearborn, Chicago.

**250 BOND** Letterheads, envelopes, billheads, cards, \$1.35 each. Economic Press, Leonia, N. J.

**WE** Print stationery, booklets, catalogs, circulars. Samples. Commercial Press, Batavia, Ohio.

**SOCIAL** And business printing. Specializing in raised letter work. Samples free. LaClyde Service, Westfield, Mass.

**PUBLICATIONS,** Catalogs, stationery. Prices reasonable. Annville Printing Company, Annville, Penna.

**BEST** Printing prices. Battlefield Press, Gettysburg, Penna. Free battlefield souvenir.

**250 BOND** Letterheads, 200 envelopes to match, \$2.49. Cash. Specialty Press, Box 193, Greenwood, S. C.

#### PRINTING OUTFITS AND SUPPLIES

**PRINT** Your own cards, stationery, circulars, advertising, etc. Junior Press \$5.90. Job presses \$11 up, power \$149. Print for others, big profit. Easy rules furnished. Write for free catalog and full information. Kelsey Co., R-11, Meriden, Conn.

**PREUSED** Printing presses and supplies. Lists 2c stamp. Popular Bargains, Richmond, Pa.

**PRESSES,** Type 50% less. Lists stamp. Bargain Counter, Statesboro, Georgia.

**PRINTING** Outfits—Presses, type supplies, type novelties. Send stamp for catalog. Model Press, York, Penna.

#### GUMMED LABELS

**1,000 PRINTED:** Name, business, address 50c. JBS Company, Box 93, Holyoke, Mass.

#### DUPLICATORS AND DEVICES

**G. S. W. STENCIL** Duplicator duplicates typewriting handwriting, drawings etc. in one or more colors. Notesize \$14.50. Letter-size \$19.50 complete. General Stamping Works, 238 E. 24th St., New York.

**YOU** Can make 50 to 100 copies of a letter, notice, etc., at a cost of three cents on a Heyer Quality Duplicator. Write for free trial offer. The Heyer Duplicator Co., 909 Jackson Blvd., Chicago, Ill.

**"EXCELLOGRAPH"** Rotary stencil duplicator \$39.00. "Two-Faced" film duplicator \$6.00. Booklet free. Pittsburgh Typewriter Supply, Dept. 601, Pittsburgh, Pa.

#### RUBBER STAMPS

**SEND** For catalogue 50a. Mansfield Rubber Stamp Works, Mansfield, Ohio.

**RUBBER** Stamps! Name, address, two lines 25c; three lines 35c. DeLuxe Stamp Works, B572M, Auburn, Nebr.

#### FOR THE HOME

**CEDAR** Chests only \$11.85—"Red-1-Kut" complete with rich copper trim—you assemble and save half—send for pictures. Kuempel Furniture Company, Guttenburg Iowa.

**WOOD** Turning on the lathe. Both interesting and fascinating. Send for a copy of Milton & Wohlers Course in wood turning. It gives you quickly a complete mastery of this manual art. 340 pages. Cloth. 141 plates. Sent C. O. D. Pay postman price \$1.50 and small amount postage upon delivery. Popular Mechanics Press, Room 806, 200 E. Ontario St., Chicago, Ill.

**FURNITURE** Finishing, decoration and patching. Valuable new book, the first in its field, contains practical instruction on doing this work and also treats on materials, tools and processes. 543 pages and 335 illustrations. Delivered to your door C. O. D. Pay postman \$5 and postage. Popular Mechanics Press, Room 801, 200 E. Ontario St., Chicago.

#### FOR SMOKERS

**SMOKE** On me free—I'll send you tree big generous sample Old Green River pipe tobacco. Enjoy the mild mellow tasty natural tobacco flavor. See how smooth and satisfying. No obligation. Send today. Pete Moberly, Box 775, Owensboro, Ky.

**JUST** Out—First book on all-electric radio sets—clear, interesting and non-technical. Covers dynamic speakers, also. Written by Kenneth A. Hathaway, Tech. Adviser, Chicago Daily News. 120 pages, cloth, illustrated. Pay postman \$1.50 plus postage upon delivery. Popular Mechanics Press, Room 801, 200 E. Ontario St., Chicago, Ill.

#### FOR MECHANICS

**SHOP** Notes for 1930. Get your copy now. Only a limited edition. Contains all the articles published in the Shop Notes department of Popular Mechanics Magazine during 1929. Send 50 cents. If you want the entire set of Shop Notes books consisting of 15 volumes including the 1930 number and 14 others issued previously we will send them C. O. D. at a special reduced price of \$4.50. Popular Mechanics Press, Room 802, 200 E. Ontario St., Chicago, Ill.

**INTERIOR** Wall decoration in a valuable new book covering all the modern methods of artistic wall treatments. Practical working instructions for both plain and decorative finishes are given. 451 pages, illustrated. Delivered to your door C. O. D. Simply pay postman \$4 and postage. Popular Mechanics Press, Room 801, 200 E. Ontario St., Chicago.

#### GUNS, FISHING TACKLE AND SPORTING GOODS

**SHOTGUNS** Restocked, checked complete, \$8.00. Bradley Gunsmith Savannah, Ga.

**BOYS!** Here's fun galore. Four large profusely illustrated books tell how to make almost everything you could want. Nearly 4,000 different articles are described (Think of it). Now \$2 per book or \$7 for the four if ordered at once. Just write a postal saying, "Send the Boy Mechanic Library." Pay postman \$7 and postage. For single books, specify either Book 1, 2, 3 or 4. Popular Mechanics Press, Room 801, 200 E. Ontario St., Chicago, Ill.

#### FIELD GLASSES, MICROSCOPES AND TELESCOPES

**\$25.00 HUE** French Binoculars. Twelve power, with leather case, worth \$65.00. Send free list field glasses, binoculars, airplane cameras and lenses, also musical instruments. Well's Curiosity Shop, 20 South Second St., Philadelphia, Pa.

#### BOATS AND LAUNCHES

**BUILD** Your own boat using ready cut semi-assembled materials furnished by originators of this system of building. Save two-thirds. 55 designs—outboard speedsters, runabouts, cruisers, sail, row, etc. Send 10c for catalog. Brooks Boat Co., etc., Box M.M., Saginaw, Mich.

**CUP** Yacht results, new yachts, outboard races, Bermuda race. Plans 27 foot speed cruiser, In August Rudder, 35c. Subscription \$3.00 year. Catalog of boat plans free. Rudder, 15 Murray Street, New York.

**PROPELLERS,** Pumps, stuffing boxes, lights, etc. Wm. H. Baker, Pond St., Quincy, Mass.

**THREE** Unused 14 foot Manitoba white-pine duck boats. Never uncrated. \$27 each. Alwin Clarine, Walker, Minnesota.



**BUILD** Your own boat—Complete directions make it comparatively easy. 14 different types for all purposes including row, motor, sail, canoe, out-board motor boats, etc. With this book is included "Outdoor Sports the Year 'Round" on making all sorts of devices for outdoor recreation. Pay postman \$1.98 plus postage when delivered. Popular Mechanics Press, Room 801, 200 E. Ontario St., Chicago.

#### RAZORS AND BLADES

**GILLETTE** Blades honed, stropped, 10 each. Petter Wetterquist, Rockford, Ill.

#### WATCH REPAIRING

**WATCH** Repairing and making shows how to clean and repair all kinds of watches. 214 page book with over 200 illustrations. Pay postman \$3 and postage when he delivers book. Popular Mechanics Press, Room 801, 200 E. Ontario St., Chicago, Ill.

#### ANTIQUES, WAR RELICS AND INDIAN GOODS

**SEND** 5c For fine new list Indian relics, antique firearms. F. E. Ellis, Webster Groves, Missouri.

**INDIAN** Relics, coins, curios. Beadwork. Catalog free. Vernon Lemley, Osborne, Kans.

#### PHONOGRAPH AND RECORDS

**BUILD** Your own phonograph, radio. Parts catalog 10c. American Phonograph Co., 3602 Wesley, Berwyn, Ill.

#### MUSIC AND MUSICAL INSTRUMENTS

**DUO-FLEX** Reeds for saxophones and clarinets, only invention affecting blowing quality of reeds. Eliminate your reed troubles get softer tones with ease. Per dozen Clarinet \$2.50, Soprano \$2.75, C Melody \$3.00, Alto \$3.00, Tenor \$3.50. Duo-Flex Reeds, 1204 First Ave., Evansville, Ind.

**SONGWRITERS**—You need this wonderful book "successful songwriting" especially written for your guidance and complete instruction by famous song-hit writer. 47 chapters. Postpaid \$1.00 limited edition! Order now! Brown Specialty Co., 30 Magnolia Ave., Jersey City, N. J.

**PIANO** Players, more popularity at parties, dances. Radio, player-roll, hot arrangements any song chorus for your performance, \$2.00, applies arrangement club offer. Earle Sparks, Box 116P, Norwich, Conn.

**GIVE** Your songs the right start. Free information. Tucker, 330 Wadsworth, New York.

**SONGWRITERS**—Write with legitimate professional writer, Tommie Malie, PM4215 North Ave., Chicago.

**COMPOSERS**—Verse or music. Brilliant opportunity. Write VanBuren, 2119 McClurg Bldg., Chicago.

**GUARANTEED** Results. Write Sequoia Songwriters Service, Sherman Branch, Los Angeles, Calif.

**PIANO**—Accordian Groff's wonder book "jazz" teaches you. Send \$3.00 today. Money back guarantee. Groff, 2828 Madison Street, P. Chicago, Illinois.

**SONGWRITERS** Information Service, Legitimate. Write Harry Battersby, Revere, Mass.

**SONG** Writers. Send for our "Publishing Agreement." McKinley Music Printers, 1501 E. 55th St., Chicago.

**SONG** Poems solicited. A different proposition. Richard Broughton, Sioux Falls, S. Dak.

**WRITE** Songs. Big money and reputation. Write for information. J. Gordon Pub. Co., 201 N. Hoyne Ave., Chicago.

**POEMS** Wanted. Work guaranteed. We publish. Great Eastern Song Bureau, Dept. 27, Thomaston, Me.

**SONGWRITERS**—Arranging, composing. Free booklet. Tucker, 330 Wadsworth, New York.

**SONG** Poems wanted, marketing proposition, if suitable. Clifford Studio, 4695 Hollywood Blvd., Hollywood, Calif.

**FREE!** Song Writers Guide. Beaver, 1257 Elm, Green Bay, Wis.

**CORNETISTS**—Trombonists—Saxophonists—Clarinetists. Get "Free Pointers." Name instrument. Virtuosi School, Buffalo, N. Y.

"MUSIC Composed" to words. Bauer Bros. (formerly of Sousa's Band), Oshkosh, Wis.

**SONG** Poem writers. "Real" proposition. Hibbeler, D1, 2104 Keystone, Chicago.

#### PATENT ATTORNEYS

**PATENTS.** Send sketch or model for advice. Free book, "How to Obtain a Patent." Established thirty years. Highest references. Prompt service. Reasonable charges. Chandee & Chandee, 908 F Street, Washington, D. C.

**INVENTIONS** Patented and Exploited. Former patent office examiner; Master patent law. Benj. Webster, Esq., No. 15 East 25 Street, New York.

**PATENTS** Procured. Prompt, careful efficient service. Highest references. Moderate fees. Send sketch or model for actual search and advice. George P. Kimmel, Master of Patent Law, 54-I Legal Bldg., Washington, D. C.

**INVENTORS**—Write for our Guide Book, "How to Get Your Patent," and Evidence of Invention Blank. Send model or sketch of your invention for our prompt examination and instructions free. Randolph & Co., Dept. 430, Washington, D. C.

**PATENTS.** Booklet free. Highest references. Best results. Promptness assured. Watson E. Coleman, Patent Lawyer, 724 Ninth St., Washington, D. C.

**LANCASTER.** Allwine & Rommel, 221 Ouray Bldg., Washington, D. C. "Originators of the Form Evidence of Conception." Before disclosing your invention to anyone send for blank form to be signed and witnessed. Form and patent information bulletin free.

**INVENTOR'S** Adviser with mechanical movements sent free. Labiner, 15 Parkrow, New York.

**"INVENTOR'S** Guide," valuable information, free. Frank Ledermann, Registered Attorney-Engineer, 1712 Woolworth Bldg., New York.

**PATENTS.** Prompt personal service. Write for information. Albert E. Dieterich, Registered Patent Lawyer, 621½ Ouray Bldg., Washington, D. C.

**PATENTS** Procured: trade marks registered—preliminary advice furnished without charge. Booklet and form for disclosing idea free. Irving L. McCathran, 704 International Bldg., Washington, D. C.

**PATENTS, Trade-Marks, Designs.** This firm has 27 years' experience and gives expert personal service at reasonable rates. We properly protect your invention. Write for free information and exact cost of procuring patent before proceeding. John B. Thomas & Co., 902 F St., N. W., Washington, D. C.

**PATENTS**—Write for free instructions. Send drawing or model for examination. Miller & Miller, Registered Patent Attorneys (former Patent Office Examiners), 259 McGill Bldg., Washington, D. C.

**TIME** Counts in applying for patents. See pages 134 and 135. Clarence A. O'Brien, Registered Patent Attorney, Washington, D. C.

**PATENTS**—Write for our free book, "How to Obtain a Patent" and Record of Invention Blank. Send model or sketch of invention for inspection and instructions free. Terms reasonable. See advertisement on pages 136 and 137. Victor J. Evans & Co., 934 Ninth, Washington, D. C.

**LACEY'S** Patent Sense. Valuable book free. See ad page 138.

**INVENTORS:** Send for booklet telling how to patent and sell your inventions at lowest cost. Ralph Burch, Patent Lawyer, 909 F St., Washington, D. C.

**REGISTERED** Patent attorney-engineer. Expert in chemical and mechanical patent matters. Former patent examiner. Correspondence invited. A. Ponack, 401 Homer Bldg., Washington, D. C.

**PERCY S. WEBSTER,** 203 Saving and Loan Bldg., Stockton, Calif. Patent booklet free.

**ESTABLISHED 1864.** Milo B. Stevens Company. Free booklet. Patents. Trade marks. Copyrights. Offices. Monadnock Block, Chicago; Barrister Bldg., Washington, D. C.

**INVENTORS**—Cash in on your invention now! Don't delay the sale any longer! Send for a free copy of our specially prepared booklet, "Turn Your Patent Into Money," today! It contains helpful information for all inventors. M. L. Rund, Mgr. Classified Advertising, Popular Mechanics Magazine, 200 E. Ontario St., Chicago, Ill.

#### FOR INVENTORS

**INVENTIONS** Wanted relating to automobile accessories for winter use. Royalty paid. Box 549, Middletown, Connecticut.

**INVENTIONS** Wanted on workingmen's lunch boxes, bird cages, fishing tackle, and roller skates that will not wobble, automobile products. Royalty paid. Box 549, Middletown, Conn.

**INVENTIONS** Patented and Exploited. Former patent office examiner; Master patent law. Benj. Webster, Esq., No. 15 East 25 Street, New York.

**COMMUNICATE** With us if you have patentable ideas in portable woodworking machinery. Porter-Cable Machine Company, Manufacturers, Syracuse, N. Y.

**TO** Inventors: We are in the market to purchase a good patent, preferably in the automobile accessory line. Will purchase outright or on a royalty basis. Purchasing Agent, 241 Front St., New York, N. Y.

**INVENTOR'S** Universal Educator: contains 900 mechanical movements; 50 perpetual motions; instruction on procuring and selling patents and selecting an attorney, etc. Suggests new ideas. Price \$1.00 postpaid in U. S. A. Address Dieterich Co., publishers, 602B Ouray Bldg., Washington, D. C.

**YOUR** Idea is worth something. Let us help you improve it, or manufacture and distribute it. You are legally protected while transacting with us. F. C. Canode Mfg. Co., 515-17 So. Laffin St., Chicago, Ill.

**LOW** Cost manufacturing. Large plant completely equipped for blanking, drawing, stamping and wire forming in any finish. Can save you money on your product. Our figures will convince. Eastern States Products, Box 721, New Haven, Conn.

**INVENTIONS**—Write for our free book "How to Obtain a Patent" and Record of Invention Blank. Send model or sketch of invention for inspection and instructions free. Terms reasonable. See advertisement on pages 136 and 137. Victor J. Evans & Co., 157 Ninth, Washington, D. C.

**TIME** Counts in applying for patents. See pages 134 and 135. Clarence A. O'Brien, Registered Patent Attorney, Washington, D. C.

**LACEY'S** Patent Sense. Valuable book free. See ad page 138.

**INVENTIONS**—Have you conceived one? There is a long, winding road to travel before your vision of rewards can be realized. Send for the new book "Inventions and Patents, Their Development and Promotion" by an eminent authority. It is designed to guide the inventor on his way and help him avoid pitfalls. Will be sent C. O. D. Pay postman \$2.50 plus postage when he hands you the package. Popular Mechanics Press, Room 802, 200 E. Ontario St., Chicago.

**INVENTOR** Wants position. I beg cordial request. Gabriel Racy, P. O. 104, South Norwalk, Conn.

**INVENTORS**—Cash in on your invention now! Don't delay the sale any longer! Send for a free copy of our specially prepared booklet, "Turn Your Patent Into Money," today! It contains helpful information for all inventors. M. L. Rund, Mgr. Classified Advertising, Popular Mechanics Magazine, 200 E. Ontario St., Chicago, Ill.

#### PATENTS FOR SALE

**OUTRIGHT** Or Royalty basis, Improved Chiropractic Table. Do your own adjusting. Manufactured at very low cost. Edw. Rosenquist, 1448, 44th Ave., Oakland, Calif.

**OUTRIGHT** Or Royalty U. S. Patent 1,761,869, Collapsible Buttonhead, a fool-proof Cuff—Collarbutton now invented. 109 South 48th Ave. W., Duluth, Minn.

**OUTRIGHT** Or Royalty, dandy tool for building trades, "Insulation cutter," write John Erickson, 5345, 41st Ave. South, Minneapolis, Minnesota.

**OUTRIGHT** No. 1,739,872 and No. 1,722,688. Mark Soss, 417 Main Ave, Spokane, Wash.

**OUTRIGHT** Or royalty, Automobile "Turn" Signal, Automatic. Patent pending. J. T. Callaway, 719 Hurt Bldg., Atlanta, Ga.

**SELL** Patent pending on small turned woodtoy. Very original and educational. Moderate downpayment, easy royalty. Guyot, 413 S. Virgil Ave., Los Angeles, Calif.

**SMALL** Advertising novelty, best offer accepted. Fred Schler, Winona, Minn.

**PARTNER** Wanted to help finance two meritorious inventions. New steel railroad tie, also rail. Homer Zuck, B3, Carthage, Mo.



**CASH Or royalty.** Hitch for trailers or like—patented, Box 32, Hartsel, Colo.

**PATENT Pending.** Combination fuse and circuit breaker. With this fuse you're never in the dark. Press top and its good again. C. R. Fogelstrom, 537 McDonald Street, Pasadena, Calif.

**FOR Royalty,** a tested invention. Address E. E. Mahr, 726 N. Pearl St., Dallas, Texas.

**FOR Sale;** my patent anti-glare safety device, for automobile lights; insures safety to drivers. Roy Zigler, Plymouth, Ohio.

**MANUFACTURERS—**Get our complete list of inventions for sale. American Society of Inventors, Crosby Bldg., Buffalo.

**FOR Sale—**Patents, improved flour sifter and improved snare. Outright or royalty. Harry Nakagawa, Tanana, Alaska.

**SPARKING** Surface spark plug. Repeat demand eighty million. Cheap. Georgias, 192 Fourth St., South Boston.

**TIME Counts** in applying for patents. See pages 134 and 135. Clarence A. O'Brien, Registered Patent Attorney, Washington, D. C.

**INVENTORS—**Cash in on your invention now. Don't delay the sale any longer! Send for a free copy of our specially prepared booklet, "Turn Your Patent Into Money," today! It contains helpful information for all inventors. M. L. Rund, Mgr. Classified Advertising, Popular Mechanics Magazine, 200 E. Ontario St., Chicago, Ill.

### ELECTRICAL

**NEW Electrical Dictionary.** Complete up-to-date electrical dictionary with special radio words and terms together with illustrations of electrical symbols, radio diagrams and other wiring diagrams. 191 pages—Vest pocket size. Price only 35c postpaid. Popular Mechanics Press, Room 801, 200 E. Ontario St., Chicago, Ill.

**FAMOUS Bailey Handbook—**Prepares you to pass the examination for any grade of license for stationary, marine and Diesel engineers, firemen and boiler inspector in any state of the Union or any province of Canada. Flexible cover. Handy pocket size. Pay postman \$2.00 plus postage when he hands you the package. Popular Mechanics Press, Room 801, 200 E. Ontario St., Chicago, Ill.

### MODELS AND MODEL SUPPLIES

**INVENTORS:** Send us sketch or crude model of your idea. Crescent craftsmen will develop it into a practical working model. 30 years of successful experience and thousands of satisfied clients. Confidential service guaranteed. Bank references furnished. Free illustrated book: "Making Inventions Pay." Crescent Tool Co., Dept. S-9, Cincinnati, Ohio.

**SHIP** And yacht model fittings. Send dime for illustrated catalog No. 6. A. J. Fisher, 1002 Etowah Ave., Royal Oak, Mich.

**WE Make** working models for inventors and do experimental work and carry a complete stock of brass gears and model supplies. Send for catalog. The Pierce Model Works, Tinley Park, Ill.

**THE Modelmaker.** An illustrated magazine devoted to practical model making. Sample 10c. Modelmaker, 122 Liberty St., New York.

**LET** Our experience be your guide. Models that are models; tools and equipment for economic manufg. Patterns of all types; manufacturing in all branches. Satisfaction guaranteed. United Machinery Company, Cincinnati, U. S. A.

**TIME Counts** in applying for patents. See pages 134 and 135. Clarence A. O'Brien, Registered Patent Attorney, Washington, D. C.

**MODEL** Steam engines and boilers for miniature power boats. Boat and boiler fittings. New catalog 15c. Model Machine Shop, 212 Price St., Rahway, N. J.

**WE Develop** Ideas, design, build models and manufacture. Logan Machine Co., 652 Lake, Chicago, Ill.

### MANUFACTURING

**WIRE** Goods made to order. Cooley Mfg. Co., 530 N. Western Ave., Chicago.

**SPECIALIZE** Complete manufacture, dies, tools, special machinery. Models made. Atlas Indicator Works, 817 W. Washington, Chicago, Ill.

**TOOLS,** Dies, models, instrument work. Lowest prices. Schmidt, 61 Park Place, New York.

**MANUFACTURING** Models, dies, stampings, brassworks, one or thousands. Circular free. Baum's Metal Specialties, Kansas City, Mo.

**SPECIAL** Machinery or parts, dies, tools, metal specialties, models, special gears, stock gears and model supplies. Send for catalog. The Pierce Model Works, Tinley Park, Ill.

**HIGH** Speed power press production. Submit samples or blueprints for equipment or stamping. Presses, feeds. Special machinery, manufactured direct. Harry Walsh, Jr., 4709 Kinzie, Chicago.

**LOW** Cost manufacturing. Large plant completely equipped for blanking, drawing, stamping and wire forming in any finish. Can save you money on your product. Our figures will convince. Eastern States Products, Box 721, New Haven, Conn.

**ECONOMICAL** Manufacturing from sheet, bar, wire or tubing. Models, dies, special machinery. Swanberg, 5124 N. Kildare Ave., Chicago.

**HAGSTROM** Model & Tool Works, makers of fine models, dies, tools and light manufacturing, Kansas City, Mo.

### BLUE PRINTS

**COMPLETE** Detail blueprints of six new designs in furniture for home woodworkers. \$1.50 postpaid. Roy L. Seybold, 4476, 28th Street, Milwaukee, Wis.

**KINKS** For machinists. 419 discoveries. For mechanic, machinist or the man who tinkers at home. 287 illustrations. Send no money. Just write a postal asking for "Machinist's Kinks." When postman hands you book pay postage and price of book, \$1.50. Popular Mechanics Press, Room 801, 200 E. Ontario St., Chicago, Ill.

### MACHINERY, TOOLS AND SUPPLIES

**16"x6" SEBASTIAN** Lathe, \$150.00; No. 1 Brown & Sharpe univ. milling machine, \$185.00; No. 60 Heald grinder, \$500.00; 24" Hendy shaper, \$250.00; 36"x18" Fifield lathe, \$750.00; 36" Cordesman band saw, \$95.00; 18" Fay pony planer, \$100.00; Crescent universal woodworker, six machines in one, \$300.00; Quincy air compressor, \$65.00; 10" new drill press, \$21.00. Write for catalog. Terms to suit. Cincinnati Machinery & Supply Co., 27 West Second St., Cincinnati, Ohio.

**WE Start** you in business. Big profit manufacturing concrete building tile. Experience unnecessary. Complete outfits as low as \$25.00. New! Patented! Send for catalogue. Economy Manufacturing Company, Atlanta, Georgia.

**BARGAINS** New and reconditioned equipment. Chromium platers, grinders, compressors, all ball bearing. Payment terms. Write Hobart Platers, Box M-903, Troy, Ohio.

**WE supply** them to students, amateurs and shop owners. Kenelpp & Son, Mt. Carmel, Ill.

**CONCRETE** Building block manufacturing is your home town opportunity. Particulars free. Concrete Machine Co., 5 Main St., St. Louis, Mo.

**MOTORS,** ¼ hp., 1 phase, \$35, and ¼ hp., 1 phase \$12.50 (New) Induction type. Also electric bench grinders; drills; saws. Klauber Machinery Co., 320 So. Third St., St. Louis, Mo.

**STEEL** Bench saw, 12x16 top \$6.00, with motor rails \$9.00. Flexible shafts ¼-in. core, 5 ft. long, bargain \$15.00. Robert's Mfg., 1829 Otto St., Chicago.

**START** Business of your own, small investment required, doing nickel, copper and silver plating. This work in big demand. Information free. Electro Platers Supply Co., 28 W. Second St., Cincinnati, Ohio.

**FOR Sale:** Ten thousand drills, taps, gears and milling cutters, set screws, gauges and machinery. Send stamps for list. Address "Tool Crib," 47 Whittier St., Bridgeport, Conn.

### ENGINES, MOTORS AND DYNAMOS

**BRAND** New motors, ¼ hp. a.c. \$6.50; ¼ hp. revulsion induction 3450 rpm. \$16.00; ¼ hp. Universal \$5.00. 32v. motors, ¼ hp. \$8.50; converters 32v. d.c.-110v. a.c. \$35.00. Large stock motors, generators and engines. Queen City Electric, 1736 Grand Avenue, Chicago.

**BIG** Catalog 20c steam and gasoline engines, motors, model makers' supplies. Howard Engine & Mfg. Co., 2417 N. Ashland Ave., Chicago.

**NEW ¼ Horse,** 110 volt alternating motors, \$6.50; some used, \$4.50. New 1-1½ horse, 110 volt universal, \$2.75. New ½ horse, 110 volt 3,450 speed alternating, \$16.50. Other bargains. Electrical Surplus Company, Dept. 12, 1911 Chicago Ave., Chicago.

**FOR Sale:** One-sixth and one-fourth hp. electric motors, 60 cycle 110 volt a.c., slightly used. One-sixth hp., \$5.00; one-fourth hp., \$6.00. Cash with order. Charles Kratsch, Inc., 160 E. Illinois St., Chicago.

**CHEAP** Gas power, from auto engines, but they need governing. We make the governors—all engines. Easily installed. \$10.00. Circulars. Candee-Smith Governor Co., 215 No. Los Angeles St., Los Angeles.

**TIME** Counts in applying for patents. See pages 134 and 135. Clarence A. O'Brien, Registered Patent Attorney, Washington, D. C.

**STEAM** Engines—One h. p. \$18.00; ½, \$12.00. James Chambliss, Bessemer, Ala.

### BENDING MACHINES

**THE Famous** Hossfeld "Wrenches" Universal Iron Bender is the last word in bending machines. Bends metal, cold or hot, into most any conceivable shape, including Eye Bolts and Automobile Spring Eyes. Bends up to 1" bars or 1½" pipe cold. Also bends "Angle Iron." Thousands in use by all classes of trade, from the smallest shops to the largest railway systems. Write for circular and prices. Hossfeld Mfg. Co., Winona, Minn.

### WELDING AND SOLDERING

**ELECTRIC** Arc welders—new and used. Terms and trial. Tell needs to Hobart Welders, Box M-908, Troy, Ohio.

### SURVEYING INSTRUMENTS

**GUARANTEED—**Rebuilt transits and levels. All types and makes. Absolutely satisfactory. Cash or easy payments. Don't delay—Write today for descriptive list M-49. Warren-Knight Company (Makers of "Sterling" Transits and Levels), 136 N. 12th St., Phila. Pa.

**VALUABLE** Kinks for Machinists. 419 time-saving ideas on various phases of machine shop work. Intensely practical. 287 illustrations. Just write for "Machinist's Kinks" and pay postman \$1.50 plus postage when he delivers the book. Popular Mechanics Press, Room 808, 200 E. Ontario St., Chicago.

### FARMS AND FARM LANDS

**LAND** Openings along the Great Northern Railway. Fertile productive improved farms, new land or rich cutover land. Opportunities in many kinds of farming; grain, livestock, dairying, fruit, poultry, small tracts or general farms in Minnesota, North Dakota, Montana, Idaho, Washington, and Oregon. Renters and owners get benefit of low prices, low interest, low taxes. We have free books on each state, can give accurate detailed information and help to find kind of location desired. Write E. C. Leedy, Dept. 557, Great Northern Railway, St. Paul, Minnesota. Low Homeseekers' rates.

**SEND** 25c And learn how to build wind-driven electric light plant. Klingsiek Mfg. Co., Optima, Okla.

**CHICKEN** Farm in Florida. About three acres. Close to Tampa. \$4 down, \$4 a week. Send for description. Box 374, Tampa, Fla.

**1000 FARM** Bargains. Hundreds of pictures in Strout's big new fall catalog country real estate and money-making farms for sale in many states. Saves you money. Just out. Free. Write today. Strout Agency, 255P Fourth Ave., N. Y. City

**SELL** Your property for cash. No matter where located. Information free. Established 26 years. Black's Realty Co., Dept. B-11, Chippewa Falls, Wis.

**OWN** A Farm in Minnesota, Dakota, Montana, Idaho, Washington or Oregon. Crop payment or easy terms. Free literature; mention state. H. W. Byerly, 119 Northern Pacific Railway, St. Paul, Minn.

**861 PRACTICAL** Ways to Reduce Farm Labor and Expense and Increase Income. One farmer writes he would not part with this information for \$100, if he could not duplicate it. Nothing experimental. These ideas have all been put to test and proven practical. Send today for a copy of our Handbook for Farmers and get ready to put these ideas into operation for your own benefit. Pay postman only 98 cents and the postage when he hands you the package. Popular Mechanics Press, Room 801, 200 E. Ontario St., Chicago.



**MONEY** Made in Michigan potatoes. \$10 down now and easy terms buys land near markets, lakes, streams. Write today, Swiggart & Co., P-601, 32 N. State St. Bldg., Chicago, Ill.

**TUNG** Oil varnish tree groves. Suburban Orchards Co., Biloxi, Miss.

**SELL** Your property quickly for cash, no matter where located. Don't pay big commission. Particulars free. Real Estate Salesmen Co., Desk B, Lincoln, Nebr.

**OZARKS:** Fishing cabin, river frontage, boating, bathing, hunting, \$200, \$10 monthly. Hubbard, 216 Grossman Bldg., Kansas City, Kans.

**REDUCE** Labor on your farm and increase income. One farmer writes he would not part with the information for \$100 if it could not be duplicated. Send today for our valuable "Farmers' Handbook" and get ready to put some of the 861 practical ideas into operation for your own benefit. Pay postman only 98 cents plus postage when delivered. Popular Mechanics Press, Room 808, 200 E. Ontario St., Chicago.

**EASTERN** Pennsylvania farms near Philadelphia. Write for bulletin giving prices, sizes and descriptions. Wilson George, Quakertown, Pa.

**SOUTHWEST** Missouri lands. 160 acres near Joplin. Sims, Mount Vernon, Mo.

**HOUSEHOLD** Automatic Refrigerating Machines. Here is the first book ever published on this important subject. Refrigeration, by Moyer and Fittz. It is a thorough treatment of present-day refrigeration systems, their operation and testing for the student and practicing engineer. 431 pages. 184 illustrations. Cloth. Sent C. O. D. Pay postman price \$4 and small amount of postage upon delivery. Popular Mechanics Press, Room 806, 200 E. Ontario St., Chicago, Ill.

#### RABBITS

**RABBIT** Supplies—America's only exclusive Rabbit Supply House. Free catalogue. Desk 11, National Rabbit Supply Company, 1126 North Dearborn Street, Indianapolis, Ind.

**RAISE** Rabbits, Pigeons, Guinea Pigs for us. Stock supplied on credit terms. Catalogue, Contract 10c. Houck's, Tiffin, Ohio.

**MAKE** Big profits with Chinchilla rabbits. Real money-makers. Write for facts. 852 Conrad's Ranch, Denver, Colo.

**MONEY** Making rabbits on easy terms. A small deposit—pay balance out of stock shipped us on contract. Write Stahl, Dept. 216, Holmes Park, Mo.

#### MUSKRATS

**MAKE** Money from muskrat fur—Raise muskrats in dry land pens or hutches. Get the facts. 652 Conrad's Ranch, Denver, Colo.

**MUSKRAT** Farming—The greatest book on one of the greatest opportunities today. Tells of the opportunity in this business and how to do everything in connection with the raising and marketing of muskrats. Pay postman only \$2.25 and postage when delivered or, outside U. S., remit when ordering. Popular Mechanics Press, Room 809, 200 E. Ontario St., Chicago.

#### DOGS AND PETS

**AQUARIUMS.** Fancy fishes for pleasure and pastime. Water plants, etc. Catalog free. German Aquarium, 3823 N. Richmond, Chicago.

**BRACE:** Trained bird dogs, sacrifice, \$50 each. Trial. Miss Clay, 306 Garland, Memphis, Tenn.

**ST. BERNARDS!** Rare, beautiful thoroughbred puppies. Photos submitted, delivery guaranteed. Helvetia Kennels, 181-P McKenna Ave., Montreal, Que.

**FOXHOUNDS,** Coonhounds, Rabbit-hounds, Blueticks, Redbones, Blacktans. Supply catalogue. Kaskaskia, E-67, Herrick, Ill.

**\$35.00** Buys a coonhound that must please you on long trial. Kevill Kentucky Kennel, Kevill, Ky.

**DOG** Lovers—Every fact regarding every phase of dog training (all breeds) including psychology, obedience, guarding, swimming, rescue work, hunting, herding flocks, teaching tricks, finding lost articles, racing, war service, police dogs, sled dogs, etc., will be found in "Training the Dog," by Will Judy. Price only \$1.50. Pay postman when delivered or, if outside U. S., remit when ordering. Popular Mechanics Press, Room 809, 200 E. Ontario St., Chicago.

#### WANTED—MISCELLANEOUS

**MAIL** Us your discarded jewelry, gold crowns and bridges, watches, diamonds, silver, platinum. Money promptly mailed. Goods returned if offer refused. United States Smelting Works (The Old Reliable), Dept. 71, Chicago.

**SCRAP**—Gold and silver refined. Returns made on actual recovery with refining charge only 5%. Universal Refining and Research Corporation, 1201 19th St., Denver, Colo.

**I BUY** Gold crowns, etc. Send today. R. G. Forsyth, 2406 Trinity, Los Angeles, Calif.

**INVENTORS**—Cash in on your invention now! Don't delay the sale any longer! Send for a free copy of our specially prepared booklet, "Turn Your Patent Into Money," today! It contains helpful information for all inventors. M. L. Rund, Mgr. Classified Advertising, Popular Mechanics Magazine, 200 E. Ontario St., Chicago, Ill.

#### FOR SALE—MISCELLANEOUS

**ADDRESSOGRAPHS,** Letter folders, multigraphs, envelope sealers, duplicators, less than half price. Guaranteed. Pruitt Co., Suite 108, 190 N. LaSalle St., Chicago.

**THAT** Concrete Job. Don't be afraid to tackle it. With the instructions found in Popular Mechanics Concrete Handbook you can easily make 173 articles of utility and beauty ranging from ordinary steps to garden furniture. This book will be sent for only 98c plus postage C. O. D. Send your order today to Popular Mechanics Press, Room 801, 200 E. Ontario St., Chicago, Ill.

**WATCHMAKERS** Lathe for sale at a bargain. R. Jaegermann, 5815 Easton Ave., St. Louis, Mo.

**RADIO** Trouble Shooting—Covers all electric sets and television. Greatest book ever published from the point of view of assisting the repairman as well as showing how the radio owner can do his own repairing. 328 pages. Over 300 illustrations. Flexible. Pay postman price \$3 and postage when he delivers it. Popular Mechanics Press, Room 801, 200 E. Ontario St., Chicago, Ill.

#### ROOTS AND HERBS

**HERB** Doctor Book—10 cents. 250 receipts for making herb medicine. Hazzard Company, Box 1, Vanderveer Park, Brooklyn, N. Y.

**\$4,223.00** PROFIT From a town lot in one year. H. Cecil Sheppard tells you his disastrous and profitable experiences in raising chickens from the start until in the sixth year he took the above net profit. He would have gladly paid \$100 for this information during the first years. Send for his book. Price only \$1. Pay postman when delivered, or, if outside U. S., remit when ordering. Popular Mechanics Press, Room 801, 200 E. Ontario St., Chicago.

#### PERSONAL

**ADVICE,** Information any subject. 25c coin up. Fred Klotz, Reading, Pa.

**LETTERS** Mailed from Detroit, 15c. From Canada, 20c. Empire Service, Box 125, Alfred Station, Detroit, Michigan.

**BUILT-IN** Furniture adds convenience, comfort and beauty to your home at very low cost. Any handy man can build a great variety of this space-saving furniture from the easily-followed instructions in our remarkable book, the only one on this subject. Delivered to your door C. O. D. Simply pay postman \$2.50 and postage. Popular Mechanics Press, Room 801, 200 E. Ontario St., Chicago.

**CALIFORNIA** Address: information, beautiful postcard 10c. Twenty \$1.00. Letters mailed 10c. Zieseco, 254 Abbey, Fresno, California.

**TOBACCO** Habit overcome or no pay. 500,000 used Superba to help stop cigarettes, cigars, chewing, pipe, snuff. Treatment sent on trial. Costs \$2.00 if successful. Superba Co., L84, Baltimore, Md.

**YODELING.** Clear, sharp and beautiful. Scientifically taught. Complete \$1.00. McConnell, 444-5 Ave. W. Twin Falls, Idaho.

**FREE!** Herbalist almanac. Over 500 herb medicine recipes for home use. Write for details. Botanicals, 145 West 112th St., Chicago.

**CARTOONING**—Let the world's most successful cartoonist tell you how to draw cartoons. Briggs in his new book gives every step in cartoon work and answers every question a beginner might ask. Elaborately illustrated. Pay postman price of book, \$3, and small amount of postage when he delivers the package C. O. D. Popular Mechanics Co., Room 801, 200 E. Ontario St., Chicago, Ill.

#### MISCELLANEOUS

**MIRRORS** Resilvered at home. Costs near 5 cents per square foot; you charge 75 cents. Profitable business plating autographs, reflectors, tableware, stoves, refinishing metalware, etc., Outfits furnished. Details free, write Sprinkle, Plater, 288, Marion, Indiana.

**For Sale**—One 20 inch lathe, one 20 inch drill, one cylinder boring machine, one emery stand, one small Bank safe, one office safe, two Prestolite Welding cylinders. Harry Kerslake, Paris, Ky.

**MIMEOCRYPTO**—Our new secret writing system is the greatest novelty out. Sample and terms, 10c. Vals Products Co., 207 South Broadway, St. Louis, Mo.

**LEARN** Lacquer system of sign painting. Valuable new book gives complete description of methods, materials and equipment with hints and helps for sign shops. Covers latest in electric, neon tube, and daylight reflector signs, etc. Delivered to your door C. O. D. Simply pay postman \$3 and postage. Popular Mechanics Press, Room 801, 200 East Ontario St., Chicago.

**TIME** Counts in applying for patents. See pages 134 and 135. Clarence A. O'Brien, Registered Patent Attorney, Washington, D. C.

**TEL-E-TAP** Tells if wife or husband unfaithful; partner, employees cheating, etc. Listen telephone conversations without detection. Switchboard not signalled. Complete \$17.50 with instructions, hints. Wink Laboratories, Box 1263, Dallas, Tex.

**HOMEOPATHIC** And biochemic preparations sent postpaid to all parts of the world. Booklets free. Halsey Bros. Co., 5547 Ravenswood Ave., Chicago. Established 1855.

**GARDENING.** There are many books on this subject but if you want the latest and most complete work covering flowers, vegetables, shrubs, trees, landscaping, the rock garden, the water garden, etc., for the average American home, you will send for Everybody's Garden by Frank A. Waugh. Sent C. O. D. 300 pages. Profusely illustrated. Cloth. Pay postman price, \$3.50 and small amount of postage upon delivery. Popular Mechanics Press, Room 806, 200 E. Ontario St., Chicago, Ill.

**TATTOOING** Outfits, supplies. Illustrated list free. "Waters," 965 Put-nam, Detroit.

**AMATEUR** Cartoonists earn \$25.00 week, spare time, copying or tracing cartoons for advertisers. 3-M Syndicate, Argyle, Wis.

**TELL** An army of 3,000,000 live readers all about your offer! If you have anything to sell, buy or exchange, or if you have any reasonable proposition, tell our readers all about it—they'll respond quickly. Our booklet "How to Create More Business" contains some very interesting, helpful facts. Write today for your copy—it's free. M. L. Rund, Manager Classified Advertising, Popular Mechanics Magazine, 200 E. Ontario St., Chicago, Ill.

# LEARN CARTOONING

## AT HOME DURING SPARE TIME

with the course that has trained HUNDREDS of beginners successfully. The Landon Picture Chart Method of teaching ORIGINAL drawing by mail makes cartooning easy to learn. This school is a Member of The National Home Study Council. Write today for sample picture chart to TEST YOUR ABILITY and examples of the work of successful students now earning from \$50 to \$200 and more per week.

Enclose 6c in stamps and STATE YOUR AGE.

**THE LANDON SCHOOL, 2838 National Bldg., Cleveland, Ohio**





# New Kind of Can Opener

*"Works Like Magic"*

## Brings Agents Up To \$8 and \$10 In An Hour!



IMAGINE having a little automatic machine to open cans! Why, to women everywhere, the very idea is revolutionary as well as amazing! No more fuss, muss or bother. And danger absolutely banished! No wonder agents who demonstrate this astonishing invention have made almost incredible sums. E. T. Barclay, N. Y., cleaned up \$117 in a day and a half. Mrs. M. Bridges, Me., made over \$300 in a couple of months spare time. O. C. Gregg, Wyo., made part time profits of \$20 in 3 hours. And why not?

### The "Million-Dollar" Can Opener

The wonder-working little machine holds the can for you so you don't need to touch it. Then spins the can quickly around. Next the lid pops up so you can take hold of it. Entire top is cut out slick, smooth and clean. Opens round, square, and oval cans. Approved by Good Housekeeping Inst. Guaranteed for five full years. If your present income is less than \$60 a week write quick for details of Territory Reservation, Sales Outfit, and FREE Test Offer.

**CENTRAL STATES MANUFACTURING CO.**  
Dept. L-704, 4500 Mary Ave., ST. LOUIS, MISSOURI



## NO MORE DANGER

Every woman knows how dangerous the old-style can opener is. Almost daily the newspapers tell of blood-poison, amputations, even death, that sometimes follow the very tiniest "can opener scratches." Now all danger is banished forever. No wonder so many buy on sight!

Central States Mfg. Co., Dept. L-704,  
4500 Mary Ave., St. Louis, Mo.  
Rush your FREE TEST OFFER.

Name.....

Address.....

Town..... State.....

Check here if interested only in one for your home.

# TRAVEL - for 'UNCLE SAM'

## RAILWAY POSTAL CLERKS

MAIL CARRIERS—POSTOFFICE CLERKS  
GENERAL CLERKS—CUSTOMS INSPECTORS

**\$1700 to \$3400 a Year for Life**

No "lay-offs" because of strikes, poor business, etc.—sure pay—rapid advancement. Many other U. S. Government Jobs. City and country residents stand same chance. Common sense education usually sufficient.

### STEADY WORK

Cut coupon and mail it before turning the page.



## MEN—BOYS 18 to 45

Use Coupon Before You Lose It



### COUPON

FRANKLIN INSTITUTE, Dept. N172, Rochester, N. Y.

Rush to me, free of charge, (1) A full description of the position checked below; (2) 32-page book, with list of steady positions obtainable; (3) Tell me how to get the position checked.

- Railway Postal Clerk (\$1900 to \$2700)
- General Clerk (\$1260 to \$2100)
- Postoffice Clerk (\$1700 to \$2300)
- Customs Inspector (\$2100 up)
- City Mail Carrier (\$1700 to \$2100)
- Rural Mail Carrier (\$2100 to \$3300)

Name.....

Address.....

## WANT SOME MONEY? Here's A Wonderful Way To Get It!

**YES** you can—anybody can make a lot of money right at home, and what's more, have real fun doing it. We show you how, we furnish everything necessary on an easy basis.

**COSTS NOTHING** to learn about our plan, all details are given you free. Write today for beautifully illustrated idea book telling all about our methods which have made so many women independent. Learn how easy it is to make from \$10 to \$25 per week in the most delightful home work you can imagine. Don't miss this opportunity.

Write Now—It's FREE

**FIRESIDE INDUSTRIES, Dept. 66-M, Adrian, Mich.**

Fireside Industries, Dept. 66-M, Adrian, Mich. Please send me, FREE, the book on Fireside Industries showing how to earn money at home by decorating Giftwares.

Name.....

Address.....

City..... State.....



Mail this Coupon today!



# BIG FUN-BIG MONEY



## Learn to MOUNT BIRDS AND ANIMALS

### Be a TAXIDERMIST

Learn this **WONDERFUL** new, fascinating and **PROFITABLE** art at home by mail. This old famous school, with over 100,000 students **GUARANTEES** success. Thousands of Popular Mechanics readers have already enrolled. Mount and preserve **GAME ANIMALS AND BIRDS** like life. Mount common and domestic animals in highly amusing and human-like groups. The actual squirrels shown above, **MOUNTED AND DRESSED** up, cost but a few cents for materials, but sold for \$40 for a window display. Rabbits, frogs, mice, cats, pigs, sparrows, pigeons—**ALL** can be mounted in funny and interesting groups, imitating human situations. Great fun, tremendously fascinating, extremely profitable.



### Quickly Learned by Mail

Men, women, boys, all learn easily and quickly, at home **BY MAIL**. From our marvellously clear course of 40 lessons. Begin **ACTUAL WORK** with the first lesson. You become a **TAXIDERMIST**, well known and popular. You learn an art of vast interest, and one that will turn spare time to big profits.

### Hunters—Anglers!

Preserve your trophies. Save your fine specimens. Have your own **MUSEUM**. Also mount for others and sell your spare specimens at fancy prices. Every **SPORTSMAN** and Nature Lover **MUST** know taxidermy, or lose half the pleasure and profits of the sport. Taxidermy is sweeping the country. **INVESTIGATE!** Send right **NOW** for our fine **FREE BOOK**.

### A Business of Your Own

Do you want or **NEED** to **MAKE MORE MONEY**? Here is your **OPPORTUNITY**. Make \$60 to \$200 a month from **SPARE TIME**. Or open a **TAXIDERMIST SHOP**. Have a life-long business of your own, one that is high grade and that can earn for you \$4,000 to \$8,000 a year. All sportsmen want their **TROPHIES MOUNTED**. Business will quickly come, and grow fast. Look into this great **PLEASURE AND PROFIT ART TODAY**. By all means write for our interesting, new,

**FREE BOOK:** 48 pages, dozens of pictures of mounted game specimens, and full particulars about our lessons and how **YOU** can become an **EXPERT TAXIDERMIST**, at home in **SPARE TIME**. Send the **COUPON RIGHT NOW—TODAY**. State **AGE**.

Send Coupon Today!

## FREE BOOK COUPON

**NORTHWESTERN SCHOOL OF TAXIDERMISTRY,**  
3376 Elwood Building, Omaha, Nebraska

Gentlemen: Please send at once, your free 48-page book on Taxidermy without any obligation on my part. Tell me how I can learn Scientific Taxidermy at home.

Name \_\_\_\_\_ Age \_\_\_\_\_  
Address \_\_\_\_\_

# Magic Electric Invention Stops Falling Hair, Dandruff and All Scalp Troubles

Now, Hot Oil Treatments, Scientifically Applied, Cost only 3c Each.



A remarkable invention, just marketed, applies electrically heated oil treatments direct to the pores of the scalp and instantly checks dandruff, stops falling hair and quickly cleanses the scalp of all disorders.

## SAV-UR-HAR Electric Oil Comb

"It Heats As It Treats"

Oil applied with SAV-UR-HAR is fed direct to the pores and is kept at the scientifically correct temperature.

Saves 15 to 45 minutes on each application. Eliminates old, messy methods of applying with cotton wads, fingers or brush. No matting or tangling of hair. SAV-UR-HAR passes through and around each strand of hair with a gentle, stimulating, soothing action. The world has waited 35 years for this remarkable invention. Write for details and low introductory price.

BEAUTY AIDS, Inc.  
Suite 2009-J, 307 N. Michigan Ave.  
CHICAGO

**\$24 a Day**  
We have a few good openings for live representatives that pay \$24.00 profit on only 3 sales per day. Write us.

## SQUAB BOOK FREE



Breed PR squabs for rich trade. Sold by millions at higher prices than chickens. Write for free 48-p. book telling how to do it and how to profit by new sales method which gets the big money.  
PLYMOUTH ROCK SQUAB CO., 634 H Street, Melrose Highlands, Mass.

## RAISE CHINCHILLA AND NEW ZEALAND WHITE FUR RABBITS

Make Big Money We Supply Stock and pay you following prices for all you raise: Chinchillas average \$3 each—New Zealand Whites \$2 each. 32-page illustrated book, catalog and contract, also copy of Fur Farming magazine, tells how to raise rabbits for big profits, all for 10c. Address **OUTDOOR ENTERPRISE CO., Box 1021 Holmes Park, Missouri**

## BIG MOVIE PROJECTOR GIVEN!

Famous QRS DeVry (size 13x12x5 inches) projects narrow home movie films perfectly. Never before offered as a Premium. Has many exact parts used on \$60.00 DeVry Projectors. Machine is fully guaranteed.

No need of being without MOVIES in your home now! Show latest releases, your own folks and friends in action. This is NOT a toy machine, but a real High Grade outfit. It's a marvel. It projects pictures clear and steady, and comes in a beautiful finish. Complete ready to show.

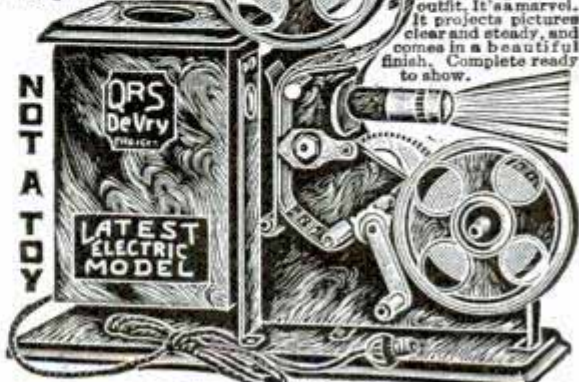

**GIVEN** for selling only 20 bottles of Perfume at 15c each giving Perfume Novelties **FREE** and remitting per plan shown in catalog. Send no money. We trust you.  
**ROBERT MORE COMPANY, DEPT. 3A78 CHICAGO, ILLINOIS**





## When words fail!!! start the Crosley ROAMIO

What married man or lovelorn swain doesn't recognize this picture? A quarrel—a misunderstanding—a late arrival at the appointed place—yet the CROSLY ROAMIO helps solve them all. Parking, spinning along the highway, driving through city traffic—this greatest of all automobile radio receiving sets will do its stuff unflinching. Thousands are already in daily use—and you'll get the kick of your motoring life out of your CROSLY ROAMIO.

The CROSLY ROAMIO is extremely selective and sensitive. You'll easily get your favorite programs. The automatic volume control maintains a practically uniform volume, even on distant stations. You lock the CROSLY ROAMIO just as you do your automobile. It uses Screen Grid tubes, Neutrodyne circuit, and employs the latest type Crosley dynamic-power speaker.

The CROSLY ROAMIO can quickly and easily be installed in your car no matter what its make. It fits snugly and conveniently under the dash, entirely out of the way. It will give you hours of satisfying pleasure and delightful relaxation. Consider too, that the price of this marvelous set is amazingly low—only \$75.00, less accessories—installation extra. Go to your nearest Crosley dealer today—see the CROSLY ROAMIO—hear it—drive with it. Or write for circular and name of nearest Crosley distributor who will arrange for installation. The CROSLY ROAMIO is recommended for use in motor boats and cruisers.

### THE CROSLY RADIO CORPORATION

1300 Arlington St. CINCINNATI

Home of "the Nation's Station"—WLW

Also manufacturers of Crosley A. C., D. C. and Battery Radio Receivers and the famous AMRAD RADIO



## COACH BUILDING MADE EASY



You can build a beautiful coach model in a few hours. We supply all the parts, cut to fit and ready to put together, of the George Washington coach, the Tally-Ho, or the Deadwood coach (famous Western stage) for \$4.98. Full instructions for building included with each kit. Build coaches for pleasure or profit. Models sent C.O.D. plus a few cents postage. Foreign orders must be accompanied by U. S. check or money order.

HISTORICAL COACH MODELS, INC.  
Dept. P. M. 4, 2206 Fairmount Ave., Philadelphia, Pa.

## Learn to Dance

### This New Easy Way

You can learn all the modern dances—Charleston, Black Bottom, Valencia, Canter, French Tango, St. Louis Hop, Latest Waltzes, Fox Trots, etc., at home easily and quickly. New chart method makes dancing as simple as A-B-C. No music or partner required. Learn anywhere, anytime. Win new popularity. Be in demand at parties. Same course of lessons would cost \$20 if taken privately.

### Send No Money

Just send your name and address. We'll ship the complete course—323 pages, 49 illustrations—without one cent in advance. When package arrives, hand postman only \$1.98, plus delivery charges, and this wonderful course is yours. Try for five days. Money back if not delighted. Send your name NOW.

FRANKLIN PUB. CO., 800 N. Clark St., Dept. 9425, Chicago



# Why it will Pay You to Come to Chicago Tech

Chicago Tech is a college for ambitious men—a college that you will want to go to if you've the will to work for success. Loafers don't come here. But serious, hard working fellows find in this college what they need to build a real future . . . a money-making future.

## Degree and Diploma Courses—College Grade



Here's why it will pay you. It offers degree courses . . . regular technical training at half cost and almost one-half the usual time. Instruction in practical subjects only without wasting time on those you can never cash in on.

### For Success—these 4 fields

Training in the four biggest fields of opportunity, **DRAFTING, ARCHITECTURE, ENGINEERING AND ELECTRICITY**—the fields where a degree and training really mean something in money-making possibilities.

### This old established College

Twenty-six years of experience behind you . . . to give you what you will need when you get out in the Technical fields. Every subject under the supervision of specialists.

### Here in Chicago

The advantages that only a resident school located here in Chicago can give you. Building activities going on all the time . . . right in the center of the world's greatest industrial metropolis—where you can see every day with your own eyes what's going on in the technical fields. Part time positions to help defray expenses. Personal contact with instructors. College activities, athletics.

**We have a special plan for men who have not finished high school. Send the coupon—it brings all the facts.**

### Send for Free 80-Page Blue Book!

This book points the way to success in the Technical fields through college training. It brings you all the facts about the great opportunity that awaits you at Chicago Technical College. Send in the coupon now . . . there is no obligation!

## CHICAGO TECHNICAL COLLEGE

Dept. M-78, Chicago Tech. Bldg.  
118 East 26th St. CHICAGO, ILL.

Chicago Technical College  
Dept. M-78, 118 E. 26th St., Chicago

I want to know how I can get a degree or diploma and be college trained in Drafting, Engineering, Architecture and Electricity in less time and with less cost. Send me your Blue Book, free, without a cent cost to me.

Name.....

Address.....

City..... State.....





# Bigger Pay

## through SPARE TIME TRAINING!

**D**O you want a better position and a higher salary? You can have these if you can do the work. LaSalle experts will show you how, guide you step by step to success and help solve your personal business problems through the time-saving LaSalle Problem Method. Our *salary-increasing plan* enables you to prepare during your spare hours, without interference with your present duties. Simply mark on the coupon the field in which you desire success, and we will mail you a valuable book describing the opportunities in that field, together with an outline of our *salary-increasing plan*. Also copy of "Ten Years' Promotion in One." There is no cost or obligation. Find out how the *salary-increasing plan* starts average men and women on the high road to success and financial independence. Check and mail the coupon NOW.

--- Find Yourself Through LaSalle ---

### LaSalle Extension University

Dept. 964-R Chicago

Please send me full information regarding the course and service I have marked with an X below. Also a copy of "Ten Years' Promotion in One" all without obligation to me.



- Business Management:** Training for Official Managerial, Sales and Departmental Executive positions.
- Modern Salesmanship:** Training for position as Sales Executive, Salesman, Sales Trainer, Sales Promotion Manager, Manufacturers' Agent, and all positions in retail, wholesale or specialty selling.
- Higher Accountancy:** Training for position as Auditor, Comptroller, Certified Public Accountant, Cost Accountant, etc.
- Traffic Management:** Training for position as Railroad or Industrial Traffic Manager, Rate Expert, Freight Solicitor, etc.
- Law:** LL. B. Degree.
- Banking and Finance:** Training for executive positions in Banks and Financial Institutions.
- Modern Foremanship:** Training for positions in Shop Management, such as that of Superintendent, General Foreman, Foreman, Sub-Foreman, etc.
- Industrial Management:** Training for Works Management, Production Control, Industrial Engineering, etc.
- Personnel Management:** Training for Personnel Manager, Industrial Relations Manager, Employment Manager, and positions in Employee Service.
- Modern Business Correspondence:** Training for Sales or Collection Correspondent, Sales Promotion Manager, Mail Sales Manager, Secretary, etc.
- Stenography:** Training in the new superior machine shorthand, Stenotypy.
- Railway Station Management**
- Railway Accounting**
- Expert Bookkeeping**
- Business English**
- Commercial Law**
- Credit and Collection Correspondence**
- Paper Salesman's Training**
- Effective Speaking**
- C. P. A. Coaching**
- Commercial Spanish**
- Stenotypy—Stenography**
- Telegraphy**

Name..... Age.....

Present Position.....

Address.....

## AUTO REPAIRMEN EARN GREATER PROFITS

Get your share of the big money being spent on automobile upkeep.

Put improved time, labor and money-saving ideas to work in your shop to-day. Take advantage of our special bargain offer and secure 3 valuable kink books at a reduced price.

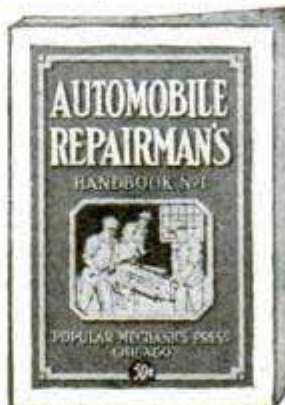

1. 334 Valuable Discoveries made by auto mechanics in our **Automobile Repairman's Handbook**. 337 Illustrations.

2. 301 Ways to use drills, drill presses, taps and dies more effectively in our **Drilling and Thread Cutting Handbook**. 298 Illustrations.

3. 259 Kinks furnished by the most expert Lathe Operators in our **Lathe Handbook**. 212 Illustrations.

**Special Offer**—These 3 books (regular price 50 cents each, \$1.50 value) are offered for a limited time for only 98 cents plus postage. Pay postman C. O. D. when he delivers or if outside U.S. send 98 cents and 15 cents extra for postage.

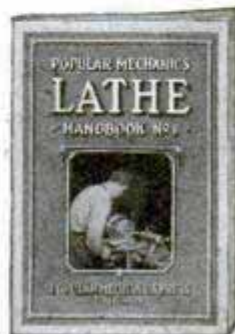

### POPULAR MECHANICS PRESS

Room P9

200 E. Ontario St.

CHICAGO

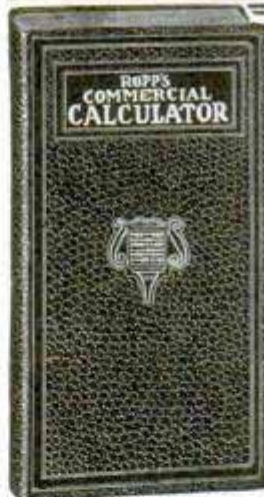

### Mathematics Made Easy by ROPP'S CALCULATOR AND SHORT-CUT ARITHMETIC

Shows the Answer as Quickly as a Watch shows the Time to all Problems likely to occur in the Office, Store, Shop, Bank, Farm, or Factory.

Over 2,000,000 Sold

Explains and simplifies every principle in Arithmetic, Mechanics, and Mensuration.

PRICES POSTPAID

Desk Size, Flexible Keratol Binding.....\$2.00  
Pocket Size, Art Leather Binding.....\$1.00  
Pocket Size, Cloth Binding, \$0.50

POPULAR MECHANICS PRESS  
Room P9 200 E. Ontario St. CHICAGO

## NEED A BETTER GRIP ON MATHEMATICS?

SEND for a copy of "Mathematics for the Practical Man," only \$1.50. By common sense methods it removes the mystery and difficulties so that algebra and even calculus are made simple.

Assuming your knowledge is limited to arithmetic you quickly and easily gain a working knowledge of Algebra, Geometry, Trigonometry and Calculus. Simply pay postman price of book plus the postage when he hands you the package.

Popular Mechanics Press  
Room P9

200 E. Ontario Street, Chicago





# Wrestling Book

Learn at Home

# FREE



Be an expert wrestler. Learn at home by mail. The greatest world's champions have prepared the most wonderful course of lessons ever written on Physical Culture and Expert Wrestling. Be strong and healthy! Handle big men with ease. This great free book tells you how. Don't delay. Write now. State your age. Farmer Burns School, 3376 Ry. Exchange Bldg., Omaha, Neb.

# A Business that is Pleasure - and Profitable - AVIATION

You Can Succeed in It

In no other business will there ever be such opportunities for GOOD men—in no other line is knowledge and hard work so well paid. The time required to learn AVIATION is comparatively short. It is intensely interesting and absorbing. Previous experience is not necessary to fit yourself for a place in this industry. Any ambitious and determined young man, who applies himself diligently will be successful.

Von Hoffmann Training is outstanding. Every phase is taught thoroughly. Instruction is given on late types of planes and with modern and complete ground equipment. Courses generously exceed Government requirements.

U. S. Dept. of Commerce approved School for Transport, Limited Commercial, Private Pilot, Ground and Flying

Prices are reasonable. A liberal deferred payment plan is available for those who desire it.

Learn more about the opportunities this great business offers you—its future and how you can fit into it. Mail the coupon below for complete information about the courses—about the School—and how to make your start.



Located on the famous \$2,000,000 Lambert-St. Louis airport

# Von Hoffmann AIRCRAFT SCHOOL

133 Lambert-St. Louis Flying Field, St. Louis

**Von Hoffmann Aircraft School**  
133 Lambert-St. Louis Flying Field  
St. Louis, Missouri. MAIL TODAY

Name.....  
Address.....  
City..... State.....  
Age..... I am interested in  
( ) FLYING COURSE ( ) MECHANICS COURSE  
( ) WELDING COURSE ( ) HOME STUDY

**LEARN TO EARN \$50 to \$150 PER WEEK**  
Write for Free Booklet  
**SWEENEY** Automotive Electrical Aviation **SCHOOL**  
1615C Grand Ave. KANSAS CITY MO.,

# WHY STAMMER?

Don't be a failure. Master perfect speech. Live a healthy, normal and happy life. Send for free book which tells you how. THE LEWIS INSTITUTE, 12962 Woodward Ave., Detroit, Mich.

# MODEL SHIPS



We can supply construction sets and all sorts of parts such as semi-finished hulls, blocks, deadeyes, special flags, anchors, steering wheels, capstans, figureheads, blue prints, books, etc., for building real fine scale models of the Flying Cloud, Constitution, Spanish Galleon, Mississippi River Steamboat, Sovereign of the Seas, Mayflower and many others. Also special construction sets for racing sail boats, power boats, model steam engines, propellers, etc., and fine tools for the model maker. Our large 48-page photographically illustrated booklet contains valuable information and hints for building ship models in addition to prices and full description of the above articles. Many people only slightly interested in models have become greatly enthused upon receiving this booklet. A copy will be sent postpaid upon receipt of 15 cts. (coin preferred).

**MODEL SHIP SUPPLY CO., DEPT. K, MINEOLA, N. Y.**

# Car Washing now a PLEASURE!

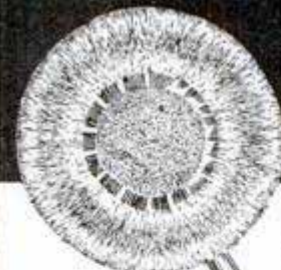

With this Amazing NEW Invention!

Simply attach a Gy-Ro Whirlo Brush to an ordinary garden hose. Make no other preparations; don't even remove your coat. Turn on the water. Then proceed to brush down the car with Gy-Ro. Don't splash or spray. Just brush down the car as casually as though you were whirling away a fly! You will marvel that such wonders could be accomplished without the use of chemicals or auto soap. Now, CAR WASHING IS ACTUALLY A PLEASURE!

**GYRO WHIRLO BRUSH**  
washes CARS  
**CLEAN!**

Even a child knows that a torrent of rushing water has POWER. But no one ever thought of HARN-ESSING that power as if poured from a garden hose. Yet that is exactly what GY-RO does. The force of the water does all the work. It makes the inside brush whirl at the speed of 1 000 revolutions per minute. This speeding center cuts right into mud and dirt, giving an auto the CLEANEST, FASTEST CAR WASH EVER! In no way, however, can Gy-Ro harm the finish of the car.  
**Rush Coupon for FREE OFFER**  
Don't wait another minute! Get your share of the big money that is being made with GY-RO. Quick action means such money in your pocket. ACT NOW!

# AGENTS WANTED

Live agents are needed everywhere to demonstrate this amazing invention, needed by auto owners, garages, service stations everywhere. 100% profit for spare or full time workers. Don't miss this chance to handle the fastest seller in many years.

**MAIL THIS Coupon TODAY!**

**GY-RO BRUSH COMPANY,**  
Dept. J-14, Ampere, N. J.

Reserve territory for me. Please send me at once, without obligation, full facts about salesman's proposition.

Name.....  
Address.....  
Town..... State.....



# ELECTRIC Books Sent Free

**On Approval!** Only 15 minutes with these wonder books will prepare you for a good electrical job in less than a year. A complete electrical course from elementary electricity through electrical subjects used by experts but written in non-technical language so that anybody can understand.

**For Beginners and Experts**

Written so you can understand every word. Printed on fine paper and bound in DeLuxe flexible binding. 8 Volumes, 4300 pages, 3200 illustrations.

**Big Field! Big Demand! Big Pay!**

Men who understand electricity are urgently needed right now in thousands of industries. Autos, airplanes, machine shops—practically every industry depends on electricity and men who know this subject make big money. Pleasant, fascinating work, easy to learn and do; learn quickly with these books. Send coupon for a set for free examination and see for yourself.



**Free** A year's consulting membership in the American Technical Society now given free to all readers of this famous cyclopedia of electricity. Many say, "That's worth more than cost of books."

**AMERICAN TECHNICAL SOCIETY**  
Dept. E-619 Drexel at 58th St. Chicago

Electricity—the biggest industry in the world—continues to grow the most rapidly and offers better jobs, bigger salaries and brighter future than other fields. Send today on this free offer. Your name and address and that of your employer or other reference is all that is necessary. No money. Examine these wonder books carefully and get, without cost, outline for organized study, quiz questions and consulting privilege with 18 experts.

**American Technical Society, Dept. E-619, Drexel at 58th St., Chicago.**

Send for 10 days' free use, 8 volume set of Electrical Engineering. In return for mailing this coupon promptly, send absolutely free, certificate of membership in the American Technical Society entitling me to free consulting privileges for one year. I will pay the few cents delivery charges on the books. If I wish I may return them in 10 days and owe you nothing, but if I keep them I will send \$2.00 after 10 days, then \$3.00 a month until the special sale price of only \$34.80 is paid.

Name.....  
Address.....  
City..... State.....  
Employed by.....  
Address.....

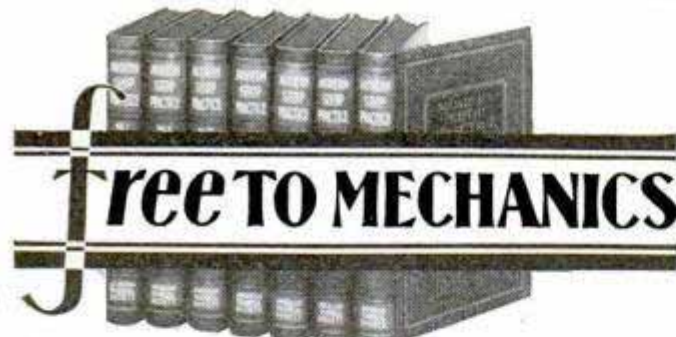

## Free TO MECHANICS

**Amazing Offer on Brand New**  
Books just off the press, which cover every phase of Modern Shop Practice. These seven big books contain over 2600 pages, nearly 3000 illustrations and are bound in special gold stamped flexible covers. Everything that any mechanic could possibly be interested in is explained in detail and in simple language that anyone can understand. Machine shop work, machine set-ups, machine repairs, mechanical drawing, metallurgy, forging, shop arithmetic, tool making, pattern making and hundreds and hundreds of other items, any one of which is worth the special price of these books.

**Shipped FREE** Anyone doing mechanical work of any kind can have these books shipped for examination without one penny down. If you want to fit yourself for a raise in pay, if you want to make yourself worth more money, if you want to be a tool maker, pattern maker, shop foreman or factory superintendent don't fail to look these books over. We mean just what we say, they will be sent to you absolutely free. Don't send us a penny, just your name and address. After you receive the books, then decide whether or not you want to keep them. This is the best way to prove that these UP TO THE MINUTE books should be in every mechanic's hands and that they are worth at least ten times their price to you.

<p><b>JIFFY INDEX</b></p> <p>Don't waste time. Don't study long hours to get a result; the Jiffy Index puts facts at your finger tips instantly</p>	<p><b>American Technical Society,</b> Dept. S-619, Drexel Ave. at 58th St., Chicago, Ill.</p> <p>Send the seven volumes, Modern Shop Practice, FREE. If I decide to keep them I will send \$2.00 in 10 days and then only \$3.00 a month until the special low price of \$29.80 is paid. Otherwise I will return the books and owe you nothing. By sending now I will get a free membership in the American Technical Society entitling me to free consultation privileges for one year by letter or wire with 18 experts.</p> <p>Name..... Address..... Employer or ref..... Address.....</p>
---	--

# Complete Drummer's Outfit

for as Little as **\$35**

**HOME TRIAL EASY PAYMENTS**

YOU can quickly learn to play the drums, then popularity is yours. Invited everywhere. Chances to play in bands and orchestras. Free book of instruction given with each outfit. Amazingly small investment to start. Leedy drums are used and recommended by America's greatest professionals. Standard since 1895. You can own a complete Leedy outfit—Bass Drum, Snare Drum and Traps for as little as \$35. Home Trial, Easy Payments. Write for free booklet and special offer.

**LEEDY MANUFACTURING CO.**  
908 Leedy Building  
Barth Avenue and Palmer St.  
Indianapolis, Ind.

**Instruction Book Included**

## If You Laughed at "The Specialist"

*"I wouldn't, Elmer," I sez, "and I'll tell you why."*

there is no telling what you will do when you read **Chic Sale's** newest masterpiece of humor, **"I'll Tell You Why"**

Yes sir, folks, **Lem has Putt** her over again and proves to everyone's satisfaction that his great success as Builder and Contractor was well deserved.

If you missed "The Specialist," it is not too late to get the book that gave the whole world its heartiest laugh.

**Chic Sale's "THE SPECIALIST," . . . . Price \$1.00 Postpaid**  
**Chic Sale's "I'LL TELL YOU WHY," . . . Price \$1.00 Postpaid**

Send your order with remittance to

**POPULAR MECHANICS PRESS**  
Room P9 200 E. Ontario St. Chicago, Ill.



## FREE BOOK CATALOG

Send today, without obligation, for our new 72 page catalog, describing books on more than one hundred and fifty practical and scientific subjects, including books on Aviation, Automobiles, Air Brakes, Alloys, Electricity, Horology, Heating, Hydraulics, Model Making, Metallurgy, Radio, Ship Models, Soaps, Perfumes, Recipes, Plumbing, Inventions, Tanning, Television, etc.  
Norman V. Henley Publishing Co., Dept. 49, 2 W. 45th St., New York, N. Y.

## New Food Idea Pays Big Profits!

Men! Women! Investigate the wonderful NEW Brown Bobby GREASELESS Doughnut. Sells like wildfire! You can easily make \$50 week spare time; \$5000 to \$8000 year full time. Investment small. No experience needed. Write today for big special offer.  
Food Display Machine Corp., Dept. 39, 500-510 N. Dearborn St., Chicago

## Learn Furcraft

Learn by mail, evenings at home, to Renew, Repair and Make-up all kinds of fur garments. Learn glazing, ironing and storage. Big demand, big need for your service in every neighborhood. \$3 an hour in your spare time or a real business now and a fur shop later. We teach you secret processes. Earnings start in 30 days. Uncrowded field for men and women. FREE BOOK—send now for free book giving details. No obligation.  
Northwestern Fur Co. 3376 Sunderland Bldg., OMAHA, NEBRASKA

Books on all subjects are sold by Popular Mechanics Press, 200 East Ontario Street, Chicago, Illinois.

Now Make

# Big Money! Give Away

**Delicious  
Confection**

Now the originators of one of America's most popular, widely advertised confections—already eaten by millions of people all over America—already sold in nearly every town in the country—has openings for more honest men to take care of the market among local stores—on a clever new plan that starts big money coming in even the first day just letting people taste it free. Already local men have taken in as high as \$200 to \$300 in a single day.

### NO SELLING TO DO

No house to house canvassing. Stores sell it for you. Generous new profit sharing plan gets it into nearly every store without need of high pressure selling. New "taste it first" plan brings enormous repeat orders. Now the market for this tempting confection is so tremendous that more men are needed quick to see that dealers are kept supplied. This opening means more to you than a mere job. It means big money quick—and the chance to build a permanent business of your own with a steady profit pouring in from local stores. Don't worry about big capital, business experience, or sales ability. We tell you just what to do to make big money at the start.

### \$365 IN ONE DAY

Ira Shook took in \$365 in a single day. Marine of California took in \$11,265 in three months. Gordon, \$4,000 profits in two months. Nazer, \$3,000 in three months. Hundreds more big profit records.

### RUSH APPLICATION

So many men will apply for these openings that we will probably be swamped. This ad may not appear again. Therefore, we urge you to rush the application below if you are interested in up to \$50 even in a day. Address H. W. Eakins, President, 928 High Street, Springfield, Ohio.

H. W. Eakins, President,  
928 High St., Springfield, Ohio.

Consider me an applicant for opening as independent manager of one of your businesses on your new plan that starts me in big business without doing any high pressure selling or house to house canvassing.

Name.....

Address.....

City..... State.....



Here is Edwin McTeer (address on request) and some of his work. The crude pen drawing was made before he had any training and the striking story illustration (worth \$100) was made after he took the Federal Home Study Course.

# He did it— Why don't you?

Edwin McTeer is only one of the hundreds of young men (and young women, too) who are succeeding in commercial art with the help of the practical training offered by the Federal Home Study Course. Well trained artists earn \$50, \$75, \$100, \$150 a week and more.

### Success In Commercial Art

begins with a liking for drawing and the ambition to follow through with the right training. Mr. McTeer was thirty years old when he clipped a coupon like the one at the bottom of this ad, and took up the Federal Course. He progressed rapidly, increasing his earnings each year until at the end of five years he was making around \$10,000 a year. Read what he wrote us:

"I was not very talented when I entered this training with you people as you certainly know, and I had not even had high school training and I know any one with a love for the work can accomplish even more than I if they will just let you people, the Federal Schools, help them.

"I suppose you remember I opened my own independent commercial-art studio, and to make a long story short, my earnings are now at the rate of over \$10,000.00 a year."

### Send For "Your Future"

If you like to draw—send for book "Your Future" and find out what amazing progress you can make with the right art training. Use the coupon now, giving age and occupation.



**Federal  
School**  
of Commercial Designing

649 Federal Schools Bldg.,  
Minneapolis, Minnesota.

Please send me "Your Future."

Name.....

Age..... Present Occupation.....

Address.....



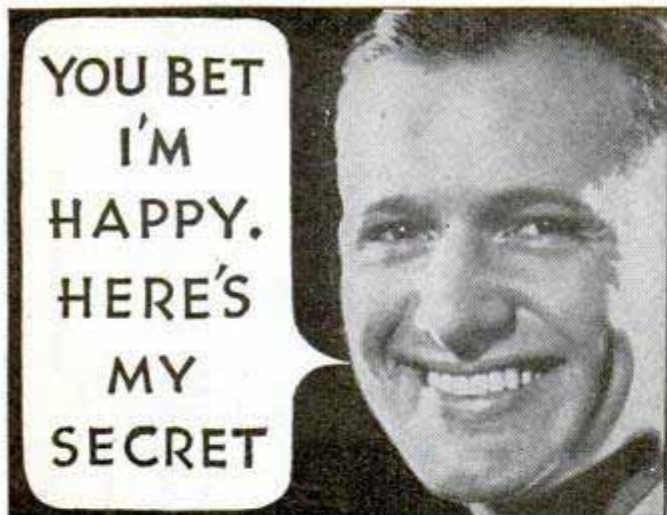

YOU BET  
I'M  
HAPPY.  
HERE'S  
MY  
SECRET

## ~ how I jumped from \$35 to \$100 a week in less than a year.

I was beginning to think that \$35 a week was my limit. I had tried many so-called "opportunities." They all offered a chance—but a slim one. Usually it was a case of sticking around, ten, fifteen or twenty years with an outside chance of making \$3,000 to \$4,000 a year by the time I reached the age of 50. No fellow with push and ambition wants to wait that long.

I had just about given up hope of finding the right proposition. One day I opened a magazine and saw an ad which told of the opportunities in Radio—how Radio's amazing growth was opening hundreds of \$50, \$60, \$75 and \$100 a week jobs every year. My hopes and ambitions had been blasted so many times that it sounded too good to be true. But I said: "I'm not getting anywhere here—it only costs two cents to find out if that's true—I'll send the coupon."

In a few days I received "Rich Rewards in Radio." That book opened my eyes. For the first time I realized that if a man wants to make good money and doesn't want to wait a lifetime to start doing it, he has to get into a fast growing field—because it's rapid growth that makes a lot of good jobs. Within a month after I started training for the Radio field I was making extra money on the side fixing my neighbors' and friends' sets. I made \$400 in the first six months. In less than a year I was pulling down \$75 to \$100 a week regularly in a Radio store. And I was doing work that was fun. Some weeks I ran my earnings up to as high as \$120.

The outfit that gave me my training certainly are square shooters. They just can't do enough for you. Mr. Smith, the President, and his large staff, never let down for a minute.

Although I went to work for a Radio store and am now in business for myself, they would have done just as much for me if I had wanted to be an Operator in a Broadcasting Station, Commercial Land Station, Operator on Board Ship, or if I had wanted to enter any of the many other opportunities in the Radio industry.

Take my tip. Find out what Radio offers and what N. R. I. offers. They will deal with you the same as they did with me—send their book and then let you decide one way or another.



**THIS COUPON STARTED ME ON MY QUICK  
RISE TO BIG PAY. BETTER MAIL IT. SEE  
WHAT MR. SMITH CAN DO FOR YOU.**

J. E. Smith, President  
National Radio Institute, Dept. OKPP  
Washington, D. C.

Dear Mr. Smith:—Send me "Rich Rewards in Radio." I want proof of what Radio offers and that your training is raising men's pay. I understand this request does not obligate me in the least and that no agent will call.

Name.....  
Address.....  
City..... State.....

# Get a Thrill OUT OF LIFE Thru Dynamic Strength



Why not be a real, live man? Why not be bubbling with energy, eager to tackle your day's duties—with full steam up and a desire to go ahead? Why not get a thrill out of life?—You can't do it if you're a weakened piece of junk. Only a healthy, vigorous man can get real joy out of life—and you can be that kind of a fellow—a 100 per cent. man!

### BE A MANLY MAN

If you are discouraged—not getting anywhere in life because of your wretched physical condition—if you cannot hold a job—if the day's duties are irksome tasks and are not performed joyously—don't despair of regaining health and vigor. There is a way out.

### STRONGFORTISM

offers you a sane way, a safe way, a SURE way out of your condition and opens wide the doors to robust health and lasting power and energy. Through STRONGFORTISM you can rid yourself of annoying ailments and weaknesses—and of catarrh, nervousness, indigestion, weak back, insomnia, heart troubles—there isn't any doubt about this.

The muscular system will do more than any fat, or diet, or drug to throw off disease. Thousands all over the world have been built up to manly vigor through STRONGFORTISM.

LIONEL  
STRONGFORT  
Builder of Men

### GIVE NATURE A CHANCE

Nature surpasses all artificial methods of gaining health and strength. It is through the NATURAL METHODS of regulating bodily organs and strengthening them that I have won such renown for STRONGFORTISM. Today it is known and acclaimed throughout the world as the "BASIC science of health, strength and energy."

### LET ME HELP YOU

Needless to go on suffering mentally and physically when STRONGFORTISM is so readily within your grasp—so easily adopted—requiring only a little of your time each day—in the privacy of your own room.

### WRITE ME WITHOUT FEAR

You need not be afraid to write me frankly, and tell me everything about your physical condition and what brought you to it. What you write will be strictly confidential.

### SEND TODAY FOR MY NEW FREE BOOK

I will send FREE my recently published illustrated book, "Promotion and Conservation of Health, Strength and Mental Energy." Get this book and learn how to build up a physically fit body.

If you want to be sound—sturdy as an oak—if you want to BRISTLE WITH HEALTH, check your ailments on the coupon below and send it to me now while you have the address right before you.

## STRONGFORT INSTITUTE

LIONEL STRONGFORT, DIRECTOR.

Physical and Health Specialist for Over 30 Years

Dept. 65, NEWARK, NEW JERSEY, U. S. A.

Send This Coupon

FREE CONFIDENTIAL CONSULTATION

Mr. Lionel Strongfort, Strongfort Institute, Dept. 65, Newark, N. J.—Please send me absolutely free my copy of your book, "Promotion and Conservation of Health, Strength and Mental Energy." I have marked (x) before the subjects in which I am interested.

- |             |                 |                      |
|-------------|-----------------|----------------------|
| .. Catarrh  | .. Constipation | .. Lung Troubles     |
| .. Colds    | .. Rheumatism   | .. Round Shoulders   |
| .. Asthma   | .. Nervousness  | .. Stomach Disorders |
| .. Headache | .. Overweight   | .. Increased Height  |
| .. Rupture  | .. Weak Back    | .. Muscular          |
| .. Thinness | .. Weak Eyes    | .. Development       |
| .. Pimples  | .. Short Breath | .. Great Strength    |
| .. Insomnia | .. Weak Heart   |                      |

Other Ailments.....  
Name.....  
Age..... Occupation.....  
Street.....  
City..... State.....





Mechanical and flying instruction under Government licensed experts. Training for all types of licenses. Day or evening. Work out part of your tuition.

2000 Allegheny Ave., Phila., Pa.

# W.M. PENN AIRCRAFT SCHOOL

## Wireless (Radio)

and Morse telegraphy taught thoroughly. School, oldest and largest; endorsed by Telegraph, Radio, Railway and Government officials. Unusual opportunities. Expenses low—can earn part. Catalog free. **DODGE INSTITUTE, Jones St., Valparaiso, Indiana.**

## Learn Watchwork, Jewelrywork and Engraving

A fine trade commanding a good salary, and your services always in demand. Address **Horological, Dept. P, Bradley Institute, PEORIA, ILLINOIS,** for our latest catalog.



## Costs Only \$16 Monthly 30 DAYS' TRIAL

Start money-making business of your own. Mechanics, filling stations, repair shops, garages, battery stations are all making big money with HB 8-Hour Battery Service. Recommended by leading car and battery makers. Lets you give a better charge than the other fellow in 1/2 the time, with a saving of 30 to 50% on current. Anyone can operate. Coupon below brings details on how to get started in this money-making work.

### 20-MINUTE CAR WASHER

Car Washing pays biggest profit right now. HB 20-Minute Car Washer does more work than others—extra profit easily pays for outfit. Coupon brings details.

### Profits in Air

Dependable Air Service brings customers right to your door. HB automatic, upright Air Service is standard equipment of money-making shops. A size for every need. Trial and easy terms. Coupon brings details.

### Get 5 Men's Wages

HB Paint Spray lets you do work of 5 brush painters. Paint automobiles, houses, barns, garages, furniture, etc., quicker and better. A size for every need. Easy terms lets it pay its own way. Coupon brings details.

### Money in Arc Welding

Hobart Welder starts you on road to success with practically no expense in the biggest money-making business of the day. Anyone can easily get into this profitable business. Coupon brings details.

## Hobart Bros., Box M90, Troy, Ohio

Send me complete information on the items checked, with 30 day trial offer, easy terms and data on how HB will increase my earnings.

- 8-Hour Charger.  20 Minute Car Washer.
- Profitable Air Service.  Portable Paint Spray.
- Constant Arc Welder.

Name.....  
Address.....



# "I'm leaving you in charge"



"It ALMOST took my breath away when the boss called me in and said that for the next two weeks I would be in charge of the office! Said he had been called to Chicago on business but he knew I was able to take care of things.

"He said he couldn't have felt that way about it two years ago. Said the greatest thing I ever did for myself or the company was when I enrolled for that International Correspondence Schools course. He's right too! That was my real beginning in this man's business!"

If your boss went on a trip today, would he leave you in charge? Have you the training required to meet the unexpected responsibility—and opportunity? Thousands of men have received this training from the International Correspondence Schools. Thousands of them have won advancement in position and salary. So can you! Let us prove it to you. A two-cent stamp is all you need risk.

Mark and mail the coupon today

### INTERNATIONAL CORRESPONDENCE SCHOOLS

"The Universal University"

Box 5502-G, Scranton, Penna.

Without cost or obligation, please send me a copy of your booklet, "Who Wins and Why," and full particulars about the subject before which I have marked X:

#### TECHNICAL AND INDUSTRIAL COURSES

- |  |  |
|--|--|
| <input type="checkbox"/> Architect   | <input type="checkbox"/> Automobile Mechanic                                 |
| <input type="checkbox"/> Architectural Draftsman                             | <input type="checkbox"/> Plumbing <input type="checkbox"/> Steam Fitting     |
| <input type="checkbox"/> Building Estimating                                 | <input type="checkbox"/> Heating <input type="checkbox"/> Ventilation        |
| <input type="checkbox"/> Wood Millworking                                    | <input type="checkbox"/> Sheet Metal Worker                                  |
| <input type="checkbox"/> Contractor and Builder                              | <input type="checkbox"/> Steam Engineer                                      |
| <input type="checkbox"/> Structural Draftsman                                | <input type="checkbox"/> Steam Electric Engineer                             |
| <input type="checkbox"/> Structural Engineer                                 | <input type="checkbox"/> Civil Engineer                                      |
| <input type="checkbox"/> Electric Wiring                                     | <input type="checkbox"/> Surveying and Mapping                               |
| <input type="checkbox"/> Electrical Engineer                                 | <input type="checkbox"/> Refrigeration                                       |
| <input type="checkbox"/> Electric Lighting                                   | <input type="checkbox"/> R. R. Locomotives                                   |
| <input type="checkbox"/> Welding, Electric and Gas                           | <input type="checkbox"/> R. R. Section Foreman                               |
| <input type="checkbox"/> Reading Shop Blueprints                             | <input type="checkbox"/> R. R. Bridge and Building Foreman                   |
| <input type="checkbox"/> Telegraph Engineer                                  | <input type="checkbox"/> Air Brakes <input type="checkbox"/> Train Operation |
| <input type="checkbox"/> Telephone Work                                      | <input type="checkbox"/> Highway Engineering                                 |
| <input type="checkbox"/> Mechanical Engineer                                 | <input type="checkbox"/> Chemistry <input type="checkbox"/> Pharmacy         |
| <input type="checkbox"/> Mechanical Draftsman                                | <input type="checkbox"/> Coal Mining Engineer                                |
| <input type="checkbox"/> Machinist <input type="checkbox"/> Toolmaker        | <input type="checkbox"/> Navigation <input type="checkbox"/> Boilermaker     |
| <input type="checkbox"/> Patternmaker  | <input type="checkbox"/> Textile Overseer or Supt.                           |
| <input type="checkbox"/> Pipefitter <input type="checkbox"/> Tinsmith        | <input type="checkbox"/> Cotton Manufacturing                                |
| <input type="checkbox"/> Bridge Engineer                                     | <input type="checkbox"/> Woolen Manufacturing                                |
| <input type="checkbox"/> Bridge and Building Foreman                         | <input type="checkbox"/> Agriculture <input type="checkbox"/> Fruit Growing  |
| <input type="checkbox"/> Gas Engines <input type="checkbox"/> Diesel Engines | <input type="checkbox"/> Poultry Farming <input type="checkbox"/> Radio      |
| <input type="checkbox"/> Aviation Engines                                    | <input type="checkbox"/> Marine Engineer                                     |

#### BUSINESS TRAINING COURSES

- |   |  |
|---|--|
| <input type="checkbox"/> Business Management                                  | <input type="checkbox"/> Business Correspondence                             |
| <input type="checkbox"/> Office Management                                    | <input type="checkbox"/> Lettering Show Cards <input type="checkbox"/> Signs |
| <input type="checkbox"/> Industrial Management                                | <input type="checkbox"/> Stenography and Typing                              |
| <input type="checkbox"/> Personnel Management                                 | <input type="checkbox"/> Complete Commercial                                 |
| <input type="checkbox"/> Traffic Management                                   | <input type="checkbox"/> Civil Service <input type="checkbox"/> Mail Carrier |
| <input type="checkbox"/> Accountancy <input type="checkbox"/> Cost Accountant | <input type="checkbox"/> Railway Mail Clerk                                  |
| <input type="checkbox"/> C. P. Accountant                                     | <input type="checkbox"/> Grade School Subjects                               |
| <input type="checkbox"/> Bookkeeping  | <input type="checkbox"/> High School Subjects                                |
| <input type="checkbox"/> Secretarial Work                                     | <input type="checkbox"/> College Preparatory                                 |
| <input type="checkbox"/> Spanish <input type="checkbox"/> French              | <input type="checkbox"/> Illustrating <input type="checkbox"/> Cartooning    |
| <input type="checkbox"/> Salesmanship <input type="checkbox"/> Advertising    | <input type="checkbox"/> Lumber Dealer                                       |

Name.....  
Address.....  
City..... State.....  
Occupation.....

If you reside in Canada, send this coupon to the International Correspondence Schools, Canadian, Limited, Montreal, Canada





# Follow this Man

*Secret Service Operator 38 is on the job*

**F**OLLOW him through all the excitement of his chase of the counterfeit gang. See how a crafty operator works. Telltale finger prints on the lamp stand in the murdered girl's room! The operator's cigarette case is handled by the unsuspecting gangster, and a great mystery is solved. Better than fiction. It's true, every word of it. No obligation. Just send the coupon and get—

# FREE!

## The Confidential Reports No. 38 Made to His Chief

And the best part of it all is this. It may open your eyes to the great future for YOU as a highly paid Finger Print Expert. More men are needed right now. This school has taken men just like you and trained them for high official positions. This is the kind of work you would like. Days full of excitement. Big salaries. Rewards.

## Can you meet this test?

Can you read and write? Are you ambitious? Would you give 30 minutes a day of your spare time preparing yourself for this profession? Answer "yes" and I'll show you how to attain all this. Send the coupon and I'll also send the Free Reports.

**INSTITUTE OF APPLIED SCIENCE**  
1920 Sunnyside Ave., Dept. 13-56 Chicago, Illinois

**Institute of Applied Science**  
1920 Sunnyside Ave., Dept. 13-56 Chicago, Illinois

Gentlemen:—Without any obligation whatever, send me the Reports of Operator No. 38, also your illustrated Free Book on Finger Prints and your low prices and Easy Terms Offer. Literature will NOT be sent to boys under 17 years of age.

Name \_\_\_\_\_

Address \_\_\_\_\_

Age \_\_\_\_\_

# Burn Oil Newest Way



The LACO

PATENTED MINERAL WICK

**No Coal-No Ashes**  
*Amazing Low Cost*

**Be the BIGGEST Oil Burner DEALER**

Somebody in your city is going to make a lot of money in the oil burner business—America's fastest growing industry. Line up with the nationally advertised complete line of Laco, World's lowest priced oil burners, and be that man. Our dealers report profits from \$10,000 to \$50,000. Send for Sensational SPECIAL OFFER Now, big discounts, and Special Selling Plan!

Don't deny yourself the convenience and care-free happiness of Automatic Oil Heat longer. Laco, America's wonder burner, cuts heating costs to a mere fraction. Revolutionary new principle—the U. S. Patented Laco Mineral Wick—burns oil with air. As the oil rises through the mineral wick, it is converted into hydrocarbon gas, the most inexpensive medium of creating heat ever known. It eliminates fuel wastes, smoke, soot, grease, and cuts fuel costs so low it doesn't pay to waste time and money on coal.

**Fits Any Stove or Furnace Instantly**

Homes, apartments, commercial buildings, everywhere that oil heat is demanded, but where every cent must be conserved, Laco meets the need. Fits instantly into present heating plant, no matter what type. Fully automatic equipped with room thermostat—safety control. Safer than the ordinary kitchen range. Meets city ordinances. Quiet. A world beater for economy and efficiency.

### EASY PAYMENTS

Priced so low, with easy payments, anybody can afford it. Write for full information, sensational low price, and SPECIAL Introductory offer.

**LACO OIL BURNER CO.**  
135 Union Street Griswold, Iowa U. S. A.

## FOR THE RADIO BUILDER

The blueprints below include the best of Popular Mechanics tested circuits. When ordering, simply quote the numbers of blueprints desired and inclose proper amount addressed to Popular Mechanics Magazine, Radio Dept., 200 E. Ontario St., Chicago, Ill. Magazines containing full descriptions of the circuits can be obtained. Send 25 cents for each magazine desired, giving date of publication.

- No. 134, Edison Type B-Battery..... July 1928.. 25c
- No. 138, Screen-Grid Perfect-Tone Six Receiver..... Nov. 1928.. 25c
- No. 139, Simple Television Receiver.. Dec. 1928.. 25c
- No. 140, Power Amplifier and B-Supply for Television..... Jan. 1929.. 25c
- No. 142, Two-Tube Screen-Grid Short-Wave Adapter..... Mar. 1929.. 25c
- No. 143, Four-Tube Screen-Grid Receiver..... May 1929.. 25c
- No. 144, Three-Tube Self-Contained A.C. Receiver..... Oct. 1929.. 25c
- No. 145, One-Tube S-G Set for Beginners..... Nov. 1929.. 25c
- No. 146, Adjustable B-Eliminator.... Nov. 1929.. 25c
- No. 147, A-Eliminator for Set and Dynamic Speaker..... Dec. 1929.. 25c
- No. 148, Adding Audio Stages to S. G. Receiver..... Dec. 1929.. 25c
- No. 149, Plug-In Power Amplifier for use with any Broadcast Receiver. June 1930.. 25c
- No. 151, Beginners Low Power S - W Transmitter..... June 1930.. 25c
- No. 152, Portable Radio Amplifier for the Deaf..... July 1930.. 25c

Material Lists for any of the above instruments will be mailed free upon application.



# Deaf-Dumb-Blind Yet "He" STOPS Auto Thieves

What in the world IS this uncanny new discovery that so instantly terrifies auto thieves? Thieves fear it worse than poison. Its terrible power literally "petrifies" them. They cannot even remove a thing. Now your car can be absolutely safe, anywhere you leave it. Don't confuse this queer new invention with anything you ever saw. It is not a bell. Not a lock. Not an explosion. Not an electrical shocker. Not a poison gas. Yet the deadly fear it puts into thieves throws them into a panic. It works automatically the instant anyone even touches your car. Cannot injure innocent persons. Recommended by police and insurance companies. No bigger than your hand. Costs only one penny a year to operate. Almost never wears out. The cheapest, surest theft insurance you can buy. And that's not all. Excites and amuses everybody. Have lots of fun with your friends.

## Mysterious New Invention Offers Agents Up To \$40 a Day

So startling, so absolutely new, so peculiar is this strange discovery that agents who have already taken it on are smashing daily profit records. The greatest crowd gatherer you ever saw. The minute you demonstrate this clever invention people are bewildered. They want to know how it "stiffens," "hypnotizes," "shell shocks" thieves. The need for this scientific protection is so great—the big profit possibilities are so almost unlimited and easy—that now we will actually pay you just to demonstrate this amazing thief chaser. You don't need to sell a single one to make this money. Just stand on the street by your car and make it perform its magic wonders that set your audience agog and bring quick profits. No use wasting your time any longer with "piker" propositions. \$40, \$50, \$75 a day is not too much to expect, is it? If we did not feel sure that you could make as much money as other men with this uncanny new discovery we certainly would not be willing to offer you pay just for demonstrating it. The protection it gives—its utter queerness—its strange power to put fear into thieves—and the fun it gives motorists make it the easiest, fastest selling, biggest money-making opportunity for you in many years.

## We Pay You Just To Show It To Motorists

The market is so tremendous—orders are pouring in so fast—that we can afford to do almost unheard of things for our local distributors. Not only will we pay you just for testing it, but we will actually send you a Free Sample offer for your own car so that your car and accessories will be protected and to start you demonstrating it. Yet that's not all. We actually offer to pay you cash for merely testing it on your car. Now we have territories for 1,600 more county distributors and 100 district managers on this generous pay plan. With our nation-wide advertising plans ready to start at once, distributors should be literally flooded with orders. We have worked out a new plan so that you don't have to do any selling or demonstrating to car owners, to make big money.



### FREE SAMPLE OFFER

Rush the coupon for your Free Sample offer—offer to pay for demonstrating and plan that gets you big money without doing any selling or demonstrating to car owners. Send no money. Just coupon. This is not an order. Nothing will be sent C. O. D. This Sample Offer is yours free of all cost. Just mail coupon now.

Allied Industries, Inc.,  
5296 Garver Bldg., Des Moines, Iowa.

I accept your generous Free Sample offer of your amazing new thief "hypnotizer" with understanding that this offer costs me nothing now or ever. Nothing will be sent C. O. D. and I am not obliged in any way to buy anything or to become your distributor. You also offer to actually pay me for just testing it on my own car. Please send details of your offer of Pay for Demonstrating It, and also your plan that offers me big money even without demonstrating or selling to car owners. If I become your local distributor you agree to give me exclusive territory.

Name.....

Address.....

City..... State.....



1045

# SERVICING RECORD ENDURANCE PLANE IN THE AIR

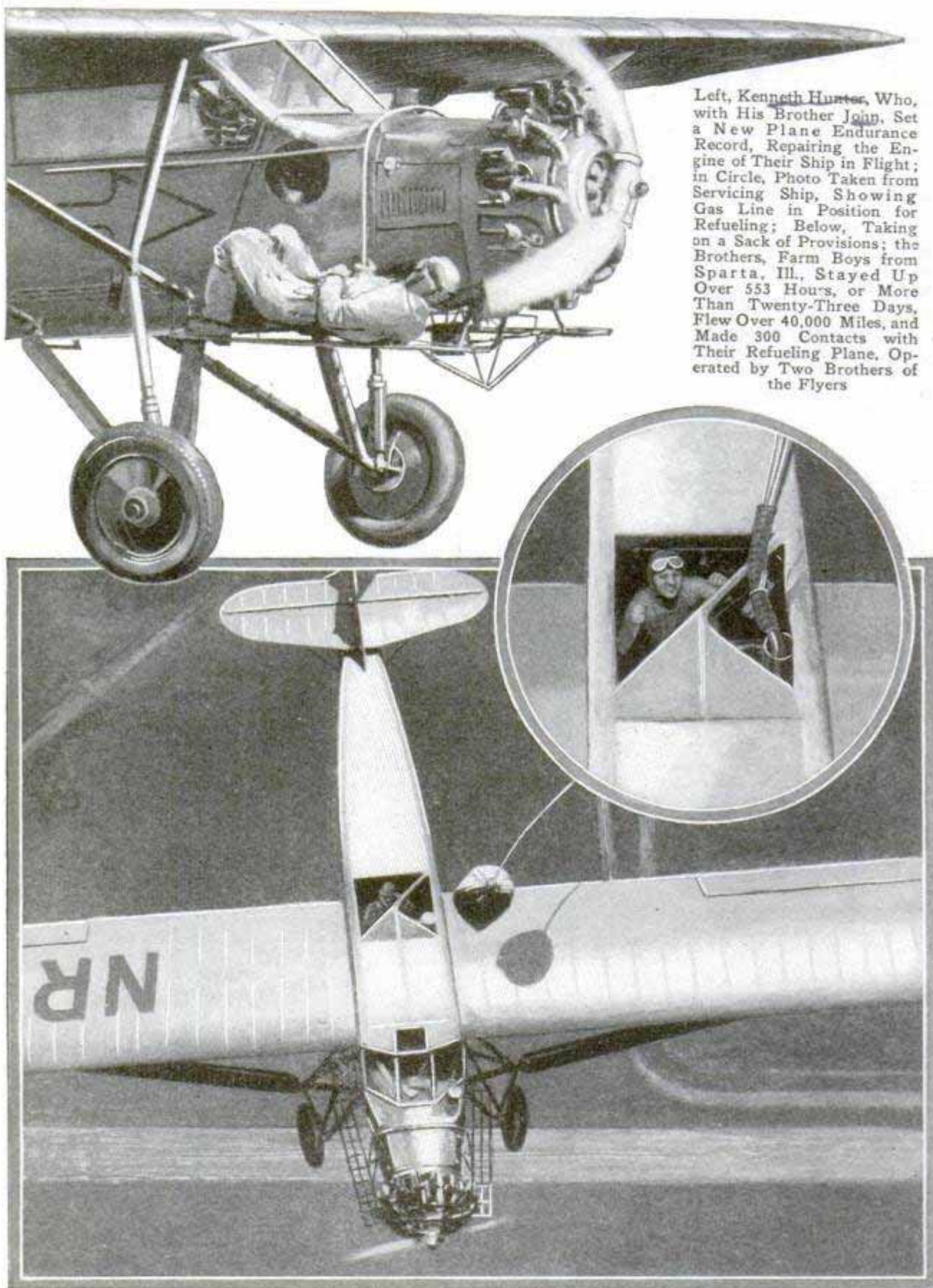

Left, Kenneth Hunter, Who, with His Brother John, Set a New Plane Endurance Record, Repairing the Engine of Their Ship in Flight; in Circle, Photo Taken from Servicing Ship, Showing Gas Line in Position for Refueling; Below, Taking on a Sack of Provisions; the Brothers, Farm Boys from Sparta, Ill., Stayed Up Over 553 Hours, or More Than Twenty-Three Days, Flew Over 40,000 Miles, and Made 300 Contacts with Their Refueling Plane, Operated by Two Brothers of the Flyers

*International*



# Popular Mechanics Magazine

REGISTERED IN U. S. PATENT OFFICE

WRITTEN SO YOU CAN UNDERSTAND IT

Vol. 54

SEPTEMBER, 1930

No. 3



1095

## The Making of a Sound Fable

**B**ETWEEN ten and twenty thousand penciled drawings, including no exact duplicates, are sketched on separate sheets of translucent tissue paper by a staff of fifteen artist-animators, to serve as the basis of a single Aesop's sound fable, animated talkie cartoon.

In addition to this prodigious task, every single one of those drawings must then be traced from the tissue to a sheet of celluloid of the same size, which is conveniently handled on an ordinary drawing board. Twenty-five artists, who are called "tracers," are engaged in this work on one cartoon.

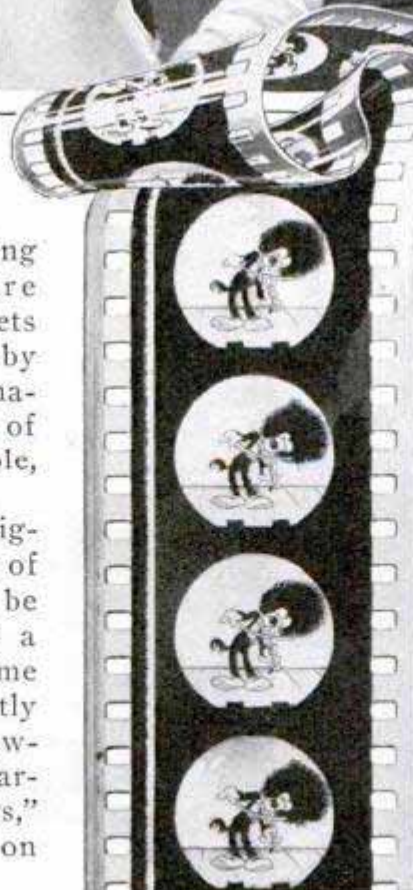

These "cells" are then used by the photographers to make the movie film, which is accompanied by music from a twenty-five piece orchestra and by the numerous supplementary sounds which the "effects men" produce. The photographers make the pictures of the cells by photographing them, one at a time, with a special camera, so that, when the resulting reel is run off, there is an optical illusion of movement, because the pictures are changed so rapidly as to deceive the eye.

So, altogether, nearly one hundred experts combine their art and skill to produce one of these amusing little

*Van Beuren Corp., 1560 Broadway<sup>353</sup>  
New York City*



1095



fables. The staff is reported to be three times the number required to make a silent animated cartoon. It requires three times as much time, too, to make a sound cartoon as it does to produce a silent one.

This new sound cartoon may be compared to the ancient puppet play in that inanimate persons and animals occupy the stage, walking, talking, singing, laughing, sighing, eating, drinking, and in other ways sustaining interest of the audience. To see how the wheels go around in the puppet play, it is necessary to go backstage. Also, it is behind the scenes that a spectator must look to view and understand the unseen human forces which are combined to produce a modern sound cartoon.

In viewing a sound cartoon, the talkie audience sees no sign of human activity, yet back of it all is the harmonious cooperation of almost one hundred actors. It starts with an idea. This idea is someone's suggestion about a possible plot. In the studio in a New York skyscraper, fifteen artists sit at drawing boards and rapidly sketch on tissue paper. They make arms and legs and funny faces and folks and animals and barns, and all sorts of seemingly unrelated things. They are visualizing various ideas of the artist-animators and other members of the staff. For several days conferences are held every morning between the artists and the musical director and the "song and dance man." You see, everything must be in time with the music. The characters that dance must be given steps that are not merely a jumble of hops and jumps, and funny "gags" must be enhanced by the music.

After many thousands of penciled drawings have been completed and approved, they are handed to the tracers, who transfer them from the tissue to celluloid sheets. The completed drawings are then numbered by the supervising artist, and the number of photographic exposures to register the desired action is made.

Sixteen pictures or frames are made per second by the ordinary motion-picture camera, but the cameras that are used in photographing sound cartoons are so arranged that only one frame or picture is taken with each turn of the camera crank. The cameras are so designed that the operator merely pushes a pedal to turn the handle which brings about an exposure.

Artist-Animator, Tracer and Cameraman at Work;  
Bottom, General View of a Fable Studio



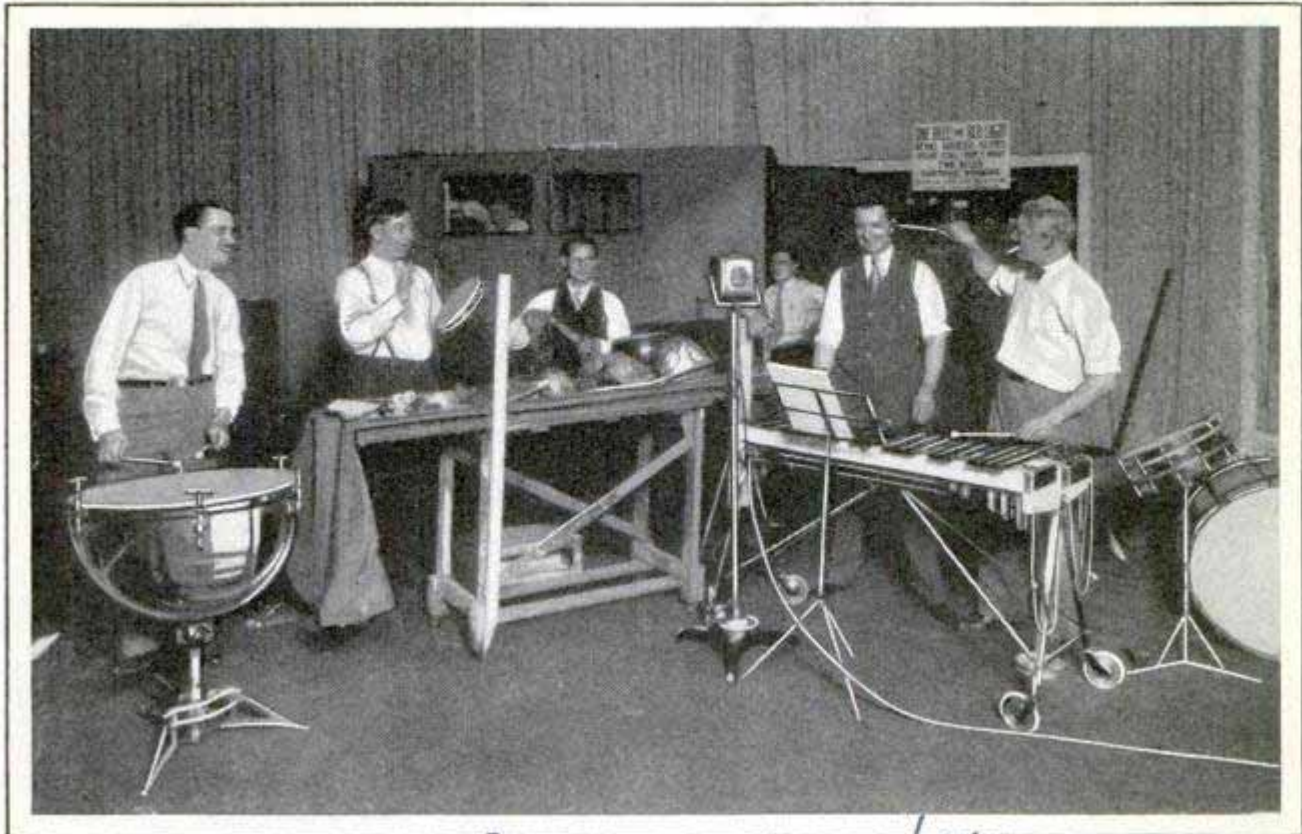

Courtesy Van Beuren Corp. *1560 Broadway New York City*  
 Effect Men for a Sound Fable; Note Different Articles Used for Sound Effects, and Also, Rear Center, the Sound-Proof Recording Room with Sound Engineer Gazing Out Window

Between 10,000 and 20,000 sheets of celluloid are handed over to the photographers. A background is placed under the lens of the camera. The cell is fitted onto two pegs that protrude from the camera table. The camera is poised above the cameraman and is directed downward to the pictures on the table. A schedule of what cells should be put together to make a completed picture hangs in front of him.

Suppose the scene shows Henry Cat emulating Robin Hood shooting an arrow into the air. Sherwood forest is pictured on the "setting sheet" or painted background. This drawing is placed under a frame directly beneath the camera, which is focused from overhead. A cell, bearing a drawing of Henry standing is superimposed over the background. This shows Henry in a natural position for archery excepting that the arms, bow and arrow are missing. On a second or a third sheet of celluloid these members appear. The extra sheet or sheets being placed atop the background and the first cell, the complete picture is photographed. To show the cat shooting the arrow, the arms are made to draw back the arrow on the string by substituting various sheets that contain

drawings of the arms and bow and arrow in stages of progressive movement.

The next step is to synchronize the picture. The scene shifts to a sound studio. Here, in front of a motion-picture screen, is seated an orchestra of twenty-five musicians. These men have their backs to the screen and face their director. A few feet from the orchestra is a long table upon which there are scores of all sorts of odd instruments and gadgets. These things are to be used by the three effects men who are behind the table.

At a signal, the lights of the studio are turned out. The animated cartoon is flashed upon the screen. As the main title appears, the conductor waves his baton and starts to lead his musicians through the picture, keeping perfect time with the action, antics and dances of the cartoon characters exactly as he planned to do when the picture was first discussed in conferences. The effects men watch alertly for those spots in the film where effects are needed.

Five times the orchestra and the effects men rehearse with a complete showing of the film. Then the final "take" is made for showing throughout the world.



10 38 356

U. S. Navy, Harry S. Wadsworth,  
18th Ave + 149th St.  
Whitestone, NY  
POPULAR MECHANICS



Diving Bell Large Enough to Hold Three Persons; It Is to Be Used in Salvaging the Cargo of a Wrecked Ship

### DIVING BELL THAT HOLDS THREE TO AID TREASURE HUNT

Three persons can occupy a diving bell designed by an eastern inventor for the special purpose of salvaging a shipment of copper which sank with a barge some time ago off the coast of Long Island. He expects to use it also for other hunts.

### SAILING THE SKIES WITH RADIO ON AIR LINERS

To save the life of a patient who was desperately ill, a doctor of Waynoka, Okla., found it necessary to take the patient to Chicago for a very delicate operation. Accordingly, he engaged passage upon a TAT-Maddux transport plane to Kansas City, and thence by another line to Chicago. Doctor and patient took off from Waynoka at 8:45 a.m. Arriving at Wichita later in the day, they found, to their consternation, that their reservation on the other air line had been canceled. Now, if it had not been for the two-way radiophone equipment carried on all TAT-Maddux planes, this story would probably

have ended there—tragically. At any rate, since there was nothing else to do, the two passengers flew on with the ship toward Kansas City. Meanwhile, one of the pilots called up the nearest ground station, telling of the plight of the doctor and his patient. The ground operator immediately stepped to the teletype and passed the word on to Kansas City. By the time the ship arrived at its destination, arrangements had been made with another line to hold a Chicago-bound ship until the doctor's arrival. Doctor and patient were rushed to the other landing field, and, making connections without delay, reached Chicago in time to save the patient's life. A pilot leaving Clovis, N. M., west-bound for Albuquerque, ran into a storm, not reported on the weather map. The sky ahead gave no promise of clearing, and there appeared to be a good chance that Albuquerque might be fog-bound. Contacting Clovis by radio, he asked the weather observer there for instructions. Teletype reports indicated that Albuquerque was indeed "steamed in." However, after a bit of calculation of wind velocities and air speeds, the observer estimated that, by the time the plane reached its destination, the fog would have blown over. This was found to be a true prediction.

querrue might be fog-bound. Contacting Clovis by radio, he asked the weather observer there for instructions. Teletype reports indicated that Albuquerque was indeed "steamed in." However, after a bit of calculation of wind velocities and air speeds, the observer estimated that, by the time the plane reached its destination, the fog would have blown over. This was found to be a true prediction.

1054

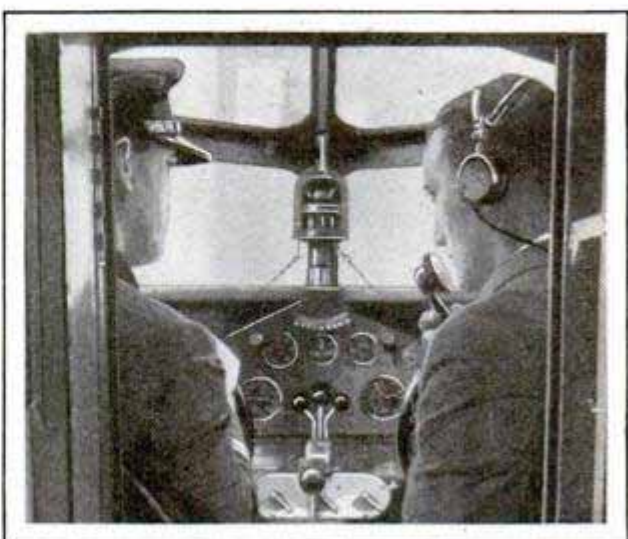

Radio Apparatus on a Modern Air Liner, Showing How Messages Are Received in Air

Cont. C. S. Gleason, 650 California Ave  
New York City



HOW HEELPRINT AND BIT OF FUR SOLVED MYSTERY

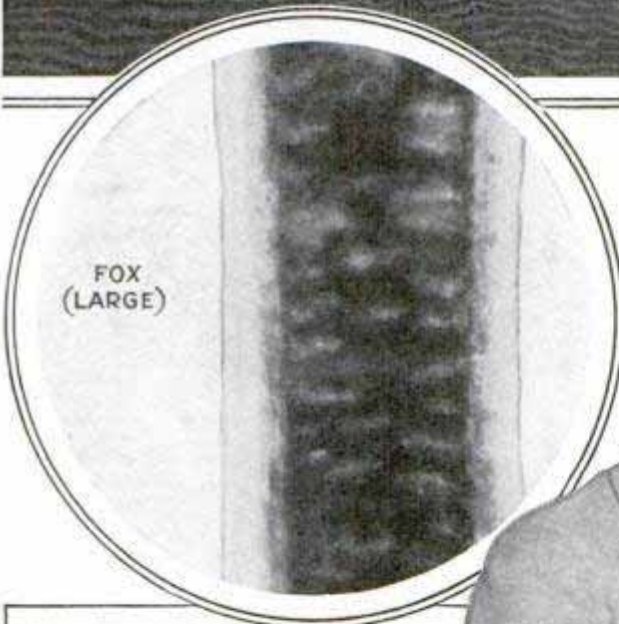
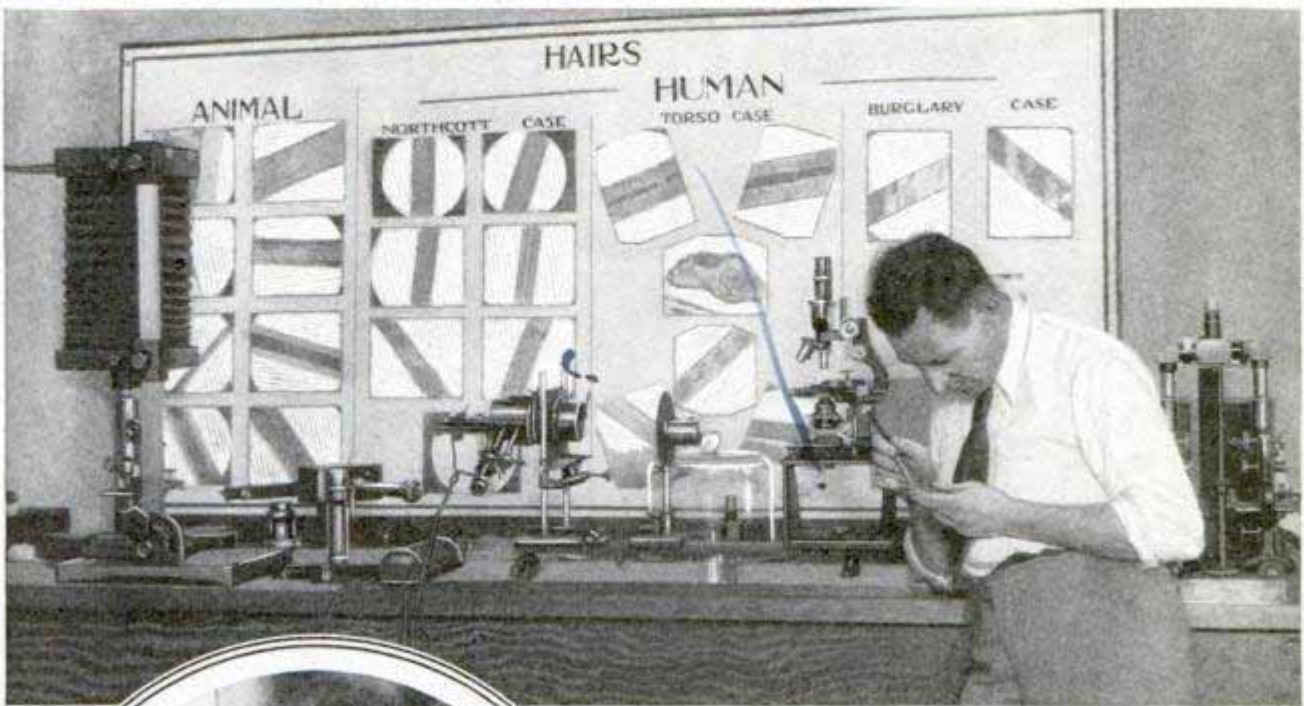

Above, Greatly Enlarged Photographs of Hairs, and, in Circle, Microphoto of White-Fox Hair, Its Pattern Identifying Its Origin and Helping to Solve a Fur-Store Robbery

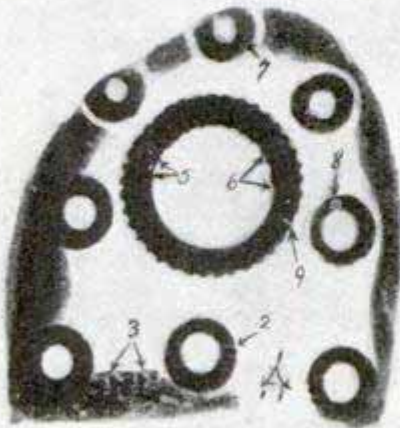

5-18-30. Nelson  
BUREAU OF IDENTIFICATION  
CITY OF BEVERLY HILLS, CAL.

The Only Clues Found after the Theft of Some White-Fox Furs from a Los Angeles Store Were a Rubber-Heel Imprint on a Bit of Glass and Some Hairs Found in a Car Seen near the Scene of the Robbery; Scientific Criminologists Found the Hairs to Be from White Foxes and Arrested Two Men Traced through the Auto; the Shoe Heel, Shown Above, of One Suspect Fitted the Heel Imprint, Left, and Both Men Were Charged with the Burglary



1096 358

Mr. H. Corley Harment  
Langley Field, Hampton, Va.  
POPULAR MECHANICS

### FLYER THROWN IN AIR IS CAUGHT ON SAME PLANE

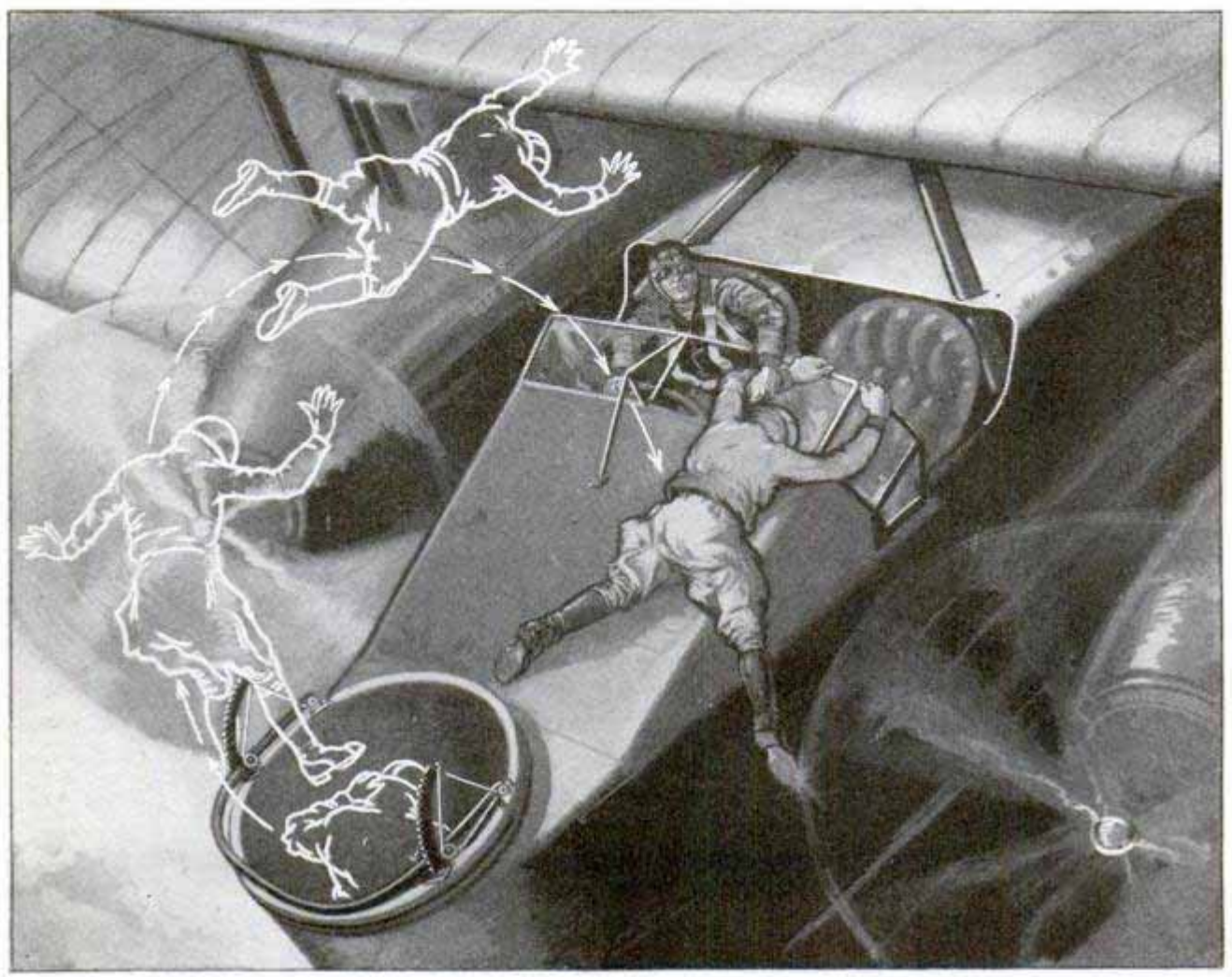

Artist's Diagram Showing How the Co-Pilot of a Big Bombing Plane Was Thrown from the Cockpit When It Struck a Down Current, Then Fell on His Ship and Was Saved from Death

Thrown from an airplane in mid-air without a parachute and caught again by the same plane is a rare experience. But this is what happened to an army aviator recently 3,000 feet above LaCrosse, Ind. A flight of big bombing planes had left an airport north of Chicago, bound for Virginia. The wind was uncomfortably cold and rough. The big planes carried two pilots who relieved each other at hourly intervals. Before his trick at the wheel, the co-pilot went forward to the gunner's compartment to put on a sweater. Just as the garment went down around his neck so he could see, the airplane encountered a sudden down current of air. It is like holding a baseball in the flat palm of the hand and quickly withdrawing the hand downward—the ball does not follow but is left suspended for a moment. When the down current struck the airplane and suddenly knocked the wings downward

about ten feet, the aviator in the gunner's cockpit suddenly felt "no bottom." Next, he was looking downward at the wings of his own plane and saw a hand outstretched before his face. This was his brother pilot reaching for him. It was grab windshield, struts, edge of wing, motor cylinder, even the spinner on the hub of the propeller as a last resort. When the plane swung back up level from the terrific down current, the flyer's left foot came in contact with the side of the fuselage just in front of the co-pilot's empty seat. His hands managed to grasp a part of the windshield and he immediately tried to swing his right foot up on the fuselage, and, in so doing, it got in the way of the propeller which was turning over 1,700 times a minute. The steel blades cut through the sole of the airman's shoe, amputating a toe, but he did not feel any pain. Slowly and with the help of the other pilot, he managed



cur. Livingston  
- Southard & Co.

17 Battery Place  
New York  
to regain his seat. Then  
a landing was made to  
obtain medical treatment  
of the injured foot.

Dr. A. J. Ashdown London Eng

EYE TURNED INTO SLOW MOVIE BY ROTOSCOPE 1099

By means of a device known as the "rotoscope," it is now possible to examine, study and time, in daylight, such rapidly moving parts as gears, ball and roller bearings, cams, springs and valves. When using the rotoscope, the observer's vision is "geared up" to the speed of the moving object, thus making a slow-motion camera of the eye by giving a direct view without photography, and allowing exact timing at any speed from 100 to 40,000 movements per minute. The main feature of the instrument is a rotary cylindrical shutter, capable of giving as many as 1,000 glimpses a second, these blending into a continuous impression on the retina of the eye. The speed of the shutter can be varied by rapid adjustments with a tiny gear box.

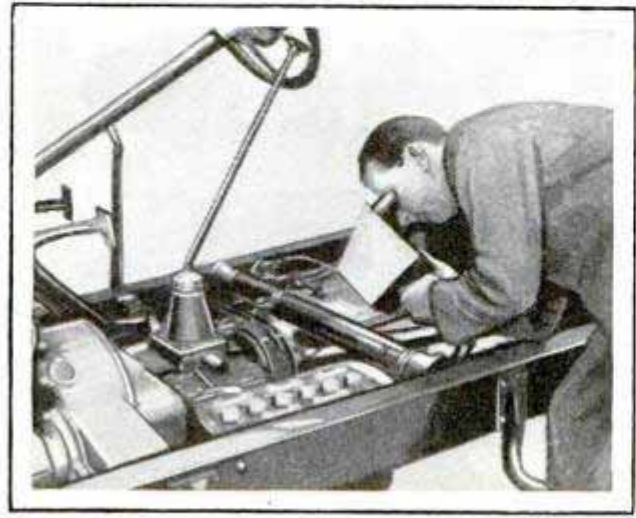

Examining Rapidly Moving Machinery with the Rotoscope Which Turns Eye into Slow Movie Camera

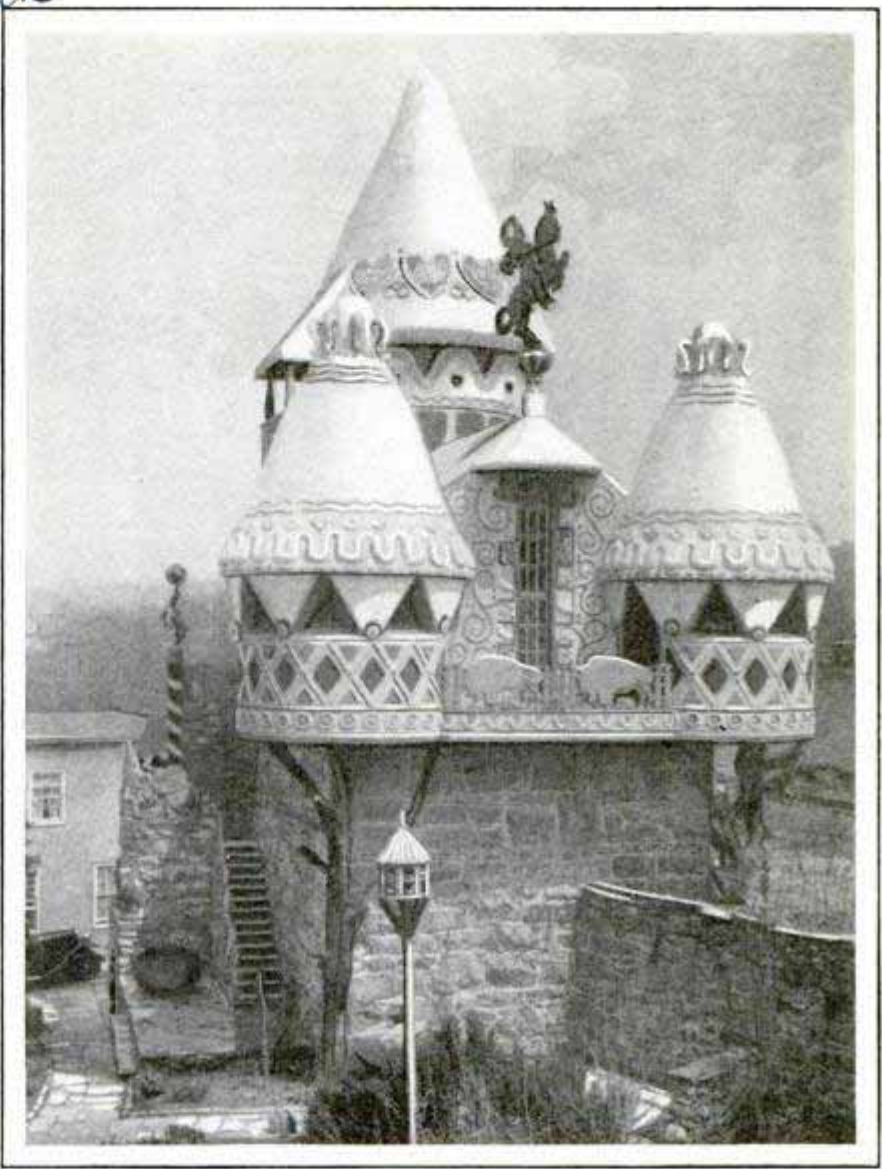

For the Enjoyment of Children This Stone Reproduction Has Been Made of the Gingerbread Palace Featured in "Hansel and Gretel"

FAIRYTALE GINGERBREAD HOUSE REPRODUCED IN STONE

Using the fairytale gingerbread palace in the second act of the opera "Hansel and Gretel" as a model, a New York manufacturer has had erected on his estate a life-size reproduction in stone of this children's wonder. The house is made of poured cement and took two years to construct. Famous fairytale characters inhabit the palace, which is topped with a roof resembling cake icing studded with hearts. It is open to children of all ages.

Farmers now produce as much wheat in a minute as their grandfathers did in an hour, forty-five minutes being the average time required to handle an acre of wheat with modern machinery.

J. H. Bennett,  
at Hamberg, Md

Joseph Urbane



Cont. H-H Stern, 9351 Georgia St  
San Diego, Calif

939

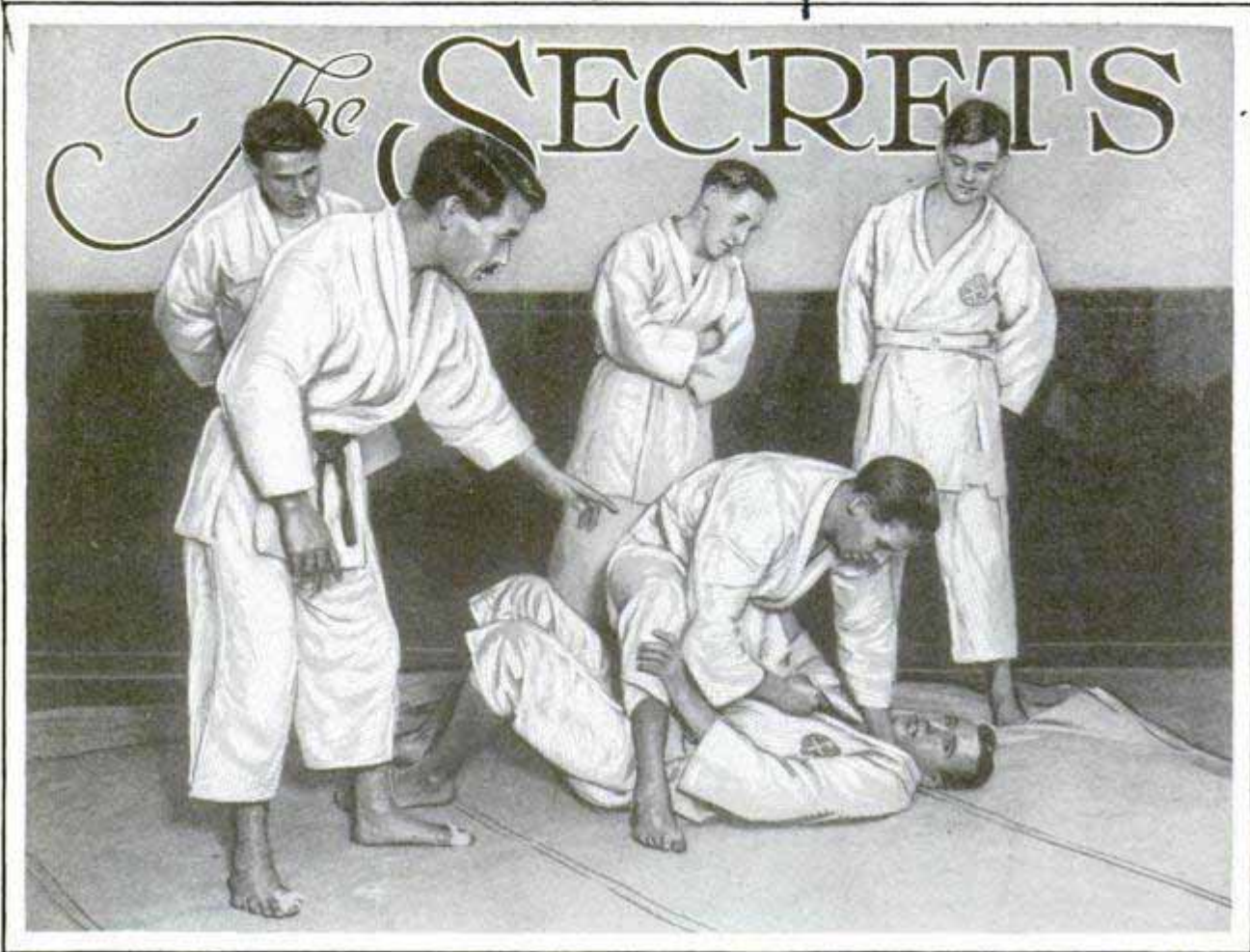

Copyright, Special Press  
A Japanese Trainer Supervising Instruction in Jiu-Jitsu of London Policemen; London Officers Do Not Go Armed, and This Fact Makes a Knowledge of Jiu-Jitsu Most Valuable to Them

By M. K. OTORO

(Instructor in Jiu-Jitsu at Kioto University)

*Kyoto, Japan*

**I**F YOU KNEW how to disable a man with a slight punch from the stiffened fingers of either hand, or to knock him senseless with a light stroke of the thin side of that hand, you would consider yourself well equipped to defend yourself. If you knew how to grip a man, with one hand, so as to paralyze his arm or his leg, you would be well prepared for any attack. Yet there are twelve such blows and more than twelve such grips in the art of self-defense as developed in Japan and called jiu-jitsu.

This name means "muscle science," and the art itself involves the exertion of force to produce maximum effect with minimum effort, by directing the adversary's physical powers so that he injures himself. The master of jiu-jitsu has at his command some 250 holds, punches (more properly, "pokes") blows and tricks of falling. It is

doubtful if one-tenth of these ever have been exhibited or demonstrated outside Japan. More than a score of them are known only to a very limited number of Japanese athletes, who are sworn never to reveal them. At least ten of the really deadly blows—remembering that there are twelve capable of causing death—probably never will be seen outside Japan.

One of these is a comparatively light blow, given with the side of the hand, which has been hardened by long pounding on a plank, delivered directly at the base of the nose. Another is a powerful punch with the stiffened fingers and arm (usually the right) just under the jawbone and beneath the ear. A third is a slashing blow with the side of the hand across either side or the back of the neck, as close to the skull as possible.

Knowledge of the laws of leverage, grav-



Books kept can supply.

Art of Wrestling and Jiu Jitsu

Liedermann. \$3.00

# of JIU JITSU

ity, balance and falling bodies, as well as accurate acquaintance with human anatomy, are the essentials of proficiency in jiu-jitsu. In the first position in a jiu-jitsu contest—presupposing that the fatal blows and grips are eliminated—each man grasps the sleeves of his opponent's jacket or blouse, just above the elbow. The men stand upright and, from their grips on the sleeves of their adversaries, attempt to work their hands to other and more advantageous holds.

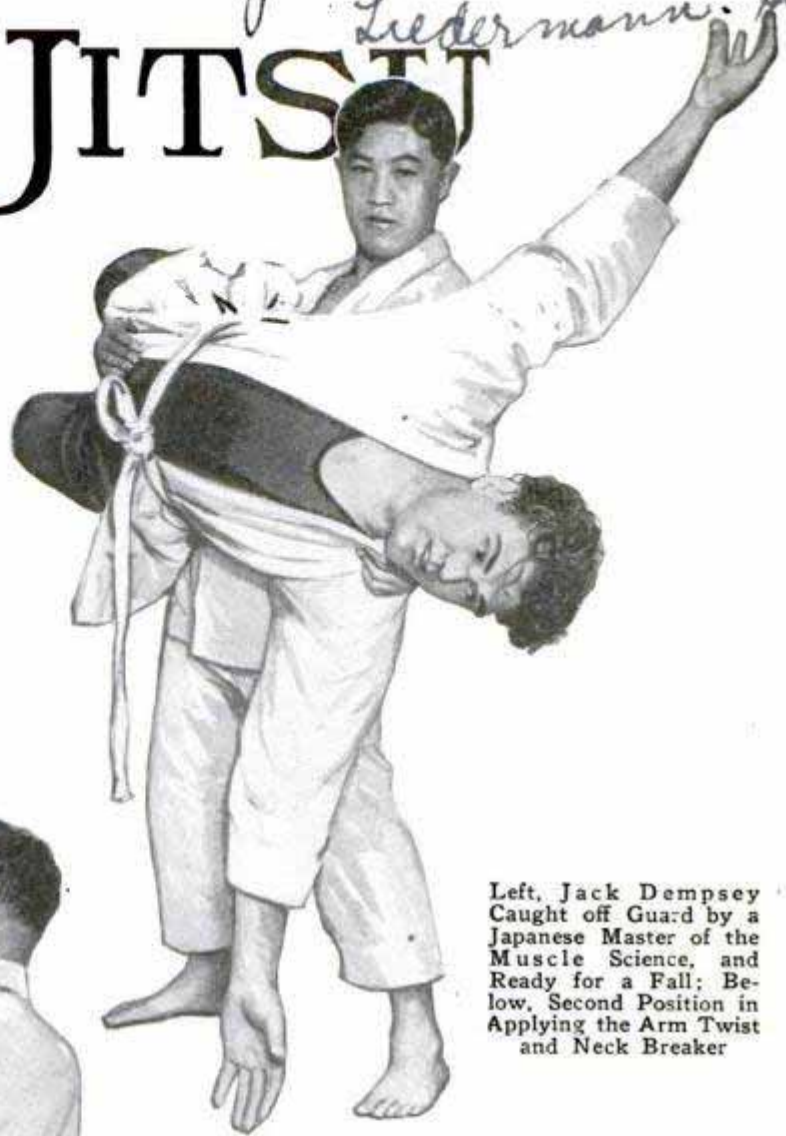

Left, Jack Dempsey Caught off Guard by a Japanese Master of the Muscle Science, and Ready for a Fall; Below, Second Position in Applying the Arm Twist and Neck Breaker



The first and simplest trick—corresponding, if successful, to the fall in western wrestling—is obtained by a quick step forward, simultaneously throwing the right leg outward and behind the adversary's right leg. At the same time, the aggressor pulls his opponent quickly toward himself and forces him back over the right leg. Precisely at the right moment, the right hand is shifted quickly from the adversary's right arm to a point where the chest and throat meet. All the aggressor's strength is then thrown into backward pressure, and the man goes down or suffers a broken back. As soon as the adversary hits the floor, the aggressor drops with him, presses his right knee into the fallen man's stomach, holding him helpless.

One of the triple tricks involves a fall,



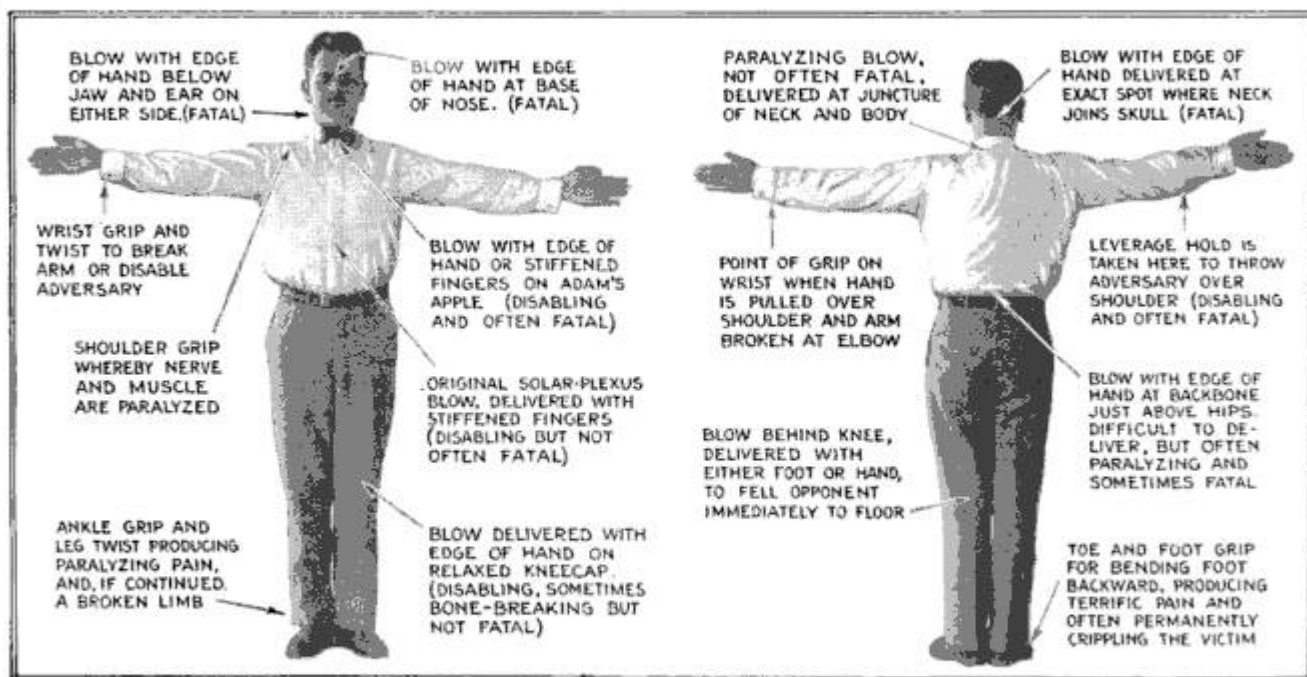

Showing the Various Vulnerable Positions at Which the Jiu-Jitsu Expert Aims in an Encounter; Blows at Some of These Points Are Often Fatal to the Person Attacked

a twist of the neck, which can be continued until death or permanent disability results, and the breaking of an arm. This comparatively simple trick is of the greatest value to a man when attacked and is much used by Japanese police and detectives in subduing criminals. Grasping the assailant quickly by either arm with what children know as the "bird-claws" grip, the man attacked steps instantly toward his opponent, turning to the left, so that his back is toward the face of the man he wishes to disable. Simultaneously he throws his own right arm over the right arm of his assailant, pulls it into the common arm lock of western wrestling, and heaves the man across his back.

In this position, the man so gripped, even though his left hand is free, is powerless to halt or delay the attack, provided it has been delivered with the necessary speed. In the next movement, which comes so rapidly that the eye hardly is able to follow, the trained man hurls his assailant over his shoulder, headlong to the floor. Dropping instantly to the right side of the fallen man, the expert draws the latter's right arm across his own right leg, between the knee and hip, and presses it downward. With his left hand, placed against the fallen man's chin, he pushes the latter's neck sharply to the left, having him in a position in which the right arm may be broken with a slight, quick pres-

sure, or the neck dislocated by putting the weight of the body on the leftward heave.

Somewhat similar to this is the neck twist from in front and the arm lift and twist from behind, accomplished simultaneously, placing the adversary in a completely helpless position while he still is on his feet. This trick—known in the western world as the handcuff—has been taught to police departments of a number of American cities and has been found invaluable in holding a man who is merely trying to escape, yet making no effort to attack or injure the officer.

The counterattack to both of these tricks is to grasp the attacker's hand with both your hands, at the very instant he shifts for his first grip, and, disregarding all his other movements, apply a sudden and powerful twist to his extended arm. Unless the attacker yields and falls to the floor, his arm will be broken. Immediately on obtaining this countergrasp, the man on the defensive thrusts his right foot directly and sharply into the pit of his adversary's stomach, and, never ceasing to twist the helpless arm, pulls his opponent against that foot. Terrible pain and punishment may be inflicted by this continued pressure on the stomach and twist on the arm, after the man has fallen.

Still another method of attack is to pull your opponent toward you, release sud-



denly your grip on his sleeves, and bend forward until your right arm, well up toward the shoulder, is between his legs. Then gripping his right leg, heave him to your shoulders, whence he can be thrown to the floor with sufficient force to knock the breath from his body, stun him or even kill him. As he goes down, the attacker follows him, thrusts a knee into his stomach, shoves his head over with the right hand, palm open, and twists the right arm with his left. Even though only slightly injured by the fall, your opponent is then powerless to move.

The solar-plexus poke is the only movement in jiu-jitsu which bears any resemblance to boxing. In this disabling trick, the grips with the hands on the sleeves of the jackets are taken as usual. Then the attacker suddenly releases the

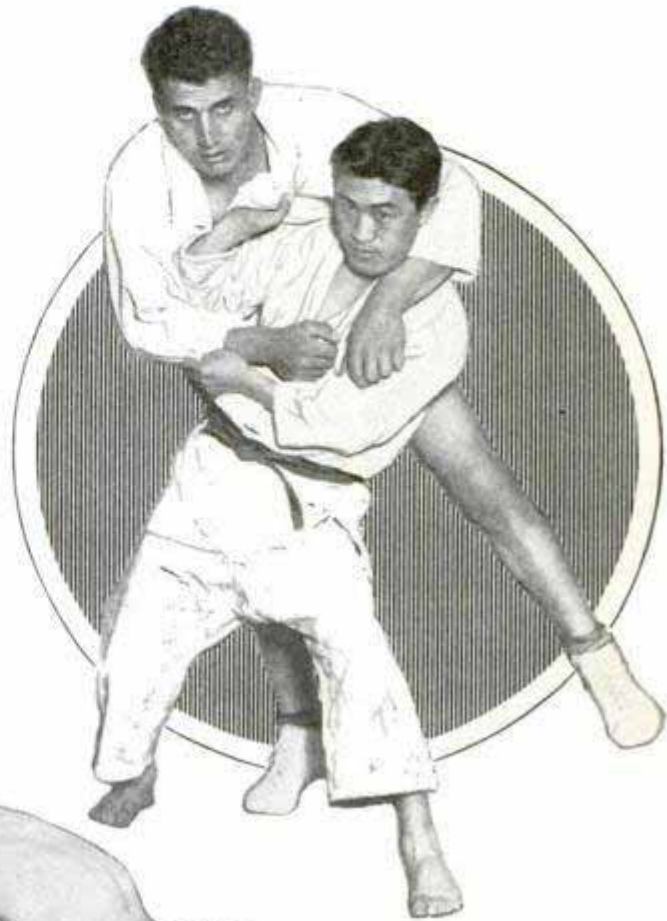

Above, First Movement of Combination Fall in Which the Attacker Whirls and Heaves His Opponent over His Shoulder; Below, the Somersault Trick or Foot Fall

hold of his right hand and throws his right arm in a circle around the left arm and hand of his adversary, trying to release the latter's grip on the attacker's jacket. If he fails, he is completely at the mercy of almost any attack his opponent wishes to press. But if he succeeds, he suddenly drives his extended right hand, with rigid fingers, into the solar plexus of his adversary. If this blow is delivered properly, and the hand twisted accurately as it is plunged into the body, the man

receiving it doubles instantly with pain, and is helpless as well as defenseless to any attack the deliverer of the poke may care to use.

Though many of the tricks of jiu-jitsu are concerned with the neck, arms and upper part of the body, there are others which are worked on the legs, with the grips and holds on the arms and neck being brought into use later, after the opponent has been tempo-

rarily disabled. One of the elements in this sport, of course, is surprise, so much so that the man attacked never knows just what form that attack will take, whether it be blow, paralyzing grip, or equally dangerous twist. One of the best defenses against surprise, and, indeed, against all attacks, is the sudden dropping, full length, to the floor by the contestant attacked.

As he falls, preferably on his right side, he hooks his right foot behind the left leg





speed will result in the "trapper" finding himself "up in the air" on the foot of the man he so recently forced to the floor. This trick, I believe, never has been shown in this country, and there are only a few jiu-jitsu experts, even in Japan, who are sufficiently trained to attempt it.

Another interesting trick is known as the foot throw. When the attacker shifts his grip on the jacket, preparatory to a surprise movement, the attacked suddenly raises his left foot, thrusts it into the pit of the attacker's stomach, and falls easily backward to the floor, pulling his man with him, yet holding him aloft on the extended left foot and leg. The attacker is virtually helpless, and may be thrown end over end by a sudden heave and the simultaneous release of the grip of the attacked on his jacket.

In all the 250 tricks known to

of the attacker, just above the ankle, and drives his left foot directly against the left kneecap of his opponent. If this maneuver is executed quickly enough, the attacker's leg will be broken at the knee, or, if less pressure is exerted, the pain will be so intense that he will drop backward to the floor, or cry out that he yields.

If the man so trapped elects to try to escape the foot grip by falling to the floor, the man who trapped him must leap forward, in a fraction of a second, thrust his left foot into the groin of the fallen adversary, and twist the latter's right foot until he yields. Failure to make this move with sufficient

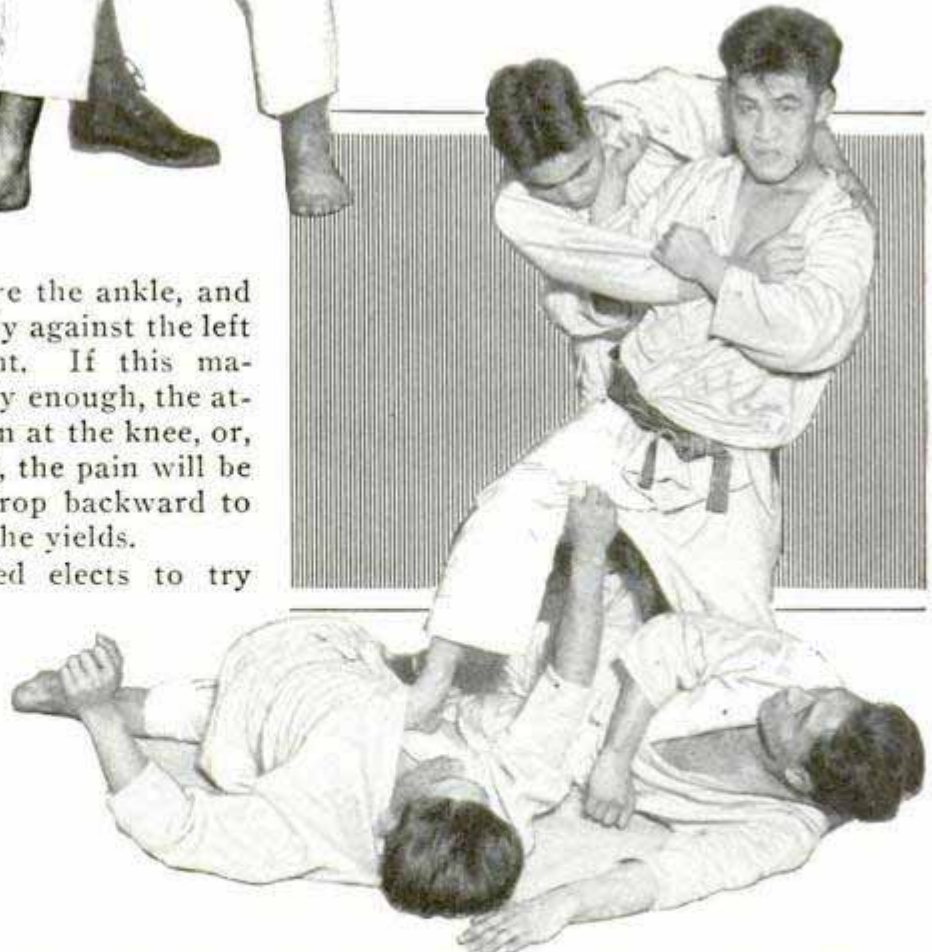

Above, First Position in a Jiu-Jitsu Encounter; Below, Two Down and One to Go; the Expert Is Ready to Heave the Third Man on the Other Two



Aviation  
Mo. Feb

jiu-jitsu, we must keep in mind that the first and fundamental training of the student of this scientific sport is in the art of falling, either of his own volition or when thrown. The jiu-jitsu expert can throw himself to the floor in any direction, landing in virtually any position without harm to himself, even though the floor be unprotected by a mattress. This enables him, in many of the maneuvers, to upset the balance of his adversary, fall away from him, and literally compel the other man to throw himself.

Likewise, he can permit himself to fall, or even to be thrown, when such fall or throw is to his advantage, and to the surprise of his opponent. Indeed, the present-day science of jiu-jitsu is the accumulation of over 2,000 years of experience in the operation of the laws of physics and dynamics.



Rapid-Fire, Air-Cooled Machine Gun Mounted in Cockpit of Airplane; It Is Capable of Firing from 600 to 800 Rounds a Minute

### DOZEN ROUNDS A SECOND FIRED BY NEW MACHINE GUN

Browning air-cooled machine guns, capable of firing from 600 to 800 rounds a minute, or at the rate of a dozen bullets a second, now are being used by some national-guard aviation units, the more rapid weapons being mounted in the planes in place of the old guns, which fired from 400 to 600 rounds per minute. The latest weapons are not only faster, but more accurate than the older ones, as they are equipped with compensating sights which move up and down with the wind in varying degrees of velocity, thus making the aim almost infallible. The guns are mounted in the rear cockpit of an observation plane for target practice.

Those wishing further information on articles in this magazine can obtain it from our Bureau of Information. The service is free.

### BARKBEETLES SLAIN BY ACID FORCED INTO TREES 1082

Fumigants, such as hydrocyanic acid, are being injected into pine trees to control the spread of barkbeetles and other harmful insects. Scientists say that, at the present stage of the experiments, the tree as well as the beetle is killed. They now are hopeful of finding a dosage that will kill the insects without harming the tree. In applying the acid, containers filled with the fumigant are fastened to the tree above a notch, that is cut in it, and the fumigant is taken up by the sap stream through a rubber hose.



Injecting Hydrocyanic Acid into Pine Tree; the Poison Is Used to Destroy Barkbeetles

U. S. Dept of Agriculture Bureau of Entomology  
H. C. Crougher, District Entomologist

Cont. E. L. Moore, 3769 Oliver St. N.W.  
Washington, D.C.



Cont. ss. Slacy,  
4639 Montgomery Ave  
366  
1084 Bethesda, Md

Tests under Mr. Coleman  
Esryth

4838  
6/20/30

POPULAR MECHANICS



Mechanical Hen, Tall as a Man, That Not Only Shows How She Lays Her Eggs But Tells about the Process

MODEL HEN TELLS AND SHOWS HOW AND WHAT SHE DOES

That historic cackling hen which you have heard so much about has gone "talkie" under the seasoned administrations of Uncle Sam's showmen. The government's latest masterpiece consists of a lifelike model of a hen, tall as a man, clothed in the feathers of former champion layers, which not only shows how she manufactures and lays eggs but simultaneously tells about how she accomplishes it. The arrangement is such that the spectators have a cross-section view of the internal workings of "Biddie" in action. The divisions of her heart are depicted by glass containers filled with red and blue liquids which are circulated by a pump. The cut-out figure shows corn passing to the hen's crop, whence the feed passes to the stomach where it is mixed with digestive juices. The natural processes are imitated to show how blood is formed and circulated, and how the egg and its shell are made.

Used in Detroit

1049 DEVICE COACHES PUPILS IN TAP DANCING

Students at the University of Illinois who are taking tap dancing have their mistakes set down against them as they dance by a machine which acts as coach in recording the foot beats on paper and compares the rhythm with a steadily beating metronome. The brass taps worn by the dancers are connected with an electric recording apparatus. The paper records, showing how well the student dancer performs, are filed to show his progress.

Device Service

1047 CARS LOADED AT ANGLE IN AUTO TRAILER TO SAVE SPACE

To conserve space and make possible the hauling of more cars, a truck and trailer for carrying automobiles from factory to dealer has provision for loading the cars at a sharp angle, the rear end being raised so that the hood of the car behind may be placed under it. On either side of the truck is a track in which are fitted several small coaster dollies or trucks with a framework to fit the differential housing of the cars. The car is backed to a track extension, and the dolly put in place, a hand-operated winch drawing the car onto the trailer. The carriers may be adjusted for various wheelbases, and the device provides for carrying five cars in a space that could not hold more than three in the conventional manner. Another trailer is double-decked, having room for two tiers of cars and thus accommodating ten of them.

W.S. Mc Lavin, 5751 Broadway, Detroit, Mich

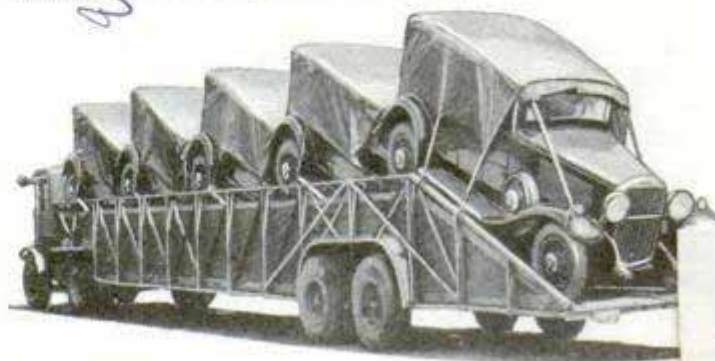

Cars Loaded at an Angle on Frames in Auto Trailer, Thus Allowing Five Autos to Be Hauled Instead of Three

Trac Trail

Tractor-Auto Car, C. Ardmore  
Trailer-Reliable Auto, Steel Body Co



# PLANE WITH ROTATING WING ACTS AS PARACHUTE

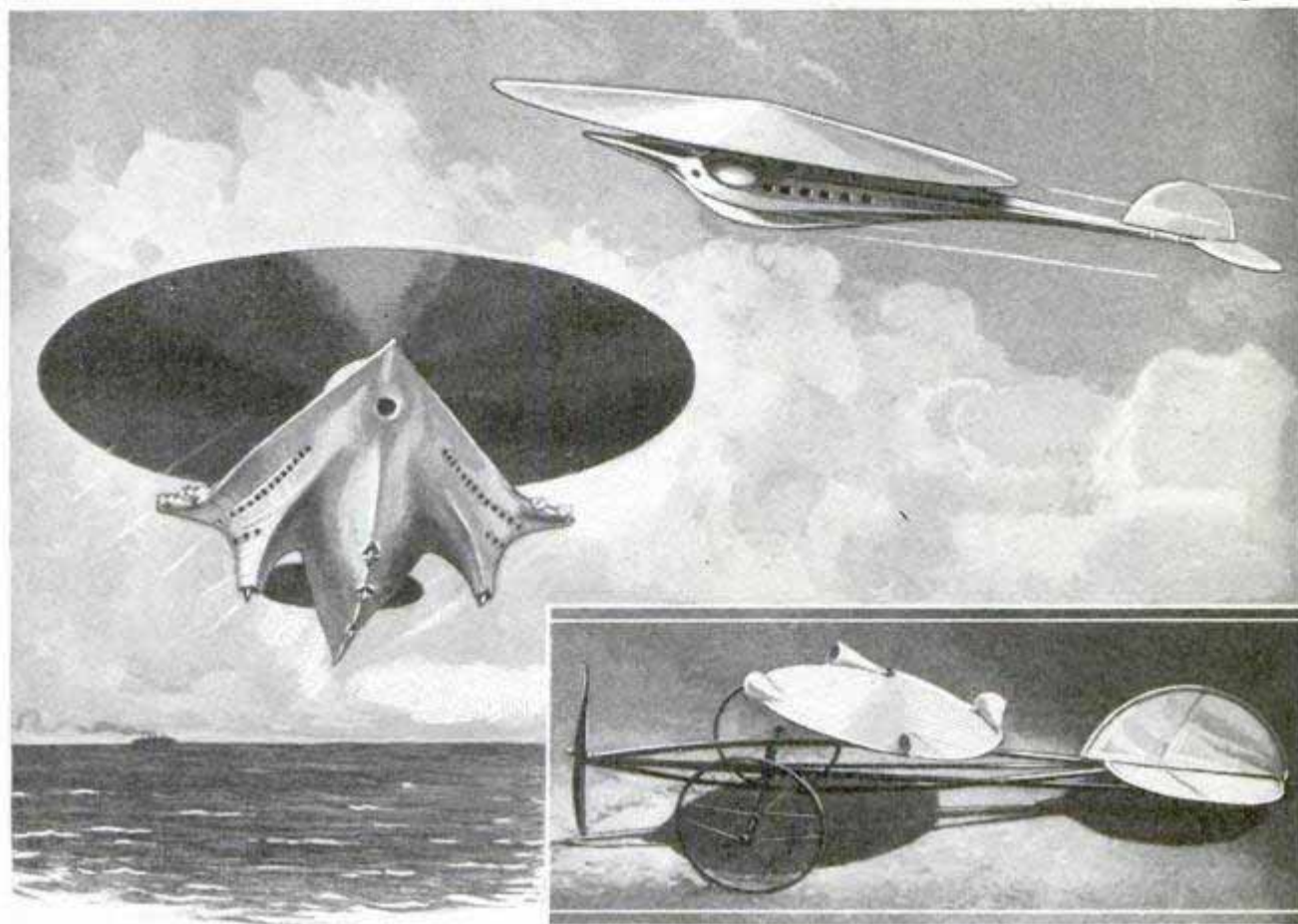

Models of a Flying Boat Equipped with a Single Disk-Shaped Rotating Wing That Is Filled with Gas or Hot Air; the Insert Shows a Small Flying Model of a Similar Craft

Features of an amphibian, a dirigible, a gyropter and an ordinary airplane are incorporated in a flying machine designed by Guido Fallei, originator of an aerial torpedo which was ready for production just as the World War closed. The craft has a single wing, a rotating disk-shaped affair filled with gas or hot air. It is turned by a gasoline engine as is the propeller, the machinery being located in the central part of the body, while quarters for crew and passengers are arranged on either side. The body has retractable wheels so that the ship can be landed on the ground or on water. The inventor believes that his craft will require less power for lift, that it will be stable and can be built at reasonable cost. In descents, the rotating wing is intended to act as a parachute. In the full-size craft the elevators as well as the rudder are designed to be replaced by smaller disks similar to the main wing and rotating, the former, in a horizontal and the latter in a vertical plane. Two models have been built and tried out with promis-

ing results, in one of which the main disk is rotated by means of compressed air blown out through openings at the edge, as shown in one of the photos.

## "MINING" LOGS FOR SHINGLES

From the swamps of southern New Jersey, white-cedar logs are being "mined" to produce shingles. Shingles cut from these tough and fine-grained logs taken from the peaty swamp soil, have been found to possess better weather-resisting qualities, and many are found in perfect condition after a century of service. Independence Hall in Philadelphia is covered with shingles from these "mines." The logs are located a few feet below the surface by probing with an iron bar. The muck is then dug away and the log is sawed into shingle lengths with a hand-saw under water, the lengths being split into shingles as they rise to the surface. Most of these logs have reposed in the swamps for centuries.

Cape May County

10 00  
Comd. Seco. H. Eckhardt,  
4528 Walnut, Phila



1035

7300 Woodward Ave

POPULAR MECHANICS

368

Aug 1930-243

FIRST AMERICAN MIDGET CAR RUNS AT HIGH SPEED

The American Austin is the first European-type small car to be put into production in the United States. Alongside it the Ford is a

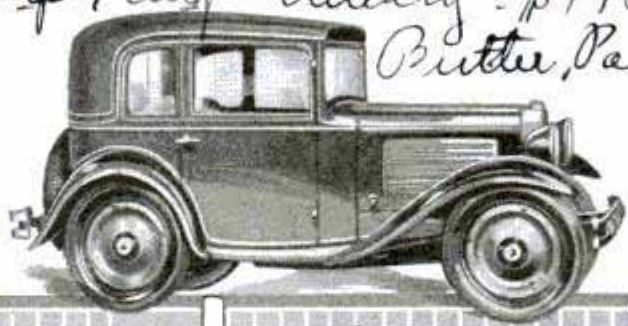

Its main novel features include a two-bearing crankshaft, the front bearing being a dual annular ball and the rear bearing a cylin-

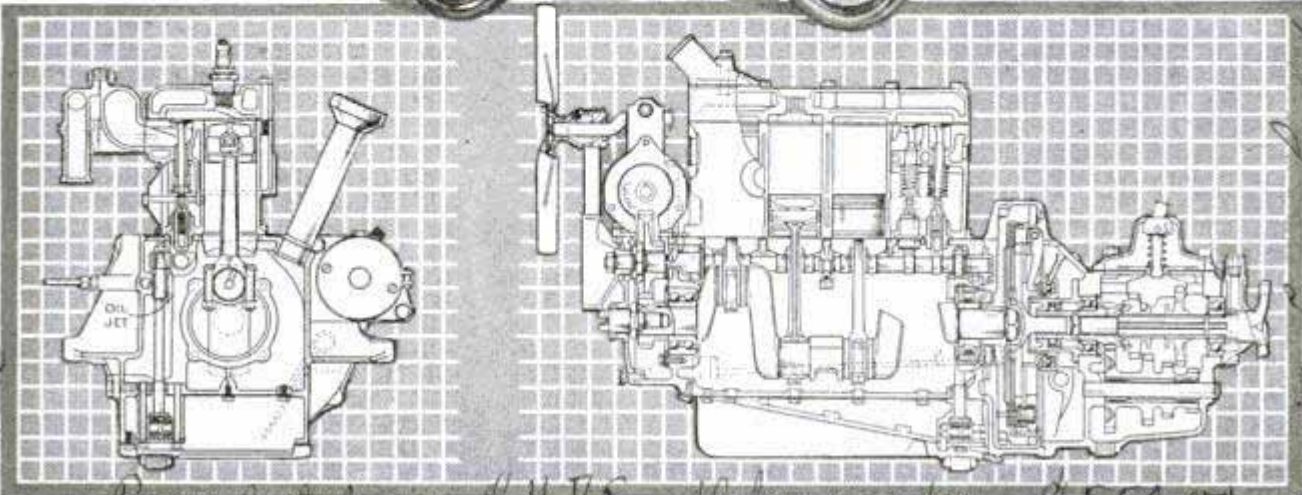

The Austin Two-Passenger Coupe, and Two Views of Its Power Plant; the Squares in the Background Represent Inches, Showing, for Example, That the Cylinder Block Is Only About a Foot Long

big car, since the Austin bantam has a wheelbase of only seventy-five inches, and a tiny four-cylinder engine which develops 14.8 hp. at 3,500 revolutions per minute. Its bore and stroke are 2.2 by three inches, giving a piston displacement of 45.6 cubic inches, which is less than one-fourth that of the Ford. The complete car weighs only 1,130 pounds. In consequence of its moderate dimensions it runs forty miles on a gallon of gasoline. In spite of its small size, there is ample leg room, the car rides extremely well and has a top speed of fifty miles per hour.

drical roller; a drop-forged steel flywheel; a special oiling system in which jets of oil are shot from the side of the crankcase into slots in the crankshaft, whence the oil flows to the connecting-rod bearings; a tapered frame mounted on a transverse front spring and quarter-elliptic rear springs, each spring being controlled by a special shock absorber. To keep the weight at a minimum, there is an extensive use of aluminum, including such parts as crankcase, flywheel housing, transmission housing, pistons, intake manifold, intake and discharge water connections, etc.

BABY INSECTS ABLE TO THINK EXPERIMENTS INDICATE

Can an insect think? Dr. Frank E. Lutz, of the American Museum of Natural History, has conducted a series of experiments on the larvæ of caddis flies, and these baby insects have shown an adaptiveness in their behavior that in some instances seems to contain an element of deliberate choice. The larvæ live in the water in a cocoonlike case which they make, the case being spun of silky threads

and reinforced with various foreign objects. Doctor Lutz deprived a number of larvæ of their cases and placed them in vessels of water with building materials to which they were unaccustomed, the larvæ being thus suddenly confronted with a serious problem. The baby insects, however, met and solved their problem, some taking to the new materials more readily than others, but all finally building themselves new houses. Varieties that had used twigs and leaf stems, for instance, worked with sand and pebbles.

Butler, Pa.

Canada - Canadian Austin Co. Ltd. 29 Campbell St. Toronto

Chicago - Chicago

Motor Car Co. due Michigan Ave 125th

Scenic Service

News Bulletin 485-9

7/7/30

Butler, Pa. features include a two-bearing crankshaft, the front bearing being a dual annular ball and the rear bearing a cylin-



LINER IS CUT IN TWO TO FIT IN BIGGER ENGINES

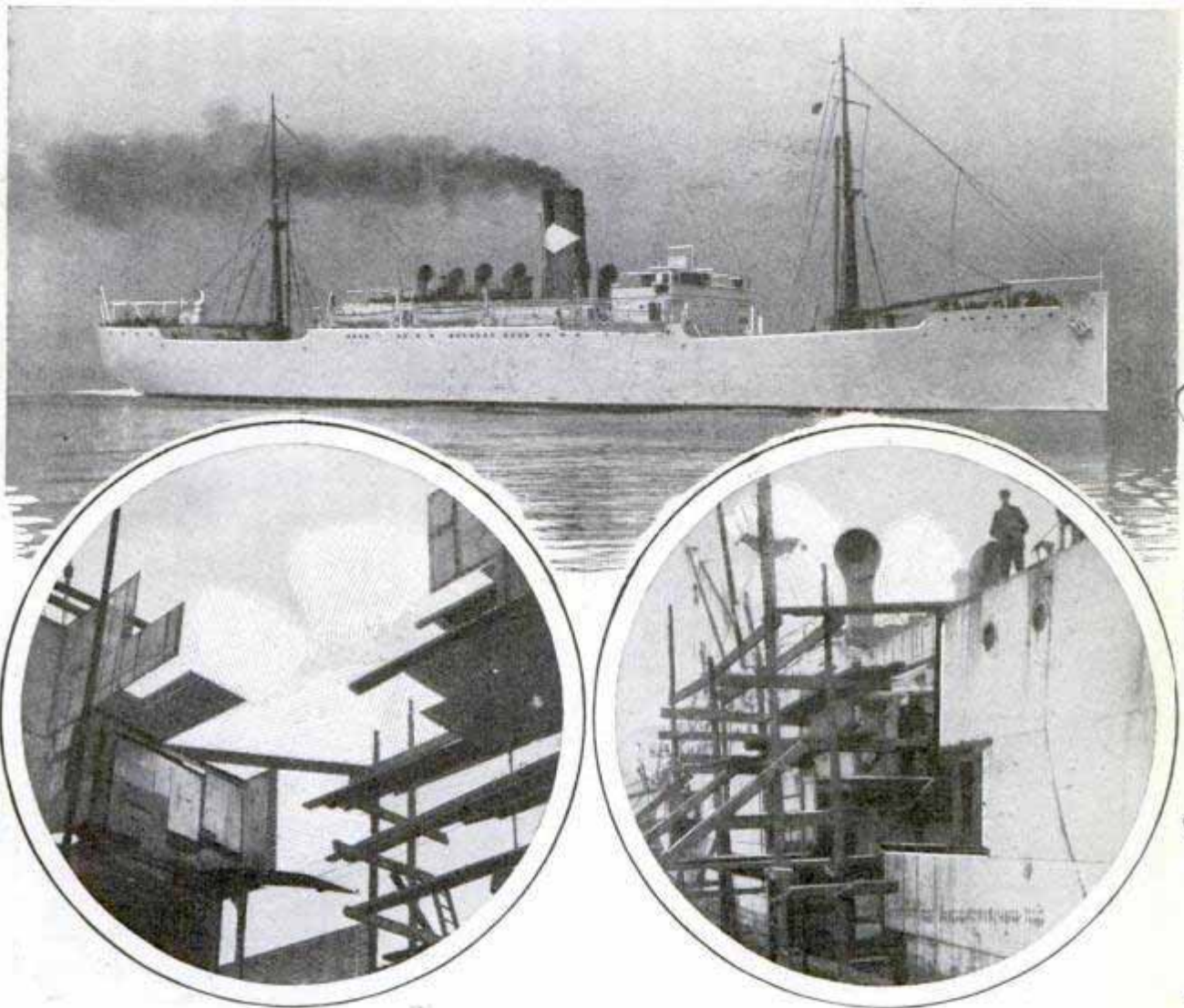

Above, Liner "Darien" After It Had Been Cut in Two and a New Section Fitted Amidships; Lower Left, the Severed Portions of the Hull; Right, Joining the Sections Together

The remarkable engineering feat of cutting in two a big fruit-carrying liner, the "Darien," taking out its Diesel engines, building in an entirely new midships portion in the wide gap and refitting it with new and more powerful turbo-electric propelling machinery so that none of the cargo-carrying space was encroached upon, recently was successfully accomplished at Belfast, Ireland. A model of the liner was first made and tests performed to find what would be the result of lengthening the ship, and what type of propeller would suit the new engines. Then the liner was towed into drydock, the rivets removed from the portions adjacent to the division on the hull amidships, and the deckhouses and superstructure cut away, together with much deck planking, pipes and cover-

ings and machinery casing. At the end of sixteen working days, the two portions of the hull were carefully moved away from the fore and aft ends of the liner which now looked like a modern skyscraper in course of erection, girded round with steel splints and beams. Between the ends of the severed hull was now a gap of thirty feet, and extreme care had to be taken to insure that the two parts remained quite upright. As soon as these parts had settled into position, the engineers started to build in a new midships portion, just as though they were constructing a new ship, the whole job being completed in six weeks.

☐ There is seventy-five per cent pure gold in eighteen-karat gold.

Cont. H. J. Williams Esq. 29 Dean's Road, Coleraine, Besley Heath, W. London England



577

# House Cleaning

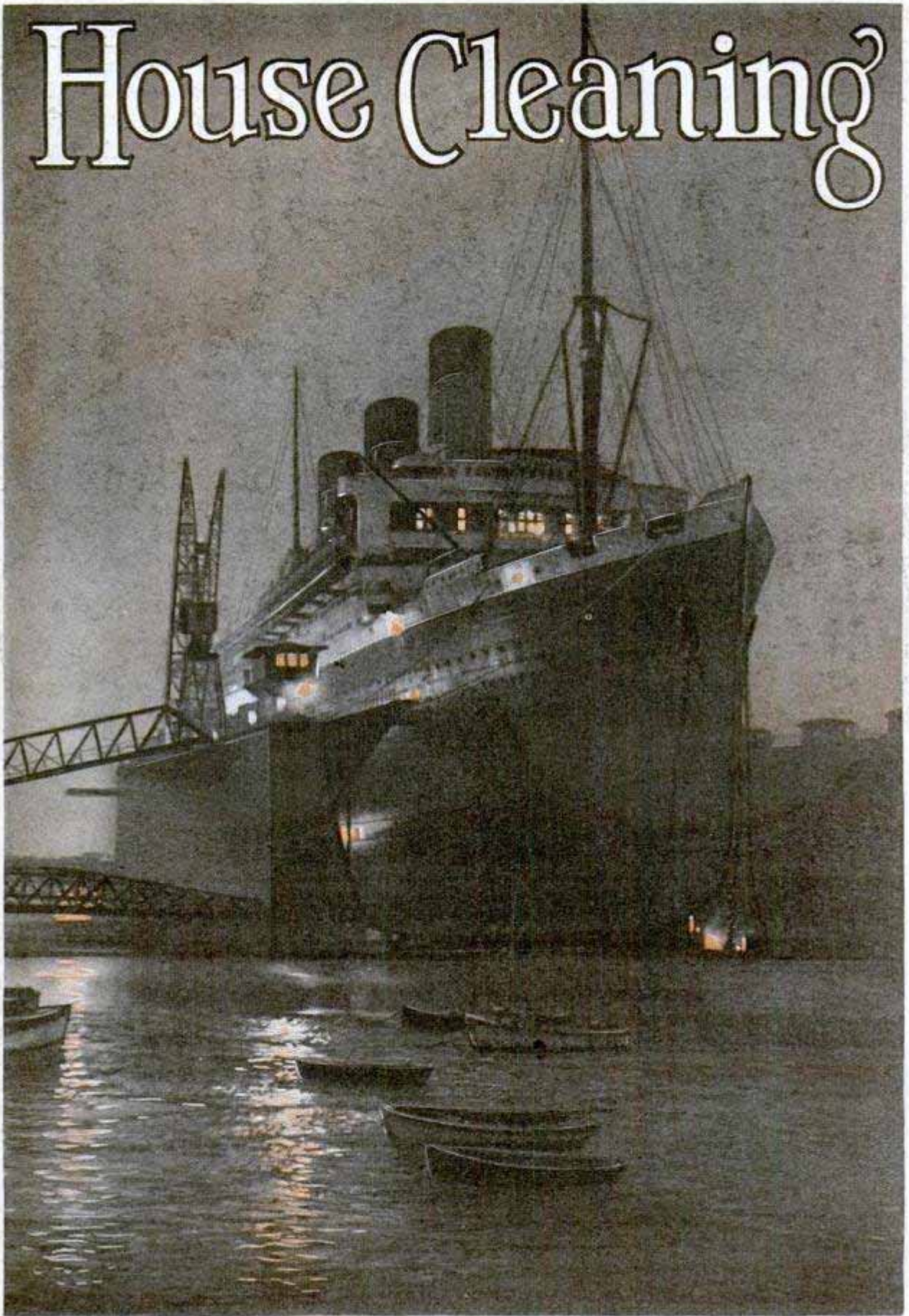

Night Photograph of the S. S. "Majestic" in Drydock for an Annual Spring Overhaul, Preparatory to a Busy Summer Season in the Transatlantic Service

Courtesy International Mercantile Marine



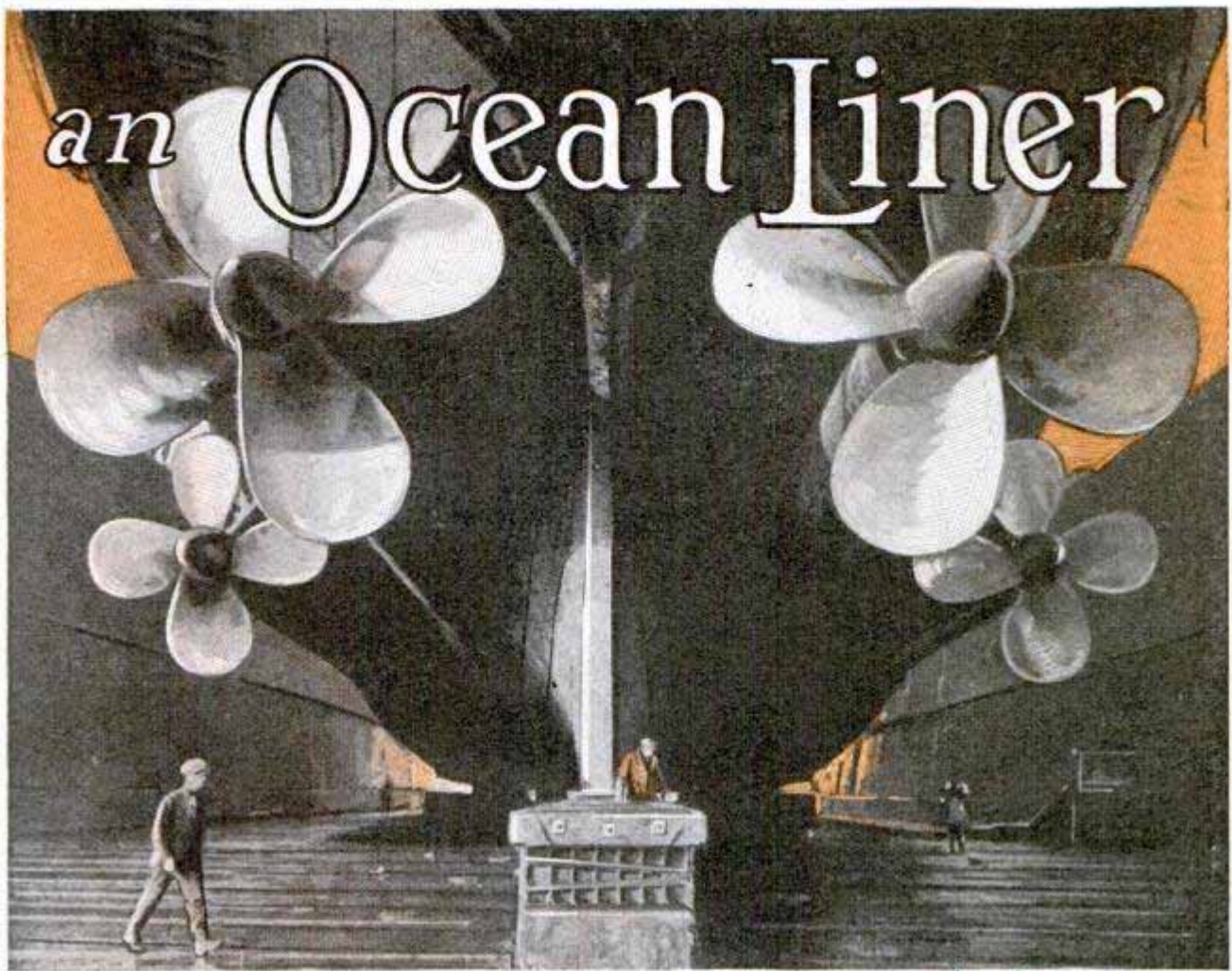

The "Majestic's" Propellers, like Gigantic Blossoms, Are Prominently Displayed as the Vessel Rests in the Floating Drydock at Southampton for a Cleaning

By DON GLASSMAN

OUT of the ocean, a floating colossus is a grand sight. In drydock, a greyhound adds depth to her length. Her warehouses and engines are below the water line. Above them tower the passenger decks that reach the altitude of modest skyscrapers.

Catering to modern travelers, the business of ship operation involves much more than merely reaching a destination on time. Recently launched super-greyhounds have caused the greatest tension in shipping circles. In order to realize fair profits on their investments, steamship companies must make their ships popular. Competition is keen.

Almost any greyhound could run several years without going to drydock, for, even while afloat, a liner is never free from paint gangs and repair crews. So a trip to drydock once and, often, twice a

year means that extraordinary precautions are being taken to insure the safety and comfort of ship and passengers.

The annual painting and examination of the hull, rudder and propellers require a ship to remain in dock for at least one week, and frequently more. About 1,000 men are employed to attend to the needs of a greyhound and the work is rushed day and night. Time in drydock frequently goes up to \$15,000 and \$20,000 per day, and if a whole fleet of passenger vessels is waiting impatiently for an overhaul in the same drydock, the cost of delays may reach a fabulous figure.

Six or seven weeks are normally required for a thorough overhaul of a 40,000-ton liner, but only a fraction of this time is spent in drydock. Estimators and engineers plan every detail of the work, so that it may proceed with dispatch and



577

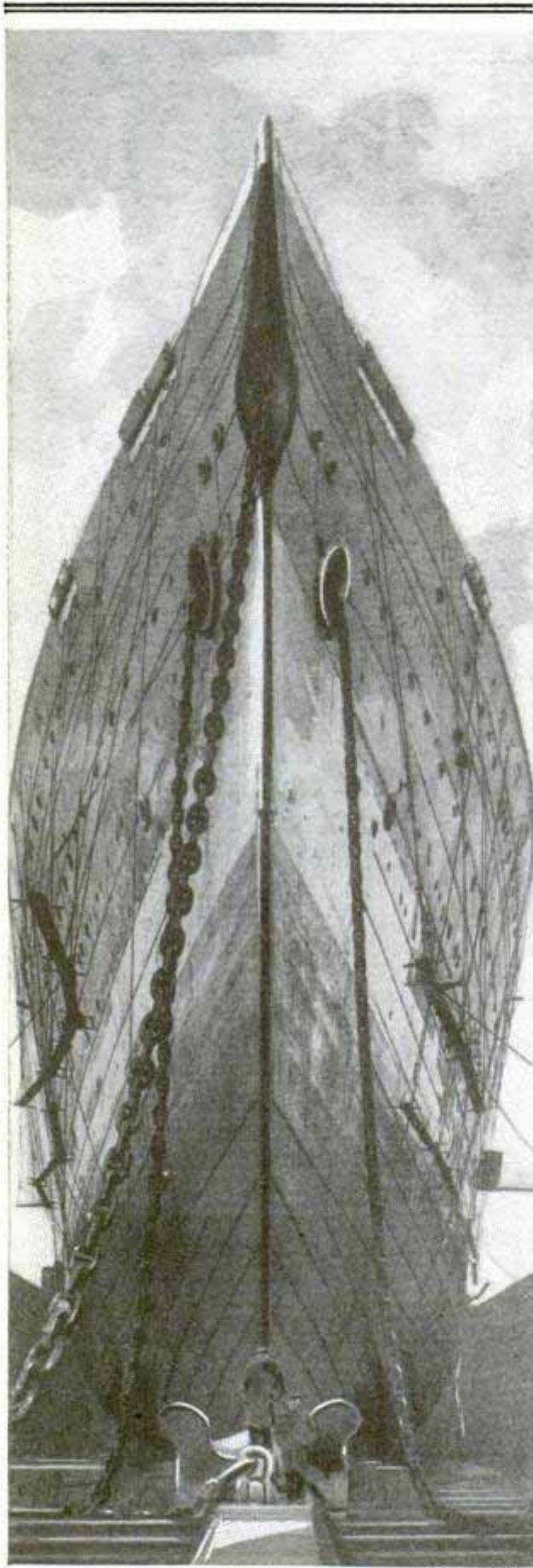

Drydock View of the "Leviathan" Awaiting Overhaul at the South Boston Yards; Note Comparative Size of Man in the Foreground

efficiency. Thus it is possible for a ship of that size to be towed back into open water within seven to ten days after dry-docking. Repairs and renovations that can be carried on while the ship floats are rarely done in drydock.

Millions are spent annually overhauling express liners. To illustrate one phase of this work on the "Majestic," the hull plates, equivalent in area to a sidewalk three feet wide and eight miles long, must be scrubbed vigorously before 12,000 pounds of paint are applied.

"The Big Three," the "Majestic," "Homeric" and "Olympic," consume three and one-half tons of putty, 6,000 gallons of paint and 120 books of gold leaf. Attendants change 2,300 pairs of curtains. Thousands of pillow slips, sheets and blankets are condemned. The exteriors are coated with six tons of enamel and fifty-four tons of paint.

The overhaul of a greyhound's linen department is a feat that must impress housewives. A great ship carries about 150,000 individual pieces, and often 100,000 of these are sent to shore laundries at one time. At these renovating plants, the turnover is so fast that every bit of a great vessel's linen can be returned within twenty-four hours. Every year there is a great sorting of good from bad. A ship is provisioned with enough extra supplies to last until the next overhaul.

Ten thousand pounds of soap vanish down the drains and scuppers as the great greyhound receives the final rub-down. Four hundred brooms pry into corners. Six hundred scrubbing, dusting and scouring brushes are worked vigorously over all surfaces suspected of harboring dirt. Is there a structure on land that receives such thorough sterilization? From keel to masthead, the renovators climb and cling. One brushes, another sweeps, another polishes, and still another scrapes.

When a greyhound docks for overhaul, the first operation of the machinists is to remove the engine heads. Then the pistons, piston rings and other wearing parts. The high-power, intermediate-power and low-power cylinder covers are removed and all pistons opened for inspection. A small auxiliary—the "turning engine"—at the base of the great driving engines,



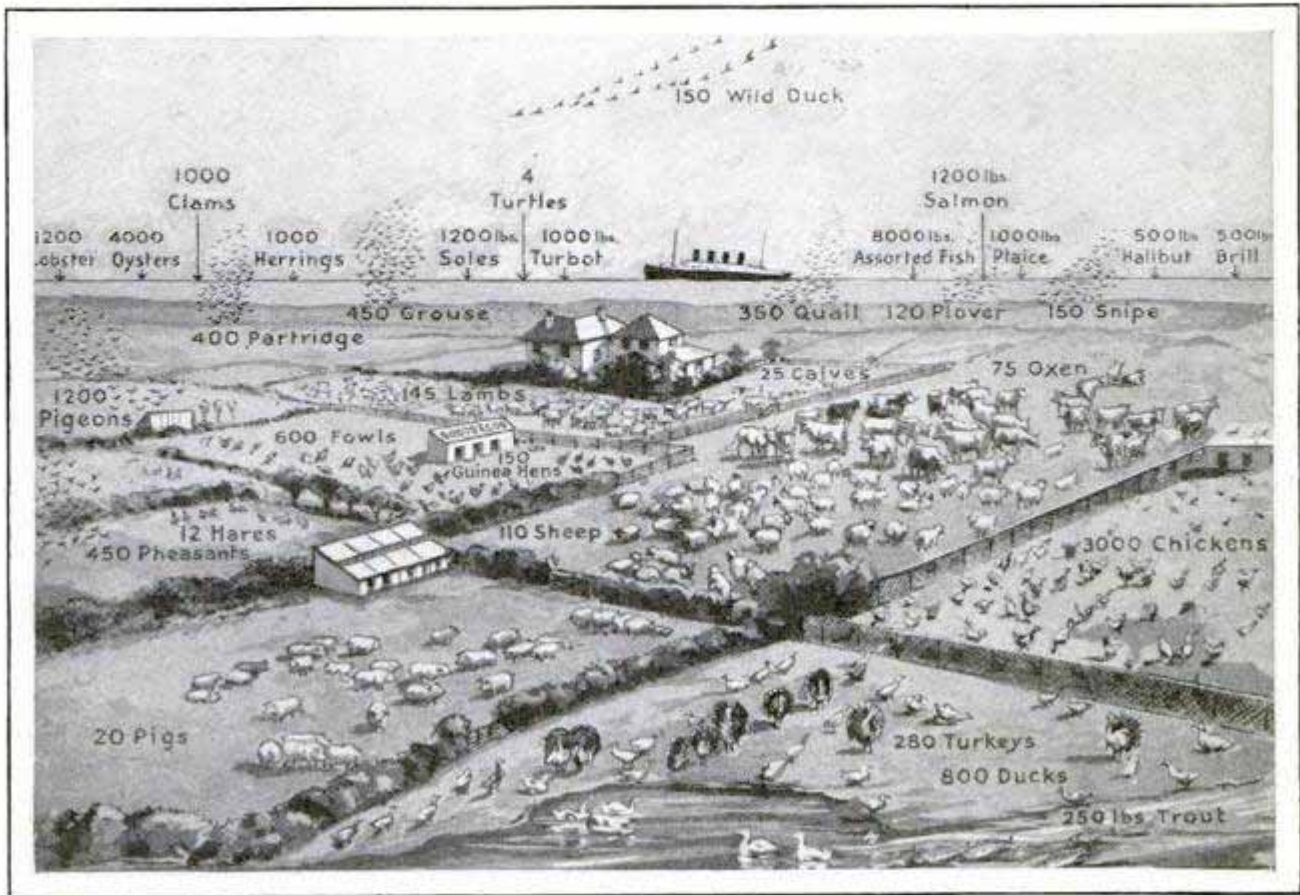

Picture Diagram to Show the Huge Quantities of Live Stock and Other Provisions Required for the Stores of the "Aquitania" on a Single Voyage

adjusts each piston to the bottom stroke, where it can be inspected. Then the main-engine valve covers are removed and valves drawn for examination. If found satisfactory, they are returned at once and reset. But if defective, the only cure is replacement.

During an overhaul, many liners pass through structural changes. Partitions are removed, either to enlarge staterooms or to add commodious bathrooms. Or a second-class dining room may be converted into an auditorium or talking-picture theater, which will soon be standard equipment on all passenger ships. When it comes to styles of interior decoration, ship operators do not allow their pets to lag. If ivory finish is the vogue, they will have the public rooms done over in ivory. If the tendency happens to be French modernistic, they employ artists to draw appropriate designs. The furniture of public rooms may be changed annually in order to keep abreast of the latest fashions.

Operators do not halt merely with changing colors and decorations. Permanent structural changes frequently are

required. The "Leviathan" started ship-to-shore radio-telephone communication. The "Majestic," not to be outdone, started the first two-way radio-telephone service. The "Bremen" and "Europa" gave their passengers fashionable night clubs. The "Leviathan" opened a mammoth club in which patrons were entertained by two orchestras. This year's overhaul of the "Leviathan" might well be considered a major operation, a beautification and modernization that cost in the neighborhood of \$500,000.

The airplane catapult is another innovation that necessitates structural changes in greyhounds. The "Ile de France" started the vogue, and it was taken up by the "Bremen." Soon no crack express liner will be without its aviator and airplane.

Stock-ticker rooms on shipboard call for more elaborate wireless equipment and extra public assembly space.

The science of ship operation becomes so specialized that owners train their personnel for particular jobs. The responsibility of managing public rooms is entrusted to skilled stewards, for the fur-



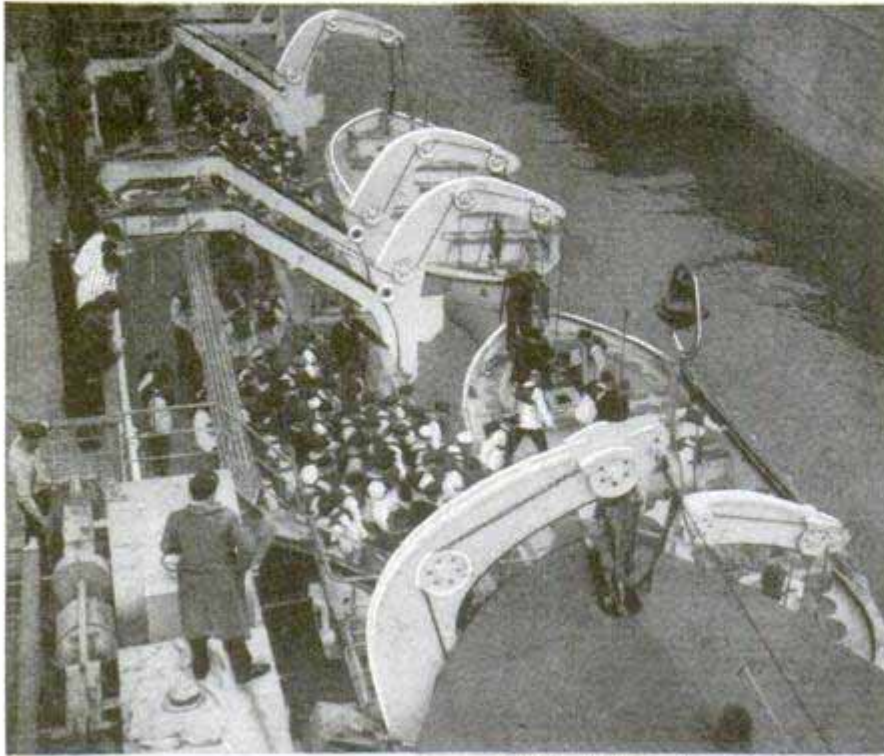

equipment, and a mast to which a sail can be attached. On large vessels, some lifeboats have small engines and wireless equipment.

Since a ship's hull receives the ocean's heaviest brunt, no expense is spared in its care. Every rivet is examined for signs of corrosion or rusting. Loose ones are removed and replaced. George H. Bates, vice

nishings of one salon may cost \$100,000; nevertheless, they are changed as often as fashion dictates.

The "Majestic's" lounge is one of the greatest rooms afloat. It measures seventy-six by ninety feet, with a ceiling twenty-six feet high. The dancing space in this room accommodates a hundred couples. Five men are regularly assigned to the care of this room and its sixty-two tables, 310 seats and 1,000-pound carpet. Every spring it receives a thorough renovation as well as new furnishings to replace those which are soiled or out of style.

To the mechanic, the most impressive phase of spring cleaning is the overhaul of external equipment. The underwriters and the government demand a thorough examination of life-saving equipment, especially lifeboats and preservers. Davits are tested, and the boats lowered to the dock wall, where they are painted and their provision lockers restocked with matches, flares, fresh water in air-tight cans, food in tins, signaling

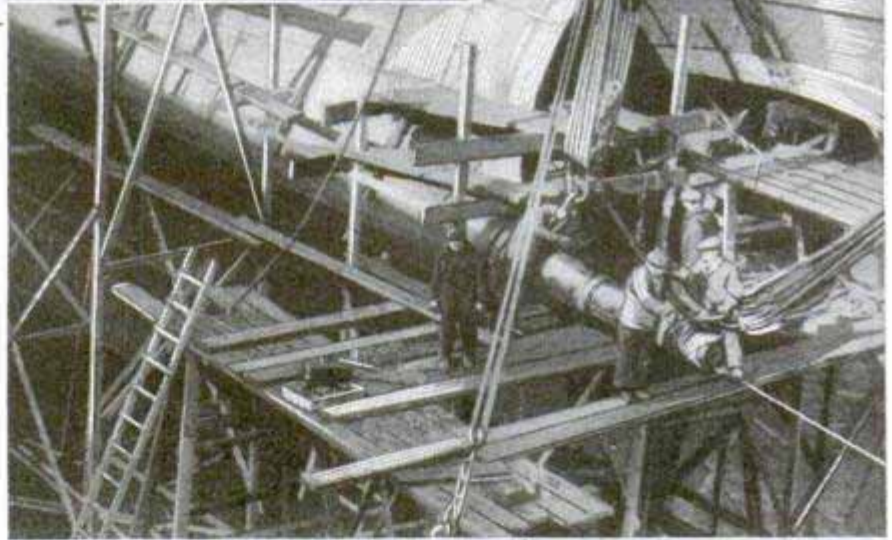

Courtesy U. S. Lines  
Members of the "Bremen's" Crew Boarding Unsinkable Lifeboats for a Demonstration, and Workers Overhauling the "Leviathan's" Propellers

president of the United Dry Docks, Inc., recently invented a "Strongback Hydraulic Bull Riveter," for use where many new rivets are necessary to the repair. Under water pressure, this riveter applies the equivalent of 100 tons to the rivet head, and another advantage over the old riveter is that it presses the plates more tightly together than was possible heretofore.

It costs around \$30,000,000 to build a modern liner. The making and fitting up of such a ship will need:

At least 30,000 tons of steel.

Ten miles of carpet.

Ten thousand electric-light fittings.



Three hundred electric motors in addition to the propelling turbines.

Miles of the finest timber.

Twenty thousand each of table crockery and cutlery items.

Her power station must produce enough current to provide light for a town of 100,000 people.

This gives an idea of the vast expenditures required in the upkeep of these floating palaces which uphold the dignity and prestige of a nation.

**LIGHT RAYS FROM AUTO LAMP  
TIME RACING CARS 903**

For timing the speed of racing automobiles, a French clock firm has invented a system which utilizes the rays of light from an ordinary auto headlamp. The apparatus consists of a chronometer and a printer which marks hour, minute, second and fractions of a second on a moving paper band. The racing car passes in front of a light ray projected from the headlamp of a standing auto, thereby establishing an electric contact which actuates clockwork moving the hammer of the chronograph. The light from the auto falls on a photo-electric cell, and when the racer interrupts the ray, a relay



Car-Timing Apparatus Set Up for Clocking a Race, and Close View of the Apparatus

automatically closes the printer circuit, causing the printer to jot the time.

no 4 2 agent hauer

*L. Le Roy et Cie,  
7, Boulevard de Madeleine*

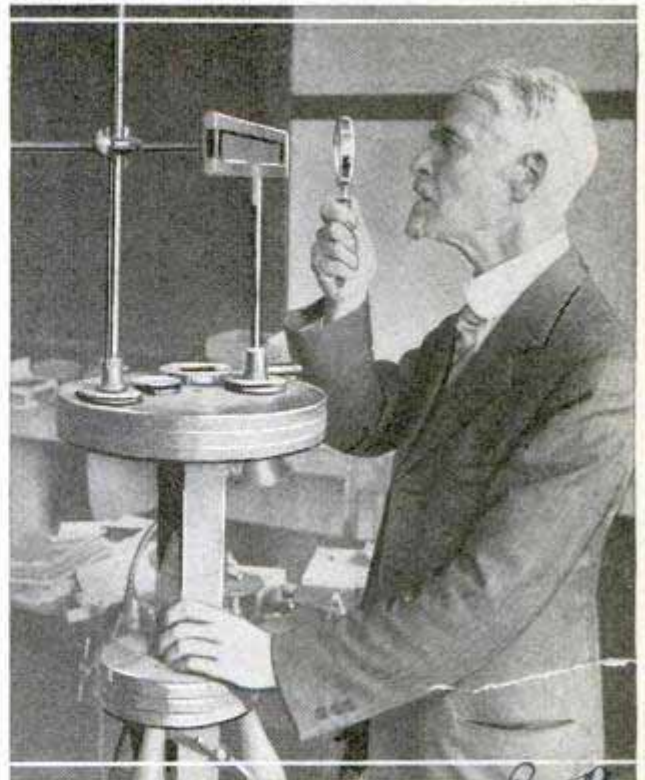

Dr. Samuel J. Barnett, of the University of California, Studying Magnetic Effects Produced by Light Rays

**MYSTERY OF MAGNETISM LAID  
TO ELECTRON'S SPIN**

That the phenomenon of magnetism is a result of the spinning of electrons about their axes is the conclusion of Dr. Samuel J. Barnett, of the University of California, who has been studying the problem for more than twenty years. His research has been conducted in a special laboratory constructed without metal. In the accompanying illustration, Doctor Barnett is examining rays of light focused from an instrument fifteen feet away and producing magnetic effects on the transparent bar in front of him.

**SELF-FILLING REFUSE TRUCK  
ELIMINATES DUST 970**

German inventors have introduced a cylindrical garbage truck that fills and empties itself without tipping, to eliminate dust and the spread of germs. The body contains a large, double-flanged screw by which it is divided into four spaces. The screw is turned by transmission from the truck engine. For filling, the screw is driven in one direction and for emptying, in the other. At the rear end, is a filling door and conical receiver which does not revolve.

*Mercedes Benz  
Mercedes Automobil-AG, A. H.  
50/51 Berlin*

Germany



1025  
376

Cont. John D. Coggeswell  
16 Edgemoor Road Belmont, Mass  
POPULAR MECHANICS

## BIG ENGINEERING PROBLEMS SOLVED WITH MODELS

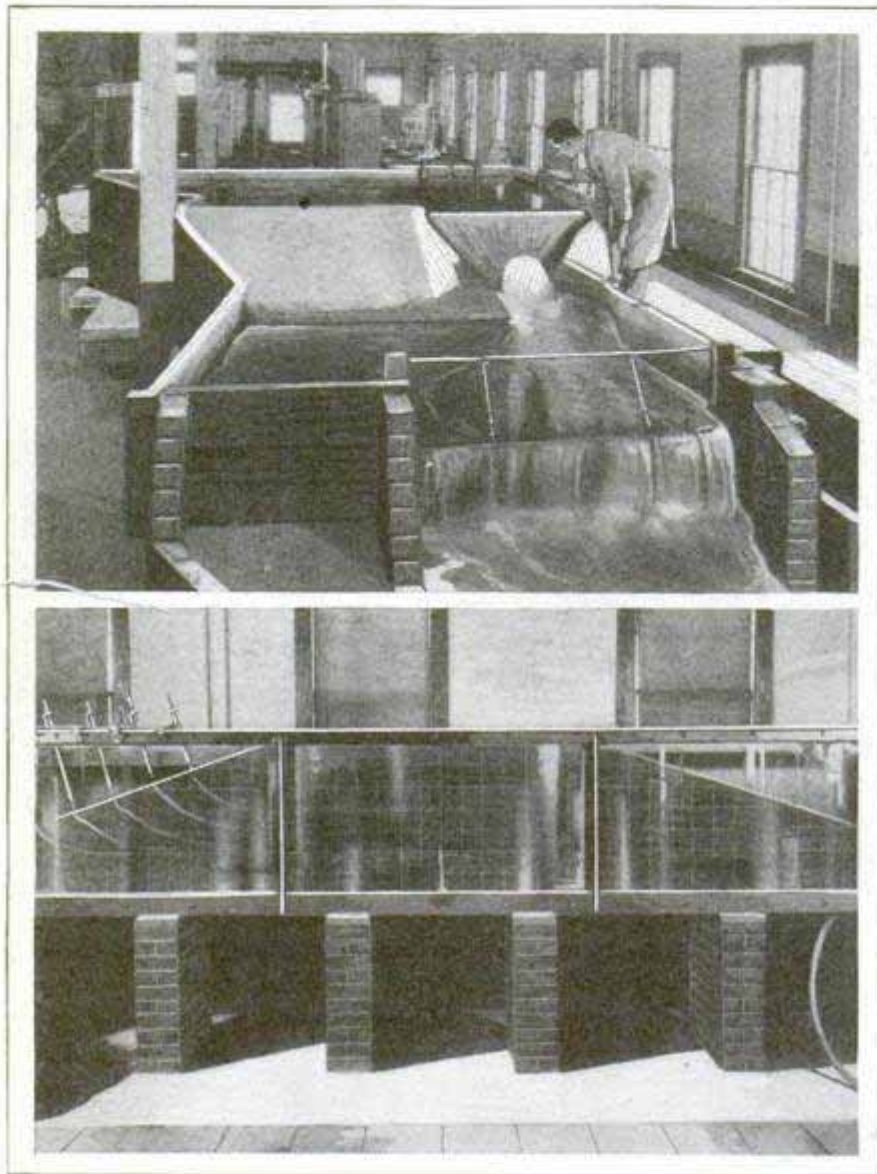

Above, Model of Dam in River Hydraulic Laboratory with Conditions at the Site Duplicated; Below, Model Section of a Proposed Dike

the river and dam, on a scale of one to sixty. Every natural condition obtaining at the actual site of the proposed dam was duplicated exactly in the model. The weaker bank was built up of the same materials as those on the Mongaup, and the rock ledge was simulated in concrete. Then the dam itself and the spillway were put in according to approved construction. A head of water corresponding to that in nature was started through and the scouring effects noted. Gradually the shape of the spillway and the apron at its bottom was changed, until a design was achieved that threw the current away from the weak bank and also prevented washing of the gravel on the river bed. So the engineer could go ahead with confidence that his structure would stand up.

The city of Hartford, Conn., wished to enlarge its aviation field. The only land available was

America's first river hydraulic laboratory, established last November by Prof. K. C. Reynolds, at the Massachusetts Institute of Technology, is already demonstrating its dollars-and-cents value in big engineering projects.

For instance, there is the new hydroelectric development of the Delaware Power company, now under construction on the Mongaup river, in New York state. The problem turned over to the river hydraulic laboratory was the designing of a spillway for the dam, that would direct the current to such a course that the rushing waters could not scour away the soft bank and river bed and undermine the structure foundations. In the laboratory, Professor Reynolds built a miniature of

subject to overflow at times of high water in the Connecticut river and was soft and boggy, during even the driest weather. The city engineers proposed building a dike, 10,500 feet along the river bank and 4,500 feet inland across the lower boundary of the field addition, from materials taken from the river bottom by dredges. Every engineer knows that any dike of earth construction will leak to a certain extent. The problem turned over to Professor Reynolds was whether or not this seepage could be controlled by a drain at the rear of the dike and a pump to throw the seepage water back into the river. In the laboratory, a tank, twenty feet long and four feet wide, with one side of plate glass, was constructed. A quantity of the



materials proposed to be used was shipped up from Hartford and pumped into the tank under exactly the same conditions that would obtain under actual construction. The result was a section of the dike, on a scale of one to fifteen, within the tank. Water was then introduced on one side of the miniature dike. The rate of seepage was easily measured. In order to gain exact knowledge of the course of seepage, bright-colored dyes were introduced along the face of the dike. The seepage lines, traced by the color, gave the best location for the drain, and the measured rate of flow disclosed the best type and capacity of pump to be installed.

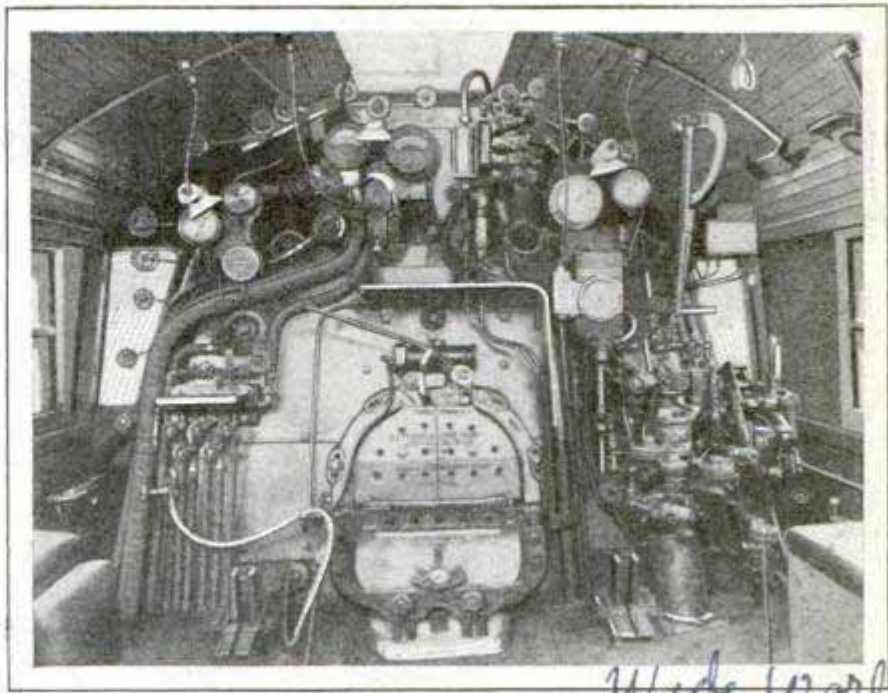

Interior of Cab of a Modern Locomotive That Is Almost Frictionless, Being Equipped Throughout with Roller Bearings

*Wade World*

**ROLLER-BEARING LOCOMOTIVE HAS LIVING QUARTERS**

As an experiment, a locomotive equipped throughout with roller bearings recently was placed in service by an eastern railroad. For an added feature, the almost frictionless engine has a section of its tender fitted up as living quarters for the men composing its crew.

*new York Central*

**ARCTIC WAS ONCE TEMPERATE BUT NEVER TROPICAL**

Old ideas that ancient arctic climates once were tropical have been disproved by scientific studies which indicate that they once may have had a temperate climate, but never a tropical one. These regions could not have been tropical, if for no other reason than that they have practically continuous night for several months, which would have starved the plants for lack of sunlight. An examination of all kinds of fossil plants from the far north has shown that the great majority belong to temperate genera, and such tropical trees as were found are also known to thrive in the temperate zone. In the more recent geological periods, fossil plants found in the arctic included such trees and shrubs as alder, sweet gum, beech, oak, elm, maple, hickory, tulip tree and sassafras.

*Science Service News Bulletin 4/12/28/31*

**SOUNDPROOF CAMERA WEIGHS BUT THIRTY-SEVEN POUNDS**

Inclosed in a case of a celluloidlike material, a soundproof motion-picture camera that weighs but thirty-seven instead of the usual 500 or so pounds, has been introduced at a western studio. It can easily be handled by one man, may be used for indoor or outdoor work, and the case is also proof against water and fire. The motor is practically noiseless, but such sound as it does make, is effectively kept from the camera.

*973*



Soundproof Motion-Picture Camera That Tips the Scales at Only Thirty-Seven Pounds

*demonstrated by Arthur Haddock Chief Engineer,*

*Prof Edward W. Berry, Johns Hopkins Univ*

*Warner Bros, 321 W. 44th, New York*



757

# Dog Heroes of



even though he has several articles which were carried over the south pole.

For somewhere in cold, bleak Antarctica, in a crystal casket, beneath a blanket of snow, the lion-hearted husky, who filled that harness so heroically that his name and fame are known to dog lovers from pole to pole, is sleeping his last, long sleep. The wailing voice of the blizzard sings his requiem, the south pole itself is his monument.

Arthur T. Walden with "Chinook," Famous Lead Dog, and Litter of Puppies Born in the Antarctic

By JOHN T. BRADY

**H**OME from the Antarctic, Arthur T. Walden, chief sled-dog driver of the Byrd expedition to the south pole, caressed the last harness worn by his grand old dog "Chinook."

It wasn't much to look at, just a few straps sewed together, with the name "Chinook" crudely printed with a pen on the saddle girth, but to Walden it is the most precious and sacred relic of the greatest adventure of an adventurous life,



Brady



# the White Hell

How "Chinook's" glorious career ended with his strange disappearance on that last adventure with his master is one of the most touching sagas of polar exploration, and is best told in Walden's own words. But before beginning the story, he told me of the heroic work done by sled dogs to make the Byrd expedition a success and why it would have failed without them.

"Without sled dogs, the headquarters at Little America could never have been established," he declared, "and but for them the geological expedition under the leadership of Dr. Laurence M. Gould could not have been accomplished." Incidentally, Admiral Byrd, on his arrival at Panama City, was quoted as saying that "the geological survey, made by dog team, was the outstanding feat of the whole expedition."

With the temperature averaging thirty to forty below zero and blizzards raging frequently, sled dogs carried Doctor Gould and his party of four dog drivers a distance of 1,300 miles in four months, though many dangerous crevasses had to be crossed en route and the journey had to be made in short stages, after outpost depots or caches of food and supplies had been established.

Near the Queen Maude range of mountains, the crevasses were especially numerous, and some were so wide that sledges and men had to be roped together and



Alert Expression of Typical Sled Dog, One of the Hardest of the Species and a Faithful Servant When Properly Trained

large knots tied in the ropes for the men to grasp in case they should break through the thin crust. Sometimes a whole string of dogs would be stretched across a crevasse like a suspension bridge, and it was not unusual for a couple of dogs to start fighting while hanging in midair.

It was in the pulling and hauling of hundreds of tons of freight from the supply ships to the site of Little America, however, that the sled dogs proved that they



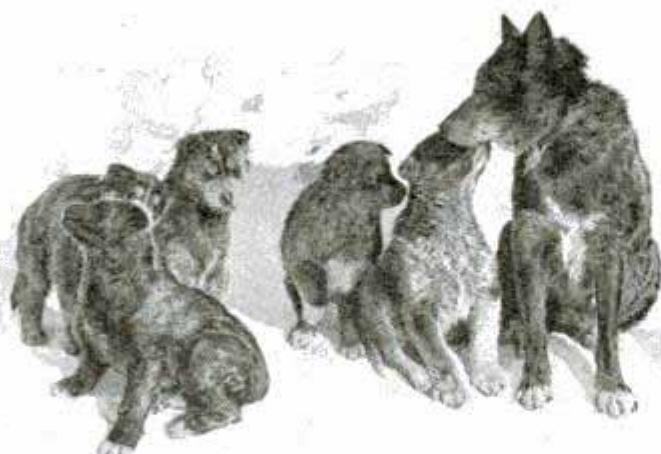

© The New York Times and St. Louis Post-Dispatch

"Lady," One of the Best Dogs with the Byrd Antarctic Expedition and Her Five Fine Pups, Born in the Snowy South

are still essential to the success of polar exploration, though the airplane has supplanted them as a means of conveying man to the poles.

When it was realized that a heavy tractor intended for freight hauling was of little or no use, the entire burden of transporting the elaborate equipment for the headquarters camp from the supply ships to the Barrier fell upon the shoulders of the sturdy, courageous huskies.

And when an auto truck, equipped with endless treads on the rear wheels and runners on the front axle instead of wheels, broke down soon after it started to lay caches of food at intervals in the direction of the pole, so that Admiral Byrd might pick them up in case he had to make a forced landing on his polar flight and walk back to Little America, the sled dogs carried on this important work of safeguarding the daring aerial explorer's life.

When the expedition first reached the Bay of Whales, the nearest the "City of New York" could get to the Barrier was twelve miles. The time to get the camp established was limited to the few remaining weeks of the antarctic summer and the dog teams were worked feverishly. In fact, for a while, they had to make two trips a day to and from the Barrier, or a total distance of forty-eight miles over pretty rough ice, with loads of from 2,000 to 2,500 pounds, or more than 200 pounds to a

dog, as there were usually nine huskies to a team.

During this rush "Chinook" was in harness as leader of Walden's team every day, and on the hardest kind of pulling he did magnificent work. Not once did he shirk, or as his master put it, "his traces were always taut." Moreover, he was a great inspiration to all the other dogs.

"The old dog seemed to sense that there was need for hurry," Walden continued. "And I took

fully as much pride in his performance on that freight-handling job as I did when he led my racing team to victory over the fleetest Canadian huskies in the first International Sled-Dog Derby.

"But when the heaviest part of the hauling had been done, I noticed that the strain had told on him. His hair had turned quite gray and he was getting deaf. So, when he began to slow up on the return trips to the ship with the empty sleds, I decided that he had earned a rest. Accordingly, I began breaking in 'Ballarat,' one of his promising sons, to take his place as leader of my team.

"'Chinook' didn't show the least sign of jealousy when I put his son in his time-honored place, and apparently he was content to be recognized as the 'king' dog of the pack, or the one that all the other dogs respect and fear regardless of his position in a team. Of course, he knew instinctively that no other dog could usurp his place in my affections so long as he lived. But there came a day when he realized that he was in danger of being deposed from his throne as king.

"By that time 'Ballarat' was fairly well broken in as a leader and I was letting 'Chinook' run loose except when I needed his strength in emergencies to start an extra-heavy load or pull it over a pressure ridge.

"He enjoyed his freedom and I enjoyed



giving it to him. But unfortunately it led eventually to the breaking of his heart. He was never the kind of bully dog that goes around with a chip on his shoulder all the time looking for a fight, yet he never was known to avoid a scrap when he was challenged, no matter what the odds were against him.

"So, when three malicious huskies ambushed him one day while he was running loose, and all jumped on him at once, he met the challenge of his kingship nobly, and though his antagonists were much younger and more agile, he succeeded in holding his

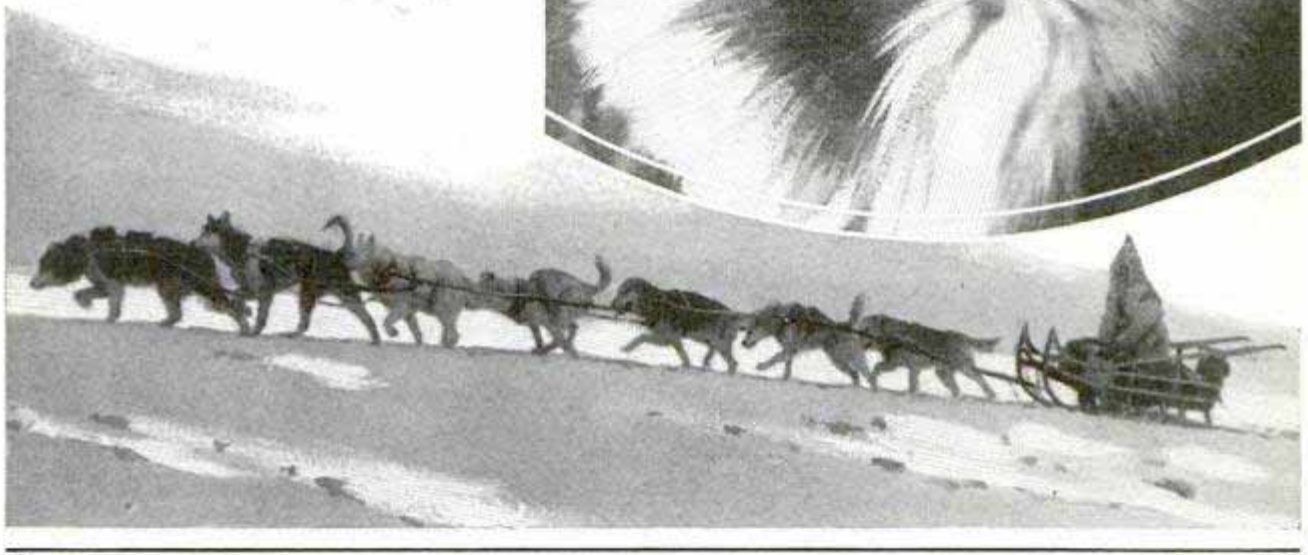
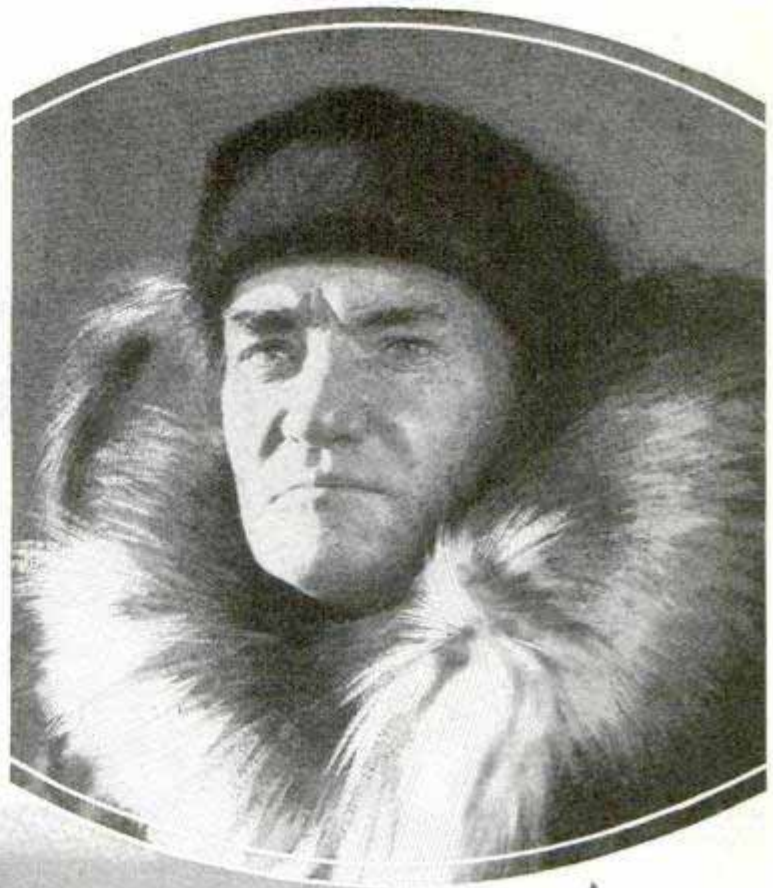

Top Photo, © The New York Times and St. Louis Post-Dispatch

Walden, Who Was with the Byrd Antarctic Expedition, Drove Dogs in the Klondike; Below, a Dog Team and Driver, Making Time over a Smooth Stretch

own for several minutes of terrific battling. But he finally went down and would have been killed in short order if I had not happened on the scene.

"I believe that when 'Chinook' was downed by those three blood-hungry huskies, he realized only too well that the end of his reign as king was near at hand. They had humbled his pride. I jumped to the conclusion that he had started the fight. So, I chastised him, and that must have hurt his feelings all the more.

"Later I learned that I had wronged him, but it was then too late to make amends. He was gone from my life forever, leaving my heart as empty as this harness.

"By a striking coincidence 'Chinook's' disappearance occurred on his twelfth birthday. On starting from Little Amer-

ica to go to the ship that day, I put him in harness at the head of my team to limber him up a bit and kept him there until after I got past the worst of the pressure ridges on the trail. Then I turned him loose with just his collar on, and he began to lag behind.

"After that, I didn't give him another thought until I had gone a couple of miles or more. Then I looked back, but he was nowhere in sight. I had passed three or four teams coming from the ship, however, and I reasoned that he had turned and followed one of them back to camp.

"But when I returned to Little America in the afternoon, I learned that he hadn't shown up there, and none of the other drivers had seen and recognized him, although one man said he had noticed a



757



Sled-Dog Mother, Proudly Surveying Her Young; Trained from Earliest Infancy, the Dogs Quickly and Eagerly Learn Their Tasks

wandered away to die by himself in the most God-forsaken spot on earth.

"One of the strangest things about his disappearance is that, the night before, he woke me up twice by placing one of his forepaws on my face just as his father 'Kim' did the night before he died. Perhaps that was his way of trying to tell me good-by."

**TRAILER FOR AUTO TO PREVENT SIDESWAY**

1022

Moving as a part of the car itself, a one-wheeled auto trailer has been introduced. An automatic arrangement causes the trailer to turn without sidesway on curves, and

the wheel adapts itself to forward or backward running. The head end of the trailer is securely coupled to the car, the fastenings being of the ball-and-socket type, and at the front are two folding legs that drop down to support the trailer when it is not in transit. The unit weighs 350 pounds and has a capacity of half a ton. It is staunchly made of electrically welded steel and is attractively finished. The trailer is well adapted to business as well as to pleasure uses. Three strong braces on each side secure the wheel to the body and are strong enough to stand shocks.

shape that looked like a dog away out on the ice to the west.

"Knowing 'Chinook's' keen homing instinct, I wasn't particularly anxious about him at first, and I went to bed feeling confident that he would come into camp sometime during the night. But when I awoke next morning to find that he was still missing, I began to get real worried over his absence and went on a hunt for him.

"All the other teams that could be spared joined in the search, but a bad storm came up early in the day and obliterated all tracks. The airplanes began to fly about that time, and Admiral Byrd ordered all the flyers to be on the lookout for 'Chinook,' but no sign of him was ever found.

"He was always so careful in avoiding crevasses that I don't think he fell into one, and there isn't a chance that he lost his way. It is my firm belief that he was broken-hearted over his failure to hold his own in a fight and so he deliberately

*U. Can. Back. patch. pens.*

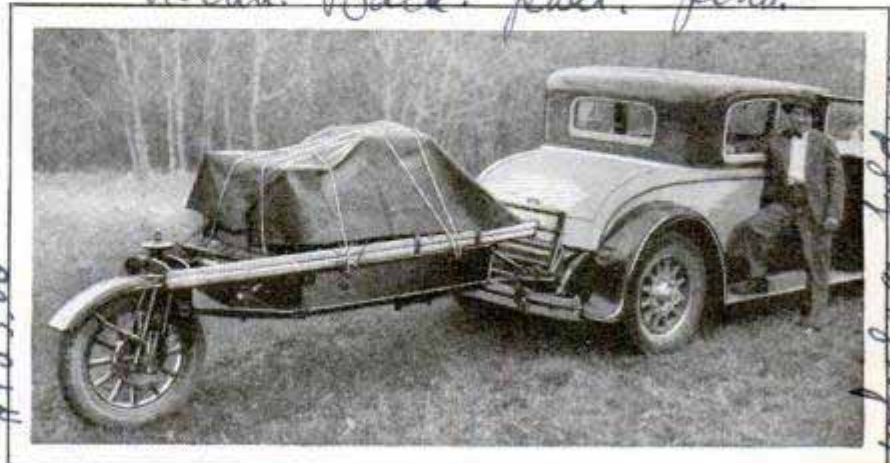

*\$125.00*

*wheels on folding front legs. Extra 7*

One-Wheeled Trailer Loaded and Attached to Car; the Single Wheel Adjusts Itself to Backing or Forward Travel

*Linn Trailer Corp  
133 Chestnut Oneonta NY*



WHOLE CITY UNDER ONE ROOF IN NEW TERMINAL

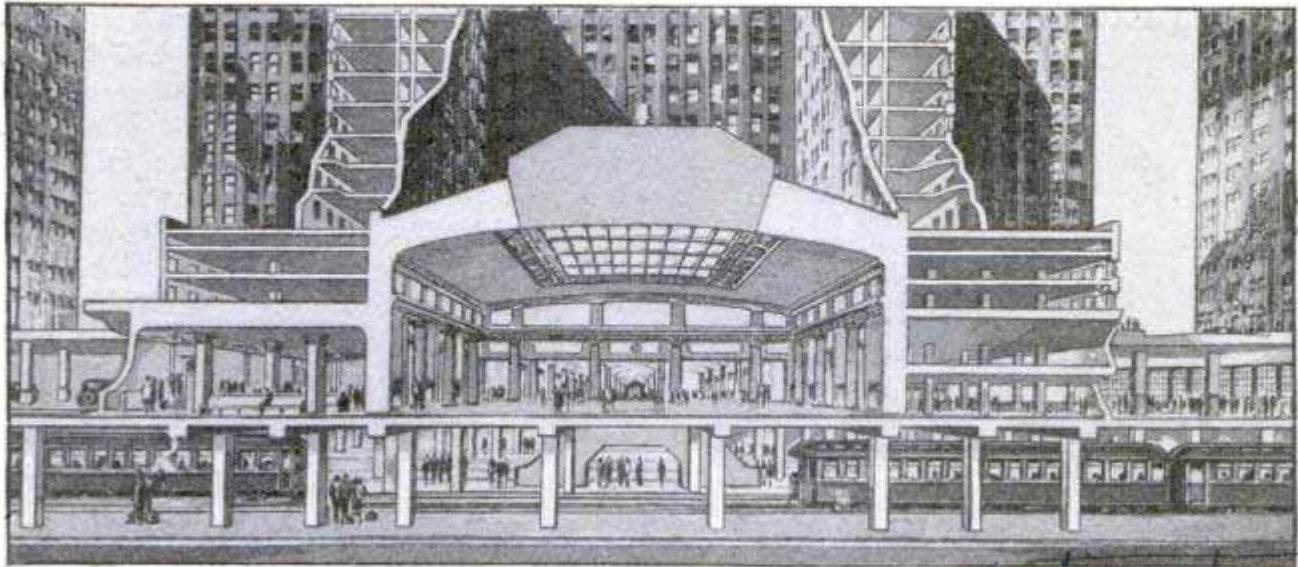

Cross-Section Drawing, Showing How Trains and Other Conveyances Pass under Union Terminal Building in Cleveland; a Hotel, Bank, Office Building and Station Are under One Roof.

*International*

A huge hotel, two eighteen-story office buildings, an eighteen-story bank structure, and a vast railroad terminal building with a tower fifty-two stories high compose what is virtually a "city within a city" under the recently completed union terminal building in Cleveland, Ohio. All these buildings are interconnected by passageways so that persons may pass from one to the other without going out of doors. A large department store and a \$7,000,000 post-office building are still to be erected on the site, which was occupied by several hundred smaller structures before the huge terminal was planned.

possible on regular trains and boats. In going around the world, the route must be taken into consideration because, at the poles, it would be possible to "go around the world" in five minutes merely by walking around the pole points.

STREET SIGN WITH REFLECTOR  
VISIBLE NIGHT OR DAY

*1034*

Easily seen at all times of day or night, a street sign, introduced in Los Angeles, is fitted with a reflector which projects the rays of the sun or of electric lights through the glass on which the characters are lettered. This plan saves the expense of special illumination for the sign.

HOW YOU COULD CIRCLE WORLD  
IN FIVE MINUTES

*1067*

As new means of transportation and communication are being developed, the time required for a trip around the world is constantly decreasing. The German dirigible, "Graf Zeppelin," in 1929 made the journey in twenty-one and one-half days of which only thirteen were spent in the air. J. H. Mears, an American, made the dash by land and water in half an hour under thirty-six days, four days faster than a similar journey made by Andre Jaeger, a German. George Griffith, an Englishman, encircled the globe in sixty-four days, seven hours and twenty minutes, using only ordinary train and steamer service and making the best connections

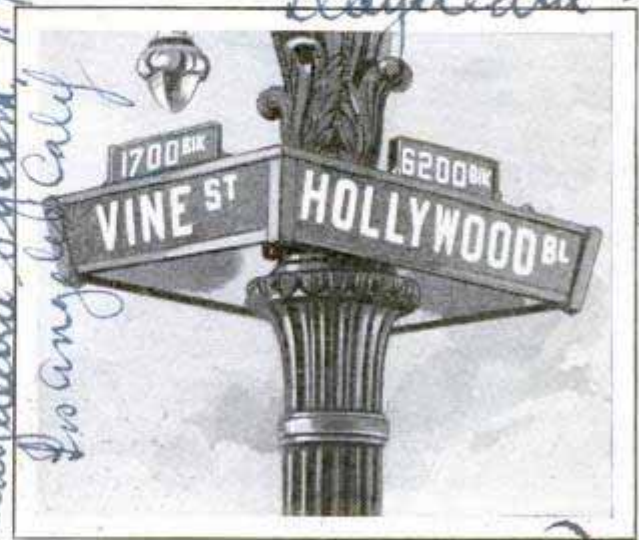

Street Sign Fitted with a Reflector, Which Makes It Visible by Night as Well as Day

*Alfred H. K. Palmer  
Los Angeles, Calif*

*Rayelectric System 79 Armandale Blvd  
Los Angeles Calif*

*Rayelectric System  
Ltd 719 E. Armandale Blvd  
Los Angeles, Calif*

*Answers 6/28/30*



2028 *Ally. Ole Peterson*  
 384 *West Cleveland, Ohio*  
 Blvd

**SOLES OF SHOES VULCANIZED  
 LIKE AUTO TIRES**

917

*Alex Easy Sole Press*

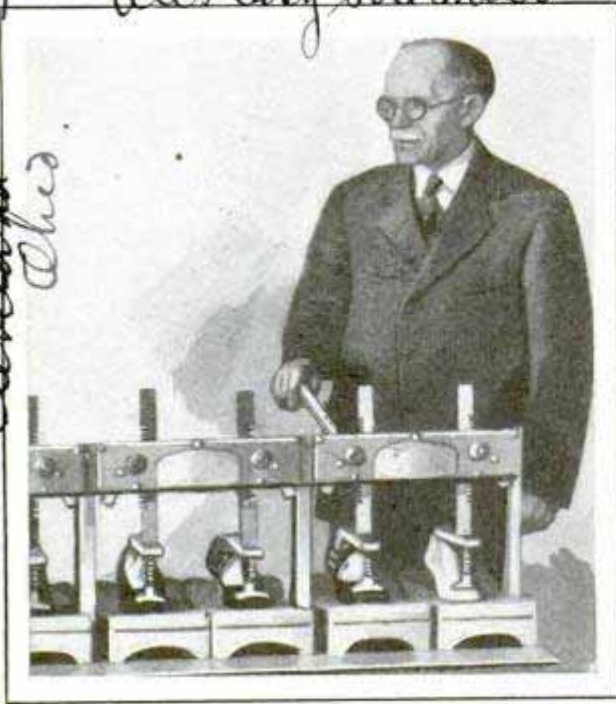

Shoes in Special Rack for Vulcanizing the Soles; Several Pairs Can Be Treated at One Time

To vulcanize shoe soles in somewhat the same manner as automobile tires are treated, an Ohio man has invented a machine which handles several pairs at one time. The operation is said to be easy, and the process prolongs the life of the shoes.

**GREAT OPPORTUNITY OF FUTURE  
 SEEN IN CHEMISTRY**

1042

Chemists can probably make anything they conceive of, and will certainly make many things they do not conceive of now, according to Dr. Willis R. Whitney, of the General Electric company.

"A something from the sun that we call light, a something from space that we call air, and a something from the earth that we call solutions—these things make green things grow. That is still only half-understood chemistry," he said. "Cows eat the grass and produce milk and the dairy maid makes butter and cheese, but these processes are also only partly understood. We eat such foods, and unwittingly produce bones, tissues and brains, and this is also only partly understood chemistry. Gradually the chemist who makes dyes so permanent that even chlorine cannot bleach them, and has learned how to make ammonia, nitrates, alcohols, ethers, and

almost anything, from lime, coal, water, air and electric power, will teach us more about the chemistry of life and better living. A very minor outcome will be the production of milk, butter, cheese, etc., directly from clean chemical elements. Then we will wake up to the fact that milk, as formerly produced, was a very dirty and buggy thing, and that cows were clumsy factories. Chemists nowadays control the quality of iron and steel, paper and paints, dyes and cements, glass and porcelain, oil and gas, water and air, metals and alloys, silk and wool, leather and rubber, explosives and cotton, foods and drinks, fertilizers and fuels, etc. During the past century they have greatly increased their productivity of new things, and so the future will be exciting."

**AUTO RADIO ON RUNNING BOARD  
 IS EASILY REPAIRED**

1021

Mounted on the running board instead of under the dash, a radio receiver for the automobile is accessible for inspection, adjustment or repair. The dial control operates through a flexible cable from the interior of the car, and the aerial is stretched under the car. A loud speaker may be placed in any handy place. The set is supplied in the kit or knockdown form and may be installed in the rumble seat of roadsters or coupes if desired.

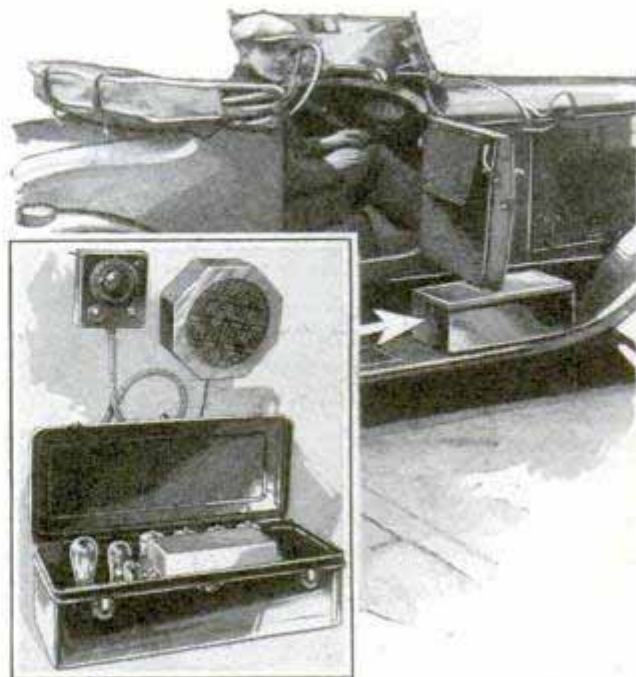

Set Mounted on Running Board, and View of the Dial Control, Loud Speaker and Cabinet

*Pilot Radio & Tube Corp*  
 323 Beason St Brooklyn

*Ally Peterson*  
 2028 *West Blvd*  
*Cleveland Ohio*  
*Schenectady, NY*



983

# LIGHT'S SPEED CHECKED THROUGH ONE-MILE TUBE

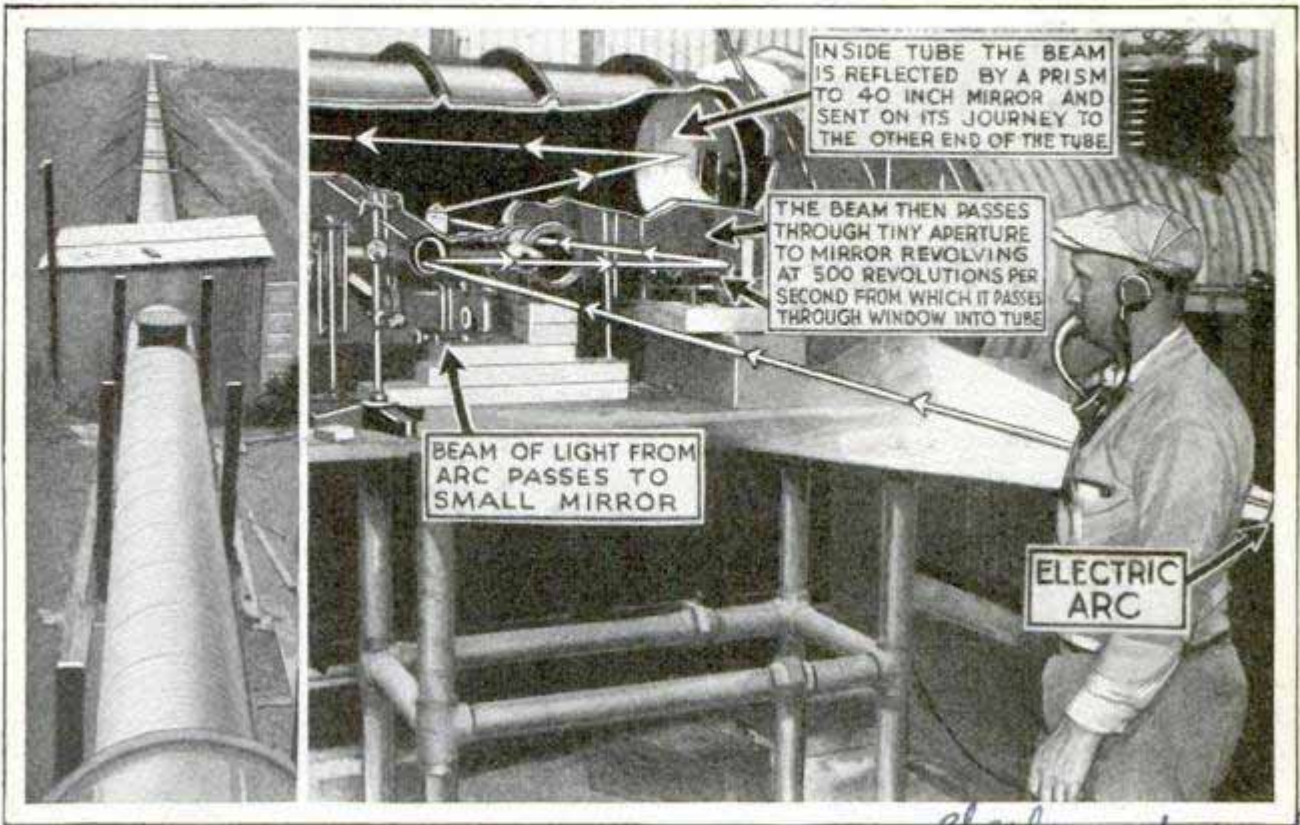

Photo-Diagram of the Mile-Long Pipe "Runway" Where Speed of Light Is Being Checked, and Arrangement of Mirrors for Reflecting the Rays

By reflecting beams of light through a mile-long pipe line from which the air has been practically exhausted, Dr. Albert A. Michelson, famous physicist, is making further checks and measurements of the speed of light. His previous research has shown that light's velocity is in excess of 186,000 miles per second, but with the improved apparatus set up in California, he expects to make more accurate timing. The light rays are sent back and forth through the tube by a system of mirrors. Creating a vacuum within the passage eliminates interference that might mar the accuracy of the tests.

an ordinary aluminum paint with a brush, by spray or dipping. As soon as the coated surface comes in contact with heat, the liquid evaporates, and the substance is said to enter the pores of the metal without discoloration or peeling.

## ALUMINUM PAINT RESISTS HEAT AND KEEPS ITS COLOR

Protection of surfaces from corrosion while at high temperatures is the chief function of a heat-resisting aluminum paint recently introduced. It is prepared from a chemically treated aluminum powder, which will withstand any constant heat up to 2,000 degrees Fahrenheit. Above this temperature, the color turns to a dark gray. The material is applied as

## ELECTRIC KNIFE'S HOT BLADE HELPS CLEAN GAME



For removing hair or feathers from game, an electric knife has been devised. Its blade becomes red-hot in a few seconds, but an insulated handle and a heat-resistant guard protect the user while he sears the object he is cleaning. The knife is so designed that the blade does not

come in contact with the table when laid down, thus preventing damage to the surface.

*Editorial*

*Wessen and F. artiched 6/19/30*

*497*

*M. Jahr, Leipzig, C. Germany.*

*Ultra Fusion Electrolytic Co. 151 5th Ave New York*

*Letter returned 11/18/30*



974  
386

Russell Parachute Co.,  
1202 Kettner Blvd. San Diego  
Calif.



Girl Wearing Vest to Which a Parachute May Be Attached, Thus Eliminating Bothersome Straps

### PARACHUTE ATTACHED TO VEST ELIMINATES STRAPS

Detachable parachutes that can be quickly fastened or unfastened instead of being adjusted with straps, have been introduced for wear on air liners. They connect by a simple hook arrangement to a special vest which the passenger dons before going aloft.

### GNAT'S WINGS HELP TO RECORD HEAT OF THE STARS 989

Bits of gold leaf, so light that they float in the air, microscopic threads of bismuth alloys, quartz filaments all but invisible to the naked eye—these are the materials with which C. Hawley Cartwright, of the California Institute of Technology, builds thermometers so sensitive that they detect changes of temperature amounting to only one-two-millionth degree Fahrenheit. Mounted in telescopes focused on distant stars, these delicate instruments, by measuring the radiation of heat, discover not only the temperature of the heavenly bodies, but also estimate the nature of their make-up and the speed of their motions. Two styles of ultra-sensitive thermometers are made by Mr. Cartwright; one, a thermocouple, the other, a radiometer. The action of a thermocouple depends on the curious fact that two wires of differing metals, joined at one end and heated at the junction,

Carl Edison Co. Inc.,  
73 Walnut Ave.  
Piedmont, Calif.

generate an electric current. The greater the heat applied, the greater the flow of electricity. Not content with developing the thermocouple to a new degree of refinement, Mr. Cartwright has also made notable improvements in radiometers of the moving type. This meter consists of a small horizontal wheel with four light metal vanes hung from the circumference, all inclosed in a partially exhausted glass bulb. One side of each vane is blackened, while the other is polished. Whenever radiant heat is falling upon the wheel, the black faces of the vanes absorb the light, heating the rarefied air near them. The resulting increase of molecular motion kicks the wheel around, the speed of rotation depending on the intensity of the light. In his radiometer, Mr. Cartwright substitutes for the wheel a short quartz bar carrying two blackened gold-leaf receivers with a mica mirror projecting a beam of light. To prevent loss of heat from the bright backs of the vanes, they are insulated with bits of gnat wings.

### ADJUSTABLE MESH SCREEN FITS ANY SIZE DOOR OR WINDOW 786

Intended as a reinforcement for door and window screens, a coarse-mesh screen now on the market has adjustable sides so that it may be made into square or narrow rectangular shapes. The wires rotate at the points of contact when the sides of the screen are changed.

\$2.25.

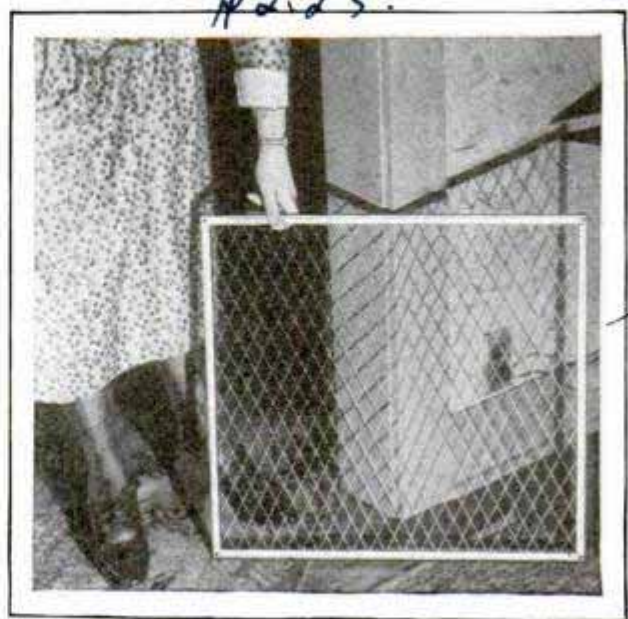

Adjustable Mesh Screen, Which May Be Changed in Dimensions to Fit into Any Size of Window

A. W. Shuy Hardware  
& Supply Co., Akron Ohio



965

7036 Crandon Ave  
Chicago 387

These proceeds not include  
light source nor lever system  
Hydraulic operator - \$100.00  
supplied by the  
concern

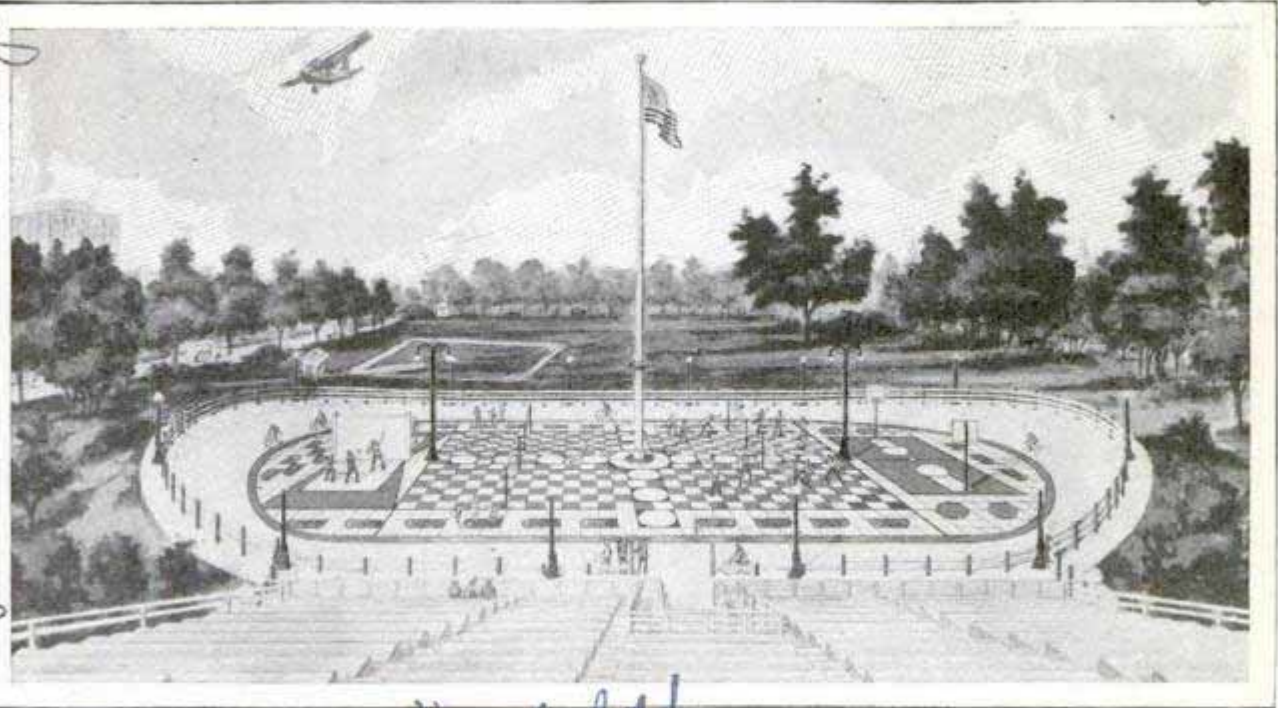

©Tomaz F. Deuther  
Park Playfield Resembling a Huge Checkerboard Where Many Games May Be Played Simultaneously; Provision Is Made for Handball, Marbles, Hopscotch, Volley Ball and Basket Ball

### CHECKERBOARD PLAYGROUND OFFERS MANY GAMES

Many games can be played at one time on an interesting concrete field recently constructed in a Chicago park. There are handball courts, marble rings, hopscotch layouts, volley-ball courts and a basketball court, besides a concrete racing track for bicyclists. Eight laps make a mile. A central flagpole, 150 feet high, has a Maypole ring above its base so that the pole may be used for May and other dances. A grandstand at one side of the field accommodates 1,500 persons, while a wide walk, just outside the rail, is large enough for many more spectators. The play space is marked off in red and white divisions, and the border lines are plainly indicated so that many can use the space without interfering with one another.

### DOOR OPENS AUTOMATICALLY WHEN APPROACHED 995

Swinging doors that open automatically as a person approaches and close in the same manner after he has entered recently were demonstrated and are expected to find wide application, particularly in hotels and restaurants where waiters with heavily laden trays must struggle with doors leading from dining room to kitchen.

en. The door is made to open and shut by an electric eye located near it. A ray of light is focused on a photo-electric cell in front of the door. When the ray is interrupted by a person passing between the cell and the source of light, it sets a hydraulic door opener to work through the agency of a relay. The slight current is amplified through three vacuum tubes and sets in motion a small motor which operates the hydraulic device. A control adjusts the time the door is held open.

### JEWELERS' LENS ON GLASSES SAVES WEARING "BARREL" 981



Jewelers and watchmakers who have difficulty in wearing the usual type of "barrel" magnifying glass, are provided with a lens that is attached to the spectacle frame. When not in use, it can be flipped

up out of the way where it is ready for immediate service again. If the worker does not wear glasses, he can use the special lens attached to a spectacle frame without lenses.

Archie Rouleau  
Willis & Hicks

General Electric Co  
Schenectady, NY



and

942

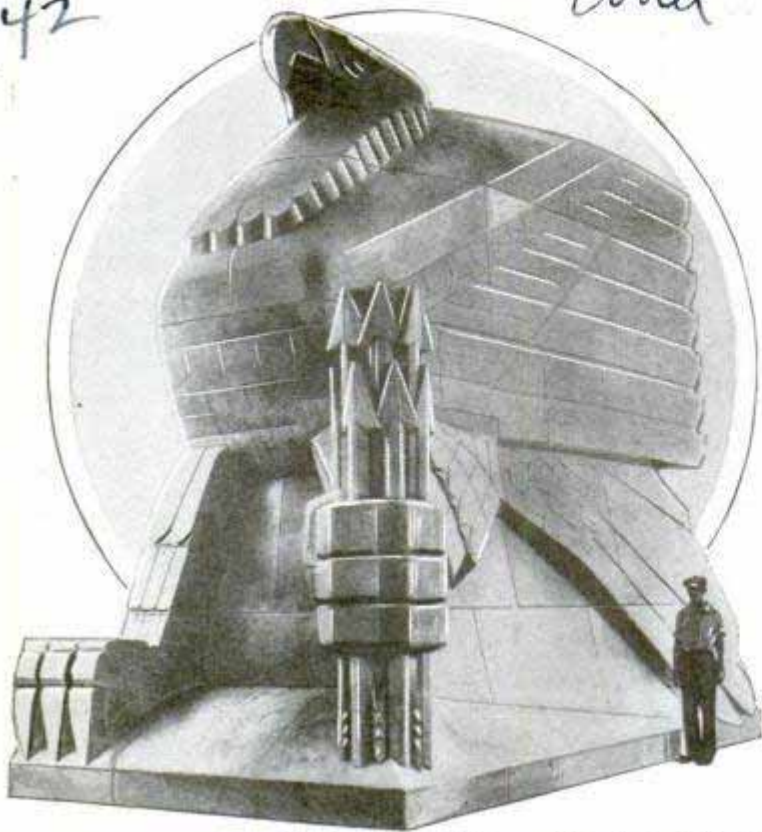

One of the 200-Ton Eagles, Carved from Limestone Blocks, Which Will Decorate a Memorial Bridge at Harrisburg

### STONE-BLOCK EAGLES WEIGH TWO HUNDRED TONS EACH

Carved in thirty-five blocks of limestone each, two huge eagles, weighing 200 tons apiece, have been designed for the soldiers' and sailors' memorial bridge at Harrisburg, Pa. Eight freight cars were required to move them from the mills. The figures are twenty-two feet high.

### MOTORBOATS FOR SELF-USE ON PARK PONDS

964

One of the latest water amusements in recreation parks is afforded on a large shallow pool where motorboats may be hired to be driven by the visitors themselves. The craft are ten feet long and of sufficient beam to prevent them from tipping over. Rubber bumpers prevent damage in case of collisions and the boats are driven in every

direction at a speed of about five miles an hour. The air-cooled gasoline engines are locked in a closed compartment so that the operator has nothing to do with the starting or stopping of them. The boat is run simply by placing the foot on a clutch which engages the propeller and stops it by removing the foot. The engines are started at the beginning of the day's sport and run continuously unless trouble develops. The sport offers the thrill of being the master of one's individual boat and also helps persons in learning to steer.

### WINGS FOR SKIING ADD THRILLS OF FLYING

839

Some of the thrills of flying are added to the winter sport of skiing with a pair of wings worn by the ski runner. The wings, made of aluminum by a German inventor, are nineteen feet from tip to tip and enable the wearer to take short flights in the air after gaining sufficient momentum on the skis. They are so constructed that the ski rider is virtually seated in the center of them when he leaves the ground. They are movable from a horizontal position and easily controlled, enabling the rider to change direction of flight.

Joseph Krupke  
Berlin.

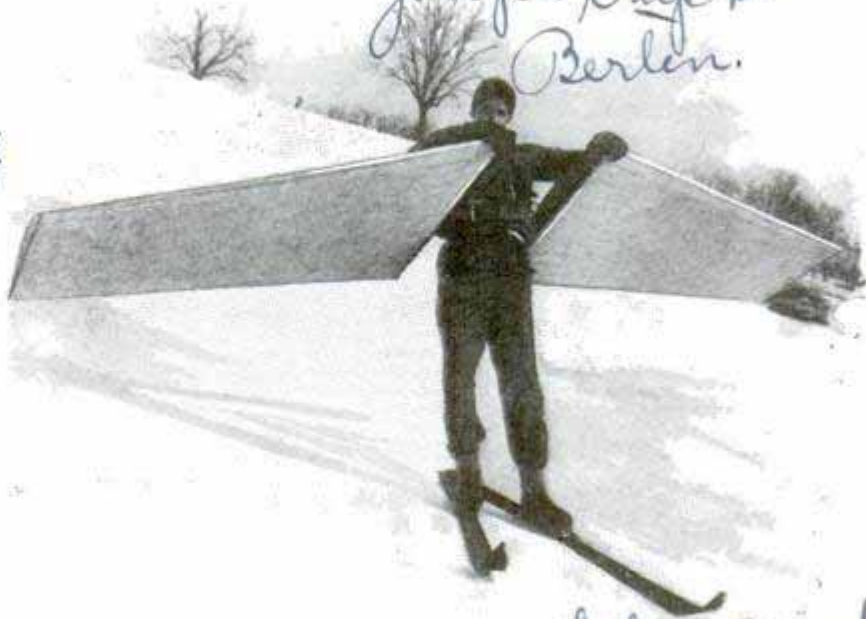

International

Ski Rider Equipped with Nineteen-Foot Wings, Which Lift Him into the Air After Sufficient Momentum Is Attained on the Skis

Installed at Woodside Park  
Water Sports Philadelphia

Lesse Bros., 2809 1/2 Fairhill St.  
Philadelphia Pa



CATAPULT FOR PLANES IS ENGINEERING WONDER

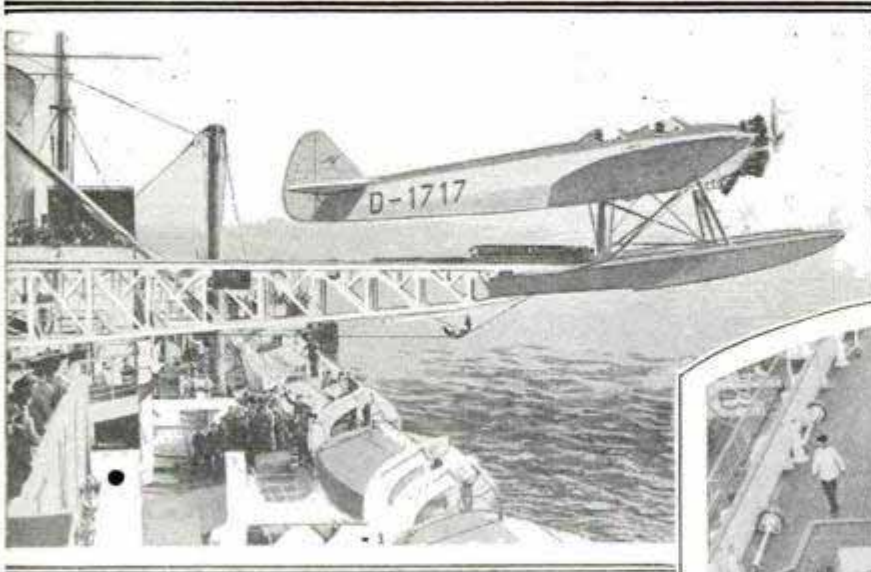

Two Views of a Catapult for Launching Airplanes from a Ship; It Is Light in Weight, but Has Unusual Strength and Dependability

Launching airplanes from the decks of commercial steamers and battleships is no longer a novelty, but few persons are acquainted with the catapult apparatus by which this is accomplished. In designing the equipment for the steamers "Bremen" and "Europa" many engineering difficulties were solved, and experiments were conducted for about three years before a satisfactory machine was made. Light weight, great strength and dependability are necessary factors for successful operation. The catapult consists of four main parts, the rail bearer, starting skid, accelerating unit, or that part which furnishes the forward movement for the plane, and the testing contrivance. The rail bearer, or launching way, is a steel and iron framework and turns on a pivot, so that the planes can be launched into the wind without turning the entire steamer. The skid slides on special shoes along the rails and to it is attached a cable that operates over rollers turned by the accelerating device, or by the motor unit, which

functions by compressed air. The testing device is an interesting and important part of the machinery. In brief, it is a flywheel and drum with a

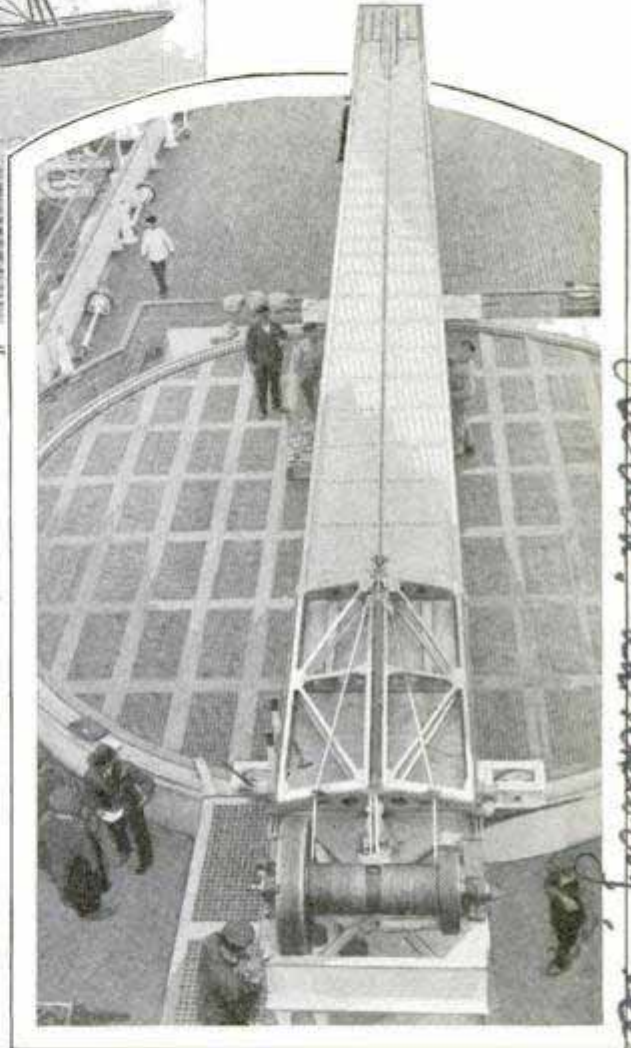

cable connection to the skid. To test the catapult before a plane is launched the skid is connected to the flywheel and shot down the rails. If it turns the wheel with sufficient speed, the operators know that the catapult is working satisfactorily and the plane can be safely placed on the starting skid.

ROCKETS TO DISPLACE CANNON IN FUTURE WARS 993

Skyrockets instead of cannon will be used in future wars, if experiments of European engineers are successful. They are making tests to find a method of propelling explosives accurately through the

air without using cannon, which are considered almost obsolete because they are too clumsy to move, too easily damaged and too costly. Skyrockets are easily transported and can be landed in a certain area by regulating the powder charge. Such rockets would contain gases, liquid fire, shrapnel or smoke-producers.

Finano, Italy, Germany.

Herald Tribune  
6/15/36

myr - H. G. Mitschbach, Schragel, Berger Strasse 5, Berlin-Lankwitz, Germany.



Pictogram Co., Box 40, Washington, D. C.

# What the Weather



The temperatures at which perishable goods are liable to damage vary greatly for different commodities; also with their condition when shipped, the length of time they are in transit, and various other factors. A large fund of information on these points and also on methods of packing and protecting the goods, collected from the merchants themselves, was digested. The next step was to start the system of "shippers' forecasts" that is now so familiar. These forecasts are issued from weather-bureau stations during the seasons of the year when dangerous temperatures may occur. This undertaking proved to be of revolutionary benefit to the mercantile world, and the rail-

By CHARLES FITZHUGH TALMAN

**T**HE WEATHER BUREAU does more than predict weather and record climate. It helps the public make an intelligent and profitable use of both weather forecasts and climatic statistics for an endless variety of purposes.

One of the biggest problems the bureau ever tackled was that of cutting down the enormous losses sustained by merchants in the shipment of goods susceptible to injury by extreme temperatures, including not only foodstuffs but also a wide range of other commodities. A single cold wave in winter sometimes entailed losses of millions of dollars on goods in transit and some hot waves in summer were almost equally disastrous.

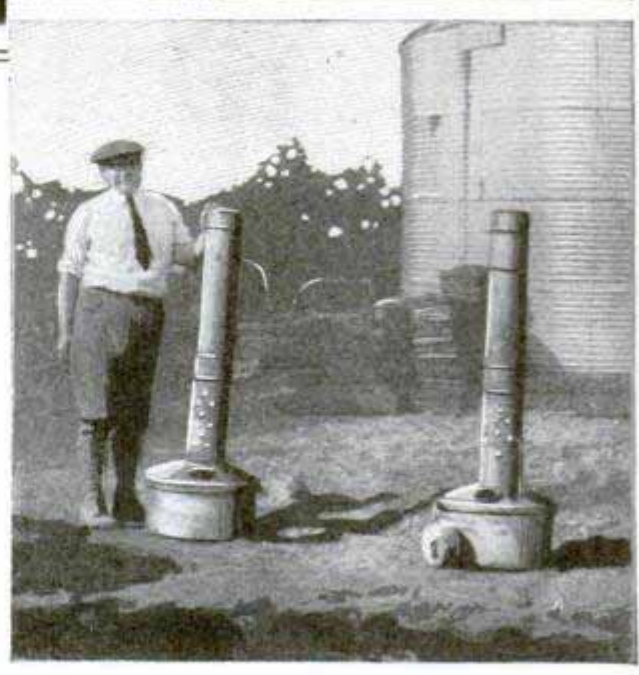

C. F. Marvin, Chief of Weather Bureau, with Map of Stations; Below, Inspecting Orchard Heaters



# Man Can Tell You

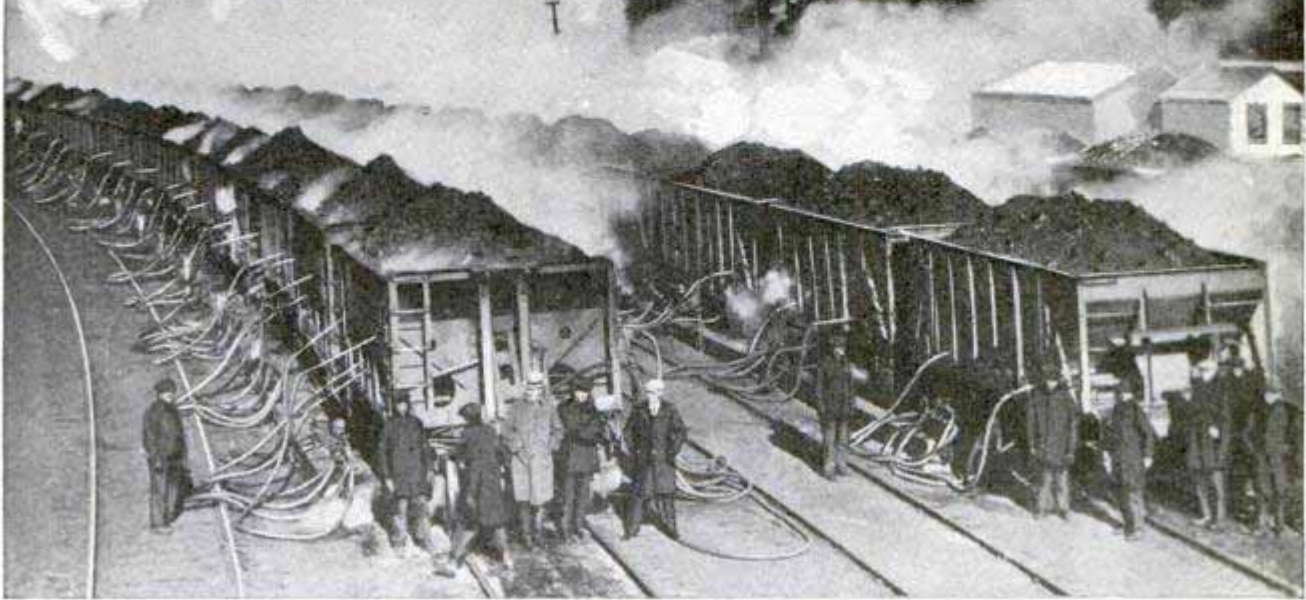

Thawing Iron Ore with Steam on Duluth Ore Dock; Cold-Weather Forecasts in Spring and Fall Have Reduced This Expensive Process to a Minimum

roads have helped to make it effective by refusing to accept perishable goods for shipment in ordinary freight cars when the forecasts indicate danger of injury.

A few years ago the weather-bureau men at Ithaca, N. Y., were asked to study methods of spraying fruit trees against scab. The spores of this fungus disease are active only when moist. The conclusion was therefore reached that the right time to spray is just before a rain. If spraying is done at that time, the fungi begin to grow and are killed by the poison, while if the spray is applied in dry weather it is wasted, as the fungi are not affected by the poison in their inactive stage. The outcome of this investigation was that the bureau undertook a system of special rain forecasts for the apple growers of seven counties in New York state, who were spending \$3,500,000 a year in spraying their trees.

To jump to another industry and another part of the country, the iron trade on the Great Lakes, which is famous for its efficient methods, at one time suffered serious losses every year through ignoring weather. Early and late in the season of navigation large quantities of frozen ore

accumulated on the docks at upper lake ports, causing much expense for thawing and costly delays in loading vessels. Finally the operators took counsel with the weather man at Duluth. Under his advice they began keeping close watch of the temperature forecasts during the colder months. Whenever a freeze was in sight, only enough ore was shipped from the mines to the docks to load vessels ready to receive it. Great savings have been effected by this plan.

Within the last two years the weather bureau has been carrying on such diverse enterprises as making daily dust counts at several of its stations for the American Society of Heating and Ventilating Engineers; measuring the thickness of ice deposits on wires for the National Electric Light association, and testing the amount of pollen in the air at various places for an organization engaged in the study of hayfever. It is hardly necessary to mention here such outstanding and well-known activities as the aid it renders, through special frost-prediction services, in the economical use of orchard heaters, its studies and forecasts of "fire weather" in the forests, and the elaborate services of



746

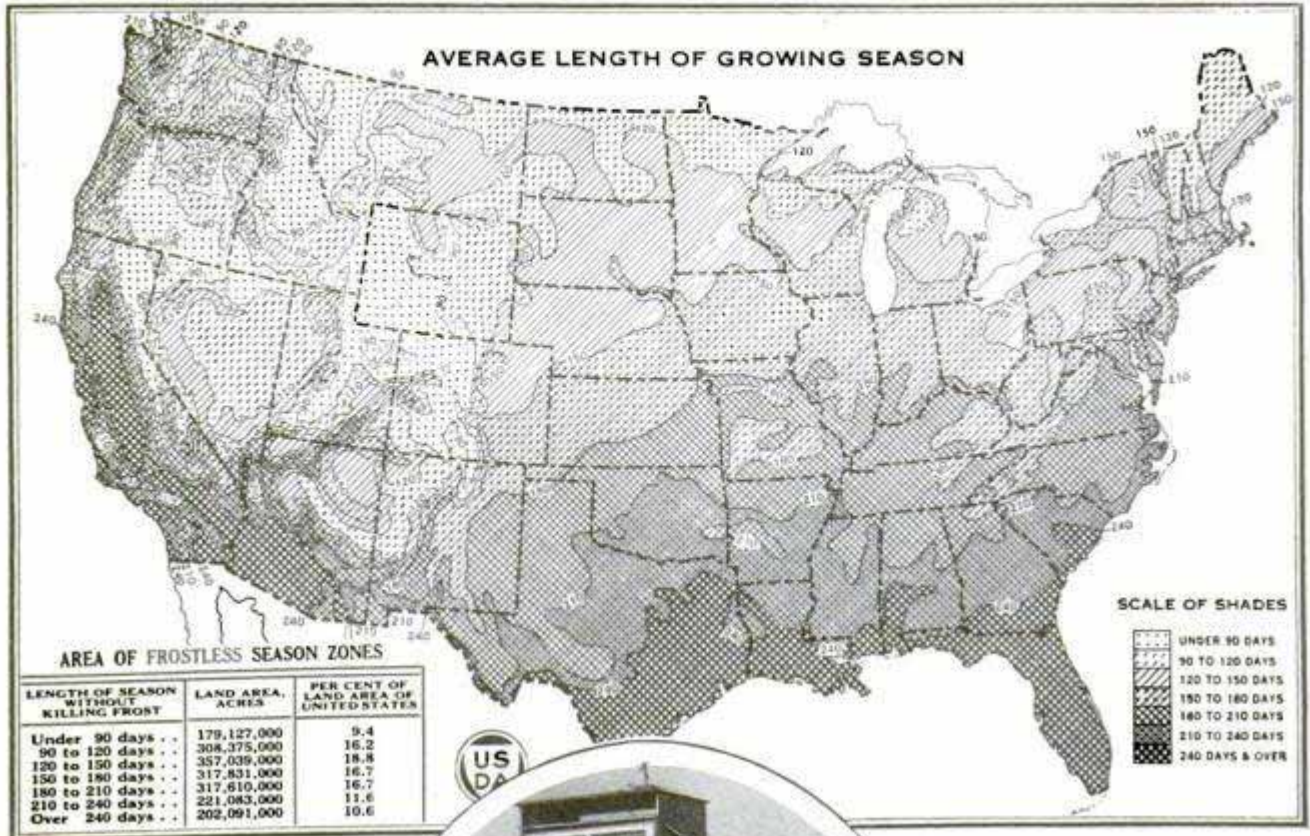

reports and forecasts recently established along the airways for the benefit of aviation.

The story is told of a certain American manufacturer of library paste who embarked upon extensive shipments of his product abroad without any preliminary study of climatic conditions in the foreign markets. Some of it went to desert regions of the near east, where, on account of excessive evaporation, the paste dried so quickly when it was applied that it had no adhesive quality. To introduce more moisture at the time of manufacture would have made the paste too thin and subject to spoilage. Laboratory experiments were undertaken, a slow-drying paste was developed, and the new product turned out to be so much better than the old one that today more of this paste is sold in the United States than any other.



Climatic Chart, Especially Helpful to Farmers and Fruit Growers; Below, Instrument Shelter on Skyscraper

It is rare indeed that failure to consider the climatic factor in developing a new market leads to any such happy result. Most American businessmen realize that adaptation to climate is a most important consideration in the sale of many commodities. Not long ago the weather bureau aided the General Electric company in making an elaborate analysis of American

climatic records in order to determine the periods of the year when weather calling for the use of electric fans normally prevails.

The recent rapid growth of weather insurance in its various forms has presented the bureau with a number of difficult problems. Such enterprises as rain and hail insurance are extremely hazardous unless based on very detailed climatic statistics, such as are hardly available at present for any part of the country. The



insurance companies can, however, use to advantage certain kinds of knowledge already possessed by meteorologists. Thus weather-bureau records show that the great majority of tornadoes travel in an easterly to northeasterly direction along a path that may be

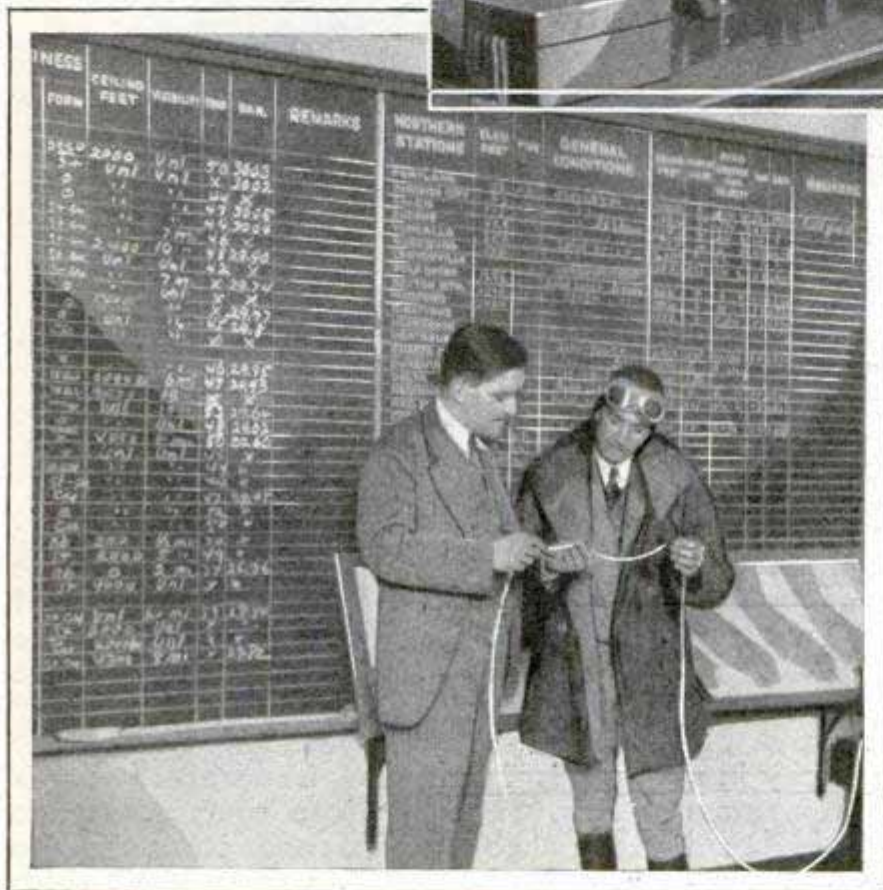
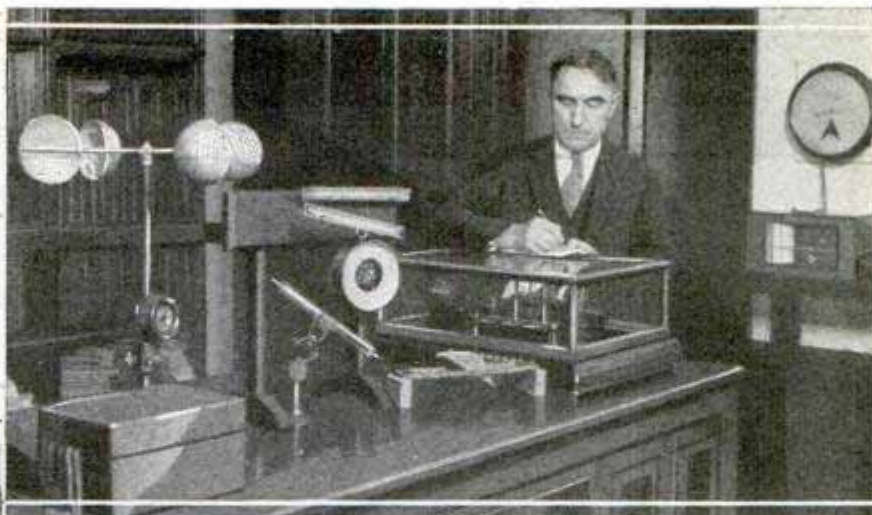

Above, Observer Consulting Quadruple Register That Makes Continuous Record of Wind Direction and Velocity, Rainfall and Sunshine; Below, Aviator Consulting Teletype Weather Report

the average dates limiting the period when concreting can be done safely without cold-weather equipment in all parts of the United States; also the extreme dates in exceptional years.

A manufacturer of "flexible glue" requires temperature data for all parts of the country, as this product must be made differently for use in different climates.

A chemical manufacturer wants to know of a place in the United States, with railroad facilities and a fair labor supply, having the lightest possible rainfall and the driest air throughout the year; these being the ideal con-

ditions for a plant he is about to establish.

hundreds of miles long but is rarely more than half a mile wide. Hence a company writing tornado insurance should distribute its risks more or less at right angles to this direction, so as to avoid the possibility of ruinous losses in any one storm.

A post and fence dealer wants to know at what time in the fall the ground freezes in different parts of the United States.

An exploration of weather-bureau correspondence files would bring to light a veritable gold mine of information supplied to the public in response to innumerable requests, and furnish striking illustrations of the many-sided relations between weather and the affairs of mankind. Here are a few specimen queries that have lately received the bureau's attention:

A large engineering firm wants to know

A dealer in summer clothing, including strawhats, bathing suits, etc., asks for data with which to combat the idea that retailers should not buy a strawhat after July 1 or a bathing suit after July 15.

Of course, the problems submitted to the weather bureau are not all commercial or industrial. Many questions come from home seekers and health seekers. Many are purely domestic, many are purely scientific—and many are fantastic.



Cont. to W. Gray, Sparkill N.Y.

938

# HOW STARS OF THE BIG DIPPER ARE BREAKING UP

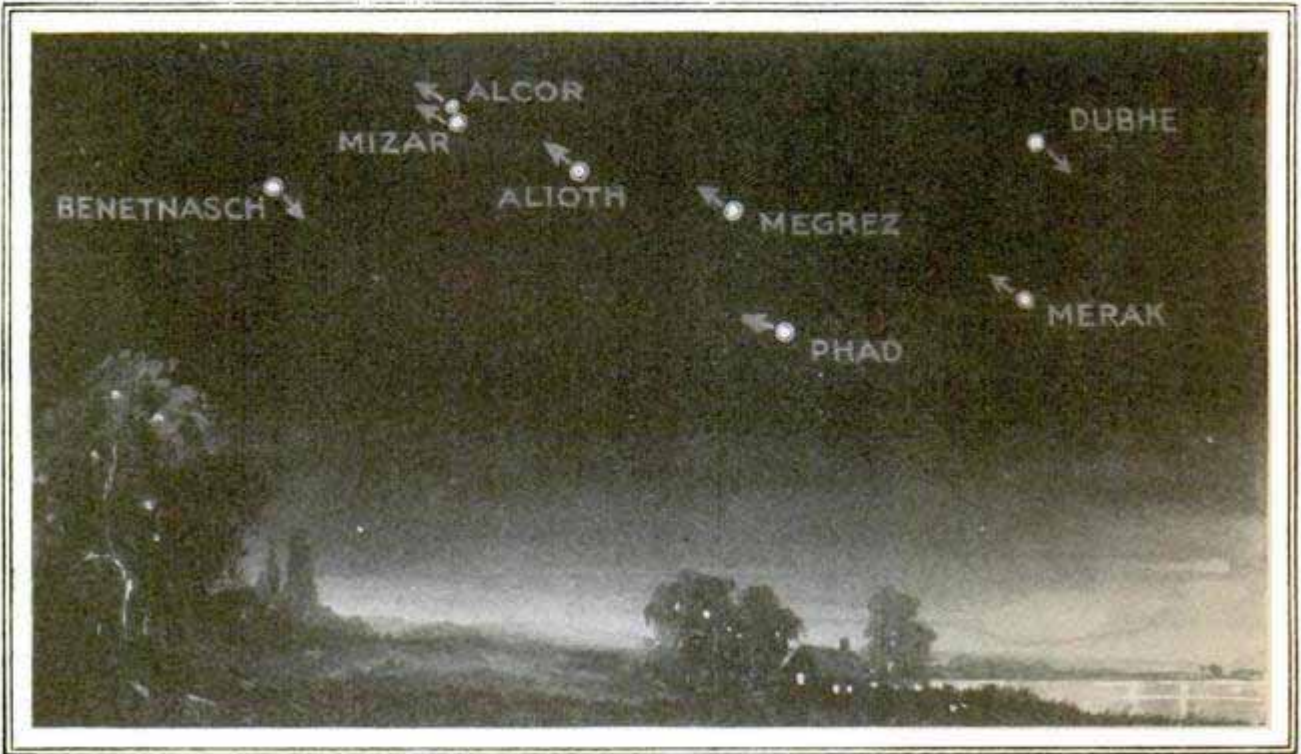

Scientists Have Found That the Big Dipper in the Sky Is Gradually Breaking Up, the Stars Composing It Moving in Different Directions as Indicated by Arrows

The Big Dipper, most spectacular and best-known of the constellations of our northern skies, is breaking up, pulling apart, going to smash. Recent astronomical measurements show that the two stars at the opposite ends of the dipper, known to the star-wise as Benetnasch and Dubhe, are moving at high velocity in a southerly direction, while the inside stars are moving as a group uniformly in a northerly direction. Because of the remote distances of these objects, the movements are not apparent to the naked eye, and no doubt the dipper appears to the casual observer very much as it appeared to the Egyptians who built the pyramids. But when photographs are made of the constellation through powerful telescopes and these measured and compared with other photographs over a period of years, slight changes in the stellar positions show up. These indicate velocities of many miles a second, and it is unmistakable that in a few thousand years the constellation will have shifted its figure so considerably that the familiar pattern we know so well will be no more. It is commonly said that the Big Dipper consists of seven stars, but if you look closely you should be able to count eight. The second star from the

end of the handle shows up as two stars to a keen pair of eyes—and indeed the ability to see the two without the aid of a glass is a test of good eyesight. This second star of the dipper was the first double star, or binary, ever discovered by the unaided eye. The brighter star of the pair is Mizar, and its smaller twin is Alcor. Though these companion stars seem almost to touch each other, they are in fact separated by a space 16,000 times the distance between the sun and the earth—in round numbers, about one and a half million million miles. Mizar is so far off, that its light must travel more than seventy-five years to reach the earth. Dubhe and Merak are generally known as “the pointers” because a line drawn from Merak through Dubhe points to the North Star. Of course, they will no longer be reliable pointers after Dubhe has traveled a few thousand years in one direction and Merak a few thousand years in another. But by that time, astronomers say, the present North Star will have ceased to be the Pole Star, and navigators and surveyors will no longer be especially interested in it. Why not? Well, it seems that the earth, as it rotates on its polar axis, is wobbling in a way that is gradually



shifting the position of its axis with reference to the stars. It is computed that, by about the year 14,000, the bright blue-white Vega will be our north-pole star.

*Science Service 481-2*  
**NEW SOURCE OF POWER IS SEEN AS NEXT GREAT DISCOVERY**

*6/14/30*  
Man has nearly reached the limit of development of steam power and will soon discover another and much more efficient method of transforming energy to his uses. This far-reaching prediction was made recently before the world power conference in Berlin by C. F. Hirshfeld, Detroit research engineer. Scientists can now calculate the limit of power production possible under theory yet to be applied, and, in fact, could attain this limit if metals strong enough to stand the increasing pressures and temperatures were available. Judging from human history, a radically different process for power development may be expected before the limit with present methods has been quite reached. Mr. Hirshfeld did not indicate what the development might be, but apparently was not considering any possibilities already projected, such as the gathering of heat from the sun, or the use of temperature differences between surface and deep water in the tropics or between sea water and air in the arctic.

*Science Service 481-2*  
*6/14/30*  
**NAIL THAT SEALS HOLE MAKES ROOFING LAST LONGER**

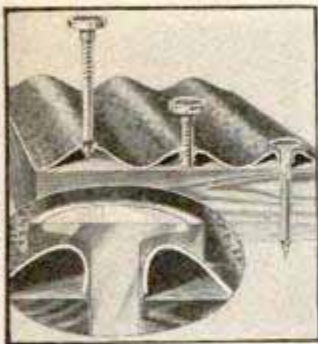

The nail can be driven through sheet steel without punching a hole.

A machine which examines eggs under light, separates them according to size, quality and weight, and counts and dates them was exhibited in Germany recently.

*no information*

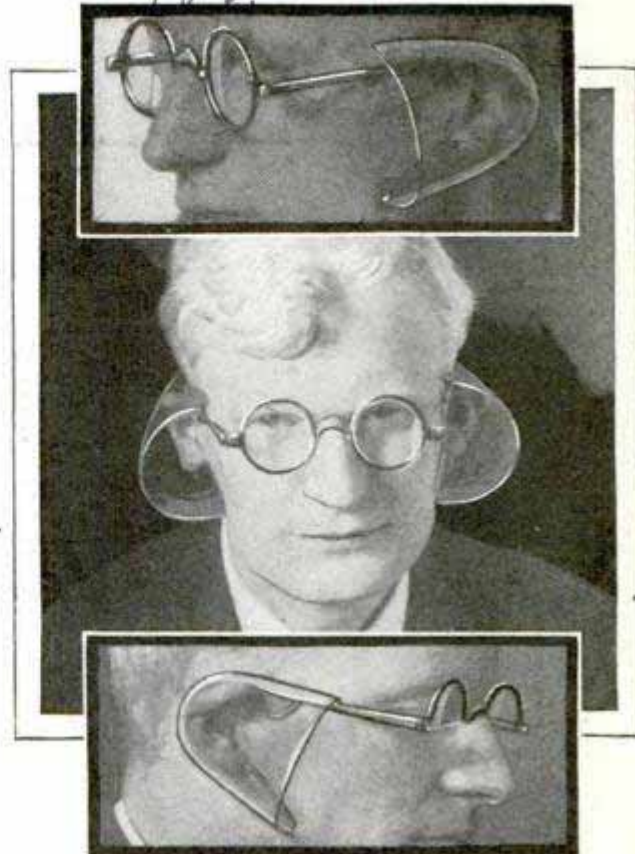

Spectacles That Aid the Deaf; They Have Shields to Cup the Ear for Better Hearing

**EAR SHIELDS ON SPECTACLES AID HARD OF HEARING**

Cupping the ear with the hand in order to hear more clearly is a common practice among persons afflicted with defective hearing, and this aid is provided without the use of the hand in a spectacle attachment introduced in Germany. The bows are arranged with shields of transparent material and hold the ears in a cupped position, the guards at the same time forming an additional chamber to catch the sound. The device can be worn with comfort and has the advantage of being without batteries.

**FLARES AS WEATHER SIGNALS WARN AIRPLANE PILOTS**

Before radio service was installed along an eastern air route, weather signals were broadcast to flyers by a system of flares. One warned of bad weather ahead, two were shown when the pilot was advised to land at once, and three gave the signal to return to the base port. The flares were sufficiently brilliant to be seen from high altitudes.

*new York Albany and*

*The Remington Co. 4856 & Western Ave. Chicago*

*Chicago Loring Pat. 6/24/30*

*Hans Burscher, Cottbus, Silesia, Germany - no U.S. agent known*

*982*

*987*

*979*

*1031*



*992  
Police Department letter recd.  
8/16/30  
Tulsa Okla*

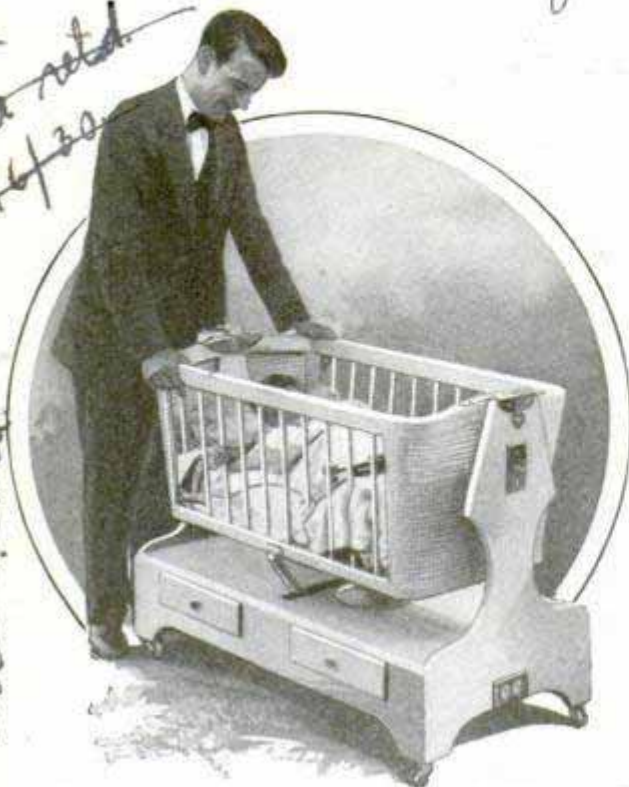

Self-Rocking Cradle Contains an Electric Motor, and There Are Drawers in Base for Clothing

### ELECTRIC CRADLE FOR INFANT RELIEVES MOTHER

Mothers who spend part of their day in rocking the baby now may turn that task over to the electric cradle and go about their housework. The cradle, consisting of a bassinet mounted on an upright frame, differs little from the conventional kind except that it contains a motor connected to a rocker arm, which functions when connected to a light socket. In the base of the stand are handy drawers for the baby's clothing.

### SECRET OF DWARF JAP PINES LIES IN SPECIAL DIET

A "starvation" diet and a special method of planting are secrets of producing dwarfed trees, such as are grown in Japan, the miniature specimens being less than a foot in height though they may be over 500 years old. Experts in the botanical gardens of the University of Pennsylvania have been investigating the dwarf pine and other trees and have discovered how they are grown. The pine cutting, for instance, is but three or four inches long at the start and is planted in a ball of heavy clay, tightly packed about the end that is to form the root. The clay ball is then

*James Lambert*

placed in a shallow dish of water and the cutting permitted to root in the clay, which is kept under water at all times. When the roots have started, the cutting is planted in poor soil. The shoot is thus kept on a starvation diet and grows but little taller than it was at the start. Small sticks are arranged to hold the small branches out straight. Within a year, the dwarfed tree will have assumed the mature appearance of one a century old. The sprig is not planted in an upright position but on a slant and the pot is placed with the sprig pointed away from the source of the sunlight. In this way, the twisted and gnarled stem which characterizes this type of tree is produced.

### CAMERAS AIMED LIKE GUNS FOR AIR PHOTOGRAPHY

Cameras are considered almost as important as guns in "shooting" objects from the clouds, and the instruments are mounted with elaborate precision just as guns are sighted and fired. One of the special services of air photography is in bombing from airplanes. The camera makes an accurate record of the ground to be covered and also helps register the

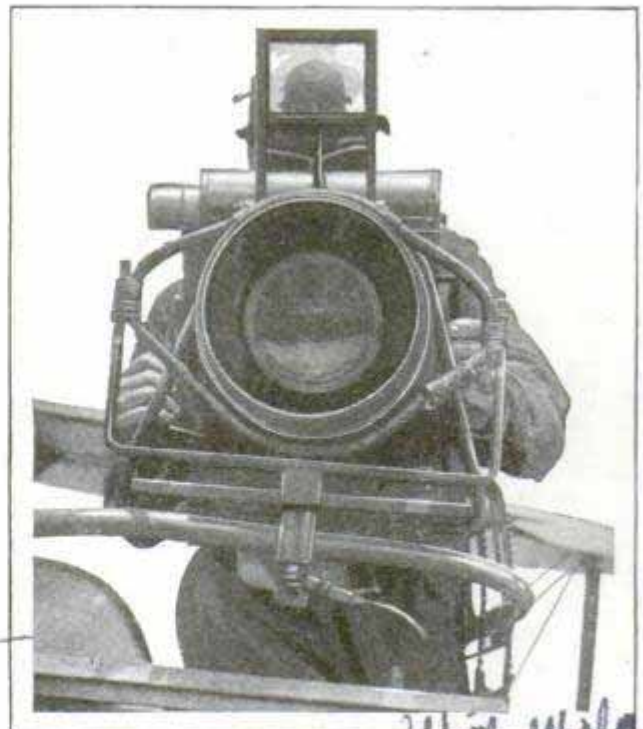

Aiming One of the Monster Aerial Cameras Developed Especially for Army Use

hits and misses, so that the bombers can improve their marksmanship.





Where Monkeys Enjoy Boat Rides and Live in a Log Cabin; Scene on Monkey Island at the Cincinnati Zoological Gardens; the Cabin Marks the Entrance to a Cool Dry Cave

**AN ISLAND HOME FOR MONKEYS IN CINCINNATI ZOO**

One hundred monkeys in the Cincinnati zoological gardens now make their home on a special island recently constructed for them. Monkey island, in the center of a large pool surrounded by a three-foot wall sloping inward to keep the monkeys from crawling out if they swim to shore, is 120 feet long and sixty-five feet across. The monkeys can jump fourteen feet, so the moat between the island and the wall was made twenty-five feet wide. A cabin door leads to the entrance of a cave where the residents find protection from the weather. Small boats, water balls and canoes are furnished the monkeys for amusement.

**FERTILIZER HELPS TREE MOST NEAR TIPS OF ROOTS**

Experiments conducted in the botanical gardens of the University of Pennsylvania show that fertilizer seems to do the tree the most good when it is placed around

*James M. Lambert*

the circle formed by the outer edges of the foliage instead of close to the tree trunk. This outer ring roughly marks the boundary of the root tips underground, and this was found to be the best place for fertilizer as well as for water.

**CLIP ON POCKET PENCIL SERVES AS LETTER OPENER**



Attached to a pencil now on the market is a hinged clip that not only serves to hold the pencil to the pocket, but, when turned back on its hinge, is transformed into a convenient letter opener. The clip fits snugly against the pocket and is easily adjusted for its double purpose. It maintains tension at all times and is practically indestructible.

*Ben J. Tuttle  
1325 Myrtle St.  
Guthrieville, Pa*

*and Ben J. Tuttle, % Cartwright  
1325 Myrtle St. Guthrieville, Pa*



734

W. Clatworthy, Esq. 59, Whitehall Road, Heatham, London S.W. 16, Eng

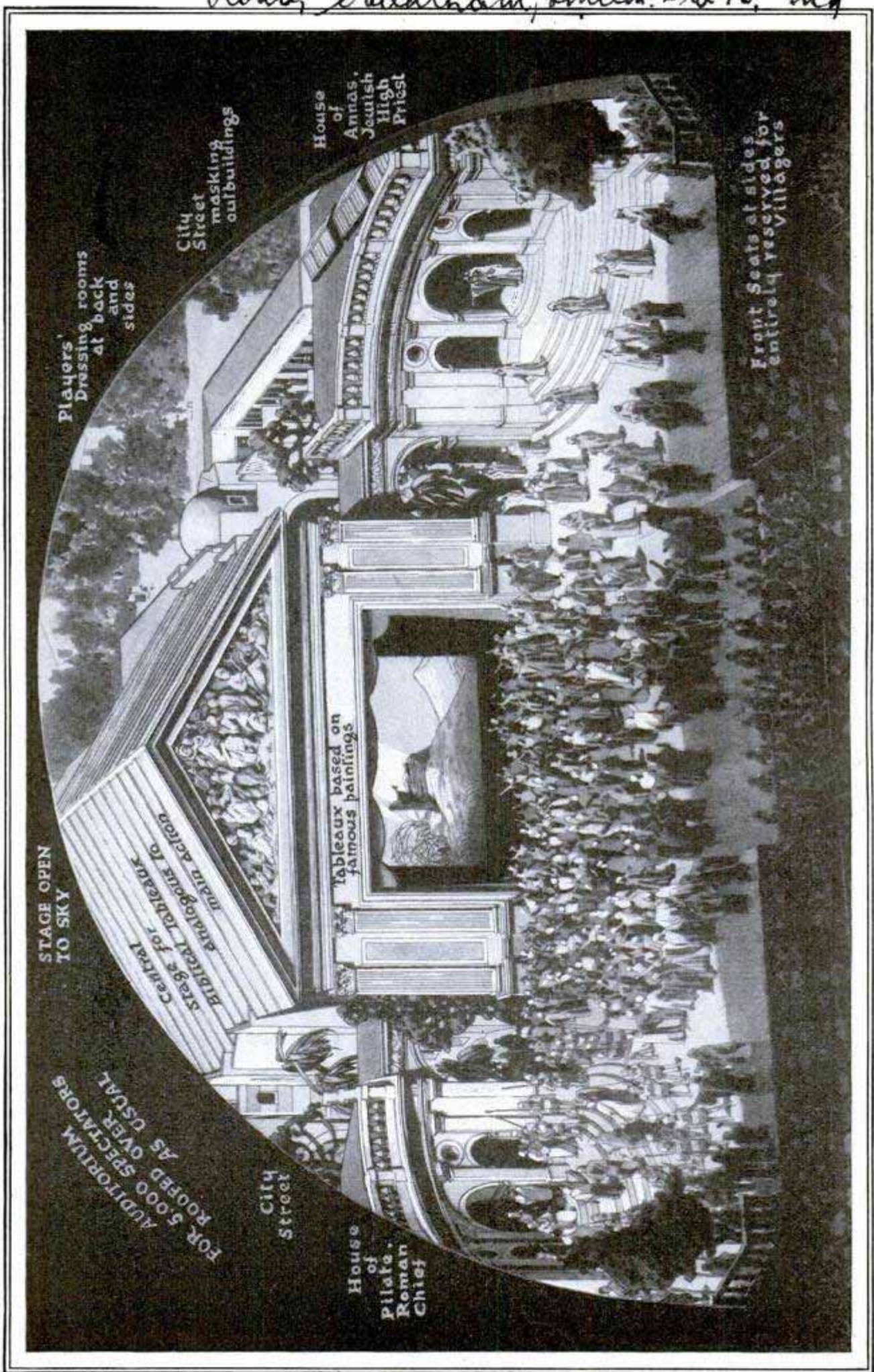

Front and Part of the Backstage of Theater at Oberammergau, Scene of the Famous Passion Play; as Many as 500 Actors Occupy the Stage at One Time in Some of the Episodes of the Play, Which Consists of Eighteen Acts and Twenty-Five Tableaux



**ROOM AT SEVENTY  
MAY STILL BE  
COLD** 1012.

Although the room thermometer may register seventy degrees on a winter day, the occupants may still be too cold for comfort. Prof. A. C. Willard and A. P. Kratz, of the University of Illinois, recently explained why this is so and pointed out the need for more efficient temperature measurements during the winter in the average home. Under the practice of most heating calculations, temperatures are generally taken at the "breathing line," or about five feet from the floor. But this is not a fair measure during intense cold because, in many homes, the inside surfaces of exposed walls, windows and other units are radiating cold that definitely affects the occupants of the rooms. For instance, at two feet six inches above the floor, the "comfort line," the temperature is generally lower than it is at the breathing line.

**PORTABLE PLAYER FOR PIANO  
FITS IN SMALL CASE** 959

Quickly attached to an ordinary piano, a portable player arrangement, devised by a British inventor, operates directly upon the keyboard over a range of eighty-five notes. Its pneumatic action manipulates the keys as a roll is unwound. The outfit weighs less than most portable radio sets.



Inventor with Player Unit That Is Adjusted on Top of Piano Keys for Automatic Operation

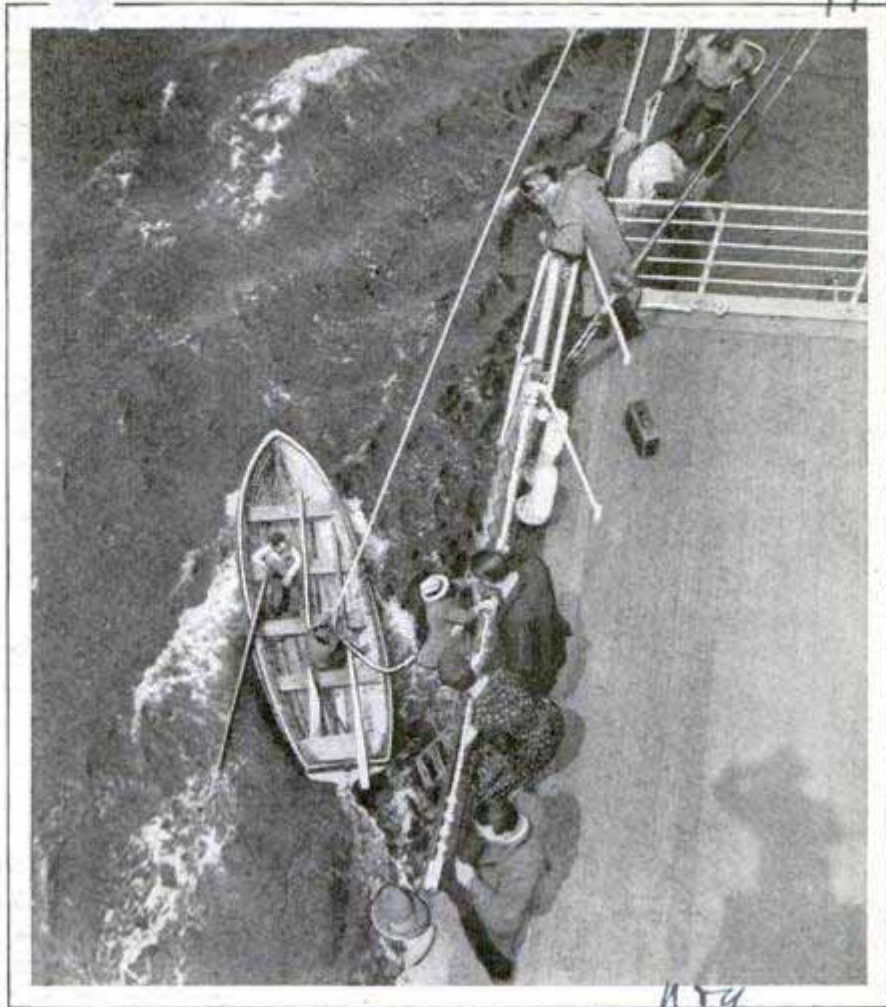

Pilot Climbing aboard Vessel to Guide It into Port; Scaling the Ladder Is Not Always an Easy Task, Especially in Rough Sea

**CLIMBING UP "JACOB'S LADDER"  
TESTS PILOT'S SKILL**

Pilots who conduct ocean liners to their piers through the maze of traffic in New York harbor face their first test of skill when they meet the incoming vessel in a small boat and clamber up the side of a swaying "Jacob's ladder" lowered to them from the ship, for, seamen though they are, they have not all the monkey-like agility of the old-fashioned sailor. An unusual photograph, taken from above, was recently made of such a feat as the pilot boarded the new Grace liner "Santa Clara," after its trial trip from Camden.

W. R. Wearham  
59. Woodward Road Hurler, O. & ...



87

W. H. S. Agard  
Ch. man

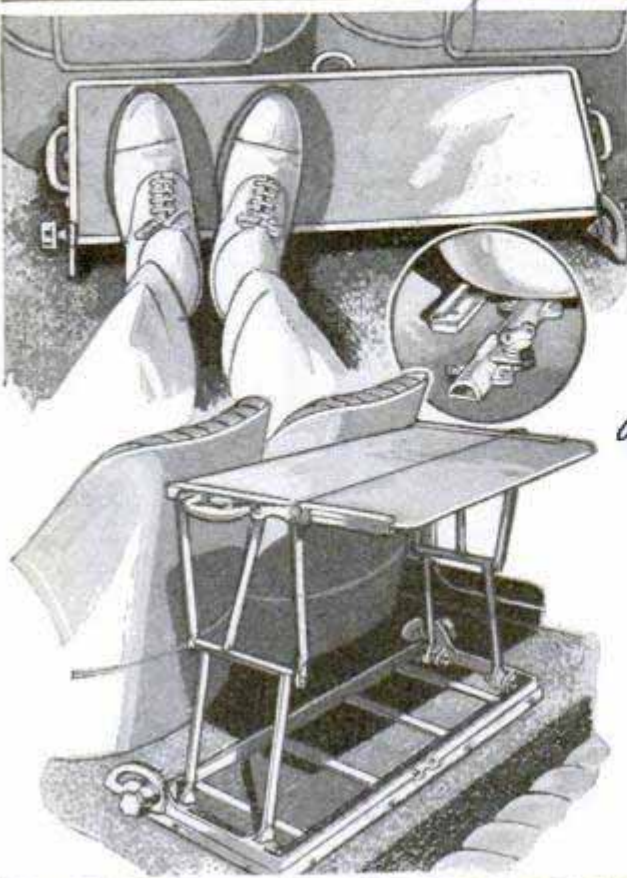

Folding Automobile Table Used as Footrest and Extended for Service in the Car

### FOLDING TABLE IN AUTOMOBILE ALSO SERVES AS FOOTREST

Used as a rest for the feet when closed, a folding table that may be set up in a few seconds, in the rear of the front seats of the automobile, has been introduced. If desired, the table may be taken out of the car and set upon the ground. It is light in weight, sturdy, and simple to adjust, and provides ample leg room.

### TALKING FILM SHOWN ON TRAIN TO ENTERTAIN PASSENGERS

1002

Talking movies recently were exhibited for the first time aboard a moving train in experiments by the Chicago and Northwestern railway to determine the feasibility of offering sound films in special movie cars for the entertainment of passengers on some of the limited trains. In the tests, an ordinary day coach and a standard portable projecting machine and sound equipment were used, and even with this experimental arrangement, music, conversation and sound effects were received clearly and plainly by passengers,

the noise of the speeding train not offering the amount of interference naturally expected. Silent movies for trains are quite commonplace, and the successful tests with the talkies led railroad officials to predict that the sound-insulated movie car soon may be as much a part of the equipment of a transcontinental train as the diner.

### POWDER SERVES AS COUPLING INSTEAD OF GEAR SHIFT

963

As a substitute for the ordinary gear-shift systems, the peculiar properties of a fine metal powder have been utilized by two Swedish inventors in an elastic coupling device for a wide variety of machine-shop and other units. The device consists of a double cylinder, one part of which is fixed to the motor axle and the other, a shell that contains the metal powder, inclosed by another cylinder, is attached to the driven shaft. When set in motion, the powder is thrown around until it gradually builds up enough pressure to establish a firm cohesion between the two cylinders, locking them together in a strong grip, thus eliminating the need of the usual gear shift. The coupler has been subjected to severe tests and is expected to be of chief use in connection with gasoline engines employed in the iron and stone industries as well as in textile, printing and other manufacturing

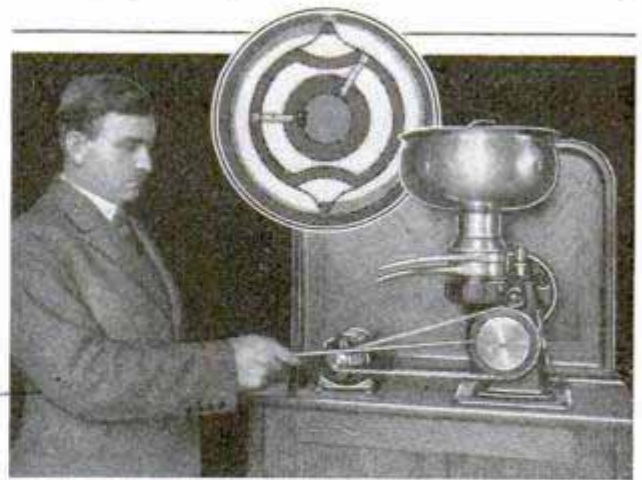

Sectional View of the Gear-Shift Substitute, and Device Employed on Cream Separator

activities. The start is made smoothly and easily and considerable economy is effected, it is claimed, through a reduction of power losses.

Invs. August Berggren  
Acre, Sweden



996 Mrs. Arthur W. Osborne  
613 S. Preckles Theatre Bldg.  
San Diego, Calif

# Black Gold

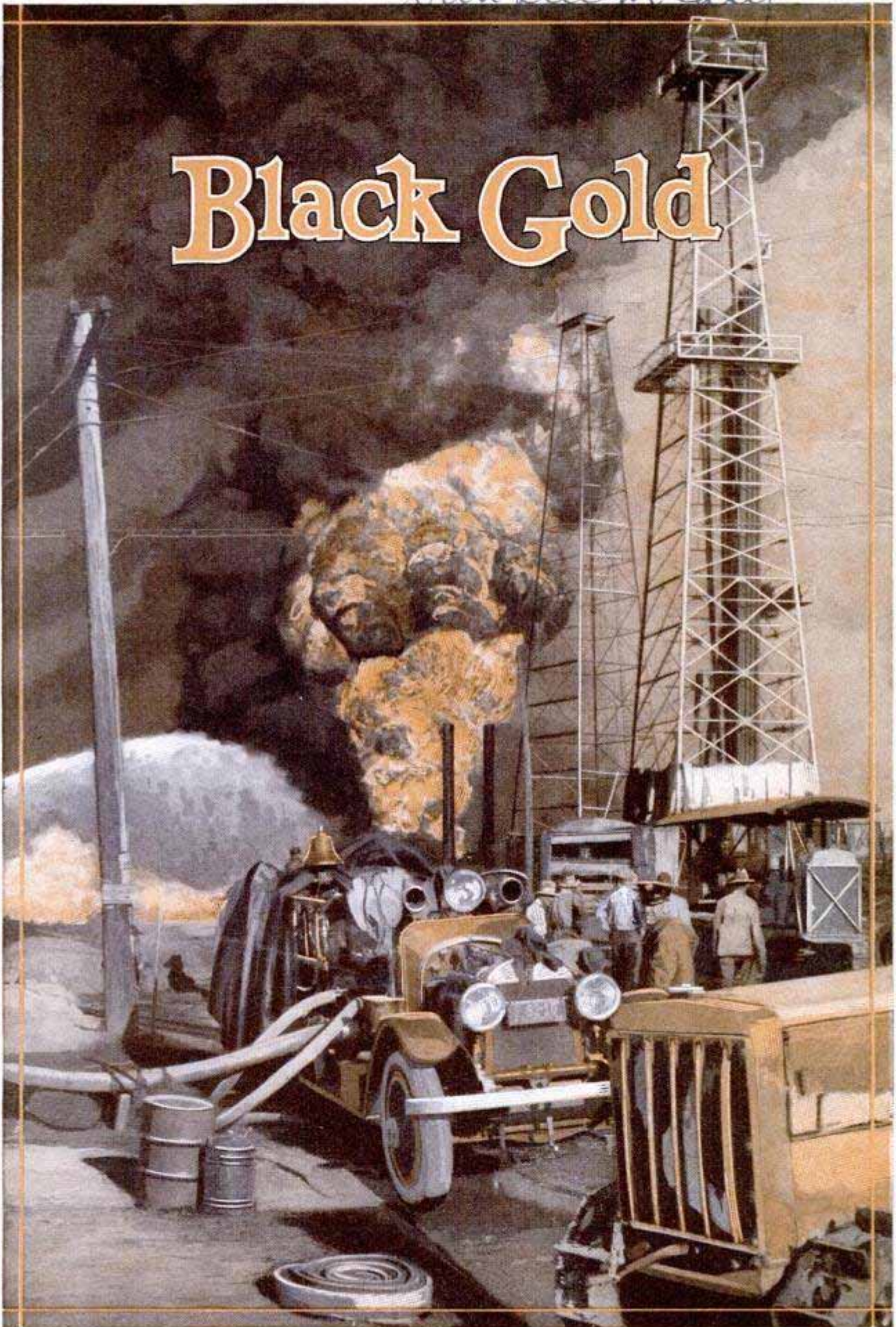

All Available Fire Apparatus Is Brought into the Oil Field When a Disastrous Blaze Starts; Close View of a Blazing Gusher in the Santa Fe Springs Area



Drilling for Oil under the Sea Has Been in Progress for Several Years and Has Yielded Large Returns; in This Photograph, Are Shown a Completed Dock and Two Wells in Operation, While, at the Extreme Right, the Dock Is Being Extended in Order That a Third Hole May Be Dug in the Floor of the Pacific



Harnessing an Oil Well and Directing Its Flow Are the Important Steps After the Drills Have Struck "Black Gold"; the Course of This Well, like That of a River, Is Being Changed by Sending It through an Underground Pipe 255 Feet from the Mouth



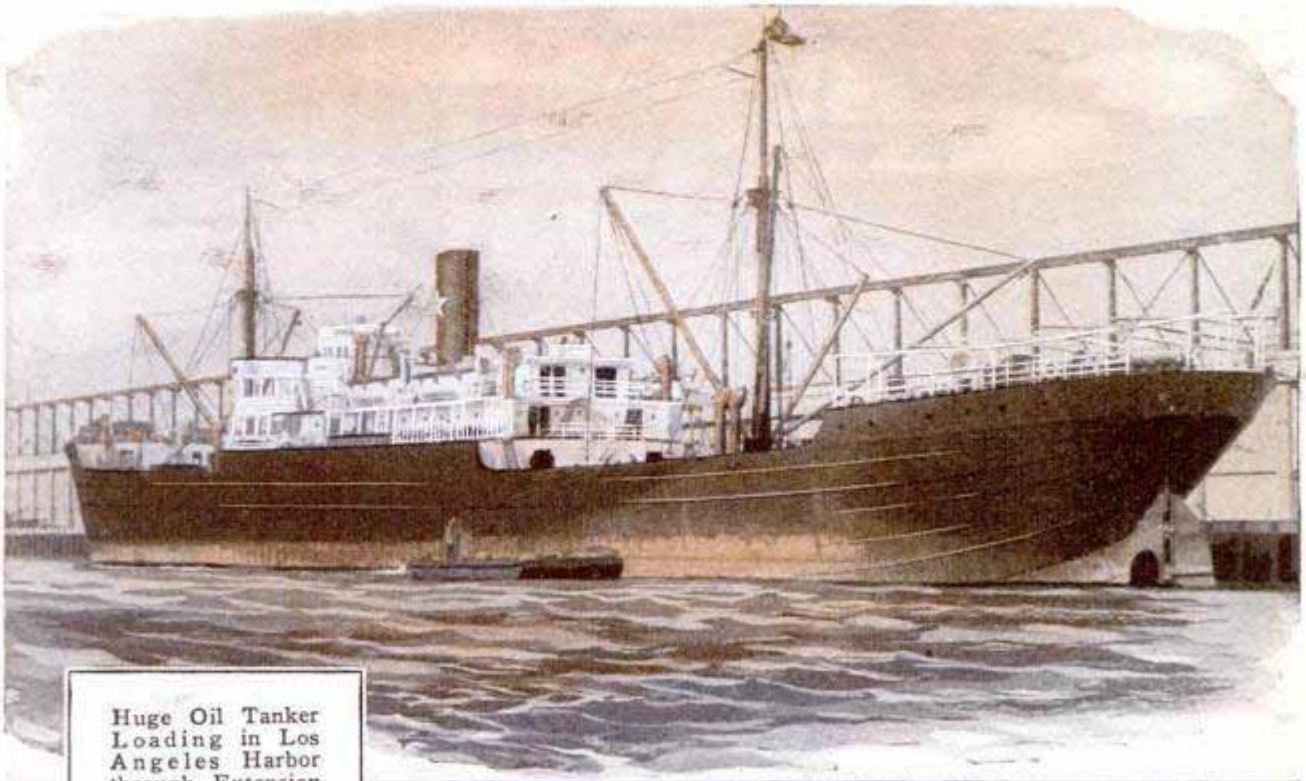

Huge Oil Tanker Loading in Los Angeles Harbor through Extension Pipe Line, and, Below, Fighting an Oil Fire; the Men Wear Asbestos Suits and Drag Their Lines as Near the Blazing Geyser as They Can; to Protect the Oil Fields More Adequately from Fire, Engineers Have Developed Chemical and Other Means





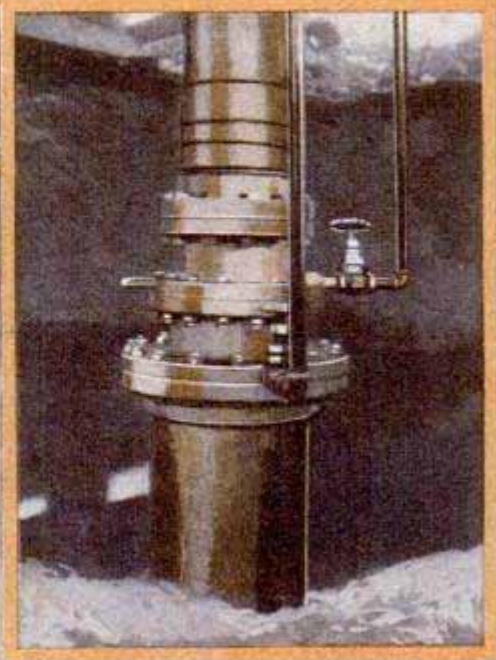
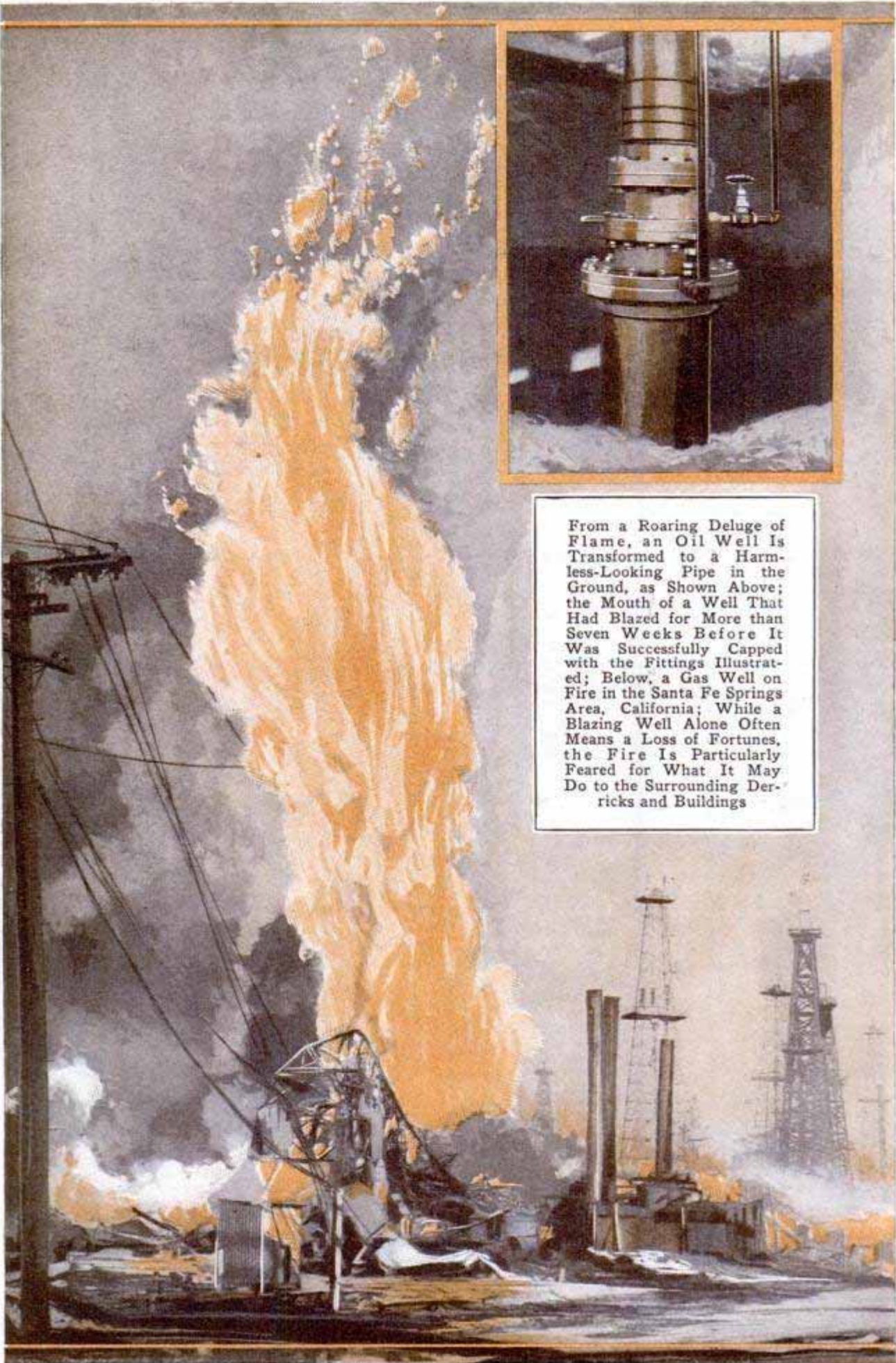

From a Roaring Deluge of Flame, an Oil Well Is Transformed to a Harmless-Looking Pipe in the Ground, as Shown Above; the Mouth of a Well That Had Blazed for More than Seven Weeks Before It Was Successfully Capped with the Fittings Illustrated; Below, a Gas Well on Fire in the Santa Fe Springs Area, California; While a Blazing Well Alone Often Means a Loss of Fortunes, the Fire Is Particularly Feared for What It May Do to the Surrounding Derricks and Buildings



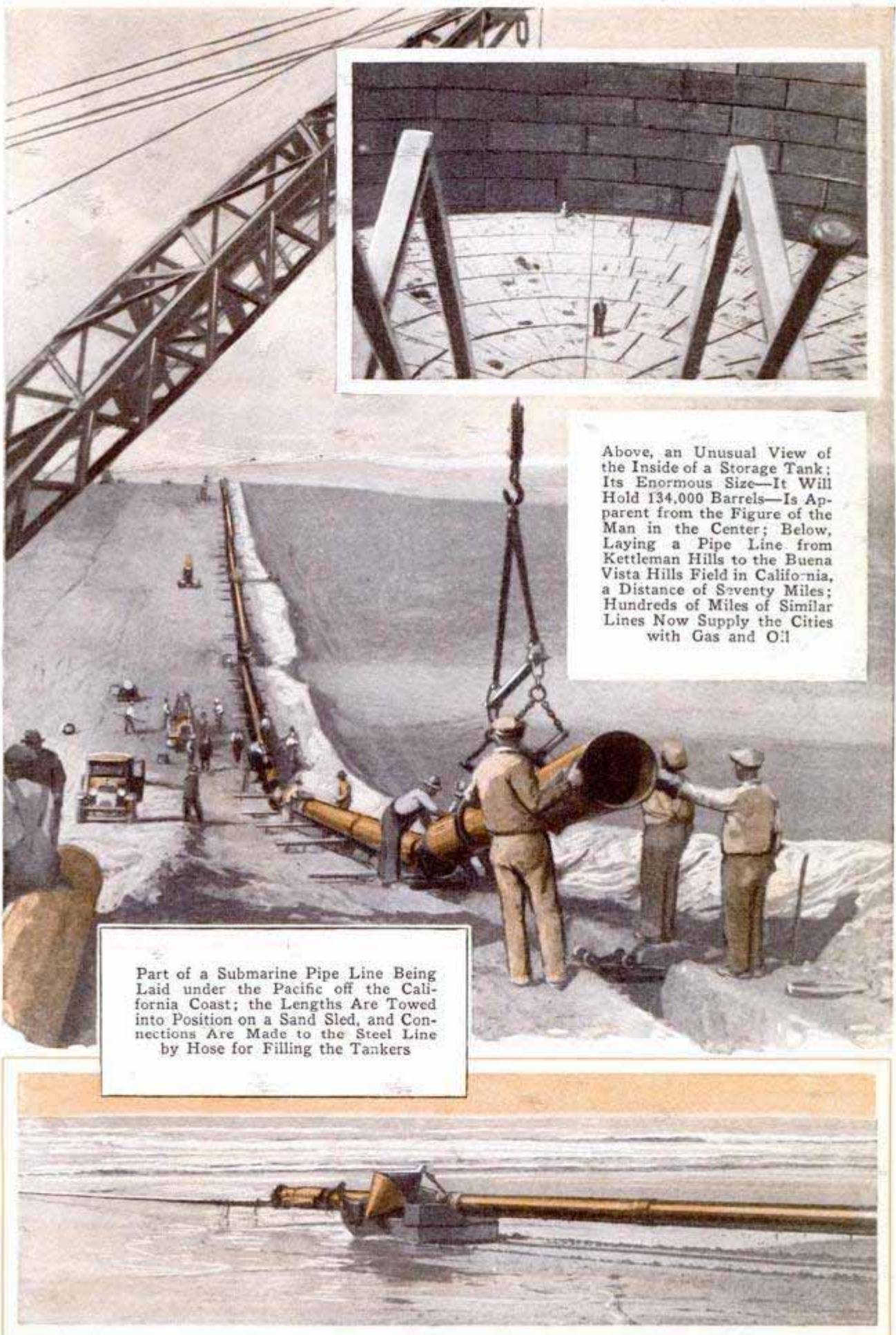

Above, an Unusual View of the Inside of a Storage Tank; Its Enormous Size—It Will Hold 134,000 Barrels—Is Apparent from the Figure of the Man in the Center; Below, Laying a Pipe Line from Kettleman Hills to the Buena Vista Hills Field in California, a Distance of Seventy Miles; Hundreds of Miles of Similar Lines Now Supply the Cities with Gas and Oil

Part of a Submarine Pipe Line Being Laid under the Pacific off the California Coast; the Lengths Are Towed into Position on a Sand Sled, and Connections Are Made to the Steel Line by Hose for Filling the Tankers



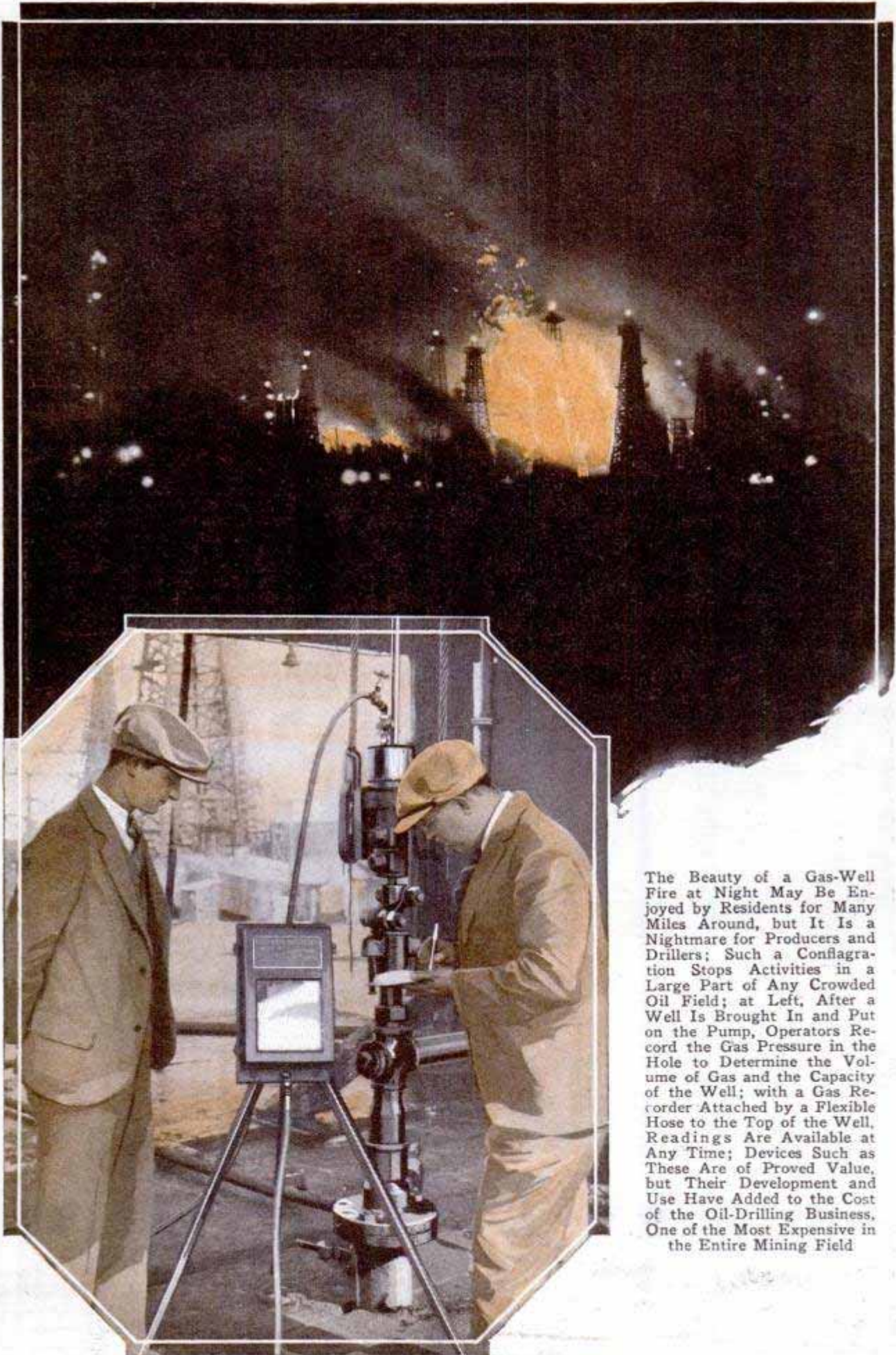

The Beauty of a Gas-Well Fire at Night May Be Enjoyed by Residents for Many Miles Around, but It Is a Nightmare for Producers and Drillers; Such a Conflagration Stops Activities in a Large Part of Any Crowded Oil Field; at Left, After a Well Is Brought In and Put on the Pump, Operators Record the Gas Pressure in the Hole to Determine the Volume of Gas and the Capacity of the Well; with a Gas Recorder Attached by a Flexible Hose to the Top of the Well, Readings Are Available at Any Time; Devices Such as These Are of Proved Value, but Their Development and Use Have Added to the Cost of the Oil-Drilling Business, One of the Most Expensive in the Entire Mining Field





After Laying a Pipe Line to Carry Natural Gas, the Crew Blows Gas down Line to Clear Out Any Obstructions, as Shown Above; at Right, Swivel, Kelley and Mud Pipe; the Swivel Holds the Square Pipe, or Kelley, Which Revolves and Also the Bit Which Drills the Hole; the Mud Hose Leads Mud through Pump Back into Hole; Below, Oil Derricks in a Residential District

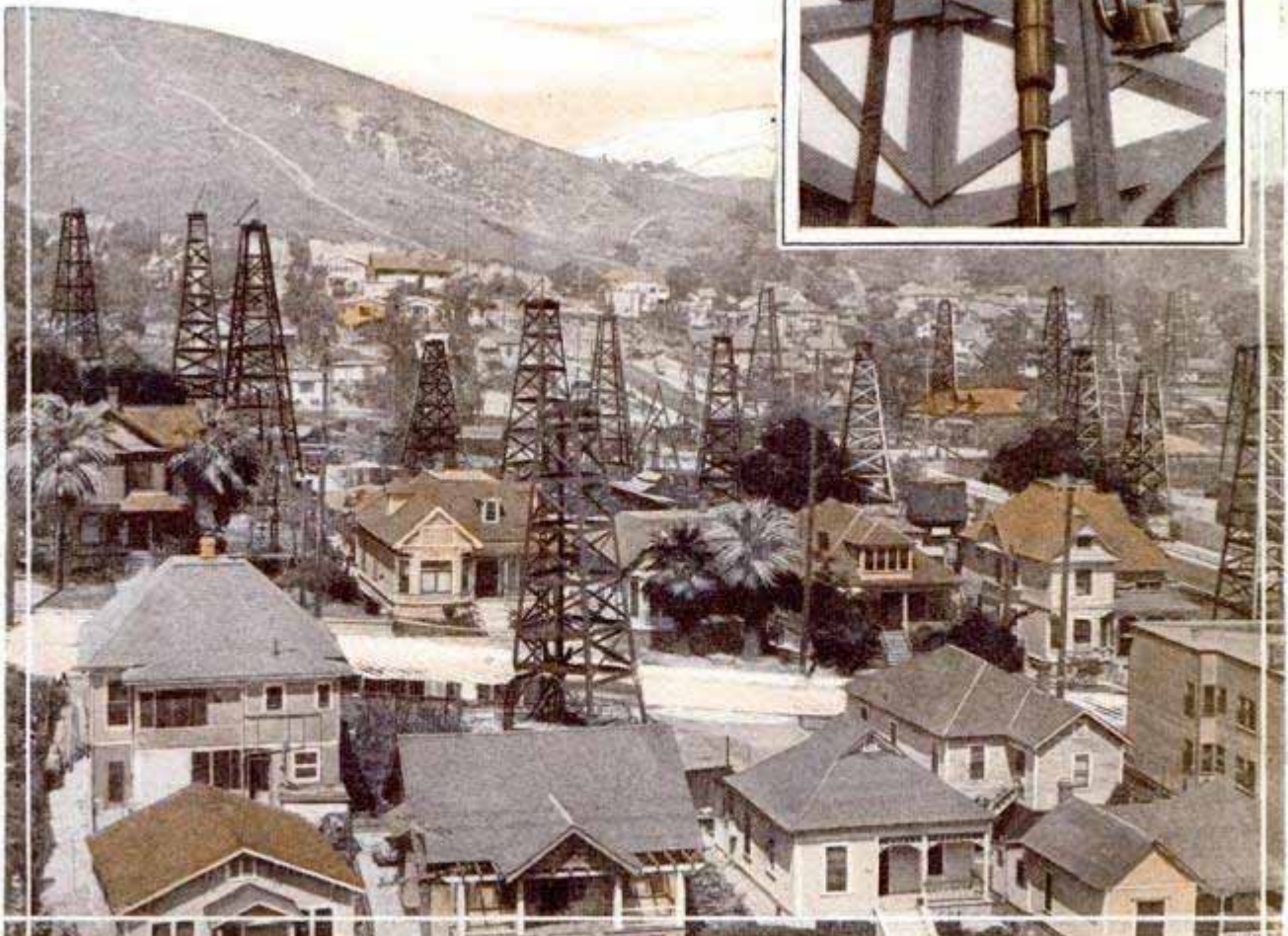
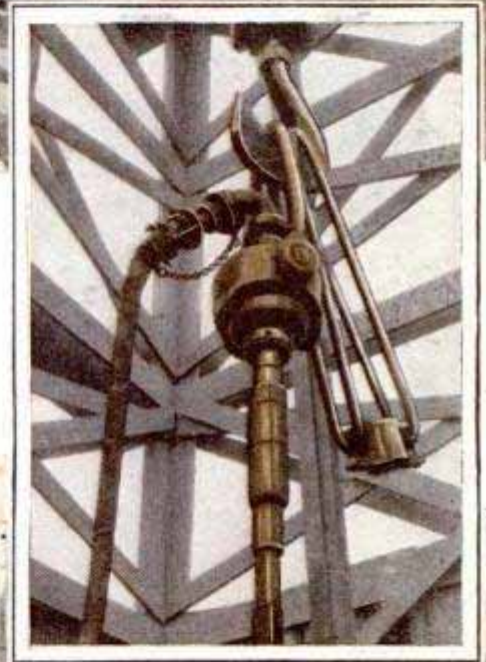



996

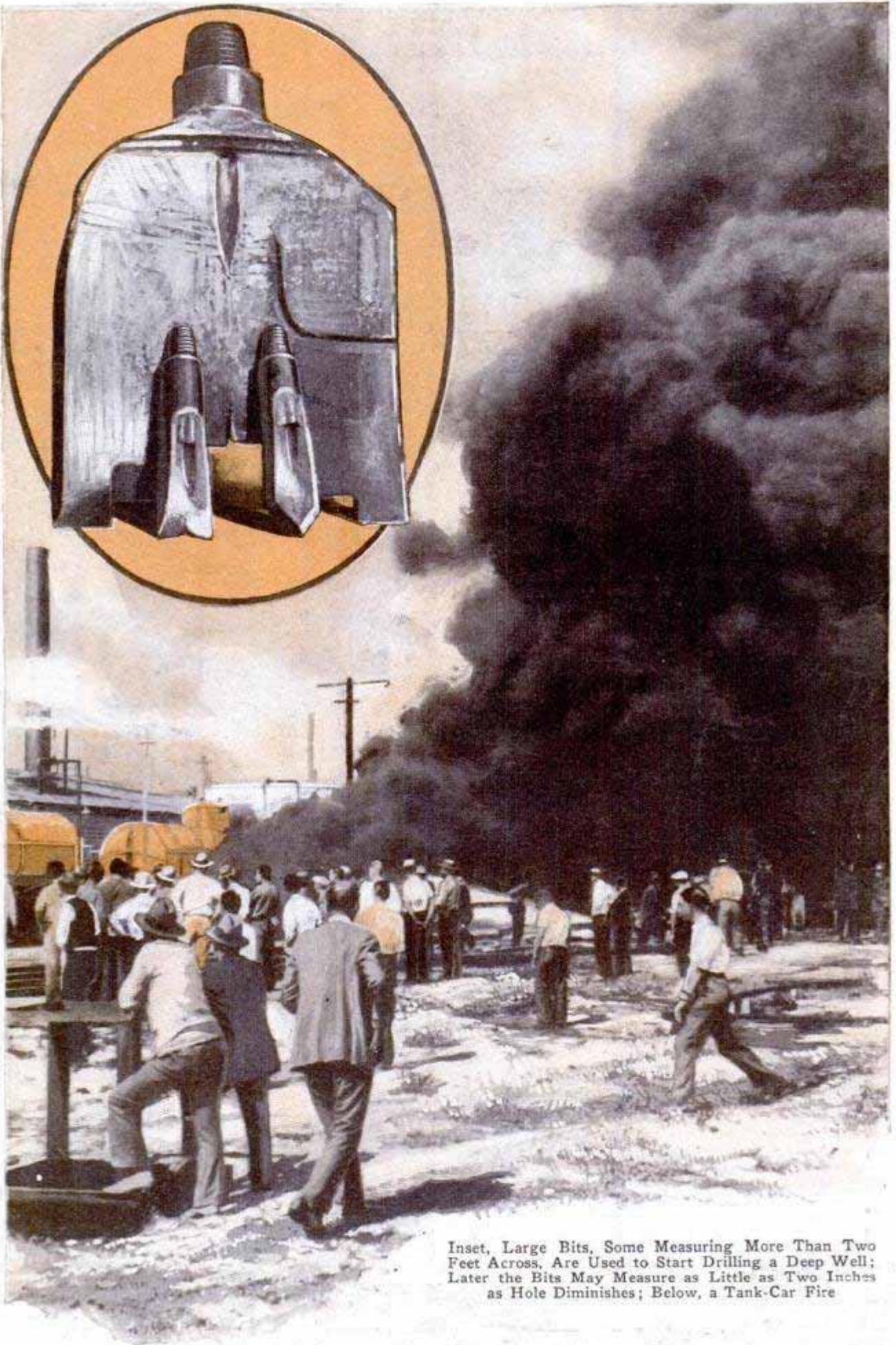

Inset, Large Bits, Some Measuring More Than Two Feet Across, Are Used to Start Drilling a Deep Well; Later the Bits May Measure as Little as Two Inches as Hole Diminishes; Below, a Tank-Car Fire



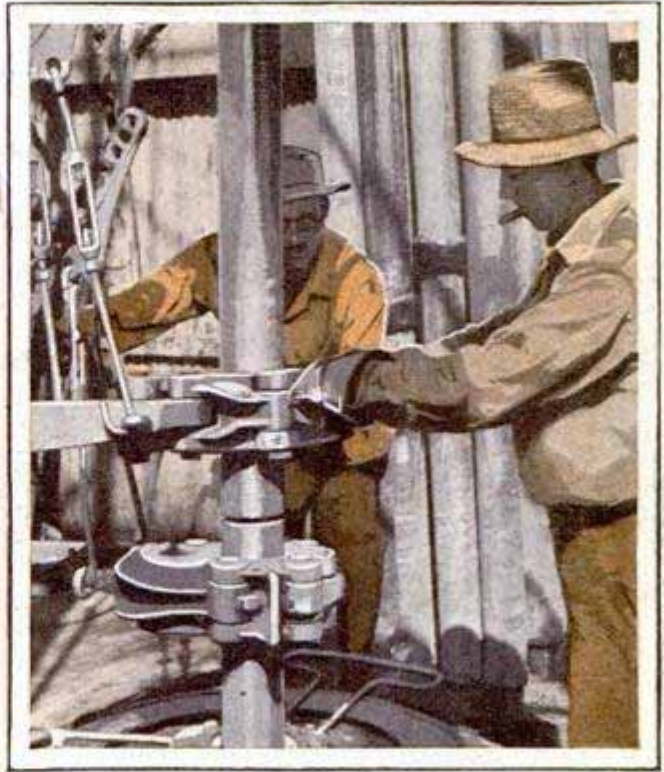

Above, Members of the Drilling Crew Are Breaking Sections as Each Length Is Pulled from the Hole; a Derrick Man Stands Above on the Platform to Stack the Pipe as It Comes from the Hole; at Left, Gas Pressure When a New Well Comes In Sometimes Shoots the Oil Hundreds of Feet into the Air; This Is a Typical Illustration of Such an Occurrence; Preparing for the Flow of Oil Is an Important Preliminary to the Completion of the Well; Temporary Sumps or Basins Are Scooped Up Out of Earth, to Catch the Flow and Save as Much as Possible, Until the Well Can Be Brought under Complete Control; a Powerful Gusher, Such as This, May Wreck the Derrick and Much of the Drilling Machinery Unless Preparations Are Made in Time

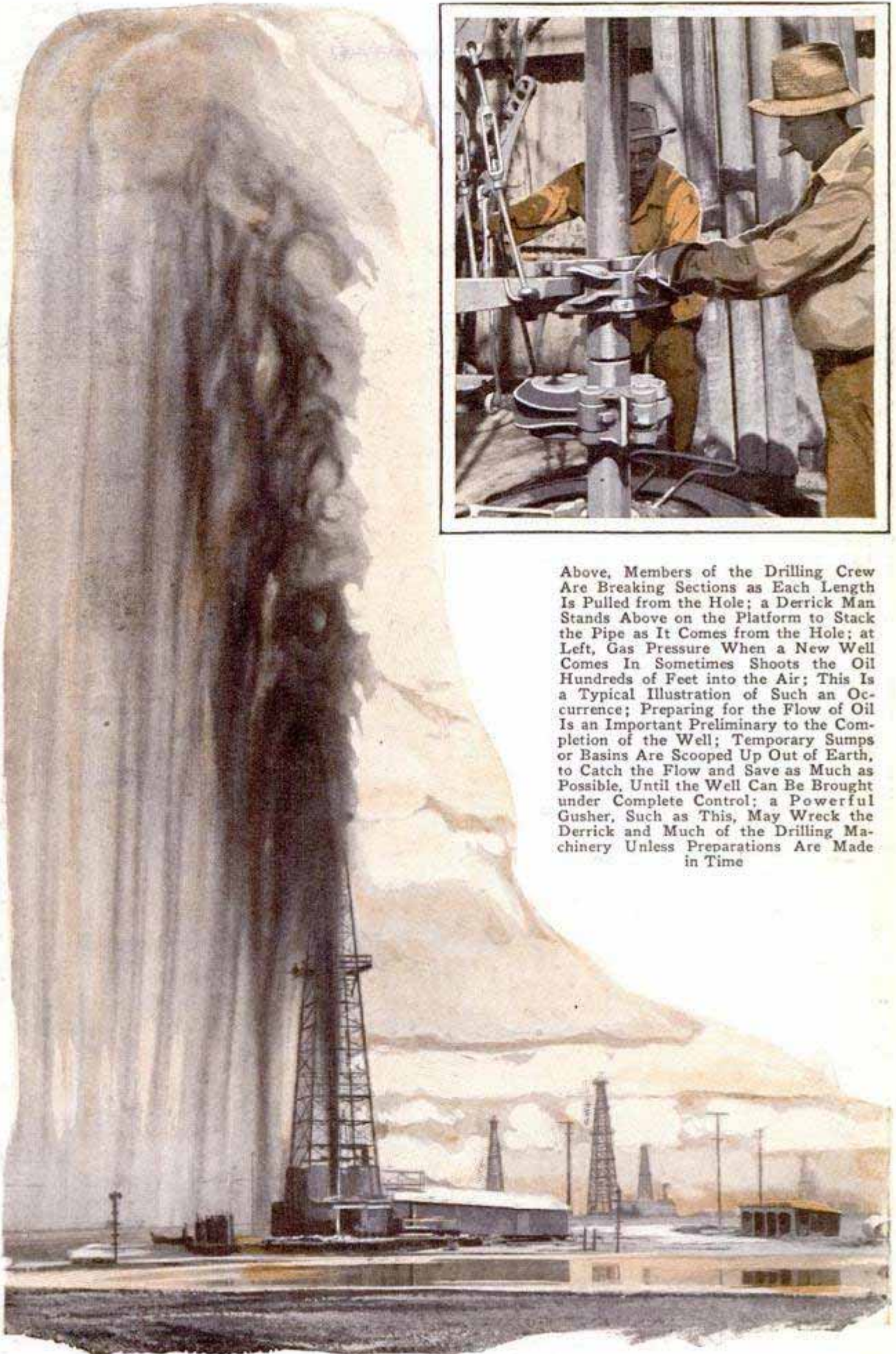



996

Wohensy Stone Drill Co  
714 W. 10th St  
Los Angeles Calif

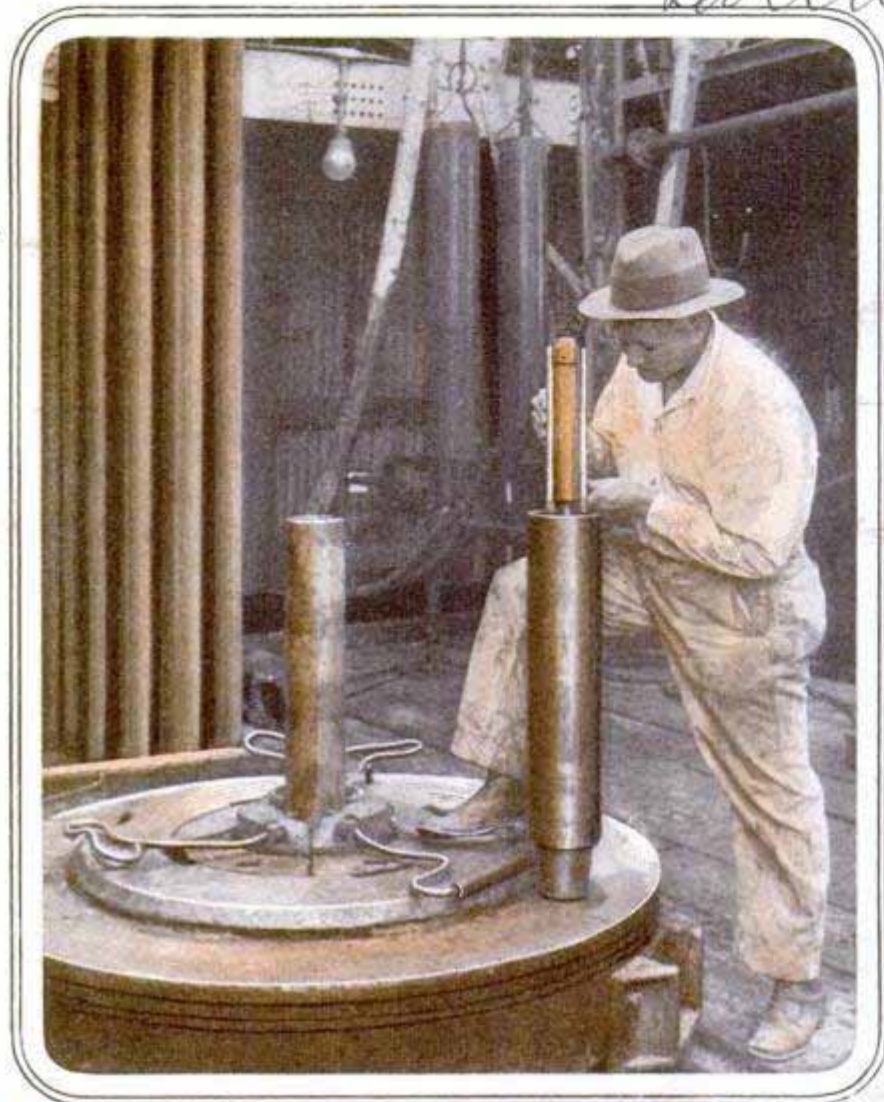

At Left, Device, Put in Small Section of Casing and Lowered into a Well, Acts as a Surveyor and Indicates by Degrees the Inclination of the Hole from the Vertical Path; the Instrument Measures Both the Inclination and Direction in Which the Well "Wanders"; Cases Are on Record in Which Wells, Drilled on Adjoining Property, Have Met Hundreds of Feet below the Surface, Requiring a Cessation of Drilling or Causing Conflict as to the Ownership of the Oil if It Is Found; Below, a Portable Foam Tower, Carried in Sections, Is One of the Latest Weapons for Fighting Fires in Oil-Tank Areas; the Tower, When Erected, Enables the Fighters to Pump Fire-Extinguishing Foam on the Surface of the Oil; the Tower May Be Erected Permanently on the Tank as Shown Here, by Fastening It with Cables and Pulleys So That It May Be Hoisted Up like a Telephone Pole When It Is Needed; Foam Has Been Found Effective in Many Blazes, as It Literally Smothers the Fire by Shutting Off the Oxygen Supply

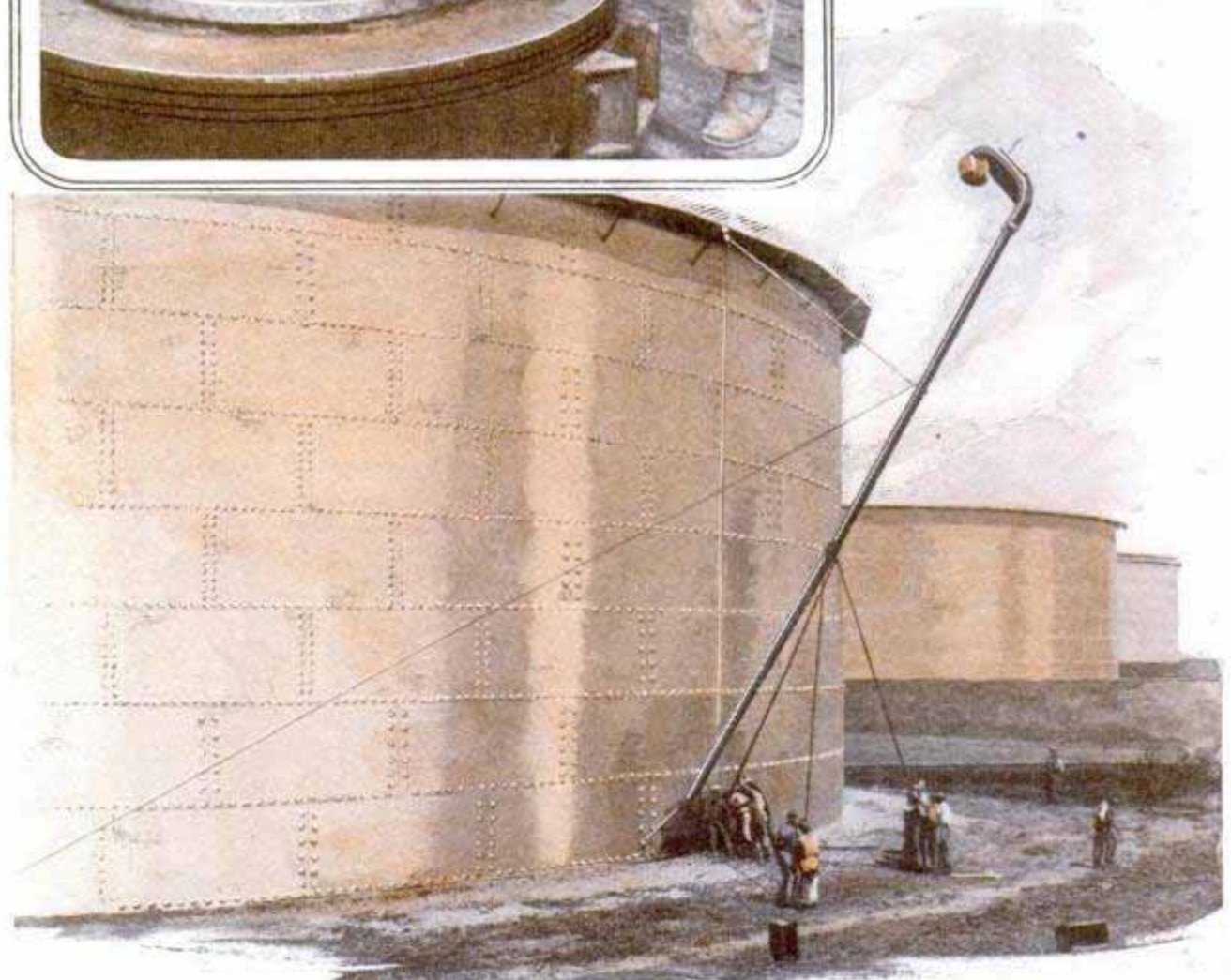





Above, Tankers Being Loaded with Oil Which Is Flowing through the Pipe Line Seen in the Foreground; the Man Directly Above Is Holding the "Mechanical Brains" of the Oil Field, the Core Bit Whose Sharp Teeth Bite Out Samples of Earth for the Oil Prospectors to Test; Below, Hauling an Oil-Line Hose aboard a Barge for Cleaning; Flexible Lengths like This Tap the Main Oil Line, for Supplying the Tankers, Loaded with a Flow That May Come from Wells Many Miles Away



996



Members of a Well Gang Spinning In a Length of Drill Pipe over a New Deep-Zone Well at Santa Fe Springs, California; the Huge Tongs, Used in Tightening the Connection, Are Just Being Swung into Place; This Is One Reason Why a Deep Well Cannot Be Drilled in a Day

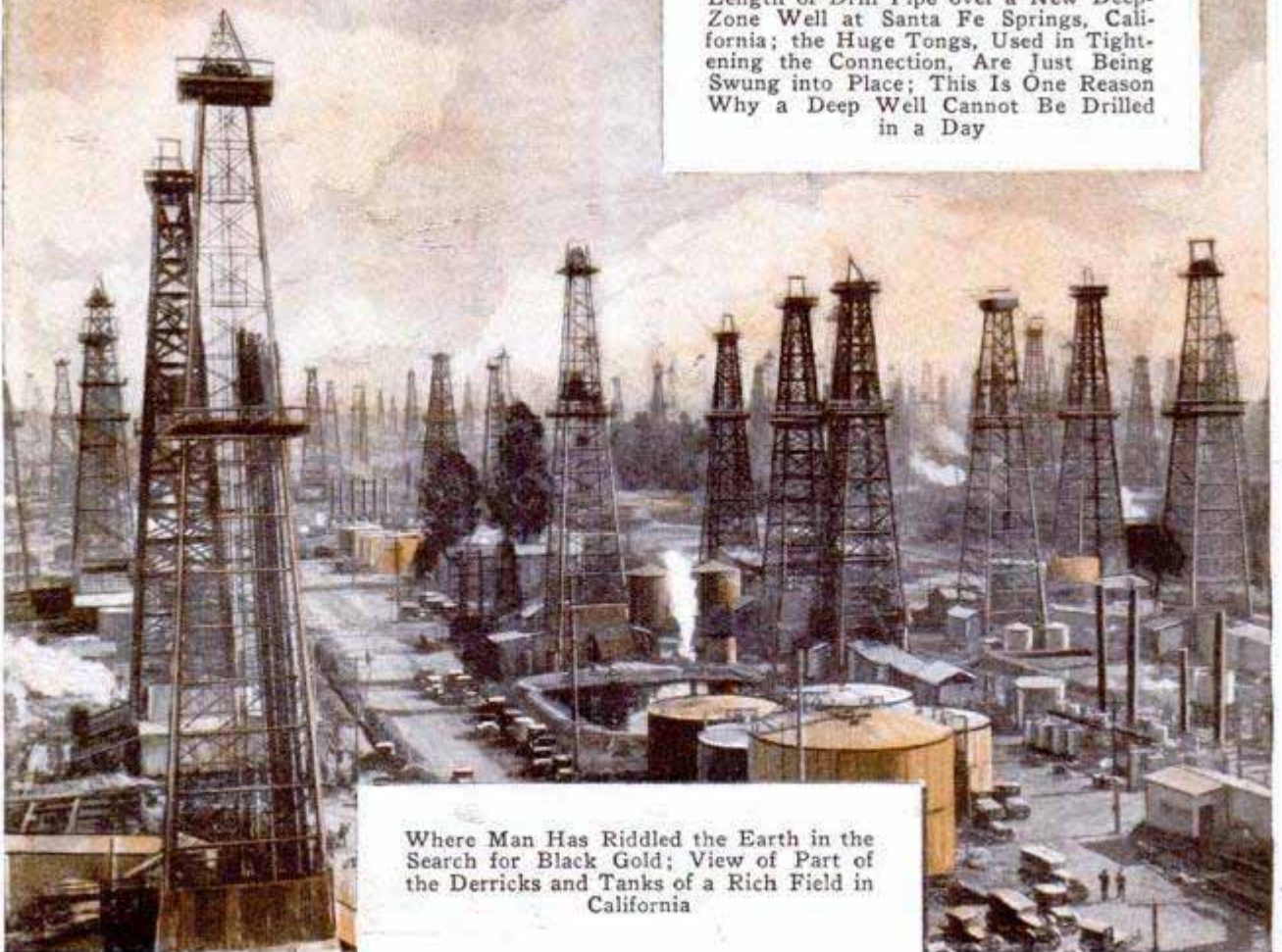

Where Man Has Riddled the Earth in the Search for Black Gold; View of Part of the Derricks and Tanks of a Rich Field in California



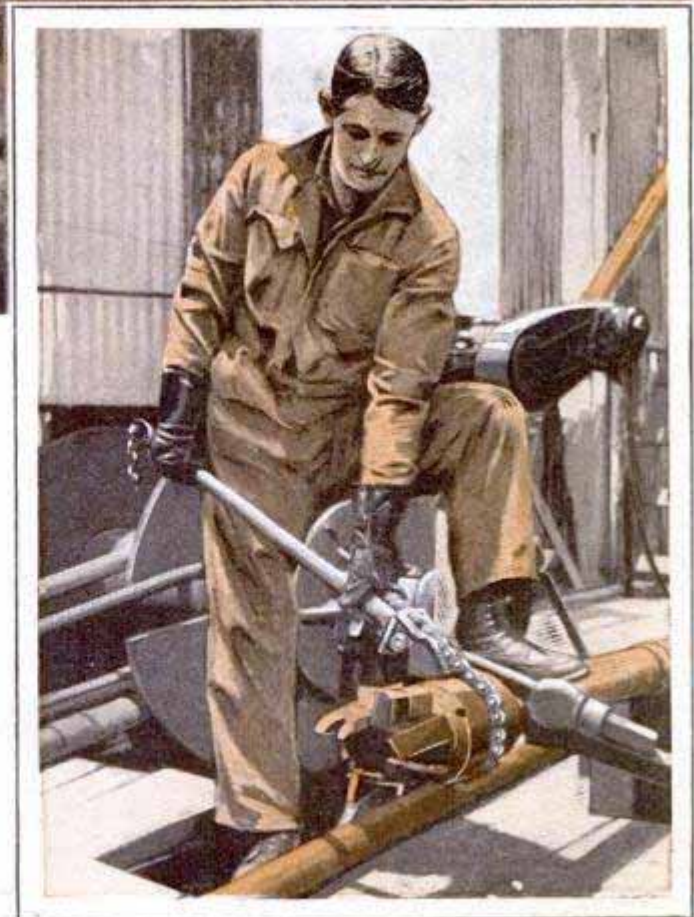
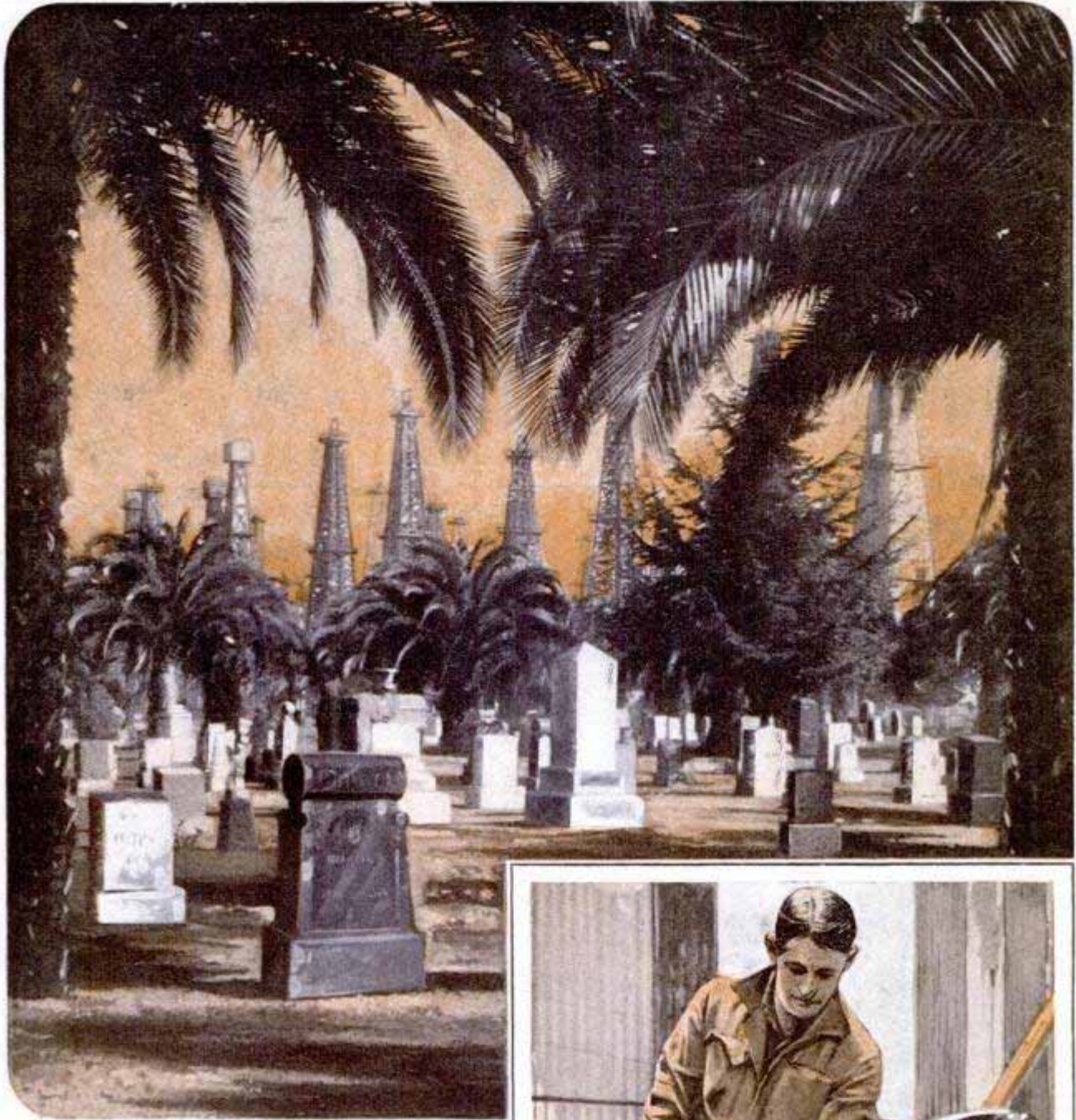

The Last Stand! Oil Wells Have Spread Out All over Famous Signal Hill, near Long Beach, California, and Now Completely Encircle the Old Cemetery and Its Beautiful Palms, Lying Halfway down Its Western Slope; at Right, Removing Core Bit from Core Barrel with a Chain Tong; the Core Bit and Barrel Are Used to Cut Out Samples at the Bottom of the Hole for Study by Geologists; the Bit Rotates and Bites a Sample Column Which Is Then Drawn Up; Scientific Prospecting Has Removed Much of the Guesswork in Hunting for Oil, the Presence of Which Can Be Detected by the Soil Formation, the Slope of the Strata and by Other Indications Easily Interpreted by the Trained Geologist; There Is Still Plenty of "Luck" in the Work; Oil May Be Found in Many Places, but Does It Exist in Sufficient Quantities to Justify Drilling and Commercial Production? Fortunes Have Been Won and Lost in Answering the Question



996

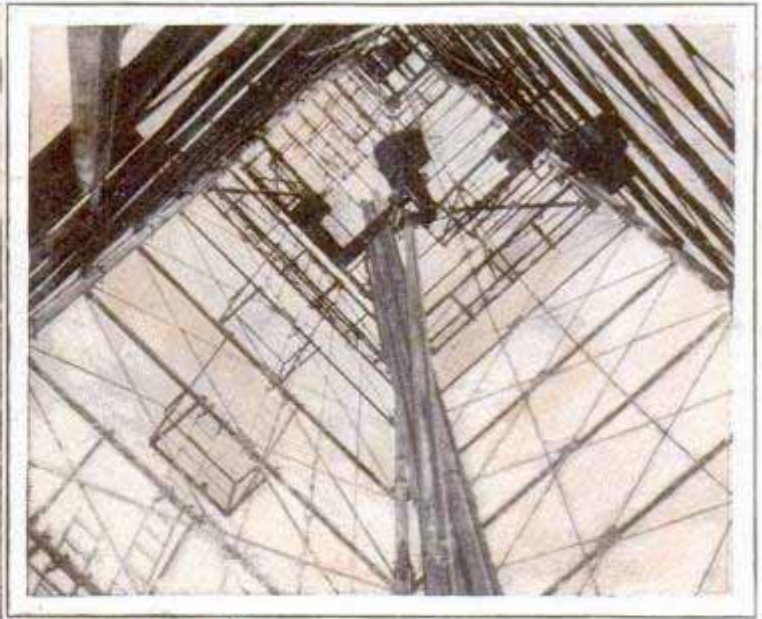
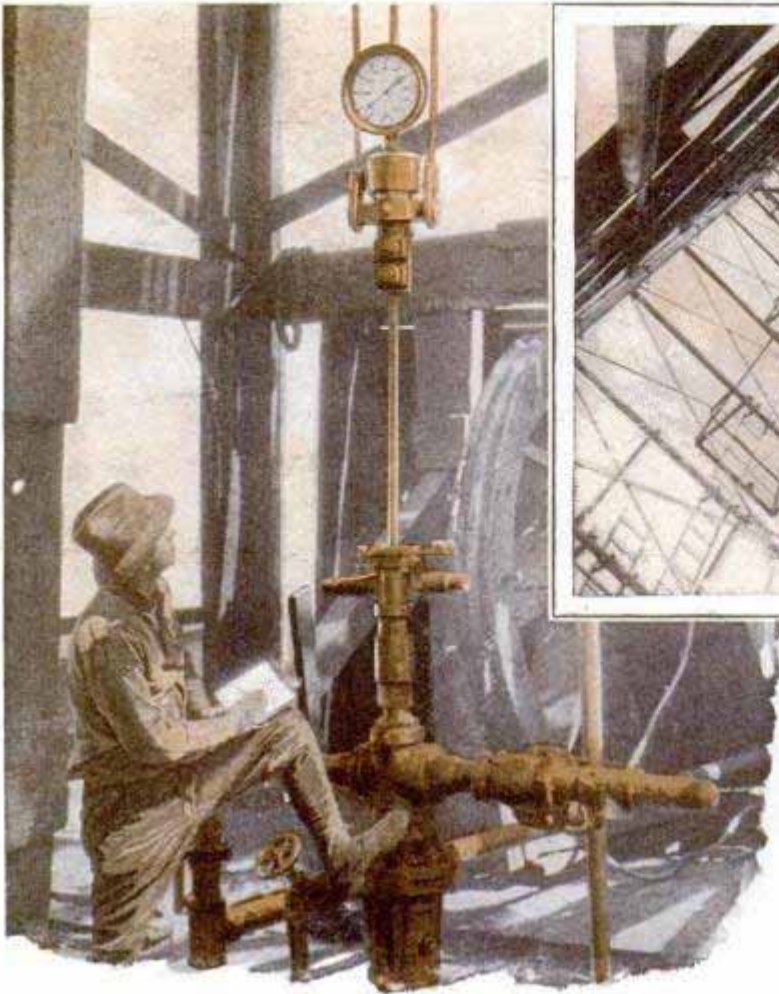

Looking Up inside One of the 120-Foot Steel Derricks Used for Deep-Zone Well Drilling at Santa Fe Springs, California; the Steel Structures Are Reinforced like Steel Skyscrapers, as They Must Support Heavy Weights; at Left, Measuring the Pull per Pound on the Pumping Rod After the Hole Has Been Completed; Pumping Becomes a Serious and Complicated Problem in Deep Wells, For Excessive Pull May Separate the Machinery

Below, Welders Riveting Twenty-Inch Stovepipe Casing before Lowering It into the Hole; This Casing Serves as a Guide for Later Drilling; at Right, Setting the Slips, the Wedges That Support the Pipe Temporarily While It Is Being Pulled Upward from the Hole

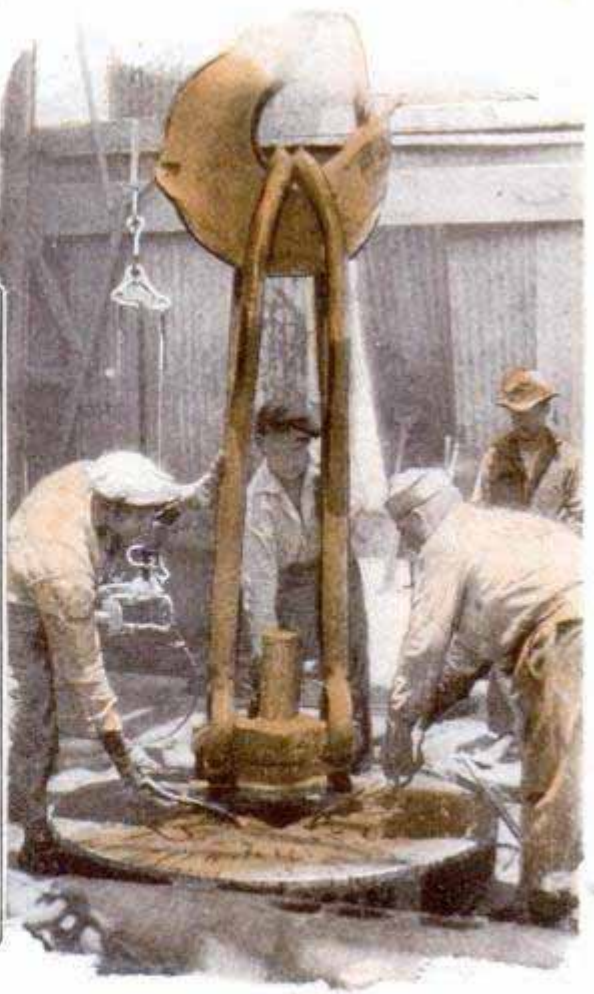
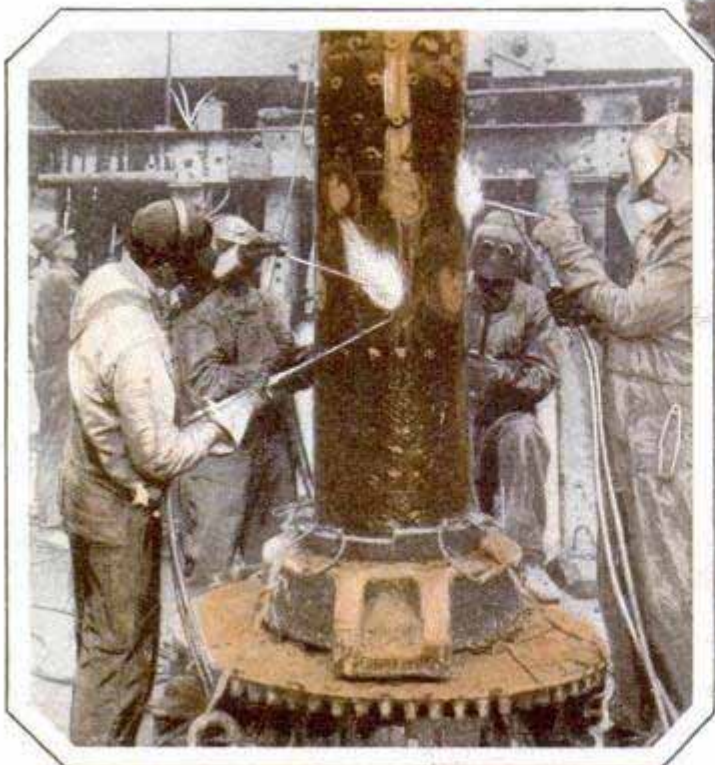





Drilling a Tunnel to a Well to Permit Capping It during a Fire; Several Outlets Were Made below the Surface to Diminish the Force of the Oil and Gas, and So Give an Opportunity for Shutting Down the Well; at Left, beneath This Derrick Is a Well of Record Depth, the Standard Mascot No. 1; It Is 9,629 Feet Deep and Required 458 Days to Drill

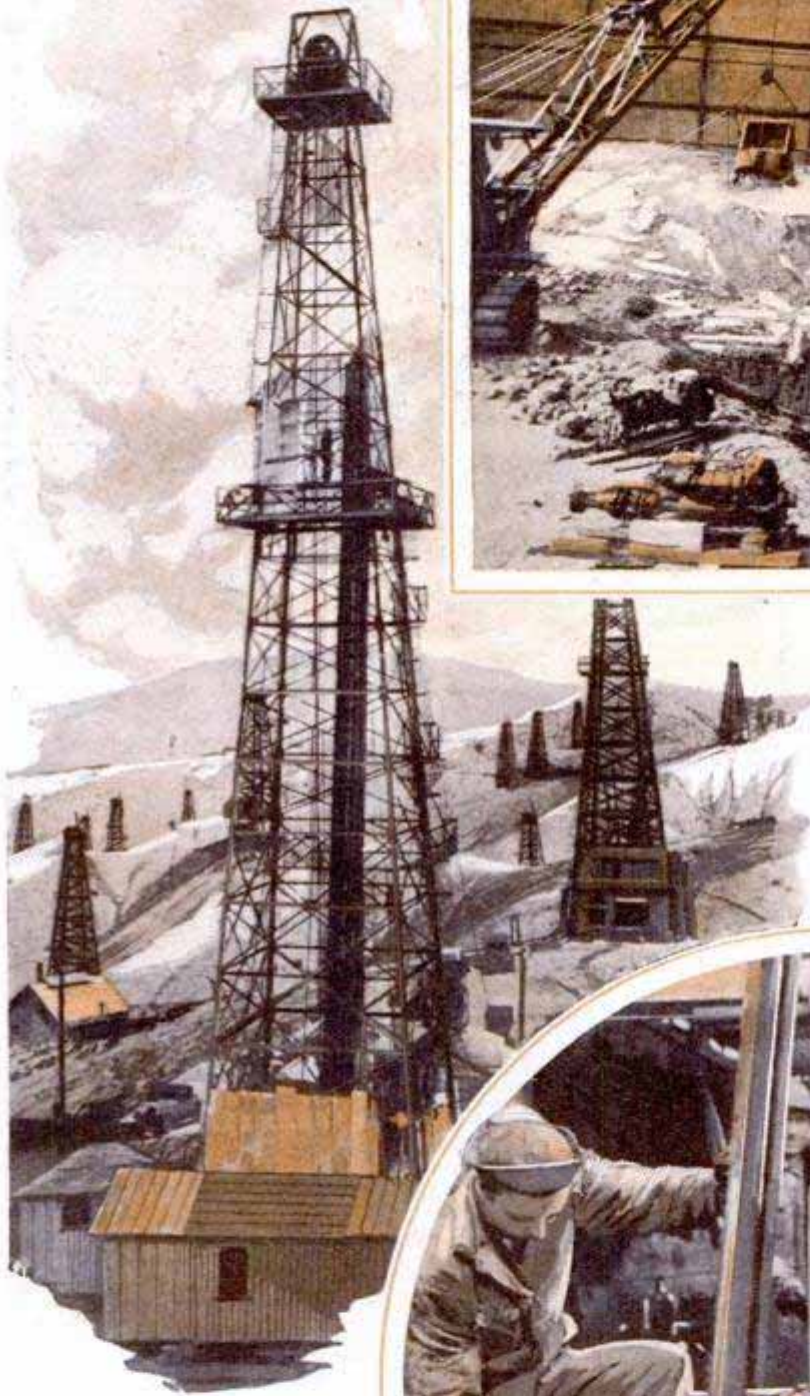

Members of the Drilling Crew Holding the Slips Which Wedge against the Drill Pipe, Preparatory to Joining New Lengths to It; They Are Getting Ready to Pull the Pipe; When One Stand Is Pulled, the Elevator Is Loosened and the Pipe Stacked against One Side of the Rigging; When Wells Descend More Than a Mile in Depth, as Many of Them Do, the Problem of Handling the Casing for So Deep a Hole Is an Expensive One

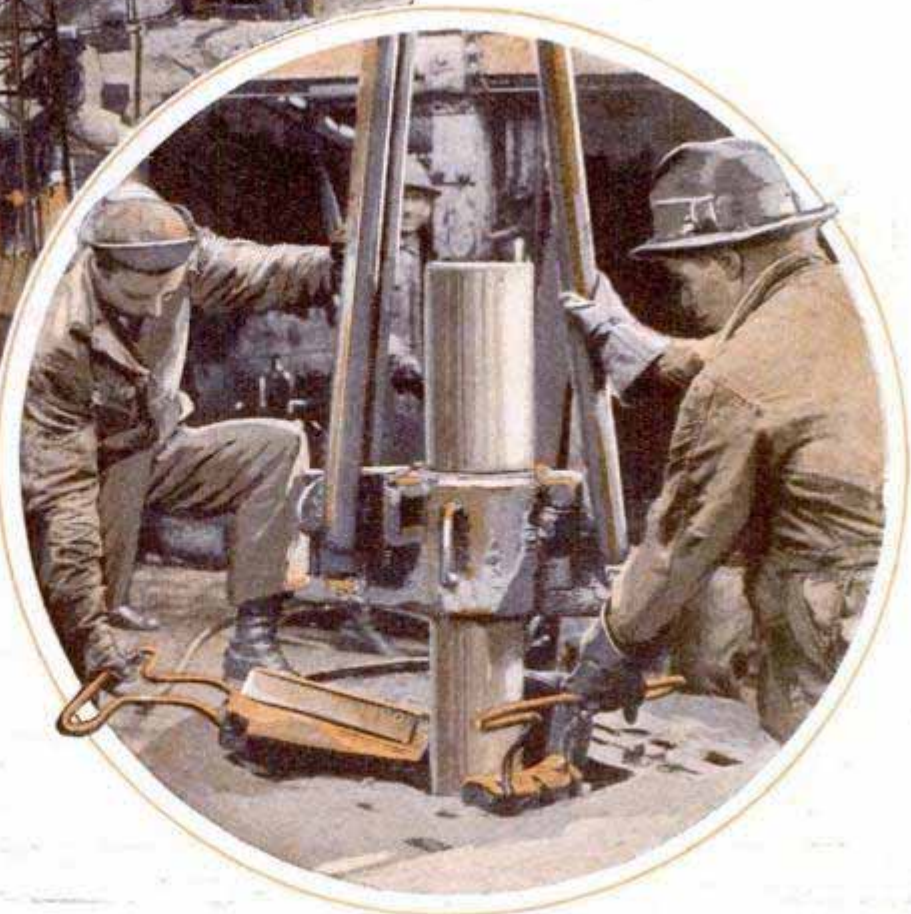



996

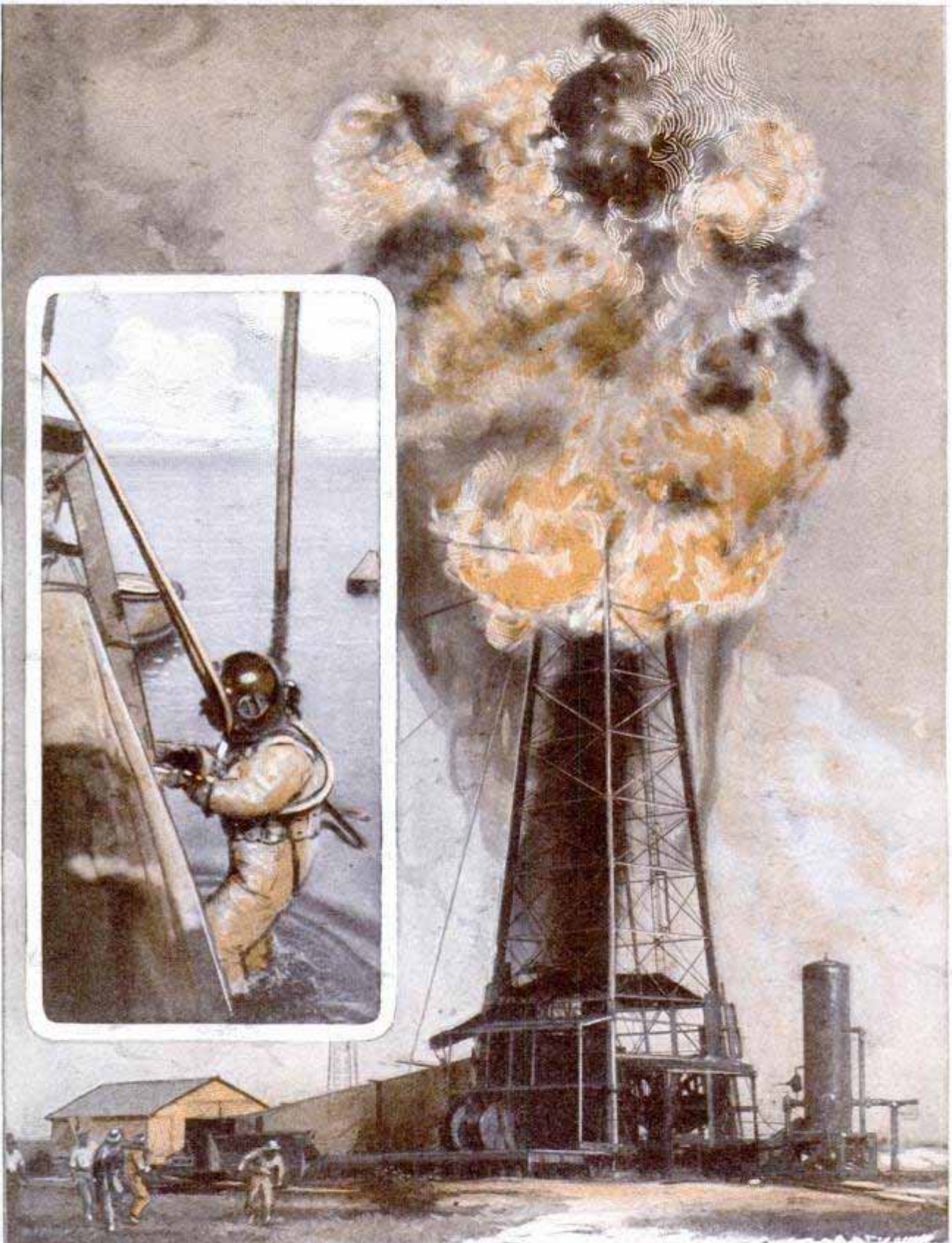

Diver Descending to Tie Hose to Pipe Line below Ocean, and, Above, Remarkable Photograph of Explosion of Gas and Oil at Top of 100-Foot Steel Derrick; the Resulting Fire Burned for Twenty-Four Hours; the Well Had Been "Shot" with Nitroglycerine and Spark from a Piece of Flying Flint Rock Is Believed to Have Caused the Gas and Oil to Ignite



*Journal of Specimens from Xenia Theological Seminary, St. Louis Mo.*  
 100 Charles Wark Engineering Works  
 417  
 Charleston, W. Va

*and American School in Jerusalem*

**PALACE ON TOP OF BIBLE CITY TO BE EXCAVATED**

Ruins of the palace which once rose above the Canaanite royal city of Kirjath-Sepher are being excavated. The city figures in Biblical record as the town which Caleb so desired to capture from the Canaanites that he offered his daughter's hand to the Israelite who would take the stronghold. The mound which represents this historic city lies about fifty miles south of Jerusalem. Ruins of six settlements in layers one above the other, have been found in earlier expeditions. Kirjath-Sepher means "book town," but so far no library has been found.

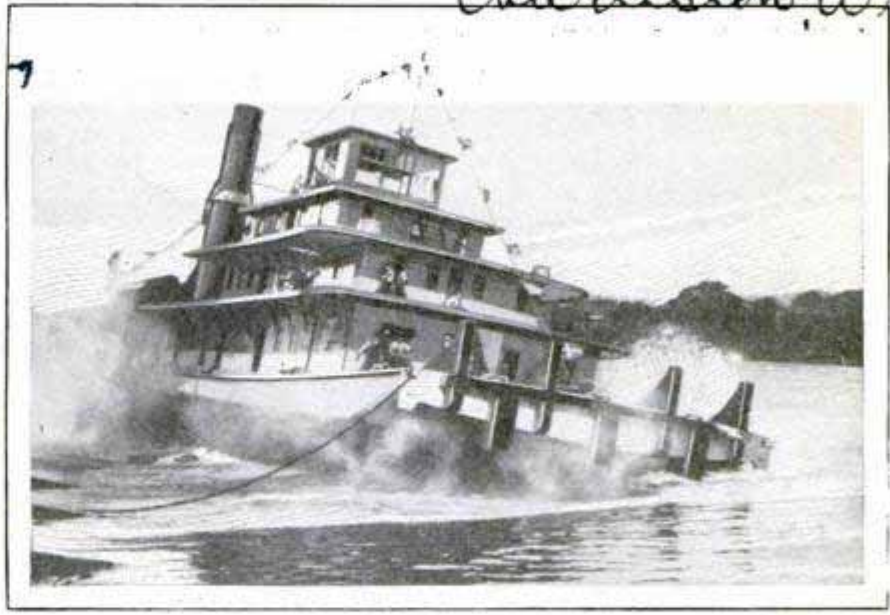

The Latest Type of River Towboat at Its Successful Launching; It Is Electrically Powered

**ELECTRIC-POWERED TOWBOAT TAKES TO THE RIVER**

The first turbo-electric river towboat recently was launched and underwent successful tests at Charleston, W. Va. The launching afforded an opportunity for an unusual picture of the modern freight engine of the river which was snapped just as the big boat made its first mighty splash as it took the water.

**STEEL NET GUARDS MOTORISTS FROM ROCKS IN BLAST**

Traffic was not interrupted and motorists were protected during blasting along a stretch near the Columbia river highway by erecting a strong steel net between high poles beside the road to shield cars from flying rocks. The net also saved the road surface from damage.

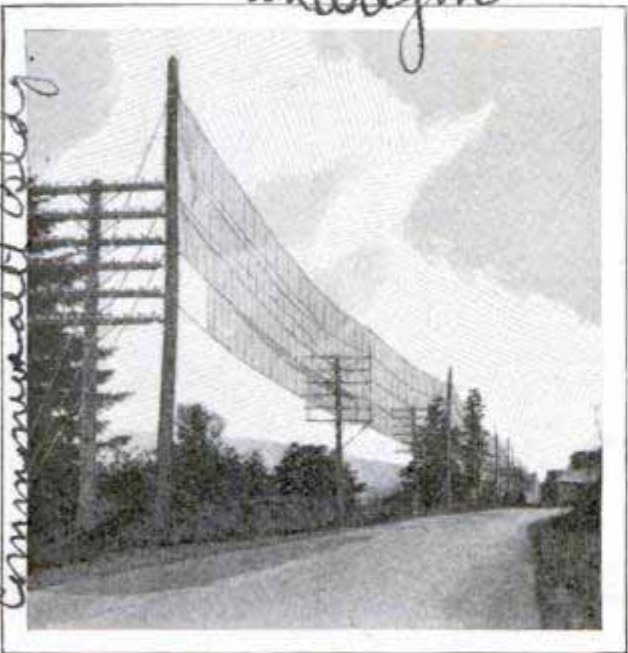

How Steel Net on Poles Protects Motorists from Flying Rocks

**WEEVIL AND WEATHER DATA FORETELL COTTON CROP**

Scientists are able to predict how much cotton will be produced, months in advance, by studying weather conditions and estimating the numbers of boll weevils that have hibernated during the previous winter. The predictions are based on thousands of weather reports from the many stations in the cotton belt by a process developed during the last twenty-one years, and the weather conditions permit an estimate as to the numbers of weevils that have been produced during a summer, how many have survived the winter or have been killed because of unusual cold or dryness. In 1926, the predicted total cotton crop was about the same as the actual production. In 1921, a year of an unusually low yield, there was an error of only seven per cent in the estimate, while in 1928 the prediction was but three per cent less than the actual total.

*J. B. Krüger, Chief of div. agri. meteorology*

*and Portland Ore. Commercial Bldg.*

*in Oregon*

*1015*



*From the Science Monitor*

28

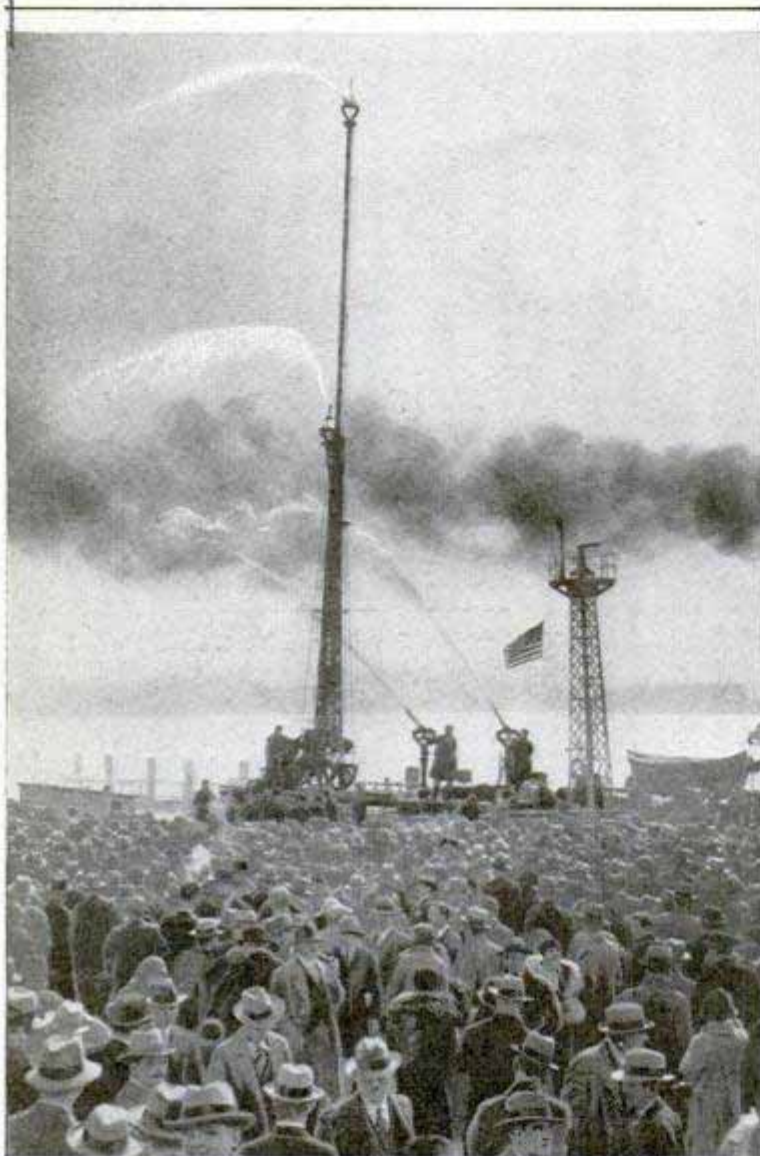

High Water Tower to Aid in Fighting Skyscraper Fires; It Is Sixty-Five Feet High and Has Four Nozzles

**TALL WATER TOWER TO FIGHT FIRES IN SKYSCRAPERS**

To battle fires in skyscrapers, a lofty sixty-five-foot water tower recently was tested in New York. It is equipped with four nozzles, capable of shooting 28,000 gallons of water a minute for a distance of 175 feet.

**CLOUDS SPRAYED WITH DRY ICE MADE TO YIELD RAIN**

After several failures, a Dutch scientist has succeeded in producing rain by throwing dry-ice powder on clouds from an airplane. The falling particles of solid carbon dioxide, used as a refrigerant, become laden with electricity, transforming them into numberless, very small drops

water supply into the furnace, through a steamer and then to a grating in the floor. The water feed is governed by a control valve, which, once set, requires no further attention. There are no moving parts to get out of order, and overflow pipes avoid any danger of damage from this source. There is only one outlet, but even distribution of humidity to all rooms is effected by convection air currents. Tests have shown that its use results in a saving of fuel.

**AUTOMATIC HUMIDIFIER SUITS ANY FURNACE**

Furnishing moist air at even temperature for the entire home, a humidifier made for attachment to any kind of furnace or heating plant, is entirely automatic in operation. It consists essentially of a series of pipes leading from the

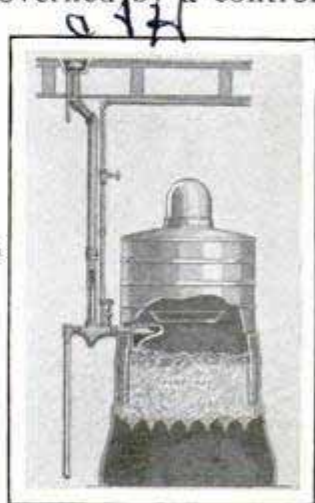

*A. Veraart, of Rijswijk near the Hague.* *W. H. Cunningham, 269 W. Hill St.*



975 Wacchus eyeglass

**NEW JOBS FOR ELECTRICITY FOUND ON FARMS** 1036

Not content merely to substitute for mechanical and man power on the farm, electricity is finding new and exclusive ways in which it can bring to agriculture advantages of research corresponding to those enjoyed by industry. Electric lubrication of the soil to make plowing easier, treatment of ensilage so that it will keep better, the heating of hotbed soil with electricity, and putting crops under electric discharges and under ultraviolet and white light to increase yield, are subjects of recent research. Water already in the soil is the lubricant for plowing. It is drawn to the moldboard of the plow by making that the negative terminal of an electric circuit. The coulter, insulated from the framework, is the positive terminal. Field experiments show that the force required to pull the plow is reduced every time the current is turned on.

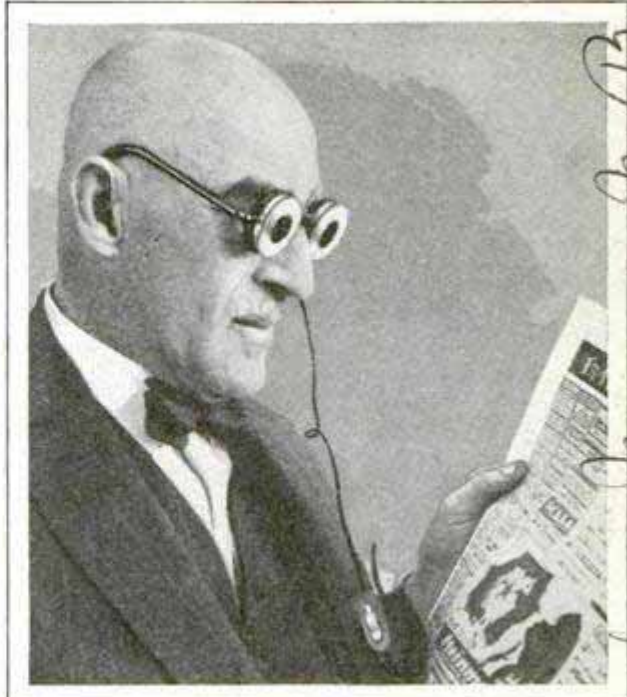

Electrically Lighted Eyeglasses Designed to Help Night Workers

**ELECTRIC-LIGHT EYEGLASSES AID NIGHT WORKERS**

Devised especially for persons compelled to do much reading at night, eyeglasses introduced by a German firm have electric bulbs on each end of the frame. They are supplied with current from a battery which can be carried in the pocket.

**TEST WARMTH OF OVERCOATS ON REFRIGERATING COILS** 101

How warm is your overcoat? An eastern firm is able to give an exact answer by wrapping the garment around a heating unit in a test machine, turning on the refrigerating coils, starting a fan and then reading the degree of the coat's resistance to the cold on special dials. The heating unit is held at body temperature and the amount of heat supplied to it is measured electrically. A wind velocity of twenty-five miles an hour can be created by the fan, and the coils are able to reduce the temperature to twenty degrees Fahrenheit. The measuring apparatus shows how many heat units are allowed to pass through the various kinds of cloth tested. Curly-faced overcoating passes slightly over two units every hour for every degree difference in temperature between the heat unit and the surrounding air, and Alaska seal less than two.

**BOAT-RACE STARTING CLOCK FIRES OFF CANNON** 146

To insure better starting of boat races, an official of an eastern outboard association has introduced an efficient clock which does three things at once. It points to the "Go" signal, dips the starting flag and fires off a cannon. The dial is about six feet in diameter, and the apparatus weighs less than seventy pounds.

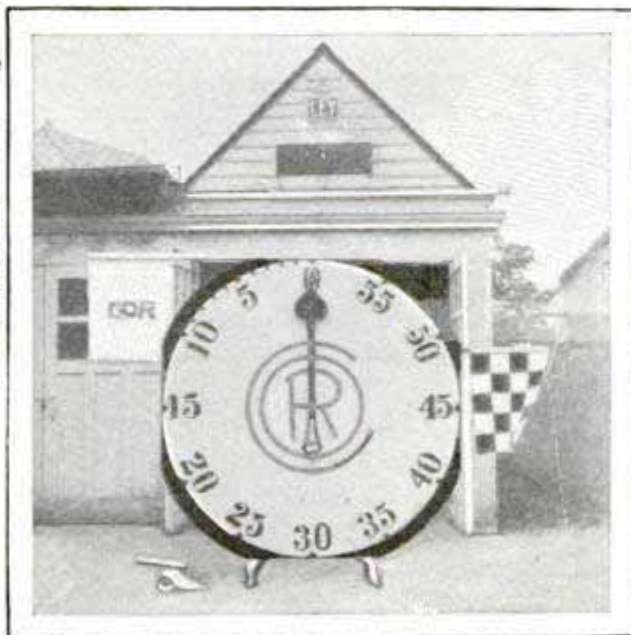

Giant Clock for Boat Races Which Dips the Starting Flag and Fires the Gun

Mr. Marcus M. Bach, Letterstrasse 76, Berlin, SW 68, Germany

Commodore, Outboard Racers Assoc.

Exp. planned by Ephraim Friedmann, 450 Lexington, N.Y. R.H. Macy Co. New York

Dr. George Ley, 191 Riverside Ave. New Haven



499

# IT'S EASY



Pilot Myers Using the Speaking Tube; It's Easy to Hear Him Even above the Roar of the Motor; Below, There's a Trick to Getting into the Ship—at First

By PAUL D. PADDOCK

"I'LL take off, fly around the field once and land," said Pilot Myers. "Then I'll ask you if you're comfortable. If you are, we'll take off again, go up about 2,000

feet, and I'll let you try your hand at the controls. Now follow through and watch what happens to the nose of the plane as we take off and as we land."

I nodded, the motor barked as he advanced the throttle to taxi into the wind, and I wondered how this adventure of learning to fly would end. I am thirty-nine years old. I don't drive a car. I have possibly less than the average knowledge of motors. Of aeronautics and the airplane, I know little. Can an office man like myself, familiar chiefly with typewriters and a notebook, master the controls of a sky-speeding plane? But they say it's easy to learn to fly. Well, we'll see, I reflected as the plane lifted on this, the start of twenty hours in the skies to win a private pilot's license.

Lifebelt snugly fastened about the waist. Right hand on the stick, held gently between the thumb and first two fingers. Feet on the rudder pedals. Parachute



# TO FLY

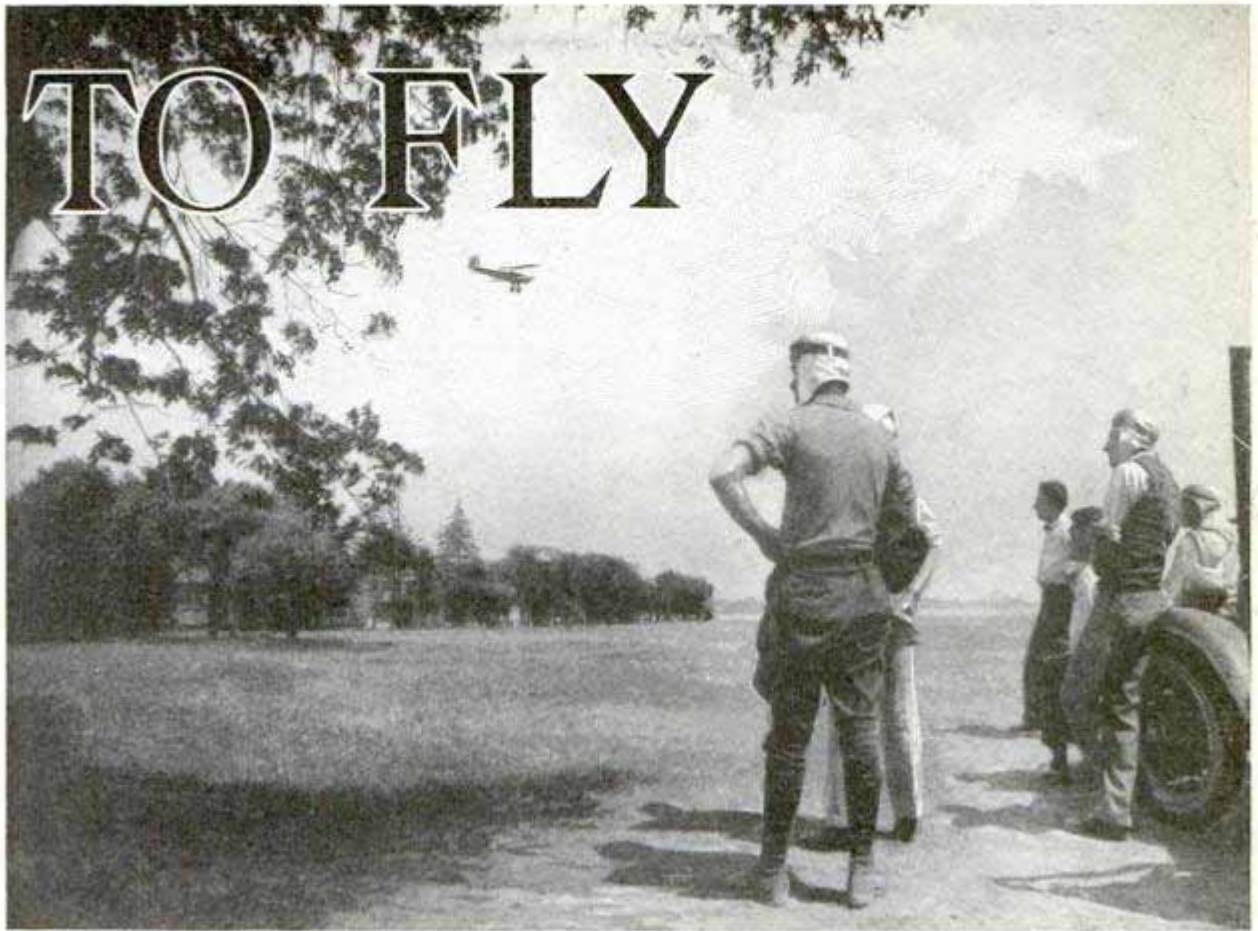

Students, Instructors and Others Are Interested Observers during a Department of Commerce Test for Licenses, When Candidates Must Satisfy the Inspector That They Have Mastered the Course

snugly, but not too tightly, buckled and forming a comfortable cushion in the seat, which can be raised or lowered until you can just see the tips of the top engine-valve covers over the nose of the plane.

Sit easily and relax. Enjoy yourself! Don't grow tense. How valuable that advice proved and how much it helps in learning to fly. Wear comfortable clothing, especially an easy pair of shoes. You cannot fly well if your feet hurt.

Learning to fly today is a progressive process of trying to do exactly as you are told, using your senses and keeping both mind and body relaxed although instantly obedient. It's keenly interesting, it's great sport as well as a profound and absorbing study.

The plane stops. It is now facing squarely into the wind, the proper position for a take-off. Myers advances the throttle all the way forward. That's "giving it the gun." With a mighty roar, the engine responds. The ship moves. As it starts, the pilot puts the stick far forward. That moves the elevator at the rear of the plane

and brings the tail up and off the ground so that we can gain speed more quickly. The brown dirt of the landing field goes blurring by and I can feel Myers kicking the rudder pedals, first this one and now that, to keep the plane going straight ahead. Remember that rudder. It's the most important part of the take-off. Back comes the stick, easily and slowly of its own accord, and, before I realize it, the crunching and bouncing of the landing wheels have stopped and we are in the air.

Full throttle for the take-off and the initial climb, but when we have reached a height of 500 feet or so, Myers eases back on the throttle until the tachometer shows the propeller speed to be about 1,500 revolutions per minute, the proper speed for cruising, and as we level off for straight flying, the nose of the ship comes down on the horizon. A gentle turn, and we are gliding down for the landing.

"We start our glide at the proper distance for making the field," says Myers through the speaking tube. I can hear him plainly now, for he throttled the en-





A Good Way to Hold the Stick, Lightly, between the Thumb and First Two Fingers Only, to Keep from Grasping It

gine down to make the glide, and about the only noise is the musical whine of the wind through the wires. "When we are about thirty feet above the ground and over the field, we start to slow down like this." He moved the stick back gently, a mere fraction of an inch. The nose of the plane came up slightly and we were flying level. The speed slackened and the ship settled perceptibly. "We're sinking a bit; feel it?" Myers continued. "Every time we feel the ship sink, we pull back a bit more on the stick. So. A little more, more, and now all the way back!" As he spoke, the "Fledgling" softly floated down on three points, both wheels and the tail skid simultaneously—a perfect landing—and we rolled to a gentle stop.

Then he gave me one of my first and

most important warnings. "I told you to follow through with your hands on the controls," he said. "That was all right. But on that landing you were pushing against the stick, weren't you? I could feel you opposing me. Never do that. Don't grasp the stick tightly and don't ever try to exert pressure on the controls when the instructor has them."

Instinctively, as the ground was coming up to meet us on the landing, I had been pushing on the stick. The wrong way too; a sort of blind effort to keep the ground from coming up, but from that moment on, I always tried to handle the stick as though it were an eggshell.

Again we wheeled into the wind and soon were climbing for the next and last part of this absorbing lesson.

"I want you to get acquainted with the country around here," said Myers, when we had gained 500 feet or so of altitude and he had throttled the engine down to cruising speed. "There's our field just below us. The golfcourse is at the right, and over there's the lake. Take a good look around. It will help you in keeping your bearings."

Suddenly the stick shook briskly, the signal for attention. Myers jerked his thumb back at me, the sign for me to take the controls.

"I want you to become familiar with the three positions of the ship when it is flying level, when it is climbing and when gliding," spoke Myers. "Push forward slightly on the stick."

I did so and down went the plane's nose.

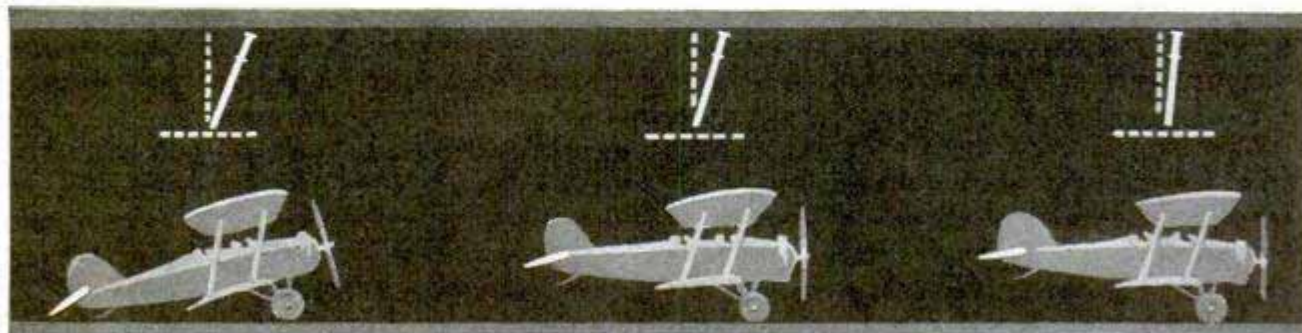

Sketch of Take-Off Positions with Diagram of Stick Movements; Far Forward as the Plane Starts, Then Back Gradually of Its Own Accord as Plane Gathers Speed

Drawings Copyright



"Pull back a little," was the next command. I obeyed but over-controlled. Up shot our plane at a steep angle that seemed to verge on a stall, but Myers firmly and quickly corrected my blunder and we were flying level again.

"You're holding the stick too tight," he cautioned. "Don't squeeze it and don't move it so fast or so far. Take it easy."

I pulled back gently at the next order and we climbed gently. Back to neutral again and then forward a bit for a glide position. How easy it was. No work at all. The "Fledgling" weighed more than a ton, but I could have maneuvered the stick with a little finger that day.

"Notice, in level position, that the nose of the plane is right on the horizon," said Myers. "Take a look at the wings. They should be level with respect to the horizon, parallel to it. You can see some sky and some land between the wings, about half of each. Remember, the horizon is your guiding line at all times. In level flying, the nose of the plane should be right on that mark."

Before climbing out of the ship, you go over every detail of the lesson with the instructor, a practice followed after every hop. Then you walk back to the school office, glowing as though you had had a shower bath and a rub-down. Twenty minutes in the skies, at a speed of eighty miles an hour or so, have set the blood tingling and the mind working.

Before this first lesson, I had taken the important step that every candidate for a flying license must take, the physical examination. Dr. W. P. MacCracken, one



Your Parachute Should Be Comfortably but Correctly Adjusted. Pilot Anderson Cautions; He Holds the Ring in His Left Hand

of the physicians delegated by the department of commerce to examine pilots and candidates for student permits, gave me a general health, eye and ear examination and explained that the tests for a private pilot's license are essentially the same as for the other grades of licenses, except that they are not so rigid as to the passing grade. You are asked to stand on one foot, close your eyes and raise the other foot without losing your balance, walk backward with your eyes closed and "drive the ponies." This is an interesting test of depth perception, the idea being to stand at twenty feet and, with cords, try to pull a movable perpendicular bar, adjusted inside a small cabinet with an opening at one end, until it appears to be exactly opposite a stationary bar of the same height and size. You are asked questions



The Standard Oil Co.

Further Positions in the Take-Off: Three Stages of the Initial Climb with the Stick Slightly Back; Note Positions of Elevator at Rear of Plane





Where the "Kiwis," the Student Beginners, Settle Aviation Problems While Waiting Their Turn for a Hop; Watching a Fellow Student Land

about your disposition, what you like and dislike, and if you lose your temper easily. All these questions reveal facts important to the business of flying and are calculated to reveal any fundamental defect that might interfere with your progress.

"You're likely to think that the ground is closer than it is when you're landing," Doctor MacCracken told me after my eye and depth-perception tests. "You may have a tendency, for that reason, to 'pancake' in or land too hard. Watch out for that." I had passed the examination by a safe margin, but was glad of this extra bit of caution, and the doctor's prophecy proved correct, although I had little

trouble when I found out where to look when landing.

From the first flying lesson, the work progressed in short, twenty or thirty-minute sessions to turns and banks, practice on take-offs and landings, "cutting patterns" around the field each time; that is, flying a prescribed course with turns at the proper points and, as a thrilling interlude to the general program, an introduction to stalls and spins.

On banks and turns, the problem is to start the ship around in the desired direction with the rudder, at the same time using the stick to bank the plane, that is, tip the wings at the proper angle to prevent skidding. The trick on the turns is to apply

the proper amount of rudder and stick and to synchronize the two.

To make a left turn you move the stick to the left and apply left rudder, that is move the left rudder pedal forward at the same time. Moving the stick sideways changes the position of the ailerons and thus tips your wings. For a left turn, for instance, you want the left wing inclined downward and the right wing upward, providing a bank. Moving the stick sideways to the left accomplishes this. Press left rudder at the same time and you turn to the left. To recover and fly straight again, rudder and stick are moved to the right, that is, right rudder is pressed

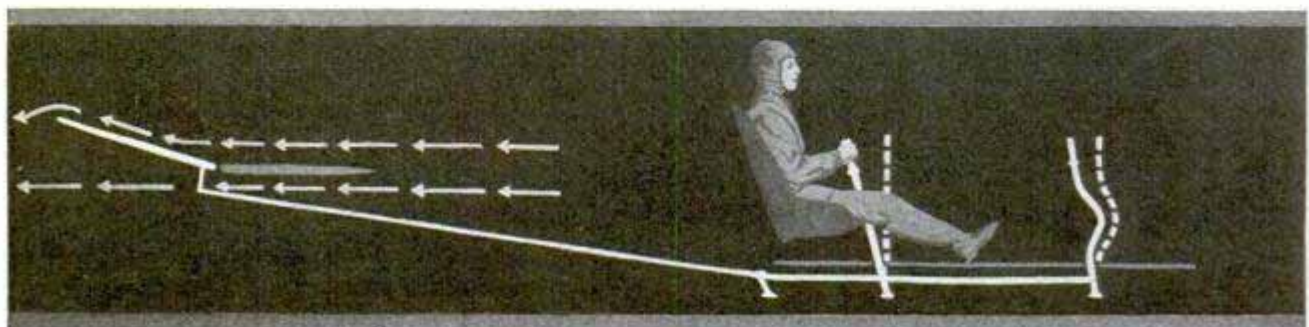

To Climb, You Pull Back on the Stick; the Movement Lifts the Elevator as Sketch Shows, Causing the Nose of the Plane to Rise; a Slight Pull Is Usually Enough



forward and the stick brought back to the right until the wings are level once more. The movements must be synchronized and the proper amount of each control administered. Another tendency gives most beginners troubles with banks and turns. There is some difficulty in keeping the nose of the ship on the horizon. In moving the stick to the side, there is a likelihood of pulling it back or pushing it forward at the same time, resulting in a climb or a dive with loss of altitude. Skidding announces itself by a blast of air on the side of the face on the outside of the turn.

With every lesson, I was given additional work on take-offs and landings. There was a big thrill in taking the ship off alone, but before I managed a successful take-off, I made the serious mistake of kicking the wrong rudder pedal once or twice. Before it has acquired flying speed, the ship steers clumsily. In other words, the rudder must be moved hard and quickly on the take-off to get response. If the ship noses to the right, kick left rudder. If it noses to the left, apply right rudder. Aim at a tree or some other object and steer straight for it, taking care not to let the plane begin to swerve any great extent, in order to prevent its getting out of control.

Wrong application of the rudder on the take-off might spell disaster. It would send the plane around into a turn, one wing might strike and an upset would be the probable result. The stick is comparatively easy to manage after it has been put forward at the start to get the tail off the



Every Word from Your Instructor Counts; Ask Him Every Question That Enters Your Mind; He Is Glad to Help You

ground. It comes back naturally and the "Fledgling" will fly itself off the ground so there's not so much to worry about as to when to pull back on the stick for the climb. But the rudder is the important problem. Ships will fly themselves off, providing they're steered properly.

"It's too bumpy for take-offs and landings," said Myers one breezy afternoon. "I think we'd better fly up a little better than 2,000 feet or so and do some stalls and spins."

He looked at me keenly and grinned. I had been expecting them. Here they were. What would they be like?

(To Be Continued)

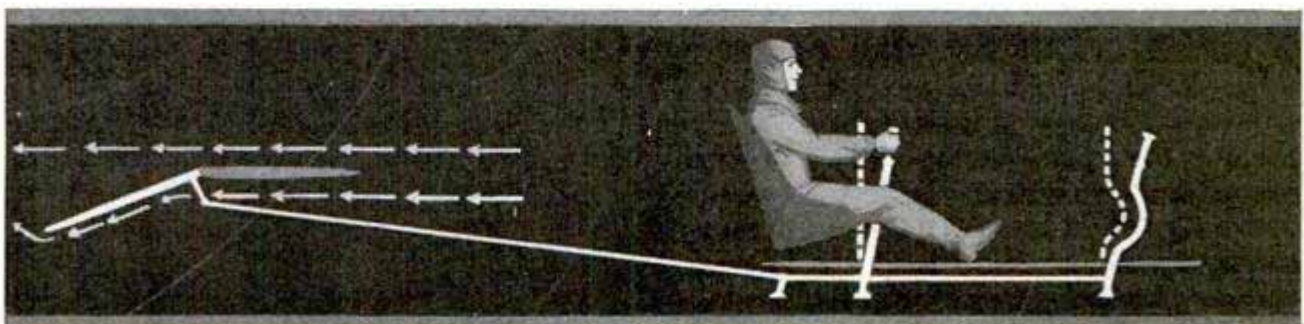

Here the Stick Is Being Moved Forward to Descend as in a Glide; the Elevator Is Lowered as Shown, Tipping the Nose of the Plane Downward



892

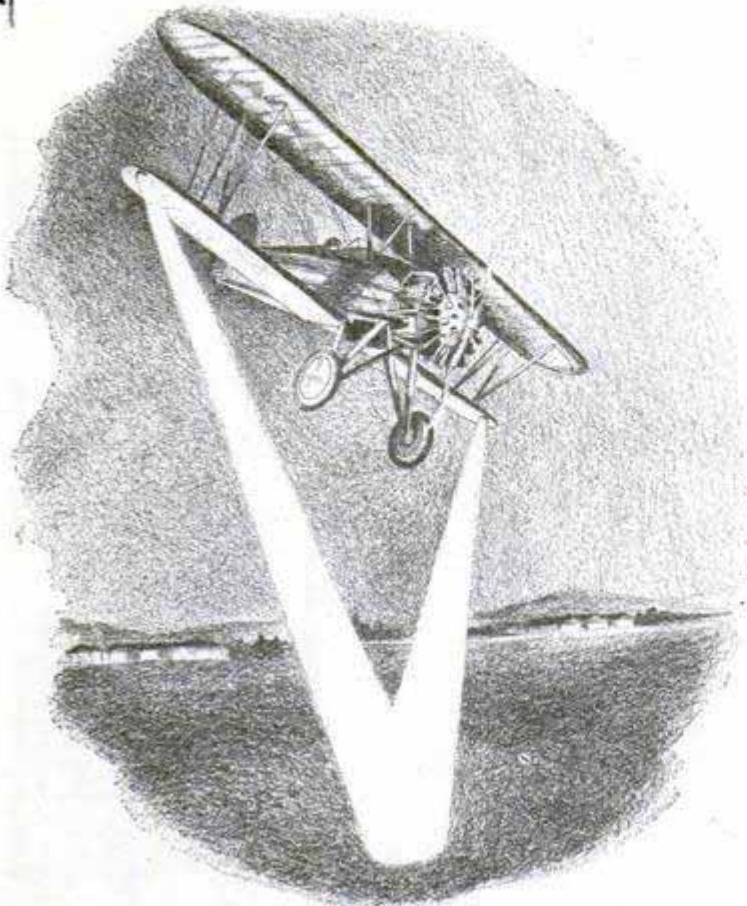

Lighted Triangle Which Enables Pilot to Tell Exact Distance His Plane Is above the Ground

LIGHTS ON WINGS SHOW PILOT HEIGHT FROM GROUND

To aid the pilot of an airplane in landing at night on an unlighted field, some British ships are equipped with small searchlights beneath each wing tip. The beams from the lights converge at a distance under the plane which is known to the pilot. As the large patch of light formed by the beams crossing each other strikes the surface, the flyer immediately has visual proof of his height from the ground and governs the ship accordingly.

SHORT-WAVE RADIO CURRENT MAY FIRE BIG GUN

1032

Short-wave radio sets aboard navy ships, and elsewhere, are a potential fire hazard, scientists have discovered, and special means have been devised to counteract the danger. Engineers have found that a fourteen-inch gun might be fired prematurely by waves from an antenna near an exposed gun, which acts as a receiver, building up sufficient current to light an electric lamp under extreme test condi-

To be used at sea used by

tions within the turret. Since the guns are fired electrically, such induced current might reach the firing circuit, resulting in a premature discharge and disaster. Radio engineers, however, have developed ways for obviating this danger. In the same way, high-frequency radio currents might set up currents in gasoline-filling hose, giving rise to a spark that might explode vapor present. Merchant vessels have been warned to guard against this danger when refueling. The hazard also exists in the air. By induction in the wires of the firing circuit of wing-tip airplane flares, sufficient current can be picked up from a radio antenna to set off the primers and ignite the flares accidentally, engineers declare.

GLASS-BOTTOMED BOAT CRAWLS ON LAND

933

To carry as many as ninety persons to and from excursions near an Oregon resort, a boat with a glass bottom, that permits a view of the sea to a depth of more than sixty feet, has an endless-tread arrangement whereby the craft can crawl on land, for launching and beaching. Lights are placed around the glass bottom to help attract fish and also to give a better view.

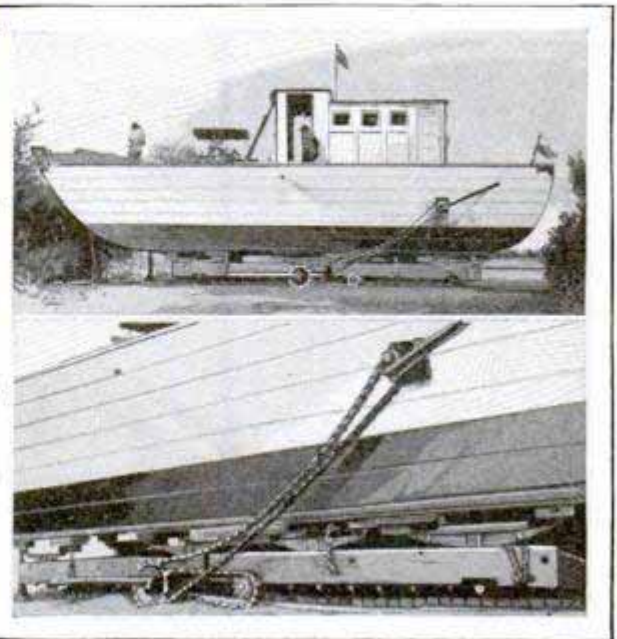

Boat with Glass Bottom for Under-Sea View and How It Crawls on Ground

Research at U.S. Naval Research Laboratory

U.S. Lt. J. Mc Lowan, Portland Ore



## WILL THE STEAM AUTOMOBILE EVER COME BACK?

A steam automobile a quarter of a century old did a little cross-country touring the other day, and performed as well as many a gasoline vehicle it passed on the road. Those who saw it asked themselves a question that has occurred at least once to every motorist: Will the

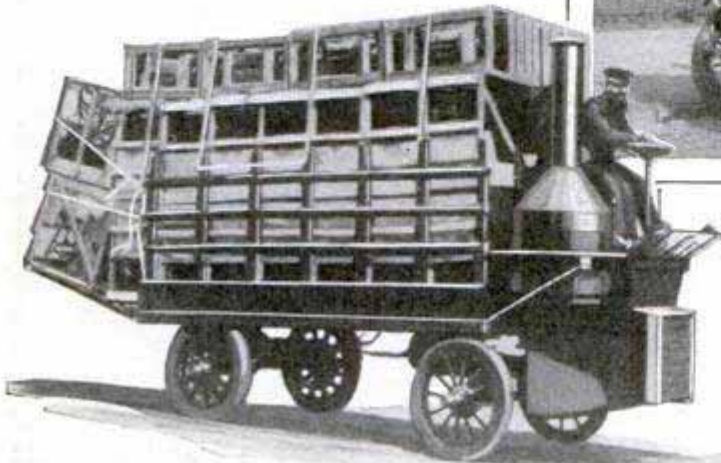

Early Steam Cars and a Truck; While Development of the Gasoline Engine Has Placed Steam Far in the Background, Some Engineers Believe It May Return for Driving Automobiles, and Airplanes as Well

steam car ever stage a come-back? Steam has been defeated hopelessly by internal combustion in the passenger-car field, but it might regain some of its lost popularity in commercial work—driving trucks, busses and perhaps tractors. That is the opinion of Arthur Scaife, vice-president of the Society of Automotive Engineers, and one of the “old-timers” in the steam-car game.

“The steam automobile owes its fall in popularity to the introduction of the electric starter for gasoline cars,” Scaife said. “It will never come back as a pleasure vehicle. The gasoline car has too great a start. The fact that the steamer requires a few minutes before it can operate, and that it cannot be stored in winter except in heated garages, will keep it from becoming popular. Even if the steamer owner does drain his boiler and steam lines to prevent trouble, the engine packing will freeze so tightly that no amount of pressure would break the seal.

“Steam busses and trucks, however, present greater opportunities to those who are willing to develop them. The few minutes of time required to get up steam, and the freezing hazard are of little importance in bus or truck operation. Usu-

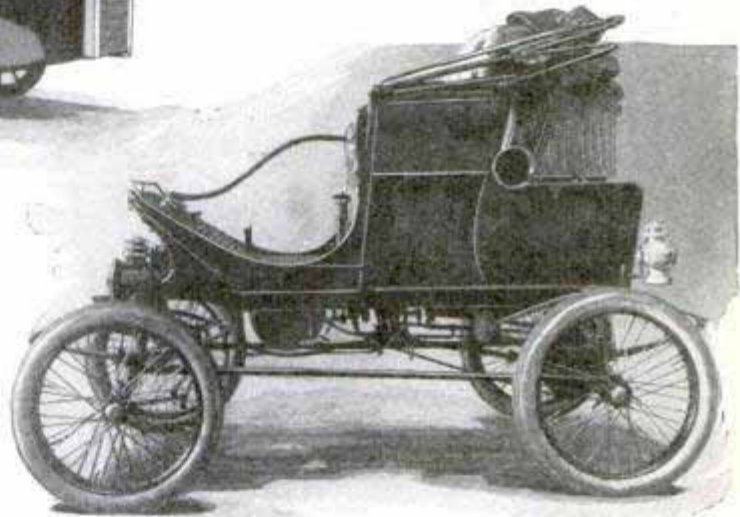

ally, such vehicles are operated over long periods each day, and are stored in heated garages during inactive hours.

“Consider the steam bus. It possesses numerous advantages over other types. It gives off no offensive odor or dangerous fumes, is quiet in operation, is much easier to start and stop, and can be operated economically. In winter, the exhaust steam can be run through the passenger compartment where it provides all the heat necessary.”

The secret of the steamer’s success was the flash boiler, invented by Rollin H. White. It consisted of a series of seamless steel-tubing coils beneath which a gasoline fire burned. Water entered at the top, was converted into steam about halfway down, and superheated at the bottom. Such a steam generator is safe. If it should



explode, there would be merely a split tube and a little steam released—not enough to injure the occupants of the car.

Steam at about 450 pounds' pressure went to a two-cylinder compound engine which, when compared with present-day gasoline power plants, ran as smoothly as a straight or V-type eight. Steam was condensed and the water returned to the boiler. The car could run fifty miles on one filling of gas and water.

Speaking of speed, no one knows exactly how fast a steam-powered automobile can travel. Of all the steamers that have been used, none have failed to show a power reserve when the driver opened them up as far as his nerve would permit.

Steam presents a possible form of power for aircraft, Scaife believes; although he thinks that the fire danger might be too great. The necessity of operating a steam generator at very high temperatures is not desirable. Still, with fuel oils, the problem is by no means hopeless. Welded boiler joints, improved burners and piston valves

lend weight to the belief that the steam age is not yet over.

If gasoline ever becomes scarce, the oil-burning steamer and the Diesel engine may vie for leadership in the industrial motor-transport field. The Diesel or semi-Diesel undoubtedly will be the passenger-car power plant of that day.

### 1006 "PORT ARMS" THROUGH THE AGES FEATURE OF ARMY SHOW

One of the interesting features of the army show in Chicago recently was a display of the uniforms worn by soldiers of all this country's wars, and a demonstration of some of the changes in the manual of arms as represented in the different periods. The "port arms" position, for instance, changed with each war from the Revolution to the world war, although the change was not very marked for the Mexican and Civil war periods. Until after the Civil war, the position was known as "support arms."

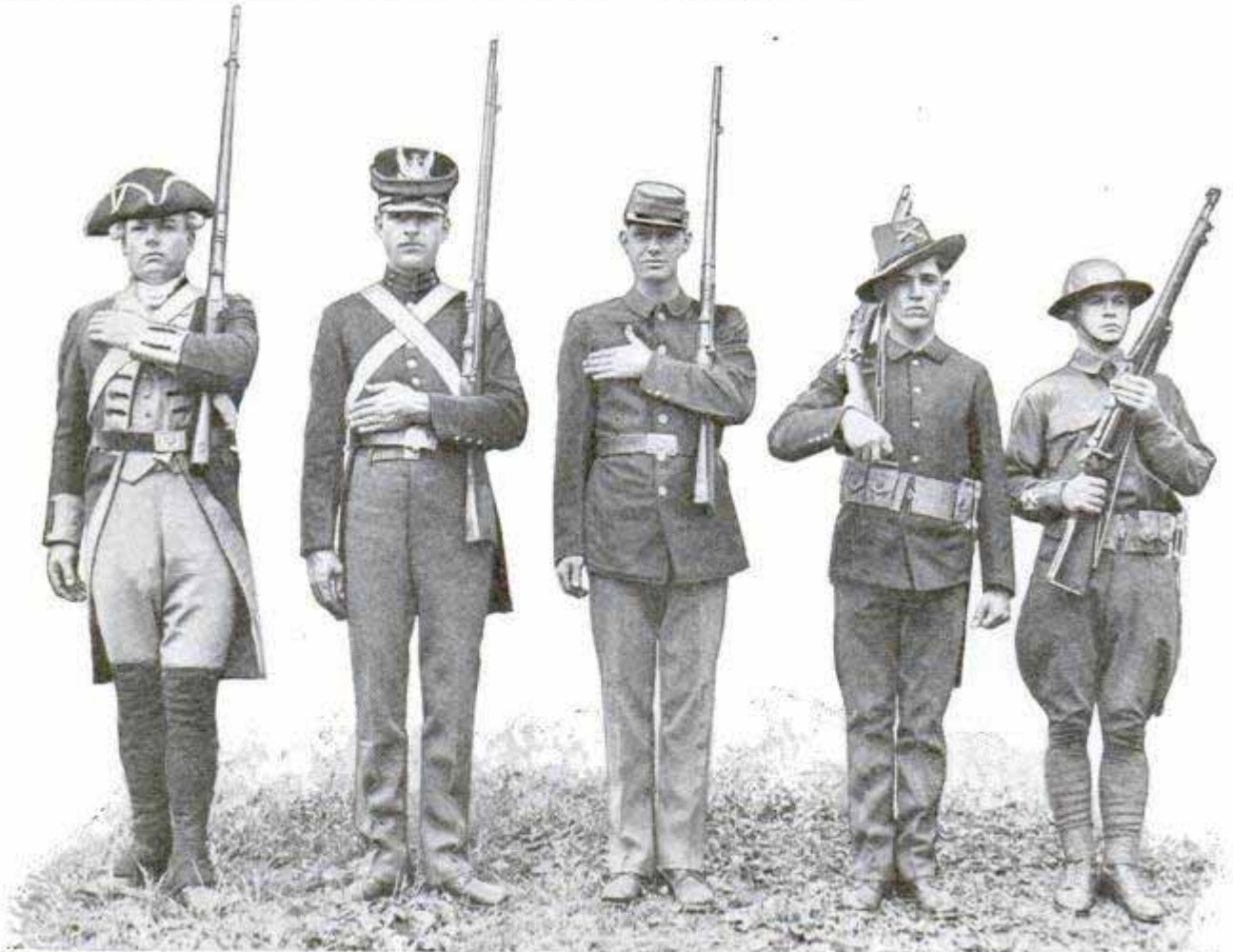

Changing Styles in Army Uniforms and Way of Doing "Port Arms" from Revolutionary Days to World War; Until After the Civil War, the Position Was Known as "Support Arms"



### "HOT ICE" MADE BY HIGH PRESSURE

10/6  
By using pressures as high as 290 tons to the square inch, the highest artificial compressions ever created by man, Dr. P. W. Bridgman, of Harvard, has caused gases to become as dense as liquids, produced a paradoxical substance, "hot ice" and performed other interesting experiments suggesting the ancient dream of a "philosopher's stone" that would change one substance into another. At pressures greater than 29,000 pounds to the square inch, ordinary ice became unstable and was replaced by other forms, one of which became stable at 290,000 pounds' pressure and had a temperature of 180 degrees Fahrenheit—a sort of "hot ice." High pressure also produced a new form of phosphorus. It looked like ordinary graphite and proved to be a conductor of electricity. It was quite stable in the ordinary atmosphere. The extreme pressures drove the atoms of the substances closer together, apparently, Doctor Bridgman concluded.

### "PHONY" DISEASE OF PEACHES TO BE STUDIED

10 39  
The government has begun war against the "phony" disease of peaches in Georgia. Phony peach trees, originally called "pony" trees because of their dwarf size, crop up in mysterious fashion. The disease appears to be associated with the roots, for grafts taken from diseased trees and set upon healthy roots produce healthy trees, whereas buds from healthy trees grafted on phony stock produce phony top growth. It has not spread beyond Georgia so far, but it is very serious and extension of its territory is much feared.



Improved Radio-Telephone Set for Flyers Enables Pilots to Keep in Touch with All Stations and Dispatchers

### BLOCK SYSTEM FOR AIRPLANES RUN BY RADIO TELEPHONE

Transport airplanes now may be operated on a block-signal system comparable with that by which railroad trains are run, except that the aerial dispatcher uses the radio telephone where the train dispatcher uses the telegraph or visible signals. Some of the transports now are equipped with radiophone sets by which the pilot can be in instant communication with any station in his division. This enables airplane dispatchers to keep in constant touch with every ship in the air. The development was made possible by a long-range lightweight telephone set suitable for planes and, through it, the pilot is enabled to check up each quarter hour on his position, receive the latest weather reports and other useful information.

Science Service News  
Bulletin 483. e

J. A. J. Maddux  
Air Lines



913 *Carl Logan U. Davis*  
*55 W. 42nd, New York*

# To Conquer KANGCHANG



LEATHER HELMET OVER WOOLEN CAP  
 DARK GOGGLES  
 WIND-PROOF GLOVES OVER WOOLEN GLOVES  
 SEVERAL SITS OF WOOLEN UNDERWEAR  
 SOLES OF BOOTS: LAYERS OF RUBBER FELT AND LEATHER

EQUIPMENT OF CHIEF CLIMBERS

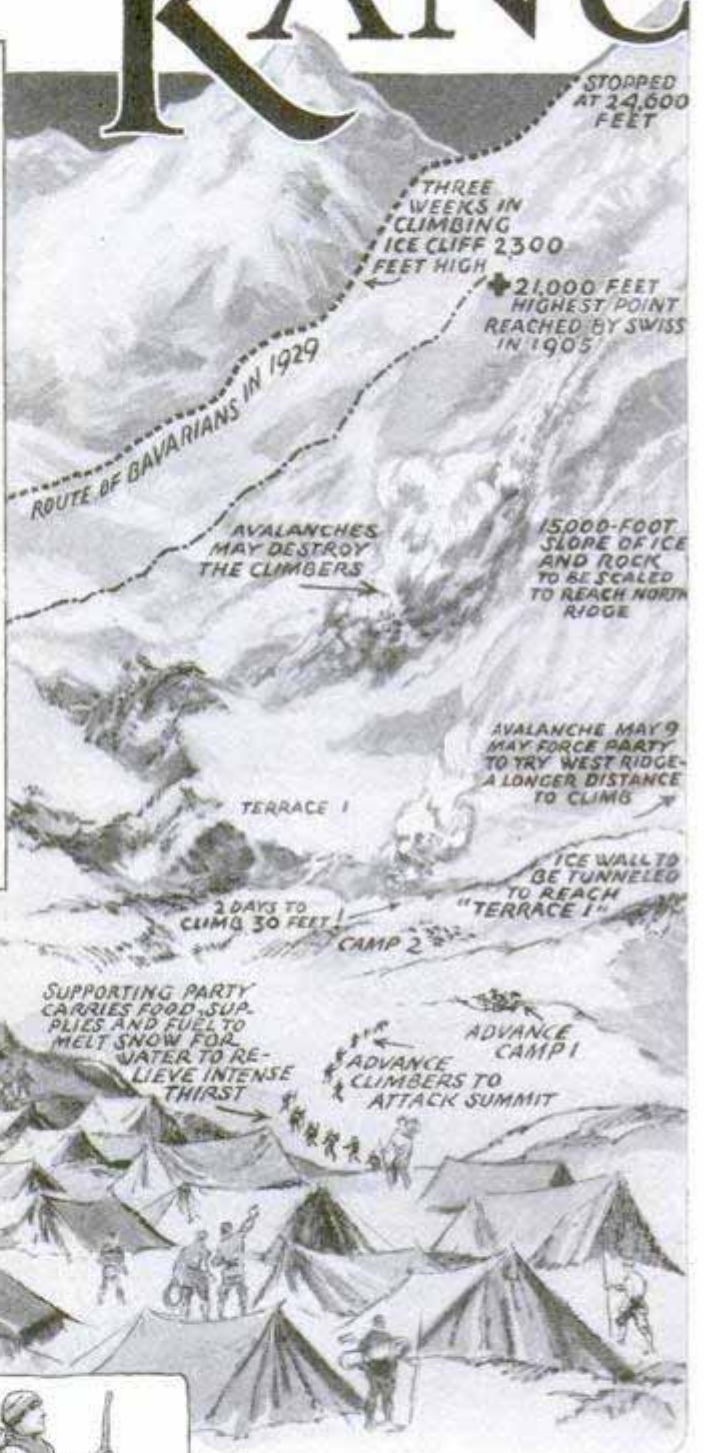

TENTS HOLD IMPROVED SLEEPING BAGS, FLOOR COVERING, OXYGEN APPARATUS AND A PHONOGRAPH IS USED TO ADD CHEER.

BASE CAMP ON KANCHANGJANGA GLACIER, ALTITUDE 17,000 FEET, WHERE PREPARATIONS FOR FINAL ASSAULT ON SUMMIT ARE MADE; CAMP ESTABLISHED APRIL 26

Artist's Sketch of the Scene Where Explorers Recently Attempted Another Ascent of the Second Highest Mountain in the World, but Were Turned Back by Avalanches and Blizzards; the Expedition Was Led by Prof. Gunther Dyrenfurth, Professor of Geology at Zurich and a Famous Mountain Climber with More Than 700 Difficult Peaks to His Credit; Although the Party Failed to Reach the Summit, Valuable Knowledge of Glacier and Other Conditions Was Obtained in the Attempt



380 PORTERS

This Peak, Second Only to Mt. Everest in Altitude, Has Unusually Severe Hazards about the Base, as Shown by the Accompanying Diagram; Terraces That Are Scaled with Great Difficulty, Avalanches and Projecting Ice and Rock Test the Skill of the Climbers Long Before They Have Reached the Upper Heights; Note Altitudes Reached by Previous Expeditions



CAMP 6 ALTITUDE-28,146 FEET; TEMPERATURE - 55° (MINUS)  
 FINAL 1,000 FEET TO VICTORY; OXYGEN SUPPLY ABOUT 1/2 THAT AT SEA LEVEL

# HANJANGA

Second Highest Mountain  
 in the World

CAMP 5 ON UPPER TERRACE  
 CAMPS HERE IF NORTH RIDGE IS REACHED  
 NORTH RIDGE, ONE OF CHIEF HOPES OF PARTY TO REACH TOP  
 CAMP 4  
 TERRACE 2

THE VIOLENT MONSOON COMING IN JUNE THREATENS DEFEAT AND DISASTER.

TO DARJEELING - FIRST BASE OF EXPEDITION - 47 MILES FROM KANCHANJANGA

KANGLA PASS 18,200 FEET HIGH

TO WEST RIDGE  
 NORTH SIDE OF MOUNTAIN MOST ACCESSIBLE; NO RECOGNIZED ROUTE TO THE TOP

COURSE OF EXPEDITION FROM DARJEELING TO BASE CAMP

TSERAM INTERMEDIATE BASE

18 DAYS REQUIRED FOR PORTERS TO CARRY FOOD AND SUPPLIES FROM TSERAM TO BASE CAMP; COUNTRY TOO DIFFICULT FOR YAKS OR PONIES  
 DISTANCE - 18 MILES



TROPICAL HELMETS AND BEARDS WORN AS PROTECTION IN THE WARM VALLEYS APPROACHING KANCHANJANGA

Successive Camps Were to Have Been Established at the Points Indicated, Preparatory to the Final Climb up the Last 1,000 Feet, Where a Temperature of Fifty Degrees below Zero and a Vastly Depleted Natural Oxygen Supply Would Have Been Encountered



Note the Drawing at Left, Showing the Comparative Heights of Kanchanjanga and Other Famous Mountains; Mt. Whitney Seems a Dwarf in the Shadow of This Mighty Peak; the Expedition Met Hard Work from the Start as Indicated by the Eighteen-Mile Trip in Eighteen Days



Chicago Daily News  
6/25/36

**FRAUDULENT PAINTINGS FOUND WITH ELECTRIC RAYS**

909



© S. K. S. News

Examining Suspected Painting Under Electric Rays to Reveal Fraud

Frauds in old paintings can be detected by electric rays under a system recently devised by Robert Maurer, Austrian scientist. The rays are able to differentiate between the genuine old masters and those that have been altered or faked. The light used is known as the "Oub ray." Maurer is a member of the Academy of Science at Vienna, and is the head of its laboratory for research on art.

**GLOWING INK OFFERS GUARD AGAINST FORGERIES**

Added to ordinary ink, a few drops of a chemical solution causes the ink to glow when it is examined under ultraviolet rays. Use of the material and the special ultraviolet microscope would simplify the detection of fake signatures and would reduce the losses by forgeries, according to Dr. August J. Pacini, Chicago chemist, who has made considerable research in this field. The ultraviolet rays are now being used ex-

tensively in crime detection, he points out, as they may reveal differences in the fluorescent qualities of different kinds of ink, and so indicate that a document, for instance, has been prepared under unusual circumstances or possibly deliberately altered. The rays are also employed to bring out secret messages that may have been written in ink which is invisible in ordinary light. Not long ago, the ultraviolet-ray microscope aided in the solution of a crime. Three persons were under suspicion of murder, and the chief clue was a strand of hair, supposed to have come from the head of one of the suspects. The hair was finally identified as that of the guilty man by means of ultraviolet rays. The prisoner had been an addict to a certain drug, which affected his hair in such a way that it glowed under the rays while ordinary hair does not.

**BULLET-PROOF CAR FOR POLICE 1065 HAS ARMORED FRONT**

Several hundred features, including a bullet-proof front section, are included in a high-speed car recently built especially for police work. The windshield and wings of the touring car are of laminated bullet-proof glass more than an inch in thickness. In the windshield is a gunport with a rubber liner for steadying the weapon. The windshield frame contains a steel lining and over the front end of the car is a sheet-metal guard, while metal guards also protect the front tires, and special lamps, built into the bumper, are safe from gunfire. The car has a 133-horsepower engine capable of developing ninety miles an hour, and is equipped with a radiator-cooled oil system.

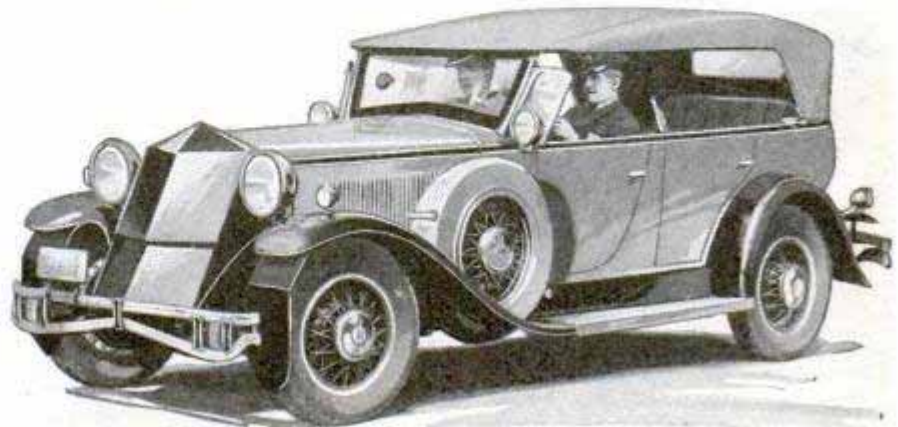

New Armored Police Car with Bullet-Proof Front Which Protects the Radiator and Similar Guards for the Front Wheel Tires

Hupmobile Co. J. E. Elliott

Attached to Academy of Science in Vienna

1555 in 110 1033

Pacini Laboratories 9 & Chestnut Chicago



1075

### RAILWAY HAS "NAVY" OF MANY BOATS

Recent compilation of the equipment of the Pennsylvania system shows that this railroad owns and operates a veritable navy. Its floating equipment includes thirteen ferryboats, forty-five tugs, 159 barges and 105 car floats. Other railroads are turning to the sea for names for their trains and cars. The New York, New Haven and Hartford has named a train running between New York and Boston "The Yankee Clipper," and the cars are named after famous American clipper ships with paintings of such vessels hung in the cars.

### FUEL GAS FOR RURAL USE DELIVERED IN TANKS

Liquefied propane, an industrial-gas preparation, is now available to rural consumers who have no access to domestic gas lines. It is delivered, under pressure up to ninety pounds, in portable steel tanks, ready to be connected to the kitchen stove. Propane is extracted from petroleum in liquid form and is a single chemical substance, and not a mixture of substances as is the case with gasoline, benzine or kerosene. For some years, there has been a trade in a very volatile mixed fuel extracted from "wet" natural gas. This product contained propane, which boils at forty-nine degrees below zero, and other substances of higher boiling points.

### LONG-DISTANCE RADIO BOTTLED ON PHONOGRAPH RECORD

During recent experiments in which Senator Marconi, the inventor, carried on communication with Sydney, Australia, from his yacht anchored near Genoa, Italy, a message from Marconi coming over 11,000 miles of space was recorded on a phonograph record at Sydney, and later retransmitted to the sender. The test led to a discussion of the feasibility of "bottling" important radio programs in like manner for rebroadcasting.

*Sit Outs 6/28/30*

*Phil Fuels Co, General Motors Bldg  
POPULAR MECHANICS Detroit, Mich  
Pacific Coast  
Shell Oil Co, 200 Bush St  
San Francisco, Calif*



Top Three Stories of the Drake Apartments, Chicago, Shown Here, Constitute a Private Dwelling

### HOUSE ON TOP OF SKYSCRAPER 1027 HAS TWO YARDS

More than 300 feet above the sidewalk, a three-story, nine-room house occupies the top of a skyscraper apartment building in Chicago. It has a front and back yard, formed by the terraces of the stories below. Each yard is approximately 120 square feet in area. The house is roofed with aluminum shingles, and the walls are of brick and stone. The large chimney at the top, into which the fireplaces of the residence open, also serves the building.

### PINE SEEDS SPROUT ON ICE 1050

Chilling on ice hurries the germination of the large, edible-nut pines regardless of their native habitats, experiments at the University of Southern California have disclosed. Tests with different varieties of these seeds showed that some species required from twenty-five to thirty days' chilling, while others needed up to fifty or sixty days for best germination.

*Dr R. Johnstone and  
Emma Shultz Clare, of*

*Aluminum Company of America  
2449 Oliver Bldg Pittsburgh Pa.*



# The World's Queerest



Sculptors Find Jobs in Motion-Picture Studios, Designing and Executing Clay Figures Used in Many Feature Productions.

By H. H. DUNN, 4351 Georgia St. San Diego, Calif

AS SHE walked across the huge sound stage, rapidly emptying of its actors, actresses, chorus girls and "mobs," she was one of the most beautiful, and one of the best-dressed, women on it. The man who followed her might have been up for the part of the grand duke in Graustark. They stepped into their limousine, spoke to the chauffeur and rolled out through the iron gates.

"Foreign big shots?" I asked.

"No," replied the director; "she's the designer and he's the 'ager'."

"What's that?"

"She knows all about everything women have worn since Eve and down to last night's newest revue. He takes men's

costumes, made yesterday, and makes 'em five years old in twenty-four hours. We couldn't make a picture without that pair."

As we walked toward the studio offices, another car tooted through the crowd of departing players, picked up a man of professional appearance, who never has faced a motion-picture camera nor spoken a word into the microphone, yet draws a salary that would make many a bank president envious. He is the one who knows more about arms, from stone-headed war clubs to airplane machine guns, than any other man, outside military service.

Neither of these three would exchange place with any actor or actress on the screen. Yet they are only examples of hundreds of men and women

who hold unusual positions—entirely unconnected with the actual filming of a motion picture—within the movie industry. From the man who makes the smoke go puff-puff from toy engines to the expert who directs the growing of whiskers of all shapes, colors and designs on the faces of the male stars, there are more than one hundred such "queer jobs" in each studio in Hollywood, with equal or even greater numbers on the New York movie "lots."

Possibly the most peculiar of all these unusual positions is that of the ager of costumes and equipment. It has been found that the cleverest designers cannot give to the costumes of mobs, vagabonds,



# Jobs

serfs and savages such an appearance of age that the camera's searching eye will not reveal their newness. This is particularly true under the new method of color photography, where the color of such costumes requires an old appearance, just as did the material itself for the black-and-white picture.

These costumes, once made to historical correctness, are turned over to the ager, who has before him charts showing

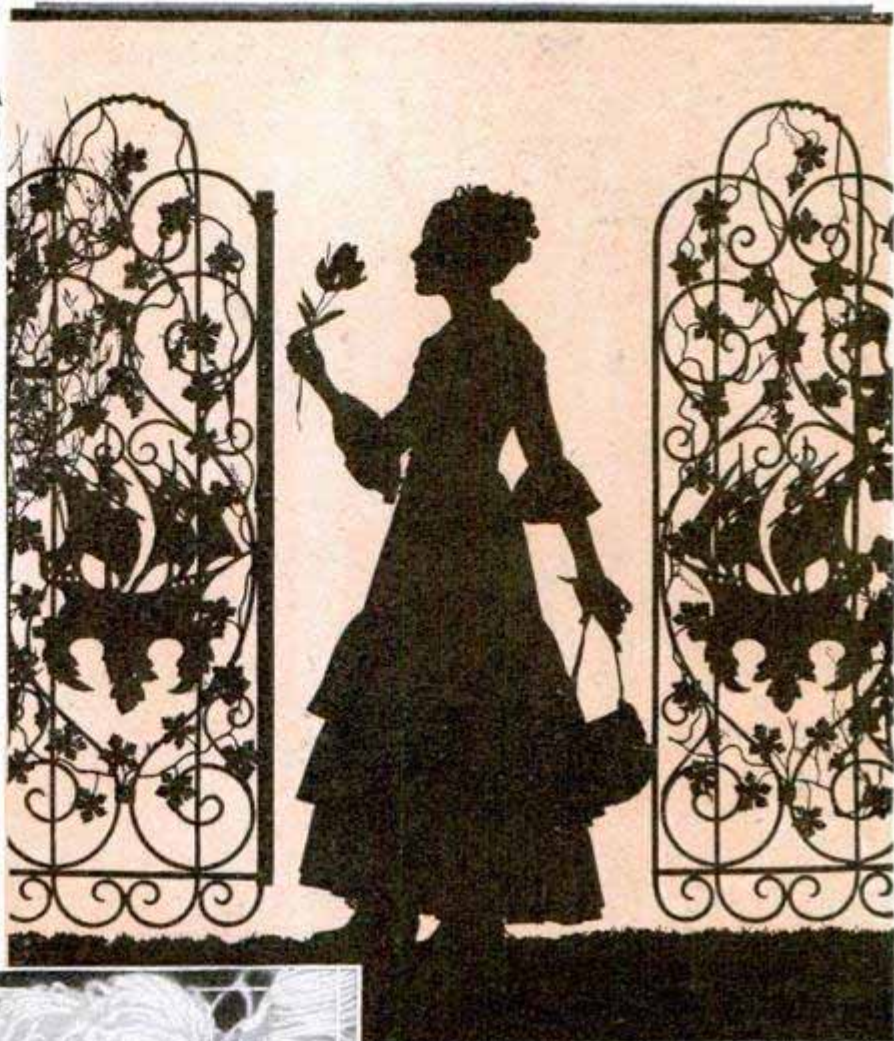

Wrought-Iron Work Done by Skilled Craftsman for Movie Scene, and Elaborate Hair Dressing, the Creation of a Specialist; as Many as 200 Hair Dressings Are Sometimes Needed in One Day

design and color, as well as condition of each piece. He puts his staff of half a score of assistants to work with earth, sand, water and hot-air driers. Often he has only twenty-four hours to prepare clothes for a rabble of several hundred men and women. First of all, the clothing is beaten with earth, torn as if by accident, stained in careless spots, then tossed about in sand and water until no two pieces are exactly the same in color or condition.

In each studio there is the designer, usually a woman for women's costumes, with 2,000 to 5,000 pieces of this equipment, ranging from the skin of a sabertooth tiger for some modernized Lilith down to complete court costumes for the ladies of a royal





banquet "some-where in Europe." Besides these, she has designs, carefully and permanently made, for as many more costumes of ancient, medieval and modern periods. Her art department consists of men and women who might have won fame as illustrators, or even as workers in oils, but who find greater financial return in the motion-picture studios. In one, there is a woman, a former dressmaker, who can outfit more than 1,000 women in costumes of virtually every period in known history, on twenty-four hours' notice.

Unique in every studio is the geographer, better known as "location director," sometimes merely as "locater." He must find, in the southwest, an exact, or nearly exact, duplication of the scenery of any spot in the world in which a motion-picture

plot is laid. The script writers must not be handicapped by time or distance. For polar scenes, the geographer sends the company to half a dozen places in the high Sierras, above the timber line, where snow and ice keep company with the barren granite backbone of the world. For the Sahara or the Gobi, he picks places in southeastern California, Arizona and Nevada; for the South Sea islands, a chain of semitropical islets along the California coast awaits his pleasure; for the coasts of the Mediterranean, the Adriatic, the Aegean, he has three or four hundred miles of sun-drenched Pacific coast, from Santa Barbara to San Diego, or even farther south.

In the files of one of the geographers, formerly a member of the faculty of one of the largest western universities, are photographs and descriptions of twenty-seven widely different "foreign locations" in southern California alone, while his south-

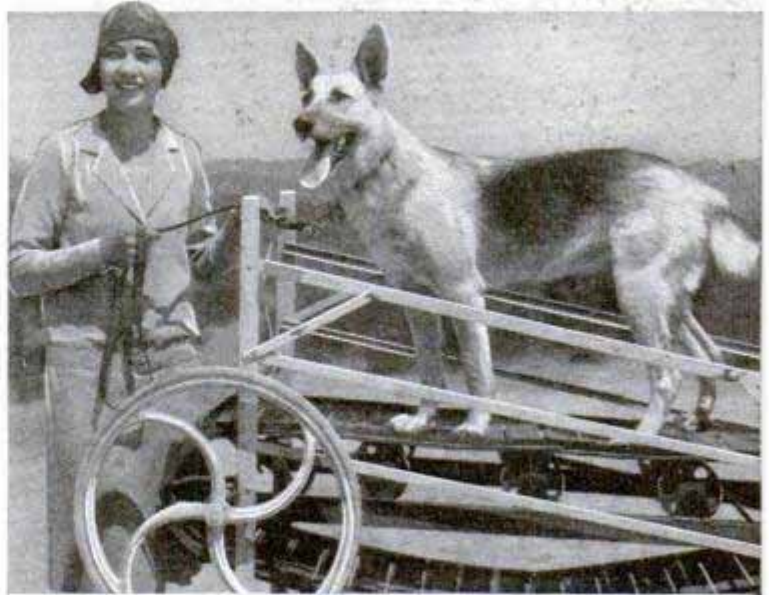

Zulu Spear, the Work of Arms Specialist; a Ship-Model Maker's Creation, and Exercising a Dog Motion-Picture Performer in Special Treadmill That Saves Owner Walking



western file, covering Arizona, New Mexico, California and Nevada, contains eighty-six different spots of this kind. Within twenty-four hours, he can put a company on any outdoor location in the world. There are thirty of these geographers steadily employed in Hollywood, and each has a collection of photographs of foreign countries which probably could not be duplicated elsewhere in the world.

The detective with the "camera eye," the sleuth who remembers and recognizes every criminal whose face or photograph he has seen, is an amateur alongside another odd-job holder in motion pictures. This man—there is at least one in every studio—must know and remember a minimum of 5,000 types, men and women. Out of an estimated 100,000 persons offer-



Designing Costumes for Colored Motion Picture, and a Fashionable Vehicle of Other Days, Kept in Repair by a Wagon Builder

ing their services constantly as players in motion pictures, this man must know, or have in his vast files, the descriptions, physical, mental and histrionic, of at least half that number.

If a script calls for 100 cavemen, he must know just which 100 of all the possible cavemen are the best. If 1,000 American Indians, Zulus, Kaffirs, Bushmen, Tagalogs, Moros, or what you will, are needed, he must know just where to reach those who will make up to the greatest

advantage and act best before the camera. A call for a score of courtiers and as many court ladies, a stage full of southern gentlemen and belles of civil war days, or a night club filled with apparently "happy" men and women of today, must be met within an hour, appointments arranged, costumes ordered, and presence on the lot assured.

High up in one of the lofty studio buildings is the largest collection of firearms, and, in fact, of weapons of all kinds, in

the world. From it could be outfitted completely 10,000 men in the full equipment of the armies of seven different modern nations. There are stone-headed clubs, stone knives, stone hatchets, knob-kerries, assegais, bows and arrows, all the equipment of the knight of the Middle Ages, boomerangs and throwing sticks, blowguns and bowguns, arquebuses and the most modern rifles, culverins and machine guns synchronized to shoot through the whirling blades of an airplane propeller,



709  
438

Thomas Chown, 200 S. Seaguy St  
San Pedro, Calif  
POPULAR MECHANICS

one of divers

John Ford • Men and  
Women

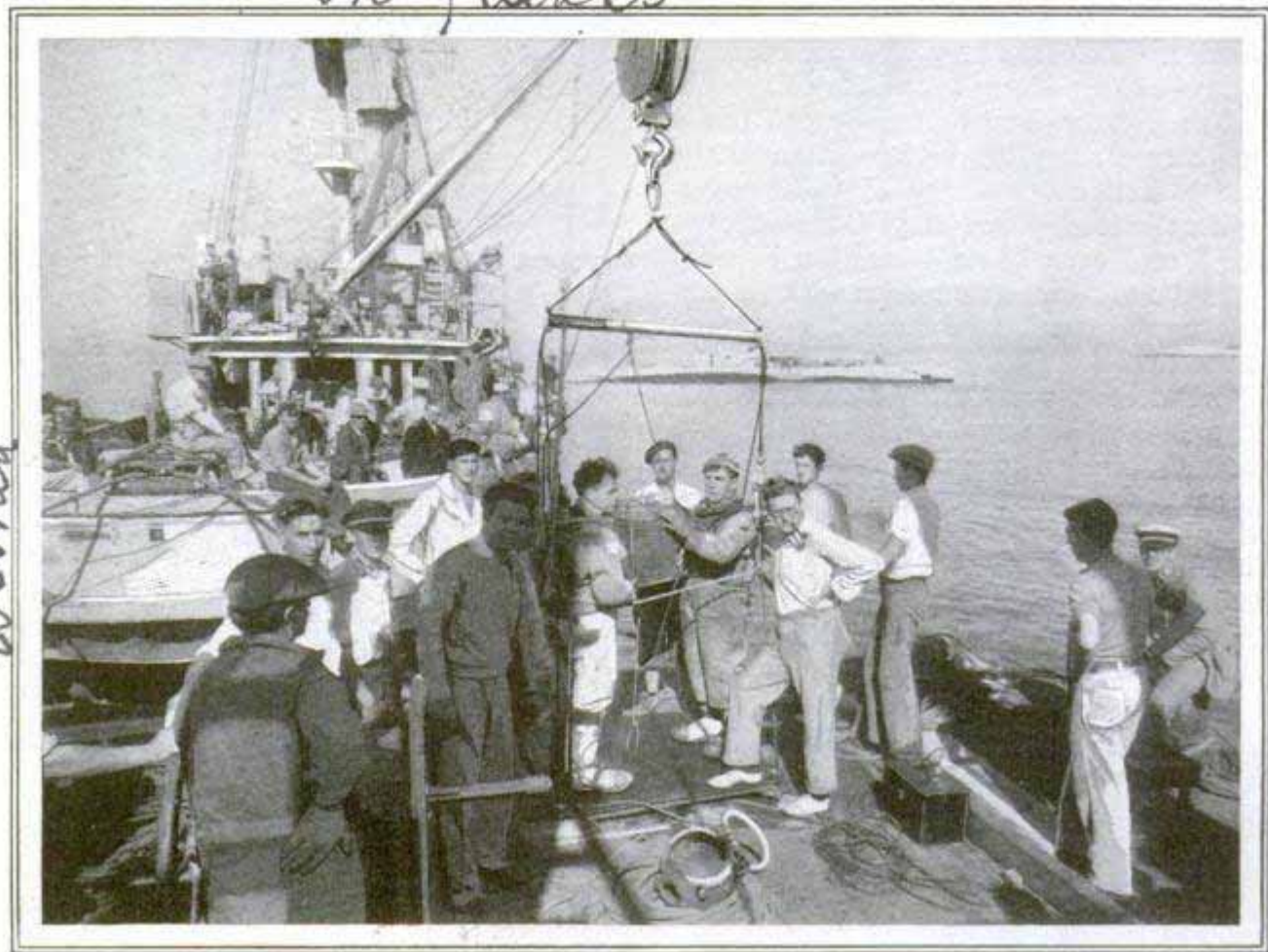

Motion-Picture Studios Frequently Hire Deep-Sea Divers as Cameramen or as Substitutes for the Stars in Making Submarine Films; Here Two Are About to Be Lowered

and anti-aircraft rapid-firers, with hundreds of other weapons used by man almost from the beginning of his days on earth.

From the outside world, the motion pictures have drawn the best of the sign and house painters, who at last have become "artists." An entire set, a block of buildings, has to be painted to a given design, and all done in ten or twelve hours. With his assistants, this painter, to whom area is measured in hundreds of square feet, attacks the job with half a dozen spray pumps and tanks containing the necessary colors. He has not had a brush in his hands since he came on the lot, but with delicate sprays he and his men lay down the colors even more accurately than the cleverest sign painter of the old days. Almost as rapidly as the paint is put on, three or four tanklike vehicles, literally breathing hot air, come along and dry the job with waves of atmosphere heated to exactly the right degree.

The sculptor, whose lot in life has not always been filled with reward, has found

a place in motion pictures, where he makes, in clay and "staff," reproductions of the marble masterpieces of the world or designs stage settings from the famous and enduring buildings of history. Mural painters, in larger numbers than ever could find sale for their abilities in the outside world, are busy night and day in the studios, making the walls of the sets seem what they are not. One Moor, an expert in the making and placing of oriental tiles, has built for himself a permanent position and a comfortable fortune, by the designing and making of real tile arches, floors, doorways and windows.

Every studio has its own nurseryman, its own florist; its own greenhouses, glass houses and gardens, wherein are maintained at all times collections of plants from all parts of the world. In one scene of a recent picture, 10,000 roses were required. More than half were produced from the studio nursery; the other half was purchased outside, and seven florists were needed to supply them.



On one of the lots in Hollywood stands a complete steamer of about 6,000 tons, a miniature of a large ocean liner, only about half the size of the deep-sea passenger carrier. The ship, which never has touched the sea, is so completely fitted out that she has a fully equipped engine room and a wireless cabin with all radio sending and receiving apparatus. She has been used, time and again, in marine pictures, yet she was built by a man who never had been on board a ship.

Every studio has such a man, at the head of "construction," who can build anything that is wanted and build it with the speed that is always the prime essential in preparing for the making of a picture.

Scattered through Hollywood are more than 200 men and women who earn good salaries as technical advisers. They are persons, each of whom knows one thing superlatively well. There are aviation engineers, automobile-race drivers, retired jockeys, interior decorators, color experts, women

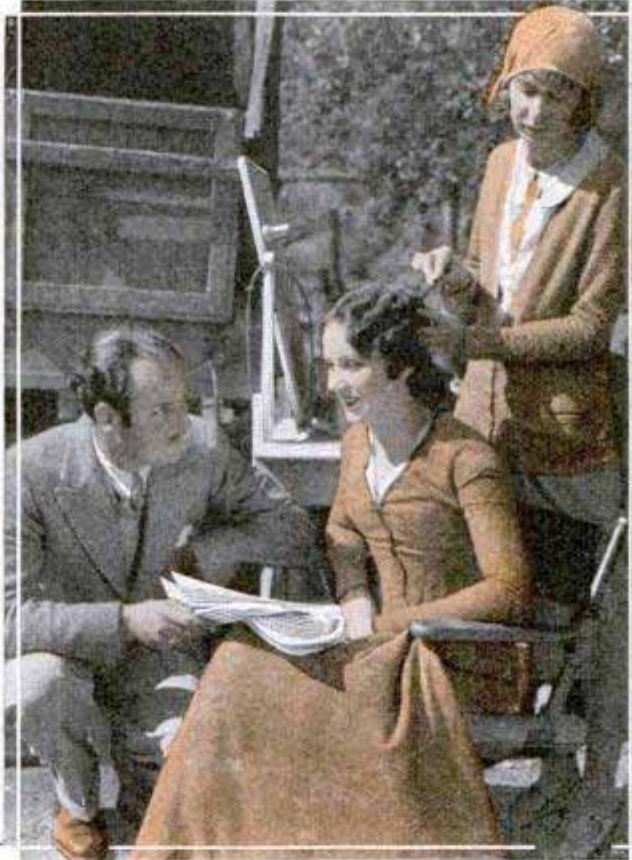

who know music and its history, though not necessarily musicians, art experts—traveled and cultured men and women who know the world and how people live and work in countries other than the United States.

From the cold-storage warehouses, the motion pictures have taken the best refrigeration engineers and put them in charge of huge plants whose sole purpose is to provide the great sound stages

with temperatures in which the players can act comfortably. For instance, during the filming of one sound picture, the actors and actresses were instructed to act as if chilled and, indeed, nearly freezing. A temperature of forty-five degrees was maintained throughout, to aid the actors in natural appearance, and on a picture from the old south, summer heat was maintained.



Mary Brian Coaxing a Racing Turtle, Fay Wray Receiving a Hair Dressing and Early Autos, Kept Repaired by an Experienced Mechanic for Use in Films Depicting Motoring of Yesterday



## FLOODLIGHTS BEAUTIFY THE "BIGGEST" BUILDING



Enough Lights to Illuminate 1,000 Homes Are Used in the More Than 600 Floodlights Employed to Decorate Chicago's Merchandise Mart at Night; the River Reflects the Display

Light sufficient to illuminate nearly 1,000 homes glows from the Merchandise Mart, in Chicago, the world's largest business building, when batteries of specially placed and focused floodlights are turned on each evening. There are 607 floodlights in all, from 250 to 500 watts each, making this the second largest floodlighting installation in the world. The largest, at this date, is on the Paramount building in New York City. A special feature of the mart's illumination is that the Chicago river mirrors the display and the projectors have been so arranged, that the architectural details of the structure have been preserved. In many floodlighting displays, diffusion of the illumination leaves a flat surface, but on this building, narrow beams, properly placed, and the use of contrasting shadows, sharply reveal the structure's lines even at night. The lights start at the fourth floor. Set-back stories near the roof are brilliantly outlined, and the entire display is capped by the lighting on the massive tower at the center. Specially designed brackets, shaped to conform with the style of the building, were made to hold the projectors. Being set close

to the walls, the lamps do not throw disturbing beams into the offices of the building. It contains 4,000,000 square feet of floor space and cost approximately \$30,000,000.

### SOUNDS HEARD THROUGH TEETH 1069 INSTEAD OF EARS

Those who cannot hear with their ears may listen through their teeth by means of an instrument invented by a professor of physics at Cornell university. Those using the device appear to sip sounds through straws, the "straws" being slender pieces of wood, sharpened at one end, which is placed in contact with a vibrating mechanism, the blunt end being held between the teeth. The vibrating element is surrounded by a sheet of rubber and attached to a wire which can be plugged into sound reproducers in a movie house or connected with a radio. The mechanism is only a trifle larger than a baseball and may be carried about by the user. Tests showed that music almost inaudible to normal ears can be plainly heard through the teeth.

Prof. Frederick Bedell



6/18/30 P. 853

### ISLANDS RISE FROM THE SEA AND DISAPPEAR OVERNIGHT 1074

Last November an ocean liner crossing the Atlantic severed several ocean cables which supposedly were resting on the sea bottom far below it, but apparently had been thrown up by a change in the ocean bed. That such changes are by no means uncommon is shown by a recent report that a vast chasm has been newly formed in the ocean bottom 150 miles east of Nantucket. Here, for a distance of 150 miles, no soundings can be taken in a section which previously gave a uniform depth of 100 fathoms. In 1927, an island between Hongkong and Manila, originally thrown up by a volcanic disturbance, suddenly disappeared and soundings taken on the spot gave a depth of twenty-five fathoms. A notorious pirate, who lived there, perished when his domain dropped from under him.

### FOUNTAIN OF MODERN DESIGN FEATURES PLAYGROUND 1040

Somewhat resembling a rhinoceros, a grotesque fountain of ultra-modern design has been erected in a children's playground in Hamburg, Germany. It is so shaped that the jet of water is thrown well to one side, where the children may stand under it in hot weather.

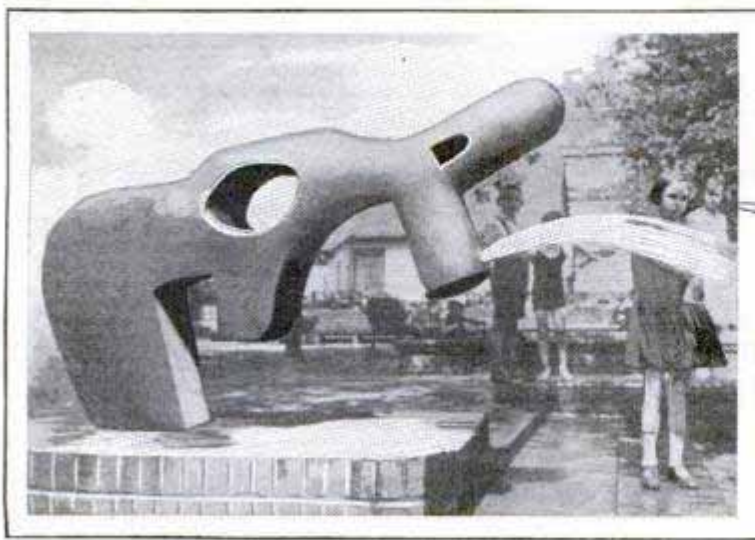

This Is Not a Monkey Wrench, but a Modernistic Fountain Adorning a Children's Playground in Hamburg, Germany



This Mink Took Its Own Picture When It Nibbled a Morsel of Food Tied to a String Attached to the Camera

### SELF-PORTRAIT OF MINK SHOWS PHOTOGRAPHER'S SKILL

By means of a trip cord for the camera shutter, cleverly concealed in a morsel of food, a wild mink was made to take its own photograph at night. The trap was set by H. V. Roberts, of the New York State College of Forestry, who has specialized in the taking of wild-animal photographs in connection with his work.

### ALLOY STEEL RESISTS EFFECTS OF HEAT AND CORROSION 1073.

Resisting the effects of heat and corrosion in a remarkable degree, an alloy steel called "Maxhete" has been made in England. It contains nickel, chromium, tungsten, copper and silicon and has been used successfully in glass-making plants where certain apparatus must withstand temperature of more than 2,000 degrees Fahrenheit. The steel does not crack or harden when quenched in water, and does not scale appreciably when allowed to cool in the air. It is being used for burner tubes, damper plates, furnace tubes, and in other places where great heat is applied.

maxhete  
no H & S agent  
Imperial Steel works  
Edgar Alley & Co Ltd  
H. Ballfield Esq



see August, 1928

6/28/30

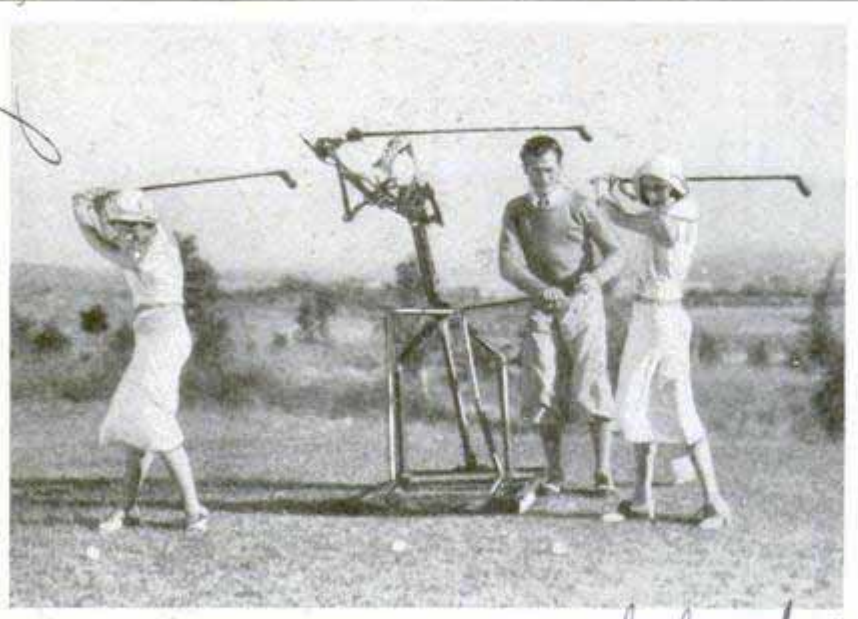

The Pipe Framework Is a Golfing Robot Capable of Making a Perfect Mechanical Stroke, Thus Aiding Amateurs to Perfect Their Swing

**AUTO BODY IS FREE FROM RATTLES AND SQUEAKS**

A radically new type of automobile body with several important advantages is being produced in England. Its two outstanding features are light weight and freedom from rattle and squeaks. The body shell is mounted at three points on rubber blocks, one block supporting each front corner and one block the rear. Floor and dash are entirely separate from the body shell, being attached to the frame. To

**GOLFING ROBOT AIDS AMATEURS IN DEVELOPING SWING**

To aid amateurs in developing a mechanically perfect swing, a golfing robot has been constructed which displays the technique of the professional with the additional advantage that it does not tire or become impatient, regardless of the number of times the operation is repeated. It consists of an iron framework with metal arms which grasp the club, a lever controlling the stroke. By imitating the mechanical golfer, the student soon develops the same easy swing.

appreciate just how greatly this construction differs from the conventional, note that it is customary to build all the body units, including floor, seats, dash, and so forth, into a single rigid structure, which is then bolted to a relatively flexible frame. When a wheel strikes a bump, the frame is bent and twisted momentarily, distorting the body, so that soon squeaks and rattles develop, whereas, with the new construction, since the body shell is mounted at only three points, distortion of the frame does not affect the body, and for this reason the body may be made lighter than usual.

**THE CHEAPEST OF METALS**

Sodium now is cheaper than iron if purchased in carload lots. This metal, of extreme purity, remarkable chemical activity and low electrical resistance, costs about \$11.50 per cubic foot, which is approximately the price of an equal quantity of ingot iron. Nickel is the most expensive common metal, the same volume costing \$192.50. Tin, copper, aluminum, lead, antimony and zinc follow in order of cost. If more uses were found for sodium, it probably could be produced at one-third its present cost. Its occurrence, in close chemical combination with other elements, is common, but electrical decomposition is necessary to separate it, and it is so active chemically that it must be immersed in kerosene to be kept pure.

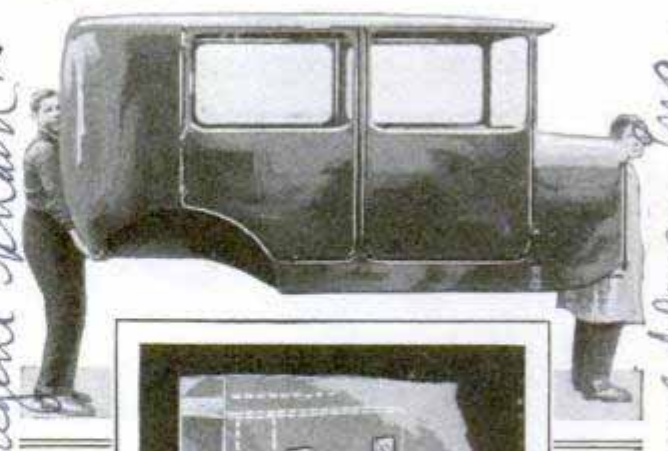

Auto Body Built Independent of Rest of Car and Mounted on Rubber Blocks as Shown Below

Dr. J. Lawrence Mesple,  
110 Sutter St.  
San Francisco, Calif.

Metals and Alloys published  
by Chemical Catalog Co

an article in Metals and Alloys

Gordon England Ltd.  
11 Palace Industry

Wembley Middlesex, Eng.



870  
Montgomery Ave. Bethesda, Md

# A Modern Robin Hood

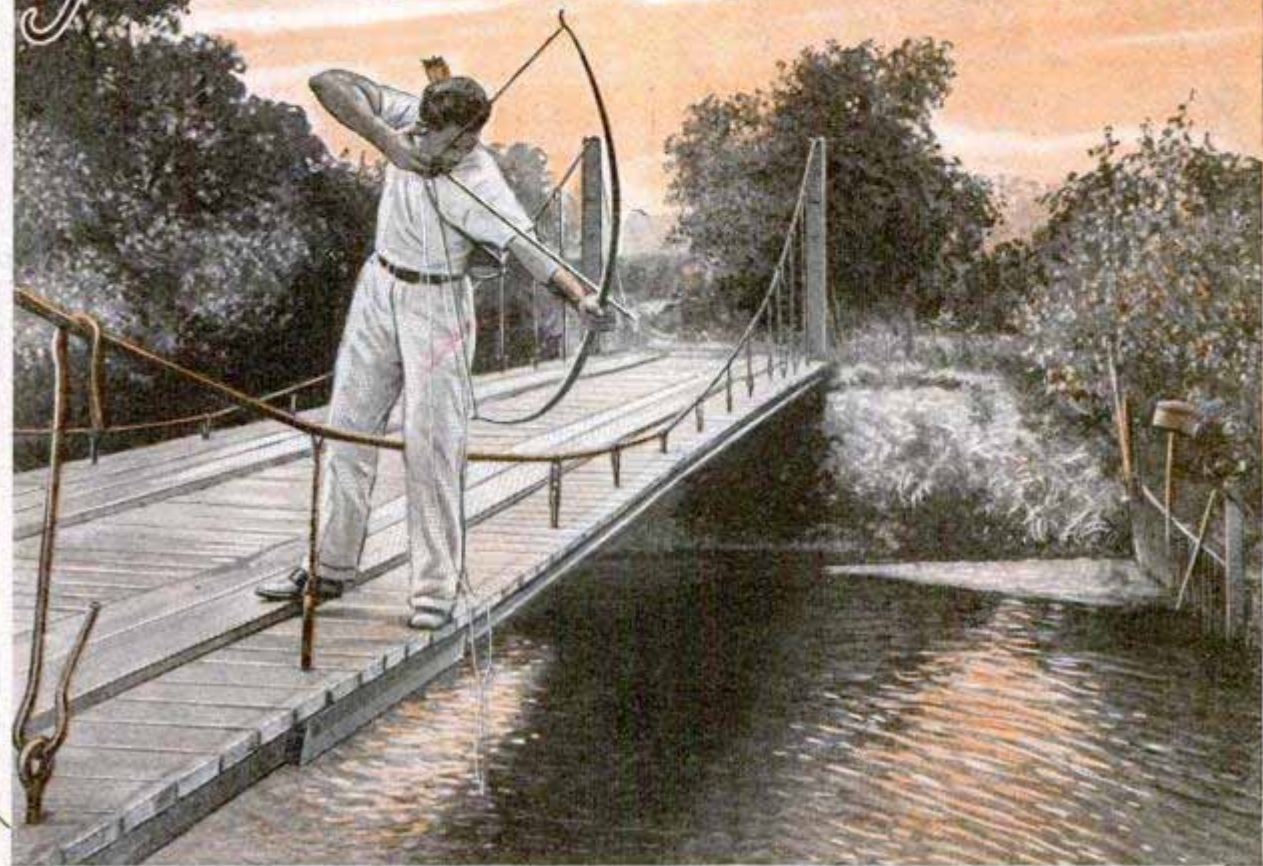

Archer Fishing from Bridge over Florida Canal; the Arrow Has a Harpoon Point, and a Seventy-Five-Foot Line Is Attached to the Feathered End of the Shaft

**H**OWARD HILL, champion American archer, is a more ingenious bowman than was Robin Hood and the historical English archers, for he not only hunts but he also fishes with bow and specially made arrows.

Whenever Hill goes out with his archery tackle on an angling trip, you can depend on it that he will bring home a full creel. One afternoon recently, he "caught" 196 bass, bream and alligator garfish ranging from one to ten pounds in weight with his bow and arrows. He fishes from bridges over canals and piers on the ocean front as well as from motorboats.

The arrows with which Mr. Hill fishes are made of Florida snakewood, a tough and heavy hardwood of much greater penetration power than arrows made of birch, yellow pine, cedar or similar materials. The arrows are thirty inches long, weigh 600 grains apiece and are provided with special points made of turned-down

brass with a two-inch point of drill rod, one-sixteenth of an inch in diameter. Two barbs, of eight-penny finishing nails, are seated in each arrow point about three inches from the tip, being set at such an angle that they hold the hardest-fighting fish as would a harpoon. A light nine-thread linen line, such as is used commonly in fly-rod casting, is attached near the feathered end of each arrow. This line is from thirty to seventy-five feet long, its other end being fastened to the belt of the archer. The art in archery fishing is to keep the fishline attached to the arrow clear and free of all obstructions. The archer-angler frequently has to "stalk" his fish in order to gain a point of favorable shooting stance.

Hill has an unofficial record of 409 yards for long-flight shooting, which is much farther than the best of the ancient archers ever shot. His official record, made in a meet sanctioned by the National Archery

J. H. Montearth Co. 20 Lewis St. New York City

Opa Locka, Florida





association, is  $391\frac{2}{3}$  yards. In setting these records, Mr. Hill used a Florida snakewood bow with a pull of 175 pounds, the mightiest bow ever used by either white man or savage. Florida snakewood trees grow along the coral-rock keys bordering the Atlantic. This wood is even tougher than yew, just as fast, elastic and resilient, is not as susceptible to heat and cold and has less vibration, or harshness, on the recoil.

The average archer uses a lemonwood or yew bow with a pull of from forty to sixty-five pounds. Howard Hill, by systematic training and progressive methods, built up his strength until he could shoot a 120-pound bow sixty times in quick succession without fatigue. Then he was ready for a try at the world's long-distance shooting record. You may wonder why he did not use his 175-pound bow in practice. Because that mighty bow had a service life of only about fifty shots. No other wood known and adapted to the making of archery tackle can withstand such a tremendous

strain, for Hill's record bow is only fifty-four inches long and no larger than an ordinary banana at its point of maximum girth.

Hill has made all his archery tackle during the last twenty-five years. He is persistent in his quest for better hardwoods for bow and arrow production. His experiments with tropical woods led him to the discovery of Florida snakewood, which, he

reports, is the best material for bow-making that he has ever worked. Unlike the majority of modern devotees of the ancient art of target shooting, Mr. Hill employs a direct point of aim instead of an artificial one—a small stake set in the ground at a given distance in front of the straw target.

The records of ancient archery, from the time of the Egyptian bowmen to the historical

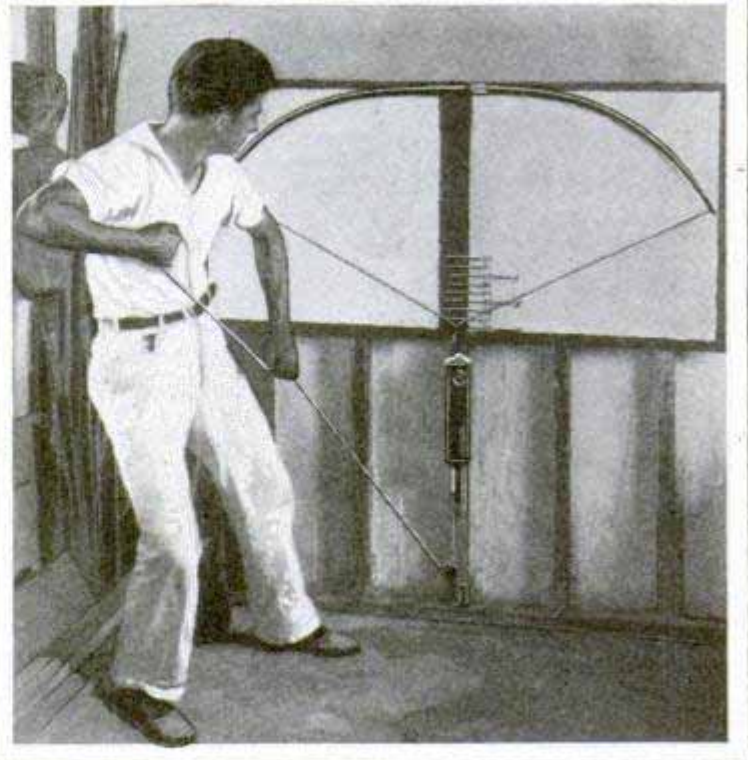
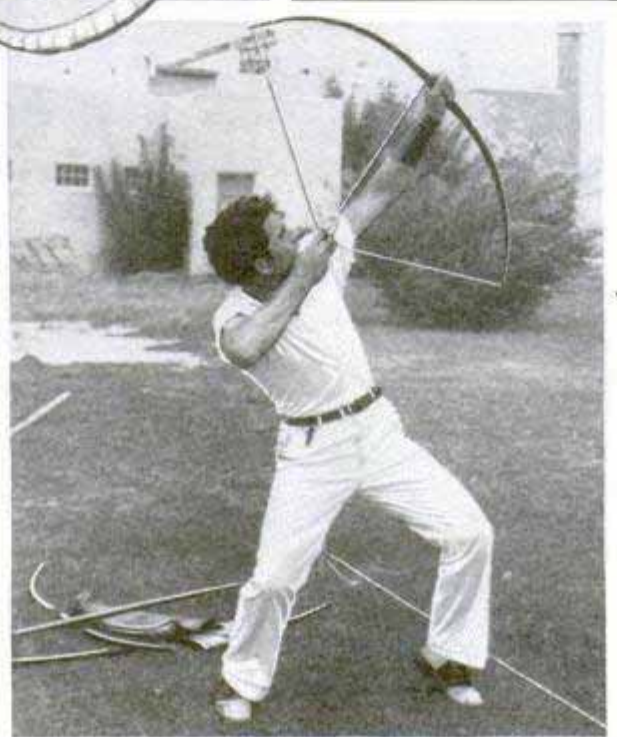

Twelve Arrows in Target from Distance of Eighty Yards; Shooting with Powerful Snakewood Bow, and Testing Its Pull



achievements of the English archers at the battle of Hastings, describe no parallel to Hill's feat in shooting a flight arrow 409 yards with his 175-pound bow. Some of the record English archers are reputed to have used bows made of osage orange or yew that pulled about 150 pounds. History relates that one of these mighty archers imbedded a battle arrow to the depth of four inches in a massive oaken door in the Tower of London, where it still remains.

In hunting with bow and arrow, this white man excels the taciturn Seminoles of the Everglades country and other southern tribesmen at their favorite sport. And in archery-golf, he occupies a position as outstanding champion similar to that of Bobby Jones in golf. Hill's best score of forty-seven for a regulation eighteen-hole golf course is the lowest ever made by an archer-golfer. In archery-golf the player counts his shots as strokes and shoots through a paper-faced metal disk on the green about the size of a golf cup.

Once while hunting wild turkeys in the headlands of the Everglades with Glenn H. Curtiss, one of the pioneers of American aviation, Howard Hill demonstrated the superiority of archery equipment over the shotgun for distance shooting. The nimrods saw a large horned owl on the limb of a tree over eighty yards away.

"I can't shoot that far with this shotgun," said Mr. Curtiss. "You'd better try your hunting bow, Hill."

The archer shot three hunting arrows at the distant owl before the bird dropped from its perch.

Which goes to show that a powerful bow will outrange a shotgun, while the archer, by reason of his weapon's noiselessness, gets three to four shots at game where the average hunter as a rule seldom gets more than one.

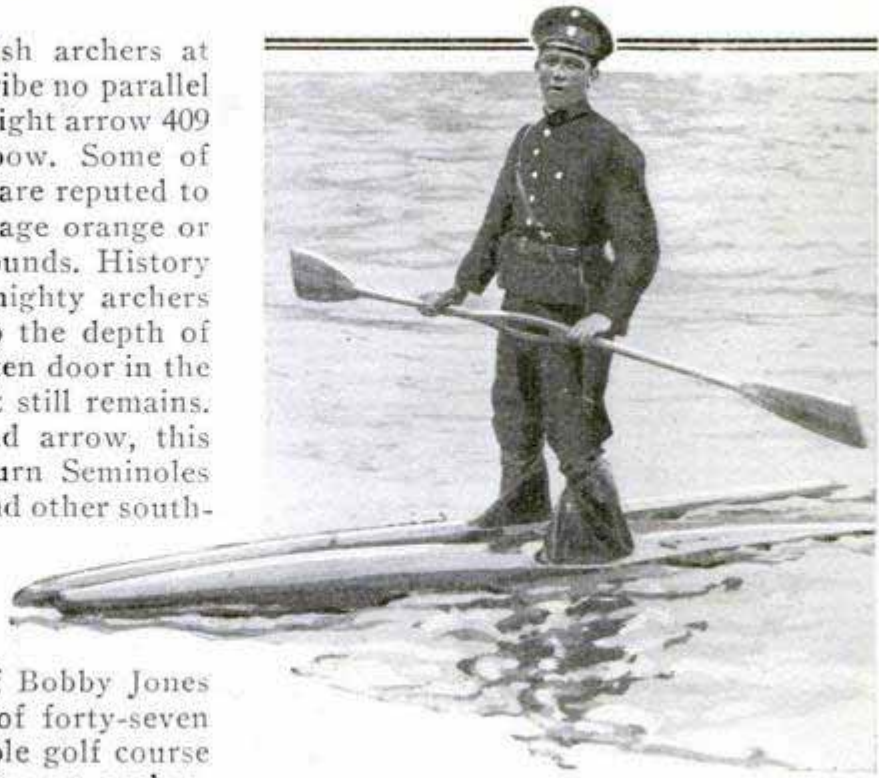

Patrolling His Beat on Water Skis; Vienna Policeman with Oar Used for Balancing and Propulsion

### WATER SKIS FOR POLICEMEN AID IN SAVING LIVES

Policemen in Vienna, patrolling the water front, wear special skis with which they can walk on water, and so quickly reach persons in danger of drowning. A double-bladed oar is used to propel the wearer and help him keep his balance.

### SCREEN ON GOLF-COURSE TRUCK GUARDS DRIVER FROM BALLS 1024

To shield the driver and helper from golf balls, a service tractor on one of the courses in Lincoln Park, Chicago, has been fitted with a strong screen. It offers constant protection on the side from which the balls are being driven, and does not interfere with the vision. When not needed, it can be taken off and stowed away.

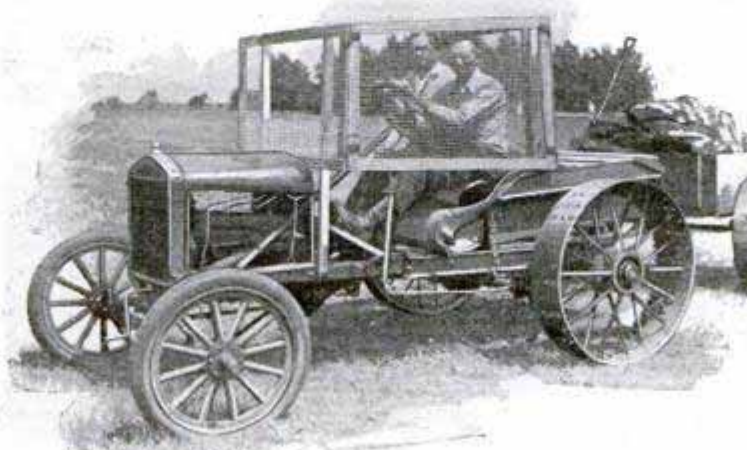

Safe from Flying Golf Balls; Course-Service Truck with Its Screen That Protects Occupants



THE DEVELOPMENT OF SHIPPING FROM ANCIENT

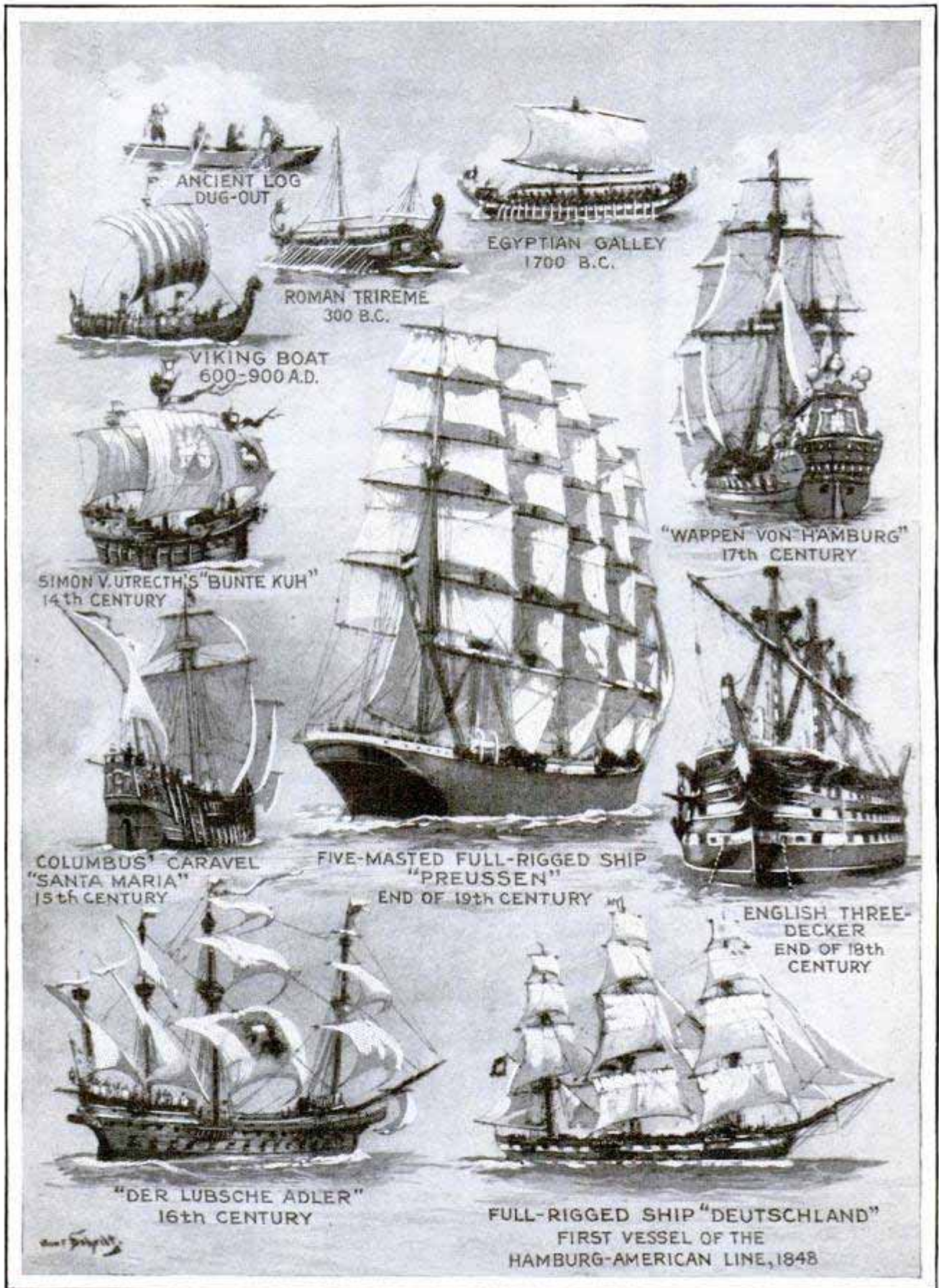

Courtesy Hamburg-

From Log Dug-Outs to Full-Rigged Sailing Vessels; Centuries of Shipping Progress at a Glance; the Greatest Advance Was Marked by the Harnessing of the Winds



# LOG DUG-OUT TO THE PALATIAL LINER OF TODAY

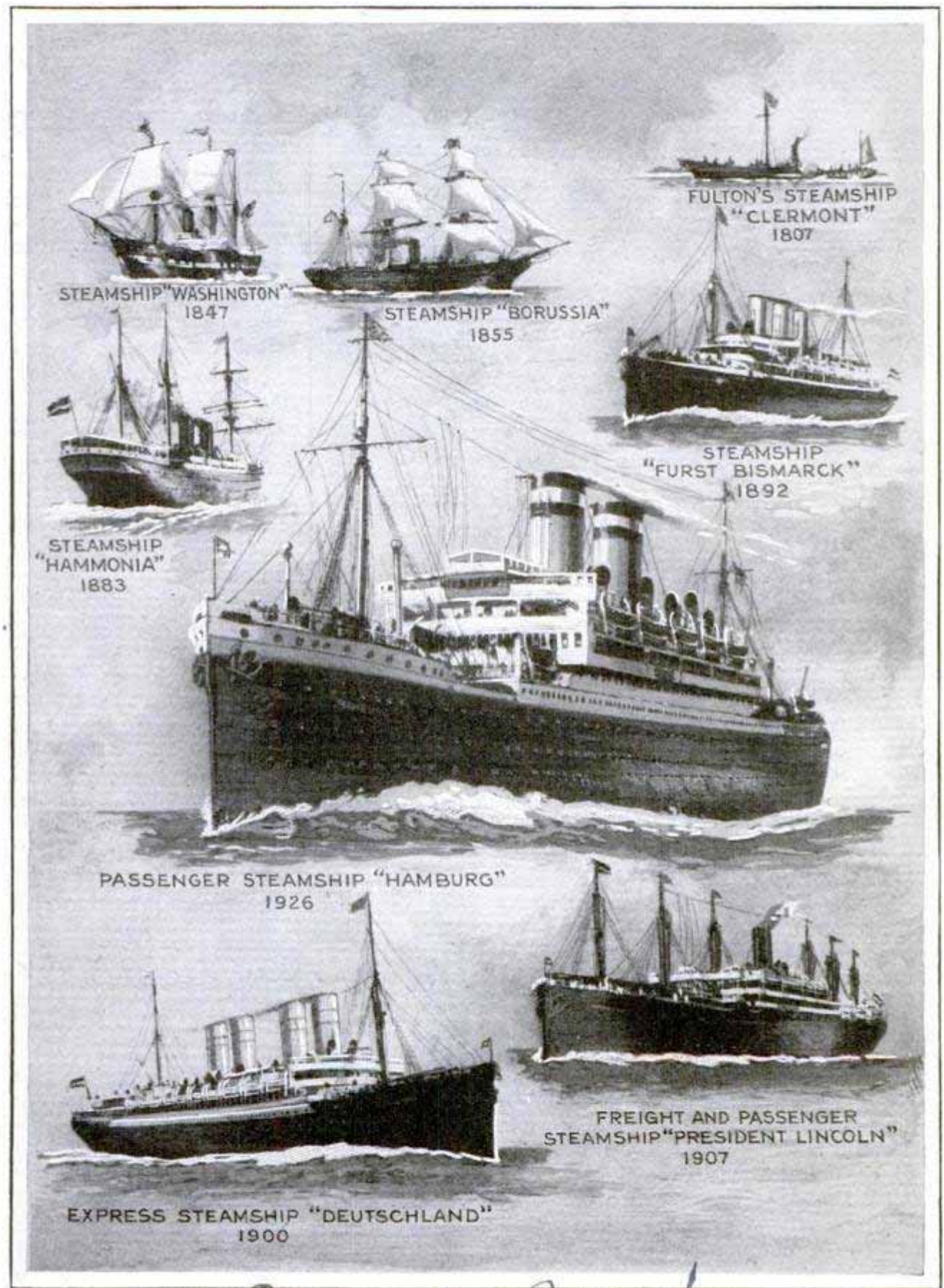

STEAMSHIP "WASHINGTON" 1847

STEAMSHIP "BORUSSIA" 1855

FULTON'S STEAMSHIP "CLERMONT" 1807

STEAMSHIP "HAMMONIA" 1883

STEAMSHIP "FURST BISMARCK" 1892

PASSENGER STEAMSHIP "HAMBURG" 1926

FREIGHT AND PASSENGER STEAMSHIP "PRESIDENT LINCOLN" 1907

EXPRESS STEAMSHIP "DEUTSCHLAND" 1900

American Line, *39 Broadway New York*  
 From Wind-Blown Ships to the Era of Engine-Propelled Giants, Luxuriously Equipped and Capable of Speeds Far Beyond the Dreams of the Early Mariners



1043

# NEW EFFORT PLANNED TO HARNESS OCEAN POWER

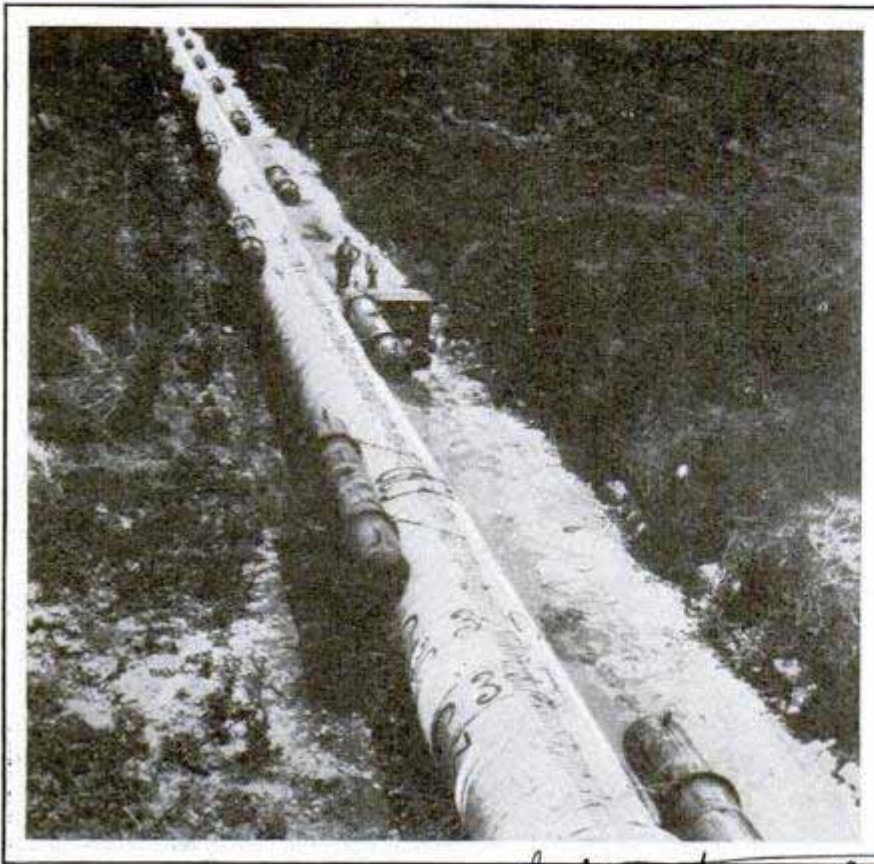

Section of Mile-Long Pipe as It Was Being Towed on Pontoons to a Position in the Gulf Stream; It Sank Before It Was in Place

Despite two failures, Georges Claude, French inventor, is making a third effort to harness the Gulf Stream for an ocean power plant. Each previous failure has been due to inability to place in position in the sea a length of insulated steel tubing six feet in diameter, and more than a mile long. In each instance the 300-ton pipe went to the bottom before it had been drawn to proper position for lowering, but a third section is being made to continue the experiment. When successfully placed the pipe will extend from the Cuban coast at Matanzas and suck up water from a depth of more than one-third of a mile. This water will have a temperature of about fifty degrees and will provide the cooling necessary for the plant which, instead of burning fuel, will utilize the relatively hot surface of the Gulf Stream, which is about forty degrees warmer than the water to be sucked from the ocean bed. The ocean plant makes use of a boiler, turbine and condenser which serve in the ordinary manner except that the boiler is at the temperature of the surface water, and instead of being subjected to hundreds of pounds of pressure, the boiler

will have much less than the atmosphere outside. Even the low pressure of the boiler, however, is to be higher than that of the condenser, and consequently, steam from the boiler would flow through the turbine to the condenser, while cold water from the depths maintains the low pressure of the condenser by cooling and condensing steam from boiler and turbine.

1079. ———

## GAME FISH GROWN BY GOVERNMENT HELP ANGLERS

Provision for spending \$5,000,000 over a period of five years for propagating game fish is contained in a bill recently passed by congress, the bureau of fisheries plan-

ning to utilize waste lands in the interior for growing the fish, which at the same time will serve as a food crop for the agriculturist. The government project will support the work already being carried on by the many states which maintain hatcheries. Individual states operate 359 hatcheries, almost ten times as many as the bureau of fisheries now has, and sportsmen's organizations have established 150 active nurseries.

1068

## HEATING AND LIGHTING FIXTURE COMBINED IN ONE UNIT

Electric heating and lighting facilities are combined in a single ceiling fixture unit by one British manufacturer specializing in electric heating by radiation. The combination is particularly suitable for large rooms, such as hotel lobbies and auditoriums. The fixture is hung at a height above the floor so that the radiated heat reaches the base of the walls. The heating elements are contained in the outer part of the fixture, and the illuminating elements within the fixture, thus combining beauty and utility.

J. H. Pride 4, Gamillies Place W. 1, London, Eng

rec sea-1930-881  
Sept. 1932-401

Birmingham Ex  
Cambridge St  
Kansas City Star 7/1/30  
Morgan Crucible Co Ltd



**MYSTERY OF RADIO ECHOES  
PERPLEXES SCIENTISTS**

976

"Long time" radio echoes, heard at an interval of a second or more after the original signal was sent, have inspired fresh interest in these phenomena and given rise to at least two theories of explanation. Had they been echoes of signals that merely went once around the world, they would have returned in one-seventh of a second or if twice, in two-sevenths of a second, according to O. H. Caldwell, former member of the Federal Radio commission and well-known radio expert. There are now two theories to explain these delayed echoes, Mr. Caldwell declares. One is that they are reflections from a collection of particles far out in space, a region visible as the zodiacal-light which can be seen after sunset and before sunrise as a band of twilight in the sky. It is a sort of Saturn's ring around the earth and some radio men have felt that reflection from it causes the radio echoes. Another theory is that the echoes are merely retarded transmissions from the earth's own vicinity beneath the Kennelly-Heaviside layer. Attempts have been made to detect radio echoes from the moon, but no authentic case of "moon echoes" has been recorded.

953

**FAN TO COOL AND DRY AIR  
HELPS PROMOTE HEALTH**



Air is cooled and brought to the proper humidity by a special fan developed for store use, but also suitable for home installations. It operates in connection with a small refrigerating plant and furnishes cool air at the rate of 1,200 cubic feet a minute, blowing it a distance of twenty to thirty feet. As warm air is drawn in, it is chilled and excess moisture removed. The fan occupies but little space, is not expensive to operate and several may be run from a refrigerating plant of suitable size.

Peerless Co. Machine Co.  
515 W. 35th St.



Mirrors at Intersections of Narrow Streets in Brussels Give Auto Drivers a View of Traffic

Wide World

**MIRRORS AT STREET CORNERS  
AID AUTO DRIVERS**

Large mirrors have been placed at intersections of some of the main streets in Brussels so that drivers may see the traffic conditions before they reach the crossings. The mirrors afford a clear view around the corners and are high enough not to interfere with pedestrians.

**VULCANIZED LIGHT EXTENSION  
FREE OF FIRE DANGERS**

292

8 x 56

Eliminating much of the danger of shorting or of fire in using an electrical extension, a rubberized cord now is on the market. Cord, socket and attachment plug are vulcanized, thus making it one piece of rubber, while the handle contains a tap for other electrical tools.

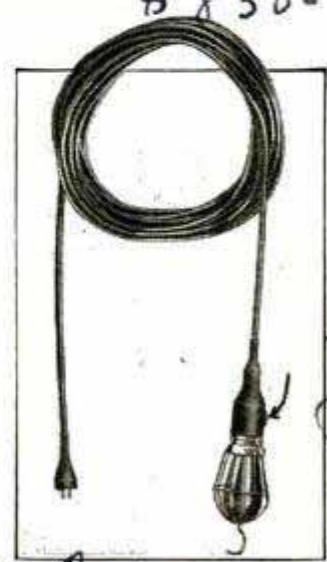

Rubberite

Barb Mfg Co. 6001 S  
Tulman Ave Chicago



935 **OUTBOARD MERRY-GO-ROUND LATEST WATER SPORT**

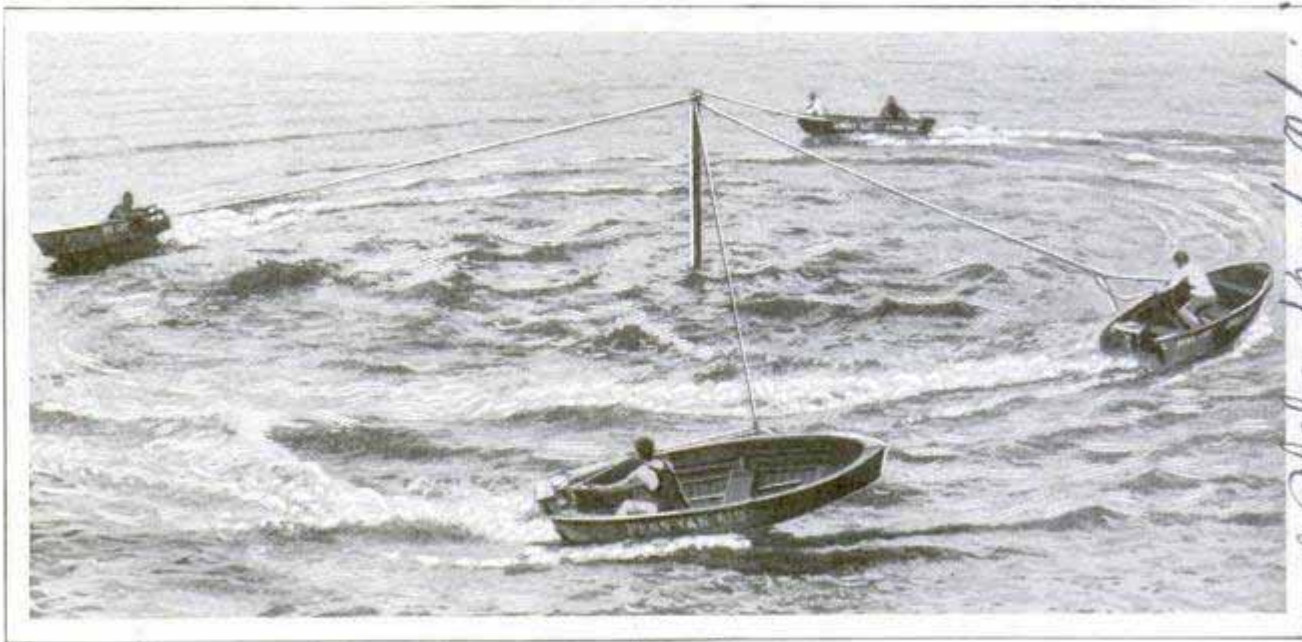

Thrilling Motorboat Races Are Possible in Small Space with This "Merry-Go-Round" Arrangement; the Lines Are of Different Lengths So That Boats Can Pass Each Other

Outboard-motor boats in a thrilling "merry-go-round" race amused and interested spectators at a Florida resort recently. Jumping platforms were introduced, and a hurdle race added variety to the contest. The boats were tied through swivel connections to a twenty-two-foot telephone pole, imbedded firmly in the bottom and extending about twelve feet above the surface of the water. The length of the ropes to the boats was varied, allowing some of the craft to operate on a shorter radius and so pass the others.

**AUTOMATIC KEY-CHAIN REEL PROTECTS SWITCHMAN**

962

When a Los Angeles switchman nearly lost his life when his key chain caught an obstruction as he was jumping off a car, he decided to invent something that would prevent such accidents. He now has a chain holder, about the size of a watch, which can be attached to his belt. It is fitted with a spring arrangement, so adjusted that the twenty-four-inch chain and the bunch of keys are quickly brought back



into place automatically as soon as the keys are released, doing away with a dangling length of chain.

982

**WHY LEAVES FALL IN AUTUMN**

Nature's wonderful skill in maintaining balanced conditions is the chief reason why the leaves fall in autumn, according to Martin L. Davey, well-known tree expert. There are huge numbers of leaves on every tree, he explains, and all the leaves give off moisture. In the winter, the tree roots absorb very little moisture so that, if the leaves remained on and functioned, the tree would be literally drained dry and would wither away. Before the leaves fall, the tree absorbs most of the food substances they manufacture, and a layer of thin-walled cells is formed at the base of the leaf where it is attached to the twig. This layer becomes a zone of weakness allowing the leaf to fall of its own weight or to be easily blown off. The scar that is left is protected by a substance which is practically waterproof. Since the tree bark is almost impervious to moisture, the tree is literally "bottled up" for the winter. During or after a long drouth in summer, the leaves fall early, as the tree naturally hastens the process in order to prevent too much evaporation of its moisture.

*Federal Bldg. Kent. Ohio. 25 Tree to rent Co., Inc. Davey*

*Dr. W. D. C. Jacobus, Sutchinori, Pac. Elec. Co. Los Angeles Cal*



700 at Lakehurst, N.J.

*Brown Technical Associates  
Parker Bldg. Schenectady, N.Y.*

*H. Graen, Jr.*

*General Electric Research Laboratory  
Schenectady, N.Y.*

**WINDOWS CLOSED BY FALLING RAIN**

When rain falls on the sill of an electric window recently invented, a circuit is closed and the window is automatically lowered, slowly and noiselessly, sparing the housewife the task of running from room to room to prevent damage from a storm. The apparatus may also be set by a clock to shut the window at any desired time whether rain is falling or not.

**PICTURE CARD HAS PHONOGRAPH RECORD**

Talking picture postcards that carry a verbal message from the sender are being produced in Germany. These cards bear a photograph of the sender, and the voice is recorded on a small phonograph disk attached to the back of the card. The recipient places the postcard on the phonograph and listens to the reproduction of the sender's voice.

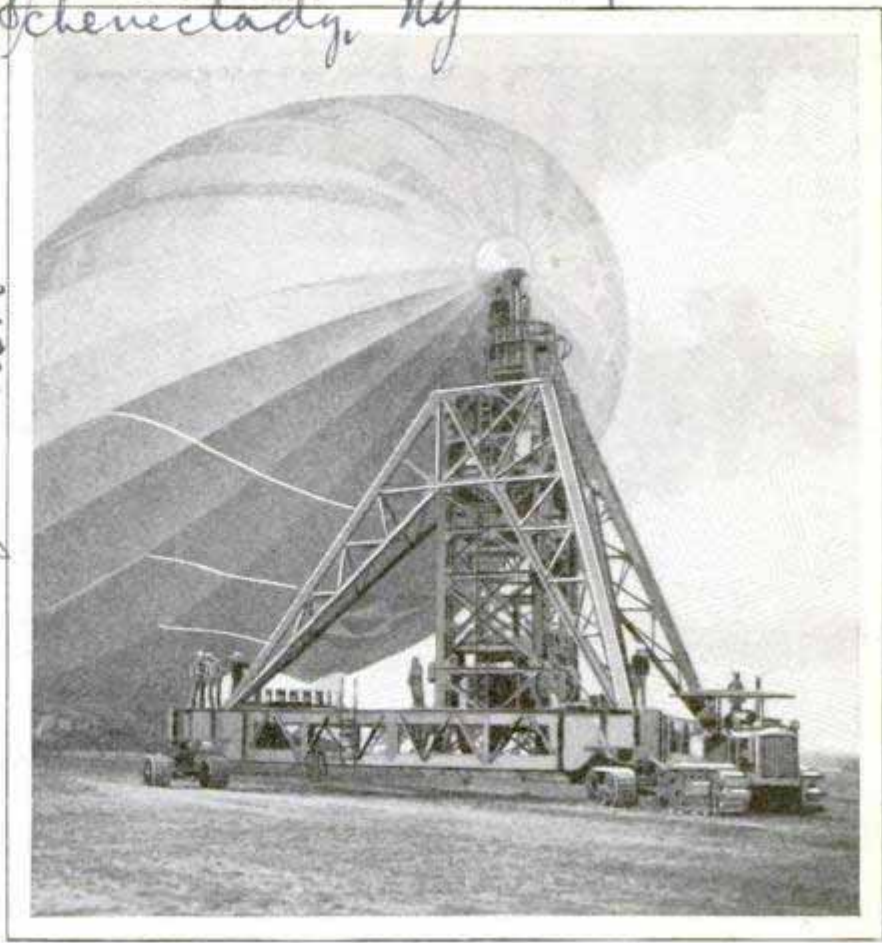

Portable Mast for Dirigible in Use; It Can Be Hauled About by a Tractor and Requires a Smaller Ground Crew

**PORTABLE MAST FOR DIRIGIBLE DECREASES GROUND CREW**

Successful tests recently were conducted with a portable mooring mast for the navy's dirigible, the "Los Angeles." The mast, consisting of an iron framework on rollers, can be drawn about by a tractor and offers added facilities for landing as well as launching. It greatly decreases the number of men composing the ground crews for either take-offs or landings.

**PILE DRIVER WORKS AS PISTON OF GASOLINE ENGINE**

A pile-driver hammer, operated by an internal-combustion engine, has been developed by a German manufacturer. The hammer head forms the outer end of the piston rod. The whole outfit weighs about 450 pounds. It requires only about two quarts of fuel and a little lubricating oil per day. Ignition is provided by a storage battery, and the hammer delivers its blows continuously until the current is shut off.



Miniature Phonograph Record Which Bears Photograph as Well as Voice Record of the Sender

*Hans Wesner, Berlin, Germany*  
*no U.S. agent known*  
*no U.S. agent known*

*The Helweg Abtungsellauff  
Esselhaen, a. H. Germany.*



# Gunfighting Police



By COL. ROY D. JONES  
Secretary United States Revolver Association  
(as told to John F. Goggswell)

*Hedgemoor Road*

DAY was breaking. Around the base of a small brush-covered hill, near a large eastern city, were strung more than a hundred police officers. Guns in hand, they strained their eyes through the dim light toward the top of the rise.

On the hilltop, two desperate gunmen were at bay. Every few minutes they sent a fusillade of revolver bullets down the slope toward the officers. Both had done murder many times over and were

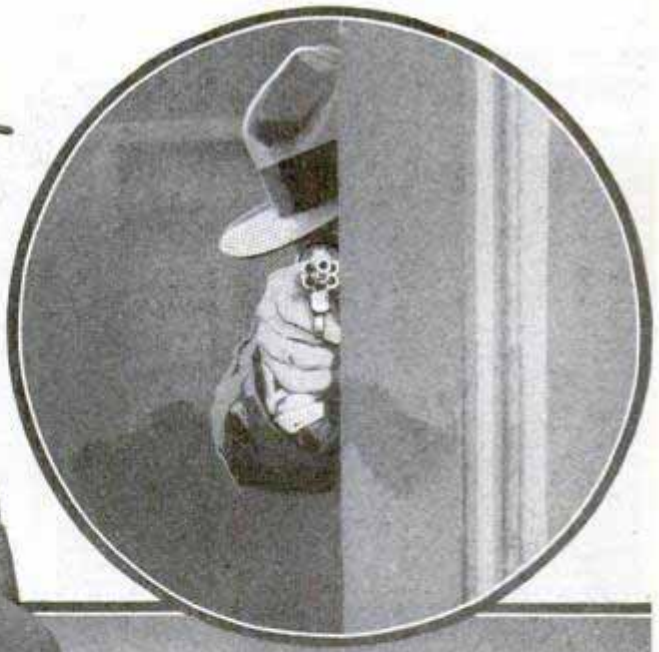

Various Revolver Holds and Firing Positions; at Top, Two-Handed While Lying Flat; in Circle, from Cover; Above, the Crouch, and, at Right, Two-Handed Hold

*Belmont, Mass*



# Doom Gangsters

prepared to exact a high price for their lives.

As the sun broke through the morning mists, the cordon of officers began closing in on the criminals. They accompanied their advance with a constant bombardment of the thicket. The air was full of lead. It seemed nothing could live through the hail of bullets, but still the bandits fought on. Finally the shooting from the top of the hill came to a stop. For a few minutes the officers waited, then they surged forward up the slope. Just before they reached the crest, one of the outlaws stepped out of the thicket, his hands in the air. The other gunman lay on his face, a bullet hole in his head. Investigation showed that he had used the last bullet in his gun on himself, rather than surrender. Not a single bul-

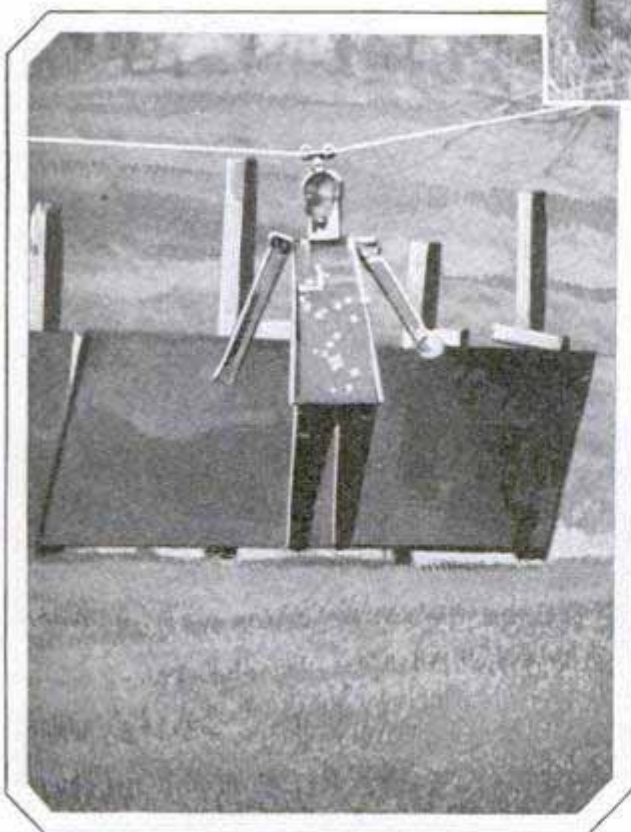
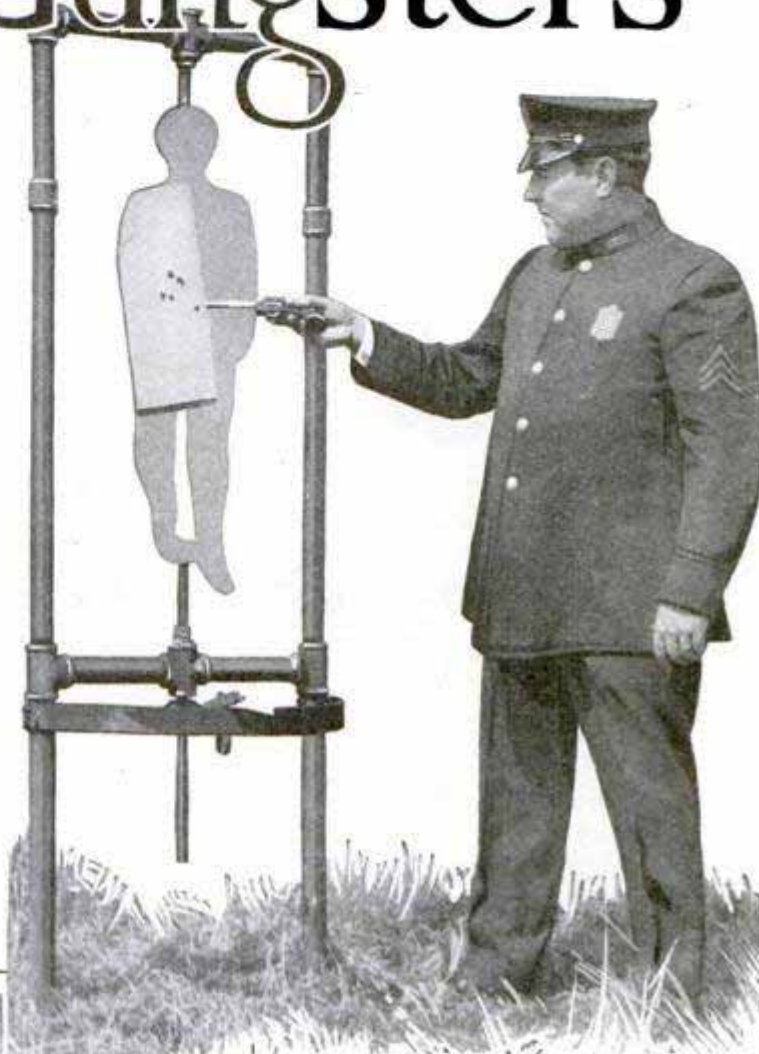

Above, Results of Good Aim at Swinging Target, and, Below, Moving Target on Cable

let had touched either bandit, in spite of the fact that the police had fired more than 2,000 shots.

That incident is indicative of the conditions that prevailed generally in police departments a few years ago. A few months past, at the graduating exercises of a police school, such as many large cities now maintain to make their policemen a gunfighting first line of defense between the citizen and the criminal, twenty-five officers reenacted this "Battle of 2,000 Misses" with far different results.

In the brush, silhouette targets had been set up in no better sight than the bandits had been—just dimly outlined in the bushes. Two hundred and fifty shot were fired. The targets were hit 249 times. When one of the policemen opened his gun to empty it of the discharged shells, he found that one had missed fire. Of course, that record could hardly be ap-



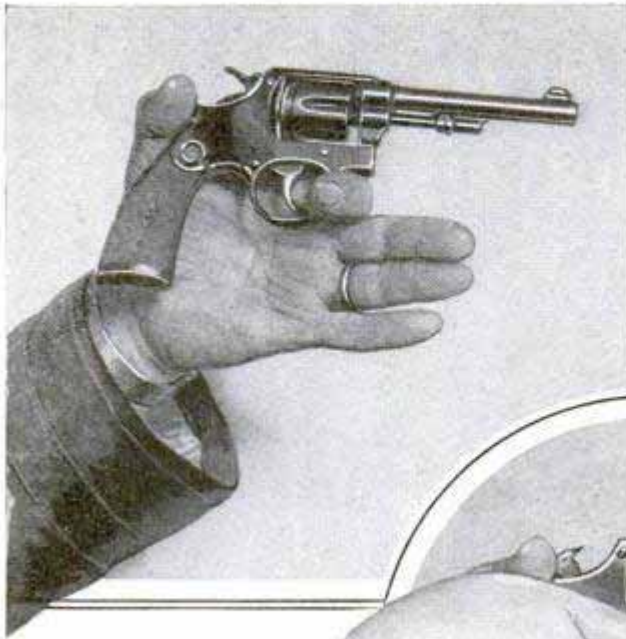

proached shooting under the same conditions at human targets, who could move about and return the fire. But the fact remains that any two gangsters at bay on the top of that hill with those twenty-five policemen advancing upon them would have been quickly wounded or killed. The only gunman who can cope with the bad gunman is the good gunman. And most of the police officers walking beats in American cities today are not gunmen—good or bad. In confirmation of that statement, let us consider the state of affairs in one city to which I was called to assist in establishing a gunnery school for police officers. The first class consisted of 100 men. To get a line on what they knew about their weapons, I took them down to the revolver range, divided them into squads and told them to go ahead and show me some shooting.

As soon as I saw them aim at the targets, I knew that

not a single one of the hundred was acquainted with even the rudiments of hand gunnery. How could they be expected to know? No one had ever taught them. Out of all the officers who blazed away at the targets, not one got a bull's-eye. A great many of them couldn't fire their guns at all.

And yet we made good gunmen out of nearly all of them. Within a month, most of the officers could bang out pretty good scores on the indoor range. That was the first step in their gun-fighting education—to teach them how to hold their sights on the target, squeeze the trigger and how to care for their guns.

The class gained some knowledge of slow and rapid fire at targets and then were ready for



Above, Correct Two-Handed Revolver Hold, and, Below, Tetrault and Gallagher, Crack Shots of the Springfield, Mass., Department



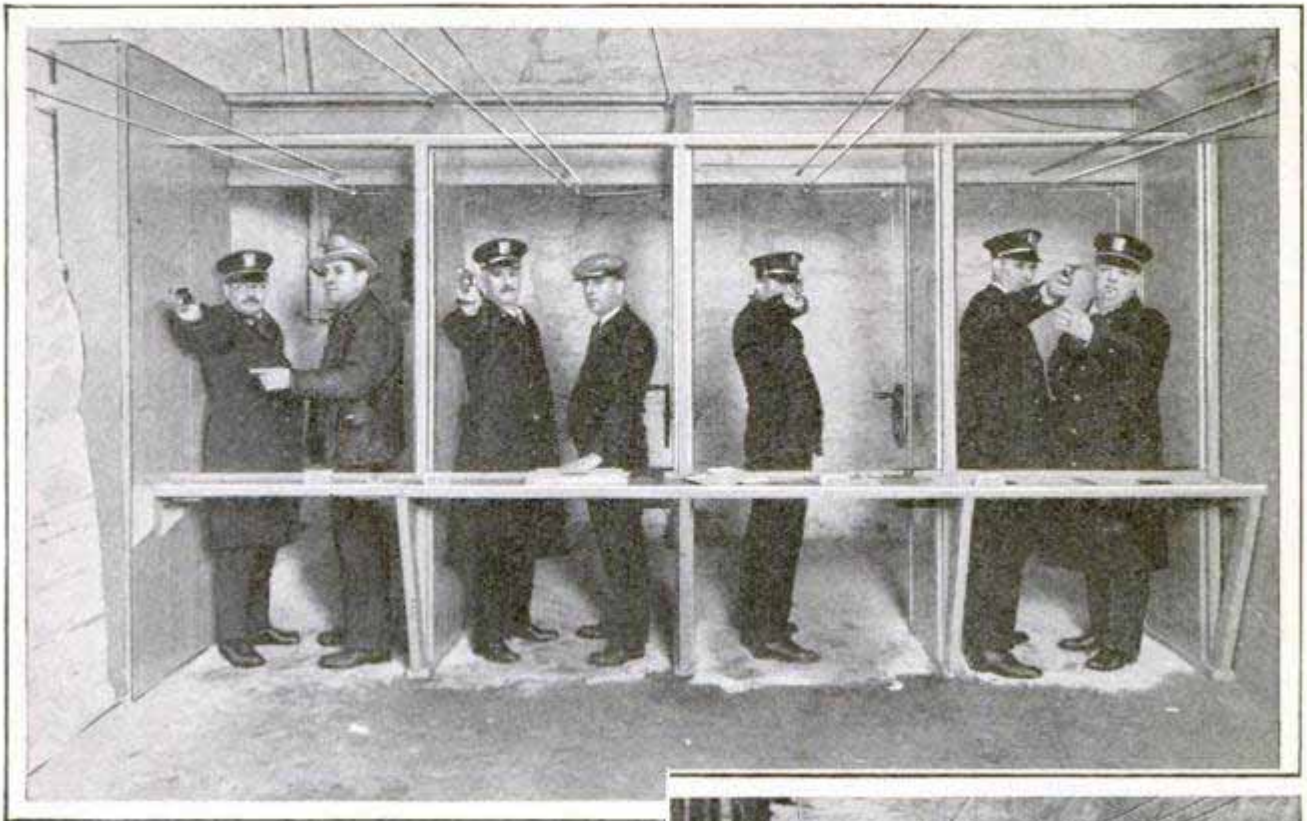

schooling in gunfighting. The first step was to get them to carry their guns in position, readily accessible in case of trouble, as the primary essential of good gunfighting is to get the gun out and into action in the shortest possible space of time—a quick draw, if you please. Years of experience have taught the best gunfighters of the nation that the ideal place for a holster is in front of the right hip, with the loop on the holster so fastened that the gun will hang diagonally with the butt straight back toward the hip and the muzzle squarely between the legs.

A draw from this position consists of one movement only. If the gun hangs properly, the right hand comes up from its position as it hangs at the side, three fingers hook under the butt, start the gun out and, as it begins to leave the holster, the forefinger finds the inside of the trigger guard and the thumb the top of the hammer, ready to cock the weapon the instant the muzzle swings toward the target. A quick draw can only be acquired by much practice. The police classes put in many a weary hour learning to draw and also to “aim with the thumb.” During this instruction, all guns are empty.

Aiming with the thumb is simply a matter of holding the revolver in such a manner that, when the sights are lined up on

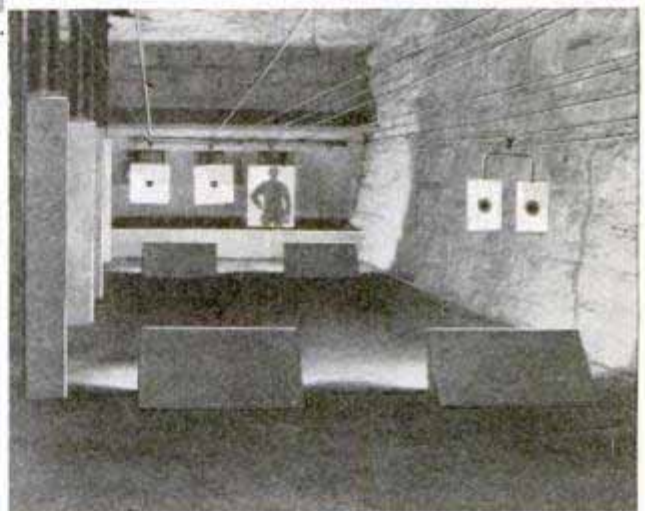

Policemen at Revolver Practice in Gallery with Targets That Run on Carriers



810



Sergeant Tetrault Shows Proper Way to Disarm Bandit; Stand as Far Back as Possible with Gun Back; if Bandit Whirls, Counter with Left Arm

the mark, the thumb is also pointing at it. A police officer rarely does his shooting under conditions that prevail on the target range. More likely, the time he must shoot straight or die is in the middle of the night, in the pitch-black interior of a looted store, or down an alleyway where the beams from the street lights send not a single ray. Under such conditions, he cannot see his sights. But he can point his thumb at even the dimmest target—try it yourself and see how easy it is to do—and if his gun barrel is held parallel to his thumb, a thumb aim is just about as good

of the body and not to try for head shots—a bullet in the midriff will stop a bandit just as quickly as one in the head, and the body is the bigger target.

An average shot will place four bullets out of ten in vulnerable spots of the silhouette, a good shot will average five or six hits out of ten and an expert seven or better. Time after time, I have seen both Sgt. V. M. Tetrault and Patrolman Ray Gallagher, of the Springfield, Mass., department, register all ten shots at twenty-five yards and frequently repeat the performance at thirty-seven and a half yards

as a sight aim, when the target is as big as a man.

Shooting from the hip and other trick firing have no more place in gunfighting than they have in target shooting. As the first step in the training for real gunfighting, the officer takes his stand, hands at side, twenty-five yards from a steel target shaped like the silhouette of a man's body. However, the silhouette is but three feet tall and half the breadth of a man. In short, conditions are the same as shooting at a man fifty yards away.

The silhouette target is mounted on a revolving rod, so that it may be turned at any angle from the shooting point. When the officer is ready for the test—gun holstered at his side—he sees only the sharp edge of his target. Without a warning word, the target suddenly swings to present its full expanse. It remains in this position for exactly three seconds, then swings away again.

In the interval, the officer must draw his gun, aim it and fire. The gunnery students are instructed to fire at the middle



—equivalent to a man at a distance of seventy-five yards—to which range the students graduate after becoming proficient at the shorter distance. However, these two are among the best shots in the country at such targets, and police officers need not develop such uncanny accuracy to be far ahead of the usual gangster.

Proficient at the silhouettes, the student advances to still more difficult shooting. Out on the range, there are three steel plates, each a foot long and three inches wide. These are hinged to wooden posts at the center so that they can stand upright or lie flat. One plate is twenty yards from the shooting point, another thirty yards and the furthest, thirty-seven and a half yards. They are placed at widely separated angles of fire.

When the marksman takes his stand at the mark, all three plates are lying flat. Suddenly, one of them—he doesn't know which it is to be—pops upright. His problem is to knock the plate flat again with one shot, and that shot must be fired within two seconds of the time the plate flashes into view. Understand that, to flatten the target, he must hit it somewhere on the top half—thus his mark is but three by six inches.

By the time he has graduated from these

targets, the officer is a marksman or he never will be. Then we put him at what, to all intents and purposes, except that no return shots are fired, is real man shooting. A hundred yards down the range there hangs from a cable a wild-looking effigy. It has the outline of a human being, six feet high, and is hinged at the neck, shoulders and hips.

The contraption runs on a wire stretched from the distant point to a position just above the shooter's head. At a signal, the effigy starts along the wire toward the officer. It swings from side to side, the arms flail about, the body jumps back and forth, and the legs kick. And yet we expect the student to get at least three out of five bullets into a vulnerable part, before the target reaches the fifty-yard mark. When he can do that or better, he's a real shooting man.

### MOTORBOAT LIKE TORPEDO WILL NOT SINK 1023

With a torpedo-shaped hull and a watertight cabin compartment on top, a novel motorboat, designed by a German engineer, has been tested with the idea of using it for a journey across the Atlantic. The hull, on body, is of steel.

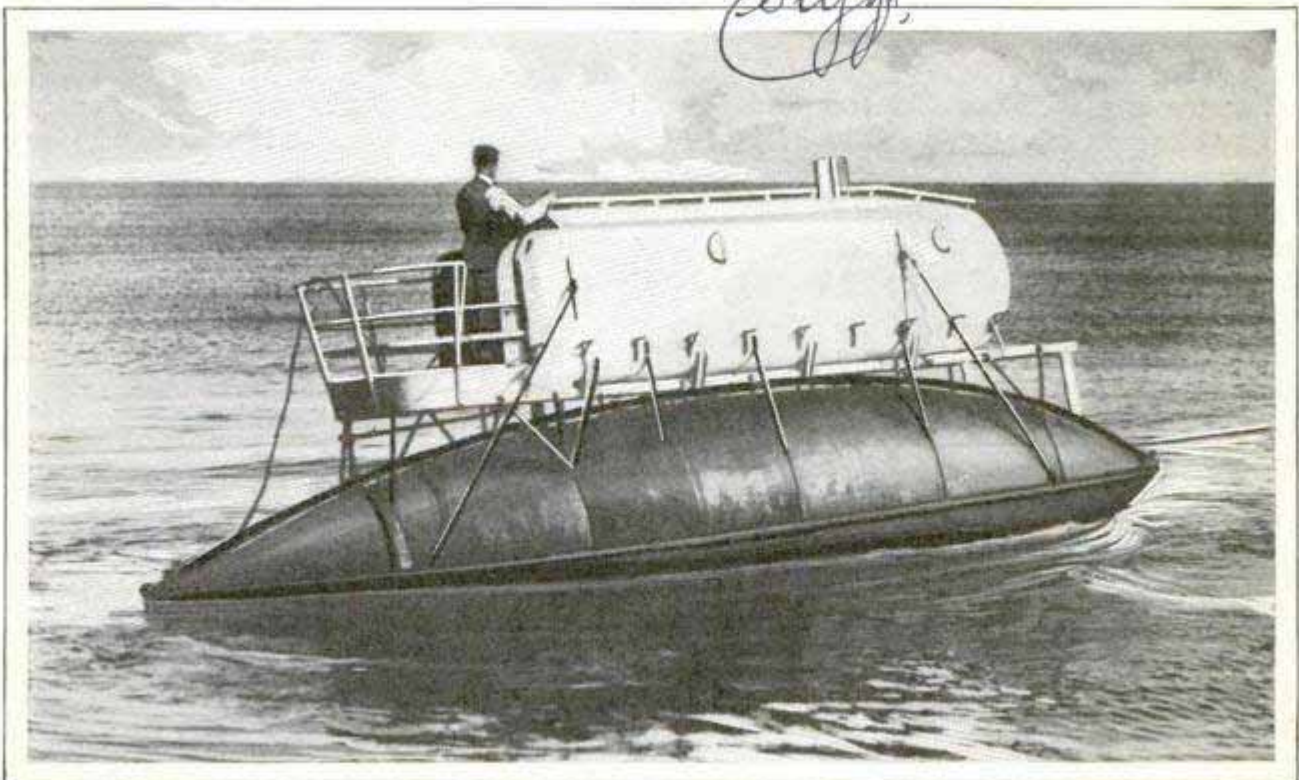

Queer Motorboat German Engineer Has Built for a Possible Trip across the Atlantic; It Has a Water-Tight Compartment or Cabin Mounted on the Torpedo-Shaped Hull

tested on River Bodensee



*Kenneth Bartlett  
Government Laboratory, Arlington, Mass.*

*924*

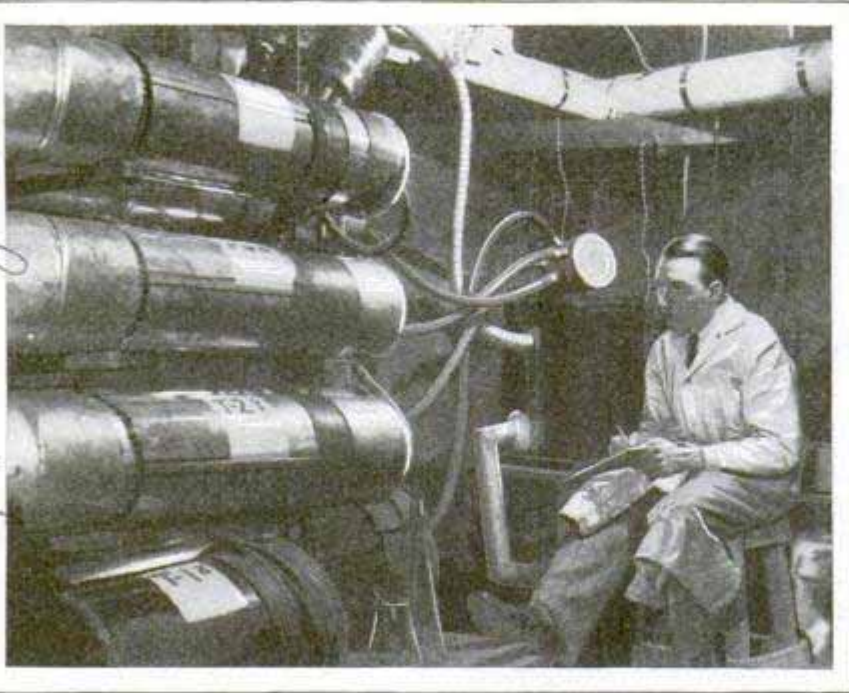

Testing Odors in Special Apparatus That Tells Which Aromas Attract Corn Borers So That They Can Be Trapped

**ODORS THAT LURE CORN BORER TO AID IN WAR ON PEST**

Government scientists have been experimenting with various odors that attract the corn borer in order to find a lure that can be used to entice the pests into traps and so protect the corn. So far, five odors from various parts of the corn have proved effective and more than 900 have been discarded as lacking attractiveness. To make the test, a drop of the substance is placed on a blotter and put in an "olfactometer," a specially designed apparatus that helps in determining the strength and reaction of the odors. The moth is put in another section of the machine and, if attracted by the smell, tries to reach the blotter.

**WEIGHT OF LIGHT FROM SUN IS MANY TONS**

Science has put both heat and light "in the scales" and weighed them with the result that an estimate can be made as to the weight of the light radiated from the sun. Accurate measurements have shown that a searchlight, requiring the equiv-

alent of fifty horsepower to operate, would radiate one-twentieth of an ounce of light and heat if it were kept working constantly for 100 years. On this basis, scientists estimate that the sun's whole surface is emitting over 4,000,000 tons of light every second. This means that the sun is becoming some 360 billion tons lighter every twenty-four hours. But this has been going on for millions of years, and scientists are assured that the process will continue for many thousands of centuries to come, so there is no need for immediate

concern that the sun will waste away. Even wireless waves weigh something. Some of the big radio stations will have transmitted fractions of an ounce apiece when they have operated a century.

**TRACTOR FITTED WITH CRADLE SPEEDS HANDLING PIPE**

Pipes for natural-gas lines in California are conveniently and quickly loaded and unloaded from trucks with the aid of a tractor that has an arm or cradle extension for picking up the pipe lengths and placing them where desired. When the tractor is not used for this purpose, the cradle can be converted into a scraper for filling trenches with earth.

*930*



Handling Pipe with the Special Loader-Tractor; the Grappling Arm or Cradle Can Be Lowered for Pushing Dirt

*Caterpillar Tractor Co  
San Leandro, Calif*

*978*

*Chicago 431 S. Jefferson*

*Ed Berts  
6/9/30*



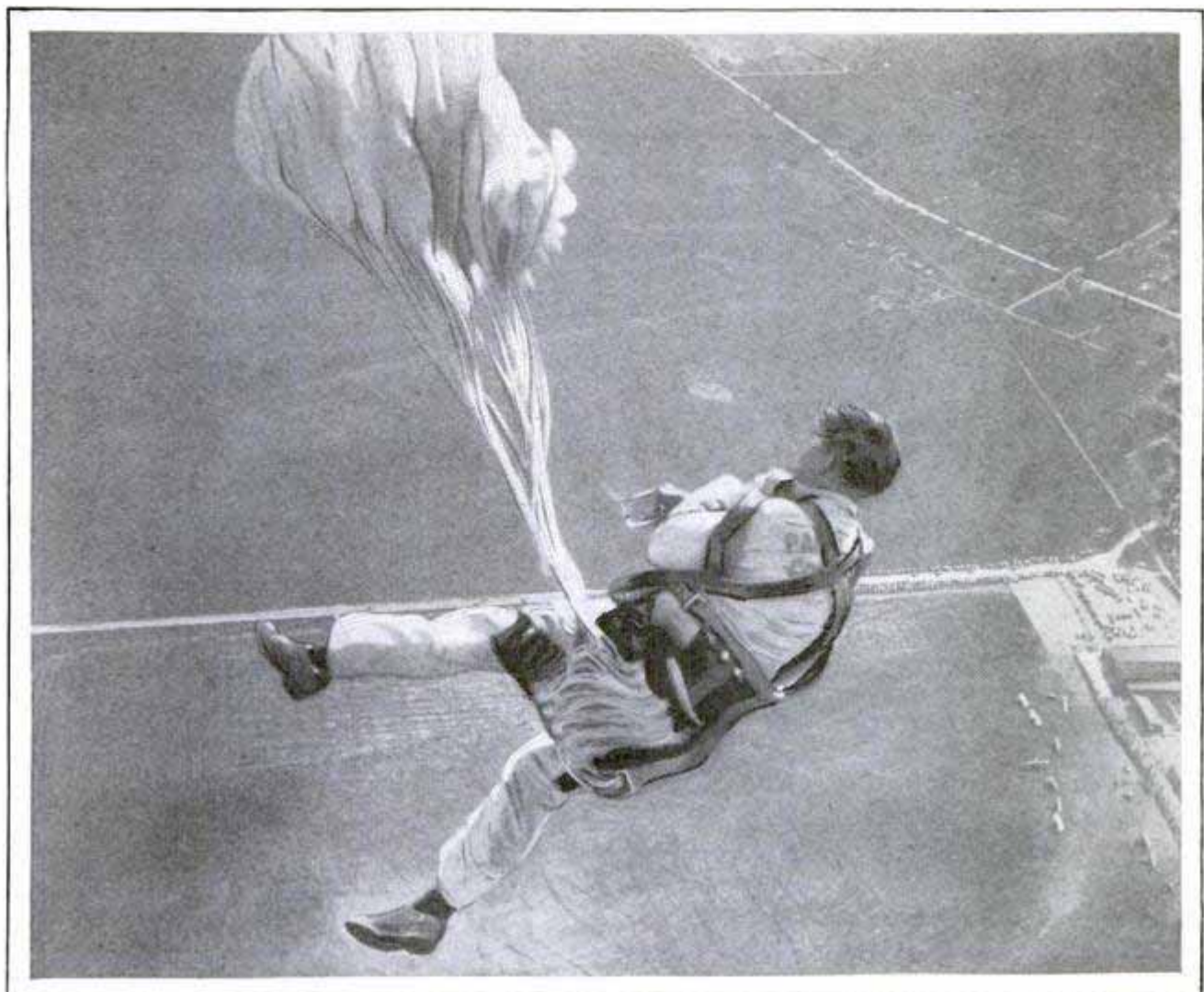

With His Parachute Beginning to Open After He Has Fallen Only Twenty Feet; Remarkable Photograph of Jump Made by Manley J. Merrell, Instructor at Parks Airport, East St. Louis, Illinois

**SAFETY OF MODERN PARACHUTE PROVED IN MANY TESTS**

While parachute jumps at low altitudes generally are considered more hazardous than those at several hundred feet and more, chutes of today are being developed to open quickly after the rip cord is pulled, so that some of the danger of a low jump is reduced. In the accompanying illustration, showing Manley J. Merrell in a jump at Parks airport, East St. Louis, Ill., the parachute is opening after Merrell has fallen but twenty feet. The rip cord and ring can be seen in his hand.

cooked or raw, produced severe cases of anemia when fed in quantities of more than half an ounce for each two pounds of body weight of the dog. Smaller amounts produced milder cases of the disease, which grew in severity as the onion ration was increased.

**DETACHABLE SPIKED SHOE SOLE PREVENTS SLIPPING 424**



To prevent slipping on ground or pavements, detachable steel soles equipped with calks now are available for leather or rubber boots and heavy shoes. The sole is held to the shoe by leather straps.

*O.A. Nordlund Co.  
Williamsport, Pa*

**ONIONS GIVE DOGS ANEMIA**

While experimenting with a diet for dogs to prevent the disease known as black tongue, a malady somewhat similar to pellagra in human beings, it was found that onions produced anemia. The onions,

*Hygienic Laboratory  
U.S. Public Health Dept.*

*Anemia Service 481-A  
6/9/30*

975



Science Service 700-12  
6/3/30

GILDED THRONE IN AUTOMOBILE  
PRESENTED TO POPE PIUS

898

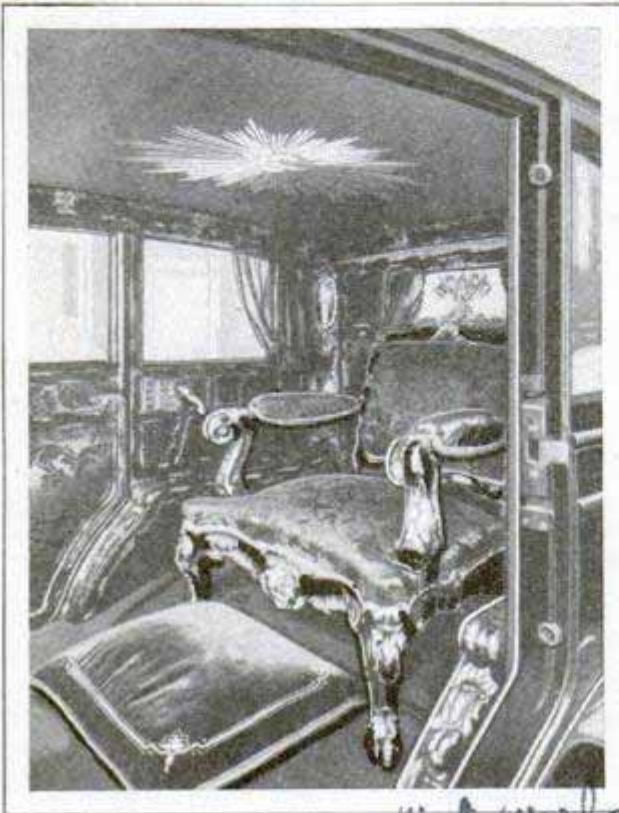

Interior of Auto Given to Pope Pius, Showing Luxurious Fittings and Throne Chair

As a gift from the city of Milan, Pope Pius XI recently received a magnificent automobile in the tonneau of which is a massive gilded throne for a seat. The luxurious car, for the exclusive use of the pontiff, is furnished with interior fittings of gold, silver and ivory.

CRICKET IS MASTER MUSICIAN  
TALKING FILM REVEALS

945

Crickets are more skillful, in some respects, than master violinists, for they can play, in a fiftieth of a second, notes that a human fiddler can reach only by sliding his finger far down on the "E"-string, and the insect repeats the feat four times at every stroke of its "bow." Dr. Frank E. Lutz and W. E. Hicks, of the American Museum of Natural History, recently assisted in the production of a "talkie," or rather a "chirpie," of a performing cricket and learned many interesting things about this famous natural musician. After the film had been prepared, the scientists made microscopic measurements of the alternating shadows and clear bands on the edge of the talk-

ing film. This study revealed that the human ear is too sluggish to hear all the sounds when the cricket chirps. They found that the insect does not slide its tiny file near the edge of its wing clear across the other wing edge at one stroke to produce a chirp. The film showed that each chirp separates itself into about four subdivisions or "pulses" with imperceptible pauses between them. Each pulse lasts, on the average, about one-fiftieth of a second and each pause is somewhat less. The human ear, too slow to catch these divisions, interprets the chirp as a single sound. Further study of the music showed that a pulse starts at the high pitch of fifth "D" above middle "C" of the piano keyboard, rises momentarily a little higher, then slurs downward approximately a whole tone, all in about one-fiftieth of a second.

HAND TESTER TELLS IF MEATS  
ARE TOUGH OR TENDER

966

To tell just how tough or tender a cut of meat may be, the department of agriculture has devised a simple tester which is being used extensively in research to find out why meat from one animal is more tender or tougher than that from another. A knife blade is pulled through small round pellets of the sample by means of a crank, and a scale in the center of the apparatus records the amount of pressure required to make the cut.

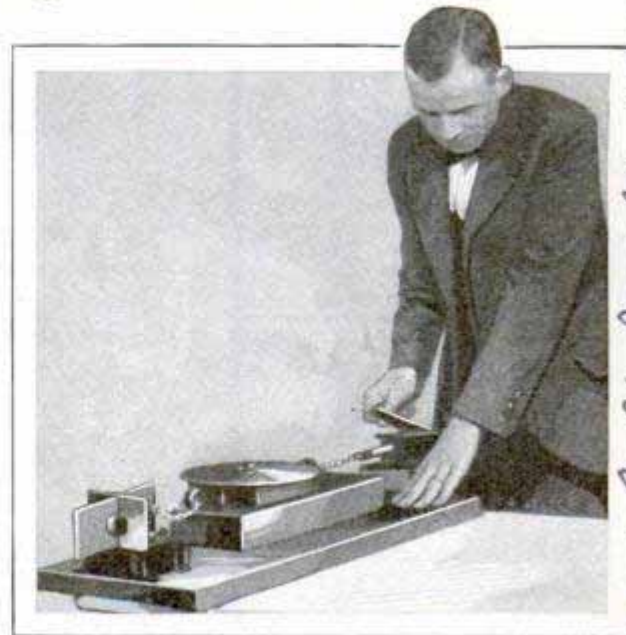

Testing Steak in Puller That Registers the Force Needed to Cut It

Used in food laboratories

wide world  
Cant. E. S. Moore, 3769 Alvin St. N.W.  
Washington, D.C.



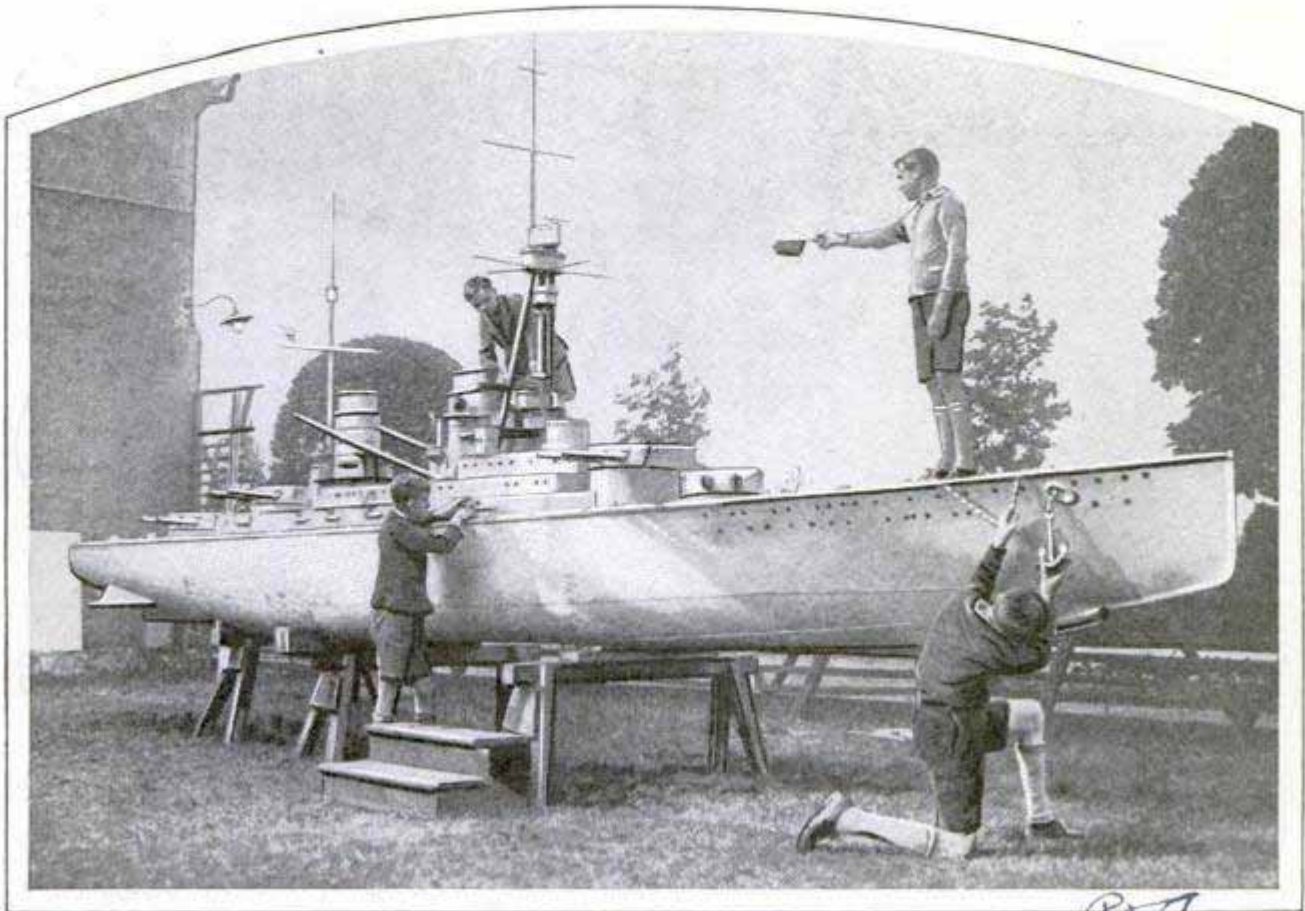

German Lads Examining Remarkable Model of the Cruiser "Hindenburg," Which Was One of the Principal Exhibits at a Recent Show in Potsdam

**MODEL OF GERMAN BATTLESHIP FEATURES BOAT SHOW**

One of the most interesting objects at a boat show held recently in Potsdam, Germany, was a large model of the cruiser "Hindenburg." Details such as turrets, guns, anchor and observation towers were faithfully reproduced in accurate scale.

**PLANTS SPROUT FROM PLASTER ON BUILDING WALLS 980**

When newly plastered walls of a Philadelphia building suddenly sprouted plants, it appeared that the structure would have vertical gardens, and, along with the mystery, the contractor was threatened with a suit. Dr. Rodney H. True, of the University of Pennsylvania, was called in to solve the riddle. He first determined that the vegetation was a plant that grows in alkaline soil, principally on the edges of deserts, and frequently attains a height of two feet. The seeds are used in horse medicine and are often imported from the Sahara desert regions. It was found that a druggist had thrown a quantity of the

*Botanical Dept*

seeds into refuse near a builder's sand pile, some of them having fallen into the sand and become mixed with the plaster. The growth was eliminated by spreading a thin coating of new and seedless plaster over the original.

**LAWN-MOWER ROLLER SPRINGS GIVE SMOOTHER CUT 936**

Better performance is assured from the lawn mower by the use of pressure springs that hold the roller on the ground, preventing the mower from bucking in tough grass and giving smoother, more even cuts. The springs fit practically all makes of mowers and can be attached without altering the machine.

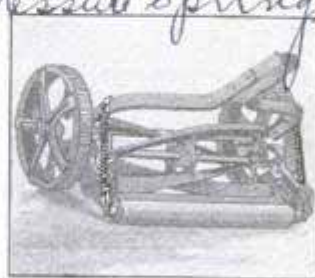

Names and addresses of manufacturers of articles described in this magazine will be promptly furnished, free, by our Bureau of Information.

*Lawn Mower Attachment Co  
Brownsville, Tenn*



# Making Home



This Coffee-pot Calls You When It Boils; the Little Bird on Top Sings and Whistles Shrilly When Steam Is Up; Pot Is Filled Until Spout Overflows, Saving Need of Measuring

An End Table, Bridge or Lunch-con Table Combined in One, Due to the Simple and Convenient Folding Top; It Is Adjusted as Shown Above at Right



To Keep Shoes from Becoming Lost; the Trees Are Fastened Together and Both Shoes Are Lifted at Once with the Handle



Delicate Garments Are Not Injured in This Hamper, as It Has Smooth Inside Surfaces and Folds Up like a Book When Not in Use



# Tasks a Pleasure

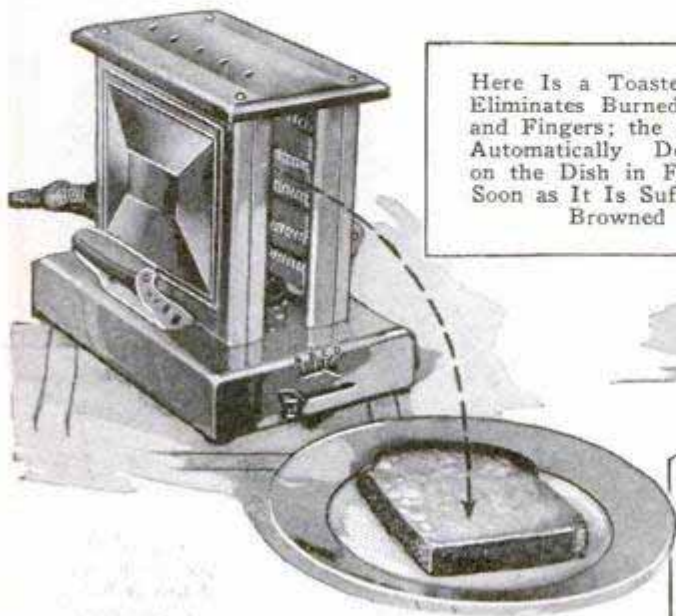

Here Is a Toaster That Eliminates Burned Bread and Fingers; the Slice Is Automatically Deposited on the Dish in Front as Soon as It Is Sufficiently Browned



Polishing Furniture with Paper: Simply Wad Up Two or Three Feet from the Roll and Use as a Cloth; the Paper Is Impregnated with Polish



This Skillet Has Grooves in the Bottom and Therefore Acts as a Grill, Eliminating Grease Fires and Holding a Chop or Steak Away from the Greasy Bottom; It May Be Used on Top of the Stove or in the Oven

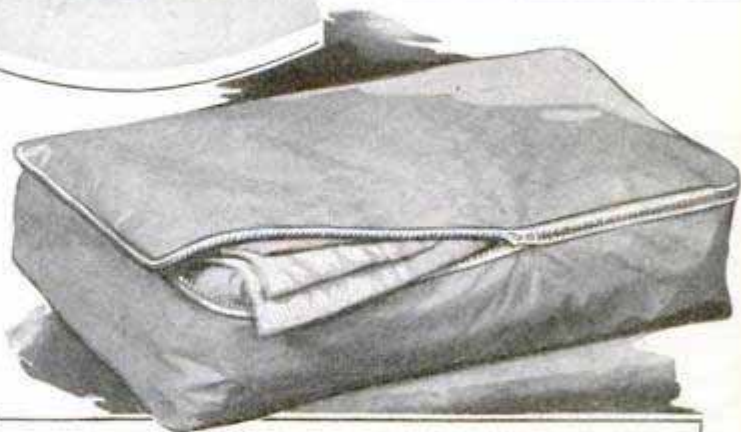

At Left, a Convenient Squeegee Mop for Cleaning and Polishing the Floor, and, Above, a Fabrikoid Blanket Case in Various Colors and with an Interlocking Fastener at the Side; It Keeps Bed Clothing or Other Articles Free from Dust and Guards Them from Moths; It Is Made in Two Sizes



GIANT OF WORLD'S BRIDGES RISING IN NEW YORK



Artist's Drawing of the New Hudson River Bridge, Now under Construction, Compared with Other Famous Structures; Note Comparative Size of Brooklyn Bridge

Scheduled for completion in 1932, the new Hudson river bridge, now in course of construction between upper Manhattan Island and Fort Lee, N. J., will have a span of 3,500 feet, twice that of any suspension bridge heretofore built or under erection. Its mighty proportions dwarf every other bridge of its kind. The famous Delaware river bridge, for instance, has a span of but 1,750 feet and the Brooklyn bridge, the marvel of the age when it was built, stretches but 1,595 feet. Its floor is eighty-six feet wide, while the new bridge will have a roadway 118 feet in width. One of the interesting features of the mammoth new structure was the preliminary work done in testing the rock for the foundations. The services of a geologist were obtained in making extensive borings to a depth of 300 feet on the New Jersey side to make sure that the strata were of the proper character to support the enormous weight of the bridge tower. The huge cables are to be anchored to the rock on the New Jersey side, and on the New York side, they will be imbedded in an almost solid block of masonry, 290 by 200 feet square at the base and 130 feet high. It will rest on bedrock. It is esti-

ated that more than 8,000,000 vehicles, 19,000,000 passengers and nearly 1,500,000 pedestrians will use the bridge during the first year. To finance the huge undertaking, bonds to the value of \$60,000,000 were issued. It is expected that the toll charges eventually will pay for the bridge.

MAIL PLANES' TOTAL MILEAGE TWENTY-FOUR MILLION

Since February, 1926, the beginning of the air-mail service, United States mail planes have flown more than 24,000,000 miles, enough to girdle the earth about 1,000 times, according to post-office figures. The exact mileage up to May of this year was 23,760,017. During that time, over 10,000,000 pounds of mail was carried and more than \$21,000,000 was paid to contractors. From nine routes, the service has extended to twenty-five. The longest is between Chicago and San Francisco.

ⓂA combination phonograph, radio receiver and clock, invented in Germany, speaks the full hours and utters such announcements as "Breakfast is ready," and "Time to go to school, children."

ms Joseph and Vincent  
Print. see article on



Verkey

Service 480-0 6/5/30

MYSTERY VEILS OLD PYRAMIDS FOUND IN MEXICO 959

Six more pyramids, recently unearthed along the "Pathway of the Dead" in the ancient city of Teotihuacan, have set Mexican and other archaeologists to further investigations into the origin of the mysterious city, which is of unknown age and history. The Aztecs who met the Spanish conquerors in the sixteenth century could tell nothing of its beginning. The pyramids are small compared with those devoted to the sun and the moon, already unearthed, but remnants of old temple walls which once surrounded the pyramids, broken pillars and several of the central altars have been found. The arrangement shows that several of the temples must have had inner sanctuaries, entered through mazelike passageways. Concrete and stone-slab-covered drainage canals have also been found along the street, indicating that the inhabitants knew how to provide outlets for storms and high waters to prevent floods.

BICYCLE PEDALS ON PONTOONS OPERATE WATER CRAFT 396

Bicycling on the water has become popular at Florida resorts with a water craft which applies the principle of the bicycle to locomotion on water. Bicycle pedals and frame are mounted on two pontoons, the pedals operating a water wheel set between the pontoons, thus furnishing the motive force.

Carrying a Passenger on the "Water Bicycle," a Pontoon Affair Propelled by a Pedal-Operated Water Wheel



Wade World  
Roy W. Howard Pelham  
and  
Howard Chandler J.  
June 19 30 P. 11 7

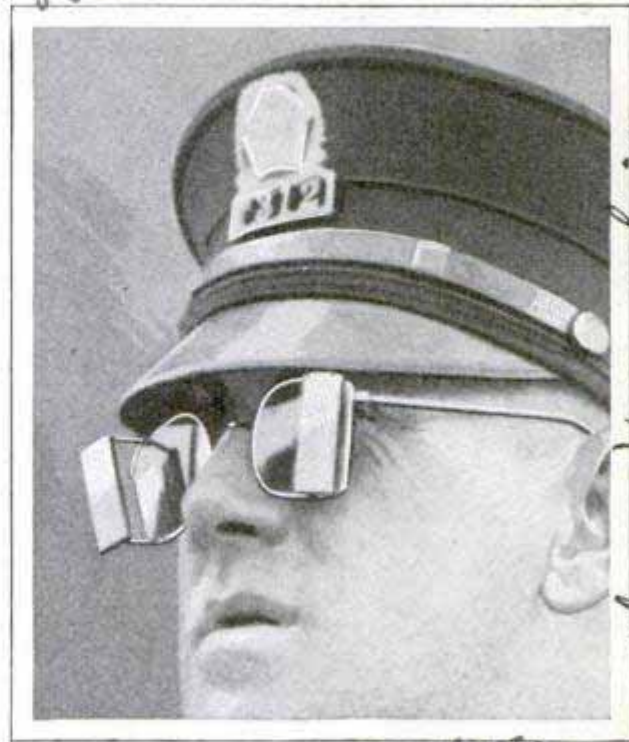

Traffic Policeman Wearing Goggles That Have Rear-View Mirrors Similar to Those on Automobile

Mr. Chas H. A. Secher,  
6, Light St. Plac.  
St. Louis, Mo.

REAR-VIEW MIRROR IN GOGGLES FOR TRAFFIC OFFICERS

To enable traffic officers to see what is going on behind their backs, the Boston police are experimenting with rear-vision goggles. The goggles, worn like ordinary spectacles, have mirrors placed at an angle in front of the lenses, thus giving the traffic officer an unobstructed view of what is going on in front of him and a good idea of what is happening behind.

WALKS OF COLORED CONCRETE LAID IN FANCY PATTERNS 968

Welded sheet-steel frames or stencils are being used in Germany in laying garden and park or other walks in patterned colored concrete. The frames, or forms, are ten by fifteen feet in size, with upright sides and interior divisions making a pattern of any design and for any number of colors. The form is set on the usual foundation and the colored concrete poured into the proper spaces until the whole frame is filled, when it is moved ahead. Two men can handle the frame and can lay 200 square yards a day.

Technik für Allg.  
June 19 30 P. 11 7



Cent. Owen A. Zoyner,  
324 Edgewood Ave.

Photographic new  
Bulletin 1898

466

West Englewood, N.Y.

47 3

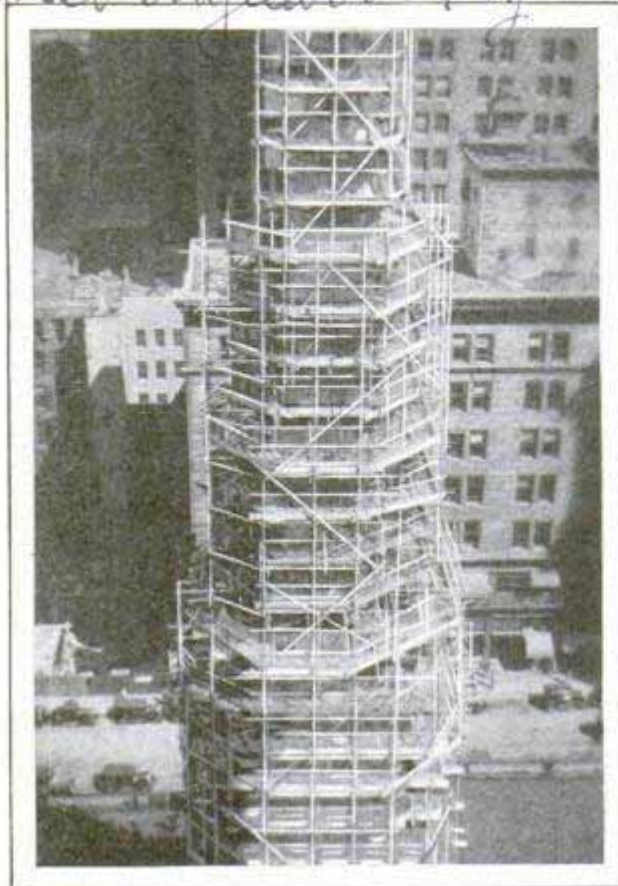

Steeple of St. Paul's Church, New York, as It Appeared Surrounded by Scaffolding during Repairs

### CHURCH PLACED IN STEEL CAGE FOR SAFE REPAIRING

To reduce the fire hazard and protect workmen and passers-by during the repairing of St. Paul's church, famous landmark of lower Broadway in New York city, the entire structure was inclosed in a steel-cage scaffolding. The cage is 200 feet high, and 5,000 couplings and 2,500 pipes were required to complete the frame.

### FLY PLANE ABOUT WATERSPOUT TO MAKE MOTION PICTURES

For the first time in history, motion pictures have been taken of a waterspout from the air. A survey party of the National Geographic society was proceeding from Key West to Cuba in a large flying boat when a heavy squall, which developed into a waterspout, blew up a short distance from Havana. Jacob Gayer, staff photographer, and Capt. Albert W. Stevens, noted army photographer, seized cameras and for several minutes took movies and stills of the writhing column as the plane was flown

around it as near as safety would permit. Frederick Simpich, in charge of the party, describes the spout as a "giant factory chimney, linking the heavens with the sea. As it grew in size and whirled and twisted, it took the shape and appearance of a great snake, spray and mist rising in clouds from where its tail lashed the sea. Yet its writhing edges were as clean-cut as a broad band of black ribbon. Gayer and Stevens made a series of pictures. First, they shot the straight dark descending line that marked the monster's formation; then its great twisting black bulk and finally, a long, grayish snakelike arm that swung off at forty-five degrees, its lower end now whipped out into thinning water strands. By my watch, it was exactly seven minutes from the time the spout first formed until it faded into the black depths of the moving squall."

### "MIKE" SWUNG ON SHOULDERS AIDS SPORT BROADCASTS

Radio announcers broadcasting sport and other events requiring some moving about, now are using portable microphones attached to their shoulders by a harness instead of being placed on a stand. The "mike" rests on the chest in a position similar to that of the mouthpiece of a headset telephone.



© Harris & Ewing  
Broadcasting a Sporting Event through Microphone Supported on Shoulders Instead of Stand

Ted Huston of  
Columbia Broadcasting

720

971



# Where do you Weigh the Most?



© Henry Miller

Government Engineer Making a Gravity Measurement on the Side of a Mountain; the Force of Gravity Differs in Various Parts of the World and Scientists Are Seeking a Master Standard or Average

By GEORGE W. GRAY, *Sparkill, N.Y.*

**T**O DETERMINE the force of gravity—the “pull” of Mother Earth—the bureau of standards has begun at the city of Washington observations and computations which will require more than three years to finish and thus to establish a world standard.

Why is such a measurement important? Because the gravitational survey of the earth, which is being carried on by the nations, requires some master value—just as the land surveyor must have a standard mile by which to rate his tape, and the chemist a standard gram by which to rate his scales.

It was in 1900 that the United States acquired its gravitational value from Germany. In that year, a representative of our coast and geodetic survey visited Potsdam, swung a pendulum there for a series of days, and determined its beat in relation to that of the official instrument. Returning to the United States, he swung the same pendulum on a pier in the basement of the survey office in Washington, and so rated the Washing-

ton value in terms of that at Potsdam. Since then, the gravity experts of the survey have year after year visited picked points in the United States, adjusted their delicate pendulum apparatus and swung it for twenty-four hours or longer—time enough to measure just how strong is the pull of the earth in that particular spot.

One party of observers took the instrument to the top of Pikes Peak and found that, of all places in the United States thus far tested, the force of gravity is weakest there. This is to be expected, for gravity diminishes with altitude—as one gets higher and therefore farther from the planet's center, the earth's attraction rapidly lessens.

The place in the United States where the force of gravity has been found to be strongest is a village in the northeast corner of North Dakota, the town of Pembina. Here the pendulum made 172,656 swings in twenty-four hours, whereas on Pikes Peak its beat was only 172,480 swings in the same period. The stronger the pull of gravity, the more



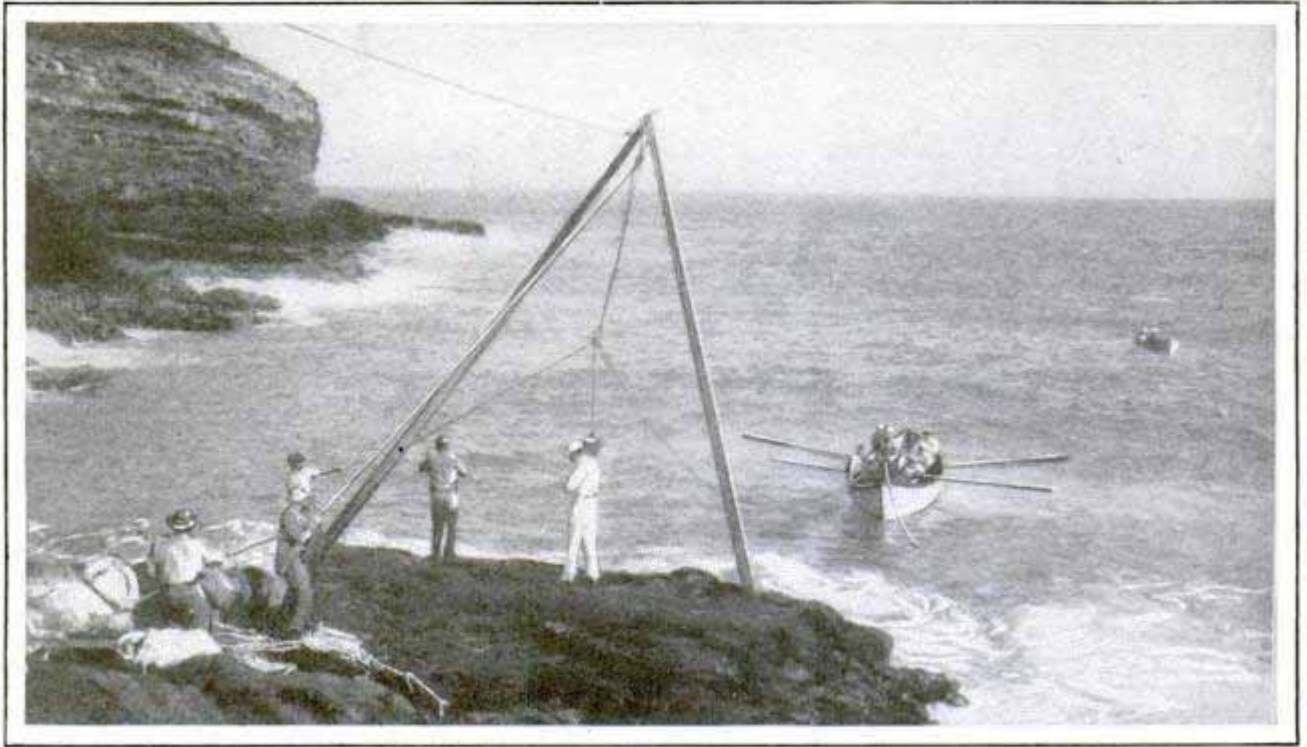

Landing the Apparatus for the Gravity Survey on Nihoa Island, Hawaii; Tests Have Been Made on Mountain Peaks, at the Equator and near the Poles, to Establish a Universal Gravity Standard

rapidly the pendulum vibrates. Gravity varies also with latitude. Thus, a pendulum clock which keeps correct time at New York will gain if moved to Labrador and will lose if moved toward Miami. A man who weighs 200 pounds in New York will weigh only 199 pounds ten ounces in Panama. The reason for these changes lies in the earth's rotation.

At the equator the speed of rotation is more than 1,000 miles an hour, whereas at Chicago it is only 772 miles an hour, and at the poles so slow as to exert no appreciable centrifugal force. It is this centrifugal force, which steadily increases as one approaches the equator, that overcomes gravity to a certain extent, and so cuts down weight, slows down the swing of pendulums, and causes clocks to lose time unless they are adjusted to the variation.

Mining prospectors, seeking mineral deposits, find in gravity variations an important signpost to hidden wealth. Many valuable deposits of oil, nickel, and other minerals have been found in this indirect way. Thus, petroleum deposits in southern Texas usually occur in connection with massive underlying domes of salt. A recent publication of the Colorado school of mines reports twenty salt domes discovered in Texas by gravity methods

within seven years. Such discoveries require extremely sensitive apparatus, but they are a demonstration of the practical results that may come from such work.

A rather interesting outcome of the development of oil fields in the Panhandle district of Texas is the discovery of an unknown mountain—unknown because it lies buried hundreds of feet under the sand, clay and other sediment deposited here ages ago. No eye has seen the buried mountain; but scientists, feeling it out through their gravity instruments, know it is there—just as astronomers more than twenty years ago “felt” the planet “X,” now named “Pluto,” which was recently added to our solar system.

#### BLOSSOMS THREE FEET ACROSS FOUND IN SUMATRA

932  
Blossoms of a plant found in the interior of Sumatra grow to enormous size, often reaching a diameter of three feet and more. The buds are only as large as walnuts and give no indication of their future proportions. Just before opening, they closely resemble a cabbage and the matured blossom is somewhat like the forget-me-not bloom. It has an unpleasant odor and, oddly enough, is usually found only along wild-~~elephant~~ trails.

Conf. Sec. H. Eckhardt.  
4528 Walnut



## INVISIBLE RAYS MADE VISIBLE SHINING ON MINERALS 958

"Black light," the ultraviolet rays that cannot be seen by the human eye, is rendered visible when it shines upon certain minerals. This phenomenon is seen in the Academy of Natural Sciences in Philadelphia, where a case containing the minerals in a dark chamber and exposed to the rays is on display. Light from a carbon arc lamp is filtered, so that only the ultraviolet rays shine upon the minerals. Immediately they glow in beautiful colors, since the invisible rays are transformed into wavelengths that can be perceived by the eye. A switch is arranged to operate the carbon arc automatically and electric lights placed at intervals, so a constantly changing spectacle can be seen.

## HOODED COCKPIT HELPS PILOTS IN BLIND FLYING 808

Blind flying, the art of governing an airplane by dependence on the instruments alone, which is often necessary in fog or adverse weather conditions, is taught student flyers of a Berlin aviation school in a special ship with a hooded cockpit. The hood shields front and side view from the student who is thus forced to rely on his instruments which are located on a panel in front of his eyes. The instructor sits alongside the student.

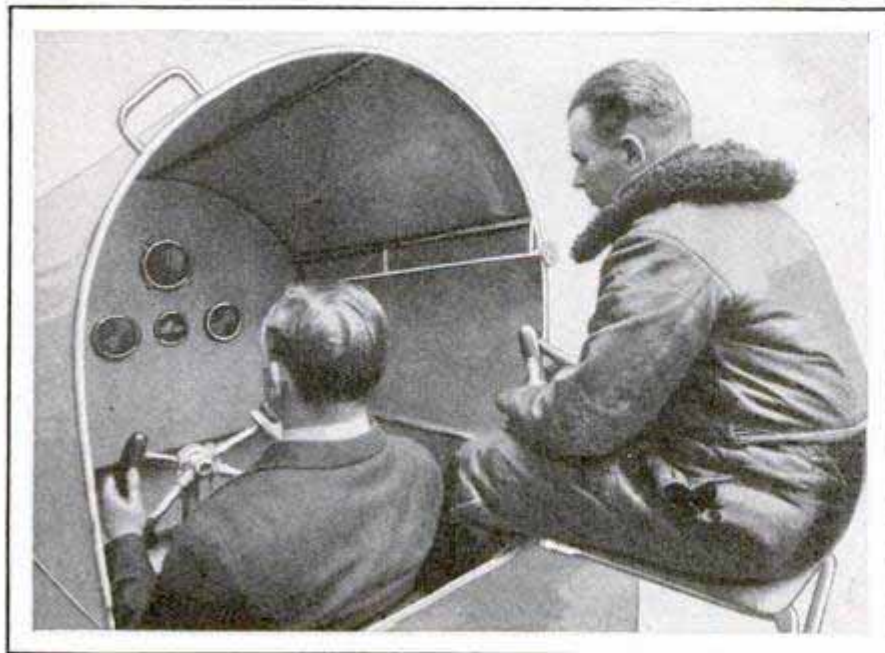

View of Hooded Cockpit of Plane Used to Teach Students to Fly through  
Sole Reliance on Their Instruments

at Staaken Airfield

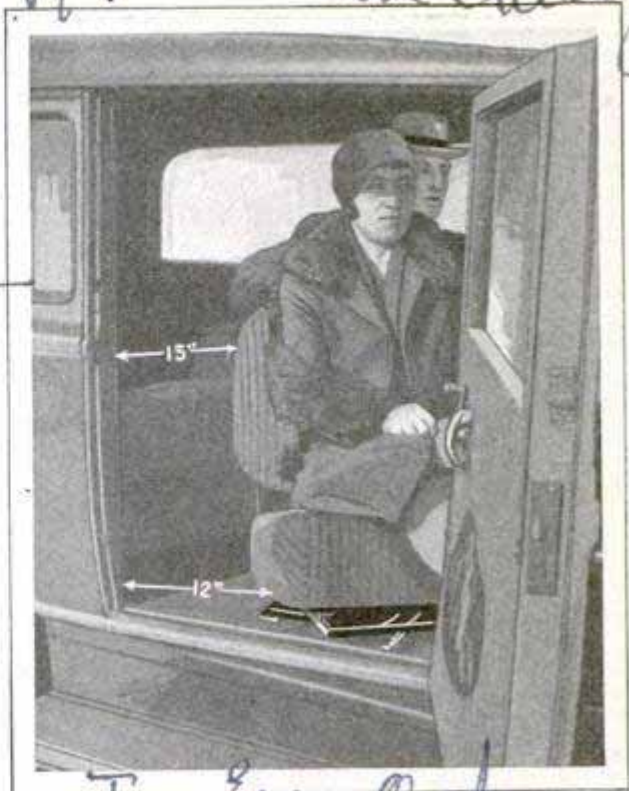

Car Door Open to Show How Seat Swings Around for  
Easier Entrance and Exit

## COACH CONVERTED INTO SEDAN WITH A MOVABLE SEAT

Converting a two-door coach into the efficiency of a sedan is made possible with an attachment for one of the front folding seats that enables the passenger in this seat to turn it toward the door so that other persons can enter or leave the car. It consists of a metal frame installed under the front seat and is equipped with an automatic device that locks and unlocks the seat with the opening and closing of the door. While it does not interfere with the tilting of the seat, this is unnecessary because the person occupying it does not need to leave the car to allow others to enter. It can be quickly installed and does not alter the car's appearance because it is under the seat.

Our Bureau of Information will answer all questions regarding articles appearing in this magazine.



**LAWN FERTILIZER IS SPRAYED THROUGH GARDEN HOSE**

882



ammonium sulphate

leat spray

*pat pend.*

M Chicago

Watering and Fertilizing the Lawn at the Same Time; the Jar That Holds Fertilizer Is near Nozzle

Applying chemical fertilizer to the lawn is simplified by a spray attachment which is fastened to the ordinary garden hose, the fertilizer being applied with the water, thus preventing danger of burning the grass, as the water carries the ingredients to the roots. An ordinary fruit jar is filled with the fertilizer and screwed to the top of the spray, which is then attached to the hose and the water turned on. The method spreads the fertilizer evenly, leaves no disagreeable odors and the proportions remain the same whether the jar is full or nearly empty. There is no pressure in the jar itself and the unit works equally well whether the water is under low or high pressure.

**TEXTILES SORTED BY THE USE OF ELECTRIC EYE**

956

Textiles of slightly varying shades are classified more accurately than would be possible by ordinary inspection with the aid of the photo-electric cell, the effi-

cient "electric eye" that science is harnessing to perform a number of important tasks. Two cells are employed in the textile-testing apparatus. They create a balanced circuit and hold an indicator needle at zero so long as both are receiving the same amount of light. But when the color of the sample under one cell differs even slightly from that of the sample under the other, the variation in light causes the needle to swing away from zero, and the inspectors know that the two materials are not exactly the same shade, although the difference may not be apparent to the unaided eye. The effects of weave and sheen, likely to cause errors in the judgment of the electric eye are overcome by rotating the cloth until the colors are melted into a solid mass of color and by using means for reflecting light from the cloth in all directions so that a concentration of light at any one point is eliminated.

**PARACHUTE FOR SHORT JUMPS OPENS IN FEW FEET**

Successful tests with a parachute that opens almost instantly and is safe for jumps from an altitude as low as ninety feet, are reported from Germany. The unit would be particularly serviceable in emergencies where many serious airplane accidents have occurred, and the ordinary type of parachute opens too slowly.

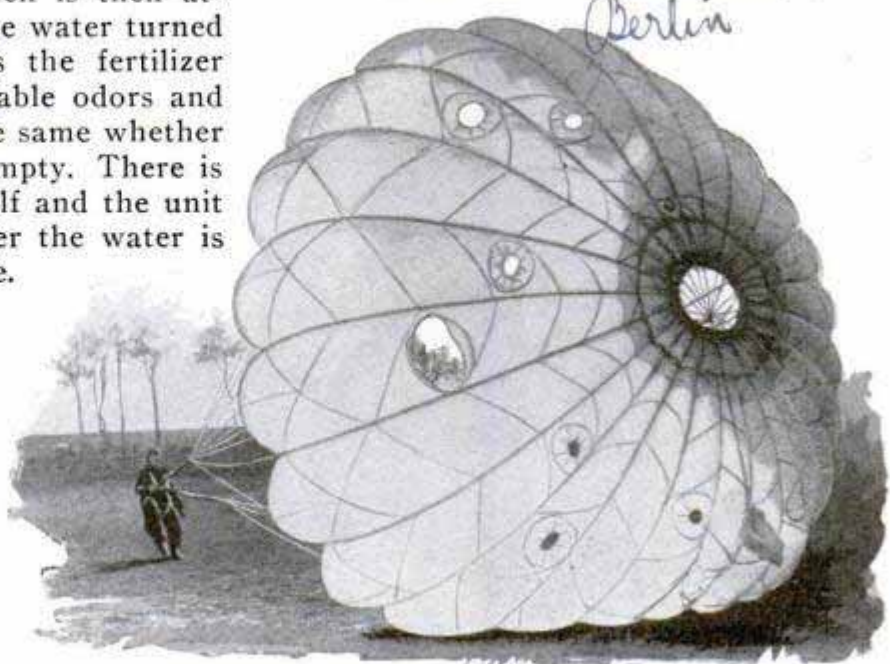

*Berlin*

German Parachute That Is Said to Open So Quickly That Jumps from Altitude of Ninety Feet Would Be Safe

cl nos. Mr. H. F. Sheldon Washington Square  
 and Mr. W. G. Schneider 40 College Washington



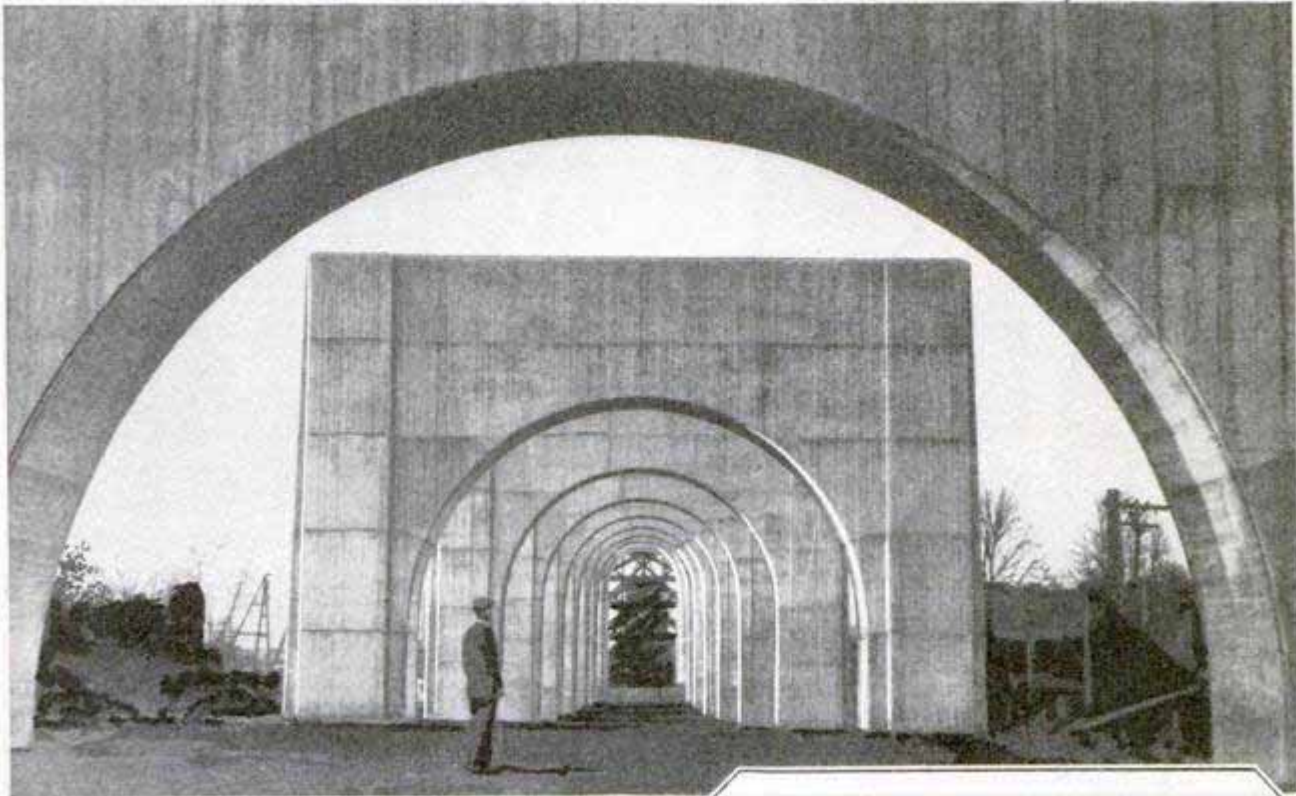

Concrete Arches and View of Partly Completed Span of the Kill Van Kull Bridge

**WORLD'S LONGEST ARCH SPAN IN KILL VAN KULL BRIDGE**

Kill Van Kull bridge between Bayonne, N. J., and Port Richmond, Staten Island, will contain the longest arch crossing when completed, with a center span of 1,675 feet. At the Port Richmond end is a long row of stately arches of concrete which will support the great steel framework and from which the big center span will launch itself across the water to the New Jersey shore. The bridge is to be finished some time during 1932.



**ELECTRIC BRAKES FOR AUTOS ADD SAFETY TO DRIVING**

Greater safety and increased ease in driving are among the advantages claimed for an electromagnetic braking system for the automobile. The brakes are operated by a pedal in the normal manner, but the operator, in depressing the pedal, simply turns on the current which does the braking, and the installation may be so adjusted that, if the car rolls backward on an incline, the brakes are set automatically on all four wheels. Operation of the system is simple. Energized by current

from a battery, a magnet exerts a gripping action on an armature of the ring type, attached to a standard brake drum and revolving with it. When the brake band expands against the drum surface, no further rotation of the magnet is possible, so that the armature slips on the magnet facing, combining its retarding force with the magnet's, which continues its pressure against the brake band. As soon as the current is cut off by releasing the pedal, the entire assembly returns to neutral or off position. The action is the same whether going ahead or in reverse. The braking power depends on the amount of current that passes through the magnet and this is controlled by the degree of pedal depression.

*not yet adopted 8/11/30*

*904*

*5/31/30  
 Automobile Topics  
 1720 Broadway*

*Warner Electric Brake Co. John Whyte  
 29.0 4 1/2 in. Attn*





# From 15 to Without

## PART I

THIS four-tube short-wave receiver has the punch and flexibility short-wave fans have been looking for, and, in addition, it is no longer necessary to shut off the set and take it apart in order to change from one wave band to the other. Although it does not employ plug-in coils, there has been no loss in efficiency, as coils of the good solenoid type have been retained. Four settings of the dial at the left on the front panel cover the entire short-wave range and bring in all short-wave stations, regardless of distance, at loud-speaker volume.

There are several other outstanding features that make this an unusually good receiver for general short-wave reception. It has been designed to use 224 a.c. tubes on a battery source of filament supply, taking advantage of the non-microphonic characteristics of these tubes in the r.f. and detector stages. These screen-grid tubes are followed by a two-stage transformer-coupled audio amplifier with a 112-A power tube in the last stage. The chassis construction is rugged and simple, and the completed receiver is well housed and shielded in a neat and simple sheet-aluminum cabinet, the construction of

which will be described in detail in the October issue.

Fig. 2 shows the schematic circuit diagram and Fig. 3 the simplified wiring diagram, with all parts plainly marked. The various photos, together with the simplified wiring diagram make the building of this set very easy, and an enlarged diagram and a detailed material list are available to all.

The chassis is made from a sheet of No. 14 gauge brass, 12 by 17 in., cut with a hacksaw and bent as shown in Fig. 1. The large cut-out at the upper left is for the tuning unit which contains the rotating coils and is housed in a copper shield. This unit extends about 1 in. below the top of the chassis and is held in position by two small lugs at the front. After all cut-outs have been made, mark off and drill the mounting holes. This done, the metal sheet may be bent on the dotted lines to form the chassis. This is easily done by clamping the sheet in a vise, between two short boards, 1 in. thick, exactly on the bending line. Place a piece of thin board against the section to be bent and use a hammer or mallet to bend the sheet over at right angles, to form the supporting sides. These sides raise the chassis about 2 in., providing sufficient room for mounting the instruments on

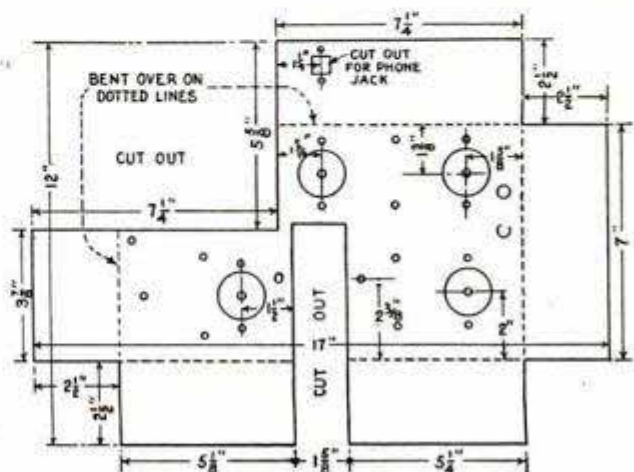

Fig. 1



# 195 Meters Plug-In Coils

by Frank L. Brittin

the underside. The sockets are the standard subpanel type and are mounted under the holes indicated by the circles, these holes being  $1\frac{1}{4}$  in. in diameter and made with a fly cutter or by your local tinsmith. Mount the sockets with two short machine screws and take care that the contact-prong terminals are in the positions shown in Fig. 3. If the terminals are not marked on the socket, mark the chassis on the underside near each terminal with a pencil for identification and as a guide for wiring.

The small chokes are soldered directly to the terminals indicated. Note that the cathode terminals K on the 224-tubes are both at the same ground potential. That is, K of the r.f. tube at the upper left is grounded on the chassis at the dial-supporting bracket, and an additional lead is taken to K of the detector-tube socket which is also connected to negative-A in common with the grounded chassis. The terminal lugs on the tuner unit, conveniently located under the chassis, provide short sturdy soldering terminals to which the fixed condensers are soldered in order to make the shortest possible leads.

The a.f. transformers used are a small type and, when mounted on the underside of the chassis, extend just far enough down to provide additional support to reinforce the weak part of the chassis at the cut-out for the dial and tuner unit. The dial and condenser assembly is mounted on two small metal brackets screwed to the dial frame, using the top holes provided for the purpose. The rotor plates of the variable condenser must be grounded with a short lead di-



rectly to the chassis at the rear, a soldering lug being mounted on the chassis with a short machine screw for this purpose. A lead, taken from terminal G on the tuner unit, is run up to the stator plates of this condenser. The flexible leads to the top caps of the screen-grid tubes must be well insulated so as not to short on the chassis. The various battery-cable leads are made as short as possible and are soldered to the points indicated. Keep the A-leads together and cable the leads to the switch and volume control as indicated. The cabled battery leads are run out at the rear of the chassis through a hole insulated with a rubber grommet or cut large enough to prevent injury to the insulation.

The  $\frac{1}{2}$ -amp. ballast to control the fila-

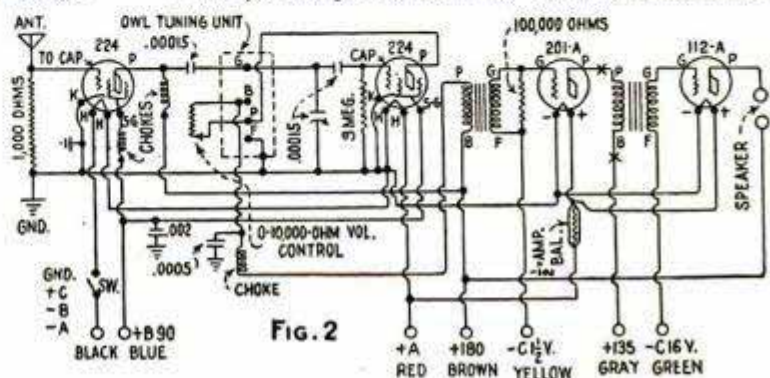







## ELIMINATING THE RATTLE IN DYNAMIC SPEAKERS

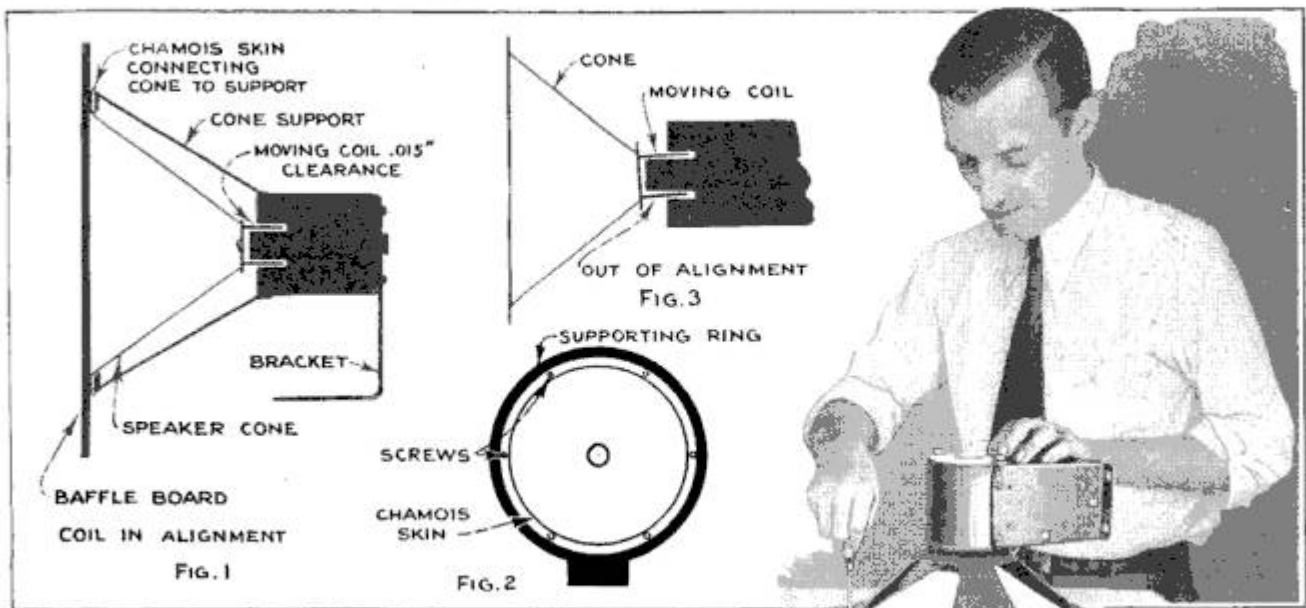

Right, Removing Retaining Ring Holding Chamois Skin to Rim; Left, Section Diagrams Showing Coil In and Out of Alignment

By D. A. BROWN

**A**FTER the dynamic speaker has been in service for some time vibration will often appear. This can be traced to three causes: dirt between the field pole and moving coil, moving coil slipping from alignment due to excessive vibration, and a warped cone caused by moisture absorption and temperature conditions.

If there is no dirt between the field pole and moving coil, inspect the latter to see if it is out of alignment, as indicated in Fig. 3. This is a common trouble and can be remedied by restoring the alignment by the use of heavy paper as a spacer, as described later.

The third cause of rattles is due to the absorption of moisture by the chamois skin supporting the cone or uneven thickness of the skin, so that its pull on the edge of the cone is not uniform, and the cone comes at an angle to the field pole.

Upon removing the cone and examining the coil, places will often be noted on opposite sides where the winding is scraped bare of enamel; this denotes rubbing against the field coil due to misalignment. Give the moving coil a light coat of shellac to cover the bare winding and then reassemble the speaker.

Loosen all screws holding the chamois skin supporting the cone in order to realign the coil, as this coil moves with the

cone. Wrap .015-in. thick paper around the coil, making only one turn and butting the ends together. This paper provides the necessary clearance between the coil and field pole.

Now assemble the remainder of the speaker and, when ready to tighten the chamois on the supporting frame, be very careful that the pull on the cone is uniform. Tighten one screw on the rim and then the one on the opposite side of the rim. While this is being done, keep slipping the paper up and down around the moving coil and note if it binds at any spot. If it does, loosen the chamois at the rim so that the binding will disappear. When the retaining ring has been tightened on the rim, remove the spacing paper and blow out any small pieces that may have been torn off.

After the speaker has been assembled, paint the chamois with a small brush dipped in denatured alcohol; this will tend to tighten the skin uniformly. After the alcohol has evaporated, the speaker can be mounted on a baffle, as shown in Fig. 1, and tested, when the interfering vibrations should be at a minimum.

For further information on any radio construction article write to the radio department; this service is free.



# Helpful Radio



Turning a Short-Wave Receiver Correctly Comes Only with Practice; the Most Important Dial or Knob Is the One That Controls the Regenerative Detector; Keep the Detector in a Continual State of Oscillation by Turning This Knob Back and Forth as You Turn the Tuning Dial a Fraction of a Degree, Resting the Forearms on the Table

Below, to Increase the Current and Voltage Output of a Power Supply Employing a Type-280 Rectifier Tube, Use Another Tube of the Same Type and Parallel the Filaments and Plates of These Tubes with Flexible Leads; This Is, of Course, a Temporary Arrangement Applicable When the Rectifier Tubes Decrease in Efficiency

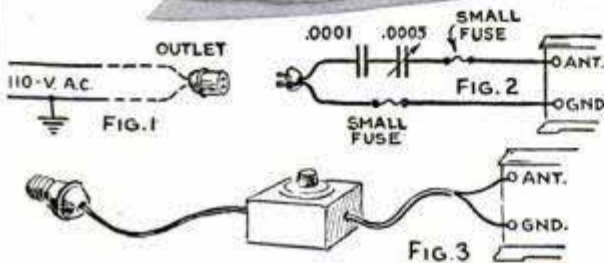

A Handy Substitute for Antenna and Ground When It Is Not Practical to Make the Usual Installation; Figs. 1 and 2 Show Details and Fig. 3 Suggested Assembly

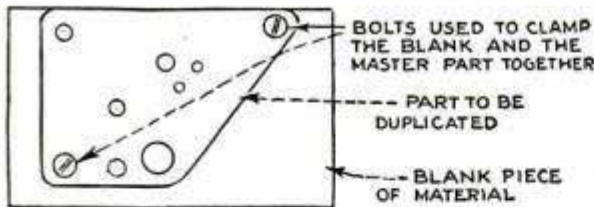
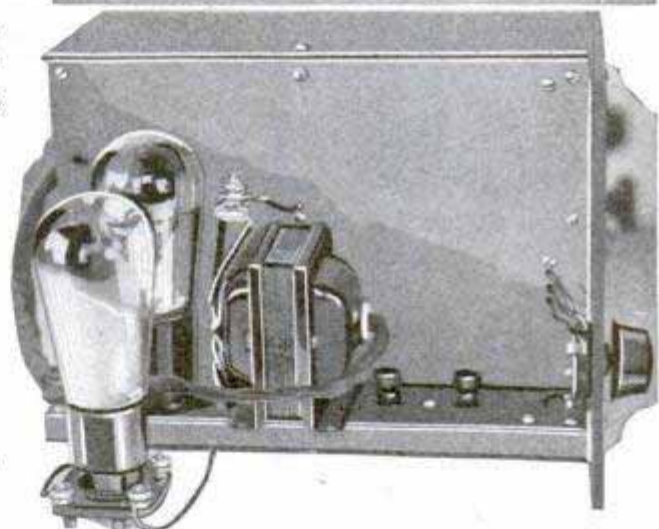

A Method of Quickly Duplicating Form and Drilling of Odd-Shaped Parts; One Edge of the Blank Is Lined Up with the Master Template and Clamped to It for Drilling, a Scriber Being Used to Outline the Shape of the Part; after Drilling, Clamp the Blank in a Vise and Cut on the Scribed Lines with a Hacksaw; Below, an 0-to-20 Milliammeter Used to Determine Correct C-Bias on the Power Tube; If Needle Drops Back with Signal, Increase C-Bias or Decrease B-Voltage

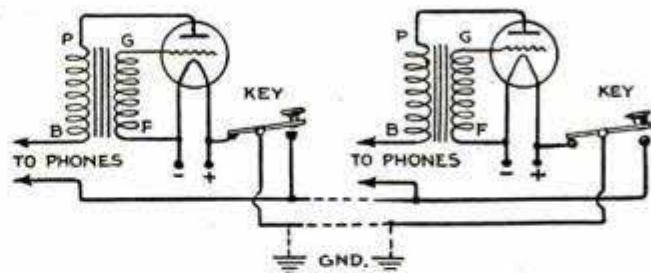

Above, a Two-Way Code-Practice Hookup Operated at Each Station with Either a 201-A Tube and a 4½-Volt C-Battery or a 199 Tube and Two Dry Cells; Right, Setscrews for Dials Made by Cutting Off the Head of Machine Screws of the Same Size and Thread and Slotting the Top with a File or Hacksaw

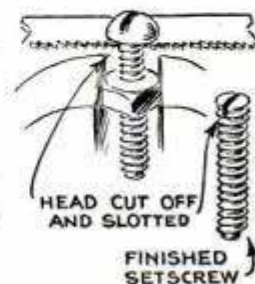
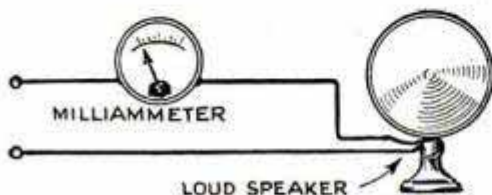



# Hints *and* Kinks

Right, Pasting the Schematic Diagram of the Receiver in the Lid of the Cabinet Enables the Owner Quickly to Check the Receiver When Things Go Wrong; Below, Two B-Eliminators May Be Connected in Series to Obtain a High-Voltage Supply, the Positive Terminal of One Eliminator Being Connected to the Negative of the Second; the High Voltage Is Obtained from the Negative of the First and the High-Voltage Tap of the Second

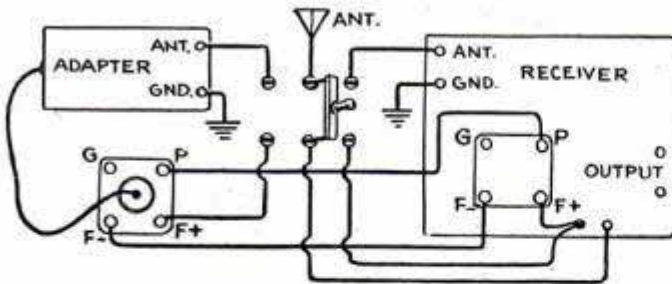
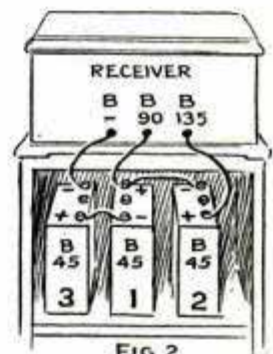
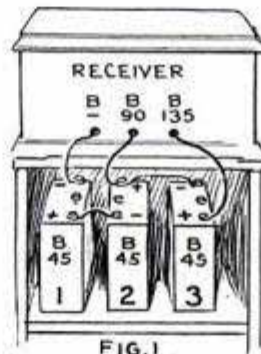
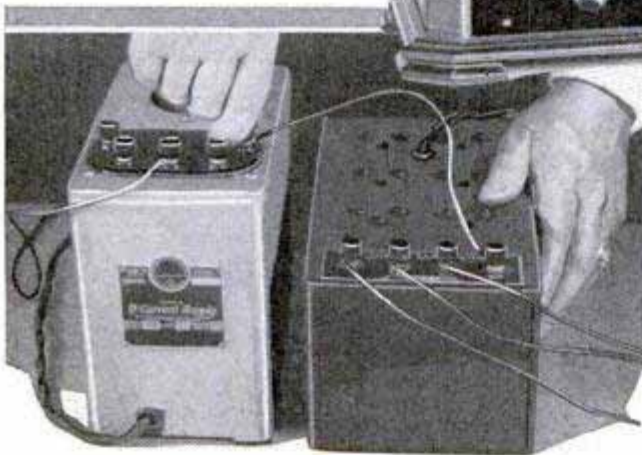
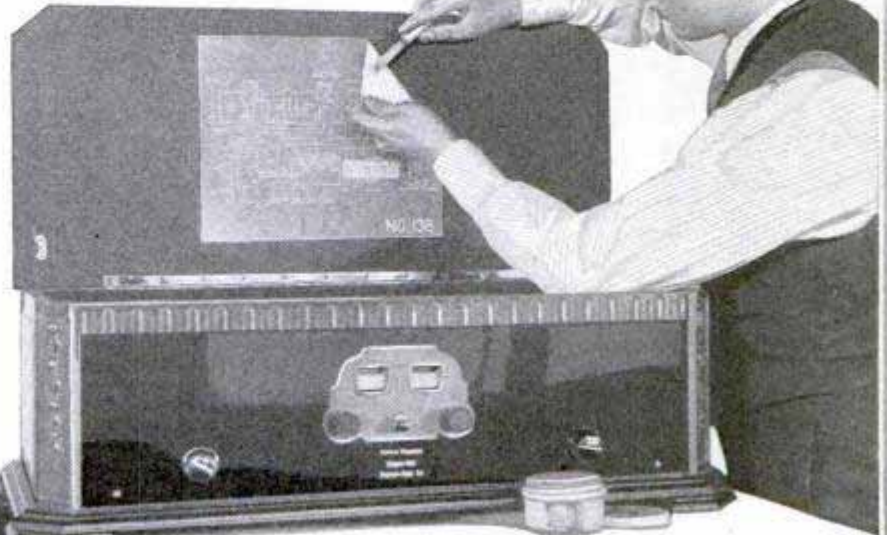

Above, to Extend the Useful Life of B-Batteries, Shift Them, After the Volume Begins to Drop, from the Position Shown in Fig. 1 to the Arrangement in Fig. 2; the Drain Is Greater on the Detector 45 and 90-Volt Taps Than on the High or 135-Volt Tap; Below, By-Pass Condensers Are Made in Two Types, as Shown; of These, the Inductive Type Should Not Be Used in Modern Short-Wave Hookups, the Non-Inductive Variety Providing the Shortest Path to Its Terminals

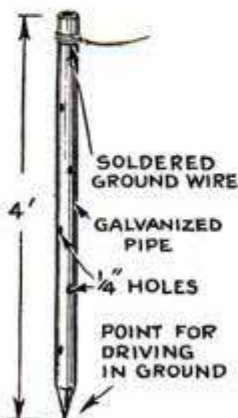

Above, for Quickly Connecting a Short-Wave Adapter to a Broadcast Receiver, the Adapter Plug Is Placed in a Spare Socket, the Wire Normally Connected to the Positive Filament of the Broadcast Detector Socket Being Disconnected and Extended Directly to the Switch Lever; Another Positive Lead Is Taken from This Socket to the Switch Terminal at Right, and the A-Supply May Then Be Thrown to the Broadcast Detector or S-W Adapter at Will; Left, Galvanized Pipe, Prepared as Shown and Filled with Salt, Makes a Good Ground

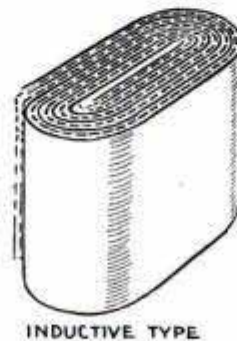

INDUCTIVE TYPE

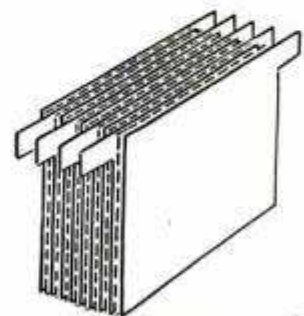

NON-INDUCTIVE TYPE



# Low Cost *of this* Simple

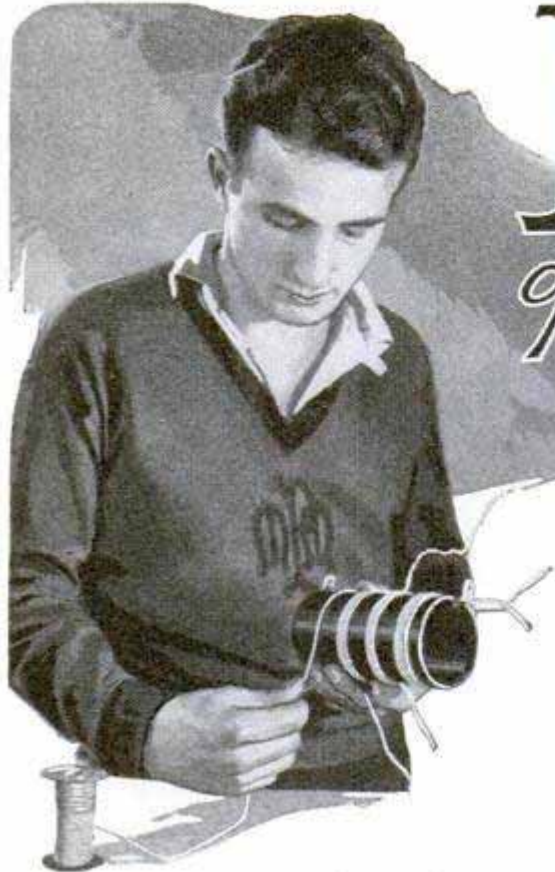

**T**HE COMBINATION phone and key transmitter described in this article is especially designed for the many would-be "hams" who have been unable to join the amateur ranks because of limited funds. It is a simple but efficient low-power apparatus, which, if made from standard parts of good manufacture, need not cost over \$20 and can even be built for one-half that amount. In either case the price, of course, does not include antenna, power supply, microphone or tubes. With tubes of 199-type and only 45 volts on the plate, the transmitter will cover two miles easily on the phone and much farther with the code key. The range may be extended by using 201-A tubes with 90 volts on the plates or type 112-A tubes with 135 volts; in fact, the instrument has been designed

so that any tube up to 5 watts may be employed. The filament voltage is supplied by dry cells or a storage battery, and the plate voltage by B-battery or a B-eliminator; the only change necessary being the increased power for the larger tubes.

The builder must first decide on which of the amateur bands he wishes to operate. This transmitter is built with fixed coils, although, if desired, the mountings may be made interchangeable. The 80-meter band requires 10 turns for the antenna coil, 7 for the grid coil, 7 for the plate coil, and 2 or 3 for the microphone coil; the 40-meter band requires 5 turns for the antenna coil, 3 for grid, 3 for plate and 1 for the microphone coil. The 80-meter band is most desirable for the beginner so this model was built for that band. The coils may be wound on cardboard or bakelite tubing, which should be 3 in. in

diameter and  $5\frac{1}{2}$  in. long. A space of about  $\frac{1}{2}$  in. is allowed between all coils. The form should be drilled and wire threaded through it and anchored at convenient points to be soldered. No. 16 d.c.c. wire is used for all coils, and the connections below the base are made with No. 14 tinned-copper busbar wire.

The r.f. choke, consisting of 125 turns of No. 30 d.c.c. wire, is

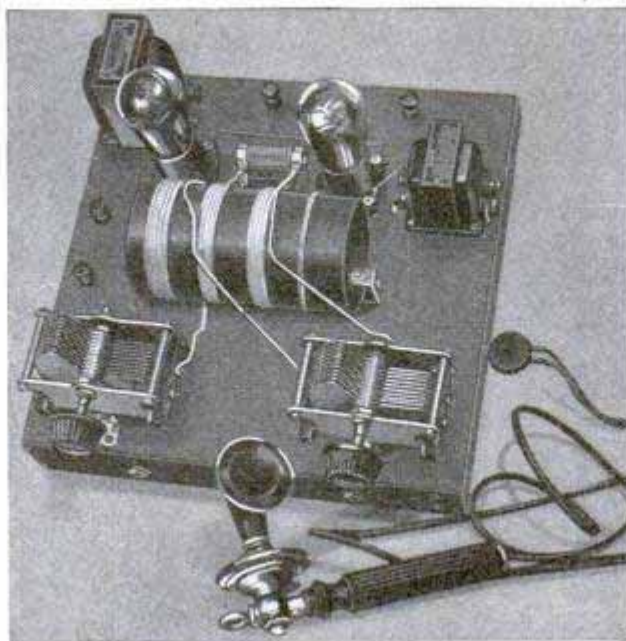

Completed Short-Wave Radiophone with Hand Microphone Plugged in at Phone Jack No. 2



# is Feature Radio Phone



wound on a  $\frac{1}{2}$ -in. wood dowel, about 3 in. long, as shown in Fig. 2, and is mounted directly on the .006-mfd. fixed condenser on the underside of the panel by means of a brass machine screw to which one end of the choke winding is soldered.

The transmitter may be used as a single-tube set by simply leaving out the modulator tube, microphone transformer and 30-henry choke, as indicated in the schematic diagram. In this case, the microphone is plugged directly into the 2-turn coil jack No. 1 for voice. The closed-circuit jack is the code-key jack, and No. 2 is the microphone jack when two tubes are used as shown in the photo of the completed job. Two tubes give much better modulation and also more reliable transmission on the phone.

The assembly is very simple, as shown in Fig. 1, and large diagrams are available for those who wish them. The base panel is bakelite,  $\frac{1}{8}$  by 12 by 12 in., but may be dry plyboard if desired. This panel is supported by one bakelite strip,  $\frac{3}{16}$  by 2 by 12 in., and one strip,  $\frac{3}{16}$  by 2 by  $11\frac{13}{16}$  in., the two forming the front and right sides of the base. The other two sides consist of wood strips,

one of which is  $\frac{1}{4}$  by 2 by  $11\frac{13}{16}$  in. and the other  $\frac{1}{4}$  by 2 by  $11\frac{1}{2}$  in. The base is now assembled with wood screws and short metal brackets for the bakelite sides.

Mount the two variable condensers and coil on short angle brackets. The jacks are the short gem type and the closed-circuit jack is wired as shown in the insert in Fig. 1. A small 6-volt flashlight bulb is mounted in a pilot-lamp socket at the left of the coil form, and its brilliancy indicates the amount of antenna current.

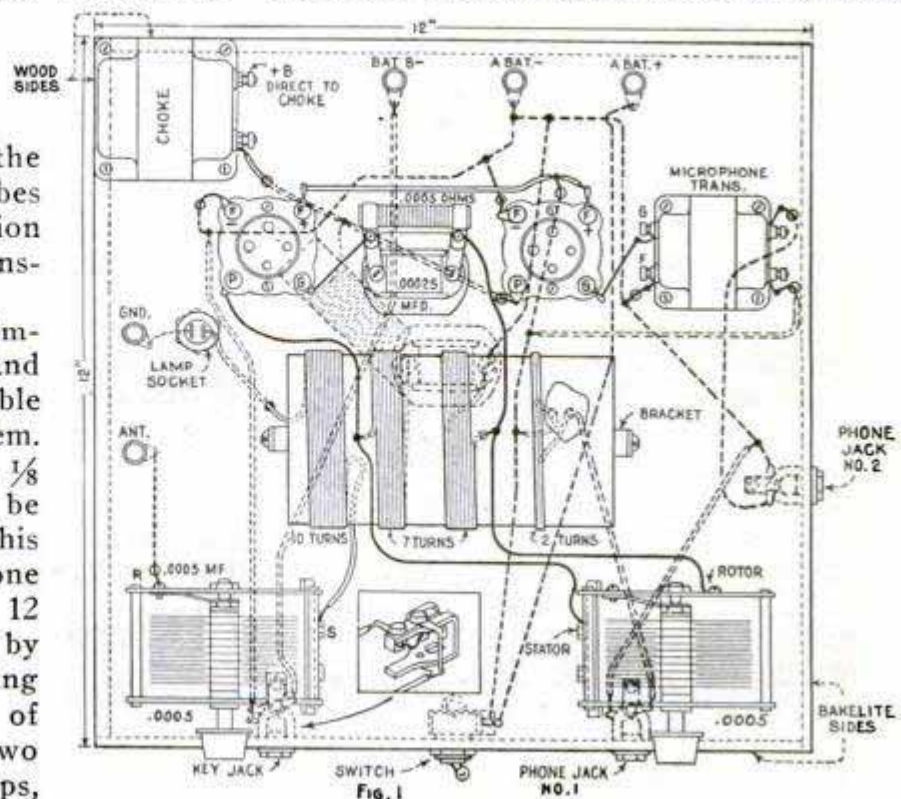



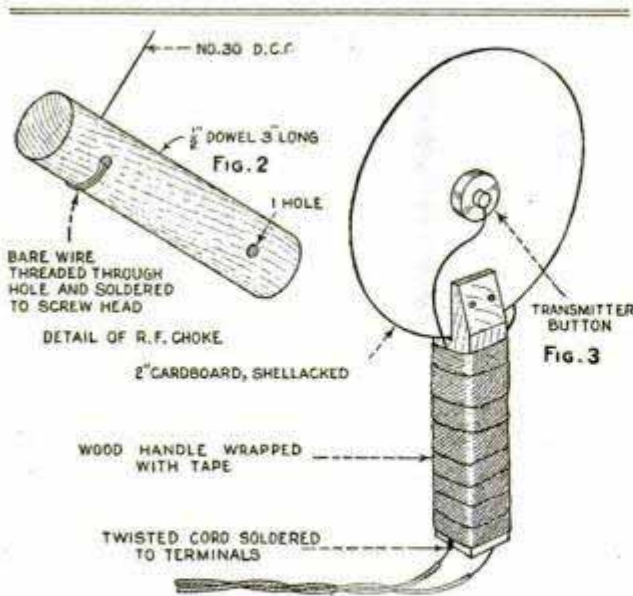

The tube sockets are then screwed to the panel, and the gridleak and condenser are mounted between them. The 30-henry choke at left rear is a manufactured type, but the secondary of a Ford spark coil can be used for 5-watt tubes, if desired. The microphone transformer is also a standard make, but those who wish to economize will find an inexpensive bell-ringing transformer satisfactory for the purpose. These substitutes are given in the material list, which is available to all.

Any antenna will work for a short distance, but if real efficiency is to be obtained, one must be constructed for the particular wavelength selected. For 80 meters an antenna about 132 ft., including lead-in and with a good ground connection, will give good results. The binding posts at the rear are for the power and filament supply, and the high-voltage B-lead goes directly to the binding post on the 30-henry choke. If only one tube is used and the choke omitted, it will be necessary to provide a binding post for this lead.

The transmitter must be tuned somewhere between 84.5 and 85.7 meters for use with phone. The wavelength should be checked with a wavemeter, or by listening to other amateurs and locating the position of the phone band on the dial of your short-wave receiver. Then, by tuning your own transmitter to the middle of the band, you are sure of being within the required limit.

The microphone shown in the photo on page 478 is a standard band type, but for those who would like to make a fairly good substitute, one of the small inexpensive microphone buttons may be mounted and wired as shown in Fig. 3.

If the bell-ringing transformer is used as a microphone transformer, the results will be fair, but not nearly as good as with a standard transformer built for the purpose. These transformers are not expensive and may be had for very little more than the bell-ringing type. The key may be an inexpensive navy type connected by means of flexible leads to an ordinary horn plug for quick operation.

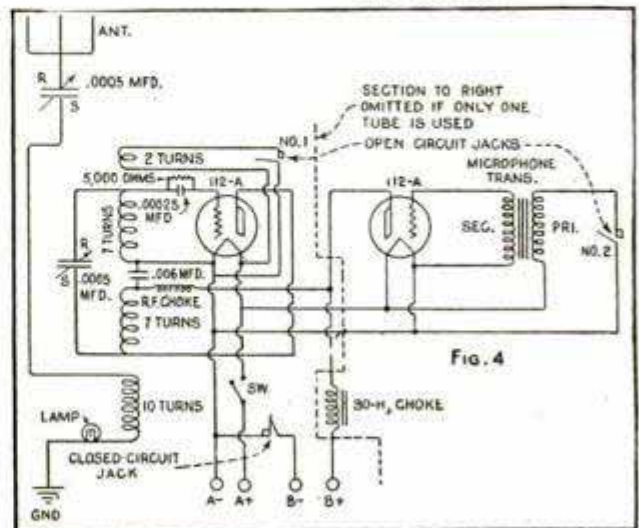
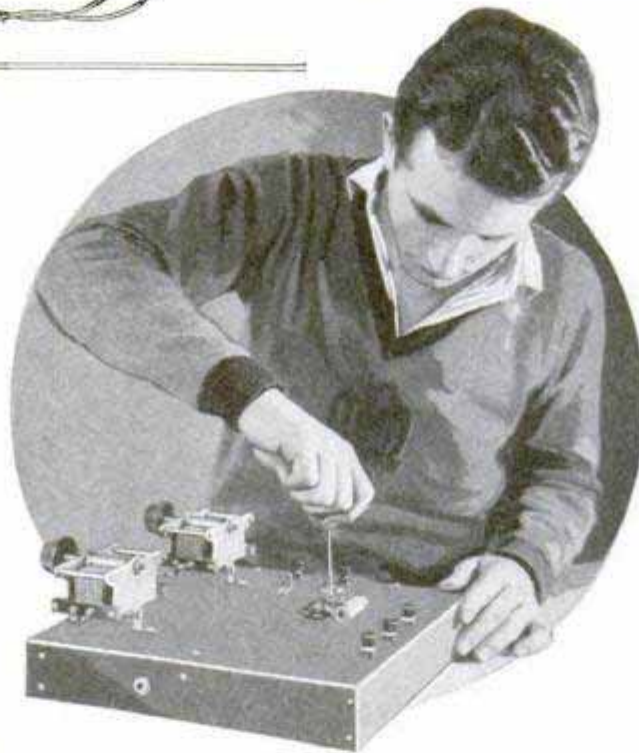

Top, Details of R.F. Choke and Homemade Microphone; Center, Assembling Parts; Bottom, Schematic Diagram of Complete Two-Tube Transmitter



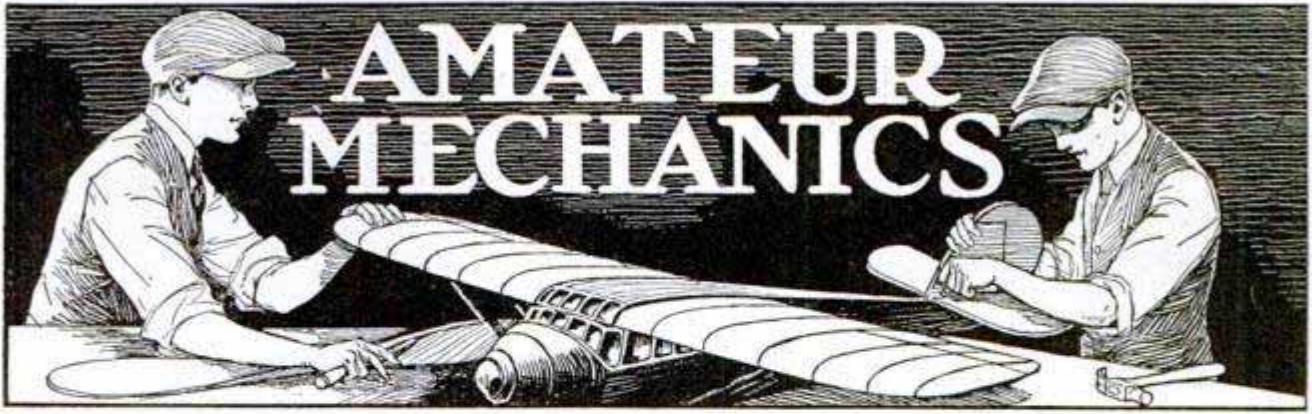

## Unique Holder "Shoots" Cigarets

By KENNETH MURRAY

**Y**OU press the button and the holder does the rest with the novel arrangement shown in the accompanying illustrations, giving automatic delivery of a cigaret direct from the original pack, which rests on top; a cigaret which is never

touched by human hands until it is projected into the hand of the prospective user.

Five wood parts and the cable release from an old folding camera make this attractive holder. The block A, on which

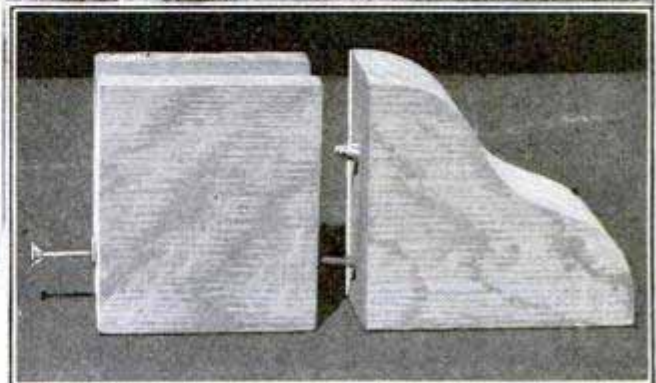
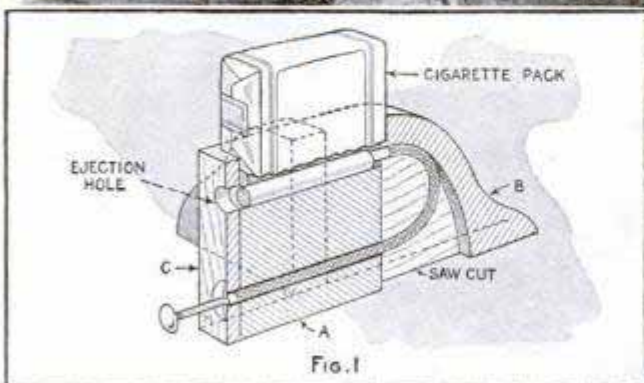
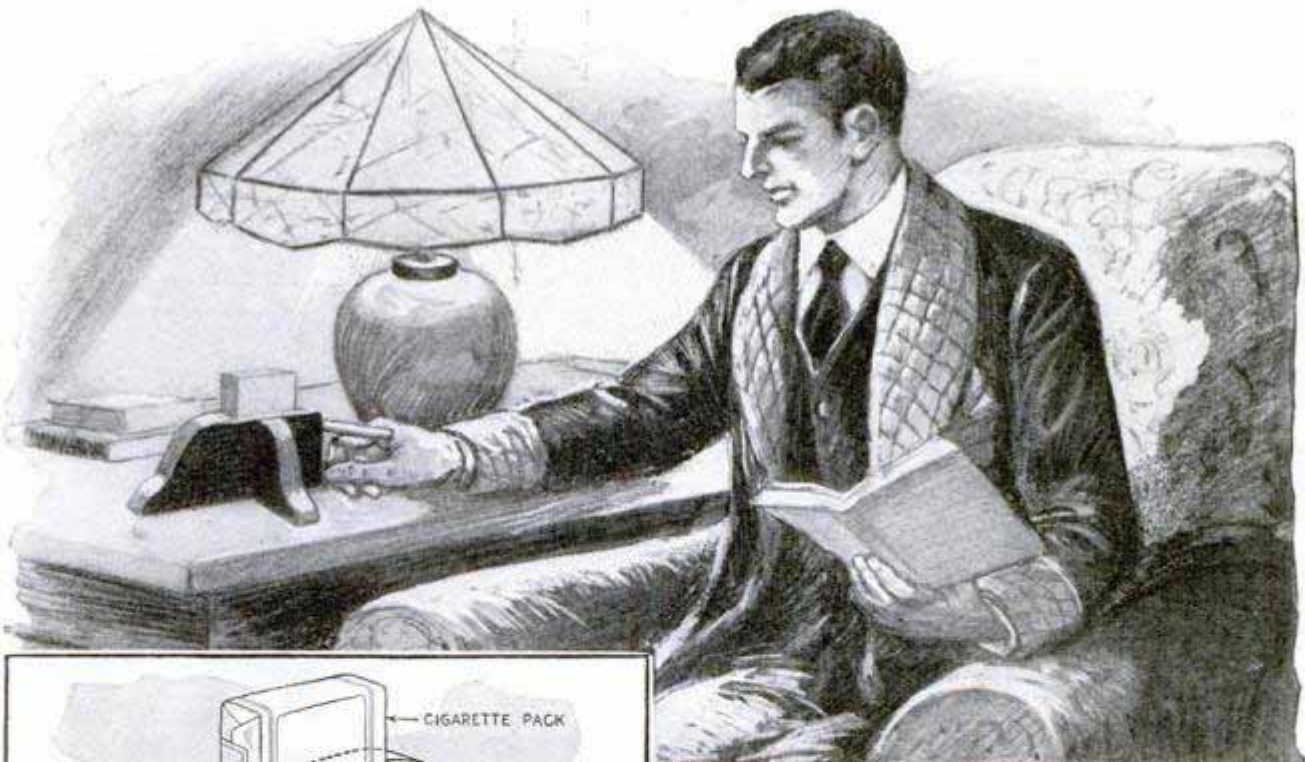

A Push on the Button and Out Jumps a Cigaret! This Unique Cigaret Holder Is Extremely Simple and Easy to Make



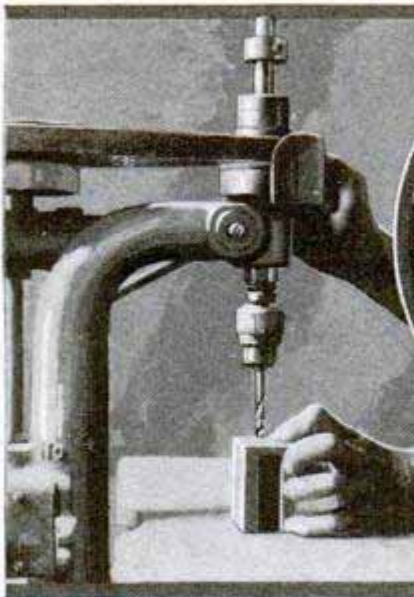

Countersinking the Inside of the Ejection Hole in Block C with a Knife



The Hole for the Cable Release May Be Drilled through Blocks A and C at the Same Time, as Shown Above, Using a Hand Drill if a Press Is Not Available

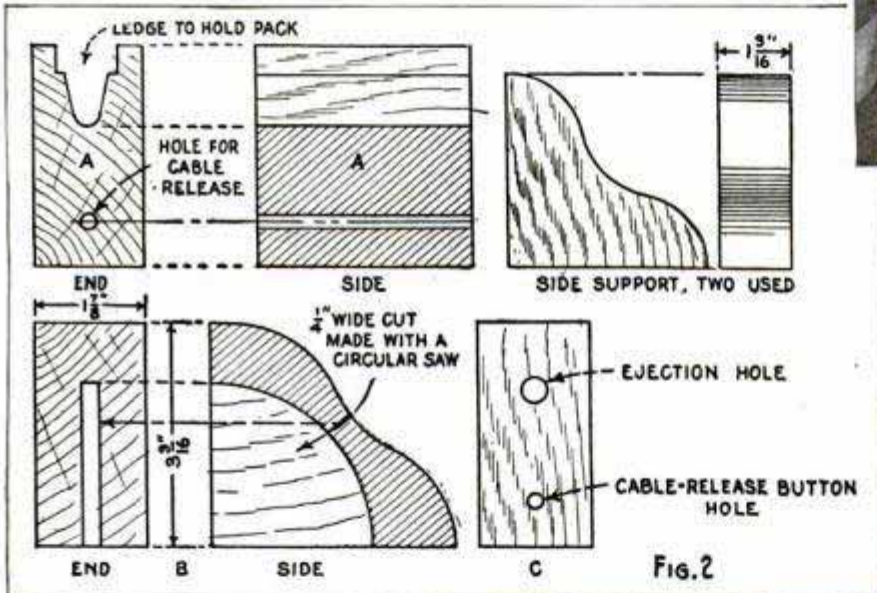

Above, Cutting the Semicircular Groove in Block B on the Circular Saw; Below, Placing an Opened Pack on the Ledge in the Groove

the pack rests, is  $2\frac{13}{16}$  in. long,  $3\frac{3}{16}$  in. high and  $1\frac{7}{8}$  in. thick. A tapered, round-bottom groove,  $1\frac{1}{4}$  in. deep, to fit a cigaret as it drops from the pack, is cut along the top of this block, then ledged to support the pack, and  $\frac{3}{4}$  in. up from the bottom, a hole is drilled parallel with the groove to pass the cable release, as shown in the sectional drawing. Block B, which is  $3\frac{9}{16}$  in. long and the same height and thickness as block A, is then cut to shape and grooved on the circular saw as shown in one of the photos, so that the cable release





will curve around and its end will just meet the groove in block A when the two blocks are placed together. Block C is  $\frac{1}{4}$  in. thick, as wide as A is thick, and is fastened to the front of the latter. Cable-release and ejection holes are drilled in this block as shown, the inside of the ejection hole being countersunk with a knife so the cigarettes will enter it easily. The side-support blocks are  $2\frac{1}{2}$  in. long,  $2\frac{3}{4}$  in. high and  $1\frac{1}{8}$  in. thick.

After all the parts have been cut out to shape, and all the necessary holes drilled, they are well sanded. The cable release is then installed. This should be of such length that it will just pass through blocks A and C, curve around in the groove in B and meet the groove in such a position that pressure on the button will eject a cigaret lying in the groove. When this has been checked, the parts may be glued together and finished.

Any wood that will take a good finish may be employed. A walnut stain was used on the holder shown, followed by an application of furniture wax. Of course, it is not necessary to stick closely to the design shown; it may be modified in any way, and the finish may be in either stain and varnish, lacquer or enamel.

To load the holder, all that is necessary is to tear the side from a standard pack, as shown in one of the photos, and drop it, open side down, on the ledge in the groove. A "cig" then drops to the bottom of the groove, and is ejected by a push on the button.

### Ornamental Windows for Garage Doors

Many garages can be greatly improved in appearance by simple methods as shown in the photo. In this case the doors were of the plainest type without windows, and the owner therefore made fancy cut-outs, which he backed with glass, forming small heart-shaped windows. Trellises and climbing vines are also used for the same purpose.

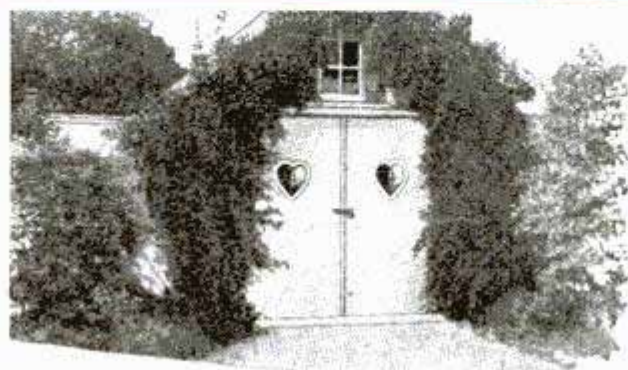

Trellises, Climbing Vines and Fancy Door Windows Improve Appearance of This Garage

### Paper Box on Bedpost Holds Clock

In order to have the alarm clock handy while in bed, a paper box was cut as shown in the drawing. A triangular hole



Paper Box Holding the Alarm Clock in Convenient Position on Bed

and a slit were cut in the back as indicated, so that the box could be attached to one of the vertical bars of the bed, which was done by gently springing the cardboard around the bar. The slit was later sealed with a strip of gummed paper as indicated in the detail. A circular hole was cut in the front of the box, to make the face of the clock visible. Due to the weight of the clock, the sides of the triangle grip the bar and hold the box in any desired position. When necessary, as when making the bed, slide the box up toward the top of the bar where it will be out of the way. If desired, the outside can be covered with colored crepe paper or cretonne.—Cecil Jones, Mount Vernon, Ohio.

☞ To bleach a stain in wood, sandpaper the work and apply a mixture of fresh lime, 7 parts, and caustic soda, 1 part.



Outboard motor 16 to 24 hp  
 Sea Horse - Johnson Motor Co.  
 3012 Pershing Road  
 "Popular Flyer" -  
 Waukegan, Ill.

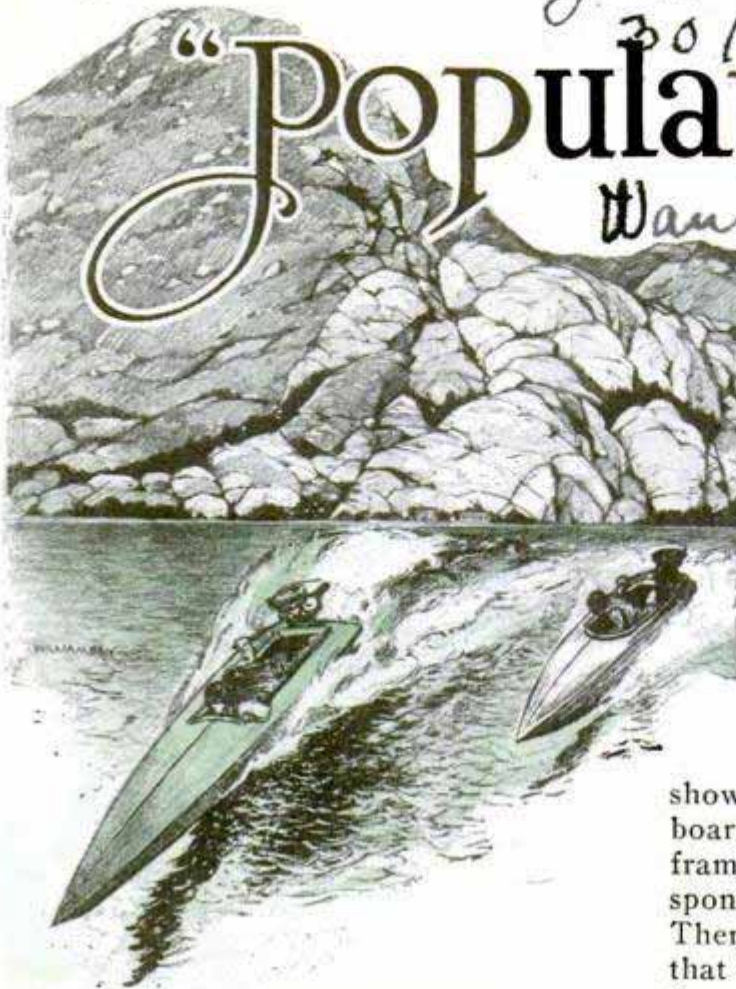

By L. J. GORENFLO

**S**PEED is the outstanding feature of the "Popular Flyer," which was designed and built especially for Popular Mechanics along the same lines as the trophy-winning model shown in the lower photo. Every step in the construction of the boat is clearly shown so that you will have no difficulty in building a similar one. The craft may be built of cypress, mahogany or Washington red cedar.

The hull is built upside down on a long 2 by 12-in. board, called the keel-support board, shown in Fig. 1. It stands on two 3-ft., 2 by 4-in. legs, and is notched to receive the frames. The width, depth and spacing of the notches are given in Figs. 2 and 4, the former being a detail of the notch for the step. The frames, which are 1/2 in. thick, are assembled as shown in Fig. 7, and also the 1-in. stern-board, according to Figs. 6 and 13. Each frame is numbered, as well as the corresponding notches in the keel-support board. There are only three after-plane frames, that is, those between step and stern, but there are four half frames which are spaced equidistantly between the after frames. Dimensions of the half frames are also given in Fig. 7, all four being exactly alike. At the center of the bottom edge of each frame and half frame, a notch is cut to receive the keel. The dimensions of the forward and after keel are given in Fig. 1, which also shows how they are laid in the center notches of the frames. The bottom of the notches in the frames should come flush with the edge of the keel-sup-

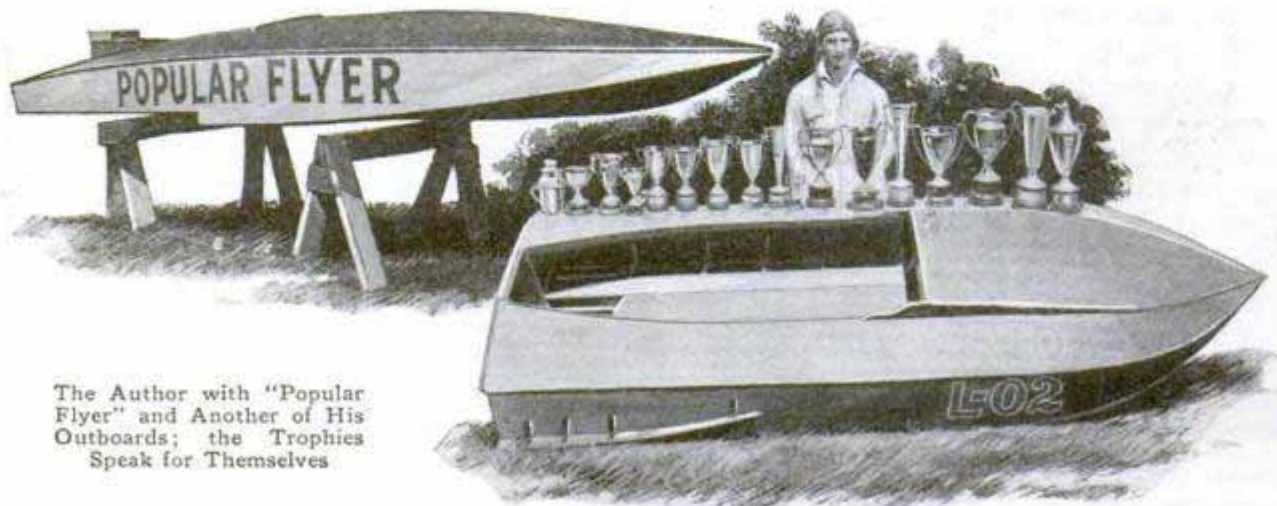

The Author with "Popular Flyer" and Another of His Outboards; the Trophies Speak for Themselves







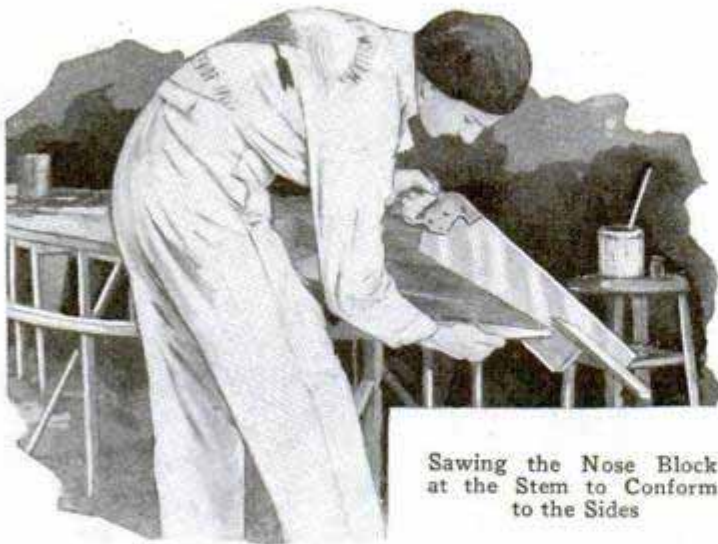

Sawing the Nose Block at the Stem to Conform to the Sides

which are recessed into notches cut at the corners of the frames, at the junction of side and bottom. The after chines run from the sternboard right through the step and fasten to frame No. 4. The forward-plane chines are laid in the same way, running from the step to the bow. They are bent in forward and fastened to the nose block as indicated in Fig. 11, the end being cut off at an angle to fit. The projecting ends of the chines are shaved off to the proper angle before the bottom planks are fitted. The small end of the tapered forward chine is fitted to the step and the large end at the bow, so as to leave enough stock for beveling off.

The deck-line battens,  $\frac{1}{4}$  by  $1\frac{1}{4}$  in., are next fitted. These run along the upper ends of the frames and form the contour of the deck. They are carefully notched into the frames to lie flush. When these are in place, nail temporary props, as indicated in Fig. 17, to the ends of each frame and the sternboard, to level up the whole boat, taking care that the props are the same length on each side. Saw off the forward end of the keel as shown in Fig. 12, to conform to the shape of the boat's sides.

Clamp a  $\frac{5}{16}$  by 10-in. by 12-ft. plank on one of the sides, as shown in the photo on page 487 and mark with a pencil along

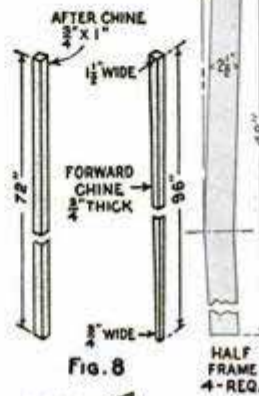
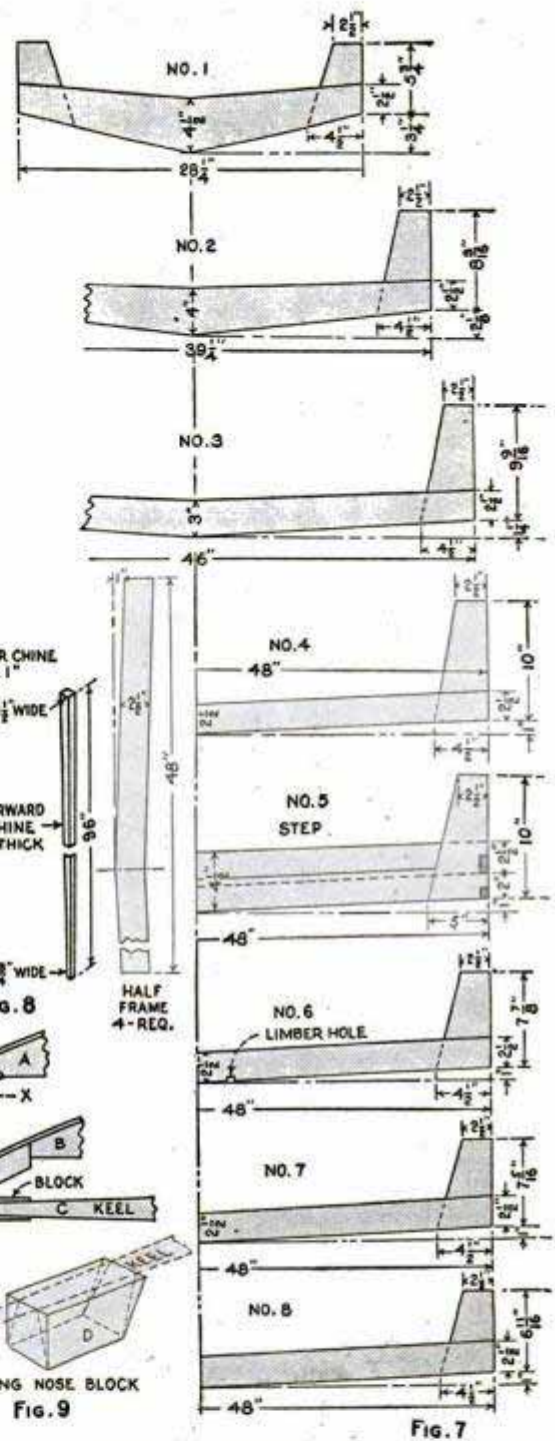

FIG. 8

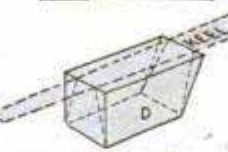
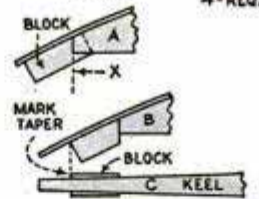

FIG. 9

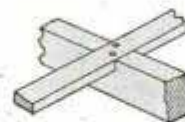

FIG. 10

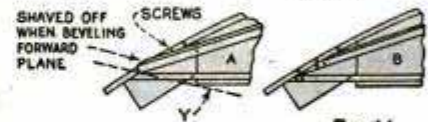

FIG. 11

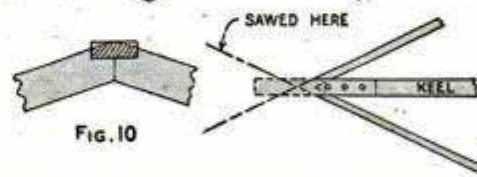

FIG. 12

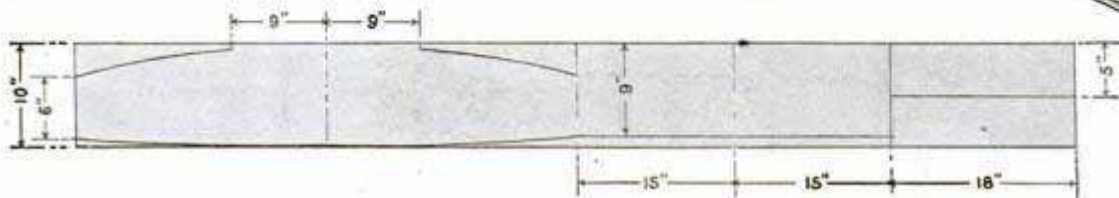
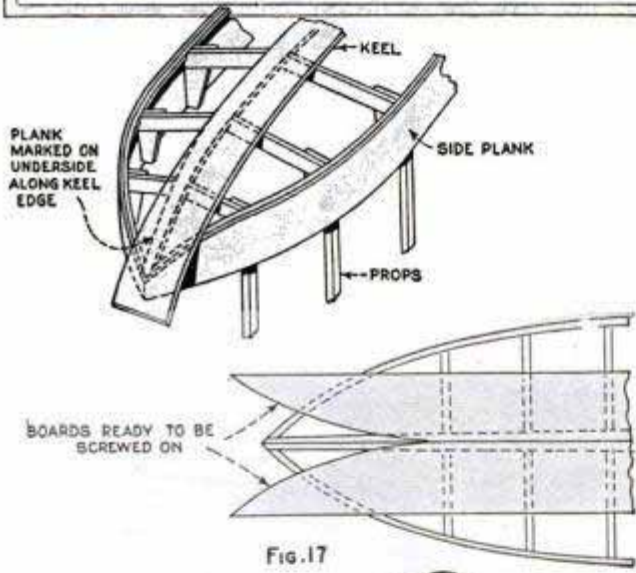
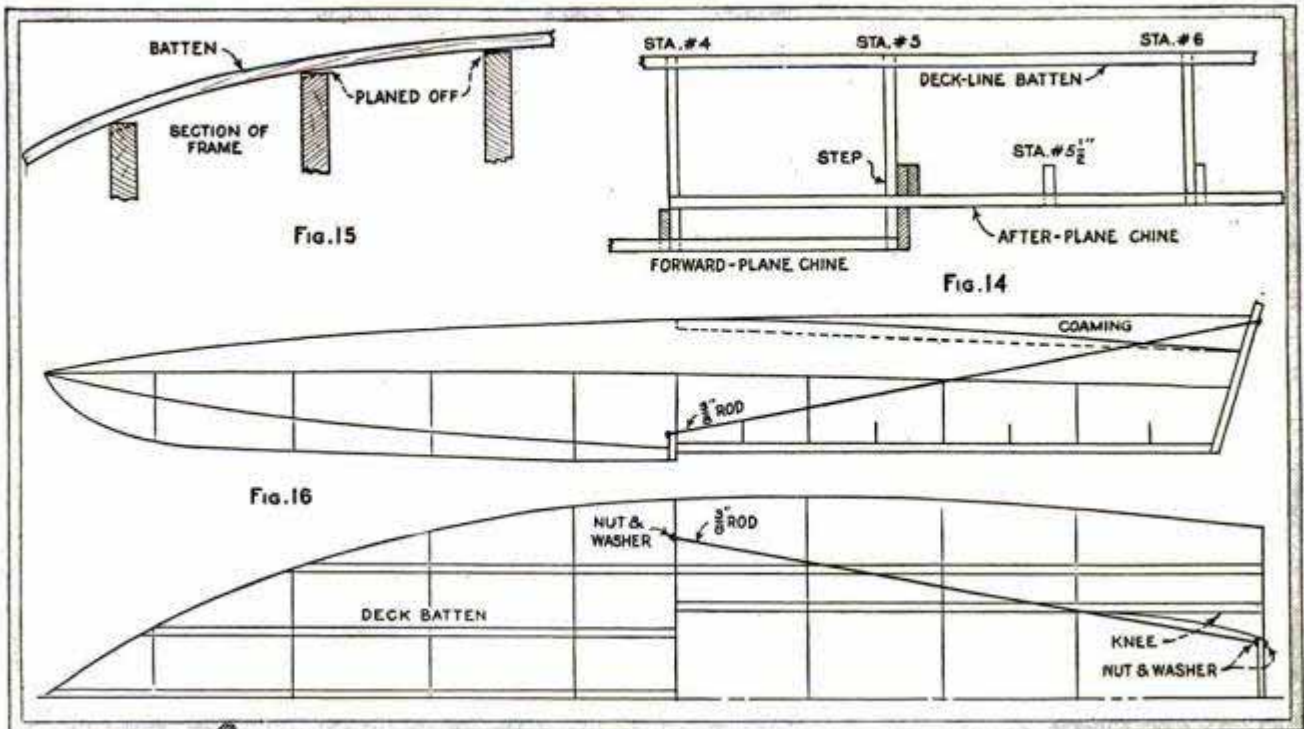
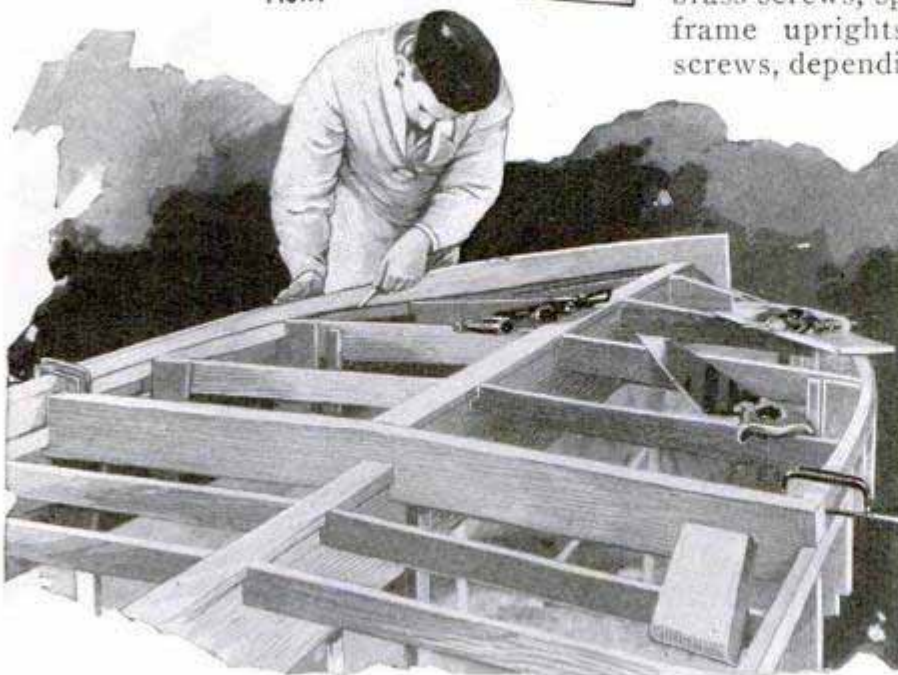

FIG. 13 HOW STERN IS CUT FROM 8 FT. BOARD





the outer edges of the chine, deck line and sternboard. Remove and saw to shape, leaving about  $\frac{1}{4}$  in. outside the line so as to be sure of having wood enough to plane smooth after the sides are fastened in place. Now apply heavy marine glue at all points on the frames, chines and sternboard that will be touched by the side planks, and lay a piece of  $\frac{3}{4}$ -in. white-cotton tape along the chines, deck-line battens and sternboard edge. This serves as calking, and is essential. Clamp the side planks in place again, and fasten along the chines with a staggered row of  $\frac{7}{8}$ -in. brass screws, spaced  $1\frac{1}{2}$  in. apart. On the frame uprights, use from four to six screws, depending on the length of the up-



Side Planking Clamped On to Be Marked for Sawing. After Which Marine Glue and Tape Are Applied to the Frame Members



right. The screws on the edge of the sternboard should not be more than 1 in. apart, and should be driven in a double row.

Cut limber holes in each frame, as shown in frame 6, Fig. 7, to allow any water that might get into the boat to run to a place where it can be removed easily. Start planking the after plane with  $\frac{5}{16}$  by 8-in. boards, one on each side of the after keel. These are known as the garboard strakes. They butt together over the flush keel, and the planking is continued out to the sides with 6-in. planks. The position of the planking joints is marked on the frames before fastening down, the planks removed, and a  $\frac{1}{4}$  by  $1\frac{1}{4}$ -in. batten sunk into the frames directly under the seam line, as shown in Fig. 18. Each plank is fastened with screws, staggered 1 in. apart, on the sternboard and with at least four screws to each frame. The battens are clinched to the board with 1-in. copper nails, 2 in. apart, and the same fastening and spacing is used on the keel. The nails are clinched over firmly on the inside.

Before planking the forward plane the chines and frames must be beveled. Take a long thin batten, about 4 in. wide, and lay it down on the

forward frames, parallel to the keel. By bending this batten down on the frames, as shown in Fig. 15, it will be seen how much should be planed off the forward edge of each frame member so that the planks will lie flat to the surface of the frames. Start planing close to the keel, on each side, checking carefully with the batten and moving the batten outward as you plane, until you come to the chines. The latter must also be planed off so that the bottom planks will lie perfectly flat on them and with a good bearing.

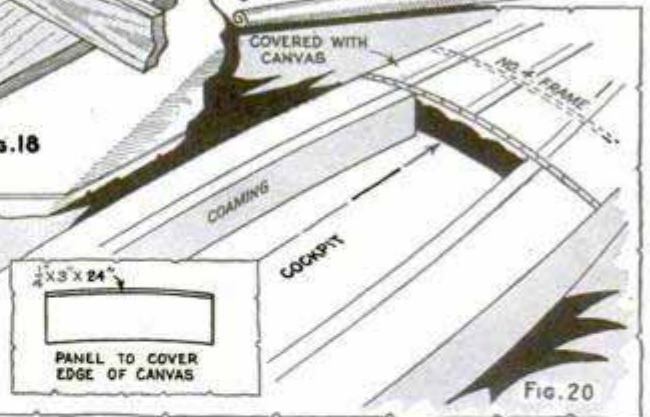
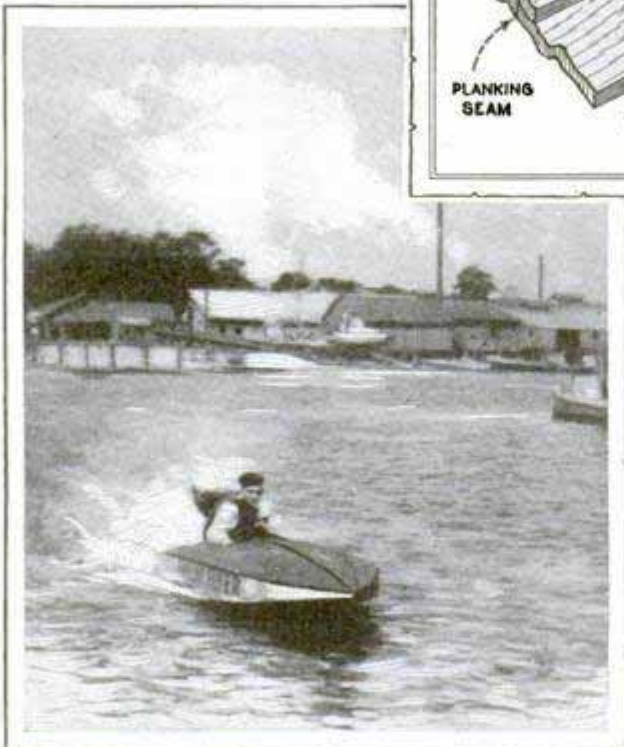
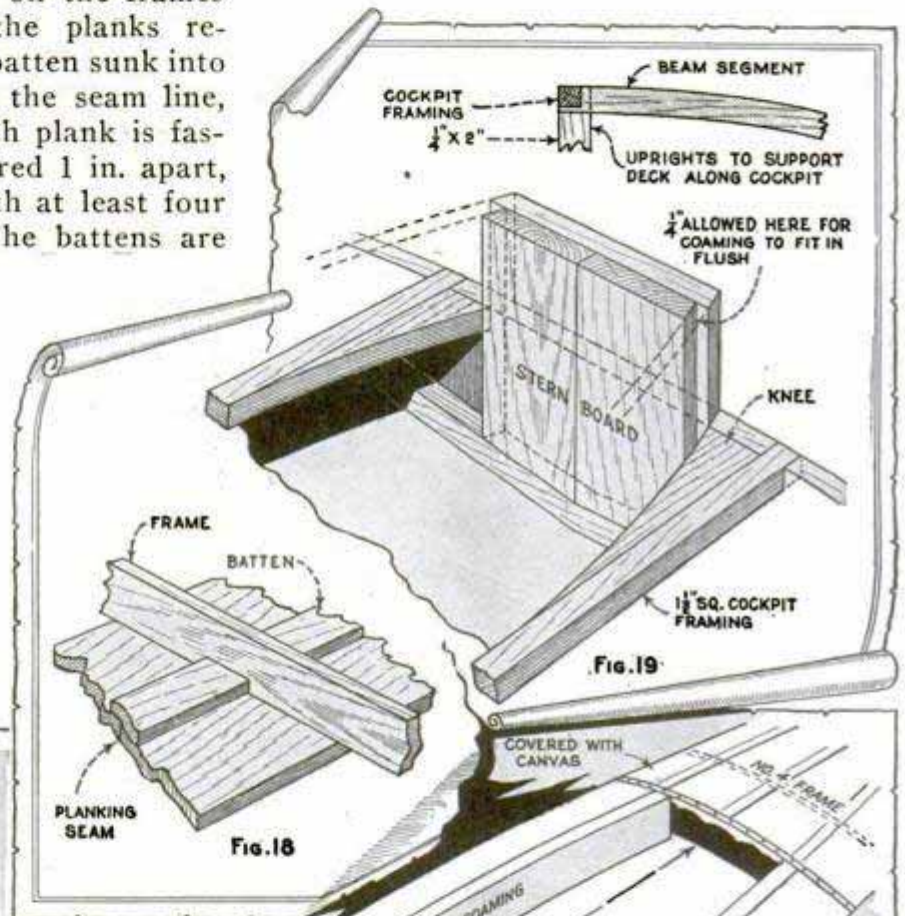

Cut limber holes in each forward frame as was done aft, then clamp a  $\frac{5}{16}$  by 8-in. board with one edge centering on the keel, as shown in Fig. 17. Bend the board down forward over the bow and clamp, then mark it with a pencil along the edge of the keel. Unclamp and saw along this line, then plane the edge smooth and with a slight bevel, so that, when the board is



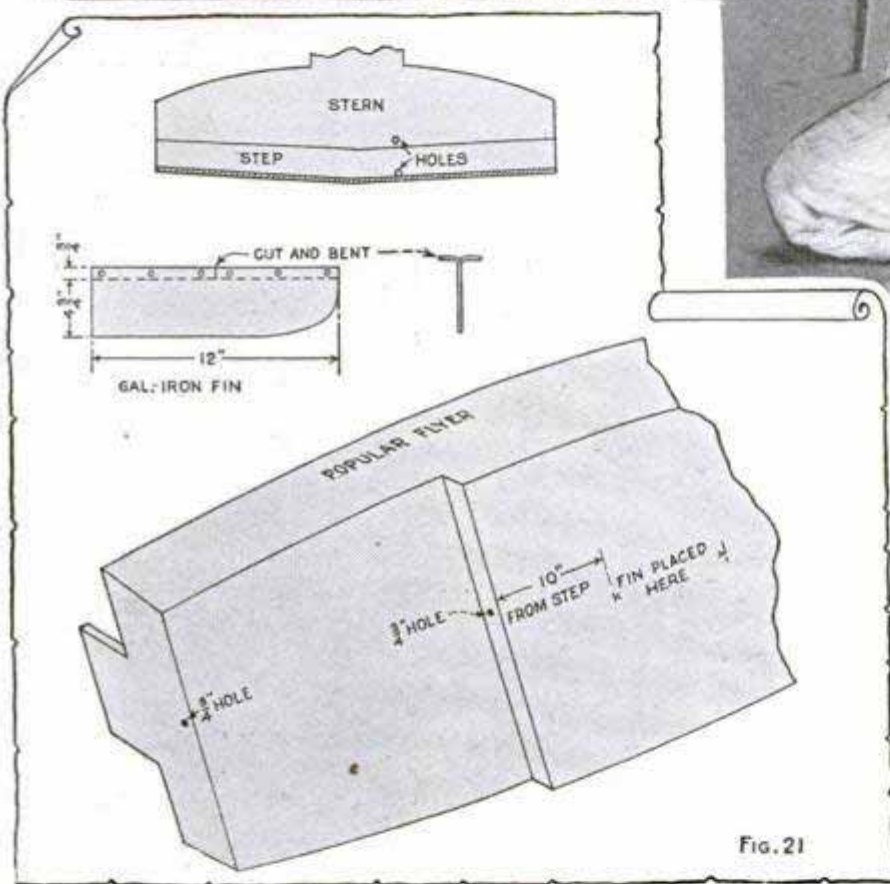
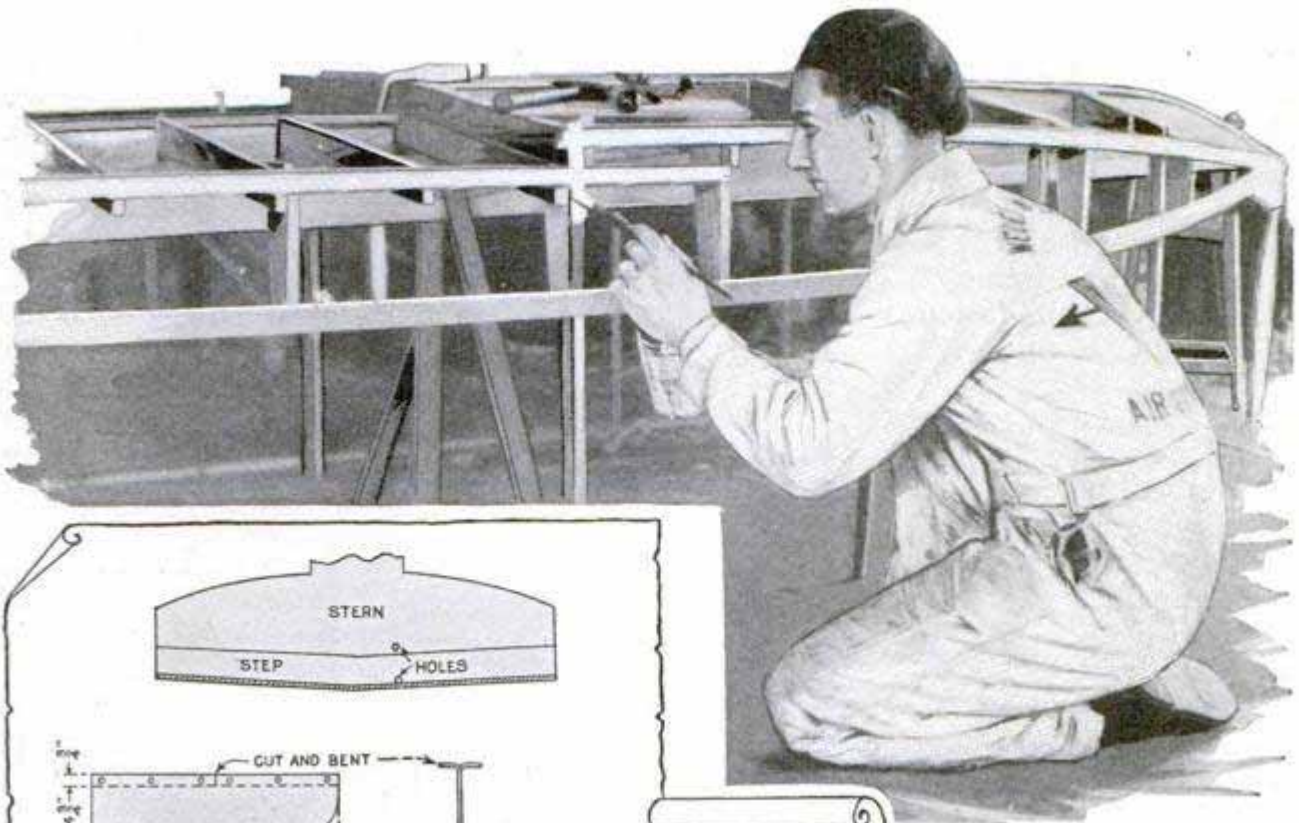

Fig. 21

in place, the edge will be vertical. Clamp in place again to check the shape of the edge. If correct, mark along the other edge on the forward chine, frames and step, so as to locate the position of the seam batten. Unclamp and sink the batten into the frames as on the after plane. Repeat the operation with the garboard strake on the other side. The shape of these planks, when cut and fitted, is as shown in the lower drawing, Fig. 17. To fasten the planks, use  $\frac{7}{8}$ -in. screws,  $1\frac{1}{2}$  in. apart, along the chines and 2 in. apart along the keel, staggered. Screws at the step should be put in a double row, 1 in. apart. The battens are clinched with copper nails as before. It is to be remembered,

just as with the side planks, that every part of the frames, chines, step and sternboard that is touched by the planks should be coated with marine glue and taped over the glued surface. The remaining boards on the forward plane are 6 in. wide, marked and fitted in the same manner.

The deck beams are as follows: four 48 in. long with a 5-in. crest; one 46 in. long with a  $4\frac{3}{4}$ -in. crest; one  $39\frac{1}{4}$  in. long with a  $2\frac{1}{2}$ -in. crest, and one  $28\frac{1}{4}$  in. long with a  $2\frac{1}{2}$ -in. crest. These beams are marked for curvature by driving a small nail at each end of a straight line on the board to be used for deck beams. Drive a third nail at the center above the line, the distance depending on the amount of crest desired. Then bend a batten around these three nails, which will give the proper curvature for the beam. All beams are 2 in. wide.

Remove all wedges and props and turn the boat over. Trim off the sides along the deck-line batten with a plane and saw off the block at the stem along the line that will conform to the curvature of the deck. Fasten two 48-in. deck beams with



5-in. crests at the step and No. 4 frame, using at least two screws at each end. The beam with the  $4\frac{3}{4}$ -in. crest is attached to No. 3 frame; the beam with the  $3\frac{1}{4}$ -in. crest at No. 2 frame, and the beam with the  $2\frac{1}{2}$ -in. crest at No. 1 frame. To make the cockpit, fasten a  $1\frac{1}{2}$ -in. square strip to No. 5 frame beam, 12 in. from the side, letting the strip extend to the stern, parallel to the side. Make two small knees and fasten them to the strips and sternboard as shown in Fig. 19.

Join the strip to the side with short lengths cut from the remaining two frames having 5-in. crests. Notch these pieces over the strip, and provide vertical uprights extending from each frame, using at least three screws at each end. Sink the deck battens flush into the beams.

Now stretch a piece of common cotton sheeting over the entire deck, tacking it along the edges of the sides and sternboard. Tack it to the edges of the cockpit, then cut out the portion of the sheeting covering the opening, so that the cockpit coaming may be put in place. Give this sheeting at least two coats of clear nitrate airplane-wing dope.

From two  $\frac{1}{4}$  by 6-in. boards, 6 ft. long, cut the coaming to fit in the cockpit, as shown in Fig. 20. The after end of each board is left full width, and fits against the sternboard, as indicated by the dotted lines in Fig. 19. Each board is tapered down to 3 in. in width at the forward end and is fastened in place so that it projects  $\frac{1}{2}$ -in. above the  $1\frac{1}{2}$ -in. strip at the forward end of the cockpit. To cover the raw end of the deck sheeting where it is tacked to the forward end of the cockpit, a small panel is fitted as indicated in Fig. 20. The panel is of  $\frac{1}{4}$ -in. material, 3 in. wide, cut with the top edge on the same curvature as that of beam No. 5 and projecting  $\frac{1}{2}$  in. above the latter.

Place a strip of  $\frac{5}{8}$ -in. half-round molding along the edges and sternboard to cover the unfinished tacked edges of the sheeting. Quarter-round molding should

be used on the sides and forward end of the cockpit, over the joint between coaming and deck. Make four  $\frac{1}{4}$ -in. floorboards, 6 in. wide, to extend from step to stern, and fasten them down  $\frac{1}{2}$  in. apart.

From  $\frac{3}{8}$ -in. round iron, make two staybolts, 6 ft. long, to extend from the step to the stern, and install them as shown in Fig. 16.

Fig. 21 shows a simple way to keep your flyer dry. Merely bore  $\frac{3}{4}$ -in. holes in step and stern, as shown. Fit corks in these holes, and, while the boat is at rest or moving slowly, leave the corks in place. As soon as the boat starts to plane, however, draw out the corks and leave them out until

ready to stop. The rush of water under the boat draws out all the water that might leak in or be splashed in by other boats. I do this to all the hulls I race with, as it is impossible to keep these boats really dry, and a boat that carries water doesn't win races. The fin may either be made or purchased.

This boat handles exceptionally well and is quite safe in the sea. For maximum speed, the driver should crouch in the hull as close to the engine as possible. In turning, he should move up in the cockpit and lean in the direction of the turn. All this, of course, comes with practice, but these two tips will help.

### Easy Method of Starting Siphon

In cases where gasoline and other distasteful liquids have to be siphoned, try the method shown in the illustration. Get a length of rubber tubing with a bulb at one end and cut a hole in

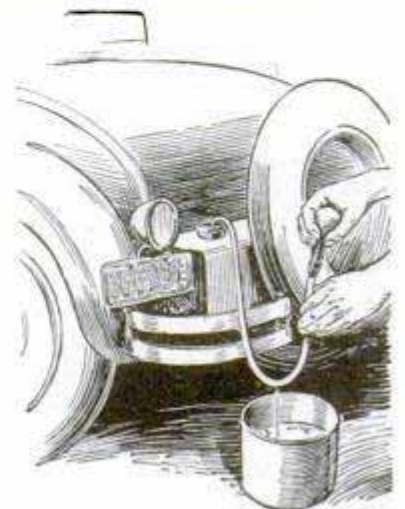



one side of the tubing about halfway between the ends. To start the siphon place one finger over this hole, and squeeze all the air out of the bulb after the open end of the tube has been submerged in the liquid. The suction when the bulb is released will draw the liquid through the tube some distance, and the finger is then removed so that the liquid can run out.

### Repair for Rusted Hot-Water Tank

Cement was effectively used to repair the bottom of a hot-water tank which had rusted through. After disconnecting the tank from the water system and unscrewing the hot-water elbow from the top, the tank was placed on two 4 by 8-in. blocks, as illustrated, care being taken to get the tank plumb. The drain hole at the bottom was plugged with a roll of cardboard, 6 in. long, well greased on the outside to facilitate its removal, and extending up into the tank about 3 in. A mixture of clean, sharp sand and cement in equal parts, and enough water to make it semi-fluid, was poured through the hot-water outlet at the top with the aid of an improvised cardboard funnel. Enough

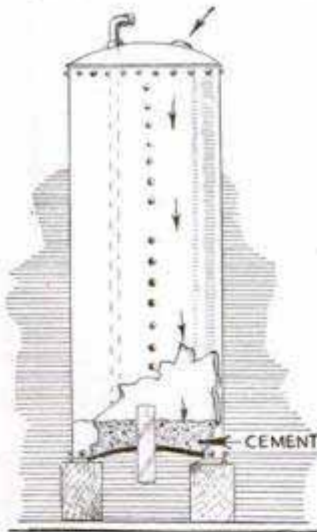

cement was used to cover the bottom of the tank about 2½ in. After the cement had set for two hours, the cardboard plug was withdrawn far enough to allow the surplus water on top to drain out. Some of the cement also was allowed to run off, in order to give the top a funnel-like shape, draining toward the hole. After seven hours, the cardboard plug was entirely removed. The cement should be allowed to set for 48 to 72 hours before the tank is put back in use.—Chas. S. Edwards, Prineville, Ore.

☐ Washing window sills with a weak solution of chloride of lime will be found effective in keeping midges, gnats and other insects out of the house.

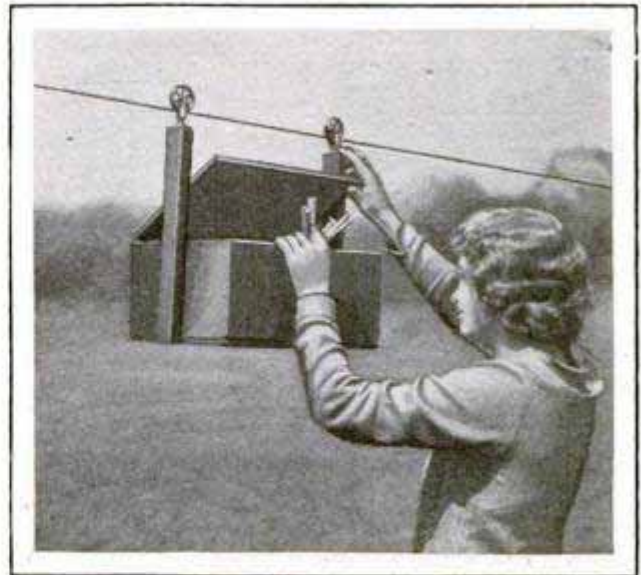

Clothespins Are Always Handy In This Box That Travels on the Line

### Clothespin Box Travels on the Line

For holding clothespins where they are always accessible, get an ordinary wooden box of suitable size and nail two uprights to the ends. Fit a pulley to the top of each and slip the pulleys over the clothesline as shown in the photo. When hanging clothes, the box is pushed ahead of the work, while the opposite procedure is followed when removing the clothes. In this way, the box is always at hand for removing or inserting clothespins.

### Improved V-Block for Drilling Rod and Tubing

When drilling rod or tubing on a drill press, difficulty is often experienced in holding the material without the aid of a V-block. Such a block can be improvised

from two short pieces of 1 by 1-in. angle iron; laid side by side on a wooden base and fastened with nails driven into the block along the outside edges of the angle iron.—Walter E. Burton, Akron, Ohio.

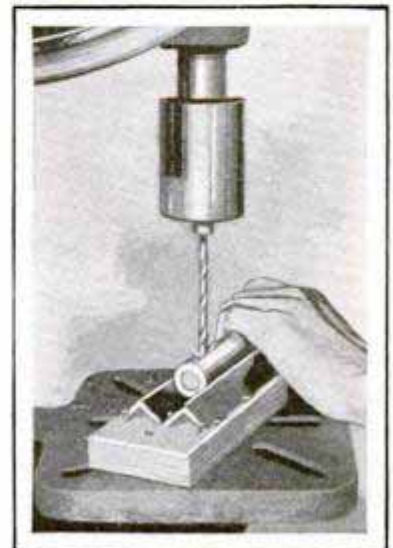



# Golf *in your*

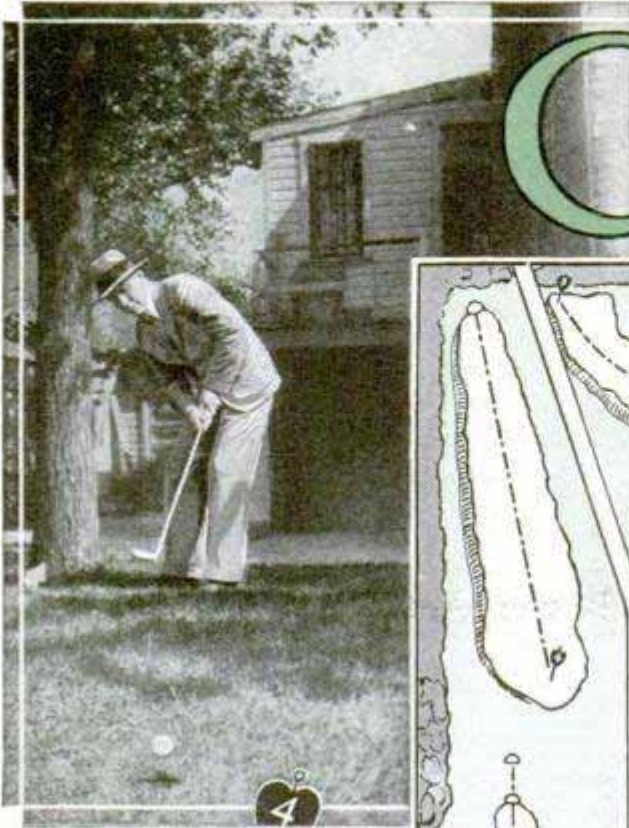

Above, Mr. Evans Putting on a Back-Yard Course; Right, Plan of Course, Which May Be Varied to Suit Almost Any Back Yard by Altering Contours of Greens or Reducing Number of Holes; Below, Even the Parkway in the Street Will Serve to Better the Ardent Golfer's Game, if Practice Holes Are Laid Out as Shown

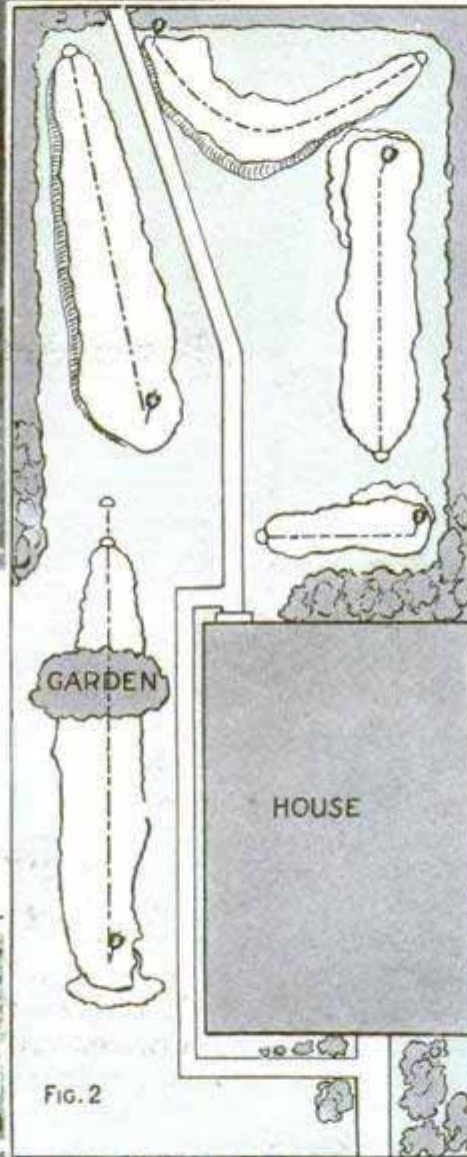

THE ideas outlined in this article are the outcome of years of experience. I really believe that I owe much of my golf success to my back and side-yard course, and to the sidewalks of Rogers Park, for, if no other ground is available, front walks and parkways can be used very nicely. I used to play down the parkways of the old street leading to the club. This is where I learned to play good golf run-up shots. I would place my ball just on one side of the walk leading to the street and then play to the next walk as close as I could. Because the walk was immediately in front of me, I would have to get



FIG. 1

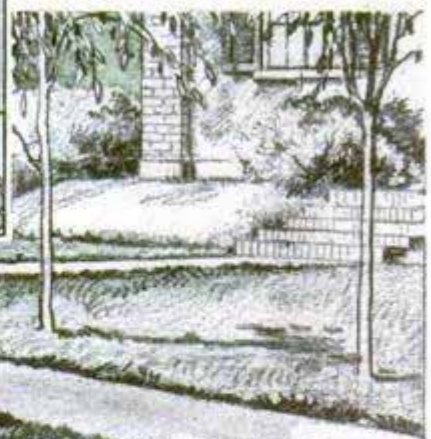



# own Back Yard

by Charles ("Chick") Evans, Jr.

the ball into the air for at least the width of the walk. This was splendid practice, for if a ball lies just off a green, a player should hit his ball so that it carries the ground immediately in front of him and to the edge of the green, and then it should run to the hole. So, for those who only have parkways in front of them, the arrangement in Fig. 1 will make a good little course.

This, of course, would be a two-hole course with no construction costs except the digging of holes. Because you are near enough to see the holes, flags will not be necessary. Players

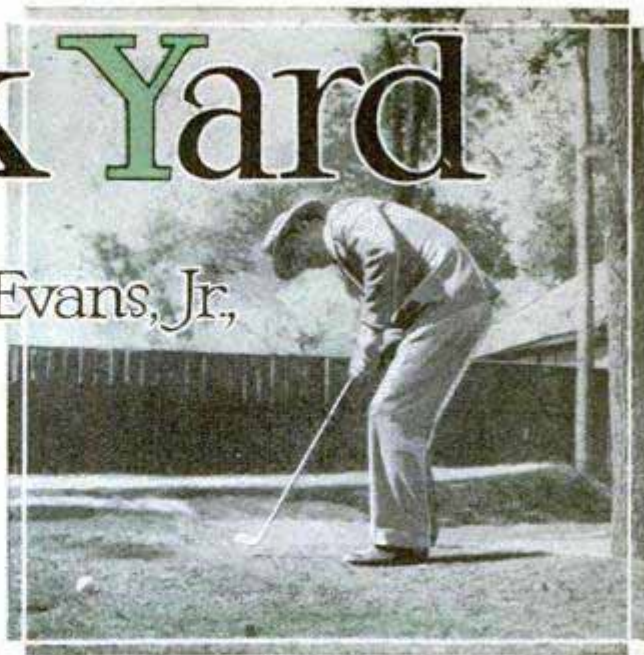

should keep the ground and grass trued up and in such condition that a ball will hit it and run over it in a fair way. Variety can be obtained by placing your ball nearer or farther away from the street, main sidewalk or front sidewalk. For putting practice, one can place the ball anywhere between the two walks, varying the distances as desired.

As a caddie at Edgewater, I could not get enough golf even though the course was near my home. There had to be something else to use up my energy in my early inclination to play better golf, and to build up a very thin body. So I conceived the little course in my back yard. Of course, the one I am presenting here is different from my course because, since that was laid out, I have had twenty-five years of golf all over the world. But the basic idea is sound. Now anyone can have one of these courses, for the number of holes and actual size of the course need not be the same as the one for which I am giving specifications. Just modify the

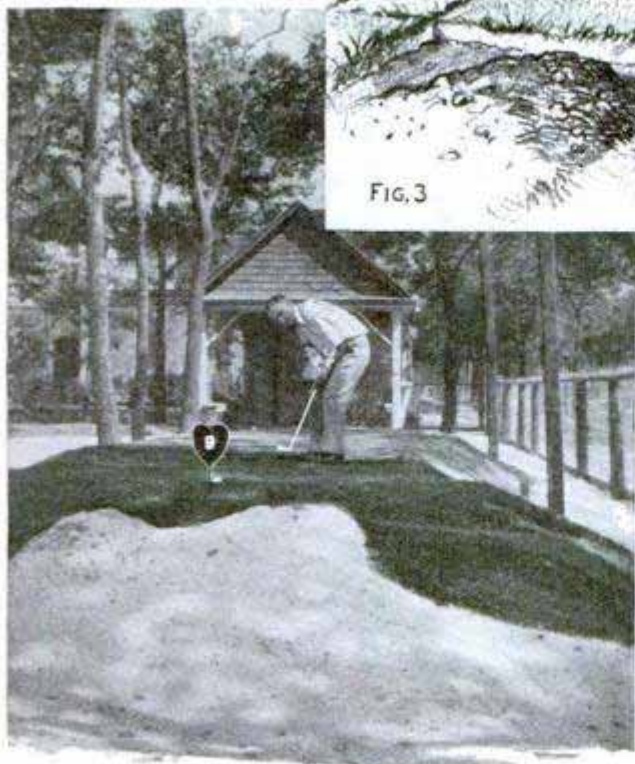





plan shown in Fig. 2 to fit the ground available in your own home situation. The same general plan, minus the pitch shot, can be used for roofs of apartment buildings, too.

The materials used for this back-yard course are not many. First of all you need to true up any ordinary lawn. I predict that there will be many of these Popular Mechanics' courses and with them will come beautiful lawns, and the neighborhood, in consequence, will be very much beautified.

Five cups at \$1 each equals \$5. In my old course I had an interesting variety of cups, such as tomato cans, flowerpots, etc., and so perhaps many of you will eliminate even this expense. The official diameter of a golf cup is supposed to be  $4\frac{1}{4}$  in. Many times it looked like  $\frac{1}{4}$  in. to me. I remember that one of our most famous putters practiced on holes only  $2\frac{1}{2}$  in. in diameter. So, size is not all important. Also there have been times when I wished that the holes were as big as bathtubs.

It is some trick to cut an even hole, and it may be that you will

need a hole cutter, which usually costs about \$6. The advantage of this tool is that it takes all the dirt and holds it to put elsewhere, as needed. The cups should be changed every once in a while, at the very first sign of wear. If this is not done, the edges begin to cave in and soon the holes are all right at the bottom, but at the top they are twice the original size. There is a trick in putting in a cup; if it is just put in flush with the ground, your ball will rebound from it and will not stay

in the hole. The top of the cup should be at least 1 in. below ground level, so that the ball hits earth instead of metal. Trim up any long blades of grass near the hole.

I would only buy



FIG. 4 SOD FILLED IN





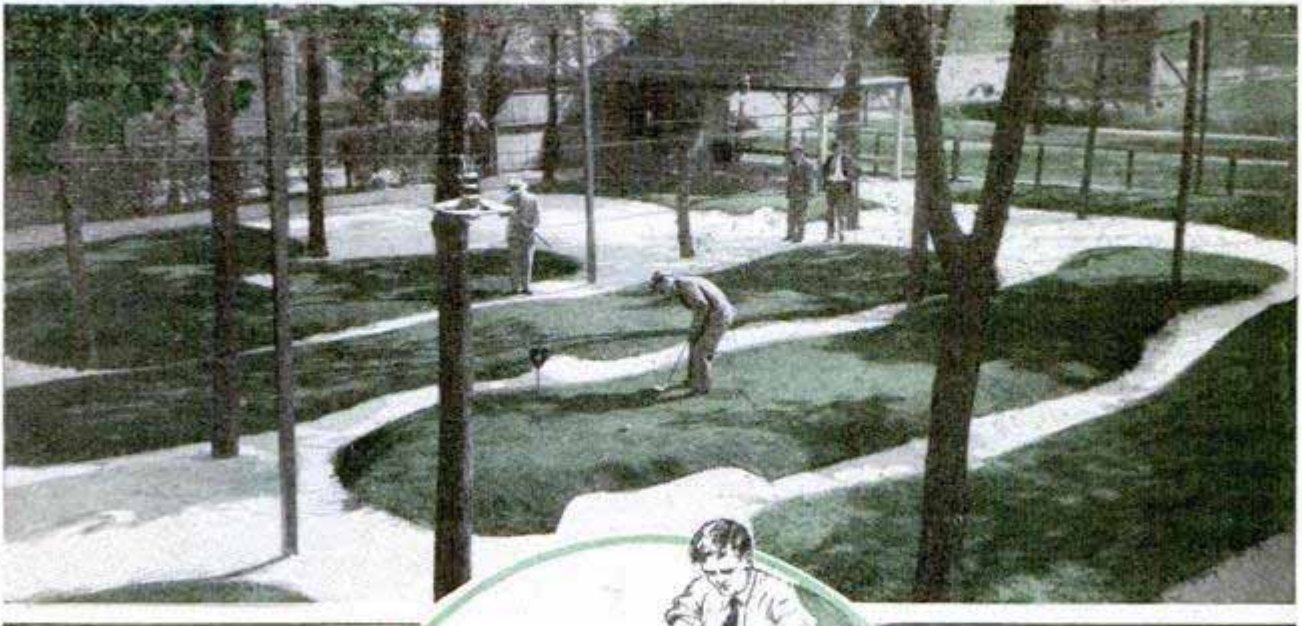

Photo Shows Miniature Course Designed by Mr. Evans, on the Principles Outlined in This Article

one flag, and that will cost about \$1, but, of course, you can probably make your own. This flag should be placed on the little green between your house and the next so that it can be seen from the road or front. Do not make it too high, or else it will lie over to one side and not look well. I would leave putting holes flagless, to avoid the trouble of taking them out and putting them in.

For 10 ft. around these holes pay special attention to the green grass. In fact, all over the little space I would true the grass and treat it. One of the best helps you can get in this operation is a small water-ballast roller which should cost about \$14 to \$18. The cutting of grass is an important item, also. A big course brings joy when it is cut well and so will a little one. The kind of mower you should buy or use depends on the sort of grass on your lawn. If it is creeping bent, you will probably need an eight-bladed mower; if blue grass, a five-bladed mower will do. You cannot count the cost of this, of course, as you would have a lawn mower anyway.

Frequent top dressing is really an excellent thing for the greens, and some good

black soil should be obtained for this purpose. If the dirt is gummy, mix with it a little fine torpedo sand. Bear in mind that this sand is a great thing for use in truing up your course. After the top dressing is on, you will need something to distribute it evenly over the surface and for this purpose there is nothing better

than a steel mat, which will cost about \$4. This is not absolutely necessary, but it is worth while. Of course, you will need a few rakes, but you will need them for your gardening anyway. A good bamboo pole to flick the worm casts off in the mornings is also a good thing. The price is negligible—about 35 cents apiece. Sprinkling is vital, so you might need a little extra hose and perhaps a sprinkler.

If you are to use your course at night, you will need an electric light, so this problem should be taken up with your local electrician. They are using some non-glare lights in Chicago that are very satisfactory, but, in most cases, one light well placed will do the work nicely.

I am a firm believer in having the feet firmly on the ground when one putts; therefore, do not make any undulations



that would place one foot higher than the other in any marked way unless the player has put himself in that position. I mean that the tees and the space around the holes should by all means permit a sound stance. You can get little tee plates (10 cents apiece) and move them around every other day so that there will not be too much wear in one place.

Your equipment will consist of four or eight putters and two mashie-niblicks. (Putters at \$1.50 each; mashie-niblicks \$2 each.) Buy your balls from a cheap place, about 50 cents apiece. Have two dozen around. If you wish to be fancy, you can put a little irregularly edged trap where it will catch balls which might interfere with play on a near-by hole. Get some white sand for these traps, to show off the green well.

There are several ways to treat the boundaries of the holes, especially the putting ones. First, you can simply leave them flat and even with the rest of the lawn. Second, you can cut, with a spade or a sod cutter, at right angles to the line of play, next cut the sod back as shown in Fig. 4, roll it back and fill under it, then tamp the sod back and fill in the cut with good soil and seed it. This gives a gentle roll to the green. In the third place, you can get a terrace effect, as shown in the various photos, by cutting with a sod cutter or spade around the curving boundaries of the greens shown in Fig. 2, then removing the sod as in Fig. 3, filling in with good earth to make the terrace the height wanted, and finally tamping the sod back in place as in Fig. 5, filling in all spaces with soil, and seeding. The edges of the terrace can be filled in with good dirt and sod, and at the traps with white sand. One thing that is important is the slope of the terrace; it should not be too sharp. A ratio of about 8 to 1 will let the lawn

mower ride over the edge without "scalping" it. Be sure that the slant of the green faces the line of play, and that the rolls for the running ball are never sharp slopes, but very gradual, smooth inclines.

In order to aid your regular golf game this miniature course should be refined on its top surface to give you what you would get playing on a regular course. They say that 45 per cent of the game actually takes place on the green. About 7 per cent more takes place just off it and not in traps. Therefore, if you conquer your miniature course, you will have control of your regular game. There is a man in the east who plays as good a game as any businessman

in the country. He keeps his game up because he not only has a miniature course in his yard, but a bunker as well, together with two full-shot distances. I have always felt that, if I had that constantly in my vicinity, I could always play championship golf and take my pleasure in oceans of health.

Referring to Fig. 2, the contour of hole No. 1 should be as nearly flat as possible. Just a simple,



A Bunker on a Miniature Golf Course, Which Offers as Much Hazard to the Golfer as Those on the Regular Course

straight putt to start out with. For hole No. 2 the surface should provide two gentle straight rolls before reaching the hole area. This means that a well-hit ball will roll smoothly up and down one, and then the other, in a straight way. If the player has used the right speed, he should just reach a hole-high or hole position. So, watch where you put these rolls. The top of the putting area on hole No. 3 should tip from left to right, but as always, on all rolls, they should be very gentle. The hole area should be equally gentle. This hole should teach the borrow from left to right. The angle of this tipping should be varied, so that a player will not allow the same distance to the left of the cup all the way up the hole.

The top surface on hole No. 4 here





Note, in This and the Other Illustrations, How the Greens Are Terraced, and How the Traps Are Placed on the Slopes

should tip from right to left the whole length of the hole, which is just the opposite of the preceding hole, to teach the ability to borrow from right to left. Here again the slope should not vary evenly down the hole.

There are two tees to hole No. 5. The garden, or flowerbed, should be like a water hazard, bunker or pit of any kind. The nearer tee will teach you to pitch over it with a low trajectory and the farther one with a higher trajectory. I cannot impress it enough on the amateur hole builder to have the ground, where the ball should fall, smooth, fair and true.

### Testing Silk

Silk fabrics are often "loaded" to give them the appearance and feel of heavy fabric, because silk so treated is cheaper than a piece of all-silk goods of the same weight. The loading process consists in

impregnating the silk with metallic salts, such as tin and lead. A chemical action is set up in the fiber by this process which weakens the goods to some extent; furthermore, when the loading materials have been removed from the fabric by washing, the garment is in many cases practically ruined. Loading also causes the silks to crack and split at folds and creases. A simple method of detecting loaded silks is a burning test. A piece of pure silk when burned, will shrivel up like wool. If metallic salts are used, the silk ash will retain its original shape and pattern.

### Dustpan Ventilator for the Auto

Even though all connections may be tight, a hot motor will usually give off some gases, which may be carried into the passenger compartment. This trouble can easily be avoided by providing ventilators on the dustpan, similar to those on the hood but deflected in opposite direction.

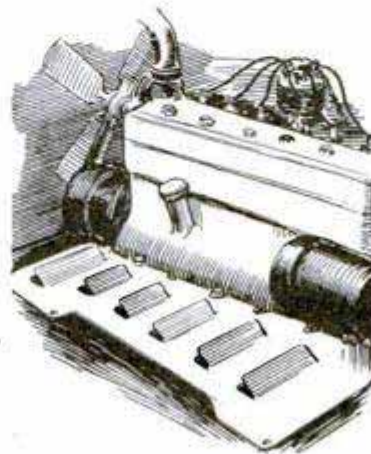



## A RADIAL ENGINE FOR MODEL AIRPLANES

Constructed of balsa wood so that it is light enough to be used on flying scale models, the radial engine shown has proved highly satisfactory, and

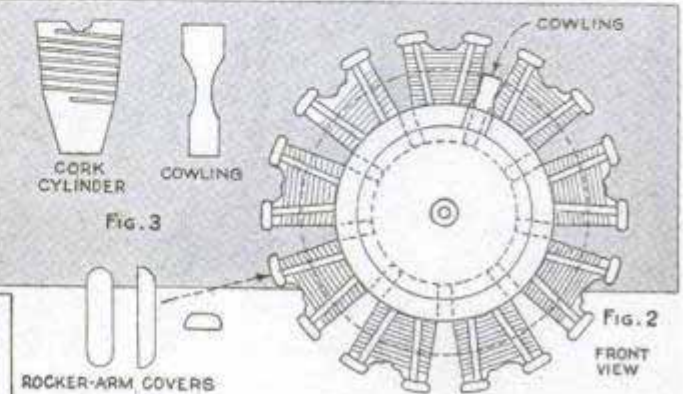
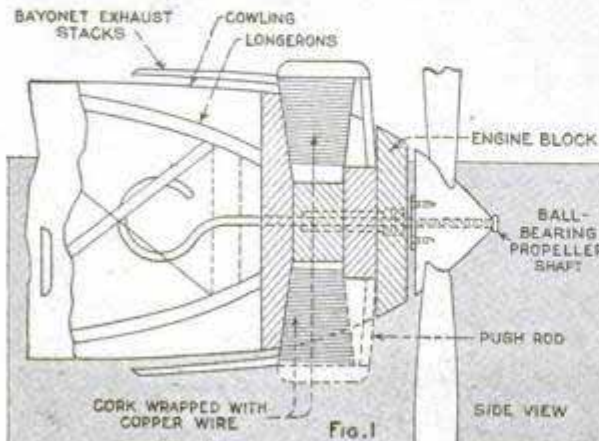

This Radial Engine for Model Airplanes Looks Realistic and Can Be Used on Flying Models

looks very realistic. The shape of the engine block makes it easy to cowl and simple to mount on any type of fuselage. Fig. 1 shows a side view and the method of mounting the engine. The shaded section is the engine block, which can be turned out on a small bench lathe. The dimensions of the block are not shown, as they have to be varied to suit the size of the plane. In turning the block, the small groove in the center is made just wide enough so that the small end of the cork cylinder fits snugly into it. The front is turned to the shape of the spinner on the propeller, or it may be rounded off just a little more than is shown and painted to resemble the shutters used on the late types of radial engines. A hole is drilled through the center to receive the propeller shaft. In this case a ball-bearing shaft was used. Fig. 2 shows the front of the engine with the nine cylinders spaced at equal distances, and the position of the rocker-arm caps and push rods. Fig. 3 shows the cork cylinder. The bottom of each cylinder is tapered to

provide clearance as shown. The top of the cylinder is grooved to resemble the cooling fins of the cylinder head. The fins on the side of the cylinder are made of copper wire. By punching a hole in the cork near the top you can insert one end of the wire to hold it in place, after which it is wrapped around the cork seven or eight times, the turns being spaced about  $\frac{1}{32}$  in. apart. The other end of the wire is bent at a sharp angle and pushed into the cork, where it will be held securely. The rocker-arm caps are made of balsa and are ambroided to the cylinder heads. The push rods are made so that they fit firmly between the rocker-arm caps and their base on the engine block. Match sticks, sandpapered smooth, are suitable for this purpose. Cowling around the cylinders consists of strips of aluminum cut to the shape shown. These are slipped under the fuselage cowling, which is in turn fastened to the large round part at the back of the motor block, while the front end is bent down and slipped in against the flat surface just ahead of the rocker arms. The exhaust stacks are of the bayonet type, made of match sticks pointed at both ends. One end is forced into the cork under the rocker-arm cap at the point where the exhaust valve is



supposed to be, ambroid being used to keep it in place. If desired, an engine of this type can be made with five or seven cylinders. The photos show a model of the Curtiss "Sea Hawk" equipped with such a radial engine.—L. J. Mandelko, Long Pine, Nebr.

### Coloring Copper Brown and Black

Different shades on copper, ranging from a light brown to a deep black, may be obtained by using a weak solution of liver of sulphur (sulphuret of potassium). A half ounce of the chemical to a gallon of water suffices to make a solution strong enough for brown colors. By increasing the quantity, using the same amount of water and bringing it to the boiling point, the same colors can be produced on brass. To obtain the popular verde-antique finish, the work is stippled with a solution made from 4 oz. copper nitrate, 4 oz. calcium chloride and 1 oz. bichromate of soda in 1 gal. of water. After coating the work with this solution, the high lights are rubbed down with a cloth and finely powdered pumicestone, after which lacquer or wax is applied as desired.

### Handy Cutter on End of Nail File



By grinding a small notch in a nail file and honing it to a razor edge, a handy nail cutter can be provided. The advantage of the grooved edge over the straight knife blade, is that you are not so apt to cut the nail and spoil its shape. Besides, the file and knife are always together.—Albert J. Monfils, Worcester, Mass.

### Removing Grass Stains from Clothing

The removal of grass stains from clothing is not the easiest task. Washing a garment stained in this way will not do. A method that is effective, is to use a small amount of ether, which can readily be obtained in any drug store. Saturate a small cloth wad and rub it over the stain.

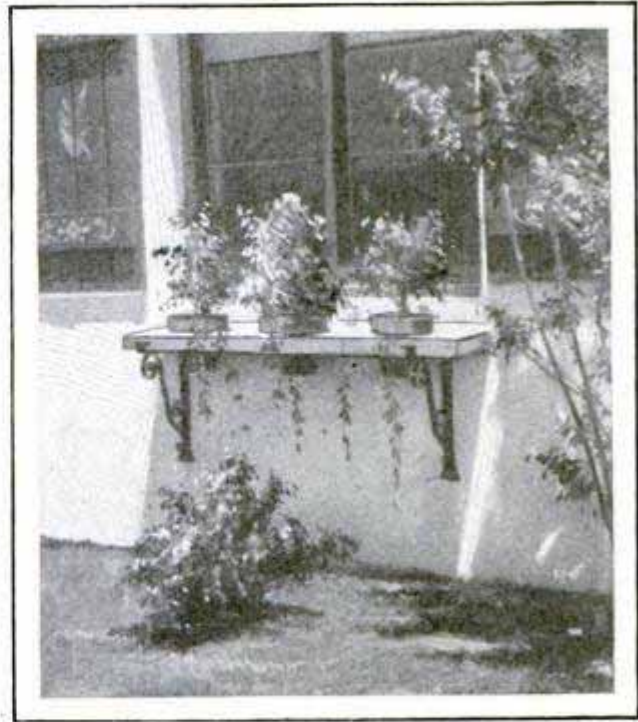

Fancy Wrought-Iron Brackets Holding a Board Make an Attractive Window Shelf

### Window Shelf for Potted Plants

Window shelves of the kind shown in the photo improve the appearance of the house. Two or three fancy iron or wooden brackets are first attached to the wall, and a suitable piece of 2 by 10-in. stock, well painted, is fastened over them. In this particular instance, wrought-iron brackets were used, which offset nicely against a stucco background. If the board is left loose, it can be removed during the winter to prevent an accumulation of snow.—C. A. Byers, Los Angeles, Calif.

### Dividers Hold Down Tracing Cloth When Lettering

When lettering with ink on a tracing, the cloth has a tendency to rise away from the board, which is rather annoying and makes lettering somewhat difficult. Holding the cloth down with the fingers often results in blotches, and it is much better to use a pair of dividers for the purpose, as shown. The dividers are held in the left hand while the lettering is done with the right.—H. L. Wheeler, Springfield, Vt.





32 W. Randolph St. Chicago  
Western Union



The Author with Trophies Won in Paddling and Sailing Canoe Fitted with the Rig Described

# RIGGING A

by C. Ed. Packer

prises an open canoe with single sail, lee-boards and a paddle for steering.

The advantages of this rig include economy, ease of handling, safety, ease of stowing or transportation and ability to show surprising speed, if properly rigged. But there is the catch. It is the purpose of this article to explain how to rig such a canoe for maximum speed and general utility.

It really makes no difference where we begin on the work of making the sailing rig, so let us first consider the sail itself. The "ladybug" model sail is an excellent type, which has been in use for over 25 years. The cloth used for making the sail should be a very fine unbleached cotton duck, commonly called "zephyr" sailcloth or "balloon silk." This cloth comes about 40 in. wide. Sew four widths together with an overlapped double seam. Then lay this large piece down on the floor and smooth it out. Referring to the sail plan, place a fine nail in the corner marked "tack." Now just smooth, but do not pull, the cloth so that you can mark off the corners "peak" and "clew" according to the dimensions given in the diagram. Very lightly nail these corners into place.

CANOE sailing has passed through many stages. Some of the earlier types resembled small schooners, others carried two sails—and a combination sailor and acrobat. But from all the various types tried, one stands out as the most practicable for all purposes. It is designated by the American Canoe association as the cruising type, and com-

Mr. Packer Winning the Canoe-Sailing Race in the First Annual Aquatic Meet of the American Legion; the Rig Is Identical with the One Described in This Article



Between these three nails, stretch a string to mark accurately the edges of the sail.

If your boat is very round on the bottom, you will want very little draft (see sail plan). On the other hand, if your boat is very flat on the bottom, you will get best results by cutting your sail with considerable draft, about 1½ in. extra material being allowed where the diagram is marked "draft." Along



# SAILING CANOE

the leach of the sail, measure out 3 in. and mark your cloth with an easy curve from the peak to the clew. With a piece of soft charcoal mark out the whole sail, allowing 1 in. outside of the dimensions given for hemming. In hemming, be very careful not to pull or force the cloth in the machine, or the edge will either pucker or draw. When the sail is hemmed, sew on a double thickness of canvas tape along the head and foot, to prevent stretching. Three batten pockets, 1 in. wide and 12 in. deep, should be sewed on at right angles to the leach, so as to divide the length into four equal parts. Light spruce battens—thin boards—are later sewed into these pockets to hold out the leach.

While grommets may be put in the tape along the head and foot of the sail, a better and easier way is to sew on  $\frac{1}{4}$ -in. galvanized rings at 6-in. intervals, for fastening the sail to the spars.

With the sail complete, it is well to make it mildew-resistant. Dissolve  $\frac{1}{4}$  lb. each of sugar of lead and powdered alum in a large pan of water. Let the sail soak in this overnight. Then, without wringing it, hang it in the shade to dry.

For the spars, nothing but clear, straight-grained spruce should be used. While tape was placed on the sail to prevent stretching, it is best to play safe and make both spars 6 in. longer than the head and foot of the sail. It is far easier to cut spars down the second season than it is to "stretch" them. It is

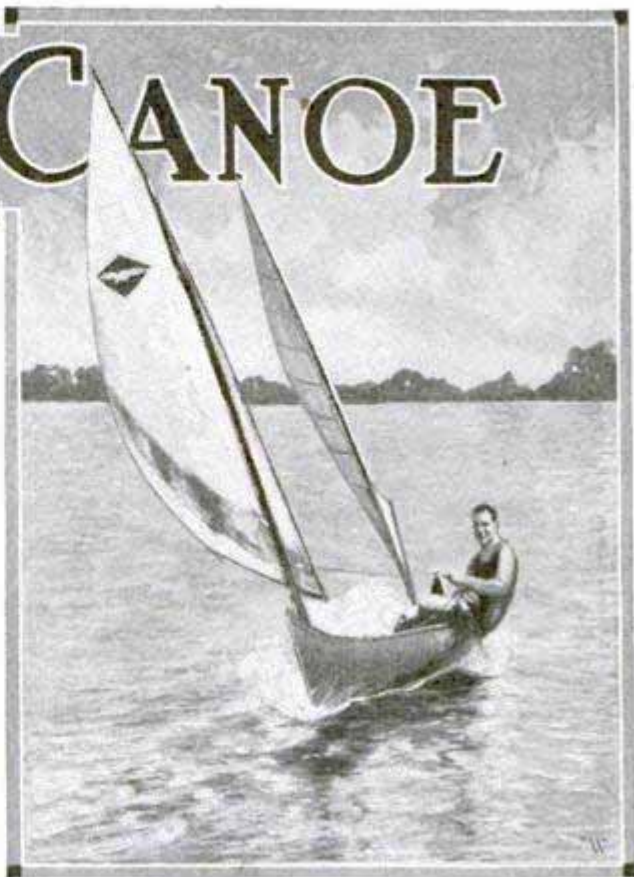

money well spent to have the spars ripped square to about  $1\frac{5}{8}$  in. From there they can be worked down with drawshave and plane to a diameter of  $1\frac{1}{2}$  in. in the center,

tapering uniformly to 1 in. at the ends.

The spars, when properly shaped, can be hinged together as shown in detail A on page 504. The material required

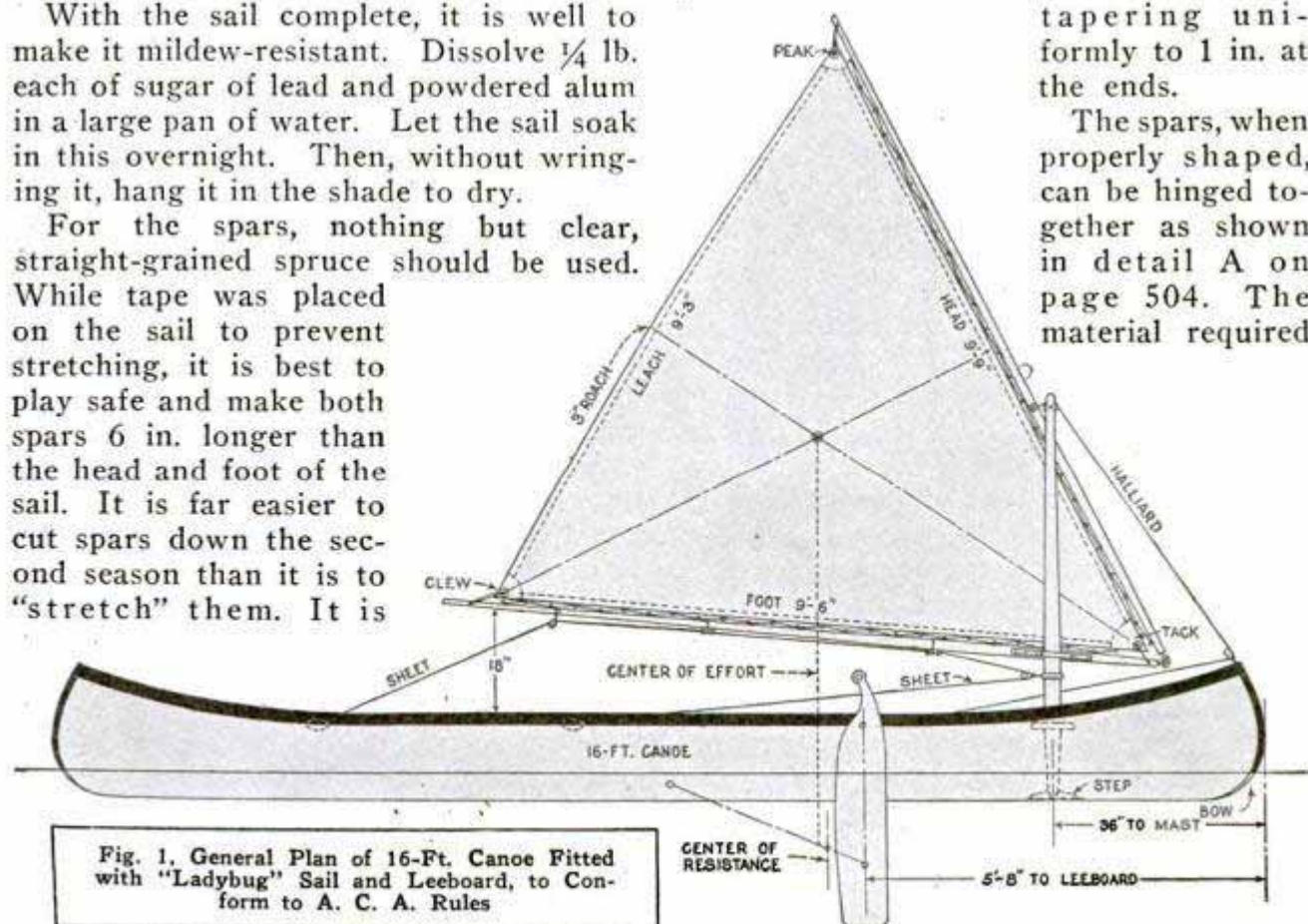

Fig. 1. General Plan of 16-Ft. Canoe Fitted with "Ladybug" Sail and Leeboard, to Conform to A. C. A. Rules



consists of two  $\frac{1}{8}$ -in. eyebolts, 2 in. long. The boom jaw is made of  $\frac{3}{8}$ -in. half-round brass. A rivet should be placed in the outer part of the jaw to prevent spreading. The jaw is attached to the boom with brass screws. It should be placed so that the distance from end of yard to center of mast is 18 in., as shown. Finish the spars with two or three coats of spar varnish.

Now lay the sail out flat on the floor and put the spars in place. Midway between the rings on the head and foot of the sail, place a mark on the spar. While doing this, see to it that the sail is drawn out smooth but not actually tight. At each mark on the spar, drive a small brass screw-eye. At the end of each spar, place a larger screw-eye. Now thread a stiff brass wire through eyes and rings, to secure the sail to the spars.

The mast (Fig. 3) should be 5 ft. 6 in. long, finished to a diameter of 2 in., 2 ft. up from the bottom. Taper it off to  $1\frac{1}{2}$  in. at the top. For hoisting, it is well to mount a sheave near the top. This can be obtained by driving the pin out of any galvanized pulley to get the wheel. Then slot the mast for the sheave, and mount it on a bolt run right through the mast. The bottom should be tapered steeply to a 1-in. square.

To mount the mast in the boat make up the steps shown in Fig. 3. These should be of any tough hard wood. The bottom step should be about 6 in. long, 2 in. wide and 1 in. thick. Shape it about as shown and square out a hole in the center to take the mast.

While it is sometimes possible to "get by" by merely boring out a thwart that is already in the canoe, it is frequently necessary to make a new step thwart as shown. There are two reasons for this. One is that the original thwart may not be wide enough to have sufficient strength after the hole is bored. The other is that the thwart may not be in the right place. Location is important and will be considered in detail later. Design your new

thwart step along the lines of the thwarts already in your canoe, but be sure to make it 4 in. wide, so as to have 1 in. of material fore and aft of the hole.



The sail equipment is now ready to be placed on the boat, but it is absolutely necessary to finish the leeboard next. The reason for this is that the point of lateral resistance must be known before the sail can be placed. One leeboard is all that is needed. In fact, for best results only one board is ever used in racing. The board may be made of almost any straight-grained wood, but spruce or mahogany are recommended.

Cut the leeboard, from 1-in. clear wood, to the shape shown in Fig. 3. Then, with a marking gauge, go around the edge of the board, marking the center of the edge carefully. With this as a guide, you can begin to taper the board to obtain lightness and reduction of resistance. Do not make the entering edge sharp, but merely round it carefully, bringing it down in width slightly like a paddle. From 2 in. back of the entering edge, the board should taper uniformly to the trailing edge. This requires lots of careful planing, but is necessary for maximum speed.

The board is carried on a crosspiece, details of which are shown in Fig. 3. The crosspiece should be 1 in. wider than the width of your canoe, as measured 68 in. from the bow. A thwart is installed so you can bolt the leeboard crosspiece in the same place each time you rig.

A brass carriage bolt or an iron one may be used. When putting it in place, see to it that the leeboard crosspiece is carefully whittled out to receive the bolt. Then, just as carefully, whittle out the end block that is to be bolted down over the large bolt. When done, the large bolt should be very firmly gripped in wood. If an iron bolt is used, dip it in spar varnish before bolting the two pieces of wood together. Then, by keeping the threads oiled, pretty fair results will be obtained. The leeboard and crosspiece should be finished with two coats of spar



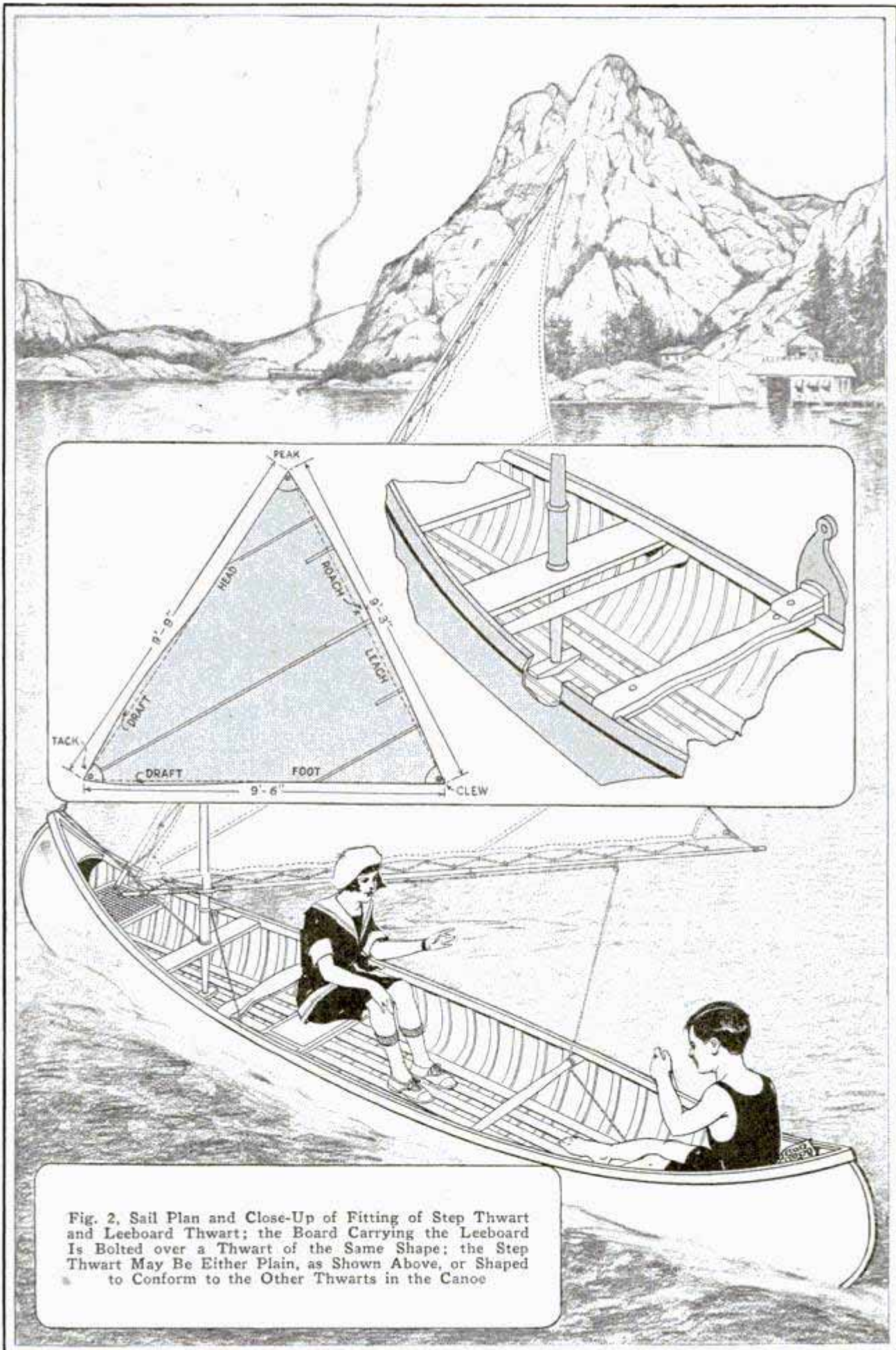

Fig. 2, Sail Plan and Close-Up of Fitting of Step Thwart and Leeboard Thwart; the Board Carrying the Leeboard Is Bolted over a Thwart of the Same Shape; the Step Thwart May Be Either Plain, as Shown Above, or Shaped to Conform to the Other Thwarts in the Canoe



varnish and the board carefully sanded and oil-rubbed for absolute smoothness.

With the leeboard installed, place the canoe in the water. Wade in with it and grasp one gunwale with one hand. Pull sideways on the boat. The combined resistance of the leeboard and keel will prevent much movement. If, when you pull the boat sideways, one end or the other tends to swing up, move your hand toward the end of the boat that does not swing up. In this way you will find a point where the canoe may be dragged straight sideways. This point is the center of lateral resistance. Mark it on the gunwale.

Lay the sail flat on the floor. Then tie a string at the tack and stretch this string out to the center of the leach, and stretch a string from the clew to the center of the head of the sail. Where these two strings cross is the center of effort. It would be well to put an ink speck on the sail at this point. With the sail hoisted, a line dropped vertically from this point should be aft (back) of the center of lateral resistance of the canoe. This is important for safety and convenience in handling.

boat that naturally heads into the wind, a paddle over the leeward side (away from the wind) has complete control. Pulling in on the paddle handle makes the boat swing away from the wind, while letting the paddle trail permits the boat to head up into the wind.

The bottom step should be put in place with four brass No. 10 2-in. screws run into the keel. These should be soaped and the holes drilled to prevent breaking the screws or splitting the wood.

With the canoe leveled, using a carpenter's level from side to side and on the keel, the thwart step should be located. This is done by slipping this part in place over the mast which is standing in its step. Then two helpers should sight to see that the mast is vertical. One should sight to see that the mast is true from side to side, while the other sees that it does not slope fore or aft. When it is vertical, mark the exact location for the thwart on the gunwales, remove the mast and fit the thwart into place.

Put the mast back in place. Lay the sail down in the canoe with the throat around the mast. Now raise the gaff

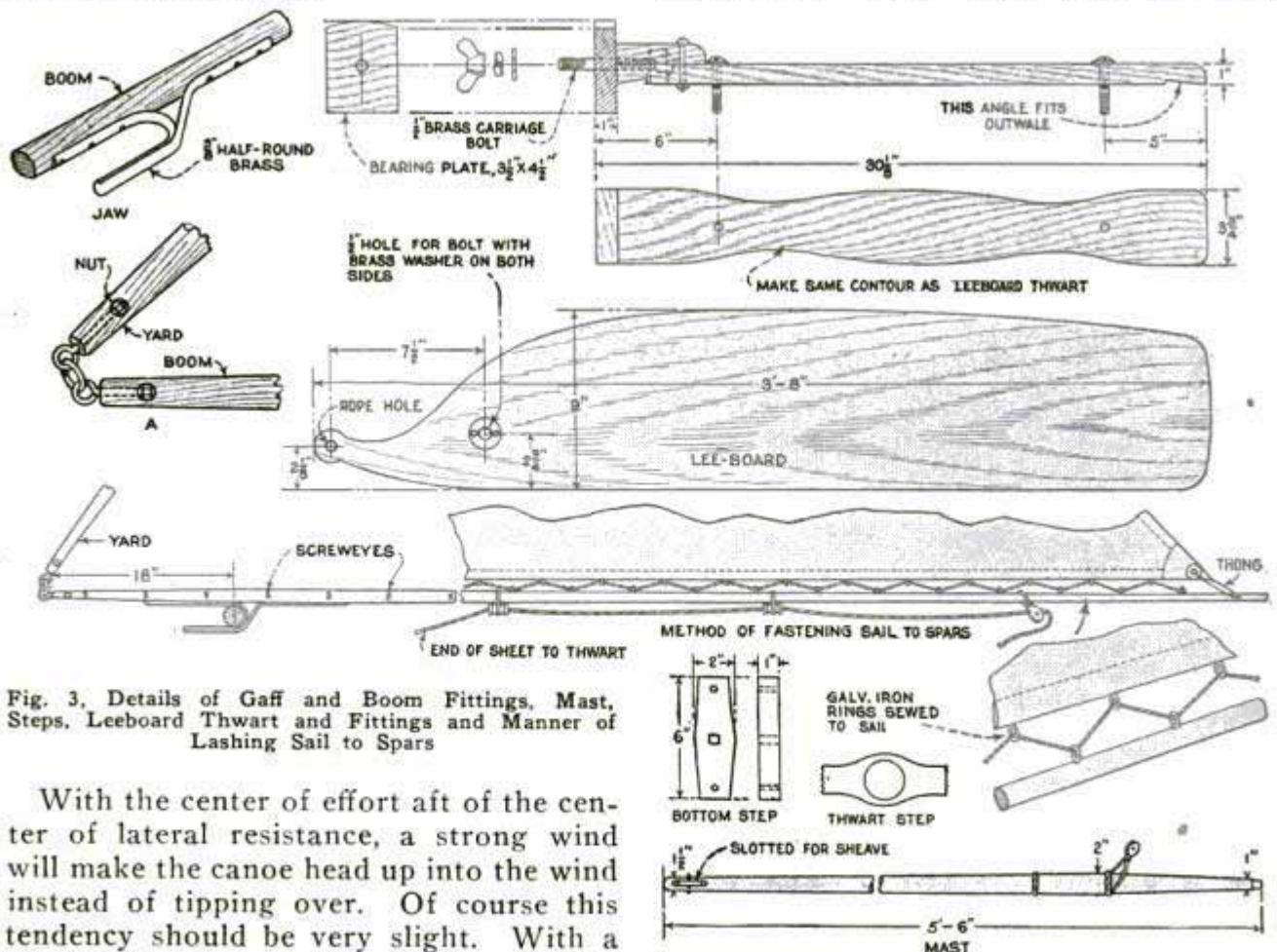

Fig. 3. Details of Gaff and Boom Fittings, Mast, Steps, Leeboard Thwart and Fittings and Manner of Lashing Sail to Spars

With the center of effort aft of the center of lateral resistance, a strong wind will make the canoe head up into the wind instead of tipping over. Of course this tendency should be very slight. With a



(spar attached to head of sail) until the tack clears the deck or gunwales of the canoe by 3 or 4 in. Note where the gaff touches the sheave in the mast when so raised. At this point, tie the halliard. The halliard should be threaded through the mast sheave and down through a pulley fastened in the bow, as shown in Fig. 1. The halliard should then be run aft to a cleat placed near the center of the boat.

The sheet (line used to pull in or let out the sail) should be tied at the thwart farthest aft. It should lead up to a pulley on the boom, as shown in Figs. 1 and 3. Two lignum-vitæ eyes should be lashed to the boom and the sheet run through these. At the mast should be another pulley through which the sheet passes as it is led back to the sailor. This manner of handling the sail relieves the strain on the arms of the sailor to a great extent and prevents the sail from blowing up when struck by a sudden puff of wind.

The only thing remaining to do is to get used to handling the boat. In trying it out, if it heads up into the wind too much, the leeboard must be moved back a little. If it falls off from the wind, the leeboard should be moved forward a little. Every time the leeboard is put on or moved, it should be checked to be sure it is absolutely parallel to the keel.

### Stabilizer Control for Model Stunt Planes

An effective stabilizer control for model stunt planes, which was devised by a California industrial-arts instructor, is shown in the illustrations. A duralumin spar is pivoted at the tail of the fuselage and a swinging double arm of wire is provided to raise and lower the leading edge. This arm is held in place by means of a pair of corrugated duralumin strips on each side of a flat retaining strip of the same material. The latter holds the wire arm in the desired notch. The corrugations are formed by running the duralumin strips

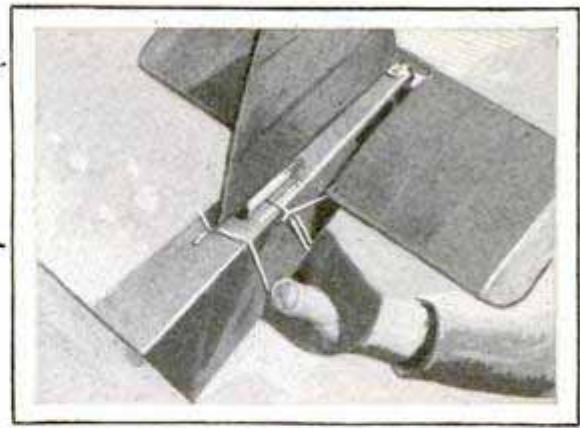
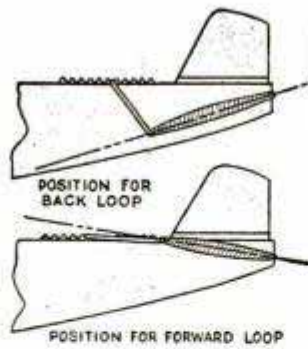

Stabilizing Control for Model Stunt Plane Allows the Pitch of the Tail to Be Varied

between a pair of loosely set spur gears. By means of this simple device, in combination with a rudder having a right-and-left adjustment, the model plane can be made to do a variety of stunts.

### Old Golf Club Makes Novelty Inkwell and Pen Holder

By drilling a hole of the proper size in the head of an old driver to accommodate a small bottle, a novel inkwell can be made. If the bottle does not fit as tight as desired, it can be sealed with wax or putty. The end of the broken shank may



be cut off flush and drilled to receive a pen. Such an inkwell will not overturn easily and will also serve as a paper weight, besides preserving a favorite driver that is no longer serviceable on the links.—Henry S. Rorer, Norfolk, Virginia.

☞ When applying more than one coat of shellac to patterns, sandpaper each coat, when dry, before applying the next.



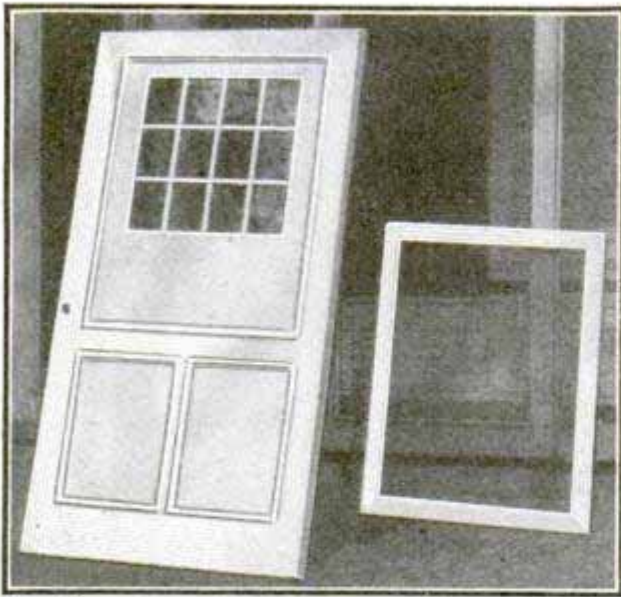

Any Screen Door Can Be Converted into a Combination Screen and Storm Door

### Combination Screen and Storm Door

Almost any screen door can be converted into a combination screen and storm door. The screen is first removed from the lower section of the door and plywood panels are substituted. Then the screen is similarly removed from the upper section and a suitable sash is trimmed down to fit in the door frame as shown in the photo. Molding is used on the outside and small turnbuttons on the inside, to keep the sash in place, although other fasteners may be used if desired. A separate screen, the same size as the sash, is then made so that it is interchangeable with the latter.—H. Rossiter Snyder, Guilford, Conn.

### "Oxidizing" Copper and Brass

The antique finish so much admired in fixtures, hinges, trays, etc., known also as "oxidized" work, is produced on both copper and brass in exactly the same way. The process is cheap and simple. A strong solution of potash and lye, using about two tablespoons to 1 qt. of water, is first made. A second solution, consisting of about 2 oz. of sulphide of potash and 2 qt. of water, is then prepared. After fastening a short piece of wire to the article, to serve as a handle, the article is dipped into the first solution to remove all grease and dirt. It is then rinsed in hot water and dipped into the sulphide solution until it has a good sharp-black color in the case of copper, and a grayish black in case of

brass. The article is again rinsed in hot water and hung up to dry. When thoroughly dry, it is buffed all over lightly on a soft-cloth buffing wheel, then buffed so that the copper will show through in spots to produce the desired effect. A little practice will enable one to buff a piece so that it will look as well as if the work had been done by an expert.

### Filling the Auto Vacuum Tank

If a funnel and small gasoline can are at hand, the simplest way to fill the automobile vacuum tank is to remove the plug at the top of the tank and pour in the gasoline. If no funnel is available, the tank can be filled quickly as follows: Close the throttle, shut off the ignition and press the starter switch; the action of the motor will then cause enough suction to draw the gasoline from the rear tank into the vacuum tank. The throttle must be kept closed, as otherwise the engine draws most of the air through the carburetor.

### Child's Toy Locomotive Made from Oil Drum

Using the chassis of a child's toy automobile, a miniature locomotive can be built from an oil drum, which serves the purpose of a boiler, and a length of stovepipe, which is used as a stack. Additional features are a cab, which is made of tin, and a cowcatcher. The engineer has a seat in the rear and supplies the power with his feet. Painted suitably, this makes a very attractive outfit.

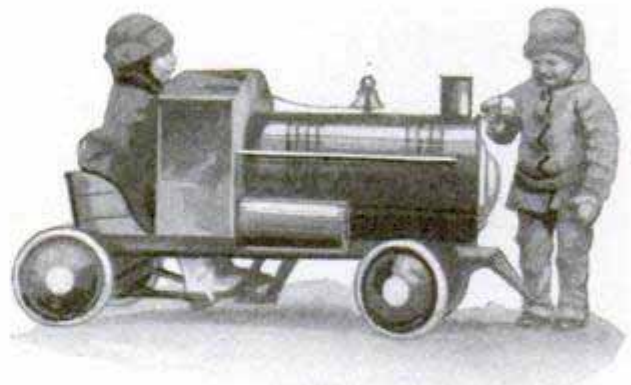

Child's Locomotive Made from Oil Drum Mounted on Toy Auto Chassis

☐ For all diameters the transverse pressure on a boiler is double the longitudinal pressure.



## SIMPLE POTTER'S WHEEL MAKES ARTISTIC JARS

THE POTTER'S wheel has been in use for many cen-

table, pushes the lower wheel around in one direction or the other as he works

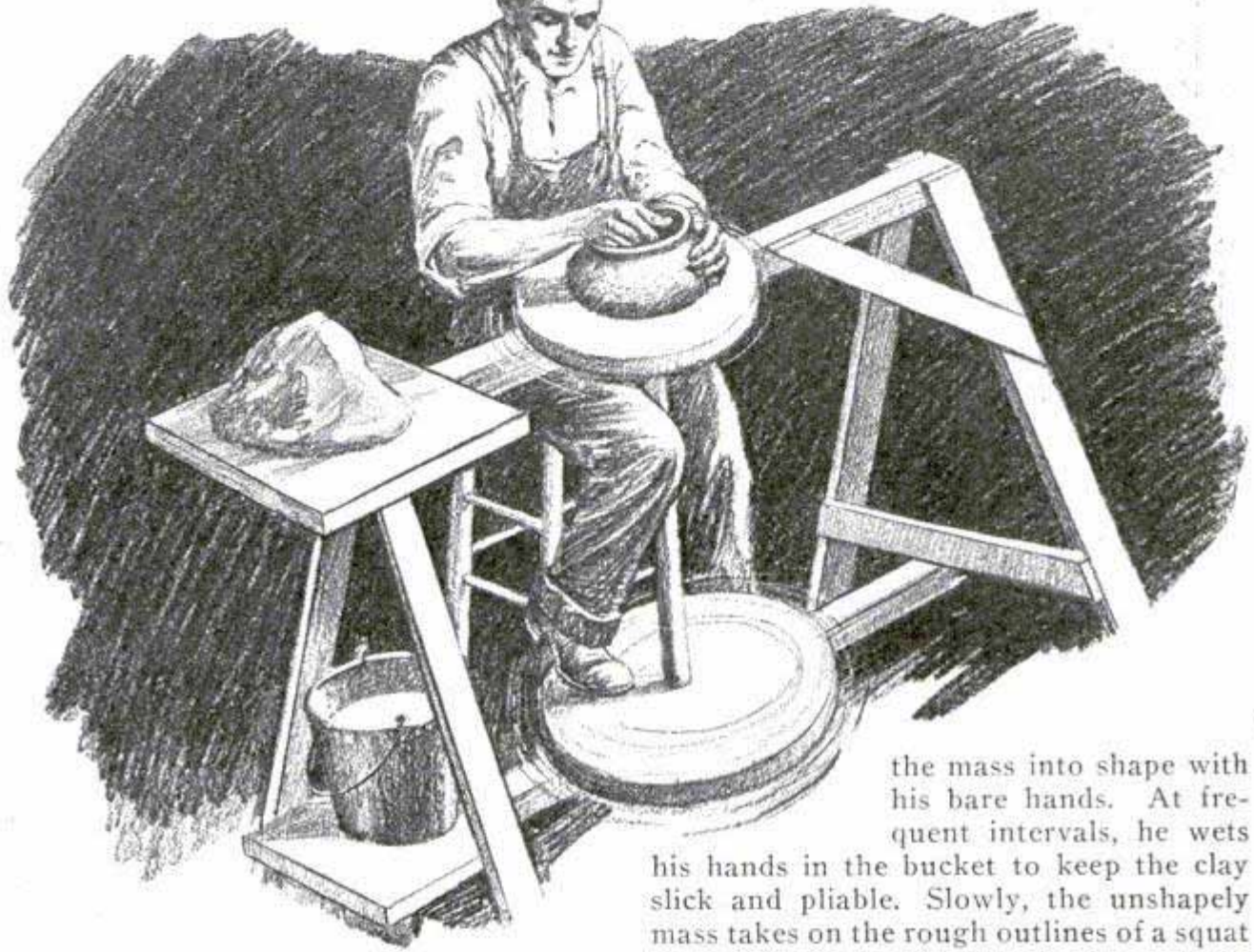

turies and still retains its fascination. With a little practice, one can make very attractive ornamental jars, vases and other forms of simple pottery.

Making the potter's wheel itself is merely a job of simple carpentry. Herein is illustrated one used in demonstrations at an old Spanish exhibition in Pasadena, Calif. The original had obviously been in use for generations, and in the drawings some improvements have been added, especially in the shaft bearings.

Note that there are no pulleys, belts, gears or levers, simply an upright shaft, with a large wooden wheel at the bottom, which is spun with the foot, and a turning table at the top supported by a saw-horse framework. The raw-clay board at one end and shelf for water bucket beneath add to its convenience.

In turning a bowl, the potter places a large lump of moist clay on the molding

the mass into shape with his bare hands. At frequent intervals, he wets

his hands in the bucket to keep the clay slick and pliable. Slowly, the unshapely mass takes on the rough outlines of a squat bowl; then, with his fingers, he works the sides thinner and higher. Sometimes a thin board, cut in the profile of the inside of the bowl, is used to remove superfluous clay. In the later stages less water is used; the vase becomes more set, that is, the clay is stiffer. When completed, a fine wire is pulled under to loosen it from the wood, and the bowl is lifted off together with the removable board.

Two-by-fours are used throughout for the frame, with  $\frac{3}{4}$ -in. boards for raw-clay and bucket shelves and for corner braces. The 10-in. molding or turning table is also made of  $\frac{3}{4}$ -in. material, having a broad cleat at the bottom, to which a pipe flange is screwed and the  $\frac{7}{8}$ -in. (outside diameter) pipe shaft in turn screwed into the flange.

A removable, circular top is provided—several of them, in fact, when a number of jobs are to be turned out—so that the work can be lifted off without damaging



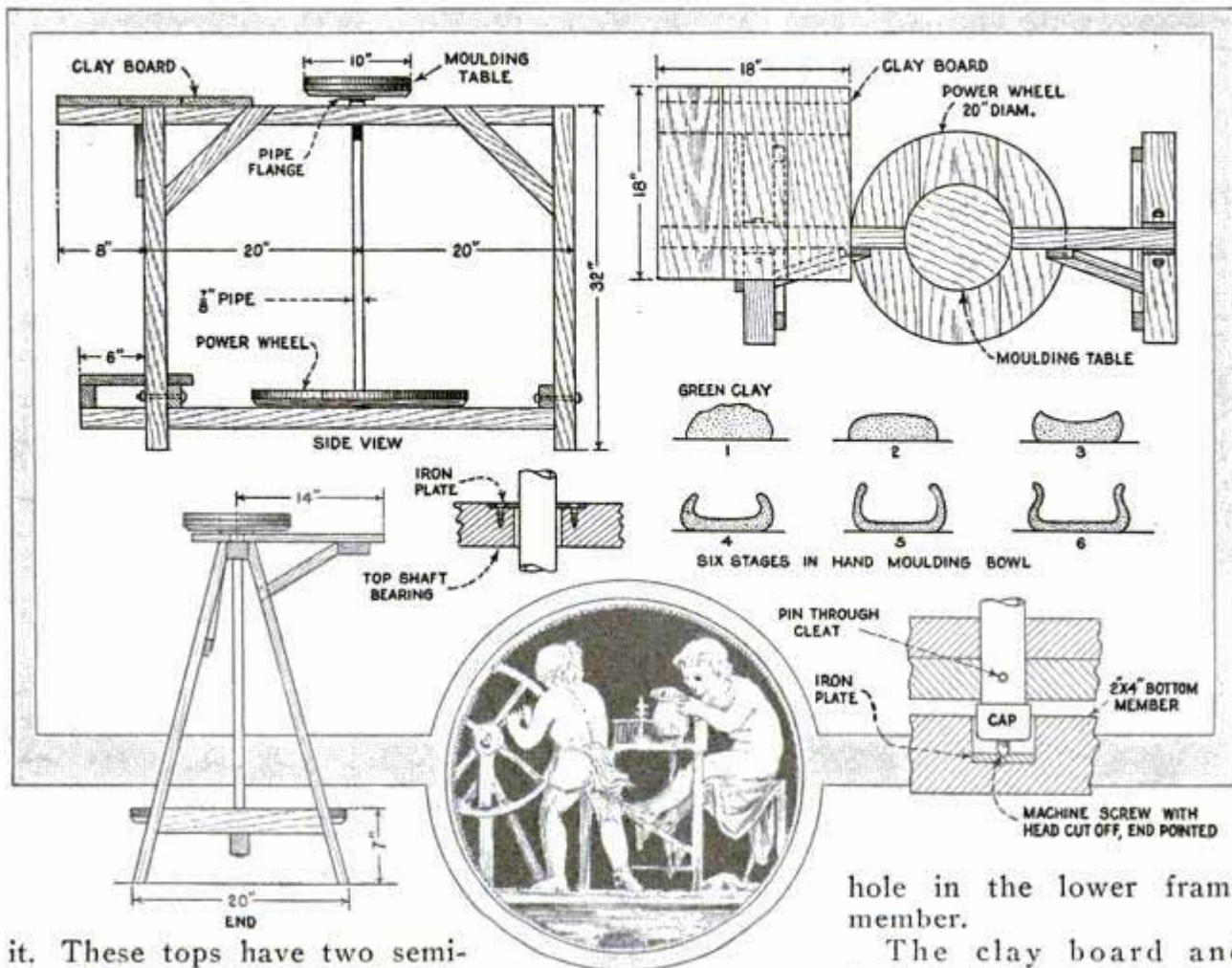

it. These tops have two semi-circular notches cut in the circumference, to fit over dowels in the rotating table.

Use  $1\frac{1}{2}$ -in. boards for the power wheel, as the extra weight serves as a flywheel to keep the device rotating between "kicks." Rubber-soled shoes, of course, give the best traction. Three cleats or battens are nailed under the power wheel, the central one of  $1\frac{1}{2}$ -in. stuff and secured to the shaft with a long pin.

For the upper shaft bearing you can simply bore a hole through the two-by-four, about  $\frac{1}{16}$  in. larger than the diameter of the shaft, to allow for swelling of the wood. A better bearing, however, is an iron plate bored for the shaft and screwed to the top frame member. At the bottom, the capped pipe can simply be set in a hole bored in the lower two-by-four, but friction will be vastly reduced by making an end bearing as shown in the drawing. This consists of a  $\frac{1}{4}$ -in. machine-screw driven into the pipe cap, the head being sawed off and the end pointed. This revolves in a countersink made in a steel plate or disk at the bottom of the

hole in the lower frame member.

The clay board and bucket shelf are nailed to extensions of the main frame. To make a first-class job, join the principal frame members together with carriage bolts.

With this simple equipment and a quantity of ordinary clay from brickyard for pottery, you will enjoy constructive entertainment and should be able to produce some very artistic pieces, such as garden-wall jars, flower bowls and vases.

### This Staple Holder Saves Your Fingers

Held in a metal handle, a slotted piece of heavy rubber has been found handy as a staple holder, preventing frequent injury to the fingers. The slot should be cut to suit the size of staples used, so that they will fit snugly. They are driven until the head comes flush with the rubber, after which the holder can be removed.

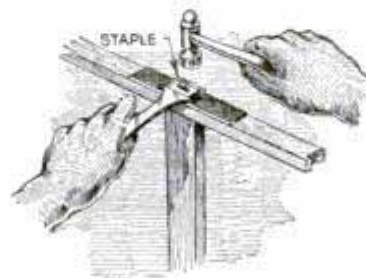



### Copying Newspaper Halftones

Many good photographers fail to get successful results when trying to copy pictures in newspapers or magazines. Success is assured if the directions given below are closely followed. Place a piece of ground glass in a printing frame, ground side up. On this lay a thin piece of clear celluloid and put the picture, face down, upon it. Fasten the back of the frame, and stand it on a table squarely in front of the camera. Illuminate the picture from the front, to avoid reflections, but do not let the light shine into the lens. Use a "process" plate, not the ordinary kind; this is slower in action, hence an exposure of about double the usual time must be made. Focus carefully and do not shake the camera during exposure. The ground glass will eliminate the grain of the halftone and paper entirely. If the halftone screen is a very coarse one, it will be found better to reverse the glass, thus placing the ground side farther away from the face of the picture.

### Crib "Gym" for the Baby

Two small bamboo poles, a trifle longer than the baby crib, lashed on firmly, help to prevent the baby from falling out and also provide plenty of exercise when he



Two Bamboo Poles Lashed to the Crib Prevent Baby from Falling Out

pulls himself up on them. Bamboo is used for this purpose as it does not splinter and can be easily painted if desired. The poles should be attached about 6 in. from the side rails to be most effective in preventing the child from climbing out.—Geo. Pommer, Jr., Minneapolis, Minn.

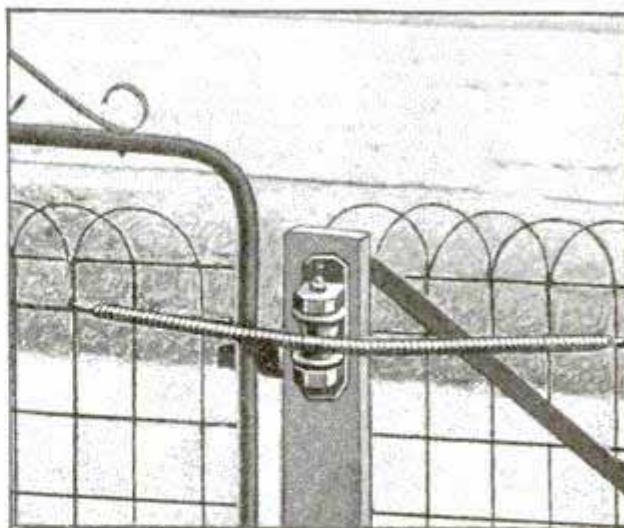

Effective Method of Attaching Coil Spring to Gate to Obtain Necessary Leverage

### Coil Spring Keeps Gate Closed

A variation of the usual method of attaching a coil spring to a door, is illustrated herewith. In this case it was rather difficult to fasten the spring as there was no point to which its dead end could be attached to exert an angular pull. A small hardwood spool was mounted so as to project a short distance from the fence, and the spring was passed over it as indicated. As the gate is opened, the spring stretches but passes smoothly over the revolving spool, losing none of its tension or pull. One end of the spring is attached to the gate and the other to the fence.—Frank W. Bentley, Jr., Missouri Valley, Iowa.

### Make Your Trunk Moth-Proof

All the advantages of a cedar chest can be obtained by lining your old trunk with red-cedar shingles, which makes it moth-proof. This idea will appeal to many who need the protection provided by a cedar chest but cannot afford to purchase one.—Miss Durfe Rockwell, Hollywood, Calif.

### Radio Scarecrow Saves Garden

A Michigan truck gardener and cherry orchardist is keeping destructive birds away by the use of a scarecrow and radio loud-speaker combination, the latter being connected to the radio set in the house. As long as it does the work, the owner says, he does not care whether he gets static or advertising.—M. W. Meier, Kalamazoo, Mich.



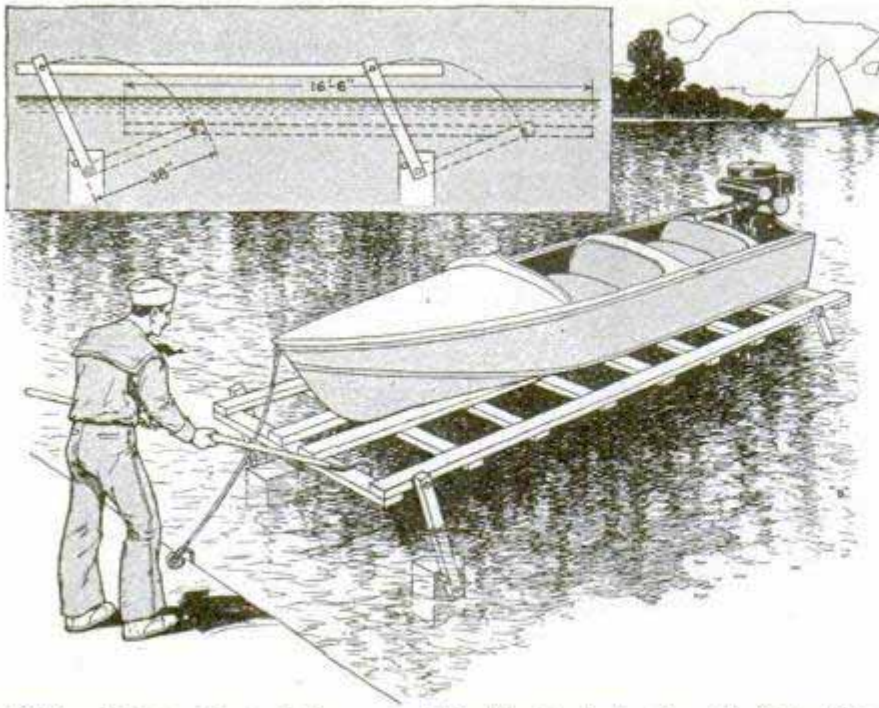

Outboard-Motor Boat, Driven over This Sturdy Rack, Can Be Pulled Out of the Water Easily

### Rack for Outboard-Motor Boat

For anyone who has an outboard-motor boat, this rack will save considerable time and labor. It consists of a cradle for the boat, the keel fitting between two long strips running lengthwise, as shown. Crossbraces, attached to the center and outside pieces, provide the necessary rigidity, flat-head bolts being used to fasten them. The rack is pivoted at four corners on suitable pieces of hardwood, such as oak, or lengths of pipe, flattened at both ends. The lower ends of these pieces are pivoted to heavy pine stakes, driven into the bottom of the lake about 2 ft. The position of the rack, as indicated by the dotted lines in the upper detail, allows the boat to be driven over it, after which the rack is easily pulled out. —Bruce Zimmerman, Valley City, North Dakota.

☞ When using a tumbler for a hot beverage, set it in another tumbler so that it can be held in the bare hand.

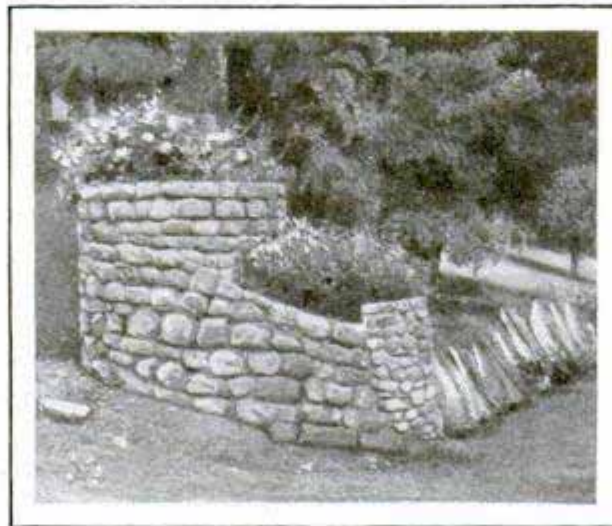

Garden on Top of Rough Stone Wall Makes It Much More Attractive

### Quick-Opening Gasoline-Tank Cap

The locking radiator cap used on model-A Fords can be applied to the gasoline tank without machine work, and makes a very good quick-opening cap which cannot be lost. The cap is screwed on the filler neck and held by the hollow setscrew as on a radiator. The only change to be made is that something must be placed in the hole drilled for the motometer, and an air vent made in it. Any of the ornaments made for use with such caps can be used by drilling a small

hole through the cap under the flange, or making a notch alongside the stem, and then filing a notch to the outer edge of the flange on the underside. A bolt having a flat nickelplated head can be used to retain the flat form of the standard cap if desired. This provides a vent which is shielded from rain. Of the two types of radiator caps furnished, the one on which the whole top turns to open is the better suited for use on the gasoline tank.

### Garden Adds Beauty to Wall

A rough stone wall often will produce an impression of coldness, owing either to the kind or color of the stone used or to the method of laying it. In such cases, a flower garden on top of the wall usually will remove this impression. Earth pockets or troughs can be made on top and planted with one or more of the many varieties of rock-garden plants available. —H. Rossiter Snyder, Guilford, Connecticut.





# SHOP NOTES

## Vacuum Cleaner Removes Machine Chips

By M. CLYDE SMOCK, JR.

MUCH of the pleasure the home worker obtains in working with his motor-driven woodworking machines is marred by the sawdust and chips raised by them. Benches, machines and floor quickly become covered, and cleaning up is a job that must be performed immediately the worker is finished with every job, if the workshop is to be kept at all tidy. The idea of using some sort of vacuum cleaner to remove the sawdust and shavings as fast as they are formed came to the writer some time ago, and the result was the

outfit described in this article. A regular vacuum cleaner would, of course, have served as well, but the household machine could not be spared from its ordinary duties, and, in the town where the writer is located, a secondhand machine could not be obtained at a reasonable price. So, since a  $\frac{1}{8}$ -hp. motor was at hand, a blower was made from it as described. While somewhat crude in appearance, it is entirely satisfactory in performance, and seems as powerful as the regular vacuum cleaner.

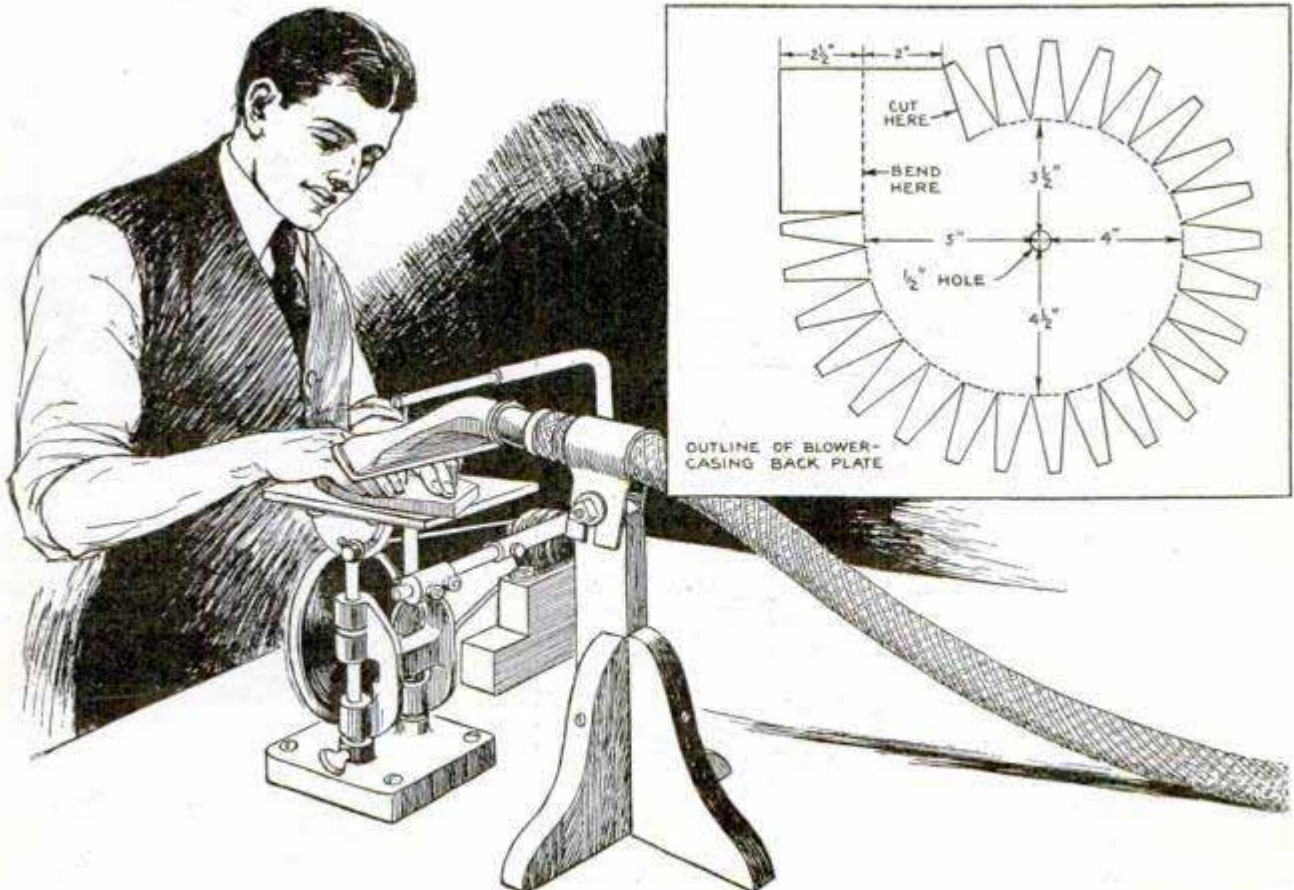



The blower-casing backplate was first cut out from heavy galvanized iron to the size and shape shown in the drawings; then the tabs were bent at right angles to the plate, taking care that the bend was not made too sharp. Next a piece of the same heavy-gauge iron was cut to fit inside the casing and riveted to the backplate with six flat-head tinner's rivets, 1 in. from the outer edge. From the same stock, a strip,  $2\frac{3}{8}$  in. wide, was cut to go around the outside of the casing, over the tabs. With a small C-clamp, the end of the strip was fastened to the end tab on top of

the casing, the edge of the strip being flush with the back of the latter. The casing was then turned, with the tabs down, on a level surface, and solder was run in the groove where the strip and the backplate met. As soon as the solder set, the clamp was moved to the next tab, this was soldered,

and the operations repeated until the entire strip was soldered around the edge of the backplate. In doing this, be sure to wash off the joint with running water after the job is completed to remove all traces of acid.

The casing was then laid, inside up, on the bench top, and a punch mark

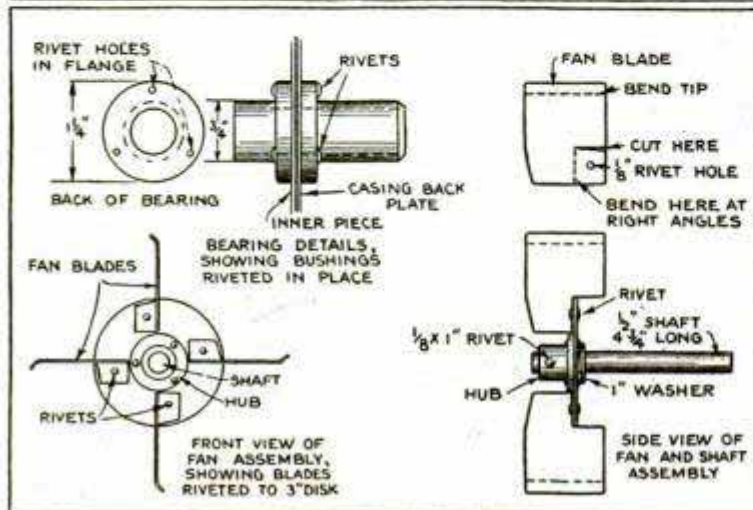
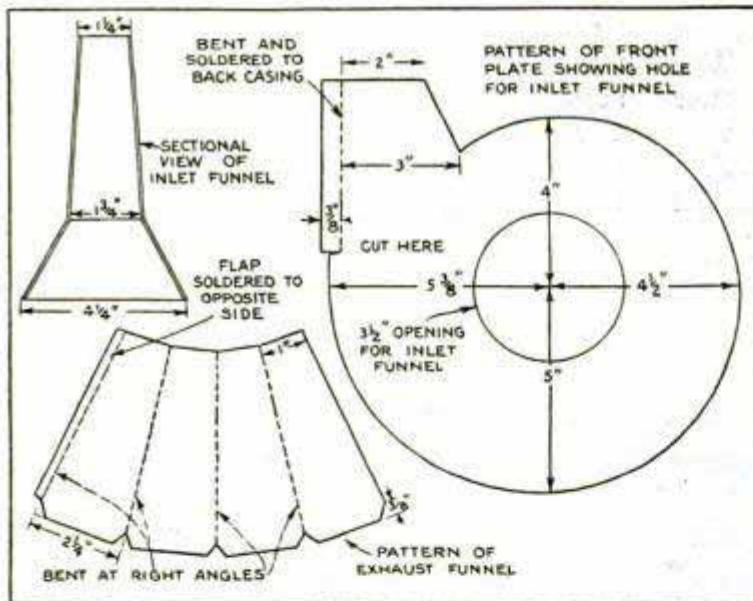
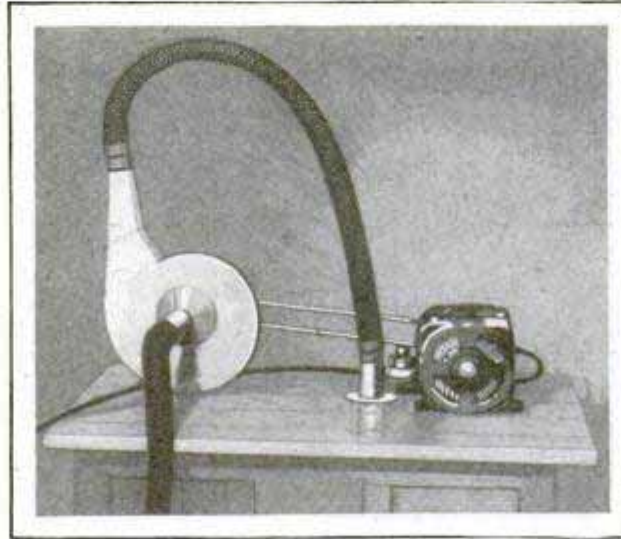

made,  $3\frac{1}{2}$  in. from the top and  $4\frac{1}{4}$  in. from the right; then a  $\frac{1}{2}$ -in. hole was drilled, using a  $\frac{1}{8}$ -in. drill first to insure the  $\frac{1}{2}$ -in. drill running true. The bearings on either side of this hole were made from two model-T Ford steering-spindle body bushings, reamed out to fit the  $\frac{1}{2}$  by  $4\frac{3}{4}$ -in. fan shaft used. Three  $\frac{1}{8}$ -in. holes were drilled in each flange, the holes being drilled while the pair of bearings were held in the vise with the shaft through them, so that they would line up. The bearing holes were lined up on the backplate by first drilling one hole and then fastening the bearings with a  $\frac{1}{8}$  by  $\frac{3}{4}$ -in. stove bolt through this hole, while the others were drilled. One of the bushings is cut to a length of  $\frac{5}{8}$  in., and the end smoothed with a fine file; this is the inside bearing. The bearings are riveted to the backplate with the shaft in place to hold them in line. After riveting, solder was flowed into the joint between outer bushing and plate, to strengthen it. Two 3 by  $\frac{3}{4}$ -in. angle brackets were then bolted to the backplate.



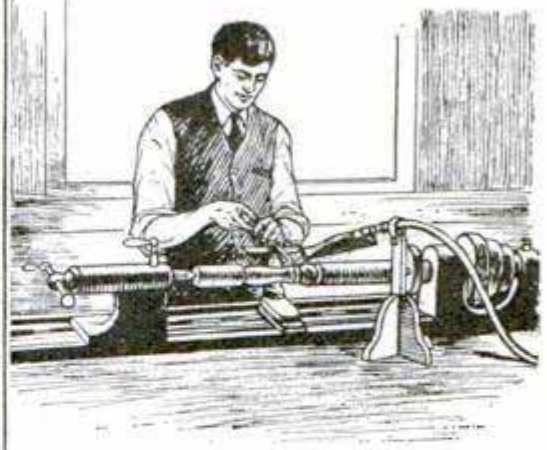
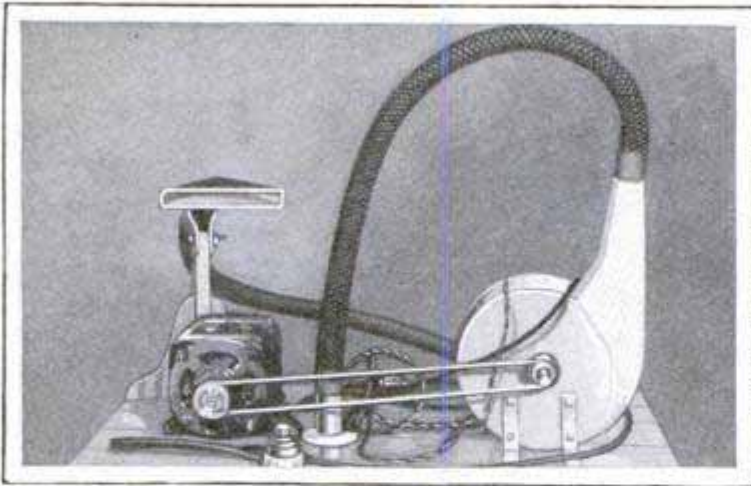

Next, four fan blades were cut to the shape shown, care being taken that they were all of the same size, and riveted to a 3-in. disk of heavy-gauge metal, aligning them opposite each other. They were fastened with a single rivet and then sweat-soldered fast. Another Ford bushing, similar to

the bearings, formed the hub to which the disk carrying the blades was riveted. This was cut to a length of  $\frac{3}{4}$  in. and pinned to the end of the shaft with a  $\frac{1}{8}$  by  $\frac{7}{8}$ -in. stove bolt. The fan assembly was then slipped into place, first putting an iron washer over the shaft, between fan and bearing. It is necessary that the shaft run freely, and that the blades clear the exhaust opening by about  $\frac{3}{16}$  in.

The casing was then turned face down on a piece of heavy sheet iron, and a pencil run around it to mark the front plate. This was then cut out,  $\frac{1}{4}$  in. oversize all around, and a  $3\frac{1}{2}$ -in. hole cut in the center, opposite the end of the shaft. It was clamped over the casing, and a heavy fillet of solder run in the angle formed by the  $\frac{1}{4}$ -in. projection and the side of the casing. A piece was cut to fit across the base of the exhaust outlet, with a flange on each side, and soldered in place, then the exhaust funnel was laid out, cut and bent to shape, and soldered in place, using plenty of solder. A 15-cent tin funnel was cut to fit over the  $3\frac{1}{2}$ -in. inlet opening

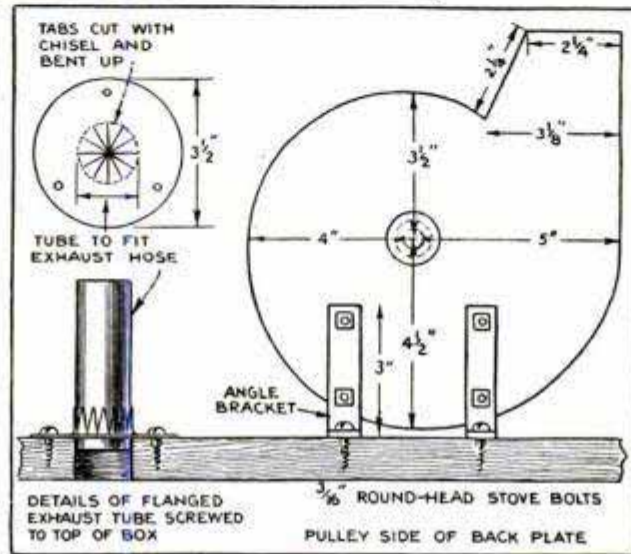

and soldered in place. As the funnel spout was too small to take a regular vacuum-cleaner hose, this was removed, and another, of a size to fit the hose used, substituted for it. The blower was now finished, with the exception of the pulley, which was selected to provide a speed of

about 3,500 r.p.m. with the motor used.

The blower and motor are mounted on an old chest with a loose-fitting lid, into which the blower discharges the sawdust and shavings. It is not necessary to use a large box, however; one 12 by 14 by 18 in. is large enough. A special funnel is made to fit the circular saw, so that most of the sawdust is thrown into it, and is removed as fast as it forms. A stand similar to the one shown in the illustration will make it possible to place the funnel in the most advantageous position near the jigsaw and lathe, or any other machine for which the cleaner is to be used. The funnel can be tilted to suit.

#### "Alemite" Fitting on Grease Cup

By installing an "alemite" fitting on an ordinary grease cup, you will find it an easier matter to fill the cup with a gun. All that is necessary is to drill and tap a hole in the cup cover to take the threaded part of the fitting.—R. M. Shelton, Dallas, Texas.



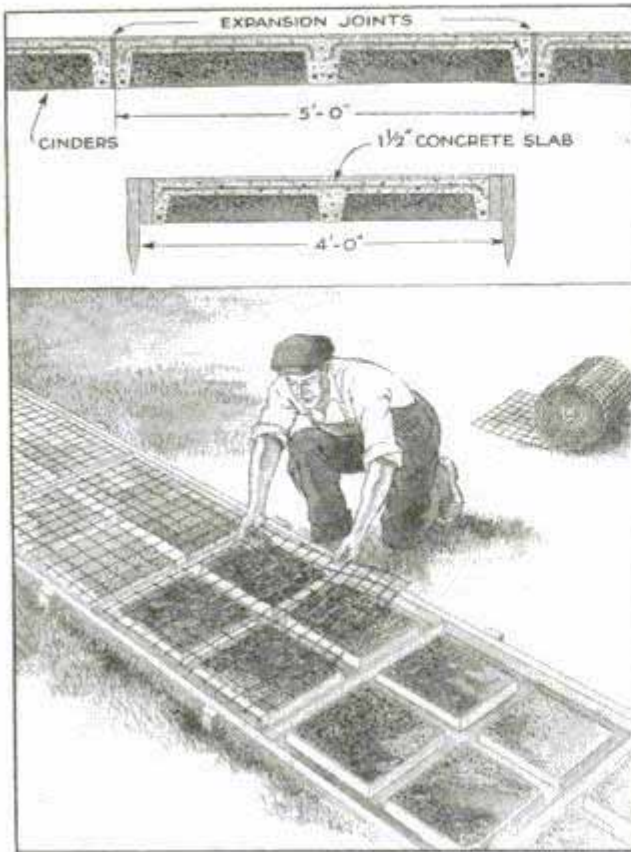

Reinforced Cement Sidewalks Require Less Material and Are Stronger Than Walks of the Usual Kind

### Cement Sidewalks Reinforced with Wire

Ordinarily a cement sidewalk is a solid concrete slab ranging in thickness from 4 to 6 in. Concrete has very little tensile strength, and, if it is not reinforced with wire or rods, requires much more material in order to give it the quality in this respect. On the other hand, the compressive strength of good concrete is enormous, and therefore this reinforced and beamed walk is stronger than the usual kind, which is 6 in. thick. After the excavating has been done and the side forms are set, a form for the beams for one section of walk is placed between the side forms and filled with cinders. The top of this form should be 2 in. below the top of the side forms, thus allowing  $\frac{1}{2}$  in. for topping. When the filling is thoroughly tamped, lift the beam form out and use it for the next

section. Repeat this until the cinders are all in place, then place the wires for the beams as indicated, using No. 6 gauge wire. After that, the woven wire fencing for the slab is cut into sections and placed. Pour the concrete, using a piece of 6-in. lap siding, with the thick edge up, to form the expansion joint. When the concrete is set enough, the siding board is removed, the joint is filled with sawdust, and the topping is put on. The same method can be used for automobile drives, basement and garage floors and other work.—H. H. Siegele, Emporia, Kans.

### Pattern Color Indicates Material

A simple and practical method of informing the foundryman of which materials parts of a pattern are to be made is to have the different materials indicated by the color of the patterns, a chart being provided for reference. With this method, it is possible to avoid mistakes and to prevent the delay necessary to trace the pattern back to the original drawing. A color scheme of this kind, which was found to be of considerable assistance in a foundry, is as follows: Black for cast iron, gray for steel, yellow for brass, red for copper and white for aluminum. The color used on the pattern was as close to the natural color of the metal as possible.

### Draftsmen Use File for Crosshatching

Architectural draftsmen and others who have occasion to crosshatch partitions in penciled building plans, will find the illustrated method quick and useful. Just lay a small flat single-cut file under the section to be crosshatched and hold the paper over it, then use a pencil as in shading.—G. M. Beerbower, Tarrytown, N. Y.

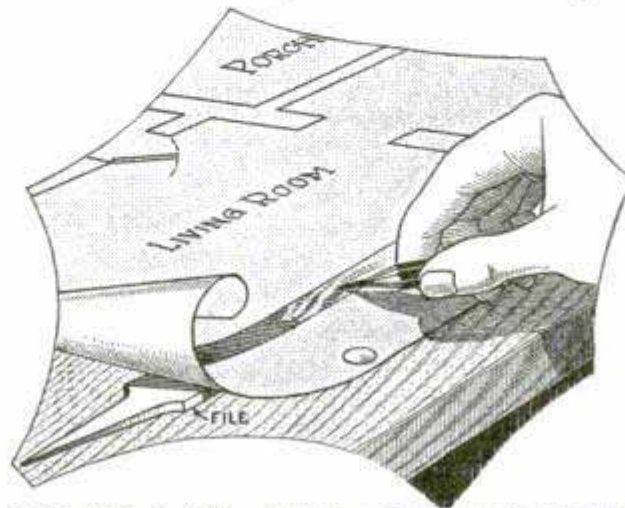

Quick Method of Crosshatching Partitions in Drafting Building Plans

☛ Clean a dirty crack of a casting with a piece of caustic (handled with care) and it can be welded at once.



### Air Supply in Fords at High Speeds

The high speed of the Model-A Ford is partly dependent upon an adequate supply of air in the gas tank at all times. This source of supply is normally received through small openings in the double shell of the cap which screws upon the opening on the bonnet. These, though small, can usually be seen upon examination. Because of the small size of the openings, these frequently become clogged with dirt, and are difficult to clean in an effective way. Air pressure, the most effective cleansing method, is difficult to apply with ordinary apparatus. In consequence, the supply of air decreases, and in rare instances is entirely shut off. The result is that, at high speeds, the gasoline is momentarily drawn into the carburetor faster than air comes into the tank, and the pressure is lowered. The gasoline supply to the carburetor is then cut down or ceases entirely, causing the car to stall. This normally occurs at speeds above 45 miles an hour, though this is dependent upon the condition of the cap. Considerable experiment has provided only one infallible remedy. A hole is bored in the top of the cap, about  $\frac{1}{16}$  in. in diameter, and this is utilized for air supply. The hole should be drilled downward, to prevent roughness around the edge.

### Double Handle for Two-Spindle Drill Press

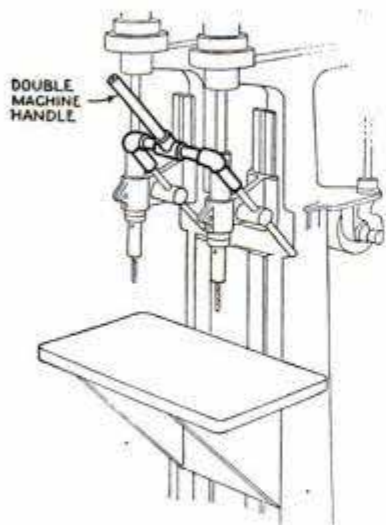

A drill-press handle, suitable for operating both feed levers of a double-spindle drill press, can be made up from pipe and fittings as shown in the drawing. This tool relieves the operator of the necessity of using both hands to feed the drills, leaving one of them free to set the parts under the drill or to hold them, and also to lubricate the drills.

A drill-press handle, suitable for operating both feed levers of a double-spindle drill press, can be made up from pipe and fittings as shown in the drawing. This tool relieves the operator of the necessity of using both hands to feed the drills, leaving one of them free to set the parts under the drill or to hold them, and also to lubricate the drills.

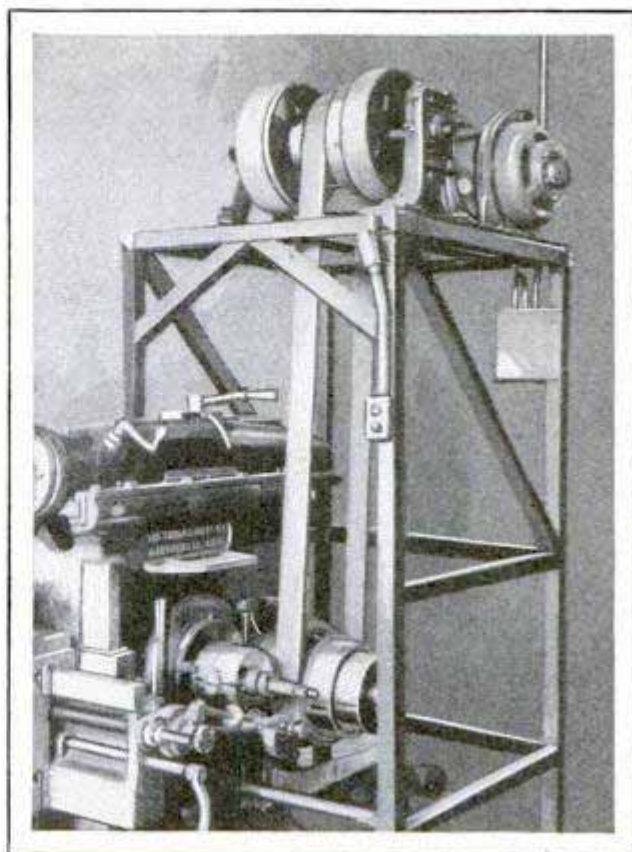

Individual Motors for Machines Supported on Frame Made of Steel Tubing

### Frame for Individual Motor Drive Straddles Machine

As a step in eliminating all the long shafts and belting in a machine shop, a number of individual motor drives were substituted. On some machines a special frame or support was necessary to hold the motor as shown in the photo. Ordinary square steel tubing is used in constructing the frames, all the joints being welded.

### Phonograph Needle Cuts Glass

Fit a phonograph-needle holder in a suitable handle as shown in the illustration and insert a sharp needle. This will be found handy as a glass cutter. When dull, the needle is easily replaced.—Henry B. O'Connell, New Haven, Conn.

☐ A newly tapped hole should be oiled before turning a bolt into it.





# Effective Plating Tricks

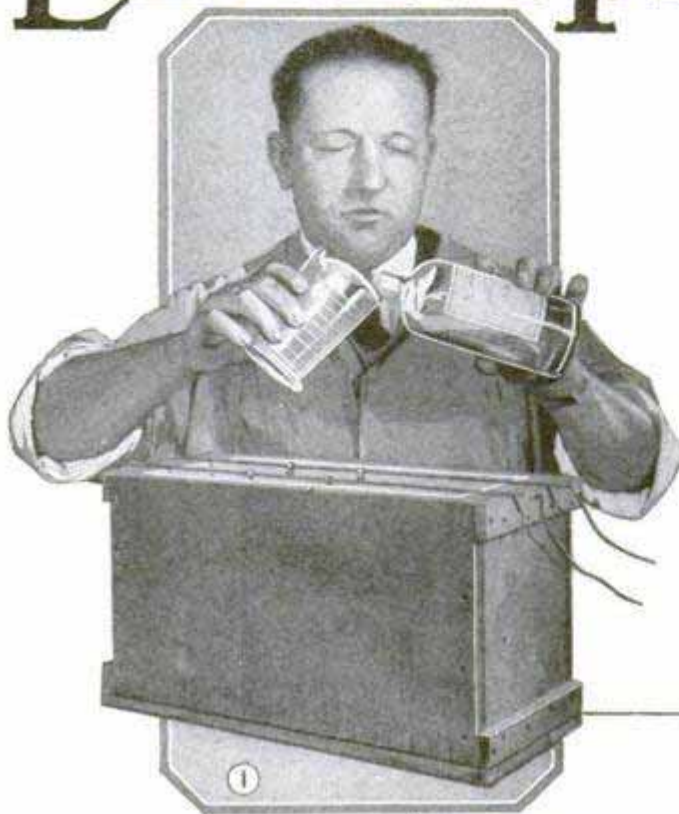

with good quality muslin and then cover the entire inside with a thick coat of hot paraffin wax, to make it water and acid-proof. Lay two copper rods in notches across the top to serve as electrical connectors and supports from which the metal and objects to be plated are suspended.

Wet-cell batteries are used, and as the construction is so well known, it need not be repeated here; cells from old A or automobile batteries can be used if they give the proper voltage, which is about 3 volts and 4 or 5 amp. A radio rheostat makes an excellent current control or regulator. Solder the wire connections between battery and the

**A** WOOD box lined with wax, two or three cells from a wet battery, some metal and a few chemicals, and you are equipped to turn out beautiful pieces of metal-plated work or permanently protect your pet tools against the ravages of rust and corrosion. You can even have the distinction of owning a goldplated steel rule, micrometer, calipers, dividers and other workshop necessities. Although gold is justly considered a rare and expensive metal, the thinness of the plate required reduces the cost to a few cents for each article plated. And then, for less pretentious work, there is silver, nickel and copper. All of them can be plated by a simple electric process or chemically with a camel's-hair brush.

For the electroplating process, make a small wood box, larger than the largest object that is to be plated. An 8 by 12 by 6-in. box is satisfactory for average small work. See Figs. 1 and 2. Line it

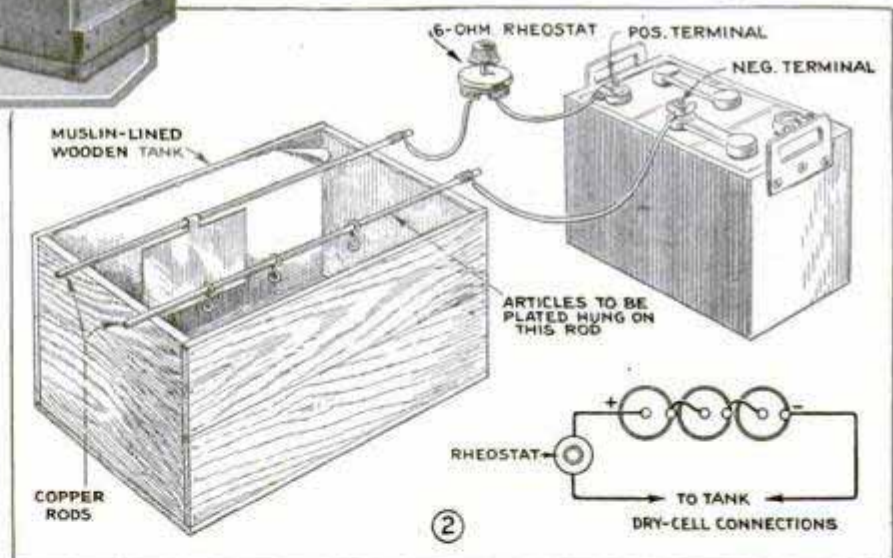

two copper rods atop the plating box. For very small jobs, dry cells may be used, but they are not recommended.

An important thing to remember is that anything to be plated must be chemically clean. And after cleaning, it is important that no fingermarks are made on the work as they invariably show as a fault in the plating, which would have to be done all over again. First see that the article is perfectly smooth; it can be made so by polishing. Then boil it for a few moments in a solution of ordinary washing soda. In the case of steel or iron, dip next in a weak sulphuric-acid solution



# Easy To Do

By K. B. Murray

and rinse in pure water. Steel or iron also requires a thin plating of copper before it is plated with gold, silver or nickel, to make the latter adhere tenaciously. Finally dip the article in a nitrate-of-mercury solution, and it may be placed in one of the following plating baths: Gold solution; dissolve  $\frac{1}{2}$  oz. gold chloride in 2 qt. distilled water and add  $1\frac{1}{2}$  oz. potassium cyanide. Silver solution; in 2 qt. distilled water dissolve 4 oz. potassium cyanide and 3 oz. silver cyanide. Nickel solution; to 100 parts distilled water add 6 parts nickel sulphate and 3 parts ammonia water; when this is dissolved, add 20 more parts ammonia. The bath is to be kept alkaline. Copper solution; to each quart of saturated solution of copper sulphate add  $\frac{1}{4}$  oz. sulphuric acid.

Enough of the solution is poured into the plating box to cover the articles to be plated. Suspend them on the bare-copper wire connected to the negative pole of the battery. The plating metal (anode) is suspended from the other rod by means of another copper wire, which in this

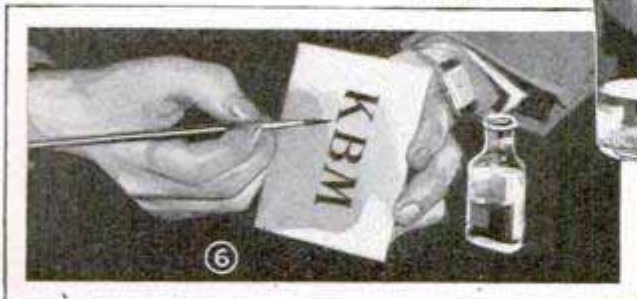
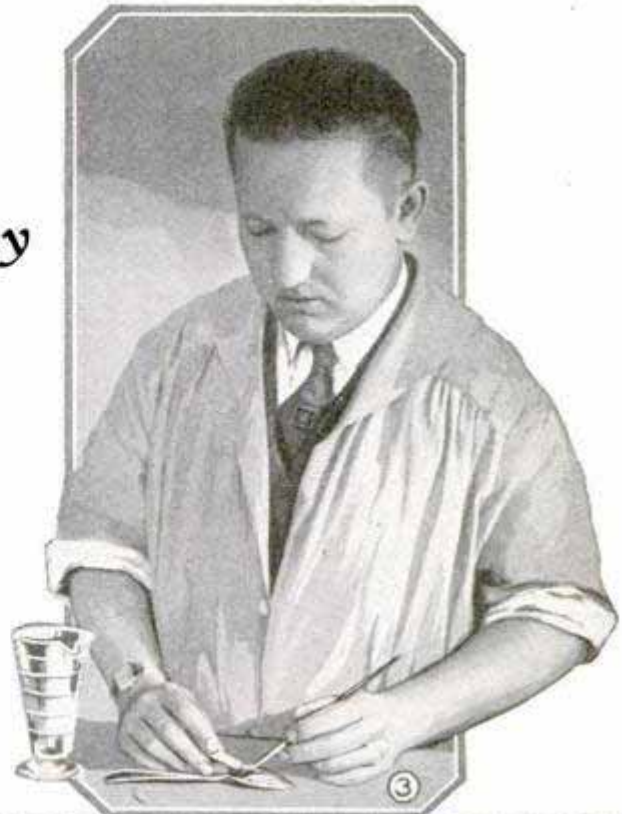

case must not touch the solution, or else as shown in Fig. 2. In copperplating, a sheet of copper is used; with expensive metals, such as gold and silver, a small piece can be easily pounded out into a very thin flat plate, which will present greater surface to the solution.

Nickel is used in the same manner as

copper, but as the pure metal is sometimes difficult to secure, a plain piece of platinum wire may be used as an anode. As no nickel

will be passed into solution to take the place of that used in plating, more nickel sulphate must be added as required. This obviates the necessity of investing in a large anode of the metal, which is many times more than required for occasional work.

The time required for plating is determined by the strength of the battery, space between the electrodes and temperature of the solution. If the plating appears granular, more current must be used; a higher amperage rather than higher voltage. If it appears dark and burnt, the current is too strong. The shorter the distance between electrodes in the plating solution, the less time is re-



quired. It is obvious, however, that the articles nearest the plating metal will receive the heaviest deposit, so they must frequently be moved about. The connecting wire must also be moved occasionally to avoid markings. When to remove the articles from the solution is determined by inspection. They should be rinsed and dried and then polished. Gold and silver-plating can be easily given a high polish with a soft chamois free of grit. A buffing applied to nickel will bring out its full brilliance.

In handling and making solutions containing the cyanides, the utmost care must be used as they are deadly poisons. Mark the cyanide bottles plainly and keep in a secure place.

Through constant usage silverware commonly wears at a particular place, exposing the base metal underneath. The spots can be easily and cheaply touched up in the following manner: Make a saturated solution of silver nitrate in distilled water, then add to this, one drop at a time, some ammonia water. The solution is ready for use when the brown color just disappears. Apply this solution to the worn spot with a camel's-hair brush, as in Fig. 3, at the same time touching the spot with a scrap of bright zinc. This should be repeated five or six times, when the spot will look dark and tarnished. It is now dried and gone over with a soft cloth, then polished with a cloth and whiting, when the new silver will be revealed in a beautiful satin finish.

Tools with flat surfaces can be coated with silver or gold by a heat process. Heat the metal to a blue color and apply evenly a piece of gold or silver foil or leaf. This is then burnished by rubbing

with a smooth surface, such as glass or a polished stone, as in Fig. 4. The plating is extremely thin, but in ordinary

use will last for years. It is not, of course, suitable for specially tempered articles.

A simple gilding solution can be made with gold chloride, dissolved in as little distilled water as possible and added to an equal quantity of ether. Painted on chemically clean steel or iron, it deposits a film of gold, and several treatments will give a wearable plating that is useful for watchcases, rings and other jewelry.

Often it is desired to gild plastic casts, polished wood, cloth or paper.

With the following solutions either gold or silver can be used. Make up the solutions with gold chloride or silver nitrate in distilled water and paint the objects to be gilded or silvered. Then place them inside an upturned glass jar (Fig. 5) into which hydrogen gas is injected. The hydrogen will throw the silver or gold out of solution and deposit it on the objects. Hydrogen gas is made with a weak sulphuric acid solution in which has been placed filings or clippings of zinc. The gas is given off in small bubbles and quickly rises to the top of the container. It should be made away from open flames. In Fig. 5 the gas passes from the lower glass into the upper through holes in the cardboard.

One of the handiest uses to which electroplating can be put in the home workshop is in the making of unusual metal nameplates, as in Fig. 6. They can be made on squares of copper, steel or brass, or directly on tools themselves, where they are decidedly unique. The ground should be of a metal contrasting in color





with the lettering. Therefore, as an example, paint in the lettering with copal varnish and, with the electric or chemical-plating method, cover the plate with a film of gold. Remove the varnish with alcohol, dry with a soft chamois and paint the ground (excepting the lettering) with



varnish. Place it in a silverplating solution until the lettering is coated with silver. Remove the varnish as before, and you have a beautiful nameplate lettered in brilliant silver on a gold ground. It may be dipped in thin lacquer, as a protection against scratches.

Copper lends itself very well to chemical color treatment, and with the following simple process, up to a dozen different colors and shades can be secured. Make up the following solution: lead acetate, 300 gr.; sodium hyposulphite (hypo) 600 gr.; water, 1 qt. Heat the solution and immerse the object to be colored. Watch the latter closely; as the solution becomes hotter, it will pass through a number of colors and shades, one after the other. When the copper is of the color desired, remove it at once from the solution, rinse and dry carefully. The chemical color forms a tough coat on the surface of the metal.

With silver electroplating you can have tumblers, wine glasses, pitchers, etc., of a beauty and exclusiveness seldom seen. Ordinary glassware is used, but when you

have finished, it has a thick outer plating or shell of pure silver, with a plain glass interior or gold-lined interior as you wish. The cost is not prohibitive.

The glass must first be "silvered" or "gilded," according to whether you desire a gold or a silver covering. As the two processes are alike, the silvering will be described. For gold, gold chloride is substituted for silver nitrate. First wash the glass with dilute nitric acid and rinse with distilled water. After this the glass must be handled with care, with the fingers inside, to prevent fingermarks on the surface. Make a saturated solution of silver nitrate and add, a drop at a time, some liquid ammonia. Stop when the precipitate at first formed is dissolved again. Turn the glass upside down, Fig. 7, and cover the bottom with the silver solution. Add one drop of formaldehyde, and stir with a toothpick. The solution will become dark, and a film of silver will be deposited on the glass. Do not touch it, but pour off the solution, and if the coating of silver does not cover the entire bottom, repeat the process.



Designed and used by  
 Consolidated Gas Electric Light  
 POPULAR MECHANICS  
 and Power Co. Baltimore, Md

To silver the sides the same method is used except that only a small portion is silvered at a time. To do this, a rubber wall must be formed about the space and silver solution poured into it. Small tumblers can be entirely silvered in one operation, as shown in Fig. 8. A waxed-paper tube is placed about the upturned glass, and several spoonfuls of the solution will cover it.

When the outside is entirely silvered, without scratches or pinholes, it is ready to be electroplated. Fasten adhesive tape to the inside, Fig. 9, so that the tumbler can be suspended from the copper rod in the solution. The connecting wire makes contact with the silvered surface at the mouth of the tumbler by means of a piece of tinfoil clamped over the edge. In a short time, move the tumbler about so that all sides will be plated evenly, and frequently move the connecting wire and tinfoil to a different place on the rim so that there will be no markings. When the glass is heavily silverplated—at least the thickness of several sheets of paper—dry and polish it with soft chamois skin.

**Device for Indicating Live Power Lines**

An interesting live-wire indicator stick, which is shown in the drawing and photo, has been put in use by an eastern electric light and power plant. When working on cables it has been the practice of this organization to place grounds on all three conductors at both ends of 13,200-volt lines. But if the workmen are not sure that the cables are dead, there is considerable danger involved. With the use of the indicator, however, this trouble is eliminated. It consists of a piece of micarta tubing inclosing a copper tube,

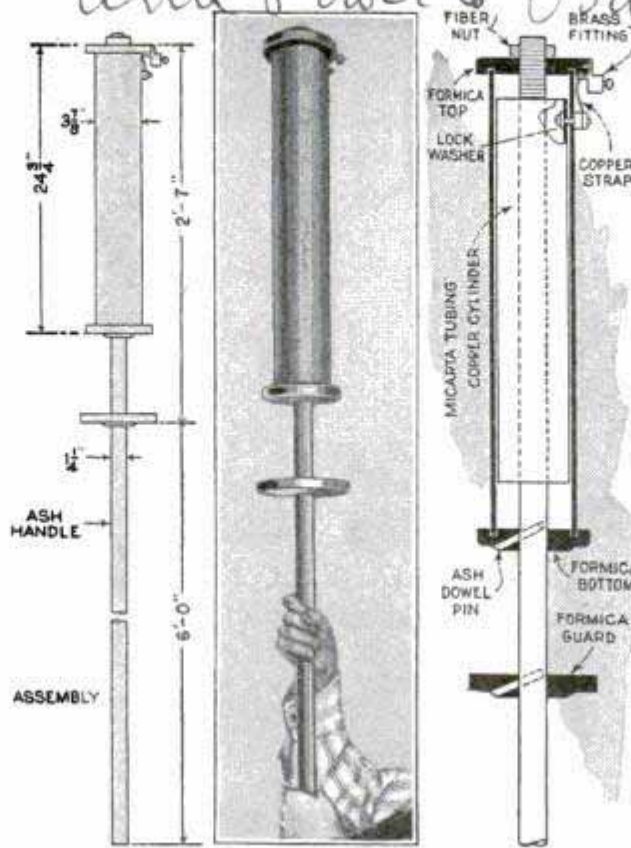

This Indicator Stick Protects Linemen from Dangers Involved in Working on High-Tension Lines

connected to a binding post and a brass contact on the formica cap of the tube. Weighing only 7 lb., the stick is easily carried about where needed. When the metal contact touches the conductor carrying 13,200 volts, and is then drawn away, there will be a spark approximately 1/2 in. in length. The noise of the spark is exceptionally clear and serves as an indication of the presence of current even though the spark may not be seen. It is claimed that a reliable indication is given on a

three-phase circuit with a potential as low as 4,000 volts, even when the frequency is as low as 25 cycles.

**Improved Pipe Vise Made from Cable Clamp**

For pipe of small diameter, an improvised vise can be made from a cable clamp as shown in the illustration. A number of file or hacksaw cuts are made on the inside of the clamp to give it the required gripping edge,

and the threaded ends are then pushed through holes drilled in the bench top, after which nuts are run on. Of course, it is necessary to provide a similarly drilled metal plate to face the bench top drilled to correspond with those in the bench top. When securely tightened, this vise will hold the pipe as well as a regular vise.—Raymond B. Wailes, Bethesda, Md.

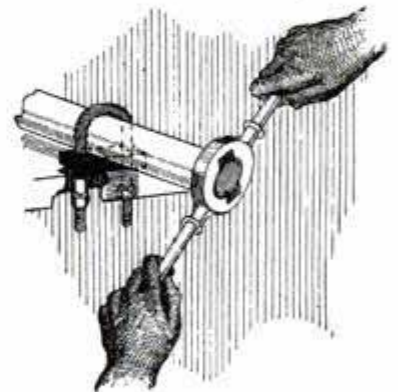



## SMALL CAMERA EASY TO CONVERT FOR AERIAL USE

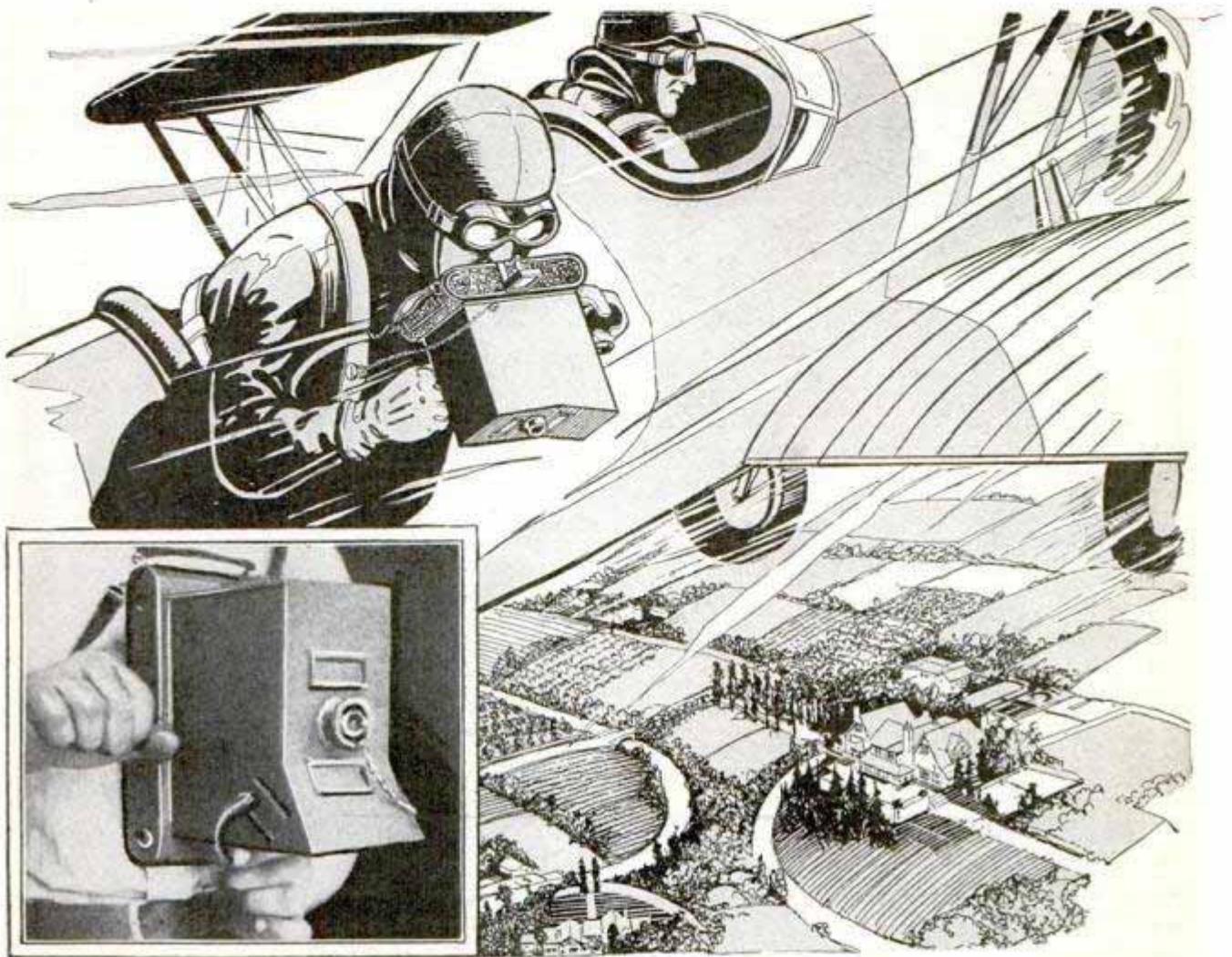

If Used on Clear Days Only, This Cheap and Simple Aerial Camera, Made from an Ordinary Postcard-Size Camera, Will Be Found Perfectly Satisfactory; Inset Shows How the Camera Is Held for Vertical Pictures

By R. F. STARZL

**N**OW that nearly every little city has an airport of some kind, and every small town its airplane owner, a new source of revenue is opened to the photographer, whether amateur or professional, who is alert enough to cash in on the new public "airmindedness."

In many parts of the country, flying photographers have made handsome profits by arranging to make aerial photographs of prosperous farms, country estates, or the small cities and towns themselves. The field of commercial aerial photography has hardly been scratched, however, as far as the ordinary photographer is concerned, because of the cost of regular aerial cameras. Ordinary cameras cannot be used because the powerful blast of air along the ship causes the bellows to flutter, and looking into the

ordinary top view finder is out of the question except for the most daring.

The illustrations show how an ordinary postcard-size camera was converted into a satisfactory aerial camera for such work as outlined above, and similar methods can be used for cameras of other sizes and types. First the camera was focused at 100 ft. or "infinity." Then a box was made of sheet metal to fit over the camera with the bellows extended to this focus. Handles were attached to one side and to the bottom, as shown, the handles, like the box itself, being fastened to the camera with small screws and rivets.

Simple slides were fitted over openings cut for the shutter-timing and lens-opening adjustments. These are not essential, but they prevent a certain amount of air from reaching the inside of the case while



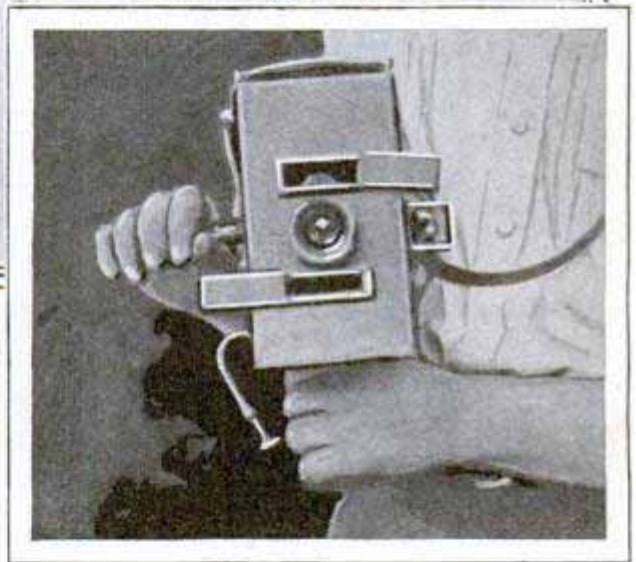
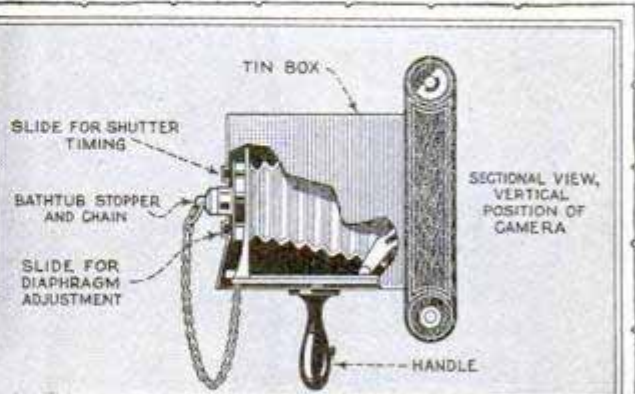
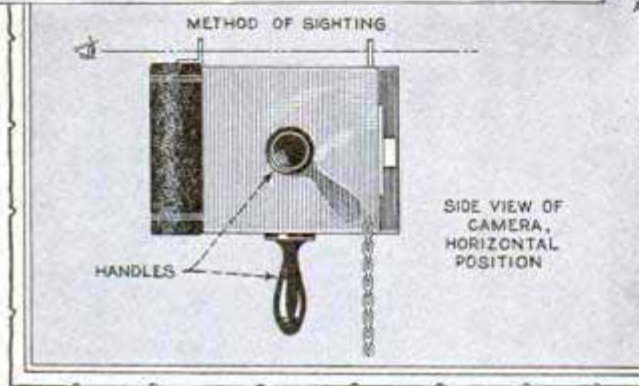
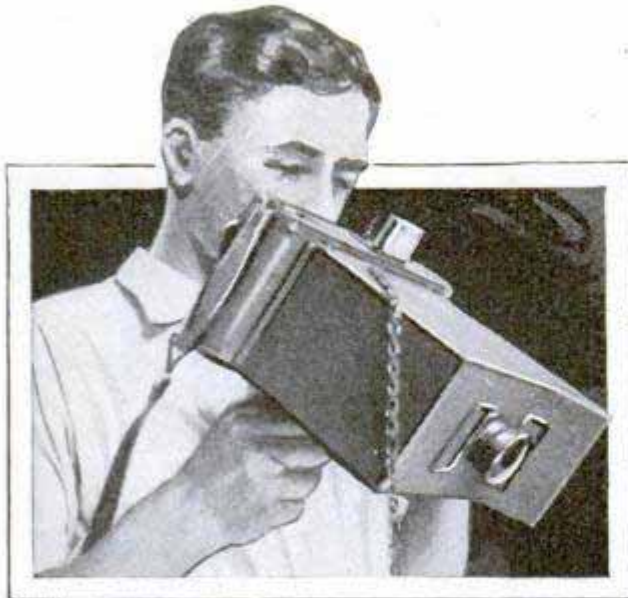

"shooting" a picture. As a finishing touch a bathtub stopper on a chain was fitted as a lens hood.

For all practical purposes, an f.8 lens can be left wide open, and the shutter timed at one-twenty-fifth second. Sighting is done by means of a bead sight and a clear-glass screen with cross lines scratched on it, mounted at the rear. Both bead sight and glass finder should be on hinged mountings, as on a Graphic camera, so that they can be folded flat to the case. The sights are on the side of the camera, but can be used for vertical pictures as well.

Provided this outfit is used on clear days only, pictures taken with it are perfectly satisfactory, and its low cost puts it within reach of anyone who may hanker to snap pictures out of an airplane cockpit.

### Tinning Black Iron

For tinning black-iron and steel objects, in order to prevent them from rusting, the following method has been found very satisfactory, leaving a thick deposit: The

scale on the surface is first removed by immersing the object in raw muriatic acid until the metal turns white. It is then put into cut muriatic acid, which is made by adding clippings of sheet zinc to raw muriatic acid, until it will dissolve no more. The cut acid leaves a zinc film deposited

on the surface of the work, so that the molten tin will adhere better. After shaking off the surplus acid, the object is dipped into the molten tin, solder or lead, as desired. If the coating is not satisfactory, dip the object into the cut acid and molten metal again.

### Old Tires Aid Road Grader

Finding that the flat steel-band tires of a road grader tossed dust in his eyes, the operator took some old auto casings, trimmed off the beads and cut them across so that they could be snugly fitted to the wheels. The cut ends were spliced together with wire. As the wheels were larger than ordinary auto wheels, it was necessary to use more than one tire to each wheel.—Dale R. Van Horn, Walton, Nebraska.



### Tools for Removing Broken Transmission Keys

With the tools shown in the drawing, it is an easy matter to remove broken transmission keys, according to an expert in a large lock factory, who takes care of auto-lock repairs. Each tool consists of a thin piece of steel, set in a suitable handle, the end of one being cut off at a bevel and the other ground to form a hook. The former is used to pry the key up as indicated by the dotted lines in the right-hand detail, which is done after the key is in the correct position to permit its removal. It will be found handy to have a couple of tools of the bevel-end type, so that one can be used to hold the key while the other is inserted for a new bite. With some types of locks, there is enough space for the hook-end tool to be slipped under the first notch of the key, after which the key is merely pulled out. Before using the tools, one should be sure that the lock is against the stop on either side. It has been found that over 90 per cent of auto-lock trouble is caused by oil gumming or by paint and varnish being inadvertently dropped on the lock. Never apply oil to the lock, but lubricate it with powdered graphite or with a mixture of graphite and tire talc in equal parts. Gasoline poured into the lock will help to clean out

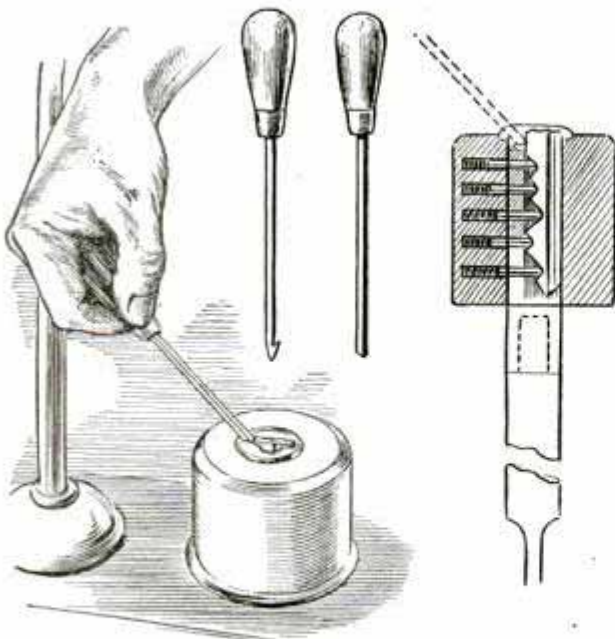

Broken Keys in Auto Locks Can Be Removed with the Aid of These Tools

gummed oil.—E. M. Spooner, Hartford, Connecticut.

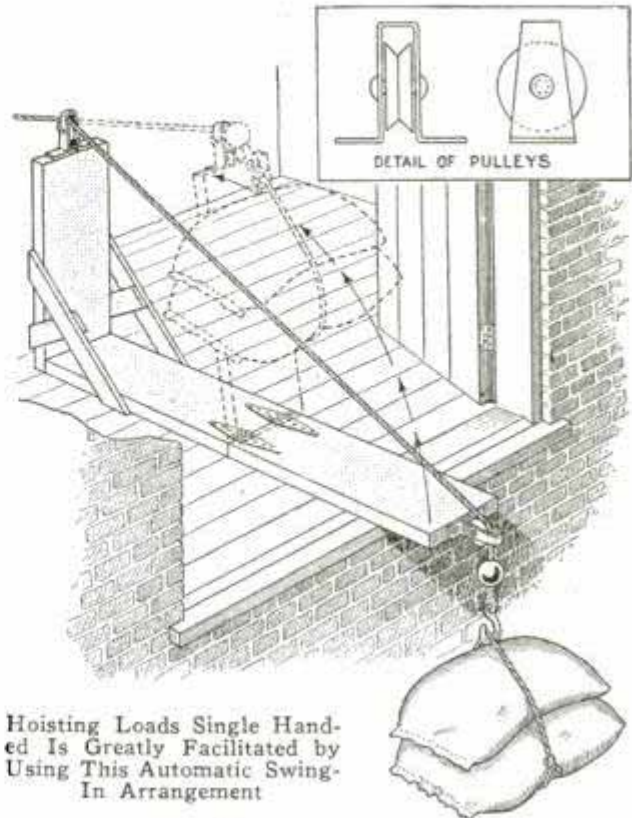

Hoisting Loads Single Handed Is Greatly Facilitated by Using This Automatic Swing-In Arrangement

### Automatic "Swing-In" for the Hand Hoist Convenient for Single Worker

Often the only available method of raising bags of material to an upper floor is by means of a pulley and rope. The objection to this method is that the bags must be swung in and landed on the floor before taking them off the hook. When a man must hoist the bags and unload them alone, the automatic swing-in shown will be found convenient. A 12-in. plank is fastened to the unloading platform and another length is hinged to it as indicated. An upright piece is fastened on at right angles, being securely braced to the stationary plank, and two inclosed pulleys are mounted, one on top of the upright and the other on the end of the hinged plank. The rope is passed over the pulleys and a ball weight is used just above the hook. The operator pulls on the rope in the usual way to raise the bag but, when the ball weight strikes the pulley on the hinged plank, the plank is also raised and swung over to the position indicated by the dotted lines, depositing the load safely on the floor without the least trouble.

—Harry Moore, Montreal, Can.

☛ A little kerosene, poured into a box before running in the babbitt, will prevent the explosion that sometimes occurs.



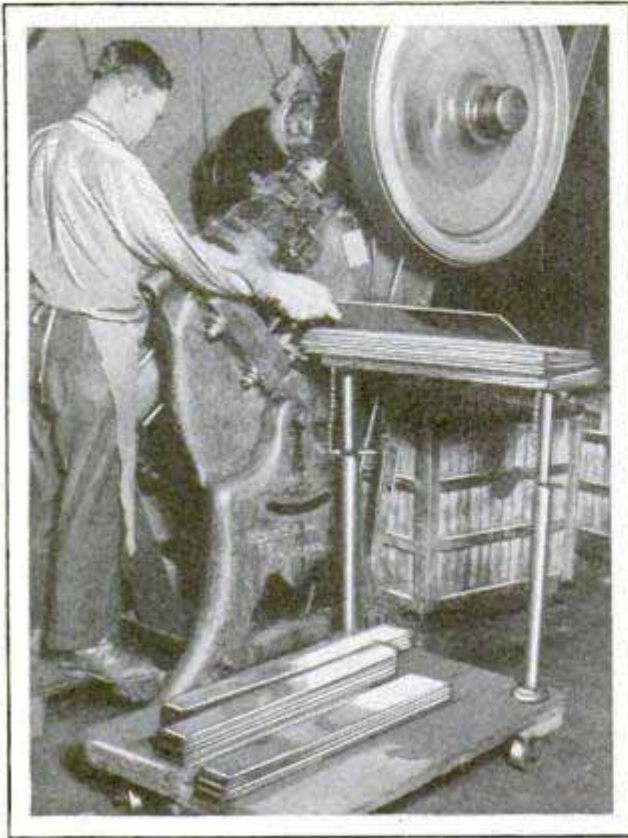

Work of Punch-Press Operator Made Easier by This Adjustable Table Attached to Truck

### Adjustable Table for the Punch Press

A truck having an adjustable table helps to promote efficiency and reduce fatigue of punch-press operators. The table, which is made of wood, is attached to two pipes arranged to slide within two other pipes fastened to the truck by means of floor flanges. A series of holes in both sets of pipes enables the operator to adjust the table to the desired height. The stock to be punched is placed on the table, and when one batch has been used, the operator simply picks up another batch from the truck and places it on the table.—A. Mathieu, Chicago, Ill.

### A Tip for Draftsmen

When the surface of a drawing board becomes badly scarred from thumbtack holes, the surface can be restored by covering the board with "battleship" linoleum. This is very thick linoleum, that comes usually in plain colors, gray, brown or green, and offers a very good drawing surface. Furthermore, it can be washed with soap and water without injury or "raising the grain." In addition, when a thumbtack is withdrawn, the hole closes

tightly and leaves no mark. It is best to fasten the linoleum to the board with hot glue, but small-headed tacks at the corners also will hold it securely.

### Micrometer Collar Enables Correct Setting of Dividers

To insure accuracy on many classes of work, dividers should be set to decimal readings, but, in the absence of any proper tool for this purpose, most mechanics resort to a scale, and set the divider points as nearly as possible to the correct measurement. It is easy to obtain an accurate reading, however, which involves no guesswork, by using the graduations on a micrometer and by adapting a collar, as shown in the photo and drawing. Upon examining a micrometer, it will be found that the edge of the thimble is about  $\frac{1}{64}$  in. larger than the sleeve. A collar is made to be slipped on the sleeve, of such thickness that the outside surface will come flush with that of the thimble, and it should be slightly less in width than the distance from the frame to the zero mark on the sleeve so that it can be slipped out of the way when not needed, as shown by the dotted lines. To assemble the collar, screw out the thimble entirely and slip the collar on the sleeve.

Then, supposing that the dividers are to be set .865 in. apart, turn the thimble to this reading, slide the collar up to touch it and set one leg of the dividers at the zero mark and the other in the line formed by the edges of the collar and thimble. The collar provides a non-slip mark for the dividers.—Harry Moore, Hamilton, Can.

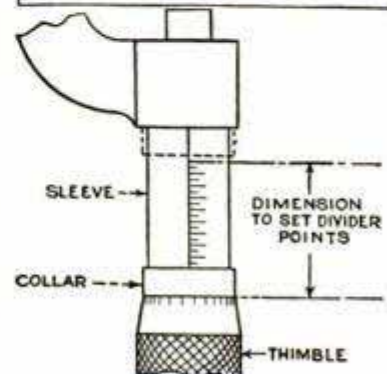
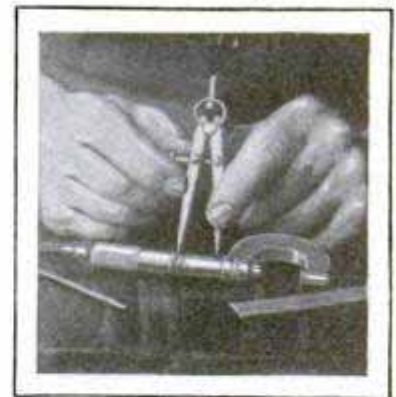



### Tamping Explosives

Metal tools of any kind should never be used for tamping explosives in bore holes, or to press the charge into place, even in soft ground, as there is always the danger of striking a pebble, which might produce a spark sufficient to ignite the charge. For loading and tamping, use a wooden stick; for shallow work, an old broom handle is ideal; for deep holes, a straight sapling can be used to advantage. For tamping horizontal holes, where a heavy stick of oak or hickory would be difficult to manipulate, one of light wood, such as pine or bamboo, is desirable. Bamboo fishing poles make ideal tamping sticks under these conditions. It is positively dangerous for a powerful man to ram a charge of high explosives into a bore hole with a heavy stick, even if it is made of wood. In deep holes, a very long, cumbersome tamping stick would be necessary, so a block is used in holes that are vertical, or nearly so. This consists of a round piece of wood, from 3 to 6 ft. long and a little smaller in diameter than the hole. A rope is attached to the center of one end, by boring a hole diagonally from the center out through the side, countersinking the hole on the side, then threading the rope through the hole from the end, knotting it and pulling it back, so that the knot is drawn into the countersink and does not interfere with the sliding of the block in the hole. The block should be made of hardwood, to resist wear no metal parts should be used, and it should not be too heavy. It is operated by raising it 1 or 2 ft. and allowing it to drop on the stemming. The block is pulled out when fresh stemming is dropped in.

Ⓞ When cutting irregular shapes of labels, etc., place the paper on strawboard or bookbinders' board, and by moving the board carefully no back gauge will be required.

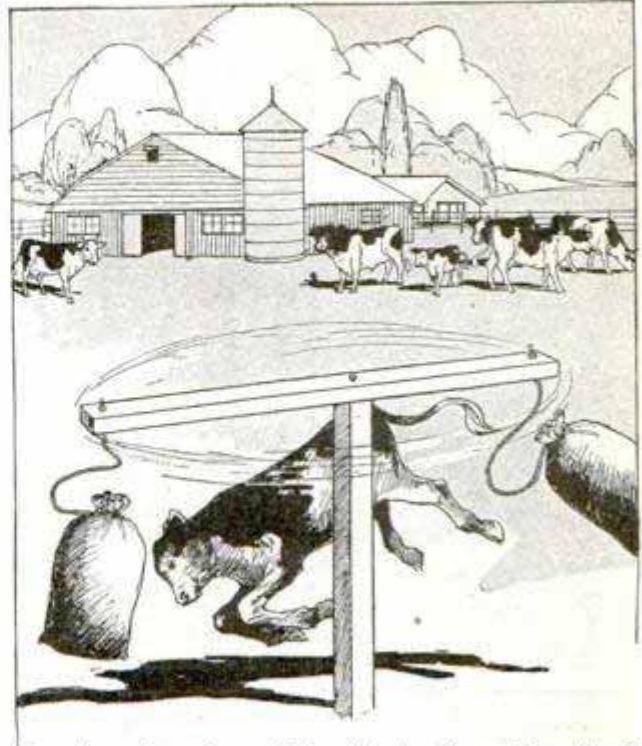

Exerciser for Penned-Up Stock Resembles Small Merry-Go-Round

### "Merry-Go-Round" Exercises Stock

For exercising penned-up stock, a western farmer built the "merry-go-round" shown in the drawing. It consists of a 10-ft. length of straight-grained 2 by 4-in. stock, set on a pivot on a suitable post; on each end a canvas sack, filled with sawdust, was suspended. The animals push the sacks without danger of injury. Young colts and calves have been observed spending several hours at play in this way.—F. W. Fickle, Seattle, Wash.

### Pit Substituted for Loading Platform

When it was found impossible to build a loading platform at a small factory, a pit was substituted. It was built of concrete and has large wooden bumpers. Trucks back into the pit, which is located next to the receiving room, and the load is removed from the back. The truck floor comes about level with the ground, making it easy to transfer the heavy material.

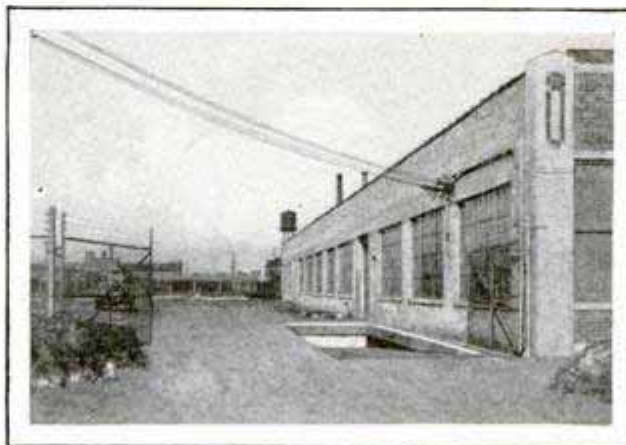

Inclined Pit Has Proved a Good Substitute for Loading Platform



### Storage Bins from Empty Cans

Empty powder cans or similar containers make convenient bins for storage purposes. Half of the head of each can

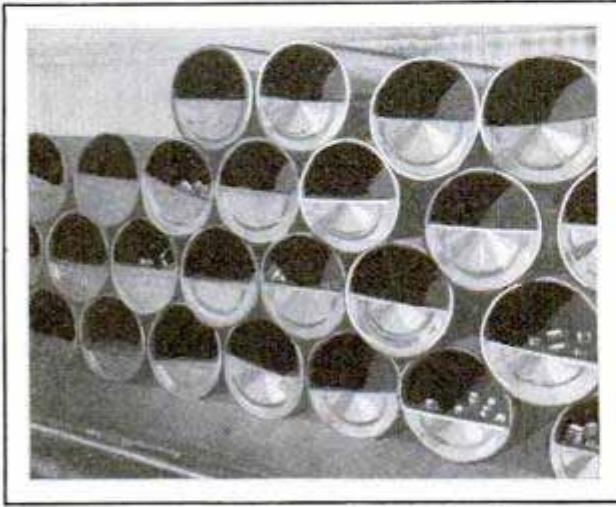

Stack of Metal Cans with Covers Partly Removed, Provides Storage Space for Parts

is cut away at one end and the cans are then stacked as shown in the photo. In this way as many bins as required can be provided quickly and removed when no longer needed. By keeping the cans painted, they look neat, and, if desired, labels may be used to designate the kind of material stored in each.

### Aircraft Streamlining

Proper streamlining is an important factor in the construction of all types of aircraft, and modern builders spare no expense in streamlining their products as perfectly as possible in order to obtain better performance. Stock airplanes to be flown in a race are sometimes "souped up" by covering all fittings and small projections with putty so as to present as little resisting surface as possible to the air stream. This system obviously has its limitations, because putty will not adhere to a large surface and, if used too generously, will add materially to the weight of the airplane. For the amateur racer or airplane builder who does not possess the money or equipment required to fit his ship with the latest in sheet-metal streamlining, an excellent material for this purpose may be prepared as follows: Mix sawdust and ordinary wing-fabric dope in the proper quantities to give the resulting mass the consistency

of putty. (Fabric dope may be procured in unlimited quantities at any airport.) Apply the material, by hand, to the part to be streamlined and mold as nearly as possible into the desired shape. The material dries very quickly and will be quite hard in a couple of hours. It may then be dressed down as desired with a wood file. If a really factorylike job is wanted, the part may be further dressed by adding several coats of dope mixed with very fine wood powder, such as may be procured from wood-grinding wheels in any woodworking shop. Pigment may be added if color is desired. Besides being easily molded to any shape desired, this material is light in weight, has a smooth hard surface and adheres tenaciously to any part to which it is applied. —Lieut. W. R. Wolfenbarger, Langley Field, Virginia.

### Handy Stand for Repair Shops

For welding and other repairs on auto engines, a western repair shop finds the movable stand shown in the photo of considerable utility. It consists of a 3-ft. welded triangular frame of 3-in. angle iron, with spacing crossbars of pipe welded in at the bottom. Each section of pipe is 2 ft. long, and those at one side of the stand slip into those at the other side and fasten with setscrews in a welded projection at the end of the outer section. This arrangement allows the stand to be adjusted to any necessary width. At the top, a 6-in. circular plate of steel,  $\frac{3}{4}$  in. thick, is welded in at each side of the frame. A similar plate is welded to

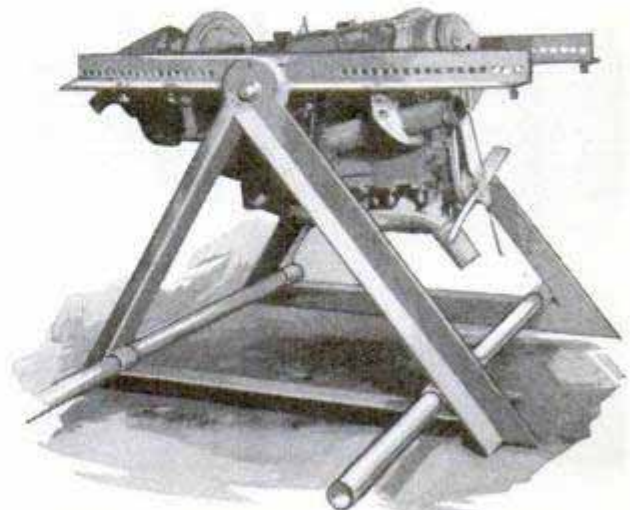

Homemade Adjustable Stand for Holding Auto Engines to Be Repaired



each of two horizontal 3-in. angles, and by means of a stud through each pair of plates, the engine may be tipped and locked in any desired position. A short block of  $\frac{1}{2}$ -in. steel is welded between the inside disk and the top edge of the angles to make the latter rigid, and  $\frac{3}{4}$ -in. holes in both vertical and horizontal flanges of the angles permit an engine to be set up on the stand merely by fastening it with a bolt at each corner.

### Self-Alining Stamp Holder

Steel stamps, either letters or figures, are confusing when they are not straight in the holder, as a "5," for instance, looks much like a "3" when turned around. It is handy to have the stamps all straight and facing the user, but it is not to be expected that everyone in the shop will put them back in that position. However, the holder illustrated will automatically take care of this. It is made from a square block of hardwood, drilled to receive the stamps and faced with a piece of sheet metal attached with screws,

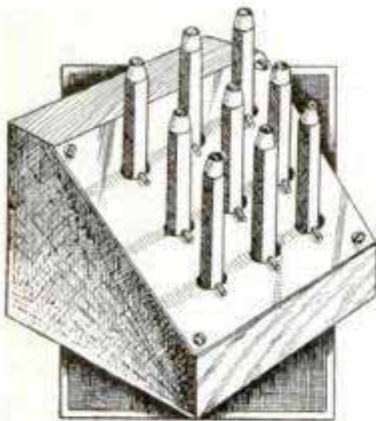

the top portion of the block being cut off at a bevel. Each stamp has a pin driven into the side near one end, so that when the pin points toward the front of the block, the letter on the stamp will be easily recognized. Naturally, when a stamp is inserted into the holder, the pin slides around on the beveled surface until it points toward the front as shown, and the letters all face the user.—Harry Moore, Montreal, Can.

### Run-Up Blocks for the Airplane

For use when warming or "running up" an airplane motor, the blocks shown in the illustration will be found convenient. They are made of heavy-gauge steel tubing, welded together in the form of a six-point star. It has been found that the most efficient size for universal use is a length of  $5\frac{1}{2}$  in. for each leg. Blocks

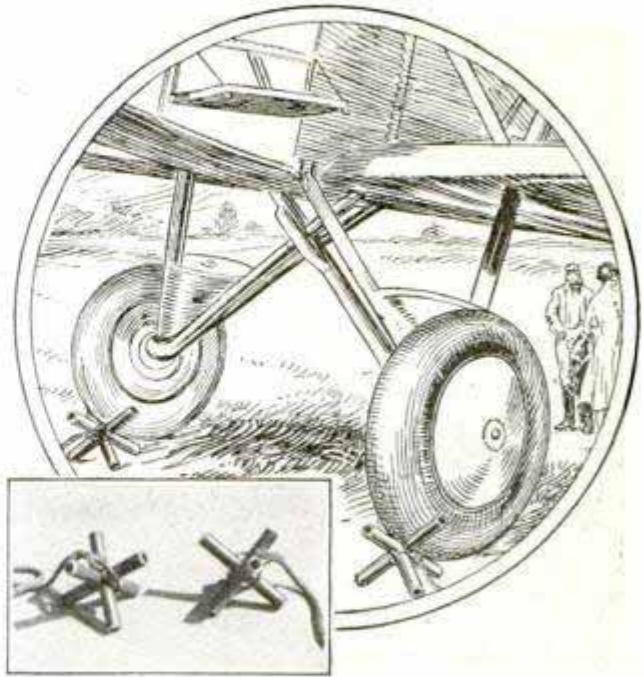

These Run-Up Blocks Are Made of Steel Tubing and Will Not Jam or Slip

of this type have been in use at the Denver municipal airport for six months and have been found to hold any pair of wheels regardless of tire size. They can be used on either dirt or concrete surfaces, will not jam after the motor has been run up, and will not slip even on ice.—L. D. Richards, Denver, Colo.

### Keeping Track of Drafting Triangles

In order to avoid misplacing drafting triangles, one engineer, who had occasion to carry them with him for use in field work, solved the problem by drilling holes in them so that they would fit the fasteners of a loose-leaf note book as illustrated. This method is especially recommended to those who have to carry their equipment around with them.—Edward H. Flaharty, Parco, Wyoming.

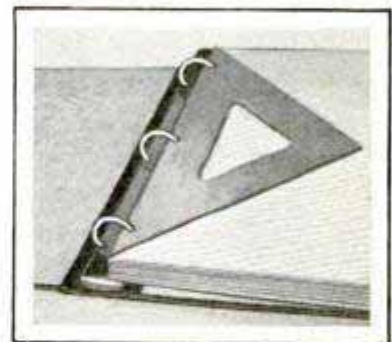

ⓘ When brushing chips and dirt from a machine, be careful to keep them from falling into journals or parts where they will cause injury.



### Small Emery Grinder for Home Shop Made from Odds and Ends

One of the most useful tools in the writer's little shop is a small motor-driven emery grinder that was made up mostly

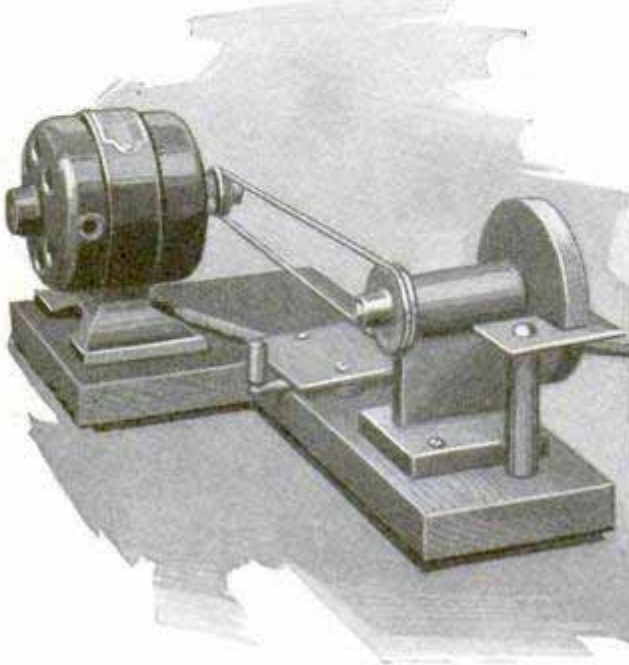

Small Belt-Driven Grinder Especially Designed for the Home Workshop

from odds and ends around the place. It is the outcome of a good deal of experimenting. At first thought it would seem much better to mount the grinder directly on the motor shaft, as is often done, but this placed the wheel in a rather awkward position for many grinding jobs, and the dust gets into the motor bearings, causing considerable wear. Besides, the weight and vibration of the wheel also damaged the bearings, which had to be renewed as a consequence. The motor is a small one of the high-speed type. Running free, it will turn about 8,000 r.p.m., but driving the wheel, it is held down to about 4,000. It drives the wheel by means of a  $\frac{3}{16}$ -in. steel-wire belt. A leather belt small enough for the job could not be made to do the work at the high speed required. The driven pulley is 25 per cent larger than the driver; both are turned from brass and are deeply grooved. The emery wheel, 4 in. in diameter, is mounted on a  $\frac{3}{8}$ -in. tool-steel shaft and fitted with the greatest care into a very long bearing in a cast-iron bracket, which was found in the junk box. Lubrication being of vital importance, special provision was made

for automatic oiling. At the middle of the length of the bracket, a  $\frac{3}{8}$ -in. hole was drilled down from the top, the drill passing through the shaft hole and going  $\frac{1}{2}$  in. into the iron below it. Both holes, above and below the shaft, were then packed with felt. The hole at the top was closed by fitting a swinging cover of sheet brass. With this arrangement, a single soaking of oil will last for a long time, and there is no excess or leakage. At the same time the upper piece of felt keeps stray dust out of the bearing. Equally important is the sealing of the ends of the bearing against leakage of oil and intrusion of dust. The ends of the bracket are true and square with the hole for the shaft. Excessive end play of the shaft is prevented by the driving pulley at one end and a large collar on the shaft at the other. In the inner faces of both pulley and collar, deep annular grooves are turned to receive thick felt washers. When the pulley is so adjusted that the shaft has just the least amount of endplay, the felt washers are lightly compressed against the end faces of the bracket, making a tight seal. After a year's use, the bearing shows no signs of dust cutting or abnormal wear. The tool rest is simply a piece of cold-rolled steel recessed to fit the wheel and supported on a single pillar of brass tubing through which a bolt runs into the baseboard. A tightly covered switch, placed between the motor and the wheel, completes the outfit. The tool is not suitable for heavy work, but is ideal for grinding small lathe tools and other stuff within its capacity. It can be moved to any convenient part of the bench and pushed back out of the way when it is no longer needed.—Howard Greene, Washington, D. C.

### Helps for Home and Shop

**YOU CAN MAKE IT**—One hundred illustrated articles telling how to make toys, furniture and dozens of other things from old boxes and odd pieces of lumber. Price Ten Cents.

**POPULAR WOODTURNING**—Especially written for the amateur, this book should be in the kit of every home workshop owner. . . . Price Twenty-Five Cents.

**MODERN HOME INTERIORS**—Crammed full of suggestions for the home owner who likes to make his own built-in conveniences. . . . Price Ten Cents.

Order any of the above from The Librarian, Popular Mechanics Magazine, 200 E. Ontario St., Chicago, enclosing the proper amount in stamps or coin.



# “Yankee” balance and comfort grip

give you perfect control and make screw-driving jobs easier. Every “Yankee” blade is twice tested by “Yankee” toolmakers. Every blade, mind you—so that the blade in the very “Yankee” Screw-driver you get won’t twist, crack, break, or bend on the edge. And the blade can’t be loosened in the handle by any use or abuse. Sold and guaranteed by your tool dealer. Ask for—

## “Yankee” Plain Screw-drivers

**No. 90** — Standard Style: Fifteen sizes, 1½” to 30” blades. Price for 5” blade, 50c; 6”, 55c; 7”, 65c; 8”, 75c; 10”, 95c. Etc.

**No. 95** — Cabinet Style: Eleven sizes, 2½” to 15½” blades. 4½” blade, 40c; 5½”, 45c; 6½”, 50c; 7½”, 60c; 8½”, 65c. Etc.

# “YANKEE” TOOLS

*Make Better Mechanics*

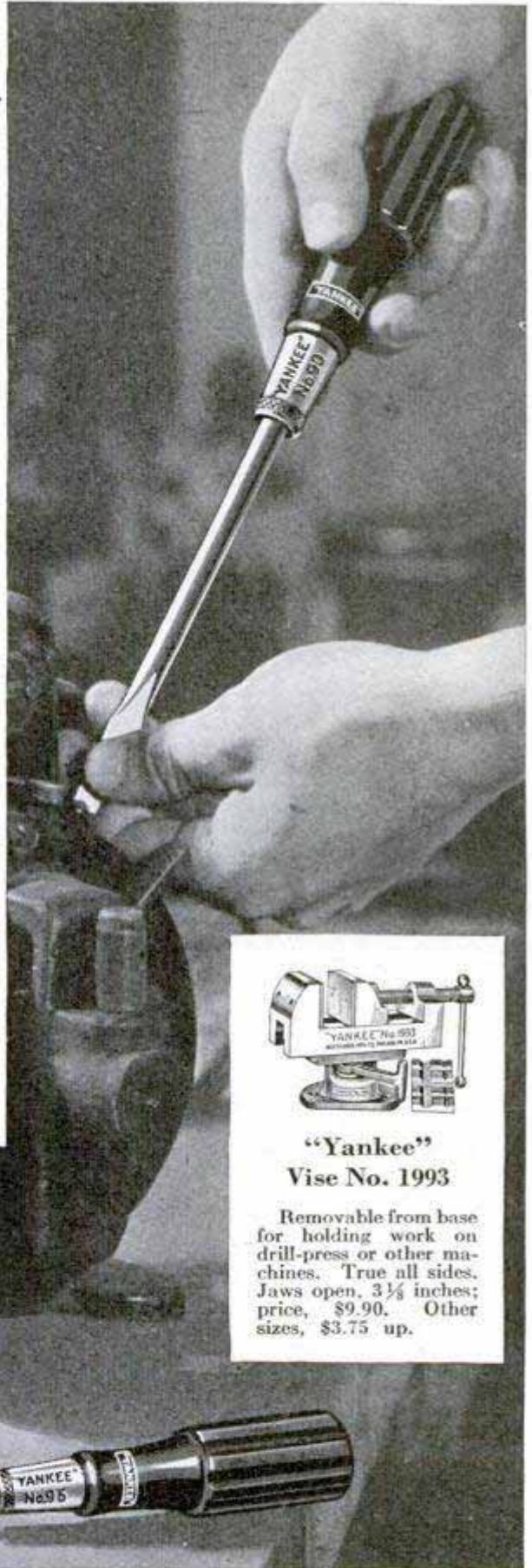

“Yankee”  
Vise No. 1993

Removable from base for holding work on drill-press or other machines. True all sides. Jaws open, 3½ inches; price, \$9.90. Other sizes, \$3.75 up.



“Yankee” Tool Book, Free

NORTH BROS. MFG. CO., Lehigh Avenue, Philadelphia, U. S. A.

Send undersigned Free Book, showing “Yankee” Tools in use: Ratchet Breast, Hand and Chain Drills, Automatic Bench Drills, Ratchet Tap Wrenches, Automatic Push Drills, Spiral and Ratchet Screw-drivers, Ratchet Bit Braces, Etc.

Name..... Address.....(pm)



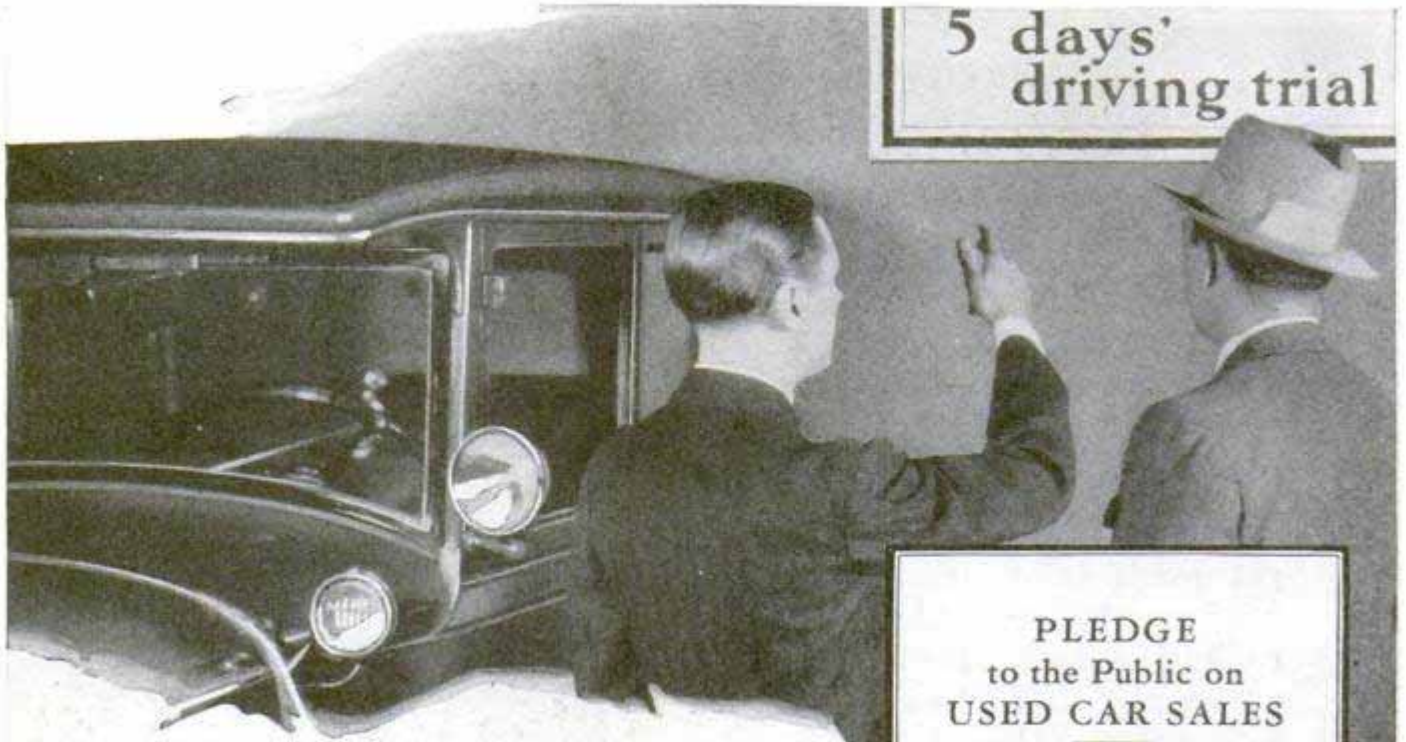

Drive the car you  
buy five days . . .  
*then decide!*

**PLEDGE  
to the Public on  
USED CAR SALES**

1. 5 days' driving trial.
2. 30-day guarantee on certified cars.
3. Lowest price marked in plain figures.

*"Can I return it within five days?"  
"Yes, the Studebaker Pledge provides  
five days' driving trial for every buyer."*

**F**IVE days on the road will tell you far more about the used car you buy than a five-minute demonstration. You test the car under the actual conditions it will meet in serving you. If it does not satisfy you, you may return the car and apply your payment on *any* car—new or used—in your Studebaker dealer's stock. This is one of the provisions of the famous Studebaker Pledge, recognized everywhere as the fairest, squarest used car sales policy.

More than 150,000 thrifty motorists bought Pledge-backed used cars last year. They bought because they wanted Studebaker Pledge protection—and because a good used car is always a better buy than a cheap car bought new.

**STUDEBAKER**  
*Builder of Champions*

Most Pledge-backed cars have been thoroughly reconditioned before being offered for sale—certified cars carry a 30-day guarantee. *Every* Pledge-backed car has its *lowest price marked in plain figures*—no codes.

See your Studebaker dealer *first* when you buy a used car—get the full protection of this famous Studebaker Pledge!

**INVEST 2c . . . . .  
YOU MAY SAVE \$200**

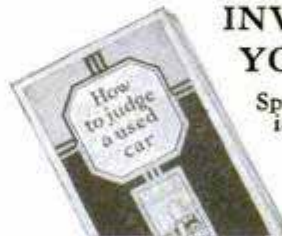

Spend 2c now for your copy of this interesting and instructive booklet, "How to Judge a Used Car"—it may save you as much as \$200 on the used car you buy. Mail the coupon now!

**THE STUDEBAKER CORP. OF AMERICA**  
Div. 159, South Bend, Indiana

Please send me copy of "How to Judge a Used Car."

Name .....

Street .....

City.....State.....



# Masonite protection costs you nothing



One of fifty beautiful Masonite-insulated homes built by The Keyes & Treuhart Co., Cleveland. Interior view below



THESE days there's no valid reason for modern homes being stuffy in summer, cold in winter, or damp and chilly at any time. Heat, cold and moisture can be controlled . . . kept where they belong . . . by Masonite Structural Insulation. You can have constant home comfort.

Today Masonite is essential in well-built homes. Its use is a wise investment, in new building or remodeling, whether your plans are modest or pretentious. Masonite comfort really costs you nothing, because Masonite pays for itself by replacing other building materials, by reducing fuel bills and by increasing the re-sale value of your home.

Masonite resists heat, cold and moisture when used as sheathing for walls and roofs; makes sound-resisting partitions and ceilings; builds extra rooms. As a plaster base, Masonite Insulating Lath produces a fine, smooth finish, and eliminates streaks.

Carpenters and home mechanics like the easy workability of this sturdy wood board. Buy it at leading lumber dealers; you can learn of its many uses in the Masonite booklet. Send for a copy; no cost.

MASONITE CORPORATION, 111 W. Washington Street, Chicago



W. B. Rosevear residence, Birmingham, Mich. Masonite sheathing and stucco base. Architect, Clair W. Dutchy; builders, Brook Heinmiller



One of twenty-five Pittsburgh homes built for Chartiers Realty Co., by Key Building Co.



In this Mentor, Ohio, home, designed and built by R. M. Case Co., Masonite added little to the cost.

# Masonite

STRUCTURAL INSULATION • INSULATING LATH  
PRESDWOOD • QUARTRBOARD

## Made Better at Less Cost with Masonite Presdwood

Manufacturers of a wide array of articles are building stronger, more durable products, and at less cost, with Masonite Presdwood. This smooth, grainless wood board will not crack, splinter or warp. Resists heat, cold and moisture. Easy to work with. Home mechanics also find many uses for it. Get the Presdwood booklet. Check coupon.

© 1930, M. C. MASONITE CORPORATION, Dept. L-9  
111 W. Washington St., Chicago, Ill.

Please send me, free, the story of Masonite.

Name.....

Street.....

City..... State.....

If interested in Masonite Presdwood check here



# Would You Believe It!

## Tests Show LePage's Glue Is Stronger than Rock Maple

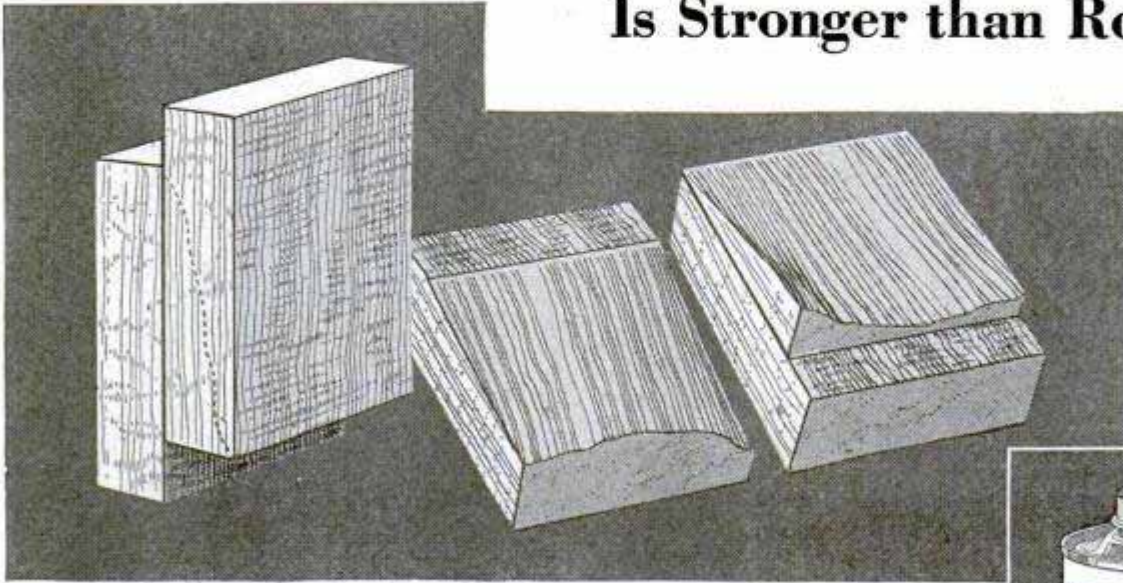

Left: Shows two blocks of Rock Maple lepaged together.

Right: Shows Rock Maple ripped apart under strain of 3000 lbs. per square inch but joint made with LePage's still perfect!

NOT just one test, but many tests. Over and over we've tried to break LePage's joints in rock maple on the Olsen Shear Testing Machine. You know what tough stuff rock maple is. But it's the rock maple that *always* gives. What a test for LePage's strength that is!

Look at the illustration above, taken from actual photographs. It wasn't the LePage's joint that gave way. It was the fibers of the rock maple that were ripped apart

under a pressure of 3000 pounds per square inch.

LePage's Glue (Liquid, Hard or Waterproof) stands pressure of 3000 lbs. per sq. in. Stronger than the fibers of the wood it joins. Every batch is tested.

Any cabinet maker will tell you your finished work is as good as the strength and permanency of its joints. Use LePage's and be assured of immense and lasting strength.

# LEPAGE'S GLUE

WHATEVER KIND OF GLUE YOU NEED LEPAGE'S MAKES IT!



### LEPAGE'S NEW WATERPROOF GLUE

For making joints that must stand the weather, use LePage's Waterproof Glue. Now available in convenient packages for home use.

### LEPAGE'S LIQUID GLUE

Always ready for immediate use. No bother of preparation. Easier to work with because it sets slowly enough to give you plenty of time to adjust joints.

### LEPAGE'S TESTED HARD GLUE

If you prefer to use a hard glue ask for LePage's Tested Hard Glue. Tested for uniform quality. No experimenting with each new lot to see how much water to add, or how long to cook.



### You See This Can Wherever You Go

Carpenter Shops  
Cabinet Makers  
Golf Pro's Bench  
Manual Training Schools  
Upholstery Shops  
In House Under Construction  
Everywhere!



### You Can Make This Spanish Galleon Yourself

LePage's Job Plan No. 26 shows how. Price complete only 10 cents. Order direct. Send 10 cents in coin or stamps. Specify Job Plan No. 26. Address: LePage's Craft League, 763 Essex Ave., Gloucester, Mass.



# IT ROARED AN ECHO TO THE THUNDER OF MANILA BAY

A year old when it ground off the news of Dewey's victory, the press at the right has roared through its weekly quota of 250,000 papers without a single serious interruption since 1897. Over 100,000 miles of paper have raced through its rolls.

Working at terrific speed, with terrific pressures, the machines in the press rooms of the great dailies are massive—bulky as brute locomotives. Their mass hides the real secret of their operation—perfect timing, perfect alignment, perfect precision of every smallest part. At sixty thousand an hour, the speed of the newest presses, the slightest error in adjustment or construction brings instant havoc—a break of the flying, fragile sheet and a costly delay in getting the edition on the street.

The performance of presses, like the performance of any complex machine which serves this speeding age, is a matter of scrupulous precision—precision that can come only from the finest precision tools, tools like Starrett's.

Your hands, at your daily work, or in your home shop, will be more adroit, more precise if they work with Starrett Tools—the tools that give precision to giant machines. The coupon will bring the new Starrett Catalog No. 25 "AP" illustrating and describing over 2500 Starrett Tools for wood and metal working.

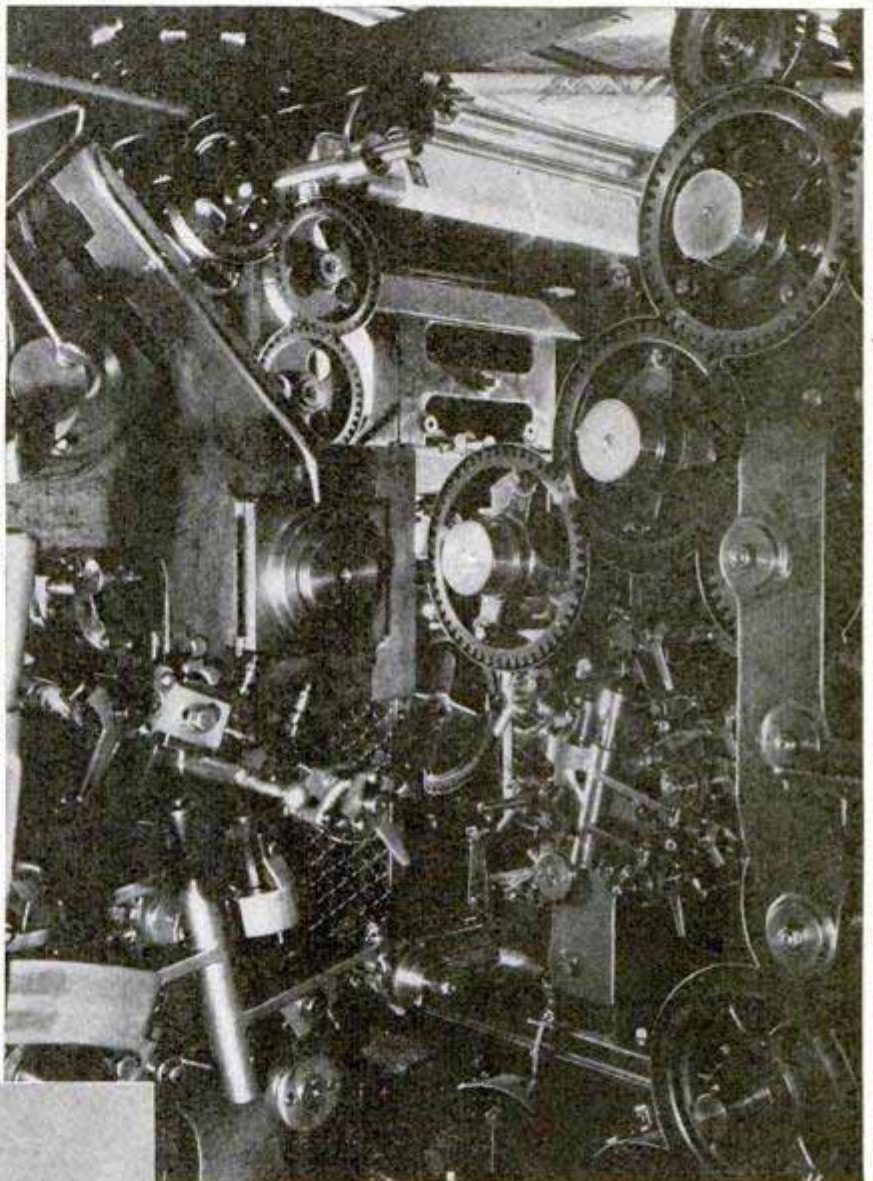

Above: a close-up of a Hoe Press, Boston Transcript. Left: Starrett Gear-Tooth Vernier Caliper No. 456, a precision tool used in making gears. Starrett Dividers No. 92 and Starrett Micrometer No. 436, two splendid tools that belong in every kit. Below: the coupon. It will bring your free copy of Starrett Catalog No. 25 "AP". Send it in.

THE L. S. STARRETT COMPANY  
ATHOL, MASSACHUSETTS

Please send me Starrett Catalog No. 25 "AP".

Name.....  
Street.....  
City..... State.....



# Use Starrett Tools



Stories of Stars who were not "Born" but "Made." No. 7

# 70,000 watched him win this game

yet he never held a football before he came to college

70,000 spectators—fourth down—60 yards to go—only a few minutes left to play—a championship team six points behind—*signals!*

The ball is snapped. Suddenly the left end darts out and tears like mad across and down the field . . . ten . . . twenty . . . thirty yards . . . then he turns and, still on a dead run, gathers in a long pass and dashes across the goal line.

Sounds like story-book stuff, doesn't it? It isn't. It really happened only a few years ago. And the star end who caught that pass had never played football before he came to college.

There are cases like this in every college and in every sport. The sharp eyes of college coaches are constantly on the lookout for men who, though inexperienced, have the makings of star players.

If you "look good" to a coach, it doesn't matter at all what your past record has been. One of the most important secrets of "looking good" is *footwork*. Learn to handle your feet.

Star players *train* themselves in footwork. You will find them taking a hundred and one kinds of exercise that help them develop swift, sure foot-action. And—notice this—more of them wear Keds than any other shoe.

There are three big reasons for Keds' superiority. (1) Keds have a "Feltex" insole that keeps your feet cool and comfortable. (2) Keds have canvas tops that are light but strong. (3) Keds' safety soles. They take hold like four-wheel brakes and absorb all the shocks of sudden stopping and starting.

Keds will help you to "look good."

The best shoe dealers in town carry Keds. Ask for Keds by name. They are not Keds unless the name "Keds" is on the shoe. Choose the style and the price that suit you best.



### Keds "Sprinter"

(left) A medium-priced Keds with suntan uppers. "Sprinter" has a tan moulded sole of a distinctive design that makes for sure footwork.

### Keds "Mercury"

(right) A light, serviceable Keds. This moderately priced shoe has uppers of either white or brown duck, trimmed with black. The sole is amber-colored with crepe knurling.

### The Dog Contest Winners!



The names of the 530 winners in the Keds Essay Contest will be announced on posters displayed in Keds stores about October 1.

Go to the Keds dealer from whom you secured your entry blank. He will have a complete list of all prize-winners and will tell you whether or not you have won one of the 50 pedigreed wire-haired fox terriers or one of the 480 pairs of Keds.

Do not write the Keds Contest Editor. The names of the prize-winners will be announced *only on the posters* displayed by Keds dealers. However, on or about Sept. 15, the Keds Contest Editor will send a personal letter of congratulations to every boy and girl who has won a prize.

Footwork builds stars

# Keds

REG. U. S. PAT. OFF.

United States  Rubber Company



Keds sell for \$1.00, \$1.25, \$1.50, \$1.75, and up to \$4.00. The more you pay, the more you get—but full value whatever you spend



# POWERFUL LITTLE DROPS

A GALLON of Ethyl Gasoline contains only about a teaspoonful of Ethyl fluid. Yet these few drops change the action of the fuel entirely when it gets inside the cylinder.

Ethyl fluid is a governor of combustion. With increased compression, the gasoline tends to burn abnormally and the engine "knocks." Ethyl fluid regulates the combustion so that instead of a sharp irregular explosion that *slaps* the piston downward, Ethyl Gasoline burns with slowly gathering force that develops a powerful *thrust*.

That's why Ethyl Gasoline gives so much more power. That's why it develops the maxi-

*The active ingredient used in Ethyl fluid is lead.*

mum efficiency of the new high-compression motors. That's why it stops "knocking" and gets additional power out of every car.

Just a few drops of Ethyl fluid, but they are *powerful drops*.

Try Ethyl. Try it on hills, in traffic, under the most trying driving conditions. Ethyl will improve the performance of your car, whatever its size, type or age. Fill up with Ethyl at any pump bearing the emblem shown below. Ethyl Gasoline Corporation, Chrysler Building, New York City.



Wherever you drive—whatever the oil company's name or brand associated with it—any pump bearing the Ethyl emblem represents quality gasoline of high anti-knock rating.

© E. G. C. 1930



**GOOD  
GASOLINE**



**ETHYL  
FLUID**



**ETHYL  
GASOLINE**







## Why 86% of you say "O. K."

**G**ENTLEMEN: No product wins first place without good cause. So when we tell you that Palmolive Shaving Cream is the fastest selling shaving cream in the world—it is only another way of describing its superiority.

Our 68-year-old laboratories asked 1000 men to dictate the effects a shaving cream should have. Time and again formulas failed to do what we demanded. Then the 130th formula brought success.

A shaving cream, made on the principles of an olive oil soap, overcame the prime objections men had to old-fashioned methods.

Won't you at least give us the opportunity of convincing you? Please mail the coupon.

**PALMOLIVE RADIO HOUR**—Broadcast every Wednesday night—over WEAF and 39 stations associated with The National Broadcasting Company. 5965



## 7 SHAVES FREE

and a can of Palmolive After Shaving Tale

Simply insert your name and address and mail to Palmolive, Dept. M-841, P. O. Box 375 Grand Central Post Office, New York City.

(Please print your name and address)

## "Your Eye Sees It—

# 250

# Times Larger"



MADE IN  
U. S. A.

## WOLLENSAK MICROSCOPE \$ 16.50

**S**OLVE the mysteries of insect, plant and mineral life with the Wollensak Microscope. Reveal to yourself the beauties of nature hidden from the unaided eye. One of these fine microscopes should belong to every student, dentist, physician, or scientist and should be part of the equipment of home, office, school, or laboratory. It gives a range of magnifications from 100 to 250 diameters in steps of 25. Elaborately finished tilting stand, nickel trim, plush lined case, prepared slide, complete instructions. Ask your dealer, or, we will send you one postpaid. *Money back guarantee.* Lower powered Wollensak models \$2.50 to \$8.50. Catalog free.

WOLLENSAK OPTICAL COMPANY  
868 Hudson Avenue Rochester, N. Y.

## Make Your FORD Into The "ACE"

GET READY FOR SPRING—BUILD YOUR ACE NOW—

\$599 Red-i-Kut life size patterns  
Class—Snap



38-inch Easy Riding Seat

Famous sure-fit RED-I-KUT life-size patterns and picture instructions show how you can easily convert your Ford into this **Fast, Saucy, Sport-Car** as thousands have done with easily obtained materials. No need to lay up the car. Makes wonderful 4-passenger car. Send 10c coin for actual photo of sport car and new manual of distinctive sport car patterns from \$5.00 up—"RKO" Steel "Swing-Lo" Irons, Tops, Windshields and many speed necessities. **ORDER RIGHT NOW** and get a real thrill.

KUEMPEL COMPANY, 124 Kuempel Bldg., GUTTENBERG, IOWA

## Build a CLOCK for Pleasure or Profit!



### FREE BOOK

of Clock Making, Money Making ideas. Gives details, prices of movements, parts. Write NOW for copy!

Shows How YOU Can Make Fine Clocks Right at Home

—for yourself, or to sell at Big Profits. We furnish instructions, parts. Works \$1.65 up; others with chimes, all prices. Make case or assemble parts. Cash-in on demand for Mantel, Banjo, Grandfather's Clocks. Write for Special Blue Print Offer, FREE Catalog.

AMERICAN CHIME CLOCK COMPANY  
1670-B Ruffner St. Philadelphia, Pa.

## Fly the NEW IDEAL "ROBIN"

Construction \$350  
Outfit

Wing Span, 24 in.; Weight 2 1/2 oz. A beautiful "job" and a wonderful flyer. Demountable, adjustable wings, balsa propeller, large landing wheels, dummy motor, tremendous power for long, fast flights. Construction is easy, quick. Ask your dealer or order direct from us.

Big Catalog Models and Supplies—5c

IDEAL AEROPLANE & SUPPLY CO., Inc.  
26 West 19th Street New York City





**12,000,000 shoppers**  
know *where to find the*

**LOWEST PRICES**

**IN 10 YEARS...**

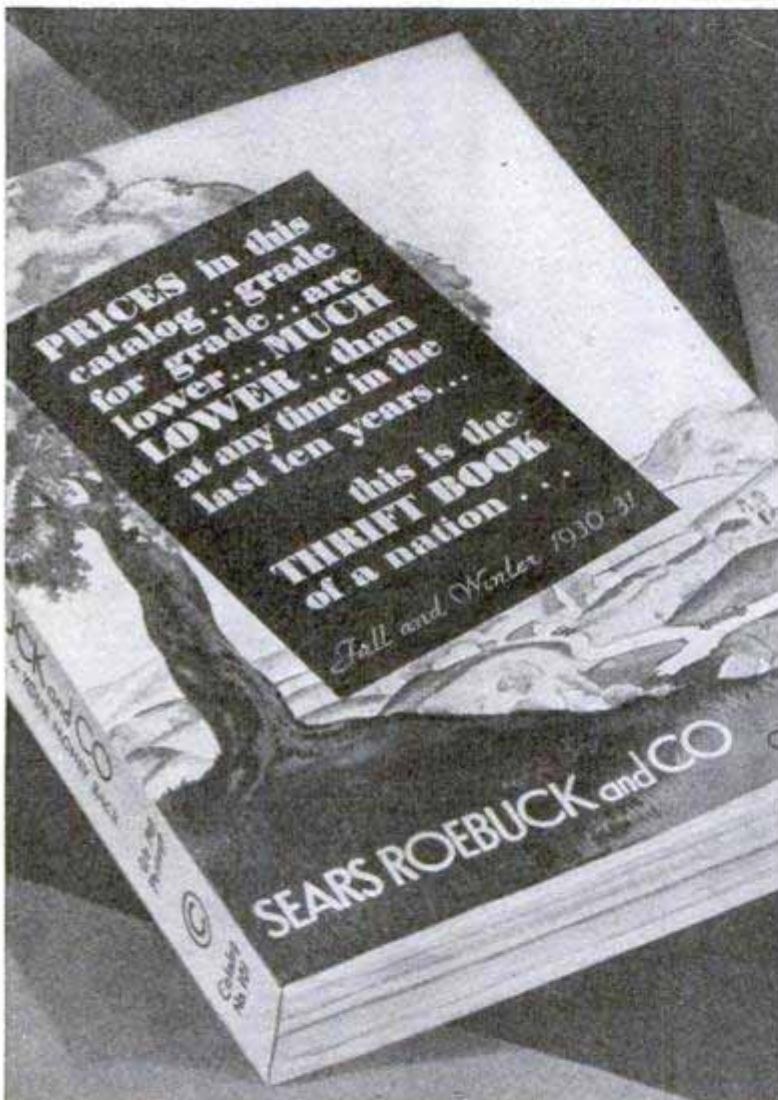

Sears, Roebuck and Co.—The World's Largest Store—presents the new "Thrift Book of a Nation." From cover to cover it tells a story of value without precedent.

*Lowest Prices in 10 Years* is not a slogan. It is a promise. And lowest prices are here coupled with the most advanced merchandise to be offered this season.

#### Smart Style at a Low Cost

If you are interested in wearing apparel, you will find this new catalog abreast of the times. Not alone that, but you will learn Sears-Roebuck buys for less and sells for less. You and your family can have more and better clothing if you will use this Thrift Book.

#### Economy for Your Home

Here we have exerted the full force of our buying and engineering ability to bring you all of the better things for the home at prices we alone can offer.

Whenever you are going to buy for your home, look in your Sears catalog first.

#### 46,000 Articles, Every One Bargain Priced—The Largest Variety of Merchandise Offered by Any Store

Whatever you want for yourself, your family, your home, your car, your shop, your farm, will be found here in this new "Thrift Book of a Nation" for Fall and Winter, 1930-31.

Use it often. Compare prices. Compare quality. Remember, we guarantee satisfaction and we guarantee a saving—on every purchase.



## SEND FOR THIS FREE BOOK

This new catalog, with its 1,000 pages of new merchandise, all at the lowest prices in ten years, is yours for the asking. Whether you intend buying from Sears or not, you will want this book to know what prices you should pay. You do not obligate yourself in any way in filling in the coupon. The book is free. Send today.

**SEARS ROEBUCK and CO**

#### SEARS, ROEBUCK AND CO.

Chicago, Philadelphia, Boston, Minneapolis, Kansas City, Atlanta, Memphis, Dallas, Los Angeles, Seattle.

(Mail Coupon to Store Nearest You) 80P01

Send me your Latest General Catalog.

Name.....

Postoffice.....State.....

Rural Route.....Box No.....

(Please give both Route and Box Number if on a Rural Route)

Street Address.....



# NOW

... THAT YOU'VE TRIED THEM ALL

# SETTLE DOWN

TO

# DURHAM-DUPLEX



**DURHAM-DUPLEX**

THE RAZOR WITH THE  
BLADES MEN SWEAR BY—NOT AT

**T**RIED them all? Now get yourself a fresh package of Durham-Duplex blades and try something that's really *new*. Not in shape—not in name—not in finish—but new in the thing that really counts—that really counts—*shaving efficiency*.

The hollow-ground edges on the latest output of blades are a pleasant surprise even to those who thought Durham-Duplex blades had already reached the peak!

Prove for yourself the merit of this wonderful blade. Secure a genuine razor complete with one blade ready for shaving from your dealer or send 25c. to cover cost to the Durham-Duplex Razor Company, Jersey City, N. J.



The  
*World's Greatest*  
Band Master  
Says:

"COMPLETE equipment with Conn instruments enhances the musical value of any band at least 50%."

Conns are the choice of the world's greatest artists. Especially recommended to beginners for quicker progress and greater musical success. Easiest to play. Many exclusive features. Yet they cost no more.

**FREE TRIAL, Easy Payments** on any Conn. Write for interesting book. Tells everything you want to know about your favorite instrument. Full color illustrations of most popular models. Write today. C. G. Conn, Ltd., 931 Conn Bldg. Elkhart, Ind.

**CONN**  
World's Largest  
Manufacturers of  
BAND INSTRUMENTS



SEND FOR THIS FREE BOOK ON  
YOUR FAVORITE INSTRUMENT

## Sport Bodies for Fords At Factory Prices



This Model in Grey Prime **\$38<sup>50</sup>**

Send 10c for catalog showing all models of bodies and other equipment for Ford and Chevrolet. High-compression heads, underslung parts, 3:1 gears, headlights, fenders. Cut shows body on Model A Ford. Also made for Model T Ford.

Make Your Ford Into Classy Car

Sport Factories, Dept. A-5 Aurora, Illinois

## Rider Agents Wanted

Select from 44 styles, colors and sizes of Mead Bicycles. Ride and exhibit sample RANGER and make money.

**Factory to Rider!** We ship on approval for 30 Days' Free Trial, direct from FACTORY. Get our marvelous offers. Easy Payments. \$5 down.

**Tires** lumps, horns, wheels, parts, equipment, and repairs at half usual price. Established 36 years.

**Mead CYCLE COMPANY** DEPT. P-110, CHICAGO

Write us today for free catalog



Model No. 21

## MONTHS of THRILLING FLIGHTS

Since July 1, 1929, *Silver Arrows* have flown 200,000 miles. In 193 recent tests out of 200, they outflew all other planes, regardless of price. A *proved* success! Not a construction toy but fully built. Ready to fly in a moment. Balsa wood wings, adjustable; aluminum cabin, propeller; strong elastic motor. Model No. 21, Cabin type, wing spread 22 in., \$2.50 (West of Miss., \$2.75). Other models, Racing and Cabin, at \$1 to \$3.50. If your dealer cannot supply you, send your order to us. Kingsbury Mfg. Co., 83-1 Myrtle St., Keene, N. H. Join *Silver Arrow* Flying Club and become a Master Pilot.

## KINGSBURY MOTOR DRIVEN TOYS



FREE! Novelty Moviescope: shows motion picture of *Silver Arrow* flight. Also complete toy catalog.

Send 10c for Kingsbury Disc Wheel, Balloon Tire Eraser. Set of 4, 35c.





# Chief Long Lance

*tells you how to train the Indian way*

"AS BOYS," writes Chief Long Lance, "we found that the more natural play we could get without tiring, the sturdier we could grow and the better we could prepare ourselves for the lives of hardship we faced. And our moccasins had much to do with the strength of foot and leg we needed for this purpose.

"Canvas rubber-soled shoes, like moccasins, give free play to the foot and leg muscles, permitting them to develop as naturally as other muscles in the body."

Join the kind of training camp that Indians have always used. The grounds of the camp are wherever you exercise or play. The equipment is a pair of Goodrich Sport Shoes.

You are in training every minute you wear them, building strength and speed by the tried and tested Indian method.

Before you buy a new pair of shoes, be sure you see the shoe which Chief Long Lance himself designed. Always ask for Goodrich Sport Shoes.

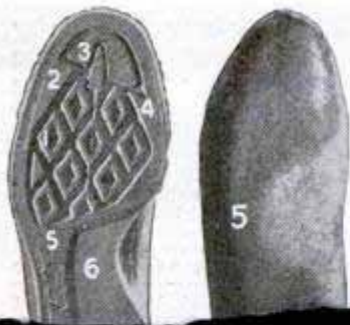

## *He teaches you the Silent Language of Scouts and Warriors*

The Indian Sign Language! Language of famous frontier scouts and Indian warriors. You've read about it. Now you can learn to use it—talk to your friends when it is dangerous to speak aloud.



IN THIS BIG 32-page booklet there are over 80 photographs posed and explained by Chief Buffalo Child Long Lance himself. Send for it today! Use the coupon below.

### TEN FEATURES of the Chief Long Lance Shoe

1. Unique Indian Design
2. Dodging Pivot
3. Emergency Brake
4. Whirling Pivot
5. Barefoot Tread







*Fix it with*  
**PLASTIC WOOD**

Reg. U. S. Pat. Off.

It is just as valuable for canoes or boats as it is around the home—Plastic Wood, that handles like putty and hardens into wood. A dent in the stem, a hole in the frame, a split rib or seat, loose fastenings—Plastic Wood makes a quick, permanent, waterproof repair that can be finished to make the job as good as new. It can be sanded to a hair edge, and takes paint, varnish, or lacquer perfectly.

To soften or thin Plastic Wood, and to clean hands and tools after working, use Plastic Wool Solvent. In 25 and 50 cent cans.

Handles  
Like  
Putty



Hardens  
Into  
Wood

Tube 25c — 1/4 lb. can 35c — 1 lb. can \$1.00

At Hardware and Paint Stores

Send for free booklet on Boat Repair and Construction  
ADDISON-LESLIE CO., 431 Bolivar St., Canton, Mass.

**AGENTS!** SELLS LIKE WILDFIRE



New improved window washer eliminates all muss and fuss wherever there is glass to be cleaned. Approved by Good House-keeping Institute. Restricted territory to producers. Write today.

**CARTER PRODUCTS CORP.**

935 Front Street

Cleveland, Ohio

**PRINT YOUR OWN**

Cards, stationery, circulars, tags, labels, advertising, menus, etc. Save money and time, cut cost.

**Print for Others BIG PROFITS**

Easy rules supplied with every outfit. Opportunity to turn your spare time into cash, or develop full time business of your own. Popular raised Printing like Engraving done with any of our presses. **Junior Press \$5.90**, Job presses \$11, \$29, Rotary \$149. Write for catalog No. 087 showing presses, outfits and all details. **The KELSEY Co., Meriden, Conn.**



**Oh! Boy!** Build this car. Speed 35 miles per hour. Driven by gasoline motor. Can be built by any boy. Parts furnished by us. Are very cheap. Send 50c for building plans and price list of parts showing how to build this boy's car.

**SYCO SALES CO., 1524 Fernwood Ave., Toledo, Ohio**

**DO YOU** WANT a new business profession of your own, with all the trade you can attend to? Then become a foot correctionist, and in a few weeks earn big income in service fees,—not medical nor chiropody—easy terms for home training, no further capital needed, no goods to buy, no agency. Address

**Stephenson Laboratory, 1 Back Bay, Boston, Mass.**

**Only 8 Sales a Day Nets You \$116 a Week**

Profits on larger size run higher. Unusual earning opportunity for ambitious men. No experience necessary; we teach. Part or full time.

**FUGO** World's Simplest Fire Extinguisher

Automatic and instantaneous action. Within reach of every home, shop, store, theatre, garage, car owner, etc. Even smallest place needs two or more. Exclusive territory to producers. You get your pay every day. Write for full details.

**The National Formetal Co.**  
6535 Metta Ave. Cleveland, O.



**The 1931 Models  
Are Out**

Better equipped, better looking, and better performing than ever. Twins, Single, and Sidecars — wide price range. Model shown is the new "45" Twin.

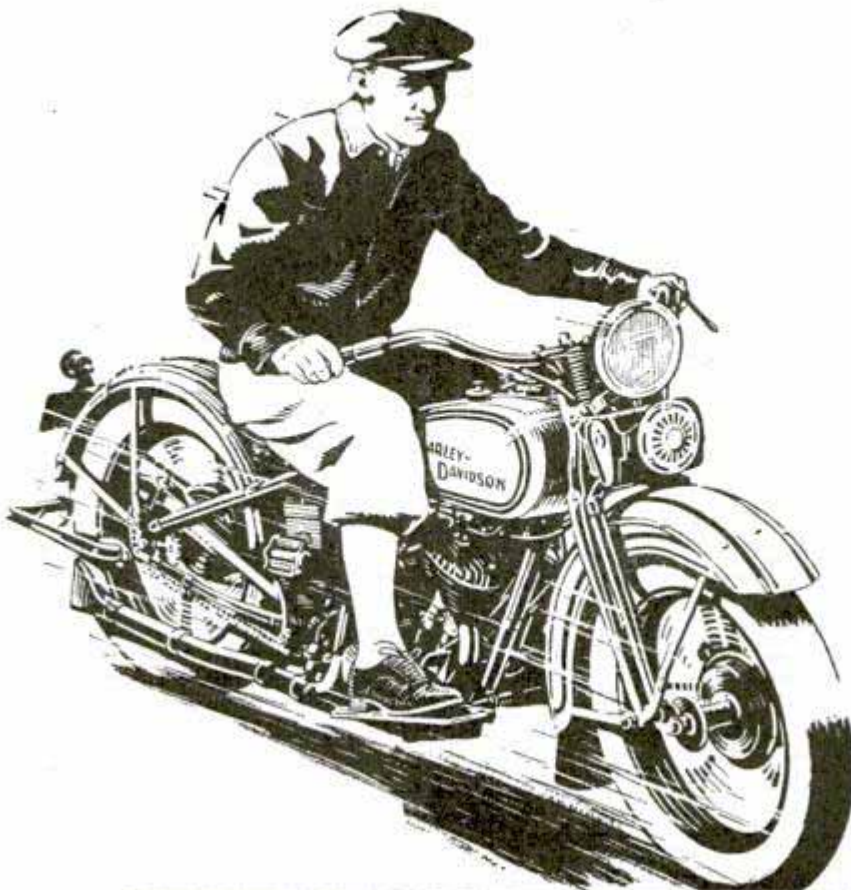

## GREATEST SPORT ON WHEELS

**T**WIST the throttle of your Harley-Davidson, and the road is yours. Flashing speed and thrilling power answer your every whim. Was that a hill you just zoomed over? Did that fellow in the new Eight think he had something under the hood?

Let more sluggish souls have their sedans. *You* want the ever-new thrills of motorcycling—a spirited mount to ride — an eager Harley-Davidson that is both a pal and a trusted servant. You want the "Greatest Sport on Wheels" — and it costs so little!

See the new models. A nearby Harley-Davidson Dealer has them—and an easy Pay-As-You-Ride Plan that will interest you.

*Mail the Coupon for illustrated literature.*

*Ride  
a*

# HARLEY-DAVIDSON

**Mail  
Coupon**

HARLEY-DAVIDSON MOTOR COMPANY, Dept. P., Milwaukee, Wis.  
Interested in your motorcycles. Send literature.

Name.....

Address.....

My age is  16-19 years,  20-30 years,  31 years and up,  under 16 years. Check your age group.





## The popular choice for workshop and tool kit

**T**HE most useful tool in many a kit is a Remington knife. Amateurs and professional carpenters and mechanics are choosing Remingtons in place of all others for two reasons:

*First*, they find in Remington knives sharp blades of fine steel that hold their edges, and sturdy construction that stands up under hard usage.

*Second*, among Remington knives there are patterns designed especially to meet the preferences of every man who makes things.

One of many popular patterns for carpenters and mechanics is pictured here. See the whole line at your dealer's. If he hasn't them in stock, send us his name with \$1.00 for R153, illustrated, and we'll see that you are supplied promptly. Remington Cutlery Works, Bridgeport, Conn.

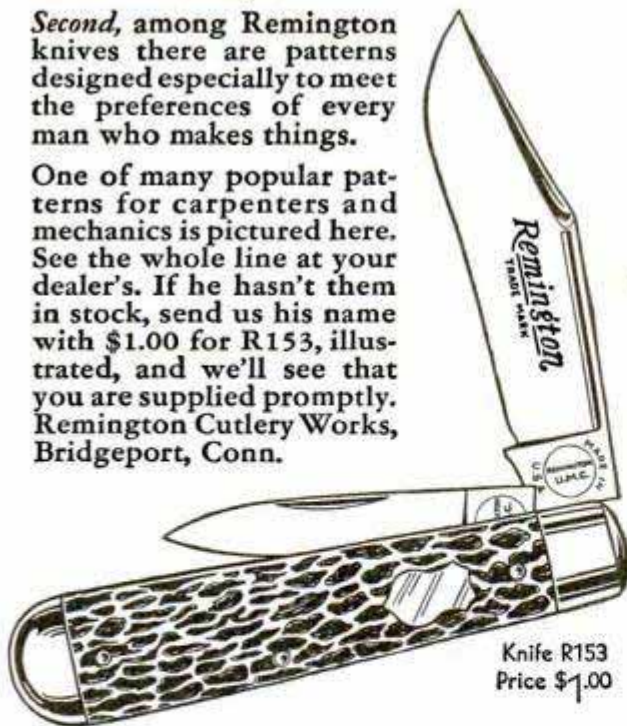

Knife R153  
Price \$1.00

REMINGTON ARMS COMPANY, Inc.  
*Originators of Kleanbore Ammunition*

# Remington



*Selling Kit  
Furnished*

## "A great idea!"

Something different—an original idea—never before seen on the market. Every man and boy a prospect.

Hook-Fast Belt and Buckle made to individual order—no two alike. Every buckle with personal initials and emblems—according to individual taste. Splendid profits made easily—**HANDSOME SELLING OUTFIT FURNISHED**—contains actual samples.

Become the official representative of Hook-Fast Belt and Buckle in your locality—Make big money—Sells itself.

Belt made of genuine English cowhide—never wears out—Buckle made of attractive plati-croyd—lasts a life time, bright and un tarnished—Specially patented Hook-Fast catch never slips.

**Red-Hot selling proposition. Get in on it now! Write for free particulars.**

**NATIONAL CRAFTS COMPANY**  
20 West 27th Street Dept. 950 New York City

## Every Coo-Coo \$1.75 for You!

A "knock-out" instant selling hit! The Coo-Coo Auto Horn (Patented) sells itself at \$4.00. Costs you \$2.25. Going like wildfire in Hollywood and Los Angeles. 1 dealer sold 3,000 in short time. Some Agents making as high as \$25 an hour. 1 horn sells 5 others. **No house to house selling**—just stand around garages and service stations—coo-coo and c'ean up. Installed by anyone in 3 minutes. Not an exhaust or motor horn. Certain in action—never fails to create a musical note that cleverly sings "Hello."



Send \$2.25 for sample horn or write for further information

**PACIFIC COAST PRODUCTS CO., LTD.**  
1616 Cahuenga Blvd. Dept. 61 Hollywood, Calif.



## BUILD "FLYING CLOUD"

Send for quality parts and clear blueprints of 20" model. Readily made in spare hours as hull fully shaped and sanded. Set includes anchor, bell, capstan, dead eyes, wheel, rigging line, etc. Complete for \$11. Postage 5 lbs. White metal figure-head 50c. Send 10c today for catalog.

**ROY HANCOCK**  
323 Douglas Ave. Portsmouth, Va.

## MAKE AN ELECTRIC CLOCK

Join thousands who are now making electric clocks for pleasure and profit. Send for free plan and details—Write today.  
**MIDLAND APPLIANCE CORPORATION**  
Dept. 2110, 225 N. Michigan Ave., Chicago, Ill.

**FREE PLAN**



## Clever Shirt Discovery Ends Collar Torture!

Now you can say goodbye to shirt grief—thanks to Shurfit—an amazing new kind of shirt! Magic celluloid tab and newly-designed neckband (both fully patented) bring relief from collar binding, choking, chafing, nervous disorders, slovenly loose-fitting collars, etc. Revolutionary Shurfit Shirts fit snug and trim around neck after repeated washing!

**Sensational Offer Brings Agents Up To \$17 In A Day!**

Here's the greatest profit opportunity in direct selling history! Tremendous untouched market. No competition. Every shirt wears a prospect—buys on sight. Unsurpassed quality, wide variety of fabrics and colors. Startling **LOW INTRODUCTORY PRICES**. Remarkable repeater. Agents report up to \$3 and \$5 an hour easy. Generous offer brings Youn Own Shirts Without Cost. Write for details NOW!

**SHURFIT SHIRTS, INC.**  
Dept. M-90, Arcade Bldg., St. Louis, Mo.





# ◀ A PRECISION TOOL ▶

For the Machine Shop, Manufacturing Plant,  
Service Station, and Electrical Shop

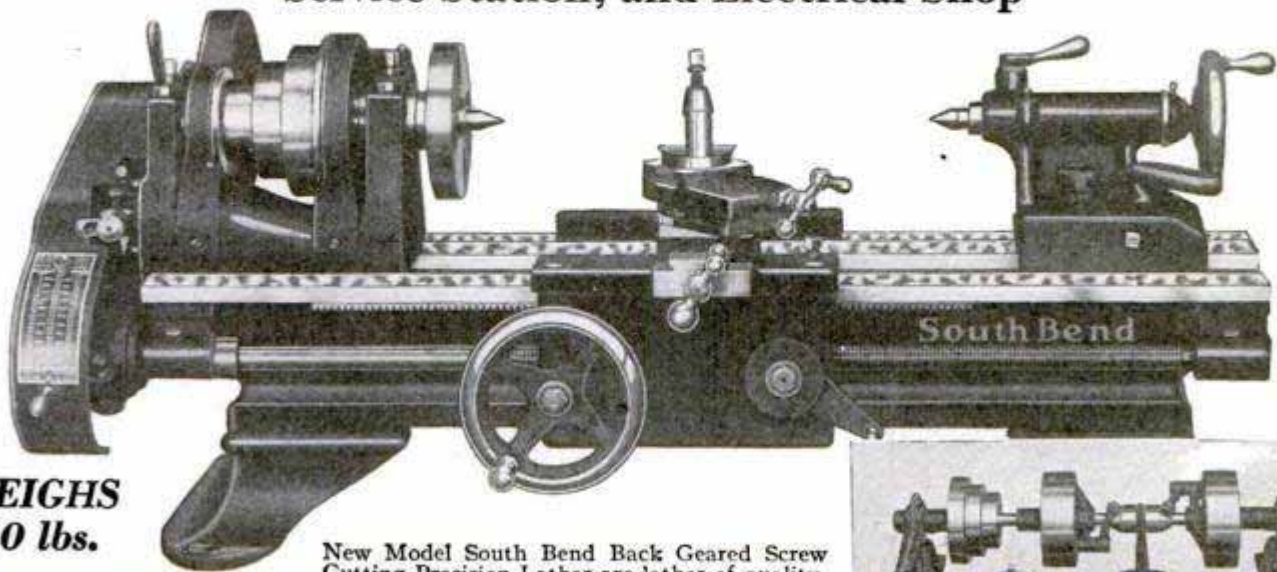

**WEIGHS**  
**350 lbs.**

**\$163**

9" x 2 1/2' New Model  
Junior Back Geared  
Screw Cutting Lathe  
with Countershaft  
and Equipment as  
illustrated.

New Model South Bend Back Geared Screw Cutting Precision Lathes are lathes of quality, accuracy and precision, used by the United States Government, Ford, Westinghouse, U. S. Steel Corporations and hundreds of other large industries. All sizes can be furnished with Countershaft or Motor Drive—Standard Change Gear and Quick Change Gear types.

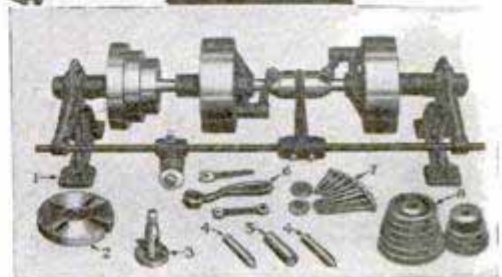

**USE THE LATHE WHILE PAYING FOR IT**

**\$32.60 Down Payment — \$11.41 Per Month**  
for twelve months puts the lathe in your own shop so you may use it while paying for it.

## Write for these Books

Catalog No. 91-A

104 pages, 6" x 9", fully illustrates, describes and prices the 96 different sizes and types of New Model South Bend Lathes and their attachments. Every lathe user will find this catalog of value for reference purposes. Mailed postpaid to any address, on request.

**Auto Mechanics Service Book No. 66**

96 pages, 6" x 9", illustrating and describing the use of the back geared screw cutting lathe in modern methods of servicing the motor, brakes and all other units of buses, trucks and automobiles. Price postpaid, coin or stamps of any country..... \$0.25

**How to Run a Lathe**

144-page book, 5" x 8", 300 illustrations. Illustrates and describes how to do all classes of metal turning work on a back geared screw cutting lathe. Price postpaid, coin or stamps of any country..... \$0.25

**Prices of Other New Model  
Screw Cutting Lathes, Floor Leg,  
Countershaft Drive**

Size of Lathe	Weight	Quick Change Type
9" x 2 1/2'	470 lbs.	\$288.00
11" x 3'	675 lbs.	\$345.90
13" x 4'	1060 lbs.	\$428.00
15" x 5'	1475 lbs.	\$525.00
16" x 6'	1875 lbs.	\$598.00
18" x 8'	2640 lbs.	\$763.00
16"-24" x 6'	2035 lbs.	\$740.00
36" x 6' Brake Drum	2195 lbs.	\$768.00

**Send Coupon  
For These  
Valuable  
Books**

**SOUTH BEND LATHE WORKS, South Bend, Ind., U. S. A.**  
625 E. Madison St., South Bend, Ind., U. S. A.  
Gentlemen: Please send me books checked.  
 Catalog No 91-A (Free).  Easy Payment Plan (Free)  
 Auto Mechanics Service Book No. 66 (25c).  
 How to Run a Lathe (25c)  
Name.....  
Address.....  
City.....  
State.....



## South Bend Lathe Works

625 E. Madison Street

South Bend, Indiana, U. S. A.

Lathe Builders for Over 24 Years — Over 50,000 Lathes in Use



Use your ingenuity  
**WIN \$250**

**Creo-Dipt Co. offers  
23 cash prizes for best uses  
of amazing new product.**

**H**OW would you like to win \$250 in cash? No work—no trouble. Before you finish reading this advertisement, you may think of the idea that will win first prize!



It's so simple. All you have to do is tell us what you think is the best, most useful, most original use for our new product, Handi-Wood. Just imagine a paste that handles like putty—yet hardens into strong wood! There are hundreds of practical uses for it. Here are a few: Filling chinks in woodwork. Patching furniture. Plugging drafty windows. Filling nail holes. Mending toys. And the man, woman, or child who can think of the most unique use for Handi-Wood gets the big \$250 first prize.

### 23 prizes altogether

Even if you don't win first prize you have a good chance to win one of the 22 others. All you have to do is use your imagination—look around the house for new uses for this new product—and let us have your ideas.

Here's your chance to cash in on your natural ability. You don't have to be an expert workman to win the prize. Nor do you have to buy any Handi-Wood. Just mail the coupon for complete details of the \$500 prize contest. Then work out your best ideas and send them in to us. You can



count on the makers of Creo-Dipt Stained Shingles to give your entry a fair chance at first prize. Handi-Wood is sold by leading lumber, paint and hardware dealers everywhere. Ask the one nearest you.

## HANDI-WOOD

### MAIL COUPON FOR RULES

CREO-DIPT COMPANY, INC.  
1651 Oliver Street, North Tonawanda, New York

I'd like to win \$250. Please send the complete information about prize contest for best uses of Handi-Wood.

Name \_\_\_\_\_

Address \_\_\_\_\_

## NEW! Automatic Power Burner for Heavy Oil



**LACO Model 'F'**

### Burns Cheap Fuel Oil Without Waste!

Now, no matter where you live, enjoy luxurious automatic oil heat at amazing low cost. Laco Model F burns cheap fuel oil and 24 West Coast Diesel Oil. Specially designed combustion chamber solves fuel waste problem—scientifically extracts every degree of heat from every drop of oil—metering it drop by drop. Burns a slow, low pressure, lazy flame, in spiral direction, not a shooting flame that blows the heat out the chimney. Every particle of oil is caught and burned. Not an atom wasted. That's the reason Laco Model F gives clean, even heat, without waste! Without soot, or carbon, or smoke!

### Quiet, Automatic

Fully equipped with electric ignition, automatic controls—room thermostat, safety lock-out system, stack switch. Operates so quietly you're never aware of it. Rubber cushioned against vibration. Colorfully finished. Only one moving part. So simple, so economical, so low priced it doesn't pay you to bother with the responsibility and labor of coal. Get amazing low price, SPECIAL OFFER, and full information now!

### LACO OIL BURNER CO.

135 Union St., Griswold, Iowa, U.S.A.

### Amazing Offer

We want dealers for Laco Model F everywhere, and will make you sensational special offer. You'll have the backing of one of the largest manufacturers in the field, national and local advertising, attractive discounts, and unusual sales helps.

### Act NOW!

Fastest selling because lowest priced burner of its kind. In great demand. Act now! Get our special discounts, and money making franchise.



### VEST POCKET ADDING MACHINE

Adds, Subtracts, Multiplies, Divides. Does work of \$300 machine. Not a toy. Million dollar capacity. Simple and accurate. Guaranteed 5 years.

**FREE TRIAL** **\$2.50**  
—SEND NO MONEY— **Total Cost**

Just name and address. We will ship Calculator immediately. On delivery, pay postman \$2.50 (plus few cents postage). (If outside U. S. send cash.) 10c additional in Leatherette Case. If not satisfied after 10 days' trial you get your money back. THOUSANDS OF SATISFIED USERS. Write for Agents' Proposition. **BABY CALCULATOR MACHINE CO.** (Mfrs.) P. O. Box 1118, Dept. 41, CHICAGO, ILLINOIS

## AGENTS 500% PROFIT GENUINE GOLD LEAF LETTERS

**S** guaranteed to never tarnish. Anyone can put them on stores and office windows. Enormous demand, large profits. Paul Clark says: Smallest day \$28.70. R. L. Reel made \$920 in two months. Write today for free sample and liberal offer to general agents.  
**METALLIC LETTER CO. 433-B N. Clark St., CHICAGO**



### BUILD SHIP MODELS

Easy to build and sell. Plans and instructions: Santa Maria, \$1.00—Clipper Ship, 80c—Viking Galley, 40c—or all three for \$2.00. Catalog 6c.  
**RICHTER'S, 3217 A. Walnut Street, MILWAUKEE, WIS.**

**EARN to PAINT SIGNS and SHOW CARDS**

We quickly teach you by mail, or at school, in spare time. Big demand, big future. Interesting work. Oldest, foremost school.

**EARN \$50 TO \$200 WEEKLY**

Otto Wiegand, Md., home-study graduate, made \$12,000 from his business in one year. John Vassos, N. Y., gets \$25 for a show card. Crawford, B. C., writes: "Earned \$250 while taking course." Write for complete information.

**DETROIT SCHOOL OF LETTERING**  
150 Stimson Ave. Est. 1899 DETROIT, MICH.

**FREE**

"Book of Facts"

Write For It



FACTORY TO YOU—SAVE to 50%—COMPARE WITH COSTLIEST OUTFITS BEFORE YOU BUY

# Enjoy a powerful new Miraco 30 DAYS FREE

Latest 1931 SUPER Screen Grid Outfit (No obligation to buy)



**NEWEST IN RADIO! TOP OPERATION**  
 in this 1931 Miraco "Easy-Chair" model with magazine racks, each end. Place it anywhere in any room. Easily moved about. Small door in top conceals dial and controls when not in use. 26 in. high, 15 in. wide—yet it contains a complete full-size radio and Super-Dynamic speaker! No outside aerial or ground required. Many other new, clever models, obtainable nowhere else, shown in free literature.

**Get Our "SEND NO MONEY" 11th Anniversary Offer!**

Latest 1931 **Super Screen Grid** FULL YEAR'S GUAR.  
 lighted 1 dial steel chassis  
 Vari-Tone and Automatic Sensitivity Control  
 Also latest PUSH-PULL Amplification

*Built like—looks like—performs like newest radios in many outfits much more costly. Latest, finest, heavy duty construction. Skillfully engineered to super-utilize a battery of "224" SCREEN GRID tubes—in addition to "245" PUSH-PULL POWER, "224" HUM-FREE long-lived POWER DETECTOR and AMPLIFIER and "280" A-C TUBES. Vari-tone feature gives any tone-pitch your ears prefer. Automatic Sensitivity Control reduces "fading," protects tubes. Phonograph pick-up connection. Built-in house wiring aerial and ground. Built-in plug for electric clock, lighter, lamp, etc. Super-sturdy power section. Razor-edge selectivity; Super-Dynamic Cathedral tone quality; marvelous distance-getter. Solid one-year guarantee if you buy! Wide choice of cabinets.*

**Easy Chair Model**  
 (as illustrated less tubes)

**Only \$49.88**  
 COMPLETELY ASSEMBLED

Values possible because you deal direct with big factory

# MIRACO

TRADE MARK REGISTERED

**CATHEDRAL TONED, SUPER SELECTIVE, POWERFUL DISTANCE GETTERS**

You need not send us a cent! For its 11th successful year, America's big, old, reliable Radio Factory again sets the pace in high-grade, latest guaranteed radios *direct to you*. And now—at history's greatest savings. With this newest perfected SUPER SCREEN GRID, push-pull, super-powered and humless electric AC set in clever, beautiful new Miraco-Mastercrest consoles obtainable nowhere else—you are guaranteed satisfaction, values and savings unsurpassed. *Get Amazing Special Offer!*

**Don't Confuse with Cheap Radios**

With Miraco's rich, clear Cathedral Tone, quiet operation, razor-sharp separation of nearby stations, tremendous "kick" on distant stations, Vari-Tone and automatic sensitivity control, and other latest features—be the envy of many who pay 2 or 3 times as much!

**EASY TERMS**  
 to reliable persons only

**USER-AGENTS WANTED**

**Exclusive Territory—Try it at Our Risk!**

Spare or full time. No contract, no experience required. Big money! Send coupon now!

Send for proof that delighted thousands of Miraco users cut through locals, get coast to coast, with tone and power of costly sets.

Miraco's are built of finest parts—approved by Radio's highest authorities. Our 11th successful year!

**Deal Direct with Big Factory**

Miraco outfits arrive splendidly packed, rigidly tested, to plug in like a lamp and enjoy at once. No experience needed. Entertain yourself 30 days—then decide. Liberal year's guarantee if you buy. Play safe, save lots of money, insure satisfaction—deal direct with Radio's big, reliable, pioneer builders of fine sets—successful since 1920. SEND POSTAL OR COUPON NOW for Amazing Offer!



At our risk, compare a Miraco outfit with highest priced radios 30 days and nights. Surprise, entertain your friends—get their opinions. Unless 100% delighted, *don't buy!* Your decision is final—no argument!

Only marvelously fine radios, of latest perfected type, at rock-bottom prices, can back up such a guarantee. Send postal or coupon for *Amazing Special Factory Offer!*

**MIDWEST RADIO CORP., 807-ES Miraco Dept., Cincinnati, Ohio**

**BEAUTIFULLY ILLUSTRATED LITERATURE, TESTIMONY OF NEARBY USERS, PROOF OF OUR RELIABILITY—**

All the proof you want—of our honesty, fairness, size, financial integrity, radio experience and the performance of our sets—including *Amazing Factory Offer*—sent without obligation!



**Free!**

**MIDWEST RADIO CORPORATION**  
 Pioneer Builders of Sets—11th Successful Year  
 807-ES Miraco Dept., Cincinnati, Ohio

**THIS COUPON IS NOT AN ORDER**

WITHOUT OBLIGATION, send latest literature, *Amazing Special Free Trial Send-Now-Money Offer*, testimony of nearby users and all Proof.  User.  Agent.  Dealer  
 Check here if interested in an **EXCLUSIVE TERRITORY PROPOSITION**  
 NAME..... ADDRESS.....

**NEW LOW FACTORY PRICES SAVE to 50%**  
 Similar Low Prices on Beautiful Variety of Latest Fine Consoles. Send Coupon!



Medium-size "Hi-Boy." Rich design, fine woods, fine finish.

Stylish small console with convenient magazine racks, each end.



Full-size wall console with latest 1931 features.





**\$2,840 Earned  
By Clynic in His  
First Two  
Months**

4 to 6 Jobs a Day—One Man—Powerful—Light

**Big Profits—and Your Own Boss**

Furnace cleaning with a Super Suction Cleaner is an all-year money maker, and you can own this new, highly profitable business on easy terms.

In his first 2 months Clynic had 178 cleanings at \$1.424; 74 repair jobs and 15 complete overhauls bringing \$1,416. Total, gross: \$2,840. And he sold nine new furnaces besides.

You need not be an expert furnace man to get big profits. Our free Plan Book tells how to make money from the start. Send coupon for it today.

The National Super Service Co.  
1958 N. 13th St., Toledo, Ohio.  
Please send Plan Book and easy terms.

Name.....  
Street.....  
City.....State.....



**Fit yourself  
Now for a  
"Softer" job**

Don't WORK for a living ALL your life when you can draw big pay for just "having fun." Short hours. Happy work. Ideal surroundings. Fit yourself now for a soft job by learning to **BUESCHER True-Tone** play a **INSTRUMENT**

Any man, woman, boy or girl can soon master a Buescher Saxophone. 3 free lessons give you quick, easy start. Play scales first hour, tunes in a week; join a band or orchestra in 90 days.

**EASY TO PAY** TAKE any Buescher instrument home with you, for six days' free trial. See what you can do. **EASY TERMS.** Play as you pay. Send the coupon today for beautiful catalog. Do it right NOW!



**BUESCHER BAND INSTRUMENT COMPANY**  
910 Buescher Block, Elkhart, Indiana B42

Without obligating me in any way, please send catalog of  
 Saxophones  Trumpets  Trombones

Mention any other..... My age is.....

Name.....

Street Address.....

Town..... State.....

**AMAZING NEW GUN**

Men all over the country are turning to this full size automatic high power rifle using round steel shot. Light. Speedy. Sporting arm balance and precision.

**TRY THE BENJAMIN 25 SHOT AUTOMATIC "THE MYSTERY RIFLE"**



OUTSHOOTS ALL OTHERS

Companion to the world famous Benjamin Single Shot. Same effective compressed air action with 25 shot automatic feed. 10 to 12 rapid fire shots on one pumping. Price \$10.00. Benjamin Single Shot Air Rifle \$5.00. Ask your dealer for demonstration or write for details and "BB MAGIC" FREE.

BENJAMIN AIR RIFLE CO., 605 North Broadway, St. Louis, Mo.

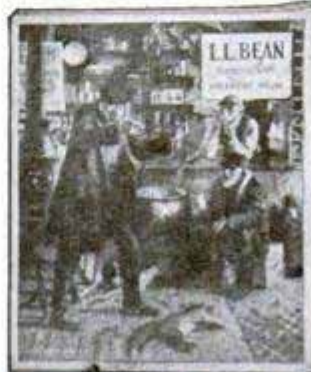

**FREE FALL CATALOG**

Just Off the Press

Showing Hunting Shoes, Duck Hunting Boots, Inner-soles, Sleeping Bags, Duffle Bags, etc.

**L. L. BEAN, Mfr.**  
118 Main St., Freeport, Maine

**Auto Seat Covers \$2.95**

Special Price Offer

**AGENTS Make \$20 a Day**

Write orders fast for this excellent Quality line Auto Seat Covers. Amazing value—quick sale. Cash daily. We deliver. Write for handsome, Free Leatherette Sample Outfit. Quality Sales, 1834-36 W. North Ave., Dept. 916, Chicago

**ELECTRIC LIGHTS ANYWHERE**

Complete 110-volt Electric Light Plant. Ideal for Farms, Camps and Summer Homes.

**\$139.00**

Runs household appliances, Install it yourself. Wiring, Fixtures and Lamps for 7 rooms, \$17.50. Also larger models D. C. or A. C. Write for circular—D. W. ONAN & SONS, 37 Royalston Ave., Minneapolis, Minn.

**WORKACE Electric WOODWORKER**

SOLD ON EASY TERMS

Complete Outfit Including Planer, Saw, Lathe, Electric Motor and Many Useful Attachments

Planer Motor Saw Lathe Buffing, Grinding, Attachments

**Fast—Accurate—Complete**

Price complete, \$89.00. Easy Terms. Write for complete information.

**J. D. Wallace & Co.,** Adams St. Chicago  
11 W. 42nd St., New York. 268 Market St., San Francisco



IF YOU ARE PLANNING A NEW HOME | IF YOU WOULD LIKE A MODERN HOME

Save Money by Installing Your Own

## HEATING and PLUMBING

For 54 years, we have supplied home builders with the latest style, fine plumbing and heating supplies. Sent direct to you—all material cut to fit—all tools loaned—free specifications by our Engineering Department—10 year Guarantee.

Surprise your friends! Be proud of your home and increase its value—Tenants stay in up-to-date flats—Modernize at a saving and make money.

WRITE TODAY FOR LATEST 36 PAGE FREE CATALOGUE

OVER 50 YEARS **HARDIN-LAVIN Co.** EST. 1876  
122-132A West Pershing Road, Chicago, Ill.

## FREE Facts About Gland Failure



Do you know why many men are old at 40, while others are young at 70? Do you know why the prostate gland slows up and why it causes bladder weakness, sciatica, pains in the back, feet and legs? Write today for scientist's new book FREE. Learn just what these symptoms mean. Learn of a new kind of treatment. Learn how 100,000 men past 40 have found quick relief without medicine. Learn facts of priceless value to you.

Write now for an interesting, illustrated book, "Why Many Men Are Old at 40." Address W. J. Kirk, 2133-W Morris Avenue, Steubenville, Ohio.



Build your own outboard hydroplane motor or sail boat. Use our plans or knock-down frames and machined parts. Many models to select from. Write for new catalog. Please enclose postage for catalog. J. B. WELCH, Inc., Dept. B, 1351 41st St., Milwaukee, Wis.

Ask the Dealer or send 20c each lineal foot

**EXACT INSIDE MEASURE**

REVERSE SIDE FOR ORDINARY MEASURE

**MASTER INTERLOX SLIDE RULE**

Every kind of Inside Measurement. Just slide out the MASTER till it reaches from stop to stop. No guessing. Quik results. Locks rigid in use. Without equal for Outside measure, too. Dealers and Agents Wanted

MASTER RULE MFG. CO., Inc., 821 E. 136th Street, NEW YORK CITY

**Wrist Adding Machine**

Hang it on watch fob, etc. Push keys with pencil. Sample \$1.00 prepaid to first agents. Sell hundred per day and make 50%. 10 days' money back guarantee.

**HANSON'S MANUFACTURING**  
3004 1st Ave. S., Minneapolis, Minn.

**MOVIES In Your Home**

Our marvelous, practical Movie Machines sell as low as \$3.75 postpaid, and use same size film as big theatres. We also have wonderful films at lowest prices—with a new film exchange service.

Don't Miss This! Write NOW for Free Catalogue.

**PARAMOUNT MANUFACTURING CO.**  
Dept. G-31, BOSTON, MASS.

## WET CELLARS MADE DRY from the Inside!

DAMP musty cellars are insanitary, a danger to health and a poor place to store valuable material.

Where water or moisture seeps in through cracks or porous spots in the floor or walls, you can make and keep your cellar dry and sweet—a fit place to work, free from odor, mold and rust—by filling the cracks and coating the moist surface with Smooth-On No. 7.

This is the one practical waterproofing that you can apply yourself, easily, from the inside, to wet or dry surface and with every assurance of thorough watertightness, even in the wettest seasons.

Excellent also for patching concrete floors, waterproofing garage, stable and washroom floors, brick walls, cisterns, septic tanks, water troughs, fountains, fish ponds, swimming pools, manure pits, etc.



Write for FREE BOOK

About 25 pounds of Smooth-On No. 7 are required for each 100 square feet of surface covered, and no experience is necessary. Complete instructions on the package.

Sold in 5-pound cans and 25 and 100-pound kegs.

**Do it with SMOOTH-ON No. 7**

SMOOTH-ON MFG. CO., Dept. 37,  
574 Communipaw Ave., Jersey City, N. J.

Please send the free Smooth-On Repair Book.

Name.....

Address.....

**Return this coupon for FREE copy of Booklet**





Diam. 2" Wt. 2 1/4 oz.

**IN THIS SMALL CUP IS COILED A SIX-FOOT STEEL RULE!**

Sounds unbelievable, doesn't it? But your hardware dealer will gladly demonstrate other unique qualities of this most remarkable of all modern tool inventions.

**The FARRAND RAPID RULE**

Patented in U. S. Nos. 1,402,589 & 1,730,199  
Write to factory for booklet and six-inch sample

**HIRAM A. FARRAND, Inc. First St., Berlin, N. H.**

**The Machine You Need!**

**CABINET SHOP SPECIAL \$247**



Includes 16" band saw, 6" jointer, and 8" circular rip and crosscut saw.

If you are ambitious and want to start a shop of your own the Cabinet Shop Special is the machine you need. This complete woodworker will build up a prosperous business for you in a few months' time.

Send coupon for complete catalog

**THE PARKS WOODWORKING MACHINE CO.**  
Dept. P-9, 1530 Knowlton Street, Cincinnati, Ohio  
GOOD woodworking machines since 1887  
Canadian Factory: 338 Notre Dame East, Montreal

Name..... City.....  
Address..... State.....



**AIR-O-AUTO POWERED COMPRESSOR SPRAY PAINTING OUTFIT**

Easy to Operate. Rugged in Construction  
Light in Weight and with it you can do first-class painting

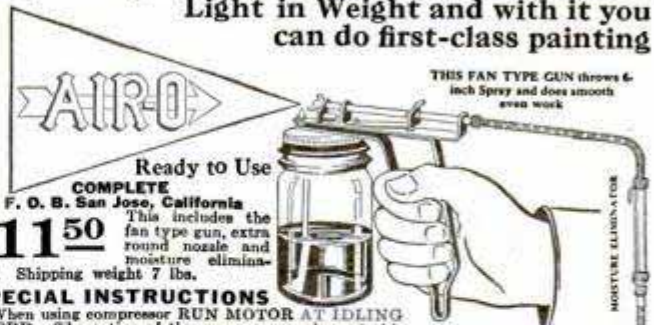

Ready to Use COMPLETE  
F. O. B. San Jose, California  
**\$11.50**

This includes the fan type gun, extra round nozzle and moisture eliminator. Shipping weight 7 lbs.

**SPECIAL INSTRUCTIONS**

When using compressor RUN MOTOR AT IDLING SPEED. The action of the compressor valves at this speed pumps its maximum air volume and air pressure, and due to the construction of the valve system, gasoline will not enter the cylinder working as a compressor.

The use of the Air-o-Auto Compressor positively WILL NOT cause any injury to the motor, as thousands of hours' use have proven.

Compressor fits 80 per cent of all cars, and with adapters No. 1 and No. 2 FITS ANY MAKE OF CAR. ABSOLUTELY THE BEST Auto Powered Compressor Paint Spraying Outfit on the market today.

WORKS FROM YOUR CAR. Remove One Spark Plug and Screw in Compressor unit.

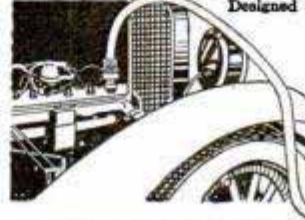

35 to 55 lbs. pressure—No Pulsation  
Designed for General Use:  
Spray Painting  
Lacquering  
Enameling  
Calcimine  
Varnishing  
Bronzing  
Oiling Springs  
Inflating Tires  
Etc.

THIS FAN TYPE GUN throws 6-inch Spray and does smooth even work



Painting Shingle Roof



Refinishing Automobile

Buy this outfit today! Do your own painting and save money! You will be proud of the fine work you can do with it

**AIR-O SPRAY MANUFACTURING CO.**  
60 South San Pedro Street SAN JOSE, CALIFORNIA

**ENGINES**

Lifetime Guarantee  
All Sizes and Styles

**300,000 In World-Wide Use**

The WITTE (Magneto Equipped) provides cheapest reliable power for farm and ranch. Does more work in less time at less cost. Put one to work—will pay for itself. Send for Big Free Catalog.

**WITTE ENGINE WORKS**  
1746 Oakland Avenue, KANSAS CITY, MO.

**SALESMEN WANTED!**

**SELL COX HOLDFAST SCREW DRIVERS**

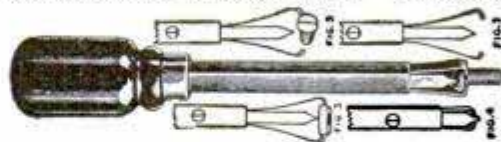

Sells on sight to mechanics for Auto, Radio and Electrical Work. Self Holding, Self Releasing.

Send 50c for sample and ask how to get Salesman's Outfit Free.  
**S. J. COX Dept. F, FRANKLIN, PA.**

**Brown & Sharpe Tools**

"World's Standard of Accuracy"

Send for Catalog No. 31 describing 2300 Precision Tools.  
Brown & Sharpe Mfg. Co., Providence, R. I., U. S. A.



**The RIGHT Tool Chest for Machinists and Toolmakers**

**GERSTNER CHESTS** are made for the most exacting Mechanics. Many sizes and styles in Free Catalog. Write for it.

*Gerstner & Sons*

481 Columbia Street, Dayton, Ohio





## A NEW PLIER for "Funny" jobs

Crescent's New Wire Cutting Plier, No. 264, is designed for those odd jobs which the ordinary types of pliers won't handle. Ideal for cutting wire box strapping, concrete reinforcing wires, baling wire, etc. Powerful cutters operate on shear principle. Their tapered edges draw wire being cut in rather than forcing it out. Fully guaranteed. One size, 5½ in. Price 35c. At your Hardware Store.

**CRESCENT TOOL COMPANY**  
Jamestown, N. Y. Cable Address "Crescent"

## CRESCENT and Smith & Hemenway TOOLS

**CRESCENT**  
Combination 4' Bench Jointer and No. 12 Saw Table

Two machines, two motors mounted on one cast iron base. Mandrel and head ball-bearing mounted. Jointer fence and saw table tilt on angles up to 45 degrees. Motors operate from any lamp socket. Exceedingly well built, accurate, handy machine for carpenters, pattern makers of the home shop at low price. We make a large line of both portable and heavy wood working machines.

Send for Free Bulletins

**THE CRESCENT MACHINE CO.**  
93 Columbia St., Leetonia, Ohio

**BURN YOUR NAME ON TOOLS WITH THE ARKOGRAF**

**PROTECT YOUR TOOLS FROM THEFT**  
Write with electricity any name or design on the hardest and finest tools and instruments, or any metal, like writing on paper with pen or pencil. Complete Outfit \$3.50—Prepaid Anywhere. Interesting illustrated circular free. Write today. Agents wanted. ARKOGRAF PEN CO., 1171 E. Stark St., Portland, Oregon

**Makes Old Ford a Tractor**

Now you can convert that old Ford car into a useful farm tractor without altering any Ford parts. We furnish the traction wheels, drive gears and auxiliary axle and mountings, ready to clamp on to the Ford frame. Pulls 16' plow.

We supply a Belt Pulley also

Write for Free Particulars.  
Shaw Mfg. Co., Dept. PM9, Galesburg, Kan.

**SOLDERALL**  
METAL IN PASTE FORM

The only convenient metal solder

Every Electrical Connection needs Solderall for perfect reception

25¢

The SOLDERALL CO., NEWARK, N.J.

## ATKINS SILVER STEEL SAWS

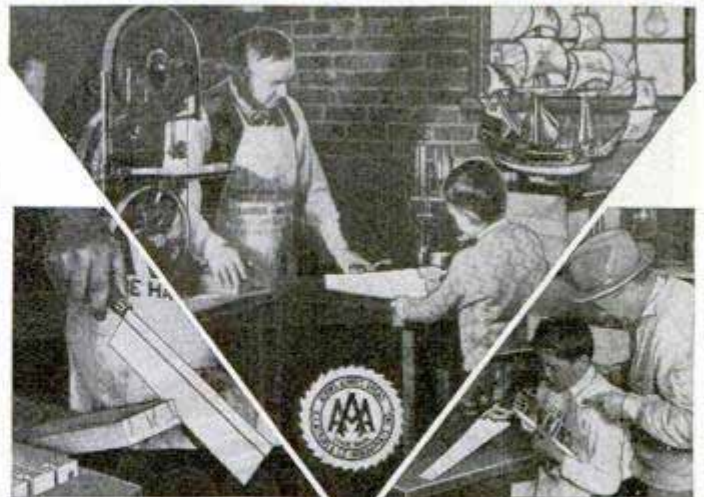

## You'll BOTH have FUN in Using GOOD Saws!

MAKE your son a partner in your home workshop! Have good times together making things! Show him your saws and explain their uses! Get him a hand saw of his own—an ATKINS "Junior Mechanic"—and teach him how to do some of the easy cutting jobs. Soon, he'll be using a saw like an "old timer."

Whether you're buying a hand saw for your boy or a circular saw for your shop machine, get an ATKINS. Made of the famous "Silver Steel," these saws MUST cut faster, run easier, hold a keen edge longer, and outlast other saws.

ATKINS makes a perfect saw for every purpose. See partial list in coupon. Ask your hardware dealer for the saws you want; write us for booklets.

## NEW Home Workshop Book!

Tells how to start a home shop . . . what tools to buy . . . how to build saw-horses, work-bench, tool-chest, etc. Large section on WOOD JOINTS and how to make them. Suggests 200 things to build. Costs only 10c—worth dollars to you.

Send Coupon for It NOW!

**NEW BOOK for Home Craftsmen**

READY SEPT. 1st

I enclose 10c for a copy of New ATKINS Home Workshop Book. Also; send free booklets on saws marked X:

<input type="checkbox"/> Band	<input type="checkbox"/> Hand	<input type="checkbox"/> Small Saws
<input type="checkbox"/> Circular	<input type="checkbox"/> Hack	<input type="checkbox"/> Planer Knives
<input type="checkbox"/> Dado Heads	<input type="checkbox"/> Jig	<input type="checkbox"/> Files
<input type="checkbox"/> Back	<input type="checkbox"/> Scroll	<input type="checkbox"/> Saw Sets

Name.....

Address.....

My dealer is.....



# PATENT

## Protect Your Ideas

### Take the First Step Today

If you have a useful, practical, novel idea for any new article or for an improvement on an old one, you should communicate with a competent Registered Patent Attorney AT ONCE. Every year thousands of applications for patents are filed in the U. S. Patent Office. Frequently two or more applications are made for the same or substantially the same idea (even though the inventors may live in different sections of the country and be entirely unknown to one another). In such a case, the burden of proof rests upon the last application filed. Delays of even a few days in filing the application sometimes mean the loss of a patent. So lose no time. Get in touch with me at once by mailing the coupon on the opposite page.

### Prompt, Careful, Efficient Service

This large, experienced organization devotes its entire time and attention to patent and trade mark cases. Our offices are directly across the street from the U. S. Patent Office. We understand the technicalities of patent law. We know the rules and requirements of the Patent Office. We can proceed in the quickest, safest and best ways in preparing an application for a patent covering your idea. Our success has been built on the strength of careful, efficient, satisfactory service to inventors and trademark owners located in every state in the Union.

### NO CHARGE for Information On How to Proceed

The booklet shown here contains valuable information relating to patent procedure that every inventor should have. And with it I will also send you my "Record of Invention" form on which you can sketch your idea and establish its date before a witness. Such evidence may later prove valuable to you. Simply mail the coupon and I will send you the booklet, and the "Record of Invention" form, together with detailed information on how to proceed and the costs involved. Do this NOW. No need to lose a minute's time. The coupon will bring you complete information entirely without charge or obligation.



My Offices  
Just Across  
Street From  
U.S. Pat. Office



Above is a view of my drafting and specification offices where a large staff of experienced experts are in my constant employ. All drawings and specifications are prepared in my offices.

# NEWS

## Inventors Write for these Free Books

### Strict Secrecy Preserved

All communications, sketches, drawings, etc., are held in strictest confidence in strong, steel, fireproof files, which are accessible only to authorized members of my staff. Feel free to write me fully and frankly. It is probable that I can help you. Highest references. But **FIRST**—clip the coupon and get my free book. Do **THAT** right now.

## Clarence A. O'Brien

Registered Patent Attorney

Member of Bar of: Supreme Court of the United States; Court of Appeals, District of Columbia; Supreme Court, District of Columbia; United States Court of Claims.

Practice confined exclusively to Patents, Trademarks and Copyrights



**Clip this Coupon and Mail it Now!**

**CLARENCE A. O'BRIEN, Registered Patent Attorney**  
708 Security Savings and Commercial Bank Bldg.  
Washington, D. C.

(Or, Suite 1106, Dept. A. 3, Woolworth Bldg., New York City)

Please send me your free book, "How to Obtain a Patent," and your "Record of Invention" form without any cost or obligation on my part.

Name.....

Address.....

(Important—Write or print name plainly and address office nearest you)



# PATENTS TRADE MARKS COPYRIGHTS



Our New York Office  
Suite 1007 Woolworth Bldg.



Our Philadelphia Office  
526 Fidelity Phila. Trust Bldg.



VICTOR BUILDING  
Our New Building Nearly Opposite U. S. Patent  
Office Specially Erected by Us for Our Own Use

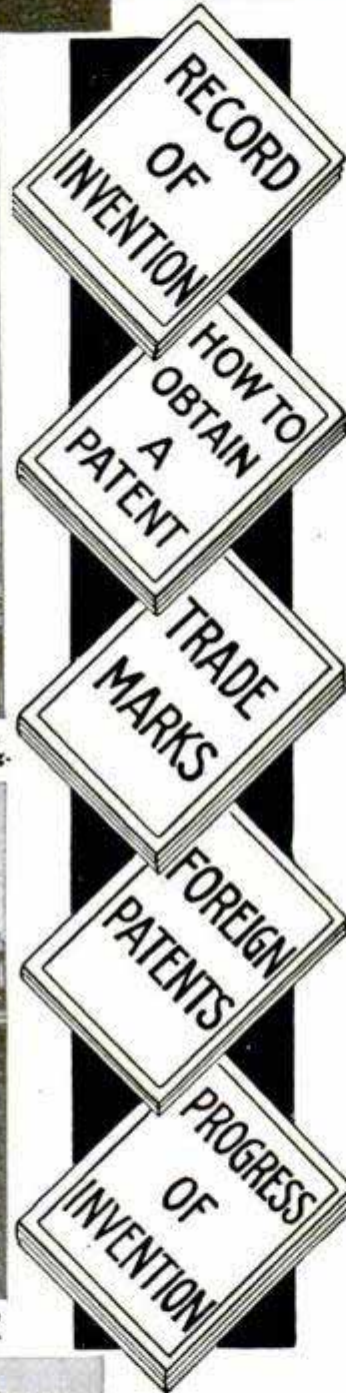

## Have You An Idea?

**Our Offer:** FOR THE PROTECTION OF YOUR INVENTION

**YOUR FIRST STEP**—The Inventor should write for our blank form "RECORD OF INVENTION." A sketch and description should be made on this Blank, signed, witnessed, then returned to us. We also give our opinion as to whether the invention comes within the Patent Office definition of a patentable invention. This "Record of Invention" will serve as "proof of conception." *There is no charge or obligation for this service.*

## Our Five Books Mailed Free to Inventors

*Our Illustrated Guide BOOK*

## How to Obtain a Patent

Contains full instructions regarding U. S. Patents. Our Methods, Terms, and 100 Mechanical Movements illustrated and described.

## Our Trade Mark Book

Shows value and necessity of Trade Mark Protection. Information regarding *Trade Marks and unfair competition in trade.*

## Our Foreign Book

We have Direct Agencies in Foreign Countries, and secure Foreign Patents in shortest time and lowest cost.

## Progress of Invention

Description of World's Most Pressing Problems by Leading Scientists and Inventors.

## Payment of Fees in Installments

It is not necessary that the total cost for the preparation and prosecution of a patent be paid in one payment. Our custom is to permit our clients to pay for their applications in three installments as the preparation of the application progresses in our office. This plan makes the payments easy for the inventor.

*We Regard a Satisfied Client* as our best advertisement, and furnish anyone, upon request, lists of clients in any state for whom we have secured patents.

*Highest References—Prompt Service  
—Reasonable Terms*

# VICTOR J. EVANS & CO.

Patent Attorneys, Established in 1898

Main Offices: 789 9th St., N. W., Washington, D. C.

*Nearly Opposite U. S. Patent Office*



# DELAYS ARE DANGEROUS IN PATENT MATTERS

## IMPORTANT! To Avoid Delay!

YOU SHOULD HAVE YOUR CASE MADE SPECIAL IN OUR OFFICE to save correspondence, secure protection and early filing date in the Patent Office. To secure **special preparation** of your case send \$25.00 on account with model or sketch and description of invention. If the invention is not patentable we will return fee less cost of search.

**We Assist our Clients to Sell their Inventions.**



MAIN OFFICE, VICTOR J. EVANS & CO.—VICTOR BUILDING, WASHINGTON, D. C.

Our Large, Comprehensive Organization has been established for 30 years and offers Prompt, Efficient and **Personal Service** by experienced Patent Lawyers and Draftsmen. Every case is in charge of a Specialist who has been selected for his knowledge and experience in certain lines of invention. Our Lawyers practice in all U. S. Courts and defend clients in suits involving Patents, Trademarks and Copyrights. All Communications, Sketches, Drawings, etc., preserved in fireproof Files, strictly **Secret and Confidential**. We shall be glad to have you consult us or to answer any questions in regard to Patents, Trademarks or Copyrights without charge or obligation.

**FREE  
COUPON**

**VICTOR J. EVANS & CO.**  
**PATENT ATTORNEYS** *Established  
in 1898*

NEW YORK OFFICES  
1007 Woolworth Bldg.

CHICAGO OFFICES  
Suite 1640-42 Conway Bldg.

PHILADELPHIA OFFICES  
828 Fidelity Phila. Trust Bldg.

PITTSBURGH OFFICES  
514 Empire Bldg.

SAN FRANCISCO OFFICES  
1010 Hobart Bldg.

MAIN OFFICES: 789-9th Street, N. W., WASHINGTON, D. C.

Gentlemen: Please send me *Free of Charge* your books as described on preceding page.

Name .....

Address .....



Our Chicago Office  
Suite 1640-42 Conway Bldg.



Our Pittsburgh Office  
Suite 514 Empire Building



Our San Francisco Office  
Suite 1010 Hobart Building



The Old Reliable Credit Jewelers

# LOFTIS

BROS. & CO. 1838

Dept. B-894  
108 N. State St. Chicago, Ill.

## DIAMONDS WATCHES

### CASH or CREDIT



No. 903  
Fine blue white Diamond. Solid 18-k white gold, \$37.50.  
**\$100**  
a week



No. 849—  
Brilliant blue white Diamond. Solid 18-k white gold, \$100.  
**\$250**  
a week

**Genuine Diamonds Guaranteed**

We import Diamonds direct from Europe and sell direct to you by mail. Lowest prices. Buy now.

### SEND FOR CATALOG!

Write for big free book of 2000 illustrations and descriptions of Diamond Rings, Dinner Rings, Pins, Brooches, Watches, Pearls, Dresser Sets, Silverware, Clocks, Kodaks, Leather Goods.

**Wrist Watch Special No. 869**  
Rectangular wrist watch in Solid 14-k white gold case, \$24.85  
**\$2.48 Down and \$2.48 a Month**

Satisfaction guaranteed or money back. Credit terms; Pay one-tenth down; balance weekly, semi-monthly, or monthly at your convenience. ALL GOODS DELIVERED ON FIRST PAYMENT.

**Standard Railroad Watches on Credit at Cash Prices**  
All Guaranteed to Pass Inspection  
Hamilton No. 992, Elgin's Latest \$60 Raymond, \$50 Illinois "Bunn Special" \$60  
Terms to Suit Your Convenience

No. 897—Elgin "Legionnaire". New Elgin for men—with white or green gold-filled case and raised figure dial, 25.00—\$2.50 down and \$2.50 a month.

## AN EASIER Way to Popularity



PLAY your way to favor with a sweet-toned, easy-playing Pan-American. You learn popular music quickly. Fun, popularity, increased income! Choose any instrument—Pan-Americans are the only complete line of nationally advertised, factory guaranteed, moderately priced instruments made. **FREE TRIAL**; write for literature; mention instrument.

### PAN-AMERICAN

Band Instrument and Case Co.  
90 Pan-American Bldg., Elkhart, Ind.

## CAN YOU USE \$100 A WEEK AND UP

An opportunity to make \$100 a week selling fine made-to-measure all-wool suits at \$23.50—\$29.50 and \$36.50 retail, direct to wearer. Biggest values—positively sell on sight. Biggest commissions paid in advance. **CHANGE TO EARN OWN CLOTHES FREE.** We attend to delivery and collections. New style outfit of large cloth samples, 100 styles—furnished Free. Write at once.

**SPENCER MEAD COMPANY** Dept. W-816  
Harrison & Throop Streets CHICAGO, ILL.

### \$23.50 ALL WOOL SUITS



## INVENTORS

who derive largest profits know and heed certain simple but vital facts before applying for Patents. Our book *Patent-Sense* gives those facts; sent free. Write LACEY & LACEY, 635 F Street N. W., Dept. 5, Washington, D. C. Estab. 1869.

# PATENTS

## To the Man with an Idea

PATENTS Procured. Trade Marks Registered. —A comprehensive, experienced, prompt service for the protection and development of your ideas. Preliminary advice gladly furnished without charge. Booklet of information and form for disclosing idea free on request.

**IRVING L. McCATHRAN**, Patent Lawyer  
Formerly with and successor to RICHARD B. OWEN  
704 International Bldg., Washington, D. C.  
41-E Park Row, New York City

### TRADE-MARKS REGISTERED

## MOTORCYCLES

### Wonderful Bargains

Small Deposit—Liberal Terms  
Indians Harley-Davidsons Ace and Henderson  
Send 10 cents for Bulletin A.  
Motorcycles shipped to all parts of the world

**WALKER-INDIAN CO., 1309 Boylston St., Boston, Mass.**



## BOW LEGS?

THIS GARTER (Pat'd) Makes Trousers Hang Straight If Legs Bend In or Out  
Free Booklet—Plain Sealed Envelope

**THE T. GARTER CO., Dept. E**  
South Bend, Ind.



## BUCHSTEIN'S FIBRE LIMB

Is soothing to your stump—strong, cool, neat, light. Easy payments. Braces for all deformities.

**D. BUCHSTEIN CO., 610 3rd Ave., So. MINNEAPOLIS, MINN.**



Send for Catalog Today

## DEAFNESS IS MISERY

Multitudes of persons with defective hearing and Head Noises enjoy conversation, go to Theatre and Church because they Use Leonard Invisible Ear Drums which resemble Tiny Megaphones fitting in the Ear entirely out of sight. No wires, batteries or head piece. They are inexpensive. Write for booklet and sworn statement of the inventor who was himself deaf.

**A. O. LEONARD, Inc., Suite 699, 70 5th Ave., New York**



## There's MONEY FOR YOU IN this better ARC WELDING!

Get into the biggest money making business of the day with Hobart Constant Arc Welder. Outfit installed at practically no expense to you. Auto mechanics, garages, in fact, anyone can easily get into this profitable business.

### COSTS ONLY \$40 MONTHLY—30 DAYS' TRIAL

Hobart Patented Unitrol Dial Eliminates Guesswork. Lets anyone weld faster, easier, more securely with lower current cost. 30 Days' Trial on money back guarantee lets you prove our claims—tremendous profits you'll make pay for equipment in short time. Write today for details.

**HOBART BROTHERS CO. Box M 901 TROY, OHIO**





# PATENTS

Booklet Free Highest References  
 Promptness Assured Best Results

Send drawing or model.

## ALL BUSINESS GIVEN PROMPT AND PROPER ATTENTION

Listed Patent Lawyer in the latest editions of the Rand-McNally Directory of Bankers and Bonded Attorneys, published by Rand-McNally & Co., Chicago, Ill.; The Baggott & Ryall Directory of Guaranteed Attorneys, published by Legal Directory Corporation, Boston, Mass.; Flugel's Law List, published by Legal Directory Publishing Co., St. Louis, Mo.; American Lawyers Annual, published in Cleveland, Ohio; Bankers Service Legal Directory, published by Bankers Service Co., Boston, Mass.; Eyre's Law List, 9 Park Place, New York City; Walters Legal Directory, Omaha, Nebraska, and the National Directory of Attorneys, Baltimore, Maryland.

**WATSON E. COLEMAN,**  
 REGISTERED PATENT LAWYER

Victor Building, 724 Ninth Street, N. W.  
**WASHINGTON, D. C.**



# PATENTS TRADE-MARKS

*Don't Lose Your Rights  
 To Patent Protection*

Before disclosing your invention to anyone send for blank form "EVIDENCE OF CONCEPTION" to be signed and witnessed.

**LANCASTER, ALLWINE & ROMMEL**  
 480 Ouray Bldg. WASHINGTON, D. C.  
*Originators of forms "Evidence of Conception."*

# PATENTS

## PROTECT YOUR IDEAS

Write today for FREE INSTRUCTIONS—or send Drawing or Model of your Invention for Examination.

Promptness Assured with Best Results

**MILLER & MILLER**  
 REGISTERED PATENT ATTORNEYS

Former Members Examining Corps U. S. Patent Office  
 255 McGill Building Washington, D. C.

The  
**BLAIR TOOL  
 AND  
 MACHINE CORP.**  
 College Point, N. Y.  
 Manufacturing  
 Machinists  
 Since 1895

## INVENTIONS

FINANCED  
 DEVELOPED  
 PATENTED  
 MANUFACTURED  
 MARKETED

Write for our free booklet.

Patent Dept.  
 at Patent  
 Law Offices  
 of  
**EDWARD  
 GOTTLIEB**  
 5 Beekman  
 Street  
 NEW  
 YORK  
 N. Y.



## How to Obtain A Better Looking Nose!

Improve your personal appearance  
 My new Model 25 Nose Shaper is designed to improve the shape of the nose by remoulding the cartilage and fleshy parts, safely and painlessly. This is accomplished thru the very fine and precise adjustments which only my patented Model 25 possesses. Results are lasting. Can be worn at night, or during the day. Money refunded if not satisfied after thirty days' trial. Write for free booklet to

**M. TRILETY,** Pioneer Nose Shaping Specialist  
 Dept. 61 BINGHAMTON, N. Y.

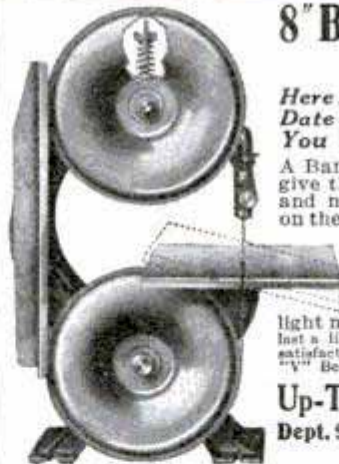

## 8" Band Saw \$13.95 Only

*Here It Is. An Ace of An Up-To-Date Band Saw. Just What You Have Been Looking For!*

A Band Saw that is guaranteed to give the same results as the larger and more expensive machines now on the market.

Has hardened and ground shafts—saw guides made of tool steel— $\frac{1}{4}$ " Atkins Silver Steel Saw Blade—will cut wood up to 2 $\frac{1}{2}$ " thick and light metal. A real machine made to last a life time, and carries a guarantee of satisfaction or money refunded. With Endless "V" Belt and Motor Pulley \$15.00.

**Up-To-Date Machine Works**  
 Dept. 90, 2909-15 South Wabash Ave.  
 CHICAGO, ILL.

# PATENTS SECURED TRADE-MARKS REGISTERED

High-class professional service for Inventors and Trade-Mark Users is necessary for PROPER PROTECTION. We Offer you our facilities on Reasonable Terms. If you have an invention send us a model or sketch and description and we will give you our OPINION whether your invention comes within the provisions of the Patent Laws. Our book, "HOW TO GET YOUR PATENT" and Record of Invention Certificate sent on request. DELAYS are DANGEROUS in Patent Matters.

Terms Reasonable. Best References.

WRITE TODAY

**RANDOLPH & COMPANY, Patent Attorneys**  
 301 VICTOR BUILDING, WASHINGTON, D. C.

Name.....  
 Address.....





## LUMINOUS PAINT

**Make Your Watches, Clocks, Etc., Visible by Night**

The very latest discovery in the scientific world. Hitherto, practically unobtainable except at an exorbitant price, we have at last succeeded in producing this remarkable LUMINOUS PAINT, which, applied to the surface of any article, emits rays of white light, rendering it perfectly visible in the dark. THE DARKER THE NIGHT THE MORE BRIGHT IT SHINES. Quite simple to use. Anyone—you can do it. A little applied to the dial of your watch or clock will enable you to tell the time by night. You can coat the push buttons or switch plates of your electric lights, match boxes, and innumerable other articles; make your own Luminous Crucifixes, Luminous Rosaries, etc. Small bottle, price 25c. Larger sizes, 50c and \$1 postpaid. JOHNSON SMITH & CO. Dept. 805 RACINE, WIS.



### Cigarette Maker

Roll your own and save money. Better and quicker; saves more than half. Use your favorite brand of tobacco. Net, useful, handy. Pocket size, weighs 1/2 oz. Made entirely of metal, nickel plated. 25c, 3 for 65c.



### GOOD LUCK RING

Very striking, quaint and uncommon. Silver finish; skull and crossbones design, two brilliant, flashing gems sparkle out of the eyes. Said to bring good luck. Only 25c ppd.



### Exploding Cigarettes

Box contains ten genuine rings of excellent quality. They appear so real, but when each cigarette is about one-third smoked, the victim gets a very great surprise as it goes off with a loud BANG! A great mirth provoker yet entirely harmless. Price 25c box.



### U. S. BABY TANK

25 Cents



It goes with real Yankee Pop—by its own power. Most remarkable toy ever invented. By drawing the Tank backward, either with the hand or over the floor or table and then placing it down, it will crawl along, overcoming all obstacles, in the same life-like manner as the larva Tank that proved so deadly in the great war. What makes it go is somewhat of a mystery, for there is no mechanism to wind up as is usually understood with mechanical toys, yet this tank will keep plodding along ten times longer than the ordinary run of toys. It will perform dozens of the most wonderful stunts; 2 1/2 inches long. Price only 25c prepaid. Postage Stamps accepted in payment of all orders.

### NOVELTY BADGES



**Kissing Permit 10c** Two very novel metal badges, nickel plated, that you can wear, giving you fun out of all proportion to their trifling cost. 10c, each badge, 3 for 25c, or 75c per doz. postpaid anywhere.

### MIDGET BIBLE

**GREAT CURIOSITY** Smallest Bible in the World. Size of a postage stamp. 200 Pages. Send to bring good luck to the owner. A genuine work of art. Must be seen to be appreciated. Make good money selling them to friends, church acquaintances, etc. PRICE 15c each, 3 for 40c, 12 for \$1.35, 100 for \$7.50. Also obtainable in Leather Binding, with gold edges. Price 50c each, 3 for \$1.25, \$4.50 per doz. Magnifying Glass for use with Midget Bible 15c.



### STAGE MONEY



With a bunch of these bills, it is easy for each person of limited means to appear prosperous by flashing a roll of these bills at the proper time and peeling off a genuine bill or two from the outside of the roll, the effect created will be found to be all that can be desired. Prices, postpaid: 40 Bills 20c, 120 for 50c, or \$3.50 thousand postpaid.

### MAGIC MADE EASY 250 MAGIC TRICKS 10c



An excellent little book containing 250 Parlor Tricks, tricks with cards, coins, handkerchiefs, SEED, FINEA, glasses, etc. So simple that a child can perform them. Profusely illustrated. Sent postpaid. To any address for only 10c, 3 copies for 25c p.p.d. 4 Other Books on Magic You Should Have: Heller's Great Book of Magic.....25c Magic for the Amateur Magician.....25c 125 Tricks with Cards.....25c Conjuring Tricks and Social Entertainer.....25c

### Wonderful X-Ray Tube



A wonderful little instrument producing optical illusions both surprising and startling. With it you can see what is apparently the bones of your fingers, the lead in a lead pencil, the interior opening in a pine stem, and many other similar illusions. Price 10c, 3 for 25c.

### SURPRISE MATCHES

More fun than lighting with your wife. Look just like ordinary matches. As the victim tries to light one he gets quite a surprise. Price 10c per box, 3 boxes for 25c, 12 for 75 cents.



### Motto Ring

Lots of harmless fun and amusement wearing these rings. Made in platinum (to resemble platinum), with an emerald, as illustrated. Only 25c Postpaid.

## BLANK CARTRIDGE PISTOL

Protection against Burglars, Tramps, & Dogs Special Offer 1 Blank Cartridge Pistol 100 Blank Cartridges 1 500-page Novelty Catalog ONLY \$1.50



Well made and effective, modelled on latest type of Revolver; appearance alone is enough to scare a burglar. When loaded it may be as effective as a real revolver without danger to life. It takes standard .32 Cal. Blank Cartridge—obtainable everywhere. Special cash with order offer: 1 Superior quality Blank Cartridge Pistol, 100 Blank Cartridges, and our new 500 page De Luxe Catalog of latest novelties; all for ONLY \$1.50. Shipped by Express only. Cannot go by parcel post. Extra Blank Cartridges 50c per doz. Special Hoister (Cowboy Type) for pistol 50c. No C. O. D. shipments.

The Lot Shipped by Express Only Cash With Order Only

## LOOK 35c LOOK Wonderful Instrument.



Greatest thing yet. Nine separate articles in one. Everybody delighted with it. Odd, Curious and interesting. Lots of pleasure as well as very useful. It is a double Microscope for examining the wonders of nature. It is also an Opera Glass, a Stereoscope, a Burning Lens, a Reading Glass, a Telescope, a Compass, a pocket Mirror, and a Laryngoscope—for examining eye, ear, nose and throat. It is worth all the cost to locate even one painful cinder in the eye. Folds flat and fits the pocket. Something great—you need one. Don't miss it. Sent by mail. Only 35c or 3 for \$1.00

## THROW YOUR VOICE



Into a trunk, under the bed or anywhere. Lots of fun fooling the teacher, policeman or friends.



### THE VENTRILO

a little instrument, fits in the mouth out of sight, used with above for Bird Calls, etc. Anyone can use it.

Never Fails. A 16-page course on ventriloquism, the Ventrilo. ALL FOR 10 CENTS

## PISTOL CIGARETTE CASE



It looks like a deadly weapon, but it is merely a novel Cigarette Case. This clever contrivance has proved itself better than the real thing in many an awkward encounter. Great fun "sticking up" your friends. They squirm and protest it might be loaded. Pull the trigger and the slide flies open disclosing the cigarettes. Well made, light and compact. Weight only 2 ounces.

PRICE POSTPAID 25c

## MAGICIAN'S BOX OF TRICKS

Apparatus and Directions for a Number of Mysterious Tricks. Enough for an Entire Evening's Entertainment.... \$1.00

### Anyone Can Do Them

It is great fun mystifying your friends. Get this Conjurer's Cabinet, and you will be the cleverest fellow in your district. It contains the apparatus for ten first-class tricks, including the MAGIC BALL AND VASE TRICK (a wooden ball is placed inside, and upon replacing the lid has disappeared and is found in someone else's pocket); the HINDOO TRICK CARDS (can be made to change completely no less than five times); DISAPPEARING COIN BOX (a coin, placed in the wooden box, vanishes entirely or changes into a coin of another denomination); the GLASS GOBLET TRICK (a coin is dropped into a glass of water and when the water is poured out the coin has vanished and is found somewhere else); the RIBBON FACTORY FROM THE MOUTH TRICK (a seemingly endless supply of colored paper ribbons comes out of your mouth); the DISAPPEARING HANDKERCHIEF (a handkerchief held in the hand mysteriously vanishes); the WIZARD'S RING COIN TRICK; the ENCHANTED BOTTLE (no one but yourself is able to make it lay down); the GREAT HAT AND DICE TRICK (a large die is placed on top of a hat, disappears, and is found underneath yet no one has touched the hat), and last, but not least, the GREAT PHANTOM CARD TRICK, or two from five leaves nothing. Full instructions are sent for performing each trick. In addition to the above, a number of other feats and illusions are fully explained for which you can easily make or procure the necessary apparatus. Price complete \$1.00 postpaid. Postage Stamps accepted.



**JOHNSON SMITH & CO.** Dept. 805 RACINE, WIS. A De Luxe Edition of our new CATALOG mailed on receipt of 25c. Handsome binding. Bigger and better than ever. Only book of its kind in existence. Nearly 600 pages of all the latest tricks in magic, the newest novelties, puzzles, games, sporting goods, rubber stamps, unusual and interesting books, curiosities in seeds and plants, etc., unobtainable elsewhere. Remit by Coin, Money Order, Check or unused U. S., Canadian and Foreign Stamps for all articles listed above.

JOHNSON SMITH & CO., Dept. 805, RACINE, WIS.



## ROYAL'S BUDGET PLAN Makes Buying Easy

**10 MONTHS TO PAY**  
Wear this handsome, "Lone Eagle" Bulova Watch! Send only \$2. and watch comes to you postage prepaid — no C.O.D. to pay on arrival.

**\$2.00**  
DOWN . . .

**10 Days Free Trial. Satisfaction Guaranteed**  
After examination and 10 days free trial pay balance in 10 equal monthly payments. No interest—no extras—no red tape. All transactions strictly confidential. You take no risk—satisfaction absolutely guaranteed or money back.

**FREE LATEST CATALOGUE TO ADULTS**  
Write for Catalog of Diamonds and Standard Watches.



**It's a BULOVA**  
**\$37.50**

**EH-40—"Lone Eagle"—** Handsomely engraved lifetime case, guaranteed 15-Jewel Movement. Radium hands and dial. Patented "dust-tite" protector. Flexible link bracelet to match. Balance \$3.55 a Month.

Est 1895

## ROYAL DIAMOND & WATCH CO.

ADDRESS DEPT. 11-J 170 BROADWAY, N.Y.

# Extra Money This Fall

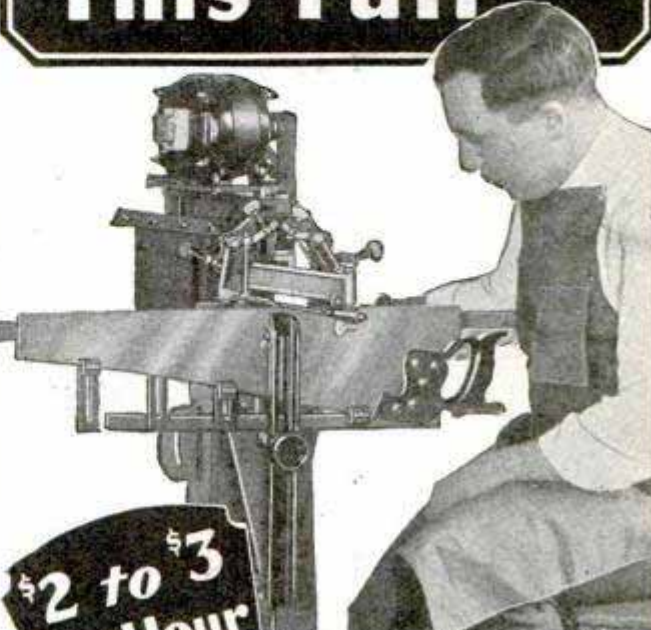

**\$2 to \$3**  
**An Hour**  
**In Spare**  
**Time**

## A Fine Paying Cash Business

## This Modern Woodworker \$45.00



**Belt Sander—Saw—Grinder—Drill**  
Has 1/4 H. P. GE Motor, switch, cord and plug, 3x24 in. sander for strips any length, 6-in. adjustable saw, 5x3/4 in. grinder for any tool or drill. Chuck takes up to 3/4-in. drills. Operates many other tools. Bronze bearings, endless belt, polished table, guards and trimmings laquered. Size 20x20. Weight 60 lbs. Lowest price known for high grade tool. Satisfactory or money back. Order now or write for circular P.

**Steiner-Fulton Products Corporation**  
5751 Easton Ave. St. Louis, Mo.



## LAWN MOWER SHARPENER

WELLS MANUFACTURING COMPANY  
Box 613, Greenfield, Mass., U. S. A.

## AGENTS AND SIGN MEN

Earn up to \$100 Weekly, and over, Putting up  
OUR GENUINE GOLD LEAF SIGN LETTERS

**R**

—on store and office windows, board signs, trucks and glass signs. We also make to order script signs and business emblems singly or by the thousands. A permanent business. No capital or experience required. Big demand in every City. Samples and Literature Free.

CONSOLIDATED SIGN LETTER CO. 71-X W. Van Buren CHICAGO, ILLINOIS



## MOTORCYCLES

**WE WILL TRUST YOU**  
Pay As Low As \$2.00 per Week  
Hendersons, Harley-Davidsons, Indians  
Slightly used and rebuilt. Hundreds to select from.  
Send 10c for list today.

MYEROW BROS. CO., 15 Berkeley St., Boston, Mass., U. S. A.

Build a good, steady, permanent business of your own that will pay you a handsome income all year 'round, filing saws on the **Foley Automatic Saw Filer**. Very little capital required—buy on easy payments. Make money while starting. Paul J. Davidson, who does spare time filing, writes, "*... have made as high as \$12 in one day. . . . My business is increasing all the time. Will soon be forced to devote my entire time to saw filing.*"

### No Experience Necessary

It is easy to file all kinds of saws on the Foley. After saw is put in machine and simple adjustments made, it files *automatically*. E. D. Toulme writes, "*Without any previous mechanical experience I operated my Foley guided by the instructions received with the machine.*"

### Start Making Money At Once

You will get all the business you can handle just as soon as you let people know you have a Foley Filer. **No Canvassing.** Others are making big money with the Foley—YOU can too. Send coupon at once for **Free Plan.**

## Foley Manufacturing Co.

205 Foley Bldg., 11 Main St. N. E.,  
MINNEAPOLIS, MINNESOTA

Please send me complete information about the Foley Filer and Free Plan for getting business.

Name.....

Address.....

City..... State.....





**W**OOD all gone—won't hold screws—doors sagging—knobs pulling out—locks loose. Here's the best way to end all those annoying repair jobs. Replace the rotten wood with Savogran Crack Filler, push the screws back in place and the job's done—for good.

Get a can of Savogran Crack Filler for your work-bench. You'll find a thousand uses for it around the house. It will not *shrink*. Takes paint perfectly and defies detection. At hardware and paint stores.

### BIG ONE-POUND CAN

# 30c

Savogran Crack Filler: 35-lb. all-metal pail (for painters, woodworkers, industrials) \$7.70; 5-lb. can \$1.25; 1-lb. can 30c. Won't harden in the can—no waste—a real buy!

### PAINTERS' SAVOGRAN

Want to make a hit with the Mrs.? Clean out the garbage can with Painters' Savogran—make it sanitary and spotless without scrubbing. Painters' Savogran cleans like magic, softens hard paint-brushes, removes paint from clothing. Saves time, money, and hard work. The professional cleaner for household use—used by painters for 40 years.



**SAVOGRAN COMPANY**  
India Wharf, Boston, Mass.

# SAVOGRAN CRACK FILLER

REG. U.S. PAT. OFF.

PAT. APP. FOR

## WILL NOT SHRINK!

When your hands  
look like this—



try **LAVA SOAP!**  
58 seconds with  
LAVA'S rich,  
pumice-filled  
lather, changes  
'em to supper-  
table hands.



Takes the dirt,  
but leaves  
the skin

A Procter & Gamble  
Product

### Catch Fish!

Eels; Mink; Muskrats with our new folding galvanized **STEEL WIRE TRAP**. Write for our **FREE TRAP OFFER** and Bargain Catalog. \$1 Box of our famous Fish Bait **FREE** to introduce our traps. **WALTON SUPPLY CO., 3502 JUNIATA AVE., ST. LOUIS, MO.**

### ALL Balsa!

A realistic scale model of a one-place low-wing sport plane. Wing spread 15 in., weight only 3/8 oz. Takes off under own power. Flies 140 feet consistently.

New all-balsa construction makes this model lighter, stronger, better-looking and far easier to build. Everything marked. Nothing to draw or measure. No tools or skill required. Set includes die-stamped aluminum propeller, disc wheels, rubber motor, quick-drying cement, balsa, clear directions and all other material. Nothing else to buy. Complete set, postpaid in U. S. and Canada, \$1.00. Satisfaction or money back. Order now.

**The Midland Model Works, Dept. E, Chillicothe, Ohio**  
(We cannot accept stamps or C. O. D.'s.  
No catalogue except with set.)





# GREAT After Driving!

When you return from an automobile trip with eyes that are weary and bloodshot, apply a few drops of harmless *Murine*. Within a few moments the tired, burning sensation will disappear, and before long your eyes will be clear again. Millions of bottles of *Murine* were used last year by motorists, sportsmen and others whose eyes were exposed to irritation and strain. Write *Murine* Company, 9 E. Ohio St., Chicago, for valuable free book on the proper care of the eyes.

## MURINE FOR YOUR EYES

### Complete Your HOME WORKSHOP EQUIPMENT with the H & A BALL BEARING SHAPER

Turn out moldings, beadings, matching—every conceivable millwork job—at a fraction of the usual cost. The first time that a practical heavy-duty Shaper has ever come within the price range of the average home shop. Also used in hundreds of woodworking and industrial shops. Portable; electric. Write for catalog and easy payment plan.

**HESTON & ANDERSON**  
609 Kirkwood Ave. FAIRFIELD, IOWA



### \$100 a Week PROVING to Merchants It Pays to Advertise

R. O. Gosden made \$321 in 9 days  
—sold 5 machines in 2½ hours.

### THE EUREKA ADVERTISER (Automatic Wrapping Paper Printer)

Turns waste space into valuable advertising. Automatically prints merchant's "Ads" on wrapping paper, bags, blotters, circulars, etc., in one or two colors. Quickly pays for itself. Flint, N. Y., sold 4 machines in two hours. Collect and keep your commission. We deliver. Every merchant a prospect. Write now for unusual opportunity.

**WOODWORKERS CO., 1206 Cortland St., Chicago, Ill.**

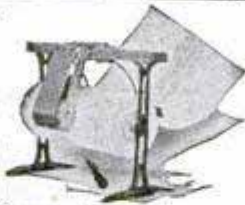

### Electrify Your Radio for

With Townsend "B" Power Unit. Over 150,000 in use. Hooked up in a few moments. Use same tubes—no changes. Better reception—distance. Send name and address for details, Proof and Free Trial Offer.

**TOWNSEND LABORATORIES, 715 TOWNSEND ST., CHICAGO, ILL.**



## MOTORCYCLES

Direct to you at wholesale prices Send 10c today for the latest Illustrated Bulletin and Confidential Price List of  
Guaranteed Indians Harleys Hendersons SuperX etc.  
(Sold on easy terms if desired)

**CRANDALL CYCLE CO.** 826-28 State St. Shipments to all parts of the world  
Motorcycles Since 1905 Springfield, Mass.

## This workshop helper does

# 3 BIG JOBS



When you pick a workshop helper you want one that is handy; one that knows how to do several things well. That's the kind of help you'll get from 3-in-One Oil.

Most any oil will provide a certain amount of *lubrication*. But 3-in-One does *three* different things to keep your tools, motors and other equipment in the pink of condition. It *cleans* the old, gummy oil from bearings and working parts. It *lubricates* perfectly. It *prevents* rust. Because 3-in-One is blended from *animal, mineral and vegetable* oils, it does all of these jobs at once—much better than any single-element oil ever can.

At good stores everywhere, in handy cans and bottles. Write now for free sample.

**THREE-IN-ONE OIL CO., DEPT. 123**  
130 William Street, New York

Factories: Rahway, N. J. - Montreal, Que.



# 3-in-One Oil

CLEANS - LUBRICATES - PREVENTS RUST



# HEAT WITH GAS

## -- No Matter Where You Live

— AT A COST OF ONLY 1½c PER HOUR!

IT'S easy to have Gas Heat—without the need of gas mains. The marvelous new Sunshine Radiant Heater is a regular gas-producing, gas-burning plant all in itself. Now, selling at unusually low price!—so low it will surprise you!



**PRODUCES AND BURNS ITS OWN GAS!**

Provides safe, clean, healthful gas heat in 60 seconds from a cold start. Does away with splitting wood, carrying coal and trimming wicks. A child can carry it from room to room while in operation. No piping, no installation expense, no buried tank. Thousands in use everywhere saving their owners big money.



**Use Anywhere**—This beautiful trouble-saving heater is just the thing for homes, stores, offices, halls, restaurants, churches, lodge-rooms, filling stations, etc.

**Only \$4.75** down payment brings this world's most wonderful heater to your home. Cash, or unusually Easy Terms.

**15-DAYS' TRIAL**—We'll send the Sunshine to try 15 days in your home. Enjoy its comfort and convenience for years—get it at the low agent's price. Know why it is the world's greatest heater bargain.

**FREE**

Startling Low Offer on 1931 Model, and literature containing full information. Write Today!

**THE SUNSHINE PRODUCTS CO., 338 Factory Bldg., 1322 Grand Ave., Kansas City, Mo.**

### AGENTS—BIG MONEY!

**"I MADE \$100.00 CLEAR IN ONE DAY"—Says R. M. Spangler**

Here's what he writes: "Have had wonderful success selling Sunshines. Today, in 5 demonstrations, I sold 8 heaters. Yesterday I made \$100 clear profit. The heater sells itself." L. Maloney writes: "—last Tuesday I made \$53.80 clear money selling Sunshines. Today I closed a deal for 100 heaters." Hundreds of others, with little or no selling experience, are making Big Money hand over fist selling this popular heater, full or part time.

**Everyone Wants** safe, clean, economical gas heat. The Sunshine exactly fills the bill. Sells on a money-back guarantee. And is backed by a concern with 21 years' reputation for honesty and square dealing. That's why this heater is such an amazingly easy seller! You simply demonstrate it. The Sunshine sells itself!

**Be the Exclusive Sunshine Distributor** in your vicinity. Write for our amazing Generous Offer today!

### AMERICAN JIFFYKOOK



Portable gasoline stove. Lights instantly like gas—no generating required. Burns with blue flame, hotter than city gas. Has built-in air pump. A similar stove is made with two burners. We make world's most complete line of pressure burners, tanks, etc. Write for free information and prices.

**AMERICAN GAS MACHINE CO., Inc.**  
Dept. 9-H ALBERT LEA, MINN.

### Strange Invention Pays Immense Profits



Sell only device in the world that prevents kinking, snarling, tangling of telephone and electric iron cords. All our agents given new kind of ironing cord that prevents scorching and saves electric bills. It's a gold mine for house-to-house workers. Don't delay. Send now for FREE offer.

**NEVERKNOT CO.**  
Dept. 9-V 4503 Ravenswood, Chicago

### \$6240 MADE BY CHAI SELLING OUR PENS

No. 10, 3 in 1 fountain pen-pencil with compass.  
"I can honestly say that I have earned \$60 weekly for the last two years selling these pens."  
—Joe. Choi, Illinois.

SEND ONLY

**39¢**

**GUARANTEED TWO YEARS**

Writes like \$7 pen.

FREE: Wholesale catalog showing over 500 fast sellers.

**SPORS IMPORTING CO.**  
730 Main St. Lesueur Center, Minn.

### Safe as a glider and more easily handled AMERICA'S MOST POPULAR SPORT PLANE

Start Building it Now For Only \$12!

Have you seen the new Heath Parasol? Do you know you can build it from clear, easy plans for only \$199—and fly it for less than one cent a mile, including every conceivable expense?

If not—consider the countless hours of flying open for the first time at a cost you can afford.



The Heath Parasol is aviation's most economical plane. With wings mounted on the side—it takes no more space than a car—and costs less to store. It requires no airport because it lands on any field or even a highway. And for ease and accuracy of handling—it is truly in a class by itself.

Build it for  
**\$199**  
Flyaway  
**\$975**

#### You too can build it

Hundreds of enthusiastic builders declare Heath plans clear and easy to follow. Parts are shipped in 11 convenient, progressive groups. \$12 brings the first shipment.

Don't delay another day. Let us tell you more about America's most popular sport plane. 10 cents in stamps or coin brings interesting illustrated booklet. Heath Aircraft Corp., Dept. P-9, 1721-9 Sedgwick Street, Chicago, Ill.



**Build Your Own Home**

5 Rooms,  
Bath  
**\$1377**



**MODERN HOMES  
World's Lowest Prices!**

Save \$500 to \$2000 at our amazing new prices. We furnish Plan-Cut materials, plans, with building instructions. Choose from 100 sturdy homes. Brick, stucco, or wood. No extras! Save 1/2 labor cost—18% waste. Send free coupon.



**Modern Garages**

**\$90 up** Easy to build with our Plan-Cut materials. Saves you one-third.

**Poultry Houses**



**\$56 up** Design shown No. 464—size, 20x20—\$152. Planned for sunshine, warmth, ventilation. Easy to build. Plan-Cut.

**Remodel Your Home**

Get our free estimate. Mill prices. Quick service. Satisfaction guaranteed or money back.

**5000 Bargains**

Lumber, windows, doors, flooring, roofing, paints, cabinets, screens, hardware, etc. Write.



**Get Free Book**

If you plan to build, repair or remodel, be sure to get our book of 100 homes and 5000 building material bargains.

**Gordon-Van Tine**

World's Largest Specialists in Home Building Since 1865  
1503 Case Street, Davenport, Iowa

Check:  Homes  Garages  Poultry Houses  
 Building Material  Estimates

Name.....

Address.....

Cal. 30-40 Six Shot



**KRAG CARBINE**

All the qualities of a high price rifle. In fine used condition, all working parts guaranteed for one year. Send today for our Free 60-page illustrated catalog of money saving values; Guns, Ammunition, Cutlery, Sports and Gov't goods.

Price  
**\$9.75**

Deposit required on all orders. Money refunded if not satisfactory  
W. Stokes Kirk, Dept. P. N. 9, 1627 N. 10th St., Phila., Pa.

**New  
FREE BOOK**  
New Styles - New Colors  
Now only **\$5.00** DOWN  
ON ANY RANGE,  
HEATER OR  
FURNACE

**SAVE 1/3 to 1/2**

New FREE book quotes **Factory Prices**. Now only \$5 Down on any stove, range or furnace. Year to pay. Choice of 5 colors in New Porcelain Enamel Ranges. New Cabinet Heaters—\$38.25 up.



Ranges **\$37.50** up



Cabinet Heaters **\$38.25** up

and sizes. Cash or easy terms. 24-hour shipments. 30-day FREE trial. 360-day test. Satisfaction guaranteed. 30 years in business. 750,000 customers. Write today for FREE book.

**KALAMAZOO STOVE CO.**  
391 Rochester Avenue  
Kalamazoo, Mich.

**"A Kalamazoo Direct to You"**  
Trade Mark Registered

**SILVER ACE**



Altiplane

Patents Pending

PLACE this beautiful little aluminum model glider on your family car and watch it rise or fall according to your speed. It will delight you. Price, 50 cents. Catalogue of 24 Flying Silver Aces, 5 cents.

**AERO MODEL CO.**

Dept. M-29, 111 North Wacker Drive, CHICAGO

**Now! Do Your Own Electric Nickel Plating**

Introductory Offer

ONLY **\$6.50**  
Plus Postage

For Plating  
Nickel, Brass,  
Copper, Silver,  
Gold, etc.



**A REAL MONEY-MAKING OPPORTUNITY**

NO EXPERIENCE REQUIRED. Do YOUR OWN Electro Plating in Your Home, Garage, Office, or Place of Business. Electrically Deposit Metal—Nickel, Brass, Copper, Silver, or Gold. You can Successfully do all the plating on your Automobile, Electric Fixtures, Faucets, Spoons, Forks, Chandellers, Tools, Coffee Urns, Surgical and Dental Instruments, Utensils, large or small, Iron Stoves, Music Instruments; recondition worn plating or plate New Work; do it Instantly without interrupting the Service or without removing the parts to be plated with the

**ALADDIN PORTABLE ELECTRO-PLATER**

Simple and Economical to operate. Not a toy, but a practical Plating Outfit with which Perfect and Durable Work can be done. Positively Guaranteed to do as we claim. BE YOUR OWN BOSS! Build up a Profitable Aladdin Electro-Plating Business of your Own. This offers wonderful ECONOMY to users and BIG MONEY-MAKING possibilities to AGENTS. Thousands in Service since 1924. Write today for FREE BOOKLET and Testimonials.

P. J. F. BATENBURG CO. Dept. 188 RACINE, WISCONSIN

—AGENTS—  
WANTED EVERYWHERE



# A REVELATION in RADIO VALUES

FREE  
168  
PAGE BOOK

## Get This Catalog

### LOWEST WHOLESALE PRICES

A wonder book of remarkable money-saving bargains . . . the latest radio attractions . . .

168 pages and over 500 illustrations . . . all your radio needs priced so low it will startle you. The latest radio devices . . . the last minute improvements in sets, accessories, parts and kits.



### New 1931 Screen Grid, Tone Control A. C. Humless All-Electric Sets Slot Machine Sets, Etc.

remote control, public address, phono-combinations, all dynamic speaker equipped. Beautiful Consoles. Bed-rock prices and unusual values on all sets, parts and appliances. You must have this catalog . . . no matter what your radio requirements . . . to tune in on the newest and greatest values in radio merchandising, made possible by the tremendous buying power of this great corporation. The catalog of catalogs. Brimful of bargain information. Money-saving values on every page at real wholesale prices. Send for it TODAY. It's FREE.

### The House of Outstanding Values

Sets, parts, kits and everything in Radio. Resources over three million.

**ALLIED RADIO CORPORATION**  
711 W. Lake Street Dept. 66 Chicago

## Buy Direct on Credit

The World Famous  
21 Jewel Thin Model

### Santa Fe "Special"



Our "Direct to You" offer and Extra Special Distribution Plan is fully explained in the New Santa Fe Special Booklet just off the press. The "Santa Fe Special" Plan means a big saving of money to you and you get the best watch value on the market today. Watch sent for you to see without one penny down.

## FREE

Write now for our New Watch Book—just off the press. All the newest watch case designs in white or green gold, fancy shapes and thin models are shown. Read our easy payment offer. Wear the watch 30 days FREE. All watches sent on approval and sold on payments. ONE MINUTE—it will only take "one minute" of your time to send for new watch book DO SO NOW.

### Santa Fe Watch Company

Dept. 96 Thomas Bldg. Topeka, Kansas

Send for copy of catalog describing over

## 1500 GOOD TOOLS

GOODELL-PRATT COMPANY, Greenfield, Mass.

## "Delta" Handi-Shop Makes Woodworking Easy

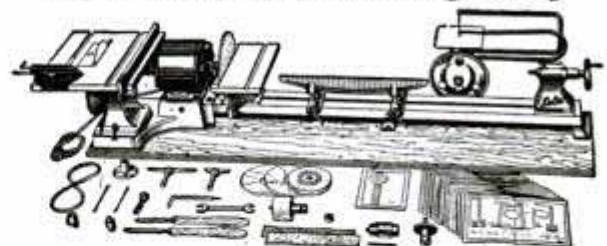

### Complete, Practical, Man-Sized Workshop of Efficient Design

The Handi-Shop includes all necessary equipment for woodturning, face turning, circular sawing, scroll-saw work, sanding, drilling, dado and joining work, grinding, buffing, tool-sharpening, and carving. This complete, motorized workshop enables you to work with wood easily, quickly, without drudgery. Saves money on repair work. Opens splendid opportunity for full or spare-time moneymaking. Full instructions and complete set of blue prints included FREE!

## 10 DAY TRIAL—EASY TERMS

You can have this husky electric workshop for 10 Days' Trial in your own home. Your choice of three convenient plans of payment. Send today for FREE illustrated literature giving complete description of the many features of the Handi-Shop. Also complete catalog of full line of Delta woodworking equipment, and details of 10-Day Trial. Easy Payment Plans.

**DELTA SPECIALTY CO.**  
1661-67 Holton St.

Dept. A-936  
Milwaukee, Wis.

Watch for announcement of new 1931 line of "Delta" Woodworking Units in next issue of Popular Mechanics



## Here's a "Break" for YOU OWN YOUR OWN BUSINESS

There's no one but yourself to keep you from doing it. You can make \$25 to \$75 a day in your own business, enjoy independence and luxuries, and build a secure future. *No books, no tuition, no schooling necessary.* YOU CAN START RIGHT AWAY. We do not profit from your earnings—you get it all. Our plan sets YOU up as a CONTRACTOR in a legitimate, high-grade business, a business man of standing mingling on the same level of respect and credit as the building contractor, electrical contractor, mason contractor, etc., in your home community. BUT, there is this difference—you can make your fat profits on very much less money than they, about \$100 is all you need to start.

It's called FLORKRAFT, and it's pleasant, easy, inside, year-round work. There is *always* a job to be done, plenty of it all around you. A powerful, fast-cutting machine, the Clarke Vacuum Portable Sander, that operates almost as easy as a vacuum cleaner, and some sand paper is all you need. That puts you in business, to make floors and wood-work velvet smooth for finishing by the painter and decorator. Here's what this work pays, 3 to 5 cents a foot for new floors, 8 to 15 cents a foot for old floors, and with the powerful, fast-cutting Clarke you can do 900 to 2200 sq. feet of new floor, or 300 to 1000 sq. feet of old floor in a day. Figure that out for yourself, no other business gives you such opportunity, so don't let time slip by. Let us tell you more about how to assure a prosperous future! Get away Now from low and uncertain wages, from the slavery of the pay envelope, and call your soul your own. Send in this Coupon, no obligation, no bunk, no cost.

**MAIL THE COUPON**

A. A. CLARKE COMPANY  
Dept. T-39, MUSKOGON, MICHIGAN  
Gentlemen: I want to know. Please tell me without obligation, how I can make \$25 to \$75 a day as a CLARKE FLORKRAFTSMAN.

Name.....  
Address.....  
City..... State.....  
Present Occupation or Trade.....



## "I'm Getting Fed-Up with this Grind"

"I've been looking around and I don't like what I see. Look at Pop Clark and Butch—been on the job for ten and fifteen years—and they don't make as much as we do because they've slowed up.

"That doesn't look so good to yours truly. Me for the boss-job, and big pay and a real future. I don't know how I'm going to get there but I'll sure bust a leg trying."

If that's how you're fixed, you'll be interested to know that the way to promotion, a better position and increased earnings is no mystery. Thousands of men have gone from the mechanic's bench and the clerk's grind to positions as Superintendent, Manager, Draftsman, Engineer, Auditor—by American School home-study courses.

We'd like to tell you how we have taken the gamble out of home-training—how we undertake to increase your salary and help you get a better position, or no cost.

## — American School —

Dept. G-647 Drexel Ave. and 58th St., Chicago, Ill.



Without cost or obligation please tell me how I can win a better position and increased pay in line marked X below. Also explain your employment plan.

**BUILDING CONSTRUCTION**

- Architecture
- Building Contracting

**DRAFTING and DESIGN**

- Machine Drafting and Design
- Architectural Drafting
- Electrical Drafting
- Structural Drafting
- Automotive Drafting

Mechanical Drawing for beginners

**ENGINEERING**

- Mechanical Engineering
- Civil Engineering
- Electrical Engineering
- Automotive Engineering
- Machine Shop Practice

**BUSINESS**

- Accounting, Auditing
- Business Management (Finance, Sales, Production, Accounting)
- HIGH SCHOOL IN 2 YEARS

Name.....

Occupation.....

St. No.....

City..... State.....

## Now! Ruined NECKTIES Look Like NEW!

TIES NEED NEVER BE THROWN AWAY! Newly invented Electric "Nek-Tie" Iron keeps them like new indefinitely. Smooths, restores, reshapes, old wrinkled ties in less than a minute.

Works smoothly, easily, effortlessly. Plug into electric socket. Slip tie over iron. That's all! Now, tie looks new, crisp and retains all the original gloss and lustre.



**AGENTS! 100% PROFIT!**  
Great Profits for agents. 10 Easy Sales a Day nets \$30.00. Reserve territory NOW. Write TODAY for Free Offer. Don't wait a minute.  
Ser-Val Products Corp.  
1060 Broad St.  
Dept. J-14 Newark, N. J.

## THIN HEAD MODEL 15° HINSDALE CHROME VANADIUM WRENCH SET

Only \$1.95

Plus Parcel Post C. O. D.

Guaranteed Forever Against Breakage



**Polished Nickel Heads**

**Openings Accurately Milled**

This "thin-head" set of wrenches is invaluable for work on modern automobiles. Made of S. A. E. 6130 heat treated chrome vanadium steel. Kitpack holds each wrench individually.

Hinsdale Thin Jaw Pliers FREE—if you order from this ad.

**SEND NO MONEY**

Just write "Send C. O. D. parcel post one Hinsdale 15° angle Chrome Vanadium Wrench Set and free pair of Hinsdale Pliers." Pay postman \$1.95 plus parcel post charges. Money cheerfully refunded if you're not satisfied.

**HINSDALE MFG. CO.**

Established 1919 213 N. Desplaines St., CHICAGO, ILL.



# 30 days FREE TRIAL You to be the Judge

We will send you—direct from our factory—a FULL SET of PAF Spark Plugs for Thirty Days Free Trial with no obligation on your part to keep them—if you are not thoroughly satisfied with their merits.

**PAF Plugs are built on entirely different principles**

The specially designed head of the PAF electrode gives a dual fire—or in other words *two* fires as against the *one* of the average plug. Many motor car manufacturers are now using two spark plugs to the cylinder. WHY? The dual fire across the head of the specially designed PAF electrode gives you a hotter, more intense spark that will never fail to ignite ALL the vaporized gas in the cylinders. There will be no unburned gas left to get into your crank case and dilute your oil—no wasted gasoline to cut down your mileage and increase your operating cost. *PAF Plugs soon pay for themselves in gas savings alone.*

## POINTS of SUPERIORITY

Will not foul. No carbon around firing point. Stops gas-knocks and spark-knocks caused by faulty plugs. Quicker starting. Saves gasoline. Gives perfect ignition at point of firing.

## SEND NO MONEY

You are under no obligation to keep PAFs if you are not fully satisfied. You can return them at any time within the 30 days and you will not owe us a penny. We take all the risk—assume all the expense—trust you implicitly—and rely entirely on your judgment. So fill in the coupon below and mail to us and a full set of PAF Plugs will be sent you at once.

**Over Two Million In Use**

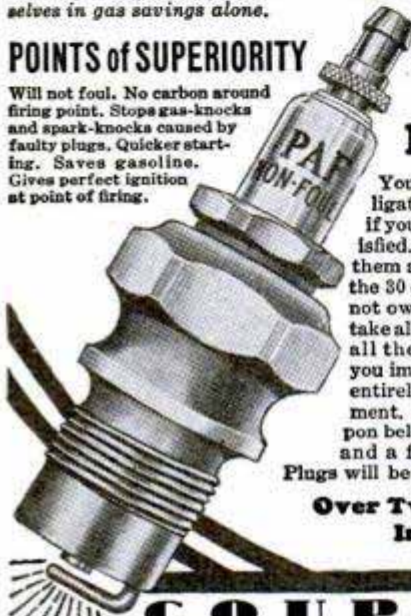

## COUPON

PAF MANUFACTURING CO.  
630 Franklin Ave., Greenville, Illinois.

In accordance with your special introductory offer you may send me a full set of PAF Non-Foul Spark Plugs for 30 days' free trial without obligation on my part to keep them. If I am thoroughly satisfied with their performance on my car I will remit the regular price of \$1.00 for each plug. Otherwise I will return them within 30 days after receiving them and owe you nothing.

Name.....  
Street No.....  
City..... State.....  
Make of car..... Model.....  
No. of cylinders..... Correct year car was made.....

**PROTECT YOUR CAR  
EVEREADY  
PRESTONE**

for preparation of the perfect anti-freeze.

National Carbon Company, Inc.  
General Offices: New York, N. Y.  
Branches: Chicago, Kansas City,  
New York, San Francisco

Unit of Union Carbide and UCC Carbon Corporation

# Be a Metalcrafter!

It's lots of fun if you use

## KESTER SOLDER



It's all the rage now to make things of metal with solder . . . models of all kinds and many useful articles. KESTER Metal Mender, the modern solder with the flux right inside, has made it possible for amateurs as well as professionals to solder easily. You can, too. Join the Metalcrafters of America and win a Metalcraft Merit Medal. Send for plans and instructions for making an all-metal model of a monoplane and an army truck with sample of KESTER Metal Mender FREE! Start the fun now! Write today!

**KESTER SOLDER COMPANY**

Incorporated 1899

4209-04 Wrightwood Ave.

CHICAGO



# KESTER FLUX-CORE SOLDER

## STEADY MONEY for YOU!



**SHOWING THIS COMBINED LINE!**  
Establish yourself in a profitable business! Take orders for brand new line of TIES—SHIRTS—UNDERWEAR—HOSIERY. Splendid opportunity for sincere men to earn money full or spare time. No investment required. Master Sales Kit and complete equipment loaned to you ABSOLUTELY FREE. Write TO-DAY!



**TIES and SHIRTS**

**PUBLIC SERVICE MILLS**  
515-30th Street Dept. J-17 West New York, N. J.  
Canadian Office—110 Dundas Street,  
London, Ont., Canada

**HOSE and UNDERWEAR**

# It's Time to Think About Those Zero Hours

**Jig Saw \$12**

Saws Wood or Metal

Summer nearly gone. Long fall and winter evenings just ahead. What do they mean to you—extra money or merely zero hours? Don't waste precious spare time. Turn it into money. We tell you how. Write for big FREE book. Filled from cover to cover with valuable information. Shows complete Home Shop Bench Machines—Saws, Lathes, Jointers, etc. Also tells what to make and how to make it. Gives details of our co-operative plan to help you sell. Now is the time to think of those zero spare-time hours. Write NOW, get full details.

**W. B. & J. E. BOICE**

Dept. P.M.-9F

TOLEDO, OHIO

**Universal Handisaw**  
Big, Powerful

**\$30**

Saws, rips, da-does, mitres, sands, bores, mortises, etc. Wonderful value.



Buy Now Pay Later



**Save Over 1/2 ON A SPRAYIT Electric Outfit!**



Only **\$14.50**

Regular Price **\$34.50**

The Same Nationally Advertised **OUTFIT**

**110 volt Universal Motor**

A fortunate purchase of entire factory surplus of the improved Master Model, electric SPRAYIT Machines enables us to offer them, while they last, at less than half price. Sprays paint, varnish, lacquer, insecticides and other solutions **ELECTRICALLY**. Saves time. Gets in all corners. Equipped with Universal motor. Can operate on A C or D C line. **GUARANTEED** to be same SPRAYIT outfit that has been selling for \$34.50. Brand new machines. Our special price, only \$14.50. Send deposit of \$2.00. Balance C. O. D., plus postage, or remit \$14.50 cash, money order or draft. Order at once.

**NATIONAL JOBBING AND EXPORT CO.**  
192 N. Clark Street Dept. Y CHICAGO, ILL.

**\$11.95 AIR COMPRESSORS**

**1 3/4 x 1 3/4**. Cap. 1.7 cu. ft. at 450 R. P. M. Requires 1/4 H. P. 125 max. pressure. Drop forged conn. rod and crankshaft. Ideal for small spray outfits, tire pumps, gas furnaces, etc. \$11.95 cash with order. Money refunded after 5 days' trial if not satisfied. No C. O. D. **UTILITY PRODUCTS CO.**  
542 W. Washington Blvd., Chicago, Ill.



**NEW ZEP-LITES FOR YOUR AUTO!**  
Install these beautiful chrome-plated lamps on your fenders for safer night driving. Racy lines. Red side lenses on left lamp, green on right. Adds class to any car. Complete with bulbs, switch and wiring; easily installed. Write today for FREE illustrated folder. **SAFEWAY ORNAMENT CO., 1590 Myrtle St., Detroit, Mich.**

**YOU CAN BUILD ONE**

**SHIP MODELS \$4.98 and \$6.98**



**COACH MODELS \$4.98**

We supply all the parts ready to put together; a pleasant and instructive occupation for summer home and camp. *Catalog FREE on request.*

**Miniature Ship Models, Inc.** Dept. RT Perkasie, Pa.

**FREE TOOL BOOK "The Disston Saw, Tool and File Book"**

tells how to choose, use, and care for tools, file and set saws, etc. Every tool user needs it. **Henry Disston & Sons, Inc.** Dept. M, Philadelphia Canadian Factory, Toronto

**New Discovery**

**STATIONS** all over the earth now come in loud and clear. Regular broadcast band. Super-powered **HFL Mastertone** for those who want finest radio at amazing price. **FREE** booklet explains all. Send for it and **Special Offer NOW!**

**HIGH FREQUENCY LABORATORIES**  
3900 N. Claremont Ave., Dept. 41, Chicago



**"I'm going to raise his salary"**

"I've had my eye on him for some time and I know he can handle bigger work."

"He studies those I. C. S. textbooks every chance he gets, and I want to tell you it has made him a valuable man for this business."

"I'm going to raise his salary and give him that new job we were talking about. I wish we had more men like him."

How do you stand when your employer checks up his men for promotion? Does he pass you by as just a routine worker, or does he think of you as a man who is ambitious to get ahead? Won't you be far more likely to get the promotion if he knows you are studying at home and are really preparing yourself to handle bigger work?

Think it over. Then act. It takes only a moment to mark and mail the coupon and find what the International Correspondence Schools can do for you, yet that one simple little step may be the means of changing your whole life. "Do it now."

**Mail the Coupon for Free Booklet**

**INTERNATIONAL CORRESPONDENCE SCHOOLS**

"The Universal University"  
Box 5699-F, Scranton, Penna.

Without cost or obligation, please send me a copy of your booklet, "Who Wins and Why," and full particulars about the subject before which I have marked X:

**TECHNICAL AND INDUSTRIAL COURSES**

- |  |  |
|--|--|
| <input type="checkbox"/> Architect   | <input type="checkbox"/> Automobile Mechanic                                 |
| <input type="checkbox"/> Architectural Draftsman                             | <input type="checkbox"/> Plumbing <input type="checkbox"/> Steam Fitting     |
| <input type="checkbox"/> Building Estimating                                 | <input type="checkbox"/> Heating <input type="checkbox"/> Ventilation        |
| <input type="checkbox"/> Wood Millworking                                    | <input type="checkbox"/> Sheet Metal Worker                                  |
| <input type="checkbox"/> Contractor and Builder                              | <input type="checkbox"/> Steam Engineer                                      |
| <input type="checkbox"/> Structural Draftsman                                | <input type="checkbox"/> Steam Electric Engineer                             |
| <input type="checkbox"/> Structural Engineer                                 | <input type="checkbox"/> Civil Engineer                                      |
| <input type="checkbox"/> Electric Wiring                                     | <input type="checkbox"/> Surveying and Mapping                               |
| <input type="checkbox"/> Electrical Engineer                                 | <input type="checkbox"/> Refrigeration                                       |
| <input type="checkbox"/> Electric Lighting                                   | <input type="checkbox"/> R. R. Locomotives                                   |
| <input type="checkbox"/> Welding, Electric and Gas                           | <input type="checkbox"/> R. R. Section Foreman                               |
| <input type="checkbox"/> Reading Shop Blueprints                             | <input type="checkbox"/> R. R. Bridge and Building Foreman                   |
| <input type="checkbox"/> Telegraph Engineer                                  | <input type="checkbox"/> Air Brakes <input type="checkbox"/> Train Operation |
| <input type="checkbox"/> Telephone Work                                      | <input type="checkbox"/> Highway Engineering                                 |
| <input type="checkbox"/> Mechanical Engineer                                 | <input type="checkbox"/> Chemistry <input type="checkbox"/> Pharmacy         |
| <input type="checkbox"/> Mechanical Draftsman                                | <input type="checkbox"/> Coal Mining Engineer                                |
| <input type="checkbox"/> Machinist <input type="checkbox"/> Toolmaker        | <input type="checkbox"/> Navigation <input type="checkbox"/> Boilermaker     |
| <input type="checkbox"/> Patternmaker  | <input type="checkbox"/> Textile Overseer or Supt.                           |
| <input type="checkbox"/> Pipefitter <input type="checkbox"/> Tinsmith        | <input type="checkbox"/> Cotton Manufacturing                                |
| <input type="checkbox"/> Bridge Engineer                                     | <input type="checkbox"/> Woolen Manufacturing                                |
| <input type="checkbox"/> Bridge and Building Foreman                         | <input type="checkbox"/> Agriculture <input type="checkbox"/> Fruit Growing  |
| <input type="checkbox"/> Gas Engines <input type="checkbox"/> Diesel Engines | <input type="checkbox"/> Poultry Farming <input type="checkbox"/> Radio      |
| <input type="checkbox"/> Aviation Engines                                    | <input type="checkbox"/> Marine Engineer                                     |

**BUSINESS TRAINING COURSES**

- |   |  |
|---|--|
| <input type="checkbox"/> Business Management                                  | <input type="checkbox"/> Business Correspondence                             |
| <input type="checkbox"/> Office Management                                    | <input type="checkbox"/> Lettering Show Cards <input type="checkbox"/> Signs |
| <input type="checkbox"/> Industrial Management                                | <input type="checkbox"/> Stenography and Typing                              |
| <input type="checkbox"/> Personnel Management                                 | <input type="checkbox"/> Complete Commercial                                 |
| <input type="checkbox"/> Traffic Management                                   | <input type="checkbox"/> Civil Service <input type="checkbox"/> Mail Carrier |
| <input type="checkbox"/> Accountancy <input type="checkbox"/> Cost Accountant | <input type="checkbox"/> Railway Mail Clerk                                  |
| <input type="checkbox"/> C. P. Accountant                                     | <input type="checkbox"/> Grade School Subjects                               |
| <input type="checkbox"/> Bookkeeping  | <input type="checkbox"/> High School Subjects                                |
| <input type="checkbox"/> Secretarial Work                                     | <input type="checkbox"/> College Preparatory                                 |
| <input type="checkbox"/> Spanish <input type="checkbox"/> French              | <input type="checkbox"/> Illustrating <input type="checkbox"/> Cartooning    |
| <input type="checkbox"/> Salesmanship <input type="checkbox"/> Advertising    | <input type="checkbox"/> Lumber Dealer                                       |

Name.....

Address.....

City..... State.....

Occupation.....

If you reside in Canada, send this coupon to the International Correspondence Schools, Canadian, Limited, Montreal, Canada



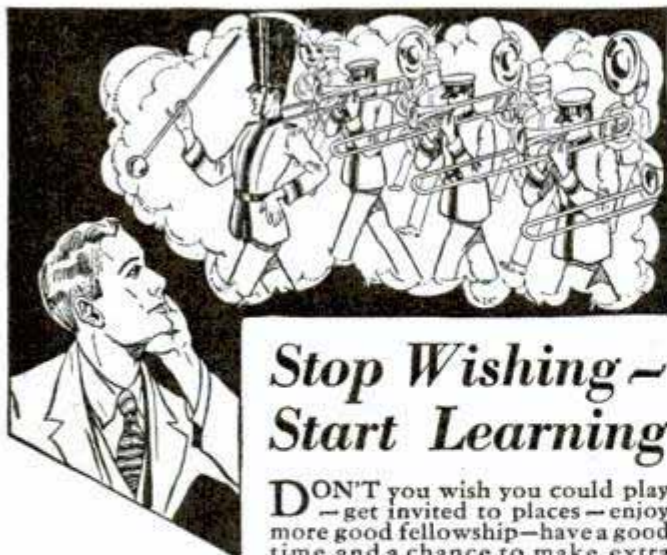

## Stop Wishing - Start Learning

**DON'T** you wish you could play **D**—get invited to places—enjoy more good fellowship—have a good time and a chance to make extra money? The man who plays is always popular, never lonesome, gets more out of life.

Wishing won't get you anywhere. You can learn to play any instrument if you have the backbone to make the start. Now is the time to do it.

It isn't hard if you get a **KING** instrument. The best musicians prefer the **KING** because of its purity of tone and easy playing. You'll be surprised how quickly you can learn. New methods make learning to play easier than ever before.

Don't put it off. It's easy to own a King. With all their superior quality, King instruments are not high-priced and are sold on easy monthly payments. *Free trial*, too, for ten days, if you wish. Mail the coupon today.

### THE H. N. WHITE CO.

5212-78 Superior Ave. Cleveland, Ohio  
Makers of **KING**, Cleveland and American Standard Band Instruments and Saxophones  
Wide Range of Prices to Meet All Requirements

THE H. N. WHITE CO.,  
5212-78 Superior Ave., Dept. 1B, Cleveland, O.  
Kindly send me free catalog and full information  
Instrument I am interested in.....  
Name.....  
Address.....  
City..... State.....



## REAL MEN WANTED

Two distinct lines in one. For either salesmen or those mechanically inclined.

**\$50.00 Value for \$6.00**

with profits accordingly large.

We can provide you with unlimited quantities of all leading makes of electric vacuum cleaners at sensationally low prices, each guaranteed perfect in action and appearance. Such extreme value and profit offers any man of average intelligence a splendid income even for spare time.

### FREE VAC COURSE

To our associates we give in bound book form, free expert advice and seldom disclosed instructions in building and servicing all vacs. Through this free training you may readily develop a permanent, well-paying business all your own. From our immense resources we supply all needs. At trifling cost and no risk you can prosper with us, the originators. Oldest and largest in the line. Literature tells all.

**URON ASSOCIATED INDUSTRIES**  
1302 ENGINEERS BUILDING, CLEVELAND, OHIO

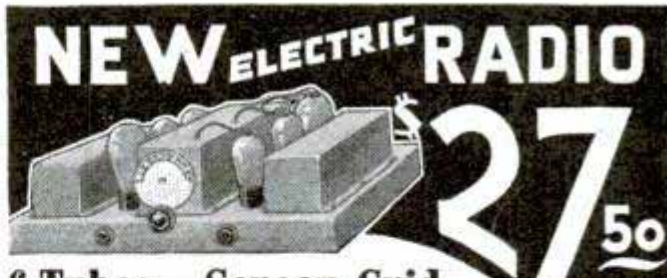

## NEW ELECTRIC RADIO

Amazing new long distance 6-tube A. C. screen grid radio at a price anybody can pay. Marvelous tone. Plenty of volume for dynamic speaker. Absolutely free from A. C. hum. The very latest in A. C. radio using three screen grid tubes and the price is only \$27.50. All ready to plug in the electric light socket and operate. This is the most startling radio bargain offer in history.

## AGENTS MAKE FORTUNES

Live agents everywhere are making big money selling this new set. Demonstration always means a sale. Add SIXTY DOLLARS A WEEK PROFIT to your present income in spare time evenings. This ultra-modern all-electric set replaces battery radios everywhere. Exclusive territory franchise worth fortune to right men but act quick as choice territory is going fast, and my company has asked me to place good men in all open territory QUICK. Write or wire immediately and be sure to give me the name of your county.

P. H. WILCOX, Secretary, 4901 N. Crawford Ave., Chicago, Ill.

## A Better Way to Grind Valves

The HALL Valve Grinder offers a better way to grind valves because it grinds valves better. A quality tool made by the world's largest manufacturers of cylinder honing and valve grinding equipment for the service trade. Laps valve into seat without ridges, grooves or hollow spots which quickly collect carbon. Produces tighter seat insuring better motor performance for thousands of extra miles. Anyone can use it. No crank to turn; no bruised knuckles on stud bolts. Just pull the handle and tool does the work and does it RIGHT. Comes complete with spring, suction cup and four adapters to fit all valves. Every service shop, fleet operator and mechanic should own a HALL Valve Grinder. Sold by leading Automotive Jobbers and Accessory Stores everywhere, or sent postpaid direct from factory on receipt of price and name of your Jobber or Dealer. Get a HALL today or, if you prefer, write for circular on this and other HALL equipment.

**Price Complete \$4.50**

THE HALL MANUFACTURING CO.  
1654 Woodland Ave., TOLEDO, OHIO

### Hall Valve Grinder

## THIS WONDERFUL INVENTION

converts any ordinary cook stove into a gas stove. OXO-GAS is made from kerosene and air. Cheaper, cleaner and more efficient than coal. Responsible distributors wanted.

**GLORIA LIGHT CO.**  
111-9 N. May St. Chicago, Ill.

## ELECTRIC MOTOR

winding models show winding and connections in plain sight. Make your own or rewind motors for your own use or for profit. In use all over the world. Quick, easy way. Write Dept. DPM, Send dime for circulars.

**Gaines Bros. Box 481 Gainesville, Texas**

## THOMPSON BETTER BUILT DUCK BOATS

**\$36 AND UP**

Swift, silent gliders, exceptionally steady—even in rough waters. Four models for open lake and river use and for still hunting in marshes and shallows. Two big Factories. Quick delivery from either one. Write for Free Catalog.

**THOMPSON BROTHERS BOAT MFG. COMPANY**  
213 Ann Street, Peshtig WISCONSIN 113 Elm Street, Cortland NEW YORK







# New Kind of Noiseless Economical HEAT

Do away forever with the drudgery of wood or coal. The most simple and economical invention on the market is now giving perfect satisfaction to enthusiastic users everywhere.

We are one of the oldest and largest manufacturers of oil burners in the country. With over 100,000 in use you have the confidence of thousands of satisfied users and the approval of engineers everywhere.

## at astonishing **LOW COST**

Heats any stove or furnace just as well as a \$400 or \$500 oil burner without electricity or gas. Simply turn one valve and have all the heat you want. Cleaner and better for heating and cooking.

### Burns 96% Air—4% Oil

The International Oil Burner fits in the fire box of your furnace or stove. It is installed in a few minutes. No noisy motors or complicated parts. Approved by National Underwriters Laboratories.

### No Dirt—No Ashes No Soot—No Odor

Enjoy the comfort of this new kind of economical heat without the dirt and ashes of coal as well as the other inconveniences that go with coal heat. You can now have this modern heat at a cost that is within the reach of every pocket book.

### Earn \$15-\$25 a Day

Our men are making big money introducing International Oil Burners. The demand is enormous! We want spare-time or full-time workers immediately. You can limit your income by the amount of time you can devote. If \$500 a month and more interests you, write or wire us for our protected territory offer.

**INTERNATIONAL HEATING CO.**  
DEPT. 204-S ST. LOUIS, MO.

Try this wonderful burner right in your own home at our risk and with it you have the opportunity of filling other orders in that territory and making big money as our protected distributor.

### EASY TO INSTALL

It is easy to install the International Oil Burner and our instructions are simple to follow. The burner was designed along simple lines to avoid any difficulty and make it easy for the housewife.

**Over 100,000 in use**

### BIG MONEY-SAVING FREE TRIAL OFFER

You have the advantage of getting one of these new burners on 30 Days' Free Trial under our big money saving offer. Simply fill in the coupon below and we will mail you complete information and without any obligation on your part. Also mark the space showing your interest in making money.

**WE ARE ONE OF THE  
OLDEST AND LARGEST  
OIL BURNER MANUFACTURERS**



### INTERNATIONAL HEATING CO. MAIL TODAY

Dept. 204-S, St. Louis, Mo.

Please mail your free booklet and free burner offer on home heating for stove  furnace  This places me under no obligation.

Name.....

St. or R. F. D. ....

City..... State.....

Check if interested in making money as International representative with protected territory.



*Think of it!* **Genuine** *Late Model* **No. 5**  
**UNDERWOOD**  
*Refinished*

**Yours for  
 10 Days  
 TRIAL**

Yes—this world-famous Underwood No. 5 is yours for full 10 days' trial. (Positively the lowest price and easiest terms ever offered.) See how beautiful and new it looks—compare its neat, perfect work with any typewriter costing twice as much.

**Direct at Less Than  
 1/2 Mfg's Original Price**



Now Only **\$ DOWN**  
**ON EASY TERMS**



Only by an exceedingly fortunate purchase direct from the manufacturer's am I able to offer this amazing low price. While they last—less than half (1/2) the manufacturer's original price—and easy terms besides. (Do not confuse this genuine late model Underwood with inferior or frail machines worth only one-half as much.) This is the full-sized late model Underwood with Standard universal 4-row keyboard of 84 characters and has all late improvements. Manufactured to sell originally for \$102.50. Fully Guaranteed in writing.

**Late Model  
 No. 5  
 Underwood  
 With Modern  
 Improvements.**

1. Genuine Underwood No. 5.
2. Standard 4-row Keyboard (84 characters)
3. 2-color Ribbon—Rising Scale
4. Back Spacer
5. Ribbon Reverse
6. Tabulator
7. Automatic Release
8. Shift Lock Key
9. Lowest Price
10. Easiest Terms
11. 10-Day Trial
12. Fully Guaranteed

**Easy Terms—Only 12c a Day**

Think of it—a genuine late model Underwood No. 5 reduced to \$44.90 (Cash).

Send only \$1 deposit for a 10-day Trial. Then only 12c a day on my easy year-to-pay plan. Use and enjoy your typewriter all the time. Remember this famous No. 5 Underwood all renewed and refinished is without question one of the greatest values ever offered at this rock-bottom price. (See column to left for its many outstanding features and improvements.)

**Money Back Guarantee!**

Accept my liberal 10-day trial offer. See for yourself the wonderful bargain this famous Underwood really is. Your deposit returned at once if you are not perfectly satisfied. Send now.

**International Typewriter Exchange  
 231 W. Monroe St. Chicago**

**Complete Course in Speed Touch Typewriting Given During This Offer.**

**Also Office Supply Set**

Learn Speed Touch typewriting. Complete Home Study Course of the Famous Van Sant Speed Typewriting System, fully illustrated, given during this offer. Easily learned. Used in schools, business offices everywhere. We also give complete office supply set during this sensational sale.



**International Typewriter Exchange,  
 231 West Monroe St., Chicago, Ill., Dept. 901.**

Please send the Underwood No. 5, F. O. B. Chicago, at the special reduced price for 10-day Trial. I am enclosing \$1.00 deposit with the understanding that if I am not perfectly satisfied I can return it Express Collect and get my deposit back. If I keep it I will pay \$3.50 a month until I have paid \$49.90 (term price) in full.

Name.....Age.....  
 Address.....  
 Town.....State.....



**"\$3.00 Spent on This Room  
NOW... Will Save You \$100!"**



# Amazing Strips of Lifetime Bronze

**Save Home Owners \$30 to \$60 a Year!**

**N**O More Big Fuel Bills! No More Cold, Draughty Rooms! No More Dust, Soot, and Smoke! Amazing New Invention Is Creating Thousands of Big Money Opportunities for Live-Wire Representatives, Red-D-Ply, New Kind of Metal Weatherstrip That Anyone Can Apply to Any Door or Window in a Few Minutes Does the Trick. Keeps Cold Draughts Out, Heat In! Guaranteed to Save Its Trifling Cost in Two Winters! Snap Up This New Money-Maker Now!

*"Our coal bills cut in half!" "Saved \$50 in a single winter!" "Not a luxury—a real investment." Folks have hitherto thought of metal weatherstripping as expensive, and difficult to install. Imagine their delight when you show them Red-D-Ply! Each package contains material to completely weatherproof any door or window in half an hour, with no experience and no tools but a tack hammer and scissors! Slides into position without removing sashes or doors. Completely closes chinks and cracks where cold draughts sneak in to steal heating dollars, besides causing endless discomfort and sickness. Red-D-Ply also keeps out rain, dust, and soot. Makes windows slide easier and banishes rattles! Does away with storm windows and doors. Is it any wonder Red-D-Ply offers such amazing profits to representatives?*

**A Double-Barreled Money-Maker for Agents, up to \$400 and \$600 a Month The Year 'Round!**

### Just Count Windows and Doors!

A single block, even in small towns, may yield you as much as \$200 or \$300 in quick commissions! Just count the outside doors and windows in any home, figure up the fuel savings Red-D-Ply will give, and your sale is already half made! For Red-D-Ply is **GUARANTEED** to save its cost in two winters—and ordinarily does it in one! The cost averages about the price of an auto tire. And the saving goes on year after year — for no matter how windows and doors swell or shrink Red-D-Ply **AUTOMATICALLY** adjusts itself to suit.

### Repeat Business—Installation Profits

The repeat business is simply enormous! Even if you don't sell a complete installation on the first call, make a test installation of one room or so—then come back for order after order, and

make the same or greater profit every time. Make extra money through installations.

### Territories Going Fast—Act at Once!

Red-D-Ply offers such surprising profits in a new non-competitive field that hundreds are dropping everything to take over territory. Exceptionally generous proposition, with ready-cut selling plan absolute proof against failure. It insures repeat business. New buildings alone furnish a wonderful field — 112,754 new homes built this year need Red-D-Ply. We furnish everything to start a permanent, profitable business. This is only half the story. Will you risk a 2c stamp to hear the rest? It may mean \$5000—\$7500 a year to you. Then mail the coupon for full particulars and a **FREE SAMPLE** of Red-D-Ply. No obligations. Get the facts and judge for yourself if this is not the proposition you have waited for all your life.

**Red-D-Ply Mfg. Co.**

Dept. M-11 1531 Washington St. St. Louis, Mo.

# Red D Ply

The Universal Weatherstripping—Anyone Can Afford  
It . . . Sell It . . . Install It

## GET FREE SAMPLE

### Mail Coupon

RED-D-PLY MFG. CO., Dept. M-11  
1531 Washington St., St. Louis, Mo.

I want to make \$5000 a year or more. Send Free Sample of Red-D-Ply and full details of your proposition to Representatives. I am not obligated by this request.

Name.....

Address.....

City..... State.....



# Now for a Camel!

Camel's mellow fragrance  
heightens every pleasure  
— a cigarette made for  
real smoke enjoyment.

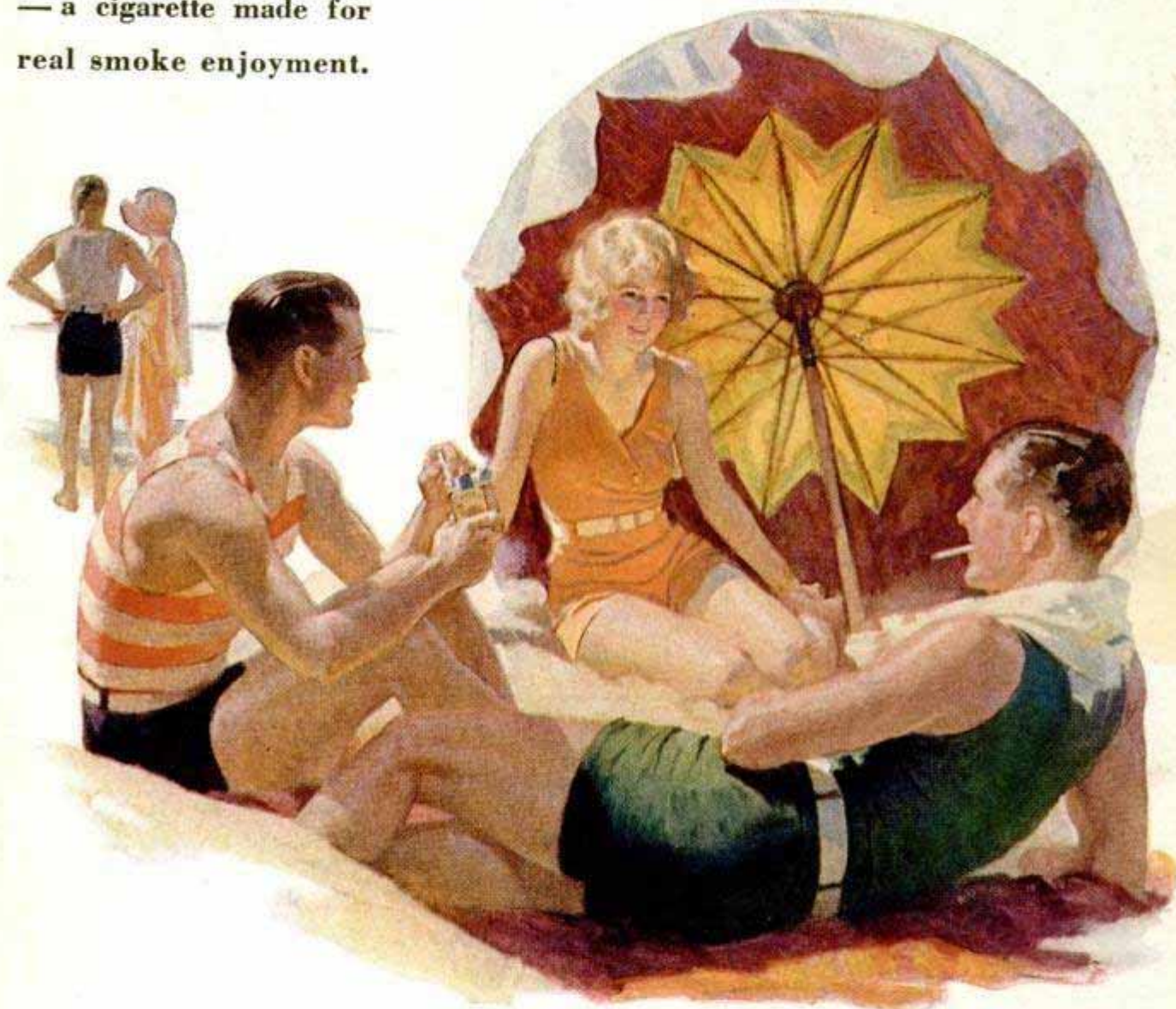

*Don't deny yourself  
the luxury of*

# Camels

© 1930, R. J. Reynolds Tobacco Company, Winston-Salem, N. C.

