

JULY

N.S.E.
25 CENTS

POPULAR MECHANICS

MAGAZINE

WRITTEN SO YOU CAN UNDERSTAND IT

REGD. TRADE MARK, GREAT BRITAIN, NO. 410426

REG. U.S. PAT. OFF.

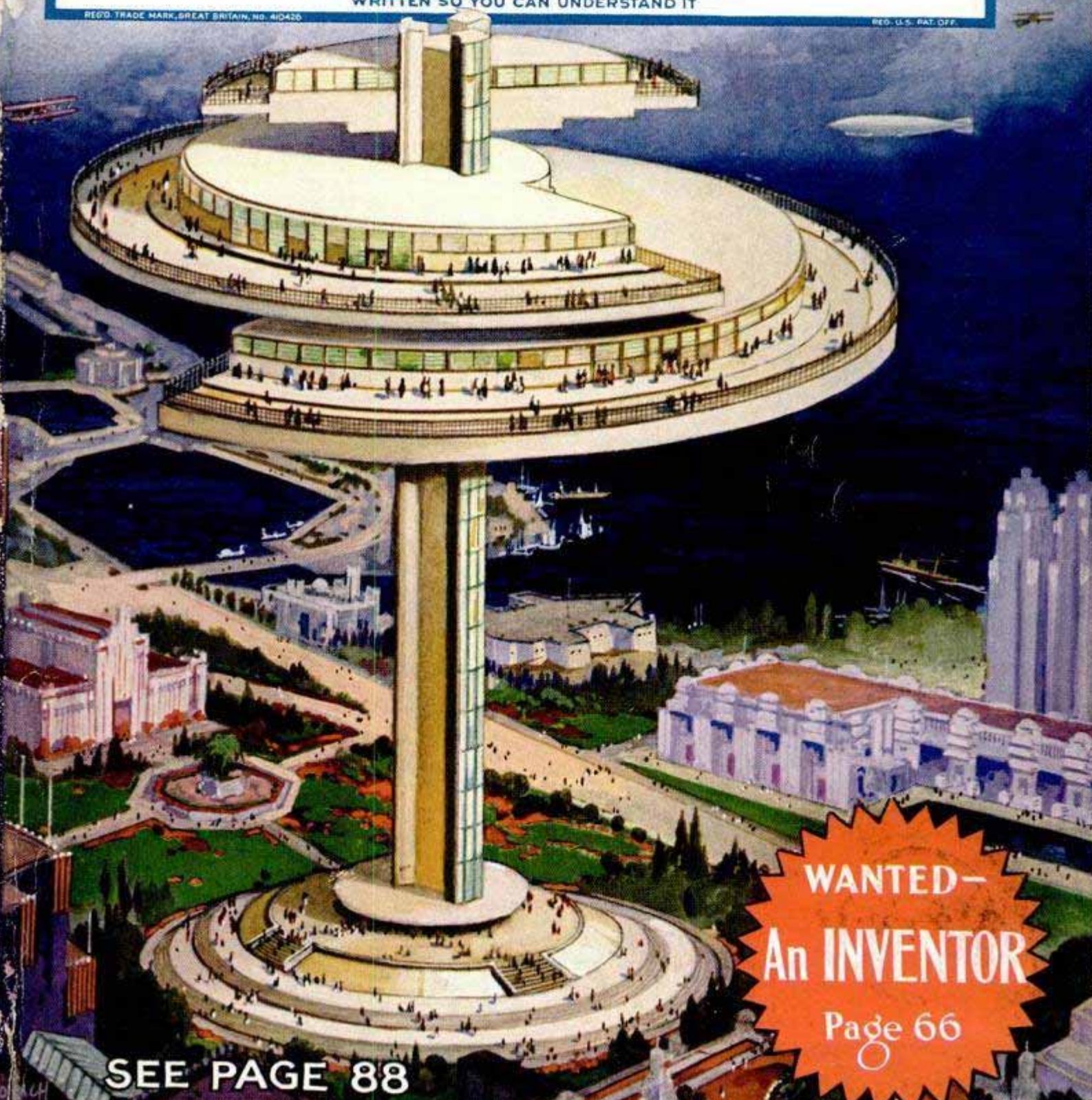

WANTED—
An INVENTOR

Page 66

SEE PAGE 88

News...if you drive a

Ford Model A **Hudson**
De Soto **Dodge**
Essex **Reo**

A new grade of Mobiloil is offered to scientifically meet the lubrication problem of your car...

Make this Chart your Guide

This abbreviated chart shows the correct grade of Gargoyle Mobiloil for most passenger cars. You will find the complete Mobiloil Chart at your Mobiloil dealer's.

NAMES OF PASSENGER CARS	1930		1929		1928		1927	
	Engine		Engine		Engine		Engine	
	Summer	Winter	Summer	Winter	Summer	Winter	Summer	Winter
Auburn 6-85	AF	Arc						
" 6-66A, 6-80, 76			A	Arc	A	Arc	A	Arc
other models	BB	Arc	BB	Arc	BB	Arc	BB	Arc
Buick	BB	Arc	BB	Arc	BB	Arc	BB	Arc
Cadillac	BB	Arc	BB	Arc	BB	Arc	BB	Arc
Chrysler			A	Arc	A	Arc	A	Arc
Chevrolet	A	Arc	A	Arc	A	Arc	A	Arc
Chrysler 70, 77	BB	Arc	BB	Arc	BB	Arc	BB	Arc
Imperial	BB	Arc	BB	Arc	BB	Arc	BB	Arc
other models	AF	Arc	AF	Arc	A	Arc	A	Arc
Dodge Bros.	AF	Arc	AF	Arc	A	Arc	A	Arc
Durant 614	AF	Arc						
other models	A	Arc	A	Arc	A	Arc		
Ekcar 6-70, 75	A	Arc	A	Arc	A	Arc	A	Arc
other models	BB	Arc	BB	Arc	BB	Arc	BB	Arc
Erskine	A	Arc	A	Arc	A	Arc	A	Arc
Essex	AF	Arc	AF	Arc	A	Arc	A	Arc
Ford Model A	AF	Arc	AF	Arc	AF	Arc		
Model T							F	E
Franklin	BB	Arc	BB	Arc	BB	Arc	BB	Arc
Gardner 6-cyl. 156	AF	Arc						
" 8-cyl.	BB	Arc	BB	Arc	BB	Arc	BB	Arc
Graham and								
Graham-Paige	BB	Arc	BB	Arc	BB	Arc		
Hudson	AF	Arc	AF	Arc	A	Arc	A	Arc
Hupmobile	BB	Arc	BB	Arc	BB	Arc	BB	Arc
LaSalle	BB	Arc	BB	Arc	BB	Arc	BB	Arc
Lincoln	BB	Arc	BB	Arc	BB	Arc	BB	Arc
Marmon Big 8, 75, 8-79	BB	Arc			BB	Arc	BB	Arc
other models	AF	Arc	AF	Arc	A	Arc	A	Arc
Moon 6-72			AF	Arc	A	Arc		
" 8-80			BB	Arc	BB	Arc		
other models			A	Arc	A	Arc	A	Arc
Nash Twin 1g. 8, 490,								
Adv. 6, Sp. 6, Twin 1g. 6	BB	Arc	BB	Arc	BB	Arc	BB	Arc
Nash (other models)	AF	Arc	AF	Arc	A	Arc	A	Arc
Oakland	BB	Arc	A	Arc	A	Arc	A	Arc
Oldsmobile	A	Arc	A	Arc	A	Arc	A	Arc
Packard	A	Arc	A	Arc	A	Arc	A	Arc
Pearless 61, 81			AF	Arc				
" 60, 69, 80					A	Arc	A	Arc
other models	BB	Arc	BB	Arc	BB	Arc	BB	Arc
Plymouth	A	Arc	A	Arc	A	Arc	A	Arc
Pontiac	A	Arc	A	Arc	A	Arc	A	Arc
Reo (all models)	AF	Arc	AF	Arc	A	Arc	A	Arc
Studebaker Com'der 8	AF	Arc	AF	Arc				
" President 8	BB	Arc	BB	Arc	BB	Arc		
other models	A	Arc	A	Arc	A	Arc	A	Arc
Whippet	A	Arc	A	Arc	A	Arc	A	Arc
Willys-Knight	A	Arc	A	Arc	BB	Arc	BB	Arc
Windsor 6-69, 6-72, 6-75	AF	Arc	AF	Arc				
other models	BB	Arc	BB	Arc				

In the cars listed above, and in certain models of other cars listed in the chart at the left, we recommend the use of the new Mobiloil "AF"—

Because—it will stand up better under the higher engine temperatures of today's fast driving, and last longer.

Because—it is heavier in body than Mobiloil "A" and lighter than Mobiloil "BB".

Because—it is made by the makers of the world's leading quality oils.

Because—it is the result of thorough engine and lubrication study by the most experienced staff of lubrication scientists in the world.

Because—it is made by the vacuum process in the world's most modern lubrication plants.

Because—it is made from the world's finest crudes, selected by the outstanding authorities on scientific lubrication.

Because—it sells at 30 cents a quart (35 cents in Southwest, Mountain, and Far Western States).

Add to the performance of your good car, the improved performance *correct lubrication* can give it. Let your Mobiloil dealer drain your crankcase today and refill with this outstanding new lubricant.

VACUUM OIL COMPANY

Makers of high-quality lubricants for all types of machinery



LOOK FOR THIS SIGN

Mobiloil "AF"

Spray-Paint!

-it's the Quick,
Easy, Modern Way

Genuine
BINKS
Outfit
only \$9.95
Complete



Binks No. 222 Outfit
consists of Genuine Binks Junior Syphon Feed Spray Gun, Air Pressure Valve and 25 feet of air hose as shown. Glass, material container (standard pint size Mason jar). Nothing else needed. Price complete. **\$9.95**

Binks No. 333 Outfit
(not illustrated) consists of Binks Special Spray Gun, All Metal Pressure Material Cup (quart capacity), Two Air Valves, "Y" Hose Connector and 25 feet of air hose. Price complete. **\$24.95**



Binks HuRo Outfit
Designed for use where large areas are to be painted. A heavy-duty outfit suitable for painting houses, barns and other buildings. Consists of Binks Special Spray Gun, All Metal Pressure Material Cup (quart capacity) 5-gallon Pressure Material Container, Two Air Pressure Valves, "Y" Hose Connector and three 25 foot sections of hose. Price complete. **\$69.50**



Binks Hurley Unit
A complete spray-painting unit operated electrically from lamp socket. Consists of Compressor, Air Chamber, 1/2 H.P. G. E. Motor, Binks Special Spray Gun, All Metal Pressure Material Cup and 10 feet of hose. Weighs only 47 lbs. Price complete with 110 volt 60 cycle, single phase motor. **\$68.50**

DEALERS
The popularity of Spray-Painting is growing by leaps and bounds. Thousands upon thousands of home and building owners are being educated to its many advantages. We want this new business to come through you. Write for catalog, describing these and other items; prices, terms, etc.

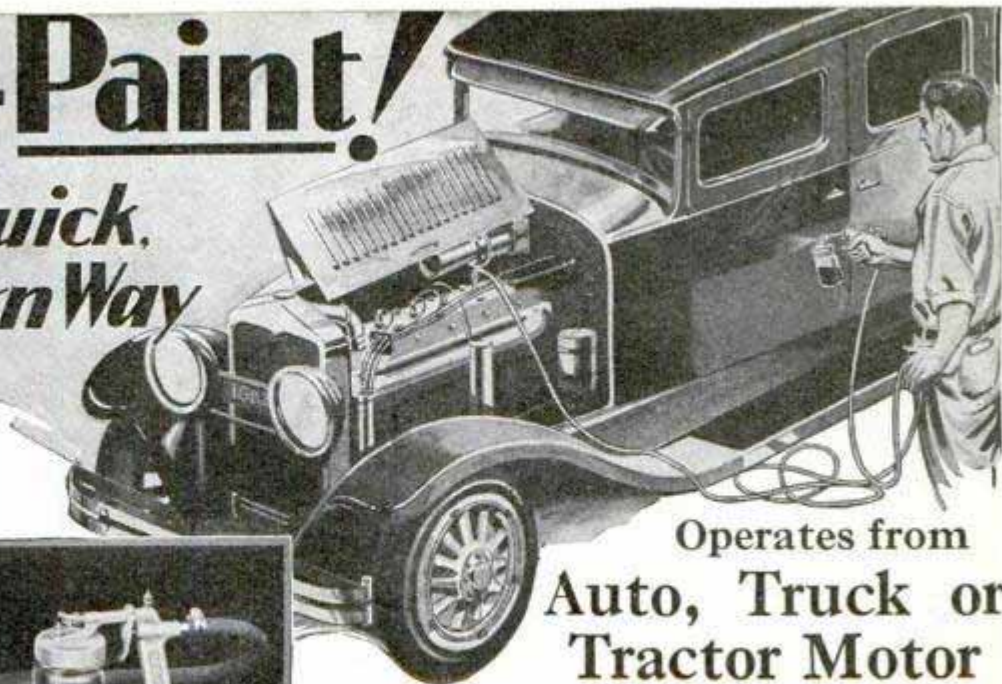

Operates from
**Auto, Truck or
Tractor Motor**

EVERYBODY can spray-paint now! Just think of it—only \$9.95 for a genuine BINKS Outfit, complete, ready to use. The wonderful Binks Air Pressure Valve makes your auto engine an air compressor. You just take out a spark plug, insert the valve in its place, and with the motor idling, you're all set to spray-paint. That's all there is to it—and it's just as simple as it sounds. By adding additional lengths of hose (up to 75 ft.) you can spray-paint indoors and out, as well as in the garage.

It's Real Fun to Spray-Paint—Profitable, Too!

THERE'S nothing mysterious or difficult about spray-painting. It's fascinating—more like play than work. And, it's not only many times quicker, much easier and cleaner, but results are far superior to hand painting. There's no dipping—no spilling—no waste. You fill the jar with material, point the gun, and pull the trigger. Out comes the paint in a finely atomized, fan-like spray that covers every particle of the surface with a smooth, uniform coating. And, it gets the paint into corners and crevices so hard to reach with a brush. No wasted time, because no lost motions. No leveling out or evening up—no brush marks. And, no messy brushes to clean when you've finished painting. Screens, radiators, fences and other hard to paint things are easy to spray-paint. You'll learn how to use your Binks Spray Gun like a professional in half an hour—then you'll say goodbye to paint brushes forever.

Quality Performance at Low Cost

Binks No. 222 Outfit enables even the most inexperienced to do a high grade, professional job. Do not confuse it with flimsy, make-shift apparatus offered to meet the demand for spray equipment at low cost. The Binks gun is a masterpiece of efficiency. The Air Pressure Valve will outperform any other. Material holder is a standard pint mason jar, easily replaced in case of accident, and a convenient, airtight container when not in use. The results obtainable from the higher-priced outfits shown here are in no way superior to those given by No. 222, except in speed of application. If your painting needs are only occasional, you will be delighted and highly satisfied with it.

Scores of Uses Around the House

Your Binks Outfit will spray any kind of liquid material. You'll use it for painting everything around the house that can be painted and for many other jobs, too—whitewashing the basement and chicken coop, applying insecticides to your garden, trees and shrubbery, spraying moth repellents and exterminators, etc. In fact, when you find what a wonderful time and labor saver it really is, you'll wonder how you ever got along without it.

Be Sure It's a BINKS!

The spray painting outfits described here are made by a company which has specialized in spray finishing equipment for over thirty years. The name is synonymous with quality. Nearly every automobile you see today was spray-painted at the factory with Binks Equipment. Most Auto Refinishing Shops will use no other. You get this same high quality, same fine workmanship in Binks Household and Portable Units, so be sure, to avoid disappointment, that you get a genuine Binks!

Ideal for Quick Drying Finishes

You can spray paint your auto with lacquer or Duco, put on two or three coats if you wish, one right after the other with no time out for drying and then use your car immediately. With the new 4-hour enamels, you can refinish furniture in the morning and use it in the afternoon. And the finish will be perfect—smooth as velvet—without streaks, splotches or brush marks.

Buy from Your BINKS Dealer

Binks Spray Painting Outfits can be purchased at Paint, Hardware and Auto Supply Stores. Your dealer has them or will order one for you. If you have the slightest difficulty in obtaining just let us know. We will see that you are supplied. Mail coupon for interesting, descriptive literature. Free, of course.

BINKS MANUFACTURING CO.

Dept. B-135—3124 Carroll Ave.

CHICAGO, ILL.

FREE INFORMATION COUPON

This One



7E20-G72-GOJQ

Name.....

Address.....

Town.....State.....

Dealer's Name.....

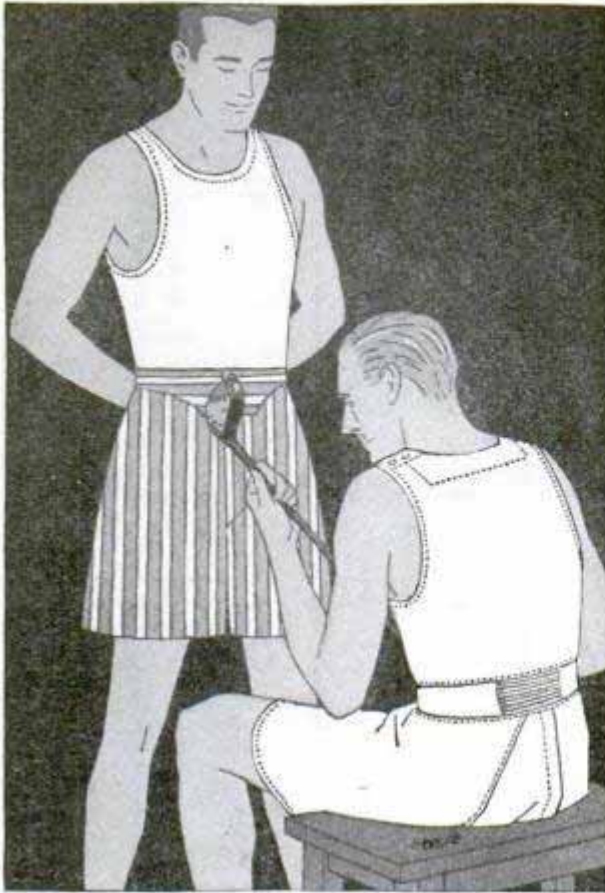

At left: Hanes *Shirt and Shorts*, 50c, 75c, \$1 the garment. All white or in handsome color effects and luxurious fabrics. At right: Samsonbak *Union Suit* with patented belt for just \$1. Others from 75c to \$2.

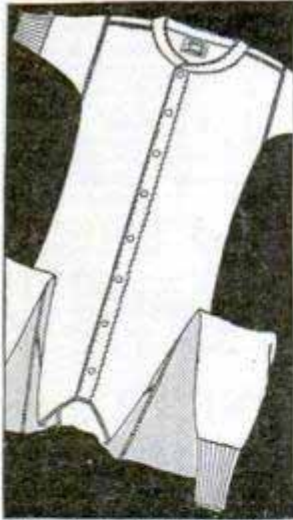

Elastic-knit Lightweight Union Suits for mild climates, \$1 to \$1.50.

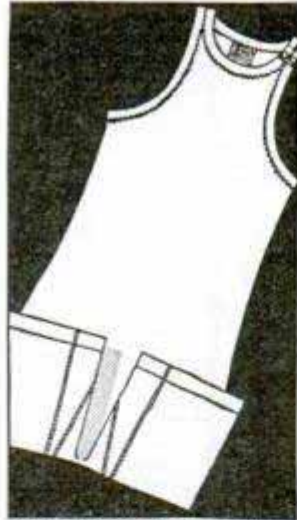

*Knit Athletic Union Suit—*shoulder-button style. Made of fine combed yarn, \$1.

HANES BRINGS YOU BREEZIER SUMMERS

EVEN THE PRICE TAGS
ON THIS COOL UNDERWEAR
ARE COMFORTING

HERE'S more "heat-control" . . . more underwear comfort than you ever thought possible—even on hot, sticky days. HANES fabrics are of fine quality and are carefully cut to full measurements to permit the air to get to your skin and keep it cool and dry. Seams are smooth, never irritating. Styles, as smart or as conservative as you please.

Be as hard to please and as tightwad as you please; be as oversized as you dare—your garments as made by HANES are tailored and waiting at your store. Price tags also figured out to hold down your temperature. If your regular store hasn't the complete line for your boy as well as yourself, write to P. H. Hanes Knitting Co., Winston-Salem, N. C.

HANES UNDERWEAR

FOR MEN AND BOYS



FOR EVERY SEASON

Popular Mechanics Magazine

200 E. Ontario Street, Chicago, U. S. A.

H. H. WINDSOR, Founder

H. H. WINDSOR, Jr., Editor and Publisher

London: Hachette & Cie.,
15, rue Sausage, Ludgate Hill, W. C. 2

Paris: Hachette & Cie.,
111 Rue Reaumur

Melbourne: Gordon & Gotch
509-513 Little Collins St.

ISSUED MONTHLY

SUBSCRIPTION:

SINGLE COPY, 25 CENTS

In United States and its possessions, Canada, Cuba, Mexico, and all countries in the Pan-American Postal Union, per year, postpaid } \$2.50

To all other countries in the Postal Union 3.00

All subscriptions are discontinued at expiration. Please examine the date printed on your wrapper.

Entered as Second Class Matter Sept. 15, 1903, at the Post Office at Chicago, Illinois, under Act of March 3rd, 1879.

Entered as Second Class Matter at the Post Office Department, Canada.

Published by POPULAR MECHANICS CO.

Copyright, 1930, by Popular Mechanics Co.

Copyright in Australia. Copyright in France

54

Contents for July, 1930

No. 1

Special Features

Just How "Good" Were the Bad Men?	18
The Hunt for Lost Atlantis	27
Where Noise-Making is an Art	38
The "West Point" of the Air	49
Wanted—An Inventor!	66
Zepps Defy Lightning	75
What Science Knows about Your Cat	82
What the Clouds Tell Flyers	90
Chaining a Mountain of Sand	99
Adding Machine—silent key in, defrauds customers	102
Airplanes— <i>model with gas engine</i> hidden faults in, revealed by "stropoglow"	32
lands on motorboat at forty-mile speed	87
one motor to fly as fast as three	32
nals—rare, are found in wilds of Abyssinia	107
Aquarium—and special Pullman car built to transport fish	117
Automobiles cold gas promises to increase power of	114
license plates tested in weather-machine	102
Automobiles—Accessories air cleaner and valve oiler combined	93
combination lock for spare wheel is theft-proof	119
extension luggage carrier has large capacity	117
folding bed fits behind rear seat	78
key inserter fastens valves	103
lock on auto gas-tank cap protects car	101
slicker for the rumble seat keeps passengers dry	46
Automobiles—Driving gearless control uses only one pedal	74
rear-vision lens for auto gives better view	48
roller shade on windshield to stop glare	95
Aviation miniature airplane powered with gas engine	79
special pier for air ferry speeds traffic	105
Bicycles—coin-in-slot locks for, chain wheels to curb	73
Billiards—passing hundred balls without a hit	46
Boats and Boating boats race in swimming pool without moving	119
speedboat wins its weight in prizes and trophies	103
Bolt—with spring effect saves lock washer	96
Bricks—that interlock without mortar	80
Bridge—wire as long as halfway to moon	23
Busses—in Germany have visible fenders to guide driver	86
Car Wheels—of wood for London subways are noiseless	37
Cigar Lighter—electric, operates when tipped	37
Cleaner—for condenser pipes removes scale easily	17
Crime—gangster car fitted with bullet-proof glass	108
Dancing—taught by radio on portable floor	104
Deafness hearing electric waves by touching wire	78
portable amplifier aids deaf	120
Dogs—wheels for crippled, enable it to walk	104
Doors lock guard holds key, foils thieves	86
setscrew for knobs can't work loose	42
Earth—is ahead of schedule	88
Electric Tools—grinder and sander with flexible shaft	89
Electricity—million horsepower carried by land and sea	94
Eyeglasses—glass disks under eyelids replace	31
Fires, Forest—fire fighting brigade helps save timber	101
Fish and Fishing bag on fishing coat leaves hands free	35
line control on fishing reel prevents backlash	47
Floodlight—for house lamps brightens entire room	44
Fly—rare, saves natives in South Sea islands	97
Food Grinder—pad for, saves table from damage	117
Football—auto-tire target develops accuracy	89
Furniture of metal offers beauty and comfort	36
palmetto/roofs and cement for making	65
Games—Athletic—fencing with toy balloons offers strenuous sport	98
Games—Card—bridge board with clips for outdoor	79
Gardening—push hoe also is spade	86
Glass cleaning huge roof of, tests workers' skill	48
"invisible" ceiling of, latest hotel novelty	37
Glass Cutter—wheel on, easily renewed	87
Golf flexible shaft on golf club gives longer drive	31
slow movie of golf swing plotted on graph	35
Guns machine gun fired by air to aid target practice	37
that drives staples eliminates hammer	96
Hammer—nail held by claw for initial blow	35

[Continued on Page 4]

Accepted for mailing at special rate of postage provided for in Act of October 3, 1917, authorized on July 1, 1930.

Stars illuminated reading

Paste, mending 98

Reading glass, illuminated 16

Wax paper 13

Lock guard for key 86

Overworks, noise maker 155

[41] [Contents—Continued]

Harvester—sugar cane, cuts forty tons an hour . . . 94
Hats—bleach straw, outdoors at English factory . . . 17
Horse—"walking" on rockers gets power from rider . . . 74
Household Devices . . . 110
House Moving—over river on temporary bridge . . . 33
Lawn Edger—like a scooter is easy to operate . . . 36
Lights—color cabinet plays lights from moving roll . . . 43
Linoleum—strips for floor borders . . . 65
Locomotive—is monster, a "he" or a "she"? . . . 96
Map—monster relief, curved to shape of earth . . . 25
Models
 locomotive fits in palm of hand . . . 106
 wax, of insects in nature study . . . 113
Museum—shark's jaws reconstructed from fossil teeth . . . 115
Musical Instruments—violin in walking stick . . . 112
Navigation—how echoes tell depth of water under ship . . . 45
Oilcan—air-pump pistol on, shoots ten-foot stream . . . 22
Pencil Leads—durability of, tested on turntable . . . 44
Photoelectric Cell—electric eye on prison wall . . . 47
Photography
 exposure meter assures better photographs . . . 102
 nature wonders seen through camera lens . . . 34
Pigeons—trained to carry automatic camera . . . 80
Postage Stamps—machine that sells, also weighs letters . . . 101
Poultry—gas brooder coaxes baby chicks to roosts . . . 78
Pump—portable that floats run by electricity . . . 95
Radio
 tips from the laboratory . . . 124
 wall log for DX-fans . . . 122
Radio—Applications
 headset for the deaf attaches to temples . . . 109
 tone improver aids talking movies . . . 33
Radio—Broadcasting—heartbeats . . . 123
Radio—Construction—improving selectivity of all wave sets . . . 128
Radio—Installation—giving the old set a new voice . . . 126
Radio—Loud Speakers—blending the tone of . . . 123
Railroads
 baggage car carries autos, horses or scenery . . . 118
 Diesel engine for, serves mountain line . . . 109
 handcar with sail hauls entire village . . . 106
Refreshment Stand—hot dog cart like engine attracts customers . . . 98
Restaurant—built on column revolves with diners . . . 88
Road Marker—saves money on traffic stripes . . . 118
Safety Devices and Measures—safety valve for gas stove . . . 65
Saws and Sawing—hand and bench saws combined . . . 24
School—light, in skyscraper aids home makers . . . 88
Screws—kept tight in wood by threaded holder . . . 113
Sculpture—in the making, from clay to bronze . . . 71
Seats—reversible, turn movie into lecture hall . . . 24
Ships and Shipping
 buoy given spring cleaning before trip to sea . . . 72
 ship hoisted aboard vessel with its derrick . . . 81
Spark Plug—has double head and is reversible . . . 81
Spectacles—shaded lens for, shuts out glare . . . 32
Tables—magic legs adjust themselves to floor . . . 115
Tools
 awl for screwdriver blade makes double-duty tool . . . 25
 motor saw and polisher save time . . . 101
Toys
 mass production of cars speeds work . . . 42
 wheel sets for cans make . . . 73
Turntable—autos are turned in street by . . . 112
Warfare—periscope hidden in mirrors protected German "Subs" . . . 72
Wood
 metal bath makes fire-resistant . . . 65
 saw handles and pipe bowls from same . . . 35

Sugar cane harvester 94
AMATEUR MECHANICS

Automobiles
 preventing accumulation of water in gas tank . . . 157
 unequal distribution of load may cause damage . . . 140
Ballroom—confetti fountain for the . . . 145
Boats and Boating
 float shows location of sunken boat . . . 158
 log skids aid in getting canoes past dam . . . 136
 motorcycle engine for boat . . . 146
 outboard motor drives real "Leaping Lena" . . . 129
Bottles
 holder for dipping baby's bottle in hot water . . . 154
 tube helps to empty quickly . . . 156
Camera—making close-ups with small . . . 137

Camping
 broiling fish over campfire . . . 146
 gasoline-saturated sand makes good fire . . . 154
 gas oven makes running-board icebox . . . 152
 "idling" a camp stove . . . 152
Cleaning—flannel bags for dusting . . . 146
Clothes Closet—improvised . . . 158
Clothes Hamper—easy to make . . . 145
Curtains—butterfly pin for holding . . . 140
Fish and Fishing—effective fish decoys . . . 157
Flower Basket—made from stones . . . 141
Flush Tank—silencer for noisy . . . 156
Furniture—old inner tubes make comfortable chair seats and bunks . . . 157
Gardening
 combination weed cutter and support for garden hose . . . 147
 marking rows in garden . . . 157
Hat Holders—easily made . . . 147
House Numbers—reflectors used for . . . 153
Kites—airplane kite releases parachutes . . . 132
Mirror—tin foil substituted for small . . . 137
Motor—Outboard
 rubber handle for starter rope . . . 154
 transporting the . . . 142
Noise Maker—a safe for Independence Day . . . 155
Paintbrushes—good, required to produce smooth undercoat for enamel . . . 152
Pests—foiling the cutworms . . . 141
Poultry—old auto hood makes good brooder . . . 137
Rabbits—effective trap for . . . 153
Revolver—rubber grip for butt of . . . 152
Roof—thatched, for the cottage . . . 141
Saws and Sawing—blower for the small jigsaw . . . 152
Shipbuilding—why not turn that model-yacht hull? . . . 138
Ticket Holder—waterproof, made from old inner tube . . . 156
Toaster—asbestos sheet speeds . . . 141
Tools
 hardening small . . . 136
 simple method of tempering . . . 158
Typewriter—word counter for the . . . 144
Vacuum Cleaner—magnet attachment on . . . 140
Water Sports—scooter provides thrills at beach . . . 148

SHOP NOTES

Annealing—steel tools quickly . . . 165
Ash Bin—for the basement . . . 176
Automobiles—Accessories—card file for salesmen . . . 161
Automobiles—Repairing
 handy jig for pulling down a bent fender . . . 173
 replacing valves . . . 174
Building Construction
 sanitary base shoe is better than baseboard . . . 164
 squaring a tapered column . . . 173
Drafting
 homemade drawing instruments . . . 162
 measuring diameter of small rod . . . 173
Exhibits—sheet steel used for . . . 176
Farm
 boardwalk for the . . . 164
 moving scarecrows are effective . . . 165
Farming—seeding large area with old auto . . . 172
Fly Paper—homemade . . . 171
Garage, Equipment and Supplies—tool for cleaning piston-ring grooves . . . 174
Hangers—self-aligning shaft . . . 161
Hogs—hog oiler for the farm . . . 176
Ice—canvas bag aids delivery of . . . 171
Insulation—battery compound as . . . 172
Keys—preventing loss of hotel . . . 161
Lathes—measuring segments in the . . . 172
Lathes—turning cams on . . . 171
Lawn—homemade harrow loosens soil . . . 173
Motor—automatic switch for water-pump . . . 174
Pattern Making—grease cup used as former for making wax pattern fillets . . . 174
Pumps—cheap power for centrifugal . . . 165
Tools—attachment makes drill chuck of automatic screwdriver . . . 164
Woodworking—ornamental reeding and fluting . . . 166
Workbench—handy outlet for the . . . 171
Workshop
 buffing head makes vertical sander . . . 159
 flywheel for hand emery grinder . . . 172
 quick return for arbor press . . . 164
 wire gripper for flat stock . . . 160

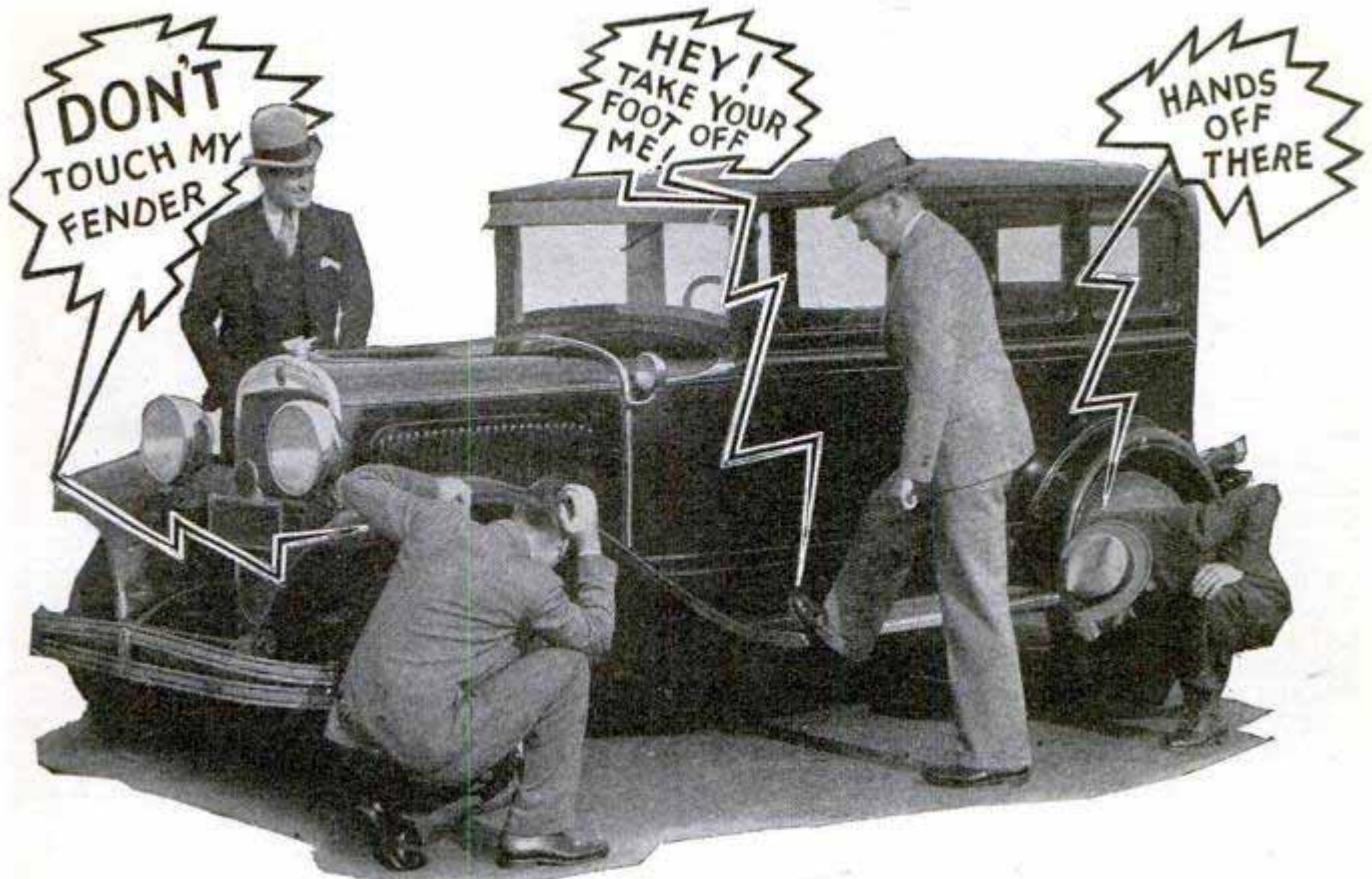

Uncanny Invention Startles Motorists Protects Your Car From Thieves, Puzzles Your Friends!

Here is something incredibly new and revolutionary. More mysterious than anything since the first discoveries of radio! As uncanny as electricity itself! Actually more

useful and valuable than the self-starter on your car! As easily controlled as your headlights! Inexpensive! No wonder it has turned the motor world topsy-turvy overnight!

Pays Agent Record Earnings Of \$138 In A Day!

IMAGINE having a car that no sneak thief can tamper with! No joy-rider can steal! No friend can touch without being warned to keep away! Then think of offering this uncanny electrical device to other motorists at a price scarcely greater than the cost of a new radio tube!

In the above few words you have the reason why G. Oliver of Illinois set a profit record of \$138 in a single day. James Harper of London, England, cables, "Devil-Dogs received, ship immediately three hundred, cable best terms for sales concession, Great Britain." A. Karratti of Hawaii writes, "Have equipped my car with Devil-Dog and am creating a sensation." Ernest Flom, No. Dakota, states, "The Police force praise it highly." Richard Jacques, Canada, writes, "Have sold one for Police armoured car and am getting letters from Chief of Police and Detective Departments." What these men say is just an indication of what motorists everywhere are saying. No wonder our agents are making money hand over fist, both spare time and full time.

can be installed by anyone in ten minutes or less. There is no cost for operation. No extra batteries to buy. An introductory offer now lets you examine the most spectacular invention since the radio first came in, on 5-day test. Profit possibilities as our agent are almost unlimited. Mail the coupon for 5-day offer and complete territory details. No obligation whatever, but do it now!



NORTHWEST ELECTRIC CORP.
Dept. K-10, Pukwana, S. Dakota

Send Quick For 5 Day Test

This astounding invention fits any car from a Ford to a Rolls-Royce without adjustment or fussing. It

Northwest Electric Corp., Dept. K-10, Pukwana, S. Dak.
Rush me your 5-day test offer and distributor's territory details.

Name.....
Address.....
Town.....State.....

What do they say behind your back?

It isn't what they say to your face—It's the whispers that circulate behind your back that tell what folks really think about you

LISTEN to what they say about the other fellow—

"I certainly pity Mrs. Jones. John says her husband is only a clerk and never will be much more."

And then this one—

"That's the Mr. Smith who just built that new house around the corner. They say he was a book-keeper a year ago and now he is Assistant Auditor. He must be a comer."

Are you proud of what they say about you—or ashamed?

How can you make sure that what folks say about you in the future will be good?

There is just one way—get into the success class—the progressive group that people look up to and admire. Go after more money by learning to earn more. You'll be surprised to find how easy it is when you once get going. The start is the hard part.

Then—what people say behind your back will take care of itself—it always does.

Now—what would you say about the following three men?

This man changed the comments—he built his own business

Life looked to Lewis E. Bartlett much as it looks to many men and as it may look to you. A university man and a war veteran with a fine record, the after-war years found him trying vainly to find his niche. First a bank, then a department store and then a wholesale grocery house—in each a fairly successful record. But because he had no specialized training, the way to the top seemed closed.



Then he enrolled for training in Higher Accountancy and afterward in Law. Today he is a member of the bar and is serving as legal and accounting counsel for

a number of corporations. His income is very satisfactory, he is his own boss, and best of all, the path to outstanding success is wide open.

Increases earnings 600 percent

When we first came in contact with Albert L. Russell of Victoria, B. C., Canada, he was a routine worker in a radio plant—and his salary was just as ordinary as his job. Within three months of his enrollment in LaSalle Modern Salesmanship training, he was offered a radio sales position with an increase of 100 percent. He accepted and six months later a larger house, attracted by his sales record, hired him and his earnings went up another 100 percent. Today he finds his earning capacity has increased 600 percent.

Order clerk to general manager

Back in 1920, V. G. Powell of New York, was a young order clerk—in 1924 he was directing sales and advertising—a year later he was general manager. In between were five years of capable, loyal service and two completed LaSalle courses—Modern Business Correspondence and Business Management.

Six months after starting his first course, he asked to handle correspondence and got the job and a raise; a few months later he suggested a new sales promotion department and was given the responsibility of organizing and directing it;

-----Find Yourself Through La Salle!-----

LaSalle Extension University

The World's Largest Business Training Institution

Dept. 764-R

Chicago

I would welcome an outline of your training plan, and a copy of "Ten Years' Promotion in One," all without obligation.

- | | |
|---|--|
| <input type="checkbox"/> Business Management | <input type="checkbox"/> Modern Salesmanship |
| <input type="checkbox"/> Law: Degree of LL. B. | <input type="checkbox"/> Higher Accountancy |
| <input type="checkbox"/> Commercial Law | <input type="checkbox"/> Traffic Management |
| <input type="checkbox"/> Modern Business Correspondence | <input type="checkbox"/> Banking and Finance |
| <input type="checkbox"/> Telegraphy | <input type="checkbox"/> Modern Foremanship |
| <input type="checkbox"/> Railway Accounting | <input type="checkbox"/> Personnel Management |
| <input type="checkbox"/> Stenotypy—Stenography | <input type="checkbox"/> Industrial Management |
| <input type="checkbox"/> Credit and Collection Correspondence | <input type="checkbox"/> Expert Bookkeeping |
| <input type="checkbox"/> Railway Station Mgm't | <input type="checkbox"/> C. P. A. Coaching |
| | <input type="checkbox"/> Business English |
| | <input type="checkbox"/> Commercial Spanish |



- Effective Speaking
 Paper Salesman's Training

Name ----- Age -----

Present Position -----

Address -----



soon after he recommended the beginning of advertising and was given that task.

No wonder he moved up fast. Any employer would welcome and reward initiative and ability like that.

How soon will they change their talk about you—and in which direction will they change it?

Perhaps folks are already talking well about you. If so, fine! But don't be satisfied or you'll stand still.

If, however, you are one of the great mass whom others discuss slightly, or, worse yet, do not even notice, your task is real and pressing. And what you do right now—as you finish these paragraphs—may make or break your future.

Below this text is a coupon—just such a coupon as started Bartlett, Russell, Powell and thousands of others in their climb to greater earning power and larger recognition.

Will you spend two minutes and two cents to find out how you can win greater success? Then clip and mail the coupon NOW.



Speechless...When a Few Words Would Have Made Me!

But now I can face the largest audience without a trace of stage fright

THE annual banquet of our Association—the biggest men in the industry present—and without a word of warning the Chairman called on me to speak—and my mind went blank!

I half rose from my seat, bowed awkwardly and mumbled, "I'm afraid you'll have to excuse me today," and dropped back in my chair.

Speechless—when a few words would have made me! The opportunity I had been waiting for all my life—and I had thrown it away! If I could have made a simple little speech—giving my opinion of trade conditions in a concise, witty, interesting way, I know I would have been made for life!

Always I have been a victim of paralyzing stage fright. Because of my timidity, my diffidence, I was just a nobody, with no knack of impressing others—of putting myself across. No matter how hard I worked, it all went for nothing—I could never win the big positions, the important offices, simply because I was tongue tied in public.

And then like magic I discovered how to overcome my stage fright—and I was amazed to learn that I actually had a natural gift for public speaking. With the aid of a splendid new method, I rapidly developed this gift, until, in a ridiculously short time, I was able to face giant audiences—without a trace of stage fright!

Today I am one of the biggest men in our industry. Scarcely a meeting or banquet is held without my being asked to speak. My real ability, which was hidden so long by stage fright, is now recognized by everyone. I am asked to conferences, luncheons and banquets as a popular after-dinner speaker.

This amazing training has made me into a self-confident aggressive talker—an easy, versatile conversationalist—almost overnight.

No matter what work you are now doing or what may be your station in life; no matter how timid and self-conscious you now are when called upon to speak, you can quickly bring out your natural ability and become a powerful speaker. Now, through an amazing new training you can quickly shape yourself into an outstanding influential speaker, able to dominate one man or five thousand.

In 20 Minutes a Day

This new method is so delightfully simple and easy that you can not fail to progress rapidly. Right from the start you will find that it is becoming easier and easier to express yourself. Thousands have proved that by spending only 20 minutes a day in the privacy of their own homes they can acquire the ability to speak so easily and quickly that they are amazed at the great improvement in themselves.

Send for this Amazing Booklet

This new method of training is fully described in a very interesting and informative

booklet which is now being sent to everyone mailing the coupon below. This booklet is called *How to Work Wonders with Words*. In it you are told how this new, easy method will enable you to conquer stage fright, self-consciousness, timidity, bashfulness and fear. Not only men who have made millions but thousands of others have sent for this booklet and are unstinting in their praise of it. You are told how you can bring out and develop your priceless "hidden knack"—the natural gift within you—which will win you advancement in position and salary, popularity, social standing, power and real success. You can obtain your copy absolutely free by sending the coupon.

Now Sent FREE



NORTH AMERICAN INSTITUTE
3601 Michigan Ave.
Dept. 135-B Chicago, Illinois

North American Institute,
3601 Michigan Avenue,
Dept. 135-B, Chicago, Ill.

Please send me FREE and without obligation my copy of your inspiring booklet, *How to Work Wonders with Words*, and full information regarding your course in Effective Speaking.

Name.....

Address.....

City..... State.....

What 20 Minutes a Day Will Show You

- How to talk before your club or lodge
- How to address board meetings
- How to propose and respond to toasts
- How to make a political speech
- How to tell entertaining stories
- How to make after-dinner speeches
- How to converse interestingly
- How to write better letters
- How to sell more goods
- How to train your memory
- How to enlarge your vocabulary
- How to overcome stage fright
- How to develop self confidence
- How to acquire a winning personality
- How to strengthen your will-power and ambition
- How to become a clear, accurate thinker
- How to develop your power of concentration
- How to be the master of any situation



MODERN ART PAYS BIG MONEY

The amazing demand for art work of all kinds is creating hundreds of big-pay opportunities every year. Trained artists are needed. This is the Age of Color . . . of Design . . . of Art in everything. Manufacturers, decorators, publishers . . . all are seeking men and women with art training.

Through the Federal School of Illustrating many who drudged at small pay have found fascinating careers . . . larger incomes. Many Federal students are now earning from \$2500 to \$6000 a year . . . others even more.

You can learn at home . . . in your spare time . . . the Federal way. Earn while you learn . . . most of our students do. The Federal Course is for practical artists who **MUST** make good. It aims at dollars and cents profit for every student.

More than fifty famous artists . . . masters of modern art . . . contribute exclusive lessons and drawings to the Federal Course. They tell you how they create new . . . striking . . . clever . . . art work. They give you their technical tricks in illustrating, cartooning, lettering, designing, etc.

Test Your Talent Free

Send for our Free Vocational Test Chart. It's simple to fill out. Our artists judge it for you and give you a definite guide to your probable talent and earning power in art. We will also send you, without charge, "A Road To Bigger Things," giving names of the famous Federal instructors . . . showing where the big money in art is . . . what others are making. Get this Book and the Test Chart. Write now.

THE FEDERAL SCHOOL of ILLUSTRATING

7130 FEDERAL SCHOOLS BUILDING

MINNEAPOLIS, MINNESOTA

Federal School of Illustrating

7130 Federal Schools Building, Minneapolis, Minnesota

Please send me free book, "A Road To Bigger Things," and Standard Art Test.

Name _____

Age _____ Occupation _____

Address _____



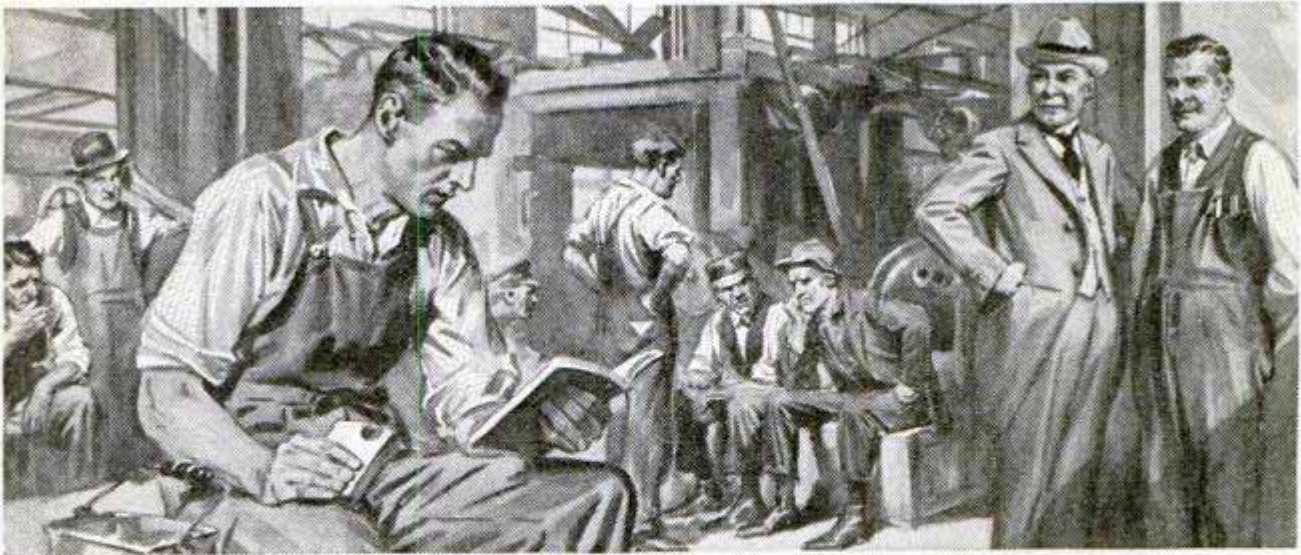

“There’s one man we’re going to keep”

“ED WILSON, there, is one of the most ambitious men in the plant. I notice that he never fools away his spare time. He studies his International Correspondence Schools course every chance he gets.

“It’s been the making of him, too. He hasn’t been here nearly so long as Tom Downey, who was laid off yesterday, but he knows ten times as much about this business.

“I’m going to give him Tom’s job, with a raise in salary. He’s the kind of man we want around here.”

How do you stand in your shop or office? Are you an Ed Wilson or a Tom

Downey? Are you going up? Or down?

No matter where you live, the International Correspondence Schools will come to you. No matter what your handicaps or how small your means, we have a plan to meet your circumstances. No matter how limited your previous education, the simply-written, wonderfully-illustrated I. C. S. textbooks make it easy to learn.

This is all we ask: Without cost, without obligating yourself in any way, put it up to us to prove how we can help you. Just mark and mail this coupon for full particulars.

INTERNATIONAL CORRESPONDENCE SCHOOLS, Box 5688-F, Scranton, Penna.

“The Universal University”

Without cost or obligation on my part, please send me a copy of your 48-page booklet, “Who Wins and Why,” and tell me how I can qualify for the position, or in the subject, before which I have marked an X:

BUSINESS TRAINING COURSES

- | | | | |
|---|--|--|---|
| <input type="checkbox"/> Business Management | <input type="checkbox"/> Cost Accounting | <input type="checkbox"/> Business Correspondence | <input type="checkbox"/> Railway Mail Clerk |
| <input type="checkbox"/> Industrial Management | <input type="checkbox"/> Bookkeeping | <input type="checkbox"/> Show Card and Sign | <input type="checkbox"/> Mail Carrier |
| <input type="checkbox"/> Personnel Management | <input type="checkbox"/> Secretarial Work | <input type="checkbox"/> Lettering | <input type="checkbox"/> Grade School Subjects |
| <input type="checkbox"/> Traffic Management | <input type="checkbox"/> Spanish <input type="checkbox"/> French | <input type="checkbox"/> Stenography and Typing | <input type="checkbox"/> High School Subjects |
| <input type="checkbox"/> Accounting and C. P. A. Coaching | <input type="checkbox"/> Salesmanship | <input type="checkbox"/> English | <input type="checkbox"/> Illustrating <input type="checkbox"/> Cartooning |
| | <input type="checkbox"/> Advertising | <input type="checkbox"/> Civil Service | <input type="checkbox"/> Lumber Dealer |

TECHNICAL AND INDUSTRIAL COURSES

- | | | | |
|--|--|---|--|
| <input type="checkbox"/> Architect | <input type="checkbox"/> Telegraph Engineer | <input type="checkbox"/> Aviation Engines | <input type="checkbox"/> Pharmacy |
| <input type="checkbox"/> Architectural Draftsman | <input type="checkbox"/> Telephone Work | <input type="checkbox"/> Plumber and Steam Fitter | <input type="checkbox"/> Mining Engineer |
| <input type="checkbox"/> Building Foreman | <input type="checkbox"/> Mechanical Engineer | <input type="checkbox"/> Plumbing Inspector | <input type="checkbox"/> Navigation <input type="checkbox"/> Assayer |
| <input type="checkbox"/> Concrete Builder | <input type="checkbox"/> Mechanical Draftsman | <input type="checkbox"/> Foreman Plumber | <input type="checkbox"/> Iron and Steel Worker |
| <input type="checkbox"/> Contractor and Builder | <input type="checkbox"/> Machine Shop Practice | <input type="checkbox"/> Heating and Ventilation | <input type="checkbox"/> Textile Overseer or Supt. |
| <input type="checkbox"/> Structural Draftsman | <input type="checkbox"/> Toolmaker | <input type="checkbox"/> Sheet-Metal Worker | <input type="checkbox"/> Cotton Manufacturing |
| <input type="checkbox"/> Structural Engineer | <input type="checkbox"/> Patternmaker | <input type="checkbox"/> Steam Engineer | <input type="checkbox"/> Woolen Manufacturing |
| <input type="checkbox"/> Electrical Engineer | <input type="checkbox"/> Civil Engineer | <input type="checkbox"/> Marine Engineer | <input type="checkbox"/> Agriculture |
| <input type="checkbox"/> Electrical Contractor | <input type="checkbox"/> Surveying and Mapping | <input type="checkbox"/> Refrigeration Engineer | <input type="checkbox"/> Fruit Growing |
| <input type="checkbox"/> Electric Wiring | <input type="checkbox"/> Bridge Engineer | <input type="checkbox"/> R. R. Positions | <input type="checkbox"/> Poultry Farming |
| <input type="checkbox"/> Electric Lighting | <input type="checkbox"/> Gas Engine Operating | <input type="checkbox"/> Highway Engineer | <input type="checkbox"/> Mathematics |
| <input type="checkbox"/> Electric Car Running | <input type="checkbox"/> Automobile Work | <input type="checkbox"/> Chemistry | <input type="checkbox"/> Radio |

Name.....Street Address.....

City.....State.....Occupation.....

If you reside in Canada, send this coupon to the International Correspondence Schools Canadian, Limited, Montreal, Canada

\$85

**a Week for
McCarty**

Kenneth McCarty, South Haven, Mich. — former \$18 week clerk — now orchestra Tenor Banjoist coinings \$85 weekly.



\$278

**Extra for
McGriff**

J. P. McGriff, Hawkinsville, Ga., playing for dances and movies, has already earned \$278 in spare-time.



\$100

**a month extra
for Abbott**

L. G. Abbott, Williston, N. D., "happiest fellow in town," cashing-in BIG every month.



You Can Make Real Cash Quick this Easy Fascinating Way

TENOR BANJO Pays Big!



McCarty, McGriff and Abbott are only three out of thousands of my students who have made more money and friends through my amazingly simple, rapid method of learning to play the Tenor Banjo. Most of them had never read a note or touched a string—but my clear, interesting instruction has made them top-notchers socially and financially. Now I'm ready to do the same thing for YOU!

Have Friends, Fun and EXTRA MONEY—Learn at Home in 1 to 3 Mos.

The Tenor Banjoist has all the friends, all the invitations, all the good times he wants. And he makes BIG MONEY — spare-time or full-time. Parties, dances, entertainments, orchestras — all of them want the melodious, snappy music of this favorite instrument. YOU can cash-in on such popularity; make yourself the most popular one in town; put plenty of good round dollars into your pocket too! And you can do it in 1 to 3 months' spare-time study at home—actually be playing your first tune within the first half hour!

Get this Big FREE Book Now—Tells How

"The Play-Way to Popularity and Big Pay" is the book that has started thousands toward popular, prosperous Success! It brings all the proof and facts about my astounding course — describes the wonderful Tenor Banjo and Outfit I send you—shows how you too can have more friends, fun and EXTRA CASH this easy way. Get this big book quick; no obligation. Don't put it off, don't delay. Mail the coupon at once!

This \$20 TENOR BANJO

Complete Outfit and Phonograph Records Come with 1st Lesson

The same day I receive your "O. K."—telling me that you want to get in line quick for good times and good pay—I'll send you at no extra cost this splendid, professional size, full-tone Tenor Banjo worth \$20; Complete Outfit of pick, tuner, strings; Gain-time Chart; rapid progress lessons and instructions — and Demonstration Phonograph Records of every selection in the course, showing you exactly how to play each note, each tune. No long, tedious practicing or "scales." Instead, real fun—easy, fascinating! Get the FREE Book first — get the facts! Send coupon now!

Clip-Sign-Send!

**A. F. Bloch, President
NEW YORK ACADEMY OF MUSIC
Studio 1070, 100 Fifth Avenue,
New York City.**

Please send me FREE Book on Tenor Banjo Success—"The Play-Way to Popularity and Big Pay."

Name.....

Address.....

Age.....



FREE BOOKS of BUSINESS HELPS

We publish over 200 Home Study Books, each a complete treatise of its subject. We have one or more for you. Books on

- Commercial Art
- Lettering
- Advertising
- Sign Making
- Radio
- Aviation
- Painting
- Silk Screen Process
- Decoration
- Automobiles
- Battery Work
- Electricity
- Carpentry
- Building
- Contracting
- Sheet Metal Work

and many other subjects. All fully described in our FREE CATALOG. Check the subjects in which you are interested and write today.

FREDERICK J. DRAKE & CO., Publishers
Room 508—179 No. Michigan Blvd., Chicago
Drake books are for sale in all book stores.

YOUR FUTURE ASSURED



Now is the time to safeguard yourself against such periods of depression as the present. Many good, profitable trades are not subject to hard times or slack seasons—trades meeting everyday human needs, such as Mechanical Dentistry. Your age, circumstances, or lack of experience need not stop you. The way is open to you. A helpful booklet, "Choosing a Trade," will be sent you without cost. Your copy is waiting. Simply ask for Bulletin 2.

BODEE INSTITUTE, 1755 Broadway, N. Y.
1305 N. Broad St., Philadelphia 85 Court St., Brooklyn

LEARN WATCH REPAIRING



You can learn by our modern and original system of instruction every part of the Watch Repairing Trade at home as good or better than at a shop. You can earn money while learning and secure a well paying position or start in business after completing our course of instruction. Good watch repairers are always in demand and earn from \$50 to \$75 per week. For particulars apply to the Wisconsin School of Watch Repairing 166 Mason St., MILWAUKEE, WIS.

BE AN ARTIST

WE CAN TEACH YOU DRAWING in your own home during your spare time. Twenty-five years of successful teaching proves our ability. Artists receive large salaries.

Write Today for Art Year Book

SCHOOL OF APPLIED ART
ROOM NO. 2 BATTLE CREEK MICH.



IF YOU STAMMER

Write for my free book "Millard's Advanced Natural Corrective Course" and a free copy of my speech magazine. 10,000 cases successfully treated. Est. 24 years. Largest school for stammerers in world. Millard Inst. of Normal Speech, 2317 Millard Bldg., Milwaukee, Wis.

BE AN OIL EXPERT!

Trained geologists, drillers, refiners, salesmen are at a premium! New, easy, practical way to learn at home in spare time!

Write Today! FREE Book!
PETROLEUM ENGINEERING UNIVERSITY, Dept. 227, FORT WAYNE, IND.

Learn to PAINT SIGNS and SHOW CARDS

We quickly teach you by mail, or at school, in spare time. Enormous demand. Big future. Interesting work. Oldest and foremost school. **EARN \$50 TO \$200 WEEKLY** Otto Wiegand, Md., home-study graduate, made \$12,000 from his business in one year. John Vassos, N.Y., gets \$25 for a show card. Crawford, B. C., writes: "Earned \$200 while taking course." Write for complete information.

DETROIT SCHOOL OF LETTERING
154 Stinson Ave. Est. 1899 Detroit, Mich.



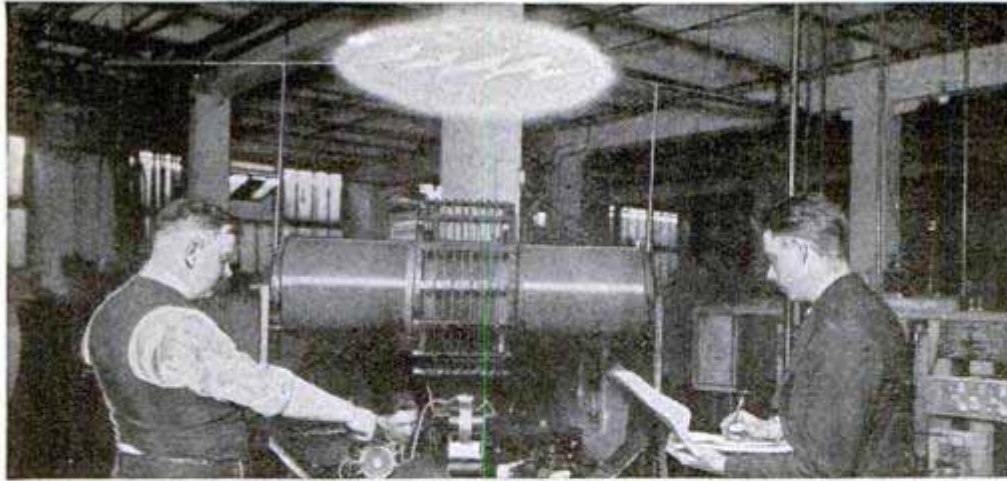

500,000 VOLTS

"Artificial lightning" being developed in COYNE School. Spark of 500,000 volts is shown jumping 30 inches. This gigantic Tesla coil is the same as that used by Steinmetz, absolutely harmless, because of high frequency.

LEARN ELECTRICITY Without Books or Lessons in 12 Weeks

By Actual Work - In the GREAT SHOPS of COYNE



Anyone who can see and understand the English language can master Electricity in 90 days. I teach you with the most complete outlay of electrical apparatus ever assembled in any school—30-foot control board—2-story transmitting stations—skeleton houses, huge motors of all kinds—dynamos—sub-stations—auto-

mobiles—switchboards. In one department we generate enough electricity to supply a small city!

No Books—No Lessons—No Classes

ENTER ANYTIME. Experts teach you without books or classes. They guide you every step of the way with individual attention. You do the actual work on real full-size machinery in full operation. Take motors for instance. Instead of learning from books and charts—you actually build motors. You can't help but know all about them. Anyone can learn this fascinating way.

No Experience Necessary

That's how my methods make men master electricity in 12 wonderful weeks. You don't need experience—Coyne training starts from the very beginning. You don't need advanced education—you learn by doing. Age is no handicap—Coyne students range from 16 to 40.

Triple Your Earning Power

I don't need to tell you about the opportunities in Electricity. They are too many and too amazing to mention. Ordinary jobs run from \$50—\$75—\$150 a week. And Coyne training leads to the biggest positions.

COYNE ELECTRICAL SCHOOL

H. C. LEWIS, President — ESTABLISHED 1899
500 S. Paulina St., Dept. BO-72, Chicago

Many Coyne men are making up to \$600 a month. Demand for Coyne men often exceeds the supply. Our Employment Bureau secures dozens of positions weekly.

EARN WHILE YOU LEARN

We help many students to secure part-time jobs to earn a good part of living expenses while learning.

RAILROAD FARE to Chicago Allowed

Right now I am including railroad fare to Chicago and complete courses in Radio, Aviation, and Automotive Electricity without extra charge.

All Details Sent Free

This school is 30 years old—Coyne training is tested—proven beyond all doubt—endorsed by electrical industry. You can find out everything absolutely free. Simply mail the coupon and let me send you the big, free Coyne book of 150 photographs—facts—jobs—salaries—opportunities. See what Coyne training can do for you in just 90 days! This does not obligate you. So act at once. Just mail coupon.

Get this Free Book



H. C. LEWIS, President

COYNE ELECTRICAL SCHOOL, Dept. BO-72
500 S. Paulina St., Chicago, Ill.

Dear Mr. Lewis:

Without obligation send me your big free catalog and all details of Railroad Fare to Chicago, Free Employment Service, Radio Aviation and Automotive Electrical Courses you are including and how many "earn while learning."

Name

Address

City.....State.....

Let RCA INSTITUTES Start You on the road to SUCCESS in RADIO

RADIO needs you . . . That's why the entire Radio industry is calling for trained men . . . That's why thousands of men who answered these advertisements are now earning from \$2,000 and up a year. Manufacturers, broadcasting stations, aviation and radio are now eagerly seeking trained RCA Institutes men . . . Never before was there an opportunity like this in Radio.

This Is the Only Course Sponsored by the Radio Corporation of America

The RCA Institutes' Home Laboratory Training Course enables you to learn Radio in your spare time. In only an hour a day, you can obtain a thorough, practical education in Radio . . . You study right at RCA, the world's largest Radio organization. You learn Radio by actual experience with the remarkable outlay of apparatus given to every student. That's why every graduate of RCA Institutes has the experience, the ability and the confidence to hold a worthwhile Radio job.

Graduates of RCA Institutes Find It Easier to Get Good Jobs
SEND FOR THIS FREE BOOK . . . Read about these practical RCA methods of training that have prepared hundreds of men for success in Radio. Everything you want to know about the opportunities in radio. Forty fascinating pages, packed with pictures and descriptions of the brilliant opportunities in this world-wide profession. RCA Institutes will back you up to the limit. Our catalogue is yours, free . . . SEND FOR IT TODAY!



Radio Mechanic and Inspector, \$1800 to \$4000 a Year.



Broadcast Operators \$1800 to \$4800 a Year.

RCA INSTITUTES, INC.

A Division of the
Radio Corporation of America

RCA Institutes, Inc., Dept. P.M.7
75 Varick St., New York, N. Y.

Gentlemen: Please send me your FREE 40-page book which illustrates the opportunities in Radio and describes your home laboratory method of instruction.

Name (Please Print).....
Address.....
State.....
Occupation.....

**Clip
this
Coupon
Now!**

IF—



you pledge yourself to secrecy we will teach you the secrets of real professional Magic

\$250 to \$1000 a Month

For the first time in the history of Magic the age-old sacredly guarded secrets of the Mystic Art are being revealed. Now at last you can learn to be a Real Professional Magician. Yes, and you can learn this wonderful art *easily and quickly AT HOME*. You are taught the *guarded secrets* of the Magic Profession. But before you study, you must sign Magician's Solemn Pledge of Secrecy.

WRITE Send for Details!

Send today for free literature telling all about amazing NEW Course in Magic. Get our Low Prices, Easy Terms. Write today stating your age.

**Tarbell System, Inc., Dept. B-135
1926 Sunnyside Ave., Chicago, Ill.**

WORLD NEEDS PLUMBERS

Old style plumbers are fading like the horse and buggy. The world demands modern Plumbing and Skilled Trained Mechanics to do it. Unlimited, swift growing field. Make \$50 to \$100 a week or start own shop. We train you quick. Learn in 8 to 12 WEEKS to do any job with skill and science. Need no previous experience. Strictly tool using system. Opportunity knocks. Investigate today —amazing offer—low tuition. World's greatest school.



Write—
UNIVERSAL PLUMBING SCHOOL
2130 Troost Ave. Kansas City, Mo.

AVIATION Information FREE

Send us your name and address for full information regarding the Aviation and Airplane business. Find out about the many great opportunities now open and how we prepare you at home, during spare time, to qualify. Our new book "Opportunities in the Airplane Industry" also sent free if you answer at once.

AMERICAN SCHOOL OF AVIATION
3601 Michigan Ave. Dept. 135-B CHICAGO

GOV'T. POSITIONS

\$35 TO \$75 WEEKLY

MEN-WOMEN

() Ry. Mail Clerk	() Steno-Typist
() Prohibition Agent	() Immigrant Inspector
() R. F. D. Carrier	() Seamstress
() Special Agent	() Auditor
() Customs Inspector	() Steno-Secretary
() City Mail Carrier	() U. S. Border Patrol
() Meat Inspector	() Chauffeur-Carrier
() P. O. Clerk	() Watchman
() File Clerk	() Skilled Laborer
() General Clerk	() Postmaster
() Matron	() Typist

AGE 18 to 55

OZMENT INSTRUCTION BUREAU, 111 Arcade Bldg., St. Louis, Mo. Send me FREE particulars How To Qualify for positions marked "X". Salaries, locations, opportunities, etc. ALL SENT FREE.

NAME.....
ADDRESS.....

We have placed machinists, carpenters, masons, plumbers, railroad men, office clerks, farmers and even laborers in fine Drafting Jobs under this plan. Mail coupon for details of our remarkable offer.



Men Who Work With Their Hands

Make the Best

DRAFTSMEN



—and we'll back them with this EMPLOYMENT CONTRACT

We are looking for more ambitious young fellows with factory, building-trade or any other kind of mechanical experience to prepare for and help place in well-paid Drafting positions. Such men, we find, are unusually successful as Draftsmen, because they know how things are done, and that's a priceless asset to the man who makes the blueprint plans. Get in touch with me and I'll tell you how you can cash in on your entire past mechanical experience.

Drafting Is Logically Your Next Move!

Of course you realize the biggest handicap to mechanical work is that you're limited in earning capacity to the output of your two hands, as long as you live. Even the skilled mechanic earning \$50 to \$60 a week has reached his limit. He can never earn more and when he gets old he will earn less. So I don't blame any man for wanting to get away from this futureless outlook. For wanting to get into something where he can use his head as well as his hands—where he will be paid for what he knows, instead of only for what he does . . . You know enough about blueprints to understand that PLANS govern every move in factory and construction job. The Draftsman who makes them is several jumps ahead of the workman who follows them. And so I want you to know that DRAFTING is a logical, natural PROMOTION from mechanical and building work—better-paid, more interesting—just the kind of work you'd enjoy doing.

Get Our NO-RISK PLAN

The way to a fine Drafting job for you—is easier than you think. It takes no "artistic talent" or advanced education. Thousands of men no smarter than you, with no more education or ability, have learned it quickly and you can, too. With the co-operation of some of the biggest employers and engineers in the U. S., we have worked out a plan to prepare you for Drafting work in your spare time at home—then to help you get a fine position when you're only half way through the course. Mail the coupon and we'll be glad to tell you all about this lifetime chance.

THE AMERICAN SCHOOL
Dept. DB-47, Drexel Ave. and 58th St., Chicago, Ill.



36-Page Drafting Book—FREE

Tells how easy Drafting is to learn—how interesting the work is—what remarkable opportunities are open for Draftsmen right now. Mail coupon for a copy—without cost or obligation.

AMERICAN SCHOOL, Dept. DB-47, Drexel Ave. & 58th St., Chicago, Ill.

Please tell me, without cost or obligation, about your training and employment service in line marked X below.

DRAFTING

- Architecture
- Building
- Electrical Engineering
- Business Management
- Accounting
- Mechanical Engineering
- Shop Superintendent
- Foremanship
- High School in 2 years
- Structural Steel
- Civil Engineering
- Auto Engineering

Name _____

St. No. _____

City _____ State _____

Age _____ Occupation _____



"I have landed a job with the Pacific Tel. and Tel. Co. in Seattle, and I must say that I am greatly indebted to the American School for my success. You have done all that you promised in helping me obtain employment."

T. C. White
Seattle, Wash.



"I have obtained a position as a junior draftsman with the Muncie Oil Engine Co., and so far I like the work real well. I appreciate your aid in obtaining this position very much."

M. N. Bareham
Muncie, Ind.

Easy home method quickly teaches HAWAIIAN GUITAR



Play all the latest hits just as the Hawaiians do! Have good times aplenty!

Win fame—friends—fortune! Play the Hawaiian Guitar!

Native Hawaiian expert directs you

You get expert instruction directed by a world-famous player and teacher, Prof. Walter Kolomoku. He quickly reveals to you the secrets of this fascinating instrument.

Only 4 Motions to learn. Then you can play any music—popular songs, classical, old-time melodies, native Hawaiian airs—or real jazz. You'll never be lonesome after you learn the Hawaiian Guitar.

Complete Course 52 lessons. Nothing omitted. Pictures explain every move. You are sure to learn—what we can do for others we can do for you. Over 50,000 successful students.

Learn at home in spare time

Study in spare time at home. Even if you don't know a note our method is so simple, plain and easy, you begin a piece your first lesson. In half an hour you can play it!

Pay as you play We make it easy for you. Start with small first payment—then pay while learning. Costs only few cents per lesson. You only pay the cost of instruction—we furnish everything.

Sweet Toned HAWAIIAN GUITAR

GIVEN when you enroll

—with genuine seal grain Fabrikoid Cover and complete playing outfit. Reliable retailers ask \$18 to \$20 for a similar instrument and outfit without the fine Fabrikoid Case, which alone is valued at \$3.50.

TENOR BANJO and other courses

The same thorough instruction on the Tenor Banjo, Violin, Tiple, Tenor Guitar, Ukulele, Banjo Ukulele—well known instructors. Write for full information.

FIRST HAWAIIAN CONSERVATORY OF MUSIC, Inc.
9th Floor, Woolworth Bldg.
Dept. 748, New York

Approved as a Correspondence School Under the Laws of the State of New York

Member National Home Study Council

Send This Coupon for Liberal Offer!

FIRST HAWAIIAN CONSERVATORY OF MUSIC, Inc.
9th Floor, Woolworth Bldg., Dept. 748, New York, N.Y.
Please mail full information about your 52-lesson Hawaiian Guitar Course. I am not obliged to enroll unless I want to.

Name _____

Address _____

City _____ State _____



Bliss Electrical School

A Special Technical School

Condensed, comprehensive course in Theoretical and Practical Electricity.

ELECTRICAL

men with training are in demand. Since 1893 this school has been training men of ambition and limited time for the electrical industries. Thorough course in Electrical

ENGINEERING

enables graduates to secure good positions and promotions. Mathematics and Mechanical Drawing. Students construct motors, install wiring and test electrical machinery. Regular course designed to be completed in **one college year.** Thoroughly equipped fire-proof dormitories, dining-hall, laboratories, shops. **THIRTY-SEVEN YEARS'** successful experience assures you maximum training in minimum time. **Catalog.**



117 Takoma Ave.

BLISS ELECTRICAL SCHOOL
Washington, D. C.



I Teach by Mail

Begin Today—Write for My FREE Book, I can make a good penman of you at home during spare time. Write for my **FREE BOOK, "How to Become a Good Penman."** It contains specimens and tells how others mastered penmanship by the Tamblin System. Your name will be elegantly written on a card if you enclose stamp to pay postage. Write today for book, **F. W. Tamblin, 418 Ridge Bldg., Kansas City, U.S.A.**



\$100 to \$500 A Week is Earned by Cartoonist Today DO YOU LIKE TO DRAW?

Billy Hon's Famous Cartoon Book Will Teach You A Simple—Complete—Interesting Course in Cartooning, consisting of 30 lessons illustrated with over 300 original drawings by one of America's famous cartoonists. No better course at any price. Sent postpaid any place on earth for only \$1.

Satisfaction Guaranteed.
BILLY HON'S CARTOON STUDIO,
P. O. Box 960 (P) HOLLYWOOD, CALIF.

You can be quickly cured, if you

STAMMER

Send 10 cents for 288-page book on Stammering and Stuttering. "Its Cause and Cure." It tells how I cured myself after stammering 20 yrs. **B. N. Bogue, 11131 Bogue Bldg., 1147 N. Illinois St., Indianapolis.**

Every Family should own this Newest, Greatest ENCYCLOPAEDIA BRITANNICA

Write for FREE Booklet
THE ENCYCLOPAEDIA BRITANNICA, Inc.
342 Madison Ave., New York City

LEARN TO Mount Birds

We teach you At Home by Mail to mount Birds, Animals, Heads, Tax Furs and Make Rugs. Be a taxidermy artist. Easily, quickly learned by men, women and boys. Tremendously interesting and fascinating. Decorate home and den with beautiful art. **Makes Big Profits from Spare Time Selling Specimens and Mounting for Others.**

Free Book—Beautiful book telling all about how to learn taxidermy sent Free if you state your AGE. Send Today. You will be delighted.
Northwestern School of Taxidermy 8337 Elwood Bldg., OMAHA, NEB.



When he speaks, they Jump

DID you notice how he cracked out that command? And did you see how quickly it was obeyed? You don't have to ask why, either.

Just take a look at those immense broad shoulders; that great chest; those shapely hips and slim, muscled waist. Get the swift, ready poise of those legs—the quick, vibrant power of those wrists. Here's a man you know can do things, not just talk about them. He's a human dynamo. Health, strength, speed, clear thinking are his. He's a leader in everything he does.

In Just 3 Months He Did It

He wasn't born with that superb body. Only 3 short months ago he was about as pitiful a specimen of manhood as ever walked the earth. He "couldn't lift a feather," and at the end of the day he was almost too tired to drag himself home. The men in his office used to laugh at his poor attempts to keep pace with them. But he learned the secret of scientific muscle-building—of gaining tremendous strength in a hurry—and look at him now. He's just one of the 100,000 men I have rebuilt in the last 19 years.

You Can Be Like Him

Folks call me the Muscle-Builder. For years I've been taking weak, worn-out men from all over the world and making them into forceful, aggressive leaders. Bankers, lawyers, plumbers or clerks—more than a hundred thousand of them have been turned out of my muscle factory with new health and strength to fight this world's battles.

15 Minutes a Day Is All I Ask

My system is simple and easy, but it certainly gets results. Just 15 minutes with me each day, and you'll begin to notice the difference in a week. And in just 30 days I *guarantee* to put one whole inch of real muscle on each of your arms, and two full inches across your chest. Remember, I *guarantee* it, not just promise it. If you follow directions, that muscle is bound to be there.

But that isn't all I do in 30 days. Your neck will begin to broaden—your legs grow shapely and strong. Inside and out you'll feel and act like a new man. Your eyes will regain that sparkle a healthy, happy boy has. You'll find it easier to think, and think clearly.

But stay with me just 60 days more, and then I'll be satisfied with the sort of man I am building up to fight his way through to health, success and happiness.

I'll Improve Your Appearance, Too

Just step up in front of your mirror at the end of those 90 days and take a good look at that handsome, erect figure before you. Was it worth while? I'll say it was. Stride down the street and notice the attention you get now. Remember how nobody even glanced at you before? Those great, muscled arms; those steel-like wrists; those broad shoulders and shapely waist—only the aggressive up-and-coming man can be like that.

Think what those 3 short months can mean to you. The right to enjoy life to the full—more friends—sweethearts—health—happiness—the difference between success and failure. Write today, let me show you what I have done for others, and what I can do for you.

Send For My New
64 Page Book

"Muscular Development"

IT IS FREE

Do you get that? It's free. I don't ask a cent. It's yours with my compliments. Take it and read it. It's the peppiest piece of literature you ever flashed your eyes on. And 48 full-page photos of myself and some of my numerous prize-winning pupils. This is the finest collection of strong men ever assembled into one book—look them over—doctors, lawyers, merchants, mechanics, and every line of trade you can think of. I swear you'll never let this book get out of your hands again. And just think—you're getting it for nothing. Don't hesitate—no strings attached to it. Grab it.

Take your pen or pencil and fill out the coupon, or even your name and address on a postal will do—do it now, before you turn this page.

EARLE LIEDERMAN

Dept. 2007, 305 Broadway, New York City

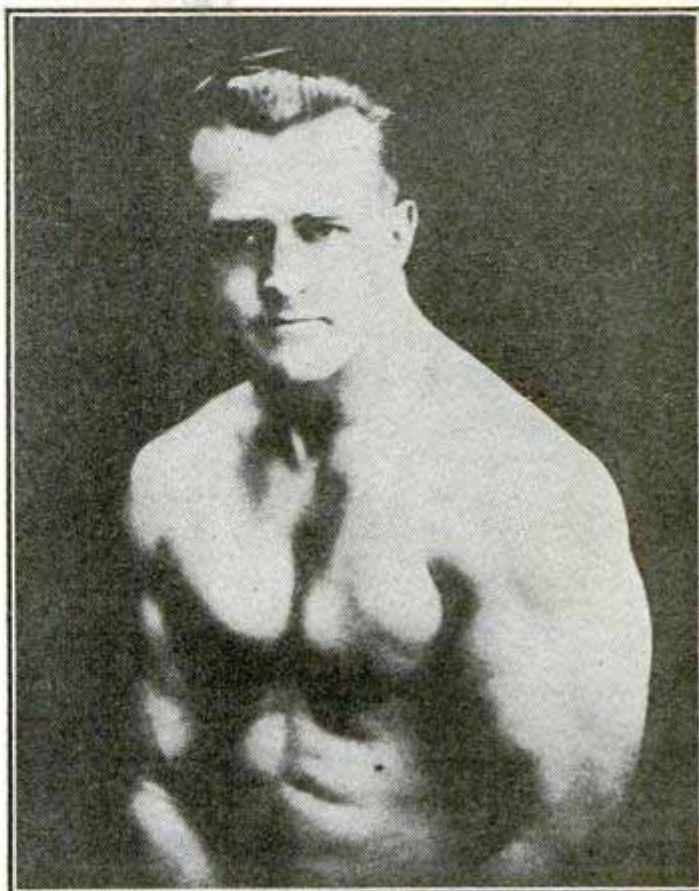

EARLE LIEDERMAN, The Muscle Builder

Author of "Muscle Building," "Science of Wrestling and Jiu Jitsu," "Secrets of Strength," "Here's Health," "Endurance," Etc.

EARLE LIEDERMAN,

Dept. 2007, 305 Broadway, New York City

Dear Sir:—Please send me absolutely free and without any obligation on my part whatsoever, a copy of your latest book, "Muscular Development." (Please write or print plainly.)

Name.....Age.....

Street Address.....

City.....State.....



SHOW CARD LETTERING

Learn at Home

HERE is the very course you need if you want to get a good paying position as a Show Card Letterer or Sign Letterer, or have a business of your own. This course is complete and practical, arranged to meet the needs of the student who studies at home.

H. L. Wood, a clerk, made more than \$700 "on the side" before he had completed his course and also won \$125 in prizes. Harry William Lord writes that he has more than doubled his salary as a result of studying this I. C. S. course in spare time.

There is no doubt that Show Card Lettering and Sign Lettering offer a real opportunity to ambitious men and women. Just mark and mail the coupon and we'll gladly send you a booklet telling all about the I. C. S. course in Show Card Lettering, or any other subject in which you are interested.

INTERNATIONAL CORRESPONDENCE SCHOOLS

Box 5690-F, Scranton, Penna.

Without cost or obligation, please send me a copy of your booklet, "Who Wins and Why," and full particulars about the course before which I have marked X in the list below:

SHOW CARD LETTERING

- | | |
|---|---|
| <input type="checkbox"/> ILLUSTRATING | <input type="checkbox"/> CARTOONING |
| <input type="checkbox"/> Business Management | <input type="checkbox"/> Advertising |
| <input type="checkbox"/> Industrial Management | <input type="checkbox"/> Business Correspondence |
| <input type="checkbox"/> Personnel Management | <input type="checkbox"/> Stenography and Typing |
| <input type="checkbox"/> Traffic Management | <input type="checkbox"/> English <input type="checkbox"/> Civil Service |
| <input type="checkbox"/> Accounting and C. P. A. Coaching | <input type="checkbox"/> Railway Mail Clerk |
| <input type="checkbox"/> Cost Accounting | <input type="checkbox"/> Mail Carrier |
| <input type="checkbox"/> Bookkeeping | <input type="checkbox"/> Common School Subjects |
| <input type="checkbox"/> Secretarial Work | <input type="checkbox"/> High School Subjects |
| <input type="checkbox"/> Salesmanship | <input type="checkbox"/> Lumber Dealer |
| | <input type="checkbox"/> Spanish <input type="checkbox"/> French |

TECHNICAL AND INDUSTRIAL COURSES

- | | |
|--|---|
| <input type="checkbox"/> Architect | <input type="checkbox"/> Automobile Work |
| <input type="checkbox"/> Architectural Draftsman | <input type="checkbox"/> Airplane Engines |
| <input type="checkbox"/> Building Foreman | <input type="checkbox"/> Plumber and Steam Fitter |
| <input type="checkbox"/> Concrete Builder | <input type="checkbox"/> Plumbing Inspector |
| <input type="checkbox"/> Contractor and Builder | <input type="checkbox"/> Foreman Plumber |
| <input type="checkbox"/> Structural Draftsman | <input type="checkbox"/> Heating and Ventilation |
| <input type="checkbox"/> Structural Engineer | <input type="checkbox"/> Sheet-Metal Worker |
| <input type="checkbox"/> Electrical Engineer | <input type="checkbox"/> Steam Engineer |
| <input type="checkbox"/> Electrical Contractor | <input type="checkbox"/> Marine Engineer |
| <input type="checkbox"/> Electric Wiring | <input type="checkbox"/> Refrigeration Engineer |
| <input type="checkbox"/> Electric Lighting | <input type="checkbox"/> R. R. Positions |
| <input type="checkbox"/> Electric Car Running | <input type="checkbox"/> Highway Engineer |
| <input type="checkbox"/> Telegraph Engineer | <input type="checkbox"/> Mining Engineer |
| <input type="checkbox"/> Telephone Work | <input type="checkbox"/> Pharmacy |
| <input type="checkbox"/> Mechanical Engineer | <input type="checkbox"/> Chemistry |
| <input type="checkbox"/> Mechanical Draftsman | <input type="checkbox"/> Iron and Steel Worker |
| <input type="checkbox"/> Machine Shop Practice | <input type="checkbox"/> Textile Overseer or Supt. |
| <input type="checkbox"/> Toolmaker | <input type="checkbox"/> Navigation <input type="checkbox"/> Assayer |
| <input type="checkbox"/> Patternmaker | <input type="checkbox"/> Cotton Manufacturing |
| <input type="checkbox"/> Civil Engineer | <input type="checkbox"/> Woolen Manufacturing |
| <input type="checkbox"/> Surveying and Mapping | <input type="checkbox"/> Agriculture <input type="checkbox"/> Fruit Growing |
| <input type="checkbox"/> Bridge Engineer | <input type="checkbox"/> Poultry Farming |
| <input type="checkbox"/> Gas Engine Operating | <input type="checkbox"/> Mathematics <input type="checkbox"/> Radio |

Name.....

Address.....

City.....State.....

Occupation.....

If you reside in Canada, send this coupon to the International Correspondence Schools Canadian, Limited, Montreal, Canada

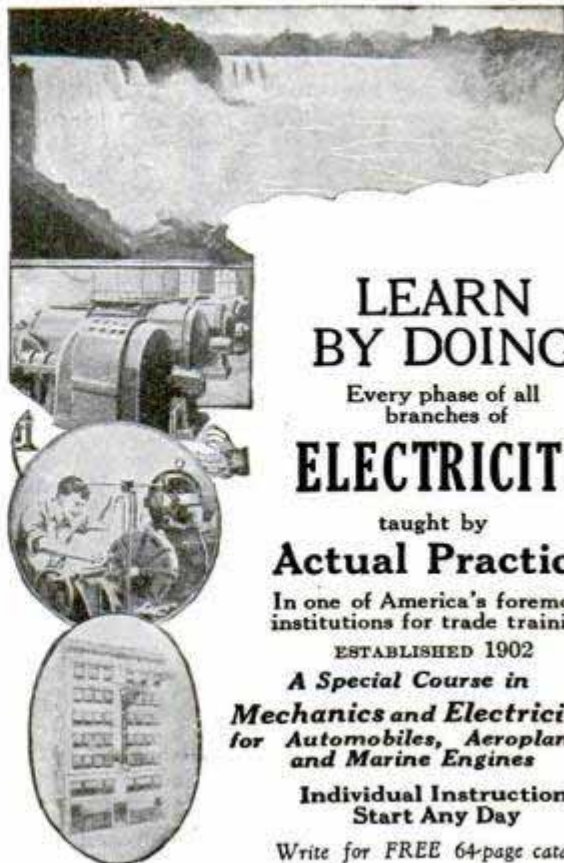

LEARN BY DOING

Every phase of all branches of

ELECTRICITY

taught by

Actual Practice

In one of America's foremost institutions for trade training

ESTABLISHED 1902

A Special Course in
Mechanics and Electricity
for Automobiles, Aeroplanes
and Marine Engines

Individual Instruction
Start Any Day

Write for FREE 64-page catalog

THE NEW YORK ELECTRICAL SCHOOL

44 West 17th Street

New York City

HOT PIANO

Ultra-modern Piano

Jazz taught by mail. Note or ear. Easy rapid lessons for adult beginners. Also Self-instruction system for advanced pianists. Learn 358 Bass Styles, 976 Jazz Breaks, hundreds of Trick Endings, Hot Rhythms, Sock, Stomp and Dirt Effects; Symphonic and Wicked Harmony in latest Radio and Record Style. Write for Free Booklet.

WATERMAN PIANO SCHOOL, 1826 W. Adams St., Los Angeles, Calif.



Wonderful new device, guides your hand; corrects your writing in a few days. Big improvement in three hours. No failures. Complete outline FREE. Write C. J. Ozment, Dept. 34, St. Louis, Mo.

LAW

STUDY-AT HOME

Legally trained men win high positions and big success in business and public life. Be independent. Greater opportunities now than ever before. Big corporations are headed by men with legal training. Earn \$5,000 to \$10,000 Annually

We guide you step by step. You can train at home during spare time. Degree of LL. B. conferred. Successful graduates in every section of the United States. We furnish all text material, including fourteen-volume Law Library. Low cost, easy terms. Get our valuable 64-page "Law Guide" and "Evidence" books FREE. Send for them NOW.

LaSalle Extension University, Dept. 764-L, Chicago
The World's Largest Business Training Institution

Learn Photography at HOME

Make money taking pictures. Prepare quickly during spare time. Also earn while you learn. No experience necessary. New easy method. Nothing else like it. Send at once for free book, OPPORTUNITIES IN MODERN PHOTOGRAPHY and full particulars.

AMERICAN SCHOOL OF PHOTOGRAPHY
Dept. 135-B 3601 Michigan Ave. Chicago, U. S. A.



National Salesmen's Training Assn.
Dept. H-103, N. S. T. A. Bldg.
Chicago, Ill.

Without cost or obligation you may send me your free book, "The Key to Master Salesmanship."

Name.....

Address.....

City.....State.....

Age.....Occupation.....

They Laughed When I Mailed This Coupon

..But It Brought Me The Book That Showed Me How to Make \$10,000 a Year!

As I walked up to the mail box, Joe nudged Ed and winked broadly for my benefit.

"Sh!" he hissed in a loud stage-whisper. "This is going to be the big turning point in Frank Parker's life! He's writing for a book that tells how to get into salesmanship. Pretty soon he'll be earning so much that he'll make the rest of us look like pikers!"

Ed snickered.

"Won't it be grand!" he grinned. "Now he can quit punching time-clocks and eating 40-cent lunches." He raised his voice. "Drop me a postal sometime when you get out into big business and start making \$10,000 a year, will you, Frank?"

They both laughed uproariously. And probably it *did* seem like a joke to them that a \$30 a week clerk would have the nerve to think he could ever get anywhere or make real money without some special "gift" or "pull."

But they laughed too soon. Just yesterday I sat down and wrote to Ed who is still at the shop, dragging along at the same old job.

"Dear Ed"—I wrote. "You asked me to send you a card when I 'got into big business and started making \$10,000 a year.' Well, here's your card. Yesterday I was promoted to the job of assistant Sales Manager of the Western Metal Works, at a salary that goes with it. I'll loan you my copy of that book on salesmanship you used to think was such a joke."

Only a book! Just seven ounces of paper and printers' ink—but it contains one of the most vivid and inspiring messages that any ambitious man can read. It reveals the real truth about the art of selling, explains the science of selling in simple terms, and tells exactly how the great sales records of nationally-known star salesmen are achieved. And not only that—it outlines a simple plan that will enable almost any man to master scientific salesmanship without spending a moment on the road—without losing a day or a dollar from his present position.

A Few Weeks—Then Bigger Pay

Reason it out for yourself. Salesmanship offers bigger returns and delivers them quicker than any other line of work under the sun. But many people have subscribed to the foolish notion that a man has to be "born" with some sort of "gift" for salesmanship. Nothing could be farther from the truth. Just like any other pro-

feSSION, salesmanship is governed by certain fundamental rules and laws—laws which you can master as easily as you learned the alphabet.

Right now an unusual demand for salesmen is being reported. City and traveling sales positions are open in nearly every line all over the country. Last year requests for over 50,000 trained men were received. This employment service is free to both employers and employees, and thousands have secured excellent positions this way.

Free to Every Man

See for yourself why "The Key to Master Salesmanship" has been the deciding factor in the careers of so many men who are now making \$10,000 a year. See how Mark Barichievich of San Francisco, Calif., for example, jumped from \$8 a week as dish-washer to \$150 as salesman. Find out how F. B. Englehardt of Chattanooga doubled his pay and commenced earning \$7,000. Learn for yourself the REAL truth about the art of selling! If we were asking \$2 or \$3 a copy you might hesitate. But the book is now FREE. You do not risk one penny nor incur the slightest obligation. And since it may alter your entire future, it certainly is worth your time to fill out and clip the coupon at the top of this page. Why not do it now!

National Salesmen's Training Association

Dept. H-103

N. S. T. A. Bldg. Chicago, Ill.



Where Shall We Send Your Copy FREE?

Mail Coupon Above Today

\$ 1 9 0 0 T O \$ 2 7 0 0 A Y E A R



FRANKLIN INSTITUTE, Dept. L173, Rochester, N.Y.

Rush to me entirely free of charge: 32 page book, with list of U. S. Gov't Jobs obtainable and particulars telling how to get the job here checked.

- ... Railway Postal Clerk - - - - - (\$1900-\$2700)
- ... Post Office Clerk - - - - - (\$1700-\$2300)
- ... City Mail Carrier - - - - - (\$1700-\$2100)
- ... Rural Mail Carrier - - - - - (\$2100-\$3300)
- ... Prohibition Agent - - - - - (\$2300-\$2800)
- ... Inspector of Customs - - - - - (\$2100 up)
- ... Immigrant Inspector - - - - - (\$2100 up)

MANY OTHER STEADY U. S. GOVERNMENT POSITIONS

- Customs Inspectors
- Rural Carriers
- City Mail Carriers
- City Post Office Clerks

MEN—BOYS 18 OR OVER

- Short Hours
- Rapid Advancement
- Pleasant Work
- Permanent Employment
- Long Vacation with Pay—No Layoffs

Mail Coupon Today Sure. Act at Once.

DO IT TODAY. TOMORROW YOU MAY FORGET.

Name

Address

TELEGRAPHY

(Morse and Wireless) and RAILWAY ACCOUNTING, taught thoroughly. Big salaries. Tremendous demand. Oldest, largest school. Endorsed by Telegraph, Railway, Radio, and Government officials. Expenses low—opportunities to earn large portion. Catalog free. **DODGE INSTITUTE**, Jones St., Valparaiso, Ind.



"BECOME A LIGHTNING TRICK CARTOONIST"

Send \$1.00 for Laugh Producing Program of 23 Trick Drawings with Instructions. Catalog of Chalk Talk Supplies Free. **BALDA ART SERVICE**, Dept. 1, Oshkosh, Wis.

ENGINEERING DEGREE IN 2 YEARS



Want to know about airplanes? Send for catalog now!

By ELIMINATING non-essentials and intensifying courses, Tri-State College offers a Bachelor of Science degree in engineering in 2 years. Courses in Aeronautical, Civil, Electrical, Mechanical, Chemical, and Administrative engineering.

Thorough instruction according to individual ability. No entrance examinations. Students who left high school can make up work. Living expenses and tuition low. Graduates hold responsible positions. 46th year. Enter in September, January, March and June. Write for catalog now! 470 COLLEGE STREET, ANGOLA, INDIANA.

TRI-STATE COLLEGE

Want Some Money?

Here's a wonderful way to get it

OUR beautifully illustrated book tells how. It tells all about our new methods of art decoration, art treatment and how anybody can learn without previous training or experience. It contains page after page of handsome color illustrations of what you can make and sell. You can make good money and this book is

FREE Our system is amazingly easy to learn and the profits are larger than in almost any other business. You can produce beautiful finished art objects almost from the beginning. You don't have to know how to draw or have any experience. Begin making money now.

All supplies are sent by us with the instructions and many have made \$25 the first week. Some society women have taken up this work for their own amusement.—Either way, pleasure or profit, it's the most delightful home work you can imagine. Write Now for your copy of this valuable book; it's FREE.



Fireside Industries

DEPT. 66-H • ADRIAN, MICH.

Ready to solo — every minute of training with Curtiss-Wright is pleasant and thrilling.

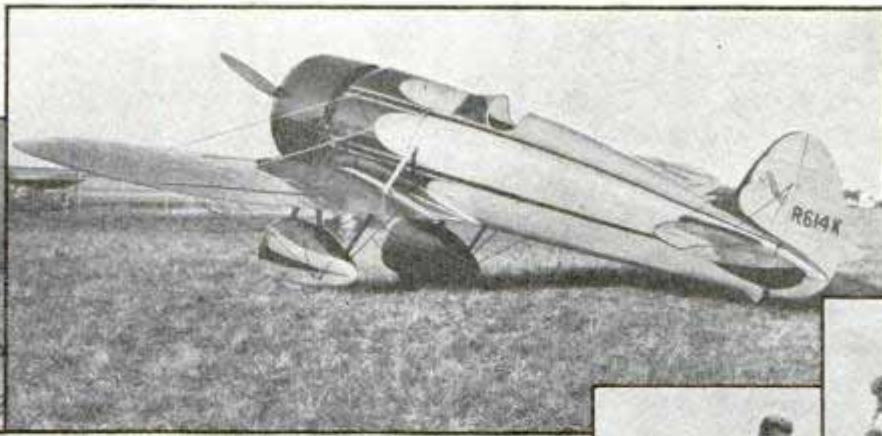

At left: The Mystery Ship, a Curtiss-Wright product, holder of all speed records for commercial planes.

When you train under CURTISS-WRIGHT

... air success is yours!



Curtiss-Wright mechanics know their jobs because they get experience on every kind and type of plane and motor.

DOES Aviation beckon to you? Regardless of your vocation, air-training is vitally essential to your business success in this fast-moving age.

Specialists in every line of work—engineering, manufacturing, sales, etc.—are taking to the air to conserve precious minutes and convert them into dollars. Today the world is seeking and rewarding the air-minded. You, too, should learn to fly—under Curtiss-Wright, the world's oldest and largest flying organization.

World Leaders in Aircraft Industry

When you train under Curtiss-Wright, your education is complete, thorough. Curtiss-Wright is the greatest name in aviation—the largest manufacturer of aircraft and engines, the largest operator of planes and airports. All over the world, Curtiss-Wright products, from the tiny Moth to the giant, 18-passenger Condor, are well and favorably known. A Curtiss-Wright product, the Tanager, won the \$100,000.00 Safe-Aircraft prize. Another, the Mystery Ship, is the world's fastest commercial plane. And the Robin holds the world's endurance record.

40 Curtiss-Wright Schools Dot the Country

You will find a Curtiss-Wright Flying School near you. Each school is a university of the air—completely fitted with the latest and best equipment. The instructors, headed by the world-famous "Casey" Jones, are the nation's leading pilots—

especially picked for their ability to impart their skill to you.

It's Easy to Learn the Curtiss-Wright Way

With Curtiss-Wright it's easy to learn to fly. You are given every consideration. Training is adapted to your special aptitude. You will learn, not only the piloting of a plane through all maneuvers, but also how great flying fields are operated, how commercial transport is successfully carried on, and how the various phases of commercial and private flying reach their greatest success.

Your Success in the Air is Assured

When you graduate from a Curtiss-Wright school your success is assured. You will be capable of taking your place among the nation's finest flyers, respected wherever you go. And you'll have no trouble turning your flying ability to profit, whatever your chosen line may be. For you will be the kind of pilot that aviation needs today.

Complete Information Without Cost or Obligation

Now is the time to learn to fly—to equip yourself for success. Spring, summer and fall—the finest training months—are just ahead. For detailed and completely illustrated booklets giving full information about Curtiss-Wright courses and methods, mail the coupon. They will be sent you without cost or obligation. Act now! Mail coupon today.



Above: The giant Condor 18-passenger Curtiss-Wright Air Liner.

This student is receiving final instructions before entering training plane.



MAIL THIS COUPON!

Curtiss-Wright Flying Service, 27 W. 57th St., N. Y.

I am interested in Aviation. Please send me, without cost or obligation, a booklet on the subject I have checked.

- Flight Instruction
- Aerial Transportation
- New Finance Plan
- Opportunities in Aviation
- \$50 Ground Course
- Free Curtiss-Wright Booklet

Name.....Age.....

Street.....

City..... State..... PM-7

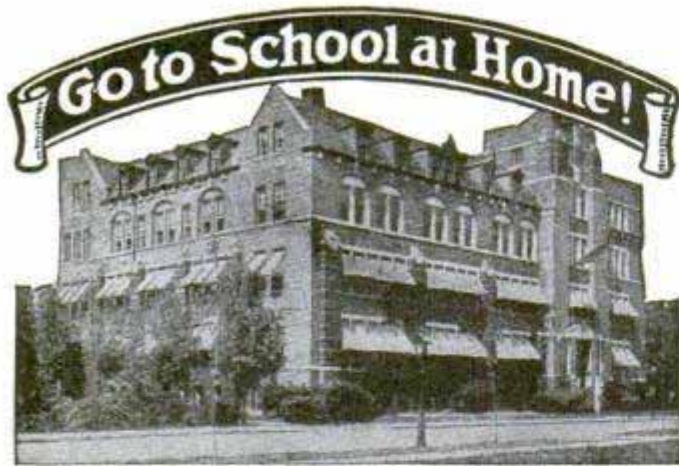

High School Course in Two Years!

You Want to Earn Big Money!

And you will not be satisfied unless you earn steady promotion. But are you prepared for the job ahead of you? Do you measure up to the standard that insures success? For a more responsible position a fairly good education is necessary. To write a sensible business letter, to prepare estimates, to figure cost and to compute interest, you must have a certain amount of preparation. All this you must be able to do before you will earn promotion. Many business houses hire no men whose general knowledge is not equal to a high school course. Why? Because big business refuses to burden itself with men who are barred from promotion by the lack of elementary education.

Can You Qualify for a Better Position

We have a plan whereby you can. We can give you a complete but simplified high school course in two years, giving you all the essentials that form the foundation of practical business. It will prepare you to hold your own where competition is keen and exacting. Do not doubt your ability, but make up your mind to it and you will soon have the requirements that will bring you success and big money. YOU CAN DO IT.

Let us show you how to get on the road to success. It will not cost you a single working hour. Write today. It costs you nothing but a stamp.

American School

Dept. HB-47 Drexel Ave. and 58th St., Chicago

American School

Dept. HB-47 Drexel Ave. and 58th St., Chicago

Send me full information on the subject checked and how you will help me win success.

- | | |
|-----------------------------|---------------------------|
|Architect |Business Law |
|Building Contractor |Lawyer |
|Automobile Engineer |Machine Shop Practice |
|Automobile Repairman |Mechanical Engineer |
|Civil Engineer |Shop Superintendent |
|Structural Engineer |Employment Manager |
|Business Manager |Steam Engineer |
|Cert. Public Accountant |Foremanship |
|Accountant and Auditor |Sanitary Engineer |
|Bookkeeper |Surveyor (& Mapping) |
|Draftsman and Designer |Telephone Engineer |
|Electrical Engineer |Telegraph Engineer |
|Electric Light & Power |High School Graduate |
|General Education |Wireless Radio |
|Vocational Guidance |Undecided |

Name.....

Address

BEDFORD YMCA TRADE SCHOOL

Aviation Mechanic
Flying
Airplane Welding
Airplane Drafting
Air Navigation
Aero Starting, Lighting, Ignition
Auto Mechanic
Machine Shop. Electric Welding
Oxy-Acetylene Welding
Radio Mechanic. Battery Repair
Mechanical, Architectural Drawing
Sign Painting. Show Card Writing
Window Dressing
Commercial Art. Fine Art
DAY AND EVENING SESSIONS
Write for Catalog 50
Brooklyn Engineering Institute
(Operated by Bedford Y. M. C. A.)
1125 Bedford Avenue, Brooklyn
New York City

Electrical Engineering

Training for men of ambition and limited time. Concise, comprehensive course in Theoretical and Practical Electrical Engineering including the closely related subjects of Mathematics and Mechanical Drawing. Students construct motors, install wiring,

test electrical machinery. Course designed to be completed in one college year by eliminating non-essentials. **THIRTY-SEVEN YEARS'** successful experience assures you maximum training in minimum time.



Send for free catalog

Bliss Electrical School

117 CHICAGO AVE., WASHINGTON, D. C.

MUSIC LESSONS IN YOUR HOME



You can play music like this quickly

Write today for our **FREE BOOKLET AND SAMPLE LESSON**. It tells how to learn to play Piano, Organ, Violin, Mandolin, Guitar, Banjo, etc. Beginners or advanced players. You pay as you learn. Costs you only a few cents a day. Thousands of satisfied students.

AMERICAN SCHOOL of MUSIC, 51 Manhattan Bldg., CHICAGO

LEARN AUTOS



At home!

Stop working long hard hours for low pay. My "Job-Way" Training in the short cut to a Real Job paying up to \$75 a week. Get my **FREE Book**. See how I train you in spare time, then help you get a good job or go into business. Read about wonderful opportunities in World's Biggest Business. Write me today.

B. W. Cooke, Directing Engineer
Motor Institute of America, Dept. B-216
Motor Institute Bldg. Evanston, Illinois

SONG WRITERS!



SUBSTANTIAL ADVANCE ROYALTIES are paid on work found acceptable for publication. Anyone wishing to write either the words or music for songs may submit work for free examination and advice. Past experience unnecessary. New demand created by "Talking Pictures" fully described in our free book. Write for it Today. **NEWCOMER ASSOCIATES**
759 Earle Building, New York, N. Y.

Learn Watchwork, Jewelrywork and Engraving

A fine trade commanding a good salary, and your services always in demand. Address **HOROLOGICAL**, Dept. P, Bradley Institute, PEORIA, ILLINOIS, for our latest catalog.

Study LAW AT HOME

Lincoln did it! Also thousands of other great lawyers, politicians and business men. YOU, too, can become a lawyer or law-trained businessman through home study guided by the successful practicing lawyers of our faculty. Write today for free book.

AMERICAN CORR. SCHOOL OF LAW
3601 Michigan Ave., Dept. 135-B, Chicago



FREE BLUE PRINTS

AND FREE BOOK "HOW TO READ BLUE PRINTS"

SHOW YOU THE WAY TO

9 BIG PAY JOBS

- | | |
|---|--|
| 1 Building Superintendent — \$5,000 to \$12,000 | 6 Building Estimator — \$6,000 to \$10,000 |
| 2 Building Inspector—\$4,800 to \$8,000 | 7 Real Estate Expert—\$5,500 to \$12,000 |
| 3 Appraiser — \$6,000 to \$10,000 | 8 Construction Foreman — \$4,500 to \$8,500 |
| 4 Material Buyer—\$5,000 to \$7,500 | 9 CONTRACTOR AND BUILDER IN A BUSINESS OF YOUR OWN—\$5,000 to \$12,000 |
| 5 Material Salesman—\$5,000 to \$12,000 | |

FIND OUT HOW Easy it is to Make Up to \$12,000 in a Year

Learn to read Blue Prints this amazing new way! Get into the world's richest industry—Building! See how quickly and easily you can train to make up to \$12,000 a year! My FREE Book "How to Read Blue Prints" discloses all the so-called "mysteries" of Blue Print Reading—also gives some startling facts about the nine best jobs in America. Don't send one penny—just mail the coupon!

NO longer need you spend years trying to pick up the "mysteries" of Blue Print Plan Reading. For now a quick, sure, practical method has been perfected that has made thousands of men Blue Print Experts in a surprisingly short time.

This is no ordinary "school course." It is practical from start to finish. It is based on many sets of real Blue Prints—plans that would cost thousands of dollars if purchased from architects. Twenty famous experts in all lines of construction work talk over these Blue Prints with you in plain, simple language. Show you every detail. Explain every short cut. Tell you the "secrets" of quick, accurate estimating. Explain Superintending. Give you for the first time many inside facts and money-making methods used by the "Giants" of the Building Industry.

This is the kind of training that quickly puts men into high-salaried jobs—or into profitable contracting businesses of their own. Yet now you get it right at home in only 2 or 3 months. It requires no extensive education. If you can read and understand what is written here you can easily master it. See what this training has done for others: Bartholomew, Calif., became a contractor at an increase of over 300% his first year; Blair, Okla.,

stepped up to Superintendent at 100% increase; Dickerson, R. I., increased his salary 700% in 12 months; Marchand, La., says: "My income has increased 200% and I now have more contracting work than I can do."

Over seven billion dollars will be spent this year in new construction! No wonder then, such tremendous opportunities are open to you when you have this "head-work" training in Blue Prints.

If you want more money—real big money! Then choose a "Blue Print" job in Building. Clerk or Salesman, Carpenter or Bricklayer, here is the one field where there are unlimited opportunities for advancement.

So accept my FREE gift of a complete set of real working Blue Prints, and my fascinating Book "How to Read Blue Prints" that tells all the interesting and instructive facts about Blue Print Plans. Don't send one penny—pay no C. O. D.—It's all FREE. Just fill out and mail the coupon today—NOW!

TWO BOOKS also FREE



IF YOU LIVE NEARBY

Visit our big day or evening school attended by over 1000 Builders. You can get the same training at home by mail—same plans, lessons and instructors. Your spare time is enough.

Chicago Technical School for Builders—Dept. H-143, Chicago Tech. Building, 118 East 26th Street, Chicago, Ill.

Please send me your free book, "How to Read Blue Prints," and complete set of real Blue Prints. I understand these are mine to keep without obligation. It is also understood that no salesman will call on me.

Name.....
 Address.....
 City..... State.....
 Age..... Occupation.....

Chicago Technical SCHOOL for BUILDERS

Dept. H-143, 118 East 26th St., Chicago, Ill.



**It Took 3 Generations
of This Great Family
of Famous European
Musicians to Develop
This Unique Method of**

VOICE TRAINING



Casper Feuchtinger, court musician to Duke of Waldeck, and one of the greatest musicians of the nineteenth century.



Joseph Feuchtinger, who was decorated with the Order of Arts and Sciences by the King of Wurtemberg for his great musical genius.



Eugene Feuchtinger, A. M. European Maestro, musician-scientist, who discovered the SILENT method of voice training.

*No matter how hopeless
your case may seem—
send for free book*

telling all about this wonderful SILENT Method of voice training that has brought astounding results to thousands upon thousands of men and women—even after all other methods failed... send for letters telling of their own true and amazing experiences... You study at home... the cost is nominal... and you pay only a little each month... with results *guaranteed* or your entire tuition will be refunded.

**100% Improvement
Guaranteed!**

Here's the best part of it all. We absolutely guarantee to improve your voice at least 100%—or refund every penny of your tuition. When before have you heard of a voice teacher *guaranteeing* results—NEVER!—because never before has there been a voice training method just like this. Don't pass up a *guaranteed* voice opportunity like this. At least send for your copy of the free book that tells you all about it and does not obligate you in any way. Mail coupon NOW.

Perfect Voice Institute
Dept. B-135 1922 Sunnyside Ave., Chicago

Perfect Voice Institute, Dept. B-135
1922 Sunnyside Ave., Chicago

Please send me FREE and without obligation, Prof. Feuchtinger's new book, "Physical Voice Culture." I have checked subject in which I am most interested.

Weak Voice Singing Stammering Speaking

Name

Address

City

State

Books on 65 Practical Subjects

Popular Mechanics Press specializes in supplying the outstanding best books on many subjects. As new books of merit appear, we will revise the list accordingly.

- AIR NAVIGATION AND METEOROLOGY**
Every flyer needs... \$3.00
- AIRCRAFT ENGINES**
Dyke's New Instructor
Best Engine Book... \$5.00
- ARCHERY**
Bows and Arrows for Boys \$0.75
- ARCHITECTURAL**
Drafting... \$2.00
- ARMATURE WINDING**
Excellent new book... \$2.00
- AUTO ENCYCLOPEDIA**
Dyke's. (Covers New Model A Ford)... \$6.00
- AVIATION**
Practical new book on flight training... \$5.00
- BIRD HOUSES**
How to Make... \$1.00
- BLUE PRINTS**
How to Read... \$2.00
- BOAT BUILDING**
35 Popular Types, Outboard Motor, Sail, Row, etc... \$3.00
- BOY MECHANIC**
Famous 4 Vol. Library, 4000 Things to Make... \$7.00
- BUILT-IN FURNITURE**
Complete Instructions... \$2.50
- CARBURETORS**
Excellent book on all makes... \$2.00
- CARPENTRY**
Hand book of 336 Kinks... \$1.50
- CHALK TALK**
How to... \$1.00
- COLOR SIMPLIFIED**
Practical new Book (for Color Users)... \$3.50
- CONCRETE**
173 Ways of Using
New Edition (Cloth)... \$1.00
- CONTRACTOR**
Building Cost Estimator... \$2.00
- DIESEL ENGINES**
(New Work). Best Authority... \$5.00
- DOGS**
Care and Raising... \$2.00
- ELECTRICITY**
Practical Lessons in... \$2.50
- ELECTROPLATING**
Practical Results Easily Obtained... \$1.00
- ENGLISH**
Self-Improvement in... \$2.50
- ETIQUETTE**
New 560-Page Book.
Only... \$1.00
- FARMER'S BOOK**
of 861 Kinks and Book for Farmers' Wives... \$1.00
- FLYING**
Stunt Flying... \$2.50
- FORMULAS**
10,000 Money Making... \$4.00
- FURNITURE (Mission)**
Homemade (3 vols.)... \$3.00
- GARDEN (Everybody's)**
Answers every question... \$3.50
- HOME REPAIRS**
Practical Book of... \$2.50
- HOME WORKSHOP**
900 Different Things to Make... \$3.00
- INVENTIONS (American)**
Popular History of
2 vols. Reduced to... \$5.00
- INVESTMENT**
Policies that pay
By Ray Vance... \$4.00
- JOINT WIPING**
(New Edition)... \$1.00
- KITES THAT FLY**
How to Make... \$1.25
- LANDSCAPING**
Practical... \$2.50
- LATHE WORK (METAL)**
and Drilling and Thread Cutting... \$1.00
- LETTER WRITING**
Social and Business
Only... \$1.00
- MACHINIST**
419 Kinks for... \$1.50
- MAGIC**
200 New Tricks for Amateurs... \$1.00
- MASONS AND BUILDERS**
Guides (4 vols.)... \$6.00
- MATHEMATICS**
Made Easy for the Practical Man... \$1.50
- MECHANICAL DRAWING**
Practical Course in... \$1.00
- MODEL AIRCRAFT**
Building and Flying... \$2.25
- OUTDOOR OPPORTUNITIES**
for Making a Living... \$2.00
- OUTDOOR SPORTS**
for All Year 'Round... \$1.50
- PAINTING**
House (Best Methods)... \$2.00
- PLUMBING**
500 Plain Facts for Every Homeowner... \$1.50
- POULTRY RAISING**
for Profit... \$2.00
- PUZZLES**
Amusing Mathematical... \$1.50
- RABBITS**
For Food and Fur... \$2.00
- RADIO**
Trouble Shooting. Covers All-Electric Sets and Television... \$3.00
- SHOP NOTES**
14 Vols. of 6000 Valuable Kinks... \$4.25
- STAMP ALBUM (Modern)**
12,000 Varieties... \$2.00
- STEEL SQUARE**
Pocket Book, Practical... \$1.00
- STENCILS**
How to Use... \$1.25
- TOY MAKING**
Complete Instructions... \$1.50
- TREASURES**
Hunting Hidden... \$2.50
- WALL DECORATION**
(Interior) Newest Methods... \$4.00
- WIRING**
House (New Book)... \$2.50
- WOOD TURNING (LATHE)**
Practical Course in... \$1.50
- WOODCRAFT**
Famous 590 Page Book by Ernest Thompson Seton; Only... \$1.00
- WROUGHT IRON**
New designs in... \$1.32

Books sent C. O. D. anywhere in U.S.

Just check the books you want, write your name and address below, and mail the advertisement. It is your order blank. When postman hands you books, pay him the price and few cents postage. If outside the U. S. remit when ordering and include 10 cents per book extra for postage. We have many other books on these and 2,000 other subjects. Catalog free.

Name.....

City..... State.....

Address.....

Mail to Popular Mechanics Press,
Room P7—200 East Ontario St., Chicago, Ill.

*There is a **JOB** for You Here*

Get Into

AVIATION

MAJOR

R.L. Rockwell

Will Train You AT HOME, and Until You Get a Job Paying You \$300 to \$400 a month

Major Rockwell—famous world war flyer, is offering to train a limited number of ambitious men who want to get into aviation and get one of the big pay jobs that aviation offers.

IN 12 SHORT WEEKS

All you have to do is devote about an hour or two a day to my Home Study Extension Course and in 12 weeks you will be mastering the principles of Ground Training and be prepared to qualify for and accept a big pay job in this branch of Aviation. If you want to fly, my Home Study Course teaches you the principles of flight. When you have completed the ground training I will arrange for you to take

your flying instructions at any licensed airport near your home at special reduced rates. Or if you want you can come here to Dayton and get training at one of the finest and best equipped airports in America. No matter where you learn to fly you can qualify for a pilot's license and a high pay job in passenger lines, mail service, and other important branches of flying.

Advance Education or Experience Unnecessary

You don't need a high education to master my course. My home course is thorough and complete. Everything is so clearly explained, with easy-to-understand text and pictures, that in a few short months you will be able to grasp every fundamental principle of Aviation ground work and get a start in Aviation qualifying for any important aviation job paying \$300 to \$400 a month. My Home Study Course will give you all the knowledge necessary to pass the government's written examination for a license.

How I Help You Get Your Job

Because of my experience in Aviation and knowledge of the work, I am in touch with large employers of trained aviation men who are constantly seeking help. Thus I am able to help my graduates get the aviation job they want at big pay. These employers prefer Rockwell Trained Men.

Money-Back Agreement

I am so sure that you can learn Aviation with my help and step into a big aviation job that if you are not satisfied when you have finished my course, I agree to return every penny of your tuition. Read my money-back agreement. Act now while my special offer lasts. Rush this coupon to me for a copy of my famous free book.

MAJOR ROB'T L. ROCKWELL
The Dayton School of Aviation
 Desk G-1 Dayton, Ohio



My Book Explains All ... Sent FREE ... MAIL COUPON



Major Rob't L. Rockwell
 The Dayton School of Aviation
 Desk G-1, Dayton, Ohio.

Dear Major: Please send me FREE and without obligation a copy of your famous book on Aviation; the details of your no-risk plan; also your special tuition offer.

Name

Address

Town..... State..... Age.....

Who else wants
**BIG
MUSCLES**
and a handsome,
healthy body?

(From a recent photo)



**CHARLES
ATLAS**

"World's Most Perfectly Developed Man"

TELL me where YOU want big, powerful muscles—tell me how many added pounds of firm, smooth flesh YOU want distributed over your body—tell me if YOU want the vitality, pep, strength and splendid bodily condition that wins for a fellow the admiration of every woman and the respect and envy of any man.

"Then let me PROVE that my amazing secret of *Dynamic-Tension* will make this new man of you—right in your own home, using just your leisure time, without apparatus or 'machinery' of any kind, without special diets, without dosing or doctoring yourself, but purely by the natural methods of my system of *Dynamic-Tension*.

"I, too, was one of the below-par boys. Then I developed and used these methods that I now offer to reveal to you. These self-same methods built me up from a 97-pound, flat-chested, skinny, no-muscle specimen to the figure of health, strength and powerful, balanced muscular development that you see in my new photo—and won for me the title of 'The World's Most Perfectly Developed Man'.

Accept this book free

"Other fellows—scores, hundreds, thousands, of them, all over the world—have used my methods with success and now you can, too! What my methods did for me and these others they can do for you. You owe it to yourself to find out how these methods can help you—how you can build-up and tone-up, outside and inside, freeing yourself of shameful ailments such as constipation, poor digestion, bad breath, pimples, skin blotches and the others that rob you of the good times and the good things of life. Find out what I can do for YOU! Write to me—I'll send you a free copy of my new 48-page book that will show you the way out. But act! Mail at once the coupon that entitles you to a free copy of my valuable book. Address me personally—CHARLES ATLAS, 171 Madison Ave., (Dept. 87), New York City."

**CHARLES ATLAS (Dept. 87)
171 Madison Ave., New York City**

I want the proof that your system of *Dynamic-Tension* will give me, too, a healthy, husky body and big muscle development. Send me your free book, "Everlasting Health and Strength."

Name.....
Address.....
City..... State.....

(Please print or write plainly)

**A Card Case Any MASON
Would Be Proud To Own**



Protects your lodge cards, \$1 auto license, passes, etc. **1** under isinglass windows, ready to be seen at a glance. A genuine leather, 5-window sturdy card case, extra pocket—snap button—gold corners, for only \$1. Stamped with Masonic Emblem in heavy gold FREE—Same price without emblem. Name and other stamping 35c a line extra. Larger cases, 9 windows \$1.50. 13 windows \$2. Send for Catalogue.

Masonic Books, Monitors, Jewelry.
 Lodge Supplies. [Check Choice]

**REDDING MASONIC SUPPLY CO.
200 Fifth Ave., Dept. P.M., New York**

ENGINEERING
ELECTRICAL · MECHANICAL · STRUCTURAL
and **ARCHITECTURE**

INTENSIVE PRACTICAL TECHNICAL COURSES. Degree in 2 years. Diploma in 1 year. Special short courses 6 Weeks to 4 Months in Electricity, Radio, Power Plant, Electric Refrigeration, Armature Winding, Wiring, Testing, Drafting, Welding. **LOW TUITION.** Expert instructors. Extensively equipped laboratories. Free life-time employment service for graduates. Part-time work while attending. Write for new free illustrated catalog giving all facts. 29th year.



FINLAY ENGINEERING COLLEGE
1001 A Indiana Avenue Kansas City, Missouri

Wrestling Book FREE



Learn to be an expert wrestler. Know scientific wrestling, self-defense, and jiu-jitsu. Develop a splendid physique, and have perfect health. Join this popular school and learn by mail. The famous world's champions—the marvelous

Frank Gotch and Farmer Burns

offer you a wonderful opportunity. Wrestling is easily and quickly learned at home by mail. Men and boys write now for splendid free book. Learn all the science and tricks. Be able to handle big men with ease. Accept this wonderful offer NOW. Send for free book today, stating your age.

Farmer Burns School of Wrestling, B337 Range Bldg., Omaha, Neb.

Rider Agents Wanted

Select from 44 Styles, colors and sizes of Mead Bicycles. Ride and exhibit sample RANGER and make money.

Factory to Rider: We ship on approval for 30 Days' Free Trial, direct from FACTORY. Get our marvelous offers. Easy Payments. \$5 down.

Tires lamps, horns, wheels, parts, equipment, and repairs at half usual price. Established 36 years.



Mead CYCLE COMPANY
DEPT. L-110, CHICAGO

Write us today for free catalog

10c NEW SCIENTIFIC WONDER



3 for 25c SILVER ONLY
BOYS You apparently see thru Clothes, Wood, Stone, any object. See Bones in Flesh. **FREE—PKG. RADIO BIG FUN**
PICTURE FILMS. Takes pictures without camera. "You'll like 'em." 1 pkg. with each 25c order.

MARVEL MFG. CO. Dept. 31 NEW HAVEN, CONN.

**QUIT
TOBACCO**



No man or woman can escape the harmful effects of tobacco. Don't try to banish unaided the hold tobacco has upon you. Join the thousands of inveterate tobacco users that have found it easy to quit with the aid of the Keeley Treatment.

KEELEY Treatment For Tobacco Habit Successful For Over 50 Years

Quickly banishes all craving for tobacco. Write today for Free Book telling how to quickly Free yourself from the tobacco habit and our Money Back Guarantee.

Home of the famous Keeley Treatment for Liquor and Drugs. Booklet Sent on Request. Correspondence Strictly Confidential.
THE KEELEY INSTITUTE Dept. A-935 Dwight, Illinois

"HEY! Get up and give a real pianist a chance!"

One of the Boys Shouted . . . but when I started to play they didn't want me to stop

BEFORE our school party at Helen White's was many minutes old a funny thing happened.

I was chatting with some of the boys when I heard my name called out across the room.

"Jim, you're a red-hot 'talkie fan'—can you hum the theme song that's so popular from Gloria Swanson's latest picture? Helen wants to know how it goes and I can't remember it to save my life."

"Sure, Harry, I know the one you mean—wait just a minute and I'll go over and play it for you."

"Play it!" exclaimed Harry. "Why we'd never be able to recognize the tune. Whistle it if you can't hum."

"Oh, it will sound much better on the piano," I replied as I sat down and began to finger the keys.

The Guests Get Nervous

"Never mind, Jim," said Helen apologetically, "forget the tune, besides we're all ready to start dancing."

"Hey, get up and give a real pianist a chance," chirped in a male voice.

That was my signal to let loose. Without paying further attention to their wise cracks, I broke into the theme song that they had requested.

You could have heard a pin drop. I only wish I could have seen their faces for I knew that I had given them quite a surprise.

They Want More

"Keep it up—that's great," shouted Harry as I finished.

"Yes, please don't stop," pleaded Helen.

"I thought you were in a hurry to dance," I replied.

"You bet we are—and we want you to play for us."

No second invitation was needed. I played every number that they placed before me and if they had had their say I would have been playing until morning. But finally

I had to beg for an intermission. Then the third degree began.

"Put one over on us, didn't you, Jim?" said Harry. "You're certainly the last person at the party I thought could play. How about letting us in on the secret?"

My Story

"Have you ever heard of the U. S. School of Music?" I asked.

A few of my friends nodded. "That's a correspondence school, isn't it?" they exclaimed.

"Exactly," I replied. "They have a surprisingly easy method through which you can learn to play any instrument by mail in just a few months without a teacher."

"It doesn't seem possible," someone said.

"That's what I thought, too. But the Free Demonstration lesson which they mailed me on request so opened my eyes that I sent for the complete course."

"It was simply wonderful—no laborious scales—no heartless exercises. My fear of notes disappeared at the very beginning. As the lessons came they got easier and easier. Before I knew it I was playing all the pieces I liked best."

Then I told them how I had always longed to sit down at the piano and play some old sweet song—or perhaps a beautiful classic, a bit from an opera or the latest syncopation—how when I heard others playing I envied them so that it almost spoiled the pleasure of the music for me—how I was jealous because they could entertain their friends and family.

"Music was always one of those never-to-come-true dreams until the U. S. School came to my rescue. Believe me, no more heavy looking-on for me."

* * *

This is not the story of just one isolated case. Over half a million people have learned to play by this simple method. You can, too. Even if you don't know one note from another you'll grasp it in no time. First it tells you



how to do a thing—then it shows you how in pictures—then you do it yourself and hear it.

You teach yourself—right at home—without any uninteresting finger exercises, tedious scales or other humdrum methods.

Free Booklet and Demonstration Lesson

To prove how practical this course is, the U. S. School of Music has arranged a typical demonstration lesson and explanatory booklet which you may have Free. They show how anyone can learn to play his favorite instrument by note in less than half the time and at a fraction of the cost of old slow methods. The booklet will also tell you all about the amazing new *Automatic Finger Control*.

Don't delay—act at once—fill in and mail the coupon below today—no obligation whatever. (Instrument supplied if desired, cash or credit.) U. S. School of Music, 77 Brunswick Bldg., New York City.

U. S. School of Music
77 Brunswick Bldg., New York City

Please send me your free book, "Music Lessons in Your Own Home," with introduction by Dr. Frank Crane, Free Demonstration Lesson and particulars of your easy payment plan. I am interested in the following course:

Have You
.....Instrument?.....
Name.....
Address.....
City.....State.....

PICK YOUR INSTRUMENT

Piano	Violin
Organ	Clarinet
Ukulele	Flute
Cornet	Saxophone
Trombone	Harp
Piccolo	Mandolin
Guitar	Cello
Hawaiian Steel Guitar	
Sight Singing	
Piano Accordion	
Italian and German Accordion	
Voice and Speech Culture	
Drums and Traps	
Harmony and Composition	
Automatic Finger Control	
Banjo (Plectrum, 5-String or Tenor)	



“We can't get married until—”

“We CAN'T get married until I earn more money.” Thousands of young men are saying that today. Thousands of girls are giving that as the reason the marriage date is being put off and off. Sometimes it gets a little embarrassing, too, to have to keep on giving that excuse. *For no girl likes to admit that the man she is going to marry is a failure!*

It takes money to support a home these days. And you're right in waiting. But don't wait too long. The years of youth are precious years. They will never return.

Thousands of men have happy prosperous homes because they had the foresight to prepare themselves for advancement through the home-study courses of the International Correspondence Schools. Hundreds of them report salary increases of \$10, \$15 and \$25 a week. Many are earning \$75, \$100 and \$150 a week. Some have doubled and even tripled their salaries. Some are earning \$10,000 and \$15,000 a year. Others have become owners of businesses of their own.

If the I. C. S. can help other men to raise their salaries, it can help you. At least find out how. It won't obligate you to ask for our Free Booklets, but that one little simple act may change your entire life. Do it now. Do it for HER!

Mail the Coupon for Free Booklet

INTERNATIONAL CORRESPONDENCE SCHOOLS

“The Universal University”
Box 5691-F, Scranton, Penna.

Without cost or obligation, please send me a copy of your booklet, “Who Wins and Why,” and full particulars about the subject before which I have marked X:

TECHNICAL AND INDUSTRIAL COURSES

- | | |
|--|--|
| <input type="checkbox"/> Architect | <input type="checkbox"/> Automobile Mechanic |
| <input type="checkbox"/> Architectural Draftsman | <input type="checkbox"/> Plumbing <input type="checkbox"/> Steam Fitting |
| <input type="checkbox"/> Building Estimating | <input type="checkbox"/> Heating <input type="checkbox"/> Ventilation |
| <input type="checkbox"/> Wood Millworking | <input type="checkbox"/> Sheet Metal Worker |
| <input type="checkbox"/> Contractor and Builder | <input type="checkbox"/> Steam Engineer |
| <input type="checkbox"/> Structural Draftsman | <input type="checkbox"/> Steam Electric Engineer |
| <input type="checkbox"/> Structural Engineer | <input type="checkbox"/> Civil Engineer |
| <input type="checkbox"/> Electric Wiring | <input type="checkbox"/> Surveying and Mapping |
| <input type="checkbox"/> Electrical Engineer | <input type="checkbox"/> Refrigeration <input type="checkbox"/> Highway Engineer |
| <input type="checkbox"/> Electric Lighting | <input type="checkbox"/> R. R. Locomotives |
| <input type="checkbox"/> Welding, Electric and Gas | <input type="checkbox"/> R. R. Section Foreman |
| <input type="checkbox"/> Reading Shop Blueprints | <input type="checkbox"/> R. R. Bridge and Building Foreman |
| <input type="checkbox"/> Telegraph Engineer | <input type="checkbox"/> Air Brakes <input type="checkbox"/> Train Operation |
| <input type="checkbox"/> Telephone Work | <input type="checkbox"/> Highway Engineering |
| <input type="checkbox"/> Mechanical Engineer | <input type="checkbox"/> Chemistry <input type="checkbox"/> Pharmacy |
| <input type="checkbox"/> Mechanical Draftsman | <input type="checkbox"/> Coal Mining Engineer |
| <input type="checkbox"/> Machinist <input type="checkbox"/> Toolmaker | <input type="checkbox"/> Navigation <input type="checkbox"/> Boilermaker |
| <input type="checkbox"/> Patternmaker | <input type="checkbox"/> Textile Overseer or Supt. |
| <input type="checkbox"/> Pipefitter <input type="checkbox"/> Tinsmith | <input type="checkbox"/> Cotton Manufacturing |
| <input type="checkbox"/> Bridge Engineer | <input type="checkbox"/> Woolen Manufacturing |
| <input type="checkbox"/> Bridge and Building Foreman | <input type="checkbox"/> Agriculture <input type="checkbox"/> Fruit Growing |
| <input type="checkbox"/> Gas Engines <input type="checkbox"/> Diesel Engines | <input type="checkbox"/> Poultry Farming <input type="checkbox"/> Radio |
| <input type="checkbox"/> Aviation Engines | <input type="checkbox"/> Marine Engineer |

BUSINESS TRAINING COURSES

- | | |
|--|--|
| <input type="checkbox"/> Business Management | <input type="checkbox"/> Business Correspondence |
| <input type="checkbox"/> Office Management | <input type="checkbox"/> Lettering Show Cards <input type="checkbox"/> Signs |
| <input type="checkbox"/> Industrial Management | <input type="checkbox"/> Stenography and Typing |
| <input type="checkbox"/> Personnel Management | <input type="checkbox"/> Complete Commercial |
| <input type="checkbox"/> Traffic Management | <input type="checkbox"/> Civil Service <input type="checkbox"/> Mail Carrier |
| <input type="checkbox"/> Accountancy <input type="checkbox"/> Cust. Accountant | <input type="checkbox"/> Railway Mail Clerk |
| <input type="checkbox"/> C. P. Accountant | <input type="checkbox"/> Grade School Subjects |
| <input type="checkbox"/> Bookkeeping | <input type="checkbox"/> High School Subjects |
| <input type="checkbox"/> Secretarial Work | <input type="checkbox"/> College Preparatory |
| <input type="checkbox"/> Spanish <input type="checkbox"/> French | <input type="checkbox"/> Illustrating <input type="checkbox"/> Cartooning |
| <input type="checkbox"/> Salesmanship <input type="checkbox"/> Advertising | <input type="checkbox"/> Lumber Dealer |

Name.....
Address.....
City..... State.....
Occupation.....

If you reside in Canada, send this coupon to the International Correspondence Schools, Canadian, Limited, Montreal, Canada

Play the Drums



IT'S EASY TO LEARN!

If you can “keep step” to music, you can learn to play the drums. Then you'll be popular. In demand everywhere. Chances to play in bands and orchestras. Fun playing at home with radio accompaniment. New, easy method. Instruction course free with every Leedy outfit. Leedy drums are best in tone, finish and construction. Endorsed by leading professionals. Yet you can own a genuine Leedy outfit; snare drum, bass drum and traps, for as little as \$35.

HOME TRIAL—EASY PAYMENTS

Easy terms. Home trial. You risk nothing. Write today for free literature and special offer.

LEEDY MFG. CO., 708 Leedy Building
Barth Avenue and Palmer St.
Indianapolis, Ind.

Leedy

HOLD ON! CAN YOU?

Is your grip as strong as the rest of your body? Our heavy-tension exerciser, now at the unheard of price of \$1.00, gives you an unbreakable grip of steel while you build up your chest and shoulders. Don't neglect this important part of your physical development. Build a mighty arm and a crushing grip. Send today... this offer won't last forever. Money back in 5 days if not satisfied with this speedy, convenient exerciser. Write now, before you forget.

GIBRALTAR EXERCISER CO., Dept. 1307
25 West 54th Street
New York City

“The TRUTH about VOICE”

Sent FREE—No Obligation to Buy!
NO MONEY DOWN

If you act quick!—we will send you, post-paid—for 30 days free reading—new Voice Book disclosing startling VOICE FACTS that may save hundreds of dollars to every man or woman seeking a strong, rich voice for either singing or speaking. A REVELATION! Know the truth about YOUR voice. Remember—sent for 30 days' FREE reading. Then, if you keep it, send only \$1.00. Otherwise, just return it—that's all!



PROF. E. FEUCHTINGER Dept. B-135
Suite 29, 1810 Wilson Ave., Chicago, Ill.



McSweeney's Amazing New Ways to a BIG PAY Job

Training takes you out of the low pay ordinary jobs. It makes you independent of hard times, strikes, shut downs, because there is always a demand for the trained man. Learn how easily and quickly you can get out of the low pay class by going into Electricity, Automotive or Aviation the McSweeney way.



Learn to control, master and apply this magical juice that rules the universe. Be a McSweeney trained electrical expert.



Every motor propelled vehicle—Automobiles, Trucks, Tractors require constant service. The trained Automotive Mechanic is always in demand.

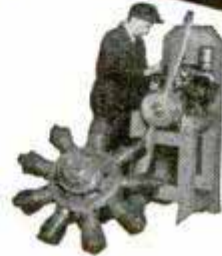

Learn to master the mechanics of this great new fast growing industry where there is a big need for trained Aviation men.

You Learn by Doing on Real Equipment in Only 8 to 12 Weeks

The McSweeney Shop Plan is the PRACTICAL way to learn Electricity, Automotive or Aviation Mechanics. You learn right here in the McSweeney Shops, on REAL equip-

No Books--No Classes

In the McSweeney Electrical Shops you use real tools instead of books. Your lessons are given on regulation electrical equipment. Here are switch boards, generators, motors. You get first hand knowledge of A.C. and D.C. armature winding, house wiring, splicing, automobile and radio electrical systems and batteries. You are given everything you need to become an electrical expert at big pay. In the automotive and aviation departments are real motors for automobiles, trucks, tractors and airplanes. You work on these motors as well as other parts and learn how to do the right thing in the right way. Expert instructors work shoulder-to-shoulder with you and guide you at every step.

Guarantee of Satisfaction

You take no risk. I am so positive that you will make a big success after taking my training that I guarantee to train you until you are permanently placed in a good job at good pay. Mail coupon for big FREE Book and remarkable tuition offer if you are over 16 years of age. Act today.

J. H. McSweeney.

McSWEENEY
ELECTRICAL
AUTOMOTIVE
AVIATION
SCHOOLS

Dept. C-10-G, Chester at 30th St., Cleveland, Ohio

ment. One entire floor of the school building is devoted entirely to electrical instruction. Another floor is given over entirely to automotive teaching. Here in 8 to 12 weeks you can complete the training in any one of these high pay fields that would take you up to two years by correspondence or through boresome books. You are taught by actual doing—no theory—no guesswork—no puzzling blue-prints. Get out of the rut. Be a McSweeney Trained Man and earn \$40 to \$150 weekly.

**Mail This Coupon
for FREE Book**

J. H. McSweeney, Pres.,
McSWEENEY SCHOOLS,
Dept. C-10-G, Chester at 30th St., Cleveland, Ohio.

Without cost or obligation, send me your big FREE book and full details of your special tuition offer. (Check school interested in.)

Electrical Automotive Aviation

Name

Street

Town..... State..... Age.....

25c for An Arm Like This



Get a 17 Inch Bicep My Complete Arm Building Course Shows How—ONLY 25c

By George F. Jowett

Get an arm of might with the power and grip to obey your physical desires. You can now build your arm from a scrawny piece of skin and bone to one of huge muscular size. I don't mean just a 17-inch bicep but a 15-inch forearm and an 8-inch wrist. This specially prepared course will build every muscle in the arm because it has been scientifically worked out for that purpose. You can develop a pair of triceps shaped like a horseshoe and just as strong, and a pair of biceps that will show their double head formation. The sinewy cables between the biceps and elbow will be deep and thick with wire cable ligaments. In that arm of yours, the forearm will belly with bulk, and the great supinator lifting muscle you can make into a column of power, while your wrist will grow alive and writhe with cordy sinew. All this you can get for 25 cents—send for this course today and you can have a he-man's arm built to be as beautiful, brawny and magnificent as the village blacksmith's.

You can't make a mistake. The guarantee of the strongest armed man in the world stands behind this course. I give you the secrets of strength illustrated and explained as you like it. Build for yourself an unbreakable grip of steel and a Herculean arm. Mail your order now while you can still get this course at my introductory price of only 25c.

RUSH THE COUPON TODAY

To each purchaser will be given a FREE COPY of *THE THRILL OF BEING STRONG*. It is a priceless book to the strength fan and muscle builder. Full of pictures of marvelous bodied men who tell you decisively how you can build symmetry and strength the equal of theirs.

REACH OUT—GRASP THIS SPECIAL OFFER

JOWETT INSTITUTE of PHYSICAL CULTURE 422 Poplar Street, Dept. 4G, Scranton, Penna.

Dear Mr. Jowett: I am enclosing 25c. Please send me the course "MOULDING A MIGHTY ARM" and a free copy of "THE THRILL OF BEING STRONG."

Name _____

Address _____

FIT YOURSELF AT HOME For a BIG PAY JOB!

Trained Men Needed
in Every
City and Town

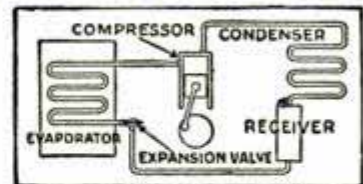

ELECTRIC REFRIGERATION Calls You

BE the first refrigeration expert in your locality. Trained experts needed everywhere. You can easily qualify at home to install, service and repair electric refrigerators. Clean, fascinating work pays big because trained men are scarce. U.E.I. training, a few tools and business cards start you at once on big money or we will help you secure a fine position without extra cost.

Now Easy To Learn By New Method

Amazing practical plan fits you at home in spare time. Unlike ordinary schooling. No textbooks. No study drudgery. Absorbing lessons—charts, diagrams, pictures and practical problems—teach you every principle and practice. Experts guide you. Easy terms. Money-back agreement. Highly praised by General Electric, Sorvel, Kelvinator, Copeland, Zerossone, etc. Hundreds of satisfied students. Get full facts and valuable BOOK FREE—no obligation! UTILITIES ENGINEERING INSTITUTE, 4103 Sheridan Rd., Dept. 170, Chicago, Illinois.



E. Berube, Mass., says: "Even before graduating I fixed several refrigerators after local servicemen failed."

Earn \$50 to \$150 a Week!

LAW Free Book

Write today for FREE 64-page book, "THE LAW-TRAINED MAN", which shows how to learn law in spare time through the Blackstone home-study course prepared by 80 prominent legal authorities, including law school deans, and U. S. Supreme Court justices. Combination text and case method of instruction used. All material necessary furnished with the course, including elaborate 25-volume law library, delivered immediately upon enrollment. Many successful attorneys among our graduates. LL. B. degree conferred. Moderate tuition, low monthly terms. Money-Back Agreement.

Write for free book today.

BLACKSTONE INSTITUTE, 307 N. Michigan Ave., Dept. 50-B Chicago

SELF CONFIDENCE DEVELOPED!

Self-Consciousness in the presence of others easily overcome. *Social Poise and Confident Personality* developed. *Charm, ease, commanding manner* can be yours. Authoritative training by mail. Send 25 CENTS for my book.

MR. RICHARD BLACKSTONE
BA-477 Flatiron Bldg. New York City

My \$5.00 Dancing Course ONLY \$1.98 Sent on 5 Days FREE TRIAL

EVERYONE wants to dance with the person who knows the smart new steps! No matter how poorly you dance now I'll make you a finished, versatile dancer—sought-after, popular, sure of a good time wherever you go!

Think what that means! You can learn the fundamental steps—in just a few hours, right in your own room, without music or partner. Then, the very next time dancing starts you can surprise your friends by stepping right on the floor with the best dancers in your set—with as much ease and assurance as if you had been dancing for years! This instruction would cost you \$24.00 if taken at a Studio.

Be Popular—Write TODAY

To prove it, I'll send you my complete \$5.00 course—through which over 400,000 people have already learned to dance—for five days' FREE trial. When it arrives give the postman only \$1.98 (plus few cents delivery charges). Then practice the steps for five days. Remember—money back if not delighted. Don't delay—write for course NOW and be a good dancer soon!

ARTHUR MURRAY Studio 139, 7 East 43rd Street
NEW YORK, N. Y.





Just Copy This Sketch
Mail It and Pocket
Rule Is Yours

See
Pay-
Raising
Tools
Below

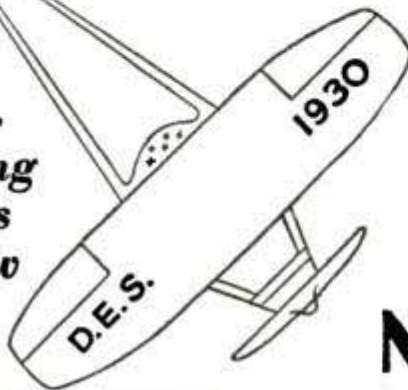

Get Into AVIATION Through Airplane DRAFTING

Send airplane sketch at once, if you are 16 or more. I will mail you entirely free Draftsman's Pocket Rule and "My Pay-Raising Plan." Opportunities for draftsmen are bigger than ever. You may now get into aviation through my airplane drafting training.

New Pay Raising Plan

FREE



This is a very valuable book for young men who want bigger pay. It is not a catalog, but my pay-raising plan and money-making advice. I prove that John Savadge, trained by me, makes \$300 a month. Earl J. Dupree, trained by me, refused \$600 a month because he makes more in his own business. A. H. Bernier, trained by me, earns \$7,000 to \$9,000 a year. Arthur DeWalt, trained by me, makes more than \$400 a month. D. C. Stroop, trained by me, makes \$475 a month. L. V. Broughten, trained by me, makes \$300 a month. No previous experience needed. You don't have to be a high school graduate. I train you at home by my practical working method. I give your money back if you are not satisfied. You may even make money while you are learning. When you have finished your course, I help you get a job without charging for this service.

Draftsmen Needed In: AUTO WORK

The automobile industry is one of the greatest in America. Thousands of draftsmen needed. I'll train you for the work.

ELECTRICITY

Electricity is the coming motive force of the world. Draftsmen are needed in every department of this fascinating work. I'll train you at home. Get a job here.

AVIATION

Aviation is just in its infancy. It is bound to expand to enormous proportions. Draftsmen are essential to it. I'll train you quickly at home.

MOTOR BUS WORK

Motor bus building and motor bus transportation have become leading world industries. Hundreds of draftsmen engaged in this work. I'll show you the way.

BUILDING WORK

There will always be building. No structure can be erected without plans drawn by draftsmen. I'll make you an architectural draftsman at home.



Get These

Pay-Raising Tools At Once!

I send you these fine quality, genuine imported draftsman's tools just as soon as you become my student. No finer tools made for practical drafting work.

Mail This

Coupon if
You Earn Less
than \$70 a Week!



I will train you at home
—Engineer
DOBE

Act Now! Before you put this magazine down. Copy airplane sketch, mail it to me and let me send you free Draftsman's Pocket Rule and "My Pay-Raising Plan." Remember, draftsmen are needed everywhere. That's the kind of profession to get into. Get started now. Get into a better position paying a good straight salary the year around.

Rule and "My Pay-Raising Plan." Remember, draftsmen are needed everywhere. That's the kind of profession to get into. Get started now. Get into a better position paying a good straight salary the year around.

Engineer Dobe 1951 Lawrence Avenue
Div. B-135 Chicago, Ill.

MAIL SKETCH ~ GET FREE RULE

ENGINEER DOBE

1951 Lawrence Ave., Div. B-135, Chicago

Here's the sketch. Send me free rule; also send me free of all cost "My Pay-Raising Plan,"—how to earn money while learning and proof of big money paying positions.

Name _____ Age _____
Address _____
Post Office _____ State _____



See How Easy You Can Learn HYPNOTISM TRY FREE 5 DAYS!

SEE for yourself how easy it is to master the great science of Hypnotism—how quickly you can learn to bend people to your will—banish fear, worry and opposition—increase your earnings—and force others to give you the recognition, power, and admiration you deserve. I'll show you how to use this great force to help you master every situation or **The Five Day Trial is FREE!**

In just a few hours I'll teach you the hidden secrets of Hypnotism—the methods used by the great operators—the amazing things you can accomplish once you understand this mighty power. You can use it to overcome obstacles, achieve your fondest ambitions and become MASTER of yourself, friends and acquaintances—either sex. Now you can quit being just one of the crowd—now you need not be unpopular, lonesome or unhappy a minute longer. Through this strange power you can learn how to stand out—dominate—to make your life what you want it to be!

In his startling NEW book, *The Science of Hypnotism*, the world famous hypnotist—Prof. L. E. Young—reveals the most carefully guarded secrets of this fascinating subject. He not only explains the methods of noted hypnotists, step by step—but tells clearly all about the nine stages of Hypnotism. The Hypnotic Mirror, Mental Telepathy, how to select your subjects, magnetic healing, methods of hypnotizing, how to wake the subject, how to make money out of hypnotism!

**Try 5 Days FREE—
Send No Money**

So confident are we that Prof. Young and his great book will quickly teach you the science of Hypnotism, that we will send you a copy without one cent in advance! Simply clip and mail the coupon below. When the book arrives pay the postman the special low price of \$2.50 plus few cents postage. Then test the powers of Hypnotism 5 days! If not amazed and delighted, return the book and money will be refunded at once.

FRANKLIN PUBLISHING CO.,
Dept. H-70, 800 No. Clark Street, Chicago, Illinois

Mysteries of Hypnotism Revealed

- How to Hypnotize at a Glance
- Susceptible Subjects
- How to Hypnotize by Telephone
- How to Give an Entertainment
- How to Make Others Obey You
- Overcoming Bad Habits
- How to Do Dozens of Hypnotic Feats
- Use of Hypnotism in Operations

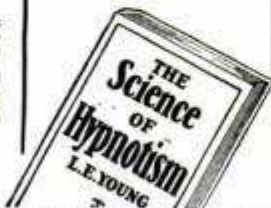

Franklin Pub. Co., Dept. H-70,
800 No. Clark St., Chicago, Ill.

Please send me your amazing new book—*The Science of Hypnotism*—by Prof. Young. When book arrives, I'll pay the postman only \$2.50 plus postage. If I am not satisfied after 5 days' trial, I may return the book and you are to refund my money.

Name

Street and No.

Town State

If you are likely to be out when postman calls, send \$2.50 with coupon and we'll pay delivery charges. Customers outside U. S. send cash with order.

Increase Your Earning Power

Apply time and labor-saving kinks to your work. Your efficiency will soon be recognized and you will be in line for advancement.

If you do machine shop work of any kind, sheet-metal work, painting, carpentry, auto repairing, farming, concrete work, plumbing, electrical work, welding, building, glass work, general repairing, tool-making, poultry raising, masonry or home repair work, get this

LIBRARY OF 6000 TIME AND LABOR SAVING IDEAS FOR SHOPMEN AND HANDYMEN

JUST PUBLISHED

SHOP NOTES for 1930

192 Pages
415 Articles
377 Illustrations

See partial list of contents below

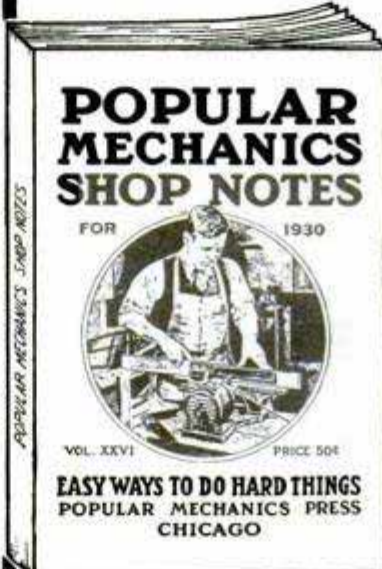

Including the new 1930 issue illustrated above, there are now 14 volumes in the Shop Notes Library of 6,000 easily understood short cuts to every-day jobs. Here are just a few of the subjects taken from the 415 articles in the latest issue.

- | | | |
|--|-------------------------------------|---|
| Animal Traps, Care of | Concrete Fountain Water, Cooler for | Sanding on the Lathe |
| Barrel Method of Slinging | Furniture, Refinishing Old | Saw, Keeping Fit |
| Bench Light, Convenient | Furniture, Restoring Damaged | Scrollsaw, Ball-Bearing |
| Bench Saw, Getting Most Out of | Hacksaw, Power, for Small Shops | Speedboats, Automatic Switch for |
| Boatswain's Chair Rigging | Hoist, Light and Strong | Stainless Steel, Soldering "Sug" Finish, How to Apply |
| Bookcase, Modern | Household Shortcuts | Summer House, Japanese |
| Brass Fixtures, Cleaning | Ice Cutter, Engine-Driven | Templates, Making Accurate |
| Builders' and Contractors' Kinks | Outboard Motor, Supercharger for | Tinners, Paint Scraper for |
| Cams, Jig for Layout of | Package Sealer, Home-made | Toolrest, Sliding, for Emery Wheel |
| Conveyor, Portable | Pipe Holder, Hammered-Copper | Tools for Home Mechanics |
| Speeds Loading | Power Saw Made from Buffing Head | Towed Car Steered by Tow Bar |
| Dadoing on Small Power Saws | Power Shears Made in Small Shop | Wood, Plastic Filler for Workshop, Homemade Combination |
| Decorating with Pastry Gun | Sand Disk for Small Lathe | |
| Diak Bender Making Ellipse, How to Lay Out "Exerciser", Electric | | |
| Farmers, Labor-Saving Kinks for | | |
| "Flagstones", Making | | |

Each volume contains approximately 500 articles and 400 illustrations and has 224 Pages. At the regular price of 50 cents per single volume this library costs \$7.00, but for a limited period we will supply the 14 vols. when ordered at one time at the special reduced price of only \$4.25.

SPECIAL OFFER COUPON

POPULAR MECHANICS PRESS,
200 E. Ontario St., Room P7, Chicago, Ill.

Send me, as per your special offer, the following books. I will pay postman price and small amount of postage. My money will be refunded if I am not satisfied. (Check what you want.)

1930 Shop Notes and Lathe Handbook, both for 98c.
 Complete Shop Notes Library (14 vols.) \$4.25.

Name

Street and No.

City State

\$80 to \$150 A WEEK **MOTION PICTURE OPERATORS EARN THIS - and MORE**

BE the man in the projection booth—it is one of the big, important jobs in the great billion-dollar movie industry. The hours are short, the work is light, fascinating—and most important of all—you can earn from \$4,000 to \$7,500 a year and more—easily, quickly!

“Sound” Picture Course **FREE** of Extra Charge

With our simplified study method your training is practical and complete—it includes all types of projecting machines and their operation, Electricity, Stage and Theater Lighting, Color Films, Complete Course in **Talking and Sound Movies** included **FREE** of extra charge with both projection and motion picture photography courses.

Motion Picture projection is just one of the big-paying branches of the billion dollar photographic field. Today there's a crying need everywhere for expert motion picture cameramen—“still” photographers—photo-finishers.

Send Today for **FREE** Descriptive Book

Our new **FREE** book tells you about this wonderfully attractive profession. Shows how you can quickly qualify for a well-paid position as Motion Picture Cameraman or Projectionist, Commercial Photographer or Photo-Finisher. Send for it **TODAY**—**NOW!** It may be the turning point of your career!



New York Institute of Photography,
Dept. O-1438, 10 West 33rd St.,
New York, N. Y.

Without cost or obligation send me a copy of your **FREE** book and details about how I can qualify as:

- Motion Picture Cameraman
- Motion Picture Projectionist
- Commercial Photographer
- Photo-Finisher

Name.....
Address.....
City..... State.....

SUCCESS COUPON →



Step INTO A BIG-PAY HOTEL JOB

Earn \$2,500 to \$10,000 a Year

In America's 3rd Largest Industry comprised of Hotels, Apartment Hotels, Clubs, Restaurants, Institutions, Schools, Colleges, Hospitals, etc. Daily calls for Lewis Trained Men. Over 70,000 high-class positions as Manager, Assistant Manager, Steward, Engineer, Room Clerk, Publicity Director, Sports Director, Purchasing Agent, Bookkeeper, and scores of other executive positions paying \$2,500 to \$10,000 a year open annually in hotels alone. Salaries up to \$3,500 to start.

We Put You in Touch with Positions

Without cost let us show you how big pay, fascinating work, quick advancement can be yours in the great hotel industry. Age is no obstacle—young and old alike can win success. A common school education is all you need with the amazing Lewis System of Sparetime Training in Hotel Operation.

Previous Experience Unnecessary

Hundreds of Lewis Students are winning success. Totally unacquainted with hotel work before taking the Lewis Course, Hillis H. Helmer is now Assistant Manager of a fine hotel. Lionel C. King rose from Head Waiter to Manager of a big Country Club in a comparatively short time, due to training he received from Lewis Schools. **YOU** can do as well. Low cost—easy terms—money back agreement. Write today for Free Book, “Your Big Opportunity” and complete details, mailed without obligation.

LEWIS HOTEL TRAINING SCHOOLS
Clifford Lewis, Pres., Room CL-339, Washington, D. C.
The Original and Only School of Its Kind in the World

SEND FOR FREE BOOK



Lewis Hotel Training Schools,
Room CL-339, Washington, D. C.
Send me the Free Book, “Your Big Opportunity,” without obligation.

Name.....
Address.....
City..... State.....

OPPORTUNITY COUPON →

These Lewis Students “Made Good”

O. F. Stuart—“I accepted the position of Manager. I know my course is going to bring me thru with colors flying.”

C. A. Jones—“I was chosen Manager of this Hotel. My success is due to the Lewis Schools.”

R. J. Gross—“I have been appointed Assistant Manager of this 400-room Apartment Hotel. I can never thank the Lewis Schools enough for their assistance.”

Henry R. Thompson—“I will have charge of the Auditing Department in this new hotel, at 100% increase in salary.”

LEARN TO FLY ON A GLIDER THAT REALLY FLIES



\$398⁰⁰

**COMPLETE
with
Launching Equipment
F. O. B. WICHITA**

If you want to learn to fly, no better means can be obtained than a Cessna Glider. It is a glider that really flies. It has been designed by a pioneer aircraft builder, the man who designed and now builds the famous Monoplanes Cessna. All of the knowledge and experience gained in the years of building airplanes of every class has been put into this glider. The facilities, equipment and workmen of one of the largest and most modern airplane plants in the country are combined to construct this glider in the most air-worthy manner. It is more than an experiment or toy. It has been proven by actual test flights under all conditions before being placed on the market.

Gliding, besides being a wonderful sport, is instructive. The Cessna Glider's controls are of exactly the same principle as those of an airplane. You can get the flying "feel." You can actually learn to pilot a power airplane by training on a Cessna Glider due to its exact likeness to an airplane in principle and flight. And you can learn economically too. The cost of the glider complete is less than a flying school course. Now is the time to form a glider club in your vicinity. Become an owner, or part owner, of one of these famous Cessna Gliders. Write today for complete details.

CESSNA AIRCRAFT CO.
WICHITA, KANSAS



There's Quicker, Bigger MONEY for YOU - in POULTRY

**Earn \$2,000 to \$5,000 a Year or
Have a Business of Your Own!**



Whether you want a job at good pay or a highly profitable business of your own—the Poultry Industry offers you more than any other. There's a shortage of poultry meat and eggs—a shortage of trained poultrymen. I'll train you quickly at home—to fill a good job in Poultry—and our FREE Students' Employment Dept. will help you get one!

**Spare Time or Full Time
YOU Can Cash-in BIG**
No matter where you live—city, town or country—or what you do now, my proved methods will assure your success right from the start. I'll help you make from \$2,000 to \$5,000 a year and UP! And, if you choose to start your own business, I'll show you how to make your tiny investment multiply itself automatically. What I've done for thousands of others—I can do for you.

**FREE Book Shows Way to
Big Pay and BIG Profits**
Mail coupon below TODAY—for my Big NEW FREE Book, "How to Raise Poultry for Profit." My forty years of experience are yours. The Poultry Industry needs YOU. You need my book. Get it—and get in line for the BIG Money that's waiting for you in POULTRY.



Mail NOW for FREE Book

**NATIONAL POULTRY INSTITUTE, Dept. 411-M
Washington, D. C., Att'n: Harry M. Lamson, Pres.**

Dear Mr. Lamson: Send me your FREE Book, "How to Raise Poultry for Profit." I want to know more about my opportunity to make \$2,000 to \$5,000 a year, spare or full time.

Name.....

Address.....

WELDING ELECTRIC ARC OXY-ACETYLENE

Taught by Actual Welding Practice.

No Finer Equipment Anywhere at Any Price. Pipe-Line, Sheet Steel, Structural Steel, Cast Iron, Aircraft and Commercial Welding, Cutting and Brazing. **LOW RATES FOR SUMMER COURSES—ENROLL AT ONCE**
Also Courses in Radio, Electricity and Automobiles.
Full Information Free on Request.

Coleman Electrical School, 1628-X Main St., Kansas City, Mo.



WHY NOT spend spring, summer and fall gathering butterflies, insects? Simple and intensely interesting outdoor work with my instructions, illustrations, price list. I buy hundreds of species for collections. Some worth \$1 to \$7 each. Before sending any butterflies, send 10c (not stamps) for my Illustrated Prospectus. It certainly would be wise to send for it right away before you turn this page, or you may forget. So—send right away.

**MR. SINCLAIR, DEALER IN INSECTS,
Dept. 6, Box 1424, San Diego, Calif.**

Learn SIGN and SHOW-CARD WRITING
In spare time few hours weekly

**FREE
"Book of Facts"
—
Write For It**

Fascinating profession. Big opportunity in this fast-growing trade. Earn while you learn the sign arts. No talent or experience required. Be your own boss or obtain a good position. Learn show cards, posters, bulletins, signs, advertising layouts and allied subjects. We teach by mail or at our school. Quick results—easy to learn.

EARN \$50 TO \$200 WEEKLY

Otto C. Wiegand, Md., home-study graduate, made \$12,000 from his business in one year. Many successful graduates. Oldest and foremost school. Don't delay. Write for complete information.

DETROIT SCHOOL OF LETTERING

193 Stimson Ave.

Est. 1899

DETROIT, MICH.

The Day-Dreamer

Will he ever wake up?

HIS life is made up of rosy visions:

He sees himself in a manager's office—as the president of a firm—with a \$20,000 salary—perhaps even as a millionaire with a Rolls Royce, a rakish yacht and a swell country estate.

But all this grandeur is in his day dreams. He lives in the golden PARADISE OF TOMORROW—and it never comes.

He does nothing with the opportunities that surround him TODAY.

He feels above his present job. He is always "going to find a place where his abilities will be appreciated." But he NEVER DOES.

He is the despair of his employers, for they know that he REALLY HAS ABILITY. He can plan with intelligence, he has original ideas, imagination. If he could only concentrate on today, instead of TOMORROW, he might have all the prosperity he craves!

What he needs is a STICK OF DYNAMITE—anything to wake him up and teach him to get results from his abilities NOW.

If he doesn't give himself a rousing jolt, he will complain more and more of not being "appreciated"—and gradually "peter out" into a failure—A JOB COWARD—a cog in a business machine.

He will always be somebody else's servant, instead of master of his own destiny.

How does he get into such a mental state? Because he uses only about ONE-TENTH of his mental energies in doing the vital things that count. Psychologists have proved that most of us use NINE-TENTHS of our brain power in day-dreaming, fortune-wishing, aimless time-killing. We are nearly all victims of the vicious habit of living far below our God-given endowments!

It doesn't help to learn that certain of your mental abilities have become WEAK THROUGH DISUSE, just as unused muscles do. Nobody knows better than you (if you are honest with yourself) that there must be a "screw loose somewhere." The proof of it is that you have failed to reach the high mark you ONCE set for yourself.

You admit it. What you want to know is, WHAT CAN BE DONE ABOUT IT?

There is one very simple thing that you CAN do—now. You can find out what Pelmanism has done for 700,000 men and women, some of whom were facing THE VERY SAME DISSATISFACTION with their attainments that you are feeling. Pelmanism developed the mental powers they lacked—it replaced procrastination with "do it now" efficiency; it put concentration in the place of mind-wandering; it substituted self-confidence for self-distrust. You will learn how Pelmanism has often awakened abilities which the individuals did not DREAM they possessed!

Since Pelmanism is the science of applied psychology, it brings SELF-REALIZATION to all classes and conditions of men and women—prominent and famous as well as obscure and unknown. And among the better known persons who use and advocate it are:

T. P. O'Connor, "The Father of the House of Commons"
General Sir Robert Baden Powell, Founder of the Boy Scout Movement

Edgar Wallace, Well-known Author and Playwright.

Frank P. Walsh, Former Chairman of the National War Labor Board

Jerome K. Jerome, Novelist

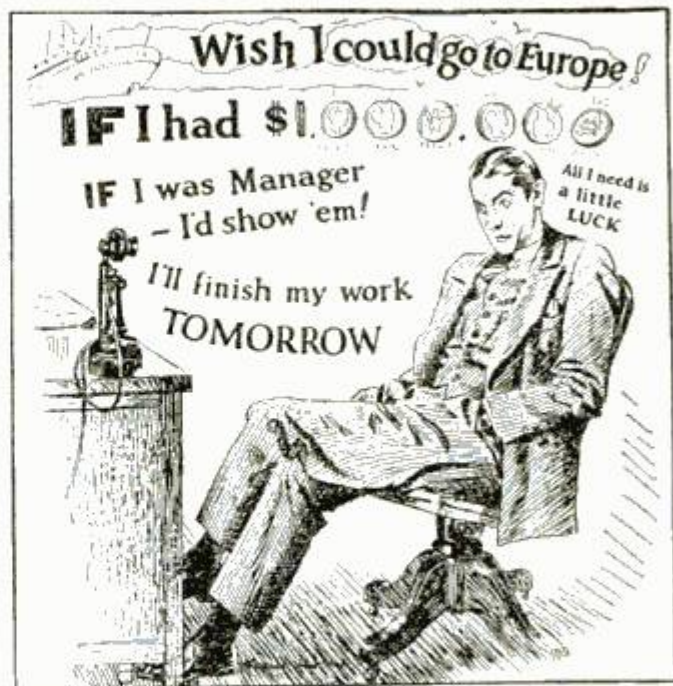

General Sir Frederick Maurice, Director of Military Operations, Imperial General Staff

Admiral Lord Beresford, G.C.B., G.C.V.O.

Sir Harry Lauder, Comedian

W. L. George, Author

Baroness Orczy, Author

Prince Charles of Sweden

—and hundreds of others of equal prominence.

A remarkable book called "Scientific Mind-Training" has been written about Pelmanism. IT CAN BE OBTAINED FREE. Yet thousands of people who read this announcement and who NEED this book will not send for it. "It's no use," they will say. "It will do me no good," they will tell themselves. "It's all tommyrot," others will say.

But if they will use their HEADS, they will realize that people cannot be HELPED by tommyrot and that there MUST be something in Pelmanism, when it has such a record with 700,000 different individuals, and when it is endorsed by the kind of people listed above.

If you are made of the stuff that isn't content to keep on "putting off" all the good things of life—if you have a spark of INDEPENDENCE left in your soul, write for this free book. It tells you what Pelmanism is, WHAT IT HAS DONE FOR OTHERS, and what it can do for you.

The first principle of YOUR success is to do something radical in your life. You cannot make just an ordinary move, for you will soon again sink into the mire of discouragement. Let Pelmanism help you FIND YOURSELF. Don't put it off. Mail the coupon below now—now, while your resolve to DO SOMETHING ABOUT YOURSELF is strong.

THE PELMAN INSTITUTE OF AMERICA

Approved as a Correspondence School under the laws of the State of New York

71 West 45th Street Suite H-217 New York City

The Pelman Institute of America

71 West 45th Street Suite H-217

New York City

I want you to show me what Pelmanism has actually done for over 700,000 people. Please send me your free book, "Scientific Mind Training." This places me under no obligation whatever

Name _____

Address _____

City _____ State _____

You Fellows Who Want BIG PAY Get into

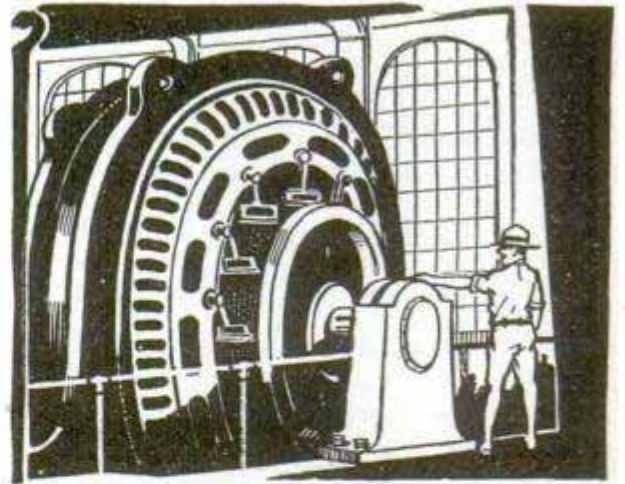

ELECTRICITY

WHY earn \$15 or \$20 or \$30 a week, when in the same six days as an Electrical Expert, when so many men are earning \$60 to \$100, do it easier and not work half so hard? Why should you remain in a small-pay, no-future job that offers no chance for big promotion—no chance for big income? Fit yourself for a real job. **Get into Electricity.** That's where the big money is being made, and always will be made.



\$30 A DAY
Dear Mr. Cooke:
I was making \$25 a week when I enrolled. Now with my own Electrical Shop I make as high as \$30 a day.
A. J. Daigneault,
225 Worcester,
Southbridge,
Mass.



\$1.50 AN HOUR
Dear Mr. Cooke:
I had to work like a slave for 45c an hour before I enrolled. Now, thanks to you, Mr. Cooke, I make \$1.50 an hour.
G. W. Oprea,
4220 N. Meade Av.,
Chicago, Ill.

Electricity — The Big Pay Field
Today even the ordinary Electrician—the "screw driver" kind—is making money—big money. But it's the trained man—the Electrical Expert—who makes the really big money. — \$10 to \$20 a day — \$60 to \$100 a week. Be a Big-Pay man, yourself. Get in line, now, for one of these "Big-Pay" Jobs.

I'll Train You At Home
I'll train you at home, — in your spare time. You work just as you are working now—at your same job. My now famous "Work-Sheet and Job-Ticket" method, guarantees you simplified, practical training along work-shop lines. In a few short months you can step out of your old job into a new job—into electrical work where you can be a Big-Pay man in this Big-Pay field.

You Earn As You Learn
To learn Electricity my way you don't have to be a College man, or even a High School graduate. You can read. You can write. That's enough. With me, you get experience as you go along and make good money while learning. I'll show you how, —and I'll give you, without extra cost, tools and apparatus to work with—6 Big Outfits in all.

Money Back If Not Satisfied
That's what I agree to do. And back of me in this agreement stands the Chicago Engineering Works, a \$2,000,000 Illinois Corporation. There's nothing like "Cooke" Training anywhere. It's the Training that big Electrical men are praising; it's the Training that employers recommend; it's the Training that one of our greatest Engineering societies has endorsed 100 per cent. **It's the Training for you.**

If You're Earning Less Than \$70 A Week — Investigate
Don't wait a minute! Find out today why "The Cooke Trained Man is the Big-Pay Man", everywhere! Find out how "Cooke" Training will help you boost your pay! Mail coupon right now for my Big FREE Book of Facts. See the Six Big Working-Outfits I give you without extra charge. See the hundreds of pictures, the proofs, the Big-Pay letters of other "Cooke" Trained Men. Get this great free Book. Send for it today. Clip, sign, and mail coupon **RIGHT NOW!**

L. L. COOKE, Chief Instruction Engineer
L. L. COOKE SCHOOL OF ELECTRICITY
Dept. 1B
2150 Lawrence Ave.
Chicago, Illinois

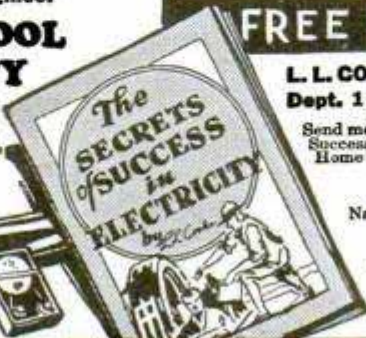

Send for my Big FREE Book that shows how other men stepped into fine jobs paying

\$60 to \$100 A WEEK!

If you earn less than \$70 a week INVESTIGATE ACT NOW



I'll train you at home in a few short months.
L. L. COOKE

FREE BOOK COUPON

L. L. COOKE, Chief Instruction Engineer, Dept. 1B, 2150 Lawrence Ave., Chicago, Ill.

Send me FREE and prepaid, your Big Book "Secrets of Success in Electricity," with all details about your Home Study Course in Electricity.

Name _____
Address _____
City _____ State _____

The "Cooke" Trained Man is the "Big Pay" Man

Classified Advertisements

WORLD'S BEST WANT AD MEDIUM

Advertisements in this section, 35 cents per word, each insertion, minimum 10 words, payable in advance.

To be printed under proper classification in August issue, copy should be in our office June 18th.

ADVERTISING AGENCIES

GET Into advertising. Learn quickly at home. Experience unnecessary. New easy plan. No text books used. Practical work. Old established school. Send name and address for interesting free booklet. Page-Davis School of Advertising, Dept. 343B, 3601 Michigan, Chicago.

ADVERTISE—24 Leading Sunday newspapers, 24 words \$15.00. Excellent for obtaining help, salesmen, or business opportunities. Information 1,000 best paying dailies, mail-order weeklies, monthlies, mailing lists, everything. Free. Wade Agency, Great Northern Bldg., Chicago.

BEFORE Advertising get our catalog. No charge. 25 years in business. The largest classified agency in the world. Ankrum Advertising Agency, 100 No. LaSalle St., Chicago, Ill.

ADVERTISERS—Brand new advertising directory just off the press. Write today for free copy. American Advertising Agency 4010 Lewis, Toledo, Ohio.

FREE—New 1930 Advertisers Rate Guide, 44 pages. Includes everything. Lowest rates. E. H. Brown Advertising Agency, 140 S. Dearborn, Chicago.

OBTAIN Canvassers, distributors through publication advertising. Martin, 276B West 43d, New York.

ADVERTISE In rural weeklies. Lists free. Meyer Agency, 4112 Hartford, St. Louis, Mo.

TIME Counts in applying for patents. See pages 134 and 135. Clarence A. O'Brien, Registered Patent Attorney, Washington, D. C.

FOR ADVERTISERS

ADVERTISE In country, daily and Sunday paper combinations. Low rates; lists free. Keator, Hartford Bldg., Chicago.

ADVERTISING: 20 Words, 50 magazines, 60c; three insertions, \$1.20; circulars mailed, 400, \$1.00. Mailing Bureau, Lawndale, Calif.

SALES PROMOTION

WRITE Any sales letter or advertisement, one dollar. Advertising specialist; national experience. Komarco, 324 Elm, Long Beach, Calif.

BRANCH OFFICE SERVICE

WASHINGTON, D. C. Representation—Mail address. Branch Office Service Bureau, 306 Atlas Bldg.

AGENCIES WANTED

NEW Zealand wants sound agencies. Tait, Aglionby St., Lower Hutt, New Zealand.

MAILING LISTS

2,000 WOMEN M. O. prospects \$10. Noah Rice, East Gastonia, N. C.

AUTOMOBILES

TIME Counts in applying for patents. See pages 134 and 135. Clarence A. O'Brien, Registered Patent Attorney, Washington, D. C.

ELECTRICAL Trouble shooting on the motor car and airplane. Don't trust to luck or guess work. Learn to make every motion count in testing and repairing. Send for our standard 493-page book for electricians and mechanics. 300 diagrams. Hundreds of practical tests. Pay postman \$4.00 plus postage when delivered. If outside U. S. remit when ordering. Popular Mechanics Press, Room 801, 200 E. Ontario St., Chicago.

SOLDERING And Brazing, by Yates, gives all the necessary "kinks" that will enable you to solder successfully. 90 pages, 64 illustrations. Delivered to your door C. O. D. Simply pay postman 75 cents and postage. Popular Mechanics Press, Room 801, 200 E. Ontario St., Chicago.

AUTO SUPPLIES

AUTOMOTIVE Tools and mechanics' specialties. Representatives wanted. Greene, Dover, Mass.

SAFETY Outside mirror; new invention. Enclose \$1 with advertisement. Will send prepaid. Ford, Chevrolet, etc. All chrome plated, 4 1/2 in. plate glass. Regular \$2.00. Limited number for advertising only. Money refunded immediately if not satisfactory. Handy Manufacturing Co., Grand Rapids, Mich.

FORD "T" Generators rebuilt, guaranteed like new. Exchange \$5 prepaid. All makes supplied proportionately. American Simplex Company, Anderson, Ind.

"SUPERBESTOS" Ford "A" brake lining sets, drilled and with rivets, \$1.75, postpaid; \$18.00 dozen. Chicago Brake Lining Supply Co., 549 W. Randolph St., Chicago, Ill.

AUTO Specialty that is a necessity. More power, less gas, eliminates carbon, fits all cars with distributor ignition. Money back guarantee. Sent C. O. D. \$2.00. Smith Specialty Co., 1842 S. Highland Ave., Berwyn, Ill.

USED Air compressors, automatic. Reconditioned, guaranteed like new. Shipped trial easy payments. Also used testers, car washers, chargers, sprayers. Box M-704, Troy, Ohio.

"SPRINGS Of silence."—Universal anti-rattler. For the noisy 4 wheel brake rods all cars. Ask your dealer. Universal Spring Co., Grand Rapids, Mich.

NEW Auto parts 25-50%. Motors, rear-ends, radiators, wheels, generators, carburetors, brakelining 50%. Used parts 40-80% off. Brightman, 2065 Main St., Hartford, Conn.

NEW Electrical Dictionary. Complete up-to-date electrical dictionary with special radio words and terms together with illustrations of electrical symbols, radio diagrams and other wiring diagrams. 191 pages—Vest pocket size. Price only 35c postpaid. Popular Mechanics Press, Room 801, 200 E. Ontario St., Chicago, Ill.

CHROMIUM Plating powder plates iron, steel, brass, copper and nickel; without electricity or machinery. Guaranteed not to tarnish. 1/2 pint can \$1.50 prepaid. Gunmetal Co., Ave. J, Decatur, Ill.

ELECTRIC Arc soldering. New, startling. Principle electric welding. Representatives, \$12.00 day easy. 100% profit. Sample \$2.00. Hurlbert Mfg. Co., Glendale, Calif.

FAMOUS Bailey Handbook—Prepares you to pass the examination for any grade of license for stationary, marine and Diesel engines, firemen and boiler inspector in any state of the Union or any province of Canada. Flexible cover. Handy pocket size. Pay postman \$2.00 plus postage when he hands you the package. Popular Mechanics Press, Room 801, 200 E. Ontario St., Chicago, Ill.

AUTO SERVICE EQUIPMENT

SAVE Money—Garage equipment reconditioned guaranteed like new. Bargains test stands, chargers, compressors, car washers. Shipped trial easy terms. Box M-703, Troy, Ohio.

BARGAINS In new guaranteed battery chargers; direct from factory. Circular free. Adams Barr Corporation, Columbus, Ohio.

PROFITS In 8-hour battery charging or 20 minute car washing. Install equipment practically no investment. Bargains in reconditioned buffers, grinders, compressors, sprays, arc welders. Box M-702, Troy, Ohio.

USED Parts most makes cars. Specialize in ignition and rear end parts. Service and satisfaction guaranteed. Bailey Brothers, Barre, Vt.

BOY Mechanic, Book One, new, revised edition—just out. 239 pages containing 489 articles of new material never before published in book form. Filled with interesting things to make and do. Owners of the old edition will want this new book. Delivered to your door C. O. D. Simply pay postman \$2 and postage. Popular Mechanics Press, Room 801, 200 E. Ontario St., Chicago.

FOR FORD OWNERS

AUBORA Underslung parts and 3.1 racing gears. Speedster bodies, headlights hi compression head. See Sport Factories ad page 128.

MOTORCYCLES, BICYCLES AND SUPPLIES

MOTORCYCLE Bargains, lowest prices, bargain sheets for stamp, special aviators supplies, motorcycle accessories largest line in America, lowest prices. Largest motorcycle mail order house in the United States, Rochester Harley Davidson Corporation, 129 West Main St., Rochester, N. Y.

REPAIR With good used parts, save 1/2 or more, state parts needed, no lists. J. B. Dahl, 3661 Archer Ave., Chicago, Ill.

HARLEY Davidson bargains at a tremendous sacrifice. All models and prices. Guaranteed. Send 4 cents in stamps for our catalog. "Money Saving Motorcycle Bargains." The Knuth Co., 2525 Fond du Lac Ave., Milwaukee, Wis.

HENDERSON, Excelsior, Indian, Harley used motorcycles, parts and engines cheap. Aircraft conversions and parts. Catalog free. Ballak & Co., 100 N. 12th, St. Louis, Mo.

MOTORCYCLES: All makes and models, biggest values ever offered. Also used Harley parts 50% off. Send stamps for particulars. Harley-Davidson Motorcycle Co., 1409-11 Olive St., St. Louis, Mo.

MOTORCYCLING—"Greatest Sport on Earth." Send 15c for latest used motorcycle catalog. Indian Motorcycle Sales, Kansas City, Mo.

AVIATION

FORD "A" Motored 2 passenger sport-plane easy construct. Blueprints \$5.00. Aeroplane hub with flange fits automobile engines \$1.00; goggles, 2 pair army type, \$1.00; helmet, \$1.50; 26x4 wheels, tires, tubes complete, \$8.00; 26x5, \$15.00. Lawrence motor, \$125.00; Gnome 50 hp., \$100.00. Turnbuckles, 1-c. Fittings all type for your sportplane 50c up. Pyrene, qt. size, \$1.00. Curtiss, Standard, Canuck parts, your own price. Famous German glider blueprints thousand sold, money back guarantee, \$3.00 set, construction kit, \$95.00, metal fittings only \$29.50. Curtiss OX5, \$125.00. 20,000 ft. Altimeter and banking indicator, \$5.00, tachometer 2,600 rpm, \$6.00. Booklet, 5c. Hopkins Airplane Company, Box 124, Hopkins, Minn.

THE New Heath Parasol, America's most popular sport plane, has no equal in performance, economy and beauty. You can start building it by our group plan on an investment of less than \$12.00 or \$199 for complete bill of material. All ready to fly at our airport \$975. Complete detailed blue prints at \$5.00. 10c in stamps or coin for large illustrated booklet. Heath Aircraft Corporation, 1721-29 Sedgwick St., Chicago, Ill.

POWERED Gliders. Build your own glider from our detailed blue prints, or buy the craft ready to fly from the inventor and builder of America's first powered glider. Illustrated literature with prices and specifications of gliders, powered with motorcycle engines, also higher power for use in high altitudes, mailed on request. Crawford Motor and Airplane, Seal Beach, Calif.

WORLD Record model kits. 12 1/2 minutes hydro \$3.00. 4 1/2 minutes R. O. G. 65c. 6 1/2 minutes championship pusher \$1.00. Rubber lubricant 15c. All postpaid. Bargain list 10c. Peru Model Airplane Shop, Peru, Ind.

HEATH Propellers represent the final word in aerial drive efficiency because each propeller is designed to fit your particular conditions by aeronautical engineers with over 22 years' experience in this line. 4c brings illustrated booklet. Heath Aircraft Corporation, 1721-29 Sedgwick St., Chicago, Ill.

DECORATE Your club or den with real airplane propellers, 8 feet long, beautiful new ones, highly polished, \$8.00; used ones \$5.00. Air Transport Equipment, Garden City, N. Y.

AIRPLANES, Monoplanes, biplanes; all types, lowest prices. Motors 30 to 300 hp., new and used; at big discounts. State your needs. Aviation Service, 925 Broadway, New York.

PROPELLERS, 3", \$5.50; 4", \$8.75; 5", \$13.25; 6", \$16.50; special Henderson, \$12.50; sportplane parts; glider parts; converted Hendersons, \$95.00 upward. Blueprints "Aerodrive" boat, only 50c. Ostergaard Aircraft, 4303 N. Narragansett, Chicago.

FOR 6 Years Heath Henderson motors have led in the light airplane field. Light in weight, long years of dependable service and low in first cost makes this the most practical power plant for all forms of light aerial drive. \$190.00 to \$325.00. See our ad page 152. 10c in stamps or coin brings large illustrated booklet. Heath Aircraft Corporation, 1721-29 Sedgwick St., Chicago, Ill.

BUILD And fly your own capital glider. Designed and engineered in the nation's capital. Complete set of drawings with assembly instructions, \$6.50. T. C. Mayo, 829 17th St. N. W., Washington, D. C.

SIMPLEX Air Model Co., Auburn, Mass. Send five cents for supply booklet.

2c POSTAGE Stamp will bring you complete Model airplane supplies price list. A. C. Model Aircrafters, 4719 Third Ave., New York.

GET Our catalog before you buy. Guaranteed Henderson & Harley motors. Propellers, hubs and supplies. Send dime for catalog. Sensenich Bros., Littitz, Pa.

FORM A Gliding club and learn to fly by this safe and inexpensive method. Write today for free complete information on organizing a Glider club. Bergholt Aircraft Company, 143 E. Lake St., Minneapolis, Minn.

CLEARANCE Sale of converted motors. Send stamp for list. Heine Motor Works, Owingsburg, Pa.

COUNTERSHAFT Outfit with propeller and light four cylinder air cooled motor. Reasonable. J. Franklin Schafer, Twenty-Nine East 16th St., Covington, Ky.

BUILD A Glider! Learn to fly. Our primary training glider blue prints, \$7.50. None better. Our books, "Gliding and Soaring," \$1.00. "Manual of Gliders and Soarers," \$1.00. "Starting and Landing," 75c. You will need all of them. Send money order. Kenyon Press, Wauwatosa, Wis.

SUPERIOR Metal tipped propellers for Henderson and Big V motors, \$10.95 each. C. D. Hibbs, Ft. Worth, Tex.

MODEL Training glider. Featherweight, flying speed 3 miles per hour. Soars beautifully. Kit \$1.00. H. Abbott, 1734 Winona St., Chicago, Ill.

BUILDING Material for sport planes and gliders. Grafton Goodwyn, 2511 Indiana Ave., Chicago.

FLYING Glory, new model, R. O. G. Commercial monoplane. Wing spread 27 in. 250 foot flight guaranteed. Kit with propeller \$2.65. New price list ready. Crescent Model, 1805 Benson Ave., Brooklyn, N. Y.

PROPELLERS For powered gliders, boats, sleds and small airplanes. Get our free price list. Crawford Airport, Sealbeach, Calif.

BLUEPRINTS For glider model of over three feet 25c coin. Spee Dee Model Co., Box 80, Jamaica, N. Y.

SET Of blueprints for a single seat power glider \$5.00. Glider, 4710 Irving Park Blvd., Chicago, Ill.

GLIDER Turnbuckles for sale 15c each. Regular 35c values. Send fifty cents for samples. Detroit Aero Motors Co., 5055-59 Townsend Ave., Detroit, Mich.

FOR Sale cheap slightly used American Eagle, Curtiss-Robin Travelair planes. Also Wright J-5, Velle, Rolls-Royce aviation motors. National Aircraft, 45-09 Northern Blvd., Long Island City, N. Y.

MODEL Airplane material at big savings. Send five one cent stamps for illustrated catalog E. Country Club Aero Supply Company, 50th and Holmes, Kansas City, Mo.

MODEL Aeroplanes and air motors. 5c for catalog. Miniature Aircraft Corp., 83 Low Terrace, New Brighton, N. Y.

GLIDER Model, new, instructive, controlled from ground. Circular on request. Spee Dee Model Co., Box 80, Jamaica, N. Y.

SELLEY Champion, semi-constructed miniature airplanes and supplies. Most realistic models ever offered. Aluminum adjustable pitch propeller, 8 in. 60c, 10 in. 75c postpaid. Send 5c for catalog. Selley Co., 1405 Gates Ave., Brooklyn, N. Y.

TIME Counts in applying for patents. See pages 134 and 135. Clarence A. O'Brien, Registered Patent Attorney, Washington, D. C.

GLIDERS, Light easy to fly, \$225. Plans \$1.50. Sailplanes wonderful performance. \$425. Plans \$2.50. Glider wings ready to cover, \$100, ribs \$29, including spars, \$35. Uncovered tapered sailplane wing, \$125; ribs, \$45. Literature 10c. Aeroglidiers, Rochester, Ind.

PRACTICAL Flight Training is a splendid, thorough instruction book written by Lieut. Barrett Studley of the Naval Air Station at Pensacola. It is the official text book from which all U. S. naval flyers are trained. You can double the value of expensive instruction time in the air by a preliminary study of the subject from this book. Pay postman \$5 and postage when he delivers it to your door. Popular Mechanics Press, Room 802, 200 E. Ontario St., Chicago.

BUILD A Ford-motored "Flying Flivver." Blue prints \$5. Circulars 10c. Storms Aviation Co., Spartanburg, S. C.

SEND 5c For bundle of balsa, reeds and price list on supplies. Aero Shop, 3030 Hurbit Ave., Detroit, Mich.

LEARN How aircraft engines work. Latest and most complete information is found in "Dyke's New Aircraft Engine Instructor." We unhesitatingly recommend this valuable book. Money refunded if not satisfied. Pay postman \$5.00 plus postage when delivered. Popular Mechanics Press, Room 801, 200 E. Ontario St., Chicago, Ill.

BIGGEST, Best catalog model airplanes; parts, supplies; 5c postpaid. Ideal Company, 19 West 18th St., New York.

\$175 WILL Build our beautiful steel fuselage, Henderson powered monoplane. Plans \$1. Also two place planes, wings, parts. Literature 10c. Barney Snyder, Rochester, Ind.

AVIATORS' Goggles, lowest prices; 24 page catalog free for stamp. Rochester Harley Davidson Corp., 129 West Main St., Rochester, N. Y.

"IF You want to fly" let Alexander Klein, brilliant engineer, teach you. With great skill whole course of training has been simplified and made crystal clear. Remarkable book teaches in most practical and easily understood fashion. Recommended by skilled flyers. Sent C.O.D. anywhere in U. S. Simply pay postman \$2.50 and postage when delivered. Sent postpaid to any address upon receipt of price. Popular Mechanics Press, Room 801, 200 E. Ontario St., Chicago.

BOOKS AND PERIODICALS

JUST Off the press! Electricity for Beginners by E. H. Thomas, price \$1.50. An elementary book, written by an experienced instructor, for those who want to begin at the bottom of their study of electricity. Contains 196 pages, and is illustrated with easily followed line drawings and diagrams. Considers and explains many of the common terms and everyday manifestations of electricity that form an excellent groundwork, and a basis for a more thorough study of the subject. Send for circular of this book, also our complete catalog. Norman W. Henley Pub. Co., 2 West 45th St., New York, N. Y.

A COLLEGE Or high school course \$3.00 postpaid. Five books—retail value \$10.00. Select your subjects! Chemistry, physics, agriculture, U. S. history, world history, literature, algebra, logic, French, Spanish, arithmetic, trigonometry, geometry, psychology, biology, economics, civics, rhetoric, pedagogy. Wilcox & Follett Co., 1251 S. Wabash Ave., Chicago, Ill. Largest Educational Book House in America. Satisfaction guaranteed.

BOYS! Here's fun galore. Four large profusely illustrated books tell how to make almost everything you could want. Nearly 4,000 different articles are described (Think of it). Now \$2 per book or \$7 for the four if ordered at once. Just write a postal saying, "Send the Boy Mechanic Library." Pay postman \$7 and postage. For single books, specify either Book 1, 2, 3 or 4. Popular Mechanics Press, Room 801, 200 E. Ontario St., Chicago, Ill.

POPULAR Science Talks. Thirteen popular lectures by faculty Philadelphia College of Pharmacy and Science. 355 pages, cloth bound; limited edition, \$1.50 postpaid. Popular Science Talks, 43rd and Kingsessing Ave., Philadelphia.

BOOKS On secret service. List free. International Service, Bandon, Oreg.

HYPNOTISM Easily learned. Lessons guaranteed. Postpaid \$1.10. Smith Pub. Co., Dept. 3, Springfield, Mass.

INDUSTRIAL Alcohol. Complete directions for making. Fully illustrated. \$2.50. Spun & Chamberlain, 120 Liberty St., New York.

USE Shortcuts in Figures. Save valuable time. The quickest ways of working all problems. Instructions for drilling yourself to become rapid with figures. Complete, yet simplicity itself. Just write a postal for "Shortcuts in Figures." Pay postman \$1.25 and postage. Popular Mechanics Press, Room 801, 200 E. Ontario St., Chicago, Ill.

PICTURES AND POSTCARDS

COMMERCIAL Postal photographs \$25. 1,000 sell anything. Expert copying. Request samples. American, Box 1711, Richmond, Va.

FUN! Send novelty photo postcards to friends. 20 assorted only 98c. Sample card 10c. Tall-NR Co., Dept. 154, Garner, Iowa.

ANOTHER Famous \$5 book now \$1. The Story of Philosophy, by Will Durant, is the latest popular book of modern times to be placed within the reach of everyone. You will want to add this to your library. The author has the knack of making the lives and opinions of great philosophers as interesting as dramas. 592 pages. Illustrated. Cloth. Sent C. O. D. Pay postman price \$1 and small amount of postage upon delivery. Popular Mechanics Press, Room 806, 200 E. Ontario St., Chicago, Ill.

GAMES, ENTERTAINMENTS AND PLAYS

PLAYS, Musical comedies and revues, minstrels, comedy and talking songs, black-face skits, vaudeville acts, monologs, dialogues, recitations, entertainments juvenile plays and songs, musical readings, make-up goods. Catalog free. T. S. Denison & Co., 623 So. Wabash, Dept. 11, Chicago.

READ Sealed Messages in Dark; messages retained by audience; burned message appears on black slate; spirit message appears on slate in sitter's presence; spirit rappings; spirits appear in the dark; answer questions written on folded papers while blindfolded. All this you can do with directions in "Behind the Scenes with The Mediums." 69 best secrets of mediums fully exposed. The best because most baffling, yet all easy to do. Send no money. Just write a postal. Pay postman \$1.50 and postal charges. Popular Mechanics Press, Room 801, 200 E. Ontario St., Chicago, Ill.

MAGIC TRICKS, BOOKS AND JOKER NOVELTIES

MAGIC—Tricks, Books and Supplies. For amateurs as well as the great professionals. Anyone can learn through our instructions. Feature Acts in Mind-Reading, Spiritualism, Rope Ties, etc. Large illustrated professional catalog, 20c. Chicago Magic Co., 140 So. Dearborn St., Dept. B, Chicago, Ill.

ELECTRIC Fun! Seventy stunts, 110 volts, \$1. Chemagic \$1. Kutting Sons, Cambell, Calif.

SEVEN Optimagical delusions. Five magic catalogs, 25c. Gilmagic, Morgan Park, Chicago.

IGHKI-IGHK Or stack the stack. Latest and greatest puzzle with instructions 25c. (No stamps.) Ighki-Ighk Novelty Company, Box 2171, Dallas, Tex.

CARD Tricks, coin tricks, hypnotism, ventriloquism; 4 instructive 64 page books, 10c each. Geo. Fenner, 2401 Jefferson, Louisville, Ky.

MAGIC Catalog 20c. Lynn, 105 Beach, Dept. 3, Jersey City, N. J.

HINDOO Trick cards, 10c set. Jollying cards, 10c pack. Modern Card Co., Bowling Green, Ohio.

200 TRICKS You can do—Mystify your friends; have loads of fun. This collection of tricks has been selected by Thurston for the average person. Neither unusual skill nor elaborate apparatus are required. Send for this 200-page illustrated book. Pay postman \$1 plus postage when delivered. If outside U. S. remit when ordering. Popular Mechanics Press, Room 801, 200 E. Ontario St., Chicago.

MAGIC Tricks, entertainments, various objects, easily learned. Illustrated. 35c. Goldmans, 424 So. Dearborn, Chicago.

CHALK TALKS

LAUGH Producing program, \$1.00. Catalog free. Balda, The Cartoonist, Oshkosh, Wis.

POPULAR Chalk talks, 33 drawings with (complete) instructions \$1.00. Samples 25c. Fleishman Syndicate, 3333 Wilson Ave., Bronx, New York.

CARTOONING—Let the world's most successful cartoonist tell you how to draw cartoons. Briggs in his new book gives every step in cartoon work and answers every question a beginner might ask. Elaborately illustrated. Pay postman price of book, \$3, and small amount of postage when he delivers the package C. O. D. Popular Mechanics Co., Room 801, 200 E. Ontario St., Chicago, Ill.

RADIO SETS AND SUPPLIES

NEW 300-Mile "pocket" radio, \$3.85. Complete with special loud receiver. No tubes or batteries required. Order direct. Spencer Laboratories, 116 Atlas, Akron, Ohio.

LATEST Items in radio! Get our new low prices on Cunningham tubes, radio sets, parts and accessories. Lowest wholesale prices. Quickest service. Nelson Electric Company, 508 South Dearborn, Chicago, Ill.

TIME Counts in applying for patents. See pages 134 and 135. Clarence A. O'Brien, Registered Patent Attorney, Washington, D. C.

OVER 9,000 Radio bargains: Write D. Howard Co., 354 South Spring St., Los Angeles, Calif.

NEW 300-Mile "pocket" radio, \$3.85. Complete with special loud receiver. No tubes or batteries required. Order direct. Spencer Laboratories, 116 Atlas, Akron, Ohio.

STAMP COLLECTING

MYSTIC "Queer Country" Packet! Contains scarce stamps from the following strange lands: San Marino, Antioquia, Congo, Cyprus, Fiji Islands, Gwalior Hyderabad, Iceland, Jhind, Kenya, Uganda, Lebanon, Monaco, North Borneo, Nyassa, St. Thomas Prince, Eastern Roumelia, Siam, Sierra Leone, Tanganyika, Trinidad Tobago, Ubangi, Upper Volta, Wallis Futuna, Alaouites. Get this wonderful packet of "freak countries" and make your friends envious! Price only 10c to approval applicants! Write today. Mystic Stamp Company (Dept. 8), Camden, N. Y.

THRILLING War scenes. A packet of all different stamps showing exciting scenes and records of nations at war. Includes siege guns; firing squad; mounted troops; prisoners of war; fire-pot hurlers; hand-to-hand bayonet struggle; bloody battle scenes; troop transport; red cross stamp; dying soldier; victory stamps, etc. Send for this thrilling "Big Parade" packet at once—limited supply. Only 10c to approval applicants. W. A. Rowell, 58 Cornhill, Boston, Mass.

500 DIFFERENT Stamps for 25c. Big collection from Bosnia, Crete, Epirus, Honduras, Iceland, Kenya, Liberia, Malta, Nyassa, Quelimane, Siam, Zambesia and other "hard" countries. Catalog value \$10. Price 25c to approval applicants! Bargains, 1,000 different 79c; 15 triangles 49c; 100 British colonies 39c; 100 French colonies 35c; 100 Portuguese colonies 50c. Five packets for \$2.00! Illustrated lists free. Loma Stamp Co., 4231 42d St., San Diego, Calif.

ANCHERS \$\$\$ Outfit—only 12c! Fine triangle stamp; set German stamps with (pre-war) value forty million dollars (interesting!); perforation gauge, mme scale; airmail set; scarce stamp from smallest republic on earth; newspaper set; packet good stamps and Travancore, Malay, Dutch Indies, etc. Entire outfit for 12c to approval applicants! (Nice pocket stock book, value 25c, with every order!) Ancher Stamp Co., Box 47, Rutherford, N. J.

FREE! Largest stamp in the world! Fine packet 65 different stamps from Cape Verde, Jamaica, Mozambique, Syria, etc., including dying soldier, beautiful women, ships, maps, savages, airplane, scenes, bird and animal stamps, for only 5c to approval applicants. Largest Stamp in the World (Rare China Wild Goose Special Delivery) given absolutely free with each order. Supply limited! Send your 5c today! Western Philatelists, 6021 Harper Ave., M7, Chicago.

203 DIFFERENT Catalog \$4.25 only 7c with approvals. L. W. Hudson, Plainfield, N. J.

VOGUE'S Big 10c packet! Contains one of the smallest stamps in the world; set of Philippine locals; 6 curious Azerbaiddian "swindle" stamps; scarce Salvador diamond-shaped stamp; packet all different from mysterious countries of Abyssinia, North Borneo, Transjordan, etc., including portraits of Julius Caesar, Joan of Arc, locomotive, ships, animals, and others. All for 10c to approval applicants! Write today! Vogue Stamp Co., Dept. "P," Port Chester, N. Y.

100 DIFFERENT Foreign stamps from 100 different foreign countries, including Africa, Asia, Australia, Europe, West Indies, etc., for only 20c. Free with each order, our pamphlet which tells "How to Make a Stamp Collection Properly," together with our price lists of albums, supplies and hundreds of bargains in sets, packets, etc. Queen City Stamp and Coin Co., Room 36, 604 Race St., Cincinnati, Ohio.

CANADA Airmail stamp free if you ask for approvals and send 15c for 25 diff. airmails or 30 diff. Canada and Nfld; both packets only 25c. We list 329 countries in our dime packets. Lists free. Special bargains—500 diff. 25c; 1,000 diff. 75c; 2,000 diff., \$2.50. Victoria Stamp Co., London, 4, Canada.

ILLUSTRATED Descriptive U. S. list, price 50c; also our 1939 32-page U. S. list free. Stanley Gibbons, 38P Park Row, New York City.

STAMP Bulletin. Published monthly. Fine stamp offerings. Profusely illustrated. Authoritative information. Sent free to advanced collectors. Reimers Co., 30 N. La Salle St., Chicago.

FREE—1,000 Mixed U. S. stamps. Particulars 2c. Weatherby, Willoughby, Ohio.

105 CHINA, Etc., 2c. Album (500 illustrations) 3c. Bullard, 446 Tremont, Boston.

200 DIFFERENT 10 Cents, 25 airmail 10 cents, 60% discount approvals. Covert Stamp, 39 State, Rochester, N. Y.

RARE Old Mauritius revenue (retailing over 10c), Iraq, Gold Coast, Johore, Trinidad Tobago, Travancore, Orange River Colony, and 50 other good stamps, absolutely free to approval applicants enclosing 4c for mailing. Viking Stamp Co., Sheephead Bay Station, Brooklyn, N. Y.

ZEPPELIN Covers and cards! Bargain list free! Home of Air Covers, Andover, Mass.

200-200-200! SEND For our 200 outfit containing 200 stamps; 200 hinges; approval sheets to hold 200 stamps; perforation gauge; millimeter scale and ruler; duplicate stamp container—all for only 15c to approval applicants. Edgewood Stamp Co., Dept. PM, Milford, Conn.

BRITISH Colonial approvals. References. Substaco, Box 321, Park Ridge, Ill.

BEST One cent approvals in America. F. Hand, 1117 So. 60th St., Philadelphia, Pa.

TEN Unused U. S. colonies 5c to approval applicants. Eastern Stamp Co., 1809 Kilbourne Place, N. W., Washington, D. C.

ALL Different—100 U. S., postage 45c; 125, \$1.30; 100 precanceled, 25c. 70% approvals. Al VanDahl, Salem, Ore.

50 STAMPS From 50 different countries 10c to approval applicants. Capitol Stamp Co., 1623 Capitol Bldg., Chicago.

1,000 WELL Mixed stamps 20c. W. I. Terrill, Brookfield, Mo.

PENNY Approvals, 5,000 Sudan, Congo, Nyassa, Liberia, etc. Also 1,400 averaging 1 1/2c. Philatelic Exchange, Huntington, W. Va.

\$2.50 CATALOG Value for 25c, not over 25 stamps per lot, no two lots alike. Approvals to applicants. DeLisle, 762 Harding, San Jose, Calif.

UNBEATABLE Bargain: Airmails, Abyssinia, Spain catacomb, scarce Romagna, Stanley Congo and oriental stamps. All for 10c to approval applicants. Palm Stamp Co., Sparrows Point, Md.

ICELAND, Complete set of 5 bi-colored stamps No. 143-7, catalog value 69c, only 10c to applicants of our low priced approvals. Johnson, Box 692, San Jose, Calif.

SAVE Money. Stamps 1/4c up. Babcock, 407 E. Fort, Detroit, Mich.

UNITED States 50c postage due, precanceled (catalogs 30c) only 3c to approval buyers. State size of collection and countries desired. Leuch, Red'lon, Penna.

FREE Stamp collection to approval applicants. Contains Iceland, Hamburg, Turkey, etc., 2c postage. 15 Confederate essays, 5c. Tatham Stampco, Milfineague, Mass.

TEN Montenegro 5c to approval applicants Prall, Somerville, N. J.

205 STAMPS Triangle, animal, airmail, with approvals, 15c. Hollister, 3523 N. Seeley, Chicago.

A MINT Tercentenary and 50 different British colonies, 10c. Roy Whipple, Ipswich, Mass.

STAMPS On approvals 1/2c up. Free premium. Keigwin, Box 103, Oakland, Calif.

FREE Airmail cover, approval applicants United States, foreign stamps; none higher one cent. Henry Lacks, 1915 So. Jefferson, St. Louis.

PRIVATE Collection. State price. Own selection that satisfy. Holden, 710 Melrose St., Chicago, Ill.

FREE 100 Different with 50% approvals. Send 2c postage. Evanston Stamp Shop, 2412 Noyes, Evanston, Ill.

301 DIFFERENT 10c To approval applicants only. Free list of bargain packets. Kansas City Stamp Co., Lee Bldg., Kansas City, Mo.

FREE, 100 Stamps with approvals. Strasser, Superior Bldg., Cleveland, Ohio.

FREE Outfit 52 stamps, hinges, pocket wallet. Postage 4c. Approvals, Milton Angle, South Berkeley, Calif.

SELLING Out! Fine general stock at cost. Lifetime opportunity! Approvals? Lists? Penna. Stamp Co., Greensburg, Pa.

1,000 DIFF. 60c With 1c approvals. "Atwood," 3831 Cliff, Rd., Birmingham, Ala.

100 GOOD Stamps from 5 parts of the world, 5 cents. Lufbery Stamp, Branford, Conn.

100 ALL Different stamps absolutely free to approval applicants. The Sedgwick Co., Dept. S, 515 Sedgwick Drive, Syracuse, N. Y.

AMAZING Offer! 250 good stamps for 50c. I don't send stamps on approval or sell sets, I repeat 250 stamps for 50c (Space does not permit description). Julius Goldin, 926 Southern Blvd., New York.

120 DIFFERENT Including stamps marking history, U. S. Louisiana Purchase, Columbian, France Joan D'Arc, Portugal, Argentina, Italy, Chili and many more commemoratives. Intensely interesting packet. Price 20c. The Stamp Shop, Holland Bldg., St. Louis, Mo.

DANDY Approvals. Beautiful set free. William Monjar, 1551 Knox, Cincinnati, Ohio.

FROM Approvals headquarters this astounding offer: 10 different old stamps from 10 different countries, none less than 50 years old, some even 70 years of age. All for only 10c to approval applicants. It sure pays to be on Globus' mailing list. Globus Stamp Co., 214 Third Ave., New York City.

ZANZIBAR! Packet Queer freakish stamps from Zanzibar, Holkar, Antioquia, Congo, Hyderabad, Goldcoast, Newfoundland, British colonies, Souamericans. Don't delay! Don't wait. This whopping packet free for 5c postage. Gray Stampeo, Toronto, Can.

STAMPS—100 Varieties, Africa, Brazil, Peru, Cuba, Mexico, etc., 10c; 25 different U. S. 25c; 1,000 mixed, 40c; 1,000 hinges, 15c. C. Stegman, 5941 Cote Brillante, St. Louis, Mo.

FREE Stamps with approvals. 2c postage. Harvey Teeple, Decatur, Ind.

SPECIAL—500 Different stamps 25c to approval applicants. Ohio Stamp Co., Box 249, Cleveland, Ohio.

ATTRACTIVE Approvals at 50 % discount and 25% discount. Noemus Stamp Co., 312 East 23rd St., New York.

40 DIFFERENT United States 12c. 60% approvals. Seidenberg, Baroda, Mich.

U. S. STAMPS Only on approval; give reference. Stamp House, 39 Torry, Dorchester, Mass.

ONLY 5c. 33 Different stamps including scarce Latvian triangular airmail stamps, 10 airmail, 12 United States (early issues, commemoratives, etc.) and 10 Canada. Approvals and illustrated pricelist sent with each order. Curhan Stamp Company, Gloucester, Mass.

STAMPS Sent on approval at 70% discount. Reference required. Emory Renoll, Hanover, Pa.

110 NEW Europe All Different, a wonderful collection cataloguing several dollars, free to collectors requesting our Net Approvals. Postage 2 cents. Badger Stamp Co., Milwaukee, Wis.

PENNY Approvals that Satisfy. Neil Gronberg, Box 5441, Philadelphia, Pa.

FREE—\$1.00 U. S. postage old issue free. If you write for our 56 page price-list of U. S. and foreign stamps. 2,000 illustrations. Also fine but cheap stamps on approval. Hussman Stamp Co., 620-3 Olive St., St. Louis, Mo.

FREE—Canada (15 Var.) for new applicant of my 1c, 2c and 3c approval, and also my 50% discount. Chas. W. Schmidt, P. O. Box No. 4832, Frankford Sta., Phila. Penna.

110 DIFFERENT Stamps, many unused, high values, free to collectors requesting our net approvals. Postage 2 cents. Christensen, Milwaukee, Wis.

FREE! Triangles, airmail, Iceland and 50 others to approval applicants inclosing 3c postage. Hawkeye Stamp Co., Cedar Rapids, 39, Iowa.

STAMPS, 100 all different. Postage 2c. Lists free. P. M. Quaker Stamp Co., Toledo, Ohio.

24 VARIETIES Cuban stamps, 10 cents. List of 6,000 low-priced stamps free. Address Chambers Stamp Co., 111P, Nassau St., New York City, N. Y.

STAMP Album—The Modern Album is unsurpassed in usefulness. Spaces for 12,000 illustrations, 330 pages. Large size 9 1/4 x 11 inches. Cloth bound. Price only \$2. Either pay postman when delivered or if outside U. S. remit when ordering. Popular Mechanics Press, Room 801, 200 E. Ontario St., Chicago.

RARE COINS

SPECIAL Prices on United States old coins. 10 large cents 83c; 10 white cents 49c; 10 flying eagle cents 73c; 10 2c bronze 79c; 10 3c nickels 89c; 5 half dimes 67c; 25 different foreign coins \$1.00. Bargain price list and old coin 10c. Arcy, Box 483, Muskogee, Okla.

COMMEMORATIVE Half dollars uncirculated. Columbian 65c; Monroe \$1.00; Pilgrim \$1.00; Grant \$1.15; Bennington \$1.15; California \$1.90; quarters 60 cents, half dollars 80 cents, both dated before 1878. Price list free. Towns Davis, Box 1791, Huntington, W. Va.

CALIFORNIA Gold—Quarter size, 27c; 3/4 size, 53c; 3c piece and catalog, 10c. Norman Shultz, Box 746, Salt Lake, Utah.

THREE BILLS and two coins, 25c. Daurer, Box 825, South Bend, Ind.

3 DIFFERENT Fine bronze or nickel coin, 2 large crisp bank notes and catalog 10c. Geo. Best, Box 283, Cedar Rapids, Iowa.

OLD Money wanted. Will pay \$100.00 for 1894 dime, S. Mint, \$50.00 for 1913 Liberty head nickel (not buffalo). Big premiums paid for all rare coins. Send 4c for large coin folder. May mean much profit to you. Numismatic Co., Dept. H, Ft. Worth, Tex.

40 OLD Coins all different, \$1.00; 100 different coins, \$3.00; 100 mixed foreign coins, \$1.00. Claud Denney, Box 315, Dallas, Tex.

BARGAINS On coins, stamps and paper money. Catalog 10c. Romanocoinshop, Springfield, Mass.

AMERICAN Coins, bought, sold. Coin value booklet 25c. Frank Saco, 735-45th St., Brooklyn, N. Y.

\$2 TO \$500 Each paid for hundreds of old coins. Keep all old money, it may be very valuable. Send 10 cents for illustrated coin value book, 4x6. Prices guaranteed. Get posted. We buy and sell. Clarke's Coin Office, Box 5, Le Roy, N. Y.

RARE United States, foreign coins, war medals, Chinese coin and catalog 10c. Alexis Mengelle, Colorado Springs, Colo.

UNITED States. Large cent, two-cent bronze, three-cent nickel and bargain list, 25c. Thirteen dates large cents, \$1.00. George Coffin, Greenwood Mountain, Me.

GET Profit and pleasure in collecting old coins. Send 10c for large illustrated coin catalog. You'll be delighted with it. Send for it right now. B. Max Mehl, Numismatist, Mehl Bldg., Dept. P, Fort Worth, Tex. Largest Rare Coin Firm in the U. S.

OLD Coins, large fall selling catalog of coins for sale free to collectors only. Catalog quoting prices paid for coins, ten cents. William Hesselein, 101A Tremont St., Boston, Mass.

CALIFORNIA Gold quarter, 25c; half, 50c. Chester Brooks, Cuero, Tex.

FOR BOYS

JOIN BE Yourself Club! 25c month. New idea mailed weekly. Headquarters 1040 East 46th St., Chicago, Ill.

USERS Of Home Shop Outfits. Here is a new book you have wanted. Principles of Woodworking, by H. Hjorth. The most complete material ever published on the use of machine wood-working tools for the amateur. It will solve all your difficulties. 307 pages. Cloth. 423 illustrations. Sent C. O. D. Pay postman price \$1.75 and small amount of postage upon delivery. Popular Mechanics Press, Room 806, 200 E. Ontario St., Chicago, Ill.

CAMERAS AND PHOTO SUPPLIES

BARGAINS. Hundreds of them listed in our latest bargain book. Send for your copy now. A few sample bargains, Vest Pocket Kodak Special with f:4.5 Anastigmat lens, \$18.50; a 2 1/4 x 3 1/4 Kodak Junior with Rapid Rectilinear lens, \$8.75. Every bargain guaranteed the same as new. Money returned if you are not satisfied after ten days' trial. Central Camera Company, 230 South Wabash Ave., Dept. P. M.-7D, Chicago, Ill.

FILMS Developed—Six beautiful, high-gloss prints, 25c. Regular price. West Supply, Huntington, Ind.

GERMAN Cameras, lenses. Bartro, 237 1/2 S. Spring St., Los Angeles, Calif.

SAMPLE Enlargement—dime, and negative (returned). Trial roll, glossy prints, 25c silver. Brown, Warsaw, N. C.

YOUR Favorite kodak picture enlarged, size 5x7, 10c. Three for quarter, coin. Send best negative (film) today. Address Darmer Photo Lab., 221 Securities Bldg., Des Moines, Iowa.

HAVE You a Camera? Write for Free sample of our big magazine, showing how to make better pictures and earn money. American Photography, 116 Camera House, Boston, 17, Mass.

FILMS Developed. Special Trial Offer. Any Size Kodak film developed 5c, prints 3c each. Trial 6x10 Enlargement in handsome folder 40c. Overnight Service. Roanoke Photo Finishing Co., 209 Bell Ave., Roanoke, Va.

MAKE Money in photography. Learn quickly at home. Spare or full time. New plan. Nothing like it. Experience unnecessary. American School of Photography, Dept. 3431, 3601 Michigan Ave., Chicago.

KODAK Films developed 5c roll. Prints 3c each. Trial offer. 8x10 enlargement 25c. Young Photo Service, 405 Bertha St., Albany, N. Y.

TIME Counts in applying for patents. See pages 134 and 135. Clarence A. O'Brien, Registered Patent Attorney, Washington, D. C.

MOTION PICTURES

SOUND Motion pictures! You must order this great and only authoritative text book on the subject by James Cameron, world's foremost authority. 400 pages crammed full of information on photo cells, Vitaphone, Movietone, Photophone, methods of recording maintenance. We are selling thousands of copies. Price, \$5.00 postpaid anywhere. Bass Bargaingram No. 199 just off the press. Red hot bargains in standard and 16 mm. motion picture cameras, projectors and accessories. Send 4c in stamps. Bass Camera Company, Motion Picture Headquarters, 179 West Madison St., Chicago, Ill.

TALKIE And movie producers are clamoring for new short story ideas, plots, etc. Perhaps you can write one that we can shape and sell for you. One writer (V. M.) received \$3,000. New York best market. Write for full particulars. Daniel O'Malley Company, Suite P, 1776 Broadway, New York.

BARGAINS. Hundreds of them listed in our latest bargain book. Ask for the green booklet. A sample bargain, 35mm., DeVry Camera with f:3.5 lens \$97.50. Every bargain guaranteed fully. Money refunded if not satisfied after ten days' trial. Central Camera Company, 230 South Wabash Ave., Dept. PM-7D, Chicago, Ill.

MOVIE Cameras, projectors, film, accessories, professional and amateur. Catalog free. Universal Photographers, 10 W. 33rd St., New York.

SAVE Money. Movie cameras, \$25; projectors, \$35; Pathex camera, \$20; stereopticon, \$25; printing machine, \$75; 35mm negative stock, 2 cents foot; 100 foot Eastman 16mm negative, \$4.50; kodak, \$5. Typewriter, \$16. Cameras and films bought and exchanged. Ray, 266 W. 46th, New York.

FOR Sale—100 thousand foot reels comedy and western \$1.00 reel. Mutt-Jeff, Felix, Gump. Complete cartoons \$5.00 each. Hundreds other bargains. Lists. Roadshow Cinema Broker, Box 524, Cincinnati, Ohio.

300 FEET Western 90c. Charlie Chaplin films. Lowell Films, Allentown, Pa.

\$1,250 FOR Original photoplay story. Our sales department sold unknown author's first story for above amount. We revise, copyright and submit to studios stories for both silent and talking pictures. Being located in the heart of motion picture industry we know production requirements. Established 1917. Free booklet. Universal Scenario Company, 206 Western and Santa Monica Bldg., Hollywood, Calif.

TIME Counts in applying for patents. See pages 134 and 135. Clarence A. O'Brien, Registered Patent Attorney, Washington, D. C.

LEARN Modern theatre management at home. Big opportunities. Theatre Managers Institute, Elmira, N. Y.

NEW DeVry 16mm motor driven talking picture machine. Guaranteed perfect complete with turntable \$150.00. Western Motion Picture Co., Danville, Ill.

PORTABLE Projector, passion play, screen, bargain. Roy Hutchason, 1245 Bacon, Pekin, Ill.

MOVIE Films, 1,000 ft. reels, \$2.50 each; shipped anywhere on receipt of remittance. Particulars on request. Independent Films, 177 Golden Gate Ave., San Francisco, Calif.

GOOD Movie film, 200 feet on reel. Prepaid one dollar. Milton, 192 Ave. B, Bayonne, N. J.

TRADE AND TECHNICAL SCHOOLS

LEARN Morse and wireless telegraphy. Big salaries. Tremendous demand. Expenses low, can earn part. Catalog free. Dodge's Institute, Fern St., Valparaiso, Ind.

LEARN Watch repairing. Hiles School, 5330 Mission St., San Francisco.

BE A blue print reader. Men in your trade have succeeded. Write for facts. What's your trade? Carroll Rumsay, Drexel Bldg., Philadelphia.

WOODTURNING For amateurs. Excellent new course just published for the amateur and home work shop owner. Contains all the needed information and is well illustrated yet published to sell at the low price of 25 cents postpaid. Send for your copy today. Mail remittance with your order. Popular Mechanics Press, Room 807, 200 E. Ontario St., Chicago

BUSINESS OPPORTUNITIES

DO You want a fine hotel position? Then come to Washington! Here is the only school of its kind in the world—a nationally recognized training school which prepares men and women for positions paying \$2,500 to \$7,500 in hotels, apt. hotels, resorts, clubs, schools, cafeterias and tea rooms. Come to Lewis—get ready for bigger earning while enjoying delightful months in the beautiful, interesting capital city. Learn under practical experts; 14-year tested, time-saving, thorough training. National employment bureau for graduates, no extra cost. Write now for free book that brings your opportunity. Lewis Hotel Training Schools, Dept. 317-CL, Washington, D. C.

WITHOUT Exception most profitable opportunity ever offered. Unlimited possibilities—plan unique—unbelievable results; small investment for instructions and advertising only; no stock to carry; permanent income; no effort required; starts paying over-night. Anyone can succeed with this most profitable business under our free guidance. For full particulars write Mutual Service Corporation, Desk K, 522 McKnight Bldg., Minneapolis, Minn.

CANDY. Home-made, is one business where little fellow has big fellow at a disadvantage. Turn your kitchen into candy shop—start making money from first day. Costs 14c, sells for 60c lb. Many now rich started with no capital. Free book explains. Capitol Candy School, Dept. D-5941, Washington, D. C.

MIRRORS Resilvered at home. Costs near 5 cents per square foot; you charge 75 cents. Profitable business plating like new, brassy worn-out autoparts, reflectors, tableware, stoves, etc. Outfits furnished. Details free. Sprinkle, Plater, 127, Marion, Ind.

AUTO Business: Get into business for yourself we have separated our used car mart from our new car service and storage garage and wish to sell this part of the business, which includes building and building equipment; a money maker for the right party. Write for further information. The Big Garage, Dodge Brothers' Dealer, Norwalk, Ohio.

START A Mail order business. Our "Practical Start" will make you think, act, succeed. Price 10c. Nagel Mail Order Enterprises, 1329 Olive, Indianapolis, Ind.

INCOME Throughout the year. Be a manufacturer in a new field that has unlimited possibilities. Learn the use of DuroStone Products. May be started on small scale, with opportunities unlimited. We will show you how to build a large successful business from a small beginning. Write DuroStone Institute, Grayling, Mich.

HERE'S Your chance! Make \$75 to \$150 a week full time or \$25 to \$50 spare time in the Coin Operated Vending Machine business. Particulars free. Klein Bros. Vending Corp., 2620 N. 23rd St., Philadelphia, Penna.

FURNITURE Refinishing, job painting, handyman shop; start yours on nearly nothing; winning plan brings customers. John Bracealand, 1439 So. Ninth, Philadelphia, Pa.

GENUINE Alligator and coconut electric lamps. Joseph Fleischman, Tampa, Fla.

AMAZING Screw-holding screw drivers. Remove, insert screws inaccessible places one-handed! Factories, garages, electricians, auto, radio owners buy on sight! Exclusive territory. Free trial. Manufacturer, 1617 Winthrop Bldg., Boston.

SCHEMER, Alliance, Ohio, 32p. monthly, prints big \$-getters. Subscriber reports \$25,000 from three; another \$19,000 from one. Try your luck! Year, \$1.00; 3 months, 25c.

MAIL Order News, America's pioneer mail-trade magazine, published 27 years. Brimful with money-making suggestions for agents, mail order men, and opportunity seekers. Send 25 for copy. May be worth fortune to you. Mail Order News, 11 West 42nd, New York.

MAKE Money manufacturing building materials, marble, granite, fireproof paint, flooring, roofing. No machinery. Cheap. Big profits. For formulas and latest methods, write Wm. Lang, 443 Washington, Portland, Oreg.

REPRESENT Icyball Refrigerator of Crosley Radio Corporation. Makes ice from heat without electricity or gas. Blessing to small town and farm homes. Costs only \$90 complete with cabinet. Only 2c day. Guaranteed. Big profits. Crosley Icyball Division, 8278 Arlington, Cincinnati, Ohio.

MAKE Candy at home. Amazing profits. Professional candy maker will show you how. 2 pound assortment and valuable information \$1.25. Coleman's Candies, Smithboro, N. Y.

LEARN To string your own tennis racquet. Have a business of your own. Make money at spare time. Start now. The Briscoe Co., Rubican Bldg., 3471 S. Grand, St. Louis, Mo.

YOUR Opportunity. A fast selling 68 page book, containing over 72 money making plans, 1,000% profit. Sample and particulars 25c. J. Hentzler, Dept. 8-B, Banes St., Bustleton, Philadelphia, Penna.

IF Contemplating opening a business, or you have an establishment, be sure that you get my instructions for reducing competition to a minimum. \$1.00. Julius Goldin, 926 Southern Blvd., New York.

FREE Information on how to start a paying (you'll notice I say paying) mail order business. Julius Goldin, 926 Southern Blvd., New York.

CHEMICAL Expert furnishes manufacturing formulas and processes with complete working directions. Reliable individual service only. No lists. Charges reasonable. Correspondence invited. Dr. Arthur VanHeeden, 7051 Bennett, Chicago.

BIG Money at home playing auto parts, reflectors, mirrors, chandeliers; by new method; experience unnecessary. Outfits furnished. Gunmetal Co., Ave. N, Decatur, Ill.

SELL By mail! Start profitable mail order business anywhere. Our tested, original plans teach you everything. Price low. Circular free. Emsen Service, 251 Audubon Ave., New York, N. Y.

MAKE \$10 Daily, extracting gold from old jewelry. New home method. Details, five red stamps. Precimetal, Box 1040, Hollywood, Calif.

AMATEUR Cartoonists earn \$25.00 week, spare time, copying or tracing cartoons for advertisers. Hendrickson's Service, Argyle, Wis.

PUBLISH Your own magazine. We issue a syndicate magazine. Sample and particulars 10c. Tasam Publishing Company, P. O. Box 3594, Washington, D. C.

DELAWARE Charters; fees small; free forms. Chas. G. Guyer, Wilmington, Del.

FREE Book. Start your own little business anywhere, selling novelties by mail. My beginner's outfit contains everything required, novelties, circulars, instructions, etc. Descriptive book free. Hadwil, 33A-74 Cortlandt St., New York.

ATTENTION! For best money making business opportunities (home, office) be sure to get our literature first. Complete list 10c. Dept. C. Frank L. Chase, Burlington, N. J.

BIG Profits operating "chain" of peanut, chewing gum, candy vending machines. Start small capital. Write Robbins Corp., Dodworth St., Brooklyn, N. Y.

BUSINESS Profession of your own and earn income in service fees. See Stephenson Laboratories, display ad page 129.

TIME Counts in applying for patents. See pages 134 and 135. Clarence A. O'Brien, Registered Patent Attorney, Washington, D. C.

250,000 ARTICLES At low wholesale prices. Directory 10c. W-Patterson Co., 4111 University, Des Moines, Iowa.

BE Your own boss. Our book of twenty-two new business opportunities shows you how. Prepaid \$1.00. Particulars free. Argonaut Sales Company, 509 Fifth Ave., New York City.

PAY Cost of patenting my (mechanical) inventions, and get three-fourths interest. Fred Petterson, Box 213, Bagdad, Fla.

SELL By mail. Books, novelties, bargains! Large profits. Particulars free. B. Elfeo, 525 S. Dearborn, Chicago.

LEARN Marbleizing: Painters, novelty makers, decorators, concrete workers. Anyone can do it with our crystal cement formulas and processes. Filmlike hardness. Resembles polished marble, all colors and veining. Brushed or sprayed on like paint over wood, wallboard, concrete, etc. We are sole owners. Free samples, Cowell Institute, Grayling, Mich.

MAKE Big money manufacturing and applying colored plastic wall texture material. Economical, no machinery required. For details write H. C. Myers, Hempstead, N. Y.

CAPITAL—For copy, the "Promoters' Hand Book," a leaflet on financing; an eye opener for capital seekers. Send \$1.00 to Amster Leonard, East Orange, N. J.

DON'T Sell for others. Employ agents yourself. Make your own products. Toilet articles, soap, extracts. Valuable book free. National Scientific Laboratories, 1935W Broad, Richmond, Va.

SUCCEED With your own products. Make them yourself. Formulas, processes, trade secrets. Expert analytical service. Catalog, circulars free. B. Thaxly Co., Washington, D. C.

FREE Booklet describes 67 plans for making \$20-\$100 weekly in home or office business of your own. Elite Co., 84 Elizabeth St., New York.

"ODD-THINGS"—Money making ideas; tips; plans; opportunities! New; different! Three months' trial, 25c. Year \$1.00. "Odd-Things Magazine," 720 Advance Bldg., Cleveland, Ohio.

CAN You draw? Spare time profits a plenty. Net a correspondence course. Samples and particulars 10c. Straco, 1013 Mulberry, Springfield, Ohio.

SELL By mail! Start your own small business anywhere. Free folder tells how. No personal selling. Everything furnished. B. Horton, Metropolitan Bldg., St. Paul, Minn.

WE Start you in business, furnishing everything. Men and women, earn \$40 to \$100 weekly operating our original "New System Specialty Candy Factories." Begin home spare time. Unlimited opportunity. Valuable booklet free. W. Hillyer Ragsdale, Drawer 4, East Orange, N. J.

UNUSUAL—Uncommon specialties always sell best. Make these yourself from Miller's guaranteed formulas. Why work for others when others can be working for you? Latest eye-opening literature brings you many specialty propositions for you an independent business. Miller, Chemist, 705-K Chemical Bldg., Tampa, Fla.

FIFTY Successful mailorder products, sales plans. K. Home, 3949 Metropolitan, Chicago.

MAN Or woman. Tested business. Has made more than \$1,000 monthly profits. Legitimate, dignified, pleasing. Experience unnecessary. We supply everything. Long-Eakins, 2060 High St., Springfield, Ohio.

I MADE \$30 A week home. French breadmaking. 15 years' experience; free booklet tells. Ashbrook 67, Marengo, Ohio.

UNPATENTED Ideas can be sold. I tell you how and help you make the sale. Free particulars (copyrighted). Write W. T. Greene, 910 Barrister Bldg., Washington, D. C.

MAKE Big profits with a fur farm in your backyard. Chinchilla rabbits, muskrat, mink. Write for facts. 252 Conrad's Ranch, Denver, Colo.

AMATEUR Cartoonists: Sell your work. Write Smith's Service, PX1194, Wenatchee, Wash.

THAXLY Formulas produce perfect products. All lines. Catalog free. B. Thaxly Co., Washington, D. C.

SIGNS And showcards easily painted. If you use Letter Patterns. Write for free samples. John Rahn, B2120 Neva Ave., Chicago.

ARTIFICIAL Marble sanitary flooring, instructions covering wood or cement flooring 1/2 inch thick, fireproof, all colors, low cost. Ornamental casting, concrete, plaster, papier-mache decorations, garden furniture, statuary, flexible molds, particulars and illustrations free. Chris. Mahler, Huntington, N. Y.

CHEMICAL Expert will furnish formulas and trade secrets. All lines. Lists free. W. L. Cummins, Ph. D., 228 Gordon Ave., Syracuse, N. Y.

LEARN The collection business. Good income, quick results. Interesting booklet, "Skillful Collecting" free. National Collectors Assn., Long St., Newark, Ohio.

A BUSINESS Of your own making—Sparkling Glass Name and Number plates. Checkerboards, signs. Big book and sample free. E. Palmer, 540, Wooster, Ohio.

TRANSFORMERS Everything you want to know about the design and making of transformers is given in Prof. F. E. Austin's two well known books, "How to Make Low-Pressure Transformers" and "How to Make High-Pressure Transformers". Sent C. O. D. Pay postman price \$1.70 and small amount of postage for both books upon delivery. Popular Mechanics Press, Room 806, 200 E. Ontario St., Chicago, Ill.

TELEGRAPHY

LEARN Morse and wireless telegraphy. Big salaries. Tremendous demand. Expenses low, can earn part. Catalog free. Dodge's Institute, H St., Valparaiso, Ind.

CHEMISTRY

"HANDBOOK For Chemical Experimenters." Hundreds of interesting experiments; illustrated, 50c. Booklet of experiments, 15c. Pricelist, 5c. General Chemical Company, Box 397, Reading, Penna.

EXPERT Advice on your chemical problem. Consultation by mail five dollars. Write me. W. Stehman Richards, Industrial Chemist Box 2102, Boston, Mass.

CHEMICAL Formulas, processes, analyses. Bert Laboratories, 693 Broadway, New York.

CATALOG Listing 2,500 illustrations chemists' supplies, 5,000 chemicals, 1,000 scientific books sent for 50c. Laboratory Materials Company, 643 E. 71st St., Chicago, Ill.

FORMULAS AND TRADE SECRETS

PRACTICALLY Any formula, 50c. Just send 50c and name it. Catalog free. Industrial Institute, Dept. 205, 64 West Randolph, Chicago.

ENTIRELY New, perpetual, guaranteeable roach and bedbug eliminators for mail, pitching, canvassing. Write Associated Chemists, Indianapolis, Ind.

MUCILAGE Paste will hold labels fast on glass and tin cost few cents gallon to make. Formula one dollar (bill) J. Maurice, Apt. 6, 547 West 142d St., New York, N. Y.

NEWEST Tested formulas. Particulars; catalog free. Grinstead Laboratories Oswego, Kans.

3,000 VALUABLE Formulas prepaid \$1.00 National Service, 3644 Tamarack, Cincinnati, Ohio.

SEVENTEEN Different solder formulas, \$1.00. Gardner, B77, Little Rock, Ark.

SAWDUST, Chemicals make marble flooring. Formula \$1.00. Universal Supply Co., 777 Boulevard, Bayonne, N. J.

FREE Formula catalog. Illustrated. Latest specialties. Western Chemical, Salem, Oreg.

FORMULAS, Chemical services, lowest prices. Free lists. Herstein, Chemist, 46 Grand Ave., Grand Rapids, Mich.

SPECIAL Formulas. Sky-Ray Research Laboratory, 1416 So. Ewing St. Louis, Mo.

INEXPENSIVE Ice-making formula, 50c. (Machinery unnecessary). Neil Tasker, Shamokin, Penna.

FORMULAS Of today's popular automobile specialties. 21 profit makers, \$1.00. Rayman, Box 707, Cedar Rapids, Iowa.

SUCCEED With your own products. Make them yourself. Formulas, processes, trade-secrets. Expert analytical service. Catalog, circulars free. B. Thaxly Co., Washington, D. C.

DON'T Sell for others. Employ agents yourself. Make your own products. Toilet articles, soap, extracts. Valuable book free. National Scientific Laboratories, 1935W Broad, Richmond, Va.

3000 Formula encyclopedia prepaid \$1.00. Sterling, 7514 Eastlake Terrace, Chicago, Illinois.

GUARANTEED Formulas, best science can produce for making popular, biggest-selling specialties all lines. Don't buy formulas till you've received valuable eye-opening literature. Miller, Chemist, 706-F Jetton, Tampa, Fla.

500 **FORMULAS** And big illustrated catalog 25c. Ideal Book Shop, Park Ridge, Ill.

FORMULAS All kinds. Catalog free. Clover Laboratories (P), Park Ridge, Ill.

15,000 **PROFIT** Making formulas. Following and many others: Accidents and emergencies, agriculture, alloys and amalgams, artist's materials, beverages, cements, glues, pastes, mucilages, bleaching, renovating, coloring metals, dyeing, glass, heat treatment of metals, household formulas, ice cream, confectionery, chewing gum, lapidary work, exterminating vermin, lubricants, paints, varnishes, photography, condiments, canning formulas, rubber, soap, candles, soldering, toilet preparations, perfumes, waterproofing, fireproofing, writing materials. Just write for "Scientific American Encyclopedia of Formulas." When postman hands you book pay \$5.50 and postal charges. Popular Mechanics Press, Room 801, 200 E. Ontario St., Chicago, Ill.

AGENTS WANTED

WANTED At once: More good men to introduce and retail Rawleigh's Good Health Products. Town and country. Wonderful opportunity. Get into business with backing of largest manufacturer of its kind, capital over 15 million dollars. Quick freight, express, parcels post service from 10 great factories and branches—one near you. Nothing new—no experimenting. No experience required. You simply follow the same old time-tested Rawleigh Methods which secure the most business everywhere and have given consumers best values and satisfaction for 40 years. 170 necessities frequently needed every home. Enormous demand. Annual sales nearly 40 million products. Big free trial inducements. Quick easy sales. Repeat every 30-60 days. Enormous profits—\$100-\$400 month and more profits. Steady year round; no lay-off. No boss—you become sole owner and manager. Practically no capital required. We supply everything—stocks, outfit, sales and service methods. Big pay every day. Profits increase every month. "First come first served." For full particulars write W. T. Rawleigh Co., Dept. G-A-PPM, Freeport, Ill.

AGENTS—Big chance to make \$19 daily. Introducing new "No-Bang" door check for screen doors and other house doors. Very low priced. Automatic. Banishes disease bearing flies, mosquitoes, bugs. Noiseless. Safe. Every house needs 2 or more. Quick seller. Big profits. Best season now on. Write quick for terms of demonstrating sample. Elmwood Check Company, File 1207, Cincinnati, Ohio.

STOP Buying blades. Use automatic sharpener for all makes. Get better shaves. Agents coinng money. Sample \$1.00. Engage territory quickly. Viking Specialty Company, 406 S. Main, Los Angeles, Calif.

SHOES Completely resoled for 3c a pair! Amazing preparation makes new shoes out of old in few minutes. Take orders—\$20 to \$40 daily easy. Write for territory and free sample offer. Perfect Mfg. Co., Dept. A-506, 220 E. 3rd St., Cincinnati, Ohio.

PORTRAIT Men, you can make money anywhere selling our guaranteed portraits. Send for free frame catalog. Portrait Agents' Supply Co., Dept. F, LaPorte, Ind.

AGENTS—Clothing sale-men. Profitable article. Eveson Brace, Cambridge, A. Mass.

EASY To sell groceries, paints, auto oils to consumers. Steady, profitable work. Experience unnecessary. Credit given. Valuable outfit free. Lovrin & Browne, 1602-A So. State, Chicago.

OLIVER Cleared \$700 in 30 days with our line of books and Bibles. Outfit free! Exclusive territory! Nichols Co., Dept. B15, Naperville, Ill.

MANUFACTURER Wants distributor for new complete "Pocket" radio. "Sells itself with music." Pays 120%. Spencer Radio, Dept. 9A, Akron, Ohio.

AGENTS—Demonstrate Minute Kleen. Fast selling cleaner for automobiles, furniture, metal and glass. Your name on labels. Quick repeater. Large profits, exclusive territory, free sample. Minute Kleen Laboratories, Evansville, Ind.

MEN: Women! Earn big permanent income as exclusive distributor our products your county. Unusual opportunity. Write today. Indianapolis Soap Co., Dept. 54, Indianapolis, Ind.

HUNDREDS Of firms need representatives in every community in U. S. Send for free sample copy of Opportunity Magazine. G-750 No. Michigan Ave., Chicago.

SELLING Like blazes. Beautiful toilet goods assortment at \$1.75 with 24 inch pearl necklace free to your customers. 100% profit. Davis Products Co., 238 North Ave., Dept. 630, Chicago.

POLMET Polishing Cloth removes tarnish from metals without the use of liquid, paste or powder. Our agents say it sells like "hot cakes." Retail 25c; sample free. Gale & Co., Inc., 15 Edinboro St., Boston, Mass.

SELL Changeable signs to stores, size 14x24; six lines, cost 35c, sells for \$1.50. Free sample offer. National Sign System, St. Louis, Mo.

PORTRAIT Agents—Highest quality enlargements, medallions, frames. Reasonable prices. Write for catalog. Adam J. Kroll Co., 2543 South State St., Chicago.

JUST Invented—new washing machine. No motors or moving parts. Automatically cleans entire washing. Fully guaranteed. Retail price \$9.50. Your profit 100%. Protected territory. Preston Mfg. Co., Dept. CP-7, St. Louis, Mo.

"QUICK Trick" automobile dry cleaning and polishing cloth (chemically treated) washes, polishes finest automobile and furniture finishes in one simple operation. Exceptional sales and profits. Sample free. Walter S. Doe & Co., Kent, Ohio.

AGENTS Make \$75 weekly with extensive line of household specialties—sponge rubber mats, fairly damask tablecovers and 50 other fast sellers. Write B. & G. Rubber Co., Dept. 449, Pittsburgh, Pa.

MIRRORS Resilvered at home. Cost near 5 cents per square foot; you charge 75 cents. Profitable business plating autoparts, reflectors, tableware, stoves, refinishing metalware, etc. Outfits furnished. Details free. Write Sprinkle, Plater, 128, Marion, Ind.

SELL Product every housewife uses daily. Big profits. Repeats. Full time or side line. Box B654, Argo, Ill.

BRING Home the bacon selling Christy's Iron Rust and Stain Remover. Sells like blazes. Write for free sample. Christy, Inc., 6567 Broadway, Newark, N. Y.

AGENTS—Men, women! Send us your name and address, we will mail you circular and particulars, free. New patented device; every home needs two or more; retails for 50 cents; 100% profit. Spriesch Mfg. Co., Buffalo, N. Y.

AGENTS—Wonderful opportunity to make \$10 a day with our big new line of soaps. Highest quality. Beautiful packages. Large orders in every home. Steady repeat business. Big profits. Particulars free. Albert Mills, 5196 Monmouth, Cincinnati, Ohio.

BIGGEST Surprise offer ever made. Be sure to answer this ad. My line of soaps, coffee, tea, spices, toilet articles, household specialties, pays you bigger profits. M. G. Roth, President, 2872 Dodier, St. Louis, Mo.

AGENTS—Give customer two pounds toilet soap free with \$1 bottle superior vanilla. 100% profit. Midwest Drug Co., Columbus, Ohio.

DON'T Sell for others. Employ agents yourself. Make your own products. Toilet articles, soap, extracts. Valuable book free. National Scientific Laboratories, 1935W Broad, Richmond, Va.

WONDERFUL Opportunity for agents to connect with 236 manufacturers and jobbers. Free particulars. Pruitt, Brookfield, Ill.

SELL Satan's hand soap. "Hell on Dirt." Every mechanic buys. 100% profit. Sample and particulars 10c. Pure Soap Co., Argo, Ill.

DON'T Sell for others. Employ agents yourself. Make your own products. Toilet articles, soap, extracts. Valuable book free. National Scientific Laboratories, 1935W Broad, Richmond, Va.

HEAVY Profits introducing new type mending fluid. Amazing scientific development. Agents, part-time workers cleaning up. Details free. Karam-Smith, 6607 Bozan, Fort Wayne, Ind.

AMAZING New device prevents electric ironing and phone cords from kinking. Every housewife buys. Over 150% profit. Chatham Electric Co., B-1160 Chatham Court, Chicago.

AGENTS With car to sell fast selling burglar alarm for autos. Demonstration sells dealers and owners. 50% commission. Chas. Nims, 741 No. Wells St., Chicago.

"HANDHOLD" Tool. Great. Holds any size screw, or 1,000,000 other articles. Inserts; removes. Long size, \$1.50. Lundberg Mfg. Co., 3508 Grand River, Detroit.

SELF-STARTING, self-selling. Marvel siphons pay immensely. Cream size, 25c; large, 50c. Marvel Co., 315 Eleventh, Long Beach, Calif.

NEW And old Gillette type blade sharpener. Latest sensational patent. Automatically hones on stone, finishes on leather. Everybody enthusiastic. Agents exceptional opportunity. Sample \$2.75. Be the first to show this clever device in your town. Money refunded after ten days' trial. Viking Specialty Company, 406 S. Main St., Los Angeles, Calif.

SELL Metal polishing cloths, all time or side line. Gold Seal Products, Box 899-E, Omaha, Nebr.

SELL "Sti-Rex" handsoap. Powdered, paste, waterless. Excellent line. Fast sellers. Repeaters. Large profits. Sample and particulars free. Wink Mfg. Co., Dept. 2-A, Racine, Wis.

LUSTELAST Polishing Cloth not only polishes all metals easily but keeps metal bright. Sales and profits unusual. Sample free. Walter S. Doe & Co., Dept. M, Kent, Ohio.

AGENTS—100% Profit and free premiums. Our line used by every housewife. Big repeaters. Write for special deal. Lusterine Mfg. Co., Bridgeport, Conn.

NEW Electric flashing sign just out—changeable letters. Beautiful neon color effect. Unbreakable. Guaranteed. Every merchant buys on sight. Retail \$13.50. 100% profit. Protected territory. Preston Mfg. Co., Dept. S-143, St. Louis, Mo.

AGENTS—Earn \$10 daily; selling Seta-cur; every woman will buy. Circular free. Thompson Co., 3737 S. State St., Chicago.

BROCKMAN Shoe Sticker, that will start you in a business of unlimited possibilities. Write factory. Oscar Brockman Company, Louisville, Ky.

AGENTS—Up to \$12 daily. Introducing hosiery guaranteed 6 months or replaced. 126 styles, color for men, women, children. Lowest prices. Auto and hose offered producers. Write for outfit. Wilknit Hosiery Co., Dept. C-9831, Greenfield, Ohio.

BIG Money selling new patented safety iron stand and cord holder; every home a prospect; big profits to agents; send \$1.00 for sample or write for free literature. American Cage Co., Racine, Wis.

BIG Profits selling Wizards. Real fool-proof cleaning device. No tricks to use. Simple demonstration gets orders. Old reliable organization. Write for sample. MacLeod Co., 2640 Greenview, Dept. PM-7, Chicago.

GOLFERS! \$50-\$100 Weekly. Latest indoor golf game. Reduces score; sells \$1.50. 100% profit. Sample 50c mail prepaid. Brooks, 1258 Russ Bldg., San Francisco.

BIG Money selling shirts and ties! Wonderful values. Finest line now ready. 54 latest New York styles. Big outfit and special samples. Everything free. Pioneer Mills, 1225 Broadway, Dept. G16, New York.

GOOD Money maker; sample free. Write Geigen Co., 6538 North Maplewood, Chicago.

ENGRAVED Nameplates, signs, numbers, initial, desk, city nameplates. Big profits. Hilton Specialty, 90 Stewart, Providence, R. I.

CHICAGO Expert valued \$3 stone at \$900. The diamond's only guaranteed rival. Greatest spare time, side-line article ever known! Amazing profits. \$5 pocket sample case free. Write quick. Mexican Gem Company, Dept. PM, Monterey, Calif.

AGENTS! You can buy 200 necessities direct from manufacturer for less than you can make them yourself in quantities you buy! Four big lines big-selling repeaters sold all over United States, Canada and Australia: Good Health Products, Stock and Poultry Raisers' Supplies, Soaps and Toilet Articles, Food Products, Insecticides, Cleansers; needed daily every home. All guaranteed exactly as represented by largest company of its kind in the world with four great factories—22 acres floor space. 10 branches—one near you. Cash or credit. Quick, easy sales. Good pay every day. Steady repeat business. First come, first served. Write for particulars. W. T. Rawleigh Co., Dept. GG-PPM, Freeport, Ill.

MAKE Ice from heat for 2c daily. Show this type refrigerator Crosley Icyball. Non-electric. Preserves foods, drinks in hottest weather One-third cost of other mechanical refrigerators. Fully guaranteed. Big profit every sale. Crosley Icyball Division, 8277 Arlington, Cincinnati, Ohio.

PRINTING Salesmen! Here is a new meal ticket without a hole in it. Samples free. Superior, 4646 Telegraph, Oakland, Calif.

MAGICLOTH. The world's best metal polish; on market twenty years. Everybody buys. Unusual profits. Magic Mfg. Co., 3317 Summit, Kansas City, Mo.

PERMALAC Ends polishing and repainting cars. Restores colors instantly. Sun, water, weather proof. Guaranteed. Write for no risk offer. Mid-West Laboratories, Mendota, Ill.

SELL New signs; embossed price tickets; wonderful selection; used in all businesses; \$1.00 samples 25c. Send \$5.00 for 100 best assorted signs; \$3.00 for 50; sell 30c each. P. Franklin Co., 3322 3rd Ave., New York.

SALESMEN—1,000 Car washings for \$3.75. Remarkable new invention washes cars faster, cleaner, cheaper. 100% profit for agents. Write today for free sample offer. Gy-ro Brush, Dept. CG-14, Ampere, N. J.

CASH Paid for Butterflies, Insects. See Sinclair Display Advertisement on page 32.

TIME Counts in applying for patents. See pages 134 and 135. Clarence A. O'Brien, Registered Patent Attorney, Washington, D. C.

MEN Wanted—to demonstrate and take orders direct from motorists. Amazing magnetic trouble light. Sticks on metallic surfaces. Our men earn as high as \$75.00 weekly. Write for demonstrator. Magno, Beacon Bldg., Dept. 16A, Boston, Mass.

\$60-200 A WEEK. Genuine gold letters for store windows. Easily applied. Free samples. Liberal offer to general agents. Metallic Letter Co., 438-B North Clark, Chicago.

MANY Thirsty thousands will buy our soft drink powders this summer. Think of it! 10 big glasses 10c, best drinks you ever tasted—prepared instantly. Sell families also stores—500% profit selling by glass. Send 25c enough 30 assorted glasses with particulars postpaid. Morrissey Company, 4417-25 Madison, Chicago.

AGENTS: Free catalog 200 household specialties, toilet preparations, food products, remedies, portraits, frames, photo pillows, medallions, religious goods, pictures, damask tablecloths. Credit. James C. Bailey Co., Station C-7, Chicago.

STRANGE New ironing cord! Prevents scorching. Saves electricity. Cannot kink or snarl. For telephones also. Up to \$25 daily. Samples furnished. Neverknot, Dept. 7-A, 4503 Ravenswood, Chicago.

MEN Making \$78 to \$119 weekly showing home owners beautiful 4-color illustrations of our dependable guaranteed trees, shrubbery, etc.; pay weekly, everything furnished free; experience unnecessary; full-part time; permanent. Perry Nurseries, R-7, Rochester, N. Y.

100% PROFIT In new mystery cigar lighter. No flint or friction. What makes it light? No wind can blow it out. Retail 50c. Sample and sales plan 25c to cover cost of mailing. New Method Manufacturing Co., Box PM-7, Bradford, Pa.

AGENTS: Permatite faucet washer, guaranteed, schools, hospitals and many others buy by the hundreds. Send ten cents for samples. Greenwood Co., 79 Southampton St., Buffalo, N. Y.

STOP: 500 Fast selling specialties from many parts of the world. Write for free wholesale catalog. Spors Co. Lesueur Center Minn.

SEND Today for our new Gypsy combination auto and camp bed proposition. Makes any automobile a hotel in three minutes; fits any car; no alterations; rolls up in compact case; no trouble to carry. Every automobile owner a prospect. Big profits and future to those acting now. Write today. Gypsy Auto Bed Company Box 511 Ypsilanti, Mich.

SELL New candy and specialties to stores. Lawrence Marable Richmond, Va.

BIG Profit putting our gold sign letters on store windows, without experience. Samples. Consolidated, 69-T West Van Buren, Chicago.

DISTRIBUTORS Wanted to sell Silk to stores, agents, wholesalers. Sets colors in any fabric, prevents runs in hosiery. Saves many times its cost. Guaranteed. 25c brings generous package and territorial proposition. Silk Corp., 209 Seneca, Seattle, Wash.

BIG Money easy. Simply showing new Polly wrench. 10 wrenches in one. Guaranteed! Fast seller. Sample furnished. Gellman Mfg., Dept. 6-U, Rock Island, Ill.

FASTEST Selling game in the world! Five auto specialty sensations! Rich haul for agents! New give-away plan. Get details immediately. Automotive Research Co., Dept. P, Saugerties, N. Y.

BIG Money daily selling shirts, ties, underwear, Sox, raincoats, overalls, pants, children's play suits. Outfit free! Experience unnecessary. Nimrod Co., Dept. 8, 4922-28 Lincoln Ave., Chicago.

STOP Punching door bells! Make big money every week placing Gitsknife counter-cards on store counters everywhere. Gits Company, E 5419 Chicago Ave., Chicago.

GIVE Away sensational non-run lingerie at half store prices! Pocket big advance commissions for merely showing women unbelievable factory bargains! No experience or money required. Everything furnished free. Write Lingerie Manufacturers, 85 Buffalo Ave., Brooklyn, N. Y.

DON'T Sell for others. Employ agents yourself. Make your own products. Toilet articles, soap, extracts. Valuable book free. National Scientific Laboratories, 1935W Broad, Richmond, Va.

AMAZING New invention. Electric water heater. Sells for \$3.75. Heats water almost instantly. Make big money. Write today. Lux-Visel Company, Dept. 23, Elkhart, Ind.

SELL Koehler's Flashy Signs. Start now. 100 9x11 \$3.50, 100 12x18 \$9.00. 500% profit. Proven sellers. Koehler's, Fourth Morgan, St. Louis, Mo.

SENSATIONAL Invention—"Reminder Watch," can be set for three appointments. Retail \$12.50, your profit \$4.00. Write promptly for valuable information. D. P. Howard, 354 South Spring, Los Angeles, Calif.

FREE "Booklet of money making opportunities," new ideas, original plans, money making secrets and other valuable information. None require peddling or outfits. Elite Co., 84 Elizabeth St., New York.

BOTTLE Your own products! Flavors, perfumes, food specialties. Free labels. Valizon Products Company, Geneva, N. Y.

THIS Advertisement may make you thousands of dollars, if you'll write immediately for my "Eye-Opening" literature describing guaranteed formulas; valuable trade processes, money-making information how to easily make the world's best-selling specialties. All lines. Investment small. Profits immense! Start in your home, room or office. Make the good money you're entitled to. Dr. Liscombe Miller, Chemist, Tampa, Fla.

\$200 MONTHLY Selling amazing new automobile trouble light. Electro magnetic. Sticks anywhere on car. It's an Everlasting Flashlight. Sells on sight. Send for demonstrator and prices. National Electric Corporation, 222 High St., Newark, N. J.

MAKE \$28 Daily demonstrating automatic gaslighters. Cost you \$8 gross, doz. \$1. Rapid Mfg., 2772 Pitkin Ave., Brooklyn, N. Y.

AGENTS Wanted everywhere. Write for further particulars. Snow & Parker, Inc., 41 Fish Pier, Boston, Mass.

SUCCEED With your own products. Make them yourself. Formulas, processes, trade-secrets. Expert analytical service. Catalog, circulars free. B. Thaxly Co., Washington, D. C.

EASIEST Window letters on the market. Big profits. 50 styles and colors. Free sample. Write quick. "Ralco," 1045 Washington, Boston, Mass.

BIG Money and fast sales. Every owner buys gold initials for his auto. You charge \$1.50; make \$1.45. Ten orders daily easy. Write for particulars and free samples. American Monogram Co., Dept. 40, East Orange, N. J.

ANXIOUS To hear from lady interested in opening little home dress shoppe. Mme. Isabelle, Gowns, P65, Times Square, N. Y.

REMNANT Store, 1514 Vine St., Cincinnati, Ohio. Greatest dry goods bargains on earth. Agents and dealers.

NEW! Rubber soles—Cement on instantly. Never loosen. Outwears leather. Waterproof. Sells fast. Big repeater. Test at my expense. Bestever Co., 195 Irving Park Sta., Chicago.

GENUINE Gold Leaf Letters anyone can put on store windows. Guaranteed to never tarnish. Large profits. Enormous demand. Free samples. Write today. Metallic Letter Co., 438-D North Clark, Chicago.

AGENTS Buy direct at lowest mill prices. Men's latest fancy hose, doz. \$1.45-\$2.00; ladies' Pointex silk hose, doz., \$4.25-\$7.00. Catalog free. Superior Knitting Company, Dept. 34, New Haven, Conn.

SELL By mail! Start your own small business anywhere. Free folder tells how. No personal selling. Everything furnished. A. Horton, Metropolitan Bldg., St. Paul, Minn.

PHOTO Medallion men and women, the largest line of photo novelties in the world. Lowest prices, quickest service. Send for catalog showing over 200 money makers. Gibson Photo Jewelry Co., Inc., 833-837 Gravesend Ave., Brooklyn, N. Y.

RADIO Trouble Shooting—Covers all-electric sets and television. Greatest book ever published from the point of view of assisting the repairman as well as showing how the radio owner can do his own repairing. 328 pages. Over 300 illustrations. Flexible. Pay postman price \$3 and postage when he delivers it. Popular Mechanics Press, Room 801, 200 E. Ontario St., Chicago, Ill.

ENGRAVED Name plates, signs, numbers, desk plates, store window signs, etc.; profits large. Brett Bros., Winthrop, Mass.

SELL Stores 5c carded breathlets, etc. Lorrac Products, Albany, N. Y.

WANTED: District manager to appoint agents. Unlimited opportunity. No canvassing. Mother Hubbard Products, 554U Congress, Chicago.

BIG Profits, quick repeats, placing Aspirin, Notartar, Flints, Silkstone, other self-selling counter cards with dealers. Over 100% profit. Sterling Co., H7, Baltimore, Md.

AGENTS: Stamping names on pocket-key protectors. Sample check with your name and address, 25c. Stamping outfits, Emblem checks, check-fobs, name plates. Hart Mfg. Co., Desk 2, 303 Degraw St., Brooklyn, N. Y.

FLAVORING Extracts—Bottle yourself! Concentrated. Labels furnished. 600% profits! Whirlwind moneymakers! Free offer! Thomas Manufacturing Company, Indianapolis, Ind.

"HOW To Secure Agents," a specially prepared booklet, tells of one of the most inexpensive methods in which to secure good live producing agents. It is free; write for your copy today! M. L. Rund, Mgr. Classified Advertising, Popular Mechanics Magazine, 200 E. Ontario St., Chicago, Ill.

WANT Distributing agent for Hanslick, powdered handsoap; removes anything from the hands without injury to skin; everybody a customer; great opportunity for hustler to get in business; sample free. Solar Products Co., J2144 So. Troy, Chicago.

GET Our free sample case. Toilet articles, flavorings and specialties. Wonderfully profitable. LaDerma Co., Dept. A, St. Louis, Mo.

AGENTS—Mosco Corn and Callous Remover will build you a steady repeat business. Send today for pocket-size trial outfit. The Moss Company, 504 Searle Bldg., Rochester, N. Y.

GREATEST Opportunity; newest proposition. Build continually paying business in your own name. Household, industrial, brushes, brooms, mops, dusters, fully guaranteed. New catalog, all net prices, no discounts to bother with. Make as high as 300 per cent and over. Write today. Wire Grip Sanitary Brush Corp., 41 East 11th St., New York.

SELL Men's neckwear—wonderful proposition. Astor-M, 39 East 28th, New York.

CALIFORNIA Perfumed beads selling like hot cakes. Agents coinng money. Big profits. Catalog free. Mission Factory P. 2328 W. Pico, Los Angeles, Calif.

WE Start you without a dollar. Soaps, extracts, perfumes, toilet goods. Experience unnecessary. Carnation Co., 641, St. Louis, Mo.

SELL Housewives something they want. A necessity. Reduces gas bills 25%. New in your territory. No competition with this guaranteed gas saving device. Exclusive sales rights. 400% profit. Box 18E, East San Diego, Calif.

AUTOMOBILE Specialties. Guaranteed formulas for all latest money makers. Lowest prices. Write for free lists. Murphy, Chemist, Tujunga, Calif.

\$50,000 **PICTURE** Man Friedman made canvassing. Beginners can make \$100.00 weekly with my sales talk. Experienced men make more. Free book "Profits in Portraits" explains. Sample free. Picture Man Friedman, Dept. 8, 109 West Austin, Chicago.

NO Dull times selling food. People must eat. Federal distributors make big money; many over \$3,000 yearly. No capital or experience needed; guaranteed sales; unsold goods may be returned. We furnish you with license, sample case and free samples for customers. Repeat orders sure; exclusive territory. Ask now! Federal Pure Food Co., A2397 Archer, Chicago.

BIG Money applying gold initials on automobiles. Easiest thing today. No experience needed. \$1.45 profit every \$1.50 job. Free samples. "Ralco," X-1043 Washington, Boston, Mass.

AGENTS—Make a dollar an hour. Sell Mendets, a patented patch for instantly mending leaks in all utensils. Sample package free. Collette Mfg. Co., Dept. 404, Amsterdam, N. Y.

AGENTS—New shirt proposition. No capital or experience needed. Commissions in advance. Samples free. Madison Company, 566 Broadway, New York.

THAXLY Formulas produce perfect products. All lines. Catalog free. B. Thaxly Co., Washington, D. C.

AGENTS Wanted—On a fast selling 25c item for the kitchen, costs you 8 1/2c. Sample sent parcel post prepaid for 10 cents. P. Seed Filfer Mfg. Co., Inc., 353 Broadway, New York.

MAN In each town to plate auto parts, reflectors, bathroom fixtures, refinish beds, mirrors, chandeliers; by new method. No capital or experience required. Simple plan of manufacturing at home starts you in big money-making business. Outfit furnished. Free particulars and proofs. Gun Metal Co., Ave. H, Decatur, Ill.

A BUSINESS Of your own—Making sparkling glass name and number plates, check-boards signs. Big book and sample free. E. Palmer, 512, Wooster, Ohio.

AMAZING Profits showing new table cloth. Looks like linen. Wash like oilcloth. No laundering. You just take orders. We deliver. Pay daily. Sample free. Bestever, 231 Irving Park Station, Chicago.

AGENTS—Clever Invention! Inkspoon makes every pen a fountain pen. Fast office seller; big profit, demand increasing everywhere. Exclusive territory offered. Sample free. H. Marui Company, Tribunes Bldg., New York, N. Y.

BIG Profits! Fast sales! \$9.75 automatic washing machine. Guaranteed. Write Storm Royalty Co., 3601 Enright, St. Louis, Mo.

DON'T Sell for others. Employ agents yourself. Make your own products. Toilet articles, soap, extracts. Valuable book free. National Scientific Laboratories, 1935W Broad, Richmond, Va.

HIGH-GRADE SALESMEN

BONUS Check for you. Adelite, the sure-fire seller. A new, spectacular electric window display; ever-changing colors, knock-out set of business and holiday posters; patented changeable letter system defying imitation. Fat commissions in your pocket every night. Bonus check on Saturday. Dignified work calling on merchants and better business houses. Special model for banks. Repeat orders credited. Special thirty day trial demonstrator offer. Display Products Co., 409-A East 31st St., Kansas City, Mo.

BIG Profit putting our gold sign letters on store windows, without experience. Samples. Consolidated, 69-V West Van Buren, Chicago.

FINANCIAL Independence and income for life without extra work. Enjoyed by our distributors because they have stopped selling slow or non-repeating articles, joining our organization marketing a product which sells on sight and repeats indefinitely. Needed by all business and professional men. 240% initial profit. Repeat commissions without call-backs. Only high class salesmen wanted. No house to house peddling. Brand new. Unusual. Copyrighted. The Commonwealth Co., 508 So. Dearborn, Chicago.

SELL Nothing, earn up to \$170 weekly empty handed. No sample case to tote. Oldest and largest punchboard firm, established 20 years, rated \$500,000, announces amazing new plan. Salesmen cleaning up! No one invests a penny. We even pay express charges. Unsaleable merchandise returnable. Big season now here. Full commission repeat business. Grab this quick! K. & S. Sales Co., 4310 Ravenswood, Chicago.

YOU Can sell business printing. Our big complete selling outfit makes it easy. Our quality and price positively beats competition. Thousands of prospective buyers. Free illustrations, big commissions daily; full repeats. Full time or part time. Write for details now. All-Trades Printing Service, 117 N. Second St., Rockford, Ill.

ONE Of America's largest manufacturers of leather and sheep lined coats, raincoats, work clothing and gloves, has a few open territories. If you are experienced write us. J. H. Cowdle Company, Des Moines, Iowa.

A SIDELINE That beats your main line. High class salesmen to call on manufacturers wholesalers retailers or professional men with very unusual and profitable sideline. Established business. Our men take 3 to 5 new and renewal contracts daily \$19 to \$75 each. No samples to carry. We bill and ship direct. Your commission half amount billed. You get full credit on repeat orders without callbacks. Most exceptional opportunity for right man. Commonwealth Company, 508 S. Dearborn, Chicago.

SEND Today for our new Gypsy combination auto and camp bed proposition. Makes any automobile a hotel in three minutes; fits any car; no alterations; rolls up in compact case; no trouble to carry. Every automobile owner a prospect. Big profits and future to those acting now. Write today. Gypsy Auto Bed Company, Box 511, Ypsilanti, Mich.

NEW Specialty—Sells every business. Four \$15 sales daily pay \$288 weekly. World's largest firms. Bell Telephone, Sears Roebuck, etc., use it. Smallest business needs it. Customer guaranteed cash return ten times price paid. Protected by \$20,000,000 surety company. Repeats. No competition. Walker made \$165 first day. F. E. Armstrong, Pres., 2012G, Mobile, Ala.

\$18 TO \$25 Daily; biggest selling line of men's suits, \$11.95, \$14.50, \$16.95, 19.95. Amazing values. Pure virgin wool overcoats \$18.95. Also raincoats, slickers, topcoats and boys' suits. Biggest commissions paid in advance. Liberal bonus. Free outfit. "Jim" Foster, Inc., Dept. 27, 2250 S. Spaulding Ave., Chicago, Ill.

300% PROFIT Selling Mystery Gas Lighter. Retail 25c. Costs you \$1.00 doz. Sample free. Square Deal Mfg., Desk PM9, Bradford, Pa.

WONDERFUL Invention. Seals fifty envelopes minute. Sells on sight at \$2.25. Attractive trial offer. Square deal. Bank references. Kendall Sealer Co., Dept. C-20, East Jaffrey, N. H.

WANTED—Responsible salesmen to carry nationally advertised and outstanding fish bait as side line. The Hofschneider Corp., 848 Jay St., Rochester, N. Y.

"ONE-MINUTE" Neckties presser, \$1.00. Proposition free. Neil Tasker, Shamokin, Penna.

MARVELOUS Discovery cleans hands like magic. Removes paint, grease, stains instantly. Sell users and dealers; enormous profit. Sample free. Kleenslick Co., St. Paul, Minn.

BE The distributor for Crosley Icyball Refrigerator. Makes ice from heat 2c daily. No gas. No electricity. Preserves foods and drinks in hottest weather. One-third cost of other mechanical refrigerators. Fully guaranteed. Big profits. Crosley Icyball Division, 8279 Arlington, Cincinnati, Ohio.

COVERALL Salesmen—Lettered garments, \$3.25. Commission 75c. Write for sample. Blue Bar Sales, 844 Dorr, Toledo, Ohio.

AGENTS—Demonstrate Minute Kleen. Fast selling cleaner for automobiles, furniture, metal and glass. Your name on labels. Quick repeater. Large profits, exclusive territory, free sample. Minute Kleen Laboratories, Evansville, Ind.

SENSATIONAL New "Three-in-one" vending machine. All merchants buy. Splendid profitmaking sideline. Other fast selling specialties. Free pocket outfit. Specialty Mfg., P-617 W. Division, Chicago.

\$7.50 COMMISSION On every one and you should sell from two to twenty every day. No town too small for three to ten of them. Good payer for purchaser. Badger Bay Company, Dept. 16, Green Bay, Wis.

SELL 3A Garage door holders, simple, automatic, quickly installed. Interests garage owners, builders, everybody. Exclusive territory proposition. Knowlson-Stevenson Co., Ann Arbor, Mich.

WANTED District managers. Oldest organization of its kind in accident and health insurance. Write today for information. Dept. 18, Inter-State Business Men's Accident Ass'n, Des Moines, Iowa.

SALESMEN—What you've always wanted! Positive money maker! Latest raincoats, sportwear, jackets. \$1.00 bag given! Complete sales outfit free! Dunsoo, 12 Williams St., Boston.

100% PROFIT Selling paint brushes direct to consumer or dealer. Undersell all competition. Territory guaranteed. Dept. 7, Bilvian Company, 415 West Broadway, New York.

AUTOMOTIVE Salesmen, full or part time, represent reliable corporation selling special cooling system process car dealers, garages, tire, battery shops, service stations, fleets \$6.50 deal. Commissions advanced. Permanent connection. Large repeat volume. Solvo Laboratories, Milford, Conn.

PANTS Salesmen. \$50.00 a week selling made to measure pants \$4.95 and \$6.95. Cino Pants, Station A, Box 71, Cincinnati, Ohio.

A REAL Surprise for you—Sell new automatic all-aluminum sandwich machine, \$16.95. Commission \$8. The last word in sandwich equipment. Write quick. Dickerson Mfg. Co., Dept. E-7, Springfield, Mo.

SALESMEN—Best pocket \$1.00 seller. Your commission 50c. Sells on sight. Riley, Dept. A, 5305 Broadway, Chicago, Ill.

40%-55% PROFITS. America's greatest printing line. Steady year round sales. 1,000 styles every business uses daily. Lowest prices, highest qualities. Main or sideline. Experience unnecessary. Kaeser-Blair, Inc., Cincinnati.

SALESMEN. Wonderful sideline. 40% commission paid daily Sells all merchants. Pocket outfit free. Willens Co., Dept. 303, 2130 Gladys Ave., Chicago.

AMAZING Screw-holding screw drivers! Remove, insert screws inaccessible places one-handed! Factories, garages, electricians, auto, radio owners buy on sight! Exclusive territory. Free trial! Manufacturer, 1618 Winthrop Bldg., Boston.

SELL Merchants our non-alcoholic pure food flavors. Thos. J. Ferguson, 7426 Richmond, Maplewood, Mo.

LIBERAL Proposition to salesmen with car. Establish independent business. Amazing introductory offer. Socket wrenches and other time saving tools. York Co., 2640 Greenview, Dept. PM27, Chicago.

EARN \$10-\$25 Daily. Exceptionally high grade motor and tractor oils, also paints and roof coating. New sales plan, attractive prices and terms make quick easy sales. Manufacturers Oil & Grease Co., Dept. J, Cleveland, Ohio. Est. 1885.

NEW Invention for Ford cars; guaranteed to save half lubricating oil. Sell garages wholesale. Retail \$2.00. Good commission. Hughey & Harvard Mfg. Co., Palmer, Tex.

PUNCHBOARD Sideline. Double your earnings. America's fastest selling line. Every merchant interested. 250% sure profit. No experience necessary. Pocket outfit free. Puritan Novelty, 1407 Jackson Blvd., Chicago.

FACE Powders! No canvassing. Melrose Works, Box 731, Chicago, Ill.

SALESMEN Wanted to sell castings. Stuart Keneipp Mt. Carmel, Ind.

SALESMEN—If you ever earned five figures a year then we want to hear from you. Box 69, Detroit, Mich.

SALESMEN Sell tires and auto accessories to garages, tire stores, filling stations, etc. Established line; repeats everywhere. Liberal commission. Write for particulars. Economy Rubber Prod. Co., 606 Burkhardt, Dayton, Ohio.

DON'T Sell for others. Employ agents yourself. Make your own products. Toilet articles, soap, extracts. Valuable book free. National Scientific Laboratories, 1935W Broad, Richmond, Va.

ADVERTISING Specialty salesmen. Write Union Co., Boonville, N. Y., for exceptional kitchen novelty proposition.

SALESMEN—Become independent. Own your business; experience unnecessary, selling our \$10,000 accidental death; \$50 accident; \$25 sick weekly benefits—\$10.00 yearly. Other amounts proportionate. Guaranteed steady income from renewals. \$250,000 deposited insurance department. Universal Policy, Dept. A, 716 Lefcourt Bldg., Newark, N. J.

DAILY Cash! Merchants can't refuse this amazing introductory offer! Sells everywhere. Big commissions. Big quick repeats—prompt checks. Pocket kit free. Sales Stimulators, Inc., 339 W. Madison, Chicago.

ADVERTISING Pencils sell fast to every line of business. New line. Quick cash commission plan. Main or sideline. Free pocket outfit to real salesmen. Chicago Graphite Co., 130 So. Clinton, Chicago.

PUNCHBOARD Salesman—Most gigantic line ever featured. Vending machines, all kinds. Make high as \$28.00 on single order. Repeat commissions. Beautiful colored catalog free. Lion Mfg., Dept. 8, 308 W. Erie, Chicago.

SELL Goodyear raincoats; \$2.95 up. Goodyear Rainwear, 682 Sixth Ave., New York.

PUNCHBOARD Salesmen make big commissions, selling punchboards and vending machines. Reliable concern, established 20 years. Largest most complete catalog in colors, free. Best season now. Write today! Lincoln Sales, 116 S. Wells, Chicago, Dept. D.

\$60-\$200 A WEEK. Genuine gold letters for store windows. Easily applied. Free samples. Liberal offer to general agents. Metallic Letter Co., 438-A North Clark, Chicago.

SALESMEN—Four \$15.00 sales to merchants net you \$40.00 daily. Sayers Systems, 2813 Sheffield, Chicago, Ill.

HELP WANTED

WOMEN: To introduce new, fast selling imported sanitary necessity. Two sales daily nets you \$51.00 weekly. No deliveries; no collections; no experience or capital required. Write Daintymaid, PM-730, Meriden, Conn.

CASH Paid for butterflies, insects. See Sinclair Display Advertisement on page 32.

MEN—Sideline; photos, 20, \$1.00. Cartoon books. Samples. GPO, Bx471, New York.

ARE You tired of hard work, long hours and small pay? Get out of the rut! I'll show you how to be your own boss and make \$15 profit a day. Simple, pleasant work. No capital required. Particulars free. Albert Mills, 5197 Monmouth, Cincinnati, Ohio.

WANTED Job as electrician or radiotri- cian. References given. Ola Sillyman, Electra, Tex.

MAKE Big profits silvering mirrors. Easily learned patented process. Plans free. Wear Mirror Works, Excelsior Springs, Mo.

10,000 MONEY-MAKING Formulas. Tells you how to make and sell almost everything under the sun; cosmetics, muckage, anti-freeze solutions, battery solutions, beverages, cheese, chewing gum, cleaning preparations, extracts, hair preparations, inks, bluing, leather polish, mirrors, perfumes, polishes, typewriter ribbons, carbon paper, washing powders, liquid soap, and hundreds of other profitable articles. Send no money. Just write a postal for "Henley's 20th Century Book of Formulas." Pay postman postage and \$4. Popular Mechanics Press, 200 E. Ontario St., Room 802, Chicago.

EDUCATIONAL AND INSTRUCTION

FIREMEN, Brakemen, baggagemen; colored train or sleeping car porters, \$150-\$250 monthly. Experience not necessary. 810 Railway Instruction Bureau, East St. Louis, Ill.

MEN 18 To 45. Become postoffice clerks, carriers, railway postal clerks. Steady. \$1,700-\$2,700. Full particulars free. Write immediately. Franklin Institute, Dept. L14, Rochester, N. Y.

DO You want a fine hotel position? Then come to Washington! Here is the only school of its kind in the world—a nationally recognized training school which prepares men and women for positions paying \$2,500 to \$7,500 in hotels, apt. hotels, resorts, clubs, schools, cafeterias and tea rooms. Come to Lewis—get ready for bigger earnings while enjoying delightful months in the beautiful, interesting capital city. Learn under practical experts; 14-year tested, time-saving, thorough training. National employment bureau for graduates, no extra cost. Write now for free book that brings your opportunity. Lewis Hotel Training Schools, Dept. 317-CL, Washington, D. C.

WORK For "Uncle Sam." Life jobs with U. S. government. Steady work. \$105.00-\$280.00. Men-women, 18-50. Thousands 1930 appointments. Many examinations coming. Common education usually sufficient. Experience unnecessary. We prepare you without leaving home. List positions and full particulars free. Write today. Franklin Institute, Dept. L3, Rochester, N. Y.

BOOKKEEPING And accounting. The foundation for business success. Simplified problem method. Thorough. Easily mastered. Personal instruction. Certificate. Accounting Institute, Duluth, Minn.

HOUSEHOLD Automatic Refrigerating Machines. Here is the first book ever published on this important subject. Refrigeration, by Moyer and Pittz. It is a thorough treatment of present-day refrigeration systems, their operation and testing for the student and practicing engineer. 431 pages. 184 illustrations. Cloth. Sent C. O. D. Pay postman price \$4 and small amount of postage upon delivery. Popular Mechanics Press, Room 806, 200 E. Ontario St., Chicago, Ill.

RADIO Announcers, Talkie Actors' Guide. Secrets of good pronunciation, English and fifteen foreign languages. Studio edition, \$1.00. Microphone Publishing Co., Box 724, Cincinnati, Ohio.

INVEST One cent—it will pay you to know what opportunities mechanical dentistry offers. Postcard brings complete details free in 48-page book, "Choosing a Trade." Ask for Bulletin 4. Bodee Institute, 1755 Broadway, New York.

WRITERS Typing, selling. Beginners service \$1.00. Box 133, Harper, Kans.

"NO Knowledge of Music required"; only \$1.00 to learn music shorthand. Box 193, Pismo Beach, Calif.

LEARN Lacquer system of sign painting. Valuable new book gives complete description of methods, materials and equipment with hints and helps for sign shops. Covers latest in electric, neon tube, and daylight reflector signs, etc. Delivered to your door C. O. D. Simply pay postman \$3 and postage. Popuar Mechanics Press, Room 801, 200 East Ontario St., Chicago.

WANTED Immediately, men-women, 18-55, qualify for permanent government positions, \$105-\$250 month; no government experience required. Paid vacations. Common education. Many needed soon. Write Ozment Inst., 101, St. Louis, Mo.

PHOTOPLAY Talking picture and magazine stories wanted for revision, development and copyright. Sell on commission. Established 1917. Booklet free. Universal Scenario Company, 406 Western and Santa Monica Bldg., Hollywood, Calif.

LEARN Rapid figuring from "Higher Arithmetic." Write for prospectus or send two dollars for book. F. A. Smith, 608 S. Dearborn St., Chicago.

BECOME A landscape architect. Uncrowded profession; wonderful opportunity for money-making. Easily mastered by mail. Earn while you learn. Est. 1916. Write for details. American Landscape School, 29 Plymouth Bldg., Des Moines, Iowa.

U. S. GOVERNMENT Wants men, \$1,700-\$1,900 and up at start. Railway mail clerk examination coming. Let our expert (former government examiner) prepare you for this and also rural carrier, post office, customs, internal revenue, and other branches. Write today for free booklet. Dept. 8, Patterson School, Rochester, N. Y.

THAT Concrete Job. Don't be afraid to tackle it. With the instructions found in Popular Mechanics Concrete Handbook you can easily make 173 articles of utility and beauty ranging from ordinary steps to garden furniture. This book will be sent for only 98c plus postage C. O. D. Send your order today to Popular Mechanics Press, Room 801, 200 E. Ontario St., Chicago, Ill.

DOUBLE Entry bookkeeping 60 hours with 8 keys; guaranteed. (Diplomas.) International Bookkeeping Inst., 8 Springfield, Mo.

INFORMATION

GARDENING. There are many books on this subject but if you want the latest and most complete work covering flowers, vegetables, shrubs, trees, landscaping, the rock garden, the water garden, etc., for the average American home, you will send for Everybody's Garden by Frank A. Waugh. Sent C. O. D. 300 pages. Profusely illustrated. Cloth. Pay postman price, \$3.50 and small amount of postage upon delivery. Popular Mechanics Press, Room 806, 200 E. Ontario St., Chicago, Ill.

STUNT Flying—A new book of flight instruction that is different. The author, Capt. Richard Duncan, has developed in this book a unique system of practicing and working out your flight manoeuvres on the ground. Use it and learn as other great flyers have done. Will save you hours of costly flying practice. 185 pages, 32 illustrations, cloth. Sent C. O. D. Pay postman price \$2.50 and small amount of postage upon delivery. Popular Mechanics Press, Room 806, 200 E. Ontario St., Chicago, Ill.

TYPEWRITERS AND SUPPLIES

TYPEWRITERS—All standard makes \$10 up. Catalog free. Northwestern Typewriter Exchange, 121 N. Francisco Ave., Chicago.

TYPEWRITERS—All makes, guaranteed, \$6 to \$34. Free catalog. Dee Typewriter Exchange, Ada, Okla.

ADDING MACHINES

NEW \$3.50 Automatic adding machine. Adds, subtracts, multiples, absolutely accurate. Capacity \$999,999.99. Fully guaranteed. 75,000 pleased users. Makes adding easy, positive, quick. Eliminates mistakes. Saves time. Postpaid \$3.50. Bassett Co., 1458-H, Hollywood Ave., Chicago.

PRINTING, ENGRAVING AND MULTIGRAPHING

LETTERHEADS, Envelopes, 500, \$1.10; 1,000, \$2.00; 5,000, \$8.00, plus postage. Samples. Coyle & Kimballs, Newport, N. Y.

LETTERHEADS \$2.50 Thousand up; envelopes \$2.95; circulars \$3.00, postpaid. New price list. Battlefield Press, Gettysburg, Penna.

EMBOSSED Letterheads, \$6.50 per M. Stationery of Merit. Write today. Radcliffe Printing Co., 10 So. 4th Street, Camden, N. J.

200 LETTERHEADS And 100 envelopes \$1.00. 200 letterheads, 8 1/2 x 11, 150 envelopes \$2.00. 250 cards \$1.00. Hoosier Print Shop, Portland, Ind.

1,000 BUSINESS Cards \$2.75 postpaid. John Miller, Montgomery Ave., Narberth, Pa.

5,000 6x9 circulars, \$7.50 folders, envelope slips, stationery. Low prices. Samples. Goodprint, Harrisonburg, Va.

BUSINESS Cards, 500, \$1.65; 1,000, \$2.65. Vellum finish. Samples. New England Card Co., Box 129, Boston (Chelsea), Mass.

250 BUSINESS Cards 69c. Samples free. Hanzer's, 1639 S. Cleveland, Philadelphia.

AMAZING Value! 5,000 Hammermill bond letterheads 8 1/2 x 11 \$11.00. 5,000 high-grade envelopes \$9.00. Write now. Hilton Printery, 139 Front, Worcester, Mass.

SOCIAL And business printing. Specializing in raised letter work. Samples free. LaClyde Service, Westfield, Mass.

NEARGRAVURE—Neargravuremboso secret processes business stationery. Samples. Solldays, Knox, Ind.

OUR Standardized plan makes it possible to print house organs and magazines at one-third ordinary prices. We print more than 1,100 different publications. Samples and particulars free. National Publishers Press, Grand Rapids, Mich.

200 LETTERHEADS, 100 Envelopes, printed \$1.00. Abbott Printery, Oswego, Kans.

WE Print stationery, booklets, catalogs, circulars. Samples. Commercial Press, Batavia, Ohio.

QUALITY Printing! Reasonable Prices! Send for Free Standardized samples and prices. Folders, Circulars, Catalogs our specialty. Earnest Fantus, 525 South Dearborn, Chicago.

250 BOND Letterheads, Envelopes, Billheads, Cards, \$1.35 each. Economic Press, Leonia, N. J.

GUMMED LABELS

1,000 PRINTED: Name, business, address 50c. JBS Company, Box 93, Holyoke, Mass.

PRINTING OUTFITS AND SUPPLIES

PREUSED Printing presses and supplies. Lists 2c stamp. Popular Bargains, Richmond, Pa.

PRINT Your own cards, stationery, circulars, advertising, etc. Junior press \$5.90; job presses, \$11; rotary, \$149. Print for others; big profit. Easy rules furnished. Write for catalog presses, type, paper, etc. Kelsey Company, Q-11, Meriden, Conn.

PRINTING Outfits—Presses, type supplies, type novelties. Send stamp for catalog. Model Press, York, Penna.

DUPLICATORS AND DEVICES

YOU can make 50 to 100 copies of a letter, notice, etc., at a cost of three cents on a Heyer Quality Duplicator. Write for free trial offer. The Heyer Duplicator Co., 909 Jackson Blvd., Chicago, Ill.

"EXCELLOGRAPH" Rotary stencil duplicator \$39.00. "Two-Faced" film duplicator \$6.00. Booklet free. Pittsburgh Typewriter Supply, Dept. 601, Pittsburgh, Pa.

"RAPIDOGRAPH" Rotary Steel Duplicator, duplicates typewriting, handwriting, drawings. Complete \$25.00. Samples free. General Stamping Works, 238 E. 24th St., New York.

MAKE Your own duplicator from which 50 to 100 copies may be reproduced. Instructions \$1.00. Julius Goldin, 926 Southern Blvd., New York.

AT Last. A rotary stencil duplicator you can make yourself. Low cost, simple, efficient. Mechanical Models 1235 Tenth St., Milwaukee, Wis.

FOR THE HOME

CEDAR Chests only \$11.65—"Red-i-Kut" complete with rich copper trim—you assemble and save half—send for pictures. Kuempel Furniture Company, Guttenberg, Iowa.

LEARN Typewriting at home. Rational typewriting, brief course by Sorelle (a Gregg publication) enables you to become proficient at typing without the aid of an instructor. 96 pages. Illustrated Cloth. Sent C. O. D. Pay postman price, \$1 and small amount of postage upon delivery. Popular Mechanics Press, Room 806, 200 E. Ontario St., Chicago, Ill.

WELLS' Outline of History now only \$1. The complete, illustrated, 1,200-page edition that originally sold for \$5.00. One of the most popular books ever published. Can be read with profit by young or old. Pay postman \$1.00 plus postage when delivered to your door C. O. D. Popular Mechanics Press, Room 802, 200 E. Ontario St., Chicago.

FOR MECHANICS

BEST Opportunity for profit in 8-hour battery charging. Practically no investment, easy terms. Bargains in reconditioned car washers, paint sprays, compressors. Write today. Box M-705, Troy, Ohio.

CARBURETOR Information every auto service man needs will be found in special carburetor supplement to the famous Dyke Auto Encyclopedia. Deals with every make of carburetor. 106 pages. 246 illustrations. Price \$2. Sent C. O. D. if you prefer. Popular Mechanics Press, Room 801, 200 E. Ontario St., Chicago, Ill.

YOU Need a better grip on mathematics? Ask us to send you a copy of "Mathematics for the Practical Man," only \$1.50. By common sense methods it removes the mystery and difficulties so algebra and calculus are made simple. Assuming your knowledge is limited to arithmetic you quickly and easily gain a working knowledge of algebra, geometry, trigonometry and calculus. Simply pay postman when he hands you the package. Address Popular Mechanics Press, Room 802, 200 E. Ontario St., Chicago, Ill.

SPORTING GOODS

GOLFERS—200 Tees for \$1.00, orange colored wood. Germany importation. Postage prepaid. Send check or cash to Mail Service, 608 Ohio Bldg., Toledo, Ohio.

FOR SMOKERS

SMOKE On me free—I'll send you free big generous sample Old Green River pipe tobacco. Enjoy the mild mellow tasty natural tobacco flavor. See how smooth and satisfying. No obligation. Send today. Pete Moberly, Box 775, Owensboro, Ky.

AUTOMATIC Cigaret making machines. Rolls, glues 50 for 10 cents; illustrated folder. Postpaid \$2.50. For home use. Automatic Cigaret Machine Works, 6247-51 Broadway, Chicago.

BOATS AND LAUNCHES

AQUAPLANES. Build your own. Send 10c stamps for pamphlet on aquaplaning and knockdown offer. Box 101, Coney Island, Brooklyn, N. Y.

BOATS—Complete illustrated list of stock cruisers and runabouts; prices, dimensions in The Rudder, June, 35c. Catalog free. Rudder, 15 Murray, New York.

HUBBELL Marine coolers convert Ford engine into marine motors. Booklet free. Ford speedboat easily built, large blueprint and directions one dollar. C. C. Hubbell, Perry Ave., Norwalk, Conn.

BUILD Your own boat using ready cut semi-assembled materials furnished by originators of this system of building. Save two-thirds. 55 designs—outboard speedsters, runabouts, cruisers, sail, row, etc. Send 10c for catalog. Brooks Boat Co., etc., Box M.M., Saginaw, Mich.

PROPELLERS, Pumps, stuffing boxes, lights, etc. Wm. H. Baker, Pond St., Quincy, Mass.

BUILD Your own boat Complete directions make it comparatively easy and you will not only save money but have lots of fun besides. The Outboard Motor Boat book covers 35 different types of the latest outboard motor, inboard motor, rowing, sailing boats, canoes, etc., with blueprints in addition to the instructions. Pay postman price, \$3, and few cents postage when delivered. Popular Mechanics Press, Room 807, 200 E. Ontario St., Chicago.

RUBBER STAMPS

RUBBER Stamps! 15c per line. Deluxe Stamp Works, B572M, Auburn, Nebr.

FIELD GLASSES, MICROSCOPES AND TELESCOPES

NEW Imported binoculars. Eight mile range. Only \$7.50. Free trial. Literature. M. G. Tarres, 4732 Griscom, Philadelphia.

\$12.50 GOVERNMENT Binoculars, six power with leather case. Send free list field glasses, binoculars, cameras, lenses and musical instruments. Well's Curiosity Shop, 20 South Second St., Philadelphia, Pa.

THE Outdoor season is here. Send for a copy of our book, entitled "Outdoor Sports the Year Round." It is on making all sorts of devices for outdoor recreation. Pay postman price, \$1.50, and few cents postage when delivered. Popular Mechanics Press, Room 807, 200 E. Ontario St., Chicago.

RAZORS AND BLADES

GILLETTE Blades honed, stropped, 1c each. Petter Wetterquist, Rockford, Ill.

ANTIQUES, WAR RELICS AND INDIAN GOODS

FOR Sale—Antique, obsolete and modern firearms, from the matchlock to cartridge. Many scarce and unusual arms. Send 10c for list 6. The Spencers, 111 East Patterson Ave., Columbus, Ohio.

INDIAN Relics, coins, curios. Beadwork. Catalog free. Vernon Lemley, Osborne, Kans.

SEND 5c For fine new list Indian relics, antique firearms. F. E. Ellis, Webster Groves, Mo.

PHONOGRAPHS AND RECORDS

BUILD Your own phonograph, radio; phonograph parts; catalog mailed for 10c. American Phonograph Co., 3602 Wesley, Berwyn, Ill.

MUSIC AND MUSICAL INSTRUMENTS

SONG, Poem, melody writers. Great opportunity by writer, of "Jealous," "Burgundy," "Highways," etc. Tommie Malle, A-4215 North Ave., Chicago.

WORDS Set to music. Melody sent on approval. Richard Broughton, Sioux Falls, S. Dak.

USED Saxophones, clarinet, cornet. Roy Harding, 15th Montgall, Kansas City, Mo.

SONG Poems wanted, marketing proposition, if suitable. Clifford Studio, 4695 Hollywood Blvd., Hollywood, Calif.

GUARANTEED Results. Write Sequoia Songwriters Service, Sherman Branch, Los Angeles, Calif.

SONG Poem writers. "Real" proposition. Hibbler, D1, 2104 Keystone, Chicago.

COMPOSERS—Verse or music. Brilliant opportunity. Write VanBuren, 2039 McClurg Bldg., Chicago.

SEND Song poems, 50-50 plan. Indiana Song Bureau, (Brookside), Salem, Ind.

VIOLINS. Deep, mellow, soulful—on credit. Easy terms for wonderful instrument. Get details today. Gustav F. Henning, 302 University Building, Seattle, Wash.

PLAY Piano by ear. A sound system. Particulars free. Boucher's Harmony Studio, Ottawa, Can.

POEMS Wanted. Work guaranteed. We publish. Great Eastern Song Bureau, Dept. 27, Thomaston, Me.

"MUSIC Composed" to words. Bauer Bros. (formerly of Sousa's Band), Oshkosh, Wis.

SONG Writers. Send for our "Publishing Agreement." McKinley Music Printers, 1501 E. 55th St., Chicago.

SONGWRITERS—Arranging, composing. Free booklet. Tucker, 330 Wadsworth, New York.

WRITE Songs. Big money and reputation. Write for information. J. Gordon Pub. Co., 201 N. Hoyne Ave., Chicago.

CORNETISTS—Trombonists—Saxophonists—Clarinetists. Get "Free Printers." Name instrument. Virtuosi School, Buffalo, N. Y.

FREE! Song Writers Guide. Beaver, 1257 Elm, Green Bay, Wis.

PATENT ATTORNEYS

PATENTS Procured. Prompt, careful, efficient service. Highest references. Moderate fees. Send sketch or model for actual search and advice. George P. Kimmel, Master of Patent Law, 54-G Legal Bldg., Washington, D. C.

PATENTS—Write for our free book, "How to Obtain a Patent" and Record of Invention Blank. Send model or sketch of invention for inspection and instructions free. Terms reasonable. See advertisements on pages 136 and 137. Victor J. Evans & Co., 934 Ninth, Washington, D. C.

TIME Counts in applying for patents. See pages 134 and 135. Clarence A. O'Brien, Registered Patent Attorney, Washington, D. C.

PATENTS. Booklet free. Highest references. Best results. Promptness assured. Watson E. Coleman, Patent Lawyer, 724 Ninth St., Washington, D. C.

INVENTORS Service Bureau will send booklet and give you free advice concerning the proper procedure for obtaining patents on easy payment plan and at least expense. Dept. B, Union Trust Bldg., Washington, D. C. Chicago representative, N. E. Hewitt, 1853 Conway Bldg.

SELL Before patenting. New, safe, effective plan. Organized co-operation in making sale. Write Chartered Institute American Inventors, Barrister Bldg., Washington, D. C.

PATENTS—Write for free instructions. Send drawing or model for examination. Miller & Miller, Registered Patent Attorneys (former Patent Office Examiners), 259 McGill Bldg., Washington, D. C.

PERCY S. WEBSTER, 203 Saving and Loan Building, Stockton, Calif. Patent booklet free.

INVENTIONS Patented and Exploited. Former patent office examiner; Master patent law. Benj. Webster, Esq., No. 15 East 26 Street, New York.

INVENTOR'S Adviser with mechanical movements sent free. Labiner, 15 Parkrow, New York.

UNPATENTED Ideas can be sold. I tell you how and help you make the sale. Free particulars (copyrighted). Write W. T. Greene, 906 Barrister Bldg., Washington, D. C.

LANCASTER, Allwine & Rommel, 221 Ouray Bldg., Washington, D. C. "Originators of the Form Evidence of Conception." Before disclosing your invention to anyone send for blank form to be signed and witnessed. Form and patent information bulletin free.

SELL Your invention before patenting. Write for free particulars. W. T. Greene, 901 Barrister Bldg., Washington, D. C.

REGISTERED Patent attorney-engineer. Expert in chemical and mechanical patent matters. Former patent examiner. Correspondence invited. A. Ponack, 401 Homer Bldg., Washington, D. C.

PATENTS Procured; trade marks registered—preliminary advice furnished without charge. Booklet and form for disclosing idea free. Irving L. McCathran, 704 International Building, Washington, D. C.

LACEY'S Patent Sense. Valuable book free. See ad page 139.

PATENTS, Trade-Marks, Designs. This firm has 27 years' experience and gives expert personal service at reasonable rates. We properly protect your invention. Write for free information and exact cost of procuring patent before proceeding. John B. Thomas & Co., 902 F St., N. W., Washington, D. C.

INVENTORS: Send for booklet telling how to patent and sell your inventions at lowest cost. Ralph Burch, Patent Lawyer, 906 F St., Washington, D. C.

ESTABLISHED 1864. Milo B. Stevens Company. Free booklet. Patents, Trade marks. Copyrights. Offices, Monadnock Block, Chicago; Barrister Building, Washington, D. C.

INVENTORS—Write for our Guide Book, "How to Get Your Patent," and Evidence of Invention Blank. Send model or sketch of your invention for our prompt examination and instructions free. Randolph & Co., Dept. 430, Washington, D. C.

PATENTS. Prompt personal service. Write for information. Albert E. Dieterich, Registered Patent Lawyer, 621 1/2 Ouray Bldg., Washington, D. C.

PATENTS. Send sketch or model for advice. Free book: "How to Obtain a Patent." Established thirty years. Highest references. Prompt service. Reasonable charges. Chandler & Chandler, 910 F St., Washington, D. C.

"INVENTOR'S Guide," valuable information, free. Frank Ledermann, Registered Attorney-Engineer, 1712 Woolworth Bldg., New York.

FOR INVENTORS

INVENTIONS—Write for our free book "How to Obtain a Patent" and Record of Invention Blank. Send model or sketch of invention for inspection and instructions free. Terms reasonable. See advertisements on pages 136 and 137. Victor J. Evans & Co., 157 Ninth, Washington, D. C.

TIME Counts in applying for patents. See pages 134 and 135. Clarence A. O'Brien, Registered Patent Attorney, Washington, D. C.

YOUR Ideas practically designed, developed, marketed. Moore, 614 Geneva, Glendale, Calif.

PATENT Wanted. Private party will purchase outright or on royalty patent of merit. Box 402, Green Bay, Wis.

SELLING Before patenting now practicable. New, safe, effective plan. Organized co-operation in making sale. Write Chartered Institute American Inventors, Barrister Bldg., Washington, D. C.

NEW Inventions wanted. Investigate before patenting. J. S. Douglass, Jr., Professional Engineer, Canandaigua, N. Y. (N. Y. State License).

LACEY'S Patent Sense. Valuable book free. See ad page 139.

INVENTOR'S Universal Educator: contains 900 mechanical movements; 50 perpetual motions; instruction on procuring and selling patents and selecting an attorney, etc. Suggests new ideas. Price \$1.00 postpaid in U. S. A. Address Dieterich Co., publishers, 602B Ouray Bldg., Washington, D. C.

AN Old, responsible manufacturing company would like a few more hardware specialties to manufacture. To receive attention your answer must give full particulars. W. K. M. Co., 23rd and York Sts., Philadelphia, Pa.

I SELL Patents. Established in 1900. A nationally-known service. Experienced, respected. Why take chances Charles A. Scott, 773PM Garson Ave., Rochester, N. Y.

INVENTORS. Share benefits of national mutual aid society. For information write American Society of Inventors, Crosby Bldg., Buffalo.

UNPATENTED Ideas can be sold. I tell you how and help you make the sale. Free particulars (copyrighted). Write W. T. Greene, 907 Barrister Bldg., Washington, D. C.

SELL Your invention before patenting. Write for free particulars. W. T. Greene, 902 Barrister Bldg., Washington, D. C.

INVENTIONS Wanted—Patented, unpatented. If you have an idea for sale write Hartley, Box 928, Bangor, Me.

LOW Cost manufacturing. Large plant completely equipped for blanking, drawing, stamping and wire forming in any finish. Can save you money on your product. Our figures will convince. Eastern States Products, Box 721, New Haven, Conn.

INVENTORS—Cash in on your invention now! Don't delay the sale any longer! Send for a free copy of our specially prepared booklet, "Turn Your Patent Into Money," today! It contains helpful information for all inventors. M. L. Rund, Mgr. Classified Advertising, Popular Mechanics Magazine, 200 E. Ontario St., Chicago, Ill.

GET Your own patents. Legal blanks, complete instructions \$1. Cutting Sons, Campbell, Calif.

INVENTIONS Patented and Exploited. Former patent office examiner; Master patent law. Benj. Webster, Esq., No. 15 East 26 Street, New York.

PATENTS FOR SALE

OUTRIGHT Or cash and royalty. Stepless transmission for automobiles. Substitutes friction clutch and shiftgear. Canadian patent 359,430. March, 1930. U. S. patent pending. Particulars. C. F. Van Der Spek, 38 Division St., Toronto, Can.

OUTRIGHT: Automobile radiator meter. Paul Carbt, 2023 W. Crystal St., Chicago, Ill.

PATENT For sale. Automatic rocker. 12 sold, more on order. P. O. Box 609, Philadelphia, Pa.

PATENTED Heating boilers, boiler covers. Stephen Baldyaz, 905 Thirteenth St., Racine, Wis.

OUTRIGHT: Most powerful wind power mill on earth. L. G. Sovereign, Milford, Nebr.

PATENT-RIGHT. Thread container. Handy, useful household necessity. Irene Fisher, 817 Broadway, Bremeron, Wash.

FOR Sale—Composition matter for manufacturing toys. Joseph F. Billy, 142 W. 67th St., New York.

A TESTED Invention for sale. Address Andrew Magnuson, Stockholm, Me.

FOR Sale—Patents, improved flour sifter and improved snare. Outright or royalty. Harry Nakagawa, Tanana, Alaska.

CASH And royalty. Automatic, compact, cigarette holder and lighter. Henry Leininger, Hales Corners, Wis.

OUTRIGHT—Sell patent pending on auto tire tread design of considerable merit. B. Omoto, P. O. Box 532, Green River, Wyo.

FOR Sale—Three mechanical toy patents. L. McVey, Rulo, Nebr.

SPARKING Surface spark plug. Repeat demand eighty million. Cheap. Georgias, 192 Fourth St., South Boston.

TIME Counts in applying for patents. See pages 134 and 135. Clarence A. O'Brien, Registered Patent Attorney, Washington, D. C.

FOR Sale or royalty. Folding pocket umbrella. U. S. patent No. 1,750,379 issued March 11, 1930. Best yet. Stanley Akrigg, Dryburg, Mich.

MERITORIOUS Patented mechanical sanitary glass ice cream quart and pint measures. Royalty. B. Kolber, 2649 N. Napa St., Philadelphia, Pa.

OUTRIGHT Or royalty, successfully proven cut-off valve device making automobiles theft proof. George Berquist, Room 514, 120 North LaSalle St., Chicago.

INVENTORS—Cash in on your invention now. Don't delay the sale any longer! Send for a free copy of our specially prepared booklet, "Turn Your Patent Into Money," today! It contains helpful information for all inventors. M. L. Rund, Mgr. Classified Advertising, Popular Mechanics Magazine, 200 E. Ontario St., Chicago, Ill.

MODELS AND MODEL SUPPLIES

MODEL Steam engines and boilers for miniature power boats. Boat and boiler fittings. New catalog 15c. Model Machine Shop, 212 Price St., Rahway, N. J.

WE Develop ideas, design, build models and manufacture. Logan Machine Co., 652 Lake, Chicago, Ill.

TIME Counts in applying for patents. See pages 134 and 135. Clarence A. O'Brien, Registered Patent Attorney, Washington, D. C.

THE Modelmaker. An illustrated magazine devoted to practical model making. Sample 10c. Modelmaker, 122 Liberty St., New York.

LET Our experience be your guide. Models that are models; tools and equipment for economic manuf. Patterns of all types; manufacturing in all branches. Satisfaction guaranteed. United Machinery Company, Cincinnati, U. S. A.

WE Make working models for inventors and do experimental work and carry a complete stock of brass gears and model supplies. Send for catalog. The Pierce Model Works, Tinley Park, Ill.

SHIP Model fittings. Send dime for illustrated catalog No. 6. A. J. Fisher, 1002 Etowah Ave., Royal Oak, Mich.

MANUFACTURING

METAL Goods manufacturer desires meritorious articles to manufacture. Die castings, stampings, chrome and nickel plating, enameling, color spraying, assembling and machining, under one roof. International selling organization. Low operating costs. Nation-wide reputation for excellence. Box 549, Middletown, Conn.

ECONOMICAL Manufacturing from sheet, bar, wire or tubing. Models, dies, special machinery. Swanberg, 5124 N. Kildare Ave., Chicago.

SPECIALIZE Complete manufacture, dies, tools, special machinery. Models made. Atlas Indicator Works, 817 W. Washington, Chicago, Ill.

LOW Cost manufacturing. Large plant completely equipped for blanking, drawing, stamping and wire forming in any finish. Can save you money on your product. Our figures will convince. Eastern States Products, Box 721, New Haven, Conn.

INVENTORS Models, metal stamping, metal spinning special tools, etc. Anderson & Danhauer, 1519 E. 37th Ave., Denver, Colo.

MONEY In your shop with my designs. 25 cents. Roy Weikel, Milton, Pa.

SPECIAL Machinery or parts, dies, tools, metal specialties, models, special gears, stock gears and model supplies. Send for Catalogue. The Pierce Model Works, Tinley Park, Ill.

WIRE Goods made to order. Cooley Mfg. Co., 530 N. Western Ave., Chicago.

MANUFACTURING Models, dies, stampings, brasswork, one or thousands. Circular free. Baum's Metal Specialties, Kansas City, Mo.

BEST Books for \$1. All formerly sold for \$2.50 to \$5 each. Select from the following list of guaranteed bargains. All brand new books: Woodcraft by Seton, Book of Letter Writing by Crowther, Etiquette by Eichler, Creative Chemistry by Slosson, Lawn Tennis by Tilden, also Revolt in the Desert by Lawrence, Trader Horn, White Shadows in South Seas by O'Brien, Count Luckner (The Sea Devil) and Outline of History by Wells. Delivered at your door C. O. D. Simply pay postman \$1 each and postage. Popular Mechanics Press, Room 801, 200 E. Ontario St., Chicago.

MACHINERY, TOOLS AND SUPPLIES

16"x6" SEBASTIAN Lathe, \$150.00; No. 1 Brown & Sharpe univ. milling machine, \$185.00; No. 60 Heald grinder, \$500.00; 24" Hundy shaper, \$250.00; 36"x18" Fifield lathe, \$750.00; 36" Cordesman band saw, \$95.00; 18" Pay pony planer, \$100.00; Crescent universal woodworker, six machines in one, \$300.00; Quincy air compressor, \$65.00; 10" new drill press, \$21.00. Write for catalog. Terms to suit. Cincinnati Machinery & Supply Co., 27 West Second St., Cincinnati, Ohio.

BRAND New motor bargains. 5/8 hp. a.c. \$7.00; 3/4 hp. universal motors, \$4.00. 32v. motors, 3/4 hp., \$8.50; 1/3 hp., \$12.50; 1/2 hp., \$19.00. Converters, 32v. d.c. to 110v. a.c., \$35.00. Write for prices on larger motors, also generators. Queen City Electric, 1736 Grand Ave., Chicago.

LATHE Castings, castings for making grinders, lathes and drill presses. All necessary castings. Stuart Kenelpp, Mt. Carmel, Ill.

VALUABLE Kinks for Machinists. 419 time-saving ideas on various phases of machine shop work. Intensely practical. 287 illustrations. Just write for "Machinists' Kinks" and pay postman \$1.50 plus postage when he delivers the book. Popular Mechanics Press, Room 808, 200 E. Ontario St., Chicago.

54 NEW Erie pipe vises, 6" capacity, regular price \$23.50 each, our price \$10.00 each, while they last. 50 new Reed No. 7A stocks and dies, will thread up to 3 1/2" pipe, regular price \$55.00 each, our price \$10.00 each, while they last. Botwink Brothers, Inc., 67 Water St., New Haven, Conn.

Tired Losing drills? Use our drill-case. Postal brings circulars. Box 516, Station C, Los Angeles, Calif.

START Business of your own, small investment required, doing nickel, copper and silver plating. This work in big demand. Information free. Electro Platers Supply Co., 28 W. Second St., Cincinnati, Ohio.

MACHINERY. Lathes, drill presses, millers, shapers, grinders and motors. Klauber Machinery Co., 320 South Third St., St. Louis, Mo.

SAVE Money—Automatic air compressors, constant potential battery chargers, reconditioned, guaranteed like new. Real value—shipped on trial easy terms. If can use, write: Box M-706, Troy, Ohio.

ELECTRIC Bench saw table only \$39.75 complete. Ask for specifications. Empire Foundry, Furnace St., Delavan, N. Y.

SHOP Notes for 1930. Get your copy now. Only a limited edition. Contains all the articles published in the Shop Notes department of Popular Mechanics Magazine during 1929. Send 50 cents. If you want the entire set of Shop Notes books consisting of 15 volumes including the 1930 number and 14 others issued previously we will send them C. O. D. at a special reduced price of \$4.50. Popular Mechanics Press, Room 802, 200 E. Ontario St., Chicago, Ill.

BLUEPRINTS

MAKE Your own blueprints! Necessary chemicals and instructions 25c coin. Practical and instructive. Spee-Dee Model Co., Box 80, Jamaica, N. Y.

BEST Radio Book—Latest revised edition—Radio Theory and Operating by M. T. Loomis of the Loomis Radio College is America's Standard Radio Text-Book. Used by the various government departments and leading radio schools. 900 pages, 700 illus., flexible kraft leather binding. Sent C. O. D. Pay postman \$3.50 and the postage when package is delivered. Popular Mechanics Press, Room 801, 200 E. Ontario St., Chicago.

INTERIOR Wall decoration in a valuable new book covering all the modern methods of artistic wall treatments. Practical working instructions for both plain and decorative finishes are given. 451 pages, illustrated. Delivered to your door C. O. D. Simply pay postman \$4 and postage. Popular Mechanics Press, Room 801, 200 E. Ontario St., Chicago.

ENGINES, MOTORS AND DYNAMOS

USED Arc welders, air compressors, buffers, grinders, reconditioned like new. Shipped on trial and easy terms. If you need good guaranteed equipment. Write today. Box M-707, Troy, Ohio.

TIME Counts in applying for patents. See pages 134 and 135. Clarence A. O'Brien, Registered Patent Attorney, Washington, D. C.

COMPRESSORS. Twin cylinder, for small tire shops. Duco spraying. J. Trockman & Sons, Inc., 310-312 Lincoln Ave., Evansville, Ind.

4HP. MOTORS Complete with chuck and grinder attachments, \$6.75. Guaranteed rebuilds. Number limited. Box 4, Council Bluffs, Iowa.

FOR Sale: One-sixth and one-fourth hp. electric motors, 60 cycle 110 volt a.c., slightly used. One-sixth hp., \$5.00; one-fourth hp., \$6.00. Cash with order. Charles Kratsch, Inc., 180 E. Illinois St., Chicago.

1/2 HORSE 110 Volt 1750 speed alternating motors \$7.00; lots of six \$6.50. One-third horse \$10.50; 1/4 horse 3450 speed \$16.50. Other bargains. Electrical Surplus Company, Dept. 12, 1911 Chicago Ave., Chicago.

ELECTRIC Motor winding models and instructions. Gaines Bros., Gainesville, Tex.

STEAM Engines—One h. p. \$18.00; 1/2, \$12.00. James Chambliss, Bessemer, Ala.

RADIO Service and repair men, dealers, salesmen, experimenters and designers—you will find Drake's Radio Encyclopedia covering 1,700 subjects arranged especially for your use. 920 pages, 1,000 illustrations. Most comprehensive radio reference book published. Delivered to your door C. O. D. Simply pay postman \$6 and postage. Popular Mechanics Press, Room 801, 200 E. Ontario St., Chicago.

WELDING AND SOLDERING

START In highly profitable arc welding business, practically no expense. Our constant arc welder starts you on road to success. Easy monthly terms. Liberal trial on money back guarantee. Write today. Box M-708, Troy, Ohio.

WELDING Encyclopedia. The latest, completely revised 1930 edition of this famous book contains every known fact regarding every kind of welding. Covers such up-to-date subjects as aircraft welding. 542 pages, illustrated. Flexibly bound. Sent C. O. D. Pay postman price, \$5 and small amount of postage upon delivery. Popular Mechanics Press, Room 806, 200 E. Ontario St., Chicago, Ill.

BENDING MACHINES

THE Famous Hossfeld "Wrenchless" Universal Iron Bender is the last word in bending machines. Bends metal, cold or hot, into most any conceivable shape, including Eye Bolts and Automobile Spring Eyes. Bends up to 1" bars or 1 1/2" pipe cold. Thousands in use by all classes of trade, from the smallest shops to the largest railway systems. Write for circular and prices. Hossfeld Mfg. Co., Winona, Minn.

SURVEYING INSTRUMENTS

BARGAINS—Rebuilt transits and levels. All takes and types. Absolute satisfaction guaranteed. Cash or easy payments. Don't delay. Write today for descriptive list M-47. Warren-Knight Co. (Makers of "Sterling" Transits and Levels", 136 N. 12th St., Philadelphia, Pa.

KINKS For machinists. 419 discoveries. For mechanic, machinist or the man who tinkers at home. 287 illustrations. Send no money. Just write a postal asking for "Machinist's Kinks." When postman hands you book pay postage and price of book, \$1.50. Popular Mechanics Press, Room 801, 200 E. Ontario St., Chicago, Ill.

FARMS AND FARM LANDS

LAND Opening—The Great Northern Railway serves an agricultural empire in Minnesota, North Dakota, Montana, Idaho, Washington and Oregon. These states abound in opportunities for small farmers or large operators to rent or purchase a farm at lowest prices and best terms of many years. Every kind of farming, grain, livestock, dairying, fruit, poultry; large acreage or small suburban tracts, rich cutover or high producing irrigated land. Write for free Zone of Plenty book with detailed information. Low homeseekers' rates. E. C. Leedy, Dept. 457, St. Paul, Minn.

TUNG Oil varnish tree groves. Suburban Orchards Co., Biloxi, Miss.

OZARKS—20 Acres, poultry land, \$100, \$5 monthly. Fishing, hunting trapping. Other bargains. Hubbard, 216 Grossman Bldg., Kansas City, Kans.

CHICKEN Farm in Florida. About three acres. Close to Tampa, \$4 down, \$4 a week. Send for description. Box 374, Tampa, Fla.

OWN A Farm in Minnesota, Dakota, Montana, Idaho, Washington or Oregon. Crop payment or easy terms. Free literature; mention state. H. W. Byerly, 119 Northern Pacific Railway, St. Paul, Minn.

FORTUNE Made in pecan groves. Care guaranteed. Monthly payments. Pecan Acres, Route 4, Houston, Tex.

EASTERN Pennsylvania farms near Philadelphia. Write for bulletin giving prices, sizes and descriptions. Wilson George, Quakertown, Pa.

MONEY Made in Mich. potatoes. \$10 down now and easy terms buys land near markets, lakes, streams. Write today. Swigart & Co., P-601, 32 N. State St. Bldg., Chicago, Ill.

REDUCE Labor on your farm and increase income. One farmer writes he would not part with the information for \$100 if it could not be duplicated. Send today for our valuable "Farmers' Handbook" and get ready to put some of the 861 practical ideas into operation for your own benefit. Pay postman only 98 cents plus postage when delivered. Popular Mechanics Press, Room 808, 200 E. Ontario St., Chicago.

SELL Your property quickly for cash, no matter where located. Don't pay big commission. Particulars free. Real Estate Salesmen Co., Desk B, Lincoln, Nebr.

\$4,223.00 PROFIT From a town lot in one year. H. Cecil Sheppard tells you his disastrous and profitable experiences in raising chickens from the start until in the sixth year he took the above net profit. He would have gladly paid \$100 for this information during the first years. Send for his book. Price only \$1. Pay postman when delivered, or, if outside U. S., remit when ordering. Popular Mechanics Press, Room 801, 200 E. Ontario St., Chicago.

DOGS AND PETS

AQUARIUMS. Fancy fishes for pleasure and pastime. Water plants, etc. Catalog free. German Aquarium, 3823 N. Richmond, Chicago.

ST. BERNARDS! Rare, beautiful thoroughbred puppies. Photos submitted, delivery guaranteed. Helvetia Kennels, 181-P McKenna Ave., Montreal, Que.

SPLENDID Broken quail, duck, pheasant dogs. Thoroughbred Kennels, Atlantic, Iowa.

WHITE Collies and other colors. Beautiful and useful. Dept. P, Shomont Kennels, Monticello, Iowa.

FOR Sale. Minks, squirrels, raccoons, foxes, ferrets, muskrats, ginseng, rabbits, skunks, wolf pups, opossums. B. Tippman, Caledonia, Minn.

DOG Lovers—Every fact regarding every phase of dog training (all breeds) including psychology, obedience, guarding, swimming, rescue work, hunting, herding flocks, teaching tricks, finding lost articles, racing, war service, police dogs, sled dogs, etc., will be found in "Training the Dog," by Will Judy. Price only \$1.50. Pay postman when delivered or, if outside U. S., remit when ordering. Popular Mechanics Press, Room 809, 200 E. Ontario St., Chicago.

RABBITS

\$2,500 YEARLY Spare time raising our rabbits. Market guaranteed. Start small, grow fast. We help you. American Rabbitries, Bethany, Mo.

BREED Rabbits for profit, immense demand. Large catalog 10c. Ransom Fur Farms, Geneva, Ohio.

HIGH Grade chinchillas at right prices. Owen Ostrout, Windom, Minn.

RAISE Fur rabbits. We buy all you raise. Send 10c for catalog, contract, etc. Goldenrod Fur Farms, Lincoln, Nebr. Dept. PM.

MAKE Big profits with Chinchilla rabbits. Real moneymakers. Write for facts. 852 Conrad's Ranch, Denver, Colo.

MUSKRATS

MAKE Money from muskrat fur—Raise muskrats in dry land pens or hutches. Get the facts. 652 Conrad's Ranch, Denver, Colo.

MUSKRAT Farming—The greatest book on one of the greatest opportunities today. Tells of the opportunity in this business and how to do everything in connection with the raising and marketing of muskrats. Pay postman only \$2.25 and postage when delivered or, outside U. S., remit when ordering. Popular Mechanics Press, Room 809, 200 E. Ontario St., Chicago.

WANTED—MISCELLANEOUS

MAIL Us your discarded jewelry, gold, crowns and bridges, watches, diamonds, silver, platinum. Money promptly mailed. Goods returned if offer refused. United States Smelting Works (The Old Reliable), Dept. 71, Chicago.

FURNITURE Finishing, decoration and patching. Valuable new book, the first in its field, contains practical instruction on doing this work and also treats on materials, tools and processes. 543 pages and 335 illustrations. Delivered to your door C. O. D. Pay postman \$5 and postage. Popular Mechanics Press, Room 801, 200 E. Ontario St., Chicago.

FOR SALE—MISCELLANEOUS

ADDRESSOGRAPHS, Letter folders, multigraphs, envelope sealers, duplicators, less than half price. Guaranteed. Pruitt Co., Suite 108, 190 N. LaSalle St., Chicago.

WATCHMAKERS Lathe for sale at a bargain. R. Jaegermann, 5815 Easton Ave., St. Louis, Mo.

FLYING Simplified—Just out. Here is a remarkable non-technical book for beginners, prospective or advanced students that teaches in an easily understood manner all you can need to know to master the art of flying. Will save you many dollars when you learn to fly. Pay postman only \$1 and postage when book is delivered at your door C. O. D. Popular Mechanics Press, Room 802, 200 E. Ontario St., Chicago.

WOOD Turning on the lathe. Both interesting and fascinating. Send for a copy of MILTON & Woblers Course in wood turning. It gives you quickly a complete mastery of this manual art. 340 pages. Cloth. 141 plates. Sent C. O. D. Pay postman price \$1.50 and small amount postage upon delivery. Popular Mechanics Press, Room 806, 200 E. Ontario St., Chicago, Ill.

PERSONAL

FOOT Powder, stops excessive sweating. Price \$1.00. James Early, 2705 Pierce St., Sioux City, Iowa.

BEST Yet to stop dandruff, itching, falling hair, sore scalp. Mailed \$1.00. John Paulius, Wabash, Ind.

TOBACCO Habit overcome or no pay. 500,000 used Superba to help stop cigarettes, cigars, chewing, pipe, snuff. Treatment sent on trial. Costs \$2.00 if successful. Superba Co., L84, Baltimore, Md.

HANDWRITING Reveals character—Send own or friend's writing with two dimes for helpful analysis of surprising facts. Francis Black, 686 W. Maryland Ave., St. Paul, Minn.

WHAT'S Your future? Develop winning personality, be popular. A pleasing personality promotes friendship and business success. Particulars free. Business Service, Box 262, West Palm Beach, Fla.

ITCHING Dandruff is loaded with microscopic parasites that live and thrive on your scalp. Makes baldness sure as death. Learn world's best remedy. Stimulates hair growth. Costs only few cents. Information only. Mailed for \$1. H. Foster (Barber), 1443 W. 82nd St., Chicago, Ill.

BATTERY Shop—How to run. Most complete and authoritative information ever compiled on tools needed, shop equipment, charging methods, opening batteries, work on plates, jars, case, etc. Covers auto, radio and farm lighting batteries. Send for big 550-page book and pay postman \$5.00 plus postage when he delivers same. If outside U. S. remit when ordering. Popular Mechanics Press, Room 801, 200 E. Ontario St., Chicago.

REGAIN Health, strength with new mineral food. Natural builder containing no drugs. Month's supply, \$3.00. Agents wanted. Mineral Laboratories, Insurance Bldg., Sioux City, Iowa.

BUILT-IN Furniture adds convenience, comfort and beauty to your home at very low cost. Any handy man can build a great variety of this space-saving furniture from the easily-followed instructions in our remarkable book, the only one on this subject. Delivered to your door C. O. D. Simply pay postman \$2.50 and postage. Popular Mechanics Press, Room 801, 200 E. Ontario St., Chicago.

861 PRACTICAL Ways to Reduce Farm Labor and Expense and Increase Income. One farmer writes he would not part with this information for \$100, if he could not duplicate it. Nothing experimental. These ideas have all been put to test and proven practical. Send today for a copy of our Handbook for Farmers and get ready to put these ideas into operation for your own benefit. Pay postman only 98 cents and the postage when he hands you the package. Popular Mechanics Press, Room 801, 200 E. Ontario St., Chicago.

REFRIGERATING Machine, homemade. Inexpensive to build. Gives better service than ice. This and 328 other practical articles in our book "Home Mechanics." Just ask for this and "Handbook for Women," containing 394 valuable household helps and pay postman 98 cents and postage for the two books. Popular Mechanics Press, Room 801, 200 E. Ontario St., Chicago, Ill.

FREE! Herbalist almanac. Over 500 herb medicine recipes for home use. Write for details. Botanic, 145 West 112th St., Chicago.

ADVICE. Information 25c coin up. Experience. Ref. Fred Klotz, Reading, Pa.

AVIATION—Every person seriously interested in this subject should make full use of the opportunity to learn aerodynamics with Alexander Klemin as his instructor, through his timely new book, "Simplified Aerodynamics." Heretofore this subject has been rather difficult for the thousands who need it but Klemin's method enables all to master it. Every pilot, mechanic, student needs this book. Pay postman price, \$3.50, and few cents postage when he delivers it. Order from Popular Mechanics Press, Room 807, 200 E. Ontario St., Chicago.

MISCELLANEOUS

MIRRORS Resilvered at home. Costs near 5 cents per square foot; you charge 75 cents. Profitable business plating autoparts, reflectors, tableware, stoves, refinishing metalware, etc. Outfits furnished. Details free. Write Sprinkle, Plater, 288, Marion, Ind.

CASH Paid for butterflies, insects. See Sinclair Display Advertisement on page 32.

TIME Counts in applying for patents. See pages 134 and 135. Clarence A. O'Brien, Registered Patent Attorney, Washington, D. C.

AMATEUR Cartoonists earn \$25.00 week, spare time, copying or tracing cartoons for advertisers. Hendrickson's Syndicate, Argyle Wis.

HOMEOPATHIC And biochemic preparations sent postpaid to all parts of the world. Booklets free. Halsey Bros. Co., 5547 Ravenswood Ave., Chicago. Established 1855.

TELL An army of 3,000,000 live readers all about your offer! If you have anything to sell, buy or exchange, or if you have any reasonable proposition, tell our readers all about it—they'll respond quickly. Our booklet "How to Create More Business" contains some very interesting, helpful facts. Write today for your copy—it's free. M. L. Rund, Manager Classified Advertising, Popular Mechanics Magazine, 200 E. Ontario St., Chicago, Ill.

CASH In your art ability, cartoon tips contains cut processes, money hunches. 350 colored cartoons. Complete \$1.00. Lyonart, Peoria, Ill.

WATCH Repairing and making shows how to clean and repair all kinds of watches. 214 page book with over 200 illustrations. Pay postman \$3 and postage when he delivers book. Popular Mechanics Press, Room 801, 200 E. Ontario St., Chicago, Ill.

MEXICAN Made holsters, lariats, horsehair articles; rattlesnake belts. Send four cents for illustrated list. Tex-Mex Leather Co., 309 Esperson Bldg., Houston, Tex.

AVIATION Books—Send for our 21-page illustrated catalog, the most complete published, describing the latest and best books of all publishers on every phase of flying. Sent free upon request. Popular Mechanics Press, Room 807, 200 E. Ontario St., Chicago.

AMATEUR Cartoonists: Sell your work. Write Smith's Service, PW1194, Wenatchee, Wash.

A BILLION Ideas. This is the title of our remarkable catalog of books along practical lines. Arranged alphabetically by subjects for easy reference. If you have not received it, send for a copy. You will find hundreds of subjects you cannot usually locate in book stores or public libraries. Sent free upon request. Popular Mechanics Press, Room 807, 200 E. Ontario St., Chicago.

New Kind of Can Opener

"Works Like Magic"

Brings Agents Up To \$8 and \$10 In An Hour!

IMAGINE having a little automatic machine to open cans! Why, to women everywhere, the very idea is revolutionary as well as amazing! No more fuss, muss or bother. And danger absolutely banished! No wonder agents who demonstrate this astonishing invention have made almost incredible sums. E. T. Barclay, N. Y., cleaned up \$117 in a day and a half. Mrs. M. Bridges, Me., made over \$300 in a couple of months spare time. O. C. Gregg, Wyo., made part time profits of \$20 in 3 hours. And why not?

The "Million-Dollar" Can Opener

The wonder-working little machine holds the can for you so you don't need to touch it. Then spins the can quickly around. Next the lid pops up so you can take hold of it. Entire top is cut out slick, smooth and clean. Opens round, square, and oval cans. Approved by Good Housekeeping Inst. Guaranteed for five full years. If your present income is less than \$60 a week write quick for details of Territory Reservation, Sales Outfit, and FREE Test Offer.

CENTRAL STATES MANUFACTURING CO.
Dept. H-703, 4500 Mary Ave., ST. LOUIS, MISSOURI



NO MORE DANGER

Every woman knows how dangerous the old-style can opener is. Almost daily the newspapers tell of blood-poison, amputations, even death, that sometimes follow the very tiniest "can opener scratches." Now all danger is banished forever. No wonder so many buy on sight!

Central States Mfg. Co., Dept. H-703,
4500 Mary Ave., St. Louis, Mo.

Rush your FREE TEST OFFER.

Name.....

Address.....

Town.....State.....

Check here if interested only in one for your home.

Come to sunny CALIFORNIA

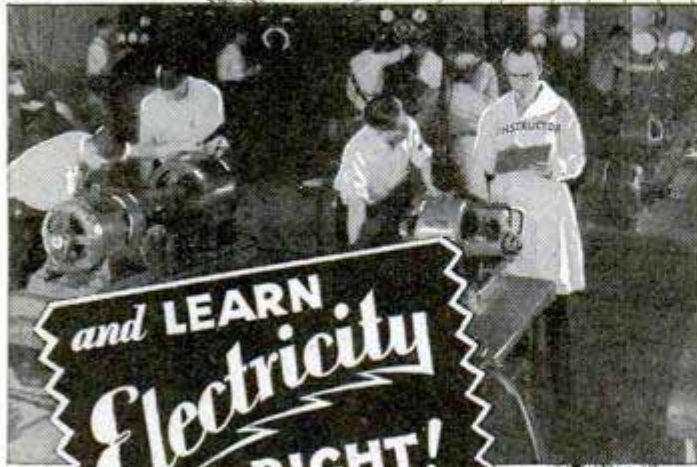

and LEARN
Electricity
RIGHT!

...at NATIONAL
In the Heart of LOS ANGELES ...

The most fascinating city in the world and the world's fastest growing city... LOS ANGELES, the center of America's most rapid electrical development is the ideal city in which to live and prepare for success in ELECTRICITY!

Become a GRADUATE ELECTRICIAN!

National is an approved trade school where in six to nine months you become fully qualified as a practical, competent electrician...prepared to take your place in the important industry where employment awaits graduates of this institution.

Study in this Approved "SCHOOL OF SHOPS"

A staff of competent instructors train you thoroughly in all branches of electricity. You secure practical experience by actually working upon thousands of dollars worth of modern electrical machinery and equipment. the most completely equipped trade school in America.

A Steady, Profitable PROFESSION...

The great electrical field offers ever increasing opportunities for trained men. Millions of dollars are being spent each year for electrical developments...thousands of properly schooled electricians are required to keep pace with the growth of this gigantic industry.

A 25 Year Old School...22,000 GRADUATES!

National is a million dollar institution, right in the heart of beautiful Los Angeles. No age limit...no previous experience necessary...start any time of the year. Guaranteed unlimited employment service to graduates and to students wishing to earn expenses while learning.



Send for
this
FREE BOOK..

NATIONAL ELECTRICAL SCHOOL
Dept. 545, 4006 Figueroa St.,
Los Angeles, California

Send me your big free illustrated catalog of Electrical Opportunities showing how I can learn quickly

Name _____
Address _____
Age _____ City _____ State _____



NATIONAL ELECTRICAL SCHOOL

34 Lesson Drawing Course \$2.98

The biggest value you ever saw advertised anywhere

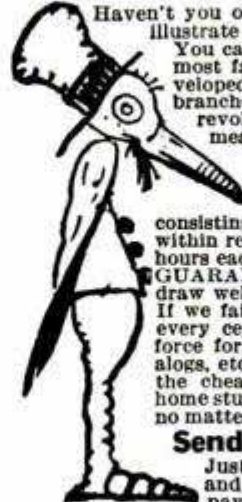

Haven't you often wished that you could draw cartoons, illustrate some idea, sketch some pretty face, etc.? You can do all of these things. One of America's most famous Cartoonists and Illustrators has developed a great, simple system for success in all branches of Commercial Art. This system has revolutionized the entire theory of drawing. It means that drawing can be as easy for you as writing—much simpler than learning shorthand, bookkeeping or typewriting. We are now placing this original system for learning Drawing, Art and Cartooning, consisting of 34 lessons with over 500 illustrations, within reach of every one. If you will devote a few hours each week to the Course WE ABSOLUTELY GUARANTEE that you will learn to draw and draw well before you have half finished the Course. If we fail to make this claim good, we will refund every cent paid us. By eliminating a large office force for answering correspondence, expensive catalogs, etc., we are enabled to make a price of \$2.98, the cheapest price ever known for a high-grade home study course. Learn to draw. It is a big asset, no matter what field you are in.

Send No Money

Just order the course and on arrival \$2.98 pay postman

plus a few cents postage, payment in full for the entire Course and Drawing Outfit. If not entirely satisfied, return within five days and we will Refund Money. Address: **LEDERER SCHOOL of DRAWING**, Dept. 812-Z, Chattanooga, Tenn. Orders from outside the U. S. A. are payable \$3.28 cash with order.

If you order the course at once, we will include a drawing outfit, consisting of artist's pencils, pens, paper, erasers, thumb tacks, etc., enabling you to go to work without any additional cost.

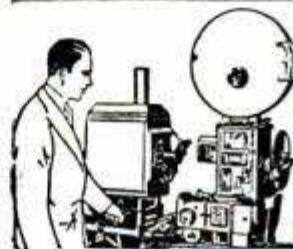

LEARN MOTION PICTURE OPERATING

Complete Home Study Course
With the privilege of attending our school, for free practical training on Western Electric Sound Equipment.

WRITE FOR FREE BOOKLET
CALIF. OPERATORS SCHOOL
103 N. Rowan Ave., Los Angeles, Cal.

DEPENDABLE ECONOMICAL HEAT at LOWER COST

The Proved! **LACO**

Makes Every Heating Live Again Instantly

Own your own business and be the leading Oil Burner man. Sell the LACO, very reliable, low in price. You can't beat it as a money-maker for the live dealer. Only a small amount of capital required. Write to **LACO OIL BURNER CO.** 133 U St., Griswold, Ia., U.S.A.

Learn Watchwork, Jewelrywork and Engraving

A fine trade commanding a good salary, and your services always in demand. Address **Horological**, Dept. P, Bradley Institute, PEORIA, ILLINOIS, for our latest catalog.

TEAR GAS GUN! FOUNTAIN PEN

100% Protection—No Injury

Amazing Invention. Has Size, Shape and Appearance of a Fountain Pen—BUT—it shoots TEAR GAS. A safe, effective substitute for dangerous firearms. Just point it—release safety trigger and—project a cloud of Blinding TEAR GAS. Instantly Stops, Stuns and Incapacitates the most vicious Man or Beast. No permanent injury. Criminals, Morons, Thugs Fear Tear Gas more than bullets. Needed in Stores, Banks, Theatres, Homes everywhere to protect life and property. No skill required. Ideal protector for Motorists and Women. Shoots far enough so as not to effect user. Uses same Tear Gas Shells as Official Police Equipment. Precision built. Not a Toy. **AGENTS: Here is the ONE BIG SELLING sensation of the year. Quick Sales—Big Profits.** Everyone who sees it wants one. Earn up to \$25.00 daily. Makes an amazing demonstration that rolls in the money. Write Today for details or send only \$3.95 for Sample Pen-Gun, Extra Ammunition and Demonstration Outfit (Retail value \$6.50). Not Sent. C. O. D. **LACHRYTE CO., P. O. Box 1719-C20, CHICAGO, ILL., U.S.A.**

We've got money ahead now



A year ago

we had almost given up hope of getting anywhere.

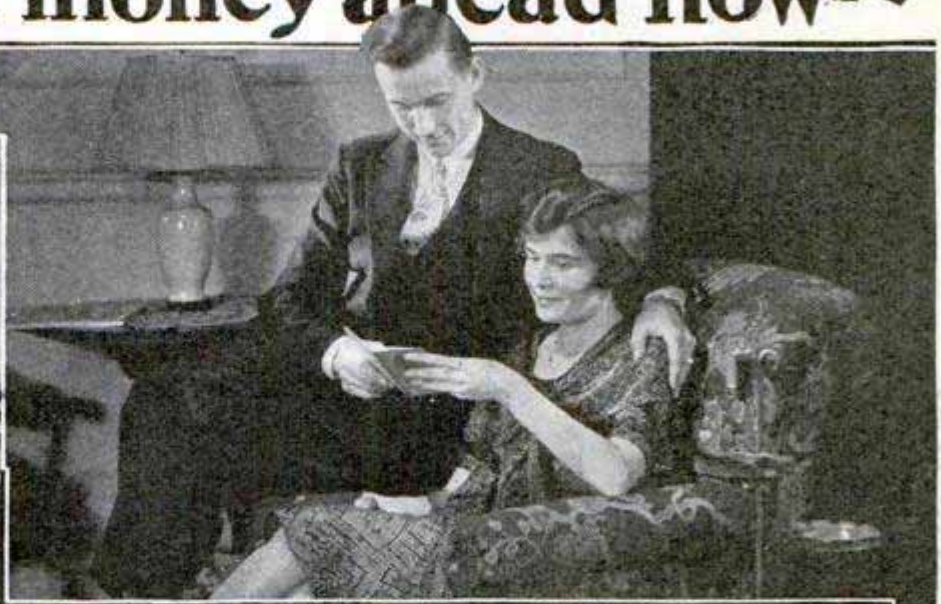

Here's our secret

A year ago all Mary and I had to show for a month's hard work were a lot of bills marked paid and quite a number left over unpaid. Did I worry? All kinds of thoughts haunted me.

What would happen if I should get sick? Suppose I lost my job—there wasn't any money in the bank to tide me over until I found another. And this had been going on for years. Perhaps you think I didn't try hard enough. Believe me, I did. I had a number of different jobs with different companies. It was always the same story. If I stuck around fifteen, twenty years or longer, I might be making \$3,000 or maybe \$4,000 a year by the time I was fifty—but I wasn't even sure of that.

I Asked Myself

"How does a man go about making good money anyway? Where are the jobs? How do you get them?" Mary and I talked the question over time and again. "What was the secret? Why was it that so many good men worked all their lives and had very little to show for it while others with no more than average ability made a lot of money quickly?"

An ad which I saw in a magazine caught my attention because it seemed to answer the questions which were in my mind. It read something like this: "Radio's amazing growth is opening hundreds of \$50, \$60, \$75 and \$100 a week jobs every year. Many who get into Radio now will be the \$7,500, \$10,000 and \$15,000 a year men of the future."

I Was Skeptical

My hopes of finding something good had been blasted so many times in the past that I doubted this statement. I said to Mary, "If this is true why isn't everybody trying to get into the Radio field?" The only answer she could give

me was that perhaps most other people were skeptical also—and didn't take the trouble to find out if that statement was true.

We talked it over and decided to send in the coupon for complete information. The only risk we took was the investment of a two cent stamp. They gave me the privilege of deciding one way or another after I read their literature.

I Found Out the Truth

The FREE book they sent me proved beyond a doubt that I had been on the wrong track. I had overlooked one great fundamental fact—that success comes easier and quicker in industries that are growing fast—that big growth brings with it many big opportunities. I read letters in that book from fellows five to ten years younger than myself who were making three times as much money as I ever made after training only six months to one year for their jobs. I wrote to some of those fellows—I wanted to find out the truth. Their answers were even more enthusiastic than the letters printed in the book.

Now I Average \$100 a Week

Within two months after starting my training I was making good money on the side repairing Radio sets for my friends, neighbors and others. I made enough money the first month to clear up my old debts. By the time I was half way through I had \$400 in the bank. In less than a year I had started a little business of my own from my spare time earnings and was clearing an average of \$100 a week.

Today Mary and I have made the down payment on a little home in the suburbs, have new furniture, much better clothes, see a good show when we feel like it, and have our new car almost paid for. Are we happy? I'll say we are. I have that feeling of independence which comes from knowing that you are in the right business; that your future success is assured; and that money worries are gone forever.

Besides, I Know This

If I should ever want to get out of the Radio business, I can step into a Broadcasting Station where jobs pay \$1,800 to \$5,000 a year, or into a Commercial Land Station where there is a big shortage for trained men right now; a Radio factory should be able to use me at a salary of \$2,000 to \$5,000 a year. If I want to I can go on board Ship and travel all over the world—because I have been trained for those jobs also. In addition I know the fundamentals of Talking Movies, Television and Air-craft Radio.

Write to Mr. Smith

Take my tip. Perhaps you're in a rut, discouraged. Perhaps your job is hard—unsteady—or has no future. Write to Mr. Smith. He stood by me like a brother—gave me the training, personal advice and encouragement I needed. He'll help you too. I wish I had written him ten years ago. Tear off the coupon below and find out for yourself that what I say is true—you'll never spend two cents to better advantage as long as you live. Send it to Mr. J. E. Smith, Pres., National Radio Institute, Dept. OGP, Washington, D. C.

J. E. SMITH, Pres.

NATIONAL RADIO INSTITUTE, Dept. OGP
Washington, D. C.

Dear Mr. Smith: Send me "Rich Rewards in Radio." Without obligating me in any way, prove that your training is raising men's pay and that there are real opportunities to make better than average salaries in the Radio industry.

Name.....

Address.....

City.....State.....

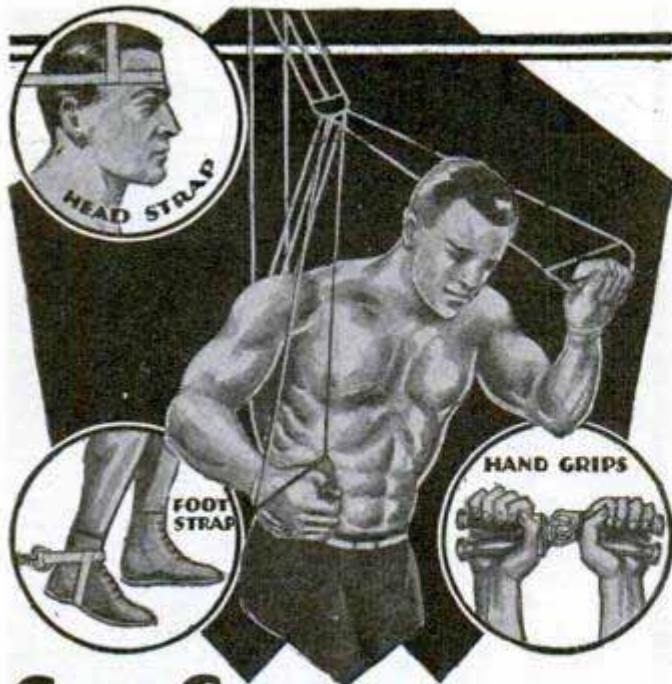

GET STRONG with these 6 improved Muscle Builders..All for \$5.00

Realize your ambition and develop muscles of a super-man. **Get strong!** Easily master feats which now seem difficult—or if you want physical culture for your health's sake, this equipment is what you need. With this special offer you **SAVE AT LEAST HALF**. We furnish 10-cable chest expander adjustable to 200 lbs. resistance. Made of new live extra strength, springy rubber so as to give resistance you need for real muscle development. You also get a pair of patented hand grips for developing powerful grip and forearms. We include wall exercising parts which permit you to develop your back, arms and legs—a real muscle necessity. The head strap permits you to exercise muscles of your neck. Developing muscles with foot strap furnished. This gives speed, endurance. In addition you get specially written course containing pictures and diagrams showing how to develop any part of your body. **ACT NOW!**

MUSCLE CLOCK FREE

New startling invention permits you to watch yourself getting strong. It accurately measures for you your weight lifting and pulling strength as you progress. Included free if you order at once.



Send No Money

Sign name and address to coupon and rush to us. We send everything by return mail. Pay postman \$5.00 plus postage. (If you desire, send money order now and we pay postage.)



GUARANTEE MONEY BACK IF NOT SATISFIED

CRUSADER APPARATUS CO., Dept. 107, Maplewood, N. J.

I accept your offer. Send me everything described in your advertisement by return mail. I will pay postman \$5.00 plus postage on arrival. It is understood if I am not entirely satisfied after examination I can return the goods and you will refund my money.

No C. O. D. Orders to Foreign Countries Except Canada.

Name.....

Street.....

City..... State.....

Car Washing now a PLEASURE!

GYRO WHIRLO BRUSH washes CARS CLEAN!

WITHOUT Chamois, Soap or Spray! "WATER PRESSURE MAKES IT WORK"

Any Garden Hose Will Do



Useful Around the Home

Gyro saves many a painting job. Also cleans screens, windows, etc.



Nothing like Gyro anywhere. No fuss—no bother. Self cleaning. Guaranteed for 100 washings.

The days are gone when an autoist must "take a swim" to wash his car! No longer is car washing a process of "deep sea diving" with a splashy hose, soap and a slippery chamois. Since the invention of the Gyro Whirlo Brush car washing has become a few moments of the easiest work imaginable. Chamois, soap and spray have been discarded as obsolete and unnecessary.

AUTO OWNERS WILD ABOUT THE GYRO!

Car owners everywhere recognized GYRO as the first real device to simplify auto cleaning. It cleans cars **CLEAN in a HIG**. It works on the simple law of water pressure. Water from ordinary garden hose pours through center—making brushes whirl. These whirling brushes cut right through dirt and mud. They do all the work. You simply brush down the car. Every autoist will buy one.

100% PROFIT FOR AGENTS!

Live agents are needed everywhere to demonstrate this amazing invention, needed by auto owners, garage service stations everywhere. 100% profit for spare or full time workers.

WRITE AT ONCE!

Send name and address for all particulars. Don't delay or you may lose territory. Even showing to friends will net you handsome profits. **WRITE NOW!**

GYRO BRUSH COMPANY Dept. G-14 Ampero, N. J.

FREE Radio Handbook

Write today for your copy of the new Radio Association handbook. Shows you easy ways to make money in Radio. Tells you how our members are cleaning up \$3.00 an hour spare time. Write for Membership Plan which need not cost you a cent and **FREE RADIO HANDBOOK.**

RADIO TRAINING ASSOCIATION OF AMERICA Dept. PM-7 4513 Ravenswood Ave., Chicago

NERVES?

Are You Always Excited? Fatigued? Worried? Gloomy? Pessimistic? Constipation, indigestion, cold sweats, dizzy spells and bashfulness are caused by **NERVE EXHAUSTION.** Drugs, tonics and medicines cannot help weak, sick nerves! Learn how to regain vigor, calmness and self confidence. Send 25c for this amazing book. **RICHARD BLACKSTONE, N-477 FLATIRON BUILDING, N. Y.**

NOW! Oil Heat at Amazing Low Cost



Turns Oil Into Gas

WORLD'S LOWEST PRICED. Cheapest to Operate Oil Burner. Amazing new invention turns oil into gas through patented Crystal Mineral Wick. **REVOLUTIONIZES FUEL COSTS.** Burns oil and air. Won't overflow or flood. Easily, quickly installed in any stove or furnace. Simple adjustments. Anybody can do it. Automatic Control—Room Thermostat. Guaranteed. Quiet. Amazing offer if you act now! Get sensational low price and complete details!

GRISWOLD OIL BURNER CO. 3009 N. Union St., Griswold, Ia., U.S.A.

DEALERS

Quick Sales — **BIG DISCOUNTS** — some reports as much as \$10,000 to \$50,000 annually.

Write today!

R. T. I. R. T. I. QUALIFIES YOU TO MAKE MONEY AND ITS SERVICE KEEPS YOU UP-TO-THE-MINUTE ON THE **R. T. I.**
 NEWEST DEVELOPMENTS IN RADIO, TELEVISION AND TALKING PICTURES



RADIO

CALLS FOR MORE TRAINED MEN

Big Money quick—the chance to more than double your salary—is offered to you now. RADIO has leaped from the experimental stage to a gigantic industry, employing many, many thousands and loudly calling for MORE TRAINED MEN to fill the Big-Pay jobs. TALKING PICTURES have taken the larger cities by storm and will sweep the entire country, opening up many new good jobs everywhere. TELEVISION now comes with even greater promise of a large number of good paying jobs and big profits for those who are prepared.

BIG MONEY NOW! MORE TO COME

Here is an entirely new field of profitable employment—Big-Money Jobs—\$2500—\$3500—\$5000 and up, right now—lots of money easily made in spare time—increasing pay for you and more and more money as this new industry grows bigger and bigger.

EASY WAY TO BIG PAY

The "R.T.I." famous "3 in 1" Home Training in Radio, Television and Talking Pictures makes it easy for men, young men and boys to get into this new field quickly. R. T. I. home training is practical and easy to understand. It trains your head and hands at the same time. Your opportunities for money-making are unlimited. Your age, amount of education, or experience make no difference. If you are interested and ambitious you can succeed. Are you willing to use a little spare time at home? That is all you need to quickly start making money with R.T.I. material and home training. You will be ready for a good job or profitable business of your own, even before you finish the training. Remember—you learn at home in your spare time on actual equipment included in fine, big outfits sent you. R.T.I. with all its connections in the industry, keeps you up-to-date and pushing forward all the time.

R. T. I. Wonderful Free Book Nothing Like It Ever Published

No one can fully realize the amazing size and future growth of the Radio, Television, and the Talking Picture industries unless they know all the facts revealed in this R.T.I. book. It will open your eyes to the vast number of new money-making jobs—enormous spare-time profits—all within easy reach of ambitious men.

Big R.T.I. Book Free—While They Last

LET F. H. SCHNELL AND THE R. T. I. ADVISORY BOARD HELP YOU.

20 years' Radio Experience. First to establish 2-way amateur communication with Europe. Former traffic Mgr. of Am. Radio Relay League. Lieut. Com. U. S. N. R. Inventor and Designer. Cons. Radio Engineer.

Assisting him is the R. T. I. Advisory Board, composed of men prominent in the Radio Industry—manufacturing, broadcasting, engineering and servicing. All these men know Radio and will help you succeed in their field.

RADIO & TELEVISION INSTITUTE
 Dept. 1-B, 4806 St. Anthony Ct., Chicago

RADIO & TELEVISION INSTITUTE
 Dept. 1-B, 4806 St. Anthony Court, Chicago

Send me Free and prepaid your BIG BOOK "Tune In On Big Pay" and full details of your three-in-one Home Training (without obligating me in any way.)

Name

Address

City State.....

\$500 in 2 Months
 Hasn't Finished the Course
 Your radio course enabled me to earn over \$500 in two months' spare time work.—J. Noffsinger, R. T. I. Box 37, Greenville, Ky.

\$80 a Week—Through R. T. I. Training
 I am earning \$60 per week and another \$20 a week in spare time Radio Work. Your Course was the best investment I ever made.—W. W. Mead, 915 W. 28th St., Indianapolis, Ind.

STEP UP QUICK TO A BIG-MONEY JOB THROUGH R.T.I. training in Broadcasting, Sales, Service, Manufacturing, Repairing, Ship and Station Operating, Installing, In business for yourself.

R. T. I. R. T. I. TRAINS YOU AT HOME FOR A GOOD JOB OR A PROFITABLE PART TIME OR FULL TIME BUSINESS OF YOUR OWN

MEN

EARN \$100

While LEARNING BARBERING



SHORT—PRACTICAL COURSE

*Protecting Laws Make It the Best Profession
in the Universe*

RALPH KUHLMAN has a Barber job on the Santa Fe running from Chicago to Los Angeles paying as high as \$60 a single trip. ARTHUR BAKER runs a shop in the exclusive great money district of Wall Street. He has accumulated a fortune. BOTH of these boys are MOLER GRADUATES. (Names of other graduates furnished on request.)

GOODNESS !!! GRACIOUS !!!

Why not learn a profession by enrolling in a school whose method of teaching and course of instruction is approved by all State Boards? There is a school near you. Write to the nearest one and see.

Standardized Branches Moler System of Colleges

139 E. 23rd St., New York City
512 N. State St., Chicago, Ill.
810 N. 6th St., St. Louis, Mo.
801 Main St., Kansas City, Mo.
206 E. 4th St., Cincinnati, Ohio
215 Huron Road, Cleveland,
Ohio
559 Michigan Ave., Detroit,
Mich.
1229-17th St., Denver, Colo.

109 S. 15th St., Omaha, Nebr.
501 E. Water St., Milwaukee,
Wis.
81 Forsyth St., N. W., Atlanta,
Ga.
81 S. Second St., Memphis,
Tenn.
1713 Commerce St., Dallas,
Texas

Address Nearest Branch

Please send me without obligation on my part your Booklet B telling how I may earn \$100 and my meals while learning barbering.

Name.....
Address.....
City.....State.....

OUTDOOR BOOKS

A select list of books on popular outdoor subjects by authors who are experts in their chosen field. Study this list. Undoubtedly several of your favorite pastimes are covered. Order under our no risk plan of refunding your money if not satisfied.

ARCHERY Bows and Arrows for Boys.....\$.75 Modern Archery.....\$3.00	OUTBOARD MOTOR BOATS How to Build.....\$3.00
BASEBALL How to Play It.....\$1.00	OUTDOOR OCCUPATIONS For Learning a Living...\$2.00
BIRD HOUSES How to Build.....\$1.00	OUTDOOR PHOTOGRAPHY How to Hunt with the Camera.....\$5.00
BIRDS Bird Neighbors.....\$1.00 Birds of the Wild.....\$1.75	OUTDOOR SPORTS The Year 'Round.....\$1.50
BUTTERFLIES Guide to.....\$1.25	POLO American by N. Bent...\$6.00
CAMPING and Woodcraft.....\$2.50	ROCK GARDENS How to Build.....\$1.00
CANES Selection, Care and Use. \$1.00	ROOF GARDENING For the City Dweller...\$1.25
DOGS Training.....\$1.50 Encyclopedia (general) \$2.00 The Coonhound.....\$1.00	RUSTIC WORK Rustic Carpentry.....\$1.00
FISHING Angler's Handbook....\$1.00 Fly Fishing.....\$1.00 Bait Casting.....\$1.00	SAIL BOATS Practical Boat Sailing..\$1.00
FLOWERS Home Flower Growing.\$3.50	SHOOTING Pistol and Revolver Shooting.....\$1.00 Rifles and Rifle Shoot- ing.....\$1.00
FLYING Flying Simplified.....\$1.00	SHRUBS Book of.....\$3.00
GOLF Modern Golf by Hilton.\$1.00	SPEED TOYS For Boys—How to Make.....\$1.25
HUNTING Wing and Trapshooting.\$1.00 Cooning with Cooners.\$1.00 Training the Rabbit Hound.....\$1.00	SWIMMING and Watermanship...\$1.00
INSECT STUDY The Insect Book.....\$5.00	TAXIDERMY Methods in Art of.....\$3.50
KITES THAT FLY How to Make.....\$1.25	TENNIS How to Play.....\$1.00
LANDSCAPING Practical.....\$2.50	TOURING Auto Tourists' Hand- book.....\$.50
LAWNS Starting and Keeping..\$1.00	TRAPPING Traps and Tralls...\$1.00 River Trapper.....\$1.00 Wilderness Trapper...\$1.00
MODEL AIRCRAFT Building and Flying...\$2.25	TREES Getting Acquainted with.....\$1.75
MOTOR BOATS Plans for Building.....\$3.00	WATER GARDENS and Goldfish.....\$1.50
MOTOR CAMPCRAFT For Your Camping Tour\$1.75	WILD FLOWERS Field Book of American.\$3.50
NATURE STUDY Wild Flowers and In- sects.....\$1.00	WOODCRAFT Book of, by Seton.....\$1.00

Books sent C. O. D. anywhere in U. S.

Simply check the books you want, write your name and address below, and mail the advertisement. It is your order blank. When postman hands you books, pay him the price and the few cents postage. If outside the U. S. remit when ordering and include 10 cents per book extra for postage.

Name.....

City.....State.....

Address.....

Mail to **POPULAR MECHANICS PRESS**
Room P7—200 East Ontario St., CHICAGO, ILL.

Sell CROSLEY
ICYBALL Refrigerator Earn
Makes ICE from HEAT up to..
No GAS No ELECTRICITY **\$100.00**
weekly



ICYBALL is an amazing new type mechanical refrigerator that needs neither electricity nor gas and costs only 2c a day to run. Be the distributor for modern refrigerator that makes its own cold. Over 30,000 in use and giving wonderful satisfaction.

For Small Towns and Farms
 Brings all the pleasure of mechanical refrigeration to homes where electricity is not available. Saves food from spoiling. Saves lives! No moving parts. Nothing complicated. Nothing to get out of order. Guaranteed. Rush name and address for information on how you can be the distributor in your locality—get your own ICYBALL Refrigerator without cost—and make up to \$100 weekly and over. Anyone can qualify. No experience required. Write today.

CROSLEY **ICYBALL DIVISION**
 827 Arlington St., Cincinnati, Ohio

Costs only 2¢ a day

LEARN MECHANICAL DENTISTRY SEND FOR FREE BOOK



Earn Big Money—Steady Work
 You can EARN WHILE LEARNING this modern moneymaking business and become independent. Big demand. You learn by doing actual work in rubber and gold. Easy terms. Individual instruction. Day and night school. Railroad fare allowed—no extra cost. Write NOW for catalog P.

NEW YORK SCHOOL OF MECHANICAL DENTISTRY
 125 W. 31st St. NEW YORK

Your Success

If You Laughed at "The Specialist"



there is no telling what you will do when you read **Chic Sale's** newest masterpiece of humor, **"I'll Tell You Why"**

Yes sir, folks, **Lem has Putt** her over again and proves to everyone's satisfaction that his great success as Builder and Contractor was well deserved.

"I wouldn't, Elmer," I sez, "and I'll tell you why."

If you missed "The Specialist," it is not too late to get the book that gave the whole world its heartiest laugh. **Chic Sale's "THE SPECIALIST," Price \$1.00 Postpaid**
Chic Sale's "I'LL TELL YOU WHY," . . . Price \$1.00 Postpaid

Send your order with remittance to
POPULAR MECHANICS PRESS
 Room P7 200 E. Ontario St. Chicago, Ill.



He Found the Key to \$10,000 a Year!

"Just a bookkeeper"—that's how J. A. Hogg, now Public Accountant at Logan, W. Va., would have classified himself six years ago when he first enrolled with LaSalle for home-study training in Higher Accountancy.

Little he dreamed that within two years—thanks to his specialized training—his yearly income would be \$5,000, and that two years later he would be making better than \$10,000 a year! But read what he writes, under recent date—

"It isn't often that an investment brings money profit of more than 7500 per cent in only six years, yet that's exactly what my enrollment in two LaSalle courses—Higher Accountancy and Law—has meant to me. I estimate it worth more than \$30,000 in cash returns, besides additional returns in personal and business prestige, in self-confidence and all-round larger success.

"Whereas when I first became a LaSalle member I was earning about \$100 a month, today I have my own successful public accounting firm, and have been mayor and police judge of my home town for the past five years, and LaSalle has made all this possible.

"I have enjoyed very much my LaSalle work. Your Problem Method has been a revelation—so much easier and more efficient than the classroom methods of my school days."

His Opportunity Is Yours—Send for Free Book

Are you ambitious to make a real success in business—to fit yourself for positions paying \$3,000, \$5,000, \$10,000 a year, and even better?

Here, then, is your chance—the same chance that faced J. A. Hogg when he clipped a LaSalle coupon.

Below is the coupon, and it will bring you—free—LaSalle's 64-page book, "Accountancy, the Profession that Pays." You will find it of the greatest help and inspiration.

If you mean what you say when you say that you want to get ahead—fill in, clip and mail the coupon NOW.

— Find Yourself Through LaSalle! —

LaSalle Extension University

The World's Largest Business Training Institution

Dept. 764-HR Chicago
 I should be glad to have details of your salary-increasing plan as applied to my advancement in the business field checked below. Also a copy of "Ten Years' Promotion in One," all without obligation.

- Higher Accountancy
- Business Management
- Modern Salesmanship
- Traffic Management
- Railway Station Mgmt
- Railway Accounting
- Law—Degree of LL.B.
- Commercial Law
- Industrial Management
- Banking and Finance
- Personnel Management
- Modern Business Correspondence
- Modern Foremanship
- Expert Bookkeeping
- C. P. A. Coaching
- Business English
- Commercial Spanish
- Effective Speaking
- Stenotypy—Stenography
- Telegraphy
- Credit and Collection Correspondence

Name

Present Position

Address



BRAND NEW GENUINE Model 3 CORONA LOWEST PRICE EVER OFFERED



**\$2.00
DOWN
BALANCE
EASY
TERMS**

HERE'S your chance to own that *brand new* Genuine Model 3 Corona you've wanted—on the easiest terms ever offered—at **LOWEST PRICE** ever offered! Complete in every detail; back spacer, etc., **MANUFACTURER'S GUARANTEE**. Recognized the world over as the finest, strongest, sturdiest, portable built. Try this wonderful portable typewriter—the same machine that has satisfied 500,000 users.

Yours for 10 Days' TRIAL —Send No Money

Experience the joy this personal writing portable typewriter can give you! Use it 10 days! See how easy it is to run and the splendidly typed letters it turns out. Ideal for the office desk, home, traveling. Small, compact, light, convenient. Don't send out letters, reports, bills in poor handwriting when you can have this Corona at such a low price or on such easy terms. Remember these are *brand new* machines right out of the Corona factory.

Carrying Case Included —If You Act Now

Leatheroid carrying case, offer, instructions, free on this offer. Send no money—just the coupon. Without delay or red tape we will send you the Corona. Try it 10 days. If you decide to keep it, send us only \$2, then \$3 a month until our special price of \$39.90 is paid. Now is the time to buy. Mail coupon today!



MONEY SAVED By Using This Coupon

**Smith Typewriter Sales Corp.
(Corona Division)
469 E. Ohio St., Chicago, Dept. 37**

Ship me the Corona, F.O.B. Chicago. On arrival I'll deposit \$2 with express agent. If I keep machine, I'll send you \$3 a month until the \$37.90 balance of \$39.90 price is paid; the title to remain with you until then. I am to have 10 days to try the typewriter. If I decide not to keep it, I will repack and return to express agent and get my money back. You are to give your standard guarantee.

Name _____

Address _____

Employed by _____

Let These Books Help You Make More Money

The books listed below will perfect you in your chosen trade—pave the way to the big positions. Written in non-technical language—easy to read and understand. *Every book covers its subject completely. An entire course of instruction condensed into one volume.* Your choice sent postpaid—money refunded in full if not entirely satisfactory. Order direct from this list.

AVIATION AND AUTO

Aviation From the Ground Up.....	\$3.50
Automobile Starting, Lighting and Ignition, by Manly. 700 pp.....	\$3.00
Brookes' Automobile Handbook.....	\$2.00
Ford Motor Car, Truck and Tractor, by Manly. Auto and Radio Battery, Care and Repair, by Manly.....	\$1.50
Motorcycle Handbook, by Manly.....	\$2.00
Motorcycle Handbook, by Manly.....	\$1.50

CARPENTRY

Modern Carpentry, 2 vols.....	\$3.00
The Steel Square, 2 vols.....	\$3.00
Modern Estimator.....	\$1.50
Timber Framing.....	\$2.00
Builders' Architectural Drawing.....	\$2.00
Concretes.....	\$1.50
Practical Bungalows.....	\$1.00
Roof Framing, by Van Gaasbeek.....	\$1.50

PAINTING, DECORATING AND ART

Lettering, Modern and Foreign, Welo.....	\$5.00
Silk Screen Process of Reproduction.....	\$5.00
Modernistic Lettering and Design.....	\$2.00
Modern Illustration.....	\$3.50
The Lacquer System of Sign Painting.....	\$3.00
How to Draw Funny Pictures—a Complete Course in Cartooning.....	\$3.00
LAYOUTS for Advertising.....	\$3.00
Furniture, Furniture Finishing, Decoration and Patching.....	\$5.00
Ross Crane Book of Home Furnishing and Decoration.....	\$3.00
House Painting Methods.....	\$2.00
Interior Wall Decoration, by Vanderwalker.....	\$4.00
The Mixing of Colors and Paints, by Vanderwalker.....	\$2.00
Automobile Painting.....	\$1.50
Wood Finishing, Plain and Decorative.....	\$2.00

SHOP PRACTICE

Practical Heating Systems, Trouble Jobs and Ventilation.....	\$4.00
Sheet Metal Workers' Manual.....	\$2.00
Oxy-Acetylene Welding and Cutting.....	\$1.25
Slide Rule and Logarithmic Tables.....	\$2.00
Handbook for Millwrights.....	\$2.00
Machine Shop Practice.....	\$2.00
Mechanical Drawing and Machine Design.....	\$2.00

STEAM ENGINEERING

Swingle's Handbook for Steam Engineers and Electricians.....	\$4.00
Examination Questions and Answers for Marine and Stationary Engineers.....	\$2.00
Steam Boilers.....	\$2.00
Swingle's Catechism of Steam, Gas and Electrical Engineering.....	\$1.50

Order Direct--on Our Money-Back Plan

For quick action order direct from this list—cross name of each book wanted and send in with price quoted. We prepay postage and send the books on our money-back plan.

POPULAR MECHANICS PRESS
Room P7—200 E. Ontario Street, Chicago, Ill.

The Model A Ford Car

is treated in a special supplement to the latest edition, the 15th, of

Dyke's Auto Encyclopedia

For 15 years "Dyke's" has been the one recognized and undisputed authority on the Automobile. Each succeeding edition has surpassed the last one. Now comes the greatest book of all—the wonderful 15th Edition—A. L. Dyke's crowning triumph—the super auto book of all times.

Some "High Spots" of the New Book!

- 1,249 pages covering every known auto fact.
- 4,200 Pictures, Plans, Diagrams and Charts.
- 15,000 lines of Index by which you can instantly locate any subject you want.
- A new section of "Trouble Shooting" Charts in Colors to enable you to quickly locate any major or minor trouble on any car.
- Special instructions on testing and adjusting every part of the automobile.
- Specifications of Gasoline Passenger Cars, Trucks and Tractors.

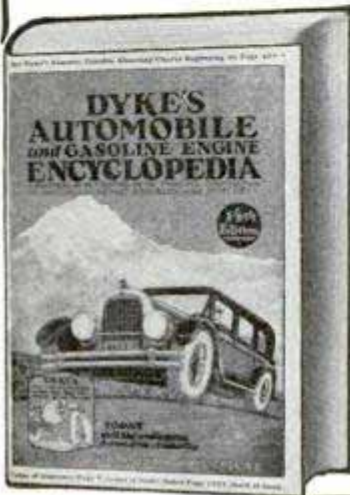

Specifications for Replacements, Accessories, Interchangeable Parts and Equipment.

Large colored Combination Chart which shows the working principles of the Automobile.

Large Charts showing the working principles of Trucks and Tractors.

Cloth \$6.00; Limp American Morocco \$7.50

Sent postpaid upon receipt of price.

Will be sent C. O. D. if preferred to any address in the U. S.

POPULAR MECHANICS PRESS
Room P-7
200 E. Ontario St.,
Chicago

20 Years of Shirt Sleeve Practice In ELECTRICITY

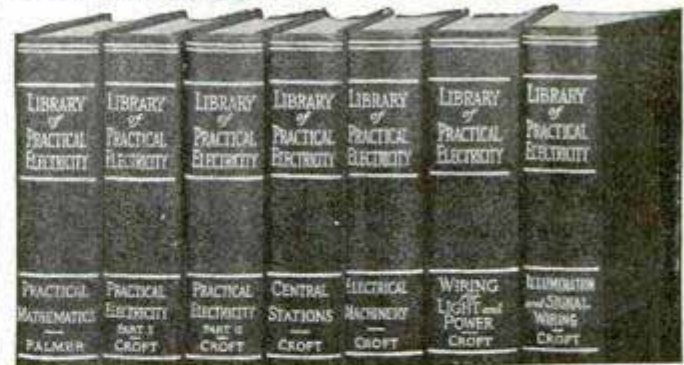

The Croft Library of Practical Electricity

JUST OUT!
Newly Revised Edition

THIS is the electrical age, with unlimited opportunities for the man who has educated himself in the finer points of electrical practice. Fit yourself for a big-pay job by knowing electrical practice complete, including inside and outside work, central stations, and the whole subject. With the aid of the Croft books you can know electricity as experts know it and put yourself in line for an expert's pay.

Standard Electrical Training

The Croft Library is a complete electrical educator. It is founded on practice—on work as it is actually done. It is jammed from cover to cover with the kind of hard-headed facts you want. Written so that the beginner can easily understand it, yet so sound, so thorough, that it is the daily guide of 59,000 highly paid electrical workers and engineers. Croft tells you the things you need to know about motors, generators, armatures, commutators, transformers, circuits, switchboards, distribution systems—electrical machinery of every type—wiring for light and power—wiring of finished buildings—underwriters and municipal requirements—illumination in its every phase—the latest and most improved methods of lighting—lamps and lamp effects, etc.—how to do a complete job, from estimating it, to completion. Make no mistake about it—there are big jobs in electricity ready for you when you're ready for them. Thousands of men who have the Croft Library know that to be a fact. The Library itself, on a FREE TRIAL BASIS, will prove it to your own absolute satisfaction.

3000 Pages, 2100 Illustrations

In these volumes Croft teaches you electrical practice complete. He takes you in quick, easy steps from the simplest principles to the complete and economical operation of a great central station. He tells you all that he has learned in twenty years of shirt-sleeve practice. With these books at his elbow a man can learn as much about electricity in six months—good practical "bread and butter" stuff—as he would ordinarily learn in a lifetime of practice.

NO MONEY DOWN SMALL MONTHLY PAYMENTS

Fill in and mail the coupon attached and we will send you the entire set of seven volumes for ten days' Free Examination. We take all the risk—pay all the charges. You assume no obligation—you pay nothing unless you decide to keep the books. Then \$1.50 in ten days and the balance at the rate of \$2.00 a month. Send the coupon NOW and see the books for yourself.



FREE EXAMINATION COUPON

McGraw-Hill Book Co., Inc., 370 Seventh Ave., New York.

Send me for 10 days' free examination the Croft Library of Practical Electricity. If satisfactory I will send you \$1.50 in 10 days and \$2.00 monthly until the special price of \$19.50 is paid. If not wanted, I will return the books at your expense. (To insure prompt shipment write plainly and fill in all lines.)

Name.....

Address.....

City and State.....

Position.....

Company..... P.M.7-30.

DRAFTING

BOOKS SENT FREE!
ON APPROVAL

Only fifteen minutes a day with these WONDER BOOKS will prepare you for a good Drafting job in less than a year! Mechanical and Architectural Drafting from simple straight lines to important, complex plans, a step at a time! Built especially for beginners, for men with only grammar schooling. Drafting room practice *plus engineering* made easy and clear!

Big Field—Big Demand—Big Pay!

Competent Draftsmen are urgently needed right now in all building and manufacturing lines at \$50 to \$100 a week. That's just the beginning—for draftsmen have the best chances for advancement! Pleasant, fascinating work, easy to learn and do. Learn quick with these books—send coupon for a set FREE, and see for yourself!

A year's Consulting Membership in the American Technical Society now given free to all readers of this famous Encyclopedia of Drafting. Many say that's worth more than cost of books.

American Technical Society
Dept. DB-19, 58th & Drexel Ave., Chicago

FREE If you send for these great Drafting Books NOW we will include without cost a complete volume "Blueprint Reading" containing 120 pages durably bound in cloth, and also a complete portfolio of 58 plates covering the basic orders of architecture. These plates are drawn to scale and are very valuable.

American Technical Society
Dept. DB-19, 58th & Drexel Ave., Chicago

Send for 10 days' free use 4-volume set of DRAFTING. In return for mailing this coupon promptly send absolutely FREE "Blueprint Reading" (Building) 120 pages, 69 illustrations, also a complete portfolio of 58 plates. I will pay the few cents delivery charges. If I wish I may return books in 10 days and owe you nothing. But if I prefer to keep them I will send \$1.50 after 10 days, then \$2.00 a month until \$14.50 (special reduced price) is paid.

Name.....

Address.....

Employed by.....

Address.....



**WANTED—
for murder!**

**\$1,000
Reward!**

In a dirty, forlorn shack by the river's edge they found the mutilated body of Genevieve Martin. Her pretty face was swollen and distorted. Marks on the slender throat showed that she had been brutally choked to death. Who had committed this ghastly crime?

Crimes like this are being solved every day by Finger Print Experts. We read in the papers of their exploits, hear of the mysteries they solve, the rewards they win. Finger Print Experts are the heroes of the hour.

More Trained Men Needed

The demand for trained men by governments, states, cities, detective agencies, corporations, and private bureaus is becoming greater every day. Here is a real opportunity for YOU. Can you imagine a more fascinating line of work than this? Often life and death depend on finger print evidence—and big rewards go to the expert. Many experts earn regularly from \$3,000 and more per year.

Learn At Home in Spare Time

Now, through this amazing new, simple course, you can learn the secrets of this science easily and quickly at home in your spare time. Any man with common school education and average ability can become a Finger Print Expert in surprisingly short time.

FREE—The Confidential Reports No. 38 Made to His Chief!

IF YOU ACT QUICK—We will send you free and with no obligation whatsoever, a copy of the gripping, fascinating, confidential report Secret Service Operator No. 38 made to His Chief and free book on Finger Prints which explains this wonderful training in detail. Mail Coupon NOW!

Don't wait. You may never see this announcement again! You assume no obligation. Mail coupon NOW—while this offer lasts!

Institute of Applied Science

Dept. B-135 1920 Sunnyside Avenue, Chicago

INSTITUTE OF APPLIED SCIENCE,
Dept. B-135 1920 Sunnyside Avenue, Chicago, Ill.

Gentlemen: Without any obligation whatever, send me your new, fully illustrated, FREE book on Finger Prints and the free copy of the Confidential Reports of Operator No. 38 made to His Chief.

Literature will not be sent to boys under 17 years of age.

Name

Address

Age

BOYS! Here's Fun Galore



Zip! Here they come! Around a turn and down the home stretch to cross the finish line with a last furious burst of speed!

You want things that will "GO"—things you can race with—scooters, pushmobiles, small autos with motorcycle engines, wind wagons, etc.—Whether on spinning wheels or glistening runners—fast ice yachts, skis, toboggans, bobsleds, motor driven sleds and snow speedsters.

You air-minded boys enjoy gliders and model airplanes. Turn your back yard into a regular amusement park with all these thrillers—ferris wheels, roller coasters, merry-go-round swings, etc.

How fascinating to imitate the big engineers and make small water wheels, pile drivers, aerial cableways and other things that "work."

When at camp or on the water you need plenty of ideas for new ways of having fun. Here are dozens such as water bicycles, push boats, water coasting toboggans, water games, etc.

On rainy days and other times when working in your home shop you have the hardest time finding interesting things to make. Here are any number such as electric locomotives, motion picture cameras, wood turning lathes, etc.

All in this great

Boy Mechanic Library

YES—ACTUALLY

4000 Worth While Things to Make and Do

Don't envy the other boys on account of the things they have. Be the boy in your neighborhood to make the others wonder where you get all your ideas.

Get the thrill of having "Made It Yourself." Everything is pictured out and made easy. Don't try to get along without these books. Send for them right away.

The complete library of 4 volumes, each book 7x10x1 1/2 inches and with 466 Pages.

Price \$7.00

or single volumes at \$2 each. Each volume complete in itself.

Books are numbered: 1, 2, 3 and 4. State the ones you want when ordering. Sent postpaid when remittance is sent with your order, or will be sent C. O. D. anywhere in the U. S. Pay postman price plus extra postage for this service.

POPULAR MECHANICS PRESS
200 E. Ontario St. Room P 7 Chicago, Ill.

RUPTURED MAN COMES BACK TO LIFE !!!



CAN you imagine a four-ounce rupture appliance so sturdy, so firm as to hold large ruptures against strain? It is another modern triumph, for with it comes comfort, ease and relaxation that many ruptured persons never dreamed possible. No harsh pressure or gouging; no unclean leg straps, no torture. The active part is flesh-soft and composed of tiny, cool air cells. The whole delightful support is anchored and cozily held by the most unusual rupture invention ever devised; it is a small buttoning device called Magic Dot. No other appliance can use it.

You can have a complete appliance made to your measure and sent for you to wear ten days, without risk. Send coupon or write at once for free literature and sample of the air-cell material. Don't delay another minute. It may be very dangerous. Let us show you how to reduce your rupture quickly and properly. John G. Homan, Director, New Science Institute, 2174 Clay St., Steubenville, Ohio.

Worth Money to Ruptured!

JOHN G. HOMAN, Director,
New Science Institute,
2174 Clay St., Steubenville, Ohio.

Send new free book and interesting free sample of air-cell material that "breathes" air, without obligation, and tell me how I can get your newest Four Ounce Efficiency Model to Wear 10 Days Without Risk.

Name

Address

City.....State.....

50,000 More Samples FREE of Air Breathing Material

Los Angeles,
CALIFORNIA
IS THE BEST PLACE TO
LEARN AUTOS



LOS ANGELES is the most fascinating city in the world... and the center of America's most rapid automotive industrial growth... the ideal city in which to live and train for success in the automobile industry.

Become a COMPETENT AUTO MAN

NATIONAL is an approved trade school, where in four to six months you may graduate as a practical and competent automobile man... prepared for employment in a gigantic industry where steady positions await students of this institution.

Train in this "SCHOOL OF SHOPS"

Competent instructors teach you thoroughly all branches of THE AUTO TRADES. You actually work on the latest models of all standard make automobiles, for NATIONAL is the most modern and completely equipped trade school in America. LIFE SCHOLARSHIP PRIVILEGES. Learn by NATIONAL'S famous "ACTUAL-SHOP" METHOD.

Learn this STEADY PAYING TRADE

The automotive industry offers ever increasing opportunities for trained men. Factory output increases yearly... and thousands of TRAINED AUTO MEN are needed to keep pace with the growth of this gigantic industry. Start training any time of the year.

Efficient EMPLOYMENT Service FREE

NATIONAL is a million dollar institution, 25 years old, boasting 22,000 graduates! No previous experience required... no age limit... start anytime. Unlimited employment service to those wishing to earn while they learn.

SEND FOR THIS BIG, FREE BOOK

NATIONAL AUTOMOTIVE SCHOOL
Dept. 736, 4006 Figueroa St.,
Los Angeles, California

Send me, absolutely free, your big illustrated Catalog of Automotive Opportunities.

Name _____

Address _____

Age _____ City _____ State _____



NATIONAL AUTOMOTIVE SCHOOL

Be a
REAL ESTATE
Specialist

Learn my amazingly successful system—right at home—in your spare time. Let me train you for real success. Let me put you in touch with big business. Let me do for you what I have done for other wide-awake men and women. D. H. Garrett says: "Made \$630 in one week before I was half through your training." Mrs. J. H. Hastings says: "Have sold two lots, receiving two hundred and forty-eight dollars in commissions. Have fine business lined up." M. I. Stokes says: "Made \$900 in three months in my spare time." Send your name and address at once for my new, free book, "How to Become a Real Estate Specialist," giving full facts about my remarkable Home-Study Course, my Free Business Service and positive proof of big success. Address PRESIDENT, Dept. GG-44, American Business Builders, Inc., 205 East 42 Street, New York, N. Y.

BE A MOTION PICTURE OPERATOR
LEARN TALKING EQUIPMENT
THRILLING WORK BIG PAY



Golden opportunities await the red-blooded young men who will learn to operate motion picture equipment and break into this great industry!... Work is comparatively easy, and thrilling... and the pay is BIG... Operators earning from \$50 to \$125 a week. Get into this fast-growing industry and become an expert in handling talking-picture projectors... Trained men are in demand... We train you quickly, easily, on standard sound projectors... One of the oldest and best-equipped schools in the country... \$50 down and \$10 a week for 10 weeks fits you to take your place in BIG PAY profession... Write for details.

MOTION PICTURE OPERATORS SCHOOL, 61 Sproat St., DETROIT, MICH.

FREE BOOK CATALOG

Send today, without obligation, for our new 72 page catalog, describing books on more than one hundred and fifty practical and scientific subjects, including books on Aviation, Automobiles, Air Brakes, Alloys, Electricity, Horology, Heating, Hydraulics, Model Making, Metallurgy, Radio, Ship Models, Soaps, Perfumes, Recipes, Plumbing, Inventions, Tanning, Television, etc.

Norman V. Henley Publishing Co., Dept. 47, 2 W. 45th St., New York, N. Y.

THIS Beautiful Ukulele, Artistic color finish—wonderful tone—regular retail price \$5.00 for only \$2.95
Included with this offer Pick Tuner & Extra set of strings; also easy instruction method. SEND NO MONEY—pay postman on delivery, plus postage.

MUSICAL SUPPLY CO.
Madison Square Station, P. O. Box 78, New York City

Gentlemen: Please send me Ukulele, together with strings and instructions method, also tuner.

Name _____
Address _____

LEARN WATCHMAKING

and become independent. We help you secure a position. Easy to learn. Send for FREE CATALOG.
ST. LOUIS WATCHMAKING SCHOOL Dept. 5, ST. LOUIS, MO.

NEW ORANGE JUICE MACHINE
Ends Drudgery
For Housewives!

EVERYBODY Pays Handsome Commissions TO AGENTS

drinks orange juice these days, but women hate the tedious task of squeezing, seeding and straining necessary with old-fashioned juicers. When you show them how KWIKWAY—this clever new machine that makes preparing orange juice a pleasure—and the price so amazingly low, they are simply wild about it. Fills a long standing need. Practically sells itself and pays a generous commission on every sale. Write at once for full description of KWIKWAY and amazing big money offers to agents.

KWIKWAY PRODUCTS, INC., Dept. K-120
1415 Pine Street St. Louis, Mo.



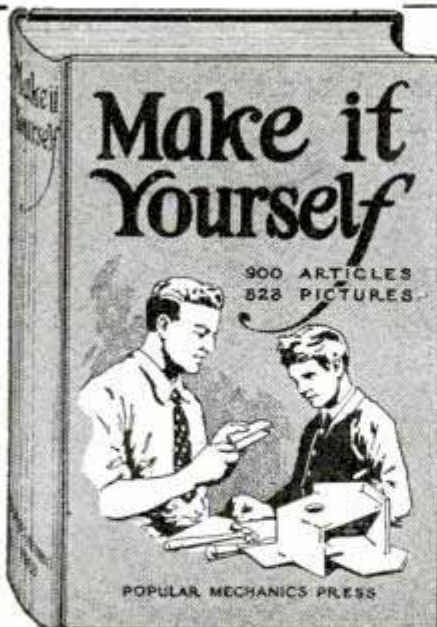

For Your Home Workshop

You should have a copy of this book recently published by Popular Mechanics entitled

Make It Yourself

The home mechanic, whether young or old, amateur or professional, will take pride and delight in making many of the things described therein.

Both father and son will find fascination and an association of interest in making useful and ornamental articles for mother to admire upon their completion.

900 Articles All Different

There are attractive ship models, a great variety of toys that operate themselves by means of an ingenious application of mechanical principles, novel amusement devices for indoors and outdoors, for both water and land, unique designs in furniture for children, scores of useful appliances for the home, things of beauty and utility for lawn and garden, etc.

Special articles instruct the amateur mechanic in the care and use of tools, special tools for special purposes, how to read and use plans, how to solder, the making of a handy work bench, cuts, joints and methods in woodworking, automobile repairing, installing radio equipment, house wiring, fixture hanging, working in glass, leather, metal, celluloid, lathe work, utilizing parts of old machines to make equipment that would be expensive to buy, etc.

Some of the Articles:

Tools for the Home
Mechanic
Ship Model Maker's Tools
Build Your Own Ship
Model
Ship Model Plans
Water Sprite
Puzzles
Crazy Clown
Walking Wampus
Winter Toboggan Slide
Colonial Bric-a-Brac
Merry-Go-Twist
Wiggling Pup
Black Cat Bench
Christmas Toys
Skating Whirligig
Venetian Swing
Bird Houses

Monorail Coaster
Writing Cabinet
Workbench
Tea Wagon
Radio Apparatus
Lawn Canopy
Camp Car
California Cooler
Musical Instruments
Hedge Trimmer
Homemade Baseball Game
Small Turbine Motor
Tools from Sewing Machines
Small Valves
Bench Lathe
Auto Glare Shield
Seesaw Merry-Go-Round
Ferris Wheel

480 Pages — 823 Illustrations. Price \$3.00
Size 7x10x1 1/2 in. Cloth Binding

Mailed Postpaid upon receipt of price anywhere in the world. If you reside in U. S., Hawaii, Porto Rico, Alaska or Mexico, we will send the book by mail C. O. D. if you prefer. Simply pay postman when he delivers the package.

POPULAR MECHANICS PRESS (ROOM P-7)
200 East Ontario St. Chicago, Ill.

How can I get into Aviation?

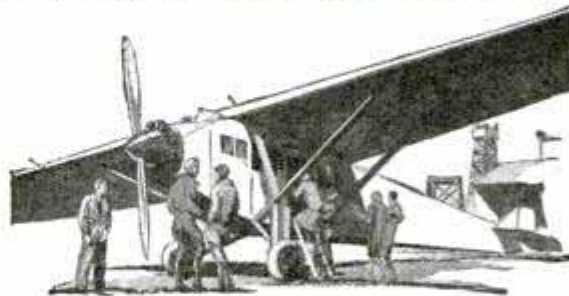

Read this Answer from

A World Famous Trans-Atlantic Pilot

AVIATION is waiting for no one! Landing fields, plane and equipment factories, air lines, service and sales organizations — all are leaping ahead in the most amazing development any industry has ever known. In such racing, feverish activity, where is there any room for a man who has nothing to offer? An empty pocketbook is no drawback — but Aviation has no place, no patience, no time for empty hands or empty heads! Aviation is taking-off for the greatest non-stop flight in history — and the men who will go along and climb to the top are the men with a foundation of FACTS under them.

**You Don't Have to Fly
—40 Ground Jobs
PAY BIG**

To succeed in Aviation — make BIG MONEY — you need not necessarily be a pilot. For every plane that flies, there's an immediate need for trained men in more than forty different important jobs on the ground. Construction, motor and instrument experts — airport man-

agers, service foremen, salesmen — and more, all make real money. But every last one of them must have the FACTS. Today's problem — YOUR problem — is to LEARN Aviation quick.

Get Your Ground Work NOW

Hinton Will Train You
YOU can train at home in spare time. Lieutenant Walter Hinton, world-famous Aviator, offers you a proved course which gives you all the facts about construction, motors, instruments, theory of flight, navigation, commercial Aviation — facts that every man must have to intelligently and profitably fill ANY job in the industry.

Get Hinton's Free Book

To take an active part in Aviation you should be at least 18 years of age. If you are under 18, please do not ask for Lieut. Hinton's Book, because it will not interest you. Serious-minded, air-minded men are reading and acting on this book. We want you to have a copy, too. Send the coupon NOW.



AVIATION INSTITUTE of U. S. A.

Walter Hinton, President

1115 Connecticut Avenue

Washington, D. C.

Mail Now for Facts

Walter Hinton, President
Aviation Institute of U. S. A.
1115 Connecticut Ave., Washington, D. C. 301-J

Please send me at once your FREE Book, "Wings of Opportunity," showing how I can get into Aviation.

Name.....

Street..... Age.....
(Must be over 18)

City..... State.....

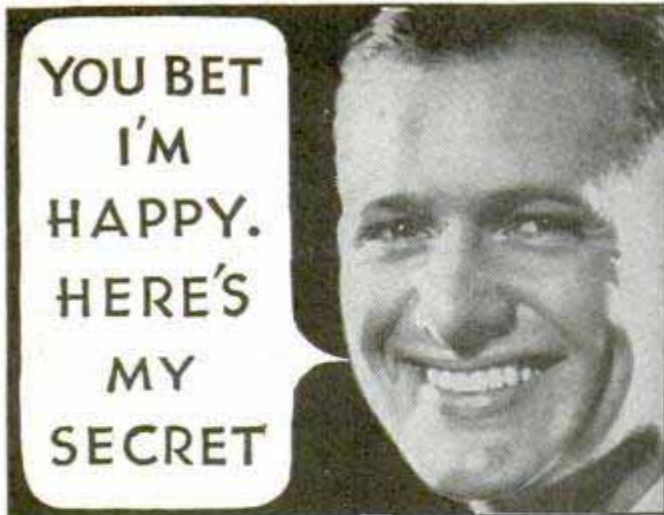

~ how I jumped from \$35 to \$100 a week in less than a year.

I was beginning to think that \$35 a week was my limit. I had tried many so-called "opportunities." They all offered a chance—but a slim one. Usually it was a case of sticking around, ten, fifteen or twenty years with an outside chance of making \$3,000 to \$4,000 a year by the time I reached the age of 50. No fellow with push and ambition wants to wait that long.

I had just about given up hope of finding the right proposition. One day I opened a magazine and saw an ad which told of the opportunities in Radio—how Radio's amazing growth was opening hundreds of \$50, \$60, \$75 and \$100 a week jobs every year. My hopes and ambitions had been blasted so many times that it sounded too good to be true. But I said: "I'm not getting anywhere here—it only costs two cents to find out if that's true—I'll send the coupon."

In a few days I received "Rich Rewards in Radio." That book opened my eyes. For the first time I realized that if a man wants to make good money and doesn't want to wait a lifetime to start doing it, he has to get into a fast growing field—because it's rapid growth that makes a lot of good jobs. Within a month after I started training for the Radio field I was making extra money on the side fixing my neighbors' and friends' sets. I made \$400 in the first six months. In less than a year I was pulling down \$75 to \$100 a week regularly in a Radio store. And I was doing work that was fun. Some weeks I ran my earnings up to as high as \$120.

The outfit that gave me my training certainly are square shooters. They just can't do enough for you. Mr. Smith, the President, and his large staff, never let down for a minute.

Although I went to work for a Radio store and am now in business for myself, they would have done just as much for me if I had wanted to be an Operator in a Broadcasting Station, Commercial Land Station, Operator on Board Ship, or if I had wanted to enter any of the many other opportunities in the Radio industry.

Take my tip. Find out what Radio offers and what N. R. I. offers. They will deal with you the same as they did with me—send their book and then let you decide one way or another.



THIS COUPON STARTED ME ON MY QUICK RISE TO BIG PAY. BETTER MAIL IT. SEE WHAT MR. SMITH CAN DO FOR YOU.

J. E. Smith, President
National Radio Institute, Dept. OGPP
Washington, D. C.

Dear Mr. Smith:—Send me "Rich Rewards in Radio." I want proof of what Radio offers and that your training is raising men's pay. I understand this request does not obligate me in the least and that no agent will call.

Name.....

Address.....

City..... State.....

LUDWIG Drummers are POPULAR

Snappy tone and the flash that marks real "class" are the two big reasons why Ludwig drums are chosen by America's foremost drummers—and why Ludwig drummers themselves are so popular, so much in demand.

TRIAL OFFER, EASY PAYMENTS. You, too, can be a jazz drummer and win rich rewards. Learn easily with Ludwig's simple self-instructor. Send now for literature and details, no obligation.

LUDWIG & LUDWIG

702 Ludwig Bldg., 1611-27 N. Lincoln St., CHICAGO, ILL.

BE A RAILWAY TRAFFIC INSPECTOR

EARN UP TO \$250 PER MONTH Expenses Paid

AGES 18 To 55 Years

Trained men needed in this important profession. Fascinating work; plenty of variety; chance to travel. Advancement rapid with experience. Report to high officials.

WE ASSIST YOU TO A POSITION paying \$120 to \$150 per mo. plus expenses, upon completion of few weeks' spare time home instruction—or refund your tuition. Advance rapidly to \$175, \$200, \$250 per mo. Cost moderate; terms if desired. Write today for free booklet which tells all about Traffic Inspection and what it can do for you.

STANDARD BUSINESS TRAINING INSTITUTE
Div. 2 Buffalo, N. Y.

DRAW CARTOONS

Turn Your Talent Into Money

Cartoonists earn from \$50 to \$250.00 per week—some even more. Remarkable new Circle System of Drawing teaches you in half the usual time. Send for **booklet** and sample **lesson plate** explaining full details of the Course.

THE NATIONAL SCHOOL OF CARTOONING
623 Penton Building Cleveland, Ohio

Government Positions

Census Clerks, Clerk Carriers, Rural Carriers, Railway Mail Clerks, Postmasters, Department Clerks, and many others. Splendid salaries, easy work, vacation with pay. Only common school education required. Examinations often. 37,976 appointed last year. Send for our Civil Service Catalog No. 6. **COLUMBIAN CORRESPONDENCE COLLEGE, Washington, D. C.**

BASHFUL?

"Shame on you!" Are you nervous, embarrassed in company of the other sex? Stop being shy of strangers. Conquer the terrible fear of your superiors. Be cheerful and confident of your future! Your faults easily overcome so you can enjoy life to the fullest. Send 25c for this amazing book.

RICHARD BLACKSTONE, B-477 Flatiron Bldg., N. Y.

Feel 10 Years Younger In 6 Days

SCIENCE now knows that the tiny prostate gland frequently causes lost health and strength, night rising, constipation, pains in the back, legs, feet, etc., in men past 40. Unless corrected this may lead to miserable old age and grave surgery. Now an amazing drugless treatment is giving swift, permanent relief to thousands. Used and endorsed by physicians, hospitals and sanitariums. Sent on trial. Feel 10 years younger in 7 days or pay nothing. Write for offer and free book of daring facts about men past 40.

W. J. KIRK, Pres.
2131 Morris Ave., Steubenville, Ohio

RUPTURE

Appliances Made To Measure



Want solid comfort? Wear a Brooks Appliance with patented Automatic Air Cushion. Get more comfort and joy out of your favorite sport. No gouging springs or hard pads, but soft, clean, washable air cushion. Allows full body freedom and still furnishes absolute

protection. Over 3,000,000 Brooks Appliances sold. Wear one on ten days' trial. Try it. Know real comfort. Write for 28-page Rupture Booklet FREE. Sent in plain sealed envelope.

Brooks Appliance Co., 107 D State Street, Marshall, Mich.

LUCKY TIGER

A PROVEN GERMICIDE



For a clean, healthy scalp use Lucky Tiger. Destroys germs, and gives to thin, falling hair a new life and lustre. Delicately perfumed; world's largest seller at Druggists, Barbers, Beauty Parlors. **Try It Today!**



How to Obtain A Better Looking Nose!

Improve your personal appearance
My new Model 25 Nose Shaper is designed to improve the shape of the nose by remoulding the cartilage and fleshy parts, safely and painlessly. This is accomplished thru the very fine and precise adjustments which only my patented Model 25 possesses. Results are lasting. Can be worn at night, or during the day. Money refunded if not satisfied after thirty days' trial. Write for free booklet to

M. TRILETY, Pioneer Nose Shaping Specialist
Dept. 61 BINGHAMTON, N. Y.



BOW LEGS?

THIS GARTER (Pat'd)
Makes Trousers Hang Straight
If Legs Bend In or Out

Free Booklet—Plain Sealed Envelope
THE T. GARTER CO., Dept. E
South Bend, Ind.

TRUSS USERS

STUART'S ADHESIF PLAPAO-PADS are patentably different—being mechanico-chemico applicators—made self-adhesive purposely to keep the muscle-tonic called "PLAPAO" continuously applied to the affected parts, and to minimize danger of slipping and painful friction. The fabric is soft as velvet, and being adhesive—

—clings closely to the body—



—without straps, buckles or springs.

Easy to apply, comparatively inexpensive and comfortable

For almost a quarter century stacks of sworn testimonials from many different countries report success, without delay from work. Process of recovery natural, after which no further use for a mechanical support. Test of the remedial herbal factor "PLAPAO" sent you **FREE** No charge for it now or ever. Write name on coupon **NOW**, and mail **TODAY**.

Plapao Co., 2621 Stuart Bldg., St. Louis, Mo.
Name.....
Address.....

FREE—Trial Plapao—FREE



"Not a dollar raise now but I'll give you a tip"

"You're getting all I can afford to pay for the work you're doing. And if you want more money you've just got to learn higher class work, and you've got to learn it on your time, not mine.

"There's the Drafting room. That's how I got my start. It's a cinch to learn Drafting in spare time. And if you do, I'll give you a chance and an immediate raise. Or you can prepare for one of the junior executive positions in the office. That's for you to figure out. But don't come back asking for more money until you can deliver a higher-paid kind of service."

That bluntly is the employer's side of the "raise" question. And thousands of men who take the tip are investing a part of their spare time in home-training—getting ready for the position-ahead and more pay before they ask for them.

There is no shorter cut to promotion than an American School course. The quicker you realize this—the quicker you can put yourself in line for advancement.

— — — American School — — —

Dept. GB-47, Drexel Ave. and 58th St., Chicago, Ill.



AMERICAN SCHOOL
Chartered in 1897 as an Educational Institution, NOT FOR PROFIT. Over 200 noted engineers, business executives and educators have helped us prepare our instruction service.

Without cost or obligation please tell me how I can win a better position and increased pay in line marked X below. Also explain your guaranteed employment plan.

BUILDING CONSTRUCTION

Architecture Building Contracting

DRAFTING and DESIGN

- Machine Drafting and Design
- Architectural Drafting
- Electrical Drafting
- Structural Drafting
- Automotive Drafting
- Mechanical Drawing for beginners

ENGINEERING

- Mechanical Engineering
- Civil Engineering
- Electrical Engineering
- Automotive Engineering
- Machine Shop Practice

BUSINESS

- Accounting, Auditing
- Business Management (Finance, Sales, Production, Accounting)
- HIGH SCHOOL IN 2 YEARS

Name.....

Occupation.....

St. No.....

City..... State.....

10,000

Chest Expanders

only
99¢
each

Think of it—99¢ for an EXTRA HEAVY-TENSIONED, FIVE-CABLED PROGRESSIVE EXERCISER, fully guaranteed—MONEY BACK IF DISSATISFIED. What more can you ask?

Get Strong Quickly

Here's an unusual opportunity for everyone to develop his body and obtain great strength. These chest expanders have proven by the hundreds of thousands sold and by the endorsement of athletes, to be one of the best means of developing each and every muscle—because these exercisers are progressive. You start with one or two cables and as you become stronger, you add cables until you are able to exercise with all the cables attached. When you can do this, you will have finely developed muscles, vigorous health and great strength.



One Week's Trial Will Convince You

In fact, the very first time you try one of these exercisers, you will realize that you are on the right road to physical perfection. You will feel better even after a few minutes' use, for your blood will be in circulation and you'll know that this is just what you have always wanted.

Manly Muscles in Double-Quick Time

The well built man commands respect and admiration. He has personality and stands out among ordinary men. You've seen him—spry step, peppy stride, an object of admiration in a bathing suit—regular handsome life guard type. People turn to admire him and wonder whether he is a fighter, wrestler, gymnast, football star or famous college athlete. Don't you want others to think these things about you?

Be Strong

The survival of the fittest is as true today as in the stone age, for the strong man outlives the weak and wards off disease. The man or boy who possesses vigorous strength and manhood and has the power to bend or break almost anything within reason, is the one who enjoys life and has unlimited energy to save and even to waste, and still carry on.

Greatest Bargain Offer Ever Made

Heretofore, exercisers of this nature were expensive, but now we are offering them for a limited time only, to fit every purse. Take advantage of this golden opportunity before it is too late, for the price may be withdrawn at any time, without notice. Here's your chance—grab it!

SEND NO MONEY

Just fill in the coupon below, designating which exerciser you want, and it will come right to your house for 99¢ plus a few cents postage—open the package—try it—and if you are dissatisfied, every cent of your money will be refunded. That's our iron-clad guarantee. We've been in business a great number of years so you know that everything is just as represented. You're the sole judge. Nothing could be fairer.

Buy two or three at this remarkable low price—they make wonderful gifts. Also in ten cables for \$1.85.

Progressive Exerciser Co.
Langdon Building, Dept. 4007
Broadway and Duane St., New York City

Dear Sirs—Please send me your 5 cable [guaranteed] @ 99¢.
 10 cable [exerciser] @ \$1.85.

(Check the one you want.) It is understood that I am to get your instructions for using absolutely free. If I am not satisfied, I can return the exerciser within five days and you will return my money.

NAME..... Age.....

STREET.....

CITY and STATE.....

BOATS

OF MANY KINDS

Building—Handling—Operating
Maintaining and Fitting Out

You will find in the following list an outstanding book on practically any boating subject you may need information about:

- Vol. I—Designs of Ideal Motor Boats..... \$2.00
By C. F. Chapman
- Vol. II—How to Build 16 Ideal Motor Boats.. 2.00
By C. F. Chapman
- Vol. III—Handling, Fitting Out and Caring
for the Boat..... 1.50
- Vol. IV—20 Easy-to-Build Motor Boats..... 2.00
By Wm. J. Deed
- Vol. V—Piloting, Seamanship and Small Boat
Handling. By C. F. Chapman... 2.00
- Vol. VI—Where to Cruise..... 2.00
By F. W. Horenburger
- Vol. VII—Build a Boat..... 3.00
By J. L. Hacker and C. D. Mower
- Vol. VIII—Modern Motor Boat Designs and
Plans. By Wm. Atkin..... 3.00
- Vol. IX—Plan Book of Cruisers, Runabouts,
Auxiliaries and Outboard Motor
Boats. By C. D. Mower..... 3.00
- Vol. X—The Outboard Motor Boat Book.... 3.00
By C. F. Chapman
- Vol. XI—The Yachtsman's Annual Guide.... 1.50
Latest edition

Any of the above will be sent C.O.D. anywhere in the U. S. A. Simply pay postman price and the few cents postage when delivered. If outside U. S., send remittance with order.

POPULAR MECHANICS PRESS
Room P7, 200 E. Ontario St., CHICAGO

Books on 32 Subjects

Popular Mechanics Press specializes in supplying books on any subject. Look over this list. Check the books you want, and mail this advertisement as your order blank. Catalog with lists on 2,000 subjects free.

- AIRCRAFT (Modern)**
Complete. Up-to-date...\$5.00
- ARTIST (Commercial)**
Money-Making Art...\$5.00
- ATLAS (of World)**
Modern. New Bound-
aries.....\$3.00
- AUTOMOBILE**
Painting.....\$1.50
- BOOKKEEPING**
Practical Handbook...\$1.00
- BRICKLAYING**
Plain and Fancy.....\$1.50
- CARBURETORS (All Makes)**
Only Book Covering...\$2.00
- CHALK TALK**
and Crayon Presenta-
tion.....\$1.25
- DRAWING**
Freehand and Perspec-
tive.....\$1.50
- DRY CLEANING (Practical)**
and Dyer.....\$3.00
- FLOWER RAISING**
1001 Questions
Answered.....\$2.00
- FLYING**
Simplified.....\$1.00
- FUR RAISING**
For Profit.....\$4.00
- FURNITURE REPAIRING**
Finishing and Decora-
tion.....\$5.00
- HOME FURNISHING**
and Decoration.....\$3.00
- INVENTIONS**
How to Make Pay....\$2.50
- LETTERING AND DESIGN**
Studio Handbook of...\$3.00
- MAGIC**
World's Best Book of...\$2.00
- PAINTS AND COLORS**
Mixing of.....\$2.00
- PICTURES (FUNNY)**
How to Draw.....\$3.00
- PLASTERING**
Best Instruction Man-
ual.....\$1.25
- RADIO ENCYCLOPEDIA**
Very Complete.....\$6.00
- REAL ESTATE**
Educator.....\$2.00
- SHOW CARDS**
Artistic.....\$3.50
- SIGN PAINTING**
Lacquer System of...\$3.00
- Steam Engineer's License**
How to Obtain.....\$2.00
- STEEL SQUARE**
How to Use.....\$1.00
- TELESCOPE (Amateur's)**
How to Make.....\$3.00
- TOOLS (Using)**
Tinkering with Tools...\$2.00
- TRICKS (200)**
For the Amateur.....\$1.00
- WOOD FINISHING**
Plain and Decorative...\$2.00
- WOODWORKING (New)**
Most Complete Book
for Amateurs.....\$2.00

SEND NO MONEY

Just check the books you want, and mail the whole advertisement. It is your order blank. When postman hands you books, pay him the price and few cents postage. If outside the U. S. remit when ordering and include 10 cents per book extra for postage.

POPULAR MECHANICS PRESS, Room P7, 200 East Ontario St., Chicago, Ill.



WANT A STEADY GOVERNMENT JOB?

RAILWAY POSTAL CLERKS

\$1900 to \$2700 a Year

COMMON EDUCATION SUFFICIENT

STEADY JOBS—NO LAYOFFS!

Many other U.S. Government Jobs
open to Men—Boys 18 to 50.
MAIL COUPON—TODAY SURE

Short Hours—Pleasant Work—Rapid Advancement—
Permanent Employment—Long Vacation with Pay

Franklin Institute
Dept. L175 Rochester, N. Y.

Rush to me free of charge: (1) A full description of the position checked below; (2) Free copy of 32-page illustrated book "How to Get a U. S. Government Job"; (3) A list of U. S. Government Jobs now obtainable.

- ... Railway Postal Clerk... (\$1900—\$2700)
- ... Post Office Clerk... (\$1700—\$2300)
- ... City Mail Carrier... (\$1700—\$2100)
- ... Rural Mail Carrier... (\$2100—\$3300)
- ... General Clerk... (\$1260—\$2500)
- ... Inspector of Customs... (\$2100 up)
- ... Immigrant Inspector... (\$2100 up)

VALUABLE COUPON

Name.....

Address.....

LEARN CARTOONING

AT HOME DURING SPARE TIME

with the course that has trained HUNDREDS of beginners successfully. The Landon Picture Chart Method of teaching ORIGINAL drawing by mail makes cartooning easy to learn. This school is a Member of The National Home Study Council. Write today for sample picture chart to TEST YOUR ABILITY and examples of the work of successful students now earning from \$50 to \$200 and more per week. Enclose 6c in stamps and STATE YOUR AGE.

THE LANDON SCHOOL, 2838 National Bldg., Cleveland, Ohio



LEARN TO EARN \$50 to \$150 PER WEEK
Write for Free Booklet
SWEENEY SCHOOL
Automotive Electrical Aviation
1615A Grand Ave. KANSAS CITY, MO.

MONEY for YOU!



A New Musical Instrument
THAT ANYONE CAN PLAY
**THE BEAUTIFUL
HAWAIIAN HARP GUITAR**
Advertised by Radio

Sells wherever shown at the amazing low price of \$9.75. You collect \$2.75 cash with every order. We deliver and collect the balance. FREE instruction book with every instrument. Write quick and let us tell you how to get

YOUR INSTRUMENT FREE

MUSIC INSTITUTE OF AMERICA, 430 S. Wabash Ave., Room 14, CHICAGO

"Pick YOUR Government Job"



Work for Uncle Sam. Get good pay, regular increases, vacations and sick leave with pay, steady advancement, pension. Send for my free book "How to Secure a Government Position"—tells about all jobs, near home or traveling, the money, what you need to know and how to get posted. Forget job hunting.

IMPORTANT NOTICE — Railway Postal Clerk examination coming. Yearly pay with allowances averages \$2759.00. Prepare yourself NOW. Send coupon at once.
A. R. Patterson, Civil Service Expert
PATTERSON SCHOOL, 87 Wisner Bldg.
Rochester, N. Y.

Please send me, without obligation, your free book "How to Secure a Government Position."

Name.....
Address.....

Weak Men Revitalized



STRONGFORT
Builder of Men

Your body can be and should be dynamic in its energy and powerful in every muscle. If you are a weakling—a make-believe man—a skinny, flabby outfit—it's your fault and yours alone. You don't have to be a weak, nervous, useless fellow. You can be strong, muscular, full of energy—and you will be if you have the sand to follow the path thousands of others like you have followed under my guidance.

Maybe you are one of those fellows who have thought they could run wild without destructive results. Maybe you've gone the speed limit in the use or abuse of your physical powers. Maybe you thought there was no end to your vitality—that you could go it day and night and dissipate to your heart's content. Now you know better—you've learned your lesson—and what are you going to do about it? I'll tell you what you can do. I'll tell you what I've done for weak men all over the world.

STRONGFORTISM Will Make a Man of You

Men who were afflicted with all sorts of ailments—annoying, destroying weaknesses—men who were ashamed of their lack of stamina and muscular power—men who had well-nigh given up hope of ever being strong again—these men—thousands of them—came

to me and they were put on their feet, revitalized, restored to health and strength through my course in STRONGFORTISM, and became men who were proud of their physique and who feared no one.

My Record in Body Building

For over 27 years I have devoted myself to the development of men's bodies into fine specimens of manhood—not that they all wanted to be athletes, but because they wanted to possess full physical powers and feel like real men. No one in history has done more in the way of body building and restoration. You can get rid of Constipation, Catarrh, Nervousness, Rheumatism, Indigestion, Dyspepsia, Weak Back, Insomnia, Palpitation and a whole string of other ailments if you will take up Strongfortism in dead earnest. I want to help you—and I can help you if you will give me a chance—if you will write and tell me what troubles you.

Send for My FREE Book

This book of many pages and dozens of pictures tells plain truths. "Promotion and Conservation of Health, Strength and Mental Energy" points the way from disease and weakness to health and strength. It is priceless. I'll send it to you on request—FREE. Write for your copy today.

STRONGFORT INSTITUTE
LIONEL STRONGFORT, DIRECTOR.
PHYSICAL AND HEALTH SPECIALIST
DEPT. 58 NEWARK, NEW JERSEY, U.S.A.

Send This Coupon

FREE CONFIDENTIAL CONSULTATION

Mr. Lionel Strongfort, Strongfort Institute, Dept. 58, Newark, N. J.—Please send me absolutely free my copy of your book, "Promotion and Conservation of Health, Strength and Mental Energy." This does not place me under any obligation. I have marked (x) before the subjects in which I am interested.

.. Catarrh	.. Constipation	.. Lung Troubles
.. Colds	.. Rheumatism	.. Round Shoulders
.. Asthma	.. Nervousness	.. Stomach Disorders
.. Headache	.. Overweight	.. Increased Height
.. Rupture	.. Weak Back	.. Muscular
.. Thinness	.. Weak Eyes	.. Development
.. Pimples	.. Short Breath	.. Great Strength
.. Insomnia	.. Weak Heart	

Other Ailments.....
Name.....
Age..... Occupation.....
Street.....
City..... State.....

STAMMERING

easily, permanently corrected. Win happiness and success. Ask for full information and special phonograph record. Send dime for postage
12972 Woodward Ave., LEWIS INSTITUTE, Detroit



Send for Catalog Today

BOW LEGS and KNOCK-KNEES UNSIGHTLY

Those afflicted with BOW LEGS should wear the "PERFECT LEG FORMS" and overcome this deformity. Trousers hang perfectly straight. Made of the highest grade Aluminum. Sanitary, Light and Durable. Easy to put on or off. Send for booklet showing photos of men with and without the "PERFECT LEG FORMS"

PERFECT SALES CO.
140 N. Mayfield Ave. Dept. 5 Chicago, Ill.

NO JOKE TO BE DEAF

—EVERY DEAF PERSON KNOWS THAT



I make myself hear, after being deaf for 25 years, with these Artificial Ear Drums. I wear them day and night. They stop head noises and ringing ears. They are perfectly comfortable. No one sees them. Write me and I will tell you a true story, how I got deaf and how I make you hear. Address



GEO. P. WAY, Artificial Ear Drum Co. (Inc.)
80 Hoffman Bldg., Detroit, Mich.

CORRECT! Your NOSE!



Improve your appearance with the ANITA NOSE ADJUSTER. Shapes flesh and cartilage—quickly, safely and painlessly, while you sleep. Results are lasting. Doctors praise it. 68,000 users. Write for 30-Day TRIAL OFFER and FREE BOOKLET.

ANITA INSTITUTE, 712, Anita Bldg., Newark, N. J.

OUTDOOR SPORTS

The Year Round

POPULAR MECHANICS PRESS CHICAGO

Thrills Galore IN OUTDOOR SPORTS

THE YEAR ROUND

Have you ever heard of Water "Bug Ball" played with round motorboats or Angling for Human "Fishes"

or the "Tumbling Barrel" popular at bathing beaches?

Do you know how to try "Solo" batting practice in baseball or improve your accuracy in tennis by trying to place the ball in numbered squares? Have you tried webfoot attachments in swimming or played Human "Checkers" on the beach?

There are 226 ideas for new and popular sports in this interesting book

Take A Copy On Your Summer Outing

Although winter sports are thoroughly covered, the following are of most interest at this time of the year:

- | | | | |
|----------|------------------|--------------------------|--------------|
| Baseball | Golf | Outdoor summer games | Photography |
| Boats | Handball | Overhead trolley coaster | Swimming |
| Camping | Model air-planes | | Tennis |
| Canoes | Motor boats | | Track work |
| Fishing | | | Trapping |
| Gliders | | | Water sports |

152 Pages Fully Illustrated, Cloth Binding

Send C.O.D. anywhere in U.S. Pay postman price, \$1.50, plus few cents postage upon delivery. If outside U.S., remit with order.

POPULAR MECHANICS PRESS
Room P7 200 E. Ontario St. CHICAGO

Leaders in AVIATION Demand the Thoroughness of VON HOFFMANN Training



That is the Reason.. VON HOFFMANN Graduates are Filling Responsible Positions

Von Hoffmann graduates, busy today at many flying fields and factories, are making good. Aviation needs capable men, carefully developed, thoroughly trained. The call is not for more men but for better men.

That is the reason Von Hoffmann courses go beyond Government requirements. Each man receives simple, clear instruction, intensively given on the most modern type equipment. Employers know that the finest type of pilots and mechanics are trained here by methods which have attained world-wide fame.

A Government Rated School located on a \$2,000,000 airport—modern concrete hangars and class rooms—a fleet of Government Approved planes, various late types, open and cabin—comfortable living quarters with all modern conveniences. Our liberal time payment plan makes it possible for you to pay half your tuition after you have finished your instruction. Make your start in aviation TODAY—mail the coupon NOW!

Von Hoffmann Aircraft School

Member Aeronautical Chamber of Commerce
131 Lambert-St. Louis Airport, ST. LOUIS, MO.

U. S. Gov't
Approved School
for Transport,
Limited Commercial,
Private Pilot,
Ground and
Flying

VON HOFFMANN AIRCRAFT SCHOOL,
131 Lambert-St. Louis Airport,
St. Louis, Mo.

Name.....
Address.....
City..... State.....
Age..... I am interested in:
 Flying Course Mechanics Course
 Welding Course Home Study

BUILD A BOAT

How to Make 35 Kinds

If you want a boat, you can save several dollars by making it yourself. Or you can pick up money on the side making boats for your friends. Besides you'll have barrels of fun. Everything is made so simple and easy in the Outboard Motor Boat Book. Complete and simple directions and necessary illustrations for building these boats:

- 7-ft. Tender, Model Sloop, Pram Type Outboard,
- 8-ft. Sailing Dinghy, Sailing Skiff, 9-ft. Sharpie,
- 9-ft. Utility Dink, 10-ft. Outboard Speedster,
- 10-ft. Folding Punt, 10-ft. Scow, 10-ft. Dinghy,
- 10-ft. Sailing Dinghy, 12-ft. Flat Bottom Dinghy,
- 12-ft. Outboard Hydroplane, Handy Utility Boat,
- 12-ft. Sailing Dinghy, 12-ft. Tender, 12-ft. Combination Dinghy, 12-ft. Outboard Hydroplane,
- 12-ft. Dink, Baby Hydroplane, Fast Outboard Hydroplane, Flat Bottom Outboard Motored Boat, 14-ft. Fishing Skiff,
- 14-ft. V-Bottom Row Boat, Outboard Engine Cruiser, 14-ft. Runabout, 15-ft. Motor Skiff, V-Bottom Runabout, Outboard Motored Runabout, 16-ft. Utility Boat, Outboard Speedster, 18-ft. Outboard Runabout, 17-ft. Serviceable Boat, Canvas Covered Canoe, a Cruising Sloop.

This book sent C.O.D. anywhere in the U. S. A. Simply pay postman price, \$3, and the few cents postage when he delivers same. If outside U. S., send remittance with order.

POPULAR MECHANICS PRESS
Room P7, 200 E. Ontario St., CHICAGO

Build Your Own Boat



HOW'D YOU LIKE to Play This Instrument?



No reason why you shouldn't. Easy, Lessons show you how. 5 days' free trial in your own home. A year to pay.

THE whole world seems different when you learn to play and now you can play the most spectacular of all instruments—the Deagan Xylorimba. No long waiting. No finger or lip exercises. No tiresome practice. Start to play the very first day even if you can't read a note of music right now. Soon you'll be the "hit" of every party. Maybe, like the Musical Hallmans (Reading, Pa.) you'll make \$65 a week spare time.

Our Big FREE Book tells all about the free trial offer, the easy lessons, the wonderful payment plan. No cost or obligation—send in coupon today.

J. C. Deagan, Inc., Dept. B145, 1770 Berteau Ave., Chicago
Send me, without obligation, full details of Free Trial offer and easy payment plan of the Deagan Xylorimba.

Name.....
Address.....

A Real Short-Cut to a Successful Professional Career



MASTER IN ONE SHORT YEAR

COMMERCIAL ELECTRICAL ENGINEERING

A new profession appealing to men who want to rise above the crowd. Learn not only the secrets of electrical engineering but how to make that training pay you a big return in salary, commissions and profits as well. New-trained men are yet scarce, offering an opportunity never equalled in history of electricity. Train here by improved method of rotating theory-practice plan. Fascinatingly easy and quick. Expensively equipped laboratories. School founded in 1903 by Oscar Werwath, internationally known Electrical Engineer. Over 26,000 graduates. Widely endorsed by electrical industry.

COMPLETE PRACTICAL ELECTRICAL EDUCATION

A plan of training and a brilliant future for every ambitious man. Short, intensive, practical courses of 3 and 6 months in Radio, Refrigeration, Armature Winding and Motor Repair. Become a full-fledged Commercial Electrical Engineer in 12 months; Commercial Radio Engineer in 12 months; Industrial Electrical Engineer, 2 years; Electrical Engineer with B. S. Degree in 3 years. Choose your own career!

A faculty of recognized specialists headed by distinguished Electrical Engineer who for years was associated with late Charles P. Steinmetz. An Advisory Council of great industrial leaders and engineers. Graduates universally accepted by electrical industry and welcomed to real, worthwhile positions. Milwaukee is great electrical center and the ideal place in America to learn Electricity.

ENGINEERS TRAIN YOU

EARN WHILE YOU LEARN

You can, through Employment Service, earn living expenses by part-time employment. A co-op plan of work and learn proven by 12 years of operation. Scholarship Foundation Fund aids earnest men of character and ability. There's a place here for every man no matter what his previous education or circumstances are.

International drive now being made to secure men to train for Electricity along these new, approved, thorough lines. A few men of outstanding merit and native aptitude may win free Scholarships. Tests by experts are given to all applicants without cost or obligation.

WIN A FREE SCHOLARSHIP



SEND FOR FREE TEST

Mail coupon for Free Aptitude Test, Catalog and full details of Free Scholarship Contest. No charge is made for this test and no obligation. Open to all ambitious young men.

SCHOOL of ENGINEERING of Milwaukee

Dept. PM-730 MILWAUKEE, WIS.

School of Engineering of Milwaukee,
Dept. PM-730, Milwaukee, Wisconsin.

Without obligation, please send me free Aptitude Test for:

- Commercial Electrical Engineering
 - Commercial Radio Engineering
- Also catalog and full details.

Name.....Age.....
Address.....
City.....State.....
Education.....

I think I will want to take up training checked.

- Junior Radio Technician, 3 months
- Radio Technician, 6 months
- Armature Winding and Motor Repair, 3 months
- Commercial Electrical Engineering, 1 year
- Commercial Radio Engineering, 1 year
- Electrical Engineering, 3 years for B. S. Degree

365 Shaves From One Blade!



A ST. LOUIS man has invented a tiny shaving machine which has enabled many users, according to their own reports, to get up to 365 shaves from one razor blade, and the keenest, coolest shaves ever! Unlike ordinary stropers. Fits any blade including new Gillette. Write for trial offer and free razor deal.

AGENTS WANTED.—Wonderful money-maker, full or spare time. King made \$66.00 in one day. Hundreds cleaning up big money. Ask for selling outfit. J. W. Diephouse, Mgr., Dept. H-3714, 4330 Couzens Ave., St. Louis, Mo.

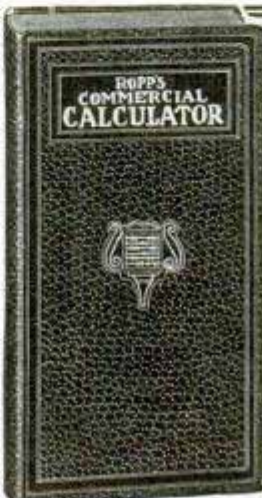

Mathematics Made Easy by ROPP'S CALCULATOR AND SHORT-CUT ARITHMETIC

Shows the Answer as Quickly as a Watch shows the Time to all Problems likely to occur in the Office, Store, Shop, Bank, Farm, or Factory.

Over 2,000,000 Sold

Explains and simplifies every principle in Arithmetic, Mechanics, and Mensuration.

PRICES POSTPAID

- Desk Size, Flexible Keratol Binding.....\$2.00
- Pocket Size, Art Leather Binding.....\$1.00
- Pocket Size, Cloth Binding, \$0.50

POPULAR MECHANICS PRESS
Room 77 200 E. Ontario St. CHICAGO

4 Big Reasons Why They Choose

MARSHALL

FLYING SCHOOL, Inc.

MARSHALL, MISSOURI

1 *Sensible Prices* with unlimited solo flying at \$7.50 per hour.

2 *Competent Instructors.* Our instructors are all experienced aviators.

3 *Modern Equipment* — and flying field.

4 *Ideal Location.* Marshall is in the center of the world's greatest aviation territory.

MAIL THIS COUPON TODAY

MARSHALL FLYING SCHOOL, Inc.,
Dept. D, Marshall, Missouri.

Please send me your booklet "Win your Wings" and other information on your popular priced courses.

Name.....

Address.....

Painting—Decorating Sign Making Art Work

Whatever help you may need along these lines, here is a list of books to choose from. They will enable you to do better work.

House Painting Methods.....	\$2.00
Mixing of Colors and Paints.....	2.00
Graining and Marbling.....	.75
Automobile Painting.....	1.50
Interior Wall Decoration.....	4.00
New Stencils and Their Use.....	1.25
Furniture, Furniture Finishing, Decoration and Patching.....	5.00
Wood Finishing, Plain and Decorative.....	2.00
The Ross Crane Book of Home Furnishing and Decoration.....	3.00
New Hardwood Finishing.....	1.50
The Lacquer System of Sign Painting.....	3.00
Art of Show Card Writing.....	4.00
Studio Handbook—Letter and Design.....	3.00
How to Draw Funny Pictures.....	3.00
Layouts for Advertising.....	3.00
Chalk Talk and Crayon Presentation.....	1.25

NO RISK ORDER PLAN

Pick out any of the above books you want and send us your order with remittance. We will mail the books postpaid. If, for any reason, you are not satisfied with your purchase, return to us and your money will be refunded. Address:

POPULAR MECHANICS PRESS
Room P7—200 E. Ontario St., Chicago, Ill.

BUSINESS BOOKS TO INCREASE YOUR PERSONAL EFFICIENCY

- Rational Typewriting, Brief Course.....\$1.00**
(Gregg System.) Ideal for individual study without the aid of an instructor.
- Personal Efficiency.....\$2.00**
By JAMES S. KNOX. Deals largely with the development of personality, one of the big factors in successful salesmanship.
- Making the Business Speech Effective..\$2.00**
By HARRY C. SPILLMAN. Practical suggestions for speech making, with outlines and analyses by one of the country's foremost orators.
- Personality—Studies in Personal Development. \$1.50**
By HARRY C. SPILLMAN. A wholesome, vigorous book on the development of personal efficiency.
- Gregg Shorthand Manual.....\$1.50**
By R. S. GREGG. A complete exposition of the Gregg System of Shorthand.
- Gregg Speed Studies.....\$1.20**
By J. R. GREGG. A combined supplementary book and dictation course dealing with speed and accuracy.
- Salesmanship and Business Efficiency...\$2.50**
By JAMES S. KNOX. A companion book to the author's other book "Personal Efficiency."

Any of the above books sent C.O.D. anywhere in the U. S. A. Simply pay postman price and the few cents postage when he delivers the package. If outside U. S., send remittance with order.

POPULAR MECHANICS PRESS
Room P-7 200 East Ontario Street CHICAGO

Why it will Pay You to Come to Chicago Tech

Chicago Tech is a college for ambitious men—a college that *you* will want to go to if you've the will to work for success. Loafers don't come here. But serious, hard working fellows find in this college what they need to build a real future . . . a money-making future.



Degree and Diploma Courses—College Grade

Here's why it will pay you. It offers degree courses . . . regular technical training at half cost and almost one-half the usual time. Instruction in practical subjects only without wasting time on those you can never cash in on.

For Success—these 4 fields

Training in the four biggest fields of opportunity, **DRAFTING, ARCHITECTURE, ENGINEERING AND ELECTRICITY**—the fields where a degree and training really mean something in money-making possibilities.

This old established College

Twenty-six years of experience behind you . . . to give you what you will need when you get out in the Technical fields. Every subject under the supervision of specialists.

Here in Chicago

The advantages that only a resident school located here in Chicago can give you. Building activities going on all the time . . . right in the center of the world's greatest industrial metropolis—where you can see every day with your own eyes what's going on in the technical fields. Part time positions to help defray expenses. Personal contact with instructors. College activities, athletics.

We have a special plan for men who have not finished high school. Send the coupon—it brings all the facts.

Send for Free 80-Page Blue Book!

This book points the way to success in the Technical fields through college training. It brings you all the facts about the great opportunity that awaits you at Chicago Technical College. Send in the coupon now . . . there is no obligation!

CHICAGO TECHNICAL COLLEGE

Dept. H-78, Chicago Tech. Bldg.
118 East 26th St. CHICAGO, ILL.

Chicago Technical College
Dept. H-78, 118 E. 26th St., Chicago

I want to know how I can get a degree or diploma and be college trained in Drafting, Engineering, Architecture and Electricity in less time and with less cost. Send me your Blue Book, free, without a cent cost to me.

Name.....

Address.....

City.....State.....

Swear Off Tobacco



Tobacco Tells on Nervous System



Tobacco Ruins Digestion



Tobacco Stunts Boy's Growth



Tobacco Robs Man of Vitality



Tobacco Steals from You the Pleasures, Comforts, Luxuries of Life

Let Us Help You Banish the Tobacco Habit

QUICK RESULTS

Trying to quit the tobacco habit unaided is often a losing fight against heavy odds, and may mean a distressing shock to the nervous system. So don't try it! Make the tobacco habit quit you. It does quit many of those who take Tobacco Redeemer according to directions.

It doesn't make a particle of difference whether tobacco has been used for a single month or fifty years, or how much, or in what form—whether it be cigars, cigarettes, pipe, plug, fine cut, or snuff. In most cases, Tobacco Redeemer removes all craving for tobacco in any form in a few days. Tobacco craving usually begins to decrease after the very first dose—there's no long waiting for results.

Tobacco Redeemer contains no habit-forming drugs of any kind and is safe, quick, pleasant, and thoroughly reliable.

Not a Substitute

Tobacco Redeemer is in no sense a substitute for tobacco, but is a radical, efficient treatment. After finishing the treatment, there is usually no desire to use tobacco again or to continue the use of the remedy. It helps to quiet the nerves, and makes one feel better in every way. If you really want to quit the tobacco habit—get rid of it so completely that when you see others using it, it should not awaken the slightest desire in you—you should at once begin a course of Tobacco Redeemer treatment for the habit.

Our Positive Guarantee

A single trial should convince the most skeptical. Our legal, binding, money back guarantee goes with each full treatment. If Tobacco Redeemer fails to banish the tobacco habit when taken according to the plain and easy directions, money will be cheerfully refunded upon request.

Let Us Send You Convincing Proof

If you are a slave of the tobacco habit and want to find a sure quick way of quitting "for keeps," you owe it to yourself and to your family to mail the coupon today or send your name and address on a postal, and receive our free booklet on the injurious effects of tobacco on the human system and positive proof that Tobacco Redeemer does quickly relieve the habit for most uses.

Newell Pharmacal Company
Dept. 300, Clayton Station, St. Louis, Mo.



Free Book Coupon

NEWELL PHARMACAL CO.

Dept. 300 Clayton Station St. Louis, Mo.

Please send, without obligating me in any way, your free booklet regarding the tobacco habit and proof that Tobacco Redeemer does positively relieve the tobacco habit in most cases. If it fails your money will be refunded.

Name.....

Street and No.....

Town..... State.....

Play a Gibson BANJO



Chief Eskimo
HARRY RESER
of the Clichot Club Eskimos

Learn to play a Banjo, Guitar, Mandolin or Ukulele. It is easy to learn and makes you popular among your friends. If no teacher in your city, ask us about Reser's Correspondence Course.

FREE TRIAL EASY PAYMENTS

Write for this **FREE GIBSON BOOK**
Gibson Inc.

703 Parsons St., Kalamazoo, Mich.

Does Your English Help or Hurt You?

Wonderful new way to improve your English. No rules to learn. No hard study. Grammar, spelling, punctuation, and expression, taught in 15 minutes a day—at home. Self-correcting feature makes it fascinating and easy. Write today for free booklet, "How You Can Master Good English in 15 Minutes a Day." Address



SHERWIN CODY SCHOOL OF ENGLISH
57 Searle Building Rochester, N. Y.

What Do You Do When You Cannot Find the Book You Want?

Don't give up in despair. Send for a copy of the unique catalog published by Popular Mechanics Press. It contains 5000 books listed alphabetically under 2000 main subjects and sub-headings—literally from A to Z—Abrasives Manufacture to Zoologist and everything in between.

FREE UPON REQUEST

Send for your copy today

POPULAR MECHANICS PRESS
200 E. Ontario Street, CHICAGO

NEED A BETTER GRIP ON MATHEMATICS?

SEND for a copy of "Mathematics for the Practical Man," only \$1.50. By common sense methods it removes the mystery and difficulties so that algebra and even calculus are made simple.

Assuming your knowledge is limited to arithmetic you quickly and easily gain a working knowledge of Algebra, Geometry, Trigonometry and Calculus. Simply pay postman price of book plus the postage when he hands you the package.

Popular Mechanics Press
Room P7
200 E. Ontario Street, Chicago

NOW FIX ANY MAKE OF AUTO



SIX BIG AUTO BOOKS ALL SHIPPED FREE

on approval; whether you want to qualify as garage owner, auto repair expert or merely wish to know how to keep your own car 100% efficient, look at these books—they are sent to you for free examination. This brand

new 1930 edition has been prepared by a large group of America's greatest automotive engineers. Anybody who can read will understand them, for this great automobile encyclopedia is a veritable gold mine of valuable facts. Take advantage of this great opportunity now; send in the coupon for FREE examination. You don't pay us a penny, you don't obligate yourself to pay anything unless you decide to keep the books. Just tell us you want to see them and the full set of 6 great volumes, just off the press, will be sent to you. Read them, look them over and prove to your own satisfaction that one fact alone, which you will find in them, may save you an expensive repair, or help you to a better job.

Aviation Motors

In addition to being a complete encyclopedia of automobile engineering, these books contain over 100 pages on Aviation Motors, and as they are just off the press they bring to you the newest and latest information obtainable. This alone makes these books invaluable to anyone.

New 1930 Edition

Imagine books which are so new that every page is right up to date—wiring diagrams, construction details, service problems—are all right up to the minute. Nowhere else that we know of can you get as complete and up to date information. Over a million dollars of resources have enabled us to give you the most up to date books on the subject ever published. You will find nearly 20 pages on front wheel drives alone. Everybody interested in automobiles in any way will welcome these books, especially on our no money offer.

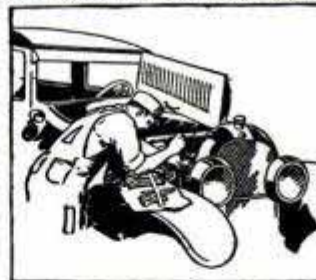

CAN YOU FIX IT?

Can you take out "play" in differential? Can you kill the "shimmy" in steering? Can you reset TIMING? Can you put your finger on engine trouble without guessing or tinkering? Can you pull the starter off and fit it? Can you adjust and repair transmission, engine, rear axle, bearing?

These Books Tell How

and they tell you how to do any and every auto job right, the first time.

6 Big Volumes

Nearly 3,000 pages, over 2,000 illustrations, wiring diagrams, equipment charts, etc. De Luxe edition with gold-stamped flexible binding. Sent FREE for 10 days' use. If not wanted return express collect. If kept, send only \$2 after 10 days, then \$3 a month until special advertising price, \$24.80, is paid.

A Year's Consulting Membership FREE!

Privilege of consulting engineers of million-dollar American Technical Society on any automotive problem for one year without charge, if you mail coupon immediately.

SEND NO MONEY

American Technical Society, Dept. A-B19,
Drexel Ave. at 58th St.,
Chicago, Illinois.

I would like to see the new 6 volume 1930 edition of your automobile books but without any obligation to buy. I will pay the few cents delivery charge only and will examine the books and return them at your expense in 10 days unless I like them, in which case I will send you \$2.00 then and only \$3.00 per month until the special price of only \$24.80 is paid. You are to include free consulting membership certificate in the American Technical Society. Send brand new 1930 edition.

Name.....
Street.....
City..... State.....
Employer's Name.....
Employer's Address.....

Home of the International Correspondence Schools

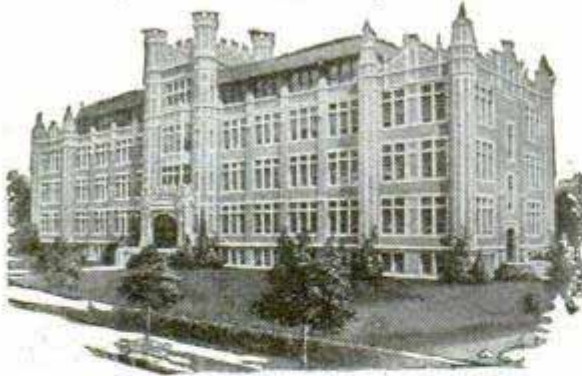

Go to High School at Home

You can secure a high school education right at home by studying the splendid new courses recently prepared by the International Correspondence Schools.

These courses are equivalent to the courses given in resident high schools. They have been specially arranged for men and women who wish to meet college entrance examinations, to qualify for a business position, or to make up the education they missed when forced to leave school too soon. A diploma is awarded at graduation.

Mail Coupon for Free Booklet

INTERNATIONAL CORRESPONDENCE SCHOOLS
Box 5692-F, Scranton, Penna.

Without cost or obligation, please send me full particulars about the course I have checked below:

- | | | |
|--------------------------------------|---|--|
| <input type="checkbox"/> English | <input type="checkbox"/> High School Course | <input type="checkbox"/> Civil Service |
| <input type="checkbox"/> Bookkeeping | <input type="checkbox"/> Salesmanship | <input type="checkbox"/> Advertising |
| <input type="checkbox"/> Accounting | | |

Name.....

Address.....

Dentists Need Men



Experts
Earn up
to
\$125⁰⁰
a week

Make Crowns, Plates, Bridgework, etc. for Dentists

We teach you to make rubber plates, crowns, bridge work, metal base dentures, etc., for dentists. After graduating you are ready for a job or can open your own laboratory. We assist you.

Demand for Men

Thousands of dentists everywhere send work to mechanical dentists. We train you quickly in day or night school for this uncrowded field. No classes—no books—no mechanical experience necessary. Work your way thru school. We help you find a job to meet your expenses while taking our training. Railroad fare allowed to nearest school.

MAIL COUPON FOR FREE BOOK

McCARRIE SCHOOL OF MECHANICAL DENTISTRY,
1338 S. Michigan Ave., Dept. 397, Chicago.

Without cost or obligation, send me your illustrated book on Mechanical Dentistry, and complete information as to my opportunities in dental laboratory work.

Name.....

Address.....

Don't Be Afraid To Tackle That Concrete Job!

With the instructions found in the new, revised edition of Popular Mechanics Concrete Handbook you can make any of the following useful articles:



- Garden Seats—Fountain and Basin—Flower Boxes and Vases—Pedestals and Bird Baths—Ornamental Pools—Sanitary Drinking Fountain—Gateposts—Auto Driveway—Sidewalks—Boat Landings and Docks—Entrance and Garden Walks—Sidewalk Flaggings—Narrow Curb Walks—Curbs and Gutters—Wall Coping—Steps—Garage Floor—Basement Floor—Fence Posts—Lawn Roller—Cistern—Chimney Cap—Refuse Burner—Culvert—Benches for Greenhouses—Tile—Retaining Walls—Foundation Supports—Engine Foundations—Septic Tank—Toy Blocks—Forge—Fireproof Safe—Ice House—Watering Troughs—Milk House—Smokehouse—Silo—Horse Stalls—Hitching Post—Rural Mail Box Post—Cyclone Cellar.

Build With Ease for Permanence and Beauty

This is a book of practical plans for using concrete about the home, farm or shop. For amateurs as well as contractors. In addition to making all the articles mentioned above the making of good concrete mixtures for various classes of construction is given; mechanical mixers and homemade tools are dealt with. All necessary form and mold making are covered as well as many other valuable pointers too numerous to mention here.

Simply write and ask us to send you this book. When postman hands you the package pay him \$1.00 plus the postage. If outside U. S. remit when ordering and include 15 cents extra for mailing.

POPULAR MECHANICS PRESS
Room P7 200 E. Ontario Street CHICAGO

AUTO REPAIRMEN EARN GREATER PROFITS

Get your share of the big money being spent on automobile upkeep.

Put improved time, labor and money-saving ideas to work in your shop to-day. Take advantage of our special bargain offer and secure 3 valuable kink books at a reduced price.

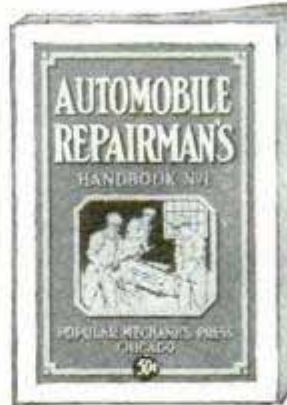

1. 334 Valuable Discoveries made by auto mechanics in our **Automobile Repairman's Handbook**. 337 Illustrations.

2. 301 Ways to use drills, drill presses, taps and dies more effectively in our **Drilling and Thread Cutting Handbook**. 298 Illustrations.



3. 259 Kinks furnished by the most expert Lathe Operators in our **Lathe Handbook**. 212 Illustrations.

Special Offer—These 3 books (regular price 50 cents each, \$1.50 value) are offered for a limited time for only 98 cents plus postage. Pay postman C. O. D. when he delivers or if outside U. S. send 98 cents and 15 cents extra for postage.

POPULAR MECHANICS PRESS
Room P7
200 E. Ontario St. CHICAGO

ICE from Heat

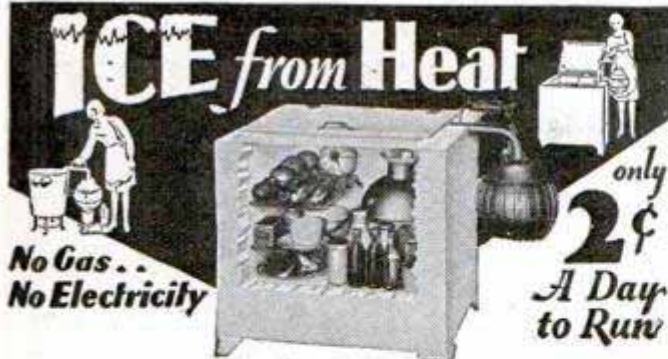

No Gas...
No Electricity

only
2¢
A Day
to Run

It's the amazing Crosley Icyball Refrigerator at the world's lowest price—both first cost and up-keep. Actually makes ice from heat. Eliminates all make-shift methods of cooling. Safeguards health. Saves food. Saves money. The only practical mechanical refrigerator for farm homes where electricity and gas are not available.

SIMPLE--NOISELESS

Has no moving parts, requires no oiling, no servicing. Absolutely noiseless. No watching, no break-downs. Refrigerant never needs replenishing. Over 30,000 in use and giving wonderful satisfaction. Absolutely guaranteed. Rush name and address for illustrated literature describing this amazing refrigerator.

Only
\$90
Complete

CROSLY ICYBALL DIVISION
817 Arlington St. Cincinnati, O.

AGENTS WANTED: Any one can qualify. No experience necessary. Write for special agent's offer.

Learn
ADVERTISING
at Home

Greater opportunities now in advertising. Learn easily and quickly in spare time. Practical work. No text books. Old established school. Low tuition—Easy terms. Send for free booklet of interesting information.

Page-Davis School of Advertising
Dept. 135-B, 3601 Mich. Av., Chicago



SQUAB BOOK FREE

Breed PR squabs for rich trade. Sold by millions at higher prices than chickens. Write for free 48-p. book telling how to do it and how to profit by new sales method which gets the big money.
PLYMOUTH ROCK SQUAB CO., 634 H Street, Melrose Highlands, Mass.



RAISE CHINGILLA

AND NEW ZEALAND WHITE

FUR RABBITS Make Big Money

We Supply Stock

and pay you following prices for all you raise:

Chingillas average \$8 each—New Zealand

Whites \$3 each. 32-page illustrated book, catalog

and contract, also copy of *Fur Farming* maga-

zine, tells how to raise rabbits for big profits, all for 10c. Address

OUTDOOR ENTERPRISE CO., Box 1021 Holmes Park, Missouri



MAKE MONEY RAISING SQUABS

Highest market ever known. Breeders shipped everywhere. Homers, Carneaux, White Kings a specialty. All other breeds. Send 10 cts for 32 page catalog and price list.

Allston Squab Co. 61 N. Beacon Street
ALLSTON, MASS.

Great New Invention

For Seekers of Health—Power—Beauty

ELCO ELECTRIC HEALTH GENERATOR

Generates High Frequency Violet Ray, Mechanical Vibration, Medical Electricity and Ozone. Four of Nature's Greatest Curative Agents. For Home Treatments at less than 50 cents per year.

FREE BOOK "Health, Power, Beauty" describing this Great New Invention. Re-vitalize yourself. Bring back energy. Be wholly alive. Write Today. Lindstrom & Co., 2322 Indiana Ave., Dept. B-135, Chicago



Will Grow Your Hair Or Cost Nothing



Before: Slavin at 45

Growing hair is now a science. Hair roots don't die. They get clogged with dry alkalis and poisons and the hair shaft simply can't grow out.

Our treatment removes these and supplies nourishment. It has grown hair on thousands of heads and is guaranteed to grow hair on your head, stop falling hair, eliminate dandruff, and relieve itching scalp or refund will be made of every cent of your money.

Don't suffer baldness or any abnormal scalp condition any longer. Send NOW for FREE information without any obligation on your part.

Slavin Institute, Dept. 11, 508 S. Dearborn St., Chicago After: SLAVIN at 65



WHAT

the World Thinks

of this National System of Govt. Approved AVIATION SCHOOLS



Let the opinions of those who know through actual experience be a guide to you in selecting an Aviation School. You cannot, then, go far wrong. Read these letters taken at random from our files:

"I thought you might be interested in knowing after completing a course in aircraft welding under your instruction that I have built a Heath light plane fuselage and did a neat piece of work on it, too. Of course, a knowledge of blueprints is very helpful to me also, but without Universal's welding course I could have never done this job. I made back part of what the course cost me."
—E. Ten Eyck

"Mr. Roscoe Prescott, procured through you about two months ago, has proven very satisfactory as our Chief Instructor. Today, we have had the pleasure of receiving Mr. H. D. Philbrick as Chief Welding Instructor, who by all appearances will prove satisfactory. We want to thank you for this service."
—Andrew L. Schaidler
President, The Aero Corp. of America

"The training received in the business class combined with my previous sales experience fitted me for this position to the satisfaction of the . . . Aircraft Corporation. I again want to thank you for your personal interest and wish you continued success."
—V. M. Huff

"This will come as a surprise to you, and I hope a pleasant one. You will see by the letterhead (. . . Airplanes) that I have succeeded, thanks again to the Universal School at St. Louis and its officials. I passed my examination for Transport Pilot the 1st and am exceedingly happy. My mother bought me a ship, and I am doing very well here. The first two months have passed and in figuring up my average earnings I find that it averages \$1500 the first two months and expect to do better."
—Harold S. Platt

Sent free You will be interested in reading, "Aviation—What It Means to You"—a book about Universal Aviation Schools which we gladly send you free. This book describes in detail the various Flying, Mechanics, Welding, Business and Extension Courses offered in Universal Aviation Schools, and gives you all information which you will want to have. Send for your copy today.

MAIL this Coupon

UNIVERSAL Aviation Schools

Division American Airways, Inc.

1047-56 Boatmen's Bank Bldg., St. Louis, Mo.

Please send me, without obligation, a copy of "Aviation—What It Means to You," and advise me what training I need to become

Pilot Mechanic Welder Office Executive

Name Age

Address Phone No.

City State or province

My past experience other than aviation is



PLEASE PRINT CLEARLY

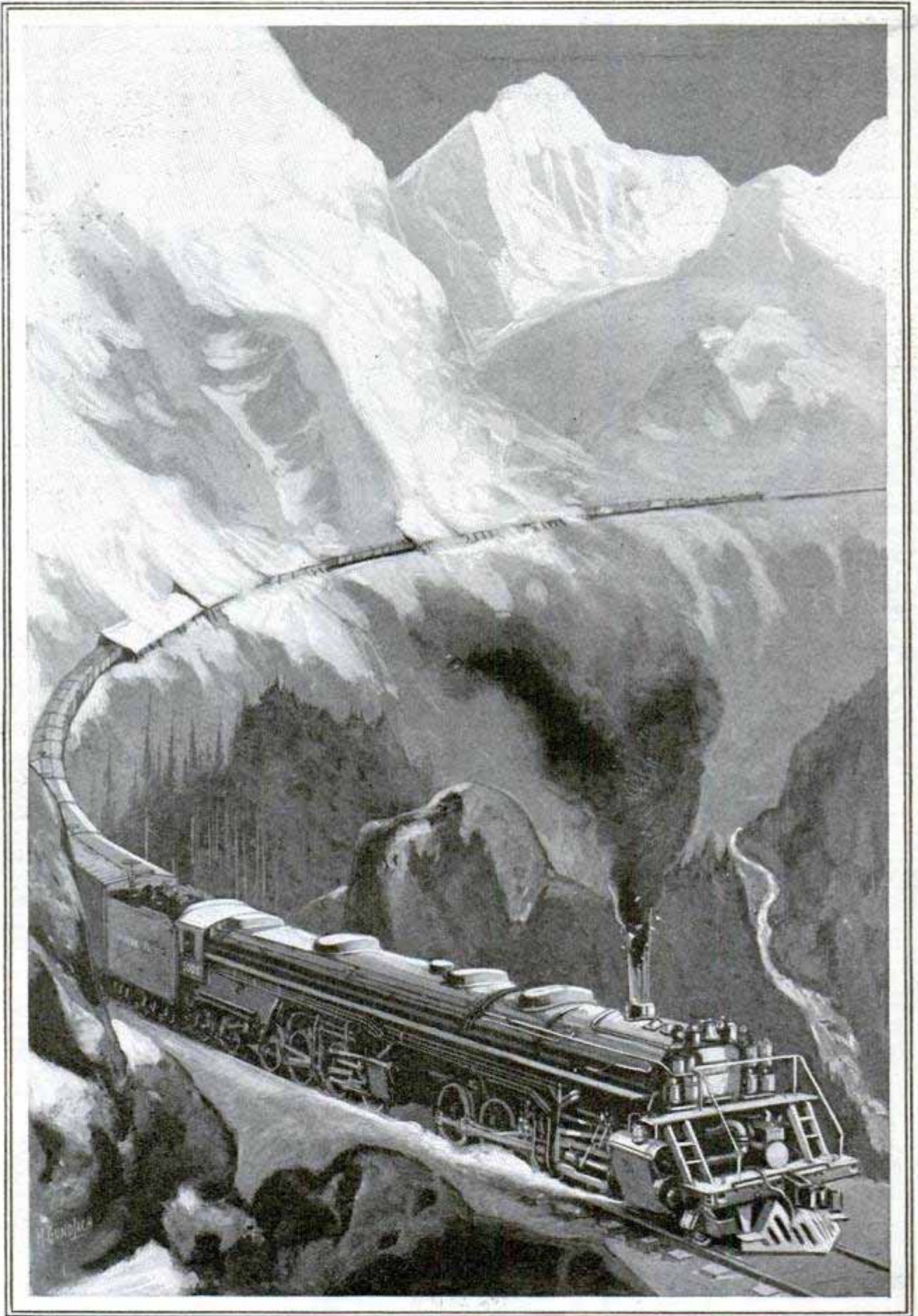

A Giant of the Rails at Work among the Mountains; Drawing of One of the Northern Pacific Railway Company's Monster Locomotives Hauling Long Train up a Steep Grade—See Page 96—

Popular Mechanics Magazine

REGISTERED IN U. S. PATENT OFFICE

WRITTEN SO YOU CAN UNDERSTAND IT

Vol. 54

JULY, 1930

797

No. 1

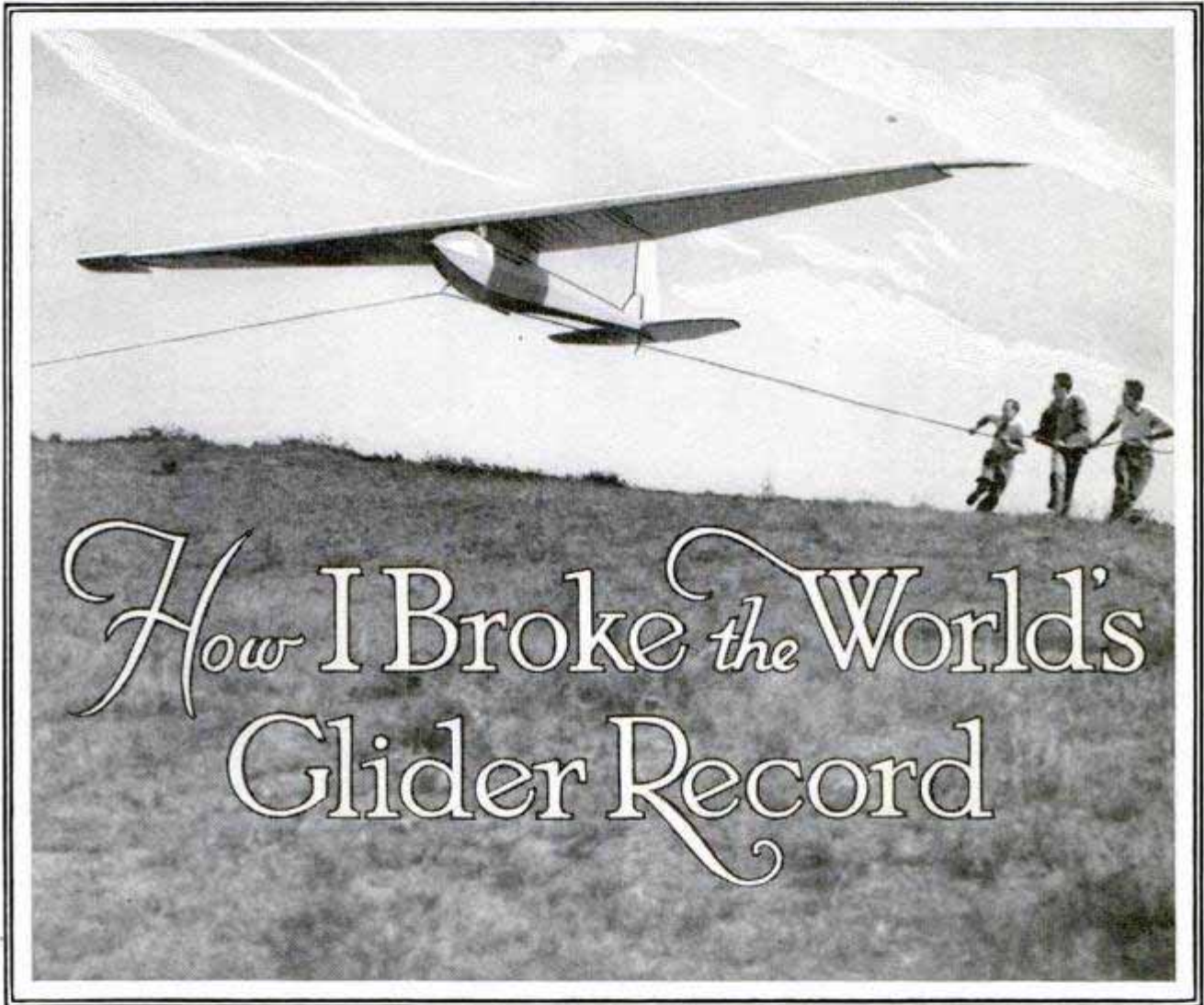

How I Broke the World's Glider Record

Barstow Being Catapulted into the Air from the Top of Point Loma in His Sixty-Foot Sailplane for the Start of His Flight of Fifteen Hours and Twelve Minutes

By JACK BARSTOW

I DIDN'T start to make or break any records, when I took off into a south wind from the top of Point Loma, near San Diego, a little after noon on April 29. I went up to try out a Bowlus sailplane and to see if I could take off from the point, 750 feet above the ocean, into a south wind, which the glider-theory experts had said couldn't be done.

When I landed, almost at the spot from which I was catapulted into the air, it was near four o'clock of the morning of April 30. I had been in the air fifteen hours and twelve minutes, beating the American

record by more than six hours, and the world record of Lieutenant Dinort, in Germany—fourteen hours and forty-five minutes—by twenty-seven minutes.

Though I had no barograph, I am certain, owing to the strength of the wind and the rate at which I was climbing, that during the night I reached an altitude of at least 1,000 feet above sea level, or more than 250 feet above the starting point of the flight. I had on only light summer clothing and no supplies, not even water. But as I felt the power of the wind and saw how easily the sailplane

Cont. H. H. Dunzi, 4351 Georgia St
San Diego, Calif.

797
2



of vision of the automobile lights and the fires, circling around them, flying on a triangular course with the ground lights in the center, or moving along a straight line on the

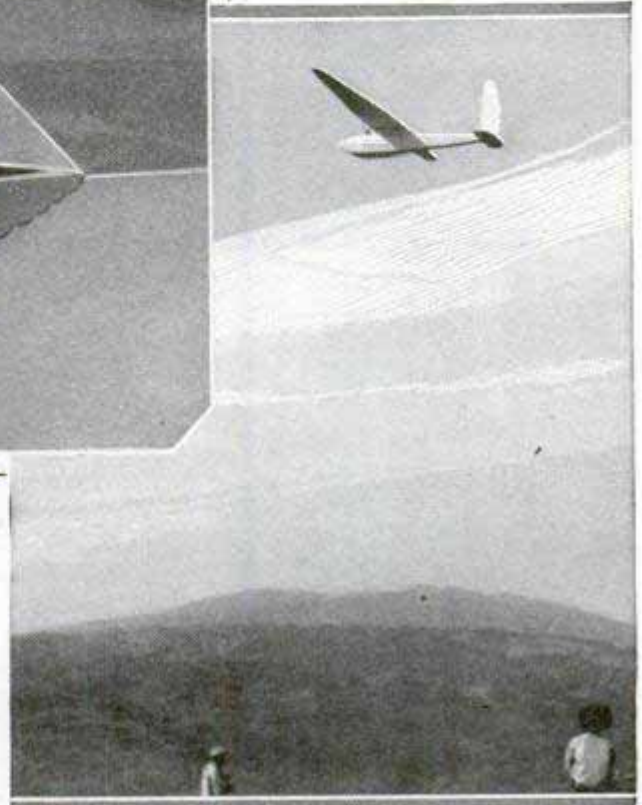

responded to the air currents, I remained aloft, even after I had proved the glider itself. Darkness came, rain in heavy gusts blew in from the sea and the wind stiffened. I had been up more than four hours. It seemed possible that I could stay up long enough to break the American record of nine hours, five minutes and thirty-two and two-fifths seconds, made this spring by W. H. Bowlus, designer and builder of the sailplane I flew, also flying over Point Loma. I did not feel the cold, hunger or thirst, but I did miss a cushion. The controls worked perfectly.

The Record Breaker in the Cockpit of the Glider and Skimming along About 200 Feet above Ground

William Van Dusen, official representative of the National Aeronautical association, held the watch on me throughout the flight. I could see the lights of the automobiles and the watch fires of my companions on the point below, but I could see nothing of the ocean, though I could hear its roar. To right and left and above. I seemed to be floating in a soft mass of gray down, through which it was impossible to see. I could not tell in which direction I was flying, so I kept within a radius

coast, until the lights became dim, when I would turn and go back.

You have no idea how lonely it is, with no roaring motor to hear, no fellow flyer to talk to, nothing but the silence, with an occasional creak from some part of the glider, or the whimper of the wind through the plane. I climbed until I could hardly see the lights and then voluntarily came down—a thing a glider pilot rarely dares do—until I could see them, when I found no difficulty in rising again, so strong was the wind.

Ten hours went by, busy but slow hours; busy, because every nerve, every muscle, was working to take advantage of every

BELIEVING that gliding is one of the most interesting of all sports and that it is the least expensive way of obtaining flying experience, Popular Mechanics will print next month a fascinating article on "I Learn to Fly a Glider," by "Bud" Perl, a sixteen-year-old boy.—The Editor.

gust, to lift the sailplane up the wind, to carry it across the air currents and still lose no altitude or lifting power. It was like being the mind and body of a bird, dependent only on the very wind itself for movement and elevation. Several times I sailed out over the ocean, which I could hear pounding on the rocks below.

At the end of these ten hours, I knew I had beaten the American record, and then I determined to stick it out for the world mark, if I could make it. I tried to fly blind, crouching down in the cockpit, so that my head and face were protected from the wind-blown mist, but I found this would not work. I needed all my faculties, up and out, to keep within range of the light of those fires and automobiles.

About 3:45 in the morning, the wind began to die down. I managed to stay up for eleven minutes more, but at 3:56 was forced to come down, landing very close to the point of take-off, fifteen hours and twelve minutes earlier.

TIGHTENING SPOKES ON WHEEL ENDS AUTO SQUEAKS 640



With the aid of a portable tightener now on the market, wooden automobile spokes are quickly readjusted, eliminating unpleasant noises, strengthening the wheel and correcting its alignment. The spoke is pressed in at the hub, the steel felloe is reset against the shoulder of the spoke, and the tenon is set tight around the neck, all in one operation and without disturbing the bearings.

Coffer Tool Co., Sandpoint, Idaho.

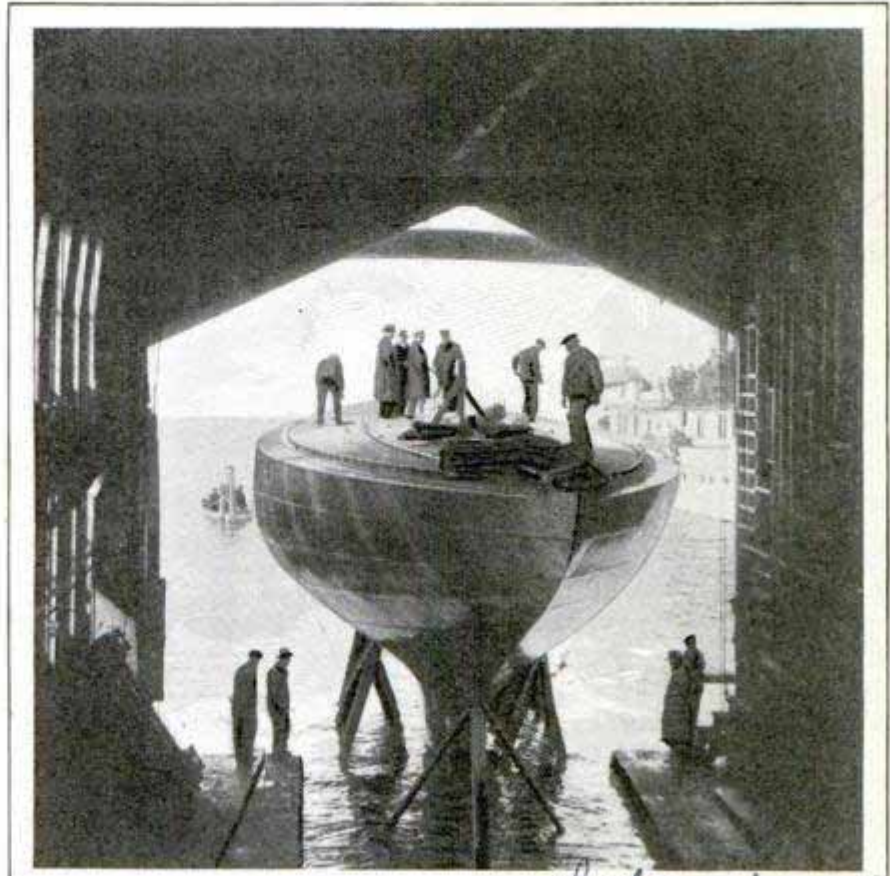

Closely Guarded Launching of American Yacht "Enterprise," Possible Defender of America Cup against Sir Thomas Lipton's "Shamrock V"

AMERICAN YACHT-RACE ENTRY TAKES TO THE WATER

Surrounded by secrecy, the trim little yacht "Enterprise," possible defender of the America cup against Sir Thomas Lipton's "Shamrock V," recently was launched at Bristol, R. I., following its formal christening. The yacht will compete with other boats for the honor of defending American supremacy against the Lipton entry. The launching took place in the early morning to avoid sight-seers, and the boat was closely guarded to prevent its details from becoming known.

ELECTRIC ENERGY IN MILK FAT GOVERNS CREAM CONTENT 803

Cream content of milk can be increased by diminishing the electric charges carried by the fat globules. These globules normally carry a negative charge which is decreased by heating to 142 degrees, and increased above that temperature. The cream layer on a bottle of milk is deeper under conditions causing a decrease in charge, as in pasteurizing.

Cont. Leslie Grear, 7754 East End Ave

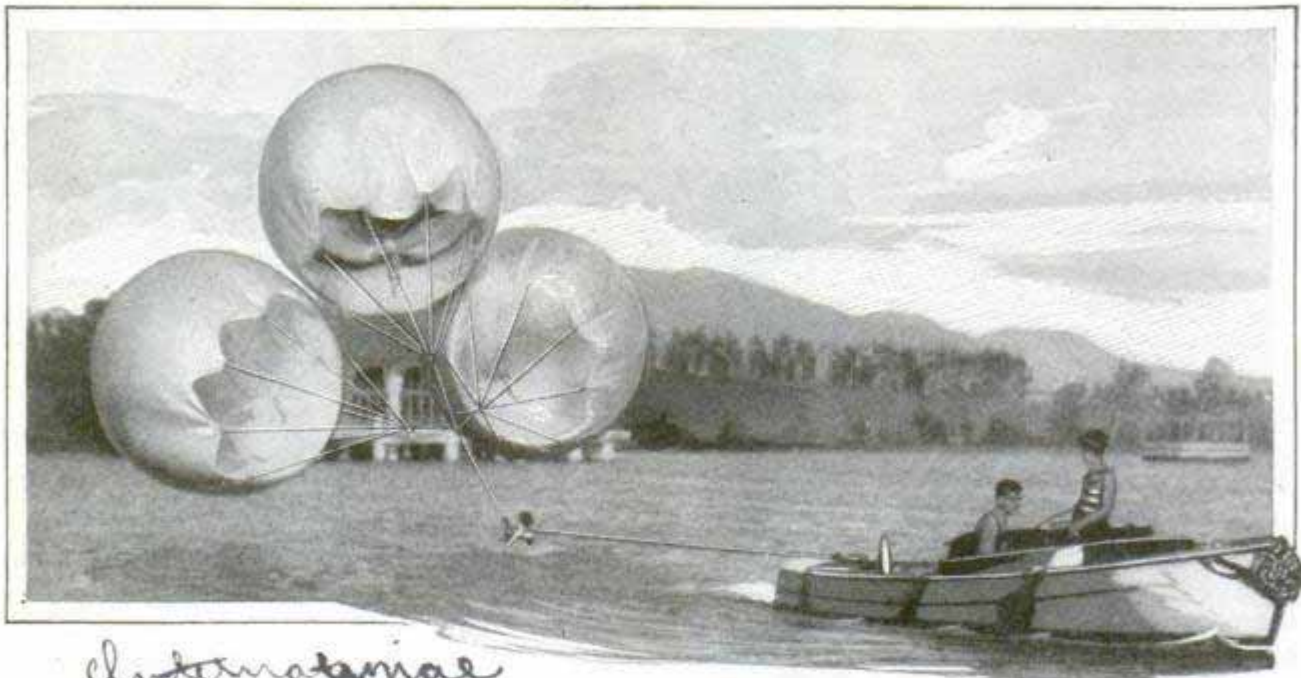

Intermaria

Three Large Balloons Used to Pull a Surfboard and Its Rider over the Water; the Photograph Shows a Motorboat Towing the Balloons and the Rider Back to the Starting Point

BALLOONS DRAW SURFBOARD AND RIDER OVER WATER

Three large balloons have replaced the motorboat as a means of motive power for surfboard riders. The balloons, traveling with the wind, draw the board and rider over the surface of the water, often at a fast clip, and when the end of the course is reached, a motorboat tows the board, rider and balloons back.

CRUDE OIL CHANGED TO EQUAL AMOUNT OF GASOLINE

Hydrogenation, the process of turning oils into lighter ones by adding hydrogen, is being employed commercially in the United States today as a means of producing 100-per-cent colorless gasoline from a given volume of crude oil or fuel oil. Refinery processes heretofore used have averaged about forty-two per cent of gasoline from a barrel of crude oil. The process, developed in Germany as a war-time necessity, also can be applied to coal, which can be made to yield gasoline and oil. Coal is carbon, and oil is carbon plus hydrogen, and the more hydrogen in proportion to carbon content, the lighter the product. The German process has been to add hydrogen atoms under great heat and pressure, in order to make lighter compounds. A German

plant already has produced a high-grade gasoline from coal, and three plants are being erected in the United States for work with crude oil. The process which converts coal reserves into potential oil reserves, and gives a 100-per-cent yield of gasoline from crude oil, removes the possibility of a motor-fuel shortage as a factor in American automotive development, and removes from the petroleum industry the problem of disposing of the overproduction of by-products that have been obtained through refining processes heretofore employed.

TABULATOR FOR BRIDGE SCORE LIKE ADDING MACHINE

Operating like a vest-pocket adding machine, a bridge-score tabulator keeps a running record of total points and honors, accomplishing most of the task automatically. It works by manipulating tabs before digits with a pencil point placed in dots for this purpose, the process causing totals to be checked in columns at the top. It also shows the number of the hand.



\$5.00

*I. So. Farber Industries A.S. Corp.
 Leuna Germany
 796*

Kansas City Mo. 67313

Standard Oil Co.

Reliable Systems Co. 303 W...

Mr. Westheimer
7754 East End Ave

Chicago

544

SHOWER BATHS FOR CABBAGES

Shower baths for cabbages that are to be used for sauerkraut improve the quality of the product, agricultural experts at the University of Wisconsin have found. Washing the cabbage in a stream of running water before cutting removes from sixty to seventy per cent of the bacteria normally present on the leaves. The outside of the head contains from fifty to sixty million bacteria per ounce and the inside about 40,000. The latter are beneficial in kraut making, but only one-fourth of the outer ones are of the desirable type. Washing produces kraut superior in flavor and aroma.

799

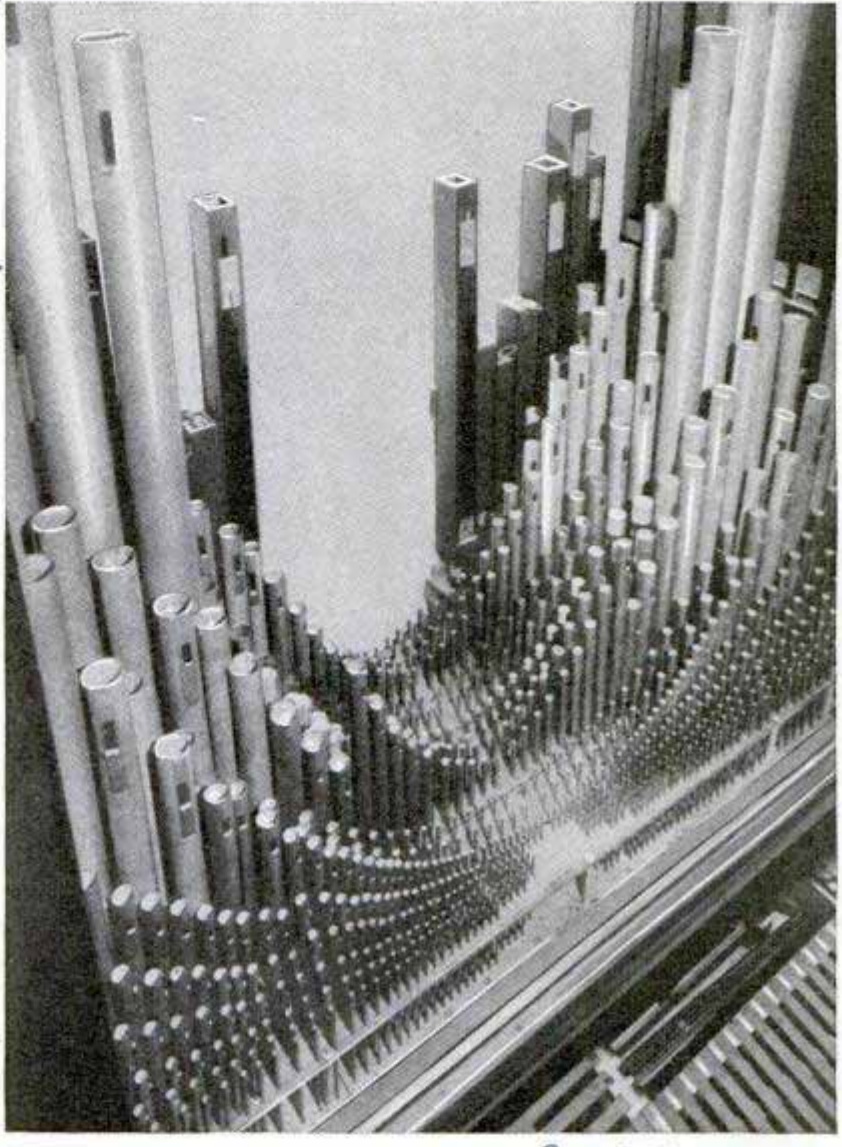

Courtesy The Illustrated London News, Mar. 8, 1930.
Bird's-Eye View of a Pipe Organ; a Photograph Taken Looking Downward on the Pipes of an Organ in a Paris Concert Hall

BICYCLE-CANOE IS DRIVEN BY PEDAL SIDEWHEEL

Some of the principles of the old sidewheel river boat, the bicycle and the ordinary canoe are combined in a bicycle-boat for water travel. It is a canoe fitted with sidewheel paddles propelled by pedals and guided by handlebars. The latest sidewheeler also can be operated by a motor.

779

DENSE FOREST OF ORGAN PIPES SHOWN IN UNIQUE PHOTO

"Pipes of the modern Pan" might be an appropriate title for an unusual picture, taken from above, of the pipes and part of the keyboard of a great organ in a Paris concert hall. The downward photograph of the forest of pipes of varying sizes might easily be mistaken for a bird's-eye view, taken from a considerable altitude, of the skyscrapers of a modern city with graduated rows of smaller buildings clustering about them.



Fitted with Sidewheel Paddles, Handlebars and Pedals for Guiding and Propelling the Bicycle-Boat

ter down to the level required

60 brand
the water
mounting
to force

tion. It

Mr. Charles H. Clark
New York City
60 brand

American Philosophical Society

6
453

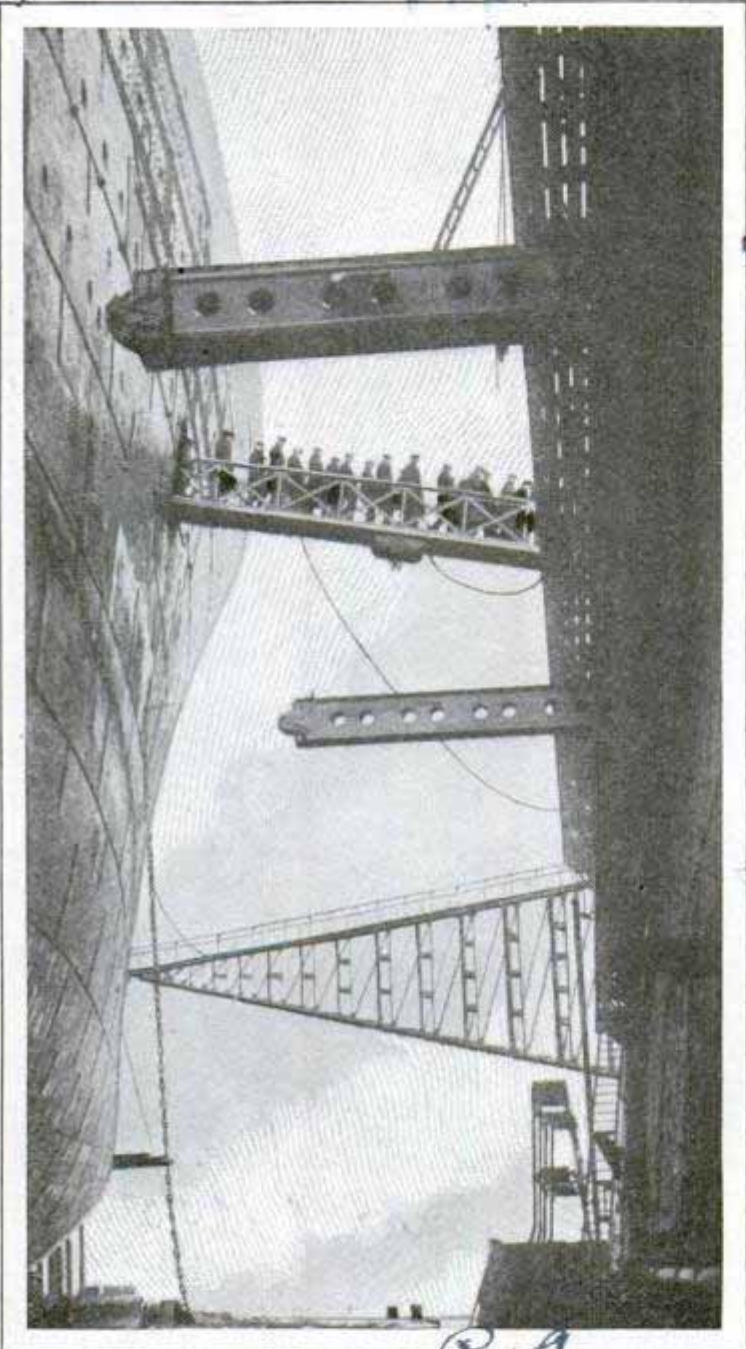

Workmen Passing over Bridge Suspended between the Giant Liner "Olympic" and Top of Her Floating Dock

BRIDGE FROM SHIP TO DOCK SHOWS SIZE OF LINER

Workmen boarding and leaving the giant liner "Olympic," while the vessel lay in her floating dock at Southampton, England, traveled by way of an overhead bridge swung from the side of the ship to the surface of the dock. The arrangement gave a startling impression of the mammoth proportions of the liner viewed from below, where the spectator, gazing upward, saw on one side the vast bulk of the towering vessel, on the other the rising dock, and between them the narrow

bridge spanning the canyon across which seemingly tiny workmen passed back and forth.

AN IMAGINARY FLIGHT TO SUN PICTURED BY SCIENTIST

771

If it were possible to speed through space at the rate of 10,000 miles an hour, a trip from the earth to the sun would consume about thirteen months, and it would cost at least \$50,000,000 a minute to keep the traveler alive after he got there. Such is the calculation of Prof. John Q. Stewart, of Princeton University, who recently described an imaginary trip from the earth to the center of the sun as the fanciful possibility of some remote future explorers. Making the astronomical flight of fancy in a space ship traveling 10,000 miles per hour, three minutes would be required to reach the top of the earth's atmosphere, one day to come to the moon's orbit, three and one-half months to reach the orbit of Venus and four and one-half months more to travel to the orbit of Mercury. From this point to the sun's corona would require four and one-half months; two weeks would be required to traverse the corona, and an hour to go through the chromosphere. It would take four seconds each to go through the intermediate layer and photosphere, and

the journey on to the sun's center would be made in forty-two hours. To make habitable a space of ten cubic feet in the ship at the sun's surface would require refrigerating machinery rated at 60,000 kilowatts, and at the center, where temperature has been estimated at 40,000,000 degrees Centigrade, the power required to keep cool would be multiplied 4,000 trillion times. If power cost one-thousandth cent a kilowatt-century, a billion times cheaper than the usual present rate, the refrigerating bill to keep the traveler alive would reach the enormous amount mentioned above.

Science Service News Bulletin 474-7

Col. J. Wilkins, Esq.
Colombiere, 29 Bean Road,
POPULAR MECHANICS
Danish inventor *Berley Beath*
no longer by

**AUTO THAT FLOATS, SUBMERGES
 OR FLIES IN THE AIR** 793

Experiments recently have been conducted by the Danish government with an automobile that can be converted at will into a boat, a submarine, or an airplane. The four-element craft can travel over land on pneumatic tires, launch itself into the sea as a boat, convert itself into an underseas craft, and, upon coming to the surface, unfurl telescoping wings and rise into the air. In appearance it resembles a tapering, all-metal boat hull with wings which can be folded by switches inside the hull. Before submerging, the wings are folded and watertight compartments are closed. On the surface of the water, the craft can be steered like an ordinary boat by means of rudder and screw. The wheels under the body can be raised or lowered.

Demonstrating with a Small Model the Method of Stopping a Train with a Beam of Light from an Electric Eye

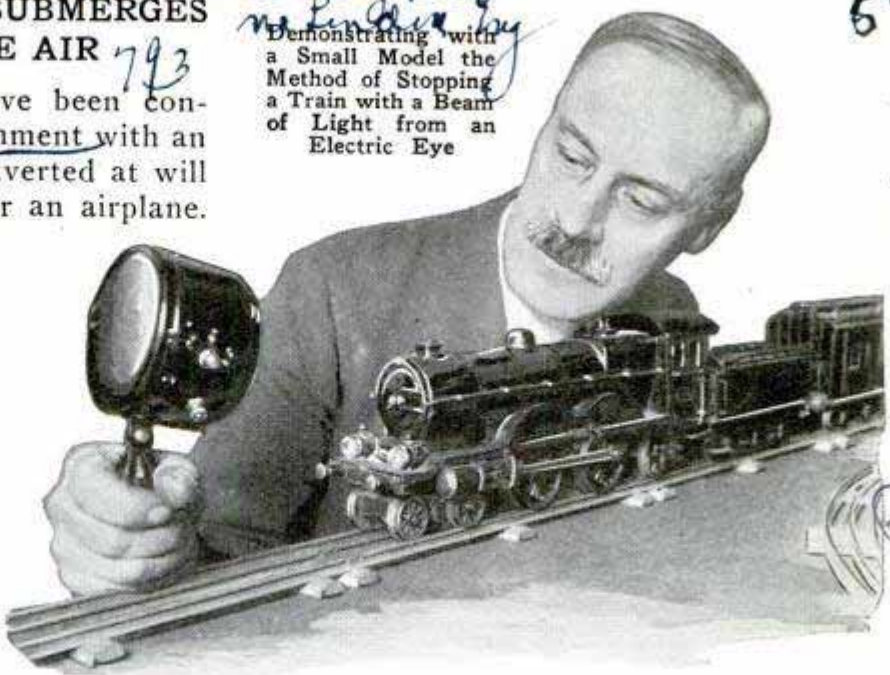

**"ALADDIN'S LAMP" HALTS TRAIN
 WITH BEAM OF LIGHT**

Demonstration of a method of halting trains by the action of a beam of light, was made with a small model recently. A small hand lamp casts a ray which strikes a light cell on the front of the engine. The cell then causes the brakes of the train to be applied through the action of relays set in operation by the effect of the light upon the cell.

7
 592
Major Raymond Phillips
Ex. Sec. England

**LOW-WING METAL MONOPLANE
 DEVELOPS HIGH SPEED** 600

Driven by a 435-horsepower motor, an all-metal, low-wing cabin monoplane, the first of its kind in this country, recently was completed by James K. Northrop, creator of the "flying wing" plane. The low-wing metal ship has a top speed of about 180 miles an hour and a cruising speed of about 150 miles.

ROADS OF STEEL RESIST WEAR 823

Highways of steel are being tested in England on routes where exceptionally heavy traffic ruins the ordinary road very quickly. The road is built with a concrete base on which steel plates are laid, intersections being filled with concrete or asphalt. Shocks created by traffic are dissipated over a considerable area instead of being localized. Such a road is claimed to wear at least twice as long as one built of any other known type of material, and even if the foundation sank, to form a safe bridge.



All-Metal, Low-Wing Cabin Monoplane, Whose 435-Horsepower Motor Develops a Cruising Speed of 150 Miles an Hour or More

Northrop Aircraft Corp.
United Aircraft, Burbank
Anthony & G. S. Green
Com. Stuart D.
London, NW9 England.

738

The Magic of

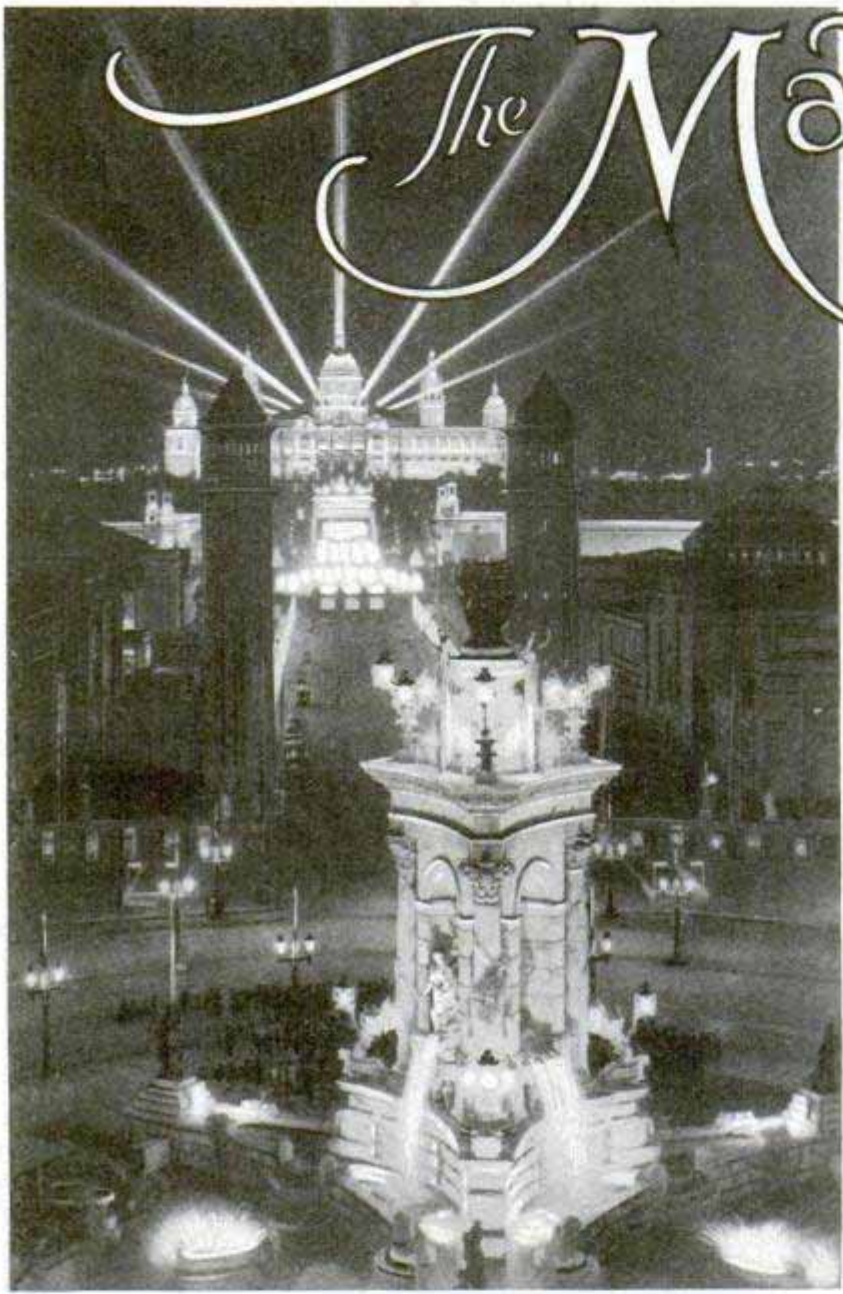

Entrance and One of the Squares of the Exhibition Grounds in Barcelona, Spain, as They Appeared at Night

By DON GLASSMAN

A RCHITECTURE of the night evolves under the sun glare of electricity and the magic of invention. Cities of men are no longer dim patches of flickering light against the heavens.

Engineers are directing powerful beams into the skies, painting skyscraper towers in pastel glows; in short, are transforming city nights into fairy wonderlands, where the dreams of inventors vie with star clusters and satellites.

Aside from the perfection of lighting equipment, the last several years have seen skyscrapers planned and constructed with

special provision for floodlighting. In choosing face stone for buildings, architects give close consideration to the effects of this illumination on the background. Hand in hand with the new architecture, which is making extensive use of colored terra cotta and tinted brick, the floodlighting engineer is experimenting with hundreds of different beams, thrown on varying surfaces, to learn their effect.

Another important advance is underwater lighting. Of course, the illumination of cataracts and fountain sprays is not new, but the underwater illumination of swimming pools, bathing beaches and aquariums by lighting units in the water is a special field which is attracting great interest.

Still another advance is the adoption of the photoelectric cell in standard sign-lighting equipment. Everybody knows how sensitive this cell is to light. It was just recently conceived that such a cell could easily displace a clock in turning current on or off. The operation is very simple; whenever natural illumination falls below a certain intensity, no matter what hour of the day, the cell completes a circuit and the current is turned on. This invention alone will save thousands of dollars in the cost of keeping men to handle switchboards for lighting units.

Colored Light

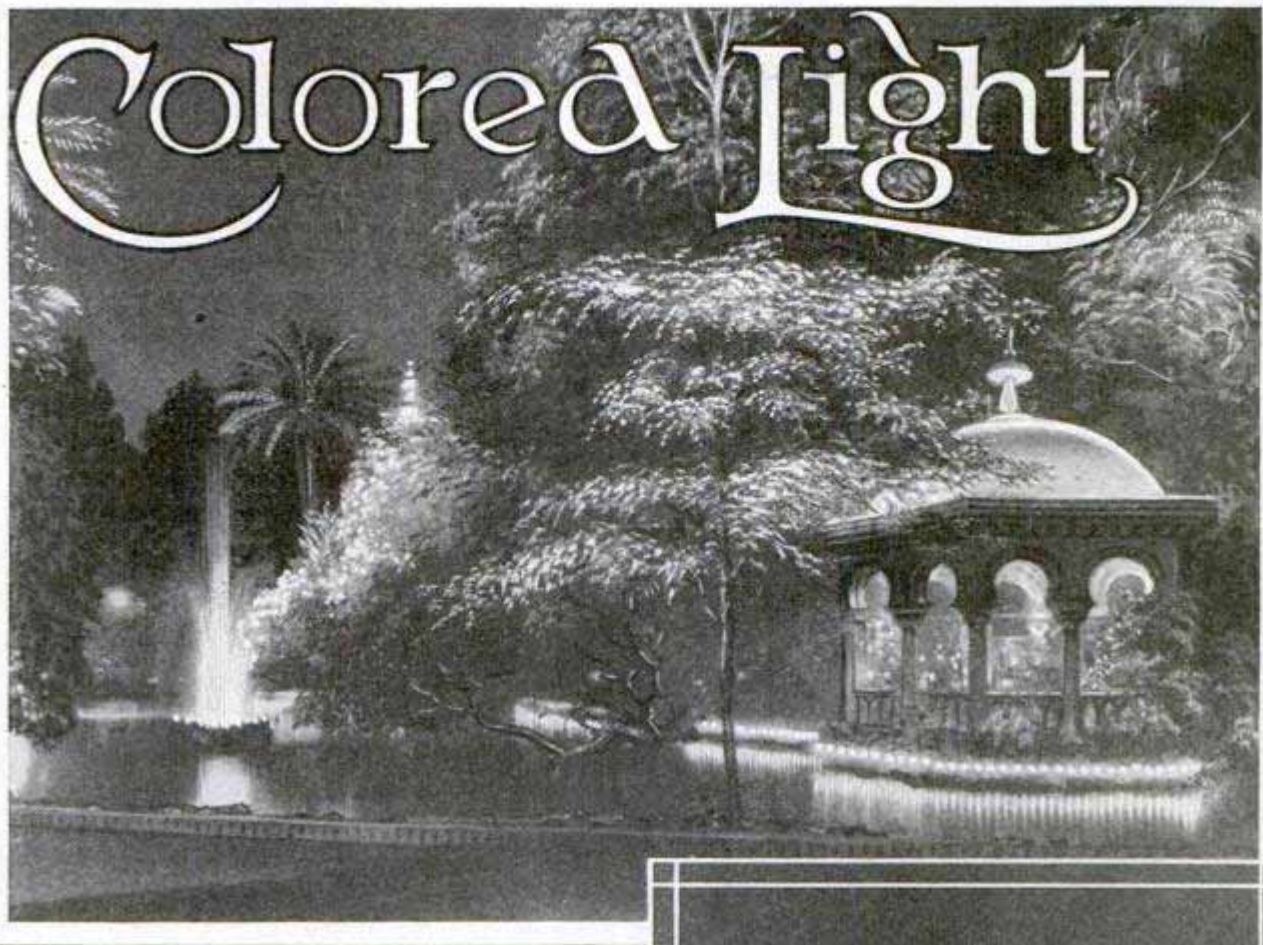

The depiction of moving figures, flashing colors and animated signs is achieved in a new invention which shortly will be thrown on the market. The signboard of this device is honeycombed like a bee's hive, and by the proper manipulation of lights, it is possible to light-paint any conceivable design and change it at will. This is the most sensational development in illuminated signs since engineers learned how to make electricity flow down a bank of bulbs like a cataract.

And what about light etching and color mixing? The present tendency is to make the city night look like a brilliant canvas. Engineers have found white light alone to be unattractive and somewhat dull when applied to all buildings and monuments along the horizon. They play with the rainbow, with a view to kidnaping its colors. The expositions at Barcelona and Seville last year showed how successful have been their attempt to diffuse white light into soothing pastel tints that are not blinding, and give the effect of weird artistry.

The mixing of colors and the sculpture of shadows are two fascinating studies



Illuminated Gardens of the Seville Exposition, and Floodlighted Tower of the Fisher Building in Detroit

Lo. E. Novels projector

that are now being carried on with intensity. Examples of color lighting on buildings are still rare, largely because architects have never demanded such from engineers. But the new set-back architect-

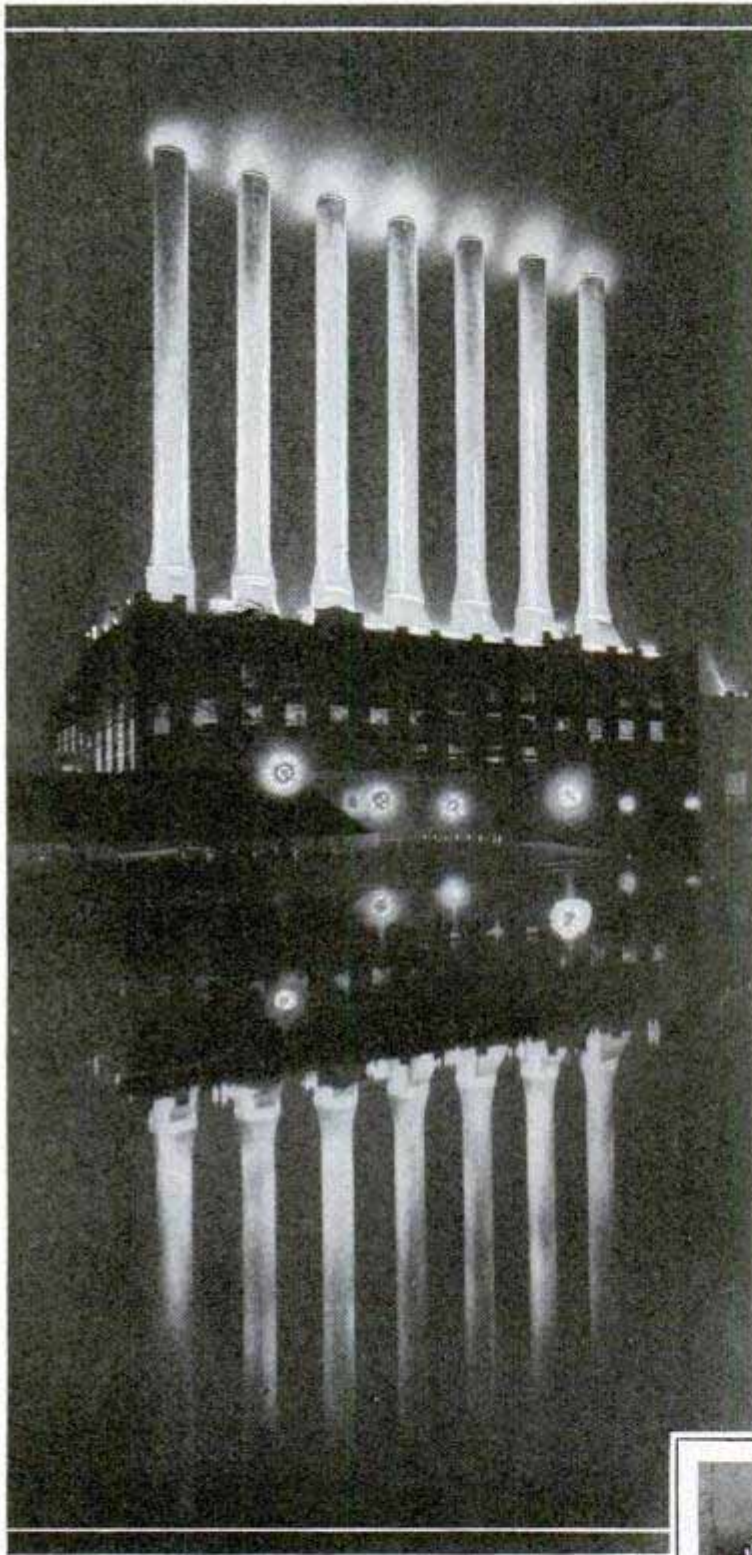

minate columns, shafts and pylons. And to relieve flatness, we are trying to effect color contrast. We might call this shadow-lighting. Until a few years ago, we knew only white lighting in architecture. Today we have the 'still color effect,' which gives different intensities and colors on different set-backs.

"The second impression we have almost perfected is the 'mobile color effect,' in which colors change continually. These effects are carried out with two wattages. If you start with one intensity for white light, you cannot use the same intensity for blue, because the latter absorbs light differently. Amber light has the lowest absorption, followed in succession by red, blue and green.

"In order to achieve a pleasing effect and even intensity, you must adjust the intensity of one color to another. For instance, in blending white and blue, you may have to step up the wattage of blue ten or fifteen times to meet the white-light intensity. But if you do not care to blend these colors, stepping up is unnecessary. In that case, different intensities are not so displeasing.

"As a substitute for mobile color, we have the 'wash-out system.' In this method we use one primary color—red, blue, or yellow—with white light. The primary color burns continually,

ture lends itself so excellently to color lighting that the field can no longer suffer neglect. Building operators also realize the advantage of distinctive lighting.

"The tendency today," a leading floodlighting engineer, A. Paulus, told me at the famous Westinghouse light laboratory, Bloomfield, N. J., "is to get variation in intensity and some relief.

"That is, we want to leave dark spaces between light spaces. We seek to illu-

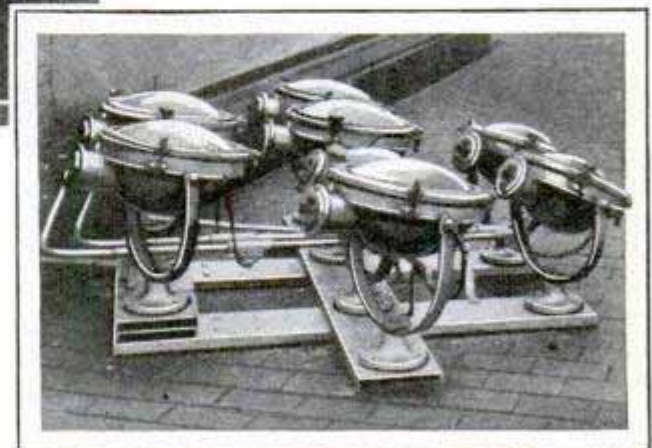

How Lights Lend Beauty to Smokestacks, and Close View of Floodlight Battery; Correctly Placing the Lamps Requires Considerable Skill

*Westinghouse
Floodlight*

*Electric Power Company
Solely
Allentown Pa*



At Left, the Beautifully Floodlighted Top of the New York City Hall, and, at Right, a Skyscraper Tinted with Well-Directed Rays to Reveal Its Lines and the Set-Backs on the Upper Floors; These Set-Backs and Shelves Form Convenient Places for the Location of Batteries of Floodlights and the Use of Different Colors



Modern Lighting Adds to the Beauty of Classic Architecture; the Lincoln Memorial in Washington, D. C., as It Appears at Night

728

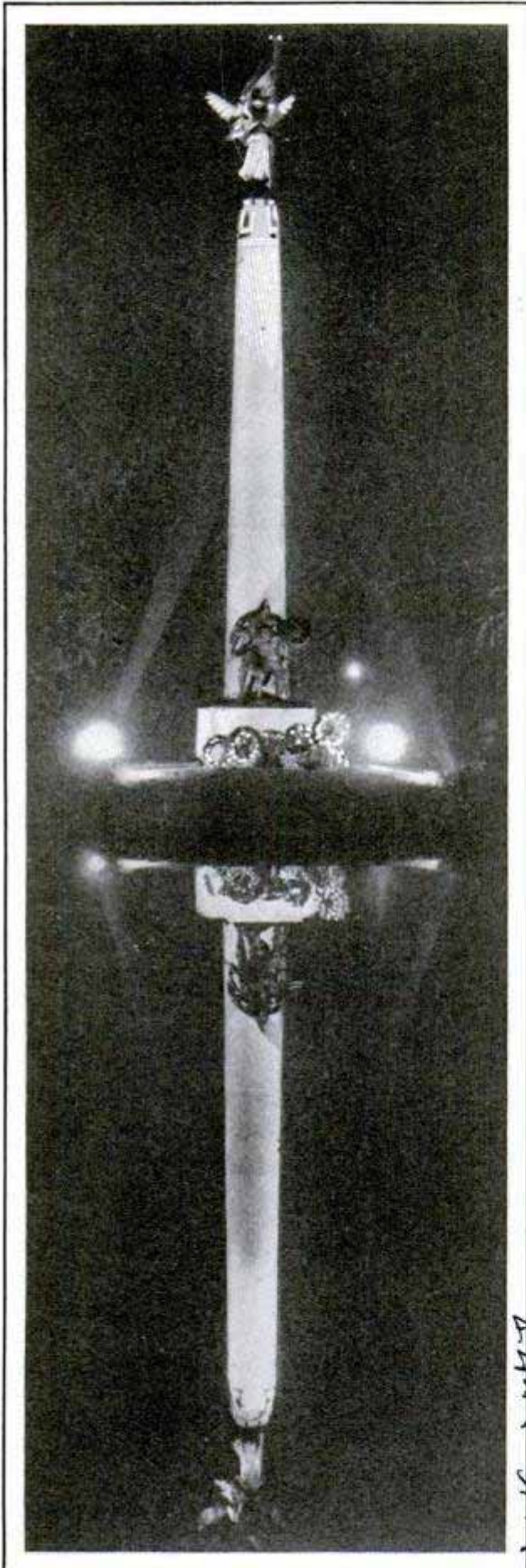

Floodlighted Memorial Column and Its Beautiful Night-Time Reflection in a Quiet Pool; Such Lighting Is Also Helpful to Aviators

while the white light is connected to dimmers and is dimmed off and on. For example, if we blend red and white, we get all shades from red to light pink tints. In this way, the floodlighting engineer achieves both motion and color."

Mr. Paulus touched upon the possibility of floodlighting ocean liners at sea. A start in this direction was made by the "Bremen" and "Europa" with giant electric signs advertising their identity to other ships passing in the night. But with keener competition for public notice, it is not unforeseen that crack passenger vessels will take to floodlighting parts of the ship whose illumination will not interfere with navigation.

America has done little with the floodlighting of bridges, but this, too, is a coming field. When more decorative bridges are built, like the new Arlington bridge at Washington, attention will naturally be turned on their illumination. On a stone-arch bridge of this type, the effect of colored lights over water will be nothing short of gorgeous.

Swimming pools are now being equipped with underwater floodlighting units that add not only to beauty but to safety as well. Every person under water will be visible. Instead of having brilliant glaring lights hang from the ceiling of an indoor pool, it is the present fashion to have the exterior illumination as dim as possible in order to accentuate the white brilliancy of the pool's tile.

In floodlighting fountains and water bodies, engineers have found that the effect is unpleasant if the illumination is over an even surface. If a cataract falls smoothly, without ripples, over the crest, the effect is flat. At Barcelona, engineers punched tiny holes in pipes and placed them across the waterfalls. Tiny jets of water burst through the holes and caused the water stream to be very uneven. The play of light beams on this rough surface gave a startling iridescence which was enhanced by the play of different light tints. The same applies to a fountain; if there is no break at the crest, it looks dull. The more spray and flying drops, the more beautiful the effect.

Wood veneers as thin as paper now are being made on a commercial scale.

see hat 1931 47-7

Alex Wood Co
919 N Michigan Ave

1750

Emp. Leslie Areas 7754 East End a
China

MAKING POPCORN POP

If popcorn contains less than thirteen or more than fourteen per cent of moisture, its popping qualities are materially lessened, and two professors of the University of Wisconsin have made a drying bin to give it maximum popping value. Dry air is driven by motor into the space for the corn, and regardless of the corn's original moisture content, the quick drying gives it the maximum popping value because it reduces the content to the required percentage and no lower. The process has been found of value also in curing sweet corn, which has been difficult to handle because of its tendency to settle in a solid mass when piled in a bin as is ordinarily done.

AUTOISTS DO BANKING FROM THEIR CARS 574

Patrons of the Grand National bank in St. Louis may drive up to the building and transact business, without leaving their automobiles, through a window built close to the curb. When the clerk is not on duty, deposits may be made through a thief-proof slot at one side of the window.

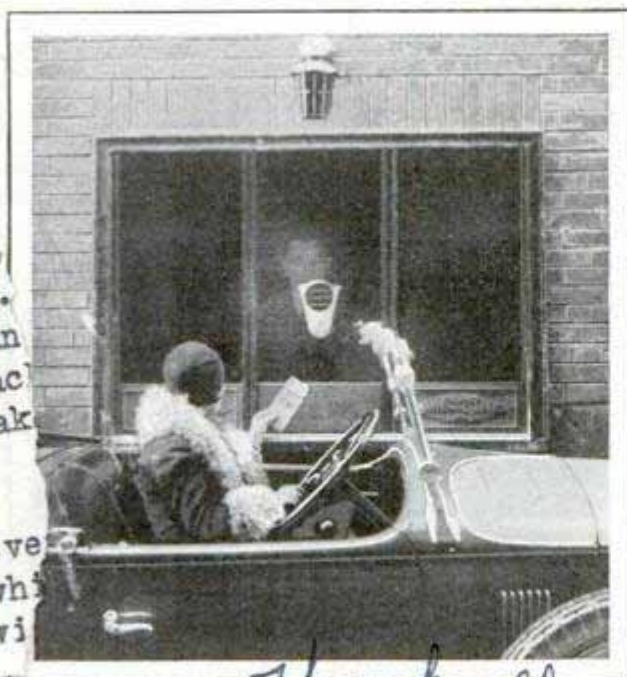

Bank Window Close to Curb, Where Motorists May Make Deposits without Leaving Their Cars

Prof. J. W. Stuffer and A. H. Wright

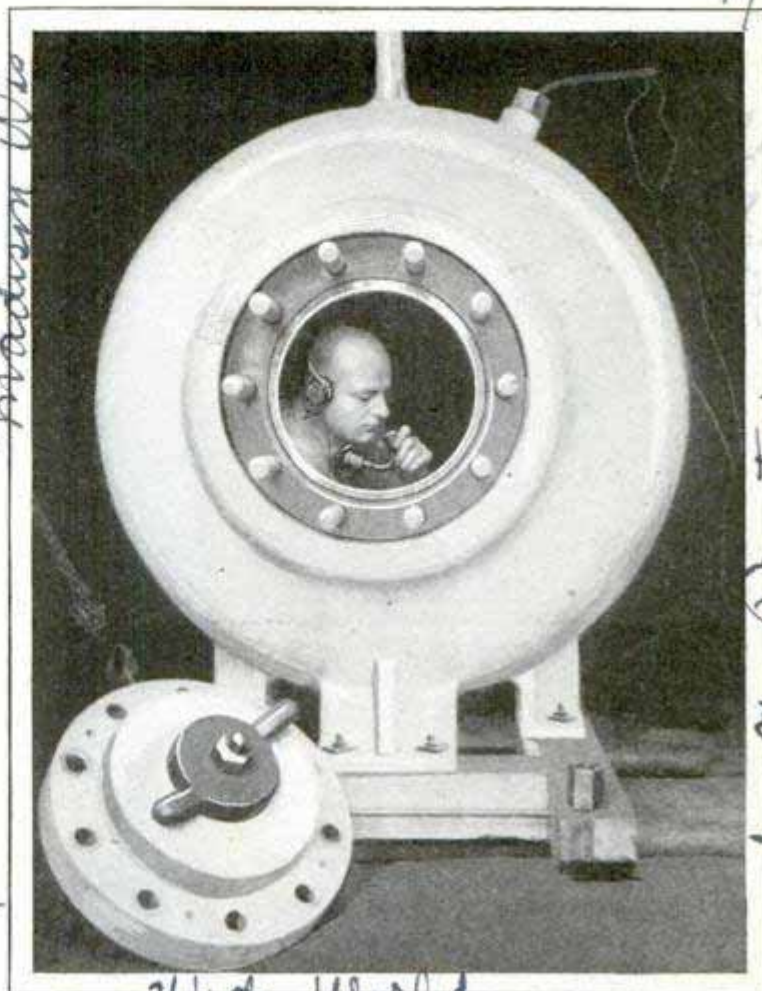

Diving Bell for Deep-Sea Exploration; It Is Fitted with Quartz-Glass "Eyes" for Observers and Camera Operation

DIVING BELL WITH GLASS EYES TO EXPLORE OCEAN DEPTHS

To make observations of the sea bed at great depths, a special diving bell is being constructed at the Museum of Natural History in New York for the use of New York zoological station in Bermuda. Three "eyes" in one end of the vessel are fitted with quartz glass, three inches thick, to provide for light and camera operation.

BARK OF TREE RESISTS FIRE 819

The bark of the California big tree is, on large specimens, as much as three feet thick and almost as fire-resistant as asbestos. A piece of it, a foot square, was only charred on the outside after having been placed in a lumber-mill furnace, surrounded by dry pine and burned for eight hours. This quality is one reason for longevity of the big trees, which are known to have attained an age of 4,000 years, and may reach 6,000 years or more.

Cont. Verne Simkins 2034 Navy Bldg

modern the

designed by Ellis Barton for use by William Beebe

4. in St. pan bac mak eve wh wi

Shackwell

790 THE WORLD'S FIRST TWO-WAY TRAIN TELEPHONE

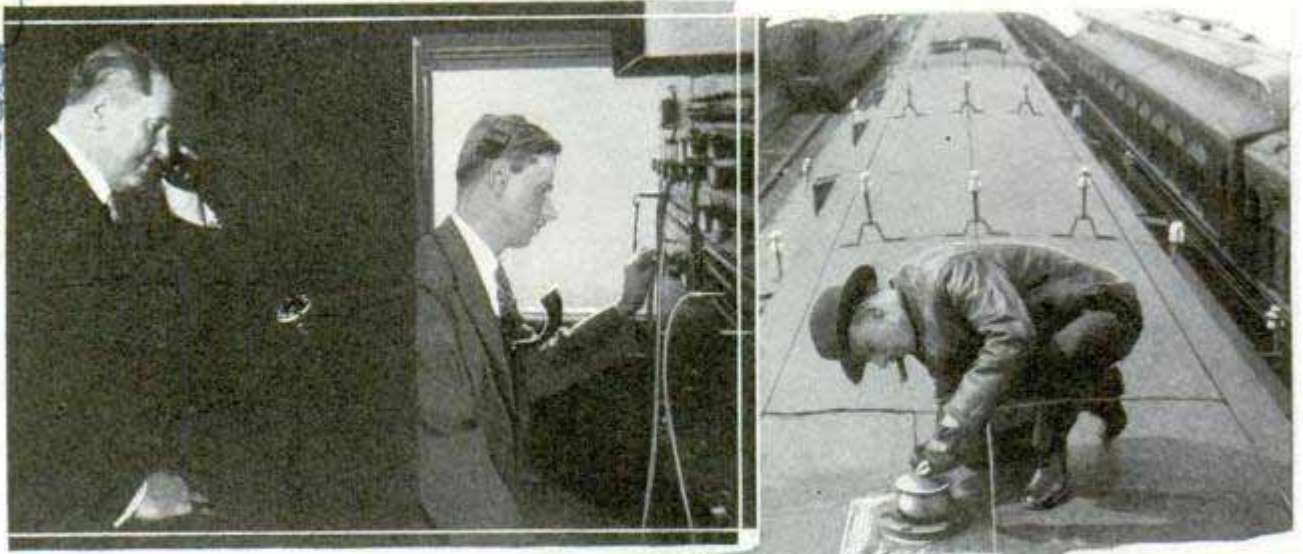

Above, Sir Henry Thornton Talking to London from Moving Train, While J. C. Burkholder Operates Switchboard; Right and Below, Connecting Transmitting Antenna and Generator on Car

By JAMES MONTAGNES

WE WERE chatting away in our comfortable parlor-car seats on the sixty-mile-per-hour express operating between Toronto and Montreal, when a uniformed young man came up to my companion and said:

"You are wanted on the telephone, sir."

Five minutes later my traveling companion came back, his face all smiles. "I was just talking to my wife and two kids back home in Cleveland. You see," he explained to me, seating himself, "when I heard that there was a telephone service on this train, I decided to try it, and so arranged to have a call put through to Cleveland."

I asked him how it sounded, and he replied that his talk with his wife and youngsters was just like putting in a call from downtown Cleveland. In fact, his wife, he remarked, would not believe that he was on a train moving away from her at a mile a minute. The conversation was as clear as on any telephone call, and in addition there was no noise from the moving train because the telephone booth had been padded and soundproofed.

It seems somehow unnatural that one should be able to talk to someone hundreds of miles distant while moving at a great rate of speed. But to the passen-

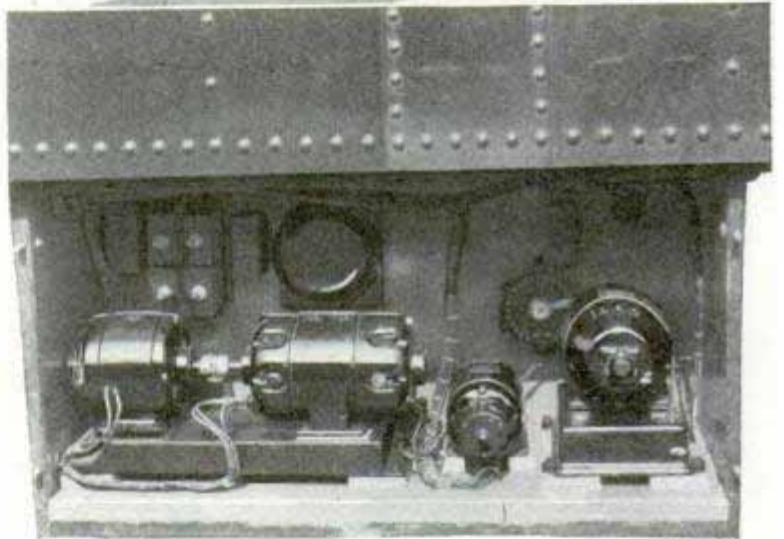

gers who board the International Limited of the ~~Canadian National~~ railways, plying between the cities of Montreal and Toronto, the service is a reality.

The world's first two-way telephone service operates on a combination of radio circuits. From a seven-wire antenna on the roof of the steel car the messages go out and are received. The middle three wires are for transmission, while reception is effected on the four outside wires of the seven. When a telephone message starts in the ordinary telephone microphone used, it sends out radio waves which jump from the antenna on the roof of the speeding car to telegraph wires alongside the track. These wires, which pick up the radio telephone signals, are known as carrier-current wires, in that each wire is capable, by means of radio instruments at the terminal stations, to handle some twenty messages at the same

Room 304, 465 Bay St. Toronto & Ont. Canada

*National Diving Board
 Champion*

time, differing from the ordinary telegraph wires. The carrier-current system allows the use of voice transmission, giving a perfect voice reproduction at the receiving end. When the telephone message strikes the carrier-current wires, it is carried along to the terminal station, where it is placed on the telephone lines to the point of destination, just as in a long-distance call.

The reception of a telephone message on the train is accomplished in the same manner, the transmission this time going from the terminal station to the carrier-current lines, preceded by an automatic calling device which tells the train operator that a call is coming through. From the carrier-current lines, the radio telephone message skips to the train antenna and is changed into voice by the train receiving set. All this occurs simultaneously, there being no delay whatever in train-telephone conversation.



Paper-Covered Hoop in Position above a Swimming Pool Forms the Target for This Human Arrow in the Latest Water Sport

Wide World

DIVER BECOMES HUMAN ARROW IN LEAP THROUGH HOOP

Human arrows shoot themselves at paper-covered targets in the latest swimming sport, introduced recently in Los Angeles. Huge hoops, covered with paper, are the targets, which are placed in position above a swimming pool. The divers vie for perfect bull's-eye scores by aiming at the center as they hurtle toward the water from the diving board.

LADY BEETLES RAISED TO WAR ON CITRUS SCOURGE

780



pa

Millions of lady beetles are bred annually in California to combat the ravages of the mealy bug among the citrus growths. The beetles are reared in tiny capsules, ten to a capsule, and turned loose in the fields upon reaching adolescence. They are propagated on a mealy-bug diet and sold to the farmers for half a cent each, the cost of production. Each year an estimate of the number of mealy bugs is made to determine the number of beetles necessary to fight them.

VEST-POCKET SAFETY RAZOR IS CARRIED IN OWN HANDLE

554

Flattened handles of vest-pocket safety razors provide carrying cases for both the razor blades and the blade holders. A small cover at the end of the handle locks blades and holder securely, and the entire outfit does not bulge the pocket. The razor is used with ordinary thin blades.



*Keenan's Rubber Service Co.,
 131 Orchard St. Elizabeth
 Cold business.*

433

NAVAL JUNK PILE RECEIVES THIRTEEN "SUBS"

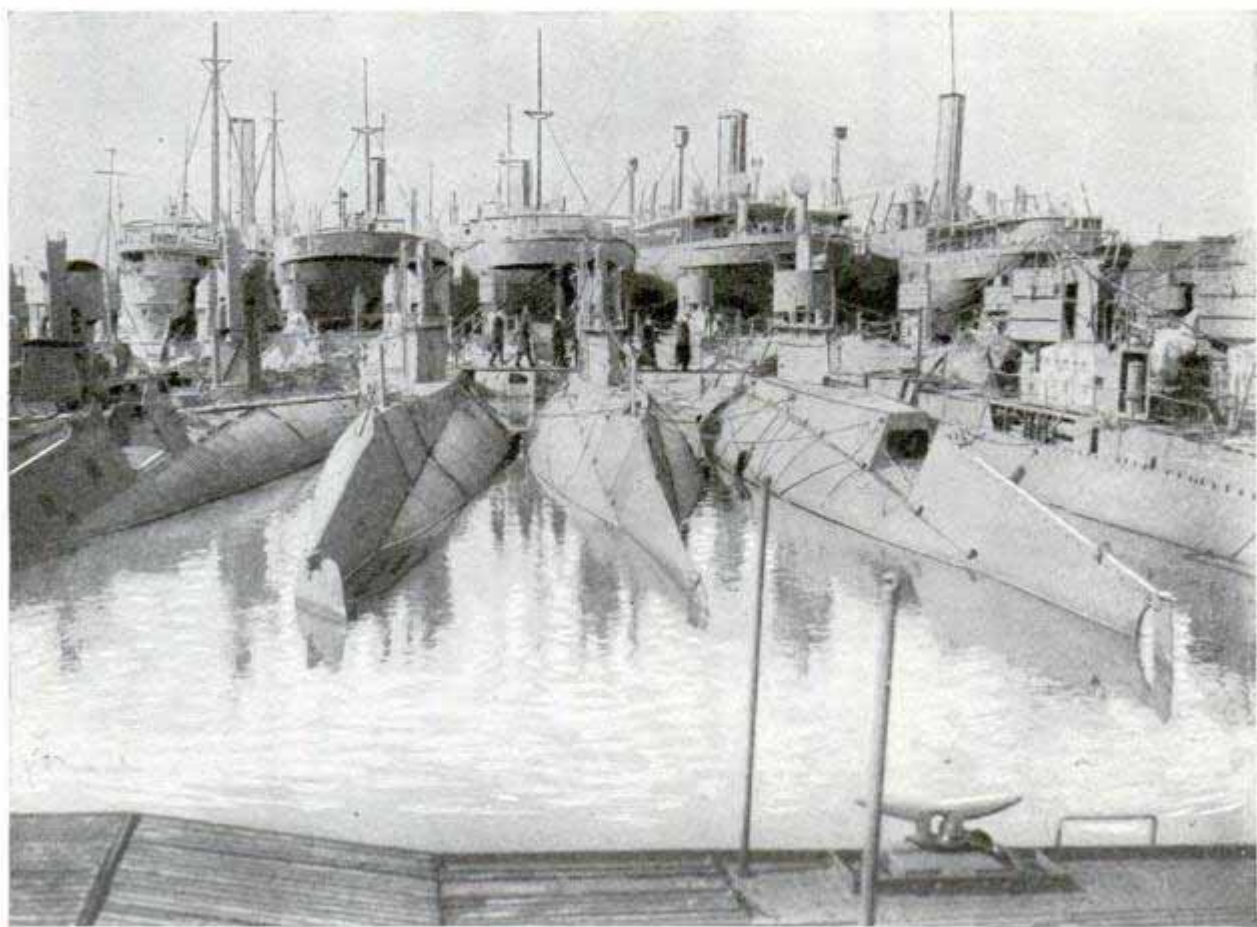

Some of the Thirteen United States Submarines Which Are Destined for the Scrap Pile under Naval Limitations Agreement; the Picture Shows the Boats in the Philadelphia Navy Yard

Thirteen submarines destined ultimately for the junk pile now rest in the Philadelphia navy yard. The underseas craft to be scrapped were built in 1917, and under the naval-limitations agreement, thirteen years is the age limit for the boats, so this year means their end.

AN AMPLIFIER FOR THE VIOLIN

To increase the tone volume of a violin, cello or viola, an amplifier recently was demonstrated with success in Paris. The violin used with the amplifier resembles the ordinary instrument, except that there are no openings in the sounding board. It is connected by a wire with a diaphragm inclosed in a sounding box like a phonograph. When the bow is applied to the strings their vibrations are transformed into electromagnetic waves which pass through a series of transformers, and are amplified by the diaphragm to produce the louder tones. Tests show that the tones

soar above the background of strings and brass of the full orchestra.

ILLUMINATED READING GLASS FOCUSED AUTOMATICALLY

Troubles with focusing and illumination, encountered with the old type of reading and magnifying glass, are overcome with a reading glass contained in a cabinet in which is an electric light. The glass focuses automatically when placed on the page, and the light may be plugged into any wall outlet to provide plenty of illumination for the object being examined, while at the same time shielding the eyes from the direct rays.



*No. 11, rue
Paris VIII
France
by a Russian,
M. Makhomov*

Ant. Wilkins

*581
Electro. Lens
Meyersonitz, Inc.
520 7th Ave New York*

7/22/3
474-03
Science Service News Bulletin

before National Academy
of Science, Washington
D.C.

FISH HAVE GOOD HEARING

745

Fish have a sense of hearing so keen that they can perceive vibrations too low for the human ear, and are able to hear sounds a little beyond the highest notes of a piano or violin. Dr. Karl von Frisch, of the University of Munich, experimenting with minnows, found that they soon learned to answer the dinner whistle. He offered them food, at the same time sounding a tuning fork or blowing a whistle. They came to know that the sound meant dinner, and soon came crowding to the feeding place when they heard it. By feeding to the accompaniment of one note, and scaring them away with a tap of a glass rod when another was sounded, the minnows learned to distinguish between sounds. No tuning-fork vibration rate was found that the fish could not hear. Some experiments indicated they may have two sets of organs for detecting sound.

CLEANER FOR CONDENSER PIPES REMOVES SCALE EASILY

555

Removing scale from the outside of boiler tubes, brine coils or oil-well casings, preparatory to painting, is easily performed with a steel-link chain cleaner. It consists of a length of steel links with a handle at each end. The links are equipped with two cutters each, which are easily sharpened by grinding. Cutters may be replaced, and the tool can be obtained in sizes for two, four and six-inch pipes.

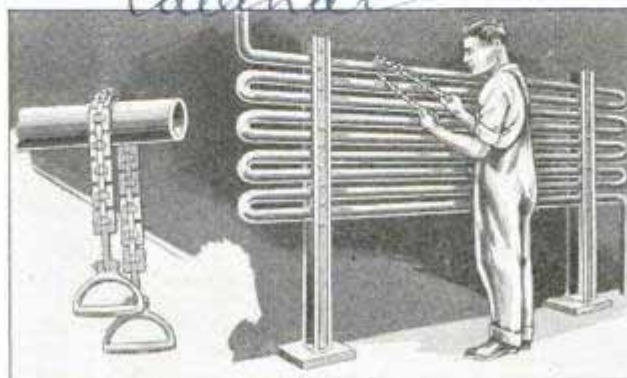

Link-Chain Cleaner for Condenser Pipes; the Links Are Equipped with Steel Cutting Blades

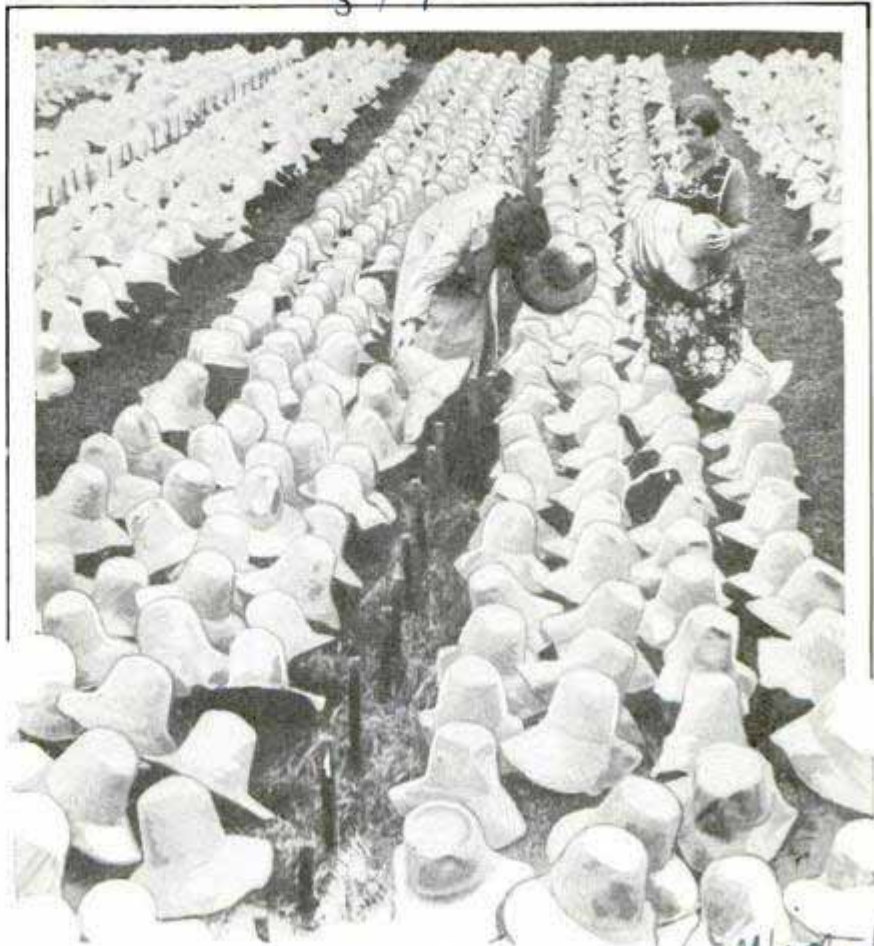

Hundreds of Straw Hats Piled on the Bleaching Pegs in Front of a Large Factory in Luton, England

Wide World

BLEACH STRAW HATS OUTDOORS AT ENGLISH FACTORY

Although chemical methods are now largely employed in the bleaching of straw for hats, the sun is an important aid at a factory in Luton, England. Hundreds of hats are placed at a time on short pegs outside the works, where they are bleached and dried before the final steps of manufacture. Hat making has been an important industry in this city for many years. During the days of King James I, a colony of straw plaiters was imported from Scotland, and their craft has been carried on until the making of straw goods has become one of the chief activities of the city.

Ⓢ A twenty-inch snow represents only about two inches of water.

Returning Mfg Co 3021 Greenview Ave

719 Just How "GOOD"

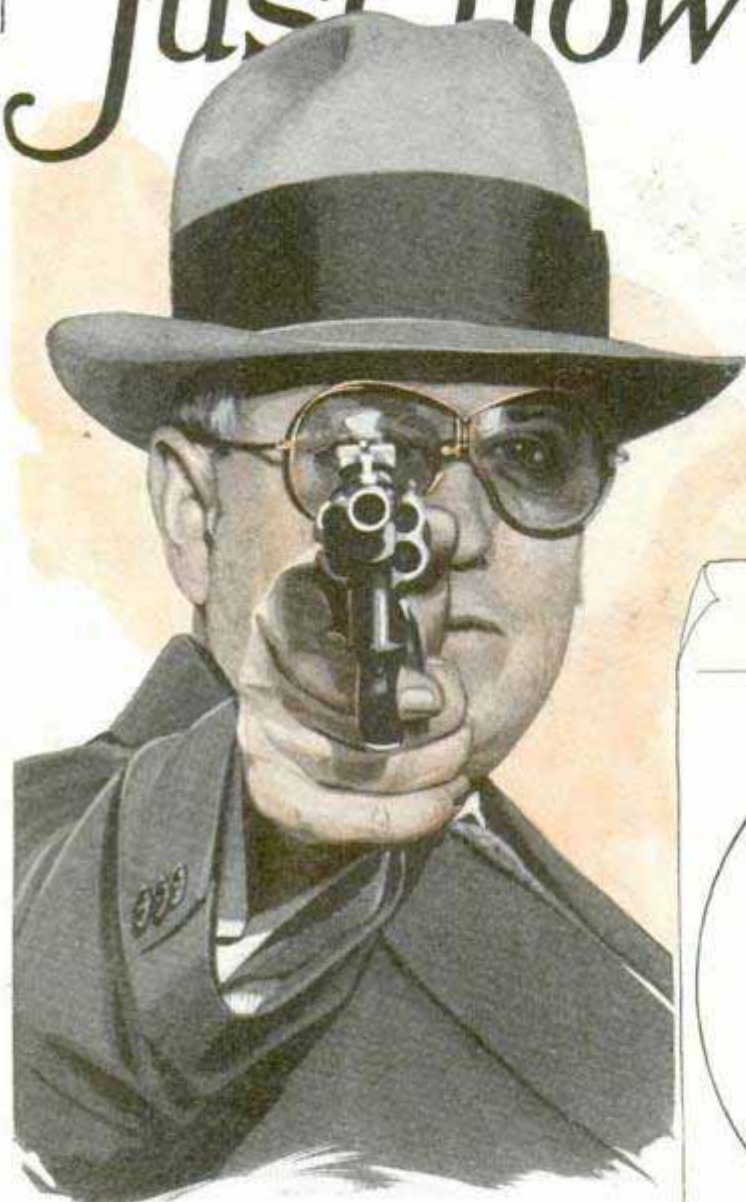

"Out in our part of the country," observed the western expert, "we fan the gun when we want to get our shots off fast."

There wasn't a single man present who had ever seen an expert fan a gun, so we immediately called for a demonstration. Gun fanning is a two-handed shooting proposition. The gun is held and aimed in the right hand, with the trigger squeezed

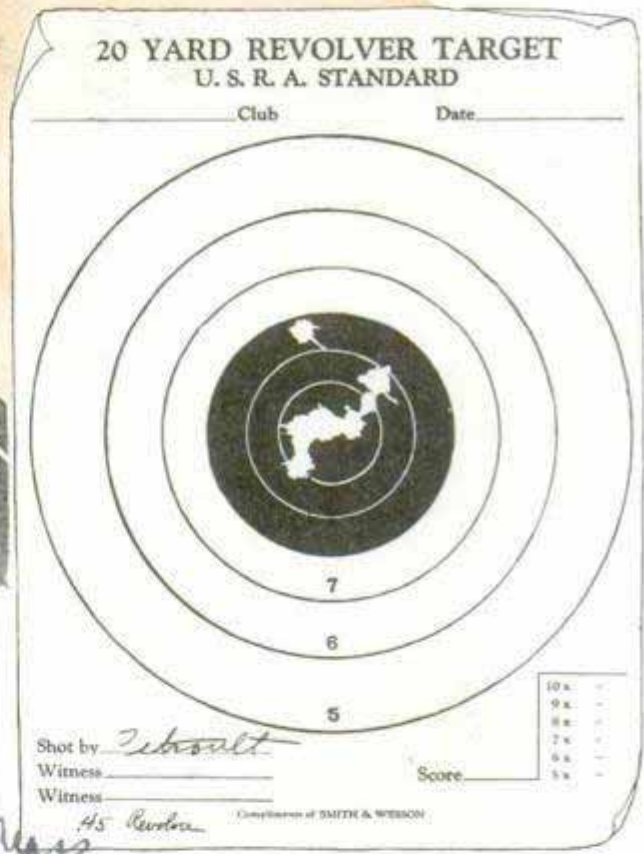

Anybody Can Become a Good Pistol Shot, Says Doctor Calkins, and in This Article He Tells How

By I. R. CALKINS, M. D.

National and International Target Pistol Champion
(As Told to John F. Cogswell)

16 Edalmoor Road, Belmont, Mass

NOT long ago, a westerner, famous for his handling of the frontier-model .45-caliber six-shooter, appeared at the indoor range of the Springfield, Mass., club of the United States revolver association.

The fame of this man was national and we gathered to see some fancy stuff with the big hand-arm that held favor when the west was wild and the six-gun was the law. We talked of big and small guns, of slow fire and quick draws, of old-time killers and modern gunmen—good and bad—of "rolling" and "fanning" guns.

back. Then the gun is fired by slapping the heel of the left hand against the cocking piece of the hammer, lifting the hammer and allowing it to drop against the firing pin and discharge the shell. According to stories of the old west, this was the fastest and most deadly method of discharging a revolver.

The westerner was willing to oblige. We hung up a twenty-two-inch target and the marksman took his stand at a distance of twenty-five feet. He got off his six shots in exactly nine seconds after the

Were the **BAD MEN**?

command to fire. None of the bullets hit the black center of the target. Two were in the white. The other four were in the sides and roof of the covered range.

"Is that as good a score as the old-time fanners used to make?" asked a police officer.

"Just about," the westerner assured him. "Fanning isn't as accurate as slow fire, but it's so almighty fast that it got the other fellow first in the old days."

Without comment, the policeman reloaded the gun, replaced it in the holster and took his stand at a distance of forty feet from the target, five paces back from where the fanner had stood. At the word to fire, his hand swept the gun from the holster and slowly brought it up to firing position. So deliberate were his movements, that they appeared slow beside the fanning demonstration.

Even as the first shot rang out, his gun rolled to the side, his thumb found the hammer and cocked it and the .45 swung onto the target again. He got his shots away fast. In fact, the stop watch clicked for the last shot just five and one-half seconds after the command to fire had been given. Five of the officer's bullets were in the black, the sixth was just out of it.

This incident is not cited in disparagement of the western man's ability as a marksman. In fact, there are few men in the world who can outshoot him with the .45—when he doesn't try fancy shooting. But it does bring out the point I wish to make: Trick shooting never could compete with plain, everyday gunwork in putting bullets into the target. And, after all, that's the main idea in firing a gun.

Furthermore, that police officer had

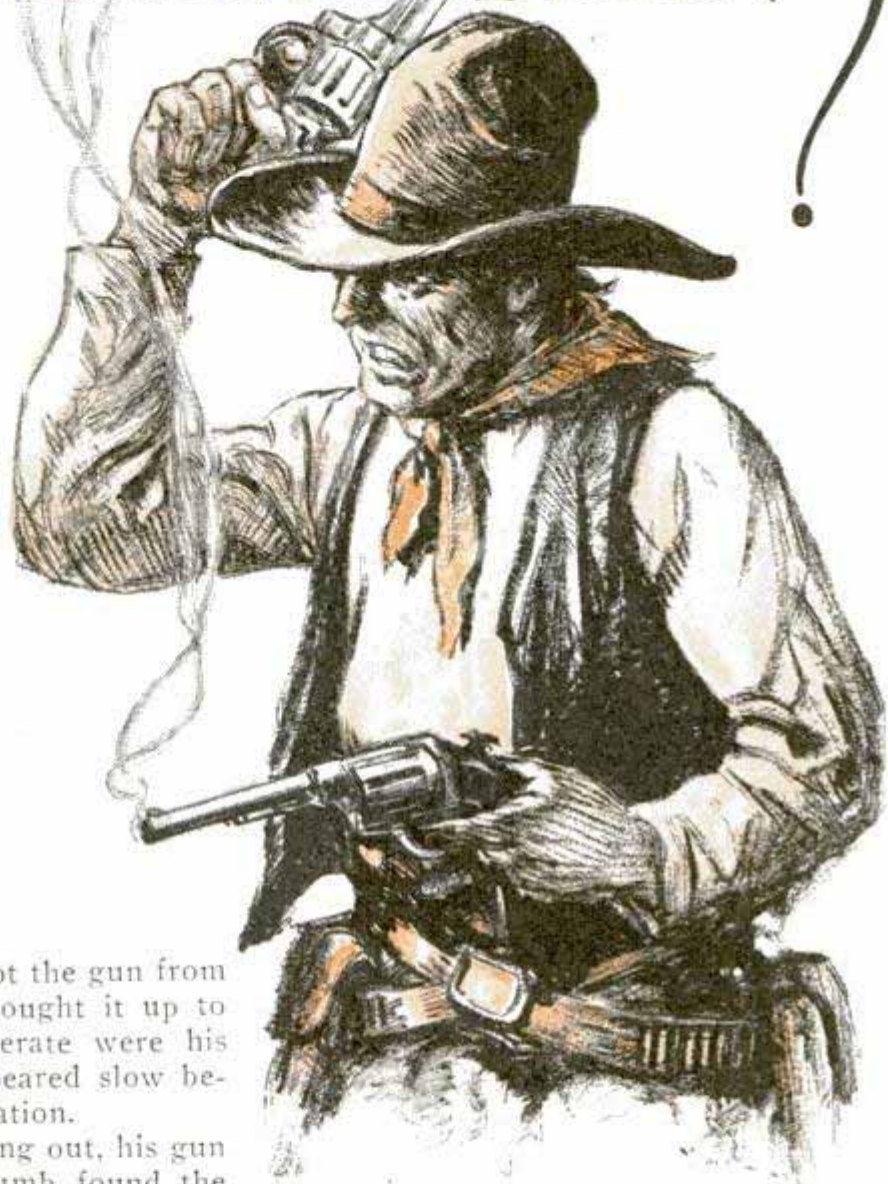

Few of the "Two-Gun" Desperadoes of Frontier Days Could Really Shoot as Accurately as Legends Tell

taken up hand-gun shooting in earnest but nine months before his encounter with the westerner, which spells encouragement for the novice. Really, accurate shooting with pistol or revolver is no complicated proposition. There are just two things that the novice must master to be well on the road to efficient marksmanship.

Anybody can become a good pistol shot. All there is to learn is to hold and squeeze, that is, to hold the sights on the target and squeeze the trigger without disturbing the aim. Hand-gun shooting is a fascinating sport—and more. It's the greatest nerve tonic that I know of—and re-

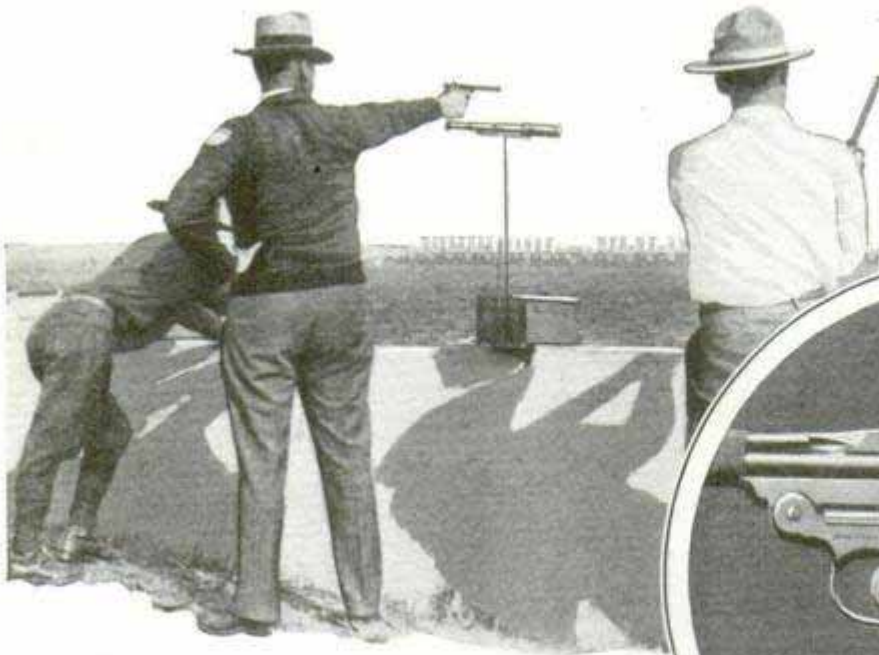

E. A. Fox of the American Olympic Team, Center, Shooting at Camp Perry, and Correct Way to Grip Pistol in Firing

member that I make that statement as a practicing physician. Two years ago, I was threatened with a serious nervous breakdown. I took a week off from my practice and went down to the range and actually shot the nerves out of myself. I know of nothing else that will snap a man out of nervous trouble as quickly as will target practice. He has to concentrate on his shots with every faculty he possesses. In this concentration, he forgets not only himself but everything about him save only the job in hand.

I advise the novice to start in with a single-shot .22-caliber target pistol. This arm is the most accurate of any made. The recoil is very slight and the charge not heavy enough to cause flinching on the part of the embryo shooter. Besides, it is inexpensive. At first, the novice should practice with an empty gun. Do not clutch the grip tightly. Let it rest loosely between the fingers and the palm, with the thumb pointed straight along the barrel. Place the first finger of the shooting hand through the trigger guard, letting the weight of the gun be taken by the other fingers and the palm.

The position of the thumb is most important. Without a gun, try pointing the thumb at any near-by object. You will find that you can snap the point of that digit onto the mark with great accuracy. Aim with your thumb; it will make you a

marksman. Another thing, the thumb along the barrel steadies it and almost compels the shooter to hold the gun in a level position.



Right from the start you should make yourself aim with both eyes open. It is easy after a little practice. Every really good marksman that I know of shoots with both eyes open. Now, hold the pistol in the right hand, at an angle of about forty-five degrees from the body, with the weapon pointing toward the floor and the arm just as straight as you can hold it without conscious effort. Let your full weight fall upon the heels and relax. Relax every muscle in your body except those of the right shoulder. Pretend that these are the only muscles over which you have any control. Practice attaining this relaxed position a while before raising the pistol any higher.

Slowly bring up the gun toward the horizontal position, using the shoulder muscles only. At the very start of the movement, slip your thumb to the hammer and cock it and then return the thumb to the position alongside the barrel. Let your raising of the pistol be slow and deliberate. Keep both eyes open and on the bull's-eye. As you raise the gun, start squeezing the trigger little by little.

The average pistol trigger has a pull of three pounds. You will find that, with some practice, you will be able to have all

but a few ounces of the squeeze exerted by the time your arm reaches firing position. As soon as the sights line up on the bottom of the bull's-eye, exert the few ounces more squeeze necessary to make the hammer fall.

Practice this many times before you load your pistol. You will soon find that you can line your sights on the bull and hold them there. In short, you have learned to hold. If you have been exerting a gradually stronger pressure on the trigger from the time you start raising the gun, instead of giving it a quick pull when the sights line up, you have also learned to squeeze. And that's the whole thing—hold and squeeze. After you have become the master of the single-shot pistol, you will find that the transition to the revolver is easy. Then you'll have to learn to roll your gun between shots.

It is well-nigh impossible to keep the revolver sighted on the bull's-eye while cocking it preparatory to sending a shot quickly after another, whether the cocking be done by the thumb or by the double-action or self-cocking arrangement with which all modern revolvers are equipped. So, the expert makes no effort to keep the gun pointed at the target between shots. Instead, he deliberately rolls the muzzle away from the bull's-eye during the cocking operation. But his extended shooting arm remains pointed rigidly toward the mark, the roll being accomplished by the wrist and fingers only.

The recoil of the powder charge tends to throw the muzzle upward. This upward movement is followed and assisted by the wrist, which also throws the barrel sideways to the right, so that the front sight describes the arc of a circle. At the top of the roll, the thumb finds the hammer. Immediately, the three fingers on the grip start drawing the muzzle

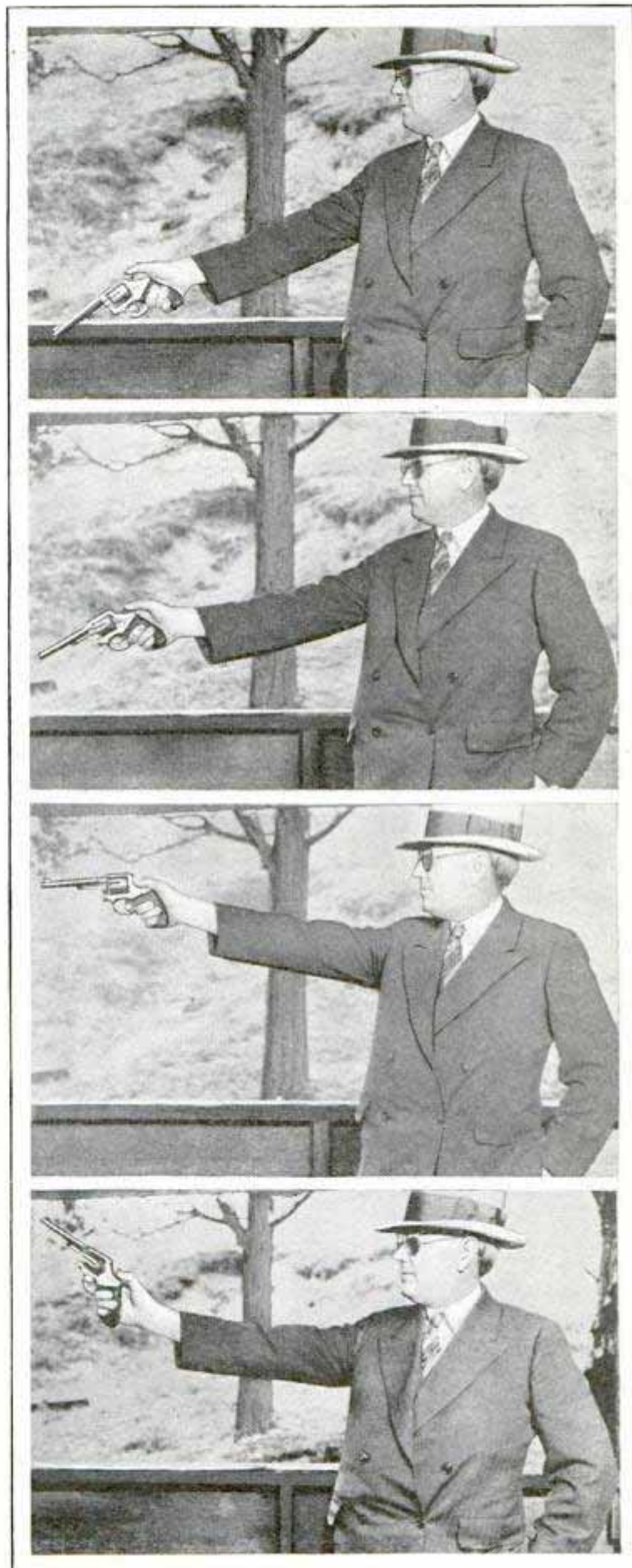

Top to Bottom, Correct Positions in Firing: Ready; Raising the Pistol; on the Mark, and "Rolling" the Gun with the Recoil after Firing

717

Western Electric News
Service Dept. Dept.
50 Church St. N.Y.C.

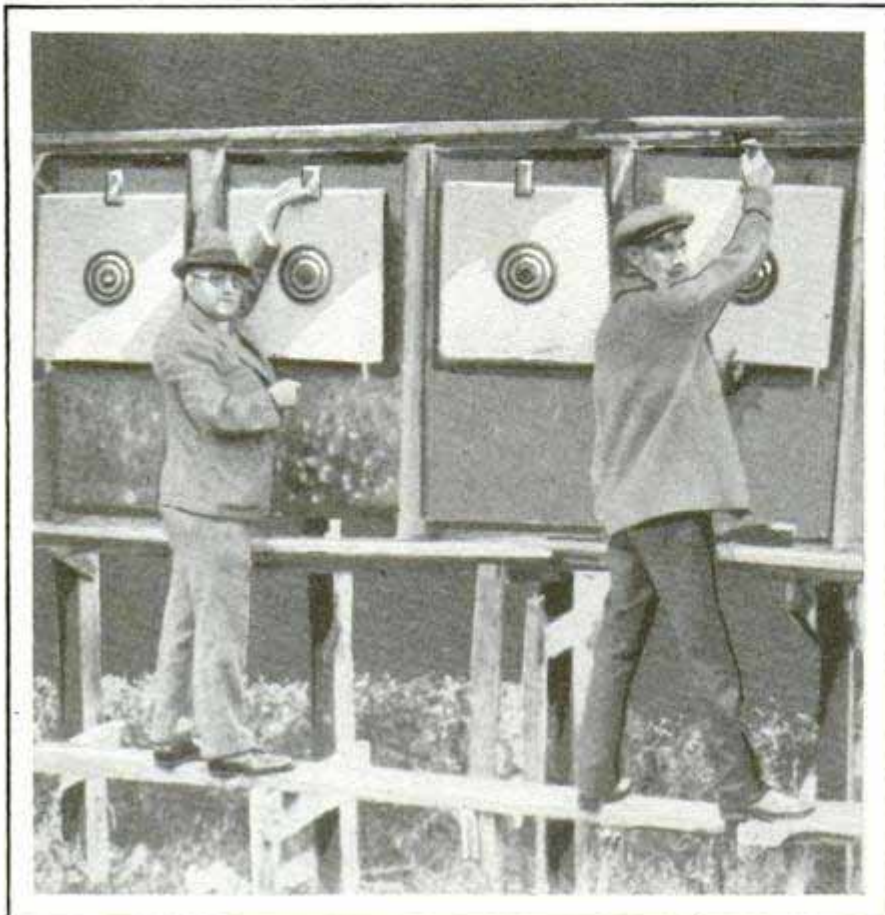

Pistol Ranges Are Not Costly; This One Has a Simple Wooden Frame and Metal Sheets for Targets

back toward the target. This action causes the hammer to press against the thumb and cocks the weapon automatically as the sights swing toward the bull's-eye. As soon as the hammer arrives at full cock, the thumb is slipped back to its position parallel to the barrel, and the marksman is ready for his next shot.

Probably the biggest thrill that a novice marksman gets in target shooting comes when he realizes that he has caught on to how to roll his gun.

SHIP-TO-SHORE PHONE CALLS REQUIRE MANY HANDS

1783

Two-way telephone conversations between a steamer such as the "Leviathan" and persons on shore, require sensitive and complicated radio apparatus and a number of persons to make the necessary connections. About all the passenger on the vessel sees is an ordinary telephone transmitter, but behind it are the receiving and transmission sets, the latter in a room of the radio cabin and the former on the port side of the wireless

rooms. For transmitting, a motor generator is inclosed in paneling, covered on the inner side by sound-absorbing material and on the outer with grounded copper sheet, the apparatus being cooled by a stream of air from a blower. Two stations on shore form the connecting link between the ship and the telephones throughout the land. Messages coming from the vessel are picked up at a receiving station at Fork River, N. J., and thence are dispatched over telephone wires. Replies from persons on shore are transmitted to the ship through another station at Deal Beach, N. J. Ship-to-shore telephony is accomplished in the same general way as any radio telephoning, but special problems have

to be solved. In the first place, the ship is moving, the space for the apparatus is exceedingly limited, and the steel ship, its vibrations, and other electrical equipment, offer sources of interference that had to be overcome.

AIR-PUMP PISTOL ON OILCAN SHOOTS TEN-FOOT STREAM

1 pistol per liquid
\$2.75



Easily attached to the top of a can of lubricating oil, an air-pump pistol can be operated with only one hand and shoots a fine stream of lubricating oil for ten or twelve feet.

Four or five strokes of the air pump in the top of the can and a pressure on the trigger set the gun into action. It shoots from all angles and positions and has been found particularly useful for lubricating auto springs and squeaking parts of the car body.

Kaint Rust Products Corp
Rahway, N.J.

Parson turbines - Yarrow boilers

ITALY BUILDING FAST LINERS FOR ATLANTIC SPEED RACE

766

Italy has decided to support her prestige at sea by the construction of two huge express liners for the Atlantic service of the Lloyd Sabauda. They are intended to make the run between Naples and New York in seven days, of which five is the time between Gibraltar and New York. One of them is to be called the "Rex." It will have a speed of about twenty-seven knots and will be equipped with high-pressure turbines. The decision to build these costly ships is all the more remarkable since the number of Italian emigrants to America is being further restricted.

Charituzze Decimo Sestris

BRIDGE WIRE AS LONG AS HALFWAY TO MOON

456

Four cables of the world's largest suspension bridge spanning the Hudson river in New York will contain, when completed, 107,000 miles of wire, enough to

circle the world four times at the equator or reach nearly halfway to the moon. Al-

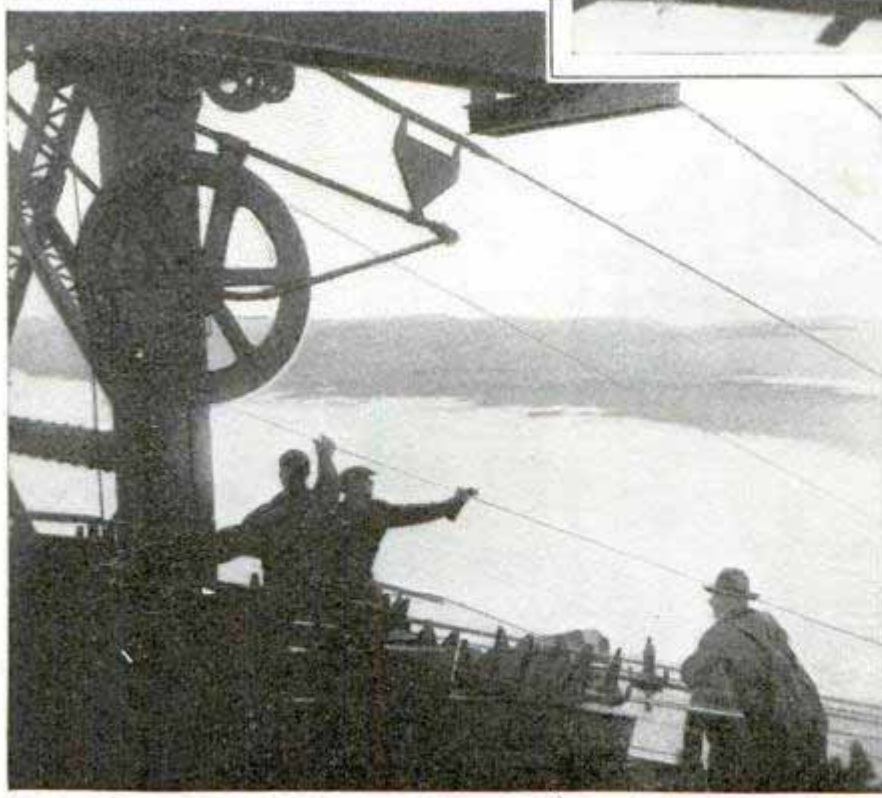
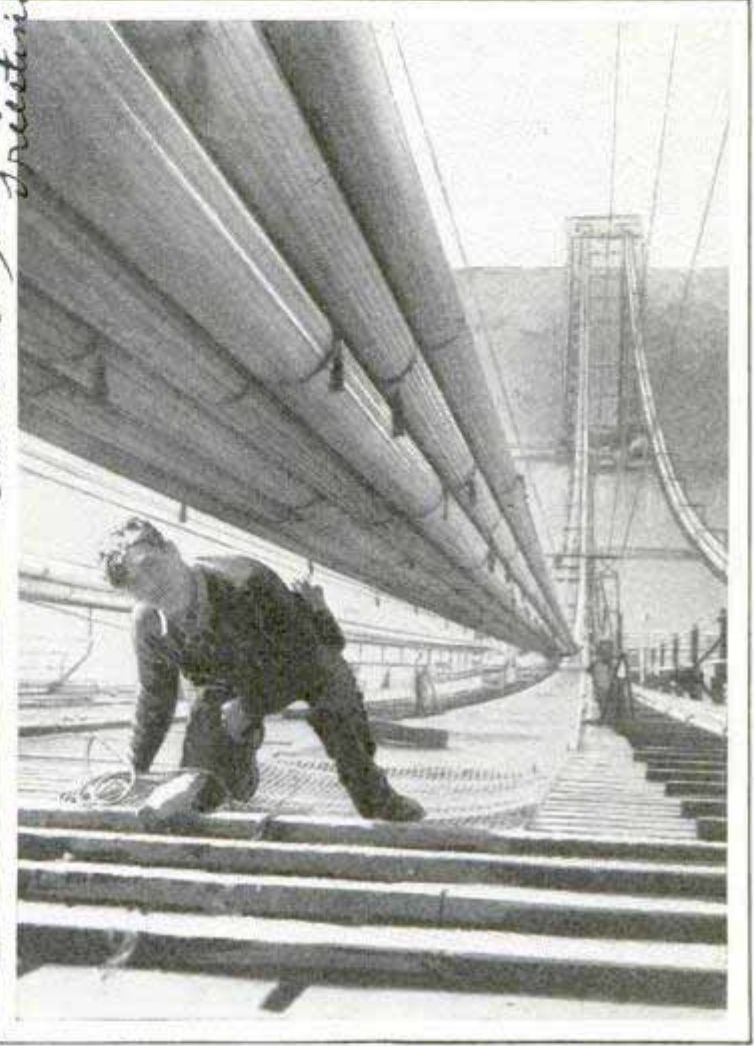

though this wire is only the size of a lead pencil it can support a load of 7,600 pounds or the pull of ten draft horses. Sixty-one giant strands, each composed of 434 wires, will be required to complete each cable. Four deeply grooved pulleys or sheaves constantly pass from the New Jersey to the Manhattan anchorages on an endless rope, unwinding the wire, which comes in thirty-mile lengths on reels six feet in diameter. On each trip the pulleys bring one wire to be added to the strand. This part of the work is half finished.

Above, Some of the Cables Supporting the Hudson River Suspension Bridge; Below, Shuttle Pulleys Unwinding Miles of Wire for the Cables

International

350

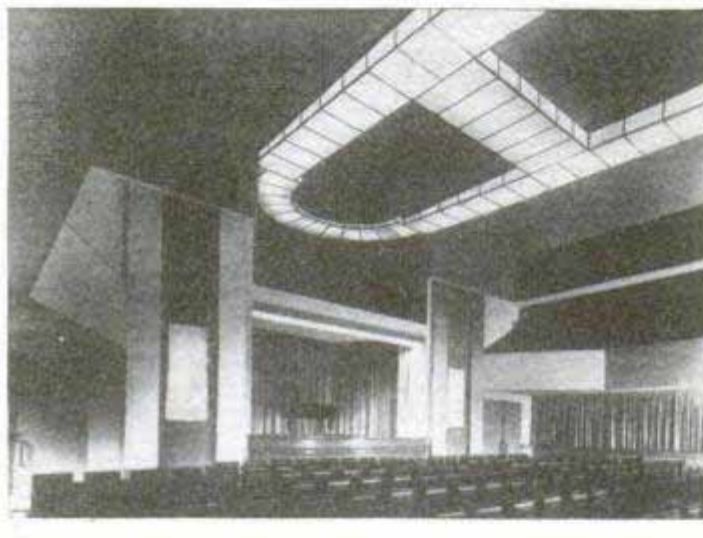
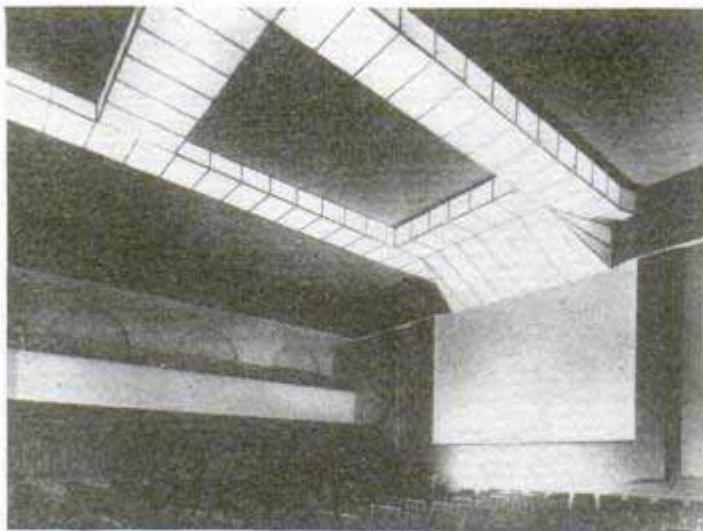

© P. & A.

Movie Screen and Lecture Platform at Opposite Ends of Church Community House Containing Reversible Seats

REVERSIBLE SEATS TURN MOVIE INTO LECTURE HALL

Making the same edifice available for both lectures and moving pictures, a church community house in Berlin has been equipped with reversible seats. The backs of the seats may be turned so the occupants face either end of the auditorium. At one end is the lecture platform, and at the other the screen for the pictures.

AVIATORS AVOID BAD WEATHER AT SIX-MILE ALTITUDE

Aviators can avoid all forms of bad weather by ascending to an altitude of 30,000 feet, or nearly six miles, the weather bureau has found. Col. Charles Lindbergh, in his recent transcontinental flight of less than fifteen hours, flew at

altitudes of from 10,000 to 20,000 feet, and even at this height avoided most of the weather dangers that beset aerial navigation. Most of the rain and snow falls from lower altitudes, and only exceptional thunderstorms reach that height. Winds three miles high over the United States blow from the Pacific to the Atlantic at about thirty or forty miles an hour throughout the year. They vary somewhat over the states along the Gulf of Mexico, changing direction in summer and fall. Temperatures at 15,000 feet are usually more than 50 degrees lower than on the earth beneath, aviators finding freezing weather even in the summer. At heights of 30,000 feet, where there is no bad weather whatever, oxygen-breathing apparatus is required.

HAND AND BENCH SAW ARE COMBINED BY 685 ATTACHMENT

In less than a minute, a power saw may be converted from the portable hand type to bench use by employing a simple table attachment which requires only the removal of a thumbscrew to make the change. The swivel base on which the saw arm swings turns in a full circle and contains a graduated scale so that, when the saw is used for stable work, the correct angle can be quickly obtained, and also in bench work.

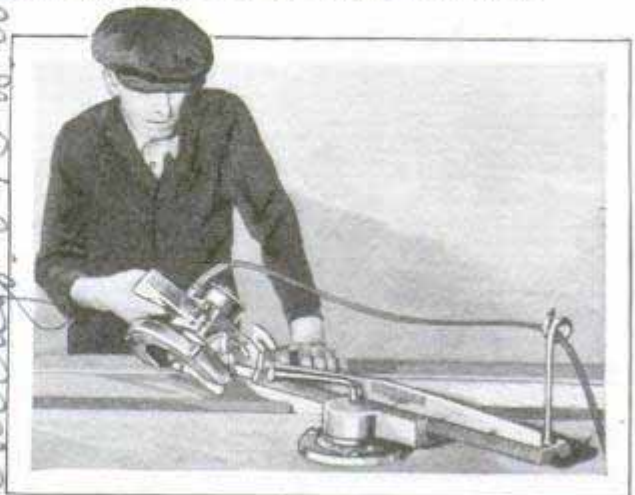

Attachment for Electric Handsaw, Which Converts It into the Bench Type in a Few Seconds

Chicago, 543 W. Washington

743

Porter Cable Machine Co
100 Wolf St. Syracuse, NY

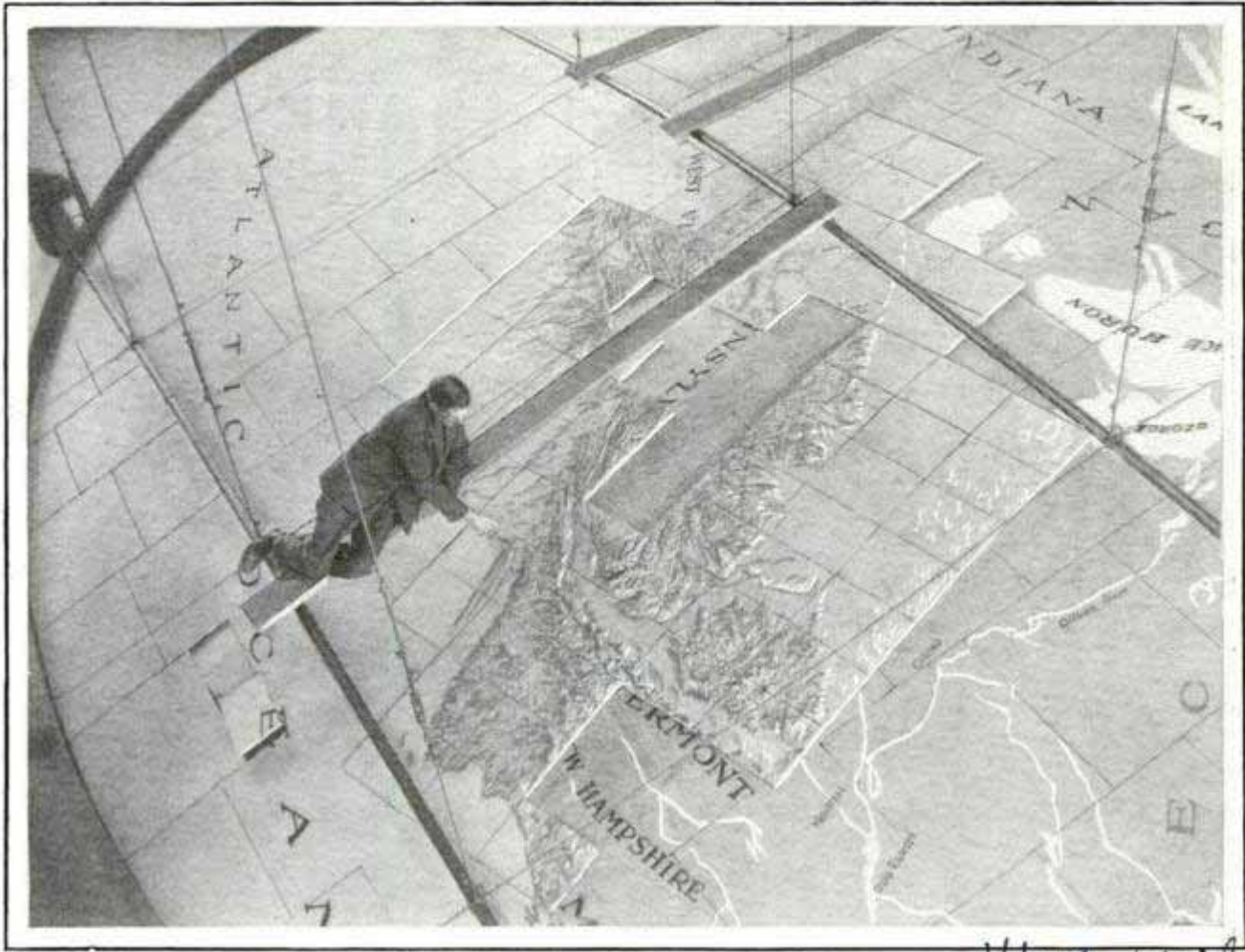

Part of Gigantic Relief Map of United States, Which, When Completed, Will Be Forty-Six Feet Wide, It Is Curved to Represent the Earth's Contour, and May Be of Aid to Aviators

MONSTER RELIEF MAP CURVED TO SHAPE OF WORLD

Planned on a scale providing a width of forty-six feet between the Atlantic and Pacific oceans, a huge relief map of the United States is being constructed at the Babson institute, at Wellesley, Mass. The gigantic map, which is curved to represent the earth's surface, is expected to be of great help to aviators in planning routes, as a glance will show mountain peaks and elevations of the terrain.

LIGHTS STOP FROGS' CROAKING

When guests of a California hotel complained that croaking frogs in near-by lily ponds disturbed their slumbers, the management stocked the ponds with ducks, offered prizes to children for capturing frogs and employed rifle shooters to rid the waters of the noise makers, all without avail. Finally, learning that frogs sing only under cover of darkness, the hotel owners illuminated the ponds at

night by electric floodlights. Now the frogs sit mute, expectantly awaiting the coming of a darkness that never appears, and the guests sleep in peace.

AWL FOR SCREWDRIVER BLADE MAKES DOUBLE-DUTY TOOL

Any ordinary screwdriver can be transformed into an awl in an instant with an attachment which fits on the driver blade to make a hole for starting the screw. The awl locks in position over the edge of the blade when in use, and when the screwdriver is employed in the regular way, it slides up against the

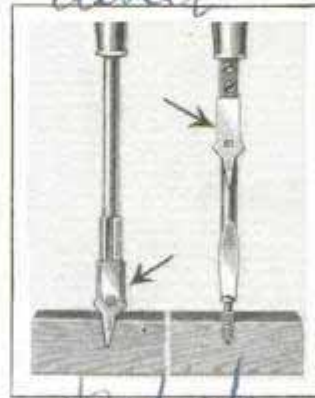

handle. Drilling a hole to start a screw with the awl takes but a few seconds, and it is then snapped out of the way.

Wick World

*Bulletin of Ill. Com. Public Utility Insp. 7/20/20
Chicago*

*D. W. Royce, manager
Hotel Huntington, Pasadena*

*A. L. Fuhlman & Industries
100 Morgan Bldg, Detroit, Mich*

4.5
Capt. Leslie Grear
77 54 East End Ave
Chicago

The Hunt for

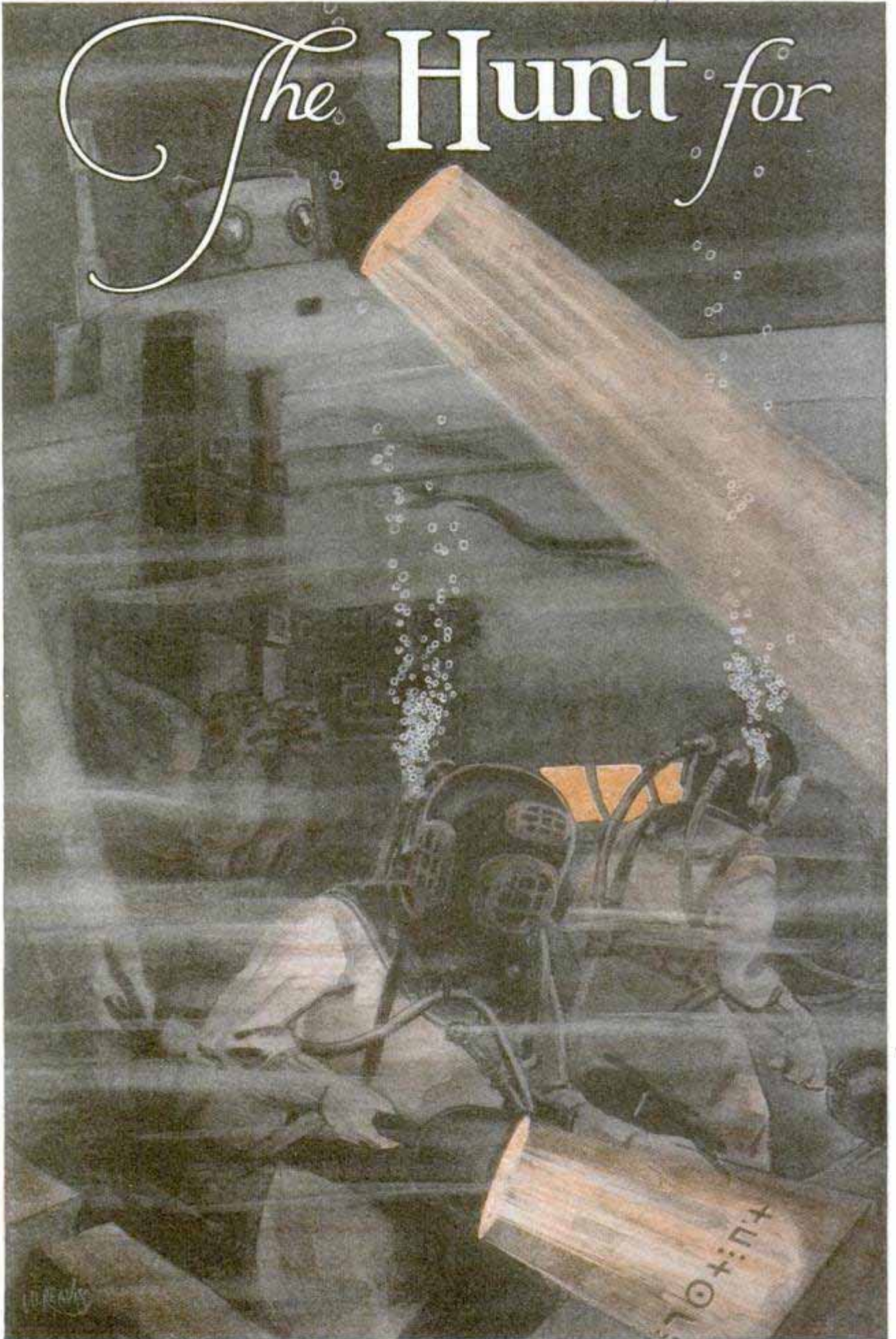

Lost Atlantis

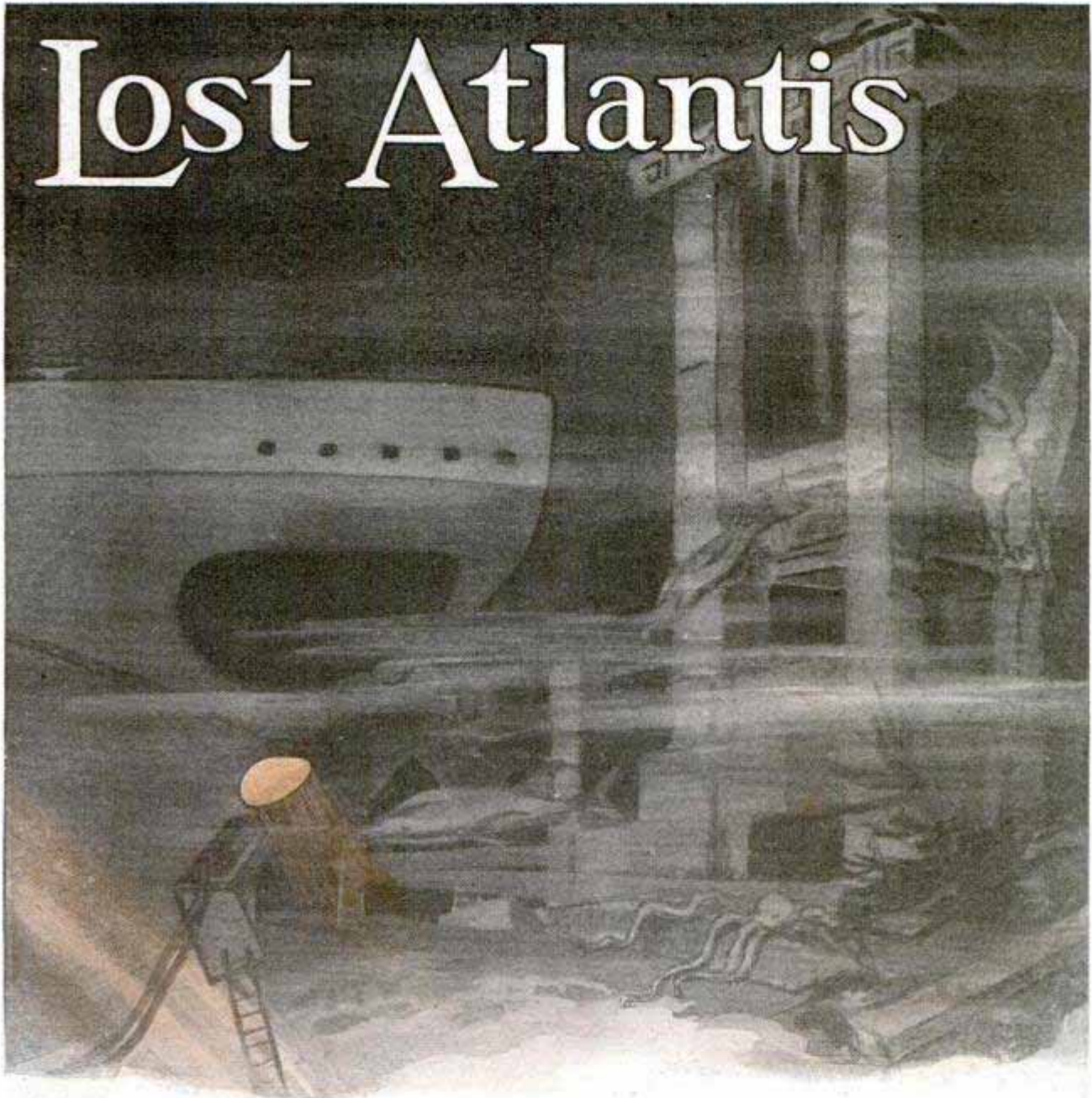

Artist's Drawing of Scene That May Become a Reality: Divers with Special Submarine Lights, Exploring the Ruins of the Fabled Atlantis, Search for Which Is to Be Renewed

By LESLIE OREAR

AT THE bottom of the Atlantic ocean, stretching westward from the Mediterranean and the northern part of Africa, lies, perhaps, the lost continent of Atlantis which, some think, once connected Africa with South America.

Within the near future, an undersea expedition is planned that should go far toward proving whether there existed, more than 50,000 years ago, a continent of rich and fabulous cities where dwelt the legendary race of Amazons, descendants of whom, it is believed, still may be found in the mountain fastnesses of the

Sahara, and traces of whom have been found in Yucatan.

Already there have been wrested from the sea the secrets of several ancient cities that were submerged by some unrecorded catastrophe, and what those discoveries have revealed inspired Count Byron Kuhn de Prorok, famed archæologist, to organize, in collaboration with French and American institutions, this new expedition in search of the lost Atlantis. Associated with Count de Prorok is Dr. H. Hartmann, whose new diving cylinder makes the success of this venture a probability.

*a. Rue de Lata 27
Paris 14^e arr.*



Despite the enormous pressure of 1,110 pounds a square inch, Doctor Hartmann's diving cylinder can descend as low as 2,500 feet under water with a crew of men—far deeper than man has ever dived before. The walls of the cylinder are made of cast iron, three inches thick, in which, at proper intervals, are set observation windows more than half as thick.

In this cylindrical compartment, suspended from the surface ship by a three-inch steel cable, and in telephonic com-

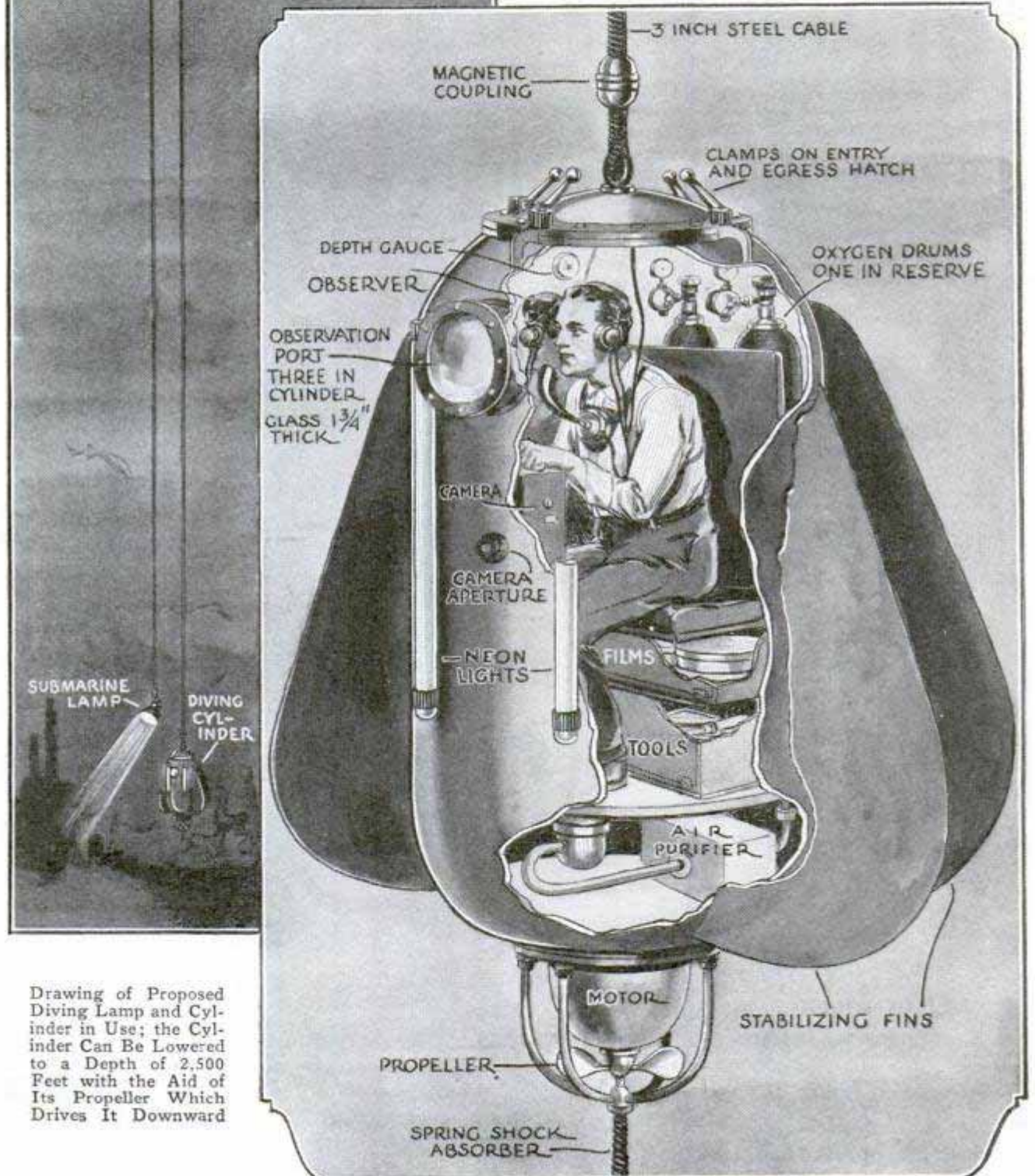

Drawing of Proposed Diving Lamp and Cylinder in Use; the Cylinder Can Be Lowered to a Depth of 2,500 Feet with the Aid of Its Propeller Which Drives It Downward



munication with the surface crew, will be two men, one observing whatever may be revealed in the light of specially designed neon lamps and the other operating a motion-picture camera. A supply of oxygen, released from two drums within the cylinder, will enable the observers to remain below water for three-quarters of an hour.

And so, equipped as no undersea expedition ever before has been outfitted, this expedition of the Deep Sea Archaeological Research society will set out to find—what? Sunken cities; kings' palaces; slaves' huts; the sea-drenched remains of the long lost life of a people who lived and loved and fought and hated centuries before the birth of Christ?

But let Count de Prorok tell it.

"The ancient history of the Mediterranean tells us of cities that have been submerged, galleys that have sunk, and other treasures beneath the sea. And the legend of the lost continent is still the subject of endless controversy. I long have thrilled at the thought that the legend of Atlantis might be an existing fact; of a submerged continent between the Americas and Africa, where ruins of a lost civilization may still be found with



The Count de Prorok Deep-Sea Expedition in Search of Lost Atlantis 1927-29, and the Count on a Camel during a Sahara Journey

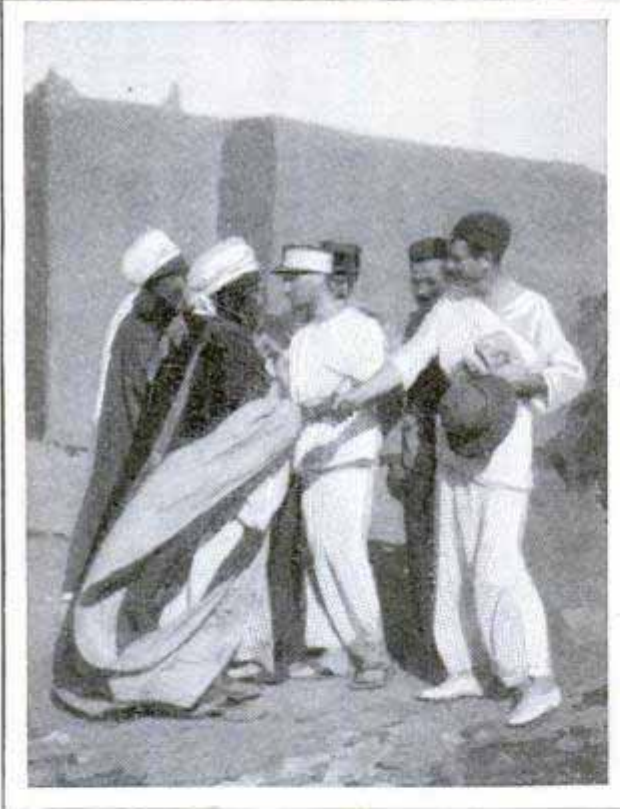

In the Sahara Desert Where an Unknown Script, Possibly a Clue to Atlantis, Was Discovered, and the Count Meeting Desert Dignitaries

temples and houses covered with the sea growth of ages to be explored and excavated by the new diving apparatus of modern invention," said he in discussing his plans for the forthcoming expedition.

But foremost in Count de Prorok's mind lies the hope, which is really more than hope, that he will be able to prove that Africa and South America once were con-

nected by land. The evidence of the skeletons points to the existence of prehistoric men of great intelligence and stature who originated in northern Africa and crossed into Europe over what the count believes were once great land bridges at Gibraltar, Tunis, Sicily, and other points, parts of which are now submerged.

It has been found that detailed measurements of the skulls of Gauchi peoples of the Madeira islands compare exactly with those of present day Tauregs of the Sahara and with certain skulls found in tombs in Yucatan. How, long before the dawn of history, did counterparts of the unusual Taureg find their way into Yucatan?

Coincident with the subterranean exploration there will be a land expedition deep into the northern part of Africa to determine just to what extent human life moved through the Hoggar and Atlas mountains, where, it is believed, the original home of the Atlanteans may have been. Skeletons identical with living Tauregs have been found there. Over the Sahara desert an expedition will go with powerful six-wheel trucks capable of traveling 800 miles without refueling; equipped with searchlights for night work, labora-

415

Wagner at the... Beach Golf Club Arnold Beach, 31

Arnold Beach, 31

tory facilities and machine guns for protection against the ferocity of the Tauregs—surly giants; remnants of a vast civilization, the last of the Atlanteans.

Both the land and sea expeditions go equipped with every known modern device that might lend itself to the success of the enterprise. Always hovering above the diving cylinder will be a 140-foot yacht. In addition to a laboratory, it will contain special grappling apparatus, wireless equipment, photographic installations, a glass bottom for submarine observation and the great windlass for manipulating the diving cylinder. It also will carry an unusual type of submarine boat from which divers may emerge into a lost world of ruins of cities, or explore the sunken treasures of ancient Carthaginian galleys.

An airplane, equipped with the latest talking-picture apparatus, will fly above both land and sea expeditions. Indeed, it was the discovery of objects beneath the sea from an airplane that gave the impetus to this forthcoming expedition. For long centuries, unsuspected, the walls of Carthage lay covered by the Mediterranean sea. And then an airplane of Count de Prorok's expedition, flying at a height of 1,000 feet, enabled the observer clearly to trace their outline and establish the fact that a part of the ancient capital of the world had slipped into the sea. In the same way the lost city of Tipasa was discovered seventy feet under the water.

"From the Atlantic to the Red Sea," says Count de Prorok, "north Africa is an open-air museum unequalled in the world. The great ones of the past seem to haunt the desert trails, and often by some lone camp fire we have evoked the mighty shadows that have thundered by, disappearing into the dim mists of history. Hannibal, Alexander the Great, Cleopatra, Scipio Africanus, Cæsar—those magic names alone have made a treasure house of memories in ancient Sahara lands.

"And now to search the sea itself for those things which are beyond history—stories told from father to son for unnumbered generations; the land of legends. We embark upon this romantic quest confident that we shall give to the world some insight into the most ancient civilizations of all time—the lost Atlanteans."

FLEXIBLE SHAFT ON GOLF CLUB GIVES LONGER DRIVE

As a boon to long-distance drivers, a golf club with a flexible shaft has made its

239

Used by Harvey Firestone



Carly

no information

Golf Clubs with Flexible Shafts Which Lend More Power to Swings for Long Shots

appearance on Florida courses. The flexibility of the shaft was found to lend more power to the swing, thus making longer drives possible. Except that the shaft bends slightly when force is applied, the club resembles the ordinary driver.

GLASS DISKS UNDER EYELIDS REPLACE SPECTACLES

448

Disks that fit snugly over the cornea of the eye and are worn under the eyelids have been made and tested successfully

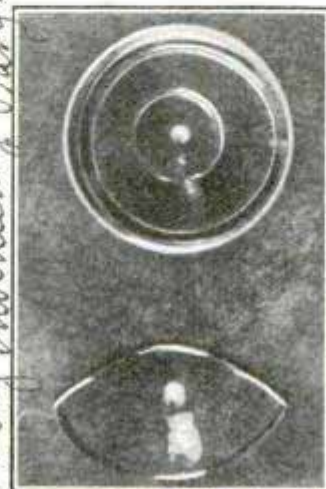

as a substitute for spectacles. Their principal advantage is that they are virtually invisible to any other person. They can be placed in position readily by the wearer, and need no adjustment when once fitted to the eye, except periodical removal for cleaning.

Probably invention of Prof. Camallor Professor

Dr. J. Heine University of Kiel, Germany

Cont. George J. Paul

Q. 809 5 37

ev ori I

281

Chicago, 5 N. Wabash



Spectacles with Upper Part of Lenses Shaded, to Protect Eyes against Brilliant Light.

SHADED LENS FOR SPECTACLES SHUTS OUT GLARE

Varying intensities of shading are available in a special spectacle lens which can be ground to any prescription. The upper portion of the lens is darkest, the bottom being almost the shade of transparent glass. It is finding favor among those whose eyes are sensitive to glare.

ONE MOTOR TO FLY AS FAST AS THREE DO NOW

748

Tri-motored airplanes will be able to fly just as fast with one motor as they do now on three when designers improve the streamlining to the point where the flow of air around the ships is smooth and free from eddies. This is the opinion of Dr. Joseph S. Ames, chairman of the national advisory committee for aeronautics, who has found, from careful estimates, that an airplane can maintain its speed with one-third the power ordinarily used if the flow of air around it is of that description. The drag of different parts of a ship can be studied separately in wind tunnels, but the drag of the machine as a whole, due to distortion of flow when the parts are assembled, may be twice as great as the

Pres. Johns Hopkins Univ. Baltimore Md.

before National Academy of Sciences 4/28/21

sum of its parts. This additional handicap, called interference drag, can be studied only by placing the entire ship in the throat of a wind tunnel. No tunnel large enough for this purpose now is in existence, but one is being constructed at Langley field, Va. The largest tunnel at present has an open throat twenty feet in diameter and produces an air stream having a velocity of 100 miles an hour.

HIDDEN FAULTS IN AIRPLANES REVEALED BY "STROBOGLOW"

709

Imperfections in airplane propellers, and in other objects, are revealed while the units are in motion by means of the "stroboglow," a flashlight device developed by Westinghouse research engineers for greater safety in flying. In examining an airplane propeller, for instance, the test is made at night, as darkness is essential to the operation of the device. The light flashes are regulated to appear at intervals to correspond to the speed of the propeller. This makes the "prop" appear motionless although it is spinning at more than 1,000 revolutions per minute. The slightest crack or irregular movement is said to be plainly visible as the lights are flashed on and off. The device is also used to detect the movement of valves in gasoline engines, the vibration of meshed gears, or the slip of a belt moving on a pulley. The stroboglow already has been employed to test planes at several airports to make sure that both engine and propeller are in good condition.

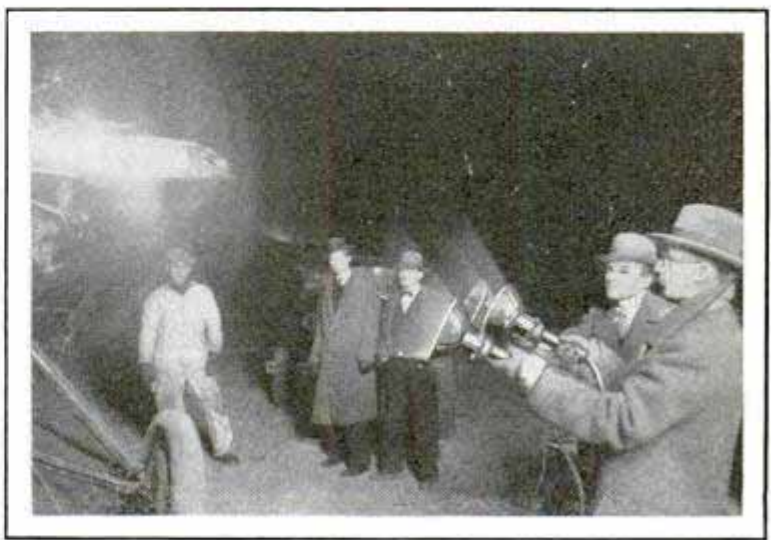

Using the "Stroboglow," a Special Flashlight, Operated through Radio Tubes, to Examine a Spinning Propeller

Inv. W. W. Knowles

HOUSE MOVED OVER RIVER ON TEMPORARY BRIDGE

After building a large home on one side of the Elbow river, a resident of Calgary, Canada, concluded he should have built on the opposite bank and decided to move the house across. After making careful measurements of depths



Pulling a House over River on Temporary Bridge with Tractor

and examining the river bed, he constructed a temporary bridge of criss-cross logs. Onto this bridge the house was pulled by a tractor and slowly made its way across the stream and onto the new concrete foundation.

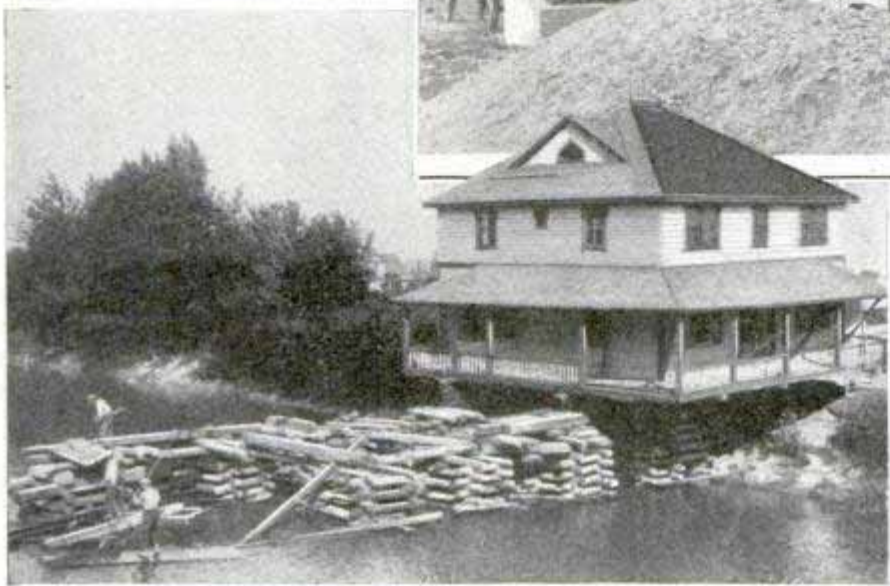

TONE IMPROVER FOR RADIO SET AIDS TALKING MOVIES

To round out and perfect the tone quality of amplified speech or music, a control unit has been introduced for wide application. It is especially useful in connection with talking-picture apparatus, according to reports, as it eliminates needle scratch from records, hiss from films and microphone noises, and is said to add brilliance and depth so often lacking in reproduced music. The unit is also suitable for use following radio set detectors, and in general use immediately precedes the main amplifier. Controls are provided for regulating the high, low and middle ranges to suit the



Samson Electric Co, Canton Mass

operator. Switches and controls enable him to select the frequency ranges to be softened, and the degree to which the volume is reduced.

DESTROYERS MAY BE BARGES

More than fifty old navy destroyers, soon to be scrapped by the government, would be used as barges to carry freight from Chicago to the Gulf of Mexico under a plan advocated by Rear Admiral Colby M. Chester. These boats, with several others too ancient for use in war service, could be equipped with Diesel engines and converted into tramp freighters for the Mississippi river service and the Great Lakes canal systems, at an estimated cost of about \$100,000. This would allow these boats to carry freight from Chicago, Pittsburgh, Cairo and St. Louis to the sea and thence to foreign ports without transshipment.

U. S. N. Retired

729
Kansas City Star
April 17, 1930

NATURE WONDERS SEEN THROUGH CAMERA LENS

520

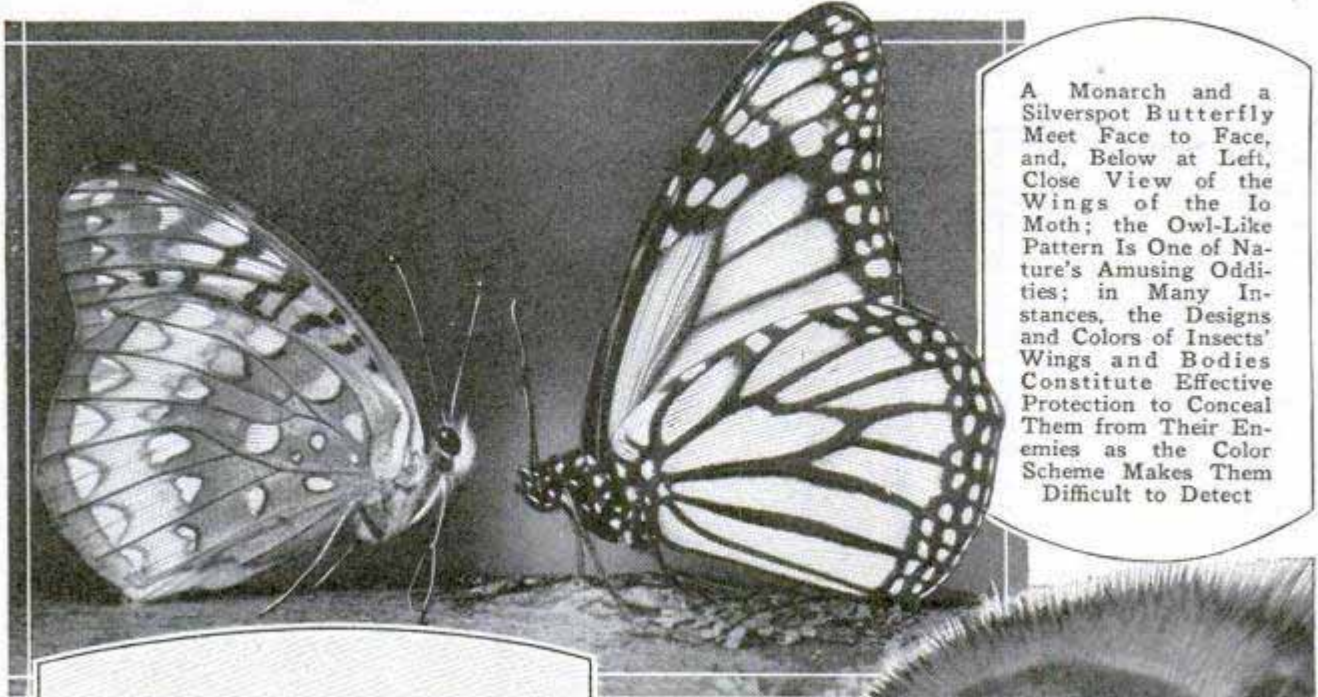

A Monarch and a Silverspot Butterfly Meet Face to Face, and, Below at Left, Close View of the Wings of the Io Moth; the Owl-Like Pattern Is One of Nature's Amusing Oddities; in Many Instances, the Designs and Colors of Insects' Wings and Bodies Constitute Effective Protection to Conceal Them from Their Enemies as the Color Scheme Makes Them Difficult to Detect



The Bald-Faced Hornet at Close Range, Showing Its Kidney-Shaped Eyes, Its Jointed Antennae and Pincerlike Mandibles, Which Are Used to Strip Off Pieces of Wood from Buildings, Old Fences and Other Places; This Material Is Masticated into a Pulp for Building the Hornet's Nest; at Left, Contrast Study of the Faces of a Bat and a Bullfrog



SAW HANDLES AND PIPE BOWLS FROM SAME WOOD 736

Millions of feet of apple wood are used annually in making handles for saws, and the cuttings from the handles are employed in turn in making bowls for pipes, so that little of the wood is wasted. The apple logs are air-seasoned for three years, after which they are inspected and sawed into proper lengths for the handles.

BAG ON FISHING COAT LEAVES HANDS FREE 696

Fishermen have less to worry about in the way of luggage when wearing a special coat that has five large pockets and a bag attached to the rear, to hold the fish. This bag is said to keep the fish in better condition than is usually possible in a willow basket, as there are arrangements for free circulation of air. The bottom is of aluminum, and the entire unit is detachable for easy cleaning. The coat has a roomy pocket for luncheon and two for bait. These have reversible linings to simplify the task of cleaning.



L. L. Bean, Freeport, Maine
Chicago - Winter 33

SLOW MOVIE OF GOLF SWING PLOTTED ON GRAPH 650

To aid the golf player in correcting faults in his swing, slow-motion pictures of the movements of the swing now may be charted on a huge graph that serves as the background for the player and the movie. The chart is a large sheet on

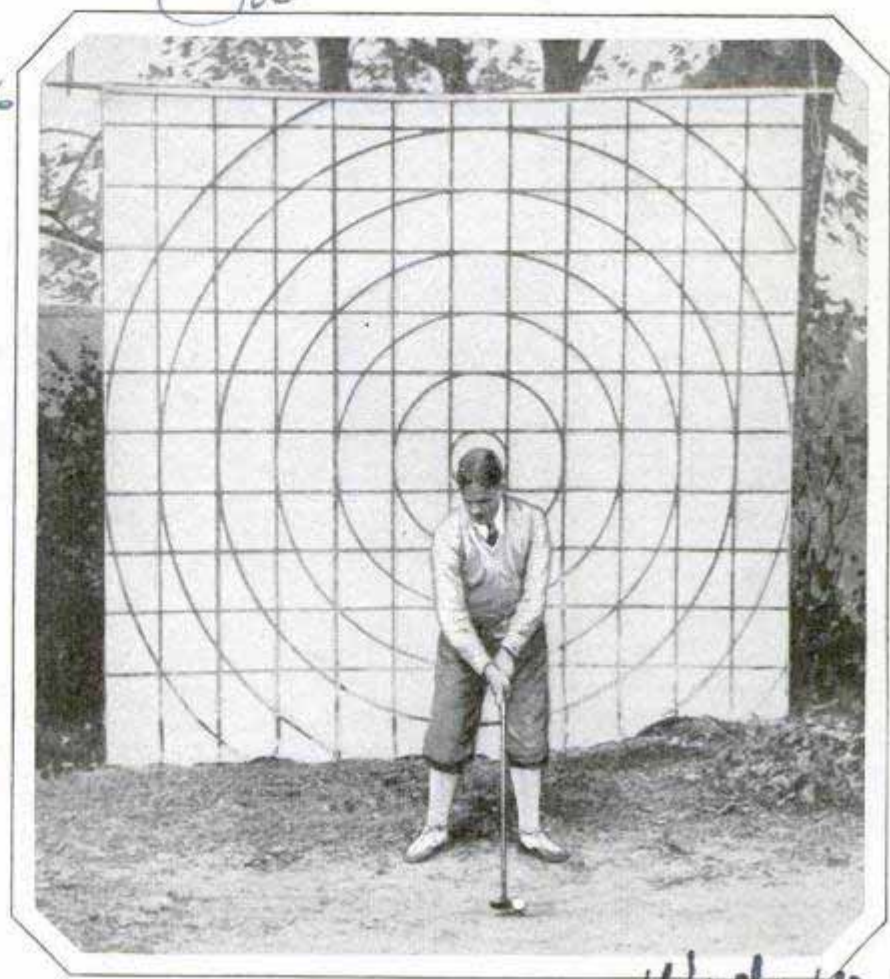

Slow Movies of the Golfer's Swing Are Taken with This Graph as a Background, so the Stroke Can Be Plotted and Faults Corrected

Wide World

which is an arrangement of squares and circles, the smallest circles on a level with the player's head. With this as a background, the slow-motion picture permits analysis of the stroke by plotting the position of club, head and hands at various positions, as the club descends and meets the ball.

NAIL HELD BY HAMMER CLAW FOR INITIAL BLOW 406

To hold a nail for the first tap, and leave it in position for successive blows, a hammer is provided with a claw attachment which fastens to the side of the handle. The claw itself terminates at the side of the hammer head, the nail being inserted in it and the first tap made with the side.



English

L. L. Hart National Open Champion

Cannot locate.

663
36

METAL FURNITURE OFFERS BEAUTY AND COMFORT

New styles of furniture in metal and other materials not usually employed

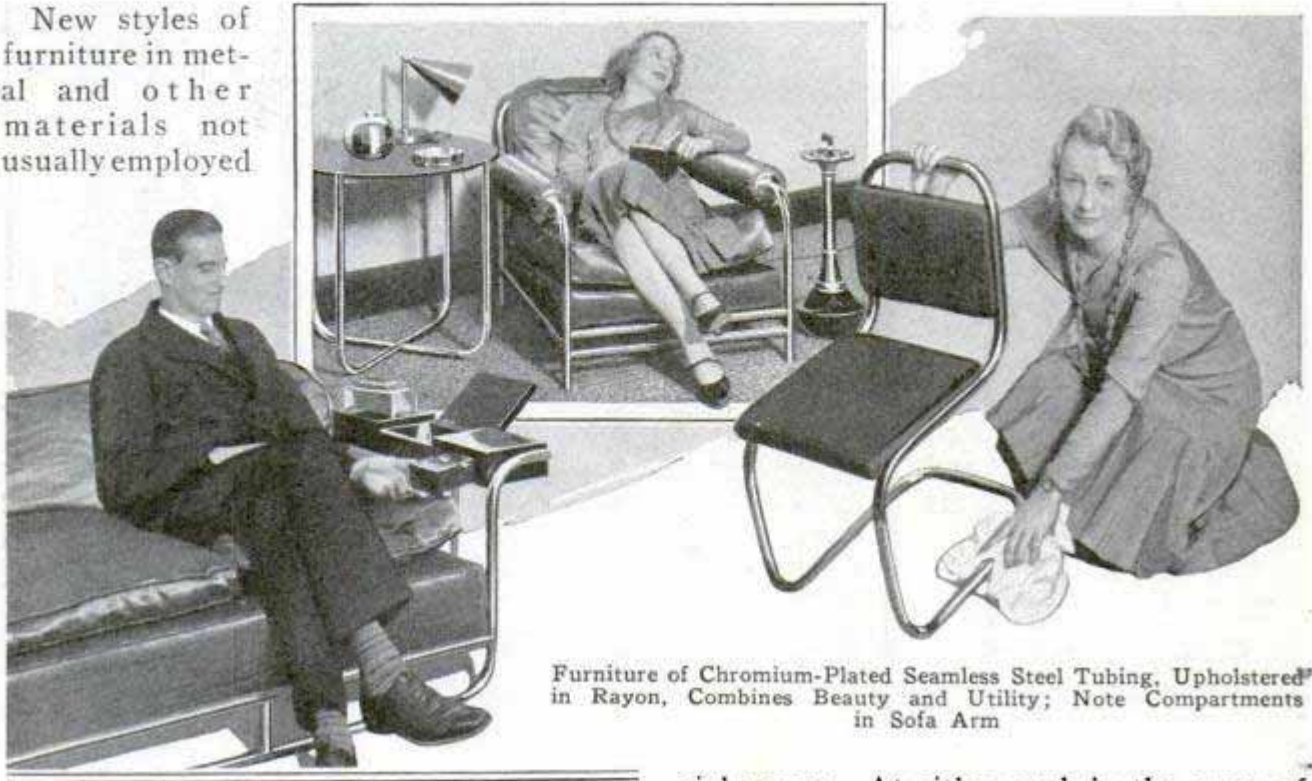

Furniture of Chromium-Plated Seamless Steel Tubing, Upholstered in Rayon, Combines Beauty and Utility; Note Compartments in Sofa Arm

in household articles, are appearing on the markets. Novel chairs, tables and divans in simple, modern designs by Donald Deskey, a New York artisan who forsook architecture to build furniture, illustrate some of the chief tendencies in the latest furniture. Seamless, cold-drawn steel tubing, plated with gleaming chromium is employed for the framework. It is indestructible and has a chief advantage in being easily kept clean and bright, so that the dusting problem is almost eliminated. There are no later expenses for refinishing or repairing. Formica, a composition material, is being widely employed as a substitute for wood in the table tops. It takes a high gloss and is also impervious to stains and burns. The upholstery in the chair and divan illustrated here is in a spe-

cial rayon. At either end, in the arms of the divan, are handy compartments for the smoker or for holding small articles for sewing, decks of cards, or such things. "Permatex," another special material, is being widely used for upholstery.

LAWN EDGER LIKE A SCOOTER IS EASY TO OPERATE

Shaped and operated like a child's scooter, a lawn edger does away with much of the hard labor of performing this work. A movable handle, which is coupled to a pawl and ratchet, enables the operator to apply considerable leverage, and a platform is provided to hold the cutting disk in the soil by the operator's weight. A wooden roller, or disk hub, carries the edger on sidewalk or driveway, while the rear is equipped with a steel skid.



Lawn Edger, Shaped and Operated Like a Child's Scooter, Which Makes This Hard Task Easier

Randelman Lawn Edger Co.
280 2 1/2 Live Oak St.

Chicago - 666 Lake Shore Drive
1148 32nd

4/8/30

438

WOODEN WHEELS FOR SUBWAY ARE NOISELESS

London's subways and tramways are experimenting with wooden car wheels, which not only are less noisy than the metal ones, but, in addition, are said to possess superior strength, endurance, resilience, and are lighter in weight. It is a laminated disk wheel, each layer being composed of six or more sectors of spruce wood. In each sector of the circle the grain runs in a different direction, successive laminations being superimposed in such a way that the joints of adjacent disks do not coincide. This is the same principle as that employed in the laminated-wood airplane propeller and has been used for centuries by masons in laying brick.

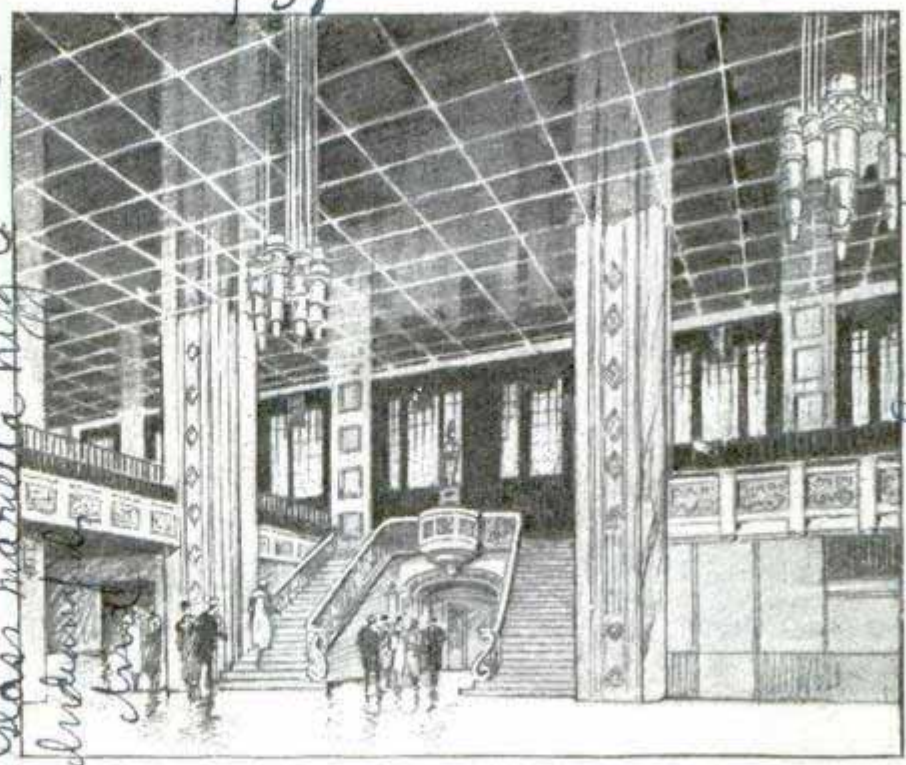

Artist's Drawing of Hotel-Lobby Ceiling in Black Glass; the Reflection Gives the Effect of a Much Higher Room

"INVISIBLE" CEILING OF GLASS LATEST HOTEL NOVELTY

Black glass as the ceiling in the lobby of a hotel now under construction in Kansas City, Mo., will reflect the floor and side walls in such a manner as to create the effect of an invisible ceiling. The glass will also give the impression of greater height to the lobby and will be more easily kept clean than usual materials. Floor and walls are of marble up to the mezzanine level, where walnut panels are used to the ceiling.

AUTOMATIC ELECTRIC LIGHTER OPERATES WHEN TIPPED

Automatically lighting and righting itself, an electric cigar lighter is operated merely by picking it up and tipping it. When upright or even upside down, it cannot light, and it is so balanced that, when laid down, it automatically rights itself and turns off the current. The bakelite base is in various colors, and the cap in different metal finishes.



MACHINE GUN FIRED BY AIR TO AID TARGET PRACTICE

Round lead balls are fired with sufficient force from a pneumatic machine gun, recently introduced, to penetrate a quarter of an inch of wood at 100 feet. Compressed air at 200 pounds to the square inch furnishes the force for the missiles which are supplied from a magazine that holds about 300 balls. The gun was devised especially for shooting galleries, but is expected to be of aid to army gunners at target practice or for sporting purposes.

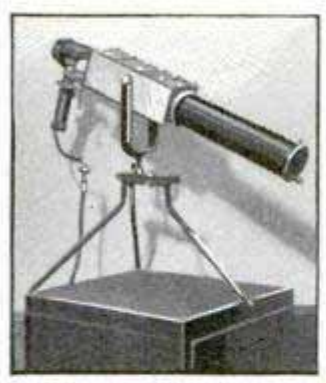

The film of a sound moving picture wears out after fifty to seventy-five days of showing, whereas the silent films last from ninety to 120 days.

Ans. R. B. Smith
1326 Candler Bldg.

Electracraft Corp.
161 Massachusetts Ave

Architects, Oscar Lane
 Kansas City Star 2/2/30
 Chicago - Manhattan Electrical Supply Co.
 Chicago - May maine
 Chicago - Wash maine

Emb. Paul Messersmith 226. Mrs
New York City

524

Working with Judson Radio Program Corp.
and Columbia Broadcasting System

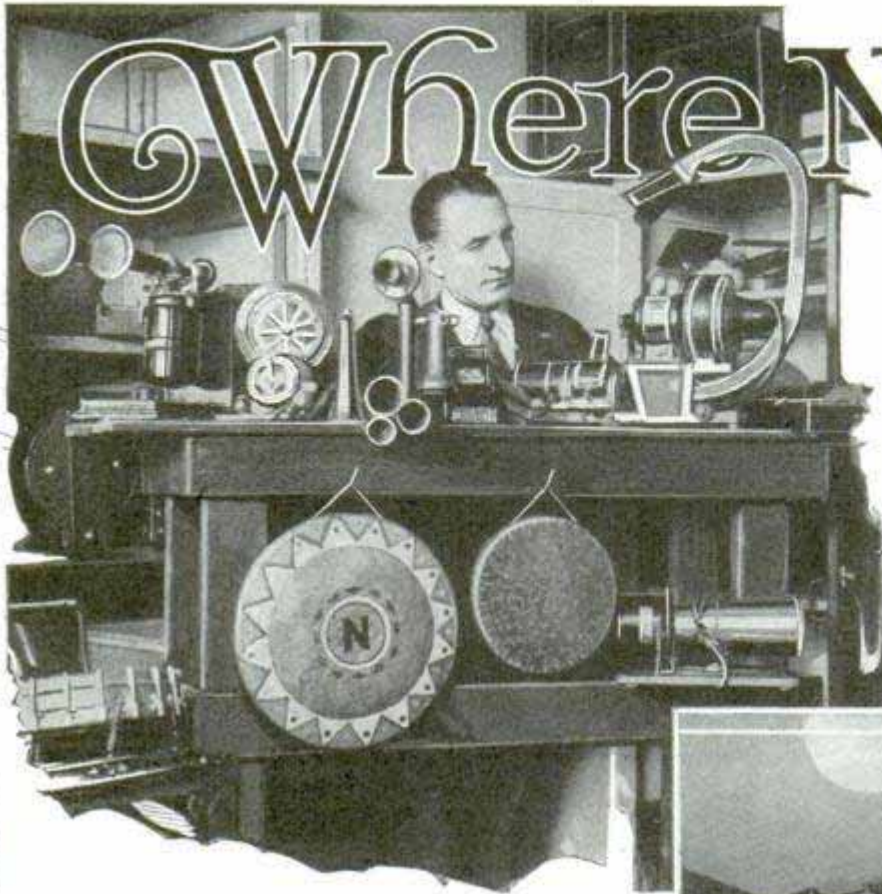

Where Noise-

tric motor operates it to make all sawing noises without the use of wood or a saw. He is a student of noises and has learned to operate this machine so that it apparently cuts pine knots, and the sound of the saw changes as it bites into a log.

More than a score of electric motors are employed to operate novel

Reproducing the Sounds of a Sawmill for the Radio; Other Noise-Making Instruments Are Shown

BEING the approaching footsteps in a broadcast play has become a profession, and A. W. Nichols, of New York, has invested more than \$10,000 in noise devices to imitate horses, guns, engines, street cars, sawmills and cash registers, and he has about three thousand other "props" of the broadcast stage. He is considered the dean of the noise-making profession, having begun his art twenty-three years ago, when he made funny sounds behind the motion-picture screen of Lyman Howe, the travel lecturer.

Nichols has seventeen patents to cover his major inventions, such as a contraption which paddles a banjo head to imitate a machine gun. A real machine gun sounds something like a typewriter when broadcast, and it cost Nichols several months of development work before he perfected the paddle gun. For long-range machine-gun fire, he uses the paddles on a leather cushion. His assistant and general manager is his wife, and he will permit none other to collaborate with him in his studio work.

Nichols has built a complete sawmill which he can carry in his arms. An elec-

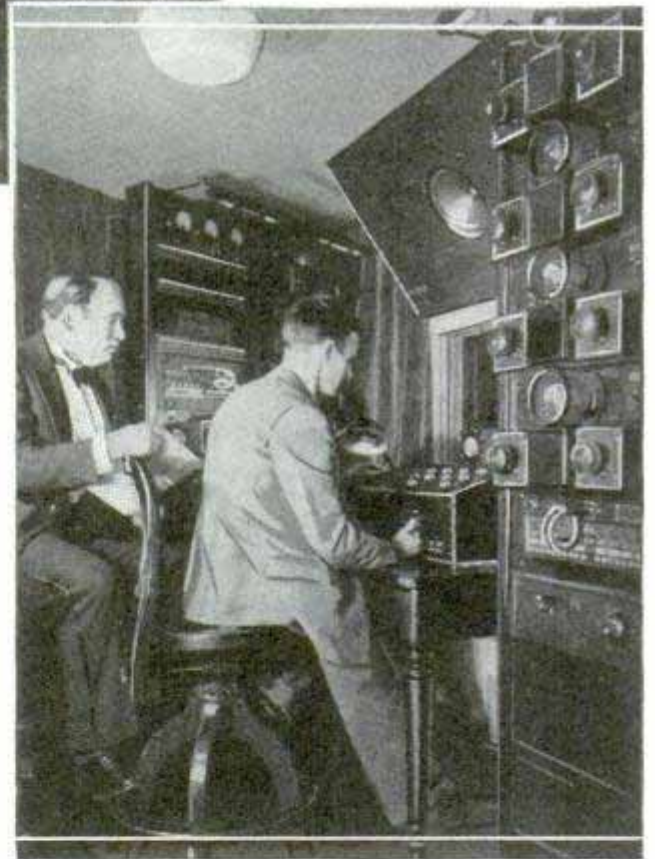

Mixing the Music of a Chicago Civic-Opera Performance as It Is Being Broadcast

sound instruments. One twirls a little ball on a chain to imitate a riveting machine. Others operate automobile horns, sirens, wind and thunder machines, imitation street cars and gasoline engines.

There is a difference between an ordinary locomotive and one which hauls freight, says Nichols. The first is imitated by rubbing steel wires over a tin

1. 113 W. 57 St. New York
2. 485 Madison Ave. N.Y.

Making *is an* Art

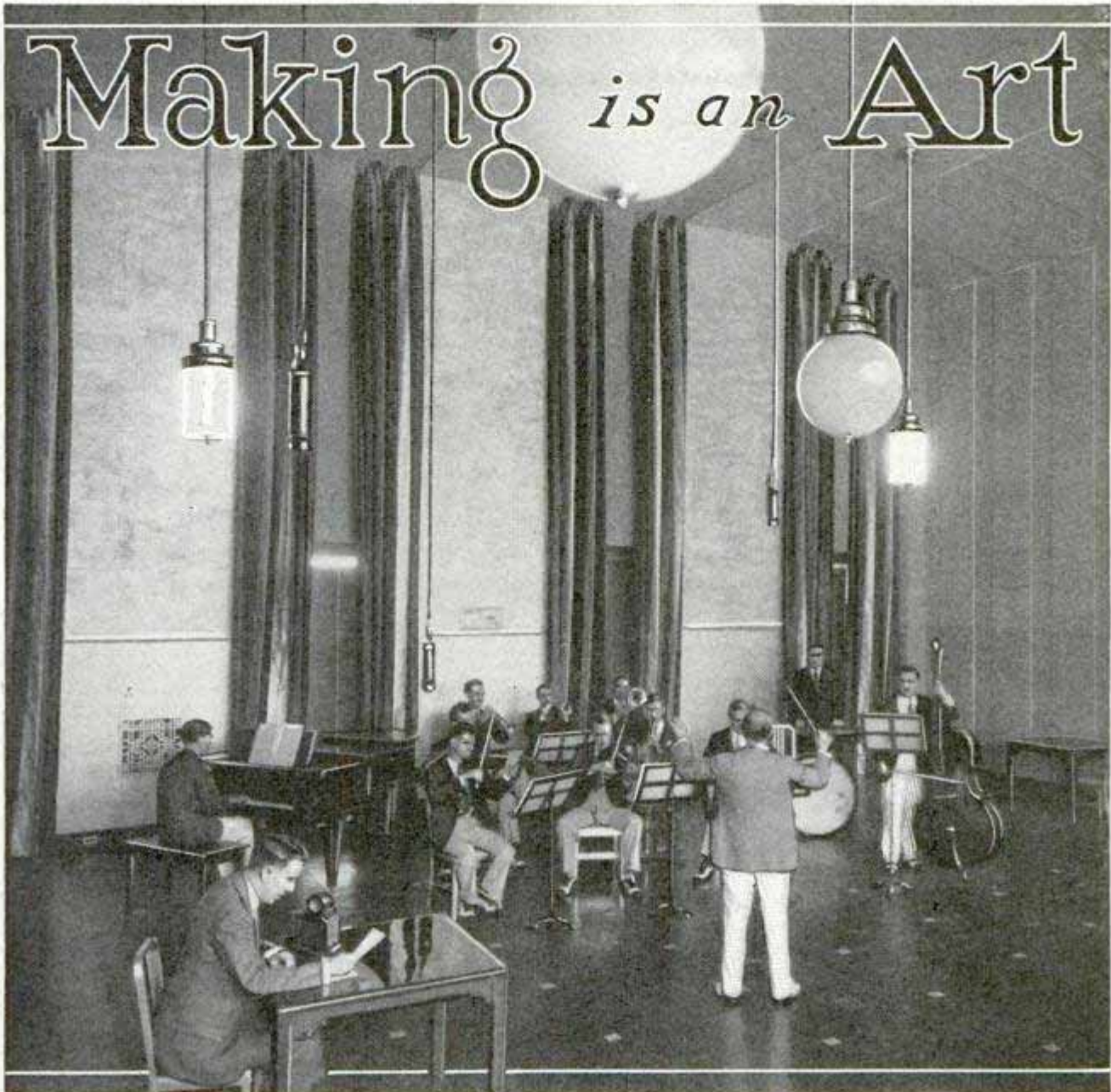

The Chicago Daily News Concert Orchestra Playing in the Spacious Studio of WMAQ; the Walls Are Lined with a Special Acoustic Material Composed Largely of a Glass Substance

box which is properly roughened and attached to an acoustic chamber. The large freight engine requires a larger box with a lever to create the roar.

For the patter of rain, he turns a large parchment cylinder and something inside continues to patter against the paper sides.

"Sand, beans, peas?"

"Maybe," replies Nichols, who has given his life to discovering the secrets of noise imitation, and has many tricks which are his professional property, and which even the broadcasting-studio managers do not know.

There is a secret about breaking glass which he reveals, however, for he realizes

that most people cut their hands with the small splinters which fly.

"Use a wooden hammer. That's all," he explained. "I've been cutting my hands for years, using a steel hammer. I went so far as to build an automatic glass crash at one time. It operates electrically. A hammer smashes a pane of glass when I press the button, and the pieces fall down a chute to make a clatter.

"I lie awake nights thinking up new things. The toughest problem I ever had was to reproduce a street car for a microphone. It has more different kinds of noise than anything else I ever tackled. I have to imitate the motor, the sound of steel wheels against steel rails, the joints

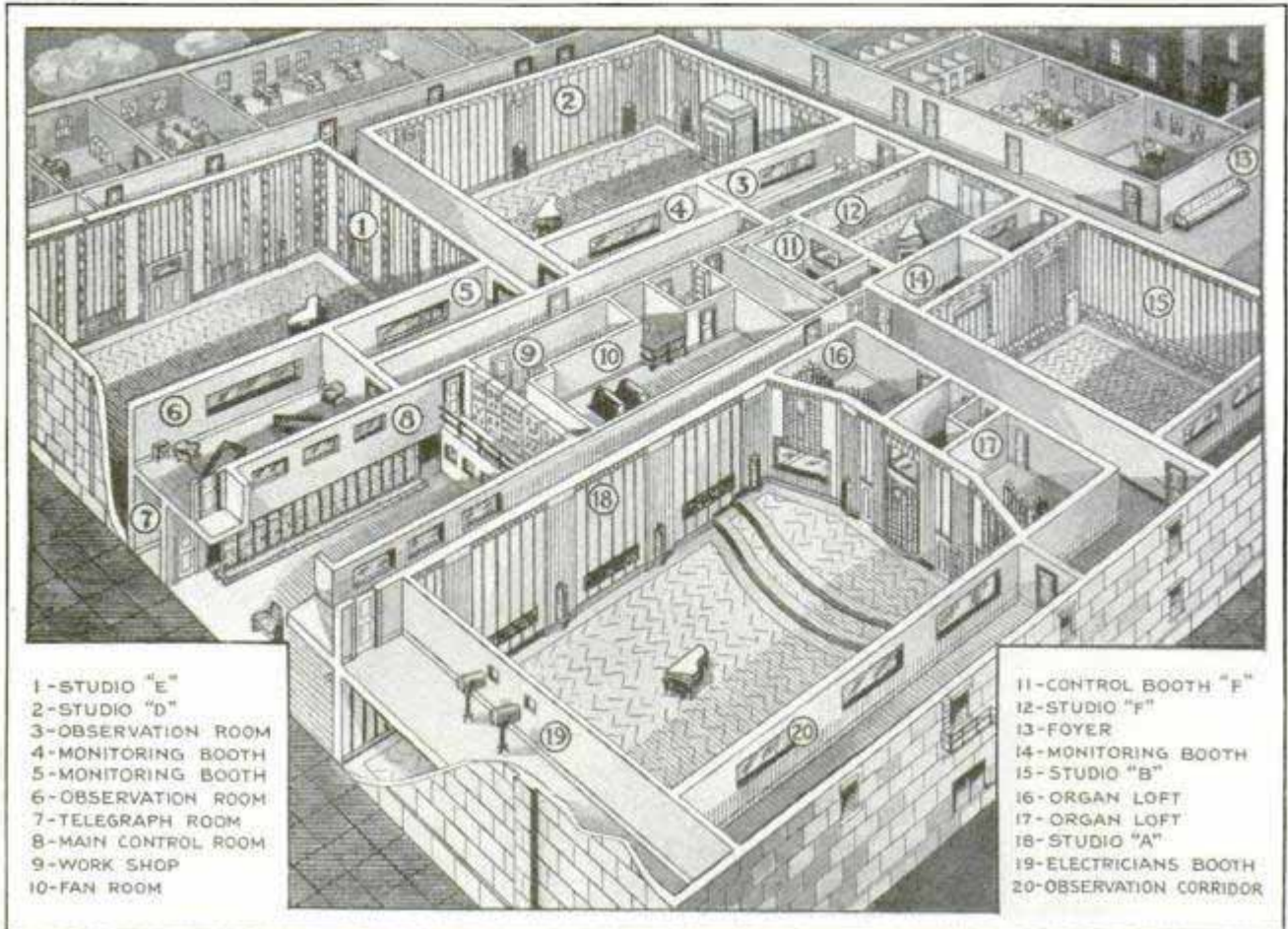

Drawing of the Chicago Studios of the National Broadcasting Company Which Are Located near the Top of the Merchandise Mart, the World's Largest Business Building

in the track which make bumps, the bell, the trolley against the trolley wire, and a few more things you would never suspect."

One of the mysteries which he cannot explain is that nothing sounds so much like pouring a drink as pouring a drink. He uses an ordinary bottle and a glass for it, clinking them with proper artistry. However, he can wet the bottle's cork, rub it on the side of the bottle and imitate a cage of monkeys.

His cell doors is one of his most widely approved offerings in radio drama where the villain is at last locked up for keeps. There is no doubt about it when Nichols slams the door, which consists of half a dozen bars of steel chained together like a fan, so that they will fall against a steel frame with a proper clatter.

"In the old days," says Nichols, "for a crash I used to drop a plank and an armful of junk, but no more. I study all the sounds, even to this."

He turned the crank of a little toy he has made, and the noise of automobile tires skidding on dry asphalt was repro-

duced with a chamois-covered roller, a little rosin and a few secrets which he alone understands.

In a small black box he keeps two cats and a lion. They are always ready to cry or roar when he pulls the strings which hang from the mysterious box.

He imitates a typewriter by clicking two flattened soda straws together, and makes body blows for a fight by striking a leather cushion with a hammer.

Several dozen bells are necessary to produce the sounds required. An electric doorbell does not broadcast well and must be imitated by a bicycle bell, operated by a spring instead of a vibrating armature. Among the other bells he uses are plates of steel of various sizes, the double bell for a telephone, trip gongs used at prize fights and in fire stations, and bells to give the impression of ambulances, police patrols and fire trucks.

A rumbling wagon requires a box by itself, filled with clattering boards. Ocean waves are simulated with a kind of steel brush with long bristles, moved expertly over a drumhead.

All types of automobile horns are represented in the four large cabinets used by Nichols to guard his many devices. He also has horns to imitate fog signals, trains, ocean liners and the bawl of a cow.

Two motors imitate airplanes by the use of fans which are especially shaped. One is for a close-up and the other for a fade-out.

On one portable table is assembled a motor exhaust, cuckoo, siren, bear growl, pig squeal, telegraph key, anvil, box of gears, nose blower, castanets, tom-tom, fireworks, baby cry, chain rattle, sleigh bells, cloth tearing, bee buzz, fly hum, cork puller, acetylene torch, ambulance bell, rooster crow, hen cackle and tinpan crash.

It is necessary for Nichols and his wife to study the manuscripts of radio plays and as-

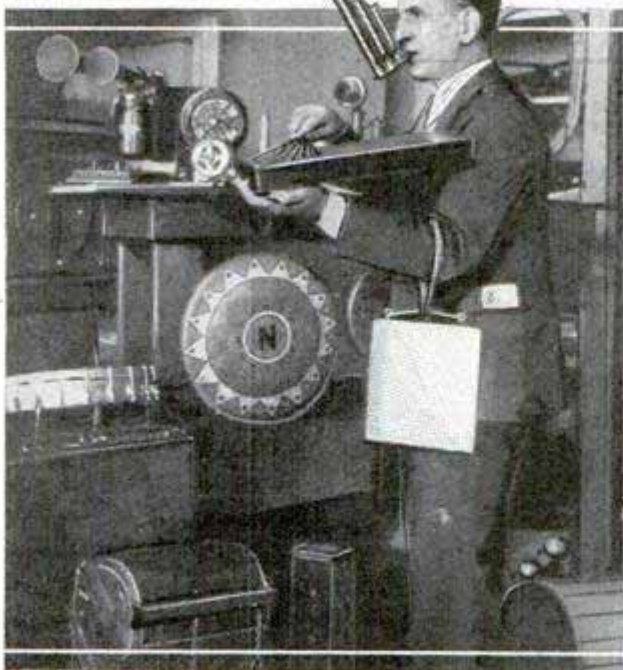
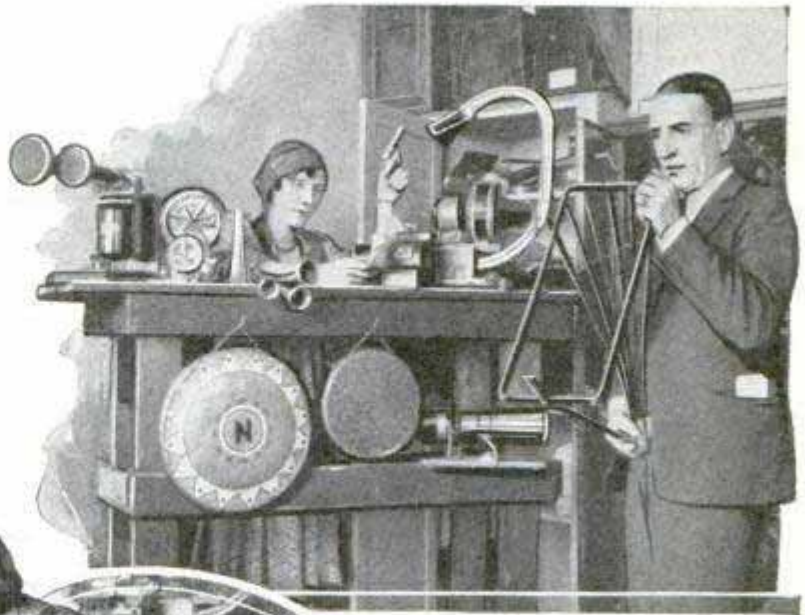

semble the noise apparatus needed. They stand at their table in the broadcasting studio before their own microphone, which is blended or mixed with the microphones of the actors and the musicians a few feet away in the same studio. The sound makers keep their eyes upon the manuscript of the entertainment which is being broadcast, reading it and waiting their turn.

Some of the sound-making devices must be held near the microphone and some several feet from it. A rehearsal or two is usually necessary, so that the radio operator who mixes the electrical impulses from the various microphones can learn the proper adjustment of his rheostats for each sound.

CAMERA IDENTIFIES DIAMONDS TO FOIL GEM THIEVES 400

"Fingerprints" of diamonds as infallible in identifying the stones as are the fingerprints of criminals, now may be made with a microphotographic camera. It takes pictures of gems enlarged from 150 to 350 times.

*Dr. Frank Heitzler
Boston Mass*

Reproducing an Escape from Prison, a Machine-Gun Battle, and the Sound of a Locomotive; Radio Noise-Making Requires Scores of Instruments

411



London
 Toy Car Factory in England Which Has Applied American Methods of Automobile Production; Conveyors Carry the Autos to Workmen Who Turn Them Out at the Rate of a Thousand a Day *Wide World*

MASS PRODUCTION OF TOY CARS SPEEDS UP WORK

Following the example of large automobile factories, manufacturers of children's model motor cars in England now are turning out the toy autos on the mass-production principle. Traveling conveyors carry the cars through the factory, just as in the big plants, and when the demand justifies, a thousand cars a day can be turned out at one of these toy factories.

VACUUM CLEANER FOR MINES GETS RID OF ROCK DUST

Operating on a principle somewhat similar to the vacuum cleaner for homes, a dust trap for removal of rock dust from mines is in use in England. This dust often causes lung diseases, and in mines where surfaces are wet before drilling, air washing is used. When this is impossible, the vacuum cleaner comes into play. It consists of a hood attached to

the drill in such a way that the dust which seeps out around the drill hole is collected into a hose attached to the hood and conveyed to a dust bag in which it is retained, the filtered air escaping through the bag.

SETSCREW FOR DOORKNOBS CAN'T WORK LOOSE

Of special interest to architects and builders is a doorknob setscrew containing a coil spring that binds against the thread to keep the screw from turning when the knob is fastened tight. Under repeated tests, this type of screw has failed to work loose of its own accord, but it can be removed with a screwdriver as easily as the ordinary kind.



pat. pend.
 be removed with a screwdriver as easily as the ordinary kind.

716

Chimas Rock Drill Engineering Works Ltd.

George W. Moore, 44 Barnsworth St. Boston, Mass

Grantham - Nottingham Line

Lumitone

TEST STEEL TIES ON ENGLISH RAILWAY

484

Steel ties, weighing, with the "chairs," 200 pounds, are being tried on a railway line in England, and engineers are awaiting the results of the experiment with interest. Will the chairs securely hold the rails under all temperature and other conditions? Will the rails give the necessary resilience to reduce the shock of the trains passing over them? Will the steel prove as durable as wood that has been treated with chemicals to reduce decay? These and other questions will be answered by the tests. The experiment recalls the time when iron rails were laid on stone sleepers. It was found that the arrangement did not allow sufficient elasticity under the car weight and was soon given up for ties of wood.

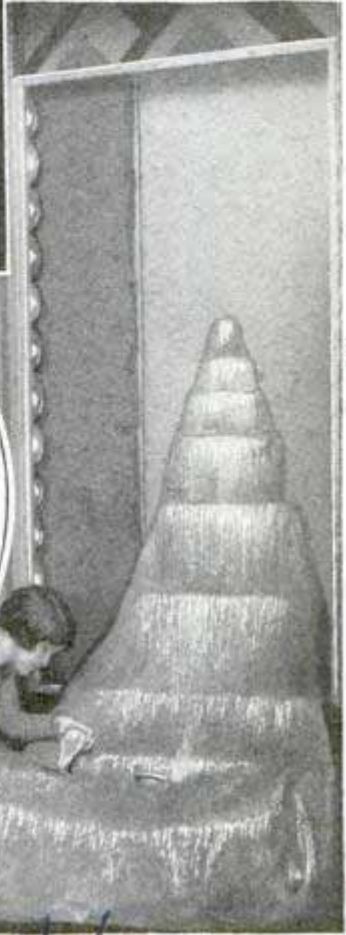
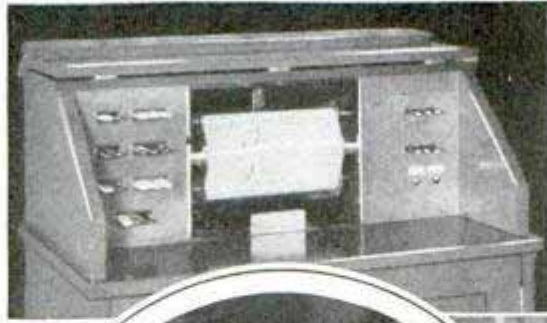

"Lumitone" Cabinet with Roll at the Control Keys, and a Lighting Display That Simulates a Fountain of Changing Colors

COLOR CABINET PLAYS LIGHTS FROM MOVING ROLL

Remote control for flickerless colored floodlighting in changing combinations is accomplished through a cabinet and keyboard installation adaptable to stores, fountains, show windows, statues, homes and many other places. Keys, like those on a pipe organ, permit the selection of color combinations at will, or prearranged effects may be produced from the roll which actuates the switches and dimmers contained in the cabinet. The roll automatically reverses itself after one unwinding and plays the program backward, repeating the process as long as the machine is in operation. There are four holes in the tracker bar over which the record roll passes, for each circuit. One of these turns on the current, one moves the dimmer up, one moves the dimmer down and one turns the current off. As the perforated paper roll passes these openings, the functions of each are performed.



Fitting Rail into "Sleepers" on the Steel Ties Installed on a Stretch of Track in England

Pat. app. for
Curlye Curtis - Lumitone
2300 Ark Ave.

1114 W. Jackson Blvd. Chicago
Curtis Lighting Co.

Curtis Lighting, Inc

44 1119 W. Jackson Blvd
Chicago

Prof. Robert Matheson
Cornell University

665

New York, 2300 Park Ave
European Curtis Lighting Co. S.A.

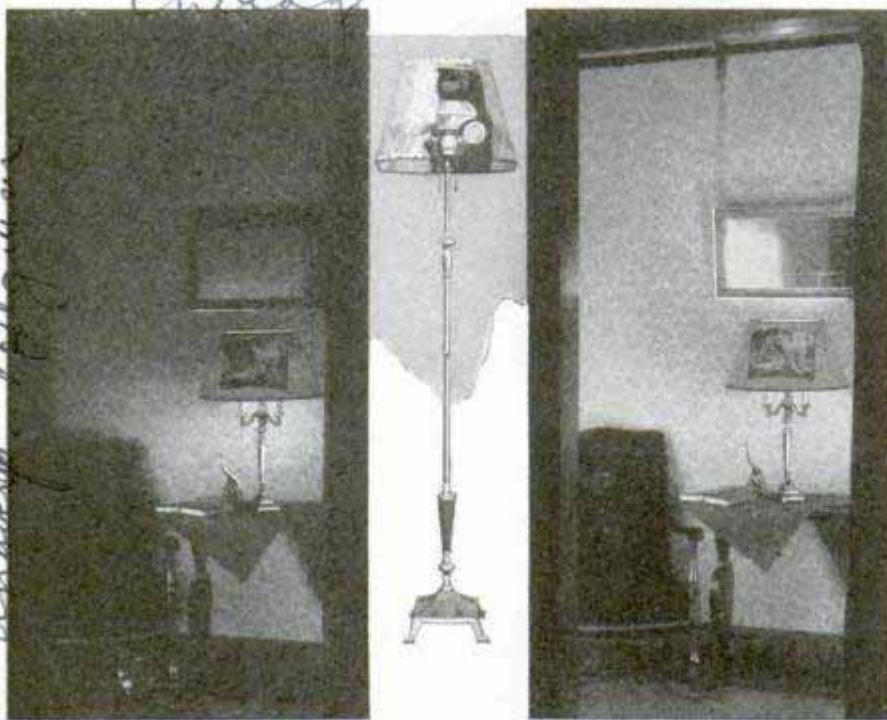

Lamp Equipped with the Special Floodlight Bulb in Top, and How Room Appears with It On and Off; Center, Sectional View

FLOODLIGHT FOR HOUSE LAMPS BRIGHTENS ENTIRE ROOM

Indirect lighting, sufficient to illuminate an entire room, is now possible from your portable table or floor lamp with the aid of an adapter unit recently introduced. It makes two lamps out of one, an art lamp and a flood lamp. The attachment is easily put on and, besides the smaller bulbs for reading or writing, has a powerful reflector that throws light from a large bulb upon the ceiling. The lower portion of the reflector is of opal glass which permits light to shine through the shade so that, when the big light is on, the others can be turned off. The effect is pleasing and restful to the eyes, adequate illumination is afforded, and the cost of a separate lamp is saved. The adapter will fit practically any electric floor or table-lamp standard, and any shade can be used, provided the opening at the top is at least six inches in diameter.



Electrically Driven Turntable for Testing Types of Lead Used in Pencils

PLANTS THAT BITE BUGS

730

Certain kinds of water plants are deadly foes of breeding mosquitoes, and one species of water-weed, the bladderwort, actually swallows and digests the wigglers. On its underwater stems are thousands of tiny, hollow green globes, each opening at one end in a little mouth fringed with hairlike appendages. These globes are under internal tension, and when a wiggler brushes against one of the hairs, the mouth suddenly flies open and sucks the luckless insect in. Inside,

m. American Naturalist

the wiggler quickly dies and is digested by the plant. Certain other types of water plants, particularly the members of the Chara family, in some way kill most of the mosquito larvæ near them.

DURABILITY OF PENCIL LEADS TESTED ON TURNTABLE

Wearing qualities of different types of lead for use in pencils are tested by an apparatus somewhat resembling a phonograph. An electrically driven turntable, covered with drawing paper, contains a center disk which revolves with the turntable. This disk is connected to two other similar disks, at the rim of the turntable, by a spring belt, thus driving these disks. One of them has four metal tubes in which the leads are inserted. Thus both the turntable and the disk containing the leads revolve, enabling a simultaneous test for the comparison of four types of lead, all under equal pressure.

Research Laboratories
Westinghouse Electric & Mfg. Co.

46 Mrs. S. W. Clatworthy Esq.
 54 Ribblesdale Road
 Breatham Manor, S.W. 16 Eng

POPULAR MECHANICS

HOW ECHOES TELL DEPTH OF WATER UNDER SHIP

45

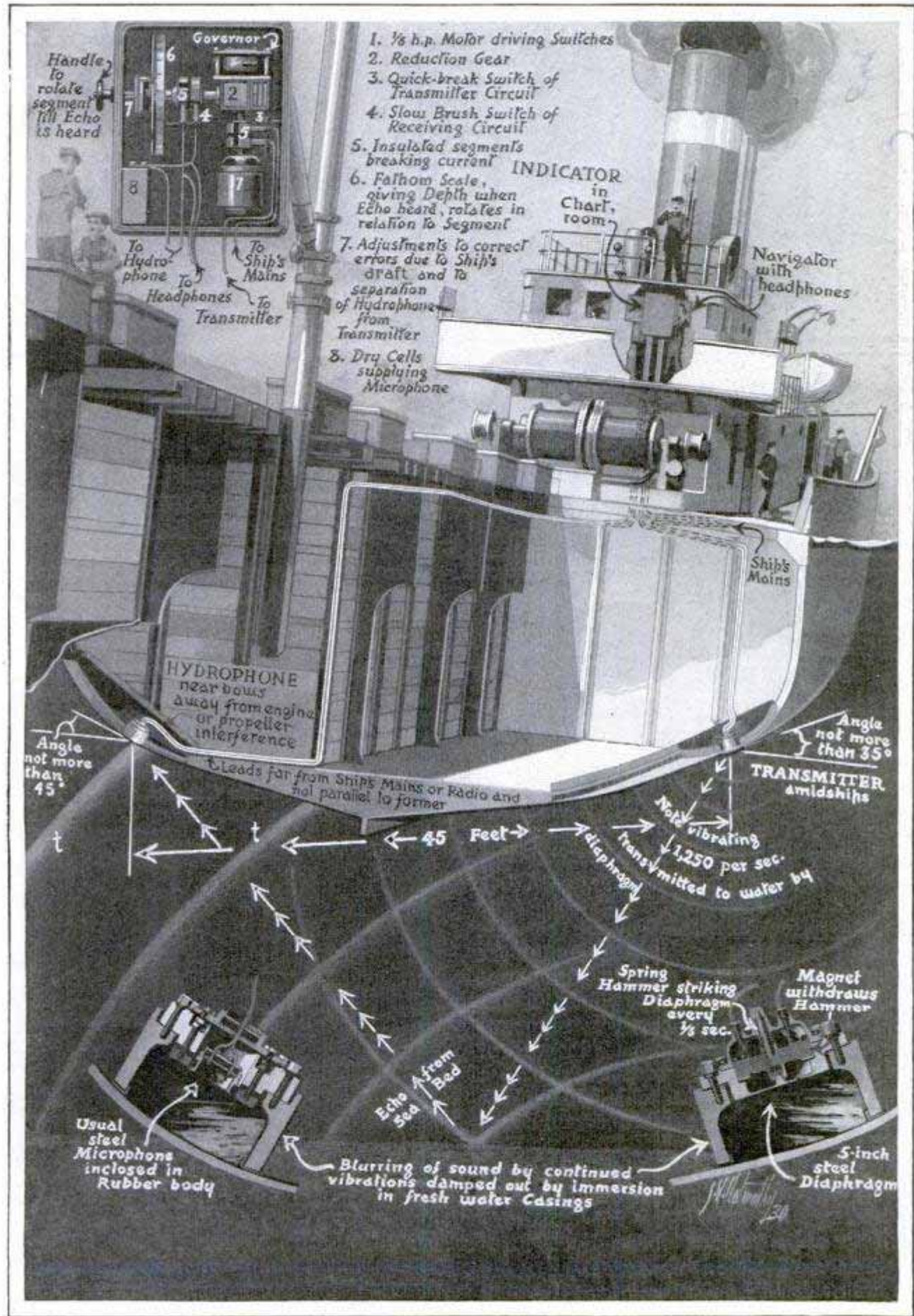

*Crafters Co 37 Antwerp
Brighton Station,
Boston Mass*

PAINT THINNED WITH WATER

Paint in the form of thick paste which can be thinned with water instead of turpentine now is available for interior use, the pigment being the same as that used in high-grade oil paint. Half the volume of water is added and the paint dries dustproof in two hours. It does not yellow with age, can be applied to any surface, and subsequent coats may be applied without removing it. It works equally well on wood, brick, metal, concrete or plaster.

712

Chicago 20th St

samples

*End. George H. Eckhardt,
4528 Walnut St
Phila.*

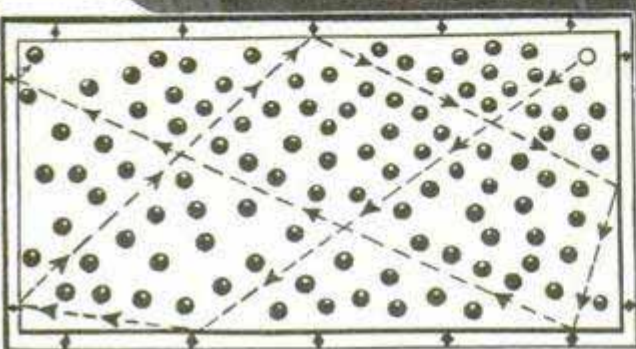

Shooting a Billiard Ball through 100 Others without a Hit, and Diagram of the Feat

PASSING HUNDRED BILLIARD BALLS WITHOUT A HIT

Billiard players marveled recently when Otto Reiselt, cue expert, shot a ball around a table containing 115 other balls without touching one until striking the last two for a perfect hit. They marveled still more when 120 balls were placed on the table and a perfect six-cushion shot was made, the ball striking the cushion six times and traveling more than forty feet in its path about the table without touching any others except the balls at which it was aimed. The secret of such an exhibition lies partly in the skill of the player and partly in the manner of arranging the balls. The path of the cue ball in making a six-cushion shot first is marked on the table with chalk after which the others are arranged so that none is in its path. Thus the one ball passes through a lane made by the others and naturally strikes none of them, provided the player has the necessary skill to send the ball through the path with only a fraction of an inch to spare on each side. The chalk mark of the path is removed before the shot.

SLICKER FOR THE RUMBLE SEAT KEEPS PASSENGERS DRY

Protection for passengers in the rumble seat of the auto during a sudden shower is afforded by a rubberized slicker installed in a few minutes without the aid of snaps, hooks, buttons or strings. When not in use, the slicker folds into a compact bag and is placed in position with sponge-rubber cleats. They are modeled so that an opening is provided for the face and a hood for the head.

\$7.50c each



Rubber Slicker for Rumble-Seat Passengers; It Folds into Compact Bag When Not in Use

*The Mura. Products Co
Canton Ohio*

ELECTRIC EYE ON PRISON WALL TO STOP ESCAPES

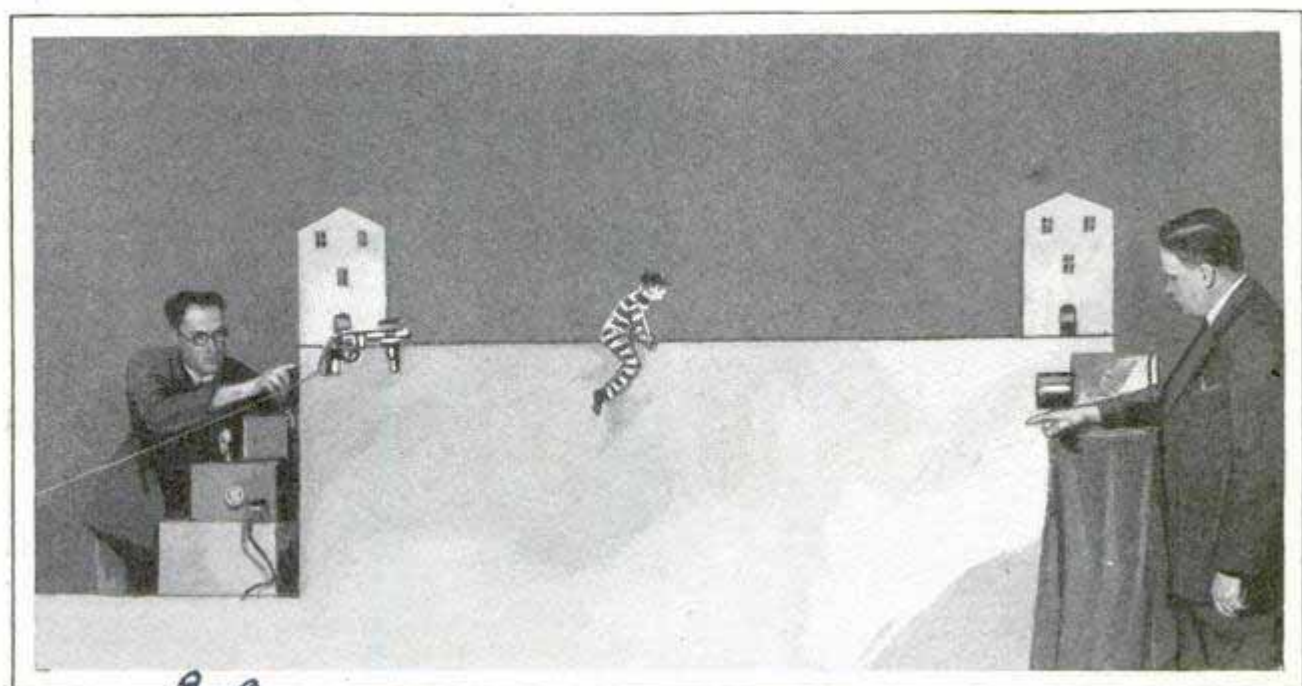

Model Showing How the Electric Eye, or Photo-Electric Cell, Serves as Sentry on a Prison Wall, Sounding an Alarm and Firing a Gun When a Convict Interrupts the Light Rays

Sentries marching back and forth on prison walls now may be replaced by an electric eye which fires a gun at a prisoner trying to scale the wall and sounds an alarm simultaneously. The eye, recently demonstrated, is a photo-electric cell toward which a beam of light is directed along the top of the wall. When the body of the escaping convict interrupts the light ray, the cell reacts by firing the gun aimed along the wall, and ringing the alarm.

system is equipped with an automatic control. The entire apparatus is electrically operated, double-sash windows and doors being kept closed in order to allow the air conditioner to supply all the cool, filtered air required.

installed in B & O R R dining car - marble

LINE CONTROL ON FISHING REEL PREVENTS BACKLASH

Preventing backlash and making unnecessary the usual thumbing as the line is payed out, a line-control fishing reel can be used like the ordinary single-action reel. The control, aiding the amateur to gain proficiency in casting, is inserted in the hub of the line guard and can be used for still fishing as well as casting. The spool has a capacity of 100 yards of fifteen-pound-test line, although the reel weighs but five ounces. When



the bait strikes the water the reel stops automatically.

*Snyder Reel Co.
37 Broadway St.*

AIR PURIFIER FOR RAILWAY CAR MAKES OWN WEATHER 722

Railroad cars now can manufacture their own weather to suit the comfort of passengers, by the use of an air-conditioning system recently tried out with success. Tests in a dining car on a warm day, with full winter heat turned on and intensified by heat from the kitchen, revealed that it was possible to reduce the temperature from ninety-three to seventy degrees in twenty minutes. Air filters remove cinders, dust and foreign material from the air as it is admitted to the car, after which the air passes over cooling coils until brought to the desired temperature, when it is forced into the car through overhead insulated ducts. The

Chicago 1607 La Salle

*Carnier Engineering Corp.
848 Franklin Ave.*

Washington

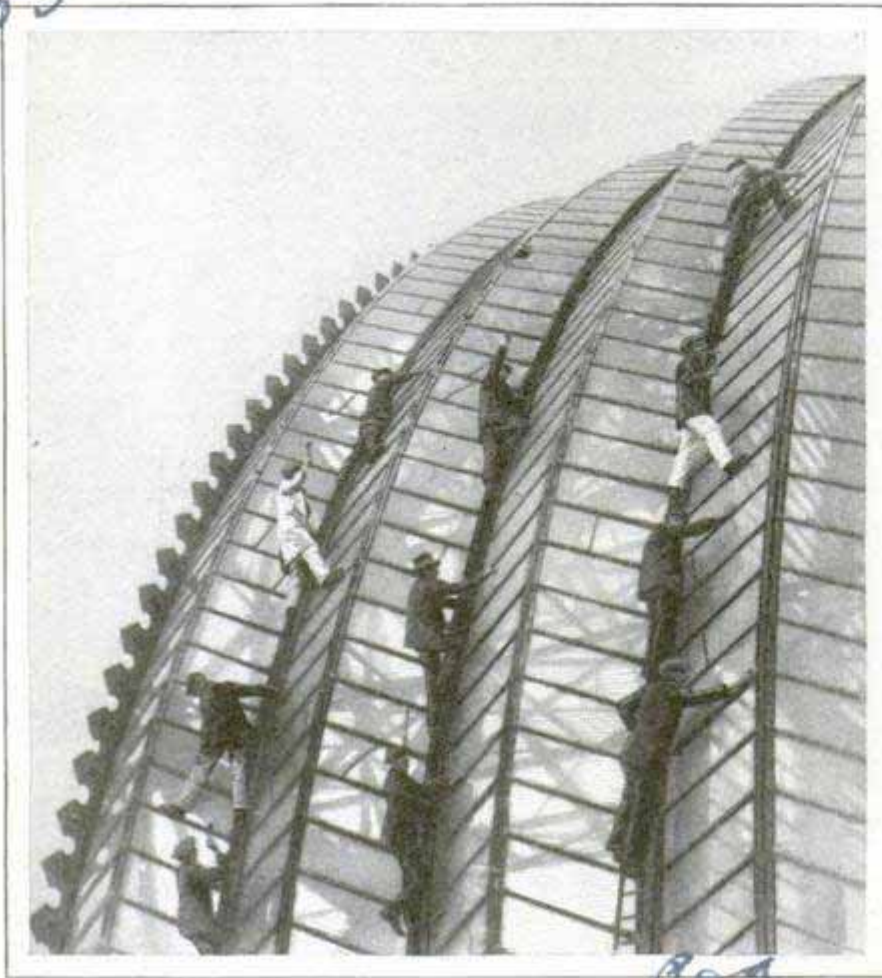

Climbing a Ladder of Windows; Workers Cleaning Some of the 500,000 Panes of Glass of the Crystal Palace, London

CLEANING HUGE ROOF OF GLASS TESTS WORKERS' SKILL

Cleaning the 500,000 glass panes of the Crystal palace, London, calls for skilled and careful workers. Ladders are used in some places, but in others, the men have to cling to the narrow steel framework while cleaning the glass. The entire exterior is thoroughly cleaned each year.

WHY CHICKEN JERKS ITS HEAD REVEALED BY SCIENCE

A chicken jerks its head when running in order that it may see better, scientists of Johns Hopkins University declare. By careful examination of slow-motion pictures of the fowls, and by other means, they found that a chicken's head moves forward only and its body catches up. Then the head jerks forward again and the process is repeated. This prevents blurring and gives the fowl a succession of clear pictures, the scientists conclude. When the specimen was hooded, its head

no longer endeavored to keep one jump ahead of its body. Ducks and swans, when swimming, do not jerk the head but the entire body moves forward slowly. The study showed that ducks appear to have a kind of head movement, just the opposite to that of the chickens.

REAR-VISION LENS FOR AUTO GIVES BETTER VIEW

To allow greater visibility through the rear window of the car when backing up, and to eliminate the glare that sometimes shines from headlights of autos behind, a small lens has been installed in the panel to take the place of the usual glass window. While it occupies much less space than the pane,

it is said to afford a much better view of the rear from the driver's seat, occupants are spared the danger of breaking glass in case of an accident, and the small lens also gives greater privacy to passengers in the rear seats. The lens is intended to function in connection with the mirror on the windshield and is said to give a wider field of vision because of the character of the special lens.

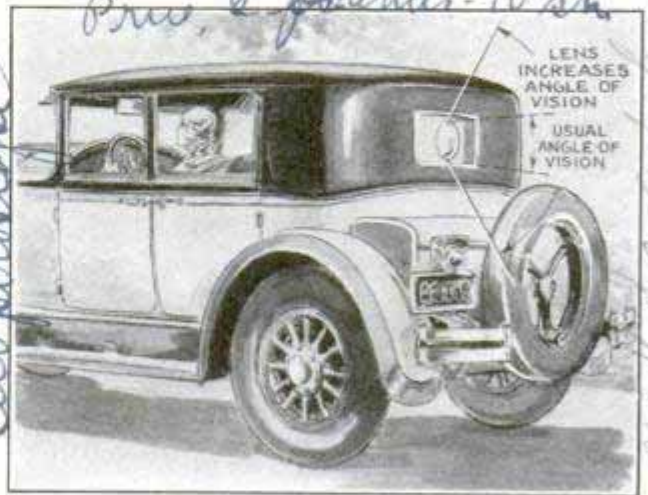

Rear-Vision Lens for Automobiles Is Used in Connection with the Mirror in Front for Wider View

before Southern Society for Philosophy and Psychology

Dr. Knight Dunlap and H. Mowser

Urostrache

Continental Hire Agency 89 Brompton Road



The "WEST POINT" of the AIR

pra

WHAT does the army air corps do in peace times? Previous installments of the "West Point" of the Air have told how and where the flying cadets are trained. What happens to the man who elects to remain awhile in the service after winning his wings? He has many absorbing duties, but perhaps the most interesting are at the various maneuvers in which the flyers have a chance to apply the knowledge they have gained and the latest equipment and the most advanced ideas in tactics of the air are given practical tests, to determine their real worth in case of actual warfare.

The Pacific coast recently was the scene of the most extensive mimic war ever staged by the air corps. More than 150 planes, under Brig. Gen. William E. Gillmore, routed a mythical "Red" enemy which supposedly had taken possession of California south of Santa Cruz. The flying "Blue" forces technically sunk the enemy fleet which had bottled up San Francisco, checked the advance of the Red troops and held them until theoretical reinforcements arrived. Pursuit, attack, bombardment and observation planes were recruited from seven flying fields. Cargo planes transported forty loads of equipment to Mather field, headquarters for the maneuvers, so that, for the first time in an engagement of this kind, motor trucks were virtually dispensed with.

Commanding officers agreed that the maneuvers further showed the importance of air forces in defense and attack. The engagements also developed several practical points. Pursuit planes, the officers concluded, should carry two pilots and their speed should be increased. Attack planes should be camouflaged in dark olive-green, fly close to the ground and be directed by radio from observation planes at altitudes of 5,000 feet and more. The officials saw the importance of having two types of bombing planes, a light one for day service and a heavier one that could carry bombs weighing up to 4,000 pounds for night attacks.

Among the notable accomplishments during the maneuvers were the remarkable high-altitude flights of pursuit planes that kept their formation, then broke up for "dog fights" and other tactics at heights that showed the practicability of raising the "fighting ceiling" to more than five miles.

see April, May, June, 1930⁴⁹

623

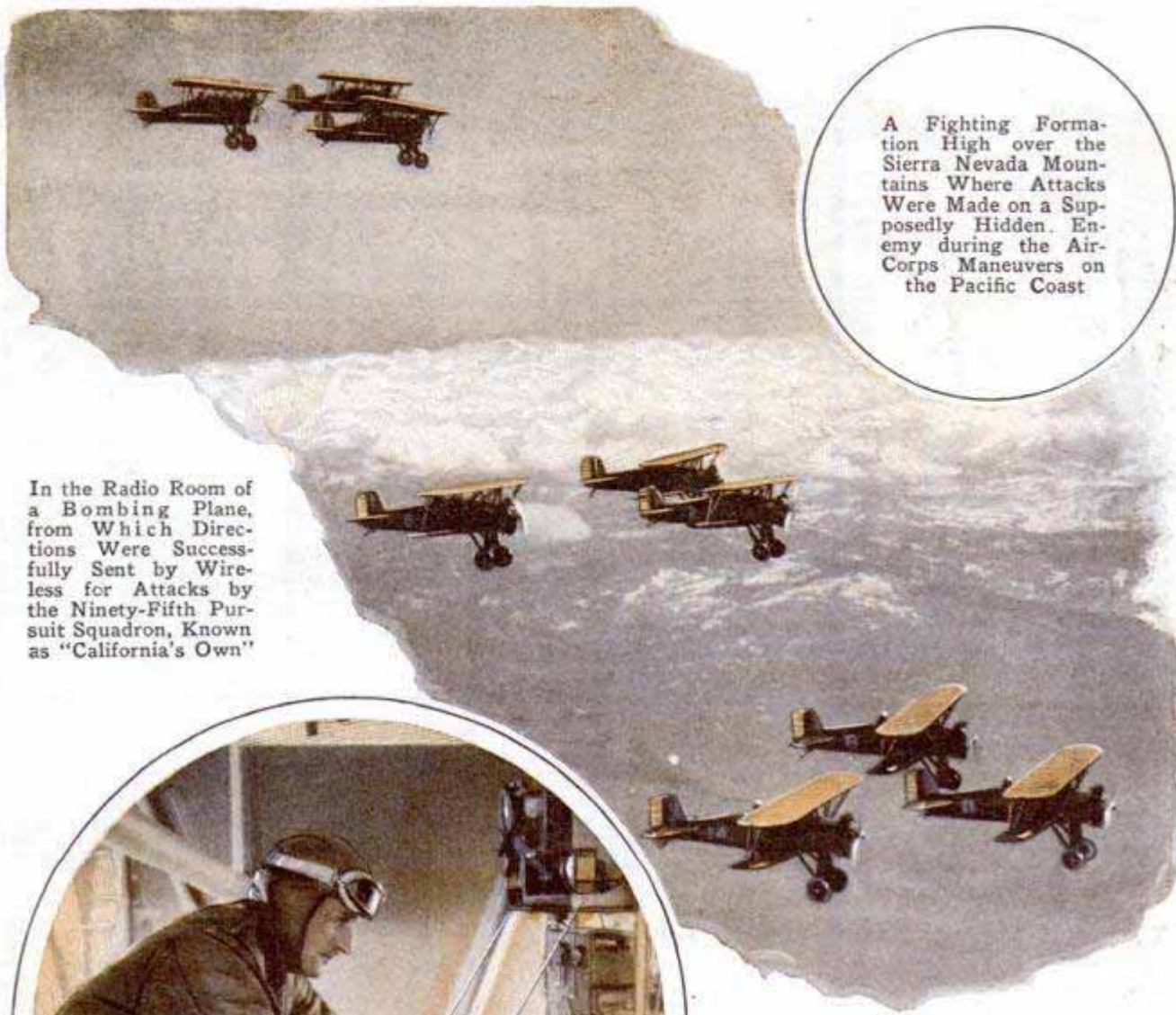

A Fighting Formation High over the Sierra Nevada Mountains Where Attacks Were Made on a Supposedly Hidden Enemy during the Air-Corps Maneuvers on the Pacific Coast

In the Radio Room of a Bombing Plane, from Which Directions Were Successfully Sent by Wireless for Attacks by the Ninety-Fifth Pursuit Squadron, Known as "California's Own"

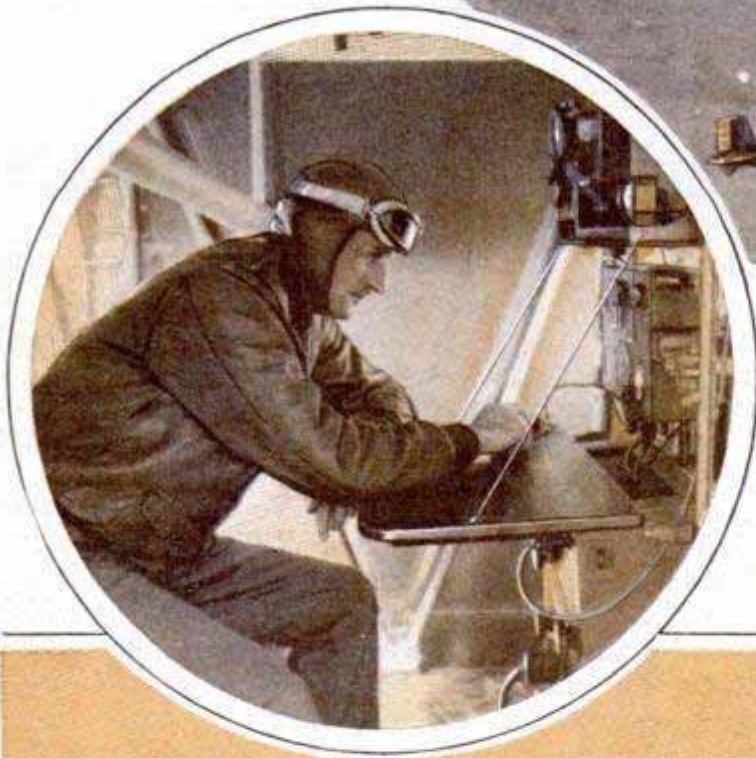

Brig. Gen. William E. Gillmore Inspecting the Nineteenth Attack Squadron Just Before a Review of the Entire Air Force Assembled for the Mimic Warfare, in Which Four Tactical Units of the Air Corps, Pursuit, Attack, Bombardment and Observation Planes, Participated against a Mythical "Red" Force That Supposedly Had Taken Possession of Part of California



623

A detailed illustration of a pilot, Captain Elmendorf, in the cockpit of a biplane. He is wearing a dark leather flight helmet with goggles and a face mask. The cockpit is open, and the background is a bright orange sky. The pilot's expression is focused.

Captain Elmendorf, Commanding Officer of the Ninety-Fifth Pursuit Squadron with Face Mask Adjusted for High-Altitude Fighting during the Mimic Air Battles on the Pacific Coast; These Maneuvers Were the Most Extensive Ever Staged by the Army Air Corps, Which Functioned without Regard to the Operation of Ground Troops

An aerial photograph showing a city, identified as Sacramento, completely obscured by a thick, white smoke screen. The smoke is dense and billowing, covering the entire urban area. The city's grid pattern and buildings are barely visible through the haze.

Dropping a Smoke Screen over the City of Sacramento, to Show How Large Areas Could Quickly Be Hidden from the Enemy Air Forces; Note the Difference between the Smoke Screen and the Smoke Curtain Illustrated on a Following Page; Both Would Prove of Importance during an Aerial Engagement Where Strategy Is Highly Essential



In the Circle, Machine Gun Installed on One of the Planes; Below, a Bomber Hanging a Smoke Curtain, and Flyers Equipped for High-Altitude Work; Each Man Wears Approximately Fifty Pounds of Clothing to Withstand Temperatures as Low as Sixty Degrees below Zero at a Height of 25,000 Feet or More; Oxygen Tanks Were Carried, and Communication Was Maintained by Radio, the Headsets Being Built into the Helmets; Successful High Flights and Engagements at Extreme Altitudes Featured the Recent Maneuvers; "Dog Fights" and Other Drills Were Performed at 25,000 Feet and Nineteen Pursuit Planes Climbed to 30,000 Feet; Night Photographs Were Taken from 2,500 to 3,000 Feet with Flashlight Powder and Flares Attached to Parachutes

The First Pursuit Squadron from Selfridge Field, Arriving for the Maneuvers, and, in Circle Below, Maj. Henry B. Clagatt, at Left, Talking over Plans for the Mimic Warfare with Brig. Gen. William E. Gillmore; They Were Responsible for the Movements of More Than 150 Planes



Uncle Sam's Latest Battleship of the Air, Which Was Flown at the Mather Field Maneuvers; It Is a Light Bombardment "No. 7" Plane with Three Motors, Totalling 1,100 Horsepower; It Carries Seven Machine Guns, Bombs Up to 2,000 Pounds in Weight and a Crew of Five Men; the Pacific Coast Tests, in the Opinion of the Commanding Officers, Further Demonstrated the Importance of the Bombing Plane as a Unit in an Aerial Detachment, Especially When Supplemented with Fast Pursuit and Attack Planes



623



Stepping Down Out of the Skies on a Mission of Battle; This Photograph Shows a Group of Pursuit Planes from Selfridge Field in Combat Formation, About to Simulate an Engagement with "Red" Planes over San Francisco Bay; the Ships Shown Here Were Members of the Victorious "Blue" Forces



Flyers with Radio Equipment and Phones Carried on Planes during the Aerial Action over San Francisco and Adjacent Territory; at the Right, the Colorful Emblem That Appears on Planes of One of the Pursuit Groups

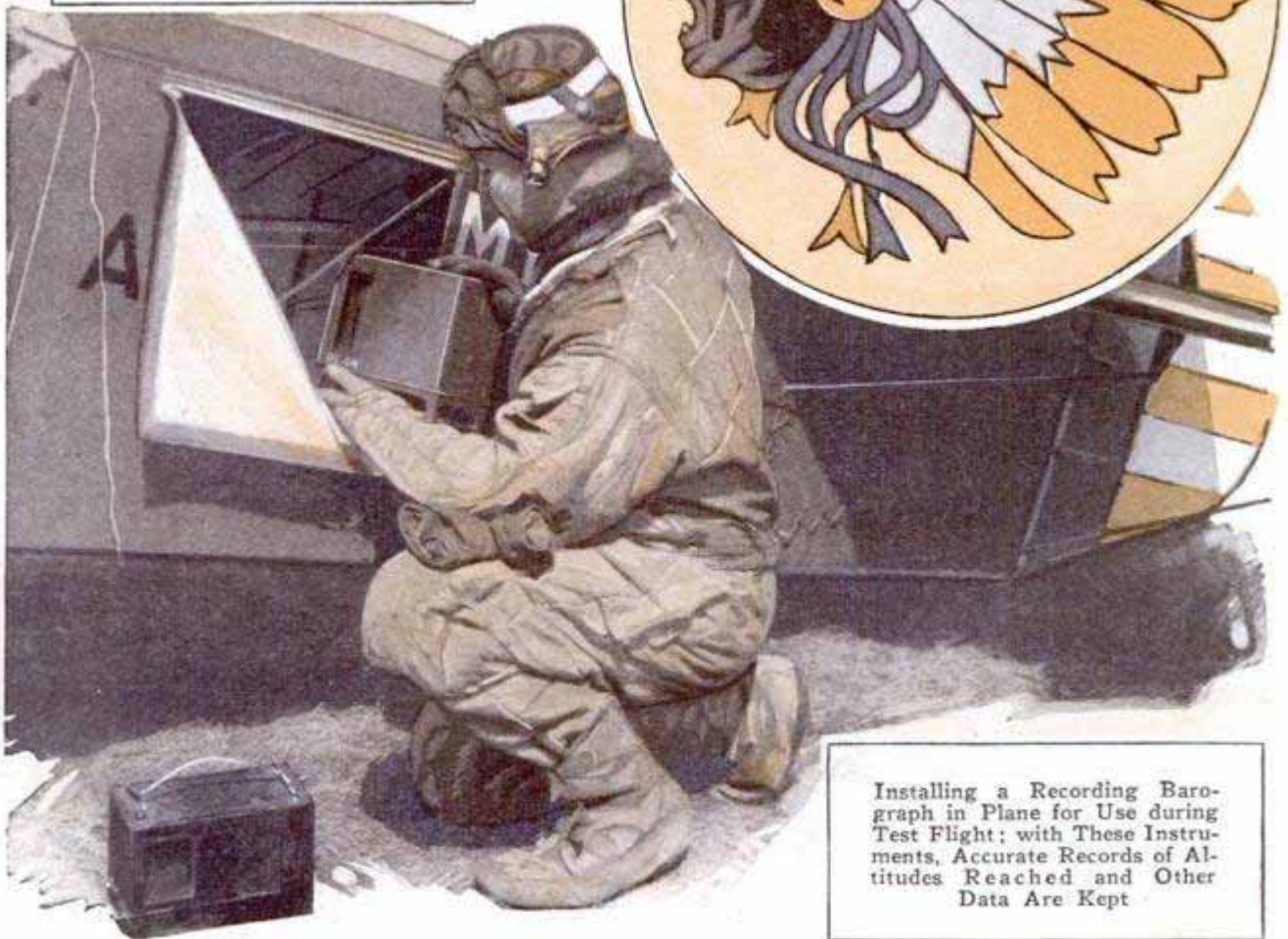

Installing a Recording Barograph in Plane for Use during Test Flight; with These Instruments, Accurate Records of Altitudes Reached and Other Data Are Kept

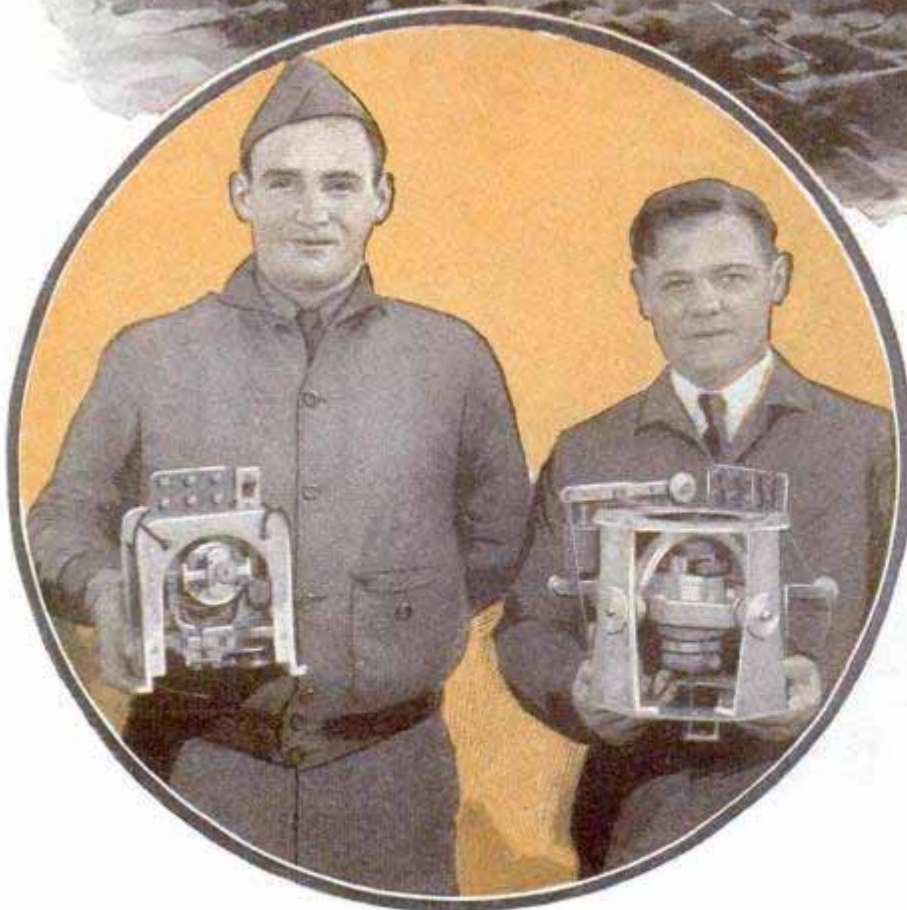
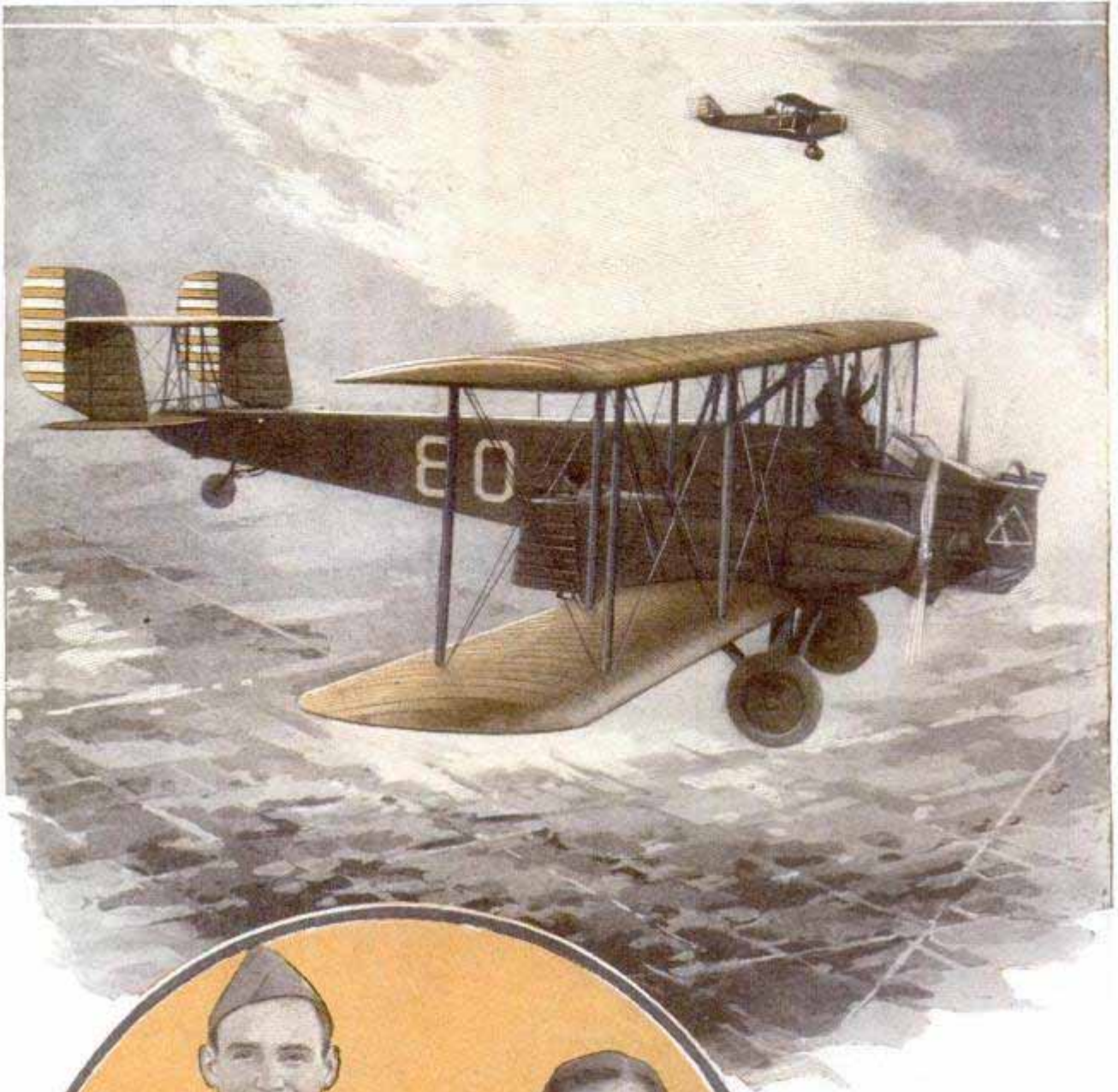

In the Upper Photograph, the Pilot Has Released the Controls of the Giant Bombing Plane and Is Waving to a Photographer, While an Automatic Pilot Keeps the Bomber on an Even Keel; for the First Time in Aeronautical History, a Giant Bomber, Piloted by a Gyroscopic Device, Was Flown from Sacramento to San Francisco in the Army Maneuvers on the Pacific Coast; at the Left, Lieut. Marion Huggins with Elmer H. Sperry, Jr., at the Right; They Are Showing the Sperry Gyroscope Compass with Which Bombardment Planes Can Be Flown without the Attention of the Pilot, Who, in the Case of an Actual Battle, for Instance, Could Devote His Energies to the Guns and Crew

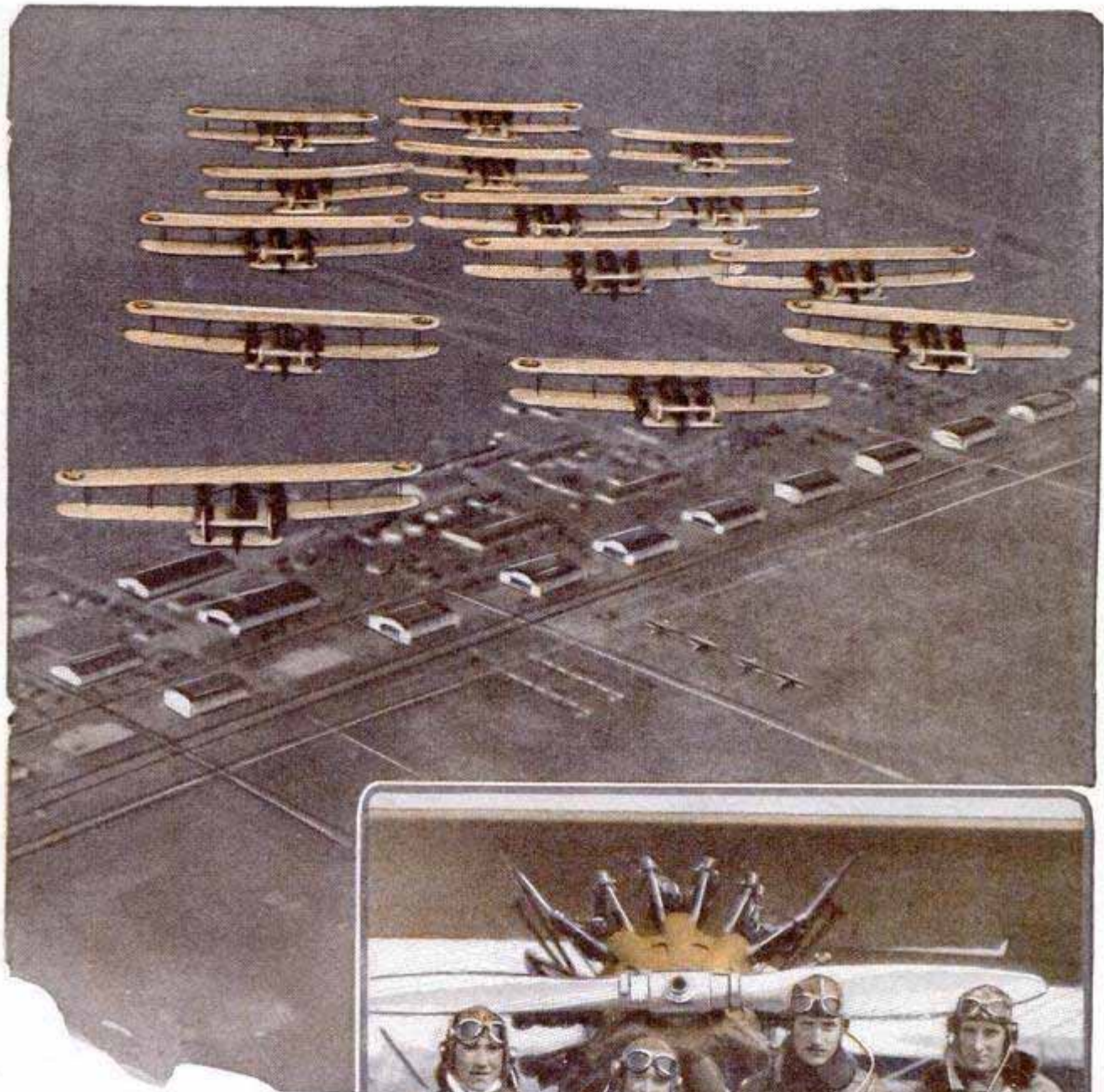

Tight Formation, Composed of Planes of the Second Bombardment Group, Flying over Mather Field during the Recent Army Maneuvers, and, Below, Officers Who Participated in the Mimic Attack on Crissy Field, San Francisco, Dressed in Their Fighting Togs; Note the Earphones for Receiving Radio Commands; Orders by Wireless, as Well as Improved Aircraft of Greater Efficiency Than Any That Ever Engaged in an Actual War, Featured the Sham Air Battles to Demonstrate the Tactics of Fighting from the Skies; a Fictitious Enemy Was Driven from San Francisco and Its Fleet Sunk, After It Had Bottled Up San Francisco Bay; the "Battle" Was Waged High over a Terrain of More Than 20,000 Square Miles

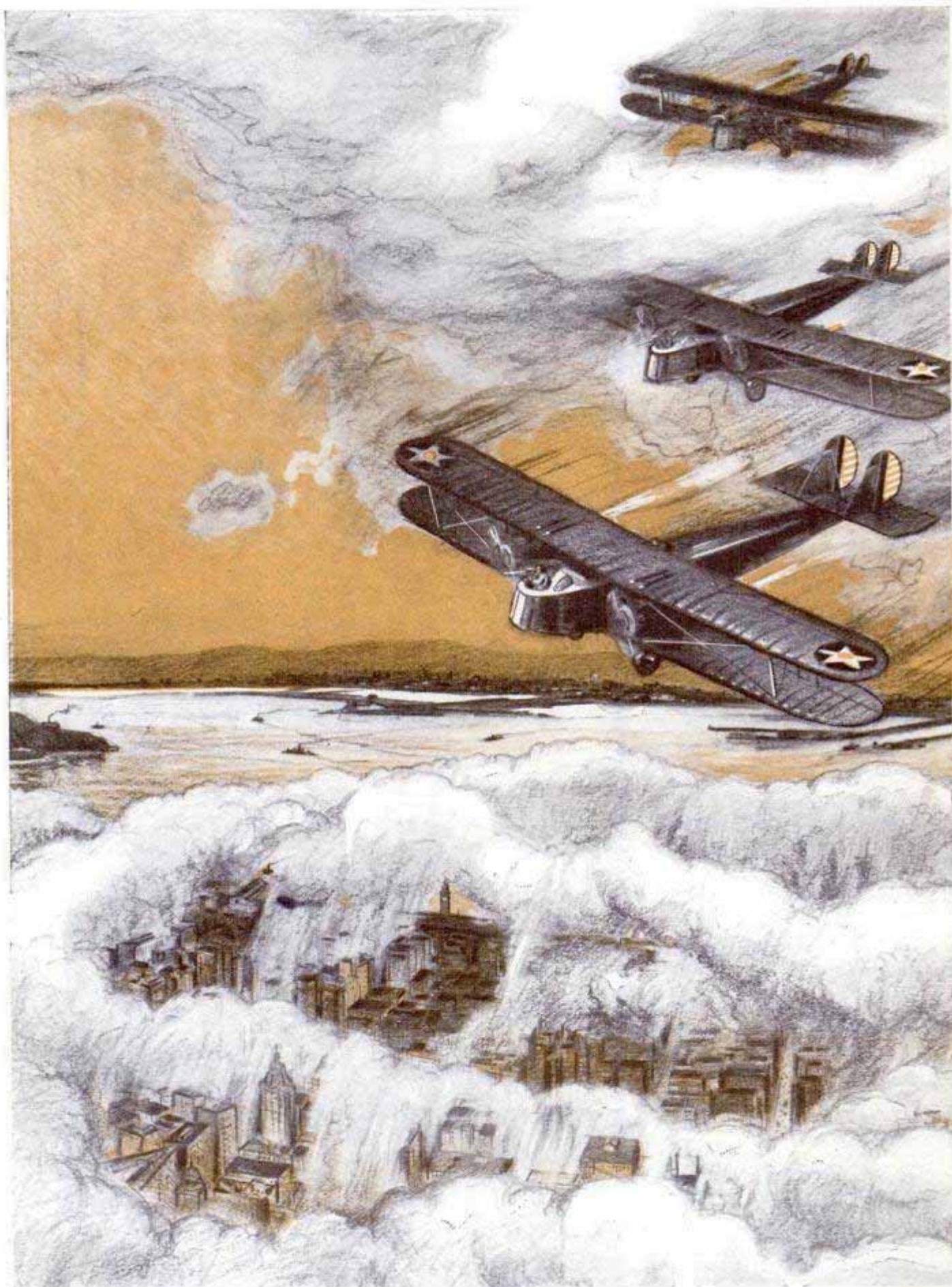

Artist's Drawing of Defense and Attack upon a City by Aircraft; in the Foreground a Bombing Squadron Is Approaching, and, in the Distance, a Defense Plane Is Spreading a Smoke Screen

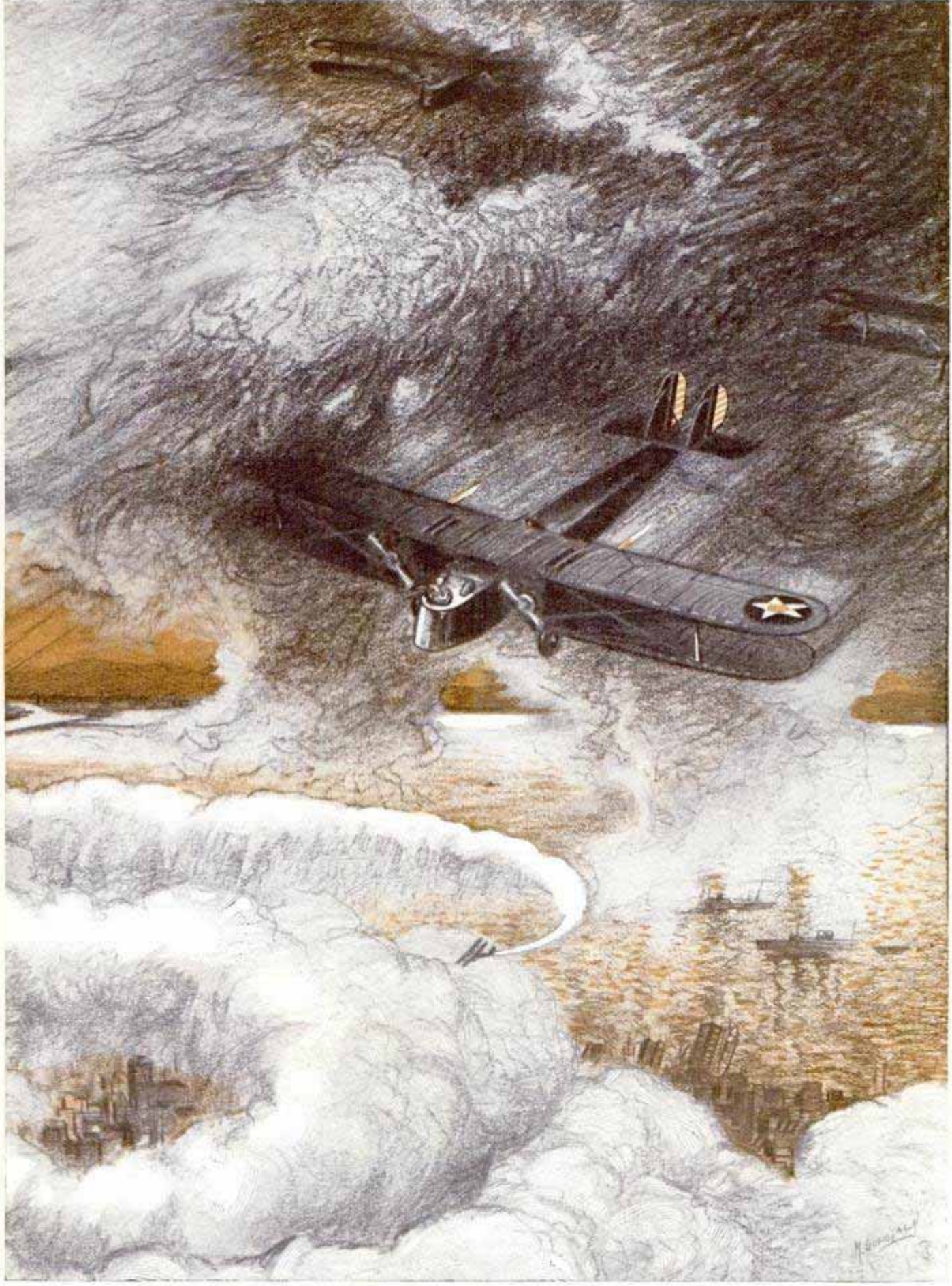

Big Bombers Are Virtually Battleships, Capable of Tremendous Destruction; a Craft Carrying 1,200 Pounds of Bombs Has Been Suggested for Day, and One Carrying 4,000 Pounds for Night Service

623
60

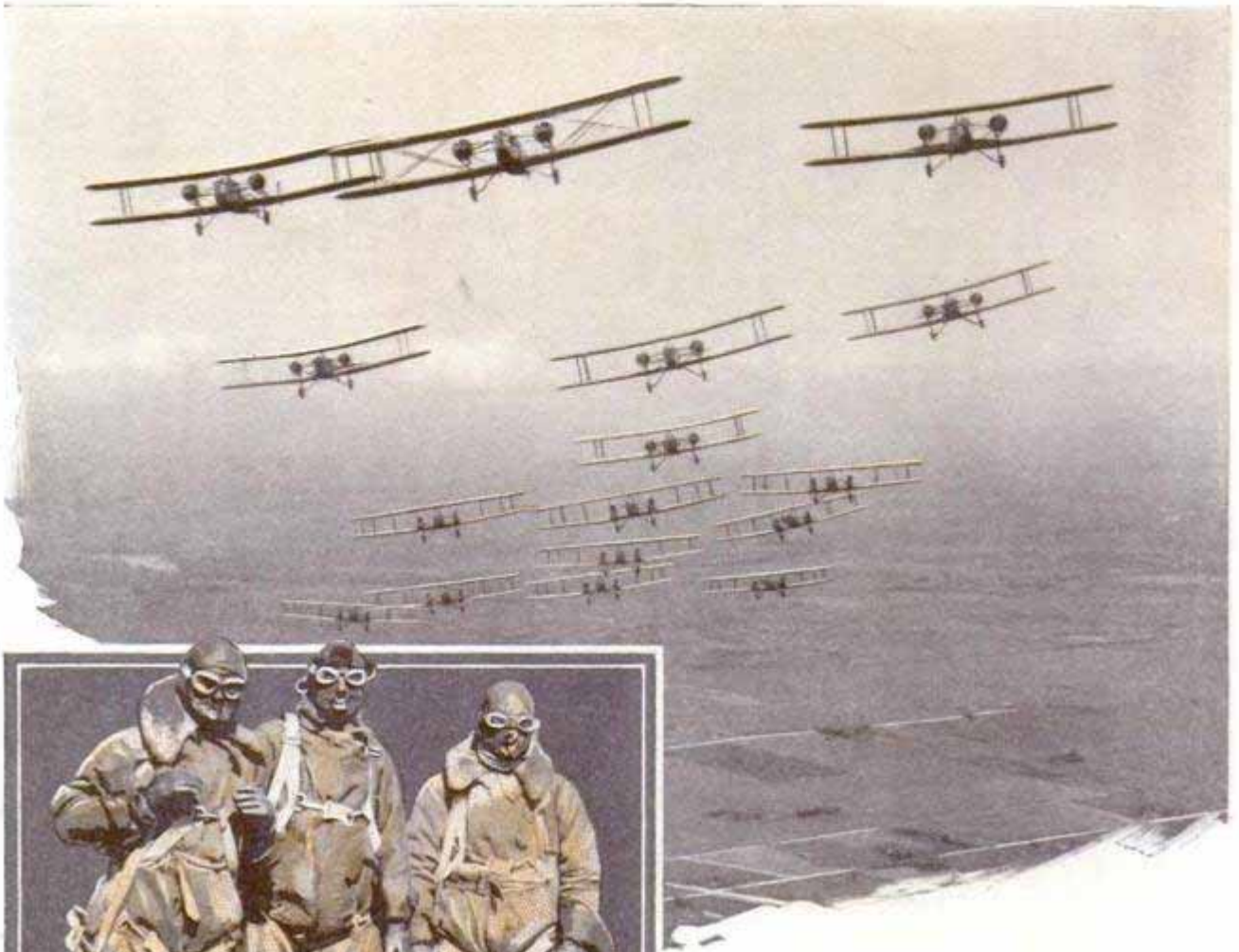

Above, Sixteen of the Army's Newest Attack Planes Coming Head-On; with Wings Almost Touching and Maintaining Perfect Formation, These Planes Are under the Direction of the Commander Who Instructs the Pilots by Radio; at Left, Pilots of the Ninety-Fifth Pursuit Squadron in Arctic Clothing, Needed in High Flying, and, Below, Placing Skids on the Landing Gear for Use Instead of Wheels When Descents Are to Be Made upon Ice or Snow; Cross-Country Flying Trips in Winter Test Planes and Pilots



Insigne of the Langley Field Bombers; the Terrifying Figure-heads of Viking Ships and the "Eyes" on the Bows of Chinese Pirate Vessels Are Recalled in the Figures on the War Planes



Group of Bombers Roaring through the Air; after the Mather Field Maneuvers, Army Officials Were Further Convinced That There Should Be a Light Bomber for Day Work and Heavier Ones for Night

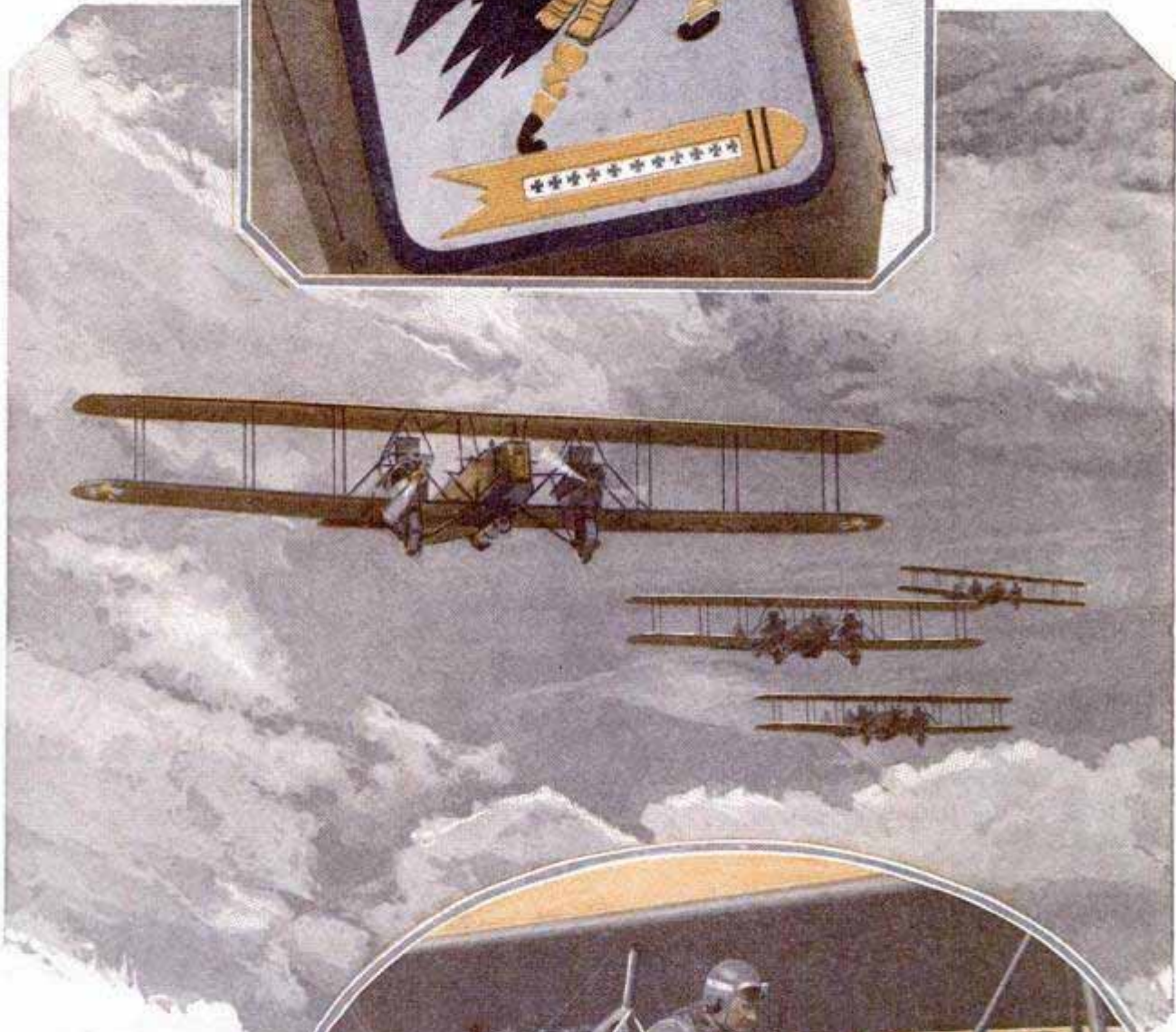

Brig. Gen. W. E. Gillmore in Command of the Maneuvers; He Is Shown Holding the Radiophone by Which the Formation Flights of Pursuit and Attack Planes Were Controlled to Simulate Actual Warfare; General Gillmore's "Blue" Forces Held Back the "Enemy," Destroyed His Fleet and Saved San Francisco



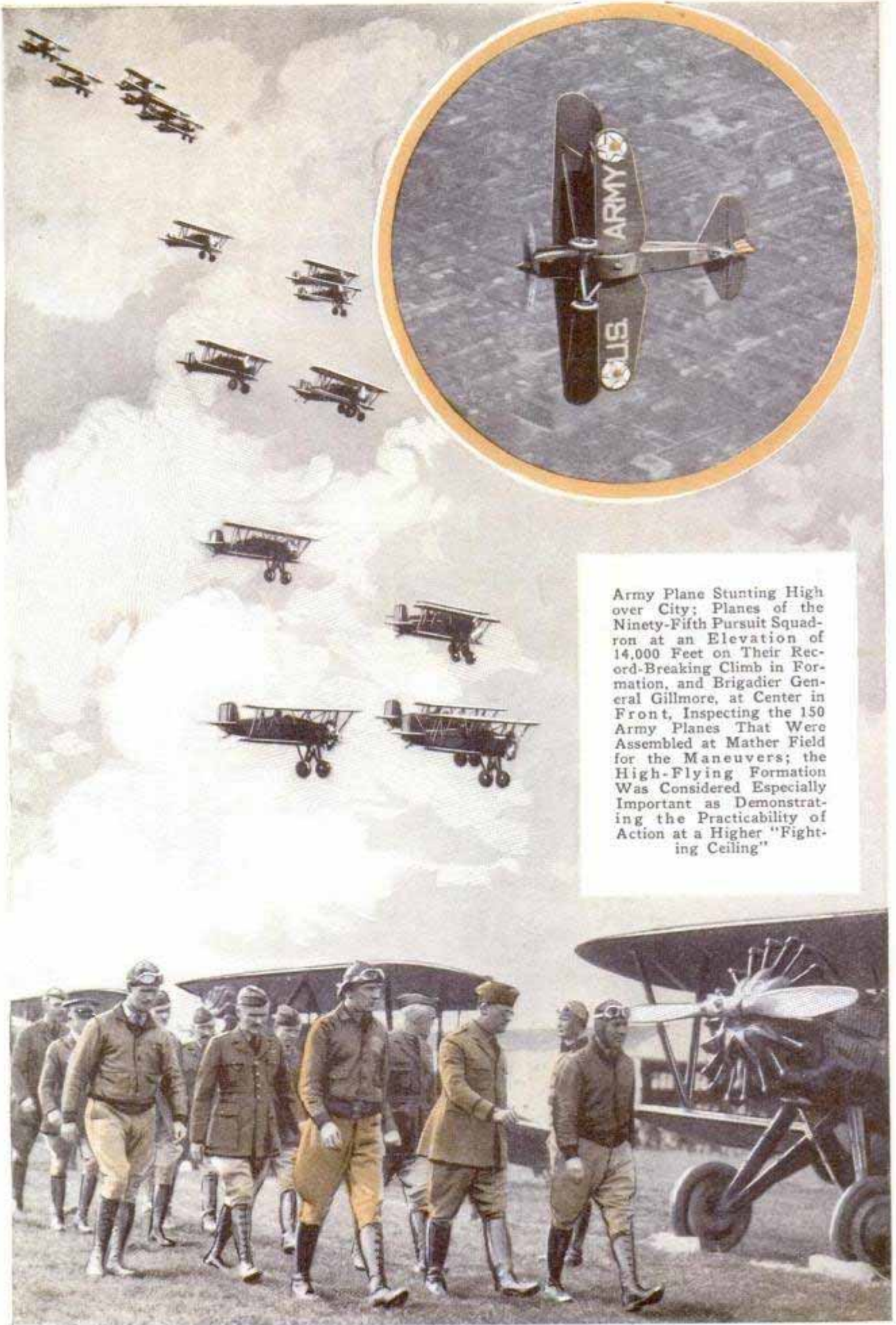

Army Plane Stunting High over City; Planes of the Ninety-Fifth Pursuit Squadron at an Elevation of 14,000 Feet on Their Record-Breaking Climb in Formation, and Brigadier General Gillmore, at Center in Front, Inspecting the 150 Army Planes That Were Assembled at Mather Field for the Maneuvers; the High-Flying Formation Was Considered Especially Important as Demonstrating the Practicability of Action at a Higher "Fighting Ceiling"



Class in Photo Hut, Showing the Various Types of Cameras Used in Aerial Photography, and, at Right, Three War Aces of the Army; from Left to Right, Capt. Frank O. D. Hunter, Capt. Victor Strahm and Lieut. J. S. Griffiths



An Aerial View of Part of the Water Front and the Main Part of San Francisco, Made from an Elevation of 6,000 Feet; in the Recent Maneuvers, This Area was "Destroyed" by the "Blue" Heavy Combat Planes Directed by Radio; Army Photographers Received Valuable Training during the Mimic War

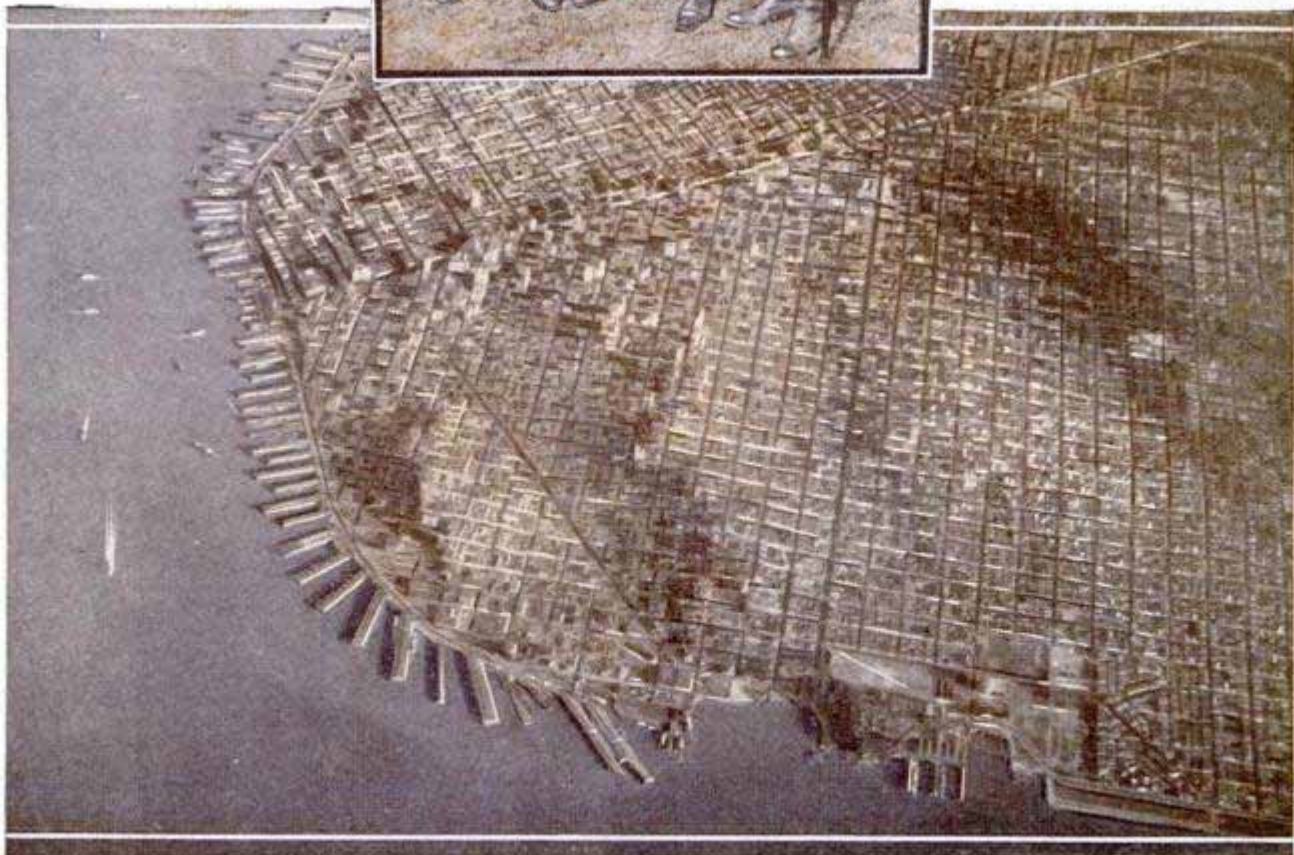

623

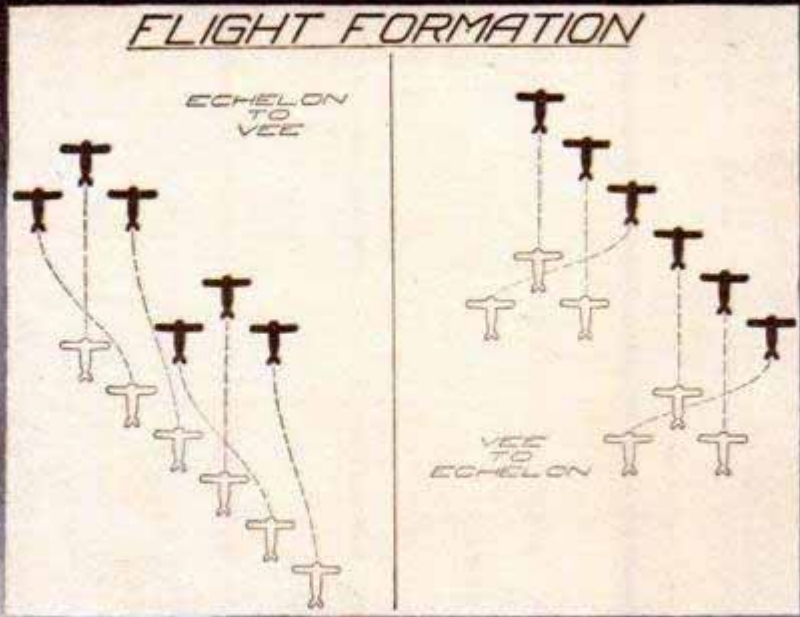
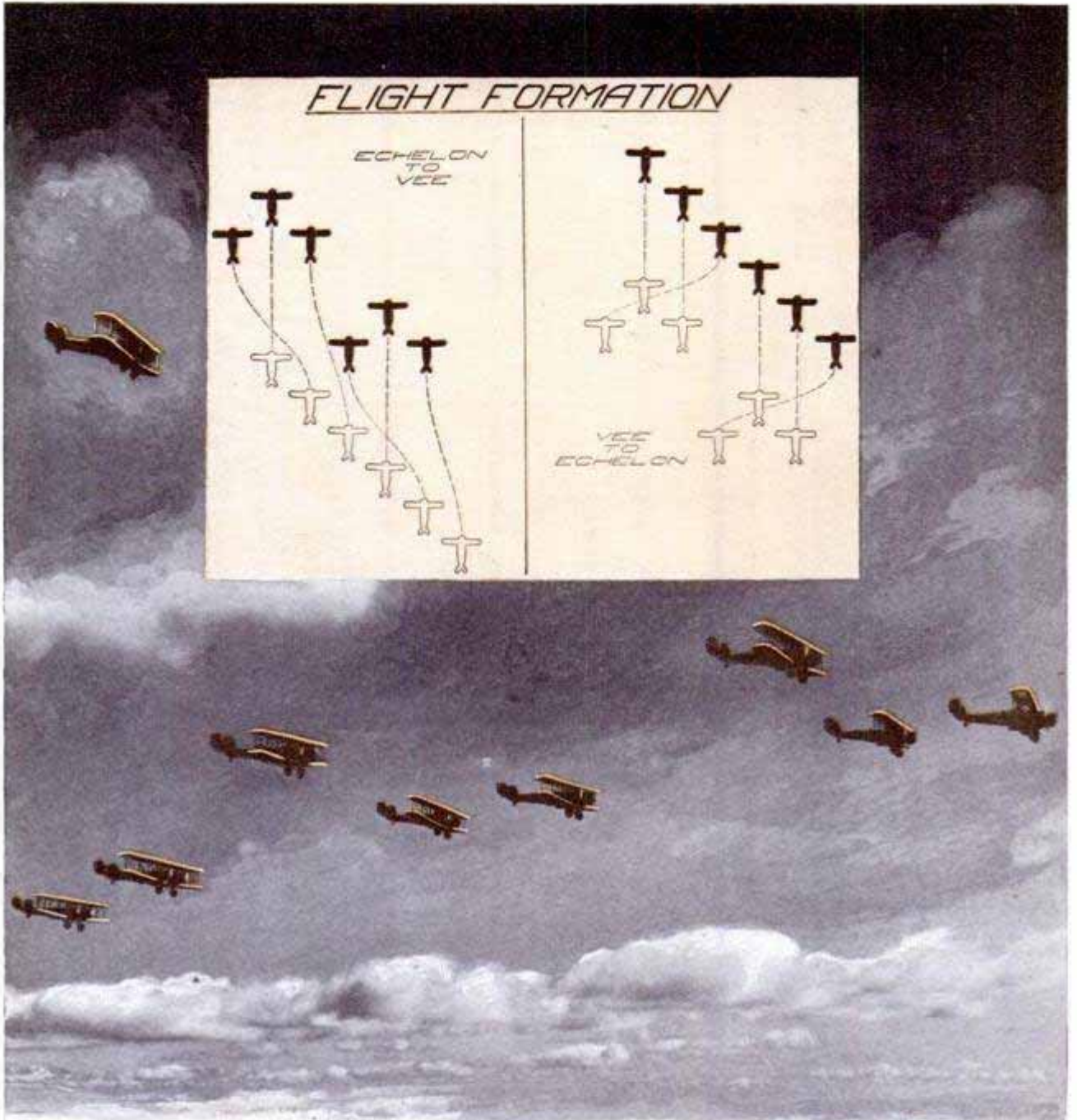

Diagram Showing Flight Formation in Changing from Echelon to Vee and Reverse, and below the Drawing, Planes Flying in Night-Attack Formation, with the Clouds Used as a Protective Screen, during the Recent Drills over a Part of the Sacramento Valley



Lieutenants of the Ninety-Fifth Pursuit Squadron in High-Altitude Flying Togs Just before Making Their Record Climb, When Nineteen Planes Reached a Height of About 25,000 Feet before Abandoning Their Military Alinement; Separate Units Went Still Higher

The Patent Valve by
Lousel & 114 St St

597 a no. e. P. Wilhelm
Punta Gorda
Fla. 65

POPULAR MECHANICS

Cleveland, Ohio

**SAFETY VALVE FOR GAS STOVE
PREVENTS ACCIDENTS** 701

To prevent the accidental escape of gas from the kitchen range, a safety valve, operating somewhat like a thermostat, may be attached to the pilot light. The valve is made on the liquid-filled-bellows principle, and the constantly burning pilot light causes the liquid to expand, thus opening the valve attached to the main supply line. As long as the pilot light burns, the gas supply is unimpeded, but should the pilot light be put out by a breeze or the boiling over of a liquid, the valve shuts off the gas supply.

**DECORATIVE LINOLEUM STRIPS
FOR FLOOR BORDERS** 670

Inset panels and strips are being employed to enlarge the decorative possibilities of linoleum floor coverings. The strips are feature borders for use around linoleum floors and are obtainable in plain and marble colors. They may be inserted as feature strips between wider borders or next to the field pattern, thus allowing multiple border effects. The panels, in two and three-foot squares, carry different designs including a swan, ship, castle, star, helmet, lion, deer and many others. They are made in two-color combinations and are installed by cutting out a piece of flooring and putting in the panel with linoleum cement.

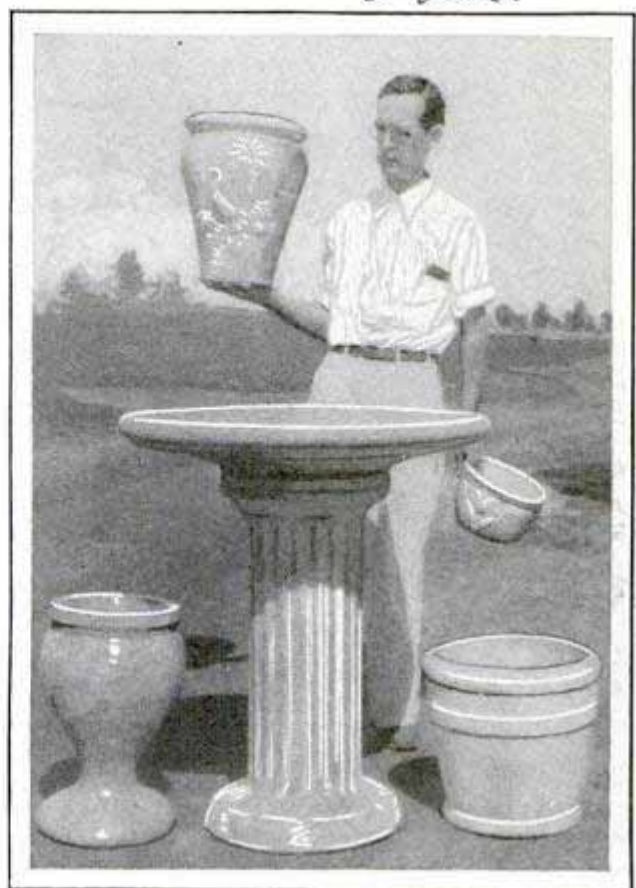

Samples of Garden Furniture Made from Palmetto-Root Fibers, Mixed with a Special Cement

**PALMETTO ROOTS AND CEMENT
FOR MAKING FURNITURE**

Palmetto roots, ordinarily considered worthless, are being used by a Florida inventor for making a number of weather-proof articles of furniture, statuary and bric-a-brac. The palmetto fiber is ground to varying grades and mixed with a special cement, making a product that is as light as wood and as strong and durable as concrete, being impervious to water and virtually unbreakable.

**METAL BATH MAKES WOOD
FIRE-RESISTANT** 691

German scientists have developed a method of metallizing wood which makes it highly fire-resistant and proof against moisture absorption without destroying the natural pattern or grain. The wood is immersed in molten metal under pressure, the metal penetrating every part. The product is easily worked with ordinary tools. Its metallic surface and non-absorbent quality, which keeps it from swelling, may make it available for bearings and other similar purposes.



Designs of Panels Intended for Inset in Linoleum Flooring to Enlarge Decorative Possibilities

Armstrong Cork Co.
P. 10

Kaiser Wilhelm
Research Institute at

Technical Journal, April 1930 P. 36

543

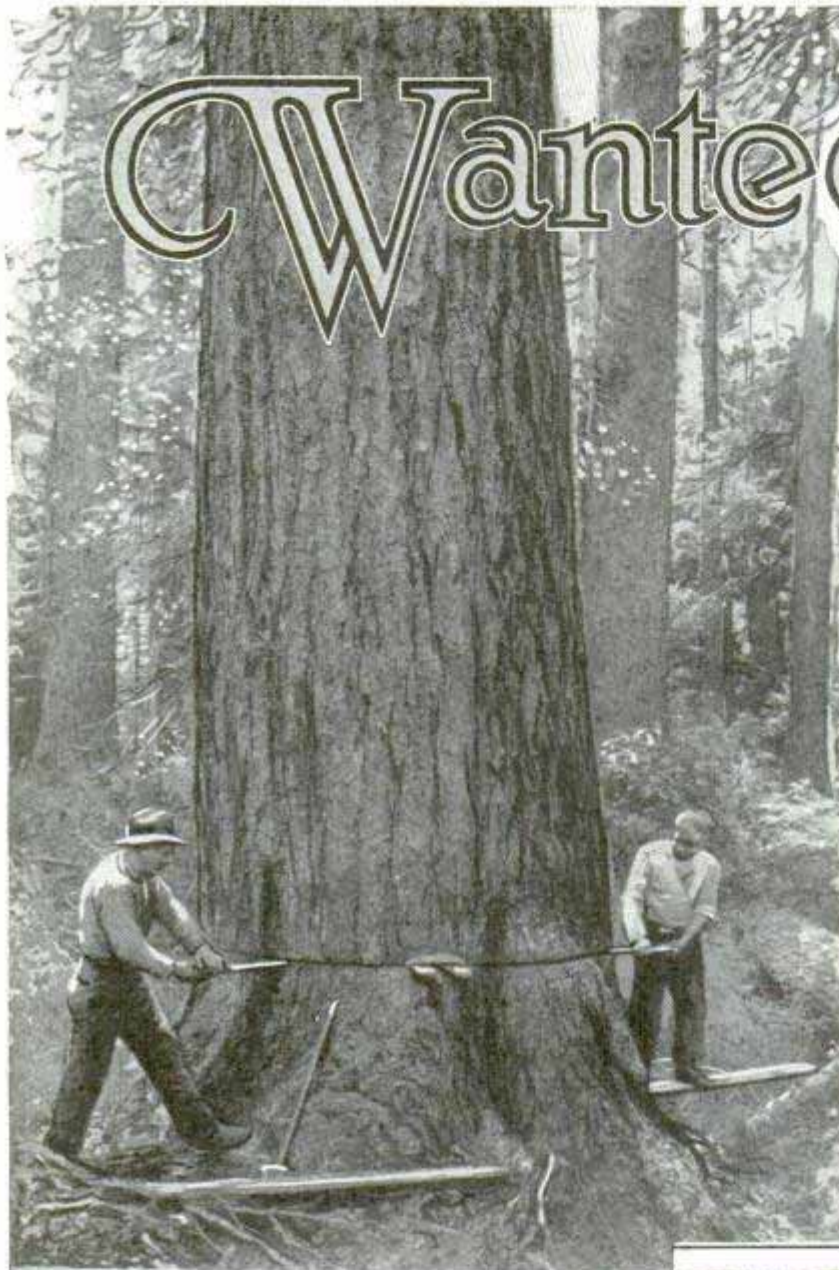

Wanted - An

the country, for the loggers, having taken out the choice timber, set fire to about 3,088,748,000 board feet of sticks ranging from cordwood size up to whole trees, three or four feet through. Of course, the wastage is all in the day's work for the loggers. They can afford to cut only the timber that will pay for itself. They can't afford not to cut, because taxes and carrying costs pile up while mature timber deteriorates. As a result, foresters are seeking new industries that may make lumber sawing almost a subsidiary of woodworking, instead of the principal one it now is in the Douglas-fir district. They see the time when cellulose may be the most important product of logging; when timber will be sawed only for bridge tim-

By K. J. WATSON 1044 E
39th St. Portland Ore

WILL it be fine fabric, papers of new and desirable qualities, a wood breakfast food, or products to which we can now assign no name?

Timbermen in Oregon and Washington ask themselves this question as they look to scientists to put an end to one of the greatest industrial wastes in modern history.

The Douglas-fir region of those two states, comprising the land west of the Cascade mountains, is one of the last stands of big-league logging in the United States. This 56,000-square-mile area now contains about one-fourth of the nation's standing timber. And every year this region sees one of the greatest bonfires in



Felling a Seven-Foot Douglas Fir; the Low Stump Indicates Economy; Below, Tractor Hauling Logs to Loading Point

bers, railroad ties, structural beams and the like; when boards will be of fiber wood with perhaps a veneer of natural wood. But most interesting of all, they watch the development of such products as rayon, the synthetic silk; "glassene"

Inventor!



Powered Arch Tractor That Gathers Big Load, and the Wheeled Rig, Forerunner of the Arch

or "cellophane," the celluloidlike transparent paper; balsam wool, the fleecelike wood product highly prized for heat and sound insulation; the expansion of the pulp and paper industry; the production of cowfeed from sawdust.

While there isn't much resemblance between the imitation silk, from which so many dainty things are made, and transparent paper, the basis for both rayon and cellophane is "alpha" pulp, first made from cotton. Chemists have recently discovered that the same alpha pulp can be made from western hemlock, of which nearly 1,000,000,000 board feet is wasted annually in the Douglas-fir region. Cellophane might be mistaken for celluloid at first glance, but it is tough, pliable and burns slowly and with the characteristic smell of wood-pulp paper.

Perhaps most interesting, in the light of the old joke about teaching the mule to eat sawdust, is the fruit of experiments



carried out at the United States Forest laboratories at Madison, Wis., cattle feed from sawdust. They actually accomplished it, though the product was not tasty enough to tempt the cattle to any great extent. It was done by converting much of the indigestible cellulose in the sawdust into sugar by cooking in dilute sulphuric acid, the acid being afterward eliminated. The resulting food was a brown meal, one-third to one-half of which was digestible and which had a woody-sweet taste and smell.

243

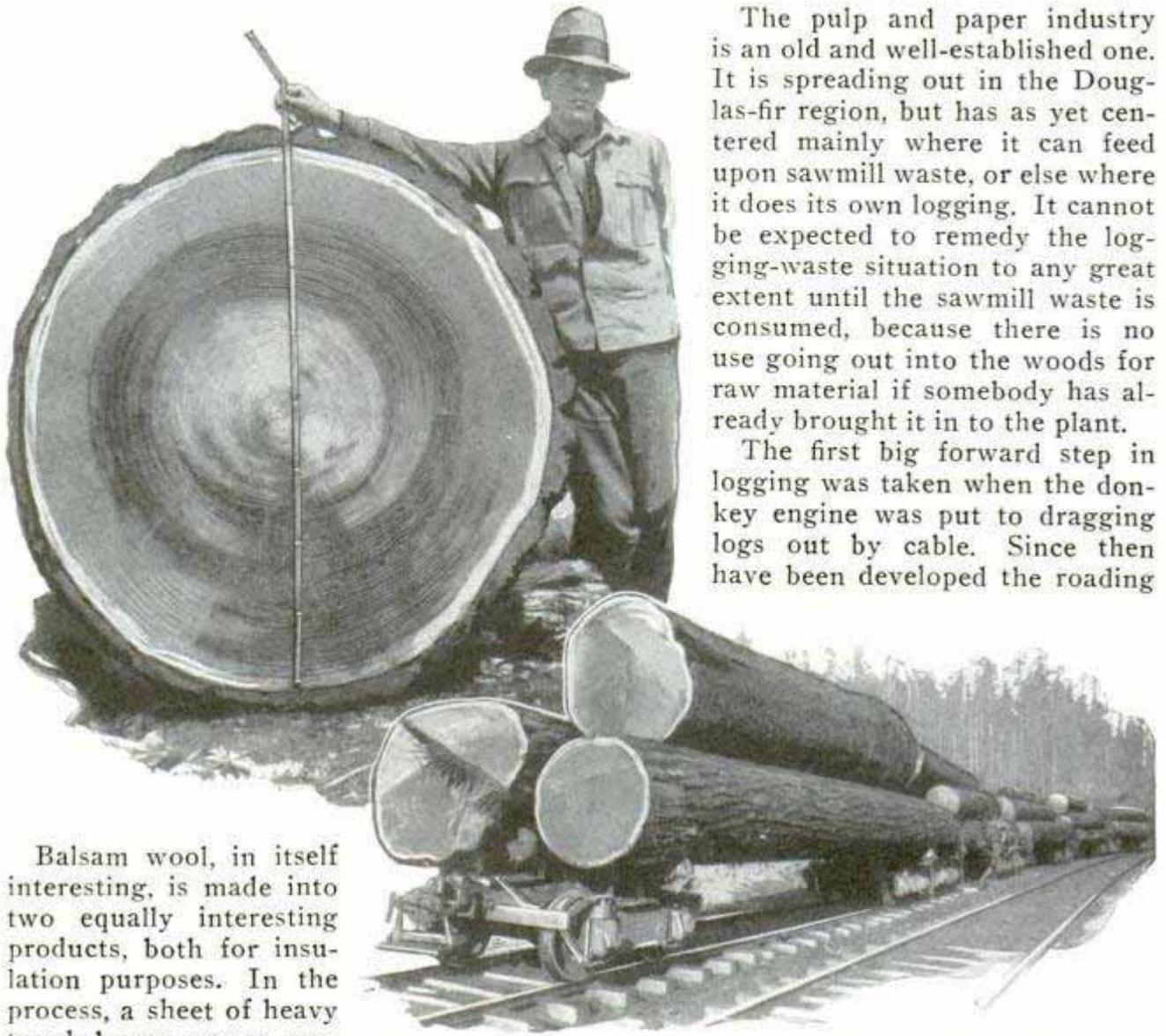

Balsam wool, in itself interesting, is made into two equally interesting products, both for insulation purposes. In the process, a sheet of heavy tough brown paper, covered with sticky asphalt, is spread out. The wool (the name is the material's best description) falls on it like snow. While the wool is falling, it is sprayed lightly with some sort of glue. When a coating of wool, several inches deep, covers the paper, a similar sheet of paper is spread on top and the whole compressed to less than an inch in thickness. It has found a ready, almost eager, market for heat insulation.

By putting cotton netting on top of the downy wool quilt instead of the brown paper, a highly salable sound-insulation material, used in construction of radio and talking motion-picture studios, is turned out. Both these products are made in Minnesota along with an excellent fiber wood, all from sawdust and trimmings from a sawmill and settlings from a pulp factory.

The pulp and paper industry is an old and well-established one. It is spreading out in the Douglas-fir region, but has as yet centered mainly where it can feed upon sawmill waste, or else where it does its own logging. It cannot be expected to remedy the logging-waste situation to any great extent until the sawmill waste is consumed, because there is no use going out into the woods for raw material if somebody has already brought it in to the plant.

The first big forward step in logging was taken when the donkey engine was put to dragging logs out by cable. Since then have been developed the roading

Fir Log Damaged by Ring-Scale Fungus, a Common Cause of Waste, and a Big Train of Logs

engine, the loader, the yarder, the yarder and loader all in one powerful machine, and now the tractor-drawn arch.

The arch eliminates spar trees and donkey engines, in theory, and has actually done so in some cases. It goes clear back to the first ground-logging methods, though, of course, with vastly improved equipment. Its introduction bears directly and favorably on the logging-waste problem because the machine tends to eliminate destruction of good timber the while it handles logs economically.

In the horse-logging days, two strong wheels, from ten to twelve feet in diameter and running on an axle which held them five or six feet apart, half carried, half dragged the logs from the woods. One or two teams of horses hitched to a long tongue furnished the power. Logs

were piled, the wheels were backed up over the stack, and a chain was passed under the logs and back to the axle, where it was secured. The long end of the chain passed over a roller on the axle to the horses, which pulled the logs up until as much of the load as possible hung from the axle. That done, the horses were re-hitched to the tongue, and away the load went to railroad or mill.

Later, the wheels were strengthened, a tractor replaced the horses, and a drum and wire cable replaced the roller and chain. The formerly straight axle was raised in an arch and a heavy steel rest crossed between the wheels about a foot from the ground. The tractor, fitted with a hoisting drum geared to its motor, pulled the logs to the wheels and lifted their front ends until they rested on the steel crossbar, while the after ends of the logs dragged. That, in a crude way, is the new arch. In this weird-looking device, the giant wheels have given way to broad-tread tractor runners.

The arch took hold first in the pine country of eastern Oregon and northern California because the country is more open and level. Operators in the Douglas-fir region are now showing interest, however. Incidentally, the company has

sold the arch and the hoist, made to fit any sort of tractor, to loggers all over the world.

The arch hits at the waste bogie from several directions. By clearing of wind-falls, breakage in falling is kept to a minimum, whereas waste in falling sometimes

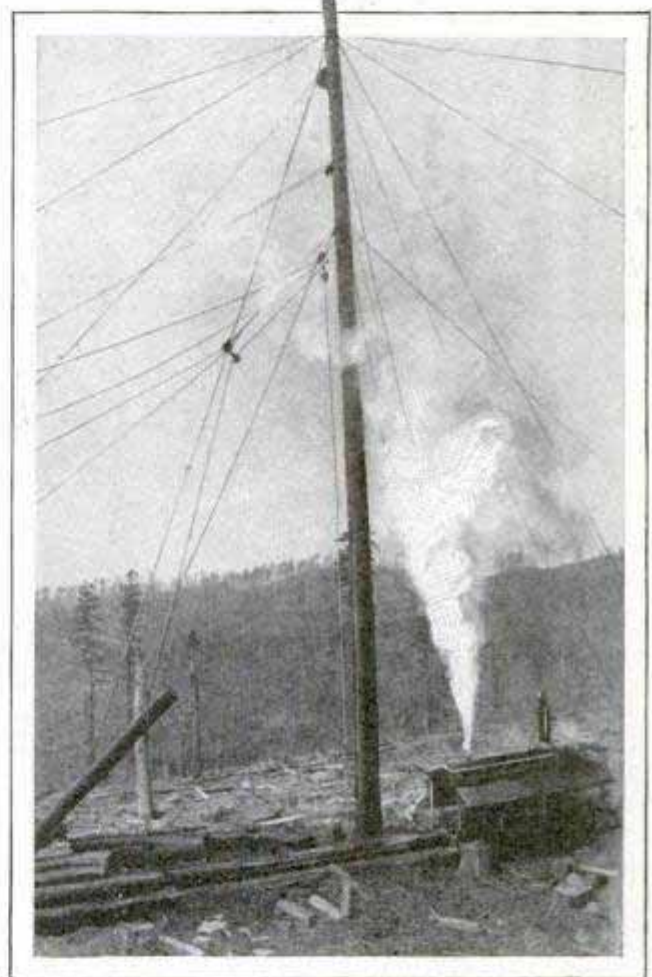

Spar Tree, to Which a Log Is Just Arriving by the High-Lead Method, and, Below, Another View of the Tractor-Powered High-Wheeled Rig for Snaking Logs Out of the Woods

543
 runs to twenty-five per cent without this prelogging. Long logs may be transported without the danger of breakage faced in both high-lead and sky-line methods. The arch yards tree-length logs without damaging them. Smaller, unlogged trees are not smashed right and left as

when logs are hitched to a high line. Logs, too small for economical handling by high line, can be yarded at a reasonable cost. Besides these, there are the other important savings in elimination of road-building, moving of high-line tackle, preparation of spar trees and operation of huge engines.

Many loggers are seeking ways out of their waste dilemma, and fuel is an important by-product of lumbering, but most of it now comes from mill waste. Another outlet for sawdust waste is wood flour, which goes into the manufacture of such varied articles as linoleum, unbreakable dolls, dynamite, bakelite, oatmeal and other wallpapers, checkers, etc.

However, regardless of these developments, the tremendous logging waste is bound to go on until the chemist or mechanical engineer finds something to turn the poorer and smaller, or less wanted, logs into products other than lumber. And all signs point to cellulose or pulp as the basis of the utilization, because the condition of the wood, so long as it is sound, makes no difference when the wood structure is to be torn down.

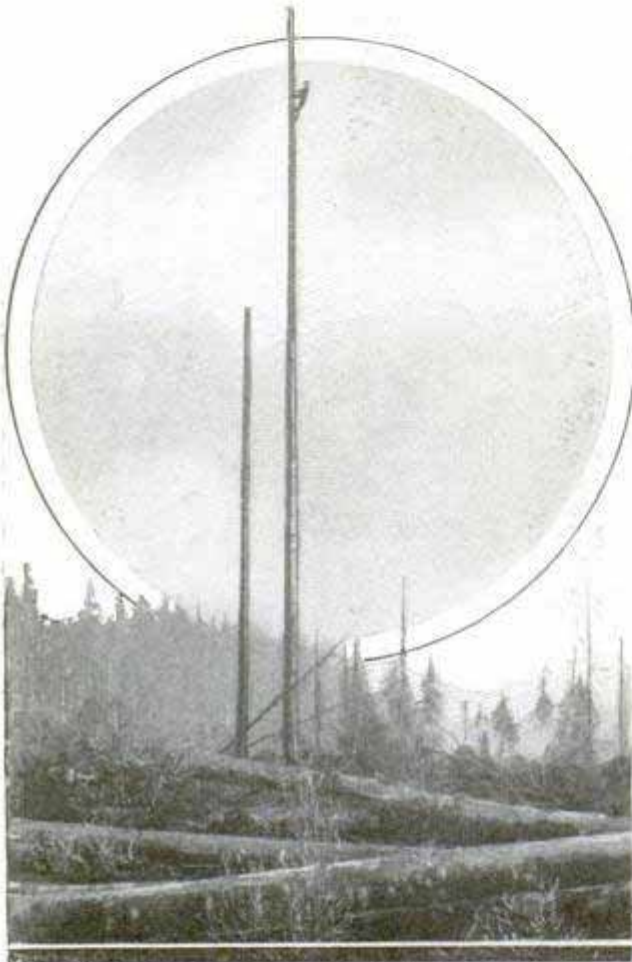

Photos Courtesy U. S. Forest Service

Topper Descending from a Tall Tree after Cutting Off the Top and Branches, and Loading Logs on Cars by a Boom Rugged to a Spar Tree

SCULPTURE IN THE MAKING FROM CLAY TO BRONZE

Depicting each process in creating a piece of sculpture, a motion picture has been made at Harvard University for the Boston Museum of Fine Arts. Among the various steps shown are the sculptor's first sketch, the modeling of the figure in



out, has changed little since the Middle Ages, but heretofore it has been impossible for those interested in the subject to witness the various processes in detail, except by visiting a sculptor in very small groups while he is at work. The

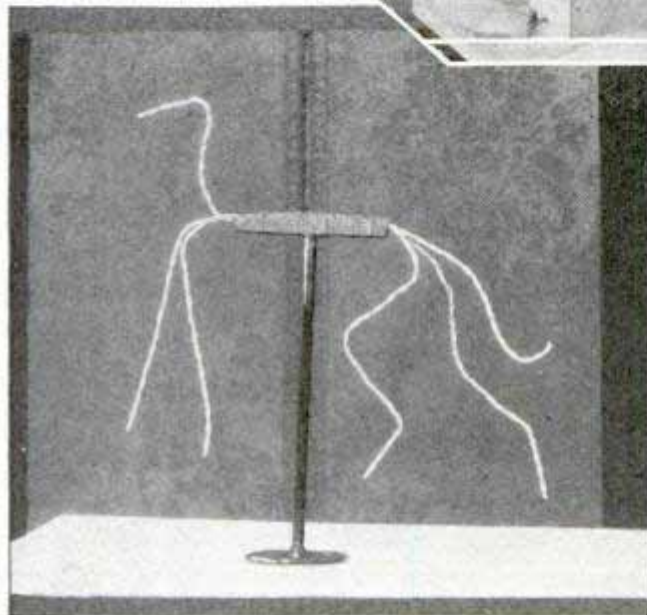

Three of the Steps in Making the Bronze Figure of a Dog; Left, the Wire Frame or Armature; Above, Modeling the Figure in Clay over the Armature; Right, the Completed Work

clay, the plaster casting of the model, and, finally, the bronze casting. Included also is a reel on sculpture in stone, showing how figures, particularly animals, are cut in marble. The taking of several scenes was hazardous as there was no possibility of retaking them if an accident occurred. Bronze casting, it was pointed

film offers several dramatic moments as the plaster caster splashes successive layers on the original model, and risks the entire work of the sculptor as he opens the plaster mold. No less exciting is the final moment when the sand mold is flooded with molten bronze at a temperature of 1,900 degrees.

PAINTLESS AUTOS SEEN NEXT IN RUSTLESS AGE

644

Automobiles without paint, lacquer or enamel may be developed as the result of the use of stainless steel in motor cars, according to expressions at a recent meeting of the American Society for Testing Materials. Research experts pointed out that it is not visionary to expect that alloy metals can be produced that will allow the

manufacture of automobile bodies requiring no finish other than burnishing, and experimenters are trying to give sheet metals contrast values in brilliancy to replace the rainbow hues for which lacquer finishes now are used. Blue for steel and gray for iron are familiar terms, and if metallurgists can produce two-tone or three-tone contrasts that approach lacquer colors in appearance, lacquering and enameling can be dispensed with.

Chicago Daily News 4/5/30

Cont. Charles H. Lorr, Lorr News Teller, Carnegie Library, 331 W. 14th St. New York

also use of absence, former captain in the Austrian technical force

BUOY GIVEN SPRING CLEANING BEFORE TRIP TO SEA

499



scopes, cleverly concealed in mirrors, were among the strange devices used by Germany during the World War, an Austrian engineer has revealed. The mirrors on the periscopes were so arranged that they reflected the waves about them, completely concealing the periscope with the result that the approach of a submarine was difficult to detect. Sliding floats of streamline shape were also placed around the periscope to eliminate the telltale ripples that sometimes revealed the presence of a sub, while deflecting plates on top of the float prevented the rising of a bow wave. Football bladders were placed inside the floats and were filled with water when the boat submerged, to keep them from collapsing. These devices proved so effective that, in some instances, submarines approached within 125 yards of an enemy vessel without being detected, and the report was spread abroad that the Germans were using submarines without periscopes. The bomb-carrying cars from the Zeppelins were lowered on long cables to within a short distance of the ground so that the Zep-

Two Views of Coast-Guard Employees, Giving Spring Housecleaning to a Whistling Buoy Before It Was Taken to Sea to Be Placed in Service

Wide world

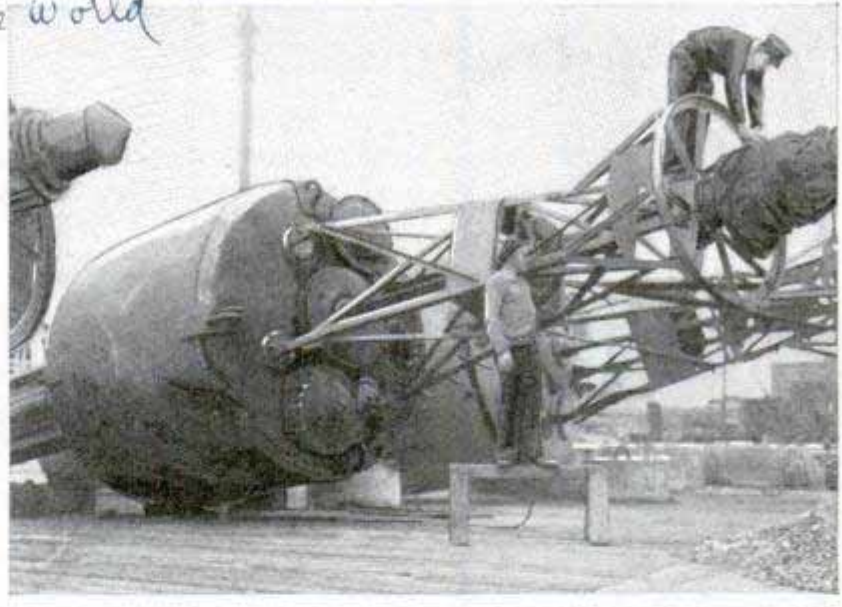

at Chelsea yard

Lighthouse and coast-guard employes, like housewives, have their annual spring-cleaning campaigns, but their efforts are confined to the buoys and other equipment used to signal or warn ships. Recently the huge whistling buoys anchored off the New England coast were given an overhauling at Boston before being taken aboard tenders to be shipped to their locations.

PERISCOPES HIDDEN IN MIRRORS PROTECTED GERMAN "SUBS"

692.

Rifle grenades that bounced in the air before exploding, bomb-releasing cars that hung hundreds of feet below their parent Zeppelins and submarine peri-

scopes, cleverly concealed in mirrors, were among the strange devices used by Germany during the World War, an Austrian engineer has revealed. The bombs were released by an occupant of the gondola, which was bullet-proof and fitted with a noiseless electric motor, a propeller and a rudder, so that it could be maneuvered about in a wide circle below the Zeppelin. The bouncing grenades leaped into the air due to an auxiliary charge and exploded with greater damage than the usual kind.

Cont. 4528 Walnut St
Phila.

**FLOWERS ABLE TO TELL TIME
DIRECTION AND WEATHER** 698

Certain flowers are able to designate time so accurately by their condition or appearance that it is possible to plant a floral clock where the time of day may be determined in summer by glancing at the garden. The naked-stalked poppy and the copper-colored day lily open at five o'clock in the morning, and within the time to six the morning glory unfolds. At seven comes the African marigold, and at eight, the pink, while the field marigold appears at nine. At eleven the star of Bethlehem opens to be followed by the ice plant at noon. After noon the flowers begin to fold with a regularity similar to their opening. At three the field marigold folds up, to be followed by the African variety at four, and the morning glories an hour later. The common nasturtium goes to bed at six, the naked-stalked poppy at seven and the copper-colored lily at eight. Certain other flowers indicate direction, the sunflower turning toward the sun and the flowers of the compass plant pointing north. The Indian licorice plant predicts weather with remarkable accuracy, being very sensitive to electric and magnetic influences which are reflected in the position of its leaves.

**WHEEL SETS FOR EMPTY CANS
MAKE TOYS FOR CHILDREN** 154

Wheel sets which may be attached to empty tin cans transform these containers into entertaining toys for the children. The two pairs of wheels are fastened to spring clips which slip over the ends of the cans, making tank cars or toy wagons of them.

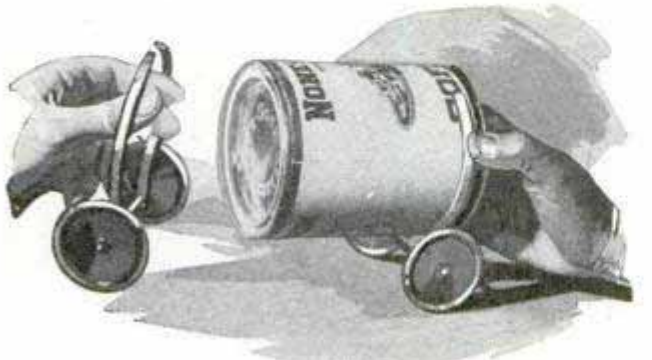

Wheel Sets Attached to Empty Tin Cans Transform the Containers into Children's Toys

A. D. Burns
3608 Wakeby St

421



Coin-in-Slot Bicycle Lock; the Owner Deposits a Coin and Receives the Key to the Lock

**COIN-IN-SLOT BICYCLE LOCKS
CHAIN WHEELS TO CURB**

Automatic safety locks for bicycles have been installed about some of the public buildings in Berlin, where this mode of transportation is popular. After the cyclist has chained his wheel to an instrument at the curb, it locks automatically. He then inserts a coin which releases the key for the lock and retains the key until ready to use the bicycle again.

**LOUD SPEAKER FOR CAR DRIVER
GIVES VERBAL WARNINGS** 700

Motorists can call warnings to pedestrians or tell other drivers that they intend to turn right or left by the use of a loud speaker for installation in the auto, which recently has made its appearance in Paris. The microphone is fixed in front of the driver who speaks into it in his normal voice. The voice is magnified a dozen times and issues from the loud speaker at the rear of the car.

Recent excavations in Rome show that the city had a seven-story skyscraper in the second century A.D.

Carl Wilkins

Sweden

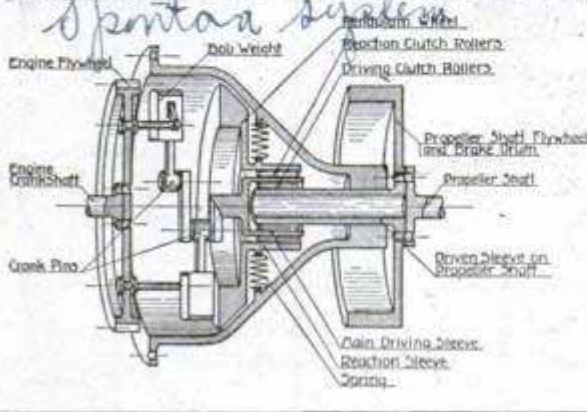
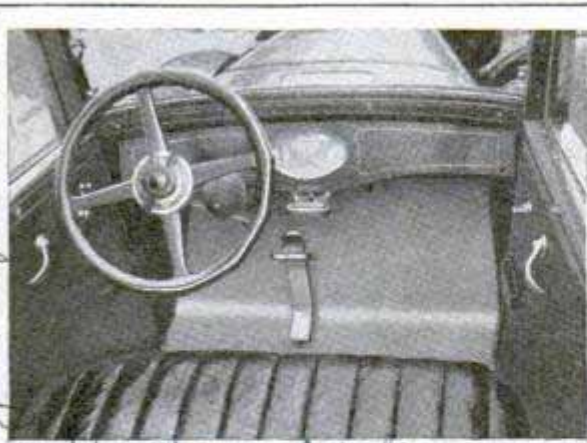

Above, Gearless Control for Auto Requiring Use of Only One Pedal; Below, Drawing of System

GEARLESS CONTROL FOR AUTO USES ONLY ONE PEDAL

Reducing the driving of an automobile to the operation of one pedal only, a Swedish engineer has invented a gearless control which replaces the usual clutch and transmission. The system has a certain flexibility, obtained through use of centrifugal weights which exert a pull on the crank pins varying with the speed at which the weights are rotated. Alternate weight impulses are transmitted to either the driveshaft or pendulum wheel through driving clutch or reaction clutch rollers. Springs store the reverse impulses carried to the pendulum wheel and react to drive the propeller shaft. At high speed and direct drive, no movement of the intermediate parts occurs, the mechanism driving as a single unit. The propeller-shaft flywheel also serves as a brake drum.

ROBOT RAILWAY CARRIES ROCK TO CEMENT MILL

Riderless railway cars which apparently run themselves are used to transfer rock from an excavating pit to a crusher near

Dallas, Texas. The secret is a system of remote control for economical operation of the stone cars. Two operators, located where they can view loading and unloading operations and the entire length of line, govern the cars. The track is divided into sections, and the motor-driven cars, each operated by a fifty-horsepower motor, collect energy from the track and a third rail. Switches before the operators control the flow of energy for each section of track. The cars are stopped by interrupting the flow of electricity to a particular section, electric brakes, operating automatically when current is shut off, serving to stop the vehicles. The direction of travel may be changed by throwing a switch. On downgrades gravity does not speed up the cars, but this energy is automatically converted into electricity and passed back to the line to run other cars.

"WALKING" HORSE ON ROCKERS GETS POWER FROM RIDER

Suitable for either a toy or for exercising in the home, a walking horse on rockers derives its power from the rocking motion furnished by the rider. It is similar to ordinary toy rockers, except that there is a separate rocker for each leg, and the legs themselves are pivoted on a spindle through the body. When rocked, the steed forges slowly ahead and direction is controlled by pulling on the reins. Sizes suitable for children and adults are made.



Walking Horse on Rockers Which Gets Its Power from Rocking Motion Supplied by the Rider

*J. F. Wilkinson,
328 Chestnut*

Dr. Gungstrom. Research Dept. Astoria, Oregon. Astoria, Oregon. Astoria, Oregon.

no 11 dayent human

Stockholm

Mr. Carver. Ashville, Ky

288

642. *Com. Walter E. Burton,*
1922 Florida Ave
Abreu Ohio

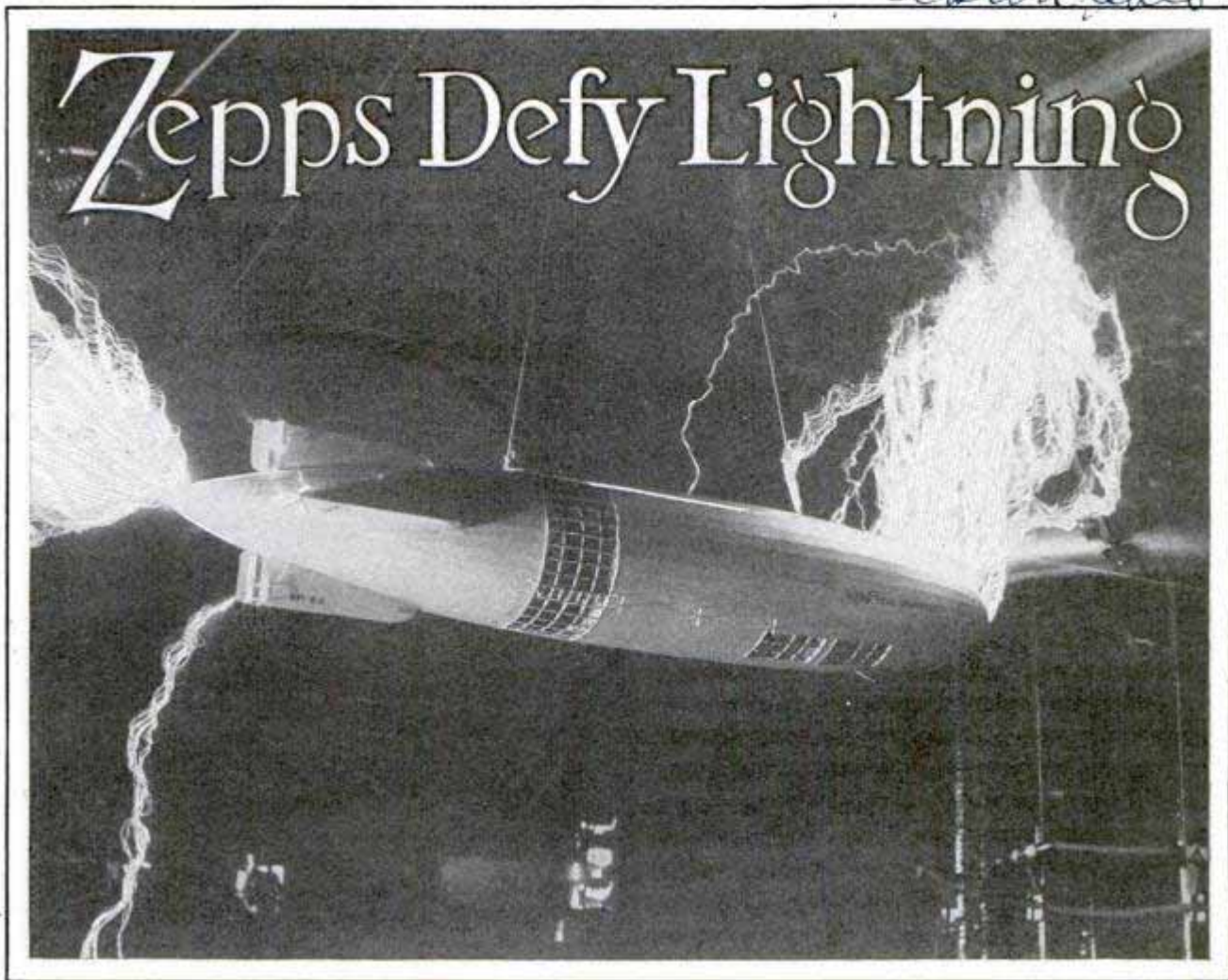

Photograph of Model of Commercial Airship in High-Voltage Test; Note the Large Number of Electrical Discharges at Right End of the Model; Framework and Covering Act as Protecting Shield

By HENRY HOYLE

LIGHTNING, one of nature's bad boys, has long been accused of being a firebug. There is little argument about its setting fire to buildings, trees and other things when conditions are just right, but when it comes to aircraft, the guilt is not so obvious.

Arthur O. Austin, who is studying the subject of the lightning hazard in flying, and performing numerous tests at the world's most powerful outdoor high-voltage laboratory, in Barberton, Ohio, has been finding out much about the fire-making abilities of lightning.

Is a lightning discharge likely to fire the fuel tanks of an airplane? Will the fabric of a plane or dirigible be ignited? If so, will it continue to burn? Can a lightning bolt damage sheet duralumin or aluminum sufficiently to cause trouble to the plane or airship? These are some of the questions that he is investigating.

At the Goodyear-Zeppelin air dock and factory a few miles from the Barberton laboratory, Dr. Karl Arnstein and his men are designing and building Zeppelin airships. Although non-burning helium gas is to be used in the cells of these dirigibles, the problem of avoiding fire is not being neglected.

A model of a commercial airship of 6,500,000-cubic-foot helium capacity was turned over to Mr. Austin for test purposes. This model was subjected to two kinds of man-made lightning. It first was bombarded with a stream of giant sparks. Then it was subjected to single impact discharges of great power. The ship came through none the worse for its treatment except that the fabric covering was scarred where the discharges had entered or left. Dr. Arnstein, commenting on the tests, said: "The metal framework of those ships acts as an excellent con-

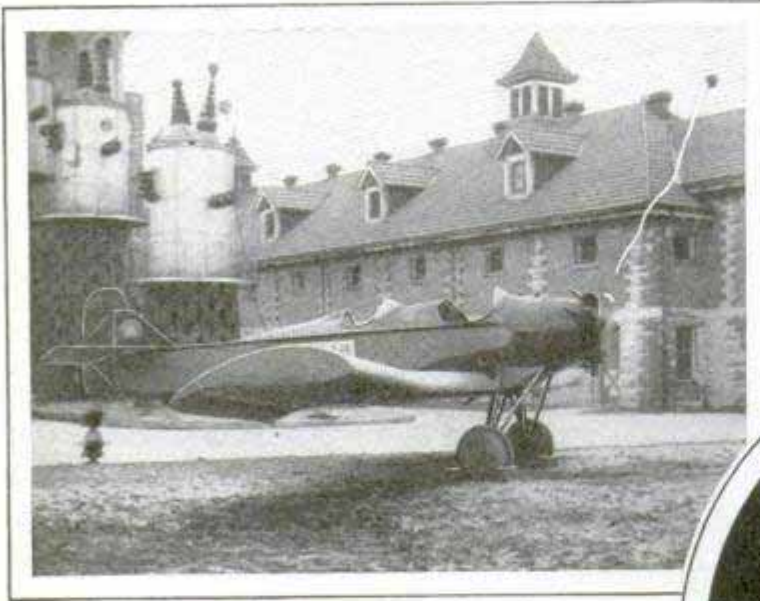

lightning on a dirigible and a plane of similar construction, as far as igniting the fabric is concerned. A Barling "NB-3" monoplane, provided by Popular Mechanics Magazine, at whose request these tests were started, was bombarded by impact discharges of artificial lightning. In

ductor of lightning, protecting the vital parts, such as the gas cells, the passenger compartment, crew quarters, engine room and fuel tanks which are located inside the metal structure. The outer cover which, on the Zeppelin-type ship, is of doped fabric, and is not called upon for retention of the buoyant gas, does not sustain combustion. Lightning strokes leave only very small local singed traces at the points of entry and exit."

In the past, rigid airships have been struck by lightning. In some instances, slight local damage, such as the fusing of a metal part, was caused; but it in no way interfered with operation of the ship. In most instances, the only marks left by the lightning on the airship were at the points of entrance or exit of the discharge.

"Experience with scores of Zeppelin ships, all of which were inflated with hydrogen, has shown that the rigid metallic, fabric-covered airship is perfectly safe from lightning," Dr. Arnstein continued.

"In spite of the fact that the highly inflammable hydrogen was used, the Zeppelin company built and operated 115 airships, none of which were lost during flight by fire except the 'L-2' and 'L-10,' and, of course, those brought down in war. The 'L-2' was burned during a trial flight due to hydrogen finding its way into a power car while the motor was backfiring. The 'L-10' was struck by lightning while valving gas."

Mr. Austin has shown that there is practically no difference in the effect of

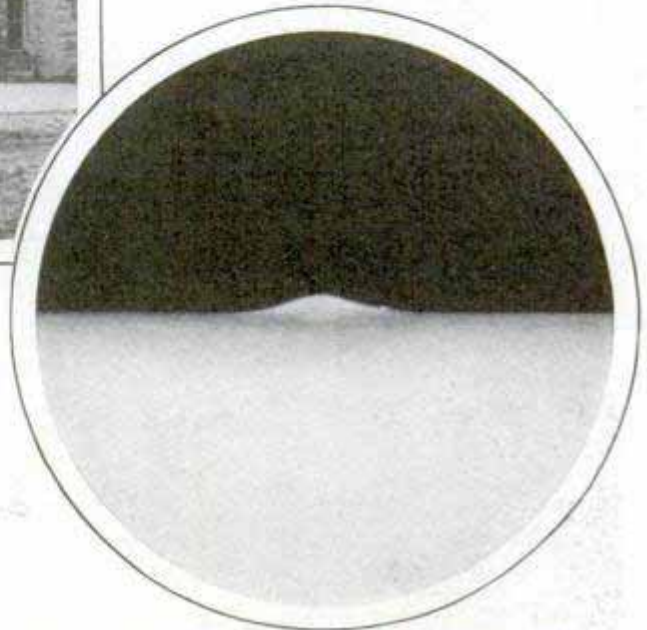

Barling Monoplane Being Struck While Motor Is Running and Cone Raised on Duralumin by Stroke of Artificial Lightning

no instance was the fabric or other part of the ship set on fire. This plane has a well-bonded duralumin framework over which a doped-fabric cover is placed, being similar to a Zeppelin in that respect. The discharge always entered the plane at some point in the metal structure. If the fabric happened to cover this metal, the intense heat of the flash would instantly vaporize the fabric, producing a small hole, in some instances as large as a lead pencil. This hole was not burned, there being practically no evidence of scorching. It was caused by the "explosion" or instant vaporization of the fabric.

"During an electrical storm," Mr. Austin said, in discussing the tests, "a stroke of lightning appears as a single discharge, whereas it may, as a matter of fact, consist of a number of discharges in rapid succession. The heating effect of several strokes may be much greater than that indicated by the maximum current developed in a single discharge.

"When lightning passes between two

metal surfaces where the heat generated cannot escape readily, burning of the metal results.

"The tests indicate that where surfaces are free or open, the fire hazard is apparently small. This has been borne out by the experience of dirigibles, and in general observation of the performance of lightning.

"To test the effect of poor contacts between metal, a strip of duralumin was laid on another sheet of the same material. This arrangement is, roughly, the same as that occurring in an airplane where a poor joint exists. When the set-up was subjected to discharges, it was found that con-

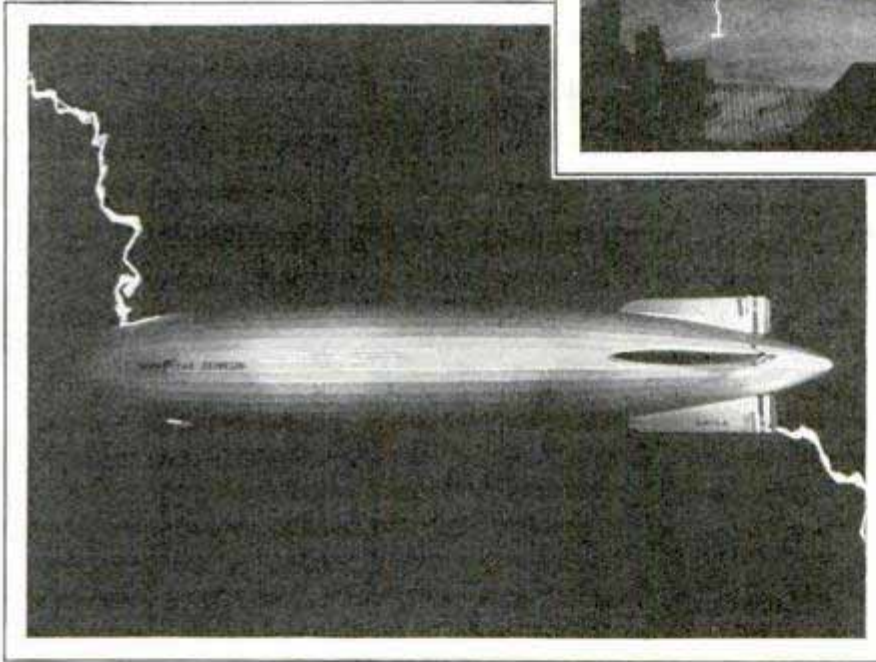
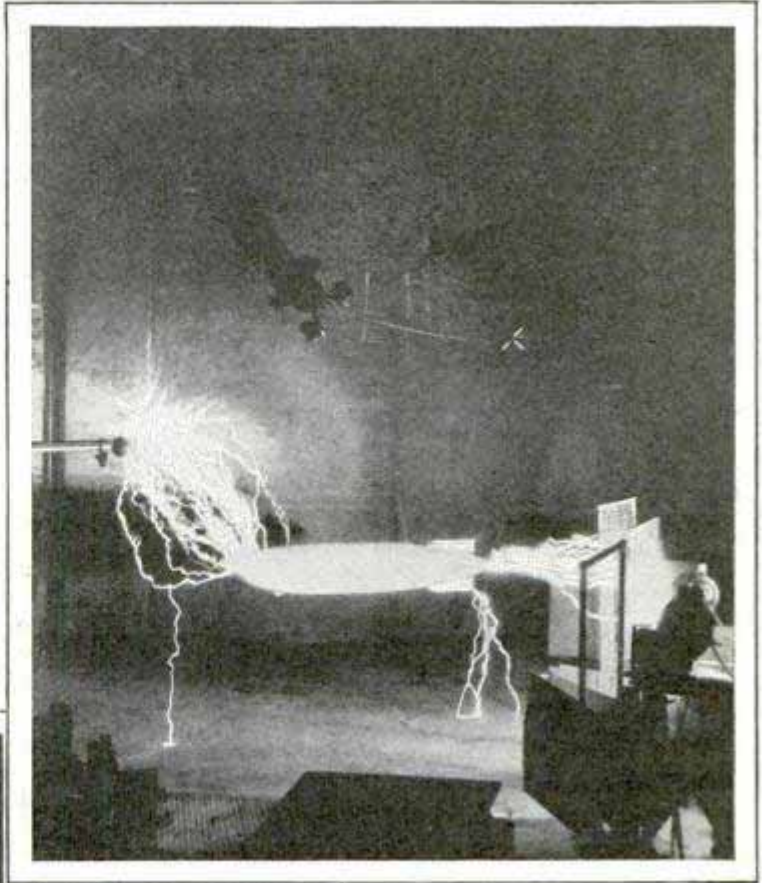

Two Interesting Laboratory Tests at Barberton Plant of the Ohio Insulator Company; the Model Commercial Airship Is Withstanding 1,250,000 Volts

siderable burning had occurred. In practice, the riveting of the parts together tends to insure a contact and reduce the danger of a hot spot to a minimum. I believe that the only cases where metal has been damaged in large dirigibles has been at points of poor contact. The present method of construction, of carefully bonding all parts in dirigibles and airplanes, should make this hazard negligible.

"The previous tests upon airplanes indicate that it is comparatively easy to localize the point of discharge by providing a small lightning rod or even a

bead of bare metal which covers the corners at points where lightning is likely to strike. These points include those at wing tips, rudders, elevators, landing gear, the nose of the plane and propeller. The research has shown also that it is comparatively easy to test joints to determine their lightning-proof qualities by placing them in the path of discharge."

Some airplane designers have held the opinion that the fuel tanks are a source of danger when the craft is in a lightning-infested region. Mr. Austin has demonstrated that no such danger need exist. During all of the tests on the Barling, there was fuel in the gasoline tanks. In some of the experiments, the engine was running; yet no explosion took place. About the only way in which fire could be started would be ignition of gasoline vapors that had collected in a pocket. It is, however, a simple matter to protect these parts by creating shunt paths through which a discharge will travel.

78
 493

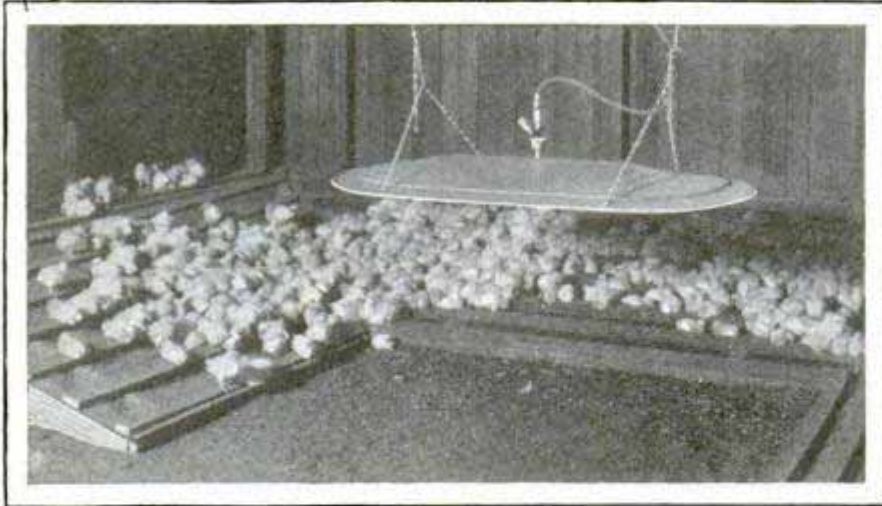

Movable Gas Brooder Which Is Placed over Roosts to Coax Baby Chicks off the Ground as Soon as They Are Old Enough

MOVABLE GAS BROODER COAXES BABY CHICKS TO ROOSTS

Because he had trouble in coaxing baby chicks to go away from the heat of the brooder when they reached roosting age, a California poultryman invented a movable gas brooder with which he takes the heat to the roosts to induce the chickens to leave the ground. The oval brooder is of galvanized iron, lined with asbestos and iron plates, and is equipped with chains for suspending it at any height. Gas connection is made with rubber tubing and the larger heaters are provided with thermostats. The movable brooder does away with most of the crowding and subsequent mortality among the chicks by thus luring them to roosts.

DEAF HEAR ELECTRIC WAVES BY TOUCHING WIRE

612.

before Austrian Medical Society

Working on the theory that human beings can be made to hear not only by a reception of sound waves, but by contact with electric vibrations or waves produced by a microphone, two Vienna scientists recently demonstrated an apparatus which, in effect, is an artificial eardrum enabling deaf persons to hear by means of electric

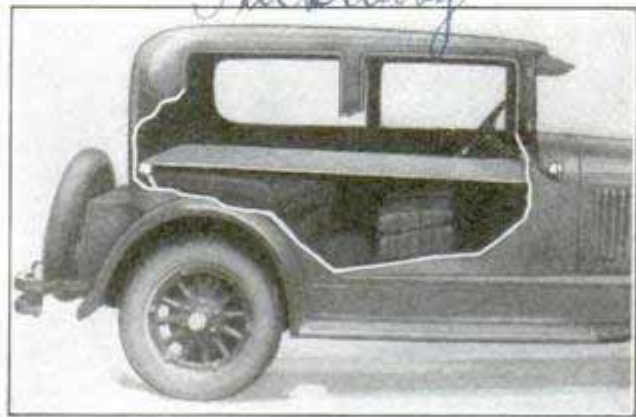

Heavy Canvas Folding Bed for the Automobile

waves transmitted to the brain direct through the auditory nerve. In the tests, a phonograph record was played in one room and the sound waves were transformed into electric vibrations which were carried by wire to another room. There deaf persons were able to hear the music merely by touching the wire to the ears. Sound waves cause the eardrum to vibrate and incite the brain nerves which results in hearing, and the apparatus apparently accomplishes the same result with the electrical waves. At present the apparatus is complicated and dangerous, because the sounds, after conversion to electric impulses, are greatly amplified.

Chicago Tribune 7/30/30

FOLDING BED FOR MOTOR CAR FITS BEHIND REAR SEAT

568

Comfortable sleeping quarters for the automobile are provided with a folding bed which, when not in use, may be tucked away behind the rear backrest. The bed consists of a heavy canvas suspended by two steel tubes. The rear tube serves as a roller in tightening the canvas with a ratchet device and the front tube is hooked by two chains to connections installed on the dash plate. The rear backrest is removed for installation, and the canvas bed fits behind it when traveling. By placing the rear backrest on top of the rear cushion when making up the bed, the comfort of a spring bed with mattress is given. The bed is suitable for cars having front seats with folding backs, or detachable front seats. For cars with rigid front seats, a bed with a frame is provided which rests like a cot above the seats, the outfit folding into a compact bundle when not in use.

Dr. Stephen Jellinek Vienna and Theodore Schreber
Stockland Harinery Corp. 1827 & 2nd

683

Club by Advanced Aviation Club
Washington Junior High School
Pasadena, Calif.

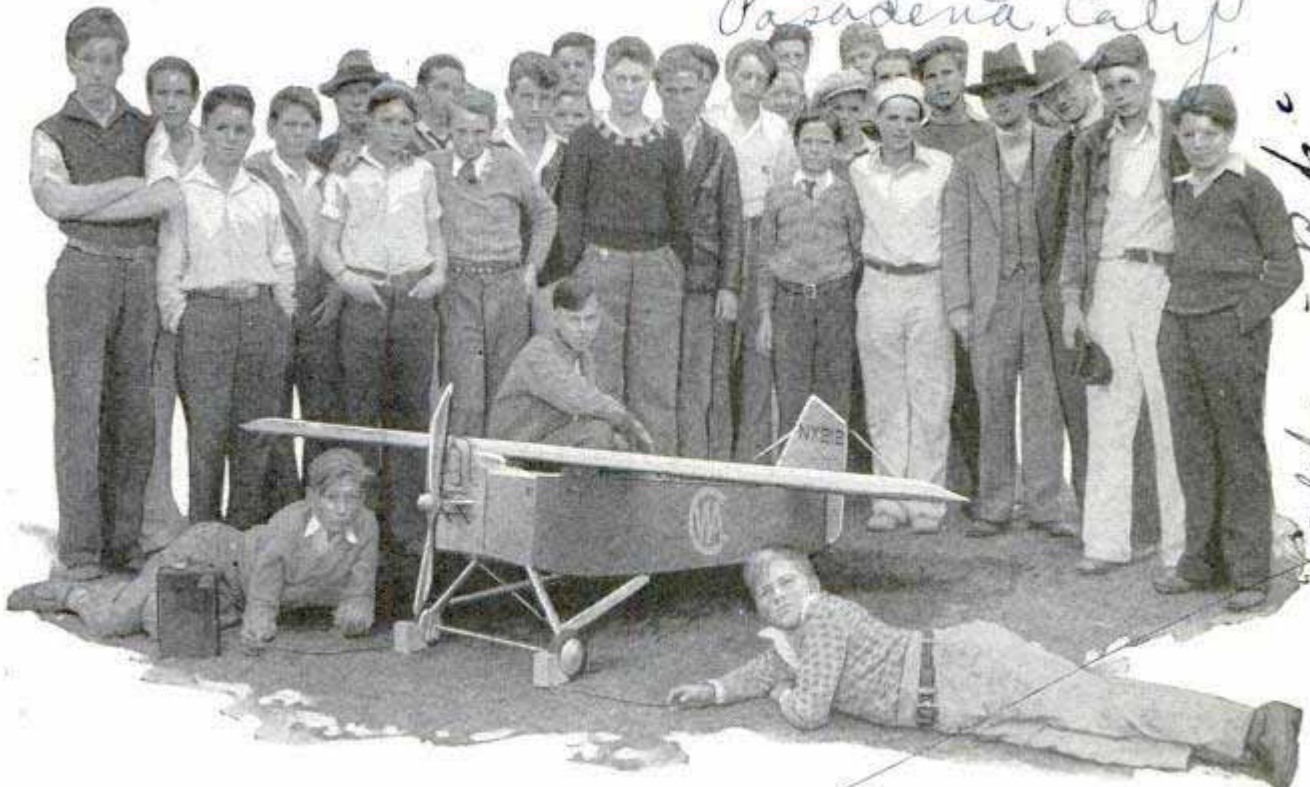

Miniature Monoplane Powered with a Model Gas Engine, Built and Flown by Junior High-School Students; the Ship Is Equipped with Automatic Controls for Taking Off and Landing

MINIATURE PLANE IS POWERED WITH MODEL GAS ENGINE

Junior high-school student members of an aviation club at Pasadena, Calif., have built and flown a miniature monoplane powered with a three-quarter horsepower model gas engine. The plane is equipped with set controls, the apparatus being set for flight and landing, so that, if the ship crashes, it will be due to an accident or defect in the mechanism.

tion. It folds so that it can be carried easily under the arm. Metal clips about the edges protect every move, from the deal to the assembling of tricks, against breezes that might blow the cards away.

NOISES IN STREET CAR REDUCED WITH TROLLEY CUSHION 69

Unpleasant noises from moving street cars are said to be greatly reduced by using an improved cushion device at the base of the trolley to curb the vibrations that originate in the wheels and often communicate themselves to the car top and the trolley with disturbing results to the passengers. The cushion is composed of two concentric steel tubes separated by a layer of special rubber. Current is carried by means of a copper connection between the two tubes. Rubber already has been employed as a silencing agent, but in the usual installation it becomes so tightly compressed under the trolley base that it loses its resiliency and hence its sound-deadening qualities.

BRIDGE BOARD WITH CARD CLIPS FOR OUTDOOR GAME 567

Playing bridge outdoors, on boats, trains or in other places where breezes blow, is facilitated with a board provided with clips for holding the cards in position.

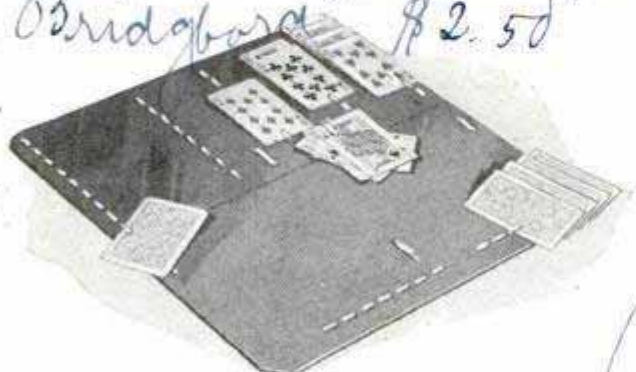

Board for the Outdoor Bridge Game, Provided with Clips to Hold the Cards in Position

Those wishing further information on anything described in the editorial pages can obtain it by addressing Bureau of Information, Popular Mechanics Magazine, Chicago.

California Prof.
Engine. Prof.
F. J. Lathrop 174 Woodway
Pasadena
Chicago 20 N. Wacker Drive.
R. J. Steneric

Proven Products Corp.
1141 42nd St. New York

Ohio Brass Co.
Mansfield, Ohio

*Mr. Ernest W. Fair
Box 64 Capitol Hill Sta,
Oklahoma City, Okla.*

ARMY PIGEONS ARE TURNED INTO PHOTOGRAPHERS

As a result of the important part played by carrier pigeons in the world war, Ger-

oil and gas quickly cutting away the pipe, once an opening was started. Another unsuccessful effort was made to place a second type of control gate in position; then field engineers made an outside cutting nipple or die, containing only outside threads made from high-grade hollow steel billets, tempered and heat-treated after the dies were cut. This capped the well and stopped its spree. About half the oil was saved from pools around the derrick, but the rest was lost in spray which extended for twelve miles, forcing the closing of many



Above, Dog with Case Containing Carrier Pigeon Strapped to Its Back; Right, Carrier Pigeon with Automatic Camera Mounted on Its Breast

man army officers recently have started extensive training of the birds and experimenting with them. Some have been taught to carry an automatic camera strapped to their breasts, the apparatus being capable of making six exposures while the birds are on the wing. Dogs are being trained with the birds, the animals bringing the birds in carriers strapped to their sides from the home port of the pigeons to officers whom the dogs have been taught to follow.



OIL MEN TAME WILD GUSHER WITH SPECIAL NIPPLE

After a battle lasting for eleven days, oil men recently succeeded in taming "Wild Mary," one of the biggest oil wells ever to go on a rampage in the Oklahoma City field, with a special nipple. When the gusher first blew itself in at 6,500 feet, it produced nothing but gas, but soon started flowing oil. Well fighters were rushed to the scene by airplane, and, at first, it was decided to cut threads on the upper part of the seven-inch drilling nipple and attach master gates and crosses. Workmen, wearing steel helmets and slickers, attempted the job, but were unable to cut the threads correctly and the nipple burst, the sand accompanying the

wells and the removal of families. In addition to helmets and slickers, men working at the scene wore cotton in their ears to shut out the roar. The gusher cost about \$75,000 a day during its rampage, not including property damage.

BRICKS THAT INTERLOCK LAID WITHOUT USE OF MORTAR

Bricks that dovetail and interlock and that are said to form a wall stronger than can be built with the usual kind, are laid without mortar. An angular ridge in the center of each brick fits into a corresponding groove in the one above it, so that no mortar is necessary to hold the units together.



*Berlin Germany
F. Neuberger-Messe
Berlin n. 24, Aramenburger St. Germany*

*Mary Sudich
Miss M. T.*

699

649

0.935

GOLD MINING IN THE PHILIPPINES

The Philippines and their 7,000 islands, of which only about 2,500 yet have names, are seldom regarded as a source of mineral wealth, but, since 1914, considerable quantities of gold have been taken from Masbate, a mountainous island, about 1,800 square miles in area. Low-grade ores, dumped and abandoned as worthless by the Chinese, who did extensive mining here in the twelfth century, have been made to yield profits with the aid of modern mining machinery and methods and new properties have been developed. In one district, the rock assays from \$2 to \$6 a ton and is easily broken up for the gold extraction processes. The miners are not without their troubles, however. Timbers have to be selected of special woods, as the white ants devour ordinary varieties, and dynamite has to be specially guarded against theft by the natives, who use it in killing fish. Bullion is shipped to the bank at Manila for later transfer to the United States.

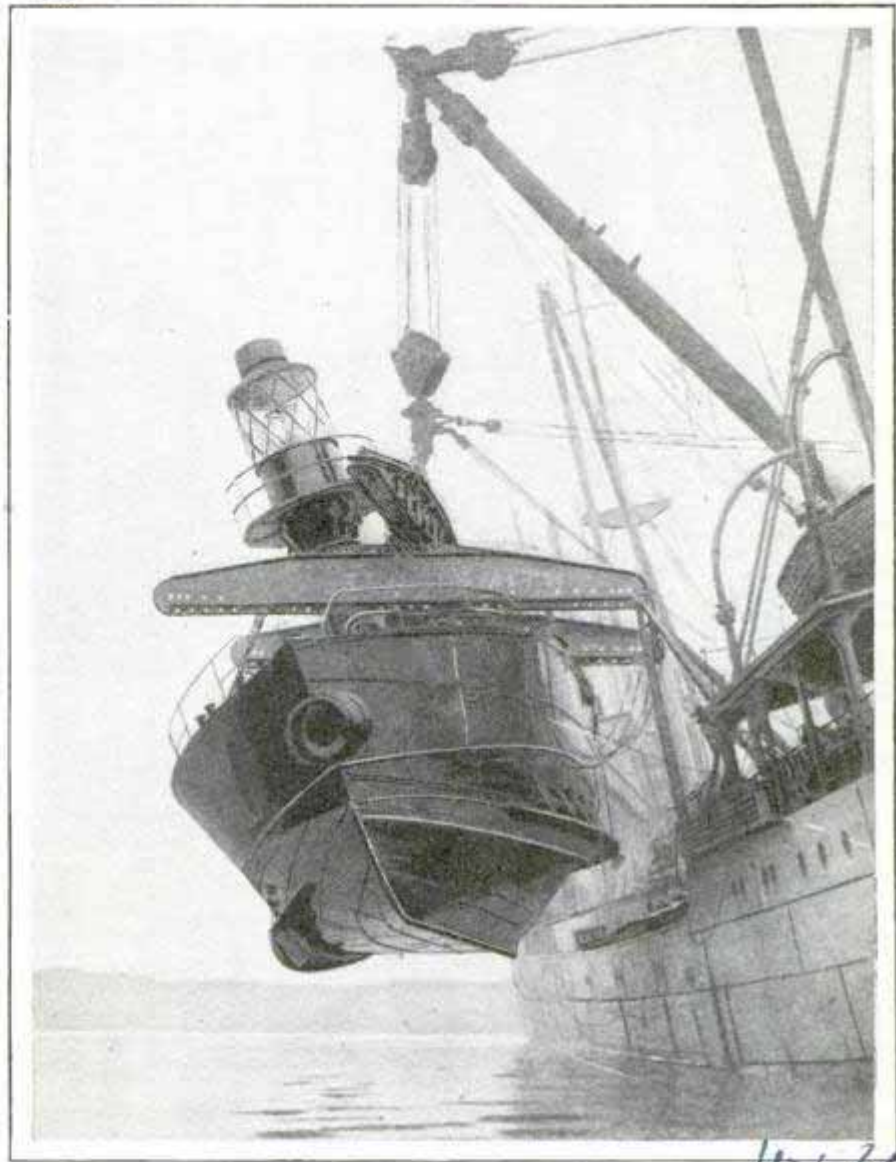

Lightship, Weighing 150 Tons, Being Lifted aboard Ocean Liner with Derrick; Note the List of the Larger Vessel Caused by the Load

SHIP HOISTED ABOARD VESSEL WITH BOAT'S DERRICK

Hoisting one ship aboard another by means of the derrick of the larger vessel recently was accomplished at Liverpool, England. A lightship, weighing 150 tons, was to be loaded aboard the S. S. "Belpameta" for shipment to the Persian gulf, and the feat was done by using the crane to pick the lighter boat out of the water and place it on the deck of the ocean vessel. The big boat listed as the lightship was raised, but the job was done without trouble.

SPARK PLUG HAS DOUBLE HEAD AND IS REVERSIBLE 391

Made so that either end can be used in the motor, a reversible spark plug with a double head now is on the market. The metal cap on the top head covers the upper end, making the plug dust-proof, and also is carrying the screw and nut for the ignition wire.

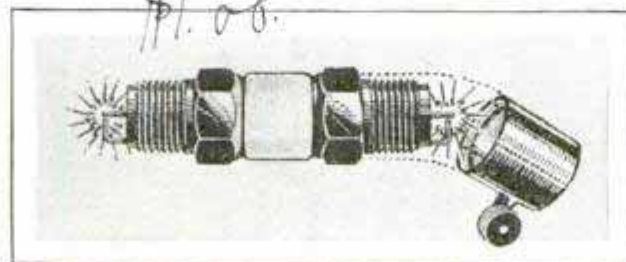

Reversible Spark Plug with Double Head; Either End Can Be Used in the Motor

Some clouds are ten miles thick.

Chicago 7323 Woodlawn Ave

Beplug Corp. Macomb Ill

What SCIENCE KNOWS

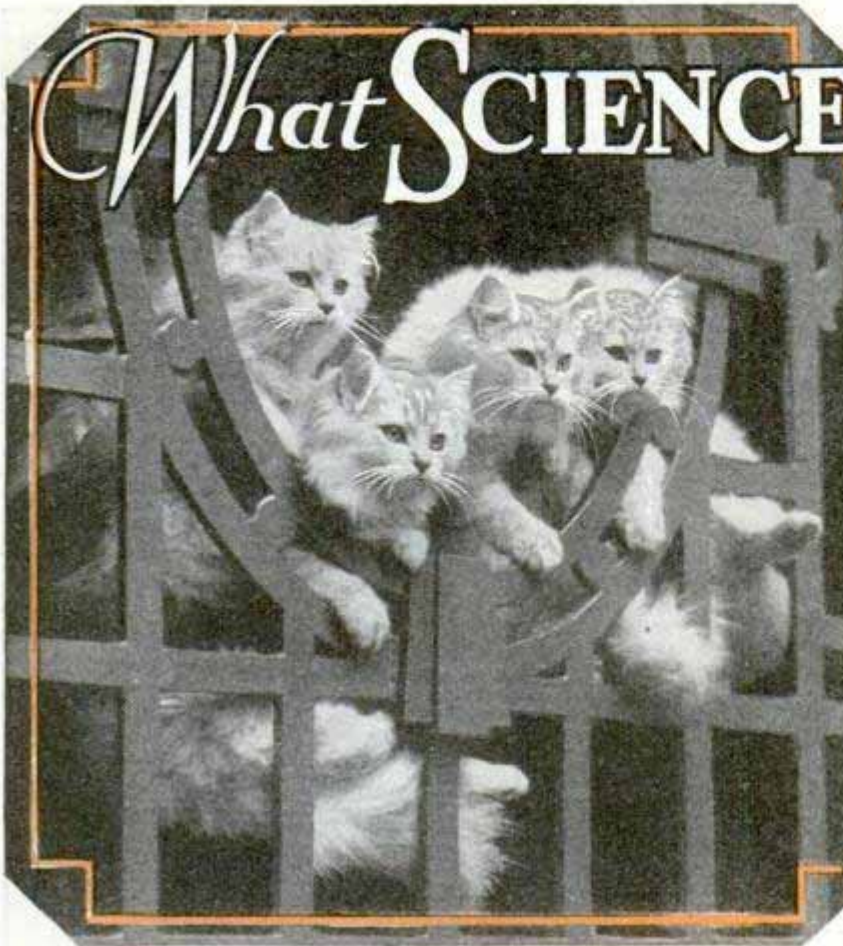

Prize Kittens, and Silhouette "Movie" Showing How the Cat, One of Nature's Most Remarkable Animals for Strength, Agility and Endurance, for Its Size, Jumps over a Fence

By MILTON FAIRMAN

CATS live in a colorless, toneless world, according to Dr. Georgina Stickland Gates, of Columbia University, who spent years in studying felines. As a result, much has been learned regarding the family tabby.

Early experimenters believed cats could distinguish colors. An elaborate test gave decisive results. A series of glass jars, each covered with paper of a different color and each made to smell of fish, were used. A small fish was placed in a red jar. After investigating each receptacle, the cat slowly learned that the red one had the fish. This seemed conclusive proof that she could distinguish colors.

The investigator, however, was patient. A certain shade of gray was finally selected for the other jars. The cat was completely baffled. She could not tell this gray from red. Tests showed that it was of the same brightness as the red. Thus it was proved that, although cats respond to varying degrees of brightness, they are color-blind.

Twilight is then the world of the cat. She cannot even recognize differences in facial expression, and objects are but shadowy outlines to her. She lives in a world like our own at dusk, and then her sight is keener than man's. An old legend says that the Chinese once told time by the size of the pupil of the cat's eye. Tests have

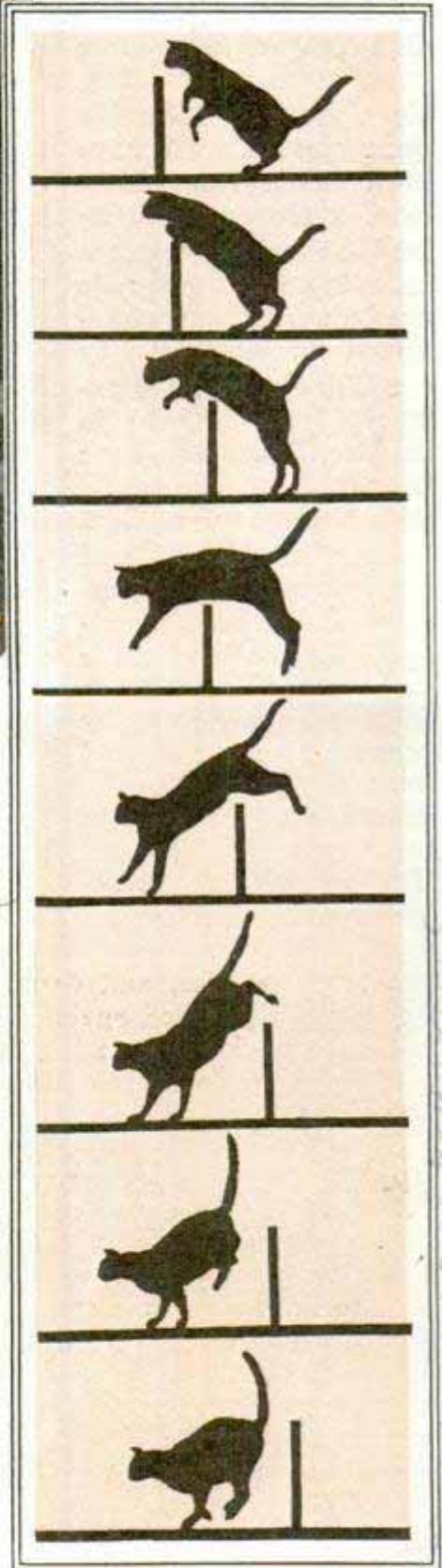

Subst. of Psychology

About YOUR CAT

shown it capable of great expansion or contraction. Contrary to popular belief, she cannot see any better than man or any other animal in pitch darkness. However, her whiskers enable her to "feel" her way about.

Her fear of water is traditional. This has been disproved by observers. They point out the frequent attacks on the fish bowl, and cite cases of cats diving for fish. Fishing cats are, however, the product of wharves or mills. Scientists explain that they learned to fish in this manner:

Chasing a rat along the wharf, Puss finally followed it into the water. Since she is attracted by any

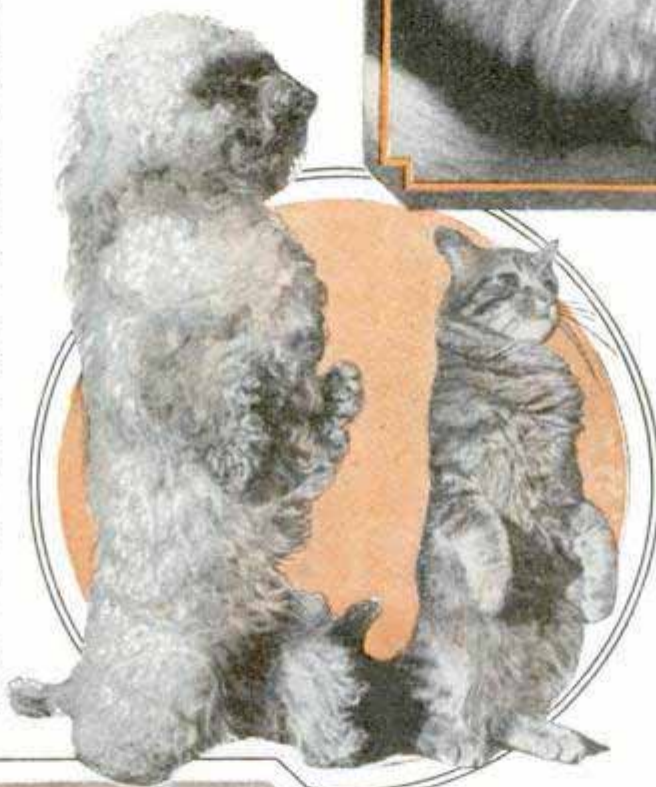
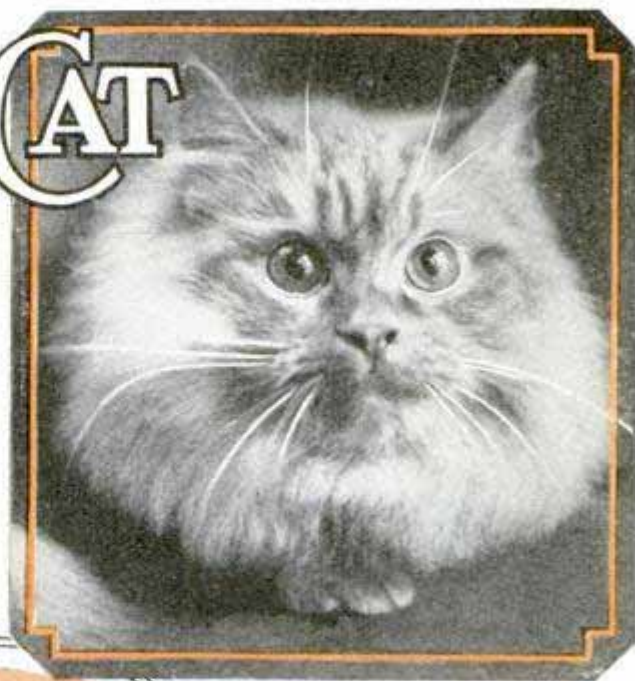

small moving object, a fish, swimming near the surface, later claimed her attention. She stalked it, and suddenly sprang upon her prey. Thus she overcame her fear of water. So Tabby's shyness near water is largely a bluff; she can, in time, become accustomed to it.

Cat fanciers were once of the opinion that their pets might have learned to fish by imitation, but one scientist placed two cats in adjoining compartments separated by a wire screen. Cat A watched cat B escape by pulling a cord to reach bait outside the cage. The experiment was repeated time after time, but A was unable to repeat the actions of B, although she carefully observed them. In another test, two cats climbed a pole to reach a fish, but a third cat, hungry and able to climb, witnessed the experiment repeatedly without learning how to reach the food.

In another test, a cat was placed in a box, escape from which might be gained by pulling a string, the cat struggled wildly. Eventually, by accident, she clawed at the cord and was freed.

Placed in the box again, experimenters



Top to Bottom, "Shadow Lassie," a Blue-Ribbon Winner; Cat and Dog Tricksters, and a Champion Siamese Cat



found that Puss' previous experience had taught her nothing. Finally her struggles brought about her freedom. After repeated experiments, the subject was still unable to free herself directly, but the time of confinement gradually decreased. Puss learned a lesson, not by reasoning out a means of escape, but by association with the cord as a step toward freedom.

An investigator taught a kitten to answer a signal, "I must feed these cats," by climbing up for food. Sixty trials were required for the lesson. Later, he tried "I will not feed them" as a signal that there was no food.



Not until after 380 trials, did the kitten seem able to distinguish between one signal and the other.

Tradition has it that a cat cannot be lost. Stories of unwanted cats who returned home despite the efforts of their masters to be rid of them are many. And, so far, this feline faculty has baffled experimenters. One cat was taken in an open boat to the center of a lake. The oarsman continued to turn the boat in circles, but Puss was always able to turn her head toward home and cry.

Science has but one explanation to offer for this rare faculty. The cat has some mysterious equipment which acts as a compass and enables her to retain her sense of direction. This "compass" operates independently of vision, hearing, or smell, and is apparently a muscle sense.

The old fable of the cat's nine lives was largely due to her success in escaping injuries in long falls. Experimenters put Tabby through a series of trials before a camera and learned some surprising things

about her. For instance, if you drop your cat, head forward, a foot from the floor, she will be able to correct her position and land on her feet.

The camera revealed the process: First the forelegs are contracted, and the front of the body rapidly twisted; then the hindlegs are contracted, and the



A Cat That Sounded a Burglar Alarm on Knocker; Friendly with a Mouse, and Diagram Showing How Cat Twists to Land on Its Feet



A Friendly Family at London Home for Animals, and a Real "Puss in Boots," Star of a New York Show.

hindpart twisted; and the change of position is completed, guaranteeing safety even for a drop of four stories. While most cats could correct their position in six inches, investigators reported all made successful falls of only one foot.

There are many cat fanciers who believe their pets cannot be broken of the bird-killing habit, but science tells us how this may be accomplished. A kitten is locked up in a coop where a brood of chicks is under the eye of a watchful and vigorous hen. The first time Puss attempts to molest one of the young, the hen administers effective punishment. The process is repeated until the kitten finds it best to leave chickens—and birds—alone. The lesson is never forgotten.

In testing the value of immediate punishment as a corrective, one experimenter placed a bowl of ice water in a box which usually contained clothing. The finery had been damaged often, and punishment had failed to keep Puss from the box. This time, the effect was so immediate that Puss was forever cured of leaping into the chest.

One curious feline trait was noted by Hans von Hentig. Before earthquakes, they draw back their ears and bristle their



hair, while their eyes glitter and bodies tremble. Von Hentig believes that the cat is sensitive to those ground disturbances which precede an earthquake.

PLAYGROUND ON HOTEL ROOF HAS FISH POND 62/

To establish a healthy spot where children of guests might amuse themselves, the Prince George hotel in New York has turned its roof into an aerial playground. It contains an artificial lake with live fish, sand piles, dollhouses and games.

Cont. William M. Myers
70.10. Continental Ore

86
247

D. W. Draper, Asst. Surgeon General, U.S. Dept. of Sanitary Reports and Statistics, Treas. Dept.
being attached to the doorknob, and the metal end inserted in the ring in the door key, the guard preventing the key from being pushed out of the slot.



Extension Frames in Front of Fenders Aid the Motor-coach Driver in Judging Clearance

VISIBLE FENDERS GUIDE DRIVER IN CONGESTED TRAFFIC

Berlin busses are being equipped with extension frames above and outside the fenders high enough to enable the driver to see them. The fender protectors show the driver the clearance his bus has and aid him in judging distance in narrow lanes of traffic on congested streets.

LOCK GUARD THAT HOLDS KEY FOILS THIEVES



Thieves who often gain entrance to a home by pushing a door key out from the outside, and then picking the lock, can be foiled with a lock guard which holds the key in position. The guard consists of a hooked piece of metal, the hook

SPRAY DUST FROM MOTORBOAT TO CURB MOSQUITOES

Equipped with an electric blower, an outboard-motor boat has been used successfully by the United States Public Health Service to spray poison dust over the surface of still waters to kill mosquito larvæ. The method was first practiced with the aid of airplanes and hydrogliders operated by air propellers, but it was found that slower speeds were more effective. and, furthermore, the little outboarder could be operated with but one man. The dust, paris green mixed with lime, is distributed over the water by the blower from a specially constructed hopper, which permits control of the dust without throttling the ingoing air supply. Extensive tests have been made on the surface of Reelfoot lake, in Tennessee, a shallow body of water where mosquitoes breed in great numbers. Using three-fourths of a pound of poison to the acre, larvæ were killed 450 feet from the point of liberation. A boat speed of five miles an hour was found sufficient.

PUSH HOE FOR GARDEN WORK ALSO USED AS SPADE

Somewhat resembling a pointed plowshare, a push hoe for gardening has many uses for which the ordinary chopping hoe is unsuited. Its pointed cutting edge adapts it particularly for weeding around small plants, and it also may be used as a spade, for furrowing and marking, for edging and trimming lawns, and, in the winter, for cleaning ice from sidewalks. The blade has more than six inches of cutting surface and the tool is operated by pushing.

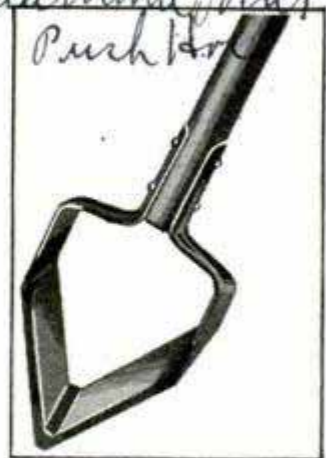

Ideal Products Co. 157 N. Townsend St.

Referend no 1280, Public Health Reports, Vol. 44, p. 17.

706

Thomson Mfg Co

2052 E. 17th St. Chicago

PLANE LANDS ON MOTORBOAT AT FORTY-MILE SPEED

Seal Beach Calif
 Clyde Schliefer. Test pilot



Nosing Down for Descent on the Motorboat Deck; While the Boat Was Speeding at Forty-Five Miles an Hour, the Plane Alighted on Its Deck and Flew Away Again without Mishap

The ease with which small planes may be maneuvered has again been demonstrated with a powered glider at Long Beach, Calif. The tiny plane landed on the deck of a motorboat speeding at forty-five miles an hour and took off from the same space without mishap. The test required close co-operation between the glider operator and the pilot of the boat. The motorboat's deck was only twelve feet long.

was used mostly in the chemical industry until recent years when its application for stainless steel and chromium plating for automobiles suddenly brought a great demand for it. Because it will not oxidize when heated to a high temperature, it is especially useful in electric-heating equipment, as well as for high-grade steel cutting tools.

4765
 CHROMIUM FOUND IN MONTANA

Chromium, one of the hardest of metals, which in recent years has been in wide demand because it gives to steel added strength and the ability to resist abrasion, now is being produced in Montana. Chrome-ore deposits have been found near Yellowstone national park at an altitude of 8,000 feet, and mining equipment, including a portable air compressor, was dragged on skids through deep snow up the mountain side to make available the precious metal. Although chromium was discovered more than 125 years ago, it

WHEEL ON GLASS CUTTER IS EASILY RENEWED 232.

Refills for a glass cutter are made quickly with a type of cutter containing a "stick pin" wheel. The wheel, or cutting element, is mounted on a pin at right angles to it which wedges solidly into the head of the cutter. To change wheels, the old one is simply pulled out and a new one inserted.



Glass Cutter with Removable Cutting Wheel

Chromium Corp. of America
 125 Broadway

London P. Smith
 Ave. Livingston, N.J.

682

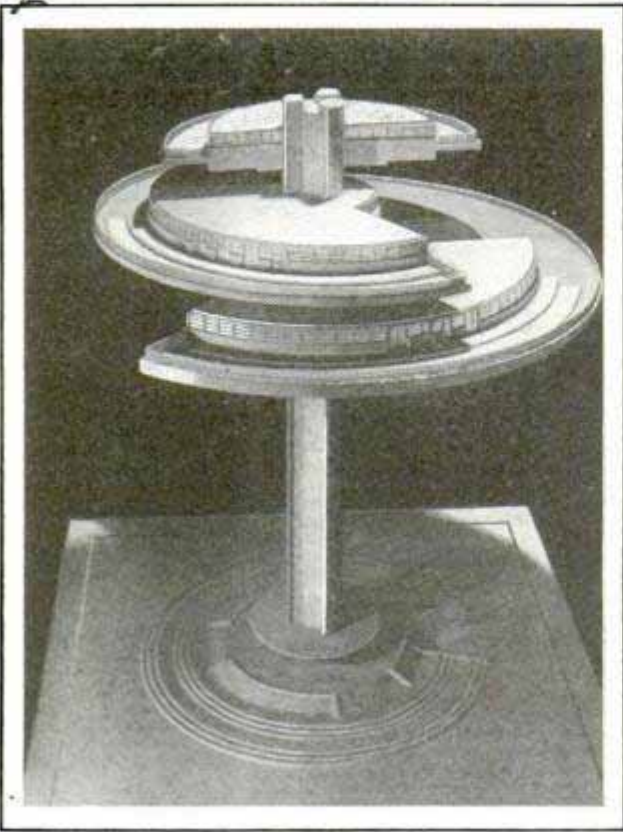

Design of Modernistic Restaurant, Built atop a Column Which Revolves with Diners or Sight-Seers

RESTAURANT BUILT ON COLUMN REVOLVES WITH DINERS

Among the modernistic building designs prepared by architects for submission to the Chicago World's Fair Centennial committee is that of a revolving restaurant mounted on a huge column. The structure is spiral in effect with promenades and space for indoor and outdoor dining rooms. Both building and column revolve once each half hour, thus affording an opportunity for sight-seeing while dining or strolling on the platforms. The model provides space inside the column for elevators, while at the base are foyers and a space for parking of automobiles.

EARTH IS AHEAD OF SCHEDULE IN ITS ROTATION

Through observations on eight different bodies in the solar system, scientists have obtained proof that the earth is ahead of schedule in its rotation, and hence is not quite reliable as a timepiece. For some years it has been suspected that the earth is not exactly regular in this respect, and at one time scientists attributed this to a shrinkage of its diameter. Dr. Ernest M. Brown, Yale mathematician, however, says

observations over many years indicate some sort of order in this irregularity. At present the earth is running ahead a fraction of a second a day. It appears to lag for a certain number of years, then to speed up for a like period. There were changes in its rate of rotation in 1897 and 1917, and the rate probably will change again in the next few years. At first the changes were attributed to the moon, but observations of the sun showed the same variations, indicating that the earth, rather than the moon, was in error, and these were borne out by studying other planets, so that now the changes in speed of rotation are accepted as fact.

LIGHT SCHOOL IN SKYSCRAPER AIDS HOME MAKERS

Better ways to illuminate homes, offices, factories, airports and other places are shown in a school established by the Chicago Lighting Institute on the thirty-sixth and thirty-seventh floors of the Civic Opera building. To demonstrate proper home lighting, a six-room bungalow has been installed, fitted with the newest ideas in fixtures and displaying methods of direct and indirect lighting. How colored patterns of light are projected on the walls and ceilings is illustrated. A special feature of the institute is its two-story

28 N. Wacker Drive

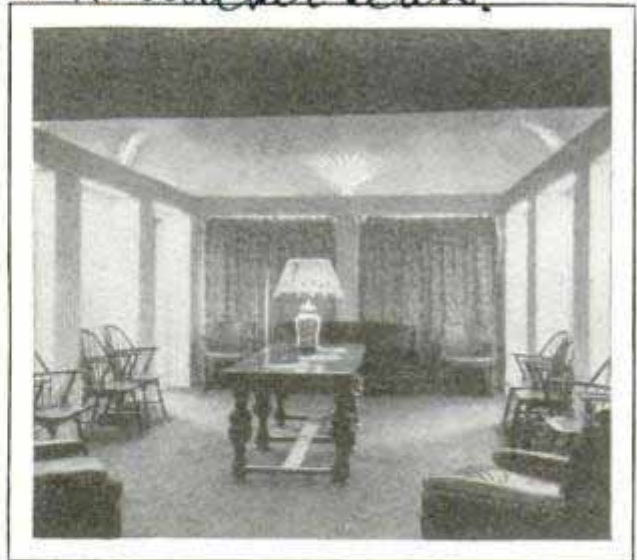
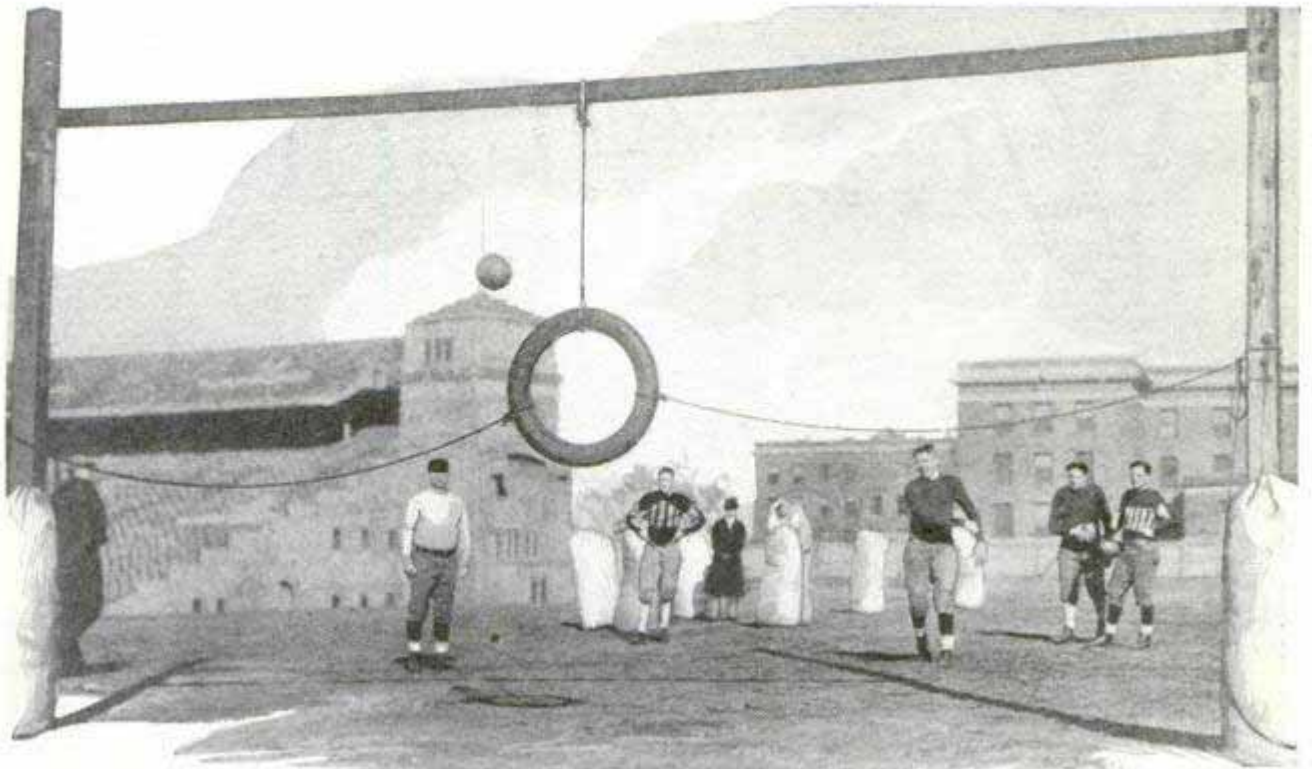

Exhibit Room in the Chicago Lighting Institute, Showing Installation of Ceiling and Wall Illumination

auditorium, seating 225 persons. The stage is set with a replica of a modern city, which is illuminated by various methods of flood and special lighting.

Chicago Tribune 4/27/30 758



Automobile Tire, Suspended between Goal Posts, Serves as a Target for University of Nebraska Football Squad, Aiding Them in Developing Accuracy, Particularly in Practicing Forward Passes

AUTO-TIRE FOOTBALL TARGET DEVELOPS ACCURACY

To aid football players in developing accuracy in tossing forward passes, a coach at the University of Nebraska has rigged up an automobile tire as a target. The tire is suspended between the goal posts, and players engaging in summer practice attempt to throw the pigskin through the tire. A point system gives credit for bull's-eye shots from various distances and angles.

GROWTH OF PLANTS IS FASTER UNDER NEW GLASS 762.

Corn, wheat, tomato and other plants grow much faster and absorb greater quantities of nitrogen when raised under certain glass substitutes than under ordinary glass, tests at the University of Wisconsin have revealed. In the case of corn and wheat, the increased nitrogen consumption is from ten to fifteen per cent greater, and the substitute glass material produces a temperature from one to two degrees higher than the plain glass. Plants raised under the special glass are not so hardy as the others when removed and exposed to light frosts, but they contain

*W. E. Tottinham
agricultural chemist*

more fatty substances and more nitrogenous compounds. Some plants grown underneath the substitute glass, which contains a high percentage of quartz, show a longer ripening period.

ELECTRIC GRINDER AND SANDER WITH FLEXIBLE SHAFT 634

Equipped with a flexible shaft, an electric sander also contains attachments for grinding and filing. The disk for sanding is attached to a length of flexible metal tubing, allowing a comfortable position for working, and the entire machine rests on rollers and so is easily portable. Different tools may be operated at different speeds and the motor is set on vertical and horizontal swivels to allow still greater freedom of movement. The base of the apparatus can be equipped with a clamp for grinding tools, and a tool tray also is provided for the convenience of the worker.

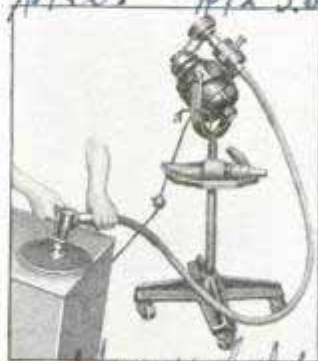

Hand power holder \$12.50

*Price flexible shaft \$5
chez 208 17th. New York*

Chicago 437 Wentworth

What *the* Clouds



Thunderheads in Colorado; Every Cloud in This Photograph Is the Top of a Separate Column of Air; Gliders Could Utilize These, but There Would Be Lightning and Wind Hazards

By DR. FORD A. CARPENTER, *1809 Central*
Bldg Los Angeles Calif.

WEATHER is so important in gliding and soaring that the hundreds of glider clubs of the United States are interesting themselves in the elements of meteorology as never before. The early gliders of history, men such as Ader, Bleriot, Chanute, Langley, and the Lilienthals, Montgomery, Penaud, Pilcher, Santos-Dumont, Wentham, the Wrights and the Voisins, were all students of meteorology. The most notable pioneers of the air, the Wright brothers, had to travel from Ohio to North Carolina to find the right kinds of wind for their historic experiments. Preceding the Wrights by several years, Octave Chanute did his gliding over the sand dunes on the shores of Lake Michigan. Later, on April 29, 1905, Prof. John J. Montgomery, a Californian, made a glider that performed a feat which, if duplicated in this day of air events, would be heralded far and wide. This was when he took his glider and pilot, Daniel Maloney, aloft in a balloon to an altitude of 4,000 feet. He then released them and they glided safely to the ground. After flying for twenty minutes, Maloney brought the glider down, landing without a jar.

One of the best ways to locate good

gliding regions is to observe the number of windmills. Windmills must be located in regions which have an average wind velocity of more than twelve miles an hour. If the wind falls below that average, the mill is inefficient as a means of power. Gliders should have winds of equal or greater velocity than windmills. Gusty winds are unreliable and treacherous, and their vicinity should be avoided. Gliding pilots recollect that near the ground the winds are choppy, like the surf pounding on the seashore. These short air waves, too, should be avoided. It is in a steady, even flow of air that the glider navigates best. In default of strong and constant winds, short wavelengths of air may be taken advantage of if their action is studied. For the experienced glider, the region of sand dunes may be utilized. Here the wind records its velocity and direction. A searcher for good gliding territory should carefully study wind tracks, whether visible on the sands or upon trees or shrubs.

Soaring flight has ever been the despair of man. He has even envied the turkey buzzard, "noblest of aeronauts." The buzzard is a most fascinating flyer. Watch where it flies, and you will find good

Tell Flyers

soaring air. Frequently it is on the windward side of some sunshiny hill. It will flap lazily toward nature's elevator and, once within the magic circle, make the wind carry it upward. Seagulls have been observed doing the same thing, only they use the upward draft from manufacturing districts. The rising currents of air, made by warming the lower levels, carry them to an altitude of as much as three or four thou-

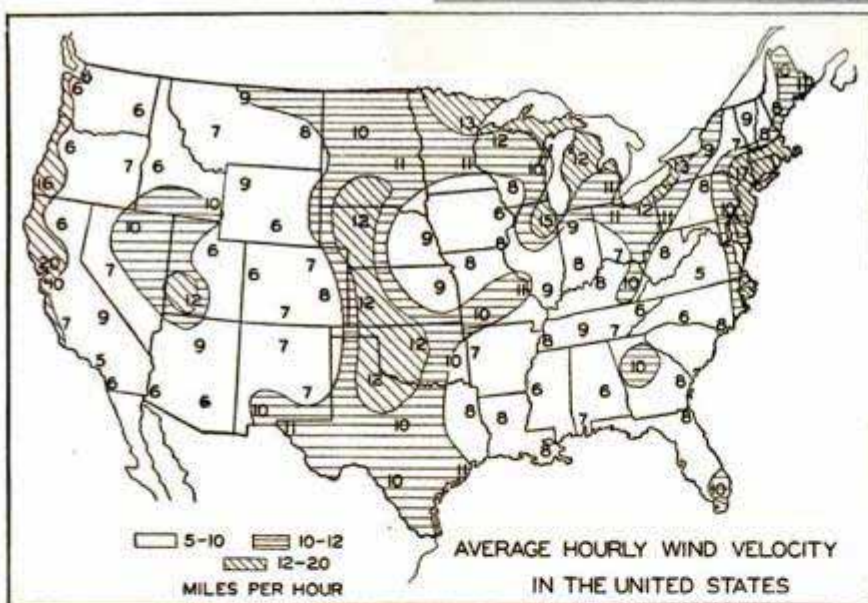
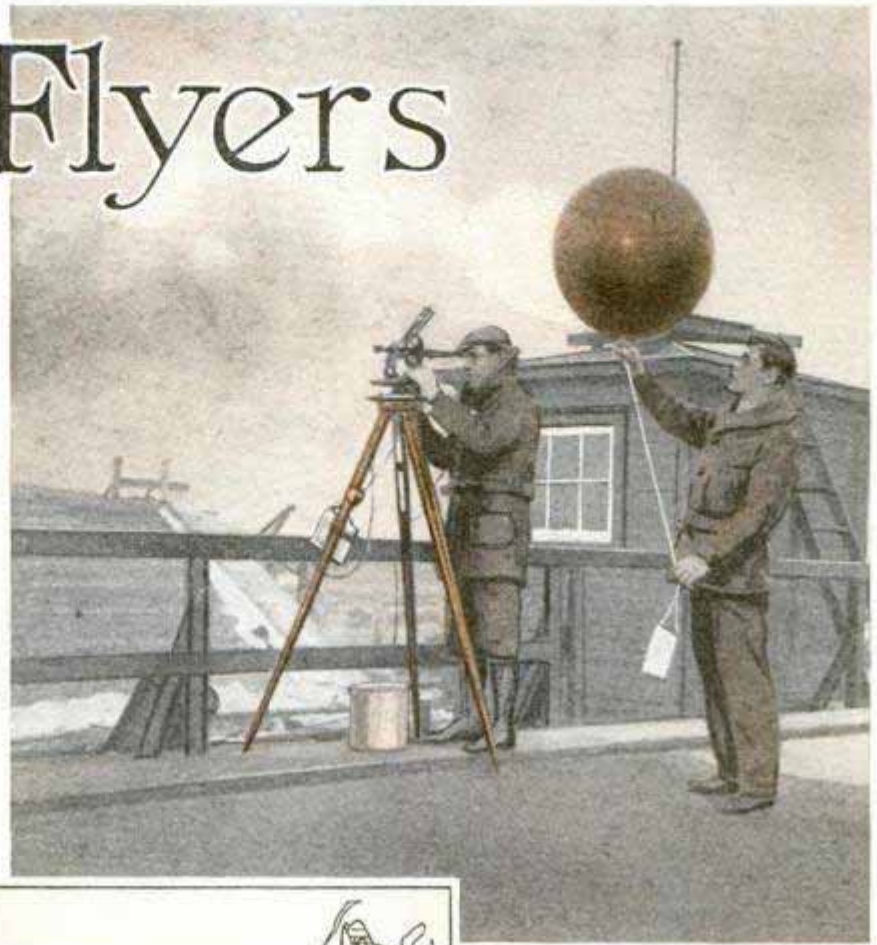

Taking Observations at U. S. Weather Bureau Airport Station in Chicago and Special Wind Map Showing Best Localities for Gliding

sand feet. As soon as the gulls achieve the desired altitude, they wheel and execute a twenty-mile glide to the ocean. Upon reaching the sea cliffs, they utilize the cliff winds.

Imitating the seagulls, W. H. Bowlus in his sailplane utilized the upward currents of air. He also used the strong ascending air currents that occur previous to rain. In his recent record flight of nine hours, he was particularly fortunate in

utilizing the lift produced by the wind blowing against the 400-foot peninsula of Point Loma, Calif. He followed the flight of the gulls and rode upon the backlash of the wind. As a careful observer of weather, he was able to keep his plane aloft in winds of low velocity. This was accomplished by using both horizontal air movement and the "splash," as well as the vertical currents occa-

sioned by cumulus clouds.

It should never be forgotten that cumulus clouds are the tops of rising currents of air. The actual vertical currents are below the cloud caps and, of course, are invisible. The only reason the tops of the air columns can be seen is that moist and warm air of the lower levels is sent upward into the colder strata. Here the air is condensed into visible vapor forming cumulus clouds, which are seen most

521

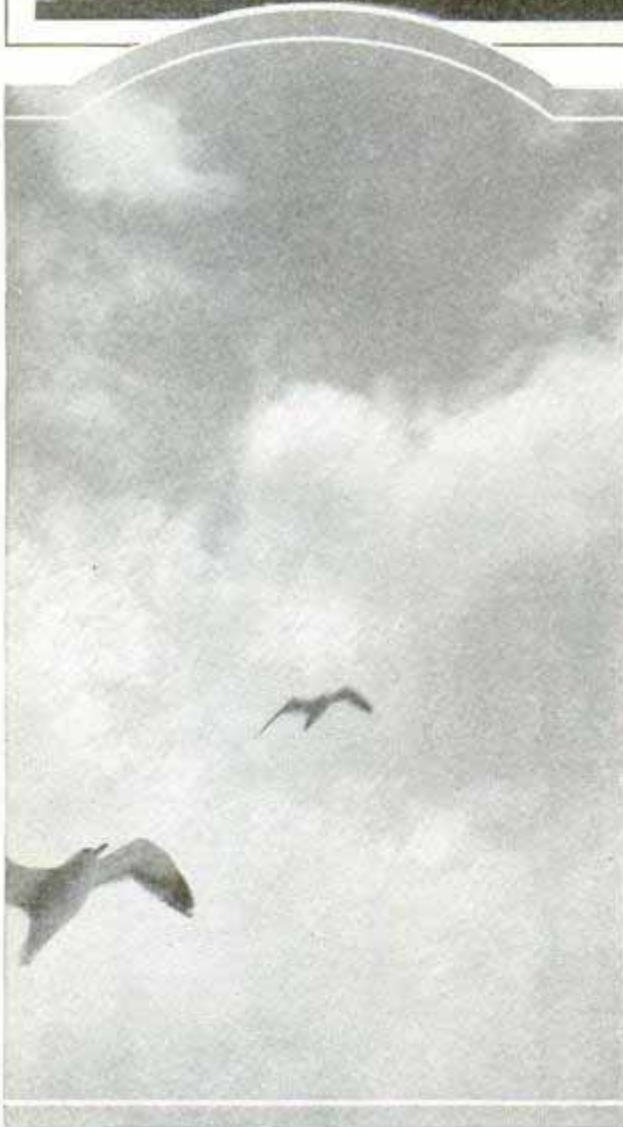

Drifting Cumulus Clouds, the Tops of Air Columns, and Seagulls in Soaring Flight, Utilizing Upward Swirls of Air

frequently in summer and spring. They rarely occur in winter, for the air is then too cool to rise. Only in storm conditions do cumulus clouds have a horizontal movement equal to or exceeding their vertical activity. Theoretically, if a glider could be catapulted from an airship into a sky filled with cumulus clouds, the pilot could navigate as long as the clouds lasted, if his physical endurance held out.

A glider pilot must be a keen observer and should know much of the science of weather. Both knowledge and action should be intuitive. Gliding depends upon two things only: gravity and wind. The glider pilot has to move his craft obliquely downward under the influence of gravity. His only support is the resistance of the air against the wings. This, of course, is augmented once headway has been established, the same as with a motored plane. There is then nearly seventy-five per cent suction on the top of the wing and about twenty-five per cent upward pressure on the bottom of the wing.

The revival of gliding in the United States is one of the most striking aeronautical events of the past year. This breaking out afresh of the interest in gliding, after a quiescent period of more than a score of years, means a corresponding awakening in weather study. As in the olden days of marine shipping, one of



Cloud Banner at the Top of Mount Hood, 11,225 Feet above Sea Level; It Tells the Airman Which Way the Wind Is Blowing

the requisites for a steamship master's license was experience in handling sailing ships, so aviators will shortly be required to have gliding experience before being given the controls of an airplane.

A glider pilot and an airplane pilot may be compared with a pilot of a sailboat and of a motorboat. The sailboat skipper has to know his weather, for it is his only motive power. The motorboat pilot's dependence is upon his engine; weather is relatively unimportant. The glider pilot is like a sailing master, he must have a good weather eye.

**ACCURACY OF CRYSTAL CLOCK
SECOND IN CENTURY**

Controlled by electrical vibrations obtained from a quartz-crystal oscillator, similar to the "singing crystal" that keeps radio stations on their wavebands, a clock has been developed that does not vary a second in a century. Two clocks keeping different rates of time can be operated from the same crystal so as not to change in their ratio over a long period of years. The pull of gravity and the magnetic field of the earth will not affect the clock, and

*Mr. W. A. Harrison
Bell Telephone Lab*

even earth vibrations cause little trouble. In fact it can be operated near electrical machinery or large moving masses, and the dial and even the rate of timekeeping can be altered without affecting the basic accuracy of the apparatus. It has been suggested that the clock will make possible more accurate radio signals.

**AIR CLEANER AND VALVE OILER
COMBINED FOR AUTO 603**

Oil, which is quick to catch and retain dust, is used to wash the dirt out of the air drawn into the automobile motor through a filter consisting of a metal cylinder containing an oil mixture through which the air passes. The cleaner does not choke or cause the car to use more fuel, and, in

tests on a wheat truck, removed a quart of dust in one day. The filter also serves as a valve oiler.



*Elvis Mfg. Co
Pendleton Ore*

Report to National Academy of Sciences 4/19/35

SUGAR-CANE HARVESTER CUTS FORTY TONS AN HOUR



that much of the cane is blown down before harvest time, and the stalks often lie nearly flat. This problem was solved by devising a bisected snout, with a prong extending forward at the front end of the cutter, to lift the fallen stalks into a vertical position so that they could easily be severed. Rotary brushes remove the leaves from the stalks and powerful air blowers discharge them to one side as the machine proceeds. The stalks are collected in a hopper and



Two Views of Sugar-Cane Harvester That Cuts the Stalks, Strips Them of Leaves and Then Piles Them

What McCormick's harvester was to the farmer, a mechanical cane cutter is expected to be to the sugar producer. It has cut as much as forty tons an hour in test runs and easily averages twenty tons an hour, doing the work that formerly required 150 field hands. Only one man is required to operate it, and searchlights enable working at night. The big machine is driven on endless-tread tractors, operated by an eighty-five-horsepower motor, which also runs the rotating blades that cut the stalks close to the ground. One of the difficulties encountered in developing the outfit was

fall in bundles onto the field, ready for collection. Successful development of the harvester permits doing all the major operations of sugar-cane raising by machines. Not long ago, a planter was constructed which has been operated with marked success.

MILLION HORSEPOWER CARRIED BY LAND AND SEA CABLE

Towers rising above the sea would support cables carrying 1,000,000 horsepower at 380,000 volts in a proposed plan to transmit electric power from Norway to

Germany by way of Sweden and Denmark over a power line 625 miles long. Norway, with its many high waterfalls, has a production capacity estimated at 16,500,000 horsepower, so the question of generation is only one of capital, as the engineering problems have been worked

V.P. Stahlberg Sugar Cane Industries, 919 Palm Beach Blvd., Chicago
 Dr. Carl Muenich, of Celotex Co., Marrero, Louisiana

769
 Elie Woche
 4/12/30

6.16 Having Elektro-
 technische Spezial.
 Fabrik, Berlin W 62,
 Germany.

out. Technical difficulties lie mainly in transmission across the arms of the sea between Norway and the German terminal at Lubeck or Hamburg, but none of these waters are wide or deep, and it is proposed to sink concrete foundations to support cable towers extending above the water. These towers, including the bases, will have to be about 600 feet high in order not to obstruct navigation. The cost is estimated at about \$200,000,000. Transmission of hydroelectric power from Sweden to Denmark across a narrow channel by submarine cable has been an accomplished fact for several years, but both the voltage and the power involved are much less.

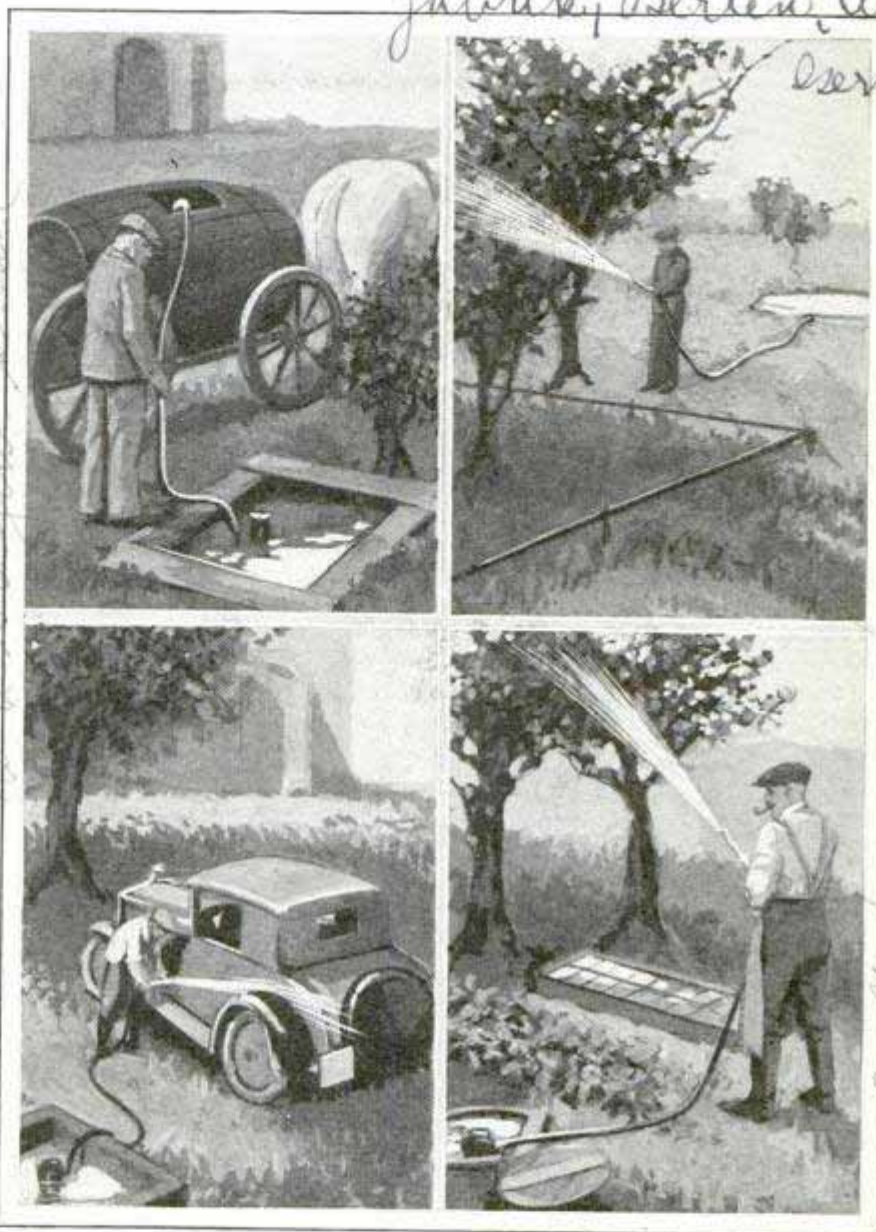

Showing Various Uses for a Floating Pump Driven by Electric Power; It Is Portable and Rests in a Watertight Casing

ROLLER SHADE ON WINDSHIELD TO STOP GLARE

To eliminate sun glare in the motorist's eyes, a green silk shade for the inside of the windshield now is available. The installation of the device is easy and it may be adjusted on a roller to the proper position for vision without glare. It also is useful for night driving to cut off glare from approaching cars' lights and to eliminate the reflection in the windshield from the lamps of following cars.

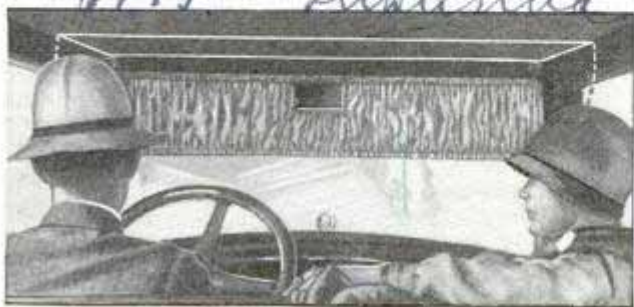

Cloth Shade for Inside of Windshield Which Stops Glare of the Sun in Motorist's Eyes

PORTABLE PUMP THAT FLOATS RUN BY ELECTRICITY

For places where a pressure water supply is unavailable, but where there is electric power, a portable floating pump, operated electrically, is being used successfully in Germany. The pump is self-contained and requires no mounting. It floats by reason of a watertight casing filled with air and is less than two feet high. It is operated by placing it in the well, stream or other source of water supply and connecting to the power source, and delivers seventy-three gallons of water per minute to a height of about thirty feet.

The electric motor was invented by Thomas Davenport in 1837.

Crane Products Co.
 17-23 W 60 St N.Y.

No. 1 agent for...

IS THIS MONSTER LOCOMOTIVE A "HE" OR A "SHE"?

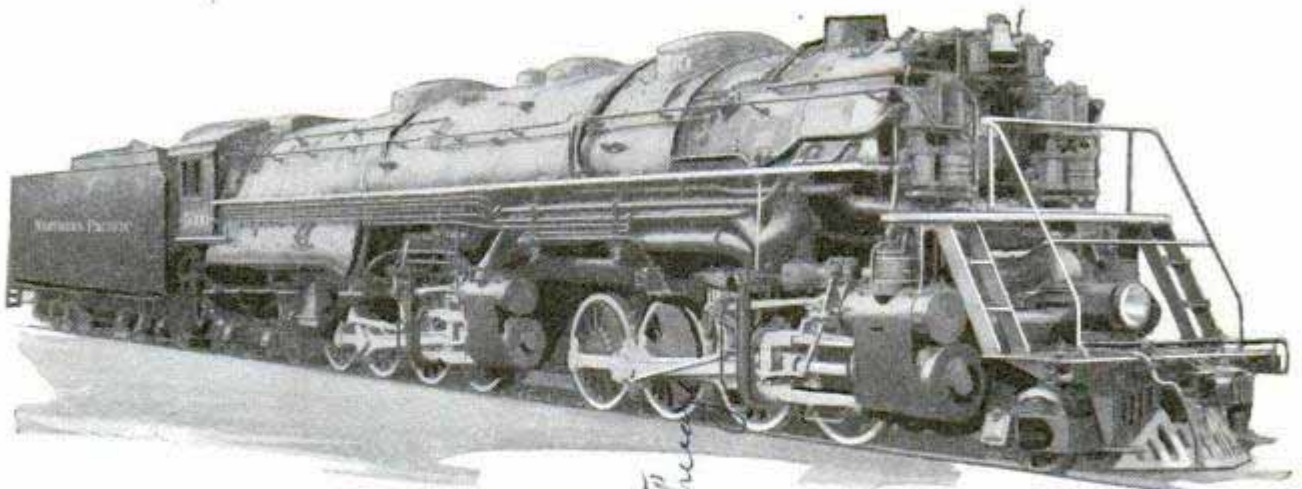

A Close View of One of the World's Largest Steam Locomotives; It Can Haul 4,000 Tons up a One-Per-Cent Grade, Burning Twenty-Two Tons of Coal an Hour

It is correct to refer to a locomotive as "he" in certain cases although the prevailing practice among railroad men and others is to use "she." This is the verdict of authorities on English, following a survey of the Northern Pacific railway. A writer describing one of that railroad's mammoth Yellowstone-type locomotives, 125 feet long and weighing more than 1,000,000 pounds wrote, "for with tremendous power, he can easily pull 100 loaded cars uphill." The word "he" awoke a storm of protest among engineers and others who affectionately refer to their charges as "she." Most of the professors agreed that the matter is one of rhetoric and not of grammar. Several maintained that "she" is the proper word to use in describing engines generally, but admitted that in the particular case under discussion, that of one of the largest locomotives in the world, the use of "he" was entirely consistent.

railroad tracks with good results. No instance of their having become loose has been reported.

GUN THAT DRIVES STAPLES ELIMINATES HAMMER

As a substitute for a hammer in driving tacks and small staples, an air gun, shaped like an automatic pistol, has been introduced. It drives from 5,000 to 10,000 tacks or staples without reloading, simply by pressing the trigger, and it is said not to jam. The "ammunition" is contained in a winding coil in the gun's magazine, while staples may be formed, cut and driven from a prepared strip of metal contained in the gun. The unit is especially serviceable in laying linoleum, carpets or roofing, and was originally intended more particularly for upholsterers.



BOLT WITH SPRING EFFECT SAVES LOCK WASHER

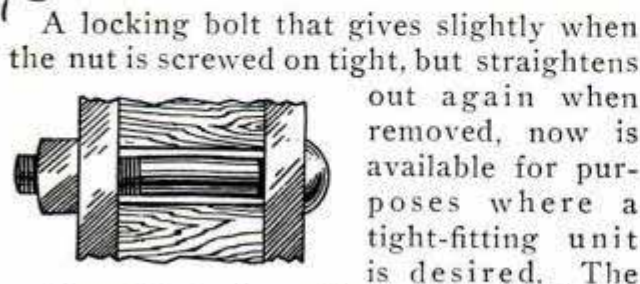

A locking bolt that gives slightly when the nut is screwed on tight, but straightens out again when removed, now is available for purposes where a tight-fitting unit is desired. The

spring effect also relieves the strain on the threads when an unusual stress occurs. The bolts have been tested by use on

NEW ELEMENT IS RADIOACTIVE

Protactinium, a new chemical element of strongly radioactive properties, has recently been isolated by a German scientist. It is a metal of the radium-uranium group, and its atom disintegrates in the same manner as the radium atom. It is the rarest mineral so far known to science, rarer even than Illinium, discovered in 1926 by University of Illinois scientists and named for the state of Illinois.

Dr. A. V. Lrosse, Director
of Institute for Chemical

Dr. A. V. Lrosse, Director of Institute for Chemical
Dr. C. A. Valmgren Jr., 7302 Dixie St. St. Paul, Minn.
From Wissen und Fortschritt Apr 30

W. C. Whippe, 637

RARE FLY SAVES NATIVES IN SOUTH SEA ISLANDS

A little fly has lifted the natives of three of the Fiji islands from abject poverty to happiness in their south-sea homes. It is, of course, in the finding of the almost unheard-of fly that the real story lies. For about fifty years, these islands have been afflicted with a small purple moth, which feeds on the leaves of coconut palms and causes the trees to cease bearing. Then Dr. J. D. Tothill began search for a bug or bird of some sort which would feed upon the caterpillar of the moth, the egg or the insect itself. The New Hebrides, the Solomon islands and Papua were searched in the order named. In every one of them beautiful coconut palms thrived and bore fruit luxuriantly with never a hint as to what it might be that kept the plague of the blue moth from them. Years passed, Doctor Tothill was almost on the verge of surrender when, from the recesses of



Above, Native Climbing a Coconut Tree in the Fiji Islands; Below, Drying the Copra; the Nuts Are Split in Half for the Process, and the Dried Meat Becomes Copra

memory, came the recollection of a peculiar fly, a native of Java, which was known to feed on some kind of insect eggs. To Java he and his associates went and there found the long-sought fly, known as the

Ptychomiya. These flies were imported. With surprising rapidity they became acclimated and went about their business. Today, trees which have been barren for fifty years are bearing full crops.

Chromograph. Vertrieb,
98 Max Breidenbach

519 Schulstrasse 5

Mang. Iserinany

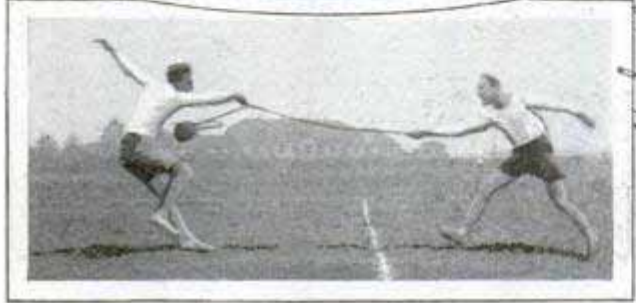
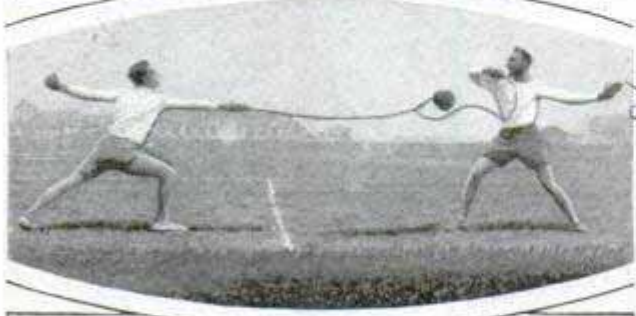

Fencing with Swing Ball Attached to Two Cords; the Object Is to Avoid Being Struck

FENCING WITH TOY BALLOONS OFFERS STRENUOUS SPORT

Fencing with inflated swing balls has become popular in Germany as a novel method of gymnastic exercise. The two players stand opposite each other in the pose of fencers in a court divided by a center line. The balloon is suspended directly over the line, each player holding one end of a cord which is attached to the ball by a short link. The object of the game is to so manipulate the cord as to strike the opponent with the ball, each player dodging and trying to avoid being hit.

PASTE FOR MENDING CLOTHES USED INSTEAD OF NEEDLE

Mending clothes is accomplished in the same manner as patching an automobile tire with a mending paste which withstands washing, boiling and ironing. To mend a rent, the garment is turned inside out and a patch slightly larger than the tear is fixed in place with the paste which

George Lunagin
Bureau of Agricultural
Economics Atlanta, Ga

is spread about the hole and the edges of the patch. Drying requires but one minute when the garment is ready to be worn. Since the paste also waterproofs, it may be used for umbrellas, raincoats, auto tops and leather and rubber shoes.

671 Box 880

LETTER IS ITS OWN ENVELOPE

Letters that fold to make their own envelope have been produced by an Atlanta inventor and tested by the post office department. The invention itself consists of a device to be attached to an electrically operated folder. As the letters run through the machine, they come out folded and sealed so that no container is necessary, but the sealing is in such a manner that the letters are not defaced by opening. For large mailers, the machine has possibilities of effecting considerable savings.

HOT-DOG CART LIKE AN ENGINE ATTRACTS CUSTOMERS

In Vienna, home of the wiener, a woman hot-dog vendor has succeeded in attracting customers by outfitting her cart like a locomotive. The kettle in which the "dogs" are cooked is disguised as the boiler of the engine, and when vapor issues from the locomotive stack, the wieners are ready to serve.



Hot-Dog Cart, Built to Resemble a Locomotive, Gets Customers for This Vienna Woman

no agent

4/8/31

67

Res. J. Peatty & Co.
100 33rd St. N.Y.C.

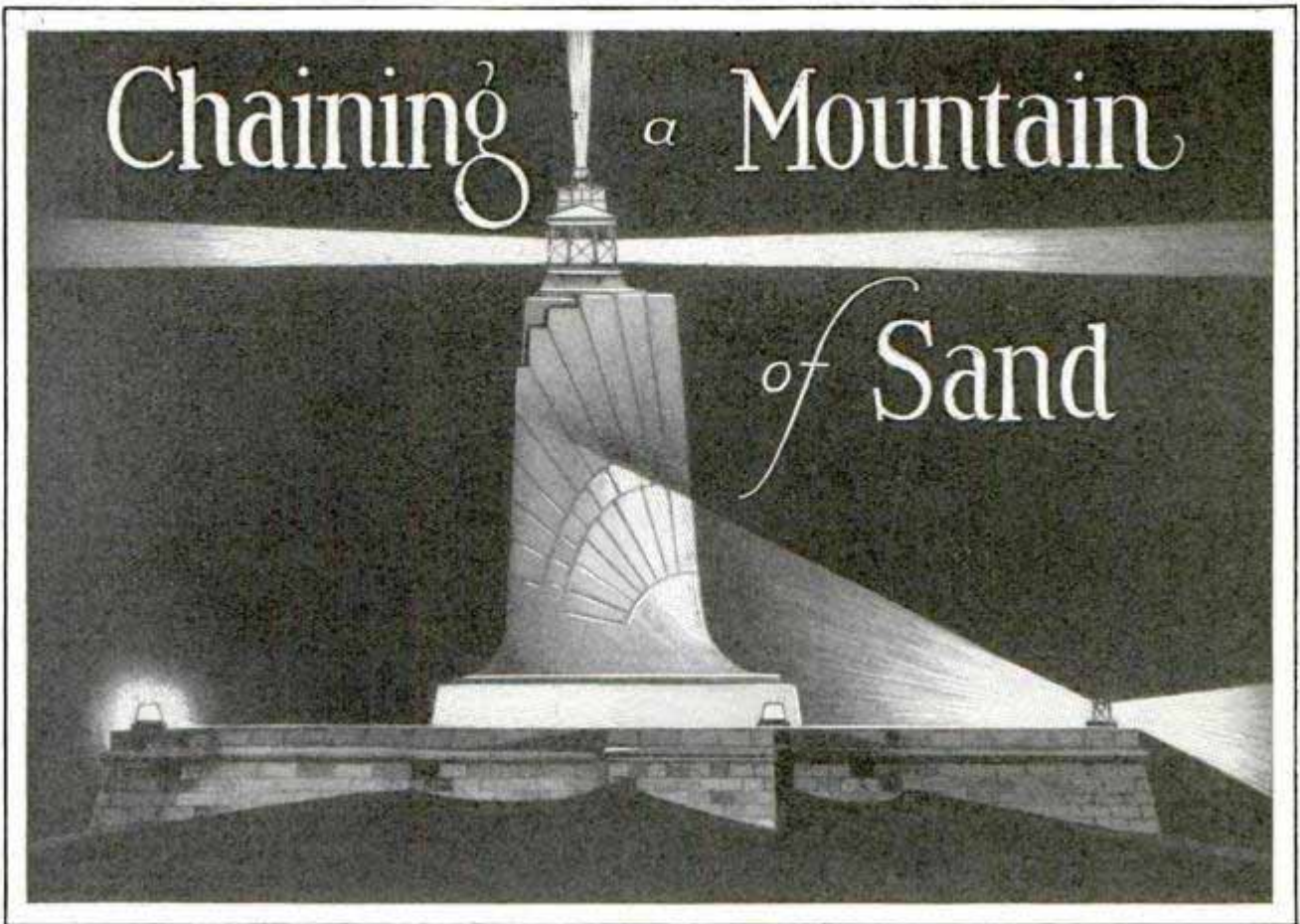

Prize-Winning Design for Memorial to the Wright Brothers to Be Erected on Kill Devil Hill at Kittyhawk, N. C.; Construction Could Not Be Planned Until the Hill's Movement Was Stopped

By HAMILTON M. WRIGHT

5 Park Row, New York

THAT vast moving mountain of sand, Kill Devil Hill, at Kittyhawk, N. C., which in the past twenty-five years has advanced 500 feet, has been chained and stabilized to form a permanent base for the monument to the Wright brothers which congress has decreed shall surmount its summit.

Kill Devil Hill is the loftiest object on the barrier beach at Kittyhawk. It rises ninety-seven feet and its prodigious base covers an area of twenty-six acres. For the past six months, under heavy north-east winds, the vast wandering cone of sand has not moved an inch, it was said by Capt. John A. Gilman, of the U. S. army, in charge of the stupendous feat. In the previous twenty-five years, under the lash of these storms, it had moved forward in a southwesterly direction at a rate of twenty feet a year. It is now more than 500 feet from its location at the time of the Wright brothers first immortal flight. It has moved that much farther from the site of a monument located at the exact spot of the take-off in that flight.

How Captain Gilman stabilized this mountain is a marvelous story of modern engineering. When congress, in 1928, voted to build a monument on the summit of Kill Devil Hill, the unruly sand mountain was as bare as the Sahara desert. Huge as it was, it was the plaything of the storms.

It was apparent when Captain Gilman took hold of the job, if a monument were to be erected upon the sand in its existing state, the mountain would walk away with the memorial. His first move after the survey had been completed was to build a fence around the hill to keep cattle from straying in and eating the vegetation he proposed to plant. The next step was to lay a strip of wood mold, two inches in depth and 200 to 300 feet in width, around the base of the hill. This wood mold consists of pine straw, rotted leaves and rotted wood. The wind does not disturb it or work under it to get a start in moving the sand, and it will support the vegetation required to form a strong surface. The mold was sown with rye, cro-

537

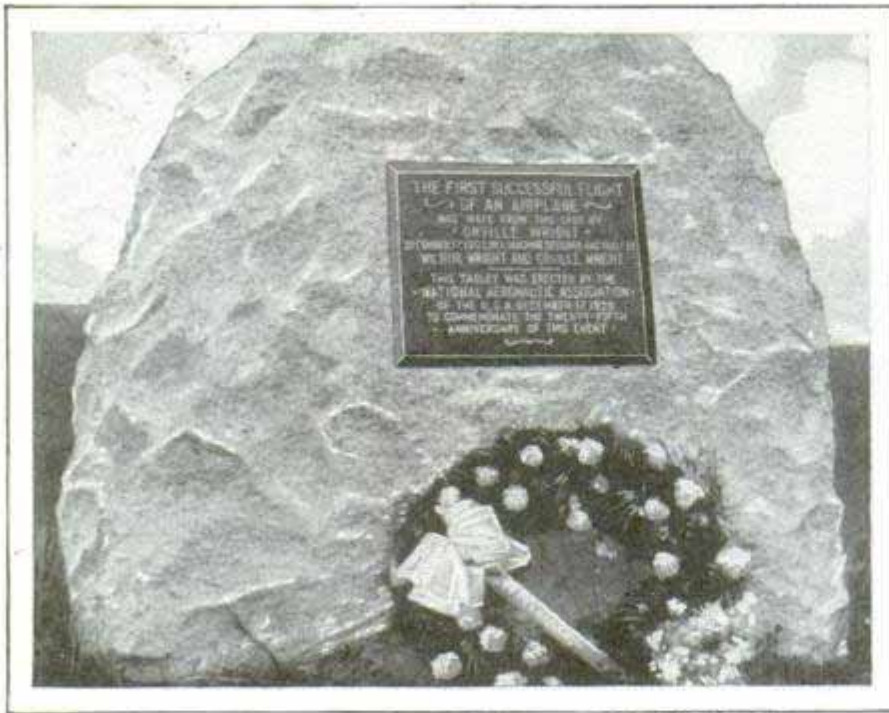

\$238,000. The material specified in competition plans was cement, but it is proposed to have this changed to North Carolina granite. The monument will be fifty-five to eighty-five feet high. A government reservation of 500 acres will be used as an airport.

The great shaft will give the impression of giant wings, uplifted as if for a take-off from the crest of the hill. This effect is to be heightened at night by floodlights projected from the five points of a star-shaped base upon the four sides of the monument.

A beacon tower will project a beam of light for the guidance of aviators and ships at sea.

Old Kill Devil Hill thus will become the

talaria from Porto Rico, some marram seed, and hairy vetch, all imported. Then was planted a native bunch grass known as bitter tannic. The final step was to form a protection to the hill itself to keep the wind from getting under and scooping out the sand. To this end, the planting of the mold was continued up the north and east sides of the hill where it was hit by the winds. Fourteen acres of the hill have been planted and only twelve remain to be completed. The total cost of the harnessing of Kill Devil Hill to date has been but \$20,000, and congress has appropriated an additional \$7,500 to complete the work.

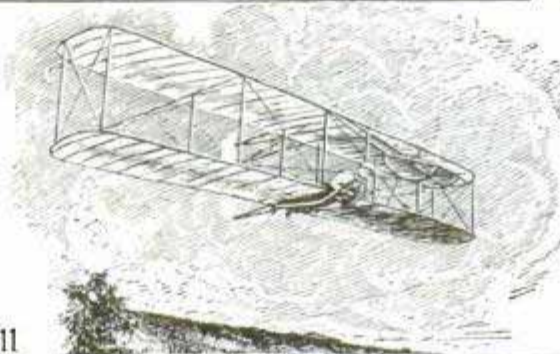

Above, Kill Devil Hill Retreated from This Monument Marking Start of Wright Brothers' Flight; Center, Drawing of Flight, and, Below, Aerial View of Hill Showing Planting Which Stopped Its Movement

The design for the Wright memorial itself has already been selected in a nationwide competition. The architects, Robt. T. Rodgers and Alfred E. Poor, of New York, will receive an award of \$5,000 for the design. The monument will cost

seat of a great national memorial. Flyers who take off at the airport to be constructed will have the satisfaction of knowing that here practical aviation had its birth.

Shudebaker Corp

South Bend Ind.

FOREST FIRE-FIGHTING BRIGADE HELPS SAVE TIMBER 679

Fire sirens sound in the San Bernardino national forest of California when blazes break out, and a completely equipped truck company speeds to the scene, in answer to alarms telephoned to the station house. Besides reels of hose, the trucks are provided with reserve supplies of chemicals for extinguishing small fires and for use where water is not available. Installation of telephones between resorts in the forest preserve and the construction of good roads have made the fire trucks practical. There are three stations in this forest, and the companies are said to have already saved more than the cost of equipment

MOTOR SAW AND POLISHER SAVE WORKERS' TIME 558

Attachable to a small electric motor, a keyhole saw and portable sander and polisher have been introduced to simplify tasks where a high degree of skill is required. The saw is especially shaped to reach difficult places and is a

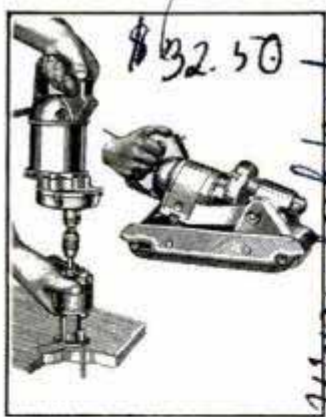

reach difficult places and is a chuck arrangement, allowing a hacksaw to vibrate up and down. It will cut board, iron or other metals, and is well adapted to work on an automobile where the floor boards or other

parts have to be cut to install heaters, exhaust pipes or similar units. The sander and polisher attachment operates with belts. They are quickly interchangeable according to the type of work to be done.

Waco Co, 526 W. King
MACHINE THAT SELLS STAMPS ALSO WEIGHS LETTERS 534

Many denominations of postage stamps, including air mail and special delivery, are obtained without extra cost from a vending machine that also includes a scale for weighing letters, a cigaret lighter and ample space for advertising material. The



The Drug-Store Post Office, a Cabinet That Includes a Stamp Vender and Scales for Weighing Letters

machine, placed in drug stores and similar places, saves the clerks the trouble of waiting on customers who wish stamps only, and the advertising space is sold at a profit. The ads are on transparent film that rotates in front of flashing lights.

LOCK ON AUTO GAS-TANK CAP 552 **ALSO PROTECTS CAR**

To prevent the theft of gasoline from the automobile tank, a lock for the cap has been introduced. It can be released only by the owner's key and is so adjusted that forcible removal can be accomplished only by mutilating the tank. The cap not only protects the gasoline and reduces the fire and explosion hazard, but is also a safeguard for the



auto, as anyone stealing the car would be able to drive it only as far as the gasoline supply would permit. Refilling the tank would be impossible without the key to the cap lock unless the container were mutilated, something the average automobile thief would be unlikely to do.

U.S. "Movie" Postage Service Corp 539-5th Ave Bradmann Bldg
Auto Tank Lock Co, 1211 A.D. Bradshaw

P. H. Walker, Chief of Varnish

Section

42 7

645

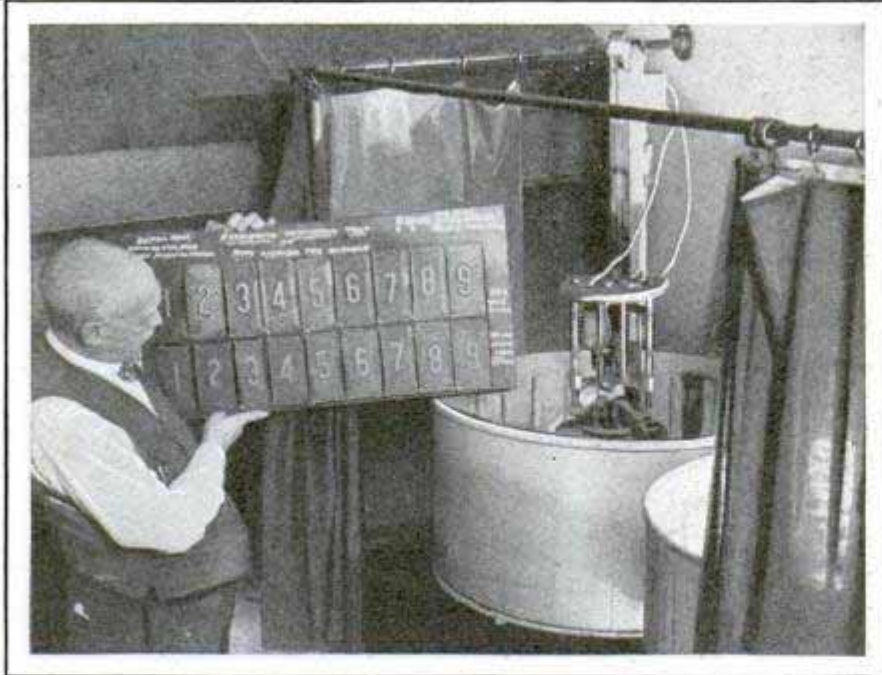

EXPOSURE METER ASSURES BETTER PHOTOGRAPHS

To eliminate the usual hit-and-miss method employed by amateurs in determining the period of exposure in taking still or moving pictures, a photometer has been developed which accurately measures light intensity on the subject to be photographed. Instead of gauging the light in a room, for instance, the exposure meter measures the amount falling on the object in the room that is to be photographed. The brightness of a small surface in the instrument

© U. & U.

Submitting Auto-License Plates to Tests in a Weather Machine to Determine Why Dull Tags Outlast the Varnished Ones

AUTO-LICENSE PLATES TESTED IN WEATHER MACHINE

In an effort to determine why some automobile-license plates fade in a short time while others last a full season, scientists of the bureau of standards submitted them to tests in a weathering machine. Some plates were given glossy coats of varnish to preserve them, while others were left dull, and all were exposed to the effects of the artificial weather maker, which in thirty-seven days subjected them to the wear and tear to be expected from months of hard use on cars. In every instance, it was found that the dull tags outlasted those that had been varnished, and stood the test better.

is made to match the brightness of the object through regulation of the incandescent filament of a small electric light which is supplied with current by a battery and regulated by a dial. When the brightness of the object and filament are the same, the dial reading shows the lens diaphragm opening to be used in the camera. This method makes it possible to measure the exposure required to register shadows or high lights, or to strike an average be-

Photometer



Looking into a Photometer Which Measures Light Intensity on a Subject to Be Photographed

SILENT KEY IN ADDING MACHINE DEFRAUDS CUSTOMERS

By making use of a "silent key" in some types of adding machines, dishonest merchants have been detected defrauding customers. This key can be shifted so that amounts punched on the adding machine will show in the total, but will not be itemized. In rush hours a tradesman wanting to be dishonest punches a small sum on the silent key, and the customer, if he checks the slip at all, merely notes the price of items, without adding them.

tween the two by taking separate readings for the dark and light portions.

*Bell & Howell
180 3 Larchmont*

W. H. Decker, Director of Agriculture, State of California

J. S. Casey, Chief of division of weights and measures

496

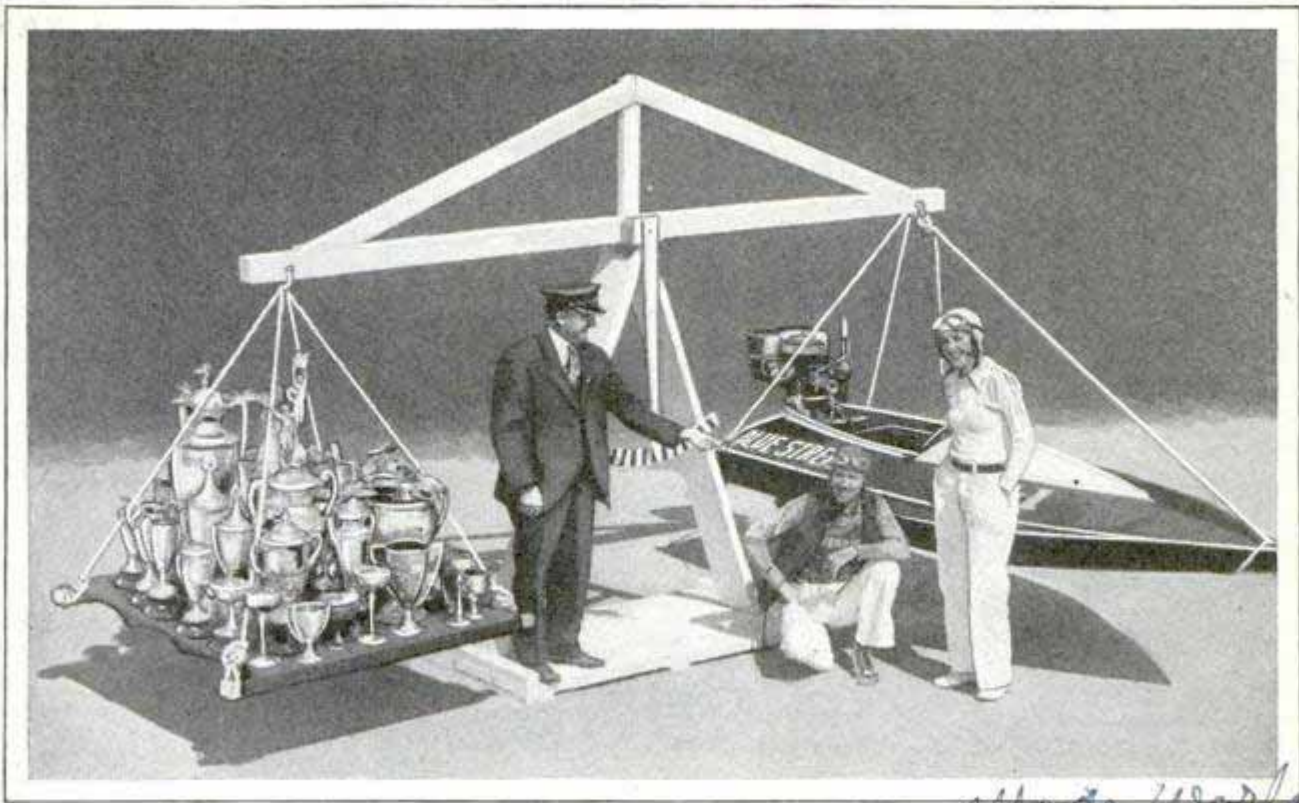

Visual Proof That the 225-Pound Speedboat, "Blue Streak," Is Worth Its Weight in Silver and Gold; Its Racing Cups and Trophies on the Scales Balance the Weight of the Boat

Wide World

SPEEDBOAT WINS ITS WEIGHT IN PRIZES AND TROPHIES

Winning its own weight in prizes and trophies is the accomplishment of the "Blue Streak," famous outboard speedboat owned by Dr. Leo Baughman of Los Angeles. The 225-pound craft has captured its weight in gold and silver cups emblematic of the many contests in which it has come in first. Visual proof of this was afforded recently when the boat was attached to one end of a balance scale and its winnings at the other.

BLUE FAVORITE COLOR OF MEN WOMEN'S IS GREEN 615

The majority of men prefer blue while green is the favorite color of most women with red their second choice, tests on 800 students at the University of Nebraska have disclosed. The experiments were made by Prof. William E. Walton with a special machine he invented for projecting different colors, controlling their intensity and the length of time they were visible. When the intensity of all the colors shown was the same, both men and women preferred red, the tests proved, indicating that intensity of shade had much

to do with color choice and that red is an excellent color for general attractiveness when it is of the proper intensity. Red was also most easily seen. Racial differences, on the whole, seem to make little change in color preferences. Red, blue and green are consistently popular with all races.

KEY INSERTER FASTENS VALVES WITH LITTLE EFFORT 241

For use on the larger cars and trucks with two-piece valves, a key inserter now is on the market which locks them in position quickly. The locks are placed in the inserter compress valve spring, and entered with a push, after which the spring is released, leaving the locks in place.



Our Bureau of Information will answer all questions regarding articles appearing in this magazine.

Ans. James R. Lowell 212 N. 11th St. Lincoln, Neb.

Instructor in psychology

Barth Mfg Co, 6001 S. Talman Ave, Chicago

525



Learning to Dance by Radio; the Pupils Move on Squares According to Broadcast Directions

DANCING IS TAUGHT BY RADIO ON PORTABLE FLOOR

Dancing instructions are broadcast by radio in Germany, and the pupils are said to learn as many as five new steps in a single week by using a portable, numbered floor to follow the directions given by the instructor. The floor is ruled into red and green squares and each division is numbered. The right foot is to be kept on the red squares and the left on the green. By obeying the detailed directions as announced, according to the numbers, the dancers soon learn the movements for a special step. A Berlin dancing master developed the method of instruction and does the broadcasting

PLANTS ABLE TO PICK COLORS IN LIGHT RAYS

Plants can distinguish between different colors when exposed to light and indicate their choice by bending toward the radiation that they find hardest on their growth, scientists of the Smithsonian Institution have determined. An electric lamp was placed at either end of a dark

chamber, the light passing through a color screen, and between the lights was placed a young plant at a point where the energy of the light beams was found to be exactly equal. Since the plant grew less on the side exposed to the more growth-retarding of the beams, it was pushed over toward this beam by the more rapidly advancing side. All kinds of visible light appeared to have a retarding effect on growth. Red light and infra-red rays were found to have little effect as also was the case with yellow. The green sector of the spectrum had a powerful influence, and the blue-violet groups were stronger still in causing growing plant tips to bend. Tests of the color likes and dislikes may eventually lead to exposing some of the secrets of the mechanics by which the chlorophyll of green leaves uses sunlight to combine carbon dioxide and water to make sugar, the scientists hope.

WHEELS FOR A CRIPPLED DOG 6/6 ENABLE IT TO WALK

"Lady Lou," a Boston terrier, probably is the only dog that travels on wheels under its own power. The animal's hind legs were paralyzed when it was struck by an automobile and its Kansas City owner mounted the dog's rear quarters on rubber-tired wheels supported by straps and braces, enabling the dog to propel itself with the front feet. It makes good time on a smooth pavement.

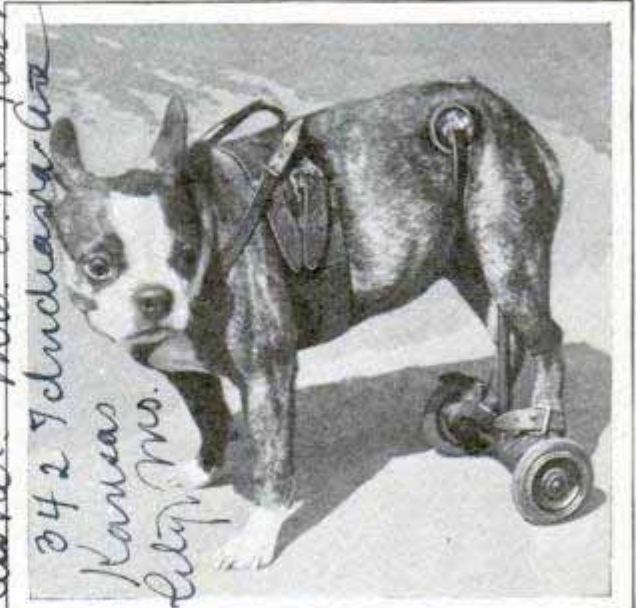

This Dog Runs About on Wheels Since Its Hind Quarters Were Paralyzed after an Auto Accident

International
Berlin
Super Mrs. A. H. J. ...
342 9th ...
Kansas City, Mo.

Dr. J. D. Brackett
and Dr. E. J. Johnston

Kansas City, Mo.

SPECIAL PIER FOR AIR FERRY SPEEDS BAY TRAFFIC

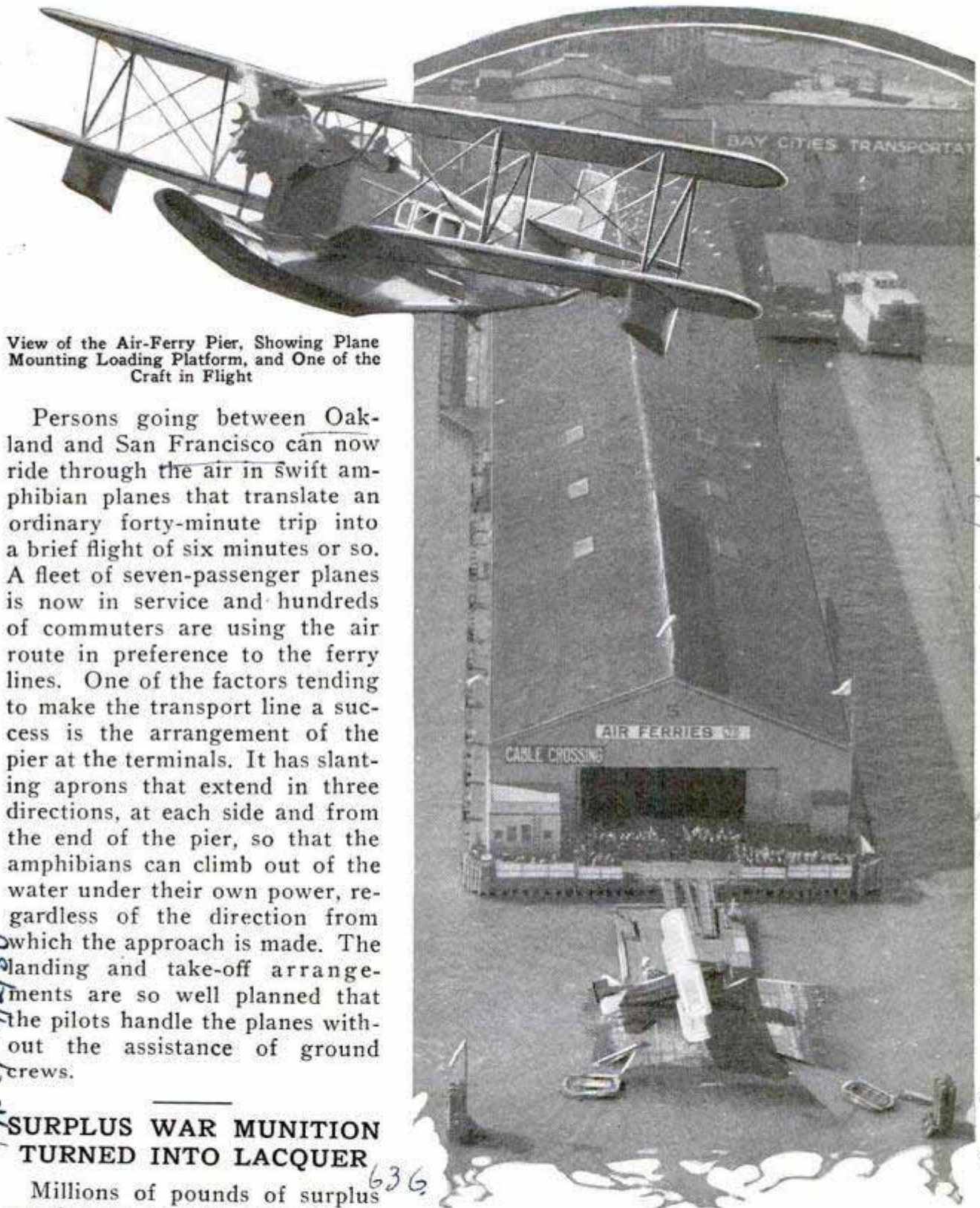

View of the Air-Ferry Pier, Showing Plane Mounting Loading Platform, and One of the Craft in Flight

Persons going between Oakland and San Francisco can now ride through the air in swift amphibian planes that translate an ordinary forty-minute trip into a brief flight of six minutes or so. A fleet of seven-passenger planes is now in service and hundreds of commuters are using the air route in preference to the ferry lines. One of the factors tending to make the transport line a success is the arrangement of the pier at the terminals. It has slanting aprons that extend in three directions, at each side and from the end of the pier, so that the amphibians can climb out of the water under their own power, regardless of the direction from which the approach is made. The landing and take-off arrangements are so well planned that the pilots handle the planes without the assistance of ground crews.

SURPLUS WAR MUNITION TURNED INTO LACQUER

Millions of pounds of surplus powder, left over from the World War, have been converted into automobile lacquers. The transformation has not been difficult as the chemical base of powder is like that of lacquer, cellulose being an important material in both. During the war, the central powers were compelled to use wood pulp in the manufac-

ture of smokeless powder as the supplies of cotton had been cut off by blockades. The allies probably would have had to resort to the same expedient had the war lasted longer, as the 1918 crop of short-staple cotton would not have sufficed for the total demand.

Described by R. L. Woodbridge, Du Pont Co, before the American Chemical Society

Source Service by B. W. C. 4/21/30

Emb. J. Duggins, c/o Bradford Kimball & Co, 111 Sutter St, San Francisco, Calif

Reported by W. A. H. Duggs
Westinghouse Lamp Co.
150 Broadway, New York
URANIUM MADE BY ELECTRICITY
MEASURES INVISIBLE RAYS

588

between
and
Ritsea, England.

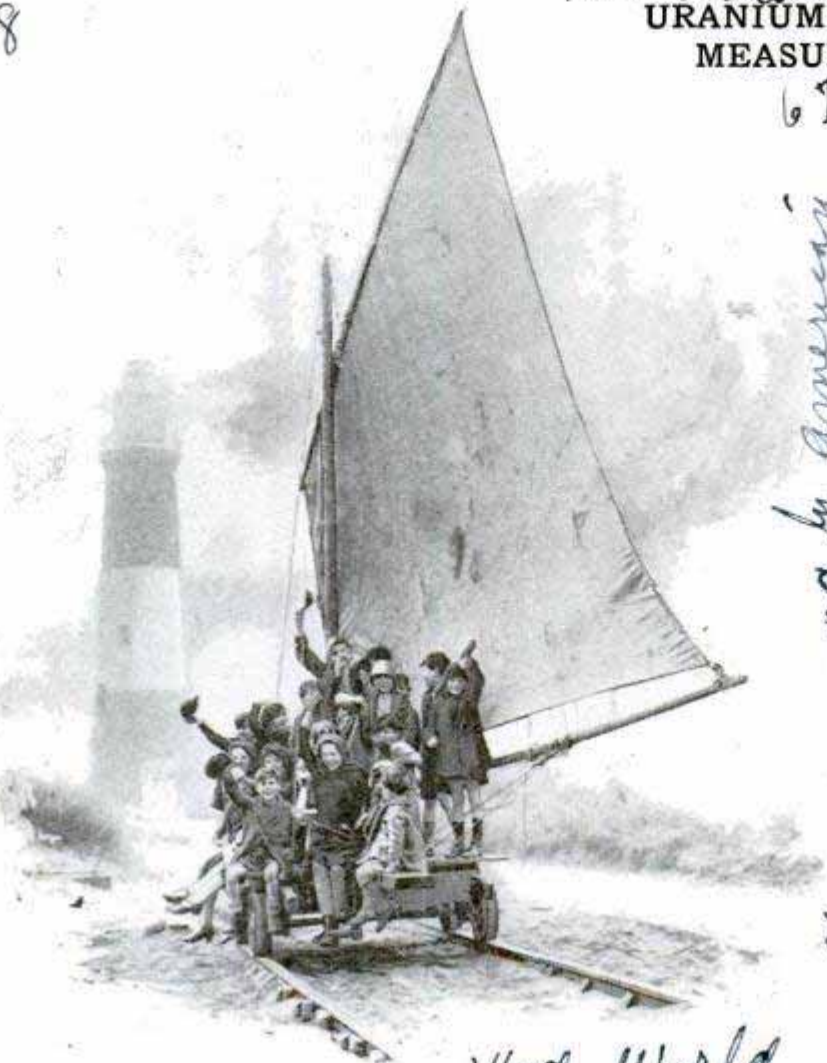

Wide World

The Entire Population of a Remote English Village Goes Sailing on a Railroad Truck, the Town's Only Means of Travel

RAILROAD HANDCAR WITH SAIL HAULS ENTIRE VILLAGE

Going sailing on the railroad tracks is the principal mode of transportation for the people of Spurn Head, an English village inhabited only by the members of a lifeboat crew and their families. It is five miles by rail from this lonely settlement to the nearest town, and the men, most of them former sailors, have rigged up a sail on a railway truck resembling an ordinary handcar. The sail-driven car can, if necessary, transport the entire settlement at one time, as is the case in the illustration.

692. Uranium, one of the elements of the earth, hitherto almost priceless because it could only be made in small quantities, now can be manufactured for about \$400 a pound. The latest method of manufacture is electrical, the most expensive part of the process being the preparation of the green salts from which the metal is obtained. The first stage produces a gray powder which is poured into molds and pressed into a metallic substance resembling tungsten. At this stage, the metal is virtually explosive if left exposed to the air, but it is reduced to a true metal in a vacuum furnace in which the fusing heat is produced by electrical induction. Up to now, its uses have been confined mostly to measuring ultraviolet light and to X-ray work. It is sensitive to ultraviolet rays, but not to visible light, and is useful in photo-electric cells to measure the ultraviolet light for persons taking such treatments.

Always arranged by American
Inventive Society

Early news 4/9/30
WORKING MODEL LOCOMOTIVE FITS IN PALM OF HAND

596

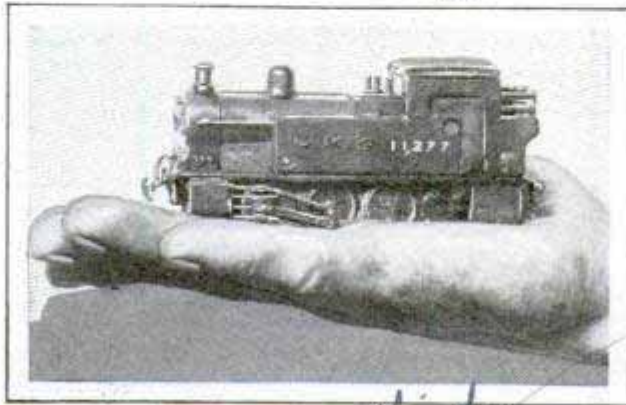

Working Model of a British Locomotive, Exact in Detail, but so Tiny It Rests in the Hand

Exact in every detail, yet so small that it rests easily in the palm of the hand, a working model of a British locomotive has been made by an English mechanic. Three months were required to complete the little engine, which is constructed to scale.

Eric Liddell

RARE ANIMALS ARE FOUND IN WILDS OF ABYSSINIA

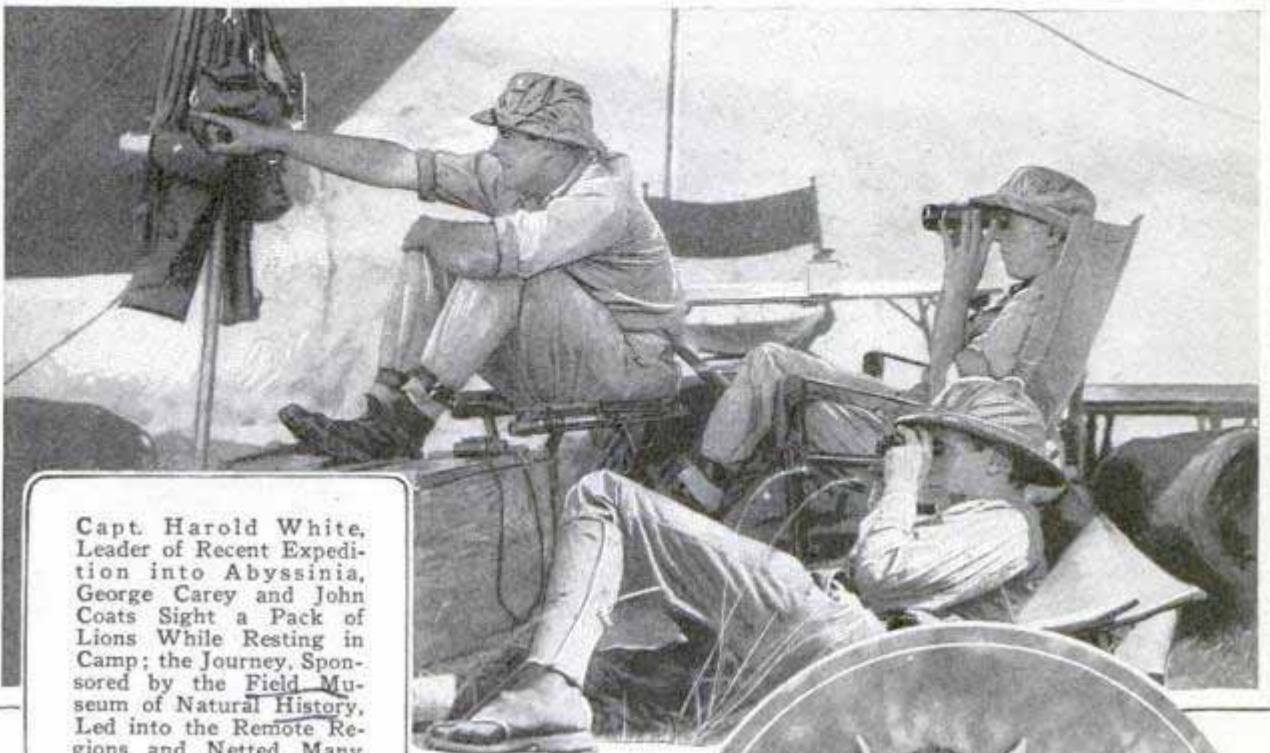

Capt. Harold White, Leader of Recent Expedition into Abyssinia, George Carey and John Coats Sight a Pack of Lions While Resting in Camp; the Journey, Sponsored by the Field Museum of Natural History, Led into the Remote Regions and Netted Many Valuable Specimens for the Museum; Right, a Captured Baby Hyena

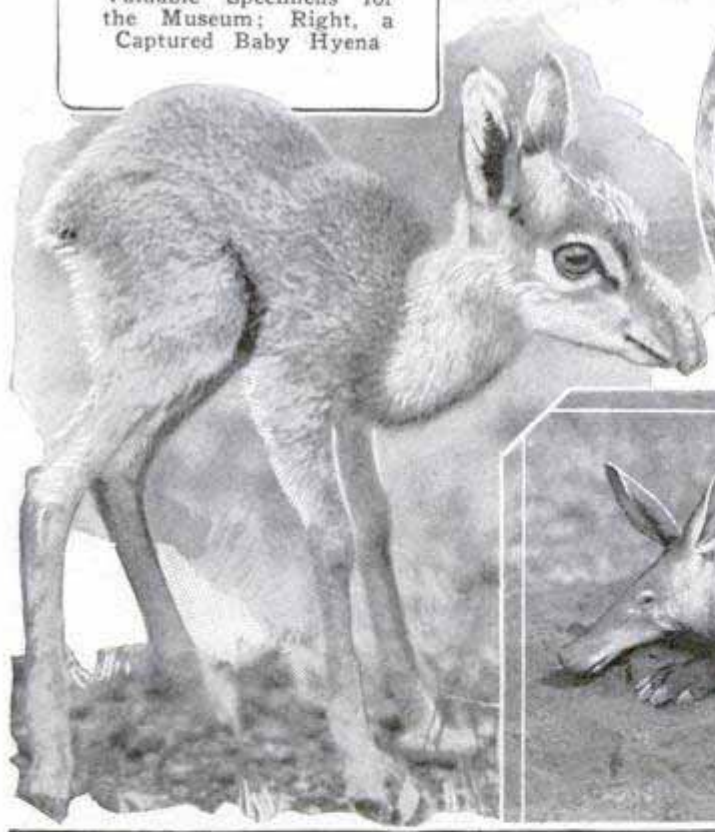

Above, a Young Dik-Dik, Small Variety of African Antelope, So Tiny That It Can Be Held in the Hand; at Right, an Arch Enemy of the Ant, the Aardvark, a Species of Ant Eater and One of the Most Difficult Animals to Capture; the Travelers Also Made a Study of the Peoples of Abyssinia

Wide World

624
108

Com. Capt. Edward C. Wasserman
142 S. Buckingham Ave
Prentwood Heights Calif

POPULAR MECHANICS

GANGSTER CAR FITTED WITH BULLET-PROOF GLASS

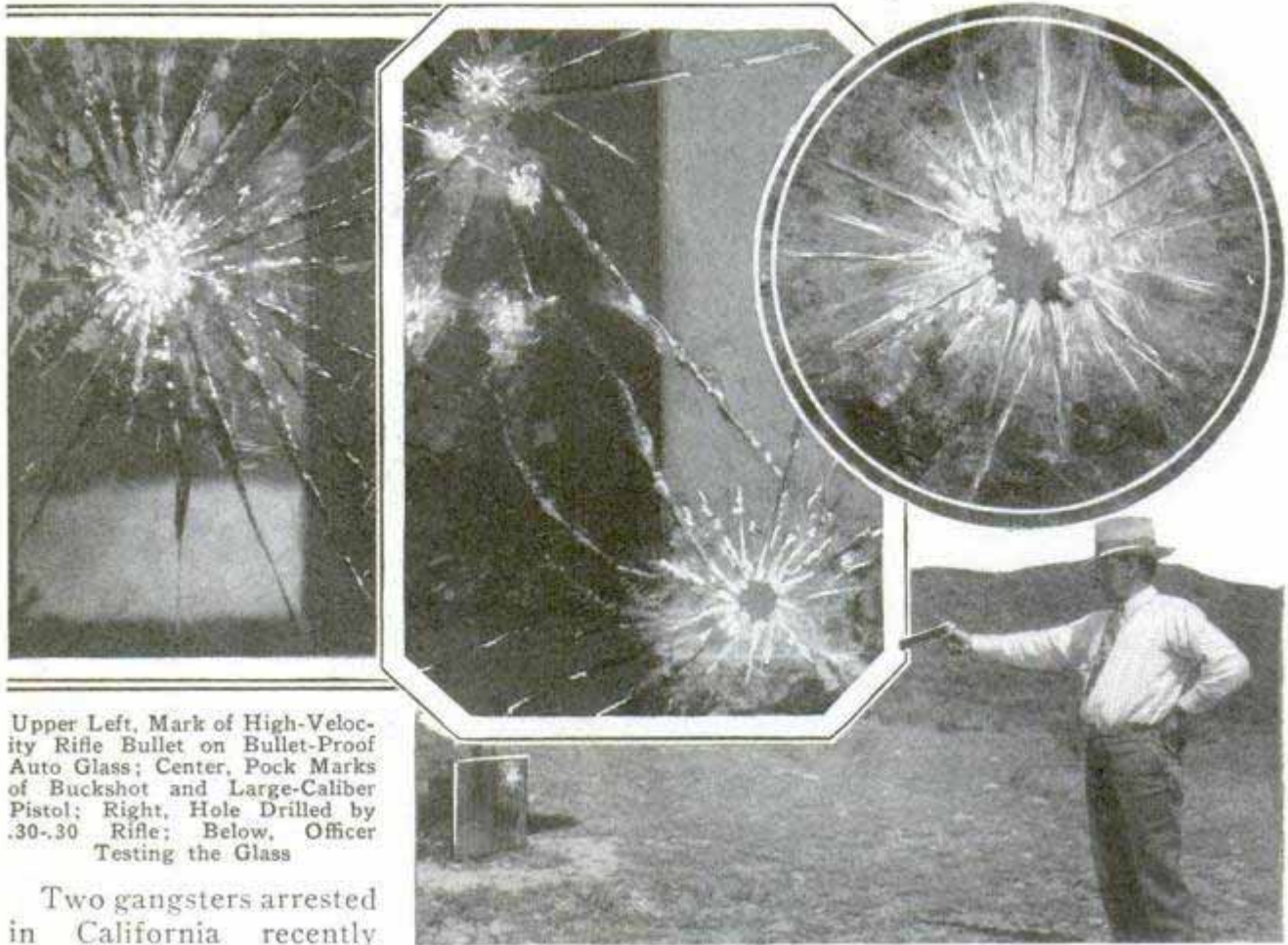

Upper Left, Mark of High-Velocity Rifle Bullet on Bullet-Proof Auto Glass; Center, Pock Marks of Buckshot and Large-Caliber Pistol; Right, Hole Drilled by .30-.30 Rifle; Below, Officer Testing the Glass

Two gangsters arrested in California recently traveled in an automobile behind a protecting shield of glass. Glass in the windshield was more than three-quarters of an inch thick and that in the windows was one and one-eighth inch in thickness. Visibility was unimpaired except when looking through the thick plates at a decided angle. The body of the automobile itself was not armored, the owners frankly explaining that bullets were aimed at the windows and not the body. The glass itself was of the non-shattering kind, built up of layers alternated with other layers of transparent material to hold the sections together, and was not in the least different from any other windshield or motor-car glass, so that it would fool even the astute gunmen of an opposing gang into thinking it nothing out of the ordinary. Before removing the bullet-proof glass from the car, the police submitted it to tests and found that it required a medium-power deer rifle, shooting a high-velocity bullet, to penetrate the windowpanes. Buckshot made a scarcely noticeable freckle on the glass,

and pistol bullets likewise failed to do more than leave a mark and start star-shaped cracks until two bullets from a large-caliber pistol were placed in exactly the same place.

BEST COLORS FOR SIGNBOARDS

702 To investigate the visibility of various colors for use in outdoor advertising, an English company recently erected a huge signboard on which advertisements were displayed in an open field for comparison under expert supervision. In general, the tests showed, that black print on a yellow background or green on white gave best visibility. Then followed red on white, blue on white and white on blue. Black on white, the common form of printing, came next, revealing that its visibility stands far down on the list. Still less effective were yellow on black, white on red and white on black. Red print on yellow, green on red and red on green all proved to be entirely unsatisfactory.

Illustrated Technic
April 3, 1930 P. 14

Herald Tribune 9/16/30

**WORLD WAYS OF TELLING TIME
TOTAL SIXTY-THREE** *658*

Sixty-three varieties of time are in use throughout the world, according to a tabulation prepared by the Royal Observatory at Greenwich, England. Local time is taken from the noon position of the sun, and therefore in its apparent movement from east to west, the local time shifts. This system was used everywhere until modern transportation complexities made the standard time belt necessary. Among North American countries Newfoundland and Labrador are the only ones that have not accepted this system, the time in these territories being twenty-nine minutes faster than that of the most easterly Canadian belt. In South America, Ecuador uses a standard time about fourteen minutes behind the real time belt, with the capital city of Guayaquil five minutes and seventeen seconds slower. The tabulation does not take into consideration daylight-saving time.

**RADIO HEADSET FOR THE DEAF
ATTACHES TO TEMPLES** *476*

Special receivers to enable deaf persons to listen to the radio now can be placed in an ordinary headset which plugs into any radio. The person who is hard of hearing places the receivers against the temples, then increases the volume until he can hear best.



Radio Headset for the Deaf, Which Is Placed against the Temples Instead of over the Ears

and George Barton French 654 Madison New York

and George Barton French

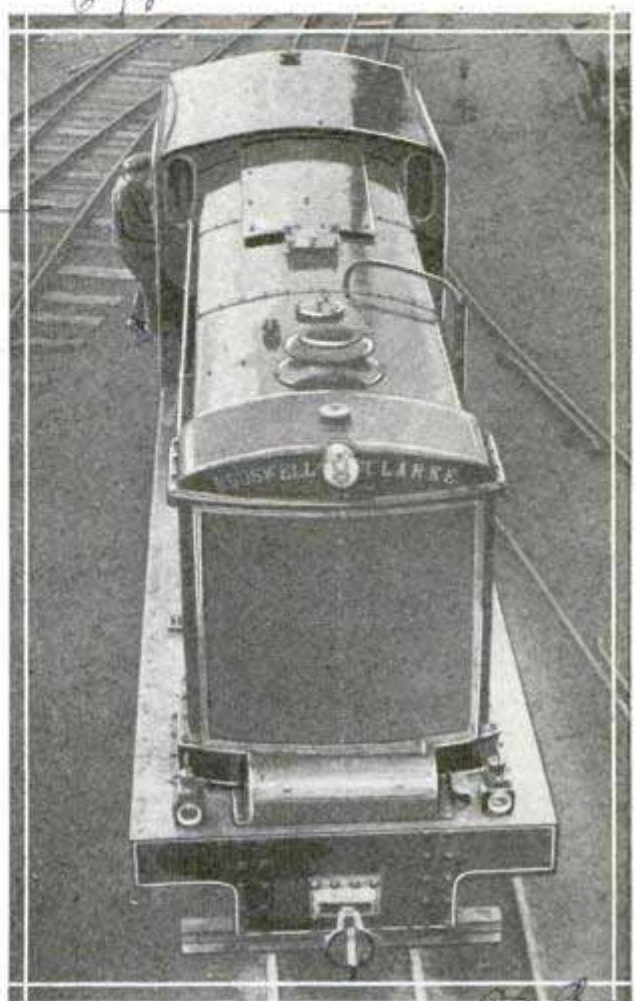

Looking Down on Diesel Locomotive Constructed for High-Altitude Service in Chile

**DIESEL ENGINE FOR RAILROAD
SERVES MOUNTAIN LINE** *Leeds*

Designed especially for service at high altitudes in Chile, a Diesel locomotive has been constructed in England. Efficiency losses in ordinary steam engines are greater when the atmosphere is rare, and these disadvantages are expected to be eliminated in this special engine.

SPEEDERS CAUGHT BY CAMERA *656*

To detect motorists who break speed laws when no officer is near, an English minister has invented an apparatus to take the picture of the license plates of offenders. It consists of hydraulic cylinders sunk in the pavement and electrically connected to a clock and camera. The cylinders cause the camera to operate when a car runs over them at excessive speed. The same apparatus also can be employed to flash a light or sound a siren at an intersection when a car approaches.

Edward G. Anthony 44 New York City

?

New Conveniences



Combined Stool and Clothes Drier Saves Kitchen Space and Time; the Rods Will Hold Many Garments; Below, the Stool in Use



Basket with Special Holders Helps Keep Dishes from Breaking

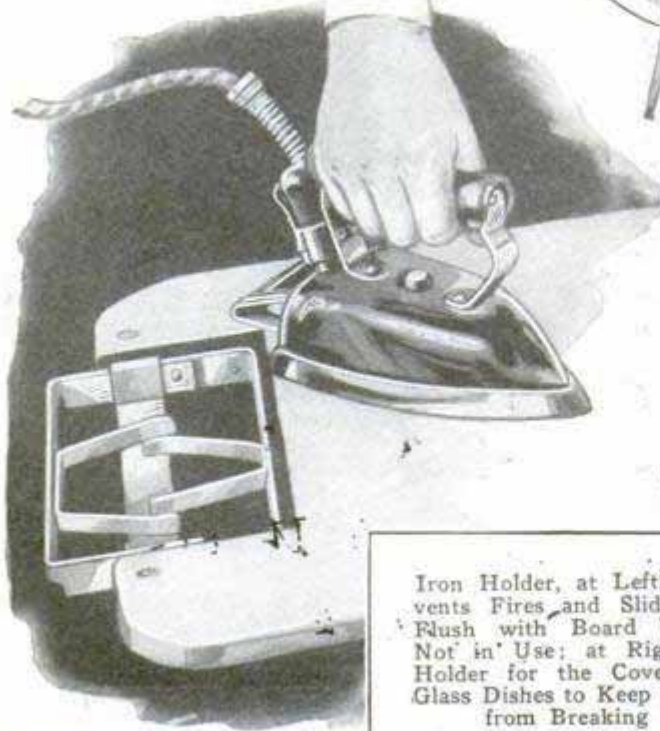
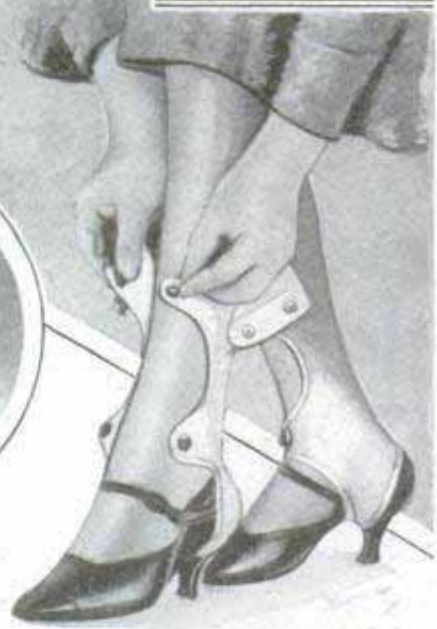

Iron Holder, at Left; Prevents Fires and Slides in Flush with Board when Not in Use; at Right, a Holder for the Covers of Glass Dishes to Keep Them from Breaking

Hosiery Protectors, Shown Above, are Easily Put On and are Furnished in Different Sizes and Colors; They Add to Life of Hose and Can be Carried in Handbag

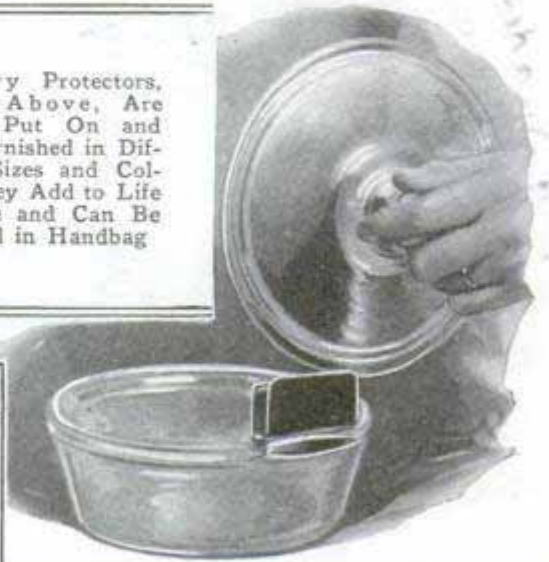

for Your Home

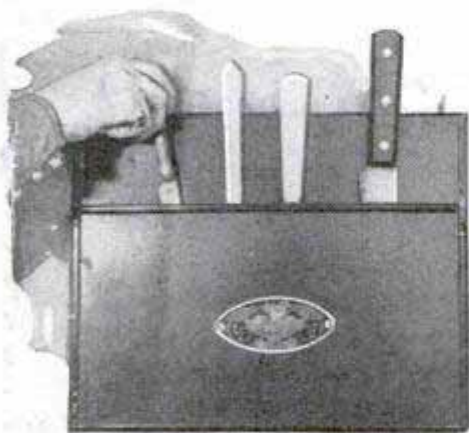

Knife Holder Protects the Blades and Housewife's Hands as Well



Electric Sprayer, Operated by Vacuum Cleaner, Spreads Moth Preventive Liquid Said to Be Effective for Five Years Unless Articles Are Dry-Cleaned or Washed with Soap

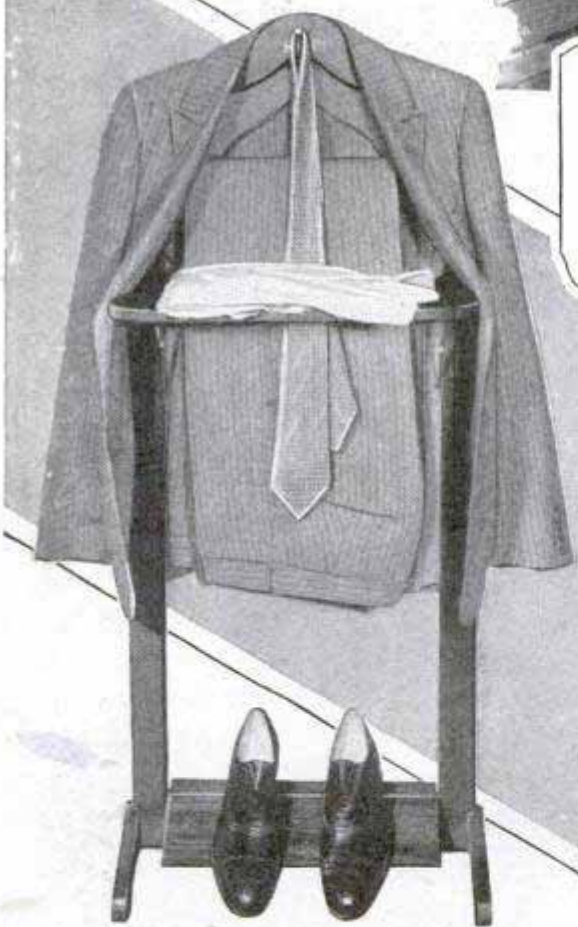

This Costumer for Men Holds Suit, Tie, Shoes and Shirt; It Occupies Little Space and Is Easily Moved About for the Convenience of the User

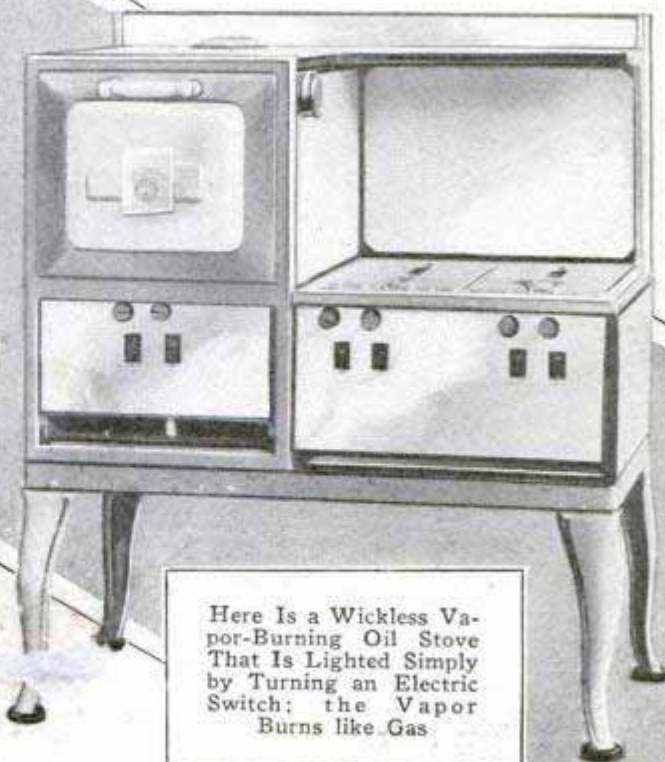

Here Is a Wickless Vapor-Burning Oil Stove That Is Lighted Simply by Turning an Electric Switch; the Vapor Burns like Gas

Philip Rosenheim

3/5



*Walking Stick
660
Violin*

Walking Stick Whose Different Parts Compose a Musical Instrument Resembling a Violin

VIOLIN INSIDE WALKING STICK MAKES MUSICAL CANE

Walking stick and violin are combined in a cane owned by a Glasgow, Scotland, dealer. The handle is unscrewed to reveal the hollow inside containing the bow, and a portion of the side may be removed to bare the strings and bridge.

LEARN TO FLY IN EIGHT WEEKS AVERAGE TIME

659

Learning to fly costs a private pilot an average of \$550 and eight and one-half weeks of his time, a survey of the department of commerce reveals. Tuitions for private licenses in approved flight-instruction schools were found to range from \$345 to \$650, exclusive of board and room, and courses ran from five and two-thirds weeks to two and three-fifths months as average minimum and maximum. For a limited commercial course, the average cost was found to be \$1,271, the average minimum time being two and four-fifths months, and the average maximum four and three-fifths of a month. The average cost for the transport pilot was \$4,255, the average

Herald Tribune 4/6/30

time ranging from seven months to a week short of a year. Variations in cost and length of courses were attributed to additional training beyond minimum requirements given by some schools, and to weather conditions. None of the schools agreed to furnish employment for their graduates.

GOOD-NATURED STINGLESS BEES PRODUCE WHITE HONEY

Caucasian bees, a silver-gray variety from Russia, that make an extremely white comb honey and seldom if ever sting, although they have stingers, have been raised with success at the New Jersey agricultural experiment station. They produce as much honey as the usual Italian colonies, they swarm less frequently, and, during three years' experience with them, the bee specialist at the station has never been stung. The gray color is due to a growth of small hairs that cover the bodies which are brown like those of other bees.

Herald Tribune 4/6/30

AUTOS ARE TURNED IN STREET BY TURNABLE

Following the lead of London, Paris now is installing turntables in some of its narrow streets so automobiles can turn around. The car in a street too narrow to make a turn is driven onto the table and swung around much like a locomotive at a roundhouse.



Auto Turntable Used in Narrow Paris Streets

420 also by New York high school students

made by Natural History Museum
Research Dept., New York

WAX MODELS OF INSECTS AID IN NATURE STUDY

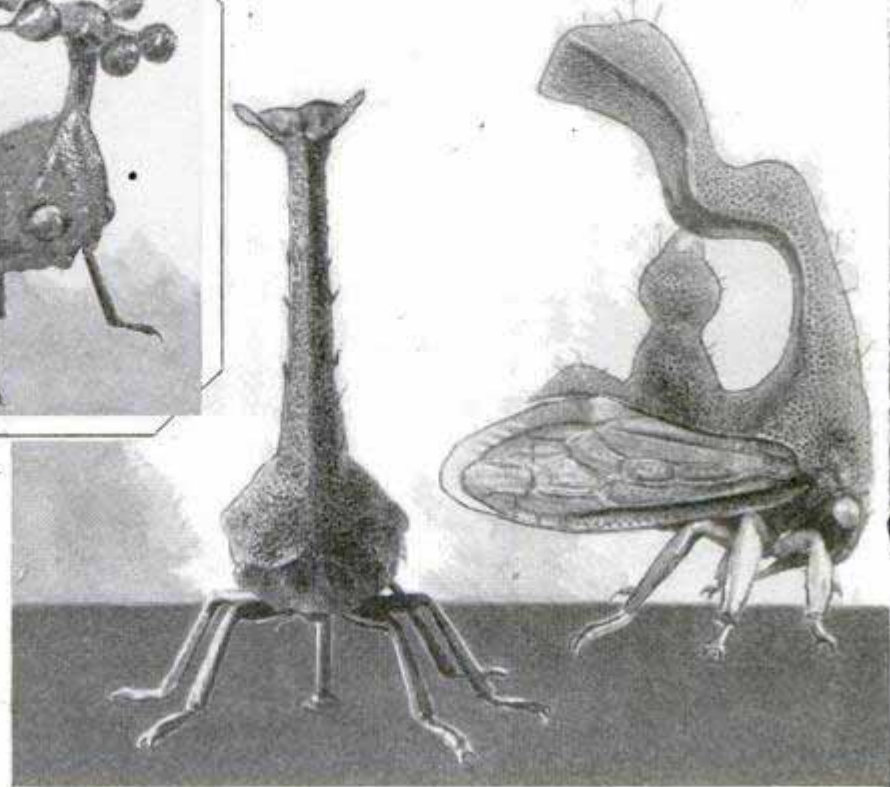
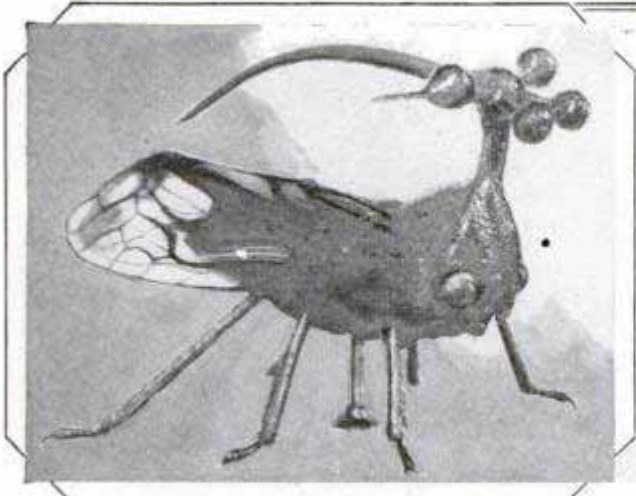

Wax models of insects, enlarged fifteen diameters, have been made for use as nature-study exhibits by a New York university. Some of the models are of tree hoppers, in appearance probably the most fantastic of the insect world. They live by sucking the juice of small plants and trees, and, being clumsy in flight, acquired their name from the habit of awkwardly jumping a considerable distance. The tropical types are gorgeously colored, and none but experienced collectors can find them because their bodies take on the color of their surroundings. Their grotesque appearance is due principally to the peculiar development of the thorax, which grows back over the body and, in different varieties, terminates in spines, horns or balls.

These Fantastic Creatures Are Not Dangerous, but Are Wax Models of Insects, Enlarged Many Times; They Represent Tree Hoppers

lawn virtually free of weeds because the strips are weed-free when placed, and the grass is far enough advanced to repel weed invasion.

SCREWS KEPT TIGHT IN WOOD BY THREADED HOLDER 605

In wood where ordinary screws and nails pull out, a threaded screw holder may be used to act as a nut for the screw. It is an oblong plate of brass with a threaded hole near its pointed end.



Grooves along the plate allow protruding ends to be broken off when it has been driven into position at right angles to the direction in which the screw is to be inserted. It will hold in wood joints and at corner

places for fastening hinges or strike plates.

Screw-Tite Co. Newark, N.J.

Chicago-175 Wackerline

READY-MADE LAWN IN ROLLS LAID LIKE A CARPET

Grass turf for lawns now is obtainable ready-grown, being purchased in rolls and laid in the yard like a carpet by unrolling the various sections. The strips are composed of creeping bent-grass turf grown in nurseries. The sod is then taken up in sections and rolled like a rug. This method of obtaining a full-grown lawn overnight has been used by golf clubs and landscape gardeners, but has not been available to the individual home owner. The grass gives a heavy, solid growth and makes a

Stolon
Bala 10/17/24

Illinois Grass Co. 18455 Reigel Road

Emb. Herbert Beardsley
Walcott Ave. Westport, Conn.

Rayton Albed

COLD GAS PROMISES TO INCREASE POWER OF AUTO

Carl Harold L. Blanchard
451-8th Ave
New York

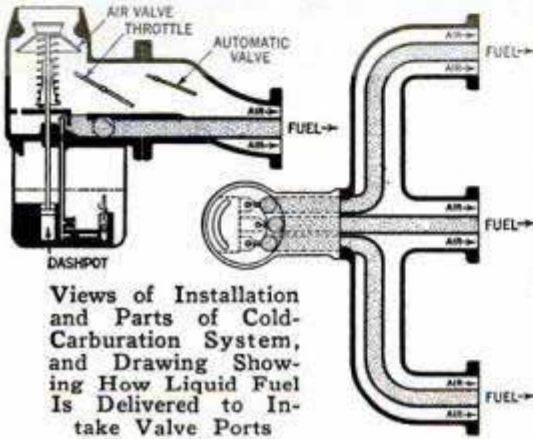
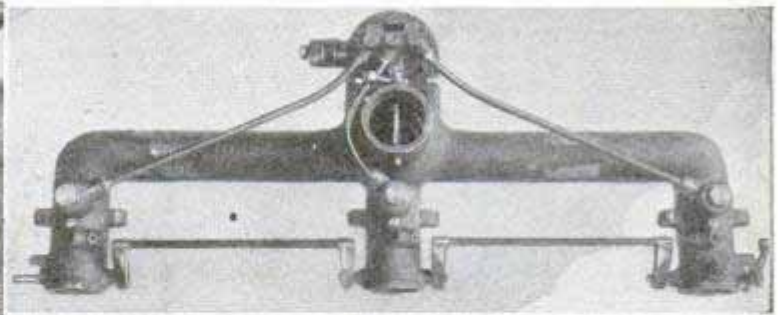
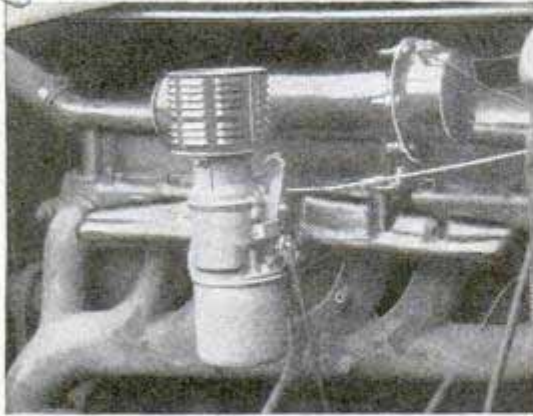

Views of Installation and Parts of Cold-Carburator System, and Drawing Showing How Liquid Fuel Is Delivered to Intake Valve Ports

A seven to thirteen-per-cent increase in power, easier starting and quicker "warm-up" are the interesting features claimed for a new carbureting system developed for General Motors. Whereas conventional carburetor and intake-manifold installations attempt to supply a mixture of (more or less) vaporized fuel and air, the "cold-carburator system" throws this principle overboard and delivers fuel which is mostly liquid direct to the intake valve ports, where it is picked up by pure air and carried into the cylinders. Looking at the diagram, it will be seen that the "outside" manifold carries pure air only, while the "inside" manifold carries liquid fuel and sufficient air to sweep the liquid particles along. These two streams meet at the intake valve ports and mix on their way into the cylinders. Within the carburetor there are three jets, one for each of the three tubes which compose the inside manifold. There are four throttles, all hooked together, and in addition there is a throttle controlling the air in the outside manifold. With present practice, the carburetor

only partially vaporizes the fuel, most of it entering the manifold as fine particles of liquid, and the air has to whisk these particles along like rain in a gale of wind. The mixture speed through the manifold at full power is usually about two and a half miles per minute. Obviously the heavy particles are thrown out by centrifugal force whenever the mixture rounds a turn. Some of these particles also collect on the walls of the manifold and flow into the cylinders in slugs. All of which means that the cylinders do not get exactly the same amount of fuel. In extreme cases, loss of power may result, but more usually the penalty is reduced fuel economy, since the carburetor must be adjusted to give an adequately rich mixture to the leanest cylinder, and thus the others receive too much fuel. A still more serious defect is the necessity for applying heat to the conventional manifold. Heat improves the distribution not only by vaporizing some additional liquid but also by breaking up the remaining liquid particles into smaller sizes which are more readily carried along by the air stream. But heat is objectionable because it reduces power, since the power which an engine develops depends on the weight of air drawn into the cylinders,

and the lower the temperature of the air the less it is expanded and therefore the more it weighs. The greater power claimed for the cold-carburation system is due mainly to the elimination of heat on the manifold, although the ability to use a larger manifold and a somewhat higher compression also assist the power. Finally, almost as soon as the engine is started, the choke may be released, and yet the engine has the feel of a warm engine—the usual period of sputtering and loss of power is eliminated.

**MAGIC TABLE LEGS
ADJUST SELVES
TO FLOOR** 36 4

Self-adjusting table legs that automatically shrink or extend to correct any unevenness of the floor on which they rest, are the product of an English inventor. The legs contain sealed chambers of glycerine for their bearings and this is the secret of the growing or shrinking. If a leg is pulled off the carpet, it automatically lengthens itself to reach the floor.



Table Legs with Glycerine Chambers as Bearings Adjust Themselves to Uneven Floor

Mr. Frank L. Morgan

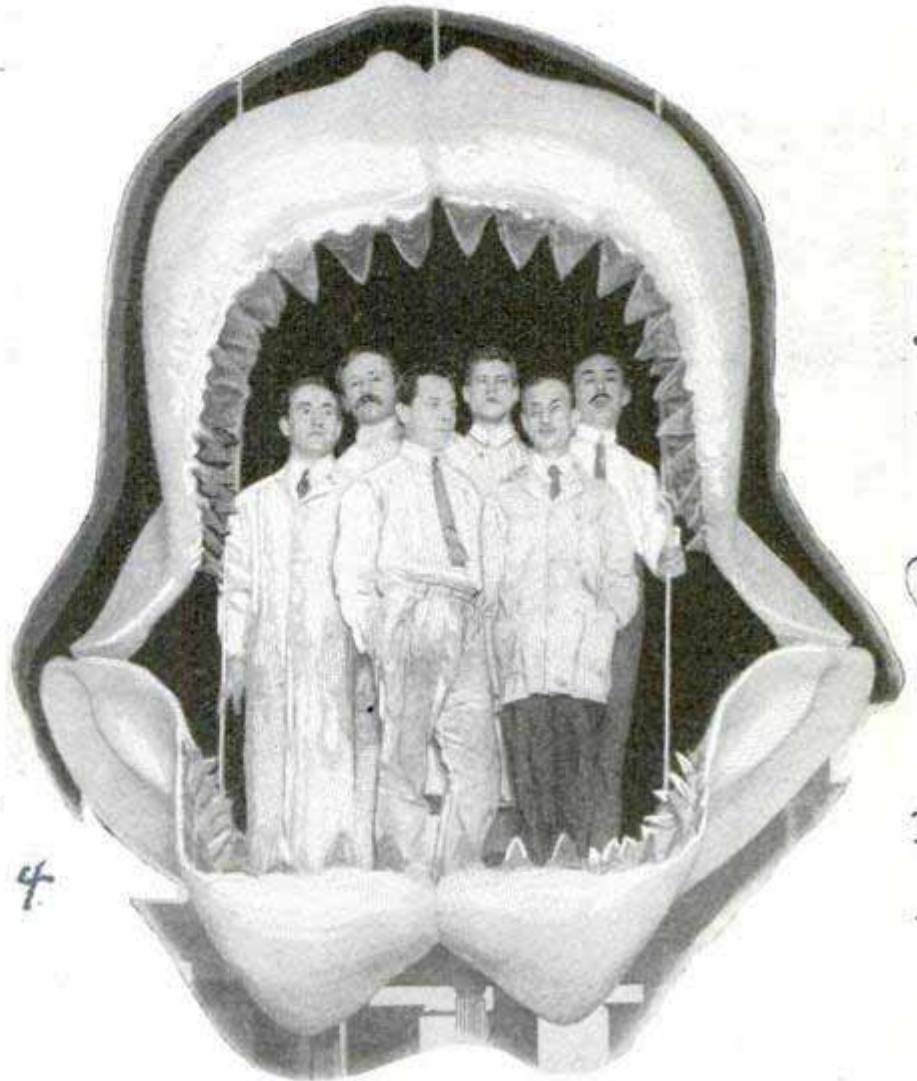

Huge Jaws of Prehistoric Shark, Reconstructed from Its Fossilized Teeth Which Furnished a Gauge to Its Mammoth Proportions

**SHARK'S JAWS RECONSTRUCTED
FROM FOSSILIZED TEETH**

From its fossilized teeth alone, scientists of the Marine Museum in New York have reconstructed the mighty jaws of a mammoth prehistoric shark, probably the most formidable creature that ever roamed the ancient seas. The battery of daggerlike teeth, many over six inches long, were found in phosphate beds on the Atlantic shores of South Carolina. These furnished the scientists a gauge in determining the size of the jaws which gape open over seven feet and hold the standing figures of half a dozen men. It is estimated the shark which owned the teeth was more than eighty feet long and weighed over fifty tons. The whale shark of today seldom measures more than forty feet. A ton of large and small marine creatures probably provided one meal for the big shark.

*Com. Herbert Beardsley
U.S. Navy
New York City*

shown at Boston Industrial Exposition

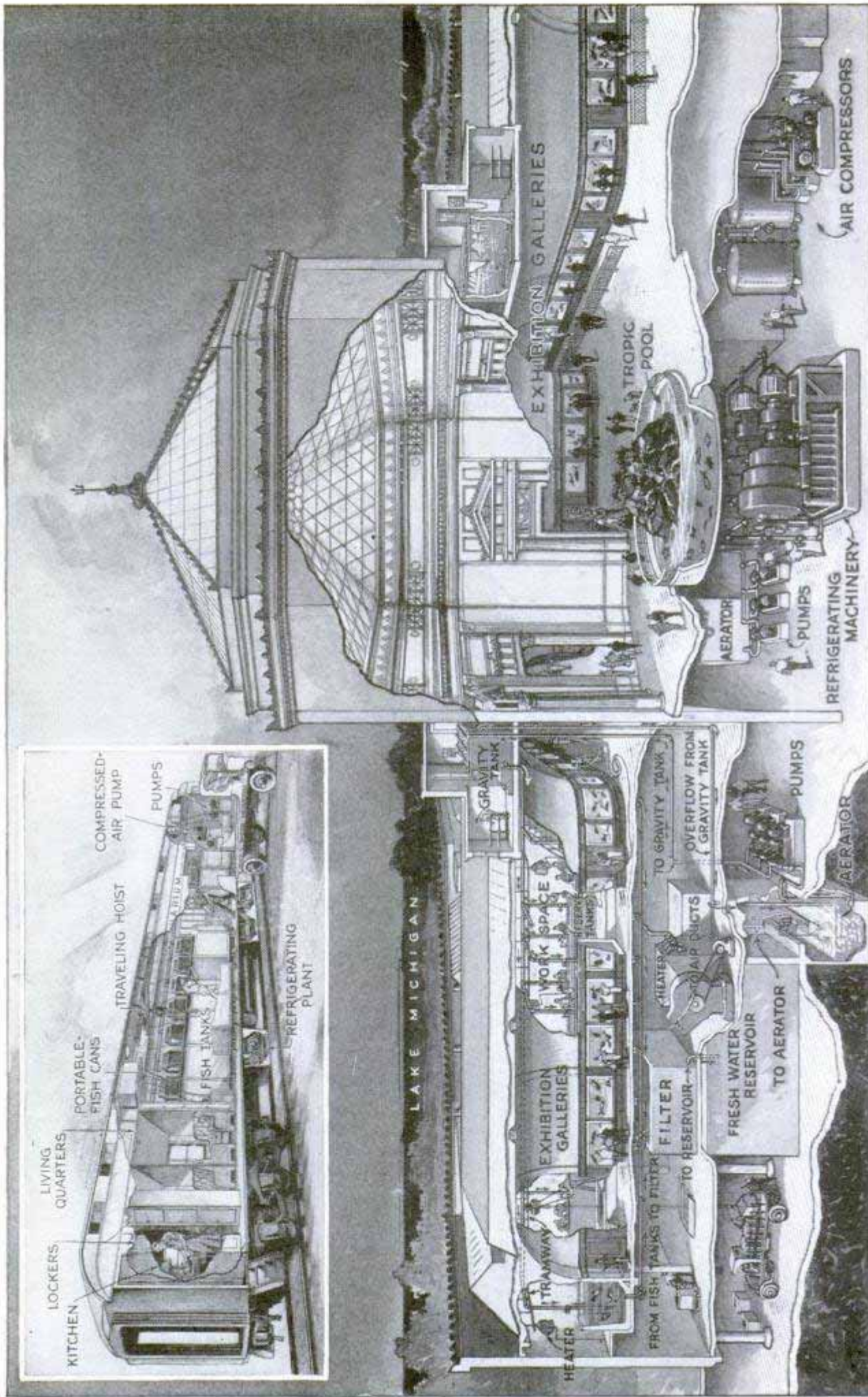

Artist's Drawing of the Shedd Aquarium and the Special Pullman Car Built to Transport Fish; It Is an Aquarium on Wheels; the Large Sketch Shows How Boxes Are Unloaded from the Motor Trucks on Electric Hoist and Placed Directly in Tanks; General Plan of Water Circulation Is Also Illustrated

FISH FIND COMFORTS OF HOME IN NEW AQUARIUM

Fish from every part of the world swim in the recently completed \$3,000,000 John G. Shedd aquarium in Chicago. The marble structure, suggestive of a Greek temple, with its 132 exhibit tanks, its five separate water systems, laboratories, hatchery, hospital for taking care of sick fish, "violet ray" glass, natural salt water hauled from the Gulf of Mexico in tank cars, and many other interesting and unusual features, is considered a triumph in scientific construction, beauty and efficiency. To facilitate the collection of specimens, a special railroad car was constructed and fitted up as a complete aquarium on wheels. Behind the scenes in the aquarium is a huge refrigerating plant which can freeze 450 tons of ice every twenty-four hours. It provides cold water for the fish that need it. In most aquariums, a trickle of bubbles is seen arising from a compressed-air inlet to supply the water with oxygen. This method of aerating the water is not necessary in the Shedd aquarium, the water being aerated as it flows into the tanks by means of a special nozzle, so constructed that air is drawn into the stream as it passes out of the pipes. Tanks supplying warm water are fitted with heating coils and a floating thermostat control so that the temperature automatically is kept at the right point. Expeditions are planned to secure specimens hitherto unknown to public aquariums and fishes that cannot be displayed alive will be exhibited in a preserved state.

PAD FOR FOOD GRINDER SAVES TABLE FROM DAMAGE

For use with the food grinder, ricer, shredder, fruit-juice extractor or other kitchen utensil with metal clamps, a pad now is available which protects the table from scratches and scars made by the clamps. The pad also prevents slipping and sliding of the device when clamped to the table.

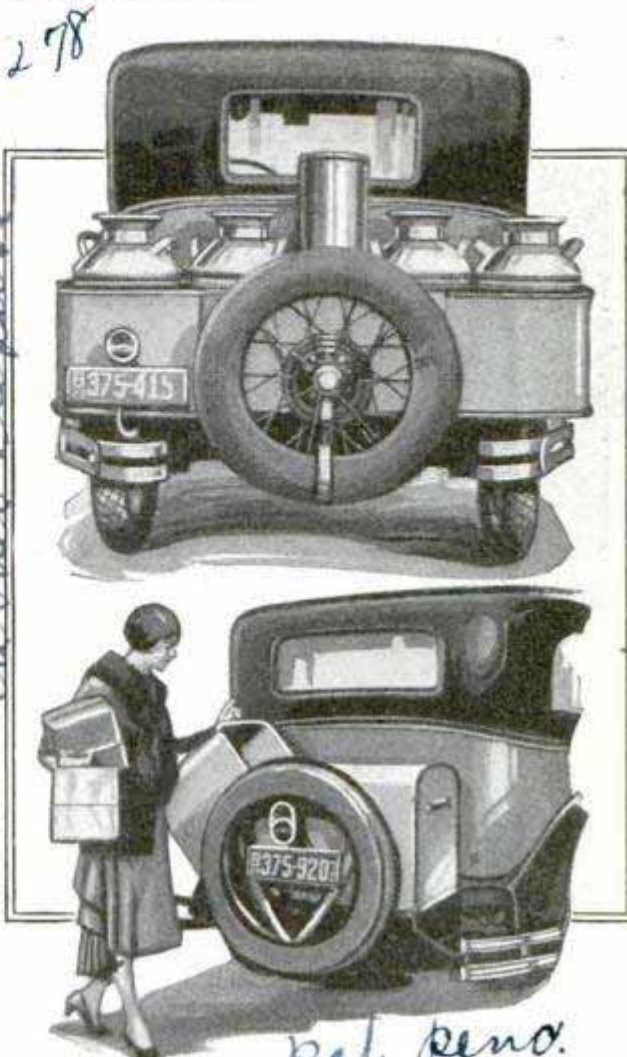
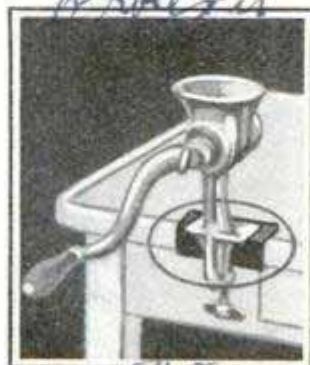

Extension Luggage Carrier with Telescoping Ends, Which Hauls Almost as Much as a Small Truck

EXTENSION LUGGAGE CARRIER HAS LARGE CAPACITY

With a capacity limited only by the weight the springs of the auto can bear, an extension luggage carrier with telescoping ends has been placed on the market. Normally it is a neat-looking trunk that is opened by swinging the two end sections outward. When the ends are locked in open position, however, it has a carrying space of fifteen by seventeen by seventy inches, which makes it suitable for the camping trip or any other occasion when bulky luggage is to be carried. It is all-metal with black lacquer finish but can be furnished also in other colors.

The Popular Mechanics' Bureau of Information offers its free service to all readers of our magazine. Names and addresses of manufacturers and dealers in articles described, and any other details in our possession, will be promptly furnished upon application to the bureau.

W. H. ...
Co. Cleveland, Ohio

Carner Leisure

Mr. Durbee - Atwood, C.
40 Wilder, Minneapolis

pat. pend.

Chicago, Collins, 2533 Cottage

J. H. ...
...

Cont. H. W. Frier 06. 917,

400 W. Madison

Chicago

DE-LUXE BAGGAGE CAR CARRIES AUTOS, HORSES OR SCENERY

46 9

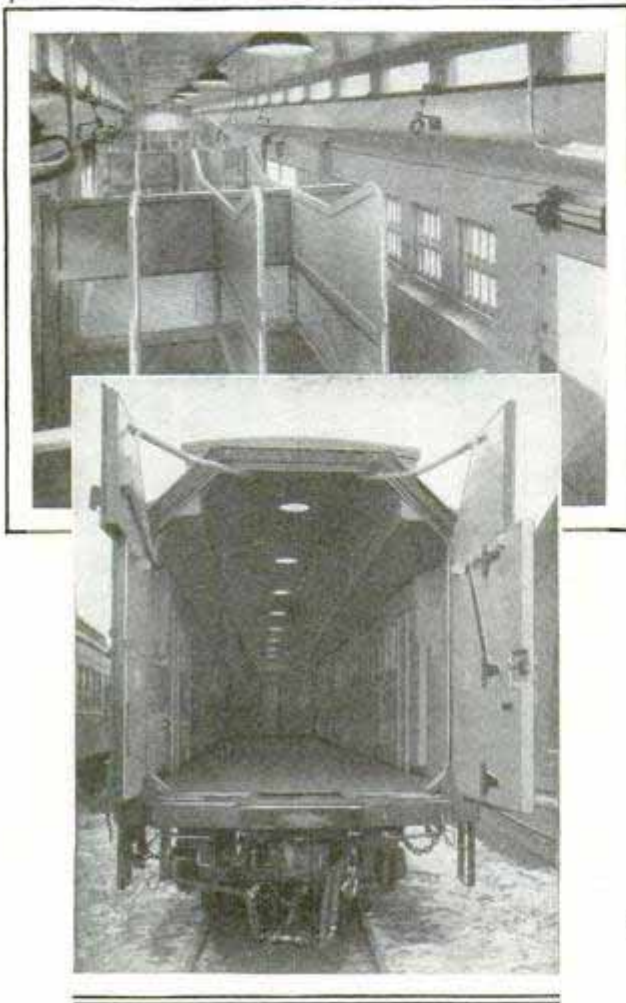

Interior Views of the Combination Car; Upper Shows the Stall Partitions; Lower, Car Open for Autos

Five special baggage cars, built to accommodate race horses, automobiles or scenery, have been placed in service on the Chicago and Northwestern railroad. Lights are recessed in the walls, windows slide up and down instead of swinging in and out, and the entire plan permits a quick change of the interior to suit the shipment. Special attention was paid to the matter of comfort when horses are carried. The interior is smooth, eliminating hazardous obstructions, twenty-eight windows, four feet from the floor of the car, are intended to prevent the horses from getting rheumatism, and there are forty-four ventilators. The entire end of the car swings open to facilitate loading and unloading. There are provisions for twenty-four or eighteen stalls, and when the car is used for shipments other than animals, the partitions are stored in one end. Electric lights, steam heat and wood-

block floors to protect horses' feet, are other features. Each car is over seventy feet long inside and approximately eight and one-half feet wide.

TOAD VENOM MAY YIELD DRUGS TO FIGHT HEART DISEASE

631

Venom of toads, for centuries used in Europe as a source of poison, and in China as a medicine, has been found to contain potent elements resembling drugs in therapeutic use today and may provide new weapons against heart disease. Doctors of Johns Hopkins University have isolated four kinds of chemical substances in crystalline form from the venom of a toad found in the river and lake regions of China. This toad secretes a poisonous substance in glands behind the eyes and the Chinese have long employed the dried venom in treating sores, sinus trouble, inflammation, toothache and bleeding gums. The venom is effective in stopping bleeding and promoting sinus drainage and some elements in it were found to have a pharmacological action quite similar to digitalis.

Science Service News Bulletin

"PAINT DONKEY" SAVES MONEY

3925

ON TRAFFIC STRIPES

Painting the white stripes in the street which direct auto and pedestrian traffic



in proper lanes and at intersections is accomplished in San Francisco by a machine called a "paint donkey." Hand-painted lines for traffic cost seven cents a foot, but the machine does the job for less than two cents a foot.

Wide World "Paint Donkey" That Marks White Lines on Streets for Pedestrians and Autos to Follow

Simons Paint Sprag + Brush Co. 17th St. Chicago

412

BOATS RACE IN SWIMMING POOL WITHOUT MOVING

Wed. World

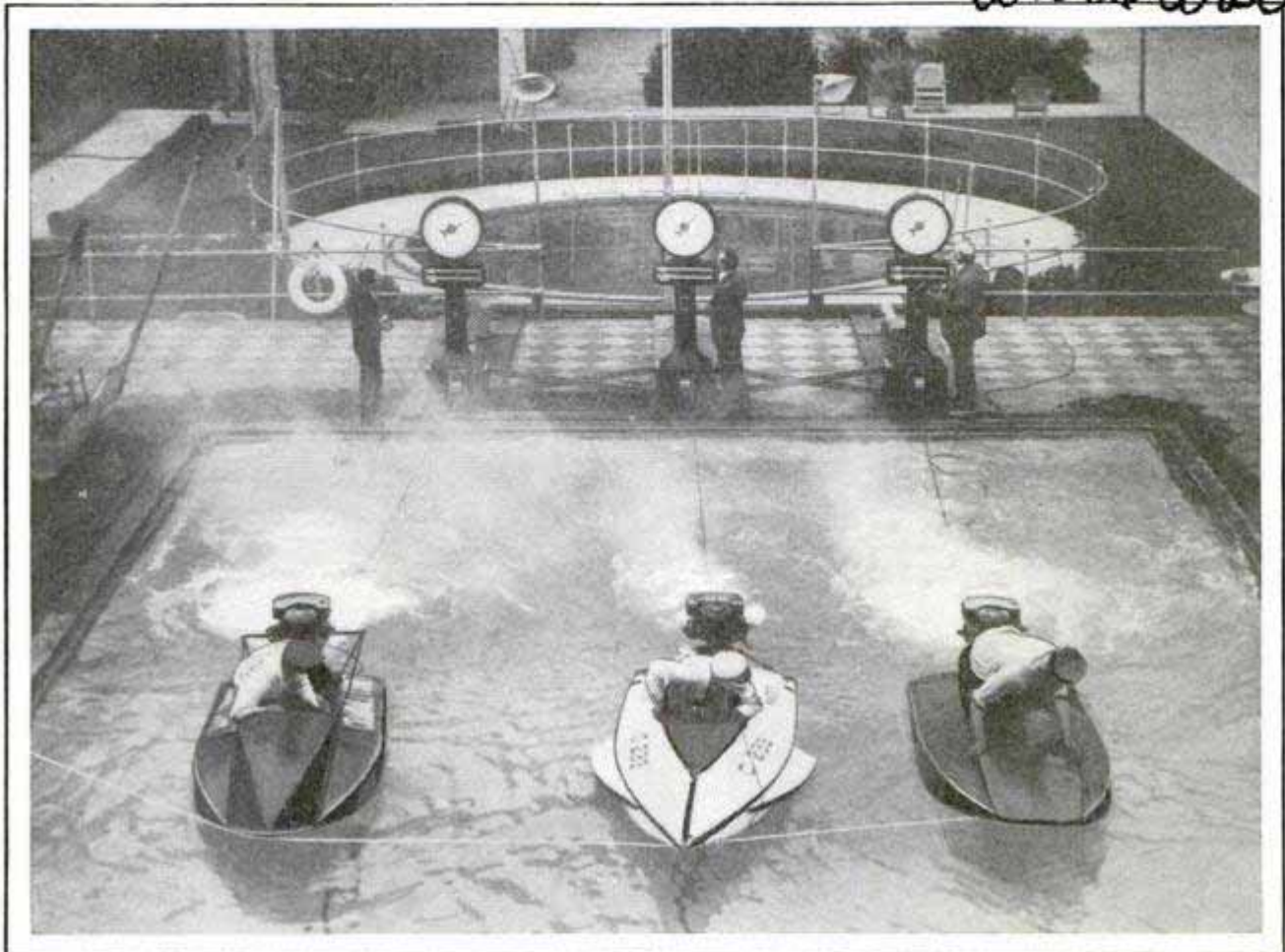

Here Is a Motorboat Race in a Swimming Pool; the Boats Were Attached by Cables to Apparatus Which Recorded Pulling Power, and the Boat with the Most Power Won the Contest

Racing tests of the fastest speedboats on the Pacific coast were held recently in a small swimming pool, the motorboats straining bow and bow with motors wide open, although in reality they were standing still. The boats were attached by cables to an apparatus which recorded their pulling power, and the winner was the craft that exhibited the strongest pull.

ditions, besides the materials already mentioned, carbon black is obtained. This is widely used in several industries.

COMBINATION LOCK FOR SPARE WHEEL IS THEFT-PROOF 561

Operated like a knob lock on a safe, a combination lock for the spare wheel of an automobile is being used in England. The lock is fitted to the bolt that secures the wheel and locked in position by twirling the knob that can only be removed by setting at a code number known to



the owner, and which cannot be discovered by touch. The external parts revolve freely, affording no grip for a wrench.

NATURAL GAS YIELDS DYES, PERFUMES AND RUBBER 601

By decomposing natural gas at high temperatures and recombining its constituents, products ranging from artificial rubber, anaesthetics and motor fuels to dyes, explosives and perfumes are being obtained, the department of commerce reports. The gas is heated to 1,800 to 2,200 degrees Fahrenheit to cause it to "crack" or break up into various substances which reunite as the gas cools to form new products. Under certain con-

U.S. Daily 3/20/30

Bureau of Mines

Hoblock
7/6d
H. M. Hobson, Ltd.
417-55. The Vale, Acton

PORTABLE AMPLIFIER



two dry cells, a small C-battery and two 45-volt B-batteries of the variety used in portable receivers.

Originally designed for a writer who was becoming so deaf that he could scarcely hear a lecturer even when seated in the front row, this amplifier enabled him to sit in the rear of an auditorium without missing a word. This is a rather strong statement, but tests carried out with a member of the staff and several other persons clearly demonstrated that the claim was not unduly exaggerated. Anyone can build this device in the manner described and illustrated, and it is possible to make it even more compact by the use of type-199 tubes and smaller batteries.

With a 4.5-volt C-battery for the filament supply, it could be easily contained in a vanity or camera case. The original case, shown in the photo on this page, is 6 in. high, 7½ in. wide and 11¾ in. long, over-all dimensions, and is made from ¼-in. stock. The hinged

THERE is no reason now for any deaf person missing his favorite opera or being unable to enjoy radio programs, lectures or other forms of entertainment. Perhaps one of the simplest and most powerful audio devices yet designed to aid the deaf is this compact amplifier recently tested in Popular Mechanics laboratory. The instrument employs two of the CX-12 tubes and is operated with

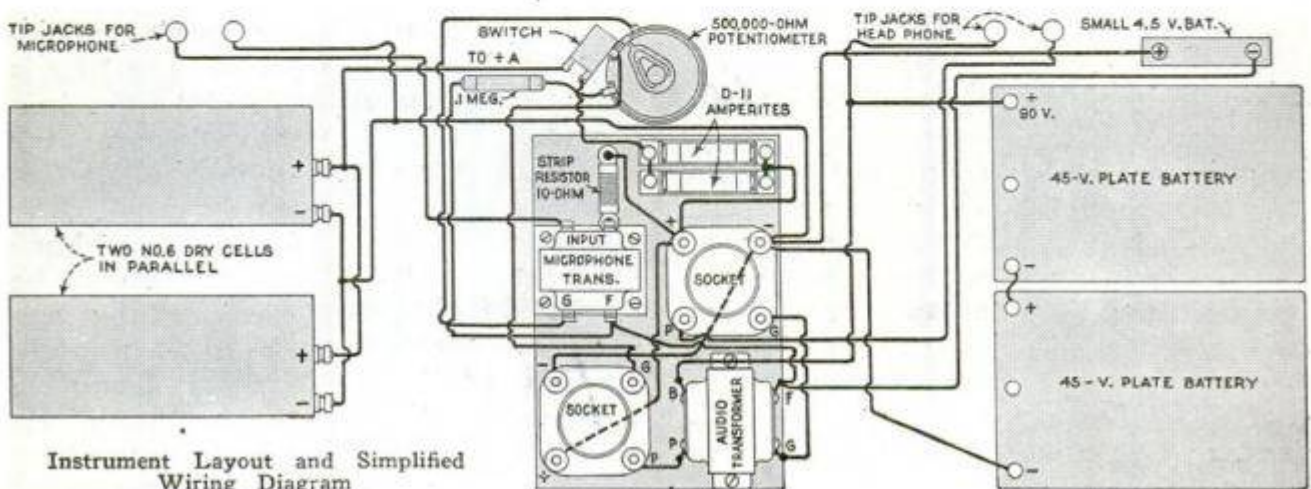

AIDS DEAF



cover is exactly 1 in. deep. The case is divided into three compartments by means of four $\frac{3}{16}$ by $\frac{1}{2}$ -in. brass strips. These strips are $9\frac{1}{2}$ in. long and are bent over $1\frac{1}{4}$ in. at each end. Two holes are drilled in the ends for wood screws, and the strips are mounted so as to hold the batteries firmly, as shown in the photo on this page.

The simplified wiring diagram shows all parts in their relative positions; in the photo above the diagram, note the potentiometer knob for controlling volume and the cord-tip jacks for the headphone and microphone. These units are mounted on the cover near the hinge; the volume control used is a combination switch and potentiometer, the knob of the latter operating the switch. If the builder desires, he may just as well use a separate switch.

The few inexpensive parts that go to make up the amplifier are mounted on a wooden board, $\frac{3}{8}$ by $4\frac{1}{4}$ by $6\frac{3}{4}$ in., to be screwed to the bottom of the case. The tube sockets are the spring-suspended type, and are mounted with their terminals in the position shown, for short and direct leads. The audio transformer is a new type with a ratio of $3\frac{1}{4}$ to 1, and the microphone transformer is a small inexpensive type designed for use with any single-button microphone. The 10-ohm strip resistor is mounted directly on one of the input terminals. All other instruments are as shown,



and are specified in detail in the material list which is available to all who are interested in the device.

Use well-insulated flexible hookup wire for the circuit; cable the leads from the dry cells to the microphone tip jacks and the filament supply leads to the sockets. The leads from the microphone transformer to the potentiometer and those to the switch as well as the B-battery leads are separately cabled by lacing with string or heavy thread.

When the wiring is completed, insert the tubes in the sockets and plug in the microphone and headphone. With the latter in position, turn on the switch and advance the knob of the potentiometer until a swishing

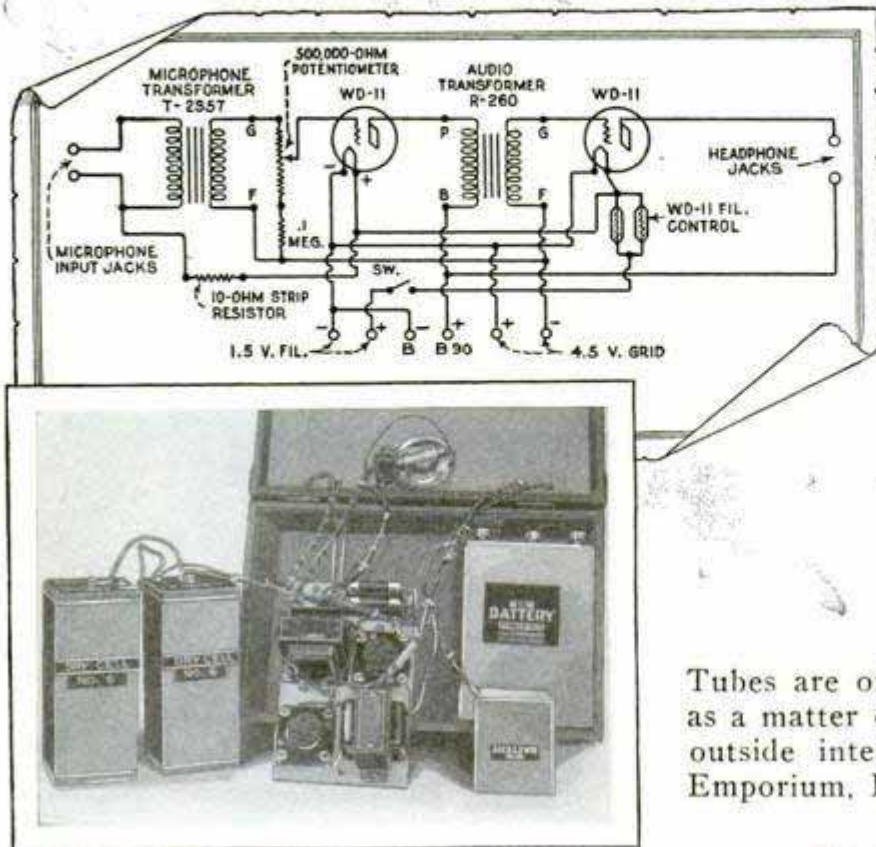

side of the line is grounded. If you take a condenser of any capacity from .010 to 2 mfd. and connect one side to the ground of the receiver and the other side to the ungrounded side of the line, a considerable amount of interference will be eliminated. The strength of the signal will decrease slightly however. In locations where neither side of the power line is grounded, better results will be obtained if two condensers are employed, one connected to each side of the line, while the other terminals are connected to ground.

Tubes are often blamed for noise when, as a matter of fact, the trouble is due to outside interference.—Walter R. Jones, Emporium, Pa.

noise is heard. Sounds will now be picked up by the microphone and greatly amplified. The efficiency of the device will depend upon the sensitivity of the single headphone, which is a common radio type, and especially upon the microphone. Microphones range in price from about \$8 to \$50. For the tests, an inexpensive type was used and worked so well that most excellent results should be obtained with a costlier one.

Power-Line Antenna Effects

Interference from outside sources is, of course, best eliminated at the source. But this is difficult and often impossible. The next best thing is to prevent as much as possible from getting in the receiver. Most of the interference is due to electrical disturbances on the power line, caused by motors and similar devices, and it is a well-known fact that a. c. sets are more susceptible to this form of interference than battery-operated receivers. This happens because the power line acts as an antenna in some receivers regardless of whether a regular antenna is used or not. In most power-supply systems, one

Wall Log for DX-Fans

A handy radio log for quick reference may be made as shown in the illustration. Made from black cardboard or bristol board, it is arranged in fan shape, to represent a dial. Each of the radiating lines drawn with white ink corresponds to the dial divisions on the set. When a station is tuned in, the call letters are written on a small piece of gummed paper and pasted on the correct line. The card may be of any size that will provide the necessary room for the station stickers and, when neatly made, it does

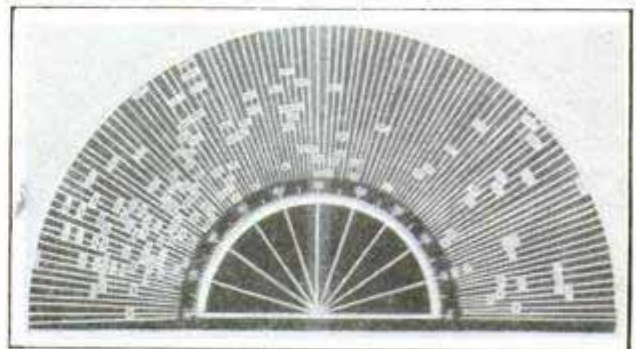

Cardboard DX-Log. Arranged like a Dial, Shows Tuning Points for Stations at a Glance

not make a bad appearance on the wall near the set.—B. L. Kobel, Frankfort, Ind.

Broadcasting Heartbeats

A recently developed instrument for the physician is an electric stethoscope that picks up and amplifies the sound of a heartbeat so that it can be heard by a large audience. You can do the same thing on your radio receiver, if you can obtain the use of a loud-speaker unit.

The unit acts as a microphone that picks up the sound vibrations and feeds them into the a. f. amplifier of your set. If your receiver is equipped with phonograph pick-up jacks, the task of connecting the unit to the set is simple. Otherwise, you will have to connect one wire of the unit cord to the grid of the first a. f. tube or the detector tube, and the other to one of the filament wires. When the unit is thus connected, and the amplifier turned on, you will be able to broadcast almost any sound through your loud speaker. This suggests a way of mystifying your friends at a party by doing your own announcing from a concealed point. To amplify heartbeats, place a short section of lead pencil or other rigid object so that one end rests against the diaphragm of the unit and the other is touching the chest over the heart. The heartbeats are conducted to the diaphragm through the stick. With the average receiver and a good speaker unit, the beats can be heard all over a good-sized room. Usually, the balanced-armature type of loud speaker makes the best microphone. It works as a generator of tiny currents, because the armature moves in the field of the permanent magnet, the generated current being picked up by the speaker coils and carried into the amplifier of the set. In addition to heartbeats, you ought to be able to hear your muscles move. The jaw muscles are particularly noisy. Rest the end of the stick on the diaphragm as before, and place the other end against the jaw, near the ear. Slowly tense the jaw muscles; and then relax them. If your set-up is sensitive, you will hear a low, rumbling sound like distant thunder. It will not be as loud as

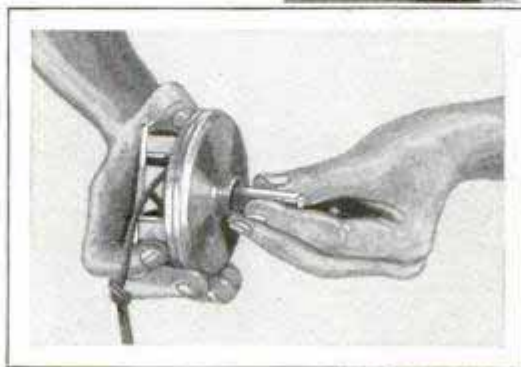

Insert Shows Short Stick Cemented to Diaphragm; Right, Station JAW Broadcasting

the heartbeats, of course. This is an interesting experiment to try on your friends.—Walter E. Burton, Akron, Ohio.

1922 2 Florida Ave. Kenmore
Blending the Tone of Loud Speakers

Those possessing a modern cone speaker and an old-style high-pitched horn may easily adopt the mixing-panel idea employed by broadcasters. The general purpose of a mixing panel for the home receiver is to obtain mellowness and depth with just the desired degree of sharpness for voice and distant reception. To do this, both speakers are connected in

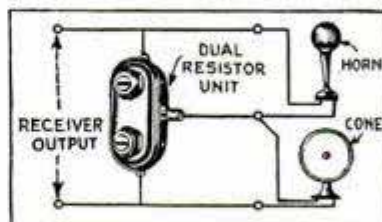

series across the output of the radio receiver, and each is shunted with a variable resistance. Both resistances should have a range of from 0 to 300,000 ohms for efficient control. Separate resistors may be used, or dual resistors mounted in a single unit.

☞ For further information on any radio construction article write to the radio department; this service is free.

TIPS from the

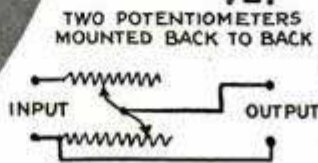
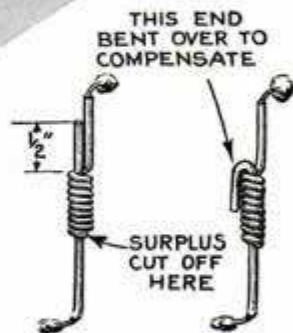

Two 5,000-Ohm Potentiometers on One Shaft Used with 0-to-100 Scale for Comparing Set Outputs

An Inexpensive Balancing Capacity Made from a Few Inches of No. 18 Insulated Bell Wire; Soldered Circuit Connections Are Shown at Top and Bottom

Connecting 45-Volt B-Battery in Series with a 90-Volt B-Eliminator to Obtain 135-Volt Output; Right, Copper Screen on Rear of Console Solves Antenna Problem in Apartment Buildings; Antenna Lead Is Soldered to Screen; It Provides Ventilation and Does Not Interfere with Speaker Operation

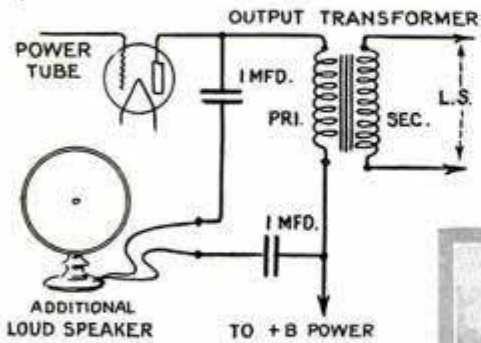
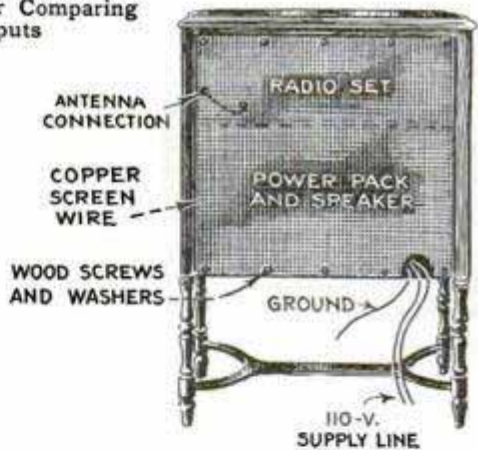
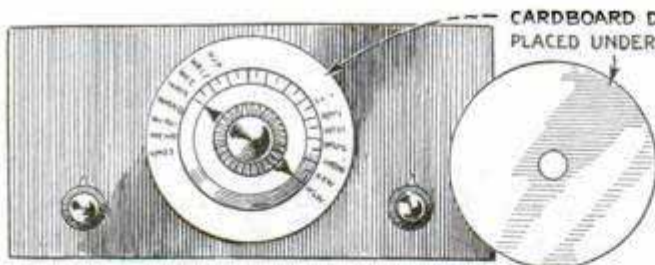

Left, Above, an Easy Method of Logging Any Set Equipped with Ordinary Flat-Type Dials; the Cardboard Disk Is Pasted on the Panel and Pointers Are Painted on the Dial to Provide Additional Logging Space on Lower Portion; Below, Adding Speakers to Sets Equipped with Built-In Dynamic Speaker; the Two Condensers and Connecting Wires Enable the Use of Four Extra Speakers on Sets Employing a 250 Power Tube

Right, Breaks in Insulated Conductors May Be Located by Means of Suitable Voltmeter and Sharpened Test Points to Pierce the Insulation; When Break Is Bridged, Meter Shows Deflection

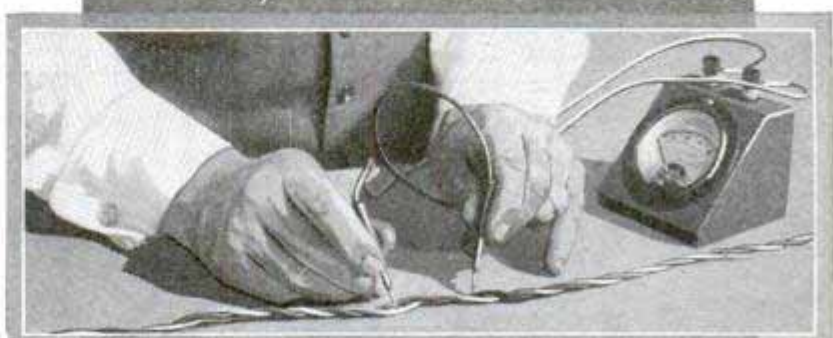

RADIO LAB.

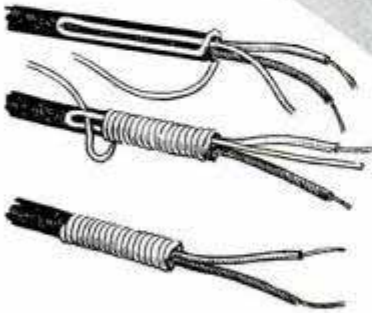
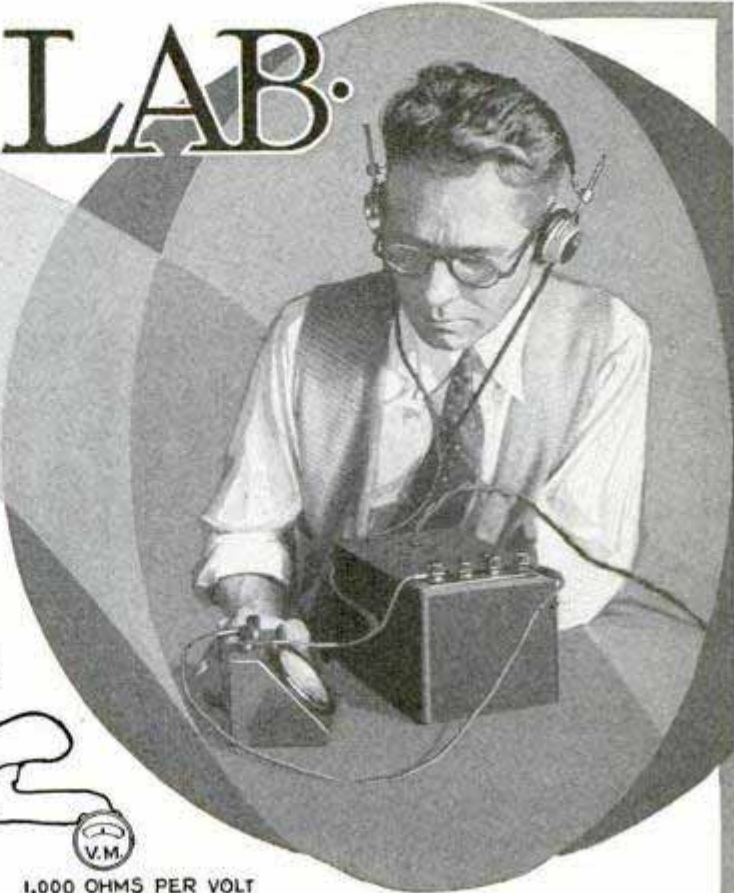

Above, Binding Lampcord to Prevent Covering from Unraveling; Right, High-Resistance Voltmeter in Series with Phones or Loud Speaker Connected across Newly Repaired B-Eliminator for Hum Test without Hooking Up a Receiver

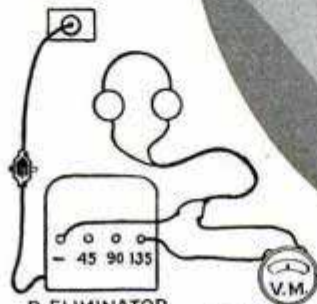

B-ELIMINATOR

1,000 OHMS PER VOLT



Left, a Clever Coil Mounting Devised by a New Zealand Experimenter; Two Pieces of Wood, $\frac{3}{8}$ In. Wide and $\frac{1}{4}$ In. Thick, Are Required; a Groove Is Cut in the Lower Strip to Clear the Winding; the Upper Piece Is Also Grooved to Hold the Coil Form Firmly, and the Complete Assembly Is Screwed to the Subpanel; Below, Modern Ganged Condenser with Trimmer Condensers Nos. 1, 2 and 3 Connected across Each Tuning Unit for Balancing Purposes; the Heavy Line at Top Represents the Rotor of Each Condenser Which Has a Common Ground on the Condenser Frame

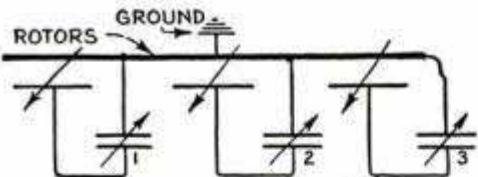

Right, Homemade Heavy-Duty Variable Resistors Made from Common Types of Electric-Heater Elements, Which Have a Resistance of About 20 Ohms Around 500 Watts and May Be Used in the Primary of Power Transformers to Reduce Output Voltage or Similar Purposes Where Heavy Currents Will Be Encountered

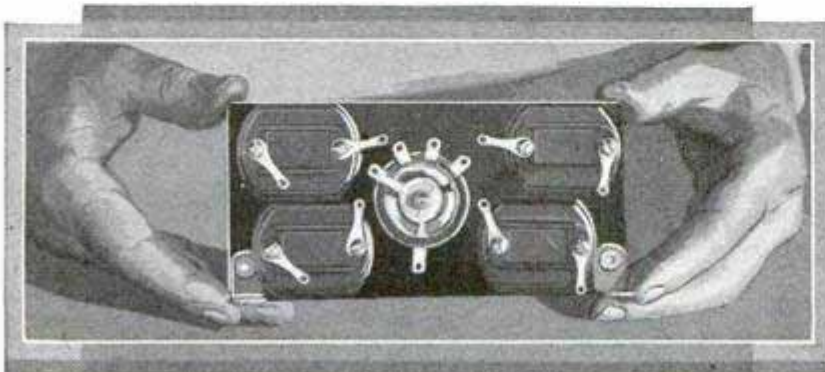
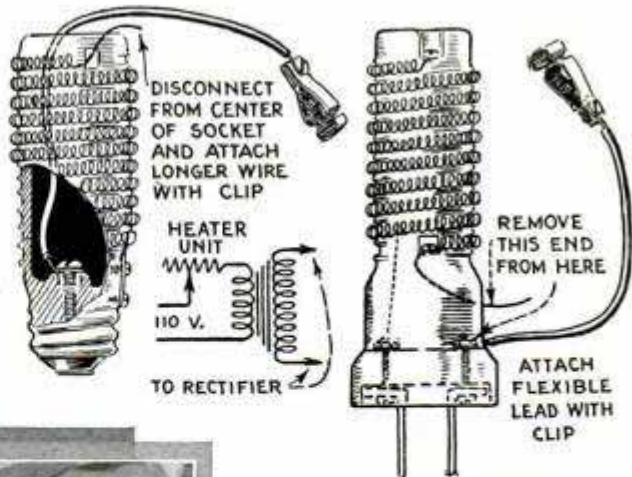

Left, Tone-Control Unit Enables Operator to Change the Quality at Will; Fixed Condensers, from .00005 to .001 Mfd., Are Mounted on Bakelite Panel with a Four-Point Switch, One Side of the Condensers Being Connected to a Common Lead; the Switch Connects One at a Time across the Secondary of the Audio Transformer



Giving *the* A New

although, for most purposes and for most built-in power packs or B-eliminators, a single tube will be quite sufficient.

The 245-tube cannot be operated from the ordinary filament lighting transformer without serious overloading, so a special filament transformer is required.

The laminations, or core material, constitute the knottiest problem, but since they can be bought ready-stamped, it is hardly worth the time and trouble to cut them out with tinsnips and hacksaw. Possibly it may be found that certain types of old transformer cores will answer the purpose, and a slight variation in dimensions of the core is permissible.

Having the core material, about 55 pieces each of the "E" and "I" laminations being sufficient for a $\frac{3}{4}$ -in. core, a tube or core is required on which the secondary and primary are to be wound. This coil tube is easily made, as shown in drawing on this page, by wrapping a layer of $\frac{1}{32}$ -in. fiber around the center member of the stack of laminations, and somewhat longer. When the strip has been properly fitted, it is removed and a line is scored at each corner. The core is then bent into shape so that the corners will be square, replaced on the stack of laminations, glued and allowed to dry before the next step. When the core has

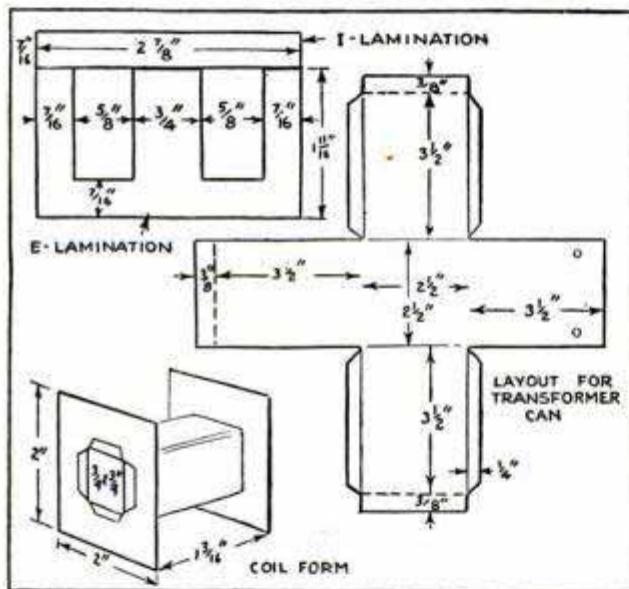

A FEW months ago the 171-tube in the last audio stage rated as the ultimate in radio; today, it is in almost the same class as the variometer in broadcast receivers. With the coming of the 245, which is even more efficient than the earlier 210, and at considerably lower plate voltages, the whole business of power amplification has reached a new stage of development.

Now, then, the problem is to take the old set with its 112 or 171 and give it a 245 voice, and the purpose of this article is to describe a self-contained adapter that can be plugged into the last audio socket without making a single alteration in the wiring of the set. This unit can be used for either one or two tubes,

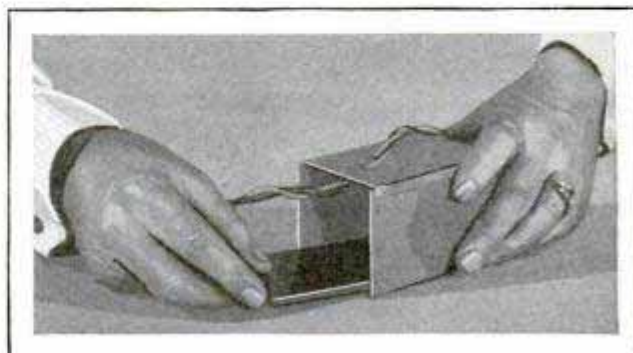

Pieces of Bakelite Inserted in the Can to Wedge the Transformer in Position

Old Set Voice *by* James Arns



dried, two square flanges are made to slip over the ends of the core. The corners of the core are cut open, and the free ends turned up and glued to the flanges. When the glue has dried, the next thing is to wind on the primary, which consists of 880 turns of No. 29 d. s. c. wire. If No. 29 wire is not available, No. 28, which is slightly larger, may be used.

There are various ways of winding coils, but since accuracy is highly desirable, a coil winder equipped with some form of counter is recommended. However, the use of a hand drill in combination with a revolution counter offers a very fair substitute.

When the primary has been wound on as uniformly as possible, wrap on a layer or so of tape and proceed with the secondary. Owing to the low voltage and high current drain, this winding requires heavy wire, and since this is sometimes difficult to obtain and always hard to wind, a substitute is offered. Take two pieces of No. 16 d. c. c. wire, about 15 ft. long, and solder them together at one end. Then wind on 20 turns of this tandem winding, and, when finished, cut off the surplus wire and solder the remaining ends together. This arrangement has the same effect as a single winding of heavier wire.

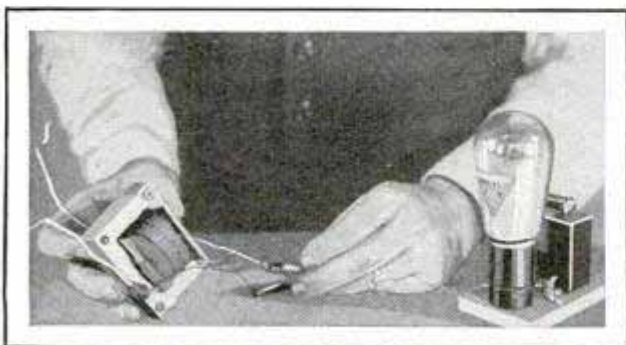

Leads Soldered to Wire Terminals; These Taped Connections Remain Inside the Can When Assembled

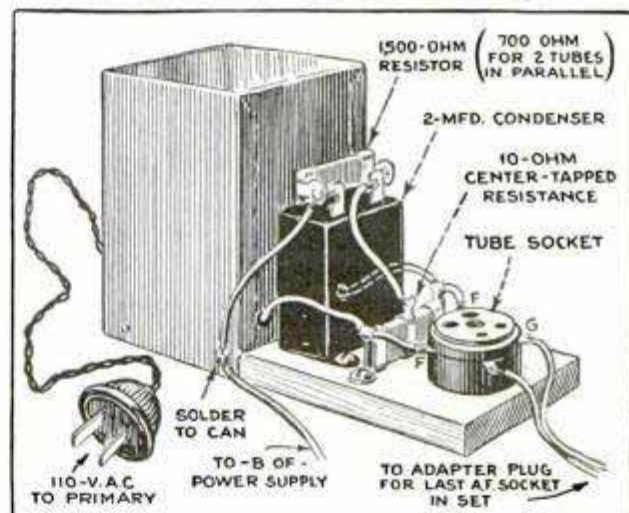

The completed coil is wound with tape, and then the core is built up by inserting, from alternate sides, the "E" and "I" laminations. When as many laminations as can be packed inside the core have been inserted, the whole is either bolted or clamped together. The finished transformer, which delivers around 4 amp. at 2.5 volts, is "canned." The can is made from either tin, brass or other sheet metal, about $\frac{1}{2}$ in. thick, and cut according to the pattern given in the illustration on page 126. Two pieces of scrap bakelite were used inside the can at bottom and front for wedging the transformer tightly in the container. It will be observed that three sides of this container are longer than the other. In the model illustrated, the whole outfit was mounted on a piece

of board, $\frac{3}{8}$ in. thick, $2\frac{1}{2}$ in. wide and 6 in. long, which makes it possible to in-

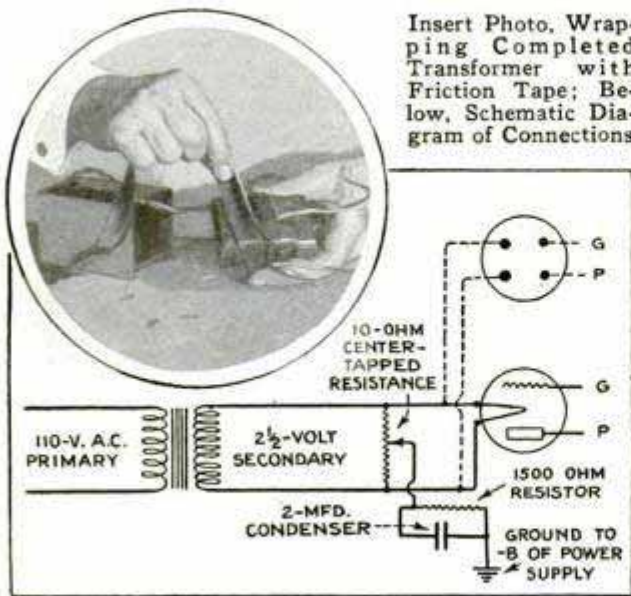

Insert Photo, Wrapping Completed Transformer with Friction Tape; Below, Schematic Diagram of Connections

sert the complete adapter unit into some corner of the set.

The wiring for the circuit is illustrated in the drawing on page 127, and that's about all there is to it. The last tube in the set is removed and the adapter is plugged in its place. In the case of sets in which there is a push-pull audio end, two tubes will be required, with separate plugs for each tube in the amplifier unit.

Marking Location of Tubes in Set

In modern receiving sets with several types of tubes with filament voltages varying from 1.5 to 5 volts, it is quite important that the tubes are placed in their proper sockets. Many manufactured sets have the sockets clearly marked, while others depend on a chart which is easily lost. For instance, if one makes the mistake of inserting a UX-226 tube, requiring but 1.5 volts on the filament, in the socket intended for a UX-171, 5-volt tube, the result will quite likely be a burned-out tube. It is a simple matter to mark the tube socket or the chassis adjacent to the socket for the type of tube with a small brush dipped in some quick-drying lacquer.

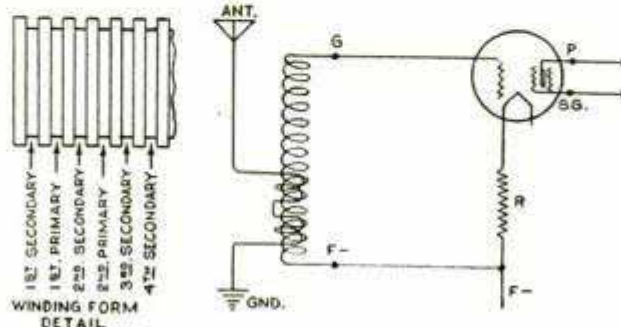

Improving Selectivity of All-Wave Sets

The writer recently constructed a short-wave receiver and added plug-in coils to extend the wavelength range up to 600 meters. An untuned screen-grid r.f. stage was employed ahead of the regenerative detector as is common practice. At first, a 10,000-ohm fixed resistor was used to couple the antenna to the grid circuit of the screen-grid tube. The selectivity was good on the distant short-wave signals, but separation of stations in the regular broadcast band with the larger coils was almost out of the question. This was remedied in a simple manner which, I believe, will be of interest to many others having the same difficulty. The idea is an arrangement whereby the grid circuit remains untuned but is inductively coupled to the antenna. The winding form was a piece of hardwood, 2 in. long by $\frac{3}{4}$ in. in diameter. Fourteen grooves, $\frac{1}{16}$ in. deep, were cut in the form, spaced equally over its entire length. The job may be done on a lathe, or if $\frac{3}{4}$ -in. dowel stock is available, the slots may be cut with a hacksaw. The secondary winding consists of 600 turns of No. 36 enameled wire and is wound as follows: 50 turns each in the first, third, fifth, sixth, seventh, eighth, ninth, tenth, eleventh, twelfth, thirteenth and fourteenth grooves. The primary, or antenna coil, has 100 turns of the same-size wire wound in the second and fourth grooves, 50 turns in each. The first section of the secondary is wound first, then the first section of the primary, then the second section of the secondary, and so on until the form is completed. Beginning with the fifth secondary section, the wire need not be cut after a groove

is finished but the winding is continued to the end. The diagram shows the position of the primary winding near the filament end of the secondary. Alternating the primary and secondary in this manner results in better coupling.— R. Wm. Tanner, Charlotte, Mich.

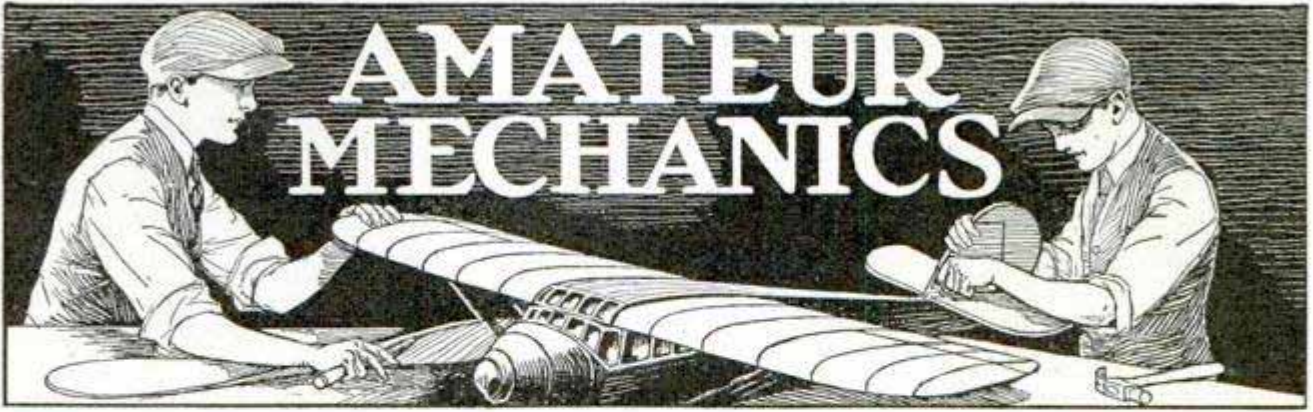

An Outboard "Leaping Lena"

By DICK COLE

THE OUTBOARD motor is forever performing new stunts. The illustrations depict its latest—driving a real "Leaping Lena"—a sport that is guaranteed to give a tingling thrill to the most bored of outboard racers.

"Pegasus," the craft shown, consists of a

light racing boat fitted with airplane wings and powered with a sturdy outboard motor. This contraption actually flies for short distances, sometimes after the style of a mammoth flying fish. When driven into a fairly fresh breeze, it plays hop, skip and jump over the waves, the pilot

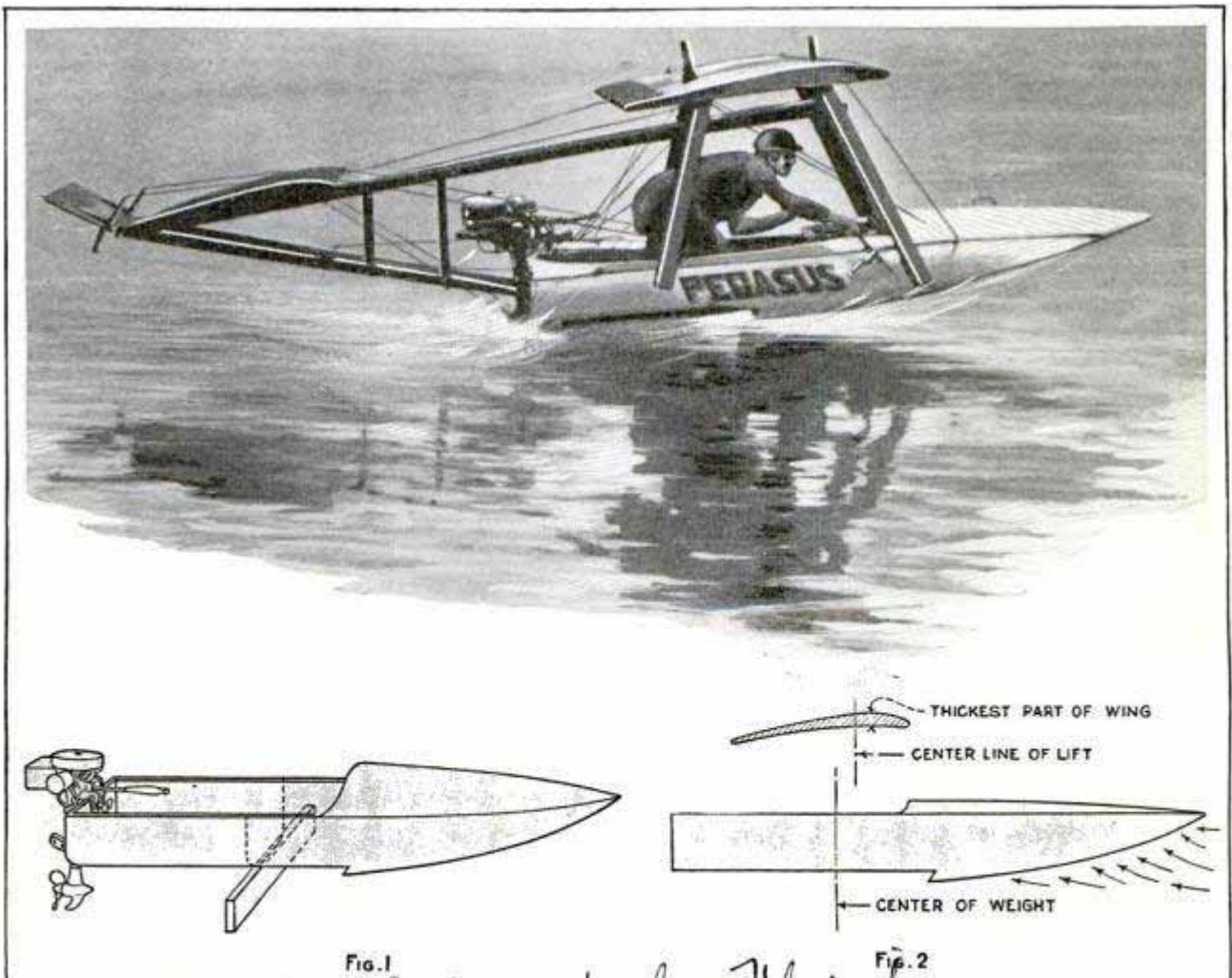

Photos Courtesy Harrison Fraser,

Auburndale, Florida
 All the Thrills of a Ride on the Hurricane Deck of a Bucking Broncho Are Given the Pilot of This Novel Flying "Seahorse," a Craft That Will Provide New Sport for the Outboard Fan

photos. *July 1927* *no. 1929* 129
 418

experiencing a series of sensations that cannot be duplicated by any amusement-park thriller. Playing jockey to a flying seahorse is a sport unto itself.

No doubt many outboard fans will wish to duplicate the performance of "Pegasus." Few, however, will desire to convert their one boat permanently into a mechanical flying fish, for, while this craft is decidedly novel, it has its disadvantages as a permanent design. It is a menace to other crafts on narrow waterways. It is clumsy to dock. A stiff crosswind perils the craft and the pilot. On a long cruise, the "drag" of the airplane wing retards the maximum speed of which the unadorned boat is capable. The winged boat is simply a novelty for sport and amusement, on waters where it can safely be used. Boats are so variable in design and in performance, that it is impossible to outline any fixed method of construction applicable to all models. To make a perfect "mechanical flying fish," one would have to make a special hull and delve deeply into the laws of aerostatics, and this, of course, is beyond the scope of the amateur outboard fan. However, a little timely advice will aid the ambitious outboarder to

weight of the boat with the motor attached. A simple way is to balance the boat on the edge of a wide plank, Fig. 1. After the point has been found, it should be distinctly marked with chalk or paint.

The next thing is to procure an airplane wing. Very few would care to build a wing, but a suitable one can often be had from another source. Back of the hangars on the local aviation field are usually some junked fuselages and wings, and a 12 or 15-ft. section of an old wing can often be had for the carting away. In any event, it can be bought for a couple of dollars. The section must have the same curvature throughout its length, otherwise two shorter, symmetrical sections must be had.

The wing is mounted about 4 ft. above the gunwales of the boat, and the center lift of the wing must be slightly forward of the center of weight of the boat. One can estimate closely the center of lift by visualizing the cross-section of the wing, and by referring to Fig. 2. Non-technically speaking, the center of lift is about 6 in. back of the thickest part of the wing.

On a boat of the sea-sled type, the wing is located farther back than in the case of a pointed-bow boat, since the inverted bottom of a sea-sled affords a few additional pounds' lift forward.

The exact method of attaching the wing to the boat must be left to the builder's ingenuity. The design of wings and of boats is too diversified to lay down any

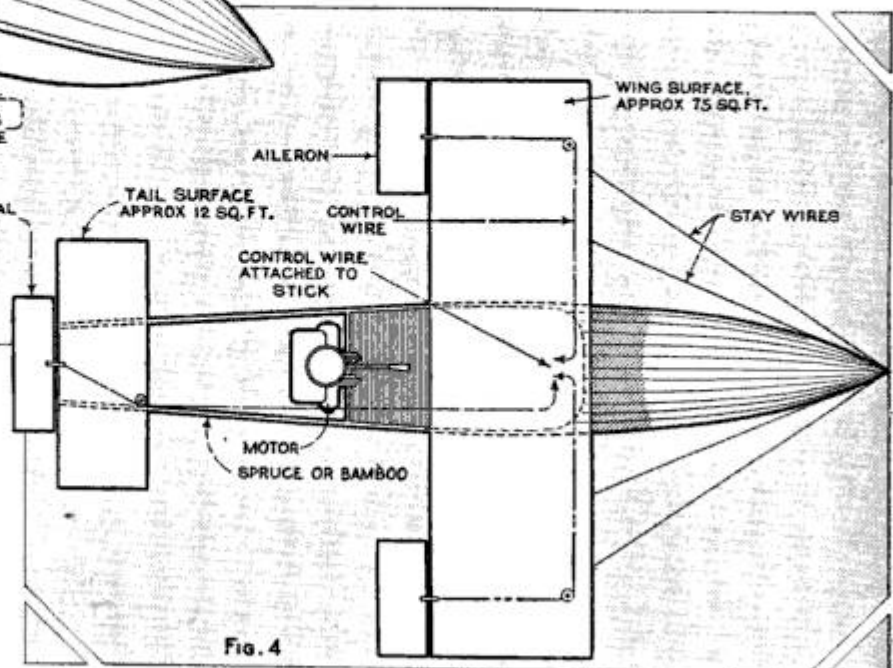
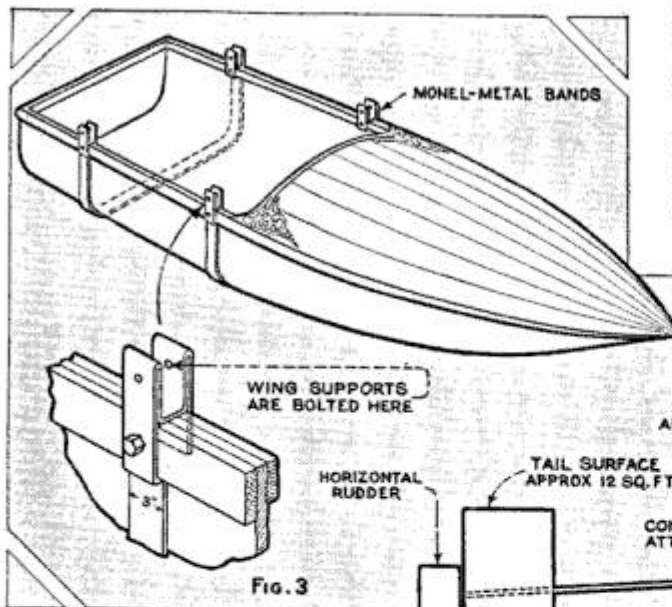

ape the fish that play "on the road to Mandalay."

The first requisite is a boat less than 100 lb. in weight and capable of a speed of at least 30 miles per hour. The next thing is to find the center of

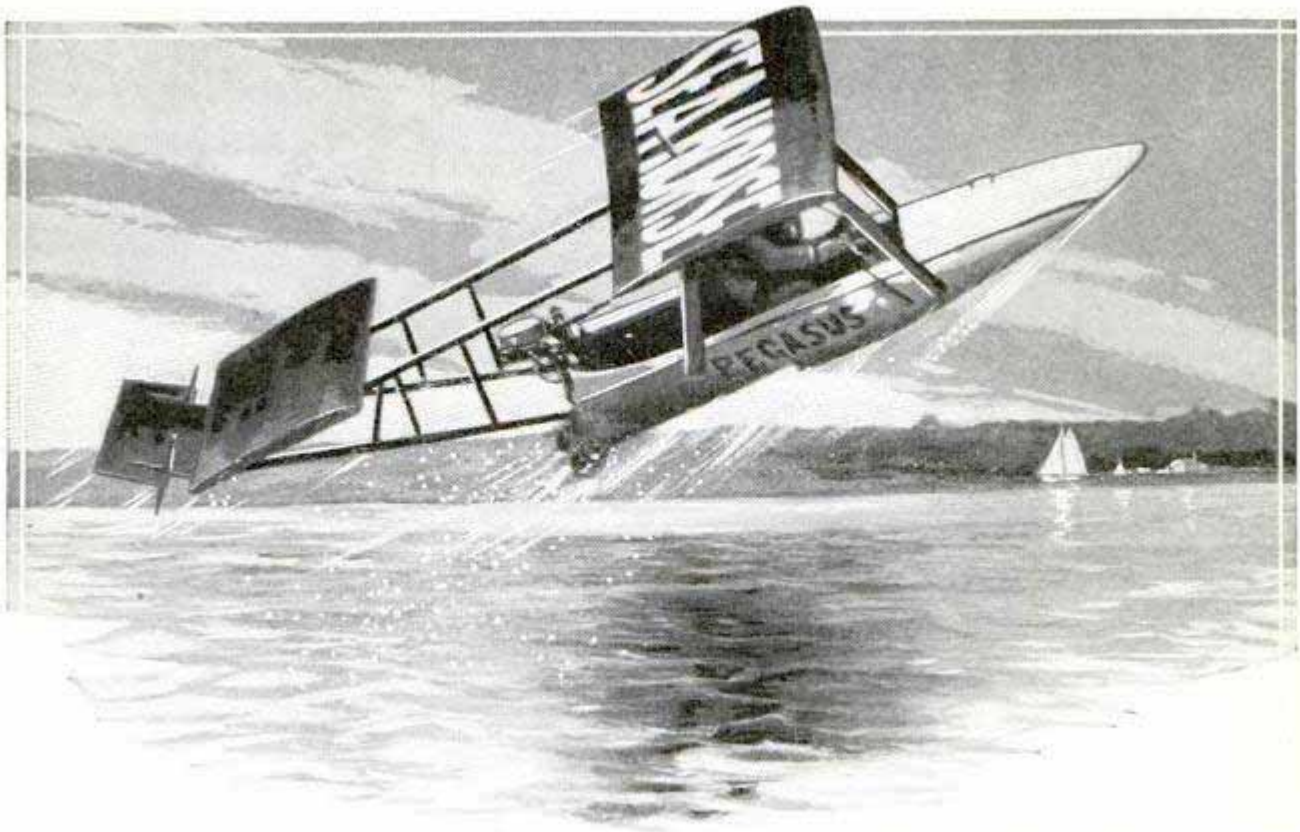

"Pegasus" in Flight; This Photo Gives a Good Idea of the Heights to Which the Ambitious and Skillful Rider of the Flying Seahorse Can Rise—after His First Course of Spills

fixed rules. The wing must not be attached so as to lift directly on the gunwales only. The resultant strain of a sudden gust of wind might rip off the gunwales or open seams in the planking. To safeguard against this, it is well to put two 3-in. bands of fairly heavy sheet metal completely around the bottom of the boat, as in Fig. 3. Monel metal is especially recommended.

Spruce, streamlined, is recommended for the supports. The tailpiece, possibly with the horizontal rudder already attached, comes from the same source as the wing. The photographs illustrate very clearly the approximate position and the construction of the tail assembly, but the exact angle of the tail can best be determined by experiment. The lower pieces of the tail-support frame are screwed securely to the gunwales or to the transom. These pieces must be cocked upward sufficiently to prevent the tail from dragging in the water when the bow lifts. The framework of the tail should be made of clear spruce or of Calcutta bamboo.

The photographs show no ailerons attached to the wings, but later experiments with "Pegasus" proved that ailerons were desirable to maintain lateral balance. Without them an occasional sideslip is

inevitable, with possible damage to the wing and danger to the pilot. The main wing should be mounted so it can be tried at various angles.

The pilot should proceed cautiously when first trying out his winged craft, and the first tests should be made on smooth water. The pilot should have his own weight well ahead of the center of weight. After the boat has gained its maximum speed, the pilot slowly moves his weight back. The bow rises, and the onrushing air hits the wing surface at a more effective angle, lifting the craft clear of the water. The moment the propeller is in the air the motor races, so provision must be made to throttle down the motor instantly to prevent damage. As soon as the propeller is out of the water, the forward thrust ceases, the drag of the wing checks the momentum of the craft and it glides down to the surface of the water.

The method of operating the control cables must be left to the option of the pilot. They can be attached to a "stick" as on an aeroplane. The horizontal tail rudder will come in for very little use, as the pilot soon learns to shift his weight involuntarily to maintain longitudinal balance. Skillful operation of the ailerons will be acquired from practice.

AIRPLANE KITE RELEASES

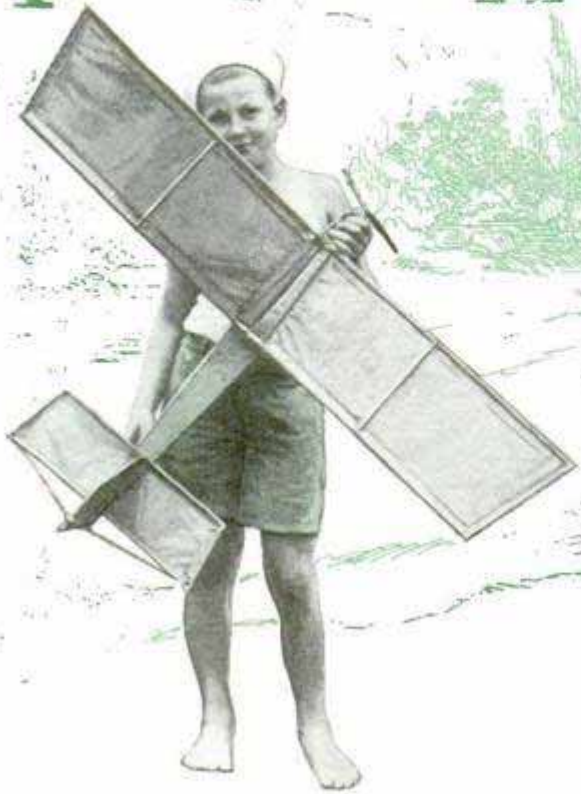

WHEN this airplane-model kite was having its first try-out, a near-sighted old lady rushed excitedly into our corner drug store and cried: "Lookout everybody! A big airship's going to crash right down on us."

And in fact the kite, zooming around in spirals against an over-cast sky, did look for all the world like a plane in trouble. The strange maneuvers were caused by manipulation of the string; in a few minutes it pulled out of its spin and soared gracefully, with a dip now and then at the will of the operator.

Making this kite is far simpler than building a model airplane, and when it is completed, you have an infinitely stronger job than any of the rubber-motored models. It is not necessary to build for lightness, and although the original of the model weighs less than 5 oz., it is surprising what a load a brisk breeze will lift even with the limited wing surface of the kite.

Spruce is used throughout, with

the exception of a balsa nose and tail-piece, and propeller, and even these can be of white pine. Begin with the V-shaped fuselage, assembling the two top longerons with the $\frac{3}{4}$ -in. balsa nose and tail blocks shown in Figs. 2 and 3, and the intermediate crosspieces. Use $\frac{1}{8}$ by $\frac{1}{4}$ -in. spruce longerons at the top corners of the fuselage; set in the central crosspieces across the two and ambroid them in place. Next draw the ends of the longerons together and secure them to the balsa nose and tail blocks, notching them in place here as shown in the drawings. It is important that the top side of the fuselage remain flat, as shown in the side

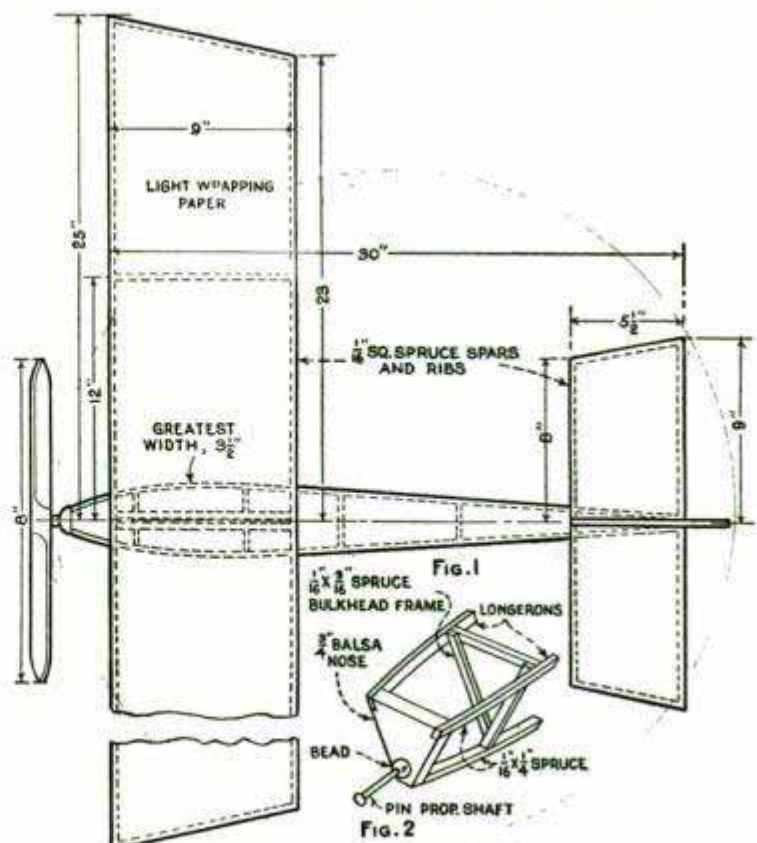

PARACHUTES

by Bob Hartley

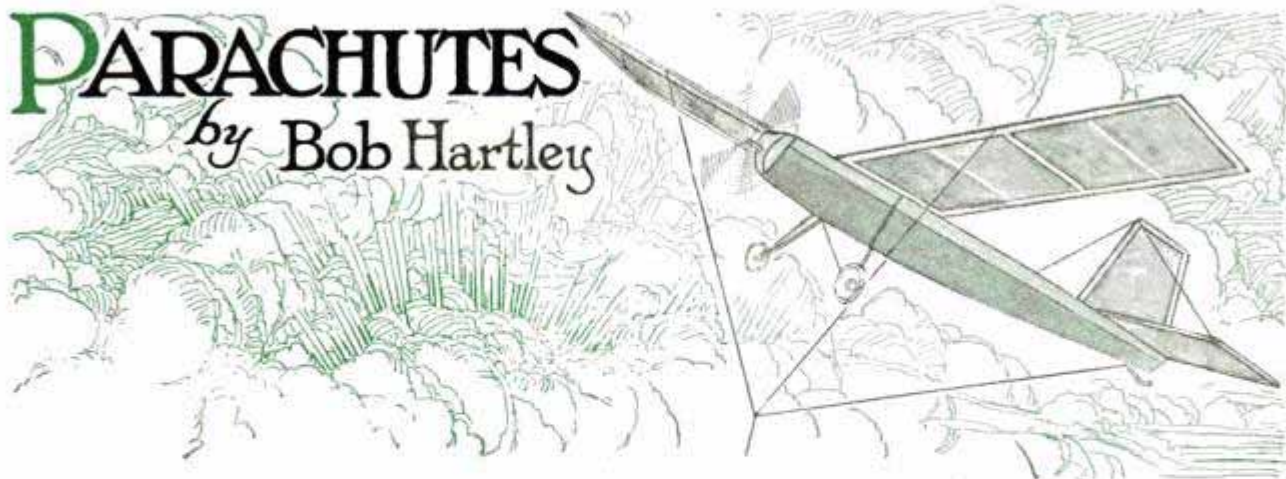

elevation, Fig. 4. In order that it may not be bent to a curve by the bottom longeron, the latter is only $\frac{1}{16}$ in. thick so that it will bend readily without imposing any strain on the rest of the fuselage.

Secure the bottom longeron to the tail block with ambroid and bind with tough thread, then build the V-shaped bulkhead frame as you work toward the nose. The bulkhead frame members are notched at the top to set against the longerons and ambroid in place. The other ends, at the bottom of the "V," are also ambroided and bound together and to the longerons with thread. The bulkheads are spaced longitudinally as shown in Fig. 4.

Note that the wing has a pronounced dihedral angle, and the frame is made in two halves, joined at the center line as in Fig. 7. To insure strength and protection against crashes when launching, the cor-

ners of the wing and stabilizer frames are lapjoined, and firmly secured with ambroid and thread binding. Half of the lap is cut in each piece, so as to leave the joint the same thickness as the spars. The two ribs midway in each half of the wing are half-lapped; that is, the ends of the ribs are cut down but not the spar, which would be weakened by the process.

Join the two halves with a 4-in. section of heavy, stiff wire, bent to the required angle and secured with ambroid and thread. This wire is used on both leading and trailing spars. In order that the wing may sit level on the top of the fuselage, the underside of the spars are built up with balsa blocks where they join.

The stabilizer (Fig. 1) is very simply made, using the same-size material as the wing and only one rib in the center. For

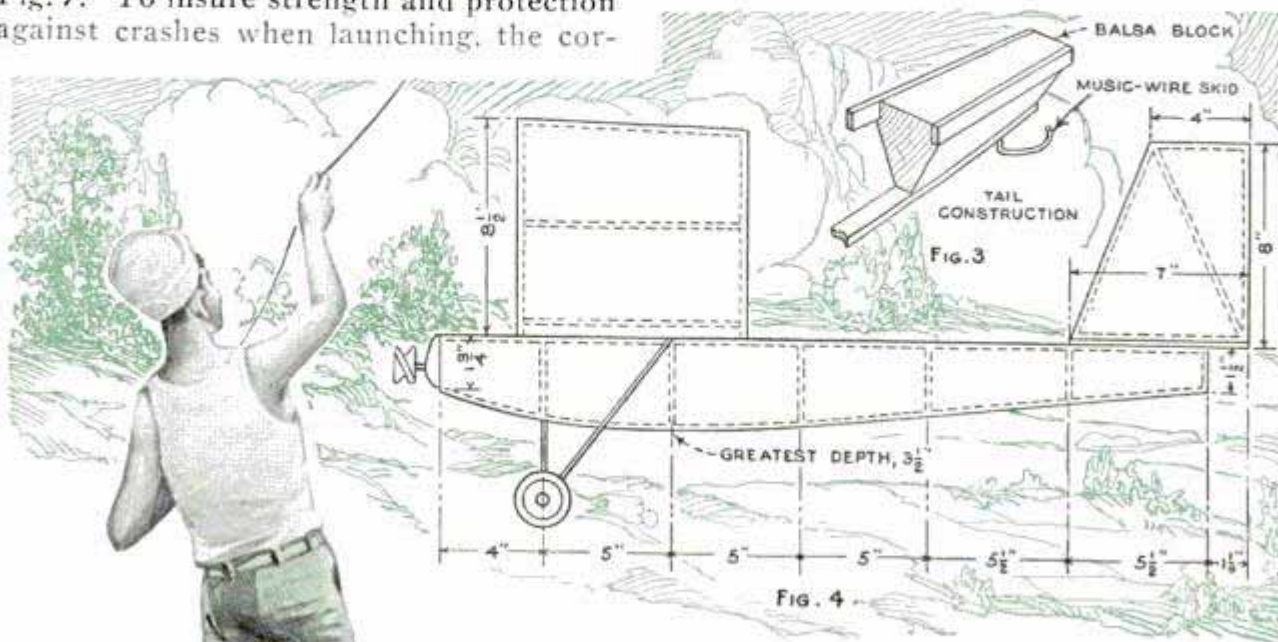
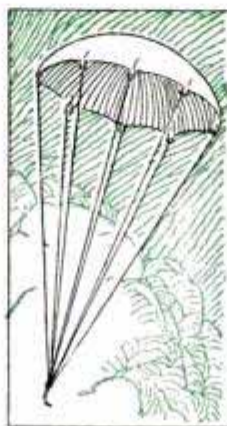

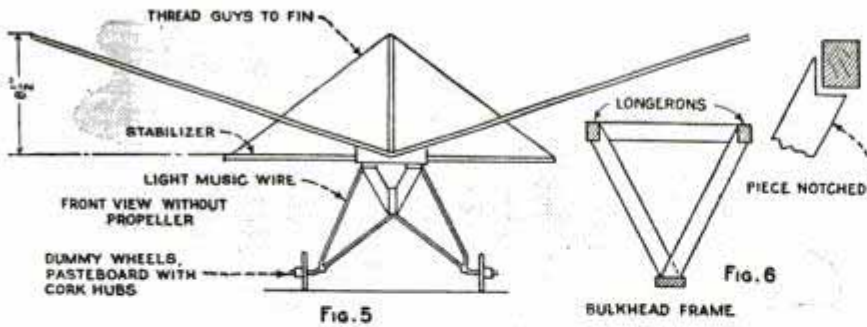

the fin, the writer used lighter pieces, $\frac{1}{8}$ by $\frac{3}{16}$ -in. spruce, with a diagonal brace. None of the fin joints need be lapped.

You need not follow model-airplane practice in making the propeller. On the contrary, the prop should be made large and conspicuous, with wide blades and moderate pitch so that it will not turn too fast to be seen. Balsa is good

material, but white pine will also be satisfactory. When completed, sandpaper it well, give it a coat of dark stain and cover about half of the blades with tinfoil, or better, if you happen to be on good terms with a sign painter, gold leaf. The latter is very hard to apply well, but the tinfoil can be laid on with a thin coating of glue, mucilage or shellac. The effect in the sunlight, as the whirling blades reflect the rays, is certainly "keen," as the boys say.

For fabric, the writer used ordinary lightweight brown wrapping paper from the grocery store. It is tough enough and at the same time light enough for all purposes, and the dark tone makes the plane more easily visible high in the air. The first experimental kite that was built was made with all balsa fuselage and spars and was covered with bamboo paper. This was not a success, as the wind simply blew holes in it, and it folded up like a limp

handkerchief in the air. So don't try to build the kite too light. Follow the instructions as given.

The paper should be put on the bottom side of wing and stabilizer and on either side, or both, of the fin. Apply a thin coating of glue on the spars and end ribs with the finger, which spreads it more smoothly than a brush, and draw the paper tightly from end to end, pressing down on the end ribs, and then from front to back. An unusually neat job can be done with this kind of paper.

It will be necessary to cover each side of the fuselage with separate pieces of paper, and, in each application, always pull from end to end first, then to the sides.

You will note that the wing is covered after the two halves are assembled. This is to make it easier to bind the frames together.

If you have patience, however, you can reverse the order and, perhaps, make a better job of the papering.

A dummy landing gear adds to the effectiveness of this novel kite, and is built of light music-wire struts with pasteboard wheels and cork hubs. The wheels, of course, need not turn on the axles, and are ambroided in place. Attach the wing-and-tail assembly to the fuselage with ambroid and thread.

The three-point string arrangement keeps the craft steadier than a two-point, as on conventional kites. Two ends are tied to the leading spars at the central ribs and the third to the tail skid. The proper length and adjustment should be determined by experiment. On the original, the apex of the three strings was just about even with the nose and 12 in. below it. Varying conditions may demand a different adjustment.

While the parachute idea is not new,

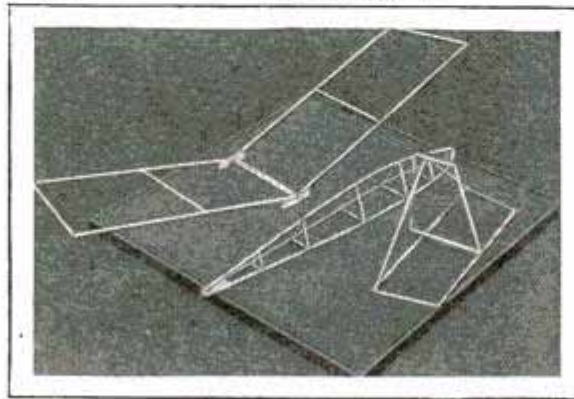

METHOD OF MAKING DIHEDRAL WING
Fig. 7

this adaptation lends new thrills. Send the parachute up with the kite, instead of after it. Hang it at the apex of the tie strings.

A parachute in the true shape, or approximating it, can be made according to the diagram, Fig. 8. When complete, it is somewhat the form of an inverted saucer. One slit is made to the center and the edge is lapped over about $\frac{1}{2}$ in. Seven other slits, 1 in. long, are made and lapped over about $\frac{1}{4}$ in. The strings are secured by strips of gummed paper pasted over the laps at the edges, and the ends of the strings (light thread should be used) converge to a bent pin. The point of the pin should have a wide angle, so that it will flip off the cord readily when the string is jerked, or snapped with the finger.

This kite is flown much the same as the standard types, except that it may be necessary to make the tie cords longer or shorter in order to vary the angle at which it meets the wind. Adjusted as described, the original rose nearly directly overhead on 600 ft. of cord.

A little experi-

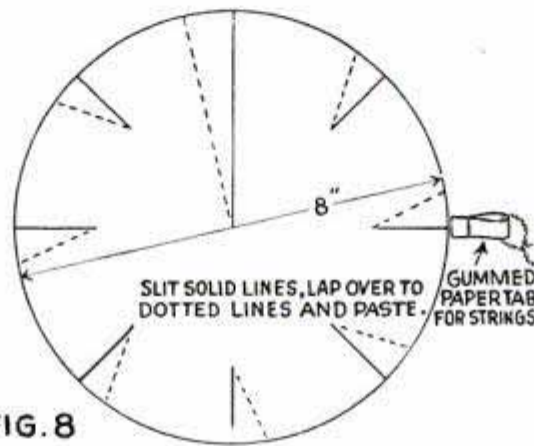
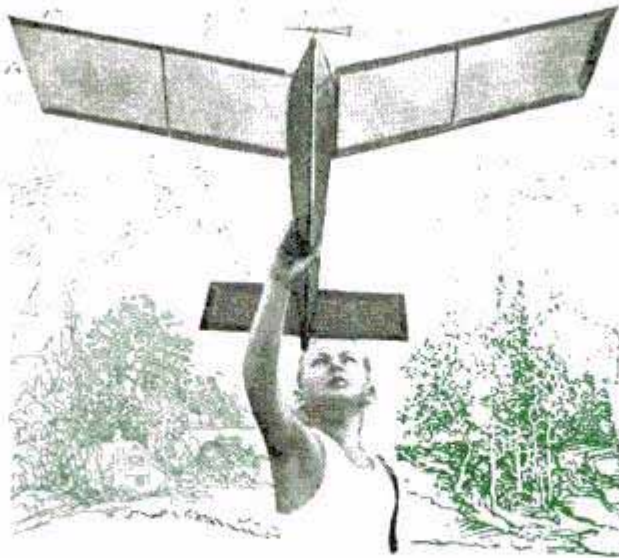
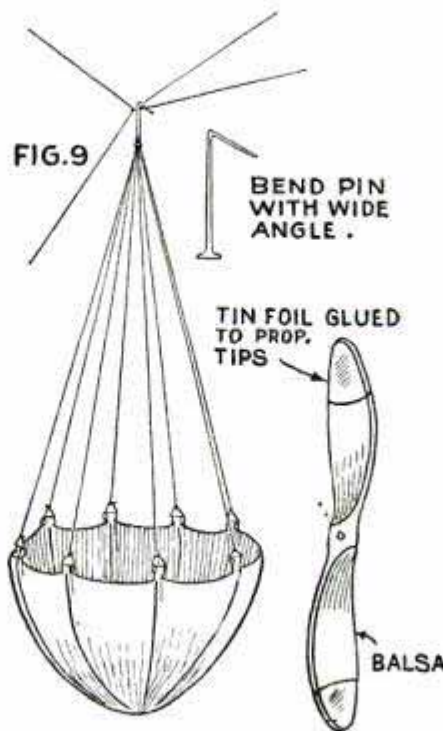

FIG. 8



PARACHUTE HANGS UPSIDE DOWN

ment will probably be found necessary in order to determine the proper length of the hook on the parachute pin, and the angle to which it is bent. The original worked very well when bent to the angle given in the drawing. More elaborate arrangements of releasing the parachute can be worked out, of course, one of the most obvious being to hang the parachute by means of a trigger arrangement which will be released by a "messenger" in the shape of a light aluminum or brass tube sent up the string. The rate at which the messenger travels upward can be increased by fitting it with tin or light-brass propeller blades, soldered onto the tube so as to make it revolve. If this is done, brass or tin will have to be used for the tube, since it is difficult for the amateur to solder aluminum. If care is taken in adjusting the parachute and in releasing the kite when starting to fly it, it will be found that the simple arrangement shown will answer. A small weight tied at the junction of the parachute strings helps it to descend more steadily.

LOG SKIDS AID IN GETTING CANOES PAST DAM

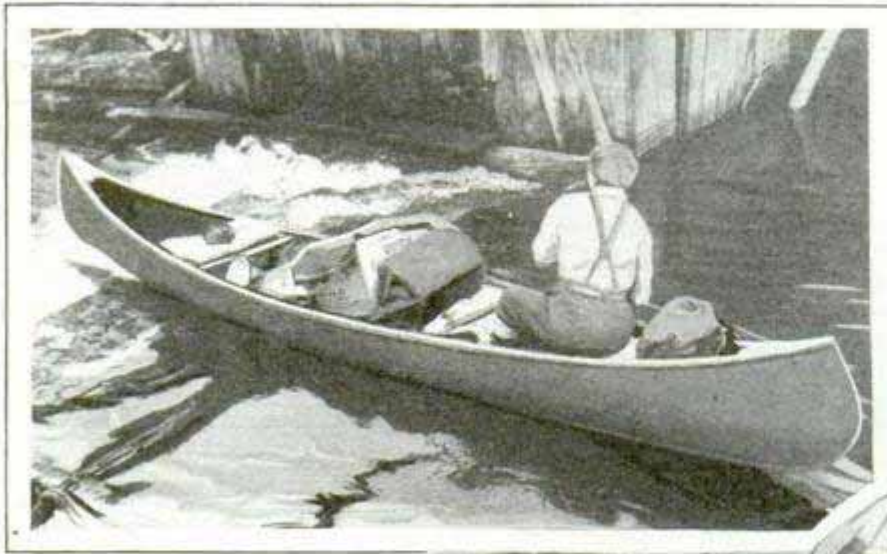

Getting a Loaded Canoe Past a Dam Is Simple with the Methods Shown in the Photos.

A dam across a stream interferes badly with canoe traffic, and is quite a nuisance to the canoeist with a heavily loaded craft, as it means unpacking and portaging around the dam. How this problem was solved in one case is shown in the photos. For canoes coming downstream, two peeled and smoothed logs were spiked to the dam, just under water and parallel to the current flow, with their lower ends



driven into the bed of the stream. Going down the canoe is pointed between the logs, and the current carries it over the dam and down the logs as on a chute. For going upstream, a track of peeled

and smooth logs is laid on the bank, from below to above the dam. Two men can easily skid a loaded canoe along this track, as shown in the lower illustration. —M. E. Cowen, Cresson, Pa.

Hardening Small Tools

The hardening of small tools, such as chisels, etc., usually somewhat of a mystery to the home-shop worker, is in reality very simple. When tool steel is heated to a bright red and plunged into water or oil, it becomes hard, too hard, in fact, for ordinary use, for in this state it is brittle and apt to break on the slightest provocation. It is necessary, therefore, to "temper" the hardness to a point where the tool will be sufficiently hard to cut properly, yet tough enough to stand up without breaking. This tempering, fortunately, is an easy matter. Taking a cold chisel as an example, it is grasped in a pair of tongs and heated to the proper heat for quenching in water. Since there is a wide variety of tool steels, and

since the "proper" quenching point varies for each, it might seem to be a difficult matter for the amateur to determine when to quench. Experience, of course, soon teaches this, but there is a simple test which anyone can apply with good results. Hang a small magnet on a piece of string near the forge or furnace where the tool is heated. As the tool grows hotter, pull it out of the fire from time to time and bring it near the magnet. When the hot tool ceases to attract the magnet, quench it. To temper the chisel, take a piece of emery cloth and polish the "business end" of the tool. Now take a piece of scrap iron, heat it to a good red heat, pull it out of the fire, and rest the chisel against it, about 2 in. back from the cutting edge. Watch the polished part of the cutting end closely, and soon you will

see colors begin to appear on the surface, as it grows hotter. First a faint yellow, blending into straw, then light brown, dark brown, purple and blue. When the color on the polished end reaches the dark blue, quench the whole tool in water. If the tempering heat is too high, the colors will run up the point of the tool too fast and close together. If this happens, dip the end in water and draw out quickly, when the colors will come more slowly. Different tools are tempered or "drawn" to different colors. Lathe and planer tools, for example, are drawn to a light straw (430° F.) or to a medium straw (450°); small drills and wood chisels to a brown (500°); center punches, scratch awls, wire cutters, screwdrivers and axes to a purple (530°), while cold chisels range from purple to dark blue (600°), depending on the purpose for which they are used.

Tinfoil Substituted for Small Mirror

A pocket mirror is often used to reflect light into small openings, but if a mirror is not handy, a piece of tinfoil taken from a cigaret package makes a good substitute. The sheet is doubled and pressed over a smooth disk, the overlapping ends being brought together to serve as a finger grip. A high polish on the foil can be obtained by rubbing it over a soft cloth, and it will reflect light nearly as

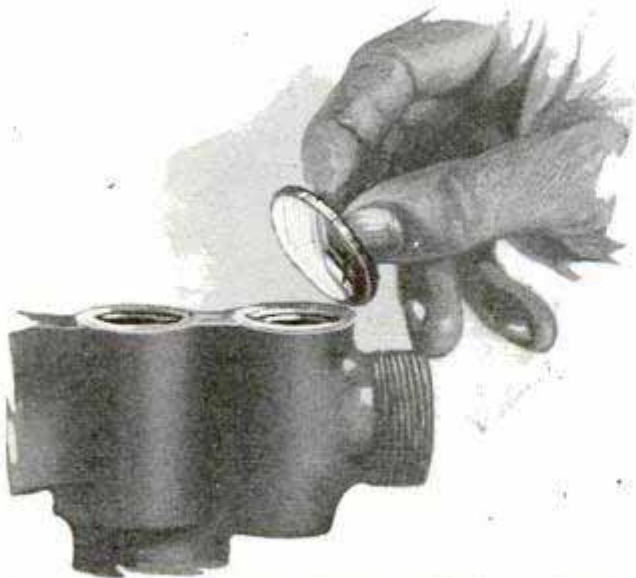

Improved Mirror, Made from Tinfoil, for Reflecting Light into Small Places

well as a regular mirror.—Frank W. Bentley, Jr., Missouri Valley, Iowa.

Old Auto Hood Makes Good Brooder

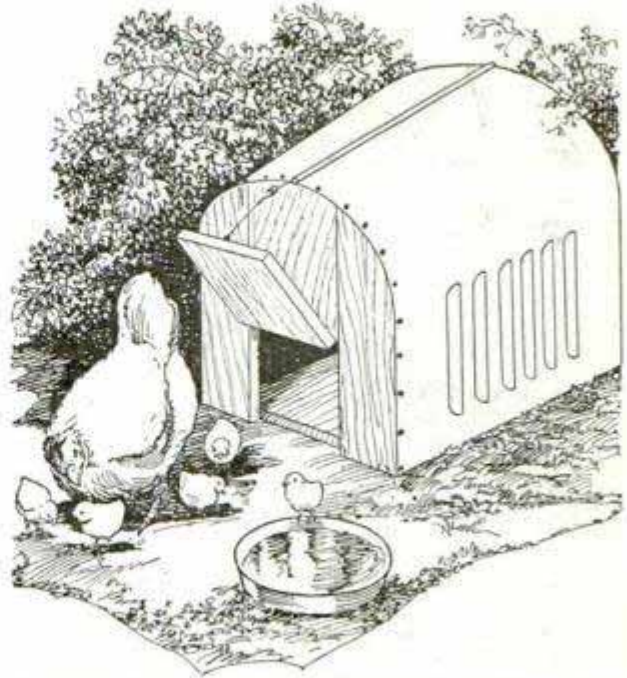

Old Auto Hood with Ends Boarded Up Makes Comfortable Coop for the Chicks

By boarding up the ends of a discarded auto hood and providing a suitable floor, a neat, clean coop can be made for the chicks. Strap hinges are used to fasten the floor to the side, which enables one to clean the inside when necessary. Besides being sanitary and waterproof, this coop is comparatively light to carry.

Making "Close-Ups" with Small Camera

Those who use an ordinary small camera frequently find that it is impossible to get close enough to a subject to get the size of image desired, even though a portrait attachment is used on the lens. However, by using two or even three or more portrait attachments, one directly over another, the focus of the camera lens can be shortened so that a very large image is obtainable. Adhesive tape can be used for holding the attachments together. In this way it has been found possible to obtain large-scale photos comparable in size even with those made with a low-power microscope.—William C. Vestal, Redlands, Calif.

☞ To prevent children from sounding your auto horn when the car is parked in the street, cut it into the ignition-switch wiring so that it can be used only when the motor is running.

Model-Yacht Hull?

by E.M. Love

Make the mast 14 in. long from truck to deck, plus the depth of the hull, tapering it from $\frac{5}{16}$ in. at the butt to $\frac{3}{16}$ in. at the tip. Drive a $\frac{3}{4}$ -in. brad halfway into the butt, file a point at the head, and force it into the bottom of the hull. Nail or screw the mast to the crossbeam.

For the deck, rip a piece of $\frac{1}{8}$ -in. stock, bore a mast hole, and nail it in place with $\frac{1}{2}$ -in. brads. Trim the edges flush.

Brace the mast with a string or wire forestay stretched between a brad in the bow and a point 10 in. up the mast. Add two backstays anchored to brads driven $1\frac{1}{2}$ in. aft of the mast, in the deck edges.

The rudder post and tiller are of balancing wire, entered through a hole bored in the solid part of the stern. Solder to the wire an oval rudder snipped from tin, flowing enough solder to cover the rudder post. Make a wooden bead $\frac{1}{2}$ in. long to hold the tiller above the deck.

Drive a brad into the deck, centering 1 in. forward of the tiller end, to which the tiller is secured with a rubber band drawn tightly enough to hold the rudder straight.

The mainsail boom is $\frac{3}{16}$ in. in diameter at the center, tapering to $\frac{1}{8}$ in. at the ends. Lash to the forward end a yoke to fit around the mast, and tie to the mast loosely enough to allow the boom to swing freely. Tether the boom with a string to the tiller, so that the boom end can swing 2 in. over the side. It will move the rudder enough to prevent the boat from veering and running before the wind.

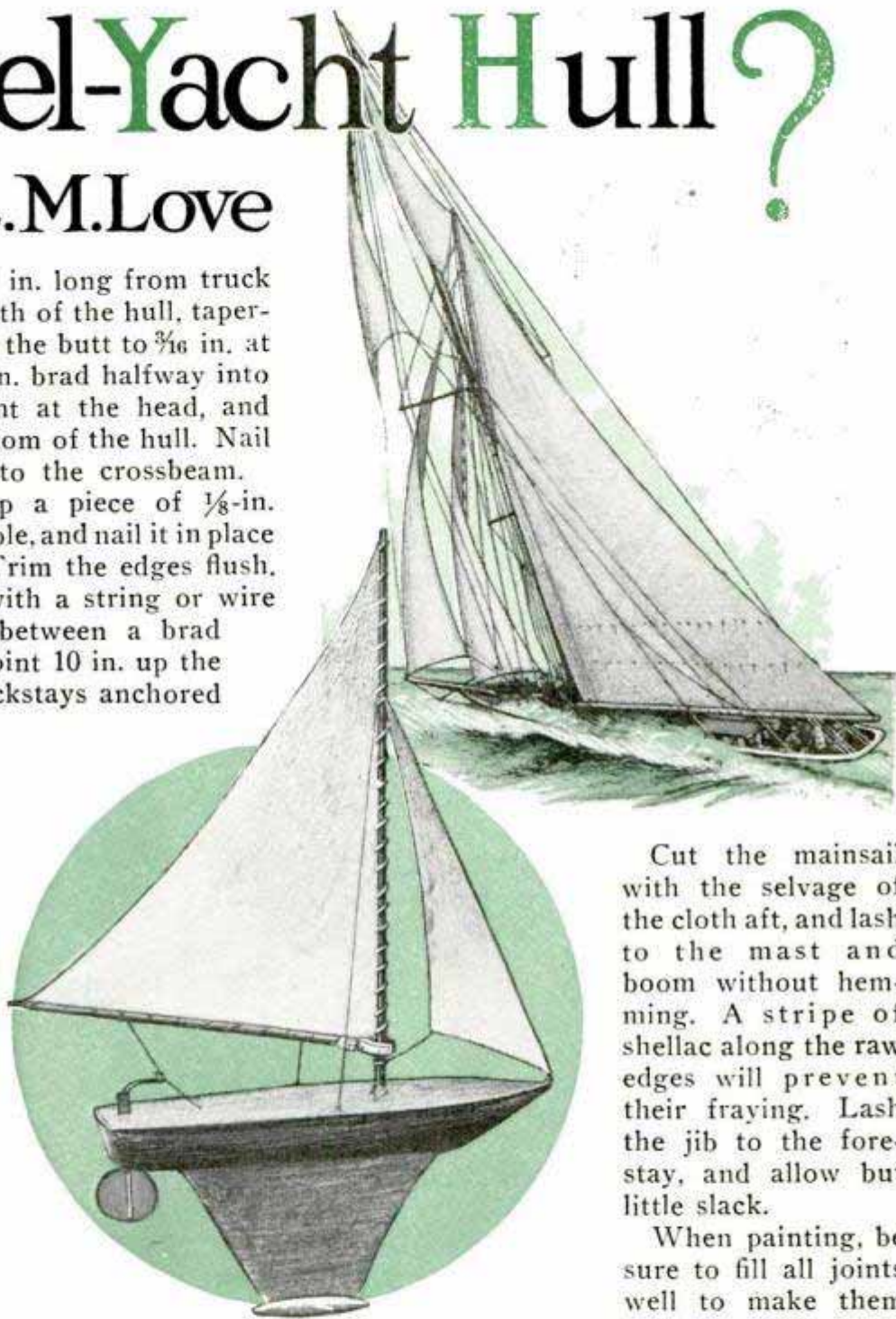

Cut the mainsail with the selvage of the cloth aft, and lash to the mast and boom without hemming. A stripe of shellac along the raw edges will prevent their fraying. Lash the jib to the forestay, and allow but little slack.

When painting, be sure to fill all joints well to make them waterproof.

It is just as well, before putting on the deck, to apply a heavy layer of white lead or thick paint around the edges of the hull, where the deck is to fit, then nail the deck in place while the lead or paint is still soft. Since the rudder post comes through solid wood, there is no need to take any precautions at this point, but the keel can be bedded to the hull with white lead and the screws dipped in white lead before driving them into the keel. The hull should be painted in two colors, and the deck, mast and boom varnished natural.

Trout Spoon Resembles Black Bug

Efficient Trout Spoon
Resembling Black Bug
Insures Many Good
Catches

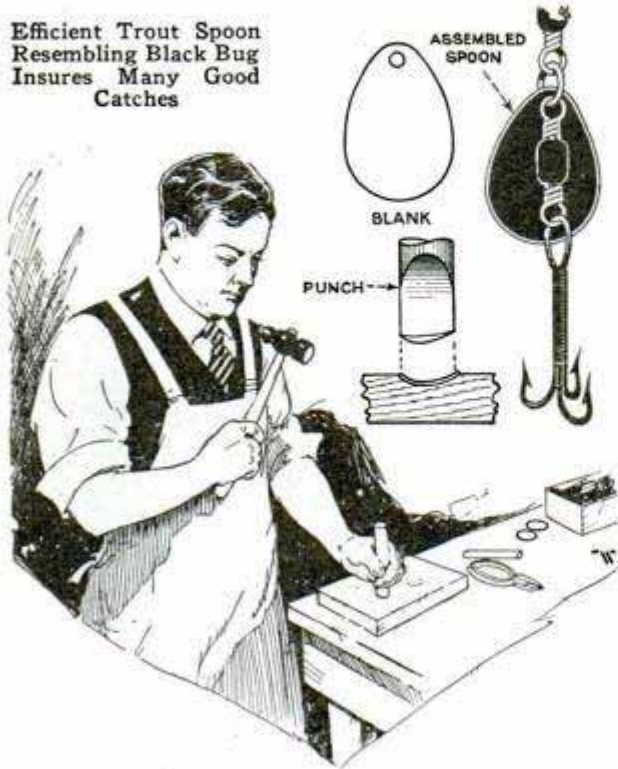

While fishing for trout without success, I found that, while they did not take anything I had to offer, they would strike voraciously at black bugs floating on the surface of the water, so I decided to make some black bugs. The spoon shown in the drawing was made of sheet brass, about .020 in. thick, using a standard trout spoon, about $\frac{3}{4}$ in. long, for a pattern. After forming the spoon, I dipped it in commercial nitric acid to which as much copper was added as the acid would dissolve, and the spoon was then heated in the flame of a blowtorch until the surface became black. It was assembled with a triple hook, swivel joint and the necessary rings, and given a thorough test which was highly satisfactory. The trout will invariably strike at the black spoon, and as a result I have made many good catches. In making a quantity of these spoons, which I proceeded to do, I ground and polished the end of a 4-in. length of drill rod to the proper curvature, and made an impression with it on a piece of maple. The spoons were cut to the required size, and a $\frac{1}{8}$ -in. hole was drilled in the narrow end of each, after which they were ready for shaping. This was done by placing them on the maple die and striking the punch a sharp blow with the hammer. After the acid treatment,

three dippings sometimes being necessary to obtain the desired black finish, I cleaned and polished the spoons with ordinary floor wax, to protect the finish.—Dick Hutchinson, Ithaca, N. Y.

Unequal Distribution of Load on Auto May Cause Damage

Thoughtless loading of luggage on an automobile easily may cause serious damage to some part of the car. As an example in point, the following experience of one motorist will serve: In order to avoid cluttering up the inside of his car with camping equipment, he mounted an extra trunk and two spare tires behind the regular trunk. Unfortunately, this arrangement was the cause of the rear spring breaking, whereas, if the load had been distributed on the running board, this would not have happened. The extension increased the leverage of the chassis on the rear spring, and it broke.

Butterfly Pin for Holding Curtains

For holding back window curtains, an attractive pin can be made from a spring clothespin and a piece of colored oilcloth, cut and painted to resemble a butterfly. The piece of oilcloth can be bunched between the jaws of the pin, which also hold the curtain as indicated, or it may be tacked on. The clothespin should, of course, also be painted to match the wings.—Jos. C. Coyle, Denver, Colo.

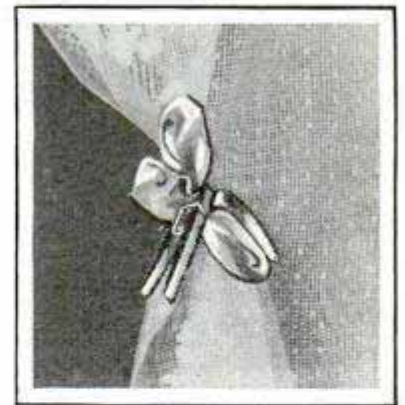

Magnet Attachment on Vacuum Cleaner

By attaching a magnetized bar of tempered steel, $\frac{1}{2}$ in. thick and about 10 or 12 in. long, according to size, to the nozzle of your vacuum cleaner, all particles of iron and steel, such as hairpins, steel pins, tacks, etc., will be picked up. Drill a hole in each end of the bar and screw it to

holes tapped in the front of the nozzle, forming a sort of bumper. In order to prevent marring the furniture with this accessory, fasten a narrow strip of inner tube to the front of the bar.

Asbestos Sheet Speeds Toaster

Toasting a single piece of bread on an electric toaster takes longer than toasting two pieces simultaneously. This is due to the loss of heat from one side and can be prevented by slipping a sheet of asbestos on the unused holder. The sheet may be fitted with a bent-wire handle, so that it can be withdrawn while hot.

Thatched Roof for the Cottage

Exposed framing and a thatched roof make the illustrated cottage picturesque. In the front part, stucco is applied to the panels between the framing, the panels being covered with metal lath, while the walls in the rear are made of untrimmed boards applied to the studs. The interior walls consist of insulating wallboard. The thatching is done by laying bundles of straw on the roof in the same way that shingles are laid, two-thirds of each bundle being overlapped by the lower part of the bundle just above it. The straw is combed down smooth and bound at the top with galvanized-iron wire. Ordinary roofing boards are first laid over the rafters, in the usual way, then heavy tar paper is applied, and after that the straw.



Thatched Roof and Exposed Framing Add to the Attractiveness of This Little Cottage



Large and Small Flower Baskets Made of Concrete and Cobblestones

Large Flower Basket Made from Stones

Constructed entirely of concrete and cobblestones, a large flower basket, having a base about 6 ft. in diameter and an arched handle about 5 ft. high, and holding a smaller basket of the same design, makes an attractive garden feature. The walls are about 1 ft. in thickness, and the handle is tapered to a thickness of about 6 in. and a width of 12 in. at the top. A small water pipe, fitted with a spray nozzle, is installed to extend upward through the center of both baskets to water them.

This piping is an additional advantage but is not essential. After filling with dirt, ferns and flowers are planted.

Foiling the Cutworms

I set about 60 tomato plants, putting a mothball into the bottom of each hole and covering it with about 1 in. of dirt before setting in the plant. The cutworms did not bother my tomatoes, while much damage was done to my neighbor's.—Mrs. R. F. Starzl, LeMars, Iowa.

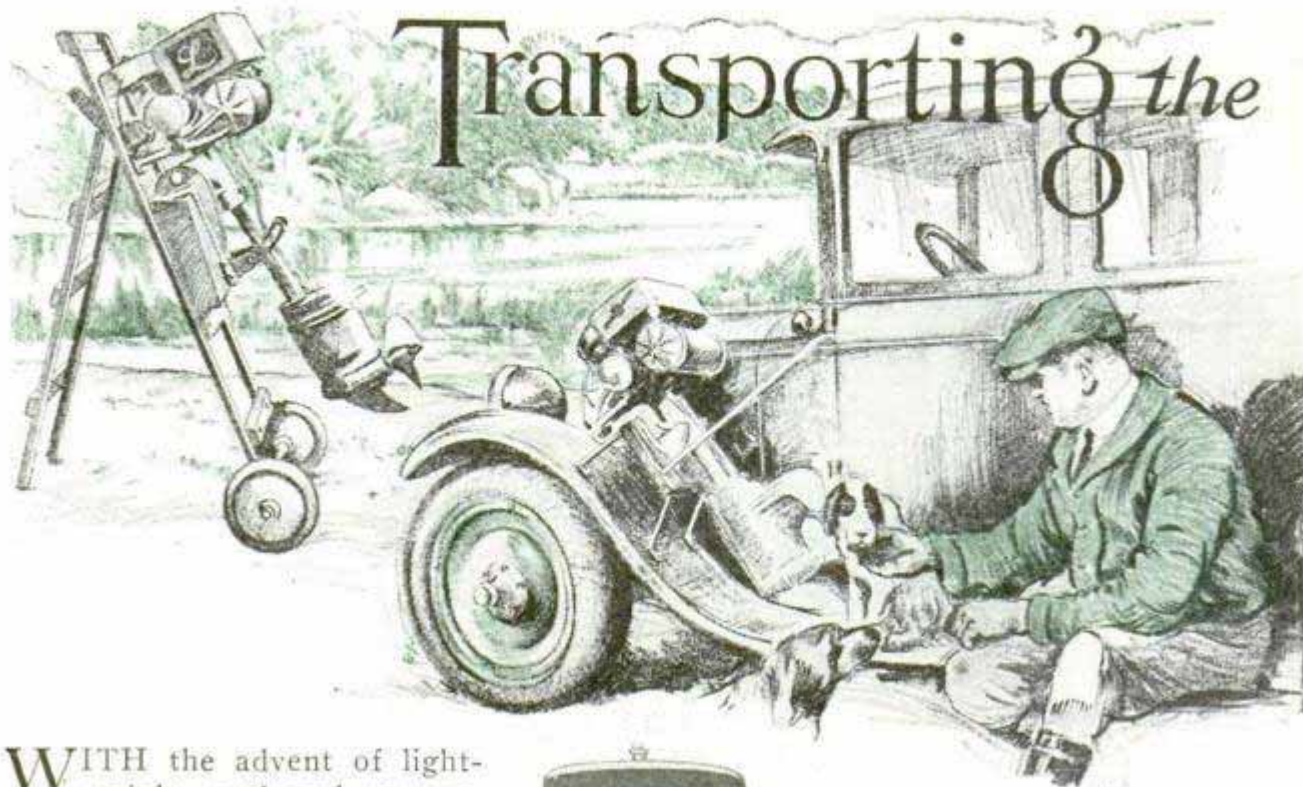

WITH the advent of light-weight outboard motors, the use of these power plants for fishing and pleasure trips took on a new aspect. The motor was neat and highly efficient, and among its many excellent features was the great reduction in weight from previous models—thirty-seven pounds as against a hundred plus—and for the same horsepower. This was a godsend for those who packed their motors into “the sticks,” but even this thirty-seven-pound load, with its sharp corners and angles, was nothing to be despised when there were two or three miles of trail between you and the boat.

When I was stationed in Panama, the boat I used for tarpon fishing on the Chagres was kept at a landing about two miles from Gatun locks, where the car was parked. Since nothing could be left in the boat with the expectation of finding it upon my return, the motor had to be packed back and forth each trip. With salt-water fittings and an extra 5-in. length of shaft, the motor weighed about 53 lb. This, with 2 or 4 gal. of gas, rods

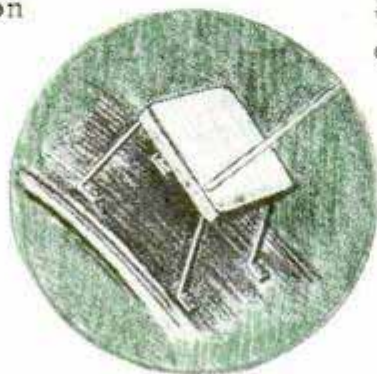
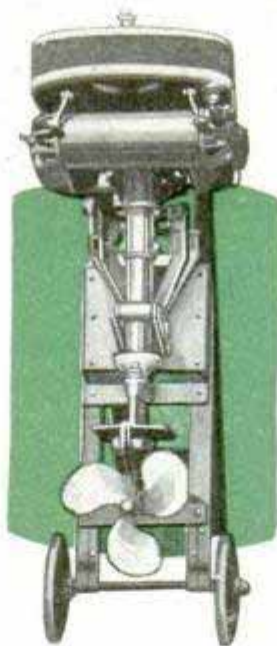

Above, Sketch of the Wheeled Carrier for the Outboard; Right, the Motor in Place on the Car; Center, Close-Up of Motor in Place on Carrier; Below, Detail of Fender Bracket

and reels, a ½-gal. vacuum bottle, a 7-ft. gaff, camera, rifle or revolver, and raincoat, was no mean load, especially when you added a tropical downpour, mud, a road consisting of the rotten ties of an abandoned railroad and a catch of fish. I made such trips as these, on an average, three times a week for three years—and I always carried the motor.

For a few trips, I tried detaching the driveshaft and transporting the motor in two pieces, which was much better than carrying it as a unit. For several reasons, this method was abandoned, however, and finally I hit upon the Indian pack-board scheme illustrated. This is merely a ½-in. pine board, 12 in. wide and 30 in. long, tapered at the lower end. Two wedge-shaped blocks were screwed on at the sides, as shown, with a piece of 1½-in. board screwed across them on which to fasten

Outboard

by Capt. F.F. Chamberlin, U.S.A

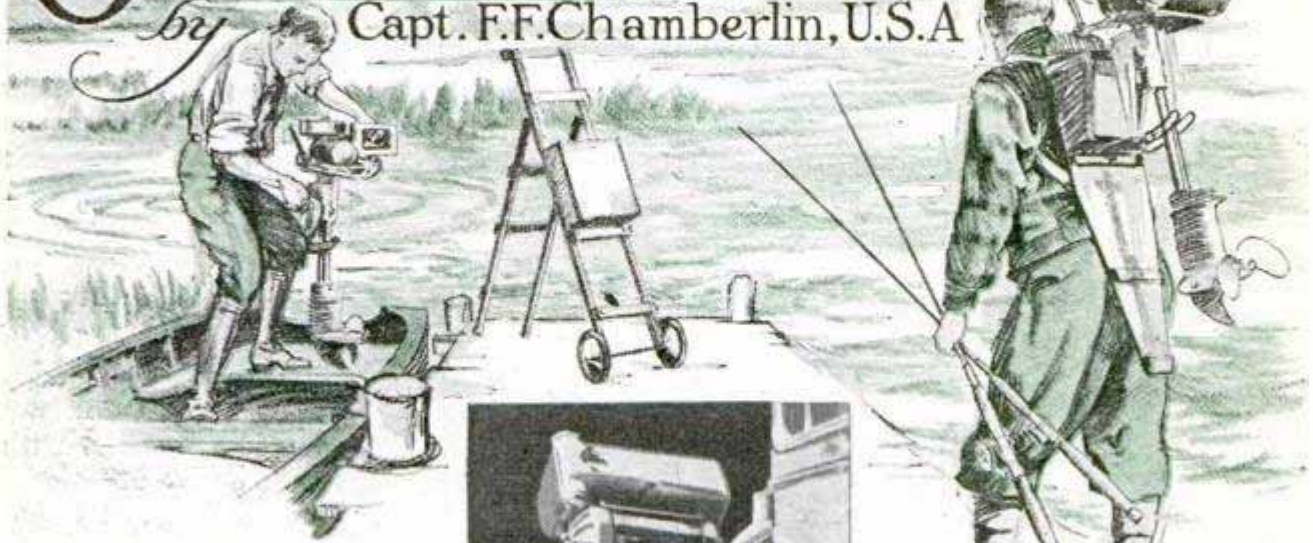

Above, Left, the Wheeled Carrier on the Dock, and, Right, the Pack Board in Use; Sketch at Bottom Shows Pack Board, and Wheeled Carrier Folded for Stowage

the motor in the same manner as it is fastened to the transom of the boat. The shoulder straps are two ordinary army web belts, with sliding pieces of leather riveted to the board. A little experimenting was necessary to determine the proper angle at which to cut the blocks, so as to keep the motor as close to the board as possible and at the same time allow the screws to be tightened securely. A strap from the lower part of the board around the waist helped steady the board on the back. Packing through mud, however, made this rather dangerous in case of a fall, and it was discarded.

I used this rig on trips without number in Panama, and, since returning to the States, it has been an important part of many expeditions. It will pack in any box that will hold the motor. On a number of occasions, I have used it on the running board of the car, holding it in place with two C-clamps. Unscrewed from the running board, the



arms stuck through the straps, it was ready to go.

Back home again, with the excellent results of the pack board to guide me, I purchased a pair of strap hinges, a pair of disk wheels, an axle and a handful of stove bolts, ripped up an old oak table leaf and made a lightweight conveyor that fits into the family auto and makes transportation a pleasure. As may be seen from the illustrations, this conveyor is practically the pack board, lightened and with the addition of the wheels and a hinged section that will make the contraption stand by itself. When not actually used for transporting the motor, it serves as a rack for storing the motor in the summer cottage or in the cellar at home.

I next turned to the problem of carrying the motor on the auto. A number of things are against carrying the motor on the floor in the rear of a sedan, even

though it will fit there, and even if the back seat is unoccupied. I tried several

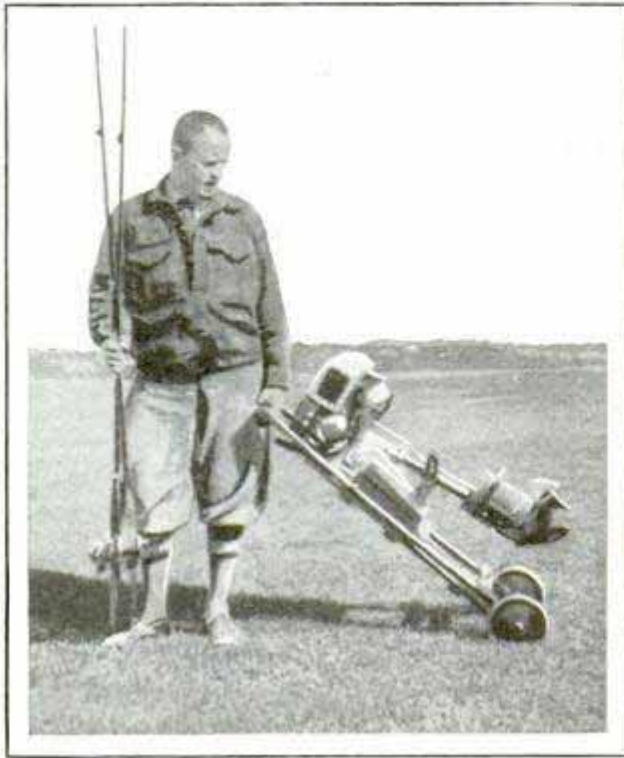

ideas and at last found one that suited the needs of the case exactly. A pair of simple brackets was made of $\frac{1}{4}$ by $1\frac{1}{4}$ -in. steel and bolted to the left front fender with a stove bolt through each leg. Across the top of these was bolted the board to which the motor was clamped. To add rigidity, and at the same time protection in case the wingnuts on the motor worked loose, a piece of the same-size steel was run from the top of the rear bracket and bolted just in front of the middle hinge of the door.

In this position, the motor does not interfere with visibility, collects no dust (particularly when a cover is used), is easy to put on and off and offers no resistance to air circulation as do brackets suspended in front of the radiator. It is on a part of the car that is of little

value for luggage transportation, and, even on a small car like my own, the location offers ample room for the large racing motors as well as for the standard type for which this bracket was used.

This arrangement has given complete satisfaction. Even when traveling over the roughest roads, where everything in the car is badly shaken up, the motor is not disturbed in the least.

If some disciple of Nimrod or of Izaak Walton desires to take a motor into country where the pack horse is the only means of entry, a few modifications of the straps on the back pack will enable him to carry a light twin either on top or on the side of the pack saddle, with the assurance that it will arrive at its destination right side up and in good order.

Baiting Rat Traps

Finding that the bait in his rat traps was nibbled away by mice, the caretaker of a shop wrapped the bait in a small piece of wire mesh, clinching the mesh securely to the pan on the trip. This prevented the mice from removing the bait, and the rats were caught.

Word Counter for the Typewriter

Any typist who has gone to the trouble of counting the words in a manuscript by averaging the words per line or by any

other tedious methods will appreciate the automatic counter shown in the drawing. It consists of a unit counter fitted with a lever and is mounted on a wooden base together with the typewriter. Place the counter next to the space bar as indicated, arranging a wire clip on the latter to trip the lever of the counter. It may be necessary to cut off part of the lever

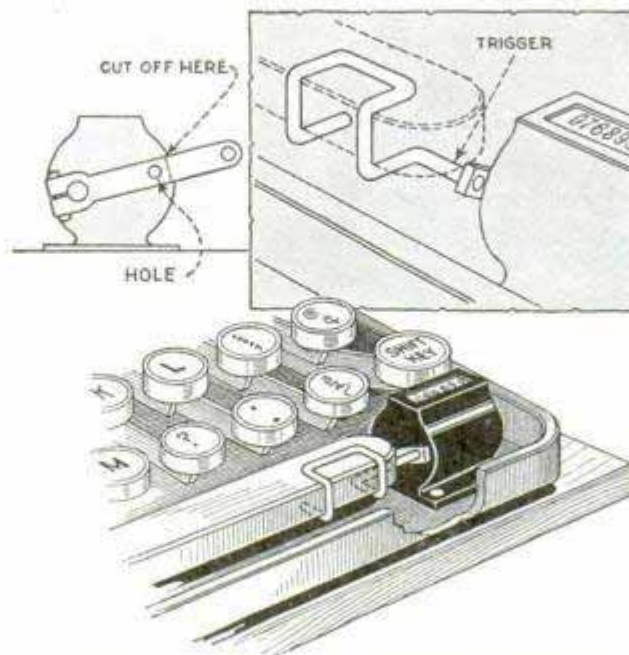

Unit Counter Attached to Typewriter Space Bar Registers Words Typed

*Angon
market made
Advice Machine Supply Co
749 S. San Pedro*

and drill a hole in the remaining part to take the end of the wire trigger. When correctly adjusted, the counter will register every time the space bar is depressed. In use, the added space between sentences on a type page will be found to be counterbalanced by the fact that the typist does not press the space bar at the end of lines.

—Warren F. Robinson, Jamaica, N. Y. 89-25

Parsons Blvd
Homemade Clothes
Hamper

Utilizing a spare piece of linoleum, the clothes hamper shown in the drawing is easy to make. The bottom is 6½ in. wide and 16½ in. long with the ends rounded to form an oval, while the top measures 9½ by 16½ in. and is similarly rounded. The linoleum measures 25 by 40½ by 42½ in., the dotted lines in the layout indicating where it is rounded. First tack the lower edge of the linoleum to the bottom with roofing nails. The overlapping edges are fastened together with rivets. A barrel hoop can be bent to the proper shape to fit over the outside of the linoleum at the top, using steam to make the wood pliable when bending. The linoleum is tacked to the rim with large-head brads. Last of all, a cover is cut from ½-in. material, to fit inside the top of the hamper. Two small cleats hold the cover from

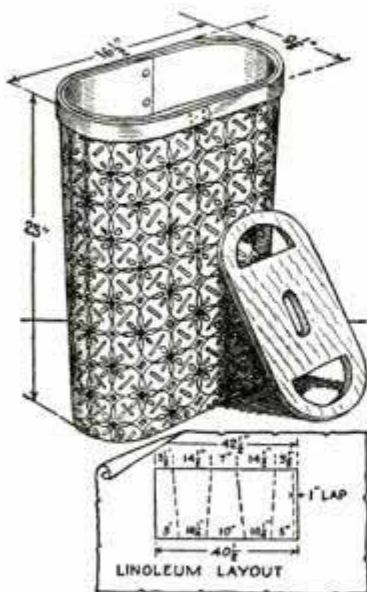

dropping inside. If desired, the cover may be hinged to the rim.—C. A. Upson, Hammond, Ind.

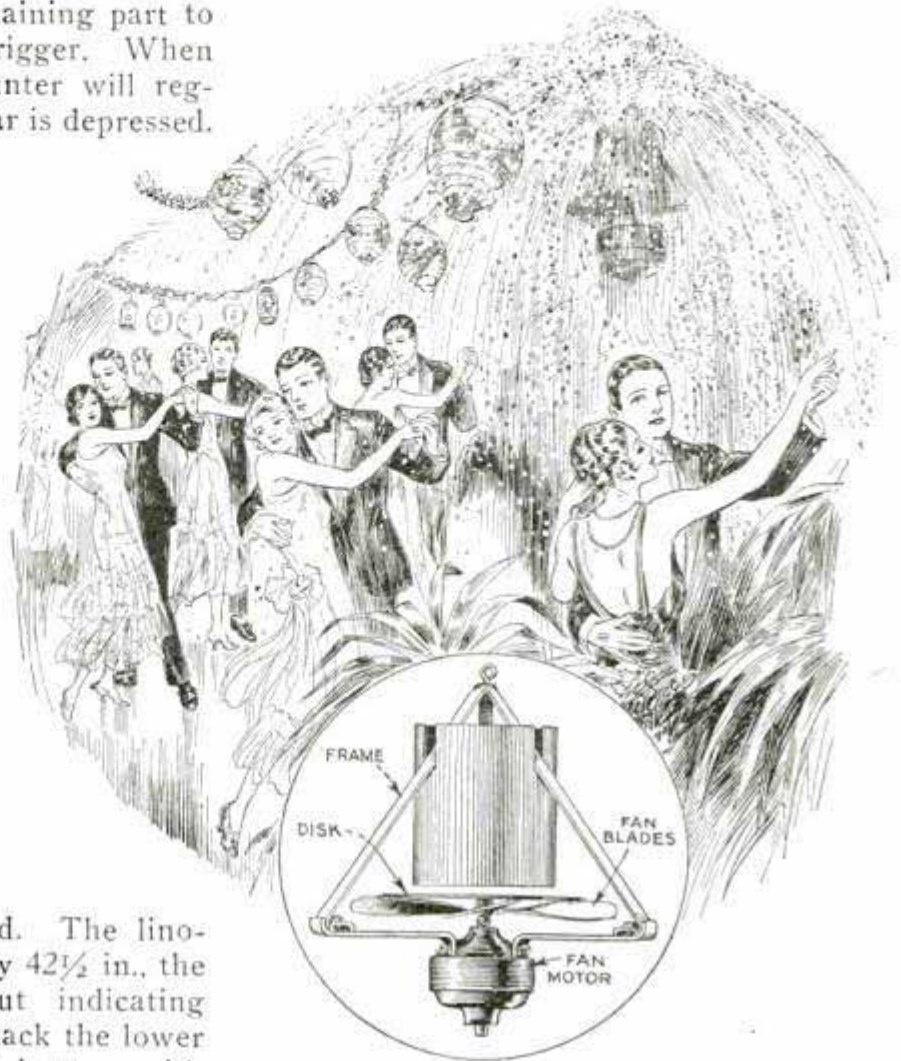

Electric Fan, Provided with Cylinder and Disk, Makes Good Confetti Fountain

Confetti Fountain for the Ballroom

Throwing confetti in every direction, the fountain shown in the drawing was found highly efficient. A frame was made, which, when suspended from the ceiling, held a 12-in. electric fan in an inverted position. An 8-in. metal disk was soldered to the surface of the fan blades as indicated, and a 6-in. cylinder was attached to the frame directly over the disk but separated from it by a ¼-in. space. With the fan at rest, the confetti was placed in the cylinder, dropping, of course, on the disk. As soon as the fan revolved the confetti was forced over the edge of the disk where it was caught in the draft of the fan and spread throughout the entire room. The cylinder is completely filled before the dance.

☐ It is false economy to purchase cheap inner tubes, as they will quickly put an expensive casing on the scrap pile.

Flannel Bags for Dusting



Flannel Bags Fitted with Snap Fasteners Are Handy as Gloves and Dust-Mop Covers

gers. Besides, they launder more easily than gloves and do not shrink. Similarly, it will be found that these bags are handy for use as dust-mop covers, being superior to cloth covers, as the latter must be pinned on, which is a waste of time.

Motorcycle Engine for Boat

It is often asked if a motorcycle engine can be used in a small boat, and the answer usually is that such an installation is not satisfactory, because of the difficulty of keeping the engine cool. An English boating enthusiast who had encountered this difficulty, tried to overcome it by fitting a fan, geared up to a high speed, but this was not satisfactory. The problem was solved, however, in the following manner: He

detached the cylinder and wound $\frac{1}{4}$ -in. copper gasoline tubing around it in the grooves formed by the fins. The tubing was wound on in a coil, a piece being chipped out of each fin so that the tubing could be led from one groove to the next. One end of the pipe was led to a small pump, driven from the engine, and the other end through the side of the boat above the water level. The intake to the pump was, of course, taken from the boat's side below the waterline. No overheating occurred in a four-hour trial run on full throttle. The cooling water flows from bottom to top of the cylinder.

Setting Color in Fabrics

Federal clothing experts, who have made tests in the use of various methods of setting the color in fabrics, say that the many home formulas for this purpose are practically worthless. If it were possible to set the color of fabrics by such easy methods as are often advocated, such as dipping in salt water or an alum solution, it would be reasonable to suppose that manufacturers would use such a process before putting their goods on sale, and the fact that they do not, bears weight as to their ineffectiveness.

Broiling Fish over Campfire

In the absence of a wire broiler the camper can readily improvise one from two 3-ft. sticks, about 2 in. in diameter, split at one end to hold the fish as shown in the photo. The fish is cleaned in the usual way, the head and fins being removed, the body split down the middle, but the backbone left intact. Have a



Two Split Sticks Can Be Used for Broiling Fish over the Campfire

flameless bed of hot coals ready and then slip the split ends of the sticks over the fish and hold it over the fire. When nearly cooked, it can be transferred to a frying pan and a little butter or bacon fat and other seasoning added.—
M. E. Cowen,
Cresson, Pa.

Insecticide for Plants

Bacterial diseases of plants are now being controlled by spraying them with a new insecticide developed by the department of agriculture. The spray has been found highly successful to control bacterial spot on peaches, a disease that costs growers thousands of dollars each year. The ingredients of the spray are as follows: zinc sulphate, 4 lb., hydrated lime, 4 lb., and water, 50 gal., all thoroughly mixed. In Indiana and Arkansas, six applications were found sufficient to bring the disease under control.

Easily Made Hat Holders

In order to prevent crushing hats, which frequently occurs when they are hung on hooks in the closet or laid on a shelf, the illustrated hat rack will be found convenient. Drill a hole in a block of wood as a base to receive the end of a piece of broom handle. Part of a cylindrical paper carton is tacked to the top of this piece and over this is provided a cushion of cotton batting covered with a piece of cloth, which is held in place with a rubber band or piece of ribbon, preferably the latter.—Mrs. C. D. Haddaway, Coral Ridge, Ky.

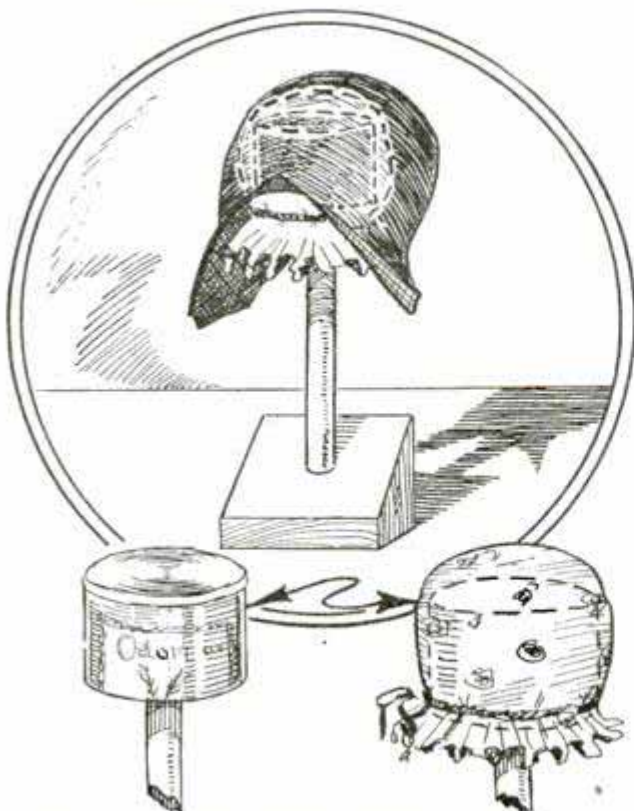

Simple Hat Holder Which Anyone Can Make Prevents Crushing Hats

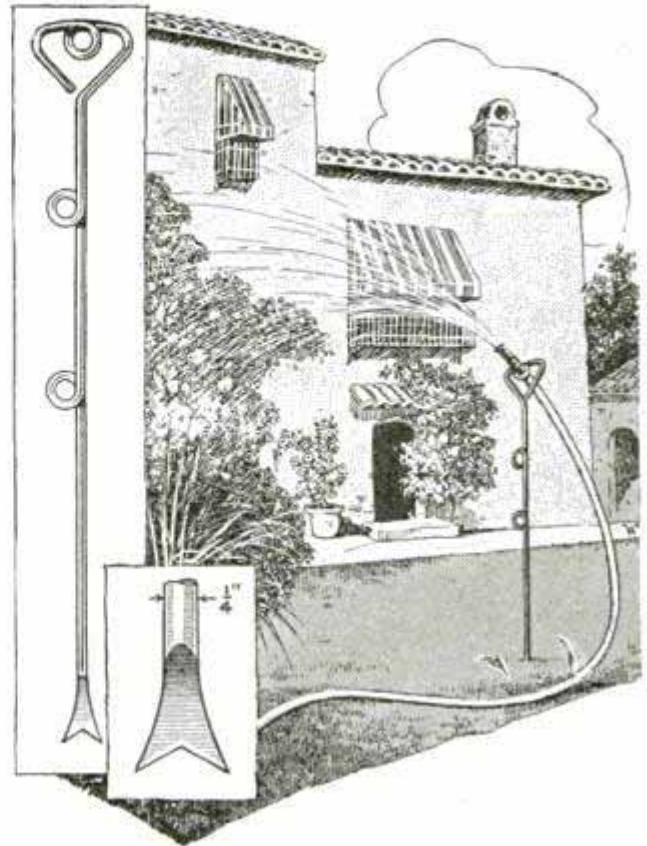

Combination Weed Cutter and Garden-Hose Support Made from Iron Rod

Combination Weed Cutter and Support for Garden Hose

The illustrated device serves the double purpose of weed cutter and hose support. It consists of a 4-ft. length of 1/4-in. iron rod bent to the shape shown. Three small eyes at various heights are made to hold the hose nozzle, and a small handle is formed at the top to hold the tool when it is used as a weed cutter. The lower end is flattened and ground to a sharp V-edge, which is forked as indicated in the detail.—Dale R. Van Horn, Lincoln, Nebraska.

Sandpaper Holds Head on Hammer

After experiencing trouble with hammer heads coming off the handles, workmen in a mid-west shop have stopped it by the use of a piece of sandpaper. The paper is wrapped around the end of the handle before it is inserted into the eye of the head, after which the latter is driven home. The friction thus provided is sufficient to keep the head on. The same idea can be used to advantage for holding together furniture joints that have come apart and are to be reglued.—Horace Lemaster, Maryville, Mo.

Sam Brown
151 Carhart,
Marion, Ohio

SCOOTER PROVIDES

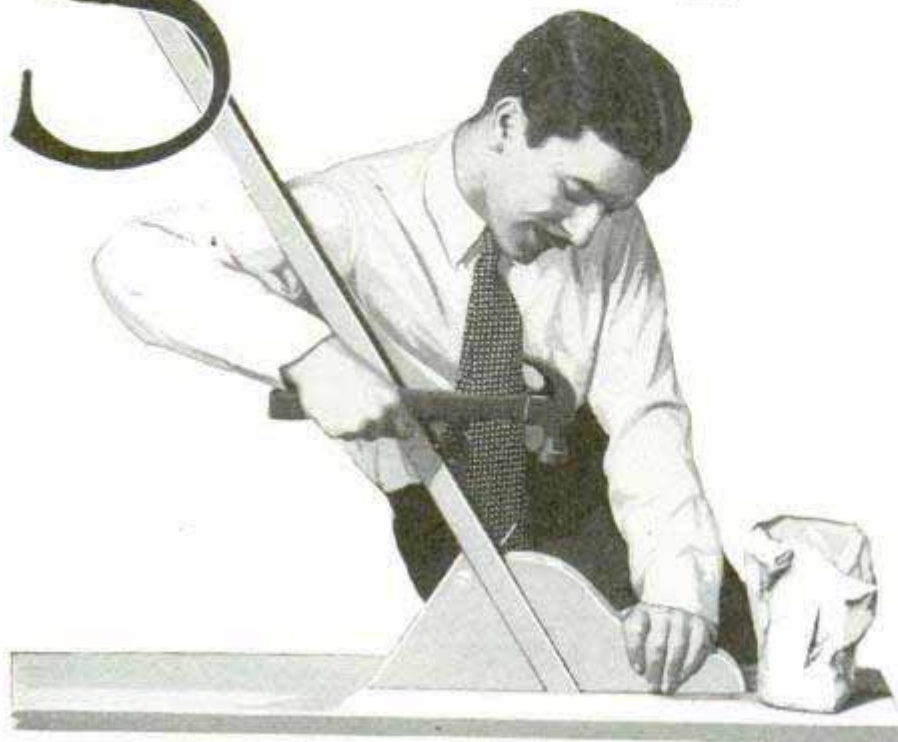

Fig. 1. Fastening the Handle and Its Supporting Brackets to the "Deck"; Handles May Be Nailed to Brackets, but Brackets Are Screwed to Plank

GET ready! Get set! Go! And away go the water scooters. And do they zip? And when you hook them up behind that peppy outboard, it's more sport than a circus! If you're looking for real summer sport, build this water scooter. And not only in the finished job, but in the mere fitting and assembling of this craft, you will find real enjoyment.

We start with a piece of redwood, or any other light, easily worked wood, 7 ft. 3 in. long, 13 in. wide, and $1\frac{1}{4}$ in. thick. We make this mere plank look like something-in-the-making by nailing into position, about 18 in. from one end, the two wood blocks and the long stem, which compose the handle for our potential water scooter. This operation is shown in

the photo, Fig. 1. Now we will use the key-hole saw or bandsaw in fashioning, from $\frac{7}{8}$ -in. wood, the piece shown in Fig. 2, and in the drawing, Fig. 4. This is nailed along the underside of the plank, as shown. In case you haven't guessed it, this piece is the centerboard. It makes for greater stability in the finished craft and eliminates side drift. Since the nails alone will not hold it rigidly in place, it should be braced here and there with short angle irons, as pictured in Fig. 2.

Forgetting all about woodworking for the

time being, we turn our attention to a little business in rubber. This has to do with three inner tubes. Almost any size will do. One of these tubes must be in pretty good shape, patched perhaps but capable of holding air. The other two tubes need not be so good. These two are to be cut in two anyhow, and a tube which has gone "bang" in one place is as

good as a new one. Visit your local junk dealer. If you can, persuade him into giving you all-over good tubes; then cut these two tubes in two, 14 in. from the valve as shown in Fig. 3. Since the cut tubes are to be slipped along the underside of your craft, as in Fig. 3, it is necessary to drill two holes in the forepart of the scooter, as in Fig. 5, so that the valve stems will



Fig. 2. In Addition to Screwing the Centerboard to the Deck, It Is Strengthened by Angle Brackets

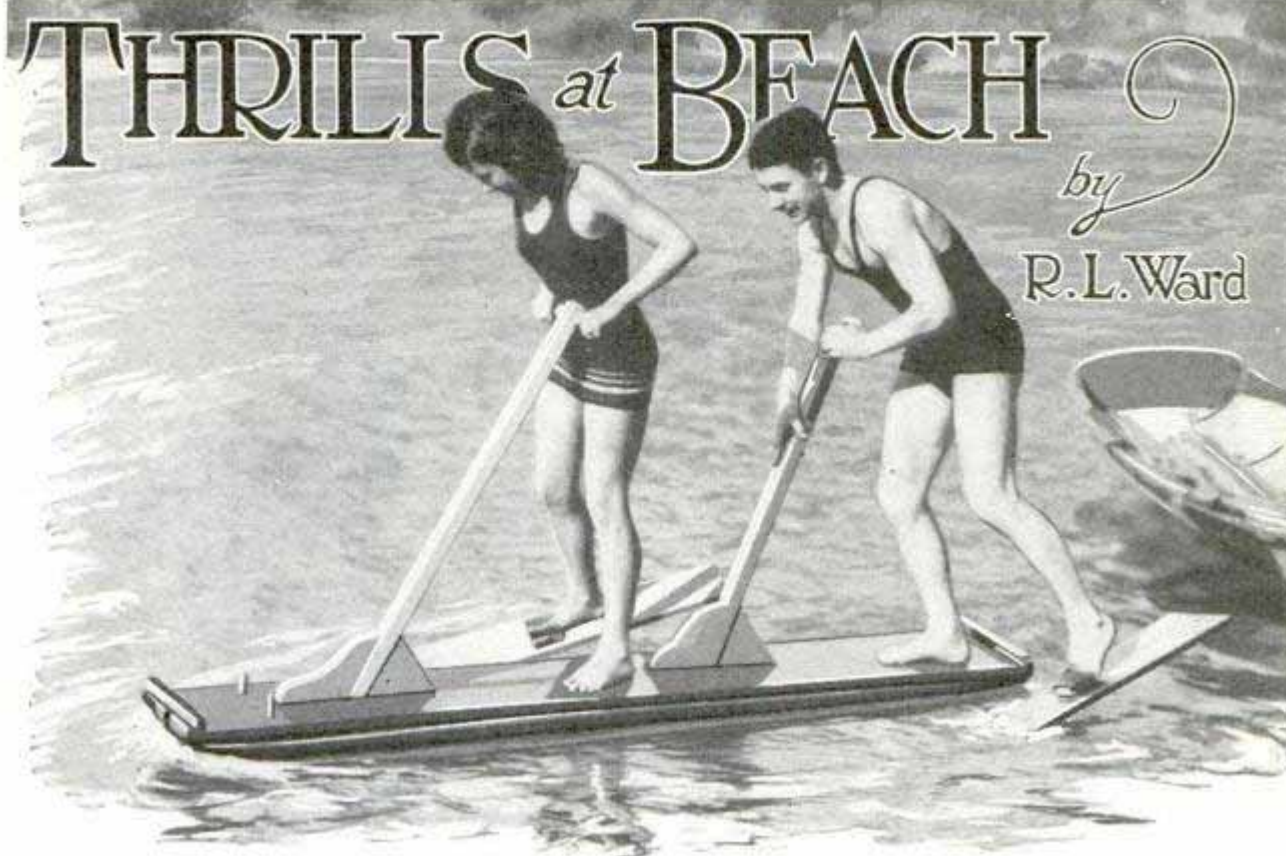

slip up through the wood base of the boat. Naturally enough, these holes may be somewhere else, to fit the tube if you find it necessary or advisable to cut the rubber at some other place than that specified. And, of course, the cut ends of the tubes must be vulcanized before you nail them into position. In nailing the sealed ends of the tubes to the wood, you must be careful to keep the nails well outside the air-holding portion; also the nails must not be driven directly into the rubber, but rather into a short crosspiece first, then into the rubber, and finally into the plank, as shown in Fig. 3. The uncut tube is slipped around the centerboard, as in Fig. 7, with the valve facing to the rear. These three tubes, together with the wood parts,

will float the average person with the deck of the scooter barely awash; if you weigh over 150 lb., snap another inner tube or two around the centerboard.

Even though the tubes have been fairly well stretched in the nailing process, they will still sag to some degree. To eliminate this, it is necessary to wire them close under the plank, using heavy wire, or, better, a wide web of canvas, as shown in Fig. 8. As can be seen from the photo-

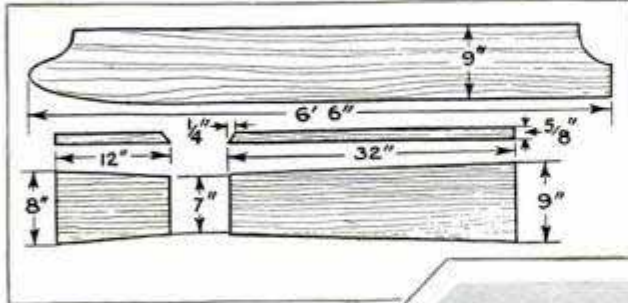

Fig. 3, Left, Nailing the Vulcanized End to the Plank; Below, Stretching Tube to Opposite End •



graph, the wire (or canvas) does not run completely around the centerboard, but through holes drilled well up under the deck of the scooter.

This completes the actual scooter. The paddle to make it go is something else



again. This calls for two pieces of $\frac{5}{8}$ -in. wood, of the size and shape shown in the lower sketch, Fig. 4. These two pieces are fastened together with two small strap hinges, after the manner shown in Fig. 9. Numerous forms of binding to strap the paddle to the foot are practical. A plain web of heavy canvas does very nicely. The average ski binding is excellent. A very simple shoe binding, and one that is better than

either of the foregoing types, is made from an old shoe, with the heel removed and the rear part of the upper cut away. Nailed into position 3 in. from the joint in the paddle, as shown in Fig. 10, it makes a very secure binding for the foot, yet it does not hold so tightly but what it can be kicked loose immediately after the inevitable ducking. The shoe should be well waxed in order to keep it from hardening by the continuous wetting. The scooter, and the paddle, too, should receive a few coats of paint or varnish.

In learning to use the water scooter, the very first thing you should, must, and will do consists in getting all wet. Like the canoe, the ski and the skate, this thing of wood and rubber has its limitations. But let's up and at it! The paddle on your right foot, your left foot on the

scooter, your hands on the handle—shove off! Immediately after shoving off, bring the paddle foot forward. If the hinges are working nicely, the forepart of the paddle stick will flap backward, as in Fig. 10, and then, when you shove your foot back in the propelling stroke, the hinged portion will snap out, scoop up the water, and, altogether, offer such resistance that you will naturally scoot forward.

But watch the return for the second stroke, You will find that the sudden lifting of the paddle from the water and

the consequent bobbing, weaving motion of the scooter is very upsetting. That is, at first. After you have learned when and when not to rely on the paddle for balance—oh, my! Six miles an hour? Easy! Eight miles an hour. Yes, sir! Ten miles an hour? You can go like a racehorse if your legs are racehorse legs.

Of course, the water scooter is not really a "scooter." It doesn't pretend to be as fast as all that. Neverthe-

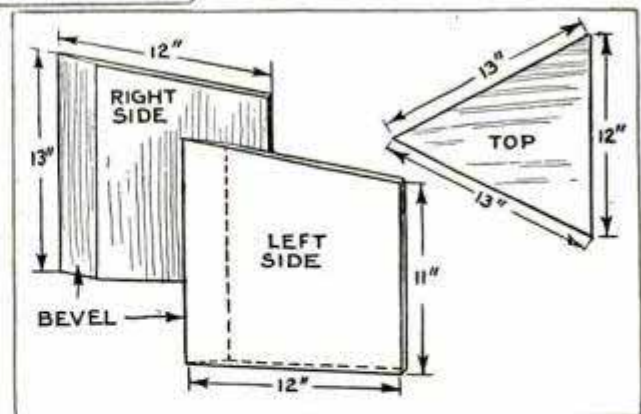

Figs. 4, 5 and 6, Dimensions of Centerboard and Paddle; Seat for "Surfboard Scooter," and, Center, Boring Holes for Tube Valves

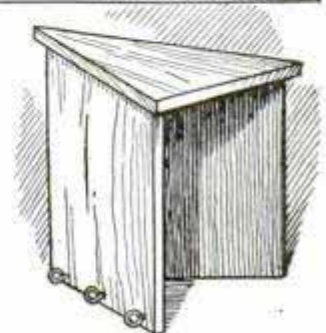

less, with the tandem rig shown in the headpiece, an amazing speed can be attained, as well as other surprising maneuvers, until the partners learn to co-ordinate their efforts.

If you want real speed, however, try aquaplaning with the water scooter. There's sport for you! Even behind a rowboat, this thing of getting a free tow has its particular appeal. In using the scooter as described as a surf-board, several minor additions are necessary. In the first place, you will need two paddles, one for either foot. These need not be of the "web" type described; a single flat length of wood will do the business. In the second place, you will

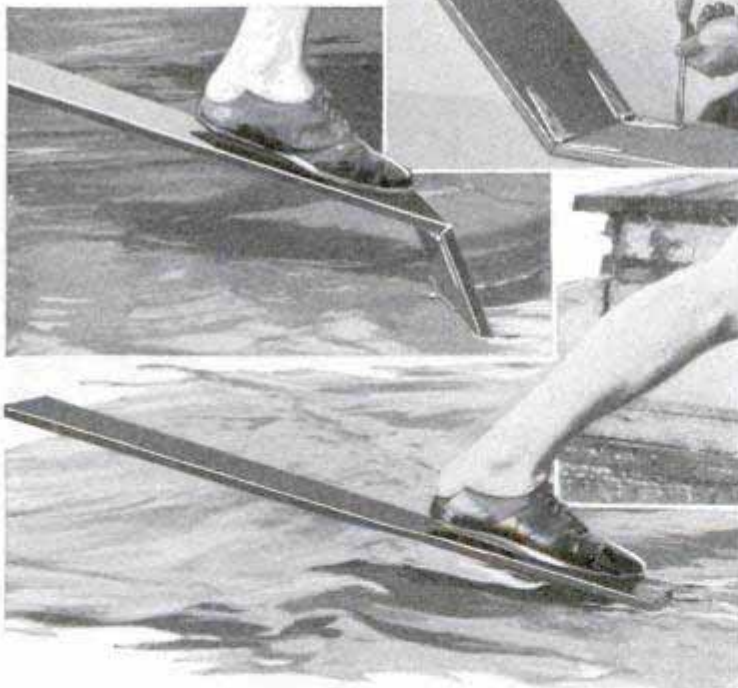
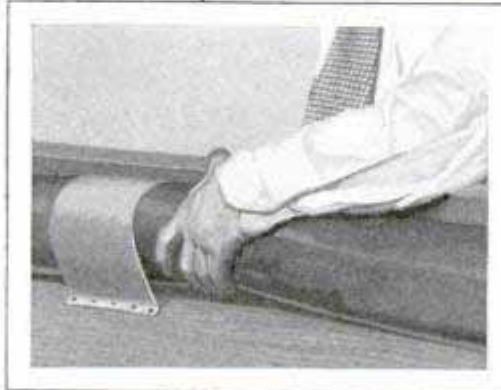
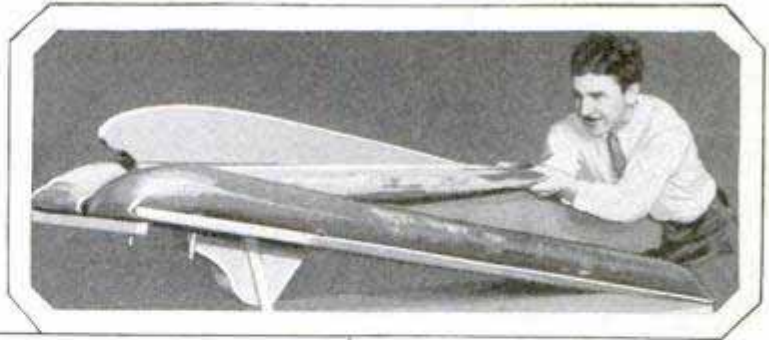

Figs. 7, 8, 9 and 10. Stretching Third Tube over Centerboard; Support for Tube; Hinging the Paddle Flap, and the Paddle in Action on Forward and Back Strokes

need a place to sit on. Rather modernistic it is, too. Fig. 6 gives you the shape and dimensions of the three pieces which compose the seat, and the three pieces assembled. In order to make the seat portable, it is not fastened permanently to the

main body of the scooter, but merely held by means of two long pieces of wire running through interlocking screweyes fitted into place along the two lower edges of the seat and the top of the plank. With such a simple device, it is a matter of a minute to change the mere scooter into a real scooter.

And it's dead easy! Doing the scooting, I mean. Despite all and sundry stories you may have heard about the knack of aquaplaning, you will find the scooter in this form a perfectly stable little craft. Oh, of course, you can make it exciting enough. Try lifting both paddles out of the water when going 25 per. Try sailing without the paddles. Try getting off the seat entirely. Try doing three back somersaults and a layout from off the handlebars. Oh, yes you will! You'll do better tricks than that—and never know about it till you hit the water!

The tandem water scooter shown in the headpiece is built in the same manner as the single craft, except that it is longer and requires more tubes to support the pilots. Note, too, that the partners use the paddles on opposite feet. Both paddles should move forward and back at the same time and with the same stroke. Of course, they won't at first, which will lead to some unexpected and disconcerting maneuvers of the scooter.



Improved Sawdust Blower for the Jigsaw Made from Powder Bellows

Blower for the Small Jigsaw

When using a jigsaw, the outline on the work constantly becomes hidden by sawdust and the worker usually has to blow the dust away. An automatic blower can be improvised from a small insect-powder bellows placed on a block located in such a position that the lower part of the saw frame will strike it, as shown in the drawing. A length of rubber tubing, slipped over the spout and tied to the jigsaw, directs the puffs of air against the point where the sawdust collects and thus keeps the work clean.

"Idling" a Camp Stove

Often a camper wishes to keep the gasoline stove lighted during short intervals between actual use, rather than to relight it. However, the flame must be kept burning rather high to keep the generator sufficiently hot. If the flame is too low, a slight breeze will readily extinguish it, with the result that

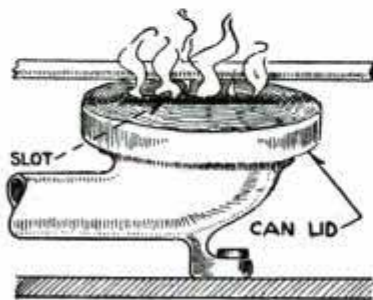

the generator cools off and the stove becomes flooded with gasoline. To avoid this trouble, get a tin-can lid to fit rather

freely over the burner, and cut a long, narrow slot across it, as shown in the drawing, the slot being placed directly under the generator tube, thereby directing all the flame against it. A stiff wire wrapped about the lid will facilitate handling it.—D. Rockwell, Hollywood, Calif.

Gas Oven Makes Running-Board Icebox

For keeping salads and other edibles cold when out on a picnic or camping trip, an ordinary gas-plate oven having an upper and lower compartment will be found highly convenient. A wooden box, large enough to hold the oven and allow a 1-in. space between the two, is fastened to the running board. Screws and wing-nuts can be used for this purpose, the screws passing through both box and running board and the wingnuts being turned on from underneath. Lock washers should be used to prevent the wingnuts from getting loose. The oven is then set in the box and the intervening space is filled with wet newspapers, which make excellent insulation. Newspapers are also laid on the top of the oven, and the top of the box is then attached with nails or screws.

Rubber Grip for Revolver Butt

Many small revolvers have such a small butt that they tend to twist sideways when the trigger is pulled. To increase the size of the handle



and at the same time provide a better grip, attach a piece of rubber, such as an eraser, as shown in the drawing. Ordinary friction tape is then wound around both handle and rubber to hold the latter in place.

Good Brushes Required to Produce Smooth Undercoat for Enamel

Many amateur craftsmen will be surprised to learn that enamel does not cover brush marks. In order to avoid them, it is necessary to have a perfectly smooth undercoat and this is not possible with cheap, coarse brushes having stiff bristles.

A good badger-hair brush may be more expensive, but is well worth the extra cost when one considers the superior grade of work made possible by its use, as the undercoat for enamel can be laid on so smoothly that very few if any brush marks will be evident and very little sanding is necessary.—L. H. Georger, Buffalo, New York.

Pitfall for Rabbits

One of the most effective traps I have ever used for rabbits is shown in the drawing. It consists of a runway made of 1-in. boards, which is set over the open top of a barrel sunk into the ground. The bottom of the runway is sawed into four sections, of which the two in the center are pivoted. Note that the outer ends of the pivoted parts are beveled so that they will trip when the rabbit reaches the bait, which consists of an ear of corn attached to the inner end of one section. Small pieces of flat iron, screwed to the underside of the pivoted sections, hold them horizontally, and cause them to return to this position after they have dropped a rabbit into the barrel. The open top of the barrel not covered by the trap is closed with a few boards, and a pile of brush is thrown over the whole.—E. E. Beach, Horton, Kans.

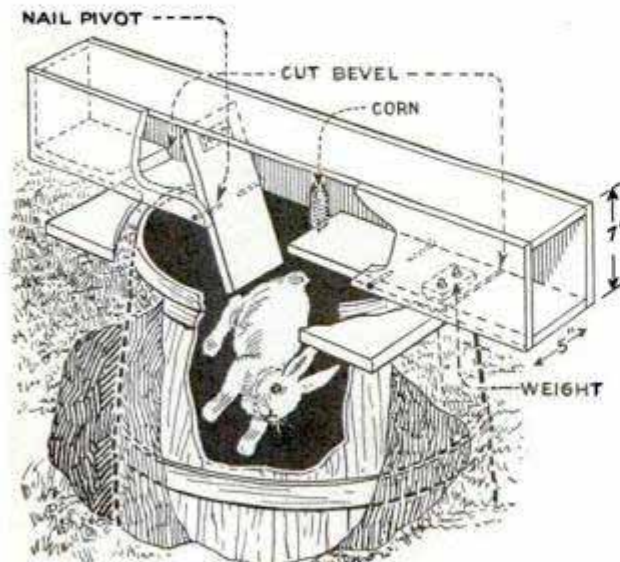

This Rabbit Trap Is Easy to Make and Has Been Found Very Effective

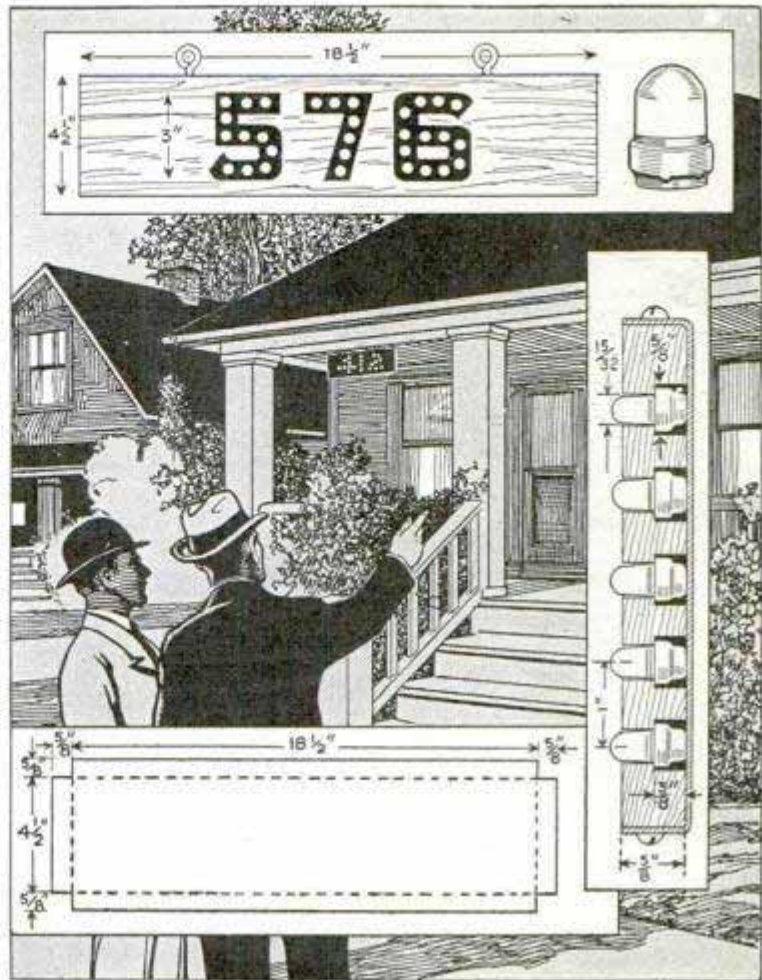

Small Colored Reflectors Make House Numbers Visible at Night

Reflectors Used for House Numbers

After noting the results obtained on highway warning signs and advertisements, I installed "reflectors" of the type shown in the drawing, for house numbers. The smallest size of reflectors obtainable was used, mounted on a 18½ by 4½-in. board. A piece of sheet metal was cut and bent at points indicated by the dotted lines of the lower detail, and was then attached to the back of the sign to hold the reflectors in place, the latter being inserted in counterbored holes shown in the right-hand detail. The number board was fitted with two screweyes so that it could be suspended in a position where it would swing freely in the wind, which caused it to reflect more light and be more easily noticed. The drawing gives all dimensions covering the installation of the smallest size of reflectors, which can be had in white, green, red and amber.—H. B. O'Connell, West Haven, Conn.

Occasionally oil the hinged joints of an umbrella to prevent them from rusting.

*Atlas. Ansonia Co. New Haven, Conn.
51 Grand St.*

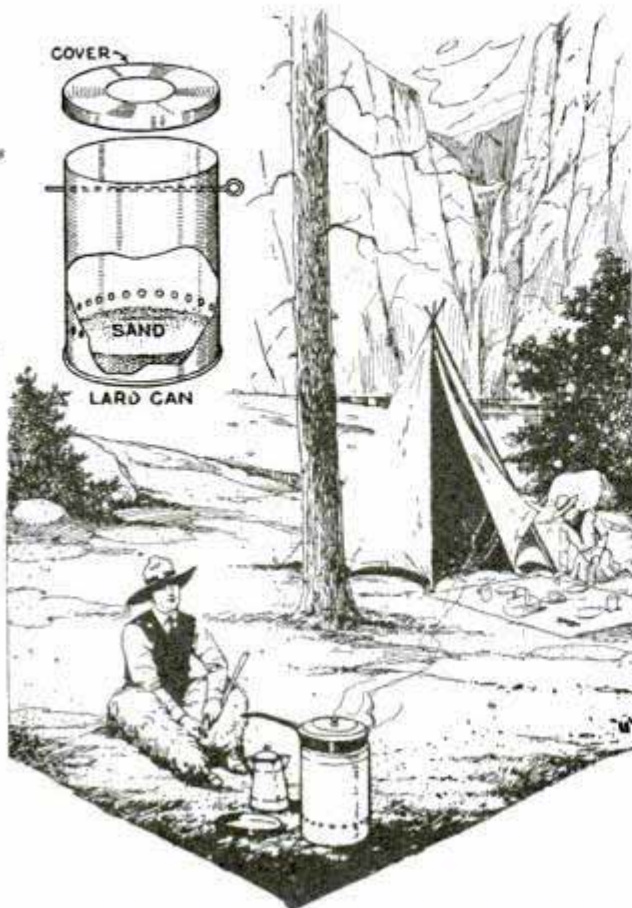

Campers Will Appreciate This Small Cookstove Which Uses Gasoline-Saturated Sand as Fuel

Gasoline-Saturated Sand Makes Good Camp Fire

One tourist found that a lard can, perforated with a row of holes about 5 in. above the bottom, as shown in the illustration, and then filled with a 4-in. layer of sand saturated with a quart of gasoline, was highly superior to the usual improvised camp stove. The advantages are elimination of smoke and soot, and production of a steady heat, which any cook will readily appreciate. It was found that a quart of gasoline, well mixed with the sand, was sufficient to enable three families to cook a meal over the blaze. After the fire dies down a little, the sand should be stirred to renew the blaze. To allow a kettle to hang just above the fire, two holes were punched opposite each other a short distance from the top of the can to receive a metal rod. A hole, 4 or 5 in. in diameter, was cut in the lid, for frying.—Clementine Paddleford, New York, N. Y.

Beeswax makes a better lubricant for dead centers than the usual white lead, oil or grease.

Rubber Handle for Outboard Starter Rope

Anyone who has had the experience of having the starting-rope handle slip out of oily hands when cranking an outboard motor, or has had the rope stick in the flywheel when the motor started, and received a whipping about the arms with the hardwood handle, will appreciate a non-slip handle of rubber. It can be made from a 2½-in. length of ribbed gas hose with an outside diameter of approximately 5/8 in. Drill or burn a hole, the exact size of the rope, through one side of the hose at the center. Then thread the rope through the hole and bring it out of the end. Slip a small washer over the rope and tie a knot. This handle is not likely to slip as quickly as a wooden one and will not hurt so much in case of a whipping.—Herbert M. Allemeier, Maumee, Ohio.

Holder for Dipping Baby Bottle in Hot Water

Sterilizing the baby's bottle in boiling water is greatly facilitated by the use of the holder shown in the drawing. Ordinary galvanized-iron wire, obtainable at any hardware store, is used for making it. The eye at one end forms a spring which forces the jaws apart. In use, the jaws are forced over the bottle and are then pressed together with the fingers. Held in this way, the bottle can be dipped in boiling water without burning one's hands.—Fred T. Pindar, Valdosta, Ga.

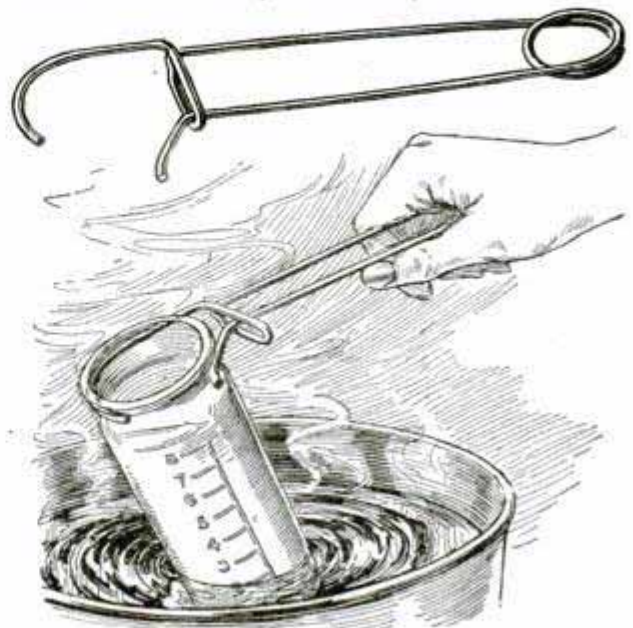

Simple Holder for Baby Bottle Facilitates Sterilizing It in Boiling Water

A SAFE AND SANE NOISE MAKER FOR THE FOURTH

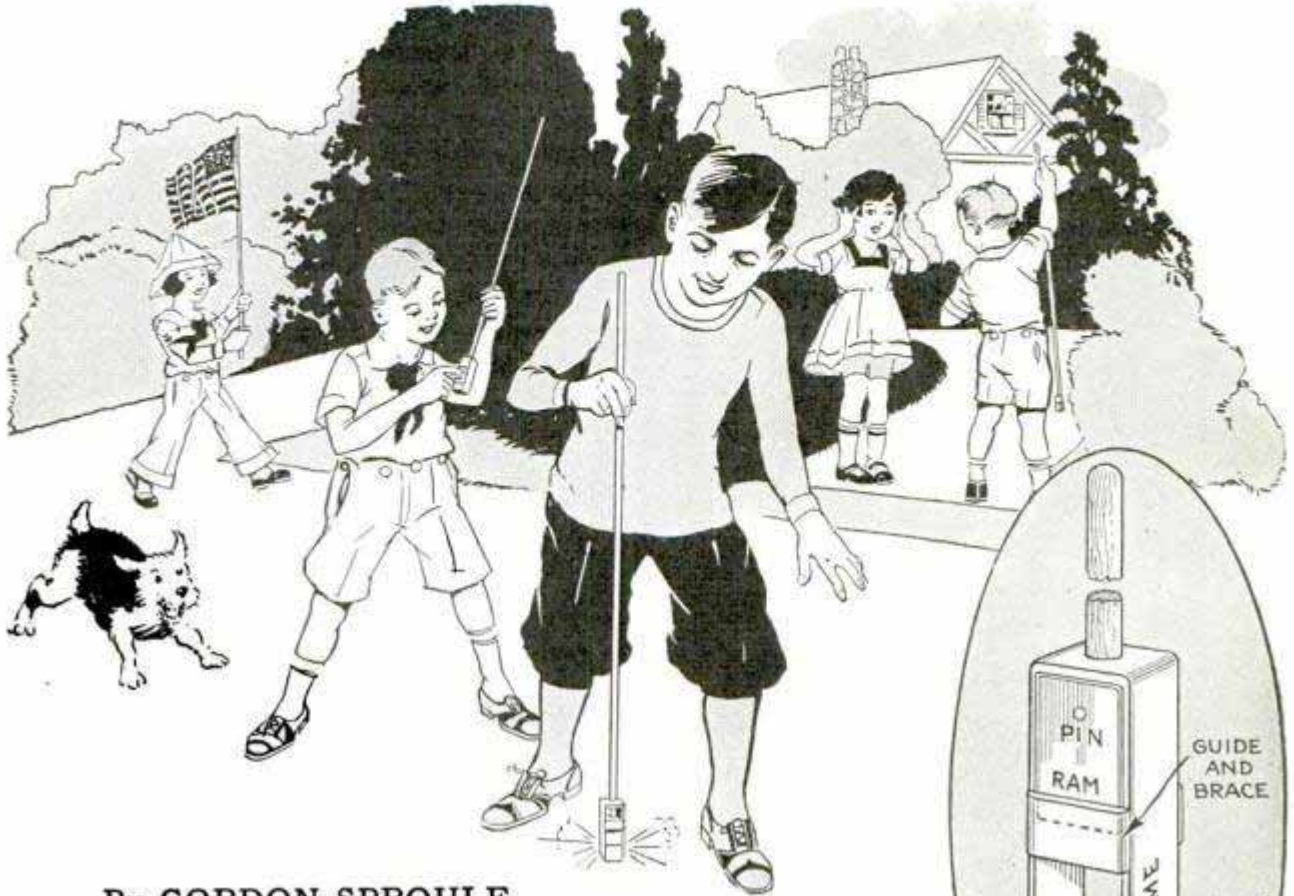

By GORDON SPROULE

INDEPENDENCE Day again looms on the horizon, and it might be well to ask ourselves well in advance: What is going to be the result of the annual check-up on fingers and eyes after the big day is over? Last year Bob nearly lost an eye. In fact, the danger to life, limb and property is so real that in our town, for example, the sale of fireworks is absolutely prohibited.

Bob's close shave suggested that something more should be done—it is not feasible to prohibit the sale of fireworks in neighboring towns—and we thereupon constructed a "banger" that has proved eminently satisfactory. The boys like it, it makes a big noise, and it is safe—no matches, no smoldering remains, no fire hazard, no flying pieces, no danger to fingers or eyes.

The drawing shows the present model, which could probably be improved, possibly making it lighter. Any mechanic can make one or more for his boys, who will be the envy of their chums, while mother can retire to an inner room knowing that each crash means the boys are all right. The banger consists of an anvil and ram, each made of 1-in. tool steel, permanently

connected by a $\frac{1}{8}$ by 1-in. flat iron, U-shaped frame. The legs of the frame are fastened to the anvil with $\frac{3}{16}$ -in. rivets, as shown. The ram slides within the "U," and is prevented from falling out sideways by means of side guides, welded on. A wooden handle, 34 in. long, works through a hole in the top of the frame, and is driven into a hole drilled into the top of the ram. After driving the handle home, a hole is drilled through both ram and handle and a pin driven through it. In the center of the anvil top a hole is drilled with a size-A drill (.234 in.) to a depth of $\frac{3}{16}$ in. This hole is drilled, of course, before the banger is assembled, and holds a capsule filled with a detonating mixture. The banger is lifted vertically a foot or so and struck smartly on the pavement, on a stone, or even on the sod. The percussion explodes the mixture in the capsule with a loud report, about equal to a good-sized "salute," but sharper.

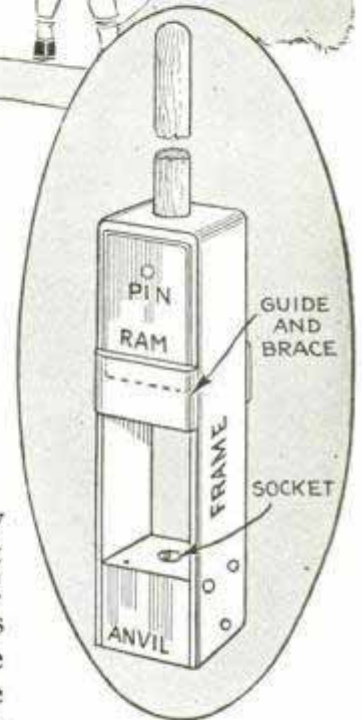

The capsules are made as follows: Get from the druggist 200 empty gelatine capsules, Parke Davis No. 2; these are regularly 35 cents per hundred. Also get 3 oz. pulverized potassium chlorate (not chloride) and 1 oz. pulverized sulphur; these chemicals will cost 25 or 30 cents. They must each be ground to a smooth, flourlike powder, and must be pulverized separately. Mix the two powders by rolling them on a sheet of paper by lifting alternate corners, or by gently shaking them together in a cardboard box. Spill the mixture out on a sheet of paper, and break up lumps if necessary by touching them with the finger. Do not rub these powders together in a mortar or bowl.

Attend to this mixing operation yourself. If some of the mixture is ignited with a match, it will fizz and flare, but not "go off" like gunpowder; friction, pressure or impact will detonate it violently.

When the powders are thoroughly mixed, spread out on a paper and load the capsules by dabbing the open end of the long part into the mixture until the shell is full, then put on the cover; the boys themselves will be tickled to do this part of the manufacturing.

A hundred capsules make a small pocketful; fifty make a good barrage. Each boy carries a hook of brass wire to extract the remains of the capsule, if any stays in the anvil.

Waterproof Ticket Holder Made from Old Inner Tube



To keep rain from damaging tickets and bill sheets, left by truck drivers near a temporary and somewhat isolated loading platform, a neat holder was made from part of an old inner tube, as shown.

Two small strips of wood were placed opposite each other on the inside of an 8-in. piece of the tube, and tacked to the wall. Another short strip was similarly used to fasten the bottom, forming a pocket. A flap, a trifle wider than the pocket, was cut and nailed several inches above it, which effectively prevented rain from getting inside.

Silencer for Noisy Flush Tank

To silence noisy flush tanks, devices on the market are designed to be placed in the supply pipe to cut down the speed of the water as it enters the tank. The same results can be accomplished in about an hour's time at a negligible expense in the following way: Get a No. 18 flat-head wood screw, 4 in. long, and a length of

wire solder. The latter is wrapped around the screw spirally, allowing $\frac{1}{4}$ -in. space between each turn and winding it in the direction opposite to the threads. The screw and spiral are then driven into the supply pipe, leaving a short piece of the screw projecting out of the end of the pipe, after which the screw head is cut off. Of course, the pipe is removed in order to do this. When the pipe is replaced, the water will be sufficiently retarded to stop the noise.—Ernest Romkee, Colorado Springs, Colo.

Tube Helps Empty Bottles Quickly

Narrow-necked bottles cannot be emptied rapidly because air cannot enter

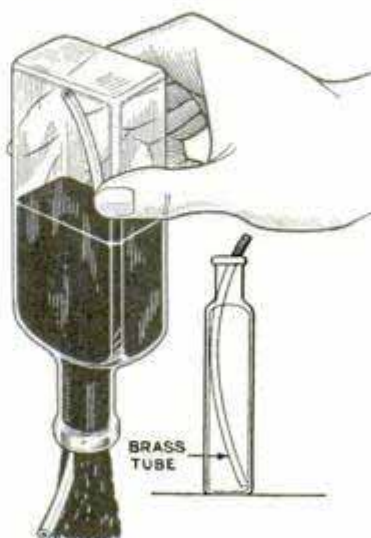

quickly to replace the out-flowing liquid. However, by inserting a piece of tubing, bent as shown, into the bottle, the bend making it possible to wedge the tube in place, air is given access to the bottom of the bottle as soon as this is turned

over, and the liquid flows out without gulping.—Harry Moore, Montreal, Can.

Marking Rows in Garden

Onions, carrots, parsnips and a few other garden vegetables have so little foliage at the beginning that weeds almost hide the rows from view, and it becomes difficult to cultivate such plants without danger of hoeing them out or covering them up, especially if a wheel hoe is used. To overcome this trouble, one farmer mixed a small quantity of lettuce seed with the onion seed, cabbage seed with the carrot seed and radish seed with the parsnip seed. The leafage of these added greens is always conspicuous, and as they grow fast they make good row markers for the slower-growing plants.—H. H. Siegele, Emporia, Kans.

Old Inner Tubes Make Comfortable Chair Seats and Bunks

Old inner tubes make good chair seats and will also be found satisfactory as substitutes for springs in a cot or bunk. Cut the tubes into 2-in. strips of the proper length and fasten the ends to the chair or bunk frame with large-head upholsterers' tacks, weaving the strips as shown. The best method of doing this is to tack down all the strips running in one direction first, then weave in the cross strips, and tack them all down. By using red and gray rubber, pleasing effects can be obtained.—Russell Alexander, Washington, Ind.

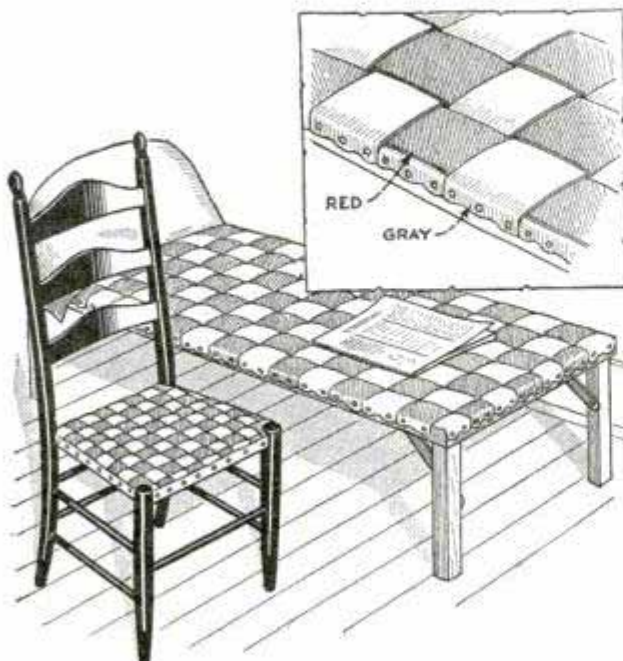

Basket-Weave Chair Seats and Bunk Springs Made from Discarded Inner Tubes



Fruit Jars Containing Minnows and Suspended in the Water Attract the Fish

Effective Fish Decoys

When fishing from the shore the decoys illustrated will often be found effective. Get several fruit jars of large size, punch holes in the tops, and, after filling the jars with water, put in the minnows. Tie a length of heavy cord to the lids and suspend the jars from tree limbs projecting over the water as shown in the illustration, then watch your luck change.—R. D. Rose, Maud, Miss.

Preventing Accumulation of Water in Gas Tank

Water, caused by the condensation of air on the sides of a partly filled auto gas tank, often causes trouble as it settles to the lowest point of the gasoline system and may then obstruct the flow of gasoline in the case of a gravity-feed system, or it may freeze if the temperature is low enough, thereby also shutting off the gasoline supply. This trouble is more likely to occur when the gas tank is kept only partly filled. If you have had any trouble with water in your gasoline system, make it a practice to keep the tank full.—C. Ed Packer, Chicago, Ill.

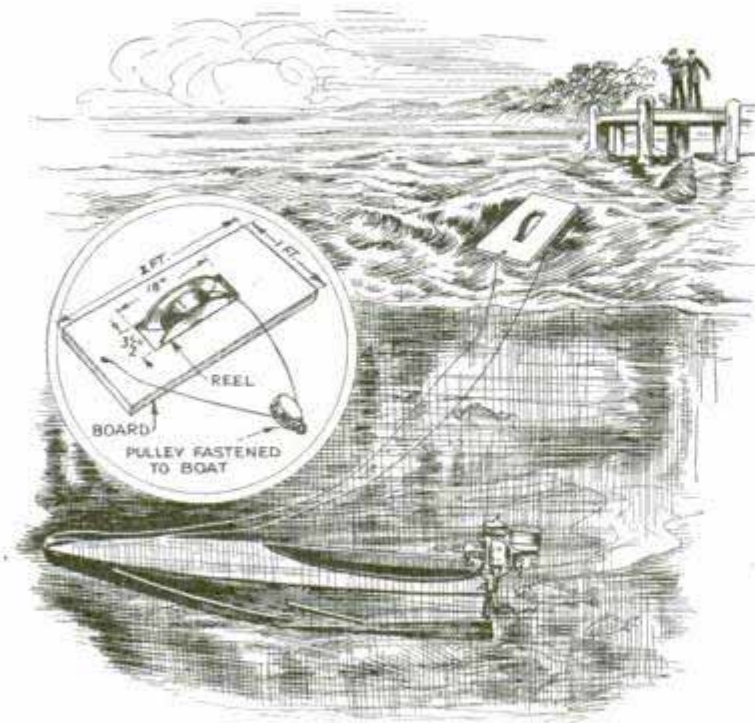

Boats Equipped with This Float Can Be Readily Located If They Have Sunk

Float Shows Location of Sunken Boat

Every year a great number of small boats equipped with outboard motors capsize and are lost in deep water. Sometimes they are recovered, but more often they cannot be located and are therefore abandoned. The trouble can easily be eliminated by providing a float fitted with a reel, which will rise to the surface and can easily be found by the searching crew. The drawing shows a float, 2 ft. long and 1 ft. wide, with a rectangular hole cut in the center to accommodate the reel on which twice as much line is wound as is necessary for the float to reach the surface from the deepest point in the lake. A pulley is fitted to the boat and the line is passed through it and then tied to the float as indicated. The buoyancy of the float will cause the reel to unwind, and the line will slip through the pulley on the boat as

the float rises to the surface. It must be located in such a position that it will not be obstructed in any way, and must be held in a suitable housing, such as a box on the deck, so that it will not fall into the water in ordinary conditions.—Harry A. Leonard, Hollister, Calif.

Simple Method of Tempering Tools

Tempering tools, such as drills, cold chisels, etc., in the regular way is a task that usually requires considerable experience. However, there is an easy method of doing this which can be followed by anyone even though he has never before attempted such work. Just heat the point of the drill or the part of the tool to be

tempered to a cherry red, and then force it about $\frac{1}{2}$ in. into a bar of lead. Leave it there for about 30 seconds, then remove and plunge it in cold water. The result will be a hard and tough edge.

Improvised Clothes Closet

Many home owners, who seldom use their attic, will find that the attic stairway can be utilized to advantage by transforming it into a clothes closet as shown. A panel as wide as the stairway, forms the back of the closet. It must, of course, be made removable, which is done by nailing two grooved 2 by 2-in. strips to the walls and sliding the panel between them. A handle is provided on the lower part so that it can be raised when necessary. Strips of $\frac{3}{4}$ -in. stock are screwed to the panel and to the walls to serve as supports for clothes hooks.



A Seldom-Used Attic Stairway Offers a Practical Solution of the Closet Problem

primarily head # 22, Goodell, Pratt Co,

SHOP NOTES



Buffing Head Makes Vertical Sander

By M. CLYDE SMOCK

THE LITTLE sander described below is not only cheap and easy to construct, but is an exceedingly useful tool in the small shop. With its drum running vertically and the table in a horizontal position, the sanding of curved pieces, such as table legs, can be done very accurately, since the lines on the work are always in plain sight.

The main element of the machine is an ordinary buffing or polishing head, having a taper screw on one end of the spindle and a chuck and flanges on the other. Such heads can be bought for as little as \$1.50, but the writer suggests that one be purchased costing from \$3.50 to \$4.50, since the higher-priced machines have split bearings for taking up wear and thus preventing spindle chatter.

Begin by fastening the two endpieces of the table, shown in the drawings, to the base, using glue and screws driven through the base into the ends. Next fasten the bottom strips to the base, and then put the table supports in place, using glue and screws.

With a hacksaw, cut off the end of the spindle that carries the chuck, allowing $\frac{1}{4}$ in. to project beyond the bearing, then fasten the head to the endpiece as shown, using long screws. The end of the bearing should be even with the tops of the endpieces, and the spindle should be made exactly vertical, before the screwing down is done.

Cut the table to size and bore or cut a 3-in. hole for the drum, then fasten it with

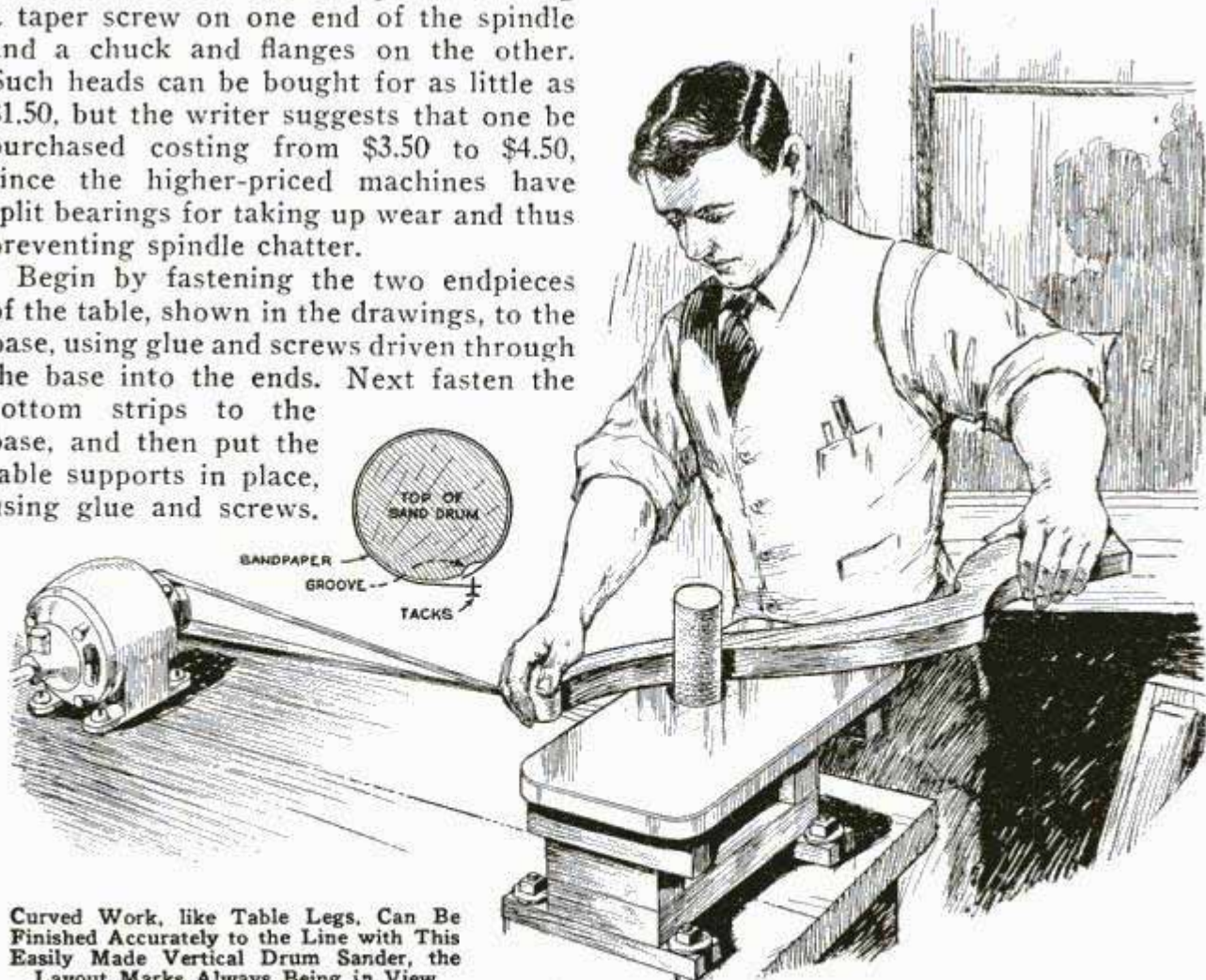

Curved Work, like Table Legs, Can Be Finished Accurately to the Line with This Easily Made Vertical Drum Sander, the Layout Marks Always Being in View

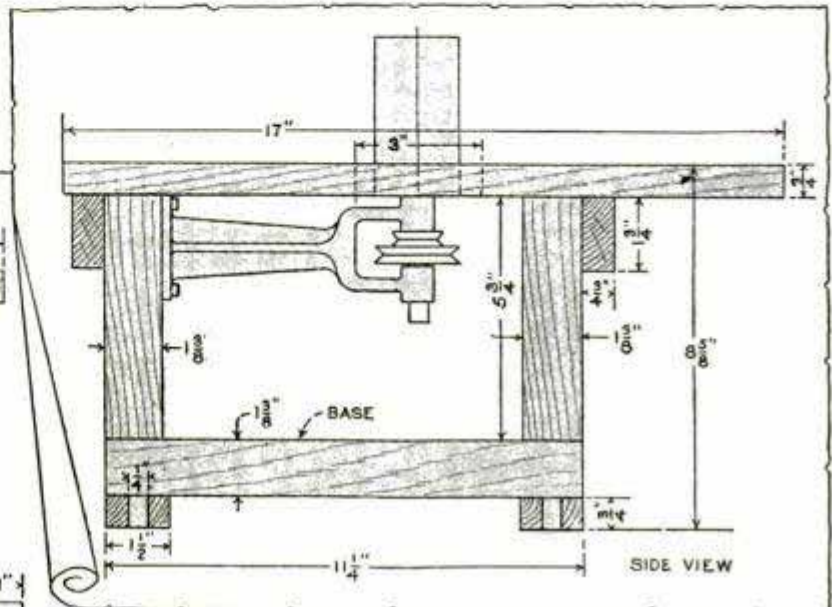
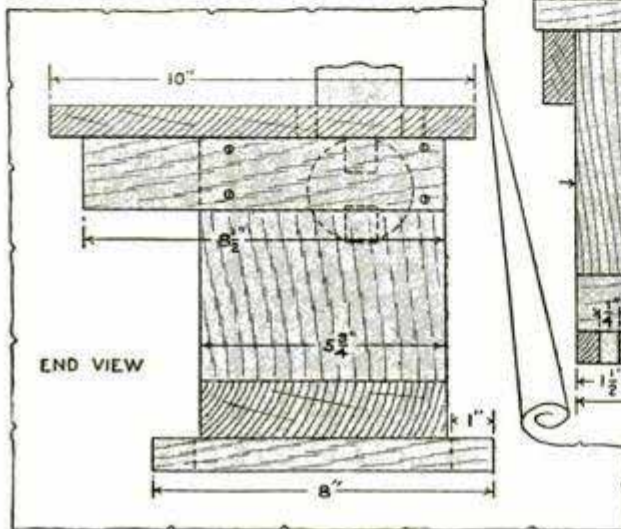
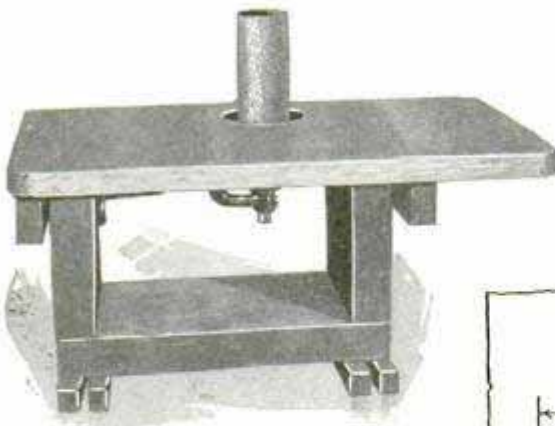

Left, Top, Completed Spindle Sander; Below, End View Showing Table Support, and, Right, Side View Showing Arrangement of Buffing Head and Drum

flat-head screws, 2 in. long, countersinking the heads into the top, so that they will not interfere with the passage of the work across the table.

The sand drum is of hardwood, preferably maple, from $1\frac{1}{2}$ to $2\frac{1}{2}$ in. in diameter and 4 in. long. A shallow groove, $\frac{1}{8}$ in. deep and $\frac{3}{8}$ in. wide, is cut lengthwise of the drum, and the sandpaper is fastened by wrapping it around the drum, with the ends overlapping in the groove, then tacking it in place, with the tacks in the groove. The hole in the end of the drum is very carefully centered and drilled, and the drum screwed on the tapered end of the spindle.

A round or flat belt, depending on the type of pulley used on the head, is run to the motor through the back of the sander. The speed should be from 2,000 to 3,000 r.p.m.

When using the machine, remember to apply a light pressure, and to keep the work moving constantly; otherwise the drum will "eat" into the wood. The spindle should run clockwise when viewed from the top.

this is not essential. Also, the whole frame of the machine may be constructed of angle iron, if the builder prefers this to wood, using $\frac{1}{4}$ or $\frac{1}{2}$ -in. angles for the legs and table supports, and $\frac{1}{4}$ -in. flat iron for braces.

Wire Gripper for Flat Stock

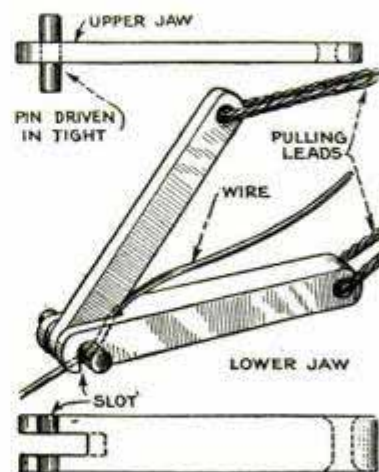

Two pieces of flat bar stock are used to make the wire gripper shown in the drawing. The lower jaw is slotted to receive the end of the upper jaw. Across the forked end

two notches are filed to take a pin which is driven tight into the other jaw. Both are drilled to take the pulling leads, and the wire is slipped between the jaws.

Self-Alining Shaft Hangers

Automatic alinement is the feature of the small shaft hanger shown, which was made almost entirely of pipe. The part housing the shaft bearing is a plain malleable-iron tee. The ends of the tee are cut away as indicated, and two holes drilled and tapped diametrically opposite each other to receive the setscrews. The ends of the setscrews are ground to the same angle as that of the drill which is used to make a seat for them in the bearing. A standard bronze bushing of sufficiently small diameter to allow it to move freely in the tee is used. As a substitute for a regular bearing bushing, an automobile spring-shackle bolt bushing has been found satisfactory. A pipe nipple is fitted into the threaded part of the tee and is then slipped into a larger nipple, in which it should make a sliding fit. Four slots are sawed lengthwise in the end of the second nipple so that this end can be compressed tightly on the smaller nipple by means of a suitable lock-nut, after the shaft hanger is adjusted. A

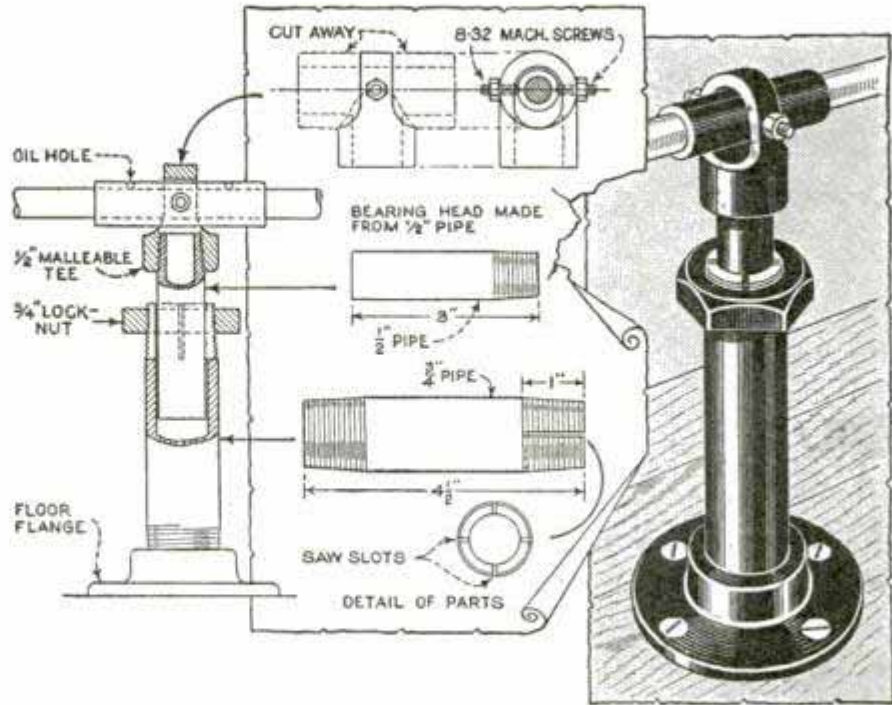

This Self-Alining Shaft Hanger Can Be Made from Pipe Fittings with Little Expenditure of Time and Labor

floor flange which fits the lower end of the larger nipple is screwed to the wall, ceiling or other support for the lineshaft. The sizes given in the drawing were followed by the writer, who used spring-shackle bolt bushings for bearings, accommodating a $\frac{9}{16}$ -in. shaft. Ordinary 8-32 machine screws were used to hold the bushing in the tee, which was of $\frac{1}{2}$ -in. size. The smaller nipple also was of $\frac{1}{2}$ -in. size, which was found to fit nicely in a $\frac{3}{4}$ -in. nipple.—G. T. Fowler, Bakersfield, California.

Card File for the Auto

For the salesman, collector or other business man covering a territory in his



Salesmen and Collectors Will Find This Card File a Great Convenience

car, a card file, installed under the instrument board, as shown in the illustration, will prove highly useful. The box containing the drawer is held in place by means of metal brackets and, if desired, the drawer can be padlocked.—M. MacDonald, Brooklyn, N. Y.

Preventing Loss of Hotel Keys

An effective method of reminding patrons to return the room keys when leaving, has been found by a summer-resort-hotel keeper. At the end of the fiber tab to which the key is fastened, a small bell is attached. The little bell tinkles a gentle reminder, which has prevented the loss of many keys.

Homemade Drawing

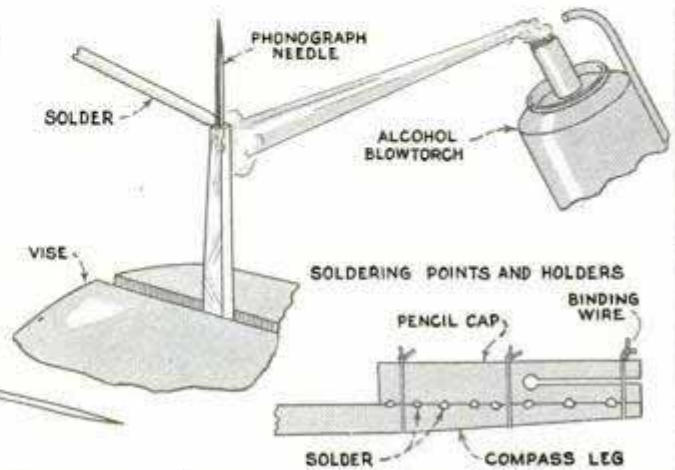
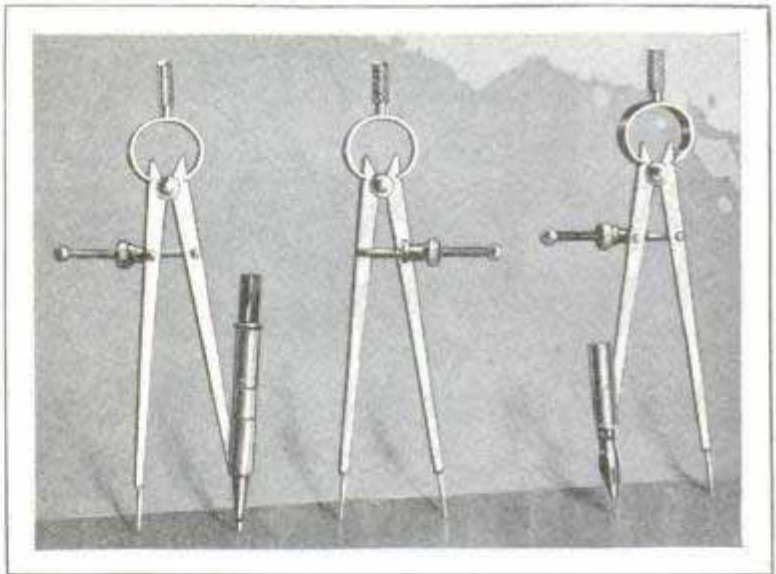
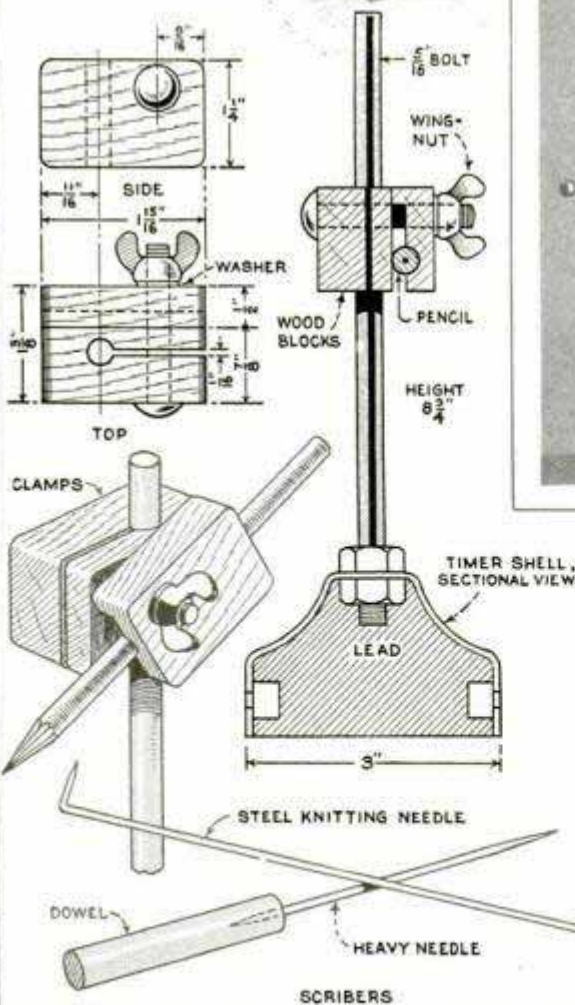
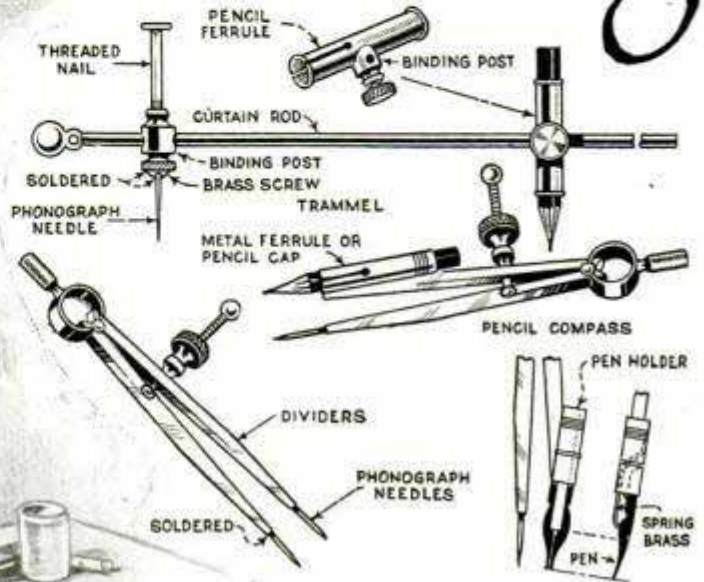

Instruments

By Edward Thatcher

THE HOMEMADE drawing instruments shown in the accompanying drawings have been in constant use for several years, and, although I have a splendid commercial set of instruments, I seldom use them, as I much prefer the quick and rigid adjustment of the homemade tools. I use them not only on the board, but also on the bench, where I constantly make drawings as I work, or utilize them to lay out the work itself. The surface gauge, while not strictly a drawing instrument, is included because of its usefulness in layout work, for which purpose I prefer it to a very expensive one I own, especially for such work as modeling

The drawings are all self-explanatory, and little need be said about the construction of the instruments. The compasses and dividers are made from common spring dividers as sold in the chain stores for machinists' work. One leg of the dividers is filed down until the surface of the end is large enough to drill a small hole to take a phonograph needle. The needle is soldered in place, using killed acid as a flux, and either a heavy soldering bit or a small blowtorch to heat it. The dividers have a needle soldered in each leg, and the pen and pencil compasses a needle on one leg and a pen or pencil holder on the other. For the pencil, a common brass pencil tube is used, and soldered to the compass leg as shown in one of the sketches. For the pen, the metal end is removed from an ordinary penholder and soldered to the leg of the compasses.

For very large circles, a good trammel bar is made up from a small-diameter curtain rod, a couple of good-sized binding posts, a pencil holder and a phono-



graph needle, assembled as shown. Two of the trammel points may be made with phonograph needles, one with a pencil holder and one with a penholder, so that the instrument can be used for all varieties of layout work and drawing. To solder the needles in place, screw into the bottom hole of the binding post an 8-32 screw, of such a length that it will not lock on the trammel bar. Force the needle into the slot in the screw head so that it stands upright, and solder firmly in place. The handle for the trammel point is a common wire nail, threaded 8-32 and substituted for the knurled-head screw.

To make the pens hold more ink, simply cut a strip of thin, springy brass and force it into place on the underside of the pen point and up into the holder as shown. Quite a quantity of ink will then be held in the space between brass and pen, and will flow to the point as needed.



Cheap Sidewalk Made of One-by-Four-Inch Boards for Muddy Patches between Farm Buildings

Board Walk for the Farm

Made of strips of 1 by 4-in. material, nailed together as shown in the illustration, this sidewalk for the farm sheds water as soon as it falls, and has been found highly satisfactory over muddy patches between the house and near-by sheds. The cost also is much less than that of a cement walk, as it can be made from old stock found around the farm. The spaces between the boards should be so narrow that they will not catch even the foot of a child.—Flora Clark Gardner, Tipton, Iowa.

Attachment Makes Drill Chuck of Automatic Screwdriver

Your automatic screwdriver can be made more useful by fitting it with a chuck so that you can use drills from $\frac{1}{16}$ to $\frac{1}{8}$ in. in diameter. Get a small T-wrench for taps, which is obtainable at any 5 and 10-cent store. Knock out the cross rod and saw off the shank a reasonable distance from the



chuck, then turn the shank to the proper diameter to fit the screwdriver. A notch, corresponding to the one on the screwdriver bit, is filed in the shank, after which the attachment is ready for use.—Warren L. Miles, Providence, R. I.

Quick Return for Arbor Press

When pressing a large number of small pieces in a bench arbor press, raising the arbor after each operation means considerable work. A good method of eliminating this is as follows: Drill and tap a hole in the top of the spindle, drop a spring of sufficient strength down over it to raise the arbor spindle, but not strong enough to interfere with the operation of the press. In doing this, use a washer on the end of the spring and insert a cap-screw through the washer, driving it into the tapped hole in the end of the spindle. The screw serves to adjust the tension of the spring besides holding it in place. The operator presses down the spindle, which rises of its own accord as soon as it is released.—Charles R. Whitehouse, Boston, Mass.

Sanitary Base Shoe Is Better Than Baseboard

Usually a baseboard has a piece of quarter-round stock on the edge. This often loosens, exposing cracks in which dust and vermin are likely to gather. To prevent this, use instead the sanitary base shoe shown in the illustration. It is nailed in place before the finish floor is laid, and its lower edge is of the same thickness as the finish floor so that both will fit together flush. When installing the shoe, plane the back side at a slight bevel so that, when the piece is nailed in place, the top edge will fit tightly against the wall. The dotted lines indicate the wrong position of the nail, which should be driven into the shoe at a 45° angle and penetrate into the subfloor.—H. H. Siegele, Emporia, Kans.

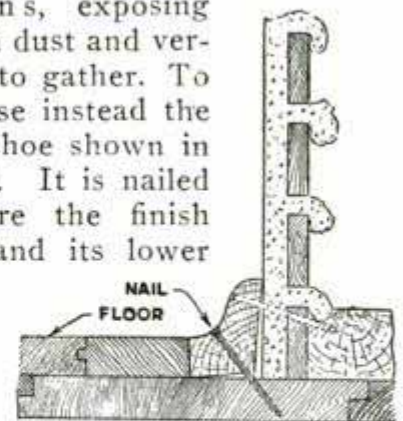

THESE MOVING SCARECROWS ARE EFFECTIVE

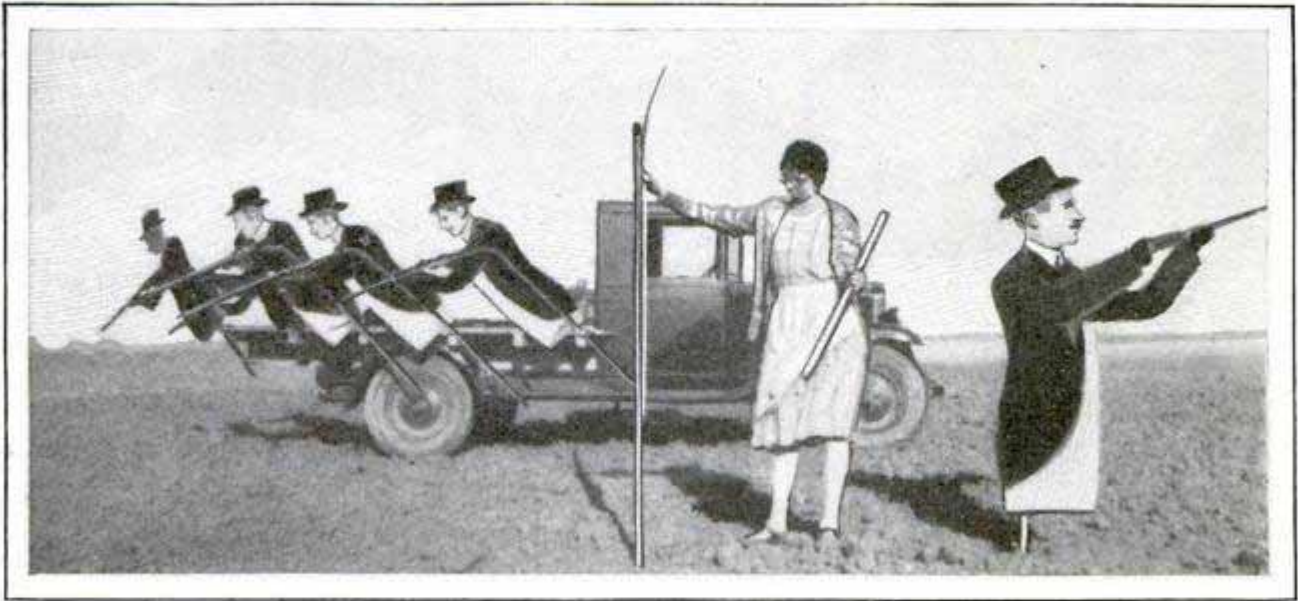

These Homemade Sheet-Metal Scarecrows, Which Rotate in the Wind, Have Been Found Effective on Farms to Keep Geese Away from Wheat Fields

Moving around in the wind like huge weather vanes and thus constantly shifting position, the scarecrows shown in the drawing have been found highly effective, 21 of them being in use on my 700-acre farm. The body portion, resembling a man holding a gun, is cut from sheet metal, and is fastened to a length of $\frac{3}{4}$ -in. pipe bent as indicated. The pipe should extend about 2 ft. below the body and is inserted into a 24-in. length of $1\frac{1}{4}$ -in. pipe, provided with a cap at its lower end and sunk into the earth. These scarecrows have kept geese from taking wheat crops, a task which formerly required the services of several hands.—W. H. Jones, Oroville, Calif.

Annealing Tool Steel Quickly for Machining

Carbon tool steel can be annealed quickly so that it can be machined, in the following way: Place it in a furnace and gradually run up the temperature to $1,360^{\circ}$ F., or if a furnace is not handy, place it in a fire and heat it very slowly until it is a little under a cherry-red, after which it is allowed to cool until it looks black in the light, but is still a dull red when held inside a keg or box. Keep the steel in such a dark place until it is just cooling from a dark red and then quench it in water at 60° F. The steel will be a

grayish white and appears to be glass-hard, but it will be soft enough to machine.—H. K. Ellis, Cincinnati, Ohio.

Cheap Power for Centrifugal Pumps

When installing two centrifugal pumps for excavating work in the bed of a stream, the contractor saved several hundred dollars by purchasing two used automobiles having good motors, to drive the pumps, one pump being connected directly to each driveshaft. The car bodies were removed and the ends of the frame cut off with a torch. An A-shaped frame of 3-in. angle iron, welded to the car frame, was used to lift the pump about with a crane.—Jos. C. Coyle, Denver, Colorado.

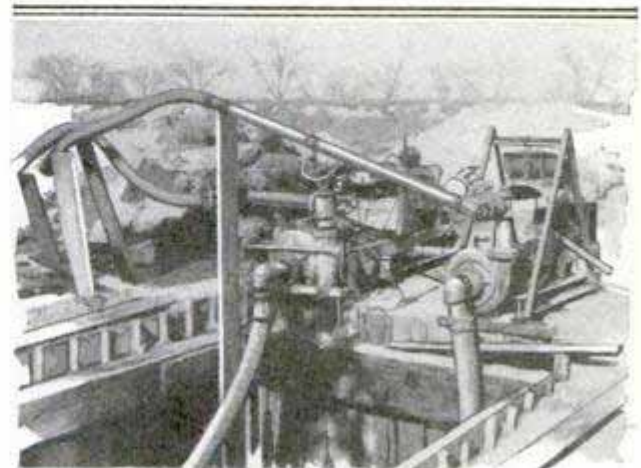

Centrifugal Pumps Connected Directly to Driveshafts of Old Autos



Ornamental

by W. Clyde Lamme

merely illustrate the method of doing the work, we are showing complete plans and dimensions for making a small occasional table, ornamented in this way, which gives an idea how the work improves the appearance of parts that are not especially attractive when left plain.

The column and four legs are first made in the rough, and then the square corner newels for the table frame are cut and their finials turned. Red gumwood, $1\frac{3}{16}$ -in. stock, is used for the base, fancy walnut plywood is obtained for the top and sides, while the remainder of the hidden work may be birch. For the column, rip five pieces from $1\frac{3}{16}$ -in. gumwood, each piece 20 in. long and 4 in. wide. Glue the

five pieces together, face to face, making a block as shown in the upper right-hand section of the drawing on page 167, and clamp solidly to dry. For the four legs, rip eight pieces from the same stock, $4\frac{1}{2}$ in. wide and 12 in. long. Glue these together in pairs to make the $1\frac{5}{8}$ -in. thickness required. Be particular, when clamping the stock, to draw the parts tightly together in order to get a good joint. For the corner newels, get a piece of solid wal-

POSSESSING a distinctive charm of its own, reeded and fluted work is not nearly so exacting as woodcarving, and it can readily be done by the home worker. Reeding and fluting are terms used to denote the corrugations cut in the surface of furniture, which are usually confined to the legs, columns and heavy framework. Reeds, often called beads, are convex in form, while flutes are concave, and are sunk into the surface. Both can also be combined in alternate reeds and flutes. In the accompanying drawings examples of both are shown, the column of the table being both reeded and fluted, while the corner newels of the top are fluted only on one side. The tools needed are merely a few curved chisels or gouges of various sizes. Rather than



Laying Off Guide Lines on the Curved Surface of the Table Column

Reeding and Fluting



nut, $1\frac{1}{2}$ in. square and 30 in. long. Plane smooth, square the ends and then cut this into four 7-in. lengths. Set up each piece in the lathe and strike lines across the four faces and $1\frac{3}{8}$ in. from one end. Turn to approximately the shape shown in the same drawing, but be sure to get the four pieces exactly alike. Sand the work smooth while in the lathe. Cut the rabbet and housing as indicated, $\frac{3}{4}$ in. wide and $\frac{1}{4}$ in. deep, on all four pieces. Run a $\frac{3}{8}$ by $\frac{1}{4}$ -in. groove close to the edge on the back face of the front newels and on the front face of the back newels. These grooves take the end panels. Stop the grooves at the turning, so that they will not deface the finished work.

After the stock for the legs has dried for 24 hours or more, remove the clamps. Make a full-size layout on cardboard, using 1-in. squares as indicated in the lower right-hand detail. Trim the cardboard template to the proper shape. Then carefully saw one end of each piece to an an-

gle of 30° , after which the form of the leg is laid out on the wood. Saw to the line with a scrollsaw, if a band or jigsaw is not available. Then sand the sawed edges smooth.

The column provides an interesting job in turning. Most small lathes used in home workshops have motor headstocks, that is, the motor is directly connected to the work so that no variation in speed of the live center is possible. For this reason, it is necessary to have the work carefully balanced so that it will drive at the

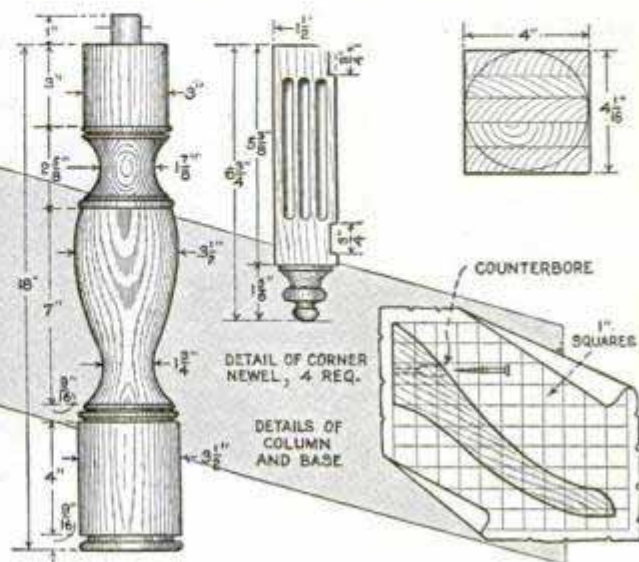
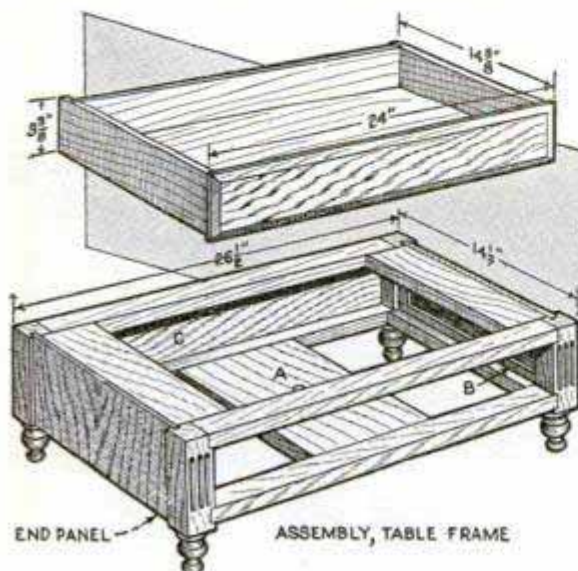

high speed without excessive vibration. Locate the center by diagonals, drawn on the ends from corner to corner. Set your dividers to a radius of 2 in. and scribe a circle on each end of the work. Plane off the four corners with a jointer plane or, if a circular saw is handy, tilt the table 45° and saw off the corners. The result will be an octagon-shaped piece whose sides are tangent to the circles scribed at the ends. If cut in this way, the piece usually will be well balanced, but if not, plane off the faces until it is. Do not permit any vibration of the work, as this is not only dangerous but is apt to do considerable damage to the motor bearings within a few minutes. First turn the piece to a cylinder of a uniform diameter of $3\frac{1}{2}$ in. Lay out the separate sections as indicated in the drawing. Turn to the desired shape and then sand with progressively finer grades of paper to a very smooth surface. Be particular about the sanding, as it contributes greatly to the appearance of the work, and makes it easy to finish

properly. Before removing the work from the lathe, set the dividers to about $\frac{1}{4}$ in. and step off the divisions of the reeds around the smallest diameter of the section to be reeded and fluted. Should the divisions step unevenly, change the adjustment of the dividers slightly until they come out accurately. On a diameter of $1\frac{3}{4}$ in., you can lay off exactly 22 divisions of $\frac{1}{4}$ in. each. Mark each division with a pencil. Set a marking gauge against the toolrest, adjust the arm until the point is directly over the axis of the work and then mark each division, sliding the gauge against the toolrest while holding the work from turning. Score the wood heavily so that the marks can be easily seen.

After the column has been marked, it is locked in a horizontal position in the vise, and the cuts are started at one end, using the gouge. Keep each cut uniformly $\frac{1}{8}$ in. in depth and work gently, giving the handle an oscillating movement with the wrist as an axis line. This will lift the chip at the edges and prevent the tendency to run out and damage the work. The line scribed as a guide must be kept in the center of the chip. Guide the gouge with the thumb and first finger of the left hand, using the right only to apply the

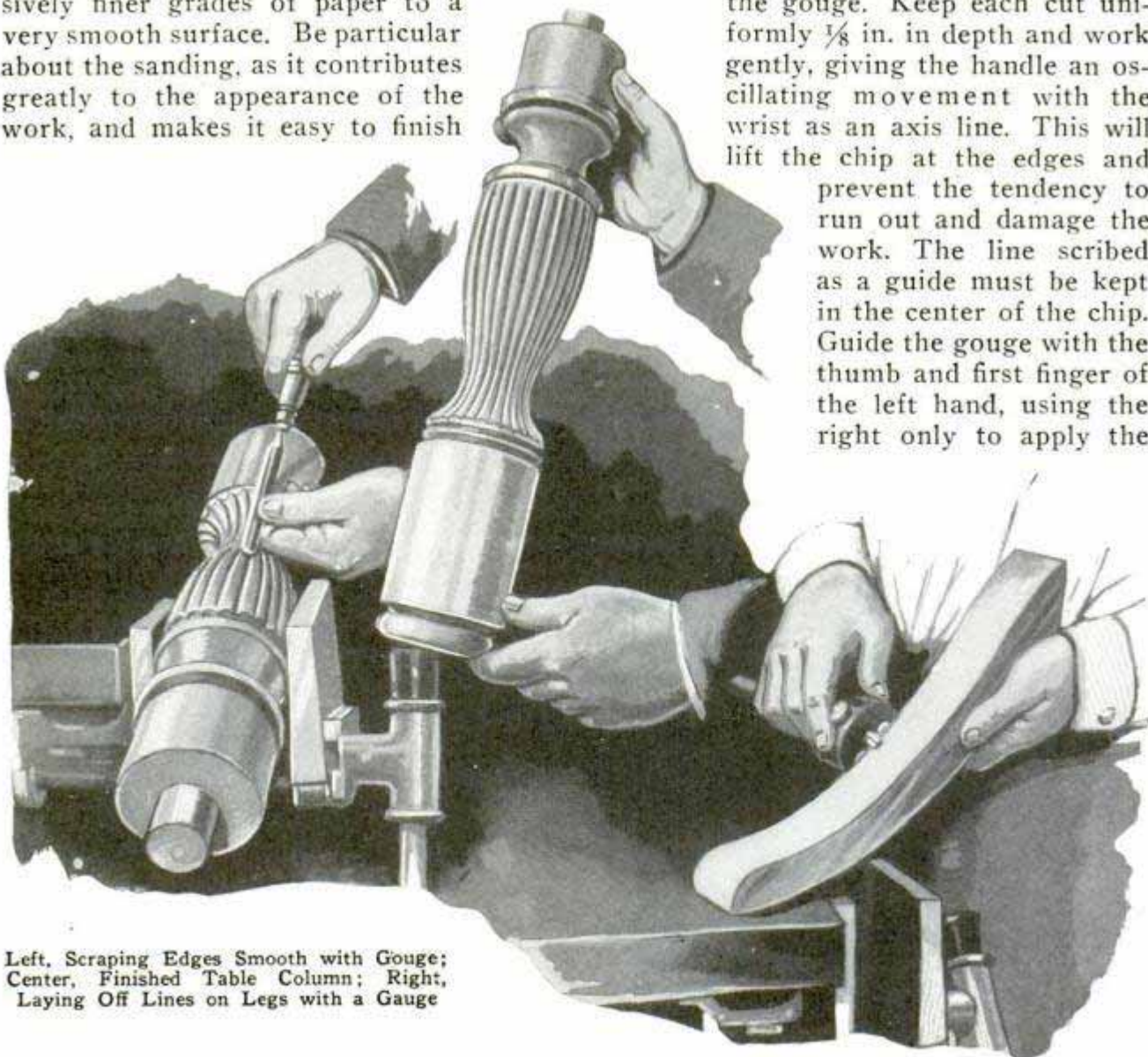

Left, Scraping Edges Smooth with Gouge;
Center, Finished Table Column; Right,
Laying Off Lines on Legs with a Gauge

pressure. It is best to begin at one end and run the separate cuts around the entire circumference, bringing them only to the point where the tool begins to meet the opposing grain of the wood. Then turn the work in the vise and repeat the operation from the other end. After the hollow cuts have been completed around the column, and work is evened up, take a $\frac{3}{8}$ -in. gouge and turn it over so that it can be

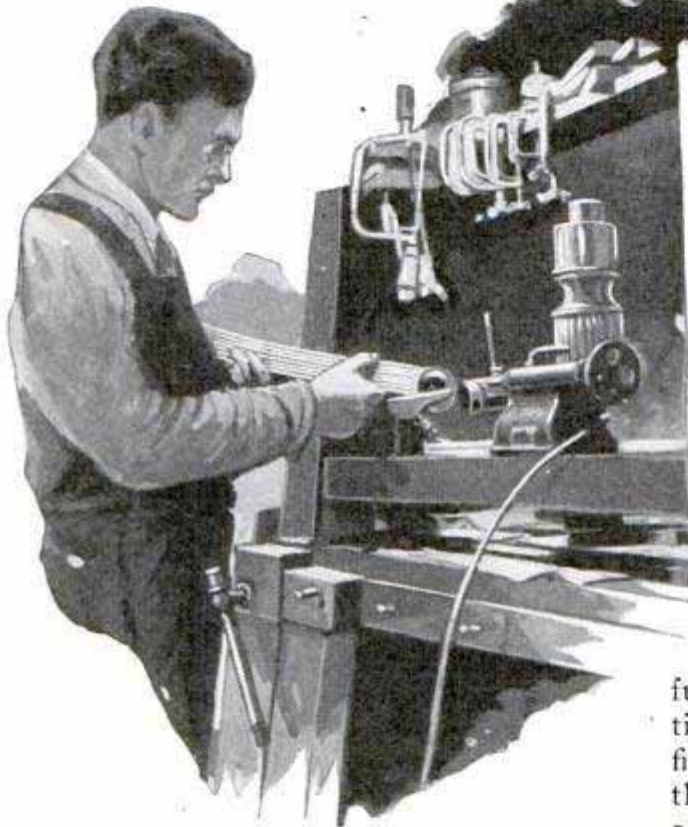

used as a scraper to round off the sharp edges of the reeding.

The fluting of the legs is done practically the same way. As the width of the leg is $1\frac{5}{8}$ in., six guide lines are made. When finished, counterbore the legs first with a $\frac{1}{2}$ -in. and then with a $\frac{1}{4}$ -in. bit at the point indicated, to accommodate a single heavy screw. The ends of the legs that join the column must be cut concave to an accurate fit. Use a wide gouge and pare the ends to a depth of about $\frac{1}{8}$ in. Then use a sanding drum of the proper diameter in the lathe, as shown in one of the photos. Sand to a perfect fit on the column. Locate four equidistant points about the circumference at the lower end of the column and drill small holes to take the screws to hold the legs. Be care-

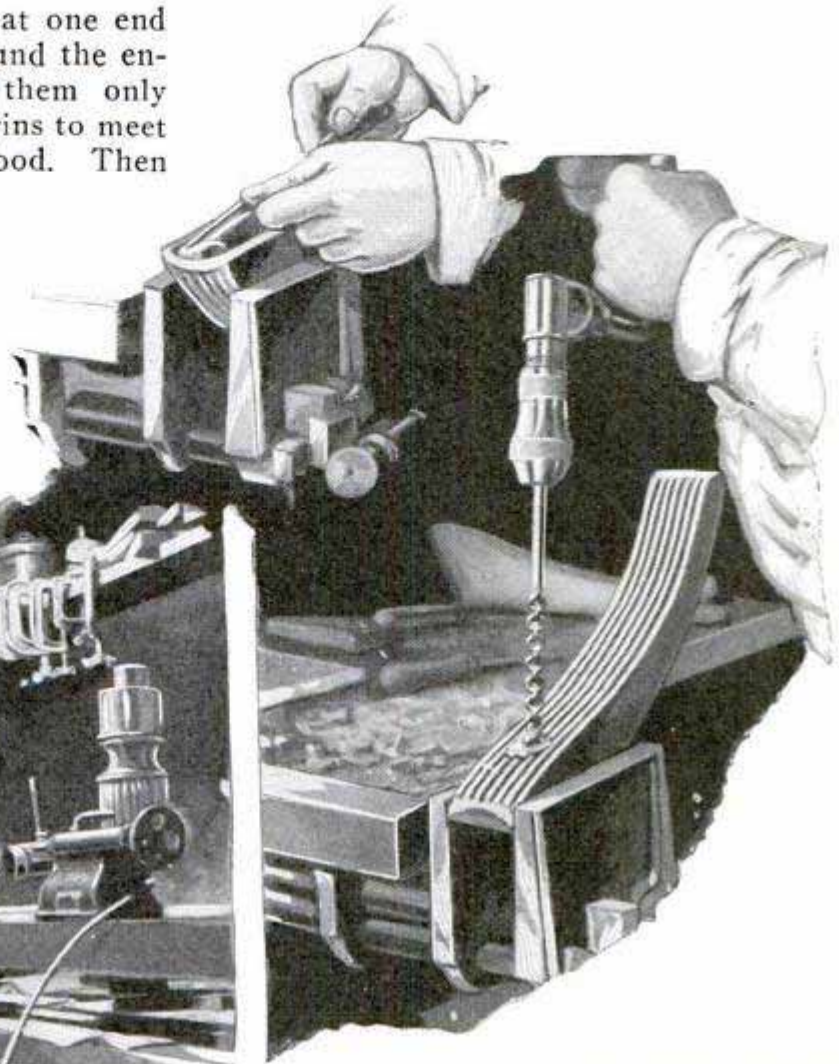

Fitting the Legs to the Column Requires Care and Accuracy

ful to locate the legs accurately in the vertical position on the column so that the finished base will stand true and firm on the floor. Spread glue on the joining ends and drive the screws home, drawing them up very tight so that the joint will fit snugly. Fill the holes up level with the top of the reeds with plastic wood, which can be later cut down to conform to the surface.

Run the fluting on the two front newels. The two front drawer rails are cut from $1\frac{3}{16}$ -in. solid walnut to exactly $24\frac{1}{4}$ in. in length and $1\frac{1}{2}$ in. in width, and are then planed to $\frac{3}{4}$ in. in thickness. A groove, $\frac{1}{4}$ in. wide and $\frac{1}{2}$ in. deep, is cut in the center of the back edge of each rail. The back rails, of birch, are made to exactly the same dimensions. Assemble the front and back rails to the newels first, using glue on the joining ends, glue-sizing the ends first before the final coating is put on and the work clamped. Cut the back panel from $\frac{1}{4}$ -in. plywood and

motor-driven fluting and reeding tool - Carter Co. Inc. Phoenix Ariz

slide it into the grooves when assembling. When dry, fit the runner and the center-piece in place, using glue at all the joints

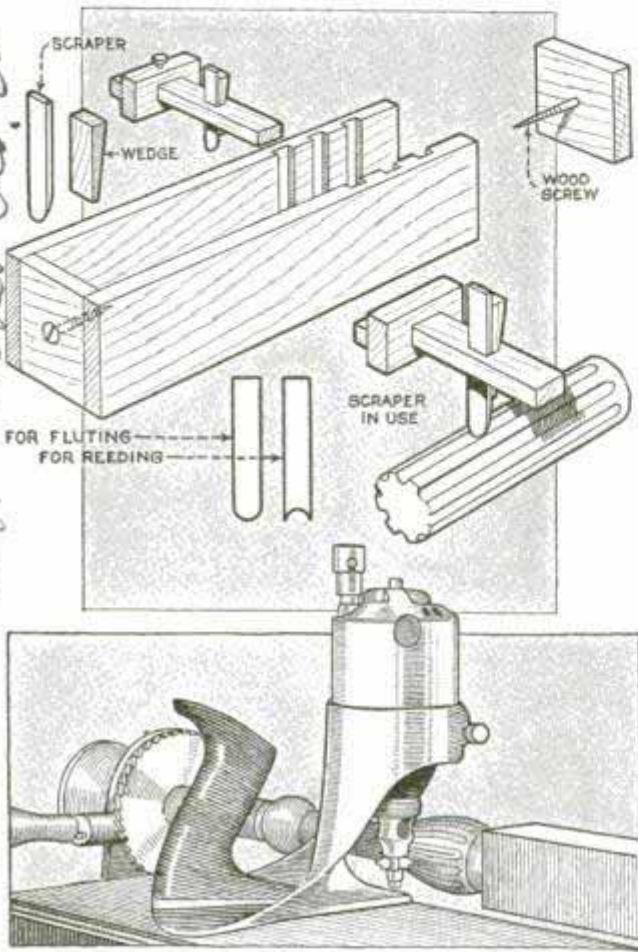

Jig for Reeding Work of a Uniform Diameter, and Motor-Driven Tool for All Kinds of Work

and clamping it tight, making sure that the parts are correctly positioned. Cut the end panels from $\frac{3}{8}$ -in. walnut plywood so that the grain will be vertical. Do not glue the end panels, but trim them to a light fit and leave loose. The drawer front is made of $1\frac{3}{16}$ -in. walnut plywood, ripped to 4 in. in width, and cut to 24 in. in length. Rabbits, $\frac{1}{2}$ by $\frac{1}{2}$ in., are run on the back edges and across the ends. For the inner construction, $\frac{1}{4}$ -in. stock is used, the drawer sides being simply nailed to the shoulder of the rabbit across each end of the front. The usual grooves are cut for $\frac{1}{4}$ -in. plywood for the bottom, and the whole is then glued together in the regular way. Round over the edges of the drawer front with a block plane and sand very smooth. Try the drawer for fit in the frame and set the guides.

The top is cut from $1\frac{3}{16}$ -in. walnut plywood to the dimensions indicated. If a molded edge is desired, take the top to a

cabinet shop where this can be done. Bore a 1-in. hole at the centerpiece of the table frame to take the dowel turned on the end of the column, spread glue underneath and, after noting that the frame is correctly positioned, lock the parts securely with four screws, equally spaced and driven into the end of the column. Lay the top on a flat surface, upside down, invert the frame over it and screw the parts together. Stain all gumwood parts with a walnut oil stain, wiping the reeding lightly to obtain an antique finish. Fill all the walnut with walnut paste filler. Allow it to dry thoroughly and then sand the wood smooth with 6-0 wet-or-dry paper and linseed oil. The oil brings out the beauty of the walnut and at the same time prevents the fine paper from clogging. After all parts have been sanded, clean up with turpentine and give them two coats of high-grade flat varnish. When dry, rub all the flat surfaces with 8-0 wet-or-dry paper and linseed oil. Then rub down with powdered rottenstone and oil, having the cloth soaked with the oil and the rubbing stone being sprinkled lightly over the surface. Continue the rubbing until a soft satin finish is obtained. Last of all, apply two bronze pendant drawer pulls to the front of the drawer.

The last drawing shows two other methods of reeding and fluting. The box in the upper detail is used for straight pieces having a uniform thickness throughout. The work is held securely by means of wood screws driven through both ends, as indicated. One end is adjustable to suit the length of the work. A device resembling a marking gauge in general construction and method of use, is provided with a fluting or reeding tool. These are virtually scrapers, made from old hacksaw blades, ground down to the required shape and sharpened to a keen edge.

The tool is placed in a square hole and tightened by means of a wedge. In the lower detail a small motor-driven tool is shown, which can be used for reeding and fluting curved pieces as well as those of uniform diameter. While the work is held rigid in a lathe or index centers, the tool is moved along the surface as indicated.

Washing Painted Walls

Anyone who has tried to wash the dirt from painted walls and ceilings knows how difficult it is to get a clean job without streaks and smears. Here is a method that results in as good a job as can be desired without the objectionable features just mentioned. Make up a hot solution of concentrated washing powder, using enough of the latter to make the mixture assume a jellylike consistency when it has cooled. This paste will not run and splash around. Apply it to the surface of the wall with a calcimine brush and use the same brush to rub the surface, which will quickly loosen the dirt. Then take a sponge, immerse it in clean water and wring it out thoroughly, after which it is used to absorb the paste and dirt on the wall. It has been found that a stiff-bristle brush is not satisfactory for loosening the dirt, and cloth cannot be used to advantage as a substitute for a sponge.—Frederick J. Pease, Wauwatosa, Wis.

Canvas Bag Aids Ice Delivery

To avoid dripping water on the floors of homes, a western ice company provides its men with waterproof canvas bags, as shown in the photo. The men also carry towels to wipe up drippings around the icebox when the ice is transferred from the bag to the ice compartment.—H. A. Konderman, Oakland, Calif.



Homemade Fly Paper

Fly paper can be made at home at a cost of about 1 cent for a dozen large sheets. All that is needed is 2 lb. of rosin and 1 pt. of castor oil. Heat these ingredients together until the mixture looks like molasses. Then take an old paintbrush and smear it on sheets of paper, doing this while the mixture is hot.—E. G. Moore, Washington, D. C.

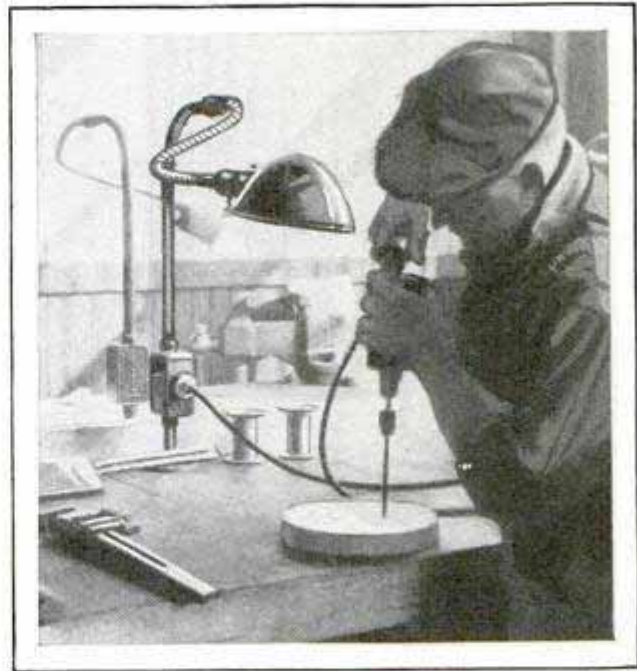

An Electric Outlet on the Workbench Will Save the Worker Considerable Time

Handy Outlet for the Workshop Bench

When using a small drill or other electric tool in the workshop, it is usually necessary to remove a lamp, which is unhandy and involves quite a waste of time. It is much better to provide an extra outlet on the bench.—A. Mathieu, Chicago.

Turning Cams on a Lathe

Turning cams on a lathe was successfully done by the method shown in the drawing. Make a bearing in the compound rest to hold the shaft or arbor. Use two pieces of cold-rolled steel with a key in one piece to fit the tool slot on the compound rest. After clamping the pieces together, a hole is drilled through them to fit the arbor. The depth of the cut can be regulated by tapping the cutter. The compound rest is set to angle B and fed in and out at that angle. The tool is set in a tool holder that is clamped to the faceplate. Quick and accurate work can be done by this method, provided the work is set up properly.

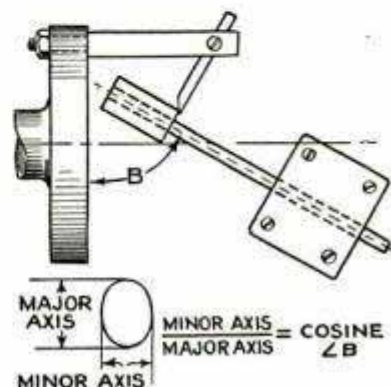

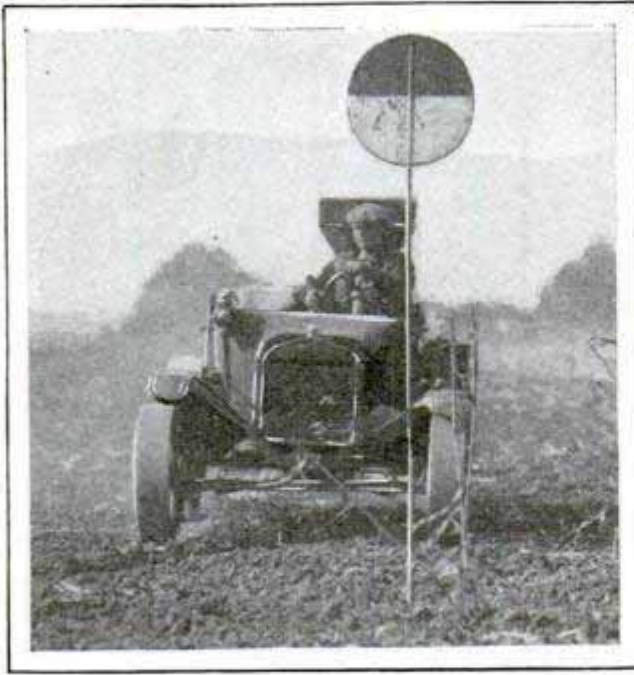

Seeder Attached to Old Auto Fitted with Iron Wheels
Covers 165 Acres a Day

Seeding Large Area with Old Auto

Equipping his old flivver with iron wheels and installing a grain seeder on the back, a San Joaquin valley farmer is able to sow 165 acres of barley a day. He keeps a straight course across the field by driving directly toward conspicuous targets placed at each end of the field, the position of the targets being changed every time he reaches them. The tracks made on the ground also help him to keep a straight course.

Flywheel for Hand Emery Grinder

It is well known that the efficiency of machinery operating under a fluctuating load can be greatly increased by providing a flywheel, and this also applies to a hand-driven emery wheel. A neat flywheel can be made by melting a quantity of lead in a round tin-can cover, the diameter of which should be about 1 in. less than the emery wheel's and its thickness $\frac{1}{2}$ or $\frac{5}{8}$ in. After the lead has hardened and cooled,

the cover is removed and a hole drilled in the exact center, the same size as the emery-wheel shaft. The disk is then slipped on the shaft after the nut and washer on one side of the wheel have been taken off. The nut is replaced but the washer will probably have to be left off, owing to lack of space. After tightening the nut, the emery wheel is revolved and the edge of the lead disk dressed off with a sharp chisel to balance it.

Battery Compound as Insulation

While doing some insulating work one day on a radio set, I attempted to make use of the sealing compound found on the top of old dry cells and B-batteries. However, after melting this material, it cooled too quickly and, if reheated, became brittle and worthless. After some experimenting I found that by stirring a little kerosene into the melted material it could be worked at about half of the heat previously required. Furthermore, the kerosene did not prevent the mixture from hardening properly.—Charles R. Powers, Owen, Wis.

Measuring Segments in the Lathe

Like many other mechanics I had considerable difficulty in measuring the diameters of half bearings, segments and other pieces in a lathe. However, I solved the problem by using a holder for the inside micrometer, as shown in the drawing. The holder was made to fit the tailstock spindle, and a hole was drilled near the end to take the spindle of the micrometer. The holder was then saw-slotted, drilled and tapped in the center for a knurled-head tightening screw. Now I can measure part of a circle just as easily as a completely bored hole. In use, the spindle is slipped in the hole of the holder, the tailstock is advanced and the spindle is slid down to touch the work, after which the

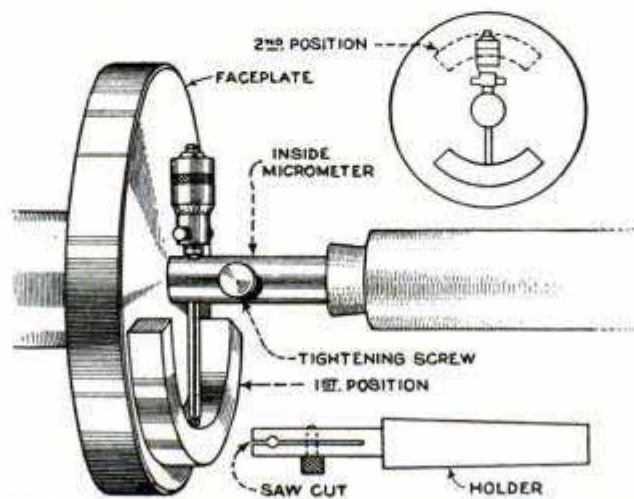

This Holder Makes It Easy to Measure Segments in the Lathe

knurled screw is tightened. All that remains to be done is to pull the lathe around until the work comes to the top, and the barrel of the micrometer is adjusted to touch it.—Harry Moore, Hamilton, Can.

Measuring Diameter of Small Rod

A draftsman, who had no calipers to measure the diameter of a small rod, used a ruling pen instead, and found it entirely satisfactory for the purpose. The sharp edges of the ruling pen are placed on the scale and the exact measurement can be read more accurately than with calipers.—F. Harazim, New York City.

Handy Jig for Pulling Down a Bent Fender

For straightening automobile fenders that are badly turned up at the ends, the simple device shown in the drawing has been found useful. It consists of a $3\frac{1}{2}$ -ft. length of $\frac{5}{8}$ -in. wire cable with a loop at each end. Attached loosely to the cable is a clamp made to fit the edge of the fender and having a setscrew for tightening it. The clamp is fastened on the edge of the fender, the loops at the end of the cable are slipped over a double hook, and

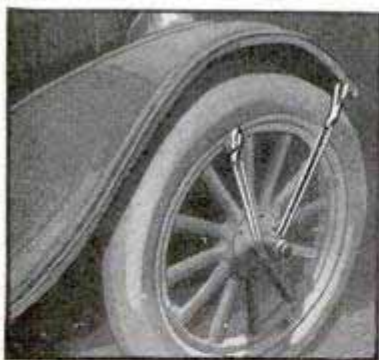

the latter is slipped over a rim bolt on the wheel. The wheel is then jacked clear of the ground and revolved as shown to pull the fender down, the rope being passed under the hub.—Jos. C. Coyle, Denver, Colo.

Homemade Lawn Harrow Loosens Soil

For loosening the soil of old lawns preparatory to seeding, the device shown has been used by a Pasadena gardener. It consists of a set of four sharp-edged disks, weighted down with a curved block of concrete, supported on a pair of rubber-

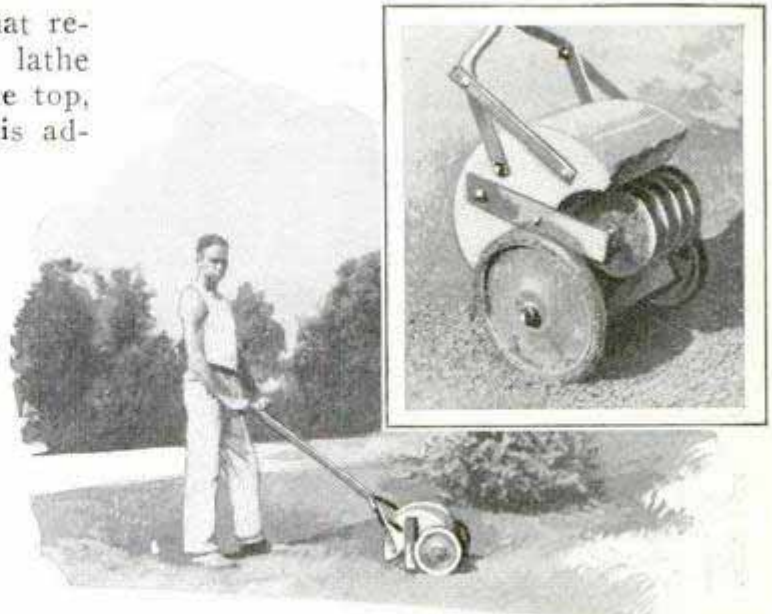

Homemade Lawn Harrow Cuts Up Grass Roots and Loosens Soil for New Seed

tired wheels, and equipped with a lawn-mower handle, so that the worker can easily push it. When renovating lawns, particularly where Bermuda grass with its long runners is present, much of the original root stock is left in the soil, making it hard for new seed to take root. The lawn harrow cuts up the roots as well as the soil, making a receptive bed for the new seed. It is run across the lawn twice, at right angles.

Squaring a Tapered Column

A simple method of squaring the ends of a tapered column is indicated in the drawing. The square is placed at the point on one side of the column where it is to be squared, and a light line marked along the blade. The square is then reversed with the blade passing through the same point and a second line is drawn as indicated. Di-

vide equally the angle between the lines thus made and the bisector AB will be the line along which the column should be cut to be square.—N. R. May, Louisville, Kentucky.

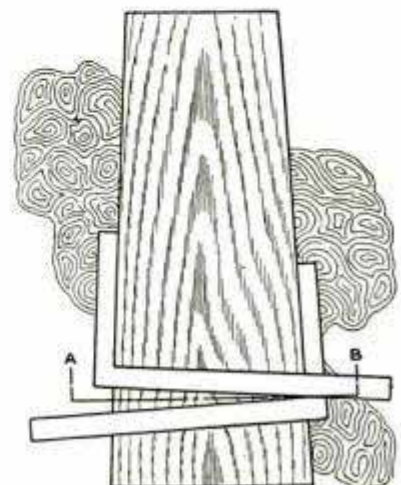

Grease Cup Used as Former for Making Wax Pattern Fillets

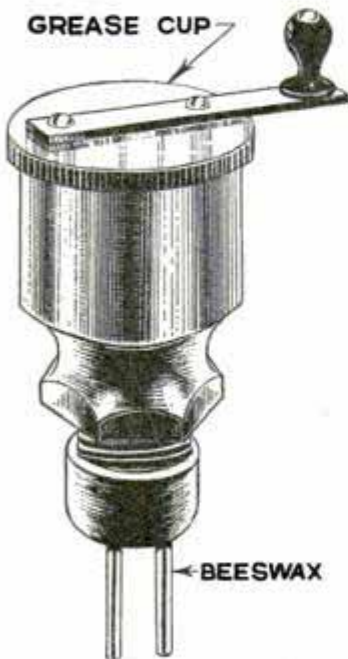

Patternmakers will appreciate the illustrated device for making wax fillets for patterns. It consists of a standard grease cup provided with a crank, and a pipe cap screwed on the end. One or more holes are drilled in the cap according to the size of the fillets desired. It is possible to make

four or five different sizes at the same time. Ordinary yellow beeswax is put in the grease cup which is held vertically in a vise.—Ralph T. Stewart, Statesville, North Carolina.

Tool for Cleaning Piston-Ring Grooves

For the garage mechanic, who has frequent need of a tool for cleaning piston-ring grooves, the one shown in the drawing will be found useful. It is made of two strips of steel, $\frac{3}{16}$ in. thick and 1 in. wide, each given a quarter twist at the end where they are pinned together. They are then bent to conform to the average diameter of pistons with the projecting ends left straight to form handles. A groove scraper is made for each width of ring in

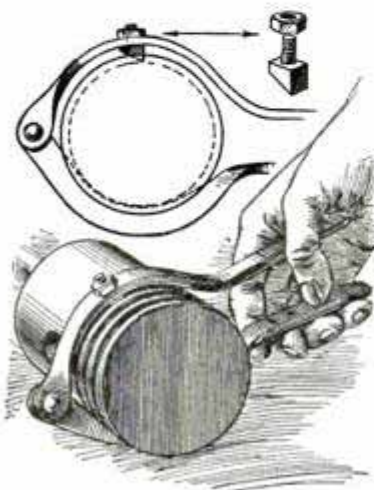

general use, namely, $\frac{3}{16}$, $\frac{7}{32}$ and $\frac{1}{4}$ in. It consists of a small piece of square stock ground at a bevel and brazed or welded to a screw, which fits in a hole drilled through one handle and is held in place

by means of a nut. In use, the scraper is inserted in the groove and the tool turned around the piston until the carbon has been removed.

Replacing Valves

When replacing the valves in an auto motor after grinding them, it is frequently rather difficult to push the stem through the small washer while the spring is being compressed. By countersinking the hole in the washer slightly on one side, the valve stem can readily be pushed through.

Automatic Switch for Water-Pump Motor

In many homes where a motor pump has been installed in the basement to force soft water from the cistern into a supply tank in the attic, constant attention must be given to prevent the motor from running after the tank has been filled. To make an automatic switch, install a knife switch next to the overflow pipe as shown in the drawing. A screwhook is driven into the end of the switch handle to support a small pail, which, when suspended from the hook with the switch closed, hangs directly under the overflow pipe. As long



as the can is empty the switch will remain closed, but as soon as enough water has entered the can, the additional weight will pull the switch open, stopping the motor. This extra switch is connected in series with the motor-control switch.—G. E. Hendrickson, Argyle, Wis.

How to Prevent Plaster of Paris from Setting Quickly

In cases where work must be done with accuracy it is highly advantageous to retard the setting of plaster of paris. This can be done by adding citric acid, $\frac{1}{4}$ oz., to every 25 lb. of plaster, which will delay the setting from 2 to 4 hours.

706

A New Service for You

TO provide additional help for its readers in solving their daily problems, Popular Mechanics Magazine has compiled a list of booklets on various subjects which may be obtained at cost by addressing The Librarian, Popular Mechanics Magazine, 200 East Ontario Street, Chicago, Ill., and inclosing the proper sum either in stamps or coin.

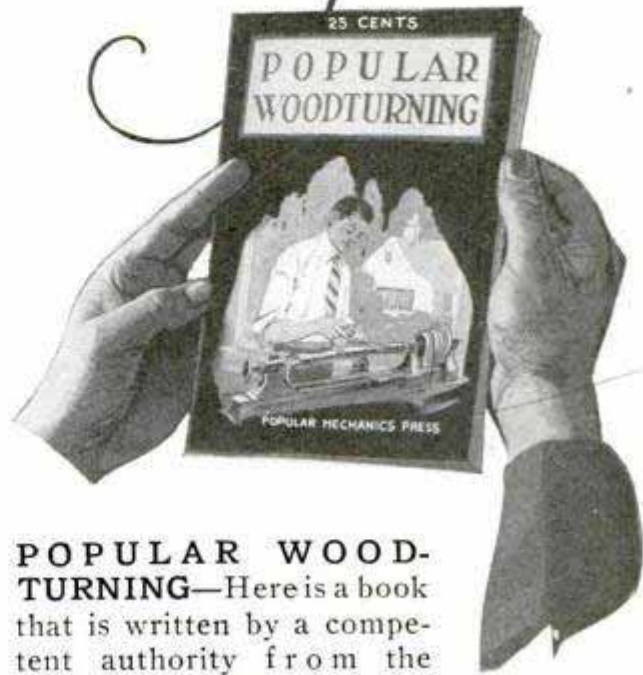

YOU CAN MAKE IT—How would you like to fool your friends with an X-ray box, put on a picture show with a reflectoscope, or show the rest of the gang how your homemade submarine can go down to the bottom of the lake and come up again? These are just a few of more than 100 articles, the directions for making which are given you in this booklet. And the best part of it is that you can make these articles out of old wooden boxes and odd pieces of lumber. You will have no difficulty in making any of the articles shown in this thirty-page booklet, since each one is illustrated, and its dimensions and directions for construction are given. Price Ten Cents.

POPULAR WOODTURNING—Here is a book that is written by a competent authority from the standpoint of the man who uses his lathe for pleasure, and who does not care so much about the "correct" way of doing certain jobs as he does about the practical way. It is different from most other woodturning books, since it not only treats the subject from the practical amateur's standpoint, but covers it completely and at a reasonable price. The book will be especially useful to the owners of the popular motorized "home workshops." Sixteen pages, 61 illustrations. Price Twenty-Five Cents.

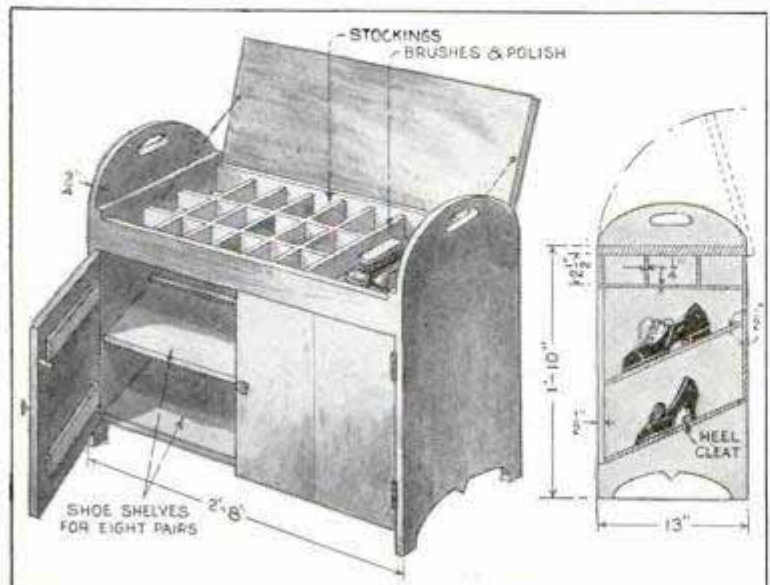

MODERN INTERIORS—This interesting book is crammed full of suggestions for the home owner and for the small-shop craftsman who like to make their own built-in conveniences. Dining alcoves, kitchen cabinets, closets, dressers, bookcases, and a dozen other things, of simple construction but very attractive design, are described and illustrated in its pages. Not only are the details of construction given for each piece, but drawings show how the units may be combined into good-looking ensembles for kitchen, dining room, living room, bedroom and bathroom. Twenty-nine pages and plates. Price Ten Cents.

One of the Easy-to-Make Things Described in "Modern Home Interiors"; Shoes, Stockings and Polishing Materials All in One Handy and Good-Looking Cabinet



Sheet Metal Is Used as Substitute for Wallboard in Miniature Exhibits

Sheet Steel Used for Exhibits

Wallboard has given way to steel, and the saw to the blowtorch in building cut-out backgrounds for miniature sets in the Los Angeles county permanent exhibit. It was found that in exhibits where water was used, wallboard or shellacked canvas could not be employed to advantage as these materials absorbed moisture and warped or swelled. Sheet steel has been found highly satisfactory for the purpose. The artist first daubs a sketch in rough outline on $\frac{3}{16}$ -in. steel plate and then cuts around it with an acetylene torch. The hot metal often runs along the edges, cooling in large drops, and this adds to the attractiveness of the finished job. A large number of miniature exhibits depicting various phases of agricultural and industrial activities, are on permanent display, one being a harbor scene with moving vessels in the water.

Ash Bin for the Basement

One way of avoiding the bother of carrying out the furnace ashes each week is to build an ash bin to accommodate all the season's ashes, which can be cleaned out during the spring at a nominal cost. Ordinarily a 4 by 4 by 4-ft. bin will be

large enough, the sides being built up of common brick seconds with a door, about 6 in. wider than the coal shovel and about 18 or 20 in. high, located in the center of one side at the floor level. Its purpose is to permit the removal of the ashes. Another door or opening is provided in the top, which consists of No. 3 grade lumber, covered on the underside with sheet metal to prevent the possibility of fire. Frequently, when building a new house, there will be enough brick left after the chimney has been completed to build such a bin.—Edgar C. Hanford, Springfield, Ohio.

Hog Oiler for the Farm

By wrapping a heavy rope around a post set up in the hog yard, the upper end of the rope being inserted into a pail containing oil, and the lower end tacked to the post, an effective hog oiler can be improvised in a few moments at practically no cost. The pail into which the rope is run is also nailed to the post near the top, and it is kept well filled with oil. A hole to receive the rope should be punched from the outside and near the bottom of the pail, and after the rope has been pushed through, the bent metal at the edge of the hole is forced back again until it comes flush with the side, which

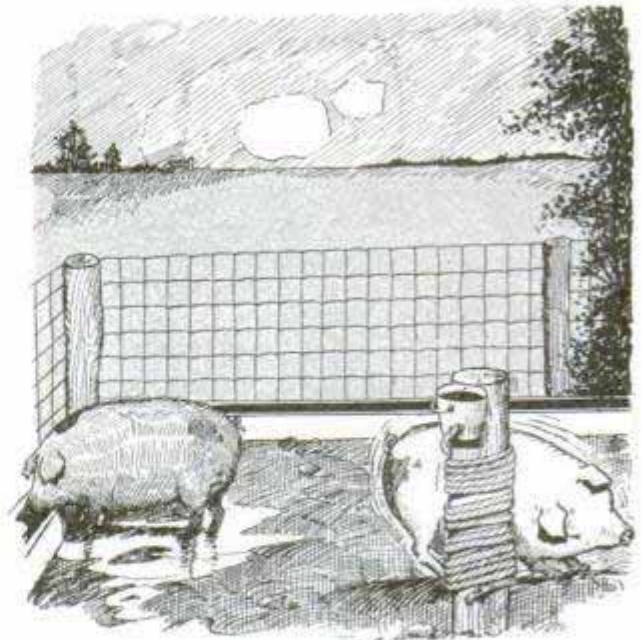

Rope Wrapped around Post Serves as Wick in This Homemade Hog Oiler

will hold the rope securely and prevent excessive leakage of oil.—A. S. Wurz, Jr., Rockyford, Can.

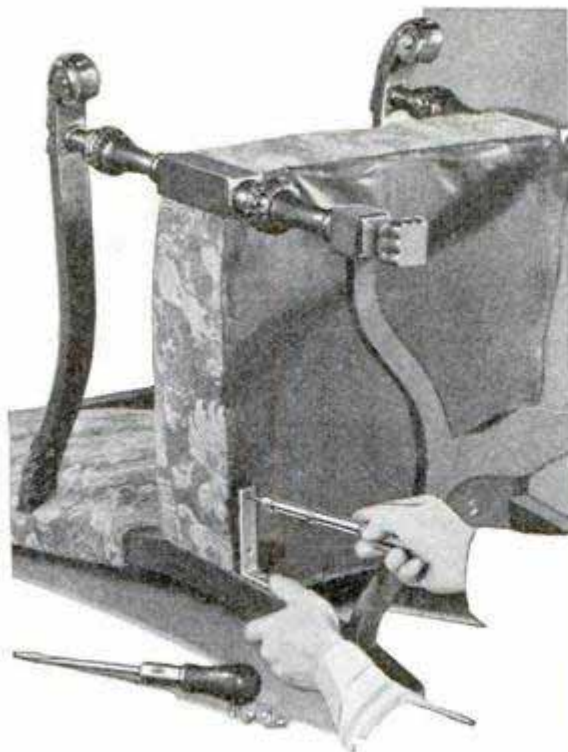

*“without
splitting
the wood”*

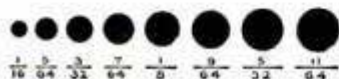
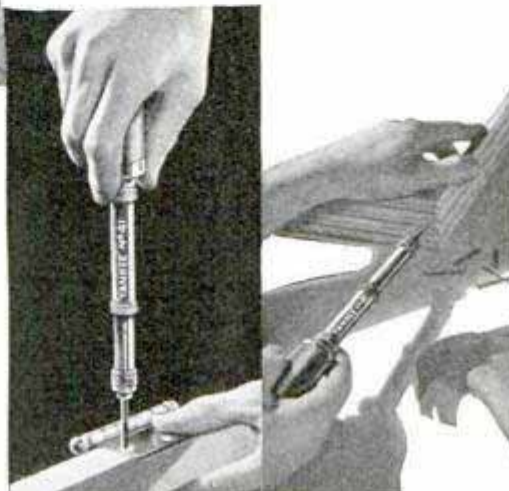

Eight “Yankee” Drill-points make holes these sizes. Each drill-point is tested.

“YANKEE” Automatic Push Drill was invented so you could drive screws (or nails) without splitting the wood.

Drill is revolved by pushing on handle. A spring brings handle back for next push; revolving drill-point backward to clear chips from hole.

Repairing furniture, putting up bathroom fixtures . . . wherever screws are driven, you need this “Yankee” Drill to bore the holes. Any size hole, from 1/16-inch to

11/64-inch. Eight “Yankee” Drill-points, each tested, carried in magazine in handle of tool.

Mechanics will tell you “Yankee” toolmaking can’t be copied . . . look for the name “Yankee” when you buy an automatic push drill.

No. 41.—Used along with “Yankee” Spiral Screw-driver, by mechanics everywhere. Price, \$2.60.

No. 44.—Adjustable Tension regulates pressure to suit kind of wood, size of drill. Price, \$3.15.



“YANKEE” TOOLS

TO HELP YOU MAKE THINGS



North Bros. Mfg. Co., Lehigh Avenue, Philadelphia, U. S. A.

My idea is to save time and labor. Send me “Yankee” Tool Book, with *action pictures* showing new Two-Speed (11-inch) Hand Drills, new Bit Braces with famous “Yankee” Ratchet, Quick-Return Spiral Screw-drivers, Adjustable Tension Push Drills, Ratchet Breast, Hand and Chain Drills, Automatic Bench Drills, Ratchet Tap Wrenches, Removable-base Vises, etc.

Name.....

Address.....(pr)



**“You have
five days to test
the car!”**

*“I can bring it back if it doesn't suit?”
“Certainly, the Studebaker Pledge provides
five days' driving trial for every buyer.”*

You have plenty of time to learn just what the used car you select will do for you when you buy it on the famous Studebaker Pledge Plan. You can make your own tests of its performance, speed and comfort. And if it does not satisfy, you may return it within five days and apply your payment on *any* car in stock, *new or used!*

Last year, more than 150,000 thrifty motorists bought Pledge-backed used cars. That's because a good used car is always a better buy than a cheap car bought new. Most Pledge-backed used cars have been thoroughly reconditioned to give new-car appearance and performance.

**INVEST 2c
you may save \$200**

Spend 2c now for your copy of this interesting and instructive booklet, “How to Judge a Used Car”—it may save you as much as \$200 on the used car you buy. Mail the coupon—*now!*



**PLEDGE
to the Public on
USED CAR SALES**

1. 5 days' driving trial.
2. 30-day guarantee on certified cars.
3. Lowest price marked in plain figures.

All certified cars sold on the Studebaker Pledge Plan carry a 30-day guarantee. And *every* Pledge-backed used car has its lowest price plainly marked—one price for every buyer!

See your Studebaker dealer *first* when you shop for a used car. Get the full protection of the famous Studebaker Pledge.

STUDEBAKER

Builder of Champions

THE STUDEBAKER CORP. OF AMERICA
Div. 157, South Bend, Indiana

Please send me copy of “How to Judge a Used Car.”

Name.....

Street.....

City..... State.....

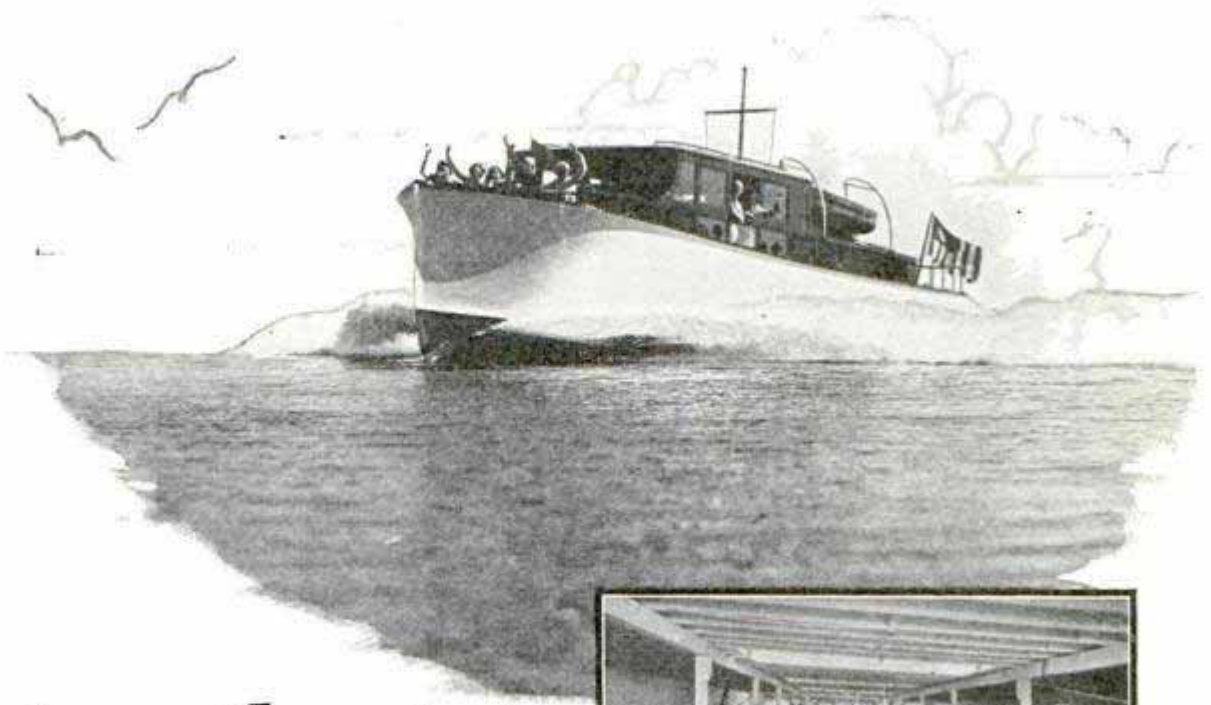

Cabin flooded— cruiser saved by *bulkheads* of Presdwood

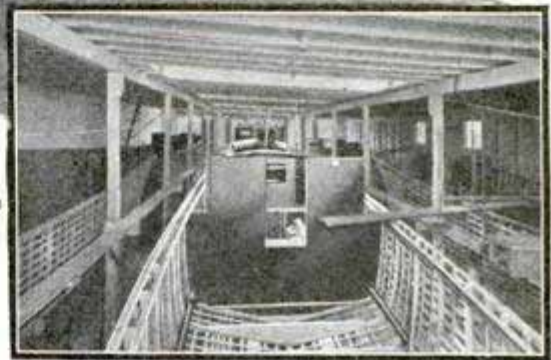

In a terrific storm at Boothbay, Maine, a Fairform Flyer crashed on the submerged rocks of the Saco River Jetty entrance, where many a yacht and numerous lives had been lost. Water flooded the main cabin, but not a drop passed the watertight bulkheads of Masonite Presdwood. The boat stayed afloat—the engines kept running—and the cruiser was brought safely to port.

This crucial test justified the Huckins Yacht Corporation in their reliance on Presdwood. Like hundreds of other manufacturers they had found this grainless wood board exceptionally strong and remarkably resistant to moisture. They had found that its smooth surface took finish beautifully, that it was easily worked, could be cut, sawed or punched and did not crack, split or splinter. Now, in dramatic fashion, this grainless material vindicated the dependence placed upon it, by saving both cruiser and crew.

In industry after industry these same outstanding qualities of Presdwood make it almost invaluable. It builds highway signs and outdoor painted bulletins. It panels fine homes and modern apartments; is used in the construction of trays, tables, toys,

clothes hampers, waste baskets, magazine racks, bird houses, beehives, motor truck bodies, kitchen cabinets, portable billiard tables and hundreds of other useful or decorative articles.

In constructing bridges, dams, skyscrapers and warehouses, Presdwood is used to line the concrete forms. It leaves the surface perfectly smooth and hard and free from grain and knot marks. It makes drastic reductions in costs, eliminates the need of hand rubbing and greatly reduces the labor of making, installing and stripping the forms.

Manufacturers, builders, contractors and home mechanics should read the fascinating story of Presdwood's manufacture. It is told in the Presdwood booklet which also lists eighty uses for this grainless wood board and tells how finishes are applied. The booklet is yours for the asking. Just mail the coupon *today*.

MASONITE CORPORATION, 111 W. Washington St.
Chicago, Ill.

Masonite
PRESDWOOD
Made by the makers of
MASONITE STRUCTURAL INSULATION

MASONITE CORPORATION © M. C., 1930
Dept. L-7, 111 West Washington Street, Chicago

Please send me, Free, a sample of Masonite Presdwood and the Presdwood booklet.

Name.....

Address.....

City..... State.....

Electric-Starting Sea-Horses ... Faster Than Any Before

WHAT A VACATION AWAITS AMERICA NOW!

Mounted on Johnson Boats to match—50% lighter, yet $\frac{1}{3}$ stronger—
they outperform anything, size for size, inboard or outboard

Now from the shores of dancing waterways, leafy branches beckon you to life at its best. To cruising at motor car speed! To racing, fishing, bathing, and exploring!

Not if you had a million dollars could you have a finer vacation than a Johnson Sea-Horse provides at \$125 up. Partial payments make it easy to own.

Powerful Sea-Horses "16," "24," and "32," introduce electric starters, with auxiliary hand starting—made 50% easier by Johnson's great Release Charger—made quiet by Underwater Exhaust.

Smaller Sea-Horses "4" and "12" introduce alternate firing cylinders. Virtually vibrationless, and making hand starting 50% easier.

Johnson Sea-Horses are easy to carry on camping trips, fit almost any boat. Yet for highest performance, and all-around seaworthiness, try with a Johnson boat to match. They are the first outboard motors and boats designed and built together.

These trim, rakish Johnson hulls come in smart colors. They introduce Sealite construction, seamless, watertight. They weigh 50% less in water-service than wood boats, are 35% stronger. And guaranteed to outlast them.

Johnson Aquaflyers start, steer and control like a motor car, from the driver's seat. Roomier than inboards because Sea-Horses are outboard in stern hatch.

Get Color Catalog by Return Mail: See the new Johnson Sea-Horses and Matched Units, all fully pictured and described. Send your address at once.

All dealers carry first-aid service parts. Sales and service stations in all parts of the country.

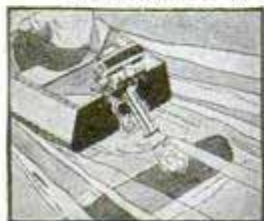

Propeller tilts safely over all obstructions

Electric Started
Sea-Horse
"32" \$395

Others \$125 and up. All prices f. o. b. factory



Sea-Horses Win More Race Classics

ALBANY TO NEW YORK MARATHON RACE, April 26th, won by Sea-Horse "32" establishing new record time of 3 hours, 25 minutes, 3 seconds. Sea-Horse "24" second. SIR THOMAS LIPTON \$25,000 TROPHY, at Palm Beach, Fla., March 22nd-23rd, 1, 2, and 3rd places won by Sea-Horse "32." COL. E. H. R. GREEN TROPHY at Miami, Fla., March 27th, 1, 2 and 3rd places won by Sea-Horse "32."

JOHNSON MOTOR CO., 2493 Pershing Road at the Lake, Waukegan, Ill. In Canada: Canadian Johnson Motor Co., Ltd., Peterboro, Ont. World's Largest Manufacturer of Outboard Motors and Matched Units.

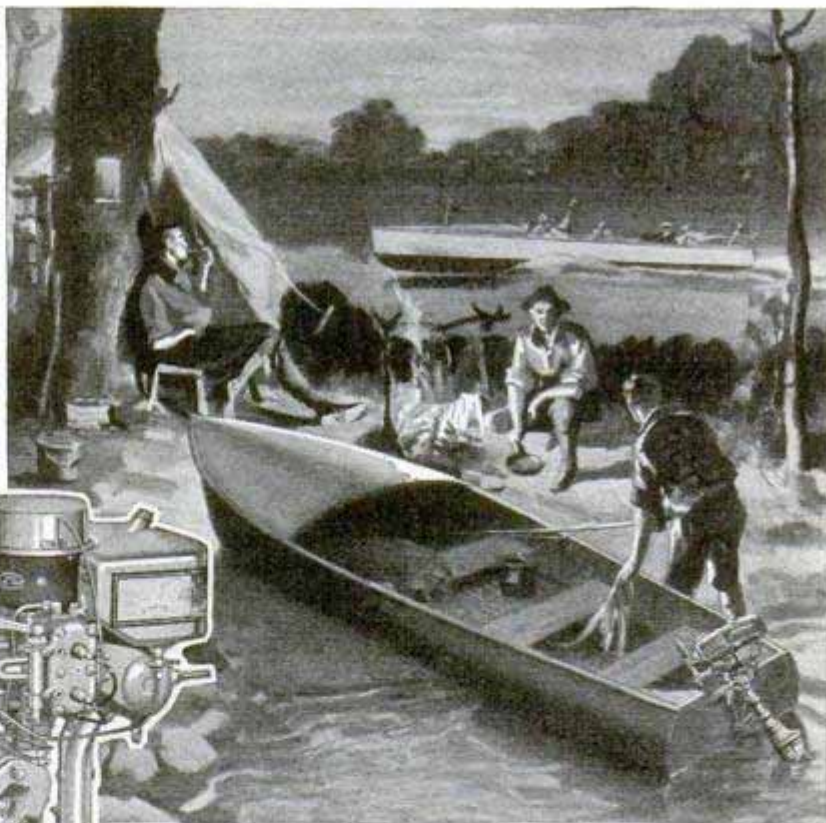

JOHNSON
Matched UNITS
SEA-HORSES
& **BOATS**

PRECISE HANDS PACK YOUR TEA

Human hands don't touch your tea . . . they're much too slow, too fumbling. Your tea is packaged by the precise, speeding hands of the steel-witted robot on your right. The robot's materials: a roll of foil, a stack of labels, a bin of tea. Its product: finished packets, the foil carefully folded, the label wrapped and glued, the tea weighed out to one-tenth the weight of a penny. Its speed: 2500 packets an hour.

This machine, and its robot-brothers that package almost all your grocer's wares, can do its job only because its thousands of parts are made with scrupulous accuracy; accuracy that comes of skilled hands and the finest precision tools—tools like Starretts.

Starrett Tools will bring precision to your hands. In your home shop, or in more serious work, Starrett Tools take the abouts and the almoses out of measuring. They put within your grasp the pride and pleasure that come from work well done.

Let us send you the new Starrett 50th Anniversary Catalog. It describes and illustrates over 2500 Starrett Tools. The coupon will bring your copy, free.

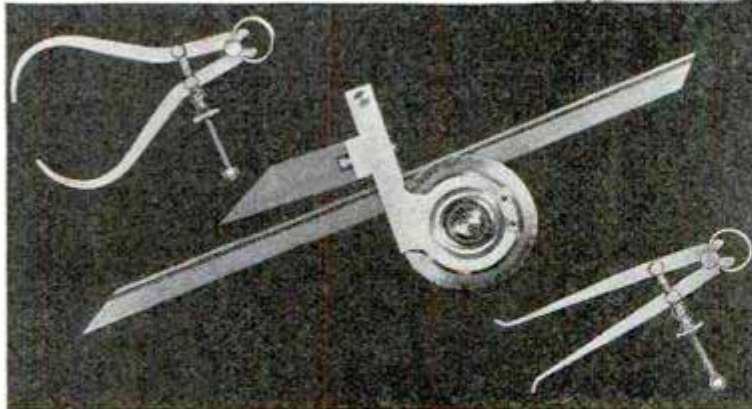
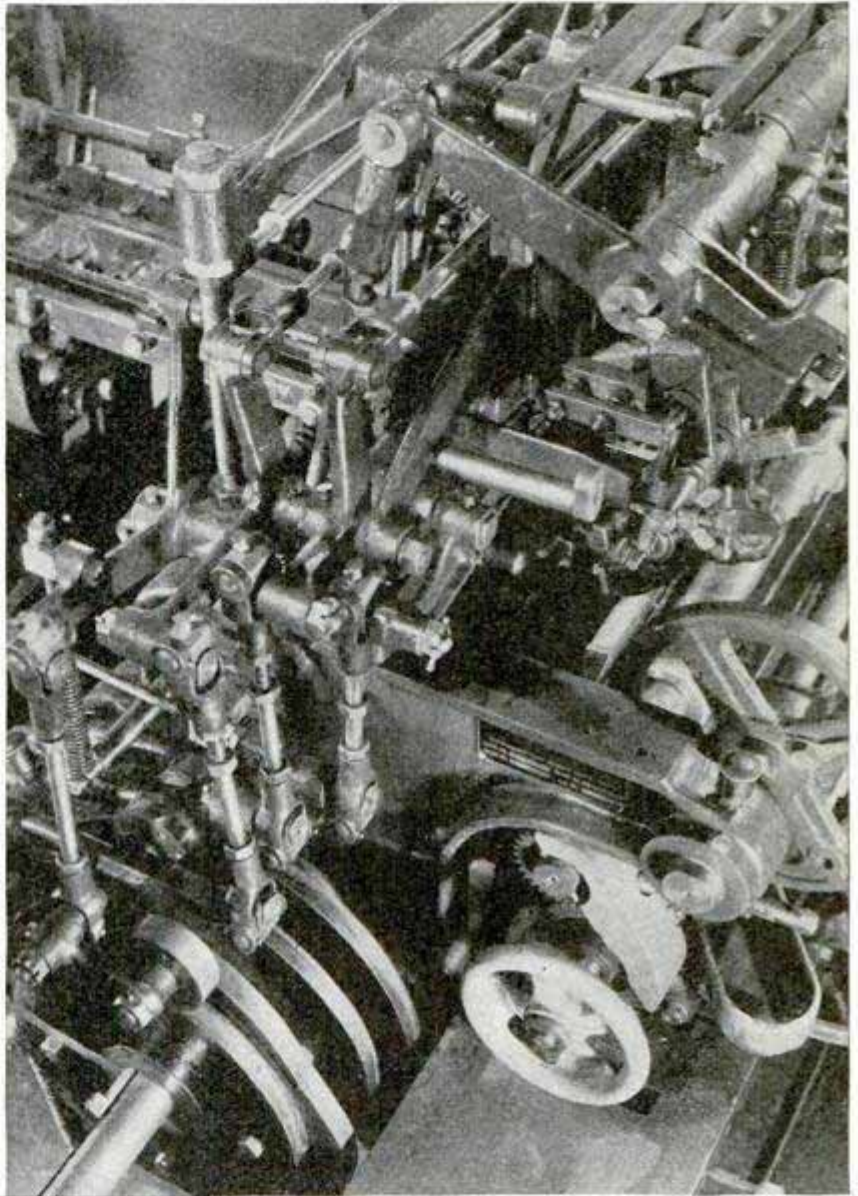

Above: Packaging machine, Salada Tea Company.

Left: Starrett Protractor No. 359, used in laying out angles for cams, etc.; Starrett Calipers Nos. 79 and 73, two of the many Starrett Tools so valuable for wood and metal-working in the home shop. Below: the coupon. Send it.

THE L. S. STARRETT COMPANY
ATHOL, MASSACHUSETTS

Please send me Starrett Catalog No. 25 "AP."

Name

Street

City State

50th Anniversary of Starrett
Tools 1880—1930



Use Starrett Tools

 Stories of Stars who were not "Born" but "Made"—No. 5

As a camper . . . an athletic failure. As a counsellor . . . a college star

A few years ago at a big summer camp for boys in the Maine woods, there was an awkward youngster who proved a handicap to every team he played on.

Two years at camp, however, worked wonders for him. By the end of that time he had overcome much of his clumsiness. Then he went to college. Three years later, he was back as a counsellor.

During those three years he had become a star college shortstop and an all-American halfback. That boy *made* himself great. You have the same chance. Whatever sport you play, learn to *handle yourself well*. The rest comes naturally.

The secret of handling yourself well is *footwork*. Learn to handle your feet. They can give you speed, poise and timing, or they can be the greatest obstacle in the way of your athletic success.

Star players *train* themselves in footwork. You'll find them taking any one of a number of different kinds of exercise—to train their feet. And for this sort of training more of them wear Keds than any other shoe.

If you are going to camp this summer, pay particular attention to those games that will develop your footwork. And don't forget to take along one or two pairs of Keds. Keds will help you. Keds have safety soles of compounded rubber that defy slipping. Keds' strong canvas tops give your ankles sure support. Keds' "Feltex" insoles keep your feet cool and comfortable.

The best shoe dealers in town carry Keds. Ask for Keds by name—Keds. Only genuine Keds have the name "Keds" on the shoe.



Keds

REG. U. S. PAT. OFF.

Footwork builds stars

United States



Rubber Company

Win a pedigreed Fox Terrier

Only two months are left in the big Keds Essay Contest open to boys and girls under fifteen years of age. 50 pedigreed wire-haired fox terriers and 480 pairs of Keds are the prizes. Get your entry blank from your nearest Keds dealer *today* or write Keds Contest Editor, United States Rubber Company, 1790 Broadway, New York City, who will see that you are told where to go.



This light Keds model gives excellent service for low price. "Holdfasts" come with either white or brown uppers and have black trimmings and black corrugated soles. A sturdy, low-priced shoe.

Keds sell for \$1.00, \$1.25, \$1.50, \$1.75, and up to \$4.00. The more you pay, the more you get—but full value whatever you spend.

BETTER FUELS *mean* BETTER CARS

and both are

PRODUCTS OF
RESEARCH

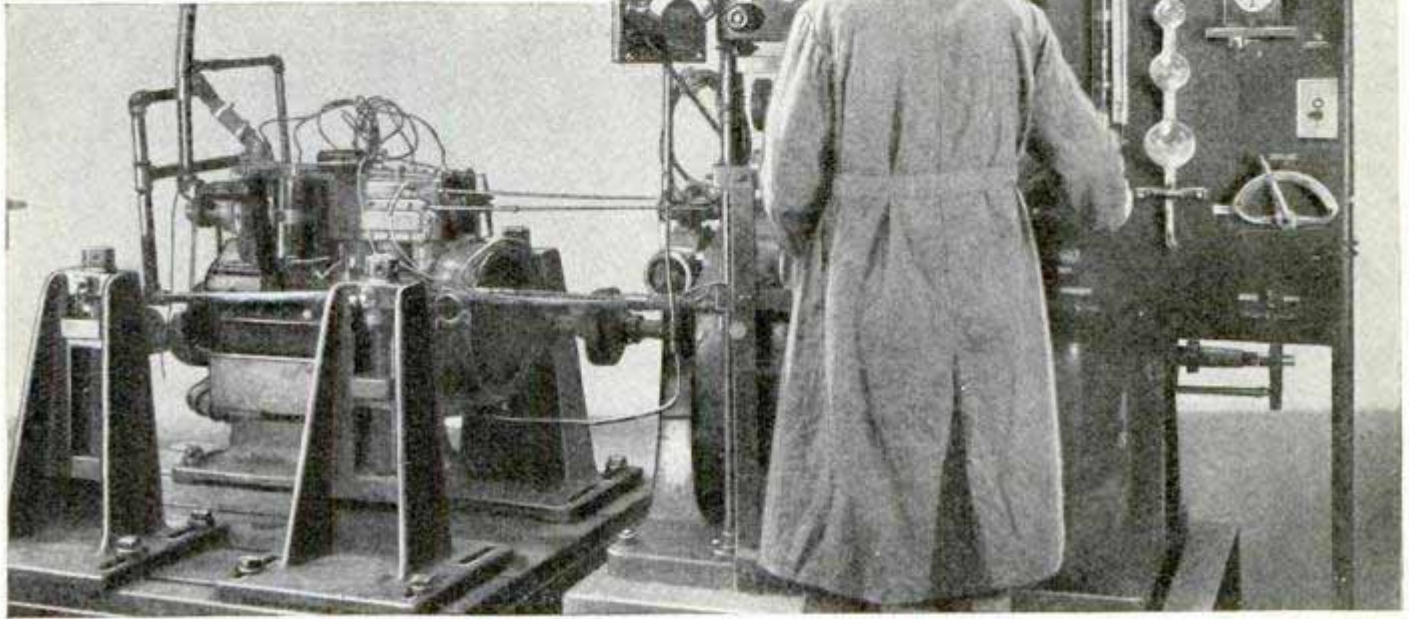

Dynamometer test of modern engine at the Ethyl research laboratories in Detroit, where hundreds of fuels are tested for their effectiveness in engines of every kind. It is from tests like these that better fuels and better cars are developed.

THE research laboratories of the Ethyl Gasoline Corporation have contributed materially to the development of better automobile engines and better fuels for their operation. Ethyl engineers are constantly working with car manufacturers and oil refiners toward still greater improvement in motor car performance.

A result of this research was the introduction of high-compression cars in 1927. In that year only about 14 per cent of the new car models were high compression (5 to 1 ratio or better) but in 1928 the proportion had grown to 56 per cent. In 1929 it was 77 per cent and this year approximately 84 per cent of the new models are of this type.

Oil companies selling more than three quarters of all the gasoline used in the United States and Canada mix Ethyl anti-knock fluid with good gasoline to form Ethyl Gasoline. Ethyl fluid, itself a product of research, was developed primarily to make possible the high-compression cars. These cars require a fuel of Ethyl's anti-knock quality to deliver the higher efficiency of which they are capable, but Ethyl improves the performance of *any* car, whatever its type, size or age.

Try Ethyl Gasoline yourself, put it to any test. On sale everywhere at pumps bearing the emblem shown at the right. Ethyl Gasoline Corporation, Chrysler Building, New York City.



Wherever you drive—whatever the oil company's name or brand associated with it—*any* pump bearing the Ethyl emblem represents quality gasoline of high anti-knock rating.



The active ingredient used in Ethyl fluid is lead.

© E. G. C. 1930

ETHYL GASOLINE



285,000

Kleanbore Cartridges
fired through one barrel



and it's still accurate

285,000 Kleanbore cartridges were fired through a Model 24 Remington .22 caliber rifle before these groups were made at 75 feet. This exhaustive test, covering regular firing over a period of almost three years, was made to determine the accuracy life of a rifle barrel when Kleanbore cartridges with *greased lead* bullets are used. At this stage of the test, the barrel, *which has never been cleaned*, is still in splendid condition, there being practically no wear and a total absence of leading, pitting or fouling. This remarkable test will be continued and the results announced.

Proof: The 10-shot groups shown were made at the Remington Ballistic Labo-

ratory with Kleanbore cartridges and *greased lead* bullets, in a regular stock Model 24 Remington Autoloading Rifle *after* 285,000 of these cartridges had been fired in that rifle. Such accuracy after such a test would have been an impossible dream until Kleanbore cartridges eliminated rust, corrosion, pitting and leading in the barrel. It would still be an impossible dream without *greased lead* bullets.

That's why more Kleanbore .22's are sold than all other makes combined.

Capt. Edward C. Crossman, noted firearms and ballistic authority, has written a special story about this remarkable test. We will gladly send you a copy of it.

REMINGTON ARMS COMPANY, Inc.

Originators of Kleanbore Ammunition
25 Broadway New York City

Remington
KLEANBORE

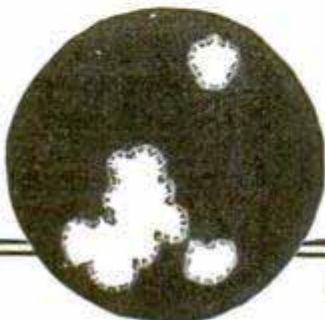

.22's

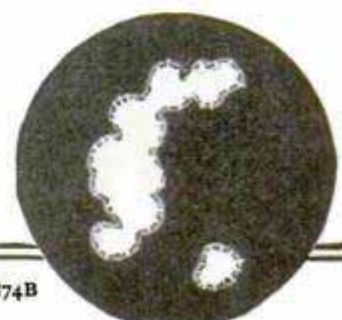



"I'll say it stops Oil Pumping

*and for the life
of the motor, too"*



Note Special Offer to readers of Popular Mechanics

If you think that oil pumping, piston slap, compression loss and power loss are as inevitable as life, death and taxes... if you think you can't stop oil pumping without costly re-grinding... fill in the coupon at the bottom of this page and get it in the mail tonight.

It will bring you a complete set of piston rings that will quickly stop and permanently prevent oil pumping in any motor where the piston clearance does not exceed .007-inch. A piston ring that takes more oil off the cylinder wall than any other ring you've ever been able to buy... that forces this oil thru the scientifically placed slots in the ring, thru the ventilations in the inner ring, thru the holes in the piston and back into the crankcase.

Not "just another piston ring"
Heretofore the difference in piston rings has been a difference in name only. Practically all piston rings have been perfectly round pieces of metal that would fit somewhat loosely in the space between the piston and the cylinder wall when the motor was brand-new. None of them provided an automatic take-up for wear. This has been the design of piston rings from the very beginning.

Obviously, no piston ring made on this principle can possibly centralize the piston and control its rocking, knocking action. Nor can such rings maintain their new-car efficiency for more than a few thousand miles. And so Ramsey has changed—and vastly improved—piston ring design.

A ring within a ring

The Ramco Replacement Piston Ring is actually "a ring within a ring." The outer ring is made of soft gray iron without tension or spring; consequently, it immediately adapts itself to irregularly shaped cylinders. The inner ring used with it provides the proper sealing pressure at all points of the cylinder wall.

By taking hold of the piston and stop-

ping its rocking motion, this inner ring eliminates the real cause of oil pumping. It prevents the piston rings from turning on the pistons, and keeps the rings from wearing bevelled. At the same time, it exerts the exact amount of pressure necessary to seal the cylinder properly without scraping or dragging. This pressure is provided thruout the entire life of the motor, because the Ramco inner ring is made of special analysis steel which is not affected by highest motor temperatures.

Special Introductory Offer

If your dealer or garage-man has not yet stocked Ramco Rings, tear out and mail the coupon below. **SEND NO MONEY.** We will immediately forward you a complete set of Ramcos in the correct size for your car. Complete set packages for Fords and Chevrolet Fours are priced at \$7.20; for Dodge Fours at \$9.60; for Chevrolet Sixes at \$10.80. A complete set of Ramcos for any Six requiring 12 compression and 6 oil rings costs you only \$11.70.

Send No Money

Your postman will deliver your set of Ramco Rings and your FREE Instruction Chart. Pay him for the rings only. We prepay all shipping charges.

DEALERS! GARAGE-MEN!

Ramco Replacement Piston Rings enable you to give your customers a first-class, permanent motor repair at surprisingly low cost. Millions are now in daily use in passenger cars, busses, taxicabs and tractors. Thousands will be sold in your community this year. If you want to triple your repair business, write now for complete details of the Ramco Ring and the Ramco dealer proposition. Give Jobber's name.



RAMCO

REPLACEMENT PISTON RINGS

(REG. U. S. PAT. OFF.)

MAIL COUPON

RAMSEY ACCESSORIES MFG. CORPORATION
3695 Forest Park Blvd., St. Louis, U. S. A.
I want to take advantage of your Special Introductory Offer to readers of Popular Mechanics. Send me C. O. D. a complete set of Ramco Replacement Piston Rings for

(Name of Car) (Year Built) (Model) (No. Cylinders)

Name.....

Address.....

Dealer's Name and Address.....
(Dealer's name should be given) P. M. 7-30

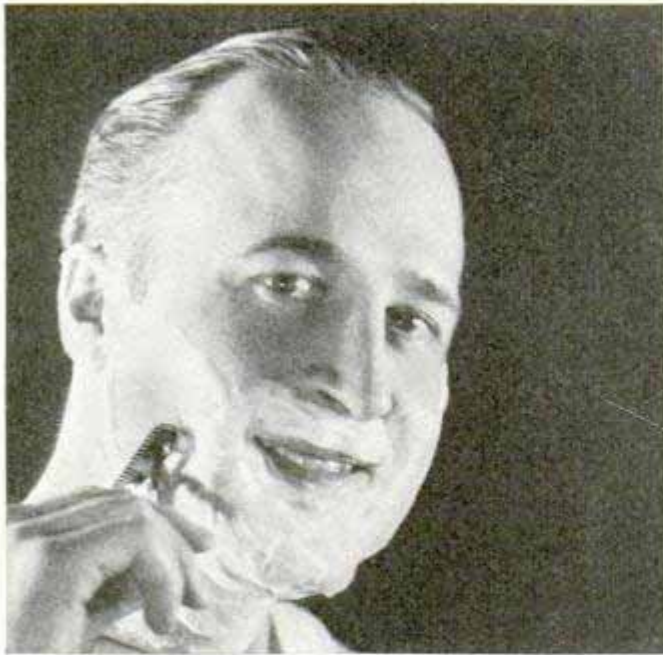

Don't Buy until you're sold

We take the risk, not you. This remarkable shaving cream is its own salesman.

GENTLEMEN: A remarkable sales policy—and a remarkable product—have made new records in the shaving cream field in the past few years.

A comparative newcomer has become the world's fastest selling shaving cream. A simple, man-to-man introductory plan has been largely responsible.

When we perfected our new product — Palmolive Shaving Cream—we offered it to men fearlessly, resting on their judgment. Instead of asking for sales, we asked for the opportunity to prove, at our expense, the things we claim.

The coupon is for your convenience. If you have not made our test, please make it now.

PALMOLIVE RADIO HOUR—Broadcast every Wednesday night—over WEAJ and 39 stations associated with The National Broadcasting Co.



5902

7 SHAVES FREE

and a can of Palmolive After Shaving Talc

Simply insert your name and address and mail to Palmolive, Dept. M-839, P. O. Box 375, Grand Central Post Office, New York City.

.....

(Please print your name and address)



Ask your barber for a free application of Murine

CLEAR EYES are a business asset

Clear, bright eyes make a far better impression than do those which are dull and bloodshot. A few drops of harmless *Murine* will quickly clear up bloodshot eyes resulting from over-use, late hours or exposure to wind and dust.

MURINE FOR YOUR EYES

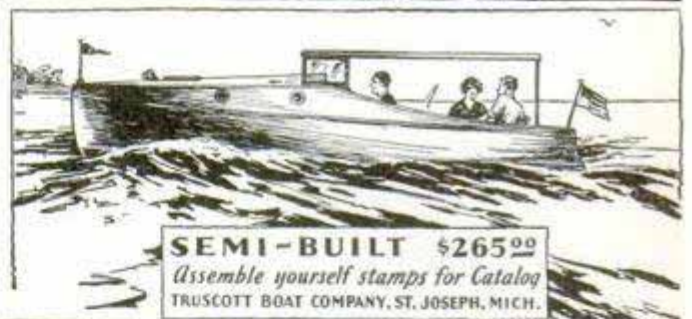

SEMI-BUILT \$265.00
Assemble yourself stamps for Catalog
 TRUSCOTT BOAT COMPANY, ST. JOSEPH, MICH.



ELECTRIC MOTOR

winding models show winding and connections in plain sight. Make your own or rewind motors for your own use or for profit. In use all over the world. Quick, easy way. Write Dept. DPM,

Gaines Bros., Box 481 Gainesville, Texas

\$85.00 CARLISLE'S No. 5A

10" Ball Bearing 3" Cut **Heavy Duty Bench Saw**

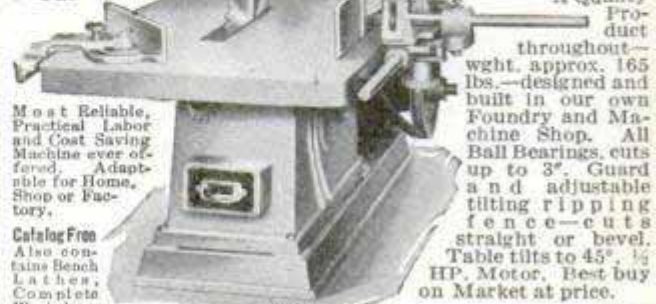

Most Reliable, Practical Labor and Cost Saving Machine ever offered. Adaptable for Home, Shop or Factory.

Catalog Free Also contains Bench Lathes, Complete Workshop, Bandsaw, etc.

A Quality Product throughout—wght, approx. 165 lbs.—designed and built in our own Foundry and Machine Shop. All Ball Bearings, cuts up to 3". Guard and adjustable tilting ripping fence—cuts straight or bevel. Table tilts to 45°. 1/2 HP. Motor. Best buy on Market at price.

Order Direct or Through Your Hardware or Machinery Dealer
CARLISLE MOULD WORKS, Inc. Dept. A-7
 Millville, N. J.

INDIAN TRAINING *in* *signs* *and speed*

CHIEF LONG LANCE *shows you the way to a warrior's knowledge and a warrior's strength*

CHIEF LONG LANCE gives you unusual knowledge. The silent language of scouts and warriors! You can use it when a sound would be dangerous! Chief Long Lance has revealed the Indian Sign Language in this big 32-page booklet, with over 80 illustrations which he has posed for and explained himself.

Chief Long Lance also tells you the secret of speed. "Canvas rubber-soled shoes," he writes, "are most like Indian moccasins in



strength building of any modern shoe." He has designed a shoe himself that has *all* the advantages of a moccasin and a modern shoe. Just fill out and mail the coupon below.

TEN FEATURES of the Chief Long Lance Shoe. 1. Unique Indian Design. 2. Dodging Pivot. 3. Emergency Brake. 4. Whirling Pivot. 5. Barefoot Tread. 6. Easy-Flexing Shank. 7. Non-Skid Heel. 8. Moccasin Grip Instep. 9. Cushion Inner Heel. 10. Form-Fit Tongue.



THE CHIEF'S OWN moccasin showing "the barefoot tread" on the worn part. Compare it with the sole of the Chief Long Lance Shoe beside it.

Goodrich

Sport Shoes

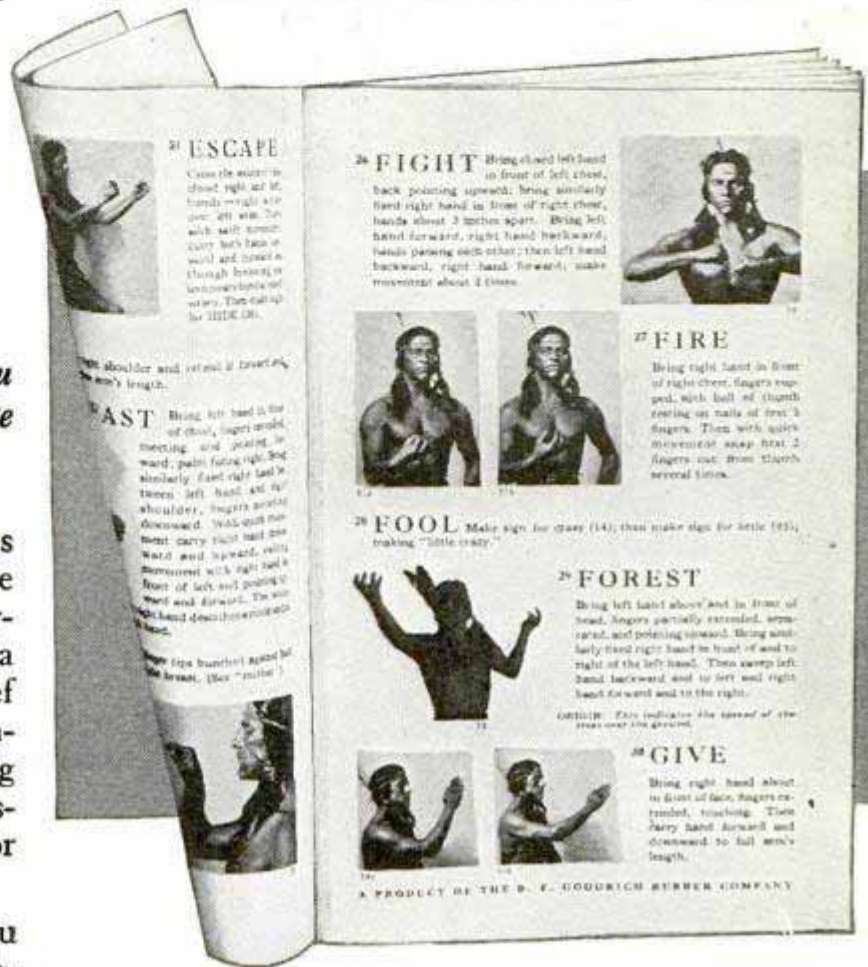

The B. F. Goodrich Rubber Company, 5M
Akron, Ohio

Enclosed find 10¢ in coin or stamps. Please send me "How to Speak in the Indian Sign Language," by Chief Long Lance.

Name _____

Address _____



3 to 45 miles per Hour

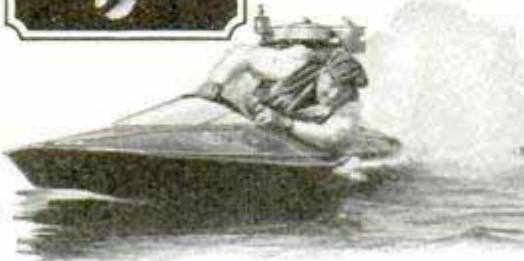

THIRTY miles an hour with an Evinrude gives you speed sensations completely lacking at 60 with your car. Go faster 35, 40 and 45 in a light hydroplane it's more fun than flying!

Have electric starting, generating and lighting at the touch-of-a-switch; underwater silencing; Propello-Vacuum cooling.

EVINRUDE

The same model Evinrude that thrills you with 45 miles per hour will throttle down to 6 on a heavy family rowboat. And 29 pound Fold-Light, world's lightest twin, will idle along at the ideal trolling pace of 3 miles an hour or give you 11 miles just as willingly. Five Evinrudes to choose from this year, 2 3/4 H. P. to 22 H. P. electric starting Speeditwin, with prices more reasonable than ever.

Easy time payments as low as \$35 down. Send for Catalog.

EVINRUDE DIVISION

Outboard Motors Corporation
Ole Evinrude, President
700-27th St., Milwaukee, Wis.

Send for
FREE
24 Page
EVINRUDE
Year Book



YOU'LL NEVER SAY, "SHE NEEDS CAULKING"

EVERY craft can't stand an outboard motor. But this "Old Town" can! She's an outboard boat by build. The stern is made so it won't sag or "give" under the motor's weight. Ribs and keel are extra-rigid. The heavy, non-leak canvas covering never needs caulking. No seams to open up! "Old Towns" are built for long life with few repairs. Swift, light and easy to handle.

Free catalog shows all craft. Paddling, sailing and square-stern canoes. Outboard motor-boats, including big, fast, seaworthy, all-wood family boats; row-boats; dinghies; and speedy step-planes. Write today. Old Town Canoe Co., 1147 Middle Street, Old Town, Maine.

"Old Town Boats"

Make Your FORD Into The "ACE"

GET READY FOR SPRING—BUILD YOUR ACE NOW—

\$599 Red-i-Kut life size patterns Class—Snap



38-inch Easy Riding Seat

Famous sure-fit RED-I-KUT life-size patterns and picture instructions show how you can easily convert your Ford into this Fast, Saucy, Sport-Car as thousands have done with easily obtained materials. No need to lay up the car. Makes wonderful 4-passenger car. Send 10c coin for actual photo of sport car and new manual of distinctive sport car patterns from \$2.50 up—"RKO" Steel "Spring-Lo" Irons, Tops, Windshields and many speed necessities. ORDER RIGHT NOW and get a real thrill.

KUEMPEL COMPANY, 122 Kuempel Bldg., GUTTENBERG, IOWA



12-INCH SCALE MODEL

of Lindbergh's Spirit of St. Louis. Scientifically designed and very realistic. Rises from ground by own power and flies 40 ft. or more. Only flying scale model sold at this price. Easily built in 2 or 3 hours. No tools needed. Construction

set, with all parts and full directions, postpaid in U. S. and Canada, only 50c (no stamp). Satisfaction or money back. Send today and print your address plainly.
MANN & BENTON
Box D, Chillicothe, Ohio



Lighter and Pencil Combined

It Lights and It Writes

PENCILITE GETS BIG PROFITS QUICK!

It's irresistible! No. 5 Bullet Style PENCILITE—a serviceable pencil and sure-fire cigar lighter. Sells on attractive display cards to all stores, soda fountains, cigar stands, etc. Big repeater. Write for Salesmen's extra big profits plan. Get sample. Protect territory now.

Sample 50c Prepaid
CHECO MFG. COMPANY
2715-17 S. Mich. Ave., Dept. 805-K, Chicago



Uses any lighter fluid. Does work of \$5 lighter or pencil. Sells on sight! Write for special offer—Now.

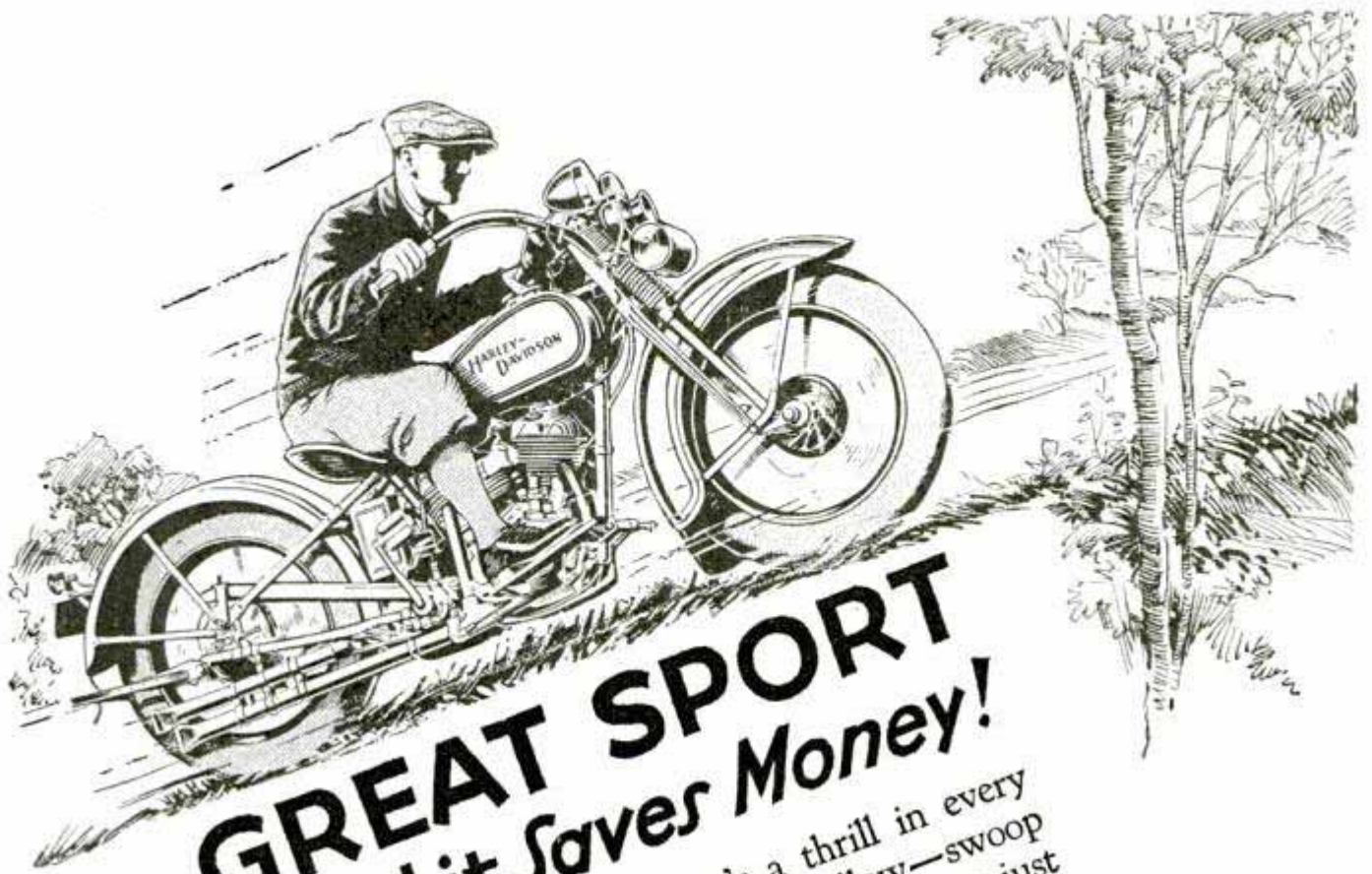

GREAT SPORT -and it Saves Money!

RIDE a motorcycle — there's a thrill in every mile! Soar over hills like a swallow—swoop down the highway past the car parades—or just loaf along a country lane with your purring motor for company!

Ride away from the heat and the traffic. Get out into the country. Join the jolly Harley-Davidson bunch on their outings and tours. Feel the red blood race through your veins as your motorcycle leaps eagerly to your touch on the throttle.

Forget expense! You can travel by Harley-Davidson as cheaply as 1¢ per mile, including everything! And the motorcycle is easy to buy, too—your dealer offers a Pay-As-You-Ride Plan that will scarcely dent your pay checks!

Let your nearest dealer show you our Single and Twin models — priced from \$260 up, f.o.b. factory.

Ride a HARLEY-DAVIDSON

MAIL THE COUPON

HARLEY-DAVIDSON MOTOR CO., Dept. P., Milwaukee, Wis.
Interested in your motorcycles. Send literature.

Name.....

Address.....

My age is 16-19 years, 20-30 years,
 31 years and up, under 16 years.
Check your age group.

COSTS
per mile

Motor-cycle
1¢

Street Car
2¢

Auto
7¢

See How You Save



It's a handout!

Anything that will get grease-and-grit-grimed hands clean in 58 seconds, without hurting a fellow's skin, is a handout—a gift—at any price. Yet Lava costs no more than soaps that dirt laughs at. Lava Soap is *different*. First, it's a fine toilet soap. Second, the pulverized Italian pumice in it cuts the dirt without hurting the skin. Third, it's quicker than any hand cleanser you've ever used. Fourth, even cold or very hard water can't keep down its rich, creamy lather. If you'll hand 6c or a dime to any grocer or druggist, and ask for Lava Soap—you'll get the finest handout of clean-hands material that can be had for love or money in America.

George, the Lava Soap Man

If you want to try Lava Soap first at my expense, mail this coupon:

Procter & Gamble, Dept. W-730
Cincinnati, O.

George: Send me a free sample cake of Lava Soap.

Name.....

Street.....

City..... State.....

Beautiful HOUSES \$900
and BUNGALOWS
CAN BE BUILT FOR And Up

Sixty-nine up-to-date designs in the most complete and comprehensive book of medium cost English and American homes published, 8 x 11 inches, nearly 250 photos and floor plans, contains a description of each design and approximate cost to build. It is the last word on home building and may save you several hundred dollars in the cost of your home. Sent Postpaid \$1.



FREDERICK H. GOWING, Architect, 101 Tremont St., Boston, Mass.

FREE TO BOYS SEND NOW!

"BB Magic" tells the wonderful story of round shot; its importance and place in boy training. Points way to leadership, self-expression, poise and concentration. Makes crack shots. Belongs in every boy's pocket, every parent's desk. Your copy FREE. Write at once.



NEW BENJAMIN
25 SHOT AUTOMATIC
"THE MYSTERY RIFLE"

OUTSHOTS ALL OTHERS



Now the wonderful Benjamin principle of compressed air action that made the Benjamin Single Shot famous for hard, safe, accurate shooting, has been applied to 25 shot automatic rapid firing—the only gun of its kind in the world. Learn about both. BENJAMIN AIR RIFLE CO., 605 North Broadway, St. Louis, Mo.

EASY MONEY MANUFACTURING THESE PRODUCTS



24 PAGES of ways to **MAKE MONEY**

People spend money willingly beautifying their homes and surroundings. These and other decorative pieces in any color, for porch, garden, walks, lawn, etc., sell themselves.

Scott of Michigan invested \$95 in equipment, cleared \$1,374. John Borgman, former factory worker, invested \$380, now writes his own paycheck. Similar investment starts you.

Make them in spare time or full time. Big demand. Nearly all profit. Note costs and selling prices. No experience necessary. Use your own basement, garage or shed, then expand from earnings. Don't let someone else beat you to this fast-growing, exclusive business. Free book gives the facts. Write today.

Colorcrete Industries
570 Ottawa Ave., HOLLAND, MICH.



LE PAGE'S GLUE HOW TO MAKE YOUR OWN ATTRACTIVE FURNITURE

Send 10 cents for LePage's New Third Home Work Shop Book, containing complete directions for making 20 different projects. LePage's Craft League, 731 Essex Ave., Gloucester, Mass.

PHOTO ENLARGEMENTS

Size 16x20 inches Same price for full length or bust form, groups, landscapes, pet animals, etc., or enlargements of any part of group picture. Safe return of your own original photo guaranteed.

98¢



SEND NO MONEY Just mail photo or snapshot (any size) and within a week you will receive your beautiful life-like enlargement, size 16x20 in., guaranteed fadeless. Pay postman 98c plus postage—or send \$1.00 with order and we pay postage.

Special Free Offer With each enlargement we will send FREE a hand-tinted miniature reproduction of photo sent. Take advantage now of this amazing offer and send your photo today.

UNITED PORTRAIT COMPANY
900 West Lake St. Dept. H-360 Chicago, Ill.



Months of Thrilling Flights

MODEL No. 21 Since July 1, 1929, Silver Arrows have flown 200,000 miles. In 193 recent tests out of 200, they out flew all other planes, regardless of price. A proved success! Not a construction toy but fully built. Ready to fly in a moment. Balsa wood wings, aluminum cabin, propeller; strong elastic motor. Model No. 21, Cabin type, wing spread, 22 in., \$2.50 (West of Miss., \$2.75). Other models, Racing and Cabin, at \$1 to \$3.50. If your dealer cannot supply you, send your order to us. Kingsbury Mfg. Co., 83-G Myrtle St., Keene, N. H. Join Silver Arrow Flying Club and become a Master Pilot.

KINGSBURY MOTOR DRIVEN TOYS

FREE! Novelty Moviescope; Shows motion picture of Silver Arrow flight. Also complete toy catalog.



Send 10c for Kingsbury Disc Wheel, Balloon Tire Eraser, Set of 4, 35c.

◀ A PRECISION TOOL ▶

For the Machine Shop, Manufacturing Plant,
Service Station, and Electrical Shop

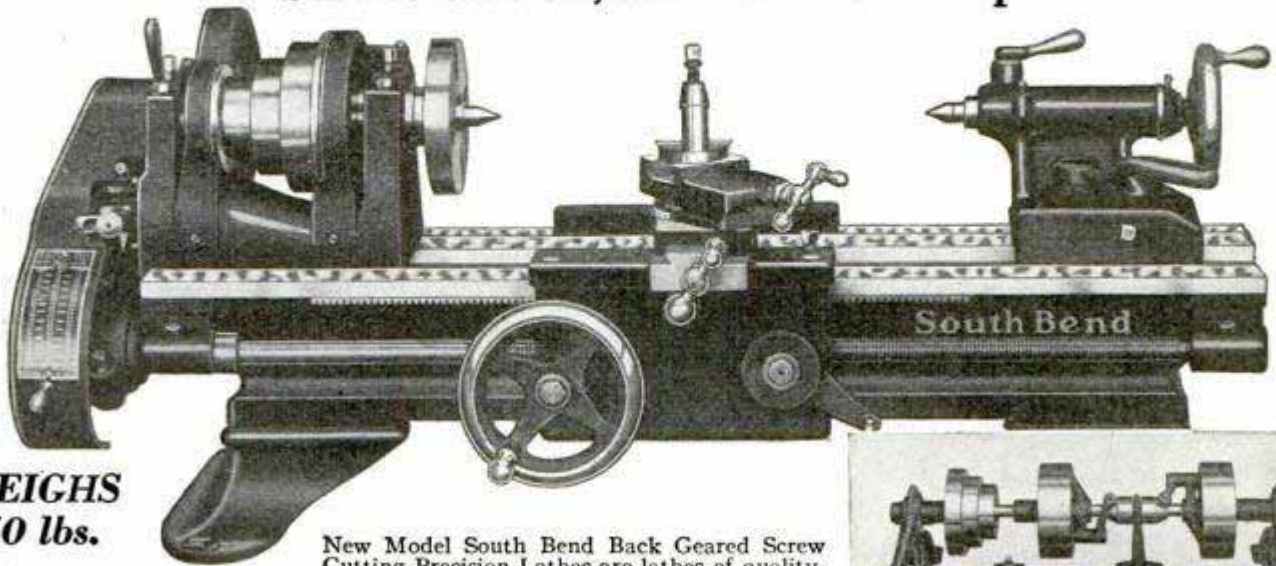

WEIGHS
350 lbs.

\$163

9"x2½" New Model Junior Back Geared Screw Cutting Lathe with Countershaft and Equipment as illustrated.

New Model South Bend Back Geared Screw Cutting Precision Lathes are lathes of quality, accuracy and precision, used by the United States Government, Ford, Westinghouse, U. S. Steel Corporations and hundreds of other large industries. All sizes can be furnished with Countershaft or Motor Drive—Standard Change Gear and Quick Change Gear types.

USE THE LATHE WHILE PAYING FOR IT

\$32.60 Down Payment — \$11.41 Per Month
for twelve months puts the lathe in your own shop so you may use it while paying for it.

Write for these Books

Catalog No. 91-A

104 pages, 6" x 9", fully illustrates, describes and prices the 96 different sizes and types of New Model South Bend Lathes and their attachments. Every lathe user will find this catalog of value for reference purposes. Mailed postpaid to any address, on request.

Auto Mechanics Service Book No. 66

96 pages, 6" x 9", illustrating and describing the use of the back geared screw cutting lathe in modern methods of servicing the motor, brakes and all other units of buses, trucks and automobiles. Price postpaid, coin or stamps of any country.....\$0.25

How to Run a Lathe

144-page book, 5" x 8", 300 illustrations. Illustrates and describes how to do all classes of metal turning work on a back geared screw cutting lathe. Price postpaid, coin or stamps of any country.....\$0.25

Prices of Other New Model Screw Cutting Lathes, Floor Leg, Countershaft Drive

Size of Lathe	Weight	Quick Change Type
9" x 2½'	470 lbs.	\$288.00
11" x 3'	675 lbs.	\$345.90
13" x 4'	1060 lbs.	\$428.00
15" x 5'	1475 lbs.	\$525.00
16" x 6'	1875 lbs.	\$598.00
18" x 8'	2640 lbs.	\$763.00
16"-24" x 6'	2035 lbs.	\$740.00
36" x 6'	2195 lbs.	\$768.00

Brake Drum

Send Coupon For These Valuable Books

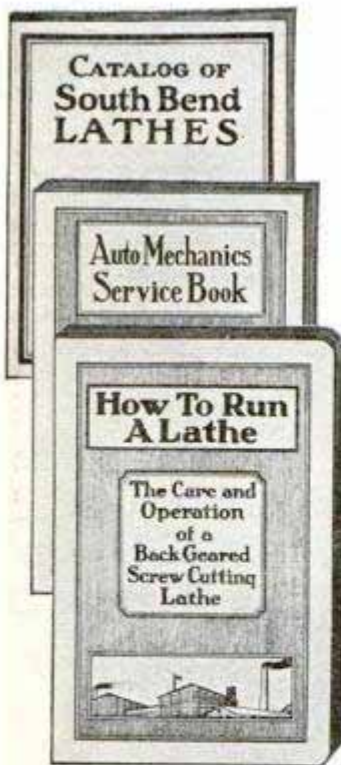

South Bend Lathe Works

623 E. Madison Street

South Bend, Indiana, U. S. A.

Lathe Builders for Over 24 Years — Over 50,000 Lathes in Use

SOUTH BEND LATHE WORKS, 623 E. Madison St., South Bend, Ind., U. S. A.
Gentlemen: Please send me books checked.
 Catalog No. 91-A (Free) Easy Payment Plan (Free)
 Auto Mechanics Service Book No. 66 (25c)
 How to Run a Lathe (25c)

Name.....
Address.....
City.....
State.....



The right knife for the job

YOU don't need many knives, but you do need more than one. When you do electrical work, wiring around the house or tinkering around a radio, you need R4548. If you're a professional electrician, you'll find it the handiest tool in your kit.

This radio and electrician's knife has screw-driver blade, especially designed for small screws. One side of this blade is sharpened for scraping wires and removing insulation. When opened, the blade locks in position so that it cannot close on the fingers. There is also a finest sturdy cutting blade—razor sharp.



Pocket Knife R4548
PRICE \$2.00

See this knife at your dealer's. If he hasn't it in stock, send us his name with \$2.00 and R4548 will be mailed to you promptly. Address Remington Cutlery Works, Bridgeport, Conn.

REMINGTON ARMS COMPANY, Inc.
Originators of Kleanbore Ammunition

Remington

Thompson BEATS the World on BOATS

THOMPSON BOATS

CATALOG FREE!

The Best that skill and experience can produce—at real money-saving prices. Prompt shipment from factories to you.

- Outboard Motor Boats** \$60.00 and up
A complete line of real fast, safe and sea-worthy boats for family use. Also fastest racing models.
- Rowboats** \$48.00 and up
Improved models. Safe and seaworthy. Strong and durable. Easy to row and handle with oars.
- Canoes** \$50.00 and up
Three models and four lengths to choose from. Including non-sinkable sponson canoes.
- MotorBoats** Six passenger
20 ft. long; speed 30 to 35 miles an hour.

CATALOG FREE—SAVE MONEY—ORDER BY MAIL
Please state the kind of boat you are interested in (30)

THOMPSON BROS. BOAT MFG. CO.
213 Ann St. PESHTIGO WISCONSIN (Write to Either Place) 113 Elm St. CORTLAND NEW YORK

MOTORCYCLES

Direct to you at wholesale prices. Send 10c today for the latest Illustrated Bulletin and Confidential Price List of Guaranteed Indians Harleys Hendersons SuperX etc.

(Sold on easy terms if desired)
CRANDALL CYCLE CO. 826-28 State St. Springfield, Mass. Shipments to all parts of the world
Motorcycles Since 1905

Sport Bodies for Fords At Factory Prices

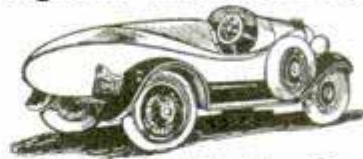

This Model in Grey Prime **\$38.50**

Make Your Ford Into Classy Car
Sport Factories, Dept. A-5 Aurora, Illinois

Factory to Rider

Save \$10 to \$25 on the Mead Bicycle you select from 44 Styles, colors and sizes.
30 Days' Free Trial
We ship on approval. If not satisfied after trial return the bicycle. **EASY PAYMENTS. \$5 down on RANGER Bicycles.**
Tires lamps, wheels, equipment at half usual prices. Write for marvelous new prices, wonderful 30 day trial offer and terms.



Mead Cycle Company Write us today for free catalog
Dept. L110 Chicago

ELECTRIC LIGHTS ANYWHERE
Complete 110-volt Electric Light Plant. Ideal for Farms, Camps and Summer Homes.
\$139.00

Runs household appliances, Install it yourself, Wiring, Fixtures and Lamps for 7 rooms, \$17.50. Also larger models D. C. or A. C. Write for circular—D. W. ONAN & SONS, 35 Royalston Ave., Minneapolis, Minn.





Popular!

YOU will be doubly welcome everywhere when you learn to play a Conn. Chances to join a band or orchestra, to travel, to make extra money. Conns are the choice of Sousa and the world's greatest artists. Easiest to play. Recommended to beginners for quicker progress.

FREE TRIAL, EASY PAYMENTS on any Conn. No matter which band or orchestra instrument interests you most, Conn will send you a special booklet on that instrument giving valuable facts.

C. G. CONN, Ltd., 731 Conn Bldg. Elkhart, Ind.



CONN
World's Largest
Manufacturers of
BAND INSTRUMENTS

Write for FREE BOOK
Mention Instrument

PROTECT YOUR CAR EVEREADY PRESTONE for preparation of the perfect anti-freeze.

National Carbon Company, Inc.
General Offices: New York, N. Y.
Branches: Chicago, Kansas City, New York, San Francisco

Unit of Union Carbide and  Carbon Corporation



ELECTRIC LAWN MOWER

Don't tire yourself out with an old style mower when you can get an electric at a price you can afford to pay. 110 volt A. C. or 32 volt farm plant. Write for particulars. Agent wanted.

Raun Lawn Mower Co.
Box 533 El Campo, Texas

DO YOU WANT a new business profession of your own, with all the trade you can attend to? Then become a foot correctionist, and in a few weeks earn big income in service fees,—not medical nor chiropody—easy terms for home training, no further capital needed, no goods to buy, no agency. Address Stephenson Laboratory, 1 Back Bay, Boston, Mass.

Only 8 Sales a Day Nets You \$116 a Week

Profits on larger size run higher. Unusual earning opportunity for ambitious men. No experience necessary; we teach. Part or full time.

FUGO World's Simplest Fire Extinguisher

Automatic and instantaneous action. Within reach of every home, shop, store, theatre, garage, car owner, etc. Even smallest place needs two or more. Exclusive territory to producers. You get your pay every day. Write for full details.

The National Formetal Co.
6535 Metta Ave. Cleveland, O.



IF YOU CAN USE AN EXTRA \$20.00 BILL

write for **this FREE BOOK**



You can save \$20.00 in no time by using **SMOOTH-ON No. 1** to do your own household repairing—and in addition you will have that proud "I-did-it-myself" feeling.

Here is what one enthusiast did with two 35 cent cans:—A \$25 lamp stand loose in base, two big leaks in heating furnace smoke pipe, loose hammer handle, and three loose hooks in tiled bathroom wall were all put into good usable condition at an average cost of 10 cents each for the seven repairs—and \$20.00 easily saved over what would have been paid to professional fixers or for new parts.

By using Smooth-On to make dozens of the simple repairs necessary in every home, you can save enough to pay your radio upkeep, buy yourself or your wife a camera, a bull pup or some other pleasure-giving article that you would otherwise hate to spend the money for.

The free Smooth-On Repair Book will show you how an astonishing number of home and automobile repairs are as easy for you to make as for somebody else, also how you can make cellar walls, concrete floors, etc., water and damp proof with Smooth-On No. 7.



Mail the coupon for a free copy and get Smooth-On No. 1 in 7-ounce or 1 or 5-pound can from any hardware store.

SMOOTH-ON MFG. CO.
Dept. 37, 574 Communipaw Ave.
JERSEY CITY, N. J.

Do it with SMOOTH-ON

SMOOTH-ON MFG. CO., Dept. 37,
574 Communipaw Ave., Jersey City, N. J.
Please send the free Smooth-On Repair Book.

Name.....

Address.....

Return this coupon for a FREE copy of Booklet

7-30



Why Do I Hold a Good Job?

Because I Use Good Tools
and for a Rule I Use

The FARRAND RAPID RULE

Modern mechanics find the FARRAND rule the answer to one of the most trying problems of the craft—the constant breakage of wooden rules. *No more leaving the job to hunt up a new rule.*

They know that it is the most convenient rule on the market. What could be more convenient than a stiff six foot steel rod that coils into a vest-pocket holder?

It ejects itself rapidly from the holder—one foot or the entire length. It comes free from the holder because it is a rule, and can be used in making end to end measurements. It is not attached to its container like a tape.

Yet it is as flexible as a steel tape and as accurate. It will measure circumferences and around corners.

The FARRAND RAPID RULE

Pays for Itself Rapidly

Ask Your Dealer for Demonstration. Or write to factory for six inch sample.

- In Convenience
- In Durability
- In Accuracy
- In Simplicity of Action

Manufactured by
HIRAM A. FARRAND, Inc.
Champlain St. BERLIN, N. H.

Note the Open Simple Holder. No parts to get out of order.



Base and Floor
one solid
piece.

Imperial Sanitary Floor

A composition material easily applied in plastic form over any kind of floor . . . laid about 1/4 inches thick. Imperial Floor does not crack, peel, or come loose from foundation . . . a continuous fine-grain, smooth, non-slipping, water-proof surface . . . fire-proof, resilient, noiseless, dustless . . . no crevices to gather grease, dirt, dust, disease germs or moisture.

An Ideal Floor

for kitchen, pantry, bathroom, recreation room, laundry, porch, garage, restaurant, theatre, hotel, factory, office building, railway station, or hospital . . . wherever a beautiful, substantial floor is desired. Choice of: Red, Green, Buff, Brown, Gray, or Blue. Full information and sample free of your first and second choice of color.

A Success for More Than Twenty Years
IMPERIAL FLOOR COMPANY
75 Halstead St. Rochester, N. Y.

OTTAWA LOG SAW



only \$39

GREATEST OFFER
EVER MADE

PUTS THIS
OTTAWA
TO WORK FOR YOU

Make Money! Wood is valuable. Saw 15 to 20 cords a day. Does more than 10 men. Ottawa easily operated by man or boy. Falls trees—saws limbs. Use 4-hp. engine for other work. **30 DAYS TRIAL.** Write today for FREE book. Shipped from factory or nearest of 4 branch houses.

OTTAWA MFG. CO., 1741 -W Wood Street, Ottawa, Kansas



Several Money Makers in One

Buy a complete Welding, Carbon Removing, Lead Burning, Soldering, Radiator, Brazing and Cutting Outfit combined, including oxygen and acetylene gas . . . \$63.18
Same Outfit, less gas . . . 30.78
Write for particulars and catalog

THE SUPERIOR OXY-ACETYLENE MACHINE CO.
Box 285 Hamilton, Ohio

Send for a copy of Brown & Sharpe Small Tool Catalog No. 31
Brown & Sharpe Mfg. Co., Providence, R. I.

Brown & Sharpe Tools

"World's Standard of Accuracy"

SOLD ON EASY TERMS

WORRACE Electric WOODWORKER

Complete Outfit Including Planer, Saw, Lathe, Electric Motor and Many Useful Attachments



Fast—Accurate—Complete

Price complete, \$89.00. Easy Terms. Write for complete information.

J. D. Wallace & Co., Adams St. Chicago
11 W. 42nd St., New York. 268 Market St., San Francisco

Get this **EXTRA QUALITY**
and **SERVICE**
without
added
cost



Quality in the Crescent-Smith & Hemenway line starts with the material. Only steel of a specified analysis, depending upon the use for which the tool is designed, goes into these punches and chisels. Crescent heat treatment puts the "stuff" in them. These tools are *hardened all the way thru*. That's why we sell them with a "money-back" guarantee. Identified by the "S&H Co." mark—red heads, blue shanks and polished points.

Crescent Tool Company, Jamestown, N.Y.

CRESCENT and Smith & Hemenway TOOLS

THE "LITTLE GIANT" RIM JACK



makes changing of tires easy. Is made of malleable iron and steel and fits all size rims. Has great deal of power and can be used for straightening and tightening purposes, for adjusting brakes, as well as ten other ways.

WELLS MANUFACTURING COMPANY
P. O. Box 613 Greenfield, Mass., U. S. A.

SALESMEN WANTED!

SELL COX HOLDFAST SCREW DRIVERS

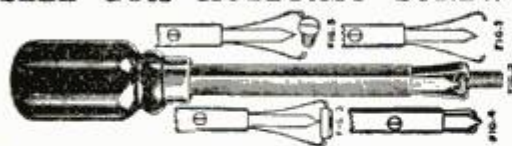

Sells on sight to mechanics for Auto, Radio and Electrical Work. Self Holding. Self Releasing.

Send 50c for sample and ask how to get Salesman's Outfit Free.
S. J. COX Dept. F, FRANKLIN, PA.

FREE TOOL BOOK "The Disston Saw, Tool and File Book"

tells how to choose, use, and care for tools, file and set saws, etc. Every tool user needs it.
Henry Disston & Sons, Inc., Dept. M, Philadelphia. Canadian Factory, Toronto



\$10⁰⁰

DOWN
Brings
this Lathe
to You

SYPPER MANUFACTURING COMPANY
Dept. D-7 Toledo, Ohio

ATKINS SILVER STEEL SAWS

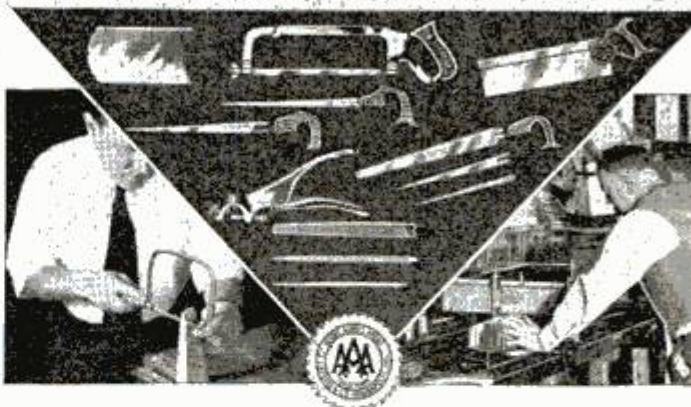

Small Saws for Fine, Fast Work

No wonder so many home craftsmen turn to ATKINS Small Saws when they have fine cutting to do. For, these are the saws the finest artisans use, the world over.

But you don't have to be an expert to do good work with ATKINS Saws. It's surprising what clean, accurate cuts even an amateur can make with these fine saws. The secret is in "Silver Steel," the world-famous saw steel used only by ATKINS.

It makes the saw take a keener edge, cut faster, run easier, stay sharp longer and outlast two or three ordinary saws. Many other features of ATKINS Saws which save you time, energy and money.

Here are a few favorite ATKINS Small Saws for home shop workers, carpenters and mechanics:

- No. 1 Miter Saw: Heavy back, rigid blade, fine teeth. 18" to 32" blades. Makes smooth joints.
 - No. 2 Back Saw: To cut miters, grooves, etc. Stiff back makes blade run true. 8" to 18" lengths.
 - No. 10 Hack Saw Frame: Adjustable for 8" to 12" blades. Pistol Grip handle. ATKINS Non-Breakable, or new Silver Steel Blue-End Blades.
 - No. 6 Keyhole Saw: Blade is extra tough and sharp. Cuts easily; hard to break. 10" and 12" sizes.
 - No. 2 Compass Saw: Cuts speedily, stands hard use. 10" to 16". No. 11 has adjustable blade.
 - No. 50 Coping Saw: Blade cuts at any angle, does extra fine work. Strong, nicked frame.
 - No. 3 Nest of Saws: 3 saws for 1 handle; compass, keyhole and nail-cutting blades.
 - No. 395 Saw Set: Makes it easy to give your saws perfect set. For saws with 4 to 16 teeth to inch.
 - Silver Steel Files: Better for every filing purpose.
 - Scraper Blades: In all styles and sizes, for fast scraping and finishing.
- Dozens of other ATKINS Silver Steel Saws. See them all at your Hardware Store.

Get these
4 Saw Books
FREE



E. C. ATKINS & COMPANY,
Established 1857
426 S. Illinois St.,
INDIANAPOLIS, IND.

Send me the FREE Booklets, "Saws in the Home," "Saw Sense," "Circular Saws," and "Dado Heads."

Name

Address

My Dealer is

To acquaint **YOU** with **GOODELL-PRATT** quality we make this **REMARKABLE OFFER**
SEND 1.00
 for **HANDY POCKET SCREW DRIVER SET**



To introduce a sample of Goodell-Pratt quality to every tool lover in America, we are offering at the special, low price of \$1.00, this handy tool. Ideal for repair work on radios, fire-arms, clocks, household appliances, etc. Contains three screw driver blades and reamer. When not in use, the chuck and blades are inside as shown. Nickel plated handle. Satisfaction unconditionally guaranteed. Pin dollar bill to this coupon and send in today.

GOODELL-PRATT COMPANY, Greenfield, Mass. Attached is one dollar for Pocket Screw Driver Set.

Name.....
 Street.....
 City..... State.....
 My hardware dealer is.....

PROFITS for YOU!

Without Motor
\$247

CABINET SHOP SPECIAL



Includes 16" band saw, 6" jointer and 8" circular rip and crosscut saw.

Why give someone else the profits that your skill and knowledge bring in? Open a shop of your own and get all the profits for yourself. The Parks Cabinet Shop Special is a compact, accurate woodworker with full-size units and is priced for the man with small capital who wants a shop of his own.

Send coupon today for complete catalog.

The Parks Woodworking Machine Company, Dept. P-7, 1530 Knowlton St., Cincinnati, Ohio. Canadian Factory: 338 Notre Dame East, Montreal.

Name..... City.....
 Address..... State.....



Every Parks guaranteed 10 years.

Build and Fly this Ideal CONDOR

The latest idea in Featherweight Models; 22 in. size and weighs only 1/4 oz. Simplified, advanced design; all Balswood construction; adjustable wings; adequate power for long flights; interchangeable landing gear; easy, quick construction. Get the CONDOR—Construction Set

Ask your Dealer, or Order Direct (Postage 15 cents extra)
Catalog of Parts, Fittings, Supplies for Model Builders 5 cents
IDEAL AEROPLANE & SUPPLY CO., Inc.
 26 West 19th Street New York

\$1

Oh! Boy! Build this car. Speed 35 miles per hour. Driven by gasoline motor. Can be built by any boy. Parts furnished by us. Are very cheap. Send 50c for building plans and price list of parts showing how to build this boy's car.

SYCO SALES CO., 1524 Fernwood Ave., Toledo, Ohio

BUILD SHIP MODELS
 Easy to build and sell. Plans and instructions: Santa Maria, \$1.00—Clipper Ship, 80c—Viking Galley, 40c—or all three for \$2.00. Catalog 6c.
RICHTER'S, 3217 A. Walnut Street, MILWAUKEE, WIS.

GERSTNER TOOL CHESTS are made better, finished attractively, and are guaranteed to be values that cannot be beaten. MACHINISTS and TOOL-MAKERS, you will be proud to use one. Catalog Free.

Gerstner & Sons
 479 Columbia Street, Dayton, Ohio

BURN YOUR NAME ON TOOLS WITH THE ARKOGRAF

PROTECT YOUR TOOLS FROM THEFT
 Write with electricity any name or design on the hardest and finest tools and instruments, or any metal, like writing on paper with pen or pencil. Complete Outfit \$3.50—Prepaid Anywhere Interesting Illustrated circular free. Write today. Agents wanted.
ARKOGRAF PEN CO., 1171 E. Stark St., Portland, Oregon

NEW No. 200 SERIES (DUPLX) MASTER SLIDE RULE

Both sides for OUTSIDE MEASURE—figures run both ways. One side for INSIDE MEASURE by direct reading—figures, etc., printed in red. No guess work—accurate. At dealer or direct. 6 ft. Size \$1.50, 8 ft., \$2.00, 5 ft., \$1.00. Agents Wanted
MASTER RULE MFG. CO., 821 E. 136th St., New York City

Makes Old Ford a Tractor

Now you can convert that old Ford car into a useful farm tractor without altering any Ford parts. We furnish the traction wheels, drive gears and auxiliary axle and mountings, ready to clamp on to the Ford frame. Pulls 16" plow.

We supply a Belt Pulley also

Write for Free Particulars.
Shaw Mfg. Co., Dept. PM7, Galesburg, Kan.

Do your own Printing!



Cards, stationery, circulars, tags, labels, advertising, book, menus, etc. Save money and time, cut cost in half. Easy rules furnished with every outfit.

Print for Others BIG PROFITS

A big opportunity to turn your spare time into cash, or develop a full time business of your own at small cost. New and popular Raised Printing like Engraving done with any of our presses. Junior Press \$5.00, Job presses \$11, \$29; Rotary \$149.

Write for catalog No. 737 of presses, type, cards, paper, supplies and full information. The Kelsey Co., Meriden, Conn.



Build your own outboard hydroplane motor or sail boat. Use our plans or knock-down frames and machined parts. Many models to select from. Write for new catalogue. J. B. WELCH, Inc., Dept. B, 1351 41st St., Milwaukee, Wis.

Build a CLOCK for Pleasure or Profit!



FREE BOOK of Clock Making, Money Making ideas. Gives details, prices of movements, parts. Write NOW for copy!

Shows How YOU Can Make Fine Clocks Right at Home — for yourself, or to sell at Big Profits. We furnish instructions, parts. Works \$1.65 up; others with chimes, all prices. Make case or assemble parts. Cash-in on demand for Mantel, Benjo, Grandfather's Clocks. Write for Special Blue Print Offer, FREE Catalog.

AMERICAN CHIME CLOCK COMPANY
1670-Z Ruffner St. Philadelphia, Pa.

AGENTS 500% PROFIT GENUINE GOLD LEAF LETTERS



guaranteed to never tarnish. Anyone can put them on stores and office windows. Enormous demand, large profits. Paul Clark says: Smallest day \$28.70. R. L. Reel made \$920 in two months. Write today for free sample and liberal offer to general agents. METALLIC LETTER CO. 433-B N. Clark St., CHICAGO

MOTORCYCLES



WE WILL TRUST YOU Pay As Low As \$2.00 per Week Hendersons, Harley-Davidsons, Indians

Slightly used and rebuilt. Hundreds to select from. Send 10c for list today. MYEROW BROS. CO., 15 Berkeley St., Boston, Mass., U. S. A.

Catch Fish!



Eels, Mink, Muskrats with our new folding galvanized STEEL WIRE TRAP. Write for our FREE TRAP OFFER and Bargain Catalog. \$1 Box of our famous Fish Bait FREE to introduce our traps. WALTON SUPPLY CO., 3502 JUNIATA AVE., ST. LOUIS, MO.

DEAFNESS IS MISERY



Multitudes of persons with defective hearing and Head Noises enjoy conversation, go to Theatre and Church because they Use Leonard Invisible Ear Drums which resemble Tiny Megaphones fitting in the Ear entirely out of sight No wires, batteries or head piece They are inexpensive. Write for booklet and sworn statement of the inventor who was himself deaf.



A. O. LEONARD, Inc., Suite 699, 70 5th Ave., New York

The Old Reliable Credit Jewelers LOFTIS BROS. & CO. Dept. B-894 108 N. State St. Chicago, Ill.

DIAMONDS WATCHES

CASH or CREDIT

GENUINE DIAMONDS GUARANTEED
Our Diamonds are blue white, of fiery brilliancy, magnificent in their perfect settings.



HOW TO ORDER
State article desired — name of employer — kind of work you do — how long in position — age — married — where live — how long there. EVERYTHING CONFIDENTIAL. Send first payment, OR goods sent for your FREE Examination on request.

CREDIT TERMS: One-tenth down; balance weekly, semi-monthly or monthly at your convenience. WEAR WHILE YOU PAY

SEND FOR BIG FREE CATALOG
2000 Illustrations

Elite Wedding Ring. solid platinum, only \$19.50. In solid 18-K white gold, \$5.00, or with 6 Diamonds, \$18.75

No. 924. Woman's Elgin Bracelet Watch \$29.50. \$2.95 Down, \$2.95 a Month

HAMILTON No. 992. 21 Jewels. Adjusted to 5 Positions. Yellow Gold filled 25-year Case \$60

ELGIN'S LATEST RAYMOND. 21 Jewels, 8 Adjustments. Runs 40 hours on one winding. Nickel Chromium finished \$50

ILLINOIS "BUNN SPECIAL." 21 Jewels. Adjusted to 6 positions. Yellow Gold-filled 25-year Case \$60

All Railroad Watches sold on convenient credit terms

HELP WANTED

We require an ambitious person to do some special work right in your own locality. Wonderful chance for big earnings. Work is pleasant and dignified. No previous experience necessary. You simply carry out our instructions. Your full time can bring you handsome profits — spare time in proportion. If you are making less than \$150 a month, write at once for full particulars. Costs you nothing to investigate. I will give you all the facts so you can decide for yourself. **ALBERT MILLS, Gen. Manager Employment Dept.** 5910 Monmouth Ave. Cincinnati, Ohio

NEW VEST POCKET ADDING MACHINE

ADDS, SUBTRACTS, MULTIPLIES, DIVIDES
Does work of \$300 machine. Guaranteed 5 years. NOT A TOY. Made of steel and indestructible. Million dollar capacity. Fits in pocket. Will not make mistakes. So simple child can operate it. Instructions furnished. Everybody should carry one for figuring.

FREE TRIAL \$2.50 Total Cost
SEND NO MONEY—Just name and address. We will ship Calculator immediately. On delivery pay postman \$2.00 (Plus few cents Postage). (If outside U. S. send cash) 10c additional in Leatherette Case. If not satisfied after 10 days trial you get your money back. THOUSANDS OF SATISFIED USERS.

Guaranteed This is lowest priced practical calculator made. "Why pay more for inferior imitations?" Order from this ad.

----- Mail Coupon Today -----
BABY CALCULATOR MACHINE CO., (MANUFACTURERS)
Dept. 41, P. O. Box 1118, CHICAGO, ILL., U. S. A.
 I am enclosing \$2.50—send adding machine prepaid.
 Send Adding Machine C. O. D. \$2.50 plus 18c postage. (10c additional in Leatherette Case)

Name.....
Address.....
City..... State.....

AGENTS Write for big commission and territory proposition.

PATENT

Protect Your Ideas

Take the First Step Today

If you have a useful, practical, novel idea for any new article or for an improvement on an old one, you should communicate with a competent Registered Patent Attorney AT ONCE. Every year thousands of applications for patents are filed in the U. S. Patent Office. Frequently two or more applications are made for the same or substantially the same idea (even though the inventors may live in different sections of the country and be entirely unknown to one another). In such a case, the burden of proof rests upon the last application filed. Delays of even a few days in filing the application sometimes mean the loss of a patent. So lose no time. Get in touch with me at once by mailing the coupon on the opposite page.

Prompt, Careful, Efficient Service

This large, experienced organization devotes its entire time and attention to patent and trade mark cases. Our offices are directly across the street from the U. S. Patent Office. We understand the technicalities of patent law. We know the rules and requirements of the Patent Office. We can proceed in the quickest, safest and best ways in preparing an application for a patent covering your idea. Our success has been built on the strength of careful, efficient, satisfactory service to inventors and trademark owners located in every state in the Union.

NO CHARGE for Information On How to Proceed

The booklet shown here contains valuable information relating to patent procedure that every inventor should have. And with it I will also send you my "Record of Invention" form on which you can sketch your idea and establish its date before a witness. Such evidence may later prove valuable to you. Simply mail the coupon and I will send you the booklet, and the "Record of Invention" form, together with detailed information on how to proceed and the costs involved. Do this NOW. No need to lose a minute's time. The coupon will bring you complete information entirely without charge or obligation.

My Offices
Just Across
Street From
U.S. Pat. Office



Above is a view of my drafting and specification offices where a large staff of experienced experts are in my constant employ. All drawings and specifications are prepared in my offices.

NEWS

Inventors
Write for these **Free**
Books

Strict Secrecy Preserved

All communications, sketches, drawings, etc., are held in strictest confidence in strong, steel, fireproof files, which are accessible only to authorized members of my staff. Feel free to write me fully and frankly. It is probable that I can help you. Highest references. But **FIRST**—clip the coupon and get my free book. Do **THAT** right now.

Clarence A. O'Brien

Registered Patent Attorney

Member of Bar of: Supreme Court of the United States; Court of Appeals, District of Columbia; Supreme Court, District of Columbia; United States Court of Claims.

Practice confined exclusively to Patents, Trademarks and Copyrights

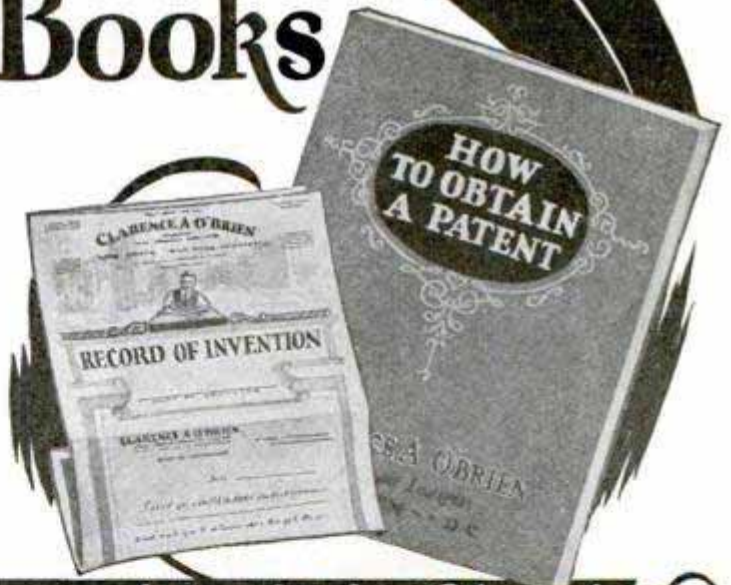

Clip this Coupon and Mail it Now!

CLARENCE A. O'BRIEN, Registered Patent Attorney
706 Security Savings and Commercial Bank Bldg.
Washington, D. C.

(Or, Suite 1106, Dept. A-1, Woolworth Bldg., New York City)

Please send me your free book, "How to Obtain a Patent," and your "Record of Invention" form without any cost or obligation on my part.

Name.....

Address.....

(Important—Write or print name plainly and address office nearest you)

PATENTS TRADE MARKS COPYRIGHTS

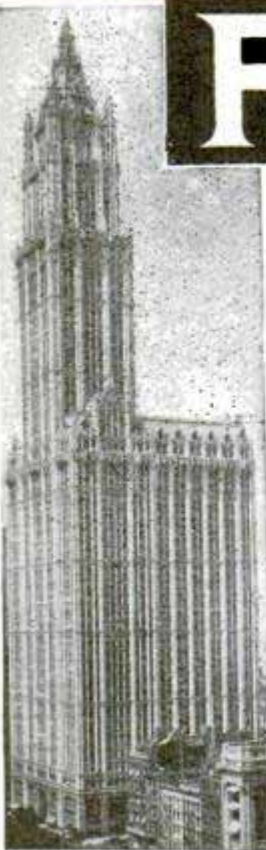

Our New York Office
Suite 1007 Woolworth Bldg.



Our Philadelphia Office
828 Fidelity Phila. Trust Bldg.



VICTOR BUILDING
Our New Building Nearly Opposite U. S. Patent
Office Specially Erected by Us for Our Own Use

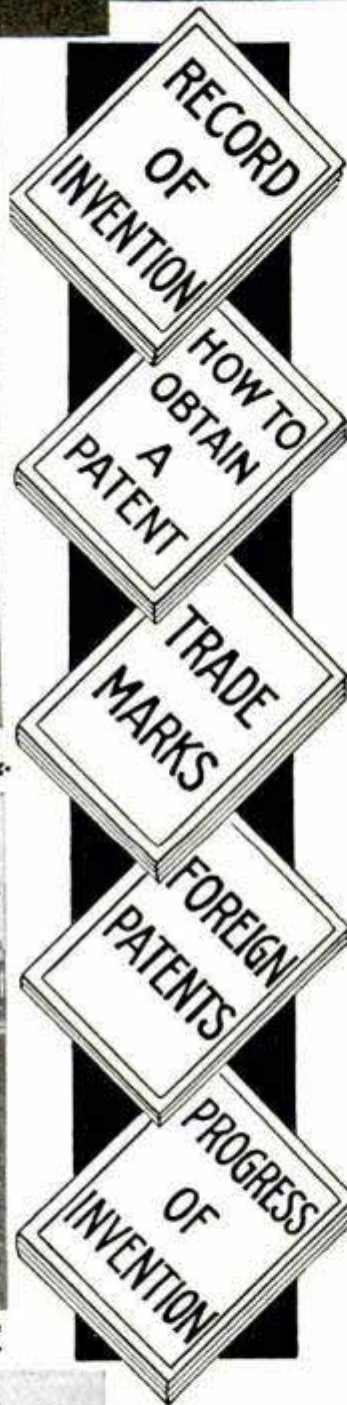

Have You An Idea?

Our Offer: FOR THE PROTECTION OF YOUR INVENTION

YOUR FIRST STEP—The Inventor should write for our blank form "RECORD OF INVENTION." A sketch and description should be made on this Blank, signed, witnessed, then returned to us. We also give our opinion as to whether the invention comes within the Patent Office definition of a patentable invention. This "Record of Invention" will serve as "proof of conception." *There is no charge or obligation for this service.*

Our Five Books Mailed Free to Inventors
Our Illustrated Guide BOOK

How to Obtain a Patent
Contains full instructions regarding U. S. Patents. Our Methods, Terms, and 100 Mechanical Movements illustrated and described.

Our Trade Mark Book
Shows value and necessity of Trade Mark Protection. Information regarding *Trade Marks and unfair competition in trade.*

Our Foreign Book
We have Direct Agencies in Foreign Countries, and secure Foreign Patents in shortest time and lowest cost.

Progress of Invention
Description of World's Most Pressing Problems by Leading Scientists and Inventors.

Payment of Fees in Installments
It is not necessary that the total cost for the preparation and prosecution of a patent be paid in one payment. Our custom is to permit our clients to pay for their applications in three installments as the preparation of the application progresses in our office. This plan makes the payments easy for the inventor.

We Regard a Satisfied Client as our best advertisement, and furnish anyone, upon request, lists of clients in any state for whom we have secured patents.

*Highest References—Prompt Service
—Reasonable Terms*

VICTOR J. EVANS & CO.

Patent Attorneys, Established in 1898
Main Offices: 789 9th St., N. W., Washington, D. C.
Nearly Opposite U. S. Patent Office

DELAYS ARE DANGEROUS IN PATENT MATTERS

IMPORTANT! To Avoid Delay!

YOU SHOULD HAVE YOUR CASE MADE SPECIAL IN OUR OFFICE to save correspondence, secure protection and early filing date in the Patent Office. To secure **special preparation** of your case send \$25.00 on account with model or sketch and description of invention. If the invention is not patentable we will return fee less cost of search.

We Assist our Clients to Sell their Inventions.

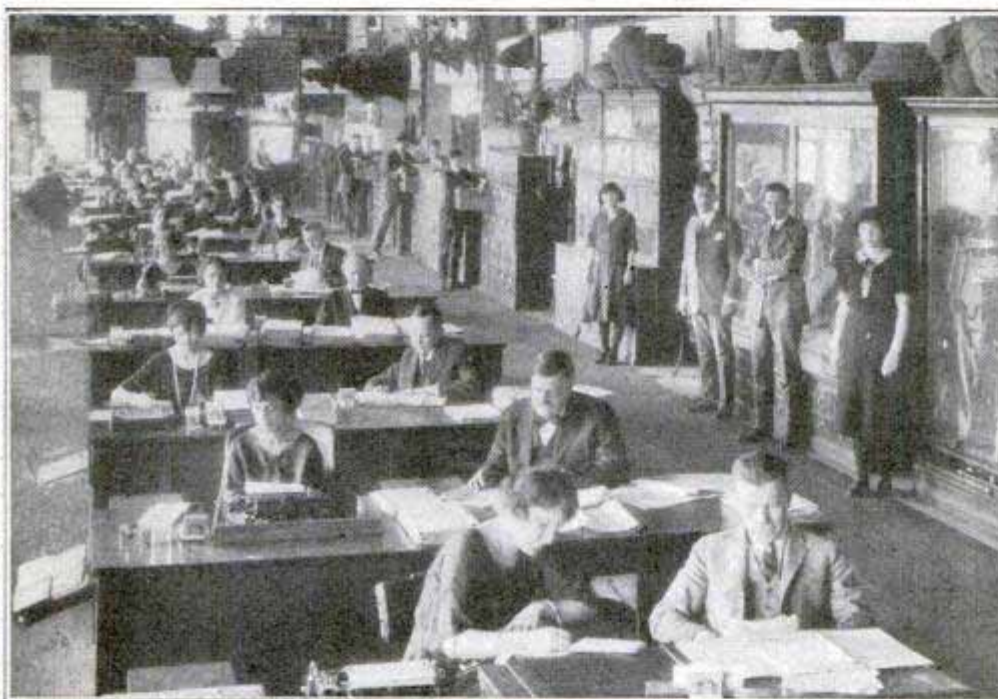

MAIN OFFICE, VICTOR J. EVANS & CO.—VICTOR BUILDING, WASHINGTON, D. C.

Our Large, Comprehensive Organization has been established for 30 years and offers Prompt, Efficient and **Personal Service** by experienced Patent Lawyers and Draftsmen. Every case is in charge of a Specialist who has been selected for his knowledge and experience in certain lines of invention. Our Lawyers practice in all U. S. Courts and defend clients in suits involving Patents, Trademarks and Copyrights. All Communications, Sketches, Drawings, etc., preserved in fireproof Files, strictly **Secret and Confidential**. We shall be glad to have you consult us or to answer any questions in regard to Patents, Trademarks or Copyrights without charge or obligation.



Our Chicago Office
Suite 1640-42 Conway Bldg.



Our Pittsburgh Office
Suite 514 Empire Building



Our San Francisco Office
Suite 1010 Hobart Building

**FREE
COUPON**

VICTOR J. EVANS & CO.
PATENT ATTORNEYS *Established
in 1898*

NEW YORK OFFICES
1007 Woolworth Bldg.

CHICAGO OFFICES
Suite 1640-42 Conway Bldg.

PHILADELPHIA OFFICES
828 Fidelity Phila. Trust Bldg.

PITTSBURGH OFFICES
514 Empire Bldg.

SAN FRANCISCO OFFICES
1010 Hobart Bldg.

MAIN OFFICES: 789-9th Street, N. W., WASHINGTON, D. C.

Gentlemen: Please send me *Free of Charge* your books as described on preceding page.

Name

Address

PATENTS

Booklet Free

Promptness Assured

Highest References

Best Results

Send drawing or model.

ALL BUSINESS GIVEN PROMPT AND PROPER ATTENTION

Listed Patent Lawyer in the latest editions of the Rand-McNally Directory of Bankers and Bonded Attorneys, published by Rand-McNally & Co., Chicago, Ill.; The Baggott & Ryall Directory of Guaranteed Attorneys, published by Legal Directory Corporation, Boston, Mass.; Flugel's Law List, published by Legal Directory Publishing Co., St. Louis, Mo.; American Lawyers Annual, published in Cleveland, Ohio; Bankers Service Legal Directory, published by Bankers Service Co., Boston, Mass.; Eyre's Law List, 9 Park Place, New York City; Walters Legal Directory, Omaha, Nebraska, and the National Directory of Attorneys, Baltimore, Maryland.

WATSON E. COLEMAN,
REGISTERED PATENT LAWYER

Victor Building, 724 Ninth Street, N. W.
WASHINGTON, D. C.

PATENTS

PROTECT YOUR IDEAS

Write today for FREE INSTRUCTIONS—or send Drawing or Model of your Invention for Examination.

Promptness Assured with Best Results

MILLER & MILLER
REGISTERED PATENT ATTORNEYS

Former Members Examining Corps U. S. Patent Office
255 McGill Building Washington, D. C.



PATENTS TRADE-MARKS

Don't Lose Your Rights
To Patent Protection

Before disclosing your invention to anyone send for blank form "EVIDENCE OF CONCEPTION" to be signed and witnessed.

LANCASTER, ALLWINE & ROMMEL
480 Ouray Bldg. WASHINGTON, D. C.
Originators of forms "Evidence of Conception."

\$165,000 REWARD for an IDEA

That sum was paid to the inventor of "Kiddie Kars." Here is a remarkable book which tells you what inventions are NEEDED in every field. Don't waste your ideas. Send today for

1000 NEEDED INVENTIONS

Prepared by Raymond F. Yates, famous inventor, former managing editor of Popular Science Monthly, who knows what manufacturers want. New, revised edition contains valuable chapters on Aviation and Television. This book may start you toward a fortune. Send no money. Just write a postcard. Pay mail man only \$1.50 plus postage when book arrives. Money back after 10 days if desired. Limited offer. Write now. Get started in right direction. (Outside U. S. \$1.70 cash with order.)

Bureau of Inventive Science 37 Wisner Building
ROCHESTER, N. Y.

<p>The BLAIR TOOL AND MACHINE CORP. College Point, N. Y. Manufacturing Machinists Since 1895</p>	<p>NOTICE INVENTIONS DEVELOPED—Models and experimental work FINANCED PATENTED MANUFACTURED MARKETED Write for our booklet.</p>	<p>Patent Dept. at Patent Law Offices of EDWARD GOTTLIEB 5 Beekman Street NEW YORK N. Y.</p>
--	---	--

MAKE YOUR INVENTIONS PAY



MILLIONS have been made from ideas properly developed and protected by inventors. One of the first steps is the development of a practical working model. Send us rough sketch or model of your idea. We will submit complete report backed by 30 years' experience in model making. Confidential service. Modern equipment. Bank references furnished. FREE booklet "Making Inventions Pay."

CRESCENT TOOL CO., Dept. A, CINCINNATI, OHIO

PATENTS SECURED TRADE-MARKS REGISTERED

High-class professional service for Inventors and Trade-Mark Users is necessary for PROPER PROTECTION. We Offer you our facilities on Reasonable Terms. If you have an invention send us a model or sketch and description and we will give you our OPINION whether your invention comes within the provisions of the Patent Laws. Our book, "HOW TO GET YOUR PATENT" and Record of Invention Certificate sent on request. DELAYS are DANGEROUS in Patent Matters.

Terms Reasonable.

Best References.

WRITE TODAY

RANDOLPH & COMPANY, Patent Attorneys
301 VICTOR BUILDING, WASHINGTON, D. C.

Name.....

Address.....

PATENTS

To the Man with an Idea

PATENTS Procured. Trade Marks Registered. —A comprehensive, experienced, prompt service for the protection and development of your ideas. Preliminary advice gladly furnished without charge. Booklet of information and form for disclosing idea free on request.

IRVING L. McCATHRAN, Patent Lawyer
Formerly with and successor to RICHARD B. OWEN
704 International Bldg., Washington, D. C.
41-E Park Row, New York City

TRADE-MARKS
REGISTERED

INVENTORS who derive largest profits know and heed certain simple but vital facts before applying for Patents. Our book *Patent-Sense* gives those facts; sent free. Write **LACEY & LACEY**, 646 F St., Washington, D. C. Established 1869.

H & A COMBINATION SAW OUTFIT—



Rip Saw and Scroll Saw, inter-changeable on same base and motor—a high quality, low-cost outfit that will handle most of the ordinary jobs in the home shop.

Complete
\$55.00

Write for special folder; also complete catalog of motor-driven wood-working tools.

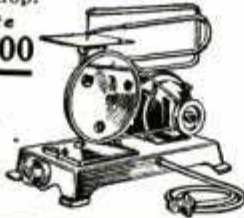

HESTON & ANDERSON
607 Kirkwood Ave. Fairfield, Iowa

MODEL SHIPS



We can supply construction sets and all sorts of parts such as semi-finished hulls, blocks, deadeyes, special flags, anchors, steering wheels, capstans, figureheads, blue prints, books, etc., for building real fine scale models of the Flying Cloud, Constitution, Spanish Galleon, Mississippi River Steamboat, Sovereign of the Seas, Mayflower and many others. Also special construction sets for racing sail boats, power boats, model steam engines, propellers, etc.; and fine tools for the model maker. Our large 48-page photographically illustrated booklet contains valuable information and hints for building ship models in addition to prices and full description of the above articles. Many people only slightly interested in models have become greatly enthused upon receiving this booklet. A copy will be sent postpaid upon receipt of 15 cts. (coin preferred).

MODEL SHIP SUPPLY CO., DEPT. H. MINEOLA, N. Y.

MOTORCYCLES



Wonderful Bargains
Small Deposit—Liberal Terms
Indians Harley-Davidsons Ace and Henderson

Sent 10 cents for Bulletin A.
Motorcycles shipped to all parts of the world

WALKER-INDIAN CO., 1309 Boylston St., Boston, Mass.

Make Your
VEST POCKET
BRING YOU \$400. A MONTH



Brand New

An article that arouses instant curiosity. Quickly demonstrated and conveniently carried in vest pocket. Protection for everybody against robbers, criminals, morons, vicious dogs, etc. yet it is not classed as a weapon, because absolutely harmless.

"Sold 17 First Day Out"

writes Hansen of Northern Illinois. Hayes of Minn. wires "Sold my first dozen in five hours. Send 3 Doz. C. O. D. at once." Agents make \$2.55 on each sale. Big extra profits on quantity. Prospects everywhere—men, women, banks, theatres, merchants, etc. You should close at least 40%.

Looks Like A Fountain Pen

INSTANT TEAR GAS PROTECTION
WITHOUT INJURY TO ANYONE

Two Tear Gas Cartridges Free

with every gun. You make 20 cents each on every extra cartridge sold.

Exclusive Territory

still open. Especially attractive proposition to men controlling force of salesmen. Send Coupon for details regarding How to get Free Demonstrator, etc.

Women are not afraid to use the Atlas Gun. Greatest protection for women ever invented.

500 Atlases recently ordered by banks in one territory alone.



ATLAS TEAR GAS FOUNTAIN PEN GUN

Atlas Tear Gas Co., Chicago, Ill.
Ogden Park Station, Dept. 57

Gentlemen: Please send me particulars regarding your Fountain Pen Tear Gas Gun agency. Also tell me how I can get a Demonstrator and two cartridges Free.

Name.....

Town.....

St. or R. F. D..... State.....

BETTER THAN WEATHER-LOX WEATHERSTRIP

ONE HALF THE COST
"AT LAST"! THE NEW INVENTION that all carpenters and builders have dreamed about—"WEATHER-LOX," the article that has all the good points of weather strips and none of their bad features and at one-fourth the cost, permanent, all metal and guaranteed. The first service agency did \$21,000.00 business in six months. We furnish everything to start you in business for yourself. Special notice to weather-strips, general repair men, carpenters, builders and salesmen. Write immediately.
Hickman Bryant Corp., 2228 Pennsylvania Ave., S. E., Wash., D. C.

CHANCE TO EARN \$150 to \$300 WEEKLY Introducing

ZENITH WHIRLGAS ENGINE BOOSTER

Whirling... Super-charging POWER, SPEED, MILEAGE
Let your Motor have increased Speed on less Gasoline, prevents Carbon. Millions of Gallons going to waste, now can be saved. NEW INVENTION proves successful, thousands being sold. Fits all Cars, Trucks, Motor Boats, Tractors and Airplanes. Big Income profit, Contract to Salesmen, Agents, Managers. We will tell you how you can obtain a sample free. Write for Free thirty day trial offer.

Dept. E, ZENITH MFG. CORP., 1456-13th Street, Milwaukee, Wis.

Speed Heads 8—12 Valve system for Ford. Hi-speed Camshaft for all Cars. Zenith Racing Carburetors.

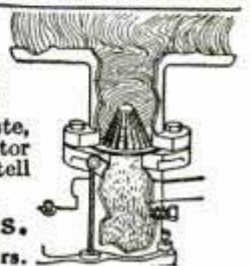

LUMINOUS PAINT

Make Your Watches, Clocks, Etc., Visible by Night

The very latest discovery in the scientific world, hitherto, practically unobtainable except at an exorbitant price, we have at last succeeded in producing this remarkable LUMINOUS PAINT, which, applied to the surface of any article, emits rays of white light, rendering it perfectly visible in the dark. THE DARKER THE NIGHT, THE MORE BRILLIANT IT SHINES. Quite simple to use. Anyone—you can do it. A little applied to the dial of your watch or clock will enable you to tell the time by night. You can coat the push buttons or switch plates of your electric lights, match boxes, and innumerable other articles; make your own Luminous Crosses, Lemniscas, etc. See our price list. Larger sizes, 50c and \$1 postpaid. JOHNSON SMITH & CO., Dept. 803, RACINE, WIS.



Cigarette Maker

Roll your own and save money. Better and quicker; saves more than half. Use your favorite brand of tobacco. Neat, useful, handy. Pocket size, weighs 1/2 oz. Made entirely of metal, nickel plated. 25c, 3 for 65c.



GOOD LUCK RING

Very striking, quaint and uncommon. Silver finish; skull and crossbones design. Two brilliant, flashing gems sparkle out of the eyes. Said to bring good luck. Only 25c ppd.



Exploding Cigarettes

Box contains ten genuine cigarettes of excellent quality. They appear so real, but when each cigarette is about one-third smoked, the victim gets a very great surprise as it goes off with a loud BANG! A great mirth provoker yet entirely harmless. Price 25c box.



U. S. BABY TANK



It goes with real Yankee Pep—by its own power. Most remarkable toy ever invented. By drawing the Tank backward, either with the hand or over the floor or table and then placing it down, it will crawl along, overcoming all obstacles in the same life-like manner as the larger Tank that proved so deadly in the great war. What makes it go is somewhat of a mystery, for there is no mechanism to wind up as is usually understood with mechanical toys, yet this tank will keep plodding along ten times longer than the ordinary run of toys. It will perform dozens of the most wonderful stunts; 2 1/2 inches long. Price only 25c prepaid. Postage Stamps accepted in payment of all orders.

NOVELTY BADGES



Kissing Permit 10c Two very novel metal badges, nickel plated, that you can wear, giving you fun out of all proportion to their trifling cost. 10c, each badge, 3 for 25c, or 75c per doz. postpaid anywhere.

Garter Inspector 10c

MIDGET BIBLE



GREAT CURIOSITY Smallest Bible in the World. Size of a postage stamp. 200 Pages. Said to bring good luck to the owner. A genuine work of art. Must be seen to be appreciated. Makes good money selling them to friends, church acquaintances, etc. PRICE 15c each, 3 for 40c, 12 for \$1.25, 100 for \$7.50. Also obtainable in Leather binding, with gold edges. Price 50c each, 3 for \$1.25, \$4.50 per doz. Magnifying Glass for use with Midget Bible 15c.

STAGE MONEY



With a bunch of these bills, it is easy for each person of limited means to appear prosperous by flashing a roll of these bills at the proper time and peeling off a genuine bill or two from the outside of the roll, the effect created will be found to be all that can be desired. Prices, postpaid: 40 Bills 20c, 120 for 50c, or \$3.50 thousand postpaid.

MAGIC MADE EASY 250 MAGIC TRICKS 10c



An excellent little book containing 250 Parlor Tricks, tricks with cards, coins, handkerchiefs, eggs, rings, glasses, etc. So simple that a child can perform them. Profusely illustrated. Sent postpaid to any address for only 10c, 3 copies for 25c, p.p.d. 4 Other Books on Magic You Should Have: Hedy's Great Book of Magic..... 25c Magic for the Amateur Magician..... 25c 125 Tricks with Cards..... 25c Conjuror's Tricks and Social Entertainer..... 25c

Wonderful X-Ray Tube

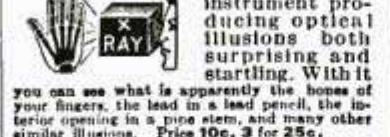

A wonderful little instrument producing optical illusions both surprising and startling. With it you can see what is apparently the bones of your fingers, the lead in a lead pencil, the interior opening in a pipe stem, and many other similar illusions. Price 10c, 3 for 25c.

SURPRISE MATCHES

More fun than fighting with your wife. Look just like ordinary matches. As the victim tries to light one he gets quite a surprise. Price 10c per box, 3 boxes for 25c, 12 for 75 cents.



Motto Ring

Lots of harmless fun and amusement wearing a motto ring. Made in platinum finish (to resemble platinum), with wording on an emerald, as illustrated. Only 25c Postpaid.

BLANK CARTRIDGE PISTOL

Protection against Burglars, Tramps, & Dogs. Special Offer: 1 Blank Cartridge Pistol, 100 Blank Cartridges, 1 500-page Novelty Catalog ONLY \$1.50. The Lot Shipped by Express Only. Cash With Order Only.



Well made and effective, modeled on latest type of Revolver; appearance alone is enough to scare a burglar. When loaded it may be as effective as a real revolver without danger to life. It takes standard .22 Cal. Blank Cartridge—obtainable everywhere. Special cash with order offer: 1 Superior quality Blank Cartridge Pistol, 100 Blank Cartridges, and our new 500 page De Luxe Catalog of latest novelties, all for ONLY \$1.50. Shipped by Express only. Cannot go by parcel post. Extra Blank Cartridges 50c per 100. Special Hoister (Cowboy Type) for pistol 50c. No C. O. D. shipments.

LOOK 35c LOOK Wonderful Instrument.



Everybody delighted with it. Odd, Curious and Interesting. Lots of pleasure as well as very useful. It is a double Microscope for examining the wonders of nature. It is also an Opera Glass, a Stereoscope, a Burning Lens, a Reading Glass, a Telescope, a Compass, a pocket Mirror, and a Laryngoscope—for examining eye, ear, nose and throat. It is worth all the cost to locate even one painful cinder in the eye. Folds flat and fits the pocket. Something great—you need one. Don't miss it. Sent by mail. Only 35c or 3 for \$1.00.

THROW YOUR VOICE



Into a trunk, under the bed or anywhere. Lots of fun fooling the teacher, policeman or friends. **THE VENTRILO** a little instrument, fits in the mouth out of sight, used with above for Bird Calls, etc. Anyone can use it.

Never Fails. A 16-page course on ventriloquism, the Ventrilo. ALL FOR 10 CENTS

PISTOL CIGARETTE CASE



It looks like a deadly weapon, but it is merely a novel Cigarette Case. This clever contrivance has proved itself better than the real thing in many an awkward encounter. Great fun "stealing up" your friends. They squirm and protest it might be loaded. Pull the trigger and the slide flies open disclosing the cigarettes. Well made, light and compact. Weight only 2 ounces.

MAGICIAN'S BOX OF TRICKS



Apparatus and Directions for a Number of Mysterious Tricks, Enough for an Entire Evening's Entertainment.... \$1.00. Anyone Can Do Them. It is great fun mystifying your friends. Get this Conjuror's Cabinet, and you will be the cleverest fellow in your district. It contains the apparatus for ten first-class tricks, including THE MAGIC BALL AND VASE TRICK (a wooden ball is placed inside, and upon replacing the lid has disappeared and is found in someone else's pocket); THE HINDOO TRICK CARDS (can be made to change completely no less than five times); DISAPPEARING COIN BOX (a coin, placed in the wooden box, vanishes entirely or changes into a coin of another denomination); THE GLASS GOBLET TRICK (a coin is dropped into a glass of water and when the water is poured out the coin has vanished and is found somewhere else); THE RIBBON FACTORY FROM THE MOUTH TRICK (a seemingly endless supply of colored paper ribbons comes out of your mouth); the DISAPPEARING HANDKERCHIEF (a handkerchief held in the hand mysteriously vanishes); the WIZARD'S RING COIN TRICK; the ENCHANTED BOTTLE (no one but yourself is able to make it lay down); the GREAT HAT AND DICE TRICK (a large die is placed on top of a hat, disappears, and is found underneath yet no one has touched the hat), and last, but not least, the GREAT PHANTOM CARD TRICK, or two from five leaves nothing. Full instructions are sent for performing each trick. In addition to the above, a number of other feats and illusions are fully explained for which you can easily make or procure the necessary apparatus. Price complete \$1.00 postpaid. Postage Stamps accepted. JOHNSON SMITH & CO., Dept. 803, RACINE, WIS.

JOHNSON SMITH & CO.

Dept. 803 RACINE, WIS.

A De Luxe Edition of our new CATALOG mailed on receipt of 25c. Handsome binding. Bigger and better than ever. Only book of its kind in existence. Nearly 600 pages of all the latest tricks in magic, the newest novelties, puzzles, games, sporting goods, rubber stamps, unusual and interesting books, curiosities in seeds and plants, etc., unobtainable elsewhere. Remit by Coin, Money Order, Check or unused U. S., Canadian and Foreign Stamps for all articles listed above.

EASY to make the BAND

WHEN you play a Pan-American you make faster progress—join the band or orchestra almost at once. Beautiful tone, easy blowing, perfect pitch. Prepare yourself for professional engagements—play your way through college. Complete line—factory guaranteed. **Moderately priced. Free Trial; Easy Payments.** Write for literature and details.

PAN-AMERICAN
BAND INSTRUMENT & CASE CO.
703 Pan-American Bldg., Elkhart, Ind.



AGENTS Some Seller at
Looks Like \$5.00 Worth **\$2.00**
Gives You \$1.00 Profit!



This Is What Gets the Coin

You should see our Lucky 11 Package. Our representatives introduce our products with a first sale of beautiful combination sets of Toilet Articles, Soaps, etc. with valuable premium with each sale at half store prices. No fancy talk—they sell on sight. Make twenty to thirty sales a day with \$1.00 profit on each.

Easy to Average \$100 a Week

Could you ask more while introducing line establishing a permanent business for yourself? 200 Quality Products—100% Profit. Write today for illustrated circulars explaining our unique plans. **Act NOW.**

E. M. DAVIS CO., Dept. 5607, CHICAGO

MAKE \$14.00 A DAY

by Taking Only Two Orders

Big Cash Profits Earned Daily selling our fine made-to-measure all-wool suits at \$23.50; \$29.50 and \$36.50 retail, direct to wearer. Biggest values—positively sell on sight. **Biggest Commissions Paid Daily.** Steady repeat business. Ford Sedan to hustlers. We attend to delivery and collections. New style outfit of large cloth samples — 100 styles furnished free.

ALL WOOL SUITS \$23.50

Write at Once.

SPENCER MEAD COMPANY, Dept. U-816 Chicago, Ill.

\$6240 MADE BY CHAI SELLING OUR PENS

No. 10, 3 in 1 fountain pen-pencil with compass.

"I can honestly say that I have earned \$60 weekly for the last two years selling those pens."
—Jos. Chai, Illinois.

SELLS FOR \$1.2

39¢ GUARANTEED TWO YEARS

Writes like \$7 pen.

FREE: Wholesale catalog showing over 500 fast sellers.

SPORS IMPORTING CO.
530 Main St. Lesueur Center, Minn.

CRESCENT \$65.00

buys a genuine 4" Crescent bench jointer, complete with powerful universal motor, ball bearings and guard. Ask for circular giving complete description.

Other Crescent machines that will help turn out your wood work to advantage are band saws, saw tables, self feed rip saw, shapers, jointers, variety wood worker, planers, planer and matcher, disk grinder, cut off table, swing cut off saws, borers, hollow chisel mortisers, tenoners, universal cut-off saw, universal wood workers.

THE CRESCENT MACHINE CO.
93 Columbia St. Leetonia, Ohio

Send for FREE BULLETINS

Need More Money?

FREE PLAN Helps You Start Your Own Business

Do you want to make \$40 to \$100 a month extra money in your spare time, and have your own, fine paying, cash business? Many men are doing it with the **Foley Automatic Saw Filer.** R. M. Bull writes, "I make \$20 or \$30 a week with my Foley..." Gottfried Johnson writes, "... in my spare time I make \$10 to \$20 a week..."



Foley-Filed Saws Bring Customers

Every saw user wants sharp saws, and you can get plenty of business because the Foley files all kinds of saws better and quicker than the most expert hand filer. They cut faster and cleaner and stay sharp longer. **No experience necessary—**machine is easy to operate and automatically evens up large and small teeth as it files. **No eye strain.**



Cash for Your Spare Time

Get started now and make extra money all year 'round. **Free Plan** helps you get started. 94c out of every dollar is PROFIT! James F. Harris filed over 1,400 saws (at from 50c to 75c each) in his spare time. Many others are making good money, too. Send coupon for complete information NOW.

Mail Coupon for FREE PLAN

Foley Manufacturing Co.

203 Foley Bldg., 11 Main St. N.E., Minneapolis, Minn.

Please send me **Free Plan** and tell me how I can make extra money in my spare time in my own cash business.

Name.....

Address.....

Save 1/2 at **FACTORY PRICES** Buy direct! **The New 1930 Waco Red Jacket**

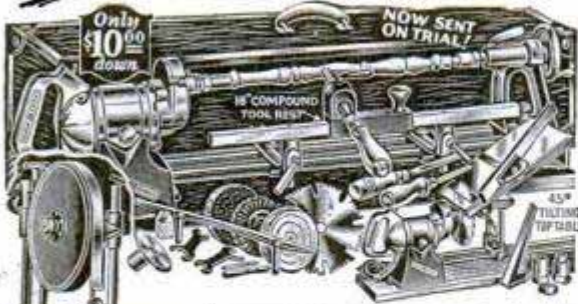

BE A REAL CRAFTSMAN

Enjoy the thrill of your new skill in making things this modern motorized way!

Now, you can do things you long have wanted to—at home in your own modern motorized work shop—with this new, improved Waco Red Jacket Wonder Shop. By buying direct from factory you save one-half or more. Complete shops or separate tools. Easy terms or liberal cash discount.

Free Craft Course
Free Blue Prints

Make It Yourself!



Complete Interchangeable Power Shop - Improved Features - Exclusive Advantages

Power saw and Jacket Master Drill Motor. Wood Turning Lathe (capacity 9"x36"). Compound and 18" Rests, Tilting Top Mitre Saw, Sander, Disc, Scroll and Jig Saw, Band Saw, and all accessories. No installation problems. Small space required.

The Waco Guarantee If it is not what you want when you get it send it back.

TODAY! Send Coupon for Interesting Facts FREE!

WACO TOOL WORKS, Inc.
5216 W. Kinzie St., Dept. 50A, Chicago, Ill.
Manager, Dept. 50A. Please send me all free information and literature on Red Jacket Assemblies and FREE Service.

Name.....
Address.....

Cal. 30-40 Six Shot **Price \$9.75**

KRAG CARBINE
All the qualities of a high price rifle. In fine used condition, all working parts guaranteed for one year. Send today for our Free 60-page illustrated catalog of money saving values; Guns, Ammunition, Cutlery, Sports and Gov't goods. Deposit required on all orders. Money refunded if not satisfactory.
W. Stokes Kirk, Dept. P. M. 7, 1627 N. 10th St., Phila., Pa.

Save Over 1/2 **ON A SPRAYIT** Electric Outfit!



Only **\$14.50**
Regular Price **\$34.50**
The Same Nationally Advertised OUTFIT

110 volt Universal Motor
A fortunate purchase of entire factory surplus of the improved Master Model, electric SPRAYIT Machines enables us to offer them, while they last, at less than half price. Sprays paint, varnish, lacquer, insecticides and other solutions **ELECTRICALLY**. Saves time. Gets in all corners. Equipped with Universal motor. Can operate on A C or D C line. **GUARANTEED** to be same SPRAYIT outfit that has been selling for \$34.50. Brand new machines. Our special price, only \$14.50. Send deposit of \$2.00. Balance C. O. D., plus postage, or remit \$14.50 cash, money order or draft. Order at once.
NATIONAL JOBBING AND EXPORT CO.
192 N. Clark Street Dept. 6 CHICAGO, ILL.

ROYAL'S BUDGET PLAN
Makes Buying Easy

10 MONTHS TO PAY **\$2.00 DOWN...**

Wear this handsome, "Lone Eagle" Bulova Watch! Send only \$2. and watch comes to you postage prepaid—no C.O.D. to pay on arrival.

10 Days Free Trial. Satisfaction Guaranteed
After examination and 10 days free trial pay balance in 10 equal monthly payments. No interest—no extras—no red tape. All transactions strictly confidential. You take no risk—satisfaction absolutely guaranteed or money back.

FREE LATEST CATALOGUE TO ADULTS
Write for Catalog of Diamonds and Standard Watches

100 GEMS
100 GEMS
100 GEMS

Est 1895 **ROYAL DIAMOND & WATCH CO.**
ADDRESS DEPT. 11-G 170 BROADWAY, N.Y.

POLISHES WITHOUT POLISH
Entirely New—Not a Dust Cloth

Without cleaner or polish; Ritzy Rag cleans, polishes, shines entire auto—Like new. Ideal for woodwork—glass—silver. Long-lasting—washable. Price \$1 and worth it. At all dealers or postpaid direct.

Exclusive territories available.
RITZY RAG CO., Dept. C
4312 E. 15th St., Kansas City, Mo.

Strange Invention Pays Immense Profits

Sell only device in the world that prevents kinking, snarling, tangling of telephone and electric iron cords. All our agents given new kind of ironing cord that prevents scorching and saves electric bills. It's a gold mine for house-to-house workers. Don't delay. Send now for FREE offer.

NEVERKNOT CO.
Dept. 7-B 4503 Ravenswood, Chicago

Electrify Your Radio for \$6.85 COMPLETE

With Townsend "B" Power Unit. Over 150,000 in use. Hooked up in a few moments. Use same tubes—no changes. Better reception—distance. Send name and address for details, Proof and Free Trial Offer.

TOWNSEND LABORATORIES, 715 TOWNSEND ST., CHICAGO, ILL.

6 Ft. LONG Large 6-foot air bag with inflators, parachute and complete instructions for flying. Send name and we will send 6 of our new reprints of wonderful oil painting pictures to dispose of on special 25c offer. Send \$1.50 you collect and for this service we'll send this wonderful Airship with instructions free.

C. M. Thomas, 337 W. Madison St. 7-K-9, Chicago

BUILD A \$100 COACH MODEL FOR \$4.98

We will supply all the necessary parts, cut to fit and ready to put together for the George Washington coach, a Tally-Ho, or the Deadwood coach (famous Western stage) for \$4.98. Full instructions for assembling are included in each kit. Nothing is simpler than fitting the parts together according to our directions. All models sent C. O. D. plus a few cents postage. U. S. money order or check must accompany all foreign orders.

HISTORICAL COACH MODELS, Inc., Dept. PM-1
2206 FAIRMOUNT AVENUE PHILADELPHIA, PENNA.

AGENTS! SELLS LIKE WILDFIRE



New improved window washer eliminates all muss and fuss wherever there is glass to be cleaned. Approved by Good House-keeping Institute. Restricted territory to producers. Write today

CARTER PRODUCTS CORP.

935 Front Street Cleveland, Ohio

AMERICAN GASOLINE PRESSURE BURNERS



World's most complete line of gasoline burners and heating units. Sizes, 2 inch diameter to 15 inch.

Ideal for countless purposes, industrial and domestic, requiring great volume of heat at low cost. Pressure tanks, fittings, etc. Write for information.

AMERICAN GAS MACHINE CO.

Dept. H ALBERT LEA, MINN.

Send 10c for 1930 catalogue, DeLuxe Edition, containing 202 pages of all the latest tricks and novelties. FREE—Our large die box trick when you have sent in orders amounting to \$25 within one year. **New Bills to Conform with Small Size Currency** With these bills it is easy for a person of limited means to appear prosperous by flashing a roll of them at the proper time. By peeling off a genuine bill or two from the outside of the roll, the effect created will be all that can be desired. Prices, postpaid: 50 bills 20c; 140 for \$50c, or \$3.00 thousand postpaid. **OAKS MAGICAL CO., Dept. 815, Oshkosh, Wis.**



New Food Idea Pays Big Profits!

Men! Women! Investigate the wonderful NEW Brown Bobby GREASELESS Doughnut. Sells like wildfire! You can easily make \$50 week spare time; \$5000 to \$8000 year full time. Investment small. No experience needed. Write today for big special offer. **Food Display Machine Corp., Dept. 37, 500-510 N. Dearborn St., Chicago**

PLASTEX

The PLASTEX INDUSTRIES offers industrious men a business with big future. An opportunity to start a business of your own, manufacturing Art Goods, Novelties, Electric Light Statuettes, Clock Stands, etc., in Plaster and Marblite castings. Cheaply and easily made by mixing plaster with water. Cheapest material everywhere plentiful. Equipment and simple instructions furnished for speed production. Small investment and big returns. Exclusive manufacturing franchise granted if productions meet requirements. Since the crash, low priced goods are needed and this line meets demand. Goods bought and sold in large quantities. Our free book will interest and benefit you. Mailed upon request.

PLASTEX INDUSTRIES, 1085 Washington Av., New York

A PRACTICAL COURSE IN MECHANICAL DRAWING

By WM. F. WILLARD

An ideal book for home study. Each exercise is clinched in the mind of the student by practical application to every day practice. 160 Pages. 157 Drawings. Cloth. Price \$1.00 Postpaid

POPULAR MECHANICS PRESS 200 E. Ontario St. CHICAGO



BANK \$150 to \$300 More Each Month

HB equipment puts you in the money-making class—with practically no investment on your part.

Costs Only \$16 Monthly —30 DAYS' TRIAL



20 Minute Car Washer

Now is the season when power car washing pays biggest profits. HB 20-Minute Car Washer will do more work than others—extra profit easily pays for outfit. Get details now by checking No. 1 in coupon.



8-Hour Charging

With this outfit you charge batteries in one-third the time required by others. Costs less to operate—you make more profit on each battery charged. No special experience required. Will pay for itself on easy monthly payments. Check No. 2 in coupon below.



Get 5 Men's Profits

HB Portable Paint Spray lets you do work of five brush painters. Paint automobiles, houses, barns, garages, furniture, etc., quicker and better. A size for every need; easy payments lets it pay its own way. Check No. 3 in coupon for information.



Profits in Air

If in automotive business there's no easier way to get customers to your door than through dependable air service. HB automatic, upright air service is standard equipment of money-making shops. A size for every need. Trial and easy terms. Check No. 4 for details.

HOBART BROTHERS CO. Box M70 TROY, OHIO

TEAR OFF AND MAIL TODAY

- Send complete information on items checked with 30 days' trial offer, easy payment terms, and information on how HB will increase my earnings.
- 1. () 20 Minute Car Washer
 - 2. () 8-Hour Charging
 - 3. () Portable Paint Spray Business
 - 4. () Better Automatic Air Service

Name.....
Address.....

WE START YOU IN BUSINESS

Eakins Co., 728 High St., Springfield, O.

Mail at once your free catalog about how to make big profits in the Crispette business with little capital.



Name.....
Address.....

\$1000 a Month Profits Possible

Now! Do Your Own Electric Nickel Plating

Introductory Offer

ONLY \$6.50 Plus Postage



For Plating Nickel, Brass, Copper, Silver, Gold, etc.

A REAL MONEY-MAKING OPPORTUNITY

NO EXPERIENCE REQUIRED. Do YOUR OWN Electro Plating in Your Home, Garage, Office, or Place of Business. Electrically Deposit Metal—Nickel, Brass, Copper, Silver, or Gold. You can Successfully do all the plating on your Automobile, Electric Fixtures, Faucets, Spoons, Forks, Chandeliers, Tools, Coffee Urns, Surgical and Dental Instruments, Utensils, large or small, Iron Stoves, Music Instruments; recondition worn plating or plate New Work; do it Instantly without interrupting the Service or without removing the parts to be plated with the

ALADDIN PORTABLE ELECTRO-PLATER

Simple and Economical to operate. Not a toy, but a practical Plating Outfit with which Perfect and Durable Work can be done. Positively Guaranteed to do as we claim. BE YOUR OWN BOSS! Build up a Profitable Aladdin Electro-Plating Business of your Own. This offers wonderful ECONOMY to users and BIG MONEY-MAKING possibilities to AGENTS. Thousands in Service since 1924. Write today for FREE BOOKLET and Testimonials.

P. J. F. BATENBURG CO. Dept. 186 RACINE, WISCONSIN

—AGENTS— WANTED EVERYWHERE



ON TOP OF THE WORLD!

That's how you feel when you Fly a Mead Glider! As you float smoothly over the launching-crew and the flying-wires whisper their song of safety, you are thrilled with a new sensation. Your Rhon Ranger controls so easily that you can talk to your friends on the ground.

And you can BUILD IT YOURSELF for only \$8950

The Rhon Ranger Kit contains every item used on the glider, from the tiniest nail to the last coat of dope; every part is numbered; you can't make a mistake. Send 10c today for illustrated literature describing this

Superb Training Glider!

MEAD GLIDERS

Dept. B 12 S. Market St. Chicago, Ill.

WORLD'S GREATEST SELLERS



Laymon's 5c & 10c Merchandise Counter Display Cards of Medical & Confection Products

Here's the Line that's in widespread demand. Big Repeats. Advertised nationally and by radio.

SALESMEN COLLECT 100% PROFIT DAILY IN ADVANCE 8 years of successful merchandising. No cash needed! Write quick for FREE complete outfit.

World's Largest Producers of 5c Aspirin WORLD'S PRODUCTS CO. 654 Main St. Spencer, Ind.

San Francisco representative made \$90 first 3 days.



Agents: 12 combs, assorted colors on display stand. Wonderful sellers to dealers or direct. Price 25c. Send 10c for sample and wholesale prices. Doz. 95c. Gross \$10.20. COMB MFG. CO., 530 Elm Ave., LeSueur Center, Minn.

AGENTS AND SIGN MEN

Earn up to \$100 Weekly, and over, Putting up OUR GENUINE GOLD LEAF SIGN LETTERS



—on store and office windows, board signs, trucks and glass signs. We also make to order script signs and business emblems singly or by the thousands. A permanent business. No capital or experience required. Big demand in every City. Samples and Literature Free.

CONSOLIDATED SIGN LETTER CO. 71-X W. Van Buren St., Chicago, Illinois

MONEY MAKING SCREENS

All-metal frames. No mortises, no mitres no tacks, nails or screws. 4 corners 50c. Frame strips 10c ft. DIAMOND HARDWARE MFG. CO., 224 4th Ave., Pittsburgh, Pa.



ESTABLISH A FUTURE

and a permanent business of your own

This girl took in \$98.30 the first week and her sales are more now.

WHY can't you do this?

Be independent and let us show you how.

Write today for full details

THE BEISSER KEY MACHINE COMPANY 407 East Fort St., Detroit, Mich.



Ford Owner Stop that ruinous chatter on your car. MAKE THIS TEST—take out your floor boards, pull your emergency brake back and forth. If you notice play at the ball joint, you need Bredar's Ball Shim. Price \$3.50. Ask your Dealer or order direct. Demand Bredar's Shim. NIC BREDAR'S SON MFG. CO., Rock Island, Ill.

Marvelous How Easily and Quickly You Make Things

Four inch Jointer, 20 inch tables. Fence tilts both ways. \$25

Enjoy the thrill of building. Make spare time useful and profitable. Have a real shop. Sturdy, strong, speedy BOICE-CRANE bench machines are what you need. Low as \$10 starts you. Send for FREE 80-page catalog. Complete descriptions of Circular Saws, Band Saws, Lathes, Jointers and Jig Saw. Also big FREE book "How to Make Screens." Get our interesting literature, low prices, and liberal terms.

W. B. & J. E. BOICE Dept. P.M.-7-F, TOLEDO, OHIO

Universal Handisaw Big, Powerful \$30

Saws, rips, dados, mitres, sands, bores, mortises, etc. Wonderful value.

Buy Now Pay Later

**Stop
A.C.
Noise!**

**Improve
Selectivity!**

RADIO reception may be made much more enjoyable by plugging in a Falck Claroceptor between the light socket and your set. By blocking out the line interference noises, this wonderful device also helps selectivity and distance. Tested, proved. Thousands now in successful use all over America. No change required in your set. Only equipment of the kind. Compact size: $3\frac{1}{2}'' \times 5\frac{1}{2}'' \times 2\frac{1}{2}''$. Made by pioneer radio manufacturer. At radio parts dealers, or write us for new free folder.

Falck \$7.50
(With Cord and Plug)
CLAROCEPTOR

Manufactured by ADVANCE ELECTRIC CO.
Dept. P M—1260 W. Second St., Los Angeles, Calif.
JOBBER AND DEALERS, GET OUR PROPOSITION

ELECTRIC OR BATTERY

TRY IT 30 DAYS FREE BEFORE YOU BUY

1 yr. guarantee

9 TUBE

TRIPLE Screen Grid Steel Chassis

\$49⁸⁸

Lighted 1 dial

MIRACO

Big choice of cabinets

Radio's most amazing bargains direct from big, old, reliable maker. Don't buy unless 30 days use proves entire outfit unbeatable at 2 to 3 times the price, for tone, selectivity, distance, volume.

Free Catalog and BIG SPECIAL OFFER

MIDWEST RADIO CORPORATION
10th Successful Year
407-GJ Miraco Bldg., Cincinnati, O.

SOLDERALL
METAL IN PASTE FORM

The only convenient metal solder

Every Electrical Connection needs Solderall for perfect reception

25¢

The SOLDERALL CO., NEWARK, N.J.

FLY THIS COMBAT MONOPLANE!



This realistic copy of a military monoplane is an unusually graceful flyer. Wing-spread 18 in. Weight only 7/8 oz. Will take off by own power and fly over 80 ft. Markings in red and blue. Can be built in 2 hrs. without tools. Construction set includes 6-in. aluminum propeller with shaft, 3/4 in. disc wheels, wood struts, rubber band motor and all other parts, with clear directions. Complete set, packed in un-

breakable container, only \$1.00, postpaid in U. S. and Canada. Order today. Satisfaction or money refunded.

The MIDLAND MODEL WORKS, Chillicothe, Ohio
(We cannot make C.O.D. shipments. No retail catalogue issued.)

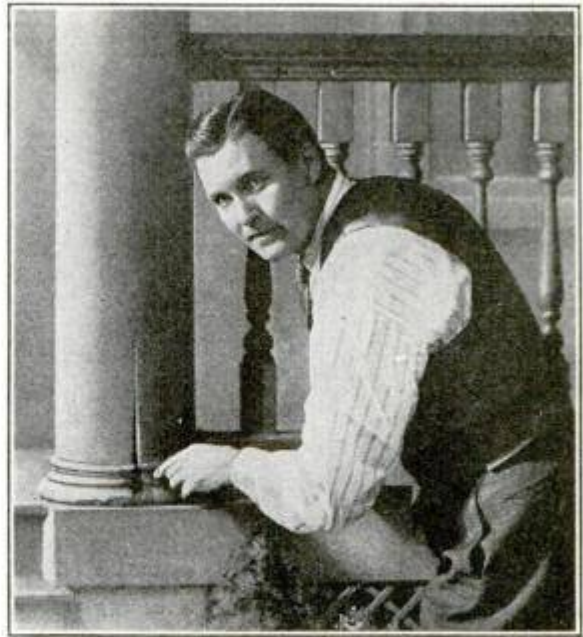

Where's the can of
PLASTIC WOOD?

(Reg. U. S. Pat. Off.)

On porches or other outside woodwork, when rot creeps in or cracks appear, Plastic Wood will save the wood. Scrape away all dirt, rot, and old paint and fill in, or build up, slightly above the surface with Plastic Wood. Then smooth off.

It handles like putty and hardens into wood that is weatherproof and waterproof, will not disintegrate or split, takes paint, varnish or lacquer perfectly, and adheres firmly to wood, metal, or other material.

Plastic Wood Solvent

To soften Plastic Wood, to clean it from the hands or tools, and to prevent it from hardening from too frequent opening of the can, use Plastic Wood Solvent. In 25 and 50 cent cans.

Handles
Like
Putty



Hardens
Into
Wood

Tube 25 cts. 1/4 lb. can 35 cts.
1 lb. can \$1.00

At Hardware and Paint Stores

ADDISON-LESLIE CO., 429 Bolivar St., Canton, Mass.



Read what an enthusiastic user says about Savogran Crack Filler:
 "In wood working, where the slip of a tool may spoil an otherwise perfect job, Savogran Crack Filler restores its original shape.
 "I am enclosing a piece of black walnut (illustrated) that I have turned and

INLAID WITH SAVOGRAN CRACK FILLER
 inlaid with a band of Savogran Crack Filler in natural wood color for contrast.
 "It also repairs wooden patterns damaged from use in the foundry. Its uses are more than I anticipated."
James H. Johnson
 60 McNeir Avenue, Amsterdam, N. Y."

HAVE YOU A WORKSHOP?

IF you like to work with tools, get acquainted with Savogran Crack Filler. It has a thousand uses—building furniture, models, toys, for clever inlay work, building up damaged edges on your work. You'll find it the handiest material you've ever used. It's great for repair jobs, too.

Savogran Crack Filler *will not shrink!* Press it into place, paint it—it defies detection and the job's done for good.

Get a can of Savogran Crack Filler today from your hardware or paint store. Use it just once and you'd just as soon give up your hammer as be without it.

BIG ONE-POUND CAN

30c

35-lb. all-metal pail (for large users) \$7.70, 5-lb. can \$1.25, 1-lb. can 30c. No hardening in the can—the biggest value on the market.

SAVE OLD PAINT BRUSHES

Don't throw them away. Soak them in Painters' Savogran—they'll come out as good as new. Painters' Savogran cleans like magic—removes paint and varnish. Indispensable if you do any painting.

SAVOGRAN COMPANY
 India Wharf, Boston, Mass.



SAVOGRAN CRACK FILLER
 REG. U.S. PAT. OFF.
 PAT. APP. FOR

WILL NOT SHRINK!

8" Band Saw \$13.95 Only
Here It Is. An Ace of An Up-To-Date Band Saw. Just What You Have Been Looking For!
 A Band Saw that is guaranteed to give the same results as the larger and more expensive machines now on the market.
 Has hardened and ground shafts—saw guides made of tool steel— $\frac{1}{4}$ " Atkins Silver Steel Saw Blade—will cut wood up to 2 $\frac{1}{2}$ " thick and light metal. A real machine made to last a life time, and carries a guarantee of satisfaction or money refunded. With Endless "V" Belt and Motor Pulley **\$15.00.**
Up-To-Date Machine Works
 Dept. 60 2909-15 South Wabash Ave.
CHICAGO, ILL.

AGENTS Represent THE Carlton Line
America's Best Paying Proposition!
SELL FROM A MILLION DOLLAR STOCK
 Shirts, Neckwear and Underwear. No Substitutions. 4 Hour Shipping Service. Highest Commissions Bonuses, Profit Sharing. Biggest Company. Mail Coupon.
CARLTON MILLS INC
 79 FIFTH AVE. NEW YORK. Dept. 593-M
 Name _____ Address _____
 Send me your Famous Sample Outfit
MAIL COUPON

DANDY MODEL PARTS
 Flying Cloud Figurehead of white metal, mighty neat, ready to set, for only 40c.
 Flying Cloud. Capstan, polished brass, 1/16" to 1/8" scale, 40c. Mail 10c for booklets "How to Paint Ship Models" and "Revised List of Blueprints Wooden Warships, Merchant Vessels, Fishermen, etc." Latest catalog a dime.
ROY HANCOCK
 323 Douglas Ave. Portsmouth, Va.

Learn to PAINT SIGNS and SHOW CARDS
 We quickly teach you by mail, or at school, in spare time. Big demand. Big future. Interesting work. Oldest, foremost school.
EARN \$50 TO \$200 WEEKLY
 Otto Wiegand, Md., home-study graduate, made \$12,000 from his business in one year. John Vassos, N. Y., gets \$25 for a show card. Crawford, B. C., writes: "Earned \$200 while taking course." Write for complete information.
DETROIT SCHOOL OF LETTERING
 150 Stimson Ave. Est. 1899 DETROIT, MICH.

FREE "Book of Facts" — Write For It

Every Coo-Coo-\$1.75 for You!
 A "knock-out" instant selling hit! The Coo-Coo Auto Horn (Patents pending) sells itself at \$4. Costs you \$2.25. Going like wildfire in Hollywood and Los Angeles. One dealer sold 3,000 in short time. Agents making as high as \$25 an hour. One horn sells 5 others. No house to house selling—just stand around garages and service stations—coo-coo and clean up. Installed by anyone in 3 minutes. Not an exhaust or motor horn. Certain in action—never fails to create a musical note that cleverly sings "Hello."
 Send \$2.25 for sample horn or write for further information.
PACIFIC COAST PRODUCTS CO., LTD. 1616 Cahuenga Blvd., Dept. 60, Hollywood, Cal.

\$25 to \$75 per day!

Big Money—YES. But it's easier than you think. All YOU need to make big money is THE RIGHT PROPOSITION. Thousands have done it, so we know YOU CAN. No scheme—no bunk, this is straight, honest, respectable and dignified business. And it DOES PAY the money we say. No books or schooling needed. About \$100 puts you in a permanent big-profit business of your own. If you have the natural desire to live well, to be your own boss, the ambition to take your place as a business man among the best in your town, then find out about Clarke FlorKraftsmanship. It can be the turning point in your life as it has for thousands of others. They did what we ask you to do—write for full details, and do it NOW. There's no obligation, and you'll be glad you did.

Clarke Sanding Machine Company

Dept. T-37, Muskegon, Michigan

INVENTORS—Read the marvelous history of American Invention, the most impressive record in the annals of human achievement. A very limited edition of Waldemar Kaempfert's Popular History of American Invention in 2 vols. 1034 Pages. Over 500 Illustrations. Cloth. \$5 per set postpaid (just half price of original edition.)

Popular Mechanics Press, 200 E. Ontario St., Chicago

BLUEPRINT READING

For the Building Trades



Every man who is ambitious to learn the last detail of blueprint reading will want this new book which is thorough, complete and up-to-the-minute. Written in a clear, non-technical manner. An ideal working tool for apprentices, teachers, students, carpenters, bricklayers, etc.

Over 100 pages—50 plans and illustrations.

Cloth—Price \$1.25 postpaid

Popular Mechanics Press
Room P 6
200 E. Ontario St. Chicago

A NEW HOUSE WIRING MANUAL

PRACTICAL — PLAINLY WRITTEN

BY J. G. WOLBER AND O. K. ROSE
Cass Technical H. S., Detroit, Mich.

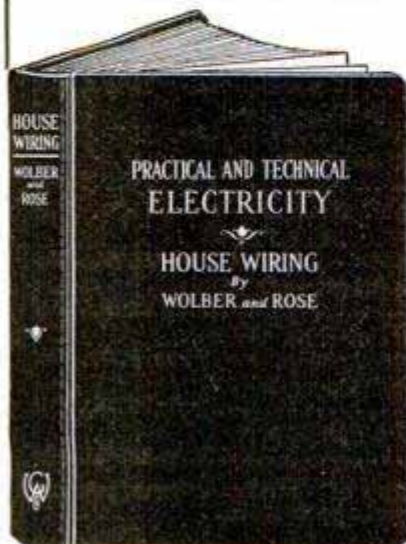

This book is the result of the author's fifteen years of industrial experience and of teaching. The material accumulated during this period of time has been worked over and over until in the author's opinion it was ready for publication.

320 Pages
662 Illustrations
Size 7 1/2 x 5 1/2 inches
Flexible Binding
Price \$2.50 Postpaid
Will be sent C. O. D. anywhere in U. S. or possessions.

POPULAR
MECHANICS
PRESS
Room P 6
200 E. Ontario
St., Chicago

LEARN TO FLY IN A WACO GLIDER

It's a thrilling sport and an easy way to get flight training at small expense

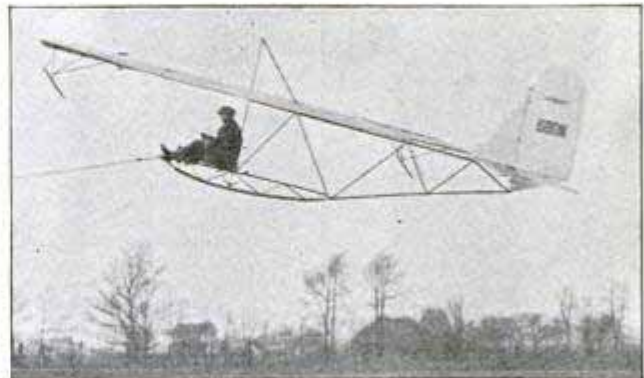

Now, you and your friends can learn to fly . . . easily . . . quickly . . . and at small cost. The WACO Glider is your opportunity. In a few hours' time you can learn to soar around, hundreds of feet in the air. Get into the game! It's great!

The price of the WACO Glider, complete, is only \$385 . . . less than the average fee for primary instruction. A few of you can get together, if you wish, form a Glider Club, share the price of the Glider . . . and the fun is on.

A Glider Built by WACO

The WACO Glider is designed and built by the makers of the largest-selling commercial airplanes in America. The fuselage is welded of aircraft steel tubing, and is braced to withstand the most abusive handling. The wings are constructed of best aircraft stock, according to best aircraft practice. Wing skids with rubber shock cord protect and support the wing tips. The positive foul-proof towing hook is of novel design. In every detail the WACO Glider reflects the practical experience of WACO designers.

Send for Full Details

Send for your copy of the descriptive folder just off the press. Just ask for WACO folder GM . . . today.

THE WACO AIRCRAFT COMPANY

Troy, Ohio



HOT WATER *à* FLASH! Greatest Household Aid Invention in Years!



The LUX ELECTRIC WATER HEATER, with special patented Heating Element. Made of pure aluminum. 8 ft. waterproof electric cord. Either A.C. or D.C. current. Safe—sure.

2-Minute
Demonstration
\$1.25 Profit for
You

A brand new and amazing invention—the LUX ELECTRIC WATER HEATER! Think of this—just plug into nearest light socket—almost instantly you have boiling water for washing dishes, making coffee, boiling eggs, filling water bag, heating baby's milk, shaving, bath or laundry.

Proving one of the greatest sellers of all time. Every housewife delighted—steaming hot water instantly day or night. Necessary as gas or coal.

A Real Sight Seller

Men, women—profits up to \$20—\$30 daily easy introducing this marvel. Lee Prentice, Calif., says, "Never made so much money in all my selling career"! No wonder. Saves hours of time—hundreds of steps. IDEAL SUMMER SELLER.

Free Goods Offer and Special Sales Plan

You'll make a clean up with the LUX. No competition. No experience needed. Write for full details. Don't delay.

A necessity for Doctors, Dentists, Nurses, Beauty Parlors, Barber Shops, Soda Fountains, Travelers and Tourists.

LUX-VISEL CO.

24 MAIN ST.

ELKHART, INDIANA



Learn
to play
the Trumpet
or Trombone

Social opportunities; money-making opportunities; friends; trips; popularity everywhere, these are the kind of "breaks" you get when you can play an instrument. Either trumpet or trombone is ideal for a young man. Buescher has made them easy to master; beautiful to hear.

Take One Home for Six Days

Try any Buescher in your own home for six days free. Test yourself. See how easy. Send coupon for beautiful illustrated folder-catalog of your favorite instrument. Easy terms. Play while you play. Tear out coupon now. Mail right away.

BUESCHER BAND INSTRUMENT CO.

710 Buescher Block Elkhart, Indiana B16

Without obligating me in any way, please send catalog of
[] SAXOPHONES [] TRUMPETS [] TROMBONES

Mention any other _____ My age is _____

Name _____

Street Address _____

Town _____ State _____

AUTOMATIC OIL HEAT At Astounding Low Cost

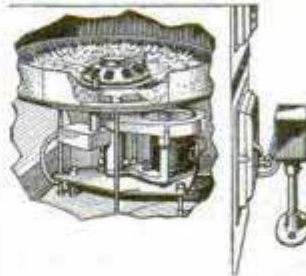

Now you can have the home heating comfort you have long been looking for. Get rid of the drudgery of handling coal and ashes NOW. The Berryman Rotary Oil Burner, the result of 11 years' experience and thousands of successful installations, is a marvel of convenience, comfort, efficiency and economy. Fully Automatic, Silent, Safe. Follow easy instructions to install in any type of furnace. Complete with all automatic controls at a price within reach of everyone. DEALERS WANTED. Write for full information.

Berryman System of Oil Heating, Inc.
1300 W. Washington Blvd. Chicago, Ill.

NOW IS THE TIME TO BUY HEATING-PLUMBING

Our NEW EASY METHOD enables any handy man to install his own heating and plumbing at a big saving. Material is cut to fit and tools are loaned for installing heating plants and plumbing. Our Engineering Department will offer complete specifications free from your sketch. Sketch blank and latest catalog mailed on request. 10 YEAR GUARANTEE.

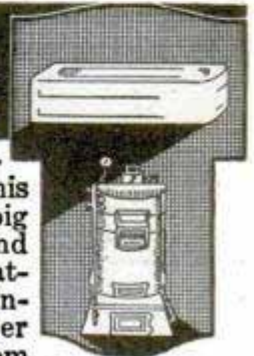

OVER 50 YEARS **HARDIN-LAVIN CO.** EST. 1876
122-32 A, West Pershing Road, Chicago

FOR THE RADIO BUILDER

The blueprints below include the best of Popular Mechanics tested circuits. When ordering, simply quote the numbers of blueprints desired and inclose proper amount addressed to Popular Mechanics Magazine, Radio Dept., 200 E. Ontario St., Chicago, Ill. Magazines containing full descriptions of the circuits can be obtained. Send 25 cents for each magazine desired, giving date of publication.

- No. 134, Edison Type B-Battery July 1928. .25c
- No. 138, Screen-Grid Perfect-Tone Six Receiver Nov. 1928. .25c
- No. 139, Simple Television Receiver . . Dec. 1928. .25c
- No. 140, Power Amplifier and B-Supply for Television Jan. 1929. .25c
- No. 142, Two-Tube Screen-Grid Short-Wave Adapter Mar. 1929. .25c
- No. 143, Four-Tube Screen-Grid Receiver May 1929. .25c
- No. 144, Three-Tube Self-Contained A.C. Receiver Oct. 1929. .25c
- No. 145, One-Tube S-G Set for Beginners Nov. 1929. .25c
- No. 146, Adjustable B-Eliminator . . . Nov. 1929. .25c
- No. 147, A-Eliminator for Set and Dynamic Speaker Dec. 1929. .25c
- No. 148, Adding Audio Stages to S.G. Receiver Dec. 1929. .25c
- No. 149, Plug-In Power Amplifier for use with any Broadcast Receiver. June 1930. .25c
- No. 151, Beginners Low Power S - W Transmitter June 1930. .25c
- No. 152, Portable Radio Amplifier for the Deaf July 1930. .25c

Material Lists for any of the above instruments will be mailed free upon application.

Make Your Own SUMMER FURNITURE

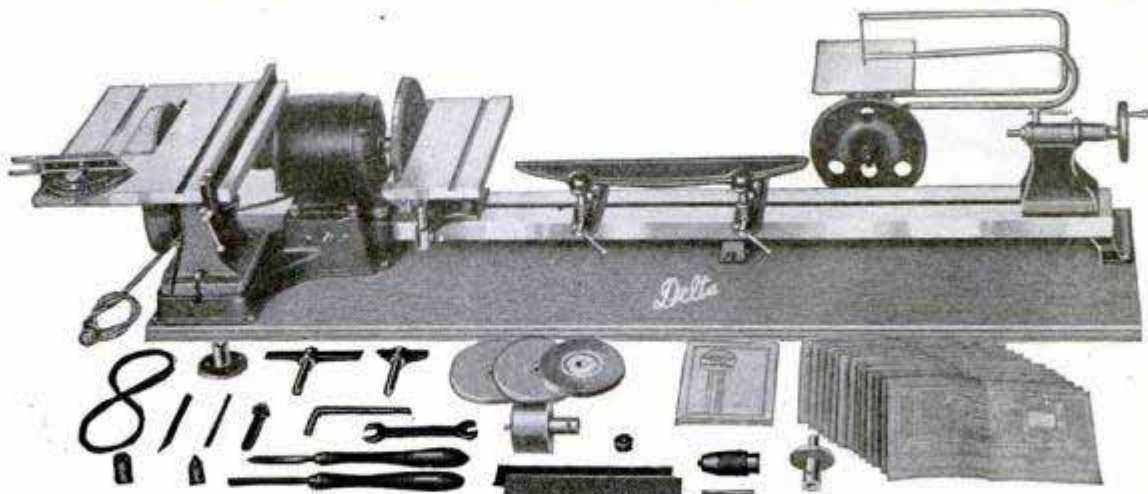

with "Delta" Woodworking Units

Blueprints

\$1 We will be glad to furnish our complete set of 10 Working Blueprints of Summer Furniture upon receipt of \$1.00.

Making things out of wood is so easy and quick with this practical, efficient, "Delta" equipment. Saves time, eliminates hard work, and produces better results. Wonderful fun, splendid relaxation as a hobby. A good money-maker too, either full or spare time. "Delta" machinery quickly pays for itself. Complete "Delta" line includes 4" Jointer, Circular Saws, Wood-Turning Lathes, Jig-Saws, Band Saw, Moulding Cutter, and numerous other items of interest to woodworkers—all at astonishingly moderate prices.

10-DAY TRIAL EASY TERMS



Send coupon for FREE illustrated literature showing new 1930 Delta line. Also full details of EASY PAYMENT PLANS and 10-DAY TRIAL OFFER. Mail coupon to Dept. A.730.

DELTA SPECIALTY COMPANY, Dept. A.730
Division of "Delta Manufacturing Co."
1661-67 Holton St., Milwaukee, Wis.

Please send me FREE illustrated literature describing 1930 model "Delta" Woodworking Units. Also details of 10-Day Trial Offer and Easy Payment Plans.

I enclose \$1.00 for set of 10 Summer Furniture Blue Prints.

Name.....

Address.....

MOVIES In Your Home



Our marvelous, practical Movie Machines sell as low as \$3.75 postpaid, and use same size film as big theatres. We also have wonderful films at lowest prices—with a new film exchange service.

Don't Miss This! Write NOW for Free Catalogue.

PARAMOUNT MANUFACTURING CO.
Dept. G-29, BOSTON, MASS.

SILVER ACE



Mail this
Coupon

AERO MODEL COMPANY

Dept. M27
111 N. Wacker Dr.
CHICAGO

I enclose 5 cents for your new 1930 catalog, describing \$1.50, 1/4 ounce, Flamingo construction set, quality supplies, 24 famous SILVER ACE ships and a History of Flight.

Name.....

Address.....

Outdoor Opportunities

How to raise rabbits, guinea pigs, milch goats, silver foxes, ferrets, white rats, white mice, dogs, cats, pigeons, pheasants, bantams, canaries, bees, frogs, mushrooms, ginseng and golden seal for profit. Practical 250-page book with 120 illustrations. Will be sent C. O. D. When postman hands you the package, pay him \$2 plus the postage.

POPULAR MECHANICS PRESS
Room P 7 200 E. Ontario St. CHICAGO

There's MONEY FOR YOU IN this better ARC WELDING!



Hobart Constant Arc Welder starts you on road to success, with practically no expense, in the biggest money making business of the day. Auto mechanics, garages, in fact, anyone can easily get into this profitable business.

COSTS ONLY \$40 MONTHLY—30 DAYS' TRIAL

Hobart Patented Unitrol Dial Eliminates Guesswork. Lets anyone weld faster, easier, more securely with lower current cost. 30 Days' Trial on money back guarantee lets you prove our claims—tremendous profits you'll make pay for equipment in short time. Write today for details.

HOBART BROTHERS CO. Box M 701 TROY, OHIO





Mechanical Engineering

Learn at Home

MECHANICAL Engineering embraces the design, construction and operation of machines and machine tools. It is a profession which offers almost unlimited opportunities to men who combine natural mechanical ability with technical training.

For this is The Age of Machinery. Almost every convenience, luxury or necessity which we enjoy depends on machinery for its production or adaptability to our needs. Every new invention multiplies the opportunities for competent designers, builders, erecting engineers, etc.

One of the best ways to train yourself to secure a position as a Mechanical Engineer is through the home-study courses of the International Correspondence Schools.

These courses are complete and up-to-date, and especially arranged to meet the needs of the student who studies at home.

They are particularly helpful because they are written by well-known mechanical engineers with years of practical experience, who know the quickest, best way to solve every problem.

Just mark and mail the coupon and we'll gladly send you Free Booklets describing the I. C. S. courses in Mechanical Engineering or any other course in which you are interested.

INTERNATIONAL CORRESPONDENCE SCHOOLS

Box 5689-F Scranton, Penna.

Without cost or obligation, please send me a copy of your booklet, "Who Wins and Why," and full particulars about the course before which I have marked X in the list below:

- | | |
|--|---|
| <input type="checkbox"/> Mechanical Engineering | <input type="checkbox"/> Toolmaking |
| <input type="checkbox"/> Mechanical Course | <input type="checkbox"/> Blacksmithing and Forging |
| <input type="checkbox"/> Drafting | <input type="checkbox"/> Patternmaking |
| <input type="checkbox"/> Mechanical Drawing | <input type="checkbox"/> Foundrywork |
| <input type="checkbox"/> Complete Shop Practice | <input type="checkbox"/> Machine Shop Practice |
| <input type="checkbox"/> Architect | <input type="checkbox"/> Plumber and Steam Fitter |
| <input type="checkbox"/> Architectural Draftsman | <input type="checkbox"/> Plumbing Inspector |
| <input type="checkbox"/> Building Foreman | <input type="checkbox"/> Foreman Plumber |
| <input type="checkbox"/> Concrete Builder | <input type="checkbox"/> Heating and Ventilation |
| <input type="checkbox"/> Contractor and Builder | <input type="checkbox"/> Sheet-Metal Worker |
| <input type="checkbox"/> Structural Draftsman | <input type="checkbox"/> Steam Engineer |
| <input type="checkbox"/> Structural Engineer | <input type="checkbox"/> Marine Engineer |
| <input type="checkbox"/> Electrical Engineer | <input type="checkbox"/> Refrigeration Engineer |
| <input type="checkbox"/> Electrical Contractor | <input type="checkbox"/> R. R. Positions |
| <input type="checkbox"/> Electric Wiring | <input type="checkbox"/> Highway Engineer |
| <input type="checkbox"/> Electric Lighting | <input type="checkbox"/> Chemistry <input type="checkbox"/> Pharmacy |
| <input type="checkbox"/> Electric Car Running | <input type="checkbox"/> Mining Engineer |
| <input type="checkbox"/> Telegraph Engineer | <input type="checkbox"/> Navigation <input type="checkbox"/> Assayer |
| <input type="checkbox"/> Telephone Work | <input type="checkbox"/> Iron and Steel Worker |
| <input type="checkbox"/> Civil Engineer | <input type="checkbox"/> Textile Overseer or Supt. |
| <input type="checkbox"/> Surveying and Mapping | <input type="checkbox"/> Cotton Manufacturing |
| <input type="checkbox"/> Bridge Engineer | <input type="checkbox"/> Woolen Manufacturing |
| <input type="checkbox"/> Gas Engine Operating | <input type="checkbox"/> Agriculture <input type="checkbox"/> Fruit Growing |
| <input type="checkbox"/> Automobile Work | <input type="checkbox"/> Poultry Farming |
| <input type="checkbox"/> Aviation Engines | <input type="checkbox"/> Mathematics <input type="checkbox"/> Radio |

BUSINESS TRAINING COURSES

- | | |
|--|---|
| <input type="checkbox"/> Business Management | <input type="checkbox"/> Business Correspondence |
| <input type="checkbox"/> Industrial Management | <input type="checkbox"/> Show Card and Sign Lettering |
| <input type="checkbox"/> Personnel Management | <input type="checkbox"/> Stenography and Typing |
| <input type="checkbox"/> Traffic Management | <input type="checkbox"/> English |
| <input type="checkbox"/> Accounting and C. P. A. Coaching | <input type="checkbox"/> Civil Service |
| <input type="checkbox"/> Cost Accounting | <input type="checkbox"/> Railway Mail Clerk |
| <input type="checkbox"/> Bookkeeping | <input type="checkbox"/> Mail Carrier |
| <input type="checkbox"/> Spanish <input type="checkbox"/> French | <input type="checkbox"/> Grade School Subjects |
| <input type="checkbox"/> Salesmanship | <input type="checkbox"/> High School Subjects |
| <input type="checkbox"/> Advertising | <input type="checkbox"/> Cartooning |
| | <input type="checkbox"/> Illustrating |

Name.....
 Address.....
 City..... State.....
 Occupation.....

If you reside in Canada, send this coupon to the International Correspondence Schools Canadian, Limited, Montreal, Canada

Buy Direct on Credit

The World Famous
21 Jewel Thin Model

Santa Fe "Special"



Our "Direct to You" offer and Extra Special Distribution Plan is fully explained in the New Santa Fe Special Booklet just off the press. The "Santa Fe Special" Plan means a big saving of money to you and you get the best watch value on the market today. Watch sent for you to see without one penny down.

FREE

Write now for our New Watch Book—just off the press. All the newest watch case designs in white or green gold, fancy shapes and thin models are shown. Read our easy payment offer. Wear the watch 30 days FREE. All watches sent on approval and sold on payments. ONE MINUTE—it will only take "one minute" of your time to send for new watch book. DO SO NOW.

Santa Fe Watch Company

Dept. 76 Thomas Bldg. Topeka, Kansas



Punch Holes for Screws

AWLETT

FITS YOUR SCREWDRIVER

Makes your screwdriver the handiest tool in the house. Punches holes for many purposes. Made of high-tempered Chromium plated Spring Steel. Slides back on

send 25¢ for 2
 (Dealer: A big seller on individual cards)
 A. L. Kuhlman Industries
 106 Morgan Bldg. Detroit, Mich.

Ogness Earned \$97.50



... IN SIX DAYS

I'll give you the same chance. Show my samples of super-value tailored-to-measure all-wool suits at \$23.50. Cash commissions in advance and liberal bonus. Astounding values, guaranteed fit. No experience needed. FREE outfit, over 100 all-wool fabrics. Write.

W. Z. GIBSON, Inc., Dept. U-518, 500 Throop St., Chicago, Ill.



You Can Make It

24 PLANS 25¢

Only 25c brings you this portfolio of valuable plans. 24 separate sheets, with complete particulars covering each operation. Collection includes Grandfather's Clock, Ship Model, Book Case, Table and many other useful and practical furniture objects, novelties and toys.

Join the thousands of men who find joy and pleasure in making their own furniture. Experience the thrill of building something that will last a lifetime. Don't miss this opportunity to get these valuable plans. Easily worth \$2.50—but while this special offer lasts—only 25c. Send now.

Midland Appliance Corporation
 225 N. Michigan Ave.,
 Dept. 1910 Chicago, Ill.

FREE Send for literature describing Mac—The Popular Mechanic Workshop—electrically operated, and details of our Free Trial offer. Enables you to do all wood-working operations in one-tenth the time. WRITE TODAY

Auto Owners Now Save Millions of Gallons of Gas

A new invention called the Whirlwind is actually saving millions of gallons of gasoline for automobile owners. Those who have installed this amazing device on their cars report almost unbelievable gasoline savings. They also report more speed and power, quicker starting and reduction of carbon.

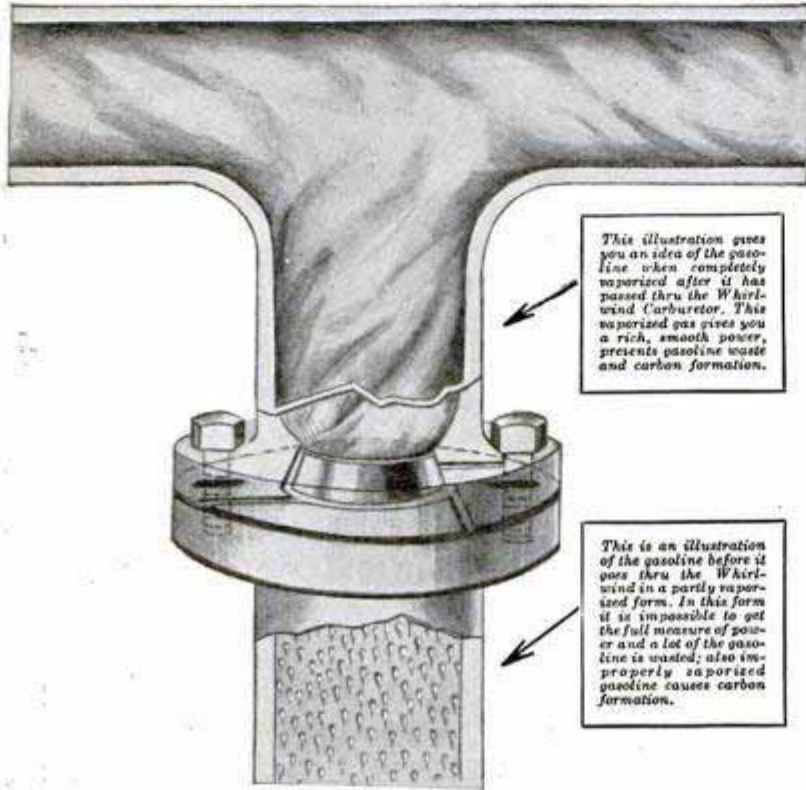

This illustration gives you an idea of the gasoline when completely vaporized after it has passed thru the Whirlwind Carburetor. This vaporized gas gives you a rich, smooth power, prevents gasoline waste and carbon formation.

This is an illustration of the gasoline before it goes thru the Whirlwind in a partly vaporized form. In this form it is impossible to get the full measure of power and a lot of the gasoline is wasted; also improperly vaporized gasoline causes carbon formation.

The marvelous thing about this Whirlwind is that it works as well on all makes of cars. Reports are received from owners of practically every known make of automobile from Fords to Lincolns and they are all equally enthusiastic in their praise.

FITS ALL CARS

In just a few minutes the Whirlwind can be installed on any make of car, truck or tractor. It's actually less work than changing your oil or putting water in the battery. No drilling, tapping or changes of any kind necessary. It is guaranteed to work perfectly on any make of car, truck or tractor, large or small, new model or old model. The more you drive the more you will save.

SALESMEN AND DISTRIBUTORS WANTED TO MAKE UP TO \$100.00 PER WEEK

Whirlwind men are making big profits supplying this fast selling device that car owners cannot afford to be without.

Good territory still open. Sample offer and full particulars sent on request. Just check the coupon.

GUARANTEE

No matter what kind of a car you have—no matter how big a gas eater it is—the Whirlwind will save you money. We absolutely guarantee that the Whirlwind will more than save its cost in gasoline alone within 30 days, or the trial will cost you nothing. We invite you to test it at our risk and expense. You are to be the sole judge.

WHIRLWIND MFG. CO.
 DEPT. 999-305-A THIRD ST.
MILWAUKEE, WISCONSIN

Free Trial Coupon

**Whirlwind Mfg. Co.,
 999-305-A Third St., Milwaukee, Wis.**

Gentlemen: You may send me full particulars of your Whirlwind Carbureting device and tell me how I can get one free. This does not obligate me in any way whatever.

NAME.....

ADDRESS.....

CITY.....

COUNTY..... STATE.....

Check here if you are interested in full or part time salesman position.

**NOW YOU CAN AFFORD
TO BUILD THAT**

HEATH

Get Started with only \$12.00

PARASOL

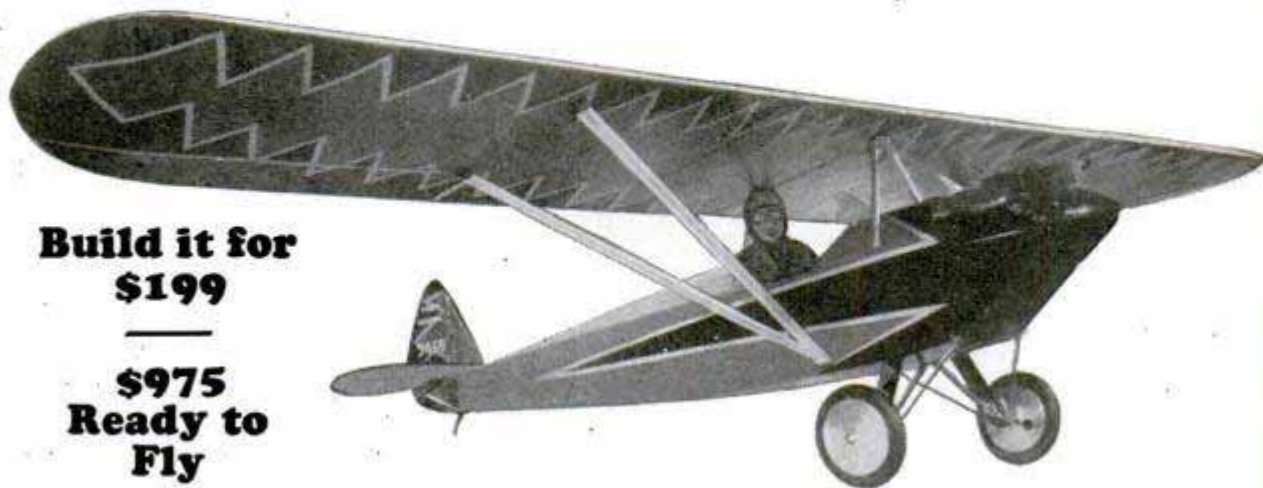

**Build it for
\$199**

**\$975
Ready to
Fly**

America's Most Popular Sport Plane

For those who cannot afford to invest the entire \$199 we have arranged the shipment of the bill of material for our HEATH PARASOL in 11 convenient progressive groups.

By purchasing in these groups you may build your HEATH PARASOL with limited capital and without delay yet enjoying the discount made possible in our complete bill of material. Thus you may purchase \$220 worth of aircraft materials on the installment basis and with a discount that makes it only \$199.00.

If there is a small lake or river near by remember you may build the Sea Plane Parasol on the same installment basis.

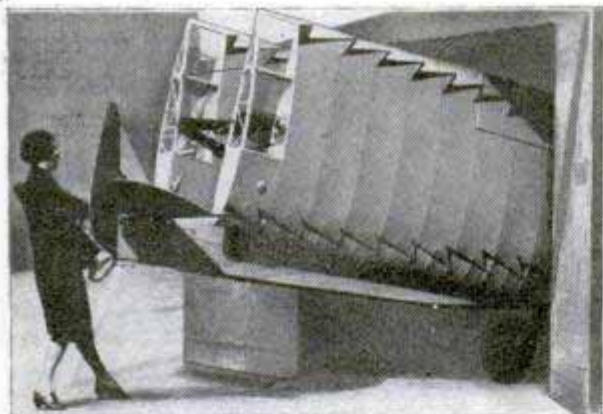

**Buy—Build—BUT FLY A
HEATH PARASOL and be sure to
use that wonderful little HEATH-HENDERSON Aircraft mo-**

**tor to insure the success of
your plane. Detailed shop
prints \$5.00. 10c in**

**stamps or coin brings
our large illus-
trated book-
let.**

**HEATH
AIRCRAFT
CORP.,
1721-29 Sedgwick
St., Dept. P-7,
Chicago, Ill.**

Gentlemen: Enclosed find dime or stamps for which send me your large illustrated booklet on the Heath Parasol.

Name.....
Address.....
City..... State.....

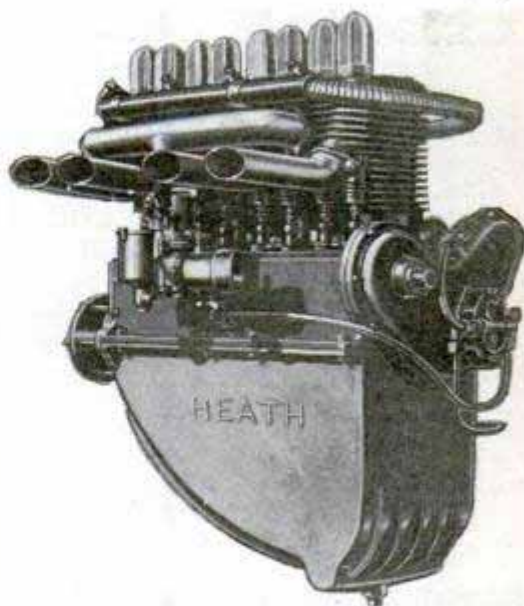

HEATH AIRCRAFT CORP.

1721-29 Sedgwick St., Dept. P-7, CHICAGO, ILL.

Clever New Invention.. Closes Any Door Without a **SLAM!**

Saves Glass, Saves Nerves, Saves Door, Saves Fuel

HERE'S A GREAT NEW SUMMER SELLER!

Now two of the worst nuisances in every home, store, office and factory can be banished—Slamming Doors and Doors Left Ajar. Close-A-Door, a clever new device, closes any door swiftly, securely, silently. Read how it saves money, fuel, nerves. Then mail the coupon for agents' introductory offer at once.

**Costs Less Than Other Kinds
of Door Checks**

Every home, office, store and factory can afford to equip every door with this astonishing new invention because it costs two-thirds less. Slamming, banging doors wreck nerves, ruin doors, smash glass. Doors left ajar cause drafts and colds, waste heat and coal and invite intruders. Green doors equipped with Close-A-Door close securely and silently—and you never see bulging or broken screens.

ITS ANY DOOR IN 3 MINUTES

Any boy who can use an ordinary screw driver can attach Close-A-Door in a jiffy. It operates automatically and never needs attention. Built of materials that last for years and years. Designed on a peculiar patented engineering principle that insures perfect operation at all times. It is neat, compact and takes up very little space on any door.

**PROTECT YOUR FAMILY
AGAINST INTRUDERS**

Every outside door should be protected with a Close-A-Door to keep the doors always closed securely against sneak thieves and intruders. Every office and factory door should be silenced with Close-A-Door to increase efficiency and save time. Don't confuse Close-A-Door with expensive g, cumbersome devices. It is NEW! BETTER! CHEAPER!

Test Offer to Agents

A liberal test offer on Close-A-Door is now being made to agents and to those who would like to make extra money in spare-time. This is a real opportunity in a field that has scarcely been touched. Get the new Close-A-Door plan and the unique and amazing demonstration outfit. Simply mail the coupon for full details and get set for the profit surprise of your life. Act right now.

CLOSE-A-DOOR
Closes Any Door Without a SLAM

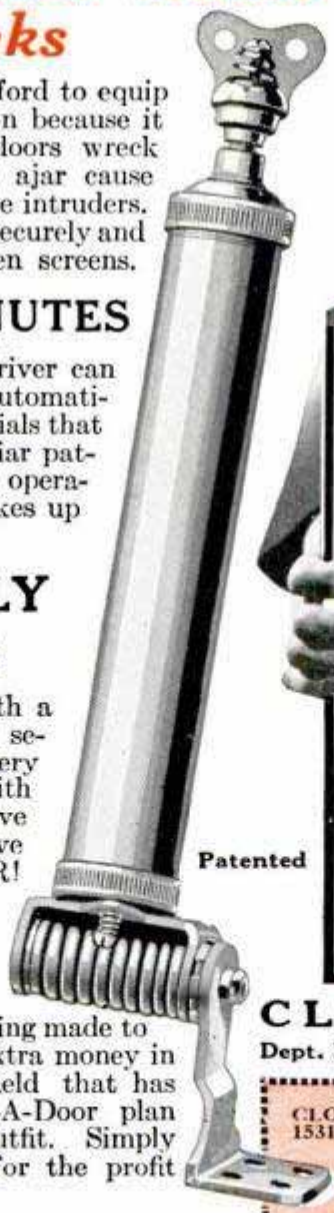

Patented

**Big Money for Agents
Full-Time or Spare-Time**

Close-A-Door has been such an amazing sales sensation that we have decided to open hundreds of new territories. Now we want live wire full-time or part-time men to demonstrate Close-A-Door to homes, offices, stores and factories and take orders. We supply miniature door equipped with Close-A-Door that makes fascinating demonstration. Just walk into every home and building and you have a chance to come out with one to a dozen profits. Thousands of doors in your territory need Close-A-Door. Sales are easy the minute people see how cleverly it works. You make money right from the start, and an opportunity is offered to build a permanent lucrative business of your own. Mail the coupon for new sales plan and demonstrator offer.

CLOSE-A-DOOR CO.
Dept. H-10, 1531 Washington Ave., St. Louis, Mo.

CLOSE-A-DOOR CO., Dept. H-10
1531 Washington Ave., St. Louis, Mo.

Send me full description of your clever new invention, Close-A-Door, and facts about big money for agents.

Name

Address

City State

The cigarette that
puts a spark of
pleasure in every
passing moment.



Camel

