

POPULAR MECHANICS

MA
NE

WRITT
ND IT

REG'D. TRADE MARK, GREAT BRITAIN, NO. 410429

REG. U.S. PAT. OFF.



SEE PAGE
386



BRAND NEW

CORONA GENUINE Model #3

Lowest Price — Easiest Terms Ever Offered



HERE'S your chance to own that *brand new* Genuine Model 3 Corona you've wanted — on the easiest terms ever offered — at **LOWEST PRICE** ever offered. Complete in every detail; back spacer, etc., *Manufacturer's Guarantee*. Recognized the world over as the finest, strongest, sturdiest portable built.

Yours for 10 DAYS FREE

Only a limited number of these splendid machines available. To get one, you must act now! Experience the joy this personal writing portable typewriter can give you! Use it ten days free! See how easy it is to run and the splendidly typed letters it turns out. Ideal for the office desk, home, traveling. Small, compact, light, convenient. Don't

send out letters, manuscripts, reports, bills in poor handwriting when you can have this Corona at such a low price on such easy terms. Remember these are *brand new* machines right out of the Corona factory.

Carrying Case FREE
If You Act Now!

Leatheroid carrying case, oiler, instructions free on this offer. Send no money — just the

coupon. Without delay or red tape we will send you the Corona. Try it 10 days. If you decide to keep it, send us only \$2 — then \$3 a month until our special price of \$39.90 is paid. Now is the time to buy. This offer may never be repeated.

Save Money — Use this Coupon

Smith Typewriter Sales Corp., (Corona Division)
469 E. Ohio St., Chicago, Ill. Dept. 33

Ship me the Corona, F.O.B. Chicago. On arrival I'll deposit \$2 with express agent. If I keep the machine, I'll send you \$3 a month until the \$37.90 balance of \$39.90 price is paid; the title to remain with you until then. I am to have 10 days to try the typewriter. If I decide not to keep it, I will repack and return to express agent, who will return my \$2. You are to give your standard guarantee.

Name _____

Address _____

Employed by _____

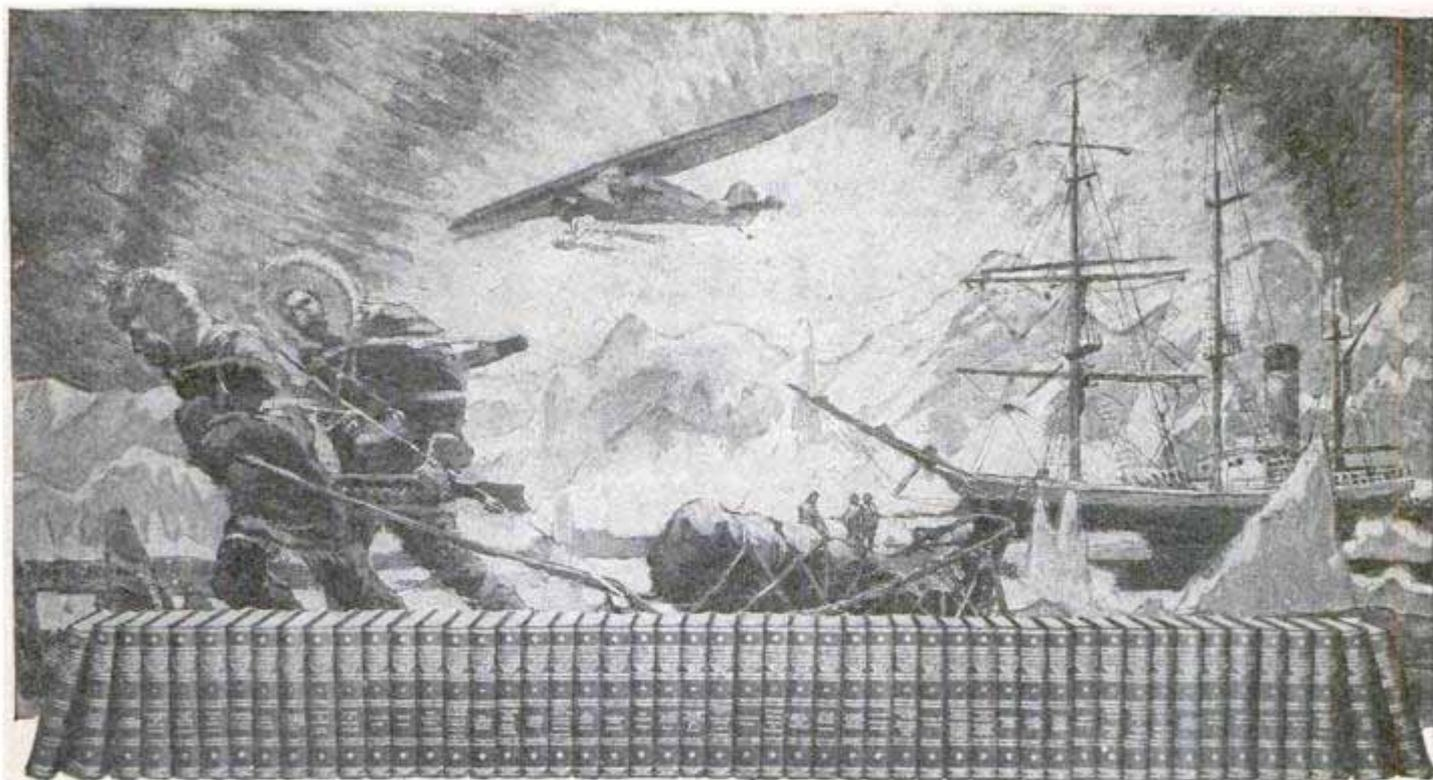

The Byrd Expedition chooses these books

P. F. COLLIER & SON COMPANY

New York.

Gentlemen:

In fitting out the Byrd Antarctic Expedition for a two-year scientific research of the Antarctic, members of the expedition have suggested that we include in our library Dr. Eliot's Five-Foot Shelf of Books.

Books will play an important part in the contentment of the personnel, particularly when the expedition winters on the ice barrier through the six months of total darkness during the Antarctic Night.

We should like to carry into the Antarctic, along with your good wishes for the success of the expedition, a set of the Harvard Classics.

You can appreciate too, aside from the indorsement value of our including the Harvard Classics in a library necessarily restricted in size, that the sixty men who will accompany Commander Byrd on this expedition will while away many hours of enjoyment and profit immensely by the fund of information contained in your volumes.

Trusting that we may have your cooperation,

Yours very truly,

BYRD ANTARCTIC EXPEDITION

Business Manager.

This letter was written to P. F. Collier and Son Company by the Manager of the Byrd Expedition, asking that the Harvard Classics be added to their very limited library. The Publishers were pleased to serve Commander Byrd and his men.

The selection of Dr. Eliot's Five-Foot Shelf of Books is typical of the vision with which the whole voyage has been planned. Men of the highest type need the best possible reading recreation, and the Harvard Classics have brought inspiration and pleasure to hundreds of thousands.

Men in the ice floes of the Antarctic need be no more remote than the people in our civilized urban world, so far as their reading is concerned. Although the explorer is limited to the few books he can take with him, we of the busy world may be so hopelessly lost in the millions of books around us that we miss the truly great ones.

The explorer must choose. And the Byrd Expedition has chosen the Harvard Classics.

Because Dr. Eliot, forty years President of Harvard University, recognized the need for easy access to the best books, he assembled in one convenient set the works which have everlasting

value, the books that stimulate, inspire, and advise. In these volumes are included the writings of 302 immortal authors.

Through Dr. Eliot's Five-Foot Shelf people have found that the classics are not dull, but intensely stirring; not beautiful antiques, but lively, stimulating, modern thought with vital application to everyday life.

P. F. Collier and Son Company has published good books since 1875. By the famous Collier plan, you can pay for these books while you read and enjoy them.

THIS FREE BOOKLET

Before you spend another penny for books, get a copy of "Fifteen Minutes a Day"—the booklet that tells how to turn precious spare time into profitable entertainment, growth, and increased power. It's ready and waiting for you. Sending for it does not obligate you in any way.

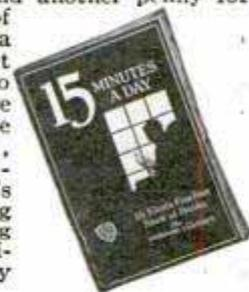

**DR. ELIOT'S
FIVE-FOOT SHELF
OF BOOKS**
(The Harvard Classics)



This One



GAJZ-7FZ-N5JR

visit now I may secure the books by small monthly payments.

Name { Mr.
Mrs.
Miss

Address.....

8049-HCM

The Encyclopaedia for a Lifetime

NELSON'S PERPETUAL LOOSE-LEAF ENCYCLOPAEDIA

Never Grows Old!

And Here's the Reason Why

Nelson's 22 years ago recognized that an Encyclopaedia bound, stitched, and glued in the ordinary way is inevitably out of date soon after it is published—because of the constant development of NEW KNOWLEDGE and the rapid changes going on every day. So Nelson's originated the loose-leaf reference system that keeps the Encyclopaedia always up to date. Each volume of Nelson's is bound with a patent loose-leaf device which makes it very simple and easy to "unlock" the binding, take out old pages and put in new ones. Every six months replacement pages are sent to subscribers, containing revisions that cover all recent developments in every branch of knowledge. By the easy Nelson device you substitute the new pages for the old ones—and you have an Encyclopaedia that is new, reliable, and dependable.

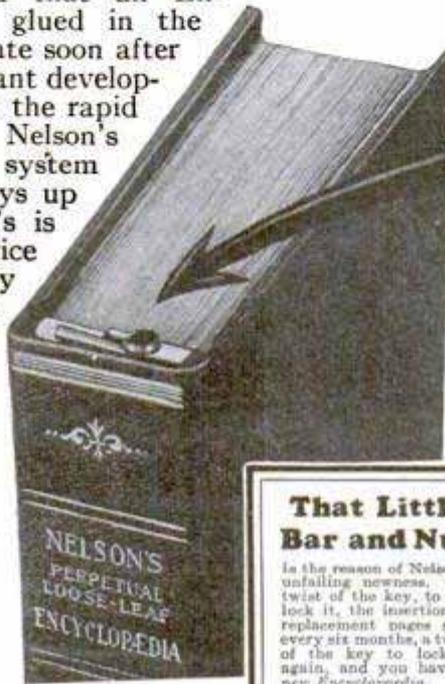

That Little Bar and Nut

is the reason of Nelson's unfailing newness. A twist of the key, to unlock it, the insertion of replacement pages sent every six months, a twist of the key to lock it again, and you have a new Encyclopaedia.

Purchasers of NELSON'S do not worry about new editions offered after they have bought an Encyclopaedia. No matter when you buy NELSON'S it is up to date and you know it will stay up to date. NELSON'S replacement pages are a guarantee to you that you will have a new Encyclopaedia every six months—that it will be always ready to meet every need for the very latest information.

The Great AMERICAN Encyclopaedia

Edited by Americans, for Americans; and covering the whole world of information for ready use by American men, women, and students. It is used in the Library of Congress, United States Senate, U. S. Supreme Court, and in Libraries, Universities, and Schools in every State of the Union.

"I cannot praise Nelson's too highly. It is truly the perfect reference system," writes F. W. Leite, President, Cornell University.

Experts from All Over World Keep NELSON'S Always Up to Date

The greatest scientists, educators, experts, and writers in all parts of the world, are constantly engaged in supplying the information to keep this great Encyclopaedia up to date. Librarians, Government Officials, College Presidents, and Specialists in every field contribute to the work of keeping Nelson's always abreast of the times.

FREE Question and Answer Service Through Nelson's Research Bureau

When you are in need of an answer to any question, old or new, you can write to this Bureau with the assurance that you will be sent without charge the latest obtainable and most dependable information.

33 Educational Reading Courses Without Extra Charge

A Reader's Guide to Nelson's Loose-Leaf Encyclopaedia is given without extra charge to every subscriber. In this Reader's Guide the vast fund of information contained in Nelson's is organized for specialized reading. It outlines thirty-three courses of reading and study on as many subjects.

Mail This Coupon for Free Booklet

THOMAS NELSON & SONS, 381 Fourth Ave., N. Y.
(Originators of the Loose-Leaf Reference System)

Publishers for 130 Years
Please mail me your illustrated portfolio of sample pages and full information about the FREE New bookcase, and how by the budget easy payment plan I can own Nelson's Perpetual Loose-Leaf Encyclopaedia, with Free Membership in Nelson's Research Library Service Bureau for Special Information, and Nelson's Reader's Guide Free.
(Pop. Mech. 3-30)

Name.....

Address.....

City.....State.....

FREE This Handsome BOOKCASE

You will be delighted with this handsome bookcase. It is richly designed and dust-proof with a leaded-glass single door—an unusually handsome piece of furniture. We are offering it now, at no additional cost, to readers of Popular Mechanics.

Send for Free Illustrated Booklet

We will be glad to send, to adults, an interesting, illustrated, loose-leaf booklet of sample pages and full information. It tells the whole story of Nelson's Loose-Leaf Encyclopaedia; gives you information about our FREE BOOKCASE offer; describes the free question and answer service of Nelson's Research Bureau and the thirty-three reading courses. The coupon to the left will bring your copy without cost or obligation.

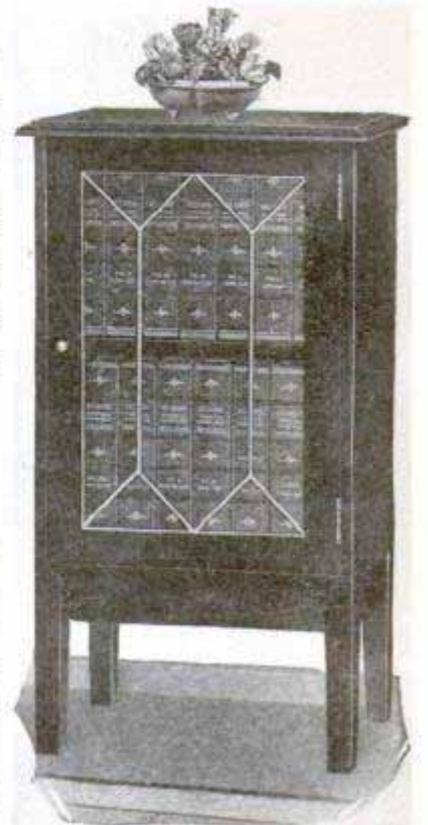

Popular Mechanics Magazine

200 E. Ontario Street, Chicago, U. S. A.

H. H. WINDSOR, Founder

H. H. WINDSOR, Jr., Editor and Publisher

London: Hachette & Cie.,
16-17 King William Street, Charing Cross, W. C. 2

Paris: Hachette & Cie.,
111 Rue Reaumur

Melbourne: Gordon & Gotch
509-513 Little Collins St.

ISSUED MONTHLY

SUBSCRIPTION:

SINGLE COPY, 25 CENTS

In United States and its possessions, Canada, Cuba, Mexico, and all countries in the Pan-American Postal Union, per year, postpaid) \$2.50

To all other countries in the Postal Union 3.00

All subscriptions are discontinued at expiration. Please examine the date printed on your wrapper.

Entered as Second Class Matter Sept. 16, 1903, at the Post Office at Chicago, Illinois, under Act of March 3rd, 1879.

Entered as Second Class Matter at the Post Office Department, Canada.

Published monthly by POPULAR MECHANICS CO.

Copyright, 1930, by Popular Mechanics Co.

Copyright in Australia. Copyright in France

Vol. 53

Contents for March, 1930

Heel hard centerals
42 7 No. 3

Special Features

Floating Oil Tanks	370
In the Land of the Devil Dancers	378
Thrills in Search for Sun's Secrets	391
England's Entry in Ocean Race	395
Man-Made Mystery Metals	402
Gold from Butterflies	410
The Strange Adventures of Spies	442
Big Shovels and Why	466
Air Mail—shrinks size of U. S. by more than one-half	423
Airplanes	
model, compressed-air motors drive	408
tilted on end to save hangar space	377
Airships—anchors for are one-ton rollers	465
Amusement Devices—"swooper" gives thrills of air-plane ride	400
Automobile Accidents—eye, tardiness of, blamed for	457
Automobile—Driving—testing skill by revolving map	454
Automobile—supercharger, water-cooled, for front-wheel drive	455
Automobiles	
abandoned fill in bay to make an airport	441
fog in front of, lifted by exhaust air	460
Automobiles—Accessories	
clock in rear-view mirror	385
frost shield for car window	430
glareless floodlight helps on turns	425
portable compressor operated by engine	465
rubber carpet with hair nap	431
thermostat is easy to fit on any auto	433
Automobiles—Lighting—portable tester adjusts lamps	449
Automobiles—Tires	
air-pressure dot on rim shows inflation	450
locking valve keeps pressure constant	416
Automobiles—Truck—store on wheels expands when parked	461
Automobiles—Wheels—axles bent into shape by strength of hand	471
Aviation	
aerial survey of the Hudson straits	418
deer hunted from airplanes	449
flying boats cut the time to South America	414
flying fashions combine utility with beauty	426
flying in Eskimo land	418
Bench—made into table by folding back rests	383
Boats and Boating	
boat propelled by pedals	369
suction eliminator increases speed	432
Bread—Slicer—cuts 1,000 loaves an hour	400
Buildings—clubhouse like an elevator	369
Church	
architecture change shows modern trend	427
floating, in Germany travels waterways	440
Compass—course and distance finders	433
Desk Pad—of composition rubber	441
Divers—test suits in tanks under air pressure	417
Fire Blanket—held on frame	441
Gas—burn coal in ground for	471
Gasoline—filter funnel strains out water	393
Gears—made from cornstalks	383
Gems—blue, colored by heating	465
Gliners—college glider club teaches low-cost flying	409
Guns—motorized anti-aircraft for the next war	458
Heating and Ventilating—a cooler for roofs	471
Horses—bucking broncho imitated with saddle and ropes	385
Household Devices	462
House Plan	528
Irrigation—sea water used	377
Lifeboat—for plane rescues	439
Light—speed trap for the earth races light beams	450
Lighting—color organ paints ballroom with magic light	401
Locomotive—has streamline boiler	383
Logs—jam of, for underground	449
Loud Speaker—electric eye works	417
Mammoth—how prehistoric man used the "killer stone"	
Maps—city guides on lamp-posts have steel leaves	471
Metals	
tin gives strength to bronze	425
zinc—base alloys improved	416
Meteors—may menace planes and ships	375
Moving Pictures	
portable movie projector has built-in screen	432
talking movies for home	407
Musical Instrument—guitar, keyboard on neck of	454
Oil	
from nuts used as fuel	432
steam shovels salvage	382

ferret farm 424
Bronze ingots strength 25

417
Canada gold 418
newspaper

[Continued on Page 4]

Lightning hazard

Photograph record
unbreakable 448

Organ color 70
Photo-electric cell 41 77

[4] *Walls fireproof*
straw 40 7

[Contents—Continued]

Photography—photograph on metal plate in broad daylight 433
 Pipe Organ—for the home resembles grand piano 375
 Plants—gigantic elephant's ear leaf 408
 Playground
 above streets for congested areas 447
 on hotel roof for golf and tennis 448
 Post Office—dead letters cost millions annually 408
 Poultry—five-story chicken hostelry 407
 Radio
 helpful hints from the radio laboratory 478
 soldering flux, homemade 484
 ultra-short waves for 407
 Radio—Aerials—furnace pipe acts as 483
 Radio—Batteries—connections simplified for charging 484
 Radio—Construction—kits for set builders 480
 Radio—Ground—wet, new device provides a 483
 Radio—Loudspeaker—horn made from cane fibers 476
 Radio—Loudspeakers—tapestry picture is condenser speaker 483
 Radio—Receivers
 a.c. demonstrating 476
 remote controls for operation 477
 ten-feet-high broadcast speeches 447
 Radio Reception
 fewer sunspots to give better yardstick to assure better 384
 433
 Radio—Transformers—a practical homemade power 472
 Radio—Tubes
 checker, combination a.c.-d.c. tubes 481
 tube-base plug-in coils 476
 type-45 power, using 480
 Railroads
 compressed-air Diesel engine 431
 rail joints kept tight by molten-metal spray 447
 trains with glass which ultraviolet rays penetrate 427
 Rats—ferret farm breeds animals to exterminate 424
 Razor, Safety—blade, machine grinds hollow edge on 455
 Roads—seismograph picks best road 374
 Rope—anchor of fiber stronger than chains 450
 Rubber—replaces metal 369
 Rugs—beauty is woven into rugs from piano-roll patterns 376
 Sawmill—one-man, for farmer 460
 Saws and Sawing—automatic saw-handle lock 415
 Setscrew—tightening 512
 Ships—liner model steams through crowded harbor 393
 Shoes—hard-center rubber heel 427
 Shooting Gallery—sparks in place of bullets 414
 Sled—toy wagon is made into 440
 Sling—carrying and lifting for bulky articles 416
 Sports—Water—scooter propelled by foot-operated oar 457
 Sports—world's greatest arena 451
 Straw—fireproof walls of for building material 407
 Street Lights—service truck has extension platform 384
 Streets—oil removed with steam and brush 447
 Submarine—new safety devices 428
 Swing—whirl-over, for children 415
 Tanks—test divers' suits under air pressure 417
 Theater—has four movable stages 425
 Tide—highest possible is fifty-three feet 427
 Tray—match, ash and glass holder attach to table 416
 Typing Machine—prints whole phrases at a time 464
 Vending Machine—umbrellas of oiled paper sold by 460
 Watch—garden-of-Eden, two hundred years old 457
 Water—electric purifier for 384
 Water Tank—five tanks supported on one tower 430
 Weather
 air is kept warm by arctic ozone 369
 asking questions of the clouds 434
 fans aid in daily observations 416
 Weeds—blue vitriol destroys 441
 Well—fire and water from one pipe 400
 Whistle—operated by a switch 446
 Windows—automatic sash ends need for pulleys 375
 X-Ray—snapshots are taken with powerful tube 375

AMATEUR MECHANICS

Airplanes—scale-model plane is easy to build 500
 Aquarium—built-in, makes living picture 485
 Automobiles—improving seating arrangement in two-door sedan 499
 Automobiles—Accessories—handy map holder 497
 Automobiles—Repairing—renewing blown cylinder-head gaskets 509

Belts—wire solder for repairing 487
 Bladder—finding leak in basket-ball 497
 Camera
 using narrow film in 497
 view, carrying case for 488
 Coffeepot—substitute for glass top 507
 Collars—simple method of dividing 506
 Doorbell—eliminating annoyance 499
 House—visualizing proposed change in 508
 Hydrant—extension for operating wall 506
 Icebox—selective lock for 509
 Ice Creepers—easily made 509
 Ice Scooter—air propelled model 507
 Insects—hints on mounting 488
 Ironing Board—portable saves space 510
 Jewelry—secret hiding place for 510
 Kites—sending aerial messages to 498
 Lantern—gasoline, asbestos curtain for 496
 Lock-door—made from old strap hinge 489
 Locks—selective lock for icebox 509
 Lumber—straightening warped boards 499
 Needle—easy method of threading 489
 Oil Gauge—handy wiper for 498
 Outboard Motor—speed indicator for 496
 Pump Tank—faucet on 489
 Silverware—removing dents from 509
 Skiing—is great sport 490
 Smokers' Accessories—windshield for the cigar lighter 510
 Stove, Oil—improving the cookstove 497
 Tampers—for feet do work of lawn roller 496
 Telephone—rubber base prevents sliding 499
 Tongs—fireplace, for handling large logs 487

Transformer

SHOP NOTES

Automobiles—Accessories—shock absorbers for auto seats 513
 Automobiles—Repairing
 removing humps from fenders 525
 replacing spring on overhead valve 521
 washers save time in fitting bearings 521
 Carpets—a carpet-beating short cut 521
 Coal—chute and pit for unloading from drop-bottom cars 512
 Drilling—elongated holes 525
 Heating—blower cuts down fuel cost 511
 Hog Trough—improved 526
 Jointer—in the home shop 516
 Oil Holes—blowing chips out of 515
 Photography—negative and print drier 525
 Pipe—trench box speeds up laying 513
 Plants—wire-screen enclosures protect 515
 Reamers—holder simplifies grinding shank 514
 Screws—vise used in driving 527
 Sketching—paper roll for 515
 Stairway—homemade disappearing 522
 Stepladder—crosspiece on protects windows 513
 Stock Tank—self-filling 514
 Track—over stairway facilitates moving of shop truck 527
 Valves—use of emery cloth in reseating 515
 Workbench—simplifies model airplane building 523
 Wrench—novel tap 514

472

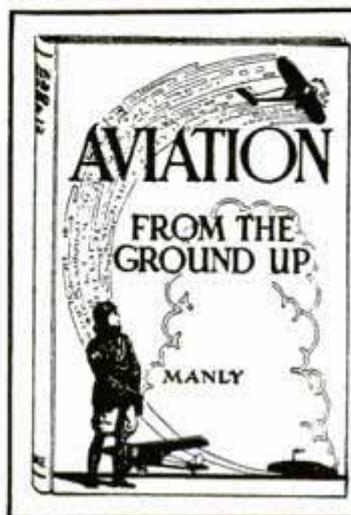

**Complete Course
 In Aviation**

prepares you to take up actual flying practice. Preliminary study doubles the value of instruction time and this practical treatise by Lieut. G. B. Manly, U. S. Army Air Service, Res., covers every phase of the subject in such an easily understood manner as to enable you to become thoroughly posted on aviation.

**400 Pages—185 Illustrations
 Price \$3.50**

Will be sent C. O. D. to any address in the U. S.

**Popular Mechanics Press
 Room P3
 200 E. Ontario St., Chicago**

Most Amazing INVENTION in 25 Years "Cleans Up" for Agents

**\$90 Weekly
in Spare Time**

Men, here is a wonder—the most sensational invention of the age! If you are looking for a rapid fire seller—an item that nets you 100 per cent profit—an item that sells itself to seven out of ten men on demonstration—I've got it in Ve-Po-Ad, the amazing new vest pocket adding machine!

**FREE
MACHINE
FOR
AGENTS**



Sells for \$2.95

You Make \$1.65

This most remarkable invention does all the work of a \$300 adding machine, yet fits the vest pocket and sells for only \$2.95! It sells on sight to storekeepers, business men, and everyone who uses figures—and makes you over 100 per cent profit on every sale!

Ve-Po-Ad does any kind of figuring in a jiffy, yet weighs but 4 ounces. Counts up to a billion. Shows total visible at all times. Perfectly accurate, lightning fast. Never makes a mistake or gets out of order. There are over 100,000 in daily use!

**Get Your
Machine
FREE!**

Live wire salesmen are dropping everything else and flocking to Ve-Po-Ad. Ve-Po-Ad brings them quick money and lots of it. Shapiro out in California made \$475 in one week! You can "clean up" too! Only 10 sales a day in spare time will bring YOU over \$95.00 a week! You need no previous sales experience—Ve-Po-Ad sells itself! If you are really interested in earning a steady, substantial income, write at once for full details of my MONEY-MAKING PLAN and FREE VE-PO-AD given to new Agents. Do it NOW—TODAY!

C. M. CLEARY, 303 W. Monroe St., Dept. 46, Chicago, Ill.

How do you measure up —by the dollar sign?

JUST how big a man are you? Not how big do you count yourself—but how do others size you up?

No use fooling yourself. The one measure is the dollar sign. It's the measure of a man in business, and many times outside of it.

The man who fills the ordinary job where a dozen applicants fight for every position is mighty small when measured by his weekly pay check.

There is only one excuse for being in this class—it's lack of initiative, lack of courage to make a decision, to make a start, and keep on going. Money cost and time cost are so small they don't count.

Thousands upon thousands of men have increased their incomes in comparatively short time through LaSalle Home Study Business Training.

So can you, BUT—

You can't unless you will. Training is no magic wand that transforms you overnight. But it's the surest, soundest, quickest method of making a man measure bigger by the dollar sign that modern business has yet developed.

Any question in your mind about it? Then read what follows—stories from actual life—three cases out of thousands like them in our files.

Changed Zero Rating Into Big Success

He stood in front of a bank in a southern town, when we first met him—just about as discouraged as a human being could be.

For one month—after giving up a routine position in a bank—he had been trying his hand at selling life insurance. Standing there in the rain, he was now trying to summon enough courage to ask for his old job back again!

"I can't talk with you about enrolling with LaSalle," said he; "I couldn't pay for the training if I took it."

Nevertheless, he *did* talk with us—on our promise not to enroll him at that time, even if he asked us to. And later, of his own accord, he sent in his enrollment!

Result? Today—only six years later—he is area supervisor for a great insurance company—his territory embracing an entire state. During those five years he has increased his income approximately 500 percent—and in a recent letter he adds this line: "*Much of my success I attribute to the principles of salesmanship so ably presented by LaSalle Extension University.*"

He Turned a Laugh Into Envy

They laughed at him when he enrolled for training in Higher Accountancy—the other boys in the Indiana drug store where he worked as a prescription clerk. They kept on laughing as he studied in his spare hours that summer—they enjoyed themselves evenings while he worked.

But they didn't laugh ten months later, for at that time he secured a bookkeeping position at

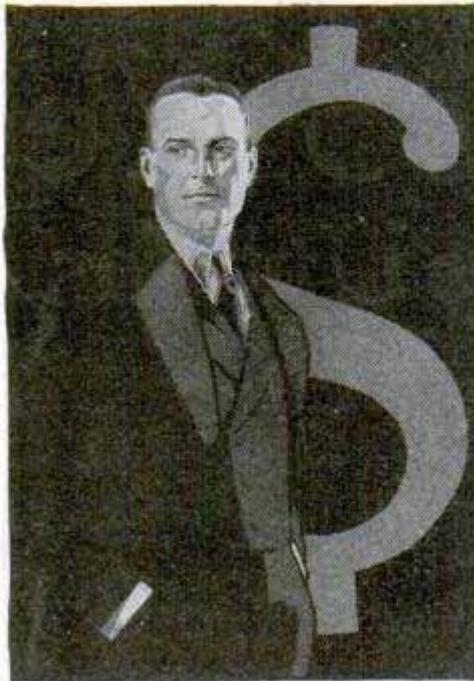

a salary bigger than either he or they had ever received—nor did they laugh when he got his C. P. A. degree three years later and then went on to open his own public accounting office and earn five or six times what he had earned as a drug clerk.

Doubled His Income Rating

The third man was repairing air brakes in the car shops of a mid-western railroad—a fine, loyal worker, 36 years old—when he enrolled for Modern Foremanship five years ago. Eight months later, his measure under the dollar sign went up 28 percent and he was made Supply Foreman. It went up again and again as he became Chief Car Inspector—first at one point, then another and another—each job more important than the one before. Today he rates more than 100 per-

cent higher than at the start and, better yet, he is marked by his superiors as a "comer."

If You Really Want to Succeed, Read This and Act I Can—I Will. That is the slogan on which LaSalle has built for twenty years: the basis on which these four men—and hundreds of thousands of others—have built their remarkable progress.

You can—if you will.

Below is a coupon—a coupon which, filled in, clipped and mailed, will bring you two interesting booklets; one, "Ten Years' Promotion in One," the other describing in detail the LaSalle plan for progress in the field of your choice. LaSalle will send both of them to you free.

You want a bigger success. Are you willing to do your part—to start by finding out about the training available? Then mail the coupon NOW.

----- Find Yourself Through LaSalle! -----

LaSalle Extension University

The World's Largest Business Training Institution

Dept. 364-R

Chicago

I would welcome an outline of the LaSalle plan, together with a copy of "Ten Years' Promotion in One," all without obligation.

- | | |
|---|---|
| <input type="checkbox"/> Business Management | <input type="checkbox"/> Law—Degree of LL. B. |
| <input type="checkbox"/> Modern Salesmanship | <input type="checkbox"/> Commercial Law |
| <input type="checkbox"/> Higher Accountancy | <input type="checkbox"/> Credit and Collection Correspondence |
| <input type="checkbox"/> Traffic Management | <input type="checkbox"/> Industrial Management |
| <input type="checkbox"/> Railway Station Management | <input type="checkbox"/> Modern Foremanship |
| <input type="checkbox"/> Banking and Finance | <input type="checkbox"/> Personnel Management |
| <input type="checkbox"/> Modern Business Correspondence | <input type="checkbox"/> Expert Bookkeeping |
| <input type="checkbox"/> Business English | <input type="checkbox"/> Commercial Spanish |
| <input type="checkbox"/> Effective Speaking | <input type="checkbox"/> C. P. A. Coaching |
| <input type="checkbox"/> Telegraphy | <input type="checkbox"/> Stenography—Stenotypy |
| | <input type="checkbox"/> Railway Accounting |
| | <input type="checkbox"/> Paper Salesmanship |

Name.....

Present Position.....

Address.....

ELECTRIC WIRING CODE TRANSMISSION



We take pleasure in announcing: "AUDELS NEW ELECTRIC LIBRARY"

New and More Uses for Electricity that come up daily offer great opportunities to men who can handle this power correctly and accurately. Modern electrification of industry calls for trained men who know how to handle electricity.

Simple as A. B. C.—"Audels New Electric Library" gives latest, exact information from foundations of electrical practice to latest modern applications. This is a NEW practical and theoretical course in electricity for home study and ready reference.

Here are the answers to your questions, giving you the real dope that every electrician must know. They chart your knowledge, taking away the uncertainty of guess work.

NEW!

Beautiful, timely books for service—pocket size; completely illustrated with diagrams and charts; simplified, easy to read and understand. No electrical man can afford to pass up this opportunity. Extremely low price; buy on your own terms.

NEW!

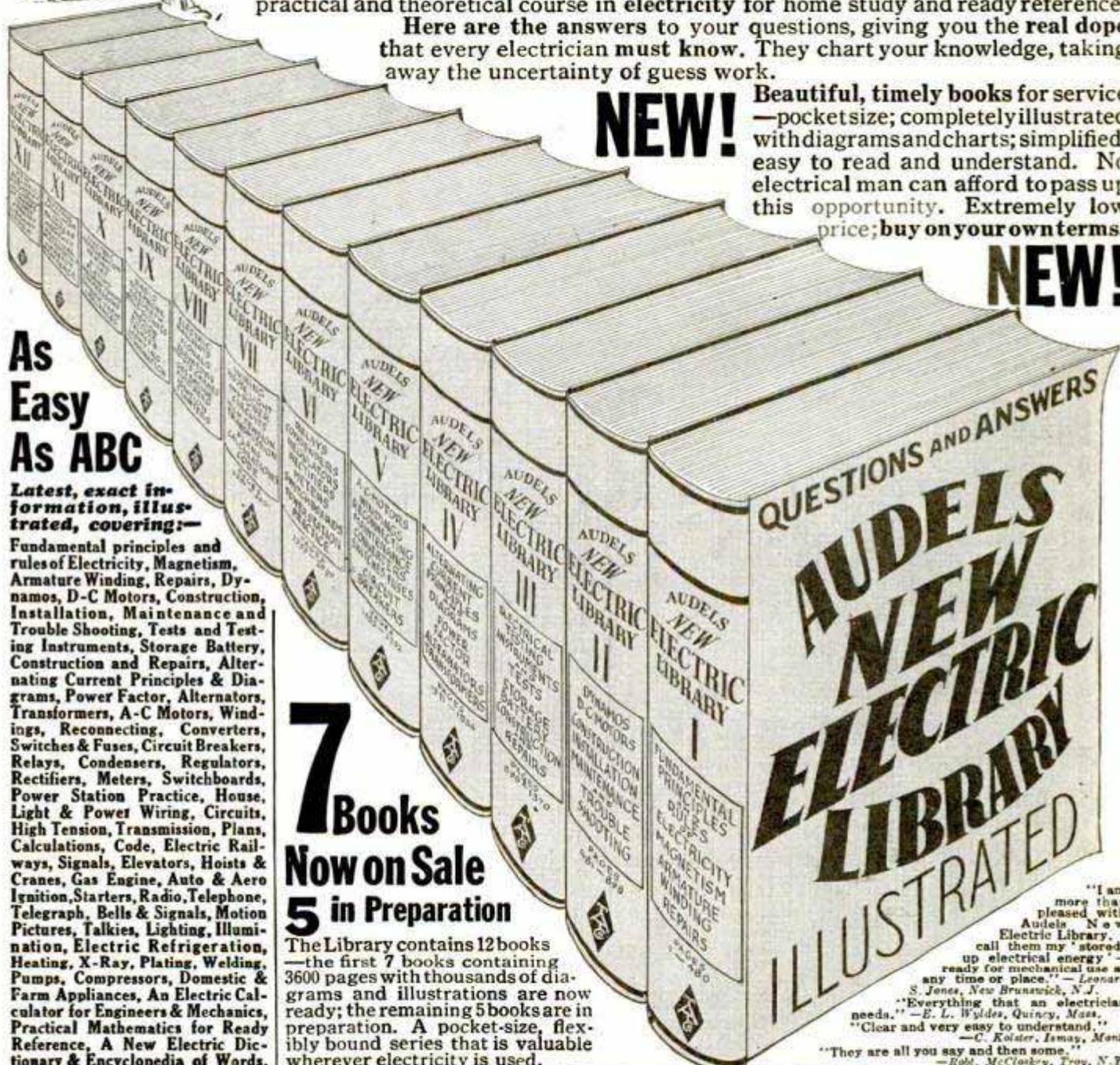

As Easy As ABC

Latest, exact information, illustrated, covering—

Fundamental principles and rules of Electricity, Magnetism, Armature Winding, Repairs, Dynamos, D-C Motors, Construction, Installation, Maintenance and Trouble Shooting, Tests and Testing Instruments, Storage Battery, Construction and Repairs, Alternating Current Principles & Diagrams, Power Factor, Alternators, Transformers, A-C Motors, Windings, Reconnecting, Converters, Switches & Fuses, Circuit Breakers, Relays, Condensers, Regulators, Rectifiers, Meters, Switchboards, Power Station Practice, House, Light & Power Wiring, Circuits, High Tension, Transmission, Plans, Calculations, Code, Electric Railways, Signals, Elevators, Hoists & Cranes, Gas Engine, Auto & Aero Ignition, Starters, Radio, Telephone, Telegraph, Bells & Signals, Motion Pictures, Talkies, Lighting, Illumination, Electric Refrigeration, Heating, X-Ray, Plating, Welding, Pumps, Compressors, Domestic & Farm Appliances, An Electric Calculator for Engineers & Mechanics, Practical Mathematics for Ready Reference, A New Electric Dictionary & Encyclopedia of Words.

7 Books Now on Sale 5 in Preparation

The Library contains 12 books—the first 7 books containing 3600 pages with thousands of diagrams and illustrations are now ready; the remaining 5 books are in preparation. A pocket-size, flexibly bound series that is valuable wherever electricity is used.

QUESTIONS AND ANSWERS
AUDELS NEW ELECTRIC LIBRARY
ILLUSTRATED

"I am more than pleased with Audels New Electric Library. I call them my 'stored-up electrical energy'—ready for mechanical use at any time or place."—Leonard S. Jones, New Brunswick, N. J.
"Everything that an electrician needs."—E. L. Wilder, Quincy, Mass.
"Clear and very easy to understand."—C. Kolster, Ismay, Mont.
"They are all you say and then some."—Robt. McClosky, Troy, N. Y.

BUY ON YOUR OWN TERMS

PLAN 1—ONE BOOK A MONTH

Please enter my subscription to "Audels New Electric Library" to consist of twelve volumes, price \$1.50 a volume (\$10.50 for the seven volumes now ready). Mail one volume each month and as they are received, I will mail you \$1.50 promptly.

PLAN 2—PAY 50c OR MORE A WEEK

Please ship me for one week's free trial the first seven volumes of "Audels New Electric Library," \$1.50 each (\$10.50 for the seven volumes now ready). The remaining five volumes to be mailed as issued at \$1.50 a volume. If satisfied, I will mail you 50c or more each week as payment for the first seven books and I will pay for the last five numbers as I receive them at \$1.50 each.

SATISFACTION GUARANTEED

"Audels New Electric Library" is backed by our 50-year record as helping hand publishers. Satisfaction always guaranteed.

THEO. AUDEL & CO.,
65 West 23rd St., New York, N. Y.

Please ship me the NEW "Audels Electric Library" on the plan marked (X).

NAME

ADDRESS

OCCUPATION

EMPLOYED BY

Answer This Ad!

If You Want Quick Success and Big Pay In AUTOS

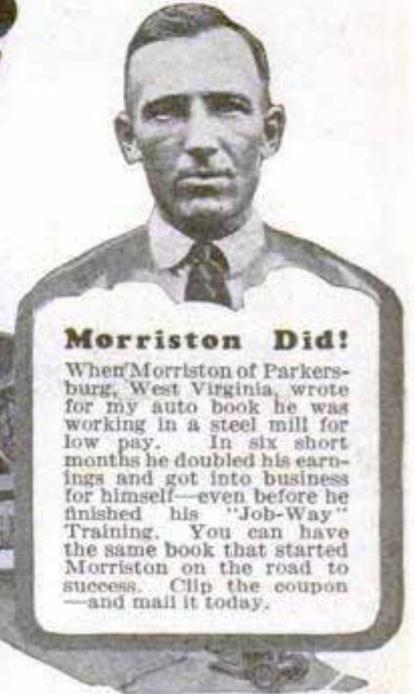

Morrision Did!

When Morrision of Parkersburg, West Virginia, wrote for my auto book he was working in a steel mill for low pay. In six short months he doubled his earnings and got into business for himself—even before he finished his "Job-Way" Training. You can have the same book that started Morrision on the road to success. Clip the coupon—and mail it today.

Earn Up to \$100 a Week

Get YOUR share of the \$7,000,000,000 spent every year on auto upkeep. Just think of it—more than 25,000,000 autos in the U. S. No wonder there are so many big pay jobs! Get into this fascinating game, now. Don't put it off another day. Get the facts. Mail coupon for big, FREE auto book. Learn of the countless opportunities in the World's Biggest Business where real jobs and big pay come quick. See how \$50—\$75—\$100 a week is possible for you now. Learn how "Job-Way" Training has brought big money—promotion—shops of their own to scores of men. Find out about my Employment Department—how it helps you get a good job in the auto business.

3 Working Outfits
also included FREE of extra charge if you act quick!

Learn at Home in Spare Time

"Job-Way" Training is the short cut to Auto Success. No need to quit your present job—no need to leave home—just use your spare time to prepare for a brilliant future—a real job paying up to \$100 a week. All you need is common schooling. I don't care if you never touched an auto before, I can train you at home. You should be able to make extra money quick—a few weeks after starting. Men from all walks of life who worked

long, hard hours for low pay are becoming garage owners, foremen and superintendents. If you like autos—if you're between 15 and 55—get the facts now. "Job-Way" Training covers everything about autos—Mechanical and Electrical Work, Starting, Lighting, Ignition, Welding, Vulcanizing, etc.—Everything you need to get in line for a big money job as an Electrical and Mechanical Auto Expert.

It's the trained man who gets the good jobs and "Job-Way" Training is COMPLETE yet so simple, so easy that you get it quick.

Send Coupon for FREE Auto Book

Get my FREE Auto Book. Learn how "Job-Way" Training has brought success to hundreds. See what it can do for you. Find out how my Employment Department helps you get a good job—about the three big outfits you get. Read my money-back agreement, my aviation course offer and many other features.

B. W. Cooke, Directing Engineer
Motor Institute of America
Motor Institute Bldg. Dept. 3163
EVANSTON, ILLINOIS
(Chicago's Largest Suburb)



Do It Now!

Don't delay another day. Clip the coupon before you turn this page. Take the first step to a big-pay auto job. Now.

B. W. Cooke, Directing Engineer,
MOTOR INSTITUTE OF AMERICA,
Motor Institute Bldg., Dept. 3163, Evanston, Ill.

Send me your free auto book. I want to succeed in the auto business. Tell me about "Job-Way" Training—about your Employment Department and your 3 testing and repair outfits offer. No obligation on my part whatever.

Name.....
Address.....
Town..... State.....
Age..... Occupation.....

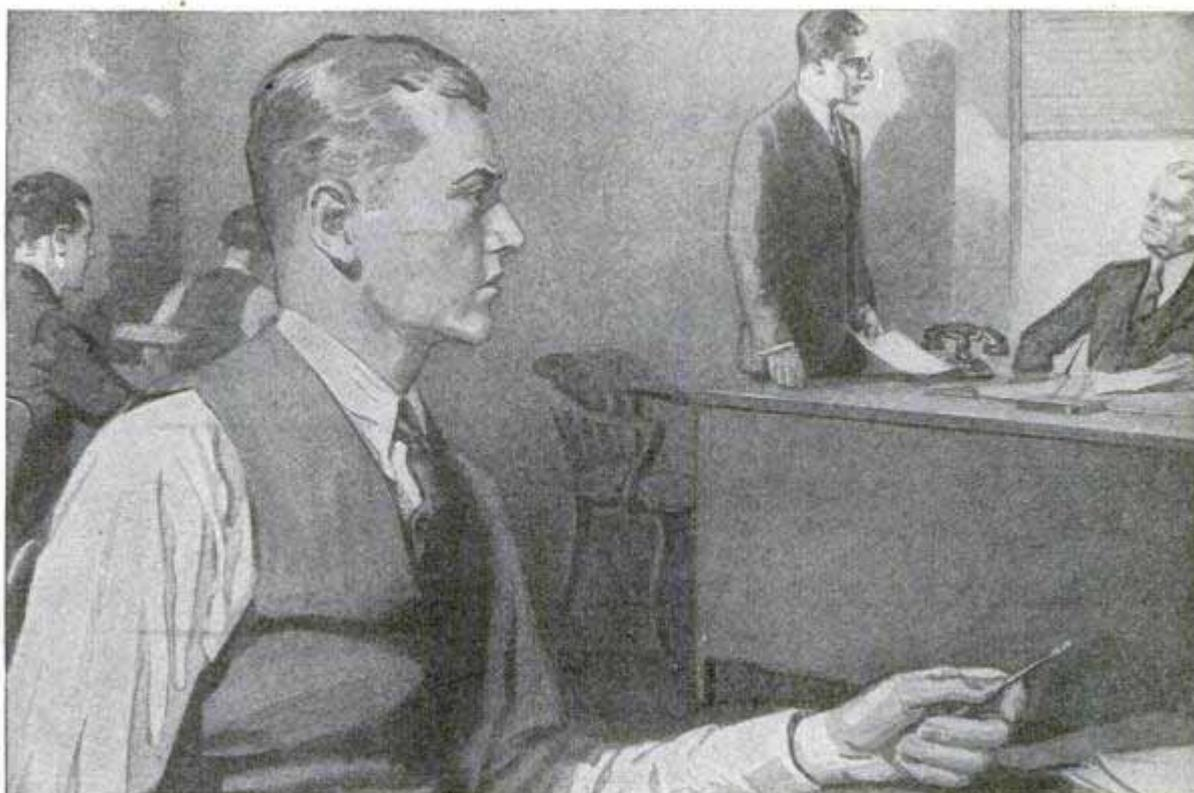

Measure Yourself for the Job Ahead

AN EMPLOYER cannot very well go to any man and say: "One year from today I am likely to need a new branch manager." He hasn't the gift of prophecy to announce: "In probably two years our superintendent will leave and we will need you for the position."

These possibilities must be left to your own vision. It is a very common thing, when a responsible post is to be filled, for many men hastily to put in their applications or to beseech friends to "speak a good word to the Boss." It is altogether too uncommon for some man in the organization to have quietly demonstrated that he is schooling himself for the larger opportunity.

Ask yourself these questions

Analyze yourself and your reasons for not getting ahead faster. Why haven't you been promoted? Why do your employers see fit to keep you where you are, and select others for jobs higher up?

You know you have the required loyalty, industry and determination. What is it that you lack? Are you trained in personnel work—the handling of men? Are you familiar with accounting systems, production records and costs? Have you studied financing, markets, selling methods, sales management, advertising?

Isn't it a fact that a sound training in any one of these subjects would lift you out of the crowd and fit you for a well-paid, responsible position?

If you are serious about wanting to advance, you can do it. The International Correspondence Schools offer you a choice of more than 300 courses. In an hour a day of spare time you can get exactly the training you need.

Honestly, is there any reason why you should delay longer in getting ready for success? Find out how we can train you for promotion and a bigger salary. It doesn't cost a cent or obligate you in the least. Mark the coupon and mail it now.

INTERNATIONAL CORRESPONDENCE SCHOOLS, Box 5670-F, Scranton, Penna.

Without cost or obligation, please send me a copy of your booklet, "Who Wins and Why," and full particulars about the subject before which I have marked X:

TECHNICAL AND INDUSTRIAL COURSES

- | | | | | |
|--|--|---|--|--|
| <input type="checkbox"/> Electrical Engineer | <input type="checkbox"/> Railroad Positions | <input type="checkbox"/> Plumbing and Heating | <input type="checkbox"/> Architectural Draftsman | <input type="checkbox"/> Automobile Work |
| <input type="checkbox"/> Electric Lighting | <input type="checkbox"/> Gas Engine Operating | <input type="checkbox"/> Steam Engineering | <input type="checkbox"/> Concrete Builder | <input type="checkbox"/> Aviation Engines |
| <input type="checkbox"/> Mechanical Engineer | <input type="checkbox"/> Civil Engineer | <input type="checkbox"/> Radio <input type="checkbox"/> Architect | <input type="checkbox"/> Structural Engineer | <input type="checkbox"/> Agriculture and Poultry |
| <input type="checkbox"/> Mechanical Draftsman | <input type="checkbox"/> Coal Mining | <input type="checkbox"/> Architects' Blueprints | <input type="checkbox"/> Chemistry | <input type="checkbox"/> Mathematics |
| <input type="checkbox"/> Machine Shop Practice | <input type="checkbox"/> Surveying and Mapping | <input type="checkbox"/> Contractor and Builder | <input type="checkbox"/> Pharmacy | |

BUSINESS TRAINING COURSES

- | | | | | |
|--|---|---|---|--|
| <input type="checkbox"/> Business Management | <input type="checkbox"/> Accounting and C. P. A. Coaching | <input type="checkbox"/> Secretarial Work | <input type="checkbox"/> Business Correspondence | <input type="checkbox"/> Railway Mail Clerk |
| <input type="checkbox"/> Industrial Management | <input type="checkbox"/> Cost Accounting | <input type="checkbox"/> Spanish | <input type="checkbox"/> Show Card and Sign Lettering | <input type="checkbox"/> Grade School Subjects |
| <input type="checkbox"/> Personnel Management | <input type="checkbox"/> Bookkeeping | <input type="checkbox"/> French | <input type="checkbox"/> Stenography and Typing | <input type="checkbox"/> High School Subjects |
| <input type="checkbox"/> Traffic Management | <input type="checkbox"/> Salesmanship | <input type="checkbox"/> Advertising | <input type="checkbox"/> Civil Service | <input type="checkbox"/> Illustrating |
| | | <input type="checkbox"/> English | | <input type="checkbox"/> Cartooning |

Name.....Street Address.....

City.....State.....Occupation.....

If you reside in Canada, send this coupon to the International Correspondence Schools Canadian, Limited, Montreal, Canada

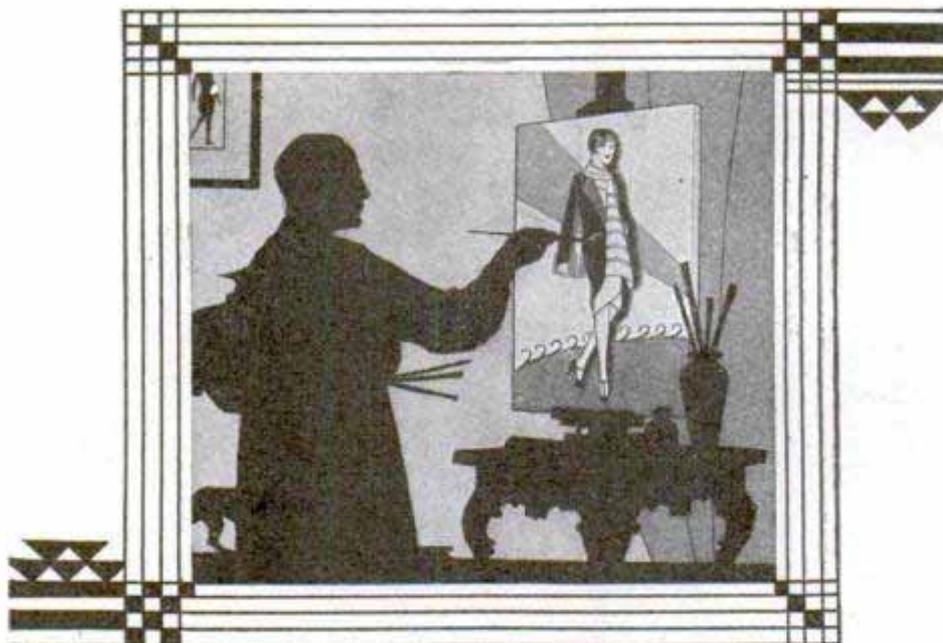

ARTISTS EARN MORE

WHILE you are dreaming of making money . . . enjoying life . . . why not train your talent for drawing? A fortune may be at your finger tips if you train them now. Many people do not realize they have artistic ability. Through art, you may find the way to a famous name and a large income.

Artists are paid more today than ever before. Since the war, rates for art work have increased tremendously. Advertisers and publishers are paying millions of dollars annually to those who are trained in Modern Art.

Think of the money paid to artists for the illustrations in this magazine alone. Hundreds of successful students of the Federal School of Illustrating are now making from \$2500 to \$6000 a year and some are making even larger incomes.

More than fifty famous artists . . . earning big money themselves . . . have contributed

their drawing secrets to the Federal Course. Clare Briggs, Neysa McMein, Sid Smith, Norman Rockwell and many others know the way to make money through art. The Federal Course teaches you their methods of Illustrating, Cartooning, Lettering, Poster Designing, Window Card Illustrating, etc. Through this course you can learn at home during your spare time.

TEST YOUR TALENT FREE

Why be content with a small income at routine work when art training offers such possibilities? Write your name, age and address on the coupon and get the Free Book, "A Road To Bigger Things" illustrated below. It gives details about how famous artists of today started their careers and shows examples of our students drawings. With it, you will receive our Free Vocational Art Test. Clip and sign this coupon now. It may be the beginning of an art career which will enable you to clip bond coupons and sign big checks later.

FEDERAL SCHOOL OF ILLUSTRATING

3130 Federal Schools Building



Minneapolis, Minnesota

Federal School of Illustrating,
3130 Federal Schools Building,
Minneapolis, Minnesota.

Please send me free book "A Road to Bigger Things" and Standard Art Test.

Name _____ Age _____ Occupation _____
Address _____



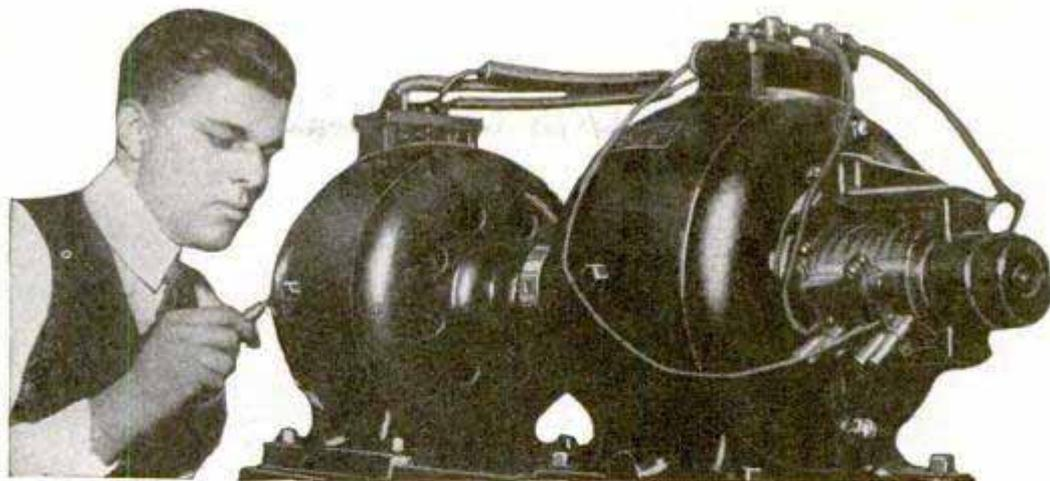

Amazingly Easy Way to get into ELECTRICITY

Don't spend your life waiting for \$5 raises, in a dull, hopeless job. Now . . . and forever . . . say good-bye to 25 and 35 dollars a week. Let me show you how to qualify for jobs leading to salaries of \$50, \$60 and up, a week, in Electricity—NOT by correspondence, but by an amazing way to teach, RIGHT HERE IN THE GREAT COYNE SHOPS. You become a practical Electrician in 90 days! Getting into Electricity is far easier than you imagine!

Learn Without Lessons in 90 DAYS By Actual Work—in the Great Shops of Coyne

Lack of experience—age, or advanced education bars no one. I don't care if you don't know an armature from an air brake—I don't expect you to! I don't care if you're 16 years old or 48—it makes no difference! Don't let lack of money stop you. Most of the men at Coyne have no more money than you have.

Railroad Fare Allowed

I will allow your railroad fare to Chicago, and if you should need part-time work I'll assist you to it. Then, in 12 brief weeks in the great roaring shops of Coyne, I train you as you never dreamed you could be trained . . . on a gigantic outlay of electrical apparatus . . . costing hundreds of thousands of dollars . . . real dynamos, engines, power plants, autos, switchboards, transmitting stations . . . everything from doorbells to farm power and lighting . . . full-sized . . . in full operation every day!



Prepare for Jobs Like These

Here are a few of hundreds of positions open to Coyne-trained men. Our free employment bureau gives you lifetime employment service.

- Armature Expert up to \$100 a Week
- Substation Operator \$60 a Week and up
- Auto Electrician \$110 a Week
- Inventor Unlimited
- Maintenance Engineer up to \$150 a Week
- Service Station Owner up to \$200 a Week
- Radio Expert up to \$100 a Week

etc., etc. That's a glimpse of how we make you a practical electrician in 90 days, teaching you far more than the average ordinary electrician ever knows and fitting you to step into jobs leading to big pay immediately after graduation. Here, in this world-famous *Parent school*—and nowhere else in the world—can you get this training!

Jobs, Pay, Future

Don't worry about a job, Coyne training settles the job question for life. Demand for Coyne men often exceeds the supply. Our employment bureau gives you a lifetime service. Two weeks after graduation Clyde F. Hart got a position as electrician for the Great Western Railroad at over \$100 a week. That's not unusual. We can point to Coyne men making up to \$600 a month. \$60 a week is only the beginning of your opportunity. You can go into radio, battery, or automotive electrical business for yourself and make up to \$15,000 a year.

Get the Facts

Coyne is your one great chance to get into electricity. Every obstacle is removed. This school is 30 years old—Coyne training is tested—proven beyond all doubt—endorsed by many large electrical concerns. You can find out everything absolutely free. Simply mail the coupon and let me send you the big, free Coyne book of 150 photographs . . . facts . . . jobs . . . salaries . . . opportunities. Tells you how many earn expenses while training and how we assist our graduates in the field. This does not obligate you. So act at once. Just mail coupon.

Get This Free Book

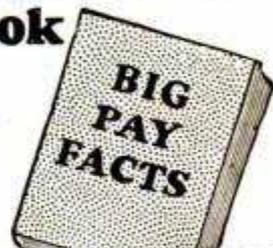

NO BOOKS

No books, no baffling charts . . . all real actual work . . . right here in the great Coyne school . . . building real batteries . . . winding real armatures, operating real motors, dynamos and generators, wiring houses

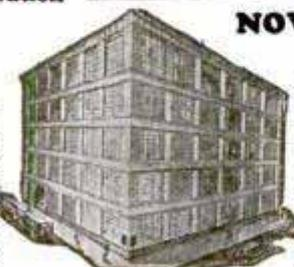

NOW IN OUR NEW HOME

This is our new fireproof, modern home wherein is installed thousands of dollars' worth of the newest and most modern Electrical equipment of all kinds. Every comfort and convenience has been arranged to make you happy and contented during your training.

COYNE ELECTRICAL SCHOOL
H. C. LEWIS, President
500 S. Paulina Street, Dept. 30-72 Chicago, Ill.

Mr. H. C. LEWIS, President
Coyne Electrical School, Dept. 30-72
500 S. Paulina Street, Chicago, Illinois

Dear Mr. Lewis:
Without obligation send me your big free catalog and all details of Railroad Fare to Chicago. Free Employment Service, Radio, Aviation Electricity, and Automotive Courses, and how I can "earn while learning."

Name
Address
City State

4 of the 40 Easy Ways to Make \$3⁰⁰ an Hour

In Your Spare Time in RADIO

THE four
plans

shown are but a sample of the many ways in which our members are making \$3.00 an hour upwards, spare time and full time, from the day they join the Association. If you want to get into Radio, have a business of your own, make \$50 to \$75 weekly in your spare time, investigate the opportunities offered the inexperienced, ambitious man by the Association.

Our Members Earning Thousands of Dollars Weekly

The Association was formed to help men cash in on Radio. It makes past experience unnecessary. As a member of the Association you are trained in a quick, easy, practical way to install, service, repair, build and rebuild sets—given sure-fire money-making plans developed by us—helped to secure a position by our Employment Department. You earn while you learn, while you prepare yourself for a big-pay Radioposition.

The Association will enable you to buy parts at wholesale, start in business without capital, help you get your share of the \$600,000,000 spent annually for Radio. As a result of the Association, men all over the country are opening stores, increasing their pay, passing licensed operator examinations, landing big-pay positions with Radio makers.

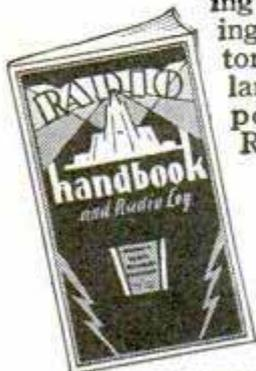

Mail Coupon for the FREE HANDBOOK

It is not only chock-full of absorbing information about Radio, but it shows you how easily you can increase your income in your spare time. Mailing the coupon can mean \$50 to \$75 a week more for you.

Radio Training Association of America
4513 Ravenswood Avenue Dept. PM-3 Chicago, Illinois

Below
are a few re-
ports from those
cashing in on the
"easy ways"

Clears \$3,000.00 Frank J. Deutch, Pa.—"Since joining the Association I have cleared nearly \$3,000.00. It is almost impossible for a young fellow to fail, no matter how little education he has, if he will follow your easy ways of making money."

\$1,100.00 in 6 Weeks J. R. Allen, Calif.—"Have done over \$1,100.00 worth of business in the last 6 weeks. Next month I am going to open up a store of my own. I never knew that money could come so fast and easy."

\$25.00 a Week Spare Time N. J. Friedrich, N. Y.—"I have averaged \$25.00 a week for the last 7 months even though I am not a graduate but just learning."

Training Lands Him Job R. C. Kirk, N. C.—"Your training has been very valuable to me. I landed a job with the big department store out here a few weeks ago because I had my membership card with me. There were a large bunch of applications ahead of me."

ACT NOW If You Wish NO-COST Membership

For a limited time we will give to the ambitious man a No-Cost Membership which need not—should not—cost you a cent. For the sake of making more money now, and having a better position in the future, mail coupon below *now*.

Radio Training Association of America
Dept. PM-3 4513 Ravenswood Ave., Chicago
Gentlemen: Please send me by return mail full details of your Special No-Cost Membership Plan, and also a copy of your Radio Handbook.

Name _____

Address _____

City _____

State _____



**Men who work
with their hands**



We have placed machinists, carpenters, masons, plumbers, railroad men, office clerks, farmers and even laborers in fine Electrical Jobs under this plan. Mail coupon for details of our remarkable offer.

WANTED!



for well-paid positions in
ELECTRICITY

**HERE'S
PROOF**



Gentlemen:
Thanks to the consistent effort of the American School I have found an entirely satisfactory job doing Electrical construction and maintenance work.
(Signed)
W. B. McClellan, Mason City, Iowa



"I have accepted employment with the Iowa Railway and Light Corporation starting at \$125.00 per month, who wrote me a letter suggesting an interview.
Thanking you very much for your splendid co-operation, I remain, Yours truly,
(Signed)
Glen Vandelaar,"
Leighton, Iowa

**—and we'll back them with this
amazing Employment Contract**

We are looking for more ambitious young men with factory, building-trade or even office experience to prepare for well-paid Electrical positions. Right now Electricity offers you unusual opportunities. You may have read in the newspapers that the big Electrical Utility magnates have promised President Hoover to spend TWO THOUSAND MILLION DOLLARS on new hydro-electric power plants, super-power transmission lines, electrification of railroads, new buildings and other gigantic new projects. All that means tens of thousands of new positions open in the world's most prosperous industry—one of the very few lines today that never suffers from hard times or unemployment.
Get in touch with me and I'll tell you how you can cash in on your past mechanical or business experience, by adding to it a knowledge of wiring, motors and generators, power-plant equipment and other Electrical subjects.

**JOBS! When You're Only
Half-Way Through**

It's easier to break into Electricity than you think—easy to learn at home in spare time by our "job-ticket" method of practical work—easy to get a good job when you're **only half-way through** your training—with our help. During the past few months we have placed **hundreds** of men, no smarter than you, no better educated—with big Electrical Companies, or in power plants—some in the factory, others in drafting, or radio, or telegraph or telephone or the selling or radio or office end. (A few typical letters are shown at the left.)

Get My No-Risk Plan

Right now we are making an interesting proposition to men who are willing to devote a part of their spare time to getting ready for a real future in the world's biggest, fastest-growing industry. Read our guarantee above, and mail coupon today for the most remarkable offer ever made to ambitious men.



Chief Engineer Dunlap — Electrical Division

American School

Dept. E-347, Drexel Ave. & 58th St., CHICAGO, ILLINOIS



AMERICAN SCHOOL, Dept. E-347, Drexel Ave. & 58th St., Chicago, Ill.

Please tell me, without cost or obligation, about your training and employment service in line marked X below.

- Architecture
- Building
- Drafting
- Business Management
- Accounting
- Mechanical Engineering
- Shop Superintendent
- Foremanship
- High School in 2 years
- Structural Steel
- CIVIL ENGINEERING
- Auto Engineering

Name.....

St. No.....

City.....State.....

Age..... Occupation.....

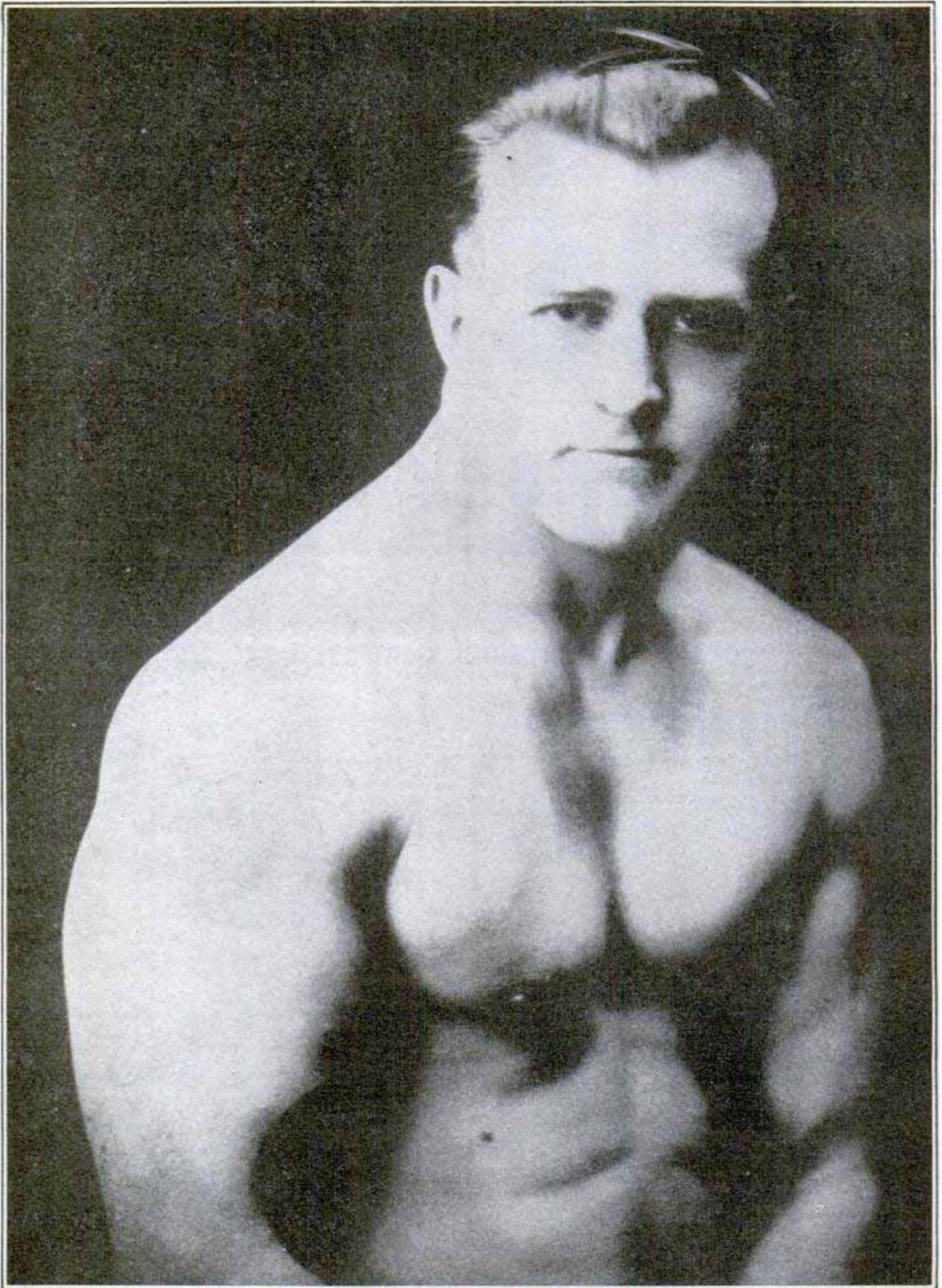

EARLE LIEDERMAN, *The Muscle Builder*

Author of "Science of Wrestling," "Muscle Building," "Secrets of Strength," "Here's Health," "Endurance," etc.

Kill This Man!

THERE'S a devil inside of you. He's trying to kill you. Look out for him! He tells you not to work so hard. What's the use? the boss only piles more work on you. He tells you not to bother with your body. If you're weak—you always will be weak. Exercise is just a lot of rot. Do you recognize him? Of course you do. He's in us all. He's a murderer of ambition. He's a liar and a fool. *Kill him!* If you don't, he will kill you.

Saved

Thank your lucky stars you have another man inside of you. He's the human dynamo. He fills you full of pep and ambition. He keeps you alive—on fire. He urges you on in your daily tasks. He makes you strive for bigger and better things to do. He makes you crave for life and strength. He teaches you that the weak fall by the wayside, but the strong succeed. He shows you that exercise builds live tissue—live tissue is muscle—muscle means strength—strength is power. Power brings success! That's what you want, and gosh darn your old hide! you're going to get it.

Which Man Will It Be?

It's up to you. Set your own future. You want to be the Human Dynamo? Fine! Well, let's get busy. That's where I come in. That's my job. Here's what I'll do for you:

In just 30 days I'll increase your arm one full inch with real live, animated muscle. Yes, and I'll add two inches to your chest in the same time. Pretty good, eh? That's nothing. Now come the works. I'll build up your shoulders. I'll deepen your chest. I'll strengthen your whole body. I'll give you arms and legs like pillars. I'll literally pack muscle up your stomach and down your back. Meanwhile I'll work on those inner muscles surrounding your vital organs. You'll feel the thrill of life shooting up your old backbone and throughout your entire system. You'll feel so full of life you will shout to the world, "I'm a man and I can prove it!"

Sounds good, what? But listen! That isn't all. I'm not just promising these things. *I guarantee them!* It's a sure bet. Oh, boy! Let's ride.

Send For My New
64 Page Book

"Muscular Development"

IT IS FREE

What do you think of that? I don't ask one cent. And it's the peppiest piece of reading you ever laid your eyes on. I swear you'll never blink an eyelash till you've turned the last cover. And there's 48 full-page photos of myself and some of my prize-winning pupils. This is the finest art gallery of strong men ever assembled. And every last one of them is shouting my praises. Look them over. If you don't get a kick out of this book, you had better roll over—you're dead. Come on, then. Take out the old pen or pencil and sign your name and address to the coupon. If you haven't a stamp, a postal will do. But snap into it. Do it *now*. Tomorrow you may forget. Remember, it's something for nothing and no strings attached, no obligation. *Grab it!*

EARLE LIEDERMAN

Dept. 2003, 305 Broadway, New York City

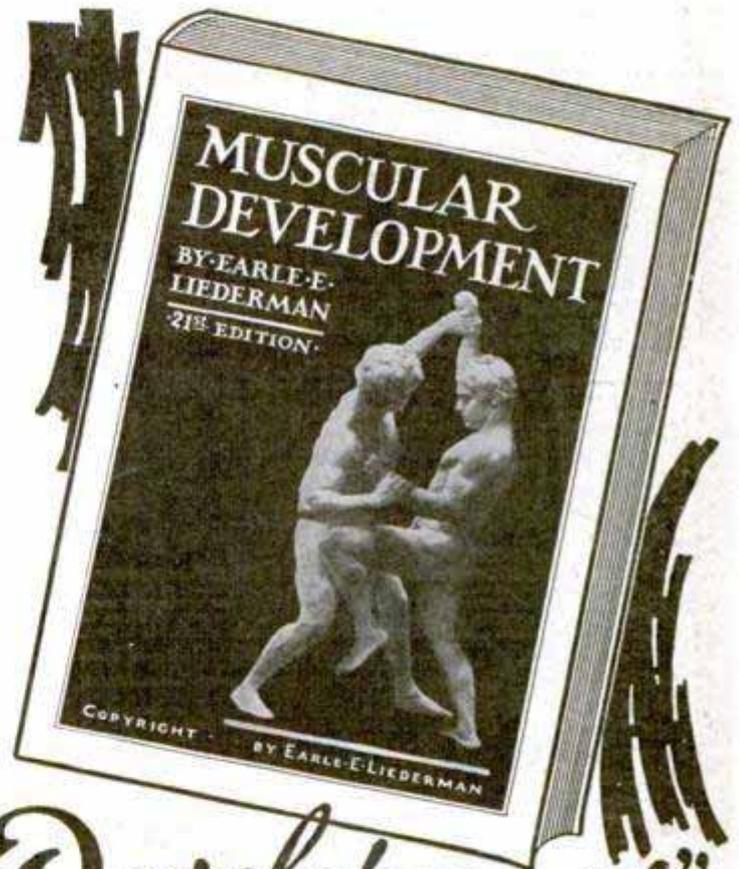

**It
Is
F
R
E
E**

**DON'T
SEND ONE
PENNY
—
YOUR
NAME AND
ADDRESS
ON A
POSTAL
WILL DO**

EARLE LIEDERMAN

Dept. 2003, 305 Broadway, New York City

Dear Sir: Please send me, absolutely FREE and without any obligation on my part whatever, a copy of your latest book, "Muscular Development."

Name..... Age.....

Street.....

City..... State.....

(Please write or print plainly.)

Quickly Learn to Play Hawaiian Guitar

Play Like This Native

Bring the romantic, enchanting, entrancing and melodious strains of the great instrument of the Hawaiian Islands into your soul. Become popular and successful. This **short cut method** of home instruction enables you to quickly master Hawaiian Guitar so you will **play as well as Native Hawaiians**.

Our staff of Hawaiian instructors have perfected a method of teaching, so **simple**, that without musical knowledge, you quickly learn to play real music from notes. **Simple as learning your A B C's** and it will not be long before you will play latest Broadway hits.

Only **four simple motions to learn**. You will then play any music, whether it be popular, dance or classical. Almost from first lesson, you play love songs like Aloha Oe.

To help you get started, we furnish without extra charge when you enroll as a student, a beautiful, full tone, genuine \$15.00 Hawaiian Guitar. Only 1,000 free instruments given away; if you want to get in on this offer, write for particulars at once—you must act quickly.



New Invention—Kno-All-Chart QUICKLY TEACHES YOU HOW TO PLAY
The newest invention of our Hawaiian instructor, which is exclusively used by us and which we call the "Kno-All-Chart,"

quickly teaches you how to play and read notes. So simple is this device that anyone can understand it and begin to play immediately.

Picture Method Easy

GIVEN \$18 Hawaiian Guitar when you enroll!

We do not depend upon our printed instructions alone for your success as a student, but we also supply you with many pictures of our professors' playing. This enables you to imitate the pictures. Isn't this easy?



Phonograph Records Given

As an additional guide, we also furnish you with phonograph records of our Hawaiian instructor's own playing of the music you are learning. This practically brings our professors from our studio to your own home and enables you to listen to their playing just as if they were actually in front of you.

Genuine \$18.00 Hawaiian Guitar Given

Enroll as a student, and secure a beautiful full tone, genuine \$18.00 Hawaiian guitar.

We also furnish every bit of equipment so it is never necessary for you to spend an extra penny. When you graduate, you get a beautifully engraved diploma and after graduation, we also give you six months' free service and consultation. Send for free particulars now.

JAZZ Your Way to Popularity and Success

No forming class to wait for. Start at once and join band, wagon of success and popularity. Do it through Hawaiian Guitar.

Send for free First Lesson and Book. So positive are we you will become one of our students, that if you write at once we will send you free our first lesson which will enable you to see just what you can expect when you enroll. You will also receive our big book of full particulars. Write for your copy and free lesson today.

Write at **Hawaiian Studio No. 52030** of New York Academy of Music, 100 Fifth Ave., New York, N. Y.

HAWAIIAN STUDIO No. 52030 of New York Academy of Music, 100 Fifth Avenue, New York, N. Y.

Please rush your book, "How to Learn Hawaiian Guitar," and my first free lesson. Also reserve a Hawaiian Guitar for me without extra charge. This obligates me in no way whatever.

Name.....
Address.....
City..... State.....

Books on 65 Practical Subjects

Popular Mechanics Press specializes in supplying the outstanding best books on many subjects. As new books of merit appear, we will revise the list accordingly.

- AIR NAVIGATION AND METEOROLOGY**
Every flyer needs.....\$3.00
- AIRCRAFT ENGINES**
Dyke's New Instructor
Best Engine Book.....\$5.00
- ARCHITECTURAL**
Drawing and Lettering.....\$2.00
- ARMATURE WINDING**
Excellent new book.....\$2.00
- AUTO ENCYCLOPEDIA**
Dyke's. (Covers New Model A Ford).....\$6.00
- AVIGATION**
By Dead Reckoning.....\$2.00
- BIRD HOUSES**
How to Make.....\$1.00
- BLUE PRINTS**
How to Read.....\$2.00
- BOAT BUILDING**
35 Craft, Popular Outboard Engined Type.....\$3.00
- BOY MECHANIC**
Famous 4 Vol. Library, 4000 Things to Make.....\$7.00
- BUILT-IN FURNITURE**
Complete Instructions.....\$2.50
- CARBURETORS**
Excellent book on all makes.....\$2.00
- CARPENTRY**
Hand book of 336 Kinks.....\$1.50
- CHEMISTRY**
For Old and Young Beginners.....\$2.50
- CIVIL SERVICE**
How to Prepare for.....\$3.00
- COLOR SIMPLIFIED**
Practical new Book (for Color Users).....\$3.50
- CONCRETE**
173 Ways of Using New Edition (Cloth).....\$1.00
- CONTRACTOR**
Building Cost Estimator.....\$2.00
- DIESEL ENGINES**
(New Work). Best Authority.....\$5.00
- DOGS**
Care and Raising.....\$2.00
- ELECTRICIAN**
214 Practical Kinks.....\$1.50
- ELECTROPLATING**
Practical Results Easily Obtained.....\$1.00
- ENGLISH**
Self-Improvement in.....\$2.50
- ETIQUETTE**
New 560-Page Book, Only.....\$1.00
- FARMER'S BOOK**
of 861 Kinks and Book for Farmers' Wives.....\$1.00
- FLIGHT TRAINING**
Practical, new book, best on subject.....\$5.00
- FORD (HENRY)**
His Philosophy of Industry.....\$1.50
- FORMULAS**
10,000 Money Making.....\$4.00
- FURNITURE**
Homemade (3 vols.).....\$3.00
- HOME REPAIRS**
Practical Book of.....\$2.50
- INTERIOR DECORATING**
Best book of new methods.....\$4.00
- INVENTIONS (American)**
Popular History of 2 vols. Reduced to.....\$5.00
- INVESTMENT**
Policies that pay By Ray Vance.....\$4.00
- JOINT WIPING**
(New Edition).....\$1.00
- KITES THAT FLY**
How to make.....\$1.25
- LANDSCAPING**
Practical.....\$2.50
- LATHE WORK (METAL)**
and Drilling and Thread Cutting.....\$1.00
- LETTER WRITING**
Social and Business Only.....\$1.00
- MACHINIST**
419 Kinks for.....\$1.50
- MAGIC**
200 New Tricks for Amateurs.....\$1.00
- MAKING THINGS YOURSELF**
900 Different Articles.....\$3.00
- MATHEMATICS**
Made Easy for the Practical Man.....\$1.50
- MECHANICAL DRAWING**
Practical Course in.....\$1.00
- MODEL AIRCRAFT**
Building and Flying.....\$2.25
- MOVIE MAKING**
for Amateurs.....\$3.00
- OUTDOOR OPPORTUNITIES**
for Making a Living.....\$2.00
- OUTDOOR SPORTS**
for All Year 'Round.....\$1.50
- PAINTING**
House (Best Methods).....\$2.00
- PETS**
For Pleasure and Profit.....\$2.00
- PLUMBING**
500 Plain Facts for Every Homeowner.....\$1.50
- POULTRY RAISING**
for Profit.....\$2.00
- POWER WIRING (D. C.)**
Electrical (Just Out).....\$3.50
- PUZZLES**
Amusing Mathematical.....\$1.50
- RADIO**
Trouble Shooting, Covers All-Electric Sets and Television.....\$3.00
- ROPE SPINNING**
Only Book on Subject.....\$1.50
- SHIP MODEL**
Making.....\$2.50
- SHOP NOTES**
15 Vols. of 6000 Valuable Kinks.....\$4.50
- STEEL SQUARE**
Pocket Book, Practical.....\$1.00
- TAXIDERMY**
Best Book of Methods.....\$3.50
- TENNIS**
By Heien Willis.....\$2.00
- TOY MAKING**
Complete instructions.....\$1.50
- WELDING**
ENCYCLOPEDIA All Methods.....\$5.00
- WIRING**
House (New Book).....\$2.50
- WOOD TURNING (LATHE)**
Practical Course in.....\$1.50
- WOODCRAFT**
Famous 590 Page Book by Ernest Thompson Seton; Only.....\$1.00

Books sent C. O. D. anywhere in U.S.

Just check the books you want, write your name and address below and mail the advertisement. It is your order blank. When postman hands you books, pay him the price and the postal charges. If outside the U. S. remit when ordering and include 10 cents per book extra for postage. We have many other books on these and 2,000 other subjects. Catalog free.

Name.....
City..... State.....
Address.....

Mail to **Popular Mechanics Press,** Room P3—200 East Ontario St., Chicago, Ill.

Outer Space

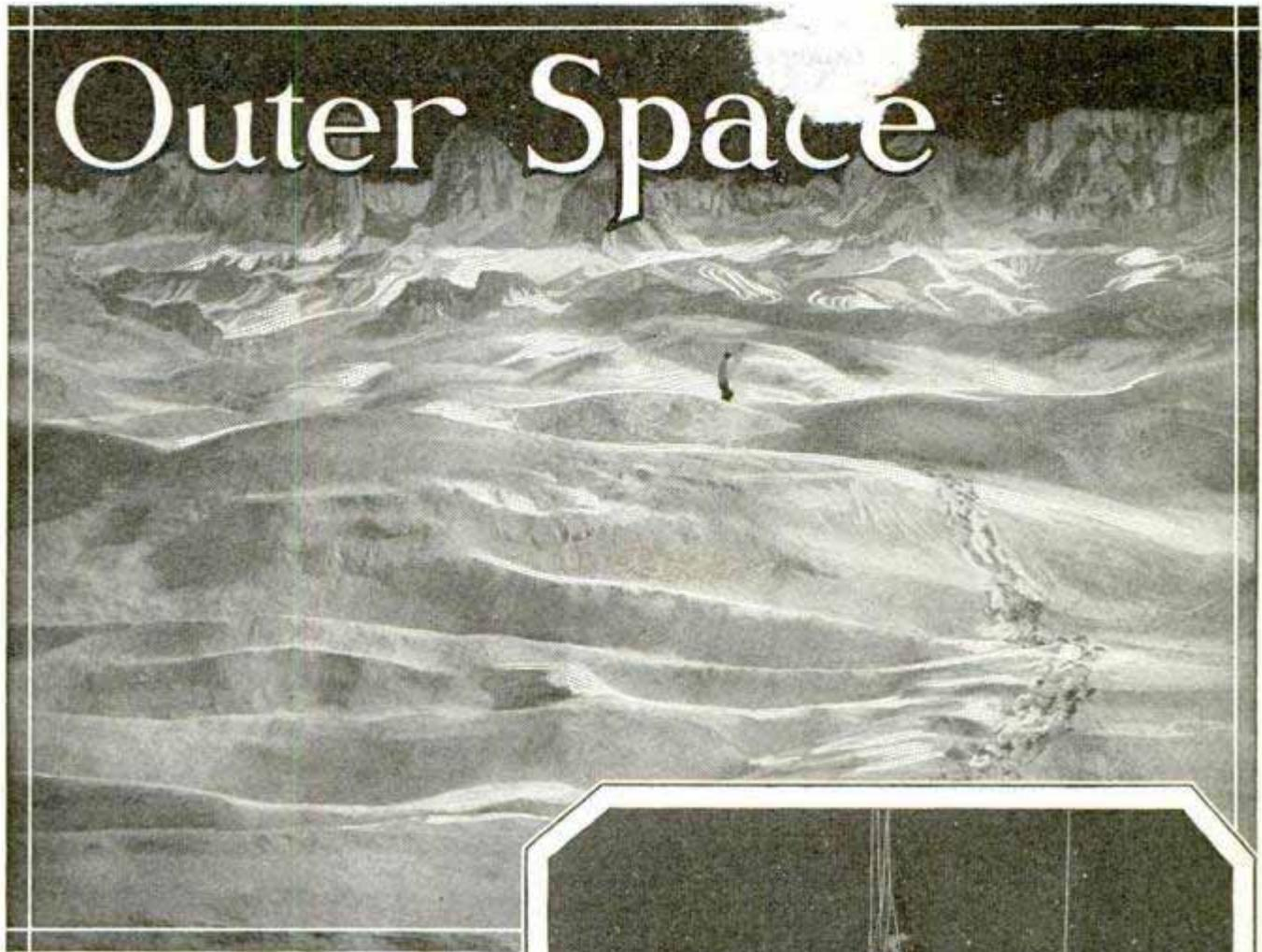

The inhabitants of Worcester, Mass., became aware of the rocket last summer when they were aroused one night by a terrific blast. The next morning the whole country knew that Doctor Goddard had sent his projectile hurtling from the experimental field with success.

A working model—a projectile nine feet long and two and one-half feet in diameter, sheathed in aluminum—had flashed up the sixty-foot shaft skyward with incredible speed. The performance convinced the scientists who witnessed it that a larger mechanism might successfully explore the unknown air regions above the earth.

Professor Goddard hopes shortly to make another attempt. This time it will be a twelve-foot rocket, propelled by the liquid used as fuel in the last experiment. Apparatus for sounding the higher regions will be sent

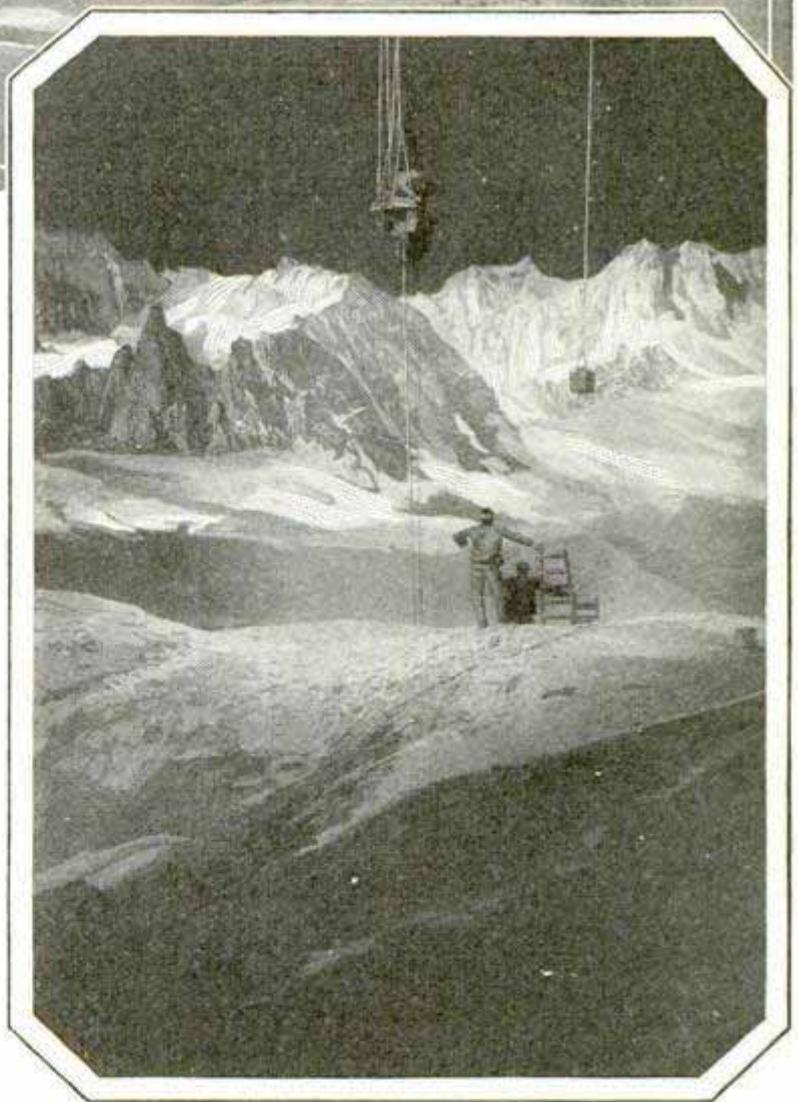

Close View of the Moon Set Constructed for the Movie and a Lunar Valley in the UFA Film

with it and may bring back startling results. In the June test, a camera, a barometer and the mechanism came down to earth by parachute uninjured.

In the meantime, Doctor Oberth is continuing his experiments. In the near future, a rocket, thirty-two feet in length, will speed heavenward, according to his plans. It will be propelled by liquid oxygen and hydrogen and guided by two rudders and two stabilizing vanes. A parachute with scientific recording apparatus will be installed in its nose to be released when the rocket reaches its expected height—somewhere around thirty miles—in about a minute after it is launched. The test will be made at Greifswalder Oie, an island off the Baltic coast, and the projectile will fall into the sea.

Such are the results of recent experiments with sky-directed rockets, and the plans of the inventors for the immediate future. Strangely enough, man knows but little of what lies between him and the stars. Some knowledge has been obtained of the atmosphere directly above for some twenty miles. No man has ascended that high, but free balloons, without occupants, have risen to that height and their instruments have brought back meager records of atmospheric and climatic con-

ditions. The sponsors of the rocket hope not to joyride to the moon, but to obtain new information on this hitherto unexplored area that aviators and agriculturists alike may profit.

Many sneered when Dr. Albert Neuberger hailed the rocket as the "supreme effort to release man from earth's gravitation." For the question of gravitation is one of the foremost considerations in contemplating lunar flights. A speed of seven miles a second is estimated to be necessary to carry the rocket past that point where earth's gravitation exerts the least pull—about 200,000 miles away. When black powder was used, Doctor Goddard foresaw that it would take 1,000 pounds of fuel to send a weight of one pound completely away from the earth. A liquefied mixture of hydrogen and oxygen worked so successfully that he found it would be possible to propel the same weight with a fuel expenditure of only 43.5 pounds.

It is obvious, of course, that consumption of fuel lessens the weight. A further step to reduce initial weight was the development of the multiple rocket. This is a series of projectiles overlapping one another in sheaths. When one rocket burns out, its shell drops off, relieving the

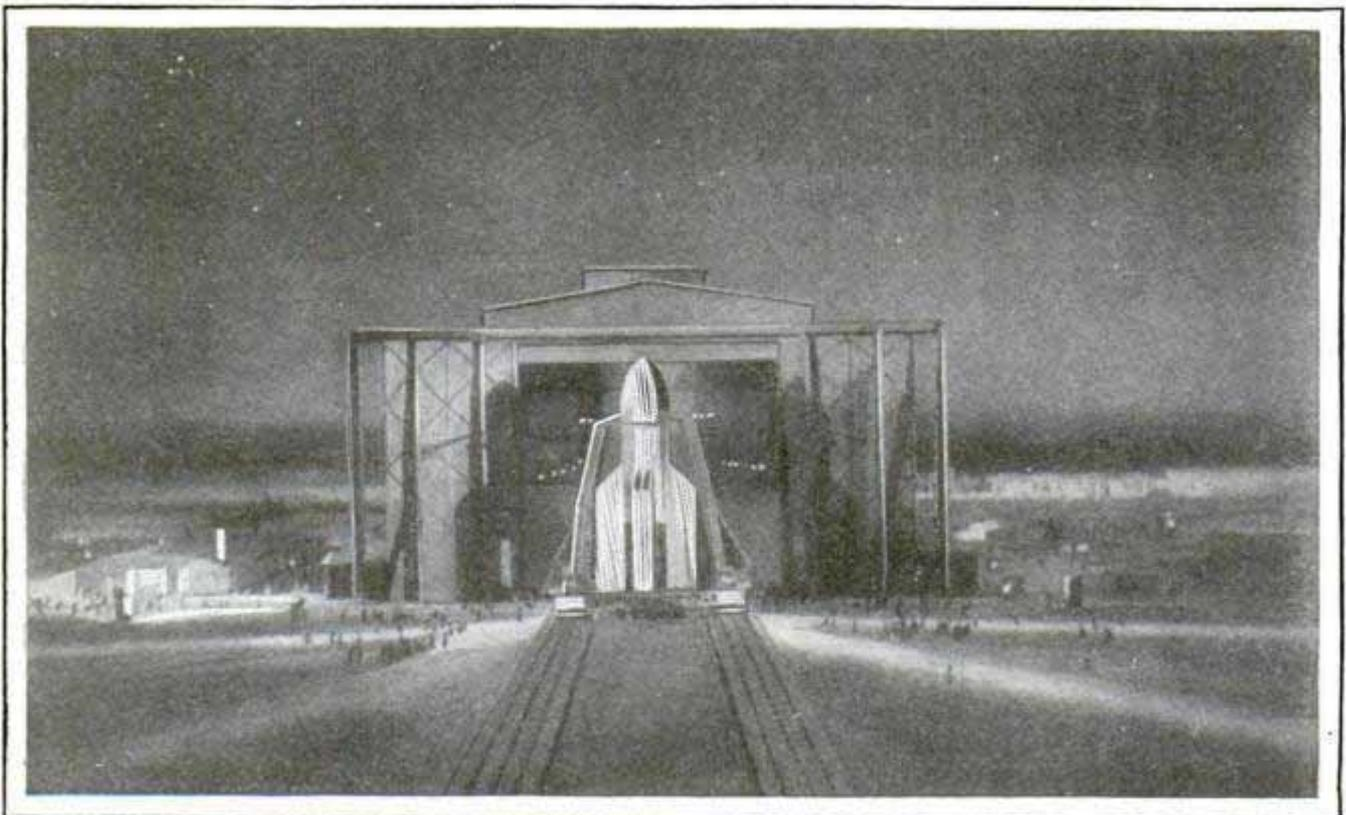

Pulling Rocket Out of Its Hangar for the Journey to the Moon, a Scene from the Spectacular German Film Which Blends Fancy and Scientific Data

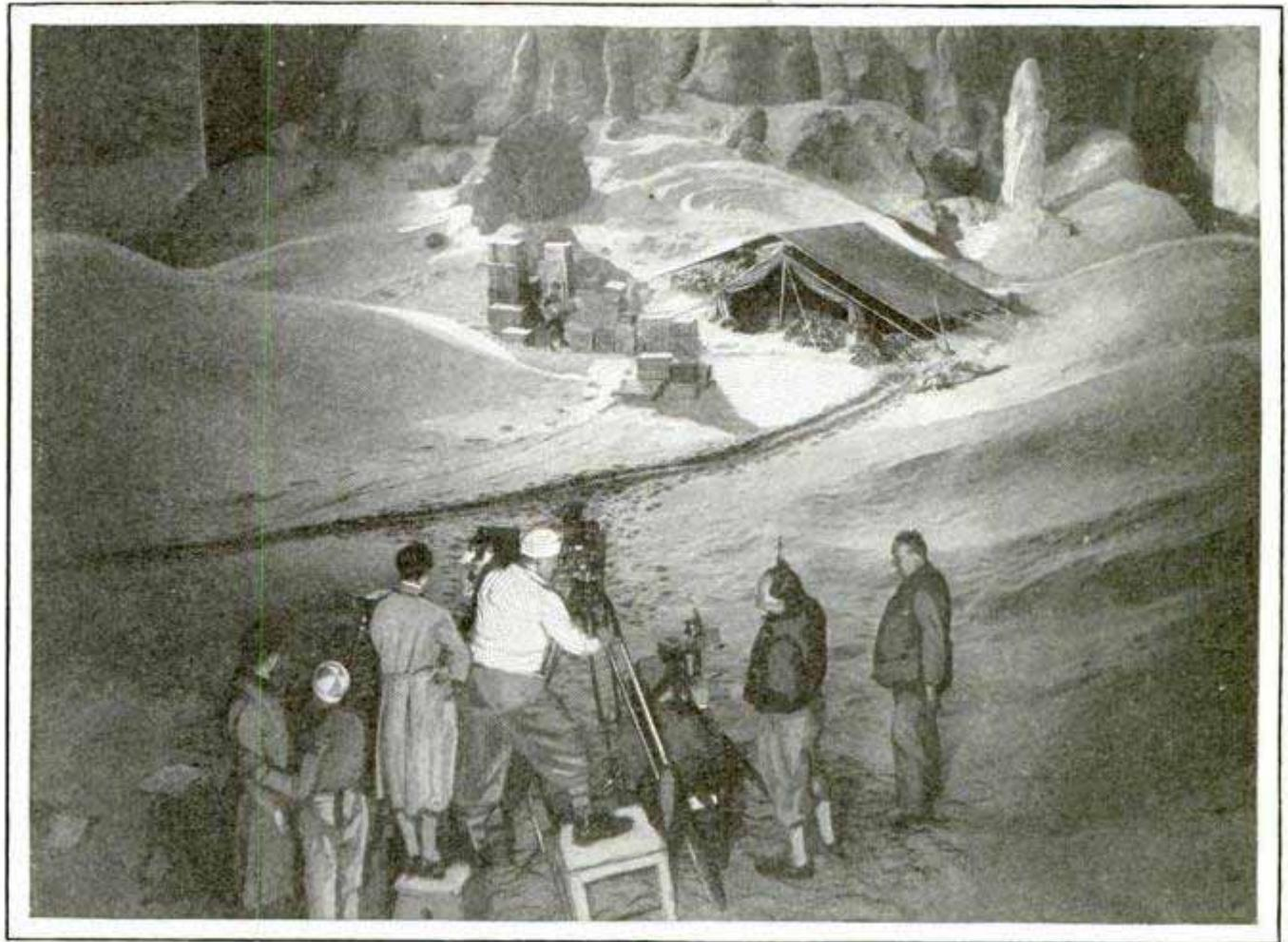

Fritz Lang Staging a Camp Scene in the Moon Valley; the Film Gave Lighting and Other Technicians Unusual Opportunities to Develop Novel Effects

main projectile of its dead load and thus increasing the speed.

Another obstacle raised by the skeptics is that a rocket cannot operate in the vacuum above the earth. This objection was based on the fallacy that the missile is forced upward by its ejected gases impinging upon the air as a cushion and thrusting the projectile upward. What propels the rocket is, however, the explosion of the fuel against an inner steel chamber forcing it ahead in the direction desired. In fact, tests have shown the rocket operates with an improved efficiency of twenty per cent in a vacuum.

Would the terrific speed at which rockets travel generate sufficient heat to destroy a moon-bound projectile? Doctor Oberth says it would not, and he suggests a jet of water from the nose of the projectile to cool it. In a vacuum, heat would, of course, be obviated.

Doctor Oberth's belief that eventually man will find the rocket a convenient and safe form of transportation has aroused much skepticism. Could a human being

survive the speed of the rocket? The scientific opinion is that he could, providing the speed was gradually attained, the passenger protected from friction and pressure, and the stop a gradual one. The speed alone, it is explained, will not affect the passenger.

In the meantime, experiments with rockets, not bound for the moon but into that mysterious region just twenty miles above us, continue. Man may thus be on the brink of some new stupendous adventure. The future of his knowledge of the world above rests largely with the results of the two experiments scheduled for the next few months.

TIRES PAINTED TO MATCH AUTO

Tires in Great Britain are being painted to match the finish of the car, a full range of colors with a rubber base having been placed on the market for that purpose. It is claimed the paint has a preservative effect on the tires, and that it will not wash off.

*County Chemical Co. Ltd
Bradford St. ...*

YORK RAILWAY CO, YORK
CHECKERED COAT FOR WORKER
GUARDS AGAINST ACCIDENTS

27 W. Market St.



Checked Coat Worn by Railroad Worker for Safety; for Night Work It Contains a Light

Rail greasers and other workers on the street railways in New York city are wearing black and white checkered coats and caps with a bright red band so that they will be plainly visible at dangerous places. On the back of the coat is a strap which supports a searchlight at night to afford additional protection after darkness. The lamp is supplied with current from a battery in the worker's pocket.

EVEN SPEED BEST IN LONG RACE
FATIGUE TESTS SHOW

A few years ago, foot racers thought that a sprint at the start of a long race and, if possible, a burst of speed at the finish, would produce the best record. Science has been at work for the benefit of the athlete and has upset many old traditions while revealing important facts with relation to the human machine and its tendency to become fatigued. Many tests have shown that a nearly even rate of speed is best for the long-distance runner. A series of experiments and measurements made by Prof. Arthur E. Kennelly, of Harvard University, have es-

Cambridge, Mass

Established that the laws of racing fatigue are substantially the same for men and horses, with horses in any of three gaits and men in any of five. When distances are doubled, about 118 per cent more time is required. Increasing the distance sixty-fold increases the time required a hundredfold, it was found. Nurmi is a remarkable runner not only because of his speed and endurance but because he established records in several different distances, something that few runners have been able to do, and this is explained partly by the fact that he has acquired a guiding sense as to the best speed to adopt for each particular distance and keeps careful check of his time throughout a long race. The tests revealed that horses are more precise racers than men. Athletes exhibit the greatest precision in walking, and next in swimming. The least precision is maintained in skating. In automobile races, the speed is practically constant, but in distances beyond 400 kilometers, some variation may be due to fatigue in the driver.

FENDER WING ON DOOR OF AUTO
KEEPS CLOTHES CLEAN

Protecting the clothing from dirt splashed over the rear fender of the automobile is the purpose of a wing which attaches to the rear door of the car and operates with it. When the door is opened, the soiled fender flap moves back, exposing a clean section against which the clothes may brush unharmed.

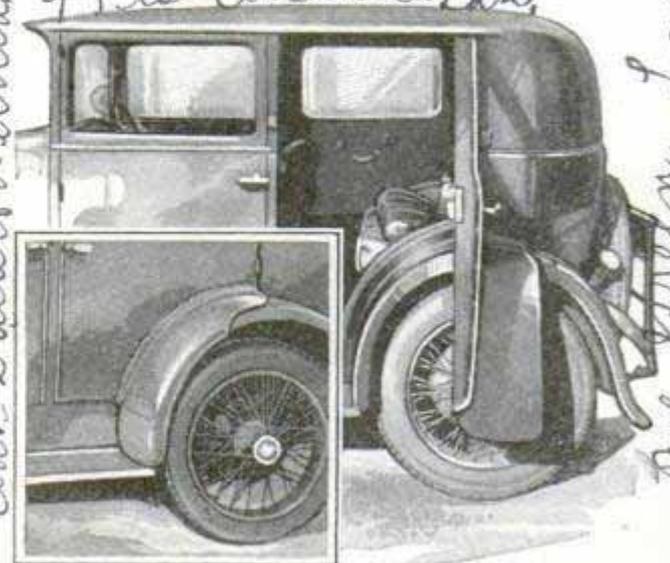

Fender Wing, Attached to Door of Auto and Opening with It, Protects Clothing from Being Soiled

Mason Bros. Paint

York, Pa.

Cent. Edward R. Anthony

London, N.Y.

Thrills *in* Search *for* Sun's Secrets

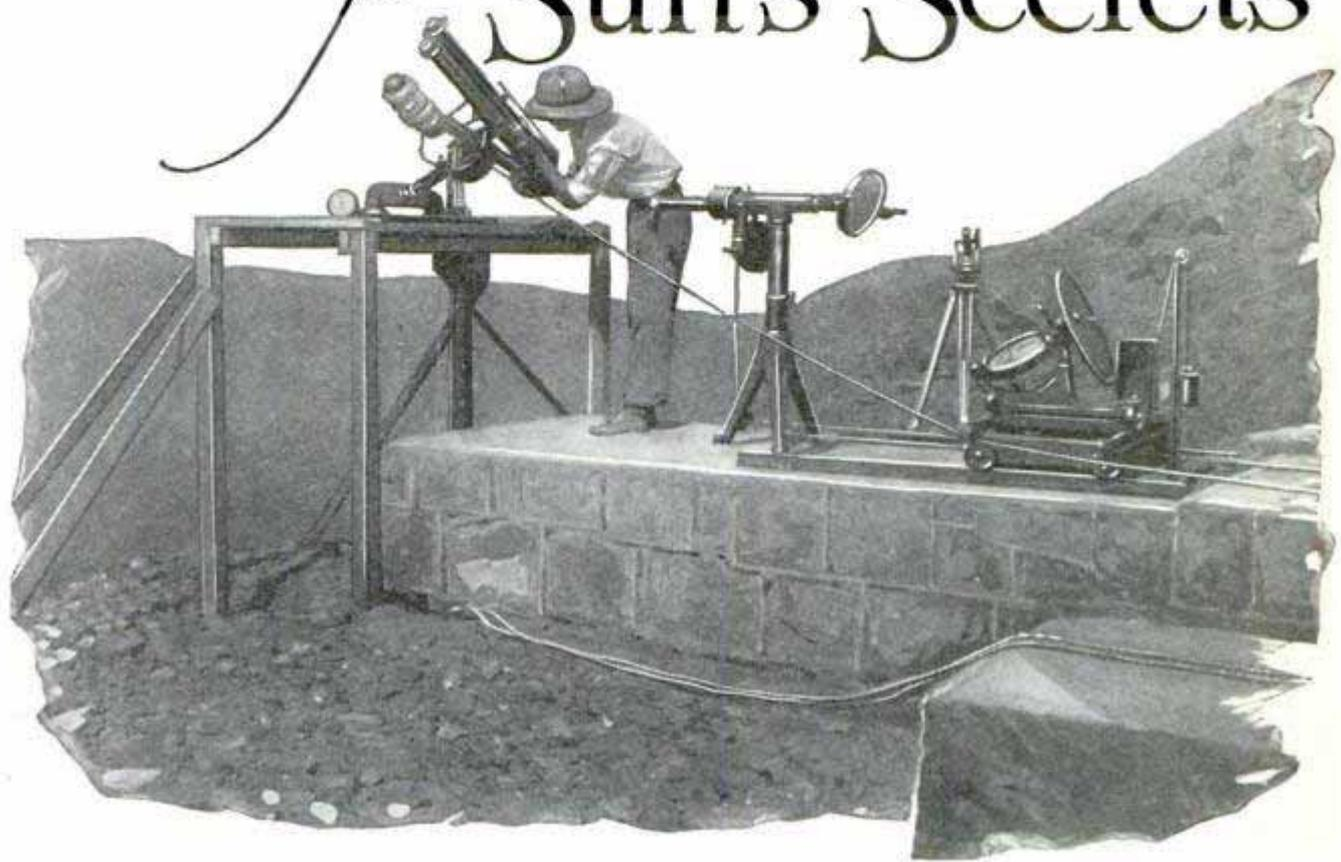

Observation Station on Mount Brukkaros in Southwest Africa, and Some of the Instruments Scientists Used in Making Observations of Sun Radiations during a Three-Year Period

By JOHN L. COONTZ, *714 Washington St. N. W., Washington D. C.*

PERCHED on top of a sun-baked mountain for three and one-half years, surrounded by deadly cobras and stalked by leopards; such was the fate of W. A. Hoover, Smithsonian scientist, who has just returned from South Africa, where he made solar radiation observations for the institution.

Mr. Hoover did his time on Mount Brukkaros, about 1,000 miles from Cape-town, in the heart of the Hottentot country, some eight miles from the nearest white man and sixty miles from the nearest settlement. His home was a wooden three-room structure covered with galvanized-iron sheets; his companions, his wife and baby, an assistant scientist, a cow and a few chickens.

"We'd open a door and push a cobra out of the way as a part of our morning routine," he declared, "and the leopards would come around, attracted by the

chickens which they hoped to feast on." Mr. Hoover had the unique experience of having a cobra spit deadly poison in his face. Fortunately the poison struck him on the cheek and did not touch his eyes, or he would have been blinded.

The ringhals cobra, native to the section where the solar observatory was established, shoots its poison at its intended victims as well as injecting it by contact through a bite. The powerful muscles controlling the poison glands of the snake are capable of projecting the destroying fluid a distance of six feet or more. Mr. Hoover, at the time he was attacked, was entering his storehouse. It was dark as he entered and he felt moisture suddenly on his cheek, as from a light spray. He sensed immediately what had taken place and lost no time in swabbing his face with his handkerchief, being careful to protect his eyes. His fright over, he retired, got

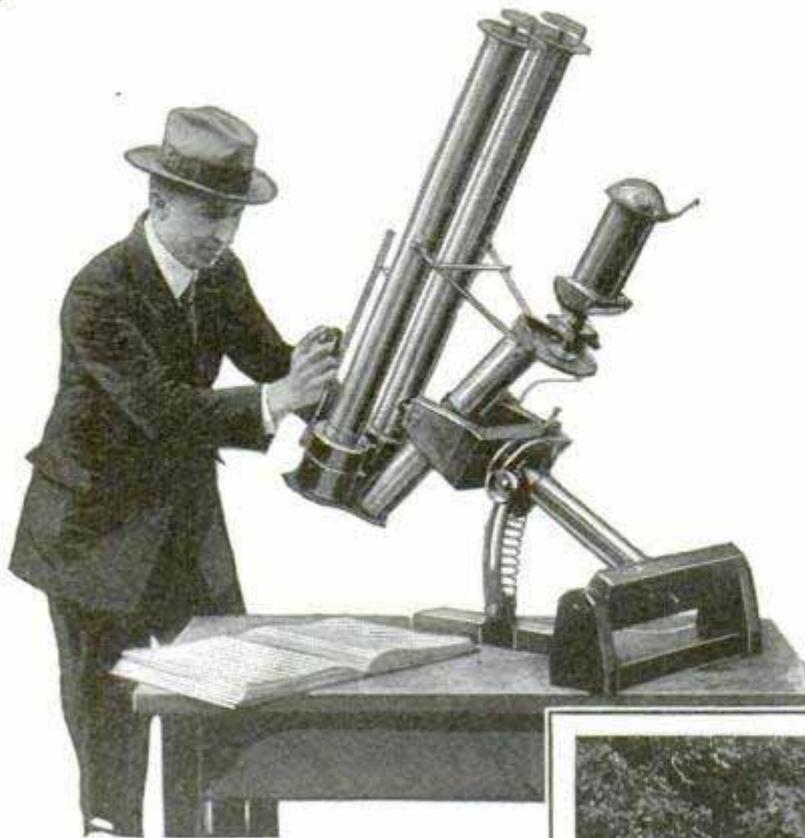

less refrigerator." This gave them ice cream in season—which was all the time—and enabled them to keep their food supplies in good condition.

The Hottentots, among whom the scientists lived, are not savage in the popular sense of the word as applied to African tribes. Many of them are Christians and nearly all affect the white man's dress, usually cast-off garments of nondescript character. Because they have never made war on the white man, these Hottentots enjoy a certain degree of local government, which is administered by the "captain" of the

a light and his gun and put an end to the snake.

The honor of bagging the first leopard ever to be killed with a .22 rifle belongs, perhaps, to Mr. Hoover and his assistant, Fred A. Greely. Hearing a noise that sounded like a lion one night and, the next morning missing three chickens, the two set out to track the marauder. Fortunately the robber was no more than a leopard which they soon cornered. It put up a fight, and charged, but rough ground was in their favor and after two or three shots they came off victorious.

Although cast in this isolated spot, Mr. and Mrs. Hoover and their companion were not without some of the comforts and conveniences of civilization. The first Christmas they were on the mountain the National Geographic society, whose grant of funds to the Smithsonian made possible the establishment of the observatory, gave them a radio. This made possible entertainment from the outside world during their leisure moments. A pressure oilstove gave them almost the service of a gas range and, with the advent of the "insides" of an electrical refrigerator, they managed to make for themselves an "ice-



Above, Pyrheliometer to Measure Heat of Sun's Rays; Below, Sun Cooker Made by the Scientists

tribe. The heat on Mount Brukkaros maintains a high average the year round. Rainfall throughout the region is not great—one of the reasons why the spot was chosen for radiation-observation work. There is no shade on the mountain and 100 degrees Fahrenheit is not unusual for months at a time. This "free" atmospheric condition makes possible an almost steady beat of the sun rays on the earth's surface.

Astronomical study of the sun and the compilation of a complete daily record of its radiation with a view to forecasting weather for long periods in advance, are the scientific aims of three solar observatories in different parts of the world.

LINER MODEL STEAMS THROUGH CROWDED HARBOR



Thirty-Nine-Foot Working Model of the Liner "Columbus," Whose Twin Motors Can Carry a Crew of Four Among the Ocean Liners in New York Harbor at a Speed of Eight Knots

Capable of making a speed of eight knots, a thirty-nine-foot working model of the North German Lloyd liner "Columbus" attracts much attention as it proceeds around the breakwater at the Battery in New York harbor. It is equipped with twin motors and twin screws, has a displacement of five tons, and carries a crew of four men, who occupy the curious position of being above and below deck at the same time.

filter consists of a funnel through the bottom of which protrudes a second funnel at the top of which is a protecting hood and a cone-shaped wire filter. Water and sediment are diverted into the trap formed by the lower section of the larger funnel, the gasoline proceeding through the wire filter into the inner funnel. The cone-shaped hood acts as a protection for the screen, a baffle plate and an anti-splash device and proves effective in breaking up the particles of water. It is particularly suited for fueling airplanes where gasoline with any water content may have serious results.

FILTER FUNNEL FOR GASOLINE STRAINS OUT WATER

4078

Water and sediment in gasoline are strained out without impeding the flow of the gasoline itself with a filtering funnel now on the market. The funnel replaces the slow method of straining through a chamois skin. The

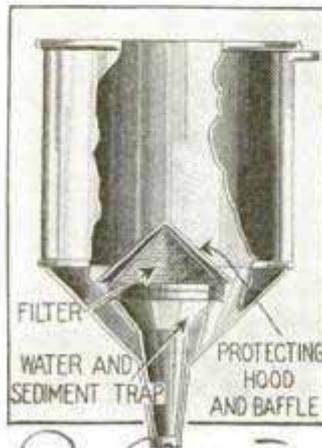

LAYING DRAIN TILE MADE EASY

4111

Laying drainage tile in irrigated lands is simplified in California by first going over the field with a mole drainer drawn by a tractor, which then pulls a string of tile into position. The tile sections are threaded on a rope, at the end of which is a plate to hold the last tile. With such an arrangement, it is possible to haul a string 200 feet long in one operation, saving much time and labor.

*Mr. Chas. R. Owens
1245 E. 1st St. Place*

*Mr. Dwight Loya
Capitol Hill Station*

4039
394

359 Edmonton St

POPULAR MECHANICS

Winnipeg, Man., Canada

CONQUERING RED TERROR OF THE WHEAT FIELDS

Wheat & former seed & nursery C. Faribault, Minn. retail - \$16.00 per bushel. \$12.00 per bu. \$1.20 per lb.



Redfield & Co.

Bureau of Plant Industry

resisting power of the other members of the wheat family. The amount of work involved is illustrated by the fact that the Winnipeg experts tested 150,000 separate plants in six months. One of the most successful rust-resistant wheats is the result of a fertile cross between Emmer and Marquis made by E. S. McFadden, a scientific farmer at Webster, N. Dak. For five years Dr. C. H. Golden, of the Winnipeg laboratory, and his staff of experts crossed plants and at

Laboratory Experiments in Crossing Wheat to Resist Rust, and Specimens of Rust-Proof Wheat That Were Thus Developed

Retail \$16.00 per bushel.

One of the most radical developments of recent agricultural research has been the discovery of rustless wheats. It is impossible to estimate the damage done by rust, but some idea of its proportions may be gained from the fact that, in 1927, it exceeded half a billion dollars in North America alone. What, then, is rust? The farmer knows it as the red-colored powder which covers the leaves and stems of wheat plants and transforms the promise of a fine crop into a wizened harvest. The expert knows it as a microscopic plant, closely related to such commonly known fungi as mushrooms and toadstools. Early experiments led them to believe that sulphur could be employed as a fungicide, but "dusting" proved only a makeshift. Rain washed off the protective armor; high winds, prevalent on the plains, prevented the dust from settling with the desired uniformity. These and other considerations convinced the experts that the real remedy is in a rustless wheat. On the one hand there are more than one thousand bread wheats, none of them immune to rust. On the other hand there are members of the wheat family which are rust-proof, but none of them will make a good loaf of bread. The plant breeders at Minnesota University and at the Canadian Rust Research Laboratory endeavored to so cross these wheats as to produce a bread wheat with all the rust-

present have eighty-six pure rust-resistant strains, twelve of which are equal to Marquis in quality, and one of them definitely superior to that king of bread wheats.

WIRE AND WOOD SCULPTURES RESEMBLE CARICATURES

Resembling somewhat in outline the caricatures of cartoonists, famous figures are sculptured in wire and wood by Alexander Calder. Instead of cutting the figures from stone, he twists a likeness from wire and mounts it on a wooden base. Among the models is one of the head of former President Coolidge.

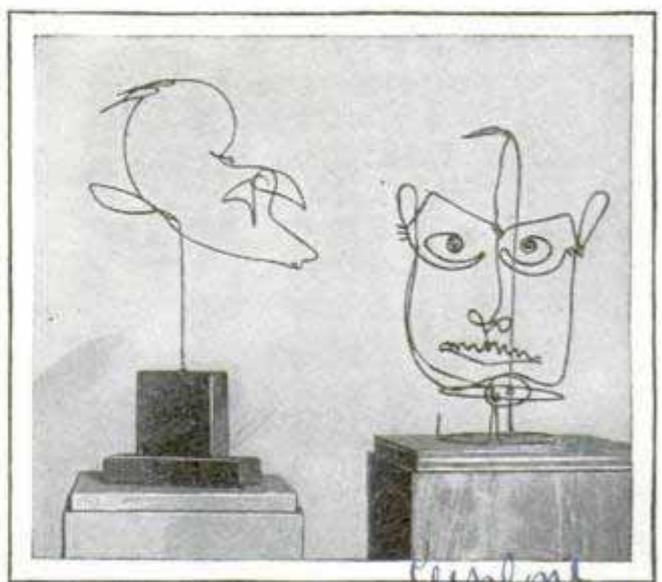

Two Examples of Wire Sculpture, the Figure at the Left Being of Former President Coolidge

151 W. 80 St. New York

England's Entry *in* Ocean Race

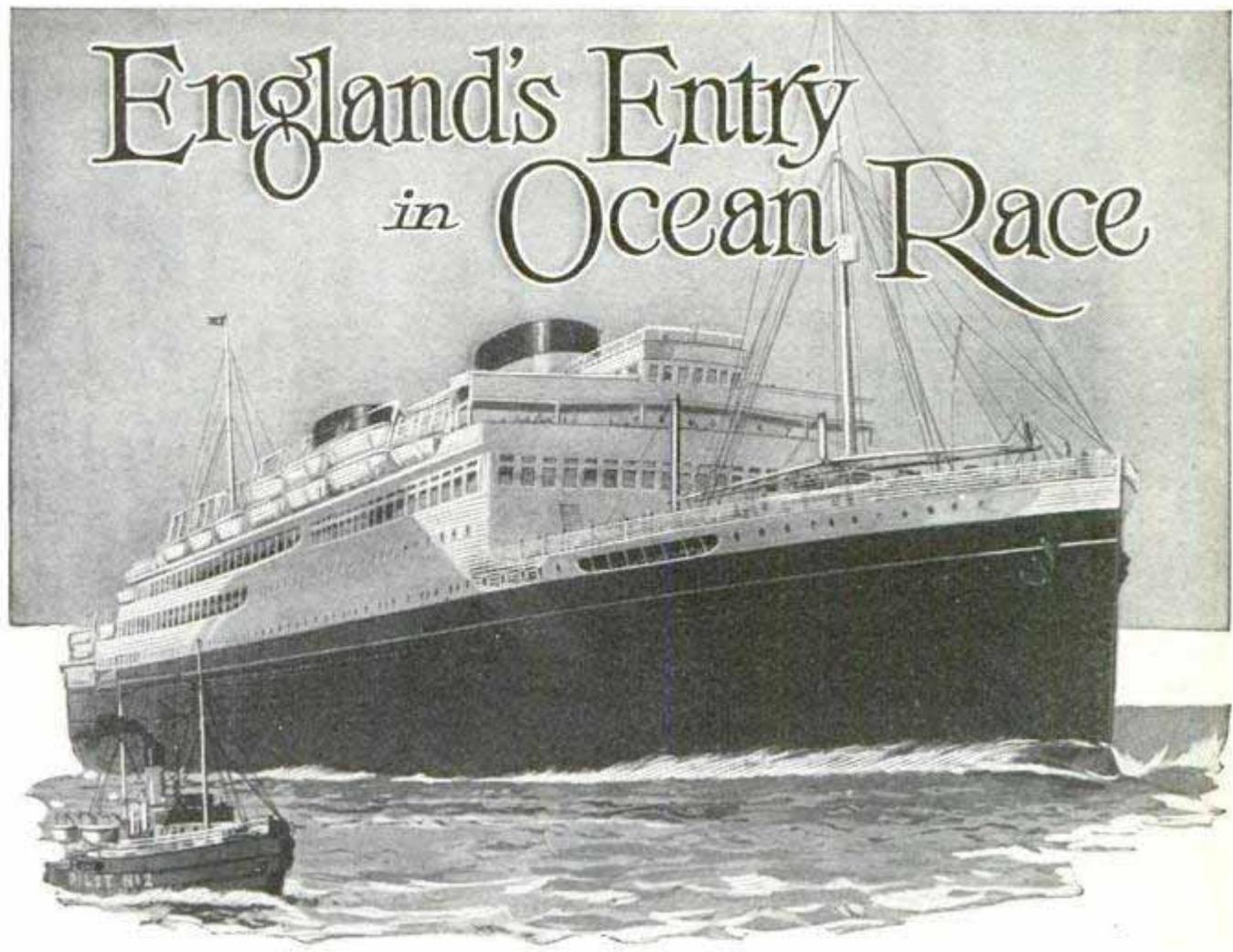

Artist's Conception of the "Britannic," Weighing 27,840 Tons and 680 Feet in Length; Note Design of the Hull to Cut Wind Resistance and the Stubby Racing-Type Funnels

ENGLAND'S entry in the great race for commercial supremacy on the Atlantic will be a 27,840-ton super-motorship, the "Britannic," to make her maiden trip this spring.

The liner is built to contours that offer least resistance to wind and water. She will have racing-type funnels, which give the appearance of sleekness and speed, and add a greyhound's grace to a man-made ship.

The new Atlantic challenger has an over-all length of 680 feet, which is considered very great for a motorship. Some notion of the stupendous electrical energy to be developed by her four Diesel-driven generators may be gathered by noting that this floating steel shell could anchor beside an ordinary city of 30,000 people and produce enough current to keep it running comfortably.

With enormous power in her engines, it is no wonder that practically all work aboard this super-ship can be performed

by electricity. An installation of 200 separate motors will peel potatoes, wash dishes, operate elevators, gears, pumps, steering apparatus and freeze ice cream, bake bread, drive printing presses and provide moving-picture entertainment. Two hundred miles of electric wiring will interconnect every room and compartment.

To keep the power plants from overheating, 13,000 tons of fresh water will circulate through jackets and cylinder covers, while 16,000 tons of sea water will pass through the lubricating-oil cooler and exhaust manifold before being discharged outboard.

The difference between these engines and that of the ordinary motor car lies in the method of firing the charge. In the automobile, a magneto fires the explosive mixture of gasoline. In the case of the "Britannic's" engines, the compression of each cylinder will be sufficient to ignite the vaporized crude oil. In the ordinary automobile, motive power is de-

Beam - 82 ft

Crankshaft weighs 185

Mo
sta
ter
is

Build by Harland & Wolff

veloped from the top side of each piston, while the "double-acting" motors in the "Britannic" will obtain power from both the bottom and top of each cylinder. The space occupied by her mammoth twin engines is equivalent to a garage large enough to park twelve seven-passenger limousines. Simply removing an exhaust or inlet valve, an engineer can climb bodily into each cylinder and inspect it.

The marine engineers have also applied their knowledge to the elimination of waste energy, and boast that they have succeeded in converting the exhaust-gas heat into steam at 100 pounds' pressure, which will perform menial labor around the ship.

The hull is designed along lines approved by the latest research with ship models, and is said to cut resistance to a minimum. To know that this shell of steel was first planned on paper with mathematical formulas is perhaps less wonderful than the fact that it is made up of hundreds of individual plates of alloy steel welded into a shapely mass by 3,000,000 rivets weighing 650 tons. The rudder itself weighs thirty-six tons, equal

to the displacement of a whole passenger ship of the seventeenth century.

As to the "Britannic's" possible speed, none of her architects or engineers will venture an opinion before she is given a trial run. They have made no claim that she will break any recent record for the Atlantic crossing, but they do hold that she will be the most modern vessel afloat when she is commissioned.

The comfort of the passengers will be stressed by the "Britannic's" appointments. Cabin, tourist and third class will provide commodious quarters for 1,550 persons. The cabin class will have a swimming pool and tennis court; the tourist and third classes will have a children's playroom and special elevators for communication between decks. The dining salon is, for the most part, two decks high, and is dignified by deeply recessed and richly paneled archways extending to a coffered ceiling.

The "Britannic's" appointments have aroused only a fraction of the interest that people show in her mechanical equipment, largely because Diesel-electric plants have only recently been adopted

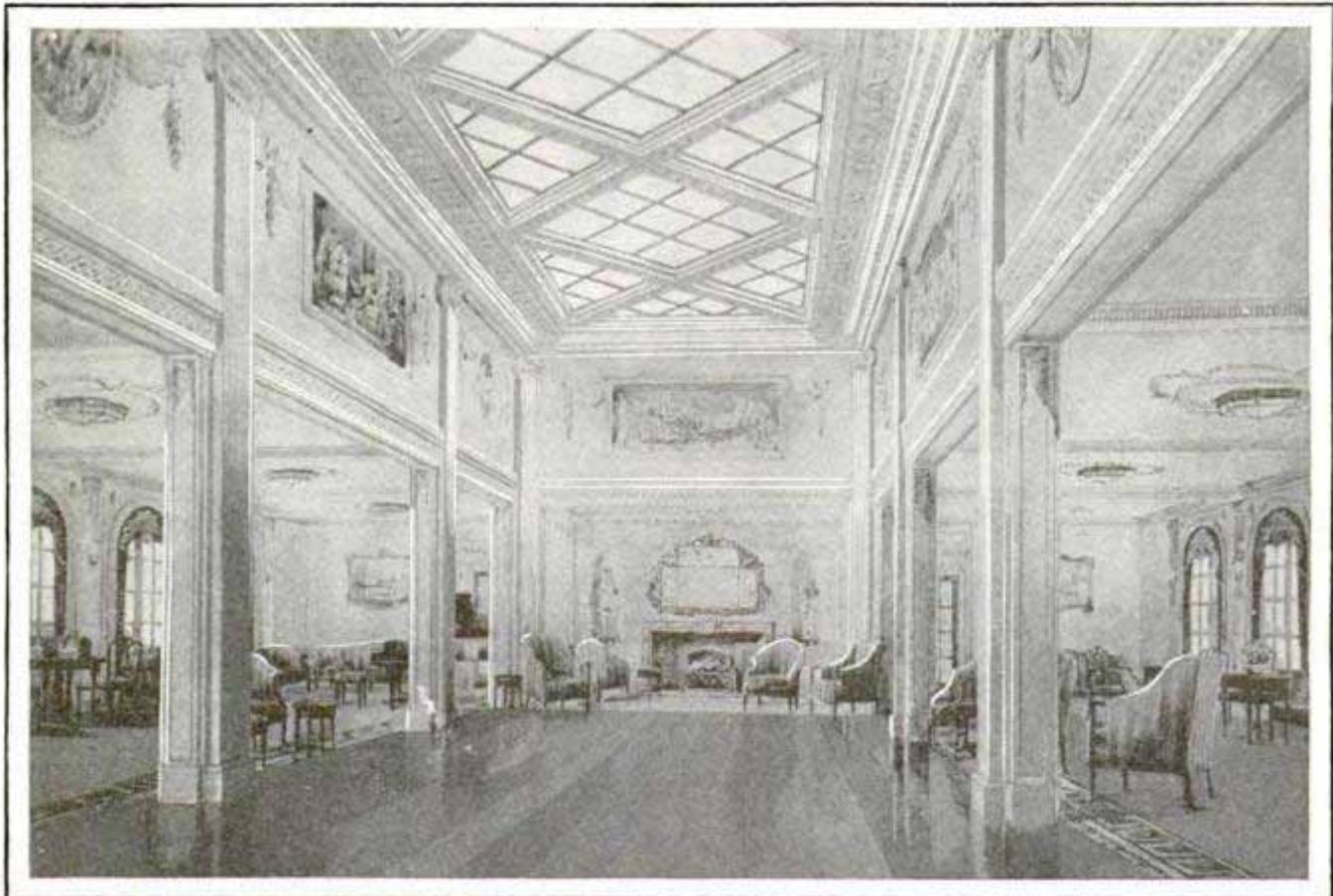

Luxurious Cabin Lounge of the "Britannic"; the Giant Motorship Also Is Equipped with Swimming Pools, Tennis Courts, Playgrounds and Electric Elevators for Travel between Decks

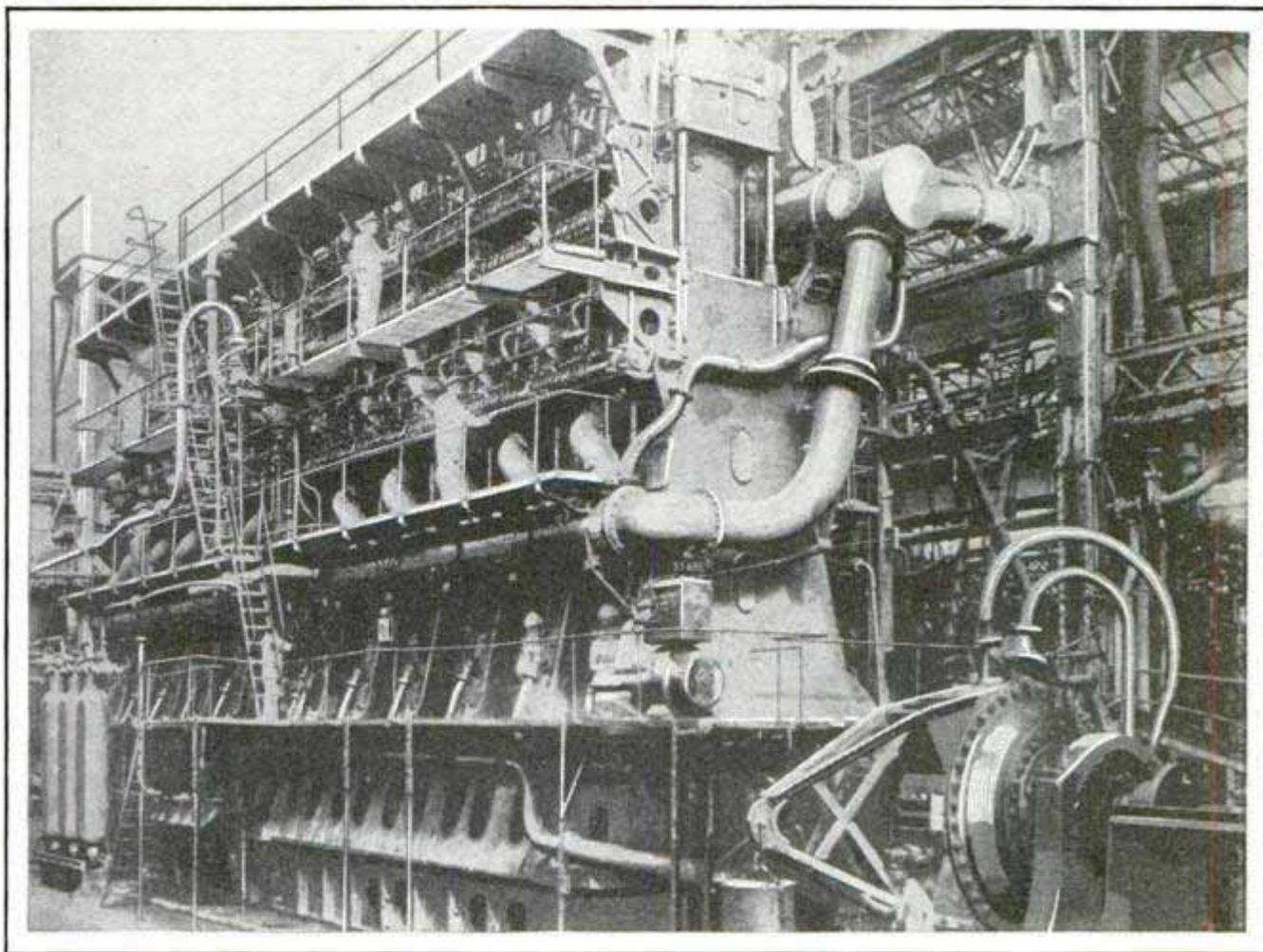

Picture of Starboard Engine of "Britannic" Taken Just Before It Was Placed in Ship; Its Cylinders Are Large Enough to Allow an Engineer to Climb into Them for Inspection

in fast ocean greyhounds. The Caspian steamer "Wandal," built in 1903, was the first sizable ship to employ an internal-combustion engine. Several submarine Diesels were fitted in German cargo ships after the war. Only since then have ship operators come to realize that Diesels in large passenger ships would mean a saving in space and running costs. In 1924, the "Gripsholm," 17,716 tons, was launched for the Swedish-American line. In the same year a great advance in tonnage was realized with the "Asturias," 22,000 tons, for the Royal Mail Steam Packet company. Since, the Italians, Germans, Hollanders and Americans have taken to motorships.

Peculiarly, all of these motorships could dispense with funnels, for they have only to get rid of their exhaust fumes. But it is for the pleasure of the public that shipbuilders give motorships funnels. A traveler might feel ill at ease were he to board a ship without one, and would certainly miss something, for a funnel adds to the grace of a ship's lines.

Since 1910, there has been a steady ten-

dency toward building more motorships. It may safely be said that half of the world's new ships are equipped with internal-combustion engines. A comparison between the old coal burners and the modern motorships indicates that there is an increase in a vessel's initial cost, but this is offset by a reduced fuel consumption, less bulk and weight, more cargo space, and a smaller payroll. In addition, oil burners offer more comfort to passengers, because they avoid soot. Ordinarily, a motorship can carry ten per cent more cargo than a coal burner.

The cost of bunkering a ship with oil is much less than coal bunkering. The number of stokers saved by liquid fuel is shown in the case of the "Olympic," whose four funnels have been converted from smokestacks to exhaust pipes. When she burned coal, the "Olympic" employed 246 men on her "black squad." After her conversion, she required only sixty men, and could have managed with less if ship operators had not heeded a plea from trade unions that unemployment would result.

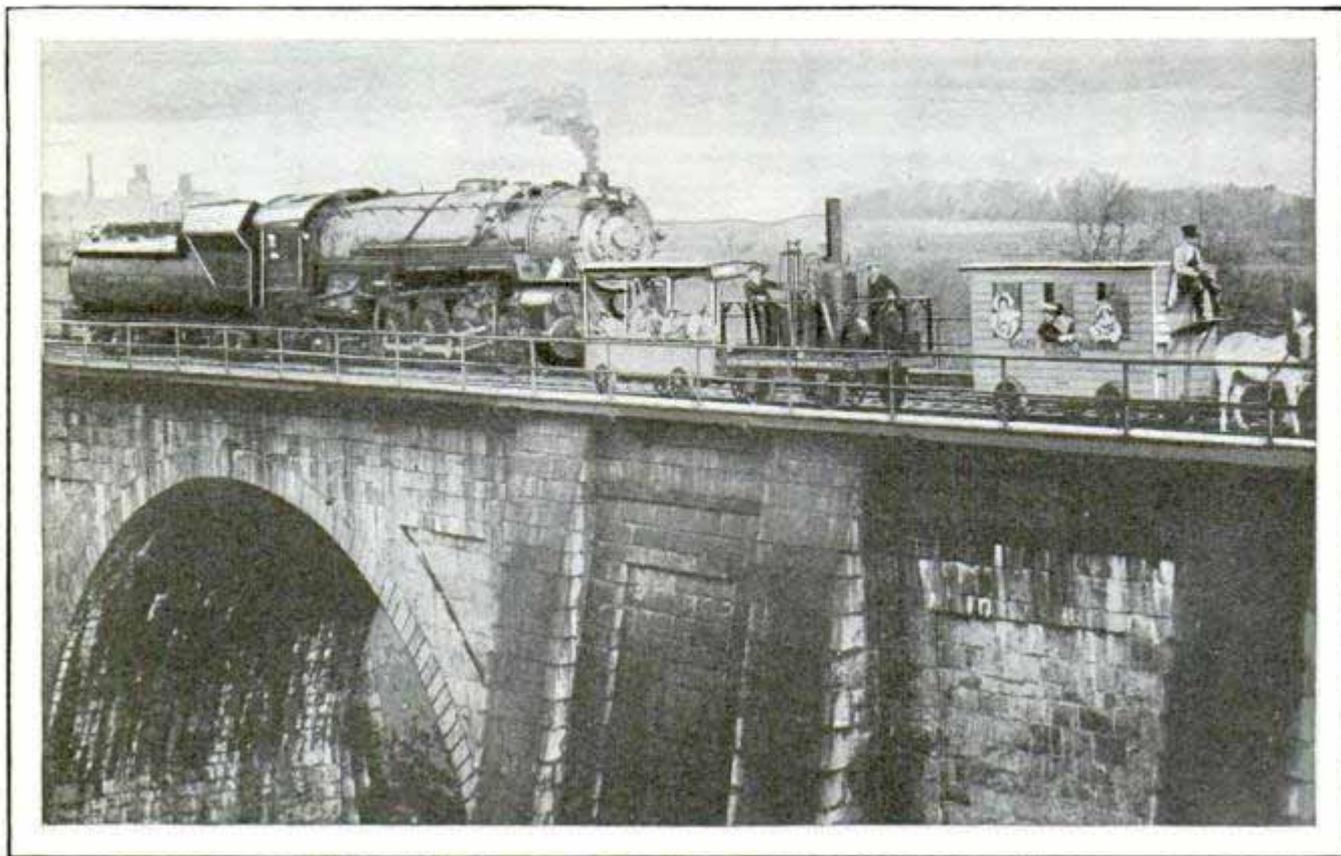
4060
 WHEN HORSES OUTRAN THE FIRST LOCOMOTIVES

© U. & U.

Stone Viaduct over Which First Baltimore and Ohio Train Was Run Still in Use in Maryland; over It Are Passing a Horse Car, a "Tom Thumb" Engine and a Modern Locomotive

Horse-drawn cars which raced America's early locomotives usually were declared winners because the engines were able to make a speed of only about eight miles an hour. At first wooden rails were used with an iron strip laid flat on top, but these were discarded when heat and frost caused them to curl up. The status of conductors was a grave question, some maintaining the conductor to have the standing of a general in charge of troops and others declaring him to be in the position of a gentleman-treasurer. In any event, the first conductors supported their dignity with plughats, frockcoats and high choker collars, using a large wooden box to collect cash fares and distributing heavy cardboard tickets which were used repeatedly. Passenger coaches were lighted at night with two candles, and as they were unheated, urchins earned pennies by selling hot stones to passengers as foot warmers. Much excitement was created when an engine, after many predecessors had failed, finally beat a horse. The engine made a trip in forty-five minutes, but the horse took seventy-five. First

trains of the Baltimore and Ohio railroad were operated over an old stone viaduct near Mt. Clare Junction, Md., one hundred years ago, and recently, over this same bridge, which is still in use, one of the old "Tom Thumb" engines puffed its way, preceded by a horse car and followed by the latest type of locomotive.

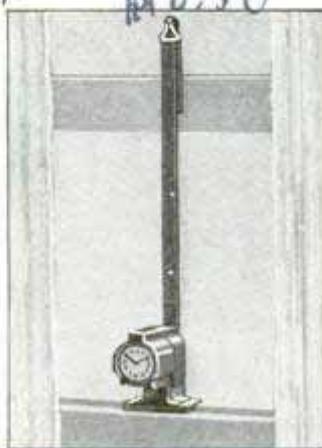
 4058
CLOCK PULLS DOWN WINDOW BEFORE YOU GET UP

4058 \$13.50

Closing the window of the bedroom on a cold morning is a task now performed by a clock which attaches to the window sill. The clock is set for a half hour or an hour before time to get up. A coiled spring provides the operating force, the clock tripping the spring's catch at the proper time, thus causing the

Lewis & Conger
 1st Ave

LOW PAY.. LONG HOURS.. ROUTINE.. NO FUTURE



Always worrying over money. Always skimping and economizing—going without the comforts and luxuries that every man **DESERVES** for his family and himself.



The Time Clock—a badge of hawk-like supervision and The Rut. A constant reminder that one is "just another name on the pay-roll."



Human cogs in a great machine. No chance to meet people, travel or have interesting experiences. A long, slow, tiresome road that leads nowhere.



Always wondering what would happen in case of a "lay-off" or loss of job. No chance to express ideas and ability—no chance to get ahead. **COULD** there be a way out?

I Said "Good-bye" to It All After Reading This Amazing Book—Raised My Pay 700%!

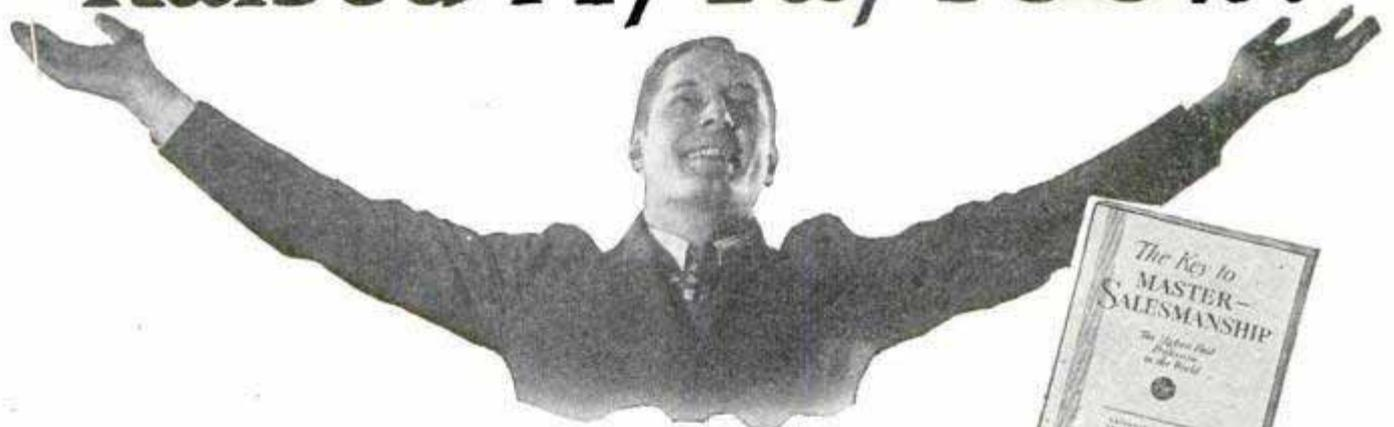

Where Shall We Send Your Copy—FREE?

WHEN a man who has been struggling along at a low-pay job suddenly steps out and commences to earn real money—\$5,000, \$7,500 or \$10,000 a year—he usually gives his friends quite a shock. It's hard for them to believe he is the same man they used to know—but such things happen much more frequently than most people realize. Not only one, but **HUNDREDS** have altered the whole course of their lives after reading the amazing book illustrated at the right.

True, it is only a book—just seven ounces of paper and printers' ink—but it contains the most vivid and inspiring message that any ambitious man can read! It reveals facts and secrets that will open almost any man's eyes to things he has never even dreamed of!

Remarkable Salary Increases

For example, R. B. Hansen, of Akron, Ohio, is just one case. Not long ago he was a foreman in the rubber-curing room of a big factory at a salary of \$160 a month. One day this remarkable volume, "The Key to Master Salesmanship", fell into his hands. And from that day on, Mr. Hansen clearly saw the way to say "good-bye" forever to low pay, long hours, and tiresome routine! Today he has reaped the rewards that this little volume placed within his reach. His salary runs well into

the 5-figure class—actually exceeding \$10,000 a year!

Another man, Wm. Shore of Lake Hughes, California, was a cowboy when he sent for "The Key to Master Salesmanship." Now he is a star salesman making as high as \$525 in a single week. L. H. Lundstedt, Chicago, read this free book—and raised himself from a stenographer to the head of a business with 600% increase in earnings. C. V. Champion of Danville, Illinois, raised his salary to over \$10,000 a year and became President of his company in the bargain!

A Few Weeks—Then Bigger Pay

There was nothing "different" about any of these men when they started. None of them had any special advantages—although all of them realized that **SALESMANSHIP** offers bigger rewards than any other profession under the sun. But, like many other men, they subscribed to the foolish belief that successful salesmen are born with some sort of "magic gift." "The Key to Master Salesmanship" showed them that nothing could be farther from the truth! Salesmanship is just like any other profession. It has certain fundamental rules and laws—laws that you can master as easily as you learned the alphabet.

City and traveling sales positions are open in every line all over the country. For years, thousands of leading firms have called on the N. S. T. A. to supply them with salesmen. Employment service is free to both

employers and members, and thousands have secured positions this way.

Free to Every Man

See for yourself **WHY** "The Key to Master Salesmanship" has been the deciding factor in the careers of so many men who are now making \$10,000 a year. Learn for yourself the **REAL TRUTH** about the art of selling! You do not risk one penny nor incur the slightest obligation. And since it may mean the turning point of your whole career, it certainly is worth your time to fill out and clip the blank below. Send it now!

National Salesmen's Training Association

Dept. C-102, N.S.T.A. Bldg. Chicago, Ill.

National Salesmen's Training Assn., Dept. C-102, N. S. T. A. Bldg., Chicago, Ill.

Without cost or obligation you may send me your free book, "The Key to Master Salesmanship."

Name.....

Address.....

City.....State.....

Age.....Occupation.....

Stop GROPING FOR WORDS!

Well, I said to Mr. er-er-er what's his name--you know who I mean--that if we were going to do business with his firm, they ought to act right-er-er-regardless of what anyone else said. You get what I mean?



IF you hesitate and stammer, and grope for words, if you say "er" or "what-do-you-call it," or "you know what I mean" instead of using exactly the right word to express your meaning—you tell every one that your mind is asleep. You publish the fact that your education has been sadly neglected. Your limited vocabulary shows clearly that you are dull and uninteresting.

Every time you talk, every time you write, you show what you are. When you use the wrong words, when you mispronounce or misspell a word, when you punctuate incorrectly, when you use flat, ordinary words, you handicap yourself enormously. A striking command of English enables you to present your ideas clearly, forcefully, convincingly. If your language is incorrect it hurts you more than you will ever know, for people are too polite to tell you about your mistakes.

For many years Mr. Cody, one of our greatest authorities on English, studied the problem of creating instinctive habits of using good English. After countless experiments he finally invented a simple method by which you can acquire a better command of the English language in only 15 minutes a day. Mr. Cody's students have secured more improvement in five weeks than previously had been obtained by other pupils in two years.

Send for Free Book on English

To achieve your ambition it is essential that you use good English as instinctively as you tie your shoes. Business today demands men and women who use correct, concise, forceful language. Society demands education and culture, demonstrated by the use of correct, interesting, and convincing language.

A new book explaining Mr. Cody's remarkable method is ready. This new free book, "How You Can Master Good English—in 15 Minutes a Day," will prove a revelation to you. Send the coupon or a letter or postal card for it now. Address SHERWIN CODY SCHOOL OF ENGLISH, 53 Searle Building, Rochester, N. Y.

SHERWIN CODY SCHOOL OF ENGLISH
53 Searle Building, Rochester, N. Y.

Please send me your free book, "How You Can Master Good English—in 15 Minutes a Day."

Name.....
Address.....

Easy as A-B-C

Play any instrument in a few months

THIS SIMPLE WAY!

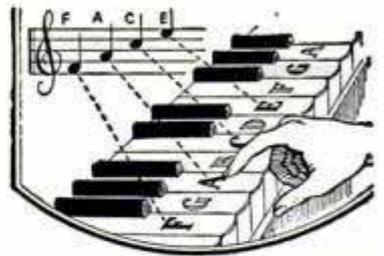

ANY one can easily learn music by this remarkable new method. And the cost is only a fraction of the old slow way. You don't need a private teacher. You study entirely at home. Almost before you realize it you are playing real melodies, both popular and classic. This wonderful new method of reading and playing music is almost as simple as reading a book. The lessons come to you by mail at regular intervals—complete printed instructions, diagrams, all the music you need. You select your own time to practice. The cost averages only a few cents a day, including the music. Learn to play and your popularity will double.

Free Book Tells All

Our free booklet, "Music Lessons in Your Own Home"—contains an offer that makes the course available at a very low price. Also a Free Demonstration Lesson which shows how delightfully quick and easy this wonderfully simple Method is. Instruments supplied when needed, cash or credit. If you really want to become a good player on your favorite instrument, write now—today—to U. S. SCHOOL OF MUSIC, 73-A Brunswick Bldg., New York City.

LEARN TO PLAY BY NOTE

- Mandolin Saxophone
- Piano 'Cello
- Organ Ukulele
- Violin Cornet
- Banjo Trombone
- Or Any Other Instrument

Electrical Engineering

Course for men of ambition and limited time. Over 5000 men trained. Condensed course in Theoretical and Practical Electrical Engineering including the closely related subjects of Mathematics and Mechanical Drawing.

Students construct motors, install wiring, test electrical machinery. Course designed to be completed in one college year. Prepare for your profession in the most interesting city in the world. Est. 1893. Catalog on request.



Bliss Electrical School

133 Takoma Ave., Washington, D. C.

LAW

STUDY AT HOME
Become a lawyer. Legally trained men win high positions and big success in business and public life. Be independent. Greater opportunities now than ever before. Big corporations are headed by men with legal training. Earn \$5,000 to \$10,000 Annually during spare time. Degree of LL.B. conferred. LaSalle students found among practicing attorneys of every state. We furnish all text material, including fourteen-volume Law Library. Low cost, easy terms. Get our valuable 64-page "Law Guide" and "Evidence" books FREE. Send for them NOW. LaSalle Extension University, Dept. 364-L, Chicago
The World's Largest Business Training Institution

LEARN WATCHMAKING

and become independent. We help you secure a position. Easy to learn. Send for FREE CATALOG.
ST. LOUIS WATCHMAKING SCHOOL Dept. 5. ST. LOUIS, MO.

Learn the Code with Teleplex!

Be an expert Morse or Continental code operator! **BIG PAY—TRAVEL—FUN—ADVENTURE.** After a few short weeks of practical study with Teleplex you will be an expert operator. This amazing instrument teaches you right in your own home. Works automatically. No knowledge needed—beginners learn at once! **Not a school. Free 10 days' trial. Write for free booklet K-10. TELEPLEX COMPANY, 72 CORTLANDT ST., NEW YORK CITY**



NOW You Can Be A College-Trained Draftsman Without College Cost!

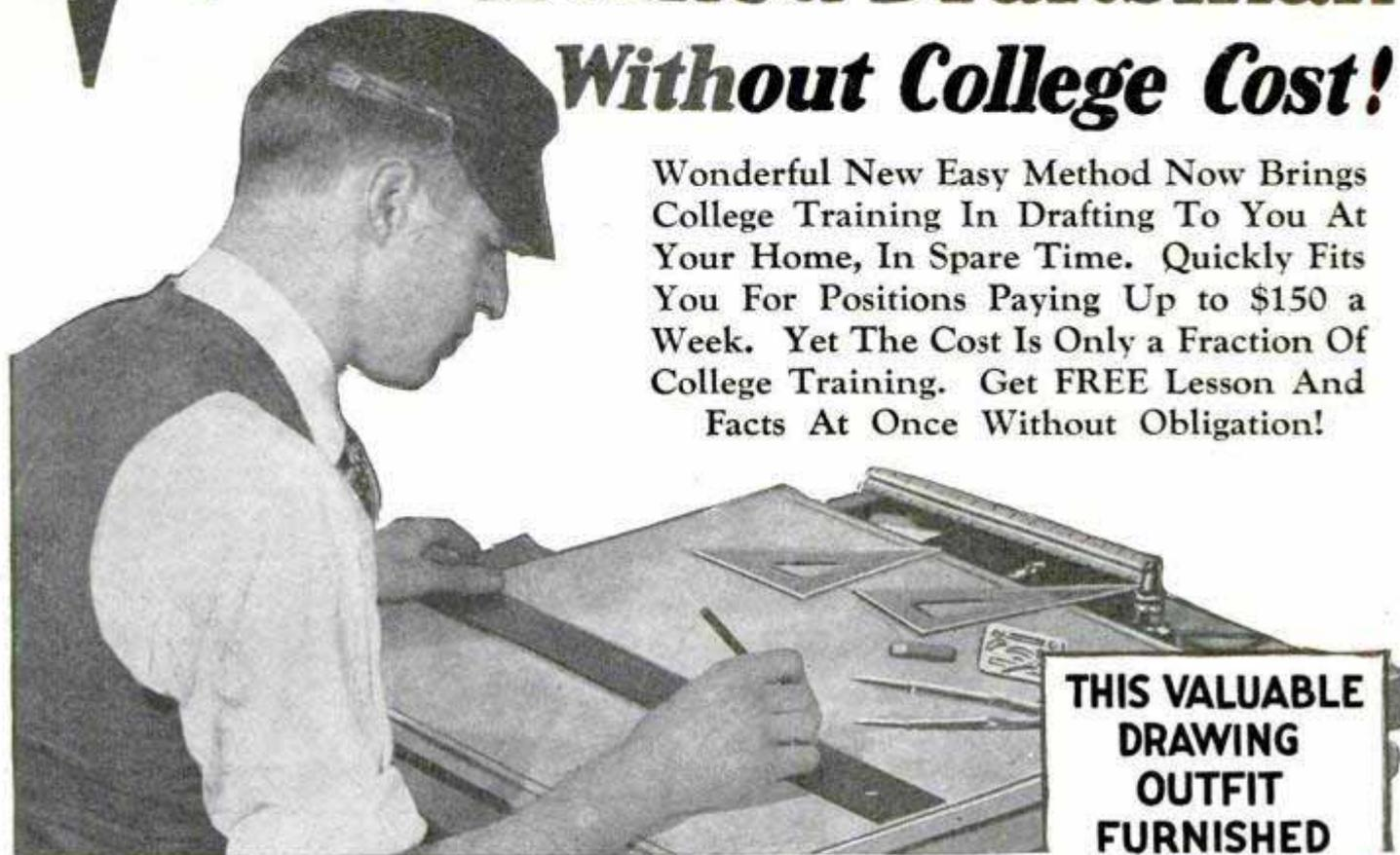

Wonderful New Easy Method Now Brings College Training In Drafting To You At Your Home, In Spare Time. Quickly Fits You For Positions Paying Up to \$150 a Week. Yet The Cost Is Only a Fraction Of College Training. Get FREE Lesson And Facts At Once Without Obligation!

**THIS VALUABLE
DRAWING
OUTFIT
FURNISHED**

Learn Professional Drafting While You Earn . . . This Easy, Fascinating Way!

Here's great news for every ambitious man who wants a real pay job in Drafting! As a result of a marvelous, practical home-study method developed by Chicago Tech, you can now become a College Trained Draftsman and prepare yourself for a big-money drafting job right at home in your spare time!

**Entirely Different . . .
Simple as A.B.C.**

Just the kind of practical training that employers are looking for in the men they hire! Training from an old-established College known and recognized the world over.

Unlike ordinary schooling. Think of

it—no hard text-books to master—no involved problems to solve! Easy and practical throughout. You get the same fine drawing outfit, the same interesting lessons prepared by trained experts and the same practical instruction as prepared and taught right at the College. In a few short weeks you master all the big-money principles you need to qualify you for a fine drafting position!

Drawing Outfits FREE of Extra Cost

A full set of fine drawing instruments in handsome pocket case, special drawing table and high-grade drawing outfit included without extra cost. Everything you need furnished!

You owe it to yourself to at least investigate this astonishing College-Training-In-Drafting-At-Home at once! The Coupon brings full convincing facts and valuable lesson FREE! Mail it this very minute!

FREE!

Send no Money. Just fill in and mail the coupon below NOW! You will at once receive absolutely free a trial lesson that shows you how remarkably easy and fascinating it is to learn College Drafting right in your own home, without leaving your job. It will pay you to investigate at once, if you want a real pay job in drafting!

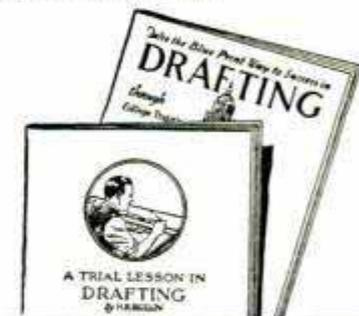

CHICAGO TECHNICAL COLLEGE

Dept. C-203, Home Study Division
118 E. 26th St., Chicago, Ill.

If you live nearby, visit the College. See how we train Draftsmen for big pay jobs. More than 1,000 attend every year.



Chicago Technical College,
Dept. C-203, Home Study Division,
118 E. 26th St., Chicago, Ill.

Send me at once the FREE sample lesson and complete facts about your new easy system that enables men to master College Drafting Training at home just as you teach it at the College in Chicago. This does not obligate me in any way.

Name.....

Address.....

Town..... State.....

Age..... Occupation.....

Check here if you prefer to come to Chicago for our short course in drafting. Opportunities to earn while you learn.

Students at work on 1929 Packard Six, 8. Other 1929 Models include: Buick, Study, Marmon, Auburn, Nash, Reo, Essex, De Soto, Chev., Ford, Oakland—and 11 more chassis.

\$25,000 worth of 1929 cars for you to work on!

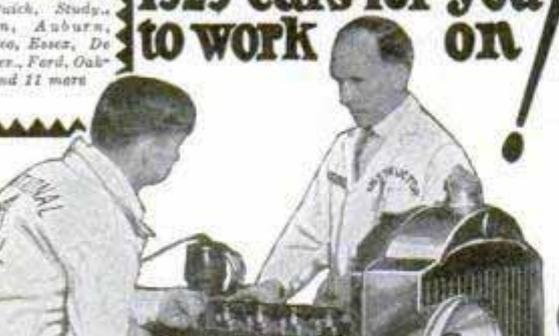

Learn Autos IN LOS ANGELES

and LEARN IT RIGHT!

1. NATIONAL—America's Best Equipped Auto School

NATIONAL is a Million Dollar institution—established in Los Angeles in 1905—recognized throughout the automotive industry as one of America's foremost trade schools. NATIONAL offers practical, intensive training in all automotive branches. No age limit. No previous experience necessary. You learn by "Actual-Shop" Methods. Life Scholarship privileges. Start any time of the year.

2. NATIONAL Qualifies YOU to Make Good

NATIONAL properly trains you in the Auto Trades in the short time of 4 to 6 months. Upon completing this Condensed Course you are fully qualified as a Practical, Competent Automobile man, and you have not risked your chances of employment because of inferior, incomplete instruction.

3. NATIONAL Guarantees YOU Efficient Employment Service

NATIONAL GUARANTEES to give unlimited and efficient Employment Service to students wishing to earn living expenses while learning; and to graduates getting started in the automobile field. This is the most any reputable school can be expected to do.

4. NATIONAL'S Training in Every Man's Reach

NATIONAL offers YOU the very best technical-practical training that money can buy at a cost within every man's reach. It does not offer to pay your railroad fare, room and board or other personal expenses, preferring to limit its activities to the PROPER TRAINING OF MEN FOR SUCCESS.

5. Come to LOS ANGELES—the Playground of America!

LOS ANGELES is the heart of the country's most prosperous automobile section—as well as the world's most ideal city in which to live and prepare for success in the auto game.

WRITE for FREE BOOK NOW

National Automotive School

NATIONAL AUTOMOTIVE, Dept. 732, 4006 Figueroa St., Los Angeles, Calif.

Send me, absolutely free, your big illustrated catalog of Automotive Opportunities.

Name.....

Address.....

Age..... City..... State.....

Your Future assured!

National Automotive
LOS ANGELES

Learn SIGN and SHOW-CARD WRITING

In spare time, few hours weekly

FREE "Book of Facts" — Write For It



Fascinating profession. Big opportunity in this fast-growing trade. Earn while you learn the sign arts. No talent or experience required. Be your own boss or obtain a good position. Learn show cards, posters, bulletins, signs, advertising layouts and allied subjects. We teach by mail or at our school. Quick results—easy to learn.

EARN \$50 TO \$200 WEEKLY

Otto C. Wiegand, Md., home-study graduate, made \$12,000 from his business in one year. Many successful graduates. Oldest and foremost school. Don't delay. Write for complete information.

DETROIT SCHOOL OF LETTERING

193 Stimson Ave. Est. 1899 DETROIT, MICH.

WORLD NEEDS PLUMBERS

Old style plumbers are fading like the horse and buggy. The world demands modern Plumbing and Skilled Trained Mechanics to do it. Unlimited, swift growing field. Make \$50 to \$100 a week or start own shop. We train you quick. Learn in 8 to 12 WEEKS to do any job with skill and science. Need no previous experience. Strictly tool using system. Opportunity knocks. Investigate today—amazing offer—low tuition. World's greatest school.

Write—

UNIVERSAL PLUMBING SCHOOL

2130 Troost Ave. Kansas City, Mo.



Learn Watchwork, Jewelrywork and Engraving

A fine trade commanding a good salary, and your services always in demand. Address **Horological, Dept. P, Bradley Institute, PEORIA, ILLINOIS**, for our latest catalog.

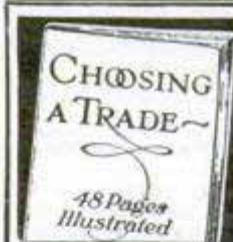

SENT ON REQUEST

Helpful discussion of this important problem and of fastest growing of Mechanical Trades—Mechanical Dentistry. Easily learned. Of interest to men of all ages. Send for Bulletin 2.

BODEE INSTITUTE

1765 Broadway, New York
1305 N. Broad St., Philadelphia
86 Court St., Brooklyn

ELECTRICAL ENGINEERING

Intensive, practical—technical courses. Engineering degree in 2 years. Diploma in 1 year. Also Special Short Courses in Practical Electricity—Power Plant Operation—Armature Winding—Radio—Electric Refrigeration—Aviation Electricity—Electric Welding. LOW TUITION RATES. Faculty of recognized experts. Extensive Laboratories. Free employment service for graduates. We help secure part-time work during training. 28th year. Write for catalog.



FINLAY ENGINEERING COLLEGE 1001-A Indiana Ave. Kansas City, Mo.

A Card Case Any MASON Would Be Proud To Own



Protects your lodge cards, \$1 auto license, passes, etc. under isinglass windows, **1** ready to be seen at a glance. A genuine leather, 5-window sturdy card case, extra pocket—snap button—gold corners, for only \$1.

Stamped with Masonic Emblem in heavy gold FREE—Same price without emblem. Name and other stamping 35c a line extra. Larger cases, 9 windows \$1.50, 13 windows \$2. Send for Catalogue.

Masonic Books, Monitors, Jewelry.
 Lodge Supplies. [Check Choice]

REDDING MASONIC SUPPLY CO. 200 Fifth Ave., Dept. P.M., New York

POCKET EDUCATORS

For all BUILDERS AND MECHANICS



Read Audels Pocket Educators for advancement and profit in your work. Every mechanic in the building trades should have this inside trade information at his fingers' ends. Learn the scope and possibilities of your profession. Any job can be done better if you are well informed. To earn more, learn more.



AUDELS CARPENTERS AND BUILDERS GUIDES—4 VOLS. \$6

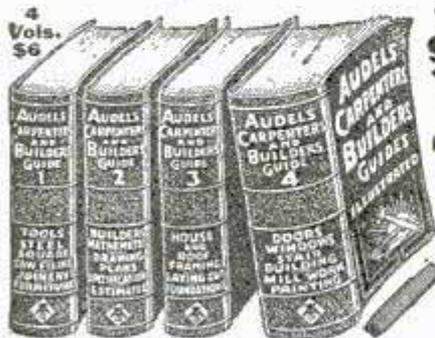

\$1 PER MO.

Inside Information for Carpenters, Builders, Joiners, Building Mechanics—all Woodworkers. **1600 pages; 3700 diagrams; flexible; pocket size.** Short-cut instructions, new methods, ideas, solutions, plans, systems—money saving suggestions. An easy progressive course for the apprentice. A practical daily helper and Quick Reference for the master worker. A Helping Hand to Easier and Better Work and Better Pay. To get this aid for yourself, simply fill in and mail the FREE COUPON below.

INSIDE TRADE INFORMATION ON:

How to use steel square; How to file and set saws; How to build furniture; How to use mitre box; How to use chalk line; How to use rules; How to make joints; Carpenters' arithmetic; Mensuration problems; Estimating strength of timbers; How to set girders and sills; How to frame houses and roofs; How to estimate costs; How to build houses, barns, garages, bungalows, etc.; How to read and draw plans; Drawing up specifications; How to excavate; How to use settings 12, 13 and 17 on the steel square; How to build hoists and scaffolds—skylights; How to build stairs; How to put on interior trim; How to hang doors; How to lay floors; How to paint.

"Audels Guides worth four times their price—handy too as I carry them in pocket for reference." W. J. Bates, Knoxville, Pa.



\$1 PER MO.

AUDELS PLUMBERS AND STEAMFITTERS GUIDES—4 VOLS. \$6

A new set—just out! A practical, illustrated, Reference Library and Study-Course for Master Plumbers, Journeymen and Apprentice Steamfitters, Gas Fitters and Helpers, Sheet Metal Workers, Draughtsmen, Master Builders, Engineers and all Building Trade Students. **1670 pages; 3642 diagrams; flexible; pocket size.** Guides explain all the principles, advances and short cuts of the Plumbing and Heating trade. Contains instructions on how to figure and estimate jobs. Use FREE COUPON below to examine, without obligation, this valuable work.

INSIDE TRADE INFORMATION ON:

Soldering, tinning, joint wiping, bending, beating, Pipe—iron—steel, threading, Mathematics, tables, physics. Materials—iron, steel, copper, brass, lead, tin, antimony. Sheet metal—galvanized—plate. Sanitation, syphonage, tanks, Drainage, sewage, purification. Fixtures—bath—kitchen. Pipe fittings, soil pipe, tools. Laying out work. Roughing, screwed fittings, flanges, joints. Pipe bending, examples. Elbows. Heating, ventilation, refrigeration. Water supply, mains, wells, tanks. Gas-fittings. Underwriters. Sheet metal work, problems, methods, brazing, heating, lead burning. Welding, various welds, methods. Blacksmithing, forges, tools.

"Audels Guides are practical, easy to understand, reliable. Cover the field in plain language." W.F. Arminger, Annapolis, Md.



\$1 PER MO.

AUDELS MASONS AND BUILDERS GUIDES—4 VOLS. \$6

A new, complete, illustrated trade reference library, for Bricklayers, Cement Workers, Plasterers, Tile Setters and Stone Masons, including a practical outline of Steel Construction. **1100 pages; 2067 diagrams; flexible; pocket size.** A practical Trade Assistant explaining modern methods of masonry construction. Easy to understand and apply. A reliable and authentic reference work and study-course for Master Journeyman and Young Mechanic. Use FREE COUPON below and find out for yourself, without obligation, whether this set will benefit you.

INSIDE TRADE INFORMATION ON:

Bricklaying, tools, materials; Brick designs, patterns, bonds; Setting frames and foundations; Mortars, scaffolds, estimating; Mortars and mortar mixing; Tile setting, mosaic, hollow tile; Straight edge test, troweling; How to figure brick work; Safe loads, piers, chimneys; Boiler settings, anchors, fire stops; Labor tables; Concrete, forms; How to figure concrete work; Stucco—on old and new buildings; Plastering; Plasterers agreement; Plastering on various surfaces; Stonemasonry; Cutting, finishing, estimating stone; Derricks, rigging; Steel construction; Fire proof; How to read blue prints.

"Audels Masons Guides are the best books on the subject. Have laid brick 12 years and am able to judge." H.A. Sonnett, Corliss, Pa.



PRACTICAL ELECTRICITY — 1 VOL. \$4

Audels Handy Book of Practical Electricity is a simplified Ready Reference and Study Course in one pocket size, leather bound volume—for Engineers, Professional Electricians and Students. **1040 pages; 2600 diagrams; flexible red leather bound.** A reliable authority and handy helper for every electrical worker. Contains important and valuable wiring diagrams, calculations, machine sketches, helps on maintenance and repair. Use this FREE COUPON today and find out, without obligation, how this handy book will help you in your daily work.

Complete in one handy, red leather bound volume

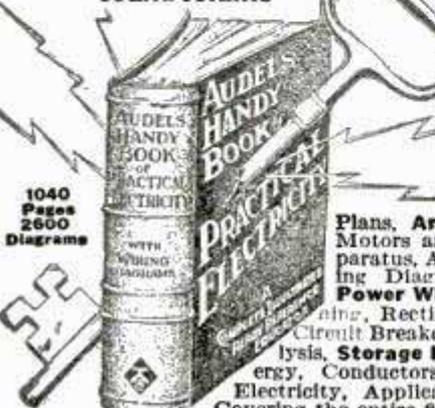

INSIDE TRADE INFORMATION ON:

Electro-Therapeutics, X-Rays, Shocks, Welding, Brazing, Radio Hook-ups, Motion Pictures, Telephone, Telegraph, Cranes, Bells, Elevators, Pumps, Tools, Ship Drive, Railways, Vehicles, Automobile Electric Systems, Ignition, Generation, Lighting, Plant Management, Power Plans, Armature Winding, Repairing, A. C. Motors and Apparatus, D. C. Motors and Apparatus, Alternator Construction, Dynamos, Wiring Diagrams, Sign Flashers, Cable Splicing, Power Wiring, Outside Wiring, Switches, Lighting, Rectifiers, Converters, Transformers, Fuses, Circuit Breakers, Rheostats, Electro Plating, Electrolysis, Storage Batteries, Magnetism, Electrical Energy, Conductors, Insulators, Static, Dynamic, Radio Electricity, Applications, Ready Reference and Index Covering the entire field of Modern Electricity

Learn More and You Will Earn More!

Know your job and you'll never be without one. The skilled man is always in demand. Knowledge is power. Learn your trade thoroughly by easy reading. This coupon is your opportunity for advancement and better pay. You risk nothing in sending for Audels Guides for free examination. Send it NOW!

FREE EXAMINATION COUPON

THEO. AUDEL & CO., 65 W. 23 ST., NEW YORK CITY

Please mail me for free examination the books marked (x) below. If I find them satisfactory, I agree to mail \$1 in 7 days, on each set ordered, and to further mail \$1 monthly on each set until I have paid the purchase price.

- 4 CARPENTERS GUIDES \$6
- 4 PLUMBERS GUIDES \$6
- 4 MASONS GUIDES \$6
- 1 ELECTRICIANS HANDY BOOK \$4

NAME

ADDRESS

OCCUPATION

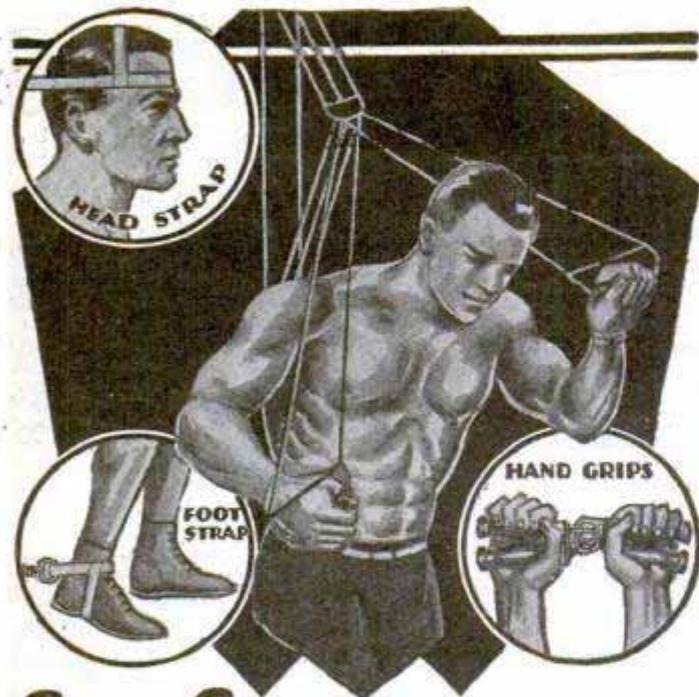

GET STRONG with these 6 improved Muscle Builders..All for \$5.00

Realize your ambition and develop muscles of a super-man. **Get strong!** Easily master feats which now seem difficult—or if you want physical culture for your health's sake, this equipment is what you need. With this special offer you **save at least half.** We furnish 10 cable chest expander adjustable to 200 lbs. resistance. Made of new live extra strength, springy rubber so as to give resistance you need for real muscle development. You also get a pair of patented hand grips for developing powerful grip and forearms. We include wall exercising parts which permit you to develop your back, arms and legs—a real muscle necessity. The head strap permits you to exercise muscles of your neck. Develop leg muscles with foot strap furnished. This gives speed, endurance. In addition you get specially written course containing pictures and diagrams showing how to develop any part of your body. **Act now!**

Send No Money

Sign name and address to coupon and rush to us. We send everything by return mail. Pay postman \$5.00 plus postage. (If you desire, send money order now and we pay postage.)



CRUSADER APPARATUS CO.,
Dept. 103, 44 Parker Ave., Maplewood, N. J.

I accept your offer. Send me everything described in your advertisement by return mail. I will pay postman \$5.00 plus postage on arrival. It is understood if I am not entirely satisfied after examination I can return the goods and you will refund my money.
Note:—No C. O. D. Orders to Foreign Countries or Canada.

Name.....
Street.....
City..... State.....

Learn to Write

I Teach by Mail

I can make a good penman of you at your home during spare time, no matter where you live or how poorly you now write. My simplified system has shown thousands of others the way to good penmanship during the past thirty-five years—it can and **WILL** do the same for YOU!

Thos C. Swope
My signatures above and below show the wonderful improvement I've made in less than six months after beginning your course.
THOS. C. SWOPE, Rt. 2 Gillespieville, O.
Thos Cwope

Beautifully Illustrated Book
"HOW TO BECOME A GOOD PENMAN"
FREE!

It contains information, testimonials and beautiful specimens of penmanship, showing what others have accomplished by the Tambllyn System. (Your name elegantly written on a card if you enclose stamp.) Write today, Address

F. W. TAMBLYN
418 Ridge Bldg., Kansas City, Mo., U. S. A.

F. W. Tambllyn

WHY NOT spend Spring, Summer and Fall gathering butterflies, insects? I buy hundreds of kinds for collections. Some worth \$1 to \$7 each. Simple outdoor work with my instructions, pictures, price-list. Send 10 cents (not stamps) for my illustrated Prospectus before sending butterflies.

MR. SINCLAIR, DEALER IN INSECTS,
Dept. 6. Box 1424. San Diego, Calif.

LEARN WATCH REPAIRING

You can learn by our modern and original system of instruction every part of the **Watch Repairing Trade** at home as good or better than at a shop. You can earn money while learning and secure a well paying position or start in business after completing our course of instruction. Good watch repairers are always in demand and earn from \$50 to \$75 per week. For particulars apply to the **Wisconsin School of Watch Repairing** 166 Mason St., MILWAUKEE, WIS.

It's a GUITAR!

BE popular with today's most favored instrument, the sweet-toned Gibson. You hear it everywhere, on the radio, records, in vaudeville and ballrooms. **EASY** to learn; you play tunes quickly. Play and sing together; just with "her," or with the crowd.

You'll have the spotlight!

Gibson

GUITARS - MANDOLINS
BANJOS and UKULELES

Carson Robison, pictured here, and many other famous radio and record stars use Gibsons, the "Music Pals of the Nation."

FREE Trial; Easy Payments. Send the coupon for complete information and copy of the **Free Book** "The Road to Happiness." Check the instrument which interests you.

GIBSON, INC., 303 Parsons St., Kalamazoo, Mich.
Please send free book and details of trial offer on instrument checked.

Name.....
St. or R. F. D.....
City, State.....

GUITAR BANJO MANDOLIN UKULELE



Major R. L. Rockwell Says:
"I'll Train You at Home
and Until You Have an Aviation
Job Paying \$300 to \$400 a Month!"

Major Rockwell
World War Flyer
Who Will Teach You

Major Rockwell is a famous world war flyer, decorated with the Legion of Honor and the War Cross. He is now devoting himself to teaching Aviation, and he will train you for a position in this great new industry as only a Veteran World War Flyer can train you. Under Major Rockwell's guidance your future in Aviation is assured.

I make this amazing offer, for a short time and to a limited number, to supply the crying need for trained men. Here is your opportunity to get into this uncrowded, fascinating field with a definite certainty of your future.

In 12 Weeks!

Just devote about an hour a day to My Home Study Course, and in 12 weeks you can be mastering the principles of Ground Training

which are necessary before you take your place in any branch of Aviation. In a few short months I will give you practical aviation training and prepare you for one of the big pay, thrilling jobs open only to men thoroughly trained in Aviation.

No Advance Education Necessary or Experience Needed

You don't need to have a high school or college education to master my course. You do not even need to know anything about airplanes, motors or mechanics. My home course is thorough and complete. Everything is so clearly explained, with easy-to-understand text and pictures, that in a few short months you will be able to grasp every funda-

mental principle of Aviation ground work and you will be well on the road to qualify for any important aviation job paying \$300 to \$400 a month. My Home Study Course will give you all the knowledge necessary to pass the government's written examinations for mechanics' or pilots' licenses.



MY GROUND SCHOOL
Course Enabled Rickels
to solo in 7 hours—at a big
saving.

Dear Major: Your excellent advice prevented me from taking up Aviation the wrong way when I wanted to learn flying first. After I had completed your ground course, which thoroughly prepared me in the principles of flight, I was able to solo in 7 hours. I always will be glad to tell anyone that I am a Rockwell trained man.

Sincerely, WM. C. RICKELS.

You Learn Principles of Aviation at Home
Then Choose Any One of 40 Ground Jobs.
—If You Want Actual Flying, My Home Study Course

teaches you the principles of flight. When you have completed the ground training I will arrange for you to take your flying instruction at any licensed airport near your home at special reduced rates. Or, if you want, you can come here to Dayton and get training at one of the finest and best equipped airports in America. No matter where you learn to fly you can qualify for a pilot's license and a high pay flying job in passenger lines, mail service, and other important branches of flying.

FORMER PHOTOGRAPHER NOW
MANAGER OF BIG COMPANY

Dear Major: The main thing about your individual method of instruction is that you not only gave me a thorough knowledge of Aviation, but you also showed me how to capitalize on what I learned. I am now General Manager for International Air Surveys and making three times what I ever earned before. I will always be a booster for your method of training.



FLOYD PROTHERO.

Satisfaction or Money Back

I am so sure that you can learn Aviation with my help and step into a big aviation job that if you are not satisfied when you have finished my course, I agree to return every penny of your tuition. Act now while my special offer lasts. Rush this coupon to me for a copy of my famous free book.

MAJOR ROB'T L. ROCKWELL
THE DAYTON SCHOOL OF AVIATION
Desk C-1 DAYTON, OHIO

Get My No-Risk Plan
My Big Book
Explains ALL
I'll send it FREE



Major Rob't L. Rockwell
 The Dayton School of Aviation
 Desk C-1, Dayton, Ohio.

Dear Major:—Please send me FREE and without obligation a copy of your famous book on Aviation; also your special tuition and position offer.

Name.....
 Address.....
 Town..... State..... Age.....

Easy home method quickly teaches HAWAIIAN GUITAR



Play all the latest hits just as the Hawaiians do! Have good times aplenty!

Win fame—friends—fortune! Play the Hawaiian Guitar!

Native Hawaiian expert directs you

You get expert instruction directed by a world-famous player and teacher, Prof. Walter Kolomoku. He quickly reveals to you the secrets of this fascinating instrument.

Only 4 Motions to learn. Then you can play any music—popular songs, classical, old-time melodies, native Hawaiian airs—or real jazz. You'll never be lonesome after you learn the Hawaiian Guitar.

Complete Course

52 lessons. Nothing omitted. Pictures explain every move. You are sure to learn—what we can do for others we can do for you. Over 50,000 successful students.

Payasyouplay

We make it easy for you. Start with small first payment—then pay while learning. Costs only few cents per lesson. You only pay the cost of instruction—we furnish everything.

Learn at home in spare time

Study in spare time at home. Even if you don't know a note our method is so simple, plain and easy, you begin a piece your first lesson. In half an hour you can play it!

Sweet Toned HAWAIIAN GUITAR GIVEN when you enroll

—with genuine seal grain Fabrikoid Cover and complete playing outfit. Reliable retailers ask \$18 to \$20 for a similar instrument and outfit without the fine Fabrikoid Case, which alone is valued at \$3.50.

TENOR BANJO and other courses

The same thorough instruction on the Tenor Banjo, Violin, Tiple, Tenor Guitar, Ukulele, Banjo Ukulele—well known instructors. Write for full information.

FIRST HAWAIIAN CONSERVATORY OF MUSIC, Inc.
9th Floor, Woolworth Bldg., Dept. 748, New York

Approved as a Correspondence School Under the Laws of the State of New York
Member National Home Study Council

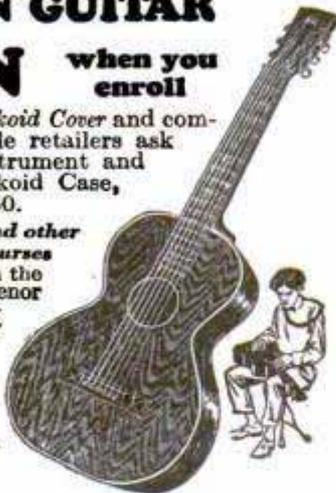

Send This Coupon for Liberal Offer!

FIRST HAWAIIAN CONSERVATORY OF MUSIC, Inc.
9th Floor, Woolworth Bldg., Dept. 748, New York, N.Y.
Please mail full information about your 52-lesson Hawaiian Guitar Course. I am not obliged to enroll unless I want to.

Name _____
Address _____
City _____ State _____

CARTOON & COURSE COMIC STRIP FOR \$2.98 ONLY COMPLETE



The Ace of Cartoon Courses

For fun and profit learn to draw cartoons and comic strips. Amazingly simple system developed by CARL ANDERSON, famous contributor to SATURDAY EVENING POST, COLLIER'S, LIFE, JUDGE, NEW YORK JOURNAL, NEW YORK WORLD and other leading publications, gives complete instructions in DRAWING, CARTOONING, COMIC STRIP AND ILLUSTRATION. These easy lessons make drawing as easy as writing. Spend only a few hours a week practicing and you will be able to draw and draw well in a very short time. 48 lessons, hundreds of illustrations, cost but \$2.98, the greatest bargain ever offered in a guaranteed drawing course. We positively GUARANTEE MONEY BACK if the course is not everything we claim. Order today—Address

SEND NO MONEY
Just order course and pay postman \$2.98 plus postage on delivery.

THE CARL ANDERSON SCHOOL, MADISON, WIS.
Send \$3.28 cash with orders from outside U. S. A.

Learn Photography at HOME

Make money taking pictures. Prepare quickly during spare time. Also earn while you learn. No experience necessary. New easy method. Nothing else like it. Send at once for free book, OPPORTUNITIES IN MODERN PHOTOGRAPHY and full particulars

AMERICAN SCHOOL OF PHOTOGRAPHY
Dept. 1353 3601 Michigan Ave. Chicago, U. S. A.

You can be quickly cured, if you STAMMER

Send 10 cents for 288-page book on Stammering and Stuttering. "Its Cause and Cure." It tells how I cured myself after stammering 20 yrs. B. N. Bogue, 11127 Bogue Bldg., 1147 N. Illinois St., Indianapolis.

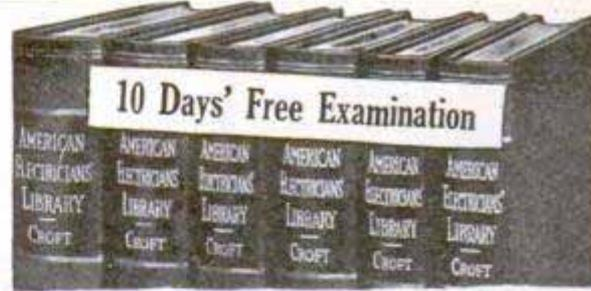

Get into the electric wiring field—big demand—big money!

THE whole wiring field covered. Kinks; helps; short cuts; practical, on-the-job electrical data, written particularly to help wiremen, trouble shooters, maintenance men, armature winders, electrical contractors and students.

American Electricians' Library

6 volumes, 2000 pages, illustrated, \$17.50 payable \$1.50 in ten days and \$2.00 a month

The books tell you all you must know about conduit wiring, armature winding, wiring for lighting circuits and switches, wiring for machinery, circuit troubles, circuit testing, or electrical machinery erection. Through a study of this great set you can push yourself into a big-pay job for life.

See it FREE—Send no money—ACT

FREE EXAMINATION COUPON

McGRAW-HILL BOOK CO., Inc.
370 Seventh Avenue, New York

Send me the American Electricians' Library for 10 days' free examination. If satisfactory, I will send you \$1.50 in 10 days and \$2 monthly until the full price, \$17.50, is paid. If not wanted, I will return the books at your expense.

Name _____
Address _____
City and State _____
Position _____
Company _____ P. M. 3-30

My \$5⁰⁰ Dancing Course ONLY \$1⁹⁸

Sent on 5 days' free trial
If You Can Do This Step

I DON'T care how poorly you dance now. I don't care if you've never been on a dance floor in your life. If you can do the simple step pictured at the right, I'll send you my complete famous course in dancing—for 5 days' *Free Trial*.

Think what that means! My new method of teaching dancing is so simple and easy to understand that you can master any of the latest steps in one evening—without music, partner, or teacher.

For I have discovered that all modern dancing is based upon five fundamental movements. The step pictured here is one of the basic movements. The other four are just as simple. Once you have mastered these key steps you can learn to do any dance—no matter how complicated it may appear—in almost no time.

Don't Be a Wallflower

There's no excuse now for playing wallflower—no excuse now for passing up good times because you can't dance! As soon as you receive the lessons you can learn the fundamental steps—in just a few hours. Then the very next time dancing starts, you can surprise your friends by stepping right on the floor with the best dancers in your set—and with as much ease and assurance as if you had been dancing for years!

How To Be Popular

You'll never regret being an accomplished dancer! Think what it means to be popular, sought after, sure of a good time wherever you go!

And dancing is great fun—wonderful exercise. It takes your mind off your worries and cares. Keeps you happy and healthy—always on your toes and full of pep. Develops poise and self-confidence—enables you to make friends easily—and often opens the door to important and social contacts.

And it's so easy now to be a good dancer, able to do all the newest, smartest steps.

My new method makes learning to dance just as simple as taking one step after another. Nothing is omitted—nothing taken for granted. You start right at the beginning and go through the entire field of social dancing. You learn to master every step from the simple waltz to the newest, smartest dances and all their variations.

Regular \$5.00 Course
NOW ONLY \$1⁹⁸
FIVE DAYS' FREE TRIAL

Yes! The complete amazing course that has shown more than 400,000 men and women how to dance at home without music, partner, or teacher—

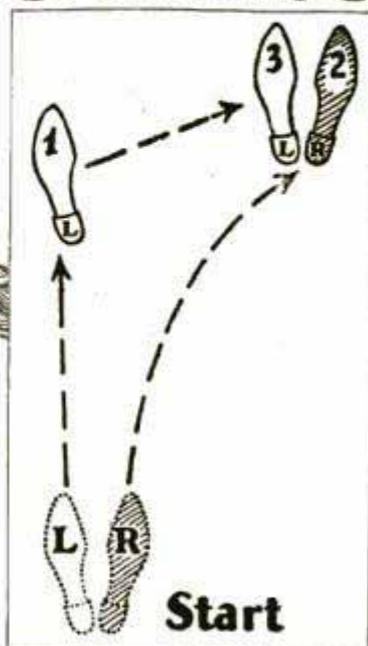

can now be yours for only \$1.98—plus a few cents delivery charges. There's not a penny more to pay. This unusually low price covers everything—from the first lesson until the last when you become a finished, graceful dancer.

I'm so sure that you, too, can become a good dancer and get your full share of fun and popularity, that in addition to this special offer I am willing to send you the complete course for 5 days' *Free Trial*.

Simply fill in and mail the coupon and when my regular \$5.00 course in dancing arrives give the postman ONLY \$1.98 plus a few cents delivery charges—in full payment. Then try it for five days. See for yourself how quickly and easily you can learn the modern Waltz, the modern Fox Trot, and all the many delightful variations of the very latest steps. If at the end of five days you are not delighted and amazed at your progress—return the course and your money will be instantly refunded. Don't hesitate to become a good dancer soon. Mail the coupon NOW. Arthur Murray, Studio 982, 7 East 43rd Street, New York City.

ARTHUR MURRAY, Studio 982,
7 East 43rd St., New York.

To prove that I can learn to dance at home without music, partner, or teacher, you may send me your regular \$5.00 course for only \$1.98 C. O. D. I understand that if not delighted I may return the course within 5 days and my money will be refunded.

Name

Address

City State

NOTE: If apt to be out when postman calls, send \$2.00 with coupon and save C. O. D. postage.



A giant plane dips and soars across the sky, leaving against the brilliant blue the one word **ELECTRICITY**

Men stop and gaze at the huge letters written so gracefully thousands of feet above the earth. Somewhere an electrical expert has groomed the giant plane for its flawless flight . . . every wire tested . . . every electrical device in perfect running order.

Today industry is as dependent upon the expert electrician as the powerful plane tracing the magic name over countless cities and towns. To him come the profits of industry and commerce. You, too, can be an electrical expert. Write today for the 48-page booklet.

NEW YORK ELECTRICAL SCHOOL

44 West 17th St., NEW YORK

MAIL TODAY

THE NEW YORK ELECTRICAL SCHOOL
44 WEST 17TH STREET, NEW YORK

Please send me **FREE** your 48-page booklet. It is understood that this request puts me under no obligation.

Name

Address

ENGINEERING - ELECTRICITY ARCHITECTURE - DRAFTING

Save time—enroll at this old established school of engineering. Enter any time, days or evenings. 1, 2 and 3 year courses. Diplomas and B. S. Degrees.



Est. 1903

Special 4 months' practical course in Drafting. Other short courses. Low tuition—easy terms. Earn while you learn. Free employment bureau. Athletics. Successful graduates every-

where. Write for our free, illustrated 80 page "Blue Book." It gives you all the facts. Address the President, Charles W. Morey, B. S., M. E.

CHICAGO TECHNICAL COLLEGE
Dept. C-78 118 East 26th Street, Chicago, Ill.

Anyone CAN LEARN

No talent or experience necessary. Fascinating work. Pays Big Money. Complete instruction book tells about: Alphabets, Colors, How to Mix Paints, Show Cards, Window Board and Wall Signs. Ready made letters, Gilding, Tricks of the Trade, also gives 100 Alphabets and Designs. Book bound in flexible imt. leather-gold edges, and four hall bearing Show Card Case. Sent postpaid \$3.00. (C.O.D.) 10c ex. Ogilvie Pub. Co., 57 Ross St., Dept. 20, N.Y. City

EARN MONEY IMMEDIATELY— WE FURNISH EQUIPMENT TO START !!

MUSIC LESSONS IN YOUR HOME



You can play music like this quickly

Write today for our **FREE BOOKLET**. It tells how to learn to play Piano, Organ, Violin, Mandolin, Guitar, Banjo, etc. Beginners or advanced players. You pay as you learn. Costs only a few cents a day. Thousands of satisfied students.

AMERICAN SCHOOL of MUSIC, 51 Manhattan Bldg., CHICAGO

AVIATION FREE Information

Send us your name and address for full information regarding the Aviation and Airplane business. Find out about the many great opportunities now open and how we prepare you at home, during spare time, to qualify. Our new book "Opportunities in the Airplane Industry" also sent free if you answer at once.

AMERICAN SCHOOL OF AVIATION
3601 Michigan Ave. Dept. 1353 CHICAGO

Wrestling Book FREE



Learn to be an expert wrestler. Know scientific wrestling, self-defense, and jiu-jitsu. Develop a splendid physique, and have perfect health. Join this popular school and learn by mail. The famous world's champions—the marvelous

Frank Gotch and Farmer Burns

offer you a wonderful opportunity. Wrestling is easily and quickly learned at home by mail. Men and boys write now for splendid free book. Learn all the science and tricks. Be able to handle big men with ease. Accept this wonderful offer NOW. Send for free book today, stating your age.

Farmer Burns School of Wrestling, 3373 Range Bldg., Omaha, Neb.

GOV'T. POSITIONS

\$35 TO \$75 WEEKLY

MEN-WOMEN

- | | |
|---------------------|---------------------|
| Ry. Mail Clerk | Steno-Typist |
| Prohibition Agent | Immigrant Inspector |
| R. F. D. Carrier | Seamstress |
| Special Agent | Auditor |
| (Customs Inspector) | Steno-Secretary |
| City Mail Carrier | U. S. Border Patrol |
| Meat Inspector | Chauffeur-Carrier |
| P. O. Clerk | Watchman |
| File Clerk | Skilled Laborer |
| General Clerk | Postmaster |
| Matron | Typist |

MENT INSTRUCTION BUREAU, 111 Arcade Bldg., St. Louis, Mo. Send me **FREE** particulars How To Qualify for positions marked "X." Salaries, locations, opportunities, etc. **ALL SENT FREE.**

NAME

ADDRESS

AGE 18 to 55



They Thought I Was A Weak Sister -But I Took Their Breath Away!

ALL of a sudden the office was very quiet, as sometimes happens for an instant or two, and a few words reached me. "Oh, he won't dare kick," the manager was saying, "he's a pretty weak sister."

Mechanically I went on with my work, wondering vaguely who the weak sister could be. A new man had just been hired for our department and desks were being moved to make room for him. A minute later I looked up and saw the chief clerk standing at my side. "Bob," he crisply ordered, "move your desk back in that corner, I want this space for the new assistant I've hired." Then he turned and strode away.

I gulped and wilted down into my chair. I was the weak sister! And I was actually being demoted! The new man was being hired for my place! This was my reward for all my hard work—this was how I won out by waiting patiently for my turn to be promoted. I had even congratulated myself on my close-lipped, reserved manner—I thought I was showing strength of character by sticking to my work and not trying to push myself—to show off.

And that was the whole trouble. I had plenty of steel in my makeup, but I had no ability to express myself. I was timid, self-conscious, and actually afraid of my own voice. I would study out the office problems and find solutions for our difficulties, but I didn't know how to present these ideas to the man up ahead. Several of the boys who had started at the time I did were now department managers—because they had the knack of forceful speech, self-confidence and personality—the very qualities I lacked.

It made me good and mad—and I resolved to show them—to get rid, once and for all, of my timidity and shyness—my bashfulness and lack of poise.

In Twenty Minutes a Day

And then suddenly I discovered a new easy method which made me into a good talker—a forceful and powerful speaker—almost overnight. I learned how to say just the right words at the right time, how to win and hold the attention of those around me, how to bend others to my will, how to dominate one man or an audience of thousands. My self-

consciousness began to vanish. One morning I got up my courage and presented the manager and the chief clerks with a complete plan for rearranging our department—stating it simply and clearly, but in a pleasing, interesting and forceful way. I actually took their breath away—they were so amazed that they gave me full power to carry out my ideas!

Soon I had won salary increases, promotion, popularity, power. And I accomplished all this by developing the natural power of speech possessed by everyone, but cultivated by so few—by simply spending 20 minutes a day in the privacy of my own home on this most fascinating subject.

Send for this Amazing Book

This new method of training is fully described in a very interesting and informative booklet which is now being sent to everyone mailing the coupon below. This book is called, *How to Work Wonders With Words*. In it you are shown how to conquer stage fright, self-consciousness, timidity, bashfulness and fear—those things that keep you silent while men of lesser ability get what they want by the sheer power of convincing speech. Not only men who have made millions, but thousands have sent for this book—and are unstinting in their praise of it. You are told how to bring out and develop your priceless "hidden knack"—the natural gift within you—which will win for you advancement in position and salary, popularity, social standing, power and real success. You can obtain your copy absolutely free by sending the coupon.

North American Institute

Dept. 1353

3601 Michigan Ave., Chicago, Ill.

NORTH AMERICAN INSTITUTE,
3601 Michigan Ave., Dept. 1353,
Chicago, Ill.

Please send me FREE and without obligation my copy of your inspiring booklet, *How to Work Wonders With Words* and full information regarding

your Course in Effective Speaking.

Name.....

Address.....

City..... State.....

What 20 Minutes a Day Will Show You

- How to talk before your club or lodge
- How to propose and respond to toasts
- How to address board meetings
- How to make a political speech
- How to tell entertaining stories
- How to make after-dinner speeches
- How to converse interestingly
- How to write letters
- How to sell more goods
- How to train your memory
- How to enlarge your vocabulary
- How to develop self-confidence
- How to acquire a winning personality
- How to strengthen your will-power and ambition
- How to become a clear, accurate thinker
- How to develop your power of concentration
- How to be the master of any situation

**NOW SENT
FREE**

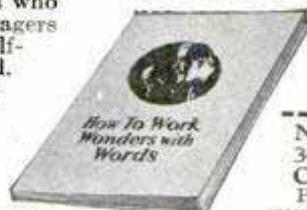

NORTH AMERICAN INSTITUTE,
3601 Michigan Ave., Dept. 1353,
Chicago, Ill.

Please send me FREE and without obligation my copy of your inspiring booklet, *How to Work Wonders With Words* and full information regarding

your Course in Effective Speaking.

Name.....

Address.....

City..... State.....

Every day sees new accomplishments which point toward a tremendous future growth in the aeronautical industry.

Why Should Young Men Learn Aviation?



AVIATION promises soon to become as great an industry as the railroad, the automobile or the radio. These industries that have made fortunes for those who entered them early and grew as they grew. So will aviation richly reward those who enter this new field now and build for the future. Aviation is the big opportunity for the young man of today.

To Learn Aviation—Fly

If you are physically and financially able, learn now to fly. Not that your future activities will be confined to flying. But the man who can fly will always have the advantage, just as the pilot today has the advantage over others.

How and Where to Start

Mail the coupon below for the interesting book, "Aviation—What It Means To You." It describes the various flight courses offered by this national system of schools and, in addition, the various mechanical and business courses available.

Let Others Dream While You Act

Get into aviation now while the industry is young and the chances are big. Don't be a dreamer. Get busy today and mail the coupon for this interesting free book.

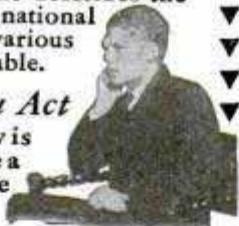

Universal Aviation Schools

A Division of The Aviation Corporation

- Universal Flying School St. Louis, Mo.
- Universal Flying School Minneapolis, Minn.
- Universal Flying School St. Paul, Minn.
- Universal Flying School Memphis, Tenn.
- Universal Flying School Cleveland, Ohio
- Universal Flying School Kansas City, Kansas



UNIVERSAL AVIATION SCHOOLS
Suite 1047-56 Boatmen's Bk. Bldg., St. Louis

Please send me at once your free book, "Aviation—What It Means To You." I am interested in:

- Flying Course Business Course
- Aviation Mechanic's Course Extension Course

Name.....Age.....

Address.....

City.....State.....

3-30 N331R93



Universal Aviation Schools are inspected and rated by the U. S. Government.

COLLEGE COURSES

AT HOME



Carry on your education. Develop power to initiate and achieve. Earn credit toward a Bachelor degree or Teaching Certificate by correspondence. Select from 450 courses in 45 subjects, including English, Mathematics, History, Education, Psychology, Economics, the Languages, etc. Write for catalog.

The University of Chicago

427 ELLIS HALL

CHICAGO, ILL.

ELECTRICITY WELDING AUTOMOBILES

PRACTICAL TRAINING ON MASSIVE LAY-OUT OF ELECTRICAL EQUIPMENT

Aircraft Oxy-Acetylene and Electric Welding, Armature Winding, Power Plants, Switchboards, Transformers, Motors, Generators, Batteries, Radio and Automobiles. Write now for Free Catalog.

Coleman Electrical School, 1628 Main St., Kansas City, Mo.

SONG WRITERS!



SUBSTANTIAL ADVANCE ROYALTIES are paid on work found acceptable for publication. Anyone wishing to write either the words or music for songs may submit work for free examination and advice. Past experience unnecessary. New demand created by "Talking Pictures" fully described in our free book. Write for it Today. NEWCOMER ASSOCIATES

759 Earle Building, New York, N. Y.



BE A MOTION PICTURE OPERATOR

LEARN TALKING EQUIPMENT

THRILLING WORK **BIG PAY**

Make big money in this easy and pleasant work. Big demand for trained operators. Write Today!

MOTION PICTURE OPERATORS SCHOOL
61 Sproat St. Detroit, Mich.

LEARN MECHANICAL DENTISTRY

SEND FOR FREE BOOK



Earn Big Money—Steady Work You can EARN WHILE LEARNING this modern money making business and become independent. Big demand. You learn by doing actual work in rubber and gold. Easy terms. Individual instruction. Day and night school. Railroad fare allowed—no extra cost. Write NOW for catalog P.

NEW YORK SCHOOL OF MECHANICAL DENTISTRY
147 W. 33rd Street NEW YORK



Wonderful, new device, guides your hand; corrects your writing in a few days. Big improvement in three hours. No failures. Complete outline FREE. Write C. J. Ozment, Dept. 34, St. Louis, Mo.

Learn Watchwork, Jewelrywork and Engraving

A fine trade commanding a good salary, and your services always in demand. Address Horological, Dept. P, Bradley Institute, PEORIA, ILLINOIS, for our latest catalog.

"The TRUTH about VOICE"

SENT FREE No Obligation to Buy If you act quick!—we will send you postpaid—for 30 days free reading—new Voice Book disclosing startling FACTS that may save hundreds of dollars to every man or woman seeking a strong, rich voice for either singing or speaking. 30 days free reading—then send \$1. Otherwise, return it. Prof. E. Feuchtinger, 1810 Wilson Ave., Suite 29, Dept. 13-53 Chicago, Ill.



"Stop clowning!"

..... HE WHISPERED



-but when I began to play

I HAD been trying—unsuccessfully—to make an impression on Helen for weeks. But she didn't seem to see me at all. Naturally, I was pretty down-hearted at the turn affairs had taken. For, at the beginning of our acquaintance, she had certainly been far more friendly with me than now. Utterly perplexed, I turned to her brother for advice.

"Forget it," he laughed. "Helen isn't annoyed by anything you've done. It's something you *haven't* done. . . . Oh, I say, I'm sorry!" he broke off suddenly, red as a beet.

"What were you going to say?" I demanded. "What haven't I done?"

"It's nothing. Just a slip of the tongue," he evaded clumsily. But I insisted that he tell me and at last he consented.

"Well, you know, Helen has always been fond of music. I once heard her say she could never care for anyone who didn't know how to play some instrument or other. Of course, that's ridiculous. Lots of perfectly nice people—congenial, charming—have no musical ability. But you know how girls are. Once they get a notion, they stick to it, come what may!"

I almost broke out into three cheers at Jerry's explanation. But that would have spoiled my secret—the secret I had kept so well all these months. Instead, I said,

"I wish you had told me this before. For I can play a bit, you know—one-finger stuff."

He laughed. "Why not try it at the party to-night? It ought to show her your heart's in the right place, anyway!"

A Dramatic Surprise

That night I sat down at the piano and did a chop-stick version of "Yes, We Have No Bananas!" to everybody's intense delight.

Calls of "What technique!" "When are you going to give a Carnegie Hall recital?" came from all over the room. But suddenly Jerry was at my side.

"Stop clowning!" he whispered. "Helen thinks I put you up to this to make fun of her!"

Instead of jumping up and apologizing to Helen, as he expected me to, I calmly swung into the opening bars of that beautiful ballad, "Garden in the Rain."

At first, astonishment kept them silent, but before long the whole crowd was singing—even Helen.

It must have been an hour before they allowed me to leave the piano. During that time I had played everything they asked for—songs, dance music, classical selections, jazz. . . .

My Secret

"Why on earth didn't you tell me you knew how to play?" demanded Jerry as we went home. "Why have you been keeping it a secret? I distinctly remember you once said you couldn't play. Yet to-night . . ."

I looked at Helen. "There was a special reason for playing to-night," I said. "I couldn't have done it months ago. Even last year Jerry's remark about my not being able to play, wouldn't have been an exaggeration."

"You see," I continued, "I discovered a method of learning music by mail, in one's spare time, at home, without a teacher."

Pick Your Course

Piano	Violin
Organ	Clarinet
Ukulele	Flute
Cornet	Saxophone
Trombone	Harp
Piccolo	Mandolin
Guitar	Cello
Sight Singing	
Hawaiian Steel Guitar	
Piano Accordion	
Italian and German Accordion	
Voice and Speech Culture	
Harmony and Composition	
Drums and Traps	
Automatic Finger Control	
Banjo (Plectrum, 5-String or Tenor)	

Then I told them all about the U. S. School course. How it does away with tiresome scales and exercises—eliminates expensive private teachers.

"Why, I played simple tunes and melodies right from the start!" I enthused. "But I didn't want to tell you folks until I was sure I could play well enough to put it over. Besides, I didn't know Helen was so crazy about music. . . ."

"Not only about music," she murmured, with a shy smile.

Demonstration Lesson and Book—FREE

This is not the story of one isolated case. Over half a million men and women have learned to play their favorite instruments the U. S. School way.

To prove how practical this course is, we will be glad to send you a typical demonstration lesson and explanatory booklet, *without charge*. They show how *anyone* can learn to play *by note* in less than half the time and at a fraction of the cost of old, slow methods. The booklet will also tell you all about the amazing new *Automatic Finger Control*.

If you really want to learn to play send for the free booklet and test lesson *today*. No obligation. (Instruments supplied when needed, cash or credit.) U. S. SCHOOL OF MUSIC, 73 Brunswick Bldg., New York City.

U. S. SCHOOL OF MUSIC,
73 Brunswick Bldg., New York City.

Please send me your free book, "Music Lessons in Your Own Home," with introduction by Dr. Frank Crane, Free Demonstration Lesson, and particulars of your easy payment plan. I am interested in the following course:

Have you
..... Instrument?

Name.....

Address.....

City..... State

Step INTO A BIG-PAY HOTEL JOB



Earn \$2,500 to \$10,000 a Year

IN America's 3rd Largest Industry. Hotels, Apartment Hotels, Clubs, Restaurants, Institutions, Schools, Hospitals, etc., are daily calling for Lewis Graduates. Over 70,000 high-class positions paying \$2,500 to \$10,000 a year open annually in hotels alone. Salaries up to \$3,500 to start. C. W. Ryder says:—"Shortly after completing your course I was appointed Purchasing Agent of a chain of hotels at a 100% increase in salary."

We Put You in Touch with Positions

Without cost let us show you how big pay, fascinating work, quick advancement can be yours in the great hotel industry. Age is no obstacle—young and old alike have equal chance for success. O. O. Miller, 55, qualified for a well-paid position thru the Lewis course. A common school education is all you need with the amazing Lewis System of Sparetime Training in Hotel Operation.

Previous Experience Unnecessary

Hundreds of Lewis students are winning success. Totally unacquainted with hotel work before taking the Lewis Course, N. Frank Hills is now Assistant Manager of a \$250,000 Apartment House. YOU can do as well. Low cost—easy terms—money back agreement. Write today for Free Book, "Your Big Opportunity," and complete details, mailed without obligation.

1000 HOTEL POSITIONS OPEN

**Lewis Hotel Training Schools
Room CD-339
Washington
D. C.**



These Lewis Students "Made Good"

Charles A. Jones:—"I was chosen for the position of Manager. My success is due to Lewis Training."
Ernest R. Jensen:—"Mr. Jarow has just named me Steward and, as the business grows, he expects to give me full charge of the house. Just think, I haven't been in the work a year and yet I fully understand what will be required of me, thanks to Lewis Training."
Leroy L. Saunders:—"October 1st, our organization moves into the new \$8,000,000 club house. I am slated to become Assistant to the General Manager. Thank you for your cooperation."
Morris S. Johnston:—"I am Manager of the finest hotel of its kind in this city. Your course is essential to hotel work."

**LEWIS HOTEL TRAINING SCHOOLS,
Room CD-339, Washington, D. C.**

Send me the Free Book, "Your Big Opportunity," without obligation.

Name.....
Address.....
City..... State.....

OPPORTUNITY COUPON

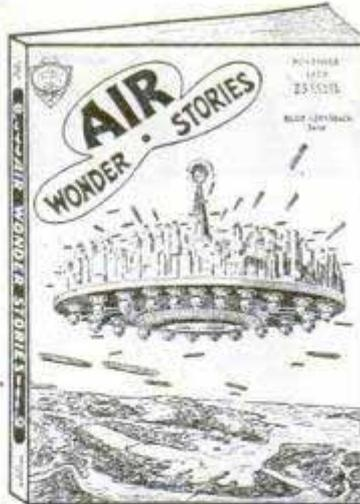

Aviation Stories of the Future

Air Wonder Stories

is a revelation in Science Fiction Stories of the Air. Many monthly contributions by noted science fiction writers.

Thrilling: Daring: Visionary

Read one issue and you will be impatient for the next.

On Sale at all newsstands—25¢ the copy. Special subscription offer—one dollar, eight months.

Stellar Publishing Company

98 West Park Place, New York City

BEDFORD YMCA TRADE SCHOOL

- Aviation Mechanic
- Airplane Welding
- Airplane Drafting
- Auto Mechanic
- Starting, Lighting, Ignition
- Machine Shop. Electric Welding
- Oxy-Acetylene Welding
- Radio Mechanic. Battery Repair
- Mechanical, Architectural Drawing
- Blue Print Reading
- Building Estimating
- Sign Painting. Show Card Writing
- Window Dressing

Commercial Art. Fine Art
DAY AND EVENING SESSIONS

Write for Catalog 50

Brooklyn Engineering Institute

(Operated by Bedford Y. M. C. A.)
1125 Bedford Avenue, Brooklyn
New York City

TRI-STATE COLLEGE



B. S. degree in 2 years in Aeronautical, Civil, Electrical, Mechanical, Chemical, Administrative Engineering. Students who left H. S. can make up work. Tuition low. Catalog.

430 College Street

Angola, Indiana

HOT PIANO Ultra-modern Piano



Jazz taught by mail. Note or ear. Easy rapid lessons for adult beginners. Also Self-instruction system for advanced pianists. Learn 358 Bass Styles, 976 Jazz Breaks, hundreds of Trick Endings, Hot Rhythms, Sock, Stomp and Dirt Effects; Symphonic and Wicked Harmony in latest Radio and Record Style. Write for Free Booklet.

WATERMAN PIANO SCHOOL, 1826 W. Adams St., Los Angeles, Calif.



LICK 'EM ALL!

Almost instantly—without tiresome study—you can now be invincible, proof against knife, gun, fist—bullies or rowdies. Develop **super-strength**—learn the simple tricks of veteran fighters—the Two Million Dollar secrets of N. Y. Police. Startle your friends by brilliant feats of strength and dexterity. Send \$1.97 stamps or M. O. for Capt. Wallander's \$2,000,000 Secrets, or pay \$2.15 on delivery. Satisfaction Guaranteed.

**EDUCATOR PRESS, Dept. PT-24
19 Park Row New York**

LEARN TO Mount Birds



We teach you At Home by Mail to mount Birds, Animals, Heads, Tax Furs and Make Eggs. Be a taxidermy artist. Easily, quickly learned by men, women and boys. Tremendously interesting and fascinating. Decorate home and den with beautiful art. Make Big Profits from Spare Time Selling Specimens and Mountings for Others.

Free Book—Beautiful book telling all about how to learn taxidermy sent Free if you state your AGE. Send Today. You will be delighted.
**Northwestern School of Taxidermy 3373 Elwood Bldg
OMAHA, NEB.**

- takes only 8 weeks to get a big job

and Earn
\$50 to \$125 Weekly
as Auto
or Aviation
Expert

What I Have Done For Others, I Can Do For You

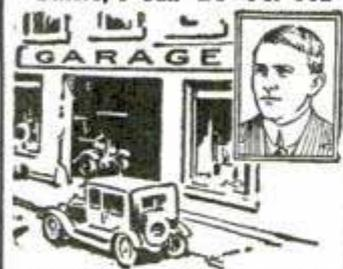

George Smith owns an agency and repair shop in West Alexandria, Ohio. He makes \$200 a week.

Learn on Real Machines

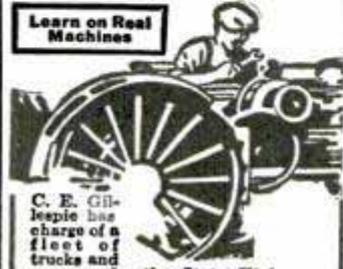

C. E. Gillespie has charge of a fleet of trucks and tractors for the State Highway Commission, due to McSweeney training.

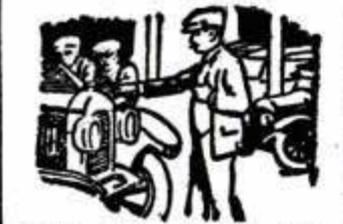

D. M. Collins, Williamsville, West Virginia, writes: "After finishing McSweeney training, I started as manager of a garage at \$300 a month."

Learn the Automotive or Aviation business by the McSweeney system. Get ready to step out and hold a real job. Earn \$50 to \$125 a week. Or, you can open a garage and repair shop and clean up as high as \$10,000 a year. It's no idle dream—no fanciful goal—but actual accomplishments of many McSweeney graduates. The Automobile, Tractor, and Aviation Business needs Trained men. Opportunities are everywhere. Good openings galore. Eight weeks training with McSweeney fits you to open your own place or go with one of the many firms seeking trained men. Read what George Smith, C. E. Gillespie and D. M. Collins have done. And there are hundreds of other McSweeney trained men who can tell you just as interesting facts. Every month McSweeney graduates are supplanting the inexperienced, untrained men.

You Do Actual Work on Real Equipment

First we tell you, then show you, then you actually do the work yourself—you learn Mac's practical way—we use no books—no lessons—an education is not necessary. A green man works shoulder to shoulder with the man who has had years of experience. The McSweeney way is the real way to big pay. Learn a trade that can never be replaced by machinery. Automobile, Tractor and Aviation repair and maintenance can never be put on a production basis.

You Can Learn in Only 8 Weeks!

Yes sir—in only eight short weeks McSweeney will train you so you can qualify for a big pay job in the Auto, Tractor or Aviation fields. You don't need any advance education. In fact, very little schooling is necessary. Any man from 16 to 60 can easily learn and master the clear, concise, simple McSweeney Course. And think of it, in just 8 weeks you can do it. In only 8 weeks you will be ready to step into a big job paying \$50 to \$125 weekly. Why fool away your time with small pay jobs when it's so easy to make real money through McSweeney training? And you can do it in such a short time. You are protected in every way. Read the money-back guarantee below. You have every chance to win out in the biggest sort of way without risk. Take advantage of my Remarkable Limited Tuition Offer by mailing the coupon to me at once. No facilities for colored students.

AVIATION Course

Aviation, the big new field for ambitious men! But Aviation will pay tremendous incomes to trained men only. With McSweeney you learn all about airplane engines, airplane wings, airplane construction, under experienced instructors. Coupon brings full details. Don't miss this remarkable opportunity.

Write for Big FREE Book

Send coupon at once for this big, illustrated book. It tells you all about the McSweeney Schools and explains how you can enroll at once and save money. Besides, the sooner you start, the sooner you will be ready to earn big pay, or get into business for yourself. Don't delay. Mail coupon today sure. The book is Free to you!



McSWEENEY
Auto-Tractor and Aviation
SCHOOLS

Chester at 30th St.,
Cleveland, Ohio

or

263 Madison St.,
Memphis, Tenn.

Money-Back Guarantee!

If, after completing my training, you are not satisfied, your tuition will be refunded. You yourself are the sole judge of McSweeney training. I want no dissatisfied students and I'm willing to go the limit to prove my sincerity and honesty. There is no catch to this, it's a straight forward, honest guarantee!



Address school nearest you.

Mail this Coupon Today

McSweeney Auto, Tractor and Aviation School,
Dept. A-11-T, Chester at 30th St., Cleveland, Ohio,
or 263 Madison, Memphis, Tennessee.
Without cost or obligation, send me your big, FREE book
on Autos and Aviation, also full details of your special
tuition offer.

Name

Street

Town State.....



“The Happiest Day of My Life!”

“OUR WEDDING DAY! A year ago it seemed like a dream that would never come true, for my salary then was barely enough for *one* to live on. I faced the facts. Unless I could make more money I had no right to keep Ruth waiting. What I had to do was find some way to make myself *worth* more.

“It was Ruth herself who showed me the way. She clipped a coupon out of a magazine and we sent it to the International Correspondence Schools for information about their courses. Within a week I had enrolled. The training I got from studying at home showed up almost at once in my office work. They gave me more responsibilities. Inside of six months I was promoted, with a substantial raise. Now I’m getting double what I was a year ago—and we’re married!”

I. C. S. Courses have given thousands the special knowledge they need to win better jobs and bigger pay. *Why not you?*

One hour of spare time a day, spent in I. C. S. study, will prepare you for the position you want, in the work you like best. Find out how. It won’t obligate you in the least to ask for full particulars. Do it now—for HER!

Mail the Coupon for Free Booklet

INTERNATIONAL CORRESPONDENCE SCHOOLS Box 5671-F, Scranton, Penna.

Without cost or obligation, please send me a copy of your booklet, “Who Wins and Why,” and full particulars about the course before which I have marked X in the list below:

TECHNICAL AND INDUSTRIAL COURSES

- | | |
|--|---|
| <input type="checkbox"/> Architect | <input type="checkbox"/> Automobile Mechanic |
| <input type="checkbox"/> Architectural Draftsman | <input type="checkbox"/> Aviation Engines |
| <input type="checkbox"/> Building Foreman | <input type="checkbox"/> Plumber and Steam Fitter |
| <input type="checkbox"/> Concrete Builder | <input type="checkbox"/> Plumbing Inspector |
| <input type="checkbox"/> Contractor and Builder | <input type="checkbox"/> Foreman Plumber |
| <input type="checkbox"/> Structural Draftsman | <input type="checkbox"/> Heating and Ventilation |
| <input type="checkbox"/> Structural Engineer | <input type="checkbox"/> Sheet-Metal Worker |
| <input type="checkbox"/> Electrical Engineer | <input type="checkbox"/> Steam Engineer |
| <input type="checkbox"/> Electrical Contractor | <input type="checkbox"/> Marine Engineer |
| <input type="checkbox"/> Electric Wiring | <input type="checkbox"/> Refrigeration Engineer |
| <input type="checkbox"/> Electric Lighting | <input type="checkbox"/> R. R. Positions |
| <input type="checkbox"/> Reading Shop Blueprints | <input type="checkbox"/> Highway Engineer |
| <input type="checkbox"/> Telegraph Engineer | <input type="checkbox"/> Chemistry |
| <input type="checkbox"/> Telephone Work | <input type="checkbox"/> Pharmacy |
| <input type="checkbox"/> Mechanical Engineer | <input type="checkbox"/> Coal Mining Engineer |
| <input type="checkbox"/> Mechanical Draftsman | <input type="checkbox"/> Navigation <input type="checkbox"/> Assayer |
| <input type="checkbox"/> Machine Shop Practice | <input type="checkbox"/> Iron and Steel Worker |
| <input type="checkbox"/> Toolmaker | <input type="checkbox"/> Textile Overseer or Supt. |
| <input type="checkbox"/> Patternmaker | <input type="checkbox"/> Cotton Manufacturing |
| <input type="checkbox"/> Civil Engineer | <input type="checkbox"/> Woolen Manufacturing |
| <input type="checkbox"/> Surveying and Mapping | <input type="checkbox"/> Agriculture <input type="checkbox"/> Fruit Growing |
| <input type="checkbox"/> Bridge Engineer | <input type="checkbox"/> Poultry Farming |
| <input type="checkbox"/> Gas Engine Operating | <input type="checkbox"/> Mathematics <input type="checkbox"/> Radio |

BUSINESS TRAINING COURSES

- | | |
|--|---|
| <input type="checkbox"/> Business Management | <input type="checkbox"/> Business Correspondence |
| <input type="checkbox"/> Industrial Management | <input type="checkbox"/> Show Card and Sign Lettering |
| <input type="checkbox"/> Personnel Management | <input type="checkbox"/> Stenography and Typing |
| <input type="checkbox"/> Traffic Management | <input type="checkbox"/> English |
| <input type="checkbox"/> Accounting and C. P. A. Coaching | <input type="checkbox"/> Civil Service |
| <input type="checkbox"/> Cost Accounting | <input type="checkbox"/> Railway Mail Clerk |
| <input type="checkbox"/> Bookkeeping | <input type="checkbox"/> Mail Carrier |
| <input type="checkbox"/> Secretarial Work | <input type="checkbox"/> Grade School Subjects |
| <input type="checkbox"/> Spanish <input type="checkbox"/> French | <input type="checkbox"/> High School Subjects |
| <input type="checkbox"/> Salesmanship | <input type="checkbox"/> Cartooning |
| <input type="checkbox"/> Advertising | <input type="checkbox"/> Illustrating |
| | <input type="checkbox"/> Lumber Dealer |

Name.....

Address.....

City.....State.....

Occupation.....

If you reside in Canada, send this coupon to the International Correspondence Schools Canadian, Limited, Montreal, Canada

Increase Your Earning Power

Apply time and labor-saving kinks to your work. Your efficiency will soon be recognized and you will be in line for advancement.

If you do machine shop work of any kind, sheet-metal work, painting, carpentry, auto repairing, farming, concrete work, plumbing, electrical work, welding, building, glass work, general repairing, tool-making, poultry raising, masonry or home repair work, get this

LIBRARY OF 6000 TIME AND LABOR SAVING IDEAS FOR SHOPMEN AND HANDYMEN

JUST PUBLISHED

SHOP NOTES for 1930

192 Pages
415 Articles
377 Illustrations

See partial list of contents below

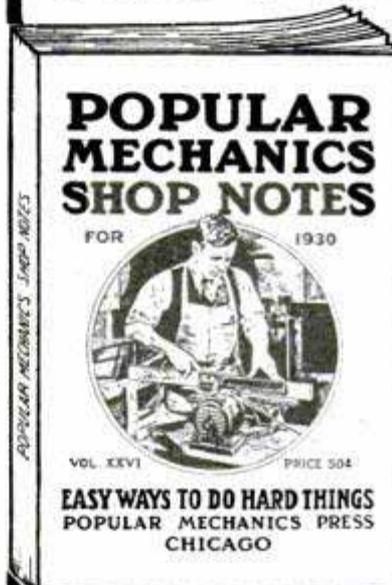

Including the new 1930 issue illustrated above, there are now 15 volumes in the Shop Notes Library of 6,000 easily understood short cuts to every-day jobs. Here are just a few of the subjects taken from the 415 articles in the latest issue.

- | | | |
|--|-------------------------------------|---|
| Animal Traps, Care of | Concrete Fountain Water, Cooler for | Sanding on the Lathe |
| Barrel Method of Slings | Furniture, Refinishing Old | Saw Mount for Home Shop |
| Bench Light, Convenient | Furniture, Restoring Damaged | Saws, Keeping Fit |
| Bench Saw, Getting Most Out of | Hacksaw, Power, for Small Shops | Scrollsaw, Ball-Bearing |
| Boatswain's Chair Rigging | Hoist, Light and Strong | Speedboats, Automatic Switch for |
| Bookcase, Modern | Household Shortcuts | Stainless Steel, Soldering "Sugi" Finish, How to Apply |
| Brass Fixtures, Cleaning | Ice Cutter, Engine-Driven | Summer House, Japanese |
| Builders' and Contractors' Kinks | Outboard Motor, Super-charger for | Templates, Making Accurate |
| Cams, Jig for Layout of | Package Sealer, Home-made | Tinners, Paint Scraper for |
| Conveyor, Portable | Pipe Holder, Hammered-Copper | Toolrest, Sliding, for Emery Wheel |
| Speeds Loading | Power Saw Made from Buffing Head | Tools for Home Mechanics |
| Dadoing on Small Power Saws | Power Shears Made in Small Shop | Towed Car Steered by Tow Bar |
| Decorating with Pastry Gun | Sand Disk for Small Lathe | Wood, Plastic Filler for Workshop, Homemade Combination |
| Disk Sander Making Ellipse, How to Lay Out "Exerciser", Electric | | |
| Farmers, Labor-Saving Kinks for | | |
| "Flagstones", Making | | |

Each volume contains approximately 500 articles and 400 illustrations and has 224 Pages. At the regular price of 50 cents per single volume this library costs \$7.50, but for a limited period we will supply the 15 vols. when ordered at one time at the special reduced price of only \$4.50.

SPECIAL OFFER COUPON

POPULAR MECHANICS PRESS, 200 E. Ontario St., Room P2, Chicago, Ill.
Send me, as per your special offer, the following books. I will pay for books C. O. D. when they arrive. My money will be refunded if I am not satisfied. (Check what you want.)
 1930 Shop Notes and Lathe Handbook, both for 98c.
 Complete Shop Notes Library (15 vols.) \$4.50.

Name.....

Street and No.....

City.....State.....



The Man with the "Grasshopper Mind"

YOU know this man as well as you know YOURSELF. His mind nibbles at EVERYTHING and masters NOTHING.

At home in the evening he tunes in the radio—gets tired of it—then glances through a MAGAZINE—can't get interested. Finally, unable to CONCENTRATE on anything, he either goes to the MOVIES or FALLS ASLEEP in his chair

At the OFFICE he always takes up the EASIEST thing first, puts it down when it gets HARD, and starts something else. JUMPS from ONE THING TO ANOTHER all the time!

There are thousands of these PEOPLE WITH GRASSHOPPER MINDS in the world. In fact they are the very people who do the world's MOST TIRESOME TASKS—and get but a PITTANCE for their work.

They do the world's CLERICAL WORK, and routine drudgery. Day after day, week after week, month after month, year after year—ENDLESSLY—they HANG ON to the jobs that are smallest-salaried, longest-houred, least interesting, and poorest-future!

If YOU have a "grasshopper mind" you know that this is TRUE. And you know WHY it is true. Even the BLAZING SUN can't burn a hole in a little piece of TISSUE PAPER unless its rays are focussed and concentrated ON ONE SPOT!

A BRAIN THAT BALKS at sticking to ONE THING FOR MORE THAN A FEW MINUTES surely cannot be depended upon to get you anywhere in your YEARS of life!

The TRAGEDY of it all is this: you know that RIGHT NOW you are merely jumping HERE AND THERE. Yet you also know that you have WITHIN YOU the intelligence, the earnestness, and the ability that can take you right to the high place you want to reach in life!

What is WRONG? WHAT'S holding you back?

Just one fact—one SCIENTIFIC fact. That is all. And when you know what it IS, then you can easily learn how to apply it; make it carry you STEADILY, POSITIVELY, AND DIRECTLY to prosperity and independence.

That fact is one which has been PROVEN and stated by the world's foremost scientists and psychologists. You are only ONE-TENTH as successful as you COULD be! Why? BECAUSE, as Science says, you are using only ONE-TENTH of your real BRAIN-POWER!

TEN per cent of his brain is all the AVERAGE person uses. He is paid for ONE-TENTH of what he really possesses because that is all he actually USES. The remainder lies dormant. The longer it is unused, the harder it becomes to use it. For the mind is like a muscle. It grows in power through exercise and use. It weakens and deteriorates with idleness.

What can you DO about it? That is the question you are asking yourself. Here is a suggestion.

Spend 2c for a postage stamp. Send in the coupon below for a copy of "Scientific Mind Training." There is no further obligation whatever. You need not spend another penny.

This little book will tell you the secret of self-confidence, of a strong will, of a powerful memory, of unflagging concentration. It tells you how to acquire directive powers, how to train your imagination (the greatest force in the world), how to make quick, accurate decisions, how to reason logically—in short, how to make

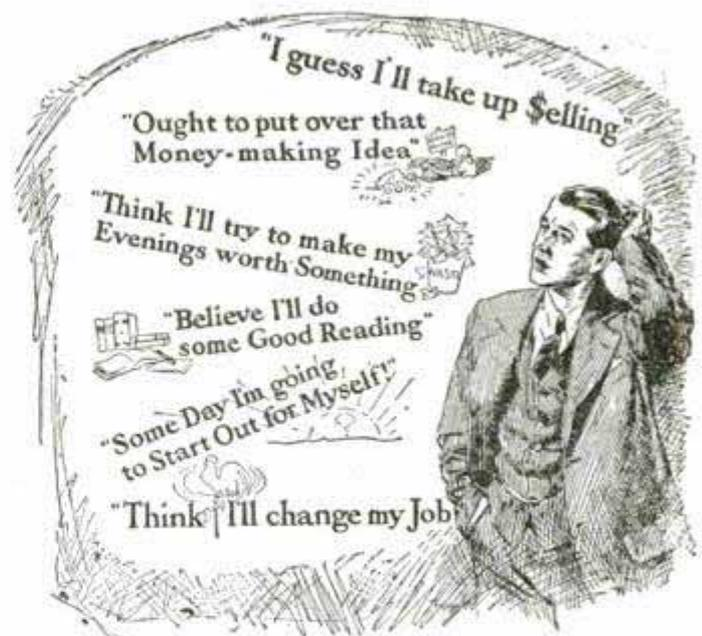

your brain an instrument of all-around POWER. It tells you how to banish the negative qualities like forgetfulness, brain fag, inertia, indecision, self-consciousness, lack of ideas, mind wandering, lack of system, procrastination, timidity.

Men like Judge Ben B. Lindsey, Sir Harry Lauder, Prince Charles of Sweden, Jerome K. Jerome, the famous novelist; Frank P. Walsh, Chairman of the National War Labor Board, and hundreds of others equally famous, praise the simple method of increasing brain power and thought power described in this free book. OVER 650,000 OTHERS PRAISE IT.

You have only TWO CENTS to lose by writing for your copy. You may GAIN thousands of dollars, peace of mind, happiness, independence!

Thousands who read this announcement will DO NOTHING about it. The effort and the will needed to send for this book—which is FREE—may be lacking. How can these people EVER gain what they hope for, crave for? They are the skeptics, the doubters, the "show me" wiseacres.

Other thousands will say, "I can lose only TWO CENTS. I may GAIN a great deal by reading 'Scientific Mind Training.' I will send for it NOW. It promises too much for me to RISK MISSING."

The thousands who are open minded—who are willing to learn something to their advantage—will ACT on their impulse to send the coupon. They will be better, stronger minded for having TAKEN SOME ACTION about their lives, even if they do nothing more than to READ a booklet about the inner workings of the mind. For your own sake—and for the sake of your loved ones, don't continue to GAMBLE that your future will be bright whether or not you DO anything about it! Mail the coupon today—NOW.

THE PELMAN INSTITUTE OF AMERICA

Suite 63. 71 West 45th Street, New York City

Offices in London, Paris, Stockholm, Delhi,
Durban and Melbourne

The Pelman Institute of America
Suite 63. 71 West 45th Street,
New York City

Please send me without obligation your free booklet, "Scientific Mind Training." This does not place me under any obligation and no salesman is to call on me.

Name _____

Address _____

City _____ State _____

There's Quicker, Bigger MONEY for YOU in POULTRY RAISING!



Wherever You Live—
Whatever You Do Now—
\$2,000 to \$5,000 a Year
Can Be Yours!

YOU Can Do What They Have Done

"Your Course on Poultry Raising is the most practical and complete in the country. You have opened up a pleasant and profitable way for me to gain an independent living."—S. Anderson, Barrington, R.I.

J. L. Mosher of Buffalo, N. Y., started at \$35 a week after 10th Lesson. F. O. Anderson of Phoenix, Ariz., writes: "Thanks to N. P. I. I got a job even before I finished your Course!"

Spare Time or Full Time YOU Can Cash-In BIG

The Poultry Industry is growing by leaps and bounds. Eggs and Poultry meat are commanding high prices—prices that mean real profits on every bird you raise—every egg your flock produces. Thousands of my students have turned to Poultry Raising for parttime extra money or alltime big pay. I'll show you how to start in a small way—in your own back yard—and make it pay—make your little investment multiply itself automatically. Or, if you want to work for someone else at a good salary—my FREE Employment Dept. will help place you in one of the thousands of splendid positions open to trained poultrymen. Why wait? I'll PROVE that I can put you among the big money makers QUICK!

My Proved Methods Assure Success Right from START

All the "mystery," all the "secrets," all the guesswork are taken out of Poultry Raising by my sure, tested, proved successful methods. I will teach them all to you. Nothing left out, nothing for you to have to figure yourself. I make it easy for you. It's fascinating, healthful, pleasant, profitable. You'll be your own boss—I'll show you how to make \$1.00 to \$3.00 for every hour of your spare time. What's more, I'll show you the way to a salary of \$5,000 a year. AND UP! Start as small as you want; my methods will get the maximum profits out of your flock and make it grow automatically, into a sure source of steady big income for YOU.

FREE BOOK Shows Way to BIG PROFITS

My big new FREE book, "How to Raise Poultry for Profit," will amaze you! It brings evidence a-plenty—absolute proof—of what I have done for thousands of others. My forty years experience as Commercial Poultryman and former Senior Poultryman in the U. S. Dept. of Agriculture is yours for real Success and Independence. The Poultry Business needs you—and you need the profits that the poultry business brings. You need my book. Get in line for QUICKER, BIGGER MONEY. Do it this minute—don't delay a day. Get this coupon into the very next mail!

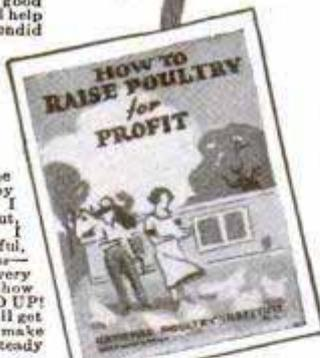

48 Pages
of Money-
making FACTS

Get this FREE Book NOW!

Harry M. Lamon, Pres.,
NATIONAL POULTRY INSTITUTE
Dept. 411-G, Washington, D. C.

Dear Mr. Lamon: Send me your FREE Book, "How to Raise Poultry for Profit." I want to know more about MY opportunity to make \$2,000 to \$5,000 a year, spare time or full time.

Name.....
Address.....
City..... State.....

FREE BOOKS of BUSINESS HELPS

We publish over 200 Home Study Books, each a complete treatise of its subject. We have one or more for you. Books on

- | | |
|--|---|
| <input type="checkbox"/> Commercial Art | <input type="checkbox"/> Decoration |
| <input type="checkbox"/> Lettering | <input type="checkbox"/> Automobiles |
| <input type="checkbox"/> Advertising | <input type="checkbox"/> Battery Work |
| <input type="checkbox"/> Sign Making | <input type="checkbox"/> Electricity |
| <input type="checkbox"/> Radio | <input type="checkbox"/> Carpentry |
| <input type="checkbox"/> Aviation | <input type="checkbox"/> Building |
| <input type="checkbox"/> Painting | <input type="checkbox"/> Contracting |
| <input type="checkbox"/> Silk Screen Process | <input type="checkbox"/> Sheet Metal Work |

and many other subjects. All fully described in our FREE CATALOG. Check the subjects in which you are interested and write today.

FREDERICK J. DRAKE & CO., Publishers
Room 508—179 No. Michigan Blvd., Chicago
Drake books are for sale in all book stores.

Learn PIANO TUNING At Home

Our TEMPERAMETER makes it easy. Earn \$10 to \$20 a day. Unusual opportunities for making extra money.



CAPITALIZE YOUR ABILITY

Reide of New York City says: "The section on Player-Piano in your excellent course is a veritable Encyclopedia."

Write for FREE book "Winning Independence"

16 BRYANT BLOCK
BRYANT SCHOOL AUGUSTA, MICH., U.S.A.

Government Positions

Census Clerks, Clerk Carriers, Rural Carriers, Railway Mail Clerks, Postmasters, Department Clerks, and many others. Splendid salaries, easy work, vacation with pay. Only common school education required. Examinations often. 37,976 appointed last year. Send for our Civil Service Catalog No. 6. **COLUMBIAN CORRESPONDENCE COLLEGE, Washington, D. C.**

Learn MECHANICAL DENTISTRY in 10 Months!



Men and Women can do this at home in their spare time. As much as \$100 weekly and even more is made by trained mechanical dentists. Steady work. Earn big money in a profession. Write for FREE particulars about our easy but complete Home Study Course.

AMERICAN SCHOOL OF MECHANICAL DENTISTRY
Dept. A-2 150 E. South Temple St., SALT LAKE CITY, UTAH

BASHFUL?

"Shame on you!" Are you nervous, embarrassed in company of the other sex? Stop being shy of strangers. Conquer the terrible fear of your superiors. Be cheerful and confident of your future! Your faults easily overcome so you can enjoy life to the fullest. Send 25c for this amazing book. **RICHARD BLACKSTONE, B-473 Flatiron Bldg., N. Y.**

CUTTING DOLLARS OUT OF MEAT

MAIL STEADY COUPON TODAY
START A MEAT MARKET
BIG MONEY

Scientific meat buying, cutting, selling and serving rapidly coming to the front. HIGH SALARIED, PLEASANT, STEADY positions open everywhere. Splendid opportunities for trained meat specialists to connect with large markets, shops, hotels, clubs, etc. Let National train you. Oldest and most reliable school of its kind. Easy, inexpensive home-study course or come to Industrial Toledo. Own your own market. Large enrollment. Many successful graduates. Write at once for large illustrated catalog and "PROOF OF OUR GRADUATES' SUCCESS." Mail coupon below today and get the NEW MEAT FACTS.



National School of Meat Cutting
604-C Summit, Toledo, Ohio.

Name.....
Address.....

Plenty of Jobs for Trained Men

\$60.00
A WEEK
AND MORE

3 BIG PAY FIELDS

Learn ELECTRICITY A BIG PAY JOB

Electricity and Radio now pays hundreds of trained men \$60, \$75, \$100, up to \$200 a week. The world's Greatest businesses. Billions—not millions—but billions of dollars are spent in them yearly. Now is the time to get away from low pay!

Learn in Only 3 Months in Great Greer Shops on Real Equipment

Mine is not a correspondence course. You start any day or any evening. It is practical, easy, quick, fascinating training. You learn on great, running live equipment in tremendous Greer Shops. Electricity is the fastest growing industry in the world—radio a close second, and yet in its infancy, is a billion dollar industry. Trained men by scores needed for positions up to \$250 a week. Find out now about my great shops training.

You Get Real Help to Big Jobs

My big Employment Department gets jobs for Greer men. You get this help before and after graduation. Don't let money hold you back. Get my free book. Learn how I get you ready so Employers gladly pay you what you are worth.

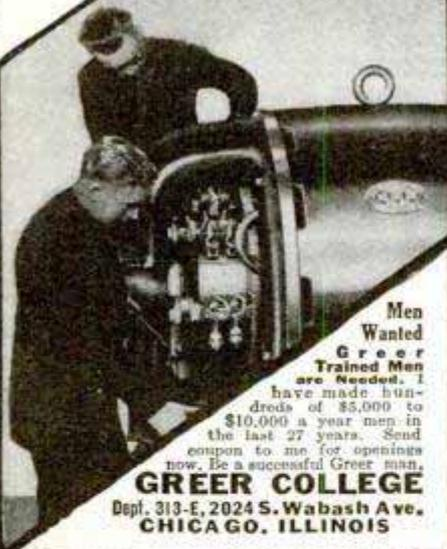

Men Wanted Greer Trained Men are Needed. I have made hundreds of \$5,000 to \$10,000 a year men in the last 27 years. Send coupon to me for opinions now. Be a successful Greer man.

GREER COLLEGE
Dept. 313-E, 2024 S. Wabash Ave. CHICAGO, ILLINOIS

FREE Electrical Book

Erwin Greer, President, Dept. 313-E, 2024 So. Wabash Ave., Chicago, Illinois.

Send Free Book and details of Special offer, without obligation to me.

Name.....
Address.....
State..... Age.....

Big Money in AUTOS OWN YOUR OWN BUSINESS

Be your own boss. Learn it all. Big men draw big money because they know the whole business. You can't make big money by just doing one single little thing. Factories pay a very ordinary salary to "Jones" who screws on nut number 39, because they can quickly teach someone else to do it just as well.

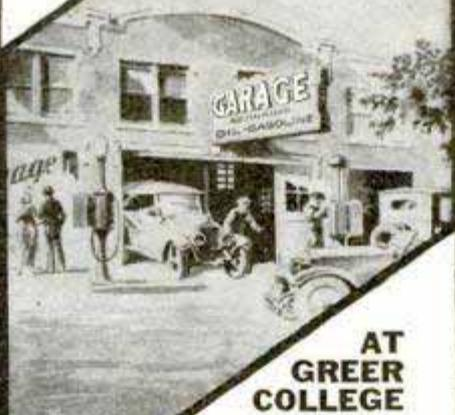

AT GREER COLLEGE

you learn how to boss the job.

Quickest, Easiest of Ways to Become Expert

I'll allow your fare here free of extra cost, then help you to a job while learning. Then I not only fit you to get a big pay job, but I'll help you hold it. Young and old, educated and uneducated, experienced and inexperienced, have found Greer Shops training easy, fascinating and valuable. You learn on big, actual full size equipment like you will work on out on the big pay job. Coupon below brings details. Don't delay! Get my free book now!

GREER COLLEGE
Dept. 313-A, 2024 S Wabash Ave. CHICAGO, ILLINOIS

FREE Auto Book

Erwin Greer, President, Dept. 313-A, 2024 So. Wabash Ave., Chicago, Illinois.

Send Free Book and details of Special offer, without obligation to me.

Name.....
Address.....
State..... Age.....

Get into AVIATION

You know the vast opportunities. Greer offers the way to get them. Now is the time.



You Learn to Fly by Flying

The 27 years' growth of Greer College, thru genuine service, speaks for itself. From 1902, to the present tremendous plant including three modern buildings and three airports in the Chicago area. Real endorsement by satisfied students and graduates have made this possible. Aviation enthusiasts come to marvel at the tremendous outlay of motors, planes, instruments, wood and metal working equipment, welding and ignition shops. Many more have come to consult our Chief Aviation Engineer, C. L. Laird, regarding airplane design and construction.

Get My Free Book "Winning Your Wings"

Learn how my students prepare for amazing opportunities in this most fascinating and alluring profession—Aviation. Learn about my great shop and field training. Rates are reasonably low because of our large enrollment. Mail the coupon below for full details of my free employment offer and the many ways I help you to pilot's and mechanic's license.

Now All Can Learn to Fly
My shop training plan equips you for any branch of Aviation. Get the details today.

GREER COLLEGE
Dept. 313, 2024 S. Wabash Ave. CHICAGO, ILLINOIS

FREE Aviation Book

Erwin Greer, President, Dept. 313, 2024 So. Wabash Ave., Chicago, Illinois.

Send Free Book and details of Special offer, without obligation to me.

Name.....
Address.....
State..... Age.....

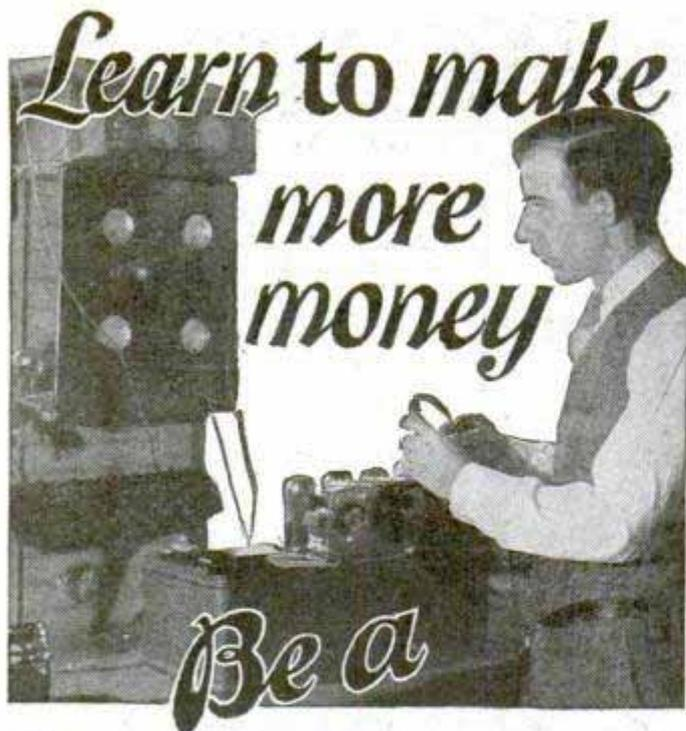

Be a Radio Expert

Hundreds of fine jobs paying \$50, \$60, \$75 a week and plenty of them paying \$100 a week are opening every year in Radio. No wonder. In the short period of a few years Radio has taken its place among the world's greatest industries. Its amazing growth has astounded the world. You can't enjoy the good things of life—a home, an automobile, money in the bank—on \$25, \$35 or \$40 a week. Why be satisfied with that for more than the short time it takes to get ready for Radio.

I'll show you how to make \$5 to \$25 a week extra on the side while learning

One month from today you can be making more money. The day you enroll I will show you how to do Radio jobs in your neighborhood. G. W. Page, 1807 21st Ave., S., Nashville, Tenn., made \$935 in his spare time while taking his course.

I will train you at home in your spare time. You must be satisfied

Hold your job. Give me only part of your spare time. I'll bring my training to you. I give you the parts for a home experimental laboratory, six big outfits, without extra charge. Further, I will refund every penny of your money if you are not satisfied upon completion with the lessons and instruction service I give you.

Act NOW. Get "Rich Rewards in Radio"

This 64-page book points out the money-making opportunities in the different branches of Radio such as broadcasting, operating on board ship which gives you world-wide travel without expense, how to start a spare-time or full-time Radio business of your own, Radio in Aviation, openings with dealers and manufacturers and many others. Clip the coupon.

J. E. SMITH, President,
Dept. OCPP

National Radio Institute, Washington, D. C.

Mail this Coupon at Once

J. E. Smith, Pres.,
National Radio Institute, Dept. OCPP
Washington, D. C.

Dear Mr. Smith: Without obligating me, send "Rich Rewards in Radio" explaining your training and Radio's opportunities for bigger success.

Name _____ Age _____

Address _____

City _____ State _____

Poor English!

How much is it costing you in wasted opportunity?

Every day your associates are judging you — by what you say and how you say it! Hazy ideas, ill-chosen words, halting sentences, crude, slovenly speech—these mark a man as loose in thinking. Thoughts clear-cut, words that give true shape and color, sentences aflame with power and originality—these are the things that proclaim ability, that win for their users swift advancement. Stop apologizing for poor English—it's inexcusable! In the quiet of your home—with LaSalle's help—you can learn to speak and write with real distinction, learn to make the words you utter and the letters you compose stamp you as educated, cultured, a power to reckon with in the business world. Complete details in an attractive 32-page book, "Effective Business English," sent you free upon request. Ask for it TODAY.

LaSalle Extension University, Dept. 364-BE, Chicago

FOREMEN!

Every foreman, factory worker, manager and ambitious mechanic will find a gold mine of inside information in "The Modern Foreman," by Robt. Grimshaw. The 28 chapters of this great work are a complete \$25 lecture course pointing the way to success, efficiency, better pay and the job higher up. A complete study course in leadership; a handy, daily reference and guide.

"The Modern Foreman" has 297 pages, quick reference index, many tables, diagrams, illustrations and forms; big type, easy to read and understand; rich binding, gold stamped. Size 6 x 9 x 1 1/4. Reg. price \$2.50. Our special sale price \$1.98. Send no money. Mail name and address only. Pay postman \$1.98 plus postage on arrival. Satisfaction guaranteed.

GREGG PUB. CO., Dept. PM, 20 W. 47 St., New York, N. Y.

PLAY A MUSICAL SAW

You have heard our "Musical Saw" over the radio, on phonograph records, and on the vaudeville stage. It is the easiest musical instrument to play. Fun for you and music your friends will enjoy. We will send you this Musical Saw with bow, hammer and lessons on five days trial. We will prove that you can play popular pieces in five days. No notes to read, no dreary finger exercises. No obligation to buy. FREE information.

MUSSEHL & WESTPHAL
16 South 3rd Street Fort Atkinson, Wis.

STAMMERING

easily, permanently corrected. Win happiness and success. Ask for full information and special phonograph record. Send dime for postage

12972 Woodward Ave., LEWIS INSTITUTE, Detroit

QUIT TOBACCO

Don't try to banish unaided the hold tobacco has upon you. Thousands of inveterate tobacco users have, with the aid of the Keeley Treatment, found it easy to quit.

KEELEY TREATMENT FOR TOBACCO HABIT

Quickly banishes craving for tobacco. Successful for over 50 years. Write today for FREE BOOK and particulars of our MONEY-BACK GUARANTEE.

THE KEELEY INSTITUTE, Dept. A-931, Dwight, Ill.
Home of the famous Keeley Treatment for Liquor and Drugs. Booklet Sent on Request. Correspondence Strictly Confidential.



ZIP-ZIP SHOOTER

THOUSANDS of boys are made happy with this wonderful Zip-Zip shooter, scientifically and practically made. If you like hunting and outdoor sports, get a Zip-Zip shooter with plenty of pep and force. If your dealer happens not to have them, order from us. Zip-Zip shooter 35c or three for \$1.00; send stamps, coin or money order.

Automatic Rubber Co., Columbia, S. C.





\$2500 Reward!

For the Capture of an Unknown Man

Twice he had entered the St. Clair Mansion. What was he after? Who? What was in danger?

Berteau, the famous Operator, had warned St. Clair that the mysterious marauder would come again. And now—a noise in the passage! The creak of an opening door. A shot in the dark! A capture!

Is this wounded stranger the mysterious intruder? Who could tell? Yet Berteau identified the man without hesitation and won the \$2500 reward.

How did he do it? Easy enough for the Finger Print Expert. He is the specialist, the leader, the *cream* of Operators. Every day's paper tells their wonderful exploits in solving mysterious crimes and convicting dangerous criminals.

More Trained Men Needed

The demand for trained men by governments, states, cities, detective agencies, corporations, and private bureaus is becoming greater every day. Here is a real opportunity for YOU. Can you imagine a more fascinating line of work than this? Often life and death depend upon finger print evidence—and big rewards go to the expert. Many experts can earn regularly from \$3,000 to \$10,000 per year.

Learn at Home in Spare Time

And now you can learn the secrets of this science at home in your spare time. Any man with common school education and average ability can learn Finger Print Identification in a surprisingly short time.

FREE

The Confidential Reports No. 38 Made to His Chief

Mail coupon now for free copy of confidential report Secret Service Operator No. 38 made to his chief. Get our big free book telling how you can become a real Finger Print Expert—gain fame and earn big rich rewards. Get our low prices and Easy Terms. But don't delay. Mail Coupon NOW!

Institute of Applied Science

Dept. 13-53 1920 Sunnyside Avenue, Chicago, Ill.

INSTITUTE OF APPLIED SCIENCE

1920 Sunnyside Ave., Dept. 13-53, Chicago, Ill.

Gentlemen:—Without any obligation whatever, send me free copy of Operator No. 38's confidential report, also your new, fully illustrated Free book on Finger Prints. Tell me all about your low prices and Easy Terms!

Name

Address

Age

TRAVEL - for 'UNCLE SAM'

RAILWAY POSTAL CLERKS
MAIL CARRIERS—POSTOFFICE CLERKS
GENERAL CLERKS—CUSTOMS INSPECTORS
\$1700 to \$3400 a Year for Life
 No "lay-offs" because of strikes, poor business, etc.—sure pay—rapid advancement. Many other U. S. Government Jobs. City and country residents stand same chance. Common sense education usually sufficient.

STEADY WORK
 Cut coupon and mail it before turning the page.

MEN—BOYS
18 to 45

Use Coupon Before You Lose It

COUPON

FRANKLIN INSTITUTE, Dept. G175, Rochester, N. Y.
 Rush to me, free of charge, (1) A full description of the position checked below; (2) 32-page book, with list of positions obtainable; (3) Tell me how to get the position checked.

Railway Postal Clerk (\$1900 to \$2700) General Clerk (\$1260 to \$2100)
 Postoffice Clerk (\$1700 to \$2300) Customs Inspector (\$2100 up)
 City Mail Carrier (\$1700 to \$2100) Rural Mail Carrier (\$2100 to \$3300)

Name

Address

PATENTS

ALL BUSINESS GIVEN PROMPT AND PROPER ATTENTION

Listed Patent Lawyer in the latest editions of the Rand-McNally Directory of Bankers and Bonded Attorneys, published by Rand-McNally & Co., Chicago, Ill.; The Baggott & Ryall Directory of Guaranteed Attorneys, published by Legal Directory Corporation, Boston, Mass.; Flugel's Law List, published by Legal Directory Publishing Co., St. Louis, Mo.; American Lawyers Annual, published in Cleveland, Ohio; Bankers Service Legal Directory, published by Bankers Service Co., Boston, Mass.; Eyre's Law List, 9 Park Place, New York City; Walters Legal Directory, Omaha, Nebraska, and the National Directory of Attorneys, Baltimore, Maryland.

WATSON E. COLEMAN,
 REGISTERED PATENT LAWYER

Booklet Free Highest References
Promptness Assured Best Results

Send drawing or model for preliminary examination and advice.

Victor Building, 724 Ninth Street, N. W.
WASHINGTON, D. C.

FREE! of extra cost—send the coupon for details of our amazing new plan. It tells you how to get a big assortment of beautiful gifts that you can paint.

This Magic Box Turns Spare Time Into Money!

We show you how and give you the complete outfit illustrated above. Also we give you our Free Idea Book which has started hundreds making easy money! Mrs. H. L., Illinois, says: "I made \$100.00 on furniture in one week." Mrs. A. K., Virginia—"My sales were \$500.00 for five weeks. This is my first year." R. M. P., Illinois—"I did \$3,500 worth of business last year and over \$12,000 worth this year." D. W., New Mexico—"I would not take \$1,000 for my course." A real desire to make money is all you have to have to make a big success at Fireside work.—No tiresome study.—You learn by doing. It is fun decorating beautiful gifts and furniture—the most fascinating pastime you can imagine. You make good money practically from the start. Our FREE book tells you how. Send the coupon for it!

No Experience Needed
 You need no experience or business ability to succeed at Fireside work and make excellent

FIRESIDE INDUSTRIES
 Dept. 66-C Adrian, Mich.

money. We help you and show you how. You can join now on the easiest plan ever offered. Get full details today. Coupon brings everything.

FREE Book on Decoration
 Mail the coupon NOW for the beautiful new book on home decoration and money making. It's FREE! A new plan for starting you at good money at once will also be included. Do this at once—while there are openings for new members!

Fireside Industries
 Dept. 66-C
 Adrian, Mich.

Send me FREE book on decoration and details of our new plan. Also how to get the big artist's outfit.

Name.....
 Address.....
 City..... State.....

GOOD FOR PLAN

RADIO NEEDS

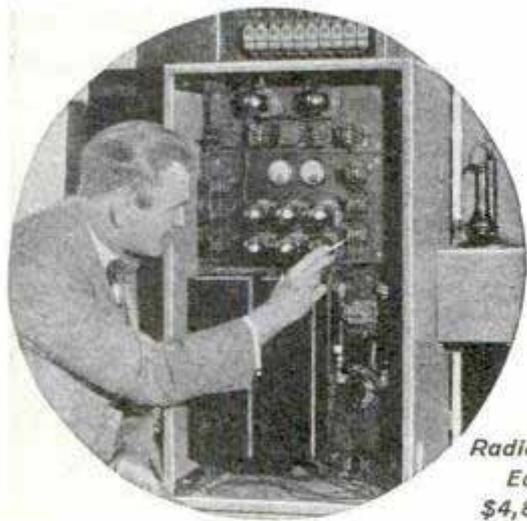

*Radio Mechanics
Earn up to
\$4,800 a Year*

YOU Let RCA Institutes

Show You the Way to

SUCCESS

in this fast-growing industry

REACH out for a big-pay job in Radio . . . Tie-up to the fastest-growing industry in the world today . . . See for yourself what other men have done . . . You, too, can do the same! Hundreds of fellows just like you are now earning from \$2,000 to \$25,000 a year in RADIO. J. H. Barron, Radio Inspector of the U. S. Department of Commerce says that a most serious shortage in trained Radio men exists right now. Thousands of trained men are needed. Broadcasting stations, manufacturing plants, retail and wholesale dealers, as well as ships at sea and planes in the air, require trained Radio men.

*Learn Radio at Home . . . RCA Institutes will
Train You for Success!*

RCA sets the standards for the entire radio industry. The RCA Institutes Home Laboratory Training Course gives you the real, inside, practical training in Radio, quicker than you could obtain it in any other way. It's easy to learn at home in your spare time. You get your lessons and criticisms direct from RCA . . . the very source of radio achievement . . .

the vast world-wide organization that has made Radio what it is today . . . that sponsors every lesson in this course.

*RCA Graduates Find it Easy to Fill
Good Radio Jobs*

There has been a radio job for practically every graduate of RCA Institutes. Graduates are actually *Trained* for Success because they learn radio by actual experience with the RCA Institutes famous outlay of apparatus given to every student of this course. You learn to solve every radio problem such as repairing, installing, and servicing fine sets. Here is everything you need to know in order to fill a well-paid position in Radio.

*Send for This Free Book
"Radio . . . the Field of Unlimited Opportunity"*

Read these 40 fascinating pages, each one packed with pictures and text that tell you everything you want to know about the many brilliant opportunities in Radio and about RCA Institutes, the world's oldest and largest radio training organization. Tune in on Radio. Send for this free book today and speed up your earning capacity!

Clip this Coupon NOW!

RCA INSTITUTES, Inc.

Formerly
Radio Institute
of America



RCA INSTITUTES, Inc.
Dept. PM-3, 326 Broadway, New York

Gentlemen: Please send me your FREE 40-page book which illustrates the brilliant opportunities in Radio and describes your laboratory-method of instruction at home!

Name.....

Address.....



“The Boss Didn't Even Know My Name”

“He said my face was more or less familiar and he remembered seeing me around, but he didn't even know my name until the I. C. S. wrote him that George Jackson had enrolled for a course of home study and was doing fine work.

“Who's George Jackson?” he asked. Then he looked me up. Told me he was glad to see I was ambitious. Said he'd keep his eye on me.

“He did too. Gave me my chance when Frank Jordan was sent out on the road. I was promoted over older men who had been with the firm for years.

“My spare-time studying helped me to get that job and to keep it after I got it. It certainly was a lucky day for me when I signed that I. C. S. coupon.”

How much longer are you going to wait before you take the step that will bring you advancement and more money?

It takes only a moment to mark and mail this coupon and send it to the International Correspondence Schools at Scranton, but that one simple little step may change your entire life. Isn't it better to do this today than to wait a year or five years and then wish you had?

Mail the Coupon for Free Booklet

INTERNATIONAL CORRESPONDENCE SCHOOLS
Box 5673-F, Scranton, Penna.

Without cost or obligation, please send me a copy of your booklet, “Who Wins and Why,” and full particulars about the course before which I have marked X in the list below:

TECHNICAL AND INDUSTRIAL COURSES

- | | |
|--|---|
| <input type="checkbox"/> Architect | <input type="checkbox"/> Automobile Mechanic |
| <input type="checkbox"/> Architectural Draftsman | <input type="checkbox"/> Aviation Engines |
| <input type="checkbox"/> Building Foreman | <input type="checkbox"/> Plumber and Steam Fitter |
| <input type="checkbox"/> Concrete Builder | <input type="checkbox"/> Plumbing Inspector |
| <input type="checkbox"/> Contractor and Builder | <input type="checkbox"/> Foreman Plumber |
| <input type="checkbox"/> Structural Draftsman | <input type="checkbox"/> Heating and Ventilation |
| <input type="checkbox"/> Structural Engineer | <input type="checkbox"/> Sheet-Metal Worker |
| <input type="checkbox"/> Electrical Engineer | <input type="checkbox"/> Steam Engineer |
| <input type="checkbox"/> Electrical Contractor | <input type="checkbox"/> Marine Engineer |
| <input type="checkbox"/> Electric Wiring | <input type="checkbox"/> Refrigeration Engineer |
| <input type="checkbox"/> Electric Lighting | <input type="checkbox"/> R. R. Positions |
| <input type="checkbox"/> Reading Shop Blueprints | <input type="checkbox"/> Highway Engineer |
| <input type="checkbox"/> Telegraph Engineer | <input type="checkbox"/> Chemistry |
| <input type="checkbox"/> Telephone Work | <input type="checkbox"/> Pharmacy |
| <input type="checkbox"/> Mechanical Engineer | <input type="checkbox"/> Coal Mining Engineer |
| <input type="checkbox"/> Mechanical Draftsman | <input type="checkbox"/> Navigation <input type="checkbox"/> Assayer |
| <input type="checkbox"/> Machine Shop Practice | <input type="checkbox"/> Iron and Steel Worker |
| <input type="checkbox"/> Toolmaker | <input type="checkbox"/> Textile Overseer or Supt. |
| <input type="checkbox"/> Patternmaker | <input type="checkbox"/> Cotton Manufacturing |
| <input type="checkbox"/> Civil Engineer | <input type="checkbox"/> Woolen Manufacturing |
| <input type="checkbox"/> Surveying and Mapping | <input type="checkbox"/> Agriculture <input type="checkbox"/> Fruit Growing |
| <input type="checkbox"/> Bridge Engineer | <input type="checkbox"/> Poultry Farming |
| <input type="checkbox"/> Gas Engine Operating | <input type="checkbox"/> Mathematics <input type="checkbox"/> Radio |

BUSINESS TRAINING COURSES

- | | |
|--|---|
| <input type="checkbox"/> Business Management | <input type="checkbox"/> Business Correspondence |
| <input type="checkbox"/> Industrial Management | <input type="checkbox"/> Show Card and Sign Lettering |
| <input type="checkbox"/> Personnel Management | <input type="checkbox"/> Stenography and Typing |
| <input type="checkbox"/> Traffic Management | <input type="checkbox"/> English |
| <input type="checkbox"/> Accounting and | <input type="checkbox"/> Civil Service |
| <input type="checkbox"/> C. P. A. Coaching | <input type="checkbox"/> Railway Mail Clerk |
| <input type="checkbox"/> Cost Accounting | <input type="checkbox"/> Mail Carrier |
| <input type="checkbox"/> Bookkeeping | <input type="checkbox"/> Grade School Subjects |
| <input type="checkbox"/> Secretarial Work | <input type="checkbox"/> High School Subjects |
| <input type="checkbox"/> Spanish <input type="checkbox"/> French | <input type="checkbox"/> Cartooning |
| <input type="checkbox"/> Salesmanship | <input type="checkbox"/> Illustrating |
| <input type="checkbox"/> Advertising | <input type="checkbox"/> Lumber Dealer |

Name.....

Address.....

City..... State.....

Occupation.....

If you reside in Canada, send this coupon to the International Correspondence Schools Canadian, Limited, Montreal, Canada

BE A RAILWAY TRAFFIC INSPECTOR

Earn up to \$250 PER MONTH Plus Expenses

THERE'S a position and a future in Railway Traffic Inspection for active men 19-55 years old. It's healthful, outdoor work with regular hours. Pays up to \$250 per month plus expenses. Unlimited opportunities—meet high railway officials—travel or remain near home.

Big Demand for Trained Men

For over eleven years, we have been training men for this permanent, profitable profession.

Railways look to us for men. We'll train you in a few weeks' spare time home instruction, and upon completion, assist you to a position paying \$120 to \$150 per month plus expenses, or refund your tuition. Rapid salary advances with experience to \$175, \$200, \$250.

Send for free booklet today

It tells all about Traffic Inspection—how we started hundreds of men to big pay jobs—what it can do for you—how we can assist you to a salaried position with rapid advancement. Send for it now! Don't delay.

STANDARD BUSINESS TRAINING INSTITUTE
Div. 2 BUFFALO, N. Y.

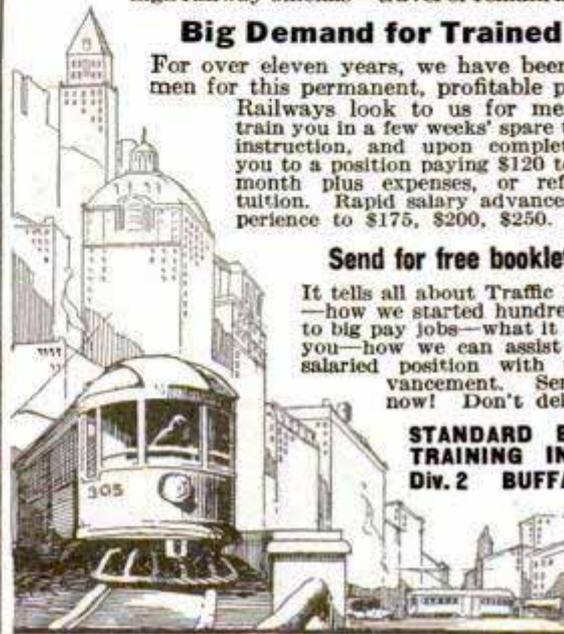

BIG Demand for Skilled Mechanics!

[The entire country is calling for skilled mechanics! Good pay—steady work—good opportunities for advancement! Master this fascinating trade with the aid of the

AMERICAN MACHINISTS' LIBRARY

6 volumes—2,000 pages—2,500 illustrations

(A combined home-study course and reference library)

This library of machine shop practice was written for practical men. It gives you the best methods for every kind of machine shop work. It explains machine tools and their operation, tool work, gears and grinding, jigs and fixtures, automatic screw machines, their tools, punches, dies, etc. Plainly written—completely illustrated—the best kind of help to the machine-shop man who wants to advance himself.

Free TRIAL

No money down—only 7c a day

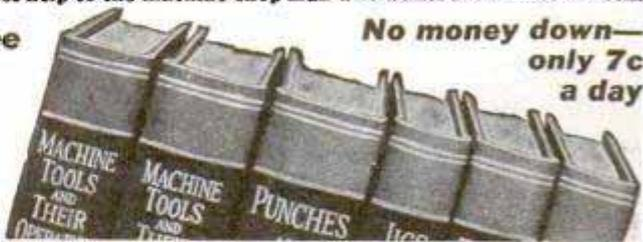

FREE EXAMINATION COUPON

McGraw-Hill Book Co., Inc., 370 Seventh Ave., New York

Send me for 10 days' free examination the AMERICAN MACHINISTS' LIBRARY. If satisfactory, I will send \$1.50 in 10 days and \$2 monthly until the special price of \$17.50 is paid. If not wanted, I will return the books at your expense.

Signed.....

Address.....

City and State.....

Position.....

Company..... P. M. 3-30

New!



Patented

Just A Twist Of The Wrist

Banishes Old-Style Can Openers to the Scrap Heap and
BRINGS AGENTS \$5 to \$12 IN AN HOUR

WOMEN universally detest the old-style can opener. Yet in every home in the land cans are being opened with it, often several times a day. Imagine how thankfully they welcome this new method—this automatic way of doing their most distasteful job. With the Speedo can opening machine you can just put the can in the machine, turn the handle, and almost instantly the job is done.

wonder salesmen everywhere are finding this invention a truly revolutionary money maker!

New "Million Dollar" Can Opener Machine

The Speedo holds the can—opens it—flips up the lid so you can grab it—and gives you back the can without a drop spilled, without any rough edges to snag your fingers—all in a couple of seconds! It's so easy even a 10-year-old child can do it in perfect safety! No wonder women—and men, too—simply go wild over it! No wonder Speedo salesmen often sell to every house in the block and make up to \$10 an hour.

End This Waste and Danger

Generous Free Test Offer

Frankly, men, I realize that the profit possibilities of this proposition as outlined briefly here may seem almost incredible to you. So I've worked out a plan by which you can examine the invention and test its profit without risking one penny.

Get my free test offer while the territory you want is still open—I'll hold it for you while you make the test. I'll send you all the facts about others making \$75 to \$150 in a week. I'll also tell you about another fast selling item that brings you two profits on every call. All you risk is a 2c stamp—so grab your pencil and shoot me the coupon right now.

CENTRAL STATES MFG. CO. C-703
4500 Mary Ave., (Est. over 20 years) St. Louis, Mo.



Central States Mfg. Co.
4500 Mary Ave., C-703
St. Louis, Mo.

Yes, rush me the facts and details of your FREE OFFER.

Name.....

Address.....

City.....State.....

Check here if interested only in one for your home.

AGENTS!



Full Time \$265 in a Week

"Here is my record for first 30 days with Speedo:
June 13, 60 Speedos;
June 20, 84 Speedos;
June 30, 192 Speedos;
July 6, 288 Speedos.
Speedo sells to 9 out of 10 prospects."

M. Ornoff, Va.

PART TIME

14 Sales in 2 Hours
J. J. Corwin, Ariz., says: "Send more order books. I sold first 14 orders in 2 hours."

SPARE TIME

Big Money Spare Time
Barb, W. Va., says: "Was only out a few evenings, and got 20 orders."

You undoubtedly know what a nasty, dangerous job it is to open cans with the old-fashioned can opener. You have to hack your way along slowly—ripping a jagged furrow around the edge. Next thing you know, the can opener slips. Good night! You've torn a hole in your finger. As liable as not it will get infected and stay sore a long time. Perhaps even your life will be endangered from blood poisoning!

You may be lucky enough to get the can open without cutting yourself. But there's still the fact to consider that the ragged edge of tin left around the top makes it almost impossible to pour out all of the food. Yet now, all this trouble, waste and danger is ended. No

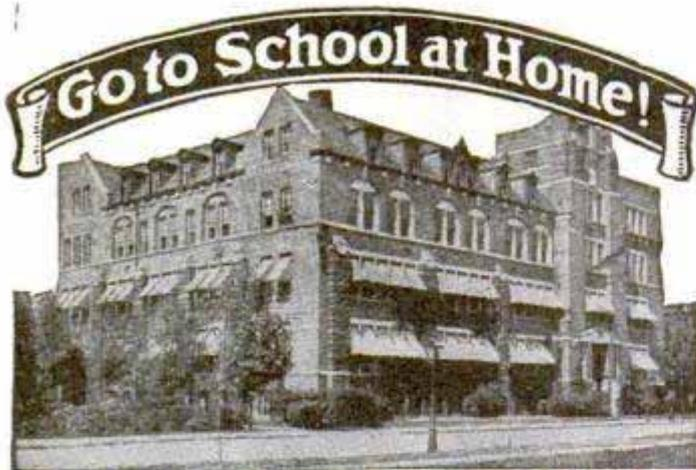

High School Course in Two Years!

You Want to Earn Big Money!

And you will not be satisfied unless you earn steady promotion. But are you prepared for the job ahead of you? Do you measure up to the standard that insures success? For a more responsible position a fairly good education is necessary. To write a sensible business letter, to prepare estimates, to figure cost and to compute interest, you must have a certain amount of preparation. All this you must be able to do before you will earn promotion. Many business houses hire no men whose general knowledge is not equal to a high school course. Why? Because big business refuses to burden itself with men who are barred from promotion by the lack of elementary education.

Can You Qualify for a Better Position

We have a plan whereby you can. We can give you a complete but simplified high school course in two years, giving you all the essentials that form the foundation of practical business. It will prepare you to hold your own where competition is keen and exacting. Do not doubt your ability, but make up your mind to it and you will soon have the requirements that will bring you success and big money. YOU CAN DO IT.

Let us show you how to get on the road to success. It will not cost you a single working hour. Write today. It costs you nothing but a stamp.

American School

Dept. H-347 Drexel Ave. and 58th St., Chicago

American School

Dept. H-347 Drexel Ave. and 58th St., Chicago

Send me full information on the subject checked and how you will help me win success.

- | | |
|------------------------------|----------------------------|
| Architect | Business Law |
| Building Contractor | Lawyer |
| Automobile Engineer | Machine Shop Practice |
| Automobile Repairman | Mechanical Engineer |
| Civil Engineer | Shop Superintendent |
| Structural Engineer | Employment Manager |
| Business Manager | Steam Engineer |
| Cert. Public Accountant | Foremanship |
| Accountant and Auditor | Sanitary Engineer |
| Bookkeeper | Surveyor (& Mapping) |
| Draftsman and Designer | Telephone Engineer |
| Electrical Engineer | Telegraph Engineer |
| Electric Light & Power | High School Graduate |
| General Education | Wireless Radio |
| Vocational Guidance | Undecided |

Name

Address

Learn AVIATION

WHERE LINDBERGH STARTED!

GET TRAINING THAT ASSURES SUCCESS!

Learn where "Lindy" learned—at Lincoln! Get **complete, thorough** Aviation training. Attend the Lincoln Airplane and Flying School. One of the largest, finest equipped civilian aviation schools in U. S. Complete courses in flying, airplane building and mechanics. Planes and pilot instructors carry the Dept. of Commerce license. Write for **FREE** Literature, stating age!

Lincoln Airplane & Flying School
208 Aircraft Bldg. LINCOLN, NEBR.



PAINT SHOW CARDS

and SIGNS. LEARN AT HOME IN SPARE TIME. WE TEACH YOU QUICKLY — FASCINATING WORK. \$75 WEEKLY. SEND 6c IN STAMPS FOR CIRCULAR.

Universal School of Lettering NEW HAVEN, CONN.



Minstrels

Unique First Parts for complete show with special songs and choruses. Make-up. Catalog Free.



T. S. Denison & Co., 623 S. Wabash, Dept. 19 Chicago

BIG MONEY JOBS OPEN

IN ELECTRIC REFRIGERATION

HERE'S your chance to escape forever from crowded fields, poor pay and limited future! America's newest and fastest-growing industry—Electric Refrigeration—needs trained men to fill service, sales, factory and executive positions at salaries up to \$50 and \$250 a week. Amazing new easy training fits you quickly at home in spare time—endorsed and praised by Servel, Kelvinator, Copeland, Champion, Zerozone and others.

Earn As You Learn New Easy Way
Unlike ordinary schooling. Fascinating—simple as A.B.C. No textbooks. No study drudgery. Trained experts guide you step by step. Charts, diagrams and pictures help you master every principle and practice. Easy terms. Money-back agreement. Free employment service. Hundreds of satisfied students. Get big new book of facts—**Rich Rewards In Electric Refrigeration**. Sent **FREE** without obligation.
UTILITIES ENGINEERING INSTITUTE
Dept. 130, 4403 Sheridan Rd., Chicago, Ill.

FREE BOOK



Simply Mail the Coupon Below NOW!

Utilities Engineering Institute, Dept. 130, 4403 Sheridan Road, Chicago, Ill.

Without obligating me, send free book "Rich Rewards in Electric Refrigeration."

Name

Address

City State

Wanted... Men To Read Blue Prints *And Run Big Building Jobs!*

**Builders! Here's
A Message of Vital
Importance to Every Am-
bitious Tradesman in Amer-
ica! To Help You Win Promo-
tion in Building at Man Sized Sal-
aries, This Old Established School for
Builders Now Offers Quick, Easy, Prac-
tical Training in Plan Reading. Coupon
Below Brings You Absolutely FREE a Val-
uable Book, "How to Read Blue Prints"; Also
a Set of Real Building Blue Prints. Write at
Once!**

**SEE HOW QUICKLY YOU CAN BECOME A SUPERIN-
TENDENT OR BUILDING CONTRACTOR BY THIS NEW,
EASY BLUE PRINT WAY TO BIG PAY**

EVERY man in the Building Industry today knows that in order to win promotion and run big building jobs he must understand Blue Print Plans and Specifications from A to Z. With a trained mind it is easier to hold a big pay job in Building.

This announcement spells wonderful news for every man who is practical and ambitious. Here at last is an opportunity for you to take a quick, easy step that will bring you the success you have hoped for—if you are of this type and are willing to supply the honest effort necessary. Remember, your spare time is enough.

Practical Blue Print Training

You've needed it, you've prayed for it and at last Chicago Tech brings it to you! For by a marvelous new practical blue print method, this old established and recognized School for Builders brings to you in an amazing short time everything you need to put you on the "headwork" side of the Building Industry. Prepares you for big pay and a real future right in your own home and in your spare time—right while you are on the job! It doesn't matter what your age is. You don't even have to have previous education. If you can read what is written here, you

can grasp every money-making principle easily.

No Text Books—Simple as A B C

This astonishing blue print training is entirely different from ordinary schooling. No study grind. No text books to wade through. No useless theory. Practical from start to finish. Based on many sets of real blue prints which we give you to examine and keep. Twenty famous experts go over these actual working plans with you step by step and explain everything in plain, everyday language you can easily understand. Fascinating throughout and as easy to understand as your newspaper.

This is the kind of training that has enabled builders throughout the country — practical, ambitious men like yourself — to make the kind of money they wanted. Samuel Schrier, Pennsylvania, reports that he has been raised to foreman with an increase of \$72.70 per week. W. Fout, Virginia, was promoted from workman to superintendent as a result of his training. Percy F. Blair, Oklahoma, writes: "When I started your course, I received \$49.50 per week working with my tools. Now I am superintendent and make \$100 a week for the same concern."

Mail Coupon for FREE Facts

Investigate this short-cut to promotion at once! Don't send one penny. Simply fill in and mail the coupon. It brings you promptly a valuable free book, "How To Read Blue Prints," and actual working blue prints as well as convincing proof. No cost or obligation. Write today—NOW!

If You Live Nearby

Visit our big Day and Evening School attended by over 1,000 builders. You can get the same training at home by mail—same lessons, same plans, same instructions—in your spare time.

Chicago Technical SCHOOL for BUILDERS

Dept. C-143, Chicago Tech Building, 118 E. 26th St., Chicago, Ill.

FREE!
**BOOK and BLUE PRINTS
To Carpenters and Builders**

Without cost or obligation, every ambitious, practical man may now secure a copy of "How To Read Blue Prints" and a set of valuable working blue prints. Also, full facts and details about the new easy at-home training that has made possible promotions and bigger pay checks for scores of builders all over the country. Remember — there is absolutely no risk for you, so fill in and mail the coupon below!

Chicago Technical School For Builders,
Dept. C-143, Chicago Tech Building,
118 E. 26th Street, Chicago, Ill.

Send me at once your FREE BOOK and complete set of FREE BLUE PRINTS which I understand are mine to keep without obligation. It is understood that no salesman will call on me.

Name.....

Address.....

City..... State.....

Age..... Occupation.....

MEN

EARN \$100

While LEARNING BARBERING



The Simplest Work in the World to Learn
SHORT—PRACTICAL COURSE
Protecting Laws Make It the Best Profession in the Universe

ART STEFFEN paid his way through a two year course of Aviation by Barbering. He came to Moler's from an Automobile Job.

RALPH KUHLMAN has a Barber job on the Santa Fe running from Chicago to Los Angeles paying as high as \$60 a single trip. A short while ago he was a farm hand.

ARTHUR BAKER runs a shop in the exclusive great money district of Wall Street. He has accumulated a fortune. He learned at Moler's.

60,000 have done as well as these boys. It is better than the average man does and it is so easy.

GOODNESS !!! GRACIOUS !!!

anybody can barber and it's put within your easy reach. There is a school near you. Write to the nearest one and see.

Standardized Branches

Moler System of Colleges

- | | |
|-----------------------------------|-------------------------------------|
| 139 E. 23rd St., New York City. | 109 S. 15th St., Omaha, Nebr. |
| 512 N. State St., Chicago, Ill. | 501 E. Water St., Milwaukee, Wis. |
| 810 N. 6th St., St. Louis, Mo. | 81 Forsyth St., N. W., Atlanta, Ga. |
| 801 Main St., Kansas City, Mo. | 81 S. Second St., Memphis, Tenn. |
| 206 E. 4th St., Cincinnati, Ohio. | 912 Main St., Dallas, Texas. |
| 215 Huron Road, Cleveland, Ohio. | |
| 559 Michigan Ave., Detroit, Mich. | |

Address Nearest Branch

Please send me without obligation on my part your Booklet B telling how I may earn \$100 and my meals while learning barbering.

Name.....
 Address.....
 City..... State.....

How To Secure A Government Position

Why worry about strikes, layoffs, hard times? Get a Government job! Increased salaries, steady work, travel, good pay. I'll help you become a Custom House Clerk, Railway Postal Clerk, Post Office Clerk, City Mail Carrier, Rural Carrier—or any other Government job you want. I was a Secretary-Examiner of Civil Service Commission for 8 years. Have helped thousands. Railway Postal Clerk examination coming.

Now FREE

My 32-page book tells about the jobs open—and how I can help you get one. Write TODAY. ARTHUR B. PATTERSON, Civil Service Expert, PATTERSON SCHOOL, 83 Wisner Building, Rochester, N.Y.

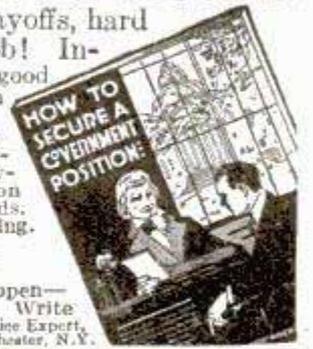

ACCOUNTING



The uncrowded, highly paid profession of Accountancy offers marvelous opportunities to ambitious men and women. Send for our 80-page book, "How to Learn Accounting," and the first easy lesson. Both will be sent free.

INTERNATIONAL ACCOUNTANTS SOCIETY, Inc.
 A Division of the
Alexander Hamilton Institute
 Dept. 123, 3411 South Michigan Ave., Chicago, Ill.

WELDING—The Busy Big-Pay Trade

We teach ambitious men by actual welding practice.
—OXY-ACETYLENE and ELECTRIC ARC—
 Pipe-line, Sheet Steel, Structural Steel, Aircraft, Cast-Iron, Aluminum and Commercial Welding. Cutting, Brazing and Plating. Splendidly Equipped to Teach You Right Rapidly and at Reasonable Rates

A Free Booklet for You—Write for it Now.
 COLEMAN ELECTRICAL SCHOOL, 1628-X Main Street KANSAS CITY, MO.

LEARN TO PLAY

VIOLIN, TENOR BANJO, HAWAIIAN GUITAR, BANJO, CORNET, GUITAR, MANDOLIN, BANJO MANDOLIN, BANJO-GUITAR, SNARE DRUM, FIELD DRUM, PIANO or ORGAN quickly by note by our copyrighted easy to learn home-study method. No teacher or talent necessary. Lessons are so simplified and so easily mastered many pupils play by note after only 10 lessons. Thousands of men, women, boys and girls have learned to play quickly and proficiently by our system of teaching. Cost is less than 10¢ a day. Play while you learn. Your opportunity to become popular and play for profit or pleasure. Write for Free Trial. Any instrument except PIANO and ORGAN furnished if desired at wholesale price.

CHICAGO CORRESPONDENCE SCHOOL OF MUSIC, INC.
 1632 No. Halsted St., Dept. 51 Chicago, Ill.

BE AN OIL EXPERT!

Trained geologists, drillers, refiners, salesmen are at a premium! New, easy, practical way to learn at home in spare time!
 Write Today! FREE Book!
PETROLEUM ENGINEERING UNIVERSITY, Dept. 223, FORT WAYNE, IND.

Study **LAW** AT HOME
 Lincoln did it! Also thousands of other great lawyers, politicians and business men. YOU, too, can become a lawyer or law trained businessman through home study guided by the successful practicing lawyers of our faculty. Write today for free book.
AMERICAN CORR. SCHOOL OF LAW
 3601 Michigan Ave., Dept. 1353, Chicago

ALWAYS Ask for DENISON'S—54 Years of Hits
 Comedy - Dramas, Farces, Musical Comedies, Revues, Musical Readings, Comedy Songs, Chalk Talk Books, Minstrels, Blackface Skits, Make-up Goods. Catalog FREE.
T. S. DENISON & CO. 623 S. Wabash, Dept. 9 CHICAGO

PUBLIC SPEAKING SIMPLIFIED

Just published—an amazing new, practical and fascinating easy way to learn Public Speaking. With this Course you will gain immediate self-confidence, and start making talks or speeches. SEND NO MONEY. Pay Postman only \$5 plus few pennies postage. 5-day examination privilege. Also "How To Get Vocabulary You Want", \$1. You'll astonish your friends.
NIAGARA SCHOOL, Inc., Dept. P., B. L. E. Bldg., CLEVELAND, O.

What Hinton Training Is

A complete course of instruction in the working knowledge, principles and practical operation of Aviation. You study it at home, under the direct personal supervision of Walter Hinton, one of America's most famous flyers—thirteen years in Aviation, over 400,000 miles of flight behind him. You learn motors, plane design and construction, theory of flight, carburetion and ignition, repairs, maintenance, management. You get the thorough groundwork that you *must* have first. Then if you want to fly, Hinton arranges special rates for you. If you want a job on the ground, his Employment Department puts you in touch with employers.

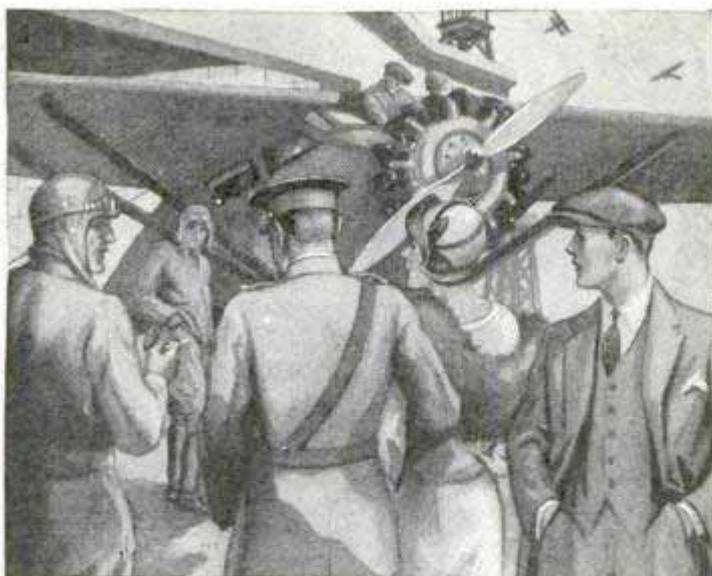

What Hinton Training Does

It puts Aviation from A to Z at your fingertips—then backs up that training with an Employment Service that gets results. J. W. Boehm, 47 Seventh Ave., Brooklyn, N. Y., has connected with the Sikorsky Company. Thomas Lapworth, 1414 Vine St., Hollywood, took the course, gave up his job and is now with the Douglas Airplane Co. Warren Mengel, 1301 N. 11th St., Reading, Pa., now has a real job with Wright. Myron H. Rettberg, Whitney Point, N. Y., credits the course and service for landing him with Pratt & Whitney. Hinton's Course gives you your start to be an Engineer, Designer, Pilot, Mechanic, Rigger, Electrician, Wood Worker, Inspector, Airport Operator, Assemblyman, Salesman—your choice of *over 40* big-pay jobs, on the ground or in the air!

What's keeping You out of AVIATION?

Is it Lack of Training?

WALTER HINTON speaking . . . What's keeping YOU out of Aviation? Lack of ambition? I don't believe it. Is it failure to see the tremendous opportunities, the profits that the Industry offers you? I can't believe that either. Something is making you wait. I don't know what that "something" is, but I *do know* that I can give you the one thing you need to get started. I can give you the one thing that will make you eligible with the hundreds of Aviation employers who are demanding More Men. I can give you TRAINING!

Are you 18 years of age?

If you are, I'll show you how to get started *without delay*. I can't drive home the importance of that too strongly. A month in Aviation sees practically as much progress as a year in any other industry. Yesterday's employees are today's bosses. Today's beginners can be tomorrow's *successes* in this richest field of all! The coupon below will bring you my book, "Wings of Opportunity." It has *already started* hundreds of men. It's vital—it's FREE. If you're eighteen or over—if you're serious—if you're ready to learn *facts about Aviation* and **FACTS ABOUT YOUR OWN CHANCES IN AVIATION**—mail the coupon now!

Walter Hinton, Pres.

AVIATION INSTITUTE OF U. S. A.
1115 Conn. Ave. Washington, D. C.



301E

Tell me more about MY chances in Commercial Aviation. Send me your FREE Book, "Wings of Opportunity."

Name.....

Street.....Age.....
(Must be 18)

City.....State.....



WALTER HINTON

Pilot of the NC-4, first trans-Atlantic plane. First flyer from North to South America. Famous war-time Navy instructor. First and only world-known aviator to give home-study students the cream of his knowledge. His FREE Book is ready to show you how to start—how to get ahead—how to *succeed* in Aviation!

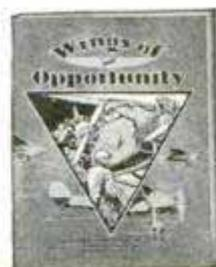

FREE BOOK

You can have a man-to-man half-hour talk with one of America's pioneer Aviators—one of Aviation's greatest instructors. You can get the facts you've waited for, and *can't afford to wait for a day longer*. This FREE Book brings them. The coupon brings the book. Mail it now.

ELECTRICITY

PAYS BIG!

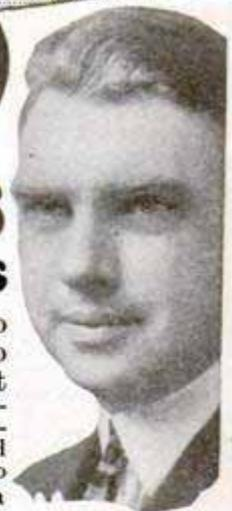

LEARN IN 90 DAYS ON ACTUAL EQUIPMENT — NO BOOKS

Don't let the world bluff you. Get into electricity—earn \$50.00 to \$150.00 a week—and hold your head as high as the next man. Do it easily by coming to my famous electrical school. In 12 short weeks you'll pack in many years of practical knowledge. You learn on real Electrical Equipment, with real Tools. My special School Shops are fitted with Switchboards, Generators, Motors, etc. You get first hand knowledge of A. C. and D. C. Armature Winding, House Wiring, Splicing, in fact everything you need to

No Education or Experience Needed

No books to read. No dry lectures to listen to. You learn by doing. I don't care if you can't tell a motor from a horse-and-buggy now. When you graduate I guarantee that you'll know electricity from "A" to "Z." If you're not fitted to fill a big-pay job I'll refund every penny of your tuition.

know to fit you for an Electrical job. Also complete instruction on Automobile, Aviation and Radio Electrical Systems and Batteries.

Satisfaction Guaranteed!

I will refund every penny of your tuition if you are not satisfied.

Big Illustrated Book Sent FREE

Today, right now, take the first step out of that low pay rut. Mail the coupon to me for big, illustrated book on ELECTRICITY. Act today. Get my special Remarkable Tuition offer.

JUST MAIL COUPON!



IT'S EASY THIS WAY

Fascinating, practical shop work in my big school fits you. Note correspondence course.

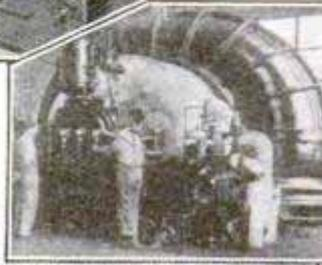

McSWEENEY ELECTRICAL SCHOOLS

Dept. E-11-T, 1815 E. 24th Street, Cleveland, Ohio, or Dept. E-11-T, 263 Madison Street, Memphis, Tenn.

J. H. McSweeney, Pres., McSweeney Elec. Schools, Dept. E-11-T, 1815 E. 24th St., Cleveland, O., or Dept. E-11-T, 263 Madison St., Memphis, Tenn.

Dear Sir: Without obligation send me a copy of your big free book on ELECTRICITY; also details of remarkable tuition offer and complete radio course.

Name.....
Address.....
Town..... State.....

COMPLETE RADIO COURSE

Learn to PAINT SIGNS and SHOW CARDS

We quickly teach you by mail, or at school, in spare time. Enormous demand. Big future. Interesting work. Oldest and foremost school. **EARN \$50 TO \$200 WEEKLY**

Otto Wiegand, Md., home-study graduate, made \$12,000 from his business in one year. John Vasson, N.Y., gets \$25 for a show card. Crawford, B. C., writes: "Earned \$200 while taking course." Write for complete information.



DETROIT SCHOOL OF LETTERING
154 Stinson Ave. Est. 1899 Detroit, Mich.

Learn Advertising at HOME

Send your name and address for free booklet giving interesting information and vital facts about Advertising. Find out how we prepare you at home, in your spare time, for the opportunities open in this fascinating business. Practical work. No text books. Old established school. Successful graduates everywhere. Just the plan you have always wanted. Write today. No obligation.

PAGE-DAVIS SCHOOL OF ADVERTISING
Dept. 1353 3601 Michigan Ave. Chicago, U. S. A.



DRAW CARTOONS

TURN YOUR TALENT INTO MONEY



Cartoonists earn from \$50 to \$250 per week—some even more. Remarkable Circle System of Drawing teaches you in half the usual time. Students from all parts of the world are enrolling for this exceptional instruction. Personal criticism service and up-to-the-minute instruction make it easy for National students to attain success. Send for interesting BOOKLET and SAMPLE LESSON PLATE explaining full details of the Course and what National students are accomplishing. No salesman will call.

The National School of Cartooning, 623 Penton Bldg., Cleveland, Ohio

Make \$50 to \$100 a Week

By BEING TECHNICALLY TRAINED THIS THOROUGH WAY

Only trained men rise to be bosses! They make the large, steady incomes! Are you ready for that? Now's the time to learn. Master a craft—your craft. Select the subjects you want to study from the list below. You can master them quickly, easily and thoroughly with the St. Louis Technical Institute's home study training. Learn right at home.

GET THE FACTS, FREE!

Our methods and lessons are so plainly and clearly defined that you'll be amazed how fast you master the work and get a raise in pay. Don't let anything stop you. Get ready for big things.

How soon will you be qualified for an increase? Write us today! Get complete information. Our big free book explains it all! Tells what you can learn.

Train at Home

CHECK THE COURSES YOU WANT TO STUDY, AND MAIL TODAY!

DO IT NOW!

Drafting (Architectural Machine)

- Heating & Ventilating Engineering
- Plumbing and Sanitary Engineering
- Sheet Metal Designing and Drafting
- Boiler Maker Laying Out & Inspection
- Steel Ship Laying Off & Plan Reading
- Contracting & Estimating
- Mathematics and Slide Rule Reading
- Aeronautical Drafting and Engineering



ST. LOUIS TECHNICAL INSTITUTE

4545 CLAYTON AVENUE, ST. LOUIS, MO.

TRAVEL FOR "UNCLE SAM"

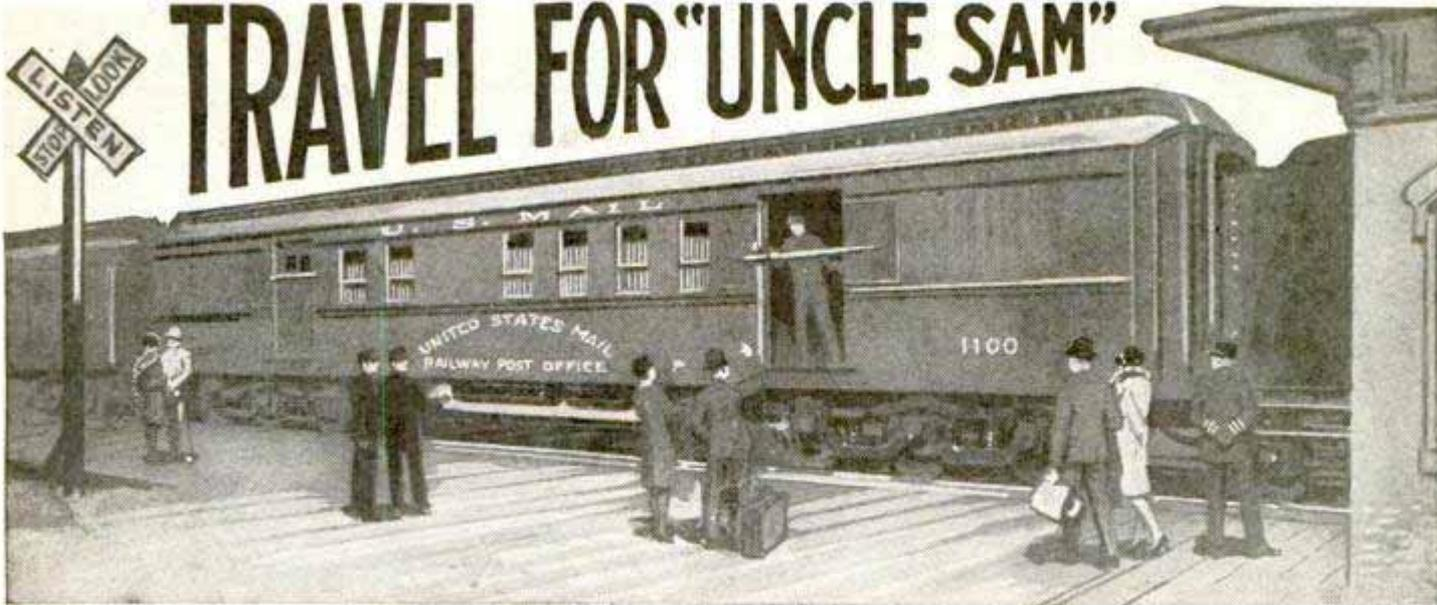

Railway Postal Clerks

\$158 Month First Year

Raise to Maximum of \$225 Month

Many Other U. S. Government Jobs Open to Men and Boys 18 Up
 POST OFFICE CLERKS RURAL MAIL CARRIERS CITY MAIL CARRIERS
 PROHIBITION AGENTS CUSTOMS INSPECTORS

These are steady positions. Strikes, poor business conditions, lockouts or politics do not affect them. U. S. Government employees get their pay for full twelve months every year. There is no such thing as "HARD TIMES" in the U. S. Government Service.

ALLOWANCE FOR HOTEL EXPENSES

Railway Postal Clerks now get \$1900 the first year regular, being paid on the first and fifteenth of each month. \$79.16 each pay day. Their pay is increased \$100 and \$150 a year. The maximum is \$2700 a year. \$112.50 each pay day. They get extra allowance for hotel expenses when away from home.

PAID VACATIONS

Railway Postal Clerks, like all Government employees, are given a yearly vacation of 15 working days (about 18 days). When on runs they usually work 3 days and have 3 days off duty or in the same proportion. During this off duty and vacation, their pay continues just as though they were working. When they grow old, they are retired with a pension. As Railway Postal Clerks are continually traveling, they have an excellent chance to see the country. We expect Spring examinations.



CITY MAIL CARRIERS—POST OFFICE CLERKS

Clerks and Carriers get \$1700 the first year regular and automatically increase \$100 a year to \$2100 with further special increase to \$2300. They also have 15 days' vacation. City residence is unnecessary.

What Will You Earn 5 Years From Now?

Compare these conditions with your present or your prospective condition, perhaps changing positions frequently, kicking around from post to pillar, no chance in sight for PERMANENT employment; frequently out of a position and the year's average salary very low. DO YOU EARN \$1900 EVERY YEAR? HAVE YOU ANY ASSURANCE THAT A FEW YEARS FROM NOW YOU WILL GET \$2700 OR MORE A YEAR, EVERY YEAR?



FRANKLIN INSTITUTE
 Dept. G173
 ROCHESTER, N. Y.

Rush to me entirely free of charge 32 page book with (1) a full description of the position checked below; (2) a list of U. S. Government jobs now obtainable; (3) tell me how to get the position checked.

- ___ Railway Postal Clerk..... (\$1900-\$2700)
- ___ Post Office Clerk..... (\$1700-\$2300)
- ___ City Mail Carrier..... (\$1700-\$2100)
- ___ Rural Mail Carrier..... (\$2100-\$3300)
- ___ General Clerk and File Clerk..... (\$1260-\$2500)
- ___ Inspector of Customs..... (\$2100 up)
- ___ Prohibition Agent..... (\$2300-\$2800)

Get FREE List of Positions

Fill out the coupon. Tear it off and mail it today—now, at once. DO IT NOW—This investment of two cents for a postage stamp may result in you getting a U. S. Government Job.

Name.....
 Address.....
 Use This Coupon Before You Mislays It—Write or Print Plainly

MAIL COUPON TODAY.....

Learn Electricity

IN LOS ANGELES

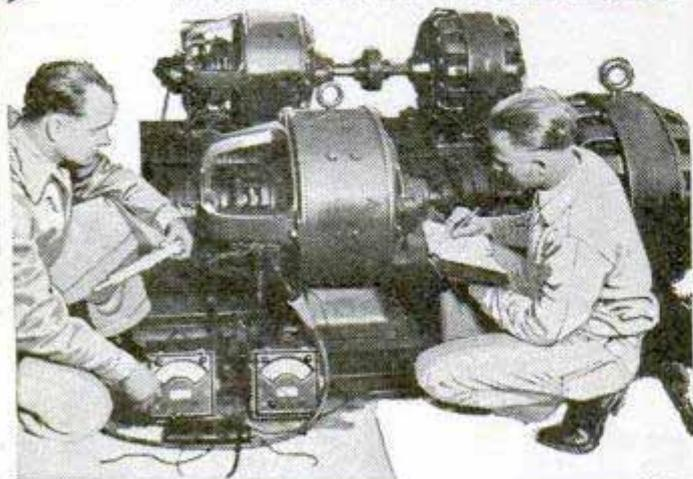

and **LEARN IT RIGHT!**

1. What Kind of a School Is NATIONAL?

NATIONAL is a Million Dollar institution—established in 1905—recognized throughout the electrical industry as one of America's foremost trade schools. NATIONAL offers practical, intensive training in all electrical branches. All technical essentials included. No age limit. No previous experience necessary. Life Scholarship privileges. Start any time of the year.

2. How Long to Learn Electricity?

NATIONAL properly trains you in the short time of 6 to 9 months. Upon completing this Condensed Course you are fully qualified as a Practical, Competent Electrician, and you have not risked your chances of employment because of inferior, incomplete instruction.

3. What Employment Service Does NATIONAL Guarantee?

NATIONAL GUARANTEES to give unlimited and efficient Employment Service to students wishing to earn living expenses while learning; and to graduates getting started in the electrical field. This is the most any reputable school can be expected to do.

4. What Inducements Does NATIONAL Offer?

NATIONAL offers YOU the very best technical-practical training that money can buy at a cost within every man's reach. It does not offer to pay your railroad fare, room and board or other personal expenses, preferring to limit its activities to the PROPER TRAINING OF MEN FOR SUCCESS.

5. Why You Should Come to LOS ANGELES!

LOS ANGELES is the heart of the country's most rapid electrical development—as well as the world's most ideal city in which to live and prepare for success in electricity

WRITE for FREE BOOK NOW!

NATIONAL Electrical School

Dept. 541, 4006 Figueroa St.,
Los Angeles, California.

Send me your big free illustrated catalog of Electrical Opportunities showing how I can learn quickly and get a Big-Pay Electrical Job.

Name.....

Address.....

Age..... City..... State.....



FUEL COSTS SMASHED



Sensational Discovery!

At last the oil burner industry's greatest problem is SOLVED! Waste of oil is eliminated! The INDESTRUCTIBLE Mineral Wick, exclusive feature of the Laco, only Wick-Type Burner on the market, does it! Now LOW OPERATION COST is combined with LOW INITIAL COST!

OIL HEAT Now At A FRACTION of PRESENT COSTS!

Oil heat revolutionized by amazing invention—BURNS AIR and OIL—cuts fuel costs, eliminates waste, dirt, smoke, grease. Costs so little the smallest home can easily afford it.

YOU CAN INSTALL IT NOW WITHOUT LOSS OF HEATING TIME

A few minutes' easy work and it's ready to heat. Save money by getting your oil burner now—3 months' bad weather coming—keep your home comfortable with oil heat at amazing low cost.

FITS ANY FURNACE OR STOVE

There is a Laco for every kind of coal stove or range—and for any kind of furnace—hot air, hot water, steam or vapor heat, etc. Fully automatic—THERMOSTAT HEAT CONTROL. Operates quietly. Complies with all ordinances. Safe as the ordinary kitchen range. GUARANTEED.

EASY TERMS

Write now for full information. Tell type of heating system or stove you now have—mention whether you have electricity. SPECIAL INTRODUCTORY LOW PRICE OFFER if you write now.

Dealer - Salesmen Wanted

The Laco has jumped from 68th to 9th place in U. S. sales almost overnight! To the man who will invest a small capital in demonstrators, then get out and SELL, we offer an opportunity big enough for ANY man. Write us now.

Laco Oil Burner Company, 129 Union St., Griswold, Iowa

Learn Watchwork, Jewelrywork and Engraving

A fine trade commanding a good salary, and your services always in demand. Address **Horological**, Dept. P, Bradley Institute, PEORIA, ILLINOIS, for our latest catalog.



"BECOME A LIGHTNING TRICK CARTOONIST"

Send \$1.00 for Laugh Producing Program of 23 Trick Drawings with Instructions. Catalog of Chalk Talk Supplies Free. BALDA ART SERVICE, Dept. 1, Oshkosh, Wis.

TELEGRAPHY

(Morse and Wireless) and RAILWAY ACCOUNTING, taught thoroughly. Big salaries. Tremendous demand. Oldest, largest school. Endorsed by Telegraph, Railway, Radio, and Government officials. Expenses low—opportunities to earn large portion. Catalog free. DODGE INSTITUTE, Jones St., Valparaiso, Ind.

Now Ready! The Newest, Greatest

ENCYCLOPAEDIA BRITANNICA

Write for FREE Booklet

THE ENCYCLOPAEDIA BRITANNICA, Inc.

342 Madison Ave., New York City

NERVES?

Are You Always Excited? Fatigued? Worried? Gloomy? Pessimistic? Constipation, indigestion, cold sweats, dizzy spells and bashfulness are caused by

NERVE EXHAUSTION. Drugs, tonics and medicines cannot help weak, sick, nerves! Learn how to regain Vigor, Calmness and Self Confidence.

Send 25c for this amazing book. RICHARD BLACKSTONE, N-473 FLATIRON BUILDING, N. Y.

10c NEW SCIENTIFIC WONDER

3 for 25c **"X-RAY" CURIO**

SILVER ONLY BOYS

You apparently see thru Clothes, Wood, Stone, any object. See Bones in Flesh. FREE—PKG. RADIO PICTURE FILMS. Takes pictures without camera. "You'll like 'em." 1 pkg. with each 25c order.

MARVEL MFG. CO. Dept. 31 NEW HAVEN, CONN.



ICE from Heat

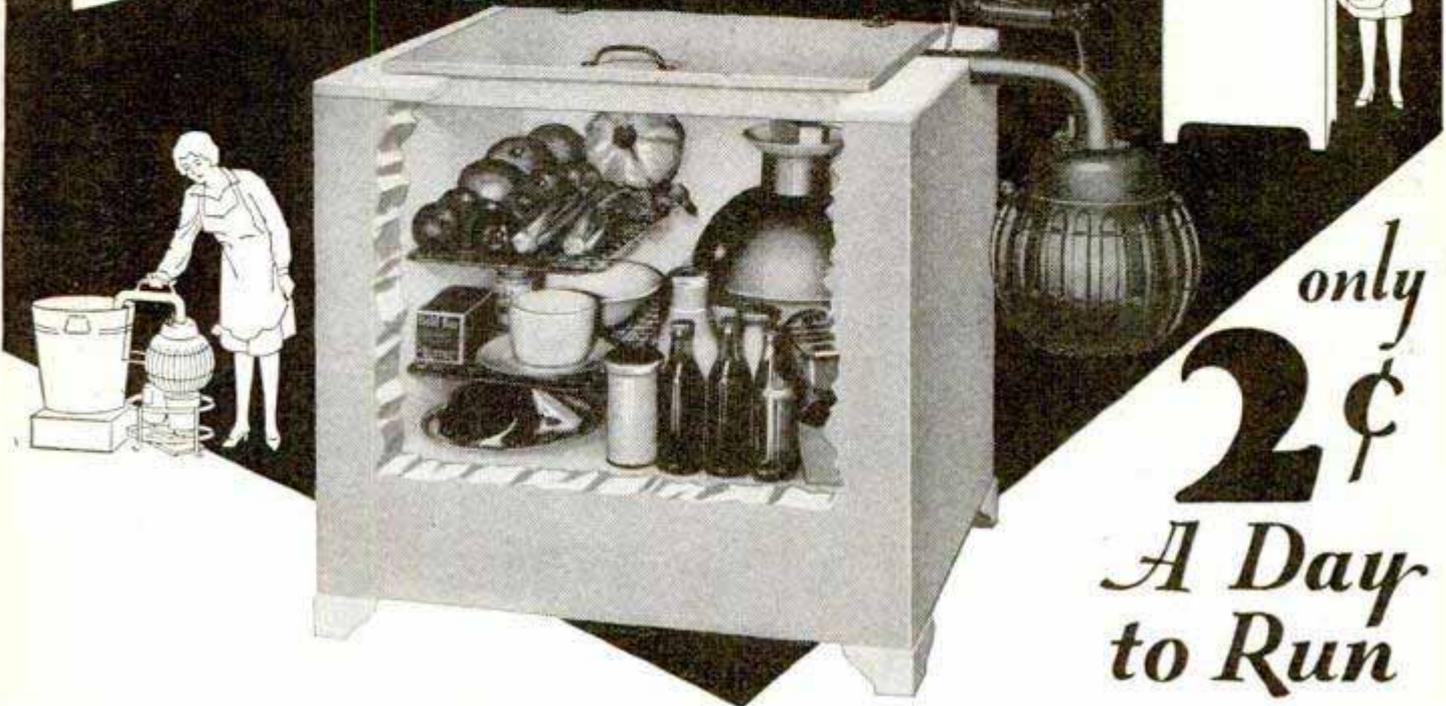

only
2¢
A Day
to Run

No Gas! No Electricity!

The ONLY PRACTICAL Mechanical Refrigeration for Small Towns and Rural Districts

Powel Crosley, Jr., president of the Crosley Radio Corporation, offers an amazing new type mechanical refrigerator that requires no gas or electric power. Now every home in small towns and in rural districts can enjoy the convenience of mechanical refrigeration at a cost of only 2c a day. The wonderful Crosley ICYBALL Refrigerator keeps food perfectly, prevents food spoilage, and protects the health of every member of the family. It is self-contained and is renewed daily by heat with the simple heat unit furnished. Requires no servicing—has no breakdowns and is absolutely guaranteed. Over 30,000 in use on farms, ranches, in homes and camps in all parts of the world. A real blessing to folks who want this luxury and haven't electric current available. Mail coupon for complete details of this amazing mechanical refrigerator.

CROSLEY
ICYBALL
REFRIGERATOR
CROSLEY ICYBALL DIVISION
823 Arlington St., Cincinnati, O.

AGENTS! SALESMEN!
Chance to Make \$10,000 Yearly
Selling ICYBALL Direct to Homes

An opportunity is open to ambitious men to represent Crosley ICYBALL Refrigerator who can reach small towns and rural districts. This is the product of the Crosley Radio Corporation. You need not know anything about refrigeration—no technical experience is necessary. No servicing problem, no installation difficulties. The ICYBALL comes to your customer COMPLETE with beautifully finished STEEL cabinet, superbly insulated, the amazing ICYBALL refrigerating unit, special heating unit with stand. CHEAPER than ice and infinitely better. Mail coupon at once and get particulars and learn how you can get your own ICYBALL without cost.

Mail Coupon for Details

Powel Crosley, Jr., President
CROSLEY ICYBALL DIVISION
823 Arlington Street, Cincinnati, Ohio.

Tell me about the OPPORTUNITY to represent the Crosley ICYBALL Refrigerator and how I can get my own ICYBALL Refrigerator WITHOUT COST.

My Name.....

My Town or R.F.D.....

County..... State.....

HOW TO MAKE EVERYTHING from Alloy to Toothpaste-

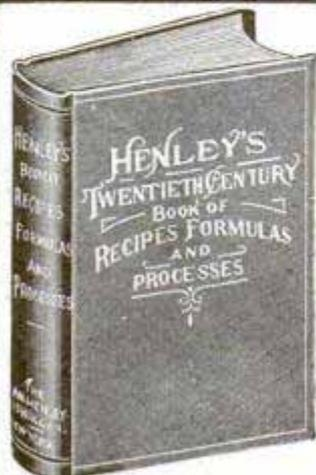

Actual size 6 x 9. 800 pages. Bound in Rich Red Library Cloth, with gold stamping

10,000 Secrets Disclosed

Formulas, Processes, Recipes

The Greatest "How To Do It" Book in the World

HOW TO make all kinds of Adhesives and Alloys for every purpose; Anti-Freezing Solutions; Battery Fillers and Solutions; Beverages—all kinds; Brass re-finishing and renovating; Bronze Powders; Cement Fillers; Cleaning Preparations; Cosmetics; Dandruff Cures; Dentifrices; Dyes; Electroplating and Electrotyping; Essences and Extracts of Fruits; Freezing Mixtures; Glazes; Inks of all sorts; Insecticides; Laundry Preparations; Leather; Lubricants; Mirrors; Ointments; Paints; Paper; Perfumes; Photography; Polishes; Soldering; Varnishes; Waterproofing; Weights and Measures. Thousands of other practical, tested methods for doing things.

MAKE MONEY WITH THIS GREAT BOOK. Just one of the 10,000 suggestions may make you thousands of dollars. Thousands of profitable full time or spare time businesses have been founded on the formulas in this great work. One reader writes: "I got one of your books and have made my living from it ever since." Start a money-making business of your own; with a practical formula. Examine this encyclopaedic work 5 days. See for yourself its great value to you. Mail the Coupon NOW.

SAVE MONEY WITH THESE FORMULAS. Make hundreds of articles of everyday use for a fraction of the money you now pay in shops. By following plain instructions, you can easily make tooth pastes—cold creams—cosmetics—hair tonics—remedies—stain and spot removers—floor finishes—varnishes, paints—compounds for mending metal, wood, glass, china, fabrics, etc. Examine this world's greatest storehouse of practical information without obligation. Send TODAY.

World's Greatest Storehouse of Practical Information for—Handy Men, Mechanics, Housewives, Farmers, Laboratory Workers, Pharmacists, Manufacturers, Garage Men, Motorists—everyone who wants to make or do things. Greatest encyclopaedia of useful information ever published. More than 10,000 clearly described formulas, plans, processes, recipes—many never before revealed. Valuable section on workshop and laboratory methods. 800 5 1/2 x 8 1/2 pages, crammed with the FACTS you want! Used by more than 100,000 practical people. Endorsed by Universities and Libraries. NEW—up-to-date! Get your copy at once. No risk! Money-back guarantee! See liberal EXAMINATION OFFER. Mail the coupon NOW.

EXAMINE IT 5 DAYS! Just send your name and address for "Henley's Twentieth Century Book of Formulas, Recipes, and Processes." Send NO MONEY. On arrival, deposit only \$4.00, plus few cents postage, with postman. If you are not thoroughly satisfied, return book in 5 days and get your money back. No obligation. Mail Coupon TODAY for your copy.

NORMAN W. HENLEY PUBLISHING CO. (Dept. 43)
2 West 45th Street New York City

MAIL THIS COUPON NOW

Norman W. Henley Publishing Co., (Dept. 43)
2 West 45th Street, New York City.

Gentlemen: Please send me "Henley's Twentieth Century Book of Recipes, Formulas, Processes." I will deposit only \$4.00 (plus postage) with postman on arrival. If I return the book within 5 days you will refund my money. (If you enclose cash with order we pay postage. Same money-back guarantee.)

Name.....
Address.....
Town..... State.....

(Outside U. S. send cash with coupon)
Free catalogue describing books on more than 50 practical subjects, including Aviation, Automobiles, Electricity, Radio—on request.

STRONG MEN MADE BY THE WHOLESALE AT WHOLESALE-PRICES



HAND GRIPS FREE

Big Muscles with This Powerful 20 Cable Chest Developer and Body Builder Course

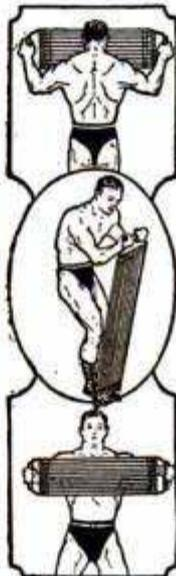

Realize your muscle dreams! The Body Builder course given with this offer permits you to get strong quickly. Alone it is worth as much as apparatus. Powerful chest developer is especially made; has double strength cables, adjustable from 20 to 400 pounds resistance. Start your muscle building training with a few cables. Add cables as you get strong until using full strength of 20 cables. Cables guaranteed finest and freshest rubber procurable. If seeking muscles to become a strong man or to keep fit, this is just what you need. Course shows how to build every part of body. Pictures and diagrams show how to develop chest, back, arms, legs and grip.

We include without additional charge a pair of hand grips which develop grip, wrist and forearm. These complete this great body building offer. Act quickly! Decide outfit you want. Sign coupon and rush to us.

Guarantee
Our money back guarantee protects you against risk—you must be satisfied or no sale.

- 20 CABLES**
20 cable chest developer, one pair of hand grips and body building course..... **\$7.95**
- 15 CABLES**
15 cable chest developer, one pair of hand grips and body building course..... **\$5.95**
- 10 CABLES**
10 cable chest developer, one pair of hand grips and body building course..... **\$3.95**
- 5 CABLES**
5 cable chest developer and body building course..... **\$1.95**

Send No Money
Mark X in coupon showing offer wanted. Sign name and address and rush coupon to us. We ship by return mail. Pay postman price plus postage on arrival.

This Course Included

Muscle Power Co., Dept. P.M.-3, 150 Nassau St., New York, N. Y.

I have checked below offer that I accept. Send this by return mail. I will pay postman your special price plus postage. It is understood my money back if I am not entirely satisfied.

- Offer No. 1—20 cable chest expander, body building course and pair of hand grips, \$7.95, plus postage.
- Offer No. 2—15 cable chest expander, body building course and pair of hand grips, \$5.95, plus postage.
- Offer No. 3—10 cable chest expander, body building course and pair of hand grips, \$3.95, plus postage.
- Offer No. 4—5 cable chest expander, body building course, \$1.95, plus postage.

Note: No C. O. D. orders to foreign countries or Canada.

Name.....
Street.....
City..... State.....

I Will Train You at Home to Fill a Big-Pay Radio Job

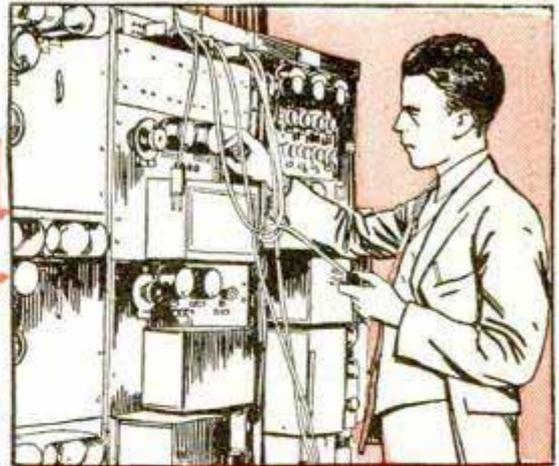
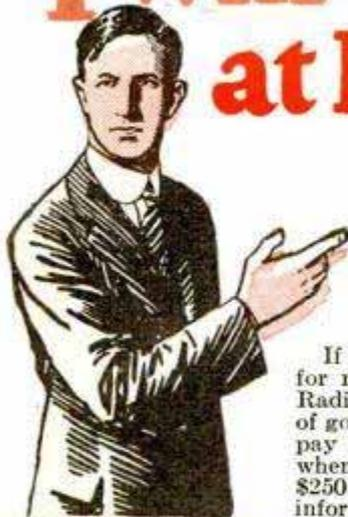

If you are earning a penny less than \$50 a week, send for my book of information on the opportunities in Radio. It's FREE. Clip the coupon NOW. A flood of gold is pouring into Radio creating hundreds of big-pay jobs. Why go along at \$25, \$30 or \$45 a week when the good jobs in Radio pay \$50, \$75 and up to \$250 a week? "Rich Rewards in Radio" gives full information on these big jobs and explains how you can quickly learn Radio through my easy, practical home-study training.

Salaries of \$50 to \$250 a Week Not Unusual

The amazing growth of Radio has astounded the world. In a few short years three hundred thousand jobs have been created. And the biggest growth is still to come. That's why salaries of \$50 to \$250 a week are not unusual. Radio simply hasn't got nearly the number of thoroughly trained men it needs.

You Can Learn Quickly and Easily in Spare Time

Hundreds of N. R. I. trained men are today making big money—holding down big jobs—in the Radio field. You, too, should get into Radio. You can stay home, hold your job, and learn in your spare time. Lack of high school education or Radio experience is no drawback.

Many Earn \$15, \$20, \$30 Weekly on the Side While Learning

I teach you to begin making money shortly after you enroll. My new practical method makes this possible. I give you SIX BIG OUTFITS of Radio parts and teach you to build practically every type of receiving set known. M. E. Sullivan, 412—73rd St., Brooklyn, N. Y., writes, "I made \$720 while studying." G. W. Page, 1807—21st Ave., S., Nashville, Tenn., "I picked up \$937 in my spare time while studying."

Your Money Back if Not Satisfied

My course fits you for all lines—manufacturing, selling, servicing sets, in business for yourself, operating on board ship or in a broadcasting station—and many others. I back up my training with a signed agreement to refund every penny of your money if, after completion, you are not satisfied with the lessons and instructions I give you.

Act NOW—64-Page Book Is FREE

Send for this big book of Radio information. It has put hundreds of fellows on the road to bigger pay and success. Get it. See what Radio offers you, and how my Employment Department helps you get into Radio after you graduate. Clip or tear out the coupon and mail it RIGHT NOW.

J. E. SMITH, President, Dept. OCP
National Radio Institute,
Washington, D. C.



You can build 100 circuits with the six big outfits of Radio parts I give you

3 of the 100 you can build

Find out quick about this practical way to big pay

Mail This FREE COUPON Today

J. E. Smith, President,
Dept. OCP, National Radio Institute,
Washington, D. C.
Dear Mr. Smith: Send me your Free book "Rich Rewards in Radio" giving information on the big-money opportunities in Radio and your practical method of teaching with six Radio Outfits. I understand this places me under no obligation.

Name..... Age.....
Address.....
City..... State.....
Occupation.....

Here's the PROOF



\$375 One Month in Spare Time

"Recently I made \$375 in one month in my spare time installing, servicing, selling Radio Sets." Earle Cummings, 18 Webster St., Haverhill, Mass.



\$450 a Month

"I work in what I believe to be the largest and best-equipped Radio shop in the Southwest and also operate KGFI. I am averaging \$450 a month."

Frank M. Jones,
922 Guadalupe St., San Angelo, Tex.

Employment Service to all Graduates
Originators of Radio Home Study Training



HERE is your opportunity to find out how much talent you have. Our simple, scientific Questionnaire tests your natural sense of design, proportion, color, perspective, etc. It may show you the way to a bigger future—a real career.

Federal Students Are Successful

Many Federal School students are making \$2,000, \$4,000, \$5,000 and \$6,000 yearly. The Federal School is recognized everywhere by employers of artists and by buyers of art work. Big prices are paid for drawings.

Learn Commercial Art at Home

If you like to draw, an almost sure indication of talent, the Federal Course will quickly develop your ability to earn money. Some students earn more than the cost of the course while studying. Many nationally known artists have contributed exclusive, illustrated lessons to the Federal Course. No previous training is needed. You will receive personal, individual criticism on your work.

Send TODAY for Questionnaire!

Just fill out and mail the coupon stating your age and occupation. There is no cost or obligation to you.



Federal School of Commercial Designing

648 Federal Schools Bldg., Minneapolis, Minn.

Send me your analysis questionnaire without cost or obligation.

Name.....
 Present Occupation.....
 Age.....
 Address.....

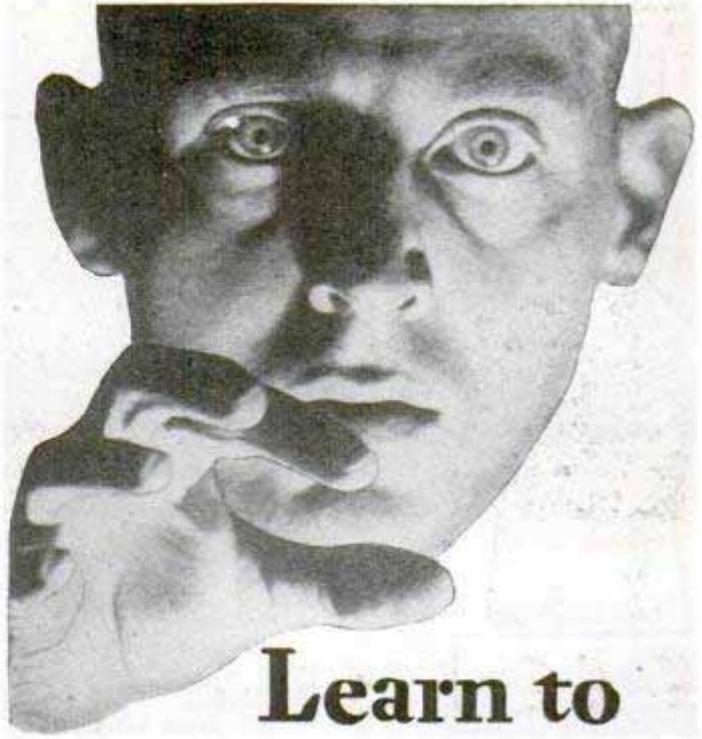

Learn to HYPNOTIZE

5 DAY TRIAL - NO COST IF NOT SATISFIED

Gain New Power!

QUIT being just one of the crowd! Stand out—dominate—make others admire and obey you! Learn how to bend people to your will; how to develop a winning, magnetic personality; how to gain popularity, success, big money—by the USE OF HYPNOTISM.

In just a few hours, I'll show you the inner secrets of this mysterious force or the **Five Days' TRIAL IS FREE!** I'll show you how to develop the hidden germ of this magic power within yourself. Once you know how, you can use it in overcoming obstacles, achieving your fondest ambitions and becoming MASTER of yourself, friends and acquaintances—either sex. See for yourself how Hypnotism can banish fear, worry and opposition—improve your memory—increase your earnings—and force others to give you the good things in life that you desire!

In this startling NEW book "The Science of Hypnotism," the world famous Hypnotist—Prof. L. E. Young—reveals the most carefully guarded secrets of this fascinating subject and TELLS ALL! He not only explains the methods of noted hypnotists, step by step—but tells clearly all about the nine stages of hypnotism. The Hypnotic Mirror, Mental Telepathy, how to select your subjects, magnetic healing, methods of hypnotizing, how to waken subject, how to make money out of hypnotism!

Try 5 Days Free—Send No Money

So confident are we that Prof. Young and his great book will quickly teach you the science of hypnotism, that we will send you a copy without one cent in advance! Simply clip and mail the coupon below. When the book arrives, pay the postman the special low price of \$2.50 plus few cents postage. Then test the powers of Hypnotism 5 days! If not amazed and delighted, return the book and money will be refunded at once! Mail the coupon now.

Franklin Pub. Co., Dept. C-70
 800 N. Clark St. Chicago, Ill.

- Mysteries of Hypnotism Revealed**
- How to Hypnotize at a glance
 - How to Hypnotize By Telephone
 - How to Give an Entertainment
 - How to Make Others Obey You
 - How to Do Dozens of Hypnotic Feats

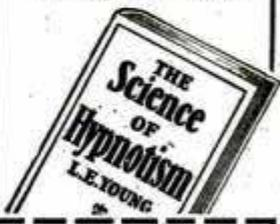

Franklin Pub. Co., Dept. C-70
 800 N. Clark St., Chicago, Ill.

Please send me your amazing new book—"The Science of Hypnotism"—by Prof. Young. When the book arrives, I'll pay the postman only \$2.50 plus postage. If I am not satisfied after 5 days' trial I may return the book and you are to refund my money.

Name.....
 Street and No.....
 Town..... State.....
 If you are likely to be out when postman calls, send \$2.50 with coupon and we'll pay delivery charges. Customers outside U. S. must send cash with order.

NOW! A QUICKER SURER WAY to BIG PAY through DRAFTING



The L.L. COOKE PICTURE

NOW the wonderful Big Pay Opportunities that Drafting offers are open to you as never before. Now, with the amazing new L. L. COOKE "See it - Do it" Training, you can become a full-fledged Engineering Draftsman in a surprisingly short time — and you don't need artistic ability nor High School education to do it. Many fellows no smarter than you qualify in a few months for Big Pay Jobs this new quick way.

STEP BY STEP YOU SEE IT-

It's just as easy as it looks in the pictures here. You go along step by step. You SEE IT done — and you DO IT yourself. Pictures guide you — actual movie-photos of your instructor's hands doing drafting show you every move of pen or pencil. Yet it's not a mere copying course. (You can't learn by copying). The pictures show you HOW to do it, and the simple, interesting text explains WHY it's done. At the same time you learn all about mechanics, engineering, shop-practice and everything a draftsman must know. In other words, you learn **Drafting**, from A to Z!

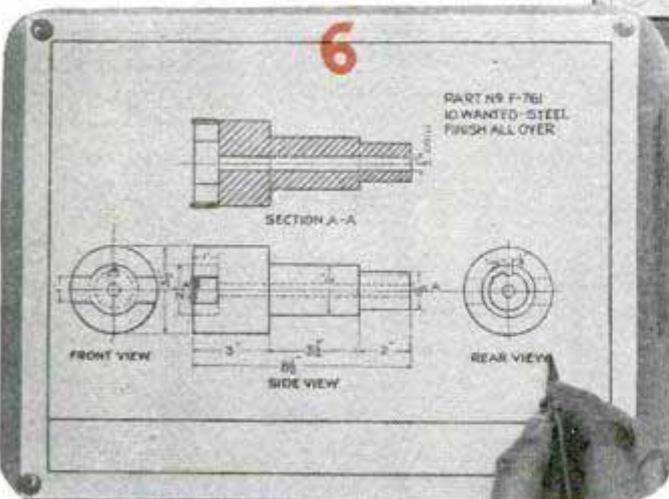

The illustrations here show only 6 of the 37 fine, instructive pictures and drawings contained in Job No. 13 of this great Training

AMAZING NEW METHOD-

Everyone knows that Drafting is the Open Door to the Big Pay Jobs in the Mechanical World — the jobs that pay \$60 to \$100 a week and up — the jobs you **can't** get unless you're a Draftsman. Why not get into this great work now that this Training has made it so easy — why put off any longer the success other fellows like you now enjoy — why don't you, too, jump into Drafting this quicker, surer way?

STEP BY STEP YOU DO IT!

Decide today to get ready for this Big Pay work. But don't sign up for any Drafting Course until you've found out all about this highly simplified "SEE IT — DO IT" Method. Get the Big FREE Book that explains all. Read about the wonderful big outfit of tools, instruments, drawing board, etc., furnished without extra cost. Read about the Nation-wide Job Service, the great Earn-while-Learning Plan, the famous Money-Back-Agreement, and the brilliant future that awaits you in Drafting when you've learned Drafting this fascinating, thorough way. Mail the coupon NOW!

Act today to increase your pay.

MAIL COUPON FOR FREE BOOK

**K. M. Boyd, Chief Drafting Engineer
L. L. COOKE SCHOOL OF DRAFTING
Dept. 13, 2132 Lawrence Avenue, Chicago, Illinois**

Send me your book "Draw Big Pay in Drafting" and tell me more about your "See It - Do It" Method. This does not obligate me in any way.

Name

Address

City.....State..... Age.....



VOICE

NOW! you can have the VOICE you want!



100% Improvement Guaranteed!

No matter how hopeless your case may seem—send for free Voice Book. New SILENT Method of Voice Training. Increases Range. Improves quality. Banish huskiness—hoarseness. 100 per cent improvement *guaranteed*—or money back. Mail coupon *at once* for free booklet—the greatest voice booklet ever written—sent FREE with no obligation!

Perfect Voice Institute, Dept. 13-53
1922 Sunnyside Ave., Chicago

Mail Coupon for Free Voice Book

Perfect Voice Institute, Dept. 13-53
1922 Sunnyside Ave., Chicago

Please send me FREE and without obligation, Prof. Feuchtinger's new book, "Physical Voice Culture." I have checked subject in which I am most interested.

Weak Voice Singing Stammering Speaking

Name

Address

City State

FREE!

Body Chart

If you will mail the coupon below, this Anatomical and Physiological Chart will be mailed to you without one cent of expense. It shows the location of the Organs, Bones of the Body, Muscles of the Body, Head and Vertebra Column and tells you how the nerves radiate from your spinal cord to all organs of the body. This chart should be in every home.

Where Is That PAIN?

It may be in the neck, back, hips, stomach, liver, legs or arms. Wherever it is, the chart will help to show you the location and cause of your ailment. For instance, this chart will help you locate verminiform appendix pains. Hundreds of lives might have been saved if people had known the location and character of the pain and had received proper attention.

Stop that Pain

By Relieving the Cause with
**Violet Ray – Vibration
Ozone – Medical Electricity**

The Four Greatest Curative Powers Generated by This
Great New Invention!



Elco Health Generators at last are ready for you! If you want more health—greater power to enjoy the pleasures and delights about you, or if more beauty is your desire—*write!* Ask for the book on these inventions which has just been prepared. It will be sent to you without cost. It tells you how Elco Health Generators aid you in leaving the lethargy and hopelessness of bad health and weakness behind forever. Re-vitalise yourself. Bring back energy. Be wholly alive. Write today!

Here's What Elco Users Say—



"Wouldn't take \$1000 for my Elco." "Has done me more good in 2 weeks than doctors did in three years." "Cured my Rheumatism." "My Eczema gone." "Cured my stomach trouble." "Cured my weakness." "Now I sleep soundly all night." "Thanks to Elco my strength and vigor are back." "No more pain." "Colds never bother me now." "Chronic Constipation banished."

These great new inventions generate Violet Ray, Vibration, Electro-ricity and Ozone—combined or separate. They operate on the electric light in your home or on their own motive power at less than 50 cents per year. Elco Health Generators are positively the only instruments which can give you in one outfit Electricity, Violet Ray—Vibration and Ozone—the four greatest curative agents. Send the coupon below. Get the Free Book NOW!

MAIL COUPON for FREE BOOK

Do not put this paper down without sending the coupon. Don't go on as you are with pains and with almost no life and energy. You owe it to yourself to be a better man or woman. You were put here to enjoy life—not just to drag through it. So do not rest another day until you have put your name on the coupon here. That will bring the whole story of these great new inventions. Do it today—now.

[Makers of Therapeutic Apparatus since 1892.]

Lindstrom & Co.
2322 Indiana Avenue Dept. 1353 Chicago
Please send me your free book, "Health—Power—Beauty" and full information of your 10-day Free Trial Offer.

Name

Address



NOW FIX ANY MAKE OF

AUTO

SIX BIG AUTO BOOKS ALL SHIPPED FREE

on approval; whether you want to qualify as garage owner, auto repair expert or merely wish to know how to keep your own car 100% efficient, look at these books—they are sent to you for free examination. This brand new 1930 edition has been prepared by a large group of America's greatest automotive engineers. Anybody who can read will understand them, for this great automobile encyclopedia is a veritable gold mine of valuable facts. Take advantage of this great opportunity now; send in the coupon for FREE examination. You don't pay us a penny, you don't obligate yourself to pay anything unless you decide to keep the books. Just tell us you want to see them and the full set of 6 great volumes, just off the press, will be sent to you. Read them, look them over and prove to your own satisfaction that one fact alone, which you will find in them, may save you an expensive repair, or help you to a better job.

AVIATION MOTORS
In addition to being a complete cyclopedia of automobile engineering these books contain over 100 pages on Aviation Motors, and as they are just off the press they bring to you the newest and latest information obtainable. This alone makes these books *incalculable* to anyone.

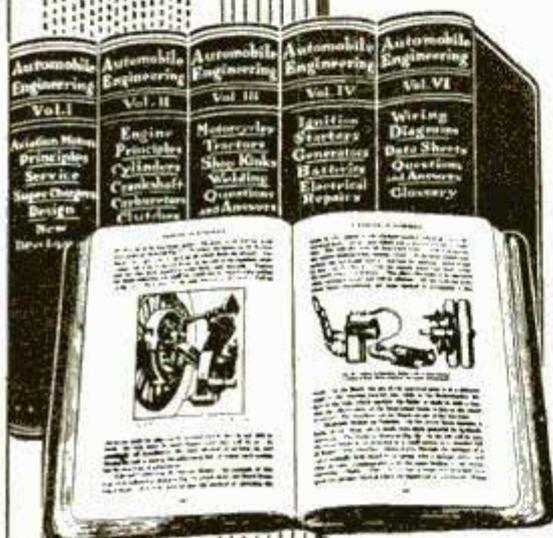

NEW 1930 EDITION EVERY PAGE UP TO DATE

Imagine books which are so new that with the co-operation of the largest automobile manufacturers we have been able to bring every page right up to date—wiring diagrams, construction details, service problems—are all right up to the minute. Nowhere else that we know of can you get as complete and up to date information. Over a million dollars of resources have enabled us to give you the most up to date books on the subject ever published. You will find nearly 20 pages on front wheel drives alone. Everybody interested in automobiles in any way will welcome these books, especially on our

NO MONEY OFFER

This plan brings this valuable information within the reach of everyone. You don't send us a single penny; you don't have to pay us anything; just send your name and address and we will send you the complete set of 6 volumes specially bound in De Luxe Flexo covers. Read them carefully, keep them 10 days, find out anything you want to know and then if you want to keep them send \$2.00 then and \$3.00 per month until the special low price of only \$24.80 is paid. There is no further obligation.

Jiffy Index
You don't have to read the books through, the special Jiffy Index enables you to put your finger on the information wanted in a jiffy.

American Technical Society Membership FREE
If you send now for this brand new 6 volume edition of automobile engineering we will include a consultation membership in this great organization. Our large staff of automobile and aviation experts will be ready to help you at all times—you can write or wire any time for special information—answers will be sent to you promptly **WITHOUT COST**. This membership is good for one full year.

Learn All About Autos
Get these 6 big new books on this liberal offer and learn all the things you want to know—carburetors, transmissions, springs and spring suspensions, brakes, four-wheel drives, front-wheel drives, lubrication systems as well as over 100 pages on Aviation Motors—all of these subjects are fully covered. These complete and comprehensive auto books are yours, if you want them, on this easy plan. Send for your set now.

SEND NO MONEY

American Technical Society, Dept. A319, Drexel Ave., at 58th St., Chicago, Illinois

I would like to see the new 6 volume 1930 edition of your automobile books but without any obligation to buy. I will pay the few cents delivery charges only and will examine the books and return them at your expense in 10 days unless I like them, in which case I will send you \$2.00 then and only \$3.00 per month until the special price of only \$24.80 is paid. You are to include free consulting membership certificate in the American Technical Society. Send brand new 1930 edition.

Name.....
Street.....
City.....State.....
Employer's Name.....
Employer's Address.....

These books will be sent free immediately upon receipt of coupon with writer's name and address and that of his employer or other business man as a reference.



Says Good-bye to \$200 a Month

Now He Earns Better Than \$10,000 a Year

At 45, C. J. Farris, of Memphis, Tenn., was earning \$200 a month as Credit Manager.

"For years," he writes, "I did general accounting work for a large corporation, doing the physical work without an understanding of the underlying principles, which caused me untold worry and a constant unsatisfied position in connection with my service."

"Finally, as a way out, I enrolled for LaSalle home-study training in Higher Accountancy, and with the daily study of principles, and the solving of practical problems in Higher Accountancy under specialized instruction, came a rapid broadening of ability—a new self-confidence that put to rout the elements of fear and indecision."

And how quickly his income mounted!

Within a year came a "raise" to \$3,000—one year later, a more responsible position commanding \$5,000 salary—then, with the winning of his degree as Certified Public Accountant, his entrance into a highly profitable profession, and the building of his own highly successful accounting firm.

Send for Free Book—

"Accountancy, the Profession that Pays"

"I wish I could cry from a mountain top to young men everywhere, 'Educate yourself—prepare—qualify—for tomorrow your opportunity may come.'"

So writes Mr. Farris—and well he may, for right in his own experience he has proved the tremendous power of home-study training as an aid to progress.

Are you ambitious to make a real success in business—to fit yourself for positions paying \$3,000, \$5,000, \$10,000 a year, and even better? You do not need a knowledge of book-keeping to make your start. LaSalle trains you from the ground up, according to your individual needs. Low cost; easy terms.

If you are dissatisfied with your present equipment, you will find LaSalle's 64-page book, "Accountancy, the Profession that Pays," of the greatest help and inspiration—and—LaSalle will send it to you FREE. For the sake of a brighter future, clip and mail the coupon NOW.

— Find Yourself Through LaSalle! —

LaSalle Extension University

The World's Largest Business Training Institution

Dept. 364-HR Chicago

I should be glad to have details of your salary-increasing plan as applied to my advancement in the business field checked below. Also a copy of "Ten Years' Promotion in One," all without obligation.

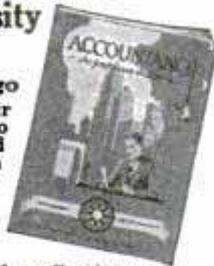

- Higher Accountancy
- Business Management
- Modern Salesmanship
- Traffic Management
- Railway Station Mgmt
- Railway Accounting
- Law—Degree of LL.B.
- Commercial Law
- Industrial Management
- Banking and Finance
- Personnel Management
- Credit and Collection Correspondence
- Modern Business Correspondence
- Modern Foremanship
- Expert Bookkeeping
- C. P. A. Coaching
- Business English
- Commercial Spanish
- Effective Speaking
- Stenotypy—Stenography
- Telegraphy

Name

Present Position

Address

ALWAYS A DEMAND for Skilled Tree Experts

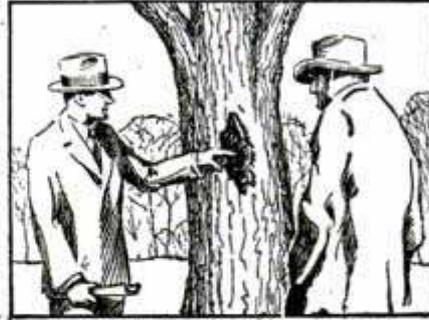

The only method that restores Tree Health NATURE'S WAY

VAN YAHRES TREE SURGERY SCHOOL
Dept. P., Westbury, New York

Big money—opportunities both in America and abroad. Anyone can learn. Little spare time home study. City park departments, private estates, forestry companies, telephone companies, fruit growers, tree surgery companies need trained tree experts at all times. Profitable healthy work. Write.

RUPTURE

Appliance Praised by Athletes



Scores of ruptured runners, athletes, golfers and sportsmen wear the Brooks made-to-measure sanitary, automatic air cushion appliance for its lightness and superior comfort. Holds rupture scientifically and promotes healing by gentle pressure that draws weakened tissues together.

Over 3,000,000 Brooks appliances sold. A vast improvement over old-style devices. Wear one 10 days on trial. Don't suffer all your life. Investigate. Free 28-page Rupture Booklet sent in plain sealed envelope.

Brooks Appliance Co., 107 C State St., Marshall, Mich.

Learn AVIATION from this GREAT BOOK



A Complete Course! "\$1,000 worth of aeronautical information," says Thos. L. Hill, Pres. Am. Society for Promotion of Aviation. Save months of groundwork. Learn everything about construction, operation and repair of all types of aircraft from this one great volume. Used in 200 schools and colleges. Examine it for yourself.

MODERN AIRCRAFT

DESIGN—CONSTRUCTION—OPERATION—REPAIR

By Major Victor W. Page, Air Corps, U. S. R.

855 pages solid information. MORE THAN 500 ILLUSTRATIONS. How and why airplanes fly; every type explained; every detail of construction and operation; latest engines; instruments; aerial navigation.

SEND NO MONEY Just mail the coupon. Deposit small price of \$5.00, plus postage, with postman on delivery. If you want to return the book in 5 days, you get your money back in full.

NORMAN W. HENLEY PUBLISHING CO., Dept. 43-A
2 West 45th Street, NEW YORK, N. Y.

Mail This Coupon Now

Norman W. Henley Publishing Co., Dept. 43-A,
2 West 45th Street, New York City.

() Mark X. Please send me MODERN AIRCRAFT, by Major Victor W. Page, for 5 days' examination. I enclose no money but will deposit \$5 plus postage with postman on delivery. My money back if I decide to return book in 5 days after receipt. (If you prefer, enclose \$5 and we will pay postage. Same return privilege.)

Name

Address

Town State

Mark X for Any of These Other Great Books

- () Modern Aviation Engines, by Major Victor W. Page. Two vols. for \$9.00. Single vols. \$5.00 each.
- () Aerial Navigation and Meteorology by Captain Lewis A. Yancey, Master Mariner, Unlimited. \$4.00.
- () Everybody's Aviation Guide, by Major Victor W. Page. \$2.00.

Airplane BluePrint FREE!

If you copy this sketch



If you are ambitious—want to earn big money as a draftsman—copy this sketch and mail to me. If I think you show talent I will send you, direct from my drafting room, a handmade Airplane blue print in three views with all main parts named and explained. Also FREE my two books, "My Pay Raising Plan," and "Successful Draftsmanship." They tell all about this fascinating profession and my working method by which I train you right in your own home. No matter what your schooling or what you are doing now—clip the coupon and learn what I can do for you.

LEARN DRAFTING

Earn Up to \$100 a Week!

Automobiles, Electricity, Aviation, Building Construction—There are good jobs for draftsmen in these industries and in hundreds of others. Everything that is made—must first be planned and drawn in the drafting room. No wonder there is such a big demand for trained men. You can prepare for one of these fine positions—without leaving home—without quitting your present job. I'll give you practical training. I have trained men who are making \$3,500 to \$9,000 a year. There is a big future for draftsmen because you plan and supervise the work for others, or you go into business for yourself. Get started today. Copy the sketch and mail with coupon!



Engineer Dobe

I Train You At Home

No need to leave home or quit your job. Not only do I give you complete practical drafting room training at home—but I show you how to earn while you are learning—in a few short weeks after you start.

AVIATION DRAFTING AND DESIGNING COURSE

Included—No Extra Charge!

To meet the demands of the Airplane industry for designers, I have prepared a complete course on aeroplane drafting. To those who act quickly, I will include this special training without any extra charge.

EMPLOYMENT SERVICE

After training you, I help you get a good job without charging you a cent for this service. Employers come to me for men because they know that Dobe Trained Men make good.

FREE

My Pay-Raising Plan

Mail coupon for this book that has started hundreds of men on the road to success.



Get These
Pay Raising
TOOLS

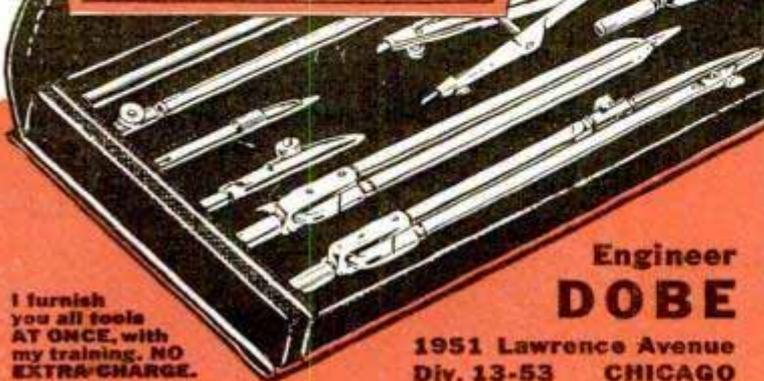

I furnish you all tools AT ONCE, with my training. NO EXTRA CHARGE.

Engineer
DOBE

1951 Lawrence Avenue
Div. 13-53 CHICAGO

MAIL THIS COUPON
If You Earn Less Than \$70 a Week

Engineer Dobe, Div. 13-53
1951 Lawrence Ave., Chicago

I am attaching sketch of Airplane. Send me the three-view blue print, as offered. Also your two books—all free to me.

Name _____ Age _____

Address _____

Town _____ State _____

if-

you pledge
 yourself to secrecy we will
 teach you the secrets of
Real Professional
Magic



Dr. Harlan Tarbell, internationally known magician and teacher of some of the world's greatest magicians.

Be a Magician!

Earn \$250 to \$1000 a Month

No Salesmen Will Bother You! For the first time in the history of Magic the age-old, sacredly guarded secrets of Mystic Art are being revealed. Now at last you can learn to be a Real Professional Magician. Yes, and you can learn this wonderful art *easily and quickly* AT HOME. You are taught the mysterious *Principles* by which the Professional Magician works. But before you can study, you must sign the Magician's Solemn Pledge of Secrecy. This means you are getting the *guarded secrets* of the Magic Profession.

Tarbell System, Inc., Studio 13-53
 1926 Sunnyside Avenue Chicago, Illinois

Tarbell System, Inc., Studio 13-53
 1926 Sunnyside Avenue, Chicago, Ill.

Gentlemen: Without any obligation send me your free literature and information all about your wonderful "Tarbell Course in Magic." Also tell me about your Low Price Offer and Easy Payment Plan.

Name

Address

Age

BE A CARTOONIST

\$100 to \$500 A Week Earned by Cartoonists Today.

Like to Draw? Learn Easily..... Billy Hon's Way.

Wonderfully simple system devised by Billy Hon, famous cartoonist, formerly with Hearst Newspapers and other well-known publications. Head of western school of cartooning. Easy-to-learn course. 30 complete lessons, over 300 cartoons. Full of trade secrets that only one with Billy Hon's many years experience could teach you. \$2 postpaid. \$2.25 outside U. S. A. SATISFACTION GUARANTEED



BILLY HON'S CARTOON STUDIO
 P. O. Box 960 P, Hollywood, California

STAMMER

IF YOU Write for my free book "Millard's Advanced Natural Corrective Course" and a free copy of my speech magazine. 10,000 cases successfully treated. Est. 24 years. Largest school for stammerers in world. Millard Inst. of Normal Speech, 2317 Millard Bldg., Milwaukee, Wis.

YOU CAN OIL PAINT

Amazing new method teaches men or women to earn after first lesson. OIL PAINT photos—portraits, landscapes or art subjects. Evn \$18 to \$50 and more a week. OIL PAINT OUTFIT GIVEN. Send now for free illustrated book. FICTORIAL ART STUDIOS Inc. Dept. MP. 2926 Broadway, Chicago, Ill.



CORRECT Your NOSE!

Improve your appearance with the ANITA NOSE ADJUSTER. Shapes flesh and cartilage—quickly, safely and painlessly, while you sleep. Results are lasting. Doctors praise it. 68,000 users. Write for 30-Day TRIAL OFFER and FREE BOOKLET.

ANITA INSTITUTE, 312, Anita Bldg., Newark, N. J.

Be a Civil Engineer!

Learn at Home!



Cyclopedia of Civil Engineering

9 great volumes. 4000 pages. 3000 illustrations. New edition just off the press, by twelve of America's greatest engineers. Includes: Surveying, bridges, railroads, steel structures, municipal engineering, water supply, road building, etc.

Earn \$5000

a Year—and Up!

"CIVIL ENGINEERING"—in plain English written so you can understand it, even if you have only a limited education. Prepares you for a well paid railroad structural or public works position. Covers every branch of Civil Engineering practice. At once a reading course for the ambitious student and an authoritative reference work for the experienced engineer. Borrow a set—free. Look over the test questions which help you master each subject quickly. Mail the coupon without obligation today!

American Technical Society
 Dept. C-319 Chicago

Loaned Free!

To prove you can learn Civil Engineering at home in your spare time. And because no description here could do it justice, to let you see for yourself the scope and simplicity, the authority and quality of this great home reading course. Cost and terms are within your reach. Send no money—just mail the coupon.

American Technical Society,
 Dept. C-319, Chicago

I want to BORROW the CIVIL ENGINEERING Cyclopedia for 15 days FREE. I will gladly pay the few cents express, but I am to pay nothing for the loan of the 9 big volumes if I return them within 15 days. If I wish to keep them I will send you \$2 after the 15 days, then \$3 a month until special advertising price, \$34.80, is paid.

Name

Address

(Attach letter stating age, occupation, employer's and references' names and addresses.)

R. T. I. R. T. I. QUALIFIES YOU TO MAKE MONEY AND ITS SERVICE KEEPS YOU UP-TO-THE-MINUTE ON THE NEWEST DEVELOPMENTS IN RADIO, TELEVISION AND TALKING PICTURES **R. T. I.**



BIG MONEY NOW!

More to Come

Radio now offers ambitious men the greatest Money-Making Opportunity the world has ever seen! Hundreds of trained service men are needed by radio dealers, jobbers, and manufacturers!

GOOD JOBS are open in all branches of Radio, where qualified men easily earn \$60 to \$100 per week and even \$10,000 a year jobs are plentiful.

BIG MONEY for spare-time Radio Work is easily made in every city and village. You can now qualify for this Big-Pay work quickly through R. T. I. Get the Big Money Now and go up and up in this Big Pay field. The Radio industry calls for More Men, and R. T. I. supplies what the industry wants you to know.

Supervised by Radio Leaders

R. T. I. training is prepared and supervised by prominent men in radio, television and talking picture engineering; distributing; sales; manufacturing; broadcasting, etc. These men know what you must know to make money in Radio. You learn easily in spare time at home with the R. T. I. wonderful combination Testing Outfits, Parts, Work Sheets, Job Tickets. It is easy, quick and practical — covers everything in Radio — includes Talking Pictures and the latest in Television.



\$60—\$70—\$80—PER WEEK AND UP. That's what R. T. I. training leads to. Send for the R. T. I. Book.

No Experience Needed

ALL YOU NEED is the ambition and the ability to read and write. The Radio industry needs practical trained men. Remember, R. T. I. makes it easy to earn spare time money while you learn at home.

More to come

THE MEN who get into this Big-Money field now will have an unlimited future. Why? Because this billion dollar Radio industry is only a few years old and is growing by leaps and bounds. Get in and grow with it. \$10 to \$25 per week and more is easily made in spare hours while you are preparing for Big Money. TELEVISION, too, will soon be on the market, so the leaders say. Be ready for this amazing new money-making field. Remember, R. T. I. "3 in 1" home-training gives you all the developments in Television and Talking Picture Equipment, together with the complete Radio training.

Warning

Do not start R. T. I. training if you are going to be satisfied to make \$15 or \$20 per week more than you are now. Most R. T. I. men will make that much increase after a few weeks. There is no reason to stop short of the Big Money Jobs or the Big Profits in a spare time or full time business of your own. No capital needed. Get started with R. T. I. now. Make money while you learn at home.

R. T. I. Book Now FREE

The thrilling story of Radio, Television and Talking Pictures is told with hundreds of pictures and facts—its hundreds of big money jobs and spare time money-making opportunities everywhere. Send for your copy now. **USE THE COUPON.**



Let F. H. SCHNELL and the R. T. I. Advisory Board Help You

Twenty years Radio experience. First to establish two-way amateur communication with Europe. Former Traf. Mgr. of American Radio Relay League. Lieut. Com. U.S.N.R. Inventor, designer, consulting Radio engineer.

Assisting him is the R. T. I. Advisory Board, composed of men prominent in the Radio Industry. These men know Radio and will help you succeed in their field.



THE R. T. I. ADVISORY BOARD. These men are executives with important concerns in the radio industry—manufacturing, sales, service, broadcasting, engineering, etc., etc. They supervise R. T. I. Work Sheets, Job Tickets, and other training methods.

R. T. I. R. T. I. TRAINS YOU AT HOME FOR A GOOD JOB OR A PROFITABLE PART TIME OR FULL TIME BUSINESS OF YOUR OWN

RADIO & TELEVISION INSTITUTE
Dept. 13
4806 St. Anthony Ct. Chicago

RADIO & TELEVISION INSTITUTE
Dept. 13, 4806 St. Anthony Court, Chicago
Send me Free and prepaid your BIG BOOK "Tune In On Big Pay" and full details of your three-in-one Home Training (without obligating me in any way).

Name.....
Address.....
City..... State.....



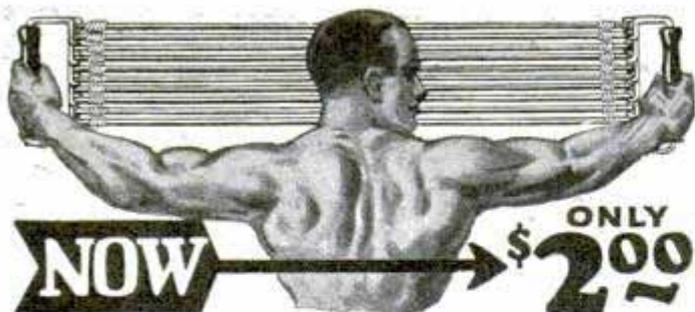

Giant Chest Expander

and

Progressive Exerciser

Be a muscular marvel. Have the muscles of a superman. Become strong for your health's sake or to astound your friends with extraordinary feats which only men of giant strength can do. In a few short weeks you will easily do feats which now seem difficult—then real muscles and strength will be yours—and yours to keep. If you want exercise to just keep in good shape you can reduce the strength of the Progressive Exerciser by eliminating as many cables as you wish. If you want great resistance so as to build up big solid muscles then use the full strength.

Send No Money Use This Money Saving Coupon

How the Giant Chest Expander and Progressive Exerciser is Made

The Giant Chest Expander and Progressive Exerciser is made with new live, springy rubber so as to give it long wearing and great resisting qualities. Do not pay more for an exerciser that has forty or less rubber strands to each cable. Get the best and most durable. The Giant Progressive Exerciser has 50 strands of the finest rubber procurable to each cable.

Free Instructions

We do not think it enough to send you an exerciser worth double what we ask, so for a limited time, we will also include instructions absolutely free. These instructions are interesting and simple to follow—they show you the short cut to health and strength. Order today before this wonderful offer is withdrawn.

Your Guarantee

The Giant Chest Expander is sold with a guarantee that you will say it is the finest you ever saw or your money back.

5 Cables or double 10 Cables for strength for

\$2 The double strength exerciser has resistance of over 200 lbs. **\$4**

How to Order—Send No Money

Sign your name and address to coupon below and get your Giant Exerciser at the present low introductory price by return mail. The price is made low because we want everyone to enjoy muscles and strength at the lowest possible cost. Don't pay more—order from us—get the most for your money. Use coupon now.

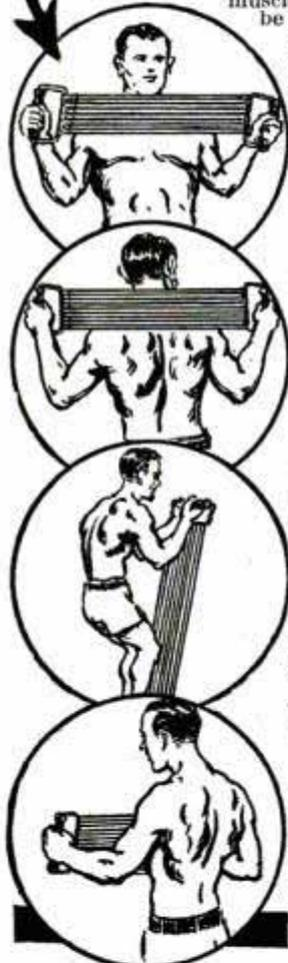

PROGRESSIVE EXERCISER CO.,
4003 Langdon Bldg.,
Broadway and Duane Street, New York

Please send Your 10 cable Progressive.
 Your 5 cable Exerciser.

Check the Exerciser you want, and it will be sent you by return mail. Pay postman introductory price, plus few cents postage on arrival. It is understood that if you are not entirely satisfied with your exerciser you may return it within 5 days and get your money back.

Name.....

Street.....

City..... State.....

If you live outside the United States, send cash with order.

BRASS WAFER THERMOSTATS FOR TEMPERATURE CONTROLS



For Incubators, Brooders, Fire Alarms; any place that a wafer thermostat can be used. Single or double unit. Made of special tempered brass.

Vacuum filled, sensitive, accurate, durable. Units separated by a solid post, gives double protection. Made in 3, 4, and 5 inch sizes.

RELIABLE INCUBATOR & BROODER CO.
2815 Chestnut St. Quincy, Illinois

Miller's American Poultry Guide FREE

Tells all about chick's-care, feeding and raising for profit. Also describes Hot Water & Electric

"IDEAL" INCUBATORS - \$9.25 Up

With Original Patented EGG TURNING TRAYS

"IDEAL" BROODERS - - - \$6.90 Up

WE PREPAY POSTAGE--WE PREPAY FREIGHT

Coal, Oil, and Electric Brooders, Poultry Supplies, Baby Chicks. Special LOW PRICES! Write Today!

J. W. MILLER CO., Dept. 12, Rockford, Ill.



RAISE CHINCHILLA AND NEW ZEALAND WHITE FUR RABBITS

Make Big Money We Supply Stock and pay you following prices for all you raise: Chinchillas average \$3 each—New Zealand Whites \$2 each. 32-page illustrated book, catalog and contract, also copy of *Fur Farming* magazine, tells how to raise rabbits for big profits, all for 10c. Address **OUTDOOR ENTERPRISE CO., Box 1021 Holmes Park, Missouri**

74 BREEDS Valuable New Poultry Book Free—100 Pages

Fine Pure-bred Northern raised chickens, ducks, geese, turkeys, eggs, baby chicks. Best laying strains at lowest prices. America's great industry. My 48th year. **W. A. Weber, Box 28, Mankato, Minn.**

MAKE MONEY RAISING SQUABS

Highest market ever known. Breeders shipped everywhere. Homers, Carneaux, White Kings a specialty. All other breeds. Send 10 cts for 32 page catalog and price list.

Allston Squab Co. 61 N. Beacon Street ALLSTON, MASS.

SQUAB BOOK FREE

Breed PR squabs for rich trade. Sold by millions at higher prices than chickens. Write for free 48-p. book telling how to do it and how to profit by new sales method which gets the big money.

PLYMOUTH ROCK SQUAB CO., 634 H Street, Melrose Highlands, Mass

RAISE PIGEONS AND RABBITS For Pleasure and Profit

OUR FREE BOOKLET TELLS YOU HOW. Over 20 varieties of Pigeons. Also Bantams. **W. V. MOORE, Box A, STERLING, ILL.**

70 BREEDS Chickens, ducks, geese and turkeys. Pure bred hardy, northern raised and most profitable.

Fowls, eggs, baby chicks, incubators; low prices. America's great plant. 37th year. Valuable new 100 page Poultry book FREE. **R. F. NEUBERT Co., Box 878, Mankato, Minn.**

BOW LEGS?

THIS GARTER (Pat'd) Makes Trousers Hang Straight

If Legs Bend In or Out

Free Booklet—Plain Sealed Envelope

THE T. GARTER CO., Dept. E South Bend, Ind.



Your NOSE Beautified

NO OPERATION--NO PAIN
..30 DAY HOME TRIAL..

Dr. Josephs Nose Corrector can make your nose beautiful by moulding flesh and cartilage to desired shape. Worn night or day in absolute comfort. Amazing and lasting results in shortest time. Free Booklet tells how. Write today.

DR. JOSEPHS, Inc. Dept. C-18, IRVINGTON, N. J.

YOU'RE NEXT

Now Watch YOUR Muscles GROW!

ONE—two—three! Look at those pictures! They show the three stages in building muscles. They show how a puny weakling may be changed into a physical GIANT when muscles are developed progressively. It takes SCIENCE to build muscles like that. And that's why Titus Training has accomplished such amazing results for thousands of men. Titus Training develops every muscle in the body. It makes muscles GROW. Step by step it builds them up—makes them bigger and bigger—until your whole body is covered with mighty layers of live, solid strength.

Come on, friend, you're NEXT. I don't care how weak or how strong you are now—or whether you're 20 or 50. If you are organically sound, Titus Training will work its wonders for YOU.

I'll Increase Your Muscles by INCHES

Yes sir, and all I want is 30 days—and just 20 or 30 minutes a day. In that short time I'll put layer after layer of muscle all over your body till they stand out like iron bands. And they'll be panther muscles, friend—muscles as live as spring steel—with the speed of lightning and the power of a battering ram. Those are the kind of muscles that make champions, the kind of muscles that will make you laugh at men twice your size.



Wear This Medal

Strong men all over the world wear it. Made of solid statuary bronze and given to you free.



ONE!

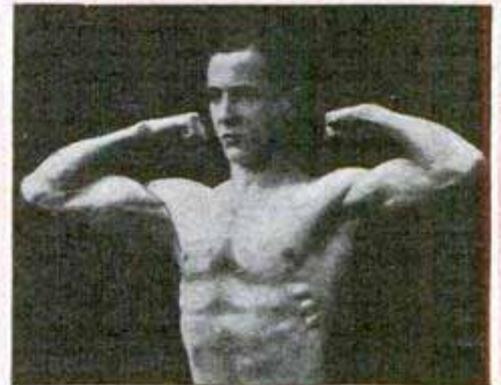

TWO!

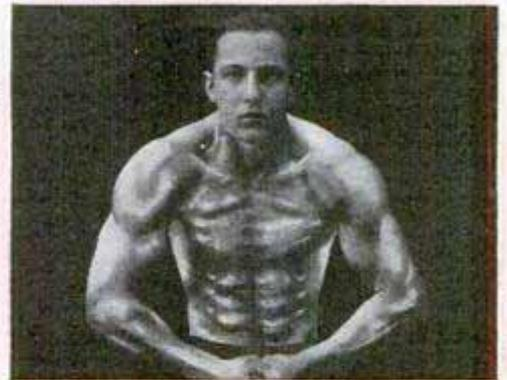

THREE!

NOTE: The pictures above are a diagrammatic visualization of the progressive development of the entire muscular system. They typify the results reported by thousands of Titus-trained men, who through the Titus system of progressive development have made their muscles GROW.

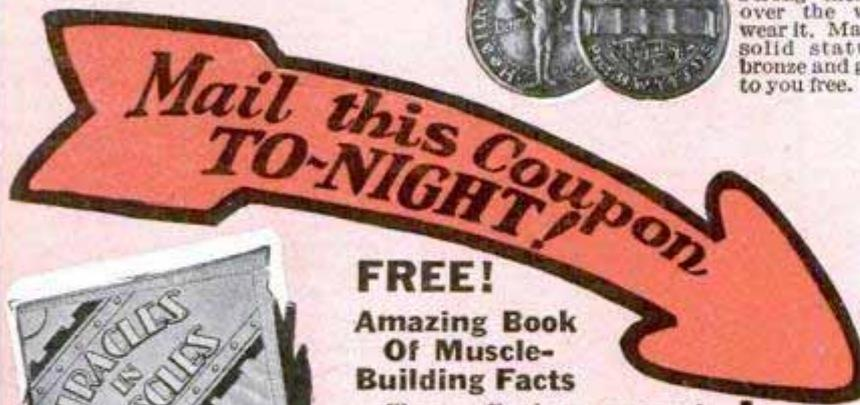

FREE! Amazing Book Of Muscle- Building Facts

Tear off that coupon! Mail it today! It will bring you FREE the greatest book you've ever seen—a book filled with astounding photographs of men rebuilt—a book packed full of Titus's own secrets of making muscles grow. No cost or obligation—just rush the coupon to Dept. M-148.

TITUS 853 Broadway
New York City

**TITUS, Dept. M-148,
853 Broadway, New York, N. Y.**

Dear Titus: Sure I'd like to have your book. Send it free.

Name

Address

Town State



Mechanical Engineering

Learn at Home

MECHANICAL Engineering embraces the design, construction and operation of machines and machine tools. It is a profession which offers almost unlimited opportunities to men who combine natural mechanical ability with technical training.

For this is The Age of Machinery. Almost every convenience, luxury or necessity which we enjoy depends on machinery for its production or adaptability to our needs. Every new invention multiplies the opportunities for competent designers, builders, erecting engineers, etc.

One of the best ways to train yourself to secure a position as a Mechanical Engineer is through the home-study courses of the International Correspondence Schools.

These courses are complete and up-to-date, and especially arranged to meet the needs of the student who studies at home.

They are particularly helpful because they are written by well-known mechanical engineers with years of practical experience, who know the quickest, best way to solve every problem.

Just mark and mail the coupon and we'll gladly send you Free Booklets describing the I. C. S. courses in Mechanical Engineering or any other course in which you are interested.

INTERNATIONAL CORRESPONDENCE SCHOOLS

Box 5674-F Scranton, Penna.

Without cost or obligation, please send me a copy of your booklet, "Who Wins and Why," and full particulars about the course before which I have marked X in the list below:

- | | |
|--|---|
| <input type="checkbox"/> Mechanical Engineering | <input type="checkbox"/> Toolmaking |
| <input type="checkbox"/> Mechanical Course | <input type="checkbox"/> Blacksmithing and Forging |
| <input type="checkbox"/> Drafting | <input type="checkbox"/> Patternmaking |
| <input type="checkbox"/> Mechanical Drawing | <input type="checkbox"/> Foundrywork |
| <input type="checkbox"/> Complete Shop Practice | <input type="checkbox"/> Machine Shop Practice |
| <input type="checkbox"/> Architect | <input type="checkbox"/> Plumber and Steam Fitter |
| <input type="checkbox"/> Architectural Draftsman | <input type="checkbox"/> Plumbing Inspector |
| <input type="checkbox"/> Building Foreman | <input type="checkbox"/> Foreman Plumber |
| <input type="checkbox"/> Concrete Builder | <input type="checkbox"/> Heating and Ventilation |
| <input type="checkbox"/> Contractor and Builder | <input type="checkbox"/> Sheet-Metal Worker |
| <input type="checkbox"/> Structural Draftsman | <input type="checkbox"/> Steam Engineer |
| <input type="checkbox"/> Structural Engineer | <input type="checkbox"/> Marine Engineer |
| <input type="checkbox"/> Electrical Engineer | <input type="checkbox"/> Refrigeration Engineer |
| <input type="checkbox"/> Electrical Contractor | <input type="checkbox"/> R. R. Positions |
| <input type="checkbox"/> Electric Wiring | <input type="checkbox"/> Highway Engineer |
| <input type="checkbox"/> Electric Lighting | <input type="checkbox"/> Chemistry <input type="checkbox"/> Pharmacy |
| <input type="checkbox"/> Electric Car Running | <input type="checkbox"/> Mining Engineer |
| <input type="checkbox"/> Telegraph Engineer | <input type="checkbox"/> Navigation <input type="checkbox"/> Assayer |
| <input type="checkbox"/> Telephone Work | <input type="checkbox"/> Iron and Steel Worker |
| <input type="checkbox"/> Civil Engineer | <input type="checkbox"/> Textile Overseer or Supt. |
| <input type="checkbox"/> Surveying and Mapping | <input type="checkbox"/> Cotton Manufacturing |
| <input type="checkbox"/> Bridge Engineer | <input type="checkbox"/> Woolen Manufacturing |
| <input type="checkbox"/> Gas Engine Operating | <input type="checkbox"/> Agriculture <input type="checkbox"/> Fruit Growing |
| <input type="checkbox"/> Automobile Work | <input type="checkbox"/> Poultry Farming |
| <input type="checkbox"/> Aviation Engines | <input type="checkbox"/> Mathematics <input type="checkbox"/> Radio |
| BUSINESS TRAINING COURSES | |
| <input type="checkbox"/> Business Management | <input type="checkbox"/> Business Correspondence |
| <input type="checkbox"/> Industrial Management | <input type="checkbox"/> Show Card and Sign Lettering |
| <input type="checkbox"/> Personnel Management | <input type="checkbox"/> Stenography and Typing |
| <input type="checkbox"/> Traffic Management | <input type="checkbox"/> English |
| <input type="checkbox"/> Accounting and | <input type="checkbox"/> Civil Service |
| <input type="checkbox"/> C. P. A. Coaching | <input type="checkbox"/> Railway Mail Clerk |
| <input type="checkbox"/> Cost Accounting | <input type="checkbox"/> Mail Carrier |
| <input type="checkbox"/> Bookkeeping | <input type="checkbox"/> Grade School Subjects |
| <input type="checkbox"/> Spanish <input type="checkbox"/> French | <input type="checkbox"/> High School Subjects |
| <input type="checkbox"/> Salesmanship | <input type="checkbox"/> Cartooning |
| <input type="checkbox"/> Advertising | <input type="checkbox"/> Illustrating |

Name.....

Address.....

City..... State.....

Occupation.....

If you reside in Canada, send this coupon to the International Correspondence Schools Canadian, Limited, Montreal, Canada

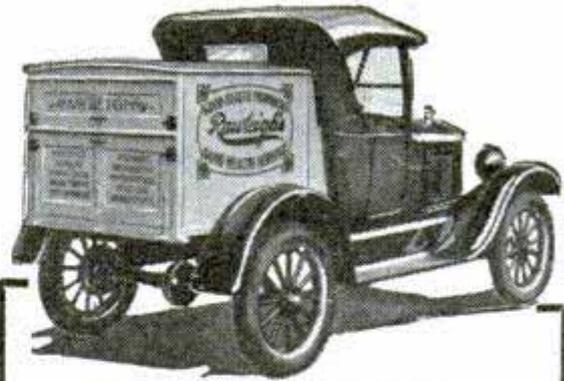

WANTED!

500 Dissatisfied Farmers and Sons to Stop Renting

And begin retailing Rawleigh's Good Health Products to Consumers. Start your own business. Make from \$100 to \$400 a month or more profit. Be your own boss. No selling experience required. We supply everything—Products, Outfit, Sales and Service Methods. Profits increase every month. No layoff. Steady year-round. Lowest prices. Best values. Most complete Service. Rawleigh Methods get the most business everywhere. For particulars write

THE W. T. RAWLEIGH CO.
DEPT. C-18PPM FREEPORT, ILL.

The man who studies gets ahead. Popular Mechanics Press will advise you what books to read to advance in your trade. 200 East Ontario Street, Chicago, Illinois.

RUPTURE IS NOT A TEAR

Your physician will tell you that hernia (rupture) is a muscular weakness in the abdominal wall.—Do not be satisfied with merely bracing these weakened muscles, with your condition probably growing worse every day!—Strike at the real cause of the trouble, and

WHEN—

The weakened muscles recover their strength and elasticity, and—

The unsightly, unnatural protrusion disappears, and— You recover your vim, vigor and vitality,—your strength and energy,—and you look and feel better in every way,—and your friends notice the difference,—

THEN—

You'll know your rupture is gone, and You'll know why for almost a quarter of a century numerous sworn statements report complete recovery and freedom from uncomfortable mechanical supports, without delay from work.

SEND NO MONEY

A Test of the scientific self-treatment mentioned in coupon below is now available to you, whether you are young or old,—man or woman. It costs you nothing to make this test.—For your own good mail the coupon NOW—TODAY.

FREE TEST COUPON

Plapao Laboratories, 455 Stuart Bldg., St. Louis, Mo.

Send me a Free 10 day test supply of the remedial factor Plapao and 48-page illustrated book on Rupture; no charge for this now or later.

Name.....

Address.....

**Start to play
Very first day**



**Free, Easy Lessons
... 5 Days' Trial ...
A Year to Pay!**

**To You Red-Blooded Fellows
Who Want MORE FUN OUT OF LIFE . .
MORE POPULARITY and BIG EXTRA-
TIME MONEY . . . This Is Good News!**

TO YOU who have so often remarked, "If only I could be as popular as some fellows," this is an opportunity. To you who a thousand times have said, "If only I could play some musical instrument," we now say, "There is no reason why you shouldn't."

Even if you can't read a note of music right now, you can, by following the free easy lessons furnished with each instrument, play a simple melody on the day you get your Xylorimba! Before you realize it, you will be playing well enough to amaze friends and relatives. Then a new life opens to you. Long, happy evenings of joy; not only invited to parties but the center of attraction—the pride of every girl and the envy of every fellow present. The thrill of having your friends listen to you over the radio! Last but not least, the same chance to earn \$5 to \$25 a night as Ralph Smith, Chicago, who says: "I played twenty minutes at a wedding—received \$20." Or the Hallmann family, Reading, Pa.—"Made \$300 in five weeks, spare time. Had never played instrument before."

We don't ask you to take our word for this. We offer to send you the

Xylorimba of your choice for five days' trial in your own home, so you can judge for yourself. See how easy it is to play. Look over the simple lessons, prepared by experts, which make a teacher unnecessary.

Keep the instrument only if you are satisfied—and then take an entire year to pay!

Was a fairer offer ever made? We make it because we want you to know the joy of creating your own music, the pleasure of being looked up to wherever you go, the profit of big extra money. Remember, this is the most fascinating of all instruments—the same make as used by national stage, radio and phonograph artists. Remember, too, you begin to play at once—no finger or lip exercises; no teacher; no tiresome practice.

Hundreds will take advantage of this chance. Will you be one of them? The coupon will bring, without obligation, our big FREE book which tells more about this amazing offer. Send it in today!

MAIL COUPON TODAY!

J. C. Deagan, Inc., Dept. 1453, 1770 Berteau Ave., Chicago

Send me, without obligation, full details of Free Trial offer and easy payment plan on the Deagan Xylorimba.

Name

Address

**5 Days' Trial
in Your
Own Home
...
A Year to
Pay!**



Fame and Money
Broadcasting



Center of Attraction
at Gatherings



Big Money at
Dances

**You Fellows
Who Want**

**BIG
PAY**

Get into

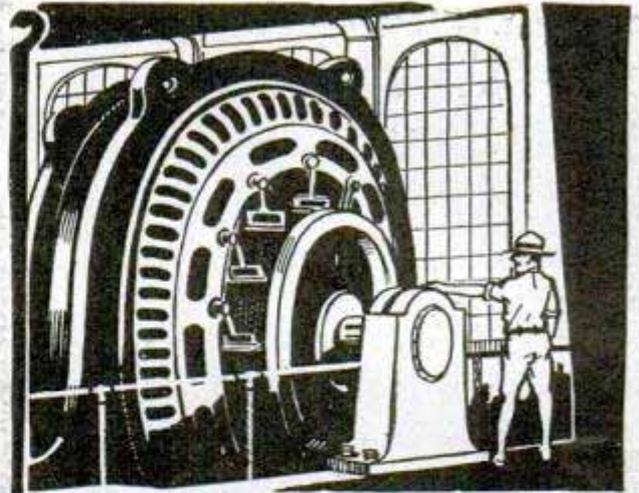

ELECTRICITY

WHY earn \$15 or \$20 or \$30 a week, when in the same six days as an Electrical Expert, when so many men are earning \$60 to \$100, do it easier and not work half so hard? Why should you remain in a small-pay, no-future job that offers no chance for big promotion—no chance for big income? Fit yourself for a real job. **Get into Electricity.** That's where the big money is being made, and always will be made

Electricity — The Big Pay Field

Today even the ordinary Electrician—the "screw driver" kind—is making money—big money. But it's the trained man—the Electrical Expert—who makes the really big money, — \$10 to \$20 a day — \$60 to \$100 a week. Be a Big-Pay man, yourself. Get in line, now, for one of these "Big-Pay" Jobs.

I'll Train You At Home

I'll train you at home, — in your spare time. You work just as you are working now—at your same job. My now famous "Work-Sheet and Job-Ticket" method, guarantees you simplified, practical training along work-shop lines. In a few short months you can step out of your old job into a new job—into electrical work where you can be a Big-Pay man in this Big-Pay field.

You Earn As You Learn

To learn Electricity my way you don't have to be a College man, or even a High School graduate. You can read. You can write. That's enough. With me, you get experience as you go along and make good money while learning. I'll show you how, — and I'll give you, without extra cost tools and apparatus to work with—6 Big Outfits in all.

Money Back If Not Satisfied

That's what I agree to do. And back of me in this agreement stands the Chicago Engineering Works, a \$2,000,000 Illinois Corporation. There's nothing like "Cooke" Training anywhere. It's the Training that big Electrical men are praising; it's the Training that employers recommend; it's the Training that one of our greatest Engineering societies has endorsed 100 per cent. It's the Training for you.

If You're Earning Less Than \$70 A Week — Investigate

Don't wait a minute! Find out today why "The Cooke Trained Man is the Big-Pay Man", everywhere! Find out how "Cooke" Training will help you boost your pay! Mail coupon right now for my Big FREE Book of Facts. See the Six Big Working-Outfits I give you without extra charge. See the hundreds of pictures, the proofs, the Big-Pay letters of other "Cooke" Trained Men. Get this great free Book. Send for it today. Clip, sign, and mail coupon RIGHT NOW!

L. L. COOKE, Chief Instruction Engineer

**L. L. COOKE SCHOOL
OF ELECTRICITY**

Dept. 13

2150 Lawrence Ave.

Chicago, Illinois

FREE BOOK COUPON

L. L. COOKE, Chief Instruction Engineer,
Dept. 13, 2150 Lawrence Ave., Chicago, Ill.

Send me FREE and prepaid, your Big Book "Secrets of Success in Electricity," with all details about your Home Study Course in Electricity.

Name _____

Address _____

City _____ State _____

**If you
earn less
than \$70
a week
INVESTIGATE**

**ACT
NOW**

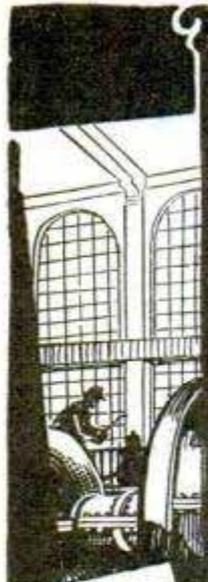

\$30 A DAY

Dear Mr. Cooke: I was making \$25 a week when I enrolled. Now with my own Electrical Shop I make as high as \$30 a day. A. J. Daigneault, 225 Worcester, Southbridge, Mass.



\$1.50 AN HOUR

Dear Mr. Cooke: I had to work like a slave for 45c an hour before I enrolled. Now, thanks to you, Mr. Cooke, I make \$1.50 an hour. G. W. Oppra, 4220 N. Meade Av., Chicago, Ill.

**6 BIG
OUTFITS
NO EXTRA
COST**

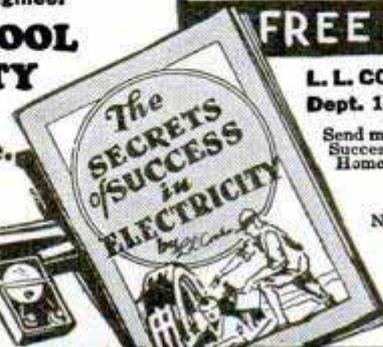

The "Cooke" Trained Man is the "Big Pay" Man

Classified Advertisements

WORLD'S BEST WANT AD MEDIUM

Advertisements in this section, 35 cents per word, each insertion, minimum 10 words, payable in advance. To be printed under proper classification in April issue, copy should be in our office February 18th

ADVERTISING AGENCIES

ADVERTISE—24 Leading Sunday newspapers, 24 words \$15.00. Excellent for obtaining help, salesmen, or business opportunities. Information 1,000 best paying dailies, mail-order weeklies, monthlies, mailing lists, everything. Free. Wade Agency, Great Northern Bldg., Chicago.

ADVERTISING: 24 Words 20 newspapers \$9; free list; magazines, farm. LeGrand Agency, 34 West 33rd St., New York.

BEFORE Advertising get our catalog. No charge. 25 years in business. The largest classified agency in the world. Ankrum Advertising Agency, 100 No. LaSalle St., Chicago, Ill.

GET Into advertising. Learn quickly at home. Experience unnecessary. New easy plan. No text books used. Practical work. Old established school. Send name and address for interesting free booklet. Page-Davis School of Advertising, Dept. 3433, 2601 Michigan, Chicago.

FREE—New 1930 Advertisers Rate Guide, 44 pages. Includes everything. Lowest rates. E. H. Brown Advertising Agency, 140 S. Dearborn, Chicago.

OBTAIN Canvassers, distributors through publication advertising. Martin, 278B West 43d, New York.

ADVERTISE In rural weeklies. Lists free. Meyer Agency, 4112 Hartford, St. Louis, Mo.

INCH Display advertisement 50 magazines year \$24. Wood's Popular Services, Atlantic City, N. J.

TIME Counts in applying for patents. See pages 138 and 139. Clarence A. O'Brien, Registered Patent Attorney, Washington, D. C.

FOR ADVERTISERS

ADVERTISE, 200 Country newspapers, 28 words \$7.50. Lists free. Roberts, Box 82, Monroe, Wis.

LETTERHEADS, Labels, trademarks, advertising illustrations. Grout, Designer, 4224 Clay, Denver, Colo.

ADVERTISE In country papers. Lists free. Low rates. Keator, Hartford Bldg., Chicago.

SALES PROMOTION

\$50 TO \$50,000 Daily sales secured for our clients. Three months from the date we undertook to overhaul this manufacturer's selling program, his closures increased from 16% (a mighty good average in his field) to 35%. Sales long since extended beyond national boundaries. They now include a dozen foreign countries too. 35 years' salesmanship-in-print experience back of our campaigns. Submit sales problems for free diagnosis. 10 years' Sales Promotion Manager Larkin Co. James C. Johnson, 118A Woodbridge Ave., Buffalo.

SALES Counsel—Successful proven plans! Banning, Times Bldg., Watertown, N. Y.

SALES ORGANIZATION

FOREIGN—Money to be made. We, as a selling organization, can sell your lines; people out here want good lines. Write all particulars, and if possible send samples to United Selling Organization, Box 5374, Johannesburg, Transvaal, South Africa.

MAILING LISTS

1,000 AGENTS' Names from original letters, \$3.00. Southern Specialty Co., Sanford, Fla.

SEND \$1.00 For names of 1,000 rural buyers. Ill. Commercial Office, 5327 Cornell Ave., Box 301, Chicago, Ill.

AUTOMOBILES

TIME Counts in applying for patents. See pages 138 and 139. Clarence A. O'Brien, Registered Patent Attorney, Washington, D. C.

AUTOMOBILE SUPPLIES

GENERATORS—Starters exchanged for all cars. Completely rebuilt and guaranteed same as new. Orders shipped same day we receive your old unit. Magneto repairing a specialty. Attractive dealers discount on bakelite, condensers, genuine tungsten points, etc. Complete stock. Rhoads Electric Co., 4142 Olive St., St. Louis, Mo.

AUTO Carburetor attachment greatly increasing power, speed, mileage. Chrysler car test over 38 miles per gallon. Mailed COD \$2. Give make, year. Whirrigas Co., 816 Ford Bldg., Detroit.

TRY Fibrol, gritless hand cleaner. Softens. Prevents chapping. Quart can 35c postpaid. "Fibrol," Wheaton, Ill.

USED Air compressors, automatic. Reconditioned, guaranteed like new. Shipped trial easy payments. Also used testers, car washers, chargers, sprayers. Write "Connor Supplies," Box M-333, Troy, Ohio.

"SPRINGS Of silence."—Universal anti-rattler. For the noisy 4 wheel brake rods all cars. Ask your dealer. Universal Spring Co., Grand Rapids, Mich.

YOU Are wanted to resilver mirrors at home. Profitable business plating autoparts, tableware, etc. Write Sprinkle, Plater, 77, Marion, Ind.

SPECIAL Automotive tools for mechanics and car owners. Representatives wanted. Greene, Dover, Mass.

SET Eight spiral expansion reamers, \$11.95. Catalog, W. Barnitz, 203 Briggs, Harrisburg, Pa.

INSTANT Starting zero weather. Electric manifold heater, starter. Saves gasoline. Money-back guarantee. Agents' sample \$2.98, lots of six \$2.00. Sells for \$5.00. Write for sample and territory. State model car, F. Bruce Co., 823 Prospect, Cleveland, Ohio.

SIMPLE Inexpensive method for removing carbon, \$1.00. Wm. Eckstein, 10101 Nelson, Cleveland, Ohio.

SPECIAL Introductory offer on Universal Socket Wrenches. Save from 25 to 50% on time-saving tools. A. J. Frey, 2610 Greenview, Chicago.

AUTO Parts new and used. Lowest prices. Bankrupt supplies, motors, wheels, radiators, transmissions, generators, gears, carburetors, touring tops complete \$15. Brakelining 50% off. Brightman, 2065 Main St., Hartford, Conn.

DYKE'S Famous Automobile Encyclopedia—Latest edition. Fully revised to cover all latest facts regarding newest developments in automobile field, including new Model A Ford. Information given on repairing and adjusting every part of all motor cars. How to find trouble and fix it. 1,250 pages, 4,200 illus. Price, cloth, \$6. Flexible Morocco \$7.50. Pay postman price and postage when he delivers book. Popular Mechanics Press, Room 801, 200 E. Ontario St., Chicago.

AUTO SERVICE EQUIPMENT

SAVE Money—Garage equipment reconditioned guaranteed like new. Bargains test stands, chargers, compressors, car washers. Shipped trial easy terms. Write "Byrum's Electric," Box M-334, Troy, Ohio.

PROFITS In 8-hour battery charging or 20 minute car washing. Install equipment practically no investment. Bargains in reconditioned buffers, grinders, compressors, sprays, arc welders. Write Ken's Service, Box M-335, Troy, Ohio.

SOLDERING And Brazing, by Yates, gives all the necessary "kinks" that will enable you to solder successfully. 90 pages, 64 illustrations. Delivered to your door C. O. D. Simply pay postman 75 cents and postage. Popular Mechanics Press, Room 801, 200 E. Ontario St., Chicago.

FOR FORD OWNERS

AURORA Underslung parts and 3.1 racing gears. Speedster bodies, headlights, hi compression head. See Sport Factories ad page 144

MOTORCYCLES, BICYCLES AND SUPPLIES

MOTORCYCLES, \$25 to \$100, easy terms. Side car, \$25; engines for airplanes, motorcycles, boats and sleds, \$15 to \$100. New Firestone tires, \$5; frames, \$3; forks, \$3; wheels, \$3; chains, \$2. Belts, magnetos, generators, tanks, cylinders, pistons, handle bars, saddles, parts. New low prices. Save dollars. Rebuilt bicycles, \$9.50. Send 25c for catalog. Price Cutter Deninger, Rochester, N. Y.

HARLEY Davidson bargains at a tremendous sacrifice. All models and prices. Guaranteed. Send 4 cents in stamps for our catalog. "Money Saving Motorcycle Bargains," The Knuth Co., 2525 Fond du Lac Ave., Milwaukee, Wis.

MOTORCYCLE Bargains, lowest prices, bargain sheets for stamp, special aviators supplies, motorcycle accessories largest line in America, lowest prices. Largest motorcycle mail order house in the United States. Rochester Harley Davidson Corporation, 129 West Main St., Rochester, N. Y.

USED Motorcycle parts half price or less. New parts, accessories, repairing. New and rebuilt Indians, Harleys, others. J. B. Dahl, 3661 Archer Ave., Chicago, Ill.

MOTORCYCLE Paris, new and used. Lists free. Tower Cycle Co., Pine Lawn, Mo.

HENDERSON, Excelsior, Indian, Harley used parts and engines cheap. Ballak & Co., 100 N. 12th, St. Louis, Mo.

AVIATION

22 YEARS Of aeronautical experience is incorporated in every Heath propeller. That is why you get superior performance on your sled, boat or airplane. 4c brings illustrated booklet. Heath Airplane Company, Chicago, Ill.

INSTRUCTION Book. Five hundred aviation questions correctly answered, postpaid \$1.00. Agents wanted. George Tuck, 73 South Shirley Ave., Pontiac, Mich.

GLIDERS, Crawford Powered Gliders will take off quickly and fly to high altitudes carrying 200 lb. man using motorcycle engine, with our propellers one can fly alone in half hour's time. We furnish complete plans and materials for home building. Crawford Motor and Airplane, Seal Beach, Calif.

HEATH-HENDERSON Aircraft motors are not motorcycle motors. They represent the refinement of seven years of constant flying and 22 years of aeronautical experience. 10c in stamps or coin brings large illustrated booklet. Heath Airplane Company, Chicago, Ill.

A MOST Complete line of sport plane parts and motors. Send dime for illustrated literature. Marsh & Cendit Airplane Co., Colby, Wis.

MODEL Airplane supply price list 5 cents (coin). Hoosier Aero Supply Shop, Lafayette, Ind.

BUILD And fly a real airplane. No technical knowledge of construction necessary. Annard Aircraft Company, Dept. G, St. Paul, Minn.

ANY Weather is good weather for a Heath parasol, the most practical airplane ever created. Build it for \$199 or fly it away for \$975. Detailed shop blue prints \$5.00 per set. 10c in stamps or coin brings large illustrated booklet. See our ad page 156. Heath Airplane Company, Chicago, Ill.

MODEL Airplane builders, 32 page catalog 5c. Many models, all supplies. National Model Aircraft & Supply Co., 20P North Ave., New Rochelle, N. Y.

HENDERSON Engines—For light aircraft use. Yours converted. Folder 10c. Ballak & Co., 100 N. 12th, St. Louis, Mo.

MODEL Flyers! Build all type of models. Illustrated catalog 10c. Independence Model Aeroplane Co., Far Rockaway, N. Y.

AIRPLANE Welding—Just out. Only book on new subject vital to all mechanics. Big demand for men thoroughly familiar with the work. Get into this big, new, unlimited field. Complete, illustrated book will be delivered to your door C. O. D. Simply pay postman \$3.50 plus postage. Popular Mechanics Press, Room 801, 200 E. Ontario St., Chicago.

GLIDER Plans. Gumreed primary training glider plans include full size rib, large details of spars, fittings, profiles; easy and economical to build. Price \$3.75. J. Wm. Reed, 1576 American Ave., Long Beach, Calif.

AIRPLANE Motors, 80 hp., cost \$4,250; unused, \$125.00; slightly used, \$95.00. Also propellers. Box 1343, Houston, Tex.

2c POSTAGE Stamp will bring you complete model airplane supplies price list. A. A. C. Model Aircrafters, 340 East 188th St., New York.

SENENICH-HENDERSON Aircraft engines completely rebuilt and converted, \$180. Propellers, hubs, etc. Send dime for catalog. Senenich Brothers, Litzitz, Pa.

FINEST Propellers, 4', \$8.75; 5', \$13.25; 6', \$16.50; special Henderson propeller, \$15.00; 'Aerodrive' sled or boat prints 50c each. Everything aeronautical. Ostrgaard Aircraft, 4303 North Narragansett, Chicago.

\$175 WILL Build our beautiful steel fuselage one place monoplane. Plans \$1. Sail planes performance guaranteed \$350. Plans \$1. Literature 10c. Barney Snyder, Rochester, Ind.

TIME Counts in applying for patents. See pages 138 and 139. Clarence A. O'Brien, Registered Patent Attorney, Washington, D. C.

SIMPLEX Air Model Co., Auburn, Mass. Send five cents for supply booklet.

SELLEY Champion, semi-constructed miniature airplanes and supplies. Most realistic models ever offered. Aluminum adjustable pitch propeller, 8 in. 60c, 10 in. 75c postpaid. Send 5c for catalog. Selley Co., 1405 Gates Ave., Brooklyn, N. Y.

LEARN How to make aerial surveys. Course includes flying, photography and engineering. Write for particulars to Hamilton Maxwell, Inc., Springdale, Stamford, Conn.

BOYS: Get a pursuit tractor kit complete 35c. No stamps. Send 5c for price list. W. & J. Aeroplane Shop, 200 Maple St., Wyandotte, Mich.

GET The latest sportplane constructor book. Full of blueprints, photographs, drawings, detail instructions, etc. Postpaid \$1.00. May save you hundreds. Circular free. Russell Aero, Box 455, Toledo, Ohio.

PROPELLERS For model aeroplanes. Semi carved, 6", 8", 10", 12" 10c each. Any size. Aero Shop, 3050 Huribut Ave., Detroit, Mich.

FLYING Simplified—Just out. Here is a remarkable non-technical book for beginners, prospective or advanced students that teaches in an easily understood manner all you can need to know to master the art of flying. Will save you many dollars when you learn to fly. Pay postman only \$1 and postage when book is delivered at your door C. O. D. Popular Mechanics Press, Room 802, 200 E. Ontario St., Chicago.

SEND For "A Billion Ideas"—our latest catalog of books just issued. Thousands of good books listed on almost every subject. Free upon request. Popular Mechanics Press, 200 E. Ontario St., Chicago.

BOYS—Model airplanes supplies 2ft. Curtiss Hawk Flying Model Construction Set containing all necessary parts. \$2.50. Baby R. O. G. Kit, 50c. Send 5c for booklet. Hawthorne Model Aero Co., Hawthorne, N. J.

BIGGEST. Best catalog model airplanes; parts, supplies; 5c postpaid. Ideal Company, 19 West 18th St., New York.

VARIOUS Sizes wood, reeds, bamboo, rubber band, wheels, propeller, onion skin covering and other supplies. Big bundle for 25c, five for \$1.00. No stamps. Will also send circular on free three foot model. Aero Shop, 3050 Huribut Ave., Detroit, Mich.

SEND For free 24-page illustrated catalog of all latest and best books on aviation. Special lists classified by subjects and recommended by well-known aviation authorities are a helpful feature of this catalog. Popular Mechanics Press, 200 E. Ontario St., Chicago.

BUILD And fly model aircraft. Complete instructions cover all types including tournament prize winners. Lindbergh's famous "Spirit of St. Louis" and others. Great sport and very instructive. Official handbook approved by leading flyers, government officials and others. Sent C. O. D. anywhere in U. S. Simply pay postman \$2.25 and postage when delivered. Sent postpaid to any address upon receipt of price. Popular Mechanics Press, Room 801, 200 E. Ontario St., Chicago.

BOOKS AND PERIODICALS

4TH EDITION, revised "Radio Theory and Operating," by Mary Texanna Loomis. The standard radio text and reference book of America. 992 pages, 800 illustrations, flexible binding. Price \$3.50 postage paid. For sale by hundreds of book dealers throughout America and many foreign countries. Or may be purchased direct from the publishers. Send check or money order to Loomis Publishing Company, Dept. 18, Washington, D. C.

INDUSTRIAL Alcohol. Complete directions for making. Fully illustrated. \$2.50. Spon & Chamberlain, 120 Liberty St., New York.

TALKIES, Stage Guaranteed dramatical course. \$1.00 postpaid. Twenty lessons. Blodgett, Box 28, Independence, Mo.

READ Northern Lights. Sensational Bible serial. Six months for one dollar. Mrs. B. E. Moyer, 2427 K St., Sacramento, Calif.

KNOWLEDGE Is power; employ your spare time profitably; send for free catalog; lists instructions on radio, electricity, aviation, chemistry; manufacture of household, auto products. Get your copy today. Manhattan Co., 333 W. Manhattan Blvd., Toledo, Ohio.

BOOKS Wanted: Scarlet Letter, 1850; Uncle Tom's Cabin, 1852; Huckleberry Finn, 1885; Tom Sawyer, 1876; Moby Dick, 1851. Dunbar, 1613 Rowena St., Boston.

YOUNG Idealists who still believe in democracy—25c gets four months' trial subscription to Democratic Youth, published at West Liberty, Ky., especially for you.

ARE You going to read Friscoe Pete. The story poem that can't be beat. Three dimes. Address Pauli, 722 Mace, Greensburg, Pa.

MILLION Books cent each. "Proverbs," San Jose, Calif. Solomon's Uncommon Sense.

NEW Electrical Dictionary. Complete up-to-date electrical dictionary with special radio words and terms together with illustrations of electrical symbols, radio diagrams and other wiring diagrams. 191 pages—Vest pocket size. Price only 35c postpaid. Popular Mechanics Press, Room 801, 200 E. Ontario St., Chicago, Ill.

WELLS' Outline of History now only \$1. The complete, illustrated, 1,200-page edition that originally sold for \$5.00. One of the most popular books ever published. Can be read with profit by young or old. Pay postman \$1.00 plus postage when delivered to your door C. O. D. Popular Mechanics Press, Room 802, 200 E. Ontario St., Chicago.

YOU Need a better grip on mathematics? Ask us to send you a copy of "Mathematics for the Practical Man," only \$1.50. By common sense methods it removes the mystery and difficulties so algebra and calculus are made simple. Assuming your knowledge is limited to arithmetic you quickly and easily gain a working knowledge of algebra, geometry, trigonometry and calculus. Simply pay postman when he hands you the package. Address Popular Mechanics Press, Room 802, 200 E. Ontario St., Chicago, Ill.

PICTURES AND POSTCARDS

FRENCH Lovers photos, love scenes, fellows and girls. Taken from life poses. Imported direct from France. 12 for \$1.00. Joy Sales, Station A, Box 53, New Haven, Conn.

IMPORTED French lovers photos. Love scenes of fellows and girls, taken from life poses. 12 for \$1.00. Carrano Novelty Co., (PM-M) West Haven, Conn.

NOVELTIES, CURIOS, ETC.

CHINESE Lucky Ring. Size adjustable. 75c postpaid. Planet, 3200 Walnut, Chicago.

GAMES, ENTERTAINMENTS AND PLAYS

200 TRICKS You can do—Mystify your friends; have loads of fun. This collection of tricks has been selected by Thurston for the average person. Neither unusual skill nor elaborate apparatus are required. Send for this 200-page illustrated book. Pay postman \$1 plus postage when delivered. If outside U. S. remit when ordering. Popular Mechanics Press, Room 801, 200 E. Ontario St., Chicago.

CHALK-TALK Your way to popularity. Audiences at your feet if you learn how to entertain with a few simple pictures. Little artistic ability needed. "How to Chalk Talk" tells what to say and what to draw. Profusely illustrated. Make money giving chalk talks. Just order on a postal. Pay postman \$1.00 and postage when delivered. Popular Mechanics Press, Room 801, 200 E. Ontario St., Chicago, Ill.

NEW Game: Word Solitaire. Pleasing mental diversion. Helps overcome sleeplessness. Copyrighted instructions, \$1.00. Address "Patents," Best Bldg., Rock Island, Ill.

PLAYS, Musical comedies and revues, minstrels, comedy and talking songs, black-face skits, vaudeville acts, monologs, dialogues, recitations, entertainments juvenile plays and songs, musical readings, make-up goods. Catalog free. T. S. Denison & Co., 623 So. Wabash, Dept. 11, Chicago.

MAGIC TRICKS, BOOKS AND JOKER NOVELTIES

TRICKS With cards. Easy to do. Produce any card called for. Name any card drawn from pack. 6 tricks for 25 cents, including large catalog listing over 600 tricks. Wizard Magic Co., Dept. 15-K, Box 1055, Station "C," Los Angeles, Calif.

MAGIC Tricks, cards, books, illusions, etc. Catalog free. Geo. Fenner, Louisville, Ky.

"THE Book of 1,000 Wonders" explains many mystifying tricks with coins, cards, handkerchiefs, etc. Also contains complete catalog magic tricks, jokes, puzzles, books, and imported novelties. Largest assortment, lowest prices. Amaze and mystify your friends. Send 10c today. Lyle Douglas, Station A-5, Dallas, Tex.

FREE! Magic of all kinds. Catalog and full information 10c. Miracle Distributing Company, Room 232-A Maryland Bldg., Washington, D. C.

MAGIC Tricks, Puzzles. Illustrated catalog 10c. J. Tillberg, Proctor, Vt.

ELECTRIC Fun! Seventy stunts, 110 volts, \$1. Chemical fun, magic, hundred effects, \$1. Kutting Sons, Campbell, Calif.

SEVEN Optimagical delusions. Five magic catalogs, 25c. Gilmagico, Morgan Park, Chicago.

MAGIC Disappearing coin trick, 15c. Fred Hargraves, Norwood, R. I.

AMAZING Optical illusion only 10c. Hirshorn, 5451 Virginia Ave., Los Angeles.

MAGIC Catalog 20c. Lynn's, 105 Beach, Dept. 3, Jersey City, N. J.

MAGIC Tricks, card tricks, coin tricks, Hindu magic, hypnotism, ventriloquism. Popular books 10c each. All six, 50c. Geo. Fenner, 2401 Jefferson, Louisville, Ky.

MAGIC—Tricks, Books and Supplies. For amateurs as well as the great professionals. Anyone can learn through our instructions. Feature Acts in Mind-Reading, Spiritualism, Rope Ties, etc. Large illustrated professional catalog, 20c. Chicago Magic Co., 140 So. Dearborn St., Dept. B, Chicago, Ill.

BEST Books for \$1. All formerly sold for \$2.50 to \$5 each. Select from the following list of guaranteed bargains. All brand new books: Woodcraft by Seton, Book of Letter Writing by Crowther, Etiquette by Eichler, Creative Chemistry by Slosson, Lawn Tennis by Tilden, also Revolt in the Desert by Lawrence, Trader Horn, White Shadows in South Seas by O'Brien, Count Luckner (The Sea Devil) and Outline of History by Wells. Delivered at your door C. O. D. Simply pay postman \$1 each and postage. Popular Mechanics Press, Room 801, 200 E. Ontario St., Chicago.

CHALK TALKS

ENTERTAIN Lodges, clubs, schools with magical chalk talks, crayon, clay, sand, smoke pictures. Learn one evening. G. E. Hendrickson, Argyle, Wis.

LAUGH Producing program, \$1.00. Catalog free. Balda, The Cartoonist, Oshkosh, Wis.

BOYS! Here's fun galore. Four large profusely illustrated books tell how to make almost everything you could want. Nearly 4,000 different articles are described (Think of it). Now \$2 per book or \$7 for the four if ordered at once. Just write a postal saying, "Send the Boy Mechanic Library." Pay postman \$7 and postage. For single books, specify either Book 1, 2, 3 or 4. Popular Mechanics Press, Room 801, 200 E. Ontario St., Chicago, Ill.

RADIO SETS AND SUPPLIES

\$5 RADIOS All makes Atwater-Kent, Majestic, R. C. A., and others. Hundreds—world's best makes. Used, new and rebuilt. Going at \$5 to \$65. Many formerly priced at \$150 to \$300. Amazing bargains. Backed by responsible guarantee and 30 years' experience. Write for big free list today. Brown's Radio Exch., Dept. E, 3018 East 91st St., Chicago.

NEW 300-Mile "pocket" radio, \$3.85. Complete with special loud receiver. No tubes or batteries required. Order direct. Spencer Laboratories, 116 Atlas, Akron, Ohio.

RADIOS At lowest wholesale prices. Free list. American Phonograph Co., 3602 Wesley, Berwyn, Ill.

TIME Counts in applying for patents. See pages 138 and 139. Clarence A. O'Brien, Registered Patent Attorney, Washington, D. C.

STAMP COLLECTING

WRITE For our free illustrated price list. The illustrated Scott price list is the most complete offering of sets, packets, junior album packets, airmail and special packets, catalogs, albums, stock books and accessories ever made available to the stamp collector. It is beautifully illustrated throughout, and contains a wonderful range of offerings from 10c to hundreds of dollars. Free for the asking. Now on sale, Scott's Specialized United States catalog, 1930 edition, Pocket size \$2.00. Scott's Airmail catalog, A complete catalog of all airmail and semi-postal airmail stamps 13c. Scott Stamp and Coin Co., 1 West 47th St., New York, N. Y.

MYSTIC "Queer Country" Packet! Contains scarce stamps from the following strange lands: San Marino, Antioquia, Congo, Cyprus, Fiji Islands, Gwalior Hyderabad, Iceland, Jhind, Kenya, Uganda, Lebanon, Monaco, North Borneo, Nyassa, St. Thomas Prince, Eastern Roumelia, Siam, Sierra Leone, Tanganyika, Trinidad Tobago, Ubangi, Upper Volta, Wallis Futuna, Alaouites. Get this wonderful packet of "freak countries" and make your friends envious! Price only 10c to approval applicants! Write today. Mystic Stamp Company (Dept. 8), Camden, N. Y.

FREE! Largest stamp in the world! Fine packet 65 different stamps from Cape Verde, Jamaica, Mozambique, Syria, etc., including dying soldier, beautiful women, ships, maps, savages, airplane, scenes, bird and animal stamps, for only 5c to approval applicants. Largest Stamp in the World (Rare China Wild Goose Special Delivery) given absolutely free with each order. Supply limited! Send your 5c today! Western Philatelists, 6021 Harper Ave., M3, Chicago.

THRILLING War scenes. A packet of all different stamps showing exciting scenes and records of nations at war. Includes siege guns; firing squad; mounted troops; prisoners of war; fire-pot hurlers; hand-to-hand bayonet struggle; bloody battle scenes; troop transport; red cross stamp; dying soldier; victory stamps, etc. Send for this thrilling "Big Parade" packet at once—limited supply. Only 10c to approval applicants. W. A. Rowell, 58 Cornhill, Boston, Mass.

500 DIFFERENT Stamps for 25c. Big collection from Bosnia, Crete, Epirus, Honduras, Iceland, Kenya, Liberia, Malta, Nyassa, Quelimane, Siam, Zambesia and other "hard" countries. Catalog value \$10. Price 25c to approval applicants! Bargains, 1,000 different 79c; 15 triangles 49c; 100 British colonies 30c; 100 French colonies 35c; 100 Portuguese colonies 50c. Five packets for \$2.00! Illustrated lists free. Loma Stamp Co., 4231 42d St., San Diego, Calif.

ANCHERS \$\$\$ Outfit—only 12c! Fine triangle stamp; set German stamps with (pre-war) value forty million dollars (interesting!); perforation gauge, mm scale; airmail set; scarce stamp from smallest republic on earth; newspaper set; packet good stamps and Travancore, Malay, Dutch India, etc. Entire outfit for 12c to approval applicants! (Nice pocket stock book, value 25c, with every order!) Ancher Stamp Co., Box 126, Rutherford, N. J.

CONFEDERATE Essay, 50 different foreign, 10 United States commemoratives. Two Liberia, four Guatemala. All for eight cents to approval applicants. Patapso, Walbrook Station, Baltimore, Md.

BUY Stamps in sets and save money. Write for a trial selection on approval. One set given to all applicants. Pickwick Stamp Co., Rahway, N. J.

FREE—5 Airmails, 2 Confederate prints, 20 unused to approval applicants sending 10c. Buckey, P35 West 5th, Dayton, Ohio.

FREE 50 British Colonials. If approvals requested. Postage 4c. Berkeley Stamp Co., South Berkeley, Calif.

100 DIFFERENT Foreign stamps from 100 different foreign countries, including Africa, Asia, Australia, Europe, West Indies, etc., for only 20c. Free with each order, our pamphlet which tells "How to Make a Stamp Collection Properly," together with our price lists of albums, supplies and hundreds of bargains in sets, packets, etc. Queen City Stamp and Coin Co., Room 36, 604 Race St., Cincinnati, Ohio.

111 DIFFERENT, including Liberia, Heligoland, Congo, Nyassa, Abouities, Russia, Siam, etc., only 10 cents to approval applicants. E. Hergenrother, 918 Grove St., Irvington, N. J.

FREE! 101 Diff. Mexico, etc., and big catalog! Supreme, 1928-8 S. Trumbull, Chicago.

40 DIFFERENT United States 12c, 60% approvals. Seidenberg, Baroda, Mich.

ATTRACTIVE Assortment, Central American with additional interesting unusual stamps, 2c postage only. Midland Stamp Company, Toronto, Can.

50 STAMPS From 50 countries 10c with approvals. Hollister, 3323 N. Seeley Ave., Chicago.

FREE, Obsolete \$1.00 U. S. stamp, to "Going Good" approval applicants. Reference required. Munger, 3892 Youkum Blvd., Houston, Tex.

300 DIFF. Foreign, album, hinges, 25 cents. Lakota, La Plant, S. Dak.

FREE—5 Schleswig. To approval applicants. J. Lyndon, Jr., 1456 Arrowhead Ave., San Bernardino, Calif.

GRENADA And Newfoundland set free with approvals. W. C. Kohl, Reading, Mass.

REAL One cent approvals. No junk. Reference please. Howard G. Stuart, Gowanda, N. Y.

GET Good stamps! Fine set Yugoslavia (catalogued \$1.81) 5c with choice approvals. References. Rosedale Stamp Company, Box 1733, Winnipeg, Can.

14 DIFFERENT Triangle stamps, all uncancelled, including Austria, Esthonia, Latvia, scarce Liberia, Nyassa, etc. Catalog value nearly \$2.00—regular price \$1.00. Special for limited time, only 35c. High-grade approval sheets. Price list free. E. Newton Searles, P.M. Pamfret Center, Conn.

U. S. STAMPS Only on approval! give reference. Stamp House, 39 Torry, Dorchester, Mass.

ILLUSTRATED Descriptive U. S. list, price 50c; also our 1930 32-page price list free. Stanley Gibbons, 38P Park Row, New York City.

50 NEWFOUNDLAND 25c; 40 different Canada 25c; 1,000 mixed 25c; 60 different France 25c. Exchange wanted. Odias Demers, Sanford, Me.

FREE—Set of stamps cataloging \$2.53 to approval applicants sending references. Importer, Box 156, Needham, Mass.

4c APPROVALS, including Liberia, Nyassa, etc. Also 14,000 averaging 1 1/2c. References. Philatelic Exch., Huntington, W. Va.

211 DIFFERENT Stamps only 9c to approval applicants. Plymouth, 463 Cyrus Place, Bronx, N. Y.

200-200-200! SEND For our 200 outfit containing 200 stamps; 200 hinges; approval sheets to hold 200 stamps; perforation gauge; millimeter scale and ruler; duplicate stamp container—all for only 15c to approval applicants. Edgewood Stamp Co., Dept. PM, Milford, Conn.

BEAUTIFUL Packet with approvals 2c. Reid, 608 Yonge St., Toronto.

2 UNITED States stamps value \$1.10, 10c with approvals. Vic Stamp Co., New Dorp, N. Y.

4,000 GOOD Mixed foreign stamps, \$1.00; 500 different British colonies, \$4.00; 500 different French colonies, \$4.00. Cloud Denney, Box 315, Dallas, Tex.

BEST One cent approvals in America. F. Hand, 1117 60th St., Philadelphia, Pa.

BIG Combination for 10c. J. Eberly, 2686 Wabash, Detroit, Mich.

APPROVALS, 1/2c And up. References. Carl Schulz, 314 So. Olive, Los Angeles, Calif.

FREE—Packet French colonials to approval buyers. Lincoln Stamp Company, Shelbyville, Ill.

WANTED—Will buy 19th century U. S. stamps. What have you? W. W. Gray, P. O. Box 14, Douglaston, N. Y.

FIVE Different surprise packets, 10 cents. Belle Butler, 89 Warren, Newton Center, Mass.

100 DIFFERENT, 2c With 50% approvals. Packets and sets 10c and up. Evans-ton Stamp Shop, 2412 Noyes, Evanston, Ill.

SMALLEST Stamp ever issued 10c. Reference for approvals. Webb Stamp Co., 1701 10th Ave., So. Birmingham, Ala.

105 DIFFERENT Iceland, Hamburg, Confederates, etc., 2c! Taibam Stamp Co., Mittleague, Mass.

3 ERITREA, 3 Libia 10c; Roumania Michel complete 15c; Onondaga Stamp Shop, 1337 Butternut, Syracuse, N. Y.

42 DIFF. U. S., including \$2 tax, 12c; 100 diff. U. S., 27c; 24 Canada, catalog 59c, only 10c. Approvals, Robert Haynes, Point Place, Toledo, Ohio.

27 LIECHTENSTEIN 4c To approval applicants. Hagen, Box 129, Sioux Falls, S. Dak.

300 DIFFERENT Stamps 20 cents; 600, 50 cents; 1,100, \$1.00; 2,000, \$3. Fred Onken, 630 79th St., Brooklyn, N. Y.

WAR Set portraits from Egypt and others to approval applicants for 6c. Earl T. Tyler, Royal Oak, Mich.

10c SET Bargains. No two stamps alike. 25 South America, 200 world, 100 unused, 150 Germany, 100 Hungary, 100 Austria, 50 French colonies, 20 Danzig, 27 Liechtenstein. Bargain lists free. 100r, 802 State Life Bldg., Indianapolis, Ind.

15 VARIETIES Airmail 12c. Norono Co., 4401 National Ave., Milwaukee.

NEWFOUNDLAND—Set of 5 caribou 10c or set of 10 from Montenegro 10c to approval applicants. DeLisle, 762 Harding Ave., San Jose, Calif.

FREE—Packet of stamps, China, Chile, etc. Send postage. H. C. Buchholz, Norwood, Ohio.

300 DIFFERENT Stamps 10c to approval applicants. Fulmen, Columbia, Mo.

AIRMAIL Packet, 60 different varieties, catalog value \$3.00, only \$1.00. Lists free. Sunshine Stamp Co., 549 East Maryland St., St. Paul, Minn.

\$3.99 STAMP Free with big combination package, 25c. Keystone Stamp Co., Chambersburg, Penna.

HUNDRED Different and three \$1.00 U. S. stamps 10c. Approvals. Blicek, 644 Cass St., Chicago.

FREE Hawaiian stamp to approval applicants. Postage 2c. Eastern Stamp Co., 1809 Kilbourne Place, N. W., Washington, D. C.

ONLY 25c For a five months' subscription to The Stamp Collector, America's finest stamp magazine. 100 all different stamps given free to each subscriber. Money refunded if you are not more than pleased. The Stamp Collector, Dept. P. M., 515 Sedgwick Drive, Syracuse, N. Y.

FREE—20 Different Africa, Bargain approvals. Atlantic Stamp Co., Garden St., Springfield, Mass.

FREE! 250 Hinges to approval applicants. H. T. Crane, 1038 Pape Ave., Toronto, Can.

BAHAMAS! 10 Diff. 50 cents (catalog \$1.22). R. Moore, Nassau, Bahamas.

WHITE Russia complete country for 8c approvals. Victoria Stamp Shop, 1458 Victoria, Chicago, Ill.

CANADA Airmail stamp free, if you ask for approvals and send 15c for 25 different airmails or 30 different Canada and Newfoundland, both packets only 25c. We list 282 countries in our dime packets. Special bargains—500 different 25c; 1,000 different 75c; 2,000 different, \$2.50. Victoria Stamp Co., London, 4, Canada.

100 FOREIGN Stamps 3 cents. Lufbery Stamp Co., Branford, Conn.

212 DIFFERENT Stamps including U. S. \$2, Dominica, Syria, etc. Catalog \$4.90, only 15c. Robert Haynes, Point Place, Toledo, Ohio.

CONGO, Free, five fine to approval applicants. Bernard Karch, Bengies, Md.

105 CHINA, Etc., 2c. Album (500 illustrations) 3c. Bullard, 446 Tremont, Boston.

1,000 DIFFERENT Stamps, 90c; 500 different, 35c; 200 different, 12c; 1,000 mixed, 35c; 1,000 hinges, 10c. Evans, Box 366, Reading, Penna.

CANADIAN Commemorative, a complete set of 9 var. air mail, 5 beautiful picture stamps and 100 other stamps, all for 5c to collectors who ask for our approval sheets. Prices on approvals, 1/4, 1/2, 3/4 1c, etc. Lowest prices and best quality. Kelgwin Stamp Co., P. M. Fernandina, Fla.

ONLY 5c, 33 Different stamps including scarce Latvian triangular airmail stamps, 10 airmail, 12 United States (early issues, commemoratives, etc.) and 10 Canada. Approvals and illustrated pricelist sent with each order. Curban Stamp Company, Gloucester, Mass.

FIVE Specials—all different, 60 U. S., 60 Latin-Americans, 60 Africans, 60 Orientals, 300 Europeans, 25c each, all for \$1. Ohio Stamp Co., Box 249, Cleveland.

FREE! Loose leaf postage stamp album at rate of 8 pages each month given with subscription to monthly journal. Send 2c stamp for prospectus. United Stamp Co., Marquette Bldg., Chicago, Ill.

BRITISH Colonials free with approvals 2c postage. Lightbowns, Southsea, England.

SEE Our latest price list. Lake Stamp Co., Paterson, N. J.

SPECIAL! 1,000 Different stamps. 72c; 100 U. S. 70c; to approval applicants. Cleveland Stamp Co., 408 Caxton Bldg., Cleveland.

FREE, 6 Different Luxemburg to approval applicants. E. D. Stamp Co., 3905 Forest Park Ave., Baltimore, Md.

10 WORTH While stamps. catalog value over \$5.00, all western hemisphere, consisting mostly of old Newfoundland, Canada, U. S., etc., for only 10c to approval applicants. We are the leading and most up-to-date approval house in America. As soon as you hear from us, you will realize that "it pays to deal with Globus." Globus Stamp Co., 214 Third Ave., New York.

MAGNIFICAROCIOUS Packet free—Beauties from distant lands, many richly colored, unusual designs. 2c postage. Empire Stamp Co., Toronto, Can.

55 DIFFERENT Including scarce countries to approval applicants 4c. Richard Lamprecht, Valparaiso, Ind.

STAMPS—100 Varieties, Africa, Brazil, Peru, Cuba, Mexico, etc., 10c; 25 different U. S. 25c; 1,000 mixed, 40c; 1,000 hinges, 15c. C. Stegman, 5941 Cote Brillante, St. Louis, Mo.

FREE Stamps with approvals. 2c postage. Harvey Teeple, Decatur, Ind.

STAMPS Sent on approval at 70% discount. Reference required. Emory Renoll, Hanover, Pa.

COVERTCO Packet, 200 different stamps 10 cents, with 60% discount approvals. Covert Stamp, 39 State, Rochester, N. Y.

FREE—31 Different stamps to applicants for Royal approvals. 2c return postage. Royal Stamp Company, Bristol, Pa.

150 GOOD Mixed foreign stamps 3 cents. Stanton, Niantic, Conn.

FREE—\$1.00 U. S. postage old issue free. If you write for our 56 page price-list of U. S. and foreign stamps. 2,000 illustrations. Also fine but cheap stamps on approval. Hussman Stamp Co., 620-3 Olive St., St. Louis, Mo.

FREE—Canada (15 Var.) for new applicant of my 1c, 2c and 3c approval, and also my 50% discount. Chas. W. Schmidt, P. O. Box No. 4832, Frankford Sta., Phila. Penna.

110 DIFFERENT Stamps, many unused, high values, free to collectors requesting our net approvals. Postage 2 cents. Christensen, Milwaukee, Wis.

PENNY Approvals that Satisfy. Neil Gronberg, Box 5441, Philadelphia, Pa.

FREE! 115 Different stamps to approval applicants, 2c postage. Paige Stamp Co., Oak Park, Ill.

110 NEW Europe All Different, a wonderful collection cataloguing several dollars, free to collectors requesting our Net Approvals. Postage 2 cents. Badger Stamp Co., Milwaukee, Wis.

FREE! Triangles, airmail. Iceland and 50 others to approval applicants inclosing 2c postage. Hawkeye Stamp Co., Cedar Rapids, 39, Iowa.

STAMPS, 100 all different. Postage 2c. Lists free. P. M. Quaker Stamp Co., Toledo, Ohio.

24 VARIETIES Cuban stamps, 10 cents. List of 6,000 low-priced stamps free. Address Chambers Stamp Co., 111P, Nassau St., New York City, N. Y.

FREE—20 Different Argentine. Approvals. List. Send 4c today for postage, etc. Reuter, Santa Ana, Calif.

118 STAMPS Free with approvals. L. W. Hudson, Plainfield, N. J.

UNITED STATES \$2 present issue (catalogs 50c) for ten cents to approval buyers. State size of collection. Leduc, Redlion, Penna.

BARGAIN Lists. Send postcard. Imperial, Box 1089, Vancouver, B. C., Can.

RARE COINS

SPECIAL Prices on United States coins. Commemorative half dollars unrecirculated; Columbian 67c, Lincoln \$1.19, Maine \$1.27, Pilgrim 89c, Alabama \$1.59, Grant \$1.19, Monroe 89c, Huguenot \$1.47, Lexington 89c, California \$1.49, Stone Mountain 85c, Norse American \$1.19, Sesquicentennial \$1.39, Oregon \$1.29, Bennington \$1.19. Special bargains, \$1.00 gold \$2.85, \$3.00 gold \$6.49, trade dollars \$1.19, 5 large cents 49c, 5 half dimes 69c. Bust type quarters 57c, bust type half dollars 79c, 5 civil war tokens 59c, old coin and bargain price list 10c. Arcy, Box 483, Muskogee, Okla.

UNITED STATES half dollars 1810 to 1814, \$1 each, 1818 to 1822, 95 cents each, 1823 to 1839, 90 cents each. Gold dollars, \$2.75. Trade dollars, \$1.15. List free. G. T. Davis, Box 1791, Huntington, W. Va.

25 DIFF. Fine foreign coins 50c, 12 diff. 25c. Willbert Bishoff, Ottawa, Kans.

CALIFORNIA Gold quarter 27c, half 52c, Confederate \$100 25c, 1845 cent 25c. A. Wylie, 365, Wheaton, Ill.

UNITED States. Large cent, two-cent bronze, three-cent nickel and bargain list, 25c. Thirteen dates large cents, \$1.00. George Coffin, Greenwood Mountain, Me.

\$2 TO \$500 Each paid for hundreds of old coins. Keep all old money, it may be very valuable. Send 10 cents for illustrated coin value book, 4x6, Prices guaranteed. Get posted. We buy and sell. Clarke's Coin Office, Box 5, Le Roy, N. Y.

RARE United States, foreign coins, war medals, Chinese coin and catalog 10c. Alexis Mengelle, Colorado Springs, Colo.

CALIFORNIA Gold—quarter size, 27c; 1/2 size, 53c; 3c piece and catalog, 10c. Norman Shultz, Box 746, Salt Lake, Utah.

GET Profit and pleasure in collecting old coins. Send 10c for large illustrated coin catalog. You'll be delighted with it. Send for it right now. B. Max Mehl, Numismatist, Mehl Bldg., Dept. P, Fort Worth, Tex. Largest Rare Coin Firm in the U. S.

OLD Coins, large fall selling catalog of coins for sale free to collectors only. Catalog quoting prices paid for coins, ten cents. William Hesselein, 101A Tremont St., Boston, Mass.

3 DIFFERENT Fine bronze or nickel coin, 2 large crisp bank notes and catalog 10c. George Best, Cedar Rapids, Iowa.

WE Pay \$1 to \$10 per 1,000 for used stamps. \$2 to \$100.00 for certain coins. Illustrated book prices paid, 10c. Rebous Co., Cohoes, N. Y.

60 DIFFERENT Coins \$1.00; 15 different coins 25c. Oddehon, Box 681, Kansas City, Mo.

OLD Money wanted. Do you know that coin collectors pay up to \$100.00 for certain U. S. cents? And high premiums for all rare coins? We buy all kinds. Send 4c for large coin folder. May mean much profit to you. Numismatic Co., Dept. H, Fort Worth, Tex.

40 COINS All different \$1.00; 100 different coins \$3.00; 20 different dates half-dimes \$2.50. Claud Denney, Box 315, Dallas, Tex.

CAMERAS AND PHOTO SUPPLIES

BARGAINS—A few practically new items taken from our bargain book issued free. 3 1/2 x 5 1/2 Autographic Kodak special with Kodak f:8.3 lens, Optimo Shutter \$36.75; 2 1/4 x 3 1/4 Graflex Junior Camera Cooke f:4.5 lens, film pack adapter, \$34.75; Vest Pocket Kodak, ser. III, with Kodak f:7.9 lens, \$8.50. For others refer to our bargain list. Everything guaranteed. Money refunded if not satisfied after ten days' trial. Central Camera Co., Dept. 2D, 230 South Wabash Ave., Chicago, Ill.

YOUR Favorite kodak picture enlarged, size 5x7, 10c. Three for quarter, coin. Send best negative (film) today. Address Darmer Photo Lab., 221 Securities Bldg., Des Moines, Iowa.

FREE Colored photo back of vanity mirror with each enlargement 8x10 colored. Framed easel back, 98c. Colorphoto Service, 561 Fairview Ave., Brooklyn, N. Y.

SAMPLE Enlargement—dime, and negative (returned). Trial roll, glossy prints, 25c silver. Brown, Warsaw, N. C.

HAVE You a Camera? Write for Free sample of our big magazine, showing how to make better pictures and earn money. American Photography, 116 Camera House, Boston, 17, Mass.

TIME Counts in applying for patents. See pages 138 and 139. Clarence A. O'Brien, Registered Patent Attorney, Washington, D. C.

FILMS Developed. Special Trial Offer. Any Size Kodak film developed 5c, prints 3c each. Trial 6x10 Enlargement in handsome folder 40c. Overnight Service. Roanoke Photo Finishing Co., 209 Bell Ave., Roanoke, Va.

MAKE Money in photography. Learn quickly at home. Spare or full time. New plan. Nothing like it. Experience unnecessary. American School of Photography, Dent. 3431, 3601 Michigan Ave., Chicago.

KODAK Films developed 5c roll. Prints 3c each. Trial offer. 8x10 enlargement 25c. Young Photo Service, 405 Bertha St., Albany, N. Y.

MOTION PICTURES

FILMS, Talking equipment, Powers projectors \$150.00. Marshall Films, Rome, Ga.

BOYS! A Bottle of Famous Griffin Guaranteed Film Cement (patented) and specially printed instructions; large movie catalog. All for 43c postpaid. Stamps accepted. This offer expires April 1, 16mm., catalogs, 12c stamps. Scholefield, Jr., 6803 S. Carpenter St., Chicago, Ill.

PROJECTORS \$6.50. Film bargains. Free list. Attardo, 200 East 76th St., New York City.

SOUND Motion pictures! You must order this great and only authoritative text book on the subject by James Cameron, world's foremost authority. 400 pages crammed full of information on photo cells, Vitaphone, Movietone, Photophone, methods of recording, maintenance. We are selling thousands of copies. Price, \$5.00 postpaid anywhere. Bass Bargaingram No. 200 just off the press. Red hot bargains in standard and 16 mm. motion picture cameras, projectors and accessories. Send 4c in stamps. Bass Camera Company, Motion Picture Headquarters, 179 West Madison St., Chicago, Ill.

BARGAINS—Just a sample few, practically new 35mm., DeVry Motion Picture Camera f:3.5 lens, \$92.50; 35mm., Universal Motion Picture, 400 foot capacity, Camera with f:1.9 Ultrastigmat lens, \$205.00; 16mm., Eastman Cine Kodak model B with f:3.5 lens, \$59.75. For other bargains see our special list mailed free on request. Everything guaranteed. Money refunded if not satisfied after ten days' trial. Central Camera Co., Dept. PM-2D, 230 South Wabash Ave., Chicago, Ill.

\$1,250 FOR Original photoplay story. Our sales department sold unknown author's first story for above amount. We revise, copy-right and submit to studios stories for both silent and talking pictures. Being located in the heart of motion picture industry it is to your advantage to deal with us. Established 1917. Free booklet. Universal Scenario Company, 206 Western and Santa Monica Bldg., Hollywood, Calif.

FILM Bargains—Mutt-Felix-Gump complete cartoons \$10. Standard toy film one cent foot any star any length. Ten thousand reels for sale. Lists. Leonard Lowe, Box 524, Cincinnati, Ohio.

FILMS, Old reels \$2.00. Features \$10; comedies, \$2.50; talking films 1/2c per foot. Savarese, Box 15, Union City, N. J.

WE Buy, sell or trade cameras, projectors, accessories. F. W. Buchanan, Johnstown, Pa.

FILM Bargains, complete features 45c up. List. Aiton Films, Box 810, Kansas City, Mo.

NEW Natural color film. Send \$1.00, 50-ft., worth \$12.50. Indians, westerns. No lists. Hemenway Co., 37 Church St., Boston, Mass.

300 FEET Film 90 cents postpaid. Power's projector cheap. Star Films, Allentown, Penna.

"INTERIOR Movie Lighting." Free book for amateurs, shows how. Write Westphalen, 438 Rush St., Chicago.

SPRING Motor 35m movie camera \$25; movie projector, \$35. Negative stock 2 cents foot. Pathe camera and projector, \$35. Bargains in 16m cameras, kodaks, type-writers. Ray, 266 W. 46th St., New York.

FILMS Cheap. List, W. E. Temple, 8 Evergreen Ave., Somerville, Mass.

BE A movie exhibitor. Big opportunity. Only moderate capital required. Complete equipment at remarkably low prices. Write Atlas Moving Picture Co., 825 So. Wabash, Chicago, Ill.

TIME Counts in applying for patents. See pages 138 and 139. Clarence A. O'Brien, Registered Patent Attorney, Washington, D. C.

GOOD Film—300 feet \$1.00. Reels \$2.45. Samples, lists, particulars for stamp. Eastin Feature Films, Galesburg, Ill.

NEW And rebuilt projectors for theaters, schools, churches, traveling shows. Supplies and complete theater equipments. Bargain prices. Free catalog. Monarch Theatre Supply Co., Memphis, Tenn.

MOVIE FILMS, 1,000 ft. reels, \$2.50 each; shipped anywhere on receipt of remittance. Particulars on request. Independent Films, 177 Golden Gate Ave., San Francisco, Calif.

FILMS, Machines, Stamp for list. Box 255, Hickman Mills, Mo.

FILMS, 300 Ft. \$1.00, reels \$1.95. List. Edgeworth Sales, Box 155, Blue Island, Ill.

MOVIE FILMS. New list of big bargains free. Write Home Movies, Box 744, Minneapolis, Minn.

TRADE AND TECHNICAL SCHOOLS

HILES Watchmaking and engraving school. The largest and best equipped school in the west 5330 Mission St., San Francisco, Calif.

OUR Extension course covers entire subject of radio. Graduates allowed three months finishing course free at the college. Tuition charge moderate. Have always placed graduates at pay ranging \$150 to \$300 monthly from the start. Write for catalog. Loomis Radio College, Dept. 7-A, Washington, D. C.

DRAFTSMEN! Be an expert. Our method trains you quickly. Books and tools furnished. Write for illustrated catalog. Columbia School, 2048 Drexel Bldg., Philadelphia.

BE A blue print reader. Men in your trade have succeeded. Write for facts. What's your trade? Carroll Rumsay, Drexel Bldg., Philadelphia.

LEARN Morse and wireless telegraphy. Big salaries. Tremendous demand. Expenses low, can earn part. Catalog free. Dodge's Institute, Fern St., Valparaiso, Ind.

BUSINESS OPPORTUNITIES

WITHOUT Exception most profitable opportunity ever offered. Unlimited possibilities—plan unique—unbelievable results; small investment for advertising matter only; no stock to carry; permanent income; no effort required; tremendous number buyers developed automatically. We warehouse and deliver for you. Anyone can succeed with this most profitable of all sales plans. For full particulars write The Finance Corporation, Desk K, 522 McKnight Bldg., Minneapolis, Minn.

MIRRORS Resilvered at home. Costs near 5 cents per square foot; you charge 75 cents. Profitable business plating like new, brassy worn-off autoparts, reflectors, tableware, stoves, etc. Outfits furnished. Details free. Sprinkle, Plater, 127, Marion, Ind.

UNUSUAL—Uncommon specialties always sell best. Make these yourself from Miller's guaranteed formulas. Why work for others when others can be working for you? Latest eye-opening literature brings you many specialty propositions for you an independent business. Miller, Chemist, 706-K Chemical Bldg., Tampa, Fla.

FIFTY Successful mailorder products, sales plans. K. Home, 3949 Metropolitan, Chicago.

"MAIL Order Selling" magazine. Contains new ideas each month. 3 months' subscription 25c. One year \$1.00. Mail Order Selling, Brookfield, Ill.

UNPATENTED Ideas can be sold. I tell you how and help you make the sale. Free particulars (copyrighted). Write W. T. Greene, 910 Barrister Bldg., Washington, D. C.

SCREW-HOLDING Screw driver! Amazing new invention. Factories, garages, electricians, auto, radio owners buy on sight. Removes and inserts screws instantly in accessible places. Sells \$1.50. Investment for merchandise only. Exclusive territory. Write quick for trial offer. Toolco, 1505 Winthrop Bldg., Boston.

SUCCEED With your own products. Make them yourself. Formulas, processes, trade secrets, all lines. Catalog free. B. Thaxly Co., Washington, D. C.

NICHOLS Business and legal service gives the facts you usually guess at, pay for or neglect. It's free! If you want to save attorneys' fees and stop losses, write Nichols Press, Dept. P, Naperville, Ill.

EARN Money making potato chips. Complete instructions 10c. Greene, Box 53, Los Angeles, Calif.

MAKE And sell your own goods. Formulas by expert chemist. 30 years in business. Thousands of satisfied clients. Catalog for stamp. B. Mystic Company, Stamford, Conn.

SUCCESS, Prosperity, with our collection of business plans. Modern. New. Trade secrets. Formulas. Mail order. Particulars free or everything \$3.25. Commercial Educators, Desk A, 311 West 13th, Kansas City, Mo.

DRY Cleaning business of your own. Cleaning hats, clothing, dyeing, pressing. Particulars free. Dry Cleaner, 403 Grand St., Buffalo, N. Y.

SELL Money-making offers by mail. Circulars free. Green, 15788 Parkside, Detroit, Mich.

250,000 ARTICLES At low wholesale prices. Directory 10c. W. Patterson, 4111 University, Des Moines, Iowa.

FREE Booklet describes daily problems. Increases income 300%. Hirschfeld's, 3216 Kossuth Ave., New York.

FLORAGRAPH Store sign making learned by clerks first day. No paints or hand lettering. Black, brown, white, other colors. Two 12x18 samples, 50c. New Splatter process, 50c. Laird's Floragraph, 5925 Eggleston, Chicago.

LATEST Business guide now ready. Modern, complete, dependable. Information free. Stamp appreciated. B. Wolf, 6618 Quinby, Cleveland, Ohio.

SMALL Capital starts profitable route peanut and gum vending machines. Particulars free. Robbins Corp., Dodworth St., Brooklyn, N. Y.

MANUFACTURE Clever new toys, novelties, foods, preparations, mail order and agents' specialties. Free list reliable plans, patterns, processes, commercial information. Manufacturer's Bureau, R22, 3937 Tracy, Kansas City, Mo.

"SCHEMER Magazine," Alliance, Ohio, prints 91g 8-getters. Subscribers report \$10,000 to \$50,000 from its schemes, ideas, formulas. 32nd year. Only \$1.00; 3 months, 30c.

THE "Naden News" contains tips! Plans! Schemes! Formulas! Sample copy, 10c; \$1.00 per year. Naden, 2901 Burlingame, Detroit, Mich.

A MAIL Order business. Splendid financial returns, with unlimited expansion. No manufacturing, exceptional plan. Samples with simple instructions. Send \$1.00, permanent income guaranteed. Dale Specialty Co., 1476 Broadway, New York.

MAN or woman. Tested business. Has made more than \$1,000 monthly profits. Legitimate, dignified, pleasing. Experience unnecessary. We supply everything. Long-Bakins, 2960 High St., Springfield, Ohio.

MAIL Order business your opportunity. Brenner's famous hand books by expert 28 years' experience show how to start selling articles you make or buy—all or part time—small capital. Fascinating, profitable. Set eleven books, \$3.25. Brenner Company, 1697 P. Sanson, Philadelphia. Sample book, 25c, pay \$3 for other ten if satisfied.

TWO Famous toilet preparations. Formulae free. Write Donahoo, Hondo, Calif.

"ODD-THINGS" Schemes! Plans! Tips! Formulas! Money making ideas! Opportunities galore! New! Different! Three months' trial subscription 25c. Year \$1.00. "Odd-Things Magazine," 720 Advance Bldg., Cleveland, Ohio.

FREE! Mail order Home Business Plan. Superior Specialties, Springfield, Ill.

MANUFACTURE Stencil inks, sell to shippers, quality ink. Instructions one dollar. Francis Co., 245 First St., Jersey City, N. J.

"WEATHER-LOX" — Carpenters, everywhere. Be independent. Work summer and winter. One agency for "Weather-Lox" made \$21,000 in six months, with \$94.00 capital. Write Hickman-Bryant Corp., Washington, D. C.

MANUFACTURING Processes that will give your product distinction and build up your business. Either you are in need of a new product to add to your present line or to start a new business on. It will pay you to write us stating your requirements. Complete analytic service. Nelco Laboratories Inc., 5401 Cicotte, Detroit, Mich.

LEARN Marbleizing. The greatest discovery in cement composition. With our processes it can be brushed on like paint. Resembles polished marble, veined perfectly, flintlike hardness, veneers over any concrete products, wallboard, lumber. Inexpensive, anyone can do. 200% profits; wonderful opportunity. Address Cowell Institute, Grayling, Mich.

\$20.00 PER 100 Stamping keytags. Sample and instructions 25c. Ruth Tag Co., Wheelersburg, Ohio.

MAKE Money manufacturing building materials. Granite, marble, fire proof paint, flooring, roofing. No machinery. Cheap. Big profits. International School of Cement Arts, 443 E. Washington St., Portland, Ore.

FAST-SELLING Specialties: Make them yourself! Best formulas, processes; guaranteed. Gerard Research Laboratories, Wheeling, W. Va.

ARTIFICIAL Marble sanitary flooring. Instructions covering wood or cement flooring 1/2 inch thick, fireproof, all colors, low cost. Ornamental casting, concrete, plaster, papier-mache decorations, garden furniture, statuary, flexible molds, particulars and illustrations free. Chris. Mahler, Huntington, N. Y.

CONCRETE Building block manufacturing. Is your home town opportunity. Particulars free. Concrete Machine Co., 5 Main St., St. Louis, Mo.

DON'T Sell for others—Employ agents yourself. Make your own products. Toilet articles, household specialties, etc. 500% profit. Valuable book free. National Scientific Laboratories, 1935W Broad, Richmond, Va.

BUSINESS Profession of your own and earn income in service fees. See Stephenson Laboratories, display ad page 144.

MAKE Your own products. Employ agents yourself. Toilet articles, soap, extracts. We furnish everything. Valuable book free. National Scientific Laboratories, 1935W Broad, Richmond, Va.

MAKE Big profits with a fur farm in your backyard. Chinchilla rabbits, muskrat, mink. Write for facts. 252 Conrail's Ranch, Denver, Colo.

BIG Money awaits you here. 250 signs and pictures an hour without press, type or machinery. Samples and particulars 10c. Strano, 1013 Mulberry, Springfield, Ohio.

RESPONSIBLE Manufacturer wants competent men open office, manage salesmen; \$200 to \$1,000 necessary. Will pay expenses to Baltimore if you qualify. Address Manager, 603 N. Eautaw St., Baltimore, Md.

AMATEUR Cartoonists: Sell your work. Write Smith's Service, PX1194, Wenatchee, Wash.

THAXLY Formulas produce perfect products. All lines. Catalog free. B. Thaxly Co., Washington, D. C.

SIGNS And showcards easily painted. If you use Letter Patterns. Write for free samples. John Rahn, B2120 Neva Ave., Chicago.

CHEMICAL Expert will furnish formulas and trade secrets. All lines. Lists free. W. L. Cummings, Ph. D., 228 Gordon Ave., Syracuse, N. Y.

SELL By mail! Books, novelties, bargains! Large profits! Particulars Free! B-Elfeo, 525 South Dearborn, Chicago.

DELAWARE Charters; fees small; free forms. Chas. G. Guyer, Wilmington, Del.

FREE Book. Start your own little business anywhere, selling novelties by mail. My beginner's outfit contains everything required, novelties, circulars, instructions, etc. Descriptive book free. Hadwilt, 3A-74 Cortland St., New York.

LEARN The collection business. Good income, quick results. Interesting booklet, "Skillful Collecting" free. National Collectors Assn., Long St., Newark, Ohio.

A BUSINESS Of your own making—Sparkling Glass Name and Number plates. Checkerboards, signs. Big book and sample free. E. Palmer, 540, Wooster, Ohio.

CHARTERS: Delaware; best, cheapest; free forms. Colonial Charter Co., Wilmington, Del.

FREE Booklet describes 67 plans for making \$20-\$100 weekly in home or office business of your own. Elite Co., 84 Elizabeth St., New York.

CAPITAL—For copy, the "Promoters' Hand Book," a leaflet on financing; an eye opener for capital seekers. Send \$1.00 to Amster Leonard, East Orange, N. J.

MAN In each town to plate auto parts, reflectors, bathroom fixtures, refinish beds, mirrors, chandeliers; by new method. No capital or experience required. Simple plan of manufacturing at home starts you in big money-making business. Outfit furnished. Free particulars and proofs. Gun Metal Co., Ave. H, Decatur, Ill.

MECHANICS, Painters, carpenters, start furniture refinishing, painting, handyman shop on nearly nothing; winning plan brings customers quickly. John Braceland, 1439 So. Ninth, Philadelphia, Pa.

TIME Counts in applying for patents. See pages 138 and 159. Clarence A. O'Brien, Registered Patent Attorney, Washington, D. C.

15,000 PROFIT Making formulas. Following and many others: Accidents and emergencies, agriculture, alloys and amalgams, artist's materials, beverages, cements, glues, pastes, mullages, bleaching, renovating, coloring metals, dyeing, glass, heat treatment of metals, household formulas, ice cream, confectionery, chewing gum, lapidary work, exterminating vermin, lubricants, paints, varnishes, photography, condiments, canning formulas, rubber, soap, candles, soldering, toilet preparations, perfumes, waterproofing, fireproofing, writing materials. Just write for "Scientific American Encyclopedia of Formulas." When postman hands you book pay \$5.50 and postal charges. Popular Mechanics Press, Room 801, 200 E. Ontario St., Chicago, Ill.

TELEGRAPHY

LEARN Morse and wireless telegraphy. Big salaries. Tremendous demand. Expenses low, can earn part. Catalog free. Dodge's Institute, H St., Valparaiso, Ind.

CHEMISTRY

"HANDBOOK For Chemical Experimenters." Hundreds of interesting experiments; illustrated, 50c. Booklet of experiments, 15c. Pricelist, 5c. General Chemical Company, Box 397, Reading, Penna.

ANALYSIS, Chemical consultation. Manufacturing ideas developed. Formulas. Write Associated Chemists, Indianapolis, Ind.

CATALOG Listing 2,500 illustrations chemists' supplies, 5,000 chemicals, 1,000 scientific books sent for 50c. Laboratory Materials Company, 643 E. 71st St., Chicago, Ill.

YOUR Chemical problems solved and formula or process furnished for \$5.00. Write me, W. Stedman Richard, Industrial Chemist, Box 2402, Boston, Mass.

CHEMICAL Analysis, processes, technical information. Robert Henderson, Laboratory, Madison, Me.

FORMULAS AND TRADE SECRETS

FREE Formulas—Free materials making \$32.00 worth of guaranteed highest class specialty-necessities. Thirty-third unequalled anniversary offers explains all. Miller, Chemist, 1707-G Jetton, Tampa, Fla.

SUCCEED With your own products. Make them yourself. Formulas, processes, trade secrets, all lines. Catalog free. B. Thaxly Co., Washington, D. C.

A HAND Soap that removes dirt and grease, yet does not contain lye or other irritants. Obtain ingredients at any grocery. Formula \$2.50. A. Egeberg, 511 Asylum St., Flint, Mich.

DON'T Sell for others—Employ agents yourself. Make your own products. Toilet articles, household specialties, etc. 500% profit. Valuable book free. National Scientific Laboratories, 1935W Broad, Richmond, Va.

NEWEST Tested formulas. Particulars, catalog free. Grinstead Laboratories, Oswego, Kans.

CAMPHERENE, Leatherex, ice cream and elder formulas, \$1.00 each. Moscato, 757 East 107th St., Brooklyn, N. Y.

FORMULAS, Chemical and engineering advice. State your problem, get our price. Science Service, Palmyra, N. J.

SEVENTEEN Different solder formulas \$1.00. Gardner, B-77, Little Rock, Ark.

FACTORY Style Duco Polish. One dollar. 1149 Myrtle, Pontiac, Mich.

3,000 VALUABLE Formulas prepaid \$1.00. National Service, 3937 Marburg, Cincinnati, Ohio.

500 FORMULAS And big illustrated catalog 25c. Ideal Book Shop, Park Ridge, Ill.

MAKE Your own products. Employ agents yourself. Toilet articles, soap, extracts. We furnish everything. Valuable book free. National Scientific Laboratories, 1935W Broad, Richmond, Va.

FORMULAS: Guaranteed, catalog free. Bestorall Laboratories, 6720 Oconto Ave., Chicago.

FORMULAS All kinds. Catalog free. Clover Laboratories (P), Park Ridge, Ill.

10,000 MONEY-MAKING Formulas. Tells you how to make and sell almost everything under the sun; cosmetics, mucilage, anti-freeze solutions, battery solutions, beverages, cheese, chewing gum, cleaning preparations, extracts, hair preparations, inks, bluing, leather polish, mirrors, perfumes, polishes, typewriter ribbons, carbon paper, washing powders, liquid soap, and hundreds of other profitable articles. Send no money. Just write a postal for "Henry's 20th Century Book of Formulas." Pay postman postage and \$1. Popular Mechanics Press, 200 E. Ontario St., Room 802, Chicago.

AGENTS WANTED

WANTED At once: More good men to introduce and retail Rawleigh's Good Health Products. Town and country. Wonderful opportunity. Get into business with backing of largest manufacturer its kind. Capital over 15 million dollars. Quick freight, express, parcels post service from 10 great factories and branches—one near you. Nothing new—no experimenting. No experience required. You simply follow the same old time-tested Rawleigh Methods which secure the most business everywhere and have given consumers best values and satisfaction for 40 years. 170 necessities frequently needed every home. Enormous demand. Annual sales nearly 40 million products. Big free trial inducements. Quick easy sales. Repeat every 30-60 days. Enormous profits—\$100-\$400 month and more profits. Steady year around; no lay-off. No boss—you become sole owner and manager. Practically no capital required. We supply everything—stocks, outfit, sales and service methods. Big pay every day. Profits increase every month. "First come first served." For full particulars write W. T. Rawleigh Co., Dept. A-3PPM, Freeport, Ill.

I START Men in a grocery business a new easy way. You use my money. Don't need to put up a penny of your own cash for stock. Expansion program now opens up many desirable opportunities also established trade. Hustlers make good money from the start, increasing rapidly as they learn the business. Not a "chain" proposition but your own business. Buy on credit. Give credit if you wish. If honest and need more money write at once for application and details to McConnon & Company, Room L-6603, Winona, Minn.

DON'T Sell for others—Employ agents yourself. Make your own products. Toilet articles, household specialties, etc. 500% profit. Valuable book free. National Scientific Laboratories, 1935W Broad, Richmond, Va.

100% PROFIT In new mystery cigar lighter. No flint or friction. What makes it light? No wind can blow it out. Retail \$50c. Sample and sales plan 25c to cover cost of mailing. New Method Mfg. Co., Box PM-1, Bradford, Pa.

OVER 100% Profit in handy holder for towels and dust rags. Laquered in variegated colors mounted one dozen to handsome display card. Retail at 15c. Costs you 75c a dozen. Sell to dealer at \$1.25 a dozen. Sample dozen and sales plan 50c. Money back if you want it. New method Co., Box PMH-1, Bradford, Pa.

BIG Money daily, selling shirts of all kinds, neckwear, underwear, Sox, pajamas, sweaters, raincoats, coveralls, pants, children's play suits. Experience unnecessary. Outfit free! Nimrod Co., Dept. 8, 4922-28 Lincoln Ave., Chicago.

EARN Big money selling shirts and ties. Liberal commissions. Self-selling outfit free. Producers earn shirts, ties. Write Public Service Mills, 519 CF-30th St., West New York, N. J.

A REAL Surprise await you! Get details of our premium deals, which make sales easy! Foods, toiletries, remedies, all guaranteed. Tostgad Corp., 32 Punion St., Kokomo, Ind.

SCOTCHMAN'S Cigarette case. Just out. Cigarettes mysteriously appear or disappear at will. All metal, highly polished. Appeals to men and women. Agents sample and plan 50 cents. Derby, 1923 4th Ave. So., Minneapolis, Minn.

AGENCIES Now open for the sensational Tear Gas Fountain Pen Gun. Startling demonstrator. Fits vest pocket like fountain pen. Official police model. Biggest seller of century. Extra big profits. Only safe substitute for revolver. 100% protection without danger. A wonderful ground floor opportunity. Get details quick. Send for new circular. The Atlas Co., Dept. 53, Ogden Pk. Sta., Chicago, Ill.

SELL Home and car owners new single action window cleaner. Washes, dries one operation. Wonderful demonstrator each \$1. 2 samples \$1 postpaid. Currier Mfg. Co., 64 Terminal, Minneapolis, Minn.

WRIST Adding machine. Swinghead flash light. Twelve new inventions. E. R. Hanson Mfg., Redstone, Mont.

SENSATIONAL! New everywhere! San-Pro-Tex protects milk from filth, thieves! Biggest money-making sales proposition in America! Absolutely without competition! Wildfire demand! Write for facts! Convince yourself! Sanprotex, Shelby, N. C.

MIRRORS Resilvered at home. Costs near 5 cents per square foot; you charge 75 cents. Profitable business plating autoparts, reflectors, tableware, stoves, refinishing metalware, etc. Outfits furnished. Details free. Write Sprinkle, Plater, 128, Marion, Ind.

NEW Profitable—Sell auto step mats. Quality rubber with owner's name molded white. Details free. Ebonite products, Dept. C-80, 895 Main, Akron, Ohio.

SHOE SALESMEN—Sell garages, gasoline stations, etc. Our five months' guaranteed shoes with special soles. Make \$50.00 weekly. Write Moench, 140 Beach, Boston, Mass.

MAKE Your own products. Employ agents yourself. Toilet articles, soap, extracts. We furnish everything. Valuable book free. National Scientific Laboratories, 1935W Broad, Richmond, Va.

GENUINE Gold Leaf Letters anyone can put on store windows. Guaranteed to never tarnish. Large profits. Enormous demand. Free samples. Write today. Metallic Letter Co., 438-D North Clark, Chicago.

AGENTS—Men, earn up to \$12 daily wearing fine felt hats and showing friends. Smartest styles. Latest shades. \$2 to \$5 saving on every hat. Samples free. Taylor Hat and Cap Mfrs., Dept. CC-135, Cincinnati, Ohio.

GREATEST Soap discovery of the age! Made from South Sea Island plants. Produces 2 and 3 times more lather. Sensational seller. \$1.25 an hour easy. Write for samples. Albert Mills, 4983 Monmouth, Cincinnati, Ohio.

BIG Profits, quick repeats, placing Aspirin, Notartar, Flints, Silktone, other self-selling counter cards with dealers. Over 100% profit. Sterling Co., H7, Baltimore, Md.

TYPEWRITER Specialty. Pays \$1.50 profit per unit. Average sales 2 units. Exclusive. Easy seller. Speedkey, 27 Columbus Place, Brooklyn, N. Y.

CHEXARUN: Latest invisible fluid, stops silk hosiery runs. Make this yourself also many unusual, biggest-selling specialties using Miller's guaranteed formulas. Investment small. Profits immense. Miller, Chemist, 706-L Chemical Bldg., Tampa, Fla.

LOIDLAC Forever ends automobile polishing and repainting; instantly restores colors. Guaranteed, sun-water-weather proof. Make this yourself; also other high-class automobile specialties from my unequalled guaranteed formulas. Miller, Chemist, 1706, Tampa, Fla.

BRING Home the bacon selling Christy's Iron Rust and Stain Remover. Sells like blazes. Write for free sample. Christy, Inc., 6567 Broadway, Newark, N. Y.

AGENTS Make \$10 daily with our new adjustable waterproof aprons and fifty other fast sellers. B. & G. Rubber Co., Dept. 432, Pittsburgh, Pa.

SELL—Safety-Service. Automobile patented device. Automatic dimmer, prevents glare, penetrates fog. Ford demonstrator with discount \$4.25. Chevrolet \$4.50. Quick seller. Safety Light Screen Company, Cincinnati, Ohio.

AGENTS: Stamping names on pocket-key protectors. Sample check with your name and address, 25c. Stamping outfits. Emblem checks, check-fobs, name plates. Hart Mfg. Co., Desk 2, 303 Degraw St., Brooklyn, N. Y.

100% PROFIT. Four new, wonderful demonstrating automobile specialties. Automotive Research Company, Kingston, N. Y.

SUCCEED With your own products. Make them yourself. Formulas, processes, trade secrets, all lines. Catalog free. B. Thaxly Co., Washington, D. C.

AGENTS: Up to \$16 day and new Buick auto offered. Sell groceries. Over 400 items for every home. Steady job. Your groceries about half price. Send for new free plan. Harley Company, Dept. C-2016, Cleveland, Ohio.

DON'T Sell for others—Employ agents yourself. Make your own products. Toilet articles, household specialties, etc. 500% profit. Valuable book free. National Scientific Laboratories, 1935W Broad, Richmond, Va.

STRANGE New ironing cord! Prevents scorching. Saves electricity. Cannot kink or snarl. For telephones also. Up to \$25 daily. Samples furnished. Neverknot, Dept. 3A, 4503 Ravenswood, Chicago.

80c PROFIT On \$1.00 sales. Wonderful cleaner for automobiles, furniture, metal and glass. Fast repeater. Your name on labels. Exclusive territory. Free sample. Minute Kleen Laboratories, Dept. E, Evansville, Ind.

PORTRAIT Men you can make money anywhere selling our guaranteed portraits. Send for free frame catalog. Portrait Agents' Supply Co., Dept. F, LaPorte, Ind.

MAN Wanted, well acquainted, reliable, energetic. No investment. No experience—just your time. Big earnings. Free outfit. Beard Paint Co., Dept. 4, Kansas City, Mo.

JUST Out—Amazing invention. One device makes window washing 75% easier. Washes, dries, polishes windows in a jiffy. Every housewife wants it. No more ladders to climb, no mussy rags to wring. Hands never touch water. Sells fast. 100% profit. Make up to \$90 weekly. Send for catalog of this and 47 other quality rubber products. Direct from Akron, the Rubber City. Free outfit to hustlers. Write quick. Kristee Mfg. Co., 1833 Bar St., Akron, Ohio.

SELL Windo-Shine. The magic cloth for all glassware. Send 25c for sample and prices. Dundee Mfg. Co., Inc., 157 Summer St., Boston, Mass.

"INSTANT Weld" welds rubber instantly without heat, gasoline or tools. Make big money all year 'round. No experience required. Write for territory. Tourists Pride Mfg. Co., Desk M-3, Minneapolis, Minn.

FULL Or part time men earn big, steady money with Gebhardt "3-Purpose" rain-coats. No experience required. Write for free actual samples, sales outfit. Gebhardt Company, Dept. 107, Minneapolis, Minn.

MAKE A thousand dollars quickly showing instant hot water from electric light sockets. A convenience selling itself to everybody. Dad's Factories, Indianapolis, Ind.

AGENTS—Give customers two pounds toilet soap free with \$1 bottle superior vanilla. 100% profit. Midwest Drug Company, Dept. P-3, Columbus, Ohio.

IMPORT Your own goods. German export magazine published in English, offers numerous bargains latest novelties; opportunity for obtaining profitable agencies. Copy 60c. Square Deal Supply, P-246 Fifth Ave., New York.

NEW Invention—Home juice extractor—oranges, lemons, grapefruit. Over 100% profit. Quick seller. Retail under \$1.50. No competition. American Utensil, C10, S. LaSalle, Chicago.

NEW! Rubber soles—Cement on instantly. Never loosen. Outwears leather. Water-proof. Sells fast. Big repeater. Test at my expense. Bestever Co., 195 Irving Park Sta., Chicago.

BIG Profits showing new table cloth. Looks like linen. Wash like oilcloth. No laundering. Rayon bedspreads. Beautiful colors. Take orders. We deliver. Selling outfit free. Bestever Co., 178 Irving Park Station, Chicago.

AGENTS—Big chance to earn \$15 to \$25 daily, introducing new, patented, safety, automatic burglar proof ventilating window lock for homes, stores, offices, banks, all buildings. Sensational seller. Anyone, even without experience, should make 3 to 10 sales in single call. Nothing else like it. No competition. Write quick for terms—territory. Elmwood Mfg. Company, 1203 Elmwood Place, Cincinnati, Ohio.

EVERLAST No pin clothes line—Needed in every home, snappy demonstration, sure sale; large commission. John Dunn, Olive Blvd., South Hempstead, N. Y.

COLOR Craze sweeping the country! Make big money taking orders for hand-painted fadeless tablecloths, bedspreads, etc. Castle Ford Co., J-230 S. Wells, Chicago.

BRAND New patented can opener. Every home, restaurant prospect. Over 100% profit. Particulars free. Western Wrench, 8427 South Chicago Ave., Chicago.

AGENTS—Absolutely new! Our hand-colored popular-priced photo statuettes going big! Everyone wants them! \$10-\$25 daily earnings possible. Samples furnished. Craver Mfg. Co., CS 2456 Jackson, Chicago.

EASY To sell groceries, paints, auto oils to consumers. Steady, profitable work. Experience unnecessary. Credit given. Valuable outfit free. Loverin & Browne, 1602T So. State, Chicago.

DON'T Sell for others—Employ agents yourself. Make your own products. Toilet articles, household specialties, etc. 500% profit. Valuable book free. National Scientific Laboratories, 1935W Broad, Richmond, Va.

AMAZING New dollar can opener. Tremendous profits. Approved by Good House-keeping. Wonderful, quick demonstration. Agents, distributors cleaning up \$60-\$124 weekly. Territory going fast. Write quick for free outfit offer. R. Harker Co., Battle-creek, Mich.

AGENTS, Salesmen, our new quality designed rubber rugs sell on sight. Big profits. Write at once for territory and terms. Modern Rug Co., Akron, Ohio.

AGENTS Earn \$6 day. Dri-Kleanit removes dirt, grease, tar, all one operation. No soap or water used. Auto looks like new. Wonderful seller. Free sample. American Accessories Co., Desk 6031, Cincinnati, Ohio.

DISTRICT Distributors wanted. Double your money, thousands of phone locks sold \$10 each. Send \$5 for sample. Phonelock Co., Black Bldg., Los Angeles.

SELLING Like blazes! Beautiful toilet goods assortment at \$1.50 with 25 inch pearl necklace free to your customers. 100% profit! Davis Products Co., 238 North Ave., Dept. 630, Chicago.

FLAVORING Extracts—Bottle yourself! Concentrated. Labels furnished. 600% profit! Whirlwind money-makers! Free offer! Thomas Manufacturing Company, Indianapolis, Ind.

AMAZING New invention. Electric water heater, sells for \$2.75. Heats water almost instantly. Agents make big money. Write today. Lux-Viel Co., Dept. T, Elkhart, Ind.

AGENTS—Every smoker buys snappy cigarette toppers on sight; \$1.75 dozen; \$18.00 gross; particulars free; act quick. Fenton Chemical Co., Jackson Heights, N. Y.

AGENTS—Sign men. Collect \$1.00 an hour. Speediest selling line; snappy, clever. Display signs for retailers. Free samples. Ever-Ready, 52-P East Ninth, New York.

HAN-DEE Cloth quickly polishes all metals. One minute's demonstration convinces. Men everywhere snapping up this rapid money maker. Retail 25c. Sample free. Ruskin Company, 1501 Euclid, Cleveland.

SANITARY Rubber goods, etc. New items. Samples free. Dependable, 716 Madison, Chicago.

"HOW To Secure Agents," a specially prepared booklet, tells of one of the most inexpensive methods in which to secure good live producing agents. It is free; write for your copy today! M. L. Rund, Mgr. Classified Advertising, Popular Mechanics Magazine, 200 E. Ontario St., Chicago, Ill.

A NEW Product prevents runs in silk stockings. Hailed with delight by women. Sample 35c. Act now. Baldwin Sales Co., Dept. 509 Fifth Ave., New York, N. Y.

200% PROFIT! Easy sales! New auto hat holder makes \$30 daily for agents. Details free. Sample \$1. Write at once. Utilities Sales, 357C, Fergus Falls, Minn.

SELL New signs, embossed price tickets and changeable signs, big profits. Wonderful selection, all storekeepers buy. 25c brings \$1.00 worth of samples. Information free. P. Franklin Co., 3322 3rd Ave., New York.

ALL Metal shade ventilators. One model instantly fits nine-tenths closed cars. No more sun glare, drafts, rain, snow, frosted windshield or monoxide gas. Popularly priced and big profits. Write quick for territory. Pritchard Products Company, Atlantic Beach, Fla.

AUTO Side-visors. All steel, instantly installed without tools. Beautiful and popularly priced. Big demand and profits. 1930 patent. Pritchard, Atlantic Beach, Fla.

AGENTS—Make two dollars an hour selling name and business cards and stationery. Samples free. Broomhall Card Shop, 21 A South St., Harrisburg, Pa.

YOUR Choice of six propositions for stores or agents. Springer, Room 665, 1440 Broadway, New York.

AGENTS 40 To 50% profit. Sell guaranteed hosiery for men, women, children. Complete line. New styles. All colors. Guaranteed to satisfy or replaced. Work all or part time. Free hose for your own use with your outfit. Write today. Fashion Silk Hosiery Co., Desk 431, Cincinnati, Ohio.

SELL "Prevents Runs." Guaranteed to prevent runs in silk hosiery. Large profits. Particulars, Specialty Mfg., 127 S. Broadway, Los Angeles, Calif.

SENSATIONAL New invention makes shaving a pleasure. Nothing like it! Pays \$2.75 profit on \$5 sale. You should make \$25 daily. Every man you meet wants one. Territories still open for state managers. Pacific Metal Industries, Dept. E, San Diego, Calif.

100% PROFIT—Build a permanent business with giant temporary transfers and permanent window letters in colors and gold. Sell every store and office. Exclusive territory. Sample free. Print-A-Sign, Akron, Ohio.

LUCKY Reach Cigarette and Match Holder replacing knob on gear shift rod fastest selling auto accessory in years. Choice six colors. Sample one dollar. State color wanted and make of car. Territory for live producers. M. Lucky Reach Co., Buffalo, N. Y.

SELL Paper plates, spoons, napkins, cups, to road stands, lunch rooms, bakeries; for lodge and church suppers, etc. Big profits. Puritan Products Company, Trumbauersville, Pa.

MANUFACTURE Auto specialties: Battery charging electrolyte, radiator seal, hand soap, puncture plugger, glass cleaner. Get my free list. John Mickman, Chemist, St. Paul, Minn.

HARPER'S New "House Cleaner" does the most and costs the least of any invention for the home. Saves labor, money, health and doctor bills. Does more than vacuum cleaners. Costs little, uses no electricity. Price sells it. Good for home, garage and public buildings. New plan sells where they haven't a cent. Profits large. Protected territory. Loan you one to start with if well recommended. Harper Brush Works, 2934 Main St., Fairfield, Iowa.

PHOTO Medallion men and women, the largest line of photo novelties in the world. Lowest prices, quickest service. Send for catalog showing over 200 money makers. Photo medallions, photo medallion clocks, photo mirrors, photo fountain pens, photo powder compacts, photo jewelry and photo buttons. Gibson Photo Jewelry Co., 833-847 Gravesend Ave., Brooklyn, N. Y.

SALES Agency offered to ambitious men pays splendid income. Complete line men's shirts, ties, underwear, hosiery. No investment. We furnish everything, deliver, collect. Guarantee satisfaction. Earn shirts and ties. Cash bonuses. Write today. Dept. S3, Quaker Shirt, 1107 Broadway, New York.

EARN More pay the Quaker way. Take orders, complete line men's shirts, ties, underwear, hosiery. Remarkable values. All quick sellers. Big commissions. Earn your shirts, ties, cash bonuses. Satisfaction guaranteed. Complete outfit free. Write today. Dept. S300, Quaker, 1107 Broadway, New York.

MAKE Big, steady income. Sell Rose-cliff quality men's shirts, ties, underwear, direct from maker. Guaranteed full year. No substitutions. Free initials. Shirts and ties to producers. Effective sales helps, complete sample line free. Write today. Dept. P300 Rosecliff, 1237 Broadway, New York.

CASH Paid for Butterflies, Insects. See Sinclair Display Advertisement on page 22.

AGENTS—Make a dollar an hour. Sell new kind of sharpeners. Sharpens all knives and tools quickly. Demonstrating sample 10c. Premier Mfg. Co., Dept. 101, Detroit, Mich.

AGENTS: Sell nursery stock. Free landscape service. Wonderful possibilities. Pay check weekly. Write for particulars. Perry Nurseries, R-3, Rochester, N. Y.

MEN Wanted—to demonstrate, and take orders direct from motorists. Amazing magnetic trouble light. Sticks on metallic surfaces. Our men earn as high as \$75.00 weekly. Write for demonstrator. Magno, Beacon Bldg., Dept. 163, Boston, Mass.

JUST Put our chewing gum outfit in your pocket. Make daily expenses. Sell to stores. Popular flavors. Outfit furnished. Helmet Corp., Dept. 57, Cincinnati, Ohio.

MAKE Your own products. Employ agents yourself. Toilet articles, soap, extracts. We furnish everything. Valuable book free. National Scientific Laboratories, 1935W Broad, Richmond, Va.

NEW Kant slip plier is just out. Sells on sight to mechanics, automobile owners. Different from all others. Make 100 per cent on the start. Orders rapidly repeat. Kant Slip Plier & Tool Co., 6036 Wentworth, Chicago.

BIG Money easy. Simply showing new Polly wrench. 10 wrenches in one. Guaranteed! Fast seller. Sample furnished. Gellman Mfg., Dept. 6-P, Rock Island, Ill.

TO Men experienced in direct selling, choice territory now open; demonstrating marvelous new money maker that gives \$5.00 electric treatments at home for 1c each. Amazing record of results. Immense profits. Vitapulser Co., Dept. 10, 4415 Olive, St. Louis, Mo.

EARN \$15 Per day. Experience unnecessary. Start at home in spare time. Big profits. No capital. Write quick. Particulars free. Sales Manager, Box 244, Elwood, Ind.

MINUTES Pay dollars demonstrating wonderful three pound Calculator. Patented 1926. Retail \$15.00. Work equals \$300 machines. Adds, subtracts, multiples, divides automatically. Five year guarantee. Big demand, large profits, experience unnecessary. Write quick for liberal trial offer and protected territory. Lightning Calculator Co., Dept. A, Grand Rapids, Mich.

WANT Distributing agent for Hanslick, powdered handsoap; removes anything from the hands without injury to skin; everybody a customer; great opportunity for hustler to get in business; sample free. Solar Products Co., J2144 So. Troy, Chicago.

MAKE Your own products. Employ agents yourself. Toilet articles, soap, extracts. We furnish everything. Valuable book free. National Scientific Laboratories, 1935W Broad, Richmond, Va.

MAKE Big, steady income. Sell Rose-cliff quality men's shirts, ties, underwear, direct from maker. Guaranteed full year. No substitutions. Free initials. Shirts and ties to producers. Effective sales helps, complete sample line free. Write today. Dept. P3 Rosecliff, 1237 Broadway, New York.

AGENTS—\$75.00 Weekly. New Sunbeam changeable letter electric sign selling fast. Every store buys. Excellent, profitable territory open. Write today for particulars. Sunbeam Sign Co., 5509 West Division St., Chicago, Ill.

BIG Money demonstrating famous DuPont Laundryless Tablecloths. Also \$2.98 trench coats, and full line waterproof necessities. Samples free. American, 724-Q Roosevelt, Chicago.

SELL Union-made-to-measure, all wool suits and overcoats at \$25-\$30-\$35. An opportunity to make \$95 weekly. Biggest commissions paid daily. Extra bonus besides. Write for details. Nearly 200 pure-wool fabrics sent free. Pioneer Tailoring Co., Congress and Throop Sts., Dept. Q-1117, Chicago.

WONDER Hotpad invention smashing sales records. Banishes water bottle and electric pads. Sales helps. Experience unnecessary. Free sample offer. Applicator Corporation, 3357-D Cottage Grove, Chicago.

MAKE Ice from heat for 2c daily. New type refrigerator Crosley Icyball non-electric. Preserves foods, drinks in hottest weather. One third cost of other mechanical refrigerators. Guaranteed. Agents wanted, \$25 profit every sale. Crosley Icyball, Division, C-823 Arlington St., Cincinnati, Ohio.

AGENTS: 800% Profit selling Miller's Magic Needle Threader. Write today for rock bottom prices. L. Miller, Box 3, Tremont Station, New York City.

VANILLA Flavor concentrated. Bottle yourself; employ agents; enormous profits. Repeat sales. Free labels. Big sample bottle, complete information, fifty cents. "United" Industries, Ashtabula, Ohio.

CARRYING Sidelines offer an opportunity to add \$3 to \$10 daily to your income. We have hundreds of fast selling sidelines that will fit any main line you carry. Articles for home, office, store, factory. Ask for list "P." Lee Brothers, 128 East 23rd St., New York.

WONDERFUL Electric clampalite, fastens anywhere. Everybody buys. Big profits. Webb Electric, 2498 Kingston, Cleveland.

AMAZING Liquid instantly waterproofs, preserves, polishes leather shoes—lasts indefinitely; liberal sample 10c. Permoshine Co., 1110A, Hartford Bldg., Chicago.

EMBOSSSED Signs. Samples and lists, ten cents. Embossed, 4614 Telegraph, Oakland, Calif.

PORTRAIT Men! Handle our portraits. They deliver—Satisfy. Finished beautifully. Likeness guaranteed. Lowest prices. Viking Portrait Studios, 60 West Washington, Chicago.

MAKE A thousand dollars quickly showing instant hot water from electric light sockets. A convenience selling itself to everybody. Dad's Factories, Indianapolis, Ind.

PROFITABLE Sideline. Embossed 2-color counter and window cards. Sample free. Embossed Show Card Co., 9420 Euclid, Cleveland, Ohio.

100% PROFIT—Novelties, general line greeting cards, birthday, congratulation, sympathy, friendship, Easter, snappy comics, bathing girls, lovers. Big fun package, bootleggers, marriage, liars licenses, samples. Price lists, 12c stamps. Klees Company, 1710 Undercliff Ave., New York.

JUST Invented. New washing machine. No motors or moving parts. Automatically cleans entire washing. Fully guaranteed. Retail price \$9.50. Your profit 100%. Protected territory. Preston Mfg. Co., Dept. CP-3, St. Louis, Mo.

EARN More money taking orders for nationally famous Edisco ties and shirts. Big profits. Write today for free sales outfit. Edisco Mens' Wear Co., Dept. 25, 1215 W. Van Buren St., Chicago, Ill.

OLIVER Cleared \$700 in 30 days with our line of books and Bibles. Outfit free! Exclusive territory! Nichols Co., Dept. B5, Naperville, Ill.

VANDERFORD Sold 100 first day. Actually removes soot from stove pipes, chimneys and furnaces. Sells 35c. Send \$2.00 for a dozen. Distributors wanted. Flukleen Chemical Co., Dundee, Ill.

GET Our free sample case. Toilet articles, flavorings and specialties. Wonderfully profitable. LaDerma Co., Dept. A, St. Louis, Mo.

\$60-200 A WEEK. Genuine gold letters for store windows. Easily applied. Free samples. Liberal offer to general agents. Metallic Letter Co., 438-B North Clark, Chicago.

DOES 300% Profit interest you? World's best polishing cloth. Everybody buys. Sample free. MagCloth, 3317 Summit, Kansas City, Mo.

GOLDEN Opportunity for making money. No competition. Sells itself. Write today. Rudley Mfg. Co., Inc., 230 Market St., Philadelphia, Pa.

NEW! Different! Milady's Novelty Clothes Brush. Rainbow colors create instant sales. Wadleigh made \$24 first day. Free sample. L. Jensen Co., 304 So. Dearborn, Chicago.

CHICAGO Expert valued \$3 stone at \$900. The diamond's only guaranteed rival! Greatest spare time side-line article ever known! Amazing profits. \$5 pocket sample case free. Write quick! Mexican Gem Company, Dept. PM, Monterey, Calif.

SELL Changeable signs to stores. 3 colors, 6 lines, size 14x24. Costs 40c, sells for \$1.50. Two sample signs postpaid \$1.00. Particulars free. National Sign System, 215 So. Broadway, St. Louis, Mo.

SELL Complete line household brushes. 100% profit. Free gift brushes furnished. Liberal territory allotment. Big sample case outfit now only \$10.00. Write for catalog. National Fibre Broom Co., St. Louis, Mo.

GREATEST Opportunity; newest proposition. Build continually paying business in your own name. Household, industrial, brushes, brooms, mops, dusters, fully guaranteed. New catalog, all net prices, no discounts to bother with. Make as high as 300 per cent and over. Write today. Wire Grip Sanitary Brush Corp., 41 East 11th St., New York.

TIME Counts in applying for patents. See pages 138 and 139. Clarence A. O'Brien, Registered Patent Attorney, Washington, D. C.

AGENTS: Free catalog 200 household specialties, toilet preparations, food products, remedies, portraits, frames, photo pillows, medallions, religious goods, pictures, damask tablecloths. Credit. James C. Bailey Co., Station C1, Chicago.

SELL Koehler's blue signs. Cost 3 1/2c, sells for 20c. Koehler, 717 N. Fourth, St. Louis, Mo.

\$10 DAILY; Amazing new iron cord holder clamps to board; keeps cord out of way; free sample offer. C. A. Myers Company, 6339 Woodlawn Ave., Chicago, Ill.

BIGGEST Surprise offer ever made. Be sure to answer this ad. My line of soaps, coffee, tea, spices, toilet articles, household specialties, pays you bigger profits. M. G. Roth, President, 2833 Dodier, St. Louis, Mo.

AGENTS—Sell vanilla, perfume free, easy sales, big profits guaranteed. Box 71, Station W, Brooklyn, N. Y.

AGENTS And demonstrators. Big money selling Porfrey Face Clay and Odorless Hair Remover. Indorsed. Guaranteed and has national demand. Norman Products, Box 178, San Francisco, Calif.

DISTRICT Managers! Crew managers! General agents: Two sales daily will pay your saleswomen \$51 weekly and net you \$55 monthly overwriting. What have you? Write Daintymaid, J-708, Meriden, Conn.

FREE Booklet describes 67 plans for making \$20-\$100 weekly in home or office business of your own. Elite Co., 84 Elizabeth St., New York.

GOLD-LEAF Sign letters; copyrighted manufacturing instructions; profits 1,000%. Johnson Co., Quincy, Ill.

\$50,000 PICTURE Man Friedman made canvassing. Beginners can make \$100.00 weekly with my sales talk. Experienced men make more. Free book "Profits in Portraits" explains. Sample free. Picture Man Friedman, Dept. 8, 109 West Austin, Chicago.

BIG Money weekly year round appointing agents. No canvassing, delivery or investment. Mother Hubbard Foods, 554U Congress, Chicago.

CALIFORNIA Perfumed beads selling like hot cakes. Agents coining money. Big profits. Catalog free. Mission Factory P, 2328 W. Pico, Los Angeles, Calif.

WE Start you without a dollar. Soaps, extracts, perfumes, toilet goods. Experience unnecessary. Carnation Co., 641, St. Louis, Mo.

TWO Money makers for agents. "Francis" Pocket Adding Machine retails \$4.85. To you \$1.00. "Excellograph" Rotary Stencil Duplicator \$37.50 retail. Write Type-writer Supply, 102 Hersch Bldg., Pittsburgh, Pa.

BIG Money and fast sales. Every owner buys gold initials for his auto. You charge \$1.50; make \$1.34. Ten orders daily easy. Write for particulars and free samples. American Monogram Co., Dept. 40, East Orange, N. J.

AGENTS To sell our metal polishing cloth, powdered hand soap, furniture and Duco polish. Sales Mgr., 1307 East Walnut, Des Moines, Iowa.

MAKE—Sell your own goods. We tell you how. Formula catalog free. Clover Laboratories (PM), Park Ridge, Ill.

SELL Housewives something they want. A necessity. Reduces gas bills 25%. New in your territory. No competition with this guaranteed gas saving device. Exclusive sales rights, 400% profit. Box 18E, East San Diego, Calif.

AUTOMOBILE Specialties. Guaranteed formulas for all latest money makers. Lowest prices. Write for free lists. Murphy, Chemist, Tujunga, Calif.

FREE Booklet describes 67 plans for making \$20-\$100 weekly in home or office business of your own. Elite Co., 84 Elizabeth St., New York.

NO Dull times selling food. People must eat. Federal distributors make big money; many over \$3,000 yearly. No capital or experience needed; guaranteed sales; unsold goods may be returned. We furnish you with license, sample case and free samples for customers. Repeat orders sure; exclusive territory. Ask now! Federal Pure Food Co., A2307 Archer, Chicago.

SELL Stores 5c candy specialties. 100% profit. Lorrac Products, Albany, N. Y.

BIG Money applying gold initials on automobiles. Easiest thing today. No experience needed. \$1.45 profit every \$1.50 job. Free samples. "Balco," X-1043 Washington, Boston, Mass.

SELL Men's neckwear—wonderful proposition. Astor-M, 39 East 28th, New York.

REMNANT Store, Bethel, Ohio. Greatest Dry Goods Bargains on Earth. Agents and Dealers.

AGENTS—Make a dollar an hour. Sell Mendets, a patented patch for instantly mending leaks in all utensils. Sample package free. Collette Mfg. Co., Dept. 404, Amsterdam, N. Y.

GOLD-LEAF Window letters and script signs; no experience; 500% profit; samples free. Consolidated, 69-T West Van Buren, Chicago.

POLMET Polishing Cloth removes tarnish from metals without the use of liquid, paste or powder. Our agents say it sells like "hot cakes." Retail 25c; sample free. Gale & Co., Inc., 15 Edinboro St., Boston, Mass.

AGENTS—New shirt proposition. No capital or experience needed. Commissions in advance. Samples free. Madison Company, 566 Broadway, New York.

THALXY Formulas produce perfect products. All lines. Catalog free. B. Thalxy Co., Washington, D. C.

AGENTS Wanted—On a fast selling 25c item for the kitchen, costs you 8 1-3c. Sample sent parcel post prepaid for 10 cents. P. Seed Filter Mfg. Co., Inc., 353 Broadway, New York.

MAKE Your own products. Employ agents yourself. Toilet articles, soap, extracts. We furnish everything. Valuable book free. National Scientific Laboratories, 1935W Broad, Richmond, Va.

MAN in each town to plate auto parts, reflectors, bathroom fixtures, refinish beds, mirrors, chandeliers; by new method. No capital or experience required. Simple plan of manufacturing at home starts you in big money-making business. Outfit furnished. Free particulars and proofs. Gun Metal Co., Ave. H, Decatur, Ill.

A BUSINESS Of your own—Making sparkling glass name and number plates, check-boards signs. Big book and sample free. E. Palmer, 512, Wooster, Ohio.

\$12.00 DAILY Showing new table cloth. Looks like linen. Wash like oilcloth. No laundering. You just take orders. We deliver. Pay daily. Sample free. Bestever, 152 Irving Park Station, Chicago.

AGENTS—Clever Invention! Inkspoon makes every pen a fountain pen. Fast office seller; big profit, demand increasing everywhere. Exclusive territory offered. Sample free. H. Marul Company, Tribune Bldg., New York, N. Y.

BIG Profits! Fast sales! \$9.75 automatic washing machine. Guaranteed. Write Storm Royalty Co., 3601 Enright, St. Louis, Mo.

QUICK Easy sales. Small simple cleaning device. Average profit \$1.00. 15 to 20 sales per day. Experience unnecessary. Free sample offer. Old reliable organization. MacLeod Co., Dept. PM-3, 2640 Greenview, Chicago.

REPLATE Brass worn-off automobile parts, reflectors, bath room fixtures, worn spoons, forks, etc., with pure silver. Looks like new. Use U-Kan-Plate Polish. Positively no mercury; \$1.00 half pints. Postpaid. Satisfaction guaranteed. Agents wanted. Dept. A, U-Kan-Plate Co., Philadelphia.

HIGH-GRADE SALESMEN WANTED

BIG Free printing line brings easy quick profits. Bigger commissions—up to 55%! Experience unnecessary. Now write orders with America's most profitable printing stationery line. Thousands of free cuts. Hundreds of standard items for every merchant and manufacturer: Letterheads, noteheads, envelopes, billheads, business cards, statements, shipping, battery, dry cleaning, tire, storage, parking and hat cleaning tags; garage repair forms; blotters; gummed shipping, drug and advertising stickers; sales books; duplicate forms; triplicate forms, etc. In fact, America's largest line. Lowest prices. Steady repeat orders. We ship everywhere. New free 1939 outfit ready. Write quick. Dept. 204, Box 498, Cincinnati, Ohio.

NEW And plenty different. Fast selling 5c-10c merchandise on attractive counter cards. 100% commission for you and dealers. Advertised by radio. No capital required. Catalog free. World's Products (Estab. 1921), 49 Central, Spencer, Ind.

SELL Nothing, earn up to \$170 weekly, empty handed. No samples to tote. Oldest and largest punchboard firm, established 20 years, rated \$500,000, announces amazing new plan. Salesmen cleaning up. No one invests a penny. We even pay express charges. Unsalable merchandise returnable. Big season now here. Full commission repeat business. Grab this quick. K&S Sales Co., 4315 Ravenswood, Chicago.

MONEY Every minute every day. Anyone can sell printing with our elaborate free outfit. 106 fast-selling items. Free illustrations. Our prices beat competition. Big commissions paid daily. Sell every merchant, manufacturer, bank, doctor, etc. Full time or sideline. Write for details. All-Trades Printing Service, 151 Second, Rockford, Ill.

300% PROFIT Selling Mystery Gas Lighter. Retail 25c. Costs you \$1.00 doz. Sample free. Square Deal Mfg., Desk PM5, Bradford, Pa.

DON'T Sell for others—employ agents yourself. Make your own products. Toilet articles, household specialties, etc. 500% profit. Valuable book free. National Scientific Laboratories, 1935W Broad, Richmond, Va.

SALESMEN—Brush salesmen. We pay highest commission and furnish your gift brushes free. Complete new line, nationally known, reasonably priced and tested and approved by Good Housekeeping Institute. Company established 1923, now expanding rapidly. Your opportunity. Act now. Donald Brush Co., Camden, N. J.

COUNTER Cards, safety razor blades, Aspirin, Flints, sells fast, sure repeats. Metro Specialty Company, 43 West Sixth St., Cincinnati, Ohio.

SELL Diamond's only rival. Blue white Zircons \$30 a carat. Goetz Gem Importers, Galion, Ohio.

PENNY A day accident policy, \$15,000,000 company. Death \$5,000. Disability \$100 monthly. Liberal commissions. Renewals. Experience unnecessary. Druyand Underwriters, 192 North Clark, Chicago.

PUNCHBOARD Salesmen. Up to \$10,000 yearly. New line. All fast sellers. Lowest prices. Full commission on repeat business. Catalog free. Puritan Novelty, 1409 Jackson, Chicago.

BIG Commission daily selling office building directories and new changeable letter display signs to hotels, banks, merchants. American Signotype Co., 544 Washington, Chicago.

EARN \$10,000 Yearly. Easy. Sure. Sell "Royal Policy." Death benefit \$5,000. Disability \$100 monthly. Sickness \$50.00 monthly. All for \$3.65 yearly. Everybody 10 to 70 years buys. No medical examination. Send your name, age, address, beneficiary's name, relationship, for 10 days free inspection of policy and proposition. American Peoples Life, Dept. 1512C, 134 N. LaSalle St., Chicago.

BIG Money side line. Write Bell Plant Co., Cotulla, Tex.

TOOL Salesmen—Sell our fast selling valve lifters and cone lock replacer to mechanics, garages. Liberal commission. Clark Mfg. Co., Ft. Morgan, Colo.

HIGH Grade salesman wanted to become local advertising representative for lifetime china. Experience unnecessary. \$185.00 monthly guaranteed under contract. Lifetime, Station V, Cincinnati, Ohio.

IT Is new. Dixie-Dew Electric Sandwich Machine. Commission \$12. Be first in the field. No competition. Dickerson Manufacturing Co., Dept. E-3, Springfield, Mo.

MAKE Your own products. Employ agents yourself. Toilet articles, soap, extracts. We furnish everything. Valuable book free. National Scientific Laboratories, 1935W Broad, Richmond, Va.

UNUSUAL Profit, unusual article, big demand for Wino Fino beverage. Repeat business. Exclusive territory. Hagen Import Company, Dept. WF1, St. Paul, Minn.

SALESMEN—Local and district representatives to sell our Reservoir Dustless Brush used extensively by schools, merchants and public institutions. Patented and non-competitive. Part time men also needed. M. D. B. Co., 22nd St., Milwaukee, Wis.

SALESMEN To sell fast selling oil burners to dealers. Car and sales experience necessary. Strictly commission. Walker Manufacturing Company, St. Joseph, Mo.

ADVERTISING Pencils sell fast to every line of business. New line. Quick cash commission plan. Main or sideline. Free pocket outfit to real salesmen. Chicago Graphite Co., 128 So. Clinton, Chicago.

COVERALL Salesmen—Lettered garments, \$3.25. Commission 75c. Write for sample. Blue Bar Sales, 844 Dorr, Toledo, Ohio.

SCREW-HOLDING Screw driver! Amazing new invention. Factories, garages, electricians, auto, radio owners buy on sight. Removes and inserts screws instantly inaccessible places. Sells \$1.50. Investment for merchandise only. Exclusive territory. Write quick free trial offer. Tooleo, 1509 Winthrop Bldg., Boston.

\$282.80 COMMISSION Possible on a \$25.00 original sale. Every merchant a prospect. Absolutely new and different. Exclusive territory. Sales Stimulators, 339 W. Madison, Chicago.

SALESMEN: Our varied line enables us to offer you a sideline for almost any class of trade. State territory and class of trade called on, also references. Bradford & Co., Inc., St. Joseph, Mich.

NEW Specialty—Sells every business and professional man. Used by Bell Telephone Co., National Radio, etc. Four \$15 sales daily pay \$288 weekly. Walker made \$165 first day. F. E. Armstrong, Dept. PM, Mobile, Ala.

SELL 3A Garage door holders, simple, automatic, quickly installed. Interests garage owners, builders, everybody. Exclusive territory proposition. Knowlson-Stevenson Co., Ann Arbor, Mich.

SALESMEN—Make \$5.00 an order, selling high-grade suits, topcoats, \$19.85. Fine materials; union made. Big repeat business. Free giant outfit. Write Metro Tailors, 879-C Broadway, New York.

SALESMEN Make \$5.00 an order selling high-grade suits, topcoats \$19.85. Fine materials, union made. Big repeat business. Free giant outfits. Write Metro Tailors, 879-B Broadway, New York.

CAPABLE Salesman wanted to call on executives and professional men, who can close on first call. Possibilities \$60.00 to \$100.00 weekly. Give references. Geographical Pub. Co., 621 Plymouth Court, Chicago.

80c PROFIT On \$1.00 sales. Wonderful cleaner for automobiles, furniture, metal and glass. Fast repeater. Your name on labels. Exclusive territory. Free sample. Minute Kleen Laboratories, Dept. E, Evansville, Ind.

BIG Money daily, selling shirts of all kinds, neckwear, underwear, socks, pajamas, sweaters, raincoats, coveralls, pants, children's playsuits. Experience unnecessary. Outfit free! Nimrod Co., Dept. 65, 4922-28 Lincoln Ave., Chicago.

PUNCHBOARD Salesman—Most gigantic line ever featured. Vending machines, all kinds. Make high as \$28.00 on single order. Repeat commissions. Beautiful colored catalog free. Lion Mfg., Dept. 8, 308 W. Erie, Chicago.

FREE Booklet describes 67 plans for making \$20-\$100 weekly in home or office business of your own. Elite Co., 84 Elizabeth St., New York.

SELL Goodyear raincoats; \$2.95 up. Goodyear Rainwear, 682 Sixth Ave., New York.

HUNDREDS Of new manufacturing units now being established by us. Managers wanted. Chain system of operation makes big profits possible and baffles all competition. All kinds of food flavors, food colors, perfumes, fly sprays, medicines and other specialties. Your own boss, dignified work, quick sales, big profits and little capital required. Act quick. Mystol Company, Dept. P, Glens Falls, N. Y.

LIBERAL Proposition to salesmen with car. Establish independent business. New introductory offer. Mechanical or auto accessory experience. Daily cash orders and commissions. York Co., Dept. PM-23, 2640 Greenview, Chicago.

BIG Money showing \$2.98 trench coats and DuPont's launderless tablecloths. Samples free. American, 724-V Roosevelt, Chicago.

SALESMEN. Wonderful sideline. 40% commission paid daily. Sells all merchants. Pocket outfit free. David Lionel Press, 312 S. Hamilton, Dept. 135, Chicago.

HONEST. Active workers wanted for special sales campaign. Protected adequate territories. Opening for district managers. Box 333, Spencer, Iowa.

SELLS On sight. "Good Luck" elephant cigarette dispenser. Twist tail, cigarette comes out. Useful, ornamental. Easy sales. Big profits. Write Midwest Novelty Company, 1499 University, St. Paul, Minn.

BUSINESS Stationery. Largest line, highest quality, quickest delivery, biggest commissions. Liberal bonuses. Free copyrighted cuts every business. Experience unnecessary. Instructions and outfit free. Willens Co., Dept. 288, 2130 Gladys Ave., Chicago.

POOL Shooter, new fascinating vending machine. Merchants everywhere buy! Splendid sideline. Big profit maker! Free pocket outfit! Specialty Mfg. Co., W617 W. Division, Chicago.

ELECTRIC Tie presser. Plugs in light socket. Makes ties new. Creases trousers. Many other uses. Fits in your grip. Going big with stores and individuals. First time advertised. Retail \$6.50. Crew manager sample \$2.95. Write for distributor proposition and territory. Hamby Specialty Co., 823 Prospect Ave., Cleveland, Ohio.

\$18 TO \$25 Daily; biggest selling line of men's suits, \$11.95, \$14.50, \$16.95, \$19.95. Amazing values. Pure virgin wool overcoats \$18.95. Also raincoats, slickers, top coats and boys' suits. Biggest commissions paid in advance. Liberal bonus. Free outfit. "Jim" Foster, Inc., Dept. 23, 2250 S. Spaulding Ave., Chicago, Ill.

PUNCHBOARD Salesmen make big commissions, selling punchboards and vending machines. Reliable concern, established 20 years. Largest most complete catalog in colors, free. Best season now. Write today! Lincoln Sales, 116 S. Wells, Chicago, Dept. D.

SELL Collection and goodwill stickers to merchants and manufacturers. Splendid variety, wonderful repeaters. Pocket samples. \$50.00 daily possible. Act today. E. L. Russell, 6 N. Michigan, Chicago, Ill.

SALESMEN: Reliable line disinfectants and paints, for merchants, schools, hospitals. Commercial Chemical Co., Marion, Ind.

EARN \$100.00 Weekly selling our \$1.50 accident and registration policy for \$1.00 per year. E. W. Shaw Company, Insurance Bldg., Denver, Colo.

OUR Men actually earn \$300 to \$500 selling our lines. Adelite, the newcomer in electric window salesmen, is making a big hit. More for the money. Business posters for every line. Changeable letter system too. Permanent business for you working with us. Territory protected and repeats credited. Fat commissions. Full details prove very interesting. Display Products, Ltd., 409-A East 31st St., Kansas City, Mo.

SUCCESS Is no accident! You will fully understand this slogan when you examine our automatic credit and collection plan. Copy-righted, brand new, unusual. 250% on original sale. Half cash on repeats without callbacks. Commonwealth Publishing, 508 So. Dearborn, Chicago.

LATEST And best House Wiring book—just published—This new book of over 250 pages and 600 illustrations represents 15 years of work in perfecting the material for the best House Wiring manual it is possible to produce. The work of two men high up in the fields of mechanical arts and electricity. Price \$2.50 postpaid. Sent C. O. D. anywhere in the U. S. or possessions. Popular Mechanics Press, Room 802, 200 E. Ontario St., Chicago, Ill.

PUNCHBOARDS—Hottest, largest money-making line ever offered. Season starting. Best commissions. Nothing to carry. Catalog free. Act! M&L Sales, 301 W. Adams, Chicago.

ELECTRICAL Tool line selling to garages, mechanics and auto owners, wonderful demonstrators, big commissions. Salesmen, write Barker Specialties, Girard, Penna.

MAIN Or sideline. Sell auto tires and auto accessories to tire stores, garages, etc. Protected territory, liberal commission. Economy Rubber Products Co., 604 Burkhardt Ave., Dayton, Ohio.

WANTED District managers—Capable men to represent us in prosperous territories with direct home office contract. Our organization is the oldest of its kind in the health and accident business and offer exceptionally remunerative compensation. Write today for information. Dept. 18, Inter-State Business Men's Accident Association, Brown Bldg., Des Moines, Iowa.

SALESMEN—Four \$15.00 sales to merchants net you \$40.00 daily. Sayers Systems, 2813 Sheffield, Chicago, Ill.

SALESMEN—Become independent. Own your business; experience unnecessary, selling our \$10,000 Accidental Death; \$50 Accident; \$25 Sick Weekly Benefits—\$10.00 yearly. Other amounts proportionate. Guaranteed steady income from renewals. \$250,000 deposited Insurance Department, Universal Policy Dept. A, 40 Clinton St., Newark, N. J.

GOLD-LEAF Window letters and script signs; no experience; 500% profit; samples free. Consolidated, 69-V West Van Buren, Chicago.

\$50-\$200 A WEEK. Genuine gold letters for store windows. Easily applied. Free samples. Liberal offer to general agents. Metallic Letter Co., 438-A North Clark, Chicago.

HELP WANTED

CARPENTERS, Electricians, painters, miners, glassblowers and other tradesmen can have a good job in the "off" season. Help us sell and install new household fixture. Day by day sure profits with occasional big winning. Easy to learn. Work in spare time later. Send quarter for particulars and sample that you can use right in your home. Art Marble Co., 318 A South Camac St., Philadelphia.

WANTED: Women who need quick money. "New idea" imported ladies' necessity sells on sight; everyone buys; representatives everywhere are cashing in big. Miss Ely has made \$1,900; Mrs. Hart \$2,200, without experience. New sales plan puts you in business for yourself. Sample free. Write Mary E. Coleman, Meriden, Conn.

IF You want to make \$100, \$500 or \$1,000 just send me your name. Wonderful new proposition. No capital needed. Particulars free. Albert Mills, 4984 Monmouth, Cincinnati, Ohio.

WHERE To buy thousands of articles wholesale. New directory. Agents wanted. Pruitt, Brookfield, Ill.

WANTED Laborers, mechanics all kinds; small wage earners "Stop that daily grind." By reliable method plating any metal article with genuine durable metal. Easily learned. Restliver mirrors, any size. Famous inexpensive process. Write Sprinkie, Plater, 5, Marlon, Ind.

CASH Paid for Butterflies, Insects. See Sinclair Display Advertisement on page 22.

AGENTS—Big chance to earn \$15 to \$25 daily, introducing new, patented, safety, automatic burglar proof ventilating window lock for homes, stores, offices, banks, all buildings. Sensational seller. Anyone, even without experience, should make 3 to 10 sales in single call. Nothing else like it. No competition. Write quick for terms, territory. Elmwood Mfg. Company, 1513 Elmwood Place, Cincinnati, Ohio.

MAKE Big profits silvering mirrors. Easily learned patented process. Plans free. Wear Mirror Works, Excelsior Springs, Mo.

AUTO Side-visions, all steel, instantly installed without tools. Beautiful and popularly priced. Big demand and profits. 1930 patent. Pritchard, Atlantic Beach, Fla.

MANUFACTURER Wants distributor for 300-mile \$2.00 "Pocket" Radio. "Sells itself with music." Pays 100%. Spencer Radio, Dept. 10, Akron, Ohio.

EDUCATIONAL AND INSTRUCTION

FIREMEN, Brakemen, baggagemen (white or colored), sleeping car, train porters (colored), \$150-\$250 monthly. Experience unnecessary. 810 Railway Bureau, East St. Louis, Ill.

SHORTHAND—Memoscript, most rapid, readable system, easily learned at home. English, bookkeeping and typewriting courses. Cook Shorthand College, Roanoke, Va.

WORK For "Uncle Sam." Life jobs with U. S. government. Steady work. \$105.00-\$250.00 month. Men-women, 18-50. Thousands 1930 appointments. Many examinations coming. Common education usually sufficient. Experience unnecessary. We prepare you without leaving home. List positions and particulars free. Write today sure. Franklin Institute, Dept. G3, Rochester, N. Y.

RAILWAY Postal clerks. \$158.00-\$225.00 month. Steady. Spring examinations likely. Common education. Men 18-35. Particulars free. Write immediately. Franklin Institute, Dept. G14, Rochester, N. Y.

COMMERCIAL Art pays good, new \$1.00 a lesson plan leads to success. Write Integral School of Commercial Art, Melrose Park, Ill.

PHOTOPLAY Talking picture and magazine stories wanted for revision, development and copyright. Sell on commission. Established 1917. Booklet free. Universal Scenario Company, 406 Western and Santa Monica Bldg., Hollywood, Calif.

LEARN Rapid figuring by studying "Higher Arithmetic." Send 2 dollars for book or write for prospectus. F. A. Smith, 608 S. Dearborn St., Chicago.

LEARN Shoe repairing at home. Send dollar for instruction book. Shoe Makers College, Aurora, Ill.

DOUBLE Entry bookkeeping 60 hours with 8 keys; guaranteed. (Diplomas.) International Bookkeeping Inst., 8 Springfield, Mo.

DON'T Prepare for any civil service examination without seeing our catalog. Free. Columbian Correspondence College, Washington, D. C.

BECOME A landscape architect. Uncrowded profession; wonderful opportunity for money-making. Easily mastered by mail. Earn while you learn. Est. 1916. Write for details. American Landscape School, 29 Plymouth Bldg., Des Moines, Iowa.

U. S. GOVERNMENT Wants men, \$1,700-\$1,900 and up at start. Railway mail clerk examination coming. Let our expert (former government examiner) prepare you for this and also rural carrier, post office, customs, internal revenue, and other branches. Write today for free booklet. Dept. 8, Patterson School, Rochester, N. Y.

WANTED Immediately, men-women, 18-55, qualify for permanent government positions, \$105-\$250 month; no government experience required. Paid vacations. Common education. Many needed soon. Write Ozment Inst., 101, St. Louis, Mo.

TYPEWRITERS AND SUPPLIES

TYPEWRITERS—All makes, \$6 to \$33. Fully guaranteed. Dee Typewriter Exchange, Ada, Okla.

TYPEWRITERS—Factory rebuilt Royals, Remingtons, Underwoods. New Royal Remington and Corona portables. New "Excelsior" Rotary Stencil Duplicator \$37.50. Catalog free. Pittsburgh Typewriter Supply, Dept. 945, Pittsburgh, Penna.

ADDING MACHINES

NEW \$3.50 Automatic adding machine. Adds, subtracts, multiplies, absolutely accurate. Capacity \$999,999.99. Fully guaranteed. 75,000 pleased users. Makes adding easy, positive, quick. Eliminates mistakes. Saves time. Postpaid \$3.50. Bassett Co., 1458-E, Hollywood Ave., Chicago.

PRINTING, ENGRAVING AND MULTIGRAPHING

TINTED Enamel folders, 3 1/2 x 6, 5,000 \$13.75. All printing low prices. Samples. Goodprint, Harrisonburg, Va.

ILLUSTRATIONS: We manufacture printing plates of every description. Send photograph of your product for prices. Art studio in connection. Wallace—Engraver, 549 Washington, Gary, Ind.

PRINTING And engraving: Another carload of bargain paper makes still lower prices possible. Submit your requirements for new quotations. Superior workmanship. Quick service. Established 1902. William Wallace, 548 Washington, Gary, Ind.

PRINT Anything. Lowest prices. Highest quality. Catalog free. National Printing, Goshen, Ind.

SPECIALISTS in printing for mail order man. New free illustrated cut service. Battlefield Press, Gettysburg, Penna.

250 BUSINESS Cards, \$1.00 postpaid. D. N. Fox, Perryville, Md.

BETTER Printing! Lower prices. Samples 2c. Grove's Press, Elcho, Wis.

SPECIAL: 200 Cards beautiful case \$1. Cedar Press, Box 64, Teaneck, N. J.

LETTERHEADS, Envelopes, 500, \$1.10; 1,000, \$2.00; 5,000, \$8.00, plus postage. Samples. Coyle & Kimballs, Newport, N. Y.

100 LETTERHEADS, Envelopes, note-heads, cards, all \$1.00. Edwin Eppley, 328 North Queen, York, Pa.

1,000 LETTERHEADS Or envelopes \$2.50. Patton Company, 534 Paxton Block, Omaha, Nebr.

OUR Standardized plan makes it possible to print house organs and magazines at one-third ordinary prices. We print more than 1,100 different publications. Samples and particulars free. National Publishers Press, Grand Rapids, Mich.

PRINTING—Low prices, fine work. New price list and samples. Stationery, circulars, folders, booklets, catalogs ruled forms. Sell direct, large or small orders. Large modern plant in small town, low operating cost. Shenandoah Publishing House, Inc., Box 1170, Strasburg, Virginia.

"NEARGRAVURE" Secret processes. Special; 500 each letterheads, envelopes, \$5.55 postpaid. Compare — Samples. Soliditys, Knox, Ind.

200 LETTERHEADS And 100 envelopes \$1.00. 200 letterheads, 8 1/2 x 11, 150 envelopes \$2.00. 250 cards \$1.00. Hoosier Print Shop, Portland, Ind.

1,000 LETTERHEADS, Envelopes, cards, circulars, \$2.75. Morganrice Press, Springfield, Mass.

WE Print stationery, booklets, catalogs, circulars. Samples. Commercial Press, Batavia, Ohio.

QUALITY Printing! Reasonable Prices! Send for Free Standardized samples and prices. Folders, Circulars. Catalogs our specialty. Earnest Fantus, 525 South Dearborn, Chicago.

250 BOND Letterheads, Envelopes, Bill-heads, Cards, \$1.35 each. Economic Press, Leonia, N. J.

CIRCULARS, 5,000—5 1/2 x 8 1/2—\$11; 3 1/2 x 6—4-Page folders \$14. Big plant, little prices. Garrison Press, Harrisonburg, Va.

PRINTING OUTFITS AND SUPPLIES

PRINT Your own cards, stationery, circulars, advertising, etc. Junior press \$5.90; job presses, \$11; rotary, \$149. Print for others; big profit. Easy rules furnished. Write for catalog presses, type, paper, etc. Kelsey Company, Q-11, Meriden, Conn.

PREUSED Printing presses and supplies. Lists 2c stamp. Popular Bargains, Richland, Pa.

MAKE Your own printing device. It's practical! Different! Particulars, specimens free. Grinstead Laboratories, Oswego, Kans.

PRINTING Outfits—Presses, type supplies, type novelties. Send stamp for catalog. Model Press, York, Penna.

GUMMED LABELS

1,000 PRINTED: Name, business, address 50c. JBS Company, Box 93, Holyoke, Mass.

RUBBER STAMPS

MUSIC Stamps, metal check. Catalog 10c. Walt Karstaedt, Dayton, Ohio.

RUBBER Stamps! Name, address, two lines 25c; three lines 35c. DeLuxe Stamp Works, B572M, Auburn, Nebr.

INFORMATION, SERVICE, COUNSEL

SAGINAW, E. S., Michigan. What do you want to know? Information on any subject. Where to buy—where to sell. Expert advice given special problems bothering you. Mail \$1 bill. Satisfaction guaranteed or money refunded. Specialty Expert, Box 273.

DUPLICATORS AND DEVICES

YOU Can make 50 to 100 copies of a letter, notice, etc., at a cost of three cents on a Heyer Quality Duplicator. Write for free trial offer. The Heyer Duplicator Co., 909 Jackson Blvd., Chicago, Ill.

"EXCELLOGRAPH" Portable rotary stencil printing duplicators \$39. Terms. Description, testimonials, printed samples, free. Pittsburgh Typewriter Supply Co., Dept. 531, Pittsburgh, Pa.

STENCIL Duplicator—Anyone can make. Practical! Different! Particulars, specimens free. Grinstead Laboratories, Oswego, Kans.

FOR THE HOME

NEED Extra money? Home weaving pays. Free book. Union Looms, Boonville, N. Y.

CEDAR Chests only \$11.65—"Red-I-Kut" complete with rich copper trim—you assemble and save half—send for pictures. Kuempel Furniture Company, Guttenberg, Iowa.

FOR MECHANICS

BEST Opportunity for profit in 8-hour battery charging. Practically no investment, easy terms. Bargains in reconditioned car washers, paint sprays, compressors. Write today. Galbreaths Automotive, Box M-332, Troy, Ohio.

BATTERY Shop—How to run. Most complete and authoritative information ever compiled on tools needed, shop equipment, charging methods, opening batteries, work on plates, jars, case, etc. Covers auto, radio and farm lighting batteries. Send for big 550-page book and pay postman \$5.00 plus postage when he delivers same. If outside U. S. remit when ordering. Popular Mechanics Press, Room 801, 200 E. Ontario St., Chicago.

FOR SMOKERS

AUTOMATIC Cigarette making machines. Rolls, glues 50 for 10 cents; illustrated folder. Postpaid \$2.50. For home use. Automatic Cigarette Machine Works, 6247-51 Broadway, Chicago.

SMOKE On me free—I'll send you free big generous sample Old Green River pipe tobacco. Enjoy the mild mellow tasty natural tobacco flavor. See how smooth and satisfying. No obligation. Send today. Pete Moberly, Box 775, Owensboro, Ky.

LEAF Tobacco—Guaranteed best quality. Chewing, 5 pounds \$1.50; 10, \$2.50. Smoking, 10, \$1.50. Pipe free. Pay postman. United Farmers, Bardwell, Ky.

RAZORS AND BLADES

NEW Gillette type razor blades. 30 for \$1.00. Every blade guaranteed. Superior Blade Co., Box 1516 Cincinnati, Ohio.

SHARPEN Razor blades. Build a business for yourself. Make a dollar per hour with our machines. Easy, light work. Ideal proposition for elderly men. Fully equipped machines \$175.00. Velvet Edger Mfg. Co., 725 West 59th Place, Los Angeles, Calif.

GILLETTE Razor blades honed and stropped, 1c each. Petter Wetterquist, Rockford, Ill.

TEN Gillette type blades, 35c, postpaid. Fred Hargraves, Norwood, R. I.

DIAMONDS, WATCHES AND JEWELRY

WATCHES—Less than half price. Ladies and gents. Elgin, Waltham, Illinois, Hamilton, Bulova, Howard, etc., rebuilt and fully guaranteed. Write for list. Watch Sales, 36 Portage Ave., Detroit, Mich.

WATCH REPAIRING

LEARN To repair watches through the medium of the Drexler Course in Watch Repairing. Very simple to understand. Write for prospectus and free drawings. Wm. F. Goldberg Co., 209 Wisconsin Ave., Milwaukee, Wis.

ANTIQUES, WAR RELICS AND INDIAN GOODS

INDIAN Relics. 100 good Indian flints, \$2.50 postpaid. Lists free. Museum, Economy, Ind.

SEND 5c For fine new list Indian relics, antique firearms. F. E. Ellis, Webster Groves, Mo.

OLD Homemade lathe. Stamp for particulars. Everett Kelly, Farmington, Iowa.

BOATS AND LAUNCHES

BUILD Your own outboard racing boat, runabout or skiff. Complete drawings patterns, assembled frames and parts. Designed by Jas. B. Welch, designer of the original "Century Cyclone." Get plans or frames of the world's fastest outboard racing hydroplane. Jas. B. Welch, 724 31st St., Milwaukee, Wis.

PROPELLERS. Pumps, stuffing boxes, bearings, etc. Wm. H. Baker, Pond St., Quincy, Mass.

MAKE 16' Rowboat. Blueprint, 30c. Weesho-Uco, 31st Office, Detroit, Mich.

EIGHTEEN Foot outboard runabout, complete plans 50c. Free boatbuilding catalog. The Rudder, 15 Murray St., New York.

BUILD Your own boat. Commence building now and be ready for next season. Use our ready cut semi assembled materials. 55 designs outboard speedsters, runabouts, cruisers, sail, etc. Send 10c for catalog. Brooks Boat Co., Box S. S., Saginaw West Side, Mich.

SPEEDY Outboards—Many prize-winners. Complete instructions with blueprints for building 35 different boats. Pay postman only \$3 and postage when delivered. If outside U. S. remit when ordering. Popular Mechanics Press, Room 801, 200 E. Ontario St., Chicago.

FIELD GLASSES, MICROSCOPES AND TELESCOPES

\$5.00 GOVERNMENT Field glasses with leather case. Send free list binoculars, field glasses, cameras, lenses and musical instruments. Well's Curiosity Shop, 20 South Second St., Philadelphia, Pa.

MINERALS, SEMI-PRECIOUS STONES

WE Are dealers in mineral specimens and polished semi-precious gems for educational and cabinet display purposes. Price lists, table of birth stones and list of gem minerals free with order for PM Specials. Six assorted rough and polished minerals \$1. or four genuine, polished gem stones \$1 postpaid, labeled; satisfaction guaranteed. The Gem Shop, Box 373, Wolf Creek, Mont.

PHONOGRAPHS AND RECORDS

BUILD Your own phonograph. Parts catalog mailed for 10c. American Phonograph Co., 3602 Wesley, Berwyn, Ill.

MUSIC AND MUSICAL INSTRUMENTS

DUO-FLEX Reeds for saxophones and clarinets. The only invention affecting the blowing quality of reeds. Enjoy playing your instrument more than ever with these perfected, doubly flexible reeds. Get softer and sweeter tones with ease. Per dozen clarinet \$2.50, soprano \$2.75, alto \$3.00, tenor \$3.50. Duo-Flex Reeds, 1204 First Ave., Evansville, Ind.

GUARANTEED Results. Write Sequoia Songwriters Service, Sherman Branch, Los Angeles, Calif.

HARMONICA Specialties: Fox Chase and Freight Train Blues. Easily learned. 50 cents each. Box 52, Miami, Okla.

VIOLIN Makers. Purfling bent to shape. Fine, medium, thick. The best made. 50 cents per set postpaid. D. P. Grant, Marblehead, Mass.

SONGS Professionally arranged for publication. Expert service. Submit poems. Brennen, 11660 Broadway, New York.

FREE! Song Writers Guide. Beaver, 1257 Elm, Green Bay, Wis.

SONG, Poem writers, investigate. French Farmer, Box 132, Cloverdale, Ind.

SONG Poets: Investigate! MacDonald's Service Bureau, 42 Keenan, Watertown, Mass.

COMPOSERS—Verse or music. Brilliant opportunity. Write VanBuren, 1964 McClurg Bldg., Chicago.

FELLOWSHIP Songs, new book, 83 songs, words and music, and Salute the Flag sheet music, both 50c prepaid. Lutz Printing Co., York, Penna.

"BANJOS" Should interest all musicians on account of the popularity of the banjo, as it easily increases a player's income. Illus. catalog of 48 pages free. The Bacon Banjo Co., Inc., Groton, Conn., U. S. A.

SONGWRITERS: Submit your song-poem or complete song! Will return it immediately if not acceptable! Chester A. Escher, Music Publisher, 125 West 45th St., New York City.

PLAY Piano by ear. A sound system. Particulars free. Boucher's Harmony Studio, Ottawa, Can.

SONGWRITERS—Arranging, composing. Free booklet. Tucker, 330 Wadsworth, New York.

SONGWRITERS: Substantial advance royalties are paid on publisher's acceptance. New booklet, "Song Requirements of Talking Pictures," sent free. Newcomer Associates, 790 Earl Bldg., New York.

SONG Poem writers. "Real" proposition. Hibbler, D1, 2104 N. Keystone, Chicago.

POEMS Wanted. Work guaranteed. We publish. Great Eastern Song Bureau, Dept. 27, Thomaston, Me.

SEND Song poems, 50-50 plan. Indiana Song Bureau, (Brookside), Salem, Ind.

VIOLINS. Deep, mellow, soulful—on credit. Easy terms for wonderful instrument. Get details today. Gustav F. Henning, 302 University Building, Seattle, Wash.

CORNETISTS—Trombonists—Saxophonists—Clarinetists. Get "Free Pointers" Name Instrument. Virtuosi School, Buffalo, N. Y.

"MUSIC Composed" to words. Bauer Bros. (formerly of Sousa's Band), Oshkosh, Wis.

SONG Writers. Send for our "Publishing Agreement." McKinley Music Printers, 1501 E. 55th St., Chicago.

WRITE Songs. Big money and reputation. Write for information. J. Gordon Pub. Co., 201 N. Hoyne Ave., Chicago.

SONG Poems solicited. A different proposition. Richard Broughton, Sioux Falls, S. Dak.

PATENT ATTORNEYS

UNPATENTED Ideas can be sold. I tell you how and help you make the sale. Free particulars (copyrighted). Write W. T. Greene, 906 Barrister Bldg., Washington, D. C.

LANCASTER. Allwine & Rommel, 221 Ouray Bldg., Washington, D. C. "Originators of the Form Evidence of Conception." Before disclosing your invention to anyone send for blank form to be signed and witnessed. Form and patent information bulletin free.

SELL Your invention before patenting. Write for free particulars. W. T. Greene, 901 Barrister Bldg., Washington, D. C.

CASH For your invention—patented or unpatented. Booklet free to inventors. Chartered Institute of American Inventors, Barrister Bldg., Washington, D. C.

INVENTOR'S Adviser with mechanical movements sent free. Labiner, 15 Parkrow, New York.

EDWARD C. Sasnett, attorney at law, formerly a principal examiner U. S. patent office. I offer to inventors and manufacturers a strictly personal service based on twenty years experience in patent work. 516 McGill Bldg., Washington, D. C.

PATENTS Procured. Prompt, careful efficient service. Highest references. Moderate fees. Send sketch or model for actual search and advice. George P. Kimmel, Master of Patent Law, 54-C Legal Bldg., Washington, D. C.

PATENTS Procured; low rates; easy terms. H. Sanders, Rand McNally Bldg., Chicago.

PATENTS—Write for our free book, "How to Obtain a Patent" and Record of Invention Blank. Send model or sketch of invention for inspection and instructions free. Terms reasonable. See advertisements on pages 130 and 141. Victor J. Evans & Co., 934 Ninth, Washington, D. C.

LACEY'S Patent Sense. Valuable book free. See ad page 143.

INVENTORS Service Bureau will send booklet and give you free advice concerning the proper procedure for obtaining patents on easy payment plan and at least expense. Dept. B, Union Trust Bldg., Washington, D. C.

REGISTERED Patent attorney-engineer. Expert in chemical and mechanical patent matters. Former patent examiner. Correspondence invited. A. Ponack, 401 Homer Bldg., Washington, D. C.

INVENTIONS Patented; confidential advice; inventions developed—representative for Blair Tool and Machine Corp.; trademarks registered. Edward Gottlieb, Patent Attorney, 5 Beekman St., New York.

PATENTS Procured; trade marks registered—preliminary advice furnished without charge. Booklet and form for disclosing idea free. Irving L. McCathran, 704 International Building, Washington, D. C.

PATENTS, Trade-Marks, Designs. This firm has 27 years' experience and gives expert personal service at reasonable rates. We properly protect your invention. Write for free information and exact cost of procuring patent before proceeding. John B. Thomas & Co., 902 F St., N. W., Washington, D. C.

INVENTORS: Send for booklet telling how to patent and sell your inventions at lowest cost. Ralph Burch, Patent Lawyer, 900 F St., Washington, D. C.

ESTABLISHED 1864. Milo B. Stevens Company. Free booklet. Patents. Trade marks. Copyrights. Offices, Monadnock Block, Chicago; Barrister Building, Washington, D. C.

INVENTORS—Write for our Guide Book, "How to Get Your Patent," and Evidence of Invention Blank. Send model or sketch of your invention for our prompt examination and instructions free. Randolph & Co., Dept. 430, Washington, D. C.

PATENTS. Prompt personal service. Write for information. Albert E. Dieterich, Registered Patent Lawyer, 621½ Ouray Bldg., Washington, D. C.

PATENTS. Send sketch or model for advice. Free book: "How to Obtain a Patent." Established thirty years. Highest references. Prompt service. Reasonable charges. Chandlee & Chandlee, 910 F St., Washington, D. C.

PATENTS. Booklet free. Highest references. Best results. Promptness assured. Send model or drawing for preliminary examination. Watson E. Coleman, Patent Lawyer, 724 Ninth St., Washington, D. C.

"INVENTOR'S Guide" valuable information, free. Frank Ledermann, Registered Attorney-Engineer, 1712 Woolworth Bldg., New York.

PATENTS—Write for free instructions. Send drawing or model for examination. Carl Miller, Registered Patent Attorney (former Patent Office examiner), 259 McGill Bldg., Washington, D. C.

PERCY S. WEBSTER, 203 Saving and Loan Building, Stockton, Calif. Patent booklet free.

FOR INVENTORS

UNPATENTED Ideas can be sold. I tell you how and help you make the sale. Free particulars (copyrighted). Write W. T. Greene, 907 Barrister Bldg., Washington, D. C.

SELL Your invention before patenting. Write for free particulars. W. T. Greene, 902 Barrister Bldg., Washington, D. C.

BIG Money made with good inventions. Get yours into action by sending full details to manufacturer with two large plants. G. W. MacDow, 200 Dartmouth St., Boston, Mass.

TO Inventors! We are in the market to purchase a good patent, preferably in the automobile accessory line. Will purchase outright or on a royalty basis. Room 403, % Popular Mechanics, 200 E. Ontario St., Chicago, Ill.

INVENTORS Notice! Your invention or improvement can be protected from theft without the expense of first securing a patent by using our new inexpensive copyrighted inventors protection system. Write for full particulars. Inventors Protection Bureau, Dept. E, 2032 Estes Ave., Chicago, Ill.

WANTED To buy, patent of merit, royalty basis. Drews, 1292 Teutonia, Milwaukee.

MARKET Your invention successfully—patented or unpatented. Modern plan; no fee; no commission. Booklet free. Chartered Institute of American Inventors, Barrister Bldg., Washington, D. C.

TIME Counts in applying for patents. See pages 138 and 139. Clarence A. O'Brien, Registered Patent Attorney, Washington, D. C.

INVENTIONS—Write for our free book "How to Obtain a Patent" and Record of Invention Blank. Send model or sketch of invention for inspection and instructions free. Terms reasonable. See advertisements on pages 140 and 141. Victor J. Evans & Co., 157 Ninth, Washington, D. C.

LACEY'S Patent Sense. Valuable book free. See ad page 143.

INVENTIONS Wanted—Patented, unpatented. If you have an idea for sale write Hartley, Box 928, Bangor, Me.

LOW Cost manufacturing. Large plant completely equipped for blanking, drawing, stamping and wire forming in any finish. Can save you money on your product. Our figures will convince. Eastern States Products, Box 721, New Haven, Conn.

GET Your own patents. Legal blanks. Complete instructions \$1. Cutting Sons, Campbell, Calif.

INVENTORS Universal - Educator - contains 900 mechanical movements; 50 perpetual motions. Tells how to obtain and sell patents. Suggests new ideas. Explains how to select your attorney and avoid patent sharks. Price (revised edition) \$1.00 postpaid. Albert E. Dieterich, 621 Ouray Bldg., Washington, D. C.

INVENTORS—Cash in on your invention now! Don't delay the sale any longer! Send for a free copy of our specially prepared booklet, "Turn Your Patent Into Money," today! It contains helpful information for all inventors. M. L. Rund, Mgr. Classified Advertising, Popular Mechanics Magazine, 200 E. Ontario St., Chicago, Ill.

PATENTS FOR SALE

HOUSEHOLD Article useful, patent pending. Arne, Birch, 5023 Mead Ave., Fordson, Mich.

PATENT For sale: Watering device, for watering plants, shrubbery at roots. Already on market. Box O, Honey Brook, Pa.

LUGGAGE Carrier for top of cars, adjustable to fit any four-door car with standard hinges. Big market; every tourist a prospect. (Patent pending.) Will sell for cash and royalty. S. Jepsen, 1001-07 State St., Racine, Wis.

FOR Sale or lease patent No. 1,668,028. Direction indicators for vehicles. May first, 1928. Address to inventor, Vicente Solla, Box 1007, San Juan, Porto Rico.

IMPROVED Sleeve holder for holding sleeve of undergarment while putting on outer garment. Austin L. Black, Colorado Springs, Colo. Box 552.

TOOTHPICK Dispenser. Patented. Write Louis Trnovec, Willow Springs, Ill.

PATENT 1,735,760. Ceiling ventilator, adjustable, inconspicuous, ornamental, removes foul air and noxious gases which collect near ceiling. J. Robt. Howard, 412 First National Bank Bldg., Tulsa, Okla.

PATENT For sale—Home automobile instructor device, enables a person to instruct himself to operate a car at home. Equipped with clutch, brake, accelerator and shift rod. Weighing 5 pounds. Self confidence after a few home lessons. Price reasonable. Patent No. 1,723,744. Issued August 6, 1929. M. J. McKenna, Inventor, 12 Condit St., Jersey City, N. J.

IMPROVED Ash tray, 2 compartments; enormous market; good proposition. James Coleman, 2111 E St., Northwest, Washington, D. C.

SALE Patent 1,581,231. Attachment for dumping fresco scraper. J. N. Rogers, 627 E. 23rd Ave., Spokane, Wash.

FOR Sale, patent on safety headlights for automobiles; prevents accidents; non-glaring. A very valuable invention. Al Biertuempfel, 37 Komorn St., Newark, N. J.

PATENTED Electric hammer, cheap; or partner to pay patent fee on 5 valuable inventions. Half interest. John Karcevsik, 1847 Superior St., Chicago, Ill.

ROBERTS' Transmission adapter for model T Ford engine gives approximately crankshaft speed to reverse. Jack Roberts, Yuba City, Calif.

FOR Shipping automobiles in box cars. A big saving for the shipper. New also practical in use. Felix Latzek, Grand Rapids National Bank, Fourth St., Grand Rapids, Mich.

CANADIAN Patent for sale. Process and composition for paint remover and several other purposes. Require only small plant, cheap to manufacture, good profits, big market. Supplying two Canadian railroads at present from United States plant. Geo. A. Beecher, Birmingham, Mich.

WE Sell patents by presenting them personally to manufacturers. Largest firm in U. S. Send description of patent or invention for examination. Harry G. Green & Company, 180 West Washington St., Chicago.

PATENTED Automatic flock trap nest. Incorporated. Sell for cash, or cash and royalties; or party to finance manufacturing. A. S. Baker, 412 West Manchester Ave., Los Angeles, Calif.

OUTRIGHT Or royalty newly patented paintbrush holder prevents curling. Wonderful possibilities. A. Justice, 206 East 78th St., New York.

SELL, Patented fountain pen. Crystal McCue, Goodells, Mich.

TIME Counts in applying for patents. See pages 138 and 139. Clarence A. O'Brien, Registered Patent Attorney, Washington, D. C.

FOR Sale one-third interest in patent No. 1,637,266. Price \$300.00. F. L. Perkins, Boise City, Okla.

PATENT On an excellent fly catcher superior to ordinary means. H. M. Linding, Os-jining, N. Y.

COMBINATION Motor truck, concrete and mortar mixer; establishing a new mixing principle and will prove a big money maker to manufacturer. Chas. Payne, 27 Fulton Ave., Waukegan, Ill., U. S. A.

OUTRIGHT Seed pan attachment to mowers. T. H. Dalton, Water Valley, Miss.

INVENTORS—Cash in on your invention now! Don't delay the sale any longer! Send for a free copy of our specially prepared booklet, "Turn Your Patent Into Money," today! It contains helpful information for all inventors. M. L. Rund, Mgr. Classified Advertising, Popular Mechanics Magazine, 200 E. Ontario St., Chicago, Ill.

MODELS AND MODEL SUPPLIES

INVENTORS—We build models. Send us your rough idea. Our master mechanics will develop it for you into a practical working model. Thirty years successful experience doing this very thing. Confidential service guaranteed. Bank references furnished. Send for free booklet "The Road To Success." Crescent Tool Co., Dept. A, Cincinnati, Ohio.

BLOCKS, Deadeyes, belaying pins, steering wheels, scale fittings. 11 W. 48th, New York City.

PRODUCERS Of results. Mechanical and consulting engineers. Our specialty models in metal. Designing, developing, building special machinery, manufacturing, experimental work, patterns, castings and model supplies. Reasonable rates. Inventors see or write us. 25 years in this work. The Johns Engineering Co., 1382 E. 17th St., Cleveland, Ohio. Dept. F.

MODEL Makers supplies. Engines, steam and gasoline books, blue prints, pulleys, gears, catalog 29c. Canada 25c. Refunded first order. Howard Engine & Mfg. Co., 2117 N. Ashland Ave., Chicago, Ill.

THE Modelmaker: An illustrated magazine devoted to practical model making. Sample 10c. Modelmaker, 122 Liberty St., New York.

TIME Counts in applying for patents. See pages 138 and 139. Clarence A. O'Brien, Registered Patent Attorney, Washington, D. C.

SPECIAL Machinery developed, designed and built. Patented or unpatented ideas developed, models made. Experimental work a specialty. Write Arthur Lansberry, Mechanical Engineer, 3009 Liberty St., Erie, Pa.

WORK With master machinist; 16 years experimental experience, well equipped shop. Albert Weiss, 161 W. 21st St., New York City.

SHIP Model fittings. Send dime for illustrated catalog No. 6. A. J. Fisher, 1002 Etowah Ave., Royal Oak, Mich.

LET Our experience be your guide. Models that are models; tools and equipment for economic manfg. Patterns of all types; manufacturing in all branches. Satisfaction guaranteed. United Machinery Company, Cincinnati, U. S. A.

WE Make working models for inventors and do experimental work and carry a complete stock of brass gears and model supplies. Send for catalog. The Pierce Model Works, Tinley Park, Ill.

SPECIAL Machine builders, tool and die makers, inventors' models production work of all kinds. Dept. L. Quality Hardware & Machine Corporation, Ravenswood and Thorndale Aves., Chicago, Ill.

MODEL Steam engines and boilers for miniature power boats. Boat and boiler fittings. New catalog 15c. Model Machine Shop, 212 Price St., Rahway, N. J.

HOME WORKSHOPS

GOOD Used hand-saws, jig-saws, wood craftsman's lathes, drills at special low prices. Waco Tool Works, 5212 West Kinzie St. Chicago.

MANUFACTURING

ECONOMICAL Manufacturing from sheet, bar, wire or tubing. Models, dies, special machinery. Swanberg, 5124 N. Klidare Ave., Chicago.

LOW Cost manufacturing. Large plant completely equipped for blanking, drawing, stamping and wire forming in any finish. Can save you money on your product. Our figures will convince. Eastern States Products, Box 721, New Haven, Conn.

SPECIAL Machinery or parts, dies, tools, metal specialties, models, special gears, stock gears and model supplies. Send for Catalogue. The Pierce Model Works, Tinley Park, Ill.

WIRE Goods made to order. Cooley Mfg. Co. 530 N. Western Ave., Chicago.

MANUFACTURING Models, dies, stampings, brass work, one or thousands. Circular free. Baum's Metal Specialties, Kansas City, Mo.

MACHINERY, TOOLS AND SUPPLIES

18"x6" VON WYCK Lathe, \$175.00; No. 11 $\frac{1}{2}$ Valley City plain milling machine, \$350.00; No. 60 Heald grinder, \$275.00; 21" Handy shaper, \$250.00; 15" Smith & Mills crank shaper, \$225.00; 30"x18" Filfield lathe, \$750.00; 20" silver upright drill press, \$80.00; Quincy air compressor with tank, \$65.00; 10" bench drill press, new, \$23.00. Terms to suit. Write for catalog. Cincinnati Machinery & Supply Co., 27 West Second St., Cincinnati, Ohio.

USED Arc welders, air compressors, buffers, grinders reconditioned, guaranteed like new. Shipped on trial and easy terms. If you need good guaranteed equipment, write today to Bob Jones, Box M-328, Troy, Ohio.

MAKE Your own lathe. Brand new castings partly finished. Stuart Kenelpp, Mt. Carmel, Ill.

LATHES, \$25 And up, also drills, millers, shapers and grinders. Klauber Machinery Co., 320 South Third St., St. Louis, Mo.

FOR Sale: Small punch press. B. L. Nortwed, Mitchell, S. Dak.

START Business of your own, small investment required, doing nickel, copper and silver plating. This work in big demand. Information free. Electro Platers Supply Co., 28 W. Second St., Cincinnati, Ohio.

CONCRETE Building block machines and molds. Easy payments. Catalog free. Concrete Machine Co., 5 North Main St., St. Louis, Mo.

USED Arc welders, air compressors, buffers, grinders, reconditioned like new. Shipped on trial and easy terms. If you need good guaranteed equipment, write today to Bob Jones, Box M-236, Troy, Ohio.

BUILD Your own lathe. About 8" swing. 12 castings postpaid for \$3.00. Stuart Keneipp, Mt. Carmel, Ill.

ENGINES, MOTORS AND DYNAMOS

NEW General Electric ½ hp. series compensated universal motor 110v., dc. or ac. 25 to 80 cycle. Speed 6,500 r.p.m. Armature mounted on Norma ball bearings. Dimensions: diameter 5½", length 9½", including shaft extension of 1"; shaft diameter ½". Note small size in comparison with standard ½ hp. motors, 1/3 size and weight. Weight complete 29 lbs. Fully guaranteed. \$25.00 f.o.b. Newburgh. Dumonvin Corp., 302 Water St., Newburgh, N. Y.

SEE Our big catalog on steam and gasoline engines, battery motors, dynamo-motors, lathes, drill presses, gears, books, blue prints, pulleys, hangers, bench saws, display tables, model makers' supplies and materials. Sent postpaid for 20c to Canada. 25c refunded first order. Howard Engine & Mfg. Co., 2417 N. Ashland Ave., Chicago, Ill.

FOR Sale: One-sixth hp. elec. motors, 60 cycle, 110 volt, a.c. slightly used, first class running condition, \$4.50 each. Cash with order. Maytag-Chicago Co., 160 E. Illinois St., Chicago, Ill.

BRAND New motor bargains. ¼ hp. a.c. \$7.50; 1/3 hp., \$10.50; 32v. motors, ¼ hp., \$8.50; 1/3 hp., \$12.00. 32v. motors with emery and buffer, \$6.00. Write for prices on larger sizes, motors and generators. Queen City Electric, 1736 Grand Ave., Chicago.

NEW ¼ Horse gasoline engines \$18.00; with 32 volt 5½ ampere generator and belt \$26.00. ¼ horse motors \$7.00; 1/3 horse \$10.50. Also other bargains. Electrical Surplus Company, Dept. 12, 1911 Chicago Ave., Chicago.

SAVE Money—Automatic air compressors, constant potential battery chargers, reconditioned, guaranteed like new. Real value—shipped on trial easy terms. If can use, write Baker Company, Box M-336, Troy, Ohio.

NEW Standard G. E. ¼ hp. washing machine motors. While they last \$9 each. Check with order. Reid-Way Co., Cedar Rapids, Iowa.

ELECTRIC Motor winding models and instructions. Gaines Bros., Gainesville, Tex.

GOVERNORS (Ours) will control any make of auto engine at any speed desired. Easy to install. \$10 C. O. D. Circulars. Candee-Smith Governor Co., 215 North Los Angeles St., Los Angeles.

TIME Counts in applying for patents. See pages 138 and 139. Clarence A. O'Brien, Registered Patent Attorney, Washington, D. C.

EDISON Phonograph motors with speed governor. Universal, \$5.00 plus express 10 lb. Geo. Schulz, Calumet, Mich.

COMPRESSORS, Twin cylinder, for small tire shops. Duco spraying. J. Trockman & Sons, Inc., 319-312 Lincoln Ave., Evansville, Ind.

STEAM Engines—One h. p. \$18.00; ¼, \$12.00. James Chambliss, Bessemer, Ala.

BENDING MACHINES

THE Famous Hossfeld "Wrenchless" Universal Iron Bender is the last word in bending machines. Bends metal, cold or hot, into most any conceivable shape. Including Eye Bolts and Automobile Spring Eyes. Bends up to 1" bars or 1½" pipe cold. Thousands in use by all classes of trade, from the smallest shops to the largest railway system. Write for circular and prices. Hossfeld Mfg. Co., Winona, Minn.

WELDING AND SOLDERING

START In highly profitable arc welding business, practically no expense. Our constant arc welder starts you on road to success. Easy monthly terms, liberal trial on money back guarantee. Write today. Hobart Industries, Box M-337, Troy, Ohio.

SURVEYING INSTRUMENTS

UNUSUALLY Low prices on rebuilt transits and levels. All makes. Guaranteed by the manufacturers of "Sterling" Surveying Instruments. Easy terms. Write for descriptive list M-43. Warren-Knight Co., 136 N. 12th St., Philadelphia, Pa.

LUMBER

33 RARE Wood samples \$2.00 postpaid, uniform size and labeled. Free price list. Craftsman Wood Service, CP-717 E. 62nd St., Chicago.

FARMS AND FARM LANDS

CANADA Tax sale, seized and sold for taxes. \$77 buys 3 acres large lake front, \$126 buys 40 acres farm, \$158 buys 82 acres on river, \$270 buys 160 acres with creek, \$360 buys 100 acres lake front, \$389 buys 200 acres Otter Creek. These properties, with several hundred others, are offered at the prices stated, no mortgage, no further payments. Beautifully situated hunting camps and fishing lodges where there is real hunting and fishing. Summer cottage sites, heavily wooded acreages, situated in Muskoka, Highlands of Ontario and the new North; also farms in Old Ontario, New Brunswick, Quebec, Prairie Provinces and British Columbia. Our 13th annual list just issued in the form of a twenty-page, illustrated booklet describes these properties and gives full particulars. It is mailed free on application. Now is the time to invest in Canada's minerals, forests and farms. Don't delay! These properties won't last long at these prices. Send no money, but send for booklet today so you will have first choice. Tax Sale Service, Room 613, 72 Queen St. West., Toronto 2, Canada.

LAND Opening—The Great Northern Railway serves an agricultural empire in Minnesota, North Dakota, Montana, Idaho, Washington and Oregon. These states abound in opportunities for small farmers or large operators to rent or purchase a farm at lowest prices and best terms of many years. Every kind of farming, grain, livestock, dairying, fruit, poultry; large acreage or small suburban tracts, rich cutover or high producing irrigated land. Write for free Zone of Plenty book with detailed information. Low home-seekers' rates. E. C. Leedy, Dept. 457, St. Paul, Minn.

OZARKS—20 Acres, poultry land, \$100, \$5 monthly. Fishing, hunting, trapping. Other bargains. Alvin Zimmerman, 1802 N. Fifth, Kansas City, Kans.

OZARKS—40 Acres Mo., \$5 month. Own a home. Jarrell, Mt. Vernon, Ill.

1,000 FARM Bargains, hundreds of pictures in Strout's big 136 page catalog country real estate and farms in 21 states. Just out! Free. Write today. Strout Agency, 255-P Fourth Ave., New York City.

GOOD Virginia farm priced to sell. Lieberg, Greenbush, Minn.

EASTERN Pennsylvania farms near Philadelphia. Write for bulletin giving prices, sizes and descriptions. Wilson George, Quakertown, Pa.

WANTED: Farms anywhere. Cash buyers waiting. National Brokers, 2515 Lakewood, Detroit, Mich.

LAND Bargains. Frank Madigan, Sharon Springs, Kans.

TO Sell, trade or buy property anywhere located write Fisher Realty Co., 108 Hannibal, Mo.

WANTED: Hear from owner having good farm for sale. Cash price, particulars. John Black, Chippewa Falls, Wis.

LAND Sale, \$5 down, \$5 monthly, buys 40 acres Southern Missouri. Price \$200. Send for list. Box 22N, Kirkwood, Mo.

MONEY Made in Mich. potatoes. \$10 down now and easy terms buys land near markets, lakes, streams. Write today. Swigart & Co., P-601, 32 N. State St. Bldg., Chicago, Ill.

PECAN Orange-Fig groves "On the Gulf." Monthly payments. Guaranteed care. Big, quick returns. Suburban Orchards, Dept. M., Biloxi, Miss.

SELL Your property quickly for cash, no matter where located. Don't pay big commission. Particulars free. Real Estate Salesmen Co., Desk B, Lincoln, Nebr.

861 PRACTICAL Ways to Reduce Farm Labor and Expense and Increase Income. One farmer writes he would not part with this information for \$100, if he could not duplicate it. Nothing experimental. These ideas have all been put to test and proven practical. Send today for a copy of our Handbook for Farmers and get ready to put these ideas into operation for your own benefit. Pay postman only 98 cents and the postage when he hands you the package. Popular Mechanics Press, Room 801, 200 E. Ontario St., Chicago.

POULTRY

20 BREEDS Baby chicks 8 cents up. Free catalog. Davison Hatchery, Grand River, Iowa.

DOGS AND PETS

ST. BERNARDS! Rare, beautiful thoroughbred puppies. Photos submitted, delivery guaranteed. Helvetia Kennels, 181-P McKenna Ave., Montreal, Que.

CHAMPION Bred wire-haired Fox Terriers, Cocker Spaniels, Collies, Glengae Kennels, Denville Ave., Boonton, N. J.

WHITE Collies and other colors. Beautiful and useful. Dept. P, Shomont Kennels, Monticello, Iowa.

COONHOUNDS, Combination fur hunters, foxhounds, beagle rabbit-hounds, cow-hide leather dog collars, name engraved, \$1.00. Texas steer blow horns, \$2.00. Running fits cure guaranteed \$1.00. Catalog. River-view Kennels, Ramsey, Ill.

FOR Sale. Minks, squirrels, raccoons, foxes, ferrets, muskrats, ginseng, rabbits, skunks, wolf pups, opossums. B. Tippman, Caledonia, Minn.

DOG Lovers—Every fact regarding every phase of dog training (all breeds) including psychology, obedience, guarding, swimming, rescue work, hunting, herding flocks, teaching tricks, finding lost articles, racing, war service, police dogs, sled dogs, etc., will be found in "Training the Dog," by Will Judy. Price only \$1.50. Pay postman when delivered or, if outside U. S., remit when ordering. Popular Mechanics Press, Room 809, 200 E. Ontario St., Chicago.

RABBITS

FINE Income from rabbits under our contract. Proposition covers housing, feeding, breeding, marketing. Build your own big business. Free particulars. Aulabaugh Fur Farms, Box 9, Waterloo, Nebr.

CHINCHILLA Fur rabbits for profits. Booklet information and instructions 10c. Parshalls Ranches, 11th and B, Lincoln, Nebr.

MAKE Money during spare time. Raise rabbits. Write for details on marketing and breeding. National Fur Farms, Kasota Bldg., Minneapolis, Minn.

STANDARD Rabbit Journal, Winchester, Ohio, 50c year, 2 months 10c.

RAISE LaSalle fur rabbits. Build big paying business. LaSalle Fur Co., Mt. Clemens, Mich.

MAKE Big profits with Chinchilla rabbits. Real money-makers. Write for facts. 852 Conrad's Ranch, Denver, Colo.

MAKE Big profit, chinchilla rabbits. Real money makers. Get the facts. Fox Farms, Inglewood, Calif.

MUSKRATS

MAKE Money from muskrat fur—Raise muskrats in dry land pens or hutches. Get the facts. 652 Conrad's Ranch, Denver, Colo.

ROOTS AND HERBS

HERB Doctor book—10 cents. 250 recipes for making herb medicines. Hazzard Company, Box 1, Vanderveer Park, Brooklyn, N. Y.

FREE! 96 Page "Medicine Man" book. Contains 250 valuable herb medicine preparations for home use. Botanics, 145 West 112th St., Chicago.

WANTED—MISCELLANEOUS

MAIL Us your discarded jewelry, gold, crowns and bridges, watches, diamonds, silver, platinum. Money promptly mailed. Goods returned if offer refused. United States Smelting Works (The Old Reliable), Dept. 71, Chicago.

HUNDREDS Of people have sent their old gold, silver, platinum jewelry, dental work to me. Why not mail yours today? Highest prices paid. Satisfaction guaranteed or goods returned. F. Polcer, 2408 South Cicero Ave., Cicero, Ill.

WANT Outboard motors, boats, guns, piano accordion, Sousaphones, coins, stamp, egg collection, rare jewelry, sculpture, fur rugs, diamonds, rare birds and animals. John Redshaw, Granville, Ill.

WANT Guns, diamonds, coins, anything valuable. Offer guaranteed radios, musical instruments. Dept. A, State Bank Bldg., Granville, Ill.

WANTED—Back numbers of Popular Mechanics Magazine. We will pay 25c each for the following copies delivered to us in good condition: July, 1924; April, 1925; November, 1926; January, 1926; March, 1928. Send to Popular Mechanics Magazine, Room 408, 200 East Ontario St., Chicago, Ill.

FOR SALE—MISCELLANEOUS

TYPEWRITERS, Radios, motorcycles, \$4.98-\$24.98. Terms, trade. Agents wanted. Knights, 1516 Locust, St. Louis, Mo.

ADDRESSOGRAPHS. Letter folders, multigraphs, envelope scalars, duplicators, less than half price. Guaranteed. Pruitt Co., Suite 108, 190 N. LaSalle St., Chicago.

WATCHMAKERS Lathe for sale at a bargain. R. Jaegermann, 5815 Easton Ave., St. Louis, Mo.

PERSONAL

ASTROLOGY—Learn what the stars predict for 1930. Will you be lucky? Will you win in love? Will your investments prove profitable? Would a change in occupation give you a larger salary? Our special 15-page astrological reading gives predictions—month by month—with exact days, dates and happenings for 1930 based on your sign of the Zodiac. Consult it before making any change in home or business affairs, signing papers, love, courtship, marriage, employment, travel, speculation, health, accidents, "lucky days," etc. Send exact birthdate with \$1.00 for complete reading. Franklin Publishing Company, 800 North Clark St., Dept. 330, Chicago.

THE Stars tell the truth. Is your life full of happiness, of all those things which you desire, or are you struggling in doubt and difficulty. Let the stars point out the pathway to health, love, success, happiness, show you your opportunities, warn you of dangers. Send 20 cents in postage stamps with your name, address and birth date and I will send you free a short but most interesting test reading of your horoscope, also a photograph and description of my wonderful Lucky Ring. Do not delay. Write now. Zanya, Edificio Castro, 25 and O, Vedado, Habana.

PYORRHEA? Trench mouth? Want relief? No medicine to sell. Personal advice by specialist. Ready for false teeth? Change your present plates to new unbreakable "Hecolite." Cash for old gold. Broken plates repaired. Dentists Laboratory, Box 691, South Bend, Ind.

LETTERS Mailed from here for 15c coin. Foster Mailing Service, 1443 W. 82nd, Chicago, Ill.

MAGIC Tricks, cards, books, illusions, etc. Catalog free. Geo. Fenner, Louisville, Ky.

MIND-READING Card set and fortune-telling dream book, 20c. G. Elsea, Bowling Green, Ohio.

ADVICE. Information 25c coin up. Experience. Ref. Fred Klotz, Reading, Pa.

BOOKLET Entitled "An Earful About California," postpaid one dollar. Greene, Dover, Mass.

YOU Can have a New York office and address. You may establish a branch office at our address for \$3.00 per month. Mail forwarded promptly. Translation in all languages. National Business Service Bureau, Room 200, 10 East 23rd St., New York City.

HOLLYWOOD Wisecrackers start another fad. Pig latin is all the rage. One hundred easy examples, including code, only 25c. Wilkie Mahoney, Author of "Hollywood Slangue," 1444 Gordon St., Hollywood.

RUPURED? Amazing invention. Pneumatic pads. Hold like the hand. Satisfaction guaranteed. Peterson, 1906 San Pablo, Oakland, Calif.

TOBACCO Habit overcome or no pay. 500,000 used Superba to help stop cigarettes, cigars, chewing, pipe, snuff. Treatment sent on trial. Costs \$2.00 if successful. Superba Co., L84, Baltimore, Md.

MISCELLANEOUS

MIRRORS Resilvered at home. Costs near 5 cents per square foot; you charge 75 cents. Profitable business plating autoparts, reflectors, tableware, stores, refinishing metalware, etc. Outfits furnished. Details free. Write Sprinkle, Plater, 288, Marion, Ind.

YOUR Personal monogrammed stationery 50c per box. Applebaum, 1258 Brook, New York.

CASH Paid for acceptable cartoons. Free particulars. Seamann Studio, 2104 Liberty, Terre Haute, Ind.

USE Radio for public address. Complete outfit two dollars. Ray Laboratories, Box 1183, San Francisco.

REFRIGERATING Machine, homemade. Inexpensive to build. Gives better service than ice. This and 328 other practical articles in our book "Home Mechanics." Just ask for this and "Handbook for Women," containing 394 valuable household helps and pay postman 98 cents and postage for the two books. Popular Mechanics Press, Room 801, 200 E. Ontario St., Chicago, Ill.

PATENTS Procured; low rates; easy terms. H. Sanders, Rand McNally Bldg., Chicago.

CASH Paid for Butterflies, Insects. See Sinclair Display Advertisement on page 22.

FREE Safety razor, value \$1.00 (Gillette style), send \$1.00 for 12 Waterman Superior razor blades. 72 shaves guaranteed or money back. Agents wanted. Waterman Razor Blade Corporation, 198 Broadway, New York.

TRANSFER Liquid—Transfers all pictures from books, magazines, newspapers, etc., 10c bottle, three for 25c. Send coins. No stamps. Address G. Clinch, Point Pleasant, N. J. Box 134.

QUIT Tobacco easy. Harmless home remedy. Nl-Ko System, Ojai, Calif.

AMATEUR Cartoonists: Sell your work. Write Smith's Service, PW1194, Wenatchee, Wash.

TIME Counts in applying for patents. See pages 138 and 139. Clarence A. O'Brien, Registered Patent Attorney, Washington, D. C.

AMATEUR Cartoonists earn \$25.00 week, spare time, copying or tracing cartoons for advertisers. 12 months contracts. 3-M Syndicate, Argyle, Wis.

MUSKRAT Farming—The greatest book on one of the greatest opportunities today. Tells of the opportunity in this business and how to do everything in connection with the raising and marketing of muskrats. Pay postman only \$2.25 and postage when delivered or, outside U. S., remit when ordering. Popular Mechanics Press, Room 809, 200 E. Ontario St., Chicago.

TATTOOING Outfits, supplies. Illustrated list free. "Waters," 965 Putnam, Detroit.

HOMEOPATHIC And Biochemic preparations sent postpaid to all parts of the world. Manual and booklet free. Halsey Bros. Co., 5547 Ravenswood Ave., Chicago, Ill. Established 1855.

CUTS Anybody can make. Simple, cheap process, \$1.25. Specimens, particulars. 2c stamp. M. Day, Windfall, Ind.

TELL An army of 3,000,000 live readers all about your offer! If you have anything to sell, buy or exchange, or if you have any reasonable proposition, tell our readers all about it—they'll respond quickly. Our booklet "How to Create More Business" contains some very interesting, helpful facts. Write today for your copy—it's free. M. L. Rund, Manager Classified Advertising, Popular Mechanics Magazine, 200 E. Ontario St., Chicago, Ill.

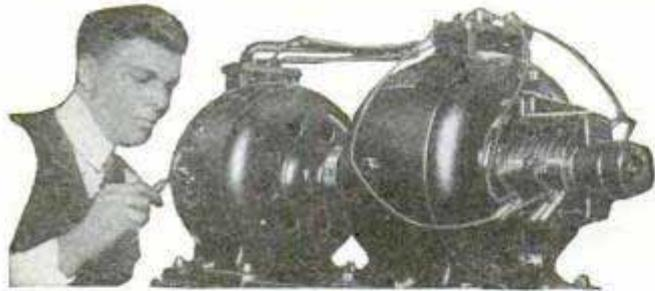

Amazingly Easy Way to get into ELECTRICITY

Don't spend your life waiting for \$5 raises in a dull, hopeless job. Now... and forever... say good-bye to 25 and 35 dollars a week. Let me teach you how to prepare for positions that lead to \$50, \$60 and up to \$200 a week in Electricity.

Learn Without Books or Lessons in 90 Days In the Great Coyne Shops

Lack of experience—age or advanced education bars no one. I don't care if you don't know an armature from an air brake—I don't expect you to. The secret of Coyne training is that it is ALL PRACTICAL WORK. No books—no dry lessons—YOU LEARN BY DOING on REAL ELECTRICAL MACHINERY. Everything from doorbells to power plants with instructors at your side at all times.

You can Earn while Learning, too

If you're short of money my Employment Department will help you FIND PART TIME WORK, and when you graduate they will help you get that BIG PAY ELECTRICAL JOB. I've done all this for thousands of others—I'll do the same for you.

AVIATION, RADIO AND AUTOMOBILE ELECTRICITY NOW

Right now I'm including my big new Aviation Electricity, Radio and Automobile Electricity courses at no extra cost.

COYNE ELECTRICAL SCHOOL
H. C. LEWIS, Pres. Established 1899
500 S. Paulina Street Dept. 30-74 Chicago, Ill.

GET THE FACTS

Coyne is your one great chance to get into Electricity. Every obstacle is removed. This school is 30 years old—COYNE training is tested—proven beyond all doubt—endorsed by many large electrical concerns. You can find out everything absolutely free. Simply mail the coupon and let me send you the big, free Coyne book of 150 photographs... facts... jobs... salaries... opportunities. This does not obligate you. So act at once. Just mail coupon. **GET THIS FREE BOOK.**

H. C. LEWIS, President
COYNE ELECTRICAL SCHOOL, Dept. 30-74
500 S. Paulina St., Chicago, Ill.

Please send me your Free, Illustrated Book on Electricity and Coyne. No obligation. Give details of special offer too.

Name

Address

City.....State.....

This "Crazy Scheme" Made Me Independent

Learn the secret of my success. Be a Real Estate Specialist. Start at home in spare time. Use my successful system. Free Book shows how.

"IT'S a crazy scheme," said some of the old-time real estate men. But with this "crazy scheme" I made a net profit of \$100,000 in less than five years—enough to make me independent for life.

So, no matter where you live, or what you are now doing, or what your sex or present age may be, if you want to learn all about my "crazy scheme"—if you want to do as I did—if you want to make big money—right at home—in your spare time—mail coupon at once for a free copy of my beautiful, new, illustrated book, which contains the biggest and best money-making business opportunity you ever heard of.

Use My Money-Making Method

When I started in real estate, I turned my back on all the ancient, threadbare, moss-covered methods of the past, and used a simple, scientific system of my own which is as far superior to the old-time methods as the radio is superior to the old-style music box.

With little education—no real estate experience, no money, no pull, I started a new kind of real estate business which met with overwhelming success.

If you want to follow the trail I blazed—if you want to use my amazingly successful system—write

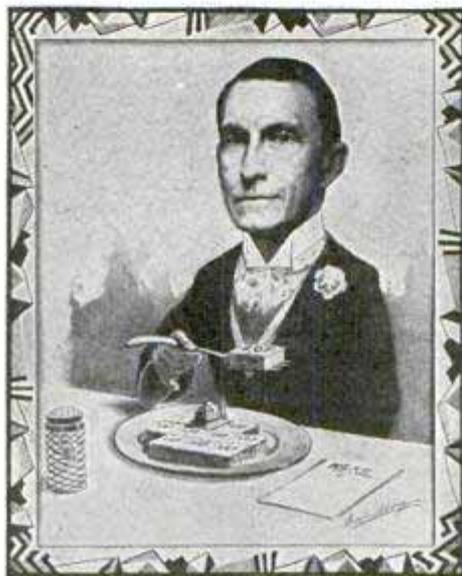

A well-known cartoonist's conception of my idea.

for my free book now. It tells how I won success, how I have helped other men and women succeed, how you, too, can succeed, how you can have a high-class business of your own and make more money than you ever made before in your whole life.

A Remarkable Business

The real estate business—run my way—is a wonderful business. It is as permanent as Mother Earth itself. And it is constantly increasing as our great country grows. It does not require years of study like most other trades, businesses or professions. And it pays big profits to ambitious men and women. Users of my methods report earnings of \$1,000, \$2,000, \$5,000—and more—on single deals; as

much as the ordinary man or woman gets for months and years of hard work. And the business is practically unlimited. Ten million properties are always for rent, sale or exchange. And you can start—right at home—in your spare time. I did. So did others. So can you. My free book tells you how.

What Others Say

Read the following record of results achieved by a few users of my remarkable system.

Anthony C. Maurell, New Jersey (former barber), reports earnings of \$4,133 in three months in my kind of a real estate business. Mrs. Kate Luke (65-year-old widow) says she has averaged \$200 weekly. W. E. Shoop, Pennsylvania (former weaver), earned \$6,000 in one deal. A. D. Perkins, Connecticut (former wood worker), reports earnings of \$1,252 in one month. J. W. Randolph, North Carolina (former grocery clerk), reports sales in 2 weeks that paid him \$510. W. B. Campbell, Kansas (former druggist), made real estate sales amounting to \$22,875 in one day.

These are a few samples of the successes you will learn about in my free book. Get it. Read it. Follow its instructions. Make big money my way.

Send for FREE BOOK

My free book, "How to become a Real Estate Specialist," is filled with astounding facts about my kind of a real estate business. It tells what I have done—what others are doing—what you can do in this big field of opportunity.

Mail coupon at once and get all of this valuable money-making information free. For although this book costs you nothing, it may be worth more to you—in actual dollars and cents—than any other book you have read. So, mail coupon now and learn all about the "crazy scheme" that made me independent for life. Address President, AMERICAN BUSINESS BUILDERS, Inc., Dept. CC-44, 205 East 42 St., New York.

Mail Coupon



For FREE Book

President, American Business Builders, Inc.,

(Established 1917—Authorized Capital \$500,000)

Dept. CC-44, 205 East 42 St., New York.

Please send me—without cost or obligation—your new, illustrated book, telling how you will help me make big money in real estate, without capital or experience.

Name.....

Address.....

City.....State.....



Which Job do YOU Want

Lawyer



Auto Expert

Try for it for This



Civil Engineer



Business Manager
way

Men don't just fall into easy jobs of big pay positions—they prepare for the big chance before it comes.

Make up your mind today what you want to be, then take the first step at once. You don't have to go to college to get ahead. Other men have gone there for you and have put the things they learned there and through years of practical experience into easily understood books which give you a short cut to a better and a bigger job.

We have picked 13 of the best paying professions and have published for your benefit new editions of the most practical, the most valuable books we have ever printed on the subjects covered.

JIFFY INDEX

Our new Jiffy Index makes each book a quick reference work—no time need be wasted in search or study—put your finger on the facts you want instantly.

Special Price List of Pay-Raising Books

- Automobile Engineering, 6 volumes, over 2,500 pages brand new 1930 edition \$24.80
- Civil Engineering, 9 volumes, 3,900 pages, 3,000 pictures . . . 34.80
- Practical Business Administration, 12 volumes, 3,400 pages. (Extra volume containing self quiz reading course of 80 lessons included free) 39.80
- Electrical Engineering, 8 volumes, 4,300 pages, 3,200 illustrations 34.80
- Modern Shop Practice, 7 volumes, 7,250 pages, 3,000 pictures . 29.80
- American Law and Practice (with reading course), 13 volumes, 6,000 pages, illustrated 49.80
- Telephony and Telegraphy, 4 volumes, 1,728 pages, 2,000 pictures 14.80
- Sanitation, Heating and Ventilating, 4 volumes, 1,454 pages, 1,400 pictures 14.80
- Drawing, 4 volumes, 1,578 pages, 1,000 pictures, blue prints, etc. 14.80
- Employment Management and Safety Engineering, 7 volumes, 1,800 pages, 540 illustrations, charts and diagrams. 24.80
- Architecture, Carpentry and Building, 5 volumes, includes 58 beautiful architectural plates free (Special Price) 19.80

SHIPPED FREE

Words alone cannot describe the full value these books may be to you, so we ship Free for Examination. Pick the set you want, the price is plainly shown, but **Send No Money**; just your name and address, and the books will be sent promptly. Take fifteen full days to read, test and examine them. You'll realize at once what a tremendous force for a better future they can be. After fifteen days you send only \$2.00; then \$3.00 per month until the balance is paid. **There Are No Interest Charges of Any Kind**; the price shown is the total cost.

MEMBERSHIP FREE

Anyone who takes advantage now of this opportunity to "Raise his Pay" will be given absolutely free, a certificate of membership in the American Technical Society, which entitles him to full consultation privileges with our experts in his chosen field. This is good for a whole year and is of tremendous value in solving special problems.

**American Technical Society, Dept. X319,
Drexel Ave. at 58th St., Chicago, U. S. A.**

Please send me set of

for **Fifteen Days'** examination. I will examine the books thoroughly and if satisfied, will send \$2.00 within 15 days and \$3.00 each month until I have paid the special price of \$ If I decide not to keep the books I will return them at your expense at end of 15 days.

Name
Address
City State
Reference

Amazing New Oil Burner.... Revolutionizes Oil Heat Costs



Now you can get Oil Heat cheaper than ever before—so cheap every home can afford it. The New Griswold Oil Burner combines low initial cost with low operation cost into the perfect burner. Saves fuel bills. Brings you the convenience and comfort that only oil heat can, and at an amazingly low price.

ABSOLUTELY FOOLPROOF

The Griswold burns oil and air a new way. Absolutely different from any other burner on the market today. By means of its indestructible patented mineral wick, it converts oil into hydro-carbon gas, the most outstanding means of creating heat ever known. Every bit of it burns. Siphonic constant level valve prevents overflow. Absolutely safe. Can't go out!

**NO SMOKE, SOOT OR GREASE
SLASHES FUEL COSTS**



There is absolutely no smoke, soot, or grease. No wasted fuel going up the chimney. Because it utilizes every bit of oil, Griswold slashes fuel costs to a minimum.

FITS EVERY STOVE OR FURNACE

Quickly, cheaply, easily installed. Fits every heating plant and heating requirement. Nothing to adjust. Fully automatic. Nothing to get out of order. No expensive replacements. Quiet. Guaranteed. Send now for complete information, sensational low price, and easy terms. Dealers get the details about our exclusive franchise. Write today.

GRISWOLD OIL BURNER COMPANY

3005 N. Union St. Griswold, Ia.
U. S. A.

Chemistry for Boys

AND OTHER BOOKS

Boys! Here's a complete library of the most interesting sciences in the world. Have fun learning chemistry and these other allied subjects. Earn extra money making and fixing hundreds of useful things. Make fascinating experiments. These four books tell how. Practical. Easy to understand. Written specially for you.

- Chemistry** 82 Illustrations 265 Pages
COVERS: Experimenting with water, gases, acids, bases, salts, metals, alloys, amalgams; practical and home chemistry; brilliant chemical tests; electro-chemical arts; chemistry in photography; acids, warfare; synthetic chemistry; apprentices tables; charts, etc., etc.
- Physics** 101 Illustrations 305 Pages
COVERS: Matter, measurements, force, machinery, liquids, gases, wave motions, sound and musical instruments, phenomena of heat, steam and other engines, light and optical instruments, x-rays, radium, future of physics, etc., etc. Over 71 experiments.
- Electricity** 125 Illustrations 333 Pages
COVERS: Home laboratories; galvanometers, batteries, magnetos, coils, condensers, dynamos, motors, transformers, telephone and telegraph sets, electric bells, fans, irons, house lighting, ignition, radio, hook-ups, circuits, etc. How to make repairs, etc. Over 51 experiments.
- Astronomy** 110 Illustrations 291 Pages
COVERS: Movements, measurements, relation, etc., of earth, sun, moon, stars, planets. Facts about sun spots, northern lights, magnetism, eclipse, comets, meteors, coronas, etc. How time is told, navigation, mapping, practical astronomy, astronomy for Boy Scouts, etc., etc.

1194 Pages
418 Illu.
121 Exp.



Complete Set Only

\$9.45

SEND NO MONEY—MAIL COUPON

E. P. DUTTON & CO., 294 FOURTH AVE., N. Y. C.
Send Dutton Science Library. I will pay postman \$1.45 plus postage on arrival and send you \$2.00 a month thereafter for 4 months. If not satisfied, return in 10 days. Money refunded.

Name
Address
City State
Note: If cash accompanies order, set is only \$8.45 Prepaid.

Be The Man Behind The Camera

**BIG PAY
FASCINATING
WORK**

\$60 to \$250 and more a week—that's the salary of a motion picture cameraman, the most fascinating job in the world. Play a major part in the production of the great movies that thrill the country.

Trained cameramen are in great demand—not a foot of film can be made without them. One of these enjoyable, lucrative positions, a position that offers big pay and future unlimited, can be yours—easily—quickly!

EASILY LEARNED THIS NEW WAY

Now, right at home in your spare time, you can quickly qualify for a well-paid position

as a skilled Motion Picture Cameraman. You learn everything there is to know about motion picture photography—from short newsreels to great feature pictures. In an amazingly short time you will find yourself ready to step into a high-salaried position—capable of going out "on location" and taking every kind of moving picture.

SEND FOR BIG FREE BOOK

Write today for your copy of our FREE book, which gives full particulars about the ever-growing field of photography—motion picture projection and photography, still photography and photo-finishing—and shows how you can quickly qualify for a well-paid position.

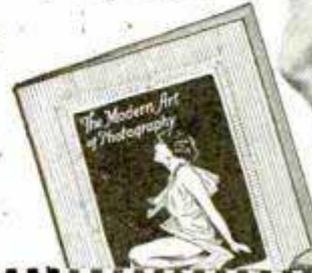
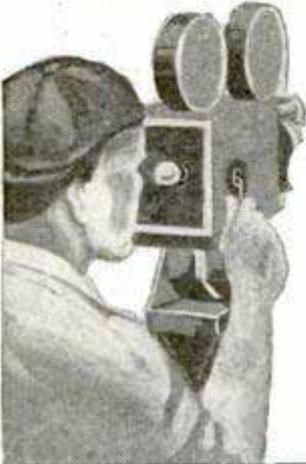

N. Y. Institute of Photography,
Dept. H-1412, 2 West 33rd St.,
New York, N. Y.

Without cost or obligation send me a copy of your FREE Book and details about how I can qualify as:

Motion Picture Cameraman
 Motion Picture Projectionist
 Commercial Photographer
 Photo-Finisher

Name.....
Address.....
City..... State.....

YOUR SUCCESS COUPON



United States
Government
APPROVED SCHOOL
for Transport-
Limited Commercial
Private Pilot-
Ground & Flying.

Trained Men Are Needed

There is money for you in aviation if you get thorough training now! Commercial aviation needs men and there is an ever-increasing demand ONLY for those who have been properly trained. Our courses will give you this training—they are taught under the direction of U. S. Licensed transport pilots and mechanics and cover everything about planes, motors, their maintenance and construction. The training which the student receives at The School of Von Hoffmann is the exact training which he must have to qualify for an immediate position on the ground or in the air.

Thorough Instruction at Low Cost

Our equipment is new and of modern design, subject to U. S. Gov't inspection—the cost is low considering actual flying and the thoroughness of ground instruction on latest modern type of planes, Wright Whirlwind and other standard motors. No student bond required. Mail the coupon for complete information—indicate course desired.

VON HOFFMANN AIRCRAFT SCHOOL
127 Lambert-St. Louis Flying Field ST. LOUIS, MO.



Easy Monthly Payments

It is easy to pay the Von Hoffmann way because small monthly payments are extended. Let us show you how you can start now and pay later, even after you have finished the course of training.

World Famous Pilots TRAINED HERE

Our field is identified in the world of Aviation as an outstanding place to enjoy the best training—a place where conditions are ideal—from here was started the 'cross the Atlantic Flight that convinced the world what could be done, and more recently the world endurance flight record was established here.

VON HOFFMANN AIRCRAFT SCHOOL
127 Lambert-St. Louis Flying Field
St. Louis, Mo. MAIL TODAY

Please mail FREE information at once.

Name.....
Address.....
City..... State.....
Age..... I am interested in
FLYING COURSE HOME STUDY
GROUND COURSE
WELDING COURSE



Who Else WANTS A GOOD DRAFTING JOB?

During the past few months we have placed *hundreds* of former mechanics, office men, building-trades workers and even beginners in fine Drafting positions—with Contractors, Architects and in big manufacturing plants all over the United States.

These men come to us because they are dissatisfied with their earnings and future prospects. Now they are doing work they like—making good money—and *have a real chance to advance still further.*



Starts at \$40 a Week

"Thanks for helping me get a Drafting position with Slyker Co., starting at \$40 a week."
*Oskar R. Ludwig
Gary, Ind.*



"I have obtained a position as a Junior draftsman with the Muncie Oil Engine Co. I appreciate your aid in obtaining this position very much."
Maurice N. Bareham

Why We Recommend DRAFTING

It will pay you to investigate Drafting. You'll find many of our most successful Contractors, Engineers, Superintendents and Executives **STARTED** in the Drafting room. The work is interesting and pleasant. The hours are easy. You'll work with a wonderful bunch of fellows. Salaries range from \$35 to \$50 a week for beginners, up to \$5,000 a year and more for experienced Draftsmen. And best of all you can learn easily in your spare time, right in your own home.

Jobs When You're Only Half Way Through!

We have recently developed a remarkable placement service which enables us to help find good positions for students when only *half way through* the course. These men are making **RAPID** progress because they are combining sparetime study with practical experience on the job.

Over 70,000 Drafting positions were advertised during the past year. Here is one of the biggest fields you can get into. Right now we are making an interesting proposition to ambitious men—mail coupon for complete information.

AMERICAN SCHOOL Dept. D-347, Drexel Ave. and 58th St., Chicago, Ill.

AMERICAN SCHOOL, Dept. D-347
Drexel Ave. and 58th St., Chicago, Ill.

Please tell me, without cost or obligation, about your training and employment service in line marked X below.

DRAFTING

- | | |
|---|---|
| <input type="checkbox"/> Architecture | <input type="checkbox"/> Business Management |
| <input type="checkbox"/> Building | <input type="checkbox"/> Accounting |
| <input type="checkbox"/> Structural Steel | <input type="checkbox"/> Mechanical Engineering |
| <input type="checkbox"/> Civil Engineering | <input type="checkbox"/> Shop Superintendent |
| <input type="checkbox"/> Auto Engineering | <input type="checkbox"/> Foremanship |
| <input type="checkbox"/> Electrical Engineering | <input type="checkbox"/> High School in 2 years |

Name.....
Street No.....
City..... State.....
Age..... Occupation.....

Books on 32 Subjects

Popular Mechanics Press specializes in supplying books on any subject. Look over this list. Check the books you want, and mail this advertisement as your order blank. Catalog with lists on 2,000 subjects free.

- | | |
|--|--|
| AIRCRAFT (Modern)
Complete, Up-to-date... \$5.00 | FURNITURE REPAIRING
Finishing and Decoration... \$5.00 |
| ARTIST (Commercial)
Money-Making Art... \$5.00 | HYPNOTISM
A Reliable Treatise... \$2.00 |
| ATLAS (of World)
Modern. New Boundaries... \$3.00 | INVENTIONS
How to Make Pay... \$2.50 |
| AUTOMOBILE (Modern)
Gasoline. New Edition... \$5.00 | MAGIC
World's Best Book of... \$2.00 |
| BOOKKEEPING
Practical Handbook... \$1.00 | MIRRORS
Silvering... \$1.00 |
| BRICKLAYING
Plain and Fancy... \$1.50 | MODEL ENGINEERING
Very Interesting... \$4.00 |
| CARBURETORS (All Makes)
Only Book Covering... \$2.00 | PLASTERING
Best Instruction Manual... \$1.25 |
| CHALK TALK
and Crayon Presentation... \$1.25 | RADIO ENCYCLOPEDIA
Very Complete... \$6.00 |
| DRAWING
Freehand and Perspective... \$1.50 | REAL ESTATE
Educator... \$2.00 |
| DRY CLEANING (Practical)
and Dyer... \$3.00 | SHOW CARDS
Artistic... \$3.50 |
| ELECTRICAL SYSTEMS
Automobile... \$3.50 | SIGNS (Artistic)
How to Make... \$3.50 |
| FLOWER RAISING
1001 Questions Answered... \$2.00 | Steam Engineer's License
How to Obtain... \$2.00 |
| FLYING
A B C of... \$1.50 | STEEL SQUARE
How to Use... \$1.00 |
| FUNNY PICTURES
How to Draw (by Zim)... \$3.00 | TELESCOPE (Amateur's)
How to Make... \$3.00 |
| FUR RAISING
For Profit... \$4.00 | TOOLS (Using)
Tinkering with Tools... \$2.00 |
| | TRICKS (200)
For the Amateur... \$1.00 |
| | WOOD FINISHING
Plain and Decorative... \$2.00 |

SEND NO MONEY

Just check the books you want, and mail the whole advertisement. It is your order blank. When postman hands you books, pay him the price and the postal charges. If outside the U. S. remit when ordering and include 10 cents per book extra for postage.
POPULAR MECHANICS PRESS, Room P3, 200 East Ontario St., Chicago, Ill.

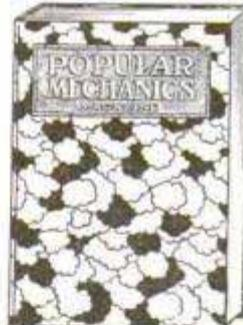

ATTRACTIVE NEW BINDERS

For Popular Mechanics Magazine
In your choice of colors; blue, green, brown, red or black. We recommend these beautiful and durable art binders to libraries, schools, reading rooms and our readers generally.

An Ornament To Any Reading Table

You will be delighted with the artistic waterproof covers in colors and other improved features.

Price \$1.25 Each
Postpaid

Your name in gold on the front cover for 25 cents additional.
Address

Popular Mechanics Company, 200 E. Ontario St., Chicago

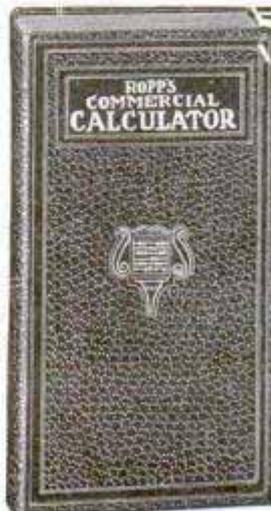

Mathematics Made Easy by ROPP'S CALCULATOR AND SHORT-CUT ARITHMETIC

Shows the Answer as Quickly as a Watch shows the Time to all Problems likely to occur in the Office, Store, Shop, Bank, Farm, or Factory.

Over 2,000,000 Sold
Explains and simplifies every principle in Arithmetic, Mechanics, and Mensuration.

PRICES POSTPAID
Desk Size, Flexible Keratol Binding... \$2.00
Pocket Size, Art Leather Binding... \$1.00
Pocket Size, Cloth Binding... \$0.50

POPULAR MECHANICS PRESS
Room P3 200 E. Ontario St. Chicago

HEALTH is POWER

Would you like to get ahead? Do you long for promotion, more money, bigger opportunities, power? You can win out over those whose natural capabilities exceed your own—if you will follow the same path that every successful business leader has trod.

Why does one man win; another fail? Search into the lives of the successful and you'll discover a certain group of characteristics common to all. These qualities have not been inherited; they have been acquired. They are—great Will Power, keen Mental Strength, high Courage. Yet your answer lies not in any one of these, nor even in all of them combined. You will find it only in the single attribute that nourishes and dominates them all. The secret of success is Energy.

WHY MANY FAIL

Vitality you must have to win—yet the glorious sense of power it gives can never be yours if your body is run down and your nerve cells exhausted. How can a man do serious, constructive mental work if his blood is like water or his whole system is poisoned by constipation? The ordinary day's routine leaves him worn out; he simply lacks energy to apply himself, which is the difference between success and failure. How can a man whose brain is foggy and whose memory falters make those lightning-swift and accurate decisions that characterize the real executive? He can't. The vim, the dash, the snap, the will-to-do simply is not in him.

Develop Your Physical and Mental Energy

Pep, push, power—vim, vigor—the will-to-do you MUST possess if you would rise above the dead level of mediocrity in business. Surprising as it may seem, it is not a mysterious property that either you have or don't have according to whether it was born within you. It is a quality that can be acquired.

LIFE'S ENERGY THROUGH STRONGFORTISM

LIFE'S ENERGY THROUGH STRONGFORTISM tells you the facts about the human body. This remarkable book explains how the modern science of Strongfortism develops and strengthens every muscle of your body—the internal muscles as well as those you can see—how Strongfortism assists your body to throw off poisonous waste material, conquers constipation, aids the assimilation of what you eat, fortifies your system against disease, clears up your present ailments, rebuilds wasted tissue in your muscles and organs, produces a richer quality and circulation of your blood, increases your lung capacity and thus purifies your blood, making it more capable of nourishing every portion of your muscular tissue, nerve cells and brain substance.

Send for This FREE BOOK

LIFE'S ENERGY THROUGH STRONGFORTISM makes no preposterous claims. It is simple, direct and written in language that everybody can understand. Reading this book doesn't make you a "big shot" in business—it does show you how "big shots" are made. Reading this book doesn't raise your salary—it does demonstrate why Strongfortism has helped to increase the earning power of thousands who have made it a part of their daily lives. Reading this book doesn't obligate you in any way, neither does it bring a salesman to your door—it does tell you the facts about yourself, your body, your life and your possibilities; the very facts you want to know and should know. LIFE'S ENERGY THROUGH STRONGFORTISM is illustrated throughout with honest, unretouched photos; it comes to you in a plain wrapper. Send now for this book with its priceless information.

LIONEL STRONGFORT

PHYSICAL AND HEALTH SPECIALIST
FOR OVER 30 YEARS

Dept. 37

Newark, N. J., U. S. A.



LIONEL STRONGFORT
Physical and Health Specialist

SEND THIS COUPON

Free Confidential Consultation

Mr. Lionel Strongfort, Dept. 37, Newark, N. J.—Please send me absolutely free my copy of your book, "LIFE'S ENERGY THROUGH STRONGFORTISM." This does not place me under any obligation and no salesman is to call on me. I have marked (x) before the subjects in which I am most interested.

- | | | | |
|----------------|------------------|----------------------|----------------------|
| Acne | Flat Chest | Lung Trouble | Sinus Trouble |
| Asthma | Falling Hair | Lumbago | Stomach |
| Arthritis | Gastritis | Nervousness | Disorders |
| Biliousness | Halltosis | Neuralgia | Skin Disorders |
| Black Heads | Hay Fever | Neuritis | Stooped |
| Body Odor | High Blood | Obesity | Shoulders |
| Bronchitis | Pressure | Pimples | Tonsillitis |
| Catarrh | Headaches | Poor Circulation | Torpid Liver |
| Colds | Heart Weakness | Poor Memory | Underweight |
| Constipation | Indigestion | Rheumatism | Weak Eyes |
| Dependancy | Insomnia | Rupture | Wandering Mind |
| Dizzy Spells | Increased Height | Great Strength | Weak Back |
| Falling Arches | Kidney Trouble | Muscular Development | Weaknesses (Specify) |

Name.....
 Age..... Occupation.....
 Street.....
 City..... State.....

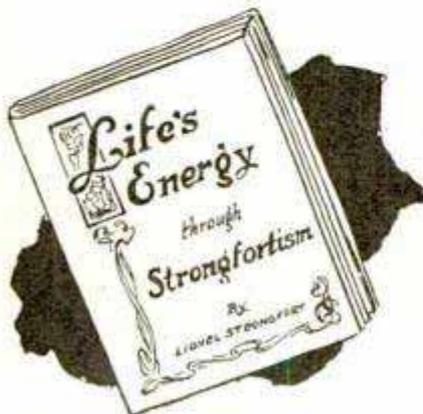



RADIO NEEDS YOU

Learn at home!

THOUSANDS of positions are opening up in the field of radio. It seems certain that for the next five years there will be more jobs than there are trained men to fill them.

This is your opportunity! Study radio now, at home. Train yourself for a position as radio operator on a ship or in one of the many new land communication stations. Get the knowledge you need to become a radio expert on installations or service.

Radio has only begun to grow. Get in now, and rise with this fascinating business.

You don't have to give up your present job, or spend your savings on tuition. The International Correspondence Schools plan lets you learn while you earn—at home, in spare time.

Famous radio authorities have prepared the great I. C. S. Radio Course. It is complete—up to the minute. Even the latest developments, such as television, are covered. Many graduates of this course are already earning big salaries in the various branches of radio.

Find out *today* just how the I. C. S. can train you for a radio position. There is no obligation in asking. Just mark and mail the coupon.

INTERNATIONAL CORRESPONDENCE SCHOOLS
Box 5675-F, Scranton, Pa.

Without cost or obligation, please tell me all about the

N E W R A D I O C O U R S E

Name _____

Street Address _____

City _____ State _____

If you reside in Canada, send this coupon to the International Correspondence Schools of Canada, Ltd., Montreal.

34 Lesson Drawing Course \$2.98

The biggest value you ever saw advertised anywhere



Haven't you often wished that you could draw cartoons, illustrate some idea, sketch some pretty face, etc.? You can do all of these things. One of America's most famous Cartoonists and illustrators has developed a great, simple system for success in all branches of Commercial Art. This system has revolutionized the entire theory of drawing. It means that drawing can be as easy for you as writing—much simpler than learning shorthand, bookkeeping or typewriting. We are now placing this original system for learning Drawing, Art and Cartooning, consisting of 34 lessons with over 500 illustrations, within reach of every one. If you will devote a few hours each week to the Course WE ABSOLUTELY GUARANTEE that you will learn to draw and draw well before you have half finished the Course. If we fail to make this claim good, we will refund every cent paid us. By eliminating a large office force for answering correspondence, expensive catalogs, etc., we are enabled to make a price of \$2.98, the cheapest price ever known for a high-grade, home study course. Learn to draw. It is a big asset, no matter what field you are in.

Send No Money

Just order the course and on arrival pay postman **\$2.98** plus a few cents postage, payment in full for the entire Course and Drawing Outfit. If not entirely satisfied, return within five days and we will Refund Money. Address: **LEDERER SCHOOL of DRAWING, Dept. 448-6, Chattanooga, Tenn.** Orders from outside the U. S. A. are payable \$3.28 cash with order.

If you order the course at once, we will include a drawing outfit, consisting of artist's pencils, pens, paper, erasers, thumb tacks, etc., enabling you to go to work without any additional cost.

Electricity for Boys

Boys! Study electricity. Have fun experimenting, repairing, building useful things. Earn extra money. This book tells how. Send for it today. COVERS: Home Laboratory, how to make galvanoscopes, batteries, magnets, telephone, telegraph sets, radio sending-receiving apparatus; hundreds more. How to repair motors, transformers, electric bells, irons, fans, etc. **333 pp., 125 ill., 51 exp. Charts, diagrams, book-ops, etc. Fun galore. Practical. Easily understood. Only \$2.45. SEND NO MONEY. Pay postman.** If not satisfied return in 10 days. Money refunded. Order today or send for circular. **E. P. DUTTON & Co., 292 Fourth Ave., N. Y. C.**

IT'S READY!

Our New Series of Pictorial Home Study Units to tell you everything you want to know about Aviation. . . .



It's Complete... Up-to-Date... Modern in Plan and Method.... Let's get acquainted!

We will introduce ourselves by sending you the First Lesson Unit FREE if you are interested enough in Aviation to pay the handling and mailing expense, 25 cents. Splendidly printed on best quality enamel paper. This text has over a hundred illustrations including a beautiful double spread art map of the world in colors showing historic flights.

ACT NOW! FREE EDITION LIMITED!

Junior Air Service of America, Inc.

75 East Wacker Drive, Chicago, Ill.

I accept your offer of the First Lesson Unit Free as advertised and enclose 25 cents handling and mailing charges.

Name _____ Age _____

Street Address _____

City _____ State _____ PM3

Did You Ever Fall in Love With Words?

Words have amazing powers. The world offers its treasures of money, power, and position to the skilful users of them. There are words for every occasion—words that thunder commands; words bristling with compelling force; words of zephyr-like delicacy; words of inspiration; words of romance; words to bend men's minds to your will; words to express every shade of meaning.

Through a justly famous easy method of spare-time study at home you may make words the playthings of your moods, the tools of your necessities. You can learn how to weave them into stories that sell; advertisements that convince; letters that win.

GET THE FREE BOOKLET

"How to Become a Master of English" tells you all about the Kleiser Practical English Course which is endorsed by famous writers as Booth Tarkington, Irvin S. Cobb, Mary Roberts Rinehart. Ask for it on a postcard, or write your name in margin and return this advertisement, and the booklet will come to you by mail, free of charge. No agents will call.

Funk & Wagnalls Co., Dept. 1273, New York, N. Y.

LEARN CARTOONING

At HOME DURING SPARE TIME



with the course that has trained HUNDREDS of beginners successfully. The Landon Picture Chart Method of teaching ORIGINAL drawing by mail makes cartooning easy to learn. This school is a Member of The National Home Study Council. Write today for sample picture chart to TEST YOUR ABILITY and examples of the work of successful students now earning from \$50 to \$200 and more per week.

Enclose 6c in stamps and STATE YOUR AGE.

THE LANDON SCHOOL
2838 National Bldg., Cleveland, Ohio

OUTDOOR SPORTS THE YEAR 'ROUND

Popular Mechanics Useful Book—Outdoor sports appeal to us all. But the fun is double when you make your own devices. There are 226 clearly written and concise articles telling how to make equipment for new and popular sports of many kinds in the **Outdoor Sports book**. There are clever devices for such sports as:

- | | | | |
|------------------|--------------|----------------------|--------------|
| Swimming | Trapping | Photography | Kite flying |
| Camping | Tobogganing | Tennis | Summer games |
| Football | Baseball | Outdoor winter games | Nutting |
| Swinging | Fishing | games | Pushmobiling |
| Trolley coasting | Golf | Skating | Racing |
| Roller skating | Boat sailing | Boating | Skating |
| | Toy making | | |

It is easy to make the devices described because there are 317 helpful illustrations. The articles are clear enough for boys, yet interesting enough for any man.

Send No Money Just write your name and address on a postal card and say that you want **Outdoor Sports the Year 'Round**. When the postman hands you the book, give him \$1.50 plus the few cents postage. That is all. If you live outside the U. S. or if you are not at home when the postman delivers the mail, then send \$1.50 with your order. Address your postal to

POPULAR MECHANICS PRESS Room 703, Popular Mechanics Bldg. 200 E. Ontario St., Chicago

LEARN Electricity This New Practical Way

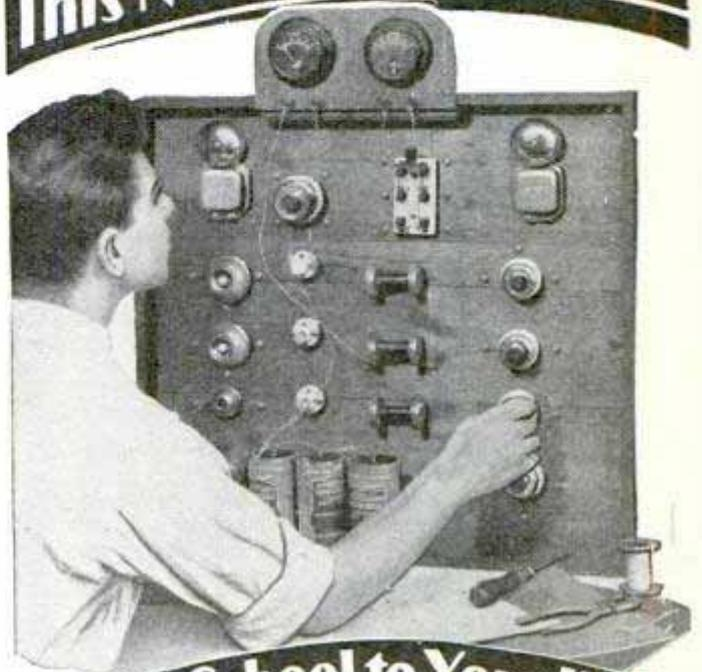

Brings School to Your Home

Patented new Unit-Board System brings full-sized electrical equipment right into your home. Enables you to "learn by doing." Now you can train at home for all electrical fields under supervision of the engineers of America's great Electrical School. Fascinating—Easy—Practical. Nothing else like it.

Train Under Skilled Engineers for Opportunity and Big Earnings!

Splendid opportunities await you in Radio, Television, Talking Movies, Power, Lighting, Automotives, and Aviation. Electrically-trained men earn \$3,000 to \$10,000 a year in these new, fast-growing fields. Tremendous demand for men with practical ELECTRICAL TRAINING. Through our exclusive Home-Shop Laboratory Plan you get same training, same methods, same faculty that have made School of Engineering world-famous. Not a mere correspondence school but great Electrical College, recognized by leading manufacturers, with graduates holding important electrical posts all over the world.

FREE! SEND COUPON for 48-Page Book

Write today for FREE illustrated 48-page book giving full details of how you can train at home for Electricity by the wonderful new Home-Shop Laboratory Method. No obligations. Please mention age when you write.

Dept. 36, Extension Division

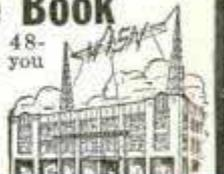

SCHOOL of ENGINEERING of Milwaukee

EXTENSION DIVISION, Dept. 36, 163 East Wells Street, Milwaukee, Wisconsin.

Please send me without obligation FREE 48-page Illustrated Book showing how I can train at home for Electricity by your wonderful new Home-Shop Laboratory Method. Also full details of your "Earn While You Learn" Plan.

Name.....

Address.....

Age.....

To be — — Really Successful in AVIATION



Requires the kind of training you get at MARSHALL

At Marshall, the original "College of the Air," you receive COMPLETE instruction in every phase of Aviation. Extensive ground courses, as well as actual flight instruction, fit Marshall students for executive jobs in this new industry.

Here you will be trained in the Barling NB3 low wing monoplanes, and other new production planes . . . here you are really EDUCATED in Aviation.

Do not fail to investigate the opportunities afforded by this splendid school to receive the highest type training at a reduced cost.

Compare These Prices

Special 10 Hour Flying Course.....	\$200
Primary Aviation Course.....	275
Sportsman's Course.....	475
Professional Course.....	875
Mechanic's Course.....	95
Welding Course.....	135

MARSHALL FLYING SCHOOL

Marshall, Missouri

Coupon

Please send me all information on
Marshall Flying School Courses.

Name.....Age.....

Address.....

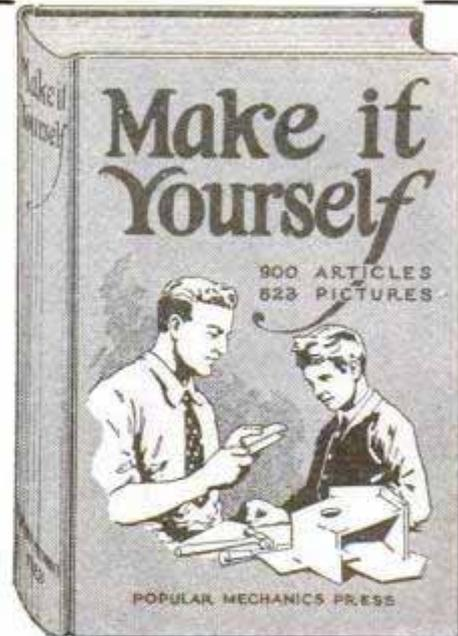

For Your Home Workshop

You should have a copy of this book recently published by Popular Mechanics entitled

Make It Yourself

The home mechanic, whether young or old, amateur or professional, will take pride and delight in making many of the things described therein.

Both father and son will find fascination and an association of interest in making useful and ornamental articles for mother to admire upon their completion.

900 Articles All Different

There are attractive ship models, a great variety of toys that operate themselves by means of an ingenious application of mechanical principles, novel amusement devices for indoors and outdoors, for both water and land, unique designs in furniture for children, scores of useful appliances for the home, things of beauty and utility for lawn and garden, etc.

Special articles instruct the amateur mechanic in the care and use of tools, special tools for special purposes, how to read and use plans, how to solder, the making of a handy work bench, cuts, joints and methods in woodworking, automobile repairing, installing radio equipment, house wiring, fixture hanging, working in glass, leather, metal, celluloid, lathe work, utilizing parts of old machines to make equipment that would be expensive to buy, etc.

Some of the Articles:

Tools for the Home	Monorail Coaster
Mechanic	Writing Cabinet
Ship Model Maker's Tools	Workbench
Build Your Own Ship	Tea Wagon
Model	Radio Apparatus
Ship Model Plans	Lawn Canopy
Water Sprite	Camp Car
Puzzles	California Cooler
Crazy Clown	Musical Instruments
Walking Wampus	Hedge Trimmer
Winter Toboggan Slide	Homemade Baseball Game
Colonial Bric-a-Brac	Small Turbine Motor
Merry-Go-Twist	Tools from Sewing Ma-
Wiggling Pup	chines
Black Cat Bench	Small Valves
Christmas Toys	Bench Lathe
Skating Whirligig	Auto Glare Shield
Venetian Swing	Seesaw Merry-Go-Round
Bird Houses	Ferris Wheel

480 Pages — 823 Illustrations. Price \$3.00
Size 7x10x1 1/2 in. Cloth Binding

Mailed Postpaid upon receipt of price anywhere in the world. If you reside in U. S., Hawaii, Porto Rico, Alaska or Mexico, we will send the book by mail C. O. D. if you prefer. Simply pay postman when he delivers the package.

POPULAR MECHANICS PRESS (ROOM P-3)
200 East Ontario St. Chicago, Ill.

“Give me your measure and I’ll PROVE that you can have a body like mine”

—CHARLES ATLAS

“The World’s Most Perfectly Developed Man”



How my secret of Dynamic-Tension can make a NEW MAN of you, too:

- Skinny? —Adds weight—develops a handsome, husky body!
- Lack Strength?—Adds inches of conquering muscle!
- Half-Alive? —Gives new pep and tireless energy!
- Always Ailing? —Brings new through-and-through health!
- Weak-Willed? —Makes you master of yourself and others!
- Timid? —Gives you the forceful personality of a winner!

YOU, too, can be PROUD of your body! You, too, can be the new man I picture above! I’ll tell you the secret of *Dynamic-Tension* that changed me from a skinny, cringing, no-muscle “weak-sister” to winner of the championship title: “The World’s Most Perfectly Developed Man.”

I’ve helped thousands of others, young and old—fellows who were missing half the fun of life because they lacked the pep and vigor and my kind of a big, powerful, evenly-developed body that puts a man on top every time. If I could help these other thousands, I can help YOU. If they could be turned into “Atlas Champions” you can, too!

Dynamic-Tension Does It!

It’s easy my *Dynamic-Tension* way. And quick! You get the PROOF in your first seven days—in one week you begin to SEE and FEEL the difference in your bodily condition and physical appearance.

If you are underweight, I’ll add the pounds where they are needed and, if you are fat in spots, I’ll show you how to pare down to the fighting trim that I am always in myself. I show you how to become a man of might and muscle—put a solid inch of smooth, powerful muscle all over your body.

And with big muscles and powerful, evenly-developed body that my method so quickly gives you, I’ll also give you through-and-through health—health that digs down into your system and banishes such things as constipation, pimples, skin blotches and the hundred-and-one other petty ailments that rob you of the good times and the good things of life.

Send for free book

First, do what my other prize-winning followers did. Send for a free copy of my 48-page book—“*Everlasting Health and Strength*,” by Charles Atlas. Gamble a 2c stamp for the biggest prize that anyone can win—a handsome, healthy, muscular body that commands the respect of anybody, any time, any place!

Get this confidential chart

With my book I’ll send you a confidential chart so that you can give me all your measurements. Then compare *your* biceps with *mine*. Measure your chest and put the figures beside mine. Do the same with legs, arms, neck, wrist and all other parts of your body—and list the weak spots in your whole system that you want brought back to par. Then get the proof of what my system of *Dynamic-Tension* will do for you—in your own home—spending as little as 15 minutes a day doing what I tell you—without apparatus—without special foods, pills, or baths—without any kind of fussy contrivance whatsoever! Give me one week and I’ll give you the proof!

Remember, it’s easy my way! No apparatus—*Dynamic-Tension* does the work. You owe it to yourself to find out what my secret will do for you. Make sure of your free copy of my book—mail the coupon NOW. Address me personally—CHARLES ATLAS, (Dept. 83) 171 Madison Ave., New York City.

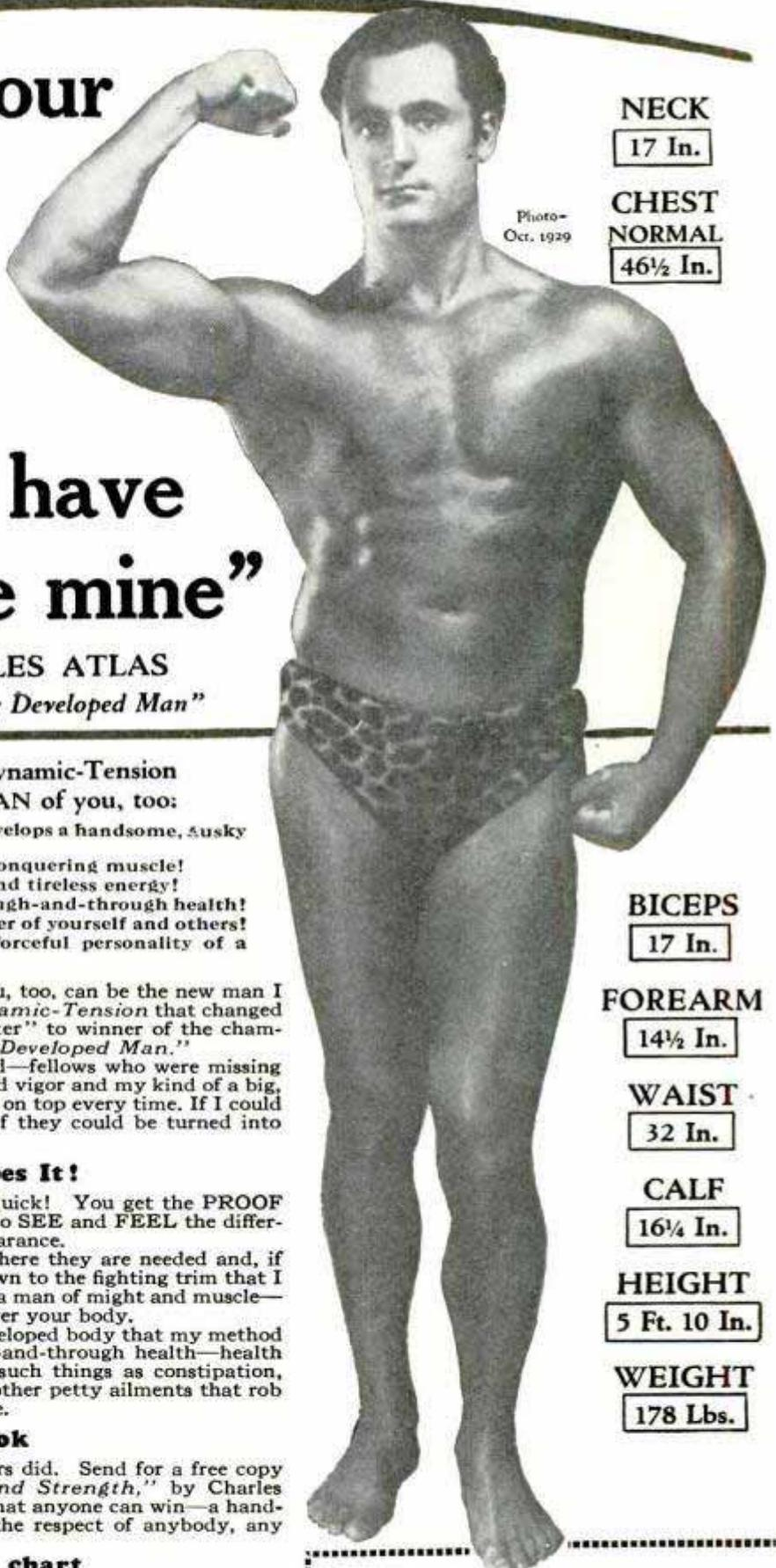

NECK
17 In.

CHEST
NORMAL
46½ In.

Photo-
Oct. 1929

BICEPS
17 In.

FOREARM
14½ In.

WAIST
32 In.

CALF
16¼ In.

HEIGHT
5 Ft. 10 In.

WEIGHT
178 Lbs.

CHARLES ATLAS (Dept. 83)
171 Madison Ave., New York City

I want the proof that your system of *Dynamic-Tension* will give me, too, a healthy, husky body and big-muscle development. Send me your free book, “*Everlasting Health and Strength*” and the confidential chart for my measurements.

Name (Please Print or Write Plainly)

Address

City..... State.....

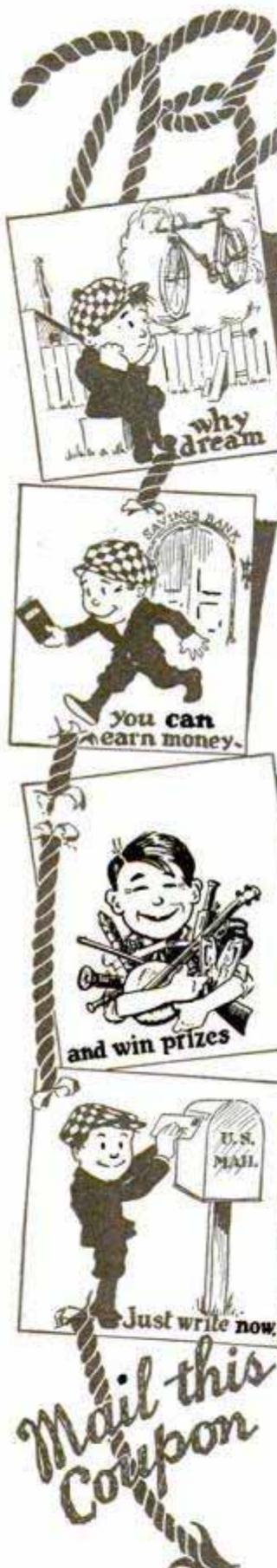

Earn Money - Win Prizes It's Easy

Don't sit and dream about the bicycle, baseball glove or ice skates you would like to have. Here's an opportunity to get these and many other prizes and besides, earn your own spending money.

You Need No Experience To Start

Be a Crowell Junior Salesman and deliver three of the best known magazines to regular customers. This will take only a part of your spare time and you need no experience to start. Act at once.

Win Many PRIZES

Earn Spending Money

Just send your name and address on the coupon below and learn what a golden opportunity awaits you.

Mail this Coupon

Mr. Jim Thayer, Dept. 140, The Crowell Publishing Co., Springfield, Ohio.

Dear Jim: I want to earn money and prizes. Please start me off as a salesman.

My Name.....

Address.....

Town..... State.....

MAKE BIG MONEY

Charging Batteries Starts You



Let me show you how to make big money right from the start. I've prepared a FREE book, explaining all details. Ralph Miranda is making \$125.00 per week in his own business. You can get a good share of the battery charging business in your community with my Service Station Charger — it's years ahead of ordinary chargers—handles more batteries. I explain everything—start you in a business of your own and put you on the way to big money. Write for Free Book.

C. F. HOLMES, Chief Engineer, Dept. W Independent Electric Works 4912 North Clark St. Chicago, Ill.

FREE BOOK—Just Out



ASK YOUR BARBER

FOR THE NEW MEDICATED MASSAGE

WHYTE-FOX



Doubles your pep. Heals as it cleanses. Those who know are "crazy" about it. Made and guaranteed by makers Lucky Tiger Hair Tonic. Ask for valuable free booklet.

Kansas Dept. A LUCKY TIGER REM. CO. City, Mo.



DRAFTING

BOOKS SENT FREE!

For Beginners

Written so you can understand every word, by 18 famous Engineers and Architects. Deluxe, flexible binding. 1750 pages, 1050 blue prints, charts and diagrams. Prepare you for a good Drafting job in mechanical or architectural lines. Sent for 10 days' free use, if you mail coupon immediately.

Only fifteen minutes a day with these WONDER BOOKS will prepare you for a good Drafting job in less than a year! Mechanical and Architectural Drafting from simple straight lines to important, complex plans, a step at a time! Built especially for beginners, for men with only grammar schooling. Drafting room practice plus engineering made easy and clear!

Big Field—Big Demand—Big Pay!

Competent Draftsmen are urgently needed right now in all building and manufacturing lines at \$50 to \$100 a week. That's just the beginning—for draftsmen have the best chance for advancement! Pleasant, fascinating work, easy to learn and do. Learn quick with these books—send coupon for a set FREE, and see for yourself!

A year's Consulting Membership in the American Technical Society now given free to all readers of this famous Cyclo-pedia of Drafting. Many say that's worth more than cost of books

"Blueprint Reading"

American Technical Society Dept. D-319, 58th & Drexel Ave., Chicago

FREE If you send for these great Drafting Books NOW we will include without cost a complete volume "Blueprint Reading" containing 120 pages durably bound in cloth.

American Technical Society Dept. D-319, 58th & Drexel Ave., Chicago

Send for 10 days' free use 4-volume set of DRAFTING. In return for mailing this coupon promptly send absolutely FREE "Blueprint Reading" (Building) 120 pages, 69 illustrations. I will pay the few cents delivery charges. If I wish I may return books in 10 days and owe you nothing. But if I prefer to keep them I will send \$1.80 after 10 days, then \$2.00 a month until \$14.80 (special reduced price) is paid.

Name.....

Address.....

Employed by.....

Address.....



Here is a micro-photograph of an ordinary razor blade—magnified 250 times. Notice that the cutting edge is not smooth, but composed of hundreds of tiny teeth. When these teeth are twisted out of line (as above) they pull and irritate the face.

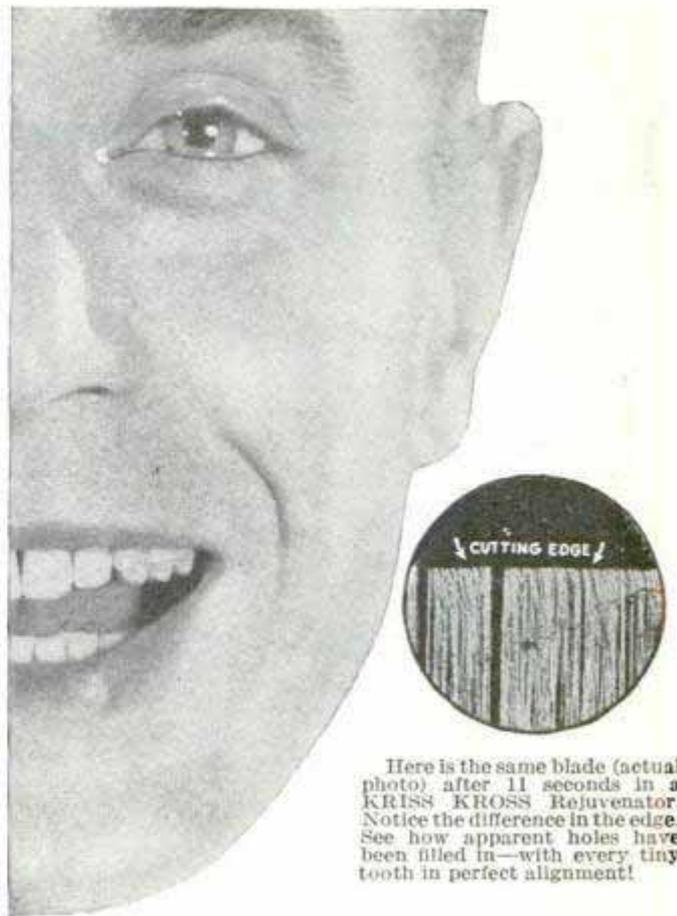

Here is the same blade (actual photo) after 11 seconds in a KRISS KROSS Rejuvenator. Notice the difference in the edge. See how apparent holes have been filled in—with every tiny tooth in perfect alignment!

Astonishing New Discovery Doubles Sharpness of Razor Blades

...Makes Them Last Almost Indefinitely!



Most men consider shaving as a "necessary evil." Frankly, we agree. Shaving takes time; it costs money and, worst of all, if you are "afflicted" with a wiry beard and tender skin. We admit all these things. And since it is impossible to abolish shaving, the next best thing is to make it just as easy and quick as possible; as cheap as possible, and as comfortable as possible. That's why we invented KRISS KROSS!

A Secret About Keen, Cool Shaving

KRISS KROSS is the most amazing aid that any shaver can discover. Its performance is so remarkable that it deserves to be called much more than a *strop*. Rather it is a super-strop or *blade-rejuvenator*. It fits all blades (except Durham Duplex). Its uncanny ingenuity enables you to take a fresh blade out of a new package and improve its keenness as much as 100% in 11 seconds. And as to old blades—KRISS KROSS renews their sharpness an amazing way, week after week and month after month! Any number of cases are on record where a *single* KRISS KROSS treated blade has lasted over a year, giving slick, velvet-smooth shaves every one of the 365 days! And just think of the economy!

A Mechanical Marvel

The operation of KRISS KROSS is simplicity itself. Just twirl a little handle for 11 seconds, and your blade will take on the keenest

cutting edge that has ever said "good-morning" to your chin—an edge that simply zips through the toughest crop of whiskers any he-man can generate!

KRISS KROSS duplicates the barber's secret diagonal stroke with uncanny fidelity. Automatic decreasing pressure. Strops heavy at first—light at the finish.

Automatic flip-flop action insures an absolutely even edge... handy to use—just 11 ounces of shiny compactness. Fits palm snugly. Milled edges prevent slipping even though hand happens to be wet or soapy. Guaranteed for ten years—built to last a life-time!

Special Offer Now!

KRISS KROSS is never sold through stores—and can be obtained only through authorized representatives who will gladly give you a demonstration without obligation. If you do not know the representative in your locality, use the coupon below for details and information. Right now we are making an especially generous introductory offer to create new friends for KRISS KROSS. Find out about it today—and see for yourself how quick, easy and painless shaving really can be! No obligation. Send the coupon now.

KRISS KROSS

KRISS KROSS CORPORATION, Dept. C-3714
1418 Pendleton Avenue ST. LOUIS, MO.

World's Largest Manufacturers of Mechanical Stropers

Canadian Address:

CANADIAN KRISS KROSS CO.

39 Wellington Street East, Toronto 2, Canada

KRISS KROSS CORP., Dept. C-3714,
1418 Pendleton Ave., St. Louis, Mo.
Without obligation, please send me illustrated information on
KRISS KROSS super-strop—*together with your special
introductory offer of a new kind of 3-way, adjustable razor
FREE.*
Name.....
Address.....
City..... State.....
() Check here if interested in becoming representative.

AGENTS

Make excellent money as our representative in your locality. Generous commissions and bonuses make \$75—\$100 a week the regular thing with lots of our men. Emil Ham (Calif.) made \$50 first day. Even spare-time demonstrators often make \$8—\$12 extra a day, showing KRISS KROSS to friends, etc. W. S. Benson made \$48 in 3 evenings. Get details of generous starting offer. Check bottom line of coupon at right and mail coupon now.

MOULDING A MIGHTY BACK



EXTRAORDINARY Complete Course on Back Building ONLY 25c

Does your back back up your physical dreams? Have you the shoulders of a Guardsman and a spine as straight as a die? If not, don't waste time craving them but GET THEM. The back is actually the easiest part of the body to develop—provided you follow the right exercise principles. No man need be narrow or round shouldered. You can build huge, powerful muscles from neck to hips in an incredibly short time by following this wonderful book, "MOULDING A MIGHTY BACK" is a complete treatise on back development packed full of splendid, illustrated muscle-building exercises and other information wonderful for developing every muscle in the back.

Make Your Spine a Column of Might

Arthur Saxon became the strongest man in the world's history through the massive Herculean muscles that surrounded his spine. The author gives you Saxon's favorite exercises—and many others, besides fascinating instruction on how to use your back muscles to perform great feats of strength. It is one of the most interesting books he has ever written. Deals conclusively with the Broad of the Back. More complete than any other course at the price. Will repay you a thousand fold in strength and muscle. With this wonderful book will be given a copy of "The Thrill of Being Strong." The sort of book you have always longed for. Right now, 25c and this coupon means your positive success in back building. Get it now while the offer holds good. Worth \$1.00 of any man's money but yours for 25c if you act today.

REACH OUT---GRASP THIS SPECIAL OFFER

JOWETT INSTITUTE of PHYSICAL CULTURE 422 Poplar Street, Dept. 4C, Scranton, Penna.

Dear Mr. Jowett: I am enclosing 25c. Please send me the course "MOULDING A MIGHTY BACK" and a free copy of "THE THRILL OF BEING STRONG."

Name _____

Address _____

Learn to Earn

\$50 to
\$150 PER WEEK

Big Opportunities Open for Sweeney Trained Men
If you are mechanically inclined. If you prefer to work with tools, you will learn under the "Sweeney System" by actually doing the work. Everything about all kinds of automobiles, welding, vulcanizing, battery, electrical and aviation ground work. No experience or education needed. No books are used. You get to work on complete gas engines, tractors and electrical equipment untraced in any school. You'll get dirty and greasy but you'll learn by the Sweeney System that fits you for big pay jobs at \$50 per week and up that are awaiting Sweeney Trained Men.

FREE BOOK Send name for Auto and Aviation catalog and Special Offer. Actual photos—lists high pay jobs.

LEARN A TRADE

Sweeney

Automotive Electrical Aviation School
1615P GRAND AVE., KANSAS CITY, MO.

NEW AUTO-MATIC RADIO GAS LIGHTER

LIGHTS GAS LIKE MAGIC
No Flint—No Friction

No spark or flame. Lights instantly mantles, gas stoves, jets, and heaters. Held directly over gas flow. Flame appears instantly. Absolutely safe.

Make
\$26 A Day

Light Gas by
RADIO
Gas Lighter

A big 25c seller, paying 400% clear profit. A gross easily sold in a day brings \$36.00 and costs you \$10.00. You make \$26.00 clear profit. Rush \$10.00 for gross, or \$1.00 for sample dozen, with amazing new sure-fire self-selling plans.

MASTERLITE MFG. CO.
Dept. R. C. 19, 110 E. 23d St., New York City



LEARN CODE TELEGRAPH

AT HOME WITH THE AUTOMATIC Omnigraph

Leads quickly to big money jobs of Aviation, Ships and Railroads. Easily and cheaply. U. S. Govt., Schools, etc., use it. The World's Hobby. Models \$17 to \$35. Catalog P7. Now. Omnigraph Mfg. Co., 810 E. 39th St., Brooklyn, N. Y.

MEN for RAILROADS

Nearest their homes—everywhere—to train for Firemen, Brakemen; Average wages \$150-\$200 monthly. Promoted to Conductor or Engineer—highest wages on railroads. Also clerks.

RAILWAY EDUCATIONAL ASSOCIATION. Dept. D-1, Brooklyn, N. Y.

A NEW HOUSE WIRING MANUAL

PRACTICAL — PLAINLY WRITTEN

BY J. G. WOLBER AND O. K. ROSE
Cass Technical H. S., Detroit, Mich.

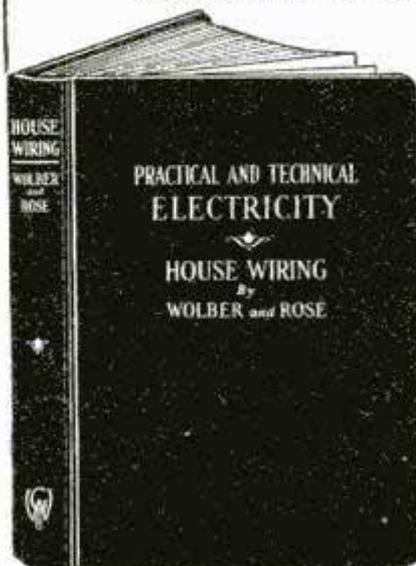

This book is the result of the author's fifteen years of industrial experience and of teaching. The material accumulated during this period of time has been worked over and over until in the author's opinion it was ready for publication.

320 Pages
662 Illustrations
Size 7 1/4 x 5 1/4 inches
Flexible Binding
Price \$2.50 Postpaid
Will be sent C. O. D. anywhere in U. S. or possessions.

POPULAR MECHANICS PRESS
Room P-3
200 E. Ontario St., Chicago

Worth Money to Ruptured!

Send New **FREE BOOK** and
Amazing **FREE SAMPLE**
of **AIRTEX**
Without Obligation

Name.....

Address.....

City.....State.....

Mail this coupon to
New Science Institute,
2170 Clay Street,
Steubenville, Ohio.

Here is an amazing offer to victims of rupture—an offer that has proved to be worth hundreds of dollars to many who have accepted it. Yet it costs you nothing.

A famous rupture specialist with a record of more than 50,000 cases will send you free of cost a newly-

edited book that contains amazing new discoveries about rupture relief . . . case histories galore . . . illustrated in detail. A few of the facts contained in this free book are given below. But do this right now. Tear out the coupon at the right and send for this unusual book!

Can Rupture Be Exercised Away? Get Newest Book Now **FREE** to Ruptured

"It was twenty years ago when I first got ruptured. Today I consider myself entirely cured. Your system is nothing short of marvelous." John Miller, Jr. "Some months ago I ordered your outfit for the treatment of rupture of my son. Our doctor fitted it on him and he was skeptical it would help cure the condition, for it was one of the worst ruptures he had ever seen. Five months later I took the boy back to the doctor. He examined him and pronounced the rupture completely healed." D. E. Lytle, Orrville, Ohio.

These are but two of many astounding letters received from people, many of whom had despaired of obtaining relief from the torture and agony of rupture.

Ruptured

and more unhampered. Thus nature is allowed to knit new tissues together so that rupture often disappears completely without a trace remaining—in unbelievable time. Incredible? Yet the facts are ready now!

appears completely without a trace remaining—in unbelievable time. Incredible? Yet the facts are ready now!

**Never Before a
FREE
SAMPLE
Like This**

Now or Never

Be fair to yourself. Get the complete facts about Magic Dot and the offer that permits you to feel this marvelous relief, before you decide to buy. Don't go through life in constant pain. Relief from rupture is certainly worth the 2c stamp it costs you to send the coupon above. Send it—not tomorrow or next week—but NOW!

**NEW SCIENCE
INSTITUTE
2170 Clay Street
Steubenville, Ohio**

Not a Truss

What is this wonderful device that has made thousands feel again the joy of living a full life? It is not a truss like men wore in the days of Lincoln. It has no steel springs, no leg straps, no bulky cushions. It can never slip off the rupture. Wearing it, you can still cough, run, jump, bend or sleep in any position. In fact, many are able to work every day—exercise as much as they desire—probably we should say truthfully actually **EXERCISING RUPTURE AWAY!**

Imagine a simple little device weighing less than a feather—little larger than a quarter—that rests firmly against the rupture without the need of strapping tightly. Think of a flesh-soft pad that yields with the slightest movement of your body—filled with millions of air-cells that breathe fresh, cool air into the spot around the rupture. And all the while blood circulation is more free

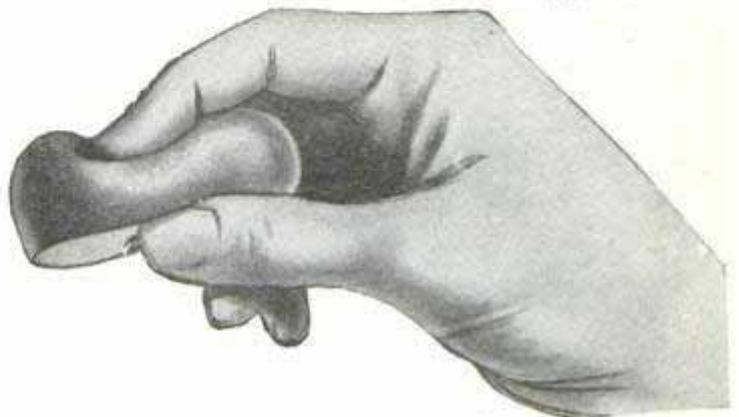



Get Strong, The German Way

Amazing Multiplex Muscle Builder—and Illustrated Course



You can develop amazing strength and proportions with the German Multiplex Strength and Muscle Builder. Positively will develop every body muscle including legs in record time. A new German invention made of a new spring steel process that has such remarkable flexible resistance it is possible to bend and stretch in any way without breaking. This amazing flexibility develops a progressive order no other exerciser can equal. If it is easy to bend one way we show you how by changing position you get a more powerful resistance. The only spring exerciser of its kind made. It is the strong man's specialty to develop muscles, to do every bending and iron breaking feat, pulling chains apart and tearing dress of cards in two. Within a few weeks your strength and new muscles will amaze everyone. Worth its weight in gold.



\$1.98

LIMITED FREE OFFER

Free. "The secret of breaking a rock apart with the hands only." Do not miss it. Snap up this introductory offer while it is red hot.

SEND NO MONEY

If you want powerful muscles, sinews of steel, a grip like a steel bear trap, thick wrists and forearms, broad shoulders, a deep chest with strong legs you cannot afford to pass up this economical, sensational offer. **Made in three strengths;** any one which we send C.O.D. with a complete course of exercise which alone is worth five dollars.

For cash with order we will explain the latest strong man feat which is now startling the world.



AMERICAN ATHLETIC APPLIANCE CO.,
3817 N. 9th St., (Dept. PM-3), Philadelphia, Pa.

Please send me the German Multiplex Strength and Muscle Builder I have checked off. Regular Strength, \$1.98. Athletes Strength, \$2.98. Hercules Strength, \$3.98. With my purchase I am to receive free a complete course of exercise. If I enclose cash I am to receive in addition "The Secret of Breaking Rocks Apart with the Hands." (Enclose Money Order for Foreign Orders.)

Name.....

Street.....

City..... State.....

Don't Be Afraid To Tackle That Concrete Job!

With the instructions found in the new, revised edition of Popular Mechanics Concrete Handbook you can make any of the following useful articles:



Garden Seats—Fountain and Basin—Flower Boxes and Vases—Pedestals and Bird Baths—Ornamental Pools—Sanitary Drinking Fountain—Gateposts—Auto Driveway—Sidewalks—Boat Landings and Docks—Entrance and Garden Walks—Sidewalk Flaggings—Narrow Curb Walks—Curbs and Gutters—Wall Coping—Steps—Garage Floor—Basement Floor—Fence Posts—Lawn Roller—Cistern—Chimney Cap—Refuse Burner—Culvert—Benches for Greenhouses—Tile—Retaining Walls—Foundation Supports—Engine Foundations—Septic Tank—Toy Blocks—Forge—Fireproof Safe—Ice House—Watering Troughs—Milk House—Smokehouse—Silo—Horse Stalls—Hitching Post—Rural Mail Box Post—Cyclone Cellar.

Build With Ease for Permanence and Beauty

This is a book of practical plans for using concrete about the home, farm or shop. For amateurs as well as contractors. In addition to making all the articles mentioned above the making of good concrete mixtures for various classes of construction is given; mechanical mixers and homemade tools are dealt with. All necessary form and mold making are covered as well as many other valuable pointers too numerous to mention here.

Simply write and ask us to send you this book. When postman hands you the package pay him \$1.00 plus the postage. If outside U. S. remit when ordering and include 15 cents extra for mailing.

POPULAR MECHANICS PRESS
Room P3 200 E. Ontario Street CHICAGO

NEED A BETTER GRIP ON MATHEMATICS?



SEND for a copy of "Mathematics for the Practical Man," only \$1.50. By common sense methods it removes the mystery and difficulties so that algebra and even calculus are made simple.

Assuming your knowledge is limited to arithmetic you quickly and easily gain a working knowledge of Algebra, Geometry, Trigonometry and Calculus. Simply pay postman price of book plus the postage when he hands you the package.

Popular Mechanics Press
Room P3
200 E. Ontario Street, Chicago

Complete Course In Cartooning

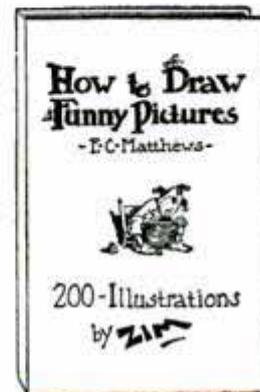

Learn how to draw pictures that have a real money value. The plan of this thorough course by E. C. Matthews is to begin with simple studies and gradually work up to the most difficult cartoon compositions. The text is illustrated with over 200 original pictures by Zim (Eugene Zimmerman). Equip yourself to get into this paying branch of commercial art work.

Price \$3.00
Will be sent C. O. D. to any address in the U. S.

Popular Mechanics Press
Room P3
200 E. Ontario St., Chicago

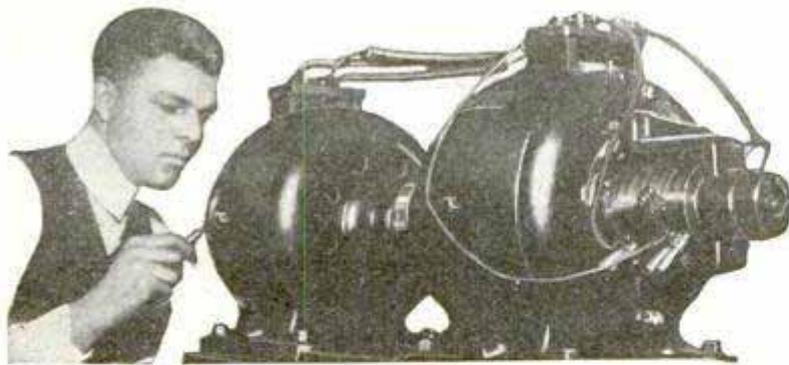

Step Out of That Low Pay No Future Job In 12 Weeks

Don't let added responsibilities or old age find you being kicked around from one job to another—never sure of a steady job and willing to work at any old price they want to pay you.

Get Into **ELECTRICITY** My Amazingly Easy Way

Right now—Today—decide once and for all to get out of that small pay, hopeless job. Now—and forever—say good-bye to twenty-five and thirty-five dollars a week. Let me show you how to qualify for real money-making jobs **LEADING TO SALARIES OF FIFTY AND SIXTY DOLLARS A WEEK AND UP**, in Electricity—**NOT** by correspondence, but by an amazing way to teach that makes you **A PRACTICAL ELECTRICIAN IN 90 DAYS**. Getting into Electricity is far easier than you imagine.

Learn By Doing In 90 Days Right Here In the Great Coyne Shops Without Books or Lessons

You don't need advanced education or any former electrical experience here at Coyne. I don't care if you don't know a generator from an airbrake—I don't expect you to! Mail the coupon today for my big Free Book. It tells you how I have taken thousands of fellows just like you out of small pay, man-killing jobs and made them happy and contented, in their new work—at twice, three and four times their former salaries.

No Books -- No Lessons

I don't attempt to teach you by correspondence, books, or lessons. I train you on real electrical machinery—not on special training machinery or toy equipment, but on exactly the same kind of machinery you will work on when you graduate from my school—hundreds of thousands of dollars' worth of equipment occupying over 50,000 square feet of our new sanitary fireproof building. You work on real dynamos, engines, power plants, autos, switchboards, transmitting stations—everything from doorbells to power plants—full sized—in operation every day.

Earn While You Learn

FREE EMPLOYMENT SERVICE FOR LIFE After You Graduate

If you are short of money, my Employment Department will help you get a part-time job while you are attending school. Then when you graduate they will help you find the Electrical Job you want.

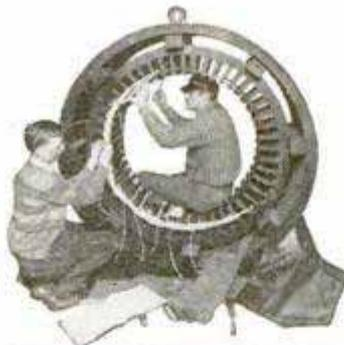

Prepare for Jobs Like These

Here are a few of hundreds of positions open to Coyne-trained men. Our free employment bureau gives you lifetime employment service.
 Armature Expert up to \$100 a Wk.
 Substation Operator to \$65 a Wk.
 Auto Electrician \$60 a Week & up
 Inventor Unlimited
 Maintenance Engineer up to \$100 a Week
 Service Station Owner \$200 a Week and up
 Radio Expert \$60 a Week and up

Our Student Service Department Handles All Your Problems

You have nothing to worry about. My student service department takes care of getting you in a good clean home where you will get room and board very reasonable. You will be among friends here at Coyne who will see that you are made comfortable and happy while you are with us. Good clean sports and entertainment are provided during hours when you are not attending school.

Aviation Electricity, Radio and Automobile Electrical Courses as well as Railroad Fare Included

Right now I am including all the above at no extra cost, and I'm offering my course for a short time at a special reduced price.

Coyne has had an unusually successful year. My graduates have made this possible and because of this, I can offer a low price to future students for a short time.

GET THIS Free Book



H. C. LEWIS, PRESIDENT
COYNE ELECTRICAL SCHOOL, Dept. 30-72C
 500 S. Paulina Street, Chicago, Ill.

Dear Mr. Lewis:—Without obligation send me your big free catalog and all details of Railroad Fare to Chicago, Free Employment Service, Radio, Aviation and Automobile Electrical Courses you are including and "how many earn while learning."

Name.....
 Address.....
 City..... State.....

COYNE ELECTRICAL SCHOOL

H. C. Lewis, Pres. **Founded 1899**
 500 S. Paulina Street Dept. 30-72C Chicago, Illinois

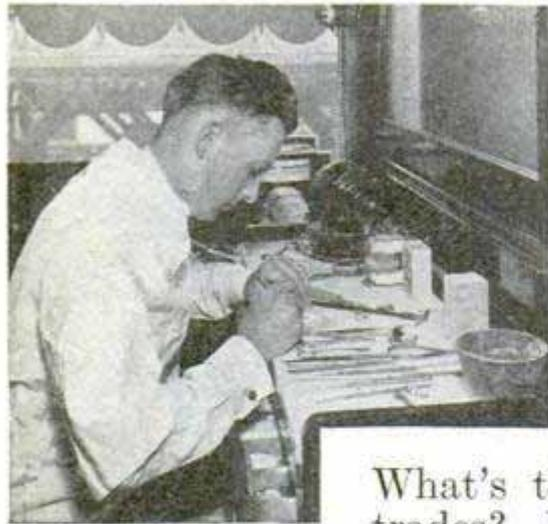

Easiest, pleasantest work you ever saw! Your own boss, money and success yours from the very beginning. You can start with a "shoe-string." We prepare you in a few months to run a business of your own, to do any job. Common schooling, ability to use your fingers **ALL YOU NEED!** R. R. Fare to Chicago, Cleveland, Detroit, Boston or Philadelphia deducted from cost of course for a limited time!

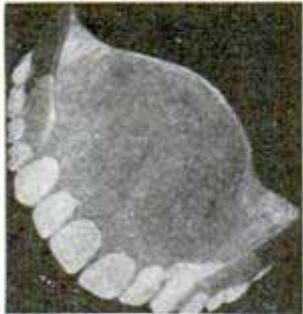

Jobs Up to \$125 a Week!

In a business where there are many times as many jobs as Experts, salaries are high, hours are easy, opportunities are everywhere! Dentists recognize the high-standing of our graduates. No books here—learn with tools and instruments. Start quick—get ready in a few months for your big opportunity! *Mail Coupon today!*

Rubber Plates

Learn to make partial upper or lower plates with soldered, cast or wire clasps, with palatal bars; with lingual bars. McCarrie-trained Students learn to make full rubber plates of every type, including Vulcanite base-plates, butted gums, carved gums, etc.

CROWNS

Here's only a small part of your practical training in Crown-work; Two-piece, seamless, open-face, Richmond, cast-base porcelain, Carmichael, split-pin, carved (swaged) cusp, cast cusp, etc.

BRIDGE WORK

Complete training in both fixed and removable bridge work. Interchangeable teeth, gold dummy, Sanitary porcelain dummy jobs—Roach, Gilmore, Bischoff and all forms of cast-clasp work is taught—not with books but in *actual Laboratory*.

METAL BASE DENTURES

Cast bases of Aluminum, Watt's metal, etc., are included in your training. Both centrifugal and air pressure casting machines are used. Free book contains complete list of subjects in course.

This Dental Laboratory Expert earns UP TO \$20 a day!

What's the use of training for the old, overcrowded trades? If you're going to prepare for big-salaried jobs or a profitable business of your own GET INTO THE FASTEST GROWING PROFESSION—"Laboratory Dentistry." Biggest opportunity for success of the century, because there are many more jobs than there are experts to fill them, because there are a dozen cities crying for Laboratories for each EXPERT capable of operating one!

64,000 DENTISTS NEED LABORATORY WORK!

Only a few hundred Laboratories in all the U. S.—most of them in the larger cities. Dentists can't afford to do their own mechanical jobs. They can buy the services of a Laboratory Expert at about \$3.00 an hour and sell their own time at \$6 to \$15 an hour. Dentists will encourage you to learn Mechanical Dentistry, start a "Lab" of your own, give them quicker service than sending their work to other cities. Dentists can't wait and keep their patients waiting. Ask your Dentist.

WE HELP YOU OPEN A LABORATORY OF YOUR OWN!

Many of our graduates open a Laboratory of their own. To encourage more men to go into this wonderful Mechanical profession, we will help you find a good location for your Laboratory, and help you towards success. Write for complete information on how you can find yourself in a profitable business of your own after you become a Dental Laboratory Expert.

INTERESTING BOOK—FREE!

Right this minute there are openings for 150 Dental Laboratory Experts in locations where they can do a business of \$5,000 to \$20,000 a year. But you can't *cash in*, take advantage of these OPPORTUNITIES until you're *Trained*. Catalog tells you how quickly and easily you can *get ready*, how hundreds of others have **SUCCEEDED!** Tells you how you learn in a few months **BY DOING ACTUAL LABORATORY JOBS** in our famous *Dental Laboratory Schools*. Brings you R. R. Fare offer and other big inducements. *Write for free Book today!*

McCarrie School of Mechanical Dentistry

1338 S. Michigan Ave.
Dept. 385 Chicago, Ill.

EARN while you LEARN!

Day students make all or part cost of course by part-time night work. Night students can find plenty of good jobs "to see them thru."
We'll help you!

McCarrie School of Mechanical Dentistry
1338 S. Michigan Ave., Dept. 385, Chicago, Ill.

Without obligation, please send me your *R. R. fare offer* and free Book with complete information about how I may become a Mechanical Dentist. How you will help me open a Laboratory, how you will help me find a job while I take my training, etc.

Name.....

St. No. or R. F. D.....

City..... State.....

FREE!
R. R. Fare
TO
Chicago
Cleveland
Detroit
Boston
or
Phila.

Think of it! Genuine UNDERWOOD

Yours for 10 Days FREE

Yes—this world-famous Underwood is yours free for full 10 days. See for yourself the real bargain it is. See how beautiful and new it looks—compare its neat, perfect work—without obligation.



Buy Direct at Below 1/2 Mfr.'s Regular Price

Now Only



My unchallenged direct sale price and easy terms on this genuine Underwood No. 4 is the lowest ever offered. While they last—less than half (1/2) the manufacturer's regular price—and easy terms besides. Do not confuse this genuine late model

Underwood with inferior or frail machines worth only one-half as much. This is the full sized standard Underwood with 4-row keyboard and late improvements, manufactured to sell regular for \$100. Fully Guaranteed in writing.

Easy Terms—Only 10c a Day

Think of it—a genuine late model Underwood reduced to \$39.90 (Cash). A saving of over \$60 by acting now. Send only \$1.00 deposit for a 10-day Free Trial. Then only 10c a day on my easy year-to-pay plan. And you use and enjoy your typewriter all the time. Remember this Underwood all rebuilt and re-finished like new is without question the greatest value ever offered at this rock-bottom price. (See column to right for its many outstanding features and improvements.)

INTERNATIONAL TYPEWRITER EXCHANGE
Dept. 394
231 W. Monroe Street, Chicago

FREE—Complete 9-Piece Office Supply Set and Touch Typewriting Course

We teach you speed typewriting Free. Complete Home Study Course of the Famous Van Sant Speed Typewriting System, fully illustrated, easily learned. We also give complete office supply set free during this sensational sale.



Send at Once!

This exceptional bargain offer is for a very limited time only. Remember, every typewriter is sent on 10-days' Free Trial and Fully Guaranteed.

12 REASONS
Why this is the Greatest Value Ever Offered

- 1 Genuine Underwood
- 2 Standard 4-row Keyboard
- 3 2-color Ribbon
- 4 Back Spacer
- 5 Ribbon Reverse Tabulator
- 6 Automatic Release
- 7 Shift Lock
- 8 Lowest Price
- 9 Easiest Terms
- 10 10-Day Free Trial
- 11 Fully Guaranteed
- 12

International Typewriter Exchange,
231 West Monroe St., Chicago, Ill., Dept. 394.

Please send the Underwood No. 4 at the special reduced price for 10-day Free Trial. I am enclosing \$1.00 deposit with the understanding that if I am not perfectly satisfied I can return it Express Collect and get my deposit back. If I keep it I will pay \$3 a month until I have paid \$44.90 (Term Price) in full.

Name..... Age.....

Address.....

Town..... State.....

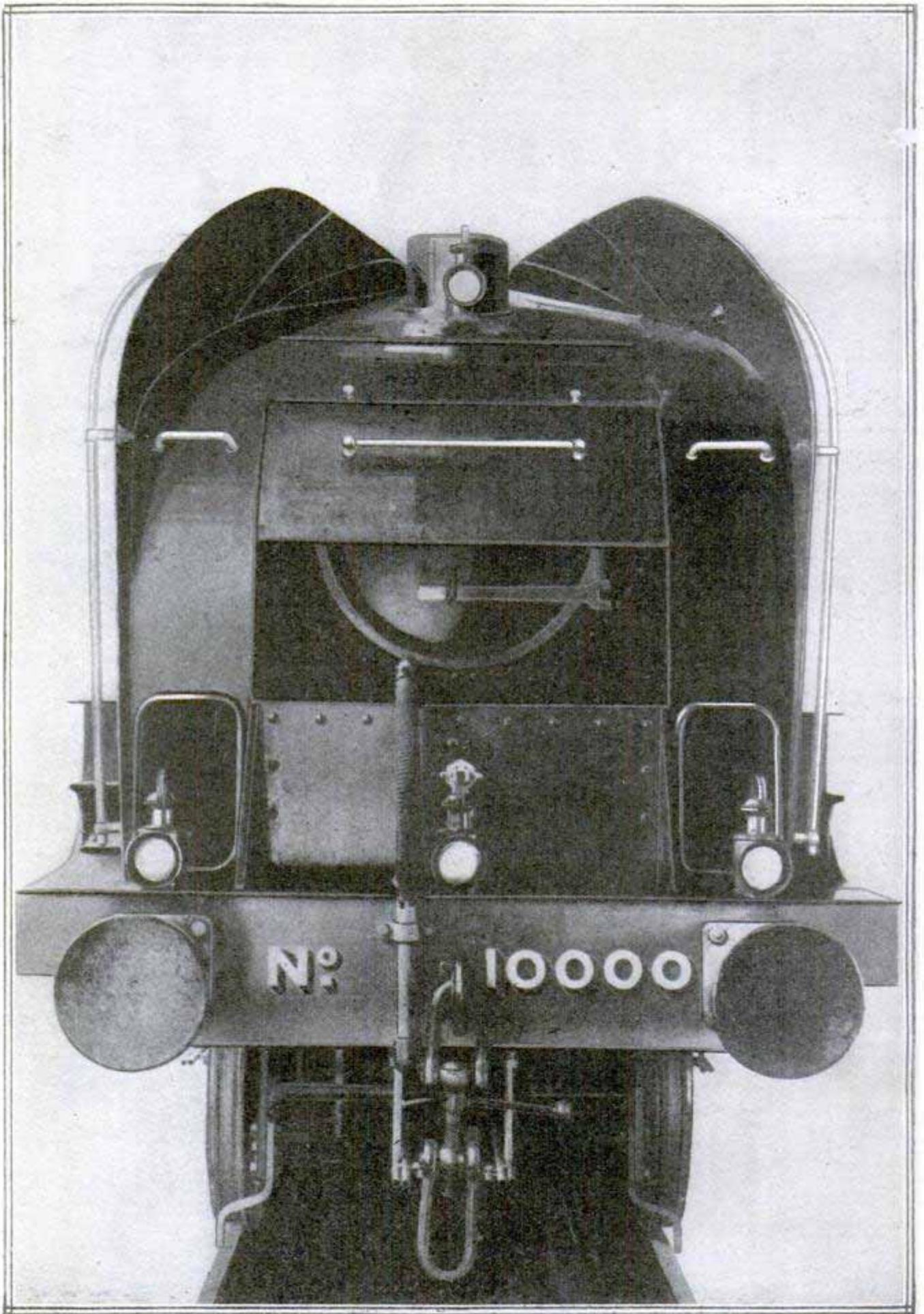

End View of British 170-Ton Passenger Locomotive, Its Boiler Occupying So Much Space None Was Left for a Smokestack Which Was Sunk within Casing Plates—See Page 383

Winnipeg, Man., Canada

Popular Mechanics Magazine

REGISTERED IN U. S. PATENT OFFICE

WRITTEN SO YOU CAN UNDERSTAND IT

Vol. 53

MARCH, 1930

No. 3

4116

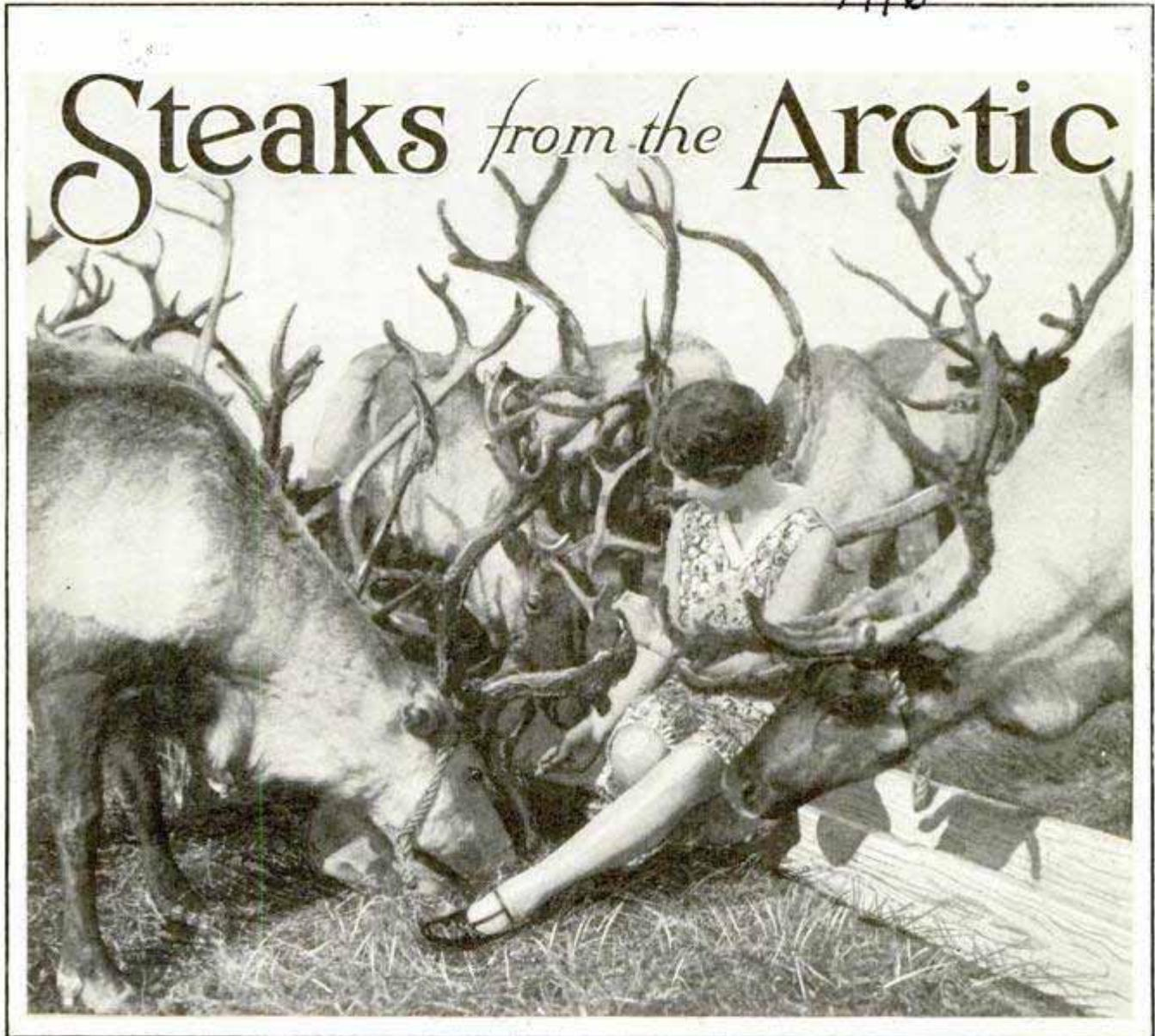

Steaks from the Arctic

Reindeer Quickly Become Tame and Friendly under Kindly Care; a Huge Herd of the Animals Has Been Sent into Far Northwest Canada to Supply the Eskimos with Food

By PATRICK DUFFY

ONE frosty morning last October an airplane roared into Nome and headed toward the Colville river. It was the aerial scout of one of the most spectacular treks in all history—nothing less than the movement of 3,000 reindeer across 1,500 miles of unpeopled, untimbered little-known arctic America. The herd has been purchased by the Canadian government and is being moved to Kittigazuit peninsula east of the historic Macken-

zie river in the Northwest territories, from Kotzebue sound on the ice-ribbed shores of Alaska.

It is a story of charity in the grand manner, into which there is interwoven dog teams and airplane, Eskimos and big business—the primitive and the modern. The airplane scouts in advance of the herd, seeking suitable grazing and camping grounds and keeping the herdsmen in touch with civilization. The herd itself

Dominion Reindeer Co., Ltd.

4116

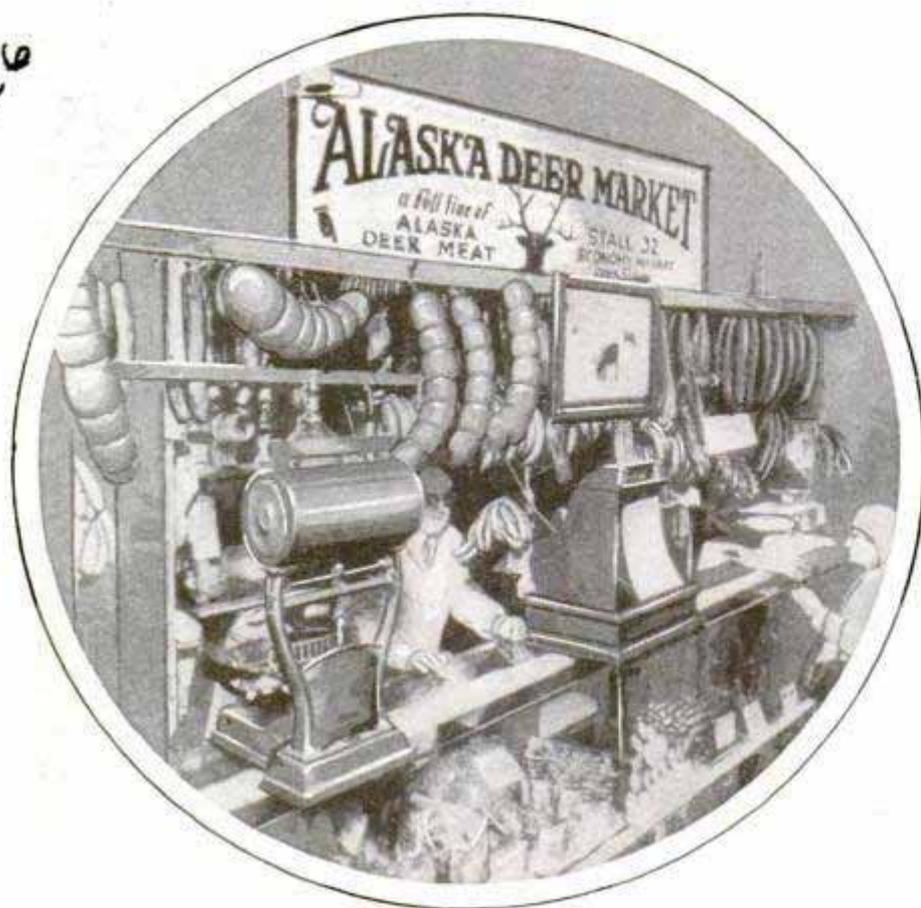

Reindeer Meat on the Market; Eskimos along the Arctic Coast Formerly Depended upon the Caribou, but Few of These Animals Are Left

is accompanied by a picturesque caravan of forty specially made sleds drawn by fifty trained reindeer, to transport the equipment of the expedition. The herds- men, mostly Eskimos, are aided by trained reindeer and sheep dogs, and will be on the trail for more than two years.

Next April the caravan will halt to allow for fawning, the journey being continued in the summer months. By the following spring it is hoped to have crossed the mouth of the Mackenzie river on the ice and to have reached the new range before the fawning season arrives. One of the advantages of reaching the new range at that time of the year is that reindeer possess a strong homing instinct, and young animals born that season will tend to settle the herd on the new pasture.

Since the dawn of history the Eskimos of the arctic coast have depended upon the herds of caribou for food, but the introduction of high-powered rifles resulted in the wholesale slaughter of these "camels of the frozen desert," and was one of the main reasons for the sudden disappearance of the herds from their usual haunts. Naturally the grim specter of

famine haunted the igloos of the Eskimos. Many of them died of hunger. Many more, rendered weak by lack of food, fell easy prey to disease.

With promptitude the Canadian government rushed to the rescue of these kindly huntsmen. Food was sent by steamer, dog team and airplane, and it was decided that the Eskimos must no longer be left in utter dependence on the caribou, but must be provided with a sure source of food. With that end in view, the government investigated the reindeer industry of Alaska and the possibilities of the Northwest territories for reindeer ranching. As the result, the government purchased 3,000 reindeer, and the herd was started

on its way. At the moment, of course, the government is bent on providing food and clothing for the Eskimos, but the venture may well give birth to an industry of great economic importance and thus repeat the history of reindeer ranching in Alaska, which now supplies more than \$2,000,000 worth of meat to American cities every year.

PLANE TURNBUCKLE WRENCH TAKES SMALL SPACE

Capable of being operated within a space of one inch, a wrench for tightening airplane turnbuckles, the sleeve with a screw thread at one end and a swivel at the other, now is on the market. The wrench maintains its grip even if the hand is released, thus allowing quick work in inconvenient positions, or even in the dark. The steel pins of the tool may be replaced when needed and reinforced bifurcations prevent strain on the pins.

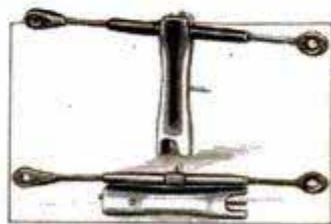

Howard St. Johnson, 1119 Howard St. Bay, Wis.

How. Carter J. Johnson, 1119 Howard St.

4053

SEA HORSE SET ON SURFBOARD TESTS RIDER'S SKILL

Riding a surfboard attached to a motorboat did not provide enough sport for



Internationa

Riding a Surfboard Pulled by a Speeding Boat Is Given an Added Thrill When the Rider Mounts a Sea Horse Attached to the Board; Above, Archer Testing Skill from His Unsteady Steed

some of the winter colonists at Miami Beach, Fla., and as a result they started riding modern sea horses. In this sport, which gives many of the thrills of broncho busting, the rider sits astride a wooden horse mounted on a surfboard pulled by a power boat, and has a much more difficult time maintaining balance than when standing upright on the board without the horse.

gan. Another part of the resonators is fitted with disks which cause the tones from the pipes to have a tremolo.

XYLOPHONE LIKE A PIPE ORGAN ELECTRICALLY CONTROLLED

Embodying many of the principles of the pipe organ, xylophone and marimba, an instrument called the "marimba celeste" has been built for a concert player. It is played with mallets, but the tone is electrically controlled. The keyboard has three manuals and a range of eighty-seven notes. A section of the resonators, or pipes suspended beneath the bars, is fitted with microphones which transmit the sound to amplifiers similar to those used in radio. Two dynamic speakers are connected to two large horns at the front of the instrument. Pedals control stops and volume like those of a pipe or-

DAYLIGHT SIGN FOR TRUCKS MOVES BY SUCTION

Advertising signs for auto trucks which change the reading matter automatically are being produced in England. The two lines of advertising are shown alternately as the sign oscillates to and fro, the movement being effected by a device resembling that which controls the ordinary suction-operated windshield wiper.



Oscillating Daylight Advertising Sign for Auto Truck, Operated by Suction from Engine

*Mr. Clair Amiar Messer,
c/o F.C. Messer, Inc.*

*C. G. Vokes, Ltd 95,
Lancaster Road*

W. H. S. agent banner.

Carella Coy, Tower Building, Bridge St. Warrington, Eng. No. U. S. agent known 18



An Umbrella for the Automobile Which Fits in a Metal Case Attached to the Door of the Car

UMBRELLA FITS IN AUTO DOOR AS PERMANENT ACCESSORY

For traveling from the automobile to shop or theater in the rain, an English firm now is producing a small umbrella and a holder which attaches to the car door. The umbrella, with short handle, fits into a metal case covered with leather to blend with the car upholstery, the bottom of the holder containing a metal cup filled with absorbent sponge rubber.

GLASS SUBSTITUTE IS FLEXIBLE AND DOES NOT SPLINTER

Hailed as a possible substitute for glass in automobile windows and windshields when further developed, an organic substance called "vitreo-colloid" is being manufactured by a British company. It is flexible, colorless and does not splinter, but at present it is being turned out in thin sheet form and is being used mostly for lamp shades. It somewhat resembles celluloid in flexibility, but is non-inflammable, more transparent and does not discolor with age. It is hard enough to prevent accidental scratching, can be readily cut, drilled or molded, and is an excellent insulator, which properties make it available for electrical use and in making toilet articles and phonograph records.

M. Newton Vitreo-Colloid, King St., St. James, King'sbury, London, W.1, Eng. Led

M. Newton Vitreo Colloid, Ltd., King'sbury

EARTH'S SPEED TWO HUNDRED 29 MILES A SECOND

That the earth, together with a large section of the universe, is whirling through space at the rate of about 200 miles a second, has been proved by Dr. J. S. Plaskett, of the Dominion Astrophysical observatory at Victoria, B. C. Using one of the largest telescopes in the world and making observations over a period of six years, Doctor Plaskett and his associates have computed the speed of the movement, which had been suspected but not clearly measured. The earth is seen as a tiny member of a vast group of bodies which are speeding toward the constellation Sagittarius, so far away that its light requires 47,000 years to reach us. Our world thus has four motions, the astronomers reveal. It rotates on its axis, it makes a yearly trip about the sun, it is drifting with the sun in a random motion apparently not in the same direction as the "great whirl," and the fourth movement is that with the rest of the adjacent universe at the high speed which Doctor Plaskett emphasizes as being "more than 2,000 times that of the Schneider cup record."

CATAPULT FIRES BUOYANT BALL 400 TO DROWNING PERSONS

Instead of throwing a lifeline, a catapult designed by a French inventor casts a large floating ball to drowning persons. The ball, with hang-on straps to which those in the water may cling, can be fired either from the deck of a vessel or from the shore.

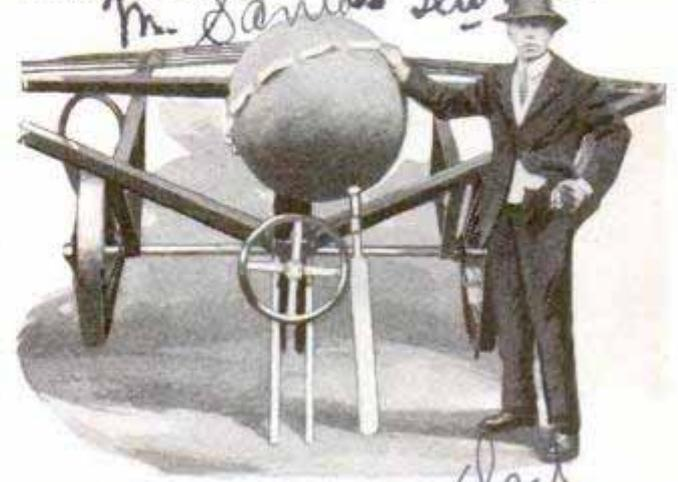

Catapult Which Throws a Buoyant Ball, Instead of a Lifeline, to Those in Distress in the Water

M. Santos Dumont

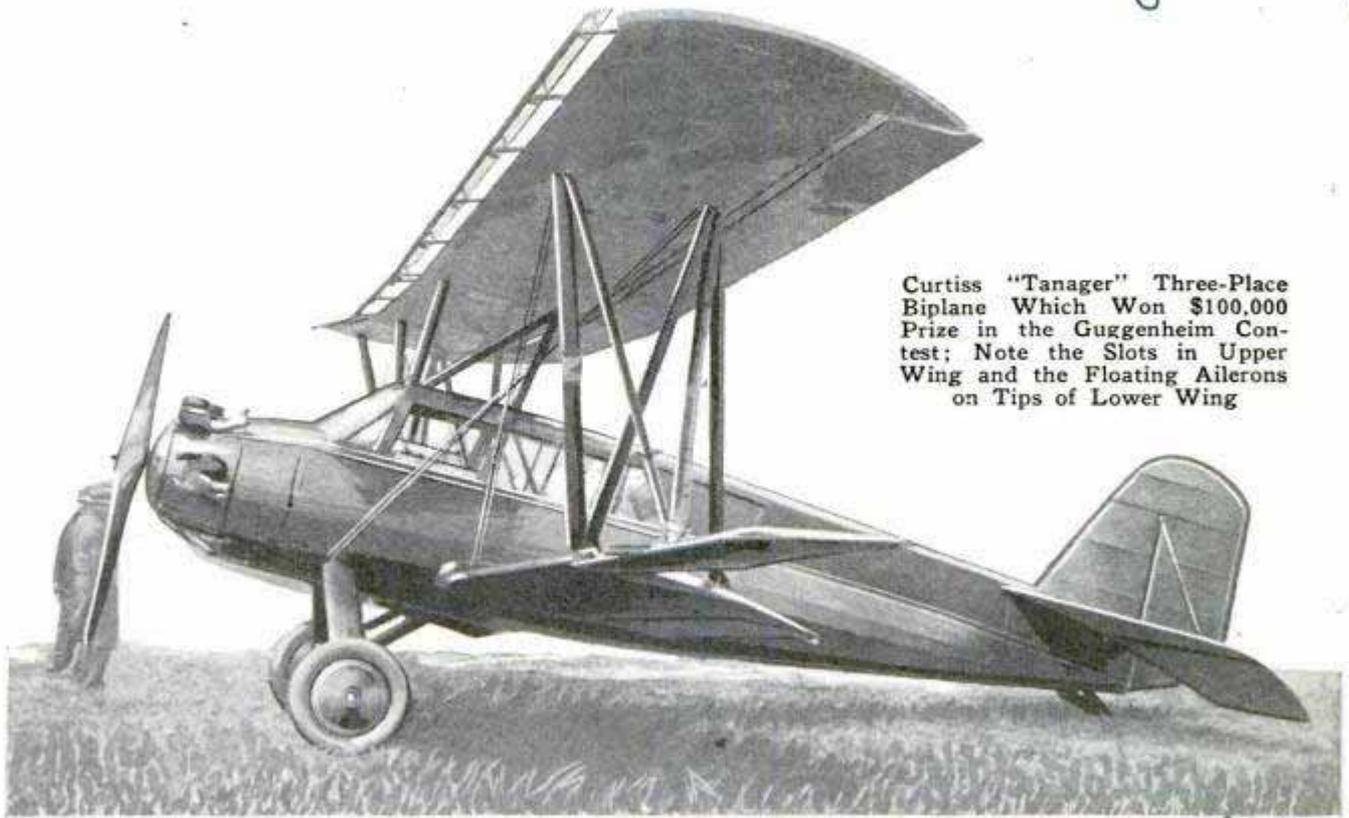

Curtiss "Tanager" Three-Place Biplane Which Won \$100,000 Prize in the Guggenheim Contest; Note the Slots in Upper Wing and the Floating Ailerons on Tips of Lower Wing

Slow landing speed, quick take-off and other desirable features of the Curtiss "Tanager" three-place biplane, caused judges in the recent Guggenheim safety contest to award the \$100,000 prize to the craft, which was entered after more than two years of wind-tunnel and other tests. During the trials, the ship showed a top speed of 112 miles an hour and the remarkably slow gliding speed of thirty-seven and one-tenth miles. Its minimum speed was thirty and six-tenths miles. It came to stop after a ninety-foot roll upon landing and took off within 300 feet. It hopped a barrier thirty-five feet high and halted within 295 feet of the base of the hurdle. On a reverse performance, it cleared a barrier of the same height 500 feet from the start. The ship's rate of climb was 600 feet per minute. With the throttle wide open, it displayed an endurance of three and six-tenths hours and a range of 405 miles. The service ceiling was 12,500 feet. The craft weighs 1,959 pounds empty and 2,841 pounds fully loaded. It has a span of forty-three feet, ten inches. Three innovations proved important factors in the ship's performance. These were its new type of ailerons, of the floating kind that automatically as-

Wide world
sume a position parallel to the air currents set up by the ship; automatic wind slots and controlled wing flaps. The ailerons may be moved relative to each other by the pilot and give control in a stall and at high speed as well as reducing yawing and spinning. Their action makes rudder correction and control unnecessary. During the Guggenheim tests the "Tanager" was flown in tight vertical banks without the use of the rudder through the function of the floating ailerons. They are mounted on the tip of the lower wing. When the plane is moving forward in level flight, they remain level and even with the lower wing and operate directly into the wind no matter what position the plane assumes in the air.

AUTOMATIC AIR VENTS PROTECT BUILDING FROM TORNADO

4112
Swinging windows and hinged skylights or roof panels in buildings in tornado districts will prevent much of the damage from such storms, experiments have shown. By placing automatic vents in from ten to fifteen per cent of the wall and roof area, the explosive effect of low air pressure outside is much reduced.

U. S. Forest Products Laboratory Madison

Genl Dwight Lloyd

TOP THAT SPINS A MAN SHOWS EFFECT OF GYROSCOPE



Tipping the Spinning Wheel Either Way Turns the Man on Ball-Bearing Platform

Remove the tire from a detached bicycle wheel, substitute a lead strip around the rim, adjust two handles to the hub and you have a powerful gyroscope that will spin you around on a ball-bearing platform and will do other interesting "stunts." The wheel may be set in rapid rotation by striking the spokes with the fingers or it may be wound up with a cord around a collar on the hub, although this is not a necessary addition. Holding the wheel as shown in the accompanying photograph, then turning it at an angle from the perpendicular, causes the operator to revolve at considerable speed on the turntable. The direction is reversed simply by tipping the wheel the opposite way. Weighted with ten pounds or so of lead, a bicycle wheel with good bearings will

spin for ten minutes or more at high speed when set in motion. The "top" will spin on either handle, balance itself on a string and do many other fascinating tricks.

SURGICAL DRESSINGS OF WOOD PULP PROVE WORTH

Impressed, but not entirely convinced, by the claims for a wood-pulp (cellulose) material, designed to take the place of absorbent cotton for wound dressings, surgeons in a Boston hospital decided to test the qualities of various dressings offered to them. Aside from the sterility of the materials, which is proved in all cases, the main point at issue was their respective ability to absorb blood. The laboratory technician presented his report in a graphic manner. He had compounded a liquid as nearly as possible of the consistency of human blood and colored it with a dark aniline dye. One drop of this liquid, he let fall on the surface of each material and all were allowed to dry under exactly the same conditions. The stain on the wood-pulp material covered twice the area and showed nearly twice the penetration as compared with the best grade of absorbent cotton.

BALL VALVE SHUTS OFF WATER WHEN FAUCET IS REMOVED

Adapted for any modern plumbing fixture, an automatic ball shut-off valve which operates when a faucet is removed, now is on the market. The fixture makes it possible to replace a worn gasket without using the water cut-off. The valve is a brass housing which screws into the faucet and contains a steel ball which is forced by water pressure against a water-tight seat in the housing to stop the flow of water when the faucet is removed. A pin extending into the housing holds the ball away from the seat when the faucet is in place.

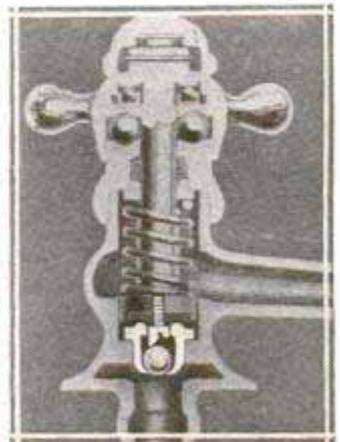

Automatic Ball Valve Co. - Bldg.

Central Scientific Co 4608 Ohio Street

Cellu-Cotton Co
180 N Michigan Chicago
Con. John B. ...
Frank & Betty Co. Hammond Ind.

4033

407

The LIGHTNING HAZARD in FLYING

By W. E. BURTON, 1922 *1st Louisa Ave Akron, Ohio*

PROOF that lightning can strike an airplane while it is in flight, and evidence that certain portions of the plane structure are more susceptible than others to bolts are among the early findings of Arthur O. Austin, who is conducting, in co-operation with Popular Mechanics Magazine, a series of tests to determine the effect of lightning on heavier-than-air craft.

Mr. Austin is chief engineer of the Ohio Insulator Company and consulting engineer for the Ohio Brass Company. He is using the most powerful outdoor high-voltage laboratory in the world at Barberton, Ohio, for the experiments.

By subjecting scale models, completely insulated from the earth and other objects, to artificial lightning whose voltage runs into the millions and amperage into the hundreds of thousands, Mr. Austin has demonstrated that a plane in the air can be struck in any of several different ways. In general, the lightning discharge usually will strike a projecting portion of a plane, and leave by a similar projection at some other point.

Thus, the bolt might enter at the rudder tip and leave by a landing wheel or wing tip; strike one wing tip and leave by another; travel from the propeller or some point on the engine to the tail skid or rudder, or strike a projecting radio mast or antenna and leave by a wheel, rudder or other projection. In one case, it was

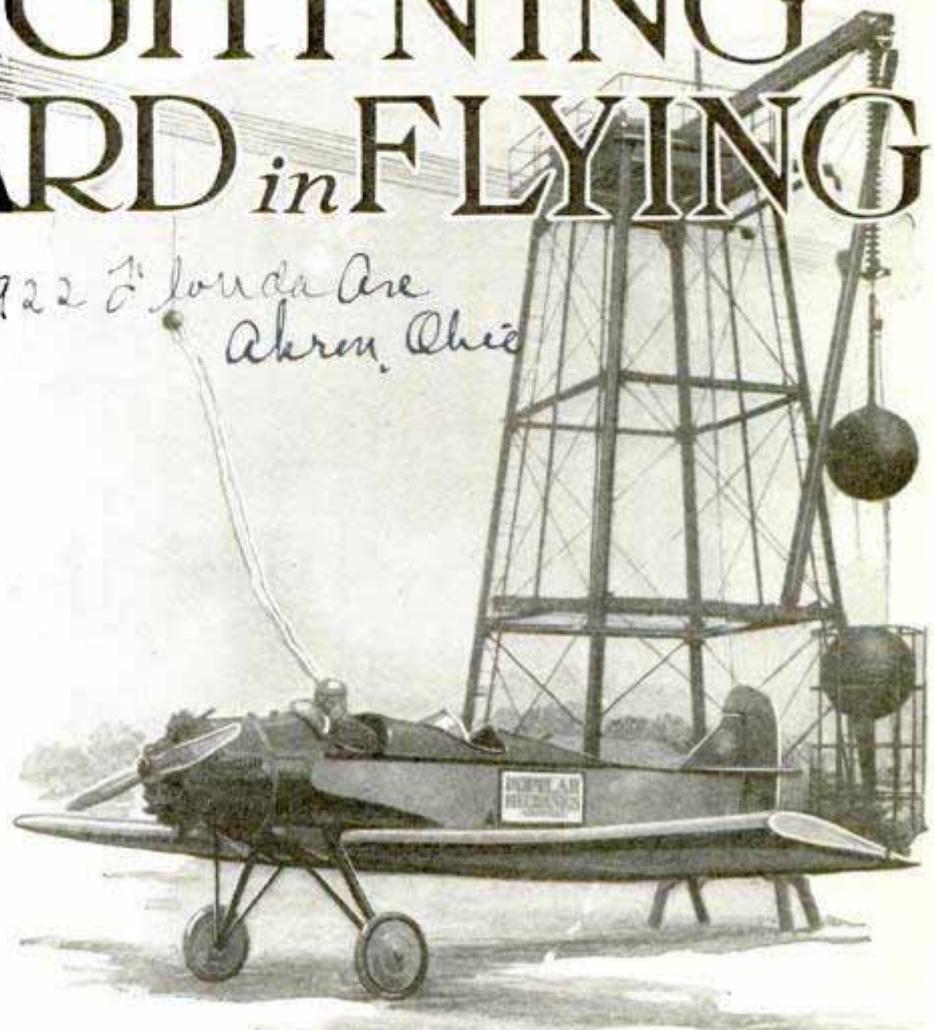

Artificial Lightning Striking Dummy in Full-Rigged Plane at Ohio Insulator Company, Barberton, Ohio, Where Tests Are Being Conducted

shown that the pitot tube of the air-speed indicator, projecting from the front of a wing of a model tri-motored monoplane, acted as the doorway for the bolt.

These, according to Mr. Austin, are among the more common ways in which a plane can be struck, but so much depends on the structure of the plane itself—its relative dimensions, shape of parts and placement of various units—that no hard and fast rules can be formulated for predicting the exact point at which a bolt will enter. The tests so far conducted indicate that in practically every case complete protection from lightning danger can be provided by proper design or by the use of adequate electrical shielding and bonding.

Following preliminary experiments with models, further tests were conducted on a Barling NB-3 all-metal frame, fabric-covered monoplane provided for the purpose

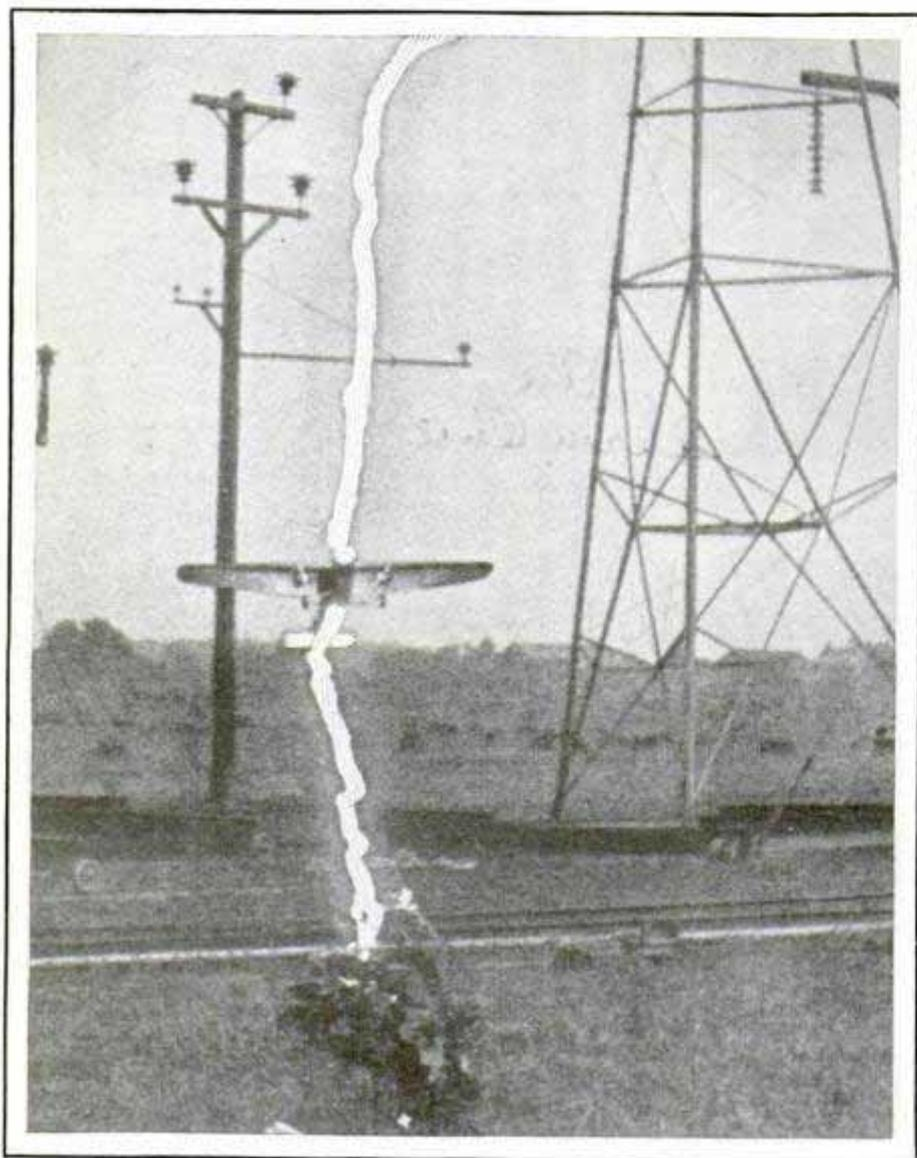

Model Plane Being Struck by Artificial Lightning; the Bolt Passed In at the Propeller and Out at the Tail of the Ship

by Popular Mechanics Magazine. The plane was placed on the ground and subjected to impact discharges of artificial lightning, to determine, among other things, vulnerable points and the effect of the discharges on the motor, tail group, propeller and other parts.

Repeated hits were obtained on the propeller, which was of wood with a metal capping that extended to within a few inches of the hub. The discharge, striking the propeller tip, traveled along the metal and then jumped across the intervening few inches of space to the motor, striking, in most cases, the nearest spark plug. All plugs had been grounded to the motor to prevent damage. This indicates that the propeller can pick up a discharge and carry it to the ignition system, with possible damage to the magneto, wiring or other vital part.

Further tests with the LeBlond 60, dual-ignition, radial air-cooled motor on the Barling revealed that the artificial lightning bolts would not stop it while it was idling. Strikes were obtained on the propeller and the cylinders. The top front spark plug had been grounded as a means of protecting the ignition, as it was anticipated that the charge would pass from the propeller sheathing direct to this plug. It is yet to be determined whether motors of other types or with different propellers will likewise continue to run under the lightning bombardment.

Strikes were obtained on other parts of the plane. Those entering the top of the rudder were of interest. Holes were produced in the fabric at points where the discharge struck. These holes, about the diameter of a lead pencil, were caused by the instant va-

porization of the fabric material under the intense heat, the resulting explosion causing the fibers to be thrown outward. The rudder had a duralumin frame, and the strikes occurred at the points where the fabric was stretched over the frame.

The question of fire hazard to airplanes during a thunderstorm—whether a bolt will set fire to the fabric of a wing, for instance—is one that involves a large portion of chance, Mr Austin claims. The producing of fire is determined largely by the materials of the fabric or paint and the rapidity with which heat is dissipated. Vaporization of moisture and fabric materials might produce a cooling effect great enough to prevent fire.

Investigation so far carried out, especially that with running motors, has indicated that there is apparently no danger of hot exhaust gases from the engine cre-

ating a path for lightning. This point is one that has been puzzling airplane men and others who have speculated on the possibility. Mr. Austin has found evidence that the heat is so rapidly dissipated, and that the propeller, in churning the air, so effectively breaks up the streams or threads of hot gases that no path is produced. Studies of this aspect of the lightning hazard have not been completed.

The tests, which have been in progress for several months, are scheduled to continue perhaps into the summer. There are a number of problems that will be studied in addition to those already attacked. One of the most important is the effect on pilot and passengers of a sudden collapse of an electrostatic field through which the plane is flying. Such a collapse occurs when a lightning discharge, not necessarily striking the plane, takes place in the immediate vicinity. Mr. Austin believes that the sudden breakdown of the field may induce such a high voltage on the ship that human occupants would receive a severe shock. Furthermore, there may result a discharge between two isolated masses of metal in the plane, so that fire or other damage might result. He believes that there is more likelihood of this occurring in an open-cockpit plane and in one that is not well bonded, than in a closed-cabin, well-bonded ship, especially the all-metal type.

An inquiry also will be made to determine whether lightning will cause fire or explosion in fuel tanks, or in the engine crankcase where there often is an explosive mixture of gasoline and oil vapor. Explorations of the charges on various parts of a plane, as inside the cabin, when the ship is in an electrostatic field, will show the manner in which charges in the cabin or cockpits are distributed and their

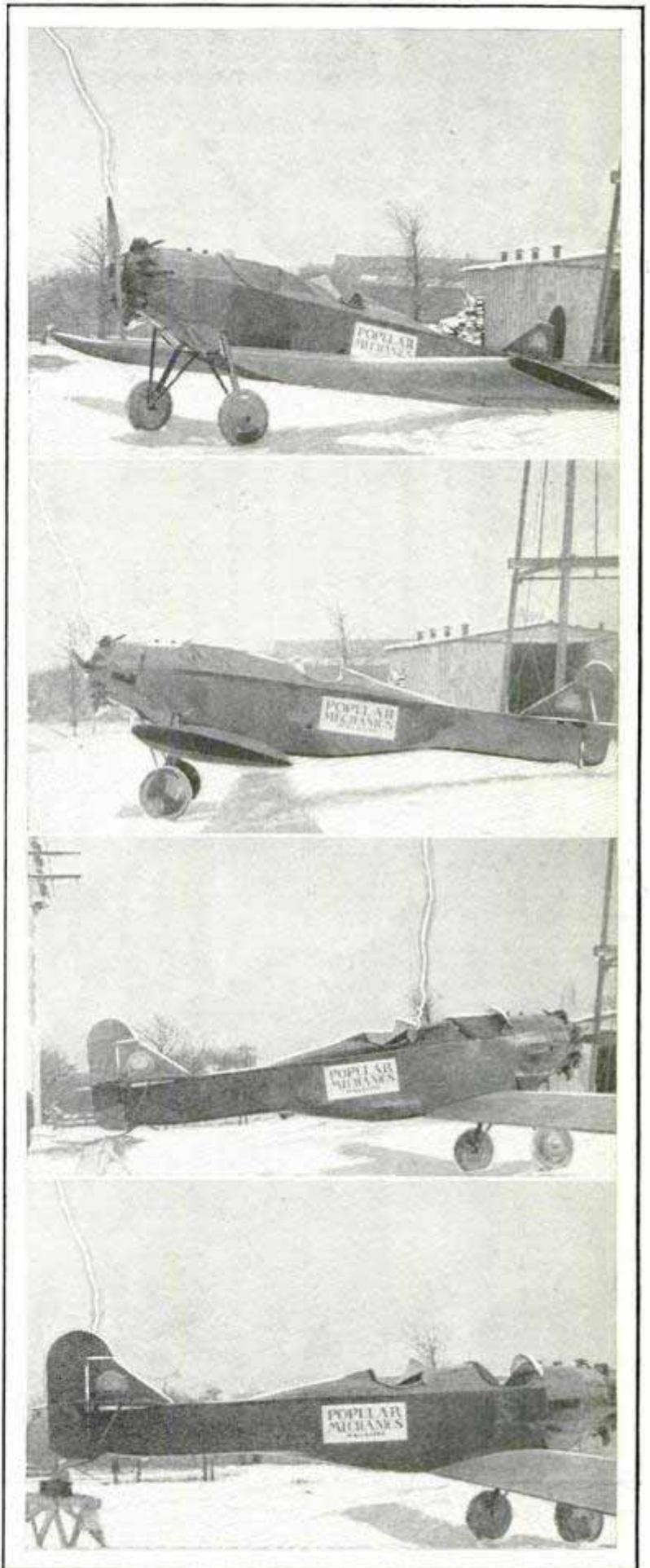

Four Hits Scored at the Barberton Laboratory Field; Propeller, Cylinder Head, Fuselage and Rudder of Full-Rigged Ship, Subjected to Bolt of Artificial Lightning

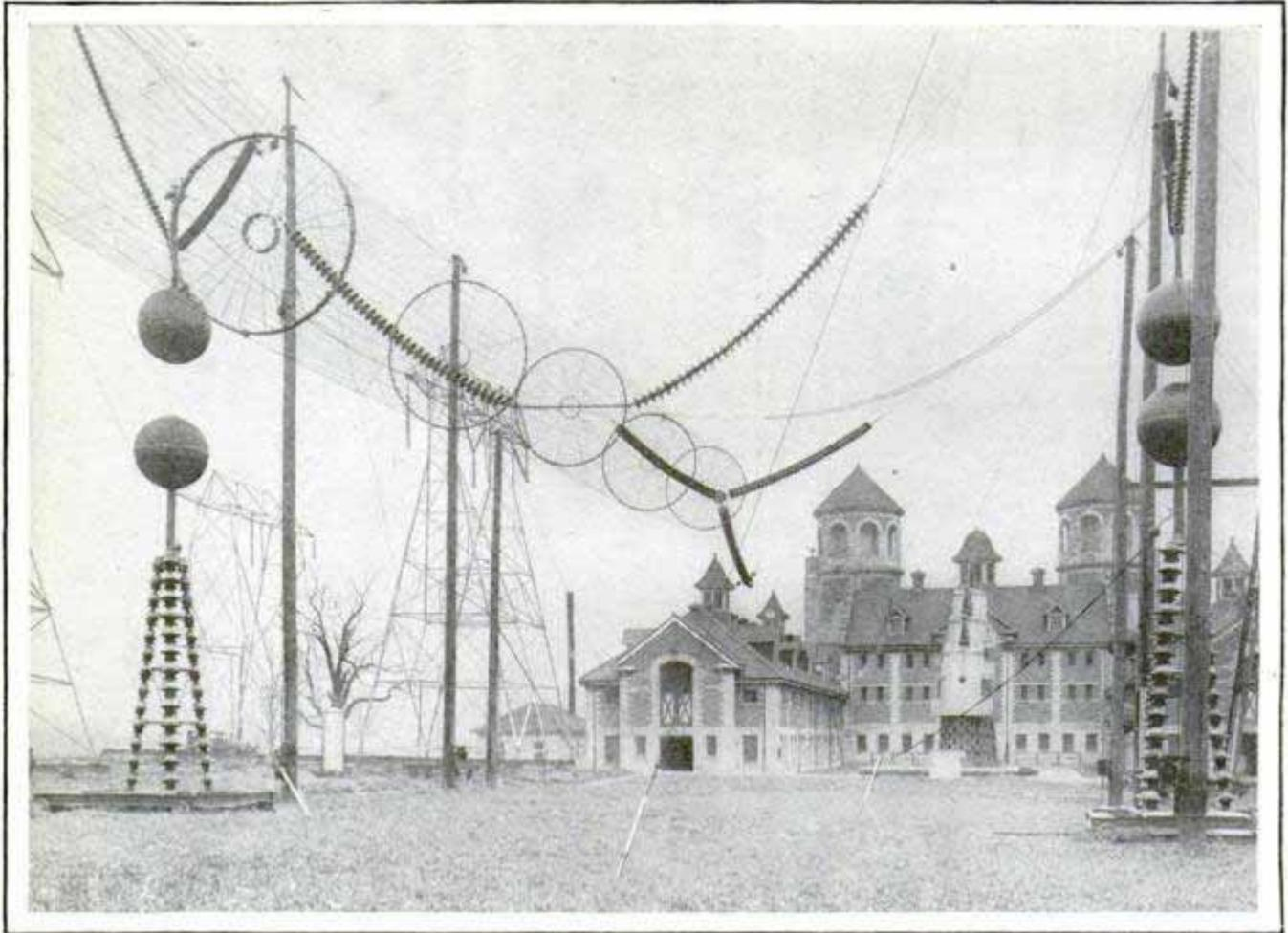

View of Part of Plant of Ohio Insulator Company at Barberton, Showing Some of Equipment Producing Artificial Lightning, Whose Effect on Airplanes Is Being Studied

effect on the instruments. Studies will be carried out to learn whether control cables are likely to be fused by lightning bolts, and whether a charge on the rudders or ailerons will be communicated to the control stick and rudder bar, and thence to the pilot.

Various general types, including all-metal cabin planes, fabric-covered wood-fuselage ships, open-cockpit jobs, planes with various kinds of wing structure, and so on, will be tested. Likewise, it is planned to study the effect of lightning on various kinds of motors, propellers, etc.

This is the first time a definite effort has been made to learn the truth about lightning as it affects the airplane. There has been, until recently, a prevailing opinion that a plane in flight cannot be struck by lightning. But the findings at the Barberton laboratory, as well as reports of pilots all over the country, sent in response to a questionnaire submitted by Popular Mechanics Magazine, indicate conclusively that there is a real lightning hazard. The comparative lack of trouble

from lightning in the past is attributed to the facts that planes have been keeping on the ground during thunderstorms, largely because of the violence of air currents, and that the number of planes has not been great enough to make the lightning hazard a large factor. But now that air travel is becoming more general and constant, the role that lightning plays is taking on a new significance.

It is to provide the airplane designer, builder, operator and user with definite information, making possible adequate protection from lightning, that the tests are being carried out at Barberton.

4092 SUBSTITUTE FOR METAL CANS AND GLASS CONTAINERS

Having the strength of metal and the transparency of glass, a possible substitute for metal cans and glass containers for preserving foodstuffs has been found in a cellulose product. The material was discovered accidentally in the laboratories of a manufacturer of photographic film.

*Eastman Kodak Co.,
Barberton, N.Y.*

Mining Corp. Ltd
Anglo-Orient House 33 Bishopsgate

LEAD ALLOY MORE EFFICIENT THAN PURE METAL

Experiments to determine the cause of breakdowns in lead cable sheathings by the British non-ferrous metals research association have resulted in the discovery of a lead alloy, only two-thirds as heavy as the pure metal and possessing many superior qualities from an industrial standpoint. The alloy consists of 98.25 per cent lead, one and one-half per cent tin, and the rest cadmium. Tests show that pipe made from the alloy is cheaper, lighter, has eighty-four per cent more tensile strength, offers greater resistance to vibration, and, in certain corrosive waters, is more durable than lead itself.



Electric-Light Bulbs Frozen under the Surface of the Ice Furnish Illumination for Skating at Night on Lake Placid

ELECTRIC LIGHTS FROZEN IN ICE THRILL NIGHT SKATERS

Skaters of the Lake Placid club in the Adirondacks have enjoyed illuminated night skating this winter through a plan of freezing incandescent electric-light bulbs beneath the surface of the ice. The lights were placed in various artistic patterns, and at night the part of the lake reserved for skating was lighted with the sunken bulbs.

RADIO OPENS GARAGE DOORS AND CLOSES THEM

A Swiss inventor has developed a radio device by which he can open and shut his garage doors without getting out of his car. Antennæ set inside the garage receive waves emitted from the car, setting in motion a small motor which raises a steel roller blind in the garage. As he approaches the garage, the autoist presses a switch on the dashboard of his car, and drives straight into the garage as the roller blind automatically goes up. When he alights from the car, he presses another switch inside the garage and the steel blind falls. When he wants to drive out of the shed, he switches the roller blind up, drives out and when clear of the garage, touches the switch on his dashboard and the garage door closes behind him.

BEST LANDING-FIELD SURFACE

Landing fields covered with white-washed crushed stone can be seen by aviators coming through a dark sky fifteen times as well as fields covered with asphalt, aviation lighting engineers have determined. Fifteen times as much illumination is required for the asphalt field as for that of stone. The latter reflects seventy-five per cent of the light it receives, and the asphalt five per cent. Reflection factors for other materials are thirty per cent for cement, and twenty-five per cent for ordinary crushed stone.



Courtesy London Daily News
Radio Apparatus in Auto, Signals from Which Cause Garage Door to Slide Open or Shut

Similar to S. D. Barber - Columbia Rockefeller etc.

Science Service News Bulletin

M. Louis Martinet *Scitgenore* *General Electric*

2 Roxbury Place

Mt. Washington

Baltimore, Md

30

General Motors Bldg. 1775 Broadway New York City

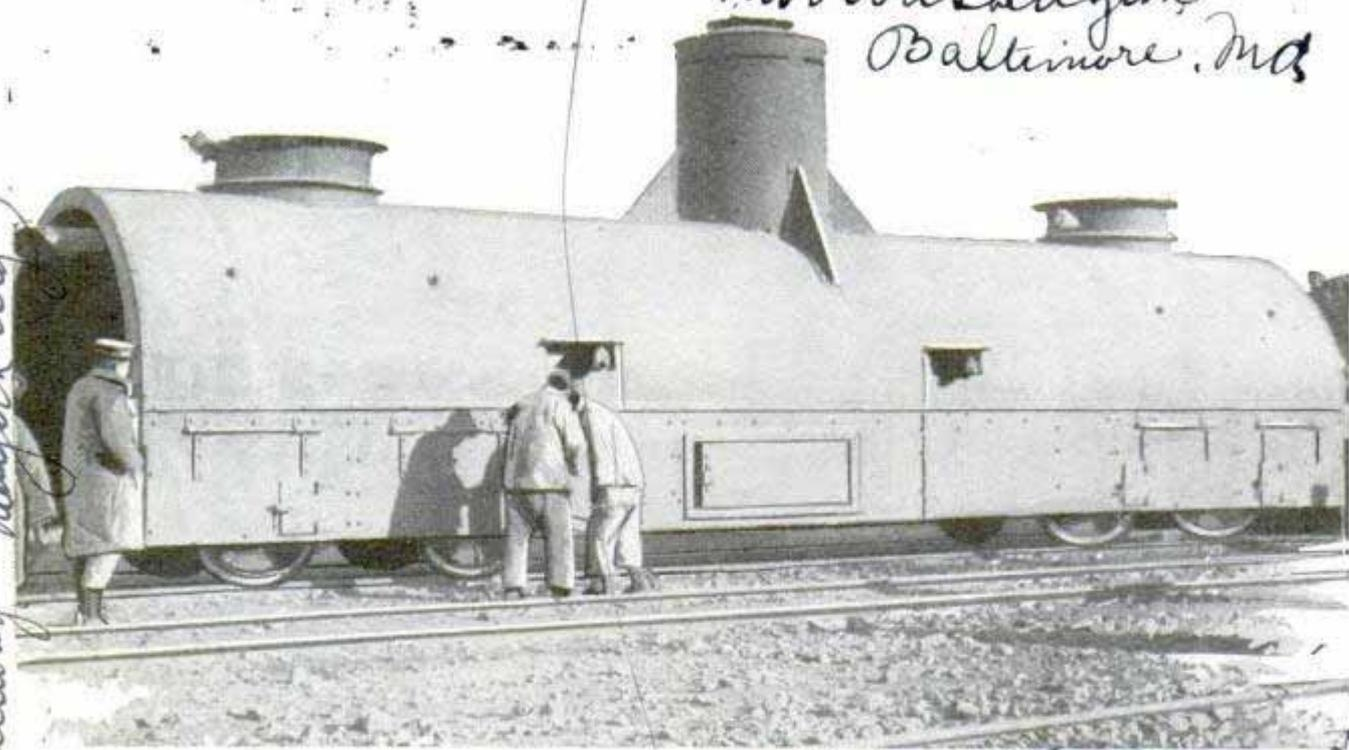

Armored Railway Car Employed by Chinese Nationalists in Recent Fighting; It Is Covered with Heavy Steel Plate, with Turrets for the Guns in the Center and at Each End

International

ARMORED CAR LIKE OIL TANKER USED BY CHINESE

Somewhat resembling an American oil-tank car, an armored railway car has been used by the Chinese nationalists in victorious battles of recent months. The formidable instrument of war is constructed of heavy steel plate with a gun turret in the center and smaller ones at each end, while openings for more guns are provided on the sides and ends.

MOVIE FILMS ARE PRESERVED IN SPECIAL CONTAINER

Constructed on the principle of a humidior, a container for movie films now is available, intended particularly for keeping home films always in condition for projection. It consists of two aluminum boxes, one within the other. The outer one is lined with cork and a dead-air space of about half an inch is provided between the boxes. A humidior pad is fastened to the bottom of the inner container and is moistened with water



before the film is placed inside and the air-tight covers of the boxes are locked. The holder has space for three 400-foot reels, and also protects against fire.

CHEMICAL MUFFLER REMOVES CARBON MONOXIDE

To eliminate the deadly carbon monoxide from the exhaust gases of automobiles, a muffler containing a chemical element has been produced to replace the ordinary muffler. Carbon monoxide is odorless, colorless and tasteless, which accounts for the fact that it claims the lives of many motorists who thoughtlessly warm up an engine in a closed garage. The chemical element, the exact nature of which has not been revealed, is known to be a catalyst, a substance causing a chemical reaction without itself participating, and transforms carbon monoxide to carbon dioxide, the same gas breathed from the lungs. The canister of the catalyst is substituted for the muffler, deadening the noise of the engine explosions and at the same time removing all the unburned fuel gases, the ill-smelling as well as the deadly. The catalyst has the task of consuming about half as much fuel as the engine, and possibly the heat may be used to warm the car.

Chicago
Hawell Co
1803 Larchmont

Carbon monoxide eliminators Corp.

Pittsburg Pa
Thomas Meade

Dr. J. C. W. Drayer
Detroit Chemistry

see Feb 1930-217

H. R. S

4040

ELECTRIC ROBOT GUIDES PLANE WITHOUT AID

Operated by electrical impulses, a robot that guides an airplane and keeps it on an even keel without aid of the pilot, except in taking off and landing, recently underwent successful tests. The electric robot differs from the gyroscopic robot in that two vanes, mounted on the forward edge of the wing, transmit variations in the air stream to a pendulum which in turn regulates electric motors operating stick and rudder. Down and upward currents are detected and corrected through electrical and mechanical connections with ailerons and elevators.

read H. T. Williams



Courtesy I. Kittle

Diver Wearing Apparatus Which Dispenses with Helmet; Tube to His Mouth Is Attached to Oxygen and Carbonic-Acid Gas Supply

HELMETLESS DEEP-SEA DIVER DODGES PERILS

A new deep-sea diving apparatus which dispenses with the need of a helmet was recently tested at Lowestoft, England. The diver, using this apparatus, wears a coat of white flannel, while the apparatus, comprising oxygen and carbonic-acid gas absorption cylinders, is strapped round his waist and back of his head. He breathes and exhales the used air through tubes connecting the cylinders, while goggles are strapped over his eyes.

McCobb Woods Chalfont
Emergham Road

CARRIER RACK AT FRONT OF CAR PROVIDES EXTRA SPACE

Space for extra luggage is provided in a carrier rack which fits at the front of Ford cars in the space between the bumper and the radiator. It consists of a metal support, twenty-four by eighteen inches and nine inches deep, and will carry 400 pounds. It has more road clearance than the car and can be slipped into place or detached without the use of any tools.

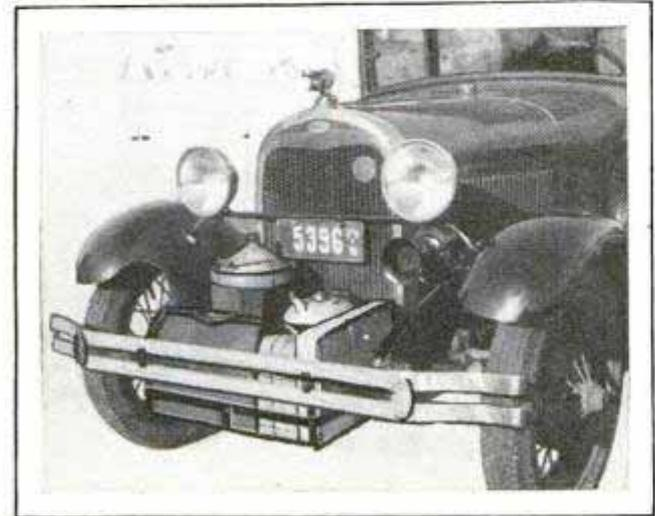

Luggage Rack for Front of the Auto Which Provides Extra Space for Bags and Bundles

SUGAR PRODUCED BY GERMS OFFERS DISEASE CURE?

By means of a form of sugar produced by tuberculosis germs, scientists are hoping to find a new way to cure the malady. Dr. William Charles White, of the United States public-health service, reports that this sugar is the chemical bond between the tuberculosis bacillus and the kind of human body cell in which the germ thrives and spreads. If the bacillus can be separated from this cell it can no longer cause the disease and a positive cure may be obtained. The sugars are harmless to healthy persons, but may be fatal to those afflicted with tuberculosis.

The Katch-All Co

Washington 20 C

Vincentines, Inc.

4006

BRIDGE SPAN RIDES ON BARGES TO POSITION

51

When contractors were refused permission to close the Illinois river to construct the draw span for a bridge at Pekin, they erected the falsework on shore and built the 260-foot span there. When the span was completed, the falsework was removed and replaced by supports on barges filled with water so that they sank to the deck level. With five barges in position and the ends of the span still resting on the falsework, the boats were emptied of the water,

thus raising the 450-ton load from its old supports. By means of cables attached to another bridge, the mammoth flotilla then was hauled 500 feet to the channel, swung into position and, by again sinking the barges, was lowered onto its permanent supports.

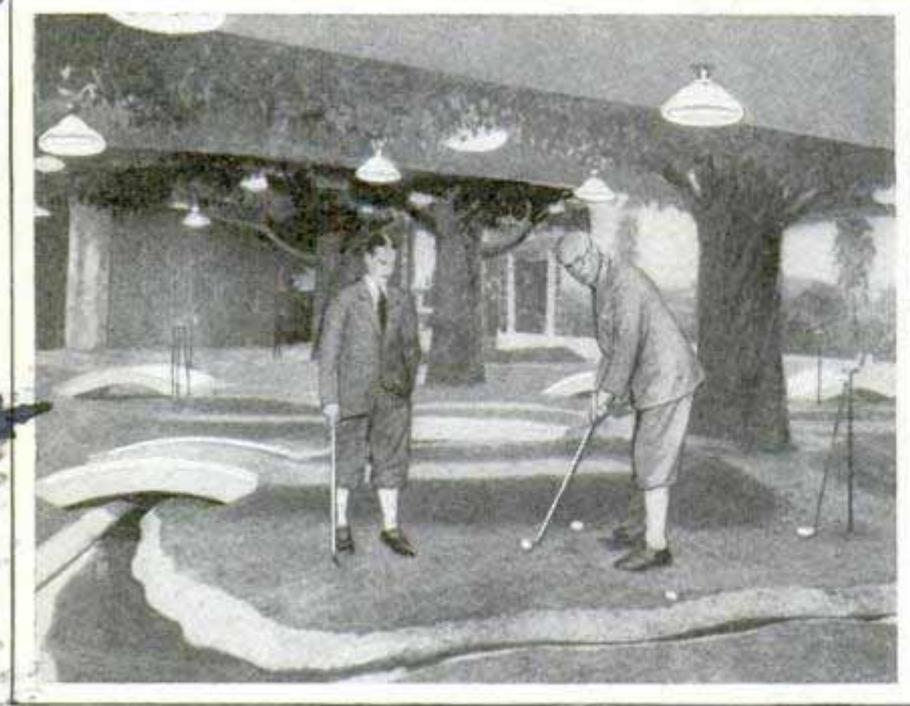

© Henry Miller

View of Elaborate Eighteen-Hole Indoor Golf Course Containing a Stream Stocked with Trout as an Extra Hazard for Players

BROOK ON INDOOR GOLF COURSE OFFERS OUTDOOR HAZARD

St. Paul man

One of the most elaborate and largest indoor golf courses in the world has been built in the St. Paul athletic club. One feature of it is a stream, stocked with live trout, which meanders over the course, bridges spanning it at various places. The course itself is a regulation eighteen-hole affair, and besides the stream, sand traps and other hazards are provided. Cottonseed hulls, dyed green, give the effect of grass and, with imitation trees, add to the outdoor appearance.

ELECTRIC EYE MARKS PHOTOS FOR BEST PRINT PAPER

Doing a task heretofore performed only by a skilled photograph worker, an instrument now is on the market which marks on photographic negatives the proper grade of paper on which each print should be made, and the length of time each should be exposed to the light in

TUNNEL FROM SPAIN TO AFRICA

Spanish engineers are considering the possibility of linking the Spanish mainland with the African coast by the longest tunnel in the world—twenty miles from end to end, and 1,500 feet below the surface of the water in the Strait of Gibraltar at the mid-point. A preliminary shaft has been sunk to determine rock formations. Although the strait is only eight miles wide at the narrowest point, the great depth of the channel and the presence of rock too hard to bore, make a tunnel there impracticable. From the shaft, further explorations are to be undertaken by means of sound waves.

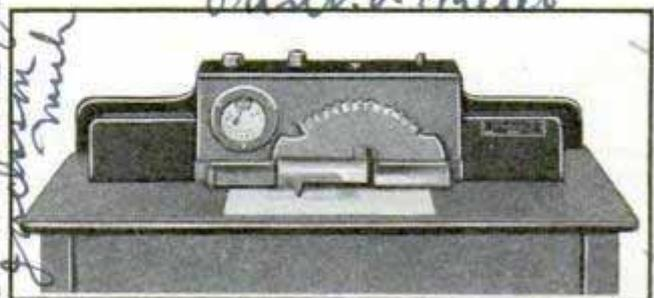

Photographic Negatives Exposed to This Instrument Are Marked with Proper Paper for Printing

printing. It is known as a "printometer" and is operated by electric and mechanical devices as the negatives are exposed.

Eastman Kodak Co.

Review of source news Bulletin no. 458-8, 12/30 34

McLinn 409 Poland & Johnson

Printometer

get on market

SHIP-TO-SHORE TELEPHONE LINK PROVES A SUCCESS

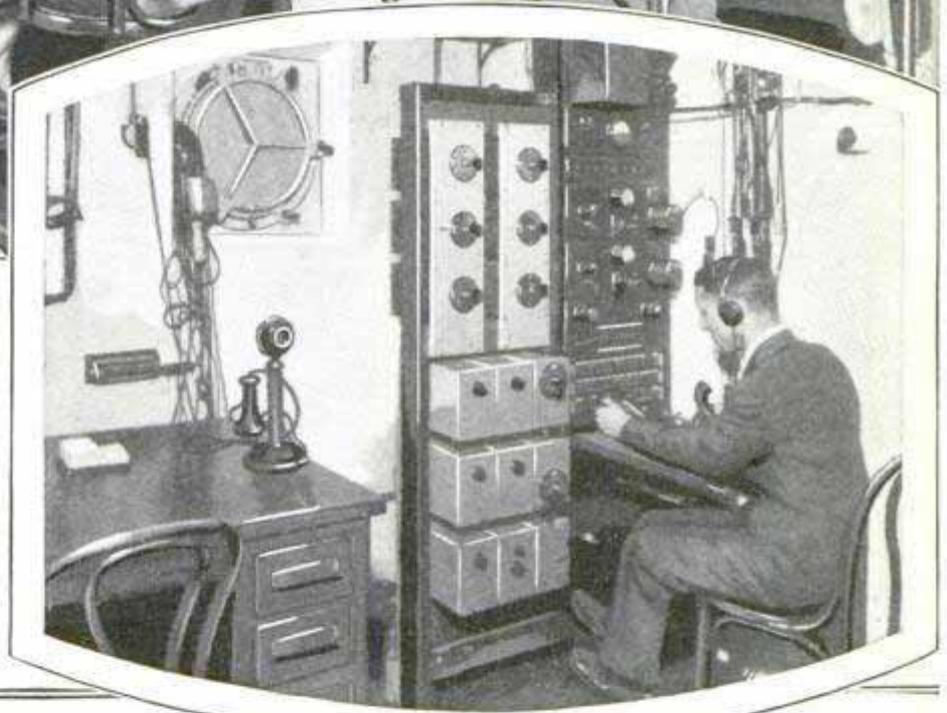
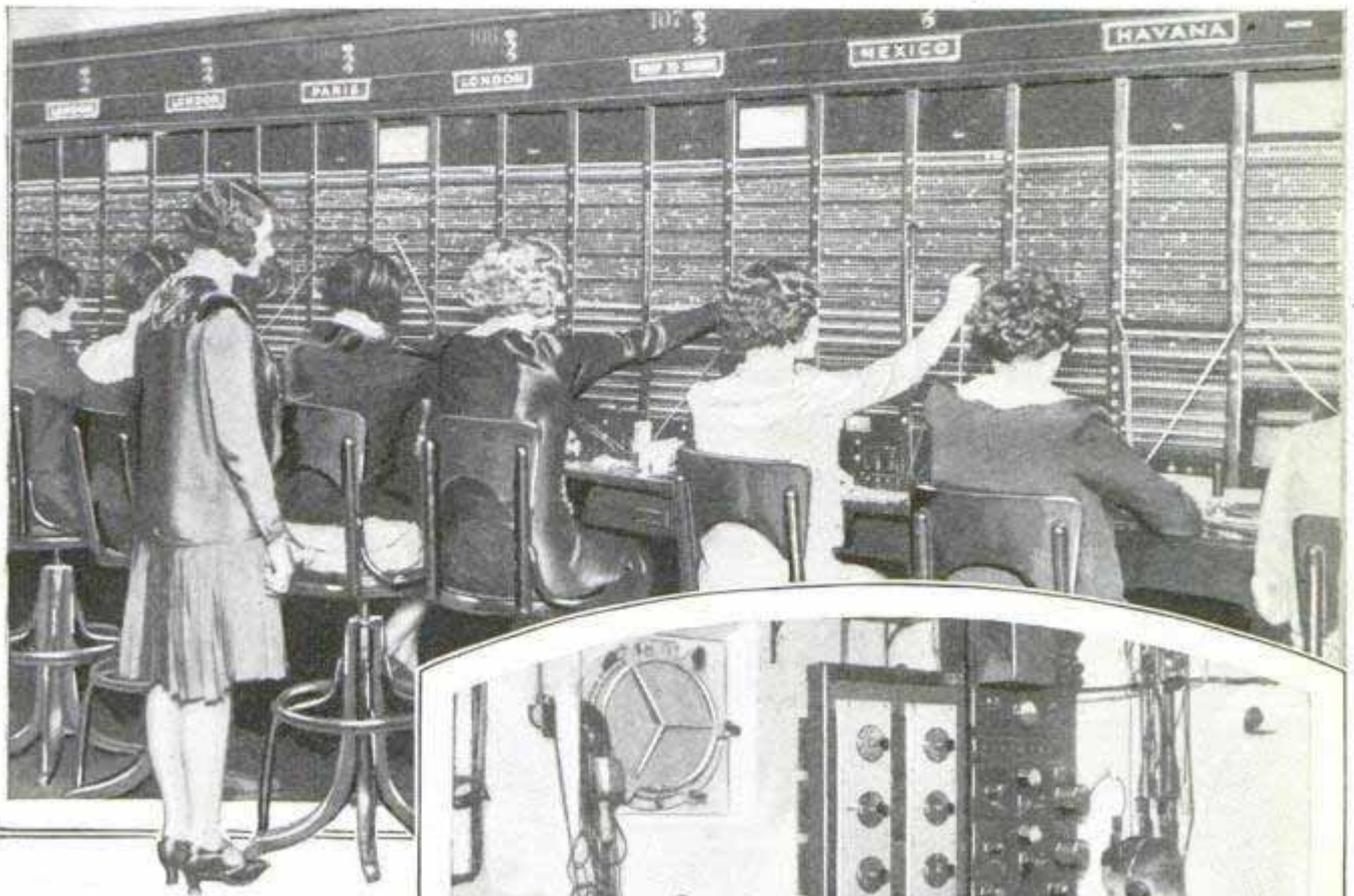

Foreign-Service Section of Switchboard in American Telephone and Telegraph Office at New York; Interior of Deck House on S. S. "Ivriathan," Which Houses Short-Wave Radio-Telephone Equipment, and Diagram Showing Path of a Call between a Shore Telephone and Moving Vessel

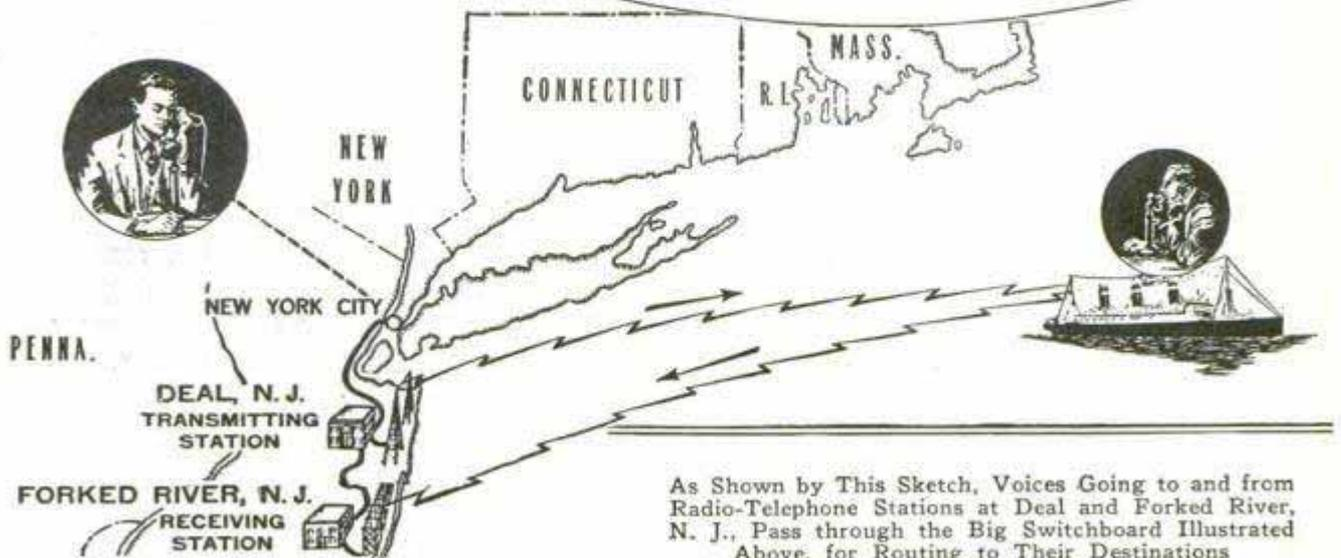

As Shown by This Sketch, Voices Going to and from Radio-Telephone Stations at Deal and Forked River, N. J., Pass through the Big Switchboard Illustrated Above, for Routing to Their Destinations

Boa

SIXTEEN-CYLINDER MOTOR LATEST AUTO WONDER

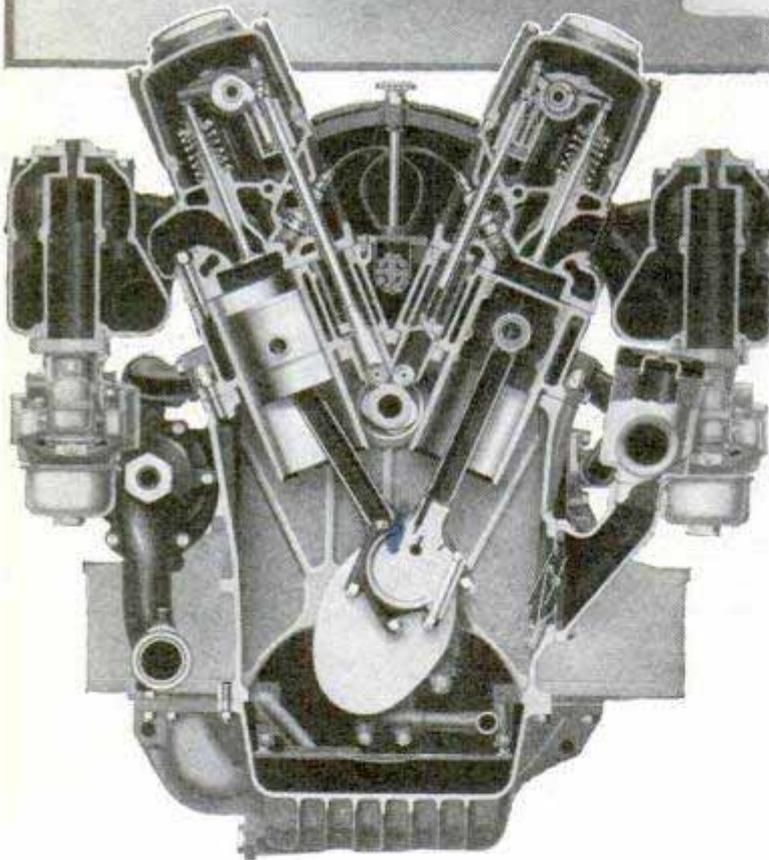
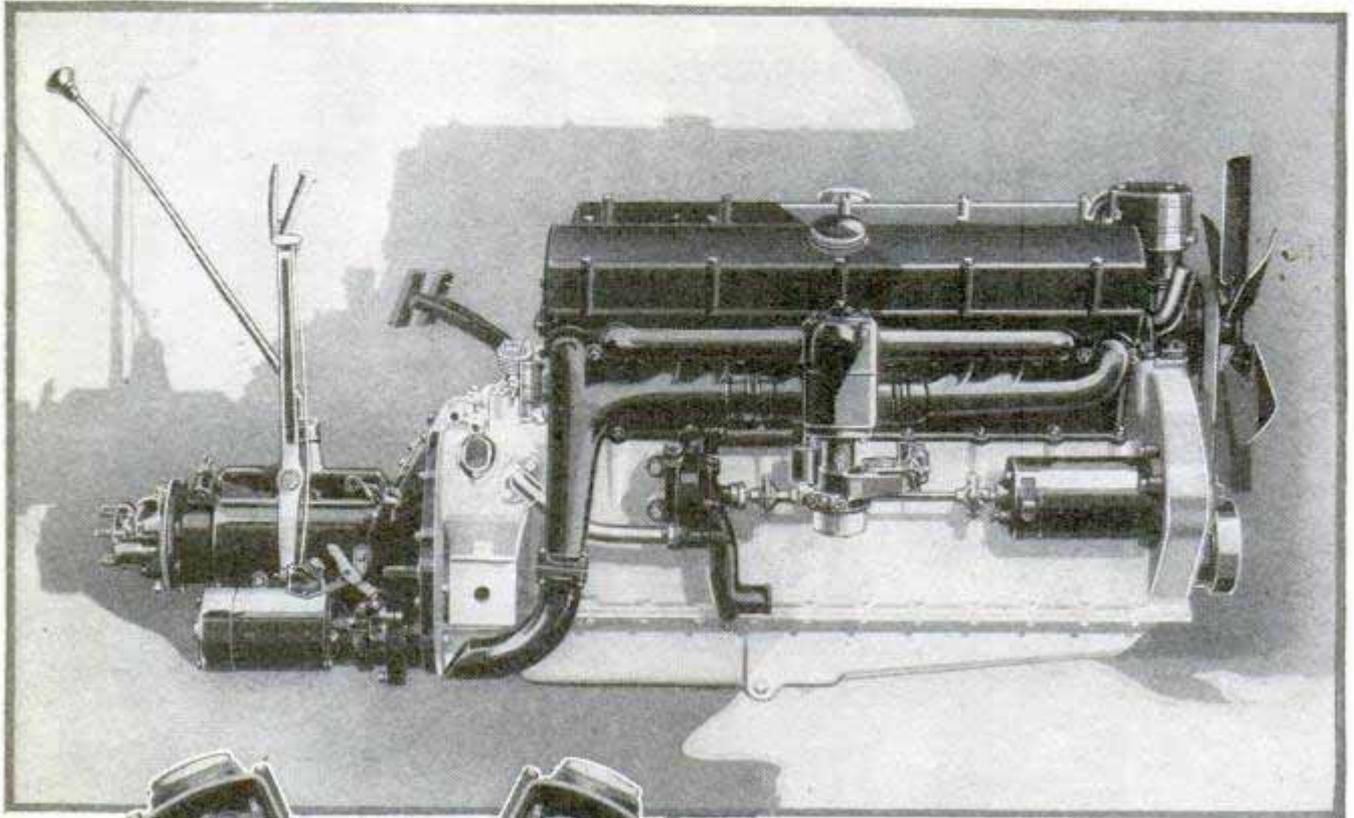

Above, Side View of Sixteen-Cylinder Cadillac Power Plant; Below, Cross Section of the Engine, Front View

To provide unusual acceleration, hill-climbing ability and speed, Cadillac has introduced a 175-horsepower sixteen-cylinder V-engine, the first sixteen-cylinder engine for automobiles to be put into quantity production anywhere in the

world. It consists of two eight-cylinder blocks forming a forty-five-degree "V," bolted to an aluminum crankcase. Each block has a separate carburetor and separate intake and exhaust manifolds, all placed on the outside of the "V," where they are readily accessible. The purpose in adopting the sixteen cylinders rather than twelve or eight cylinders was to insure extreme smoothness, since the relatively small pistons and connecting rods and the short stroke give greater smoothness and silence than would be attained in an engine of the same piston displacement having a less number of cylinders. The most interesting feature of this new engine is a simple arrangement which keeps the valves automatically adjusted at zero.

Each rocker arm is mounted in an eccentric sleeve which in turn is mounted on the rocker shaft. If the valve mechanism tends to become too tight or too loose, the bushing is automatically rotated to raise or lower the rocker until the clearance becomes zero.

Cadillac motor car to Detroit, Mich.
2860 Clark St.

114

AIR IS KEPT WARM OVER ARCTIC BY OZONE

4118

Why is the upper air over the arctic warmer than it is over the equator? The question long has puzzled scientists and still remains a mystery, but Dr. W. I. Humphreys, of the United States weather bureau, offers a partial explanation by the fact that there is a thicker "blanket" of ozone over this part of the globe than over the equatorial regions. This has been determined by observations, and as ozone absorbs radiations from the earth and reradiates part of them back again, there is less heat loss where ozone is plentiful.

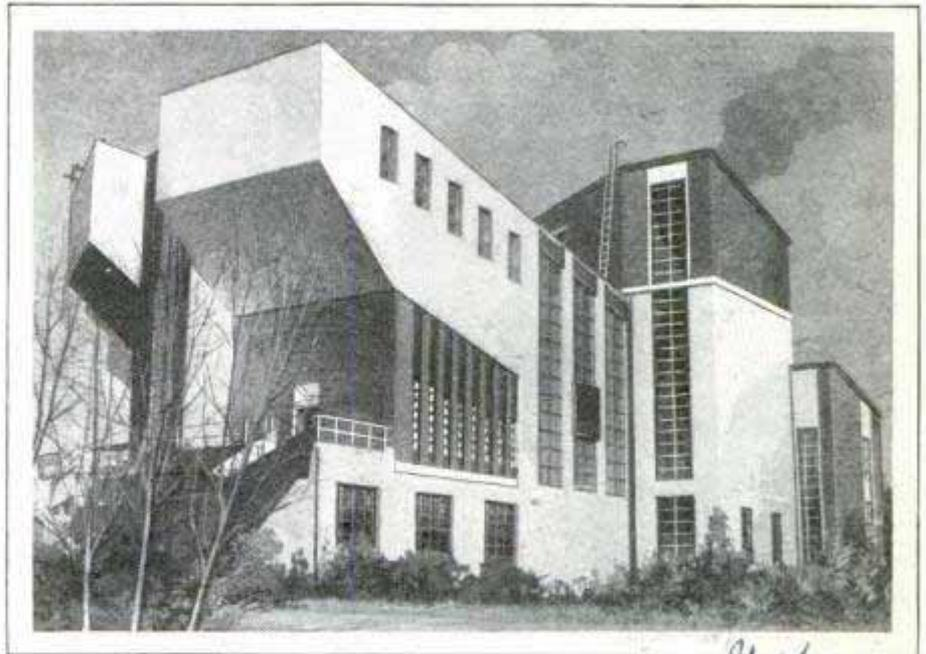

Resembling an American Grain Elevator, This Striking Piece of Architecture Is in Reality a Club for Moscow City Workers

CLUBHOUSE LIKE AN ELEVATOR FOR MOSCOW WORKERS

Resembling an American grain elevator or coal chute, a clubhouse, strikingly original in architectural design, is nearing completion in Moscow. The building will be occupied by the municipal workers of the Moscow city district.

BOAT IS PROPELLED BY PEDALS AND GUIDED LIKE AUTO

Propelled by means of pedals in the bottom of the craft which connect to oars, and guided by a wheel like an automobile, a children's boat in England is attracting much interest. Children's sizes are built to resemble various water birds, and adult models also are being made with two or more sets of pedals. No experience in rowing is necessary to operate the craft which can make a speed of three or four miles an hour.

3987

Williamson's Pedals Dubler & Lloyd

RUBBER REPLACES METAL

There has recently been produced a new kind of rubber which is said to possess superior properties. This material is made direct from the latex, permitting a more thorough mixture. It can be turned out only in sheet form, but the sheets, through the use of a special solution, can be built up into a variety of shapes. The Malay tin mines were among the first to apply this material, and they used it instead of white iron and manganese for lining launders and chutes of dredges. Although much lighter than the metal lining, which had to be removed every four or five months, the rubber material has shown no signs of wear after eighteen months of service. Shoes of gravel pumps, throats of hydraulic elevators, and bores of pipes conveying abrasive mixtures have been similarly protected.

Latex (Batu Caves) F. S. ...

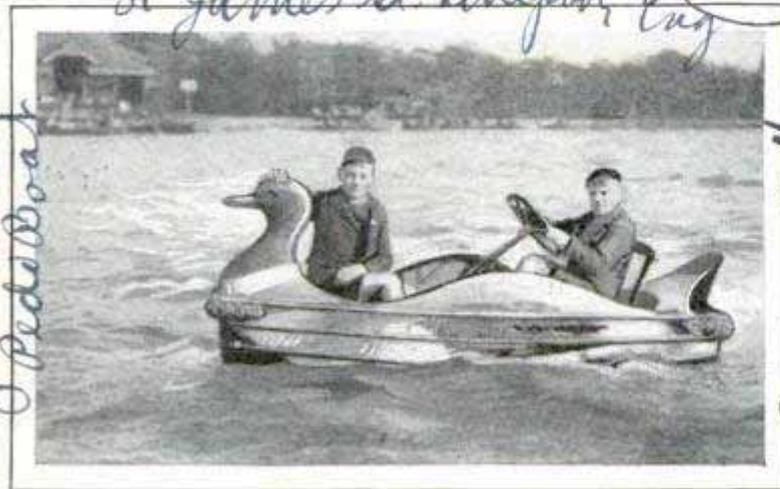

Children's Boat, Built to Resemble a Duck, Operates with Pedals and Is Steered like an Automobile

W. H. Sargent known. Pedal Boat

The Lake and Seaside

Mrs. Bernard Williamson

Wilkinson

3886

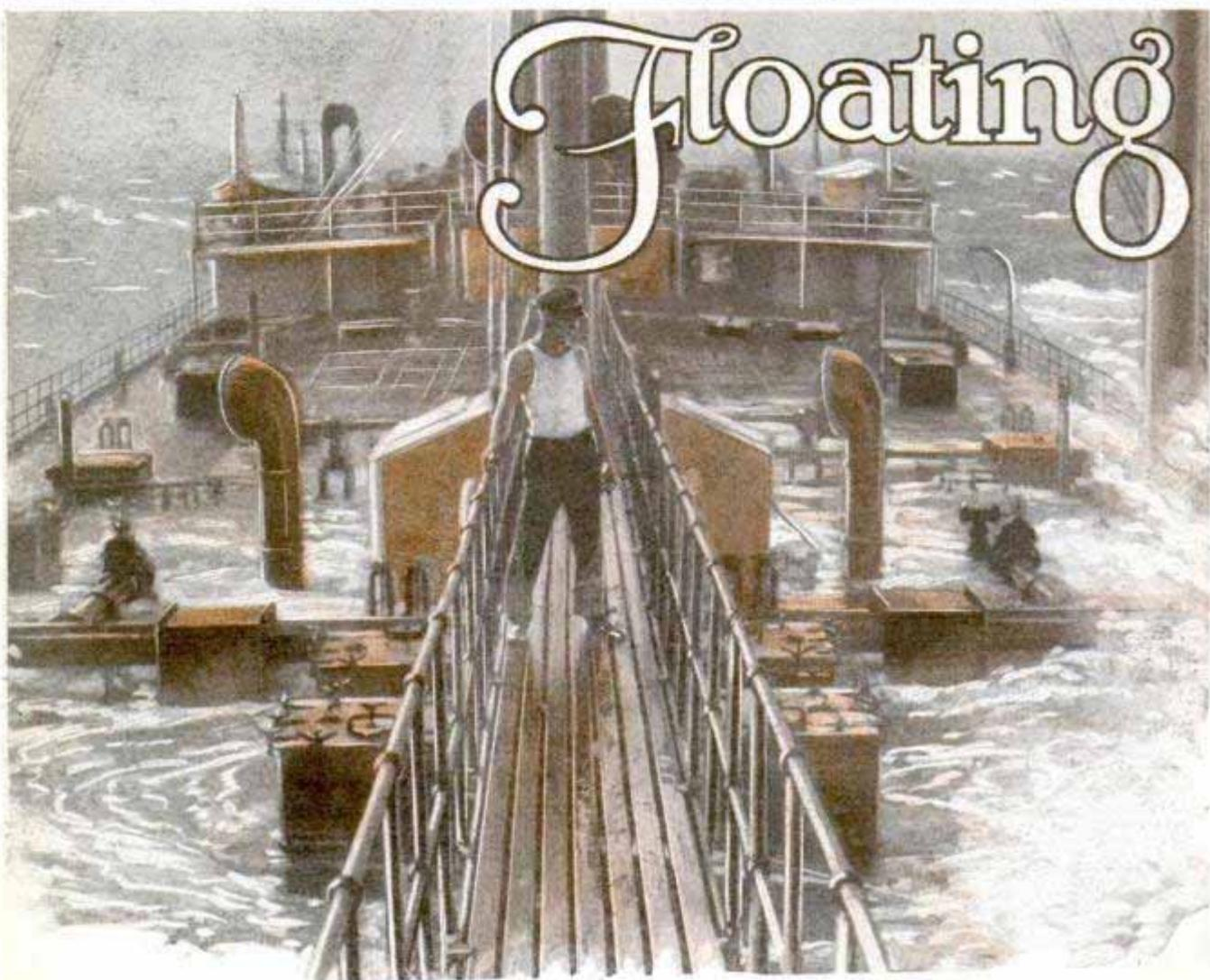

On a Tanker's Fore-and-Aft Bridge, a Structure Made Necessary by the Fact That the Deck, as Shown Here, Is Frequently Awash during a Voyage

By DON GLASSMAN *151 Wash St. N.Y.*

THE HEYDAY of tankers is here. It comes with the age of oil, the age of mechanical locomotion and exploitation of the earth's petroleum.

Thirteen hundred and twenty-four tankers, aggregating 10,500,000 tons, ply the ocean's trade routes. During one year, they transport almost a billion barrels of petroleum and its products.

The search for oil is no less heroic than the search for gold. Companies with billions of capital send wizard geologists into jungles, deserts, snow fields and lonely islands to find rock structures favorable for drilling. And so they have gone into the Persian desert, into the jungles of Colombia, lava-baked plateaus of Mexico and cannibal lands of New Guinea. Then come engineers, drillers, riggers and at last towers that point like daggers into the clouds. A steel bit bores

bedrock. The hole goes down hundreds, thousands of feet. A million dollars in a hole! One day, as the rigging crew lunches under a tree, in a South American jungle, one hears a muffled boom, followed by a column of black mist.

"There she blows!"

Oil—liquid gold—comes spouting from the earth like water from a geyser, 30,000 barrels a day.

A great gusher has been tapped in the heart of a jungle, where venomous snakes are more common than men, and the chug of an automobile has never been heard.

Transferring oil to the coast usually necessitates a pipe line. And laying one pipe in a jungle may equal the ransom of a king. Millions of dollars are expended on arteries to convey oil from wells.

Now the tanker enters the picture. The first tankers, in the nineteenth century,

Oil Tanks

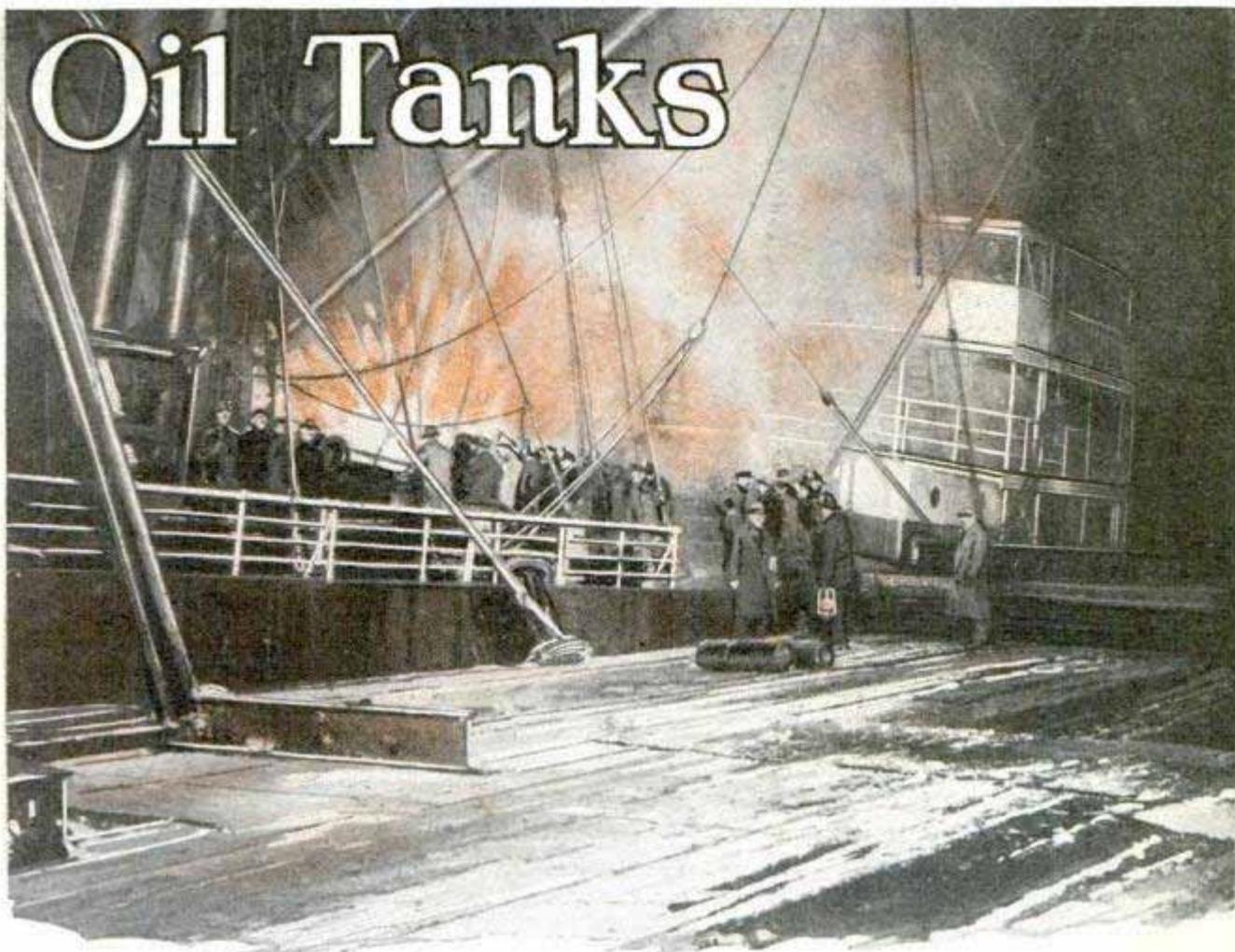

Firemen Fighting a Blaze on a Big Tanker That Sank at the Wharf in Philadelphia with the Loss of a Valuable Cargo of Linseed Oil; the Fire Required Use of Chemicals

were sailing vessels, and carried cylindrical vats of a capacity of several hundred barrels. Today some tankers have reservoirs that might comfortably hold a schooner and all her equipment. The world's largest tanker, the "C. O. Stillman," is under the Canadian flag, and can transport 163,000 barrels, besides crude oil for her own Diesel engines. The second largest tankers are the "John D. Archbold" and "John D. Rockefeller," sister-ships under the American flag.

On a crack tanker, there are from thirty-five to forty-five men in the crew. Either at sea or in port, the life on board is no humdrum existence. And contrary to prevailing belief, the crew's quarters are not grimy and greasy. One is hardly aware of a cargo aboard, for it does not require attention. In discharging and filling her reservoirs, a tanker rarely loses a drop. As a matter of safety, as well as economy, all shore connections are perfectly tight.

As long as oil can be drawn from rock, tankers will plow the seven seas. They have advantages over railroads. When one oil field is drained, the route of tankers is merely shifted to another scene. But in the case of a railroad or pipe line, much equipment must be junked. Since the service life of a tanker is from twenty to twenty-five years, there is ample time for the owners to realize profits. While the principal products carried are crude oil and gasoline, there is also some commerce in kerosene, furnace oil, gas oil and lubricating oil.

A reservoir cannot be used to carry different oil products unless it has had a thorough cleaning. This is an elaborate operation and is carried out in port by special crews. The first step is a bath from smothering steam lines that force hot vapor into the tanks under a pressure of 200 pounds for eight hours. Then the tank lids are raised one at a time, and the inside walls washed with hot water thrown

3886

by hose. A chemist analyzes the tank air before men are allowed to climb down. If he finds the air non-poisonous, a cleaning crew descends.

One enjoyment denied a tanker's crew is smoking all over the ship. It is permitted only in one's quarters, and is prohibited everywhere when the ship docks. On a steel tanker, there is little chance of fire breaking out; indeed, it has happened rarely, since the tank covers are clamped down tight, and volatile gases are carried off through pipes alongside the masts.

When loaded, a tanker's freeboard is frequently as low as seven feet. The long, low deck amidships is swept by breakers, and the ebb tow is powerful enough to carry an able-bodied man off his feet. When a tanker is bucking a strong swell, the crew communicates with different parts of the ship by way of the fore-and-aft bridge, which runs from amidship quarters to after quarters, along the backbone of the ship.

Tanker crews have their adventures, of course. In a recent hurricane along the Florida coast, the good tanker "E. J. Sad-

ler" ripped into snorting winds and a black fog at ten knots.

It was midnight. The sudden wild chatter of the radio awoke the operator with SOS signals; a message from another tanker, the "Garnet Hulings."

"On the rocks!" said the "Garnet Hulings'" wireless, "and pounding badly."

"What's your position?" asked the "Sadler."

"Not sure, but think it's near Sombrero reef."

That meant little to the skipper of the "Sadler" on a night when the world was a wind tunnel, and his vessel was lashed by whipping breakers. He had a radio direction finder and immediately put it to work. He ordered the "Garnet Hulings" to send radio test signals every half hour; he would guide on them. On top of the navigation room is the wireless loop for locating the direction of signals. It was turned until they came loudest. The "Sadler's" radio loop told its skipper that the rockbound ship was not on Sombrero reef, but ten miles south of Gun Key, or 110 miles from her reported position.

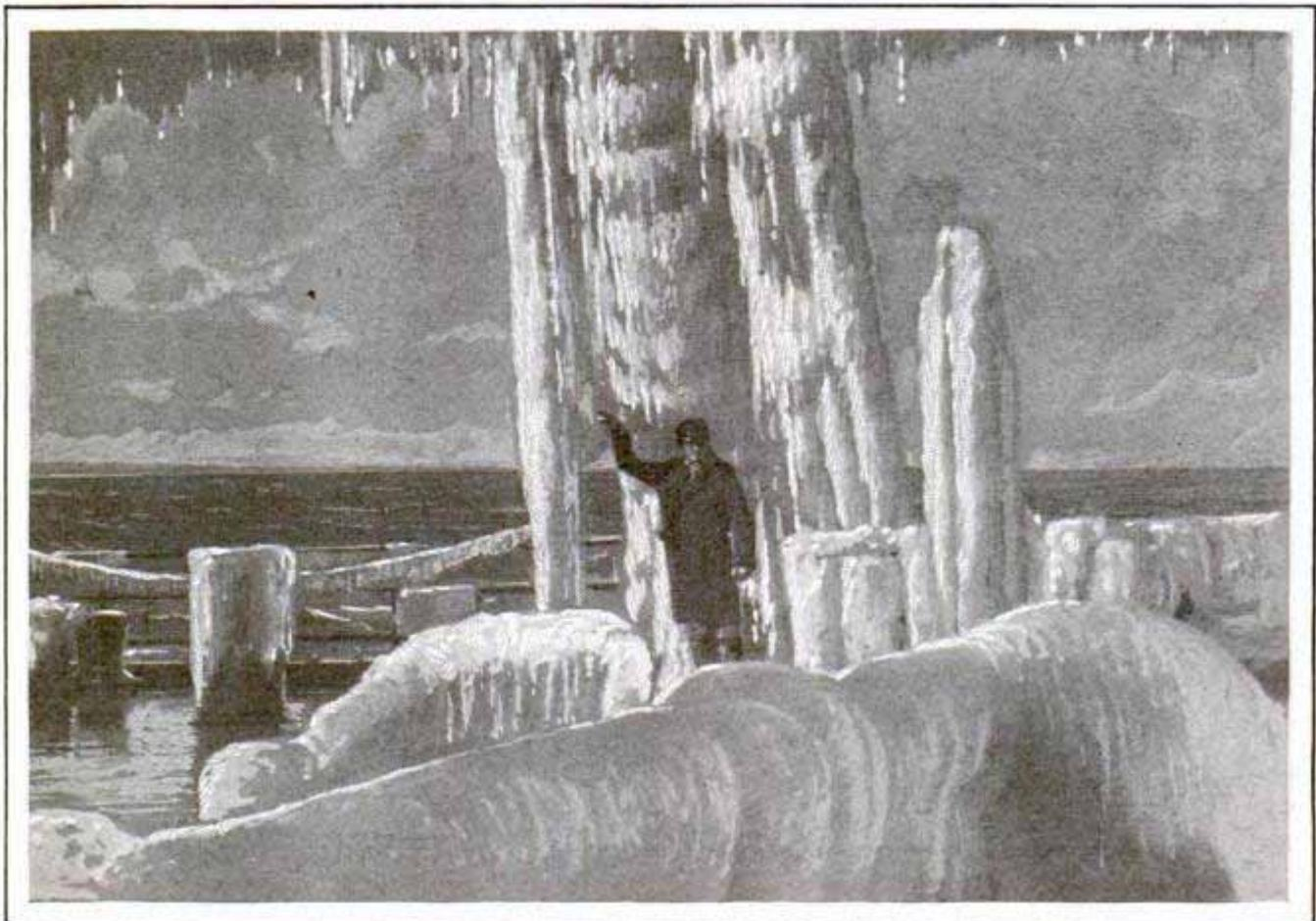

On a Tanker's Deck after a Winter Storm; This Particular Craft Battled a Heavy Sea on the Way to Halifax in December



Nosing into the Waves with a Load on Deck and a Heavier One Below; Tightly Closed Hatches Are Highly Important in a Storm like This

The "Sadler's" chief engineer took charge of the engine room and piled on all possible steam. Like a thing alive, she leaped into the frothing combers until her deck was awash. Signals from the "Garnet Hulings" kept coming stronger and stronger. "Hurry! We're pounding hard! Hurry!"

At 4:00 a. m., the weather and sea began to moderate, and the "Sadler" forged into strong currents, setting north, and southeast wind. At 7:03 a. m., the vessel came abeam of the Gun Key light. At 8:15, she sighted the "Garnet Hulings," and began to crawl slowly over treacherous reefs, taking soundings frequently. Shortly after 9:12, the crew sounded nine fathoms and order was given to let go the starboard anchor.

The "Sadler's" skipper launched the starboard lifeboat and ordered the crew to mark a channel. Although they pulled like madmen, the wind and current were so strong that after half an hour of exertion with double-banked oars, they had advanced only 200 feet. The skipper ordered them back. The "Garnet Hulings"

had pumped the cargo out of two of her tanks; even this did not float her.

The "Garnet Hulings" launched one of her lifeboats with a small Lyle gun, which was attached to a running line aboard the "Sadler," whose skipper ordered both anchors payed out until 120 fathoms were out on the port chain and 105 on the starboard chain. At 3:30 the hawser was made fast and the "Sadler" started her engines. It pulled the "Garnet Hulings" off the reef and, with a toot of her whistle, the "Sadler" was on her way once more, off to Baton Rouge.

Capt. Thomas J. Gilroy, in charge of the Standard Oil company (New Jersey) fleet, tells how, on one of his thirteen crossings of the war zone in a tanker, his ship was torpedoed 185 miles west of the Straits of Gibraltar. It was the S. S. "Platuria." She had discharged a cargo of aviation naphtha and was returning to New York.

"We had been riding through heavy fog for some hours," said Captain Gilroy. "Suddenly, on coming into a clear patch, the lookout saw the foam of a torpedo.

"He cried out, of course. But it was

3086

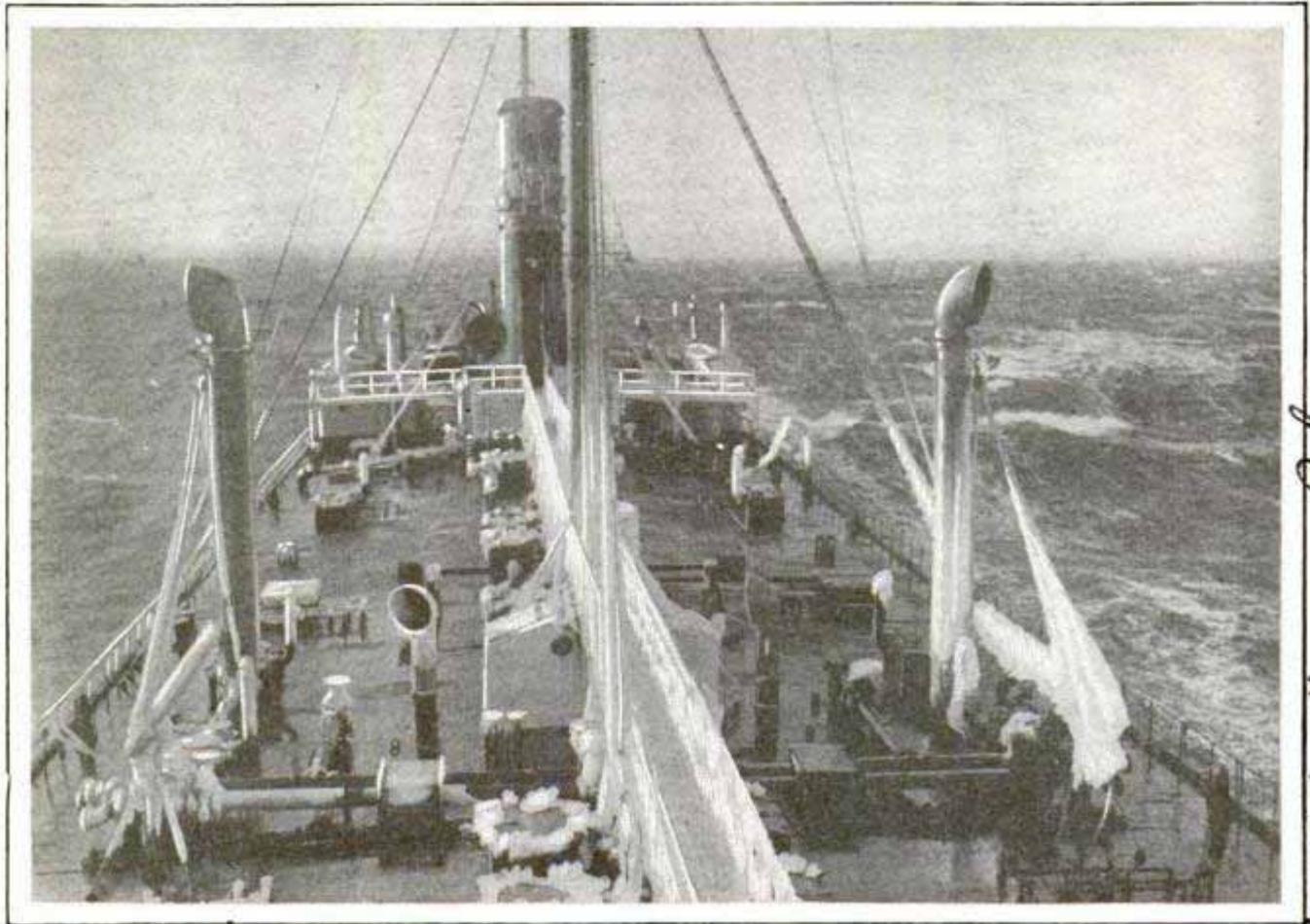

Remnants of the Icy Gale: Oil Will Smooth a Heavy Sea but Not When It Is Loaded inside the Tanker, Which Rests Low in the Water So That Waves Will Wash the Deck

too late. Before the helmsman could swing her around, we were struck amidships on the starboard side. She turned over on her beam ends immediately. We managed to shove over only one lifeboat. Those who couldn't climb in, jumped into the water.

"When the sub came to the surface, she picked up all the swimmers and carried them alongside a capsized lifeboat, which her crew righted. They set us all adrift in the two boats. Nine of our men were drowned.

"It was late in the afternoon when I ordered my men to hoist the sail. I set a course for Africa. I had a compass, but it was of little use. When darkness fell, I set a better course by keeping the North Star abeam. We sailed due east.

"There was little to see on the dark ocean that night. We were looking for ships, but there was small chance of finding one, because they hid their lights. Meanwhile, my men began to cry for water. Well, there was water in a sealed tank, but I held them off for a while, not knowing how long it would have to last.

Toward daylight, they began to get real thirsty, so I ordered the tank opened. The odor of that water was so foul we had to throw it away.

"Just before noon, we saw a collier making for us. She turned out to be an Italian ship, and her skipper offered to take us into Norfolk, but we wanted to return to Gibraltar. Finally, we compromised, and he landed us on the island of Madeira, where we lived comfortably for a month, until another vessel picked us up."

SEISMOGRAPH PICKS BEST ROAD BY RECORDING VIBRATIONS

Seismographs, primarily designed to register earthquakes, now are being used in road building. In California seismographs have been placed along several highways to record the vibrations set up by passing trucks and automobiles, measuring simultaneously the extent of horizontal and vertical movements. The records are expected to prove helpful in showing the difference in service life of various kinds of roads.

Box 96 Denver, Colo
Lloyd S. Carpenter Hill Sta
cm. L. Wright

4090

**METEORS MAY MENACE
PLANES AND SHIPS**

4109

Meteors may be to blame for mysterious airplane accidents, forest fires, destruction of ships, and even bad weather, a French meteorologist has suggested. Red-hot meteors may set up electrical disturbances as they sizzle through space, such disturbances affecting both airplanes and ships. It has been calculated that a two-ounce meteor, the size of a hazelnut, would travel thirty miles a second as it nears the earth, and have the force of a 500-ton train. Meteors are so numerous as often to cause "bombardments," and may be responsible for accidents such as that which occurred recently in Budapest when a girl on her way to a wedding was killed by one. Airplanes, too, may be struck down and ships destroyed. A meteor also might possibly explain freak accidents like the recent destruction of a powder magazine without apparent cause.

3947

**SMALL PIPE ORGAN FOR HOME
SHAPED LIKE GRAND PIANO**

Intended for installation in private home or apartment, a pipe organ has been made which takes up no more space in the living or music room than the large grand piano which it resembles. The 231 pipes are contained within the case and the organ is mounted on casters so that it can be moved from one room to another.

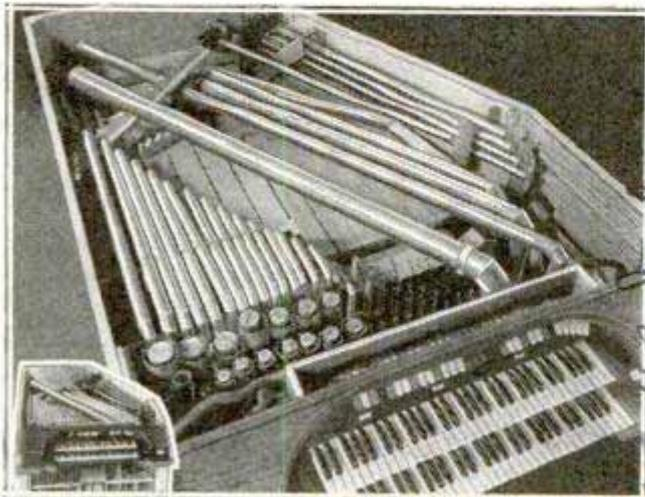

Pipe Organ for the Home with Its Pipes Contained in a Case Resembling a Grand Piano

Estey Organ Co

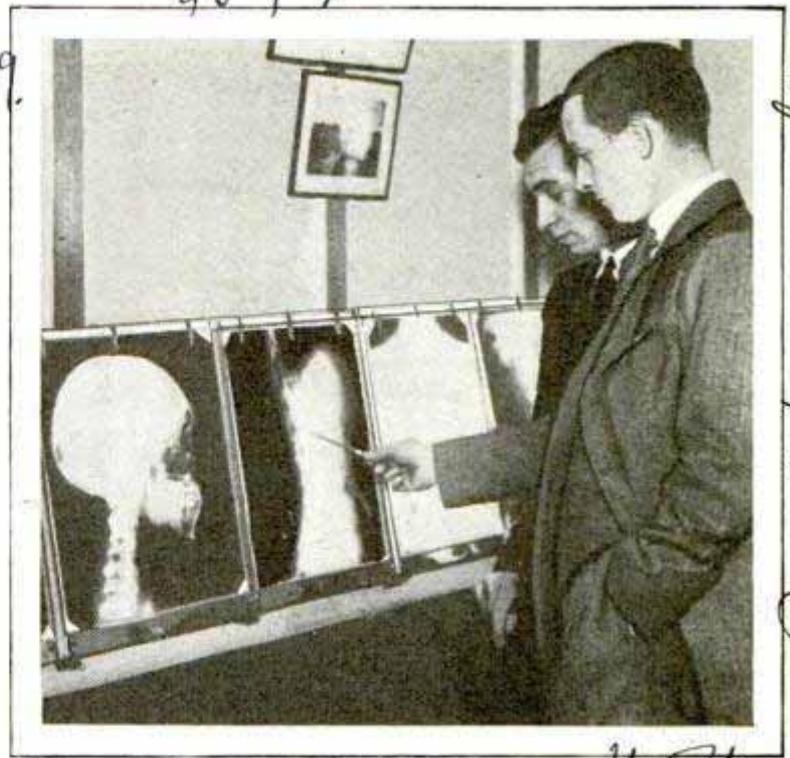

Pictures Taken in One-Twentieth of Second with Powerful X-Ray, Which Is Shock-Proof for Operator and Patient

**X-RAY SNAPSHOTS ARE TAKEN
WITH POWERFUL TUBES**

Taking a picture in only one-twentieth of a second, the most powerful shock-proof X-ray apparatus in the world recently was exhibited at the British Institute of Radiology. With it, interior pictures may be taken almost instantaneously without risk either to the subject or the operator.

**AUTOMATIC WINDOW SASH ENDS
NEED FOR PULLEYS**

4094

Eliminating weights, cords and pulleys and the ordinary box frame, a window-sash holder now is on the market which operates on rubber rollers on an interlocking shoulder track set directly into the window frame. A sliding type also is provided for lightweight sash, and both kinds have weather strip attached to the track and are provided with adjusters, making it possible to regulate the tension without removing the sash. Use of the sash holder not only eliminates the usual cords and pulleys, but also enables a saving in construction costs, because box window frames are unnecessary, and the solid frame keeps out cold air and dirt that cannot be hindered effectively from filtering in around the box type.

Robinson Island

Seamless Sash Holder
1548 160 11

Victor X-Ray Corporation, Ltd.
314 Broadway, N.Y.C.

Worcester Mass

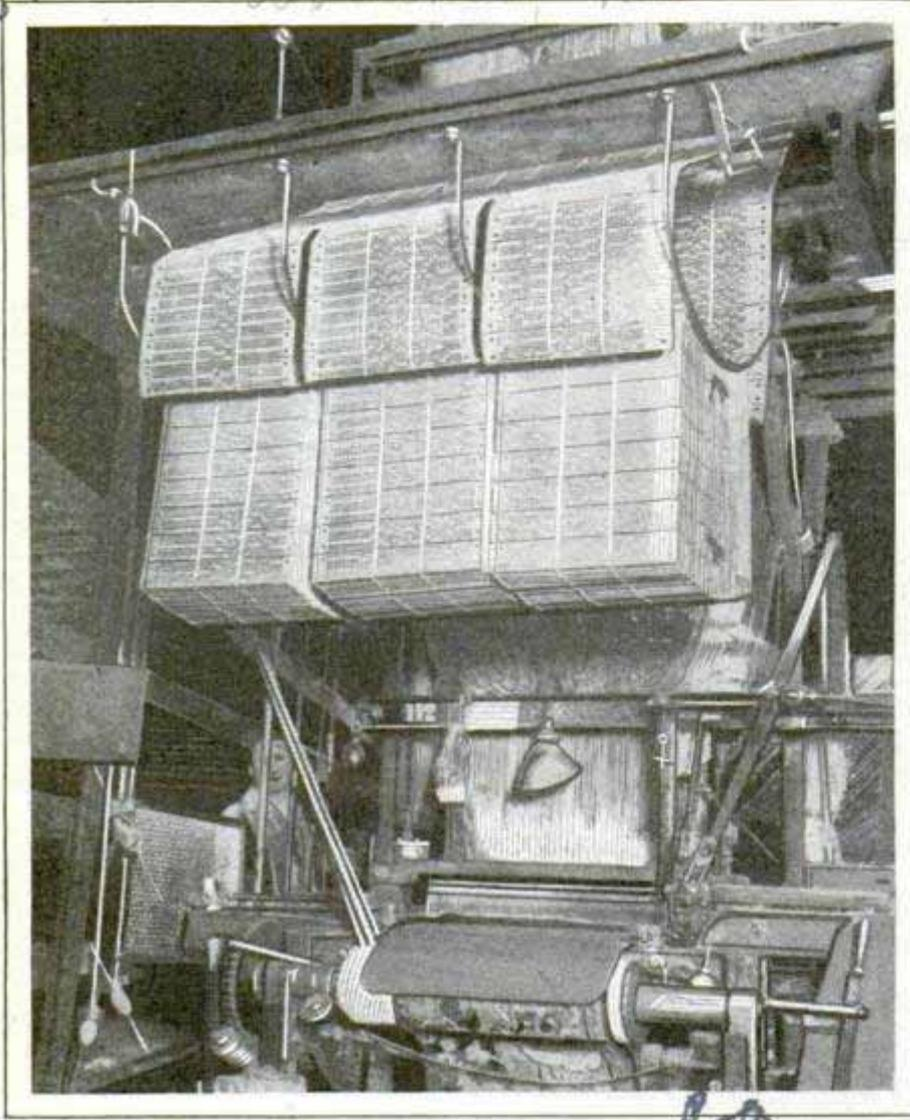

Needles Dropping through Combinations of Holes in Perforated Rolls Weave Intricate Designs in Factory-Made Rugs

BEAUTY IS WOVEN INTO RUGS FROM PIANO-ROLL PATTERNS

Weaving of intricate and beautiful designs into machine-made rugs is accomplished by a complicated loom that fashions the patterns almost as exactly and artistically as the slow hand process employed abroad. Needles drop into various combinations of holes and thus control the patterns produced.

CHEESE PACKED IN VACUUM BOX RETAINS ITS MOISTURE

Vacuum containers for shipping cheese are undergoing tests in New Zealand after the system was found acceptable for packing butter. The container consists of two pieces of metal stamped to conform to the shape and size of the cheese. These pieces are fitted around the cheese and the

contact edges soldered with a wire buried in the solder strip, one end of it protruding. Mechanical exhaustion of the air in the chamber and sealing of the exhaust portal complete the packing. Tests have shown that cheese so packed for fourteen months lost only one pound in weight, had no rind, kept its flavor and was well cured.

WEATHER SENSE OF ANIMALS DUE TO AIR PRESSURE?

4106 That the mysterious tendency of many animals to sense approaching changes in the weather may be due to sudden variations in the air pressure as a result of atmospheric disturbances has been suggested by H. P. Lasher, weather and crop reporter of Cushing, Iowa. Mr. Lasher points out that, under normal conditions, a human being sustains an

atmospheric pressure of approximately fourteen tons. Would any sudden fluctuation in this pressure react upon him in such a way as to cause him to become restless or to affect his appetite? A few individuals appear to be sensitive to weather changes, but animals possibly are more so, because they are not constantly sheltered under roofs and, hence, their "sixth sense" is more acute than it is in the case of human beings. Fowls, hogs and other domestic animals often manifest evidences of their "weather sense." Many farmers know that, when hogs begin lining their sleeping quarters with straw in the winter time, a storm is brewing. Mr. Lasher reported that his own records did indicate a relationship between pressure and another natural phenomenon, namely the flow of honey. He found that the greatest flow in northwestern Iowa, for instance, was during

Garajah Dairy

4011

periods of low pressure and high humidity. In that section of the country, the alfalfa bloom seldom yields nectar, he declares, although in the high altitudes near the Rocky mountains, it is considered one of the best honey yielders.

PLANES ARE TILTED ON END TO SAVE HANGAR SPACE

3950

Storing airplanes in hangars and removing them is simplified by means of a system of small carriages that run on tracks and tip the planes at an angle so that more can be stored in one hangar than is possible by the usual method. The ship is taxied up until its wheels rest in grooved holders on each side of the carriage. By turning the crank of a cog wheel at the front, the ship is tilted and comes to rest at an angle of approximately thirty degrees. The plane and carriage are then pushed into the hangar. Only one man is required to take care of the planes with this device, and the hangar can be designed so that less room is wasted on the airport site. The system also eliminates the necessity of pushing several planes out of the hangar when one is desired, reduces the number of men needed at the station and helps protect the planes, as they are less likely to be damaged in getting them in and out of the hangar.

dr. Lytle V. Adams

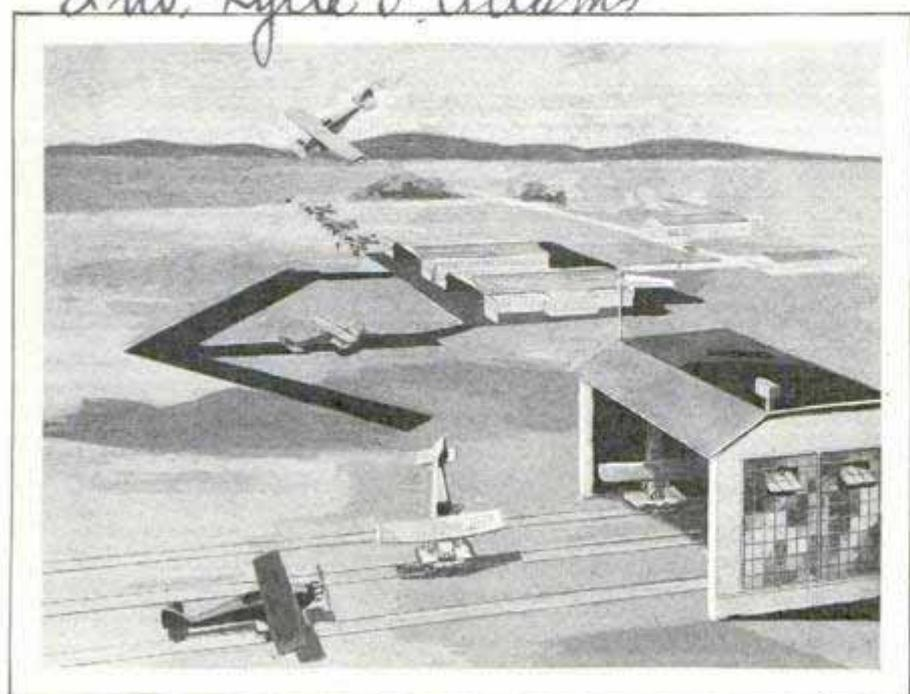

Airplanes Taxi onto a Track Which Elevates Them at an Angle Before They Are Pushed into This Hangar, Thus Saving Space

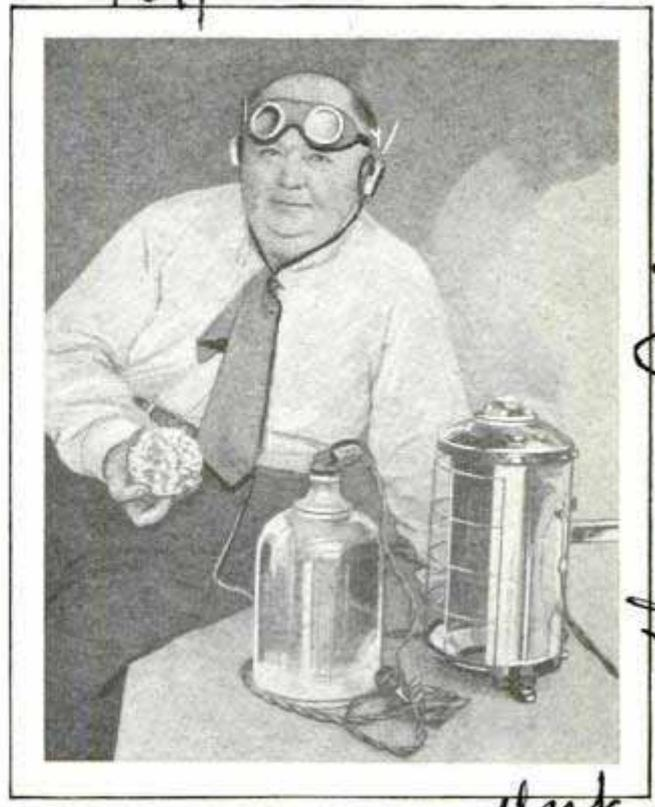

Crystallized Salt Removed from Chemically Treated Sea Water to Make It Available for Irrigation

SEA WATER USED TO IRRIGATE BY CRYSTALLIZING SALT

Sea water, chemically treated to remove its salt, is proposed by a Los Angeles agronomist as the solution of southern California's irrigation problem. At first plans were made to treat sea water in such a way as to obtain the valuable fertilizing minerals and substances it contains, but during experiments it was found possible to utilize these substances without removing them from the water by crystallizing the salt held in solution in the sea water. Instead of allowing the salt to crystallize in particles of dirt to form a crust handicapping growth, it was found it could be made to crystallize before reaching the soil by running high-frequency current through the water and at the same time treating it with ultraviolet and cathode rays. Laboratory tests of this method have been satisfactory.

dr. h.

1415 Thayer Ave
West Los Angeles Calif

Thomas W. Hick

Work being done

1009
Capt. James N. Muller 226 Park
Central Hotel, Washington
D. C.

In the Land of the

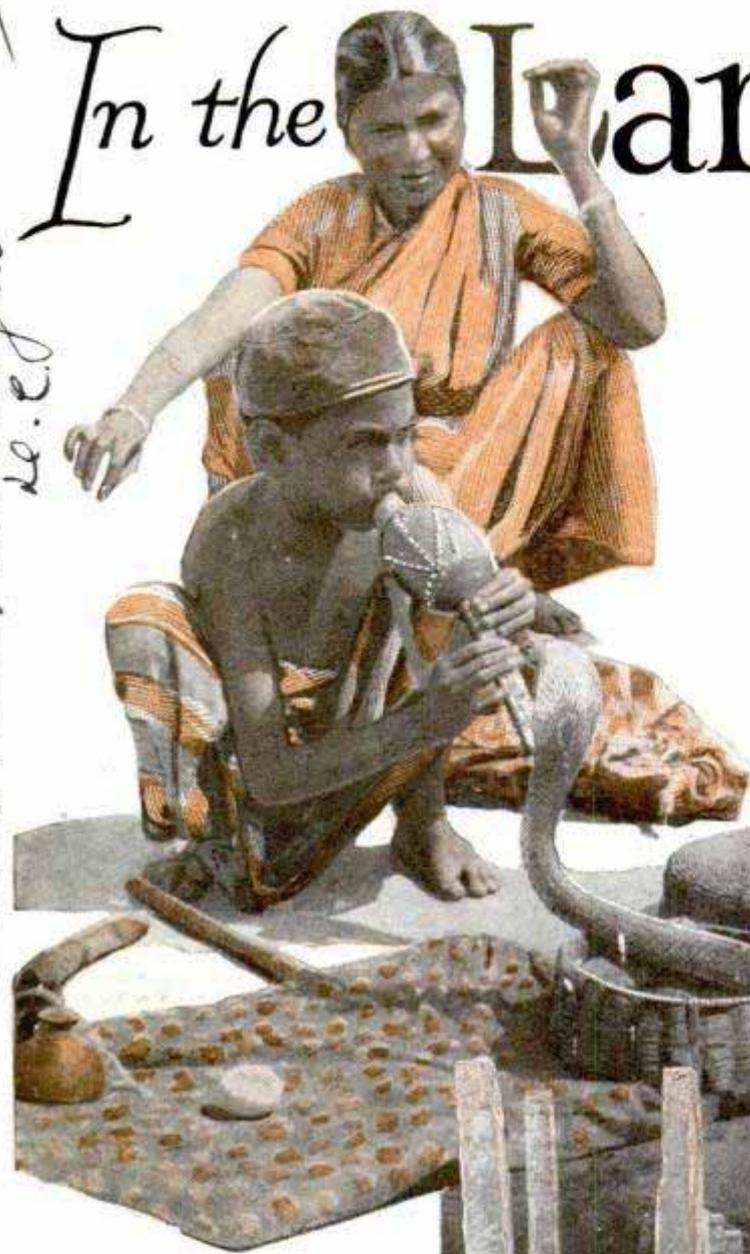

birds that sew and stitch with almost human skill, "architect" ants that build a remarkable type of living structure, and weird devil dancers.

In the course of his thrilling experiences, Doctor Wood was accompanied only by native guides when he stumbled upon the great artificial lake which he refers to as the "Giant's Tank." "It was an irrigation reservoir," he says. "I spent several days studying its marvelous construction and found it to be crowded with thousands of croco-

Photo Ewing Galloway

STRANGE adventures befell Dr. Casey A. Wood, famous naturalist, during a two-year study of the wildest jungle region in Ceylon, mysterious pear-shaped island off the coast of India.

Doctor Wood found an immense artificial lake, covering more than a hundred square miles, built probably five centuries ago, and thickly infested with man-eating crocodiles, outlaw elephants that turn bandits and slayers, wild water buffaloes that attack man on the slightest provocation, ferocious marsh bears, vicious little land leeches, queer "tailor"

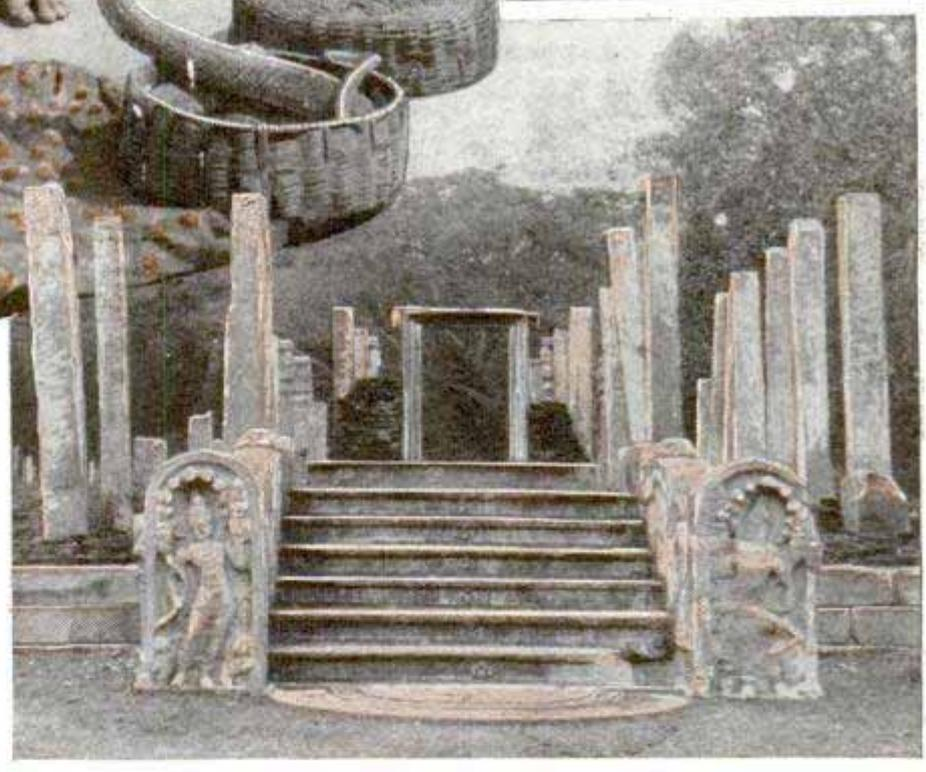

Top, Eight-Year-Old Ceylon Boy Learning to Charm a Cobra as His Mother Watches; Below, Ruins of Temple of the Tooth at Anaradhapura, Ceylon, Dating Back to 300 B. C.

diles. Some individuals of this species attain a length of sixteen feet or more. They live on waterfowl, tortoises and fish that abound in the lake."

Concerning the outlaw elephants, Doctor Wood points out: "Writers devote

Devil Dancers

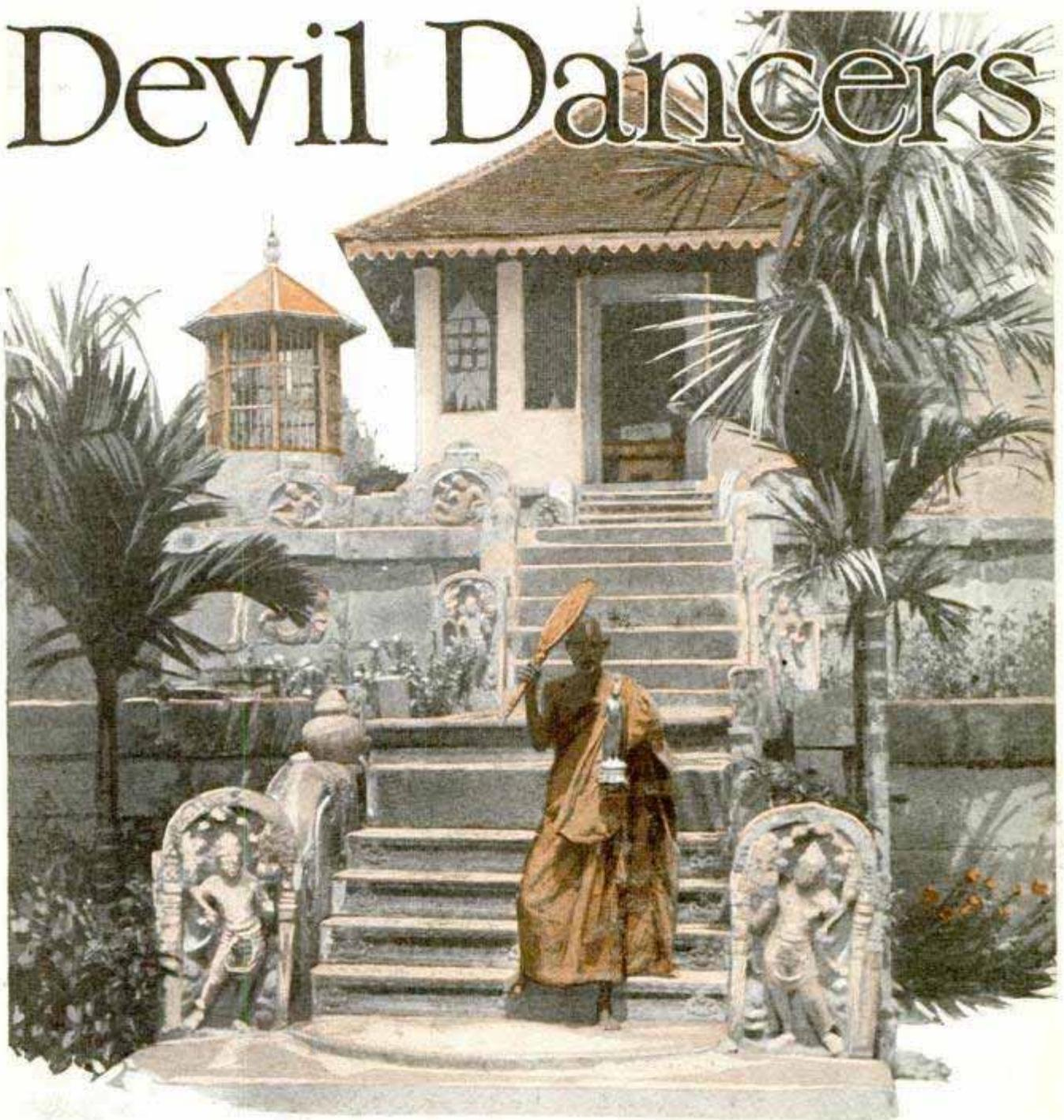

Buddhist Priest Bearing Image and Screen at Entrance of Isuruminigo Temple in Ceylon; Note the Semi-circular Carved Stones Marking the Entrance to All Religious Buildings in Ceylon

much space to the 'rogue,' or Singhalese 'hora,' and it certainly is a pitiful and picturesque figure. Nearly always it is a male, who, an outcast from its herd, owing to some breach of jungle law, is not allowed to join any other group, and becomes a veritable Ishmaelite. It may drink, bathe and eat in the vicinity of a herd but any attempt at familiarity or intimacy with any of its members is at once resented, and the intruder is driven off, the process being punctuated by heavy blows with the trunk and butting with the head, administered, it may be, by previous

friends and companions of the outcast.

"No wonder this otherwise gentle and social animal becomes savage, morose and dangerous under such treatment. He turns bandit and killer, spends his nights in destroying plantations, overturning huts and pulling up rice plants and young coconut palms. Hiding in the jungle by day, these crazed beasts often prowl about unfrequented roads and jungle paths, and it is extremely dangerous for an unarmed man to approach their haunt. Instances where they have killed innocent natives have caused government authorities to

issue licenses, free of charge, for the slaying of particularly notorious offenders.

"Unlike the India elephant, the Singhalese variety does not depend upon his trunk or tusks as weapons of defense, although he may occasionally use them for that purpose. Butting with his ponderous head and utilizing the enormous crushing force of all four legs, he holds the smaller animal with his trunk while he endeavors to tread the life out of it by alternate trappings with his enormous feet.

"Just as few persons have ever seen a dead mule, so infrequently has the body of a dead elephant been found in the Singhalese forests. The natives believe that elephants bury their dead much like humans, and some assert that when an aged beast senses the approach of death, he sets out for a remote and quiet valley and there patiently awaits his end. I know of a certain forest near Anaradhapura that conceals one of these reputed elephant cemeteries, but so well hidden is it that no man knows its exact location."

Tame elephants have a wide variety

especially of the white outlander, and may attack him head on unless he is able to escape, preferably by climbing some friendly tree.

The marsh bear is one of the most dangerous animals of the Ceylon jungles, Doctor Wood believes. When frightened, it never hesitates to attack anyone that crosses its tracks. Always it attempts to bite and claw the head of its victim. Many a time the naturalist had the misfortune of acquiring a substantial covering of vicious little land leeches. The chief danger of the bites from the several hundred teeth of this creature is the infections and ulcers that follow.

The maneuvers of the tailor bird aroused Doctor Wood's amazement. Probably the most remarkable example of sewing and stitching noted by the naturalist was a nest mass made of four hibiscus leaves, about six and one-half inches long. It was built about four feet from the ground and was entirely hidden from view. The body of the nest was filled with a curious floss, mixed with vegetable fibers,

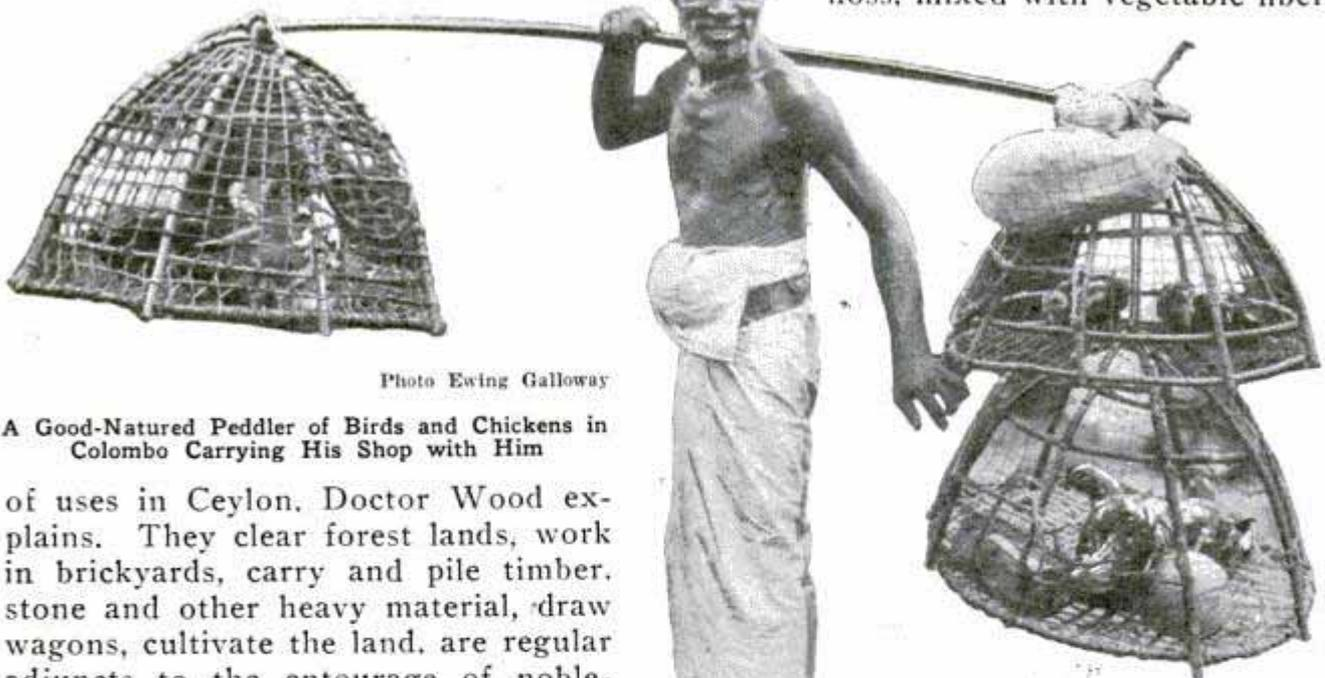

Photo Ewing Galloway

A Good-Natured Peddler of Birds and Chickens in Colombo Carrying His Shop with Him

of uses in Ceylon. Doctor Wood explains. They clear forest lands, work in brickyards, carry and pile timber, stone and other heavy material, draw wagons, cultivate the land, are regular adjuncts to the entourage of noblemen and serve as ceremonial animals at holy temples.

Wild water buffaloes are not particularly ferocious-looking, the naturalist points out. They delight in reposing for hours covered with mud while the helpful crow picks from their smooth, leathery backs the ticks that burrow into their skin. However, the Singhalese variety hates the very smell of the stranger,

a few hairs and a papyruslike bark. The nest cavity extended to the bottom of the structure and was carefully lined with floss over an intertwining layer of fibrous material.

Hardly less interesting were the naturalist's frequent encounters with the work of the architect ant. Red in color, it does not sew, but instead glues, the edges of



Elephants Are Used in Many Ceremonial Parades of Religious Significance in Ceylon, and the Picture Shows Such a Scene with the Pachyderms Bedecked as for an American Circus

leaves together, afterward lining its nest cavity, not with cotton or other fiber, but with a kind of self-made transparent paper which is also used for joining leaf edges.

"Many a time," explains Doctor Wood, "I have watched these industrious architects at work. The object of this house building is to form a globular casing in which food and breeding cells may be stored. First, several ants stand on the margin of one leaf, grasping the edge of another leaf in their mandibles. Next they draw this to the border on which they are standing, while meantime other highly specialized experts paste the approximated margins together.

"If the neighboring leaf is too far away, the factory workers make a chain of their bodies to reach the desired contiguous blade, which is then drawn up and cemented. This work is so thoroughly done that, long after the leafy materials have dried and are partly disintegrated, the original structure holds its shape and a good deal of force is required to tear it apart."

In certain obscure jungle regions the naturalist came upon elaborate ceremonies performed, under the direction of holy men of the Singhalese tribe, by individuals known as devil dancers. The procedure usually employed is as follows: First of all, the victim appears, presumably to be relieved of the devils that have entered his body and caused some sort of ailment or disease. Now the band strikes up, composed of tom-toms, reeds, viols, cymbals and crude pipes. This is a sort of overture to the main series of dance movements. It is symbolic of the affliction of the person being treated. Assuming that he has a certain disease, all his expressions of pain and agony are simulated by the various sounds of the instruments. Next the dancers, known as the "Natun Karayo," band together into a large charmed circle, so called because it has been blessed previously by the sacred men of the tribe. Their dress is fantastic and fearsome—they wear short skirts that are accordion-pleated and of brightest colors. Some wear hideous masks and

4009
382

581 Glenwood
Kansas City, Mo

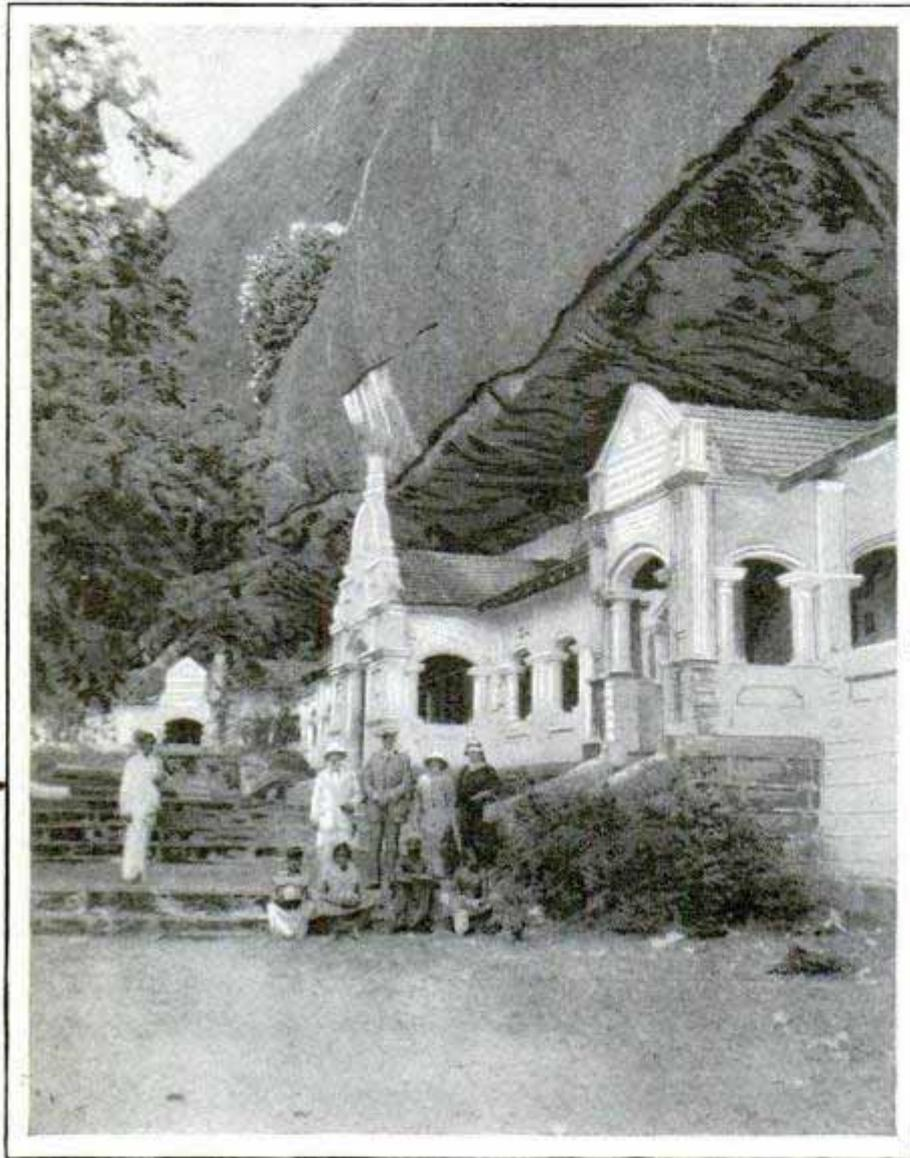

Cave Temple at Dambulla Where a King Withstood a Thirteen Months' Siege About 100 B. C., and Out of Gratitude Transformed the Cavern into a Memorial Temple

dance proper is said to be officially over, the victim falls prostrate, and tells the priest that he is clean again, whereupon all the natives eat betel root or drink large quantities of crudely made liquors.

Ceylon is filled with the ruins of temples, palaces and great cities, but its glory is now but a memory of a long departed splendor.

STEAM SHOVELS 4113 SALVAGE OIL

Steam shovels are digging oil in the famous Yates field in Pecos county, Texas, where more than 1,000,000 barrels of seepage have been recovered by this and other processes. The big 1,000 to 1,600-foot wells were found to be leaking oil from around the casing, the seepage passing into a bed of coarse gravel that leads to the Pecos river. The oil was first noticed in a water well and later it was seen

charms made of wild blossoms; others, instead of masks, have their faces painted in red and white, while still others wear the skins of the leopard, cheetah, jaguar and jackal.

Probably the most impressive part of the entire ceremony is the occasion, well on in the dance, when the high priests commence to chant a series of loud supplications, demands and exhortations. Usually the holy men stand in the center of the charmed circle while the dancers and spectators watch and listen with genuine apprehension. Incense offerings are presented to the native gods by burning various strong scents in jars or braziers.

The length of the dance depends upon whether the priests have been able to persuade the evil spirits to remove their presence from the body of the afflicted person. When they are so persuaded, the

running into the river. The company owning the river-bed lease placed a wooden boom across the river and turned the oil into ditches from which it was pumped to tanks, thus recovering nearly 200,000 barrels. The steam shovels were used by another company to dig a trench thirty feet deep, the oil soon filling the space. Small pumps were placed at the end of the ditch and more than 650,000 barrels were thus recovered. A number of shallow wells were also sunk to the gravel stratum and small pumps erected over them.

Popular Mechanics Magazine does not publish the name of the maker or seller of any device described in its pages, but this information is kept on file and will be furnished, free, upon application to our Bureau of Information.

"HUSH-HUSH" LOCOMOTIVE HAS STREAMLINE BOILER

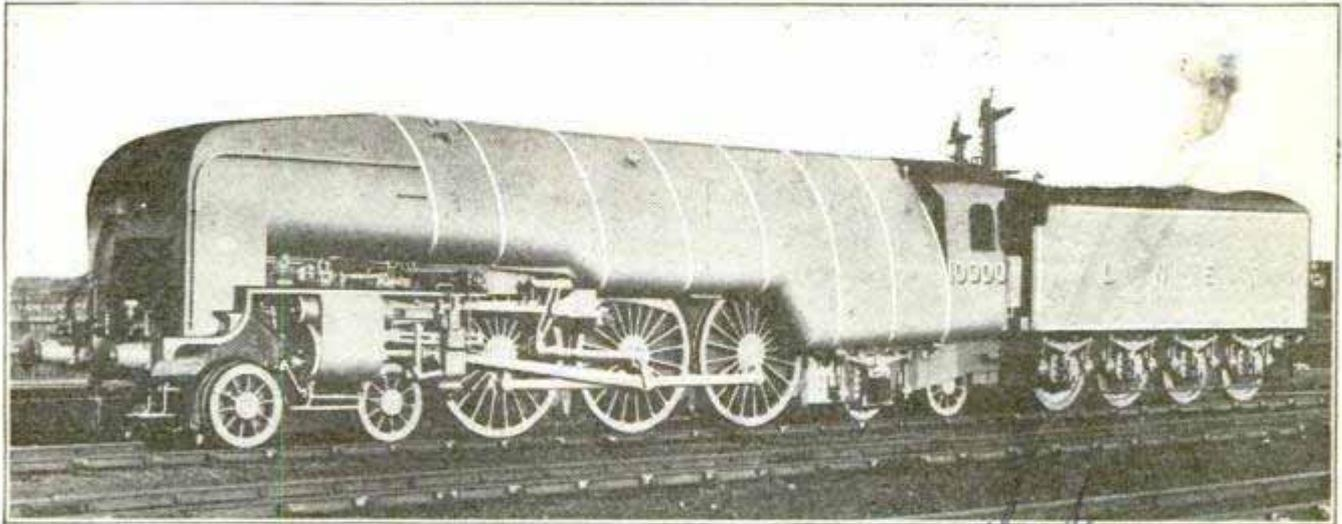

Great Britain's Newest High-Speed Locomotive with Streamlined Boiler; It Was Called the "Hush-Hush" Engine Because of the Secrecy Which Surrounded Its Construction

England's latest high-speed locomotive, embodying many novel principles of boiler design, including a streamline effect, recently made its first public appearance and attracted widespread attention among railroad officials. It is known as the "hush-hush" engine because of the secrecy surrounding its construction.

GEARS MADE FROM CORNSTALKS GIVE LONG WEAR

Seven gear wheels manufactured from cornstalks have been in service for more than two years at the Iowa State College and show practically no signs of wear. The material is but one of the many useful forms that cornstalks and corncobs are taking under methods developed by Dr. O. R. Sweeney and associates. A substitute for teakwood which is sixty per cent stronger than the natural wood is being manufactured after the stalks are beaten and ground into a substance that quivers like jelly before it is dried. Airplane propellers can be made from the synthetic wood, and cornstalks also have been used in a material that serves as a substitute for tile floors. It is quickly applied and be-

comes hard in a few hours. Markings are placed in it to resemble the spaces between tiles. From the pith of the stalks, a material that is lighter than balsa wood is being prepared. It has insulating and acoustic properties that make it suitable for many applications. The cornstalk product can be made in almost any size, while natural balsa wood is obtainable only in comparatively small pieces, as the trees do not grow large. A substitute for cork is also being manufactured from cornstalks.

PARK BENCH MADE INTO TABLE BY FOLDING BACK RESTS

Combining two benches and a table into one piece of equipment, a novel type of park furniture now is available. Two long benches are fastened back to back by crosspieces, and by lifting up and folding over the back supports, a substantial picnic table is made with the benches already in position, thus saving the assembling of heavier benches and tables. Single-seat benches also are similarly designed, the back folding to rest on two supports which, with the bench itself, hold the back as a table top.



Double Park Bench Which Is Converted into Picnic Table by Folding Over the Back Rests

Chicago, Ill. 55 West
Logan Co, 202 N. Louisville

ELECTRIC PURIFIER FOR WATER WORKS FROM SOCKET

4056

Electro Osmose



Electricity Is Employed in This Apparatus to Purify Water, the Current Killing Injurious Germs

Purifying water by electricity is done in an improved manner in a compact unit operated from the lighting circuit. As the water passes through various chambers in the purifier, it is subjected to the action of electrical currents which remove foreign particles of matter and also kill injurious germs. The supply becomes more pure as it passes through the chambers until it is finally delivered in a state equal to that of distilled water. The apparatus requires practically no attention once it is installed; the chambers are kept washed free of accumulations by the flow of the water under treatment, and great efficiency is claimed since there is no necessity for heating with the consequent loss by evaporation and radiation.

FEWER SUNSPOTS GIVE PROMISE OF BETTER RADIO RECEPTION

410

According to Dr. Harlan T. Stetson, of Ohio Wesleyan University, 1930 should be a good year for the radio lover, because better reception is probable with the decreasing number of spots on the sun. As the year waxes, the number of spots is expected to wane, resulting in a corre-

sponding increase in radio-signal strength in the broadcast zone. Reception last year followed the fifteen-month cycle observed in the sunspot numbers with a marked depreciation during the fall maximum, when, under normal conditions, radio reception should have been improving with the decreasing hours of sunshine. With the development of the radio, scientists have been afforded a valuable new tool with which to study solar radiation and other phenomena. Apparatus has been devised for the automatic registering of radio-signal strength at all times of the year, so that the connection between the clarity and strength of the signals and the condition of the sun, can be more accurately determined.

STREET-LIGHT SERVICE TRUCK HAS EXTENSION PLATFORM

4010

Easy access to street lights by workmen cleaning or replacing globes and bulbs is afforded by an extension platform mounted on a service truck. The ladder is curved in such manner that the platform stands beside the street light at the proper height for workmen when the truck is parked at the curb.

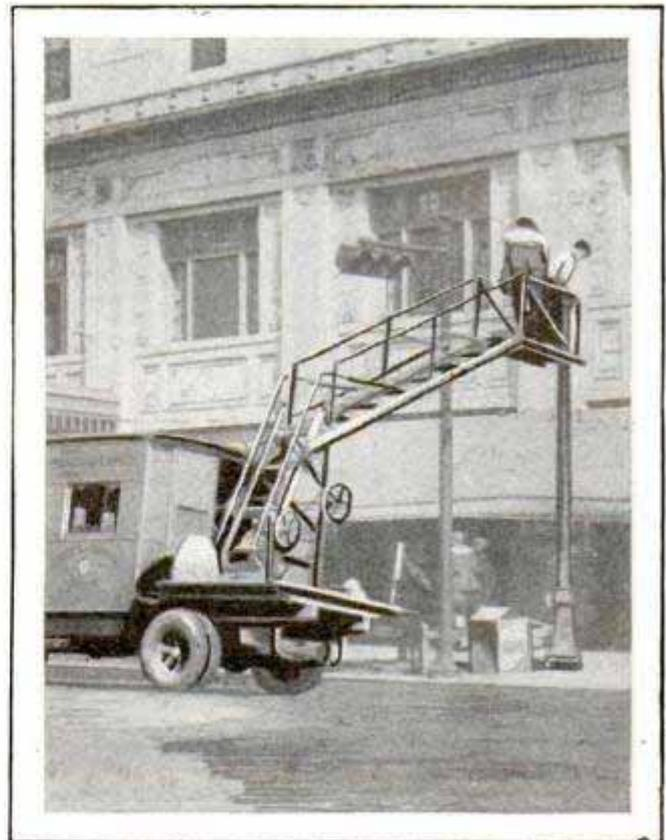

Extension Platform on a Street-Light Service Truck Gives Easy Access for the Repair Crew

Hayton Power Light

Siemens & Halske, Germany

Perkins Observatory

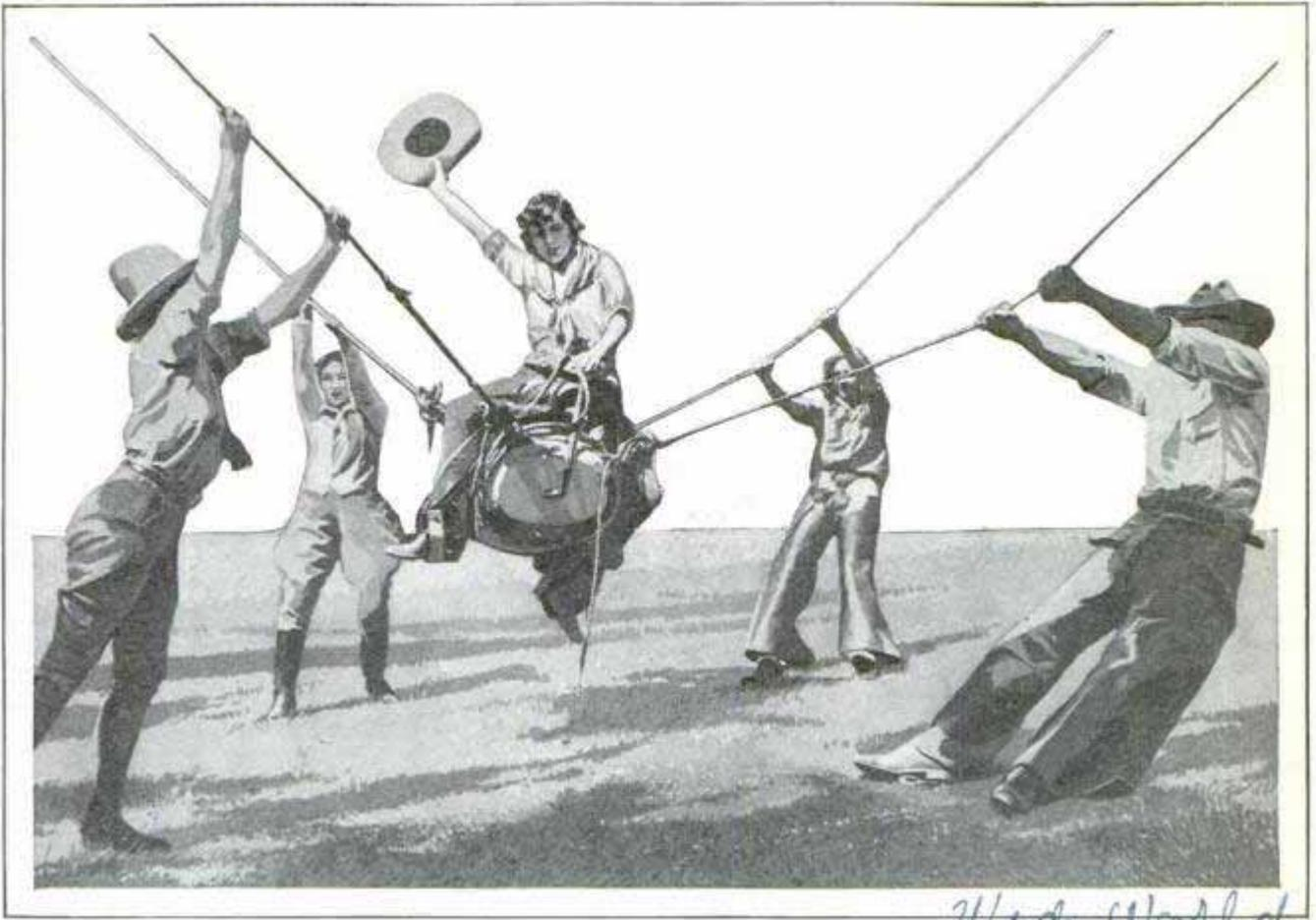

Thrills of Riding Wild Horses without the Attendant Danger Are Furnished with This "Buckaroo," the Saddle with Four Ropes Attached, Each Being Tugged in a Different Direction

Web World.

BUCKING BRONCHO IS IMITATED WITH SADDLE AND ROPES

etc

Greenhorns on a "dude" ranch in Montana who aspire to ride bucking bronchos are given their first taste of such sensations on the "buckaroo," which provides most of the thrills of a wild cow pony without much of the danger. The buckaroo is a saddle to which are attached ropes extending to the four points of the compass, each rope being secured to a tree. With the would-be cowboy or cowgirl in the saddle, four men begin tugging at each of the four ropes and the tossing and pitching dude tries to hold his seat.

SCIENCE SEEKING "SUPER-CORN" TO INCREASE YIELD

7

Within ten years, scientists hope to develop a variety of corn which will have a stiffer stalk, a more uniform ear and a stronger shank. It may result in so much larger production that it will be possible for farmers in the corn belt to raise on 40,000,000 acres of land as much as they now produce on 50,000,000 acres, accord-

*Henry A. Wallace,
Editor Wallace's Farmer*

ing to experts who appeared before the recent meeting of the American Association for the Advancement of Science. The 10,000,000 acres of land so released could be employed for other purposes and a saving of 15,000,000 hours in man labor would be brought about.

SOFT CUSHION FOR AUTO FLOOR PROTECTS HIGH HEELS

4057



For the woman auto driver, a mat of wool fur with rubber base now is on the market for the floor of the car, to protect high heels and dress shoes from becoming chafed or soiled while driving. The mat relieves foot fatigue, protects fine shoes and prevents wear on the floor covering.

More than one hundred chemicals enter into the manufacture of an automobile.

*The Nevins Co.
441 Illinois St. N.Y.*

390 4

1540 Broadway
New York City

The Race to Explore

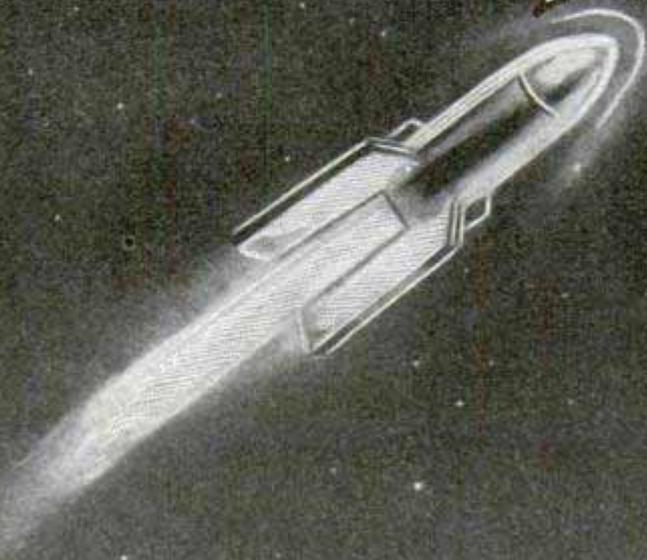

Photos Courtesy UFA Films

Reaching for the Moon; Striking Photograph of Rocket Scene from German Film, "The Woman in the Moon," an Unusually Interesting Story in View of Recent Attempts to Probe Higher Altitudes

By MILTON FAIRMAN

MAN'S valiant struggle to conquer his universe seems now on the eve of another epic victory. In preparation for the morrow's conflict, two scientists are assembling their armaments. Their laboratories are 4,000 miles apart. An ocean lies between them, but their aspirations are the same—the conquest of space.

If this were not the age of the seemingly impossible, their hopes might seem absurd. This is, however, the century in which the thousands who scoffed at the Wrights and Marconi are soaring through the clouds while radio brings them news of the cities below.

Thus the plans of Prof. Robert H. Goddard, of Clark University, and the German scientist Herman Oberth are being received with higher regard than were the first pronouncements of Doctor Goddard some twenty years ago. The scientific world is becoming rocket-conscious. The poles have been covered, the skies saddled, the mountains penetrated by engineers, nature's submarine secrets have

been disclosed to the camera. Why not probe the interplanetary spaces?

The first steps already have been taken. Rockets have been developed with aerial exploration in view by both Doctor Oberth and Professor Goddard, and Fritz von Opel's experiments with rocket cars and planes have met with gratifying success. Perhaps it is an exaggeration to talk of reaching the moon. Neither of the leading experimenters have any immediate hopes of doing so. But their preliminary tests have led them to make sanguine prophecies. Some day, the American asserts, man may send a rocket across those 221,614 miles to the moon. Before that, his German colleague believes, rockets may be speeding across the Atlantic bearing mail. Within four years, he asserts, there may be passenger rockets. The soundness of the efforts to send such projectiles to explore the space above us has been endorsed by the Smithsonian Institution, Clark University and the French Academy of Science.

Israton. Conn.

*1103 Broadway, New York 399
4059 Ever Warm Safety Suit*

spring to pull down the window so that the sleeper wakes in a warm room. The window may be lowered from various levels, and the clock is fastened to the sill in a few minutes.

BARGE WELDED IN ONE PIECE CONTAINS NO RIVETS

Designer - Eric N. Zwarty

Containing not a single rivet, a barge welded into a solid piece recently was launched in New York and has attracted much attention among shipbuilders since it represents virtually a one-unit vessel. The welding process was found to offer a saving of twenty per cent in building cost, twenty-five per cent in weight and twenty-five per cent in time required for construction. Maintenance costs also were reduced. Leakage of liquid cargo around corroded or sprung rivets is obviated, an important point to shippers, as three per cent of liquid shipments, such as oil, usually is lost through leakage in transit.

ROLLERS ON SURFACE OF SLIDE SAVE CHILDREN'S CLOTHES

Chicago - 35 E. Wacker Drive

Saving the clothing of children who enjoy the slides in the park playgrounds, a slide with a series of metal rollers instead of smooth runners now is available. The rollers are set so close together that there is no jar in passing over them and no opportunity to catch clothes or injure fingers. The top of the slide is inclosed to prevent the youngsters from falling.

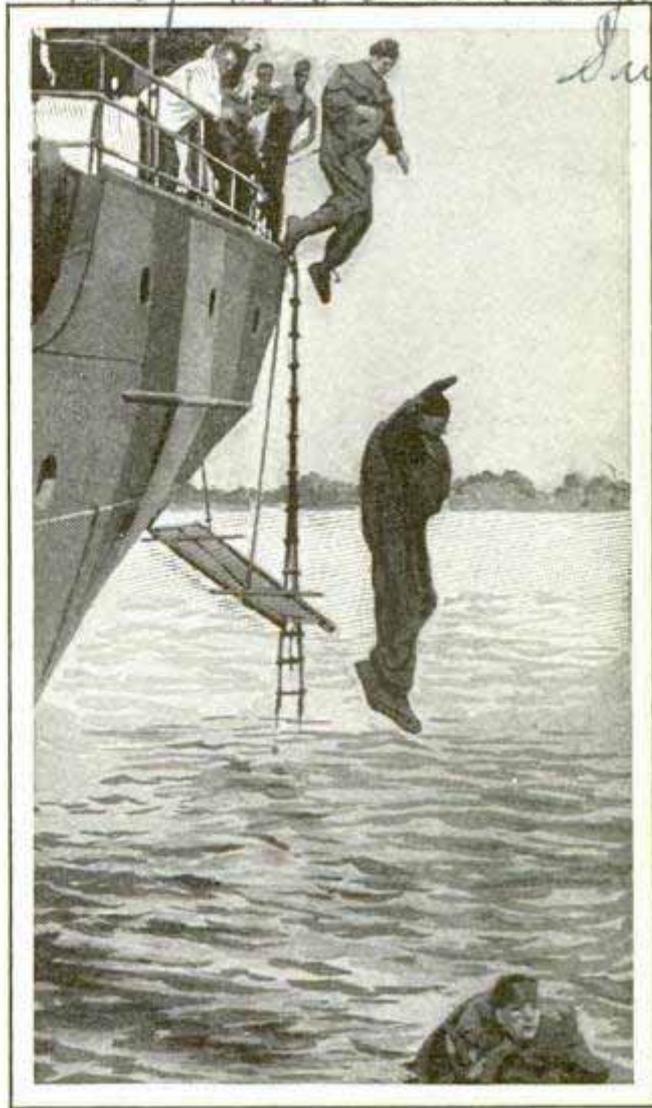

Testing a Water-Tight Safety Suit Which Protects Wearer from Exposure While in Water

SAFETY SUIT LIKE "COVERALLS" WARM AND WATER TIGHT

Providing complete protection from exposure, as well as saving the wearer from drowning, a safety suit that resembles a pair of "coveralls" now is on the market. The suit is donned by stepping into it and pulling it over the clothing, slipping an elastic collar over the head, and turning locking levers which seal the suit at all openings against water. Life-preserving pads fastened to the outside of the suit keep the wearer afloat and he is held upright by weighted soles of the shoes. It keeps the wearer warm in the water, and is provided with a pocket for carrying liquid nourishment. The suit may be packed in a small bag.

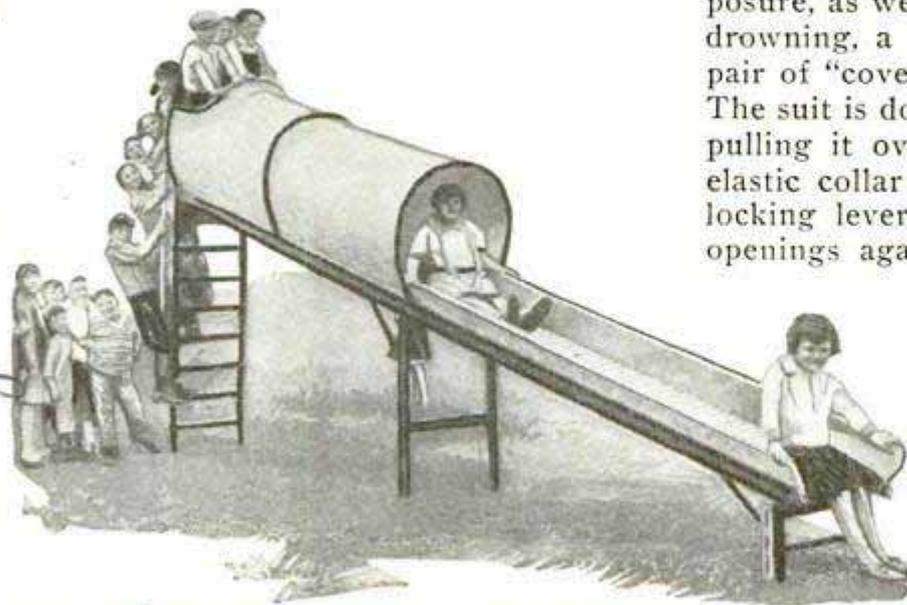

Slide with Top Part Inclosed and Surface Equipped with Rollers to Make This Popular Children's Sport Doubly Safe

Logan Co., 202 N. Buchanan St.

*Dr. A. B. Jewes, 90 Papendick Bakery
St. Louis, Mo.
3500 N. Florissant St.*

39 46

*400 % Papendick Bakery
St. Louis, Mo.
3500 N. Florissant St.*

*Anniston Star,
Anniston, Ala.*



Bread Slicer Which Cuts and Wraps 1,000 Loaves an Hour Ready for Housewife to Serve

BREAD SLICER CUTS AND WRAPS THOUSAND LOAVES AN HOUR

Bread that comes to the housewife ready-cut is now on the market in many cities, a slicing and wrapping machine doing the cutting and packing the cut loaf in a waxed container to keep it fresh. The machine cuts 29,000 slices an hour from 1,000 loaves. The bread, ready for using when unwrapped, is particularly adapted for sandwiches, because it is evenly and smoothly cut.

FIRE AND WATER FROM ONE PIPE OF WELL

Water at a temperature near freezing and a flame hot enough to fry eggs both flow from the same pipe of an artesian well in southern Alabama. The well was drilled by a company searching for coal deposits. No coal was

4050

Jefferson County

found, but water so cold that it could be used for refrigerating purposes gushed forth to supply near-by campers. One camper happened to hold a match near the water and was startled when it burst into flame. The flame, however, does not heat the water, which remains at about the same temperature. Physicists explained the phenomenon by determining that the well had punctured a gas pocket. The gas, when released from pressure, cooled the water, but, when coming from the mouth of the pipe, could be lighted.

"SWOOPER" GIVES ALL THRILLS 3980 OF AIRPLANE RIDE

With four speed changes every round, an amusement park ride that gives some of the sensations of a trip in an airplane now is being produced. The apparatus, called a "swooper," somewhat resembles a Ferris wheel, except that it is oval in shape and the arms to which the seats are attached are rigid, although the seats themselves turn with the motion of the body. On entering the car, the occupant gradually starts backward on a straightaway, then suddenly rises at about three times the former speed, proceeds forward for some distance at decreased speed, and as suddenly swoops downward at the other end of the oval, giving combined sensations of Ferris wheel and airplane.

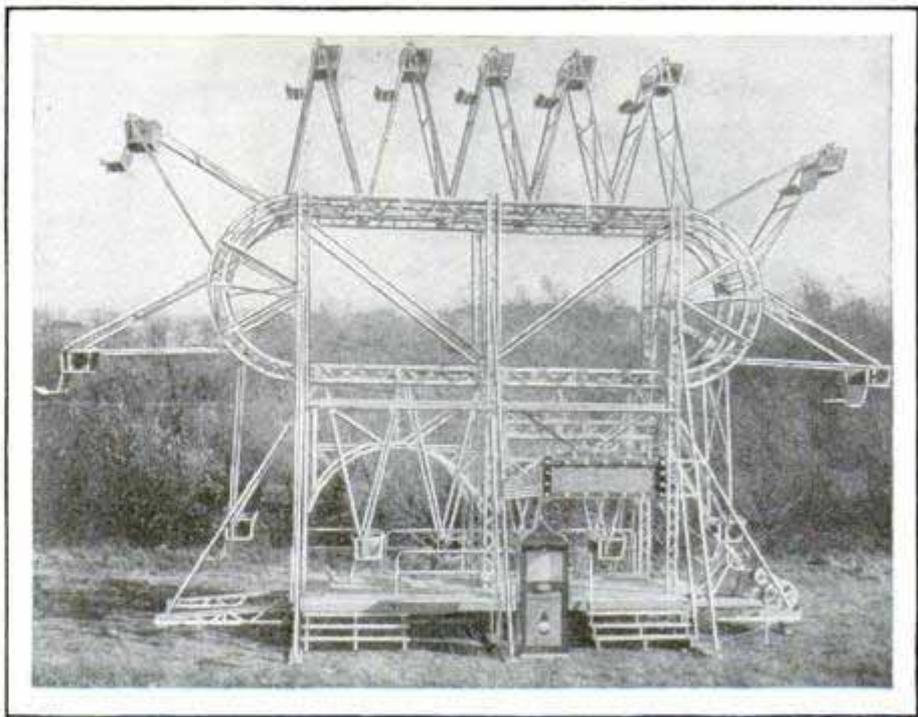

Oval-Shaped Wheel Giving Four Changes of Speed with Each Revolution Provides Some of Thrills of Riding in an Airplane

Sellner Mfg. Co.

see April 1924 - 515

COLOR ORGAN PAINTS BALLROOM WITH MAGIC LIGHT

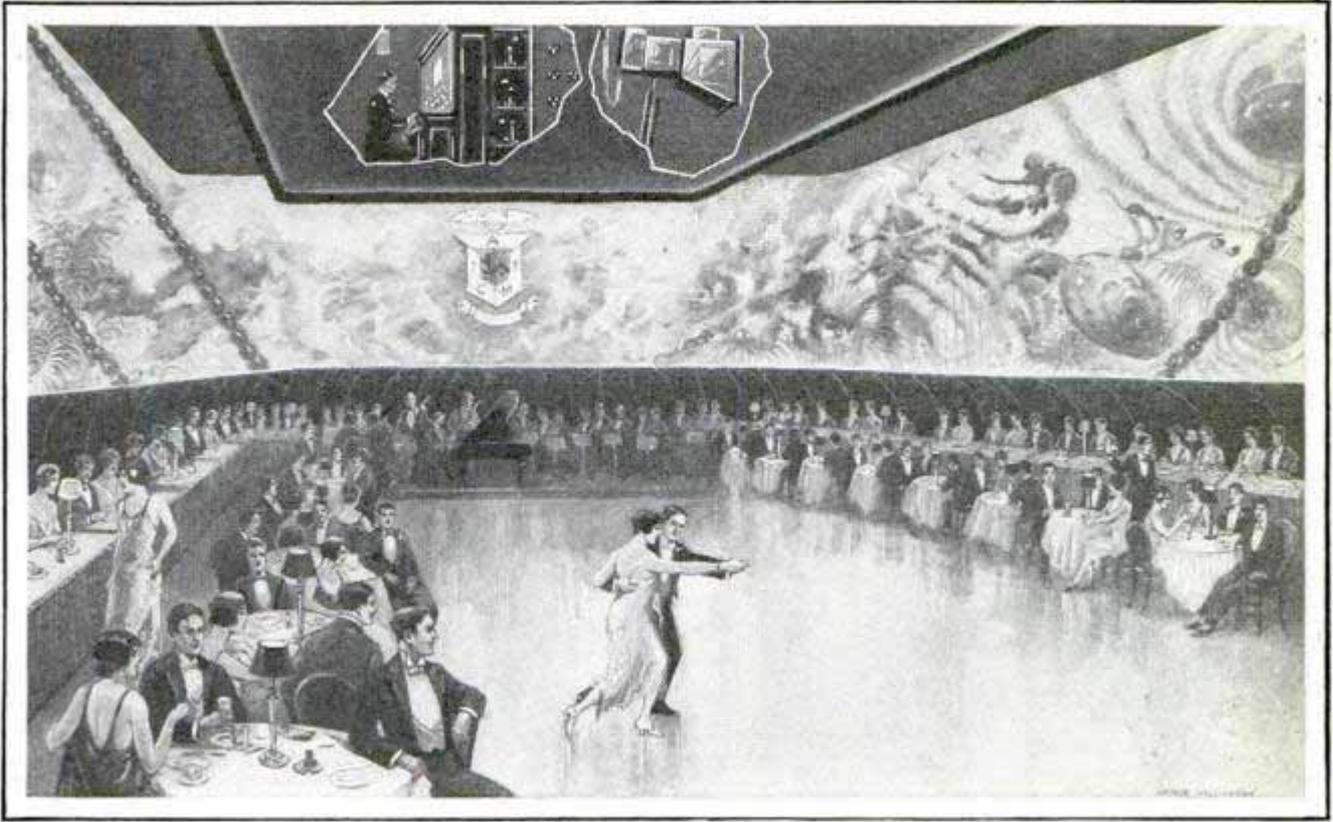

Artist's Drawing of the Bal Tabarin, Hotel Sherman, Chicago, Showing the Installation of Thomas Wilfred's "Clavilux" and the Effects It Produces on the Walls, Which Are Literally Painted with Light

Oriental gardens, desert mirages, swirling stars and other unusual effects glow and dissolve on the walls of the Bal Tabarin in Hotel Sherman, Chicago, where practical application has been made of Thomas Wilfred's "Clavilux." This was hailed as the birth of a new art when it was first introduced, but few persons saw, at that time, more than an unusual exhibition of lighting phenomena. Now it promises wide use in theatrical and other fields. Scenery for the stage of the future may be projected as light instead of being constructed of materials. Whole schemes of interior decoration can be altered in a few seconds.

The hotel's ballroom walls, about 3,000 square feet of surface in all, in reality are blank. Suddenly, stately Grecian pillars appear. They look as solid as stone. They glow with changing colors against what appears to be a sky of infinite depth. A sea opens up behind the columns, ships loom out of the dim horizon, then disappear. The entire scene dissolves and gives place to a performance of slowly whirling light masses that suggest the nebulae of the heavens. A sort of mechanical seance gives evidence of the

magic accomplishments of expert lighting artists and engineers. As the mysterious figures fade, the walls assume the appearance of the bottom of the sea where weird shapes slip about, and the entire area glows with a soft hue, associated with the depths of tropical waters.

The source of these bewildering apparitions is in the ballroom's ceiling. From a specially constructed projection room, an electrical engineer, seated at a light keyboard is "playing" the illumination that paints three entire sides of the room. Twenty-seven hidden projectors, all operated from this central keyboard, are so arranged that they furnish the entire scheme of decoration for the whole room. This is the first ballroom in the world to use light exclusively for interior decoration. A special feature of the installation is that lodge and club insignia or special signs of any kind can be projected with the display, saving the construction of huge banners and other devices usually required to decorate the walls.

Our Bureau of Information will answer all questions regarding articles appearing in this magazine.

Huntington L. C. New York

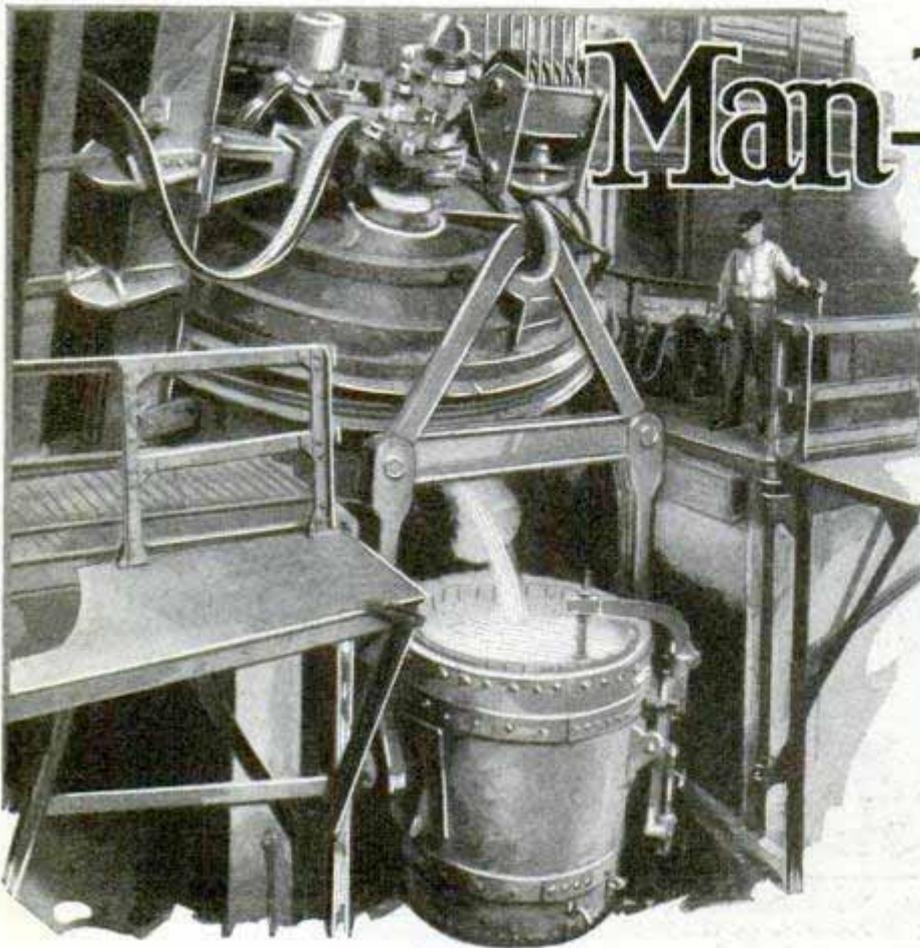

Man-Made

the rarer metal. Tantalum will allow an electric current to flow only one way. An alloy of tantalum and nickel for making instruments and parts of chemical apparatus resistant to chemicals and oxidation, has been patented. It is said to be very tough, easily hammered and drawn, and has a breaking strength "which decidedly surpasses that of the best steel."

Titanium, another rare metal, is just now coming into more extensive use in the manufacture of pigments. It is being used in baked enamel, lacquer, printing ink, wall paper, rubber,

Molten Metal Flowing from One of the Smelting Industry's Highly Developed Aids, an Electric Furnace Used in Making High-Tension Steel

By JOHN DRAPER

MYSTERY metals that possess strange properties of medical and industrial value are yielding their secrets to scientists of the bureau of mines in a special laboratory which has been set up for that purpose at Reno, Nev.

A collection of rare metals from all over the world has been assembled, and efforts are being made to find substitutes for those of which this country does not possess an adequate supply. Some of the more important metals in the group include vanadium, radium, uranium, tungsten, titanium, tantalum and molybdenum.

The strange qualities of tantalum have long baffled the scientists. It is one of a pair of metals that are unknown separately, although columbium, the other member of the pair, is sometimes reported alone in minerals. Tantalum at first was used as a filament in electric lamps, but tungsten was soon applied to the same use and was so much better, owing to its higher melting point, ease of working and abundance, that it promptly superseded

oilcloth, linoleum and window shades. The metal is found in beach sands at Redondo, Calif., and at Jacksonville Beach, Fla. On the Pacific coast it is believed that the deposits in the beach sands at Redondo were carried down from the San Gabriel mountains north of Los Angeles by tributaries to the Los Angeles river, and thence along an ancient course to Redondo instead of to San Pedro where the river now empties into the Pacific.

Tungsten, wonder metal of the world, credited with playing an important part in the winning of the world war and an equally important part in the phenomenal expansion of American industry since the war, is being made the subject of special study. No other metal produced in such small quantity, say the government scientists, has the industrial importance and has such an influence on the comfort of people at large as tungsten. Its use in incandescent lamps in place of the carbon filament it superseded saves large quantities of electricity. It gives a quality of

Mystery Metals

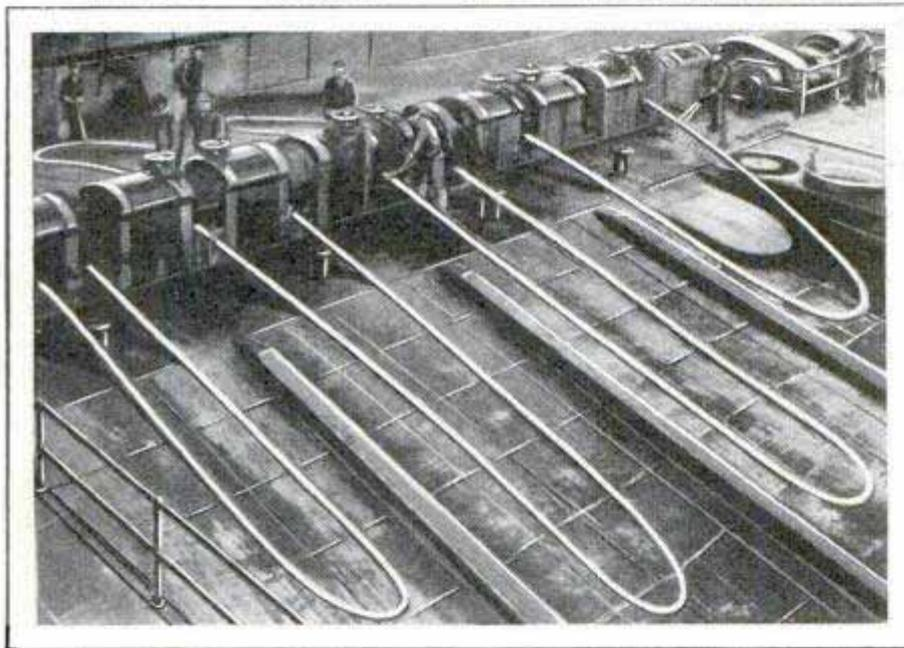
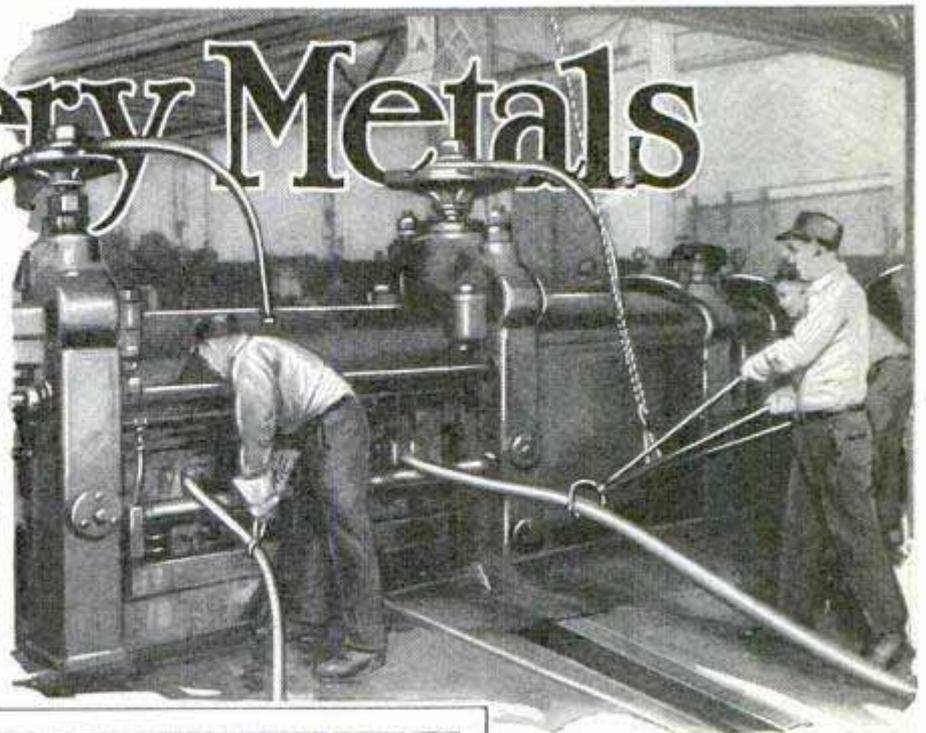
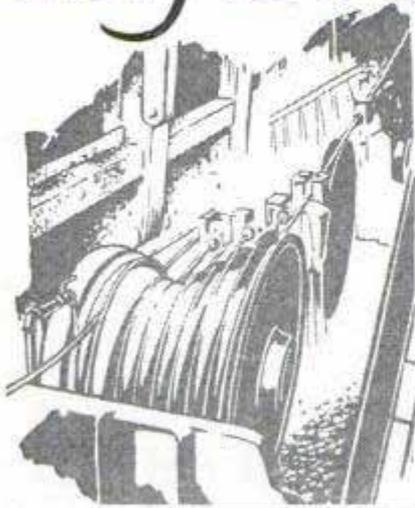

Rollers That Convert a Copper Bar into a Thin Rod Speed the Manufacture of Wire and Cable

light otherwise practically unattainable. It has made possible the flashlight and an X-ray tube which generates rays so hard that almost instantaneous Roentgenographs of the body can be taken.

For all these uses, not more than 100 tons of tungsten concentrates, valued at \$60,000 to \$65,000, is used annually. Most tungsten is used in tool steels for forming metals. It is estimated that one man with one lathe and tungsten-steel tools can do as much work as five men with five machines and carbon-steel tools. The metal is being used in radio tubes, electrical contacts, airplane and automobile valves. An automobile manufacturer de-

clared recently that, if he had to use the old carbon tools, the cost of production would be increased \$200 per car over present prices. The government scientists aver that, but for tungsten tools, it is doubtful whether shells and other cut steel could have been supplied in the war in the quantities needed. It would probably have been impossible to find the men, machines and shop room necessary to

turn out the indispensable munitions in the time available.

Mankind plants infinite faith in new alloys. They make possible swifter aircraft, larger ships, longer bridges, higher buildings, sharper tools, fireproof structures and more sanitary living. Civilization enters an area of supermetals, where high-tension steels, rustless cutlery, stainless alloys, magnaliums and combinations of rare metals command on every front. But they are merely forerunners of metallic substances which will enable men to control many natural forces.

Some years ago, a bridge span fell into the St. Lawrence river, killing several people. Blame could hardly be laid on the

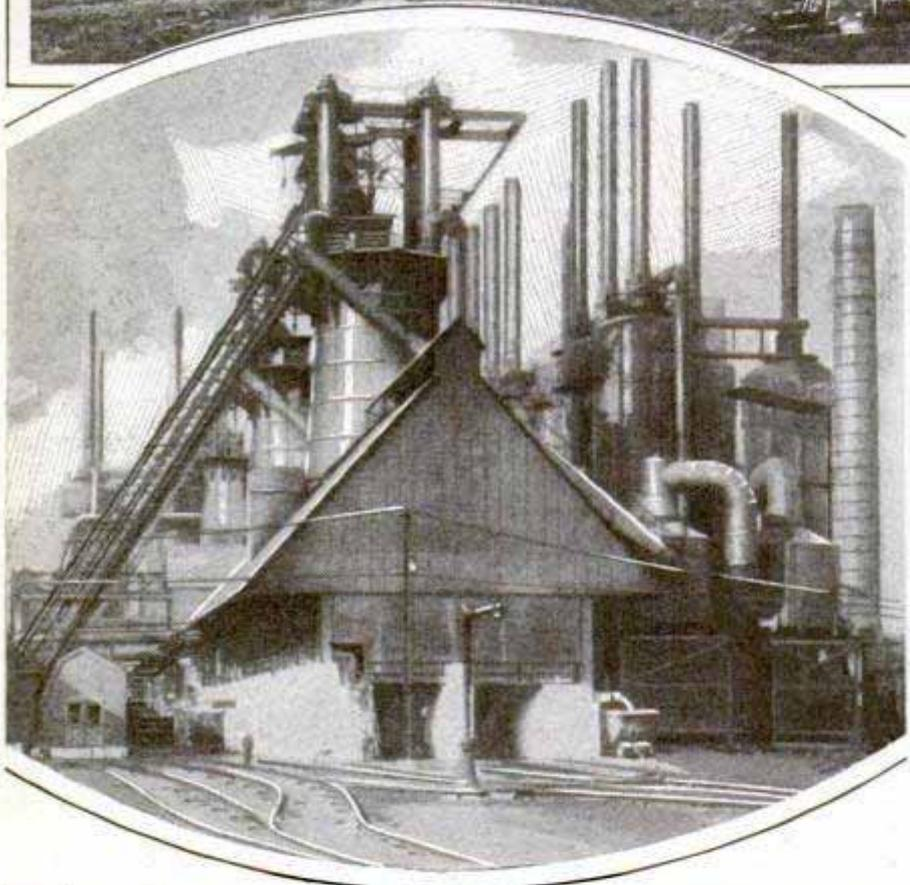

applied to metal its shape alters. If a girder is properly designed, it resumes its initial form after the force is removed. The change in dimension is called "strain."

The importance of fatigue can hardly be overestimated. It concerns the safety of everybody. When a bridge buckles, a roof collapses, or a car wheel breaks, in eight out of ten cases, the cause of failure is fatigue. The mishaps come suddenly, for metals cannot cry out when too tired to stand up. But metallurgy has not despaired of eliminating fatigue. The antidote will come

Scene in the Famous Great Lakes Iron-Ore Region, and a Modern Blast Furnace Where Ore Is Melted

engineers, who were faithful and sincere in their duties. What had happened? The steel members merely tired of holding up. When one girder slipped, the load taxed the bridge structure and the whole collapsed. This tiring of steel applies to other metals also. It is usually called "fatigue."

Fatigue is a nightmare of metallurgy. Not much is known about it, although engineers clamor continually for more light on the subject. Whenever force is

with the perfection of truly elastic metals. Extra-light alloys are substances to conjure with. Chemistry and metallurgy produce them in amazing abundance and variety.

The yardstick of airplane construction and design is "pounds per horsepower." When you decrease weight, you amplify horsepower. Manufacturers discovered aluminum and its alloys early in airplane history. Here is a metal, one-third as heavy as steel. Duralumin is the name ap-

plied to a whole group of super-light alloys containing about ninety-four per cent of aluminum, four per cent copper, one per cent magnesium and one per cent manganese. Aeronautics would still be in its infancy if it were not for duralumin.

If aluminum is alloyed with silicon or magnesium, its weight is reduced. All other metals increase the initial weight. The presence of silicon in aluminum was formerly considered harmful, but recently alloys with eleven per cent of silicon were created, and they promise to be the most valuable light casting alloys.

The story of aluminum is phenomenal and arresting. In 1869, when Dr. C. F. Chandler, the American chemist, visited Paris, he bought an ornamental basket of four ounces for \$9. It was made of rare metal—aluminum! For fifty years, European chemists sought to separate aluminum commercially from its minerals. But an American youth, Charles Martin Hall, student at Oberlin College, performed the miracle. He had learned that the metal could not be electrically isolated in the presence of water, and it was insoluble in alcohol,

ether and benzol. After much experimentation, he succeeded in dissolving aluminum ore in the mineral cryolite. Later, he obtained the pure metal by electrolyzing the solution.

A metal called chromium competes with aluminum for fame. Chromium is the substance that keeps table cutlery clear of spots; it preserves the luster of the auto radiator; it makes printing rolls resistant; it gives steel a rustless quality. In short, here is a metal whose role in daily life commands respect.

Some of the newest alloys are nickel-chromium compounds. They resist corrosion well but soften at lower temperatures than steel.

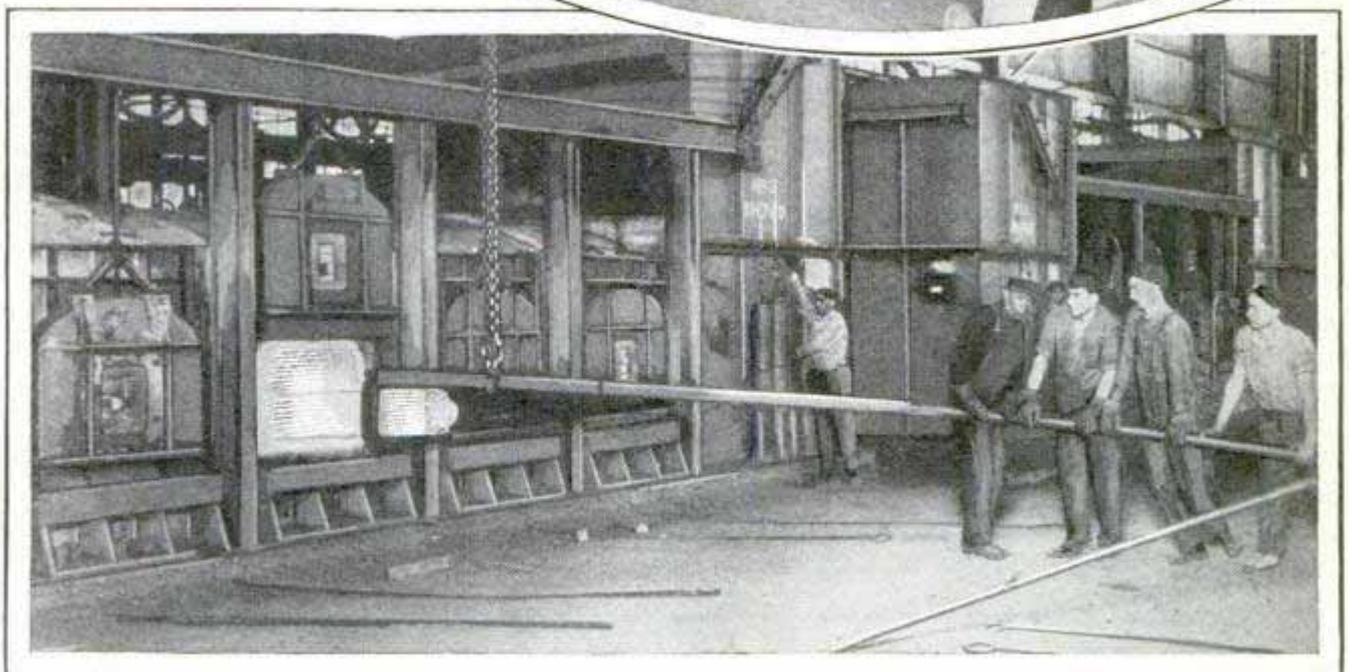
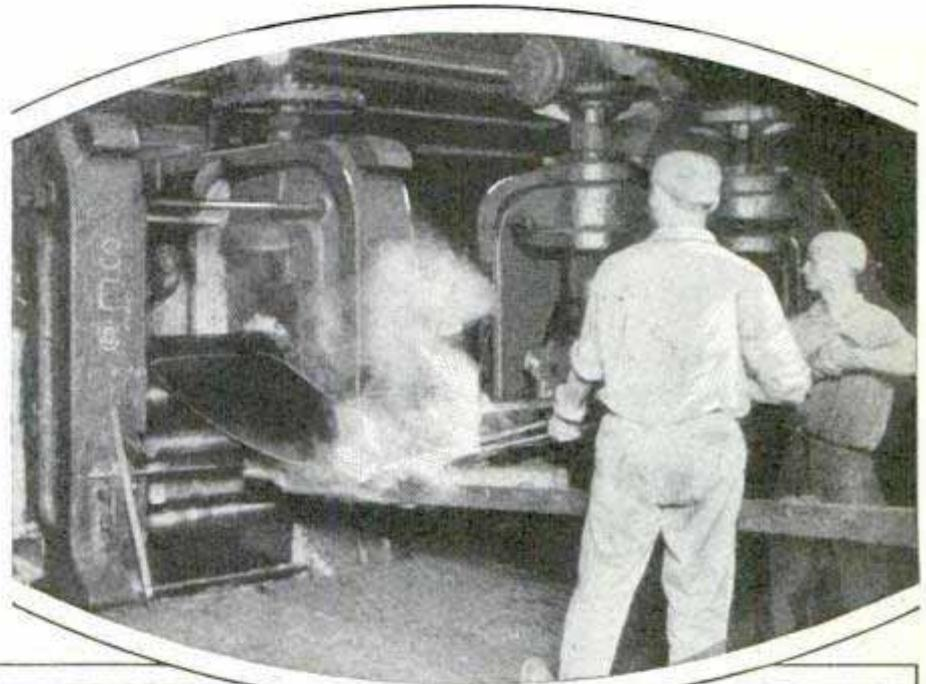

Preparing a Sheet of Nickel Alloy of the Right Thickness by Rolling It between Powerful Rollers, and Heating a Nickel Ingot to the Proper Temperature

3856
406

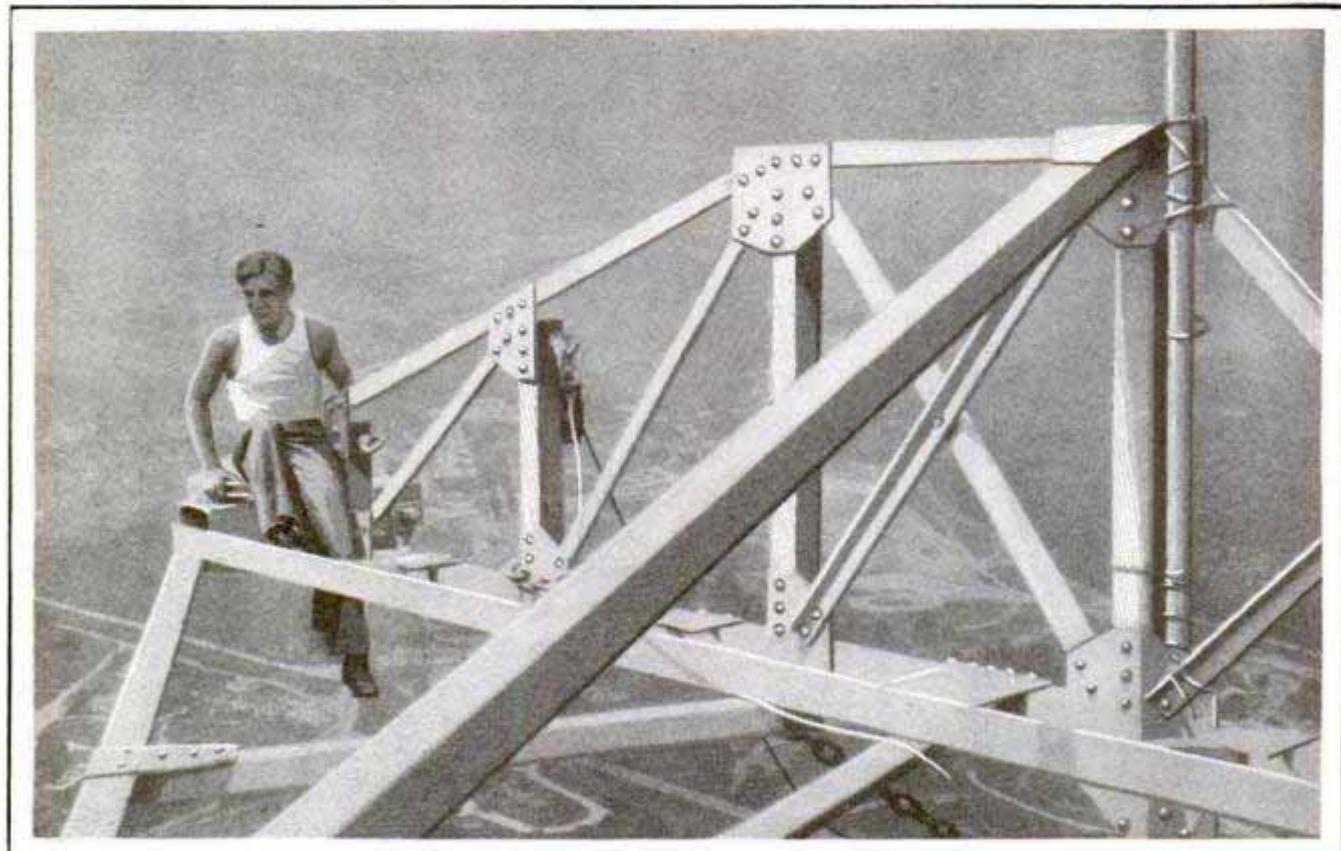

Courtesy U. S. Navy

Sailor Perched on Top of a 600-Foot Radio Tower at Arlington, Va.; Rust-Proofed Steel Alloy Has Made the Construction of Such Towers Practical

For industrial uses, there is promise in the new "nitrided" steels which can produce excellent casehardening without distortion. A lead-calcium alloy with high fatigue strength was recently discovered.

Copper also finds a place in the present research. A copper-beryllium alloy has the highest tensile strength ever reached in nonferrous metals.

Another alloy with ninety-five per cent silver, and small doses of copper and aluminum, resembles sterling silver. It has possibilities as a coin silver and also for tableware.

In the cast-alloy field, a process called "modification" is being developed; it is a science based on the proposition that, by adding a small quantity of another element, the desirable properties of an alloy are increased.

Permalloy, a superior magnetic material, can now be furnished in a ball mill, molded into rings and hardened for use in long-distance telephone transmission. The use of permalloy has decreased the size of the ring to one-eighth the former size and effected an annual saving of \$1,500,000.

The commercial possibilities of rare

metals and uncommon ores have recently been exploited. For instance, the metal caesium became famous almost overnight. It has a silvery luster on a fresh surface and greatly resembles potassium. Before 1926, caesium was a chemical curiosity. Then the radio industry discovered that it could be compressed into "pills" and used to extract minute remnants of air in radio vacuum tubes.

The iron-gray metal cerium has been made to alloy with iron, zinc, magnesium and aluminum. It is used as a "sparkling" metal in ignition devices, such as pocket lighters and gas lighters.

Selenium, once very obscure, has found commercial uses. It is employed in the manufacture of ruby glass and red enamels. It also increases the toughness of rubber in sheathed wire cable.

The metal thallium was recently discovered to be an effective poison for rodents and ants. It is superior to arsenic, strychnine and phosphorus, being tasteless and odorless. The metal also is necessary in the manufacture of photoelectric cells.

And so the earth's materials are yielding to inventive magic.

FIVE-STORY CHICKEN HOSTELRY HAS ELECTRIC ELEVATOR

4080

Equipped with every convenience a fastidious hen could ask, including electric lights, running water, air ventilators, a vacuum-cleaning system and an electric elevator, a five-story "hen hotel" has been constructed by California poultry raisers. It houses 3,200 laying hens and an addition, when completed, will bring the capacity to 10,000 chickens. The present unit is forty-eight by fifty-eight feet, each floor being divided into four pens. The building has east and west exposures and is covered by glass sash. Each hen has three square feet of space and all "furniture," including nests, roosts and mash hoppers, is elevated. The electric elevator takes the feed up and the eggs down.

TALKING MOVIES FOR HOME NOW EASILY MADE

3984

Talking motion pictures are taken and displayed in the home with the aid of a compact outfit that also includes a radio. A phonograph record is synchronized with the film so that the voices or other sounds are registered at the same time that the picture is taken and are reproduced again in proper agreement with the reel. The radio can be played as an accompaniment to non-talking films.



Compact Outfit for Taking and Displaying Talking Movies in Home Also Contains a Radio

Sonora Products Corp

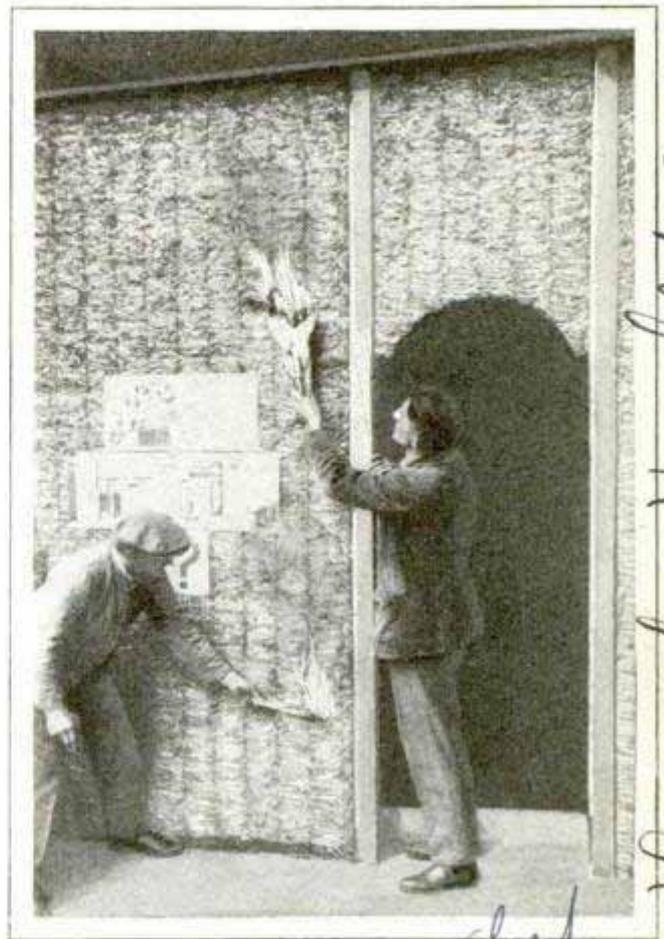

Workmen Demonstrating That Walls Made of Chemically Treated Straw Have Been Fireproofed

FIREPROOF WALLS OF STRAW FOR BUILDING MATERIAL

Non-inflammable walls made of straw were exhibited at a builders' show in Berlin recently. The straw, treated to make it fireproof, is pressed and bound in layers, and its makers claim that the product is ideal for construction purposes with the fire hazard eliminated, particularly as a means of making a house weatherproof.

ULTRA-SHORT WAVES FOR RADIO

Application of ultra-short radio waves that vibrate almost as fast as infra-red rays, for radio messages has been accomplished successfully by a German scientist. These wavelengths, perceptible only by their production of heat, extend in length from a few decimeters down to one-thousandth of a millimeter, reaching thus into the sphere of invisible light rays. A detector sufficiently sensitive to react to such rays was found in a selenium cell with an alloy of tellurium sulphide. A transmitting tube of only 100 watts was used for telephone and radio messages.

Deutsche Herablit. A. S.

4181 Berlin Germany

Dr. Schroeter

Bureau of the Census
Washington, D.C.

3889

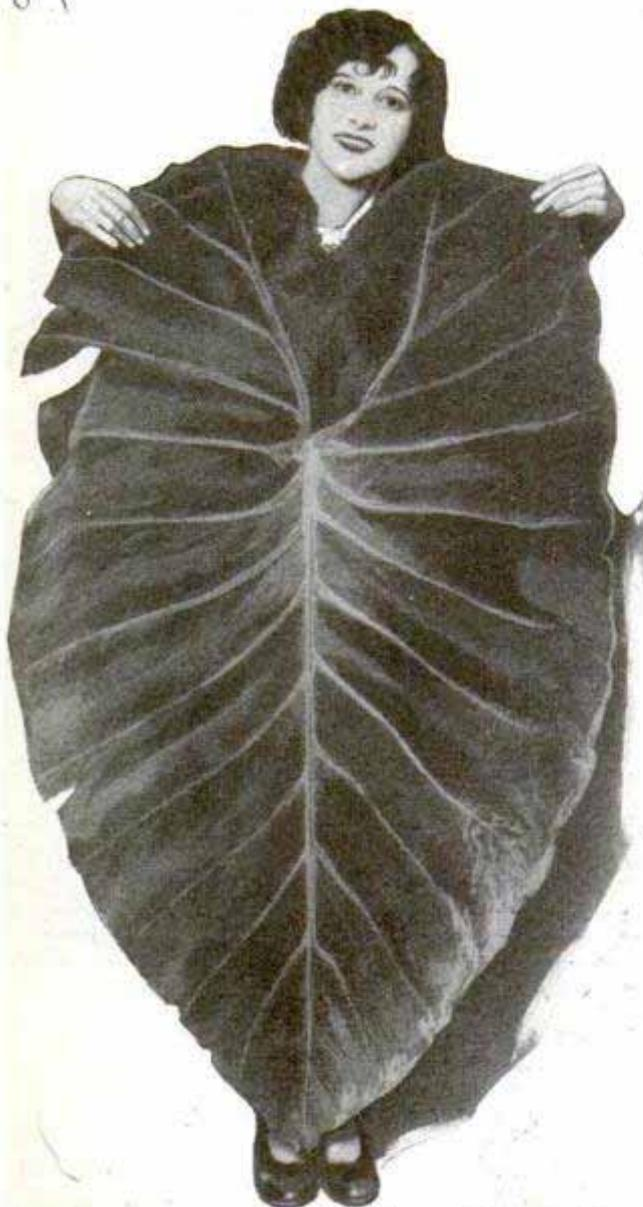

A Giant Elephant's-Ear Leaf, Almost Five Feet Long, Is the Unique "Dress" for This Girl

GIGANTIC ELEPHANT'S-EAR LEAF MAKES MODEL FOR DRESS

Almost five feet long and thirty-eight inches wide, a mammoth caladium plant, more commonly known as an elephant's ear, has been grown by a resident of Fresno, Calif., in his front yard. The leaf, draped about a girl of average height, almost enveloped her and, without any alteration, formed a unique dress model.

DEAD LETTERS COST MILLIONS TO GOVERNMENT ANNUALLY

Operation of the dead-letter office costs the government about \$5,000,000 annually, most of which could be saved if those who use the mails exercised greater care in addressing. A letter is pronounced dead

and sent to the morgue for defunct mail after it has, in many cases, made seven or eight trips back and forth between the city where the sender lives and the city to which it is addressed, with frequent side journeys to many other places in the government's effort to deliver it. Innocent-looking missives are found to contain anything from the message of a love-lorn swain to a poisoned needle, or a powder capable of bringing on sleeping sickness; so, great care is exercised in opening the dead letters. Out of 25,000,000 pieces of mail handled annually by the dead-letter office, about 500,000 find their way back to the senders. Once a year there is a general house cleaning when valuables found in letters are sold, letters containing nothing of value are destroyed, eventually finding their way to the government printing office as wood pulp, and money contained in letters is turned over to the treasury. It has also been estimated that 200,000,000 pieces of mail yearly are given directory service, which means that postal employes find the person to whom such mail is addressed by scanning telephone and city directories.

TINY COMPRESSED-AIR MOTOR DRIVES MODEL PLANE

Model airplanes, powered with compressed-air motors of six or eight cylinders and weighing from four to six ounces, now are being produced. The motor is constructed of aluminum and may be detached from the air tank. The air control allows it to idle for five minutes or run full speed for one minute. The six-cylinder motor turns a seventeen-inch propeller at 1,200 revolutions per minute, and drives models up to thirty ounces in weight and with a wingspread of from four to six feet.

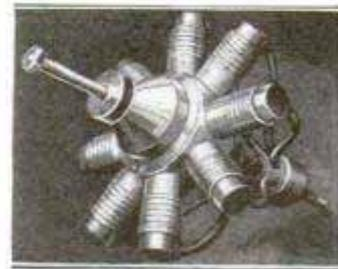

It is three and one-half inches wide, has a three-eighth-inch bore and a three-eighth-inch stroke, and weighs four ounces. The eight-cylinder type is slightly larger and weighs six ounces, while the tanks weigh from ten to twelve ounces.

Miniature Aircraft Corp
23 South Terrace

D. S. Stewart

4049

7/2/35

COLLEGE GLIDER CLUB TEACHES LOW-COST FLYING

City, Utah

Financed entirely by small dues and assessments, a motorless-aviation club, organized a year ago by students of the University of Utah, has constructed its own glider and taught most of its members to fly alone. The first ship was built by the students at a cost of \$180, and club members state that it could be duplicated today for half that sum. Members now are planning to build a secondary training ship with a forty-four-foot span, streamlined fuselage, pilot's cockpit and capable of soaring. Plans for the first glider were

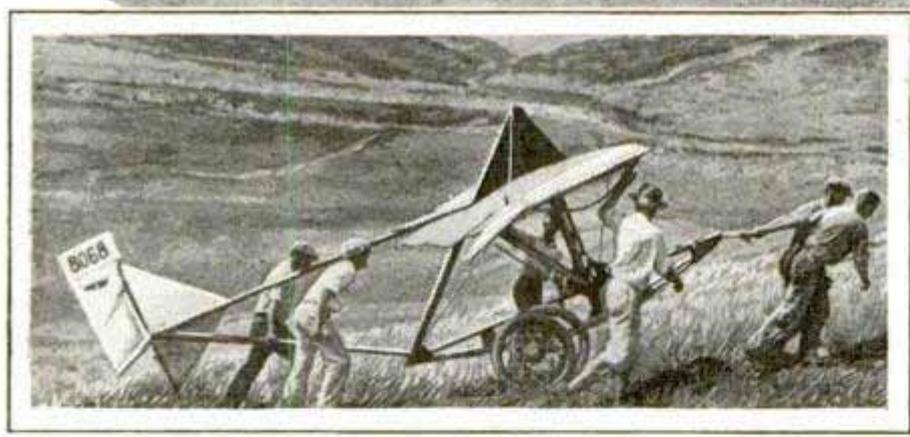
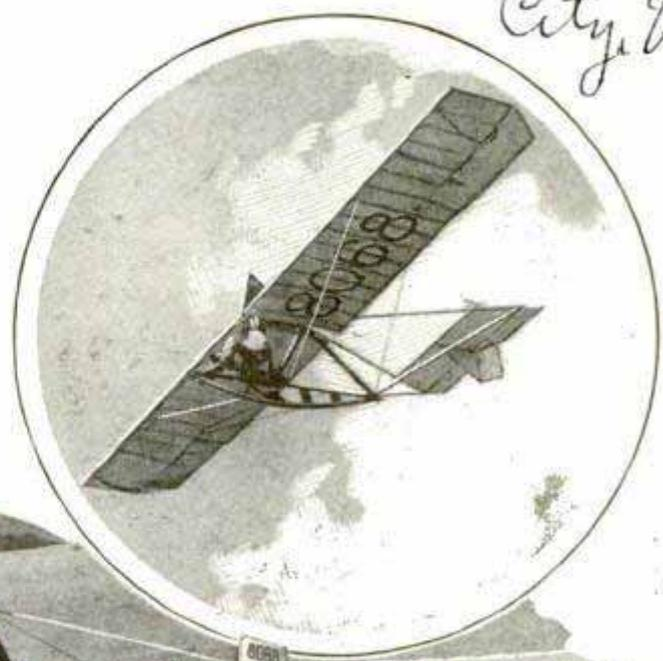

Three Views of a Glider Built for \$180 by College Students; All Student-Members of the Glider Club Learned to Fly in It

checked by engineering professors of the university, and after a series of short test flights by the only member of the club with previous flying experience, novices took the controls, the ship being held down by ropes which allowed it to rise only about six feet. It was discovered that any person with a minimum of flying experience in a motored plane—as little as twenty minutes at dual controls—could fly the glider without trouble, and with inexperienced men, even the most timid, the technique of managing the sailplane was learned in a slightly longer period, but club members advised all glider stu-

dents to take some flying instruction in a motored plane before attempting to glide. Men with flying experience even in minimum amount had virtually no accidents, it was found, and while one inexperienced man cracked up the ship considerably, there were no serious ac-

cidents to glider or students in more than 180 flights, some of them from 150 to 400 feet from the ground. Motorless flying was found to be a successful and inexpensive way to gain flying experience, due to the fact that the cost of the student-built plane was moderate and its upkeep virtually nothing, and those flying a glider were forced to rely entirely on the sense of equilibrium, an important accomplishment for the pilot, and one gained more easily in a glider.

☐ It takes seven years to bring an orchid plant to maturity.

3860



Gold from

collectors, in spite of the great number of butterflies to be collected. First, there is the scientist, who seeks new varieties and to know better those which have been discovered and classified. Second, there is the collec-

By H. H. DUNN 435
Georgia St. San Diego, Cal.

COLLECTING anything so fragile and so short-lived as a butterfly would appear to be at best an uncertain method of meeting the modern cost of living, yet within the last five years it has developed into an industry of some size, especially in certain favored localities.

Just when butterfly collecting began no one seems to know, but there are specimens in British museums which are known to have been caught and preserved more than 100 years ago. Early in the eighteenth century butterfly hunters, called "aurelians," were held up to mild ridicule. Less than fifty years ago, the man who was seen, net in hand, pursuing insects across the fields was laughed at as a sort of harmless lunatic.

But all this has changed. Through the efforts of butterfly and moth collectors, it has been learned, for example, that there are more than 8,500 species and subspecies of butterflies and moths in the United States. Of these, less than 700 are butterflies, so that there are more than 7,800 kinds of seldom seen moths in this country.

There are only two kinds of butterfly

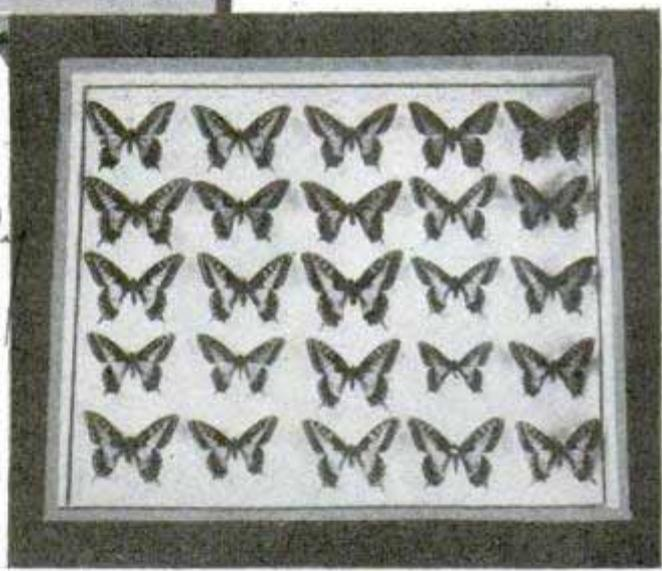

Collector Placing Prepared Specimens in Insect-Proof Drawer, and Sample Case of "Swallowtail" Species

tor and breeder, who seeks only the brilliantly colored specimens for the making of jewelry, fans, screens and for other ornamental bric-a-brac. The accomplishments of the scientist appear only in museums and private collections; those of the commercial collector are sold from the shops of New York to the annual fair at Nijni-Novgorod. The financial returns to the scientific collector average probably less than ten cents a specimen; those of the commercial collector and breeder range up to twenty-five dollars per butterfly or moth. Both are artists, the one adding materially to the sum of human knowledge and the other adding beauty

Butterflies



Field Class Studying Habits of Moths and Other Insects; This Work Has Become Increasingly Popular in Grammar and High Schools Recently and Is an Aid to Future Farmers

and attractiveness to human surroundings.

Recently, a private collection of American butterflies and moths, embracing more than 400,000 specimens, was offered to the Smithsonian Institution at \$350,000. This is considered a nominal price by those familiar with the collection, as it is estimated that it actually cost its owner more than half a million dollars. Six large screens, each about five by ten feet, and each containing approximately 100 butterflies and moths, sold recently for \$2,500. No two specimens in these screens are alike; they came from all parts of the world, and all are brilliant, perfect insects. The cost of collecting and preparing the butterflies and moths, and inclosing them in the screens, is estimated at \$1,250, leaving a better proportionate profit for the commercial collector than the scientist will receive for his huge collection, if and when he sells it.

Both kinds of collectors use the same methods of finding and capturing their fragile trophies, but the commercial collector frequently rears his moths and butterflies from the caterpillar stage in large numbers so as to obtain perfect specimens. Probably no other form of collect-

ing is so difficult, nor the preparation of specimens so delicate a task as that of the butterflies and moths. The wing surfaces are covered with tiny, rainbow-hued microscopic scales, finer than dust. Whenever a wing is touched, these scales are rubbed off and some part of the coloring destroyed.

Yet, from the jungle-covered interior of the tropics and from the remotest islands of the seven seas, tireless scientists bring back perfect specimens, the "bloom" of their wings uninjured. One such collector, working in the interior of an island in the West Indies, found a butterfly which exists only in a limited area on this island. He brought back enough perfect specimens to pay the expenses of his expedition, receiving as high as twenty-five dollars each for them.

Most butterflies are taken in nets as they hover over plants; a few are reared from caterpillars. The majority of moths are caught in traps in which a light is the lure, captured with a sweet bait smeared on tree trunks, or reared as are the butterflies. When one remembers that there are more than 7,800 species and subspecies of moths in the United States alone,



One of the Several Forms of the "Swallowtail," a Common but Beautiful Variety Abundant in the United States

it will appear that for the scientific collector this field is almost inexhaustible.

The collector, scientific or commercial, fares forth armed with a fine-meshed net, with a ringed aperture about fifteen inches in diameter, and a soft bag, two feet long, the size varying with the fancy of the man using it. Knowing the haunts of butterflies, he visits gardens, flower-covered fields, brushy hillsides, watercourses and wayside pools, literally skimming his multicolored insects from the air. In a knapsack slung over his shoulder are two or more large-mouthed jars, about quart size, with close-fitting lids. In the bottom of each jar is a layer of cyanide of potassium crystals, held in place with a thin covering of plaster of paris. Into these he drops the larger butterflies or moths, sometimes putting a drop of chloroform on the body of each as he lifts the insect from the net, so that it will not flutter while being killed in the cyanide jar. In his knapsack, too, are a number of large test tubes, well corked and bottomed with cyanide, for the smaller butterflies and moths.

In a notebook, the scientific collector records the date, place, vegetation and other conditions of the capture, as well as the species. The commercial collector, of

course, does not bother with such details. The important facts in this record, with sex of insect, he writes on a tag to be placed with the specimen in the collection to which it goes. When the moth or butterfly has succumbed to the cyanide fumes, it is removed and placed between sheets of thin cotton batting, in a collecting box, for transportation to the preparing room.

A few day-flying moths are caught in this manner, but the greater number come from careful search among bushes, in weedy growths along streams, in crevices in the bark of trees, in brush heaps, and from trapping. However they may be captured, the specimens are taken to the preparing room kept at an even, warm temperature. There they are removed and relaxed by placing them in a warm, slightly moist

container, and thereafter spread on blocks of soft wood, so that their wings may be displayed to the greatest advantage.

The scientific collector mounts only such insects as he wishes to place in cabinets. The other specimens, with their wings folded, are inserted in small envelopes, on which the necessary identification and descriptions have been placed, and filed in small drawers, similar to those of a card-index system. Thus, while a museum or private collection may have only a few specimens of each species on display, it also may have thousands of other butterflies and moths, put away in envelopes for study or for exchange with other collectors.

The commercial collector mounts all of his specimens, spreading their wings and drying them, usually in an oven specially constructed for this purpose, where heat only slightly above that of the normal house warmth is maintained. The scientific collector does not favor the oven, as it has a tendency to shrink the bodies and to so dry out the insect that eventually it will crumble to dust when handled. Since the commercial collector's butterflies are to be closely and permanently protected by glass, he does not have to guard against this crumbling.

Formerly, the winged insects were mounted by both collectors on boards, eighteen inches to two feet in length, an inch or so in thickness, with a groove down the center large enough to receive the body of the butterfly or moth. Such boards, varying in width according to the wing spread of the insect to be mounted, were somewhat unwieldy, and it was difficult to keep the wings spread flat without rubbing, thereby destroying the minute scales and ruining the appearance and colors of the wings. William Sherman Wright, of the San Diego Museum of Natural History, employs a method of using a separate grooved wood block for each of the specimens, wrapping wings and block with fine, soft thread, thereby making handling easier and reducing possibility of damage to the specimens to a minimum.

The rearing of butterflies and moths from eggs, caterpillars or cocoons is largely a matter of finding the specimens in good condition, providing them

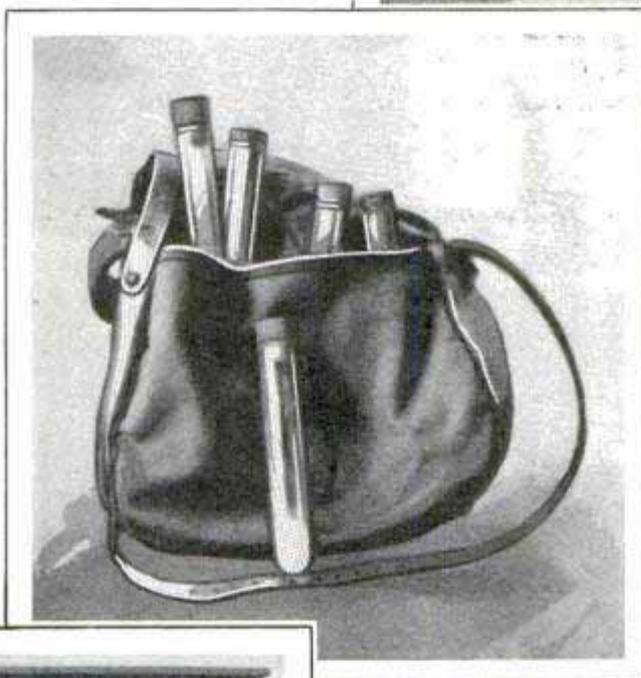
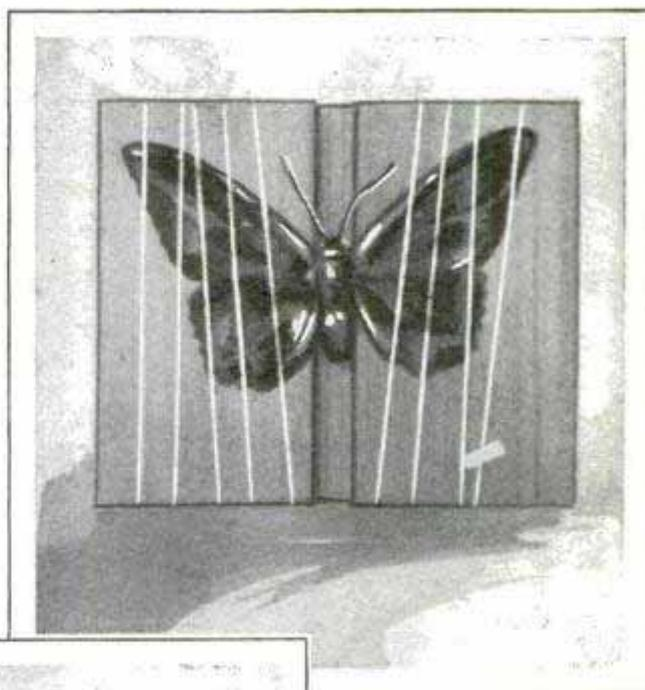

with the vegetable food on which they best thrive, and wearing out a large stock of patience and infinite care. Remarkably fresh, brilliantly colored and large specimens may be obtained, while the financial returns from successful butterfly "farming" are not small. Elaborate equipment is not essential to this form of collecting,

and a vacant room in almost any weather-proof house, equipped for the maintenance of heat only slightly above the normal comfortable warmth of a home, will serve the butterfly and moth breeder very well. Cages made of soft cloth, like mosquito bar, or very light cheesecloth, may be used for each species, but many breeders merely build racks to contain the food on which the caterpillars live, trays to hold earth in which some hibernate, and branches for the butterflies and moths to cling to as they dry after coming out of the cocoons. Methods applicable to the rearing of silkworm moths will work equally well with the majority of the wild moths and butterflies, according to those who have made a success of this industry.

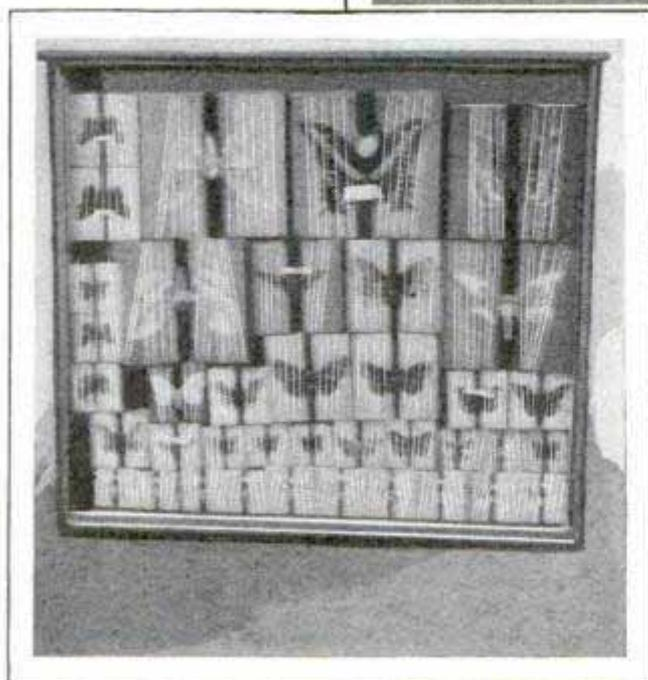

Moth Specimen Drying; a Collector's Knapsack Containing Tubes and Chemicals, and Drawer of Specimens Drying

399

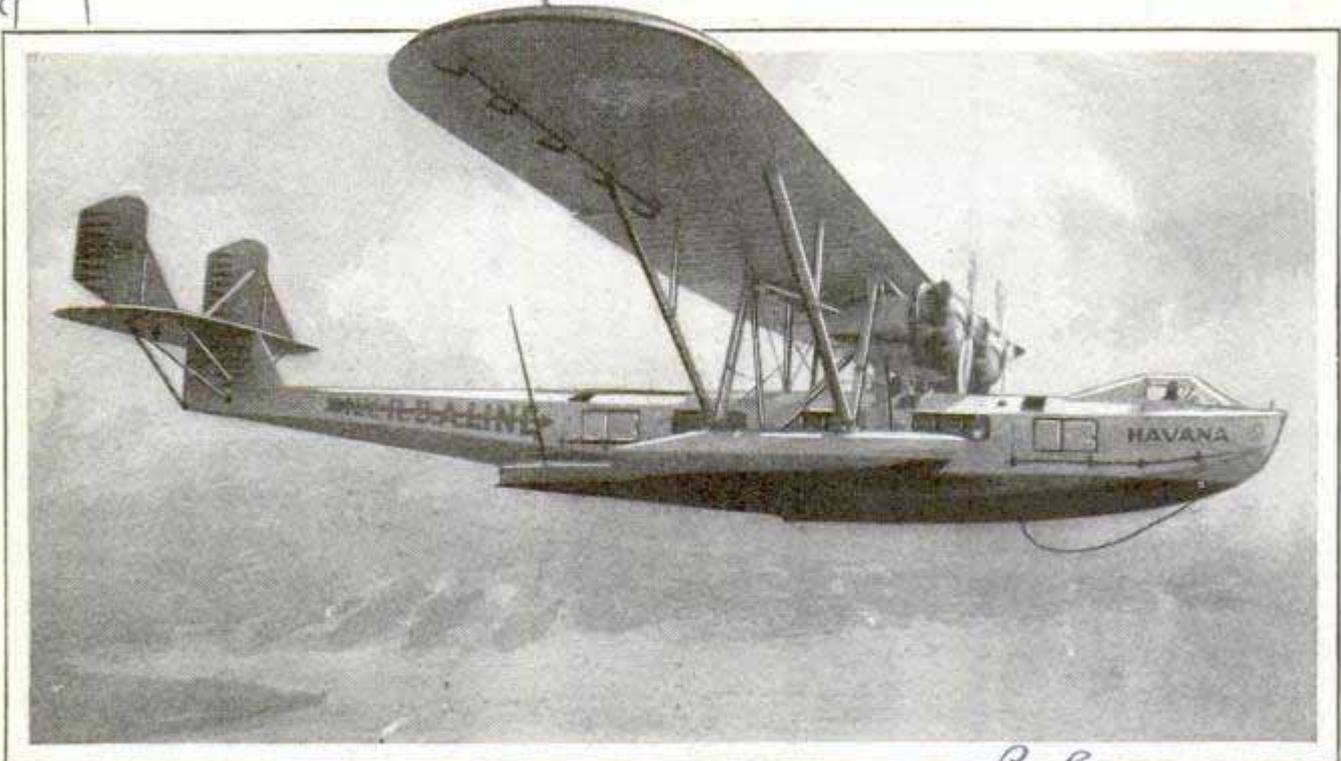

First of Twelve Huge Twenty-Passenger Flying Boats Which Will Carry Mail and Passengers between New York and Buenos Aires, Establishing Seven-Day Service

FLYING BOATS CUT THE TIME TO SOUTH AMERICA

Seven-day service between New York City and Buenos Aires is being inaugurated by giant twenty-passenger flying boats, the first of which has been delivered. Twelve ships in all will take part in this daily spanning of two continents and will carry both passengers and mail.

MILLION BITS OF DUST INHALED WITH EVERY BREATH

With every breath of air, a million particles of dust, spores and microbes are inhaled regardless of the purity of the atmosphere, Dr. W. J. Humphreys, of the United States weather bureau, declares. Every desert wind picks up tons of dust to be scattered for hundreds of miles, fragments of vegetable fiber and pollen of plants litter the atmosphere and are breathed regularly, and smoke from kitchens, factories and forest fires contributes its part to pollution of the air. Even the

ocean, with its evaporated spray, makes a salt mine of the air, and lightning sprays acids into the atmosphere, while volcanoes hurl tons of rock powder aloft to be carried for thousands of miles. In addition to all this, the atmosphere to its outermost limits is filled with the ashes of millions of incinerated meteors. Luckily nature has provided the bronchial tubes with chimneysweeps to get rid of a part of this dirt before the air enters the lungs.

SPARKS IN PLACE OF BULLETS SHOW TARGET HITS

Shooting in every respect the same as an ordinary target rifle, except that it contains no bullets, a rifle registering a hit by an electric spark now is provided by some shooting galleries. The rifle is mounted on a cabinet and by inserting a coin, an illuminated target is thrown on a wall or screen. When the trigger is pressed, an electric spark shows where a bullet would have hit the target, which may be thrown eighty feet or less.

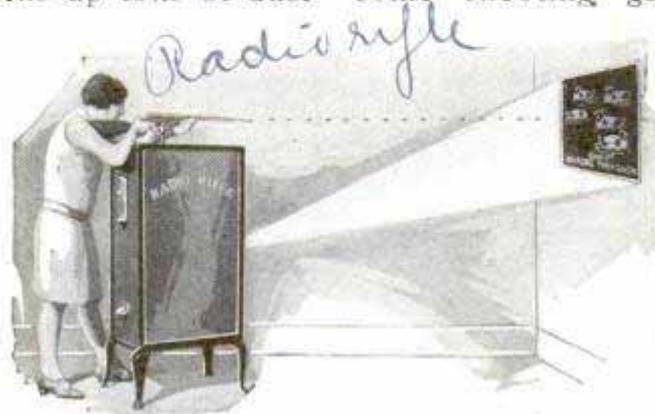

Rifle for Target Use Which Registers a Hit by an Electric Spark Instead of a Bullet

Science Service News Bulletin
456 B 12/19/29

399
Coin. O. Matic Corp
13.3 Division

4048

Subscription 4562

12/18/29

Chickasha, Okla.

THREE LIVES IS AVERAGE PRICE OF MILLION TONS OF COAL

Every million tons of coal extracted from the earth in the United States costs on an average three and one-half human lives, and the bureau of mines has engaged in the country's most vigorous safety campaign to make the mines safe for the miners. Eleven rescue railroad cars have been placed at strategic points to be rushed to mine disasters, and one or two of every hundred miners have been trained in mine-rescue and recovery work, while about 365,000 are trained in first aid. Auto trucks equipped with rescue apparatus also are held in readiness. Prevention, rather than rescue, however, occupies most of the time of mine-safety engineers. Lights that will not ignite the gases and coal dust, explosives that do not set off these gases, and mining machinery and motors that do not spark, are among the equipment used for preventing explosions. Dusting the mine with rock dust to dilute explosive coal dust is another safety measure. However, only eight to twelve per cent of coal-mine fatalities are due to explosions, more than half of the 2,500 lives lost annually being the results of falling coal and rock.

3867

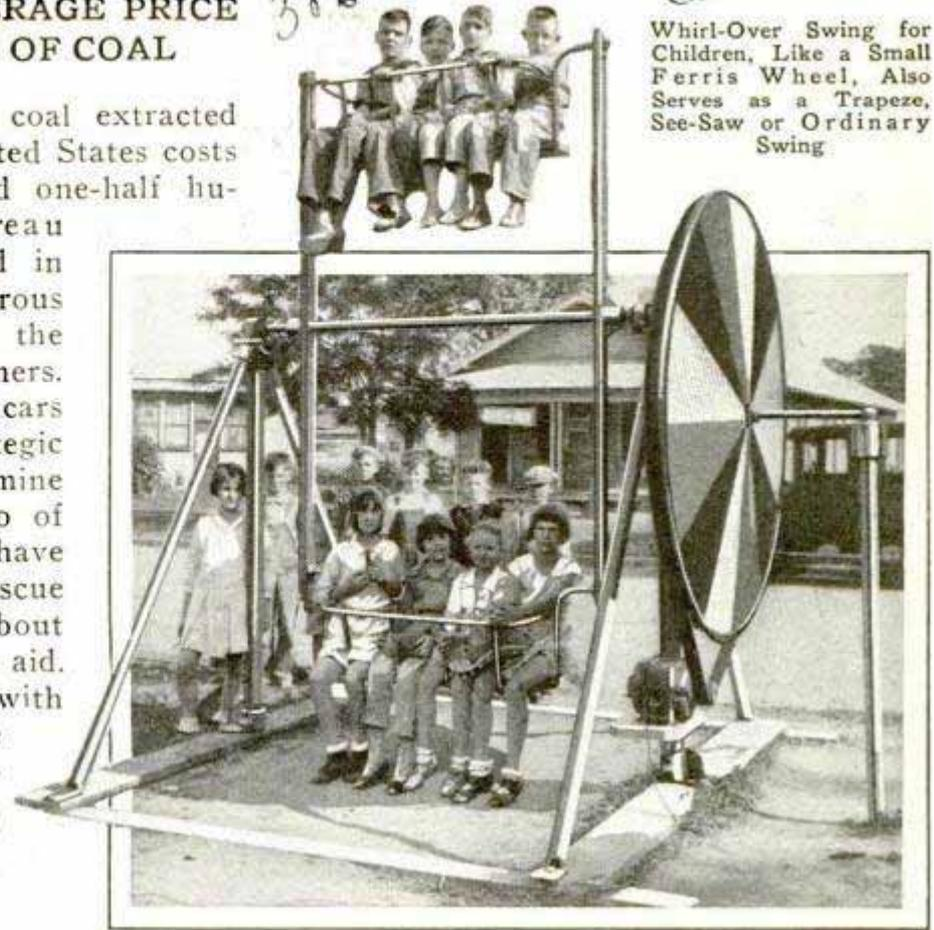

Whirl-Over Swing for Children, Like a Small Ferris Wheel, Also Serves as a Trapeze, See-Saw or Ordinary Swing

WHIRLING SWING FOR CHILDREN LIKE SMALL FERRIS WHEEL

Operating on a principle similar to the Ferris wheel, a whirl-over swing for children now is on the market, being particularly suited to playgrounds or amusement parks. It is constructed of steel, turns on roller bearings, is regulated by a governor and may be obtained with or without a motor. The seats are so arranged that the children are in little or no danger of falling out of the swing. It also may be used as a seesaw, ordinary swing or trapeze.

AUTOMATIC SAW-HANDLE LOCK FASTENS BLADE IN PLACE

3973

Screws and levers are eliminated in a saw handle which contains a plunger that locks the blade. Pressure on the plunger releases it. The handle has a square top so that it does not interfere with work when the blade is reversed for undercutting.

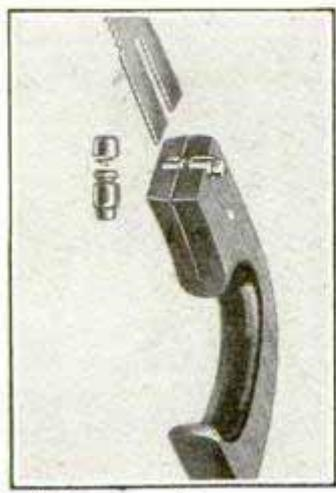

BABIES GIVEN MENTAL TESTS

Dr. Paul H. Furfey, of the Catholic University of America, has tested sixty-two babies between the ages of fifteen minutes and fifteen days to determine at what stage the general intelligence begins to function. He found that babies begin to display mental alertness by following moving objects with their eyes, by grasping with foot or hand when an object is placed within reach, by reacting to a bell, and by other reflexes.

Chicago - 1112 Jefferson

4047

Science Service News Bulletin 456-C. 12/18/29

Henry L. Weston & Sons, Inc.

Before American ... in for adv.

46 Parc St. Newark, N.J.

3830

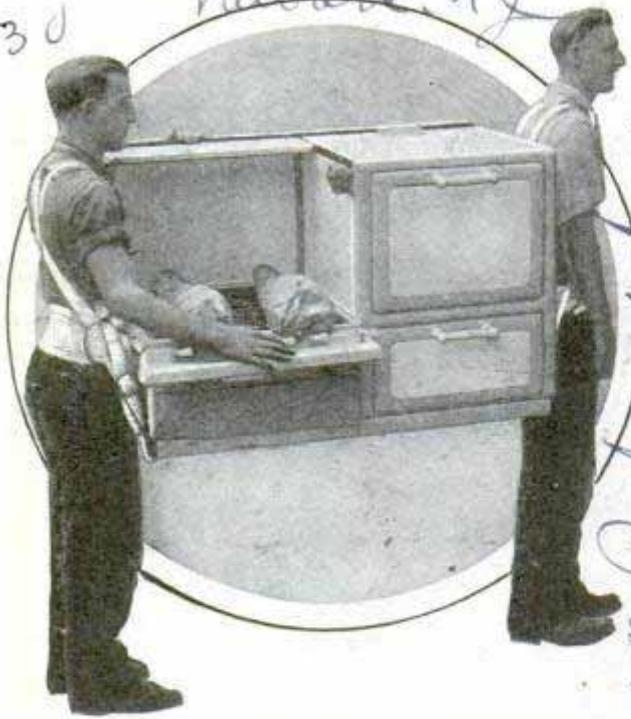

Carrying and Lifting Sling for Two Persons to Facilitate the Moving of Bulky Objects

CARRYING AND LIFTING SLING FOR BULKY ARTICLES

For easy moving of heavy and unwieldy objects, particularly gas and electric ranges, a carrying and lifting sling now is available. It includes a harness which fits around the shoulders and waist of the movers and hooks which attach to the article to be transported. The harness is of strong webbing capable of withstanding a pull of more than 750 pounds.

MATCH, ASH AND GLASS HOLDER ATTACH TO TABLE

Easily attached to a corner of the card table, a tray now is on the market which holds a glass of liquid, and also has a container for matches and an ash receiver. The glass holder may be detached and placed on the table if desired. The three-purpose tray keeps ash receiver, matches and glass

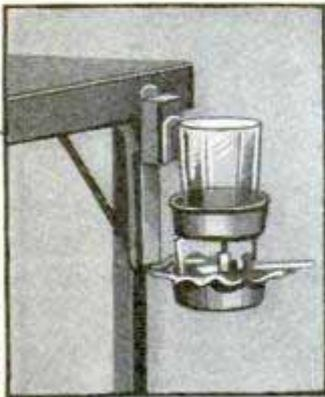

within easy reach of the card player, but at the same time out of the way so none is in danger of being spilled.

WEATHER FANS AID UNCLE SAM IN DAILY OBSERVATIONS

Approximately 5,000 voluntary weather observers throughout the country are assisting the federal bureau in its work of reporting and recording the daily weather, according to Clarence J. Root, of the United States weather bureau, at Springfield, Ill. Some of them have served for forty years, others for ten, twenty and thirty years, keeping their own records month after month and so supplementing the work of the main bureau. Their reports have been widely consulted and used by engineers, manufacturers, farmers and others, and have been employed frequently in helping to settle law suits.

LOCKING TIRE VALVE KEEPS PRESSURE CONSTANT

Keeping pressure in automobile tires constant, a tire-valve lock now is available. The lock fits all sizes of tires and is installed by re-

moving the ordinary valve inside and inserting the locking valve. Then the tires are inflated to the proper pressure and the valve is locked by tightening a screw at its top. For protection, the valves, in sets of fives, come packed in individual, transparent, air and moisture-proof containers.

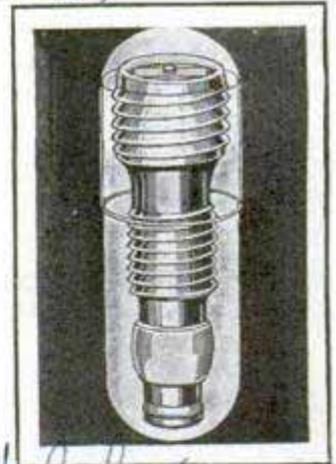

ZINC-BASE ALLOYS IMPROVED

Zinc-base alloys used for die castings, formerly suitable only for small parts which were under no strain, now have been improved until they may be used for parts where a tensile strength of from 40,000 to 50,000 pounds per square inch is essential. Such alloys have been used as washing-machine agitators, gears for hoists, carburetors, motor housings and door knockers. The tensile strength of some is greater than brass and bronze.

Richmond Metal Products Co. Richmond, Ohio

4031 New Way

The Co. - Dan Co. La Salle, Ill.

New Jersey Zinc Co. 4086

Root & Fletcher, N.Y.

Valvolox

Iron Age, Dec. 19, 1929.

Schenectady, N.Y.
ELECTRIC EYE WORKS SPEAKER
3986 WELCOMING VISITORS

Photo-electric tubes, or "electric eyes," heretofore used for various processes, including counting persons passing any given point, now have been set to work as official greeters, and may also be used as watchmen or policemen. Visitors to the Museum of Peaceful Arts in New York are greeted by the words, "Will you please register?" as they step from the elevator, although no one is in sight. The words come from a loud speaker and are contained on a record which starts when anyone passes through a beam of light watched by the eye. At night the record may be changed to a warning to "Throw up your hands," or some other threat to prowlers. The apparatus consists of a photo-electric cell, a light source directed on it and the speaker. When the light to the cell is interrupted by a person passing through it, the cell starts a motor which in turn operates the record.

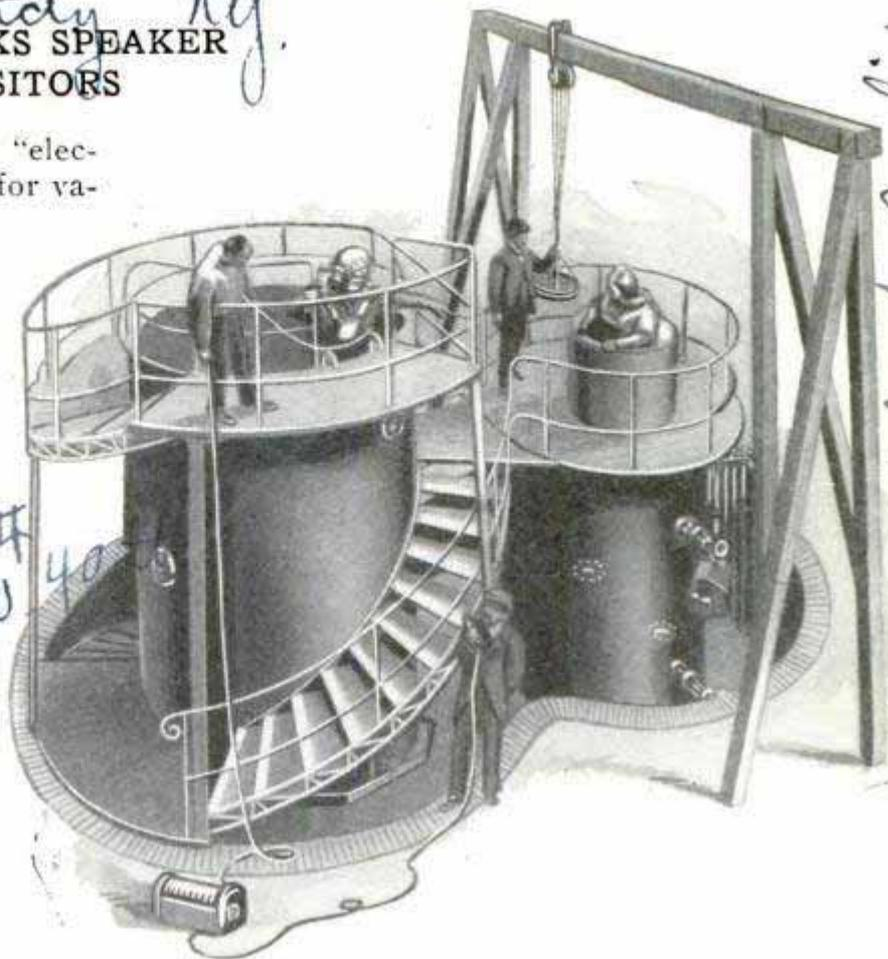

Tanks Capable of Standing Air Pressure Equivalent to Water Pressure at Various Ocean Depths Are Used to Test Divers' Suits

TEST DIVERS' SUITS IN TANKS UNDER AIR PRESSURE

Tanks capable of withstanding air pressures which are the equivalent of water pressures at various depths under the sea are used by a German manufacturer of diving suits to test the diving apparatus for safety before it is placed in actual use. Experienced divers don the suits and descend into the tanks. They are in telephone communication with those on the outside as the pressure is applied, thus being able to record their reactions during progress of the test and to give warning in case a defect is found in the equipment.

AIRPLANE THERMOMETER GIVES WARNING TO PILOT 3998

Automatically recording the minimum temperature of the air through which an airplane is passing, a thermometer particularly helpful in high-altitude flights has recently been developed. The instrument is mounted on one of the struts, and warns of ice forming on the wings.

CLOCK IN REAR-VIEW MIRROR CAN BE SEEN BY ALL 3935

Rear-view mirror and an eight-day clock have been combined into one auto accessory by an English manufacturer. The clock in the wide mirror can be readily seen by all the passengers in the car, or observed by the driver without taking his eyes from the road.

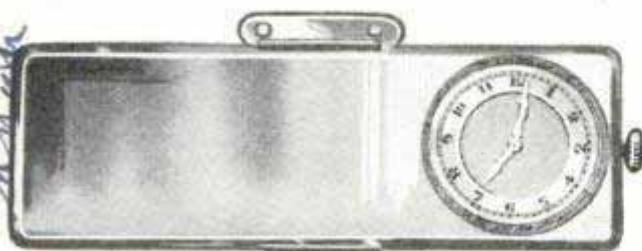

Clock Built into a Rear-View Mirror Where It May Be Readily Seen by All in the Car

Technic. Photographs by Archib. F. Fiedler
Magazine 6-5-66

We had agent

Stadium Ltd
London E.C.9

Dr. H. B. Henricson
Bureau of Standards

3391

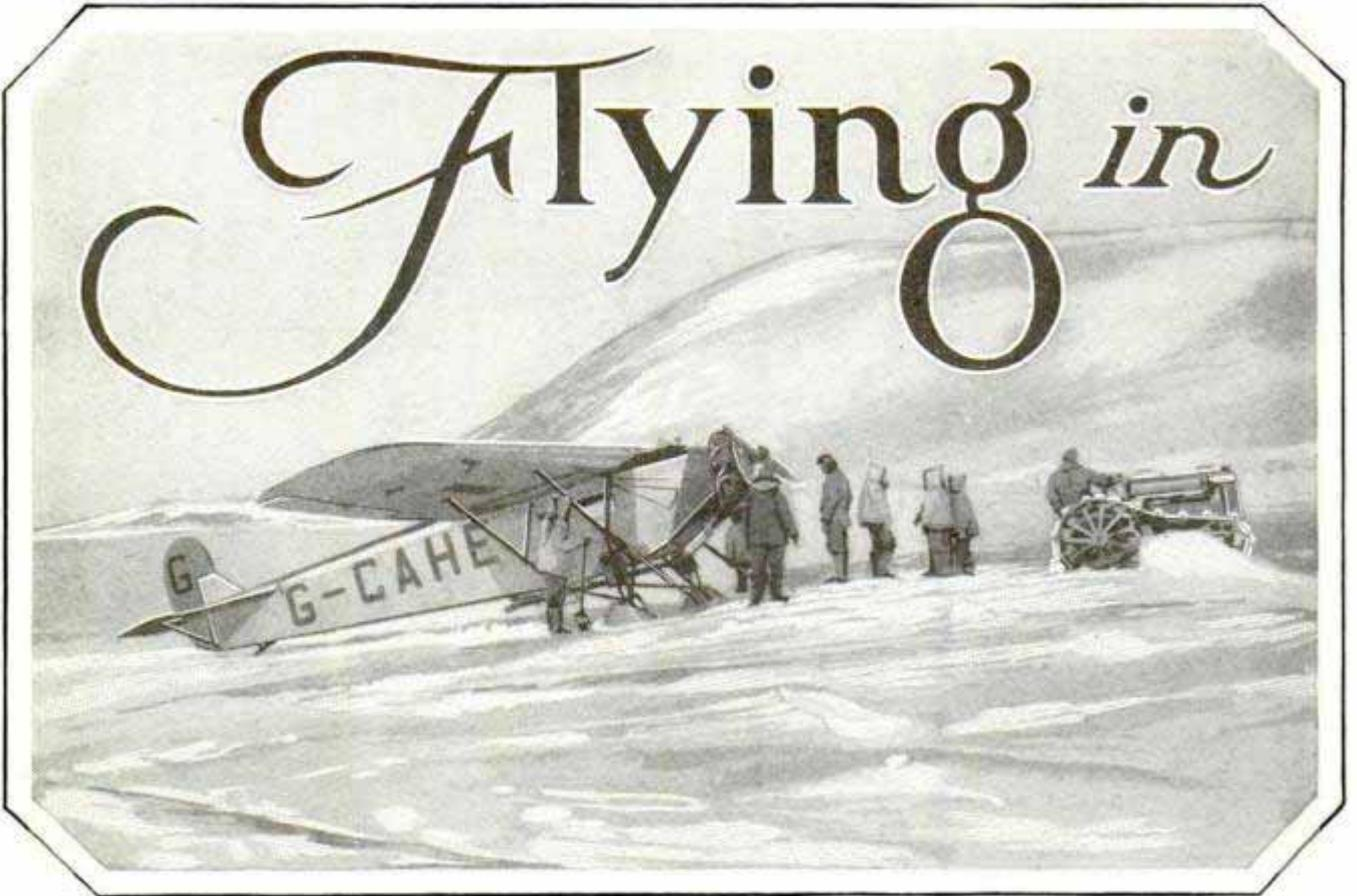

The Tractor Proved an Important Aid to the Planes When Ground Conditions Made It Dangerous to Taxi; the Tractor Was Used Also in Hauling Supplies and Moving Camp

PART IV

A PASSENGER train puffed to a stop at Port Churchill, far up on the western side of Hudson bay in September last year, a distinguished gathering descended, and with due ceremony solemnly drove a golden spike to symbolize the completion of the railroad, and the work that Henry Hudson started nearly 320 years ago was completed.

His bay had been opened to the commerce of the world.

Behind that simple ceremony under the eyes of a few guests, railroad and port workers, a scattering of Cree Indians and Eskimos, and the ever-present North West Mounted Police and factors of the "Company of Gentlemen Adventurers Trading Into Hudson's Bay"—otherwise the Hudson's Bay company—lay one of the greatest dramas of the north, a drama that, save for one incident, passed almost unnoticed.

That was the aerial survey of the Hudson Strait expedition, which for one solid year rode herd from the air on the tossing icebergs that sail in endless procession down the 500 miles of waterway from the

bay to the open Atlantic. From Port Burwell, in the lee of Cape Chidley, the northeasternmost point of Labrador, from Wakeham bay, midway of the straits, and from Nottingham island, which lies athwart the western entrance to that 500-mile ice-parade course, three groups of Royal Canadian Air Force pilots spent the winter of 1927 and the spring and summer of 1928 on ice patrol.

To get them in to those isolated stations, with their planes and hangars, stores and buildings, long and short-wave wireless sets and tall steel masts, and a base crew, complete from doctor to cooks for each of the three camps, and to take them out again the following year, with all their equipment worth salvaging, was a thrilling adventure that dragged out sixteen months long.

From the time the last steamers fled before the ice on Armistice day, 1927, until the supply ship returned on July 3 of the next year, the three little base camps in the Arctic were linked to civilization only by radio.

In that period, the flyers flew thousands

Eskimo Land

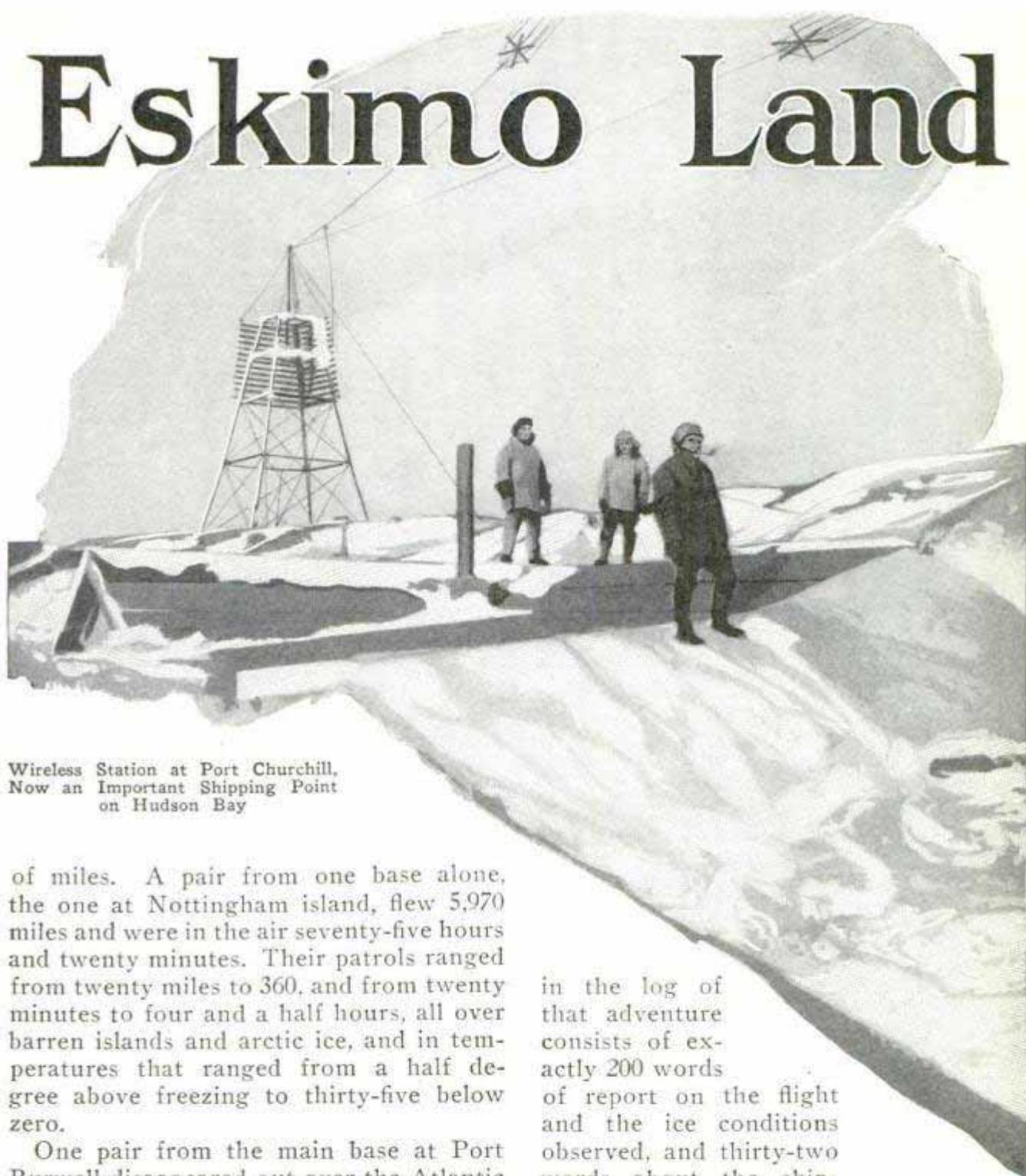

Wireless Station at Port Churchill,
Now an Important Shipping Point
on Hudson Bay

of miles. A pair from one base alone, the one at Nottingham island, flew 5,970 miles and were in the air seventy-five hours and twenty minutes. Their patrols ranged from twenty miles to 360, and from twenty minutes to four and a half hours, all over barren islands and arctic ice, and in temperatures that ranged from a half degree above freezing to thirty-five below zero.

One pair from the main base at Port Burwell disappeared out over the Atlantic one day, accompanied by an Eskimo hunter, and the three were not seen again for two weeks. The official log of the expedition dismisses that two-week adventure in one sentence. It doesn't mention the labor paddling a crazy rubber boat from ice floe to ice floe. It doesn't mention how they lived on the meat of a few seals killed by the Eskimo, or how he guided them for a week across the ocean, alternately walking and paddling, and then guided them another week across Labrador to the camp. The whole entry

in the log of that adventure consists of exactly 200 words of report on the flight and the ice conditions observed, and thirty-two words about the shipwrecked flyers.

Under date of Feb. 17, 1928, the log says:

"Air Patrol No. A-11-A.

"Route of Patrol—north to Button islands, north to Resolution island, north-northwest up west coast of Resolution to Lower Savage island, north to east bluff on Baffin land, north over Baffin land to Grinnel glacier, south to Lower Savage island, south-southeast down west coast of Resolution island, south toward Port Burwell, east over mainland of Labrador,



Fashions and Figures from the Bay District; Indian Women, Here as Elsewhere, Have a Weakness for Garments of Bright Color

flagships of the fleet that took the expedition to the straits and brought it out again—are equally terse. They finished their work by erecting radio direction-finding stations at either end and in the middle of the straits, so that the procession of wheat boats expected next year, when the Hudson Bay railroad begins delivering grain to Port Churchill, can navigate in safety.

The expedition was organized in the fall of 1926, when the Canadian government decided to complete the railroad, which, started in 1910, had been halted during the war and gradually al-

lowed to fall into ruin. Machine landed on ice in Atlantic ocean.

“Visibility five to fifteen miles.

“Considerable amount of open water due east in Atlantic as far as visibility, practically all open water in Gray straits. Number of large leads throughout whole width of straits, considerably more than on previous patrols. Leads much more numerous in the vicinity of Resolution island and around the island practically open water. Ice due west and southwest in the strait much denser as far as visibility permitted. East, ice conditions similar to vicinity of Resolution island, several icebergs being observed just off the west coast and the ice appeared to be extremely thin. Between lower Savage island and Baffin land practically all open water. Ice in Gabriel straits very thin. Around the coast of Baffin land all open water.

“Time in air—four hours, thirty minutes.”

After walking over ice and paddling between ice cakes for one week in the Atlantic ocean, and walking over land for another week, the personnel of the aircraft reached their base safely.

The logs of the “Stanley” and “Montcalm”—two Canadian government steamers, the latter an icebreaker, which were

lowed to fall into ruin. Simultaneously it was decided to reopen the question of destination, and after the flyers went north in 1927, they learned the government had decided to abandon Fort Nelson as terminus, though \$6,000,000 had been spent there on harbor works, and go on to Port Churchill, nearly a hundred miles farther north, because it offered a better harbor.

With no one resident at the straits save mounted policemen, Eskimos, factors of the Hudson’s Bay company and Revillon Freres, a French fur company, and an occasional missionary, everything required by the flyers and base crews during their year in the Arctic had to be taken in. Lumber for houses, hangars, storerooms, power houses, radio plants and blubber houses, in which to store fresh seal meat, was cut, fitted and marked, all ready to be set up by crews of carpenters taken along for the purpose.

Some of the equipment required for each of the three base camps included two Fokker airplanes, complete with pontoons, skis and wheels for alternate forms of landing, and all necessary accessories and spares, the latter including one spare engine, one thirty-foot motor launch, one tractor, seven buildings, bricks, bags of sand, barrels of cement, long and short-



Survey Plane Landed in Open Water and Resting on Pontoons; the Craft Were Also Provided with Skis and Wheels for Alighting on Ice and Ground



Unloading Supplies; It Took an Ocean Freighter and Ice Breaker to Get the Materials to the Base, and Then Came the Task of Erecting the Buildings Including a Hangar Such as Shown at Left; the Expedition Required Two Fokker Airplanes, a Thirty-Foot Motor Launch, a Tractor, 160 Tons of Coal and Nearly 500 Drums of Gasoline, Oil and Kerosene, Besides Food for Sixteen Months

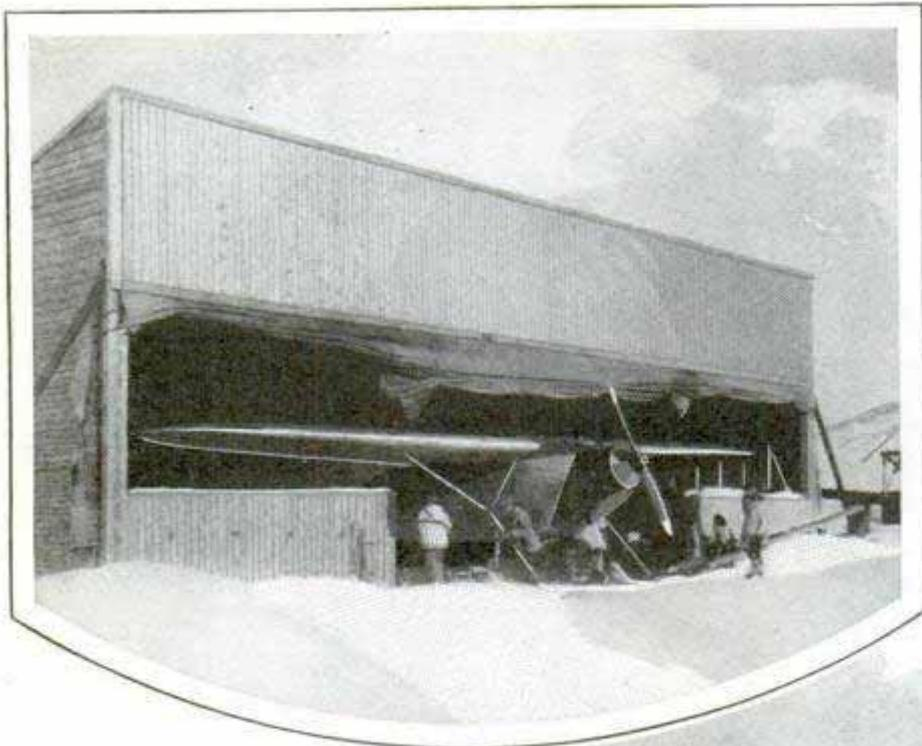

wave radio transmitters and receivers, two 150-foot radio masts, two gasoline engines to generate power, nearly 500 drums and cases of gasoline, oil and kerosene, 160 tons of hard coal, stoves, beds, bedding, clothes, food for sixteen months, two dories, one skiff, guns, rifles and ammunition, dishes and utensils, and meteorological instruments.

It took one big ocean freighter and one ice-breaker each year to haul the supplies and men.

The tractors not only hauled the planes up the slipways out of the water, and over the ice in winter, but they also solved the problem of getting all the supplies landed, moved to camp sites and erected in the few short weeks available. Attached to stone

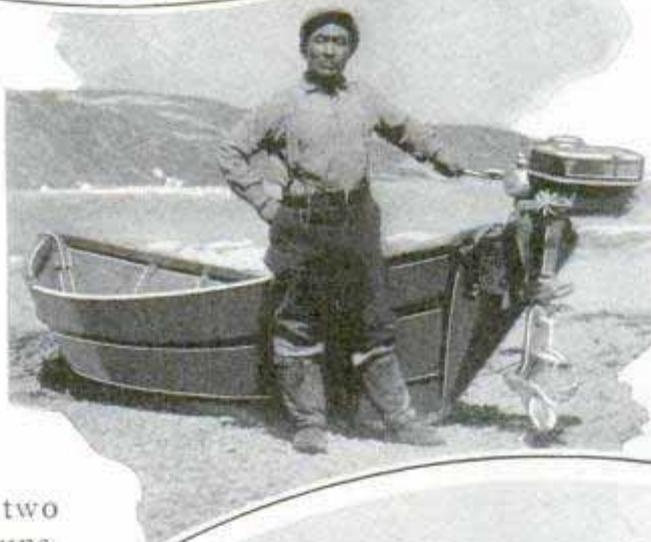

boats—rough and heavy wooden sleds—they hauled the materials for buildings and radio masts up steep hillsides and over rocky beaches, usually working in weather so bad that frequently, for days at a time, small boats could not bring more materials ashore.

When the weather was good, the crews started after an early breakfast and frequently worked until ten or eleven at night, when an hour or two of dusk began to fall before the next day's sun came up. When the weather was bad, as it was most of the time, work was often impossible, and always dangerous. On one occasion, three men started to walk a few hundred yards back to the shore from a camp site at

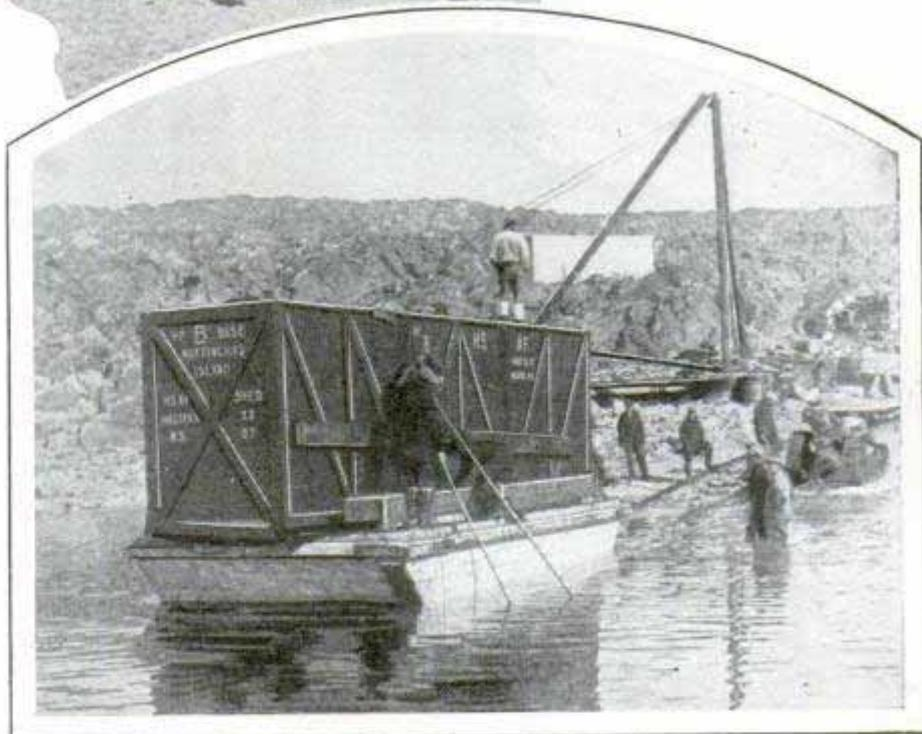

Plane in Its Special Hangar; Outboard-Motor Boat, and Pulling Supplies Ashore with Tractor and Barge

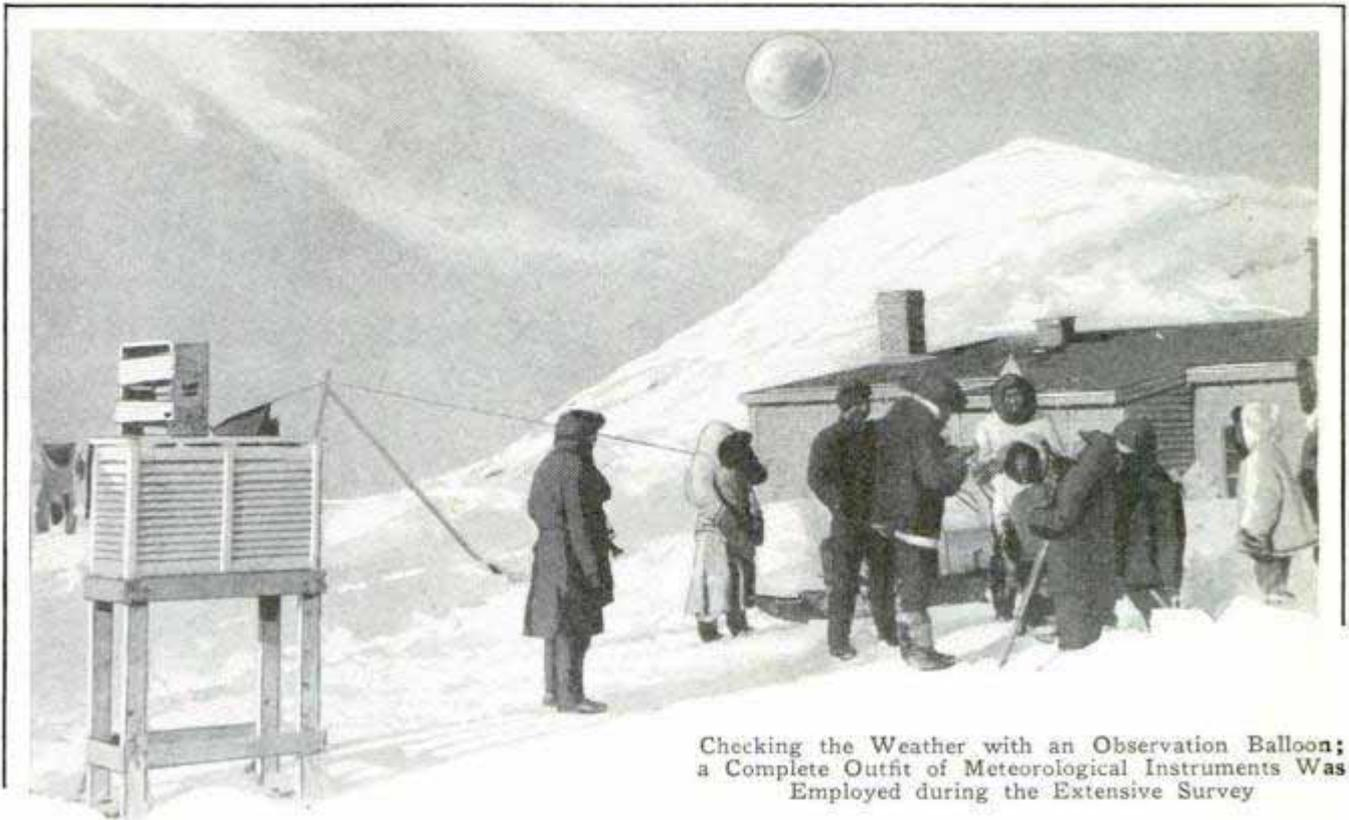

Checking the Weather with an Observation Balloon; a Complete Outfit of Meteorological Instruments Was Employed during the Extensive Survey

Cape Hope's Advance, took a wrong turning and were not found until nearly noon the next day, though shots were fired and whistles blown throughout the night.

As the result of the aerial survey, Canada learned that the straits may be kept open to navigation for two months or more after the wheat harvest begins to move into Port Churchill. Hudson bay itself does not freeze in winter, save for shore ice extending out several miles, but Churchill harbor is closed about late October or early November, and the west end of the straits begins to close at the same time.

Stanch icebreakers are being built, however, to extend the open season and protect less able commercial ships, whose thin plates are always endangered by cracking ice floes. Ice and tides and barren rocky hills are so bad in the region of Cape Chidley that it will be necessary to re-fuel the icebreakers from tankers in one of the more protected harbors, as a land station is impossible.

From Hudson's little "Discovery" to wheat ships, and from the canoemen of the early voyagers to the "Iron Horse" at Churchill is a long step, but typical of Canada's progress since the war.

(The End)

AIR-MAIL SHRINKS SIZE OF U. S. BY MORE THAN ONE-HALF ^{39 75}

Measured in hours between points instead of miles, the air-mail service has reduced the size of the United States by almost two-thirds. By air mail the country now is only thirty-two hours wide, that time being required for carrying a letter from the Atlantic to the Pacific coast. Using as a standard a map representing the hours



Courtesy N. A. T.

Small Map Superimposed on Large One Shows How Air Mail Has Shrunk Size of U. S. in Hours

necessary to cross the country by fastest previous means and superimposing on it a map representing the air-mail hours, it is seen that a letter now may travel from coast to coast in the time previously required to cross the middle-western states.

Art. Shackwell.

GLIDING SCHOOL FOR WOMEN OPENED IN GERMANY

From Photo Union - Paul Lamm, Hulleche Strasse 22, Berlin S.W. 11 Germany

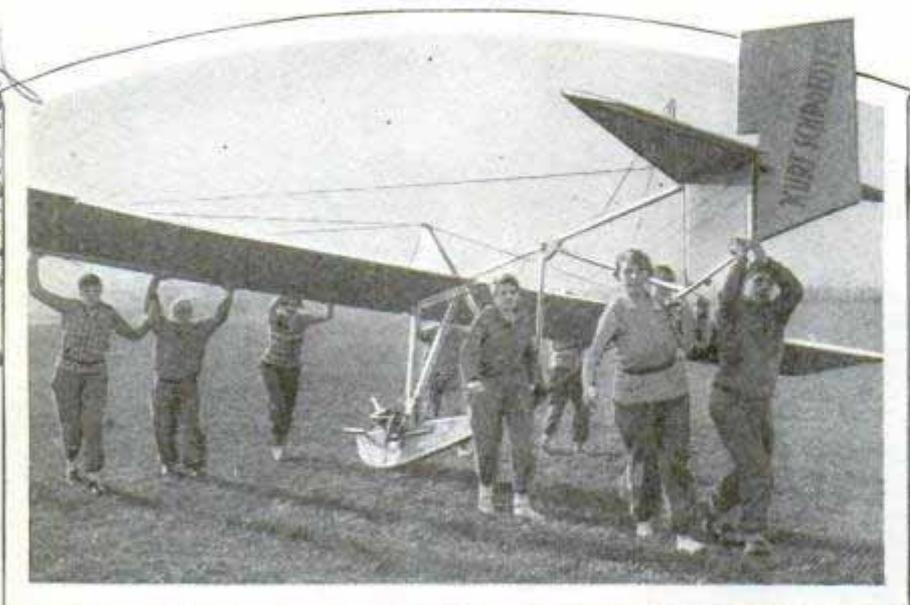

Upper Left, German Girls at a Glider School for Women, Pushing Ship up Slope for Take-Off; Lower Left, Assembling Glider; Right, Ready to Go



Under the auspices of a national organization for the promotion of motorless flying, a gliding school for women only

has been opened in Germany. Gliders for trial flights are furnished and the instruction is free. Because so many German women and girls have interested themselves in automobile driving and various forms of aviation, the glider school is expected to be popular as evidenced by early enrollment. Various tests are given the students until they are judged able to fly a glider alone.

FERRET FARM BREEDS ANIMALS TO EXTERMINATE RATS

4015

Ferrets, cousins to the weasel and deadly enemies of rats and other rodents, are bred on an Ohio farm which boasts about 500 of these lithe little animals. Apartment houses in New York, wharves in San Francisco, grain elevators in Minneapolis, warehouses in New Orleans and boats in Boston harbor all have benefited by the

activity of these rat exterminators. The animals are between eight and twelve inches long, with cream-colored, brown or black bodies, and sell for three dollars or more each. The ferrets are kept in pens and fed horse meat and a mush of ground wheat and milk. Because they also kill rabbits with even greater success than rats, some states have forbidden their importation entirely, and others prohibit the use of ferrets in hunting rabbits.

Clair C. Ross, Mendota Ferret Farm

Bigalle
Paris, France!

3861

*Contrib. by Alfred Bradley with
Friedrich Berns
Copyright 1920, Berlin*

**WINTER STOPPAGE OF BUILDING
AVOIDED BY SHELTER**

4034

Construction work in winter may be carried on the same as in summer by utilizing the invention of a Berlin engineer who has made a weatherproof, portable shelter to cover the house under construction and govern the temperature. The walls of the shelter are made of a light wood frame which also constitutes the scaffolding. Into the framework water-tight plates of fireproof material are fitted, the joints closing of their own accord. Over the framework a simple tent roof is used, the shelter providing the same insulating protection from cold as a two-brick wall, and giving a temperature in which all building materials can be handled safely. As the shelter is portable and used repeatedly, the cost is small considering the advantage of being able to work in the coldest weather.

**GLARELESS AUTO FLOODLIGHT
HELPS ON TURNS**

3970

Providing a flood of illumination that lights the highway far ahead and both sides of the road without glare to annoy approaching drivers, an auxiliary lighting unit for the car now is on the market. It is attached to the crossbar between the headlamps, the reflector and lens intensifying and then spreading the light rays thousands of times, and casting a fanlike beam of light wider and farther than the ordinary driving lamps.

*\$10.00
West of
Rockies*

\$9.50



Glareless Auto Headlight Which Gives a Flood of Light to the Roadside on Sharp Turns

Alco Sales Corp.

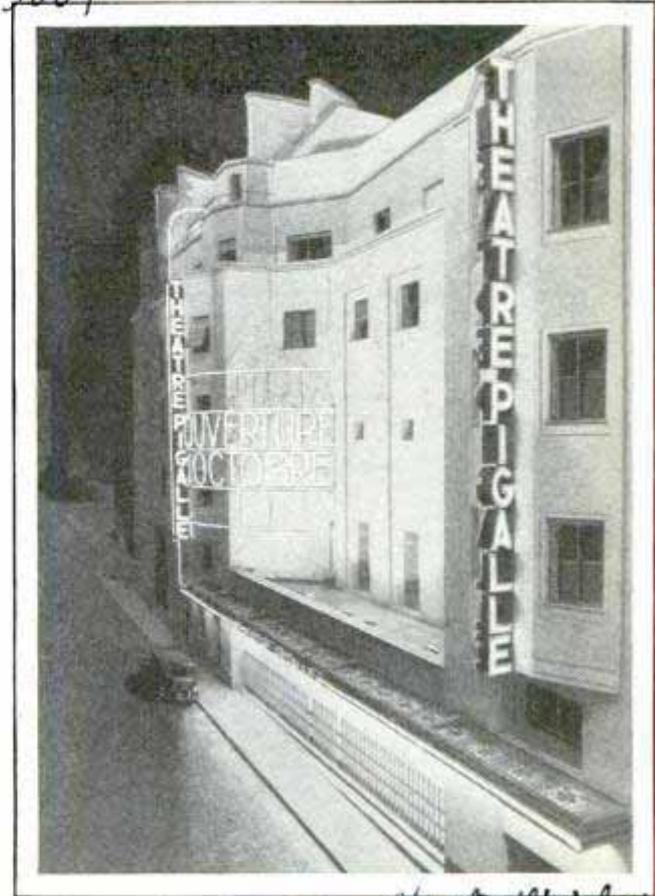

Paris Theater Which Has Four Movable Stages, Manipulated on Vertical and Horizontal Tracks

**FOUR-STAGE THEATER CUTS
TIME BETWEEN ACTS**

Waiting time between acts is reduced to a minimum in a theater recently opened in Paris. It has four stages, each equipped with improved mechanical and electrical apparatus with which two men can control the entire show, one to run the switchboard and the other to manipulate the stages which move on vertical and horizontal steel tracks. Not long ago, a play with twenty-five acts was produced in the theater, employing all four moving stages.

Wide World

CHINESE CAN BAMBOO SHOOTS

4005

Bamboo shoots, regarded by Chinese epicures as a vegetable delicacy, now are being canned for export. The fibrous part of the shoot is first removed, after which they are boiled until they become tender, the taste being somewhat similar to that of some varieties of beans.

Tin in large proportions gives greater tensile strength to phosphor bronze, according to the British engineering standards association.

*Chinese Economic
Bulletin, 4th floor,
Broad Street*

FLYING FASHIONS COMBINE UTILITY WITH BEAUTY

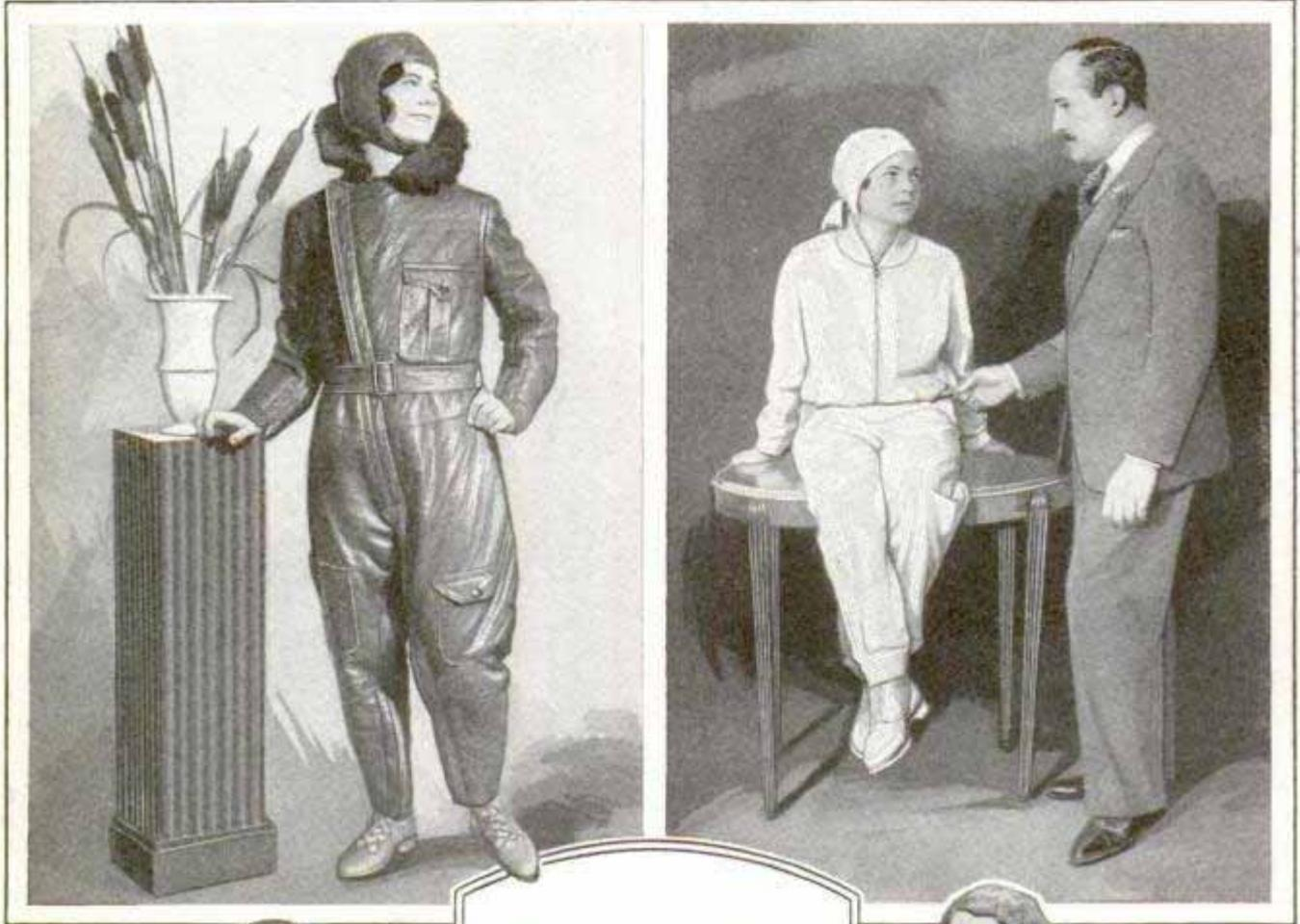

The Suit at the Upper Left Is of Blue Leather, Lined with Camel's Hair, and Has a Wide Turn-Up Fur Collar; to the Right Is a White-Suede Pilot Outfit Designed for Comfort and Style; for the Woman Who Does Not Care for a Complete Pilot's Costume, the Coat Lined to Match the Dress Is Offered, and a Comfortable "Cover-All" Suit Is Seen at Lower Right



Wide World

HIGHEST POSSIBLE TIDE
IS FIFTY-THREE FEET

There is great difference in the tides in the Atlantic ocean, the rise being greatest in the Bay of Fundy. The influence of the moon on the tides takes place in three distinct periods: the well-known month of the moon's phases from new moon to new moon; the period of the moon's distance from perigee, the point in the moon's orbit when it is nearest the earth, to apogee, the point when it is farthest away, and the month of the moon's declination north and south of the equator. The three periods differ in length and overrun each other. Under a combination of these conditions, each overlapping the other, it is possible for the tide to rise fifty-three feet, which is the extreme, apart from storm disturbances.

4035

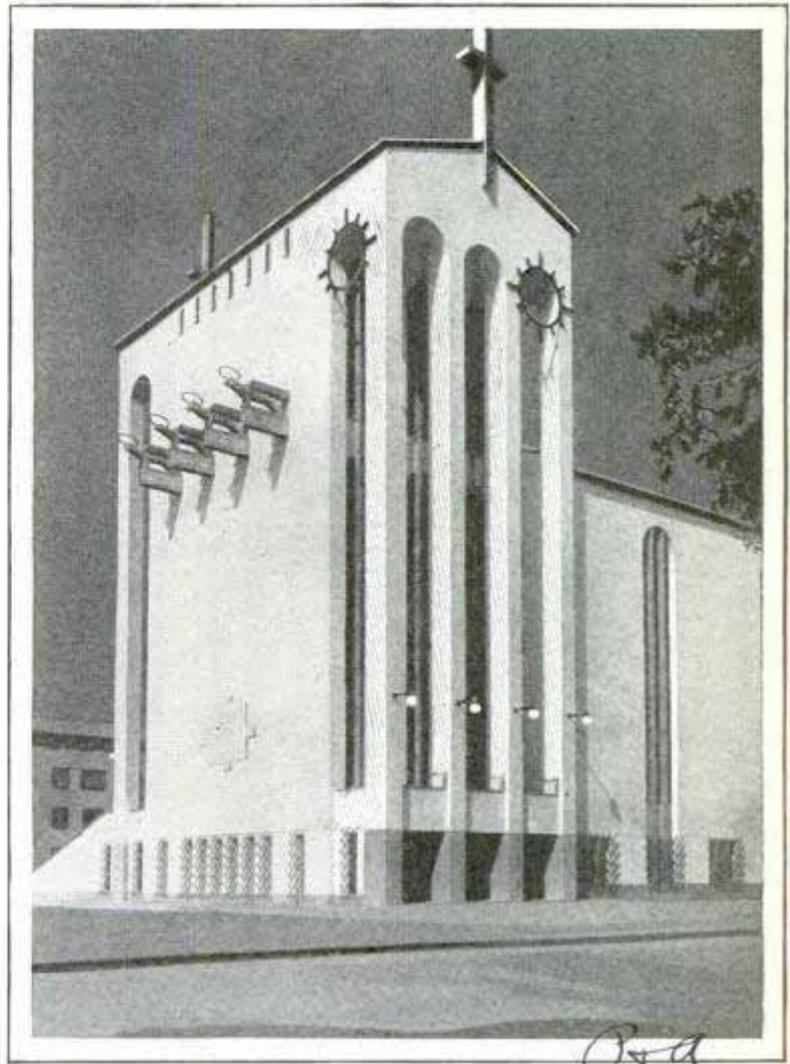

Lines Like Those of an American Skyscraper Show the Modern Trend in Architecture in This German Church

HARD-CENTER RUBBER
HEEL IS EASY TO APPLY

Rubber heels that will hold regardless of where the nails are driven now are being produced. The heels do not differ in appearance from the usual type, but, instead of imbedded metal washers to prevent nails from pulling through, there is a plate of hard rubber mixed with either hair or oat hulls.

4000

The plate, which forms about one-third of the heel volume, is cured as an integral part of it, and can be made as tough as sole leather. It is cheaper to make than the ordinary heel and easier to apply, particularly

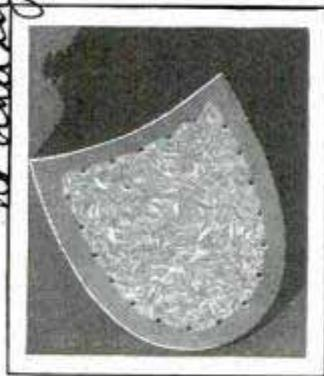

in factories where machines are used for the purpose.

□An English railway has fitted some of its trains with glass which ultraviolet rays penetrate.

CHURCH-ARCHITECTURE CHANGE
SHOWS MODERN TREND

Churches, being erected in Germany today, are showing the modern trend in architecture, contrasting strangely with the long-famous Roman and Gothic cathedrals of the country and the baroque churches built in medieval times. One of the most modern is a Catholic edifice recently built at Frankfort whose vertical lines and columns remind of the American skyscraper type of architecture.

HOT AIR DRIES ATHLETIC FIELD

Rainy weather does not mean a wet athletic field at Purdue University unless it rains while the games are in progress. At the first sign of bad weather, big canvas sheets are placed over the field and staked to the sidelines, after which three commercial corn driers go into action and force hot air under the whipping canvas.

4018

Send to H. Willis, Akron, Ohio
re changes

Seiberling Rubber Co.

Carl W. S. Neptune
106 North 11th

3855
428

Boston News
WHY NAVAL EXPERTS SAY THERE WILL NEVER

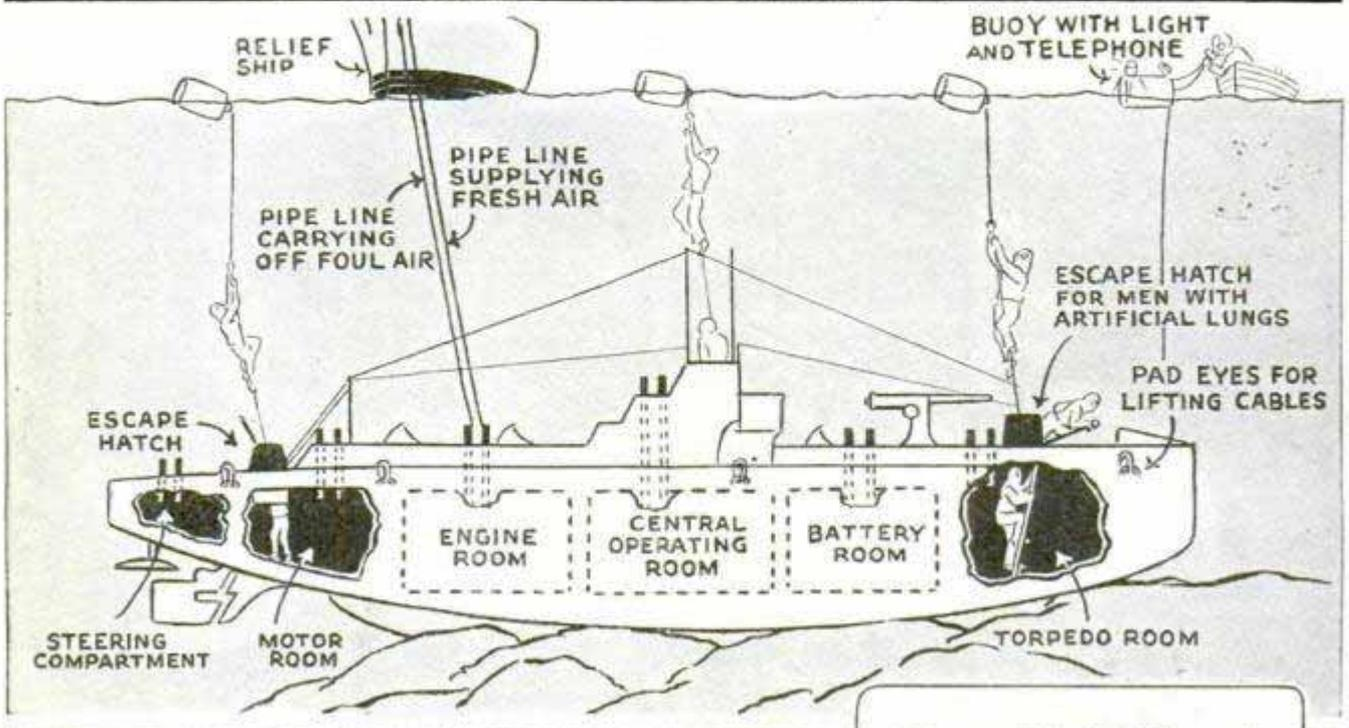
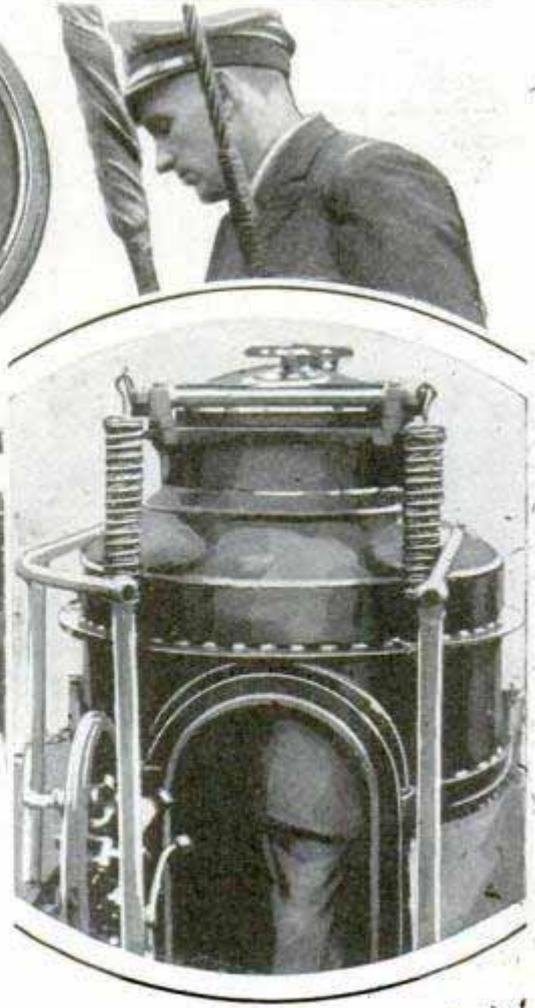
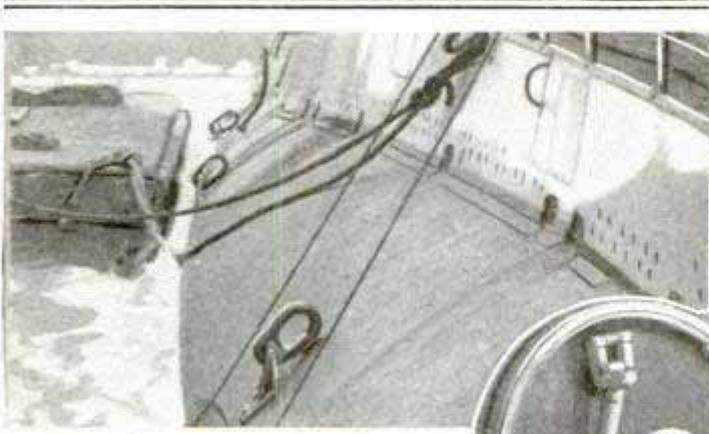

Diagram Showing Where the Various Safety Devices on the "S-22" Are Placed; Note the Location of the Several Special Escape Hatches



Lieut. H. B. Bell, Safety Officer of the "S-22," at Left, by Open Door of the Main Escape Hatch; This Is Used as a Ventilator for the Torpedo Room When the Ship Is Running on Surface; at Right, the Main Escape Lock with Man at Door, Which Is Used in Leaving the Submarine; This Lock Is Considered the Most Important of All the New Safety Devices for Underwater Craft

BE ANOTHER AMERICAN SUBMARINE TRAGEDY



Rings on Each Side of the Submarine for Connecting Pontoons; Each of the Six Is Tested to Stand a Lift of 160 Tons

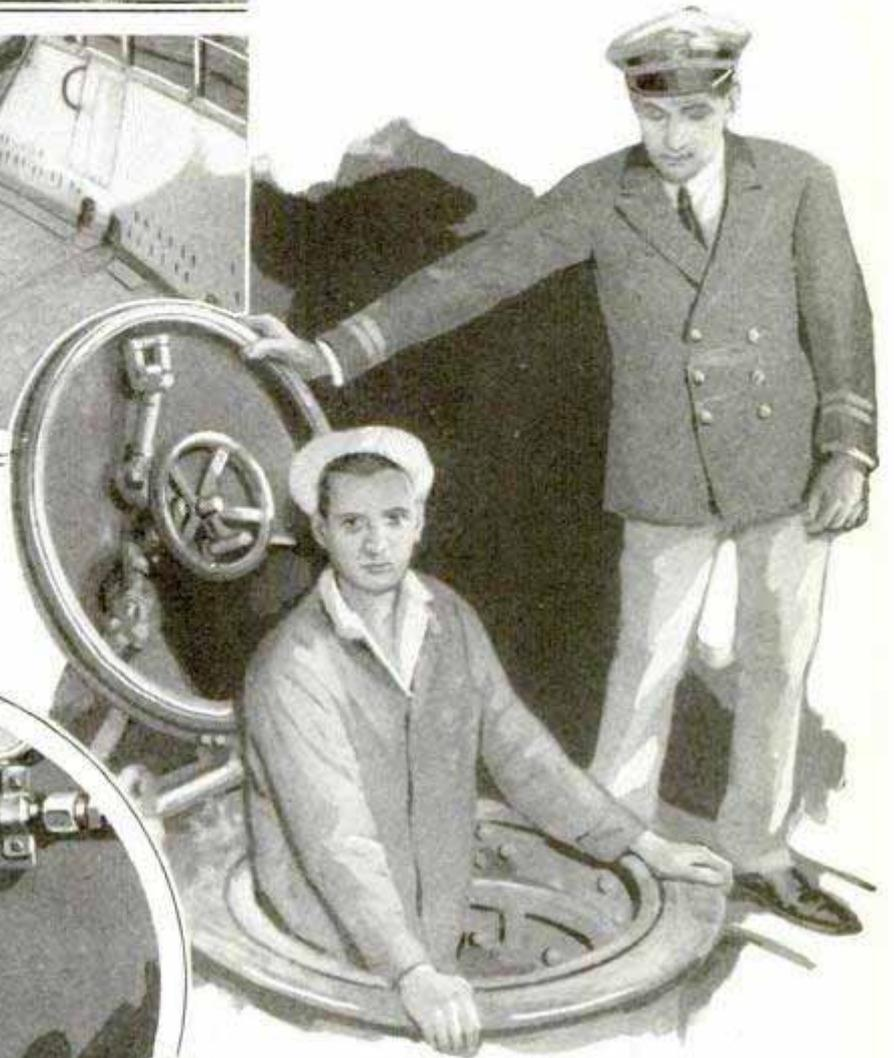

Escape Hatch over the Motor Room in the Stern of the "S-22," Showing Lieut. Harold J. Walker, the Commanding Officer, Standing, and a Sailor Emerging from the Hatch

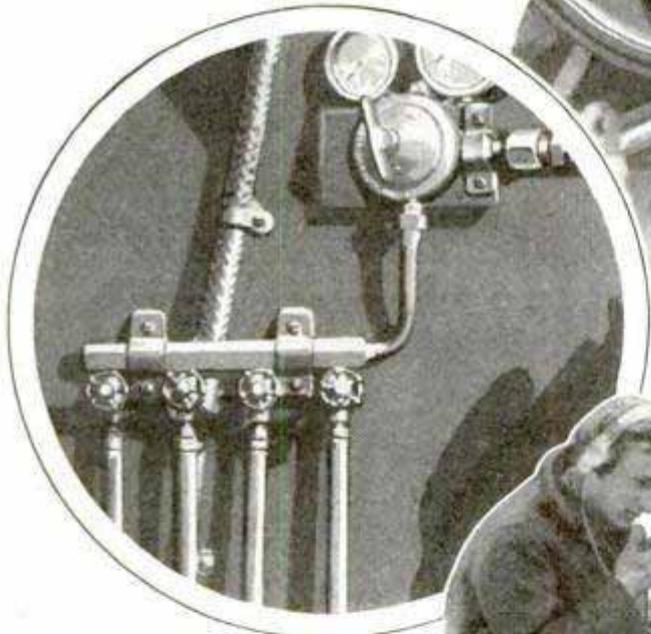

Oxygen Pipes in Main Escape Lock to Inflate Artificial Lungs Just before Men Leave the Lock and Start for the Surface

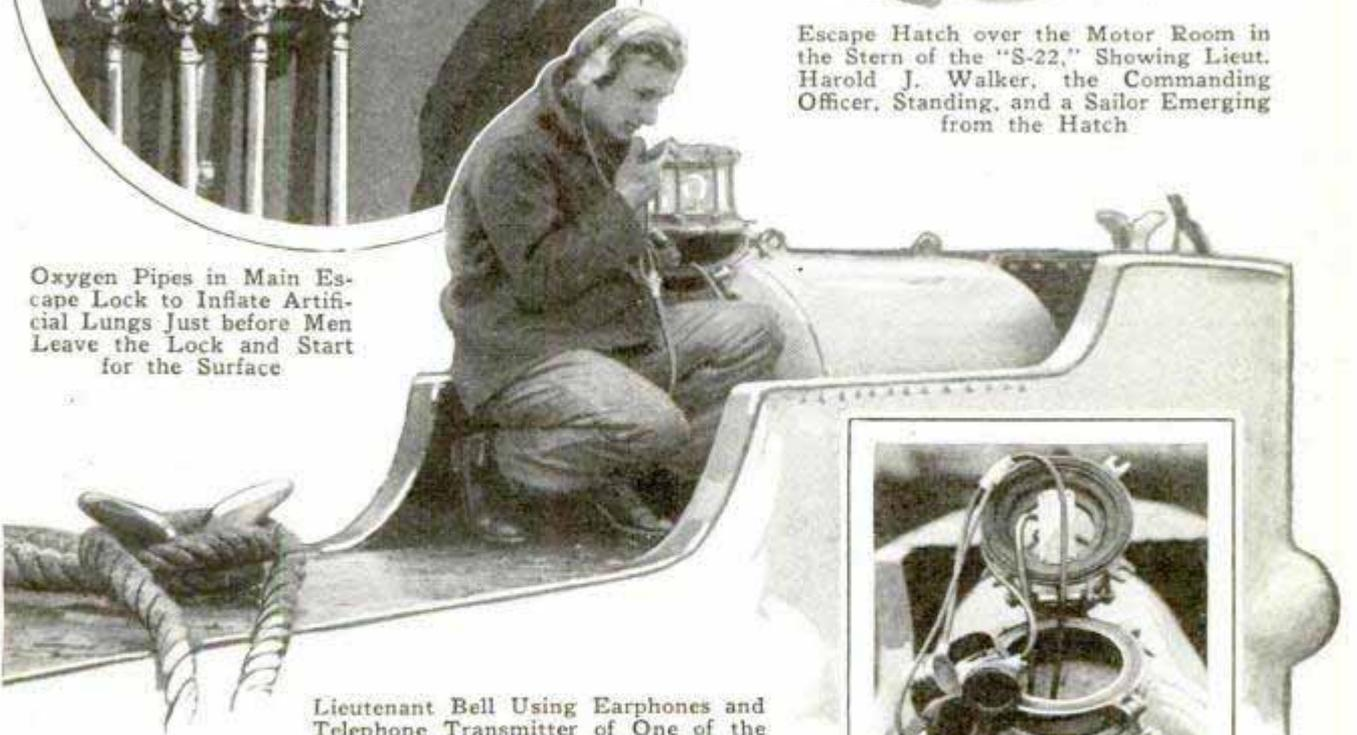

Lieutenant Bell Using Earphones and Telephone Transmitter of One of the Ships's Marker Buoys from Which a Boat on Surface Could Establish Communication with Helpless Submarine or Supply It with Lights; at Right, Close View of Buoy and Part of Its Equipment; the "S-22" Has Two of These Buoys Which Are Released Automatically in Case of Need

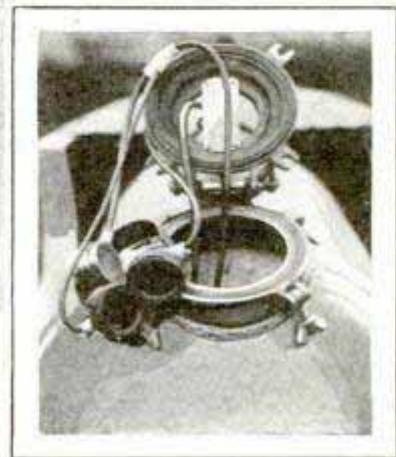

TOWER SUPPORTING FIVE TANKS USED AS OFFICE BUILDING

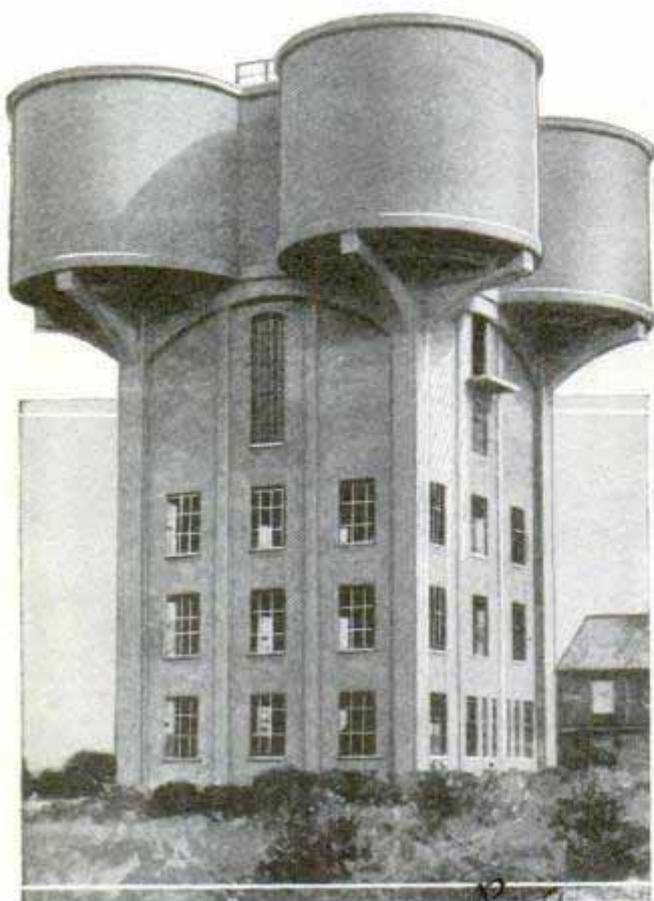

Three of Five Water Tanks Supported on One Tower, Which Also Contains Business Offices

Five circular water tanks are supported atop one eighty-foot concrete tower at Suffolk, England, where artificial silk is being produced. The lower floors of the tower are used for offices, and above them is a water-softening plant where the water is treated before being passed to the tanks for distribution to the plant.

SOIL IMPROVED BY HEATING

Soil is benefited and partly sterilized by applying heat to it, recent tests in England have indicated. Soils heated for half an hour at the temperature of boiling water were found to be free of pests and diseases and also to be more fertile and to produce healthier plants. Heavy soils required more heat than light ones, and while bacteria and fungi causing disease in plant roots were destroyed, the beneficial soil bacteria were not killed. The heat also caused complex organic and inorganic substances to be converted into simpler forms more useful for the plant and soil bacteria. Heating may be carried out

either by baking the soil or passing steam through it, the latter method being the better. Heating must be thorough, as a center of infection will rapidly spread to the sterile sections.

PROVE SUN CONTAINS CARBON BY MOTION PICTURES

Because movie producers wanted a film that would give night effects to pictures taken in the daytime, astronomers of Mt. Wilson observatory have been able to prove conclusively the presence in the sun of carbon. The movies, hunting for a way to make night scenes by day, found that photographs made by infra-red light gave a black sky, and a film bathed in a new dye, neocyanin, was found to acquire sensitivity to infra-red rays. The film was used for spectrum photographs of the sun, and showed spectrum lines corresponding to those for carbon from a terrestrial source. As the spectrum readings for the various elements never vary, the pictures proved the presence of carbon in the sun, the same as on the earth.

FROST SHIELD FOR CAR WINDOW GIVES CLEAR VISION

Affording clear vision in cold weather through frosted auto windshields or windows, a shield now is available for attachment to windshield, rear or side windows. The shield, in a metal frame lined with felt to create an air space between it and the window, is attached with vacuum cups.



Shields Attached to Windows with Vacuum Cups Prevent Frost from Obscuring Motorist's Vision

Handwritten notes: Babcock, Bulletin 455, Science 12-11-29

Handwritten notes: 372, at Chesnut, England, 3768

Handwritten notes: 3838, Comb. with glare shield \$1.25

Handwritten price: \$1.00 each

Handwritten text: Peerless Novelty Co.

Handwritten text: H. W. Beeley

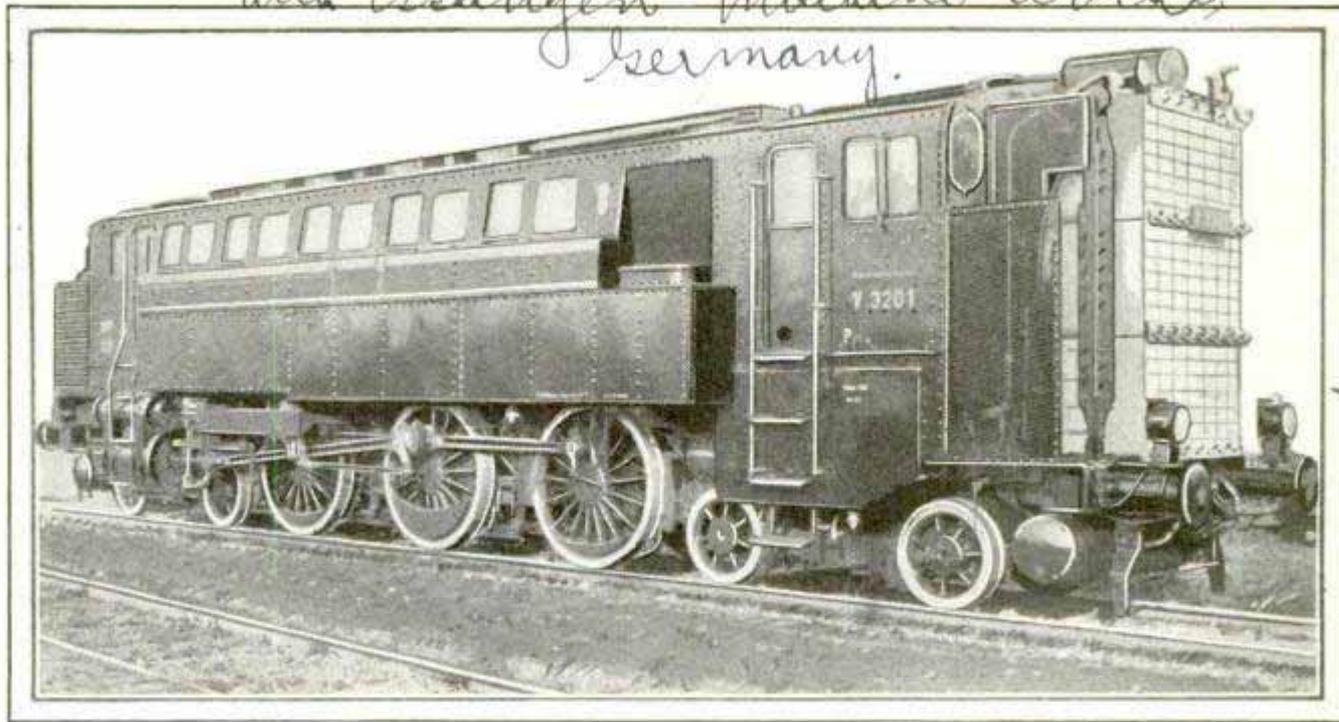

Diesel-Type Locomotive Driven by Compressed Air Which Is Heated by Exhaust Gases and Allowed to Expand in the Cylinders

COMPRESSED-AIR DIESEL ENGINE HAULS TRAIN AT LOW COST

Driven by compressed air, a large Diesel-type locomotive has undergone successful tests in Germany, pulling a train of 233 tons up a steep curved incline at a speed of more than twelve miles an hour. In previous types of Diesel locomotives, power was transmitted either electrically or by gearing, but in this case the engine drives an air compressor, the compressed air being heated in a compartment by exhaust gases from the engine and allowed to expand in the locomotive cylinders. The engine is operated more efficiently than either the steam or electric type, the combustion heat of coal being poorly utilized, while the electric type is costly. The compressed-air engine may be moved anywhere, being bound to no line or power station, and will complete a run of more than 600 miles without replenishing water or fuel, something impossible with the type utilizing steam.

PILOT'S FLARE TURNS ON ALL LIGHTS AT AIRPORT

By dropping a flare when he is from 600 to 1,000 feet above an airdrome on which he is descending, an airplane pilot automatically switches on all boundary, obstruction and floodlights. As the flare

drops, it comes within range of a light-sensitive electric cell, set on top of a concrete pillar, three feet high, and controlling the airdrome lights. The location of the pillar is shown to the descending pilot by a triangle of colored lights. Two hundred feet away from the light cell, the lit flare causes a minute electric current to pass, and this is amplified in a series of relays until a powerful current travels through the airdrome and switches on all the landing lights. The lights can be turned off by another switch.

RUBBER CARPET WITH HAIR NAP FOR FLOOR OF AUTO

Intended for use on the floors of automobiles as well as in the home, a rubber carpet with a wear-resisting hair surface now is being produced. The material consists of a layer of flexible sheet rubber over which is applied a thin layer of rubber and hair mixture. The layers are cured into one piece, and a scratch brush is run over the surface to remove the rubber and cause the hair to be exposed, producing a finish similar to that of a carpet.

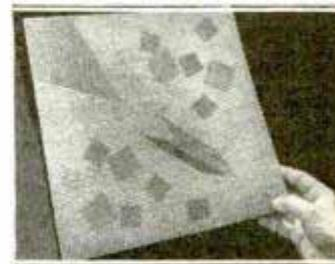

Dr. H. A. Agent Bremen

Dr. Helen H. Wilber

*Representative in London
R. North*

*J. M. Señor Sánchez
Quimicos de Ibañeta*

*Señor Sr. Ruber Co
Trump Co. - Laborer chi*

Office - U. S. Dept. of Foreign and Domestic Commerce

MOVIE OUTFIT FOR SALESMEN HAS BUILT-IN SCREEN

3992

\$10.00



Portable Movie Projector with Built-In Screen, Permitting Salesmen to Display Their Products

Salesmen now may carry their own movie outfits to demonstrate their products at the desks of their customers. A portable movie projector, weighing but nineteen pounds and contained in a compact case, has been designed particularly for the salesman, although it can also be adapted for the home. It is equipped with a self-contained screen, thus requiring no preliminary preparation aside from opening up the case and plugging into a light socket. If power is unobtainable, a model is available that is cranked by hand and illuminated from a six-volt battery. For an audience of more

Business Kodascope

3997 FUEL OIL FROM NUTS

Oil of the babassu tree, a little-known member of the cocopaln family, besides comparing favorably with other edible vegetable oils, has a high value as a source of fuel oil. Ships of the Brazilian navy were fired with oil of this kind during the World War when there was a shortage of fuel oil. The tree and its products serve the natives of northern Brazil as food, shelter, clothing, fuel and illuminant, and it is also used in the curing of rubber because of the properties of the smoke from its burning nuts.

3876 SUCTION ELIMINATOR FOR BOAT INCREASES ITS SPEED

To increase the speed of the modern power boat by getting rid of the suction astern, the fishermen of Provincetown, Mass., have installed suction eliminators at the stern of their craft. The device somewhat resembles a wooden scoop and consists of a wedge-shaped box open at

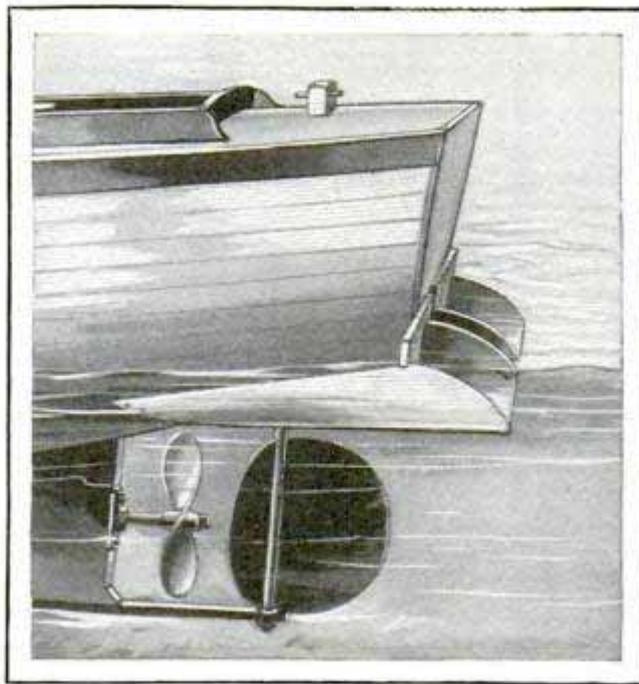

Wedge-Shaped Scoop above the Propeller, Which Eliminates Suction Astern a Power Boat

the top, made of seven-eighths-inch planking about eight inches long and of a width corresponding to the proportion of the waterline of the craft to which it is attached, usually from three to four feet. The suction at the stern causes the boat to settle deep in the water, but the eliminator allows the stern to ride high, because the waves, instead of curling in toward the craft, sweep out from it.

Wm. J. Small

4036

Graduate student from
Craffney, S.C. 433

**RADIO YARDSTICK TO ASSURE
BETTER RECEPTION**

4071

Functioning with an exactness of better than one part in 1,000,000, a radio yardstick has been designed by the bureau of standards for measuring the frequencies or wavelengths of the 600 broadcasting stations, 16,000 amateur stations, and other radio transmitters. It will detect broadcasting stations that are wobbling, or straying from their assigned wavelengths, and it means improved reception to the estimated 10,000,000 listeners. This new radio yardstick consists of four miniature transmitters. The heart of the instrument is the quartz crystal or mineral, which acts as a governor of the transmitters. Heretofore, these slabs of minerals have been cut in disk, or other, shapes, but here they take the form of rings. Tests have shown that ring-shaped crystals are least subject to variations of temperature and, therefore, are more constant and precise as governors of radio wavelengths or frequencies. The crystal governors are further protected from moisture and pressure variations by enclosing them in a bell jar, at a pressure slightly below atmospheric. Also they are covered by a shell of aluminum, with a wall one inch thick. The wall holds a heater and a thermostat element.



Untreated Metal Plate on Which Photographic Impressions Have Been Made in Broad Daylight

**PHOTOGRAPH ON METAL PLATE
IN BROAD DAYLIGHT**

Based on the discovery that metals record impressions from streams of electrons and that these impressions can be developed, an appliance has been invented for photographing pictures directly on untreated metal. The advantage of the discovery lies in the fact that the metal plates will record the image projected upon them in broad daylight.

**COURSE AND DISTANCE FINDER
FOR BOATS AND PLANES**

3921

Combining a transparent compass and a tape scaled to a chart, a course and distance finder for the use of ships and airplanes now is on the market. The compass dial is centered over the position of boat or plane, and the tape is drawn across the center of the compass to any desired position on the chart beneath the transparent compass. The course is read on the compass dial, and the distance is computed from the tape scale.



Pat # 1638974

10. Second Course
1st to 3rd

Cornell University, Ithaca, N.Y.

Chicago - 1601 S. Mick.

**THERMOSTAT IS EASY TO FIT
ON ANY AUTO**

4066

A thermostat, entirely automatic in operation, is now on the market. It is installed in a few minutes as an integral part of the engine, and regulates the temperature of the cooling system without further attention or adjustment when set in the required position. It is intended for use on cars which are not so equipped and is particularly useful during cold weather.



(Switzerland develops so much more hydroelectric power than it needs that in the last year it exported over one billion kilowatt-hours)

Apco Mossberg Corp.

3342

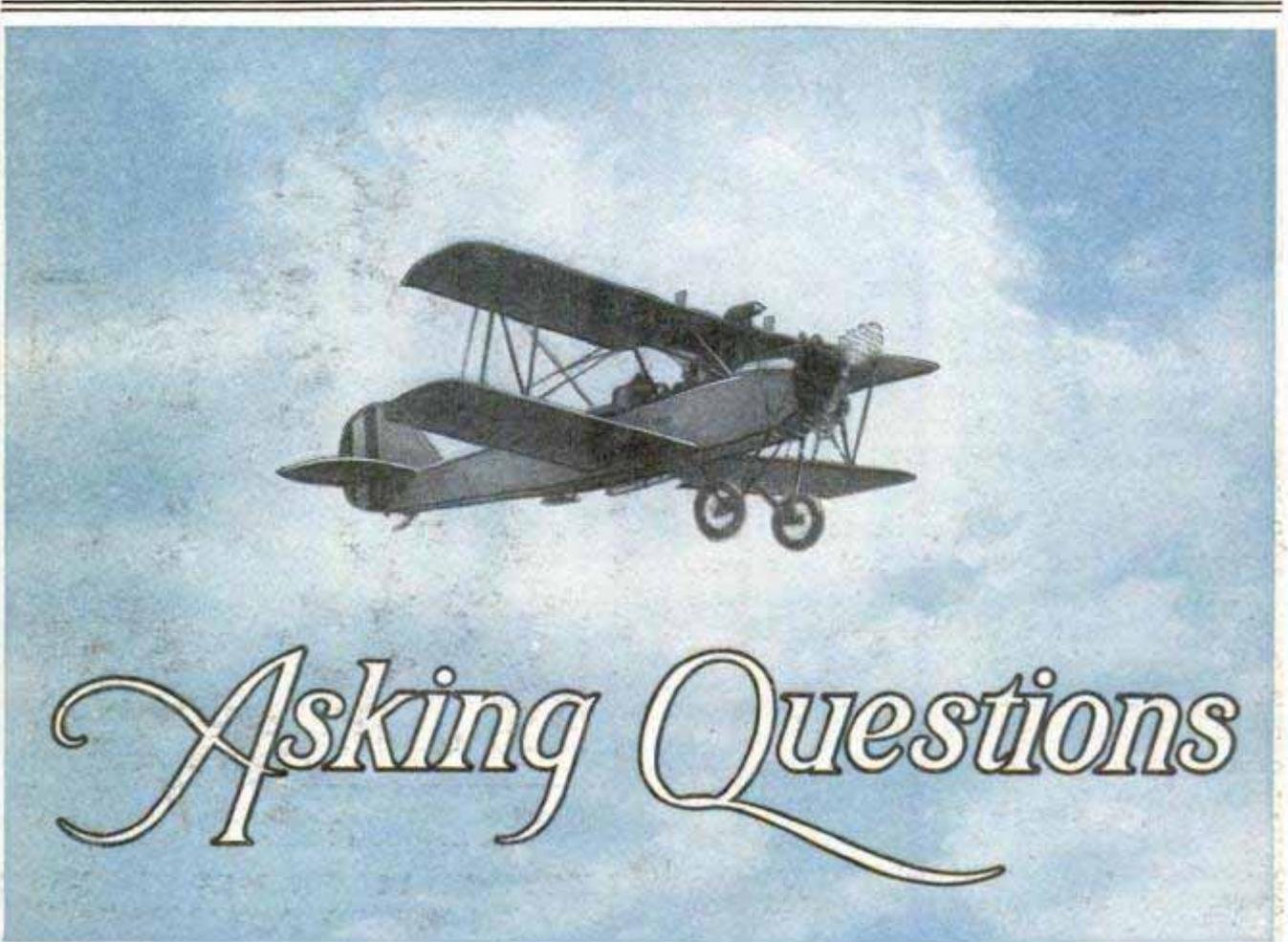

Off for the Daily "Weather Hop"; a Navy Plane with Observers Aboard, Gathering Data for Reports on Wind, Temperature and Other Conditions near a Naval Air Station

By CALVIN FRAZER, *for the Pictograms Co*
Box 890, Washington, D.C.

TO OUR grandfathers the clouds were interesting mainly as indicators of coming weather. They, and their ancestors for ages before them, sought in the aspect of these vapory masses portents of rain or fair weather, stormy winds or gentle breezes. Such popular maxims as

"Mares' tails and mackerel scales
 Make tall ships carry low sails"

were current in the world long before science began to call mares' tails cirrus and mackerel scales cirro-cumulus, or had acquired any real knowledge of clouds not possessed by humanity from time immemorial.

About a generation ago, science began to seek information of another kind from the clouds. It was recognized that through their systematic observation much might be learned about the circulation of the earth's atmosphere; not merely at the surface of the earth but at various higher levels. A cloud is a natural weather vane of the upper air. It shows

the direction of the wind by which it is drifted along, but it does not show the height of this wind or its actual speed unless the height of the cloud is known.

As a means of exploring the entire wind system of the globe, elaborate plans were laid for making daily measurements of the heights and the movements of clouds, by uniform methods, at a number of meteorological observatories in different parts of the world. The observations were carried on for a year, beginning May 1, 1896, and the enterprise is generally referred to as the "International Cloud Year." It furnished the basis of what is now known about the upper winds and also about the relative heights of the different types of cloud, from the lofty cirrus, which has sometimes been observed at an altitude of twelve miles within the tropics, down to the low stratus, which is merely an elevated fog and often merges into ordinary fog lying on the earth's surface. In general, clouds of all types were found

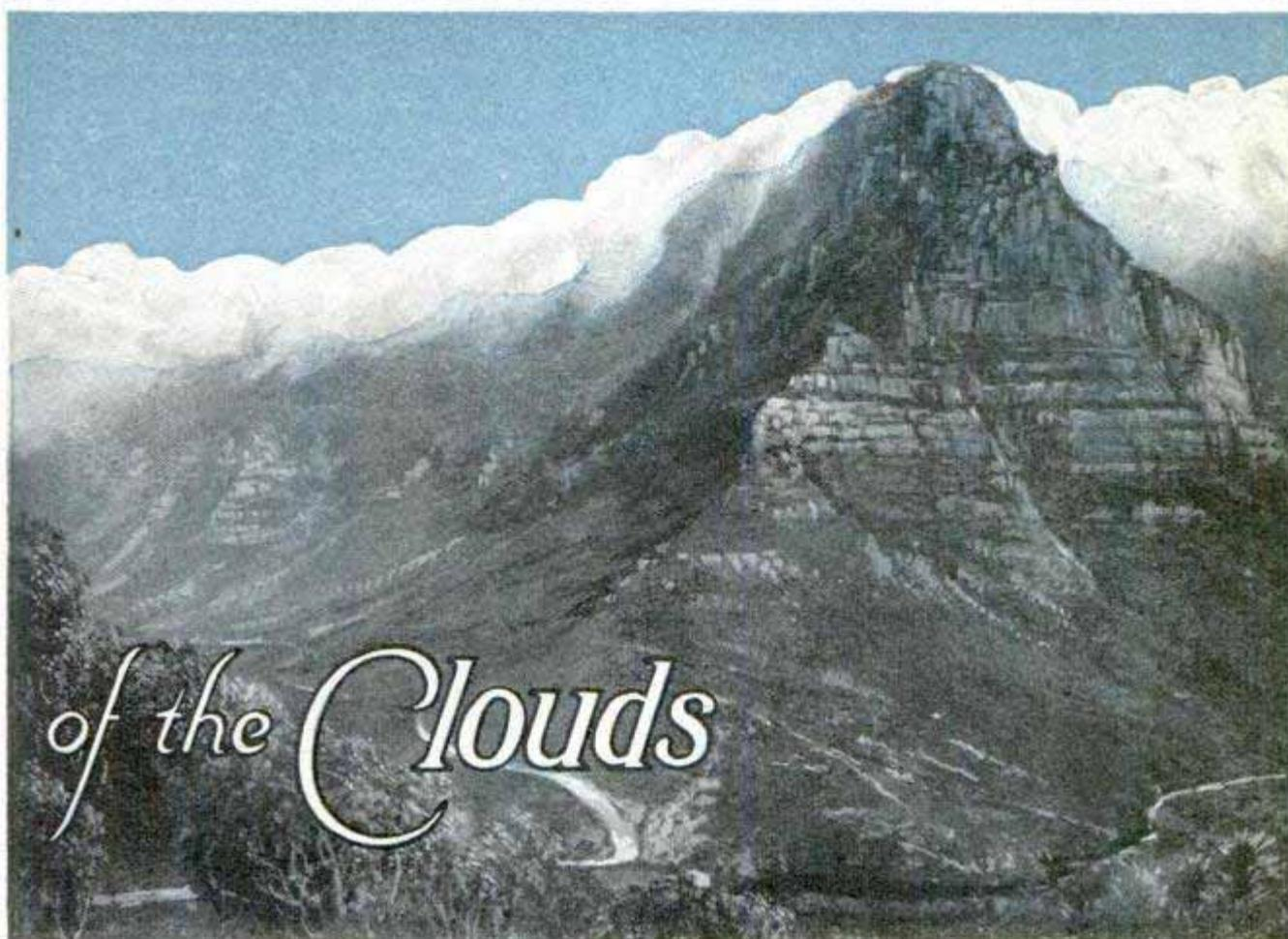

One of the Most Famous Cloud Formations in the World; the "Tablecloth" Spreading over the Top of Table Mountain in South Africa

to be higher in summer than in winter, higher over deserts than over humid regions, and higher in low latitudes than in high latitudes, being lowest of all in the polar regions.

A third stage in the observation of clouds has lately been entered. There are now hundreds of places in this country and abroad—and there will soon be thousands—where clouds are observed several times a day, not primarily for the sake of getting a line on future weather changes nor as a means of learning how the winds blow aloft, but in order that aviators may be advised of the presence and height of clouds occurring at flying levels. Such clouds, which generally limit the height to which a plane may safely fly, are known to aviators as the "ceiling."

Still other observations of clouds are made for the purpose of learning their mode of origin, their structure, the sizes and numbers of water drops or ice crystals they contain, their capacity of reflecting and absorbing light and heat, and so on.

Lastly, one of the big tasks of climatology is to determine the distribution of cloudiness over the globe and the variations to which it is subject. Many meteorologists specialize in cloud studies and there is an international commission on this subject, headed by the director of the French meteorological service.

How does science study the clouds? First of all, there is the problem of measuring cloud heights and this is solved in a great variety of ways. The most exact methods involve simultaneous measurements of the angular elevation of some part of a cloud, as sighted from the ends of a measured base line. From the data thus obtained the height of the cloud is worked out. Less precise measurements can be made by a single observer with the aid of a range finder, such as is used by artillerymen.

In a mountainous country, the mountains, if their heights are known, serve as measuring sticks for determining the heights of clouds enveloping their sum-

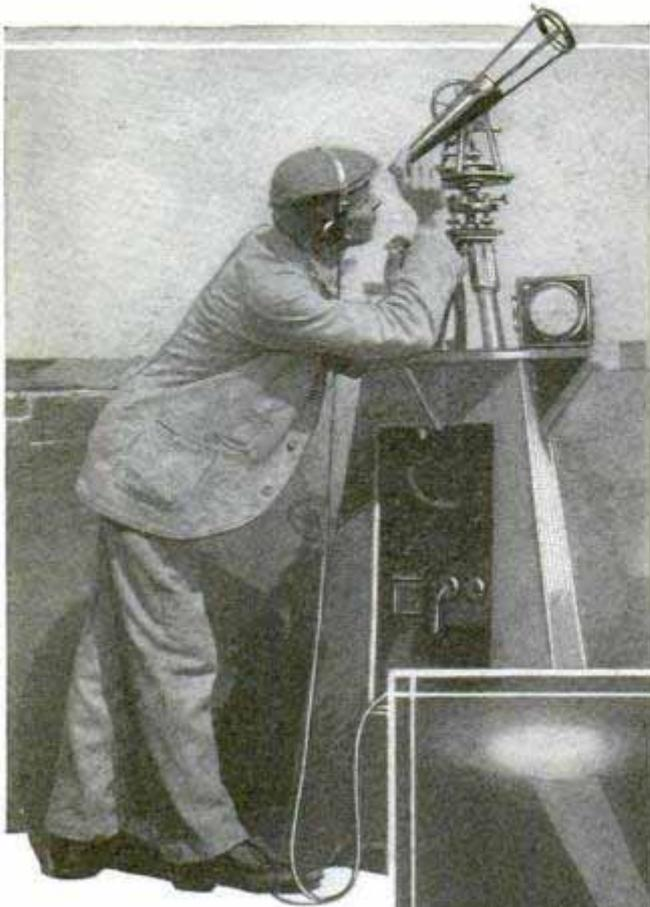

mits or extending down their slopes. The height of a cloud overhead can be measured by releasing a pilot balloon, which ascends at a known and constant speed, and noting the time elapsed before it enters the base of the cloud. Cumulus and cumulo-nimbus clouds—popularly called “woolpacks” and “thunderheads”—are formed by the cooling and condensation of moisture in ascending air currents. The base of the cloud marks the level where condensation begins, and its height can be calculated somewhat roughly from the temperature and humidity of the air at the earth's surface.

At flying fields, the height of low clouds is measured by night, and sometimes by day, with a special form of searchlight, known as a “ceiling light.” This throws a beam on the cloud at an angle of forty-five degrees to the horizontal. The observer paces off the distance from the

searchlight to a point directly under the spot of light on the cloud, and this distance is equal to the height of the cloud.

One of the routine tasks of weather observers throughout the world is to note the direction in which the clouds are moving at the observation hours. In most cases no instruments are used, but certain precautions must be taken to get the true direction, unaffected by perspective or other sources of error. For exact determinations it is necessary to use one of the various instruments known as “nephoscopes.” These are made in numerous patterns, but they all fall into two general classes: reflecting nephoscopes and direct-vision nephoscopes. In the

former there is usually a horizontal black mirror, with compass points or degrees drawn on the mirror or on the surrounding frame, together with an adjustable rod projecting above the mirror. The rod serves as a fixed point for noting the direction in

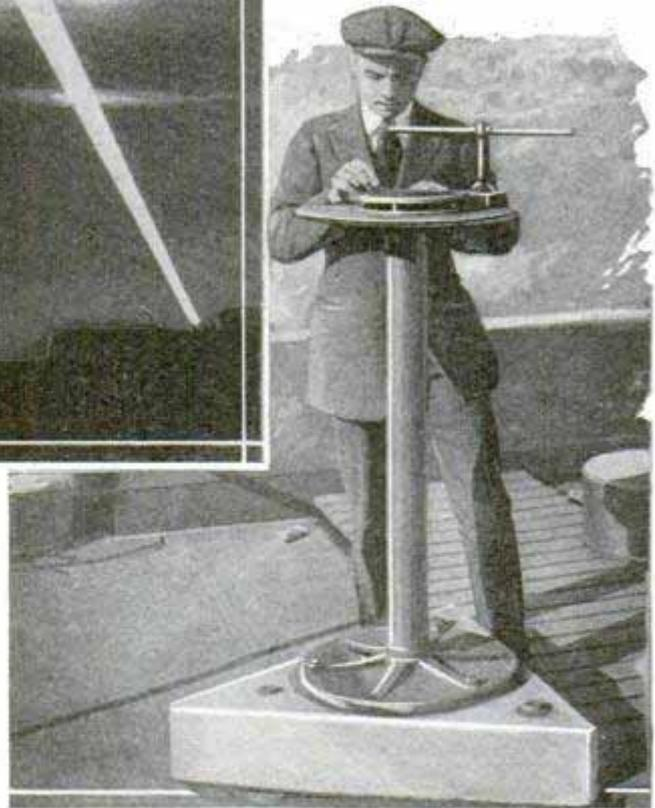
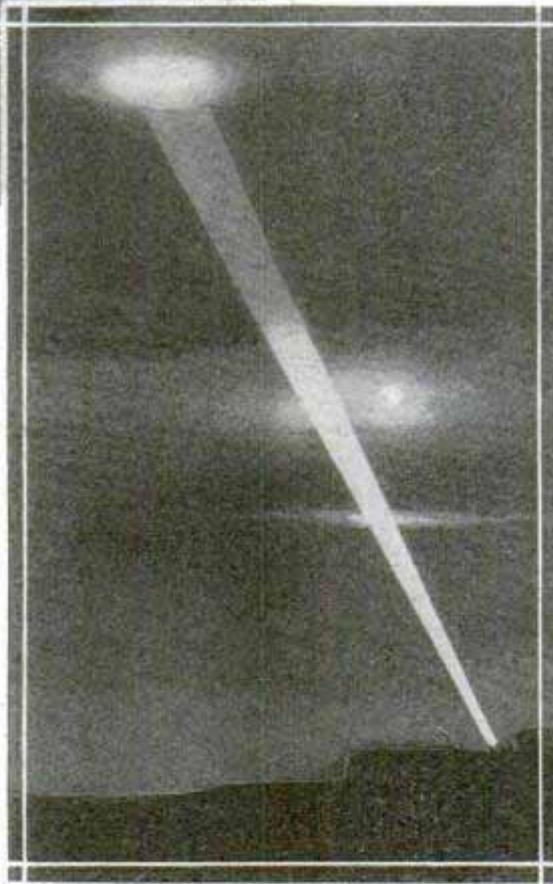

Top to Bottom, Measuring Cloud Heights with a Theodolite; Ceiling-Light Measurement, and Observing Cloud Movements; the Ceiling Light Is Widely Used at Airports



Jove's Anvil Forging Thunderbolts; a Splendid Example of Cumulo-Nimbus Clouds, Photographed in Spain; at Right, "Pocky" Clouds Which Usually Indicate Approaching Thunderstorms; the Sacklike Protuberances Have an Odd Look of Being Upside Down; Such Clouds Usually Mean Strong Winds and Sudden Changes



Cirrus Clouds Often Resemble the Markings of a Painter's Brush and Usually Form at High Altitudes; They Are Frequently Composed of Tiny Particles of Snow or Sleet and Sometimes Give Graphic Evidence of Wind Currents

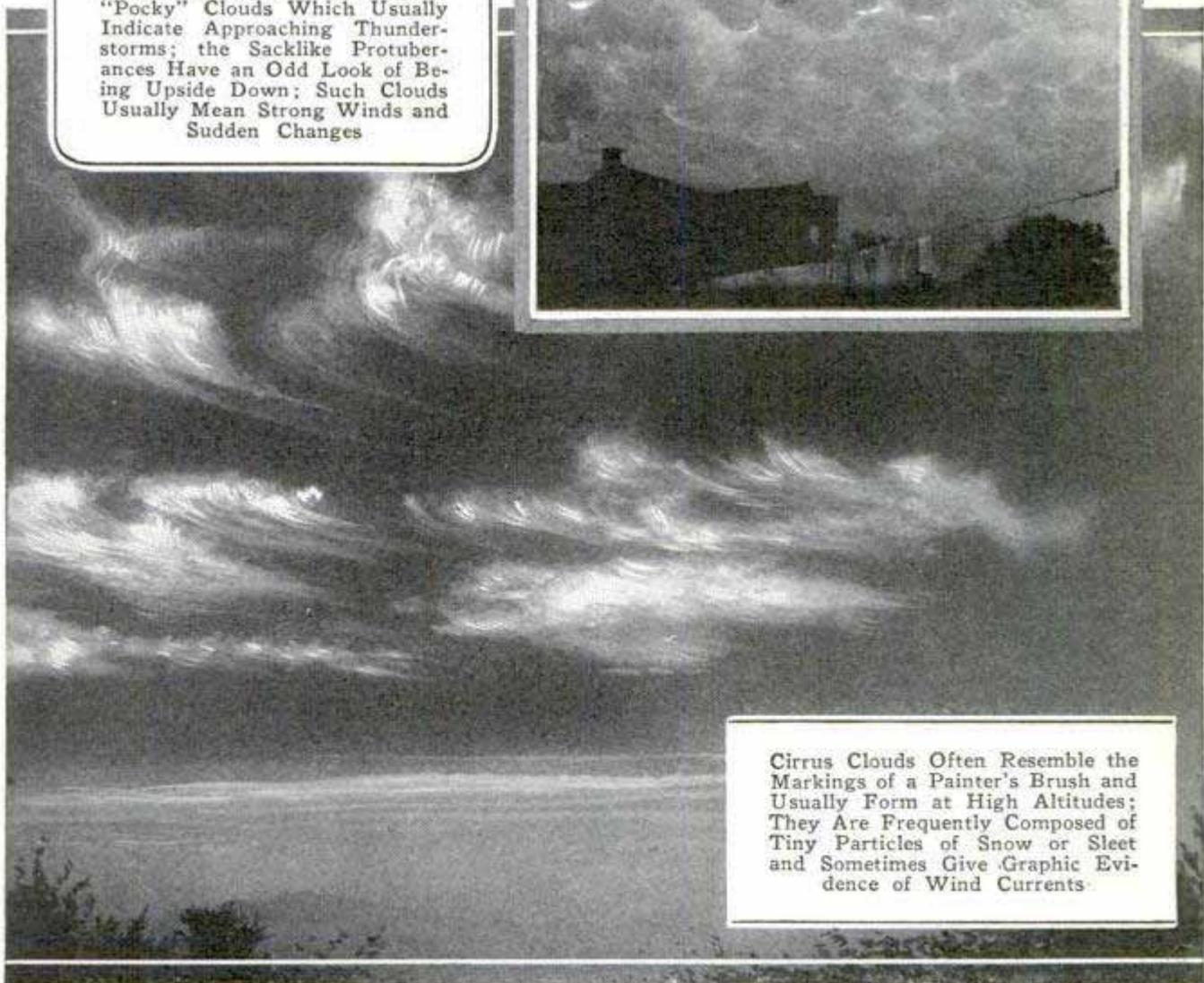

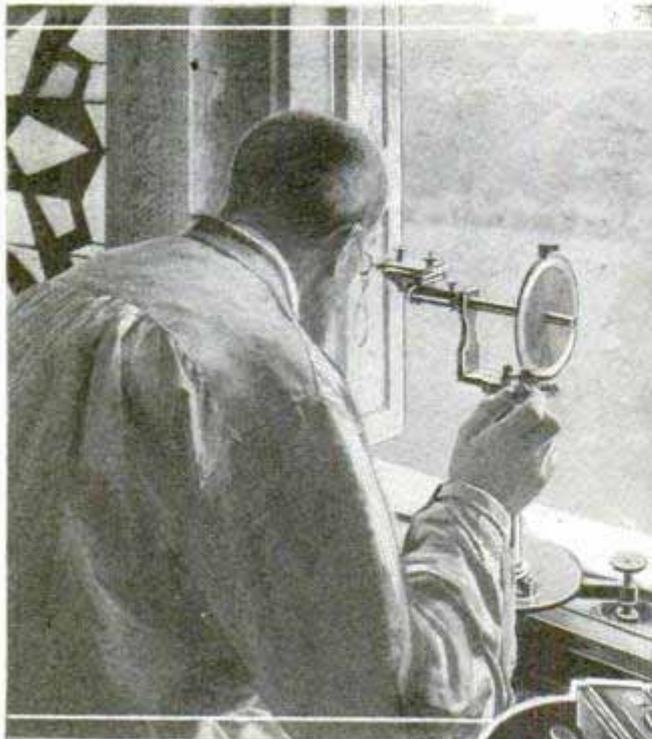

which the image of the cloud moves across the mirror.

The best known direct-vision instrument is Beson's "comb nephoscope," widely used in Europe. This consists of an upright brass rod about nine feet in height, with a horizontal crosspiece at its upper end. The crosspiece bears a row of equidistant spikes. The observer stands a few feet away from the instrument and rotates the rod by means of a pair of cords until the cloud that he is observing appears to move along the row of spikes. Its direction of motion is then read from a graduated circle attached to the base of the rod.

In recording cloudiness, the observer notes the fraction of the sky, in tenths, covered with clouds, without regard to the thickness of the latter. Such observations are usually made without instruments, but there is

a device called a "nephometer," consisting of a hemispherical black mirror ruled in sections, with which cloudiness can be observed with special accuracy. The reflection of the sky in this mirror is viewed from two or more angles, through a movable eyepiece, so that the whole sky may be observed. Another instrumental device is a revolving camera which photographs the whole sky on one plate, thus making a permanent record of both cloudiness and the kinds of cloud present.

One of the most remarkable facts about clouds is that, with the exception of the fibrous types (cirrus and cirro-stratus), they always consist of unfrozen water drops, even in the coldest weather and in the polar regions. The fibrous varieties

are composed of tiny ice crystals. Optical phenomena seen in the clouds provide a criterion for distinguishing ice clouds from water clouds; the former producing the different kinds of halo around the sun and moon, while the latter produce the diffuse



Measuring Cloud Movements by Reflections in Pool; a Revolving Cloud Camera, and One of the Photographs It Takes; This Instrument Permits a Study of the Cloud Formations in All Parts of the Sky

luminous rings called "coronas" and certain kinds of iridescence. Information obtained in this way is confirmed by the direct observation of mountaineers and aeronauts, who have examined the different kinds of cloud at close range.

Since water is a comparatively heavy substance—and since, moreover, raindrops are seen to fall rapidly—most people are puzzled by the fact that a cloud "floats on high o'er vales and hills." Wordsworth's line does not describe the process with scientific accuracy, as clouds do not actually float, but the minute particles of which they are composed settle down very slowly against the resistance of the air, or are borne aloft by slight upward air currents. The speed with which a drop falls through the air increases with its size and an average cloud droplet is only something like one eight-hundredth of an inch in diameter. Millions of such drops must be combined to form an ordinary raindrop.

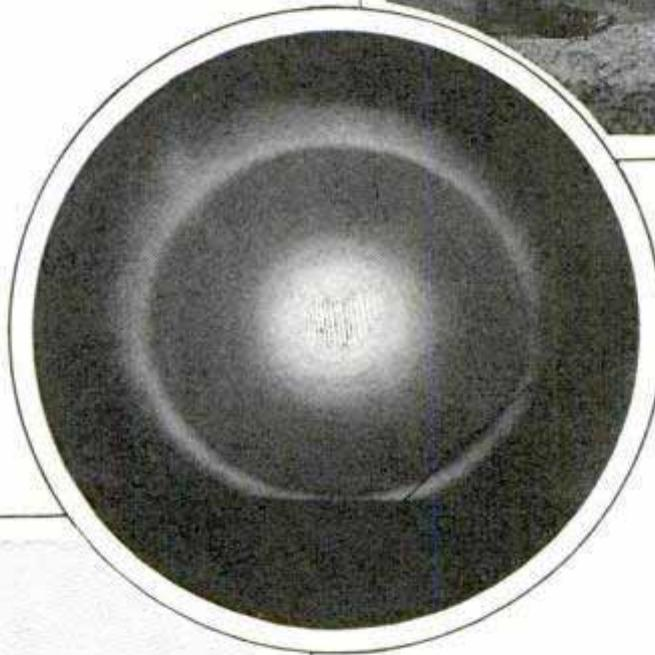
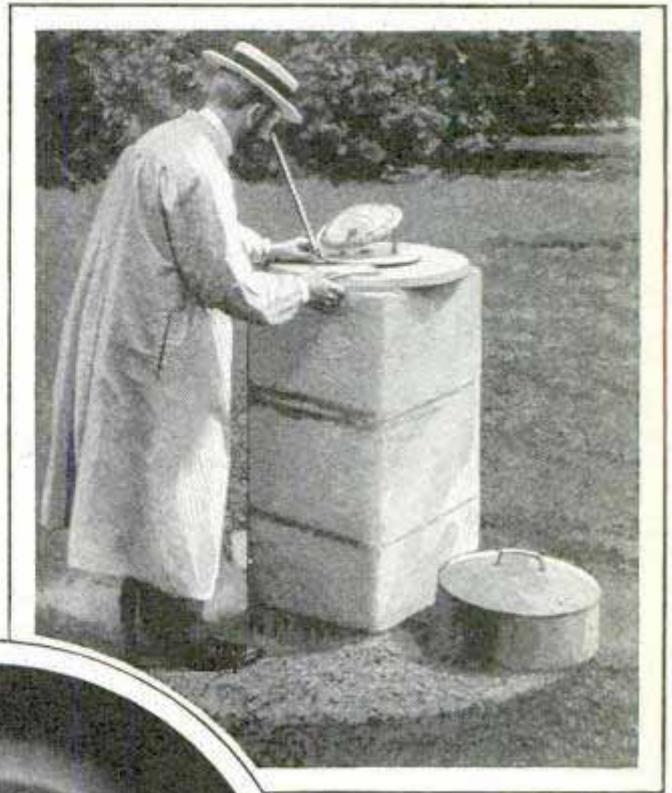

Mountains are responsible for several other striking varieties of cloud, including so-called "cap clouds," "banner clouds," and "crest clouds." Some of these form so often on particular mountains that they have acquired individual names.

The most celebrated example is the sheet of cloud that spreads at times over the flat top of Table mountain, in South Africa, and dangles in a vertical fringe over the leeward edge. This has been known for three hundred years as the "Tablecloth."



Nephometer for Measuring Degree of Cloudiness; How Sun Looks through Cloud of Ice, and Comb Nephoscope to Record Cloud Speed.

LIFEBOAT FOR PLANE RESCUES IS WORLD'S FASTEST 3929

Intended primarily for going to the rescue of airplanes coming down at sea, the world's fastest lifeboat has been stationed at Dover, England, where there is heavy daily passenger airplane traffic as well as steamer traffic. The motor lifeboat is sixty-four feet long, has two engines, each of 375 horsepower, and a speed of seventeen to eighteen knots.

for Royal Inst. of London

Thornycroft & Sons, Limited, Square, Westminster

Built by Messrs. John F. ...

3908



Somewhat Resembling a Houseboat, This Floating Church Carries the Gospel to Many Out-of-the-Way River Hamlets in Germany

FLOATING CHURCH IN GERMANY TRAVELS WATERWAYS

Traveling from town to town along the numerous waterways of Germany, a floating church, similar in construction to a land edifice except that it is built on a boat, brings the gospel to many out-of-the-way hamlets. The church, complete even to bell and spire, somewhat resembles a huge houseboat, except for the features marking it as a place of worship.

TOY WAGON IS MADE INTO SLED BY ATTACHING RUNNERS

Sled runners which may be attached to the wheels of the toy wagon to transform it into a vehicle for winter sport now are on the market. The runners are easily fastened to the wheels or detached from them, and

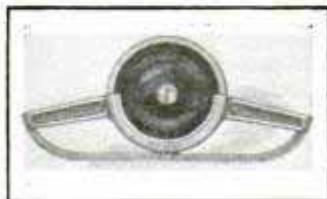

Wm. Williams & Segeth, 3-21 Park St., Boston, Mass.

when in place, the wagon steers in the same manner as when the runners are not attached.

TREE-FIRE MYSTERY SOLVED BY PLANT DETECTIVE

The telephone in the trouble department of the public-service company, Camden, N. J., rang repeatedly. A huge tree, through which high-tension wires passed, was smoking and obviously was afire. The trouble crew hurried out to examine the insulation on the wires passing across the top of the tree. It was found to be intact—yet the tree smoked. Finally Dr. Rodney H. True, director of the botanic gardens of the University of Pennsylvania, was called and explained the mystery.

The tree was a paper mulberry, of the male species. Now, this tree, explained Doctor True, is not content with allowing its pollen to drift off, as is the case with most trees, but "shoots" it out in little powdery puffs. These little explosions, and the resulting clouds of pollen gave the tree the appearance of sending off smoke. So the mystery of the burning tree was solved, and in a few days, when the season of pollination was over, there were no more "trouble calls." This was only one of many interesting experiences by the botanist, for time and again the engineers of large plants call on him for expert advice. Recently a large oil plant in southern New Jersey was sued by the owners of adjoining farms, who claimed that the water pumps of the company were draining their farms, from below, creating an underground desert as it were. It was obvious that the crops had suffered, but whether or not it was the fault of the oil company's pumps was the question. Now it is an established fact that the rings of growth on the cross sec-

Carl George H. Eckhardt

4072

pan

*Armed
 Maine*

456 A
 12/14/29

tion of a tree trunk show whether or not the season of growth was one of abundant water supply, for in years of drouth the rings are not so thick. Doctor True had a number of trees cut down in the section, and studied them for the periods before and after the establishment of the oil plant. From his observations, he showed that the company pumps were not draining the land, but that leakage from an old oil tank, years before, had affected the trees which showed stunted growth.

406 7

BLUE VITRIOL DESTROYS WEEDS BUT SPARES SMALL TREES

Bluestone, better known as blue vitriol, has been found an efficient destroyer of weeds in a bed of conifer seedlings because it does not harm the small trees. Eight grams of bluestone dissolved in water and sprinkled over one square foot of ground kills practically all varieties of weeds but does not interfere appreciably with germination of the seeds and the growth of the little trees.

399 4

COMPOSITION-RUBBER DESK PAD DOES NOT BLOT OR STAIN

Made of flexible composition rubber in various color combinations, a desk pad that does not blot, stain, or collect dust and lint like the ordinary blotter pad now is on the market. Ink does not stain it and a burning cigaret leaves no scar. A single sheet of paper lies firmly on the pad, making writing with one hand easy, so that the other hand is free to hold a telephone receiver or perform other tasks.

no. 03101



Composition-Rubber Desk Pad Grips Paper Firmly and Does Not Stain from Spilled Ink

Sandell Mfg Co.

20 X 34 = \$6.25

12 X 19 = \$2.75
 19 X 24 = \$3.75

FIRE BLANKET HELD ON FRAME IS QUICKLY DONNED

\$25.00

3923

Supported on a roller on an upright frame, an all-woolen fire blanket, virtu-

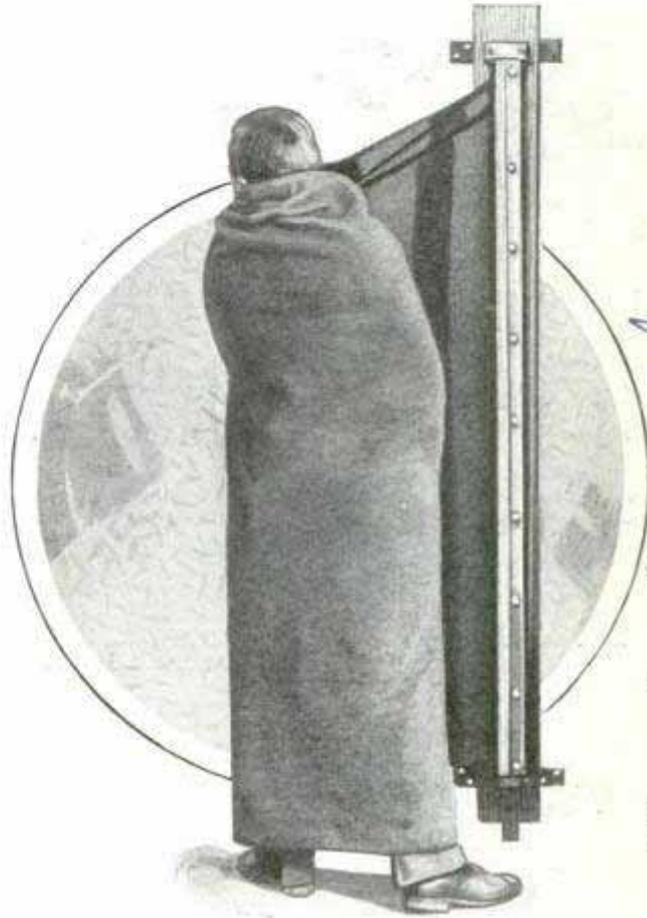

Fire Blanket, Held on Rollers in an Upright Frame, Used to Run through Flames

ally fire and moth-proof, now is available to be placed where fire hazards are present in an extra degree. The blanket, wide enough to enfold a large person and long enough to cover the body, is always ready for use, and is donned in a moment by snatching a catch rope and unwinding it from the roller, at the same time wrapping it about the body. It detaches from the roller automatically.

ABANDONED AUTOS FILL IN BAY TO MAKE AN AIRPORT

4028.

Officials of the Borough of Queens, New York, have found a use for abandoned automobiles. Ten thousand old cars have been dumped into Bowery bay to riprap the foundation for extension into the bay of the North Beach airport by 500 feet. The old cars were found to be almost ideal material for this purpose.

*Pub. Service News Bldg.
 412 Santa Fe Bldg.*

*Dullard. Signis d me.
 67 Wall St. New York. 275. 8th St.*

3924

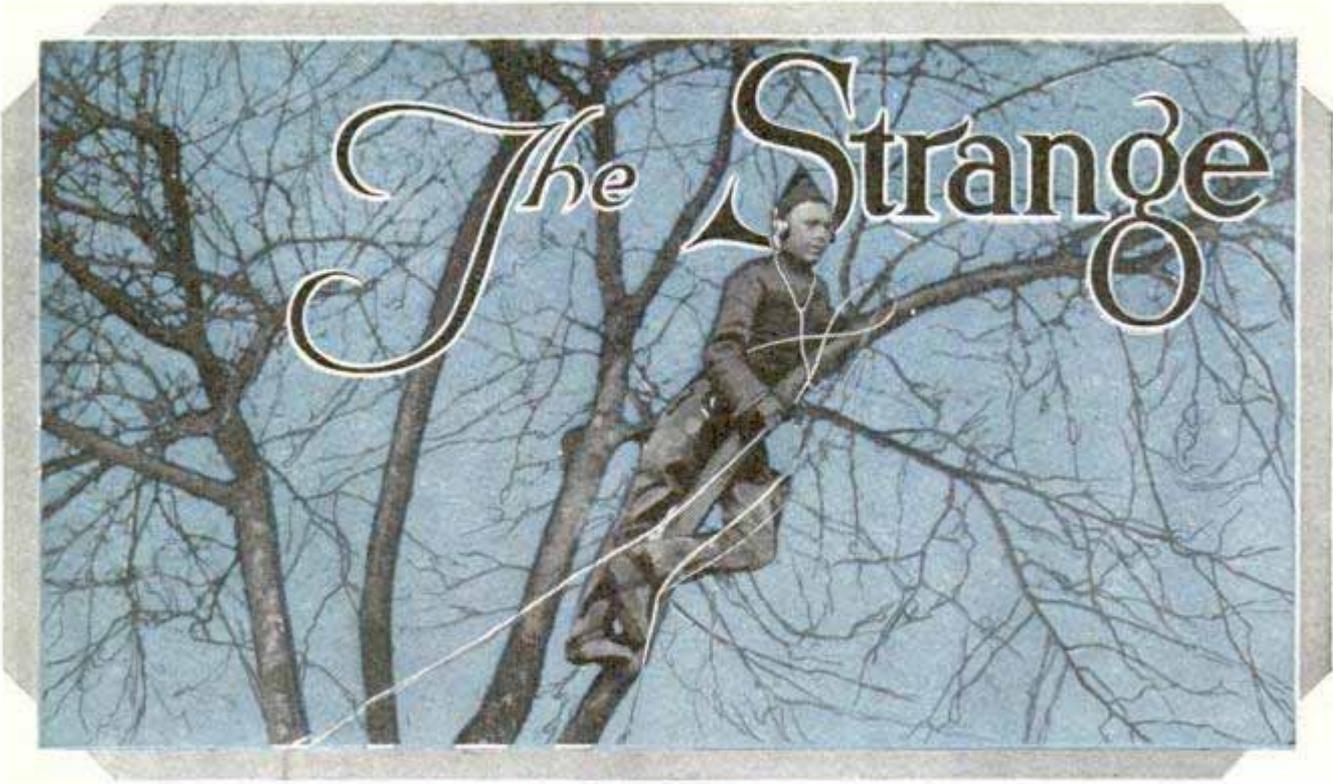

An American Spy during the World War in a Lookout in a Tree; He Is Equipped with Headphones Connected to German Lines and Is Listening for a Possible Enemy Secret

By JAMES N. MILLER

*326 Central Hotel
Washington, D.C.*

MYSTERY, intrigue and adventure abound in the true stories, now being told for the first time, about the exploits of world-war spies. Until very recently these tales—many of them almost beyond belief—have been kept under lock and key in the government's secret files at Washington.

One of the cleverest spies operating in America was a woman in the employ of the German government. She had been suspected for some time but no direct evidence could be lodged against her. Finally she was arrested by army intelligence officers and searched. An unusually large number of pins was discovered in her garments. A cipher expert examined them and found curious marks scratched on the heads of the pins. The little marks proved to be a code which was finally deciphered. The woman had been carrying important messages in this manner for weeks.

Another story concerns radio messages in code which were sent from German warships and recorded on a phonograph disk by the British admiralty. The men assigned to decode the communications were baffled. All they could hear when the records were played was an unintelli-

gible gibberish that defied translation. Then a lucky accident led to the solution. A tired agent let his phonograph run down one day. Suddenly he jumped to his feet. The message was being spoken in plain German! The slowing down of the instrument had made the talk understandable. The Germans had made records of their messages and sent them through the ether at terrific speed, but the slow phonograph had betrayed them.

In another case, a woman spy devised a 3,000-word report in such a manner that she could paste it on the lens of her spectacles. Also, a dancer dining in a Paris cafe waved her fan in certain fashion, spelling out a message that led to the sinking of a French transport off the coast of Morocco.

A German spy jumped from an airplane, landed in a British camp in British uniform and immediately ordered other officers to collect information for a projected British attack. Another German spy was so active that the British were compelled to send several warships and several thousand troops to stop his plans and capture him.

That world-famous authority on the

Adventures of Spies

various methods of espionage, Maj. C. E. Russell, says graphically:

"Secretly and alone, the man from the espionage service fights a single-handed battle. He makes his way behind the lines of the enemy, his brain pitted against the combined brains of the enemy's secret service.

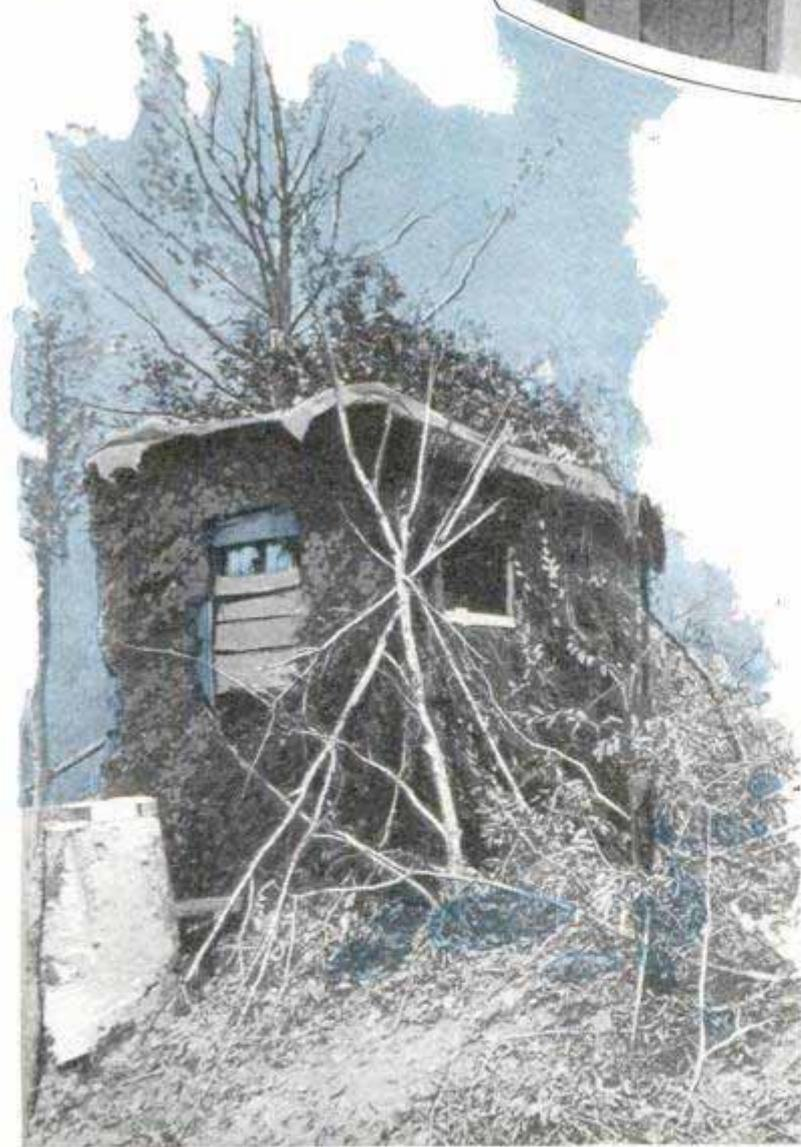
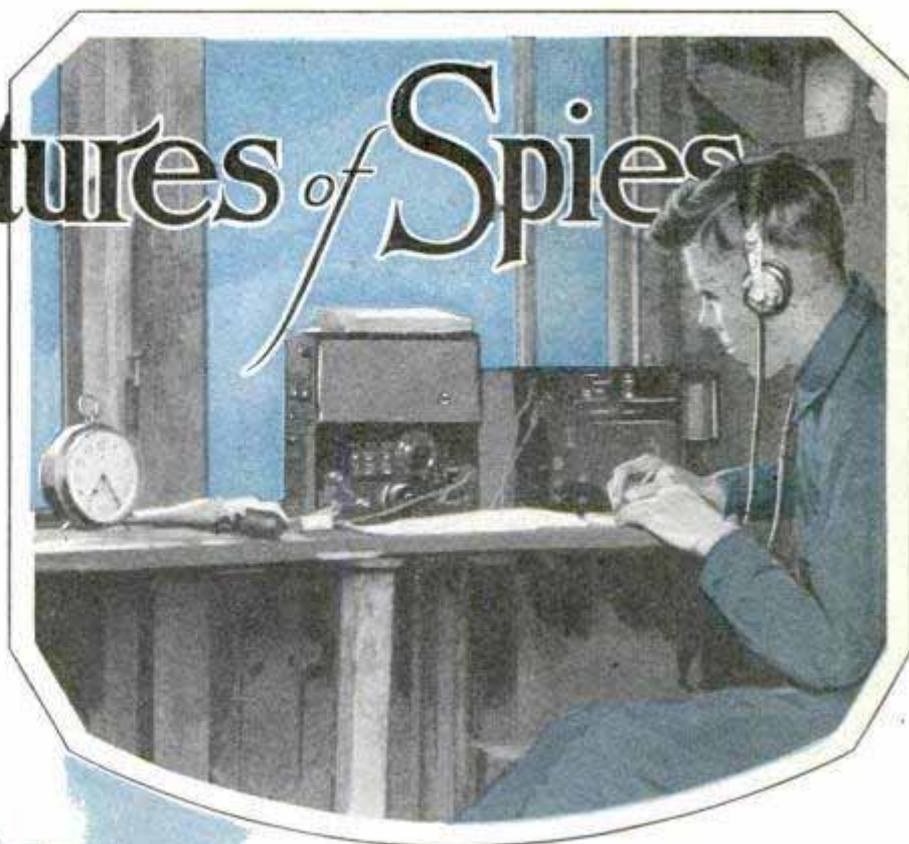

Top, Receiving Code Message from Spy in Enemy Lines; Below, Bomb-Proof Code Station Used by German Spies

The stakes for which he plays are the highest in the world—the lives of thousands of his fellow soldiers, and potentially at least, the welfare of the loved ones at home. Yet, in the face of all this responsibility, he carries on, knowing full well that the reward is at best meager. There are no medals of honor, the general's quiet nod of approval being about the utmost that can be expected."

Concerning how our spies got through the enemy's lines in the late war, Major Russell explains that three principal methods were employed, all of which were useful only if the secret agent had an expert speaking knowledge of German and developed painstakingly the traits of observation and memory. The first ruse was to adopt the uniform of the enemy, usually that of an enlisted prisoner, and fight one's way through by day. The second was to go over in the blackness of night, and, remaining hidden by day, listen to all that could be overheard, and

39 24
444



An Underground Trench Station during the World War as Preparations Are Being Made to Send a Cipher Message

witness, by means of unusually powerful field glasses, all that might be seen. The third, and supposedly the best procedure, was to gain permission, by way of a neutral passport, to travel unhampered from place to place.

Communication between spies and their chiefs was accomplished by a wide variety of methods. Wireless telegraphy, of course, was the most common, and it ultimately led to the perfection of a spy-proof code cipher. It is a modification of the crossword puzzle. A key is employed, consisting of a number of squares in each of which are all the letters of the alphabet. Over these squares is laid a piece of tracing paper and a line is drawn from letter to letter, back and forth, spelling out the message. Then the zigzag picture is wirelessed as a single unit. The job of the man on the receiving end is to transfer

the zigzags to transparent paper, place them over his key and then untangle the message. To wireless such a picture or map requires two cylinders of the same size, revolving at a predetermined speed in perfect synchronism. Size and speed can be varied at will, a fact that makes for the safety of the code, even though the key be stolen.

Invisible inks of various compositions were used widely in writing messages on sundry articles of clothing. Even bandages and the insides of trunks were utilized for this purpose. The famous "petticoat case" is known to intelligence officers of practically all the nations engaged in the late war. It seems that a famous opera singer had just completed a concert tour of France and was returning to Switzerland. Her presence did not create particular excitement, until one of the custom officials noticed that she wore a thickly starched petticoat that was absurdly out of style. His suspicions aroused, the official ordered one of his woman aides to have the petticoat examined. Whereupon the garment was given the "acid" test and a message revealed.

Strangely enough, perhaps the most common chemical used by spies in writing invisible reports is ordinary lemon juice. It dries readily and later on, when heat is applied, the writing stands out bold and black. The kind of paper preferred is onion skin, since it is very thin and strong and is readily compressed within a surprisingly small space.

Wrapping paper was also used to a considerable extent as a message purveyor, for the reason that it did not tend to arouse suspicions if the paper was tied



One of the Spy Centers of the American Forces during the World War; This Is a Standard Code Center Which Received Messages from American Spies in the German Lines

around an innocent article like bread, or perhaps a book. Books themselves were employed, especially those with wide spaces between the printed lines. Newspapers with broad margins also were used. Various acids, which possessed the virtue of revealing maps or messages only when water was applied, were tried out with success. A case in point is the well-known "bathtub affair," which caused many a smile to secret-service officials. A rather stupid-looking fellow, claiming to be a neutral, was trying to get through France to Germany. Held for observation with a group of other men, he was asked to take a bath. He refused point-blank, even though he admitted that water had not bathed him for over a week. Willy-nilly, he was showered liberally with water, with the result that on his back was found an important message for the enemy!

Still another invisible-writing method was made possible by the micro-pantograph, a device actually able to write a complete message on tiny pieces of glass and metal. Even the head of a pin or

needle, eyeglass or tip of fountain pen was utilized. Needless to say, it was impossible for the human eye to detect the ruse, the only means of discovery being a high-powered microscope.

Besides these written means of communication there was employed the so-called visual method which used natural or customary objects or actions to convey messages to the enemy. An ingenious fellow was the Alsatian with his flock of sheep. For several months he was in the habit of pasturing his animals in the rear of a French division. By dividing his flock into three parts and letting them feed in different fields, he had many combinations to use in telling the Germans in their observation balloons and planes what was being planned by the French.

The three groups in three fields meant there was nothing of importance to report. Two flocks in the right field and one in the left meant, "look out for activities on the left front"; when all were in one flock, the French were concentrating on an attack in the center; whereas when all were in the farthest field, the

3924
446



Army Officer Sending a Code Message: It Was over Equipment Such as This That Much of the Information from American Spies Was Received and Transmitted during the World War

French had withdrawn troops from that sector. After repeated failures of their secret plans, we are told by Major Russell, the French discovered the farmer and his sheep.

Hardly less clever was the Belgian who used the arms of his windmill to signal the German aviators the plans of the Canadians. A young Canadian officer in an idle moment happened to be drawing a picture of the mill when he was astonished to discover that the arms were moving against the wind. This continued for over an hour, so the officer reported his discovery to his superior. Very soon the Belgian was captured, and confessed, furnishing the Canadians with his code. Utilizing their knowledge, the Canadians surprised the Germans. The signal was given. "Troops withdrawn," with the result that the enemy walked into a trap.

Then there was the instance of the French peasant woman who seemed always to be spinning outdoors when the Germans flew their planes overhead. She had her yarn running through a shutter

of the house, and as she spun she manipulated the shutter, thereby sending code messages. Suspicions were aroused because her house, though in the danger zone, was never fired by airplane bombs.

Major Russell believes that in the event of another war, many new inventions will be used to advantage for signaling. In this connection, invisible light is opening a new field of secret communication. Infra-red rays, the long light waves which ordinarily produce no color sensation, can be employed in military signal lamps for flashing signals which can be seen only by observers using a special screen.

9110
WHISTLE OPERATED BY SWITCH

For the protection of workmen, a mining company has installed a whistle connected to the switch and also to a compressed-air line. When the switch is thrown to direct a train of cars into the crosscut, the whistle is blown automatically, thus warning all workmen of the approach of the train.

*Capt. Dwight Lloyd
Capitol Hill Station*

*news
metalayer*

Merada Tribune 12/18/29

4046

4049

RAIL JOINTS ARE KEPT TIGHT BY MOLTEN METAL SPRAY

Electric railways, faced with the heavy expense of tearing up pavements to tighten loose rail joints, are interested in a process which has been developed to keep them tight indefinitely. The inventor of the process worked on the theory that the rails were not loosened by vibration but by rust and mill scale at the rail ends. The permanent-tightening process involves the spraying of molten metal at the connections, compressed air being used to blow a fine mist of molten metal over the entire area to be assembled. Brass, zinc, copper, steel, chromium, nickel or any other metal may be used for the plating.

Supplies, 303 Albany Ave

D.A. Barbery, Railway 3692

OIL REMOVED FROM STREETS WITH STEAM AND BRUSH

Tests are being made by Berlin officials in fighting the menace of slippery streets which are blamed for many automobile accidents. Steam has been used to remove the slippery oil from some thoroughfares, while elsewhere city employes have been equipped with scrubbing brushes and powder to eliminate the film.



Above, Scrubbing Oil Film from Berlin Streets; Below, Using Steam for the Same Purpose

on Charlottenburg Road

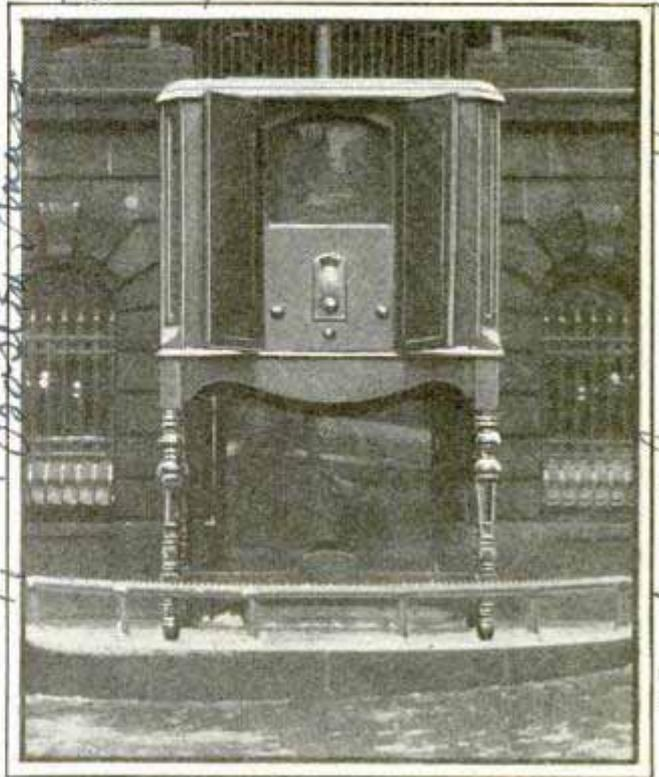

Gigantic Radio Receiver Outside a Cleveland Building Which Broadcasts Luncheon Programs

RADIO RECEIVER TEN FEET HIGH BROADCASTS SPEECHES

More than ten feet high and six feet wide, a gigantic radio receiver stands outside a Cleveland building where it is used to broadcast speeches and luncheon programs to the public. The cabinet is built to scale with one of ordinary size, and the receiving equipment is a magnified duplication of a standard chassis, the only difference being that in the large cabinet are special amplifiers and speakers to furnish the tremendous volume required.

PLAYGROUNDS ABOVE STREETS FOR CONGESTED AREAS

Elevated playgrounds for children over the streets in the congested areas have been proposed by a New York architect. Such playgrounds, it was estimated, could be constructed for about \$25,000 each, only a fraction of the cost of acquiring property for them, and at the same time providing the facilities where most needed, instead of in isolated sections difficult for the children to reach. The grounds would be built of reinforced concrete with a steel superstructure and surrounded by a wire net with flower boxes outside the netting to give the effect of a roof garden.

Harry Allen Jacobs

Cont. Coleman W. Worley, 1205 Hayden A. Bldg - Cleveland Ohio

4054

eml. Kratzyner.

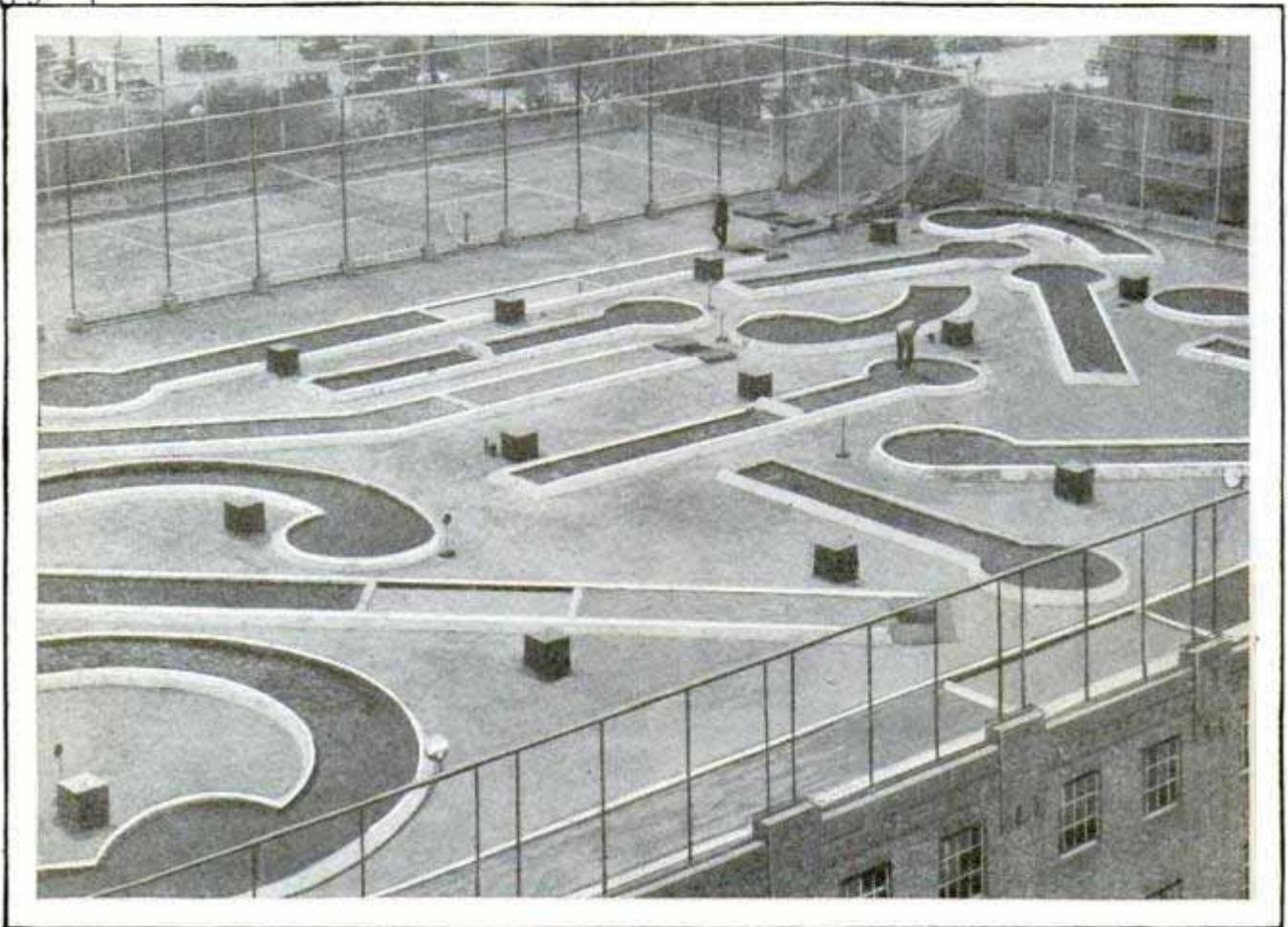

In Foreground Is Shown an Eighteen-Hole Golf Course with Many Unusual Hazards on a Hotel Garage Roof, with a Tennis Court in the Rear; Both Are Floodlighted for Night Playing

PLAYGROUND ON HOTEL ROOF FOR GOLF AND TENNIS

Golf and tennis players enjoy games and practice work by day or night on the roof of the garage of the Hotel Plaza, San Antonio, Tex. The area has been fitted up for an eighteen-hole golf course with interesting hazards, a cage for driving practice and a tennis court. The golf player is afforded excellent tests for his skill at putting and difficult shots, as practically every "fairway," inclosed in a concrete border with traps and water hazards, offers chances for careful shots. Floodlights illuminate the playground at night.

SOLIDIFIED LIQUID IS HARD AND FLEXIBLE AS PAPER

Discovery of a chemical composition combining hardness and flexibility in a remarkable degree, which is expected to be used in a score of industries, has been announced by Dr. Hal T. Beans, of Columbia University. "Durium" is the name of

the composition, described as a liquid in its original form which is transformed by heat into an insoluble, infusible solid. A thin film of durium, so hard it can scarcely be broken with a hammer, is almost as flexible as paper. It hardens quickly and therefore can be used in stamping processes at the speed of a printing press. In appearance, it somewhat resembles amber but is highly heat-resistant, making it ideal for molds or matrices. In liquid form, it may be used as a fire-resistant and waterproof spray paint. Its first practical application will be in the making of phonograph records. Durium records are as light as cardboard, flexible and, at the same time, more durable than the ordinary type. Aside from being less fragile, they will also be much cheaper, and are to be released weekly at news stands. The composition also is expected to be used in the large disks for talking motion pictures, for certain types of molding, electric insulation, stereotype matrices and as a varnish where great durability and high luster are important.

New York City

Durium Products Corp

hydrographic engineers.

instead of
(Lieut. Thomas Kelly Field)

**SOUNDING BY ECHO
IN HUDSON BAY.**

A new type of British admiralty depth-finding equipment was used in Hudson bay for a survey of the floor of the inland sea to make corrections and complete the charting prior to the opening of this waterway to commercial shipping. The instrument on the bridge of the ship shows accurately the depth of the water in fathoms. This is automatically measured within the instrument box, the measurements being based on the time-interval principle of sound travel in water. A note is set up in the hull of the ship by an automatically controlled hammer striking a metal disk and travels to the bottom, setting up an echo which returns to the instrument and enables calculation of the depth. It also warns of approaching shallow water.

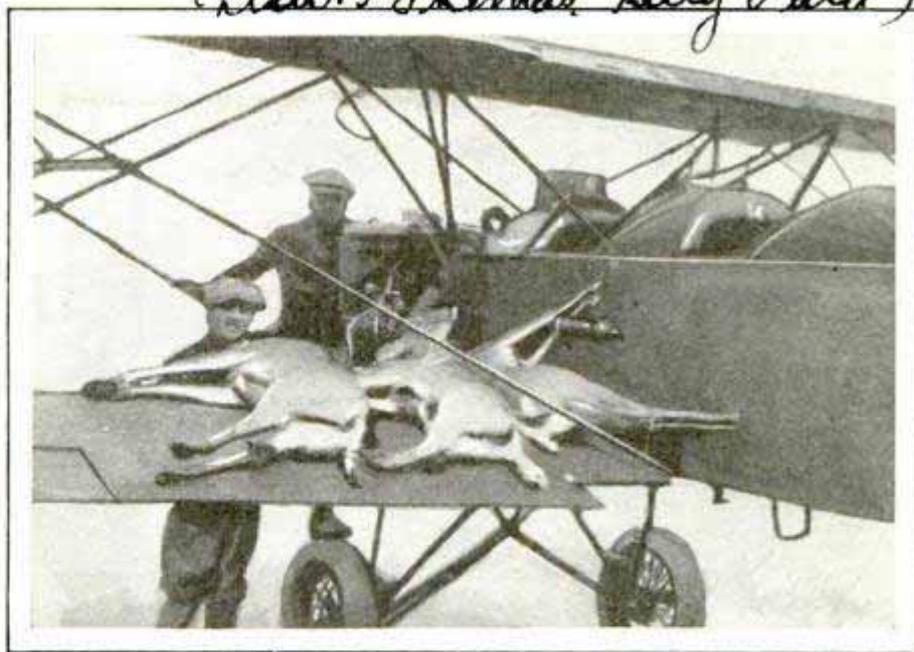

Airplane, Used by Deer Hunters in "Spotting" the Game, Landing with the Day's Kill Which Has Been Strapped to the Wings

**DEER HUNTED FROM AIRPLANES
AND CARRIED ON WINGS**

Deer hunting from airplanes is done in certain sections of the southwest where landing spaces abound in the game country. The planes are particularly useful in "spotting" the deer. Flying at high altitude, the hunters are able to detect herds or single animals from a great distance. Care is taken not to fly too low, as that scares the animals and, by the time the hunters have landed, they have disappeared. When the deer are not too large, they may be carried safely on the lower wings of a biplane, strapped securely and the load balanced.

**PORTABLE HEADLIGHT TESTER
ADJUSTS DRIVING LAMPS**

Focusing automobile driving lights in any desired position is made easy with a portable headlight tester now available for garages. The tester may be used indoors or outside in broad daylight, and with it a beam may be made to strike the road at any desired distance from the car.

396A

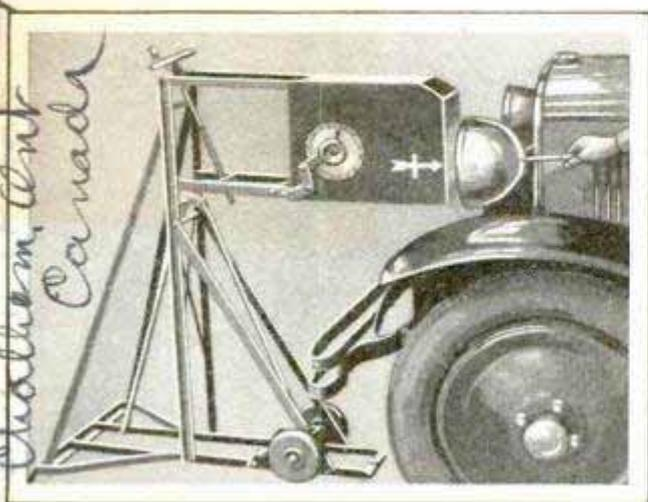

Portable Headlight Tester by Means of Which Auto Driving Lights Are Quickly Focused

LOG JAM FAR UNDERGROUND

Workmen excavating a tunnel for a Tacoma, Wash., power project in the side of a hill high above the bottom of the canyon of the Skokomish river found a huge jam of logs such as sometimes piles up in a river. The logs, many of them fir, seemed to be as sound as when they were uprooted, although they were discovered 200 feet beneath the ground. The most plausible theory is that the river in remote times piled the logs up, then was forced by the jam to change its course, earth in time covering the logs while the river continued to cut its channel down through the ground until it reached the rock forming its present canyon.

3962

Lake Cushman power project

Carl James Montgomery R 304
6500
Wearer Canadian Co. Ltd.
Chatham, Ont.
Canada

707 St. Helen's Ave. Tacoma Wash.
Carl B. W. Brintnall
Chatham, Ont. Canada

*51 William St,
 Melbourne
 Victoria
 Australia*

3819

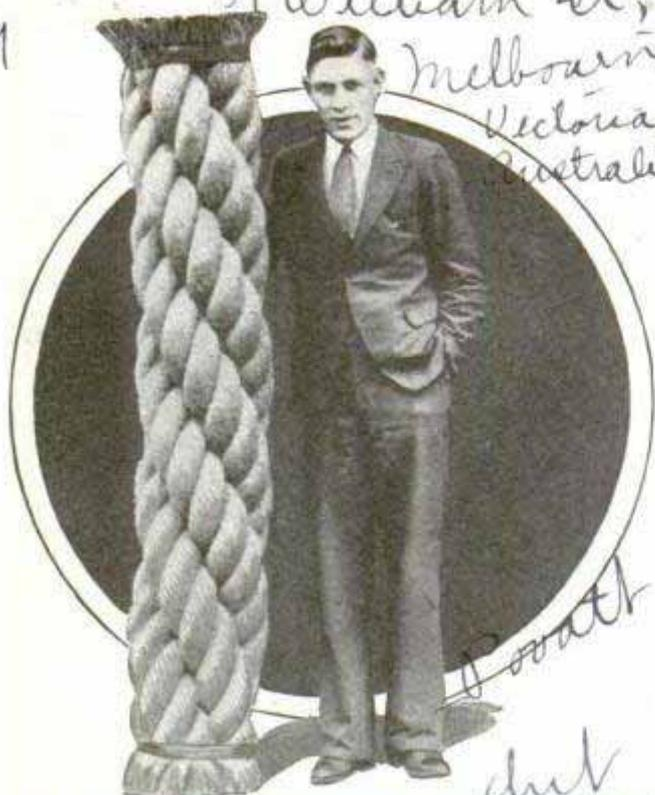

This Huge Rope, Three Feet in Circumference, Is Used to Hold Steamer Anchors

embroidery of company
BIG ANCHOR ROPE OF FIBER STRONGER THAN CHAINS

Fibers, woven into a thick rope, stand strains that snap metal chains in holding the anchors of steamers off some of the Pacific islands where there is an unusually strong ocean swell. What is claimed to be the world's largest rope for this purpose was seen in Melbourne, Australia, recently. It is three feet in circumference, 460 feet long and weighs nearly two tons.

SPEED TRAP FOR THE EARTH RACES LIGHT BEAMS

In a sheet-iron shed, that looks like a hot-dog stand closed for the winter, attempts are being made at the Case School of Applied Science in Cleveland, to catch the earth. Out of it is coming information that threatens the Einstein theory which has attracted so much attention in recent years. In 1887, near the site of the little building, Profs. A. A. Michelson and Edward W. Morley performed experiments to determine whether the earth creates waves or ripples in the ether through which it is supposed to move. Their results were zero, or at least they thought so. They tried to detect the ether drift by measuring the velocity of light in

different directions. It is upon the zero they obtained that Dr. Albert Einstein based his theory of relativity. But during the past several years, Dr. Dayton C. Miller has been performing the same experiment with almost the same equipment—trying to find zero—and has failed consistently. In other words, the more than 150,000 readings that he has made all indicate that there is an ether drift, evidenced by difference in the speed of light traveling north and that going east and west. If his findings are accepted, the Einstein theory will be scheduled for remodeling. Scientists have regarded light waves as vibrations in an imaginary substance called ether, that is supposed to be present in all space. The earth and other planets are known to be moving through space at a tremendous speed. Therefore, if there is an ether, it is reasonable to believe that the earth and its neighbors create waves in it, much as a boat sets up waves in a lake, and light, being a vibration in this ether, ought to travel back and forth in the direction of the solar system's motion at a speed slightly different from that across the path of motion. Einstein claims that no one ever will be able to measure this difference in the speed of light—to detect ether drifts. So, if anyone can find positive proof of the presence of ether, the Einstein theory will tumble.

AIR-PRESSURE DOT ON WHEELS SHOWS TIRE INFLATION

Permanently installed through the rim of the new Ford, individual tire gauges for each wheel of the car now are on the market. The pressure indicator is installed in a hole drilled in the rim and is so adjusted that, when a red dot on its top is flush with the rim, a pressure of thirty-five pounds is in the tire. Overinflation is indicated when the dot rises above the rim, and underinflation when it recedes below the rim.



*The Pressure Slot Co.
 Truckhol 99*

made in Sydney

*Emb. Walter E. Burton, Akron Ohio
 222 Bondy ave.
 Kenmore Station*

pressure slot Co. or to inquire

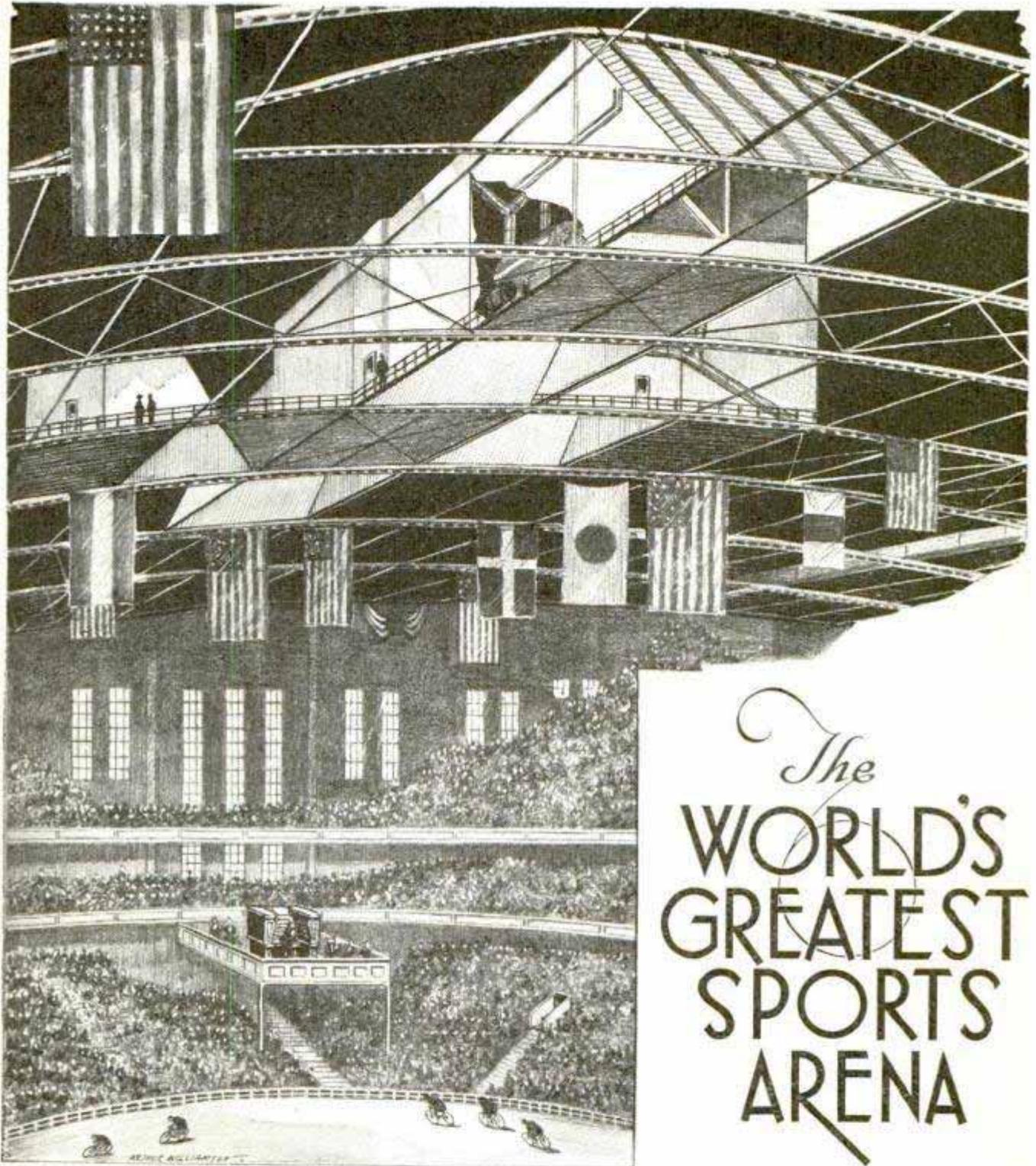

The
**WORLD'S
 GREATEST
 SPORTS
 ARENA**

By PAUL D. PADDOCK

GAMES and circuses are staged under a "big top" of steel in the Chicago stadium, where the latest wonders of mechanical and engineering science have been applied for the better enjoyment and performance of sports.

The structure combines twelve buildings in one. There is room for a football field or a three-ring circus with seats for 18,000 persons. Wrestling or boxing matches can be witnessed by an audience

of 25,000, and, a few hours later, ring and mat have disappeared and the floor becomes a skating rink, 150 feet wide and 250 feet long, for hockey games to thrill a crowd of nearly 20,000.

Music roars down from a six-console organ, the pipes and trappings of which are housed in the stadium roof and form the equivalent of twenty-five complete brass bands of 100 instruments each. A 100-horsepower blower furnishes the wind

for this mighty assembly and, at the same time, from each corner of the huge arena "manufactured weather" in the form of carefully washed and temperature-regulated air is pumped out to the spectators at the rate of twenty-three tons a minute.

The roof is a story in itself. Architects realized that an unobstructed view from any part of the building would be one of the stadium's chief assets, so they designed a series of twelve semi-arched trusses, each 262 feet long and 114 feet above the arena. The center one weighed 210,000 pounds and the others 180,000 pounds, and all were installed in such a way that no posts or braces cut across the field of vision from any part of the interior.

Besides forming a covering for the stadium, the roof provides the housing for the organ paraphernalia and hoists to raise the lights from over the boxing ring when the matches give way to other forms of entertainment. To make the necessary connections, 5,000 miles of wire were installed. There are five huge organ lofts with "loud-speaker" chambers so ar-

ranged that the sound is evenly distributed to all parts of the stadium. The organists can vary the music to suit the performances. For instance, during the sprints at bicycle races, music calculated to inspire the contestants to their best efforts, may be played.

The stadium rests on unexcavated ground, and the main floor proper is of terrazzo. Within this material are hidden the refrigerating pipes for freezing the ice. In a few hours, the skating floor is melted and the area is available for other purposes. The refrigeration plant may be adapted to help cool the air for the building in the summer. For circuses and other events requiring a dirt floor, soil is spread over the terrazzo and then covered with tanbark or sawdust. Flexible mats are laid on the terrazzo before the dirt is applied and then lifted off in units when the rodeo or circus is over.

Special attention was paid to the boxing ring. The powerful lights that shine above the fighters' heads are of a design that creates a minimum of heat. An auto-

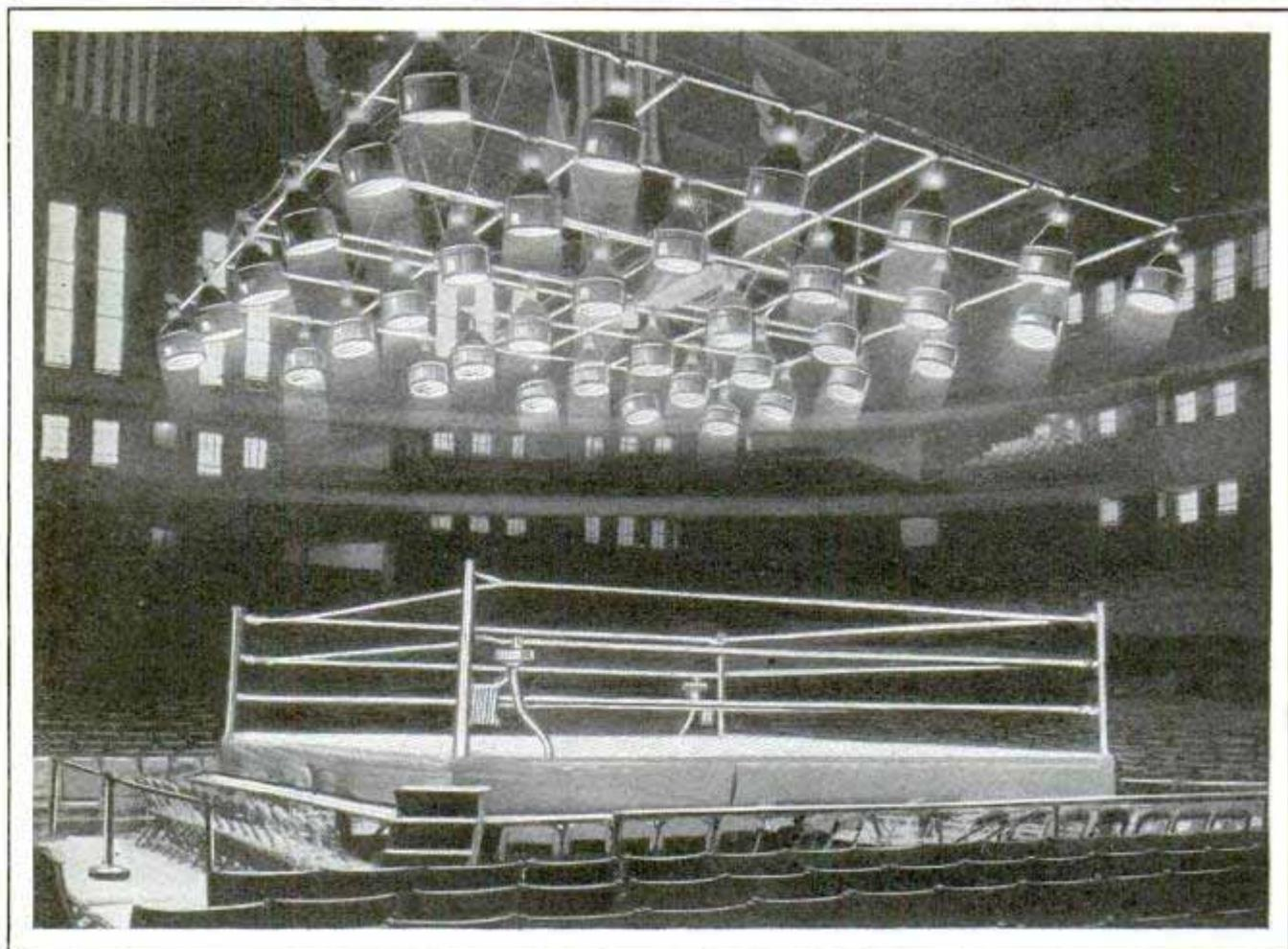

Brilliant Lights above the Boxing Ring Are of Special Design to Minimize the Heat; the Entire Lamp Frame Is Hoisted into the Roof When the Bouts Are Over; Note the Fountains at Corners

Boxing Ring in the Chicago Stadium, Showing the Automatic Timing and Recording Apparatus for the Bouts; the Number of the Round Is Flashed on Panel at Left; the Clock Hand Keeps Count of the Minutes in Each Round, and Gong and Siren Are Sounded Automatically; Inset Gives a Close View of the Control Station

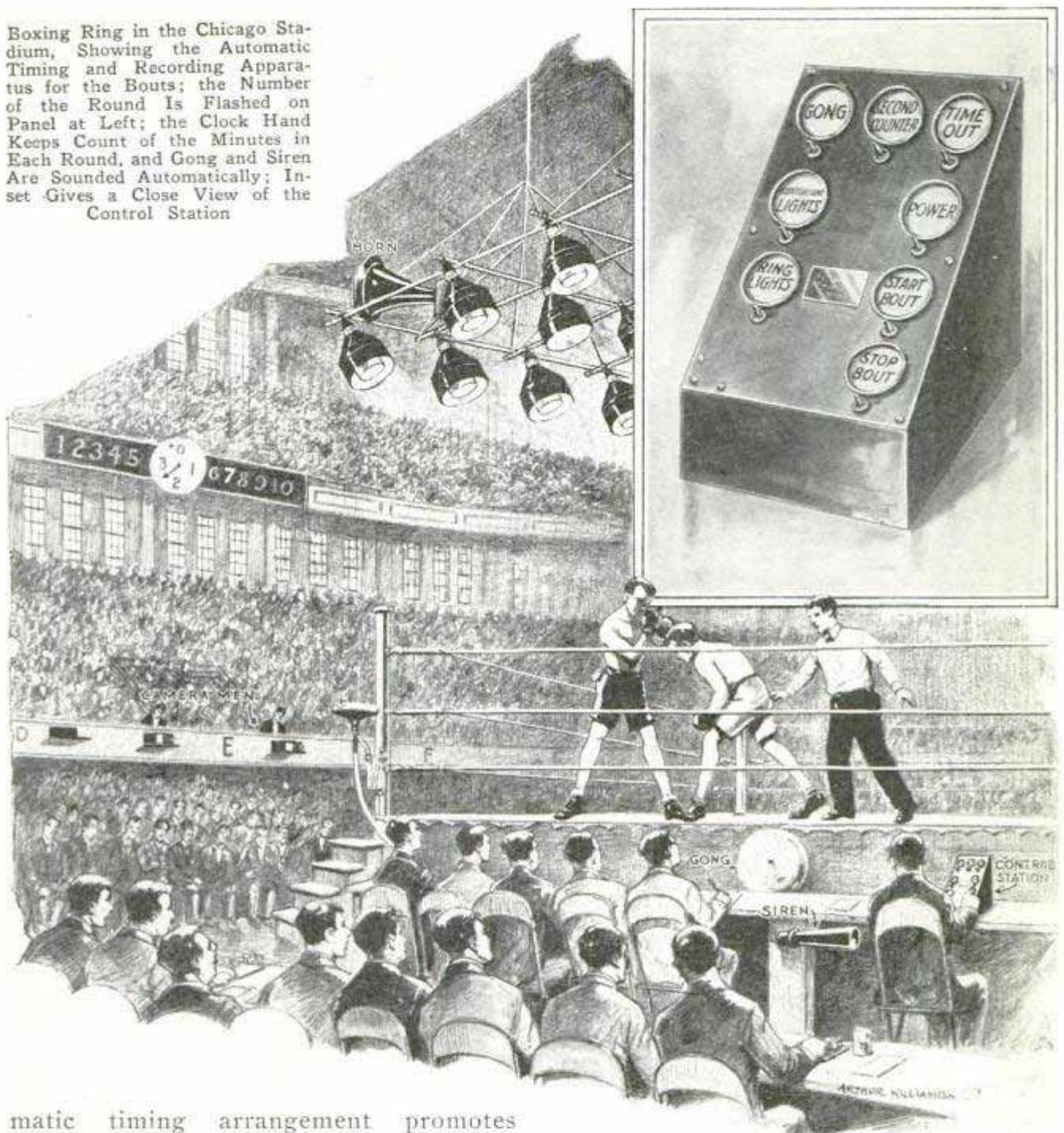

matic timing arrangement promotes greater accuracy in handling the matches. The number of each round is displayed in luminous characters at each side of the stadium where all the audience may see. The gong and siren signals are automatically sounded and electric clocks tick off the seconds of each round and indicate the time for each by means of an arrow that travels around a dial, showing just how much time is left in each round. As soon as a round is finished, part of the lights automatically go out and the auditorium lamps are turned on.

In case time out is required, the man who operates the control station presses a button which stops the arrows on the

clock dials, but the mechanism inside keeps running so that the round continues from the exact second at which it was halted. Should a boxer be knocked down, the second count is audibly registered to every person in the stadium by means of a loud buzzer which rasps out the seconds at the touch of a button. While this system is even more accurate than the usual stop-watch method of timing the boxers, it does not yet supplant the watches, although many experts have declared that it could be employed altogether and the chances of error and disagreement among the timers greatly reduced.

REVOLVING MAP TESTS SKILL OF AUTO DRIVERS

3928



Applicant for Auto Driver's License Tracing Course He Would Drive on a Street Map

Applicants for automobile drivers' licenses in Vienna, Austria, undergo many difficult tests, including marking on a map the course over which they would drive a car. The candidate grasps a driving wheel controlling a pencil with which he marks his course on a revolving street map of the city fixed on a drum in front of him. If he negotiates the streets on the map without error, he passes this particular test.

ROBOT HAS AN ELECTRIC EYE AND RADIO-TUBE BRAIN

3999

Using an electric eye to keep chemical processes under control, an apparatus that performs many laboratory operations, thereby saving the time of the chemist, was exhibited recently in New York by W. C. MacTavish, professor of chemistry, New York University. Its ability to control operations is due to its sensitivity to slight variations in color and light intensity. The working parts consist of an electric light, a photo-electric cell, which detects differences in the degree of light impinging on it, a radio tube amplifying the signal received from the cell and operating the relays controlling automatic valves. Between the electric light and the cell, for instance, is placed a glass vessel containing an alkali to be neutralized.

Above is a tube from which acid drips into the glass. A small amount of chemical indicator added to the alkali maintains a red color until it is neutralized. When the red color disappears, more light passes through the liquid to the cell, causing a signal to the radio tube which operates the relay and closes the valve, to shut off the supply of acid. Professor MacTavish also demonstrated a method of separating two kinds of hydrogen from the ordinary variety of gas and illustrated micro-analysis by accurately weighing a ball of gold which tipped the scales at one-thousandth of a milligram, which is one-twenty-eight-millionth of an ounce. Lithium, a rare, light and strange metal, weighing one-fifteenth as much as iron, and so light it floats even on kerosene and burns if exposed to air, was exhibited at the demonstration before the New York Electrical society.

KEYBOARD ON NECK OF GUITAR MAKES PLAYING EASY

3858

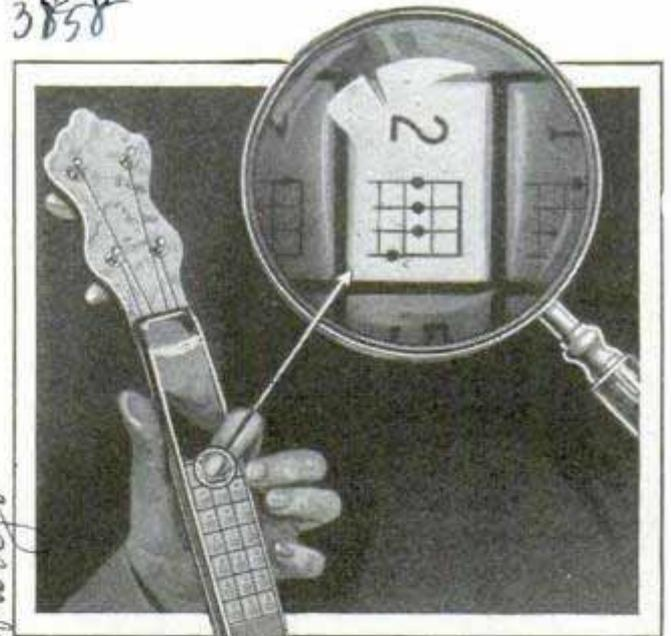

Keyboard for Strings to

Guitar. Each Key Pressing Give Chord Marked

Eliminating fingering and making chording on a guitar easy, an instrument has been developed with a keyboard on its neck where the fingering is done. The board contains twenty-one keys, each of which, when depressed, presses the strings. Popular music has chord symbols printed above the voice notes, and each chord symbol is duplicated on the keyboard.

The Keyboard Banjo Co
1925 E

at Psycho. Technical Institution

Wide world

Before N.Y. Electric Society at Science Forum

also bango

**WATER-COOLED SUPERCHARGER
 FOR FRONT-WHEEL DRIVE**

Radically different from any automobile motor yet designed is a water-cooled supercharged V-type eight-cylinder engine for front-wheel-drive cars which recently underwent tests. It is the first gasoline motor to have a water-cooled supercharger. The centrifugal water pump is at the rear of the motor which is a combination of two four-cylinder 151-cubic-inch hydroplane motors. The radiator has two caps, one for water and the other for oil. The oil passes under pressure through vertical tubes located in front of the radiator core, thus furnishing cool oil to the motor and retaining the full lubricating value. In cars of the past, gasoline has been forced, partly compressed through the medium of the supercharge, the fuel being either warm or hot as it reached the combustion chamber as the temperature varied. With the water-cooled supercharger, however, the shot to the combustion chamber is cool, thus salvaging much of the power lost under heated supercharging. Exhaust manifolds and ignition are dual, and the motor is rated at 300 horsepower. It will be eligible for the new type of racing to be in-

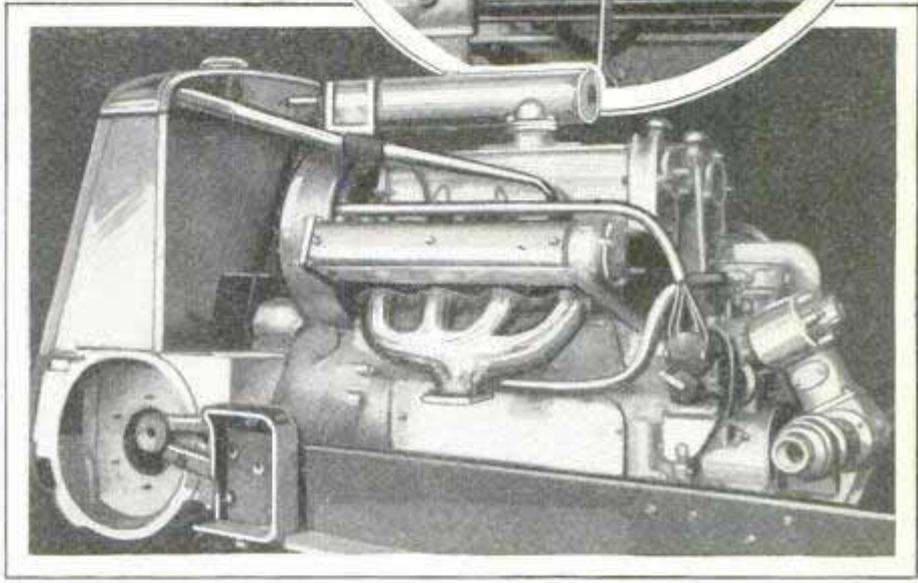
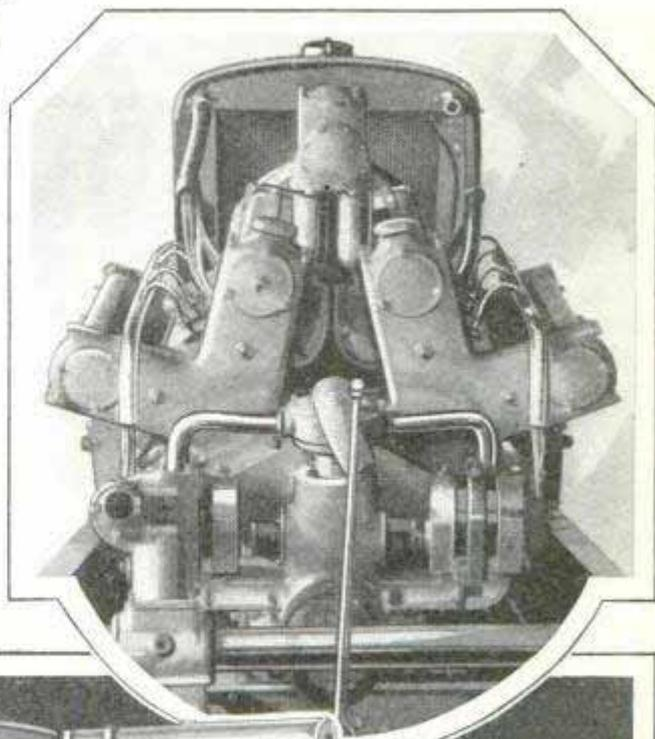

Side and End Views of Water-Cooled Supercharged V-Type Eight-Cylinder Engine for Front-Wheel-Drive Cars; Note Water Pump at Rear

augurated at Indianapolis on Memorial Day this year.

used razor and blade
 \$4.25
 \$3.75

**MACHINE GRINDS HOLLOW EDGE
 ON SAFETY-RAZOR BLADE**

Grinding and stropping in one operation requiring only a few seconds, a hollow grinder for safety-razor blades which concaves the edges like those of a hollow-ground straight razor, now is on the market. All faces of the blade are hol-

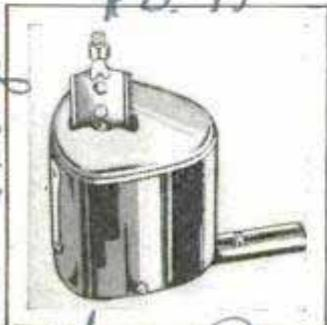

low-ground simultaneously when it is inserted in the grinder between rolls made of cellulose containing an abrasive material which needs renewal only once a year. The grinder substitutes the concave edge for the wedge-shaped one, and saves both time and money.

low-ground simultaneously when it is inserted in the grinder between rolls made of cellulose containing an abrasive material which needs renewal only once a year. The grinder substitutes the concave edge for the wedge-shaped one, and saves both time and money.

☐The Popular Mechanics' Bureau of Information offers its free service to all readers of our magazine. Names and addresses of manufacturers and dealers in articles described, and any other details in our possession, will be promptly furnished by addressing the bureau.

The Bello Corp
 Escondido, Mass

3953

HOW PREHISTORIC MAN USED THE "KILLER STONE"

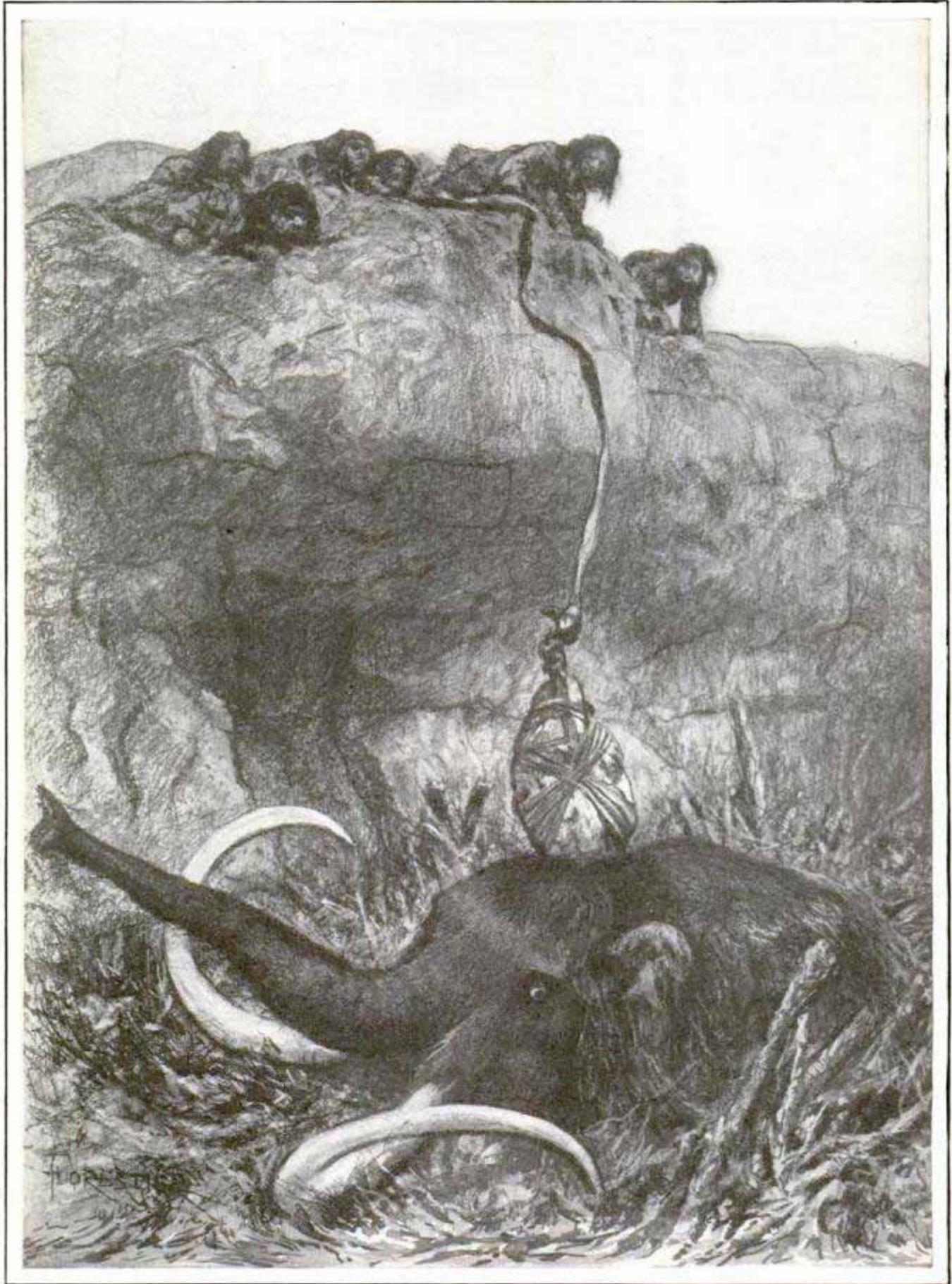

© The Illustrated London News

Reproduction of Drawing by A. Forestier from Material Supplied by Dr. Karl Absolon, to Show How Early Hunters Possibly Killed Mammoths after Trapping Them in Pitfalls

London Electrotyping Agency, London Eng

15th Central Ave
Hodge City, Kans

**TARDINESS OF THE EYE
BLAMED FOR AUTO
ACCIDENTS**

3961

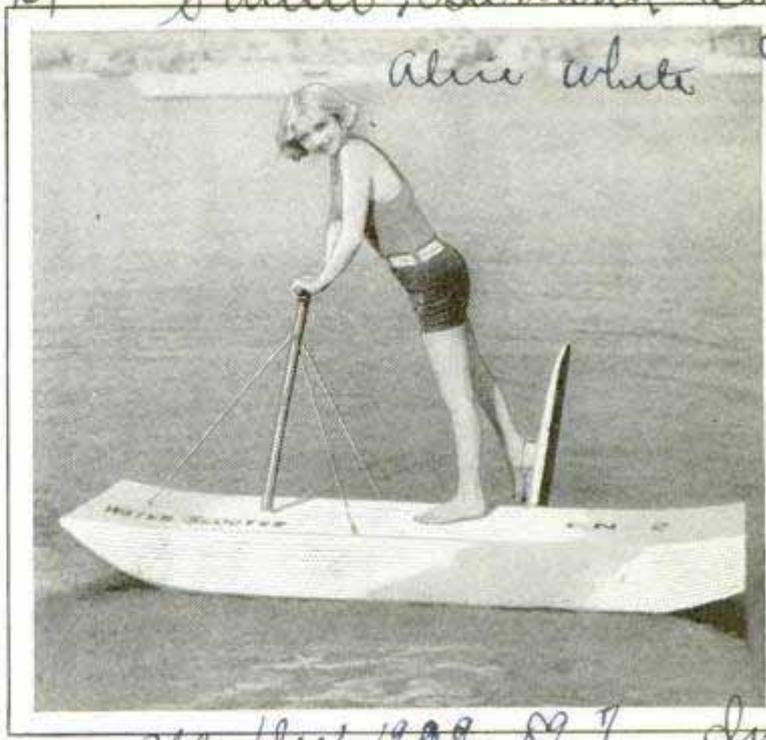

Water Scooter, Similar to the Pavement Kind, Which Is Propelled by an Oar Attached to the Foot

**SCOOTER PROPELLED IN WATER
WITH FOOT-OPERATED OAR**

Water scooters, similar to the pavement scooter in operation and in appearance, except that a boat takes the place of wheels, have been added to novel forms of water sport. The scooter consists of a support shaped like a rowboat on which the operator stands. The craft is propelled with an oar attached to the foot.

**MAGGOTS FIGHT INFECTION
BY EATING DEAD TISSUE**

Treating wounds with maggots to prevent infection is being investigated as a result of observations made during the war by Dr. William S. Baer, of Johns Hopkins University. He noticed that when wounded men had been left lying on the field unattended for some time, and were brought in with wounds covered with tiny maggots, they did not develop infections in their injuries, while many of those whose wounds were treated immediately on the field later showed evidences of infection. Further tests disclosed that the maggots were eating the dead tissues, bone and flesh, thus destroying the material that furnishes a breeding ground for bacteria. Doctor Baer has used this treatment to hasten the healing of wounds after operations since the war, with good results.

Split seconds required by the eye to register the image of a speeding automobile often represent the direct cause of automobile accidents in the opinion of Dr. T. H. Shastid, of Duluth, Minn. He found that it required one-fifth of a second for even the quickest-sighted person to develop the image of an object in the eye, and some slower-sighted persons take as long as two-fifths of a second. An auto seen traveling at fifty miles an hour, therefore, is, at any given moment, from fifteen to thirty feet in advance of the point where it appears to be, this being the distance covered by the car in the one-fifth or two-fifths of a second taken by the eye to see it. As a result pedestrians often miscalculate the car's distance from them, and the time element also is responsible for statements sometimes made by the victim of an accident that the car appeared to speed up just before he was struck.

**GARDEN-OF-EDEN TIMEPIECE
TWO HUNDRED YEARS OLD**

3926

Brought to America from Sweden many years ago, a watch depicting on its face a scene from the Garden of Eden is in the possession of a Seattle man. The timepiece, about 200 years old, shows Adam and Eve, the serpent and the apple and also includes various animals which in years past represented virtues or vices of men. The serpent serves as a second hand, making a path about the scene depicting Adam and Eve with the apple. The remarkable coloring of the garden scene, including reds, blues and other vivid shades, has been faithfully retained.



A. H. Wannenberg

Clinical professor

Cont. C. Wash Littlejohn, 2523 Jewett St. Seattle

Science Sub 11/29/29

Publcity Dept West Hall. 457
Studio, Burbank Calif

Alice White

railroad with pontoon, 6 ft long
sold by U.S. Army

36 98
458

POPULAR MECHANICS
16 Edgemont Road, Belmont Mass
FAST, MOTORIZED GUNS WITH STEEL BRAINS

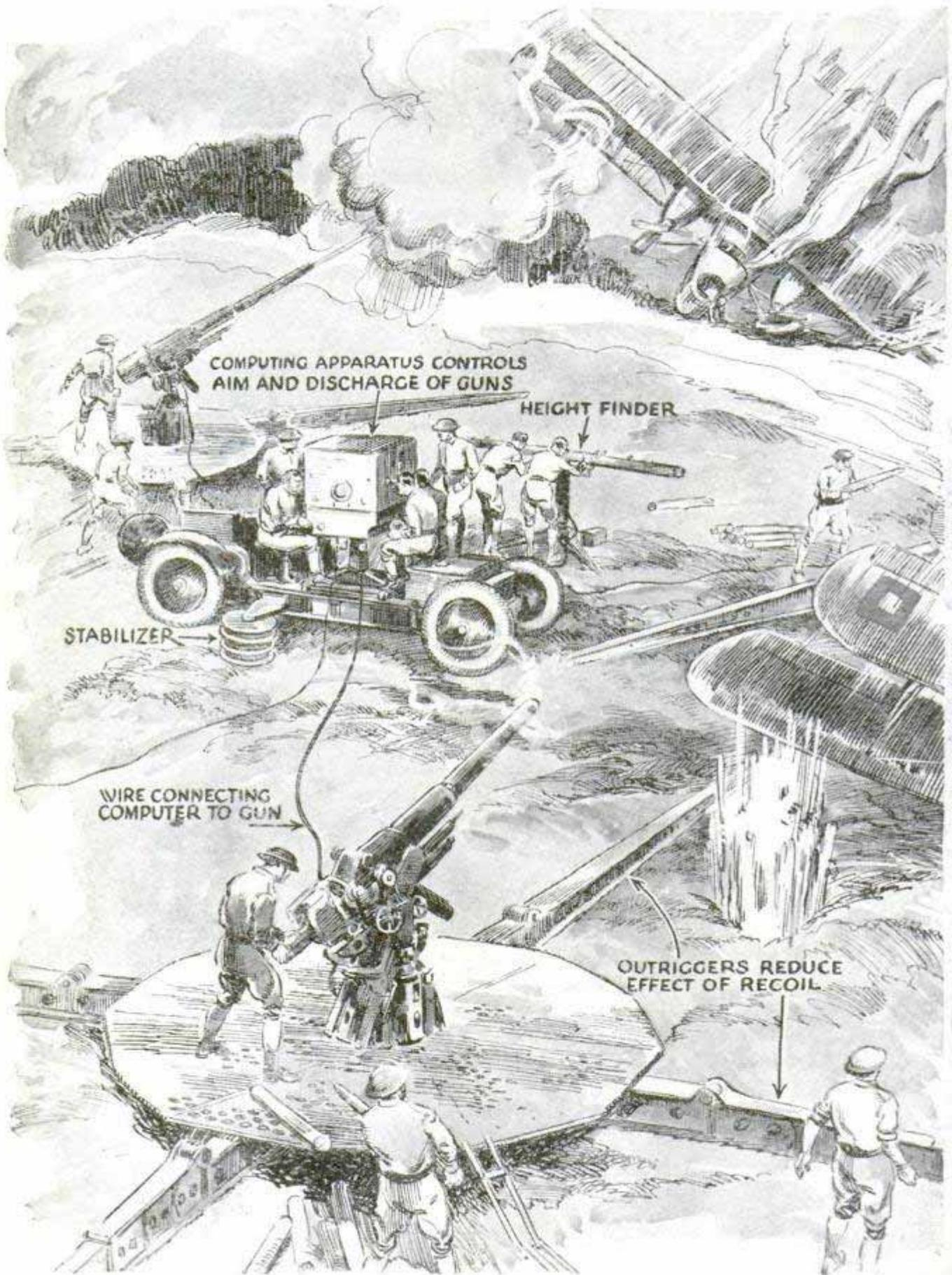

Artist's Drawing of Special Anti-Aircraft Gun Unit, Showing the Range-Finding Car and Electrical Controls That Aid in Firing; This Is a Three-Inch Gun with Six to Nine-Mile Range

BUILT TO HUNT PLANES IN THE NEXT WAR

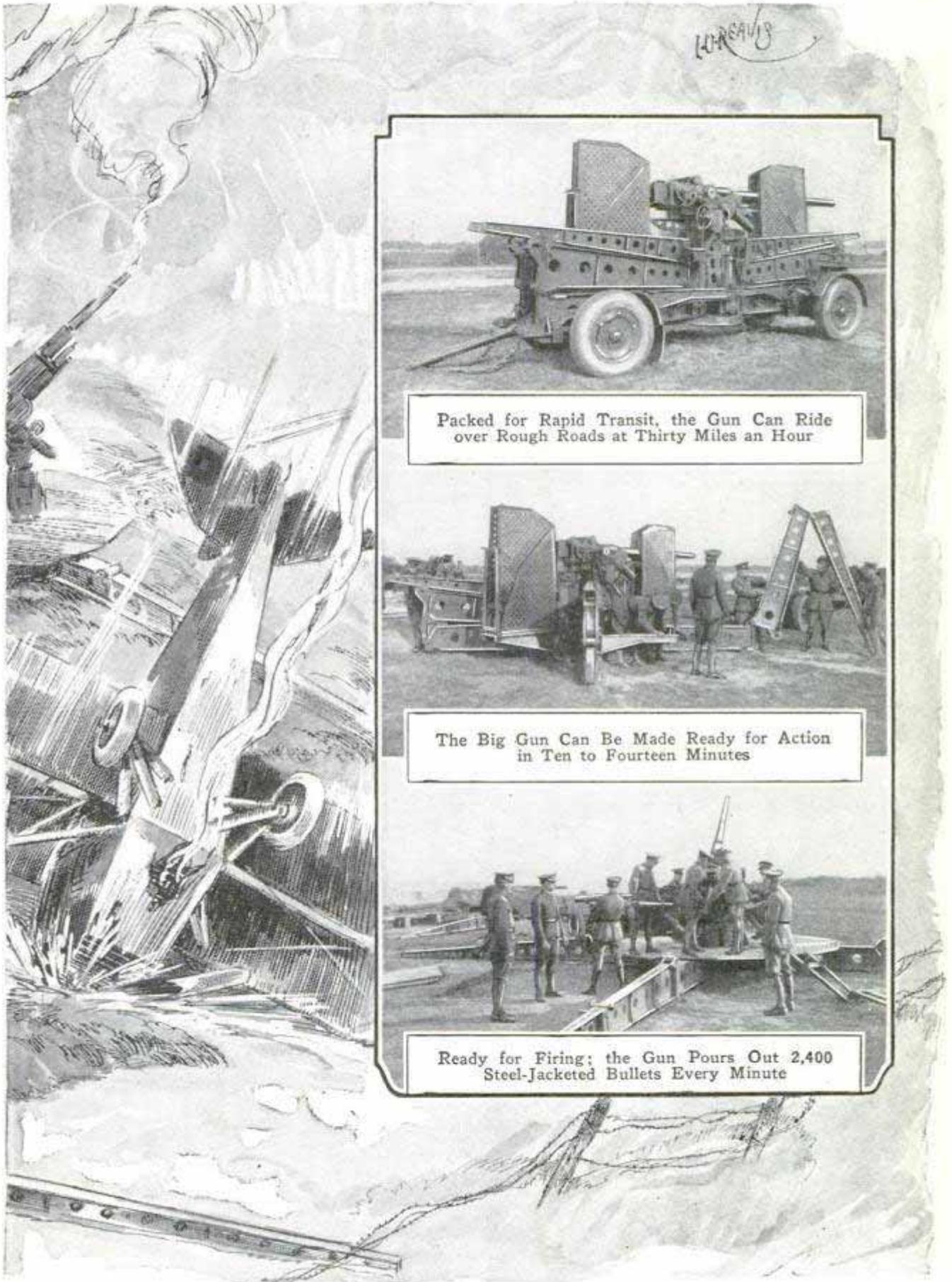

Packed for Rapid Transit, the Gun Can Ride over Rough Roads at Thirty Miles an Hour

The Big Gun Can Be Made Ready for Action in Ten to Fourteen Minutes

Ready for Firing; the Gun Pours Out 2,400 Steel-Jacketed Bullets Every Minute

Photographs Showing Steps in the Assembly of the Gun for Firing; This Weapon Was Demonstrated at the Aberdeen Proving Grounds Last Fall before Army Ordnance Experts

*Sphinx House
Patton Garden, E. C. 1
London, E.*

3893

*Dr. Paul Kruger,
Berlin Germany.*



Umbrella-Vending Machine in Berlin, and One of the Oiled-Paper Parasols It Dispenses

AUTOMATIC UMBRELLA VENDER SELLS PAPER PROTECTORS

Umbrella-vending machines in Berlin do a thriving business on rainy days or when an unexpected shower catches German shoppers unprepared. An investment of fifteen cents in the automatic vender brings forth an umbrella of oiled paper which will turn a hard rain.

LIGHT ARMOR FOR SOLDIERS RESISTS BULLETS

Secret tests of a type of lightweight armor plate of exceptional resisting power, which recently have been made by British military and naval authorities, have led to the possibility that armies of the future may go into battle wearing coats of mail or equipped with bullet-proof shields. The lighter armor plate was made by rolling down the thicker and hardening the surface, thus differing from the usual type of bullet-proof plate which is uniformly hard throughout. Heretofore excessive weight has been a great drawback in the use of armor, whether for tanks, infantry shields or warships. The reduction of the

Chicago Trib. 12/11/29

weight of sheet armor by half without diminishing its protective effect would greatly simplify tank construction as well as protection of warships.

FOG IN FRONT OF AUTO LIFTED BY HOT AIR FROM EXHAUST

Driving in a London fog has been divested of some of its danger by a British inventor who has made an instrument to dispel the fog immediately in front of an automobile. It consists of a metal tube about a foot long, attached to the exhaust pipe, which projects a stream of hot air in front of the car with a beam of light, absorbing the fog for several feet and leaving clear visibility for about a car length. Motorists with the device are enabled to proceed through traffic in a fog with safety at a speed of about fifteen miles an hour, tests indicated.

ONE-MAN SAWMILL FOR FARMER ADDS TO LUMBER PROFIT

Making it possible for the farmer to operate his own sawmill without employing other help, a one-man sawmill now is available to turn into profit much of the timber that formerly was used for fire wood or wasted entirely. The mill is so arranged that all the levers to manipulate it are within easy reach of the operator and, aside from sawing out standard-size lumber, will also cut shingles, lath and railroad ties. Stationary or portable mills may be obtained and both are operated by stationary engines, electric motors, water power, or by a belt from a truck.

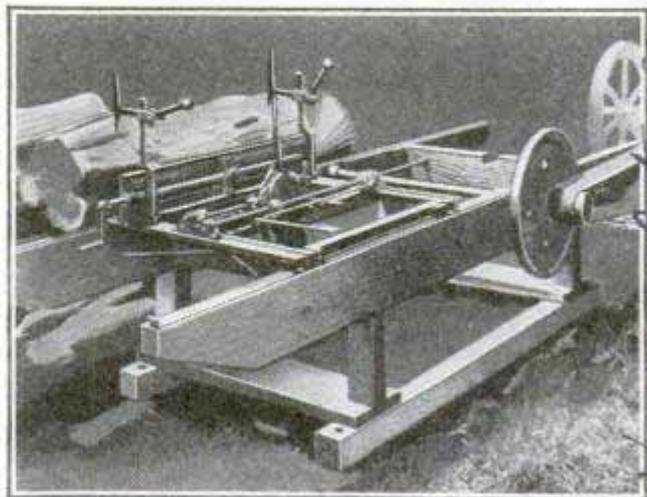

Sawmill Designed for the Farmer with Levers So Arranged That One Man Can Operate It

Belsay Machy. Co

at Woolwich Arsenal

*Dr. Patentee, H. G. Lloyd Sanders
3990*

Kansas City, Mo.

STORE ON WHEELS EXPANDS WHEN IT IS PARKED

Traveling the highways as a fast motorized unit, no wider than the ordinary automobile, but expanding, when parked, in both width and height, a traveling store or display room on wheels is now available to merchandising organizations. The vehicle is transformed in ten seconds from an ordinary commercial truck into a commodious display room by manipulating a lever

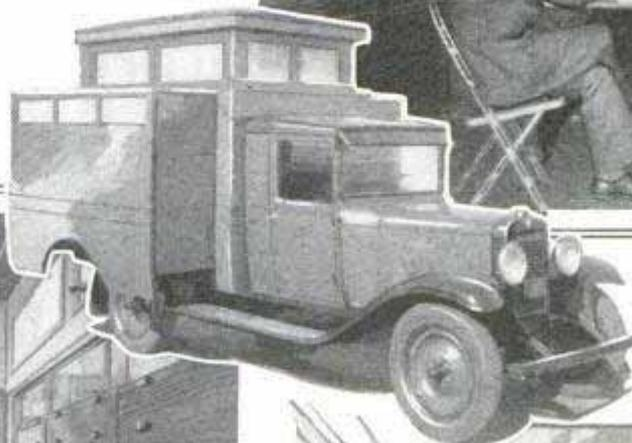

Interior and Exterior Views of a Traveling Store; When Parked, the Sides May Be Expanded and the Roof Raised to Form a Commodious Interior

which doubles the width by extending the sides, and also increases the height by lifting the roof, which brings glazed windows into view. The body fits on any standard chassis and its interior is decorated with dome and lights and affords sufficient space for display of goods and advertising material, as well as for customers. When closed, the two sides move inward without disturbing the displays on walls or racks. Drawer space also is provided where needed. Aside from being used as a traveling branch store, the unit is also valuable for salesmen visiting retailers. The half-sides of the body are expanded, and the roof is

raised simultaneously by a lever in the front compartment which operates an electric motor with automatic control. Each of the half sections, when expanded, will support a ton of weight, making possible the mounting in these sections of machinery in operation for display purposes. The wide rear step is constructed to serve also as a rear bumper. There is sufficient floor space for installation of folding desks or chairs which do not interfere with the closing of the body. Triple locking equipment gives security to the shop and its contents whether open or closed. Expanded, the body is 80 inches high, 103 inches wide and 91 inches long.

\$2165.00 f.d. A report of it

3583

Making Home

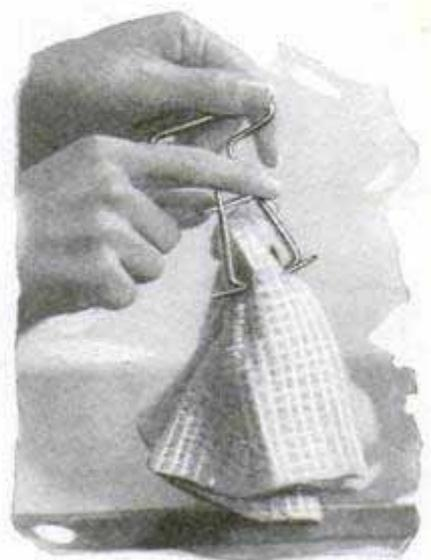

To Hold Cleaning Cloths and Polishers, This Adjustable Grip Spares the Hands and May Also Be Used for the Scraping of Pots

Here Is an Efficient Electric Range That Is Built Up or Taken Down in Units like a Sectional Bookcase for Kitchens of Different Size and for a Wide Variety of Cooking Tasks

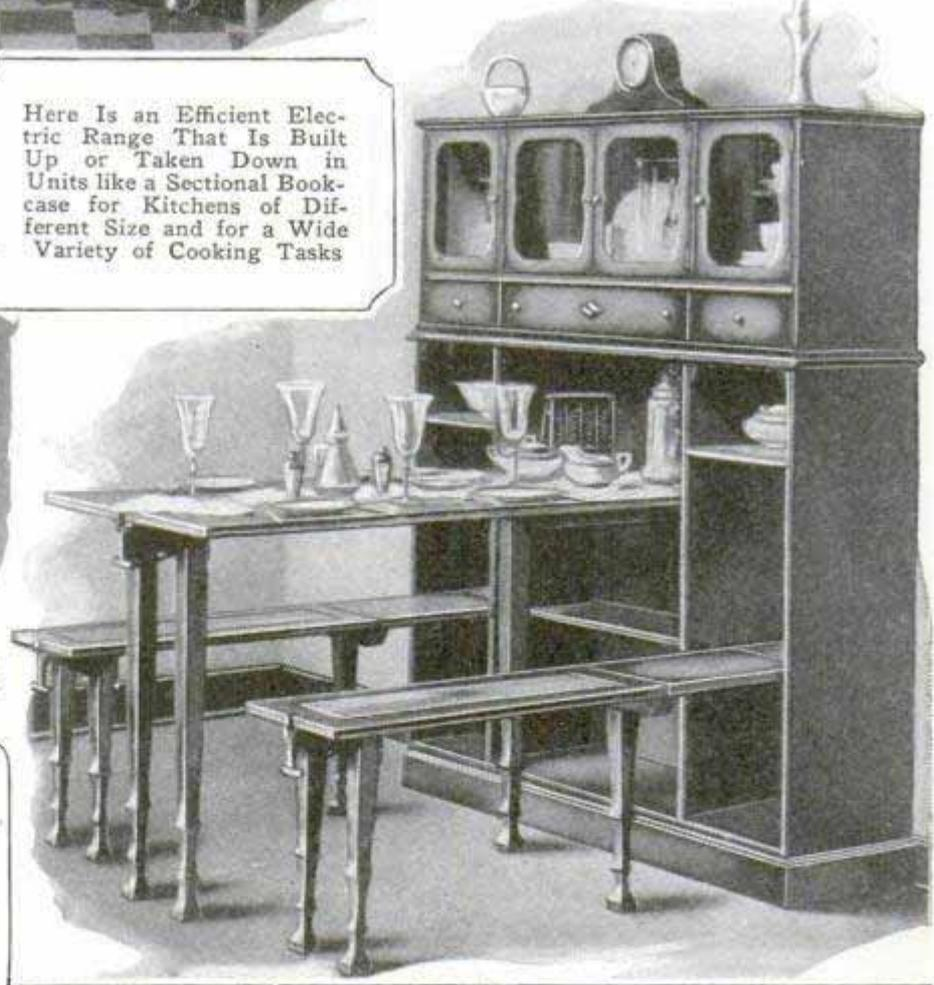
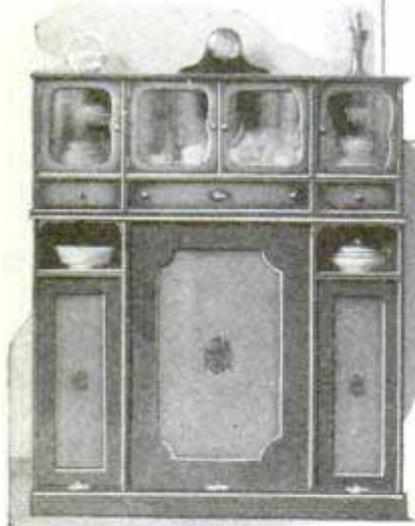

When Folded Up, This Breakfast Set Serves as a China Closet, Yet Seats Four or Five Persons When Extended; It Can Be Built into the Wall to Save Further Space and Is Easily Adjusted

Tasks a Pleasure



Trousers' Hanger with Drop Rack Fits in Small Space and Simplifies the Task of Putting the Garments Away; It Can Be Used on a Closet Door



A Cup Holder with Handles for Baby's Bottle Prevents Breakage, Helps Keep the Milk Warm as It May Be Heated, and Protects the Infant from Disease, as It Keeps the Bottle Clean



Vegetable and Fruit Shredders of Different Degrees of Fineness Have Wide Usage and Save Time in Preparing Many Foods



Electric Hair Drier That May Be Attached to the Wall Is Serviceable for the Bathroom, the Gymnasium Locker Room or the Swimming Pool



The Back of This Strong Kitchen Spoon Is Corrugated for Grating Foods, and Prong at End Aids in Handling Croquettes, Sticky Potatoes and Similar Foods

380 3

Inventor and Patentee
Clyde C. Galston, N.Y.

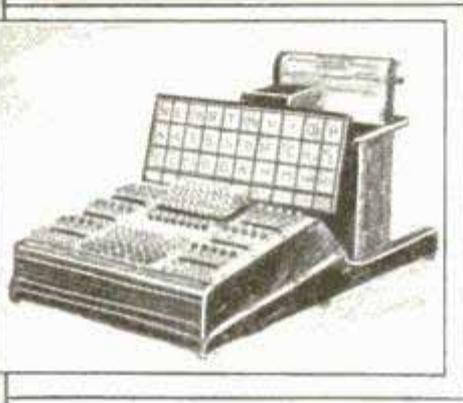
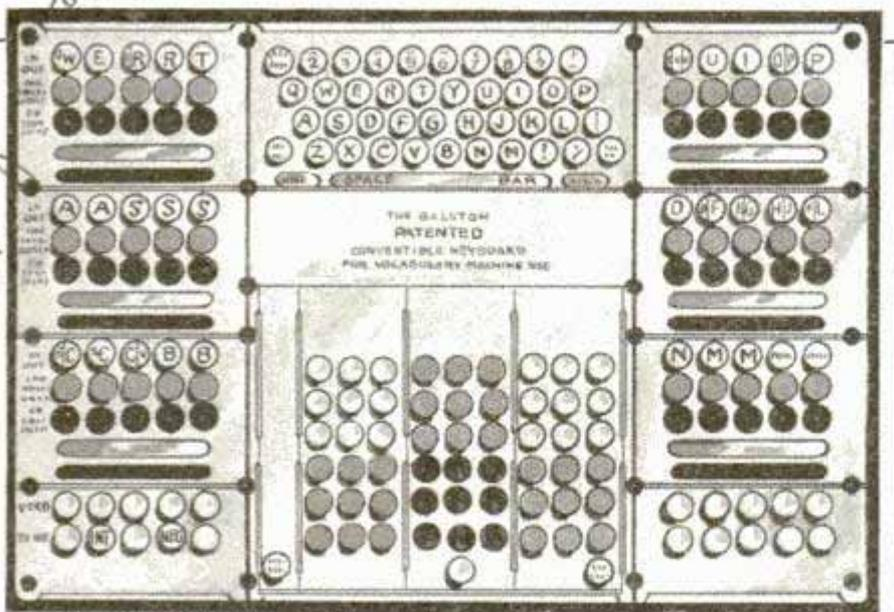

turn mail" and others commonly written are likewise reproduced almost instantly, often but five or six key operations being sufficient to write a whole line. The machine can be adapted to special tasks, such as billing telephone tolls and similar work. With little practice, it is said, a novice can learn to use the machine very rapidly.

REMOVING TATTOO MARKS IS TASK FOR DOCTORS

Tattooing, according to Dr. Melvin D. Shie, of Cleveland, who has specialized in the removal of skin designs, is of ancient origin. The Egyptians practiced the art of decorating their skin, as indicated by tattooed mummies. But the art is by no means associated only with primitive peoples. It is practiced more widely today than ever

Rapid Typing Machine That Prints Whole Words and Phrases at a Time, View of Keyboard, and Some of Word Combinations

RAPID TYPING MACHINE PRINTS WHOLE PHRASES AT A TIME

Whole words and phrases are instantaneously spelled and written by the depression of only two keys on a rapid-typing unit an eastern inventor has developed. It is essentially a typewriter in function, but greatly speeds the operator's performance, 300 words per minute being easily printed when writing single words only, and many more when whole phrases can be employed. The principle of the machine is based on the fact that about 100 common words constitute more than fifty per cent of the contents of the usual business letter. The great bulk of ordinary conversation and daily speech is confined to about 400 different words. Recognizing these facts, the inventor arranged the machine in such a way that depression of two keys would print the entire word. Such phrases as "My Dear Sir," "by re-

before, Doctor Shie claims. Although the electric needle and modern methods have done much to remove most of the risk attending the decorating of the epidermis, there still is considerable danger when the tattoo artist does not use surgical precautions to prevent infection. Tattooing, in general, consists in imbedding pigment in the skin. If the coloring matter is deeply applied, the tattoo is quite permanent. Otherwise it may fade or be removed by some process such as accidental burning or action of light. The pigments are applied by puncturing the skin and forcing them into the wound. Since tattooing is merely an imbedding of pigment in the skin, its removal consists mainly in extracting the coloring matter, but to do this without excessive scarring or discomfort is not always easy. Tattooing designs can be removed by chemical, electrical or surgical means, but the removal is often more painful than the original ap-

Cont. Walter E. Burton
1923 7 1/2 Ave. N.Y.

plication, and it usually leaves some kind of scar. Small, outlined figures, such as daggers, are easily removed by surgical means, leaving only a fine, hairline scar. But when someone approaches the doctor with a request to erase a four-masted schooner or a well-equipped battleship, the problem is a little more complicated. Although there are several methods by which tattooed designs can be taken away, one of the most satisfactory involves treatment of the tattooed area with tannic acid. The acid is imbedded in the skin thoroughly by means of an electric needle, dental engine or a group of needles fastened in a cork. Then the tattooed skin is rubbed with silver nitrate which, reacting with the tannic acid, produces silver tannate. After several days the scab that forms over the area is removed, taking with it the pigment.

PORTABLE COMPRESSOR ON CAR OPERATED BY ENGINE

Driven by the automobile or truck engine, a portable compressor which may be attached to the front of a car now is on the market. It is operated by hand-lever control and is driven from the motor crankshaft. Garage road-service trucks find it useful in obtaining air for tires, and it may also be used for paint spraying and operating pneumatic tools. It can be mounted on any make of car or truck.



Four One-Ton Ground Rollers Like the One Shown Are Used to Anchor This Big Dirigible

ANCHORS FOR GIANT DIRIGIBLE ARE ONE-TON ROLLERS

Four one-ton ground rollers serve as anchors to hold the giant British dirigible "R-101" in place when the ship is moored to its mast at Cardington. The rollers are suspended from the tail end of the ship, to keep it from swaying and hold it at a constant level.

BLUE GEM COLORED BY HEATING

Jewelry experts, puzzled by the appearance of a sparkling deep-blue zircon, have decided that the comparatively new element, hafnium, is responsible for the color. It was learned that crystals of blue zircon all originated from a certain locality in Siam where the brown mineral, before being cut, was heated for some hours in a closed crucible with cyanide of potassium, emerging in colors ranging from nearly white to deep sapphire-blue. Only the heavier varieties of the mineral turn blue, and these are the ones containing hafnium, which is believed responsible for the color manifestation.

Chicago 624 S. Merch

Auto Service News Bulletin 12/9/29-455-9

Wide World

*3967
Nathan G.
71 Nassau St.*



Portable Compressor Attached to Auto, Which May Be Used for Paint Spraying or Tire Inflation

Iskole Mfg Co

Mr. George J. Kunin

3764

Box 840, Washington, D.C.

Big Shovels



AN able-bodied laborer, armed with a hand shovel, digs a cubic yard of loose dirt an hour. Working eight hours a day, it would take him two whole days to dig enough to fill the dipper, alias the bucket, of an electric shovel constructed a few months ago.

In dipper capacity, though not in some of its other dimensions, the shovel in question is the world's biggest up to date. Its total weight is 1,036 tons. The dipper alone weighs twenty-six tons. Filled evenly to the brim it holds sixteen cubic yards. In actual digging, the material is usually heaped above the brim, so that it handles seventeen to eighteen cubic yards at each filling. The steel cables that hoist it through the dirt are as thick as a man's arm.

The famous steam shovels that dug the Panama canal were puny in comparison with this electric giant, yet it was designed for no romantic feats of engineering. Shipped unassembled on twenty-eight railroad flat cars to southeastern Kansas, it was erected on the open prairie and put to work scooping up a layer of soil, about twenty-five feet deep, overlying a

three-foot seam of coal. The process is called "stripping."

Several other shovels of spectacular size have been built within the past three years for similar work. They have made possible a striking increase in the open-pit mining of coal; an operation still unfamiliar to most Americans, though it was the earliest method of mining coal in this country. Originally the surface earth and rock was removed by pick and shovel, loaded into wheelbarrows, and dumped. Some of the early wheelbarrow runs

James D. Lane Co. Chehalis, Tex.

11/4 70
 Courtesy Link-Belt Co.
 Gas-Powered Shovel Loading Boulders Too Big for the Scoops at a Texas Quarry

9/10 S. Michigan Ave

and Why

and dumps can still be seen in the anthracite district of Pennsylvania. Later, somewhat deeper coverings were removed by means of horse-drawn scrapers, but the seams of coal near enough to the surface to be reached by these primitive methods were worked out years ago, and this kind of mining ceased to be of any importance.

With the advent of big power shovels, a revival of coal stripping began. Lately it has made such progress in some parts of the country that near-by underground mines find it difficult to compete with the cheaply operated surface mines. As recently as the year 1914, only three-tenths of one per cent of all the coal mined in the United States was obtained by stripping, but the amount has since risen to more than three per cent and is steadily increasing. A total of 19,000,000 tons of coal is now mined by this process in an average year.

A single open-pit mine in Indiana is producing 4,500 tons of coal a day. The methods followed at this time afford an interesting contrast to those traditionally associated with the mining of coal. Though no shafts need be sunk or tunnels driven, as in underground mining, the task of reaching the coal is by no means an easy one. The seam lies from ten to sixty feet below the surface and is overlaid by a thick layer of solid rock, mainly limestone.

Before this cover can be removed by the shovels, it must be blasted. At this 5,000-acre mine, as at several other large-scale stripings for coal and ore

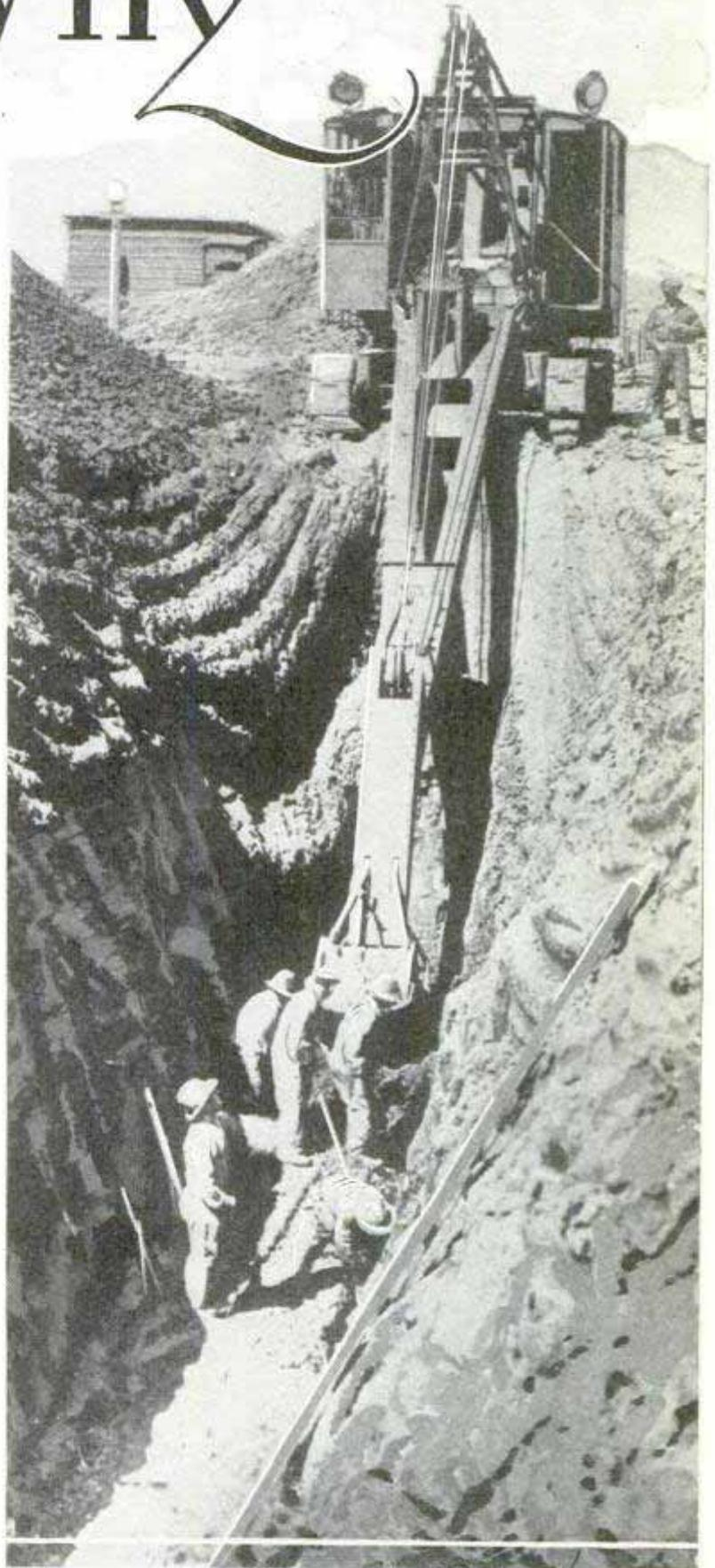

Courtesy Link-Belt Co., 300 W. Pershing
A Huge Shovel Turns Trench Digger and Tears Out a Ditch
Eighteen Feet Deep, a Cubic Yard at a Time

Coal, Chicago 467
910 S. ...

3764

South Milwaukee, Wis.

in this country and abroad, black powder and dynamite have been replaced, for blasting, by the equally powerful and much less expensive liquid-oxygen explosive, known to miners as "LOX." The liquid oxygen is produced at the mine. The cartridges consist of bags of powdered carbon soaked in this temporary liquid and are prepared shortly before blasting, as the effective life of a cartridge is only about forty-five minutes. They are lowered into drill holes and fired with an electric battery.

Half a dozen big shovels perform the stripping at this mine, the biggest being an electric shovel that takes twelve cubic yards at a bite. Smaller shovels dig out the coal after it is uncovered

and load it into mine cars, which carry it to a tippie, where it is screened and prepared for market.

Another huge coal stripping, located near Du Quoin, Ill., is equipped entirely with electric shovels and drag lines. The largest shovel used here has a dipper with a capacity of fifteen cubic yards, while in

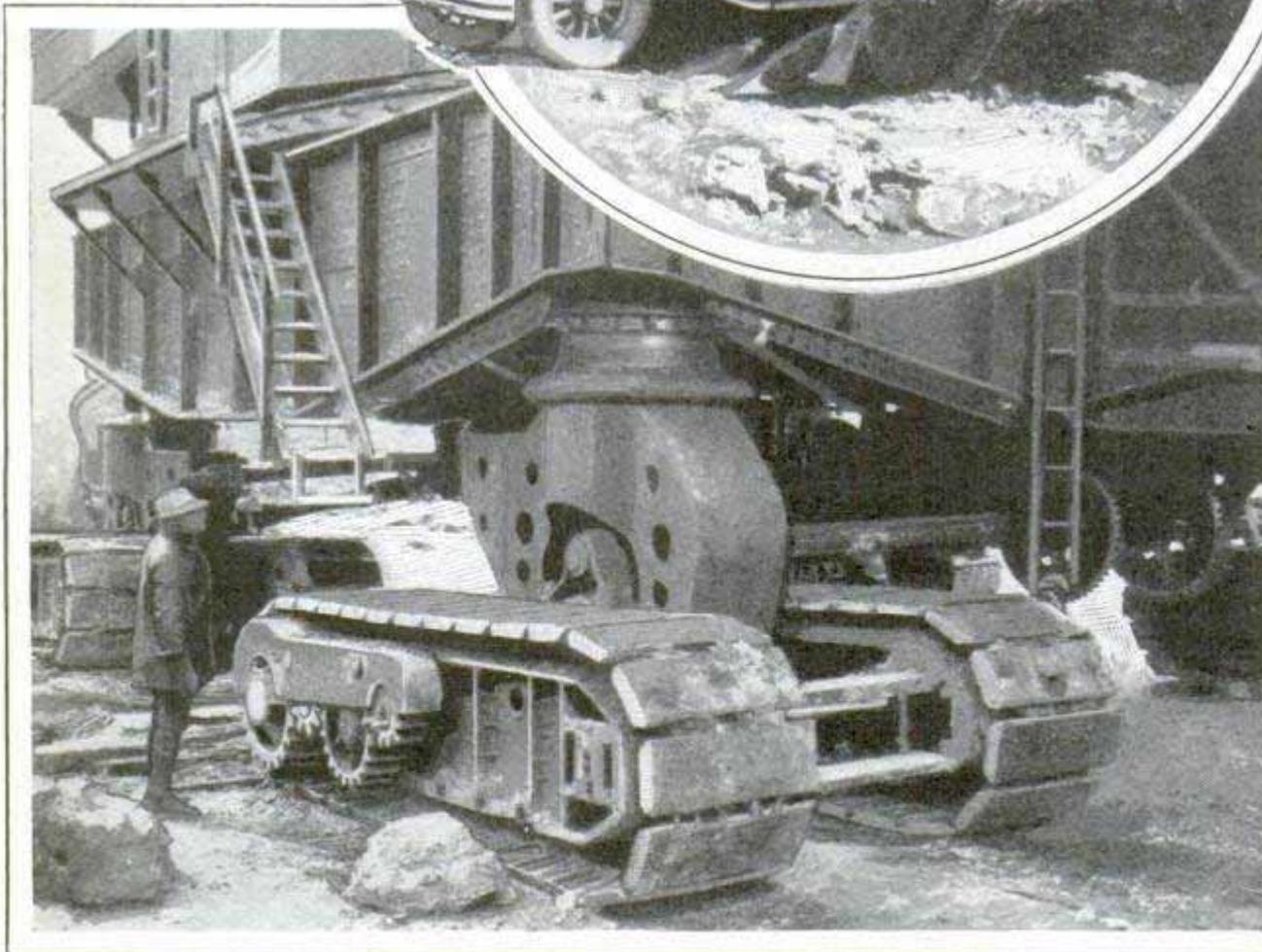

South Milwaukee, Wis.

Courtesy Bucyrus-Erie Co.

In Circle, Colossal Bucket of Huge Shovel Built for Stripping Coal in Kansas; It Bites Sixteen Cubic Yards at a Mouthful; Below, Traction Trucks and Hydraulic Jacks of the Monster Shovel

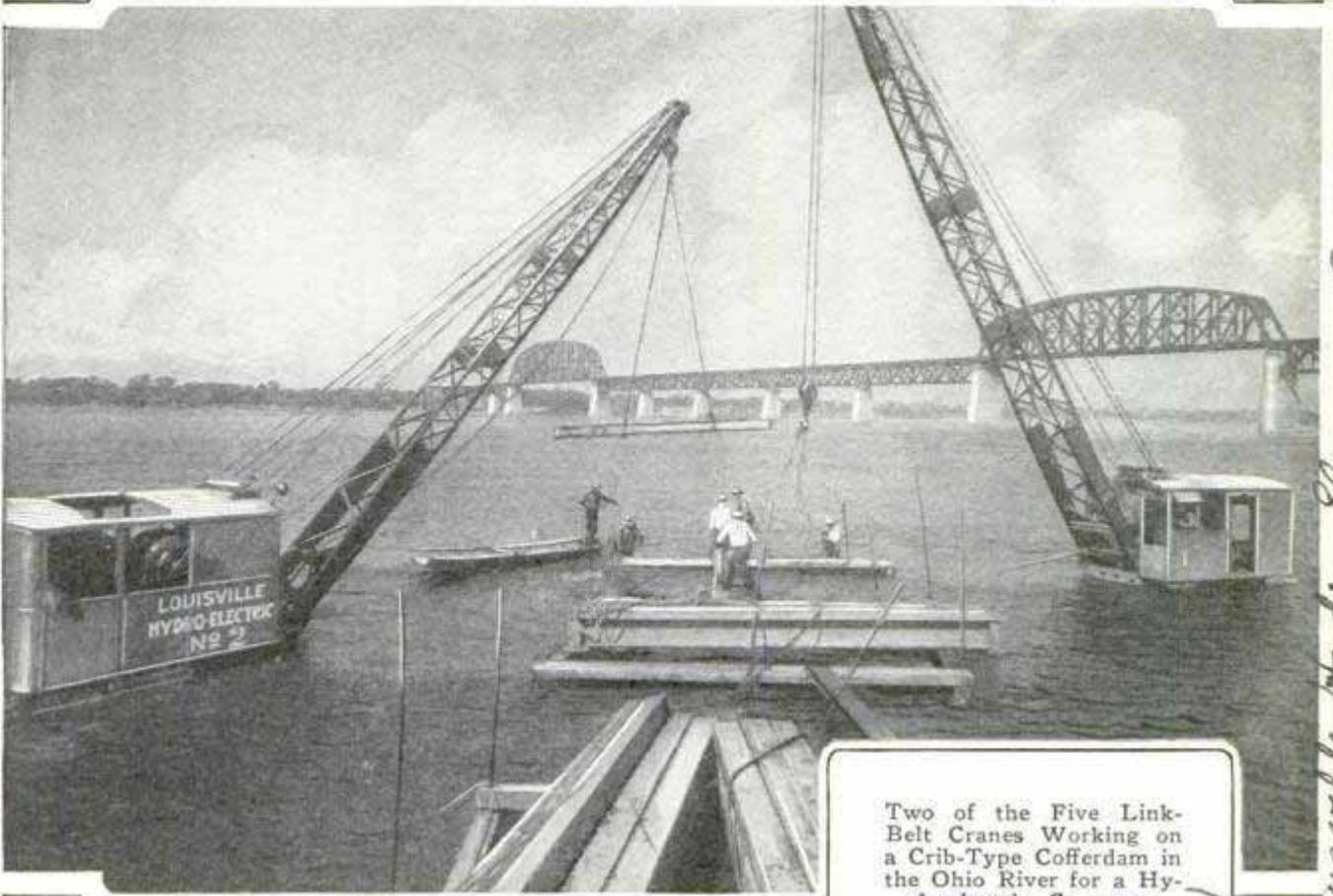

Two of the Five Link-Belt Cranes Working on a Crib-Type Cofferdam in the Ohio River for a Hydroelectric Company

*Louisville Hydro. Electric Co.
Louisville, Ky.*

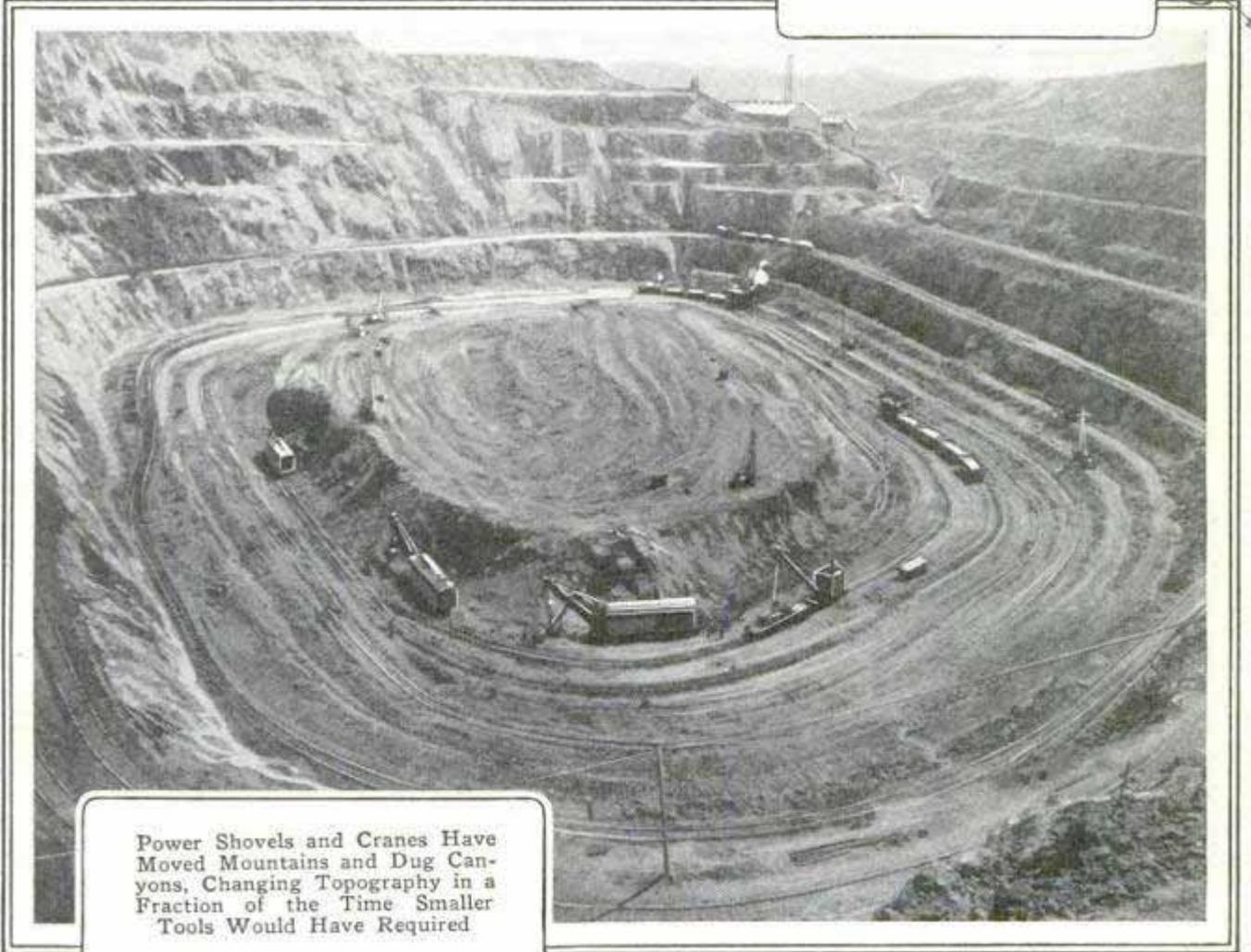

Power Shovels and Cranes Have Moved Mountains and Dug Canyons, Changing Topography in a Fraction of the Time Smaller Tools Would Have Required

some of its features it even surpasses the Kansas machine, previously mentioned. So great is its reach that it can place material eighty-five feet above the ground, or on top of a seven-story building. Its total weight is 1,600 tons.

It is estimated that upward of 550 power shovels of all kinds are in use at open-pit coal mines in the United States, and more than ten per cent of these, including all of exceptionally large size, are driven by electric motors. The huge electric shovel is the most economical of all digging machines, and with this tool at his disposal, the miner finds it profitable to go deeper for thin seams of coal than was ever practicable with the use of steam shovels. The rule of thumb at strippings where this type of machinery is employed is that it pays to remove a foot of surface material for each inch of coal in the underlying seam—to remove, for example, thirty feet of waste to reach a thirty-inch coal seam—but at some electrically equipped mines the proportion of material stripped is actually much greater than this.

Although the first electrically operated shovel was built in 1899, the development of such machines was so slow that up to 1914 only about twenty had been constructed in the whole world. If they had been perfected a few years sooner, they would undoubtedly have been employed in preference to steam shovels in digging the Panama canal, and their use would have greatly accelerated that historic job.

The open-pit method of mining iron ore is more familiar than the stripping of coal because the most productive iron mines in the world, located in the Lake Superior region, have been worked by this method for many years. Steam shovels were first employed at some of them in 1893 and electric shovels were introduced in 1920. While much iron is mined underground in the same region, there are nearly eighty open-pit iron mines. The Hull Rust mine, on the Mesabi range in Minnesota, is a far bigger man-made hole in the ground than the Culebra cut in Panama, and from this pit alone more than 100,000,000 tons of

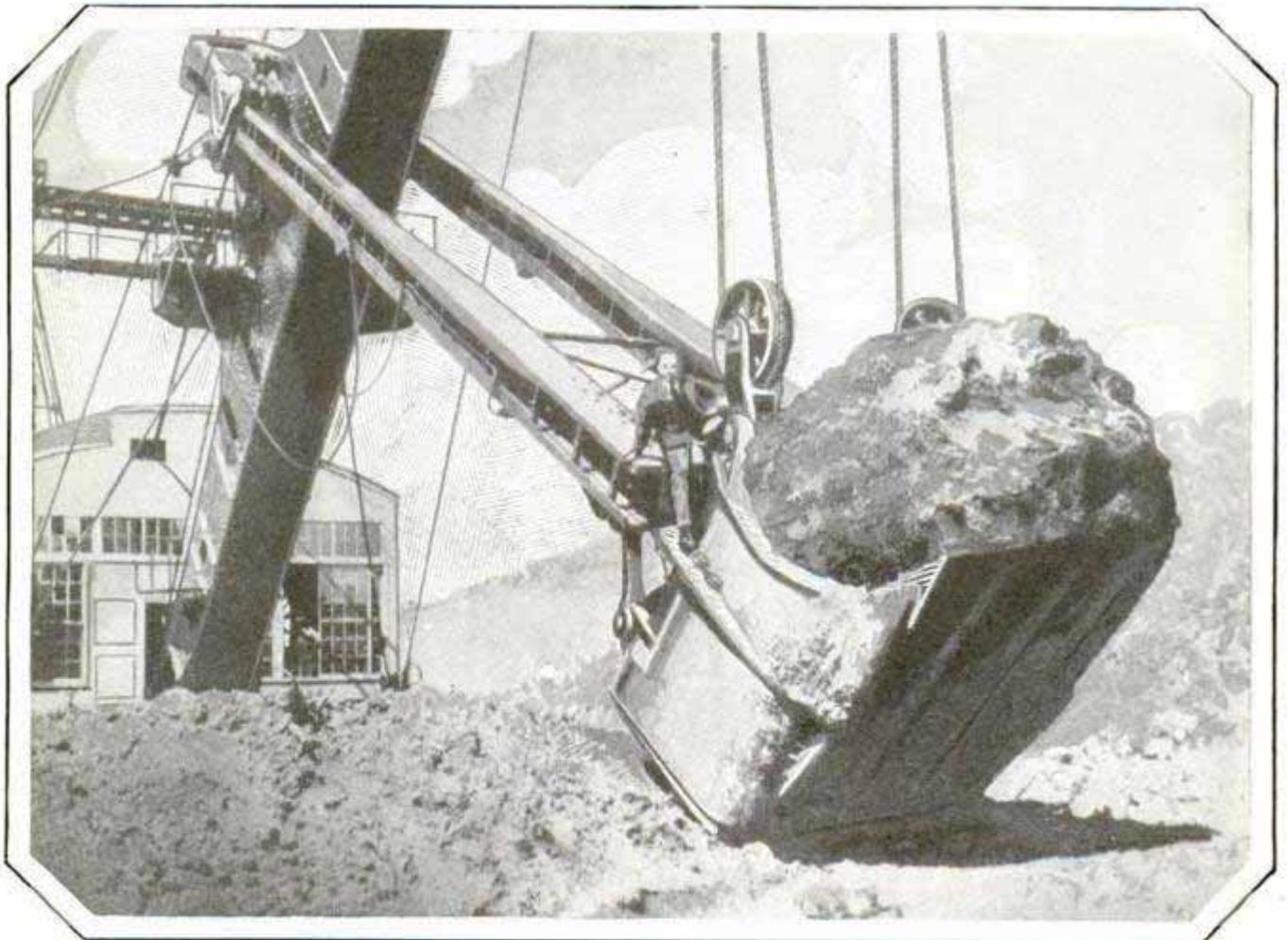

Another View of the Sixteen-Cubic-Yard Dipper; It Would Take a Laborer with a Hand Shovel Two Eight-Hour Days to Dig This Quantity of Dirt

iron ore has been dug up to date—about two-thirds the average annual supply of the entire world.

All the larger pits are terraced down the sides and standard-gauge railroad tracks are laid on the ledges for the trains that spiral down into the pit and return to the surface laden with ore or waste. A few of the mines are now completely electrified, using electric locomotives to haul the cars as well as electric shovels for stripping and mining.

A COOLER FOR ROOFS

3934

Providing a constant inlet of air to supplement drafts, through openings cut in the ordinary sheet lengths, a system of air circulation for iron roofs has been devised to keep them as cool as those of tile. Entrance of rain is prevented by metal covers over the openings and insects are kept out by metal gauze. The inlets, about nine inches in diameter by twenty inches in length, are located near the lower part of the roof, above the ceilings of rooms, and operate with a ventilating cowl near the ridge. An opening in the ceiling of the room allows heated air to rise into the roof and be carried out.



Consulting Guide Attached to Lamp-Post; Steel Leaves in the Directory Withstand Weather Conditions

CITY GUIDES ON LAMP-POSTS HAVE STEEL LEAVES

Street directories are easily available to travelers in Oakland, Calif., in the form of books with steel leaves attached to lamp-posts at the intersections. Maps and directions for reaching points of interest are contained in the guides, which are six inches wide and sixteen inches long.

BURN COAL IN GROUND FOR GAS

3940

Patents have been sought to cover a process of burning coal underground and piping the resulting gas to the surface. By controlling the burning fuel, either petroleum or carbon dioxide may be produced, the former being refined into gasoline and the latter being used for dry ice, both at low cost. The gas can be piped to the consuming area or burned at the mine to generate electric power.

Chicago - 2540 d Wabash

AXLES BENT BACK INTO SHAPE BY STRENGTH OF HAND

3868

Reducing or increasing the camber of the front wheels of an automobile is easily accomplished in a few minutes with a hydraulic axle setter now available for garages. It takes the strength of only one hand to cold-bend a car axle up or down while it is attached to or detached from the car. The setter is light and portable and may be used to bend either end at will, or to alter both ends simultaneously, requiring from eight to fifteen minutes for the average operation.

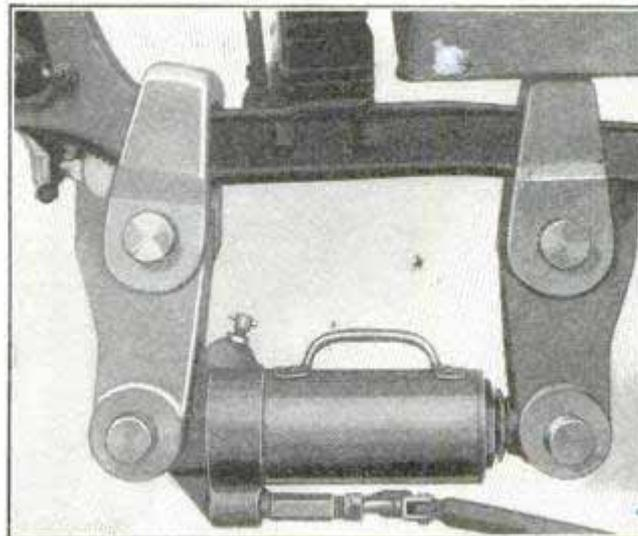

Hydraulic Axle Setter Requiring Strength of Only One Hand to Bend Auto Axle Cold

Christian & Co. member of New Jersey Steel & Iron Co. of New Jersey

Patents owned by Steel Co. of New Jersey
 Standard Steel & Iron Co. of New Jersey

Mfr. A. E. Ferragen Inc.
 211 ... Wheel Corp.

A Practical Power



By J. S. Hagans, 10/53
Prospect Ave. Chicago

this is provided with a center tap. The output windings for the rectifier plates are wound for 550 volts each. If only half-wave rectification is desired, only one of the high-voltage windings is used with one of the 81-tubes. For smooth full-wave rectification it will, of course, be necessary to use both high-voltage windings and two of the type-81 half-wave rectifier tubes. If two of the 210 or 250 power amplifier tubes are used in push-pull, it will be necessary to use full-wave rectification.

THE DESIRE of an experimenter to try out different a.c. circuits and power amplifiers requiring high plate voltages is frequently blocked by the lack of a power transformer with secondary windings to suit a wide variety of circuits. The transformer to be described has been designed to meet these requirements within the widest possible range at a comparatively low cost.

The diagram, Fig. 1, shows the various windings and their positions on the core. It will be noted that this transformer supplies 1½, 2½, and 7½ volts, the 7½ volts to supply either one or two of the type-210 power amplifier tubes. There is also a 7½-volt winding for either one or two of the half-wave rectifier 281-tubes, and

The first step in construction is to prepare the laminations for the core. These may be cut by hand from silicon-steel blanks or purchased, ready-punched to the specified dimensions. The ready-punched laminations will only cost about \$2, so little will be gained in cutting out your own unless you happen to have the blank core material on hand. About 150 of these E-laminations are required to build up the core to the necessary thickness and the same number of the end or I-laminations. The laminations should be coated on one side with lacquer to insulate them from each other for cool transformer operation, although this is not absolutely necessary.

Next make a spool or form on which the primary and several secondaries are to be wound. The simplest way of doing this is to wrap a piece of 1/32-in. fiber around the center leg of the full stack of E-laminations.

Next make a spool or form on which the primary and several secondaries are to be wound. The simplest way of doing this is to wrap a piece of 1/32-in. fiber around the center leg of the full stack of E-laminations.

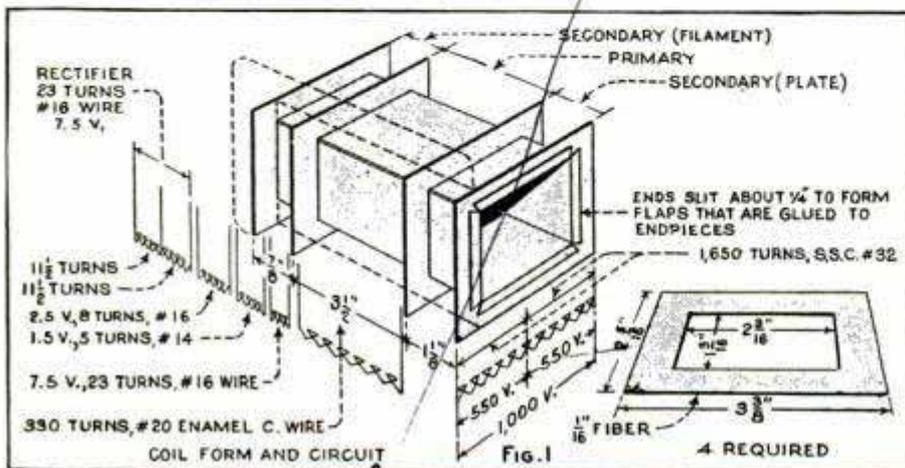

Lamination Stampings Co

Homemade Transformer

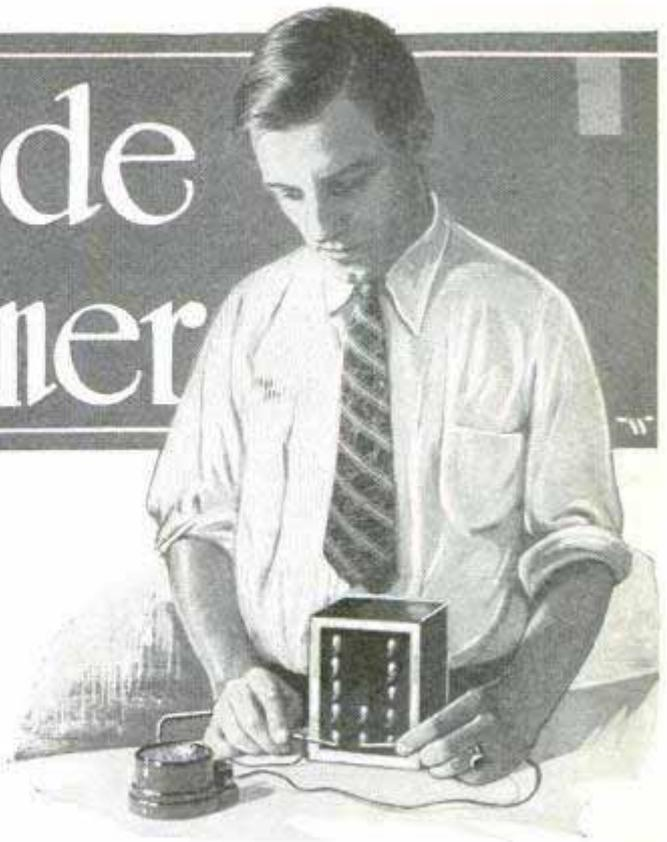

Make this strip of fiber about 1 in. longer than the core leg, then wrap the strip around the center leg of the core to find exactly where the spool is to be folded in order to fit accurately. Lap the edges over each other, apply glue and clamp until dry. (See photo and diagram Fig. 2.) When the glue is thoroughly dry slip the spool off the core and slit the ends which are turned back, to make flaps to be glued to the endpieces of the form. Four of these pieces, as detailed in Fig. 1, are required, and they must be placed on the spool before the endpieces are glued in place. These spacers divide the various windings, and their proper spacing is shown in the same illustration.

Inasmuch as the windings are to be put into their spaces individually, it is a good idea to hold the spacers in place with blocks of wood bound together with tape. This will keep the spacers from being pushed out of place while the individual windings are being wound. The spool, when completed, should make a close fit inside the stack of E-laminations so that the I-pieces, when the core is assembled, will butt against the E-laminations. It will be well to remember, before the winding is started, that none of these coils, including the friction-tape insulation, should extend beyond the outside edge of the spacers. This is highly important, because, if the windings are allowed to bulge over, especially on the long side

of the spacers, difficulty will be met with later in getting the completed winding on the iron core.

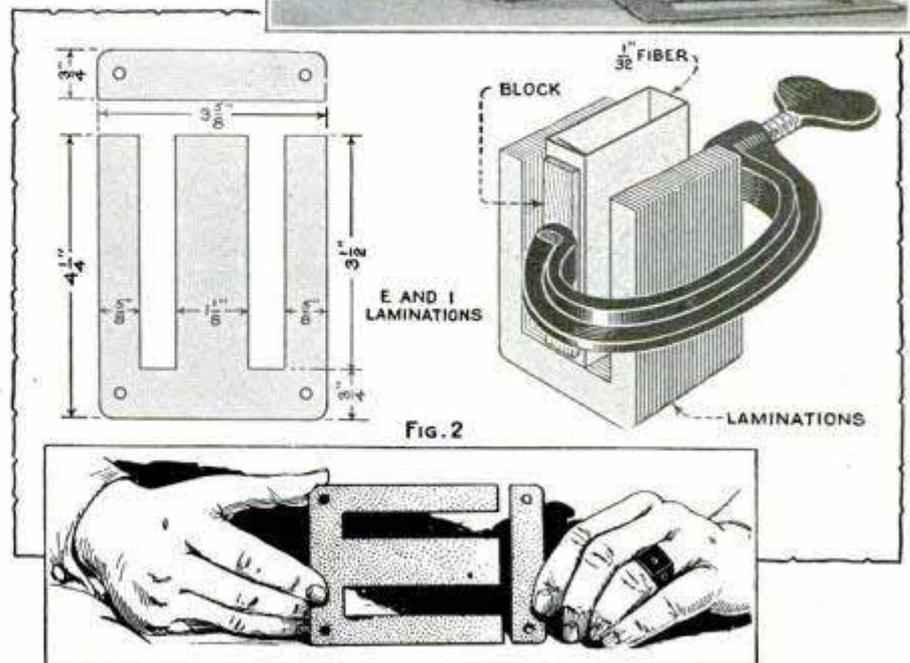
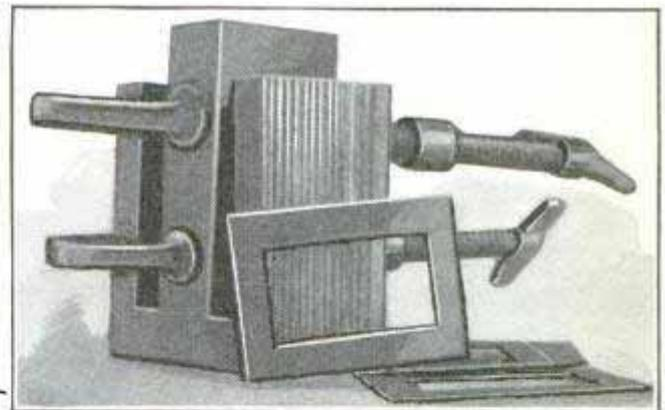

The winding may be started at any point, but the hardest part of the job will be the several thousand turns of No. 32 s.s.c. wire, and hence it is best to get this winding out of the way first. A simple coil winder with a turn counter is necessary for this operation, as the layers of wire must be put on smoothly and the number of turns accurately counted. Two $\frac{1}{4}$ -lb. spools of this wire will be sufficient for these windings. If only one of the high-voltage windings is to be used, as in the case of half-wave rectification, one spool will be sufficient. If the two windings shown in the diagram are employed, the center tap will come off somewhere about the end of the first spool, so that cutting the wire and soldering on the end of the new spool will make a convenient way of taking off the tap.

Before starting the winding of this fine wire, it will be necessary to solder on a short piece of insulated flexible wire which will later serve as a lead to the terminal on the panel. These flexible leads must be carefully soldered and all exposed joints insulated with friction tape. Each of the plate windings consists of 1,650 turns of wire. With the average coil

winder, the builder will find it necessary to cut a wooden form to slip inside the coil form, and it may also be necessary to drill a hole through the wooden form so that it can be slid on the winder shaft. This will depend on the type of winder used.

After the 550-volt windings have been completed, you are ready to wind on the primary, consisting of 330 turns of No. 20 enamel-coated wire for a 110-volt 60-cycle source. If your line voltage happens to be 120 volts, add 30 turns. When this winding is in position, wind on a layer or two of friction tape. This also applies to all the other windings. Take care, in handling the enamel-coated wire, not to injure the insulating coating, which may cause a short circuit between turns.

Finally the several filament-heater secondaries are wound in the remaining space on the coil form. The rectifier-filament center-tap is taken off at $11\frac{1}{2}$ turns. The wire used for the amplifier, rectifier and other filament-heater secondaries is s.c.c., and the sizes are given on the wiring diagram.

For convenience as well as accuracy, except in the plate windings where a counter is a necessity, start and finish all windings on the narrow side of the spool. This brings all terminals out on the same side of the completed coil as shown in Fig. 3.

When the windings are completed, they should all be tested with a voltmeter and battery, or battery and headphones. Test each winding individually and against all the other windings and the core, for continuity and possible shorts. If a short is found, it will most likely be

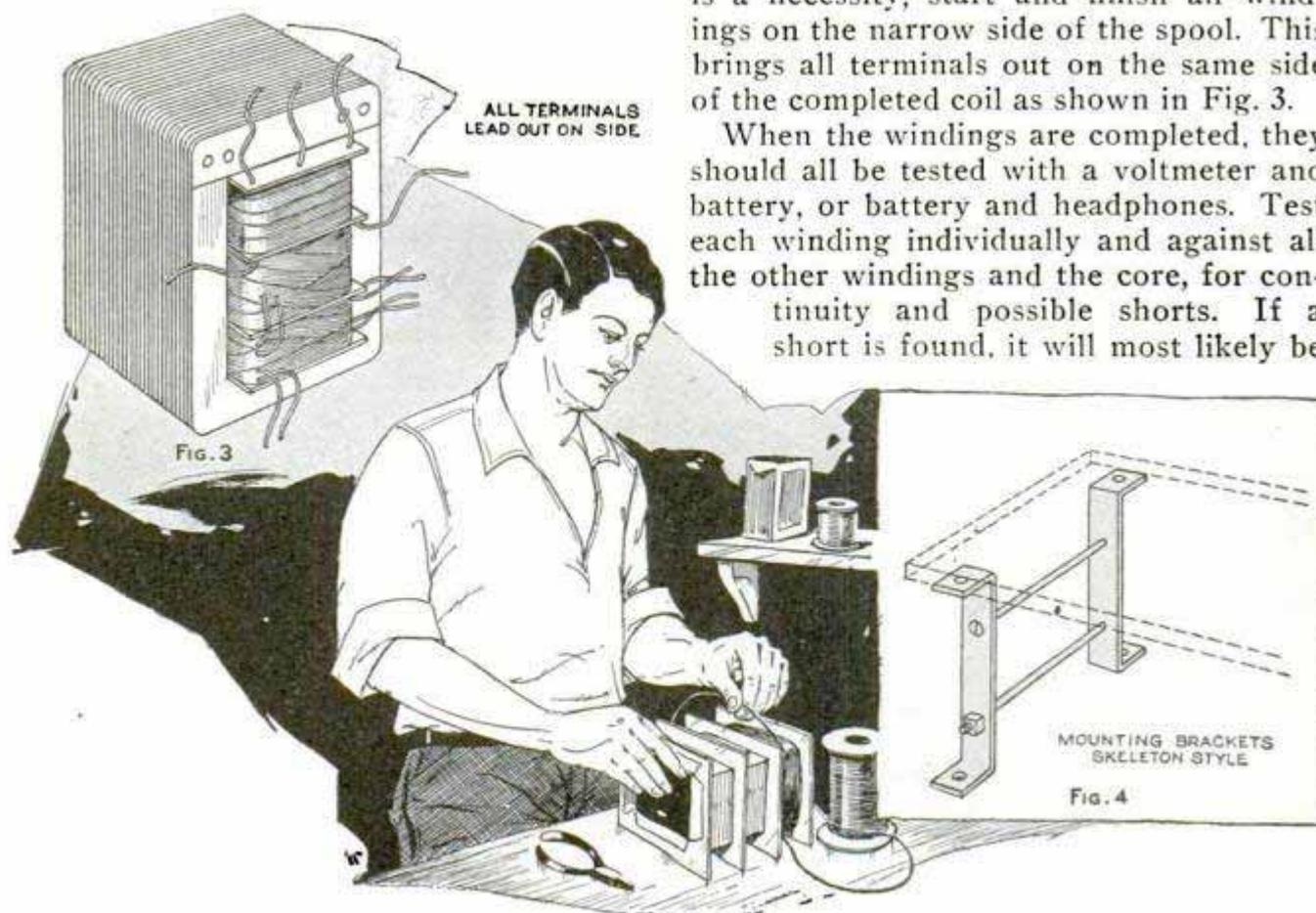

in the filament windings where s.c.c. wire is used for economy and saving of space. The only remedy for a short is to take off the winding until the short turn is found.

The assembly of the core is next in order. If the coils have been wound within the limits of the spacers, no trouble will be encountered when the E and I-laminations are inserted alternately so as to break the opposite joints. Manufactured laminations are punched with holes so that

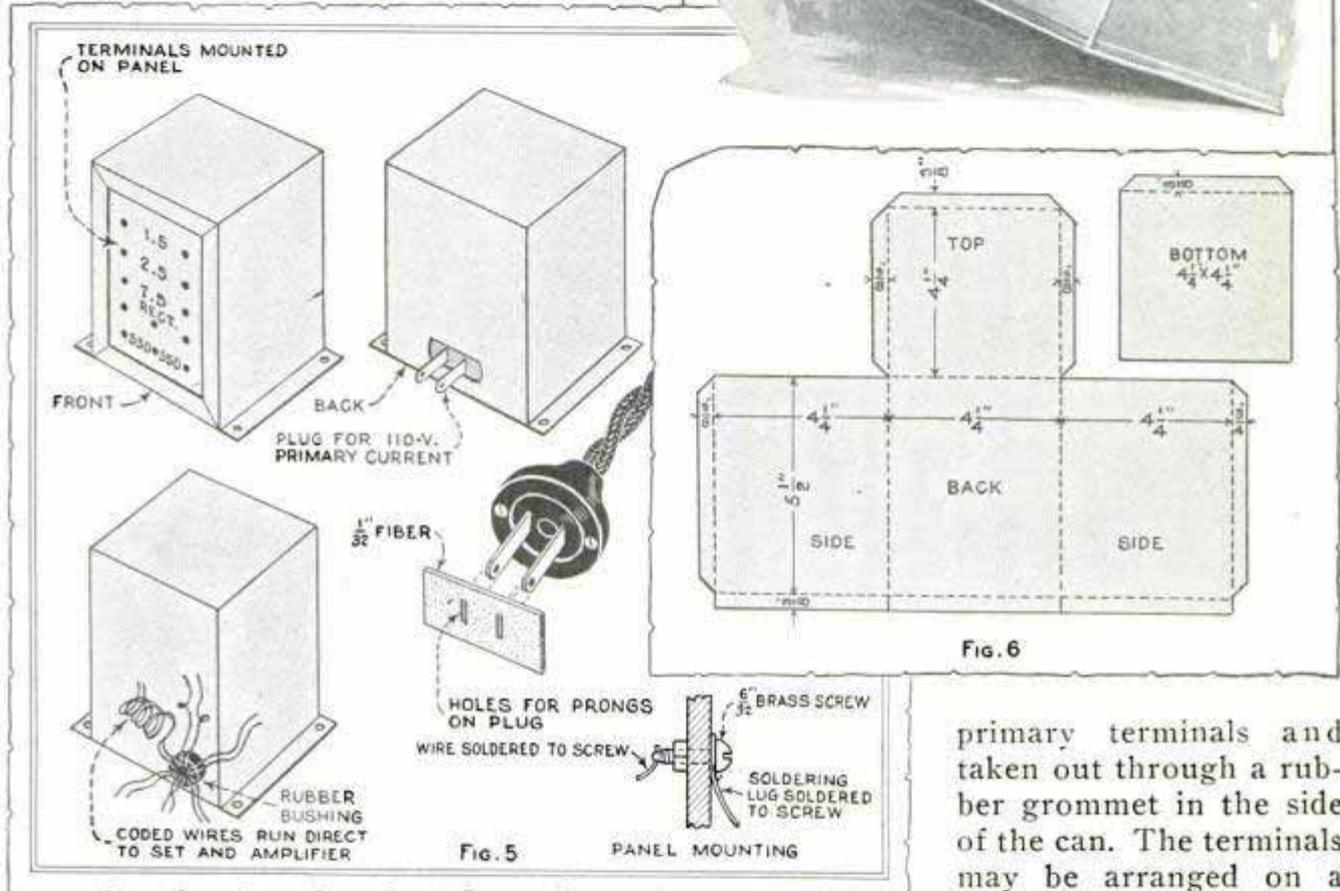
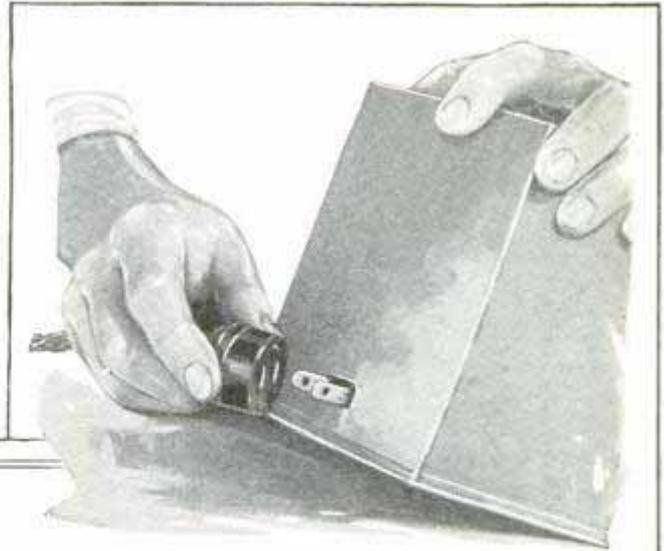

primary terminals and taken out through a rubber grommet in the side of the can. The terminals may be arranged on a panel or cabled together,

as shown in Fig. 5. bolts may be used to hold the laminations together. *The core should form a practically solid block of metal whether bolts are used or not; if it does not, insert wedges and see that the coils fit tightly.

The completed transformer may be mounted on brackets in skeleton style without a can, as indicated in Fig. 4.

Be sure that all leads are carefully identified before the transformer is placed in the sheet-tin container, for, after the sealing compound is poured in, it will be too late to rectify mistakes. The plug arrangement is inserted through the fiber strip from the inside and connected to the primary-coil terminals for the external plug from the 110-volt supply, or lampcord may be soldered directly to the

as shown in Fig. 5.

The can details are very simple and are clearly shown in Figs. 5 and 6. Insulating compound or melted rosin may be used to seal the can. The transformer is stood on its head as the sealing compound is poured in, and it will be necessary to place a small wood block between the top of the can and the core to keep the two apart during the sealing process. Then the bottom is soldered on, and the separate windings are again tested before connecting the transformer to the 110-volt line.

☛ Loud clicks and rasping noises heard at certain points when the tuning dial is varied, usually indicate touching condenser plates.

Robert ... 200 Mt. Pleasant Ave. Newark, N.J.

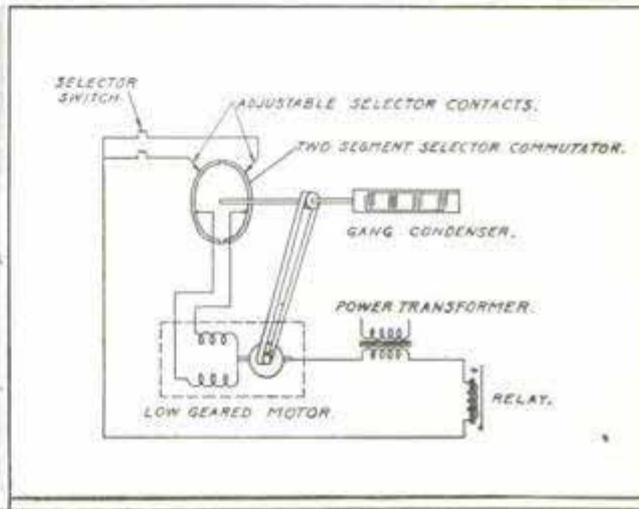
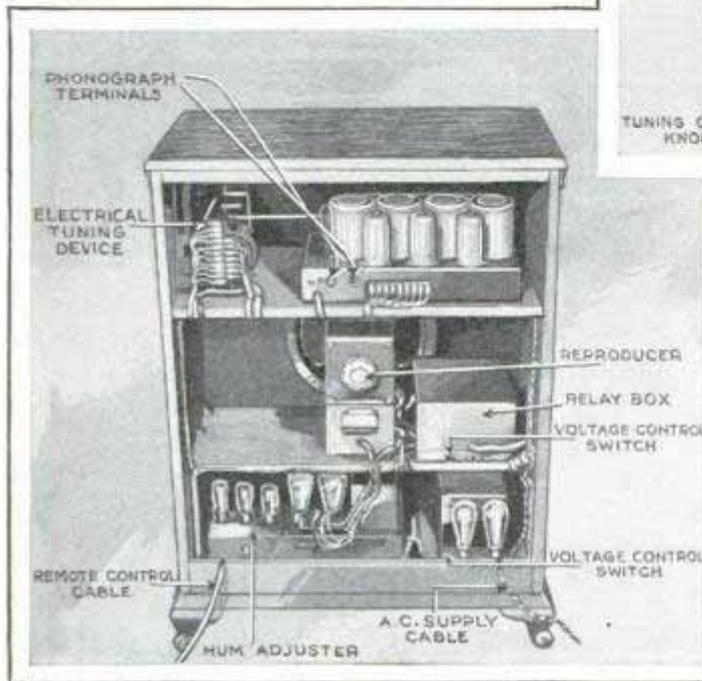
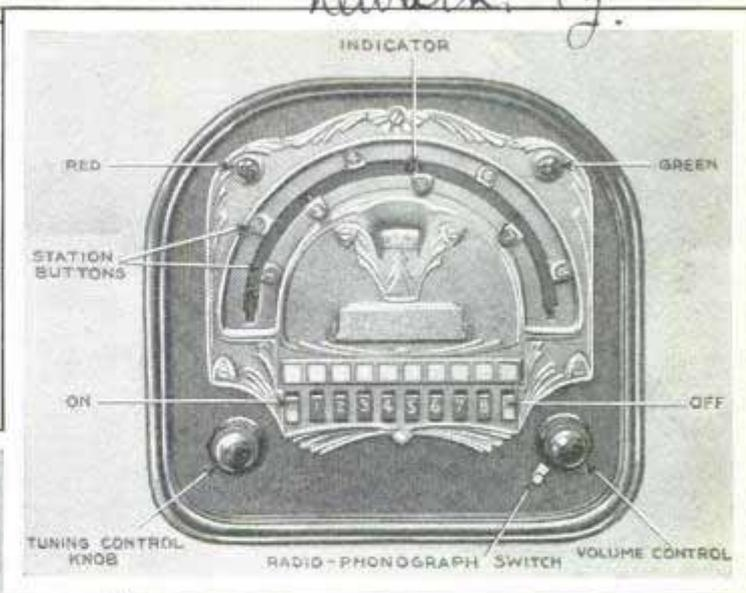
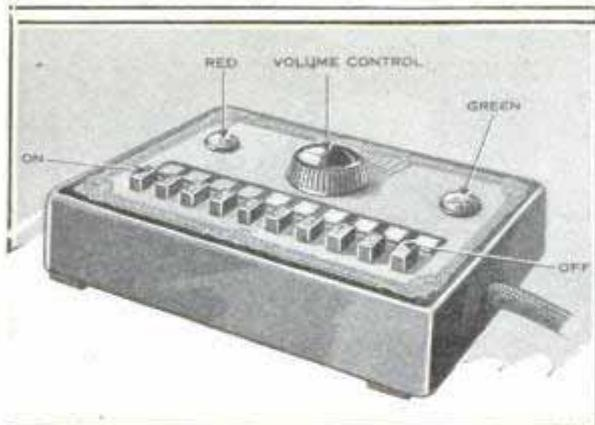

Upper Left, Remote-Control Unit Showing the Various Controls; Right, Local-Control Panel; Lower Left, Complete Installation in a Modern Receiver; Right, Diagram of the Automatic-Tuning Method

Remote Controls for Set Operation

A number of remote-control devices for use with standard receivers, enabling the owner to operate the receiver from any room in the home, have made their appearance during the past few months. By means of these ingenious arrangements, the receiver is automatically turned on, stations are selected and volume regulated to suit the individual. A control unit, scarcely larger than a man's hand, contains all the equipment for actual remote control, in the device illustrated. Switching on the set is done by pressing a small button on the box, marked "Start." When the tubes are lighted and the set is ready for reception, a small red light glows on the control box and another at the set. A station is then selected merely by pressing any of the eight buttons in the control box, the buttons being marked to correspond to the call letters of the stations

to which the receiver is set. The operation of the receiver is not limited to the remote-control point, since all controls on the set may be used in the ordinary manner. When the button on the control unit is pressed, a green light glows; the button is kept pressed down until this light goes out, indicating that the receiver has "tuned itself" to the station desired. The automatic tuning is accomplished by means of a small motor in the set, which rotates the variable condensers to the proper point. A "Stop" button on the control box automatically disconnects the power from the receiver, and the red lamps then go out. The selection of the stations that are to be controlled from a distance is merely a matter of setting a few "station buttons" on the control dial on the receiver. These buttons may be set for any station; they operate brush contacts on an insulating segment located on a moving drum.

Helpful Hints

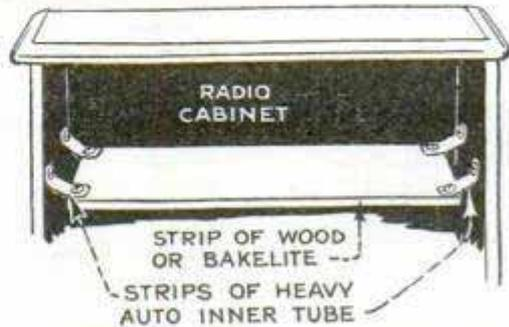

Shock-Proofing Tubes in Experimental Hookups; the Same Idea May Be Applied to Portable Receivers or Installations in Automobiles

To Check Plate Voltages from Resistor Bank, Ground the Negative Side of a High-Resistance D.C. Voltmeter to Chassis; Left, Busbar Supports for Inductance Coils, with Circuit Connections Made at Subpanel Screws

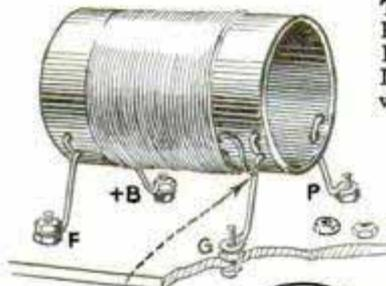

END OF WINDING SOLDERED TO SUPPORT

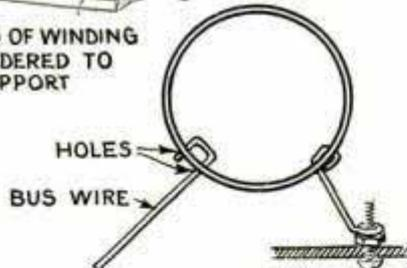

Below, Handy Means of Providing a Gridleak Mounting When the Leak Is Connected Directly between the Grid and Filament; This Method Is Now Used in Many Receivers, and Especially in Short-Wave Sets

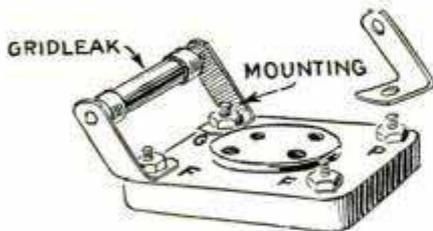

In Circle, Filament Switches of the Push-Pull Type, Still Used in Many Battery Receivers, Have Two Flat Springs, Which Drop into a Groove on a Metal Disk When the Circuit Is Closed; When These Springs Weaken and Make Poor Contact, a Rubber Band around Them Will Restore Good Contact

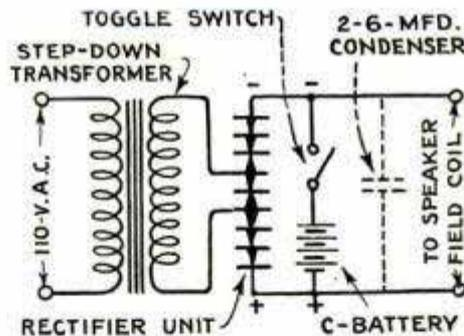
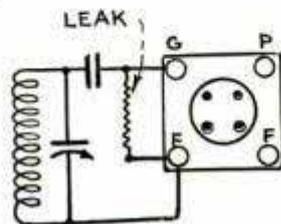

Above, for Low-Voltage Dynamic-Speaker Hum Elimination, Use Small Dry Battery of Same Voltage as Rectifier; if over 10 Volts, Use Condenser Instead of Battery

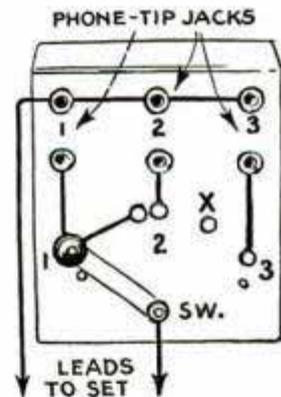

A Triple Speaker Switch; Contact No. 1 Is for Single Speaker, No. 2 for Two Speakers, and No. 3 for Remote Speaker; X is a Blank Contact

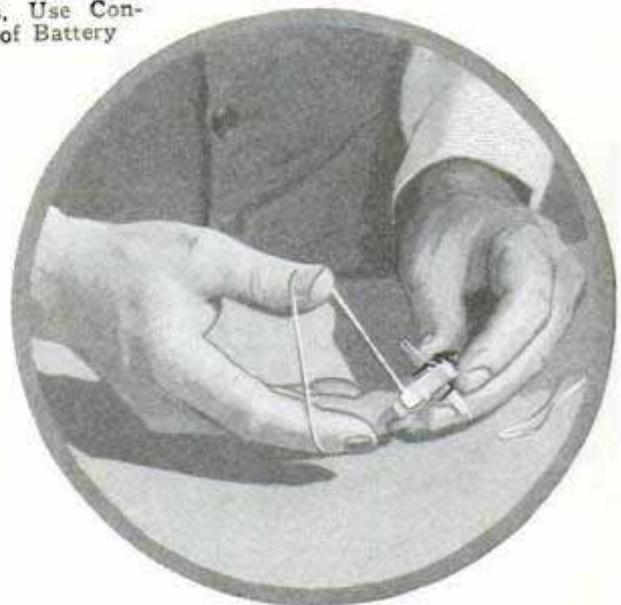

from the Radio Lab.

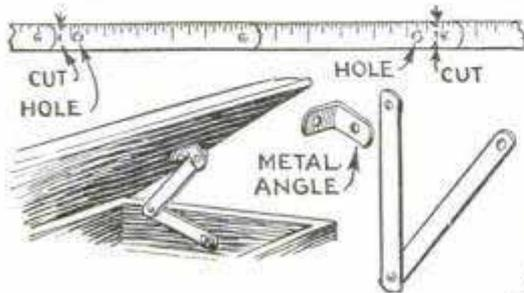

A Handy Lid Holder for the Home-made Radio Cabinet May Be Easily Made from a 10-Cent Folding Metal Rule; Two Sections and One Hinged Joint Are Employed, the Length Being Varied to Suit the Cabinet

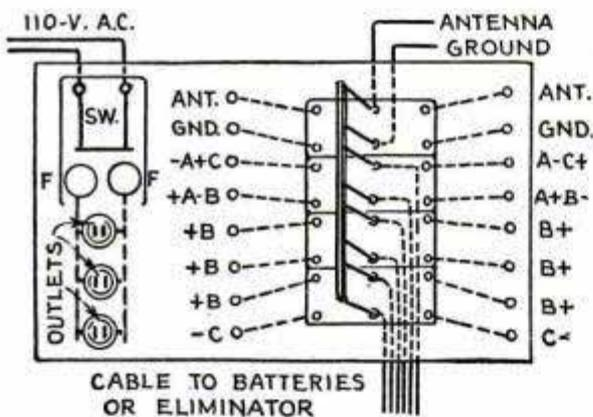
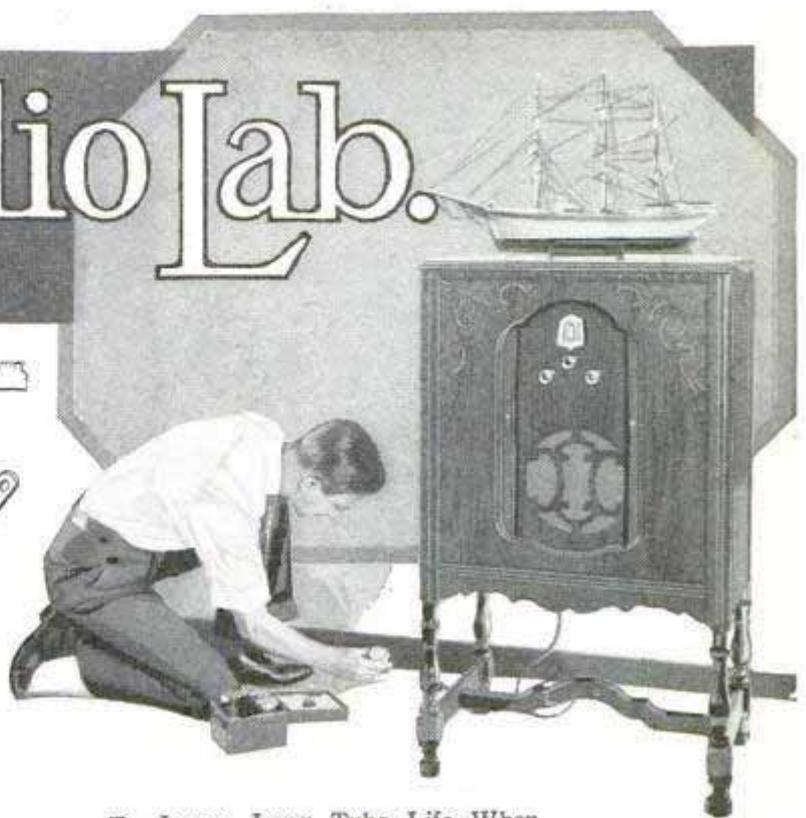

Above, Power Outlets from Fused Switch Block for B-Eliminator, Trickle Charger, etc.; Also an Experimenters' Double-Outlet Board

To Insure Long Tube Life When Installing A.C. Receivers, Measure Line Voltage during Low-Load Period; if above Set Rating, Use a Line-Voltage Regulator

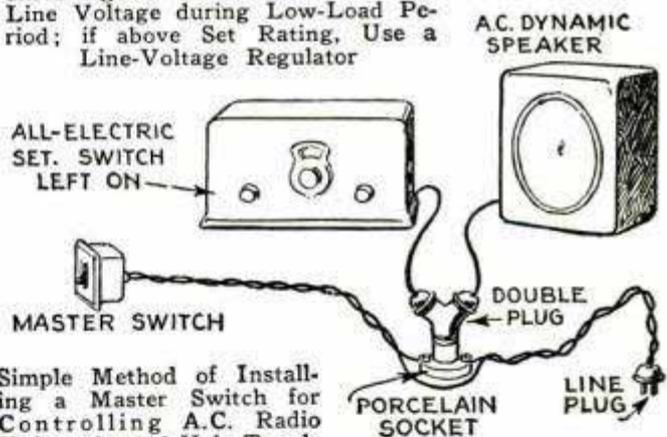

Simple Method of Installing a Master Switch for Controlling A.C. Radio Units; the 110-Volt Toggle Switch May Be Mounted at Any Convenient Point

A Simple Continuity Tester for Coils and Transformers. Made from a Porcelain Fuse Block Connected to the 110-Volt Line through a Light Bulb; If the Bulb Lights, the Circuit through the Winding Is Complete

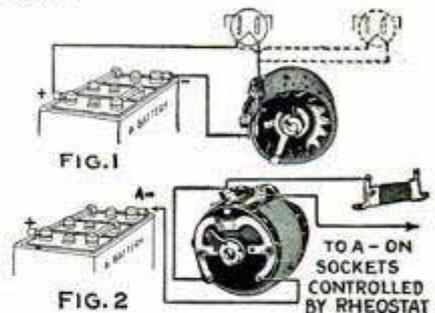
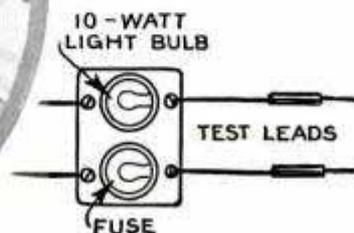
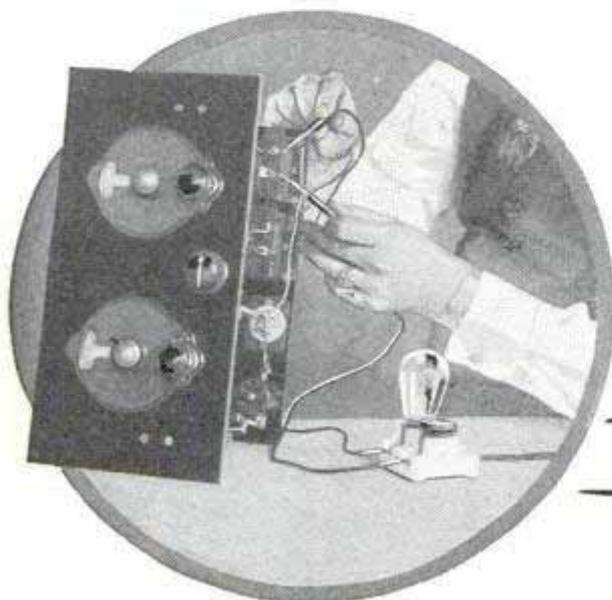
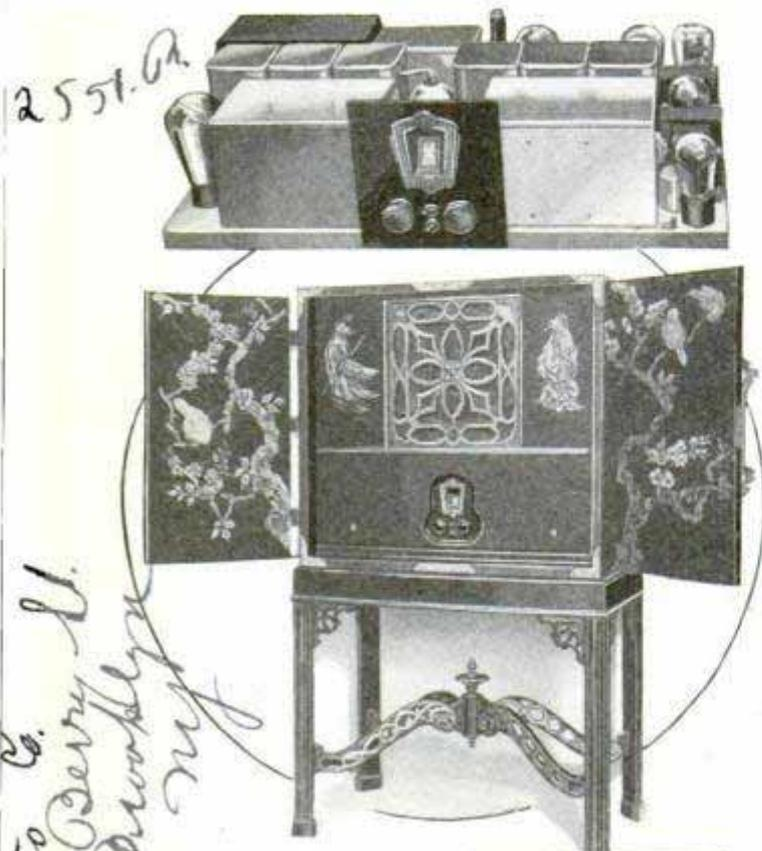
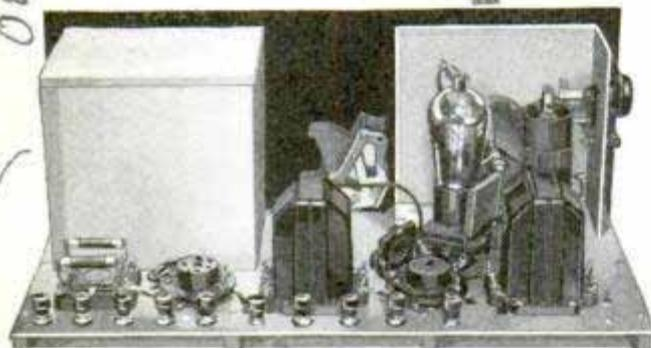

Fig. 1 Shows the Method of Connecting an Ordinary Rheostat in the Filament Circuit to Control the Voltage to One or More Tubes; Fig. 2 Gives Connections to a Combination Rheostat and Filament Switch; the Fixed Resistor Strip Limits the Voltage to Tubes Other Than Those Which Are Controlled by the Rheostat





*Patent Radio Co.
323 Perry St.
New York*



Above, Two of the Newest and Most Advanced Kits for the Custom and Home Set Builder

New Kits for Set Builders

Several outstanding kits, two of which are shown in the accompanying photos, have recently been announced. Complete down to the last screw and nut, they offer a means of quickly assembling circuits of advanced design. The 9-tube receiver at the top of the illustration includes a line-voltage regulator and six tuned circuits, consisting of a tuned 3-stage band-pass filter and a 3-stage tuned screen-grid r.f. amplifier. The audio unit consists of a power amplifier employing 45-type tubes in push-pull and a phonograph connection. Auditorium volume is available without distortion, and the specially designed power pack delivers humless full-wave rectification. Other features are one-dial centralized control and wired-unit construction to facilitate quick and accurate assembly. Tubes, coils and con-

densers are shielded individually and collectively with special attention given to circuit isolation to prevent interaction. One or more units may be purchased, or all equipment for a complete receiver or tuner for either a.c. or battery operation. This kit is suitable for installation in the finest of cabinets, like the red-lacquer Chinese Chippendale console shown in the illustration. The fitting of the set into such cabinets is very simple, as the receiver is merely pushed into the set compartment against an opening cut in the wood front panel for the controls.

The kit below the console is a short-wave receiver designed to operate on alternating current. Additional features are a tuned screen-grid stage, double shielding and a 14 to 500-meter wavelength range obtained by means of plug-in coils. It employs a special type-227 tube for use in the detector stage.

Using Type-45 Power Tubes

To equip a set with a type-45 tube in place of a 171-type is not a difficult matter; it is merely necessary to arrange for the supply of 2.5 volts to the filament, 250 volts to the plate, and a negative grid bias of 50 volts. A simple method of obtaining the filament voltage is by means of a separate transformer, having a 2.5-volt secondary. The 5-volt leads to the 171-tube are clipped, and the filament posts wired to the 2.5-volt transformer. A variable center-tapped resistor of 60 ohms is connected across this winding as shown in the diagram. The negative grid bias may be obtained in either of two ways. The preferred method is by the plate-current drop across a 1,500-ohm resistor, by-passed with a 4-mfd. condenser. However, if the plate voltage available is less than 300, it is usually better to furnish the bias by means of a C-battery, as the biasing voltage across the resistor is necessarily subtracted from the available plate voltage.—George Lewis, New York City.

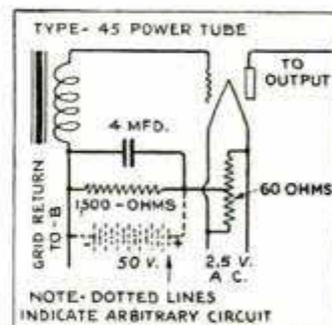

Combination AC-DC Tube Checker

by
A.O. Davison



THIS tube checker, built from odds and ends found around the experimenter's workbench, will enable the user to pick out good, fair and poor tubes of both the a.c. and d.c. types.

The meters are of an inexpensive type and the switches were obtained from a dealer in discarded telephone-switchboard apparatus. These switches are of the toggle type but are shown in the wiring diagram as ordinary knife switches to simplify the layout, and, of course, small switches of the latter type may be used if desired.

The cabinet is very simple, and may be made of any wood that happens to be handy. Two pieces, $\frac{1}{2}$ by 11 by 5 in., are required for the top and bottom; the sides consist of two pieces, $\frac{1}{2}$ by 14 by 5 in. The back is 11 by 13 in., and may be of thinner material. The front, or instrument panel, is bakelite, $\frac{3}{16}$ by 12 by 14 in. in dimensions.

Subpanel-mounting tube sockets are used for the various types of tubes indicated in the diagram. A hole is drilled in the left side of the cabinet for the battery-connector plug and a wall-plate receptacle is mounted on the right side of the case for the power connection to the filament-

heating transformer for the a.c. tubes.

The transformer is of the type having $1\frac{1}{2}$ and $2\frac{1}{2}$ -volt secondary windings. The voltmeter and milliammeter ratings are clearly shown in the diagram, and the battery-cable connector plug is of the usual seven-conductor type, connected as indicated by the color code. The variable resistance across switch No. 7 consists of a 10-

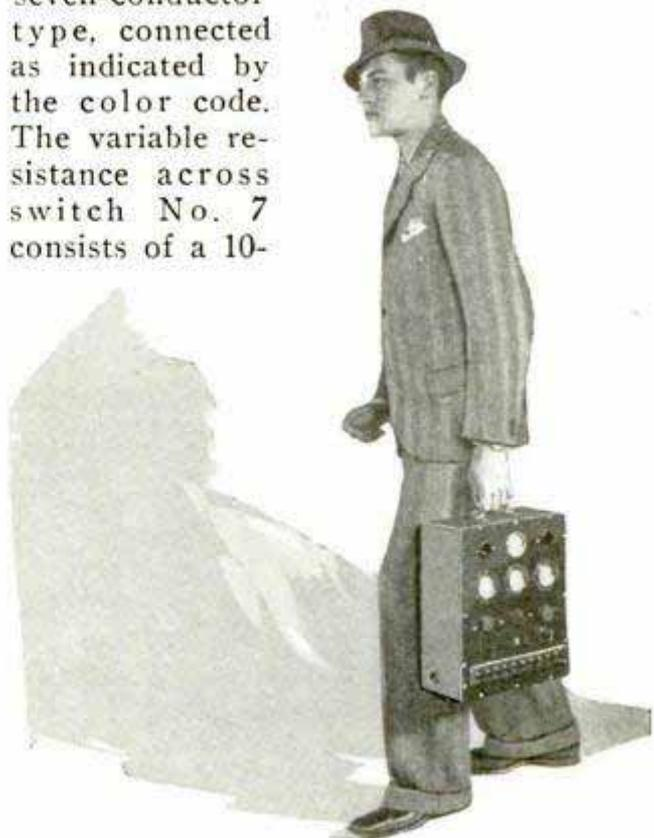

ohm potentiometer, and the other resistors are as indicated.

Flexible rubber-covered wire should be used for all connections and all joints carefully soldered. The biasing voltage for d.c. tubes is taken from the 6-volt battery, and the table shows the actual readings obtained with the B-voltages indicated.

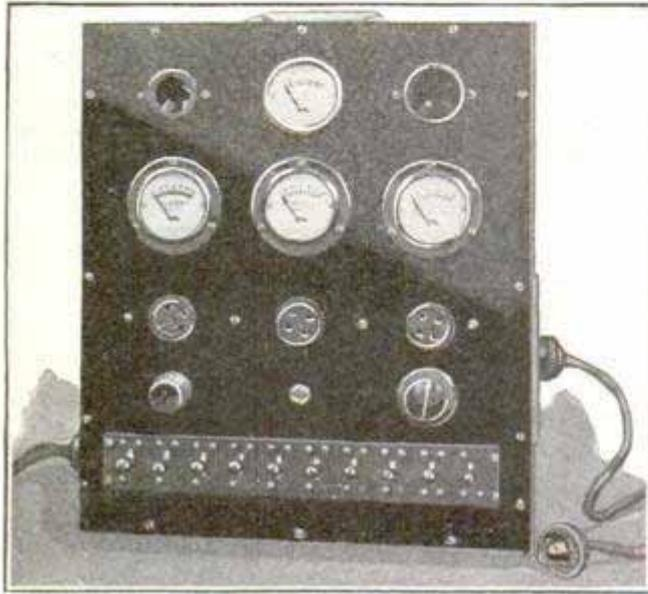

filament voltmeter. Switch No. 10, in the up-position, puts 45 volts on the plate of the tube; in the down-position, it places 90 volts on the plate. By closing switch No. 9 the plate-voltage reading appears on the plate voltmeter. Now note the reading on the milliammeter by throwing switch No. 1 down, which puts a positive charge on the grid. The milliammeter should now give a higher reading than that obtained by switch No. 1 in the up or negative-bias position. It is then a simple matter to find the quality of the tube by subtracting the first milliammeter reading from the second, and referring to the table. Use the same method for all types of d.c. tubes.

For testing the type-226 a.c. tubes, switches Nos. 2, 3, 4, 5, 6 and 7 are kept down. Switch No. 8, up, puts a negative bias on the tube, and down places a positive bias. The biasing voltage is obtained by using a separate 6-volt C-battery. When the grid has a negative bias, it will read on the filament voltmeter. The same

test is used for the type-227 a.c. tubes, except that switch No. 5 must be up in order to give 2½ volts a.c. on the filament.

When testing type-227 a.c. tubes, switch No. 2 is thrown up for 45 volts on the plate, when the tube is to be used as a

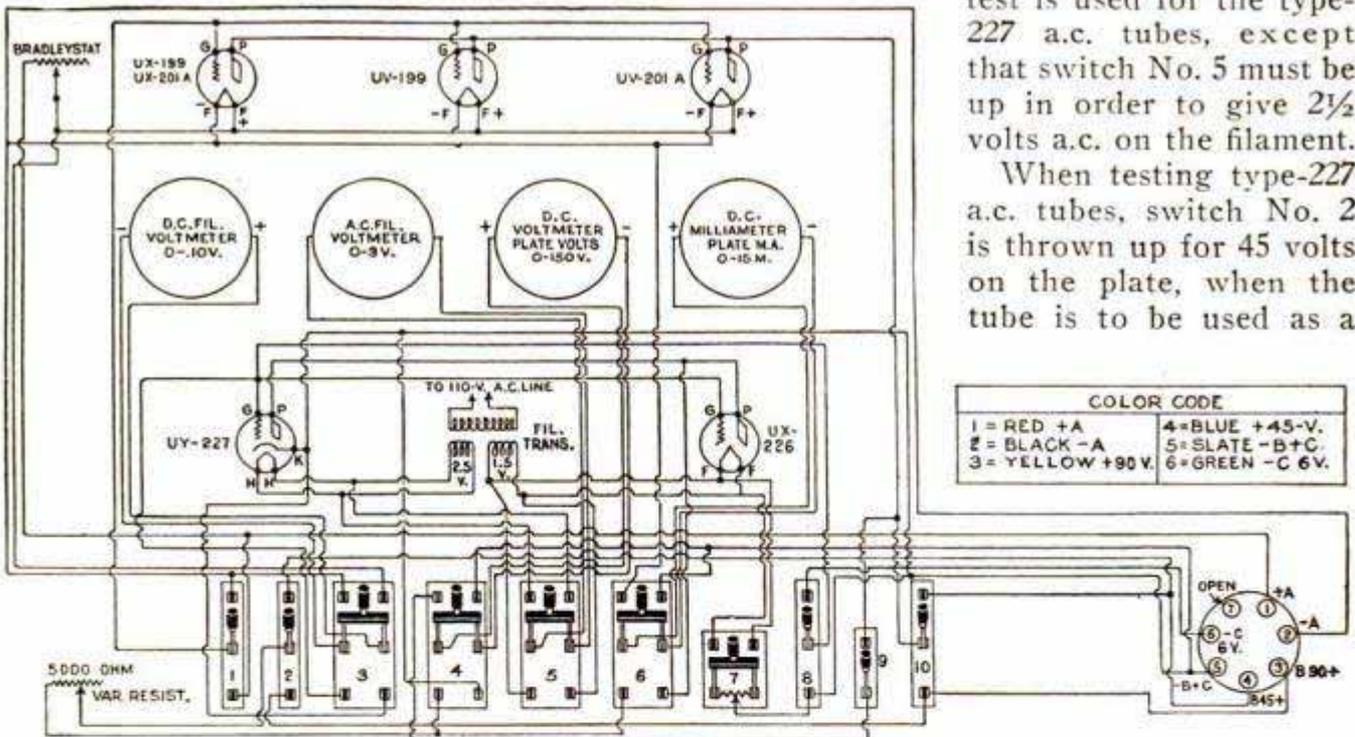

COLOR CODE	
1 = RED +A	4 = BLUE +45-V.
2 = BLACK -A	5 = SLATE -B+C.
3 = YELLOW +90 V.	6 = GREEN -C 6V.

Combination Tube Tester, Showing Arrangement of Panel; Simplified Wiring Diagram, Color Code and Tube-Comparison Table

For testing d.c. tubes, be sure that the Bradleystat is turned entirely off before inserting the tube in the socket. Switches No. 3, 4 and 6 must be in the up-position. Turn the Bradleystat to the right until the required filament voltage appears on the

TUBE COMPARISON TABLE						
B VOLTS	PLATE-CURRENT READING IN MILLIAMPERES			TYPICAL PLATE CURRENT WITH BIAS ON GRID FOR GOOD TUBES		
	GOOD	FAIR	POOR	-BIAS	+BIAS	
4.5	1.5	1.0	.5	1.5	6.5	UX OR UV 201-A OR SIMILAR TUBES
90	3.5	4.5	1.5	5.5	13.0	
4.5	1.6	1.	.5	1.6	4.0	UX OR UV 199 OR SIMILAR TUBES
90	4.6	3.8	1.4	4.6	7.8	
90	3.	2.5	1.8	3.	8.6	UX-226 OR SIMILAR TUBES
4.5	1.2			1.2	5.8	UY-227 OR SIMILAR TUBES
90	4.8	3.6	2.6	4.8	12.2	

*United Reproductions
St. Charles, Ill*

detector, and down for 90 volts on the plate, when it is to be used as an amplifier.

To find the amplification factor, note the reading on the milliammeter with negative charge on the grid, then note the difference when a positive grid charge is applied. Return the setting of the grid-test switch to negative charge, then find the change in plate voltage that will cause the same change in plate current. This is done by varying the 5,000-ohm resistor, the change in plate voltage being greater than the change in grid voltage. Divide the voltage change in the plate by the voltage change in grid to obtain the amplification factor of the tube.

To find plate resistance, divide the value of the plate voltage by the plate current drawn by the tube. Reading of the milliammeter is taken with the grid negative.

To find plate impedance, divide the change in plate voltage by the change in plate current that it causes. When both the amplification factor and plate resistance of the tube are found, the mutual conductance in mhos, which is the reciprocal of ohms, equals the quotient obtained when the amplification factor is divided by the plate resistance.

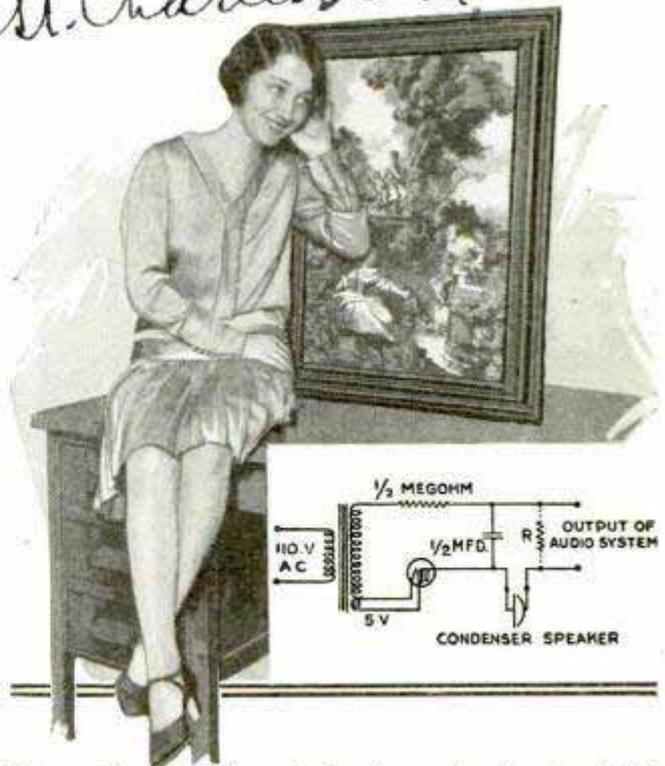

Picture-Frame Design of Condenser Speaker for Wall Installation, and Diagram of Speaker Hookup

Tapestry Picture Is Condenser Speaker

For a number of months speakers of the condenser or "static" type have been available in certain console receivers, and now the manufacturers have designed a speaker of this type installed in a neat tapestry-covered frame for wall installation. The tapestry in no way interferes with the radiation of sound, and the frame serves as a baffle to force the longer sound waves to radiate into the room. In a crowded modern apartment, this saving of space is of decided value, as the set can be relegated to an adjoining room or closet, if remote-control devices are used. A speaker installation of this type enables the user to obtain various acoustic effects. By hanging the frame in a corner the diverging walls increase the baffling and vary the resonance. The wall unit may be draped to cut off high frequencies.

Furnace Pipe Acts as Antenna

The pipes of a hot-air heating system often make a good antenna. Connect a lead from the antenna binding post on the set to the hot-air register at a point free from paint or enamel. Distant reception can hardly be expected from an antenna of this type, but it will do for locals when a temporary antenna is required.—G. Curtis Engle, Ridgewood, N. J.

New Device Provides a Wet Ground

The device shown in the sketch insures a good wet ground for the radio receiver. In dry or sandy soil, where a wet ground connection is rather difficult to maintain, this device fills a real need and is simple to install. The jointed pipe at the left contains a cotton wick which extends beyond the pointed end below. The pipe is driven into the ground and the driving cap at the top removed. The copper tank is then screwed on at E, and filled with water; the needle valve F permits regulation of the flow to keep the cotton wick saturated at all times. The ground wire from the radio receiver is connected to the binding post G.

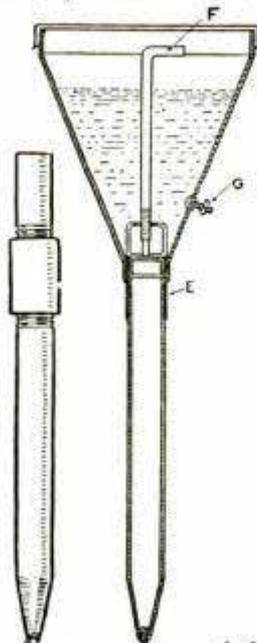

*Radio Wet Ground by G. Curtis Engle
4-7-31 7th St. East, N.J.*

Simplified Battery-Charging Connections

Arrange the power units in their compartment as shown at the right in the

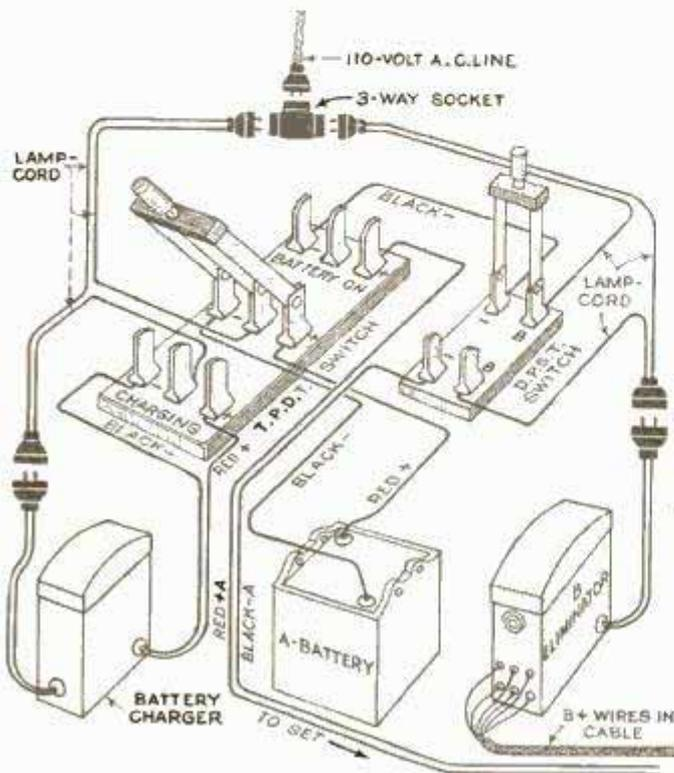

Arrangement of Switch for Battery-Charging Purpose and Installation in Cabinet

drawing, mark the various switch terminals plainly before starting the wiring and mount the switches as indicated. Use standard lampcord for the a.c. leads to the various plugs and for the leads from the

Homemade Soldering Flux

The best flux for soldering radio connections is, of course, one that will not corrode, and rosin is ideal for this purpose when properly handled. To make a rosin paste, melt two parts of rosin and then add one part of melted vaseline or enough to obtain the consistency desired. The rosin must be melted slowly and care must be taken to prevent it from burning, as the paste will not function as a flux if this happens. A safe way to melt the rosin is to use a sand bath, which diffuses the heat with less danger of scorching, although, of course, it would have to be watched: A good soldering fluid is made by dissolving a sufficient quantity of powdered rosin in denatured alcohol to form a thick liquid, which is applied to the parts

A-battery to the switches. From the switches to the set, use well-insulated rubber-covered wire. The double-pole, single-throw switch for turning the set on and off is mounted on the side of the battery compartment or in any other convenient position. When charging the battery, this outside switch must be off, and the three-pole switch is thrown to the charging position. The usual filament switch on the front panel of the receiver is not used with this arrangement. By pulling out the three-way socket from the main-line plug, all units are disconnected. The switches used are of the standard porcelain-base type, not the small ones usually employed in radio circuits.—Henry S. Laraby, New Haven, Conn.

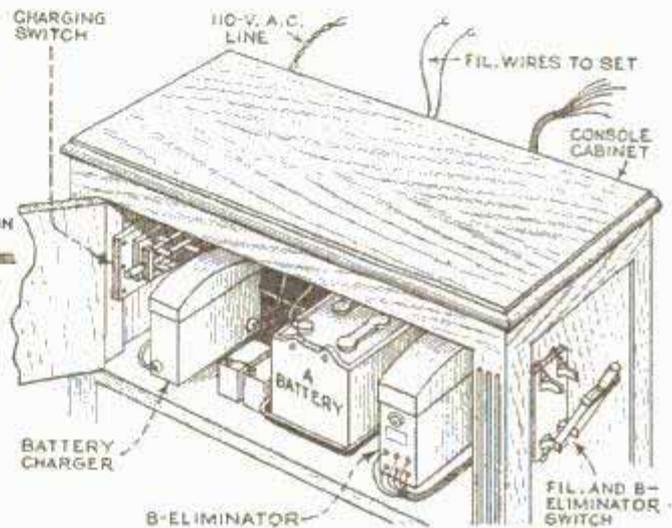

to be soldered with a small brush. This solution can also be used as a binder to hold turns of wire in place on coils, as it dries quickly and leaves a hard layer of rosin which will not be affected by ordinary heat or handling. To determine if a commercial soldering paste is corrosive, take a piece of copper wire that is slightly tarnished and smear some of the paste on it. Allow it to remain on the wire for a day or two, then rub it off. If the surface is bright, the paste is corrosive and should not be used in a radio set.—W. H. Hardy, Albuquerque, N. Mex.

Popular Mechanics' radio department offers its information service free to all readers of our magazine. We will be glad to help you with your problems, and will promptly answer all inquiries.

AMATEUR MECHANICS



Built-In Aquarium Makes Living Picture

By HI SIBLEY

WITH all the ingenious devices incorporated in modern homes, the built-in aquarium is next in line. An appropriate place for this would be over the buffet in the dining room, or as a feature of a boy's bedroom or den.

Built with the glass front flush with the interior wall and framed like a seascape painting; the fish and aquatic plants suffused with a delicate green or blue light

from a concealed bulb, it makes an uncommonly attractive item in the decorative scheme of the room. A miniature wreck adds to its appeal.

It can be built into an old house as well as a new one. In the former case, it is necessary to cut out a section of only one stud, as shown in the drawings. In either case, of course, an extension from the outside wall must be built to house it, but finished the same as the general exterior it will not be unsightly. In cold climates, where danger of freezing exists, it will be necessary to make a double skin for the extension and to insulate it. Grills above and below the opening allow the

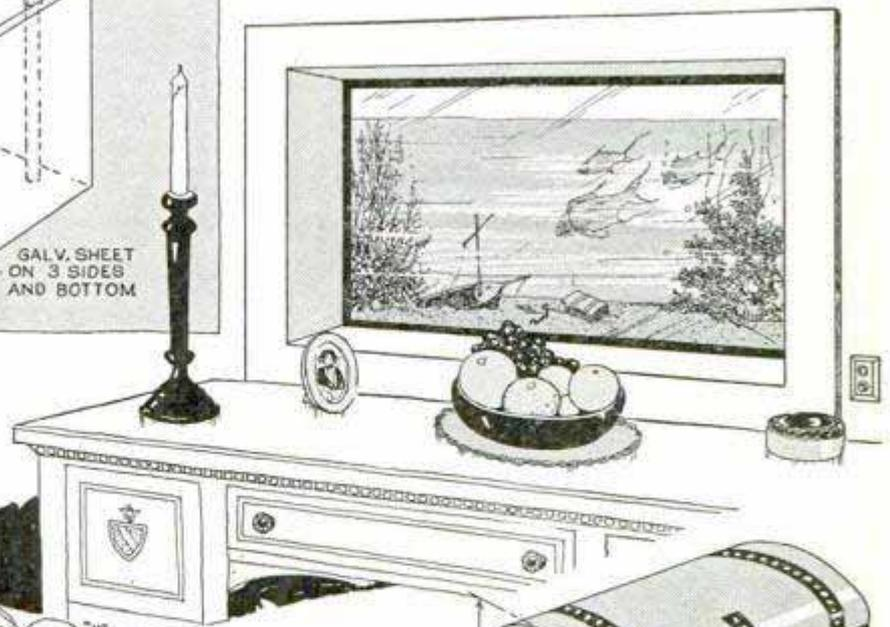
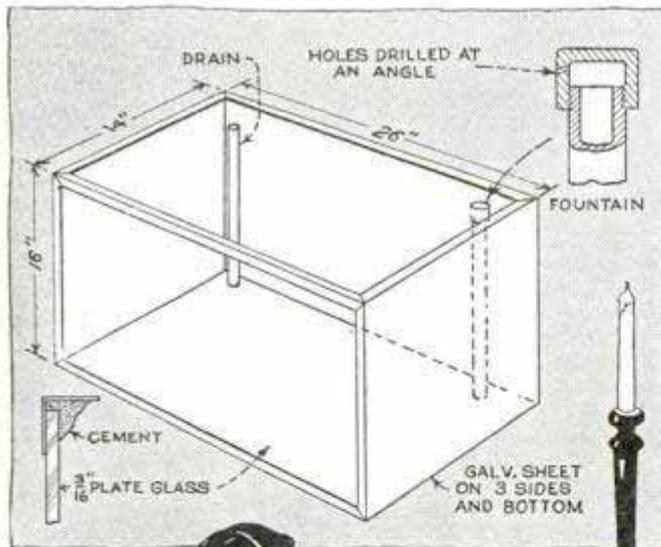

SOLID-WOOD BLOCK WITH WEIGHT ON BOTTOM

MINIATURE PIRATE CHEST

A Permanently Attractive Novelty for the Home Is a Living Picture Formed by a Built-In Aquarium; a Miniature "Wreck" and Pirate Chest Add to the Interest of the Scene

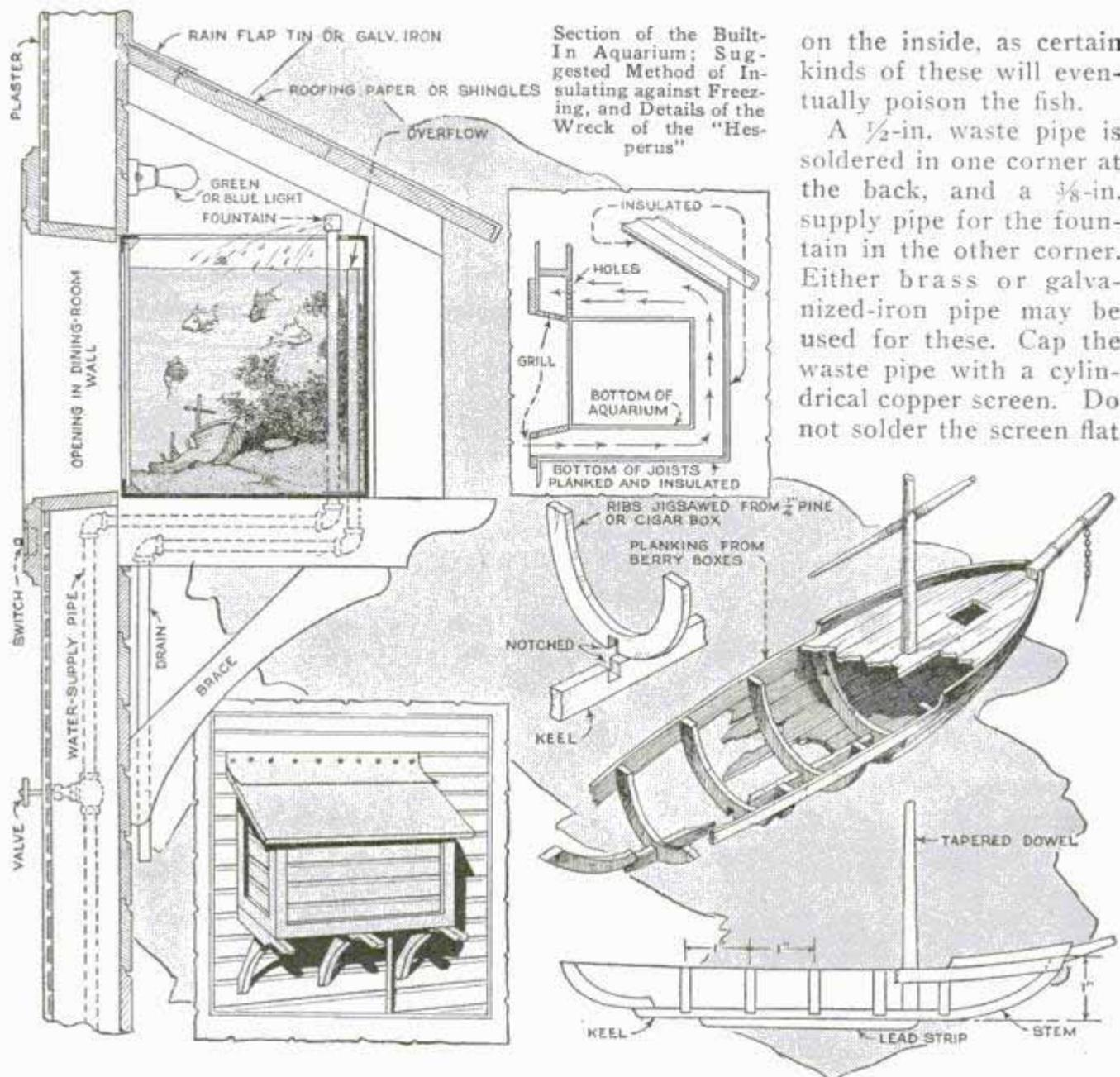

Section of the Built-In Aquarium; Suggested Method of Insulating against Freezing, and Details of the Wreck of the "Hesperus"

on the inside, as certain kinds of these will eventually poison the fish.

A $\frac{1}{2}$ -in. waste pipe is soldered in one corner at the back, and a $\frac{3}{8}$ -in. supply pipe for the fountain in the other corner. Either brass or galvanized-iron pipe may be used for these. Cap the waste pipe with a cylindrical copper screen. Do not solder the screen flat

warm air from the room to circulate around the tank, as suggested in the sketch on this page, effectively keeping the supply and overflow pipes from freezing. In California no such precaution has been found necessary. The aquarium, of course, might also be built into an interior wall, where the arrangement of the house makes this feasible.

The tank itself is made of heavy galvanized iron, reinforced at the top edges by angles of the same material. Only the front side is glazed, having a pane of about $\frac{3}{16}$ -in. first-class plate. If obtainable, use regular aquarium cement; if not, roofing asphalt, which is impervious to water, will do for cementing the glass to the tank. It should be heated to a gummy consistency and pressed in place in this condition. Do not use paint, varnish or shellac

on top of the pipe as it will clog quickly. The cap for the fountain has a series of pinholes drilled at a slight angle so that the water will be thrown down upon the surface. These holes should be as small as possible in order to aerate the water. Introduction of minute air bubbles containing oxygen freshens the water and keeps the fish in fine condition.

The arrangement of the piping is shown in the sectional view. Note that the supply pipe runs up through the wall with a shut-off valve conveniently located on the inside. Overflow water can be used to irrigate shrubbery along the outside wall. Slope the horizontal section of the drain pipe toward the outlet, so that water will not accumulate here and freeze.

A hinged lid to the housing enables inspection of the tank, rearrangement of

plants, etc., and periodical cleaning. Sediment on the bottom is siphoned off when necessary with a garden hose of sufficiently large enough diameter to carry away dead plant leaves, and the like.

Place the switch for the bulb in the frame of the aquarium. A porcelain wall socket makes a suitable fixture, and the bulb can be changed from the outside.

The plants and miniature shipwreck can be made very effective by placing the former in a semicircular background, concealing that wall of the tank and the pipes. Set the wreck to one side of the center in the foreground, partly buried in the sand, and the pirate chest near by. A miniature anchor and the usual seashells add realism to the submarine setting. Slope the sand toward the front. Incidentally, the sand should be washed thoroughly before the fish are put in.

The wreck is a very simple affair, consisting of a backbone or keel with stem and sternpiece nailed on with tiny brads. White pine is satisfactory material, since it is easily worked and does not split readily. A jigsaw is handy for cutting the curved pieces. Note that the ribs are mortised to the keelson. For planking, the thin wood used in berry boxes is suitable. The planks are nailed to stem and ribs with brads, and here and there the ends are broken off to carry out the wreck idea. Give the entire job a dark walnut stain or similar shade, attach bits of string and broken chain to mast, spar and stub of bowsprit. A strip of lead on the keel keeps the wreck submerged. Keep under water for two or three days to dissolve any injurious matter it may contain before putting it in fresh water with fish.

The pirate chest is whittled from a single block of white pine, and is stained and decorated with copper strips fastened with small escutcheon pins. It, too, should be provided with a lead weight on the bottom to keep it under the water. The weight may be recessed.

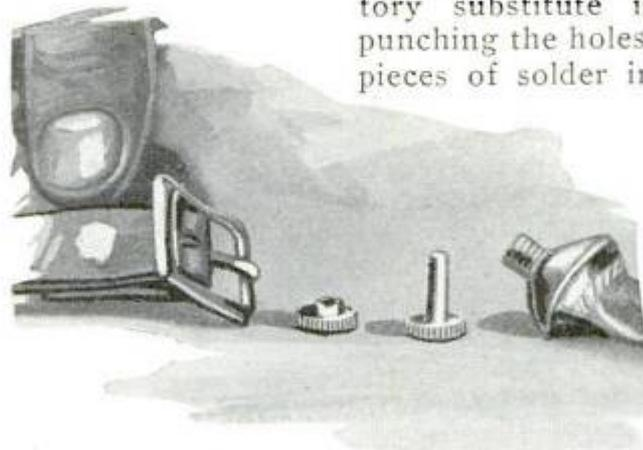

Wire Solder or Plug of Foil Tube Makes Substitute for Rivet When Repairing a Belt

Fireplace Tongs for Handling Large Logs

For handling large logs in the home fireplace, the tongs shown in the photo

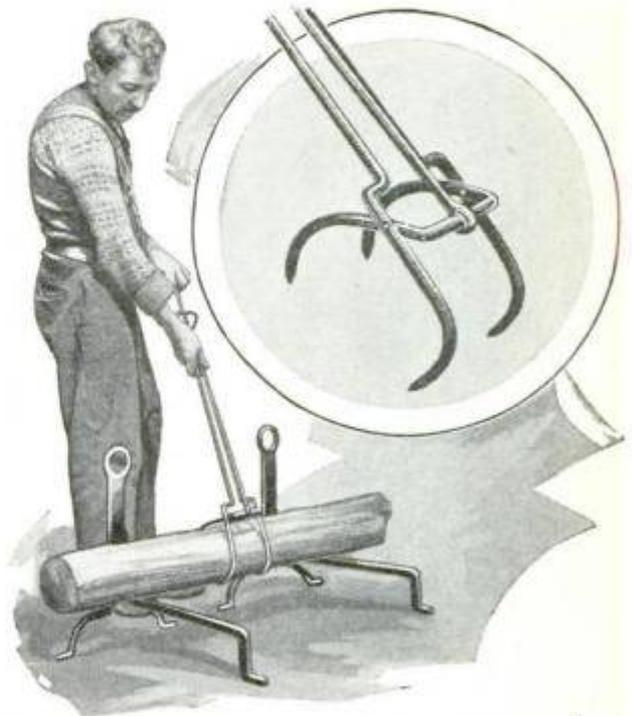

Homemade Iron Tongs for Handling Large Logs in the Fireplace

will be found convenient. Three pieces of iron are used to make them. They are bent over and pivoted as shown in the detail. One fork with its two tines extends to form a handle, while the other is U-shaped. To this a rod is pivoted so that, by manipulating the handle and rod, the tines can be drawn together and will then hold any log firmly.—Sam E. Vonner, Auburn, Me.

Wire Solder for Repairing Belts

When no rivets are at hand for repairing broken belts, a practical and satisfactory substitute is wire solder. After punching the holes for the rivets, slip short pieces of solder into the hole and hammer the ends down to spread them. If there is no wire solder available, a part of a tapered plug from a collapsible tube, as shown in the photograph, can be used as a substitute.—Frank W. Bentley, Jr., Missouri Valley, Iowa.

Carrying Case for the View Camera

For the view camera, the illustrated case has been found convenient. It is

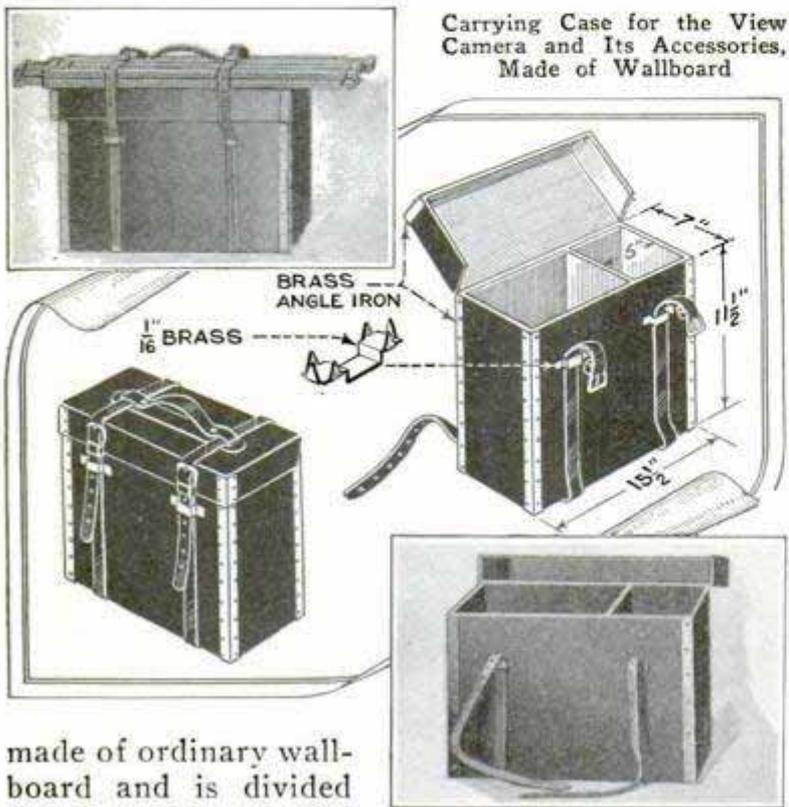

made of ordinary wallboard and is divided into two compartments, one of which is roomy enough for the plate holders, focusing cloth and other accessories, and the other for the camera itself. It can be made of any suitable size and the dimensions changed to suit the size of camera you have. The sides, bottom and ends are first cut and fastened together with strips of cloth, 1 in. wide. These are glued on, both to the inside and outside. The partition is likewise fastened in place, after which the cover is made, following the same method of construction. The cover should fit over the body. Both parts are covered with imitation leather or similar fabric to suit the builder. Corner angles can be purchased or they can be made of $\frac{1}{32}$ -in. sheet brass. If they are made, they should be about $2\frac{3}{4}$ in. wide to allow the edges to be turned under for neatness. Tack them on with small brass escutcheon pins. Two small, heavy staples are made of $\frac{1}{16}$ -in. sheet brass as shown in the detail. They are fastened to the front side of the box, about 4 in. from the top and the same distance from the ends. The pointed ends of the staples are inserted through slits cut in the side and are then bent over on

the inside. Get a shawl strap and rivet it to the center of the top, which is glued on. Line the inside of the case with black cloth or other material for better protection against light.—Wm. J. Edmonds, Whitehall, N. Y.

Hints on Mounting Insects

The use of adhesive tape in mounting insects is a great time and labor saver and enables preservation of the specimens in a natural pose, which greatly improves the appearance. Cut the tape into very short and narrow strips of suitable size for each specimen. Place the insect on a card, spread the legs to their natural position and fasten a strip of tape over each. With this method of mounting, it is unnecessary to fasten the specimen with a pin through the body. To remove the specimen from the card, lift each strip of tape carefully to release the legs. The strips will be found not to stick

to the legs unless they have been pressed down too firmly. If you wish to keep the specimens in envelopes, in the absence of a display case, mount them at one end of an oblong piece of stiff cardboard, and fold the other end over it, book fashion. The latter piece always tends to open up unless it is folded too sharply, thus providing plenty of space for the insect and protecting it against crushing.—Kenneth R. Deardorf, Bemidji, Minn.

Decorating Glass and Pottery

By using various cheap articles of glass and pottery and some paint, unusual and attractive effects can be produced. The work is simple and interesting, and requires nothing more than a bucket of water and some small cans of quick-drying enamel of various colors. The bucket is filled with water and the paint, after each kind has been thoroughly mixed in its own can, is dropped on the surface of the water with a stick. It will be observed that a drop of red will not mix with a drop of blue or any other color dropped into the center of it, and that the various paints

may be drawn out into strings and ribbons without mixing. When the water has been thus covered with paint, take a jar or other article to be decorated, and dip it into the water, the work having been previously washed clean so that the paint will adhere to it. The paint will be attracted to the surface of the jar both when it is immersed and when it is withdrawn from the water, which will give it a coating beautiful in design. By revolving the work as it is being withdrawn from the water, diagonal and horizontal patterns can be obtained. The operation can be repeated as often as desired to get any suitable effect. From time to time more paint must be added to replace that used on the work. After the articles have been set away to dry, the paints will run together slightly at the edges, giving a "marbled" effect.

Door Lock Made from Old Strap Hinge

The ordinary plank type of shed door can be locked by means of a simple device made from an old strap hinge, as shown in the drawing. One part of the hinge is

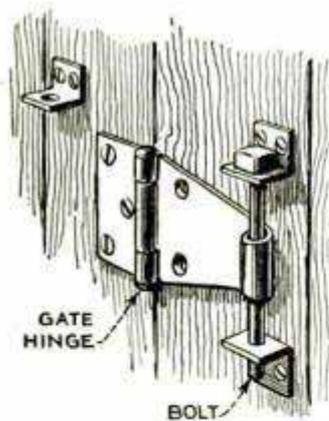

screwed to the door jamb while the tapered end is bent to form an eye through which a bolt can be slipped. Two small pieces of angle iron are attached to the door in line with the eye formed on the hinge, and a hole drilled through the angle brackets allows the bolt to be slipped through both brackets and hinge as indicated. This improvised lock will hold the door securely.—Erwin C. Schroeter, Chicago, Ill.

Quick Repair for Glasses

A quick emergency repair for a broken temple on a pair of spectacles can be made with a piece of rubber tubing of the kind used for auto-windshield wipers. Both broken ends are slipped into the tubing, which will hold them together firmly until a permanent repair can be made.

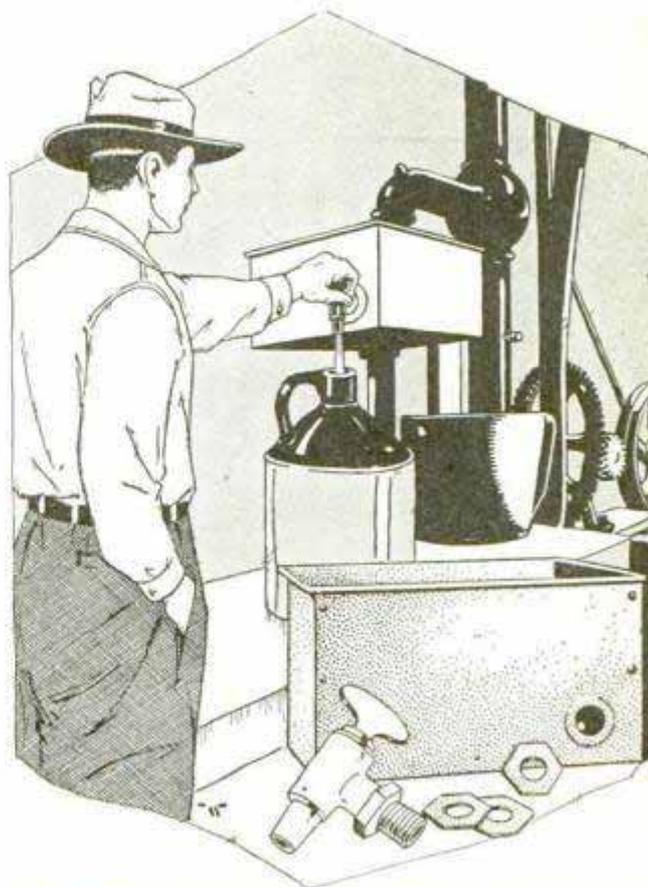

Old Faucet Attached to the Pump Tank Adds to Its Convenience

Faucet on Pump Tank Found Handy

On many farms the pump delivers the water into a small tank that overflows into a trough, which in turn conducts the water to a stock tank. During the summer months, when the kitchen water jug must be filled often, it is rather unhandy to dip the water out of the tank. To facilitate the task more, a faucet from a discarded separator can be attached to the bottom of the pump tank as shown.

Easy Method of Threading a Needle

Threading a needle, even a fairly large one, is frequently a tedious job if your eyes are none too good. The difficulty is removed if you proceed as indicated in the photo. Take a small piece of stiff white paper and hold it under the needle. This will provide a contrasting background and will enable you to see what you are doing.—F. W. Bentley, Jr., Missouri Valley, Iowa.

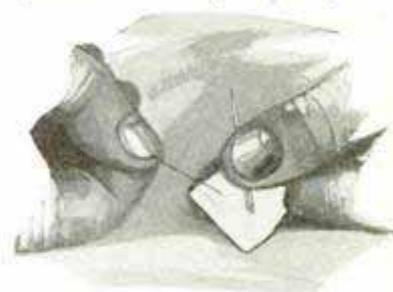

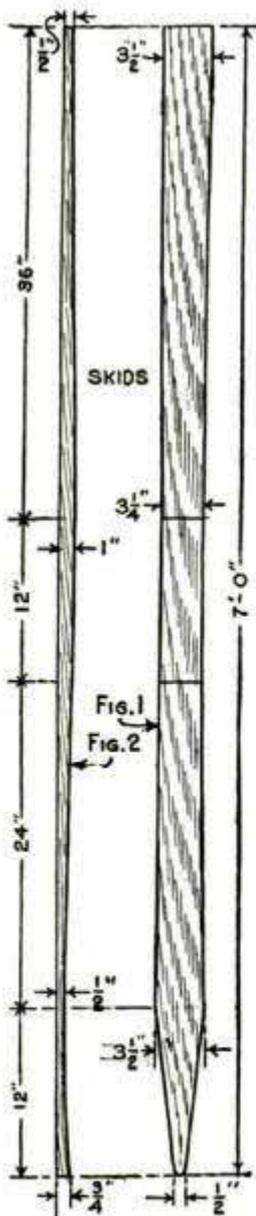

SKI tracks—up the hill, down the hill, in back lot and forest trail, from Maine to Oregon—ski tracks. Tracks made by people who know how to go after real sport when Jack Frost spreads his white blanket. Tracks that mutely speak of the pleasure and sport in “them thar magic slippers.”

Going to try it? The first part of your job is to make the skis. Start by making the two paper patterns shown in Figs. 1



and 2. Then mount pattern No. 1 on a smooth, straight-grained piece of hickory, ash or birch, and with a keyhole or coping saw, cut away the wood which is not covered by the pattern, as in Fig. 3. Fasten pattern No. 2 in place on the side of the wood strip, and shave away the wood to the pattern's edge, as pictured in Fig. 4.

The next job consists in grooving the bottom (flat) side of the ski. This groove can be put in very easily and quickly with a grooving plane, but if you do not happen to be the owner of such a tool, you can do a workmanlike job by cutting out a piece of metal shaped as shown in Fig. 5, and then scraping with this piece down the center of the ski. A straight length of wood clamped into place serves as a guide line, as shown in Fig. 6.

You are now at the halfway mark in the construction of this ski, and about to take a crack at the important process of steaming it to the proper shape. This step consists in bending the whole ski as well as shaping the forward part of your wooden shoe. You will need a boiler or other large vessel which will hold water. Get this water boiling hot, and then place the ski in position over the rising steam. After about twenty minutes of this steam, swath the whole length of the ski with pieces of rags, and then pour over these rags quantities of boiling water. Keep it up for about thirty minutes, paying particular attention to the forward part of the ski, which will take the toe bend. Then, off with the rags and onto the bending frame. This consists of an ordinary stepladder, and the method of

Great Sport!

By Sam Brown, 157 Carhart
St. Marion,
Ohio.

clamping the ski to the steps is shown in Fig. 7. The toe, as you can see, is slipped under one of the steps, and the balance of the ski is securely clamped down. The heel of the ski should be held about $1\frac{1}{2}$ in. out from the step by means of a wood block so that the full length of the ski will be curved in a slight arch. Leave the ski in place for about forty-eight hours; it will then retain its shape permanently.

You will, of course, bend the two skis at the same time in order that the toe bend and arch may be uniform.

Now for the binding. With a wood chisel, cut a long slot through the thickness of the ski, as shown in Fig. 8, locating the slot a trifle forward of the balanced center of the ski. Then cut from heavy metal a piece of the shape shown in Fig. 9, and by means of the four holes shown in the corners, rivet a piece of leather to one side of the piece. Insert the metal strip into the slot in the center of the ski, and then, by using a vise as in Fig. 10, press the ends of the strip upward. Remove the ski from the vise, and nail a 12-in. length of rubber tread into place for your foot to rest on.

The actual binding of the shoe to the ski is a matter of two straps—one to go around the toe, and another, lighter, to slip around the heel—as in Fig. 11. Finishing touches consist of staining and varnishing the upper part of the ski. The bottom should not be varnished, but should receive a liberal application of linseed oil followed by a paraffin rub.

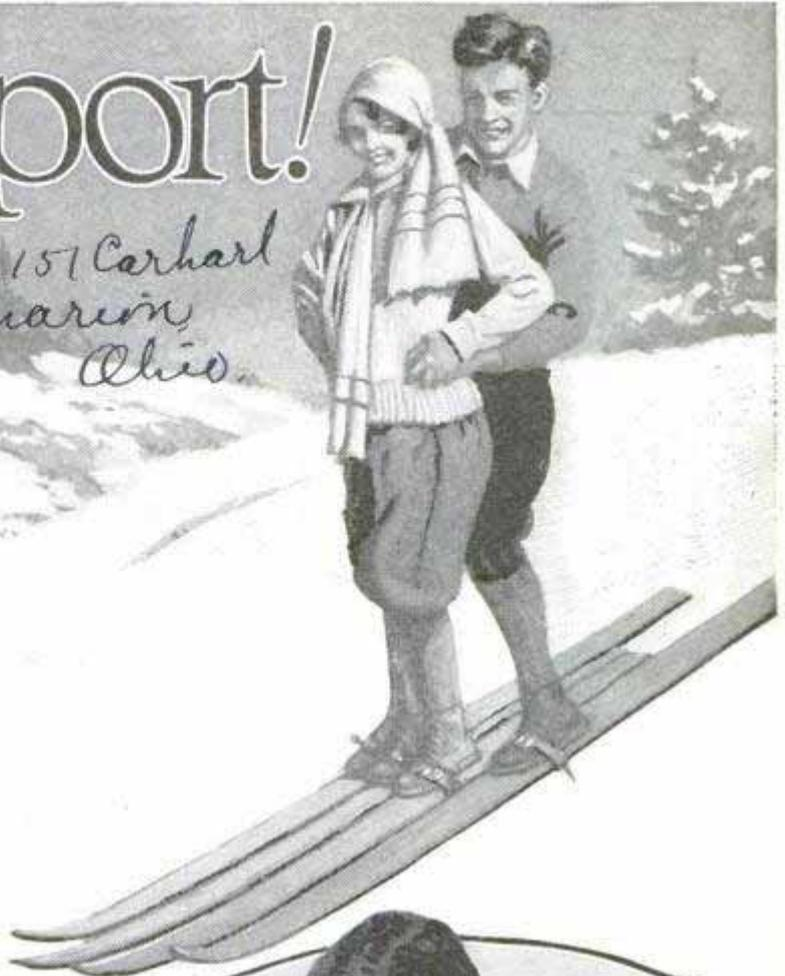

PROJECTION $\frac{1}{8}$ " DEEP
BY $\frac{1}{4}$ " WIDE



Fig. 5



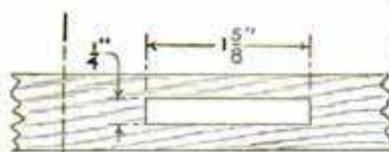

FIG. 8

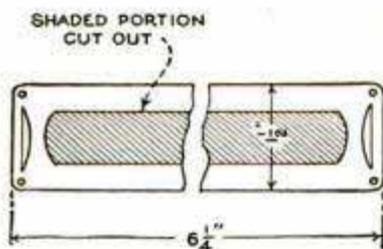

FIG. 9



Start by standing quite still for a few minutes until you get the feel of your huge "feet." Hold the skis parallel and close together. Your poles have been left at home, since they are not necessary in this first lesson. Now, push the right foot ahead, until the knee is bent just so far that, on looking down, you cannot see your foot. Your body is leaning forward. When it seems that you are headed for a pitch on your nose, push your left foot forward, and quickly straighten the right leg. Slide! Don't walk! Bear this in mind always, for it means all the difference between pleasure and work, and is the fundamental rule which must be mastered. Keep your skis flat on the snow.

You should do this initial practicing on a level piece of ground where a slight crust has formed on the snow. And keep at it! It would be grand, no doubt, to start at once by shooting down one of the steep hills on which



Ski sticks are another essential in the equipment of the skier. A 4-ft. length of bamboo makes the best pole. Tightly wire a baby-buggy wheel, with hub removed, about 6 in. from one end of this, as in Fig. 12. The wheel end of the stick is capped with an iron spike set in rosin, while the opposite end of the stick is topped with a leather thong to fit over the wrist.

Now for the dirty work! To find yourself for the first time in your life standing on a pair of skis, a stick in either hand, and with no earthly idea of what to do or how to do it—that's the ultimate in feeling absolutely awkward. And when you finally do start, downhill, going like the wind, with a tree stump coming at you with cannonball speed—oh, for the comfort of the fireside, and the aroma of a good pipe, and the feel of soft slippers.

But it's soon forgotten. In no time at all you are zipping along in great style.

you see other skiers enjoying themselves, but get that long, easy glide before you try anything more difficult.

After mastering running on the level on flat ground, you will be ready for a try-out on a slightly rougher surface. Get out the ski poles, and learn to use these to help yourself along with each stride. If two



poles are used they can be either swung forward and backward alternately, or both swung forward at the same time. The alternating movement will come quite naturally if you will take care to set your poles as far ahead and as close to the skis as possible; but the correct manner of performing the double movement is a bit awkward. Here, you should throw both poles forward simultaneously, as in Fig. 13, taking two or three running steps at the same time, bending your body as far forward as possible and pushing with your whole weight on your arms until they are as far back as they will reach, as in Figs. 14 and 15. Bringing the poles back for a second stroke is the difficult part of the maneuver. They are not brought forward parallel to the skis as would seem natural, but are flipped outward, describing a half circle, from the tail to the tip of the skis, the ends of the poles barely clearing the snow.

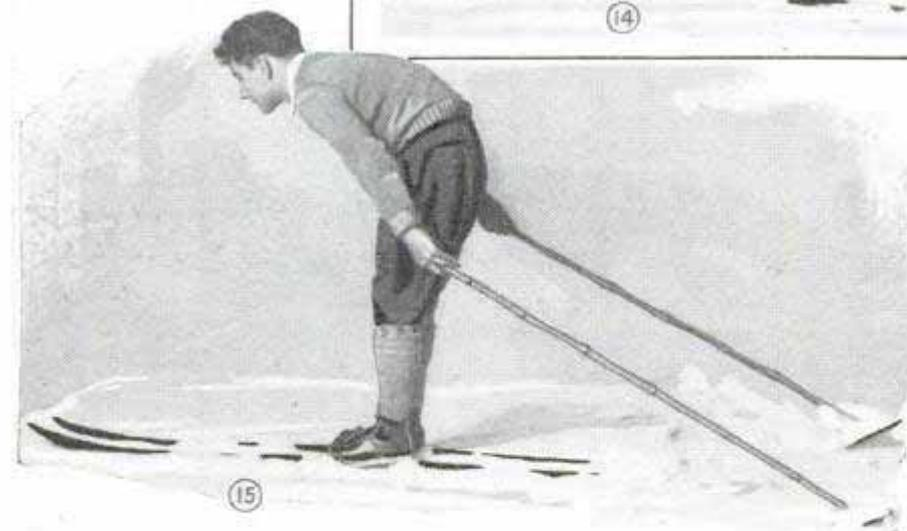

After you get the hang of level running, try the hills. Funny thing about hills—you stand on the very brink of the slope, yet your skis do not at once commence to slide as you expect. So you jerk backward and forward a few times, and there! the skis bound joyously forward while you

do not. Result: You do more or less skiing on various portions of your anatomy other than your feet.

Of course, there's a better way. It consists in running off with the skis before the skis run off with you. Get back a few yards from the edge of the hill and take a few sliding

steps forward. Once you are headed down the slope, push one ski ahead of the other so that you will be better able to maintain your balance. Keep the skis close together; the expert skier never leaves a double track in ordinary downhill running. In going downhill, your poles should be held to the rear and a little above the snow surface. Keep your hands out of the leather loops so that you can let go quickly in the event of a tumble.

Going downhill is heaps of fun and all that, but hills do not forever go down, so it becomes necessary to learn something of the more arduous technique of

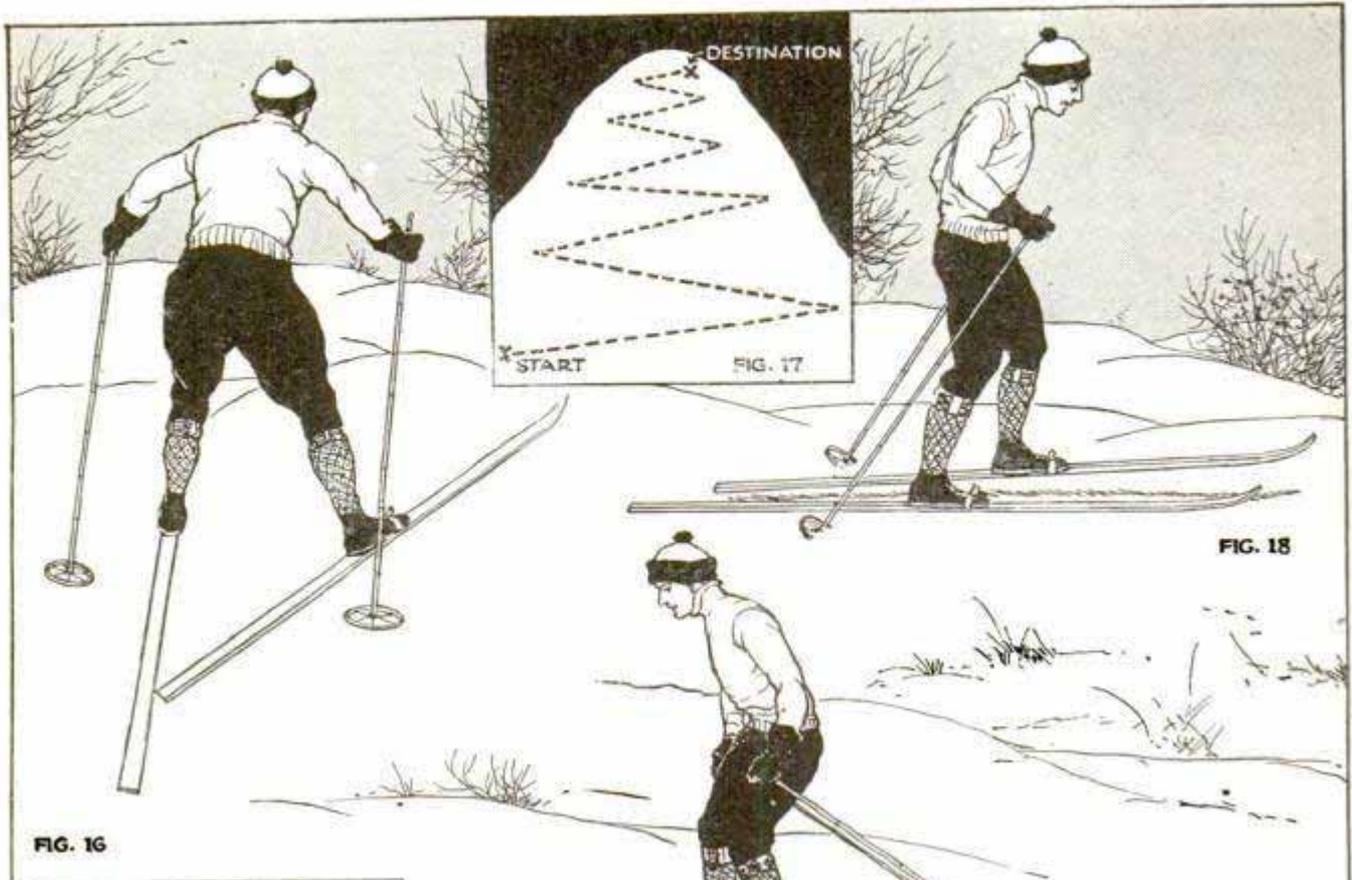

climbing up. If the hill is a short one and you feel full of pep, then you can use the speedy but strenuous "herringbone." Face uphill, push the skis, alternately, forward and outward, as in Fig. 16. Use the poles to help yourself forward. Make certain that the forward ski has a firm grip on the snow before you make the next step ahead.

A simpler, commoner and far easier way to climb hills is to tack. That is, you do not go directly up the face of the slope, but travel at an angle across its surface, as in Fig. 17, and by zigzagging back and forth in this fashion you eventually come to the top of the hill. In tacking, you use a step somewhat similar to that used in straight running, with the exception that the skis are lifted slightly at each step in order to make possible the uphill course, as in Fig. 18.

Whatever the method of getting uphill, the slide down again is surely worth the effort. If, on sliding downhill, you should attain a speed which seems too great, you can easily slow down by snowplowing. This consists in turning the skis in, and letting the inside edge of each of the wooden shoes bite into the snow, as in Fig.

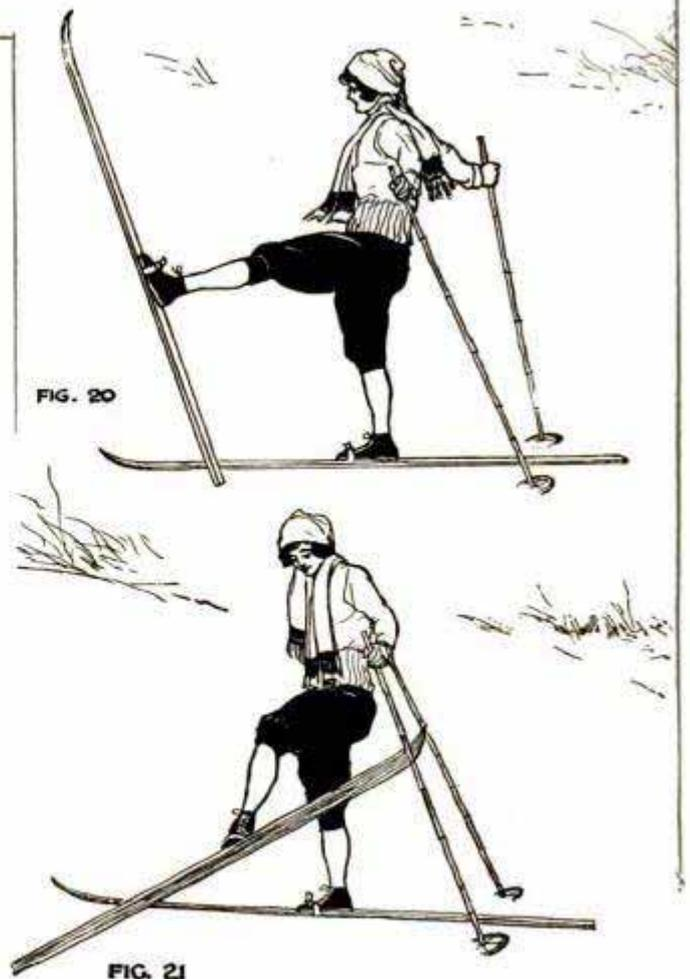

19. Knock your knees together. An emergency form of braking can be done by digging the poles sharply into the snow.

When you reach the bottom of the hill and wish to turn around, use the simple kick turn. This is done by lifting the point of one ski, say the left, until the heel rests on the snow, as in Fig. 20. Continuing the movement, the left ski



is turned out and back until it can be brought down, point to heel with the right ski, as in Figs. 21 and 22. The rest of the turn consists in lifting the right ski high, wide and handsome, so that it can be swung over the left ski and into position.

Naturally enough, there is a lot more to skiing technique than the few principles mentioned in this short article. Straight running, swooping down hills, and snailing up hills, however, are more than enough for the average beginner.

Ski games and stunts, too, can be enjoyed by any beginner. Of these ski diversions, perhaps ski-kjoring is the most popular. This calls for a length of rope, and a "hoss," motorcycle or automobile, as suits your fancy. Ski-kjoring behind an automobile seems to have the preference in this country. Learn the snowplow, as pictured in Fig. 21, before you go ski-kjoring, as it is a very necessary maneuver when you find yourself, on hills especially, going faster than the car ahead.

Obstacle races, in which the skier is required to pass through five or six open-ended barrels, furnish considerable fun for both contestants and spectators. A two-legged race makes for another good laugh. A man and a woman make up a team. The man takes off his left ski, and the woman her right. Now, holding to each other, as in Fig. 23, they slide

downhill with the free foot in the air. Distance, of course, is the sole object. And try shooting downhill in tandem formation or in the horseback fashion shown in the headpiece.

Believe it or not—there's lots of fun waiting for those who tread the winter snow on magic slippers.

Putty for Filling Nail Holes

Putty should not be used for filling nail holes, etc., on work to be finished with flat white paint or white enamel, as the linseed oil in the putty will penetrate the paint and cause yellow spots. A much better filler is the paste found on the bottom of a fresh, unstirred can of flat white paint. Put some of it on a glass plate and add whiting to make a satisfactory putty. Only enough of this composition should be mixed for immediate use, as it dries very hard. It sticks like glue and does not shrink, crack or stain the paint.



Dirt Tampers for Feet Do Work of Lawn Roller



Wooden Foot Tampers Used to Pack Down Soft Dirt in the Absence of a Lawn Roller

After preparing and leveling off the black dirt on my lot in the preparation of a lawn, a roller was not available, and I made a pair of foot tampers to use as a substitute. They were made of 1-in. stock and measured 10 by 14 in. in dimensions. While standing on them, I drove two small nails on each side of each foot and tied a length of heavy twine from nail to nail across the shoe to hold the tampers. —John Hessemer, Seattle, Wash.

Speed Indicator for Outboard Motors

When the outboard motor is put up for the winter, it is a good time to overhaul it and provide such extra fittings as may be desired. One of them, which can be installed by the owner, is a speed indicator. A tachometer, or instrument indicating revolutions per minute, can be

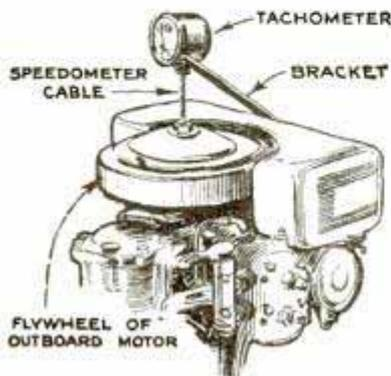

made from an automobile speedometer of the fly-ball type. Remove the mileage-counting arrangement, leaving the fly ball and the pointer. You will note

that the fly-ball ring has a slight spring tension applied to restore it to its normal position and keep it from becoming horizontal out of proportion to the speed. Bend this spring with a pair of small pliers so that the tension will be slightly greater than it was originally, then remount the indicating face of the speedometer and paste a disk of white paper over it. Draw an arc for a scale on the paper, but leave it otherwise blank. Take the tachometer to any automotive electric shop and have the scale graduated according to a standard tachometer used for checking generator and engine speeds. The completed instrument is mounted on the motor by means of a strap-iron bracket so that its drive-shaft comes exactly over the center of the motor flywheel. The two are then connected with a short piece of speedometer cable.—D. A. Brown, Marion, O.

Asbestos Curtain for Gasoline Lantern

A gasoline lantern, set on the floor of the tent, will provide sufficient heat to make the interior comfortable at night, but there are times when the brilliant light is not desired. To reduce this, yet retain the heat,

provide an asbestos curtain for the lantern as shown in the drawing. Woven asbestos cloth should be used for this purpose. When not in use, the curtain is rolled up and put away, or slipped around the base of the dome. Such a curtain will be appreciated by fishermen and hunters, as well as campers.—Durie Rockwell, Hollywood, Calif.

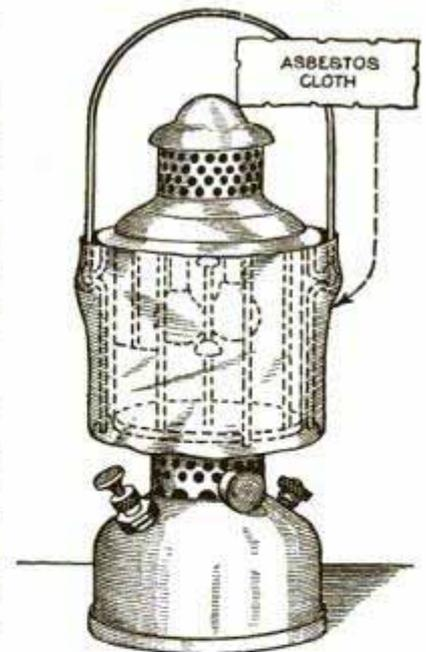

Keep the spark plugs adjusted to the gap specified for the car. Do not guess at the distance, but use a gauge to test the length of the gap.

Improving the Oil Cookstove

In our vicinity, where gas for cooking purposes is not available, we use an oil stove. It has all the good features of the numerous makes on the market, as I have taken a tank from one, leveling legs from another, burner lift from a third, and so on, combining all these parts to make a better stove than any one of the contributing types. The idea proved successful. There is one objection I had to all of the stoves, which I have also corrected. The lighting ring is usually of ordinary tin-reinforced asbestos, and these carbonize in a comparatively short time, making it necessary to replace them. I used discarded auto-brake lining for the asbestos wick and found it would last about six times as long as the commercial kind. Heat the lining red-hot to burn off all the grease and oil, and after it has cooled sufficiently, cut it to fit the stove burner. It may be necessary to flatten it with a hammer in order to make it fit.—Sidney Cornell, Southport, Conn.

Using Narrow Film in Camera

A photographer found himself out of film at a time when it was absolutely necessary to get certain pictures. The local drug store did not carry the size of film required but did have on hand narrower rolls of the same length. After a moment's reflection, the photographer adapted the narrow size to his camera by attaching a small wooden spool at one end of the narrow film spool as shown in the illustration. To do this, a notch was cut at one end of the spool and a number of matches were driven into the other end so that this could be wedged onto the film spool. A standard spool was cut to the required size. After the film was exposed and wound on a large-size film spool, it was removed from the camera in subdued light and immediately wrapped in tinfoil.

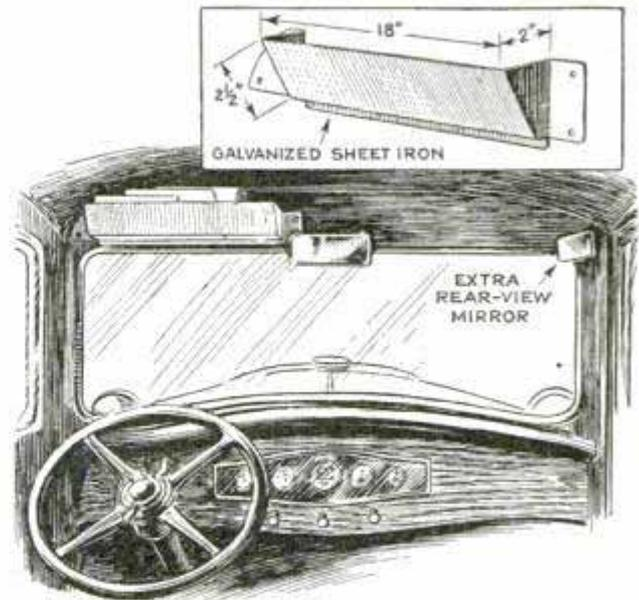
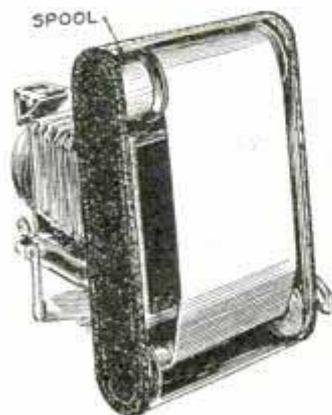

Maps and Other Papers Are Convenient, Kept in This Sheet-Metal Container

Handy Map Holder in Car

Made of galvanized sheet metal, the container shown in the drawing has been found handy for holding maps and other papers carried in the car. It is trough-shaped, having only one side and two ends, and is attached above the windshield by driving a few short woodscrews through the extending ends. These are then bent over flush with the surface. Another accessory I find convenient is an extra rear-view mirror, mounted in the angle at the right-hand side of the windshield. This shows when another car pulls out to the left to pass me.—S. M. Hunt, Prague, Okla.

Improvised Cake Tins

When baking a number of cakes at one time, and not having enough small tins, I took a rolled-oats carton and cut it to the height of the tins. These I set in pie tins, greasing both the tins and the cartons, after which the dough was put in and baked, with perfect results.—Mrs. Eleanor Durr, Portland, Oreg.

Finding Leak in Basket-Ball Bladder

To find a leak in a football or basket-ball bladder, remove it from the casing, inflate it to normal size, and hold it up to the light. This stretches the rubber so that one can see blemishes and small holes easily.—R. P. Deneen, St. Cloud, Minn.

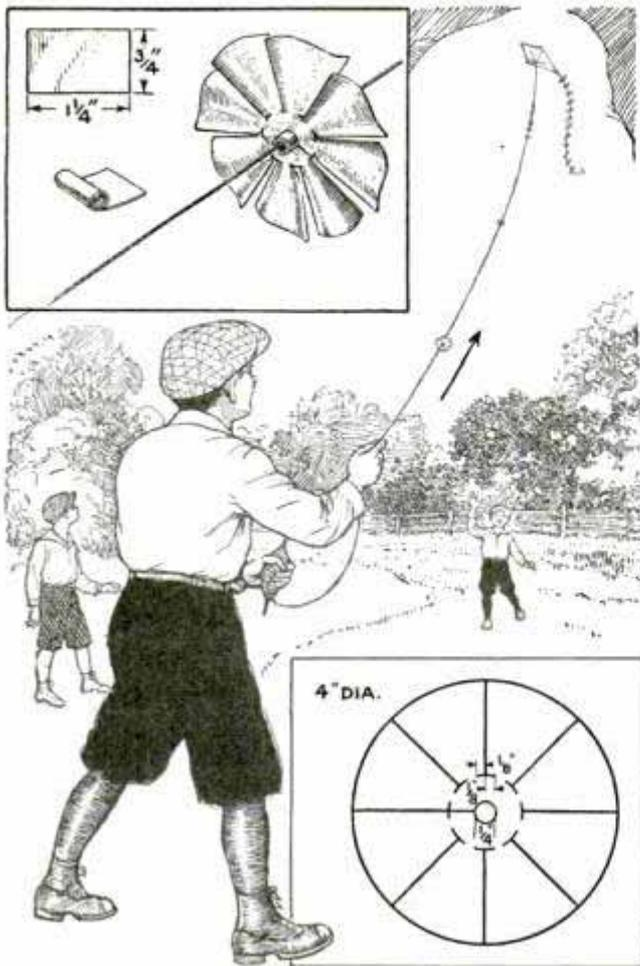

Circular Disk with Numerous Blades Makes a Speedy Kite "Message"

Sending Aerial Messages to the Kite

When flying kites it is quite customary to send "messengers" up to the kite. Quite an improvement over the usual form is shown in the drawing. Cut a disk about 4 in. in diameter from a piece of light cardboard and make radial cuts as indicated in the detail, being careful to follow the dimensions given. Then roll up a narrow strip of paper to form a bushing which is pushed through a hole cut in the center of the disk. The sections are bent outward to form blades and the device is slipped on the kite string. It is amusing to see how fast these messages climb up the cord toward the kite.—Douglas H. King, Irvington, N. J.

Cutting Ice-Cream Containers

It is often quite a task to remove ice cream from a paper container by the usual method of first letting it melt a little and then digging it out with a spoon. The following method eliminates this trouble: Cut the container, with the ice cream in it,

in the same way as you would cut a cake. The container, with the lid closed, is laid on its side and slices of any width can be cut with a sharp knife. To serve, merely slip off the paper "rind." This method has been found especially useful with cylindrical containers.

Hanging Two Tiers of Garments in the Wardrobe

Placing the coat hangers on a rod supported by cleats on opposite walls of the wardrobe is the usual method of disposing of garments with the least waste of space. A second tier may be hung by arranging a rod near the ceiling and nailing staves on the coat hangers to be used on the top rod. Thus the garments can be hung up and removed without the use of a stepladder.

Handy Oil-Gauge Wiper

Keeping a rag under the hood of your car for wiping off the oil gauge is poor practice, owing to the possibility of the rag igniting if it comes in contact with the exhaust pipe. On the other hand, a greasy rag cannot very well be kept any other place about the car. To have a wiper handy without these objectionable features, I installed the one shown in the drawing, and found it entirely satisfactory. It consists of a piece of heavy tin, cut to a T-shape and then bent over to form a clip. Before bending it, a strip of heavy felt is attached by crimping the corners over as indicated. In use, the gauge is drawn between the wiper, which is attached to the motor near the oil gauge.—A. C. Wilson, Columbia Cross Roads, Pa.

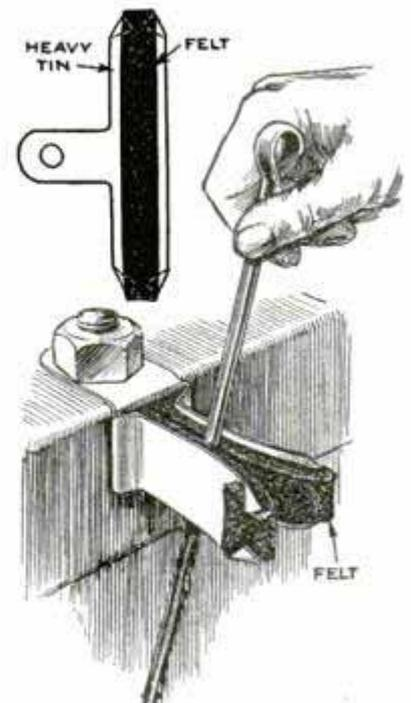

Straightening Warped Boards

Lumber as it comes from the mill to the amateur woodworker is not always properly seasoned, or, if it has been resawed to thickness, the moisture content of the inside of the original board, being greater than that of the outside, often causes the resawed board to warp or curve. When you receive your wood, store it so that it will stay flat, weighting it if necessary to keep it so. If, in spite of precaution in storing, you find a board warped, it can often be straightened by holding the concave side over the steam from a kettle for a few minutes, and then exposing the convex side to heat. The moisture absorbed by the concave side will expand the cells on this face of the board, while moisture will be extracted from the cells on the convex side by the heat. With a little coaxing the board can usually be flattened. Then it should be laid on a flat surface and weighted to keep it in shape until it is to be used.

Eliminating Doorbell Annoyance



PUSHBUTTON



PULLBUTTON

A semi-invalid who found it annoying and difficult to answer the doorbell time after time only to find peddlers and agents there, had a simple change made in the pushbutton so that it had to be pulled instead of pushed in order to ring the bell. As the secret of its operation was only given out to friends, no more trouble was experienced, as pressing the button had no effect. A small groove turned in the button helps to hold it. The illustration clearly shows how the mechanism inside was changed.—Harold E. Benson, Denver, Colo.

Improving the Seating Arrangement in Two-Door Sedan

In many two-door sedans there is quite a bit of space between the front seats which can be utilized to advantage, as shown in the illustration. The right-hand seat is mounted on a steel rod so that it

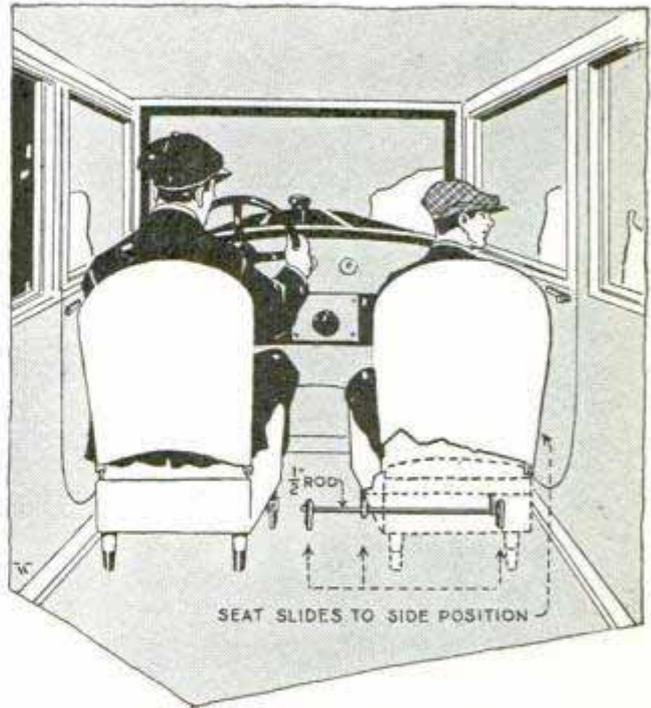

Sliding Front Seat in Two-Door Sedan Makes It Easier for Occupants to Enter and Leave

can be slid toward the driver's seat. This gives the occupants of the rear seat more room to get out of the door, by sliding the seat to the left. Remove the pins from the front legs of the seat on which it hinges, and ream out the holes on both legs and supporting brackets to receive a piece of $\frac{1}{2}$ -in. cold-rolled steel. The right-hand bracket must be moved closer to the car wall, and the other one close to the driver's seat, while the rod must be long enough to allow maximum movement of the seat. The rear-seat passengers get out between seat and door, without the front passenger leaving his seat.—John L. Blaker, West Auburn, Mass.

Rubber Base Prevents Sliding of Phone

To prevent a desk phone from sliding, get a rubber coin pad of the type shown in the illustration and glue it to the underside of the base. There will be no more trouble. It takes only a few moments to apply a rubber pad, which can be bought at any rubber-goods store.

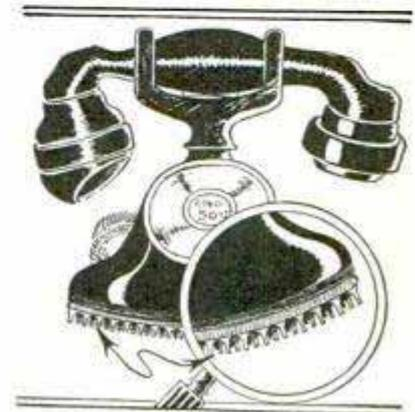

A Scale-Model Plane *is*

by



NEXT in order is the job of assembling the engines. The Pratt & Whitney "Wasp" motors of this ship are the familiar nine-cylinder, air-cooled, radial type. The lead die castings made for the model cylinders are an exact replica of the latest Wasp design. They are mounted at angles of 40 degrees to each other on the engine nacelle.

Referring to Fig. 32, in the preceding chapter, you will see the nacelle tapers at the front, where the cylinders are to be mounted. Mark a line around the nacelle, $\frac{3}{16}$ in. back from the front edge, as shown in Fig. 33, as a center line for the cylinders. If the nacelle is exact size, the diameter on the line will be $\frac{7}{8}$ in. Anyway, caliper the exact measurement, lay out a circle of the same size on paper, and draw nine radial lines 40° apart. Adjust a pair of dividers to one of the divisions, and step the distance off on the nacelle, checking to see if it comes out even; then mark the points for the cylinders.

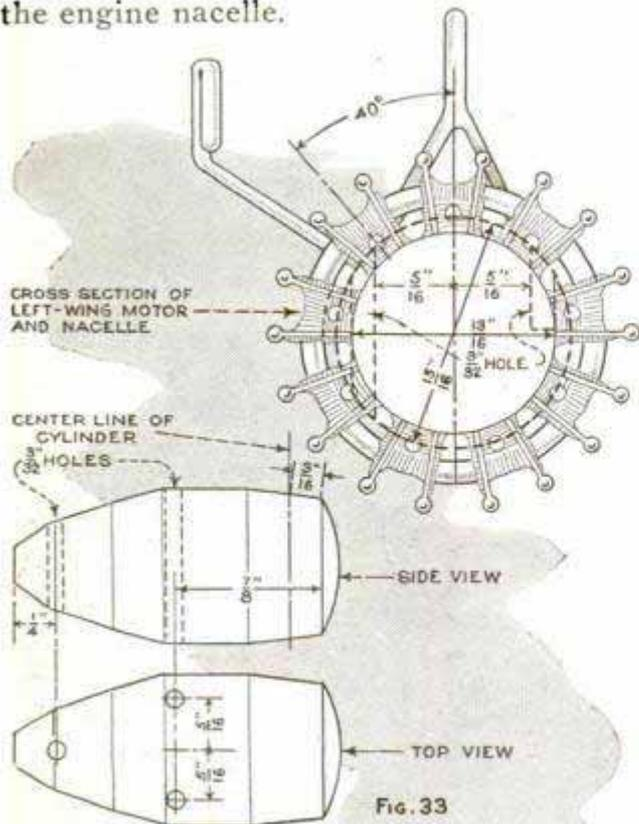

The nacelle should now be drilled to take the supporting and landing-gear struts. Selecting one of the cylinder positions as the top of the nacelle, draw a line lengthwise of the block, passing through the cylinder point. Referring to the side view, Fig. 33, measure $\frac{7}{8}$ in. back from the nose, and $\frac{5}{16}$ in. from the center line, on either side, to locate the forward supporting struts. The inside hole is drilled entirely through the nacelle, the lower end of the hole taking the landing gear strut. As one nacelle is left-hand and the other right, the holes must be on opposite sides of the two engine mounts. A $\frac{3}{32}$ -in. drill is used. Next, $\frac{1}{4}$ in. from the tail, drill the other $\frac{3}{32}$ -in. hole, on the top center line,

Easy to Build

Walter Bullock

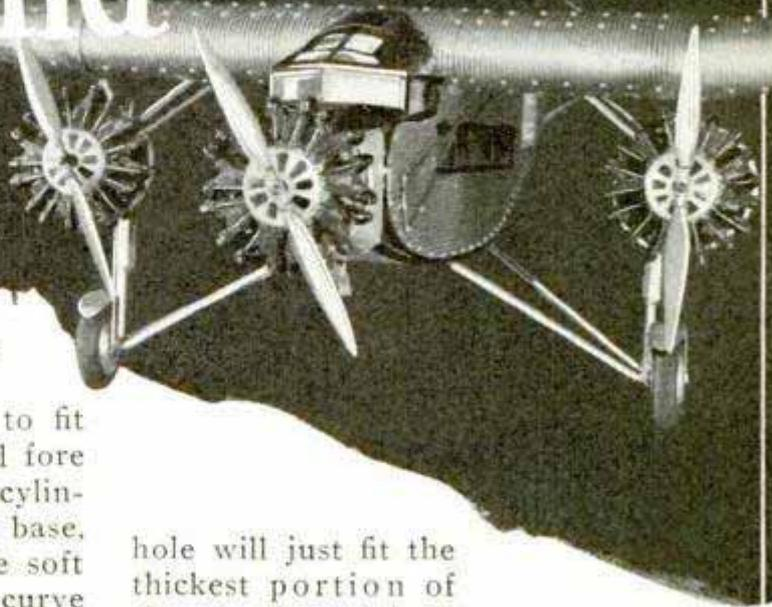

for the rear strut, about halfway through the block.

The cylinders must be rounded to fit the nacelle surface, and also tapered fore and aft, as shown in Fig. 34. The cylinders are cast with the curve in their base, but must be tapered by cutting the soft lead with a knife, maintaining the curve at the same time.

Drill a No. 60 hole vertically through each cylinder, to take the brad by which they are fastened, and a hole, $\frac{1}{16}$ in. in diameter and about $\frac{1}{8}$ in. deep, in the rear side, to take the end of the exhaust pipe. The back of the cylinder, Fig. 34, has the intake manifold cast on and, opposite its upper end, a small flat place where the exhaust outlet is to be drilled. On the bottom of the cylinder is a small casting lug. Cut this off, mark the center, and drill lengthwise for the brad. A small hole cut in a block of wood will hold the cylinder fairly steady and eliminate marring of the cooling fins. Centering the hole in the bottom is imperative if the cylinders are to line up properly.

With all cylinders drilled, you are ready to assemble the first engine. Fig. 34 shows the center line, which is to be kept at right angles to the crankshaft line, or center of the nacelle. Cut away the lead until you get a good fit, keeping this line at right angles to the longitudinal axis of the nacelle, and with the cylinder in a radial line through the shaft position. A brad, through the cylinder and driven a short distance into the nacelle, will aid in this. When correct, nail the cylinder on and proceed to the next one. A convenient jig to keep the nacelle lined up fore and aft and protect the cylinders already in place as more are added can be made by drilling a $\frac{15}{16}$ -in. hole $1\frac{3}{8}$ in. horizontally into a block of wood. The

hole will just fit the thickest portion of the nacelle and hold it firmly. Both wing and nose motors are assembled in the same way. The top cylinder of the nose engine is placed on the center line of the nose, as with the wing engines.

The exhaust pipes and ring, Fig. 35, come next, and when they are in place, the cylinders will be firm and rigid. The

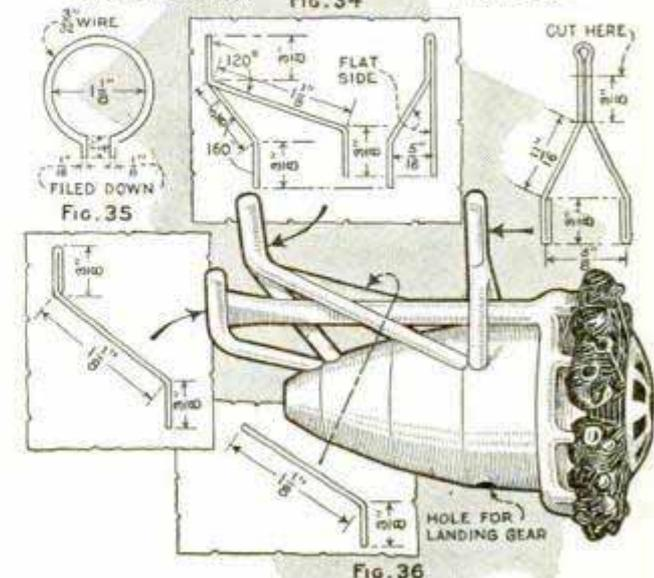
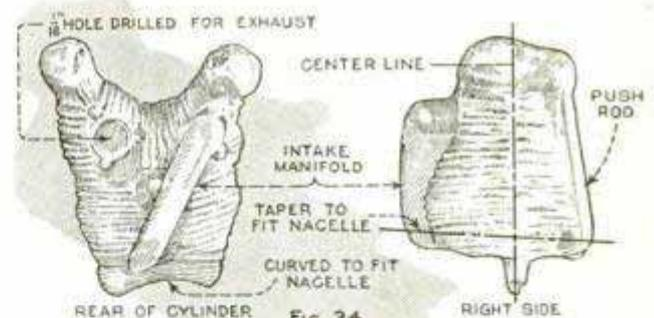

short "pipes" from the holes drilled in the cylinders to the ring are made from $\frac{1}{16}$ -in. wire. Cut seven short pieces that will fit in the holes and project $\frac{1}{8}$ in. to the rear of the cylinders. Standing the nacelle on its nose, solder each in place. None are needed in the two bottom cylinders.

The ring is formed from $\frac{3}{32}$ -in. wire, and should have an inside diameter of $1\frac{1}{8}$ in. At the end of the rod, $\frac{1}{4}$ in. is bent at right angles to form the connection to one of the two bottom cylinders. This portion is filed down to match the other connecting pipes. The opposite end is bent and cut to fit the other cylinder, and the end filed down to match. Solder the outer ends of the short pipes to the ring, and smooth down all joints with a file.

The supporting struts, by which the nacelles are suspended beneath the wings, are made from $\frac{3}{32}$ -in. cotter pins, 2 in. long. Full details of the left-wing nacelle supports are shown in Fig. 36. The forked part at the right is the same for both wings. The other three pieces are made in left and right shapes. After you have completed the left-wing mount, the right will offer no difficulties.

Starting with part A, Fig. 37, file the ends of one of the 2-in. cotter pins off to equal length, spread them far enough apart to handle each side with the pliers, and bend over $\frac{3}{8}$ in., to form full rounded ends, which may be soldered. Next bend the $1\frac{1}{16}$ -in. legs, squeeze the shanks back together with the pliers and solder, then cut off the head, leaving a $\frac{3}{8}$ -in. shank to be soldered into the wing. Two pieces are made exactly alike.

For the piece behind this, part B, straighten out a pin to its full length, hammer out the bends and start with the lower rear leg. Holding the pin with the pliers in the right hand and the flat side

of the pin toward you, bend it to the left to form the 160° angle. Bend the upper shank back to the right parallel to the lower one, then double up the pin, as in the front view. The doubled portion is soldered. The long end of the pin is bent forward and upward to form the 120° angle, and the forward end downward and clipped off to a length of $\frac{3}{8}$ in. The forward strut is then bent outward to form one side of the forward brace. Piece C, which forms the other side of the brace, is bent with the flat

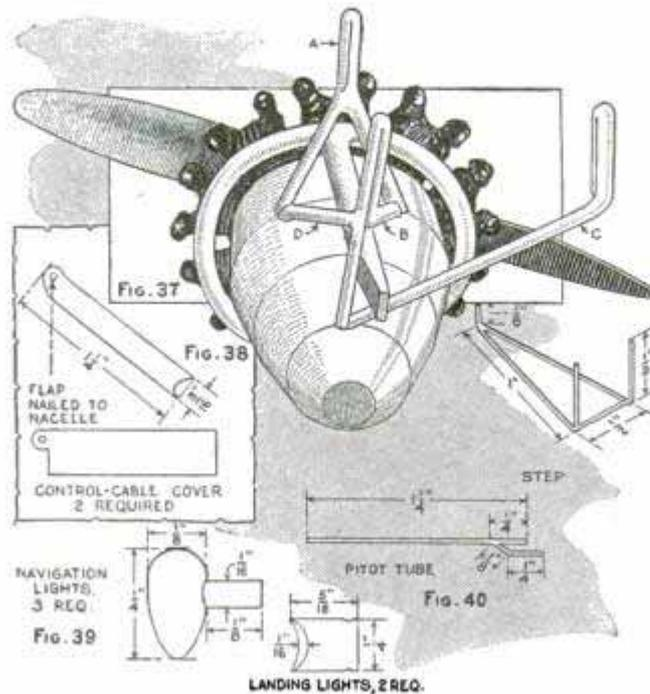

side of the pin inside. The fourth support, D, has a $\frac{3}{8}$ -in. shank at the bottom, and is soldered to the rear shank of B. When the straight fork A is completed, force it into place, and then, drilling as close to the legs of the fork as possible, bore two more $\frac{3}{32}$ -in. holes to take the forward legs of B and D. After they are in place, a drop of solder can be used to join the two, the surplus being filed down smooth and rounded between the struts.

The exhaust stacks for the wing motors are made from $\frac{1}{8}$ -in. brass rod, $1\frac{3}{4}$ in. long. The rear end is hammered down in a tapering wedge, $\frac{3}{8}$ in. long, $\frac{1}{16}$ in. thick at the end. The forward end is hollowed with a file to fit snugly against the exhaust ring. Solder in place and solder the stack to the rear vertical strut, B. Complete the struts for the other wing engine, remembering to bend them in the opposite direction, and add the exhaust stack.

Engines and nacelles are then ready for painting. The cylinders, the rear end of the nacelle, the point of the wedge-shaped exhaust stack and the shutter openings on the nacelle nose are black. The woodwork, struts and exhaust pipe are painted with aluminum paint, or, as previously explained, may be nickelplated. If aluminum paint is used, do not paint

the strut shanks, as they are to be soldered to the wing. The painted shutter has nine openings, the sides of which are located by drawing lines down from the push rods on the cylinders. The outer edge of the shutter is marked by a circle $\frac{1}{16}$ in. from the edge of the nacelle, and the inner edge by a $\frac{5}{32}$ -in. circle. Inside this, the center of the nacelle has a $\frac{3}{16}$ -in. black circle, to represent the shaft hole through the cowling.

Now locate the positions and attach the cylinders of the nose engine, centering the top cylinder. As the exhaust stack for the nose motor is located beneath the fuselage, the ring starts with the top cylinder and ends with the one on its left; otherwise all details are the same as for the wing engines. The exhaust stack is made from $\frac{1}{8}$ -in. brass rod, $2\frac{1}{4}$ in. long. Instead of flattening one end, it is bent, as shown in the photographs. The forward end is hollowed and soldered to the ring between the two bottom cylinders. Halfway along its length, a dot of solder holds it away $\frac{1}{8}$ in., and the end, just forward of the curve, is supported in a loop of tinned wire, the ends of which are soldered into No. 60 holes drilled into the fuselage.

Rig the rest of the controls before mounting the wing motors and landing gear. Cut two straight single horns from galvanized iron, $\frac{1}{2}$ in. long and $\frac{1}{8}$ in. wide at the wide end; a

$\frac{1}{16}$ -in. hole is drilled in the wide end and a No. 60 hole in the other. These are for the rudder controls. Drill a $\frac{1}{16}$ -in. hole in the nose on either side at the rear edge of the nose cowling, insert a short length of $\frac{1}{16}$ -in. wire, solder in place and solder the horn on the end, pointing the latter backward and down at an angle of 45° . The control cables from this and the ends of the flipper horn, already in place on the end of the control-stick rod, lead up to the wing at a point $\frac{1}{4}$ in. back of the front edge of the second cabin window. Drill two No. 60 holes into the bottom of the wing, as close to the fuselage as possible, placing the second hole $\frac{1}{8}$ in. to the rear of the first. A third hole is drilled $\frac{1}{8}$ in. out from the front hole. Solder the end of a length of tinned wire into each hole, lead the two nearest the fuselage through the ends of the flipper horn, draw them tight and solder; solder the third through the rudder horn.

The cables from the wing to the tail surfaces lead into the wing $\frac{1}{4}$ in. from the trailing edge, three holes being drilled in the same manner as before, the outer hole for the rudder cable. Solder the ends of the three wires into the wing. Next form four $\frac{1}{8}$ -in. rings out of wire and twist the ends together for $\frac{3}{8}$ in. Drill two No. 60 holes in either side of the fuselage, just below the roof and

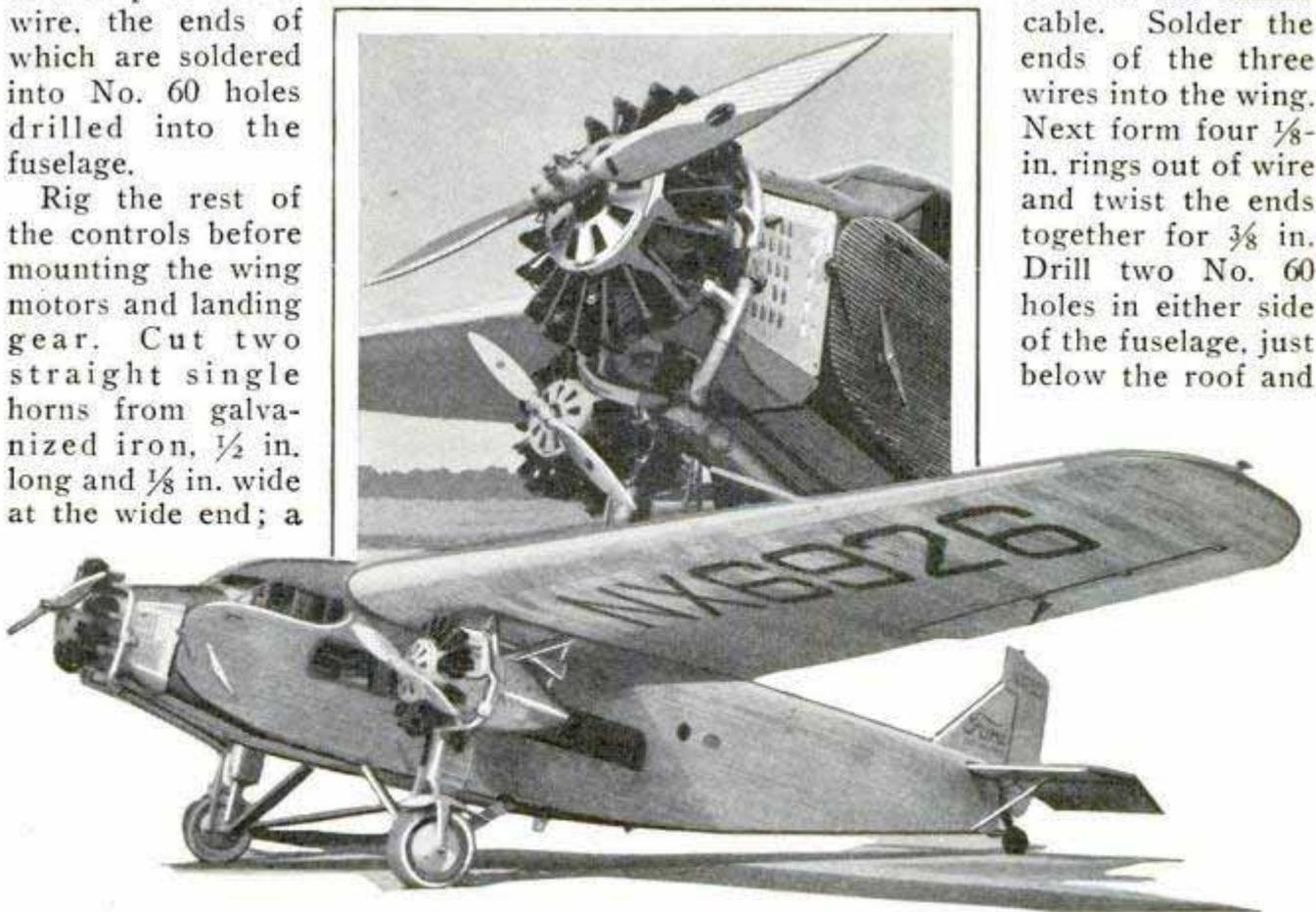

Above, Nose of the "Grey Eagle," a Northwest Airways Transport; Below, View of the Same Plane, Showing Wing Numbering and Name on Stabilizer

1 in. to the rear of the last cabin window, placing one hole on each side $\frac{3}{16}$ in. below the other. Solder the shanks of the ring to the fuselage and pass the top flipper control through the top ring and the lower flipper and rudder cables through the lower one, draw the wires tight through the holes drilled in the horns, solder and cut off the ends.

The lavatory window, on the left side of the fuselage comes next. The center of the small round deadlight is $\frac{3}{4}$ in. aft of the rear edge of the window and $\frac{5}{16}$ in. above the window's top line. Drill a $\frac{1}{8}$ -in. hole a short distance into the wood, then, using a $\frac{5}{16}$ -in. wood bit (not a metal drill), carefully ream out the metal to that diameter, and drill a short distance into the wood beneath. Paint the hole black, cut a $\frac{5}{16}$ -in. disk of celluloid and glue it over the opening. The celluloid may be

sprung in under the metal to look better.

To mount the wing engines and landing gear, drill a $\frac{3}{32}$ -in. hole in the wing on a line with the front row of rivets on the underside, centering it in the first corrugation inside of the strip of smooth metal which passes around the wing. Place the front wing-engine strut in this hole, and mark the position of the rear strut, in the same corrugation. Drill out the hole, then mark and drill for the third strut. Force the supports into place until the vee of the struts is close against the wing. Slip the landing gear into the hole in the bottom of the nacelle and mark the position for the holes by which the diagonal struts will be attached to the fuselage, keeping the forward strut at right angles to the body. Drill the two holes, the rear one at an angle. Cut off excess streamlining and the ends of the landing

gear rods until the gear fits into place, with the top of the shock-absorber housing resting against the bottom of the nacelle, the strut on which it is placed vertical, and the other two fitting the fuselage snugly.

If any parts are slightly off, soften the solder joining them and readjust to get a good fit. Keep the strut leading up to the nacelle vertical. Make the cover over the engine-control cables and the brake rods before attaching the engine assembly and landing gear. The cover is shown in Fig. 38. It is formed around a length of $\frac{1}{16}$ -in. rod. The flap is tacked to the nacelle with a small brad, and the other end soldered to the wing. When completed, it is not parallel to the rear supporting strut, but extends slightly nearer to the

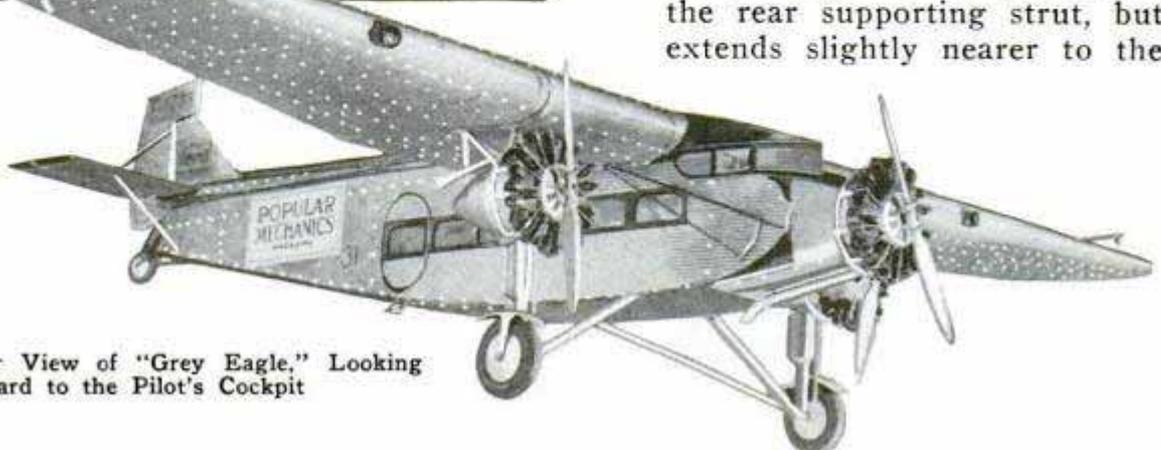
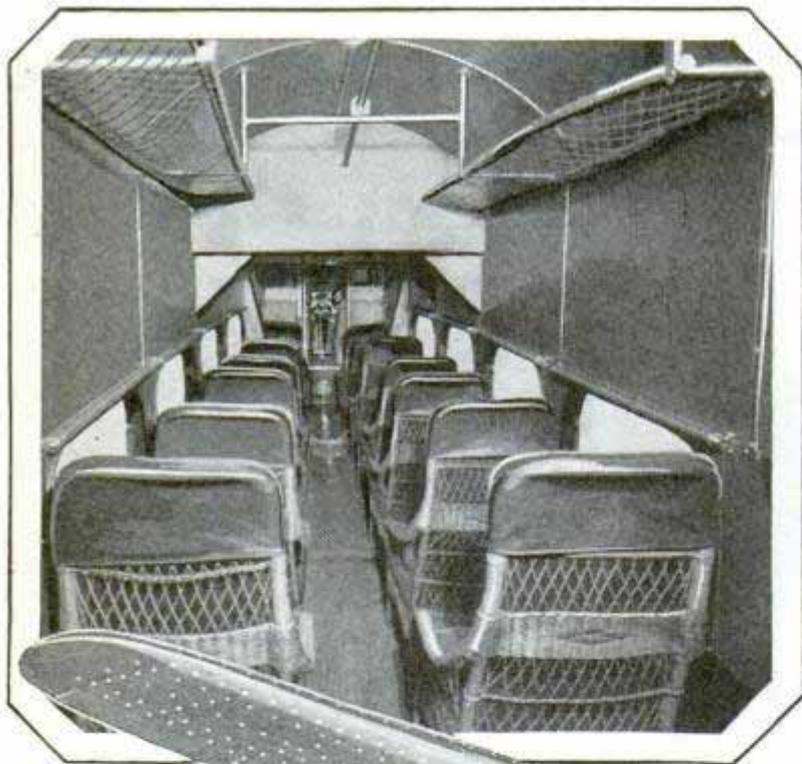

Above, Interior View of "Grey Eagle," Looking Forward to the Pilot's Cockpit

fuselage. Remember left and right flaps are needed.

The brake rod on each wheel is a length of $\frac{1}{16}$ -in. rod. Hold it against the front of the shock-absorber housing, with the end resting on the nacelle, mark the position of the end of the nacelle, drill a $\frac{1}{16}$ -in. hole halfway through the nacelle, and slip the rod into it. Mark the rod on a line with the axle, and cut it $\frac{1}{8}$ in. longer than required. Bend the extra $\frac{1}{8}$ in. at right angles, so the end will press against the wheel, and secure the rod with a drop of solder to the mudguard. The end then appears to enter the wheel. Attach the three propellers with round-head nicked escutcheon pins, and the engines are complete.

To make the navigation lights, cut three pieces of the plain uncorrugated metal to the size shown in Fig. 39. Each light is formed of one of these pieces as a center for two drops of solder, and is secured to the plane by the small projecting tee. Drill $\frac{1}{16}$ -in. holes in the wing tips at the point of greatest length of the wing, and a third in the top of the rudder $\frac{1}{8}$ in. from the leading edge. Solder the small flat pieces in place, the wing lights parallel to the wing, and the tail light vertical and in the plane of the rudder. Then, taking a big drop of solder on the iron, drop it onto the light, and the shape of the metal center, plus surface tension, will mold the drop into one-half of the streamline form. Turn the ship over and drop another drop on the other side. The plane should be tilted with the light pointing slightly downward during the process to keep the solder from spreading to the wing, and may be tilted slightly forward to make the drop fill out the form.

The landing lights, one on each wing, are cut from $\frac{1}{4}$ -in. dowel stock, as in Fig. 40. Instead of pointing straight ahead, they point slightly out, to illuminate a broader path. The rear of each light is hollowed to fit the leading edge, the cut being made $\frac{1}{16}$ in. deeper on one side to point the light outward. A small bead is

formed to represent the rim of the lens. The light is mounted 1 in. in from the inner end of the smooth metal at the tip, so that it points straight ahead with the tail down on the ground. The front of the light is black, then covered with celluloid attached with ambroid. The edges are painted the same as the ship's trim.

The step for the passenger cabin is made from wire approximately $\frac{1}{32}$ in. thick, as shown in Fig. 40, and sol-

dered in place beneath the cabin door. A pitot tube, the business end of the air-speed indicator, is made from the same size wire and soldered into a hole drilled in the leading edge of the left wing, directly in front of the aileron horn.

Painting completes your ship. I paint the Northwest Airways insigne on my models, the same as on the ship I fly. It occupies a circle $1\frac{3}{8}$ in. in diameter.

The cowling over the pilot's cockpit, the cockpit window frames, the narrow edge around the cabin door, the space between the cabin windows, and a $\frac{1}{8}$ -in. frame around the cabin windows should be painted. On the Northwest Airways Ford ship I fly, the color is maroon. We also paint the top quarter of the nose cowling to keep it from reflecting the sun's rays into the pilot's eyes, using the same color. The ship's identification numbers, as required by law, are painted on either side of the rudder, on the top of the right wing and underneath the left wing. The number of the ship I fly is C7739, the "C" standing for commercial. The wing numbers are $\frac{3}{4}$ in. high and occupy a space $3\frac{1}{2}$ in. long, centered behind the landing lights, as shown in the photographs. The rudder numerals should be $\frac{1}{4}$ in. high. The name on the vertical stabilizer consists of the word "Ford" in the familiar script, with the word "Tri-Motor" in block letters below it, the whole occupying a space $\frac{3}{4}$ in. square. A reinforced space on top of the wing, used by the mechanics when fueling the ship, bears the words, "Walk Here," in black, inclosed in a box $\frac{3}{4}$ by $4\frac{1}{2}$ in.

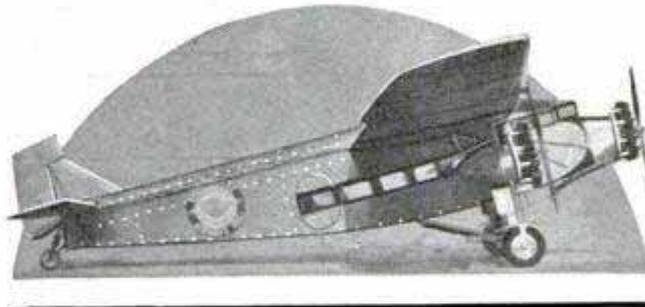

Side View of Model, Showing Position of Insigne

Extension for Operating Wall Hydrant

Shrubbery along the wall of our home made it very difficult to get at the hydrant,



Operating the Wall Hydrant through Dense Shrubby Is Easy with This Extension

so I made the extension shown in the illustration. It consists of a stout pole with three wood screws partly driven into one end to engage with the hydrant handle. The other end of the pole is fitted with a short iron crossbar, and a support, with a V-notch at the upper end, is driven into the ground as indicated. The handle is just visible, and is easily accessible.—Hi Sibley, Pasadena, Calif.

Simple Method of Dividing Collars

A timesaving method of dividing collars as compared with the usual procedure of marking one or two collars at a time with a surface gauge while holding them in a V-block, is indicated in the drawing. The collars are stacked on top of each other over a rod. A square is then brought up against the sides and lines are scribed from top to bottom diametrically opposite each other, using the eye alone as a guide. The collars now appear as shown in stack 1. Turn the top collar to the position shown in

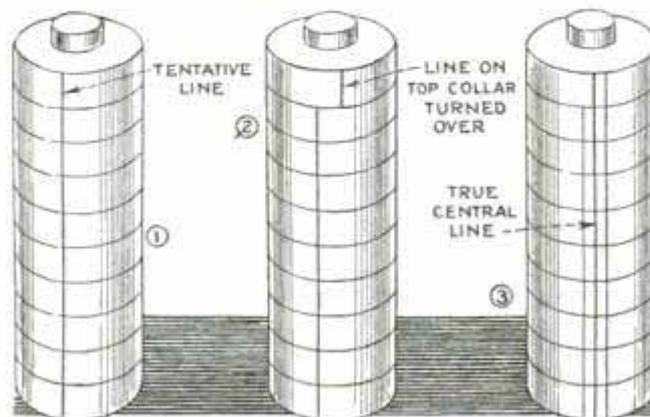

Simple Method of Marking Collars with Two Lines an Equal Distance Apart

stack 2, matching one of its lines to the others in the stack. The line on the opposite side will then be found offset about as shown. Scribe a second line down from the mark on the top washer on this side of the pile. Divide the distance between the two lines and scribe a new center line.

Sewing-Machine Troubles

Sewing-machine troubles are usually very small and when one knows how to locate them, the remedy is simple enough. The most common troubles are skipped or missed stitches, breaking of the thread, uneven tension, and rough needles. Stitches are missed when the needle thread forms a loop as the needle reaches its lowest point, and the point of the hook or shuttle does not enter the loop. Bent needles are the common cause of missed stitches, as the loop is formed too far away from the shuttle point. Skipped stitches may also be caused by using too small thread or too large a needle. After determining the thread to be used, choose a needle that has an eye just large enough for the thread to pass through freely. Thread breaking is caused by too much tension or by using a rough needle. The hole through which the thread passes and other parts of the needle can be made quite smooth with emery cord or cloth. If the thread still breaks, see whether the tension is right and examine the needle very closely. The long groove is often made rough by the end of the shuttle touching it, and a needle in such condition should be replaced with a new one. A correct lock stitch is one where the top and bottom threads lock in the middle of the thickness of the material. If the bottom thread shows on top of the material, increase the bottom-thread tension or decrease the top-thread tension. When the top thread is seen on the underside of the material increase the top-thread tension or decrease the bottom-thread tension. It often hap-

pens when hard or rough material is sewed that the needle point becomes rough or turned up, which results in breaking the bottom thread, skipped stitches, large holes in the material and poor or irregular feeding of the work. This can often be remedied by replacing the needle or making the point smooth. If, after these corrections have been made, the machine won't sew, see that it runs on time. This is done as follows: Tip the machine back and turn the wheel by hand slowly, watch the needle get to its lowest point and ascend $\frac{1}{8}$ in.; the shuttle point should now be just above the needle eye. This is the correct timing. If adjustments are necessary, raise or lower the needle bar by loosening the screw holding it in position and tighten it again after the correct adjustment has been made.—J. D. Calvert, Preston, Can.

Substitute for Glass Coffeepot Top



in most coffeepot lids.—Mrs. Ella Besocke, Chicago, Ill.

⦿Lard oil should be used with thread dies.

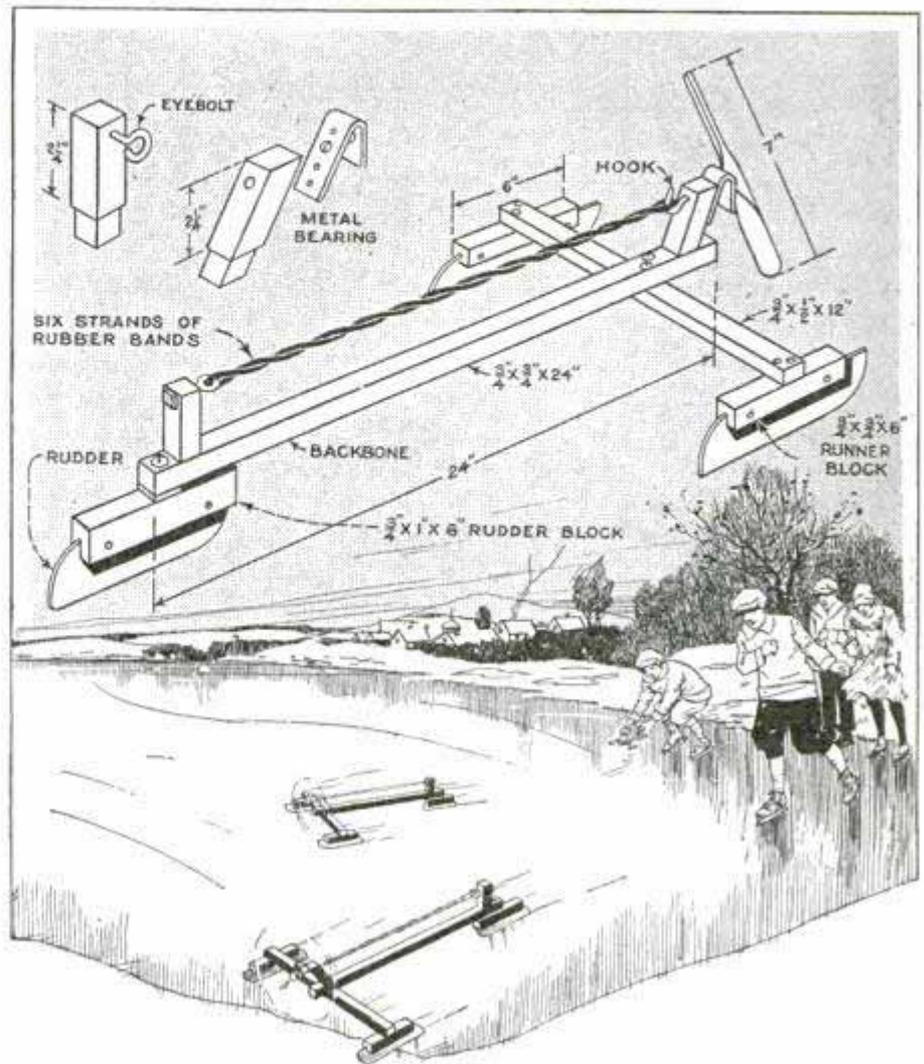

You Can Have Great Sport with an Air-Propelled Model Ice Plane, and the Cost of Building It Is Very Small

Air-Propelled Model Ice Scooter

Anyone who has built a model airplane or who is interested in this recreation, will find nearly as much enjoyment in building an air-propelled model ice plane, and the cost will be much lower than that of an airplane. The backbone consists of a single stick of white pine, 24 in. long and $\frac{3}{4}$ in. square. At each end a small block is attached to which the rubber motor is fastened. The rear block is vertical and projects from an opening in that end of the backbone. The other block is pitched forward so that the propeller will clear the front end. The height of the blocks should be about $2\frac{1}{4}$ in. above the backbone. The propeller is 7 in. long and can be carved from any lightweight soft wood, such as white pine, whitewood or even clear spruce. Cut it to general model-airplane proportions and then drive a piece of bicycle-spoke wire through the exact center for a shaft. The bearing is

a piece of stiff brass screwed to the front of the forward support and bent over as shown. A hole for the shaft is drilled horizontally through both the brass bearing and the rear support. Hook the rear end of the shaft over as shown, after placing a washer between the propeller and the front end of the brass bearing to take up wear. The runner plank is a 1 by 1½-in. piece of white pine fastened across the backbone at right angles, 2 in. back of the bow end. At each end, screw a 1-in. square block parallel to the backbone. Make a lengthwise slit in the bottom of each to accommodate a runner cut from light sheet steel, 6 in. long and sharpened to a V-edge on the bottom. The runner should fit snugly in the slot and should be driven into place. At the stern end of the backbone, drill a vertical hole just back of the rear support, and slip a small bolt through the hole to permit fastening another runner block, the bolt serving as a pivot. The rudder, which is held

cient. Attach one end of the bundle to the hook in the propeller shaft and the other end to an eyebolt provided at the top of the rear support. The bands should stand the strain of 250 or 300 turns without breaking. Choose a field of smooth ice, wind up the motor in a direction opposite to the propeller thrust, and give the boat a slight push at the same time you release the propeller. If properly built, such an iceplane will travel several hundred yards at a high rate of speed. The angle of the rudder will control the direction in which the scooter travels.

Visualizing Proposed Change in House

Let your camera aid you in visualizing any proposed changes about the house or grounds. Take a photo of that part of the house or grounds where the change is to be made and make two prints. On one of them sketch in the change you are considering and be careful to draw the details

the same relative size as the photo. Then you will have before you two photos showing the grounds before and after the change, which can be placed side by side for comparison, and you can decide whether or not it will really prove satisfactory.—C. L. Meller, Minneapolis, Minn.

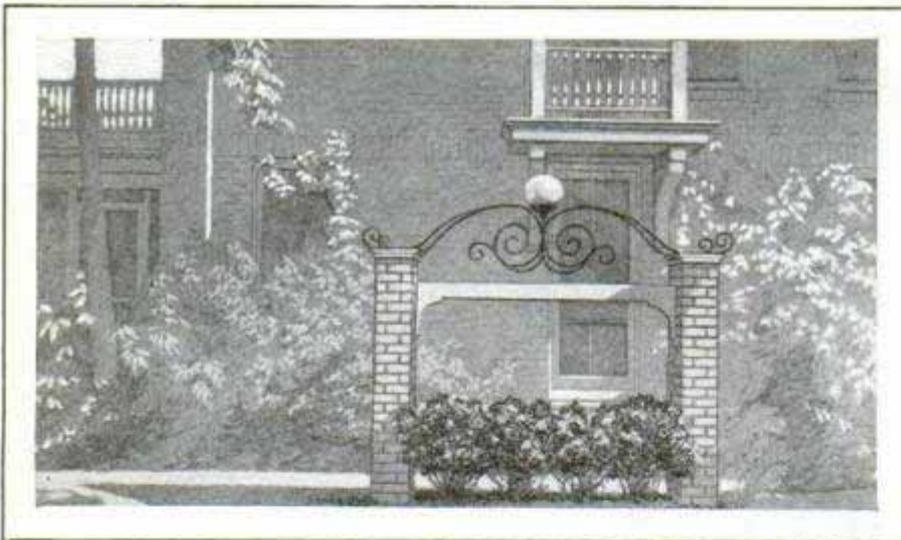

by this block, is made of the same material as the runners and is cut to the same shape. The pivot bolt should have a lock washer between the block and the backbone, so that the rudder will turn stiffly. Varnish or oil should be applied to all the wood to protect it against moisture. The motor consists of six strands of ⅛-in. rubber band. A 12-ft. length will be found suffi-



Before Making Changes in Your House or Grounds, Take a Picture and Make Two Prints; Then Sketch In the Proposed Change on One of Them

Renewing Blown Cylinder-Head Gaskets

Before putting in a new cylinder-head gasket, let it soak in water for an hour. This will expand the asbestos and make the gasket soft, so that it will fit into every irregularity of the metal when the cylinder head is drawn down. The gasket then becomes securely anchored in the irregularities instead of bridging over them, and the resulting tight fit prevents combustion gases from working under the gasket and burning it out. One precaution is necessary, however, and that is to tighten the nuts again after the engine has cooled down after its first run.—C. E. Packer, Chicago.

A Selective Icebox Lock

Where the family icebox is placed on the back porch, it is advisable to safeguard the contents by providing a padlock. In one case where the icebox had four doors, all of them except the ice compartment were locked by using one padlock and a sheet steel plate as shown. The latter is about 6 in. square and has two slots forming a cross in the center, which are large enough to be slipped over a staple attached to the ice-



box. One corner is cut out to leave the ice compartment accessible to the iceman, and by turning the plate one half or quarter turn, any one door can be opened while the rest are kept closed. If desired, a second plate, similar to the first but with all corners whole, can be used to lock all the doors.—Elton Sterrett, Savannah, Ga.

Removing Dents from Silverware

The drawing shows a method of removing dents from silverware that has been found easy and effective. All the material necessary is a piece of wood to form a paddle as indicated. It is made of maple



Maple Paddle with Smoothly Rounded Handle Used to Remove Dents from Silverware

or other close-grained hardwood. The narrow end is rounded and the surface carefully sanded smooth, while the flat end is screwed to the top of a bench or clamped in a vise. In use, the piece of silverware is grasped in both hands, slipped over the rounded portion of the paddle and the dent can then be pressed or hammered out with a suitable mallet.—Harry E. Gifford, Medford, Mass.

Easily Made Ice Creepers

An ice creeper that can be made quickly at practically no expense is shown in the drawing. It consists of a metal plate, 1½ or 2 in. square, with the corners bent at right angles to form teeth. In use, it is placed in the arch of the shoe and held in place by means of heavy rubber bands cut from an old inner tube. The sheet metal used for the purpose should, of course, be heavy enough to dig into the ice without bending.—Glen F. Stillwell, South Haven, Mich.





Portable Ironing Board of Small Size Is Held Securely on Any Table

Portable Ironing Board Saves Space

For those who desire a small, compact ironing board that can be attached to any table and stored in a trunk or suitcase, the one shown in the drawing is hard to beat. It consists of a piece of $\frac{3}{8}$ -in. plywood having two small blocks hinged to the underside, and is equipped with a hook at the end, which is slipped over the table edge.—Durfe Rockwell, Hollywood, California.

Windshield for the Cigar Lighter

A cigar lighter often is blown out when used outdoors, but this trouble can be overcome by fitting it with a shield as shown in the drawing. It consists of a piece of fairly light sheet brass or tin, cut and bent to fit over the top of the lighter. It is best to use metal that is slightly

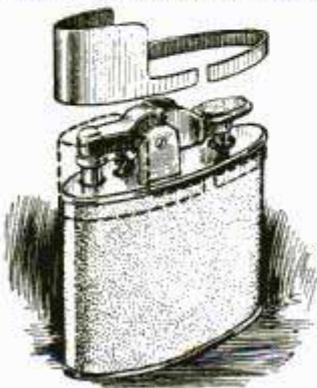

springy so that the shield will stay in place. The wide portion incloses the flame and prevents it from blowing out.—Myron L. Harmon, South Bend, Ind.

Aluminum Is Best Metal for Lining of Window Sills

A piece of 30-gauge sheet aluminum, screwed to the top of the kitchen-window sill, makes a good shelf for pots and pans when the contents need cooling. Tin and galvanized sheet iron have been tried, but these metals soon become dirty and stained and zinc is too soft, but aluminum has been found satisfactory and is easily kept clean. Besides its use in the kitchen, such an aluminum plate is an ideal lining when flowerpots are set on the sills.

Secret Hiding Place for Jewels

For hiding jewelry in a comparatively safe place, which can be provided without the necessity of calling in the help of any outside workman, get a brace and a 1-in. bit, and bore a hole in the top of a door, as shown in the drawing. Then make a sheet-metal tube to serve as a container. The bottom of the tube is closed by a disk soldered on, and small lugs at the top are bent outward to prevent the container from dropping into the hole too far. If desired, a hinged lid can be fitted on the tube or a cork inserted in the open end, taking care, of course, that it does not project far enough above the door to interfere with opening and closing it, and above all, that it is not noticeable.

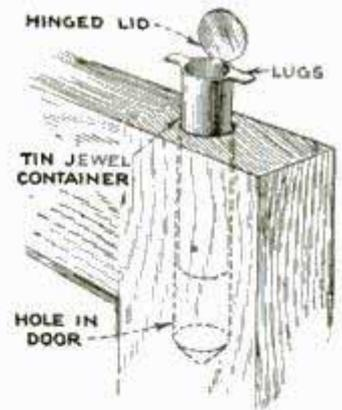

Removing Ink Stains from Rug

Make a paste of starch and buttermilk, and spread it over the ink spot on the rug. Let it remain there until dry and then rub off. No trace of the ink will be left. Of course, this remedy only applies to ink spots that are still wet. The remover should therefore be used immediately.

SHOP NOTES



Blower Cuts Down Fuel Cost

By BARRY A. ROSS

TO THE owner of a small home who is interested in a large saving in heating his home every year, I believe the following outfit which I have rigged up in my home and have used for two years, will be of interest. I have saved about \$50 a year in the cost of my coal since I started using this device. In place of stove or nut coal at \$16 a ton, I am now heating my home with the same amount of fuel, using buckwheat coal at \$9 a ton, thereby saving \$7 on every ton of coal burned.

The attached diagram shows the arrangement of the various parts, which can be hooked up and installed by any home mechanic for a few dollars. The cost of the apparatus is more than offset

by the saving in coal. I purchased a secondhand thermostat with control box for \$20, and the forge blower which is used cost me \$3. The rest of the apparatus was made in my own workshop.

The forge blower is hooked into the draft plate on the ash pit of the furnace. It is not necessary to use the hot-air intake shown, but I believe that this is an added advantage, as the fire is then fed with hot air, which is drawn in around the stack before it enters the chimney.

The thermostat and its control motor are hooked up according to the directions which accompany it. Then the front arm

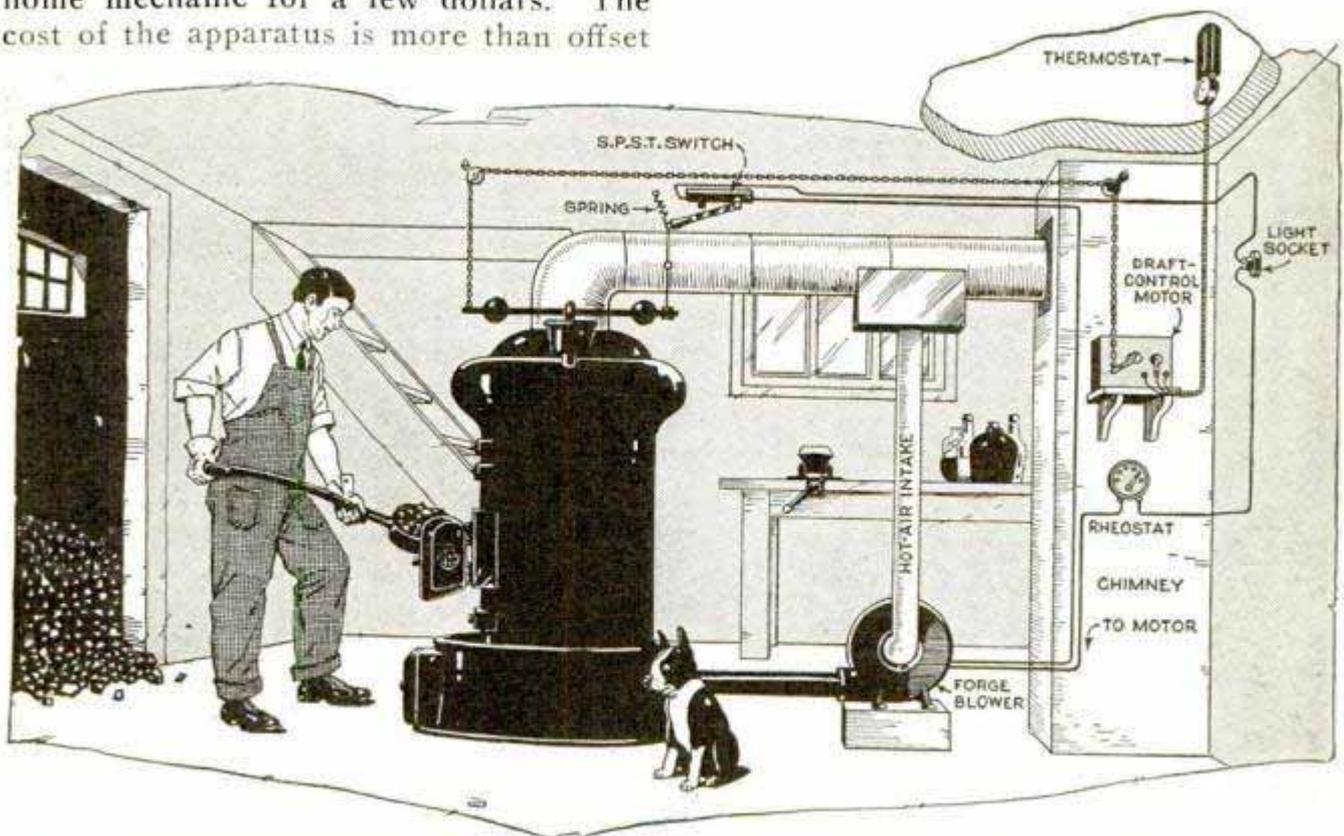

This Simple Arrangement Saves Mr. Ross from Fifty to Sixty Dollars a Year on His Coal Bill, by Burning Buckwheat Coal Instead of More Expensive Grades

of the regulator valve is connected to the arm of the control motor, so that the draft will be opened and closed by the action of the thermostat. The back end of the furnace-regulator arm is attached to the handle of a switch by a threaded eyebolt, which is set so that it will automatically open the switch at any desired steam pressure, independent of the thermostat control. This adjustment will necessarily have to be determined by experience after the furnace is in operation. The end of the switch handle is also held in a closed position by a light spring, as shown in the drawing.

The switch referred to is a single-pole single-throw switch, attached to the ceiling over the furnace so that the handle of the arm is directly over the back end of the furnace-regulating arm, and con-

nected in one side of the line from the electric-light socket which drives the motor of the blower. The other side of the light line runs through a rheostat which controls the speed of the blower motor. As soon as the regulator arm opens the draft, the blower goes on, and when the draft is closed the blower stops. This arrangement, of course, may be altered to suit the type of furnace which is in the home. The thermostat control box can be run from batteries, or connected with a bell transformer using the terminals.

Any home mechanic can, with a little labor, install this outfit and save more than its cost in the first year. I am burning No. 1 buckwheat, and can get up 5 lb. of steam in about five minutes with this arrangement. It has not been necessary to change the furnace grate.

Chute and Pit for Unloading Coal from Drop-Bottom Cars

Nearly all coal cars now have drop bottoms for side delivery, but in many small towns and even large yards in cities there often are no modern silos and unloading devices. A simple substitute arrangement, consisting of a suitable steel chute and a sloping pit to accommodate delivery trucks, can be provided as shown, so that the coal runs directly into the

trucks. Besides saving time in unloading, this method also involves less breakage of coal than when it is thrown over the side of an open car. The chute is made of heavy steel and is supported by two stout wooden horses. It is, of course, advisable to provide strong, reinforced concrete walls and floor for the pit, to withstand the weight of the trucks.

Cleaning Out Kerosene Cans

Frequently one wishes to clean out some receptacle which has contained kerosene. Just empty out whatever dregs the container has in it, and drop a tablespoonful of denatured alcohol into the container, swilling it around to make the spirit cover as much area as possible. Stand clear and drop a lighted match into the container, and after the spirit has burned out, it will be found that the receptacle will be quite free of kerosene.—V. Clapham, Pietermaritzburg, South Africa.

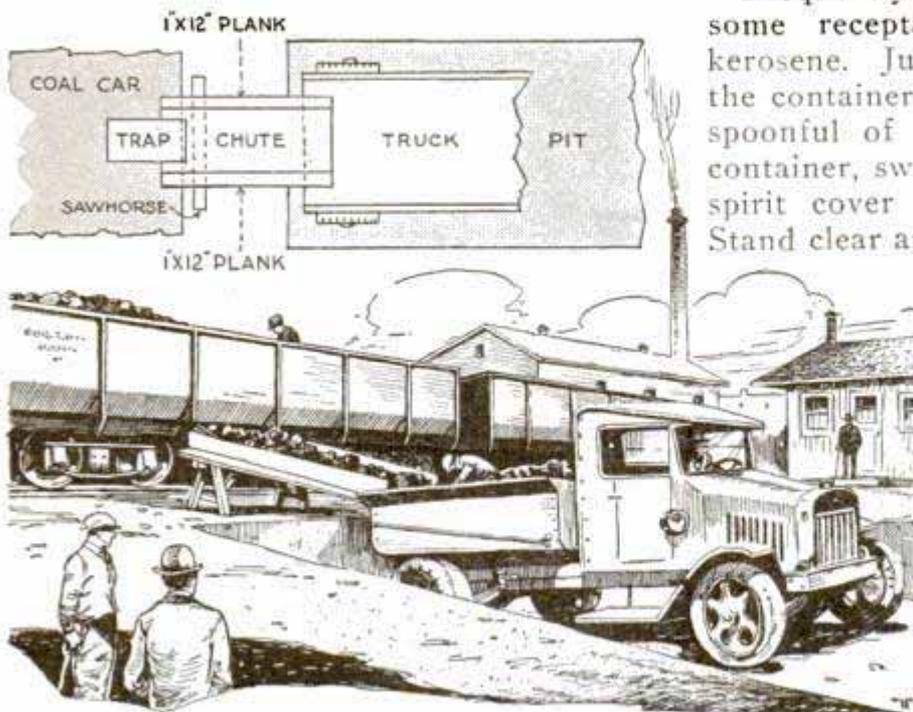

Steel Chute Delivers Coal from Drop-Bottom Cars to Truck Located in Pit Alongside of Tracks

Ⓛ Setscrews can be tightened without the usual danger of twisting them off if the heads are lightly tapped with a hammer while drawing them tight with a wrench.

Shock Absorbers for Auto Seats

Shock-absorbing coil springs for the front seats of two-door sedans have been placed on the market. They consist of heavy coil springs, four to a set, one being slipped over each seat leg. It is frequently found, however, that this arrangement raises the seat too high, or that the springs are too stiff to produce the desired action, especially if the occupant is of light weight. A simple remedy consists in using only one spring under each seat instead of two. It can be fastened either to the floor or to the underside of the seat, as desired, in the center near the rear edge. To attach them, proceed as follows: Cut a square piece of heavy sheet iron, large enough to support the spring; round the edges, drill a small hole at each corner for woodscrews to hold the plate in place, and drill a large hole in the exact center to receive a stovebolt. Get a strip of fairly heavy iron or brass, cut it about $\frac{1}{4}$ in. longer than the diameter of the spring at the end where it is to be attached, and drill a hole in the center for the stovebolt.

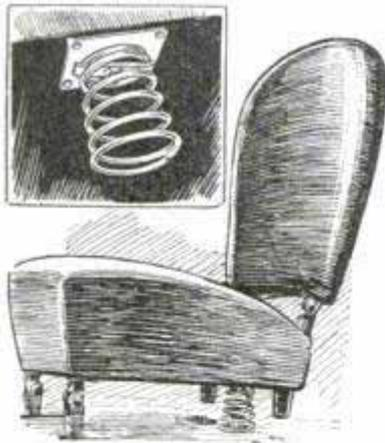

The end coil of the spring is clamped between the strip and the plate, the stovebolt being used to hold the assembly tightly together. Another metal plate may be provided to serve as a bumper for the other end of the spring. Springs arranged in this way have been found to improve the riding quality of the seats considerably.—Walter E. Burton, Akron, Ohio.

Trench Box Speeds Up Pipe Laying

A western contractor has found that the use of built-up trench boxes, open at the ends, top and bottom, as shown in the drawing, speeds up pipe laying in wet or mucky soil. A shallow trench is first excavated by dragline or steam shovel and the box is then placed in the trench to

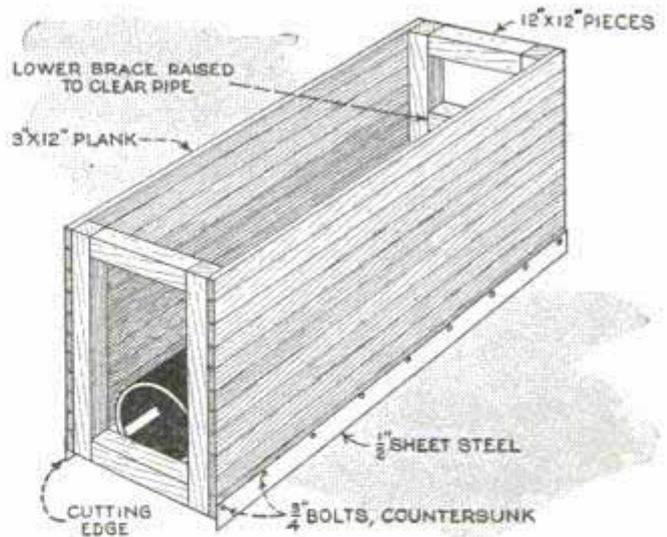

Substantially Made Trench Boxes Save Time and Labor in Excavating Trenches for Pipes

facilitate the remaining excavation by hand. The sides of the box are provided with steel cutting edges at the bottom, and its weight forces it down as fast as the earth is removed. This method is adapted to practically all sizes of pipe, when laid in trenches not more than 10 or 12 ft. deep. It saves the expense and time required for driving sheet piles and installing crossbraces. The boxes must be substantially made of suitable plank. They can readily be moved about by means of the dragline or steam shovel and can be used over and over again.—Ivan E. Houk, Denver, Colo.

Crosspiece on Stepladder Protects Windows

For use around windows and greenhouses, a stepladder, provided with a crosspiece at the top, as shown in the illustration, will be found a convenience as well as a protection for the window. It consists of a length of angle iron or stout piece of hardwood bolted to the top step. The piece straddles the window so that the ladder will not slip against it.





Simple Arrangement for Automatically Supplying Water to the Stock Tank

Self-Filling Stock Tank

For filling the farm stock tank automatically, the arrangement shown in the drawing has been found effective and durable. The tank is mounted on a platform bolted to a pair of wagon springs, which are in turn bolted to a couple of planks or other suitable base of 2-in. material. A wooden connecting rod is pivoted to the faucet handle of the water supply and to the platform on which the tank stands. When the tank is full, the weight of the water compresses the springs, allowing the tank to sink several inches, and when it is empty the springs force the tank up again. This vertical movement closes and opens the faucet and, once adjusted, makes further attention unnecessary.

Holder Simplifies Grinding Reamer Shank

In making a large quantity of reamers, having the firm's name stamped on the shank, it was necessary to file off the burr after the stamping. The filing was done while the work was revolving, but the results were unsatisfactory.



factory, as this operation tended to get the shanks out of round. To eliminate the trouble, the illustrated holder was made, which allowed the reamers to revolve while they were held against a disk grinder. The burr was removed without touching the rest of the shank, and the surface was then polished on a buffing wheel while the work was still in the holder. The work can be held firmly or allowed to revolve at will.—W. L. Miles, Providence, R. I.

Getting Tension Spring in Place

It is often rather difficult to get a tension spring back in position after it has been removed, but in many instances this can be done by tying a length of cord to the end of the spring and then pulling the spring into place.—A. G. Robinson, Cristobal, C. Z.

Novel Tap Wrench

The drawing shows a tap wrench having four movable jaws which can be adjusted to increase or decrease the size of the opening. The jaws are made to slide against each other diagonally and against the sides of the square opening in which they fit, so that movement of one jaw causes an equal and corresponding movement of all the others. To adjust the jaws and to hold them in any desired position, a hole for a thumbscrew is drilled and tapped partly into one jaw and partly into the adjacent portion of the frame, as indicated.

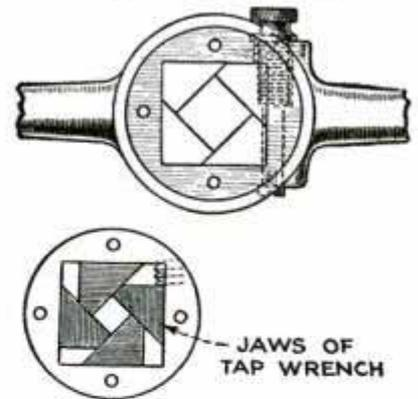

Easy Method of Lining Brake Bands

When a brake-relining machine is used, the lining usually is fastened by means of tubular rivets. Without such a machine, it is better to use split rivets and clinch

them into the lining. These rivets are rather awkward to handle, however, and it is hard to spread and clinch them single-handed. Old flywheels and transmission drums are often used to spread the rivets but they are not always satisfactory, because the rivet has a tendency to merely flatten out instead of spreading. The best thing I have found for the purpose is a spoke of an old auto wheel. This is fastened in a vise so that the end projects just a trifle above the vise jaws. The rivets are then driven into it. The shape and hardness of the wood make the rivets spread without the tendency to flatten on one side only. Clinching is done afterward with a hammer.—Glen F. Stillwell, South Haven, Mich.

Use of Emery Cloth in Reseating Valves

When using a valve-reseating tool on a hard spot in a cylinder valve port, it occasionally happens that the cutter will not take hold, especially in the case of the exhaust-valve port. To overcome this trouble and save the cutter, use a small piece of emery cloth under one side of the cutter. This will remove the glaze so that the cutter will take hold.—Edwin Schubach, Orofino, Idaho.

Wire-Screen Inclosures Protect Plants from Frost and Wind

Wire-screen inclosures are the most recent innovation in agricultural practice of some southern states. They are used for protecting plants from frost and wind and it is claimed that the interior is sometimes as much as 12° warmer than the exterior. The structures are arranged to point north and south, leaving their longer sides facing east and west in order to minimize obstruction to the sun's rays, and the narrow sides of the uprights are also set east and west. Wire screen of $\frac{1}{16}$ -in. mesh is used.

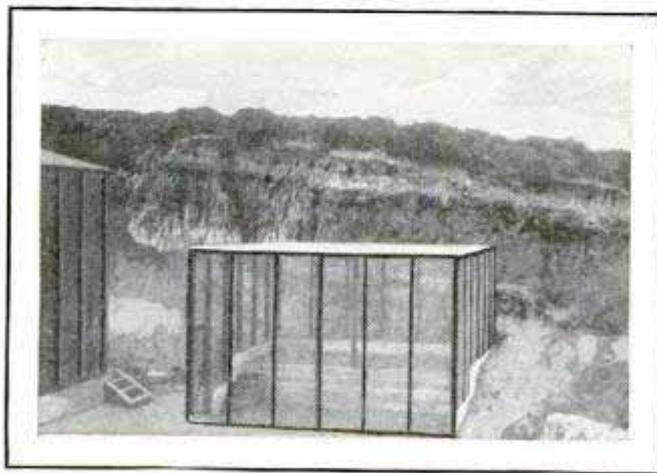

Fine-Mesh Wire-Screen Inclosures Keep Frost and Wind from Plants in Southern States



Commercial Artist Uses Roll of Paper on a Handy Holder for Sketching

Paper Roll for Sketching

Ordinary white wrapping paper, which can be obtained by the roll, will be found entirely satisfactory by the commercial artist for making preliminary sketches. It is mounted on a suitable board, as shown in the illustration, brackets for the roll being mounted at the upper end. Part of an old hacksaw blade is fastened across the bottom of the board and the paper is slipped under it, so that it can be torn off.

Blowing Chips Out of Oil Holes

After watching the oiler at a planing mill dig out the oil holes with a stick, I suggested that he blow them out with a tire pump. He spliced a length of tube to the pump hose so that he could reach all the holes. One or two vigorous strokes sufficed to blow the dirt out of any hole thoroughly, whereas digging it out was very slow.—Graham Stuckley, Alexandria, La.



Jointing by Machine

THE COMING of the smaller type of jointer, which can be hooked up and run from any ordinary light socket, bids fair to revolutionize methods of working employed in home shops and small carpenter shops. Once a man becomes acquainted with the machine, he finds that there is much more that can be accomplished on it than merely the making of joints. However, before we go into any special problems, we will first take up the matter of knife jointing and setting. The home worker will find it best to ship his jointer head to the maker of his machine, and allow him to grind and set the knives.

The Jointer in the

Where this is not advisable, the following instructions will enable a workman-like job to be done:

In getting knives in shape for any jointer, they must be of equal weight, so that running balance may be maintained. For this purpose, a pair of little balancing scales is the best thing to use, and the knives accurately checked one against another, grinding a little more from the heavier knife or knives until all have been reduced to equal weight. In grinding jointer knives, most of us must make a set-up at an ordinary grinder or wheel stand. Fig. 3 shows how this may be done. The guide strip may be a piece of hardwood, rabbeted out, or it may be a piece of angle iron dressed straight and smooth within. In any event, it must be perfectly straight and true, and must be fastened firmly so that it holds its relative position to the wheel. It should be about twice the length of the knife being ground, and the center of its length should be opposite the wheel. A little study will show that the degree of bevel on the knife will be

governed by the distance the strip is set from the wheel. While woodworkers in general vary the bevel in working different woods to some slight extent, a good general rule is to make the length of bevel twice as great as the thickness of the knife. This will be found to give very satisfactory results. In grinding time after time, it will become necessary to set the guide so that grinding be-

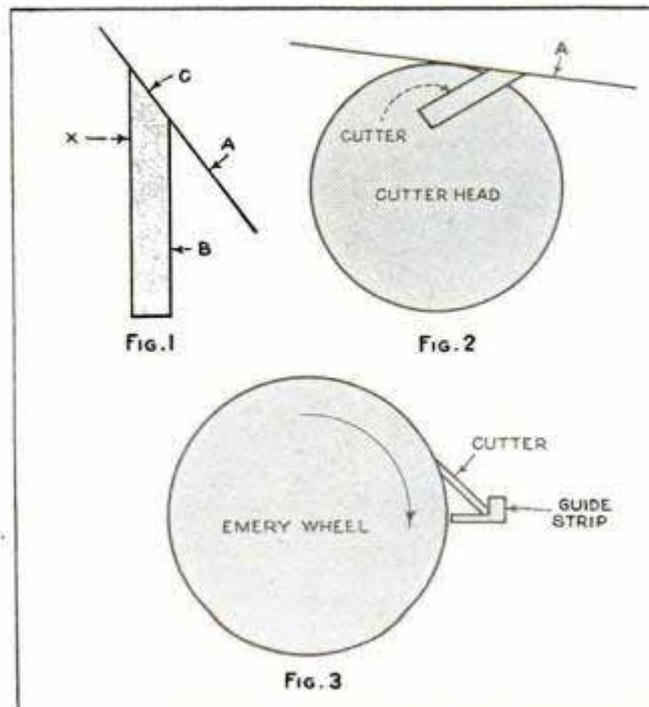

Home Shop

by John E. Hyler

gins at the side of the knife farthest from the edge, for if set centrally, the bevel will be reduced somewhat by the time the grinding is done. The grinding must be done slowly as the knife approaches an edge, if ground dry, to prevent burning it. Those accustomed to grinding cutters for metal will need to remember that this edge is much thinner and more delicate and will therefore not stand so much pressure on the wheel. The corners of the knives will need to be carefully watched to avoid dubbing them off, particularly those corners at the front of the knives, for, unless sharp, square corners are preserved, it will not be possible to make a good clean rabbet with the jointer. To sum up: these knives must be ground to equality in weight; their bevel must be twice as long as their thickness; care must be used to avoid burning them by dipping them in water frequently, and you must watch the corners.

There are one or two other things essential in grinding, one of which is that knives must be kept parallel, and another is that their edges must be perfectly straight. Knives which are out of parallel may balance perfectly on the scales, and not balance at all on the run. The reason straight edges are necessary is too evident to need much comment, but the way in which they are made straight when using a set-up like Fig. 3 is by holding them against a straight-edge, preferably one of metal. Grinding is a job requiring much care and patience, and unless it is properly done you cannot possibly expect to do



Jointing by Hand

anything like good work on the jointer.

In considering the setting of jointer knives, first refer to Fig. 1. In this drawing, B represents the jointer knife. After the knives are ground, and before they are set, it is necessary to whet them to remove the wire edge left by the wheel. Knives are always slightly hollow-ground as a result of grinding, and this is fortunate, as it allows you to whet them with much less effort. A represents the face of the whetting stone, and shows its application to the knife; the stone is best used with a rotary motion, and occasionally it is rubbed across the face of the knife, or side X, in order to remove any

wire edge. It must be held perfectly flat to the face when doing this.

Fig. 2 shows an essential to be observed in setting the knives in the jointer head, and that is that the knife bevel has a certain relation to knife projection. The knives should always be held far enough back in set-

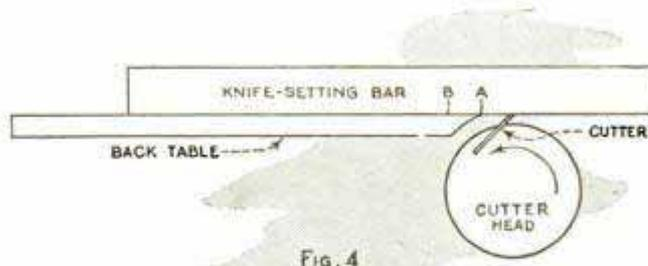

Fig. 4

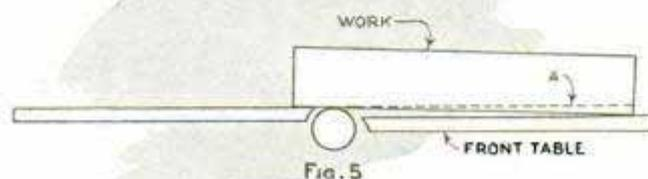

Fig. 5



so that when the jointer head is revolved slowly backward as shown by the arrow, the knife edge barely contacts with the stick. The contact should be of such lightness that the stick will not move, which can be detected when the hand is laid on the mid-length of the bar. Moving the stick backward and forward across the bed or back table, gradually brings all the knives to that same perfect setting with the back bed. Never rush this part of the job, for on its accuracy good machine work is dependent. Once a perfect setting is obtained, the knives may be tightened securely in place, and the machine is ready.

Another method of setting the knives is as follows: Drop the back table a little, so that the knives, when revolved forward (in the direction opposite to that shown by the arrow in Fig. 4) will catch in the knife-setting bar and carry it forward on the table a certain distance. Lay the bar on the table, with the front end pro-

ting them so that, when the slip stone is laid across as shown at A, it will make contact both with the edge of the knife and with the head, and the edge will be whetted several times in the head before the stone starts removing anything from the back of the knife. Insufficient projection will result in dubbing off the knife edge in whetting, and too much projection will throw the back of the knife into contact with the stone, both of which must be carefully avoided. Set all knives approximately correct in this way, and then proceed as shown in Fig. 4.

Only one knife is shown in the head here, though there are never less than two, generally three, and sometimes four. All knives must be dealt with alike. The front jointer table is not shown, as it is not used in setting the knives. The knife-setting bar is made of some kind of hardwood, jointed perfectly straight and true. It is placed, as shown, on the back table,

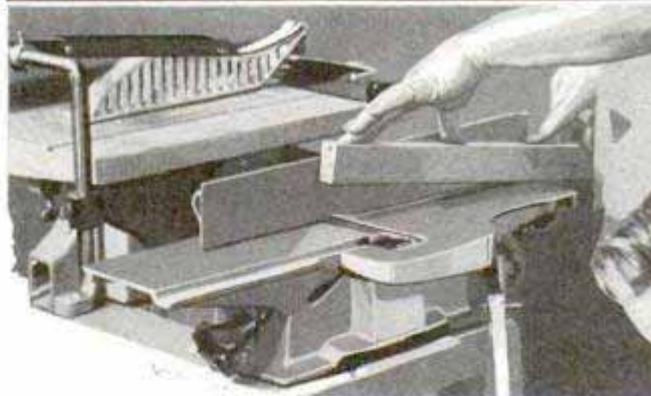
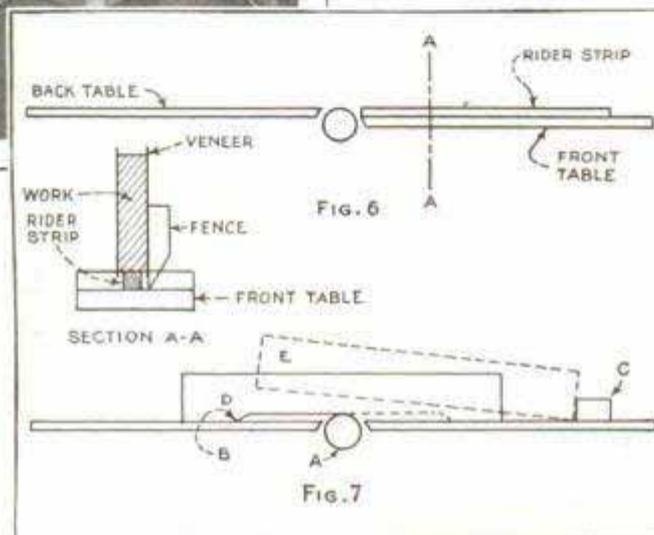

Top, Setting the Knives to the Back Table; Center, Starting to Plane a Taper; Below, Checking the Back-Table Setting

jecting over the path of the knives, but with none of the knives in contact with it. Make a mark, A, on the bar, exactly at the edge of the back table. Now rotate the head so that the knife moves the bar forward, and make a second mark, B, on the bar, exactly at the edge of the table. Move the jointer head back, until the same knife is in the first position, move the bar back until mark A is again at the edge of the table, and the bar is at the opposite end of the knife. Then revolve the head forward again, and see if this end of the knife moves the bar forward the same distance. If it moves it farther, obviously this end of the knife is higher than the first; if it does not move it as far, this end of the knife has not enough projection. When one knife has been set, proceed to set the others.

In cutting ordinary joints for glued-up work, it is necessary to get a true edge. You can tell whether the setting of the back table is correct by the way the stock acts when being pushed across. Note particularly that the front bed of the jointer never has anything to do with this; the solution of trouble is always in the relative position of the head and the back table. That is why we set the knives from the back table. It some-

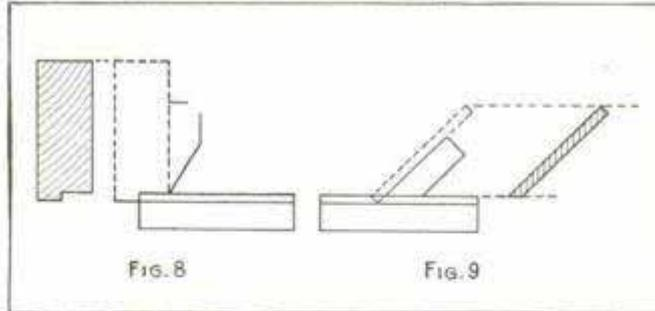

FIG. 8

FIG. 9

times happens, after the knives have been set, that the back bed is a little low, and this is best cured by running a stick out a little way across the head, then raising the back bed to contact lightly with it. It also sometimes happens that the back bed will get too high, and this results in crowding the piece up and away from the knives. When it is too low, the knives will snip the

last end of the stock as it leaves the front bed. When jointing, be sure to apply pressure to the stock on the back table, just as soon as it is over the head.

There are a few little tricks which can be practiced on the jointer, aside from its regular job. A great deal of tapering of different kinds can be done on the jointer, and one type of job is shown in Fig. 5. Notice that the first end of the piece is carefully laid over the head on the back table. Let the work down slowly and steadily, then push it forward as in any ordinary cut, and the knives will remove

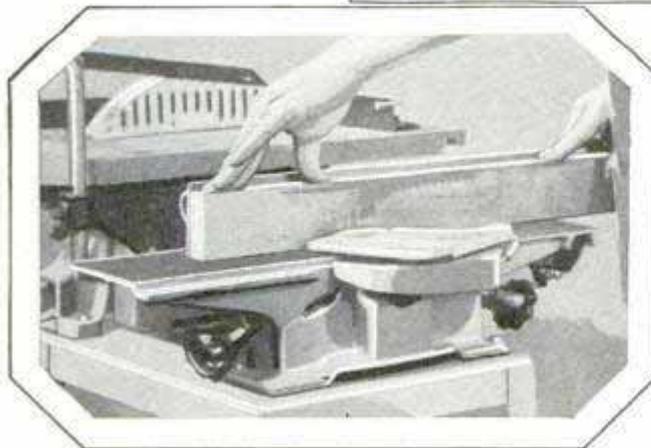

Top, Cutting Recess with Stop on Front Table; Center, Beveling Stock; Below, How Stock Is Held Down on Back Table

everything that is below the dotted line A.

When veneering, the veneer, after gluing, usually overhangs the edges of the core stock. In such cases, the excess veneer can be trimmed flush on the jointer by using a rider strip. The front table is dropped down and a strip, such as that shown in Fig. 6, can be attached to it. The strip comes even with the top of the knife swing, in alinement with the back bed. The jointer fence is set up as shown in the section AA, and the veneer will be trimmed off clean and true with the core. Cuts can be gauged on plowed and rabbeted material in the same way, and, by the use of a curved rider and a correspondingly curved strip nailed onto a piece of material, curves can be successfully cut on the jointer.

Figure 7 illustrates a different kind of work, in which it is necessary to drop both tables. This is a hazardous proposition unless certain precautions are taken. A stop block must be fastened securely to the front jointer bed, as at C. This may be fastened by clamping or otherwise, but should be made secure in every case. The dotted lines at E indicate how the cut is first started. The back end is placed firmly against the back stop, and the piece is let down slowly and carefully on the knives as at D. Once the cut is started, and the piece moves forward, the danger is over. Danger is always present on woodworking machinery as long as solid wood lies directly behind the cutters, whether it be a saw or a knife machine. At B, where the piece is first let down on the knives, the cut will be perfectly smooth, as the knives are cutting with the grain. At A the cut

is against the grain, and some tearing will occur, unless the cut is light, and the piece fed slowly. To overcome this, cut a little

past the halfway mark, turn the piece end for end, drop in again from the other end, and run forward till the two cuts meet. In cases where the cut starts farther from one end than the other, it will be necessary to handle the material twice, and to reset the stop block after the first handling.

Rabbeting is one of the jobs that is handily done on the jointer, as shown in Fig. 8. The depth of the rabbet is controlled by the cut-out on the fence, or the depth of the rabbeting ledge, but the width is limited only by the length of the head. Small tenons are cut in

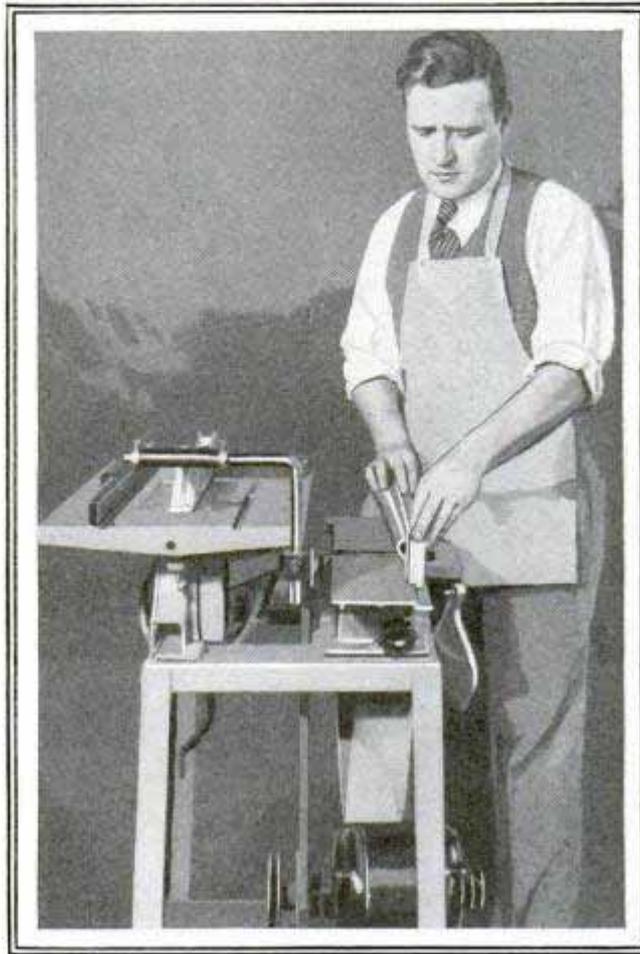

Rabbeting on a Combination Jointer and Saw; Note How Rabbet Fits Ledge on Machine

the same way, simply by rabbeting on each side of the stock. Fig. 9 shows how the fence is set for beveling a piece of stock, and this is a very valuable feature of the jointer.

It is dangerous to joint short pieces on the jointer, so if this must be done, use a "pusher," which consists merely of a piece of hardwood about 6 or 8 in. long, and about 1½ in. wide for 2 in. of its length. The remaining length is 1 in. wide. The notch formed in this way is placed against the back of the work, and pushes it forward, while the longer portion rides on the work and holds it down.

Do not crowd the work, for, if this is done, the head is unable to clear itself of all the shavings made, and a certain number of them are carried around with it, getting in between the knife edges and the work, and causing a bruised or pitted appearance. So, on fine work, take light cuts and don't feed too fast.

Preventing Wood Rot in Porch Columns

Wood rot in porch columns invariably occurs at the bottom where the moisture collects. The trouble can be successfully prevented by filling the bottom of the column with cement, which can be poured in from the top at the time the column is set up. It is, of course, also possible to follow the same method to fill portions of new columns which are used to replace the defective bottom portions of old ones, although this involves more or less difficulty and takes considerable time.—L. H. Georger, Buffalo, N. Y.

Washers Save Time in Fitting Bearings

When fitting connecting-rod bearings, considerable time is usually spent in running the cap nuts into place and tightening them, because a good bearing job nearly always requires a number of fittings before the correct adjustment is obtained. By inserting very thick washers as spacers on the cap bolts, the nuts can be run only a few threads, instead of all the way against the cap, thus saving time.—A. C. Wilson, Columbia Cross Roads, Pennsylvania.

Replacing Spring on Overhead Valve

When replacing a spring on an overhead valve in a motor of the type shown in the drawing, and it seems necessary to remove the engine block in order to hold the valve in position while the spring is being compressed, use the illustrated method, which will be found a great timesaver. A $\frac{3}{8}$ -in. iron bar is bent as indicated and inserted into the cylinder head through a spark-plug opening and is forced up against the valve while the spring is being slipped on.—G. A. Luers, Washington, D. C.

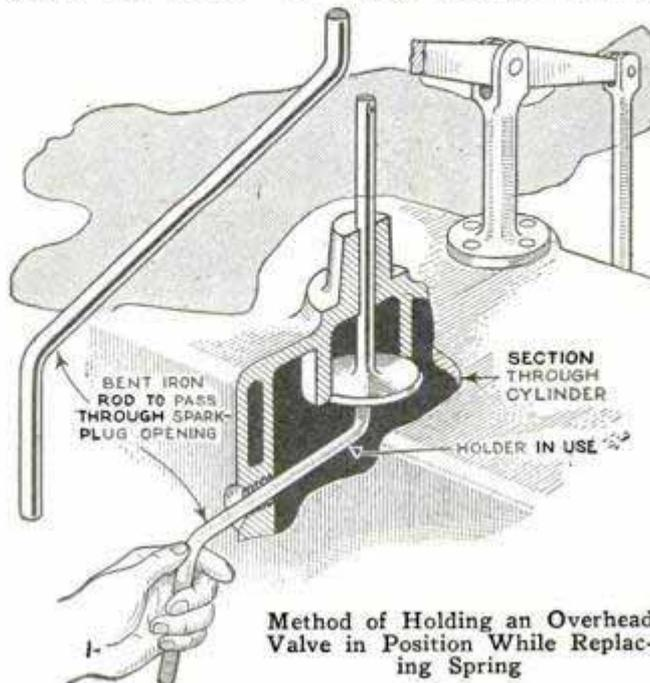

Method of Holding an Overhead Valve in Position While Replacing Spring



Use of Long Clothes Pole Makes It Easy to Hang a Carpet on the Line Single-Handed

A Carpet-Beating Short Cut

Carpets to be beaten can be hung on the line single-handed by following the method indicated in the illustration. Lay the carpet on the lawn with the pattern side down. Then fold it in half and run a clothes pole as near to the fold as possible, taking care that the ends of the pole project beyond the carpet. Lift one end of the pole up to the line and wrap the rope around it a few times. When doing this, the carpet should be held to prevent it from slipping down the pole. Follow the same procedure at the other end and the carpet will be hanging without sag. To remove it, uncoil the rope at one end and lower the pole until it rests on the ground and then do the same at the opposite end.—Ivie P. Holden, Chesterfield, England.

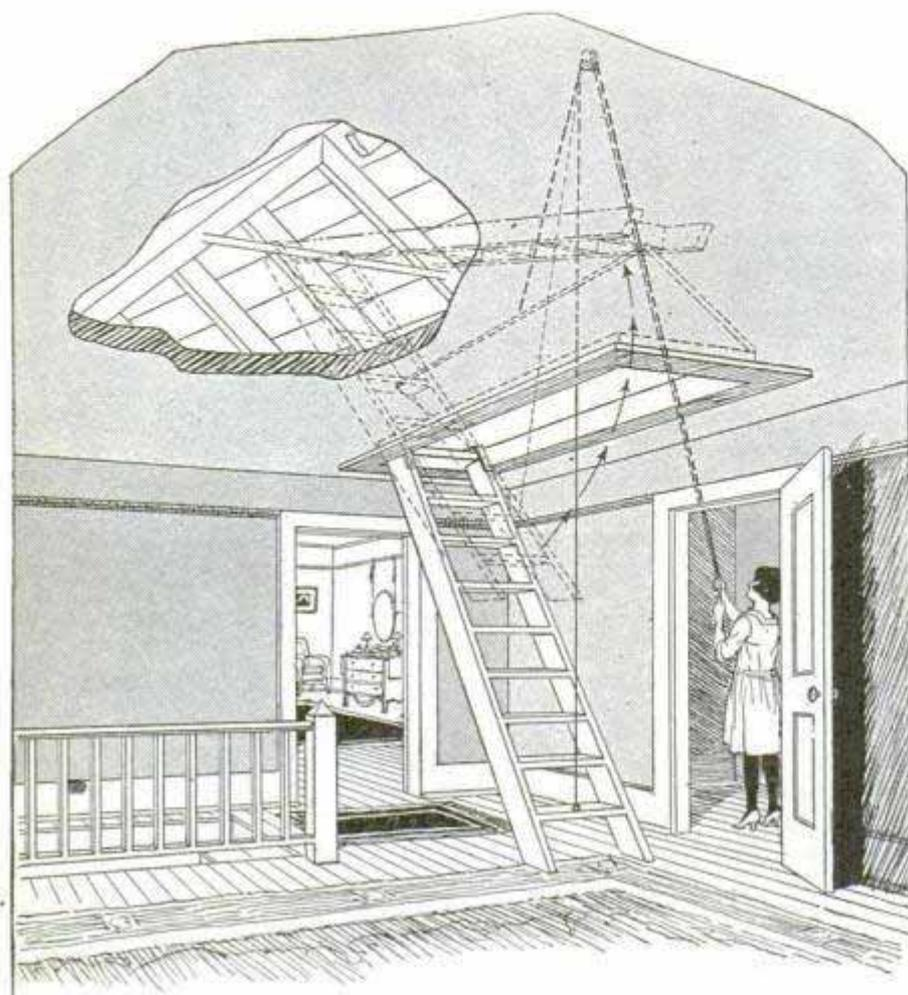

This Homemade Disappearing Stairway Is Handy and the Cost of Building It Was Only Three Dollars

Homemade Disappearing Stairway

When building a small house there was not enough space for an ordinary stairway from the second floor to the attic. On investigation we found that the cost of a ready-made disappearing stairway was about \$75, but as we could not afford it at the time, we resorted to the use of a stepladder. The practice, however, of getting it from the garage, which was necessary quite frequently, was rather irksome, so we decided to make a ladder that could be hoisted into the attic by means of a rope and could be lowered in the same way. As the distance from the second floor to the attic floor was 8 ft. 7 in., the ladder was made 10 ft. long, lengths of $1\frac{1}{8}$ by 3-in. stock being used for the side rails, and narrow boards from old shipping boxes for the steps, these being spaced 12 in. apart center to center. Long stove bolts were used to draw the side rails together under each step. The ladder could be set at a convenient angle for climbing. At the upper end of each

side rail a hook made of strap iron, about 1 in. wide and $\frac{3}{16}$ in. thick, was attached. These were bent so that, when the ladder was standing in position for use, they engaged a length of 2 by 2-in. wood nailed to the attic floor close to the opening as shown. Two sash cords, each running through two pulleys fastened to the rafters in the attic at suitable points, and led through the attic floor into a closet on the second floor, served to raise or lower the ladder and the trapdoor, the latter being hinged at the side to facilitate closing the opening when the ladder was not in use. At the lower end of the rope holding the trapdoor a ring was provided and this was slipped over a hook on the wall of the closet in order

to hold the door open. One end of the second rope is attached to the bottom step of the ladder, which enables one to hoist it into the attic, two positions of the hoisted ladder being shown by the dotted lines. From its position on the floor it is raised so that the hooks are slipped over a second 2 by 2-in. crossbar nailed to the attic rafters for holding the ladder. In this position the bottom of the ladder projects below the attic floor until it is pulled up still farther. The cost of the material needed for making this disappearing stairway was less than \$3, which meant quite a saving.—N. G. Mellon, West Lafayette, Ind.

Wallpaper Protection behind Pictures

The condition of the paper on a wall behind pictures may be kept similar to that on the uncovered surfaces by placing a glass push pin in the wall where each lower corner of the frame rests. This keeps the picture away from the wall and allows the air to circulate freely.

Handy Workbench Simplifies Model Airplane Building

THE AVERAGE model-airplane builder works in a chaos of shavings, wire, small parts, tools and odds and ends. If he mislays, for instance, a tiny prop-shaft bearing, he is liable to be up in the air longer than the Fort Worth plane before he finds it again, and tugging at what seems to be a loose end of thread may pull down some heavy tool on top of a delicate wing frame and upset the glue.

A spare room in my house was turned over to the young balsa craftsmen of our neighborhood, but inside of two days, table, chairs, trunks and shelves were piled so high with a confusion of things that work on a commercial plane was almost at a standstill. And when the boys couldn't find a 3-ft. fuselage in the mess, I thought it about time to step in and install a new system.

The workbench illustrated here is the result. There is nothing unusual about it; simply a place for everything, and everything is returned to its place after the day's work. Two redwood boards, 10 in. wide and 9 ft. long, were laid on two packing boxes of the same height. A 3-in. board was nailed to the back edge to keep things from falling off; at one end a shallow bin was made for hand tools and, at the other, four sizes of bolts, from $\frac{1}{8}$ to $\frac{1}{2}$ in., were screwed into a two-by-four, and the heads cut off for forms around which to bend the stiff music-wire loops and hooks. In the center, a chart, 24 in. long and 6 in. wide, was laid out in $\frac{1}{2}$ -in. squares, with inches marked each way from the center line. At one end are a number of semicircles and at the other several typical wing-tip curves. In laying out a wing frame, a piece of waxed paper is placed over the chart and the frame members are assembled over this, cemented and

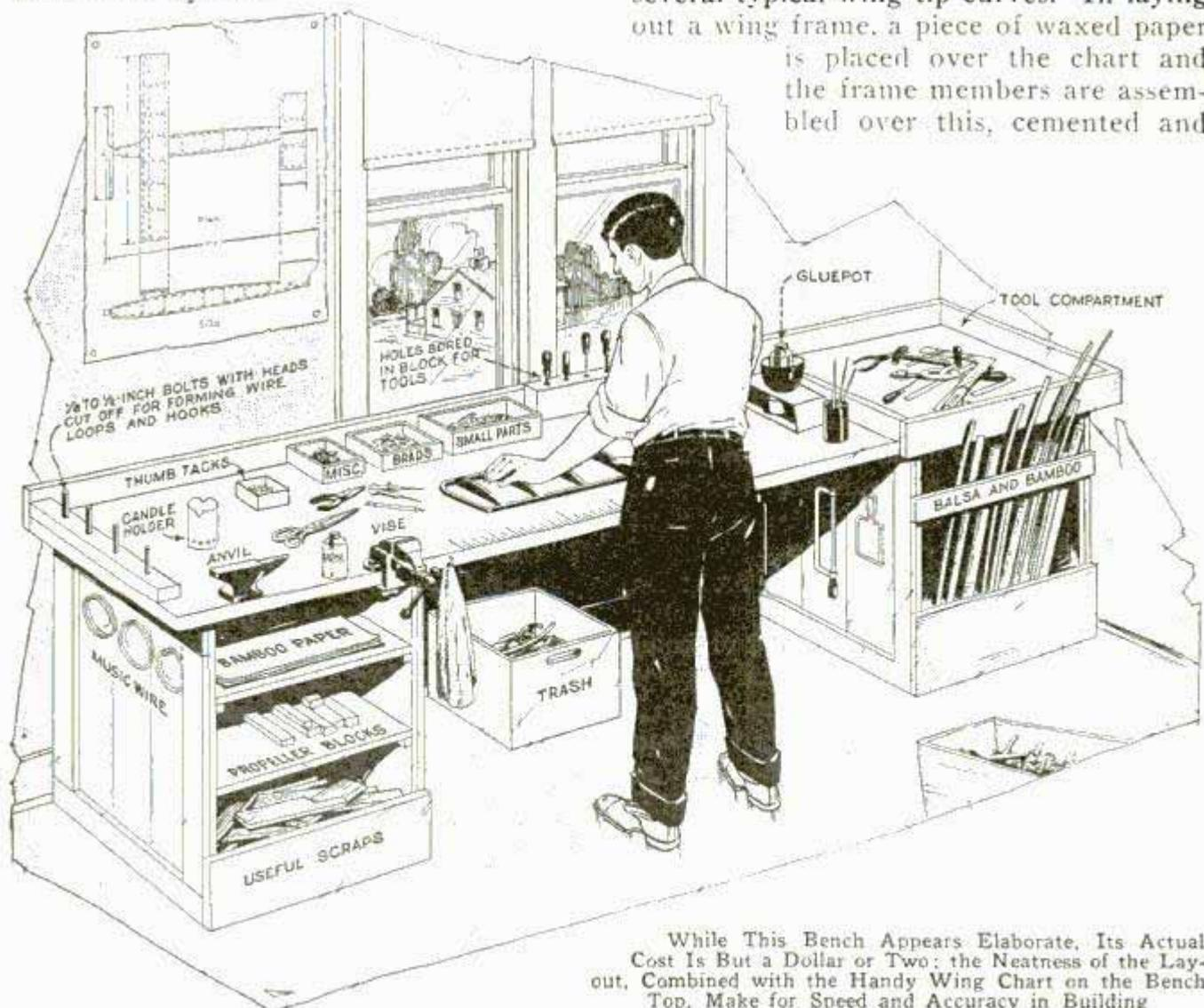

While This Bench Appears Elaborate, Its Actual Cost Is But a Dollar or Two; the Neatness of the Layout, Combined with the Handy Wing Chart on the Bench Top, Make for Speed and Accuracy in Building

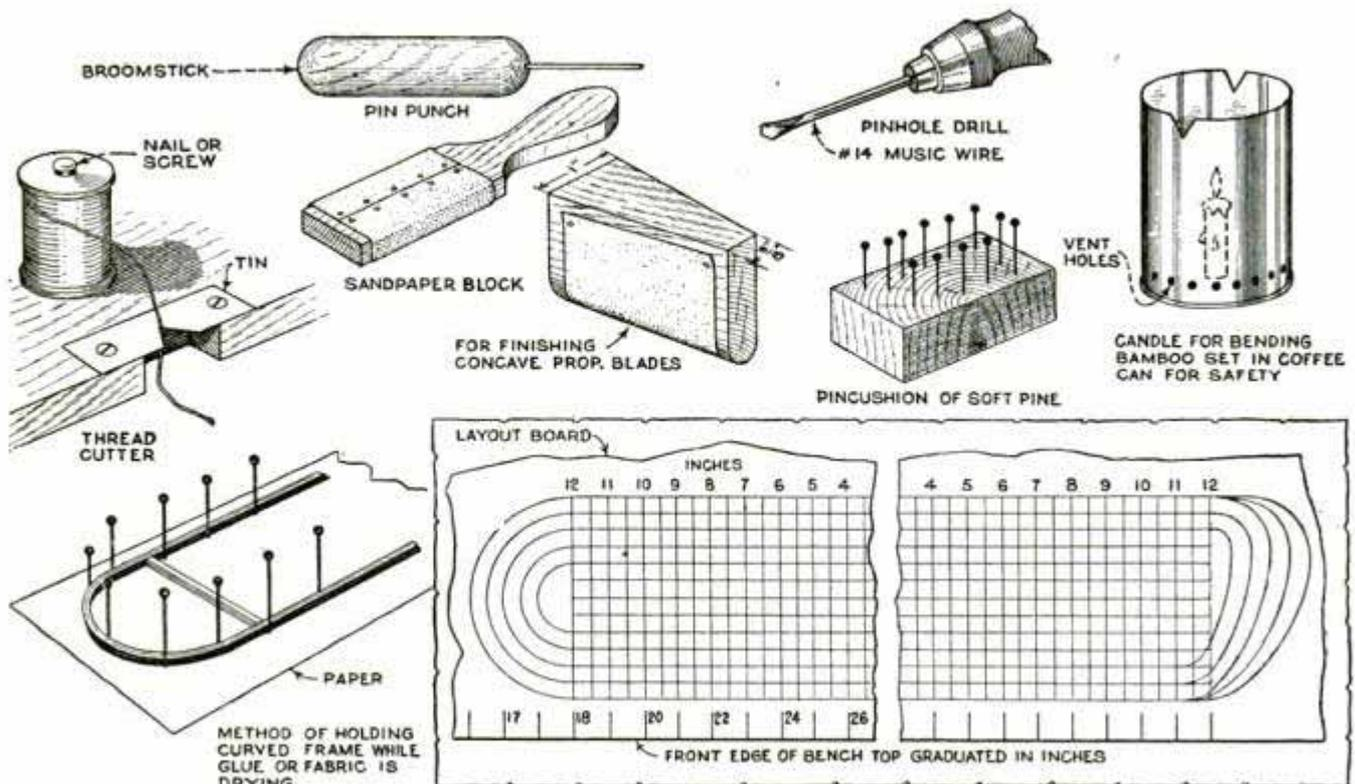

Details of the Bench Accessories; Above Are a Number of Handy Tools, and Below Is Shown the Chart Laid Out on the Bench Top to Facilitate Assembling of Wings

held in position by steel pins until the cement hardens. The waxed paper prevents sticking to the bench top. In this manner frames can be laid out quickly and accurately. The front edge of the bench is graduated in inches to facilitate measuring frame sticks and other material.

Using a nail or long screw for a shaft, a spool of thread is secured to the bench and a strip of notched tin set over a recess in the edge of the bench for cutting the thread. The recess allows the tin to be set back so that it will not tear clothes. Since all model builders find the two hands provided by nature none too many, the thread-cutter is a decided convenience.

Tools, such as chisels, files, punches, etc., are kept handy in a block of wood with holes bored in it. Saws hang on the side of the boxes; brads for motor bearings, strips of brass and tin, and small parts, are kept in cigar boxes and do not get lost. By using a double boiler, heated by "canned heat," glue will thin out and is much more easily applied than when cold. This is especially important in gluing bamboo paper to delicate wing frames, etc., and makes a far neater job.

Cement is best applied with a flat or pointed stick. Brushes are not of much use, since ambroid and similar cements harden so quickly and there are few prac-

tical solvents. Keep a supply of sticks on hand and throw them away after they are used a few times. A small anvil comes in handy for flattening wire, brads, etc., and a small vise will serve many purposes. Both items can be purchased in hardware stores.

Shelves and racks in the packing boxes accommodate raw material and prevent the delicate sticks from being broken. I have found a tapered and rounded block, covered with sandpaper, indispensable for making the concave side of prop blades; sandpaper on a flat piece of wood also has many uses. The coffee-can holder for the candle makes for safety and convenience when bending the thin pieces of bamboo over the flame.

A workbench of this nature can be put up in two or three hours, including all the accessories, and it will easily save you many times that on every job. Besides, you can do far better work. Complete as the workbench appears, its cost is negligible.—Hi Sibley, Pasadena, Calif.

When scraping carbon from automobile pistons, and from the face of the cylinder block, use short headless setscrews to keep the particles of carbon out of the cylinder-head bolt holes. This method is easy and quick.

Kink for Model-A Ford Owners

Model-A Ford owners will appreciate knowing that when the water pump throws too much water out of the overflow pipe at high speed, which occasions a loss of water and causes the motor to overheat, the trouble can readily be overcome in the following way: Make a tin shim or gasket with a smaller opening than the one on the overflow pipe, and place it between the pump and the water connection at the top.—R. M. Shelton, Dallas, Tex.

Drilling Elongated Holes

Although a drillpress and a milling machine are usually required to drill elongated holes, I found a good method of doing this without any special tool. A batch of brass plates had to have holes drilled in the center, the holes being elongated $\frac{1}{8}$ in., as shown in the drawing. I clamped ten of them together and drilled the hole off center the right amount to bring the finished hole in the exact center. After this the clamps were removed, the plates arranged with holes of adjacent plates off

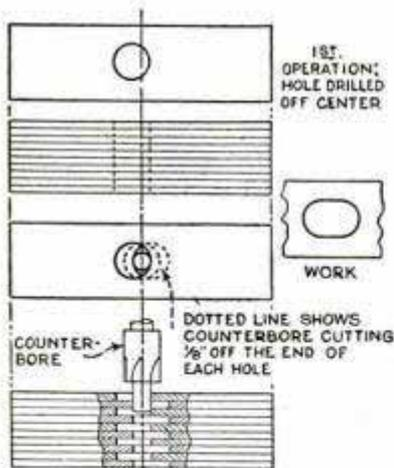

center in opposite directions, then clamped together again. Next I got a standard $\frac{1}{2}$ -in. counterbore with a $\frac{1}{4}$ -in. pilot and ran it through the plates in the exact center.

By this means a hole like that shown in the detail at the right was produced.—Harry Moore, Hamilton, Can.

Device for Removing Humps from Auto Fenders

Humps in auto fenders are removed in a Denver radiator and fender shop by means of the illustrated tool. It consists of a 3-ft. piece of $\frac{1}{4}$ by $1\frac{1}{2}$ -in. steel bar, which is used as a lever. A leather pressure pad is looped over and bolted to an

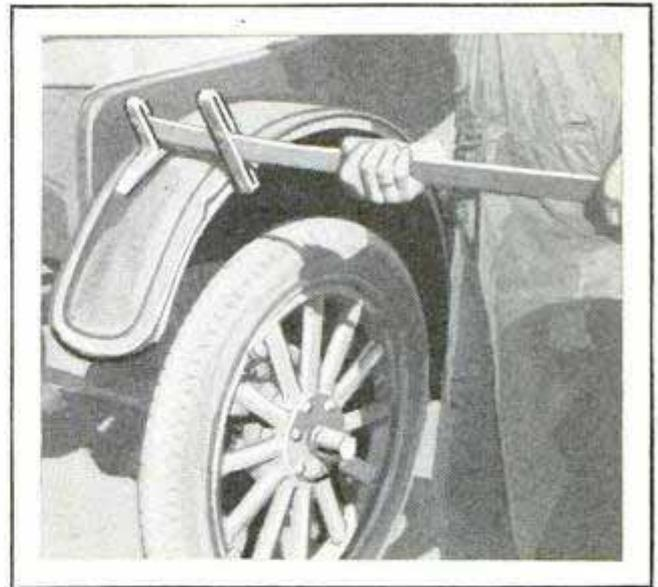

It Is Easy to Take the Humps Out of Fenders with This Improved Tool

8-in. length of the same-size bar, which is bent to form a loop as indicated, and is welded to the extreme end of the lever. Another 8-in. length of the same stock is bent to form a hook and is also doubled so that it can be slipped over the lever and adjusted to any size of fender. It has been found convenient to have a number of different-shaped pads for use with this device. The method of using it is clearly shown in the photo.—Jos. C. Coyle, Denver, Colo. *538 Santa Fe Drive*

Electric Fan and Heater Element Supplies Warm Air

Combining the advantages of an electric fan and a heating element, a western photographer made the illustrated print and negative drier, which he found highly satisfactory. A porcelain screw socket was mounted on the frame of the fan as indicated to hold the heater element, and the terminals on the socket were connected to the electric cord of the fan so that both would operate simultaneously.

The same idea can also be used to circulate warm air through a room, and for any other purpose where a warm draft is desired.—Carlton Groat, Portland, Oreg.

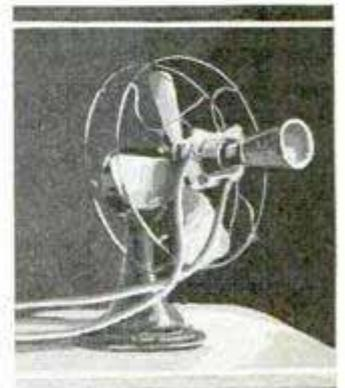

Improved Hog Trough

Here is a hog trough that has several features of interest. It has the regular V-shape, is divided at regular intervals by iron bars and provided with a wooden rail running lengthwise over the center, which is supported by metal brackets at both

trough can be conveniently hinged. The bottom board, A, of the fence is pivoted at one end so that it swings upward when the trough is emptied. A cleat near the

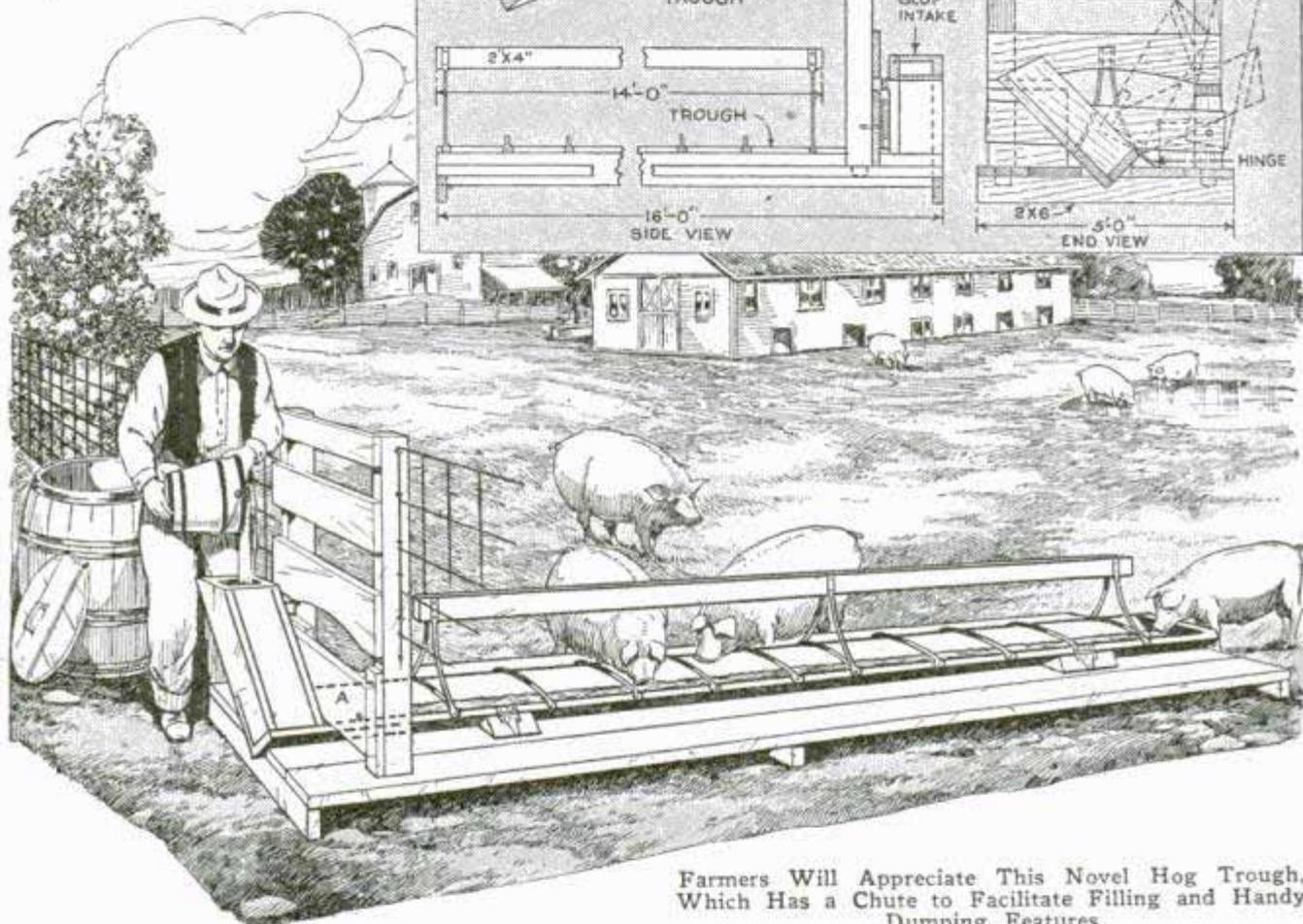
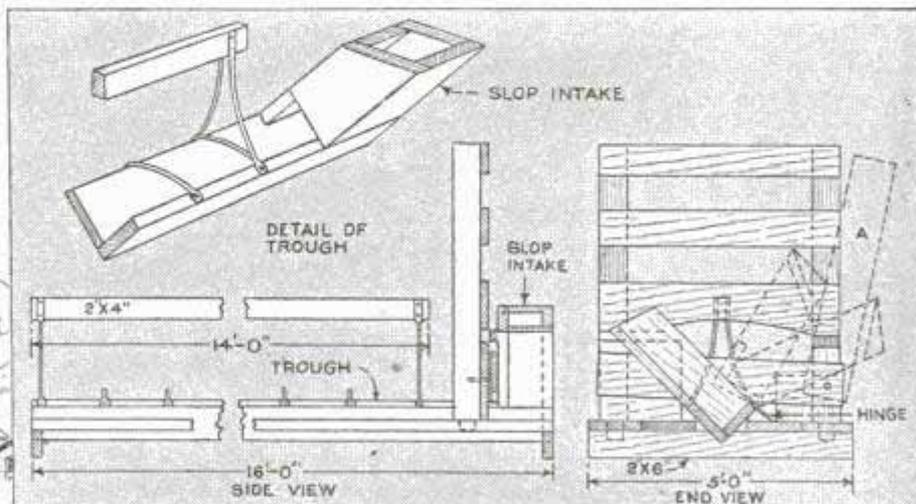

Farmers Will Appreciate This Novel Hog Trough, Which Has a Chute to Facilitate Filling and Handy Dumping Features

ends and the center. The novelty and utility of the trough consist in its hinged mounting, which permits easy dumping, and in the addition of a chute at the end, which serves the double purpose of conducting the slop into the trough and of a lever for dumping. It is, of course, necessary to provide a platform to which the

top on the side of the chute nearest the fence, forces the board back into position when the chute is pulled back after dumping. The details of construction are clearly shown in the illustration and should be studied carefully before attempting to build one.—Luther Strosnider, Onaga, Kansas.

What to Do When Fords Boil

Everybody knows the usual causes of water boiling in the auto radiator, which include wrong timing, incorrect mixture, tight engine, wrong kind of oil, etc. However, an unusual condition, that has given

trouble to many owners of new Ford cars, is the loss of water and the consequent boiling of the remainder when the car is driven for a long distance at a high rate of speed. A number of cars having this trouble were carefully checked and everything in connection with the engine and

chassis seemed to be in good condition. In an effort to learn where the leakage occurred, the overflow pipe of the radiator was plugged up tightly. A road test was given and the water did not boil. Careful inspection then brought to light the fact that, on the cars having the top of the overflow pipe bent over toward the front of the filler neck, considerable water was lost when the motor was run at high speed, which was caused by the pump forcing it through the circulation system so fast that it was thrown into the overflow pipe until so much water was lost that circulation stopped. The remedy lies in bending the end of the overflow pipe toward the rear. Restricting the flow of water is not advisable.

Vise Used in Driving Screws

There are occasions when the mechanic has to loosen or tighten a screw with the aid of a large screwdriver and a wrench. Usually the screwdriver slips out of place when pressure is applied to the wrench. In cases where the work can be held in a vise, the illustrated method is highly convenient and the trouble is entirely eliminated. A short screwdriver shank is used. It is held in the slot of the screw firmly by bringing the vise jaw against it, making slipping impossible when the wrench is applied.—Henry Laraby, New Haven, Connecticut.

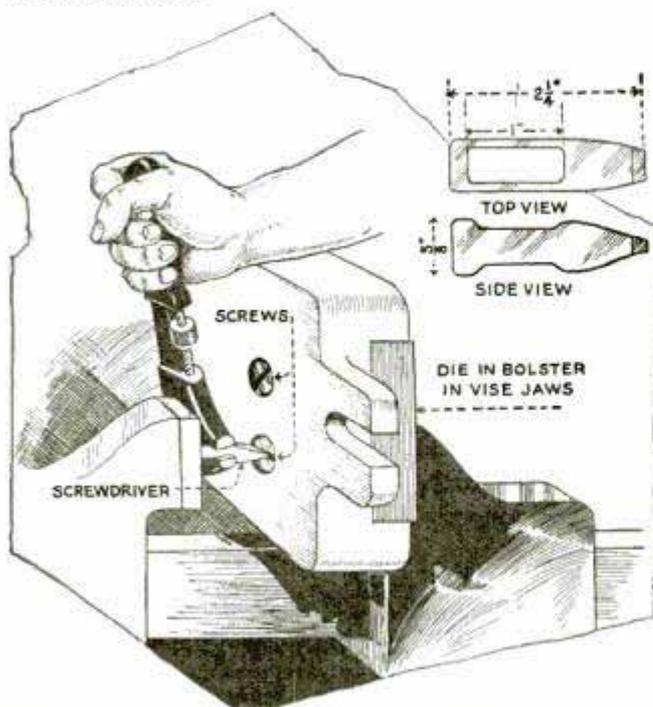

Handy Method of Using a Vise to Prevent Screwdriver from Slipping

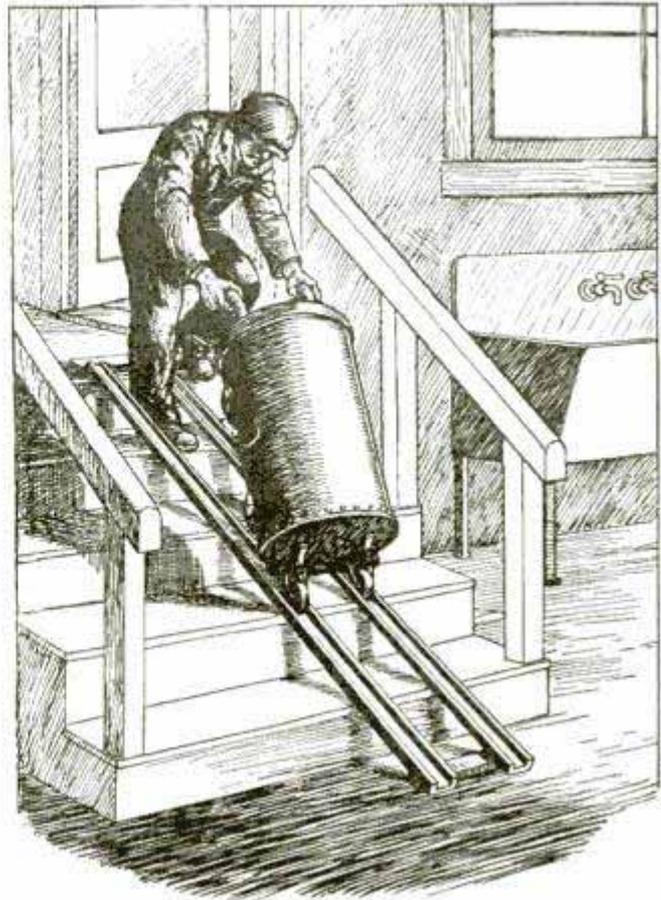

Channel-Iron Track over Stairway Makes It Easy to Pull Up the Shop Truck

Track over Stairway Facilitates Moving of Shop Truck

When it is necessary to haul loads on hand trucks up a few steps, as is the case when adjoining floors in two buildings are not on the same level, the illustrated track will be found useful in that it saves considerable time and effort. It consists of two lengths of channel iron of sufficient width to accommodate the truck wheels. Both tracks are securely fastened to cross-pieces to make a single unit, which can be set aside when not needed.—W. E. Trotter, Richmond Hill, Long Island, N. Y.

Old Files Are Made Serviceable by Acid Treatment

Files that have been worn until they are no longer fit for use may be made to render additional service by soaking them for 48 hours in a weak solution of sulphuric acid. The worn teeth are corroded so that numerous sharp cutting edges remain. When using sulphuric acid, it should be remembered that it is poisonous and corrosive, and, therefore, should be handled with great care.

3981

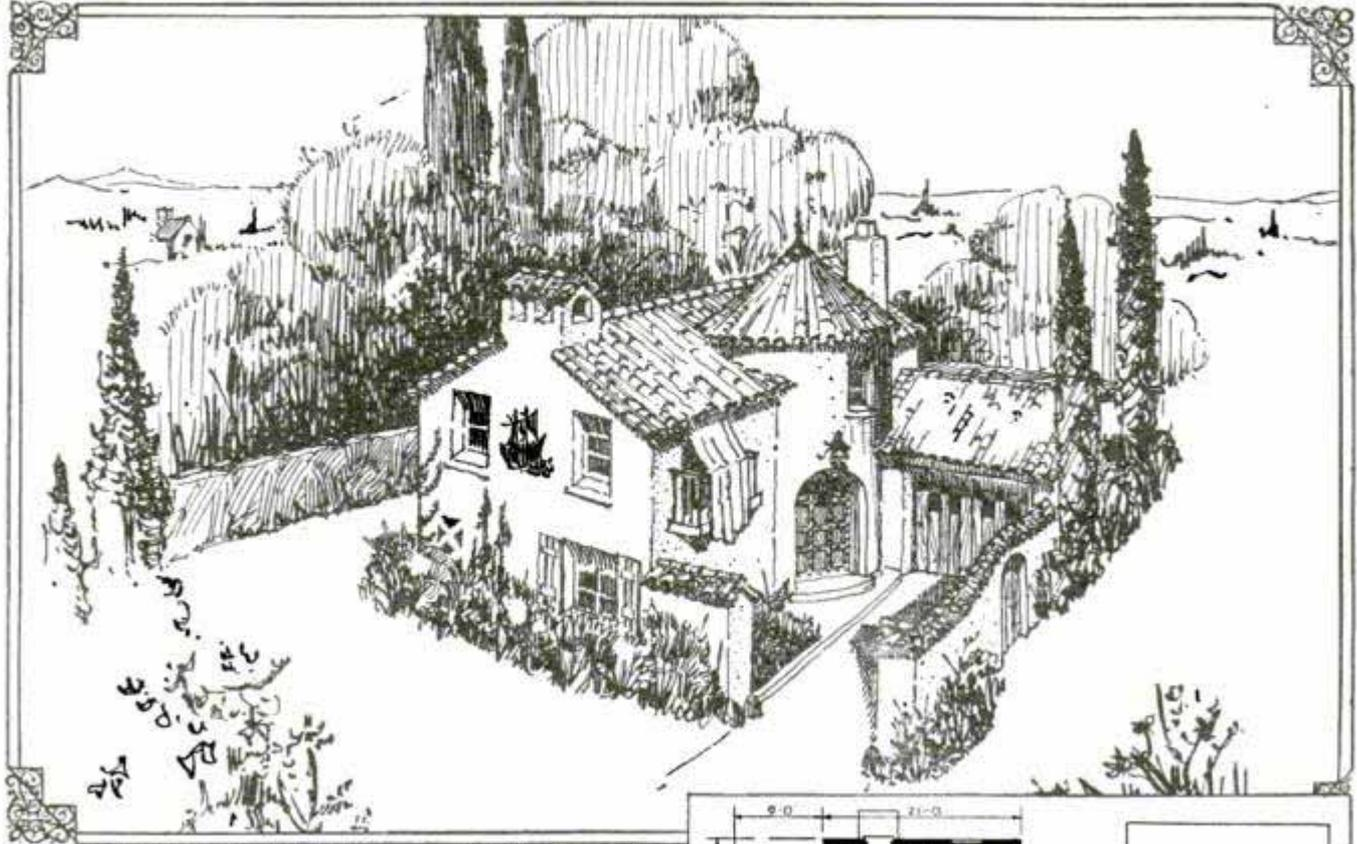

COPYRIGHT POPULAR MECHANICS PLAN NO. 5-5-22

A Style of the Hour is A House With a Tower

ARE you searching for something new in house styles? Do you want a picturesque little house brimful of decorative features along with a flexible plan and low cost? If so, this new design for a tower house should please you.

Old-world Spanish, Italian and Normandy features are here happily combined with all the practical demands by the modern American family. You can build the house on a thirty-foot lot. You can build it with or without a cellar. Without a basement, there's a saving of perhaps \$400; may be more. You have a choice of materials. As shown, it is frame with stucco on metal lath. It will build well of solid masonry; common brick whitewashed, skintled brick or face-brick veneer.

Features are a circular stairway and a living room two steps below the level of the entrance hall. The fireplace has a raised hearth. A deep recessed window may be flanked with bookcases. An arched opening between dining and living

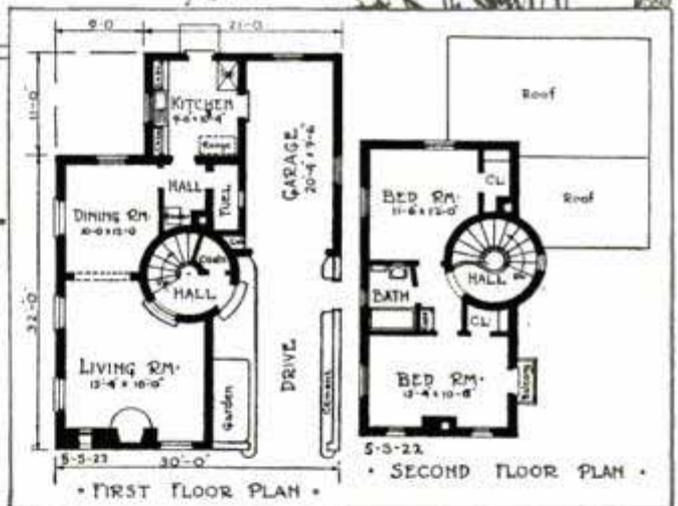

room and rounded walls in one end of the latter are details which add style and picturesqueness to the interior. The kitchen is planned for efficiency and step saving. The front bedroom on the second floor opens onto a balcony with iron rail. A door in the rear of the attached garage opens directly into the kitchen. There's a wall opening in the front of the garage for fuel passage to a storage bin.

The roof is of red tile or may be thick-butted asbestos shingles. An inclosing wall, capped with red tile, gives your yard privacy and retains the spirit of the style.

Popular Mechanics Magazine will supply readers a one-sheet blueprint of any house appearing in the magazine for \$1, and a new bungalow book will be sent for ten cents.

The TEST



“that **YANKEE**” makes

“**YANKEE**” makes this test of screw-driver blades—each and every one of the hundreds of thousands. . . .



fastened in the handle, and can't be loosened by use or abuse.

Well balanced and with comfort grip, a “Yankee” Screw-driver makes work easier. Pay a few cents more: get a genuine “Yankee.” Sold and guaranteed by your tool dealer.

Because,—the brand “Yankee” on the tool you buy must always mean the utmost in quality, efficiency, and durability.

“Yankee” blades won't twist, crack, break, or bend on the edge.

Every blade is “Yankee”-

“Yankee” Plain Screw-drivers

No. 90.—Standard Style: Fifteen sizes, 1½-in. to 30-in. blades. Price for 5-in. blade, 50c; 6-in., 55c; 7-in., 65c; 8-in., 75c; 10-in., 95c.

No. 95.—Cabinet Style: Eleven sizes, 2½-in. to 15½-in. blades. 4½-in. blade, 40c; 5½-in., 45c; 6½-in., 50c; 7½-in., 60c; 8½-in. 65c.



“Yankee” Vise No. 1993
Removable from base for holding work on drill-press or other machines. True all sides. Jaws open, 3½ in.; price \$9.90. Other sizes, \$3.75 up.

“YANKEE” TOOLS

—TO HELP YOU MAKE THINGS—

NORTH BROS. MFG. CO., Lehigh Avenue, Philadelphia, U.S.A.

I know the advantage in using tested tools: Send me “Yankee” Tool Book, with action pictures showing new Two-speed (11-inch) Hand Drills, new Bit Braces with famous “Yankee” Ratchet, Quick-Return Spiral Screw-drivers, Adjustable Tension Push Drills, Ratchet Breast, Hand and Chain Drills, Automatic Bench Drills, Ratchet Tap Wrenches, Removable-base Vises. Etc.

Your Name.....

Address..... (pm)



PLEDGE
to the Public on
USED CAR SALES

1. 5 days' driving trial.
2. 30-day guarantee on certified cars.
3. Plainly marked prices.

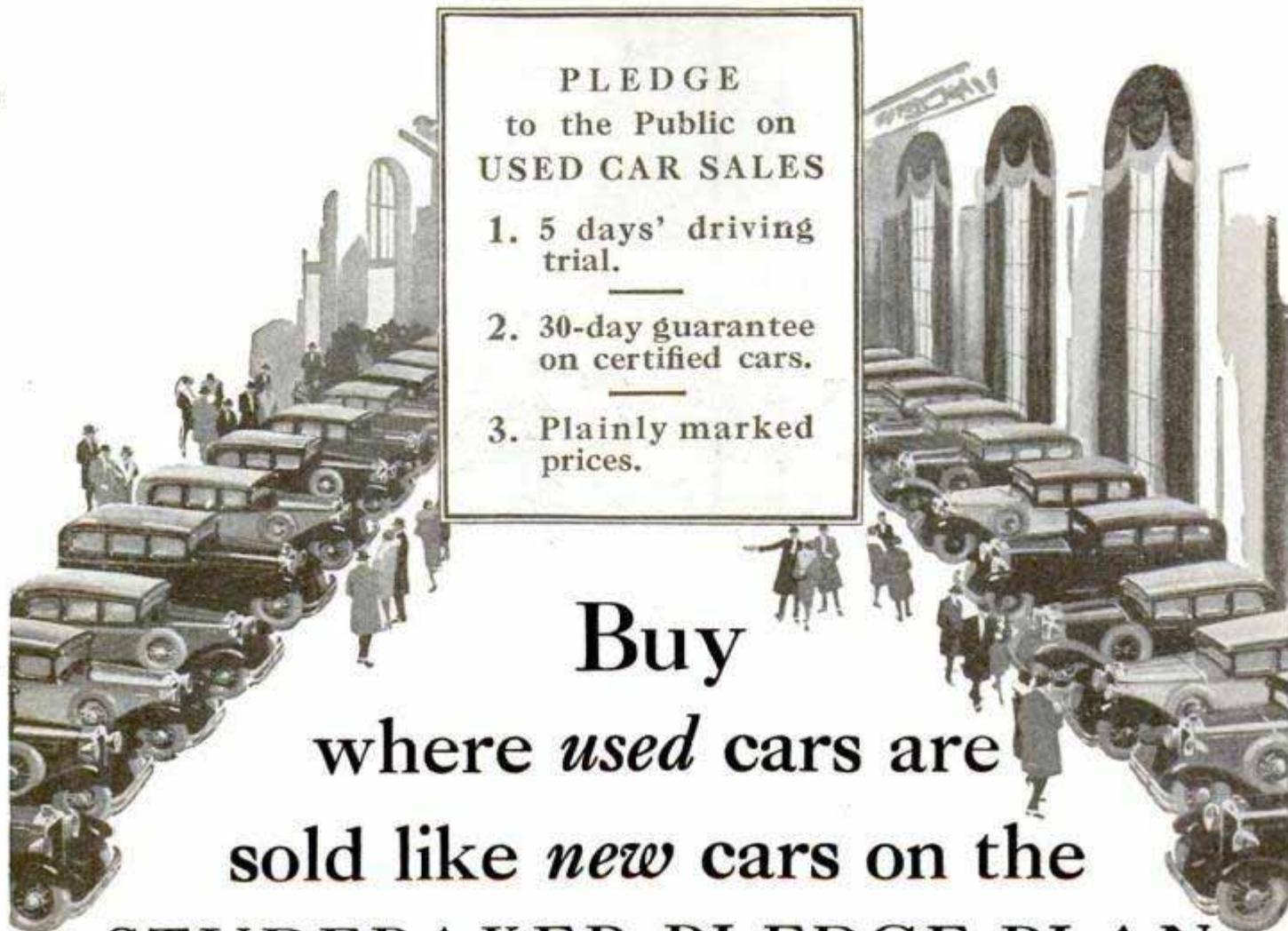

Buy
where *used* cars are
sold like *new* cars on the
STUDEBAKER PLEDGE PLAN

NOWHERE in the used car market will you find a fairer, squarer basis for used car sales than the famous Studebaker Pledge Plan. More than 150,000 people, appreciating this fact, bought Pledge-backed used cars last year.

When you buy a Pledge-backed used car, you invest in unused transportation. Most of these cars look and perform as well as they did when new.

Under the terms of the Studebaker Pledge, you get five days' driving trial with the used car you select. All Certified cars carry a 30-day guarantee. And all Pledge-backed used cars

carry plainly marked price tags—one price to every buyer! Your Studebaker dealer can show and demonstrate Studebakers, Erskines and other makes of cars in a variety of models. You will find the motor car you want—and the protection for your purchase that your business sense demands.

Invest 2c—you may save \$200

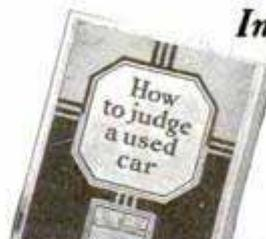

Mail the coupon below for the free booklet. A 2c stamp is an investment which may save you as much as \$200 in buying a motor car!

STUDEBAKER

Builder of Champions

STUDEBAKER CORPORATION OF AMERICA
Div. 153, South Bend, Indiana

Please send me copy of "How to Judge a Used Car"

Name.....

Street.....

City..... State.....

Accept This Offer from Disston

A New and Better File Handle and "The Disston Saw, Tool, and File Book" Are Yours for Just a Dime

NOW Disston brings you the *Stronghold* File Handle, of new design, shaped to fit the hand, to give better control of the file, to insure more accurate work. Easier to apply, easier to use.

Coiled spring-steel ferrule holds tang of file tightly, prevents slipping. File removed and replaced readily without injury to handle.

Comfortable grip lessens wrist-strain, and helps to make the amateur a better filer.

To introduce this improved file handle quickly, Disston will send one direct to you, with "The Disston Saw, Tool, and File Book," for 10 cents, Ready Feb. 15; your hardware merchant can supply them soon afterward. Mail coupon now.



Files for the Wood Worker

Disston Cabinet Files (fine teeth) for smoothing and finishing wood surfaces, easing tight doors and drawers, etc. Disston Wood Rasps (coarse teeth) for rough and fast cutting, enlarging holes, etc. Half-round 8" Cabinet File, 65c. Flat 8" Wood Rasp, 50c.



Files for the Metal Worker

Every kind, size and style. A Disston 8-inch Mill File, bastard cut, is fine for sharpening axes, lawn mowers, garden tools, and general work in the home and shop. Excellent for finishing metal surfaces. 25 cents each.

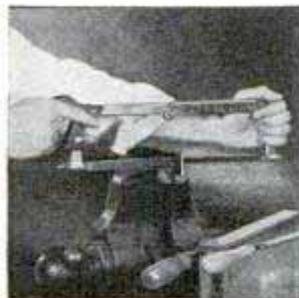

Hints on Using a Hack Saw

For cutting pipes, bolts, nails, curtain rods, etc. Strain blade tight. Cut on forward stroke. Disston No. 36 1/2 Hack Saw Frame takes 8" to 12" blades, \$2.10. Blades, 8" 55c doz.; 10", 65c doz.; 12", 75c doz.

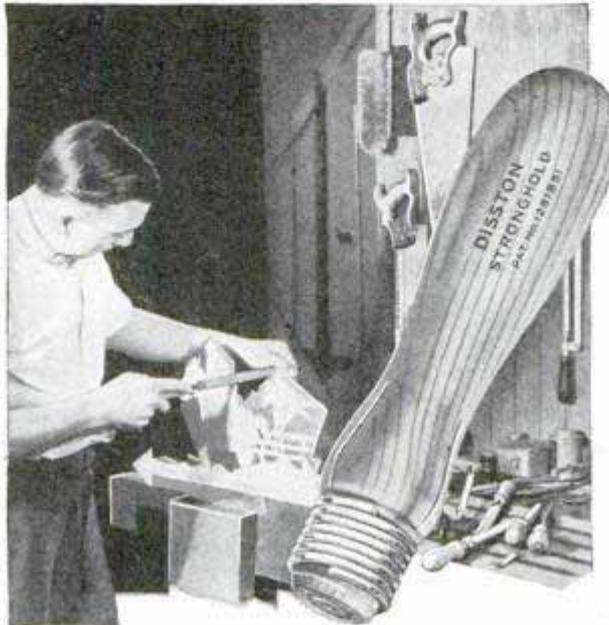

Disston No. 2 Stronghold File Handle. Actual length 4 1/2". Four other sizes made.

USE Disston Files in Disston Stronghold File Handles. Disston Files are the only files made of Disston Steel, the world's great cutting steel, which adds stamina, toughness, and long cutting life to every Disston Saw, Tool and File. Daily use of Disston Files, by Disston sawmakers, guards the quality of all Disston Files.

You will find a Disston File still cutting true, long after another file would be useless. Far longer service, mechanics say, and better service *always*.

For fast cutting, use Disston bastard double-cut hand, flat or half-round files. For a fine finish use Disston single-cut mill or taper files. For filing your hand saws, use Disston Special Extra Slim Blunt Saw Files.

Hold file firmly against metal to be cut. Allowing file to slip dulls it quickly. Cut on forward stroke, use full length of file, and lift file slightly on return stroke. To control the cut, hold thumb of left hand at point of file. For fast cutting, rest ball of left hand on file. Keep file free from chips.

Disston makes files for every purpose, sold by good hardware merchants everywhere. Ask for Disston! Not only files, but also hand saws, circular saws, and every other type of saw for hand or machine work.



Coiled spring-steel ferrule holds file tightly.



Note slits compressed by ferrule.



"The Saw Most Carpenters Use"

The two handiest saws for the home work-shop are the 26-inch 8-point for cross-cutting, and the 26-inch 5 1/2-point for ripping. You will need these on almost every job. The popular "D-8" Lightweights cost \$3.45. Many other styles and sizes.

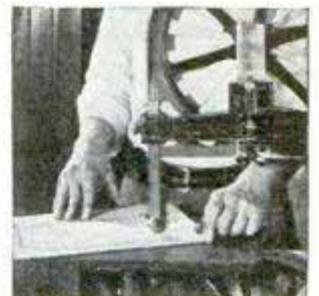

Band Saws for Better Work

Disston "Thin Gauge" Narrow Band Saws are 2 to 3 gauges thinner. They run better on machines with wheels up to 26" diameter. Saw 9' 8" long, 3/8" wide, 25-gauge, brazed, \$2.03. Other sizes in proportion.

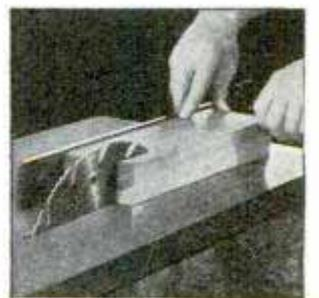

For Your Power Saw Outfit

Disston Saws insure better work. Cut easier, stay sharp longer. Disston Circular Saws—cross-cut, rip or combination—are made to fit any make of machine. If your dealer cannot supply you, write to us for prices.

DISSTON

Makers of "THE SAW MOST CARPENTERS USE"



Mail the coupon at the right, with a dime or stamps, and get the new Disston No. 2 Stronghold File Handle, 4 1/2" size, and "The Disston Saw, Tool, and File Book," an illustrated manual on the selection, care and use of tools.



Henry Disston & Sons, Inc., Philadelphia, U.S.A.
(In Canada, address Henry Disston & Sons, Ltd., Toronto)
For 10 cents, enclosed, send Disston File Handle and Disston Book to:

Name and Address.....



That's the Rule I want

The **FARRAND RAPID RULE**

THE ORIGINAL RIGID-FLEXIBLE-CONCAVE RULE

The most remarkable practical invention in years. Six and eight foot steel rules coiled in vest-pocket size holder. Instantly available for measuring straight or curved surfaces, or around corners. Made of finest steel in the world, will last for years. Can be entirely removed from cup and used for end-to-end measurement.



Models A and B
Model A: Nickeled Cup, 8 foot rule \$5.00
Model B: Brass Cup, 6 ft. rule \$3.75

Ask your dealer to demonstrate or write to factory for six-inch sample and descriptive folders.

Manufactured by
HIRAM A. FARRAND, Inc.
Berlin, N. H.



Model C
Nickeled Cup 6 ft. rule \$3.00
(The New "Light-Six" Model)
Weight 2 ounces

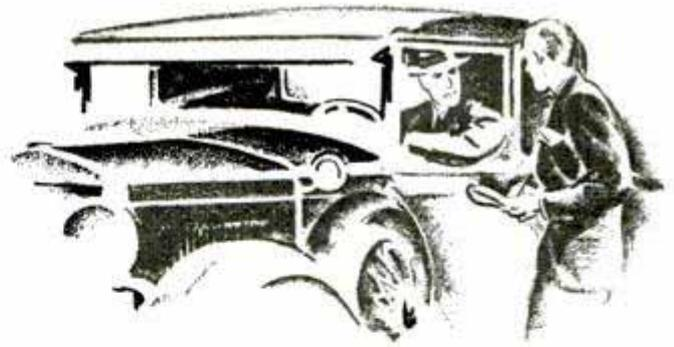

When we ask
motorists, one fact stands
out above all the rest—

“the New Mobiloil
lasts longer”

We first proved both on the speedway and in the laboratory, that the New Mobiloil would stand up better and last longer than competing oils of similar body.

Then—after this new oil had been used by motorists everywhere and under every driving condition, we dispatched special investigators to ask motorists this one question:

“What is most noticeable about the performance of the New Mobiloil in your engine?”

Almost without exception they replied, “Mobiloil lasts longer.”

Thus Mobiloil users add the conviction of everyday, run-of-the-road driving experi-

ence to our statement, that continued use of the New Mobiloil will keep that *first-year feel* in your engine.

It is an established fact that in comparing oils of similar “body,” engineers have proved that the oil which *lasts longest*, also lubricates best.

There is a Mobiloil dealer near you. He offers you a grade of the New Mobiloil especially produced with your engine in mind. His copy of the Mobiloil Chart will tell you exactly which grade you need.

VACUUM OIL COMPANY

Makers of high-quality lubricants for all types of machinery

the New



Mobiloil

True Stories of Stars who were not "born" but "made." No. 1

How a high school "failure" beat out 2 ex-captains and became a college star

SIX former captains, besides many other prep and high school stars, were on the freshman basketball squad of a certain great university in the Fall of 1926. Competition for the five regular positions was unusually stiff.

And yet, when the team was finally picked, a boy who hadn't been able to make his high school team the year before was playing regularly at left forward.

That boy, even with his limited experience, "looked good" to the coaches. They noticed him. He handled himself like a star and they gave him a lot of attention. They made him a star.

If you take this suggestion to heart, you have the same chance. Don't worry about your past record. In any sport, if you can "look good" to the coach, it doesn't necessarily matter how much or how little you have played before.

"Looking good" means *handling* yourself well. And one of the most important secrets of handling yourself well is *footwork*. You can tell a star athlete by the way his feet behave. They move like a flash yet he never stumbles or trips over them. They guide his body. They're like the rudder and propeller of a boat all in one.

Learn to handle your feet. Star athletes in all sports are constantly training themselves in footwork. They know how valuable it is. They may be football stars or basketball stars or baseball stars, yet they are constantly boxing, jumping rope, playing handball, etc.—to train their feet. For this sort of

workout there is only one best shoe—Keds, and they know it. That is why most of them wear Keds.

There are good reasons for this. Keds are scientifically constructed athletic shoes. Keds' "feltex" innersoles keep your feet snug and comfortable. Keds' canvas tops are cool but they're tough. They stand the strain of fast play and give strong support to your ankles. Keds' safety soles are of specially compounded rubber and hold like four-wheel brakes. Keds will help you to "look good."

You can get Keds at all the best shoe stores. They are not Keds unless the name "Keds" is on the shoe. Ask for Keds by name.

FOOTWORK BUILDS STARS

Keds

REG. U.S. PAT. OFF.

The shoe  of Champions

United States Rubber Company

Keds "Spring-step"

(Right) A star basketball model worn by many champions. Keds basketball shoes start at \$2.00— from there on up to \$4.00.

Keds "Big Leaguer"

(Left) Keds moulded-sole models, of which "Big Leaguer" is one, range in price from \$2.00 to \$3.00.



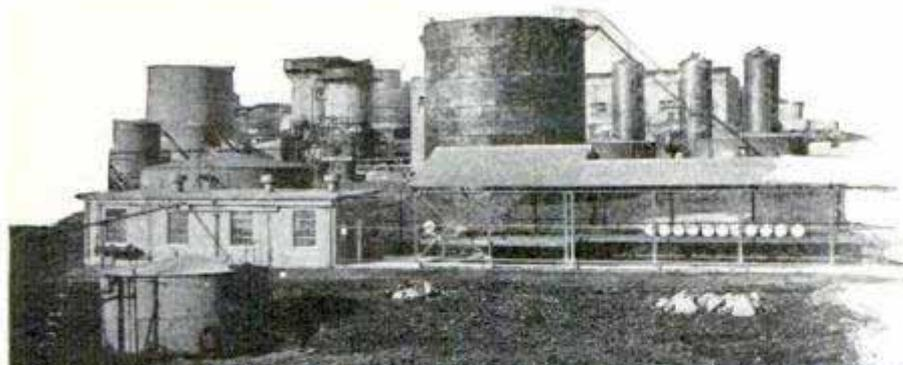

LEFT — Typical refinery scene with Ethyl mixing plant in foreground.

BELOW — Close-up of Ethyl mixing plant. Drums on runway contain Ethyl fluid about to be mixed with gasoline.

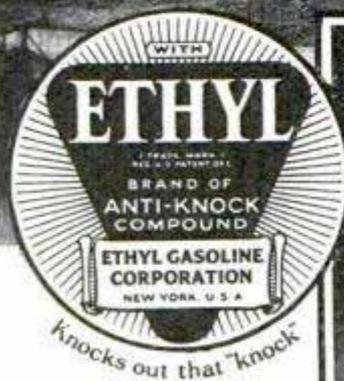

Any pump bearing the Ethyl emblem represents quality gasoline of anti-knock rating sufficiently high to "knock out that knock," in cars of average compression and bring out the additional power of the new high-compression cars.

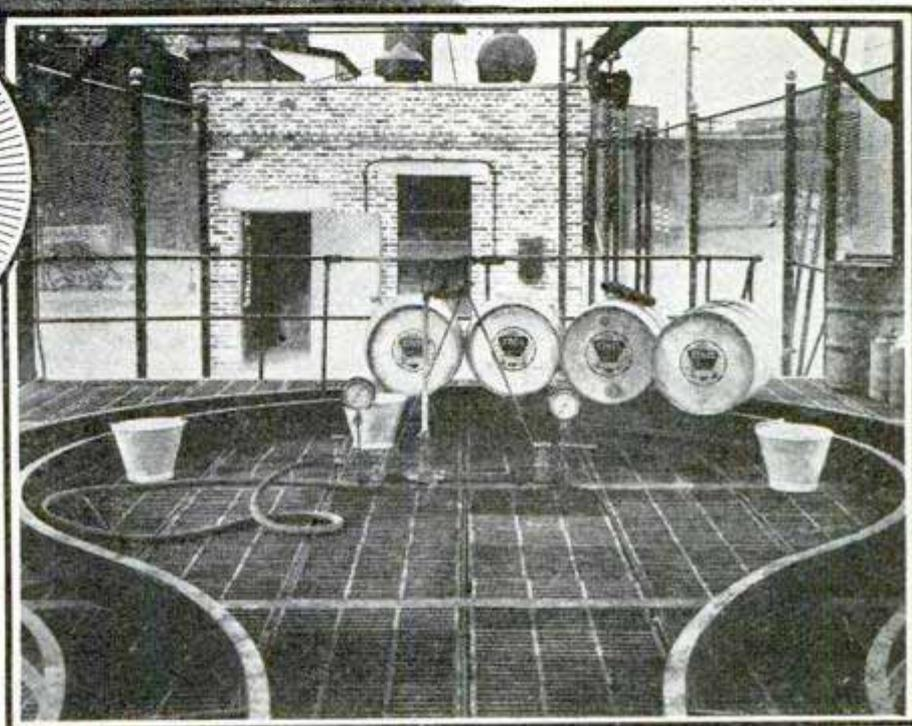

How Ethyl Fluid is mixed with gasoline

ANYONE interested in practical chemistry would enjoy a visit to one of the plants in which the oil companies mix Ethyl fluid (containing tetraethyl lead) with their gasoline to form Ethyl Gasoline.

What would probably be most impressive would be the

precision with which it is done. Engineers from the oil company or from the Ethyl Gasoline Corporation supervise every step of the process.

First, the base gasoline with which Ethyl fluid is to be mixed is tested at an Ethyl laboratory. From this test, the exact amount of Ethyl fluid necessary to bring

the gasoline up to a rigid standard of anti-knock quality is determined. An accurate measuring device is used at each refinery to insure that this quantity of Ethyl fluid goes into every gallon of gasoline.

Look for the Ethyl emblem. Ethyl Gasoline Corporation, New York City.

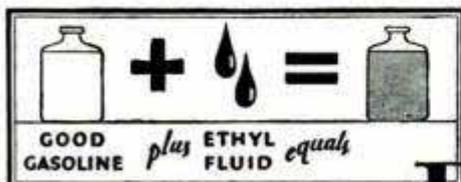

The active ingredient now used in Ethyl fluid is tetraethyl lead.

ETHYL GASOLINE



GET READY TO RIDE AWAY!

SPRING is just around the corner. Budding branches will soon be waving to you — beckoning you out to the Open Road.

Ride away with the “early birds” this Spring. Get your Harley-Davidson now, so you both will be well acquainted and rarin’ to go when the first whiff of Spring comes in from the country.

Drop in on your nearest Harley-Davidson Dealer—look over the 1930 models with their scores of improvements — try out the wonderful “45” Twin shown here — and ask the dealer about his Pay-As-You-Ride Plan that makes motorcycle buying so easy.

Mail the Coupon for literature showing full line—the Single, Twins, and Sidecars.

Ride

a **HARLEY-DAVIDSON**

**MAIL
THE
COUPON**

Interested in your
motorcycles.
Send
literature.

HARLEY-DAVIDSON MOTOR COMPANY, Dept. P., Milwaukee, Wis.

Name.....

Address.....

My age is 16-19 years, 20-30 years, 31 years and up, Under 16 years.
Check your age group.

Send for the New Starrett Catalog

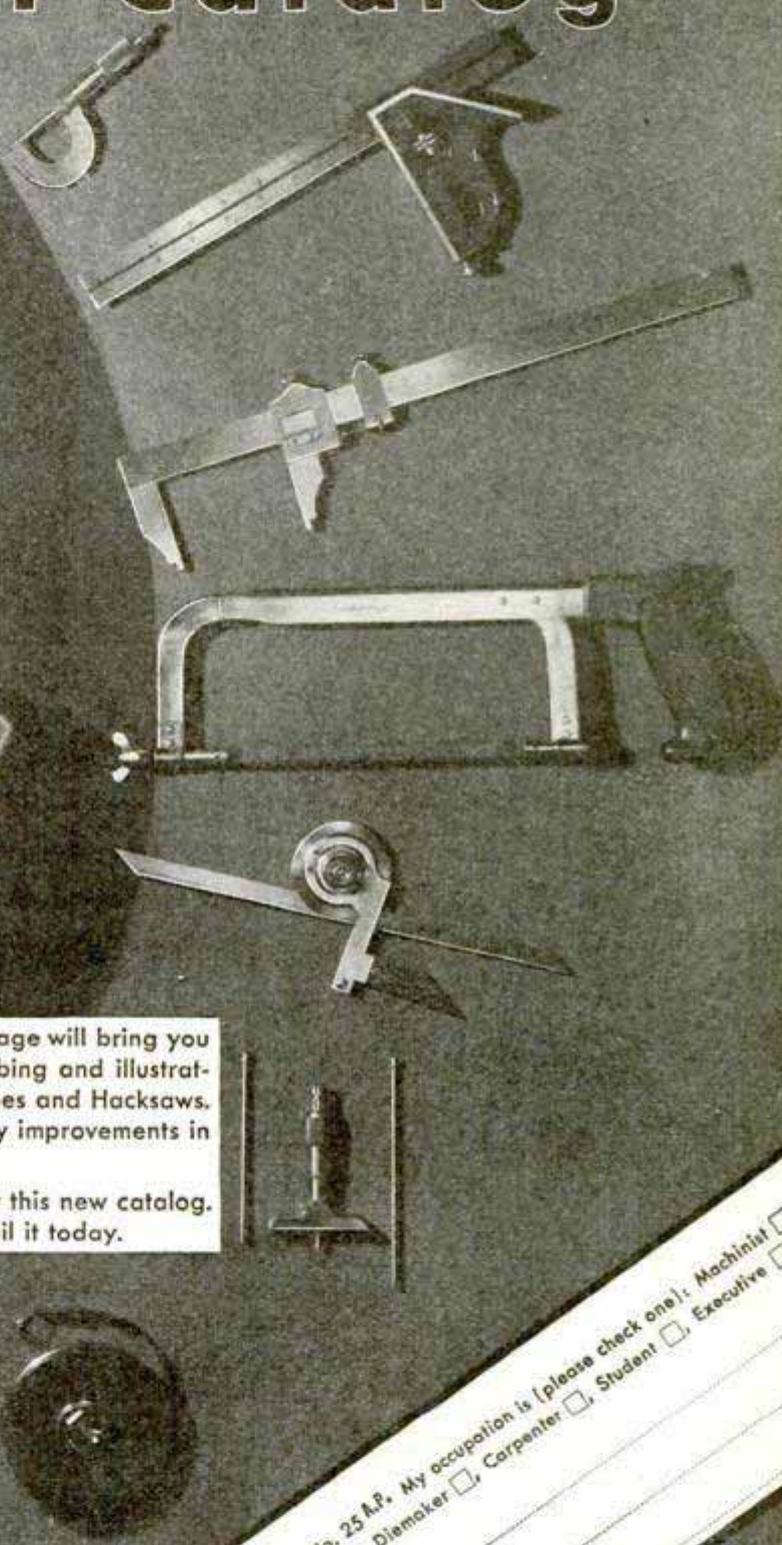

THE coupon on this page will bring you the new Starrett Catalog, describing and illustrating over 2500 Starrett Tools, Tapes and Hacksaws. It presents many new tools, many improvements in the tools you already know.

Your kit isn't complete without this new catalog. Tear out the coupon; fill it in, mail it today.

GOLDEN ANNIVERSARY
OF STARRETT TOOLS
1880-1930



My occupation is (please check one): Machinist
 Carpenter Student Executive
 Diemaker Airplane Mechanic

NAME _____ ADDRESS _____

Use Starrett Tools

The L. S. STARRETT CO., Athol, Massachusetts
Gentlemen: Please send me my copy of Starrett Catalog No. 25 A.P.

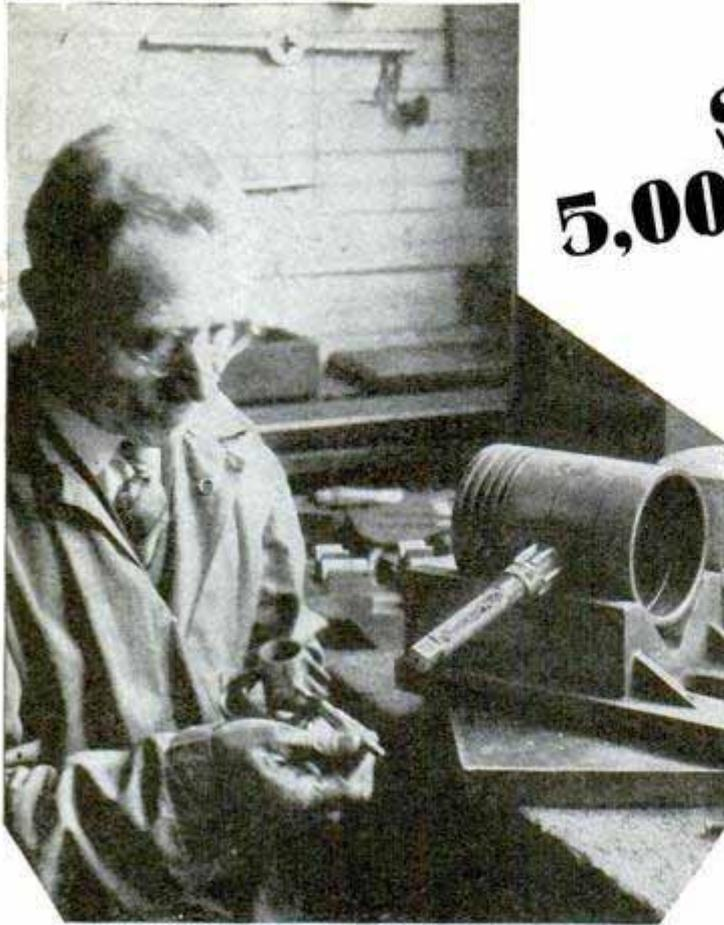

**Schedules of
5,000,000 miles a day
depend upon
accuracy**

Latest estimates of the total bus miles per day in this country approximate five million miles.

This tremendous mileage not only requires accuracy in manufacture but also accuracy in maintenance. Skilled mechanics are constantly checking the performance of

every part of the powerful motors that drive these busses. Pistons, crankshafts, camshafts, bearings, wrist pins — all must be accurate if they are to stand the grind of exacting schedules.

And this huge transportation industry is but one of the many important industries where Brown & Sharpe Tools are used in making important measurements. Wherever accuracy is required, Brown & Sharpe Tools are chosen for their reliability and improved designs.

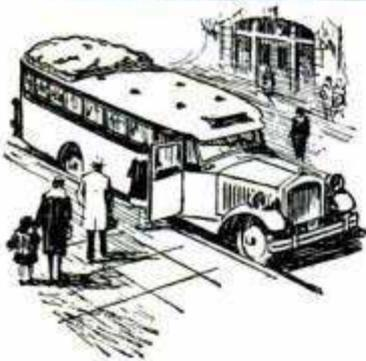

B.S

A copy of our Small Tool Catalog No. 31 will be sent upon request. Address Dept. P. M., Brown & Sharpe Mfg. Co., Providence, R. I., U. S. A.

Brown & Sharpe Tools

"WORLD'S STANDARD OF ACCURACY"

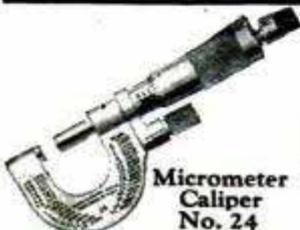

New Model SOUTH BEND LATHES

BACK GEARED SCREW CUTTING LATHES

45,000 Lathes in Use in U. S. and 78 Foreign Countries

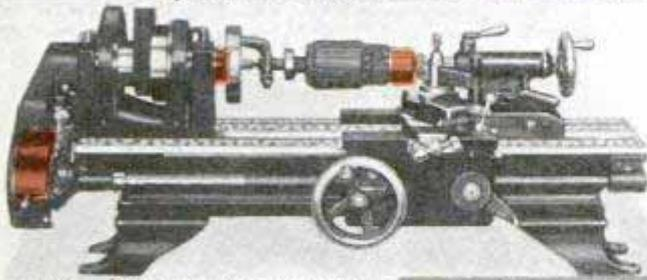

9" x 3' New Model South Bend Jr. Back Geared Screw Cutting Lathe (Weight 375 lbs.) Complete with Countershaft and \$169 Equipment shown only

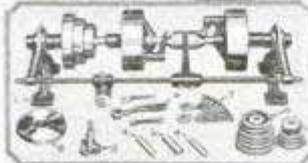

FOR THE

Manufacturing Plant	Service Station Maintenance
Tool Room	Airport
General Repair Shop	Electrical Shop
Machine Shop	Engineering Shop and Laboratory

USED BY MANUFACTURERS OF

Automobiles	and
Electrical Parts Machinery	Government Departments
Aircraft	National and State
Textile Machines	

Prices of 9-in. Junior Bench Lathes Including Lathe Equipment

Size of Lathe	Shipping Weight	Countershaft Drive	Horizontal Motor Drive
9" x 2 1/2'	350 lbs.	\$163.00	\$248.00
9" x 3'	375 lbs.	169.00	254.00
9" x 3 1/2'	400 lbs.	175.00	260.00
9" x 4'	425 lbs.	182.00	267.00

New FREE Catalog

Shows 96 Sizes from 9-in. to 18-in.

Write or send coupon today for the New South Bend Lathe Catalog. This complete book illustrates and describes 96 sizes and types of Countershaft Driven Lathes, Motor Driven Lathes, Quick Change Gear Lathes, Standard Change Gear Lathes, Tool Room Lathes, Gap Bed Lathes, Brake Drum Lathes and Bench Lathes. Investigate the New Model Lathe as it has all the latest improvements.

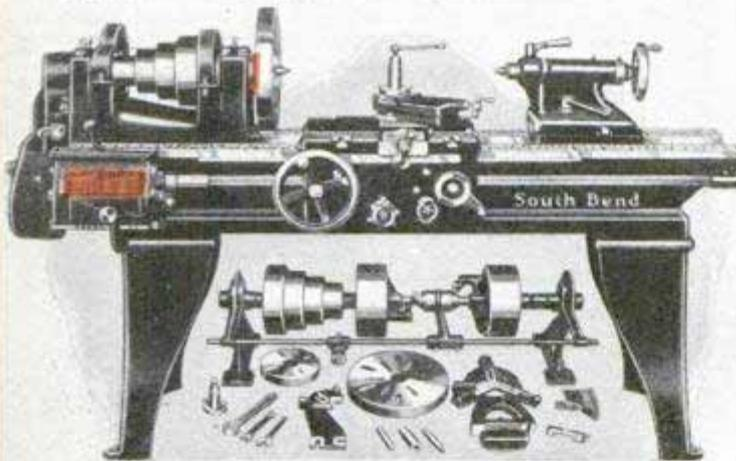

16" x 6' Quick Change Gear New Model South Bend Lathe - - - \$598

Prices of Popular Sizes of Quick Change Gear Lathes with Lathe Equipment

Size of Lathe	Shipping Weight	Countershaft Drive	Silent Chain Motor Drive
9" x 3'	490 lbs.	\$294.00	\$398.00
11" x 4'	725 lbs.	359.00	498.00
13" x 5'	1110 lbs.	443.00	602.00
15" x 6'	1550 lbs.	543.00	720.00
16" x 8'	2035 lbs.	638.00	817.00

Easy Payments

We ship any South Bend Lathe immediately upon receipt of only 20 percent of Catalog Price. Balance in 12 equal monthly payments. Write for Time Payment Catalog.

SOUTH BEND LATHE WORKS

619 E. Madison St., South Bend, Ind., U.S.A.

Lathe Builders for 23 Years

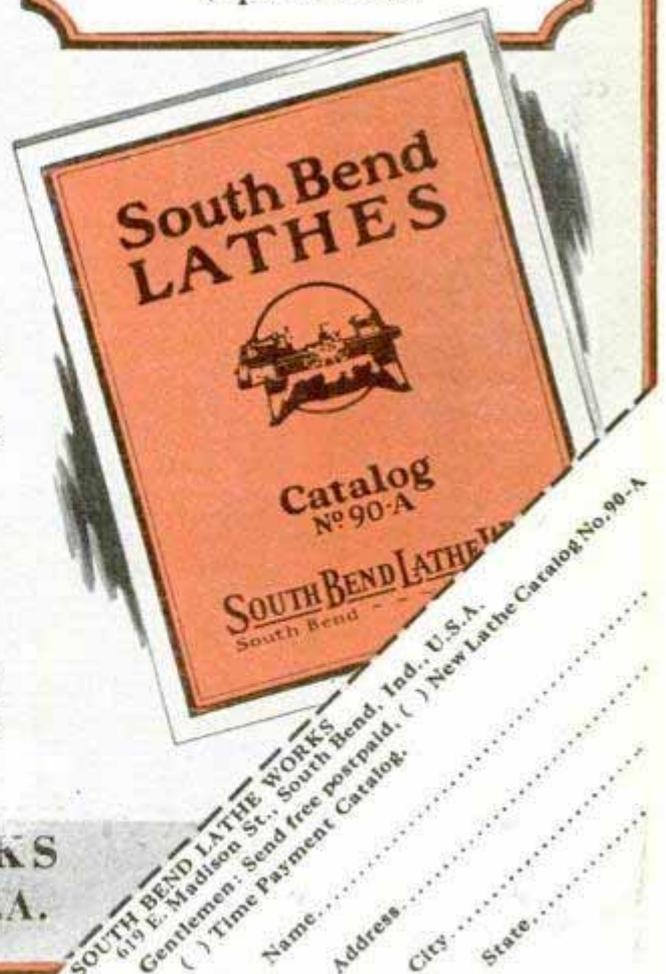

SOUTH BEND LATHE WORKS
619 E. Madison St., South Bend, Ind., U.S.A.
Gentlemen: Send free postpaid, () New Lathe Catalog No. 90-A
() Time Payment Catalog.

Name.....
Address.....
City.....
State.....

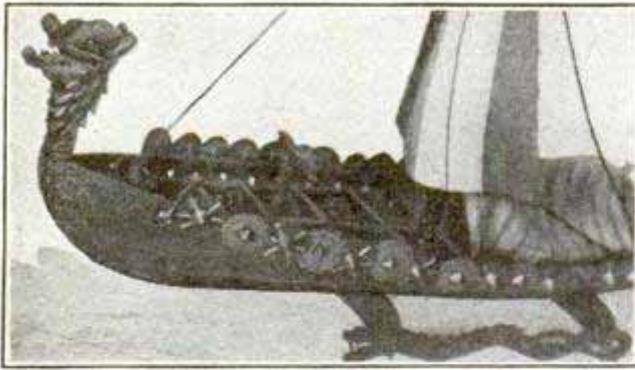

Improving Model Ships With

PLASTIC WOOD

[Reg. U. S. Pat. Off.]

For making repairs, when a tool slips, or the wood chips or cracks, Plastic Wood, which handles like putty and hardens into wood, is the first aid to every ship model maker.

Plastic Wood, however, has even greater value in model ship construction. The Ship Model Makers Club (55 Middagh St., Brooklyn, N. Y.), a nation-wide association of those interested in model boats, recommends Plastic Wood for such uses as moulding figure heads, making blocks and dead eyes, model waves and hatchway gratings.

Here, for example, is their suggestion for making gratings. Cut a rectangular section of wood to overall size desired and, with a saw, make criss cross cuts to scale not less than 1/16 in. deep, chiseling off the shoulders. Soak mould in water, press Plastic Wood into cuts and cover to a full 1/8 in. thick. Loosen the Plastic Wood from mould while still pliable, replace lightly and allow to harden. When hard, sandpaper down to the grating holes, square off, smooth and dry under light pressure.

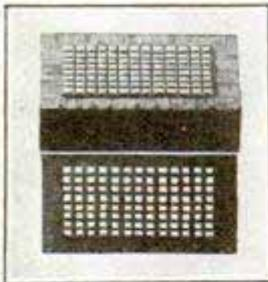

Handles
Like
Putty



Hardens
Into
Wood

Tube, 25c.—1/4 lb. can 35c.—1 lb. can \$1.00
Plastic Wood Solvent, 25c.

At Hardware and Paint Stores

ADDISON-LESLIE CO., 425 Bolivar St., Canton, Mass.

Thompson BEATS the World on BOATS



CATALOG FREE!

The Best that skill and experience can produce—at real money-saving prices. Prompt shipment from factories to you.

Outboard Motor Boats \$60.00 and up

A complete line of real fast, safe and sea-worthy boats for family use. Also fastest racing models.

Rowboats \$48.00 and up

Improved models. Safe and seaworthy. Strong and durable. Easy to row and handle with oars.

Canoes \$50.00 and up

Three models and four lengths to choose from. Including non-sinkable sponson canoes.

MotorBoats Six passenger

20 ft. long; speed 30 to 35 miles an hour.

CATALOG FREE—SAVE MONEY—ORDER BY MAIL
Please state the kind of boat you are interested in (30)

→ TWO LARGE FACTORIES ←

THOMPSON BROS. BOAT MFG. CO.

213 Ann St.
PESHTIGO
WISCONSIN

(Write to
Either Place)

113 Elm St.
CORTLAND
NEW YORK

BIG MONEY

easily made sanding floors with the new model "American Handy Sander." Operates from light socket—weighs only 34 lbs.—easily carried with one hand—produces highest quality work. Build up a sanding business all your own—Large capital and experience not required. Write NOW for free information.

The American Floor Surfacing Machine Co.
523 South St. Clair St. Toledo, Ohio



CLASS PINS 35¢

FREE CATALOG SHOWING 200 DESIGNS
PIN SHOWN, SILVER PLATE 35¢ EA., 12 OR MORE, \$3.50
DOZ.; STERLING SILVER OR GOLD PLATE, 70¢ EA.
12 OR MORE \$6.50 DOZ. 1 OR 2 COLORS ENAMEL;
45825 3 OR 4 LETTERS; DATES 1930-31-32-33.

BASTIAN BROS. CO. 925 BASTIAN BLDG., ROCHESTER, N. Y.

Chemical Tricks for Boys

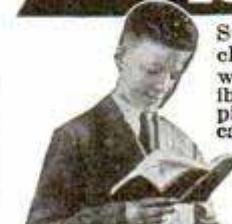

Surprise and puzzle your friends with magic chemical tricks; make ink; dye cloth, test water and soil, write secret letters with invisible ink; pour blue, brown and black liquid from a pitcher of water. All these and many more chemical stunts are easy with Chemcraft Junior. It's the best box of fun you ever had! Get yours now.

ONLY 25c POSTPAID



FREE Magazine
to every boy who writes for it now. Contains Chemical, Electrical and Wood Working information. Write for yours right away.
The Porter Chemical Co.
54 East Washington St.
Hagerstown, Md.

How to Make a Chess and Checkers Table



LePage's Third Home Work Shop Book, only 10 cents, Shows How to Make These 20 Projects

Cape Cod Chest of Drawers, Alexandria Nest of Tables, Old Salem Ship's Cupboard, Plymouth Built-In China Closet, Lady Washington Sewing Cabinet, Set-Back Book Shelves, Modernistic Desk, Modernistic Table, Modernistic Folding Screen, Modernistic Fire Screen, Chess and Checkers Table, Smoking Table, Caned Side Chair, China or Book Cabinet, Book Trough and Magazine Stand, Magazine Carrier, Vanity Case, Book Stand, Fernery Stand and Folding Sewing Screen.

Job Plans 10 cents each. Order by Number as indicated in Coupon.

- 16 Sheraton Writing Desk
- 17 Sheraton Desk Chair
- 18 Colonial Hanging Book Shelves
- 19 Smoking and Reading Cabinet
- 20 Colonial Mirror
- 21 Tea Wagon
- 22 Telephone Cabinet
- 23 Stool for Telephone Cabinet
- 24 Manual Training Work Bench
- 25 Home Worker's Tool Cabinet
- 26 Spanish Galleon
- 27 Vanity Table

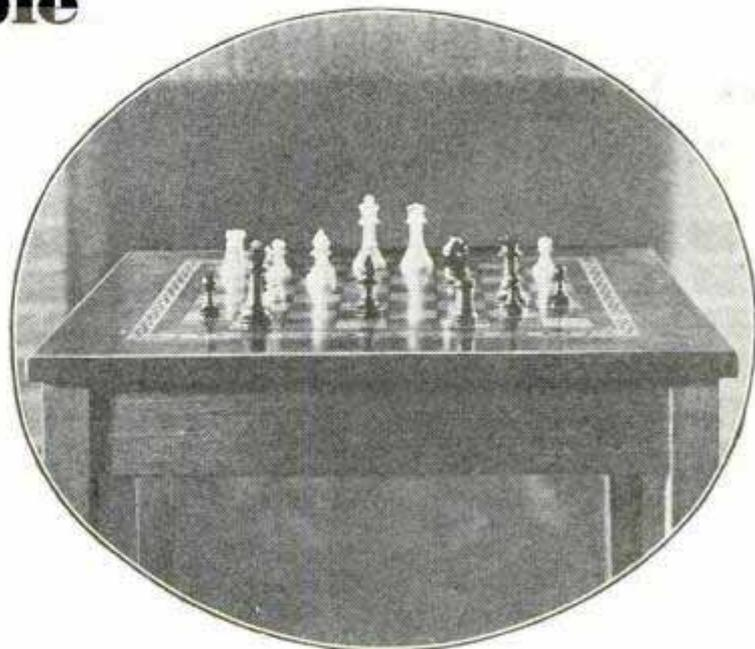

Complete easy instructions in LePage's Book Show You How

Like to play Chess or Checkers? Why not have a real game table that you can make yourself at little cost? Complete, easy-to-follow directions are given on page 15 of LePage's Third Home Work Shop Book. If you are at all handy with tools, you'll find it easy and good fun too. Or you can make any of the other projects presented in LePage's Book or Job Plans.

Expert Instruction

You have expert instruction to guide you. The designs, dimension drawings, photographs, step-by-step directions and the actual furniture itself were made by William W. Klenke, Instructor in Woodworking, Central Commercial and Manual Training High School, Newark, New Jersey. His experience as an expert gives assurance that each project and the

directions for making it are thoroughly practical.

Look over the contents of LePage's book and the Job Plans available as shown in the column at the left. The price of the book is 10 cents. The Job Plans are 10 cents each and are for projects requiring more elaborate instructions than those shown in the book. In all cases the instruction consists of printed step-by-step directions, dimension drawings or full-size patterns, and a photograph of the finished article.

Send 10 Cents for LePage's Third Home Work Shop Book

Simply use the coupon below, sending it to us with 10 cents in coin or stamps, and we will at once send you a copy of this latest LePage's Book, postage paid.

**Mail
This
Coupon**

LEPAGE'S CRAFT LEAGUE
727 Essex Ave., Gloucester, Mass.

Gentlemen: Enclosed please find 10 cents (coin or stamps) in payment for LePage's New Third Home Work Shop Book. Please send a copy of this book to:

Name.....

Street.....

City.....State.....

Please also send the following Job Plans.....(indicate by number those you want. See column at left), for each of which I enclose an additional 10 cents.

**LEPAGE'S
GLUE**

HANDIEST TOOL IN YOUR WORK SHOP



... Made for men who make things

CARPENTERS and mechanics, professional or amateur, are more critical in judging a knife than any other class of users. Remington knives have been judged by these men who make things—judged in the practical test of use. The result of this testing is that you will find Remington carpenters' and mechanics' knives on thousands of work benches—in thousands of tool kits—in the pockets of thousands of men who want a handy tool always within reach.

The blades in these knives are of high-carbon steel, forged, hardened and tempered to take and hold a keen edge. The blades are sharp—hand-honed. Design, finish, and construction are right.

One of the popular patterns is pictured here—R4223. You can get it where good cutlery is sold. If your dealer hasn't it in stock, send his name with \$1.50 and knife R4223 will be mailed to you promptly. Address: Remington Cutlery Works, Bridgeport, Conn.

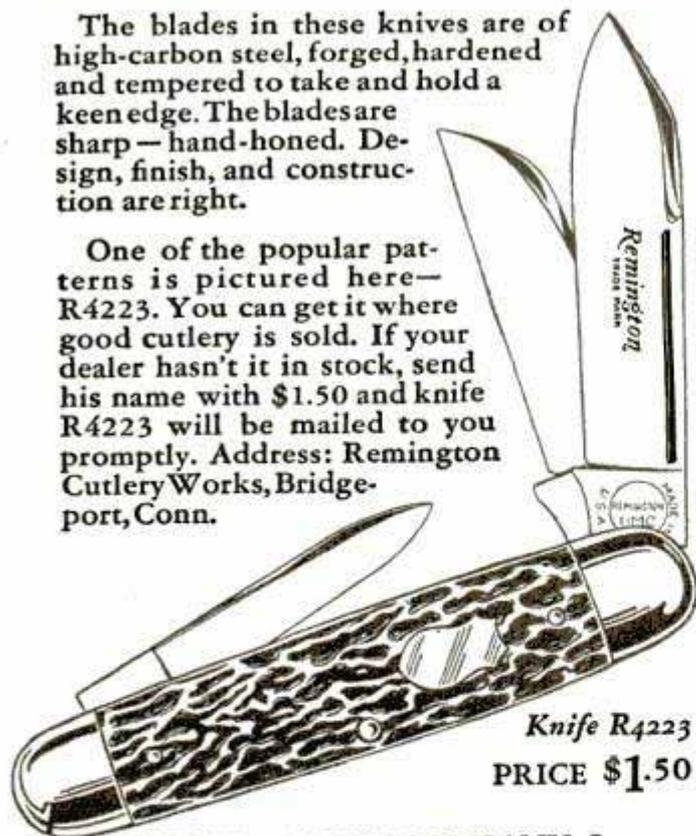

Knife R4223
PRICE \$1.50

REMINGTON ARMS COMPANY, Inc.
Originators of Kleanbore Ammunition

Remington

FREE! RADIO BARGAIN CATALOG



ALSO FREE RADIO GIFT

Send now for this new free radio catalog which saves you many dollars on radio outfits, kits, parts, tubes and accessories! Also **TIME CONVERSION CHART FREE.** Tells you instantly what time it is in any part of the world! Given free if your request for catalog reaches us this month.

20TH CENTURY MAIL ORDER CORP.

238 So. Wells St., CHICAGO, ILL.

Genuine **PILOT** Parts



TONATROL

The Radio Volume Control with a REPUTATION

TONATROLS are famed for their smooth operation and wear-resisting construction. Models for all sets, with or without filament switch, \$1.50 to \$3.00.

Also the 5-watt Super-TONATROL for high powered receivers \$2.40 to \$3.50.

Write Dept. PM3 for interesting circulars showing types and recommended uses.

175 Varick St., New York, N.Y.

ELECTRAD

ELECTRIC OR BATTERY

TRY IT 30 DAYS FREE BEFORE YOU BUY

1 yr. guarantee
AC-7 \$39.85

9 Tube Screen Grid Steel Chassis \$49.88

Lighted 1 dial



Factory to you. Save 50% on latest AC Electric or Battery Radio. Get 'Send No Money' Offer.

Big choice of cabinets

MIRACO

Radio's most amazing bargains direct from big, old, reliable maker. Don't buy unless 30 days use proves entire outfit unbeatable at 2 to 3 times the price, for tone, selectivity, distance, volume.

Free Catalog and BIG SPECIAL OFFER
MIDWEST RADIO CORPORATION
10th Successful Year
407-GM Miraco Bldg., Cincinnati, O.



BIG DISCOUNTS to User Agents

Rotary Stencil Duplicator \$39

Print Bulletins, Circulars, Programs, Letters, with the Amazing "EXCELLOGRAPH"

Simple and easy. Just write, typewrite, draw or trace on dry stencil; place in position and print up to 1,000 copies per hour. All supplies and instructions furnished. Guaranteed 10 years. Prints any size from postcards to sheets 9x14. Does beautiful work.

SAVE MONEY—MAKE MONEY
Saves and makes money for Merchants, Ministers, Teachers, Offices, etc. Use it to build your business. Do work for others at big profits.

Write for Free Book—TODAY

Shipped at our risk. POSITIVE MONEY-BACK GUARANTEE. Amazing value. Thousands in use. Get free book describing all details and easy payment plan.

PITTSBURGH TYPEWRITER & SUPPLY COMPANY
Dept. M-5 339 Fifth Ave. Pittsburgh, Pa.



Making Real Money!

\$4.00 to \$6.00 an hour

You can do it too with the **IDEAL** Lawnmower Sharpener

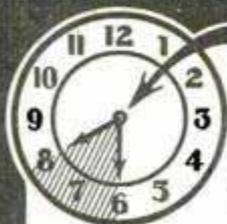

A days pay ~
for
2 hours work!

And That's What You Can Do!

Herman Barber, 1505 E. Carter Ave., Ashland, Ky., writes: "I have sharpened to date 459 mowers, receiving \$988.30. These were sharpened in evenings and in spare time. I have seen other machines, but this is the most perfect one I have seen yet."—And hundreds of others are cashing in with this efficient machine. **OUR FREE BOOK TELLS YOU HOW**—It tells how others have made themselves a business of their own—built permanent businesses on spare time work which has helped to buy the extras for the home, etc., that everyone wants. Send for this book—It's Free.

Use Your Spare Time If you work at a trade, put an Ideal in your basement and earn \$4.00 to \$6.00 an hour evenings and Saturday afternoons. E. W. McCormick, Saginaw, Mich., writes: "Five years ago I bought an Ideal Sharpener on which I have ground over 5,000 mowers. In the last few weeks I worked at my trade, machinist, full time 9 hours a day. I also ground 97 mowers which netted me \$114.10 clear gain."

A Nice All Year Business S.E. Raup, 1312 N. Cameron St., Harrisburg, Pa., writes: "I have been using two Ideal and one Peerless grinders for four years with fine success and have been able to build up a nice all-year business. At present I am employing one man and a boy to help me."

Same Customers Each Year—D. N. Wood, Winchester, Ky., writes: "This is the third year I have been using your machine and I have built up a nice repeat trade. Evidently the work is satisfactory or I would not get the same customers each year; also each one generally sends a new one."

Profits Year After Year C.S. Coburn, Little Rock, Ark., writes that his "Ideal" Sharpener earned enough in 18 months to pay for itself and \$1857 worth of additional machinery.

Zeno Brandon, Middletown, Ohio, writes: "I have made \$820.70 in 55 days with my 'Ideal.' Have made as high as \$38.70 in one day."

W. F. Kendt, Buffalo, writes: "I have sharpened 994 lawnmowers last season and the receipts were nearly \$2100—not bad for a side line."

Hundreds of Dull Mowers Waiting For You

to sharpen them right in your locality—and no town is too small. William G. Mercier, 178 E. Mohawk St., Oswego, N. Y., writes: "We have our shop on a truck and we travel all over the county." W. W. Dresser, Sanford, Florida, writes: "I live five miles out of town so have no real to pay. Collect and deliver mowers. Get \$2.00 or better. Buy up old mowers and repair same and therefore make from \$4.00 to \$10.00 on same, which counts up in a season. Am well pleased with the machine."

Here Is Your Chance Send for the book, "Let George Say It"—It's the proof of what we advertise. We also show you the best ways to get the mowers to sharpen.

THE FATE-ROOT-HEATH CO.
Dept. M, 918-944 Bell Street, Plymouth, Ohio, U. S. A.



Sharpens Lawnmowers to Razor Edge

The Ideal Lawnmower Sharpener is a wonderful, but simple, machine that sharpens lawnmowers perfectly, scientifically, without dismantling the mower. Sharpens them as emery dust, files and obsolete methods never could.

Sharpens Any Mower in 20 Minutes

Just pick up any mower, set it in the Ideal, make a few simple adjustments and proceed to sharpen. In 15 to 20 minutes after you pick up the mower it is ready for the lawn, and you have made \$1.50 to \$2.00, depending on the charge you fix.

No Training Required

You don't have to be a mechanic to use the Ideal. Its operation is simple and practically automatic once you start to grind.

Set Up Ready to Grind in a Few Minutes

Shipped practically completely assembled. Uncrate it, place in position, plug into a light socket and it is ready to start earning for you.

Special Grinding Wheel Attachment

For sharpening grass shears, hedge shears, sickles, scythes, axes, etc., etc. Will add many dollars to your income.

Skate Sharpener Attachment Included

Sharpens all makes of skates—including hockey with shoe attached. The "Ideal" earns money all the year round.

Uses Little Power

Operated by 1/4-H.P. Motor attached to light socket or can be run direct from line shaft.

Here's what you'll want to read
Send for it NOW!

Sign and Mail This Today

The Fate-Root-Heath Co.,
Dept. M, Plymouth, Ohio.

You'll have to prove that I can make real money with the "Ideal" Sharpener. Send me your FREE BOOK.

Name

Address

City State

Car Washing

now a PLEASURE!



GY-RO WHIRLO BRUSH
washes CARS CLEAN!

WITHOUT Chamois, Soap or Spray!
"WATER PRESSURE MAKES IT WORK"

Any Garden Hose Will Do



Useful Around the Home
Gy-ro saves many a painting job. Also cleans screens, windows, etc.



Nothing like Gy-ro anywhere. No fuss—no bother. Self cleaning. Guaranteed for 1000 washings.

The days are gone when an autoist must "take a swim" to wash his car! No longer is car washing a process of "deep sea diving" with a splashy hose, soap and a slippery chamois. Since the invention of the *Gy-ro Whirlo* brush car washing has become a few moments of the easiest work imaginable. Chamois, soap and spray have been discarded as obsolete and unnecessary.

AUTO OWNERS WILD ABOUT THE GY-RO!
Car owners everywhere recognized GY-RO as the first real device to simplify auto cleaning. It cleans cars *CLEAN* in a *flash*. It works on the simple law of water pressure. Water from ordinary garden hose pours through center-making brushes whir. These whirling brushes cut right through dirt and mud. They do all the work. You simply brush down the car. Every autoist will buy one.

100% PROFIT FOR AGENTS!

Live agents are needed everywhere to demonstrate this amazing invention, needed by auto owners, garages, service stations everywhere. 100% profit for spare or full time workers.

WRITE AT ONCE!
Send name and address for all particulars. Don't delay or you may lose territory. Even showing to friends will net you handsome profits. WRITE NOW!

GY-ROBRUSH COMPANY
Dept. C-14 Ampere, N. J.

CAMPBELL'S

INFRA-RED RAY LAMP



STOPS PAIN QUICKLY
Have You Some Troublesome Ailment?

I want to send you one of my INFRA-RED Lamps to use for 30 days without obligation to purchase—so you see for yourself how quickly you will be relieved. Infra-red (invisible) rays *penetrate deeply* into the tissues. This creates an active circulation in the congested parts, stopping pain almost instantly. *Nature herself does the healing by stimulating the normal circulation of blood.*

Sent on 30 days' trial
May be used safely by anyone. Just plug into any light socket, and concentrate the Infra-red beam on the affected part. A blessing in the home both for children and adults. Physicians say most ailments are due to congestion—relieve the congestion with Infra-red rays and you relieve the ailment.

New—low factory price and easy terms

Write today for free book quoting medical authorities and hundreds of users. For a limited time low introductory price and small monthly payments.

WM. CAMPBELL CO., Dept. 1040, ALLIANCE, O.

Sinus Trouble
Sore Throat
Lumbago
Bronchitis
Neuralgia
Rheumatism
Neuritis
Tonsillitis
Catarrh
Ear Trouble
Hemorrhoids
Backache
Asthma
Gall Bladder
Try my Infra-red Lamp at my risk for these and other ailments.

Free Book Tell us your trouble, and we'll send free valuable suggestions for Infra-red treatment during 30-day trial period.

MOVIES AT HOME

LET US SEND OUR INTERESTING AND FREE CATALOGUE OF MOVIE MACHINES—AS LOW AS \$3.75 POSTPAID—USE STANDARD 8 OR 16mm SIZE—COMPLETE LINE OF FILM SUBJECTS AVAILABLE WITH EXCHANGE SERVICE—LOWEST PRICES—DON'T DELAY—WRITE FOR FREE CATALOGUE NOW!

PARAMOUNT MFG. CO.

BOSTON DEPT. 6-25 MASS.

RUN SHOWS EARN EXTRA MONEY!

NEW SUPER-WASP AC & DC SHORT-WAVE RECEIVER
In Kit Form or Completely Constructed

1930 Catalog Free Set Builders! Write for your Copy. Complete line of Short-Wave Supplies, standard parts and Accessories.

CHICAGO RADIO APPARATUS CO., Dept. PM
415 S. Dearborn St. Chicago, Ill.

Turn Spare Hours into MONEY!

Buy Now Pay Later

You can. Others have. A modest equipment of Bolice-Crane machines installed in basement or garage workshop does it. **G. W. Fountain, Rocky Mount, N. C.**, starting with one B-C machine working part time in rear of grocery store grew in three years to occupy a 1/2 acre of ground in new building 50 by 70 ft.

Joseph Broemmers, Hannibal, Mo., first bought a \$17.00 B-C machine and 1/4 h. p. motor for home shop. In 2 years he was occupying two story brick 40 by 50 ft. Now after four years he needs more room.

Though in poor health, **W. H. Duer, Marquette, Mich.**, supported family of four in basement shop earning as high as \$25.00 a day. Original investment \$75.00. Earnings easily meet monthly payments.

Send 10c for 80 page catalog describing Bolice-Crane circular Saw; Jig Saw; Lathes; 4-inch, 6-inch Jointers. Let us tell you how to turn spare hours into money. Catalog free if you send name of your hardware or machine dealer.

Have a Business of Your Own

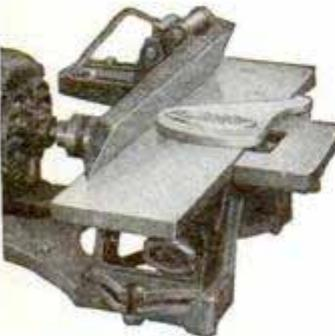

4" Handi-Jointer
Tables 20-inch. Planes 1/4-inch x 4 inches. Fence tilts 45 deg. both ways. Bronze bearings. Improved rabbet arm. Safety guard \$3



12" Band Saw
Table 10 inches x 12 inches tilts 45 deg. Cuts 4 1/2 inches deep. Bronze bearings. Sturdy. Guards \$8. Without motor or guards. \$35

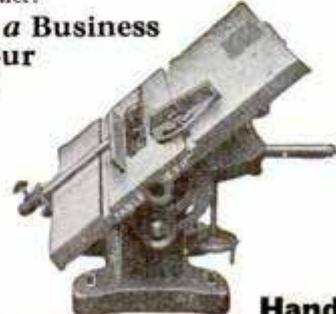

Handisaw
Universal. Table 15 inches x 17 inches tilts 45 deg. 8-inch saw cuts 2 inches. Elevates for dadoing. Attachments for dadoing, jointing, disc and drum sanding, boring, planing, grinding. \$30

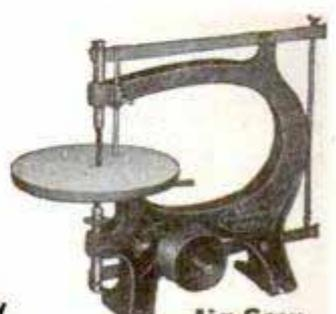

Jig Saw
Table 8-inch diam. Tilts 45 degrees. Stroke 1 1/2 inches. Capacity 10 in. to frame. 600 R. P. M. 6 sizes of blades. \$12

W. B. & J. E. BOICE, Dept. P.M. 3-F, TOLEDO, OHIO

NEW INVENTION

Automatic WASHING MACHINE

A simple new kind of washing machine has just been invented. It has no motors or moving parts, yet it is just as efficient as machines costing \$100. This new machine simply sets in any ordinary boiler and automatically cleans and sterilizes an entire washing in about 20 minutes. No rubbing or strong soap or lye is required. No wear or tear. Washes the finest fabrics. It has been tested and approved by leading engineers.

Costs no more than a pair of shoes

Sent on Ten Day Trial

One of these new washers will be sent on FREE trial to one person in each locality. Act quickly. Write for FREE BOOKLET at once.

AGENTS Write or wire for particular territory and free sample offer.

PRESTON MFG. CO.
Dept. P-3 St. Louis, Mo.



12-INCH SCALE MODEL

of Lindbergh's Spirit of St. Louis. Scientifically designed and very realistic. Rises from ground by own power and flies 40 ft. or more. Only flying scale model sold at this price. Easily built in 2 or 3 hours. No tools needed. Construction set, with all parts and full directions, postpaid in U.S. and Canada, only 50c (no stamps). Satisfaction or money back. Send today and print your address plainly.

MANN & BENTON
Box D, Chillicothe, Ohio



BOYS! Make Big Money

BUILD BIRD HOUSES

Here's a real money maker. With my simple instructions any boy can build and erect Grandpa Bird Houses. They sell at \$2 to \$97.50 each. \$2000 worth sold in Oak Park, Ill., in a year. Send \$1 for my big collection of work shop plans for boys who want to have fun and make money building my famous bird houses. Valuable information about song birds and tips and advice on making sales included Free.

GEO. J. BREIDERT, 1040 N. Elmwood Ave., Oak Park, Ill.

AGENTS

Make big earnings, taking orders for made-to-individual measure suits at less than ready-to-wear prices. Giant Chicago wholesale house makes world's greatest values at \$23.50 and \$29.50. Your profit \$4 and \$5 per sale in advance—we deliver and collect. No experience needed, work full or part time. **FREE OUTFIT** Send no deposit. Write for details of our unique money-making plan. Nothing like it ever before offered. Act at once.

GENERAL TAILORING CO., DEPT. 3X 618 W. Jackson Blvd., Chicago

Any Wurlitzer Instrument

Try in Your Own Home

See for yourself the superior quality of these famous instruments, the result of 200 years' experience. Every known instrument. No expense for trial. Easy terms if desired.

Send for New Catalog—Free

Rudolph Wurlitzer Co., Dept. 1773 Cincinnati, Ohio



You'll Be Proud of the Work You Turn Out With the H&A WOOD LATHE

Whether expert or novice, you'll sense its balance, its sturdiness, its splendid accuracy. A really remarkable machine, at surprisingly low cost. Write

HESTON & ANDERSON
603 Kirkwood Ave., Fairfield, Ia.



Here's an Amazing New Business THAT PAYS UP TO \$1,000 A MONTH

MEN, here is a real, red hot money-making opportunity! It's a chance to jump into business for yourself and make more money every week than the average man makes in a month. Surprising as it may sound, we actually put you in a business, with the first day's profits often running from \$18 to \$55. \$350 to \$600 the first month is not unusual for ambitious men.

Cut in on the Big Money

All you need is the ambition to make real money. We supply you with complete equipment to make and sell that famous new food specialty—Brown Bobby—a greaseless doughnut baked by electricity! It's a crispy, flaky, delicious new kind of doughnut cooked without one drop of oil or grease. Easily digested by everyone. More appetizing than old-style doughnuts ever were. Costs less to make. Sells four times as fast. No baker's skill required. Just add water to our prepared "Mix." You can open a shop; rent cheap floor space in a grocery, delicatessen, lunch counter, drug store, etc. Or start at home—and make up to \$250 your very first week.



"I made \$3,000 in 3 months from my greaseless doughnut business!" — T. Chas. Minch, Fla.

Start at Once ANYWHERE!

Men and women everywhere are starting in this business daily! YOU cannot afford to delay! Details will gladly be sent without obligations of any sort. Such an amazing money maker may never come your way again. So fill in and send the coupon at once! TODAY—

FOOD DISPLAY MACHINE CORP.
Dept. 33, 500-510 N. Dearborn St., Chicago, Ill.

Food Display Machine Corp.,
Dept. 33, 500-510 N. Dearborn St., Chicago, Ill.

Gentlemen: Please send me the plan by which I can cash in on Brown Bobby, the Greaseless doughnut. It is understood that this obligates me in no way whatever.

Name.....

Address.....

City..... State.....

**Unsightly
cracks ...
Easily
resurfaced**



You can easily make cracked walls and ceilings good as new with Rutland Patching Plaster—the quick, money-saving mender. Just mix with a little water, then fill crack or hole. If you want a perfect, lasting job, be sure to ask for *Rutland Patching Plaster*—made by the secret Rutland formula that insures absolute whiteness and permanence. At paint, wall-paper and hardware stores. Rutland Fire Clay Co., Rutland, Vermont.

**RUTLAND
PATCHING
PLASTER**

Canada Airmail Stamp Free

If you ask for approvals and send 15c for 25 diff. airmails or 30 diff. Canada and Nfld; both packets only 25c. We list 329 countries in our dime packets. Lists free. Special Bargains—500 diff. 25c; 1000 diff. 75c; 2000 diff. \$2.50. Victoria Stamp Co., London, 4, Canada.



ELECTRIC LAWN MOWER

Don't tire yourself out with an old style mower when you can get an electric at a price you can afford to pay. 110 volt A. C. or 32 volt farm plant. Write for particulars. Agent wanted.

Raun Lawn Mower Co.
Box 533 El Campo, Texas

EASY MONEY MANUFACTURING THESE PRODUCTS



**24 PAGES
of ways to
MAKE MONEY**

People spend money willingly beautifying their homes and surroundings. These and other decorative pieces in any color, for porch, garden, walks, lawn, etc., sell themselves.

Scott of Michigan invested \$95 in equipment, cleared \$1,374. John Borgman, former factory worker, invested \$380, now writes his own paycheck. Similar investment starts you.

Make them in spare time or full time. Big demand. Nearly all profit. Note costs and selling prices. No experience necessary. Use your own basement, garage or shed, then expand from earnings. Don't let someone else beat you to this fast-growing, exclusive business. Free book gives the facts. Write today.

Colorcrete Industries
570 Ottawa Ave. HOLLAND, MICH.



AGENTS 500% PROFIT GENUINE GOLD LEAF LETTERS

S

guaranteed to never tarnish. Anyone can put them on stores and office windows. Enormous demand, large profits. Paul Clark says: Smallest day \$28.70. R. L. Reel made \$920 in two months. Write today for free sample and liberal offer to general agents.

METALLIC LETTER CO. 433-B N. Clark St., CHICAGO

**TRICKS
MAGIC
JOKES
FREE**
SCIENTIFIC NOVELTY CO.
88-2 PARK PLACE, N.Y.C. CATALOG POSTAL BRINGS IT

"LITTLE SAXO" Auto Clothes Hanger for Tourists

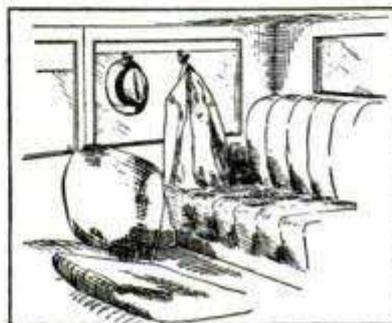

Handy as a wardrobe—Holds hats, coats, road maps, clothes, purses, anything—out of the way. Slips on window in a jiffy. Does not interfere with opening or closing—Wonderful souvenir. Send 15c for sample. Box 50, for \$4.00. Salesmen wanted everywhere.

FRANK SAXTON MFRS., 13 Adrian St., Blissfield, Mich.

WE PAY FREIGHT

\$845

Beautiful 6-room home with porch

Others \$392

to \$1558



\$845

Buy Direct
Save \$300 to \$1000

T. F. Connor saved \$700. A. R. Bates saved \$1500. O. P. Fickling saved \$300 to \$1200 by building the Liberty way. You can do as well. No waste. No worry. 40% less labor. Substantial, permanent homes.

FREE Beautiful Book of **LIBERTY HOMES**. Pictures wonderful homes from \$392 to \$1558. Price includes all lumber cut-to-fit, millwork, roofing, lath, hardware, paints, nails. Materials fully guaranteed. Plans FREE. 3 years to pay if desired. Write for Catalog now.

Lewis Mfg. Co., Dept. 12-C, Bay City, Mich.



Photos ENLARGED

Size 16x20 inches
Same price for full length or bust form groups, landscapes, or pet animals, etc., enlargements of any part of group picture. Safe return of your own original photo guaranteed.

98c

SEND NO MONEY Just mail photo or snapshot (any size) and within a week you will receive your beautiful life-like enlargement size 16x20 in. guaranteed fadeless. Pay postman 98c plus postage or send \$1.00 with order and we pay postage.

With each enlargement we will send FREE a hand-colored miniature reproduction of photo sent. Take advantage now of this amazing offer -- send your photo today!

UNITED PORTRAIT COMPANY
900 West Lake St. Dept. C-360 Chicago, Ill.



MODEL SHIPS

We can supply construction sets and all sorts of parts such as semi-finished hulls, blocks, dead-eyes, special flags, anchors, steering wheels, capstans, figureheads, blue prints, books, etc., for building real fine scale models of the Flying Cloud, Constitution, Spanish Galleon, Mississippi River Steamboat, Sovereign of the Seas, Mayflower and many others. Also special construction sets for racing sail boats, power boats, model steam engines, propellers, etc. and fine tools for the model maker. Our large 48-page photographically illustrated booklet contains valuable information and hints for building ship models in addition to prices and full description of the above articles. Many people only slightly interested in models have become greatly enthused upon receiving this booklet. A copy will be sent postpaid upon receipt of 15 cts. (coin preferred).

Model Ship Supply Co., Dept. C, Mineola, N. Y.

SOLDERALL

METAL IN PASTE FORM

The only convenient metal solder

Every Electrical Connection needs Solderall for perfect reception

25c

The SOLDERALL CO., NEWARK, N.J.

Build a CLOCK for Pleasure or PROFIT!

FREE BOOK of Clock Making, Money Making ideas. Gives details, prices of movements, parts. Write NOW for copy!

AMERICAN CHIME CLOCK COMPANY
1670-T Ruffner St. Philadelphia, Pa.

Shows How YOU Can Make Fine Clocks Right at Home —for yourself, or to sell at Big Profits. We furnish instructions, parts. Works \$1.95 up; others with chimes. All prices. Make case or assemble parts. Cash-in on demand for Mantel, Banjo, Grandfather's Clocks. Write for Special Blue Print Offer, FREE Catalog.

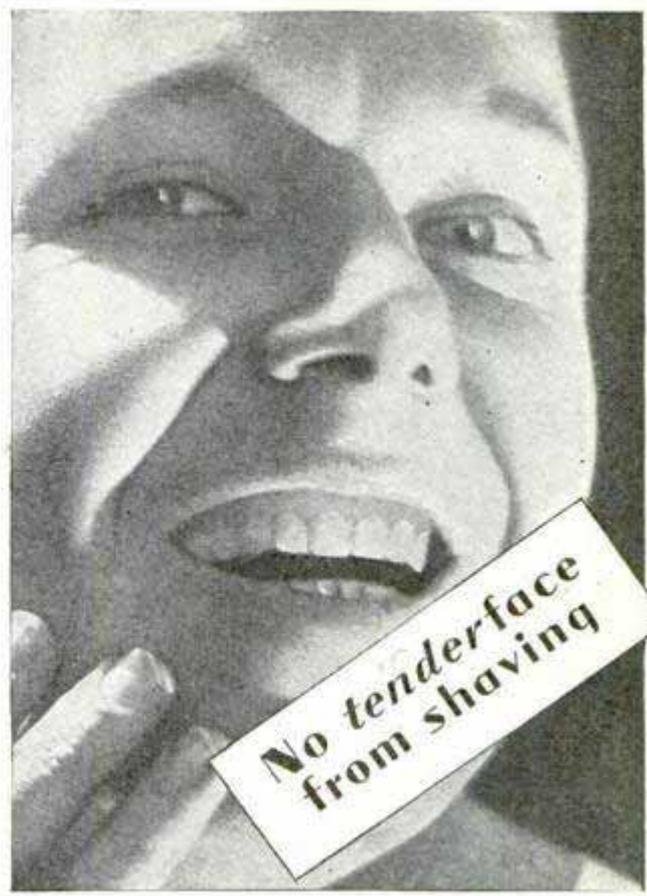

No tenderface from shaving

New! Double-dense lather

LIFEBUOY

Shaving Cream

MEN! Here's the new Lifebuoy Shaving Cream! Its double-dense lather gives the smoothest shave ever.

Most shaving irritation is caused by friction—razor scraping over skin. End friction by complete lubrication and you end *tenderface* forever.

Ordinary light, bubbly lather cannot completely lubricate. But Lifebuoy lather is rich, creamy, double-dense. It clings to the face—lubricates the shaving surface perfectly. No pull. No friction. Just a marvelously clean shave—yet the razor scarcely seems to touch your face.

And Lifebuoy Shaving Cream gives the same anti-septic protection as the famed Lifebuoy Health Soap. Soothes and heals. Get the big red tube today. Or mail the coupon for a free trial tube.

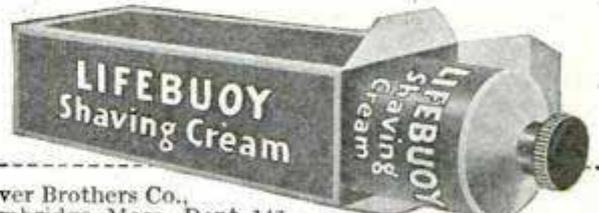

Lever Brothers Co., Cambridge, Mass., Dept. 143

Please send me a 12-day "Show Me" trial tube of Lifebuoy Shaving Cream.

Name

Address

City State



Just a year old...
on MARCH 1, 1930
but what a big baby
it's grown to be!

Who ever heard of such an astounding growth in one year? Born March 1, 1929 of distinguished parentage, this promising infant of the Millers Falls family was soon permanently adopted by thousands of experts—carpenters, cabinet makers, craftsmen . . . men who know and use good tools.

On behalf of the truth it must be stated that the Millers Falls Line of Planes started in life with unusual advantages. Months of careful experimentation by capable engineers, years of experience in fine tool making—these were but a beginning. The final result was a line of Planes that improved the good points and eliminated the difficulties hitherto experienced.

Chattering—the age old cause of trouble—is done away with in Millers Falls Planes. A new feature in Planes—a 3-point bearing of the lever cap—keeps the cutter flat the entire length of the seat and holds the blade firmly at the correct cutting angle.

Other improvements include improved plane cutters which need less reconditioning, extra reinforcements of the bottoms and frogs and an extra thickness and width of the lever cap—the most frequent point of breakage—which enables you to clamp the cutter as tightly as you want. The Millers Falls Line of Planes is complete, too—bench planes from 7 to 24 inches and 21 models of block planes.

Ask your dealer to show you Millers Falls Planes. See for yourself the new features of the line and what they'll do for you. We'll be glad to send you a leaflet free of charge showing the complete line. Write today to the Millers Falls Company, Millers Falls, Mass.; New York: 28 Warren Street; Chicago: 9 So. Clinton Street; Cable Address: MILLERFALL NEW YORK.



MILLERS FALLS TOOLS

PARKS

WOODWORKING MACHINES

*Cabinet Shop
Special No. 10*

\$290

With Motor

You ought to have this handy Parks in your shop. Compact, complete machine designed like a big production outfit at 1/2 the cost. Floor space required only 42x72 in. Does any kind of cabinet and joinery work. *Write for circular.*



The Parks Woodworking Machine Co.

Builders of quality woodworking machines since 1887
1500-40 Knowlton St. Cincinnati, Ohio

Canadian Factory: 338 Notre Dame East, Montreal

OTTAWA LOG SAW



Make Money! Wood is valuable. Saw 15 to 20 cords a day. Does more than 10 men. Ottawa easily operated by man or boy. Falls trees—saws limbs. Use 4-hp. engine for other work. **30 DAYS TRIAL.** Write today for **FREE** book. Shipped from factory or nearest of 4 branch houses.
OTTAWA MFG. CO., 1741 -W Wood Street, Ottawa, Kansas

Makes Old Ford a Tractor

Now you can convert that old Ford car into a useful farm tractor without altering any Ford parts. We furnish the traction wheels, drive gears and auxiliary axle and mountings, ready to clamp on to the Ford frame. Pulls 16' plow.



Write for Free Particulars.
Shaw Mfg. Co., Dept. PM3, Galesburg, Kan.

BURN YOUR NAME ON TOOLS

WITH THE ARKOGRAF

PROTECT YOUR TOOLS FROM THEFT
 Write with electricity any name or design on the hardest and finest tools and instruments, or any metal, like writing on paper with pen or pencil.
Complete Outfit \$3.50—Prepaid Anywhere
 Interesting illustrated circular free. Write today. Agents wanted.
ARKOGRAF PEN CO., 1171 E. Stark St., Portland, Oregon

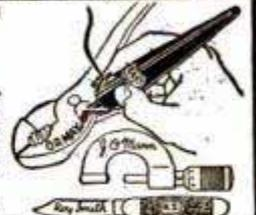

SALESMEN WANTED!

SELL COX HOLDFAST SCREW DRIVERS

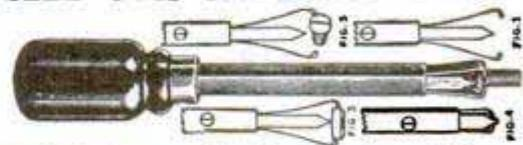

Sells on sight to mechanics for Auto, Radio and Electrical Work. Self Holding, Self Releasing.

Send 50c for sample and ask how to get Salesman's Outfit Free.
S. J. COX Dept. F. FRANKLIN, PA.

SAMPLES OF 33 RARE WOODS

ALSO, 20 cabinet and 20 inlay, \$1.75 **ONLY 25c**
 —or your choice \$1.00. Sets labeled and postpaid. We carry WOODS of all kinds, including panels, veneers and inlay woods. Write for **FREE** Price list.

CRAFTSMAN WOOD SERVICE
 PM-717 E. 62nd St., Chicago, Ill.



**A
SIDE CUTTING
SLIP JOINT
PLIER**

75^c

A thin pointed nose and narrow jaws make this plier extremely handy in awkward places. It is equipped with a keen, specially tempered side cutter and has a wobble-proof slip joint giving it great range and capacity. The LS 26 is a fine tool, heavily nicked, and fully guaranteed. 75c at hardware stores. Write for Crescent catalog.

No. LS 26

**CRESCENT TOOL COMPANY
JAMESTOWN, N. Y.**

ATKINS SILVER STEEL SAWS

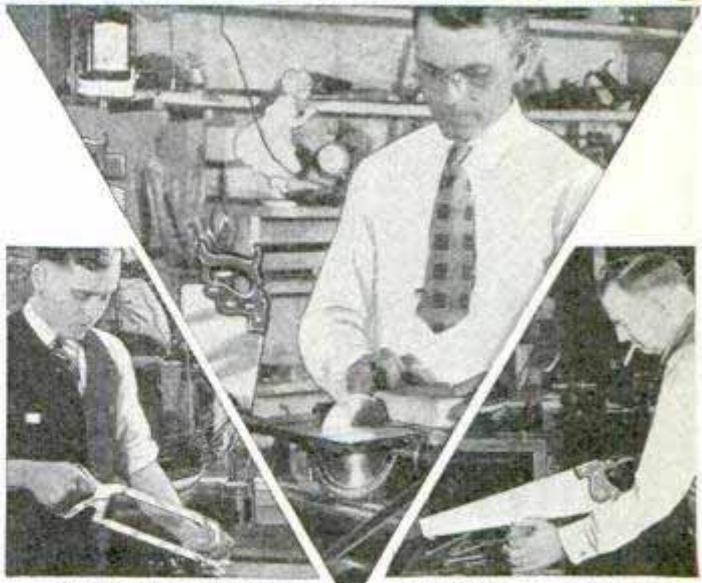

ATKINS Silver Steel Circular Saws, Hack Saws and Hand Saws are saving time and effort in home work-shops everywhere.

These Finer Saws Cut Faster, Easier

FOR real speed, ease and accuracy in cutting wood or metal—whether by power or hand—thousands of home craftsmen know that no other saws equal “ATKINS.”

The reason is that only in ATKINS Saws do you get the world-famous SILVER STEEL, which takes a keener cutting edge and holds it longer. This finer steel, plus other exclusive features ATKINS has perfected, makes a “Silver Steel” Saw run easier, cut faster, and outlast two or three ordinary saws.

You can get ATKINS Hand Saws for cross-cutting or ripping! Circular Cross-Cut or Rip Saws to fit any power sawing outfit! Back Saws to do fine work! Dado Heads to cut grooves quickly! Hack Saw Frames with Blades that cut metal twice as fast and last six times longer than old-style blades. Narrow Band Saws! Machine Knives for planers, etc. Cabinet Scrapers, Grinding Wheels and Files! Hundreds of other fine tools for home craftsmen!

Send coupon below for helpful booklets every tool user should have.

CRESCENT and Smith & Hemenway TOOLS



MEASUREMENT **14** BETWEEN WALLS

Ask the Dealer or send 20c each lineal foot.

MASTER INTERLOX SLIDE RULE

Every kind of inside measurement. Just slide out the MASTER till it reaches from stop to stop. No guessing. Quick results. Locks rigid in use. Without equal for outside measure, too. Dealers and Agents Wanted.

MASTER RULE MFG. CO., Inc.
21 E. 136th Street NEW YORK CITY



TOOL CHESTS OF QUALITY

for Machinists and Tool makers are shown in free catalog. Write to-day for a copy.

H. Gerstner & Sons

475 Columbia Street, Dayton, Ohio

STANDARD GARDEN TRACTOR

Plows Seeds Cultivates Mows Hay and Lawns

A Powerful Tractor for Small Farms Gardeners, Florists, Nurseries, Fruit Growers and Poultrymen

DOES 4 MEN'S WORK

Walking & Riding Equipment

Free Catalog. Does Belt Work

STANDARD ENGINE COMPANY
3221 Como Ave., Minneapolis, Minn.



\$10⁰⁰ DOWN

Brings this Lathe to You

Lathes \$6.00 to \$75.00 Largest line of small lathes in America. Send six cents for 32 page catalog of lathes, drill presses, bench saws, jig saws, band saws, etc.

SYEPHER MANUFACTURING COMPANY
Dept. D-3 Toledo, Ohio

Send Coupon — Get **These 4 Saw Booklets FREE**



Send me the FREE Booklets, "Saws in the Home," "Saw Sense," "Circular Saws," and "Dado Heads."

Name.....

Address.....

My Dealer is.....

E. C. ATKINS & CO., Est. 1857
426 S. Illinois St., INDIANAPOLIS, IND.

10th Anniversary Offer



THIS great 10-tool kit at \$10 celebrates our 10th Anniversary. A **Special CORNWELL Offer**, the first ever made. Just the tools you need for daily use. Order this kit at once. **Every tool of standard, genuine, CORNWELL Quality.**

TEN "CORNWELL" TOOLS for TEN DOLLARS

HERE are the tools in the Anniversary Kit—10"x1" Flexible Wire Carbon Scraper, 3/4"x9" Flat Chisel, 10" Screw Driver, 1/2"x3/4" opening 7 1/2" length 12-Pt. Box Wrench, 5/8"x7" Flat Chisel, 1/2"x9" Drift Punch, Cornwell Nu-Thred Thread Restorer, 3/8"x3/8" USS Open End Wrench, 7" Combination Side Cutting Plier, 3/4"x3/8" SAE Open End Wrench.

CORNWELL Tools have been on the market 10 years. Their marvelous quality has made them the choice of mechanics everywhere. Millions are in use. **Every tool is amazingly strong, being hand-made from Swedish Chrome Molybdenum Steel—hardened and heat-treated by our special CORNWELL process.** CORNWELL Tools will stand severe tests and strains that no other tools can endure.

Order this special kit today or mail the coupon for catalogue of our complete line. **Remember, there is no substitute for Cornwell Quality.**

The Cornwell Quality Tools Co.
Dept. V, Mogadore, O.

Send me new illustrated catalog with prices on full line of CORNWELL Hand-made Tools.

..... Where Employed
Name.....
Suburb of Akron Address.....
City..... State.....

CORNWELL QUALITY TOOLS CO.

Mogadore, Ohio

AR-CON UTILITOO

—the REAL Work Shop You've Been Waiting For

—a complete, thoroughly practical outfit that has the power and sturdiness of construction essential to fast and accurate workmanship. 1/2 HP repulsion-induction motor — no radio interference.

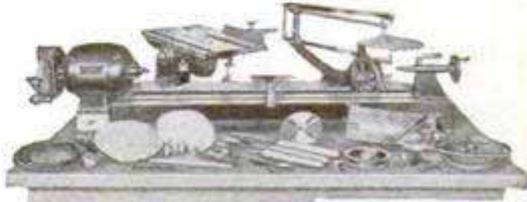

Try It Free! Buy on Time!

Mail this ad with your name and address on margin for full description, prices and terms.

THE AR-CON TOOL CO.
500 Fassett St. Toledo, Ohio

THE WELDON JUNIOR

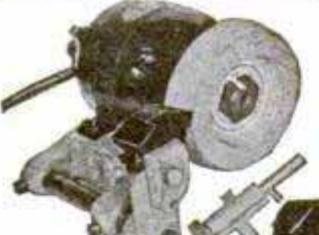

sharpens shears, scissors and knives; is electrically driven and equipped with two rests, switch, cord and plug.

WELLS MANUFACTURING COMPANY
Box 613, Greenfield, Massachusetts, U.S.A.

CARPENTERS' AMAZING POCKET RAFTER BOOK—13 rises. 81 house widths, thousands of lengths, common rafters, hips, valleys and jacks, \$1.00. **T. W. MARTIN, 718 E. 4th St., Charlotte, N. C.**

GET INTO THE VENDING MACHINE BUSINESS

LARGE PROFITS BEING MADE!

You buy machines and place them in stores paying merchants 25% of receipts. Gum and peanuts used allow you from 100% to 200% profit! Start with small capital during spare time. A route of our machines will make you financially independent!

Write for catalog and full details *Today!*

D. ROBBINS & COMPANY 28-P DODWORTH ST., BROOKLYN, N.Y.

Make Your FORD Into The "ACE"

GET READY FOR SPRING—BUILD YOUR ACE NOW—

\$5.99 Red-i-Kut life size patterns Famous sure-fit RED-I-KUT life-size patterns and picture instructions show how you can easily convert your Ford into this **Fast, Saucy, Sport-Car** as thousands have done with easily obtained materials. No need to lay up the car. Makes wonderful 4-passenger car. Send 10c coin for actual photo of sport car and new manual of distinctive sport car patterns from \$5.80 up—"RKO" Steel "Swing-Lo" seats. Tops, Windshields and many speed necessities. **ORDER RIGHT NOW and get a real thrill.**

KUEMPEL COMPANY, 118 Kuempel Bldg., GUTTENBERG, IOWA

Cal. 30-40 Six Shot



KRAG CARBINE

All the qualities of a high price rifle. In fine used condition, all working parts guaranteed for one year. Send today for our Free 60-page illustrated catalog of money saving values; Guns, Ammunition, Cutlery, Sports and Gov't goods. Deposit required on all orders. Money refunded if not satisfactory.

W. Stokes Kirk, Dept. P. M. 3, 1627 N. 10th St., Phila., Pa.

Price **\$9.75**

KINKADE GARDEN TRACTOR

and Power Lawnmower

A Practical, Proven Power cultivator for Gardeners, Suburbanites, Truckers, Florists, Nurserymen, Fruit Growers.

New Low Prices—Easy Terms
AMERICAN FARM MACHINE COMPANY
1058, 33rd Av. SE. Minneapolis, Minn.



Catalog Free

Only 8 Sales a Day Nets You \$116 a week

Profits on larger size run higher. Unusual earning opportunity for ambitious men. No experience necessary; we teach. Part or full time.

FUGO World's Simplest Fire Extinguisher

Automatic and instantaneous action. Within reach of every home, shop, store, theatre, garage, car owner, etc. Even smallest place needs two or more. Exclusive territory to producers. You get your pay every day. Write for full details.

The National Formetal Co.
6535 Metta Ave. Cleveland, O.



FLY THIS COMBAT MONOPLANE!



This realistic copy of a military monoplane is an unusually graceful flyer. Wing-spread 18 in. Weight only 7/8 oz. Will take off by own power and fly over 80 ft. Markings in red and blue. Can be built in 2 hrs. without tools. Construction set includes 6-in. aluminum propeller with shaft, 1/4 in. disc wheels, wood struts, rubber band motor and all other parts, with clear directions. Complete set, packed in unbreakable container, only \$1.00, postpaid in U. S. and Canada. Order today. Satisfaction or money refunded.

The MIDLAND MODEL WORKS, Chillicothe, Ohio
(We cannot make C.O.D. shipments. No retail catalogue issued.)

Cuts Radio Tube Costs



tubes \$2.50
tubes \$1.95
tubes \$3.50

AMPERITE automatically keeps voltages exactly right for tube efficiency. Lengthens tube life. For all tubes. \$1.10 with mounting (in U.S.A.) At all dealers.

This symbol in a radio diagram means—



AMPERITE
REG. U.S. PAT. OFF.

The "SELF-ADJUSTING" Rheostat

AMPERITE Corporation
661 BROADWAY, NEW YORK
FREE—"Amperite Tube Chart." Write Dept. PM3.

AUTOMOBILE RADIO

Are You Interested In It?

We have new information for you. Write us today mentioning Popular Mechanics Magazine.

NATIONAL COMPANY INC.
ENGINEERS AND MANUFACTURERS
61 SHERMAN ST., MALDEN, MASS.

Est. 1914 W. A. Ready, Pres.

NEW! CarryAll CarNet

AGENTS
MAKE
\$15-25
A DAY



Suspends from top of your car. Carries papers, clothes, maps and other small articles in neat, safe, compact position. Meets instant approval of car owners everywhere. Takes 5 minutes to install. Agents wanted. Write for FREE TRIAL OFFER. THE GRACE COMPANY, 706 Grand, Des Moines, Iowa

MOTORCYCLES



Price \$10 and up purchased through our Co-Operative Plan for as low as \$1.00 down and \$1.00 per week
Indians Harley-Davidsons Ace Henderson and Cleverlands
Send ten cents for Bulletin A.

WALKER-INDIAN CO., 1309 Boylston St., BOSTON, MASS.

\$4.99 22 Cal. Blank Automatic



100 CART. RIDGES Free!
You need no license or permit to own this 6-shot blank Automatic. Use for fun, keeps away tramps, thieves, dogs. Fool your friends. Same as an expensive automatic in construction, finish, appearance, durability; automatic magazine loading and ejection of cartridges, powerful report. Guaranteed absolutely safe. Send no money. Pay on delivery \$4.99.
JENKINS, 685 Broadway, New York, Dept. 37-J-3

CAN YOU USE \$100 A WEEK AND UP

An opportunity to make \$100 a week selling fine made-to-measure all-wool suits at \$23.50—\$29.50 and \$36.50 retail, direct to wearer. Biggest values—positively sell on sight. Biggest commissions paid in advance. CHANCE TO EARN OWN CLOTHES FREE. We attend to delivery and collections. New style outfit of large cloth samples, 100 styles—furnished Free. Write at once.

SPENCER MEAD COMPANY Dept. Q-816
Harrison & Throop Streets
CHICAGO, ILL.

\$23.50 ALL WOOL SUITS



WORLD'S PREMIER CUSTOM RADIO



MAIL COUPON FOR 48-PAGE MANUAL
HAMMARLUND-ROBERTS, INC.,
424-438 W. 33rd Street, New York
Dept. PM3—Enclosed 25c (stamps or coin) for 48-page "HiQ-30" manual



Name _____

Address _____

30 DAYS' FREE TRIAL



We Ship On Approval

and 30 days' trial direct from our factory. Select from 44 styles, colors and sizes.

Save \$10.00 to \$25.00 No extravagant selling expenses enter into the cost and selling prices of these bicycles. Factory-to-Rider saves you big money and assures you service.

EASY PAYMENTS if desired. Only \$5 down.

We allow 30 days for trial and test. If it does not suit—return at our expense. Do business direct with makers of Ranger—Pathfinder—Crusader bicycles.

TIRES, Lamps, Wheels, Equipment and Sundries at half usual prices.

RADIO—Musical Instruments. Complete line—exceptional prices and terms. Please mention which catalog you wish.

Write today for catalog and marvelous new price offers and terms.

Mead cycle Co., Dept. E110 Chicago

Beautiful HOUSES \$900 and BUNGALOWS CAN BE BUILT FOR And Up

Sixty-nine up-to-date designs in the most complete and comprehensive book of medium cost English and American homes published, 8 x 11 inches, nearly 250 photos and floor plans, contains a description of each design and approximate cost to build. It is the last word on home building and may save you several hundred dollars in the cost of your home. Sent Postpaid \$1.

FREDERICK H. GOWING, Architect, 101 Tremont St., Boston, Mass.

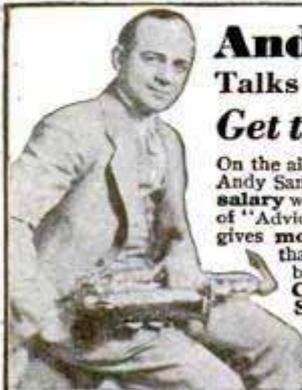

Andy Sannella Talks to Reed Players. Get this Free Book!

On the air tonight, and every night, Andy Sannella is earning a **fabulous salary** with his Selmer Sax. In his book of "Advice to Saxophone Players," he gives **more valuable information** than in ten private lessons. This book also contains **Talks to Clarinetists by Alexandre Selmer.** Send for free copy.

If you will mention the instrument you play, we will send also, **free samples** of our Alexandre Reeds. **They Play!**

Selmer

265 SELMER BUILDING, ELKHART, INDIANA
(In Canada: 516 Yonge St., Toronto)

BORN WITH Club Foot

How Harry McGuire's deformity was corrected at McLain Sanitarium is shown by photos and father's letter:

Our boy was born with a Club Foot. Plaster Paris was used and the foot operated on without satisfactory results. Finally we took him to your Institution. His foot is now straight and he walks, runs and plays as though he never had a crippled foot. We will gladly answer letters.

LENARD MCGUIRE, R. R. No. 8, Mt. Vernon, Illinois



McLain Sanitarium (established 1898) is a private institution devoted to the treatment of crippled, deformed and paralyzed conditions generally. No surgical operation requiring chloroform or general anaesthetics. Plaster Paris not used. Patients received without delay. Parents retain full charge of children if desired.



WRITE FOR FREE BOOKS

"Deformities and Paralysis," and "References," which show and tell of McLain Sanitarium's facilities for treating Club Feet, Infantile Paralysis, Spinal Diseases and Deformities, Hip and Knee Disease, Wry Neck, etc. Also illustrated magazine, "Sanitarium News," mailed free every 60 days.

McLAIN ORTHOPEDIC SANITARIUM

902 Aubert Ave., St. Louis, Missouri, U. S. A.

NS95

\$2.00

INKOGRAPH PENCIL POINTED FOUNTAIN PEN

FREE 10 DAYS TRIAL

Writes with ink smooth as a lead pencil on cheapest or finest paper, without miss, skip or blur. Won't blot, scratch or leak.

Makes 3 carbon copies at one time with original in ink. Any one can use your Inkograph—hard pressure cannot spread or injure its 14 Kt. gold point. Patent automatic feed prevents point from clogging. No complicated mechanism. Best material and workmanship. Fully Guaranteed.

Send No Money. Pay postman \$2.00 plus postage. Sent prepaid if remittance accompanies order. Money back if not satisfied within 10 days.

INKOGRAPH CO., Inc., 161-79 Centre St., New York City

AGENTS Send for Inkograph or FREE sales plan booklet. Sells on sight, no investment, immediate commissions.

SELL DRESS GOODS

Oh How Lovely!

Show finest silks, dress goods, wash fabrics, drapery materials. Special pattern service. Also hosiery, underwear, etc. Liberal commissions and bonuses. Repeat sales all year. Outfit free.

THE NATIONAL IMPORTING CO.
559 Broadway, Dept. 5-38 New York

Do your own Printing!



Cards, stationery, circulars, tags, labels, advertising, book, menus, etc. Save money and time, cut cost in half. Easy rules furnished with every outfit.

Print for Others BIG PROFITS

A big opportunity to turn your spare time into cash, or develop a full time business of your own at small cost. **New and popular Raised Printing like Engraving** done with any of our presses. Junior Press \$5.90, Job presses \$11, \$29, Rotary \$149.

Write for catalog No. 737 of presses, type, cards, paper, supplies and full information.

The Kelsey Co., Meriden, Conn.

FREE New Book FACTORY PRICES

Save $\frac{1}{3}$ to $\frac{1}{2}$

New FREE book quotes **Reduced Factory Prices. Lower terms—year to pay.** Choice of 5 colors in New Porcelain Enamel Ranges. New Cabinet Heaters—



Furnaces \$61⁹⁵ up



Ranges \$41⁵⁰ up

\$38.25 up. 200 styles and sizes. Cash or easy terms. 24-hour shipments. 30-day FREE trial. 360-day test. Satisfaction guaranteed. 29 years in business. 750,000 customers. Write today for FREE book.

KALAMAZOO STOVE CO.
391 Rochester Ave.
Kalamazoo, Mich.

"A Kalamazoo Direct to You"
Trade Mark Registered

AGENTS AND SIGN MEN Now Making \$50.00 to \$100.00 and Up Per Week Selling Our GOLD LEAF SIGN LETTERS



For store and office windows, board signs, trucks and glass signs. We also make to order script signs and business emblems singly or by the thousands. A permanent business. No capital or experience required. Big demand in every city. *Samples and Literature Free.*

CONSOLIDATED SIGN LETTER CO. 71-X W. Van Buren CHICAGO, ILL.

YOUR TREASURE SHIP!

Get this yellow book crammed with golden ideas. Follow a hobby that turns spare hours into money. True hand-carved ship models built from Hancock parts are readily sold. See Nancy Lee and Jumbo. Send 10¢ for copy right now.



ROY HANCOCK
323 Douglas Ave. Portsmouth, Va.

AN OPPORTUNITY TO EASILY Earn \$100 a Week Profits in Advance

Sell Gibson extra fine men's made-to-order all-wool suits at \$23.50 and \$31.50, direct to wearer. Biggest values—Most liberal commissions, with bonus, to producers. **Frequent opportunities to get own clothes at no cost.** We deliver and collect. 6x9 cloth samples—over 100 styles—complete outfit in handsome carrying case furnished FREE to ambitious men who are willing to hustle. Write today.

W. Z. GIBSON, Inc.
500 S. Throop St. Dept. Q-516 Chicago



this 140 Page Book of Record Keeping Forms

Free!

HERE'S a book that will help you with your record-keeping problems. Contains wide variety of life-size Bookkeeping forms, completely filled in, illustrating uses. For office or factory—business or profession—it shows you simplest and most efficient methods of accounting now being used by 300,000 leading firms. Book sent FREE when requested on business stationery. No obligation!

JOHN C. MOORE CORP., Est. 1839
6058 Stone Street, Rochester, N. Y.

Merely Fill in Coupon and 140-page Book Will be Sent you FREE

Name _____

Business _____

City _____ State _____

Going to Build Remodel or Repair?

DON'T think of building a new home or repairing an old one without a copy of our free wood-work catalog.

To those who contemplate building or remodeling, this book is a valuable work of reference. In it are found the latest ideas and most advanced styles for everything in millwork. It illustrates and describes windows and sash of all kinds, including porch and storm sash, doors, frames, mouldings, screens, porchwork, stairwork, hardwood flooring, interior finish, cabinet work—in fact, practically everything in manufactured millwork.

Every article in the book shows a low money-saving price direct to you.

FREE ESTIMATES

Send us your lumber and millwork bills for a free estimate. Let us quote prices on your material and tell you the exact amount of freight. Then compare our prices with others. This service costs you nothing and places you under no obligation whatever.

CHICAGO MILLWORK SUPPLY CO., 1444 W. 37th St., Chicago, Ill.

PLEASE SEND ME YOUR FREE BOOK

Name _____ St. No. _____

Town _____

State _____

Occupation _____

Book is Free

PATENT

Protect Your Ideas

Take the First Step Today

If you have a useful, practical, novel idea for any new article or for an improvement on an old one, you should communicate with a competent Registered Patent Attorney AT ONCE. Every year thousands of applications for patents are filed in the U. S. Patent Office. Frequently two or more applications are made for the same or substantially the same idea (even though the inventors may live in different sections of the country and be entirely unknown to one another). In such a case, the burden of proof rests upon the last application filed. Delays of even a few days in filing the application sometimes mean the loss of a patent. So lose no time. Get in touch with me at once by mailing the coupon on the opposite page.

Prompt, Careful, Efficient Service

This large, experienced organization devotes its entire time and attention to patent and trade mark cases. Our offices are directly across the street from the U. S. Patent Office. We understand the technicalities of patent law. We know the rules and requirements of the Patent Office. We can proceed in the quickest, safest and best ways in preparing an application for a patent covering your idea. Our success has been built on the strength of careful, efficient, satisfactory service to inventors and trademark owners located in every state in the Union.

NO CHARGE for Information On How to Proceed

The booklet shown here contains valuable information relating to patent procedure that every inventor should have. And with it I will also send you my "Record of Invention" form on which you can sketch your idea and establish its date before a witness. Such evidence may later prove valuable to you. Simply mail the coupon and I will send you the booklet, and the "Record of Invention" form, together with detailed information on how to proceed and the costs involved. Do this NOW. No need to lose a minute's time. The coupon will bring you complete information entirely without charge or obligation.

My Patent Law Offices
Just Across
Street From
U.S. Pat. Office



Above is a view of my drafting and specification offices where a large staff of experienced experts are in my constant employ. All drawings and specifications are prepared under my personal supervision.

NEWS

Inventors
Write for these

Free Books

Strict Secrecy Preserved

All communications, sketches, drawings, etc., are held in strictest confidence in strong, steel, fireproof files, which are accessible only to authorized members of my staff. Feel free to write me fully and frankly. It is probable that I can help you. Highest references. But **FIRST**—clip the coupon and get my free book. Do **THAT** right now.

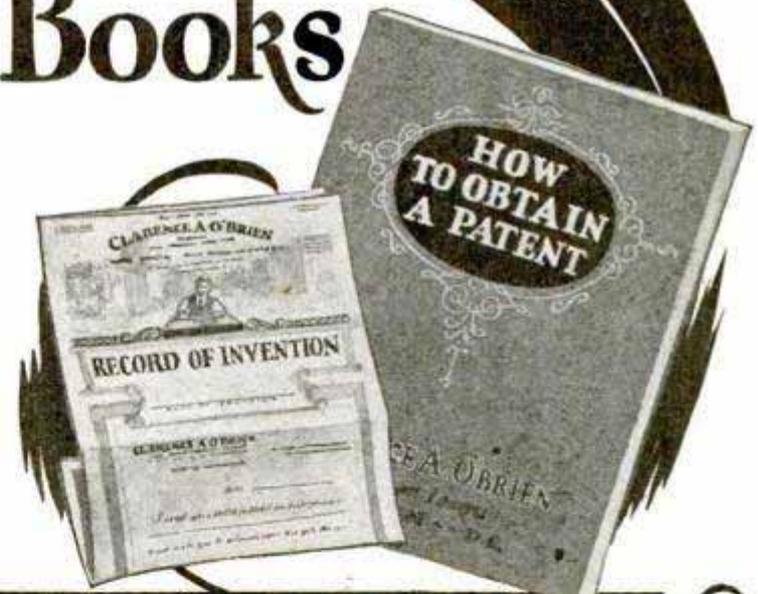

Clarence A. O'Brien

Registered Patent Attorney & Attorney-at-Law

Member of Bar of: Supreme Court of the United States; Court of Appeals, District of Columbia; Supreme Court, District of Columbia; United States Court of Claims. Practice confined exclusively to Patents, Trademarks and Copyrights

Clip this Coupon and Mail it Now!

CLARENCE A. O'BRIEN, Registered Patent Attorney & Attorney-at-Law

702 Security Savings and Commercial Bank Bldg., Washington, D. C.

OR

Suite 1106 Woolworth Bldg., New York City

Please send me your free book, "How to Obtain a Patent," and your "Record of Invention" form without any cost or obligation on my part.

Name.....

Address.....
(Important—Write plainly and address office nearest you)

PATENTS TRADE MARKS COPYRIGHTS

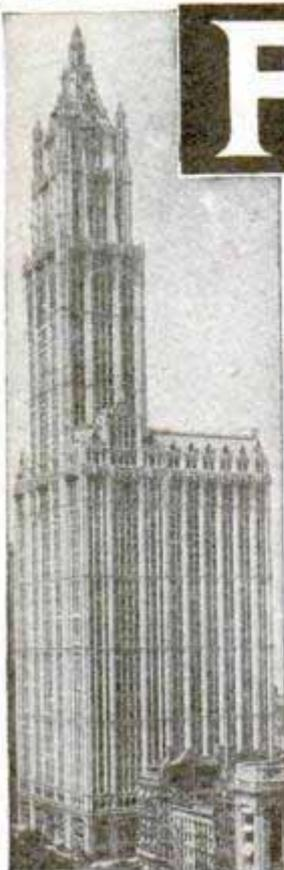

Our New York Office
Suite 1007 Woolworth Bldg.



Our Philadelphia Office
828 Fidelity Phila. Trust Bldg.



VICTOR BUILDING
Our New Building Nearly Opposite U. S. Patent
Office Specially Erected by Us for Our Own Use



Have You An Idea?

Our Offer: FOR THE PROTECTION OF YOUR INVENTION

YOUR FIRST STEP—The Inventor should write for our blank form "RECORD OF INVENTION." A sketch and description should be made on this Blank, signed, witnessed, then returned to us. **We also give our opinion** as to whether the invention comes within the Patent Office definition of a patentable invention. This "Record of Invention" will serve as "proof of conception." *There is no charge or obligation for this service.*

Our Five Books Mailed Free to Inventors

Our Illustrated Guide BOOK

How to Obtain a Patent

Contains full instructions regarding U. S. Patents. Our Methods, Terms, and 100 Mechanical Movements illustrated and described.

Our Trade Mark Book

Shows value and necessity of Trade Mark Protection. Information regarding *Trade Marks and unfair competition in trade.*

Our Foreign Book

We have Direct Agencies in Foreign Countries, and secure Foreign Patents in shortest time and lowest cost.

Progress of Invention

Description of World's Most Pressing Problems by Leading Scientists and Inventors.

Payment of Fees in Installments

It is not necessary that the total cost for the preparation and prosecution of a patent be paid in one payment. Our custom is to permit our clients to pay for their applications in three installments as the preparation of the application progresses in our office. This plan makes the payments easy for the inventor.

We Regard a Satisfied Client as our best advertisement, and furnish anyone, upon request, lists of clients in any state for whom we have secured patents.

*Highest References—Prompt Service
—Reasonable Terms*

VICTOR J. EVANS & CO.

Patent Attorneys, Established in 1898

Main Offices: 789 9th St., N. W., Washington, D. C.

Nearly Opposite U. S. Patent Office

DELAYS ARE DANGEROUS IN PATENT MATTERS

IMPORTANT! To Avoid Delay!

YOU SHOULD HAVE YOUR CASE MADE SPECIAL IN OUR OFFICE to save correspondence, secure protection and early filing date in the Patent Office. To secure **special preparation** of your case send \$25.00 on account with model or sketch and description of invention.

ACT NOW—Often two or more inventors file applications for practically the same idea. In such cases the burden of proof rests upon the last application filed. Therefore, delays often cause the loss of a patent.

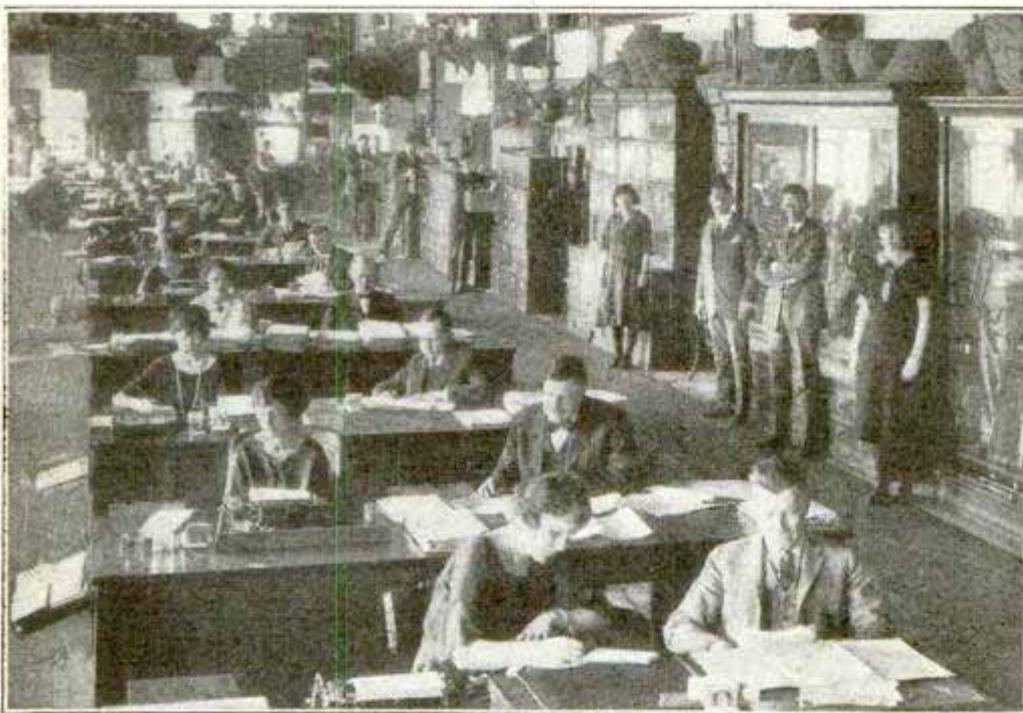

MAIN OFFICE, VICTOR J. EVANS & CO.—VICTOR BUILDING, WASHINGTON, D. C.

Our Large, Comprehensive Organization has been established for 30 years and offers Prompt, Efficient and **Personal Service** by experienced Patent Lawyers and Draftsmen. Every case is in charge of a Specialist who has been selected for his knowledge and experience in certain lines of invention. Our Lawyers practice in all U. S. Courts and defend clients in suits involving Patents, Trademarks and Copyrights. All Communications, Sketches, Drawings, etc., preserved in fireproof Files, strictly **Secret and Confidential**. We shall be glad to have you consult us or to answer any questions in regard to Patents, Trademarks or Copyrights without charge or obligation.



Our Chicago Office
Suite 1640-42 Conway Bldg.



Our Pittsburgh Office
Suite 514 Empire Building

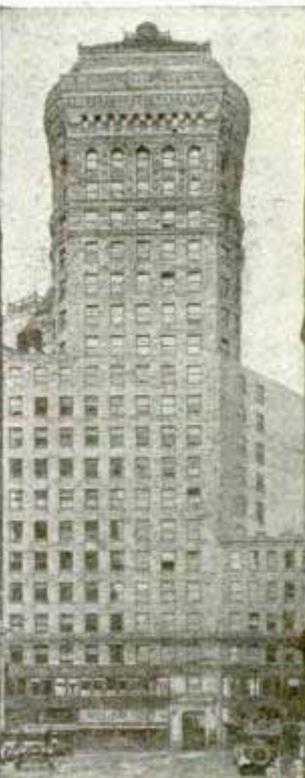

Our San Francisco Office
Suite 1010 Hobart Building

**FREE
COUPON**

VICTOR J. EVANS & CO.
PATENT ATTORNEYS *Established in 1898*

NEW YORK OFFICES
1007 Woolworth Bldg.

CHICAGO OFFICES
Suite 1640-42 Conway Bldg.

PHILADELPHIA OFFICES
828 Fidelity Phila. Trust Bldg.

PITTSBURGH OFFICES
514 Empire Bldg.

SAN FRANCISCO OFFICES
1010 Hobart Bldg.

MAIN OFFICES: 789-9th Street, N. W., WASHINGTON, D. C.

Gentlemen: Please send me *Free of Charge* your books as described on preceding page.

Name

Address

PATENTS

Booklet Free Highest References
Promptness Assured Best Results

Send drawing or model for preliminary examination and advice.

ALL BUSINESS GIVEN PROMPT AND PROPER ATTENTION

Listed Patent Lawyer in the latest editions of the Rand-McNally Directory of Bankers and Bonded Attorneys, published by Rand-McNally & Co., Chicago, Ill.; The Baggott & Ryall Directory of Guaranteed Attorneys, published by Legal Directory Corporation, Boston, Mass.; Flugel's Law List, published by Legal Directory Publishing Co., St. Louis, Mo.; American Lawyers Annual, published in Cleveland, Ohio; Bankers Service Legal Directory, published by Bankers Service Co., Boston, Mass.; Eyre's Law List, 9 Park Place, New York City; Walters Legal Directory, Omaha, Nebraska, and the National Directory of Attorneys, Baltimore, Maryland.

WATSON E. COLEMAN,
REGISTERED PATENT LAWYER

Victor Building, 724 Ninth Street, N. W.
WASHINGTON, D. C.

PATENTS

PROTECT YOUR IDEAS

Write today for FREE INSTRUCTIONS—or send Drawing or Model of your Invention for Examination.

Promptness Assured with Best Results

CARL MILLER
REGISTERED PATENT ATTORNEY

Former Member Examining Corps U. S. Patent Office
255 McGill Building Washington, D. C.



PATENTS TRADE-MARKS

*Don't Lose Your Rights
To Patent Protection*

Before disclosing your invention to anyone send for blank form "EVIDENCE OF CONCEPTION" to be signed and witnessed.

LANCASTER, ALLWINE & ROMMEL
480 Ouray Bldg. WASHINGTON, D. C.
Originators of forms "Evidence of Conception."

This INVENTION
PAID
\$1,000,000



Housewives welcomed automatic thermostatic control on electric iron. Inventor made fortune. Wealth awaits you, too, if you concentrate on things that are NEEDED. To make your invention PAY BIG get Raymond Yates's new book

"1000 NEEDED INVENTIONS"

Costs only \$1.50 and directs your "inventive knack" along right lines. Find out what is practical and needed by industry and public. Book tells what inventions are wanted in fields of Radio, Automotive, etc. Send no money. Write postal. When book arrives, pay mail man \$1.50 plus postage. Money back, if desired. Limited offer. Write TODAY and prepare for real profits. (Outside U. S. \$1.70 cash with order.)

Bureau of Inventive Science, 33 Wisner Building, Rochester, N. Y.

PATENTS

Trade Marks, Copyrights, Patent Litigation Handbook with illustrations, 100 mechanical movements. Sent free on request.

ALBERT E. DIETERICH
formerly member Examining Corps U. S. Patent Office

REGISTERED
PATENT LAWYER and SOLICITOR
621-A, Ouray Bldg.
30 Years' Experience Washington, D. C.

PATENT YOUR INVENTIONS

EDWARD GOTTLIEB

Attorney in Patent Causes
5 Beekman Street New York

Inventions Developed—Representatives for
BLAIR TOOL AND MACHINE CORP.

INVENTORS PROTECT YOUR IDEAS

Write for our Guide Book, "HOW TO GET YOUR PATENT," and Evidence of Invention Blank, sent Free. Tells our terms, methods, etc. Send model or sketch and description of your invention for INSPECTION and INSTRUCTIONS FREE. Terms Reasonable. Best References.

.....WRITE TODAY.....

RANDOLPH & COMPANY, Patent Attorneys
301 VICTOR BUILDING, WASHINGTON, D. C.

Name

Address

PATENTS

To the Man with an Idea

PATENTS Procured. Trade Marks Registered. —A comprehensive, experienced, prompt service for the protection and development of your ideas. Preliminary advice gladly furnished without charge. Booklet of information and form for disclosing idea free on request.

IRVING L. McCATHRAN, Patent Lawyer
Formerly with and successor to RICHARD B. OWEN
704 International Bldg., Washington, D. C.
41-E Park Row, New York City

TRADE-MARKS REGISTERED



GEARS IN STOCK—immediate delivery

Gears, speed reducers, sprockets, thrust bearings, flexible couplings, pulleys, etc. A complete line is carried in our Chicago stock. Can also quote on special gears of any kind. Send us your blue-prints and inquiries. Write for catalog No. 10.

Chicago Gear Works
769-773 W. Jackson Blvd., Chicago, Ill.

INVENTORS who derive largest profits know and heed certain simple but vital facts before applying for Patents. Our book *Patent-Sense* gives those facts; sent free. Write **LACEY & LACEY**, 646 F St., Washington, D. C. Established 1869.

QUIT TOBACCO

Don't try to banish unaided the hold tobacco has upon you. Thousands of inveterate tobacco users have, with the aid of the Keeley Treatment, found it easy to quit.



KEELEY TREATMENT FOR TOBACCO HABIT Quickly banishes craving for tobacco. Successful for over 50 years. Write today for FREE BOOK and particulars of our MONEY-BACK GUARANTEE.

THE KEELEY INSTITUTE, Dept. A-931, Dwight, Ill.
Home of the famous Keeley Treatment for Liquor and Drugs.
Booklet Sent on Request. Correspondence Strictly Confidential.

DEAFNESS IS MISERY

Multitudes of persons with defective hearing and Head Noises enjoy conversation, go to Theatre and Church because they Use Leonard Invisible Ear Drums which resemble Tiny Megaphones fitting in the Ear entirely out of sight. No wires, batteries or head piece. They are inexpensive. Write for booklet and sworn statement of the inventor who was himself deaf.

A. O. LEONARD, Inc., Suite 699, 70 5th Ave., New York

BUCHSTEIN'S FIBRE LIMB



is soothing to your stump—strong, cool, neat, light. Easy payments. Braces for all deformities.
D. BUCHSTEIN CO.
610 3rd Ave., So. MINNEAPOLIS, MINN.

Send for Catalog Today

BASHFUL?

"Shame on you!" Are you nervous, embarrassed in company of the other sex? Stop being shy of strangers. Conquer the terrible fear of your superiors. Be cheerful and confident of your future! Your faults easily overcome so you can enjoy life to the fullest. Send 25c for this amazing book. **RICHARD BLACKSTONE, BA-473 FLATIRON BLDG., NEW YORK**

SHOOT THE REAL THING!

Here is that famous genuine pump boys everywhere are turning to. Single stroke outshoots all others. Two to three strokes now give full shooting force. New rear peep sight, leak-proof valves, fully enclosed action. A beauty. Amazing accuracy. Full factory guarantee for one year. Uses regular air rifle lead shot. Photo shows flattening power at 30 ft. on steel target. The biggest money's worth in genuine air rifles ever offered.

"The Shooter's Art" FREE
Tells how to hold, aim and handle rifles; helps you guide others in correct knowledge of guns. Gives facts that make crack shots. Contains safety and common sense instructions every parent and boy should have. Helps to make boys leaders. Your copy free. Write at once.



\$5 at your dealer's or sent postpaid

NEW MODEL "G" BENJAMIN

Genuine Pump Air Rifle
BENJAMIN AIR RIFLE & MFG. CO., 645 N. Broadway, St. Louis, Mo.

Learn to **PAINT SIGNS and SHOW CARDS**

We quickly teach you by mail, or at school, in spare time. Big demand. Big future. Interesting work. Oldest, foremost school. **EARN \$50 TO \$200 WEEKLY**

Otto Wiegand, Md., home-study graduate, made \$12,000 from his business in one year. John Vassos, N. Y., gets \$25 for a show card. Crawford, B. C., writes: "Earned \$200 while taking course." Write for complete information.

DETROIT SCHOOL OF LETTERING
150 Stimson Ave. Est. 1899 DETROIT, MICH.

NEW VEST POCKET ADDING MACHINE

ADD, SUBTRACTS, MULTIPLIES, DIVIDES
Does work of \$300 machine. Guaranteed 5 years. NOT A TOY. Made of steel and indestructible. Million dollar capacity. Fits in pocket. Will not make mistakes. So simple child can operate it. Instructions furnished. Everybody should carry one for figuring.

FREE TRIAL \$2.50 Total Cost

SEND NO MONEY—Just name and address. We will ship Calculator immediately. On delivery pay postman \$2.50 (Plus few cents Postage). (If outside U. S. send cash.) 10c additional in Leatherette Case. If not satisfied after 10 days trial you get your money back. **THOUSANDS OF SATISFIED USERS.**

Guaranteed This is lowest priced practical calculator made. "Why pay more for inferior imitations?" Order from this ad.

Mail Coupon Today

BABY CALCULATOR MACHINE CO., (MANUFACTURERS)
Dept. 41, P. O. Box 1118, CHICAGO, ILL., U. S. A.

I am enclosing \$2.50—send adding machine prepaid.
 Send Adding Machine C. O. D. \$2.50 plus 18c postage. (10c additional in Leatherette Case)

Name.....
Address.....
City..... State.....

AGENTS Write for big commission and territory proposition.

See the Metal Flow

ELECTRO-PLATING



This Easy, New, Scientific Way...

With an **ALADDIN** Portable

You actually see the metal flow—gold, silver, brass, copper, nickel, etc.

NO EXPERIENCE REQUIRED

This Miraculous New Invention enables Anyone to successfully plate **Anything, Anywhere, Instantly:** Auto Parts; Bathroom, Kitchen, and Electric Fixtures; Faucets, Spoons, Forks, Knives, Silver Service, Tools; Restaurant and Soda Fountain Fixtures; Surgical and Dental Instruments... No interruption of Service... No Parts to be removed. Renew Worn plating or plate New work. Add this magic touch of prosperity to your home, shop, or office.

Be Your Own Boss

Free
ELECTRO-PLATING

Agents & Dealers
—WANTED—

NOT A TOY
but a practical, portable Electro-Plating Outfit with which Perfect and Durable Work can be done. Deposits the metal electrically. Easy, Simple, and Economical to Operate. **Positively Guaranteed** to do as we claim.

MAKE UP TO \$500 A WEEK

Be Your Own Boss! No Sales Experience required. Build up a Profitable ALADDIN Electro-plating Business of Your Own. Thousands in Service. A Big, Easy, Money-maker for Agents and Dealers. Take advantage of our Introductory, 30 day trial offer... \$6.50 for Master Outfit "A" to plate with Nickel. Order Today. Ask for FREE booklet and inspiring testimonials.

P. J. F. BATENBURG CO., Dept. 182, Racine, Wis.

DO YOU

WANT a new business profession of your own, with all the trade you can attend to? Then become a foot correctionist, and in a few weeks earn big income in service fees,—not medical nor chiropody—easy terms for home training, no further capital needed, no goods to buy, no agency. Address

Stephenson Laboratory, 1 Back Bay, Boston, Mass.

On your feet-

In a good Paying Business

We start you in the shoe and hosiery business. Inexperienced workers earn Big Money yearly.

Direct-to-Wearer plan. Just show Tanners Famous Line of Footwear.

We tell how and where to sell. Perfect fit through Patented System. Collect your pay daily We furnish \$40.00 Sample Outfit of actual shoes and hosiery 83 styles.

Send for free book "Getting Ahead" and full particulars. No obligation

TANNERS SHOE CO.
873 C Street, Boston, Mass.

Do You Want— a Runabout a Sail Boat an Outboard Speedster



Here's how you can have it and save $\frac{2}{3}$ your money.

The boat you've always wanted can now be yours at $\frac{1}{3}$ the usual cost. Choose the craft—we send you the parts—all cut and numbered. You fit them together from easily-followed, simple instruction sheets. You don't need to be a carpenter to do it either. Lots of fun and a big money saver. Thousands have built their own boats the Brooks way. Send 10c now for new 1930 book showing 55 different Brooks models. Write today. Then choose your craft.

BROOKS BOAT COMPANY, INC.

Dept. C-4

Saginaw West Side, Mich.

Catch More Fish In 1930
Hildebrandt's Hints, tells you how—shows you the old favorites—fish-catchers for thirty years—and many new items. Hildebrandt Spinners spin so easy—good for all game and pan fish. Send for your HINTS—IT'S FREE.

John J. Hildebrandt Co., 1143 High St., Logansport, Ind.

MOTORCYCLES

WE WILL TRUST YOU
Pay As Low As \$2.00 per Week
Hendersons, Harley-Davidsons, Indians

Slightly used and rebuilt. Hundreds to select from.
Send 10c for list today.

MYEROW BROS. CO., 15 Berkeley St., Boston, Mass., U. S. A.

SPORT BODIES FOR FORDS

at FACTORY PRICES

This Model in Grey Prime **\$38.50**

Send 10c for catalog showing all models of bodies for Fords and other equipment. Also radio, boats, tents and camping outfits.

Hi-compression heads, underslung parts, 3-1 gears, headlights, cowllamps for Ford & Chev. Seat Covers for all cars.

SPORT FACTORIES, Dept. A-2, AURORA, ILL.

PROTECT YOUR CAR National Carbon Company, Inc
EVEREADY General Offices: New York, N. Y.
PRESTONE Branches: Chicago, Kansas City, New York, San Francisco

for preparation of the perfect anti-freeze. Unit of Union Carbide and **UCC** Carbon Corporation

MOTORCYCLES

Direct to you at wholesale prices Send 10c today for the latest
Illustrated Bulletin and Confidential Price List of
Guaranteed Indians Harleys Hendersons SuperX etc.
(Small Weekly Payments Now—Spring Delivery at Winter Prices)

CRANDALL CYCLE CO. 826-28 State St. Shipments to all parts of the world
Springfield, Mass. **Motorcycles Since 1905**



PATENTS

Send us sketch or model for advice and exact cost of patent. Our book "How to Obtain a Patent" sent free. It tells how to apply for Patents, Trade Marks, Foreign Patents, Copyrights, etc.; gives information on Patent Procedure; tells what every inventor should know. Thousands of Inventors, who are our clients, are our reference.

CHANDLEE & CHANDLEE, 25 Years' Experience
912 F Street Washington, D. C.

Patents

Trade Marks

Edward C. Sasnett

Atty. at Law, Registered Patent Atty.

Formerly a Principal Examiner U. S. Patent Office

516 McGill Bldg., Washington, D. C.

Personal Service

Enjoy the Thrill of Making Things Quickly and Easily with the NEW 1930 Delta ELECTRIC Handi-Shop



You will be delighted with the sturdy construction, splendid efficiency, and moderate cost of this Delta equipment. You will appreciate keenly in the "Handi-Shop" such exclusive constructional features as the Patented Tilting Tables, Automatically-Oiled Bronze Bearings, Heavy U-Shaped Lathe Bed, and Circular Saw Raising Lever. Full instructions and complete set of blue prints included. Send coupon for full details.

New Workworking Units

The Delta Jointer and Circular Saw Units mark a new era in moderate-priced woodworking equipment. Now, for the first time, are available sturdy, practical machines in compact, convenient form at price levels astonishingly low. The Combination Unit affords a compact, convenient arrangement which permits sawing and planing in one quick operation. Either Jointer or Saw can be operated separately or both together. Welded steel stand of convenient height. All three units are furnished with or without motor, as desired.

10-DAY TRIAL!

Easy Terms

For full description of the new 1930 Delta line, send coupon for FREE illustrated literature. Gives full details of 10-Day Trial Offer. Choice of three convenient payment plans. Mail coupon TODAY!

New "Delta" MOULDING CUTTER

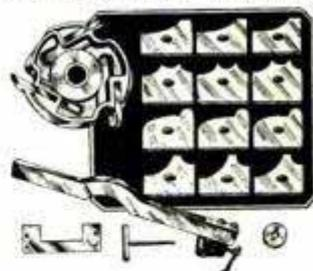

High speed blades produce over 10,000 cuts per minute at 3,500 R. P. M. Blades require no individual adjustment. Quickly and easily locked in position. Special guide fence. Unusually low price. **Cuts over 50 moulding shapes with only 4 sets of blades.**



19 20 21

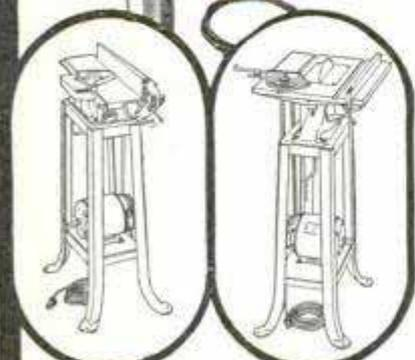

4-inch
Jointer Unit

8-inch
Circular Saw Unit

DELTA SPECIALTY CO.

Division of "Delta Manufacturing Co."

1661-67 Holton St., Dept. A. 330, Milwaukee, Wis.

DELTA SPECIALTY COMPANY, Dept. A. 330
Division of "Delta Manufacturing Co."
1661-67 Holton St., Milwaukee, Wis.

Please send me FREE, illustrated literature describing 1930 model "Delta" Woodworking Units. Also details of 10-Day Trial Offer and Easy Payment Plans. (Check special information desired.)

- Handi-Shop Moulding Cutter
 4" Jointer Units 8" Circular Saw Unit
 Combination 4" Jointer and 8" Circular Saw
 I am interested particularly for home use
 I am interested for shop and professional use

Name.....

Address.....



JAPANESE ROSE BUSHES

The Wonder of the World

Japanese Rose Bushes bloom all the year round. Just think of it. Six weeks after planting the seed, the plants will be in full bloom. It may not seem possible, but we positively guarantee it to be so. They will bloom every ten weeks, Summer or Winter, and when three years old the bush will be a mass of roses, bearing from five hundred to a thousand roses on each bush. The flowers are in three shades—white, pink, and crimson. The plants will do well both in and out doors. We guarantee at least three bushes to grow from each packet of seed. Price, 10c packet, 3 pkts. for 25c postpaid.

Chinese Fragrant Tree Fern

Just introduced; noted for its rapid growth. An exceptionally pretty ornamental plant. Foliage is rich dark green. Forms grand pyramidal bushes about 6 feet high. Branches very desirable for decorative purposes, wreaths, etc. Seeds 15c pkt., 3 for 40c.

Weather Plant

NATURE'S WEATHER PROPHECY By mysterious changes that take place, this remarkable plant accurately forecasts the weather many hours in advance. Will grow anywhere all the year around. An interesting house plant. Bears large, fragrant, pink, butterfly shape flowers. Seeds, 15c packet, 3 for 40c, postpaid

GROUND ALMONDS

Amazingly Prolific—Easily Grown From Seed The Ground Almond has a flavor that is MOST EXCELLENT, resembling the cocoanut. The meat is snow white, covered with a shell or skin of brown color. It grows close to the surface and anything from 200 to 300 Almonds may be expected from a single nut. There is no trouble whatever in growing anywhere and in any kind of soil. May be planted any time, and in eight or ten weeks from time of planting you will have an ENORMOUS CROP of the MOST DELICIOUS ALMONDS YOU EVER TASTED. Seeds 15c Pkt.

Perfume Plant

Blooms only at night, giving forth the most delightful scented fragrance for quite a distance. Causes much comment. For house or garden. Also valuable because of rare perfume made from it. SEEDS, 10c pkt., 3 for 25c.

SENSITIVE PLANT

Marvel of the Philippines. Leaves curl, fronds droop when touched. Apparently resents interference. A handsome shrub for house or garden; very curious and interesting. Seeds, 15c pkt., 3 for 40c.

Calabash or Pipe Gourds

A luxuriant and rapid growing climber; thrives anywhere. Produces the ornamental gourds from which the famous African calabash pipes are made. Grow this interesting vine and make your own. Seeds, with instructions, 15c pkt., 3 for 40c.

Japanese Nest Egg Gourd

Very curious. Produces fruit same size and shape and color of nest eggs. Matured fruit does not crack. Will serve for years as a nest egg, stocking darning, ornamental purposes, etc. Seeds 15c pkt., 3 pkts. for 40c. J.S. & CO.

Mammoth Peanuts

Peanuts can be easily cultivated. Their culture is very simple and exceedingly interesting. Mammoth Peanuts grow to an astonishing size. It is a good producer, very prolific, and the giant nuts have a thick, heavily ribbed protecting shell. The plant is very attractive, the leaves being of odd shape and a handsome green shade, tinted through the center with white. You will derive much pleasure cultivating this interesting species. Seeds 15c pkt., 3 pkts. for 40c.

Musk Plant

A universally admired favorite for house, flower garden or greenhouse. A very fine house plant. Lives for years. Is of the sweet scented variety, giving forth much fragrance. Also valuable on account of the perfume that can be made from it. Seeds 15c pkt., 3 for 40c.

Japanese Climbing Cucumber

Unusually strong and vigorous growing vine. Attains twice the size of ordinary varieties. Grows readily on fences, poles, trellises, etc. One hill will keep an entire family supplied all summer. Seeds 15c packet, 3 for 40c, postpaid.

GIGANTIC NEW GUINEA BUTTER BEANS

The NEW EDIBLE VEGETABLE WONDER Grows to an astonishing size, the Beans measuring from 3 to 6 feet long, and weighing anything from 10 to 16 lbs. and even more. One Bean is sufficient for a family for several meals. Very palatable and rich in nutritious materials. The delicate Buttery Flavor is much appreciated. This Vine is easily grown, very prolific, and a most welcome and valuable adjunct to your garden. Try them; you will find them the most delicious vegetable you have ever tasted. Imported direct. Unobtainable elsewhere. Sample package of Seeds with full directions for cultivating and cooking. 25c, postpaid.

Kudzu Vine

Most rapid growing vine known. Will grow 20 feet in one week. Luxuriant foliage, lovely purple flowers, very fragrant. Nothing so equal to it for shade purposes and quick growth. Seeds 15c packet, 3 for 40c.

Yard Long Bean

Produces enormous crop of long, slender, round pods, of excellent quality for snap beans. Pods grow from 2 to 5 feet in length. Very tender and fine flavor. The vine is rampant grower; an interesting curiosity. Seeds 15c pkt., 3 for 40c.

THE REMARKABLE FIREFLY PLANT

A Vine that Blooms at Night Fills the Atmosphere with Fragrant Aroma One of the most rapid growing vines known. Under favorable conditions this vine has been known to grow OVER 25 FEET IN A SINGLE WEEK. In a very short space of time indeed the Vine has climbed to a great height, and is covered with IMMENSE FLOWERS, from 5 to 7 inches in diameter. It is, indeed, a great novelty, for, unlike other plants, the flowers OPEN IN THE EVENING, and remain open until about noon the following day. In dull weather they will remain open all day. It is a most INTERESTING SIGHT to watch the opening and closing of the flowers as the clouds appear and disperse. As the flowers open they give forth the most DELIGHTFUL AROMA and the whole atmosphere around is full of scented fragrance. It is always the object of favorable comment, and much curiosity is aroused by people passing at night time as to the cause of the charming aroma, frequently stopping in an endeavor to satisfy their curiosity. PRICE, 19 CENTS packet, two packets for 35 CENTS, POSTPAID. JONSON SMITH & CO.

The Great Wonderberry

A luscious berry that may be grown and ripened from seed in any soil or climate in 3 months. The flavor is fine and unsurpassed for eating raw, cooked, canned or preserved in any form. The fruit is blue-black in color, and tastes like a luscious, rich blueberry. One bush will produce an enormous amount of fruit, yielding great masses of rich fruit all Summer and Fall. Packet, 10c, 3 pkts. for 25c, postpaid.

Bush Musk Melon

A vineless Musk Melon, grows in bushes, and thus can be cultivated in the smallest garden. The fruit is of the peculiar "Jenny Lind" type, but larger, averaging 5 inches in diameter. The flesh is very deep, edible almost to the rind and is colored light green, flushed with salmon toward the center. The quality is superb, unusually sweet and juicy. Packet of seeds, with full directions for culture, 15 cents, 3 packets for 40 cents, p.pd.

The Great Umbrella Palm

A Graceful House or Conservatory Plant Easily Grown From Seed Winter or Summer The Japanese Umbrella Palm is a semi-aquatic plant. It is easily grown from seed either in a bowl of water or in very damp soil. Probably the most usual, as well as the most interesting method, is to cultivate the plant in a bowl or jardiniere filled with water, with two or three inches of good garden soil at the bottom. The seeds soon commence to germinate, and the plant shoots up stems two to three feet high and rapidly assumes a most pretty palm-like appearance, as shown in the engraving. The tops of the stems are surmounted by a whorl of umbrella-shaped leaves, of a waxy appearance. We will send a package of this seed, with full instructions for culture, for only 15c or three packets for 40c postpaid.

Butterfly's Own Bush

This plant is a veritable refuge or haven for butterflies, and it attracts all the most beautiful types of butterflies to the neighborhood. Been, too, a very fond of it. It is a pretty plant bearing perfectly double flowers, ranging from white to rich crimson, deep red and pink, like and other delicate shades. Packet 10 cents, 3 for 25 cents postpaid.

FAMOUS MEXICAN FIREFLY PLANT

Beautiful hedge plant, grows 2 to 2 1/2 feet high and resembling a closely clipped evergreen. The globe-shaped or pyramidal bushes are close and compact, and of a pleasing light green color. May be grown singly or in the form of a hedge or background. In early autumn the whole bush becomes carmine or blood red, hence the name of Mexican Fire Plant, or "Burning Bush," as it is sometimes called. Selected Seeds, 10c

CROWN OF THORNS

A very curious clover-like plant, can be cultivated indoors or outdoors, the three red blotches on the leaves representing the three wounds of Christ. Has curious thorny seed hull; if loosened at tip the hull is found to consist of a long prickly-edged band wound spirally around the seed cluster, giving the plant its name. Seeds 15c packet, 3 for 40c.

Asparagus Sprengeri

The best plant for hanging baskets. Masses of rich, gleaming foliage droop in a very graceful manner. The foliage when cut for decorative purposes will last for weeks in water. The seed pods are very pretty red berries adding to its beauty. Packet, 25c, 3 pkts. for 65c postpaid

"Wong-Bok" Chinese Cabbage

Novelty from China and should be grown in every garden. Seems to be a cross between Celery and Cos Lettuce. Flavor is more mild than any other cabbage. Can be served on the table and eaten raw or cooked like cabbage, spinach or lettuce or made into salad. Grows very rapidly, easy to cultivate. You can create quite a sensation by cultivating this remarkable novelty. Seeds, 15c packet, 3 pkts. for 40c.

TREE OF HEAVEN

This splendid ornamental tree is a native of China, and is called the Tree of Heaven, on account of its great beauty. Very hardy, thrives in any soil, no matter how poor, and grows from 6 to 10 feet high from seed the first summer. The leaves are from 5 to 6 feet in any length giving it a grand appearance. Nothing outside the tropics can rival it for lawn decoration. Large panicles of bloom, followed in season by great clusters of colored seed pods, make the tree a continual thing of beauty. Packet, 15c; 3 packets 40c

SURPRISE FLOWER GARDEN

Over Hundred Varieties of Mixed Flower Seeds MANY RARE AND CURIOUS NOVELTIES An Abundance of Flowers Assured Throughout the Season A mixture of easily grown annuals that bloom very soon after sowing the seed; others vary in their time of blooming. Those who cannot give the constant care necessary for finely arranged flower beds will be delighted with the Surprise Wild Flower Garden. Will prove a continual surprise and pleasure, as new varieties and the old garden favorites flower successively throughout the season. There are over a hundred varieties of seeds. Many of the plants may be taken inside as house plants and will bloom during the winter. Fine for children, also teachers for school gardens. Packet, 15 cents, three packets for 40 cents, postpaid. J.S. & CO.

Swear Off Tobacco

Let Us Help You Banish the Tobacco Habit

QUICK RESULTS

Trying to quit the tobacco habit unaided is often a losing fight against heavy odds, and may mean a distressing shock to the nervous system. So don't try it! Make the tobacco habit quit you. It does quit many of those who take **Tobacco Redeemer** according to directions.

It doesn't make a particle of difference whether tobacco has been used for a single month or fifty years, or how much, or in what form—whether it be cigars, cigarettes, pipe, plug, fine cut, or snuff. In most cases, **Tobacco Redeemer** removes all craving for tobacco in any form in a few days. Tobacco craving usually begins to decrease after the very first dose—there's no long waiting for results.

Tobacco Redeemer contains no habit-forming drugs of any kind and is safe, quick, pleasant, and thoroughly reliable.

Not a Substitute

Tobacco Redeemer is in no sense a substitute for tobacco, but is a radical, efficient treatment. After finishing the treatment, there is usually no desire to use tobacco again or to continue the use of the remedy. It helps to quiet the nerves, and makes one feel better in every way. If you really want to quit the tobacco habit—get rid of it so completely that when you see others using it, it should not awaken the slightest desire in you—you should at once begin a course of **Tobacco Redeemer** treatment for the habit.

Our Positive Guarantee

A single trial should convince the most skeptical. Our legal, binding, money back guarantee goes with each full treatment. If **Tobacco Redeemer** fails to banish the tobacco habit when taken according to the plain and easy directions, money will be cheerfully refunded upon request.

Let Us Send You Convincing Proof

If you are a slave of the tobacco habit and want to find a sure quick way of quitting "for keeps," you owe it to yourself and to your family to mail the coupon today or send your name and address on a postal, and receive our free booklet on the injurious effects of tobacco on the human system and positive proof that **Tobacco Redeemer** does quickly relieve the habit for most uses.

Newell Pharmacal Company
Dept. 300, Clayton Station, St. Louis, Mo.



Free Book Coupon

NEWELL PHARMACAL CO.

Dept. 300 Clayton Station St. Louis, Mo.

Please send, without obligating me in any way, your free booklet regarding the tobacco habit and proof that **Tobacco Redeemer** does positively relieve the tobacco habit in most cases. If it fails your money will be refunded.

Name.....

Street and No.....

Town..... State.....



Tobacco Tells on
Nervous System



Tobacco Ruins
Digestion



Tobacco Stunts
Boy's Growth



Tobacco Robs
Man of Vitality



Tobacco Steals
from You the
Pleasures, Com-
forts, Luxuries
of Life



**This Is the Way/
To Make MONEY!**

That is what hundreds of men are saying about the Foley Electrakeen Lawn Mower Sharpener business they have started. Last year Woodmancy earned \$25 to \$30 a day. Morse earned \$1520 in five months.

Start Your Own Cash Business at Home Now!

There is no other method for sharpening lawn mowers to compare with the Foley. You can turn out perfect work quickly and easily. Simply put the lawn mower in the machine and turn on the power—the Foley Electrakeen System automatically sharpens ALL blades at once.

Foley Electrakeen Lawn Mower Sharpener

Uses same system as the leading lawn mower factories. Sharpens all sizes and types of lawn mowers. Costs you only 1c a job and you get \$1.00, \$1.25, \$1.50 each. Walter Dambek writes, "I purchased a Foley Electrakeen Lawn Mower Sharpener three weeks ago and have already made enough money to pay for the machine and all expenses . . ."

Big Profits Can Be Earned

There is plenty of business waiting for you. People would rather have their lawn mowers sharpened the Foley way because they cut better and stay sharp longer. YOU can start this business in spare time and make BIG MONEY! Small investment—easy monthly payments—Start Now!

Send for Complete Information Today



Foley Manufacturing Co.

1435 Foley Bldg., 11 Main St. N. E.,
Minneapolis, Minnesota

Tell me how I can start my own Cash Business and make Big Profits with the Foley Electrakeen Lawn Mower Sharpener.

Name.....
Address.....
City..... State.....

THIS "STERLING'S HOME for 1194



Big Special Discount for Cash!

Here's a modern 7-room home that you can build yourself and save money. We ship you the lumber cut-to-fit, freight paid to your station. Our simple plans and new system of cutting makes it easy for anyone to build a Sterling home. No skilled labor necessary. Our customers claim average savings of 47% over local builders' prices.

Rock-Bottom Prices!



Our large volume of sales enables us to quote rock-bottom prices and sell on time-payments without high interest or financing charges. Terms as low as \$8.10 per month. Send 25c today for beautiful Color Book of NEW Sterling Home Plans and learn how you can buy a home with your rent money.

International Mill & Timber Co.
334 S. Wenona Ave. Bay City, Mich.

231 miles an hour!

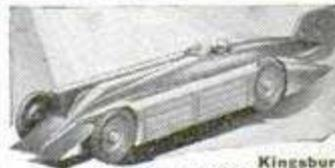

Kingsbury "Golden Arrow" 21 in. long. \$3

Most sensational toy in years! Exact copy of the fastest car in the world—Major Segrave's "Golden Arrow." Lifelike in every detail. Beautiful golden-bronze finish like original. Hidden wheels. Real Dunlop rubber tires. Built all of steel. Equipped with racing speed clock-steel motor. Fastest toy on wheels. 21 inches long, \$3. (West of Miss., \$3.30.) Also Sunbeam and Blue Bird Racers, \$3 each. If your dealer cannot supply you, send your order to us. KINGSBURY MFG. CO. 83C Myrtle St. Keene, N. H.

Send 10c for a Kingsbury Disc Wheel, Balloon Tire Eraser. Set of Four, 35c.

KINGSBURY MOTOR TOYS

With a Pan-American it's EASY » » »



YOU LEARN to play tunes at the very start with an easy-playing, sweet-toned Pan-American. Be popular; increase your income. Pan-Americans are the only complete line of nationally advertised, moderately priced, factory guaranteed instruments. Send for details of **FREE TRIAL**; Easy Payments on any instrument for the band or orchestra.

PAN-AMERICAN BAND INSTRUMENT AND CASE COMPANY
303 Pan-American Building, Elkhart, Indiana

Science and mechanics dramatized!

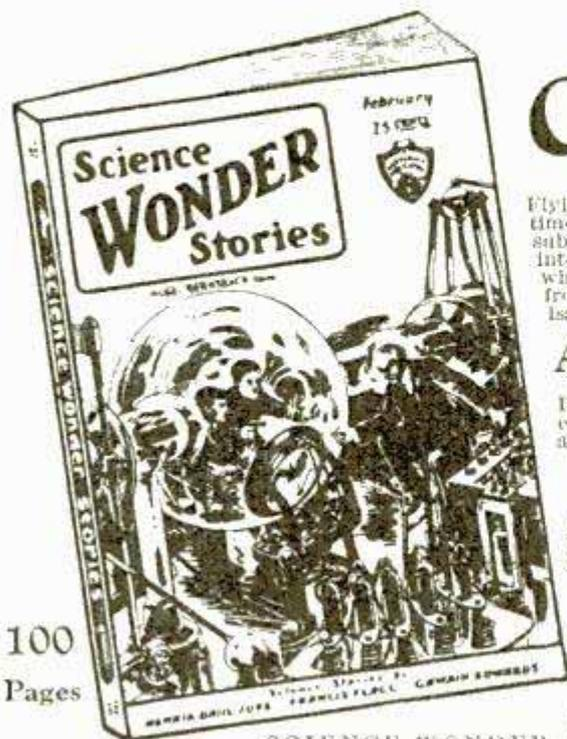

100 Pages

Flying thru space—talking to Mars—nullifying gravity—the 4th dimension—flying in time—transmission of death rays—these, and many other astounding super-scientific subjects are written into fascinating story form in the most interesting magazine ever set into print. SCIENCE WONDER STORIES is published every month. It tells you now, what is likely to happen in the scientific world next year, 100 years from now, 1000 years from now, and 10,000 years hence. You won't be able to wait for the succeeding issues. Begin now.

Also Contains Science Questions and Answers

In SCIENCE WONDER STORIES there is a department that answers your questions every month on any scientific, mechanical subject that you can think of: mechanics, astronomy, physics, aviation, etc. . . also

Science News of the Month

In this department you will find the latest scientific and mechanical developments in a condensed version every month. The greatest source of information in any magazine. Forty-two scientific and mechanical magazines are reviewed here every month.

Special Offer—Next 4 Months for

SCIENCE WONDER STORIES is 25c per copy, or \$2.50 a year on regular subscription. For a limited time only we will accept your 4-month subscription for only 50c and the coupon from this announcement. Clip—mail coupon today.

50¢

SCIENCE WONDER STORIES is on sale on all newsstands. It is full 9 in. x 12 in. and contains 100 pages. Many page size illustrations. Beautiful 4-color cover. This is the biggest reading value ever offered. See offer. Send coupon today.

SCIENCE WONDER STORIES

Dept. P3, 96 Park Place, NEW YORK, N. Y.

SCIENCE WONDER STORIES, 96 Park Place, Dept. P3, New York

50c enclosed. Send me SCIENCE WONDER STORIES for the next 4 months.

Name.....

Street.....

Town..... State.....



Ford Owner Stop that ruinous chatter on your car. **MAKE THIS TEST**—take out your floor boards, pull your emergency brake back and forth. If you notice play at the ball joint, you need Bredar's Ball Shim. Price \$1.60. Ask your Dealer or order direct. Demand Bredar's Shim.
NIC BREDAR'S SON MFG. CO., Rock Island, Ill.

Men and Women Make Big Money

Something new. No competition Exclusive virgin territory Full time workers earn up to \$100 per week. Year 'round seller. Write for details giving past experience.

TORCHETTE CO., 152 Farwell Ave., Milwaukee, Wis.



WAD E AMATEUR MECHANICS, REPAIR SHOPS, INVENTORS, STUDENTS

BENCH LATHE A real machine tool for the home work bench—capacity 4" dia. x 12" length. For Metal—Wood—Composition materials. Turning—Facing—Boring—Drilling—Winding—Thread Cutting. Accurate—Strong—Quiet—Compact. Slide-rest has travel entire length of bed. Leadscrew inside bed. No. 1 Lathe, plain headstock, \$40.00. No. 2 Lathe, back-gear headstock, \$68.00. Extra for lathes with 18 inches between centers, \$7.00. Complete line of accessories at equally low prices. Write for free catalog.

THE GEROLD CO. Dept. P-61 120 Liberty St. New York



A \$100 SHIP MODEL FOR \$4.98

LET THE WORLD'S LARGEST BUILDERS OF SHIP MODELS supply you with all the necessary parts cut to fit and ready to put together. You need not know anything about ship building to assemble one of these models. If you have never seen a ship model you can put one of these models together in a few hours by following our diagram and instruction sheets, which explain and show you exactly what to do with each part. All you need is a small tack hammer to tap the parts in place. These models, when completed, are exact in every detail of the famous old ships they represent, and when completed will add a distinctive touch to your home. We have parts for models listed:

- SANTA MARIA—25 in. high, 11 in. wide, 27 in. long.....\$4.98
- LA PINTA—26 in. high, 11 in. wide, 27 in. long..... 4.98
- MAYFLOWER—26 in. high, 10 in. wide, 30 in. long..... 4.98
- CONSTITUTION—25 in. high, 8 in. wide, 29 in. long..... 6.98
- FLYING CLOUD—33 in. high, 27 in. wide, 24 in. long..... 6.98

Models sent C.O.D. anywhere in United States. All foreign orders must be accompanied by U. S. Money Order or Check. Write for our beautiful illustrated booklet containing photos and information on all our models.

\$4⁹⁸

SANTA MARIA—25" High; 11" Wide; 27" Long.

MINIATURE SHIP MODELS, INC.

Dept. RT-3 SELLERSVILLE, PA.

MINIATURE SHIP MODELS, INC., Dept. RT-3, Sellersville, Penn.

Please send me the complete parts, cut to fit and ready to put together for the model.....

I will pay postman..... plus a few cents postage. Please write name and address plainly and avoid delay.

Name.....

Street or R. F. D.....

City..... State.....

Earn BIG MONEY with this Making Money Equipment



30 DAYS TRIAL Pay out of Income Terms

No Expense to You **Only \$16 Monthly**

Start a Money Making Business of your own. Mechanics, Filling Stations, Repair Shops, Garages and Battery Stations are all making BIG MONEY with HB 8 Hour Battery Service. Recommended by the leading car and battery makers. Constant Potential lets you give a better charge than the other fellow in one-third the time, and at a saving of 30% to 50% on current. Anyone can operate. Check coupon below for full information on how to get started in this money making work. **Shouldn't Cost You a Cent. Pays for Itself—Brings a Big Profit Besides.**

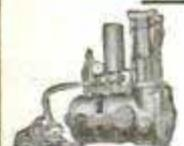

20-Minute Car Washing

The best paying work in automotive field today is 20 minute car washing. Puts you above competition—eliminates all drudgery! Users report \$100 weekly profits. Liberal trial, easy terms. Savings in labor and material over other methods will easily pay for it.

CAR WASHER

Earn 5 Men's Wages

Portable Paint Spray does the work of five brush painters. You get four men's wages as profit. Paints Cars, Houses, Garages, Barns, Furniture. No experience necessary to operate. Check coupon for trial offer and terms.



Paint Spray

Profitable Air Service

Free Air Service costs you only \$10 monthly for a few months. Fully Automatic day and night service will draw customers to your shop as well as operate your air tools. Check coupon for full details without obligation.



Air Service

HOBART BROS., Box M33, Troy, Ohio

-----Tear off and Mail Today-----
 Hobart Brothers, Box M-33, Troy, Ohio.
 Send me complete information on the items I've checked—your thirty-day trial offer—easy payment terms—information on how HB equipment will increase my earnings.

HB 8 HOUR BATTERY CHARGER
 HB TEST BENCH HB PAINT SPRAY
 HB AIR SERVICE HB 20-MINUTE CAR WASHER

Name.....Address.....

Handee-Trailer

For Touring, Carrying Boats or General Use

Can be folded in its own box for storing or shipping. Together or apart by removing seven bolts. Weight 250 lbs. cap. 650 lbs. fitted with trailer connector for attaching to your car.

Price \$49.50 Including Freight

Handee-Trailer Co., 1639-S-State St., Chicago



SAVE 1/2 ON PLUMBING HEATING



Any handy man can install his own plumbing or heating by our new easy cut-to-fit method. Low wholesale prices on highest quality Grade A goods enable you to save one-half!

WE SHOW YOU HOW—BOOK FREE

Send for our new wholesale catalog. Save waste material and high labor costs. This book has saved money for home owners and builders for over 50 years.

Free Estimate—Send for Sketch Blank

MILLION DOLLAR BONDED GUARANTEE PROTECTS YOU

OVER 50 YEARS **HARDIN-LAVIN Co.** EST. 1876
 122-32A West Pershing Road, Chicago, Ill.

New Complete "Wonder" Workshop

Outfit saves you \$15.00



Now you can have this new, amazing 8-in. Combination Saw (18 tools in one) shipped on 15 days' approval, at manufacturer's risk. A complete ideal machine shop for factory, workshop or home; will rip, cross cut, bevel, miter, mortise, drill, groove, tenon, grind, rabbet, buff and polish. 1/3 H.P.-A. C. motor included with all attachments. Write quick for special 10 day offer.

S & B MFG. CO.
 Dealers Wanted 4611 W. 20th St. CHICAGO, ILL.

IDEAL SMOKER'S GIFT



Cleanest, safest sanitary receiver made! Push top—ashes disappear—springs back, closes self tightly. No more ashes spilled on rugs—tables, etc. No cigar, cigarette, match ends in sight. Odorless—makes smoking no longer objectionable. Quickly, easily emptied, no dirt or trouble cleaning. Ideal for home—office. 5 in. wide—set anywhere. Attractive appearance. Soft red, green or blue finish. Handsome nickel top. Send no money, just name and address. Pay postman only \$1.29 and few cents postage, or save postage by sending only \$1.29 in form of Money Order or Check. Ash Receiver will be sent you by return mail, postpaid.

\$1.29

L. A. RICKER, 2458 S. St. Louis Ave., CHICAGO, ILL.

NO JOKE TO BE DEAF

—EVERY DEAF PERSON KNOWS THAT



I make myself hear, after being deaf for 25 years, with these Artificial Ear Drums. I wear them day and night. They stop head noises and ringing ears. They are perfectly comfortable. No one sees them. Write me and I will tell you a true story how I got deaf and how I make you hear. Address

GEO. P. WAY, Artificial Ear Drum Co. (Inc.)
 80 Hoffman Bldg., Detroit, Mich.

NEW EDITION MODERN GASOLINE AUTOMOBILE

The type matter has been entirely reset for the thorough revision of this authoritative book by V. W. Page. With 1000 new illustrations this strictly modern work shows every recent improvement in automobiles and their component parts. This most complete and practical treatise describes every part of all types from light cars to heavy-duty trucks and road tractors.

The first book to devote many of its 1150 pages to a complete, illustrated description of the

NEW MODEL A FORD

Design, construction, operation and maintenance are the broad divisions of the text matter.

All latest developments are dealt with in minute detail.

Size, 6x9 in. Fabrikoid Binding
 Price \$5

Will be sent C. O. D. in U. S. Pay postman price and postage.

Popular Mechanics Press
 Room P-3
 200 E. Ontario St. Chicago

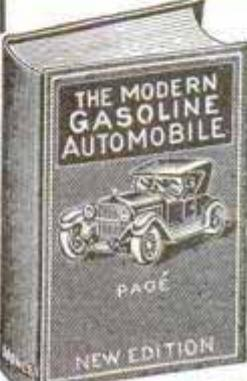

"COAST TO COAST"

Over 100,000 in use

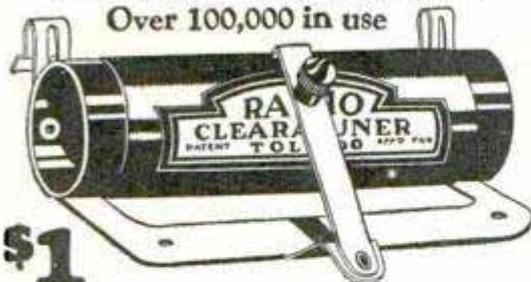

\$1

**TUNES YOUR AERIAL
THE NEW RADIO
CLEARATUNER**

Will Help You Get
Those Distant Stations

We guarantee greater distance,
greater volume, greater selectivity,
less static, less interference and
better tone quality. \$1 postpaid.

De luxe Model \$2, postpaid.
Money back if not satisfied.

RADIO CLEARATUNER CO.
Gardner Bldg., Toledo, Ohio

ELECTRIFY YOUR RADIO FOR ONLY \$6.85 COMPLETE

Why discard your present good set when you can electrify it for only \$6.85, and banish the annoyance and expense of buying new "B" batteries?



Over 150,000 Townsend

"B" POWER UNITS IN USE
Hooked up in a few minutes. Delivers 90 V. on any set. Use same tubes—no changes. You'll be amazed at the improvement in reception and distance getting. Send name and address today for full details, proof and Free Trial Offer. TOWNSEND LABORATORIES, 715 Townsend St., Chicago, Ill.

Information on any book free. Write Popular Mechanics Press, Chicago, Ill.

See Miles Away

Big 3 1/2 Ft. Telescope



Solar Eye Piece

Lend wings to your eyes! People and objects miles away seem close. Wonder telescope brings new pleasures to home, farm, camp, travel, sport. Study the mysterious Sun spots; see Moon and Stars as never before. See people on the beach, on the mountains, etc.

FREE

Yes, absolutely free! A handsome leatherette Carry-case and Shoulder Strap. Also Solar Eye Piece to view the sun—a special feature, found only on expensive instruments.



CLIP THIS AD

5 Sections
8 Power Lenses
Brass bound; measures 12 in. closed; powerful achromatic lenses protected by dust caps.
Thousands Pleased
Thousands who have ordered this big telescope have written us how delighted they are—how much fun they have had. Satisfaction guaranteed.



Beach Views



Sports



Boat Views

SEND NO MONEY

On delivery of Telescope, free Case, Strap and Eye Piece pay Postman only \$1.85, plus postage (2 complete outfits \$3.50), or send price with order and we'll pay postage. Satisfaction guaranteed or money refunded. Send today, entertain your friends! Be first.

FERRY & CO., Dept. 180, Chicago, U. S. A.

GOODELL-PRATT

1500 GOOD TOOLS



**Mr. Punch
The Hole Maker**



This automatic drill carries in the handle eight sizes of drill points — 1/16" to 1/4". Around the top are sample holes showing the exact size made by each drill point. Pick out the size you want, insert it in Mr. Punch's steel jaws, place point where you want the hole. You push. He twists. In goes the point and—presto, you have a clean smooth hole in

any wood. Also can be used in plaster. Remember the name when you go into a hardware store and for your protection look for Mr. Punch on the green-covered box.

Other GOODELL-PRATT Tools Are

Automatic Drills, Automatic Screw Drivers, Breast Drills, Bit Braces, Calipers, Electric Drills, Hand Drills, Hack Saw Blades, Levels, Micrometers.



To acquaint you with GOODELL-PRATT quality, we make this Remarkable Offer!

Send \$1.00 for Handy Pocket Screw Driver Set

To introduce a sample of Goodell-Pratt quality to every tool lover, we are offering this handy tool at the special low price of \$1.00. Ideal for repair work on radios, household appliances, etc. When not in use, the chuck and blades are inside as shown. Pin a dollar bill to this coupon and send in today.



GOODELL-PRATT CO., Greenfield, Mass.

Attached is one dollar for pocket screw driver set as offered in March Popular Mechanics magazine.

Name.....

Street.....

City.....State.....

My hardware dealer is.....

Stage Money



New Bills To Conform With Small Size Currency

With these bills it is easy for a person of limited means to appear prosperous by flashing a roll of them at the proper time. By peeling off a genuine bill or two from the outside of the roll, the effect created will be all that can be desired. Prices, postpaid: 50 bills 20c; 140 for 50c, or \$3.00 thousand postpaid.

Fire-Eater

A great trick by which you appear to breathe fire from mouth. Quite harmless. All necessary apparatus sent complete for only 30c, postpaid.



Black Art

This book tells of the sciences of Magic, Witchcraft, Alchemy, Necromancy, Mesmerism, etc. It tells how to make persons think of you, how to charm those you love, etc. The book contains 122 pages. Price 30c prepaid.



OAKS' MASTER BOX OF TRICKS

Mystery and entertainment for every day in the year. Whole evening's entertainment complete for \$1.00. Without practice or experience, anyone can give a complete entertainment with these mechanical and self-working tricks so simple that a child can perform. Contains apparatus for 7 complete tricks. The Magic Ball and Vase Trick. Wooden ball is placed inside, and upon replacing the lid has disappeared and is found in someone else's pocket; Disappearing Spots. This trick consists of changing four Kings to four Aces, and then to blank cards; Magnetic Wand. Magician's Wand clings to fingers and floats about as if magnetized, yet falls when anyone else tries; Ribbon Factory from the Mouth Trick. A seemingly endless supply of colored paper ribbon comes out of the mouth; Disappearing Handkerchief. Handkerchief held in the mouth mysteriously vanishes; Enchanted Bottle. No one but yourself is able to make it lie down; Great Hat and Dice Trick. Large dice is placed on top of hat, disappears, and is found underneath, yet no one has touched the hat. Only \$1.00 for all.

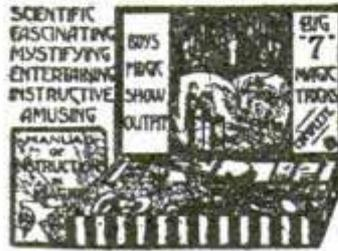

OAKS' CARD MIRACLES



Complete box of our most popular card tricks. Easily performed with instructions for each trick. Box contains Disappearing Spots, Hindoo Cards, Phantom Cards, Pick It Out Cards, Satan Card Trick, Educated Card Dice Trick, Knockout Cards, Diminishing Card Trick and Wonderful Ace Trick. If purchased separately would cost \$1.00. Special complete, only 50c.

MULTIPLYING BILLIARD BALLS



Magically producing a solid billiard ball, the conjurer simply moving his hand thru the air, causes a second ball of the same size to appear beside it. Everyone watching closely, a third appears in like manner. Then to the amazement of all, a fourth appears. Make them vanish singly until hand is empty. Per set, 35c. Larger sizes, \$1 and \$1.25.

Buddha's Money Mystery



With this contrivance it is apparently possible to change a blank piece of paper into a bill of any denomination. Can be performed easily by anyone. Only 25c.

Serpent's Eggs



When lit with a match each egg hatches itself into a snake several feet long, curling and twisting in life-like manner. Box of 12, 10c postpaid; 3 for 25c.

Send 10c in stamps or coin and our 1930 catalogue, DeLuxe Edition, containing 202 pages of all the latest tricks and novelties, will be sent to you. We are the largest dealers in tricks of all kinds in the world. Order from this advertisement or send for our catalogue today. FREE—Our large die box trick when you have sent in orders amounting to \$25 within one year.

OAKS MAGICAL COMPANY

Dept. 811 Oshkosh, Wisconsin

SALESMEN 4 SALES DAILY WANTED PAY \$288 WEEKLY

Experience unnecessary—we train you. Sensational new specialty sells every business or professional man. World's largest firms—Bell Telephone, Sears Roebuck, National Radio, etc., are among our customers. Enormous repeat. Walker made \$165 first day. Write at once. F. E. Armstrong, Pres., Box 601W Mobile, Ala.

It's a BULOVA—Sent with a Mesh Band! For \$1.00

TAKE 12 MONTHS TO PAY

Send \$1.00 with order and tell us a little about yourself: (A) How long at present address, (B) Age, (C) Married or Single, (D) Name of Employer, (E) Position, (F) How long employed. All information held strictly confidential. We make no direct inquiries of anyone—not even from your employer.

10 Days Free Trial—Satisfaction Guaranteed

This genuine Bulova watch comes to you postage paid—no C.O.D. to pay on arrival. You take no risk—satisfaction guaranteed or money back.

Estab. 1895

\$2975

DG5-

15 jewel BULOVA gent's wrist watch. White Gold filled case; "dilat-tite" protector; radium dial and hands; latest woven mesh wristband. Guaranteed. \$1 now. \$2.39 a mo. *Nationally advertised cash price, no extra charge for credit.*

Catalog New catalog of genuine diamonds, standard nationally advertised watches, fine jewelry. Write for it now.

ROYAL DIAMOND & WATCH CO.

ADDRESS DEPT. C 11 170 BROADWAY, N.Y.



BUILD SHIP MODELS

Easy to build and sell. Plans and instructions: Santa Maria, \$1.00—Clipper Ship, 80c—Viking Galley, 40c—or all three for \$2.00. Catalog 6c. RICHTER'S, 3217 A. Walnut Street, MILWAUKEE, WIS.

\$100.00
for a
Name
AND \$25
EXTRA FOR
PROMPTNESS

Perfume

We want a name for our exquisite perfume and we will pay you \$125 if you suggest the one selected. Even a name you don't think much of may win. A simple name has as much chance as any other.

Hints: It may be a single word or more than one word. A "coined" word, the name of a flower, like Rose. The name of a place, a Movie Star or any person. Names are almost unlimited. It costs nothing to submit a name. Someone wins \$125.00 for a few moments' thought—why not you?

Any Simple Name May Win

Send only one name. If anyone submits more than one name, all names sent by that person will be disqualified. The name found most suitable will receive \$100 cash. If you send the winning name within 3 days after reading this announcement you get \$25 extra for promptness. Contest closes April 30, 1930, and in case of ties, duplicate prizes will be awarded.

We want to hear from you at once. Send a name on any kind of paper. Neatness does not count. No obligation. Nothing else to do. You may win \$125.00 for the name you suggest. Do it today.

L. M. STONE

844 W. Adams St. Dept. 750 Chicago

Your BRAINS and this machine can make anything

Why waste your time and money on toy machines when you can get this real rig at such a low price?

RIPS...MITERS...
CROSS-CUTS...
BEVELS...DADOES...
PLOUGHS...
GROOVES...
RABBETS...
SANDS...
BORES...
GRINDS...
POLISHES...ETC.

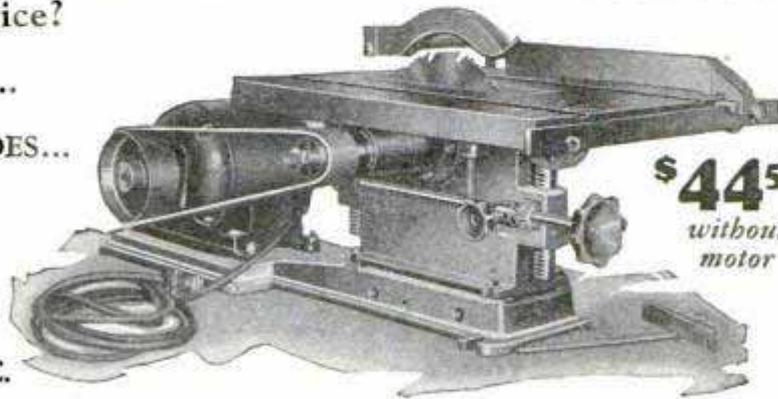

The SAFETY-SAW MODEL N

Easy to operate
Easy to own
BALL BEARING
Table Top 18" x 14"
Raises and lowers
on a level.
Saw Arbor 3/4" Dia.
Cuts 2 1/2" Thick
Rips 12" Wide
Cross-cuts any width
Bevel Rips to 45°

Send Coupon
Now for Details,
Illustrations and
EASY TERMS

TRY THIS Safety-Saw AT OUR EXPENSE

Put this machine on your work bench . . . give it a thorough test . . . compare it with others . . . and then if you're not more than satisfied with it in every way . . . send it back and we'll return every cent of your down payment and pay the transportation charges both ways. You can't lose a nickel, but you can gain a lot. Don't buy any machine until you've read our FREE descriptive folder . . . It shows Bench Saws . . . Band Saws . . . Lathes . . . Jointers . . . and all equipment.

SAFE TOOL MFG. CO. • BRIDGEPORT, PA.

SAFE TOOL MFG. CO., Bridgeport, Pa.

Please send me full information about your woodworking machines.

Name.....

Address.....

FOR THE RADIO BUILDER

The blueprints below include the best of Popular Mechanics tested circuits. When ordering, simply quote the numbers of blueprints desired and inclose proper amount addressed to Popular Mechanics Magazine, Radio Dept., 200 E. Ontario St., Chicago, Ill. Magazines containing full descriptions of the circuits can be obtained. Send 25 cents for each magazine desired, giving date of publication.

- No. 111, Homemade Tube Tester..... July 1926.. 25c
- No. 116, Three-Tube Loop Set..... Dec. 1926.. 25c
- No. 123, Economy-Nine Super-heterodyne..... Nov. 1927.. 50c
- No. 134, Edison Type B-Battery..... July 1928.. 25c
- No. 138, Screen-Grid Perfect-Tone Six Receiver..... Nov. 1928.. 25c
- No. 139, Simple Television Receiver.. Dec. 1928.. 25c
- No. 140, Power Amplifier and B-Supply for Television..... Jan. 1929.. 25c
- No. 142, Two-Tube Screen-Grid Short-Wave Adapter..... Mar. 1929.. 25c
- No. 143, Four-Tube Screen-Grid Receiver..... May 1929.. 25c
- No. 144, Three-Tube Self-Contained A.C. Receiver..... Oct. 1929.. 25c
- No. 145, One-Tube S-G Set for Beginners..... Nov. 1929.. 25c
- No. 146, Adjustable B-Eliminator... Nov. 1929.. 25c
- No. 147, A-Eliminator for Set and Dynamic Speaker..... Dec. 1929.. 25c
- No. 148, Adding Audio Stages to S. G. Receiver..... Dec. 1929.. 25c

CAILLE REDHEADS

*Newest Thing in
Outboard Motoring!*



Electric Starting . . . Multi-Flexible Control

Simply touch a button and your motor starts! The same dependable starting you enjoy in your automobile, combined with three speeds forward, neutral and slow reverse. Load your boat with motor running . . . back away from the dock by a simple move of a hand on the control lever . . . go forward at trolling speed or shift into high in a jiffy, with all the ease and maneuverability of a modern motor car. This is brought to you in the 1930 Caille REDHEADS. Get the complete story.

CAILLE MOTOR COMPANY
6219 Second Blvd. Detroit, Michigan

Mail Coupon
at once for
New Caille
Catalog



Please mail complete information on the New 1930 Caille Redheads.

Name.....

Address.....

City.....

State.....

SENT FREE  **ON THIS COUPON MAIL NOW**

■ This E-F ANGLE SCREWDRIVER—of tempered crucible Spring steel—7 powerful edges for large and small screws.
 ■ Works under obstructions where others won't—101 uses.
 ■ Carries like pen-knife—often more valuable.

■ (PRINT*)
 ■ Name.....
 ■ Route.....
 ■ No., St.....
 ■ P. O.....
 ■ City, St't.....

■ Interested in Plier Rench Representative Prop's't'n!
 ■ In User Literature! **THE FLASH SALES CORP**
 P.M.C. 4809 N. Ashland Ave., CHICAGO, ILL.

Also FREE—Amazing 125-Picture Story of **The "Pocket Machine Shop!"**
 Its GEAR gives Your Hands the 1-TON grip of 20 hands, that outgrips a 40-Lb. Vise!

An Automatic Lock-Grip Ratchet Wrench
 Speed VISE
 Parallel PLIERS Plus

EIFEL-FLASH PLIERENCH KIT
 (Say "Eye-fel-Flash") "The T.N.T. of Tools"
 A 1-Second change of Gear-Jaws gives you 1, 2 and 3, in this 24 oz. Master KIT—for the Price of 1 tool. They DO the Work of 60 Lbs. of Other Tools costing \$50, and things no other tools can do!

A GREAT ALL-YEAR MONEY-MAKER
 for PlierRench Representatives—Full or Part time. \$75.00 to \$200.00 Weekly!
NEW LOW PRICES—Mail Coupon!

(Ad. 30-25-54)
 © 1950 by J. Kiffin

How to set up a "POWER" WORKSHOP

This book contains valuable information for those interested in learning how to get the most out of power (electric) tools, either for home workshop use or small shop operations.
 It tells in simple terms the best method of setting up a home workshop.

Chapters on the use of a wood turning lathe. Use of the dado and circular saw. Operating the jig saw, jointer, belt sander, etc. Wood joints and how to make them, illustrated.
 Uses for the flexible shaft illustrated. Also eight blue-prints with specifications and bill of materials of useful furniture easy to make.

mail 50c today

"THE DRIVER MANUAL"
 By the Manufacturers of "DRIVER" Power Tools

8 BLUE PRINTS and Working Drawings of Workbench and Furniture

Walker-Turner Co., Inc., 70 York St., Jersey City, N. J.

NAME.....
 STREET.....
 TOWN..... STATE.....

Catch Fish! 

Eels, Mink, Muskrats with our new folding galvanized **STEEL WIRE TRAP**. Write for our **FREE TRAP OFFER** and Bargain Catalog. \$1 Box of our famous Fish Bait FREE to introduce our traps.
WALTON SUPPLY CO., 3502 JUNIATA AVE., ST. LOUIS, MO.

STRANGE INVENTION!
PAYS YOU IMMENSE PROFITS
NEW FIELD for AGENTS

Sell only device in the world that prevents kinking, snarling and tangling of telephone and electric iron cords. Housewives and business men buy 1 to 50.

NEW KIND OF CORD SET FREE
 Every Neverknot Salesman is given FREE the complete Neverknot Switch Plug Cord Set pictured. This new kind of ironing cord automatically coils itself out of the way and a new kind of switch plug prevents scorching and saves electric bills. This set is a "gold mine" for house-to-house workers. It's different and it's yours free if you work for us. Don't delay! Send now for free offer.

Dept. 3-V
NEVERKNOT CO. 4503 Ravenswood, Chicago

 **The Plug That Saves Electric Bills.**

AGENTS! SELLS LIKE WILDFIRE



Fill reservoir with water. Holds enough to clean 40 windows.

Removable Rubber Squeegee dries, cleans, polishes with one stroke.

Water feeds thru felt to window pane.

Remove cap and insert broom handle for high windows.

Rust-proof. Fool-proof. Lasts for years.

New improved window washer eliminates all muss and fuss wherever there is glass to be cleaned. Approved by Good Housekeeping Institute. Restricted territory to producers. Write today.

CARTER PRODUCTS CORP.
 935 Front Street
 Cleveland, Ohio

\$12.75

SLIDING TOOL RESTS
 for all lathes from 7½ in. to 12 in. swing \$12.75. Ways are accurately milled and gibbed for take up, has 16 in. travel, furnished with tool holder and H. S. bit. Shield instantly removed for working up to the face plate, etc. Weight 18 lbs.

State swing with order
GOODWIN MFG. CO.
 OTTUMWA IOWA

Get Into A Business of Your Own—EARN \$150 to \$300 Monthly

8 HOUR BATTERY CHARGING

Start a **BIG PROFIT-MAKING BUSINESS** of your own—"8 Hour Battery Charging." Requires **SMALL SPACE** and **PRACTICALLY NO INVESTMENT**. Anyone can successfully operate. Charges batteries in ½ the time at ½ the cost. **EVERY CAR OWNER A CUSTOMER**. 20 minute Car Washing, Electrical Service, Spray Painting and Arc Welding offer same opportunity. **HB shouldn't cost you a cent—it will pay for itself on EASY MONTHLY PAYMENT PLAN**, with practically no expense and with a handsome profit for you. **WRITE NOW** for details stating what you're interested in to **Hobart Brothers, Box M338, Troy, Ohio.**

30 DAYS TRIAL—Pay Out of Income Terms

GREAT After Driving!

When you return from an automobile trip with eyes that are weary and bloodshot, apply a few drops of harmless *Murine*. Within a few moments the tired, burning sensation will disappear, and before long your eyes will be clear again. Millions of bottles of *Murine* were used last year by motorists, sportsmen and others whose eyes were exposed to irritation and strain. Write *Murine* Company, 9 E. Ohio St., Chicago, for valuable free book on the proper care of the eyes.

MURINE FOR YOUR EYES

AUTOMATIC WINDOW WASHER

Price \$1.95

Washes, Cleans, Dries
Polishes in One
Quick Operation



Amazing new invention. CARRIES OWN WATER SUPPLY! Eliminates all drudgery and splashing! 5 times as fast as old methods. Patented features: **No pail. No brush. No sponge. No chamols.** Can be used with or without a pole. \$90-\$150 weekly easy for agents. Sells on sight. Sensational demonstration! Every housewife, autoist, store-owner a prospect. Write for our **Free Sample Offer** and big money-making proposition. Be first.

NATIONAL INDUSTRIES, 67 E. Lake St., Dept. 153, Chicago



FORD TriMotor
MONOPLANE

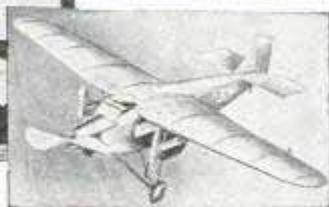

Build Model Airplanes

Plans for Model Airplanes 25c each.

FORD MONOPLANE
Fokker Monoplane
New York-Paris Plane
Curtiss BiPlane
DeHAVILLAND BiPlane
NC-4 Naval Seaplane
Blériot, Nieuport or Taube
Monoplanes
Cecil Peoli Racer

Build this perfect, 3 ft. Flying Model of the famous FORD MONOPLANE in which Comm. Byrd flew over the South Pole. It is guaranteed to fly. The Ideal Construction Outfit contains everything needed; all materials with Plans and Instructions. Ask your Model Airplane dealer, or order direct. The price is \$8.50.

48-page Catalog of Model Airplanes, Parts, Materials and Supplies for Builders, 6c.
IDEAL AEROPLANE & SUPPLY COMPANY, Inc.
26 West 19th Street, New York City

Just What You've Been Waiting For!



A CRACK FILLER THAT WON'T SHRINK

For filling holes in wood, stone, and metal surfaces, building models, mending furniture, patching walls, and other general repair work, use Savogran Crack Filler.

It makes a *permanent* job that defies detection. Takes paint perfectly and does not show through like putty.

Once you use Savogran Crack Filler you will never want to be without it again. Ten cents brings a good-sized can for your work-bench. Use coupon below.

Made by the makers of Painters' Savogran—the work-saving cleaner used for 35 years by painters and householders for softening hard brushes, cleaning paint work, removing paint and varnish. Get acquainted with Savogran Products — at all paint and hardware stores.

SAVOGRAN CRACK FILLER

PATENT APPLIED FOR

Big One-Pound Can 30c

A POUND of Savogran Crack Filler costs you only 30 cents. It is also sold in 5-lb. cans (\$1.25) and in 35-lb. all-metal pails (\$7.70) for painters, industrials, and other quantity users. Low price—no hardening in the can—no waste—here's the biggest value on the market.

Special Offer

To make new friends for this popular filler we will send you a quarter-pound can of Savogran Crack Filler on receipt of ten cents. Use this coupon.

SAVOGRAN COMPANY, Dept. M3,
India Wharf, Boston, Mass.

Send me a ¼-lb. can of Savogran Crack Filler at your Special Introductory Price. I enclose 10c.

Name.....

Address.....



A 1/4 Century House, Financially Rated over \$1,000,000.00, offers the following:—

Actual Regular Prices TO DAY \$55 to \$65

21 Jewels \$29⁴⁸

Hamilton '992'
ILLINOIS Bunn Special
ELGIN B.W. Raymond
and Others

Forced Sale for Loan and charges Only

High grade, Hamilton 11-12, Elgin and other famous railroad makes, perfect conditioned, 21 jewel adjusted movements—each and every watch has sold—sells now—at \$55.00 to \$65.00. Yet offered here at only \$29.48. Why?—Simply because they have been carried in the pocket a short time and used as collateral for loans at this big association of 10 loan firms combined. Of course not all loans are repaid. These, the real opportunities for you to buy at forced sale prices—pay merely the amount loaned plus interest, charges.

Guaranteed to Pass Railroad Inspection

No better running watches—no better timekeepers—than these. Then, why pay full prices for the identical makes and grades of foremost railroad timepieces we offer you here at a fraction of original costs,—

Low as 33c on the \$1 (of original costs)

Of course you wouldn't want to sell your perfectly good watch, keeping perfect time, at any such tremendous loss in price to you—unless you just had to have the money. Well, these watches were never intended to be sold by the individuals who owned them. These represent circumstances where money was borrowed. The owners expected to repay. They failed to meet their obligations. Hence, these watches must be sold to get back the cash loaned and accrued charges only.

Send for Latest List—Examine Watches Free

These and many other unusual offers in latest list. Mail coupon below. Examine any watch on approval—no risk, no expense to you. No obligation to buy if not acceptable.

Don't Delay! Just a limited number in Each Lot. Fill in below for Free List.

JOS. DeROY & SONS. (10 Large Loan Firms Combined)
Opposite Post Office 1990 DeRoy Bldg., Pittsburgh, Pa.

References by permission—
Bank of Pittsburgh—
Third National Bank—
Union Trust Co. Pitts-
burgh, Pa. Your bank can
look us up in mercantile
agencies.

Name.....

Address.....

Low as \$60 a Carat for Diamonds

Own Your Own Big Money-Making Business

\$3000. PROFITS IN FOUR MONTHS
by Geo. Alexander, Pennsylvania.

A NEW BUSINESS IN YOUR TOWN
A delightful, dignified and fascinating business. Make and sell Crispettes. Delicious confection. Everybody loves them. Can't get enough. Come again and again for more. Easy to make. Easy to sell. I supply everything. Raw material plentiful and cheap. Profits big.

QUICK SUCCESS POSSIBLE anywhere—cities, towns, villages.
Amazing market—crowded streets; surging throngs at parks, carnivals, fairs, etc.; open a little retail store; or, begin at home; wholesale to stores, grocers, bakers, druggists, parks, baseball games, picnics, wayside stands. No town too small. Start now.

PHENOMENAL PROFITS \$11,265 sales in 3 months reported by California man. New Jersey \$4000 profits in less than 2 months. Revel of Michigan wrote: "Made \$25 on my first day". A. Leib of Montreal wrote: "My sales averaged \$400 per week".

WE START YOU IN BUSINESS Supply machines, secret formulas, and raw material. Little capital starts you on road to phenomenal earnings.

WRITE FOR "BOOK OF FACTS"—It's free, contains success letters from others—shows their places of business, tells how to start.

Eakins Co., 328 High St., Springfield, Ohio
Mail at once, your Book of Facts



Name

Address

ON WHEELS, FLOATS, OR SKIS

Build It for \$199

\$975 Ready to Fly

The HEATH PARASOL reigns supreme. 10c in stamps or coin brings large illustrated booklet.

Heath Airplane Company 1721-29 Sedgwick St. Dept. P-3 CHICAGO, ILL.



Win \$3,500.00

Prizes from \$1800.00 to \$4245.00 each have been won through our unique advertising plan. In our last, an old man of 69, out of work, won over \$5000.00. A boy, only 15, won \$900.00. In next 3 or 4 months thousands of dollars will be awarded to fortunate persons who solve our puzzles and win our prizes.

FIND THE TWIN FLYERS

Watch out! These twelve pictures of a famous woman flyer all look alike—BUT—two, and only two, are exactly alike. Find these twin flyers! Some pictures are different in the collar, helmet, goggles, or tie. Remember, only two of the twelve are exactly alike. Find them, and send the numbers of the twin flyers on a post card or letter today. If correct, your answer will qualify you for this opportunity.

\$7160.00 IN PRIZES GIVEN THIS TIME

Over 25 prizes, and duplicate prizes in case of ties. It's up to the winner whether he or she chooses \$2875.00 in cash or a new Waco airplane, a big automobile, or a new home. A gorgeous prize list!

ANYONE WHO ANSWERS THIS PUZZLE CORRECTLY AND QUALIFIES MAY RECEIVE PRIZES OR CASH.

\$625.00 ADDITIONAL FOR PROMPTNESS

Be prompt! It pays. Find the real twin flyers, and I will send Certificate which will be good for \$625.00 if you are prompt and win first prize. Imagine, a first prize of \$3500.00!

NO MORE PUZZLES TO SOLVE. Any man, woman, boy, or girl in the U. S. A.—anyone at all, except residents of Chicago, Illinois, and former major prize winners. 25 of the people who take up this offer are going to win these wonderful prizes. Be one of them. Send the numbers of the twin flyers. Send no money, but be prompt.

J. D. SNYDER, Dept. 420, 54 W. Illinois St., Chicago, Ill.

Mac WORKSHOP

Electrically Operated

Dependable—Accurate



AMAZINGLY BETTER WORK SHOP!

Home Mechanics, Inventors, Model Makers, Craftsmen! Now you can expect new things—amazing improvements, new easy ways to make and repair a thousand and one different articles right in your own home. Here is everything you need to gratify your creative instincts—and to make big money, too. Even in unskilled hands results are surprising. MAC is a strong, sturdy, practical workshop—designed to perform the most difficult feats of woodcraft.

Now Sent on 10 Days' FREE TRIAL!

We'll gladly send you this superb craftsman's shop on approval for 10 days' FREE TRIAL. Embraces everything necessary for a complete motorized workshop. 1-3 H.P. Motor; 8-inch Circular Saw; 36-inch Lathe; 4-in. Jointer; Sturdy Jig Saw and complete accessories for all woodworking operations. Guaranteed to give the highest degree of service. Never before has machinery of this character and quality been offered at such amazingly low prices.

Small Monthly Payments

Complete outfit shipped to you on approval. 10 days' Free Trial. Then convenient monthly terms if you decide to keep it—as low as \$5.94 per month. The things you make will be worth many times the small monthly payments.

Plans and Instructions Given

We'll help you to develop your mechanical talents. A complete service, including instructions and plans, is given. It is simple to master the art of wood turning. In a short time you can become an expert cabinet maker.

Write Today for Complete Details!

Send us your name and address and we will mail literature illustrating and describing MAC—The POPULAR MECHANIC Workshop—and details of our Free Trial offer and liberal monthly terms. Write today!

MIDLAND APPLIANCE CORPORATION

Dept. 1510, 225 N. Michigan Ave., Chicago, Ill.

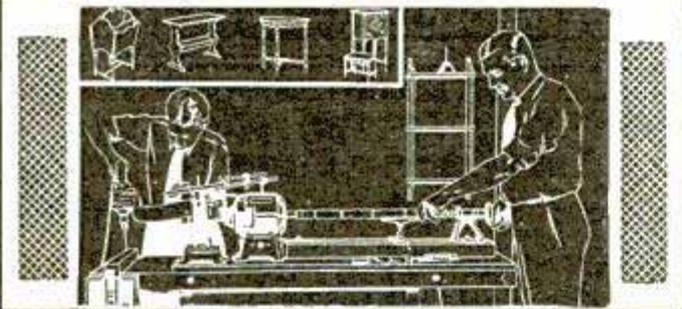

Mechanical Toys

Ship Models, Colonial Bric-a-Brac, Leather and Collloid articles and hundreds of other useful things are described in our new book, Make It Yourself. 460 Pages. Illustrated. Price \$3 Postpaid.

POPULAR MECHANICS PRESS, 200 E. Ontario St., Chicago

AUTO SEAT COVERS

Direct from Factory

Protect and beautify your car with "Supreme" Auto Seat Covers at new low "direct-from-factory" prices. Complete sets as low as \$6.95. Tailored to cover entire upholstery, including seats, back of front seat, doors, side panels and arm rests. Perfect Fit Guaranteed! Attached in a jiffy with patented glove fasteners (no pins). Made of durable materials in 18 attractive patterns. Supreme Auto Seat Covers protect upholstery from dirt and damage. Cool, comfortable and sanitary. Add to car appearance and trade-in value.



Big Discounts For Agents

AGENTS wanted to meet tremendous demand from millions of car owners. Big discounts and liberal commissions. Write Today for Free Sales Kit, material swatches, prices and details of money-making plan. No obligations.

Supreme Auto Seat Cover Co. 2241 Indiana Ave. Dept. 173 Chicago

Tool Oil

Automatic tools are, after all, just machines with working parts that need good oil to minimize friction. They need it regularly, too, just as other and larger machines do.

3-in-One is ideal tool oil — a scientific blend of three high quality oils—animal, mineral and vegetable—therefore has valuable properties that no ordinary single oil can have. Penetrates quickly; stays put—oils perfectly. Try it!

3-in-One

is also a superior rust preventive. Always rub on all tools before putting away. The resulting oil film sinks into the pores of the metal and is impervious to moisture; even damp salt air.

Manufactured since 1894

Three-In-One Oil Co.

130 William Street
New York, N. Y.



3-in-One is sold everywhere by good hardware, sporting goods, grocery, drug and general stores, in two size Handy Oil Cans and three size bottles.

FREE SAMPLE

Send postal for generous sample and illustrated Dictionary of Uses. Both free.

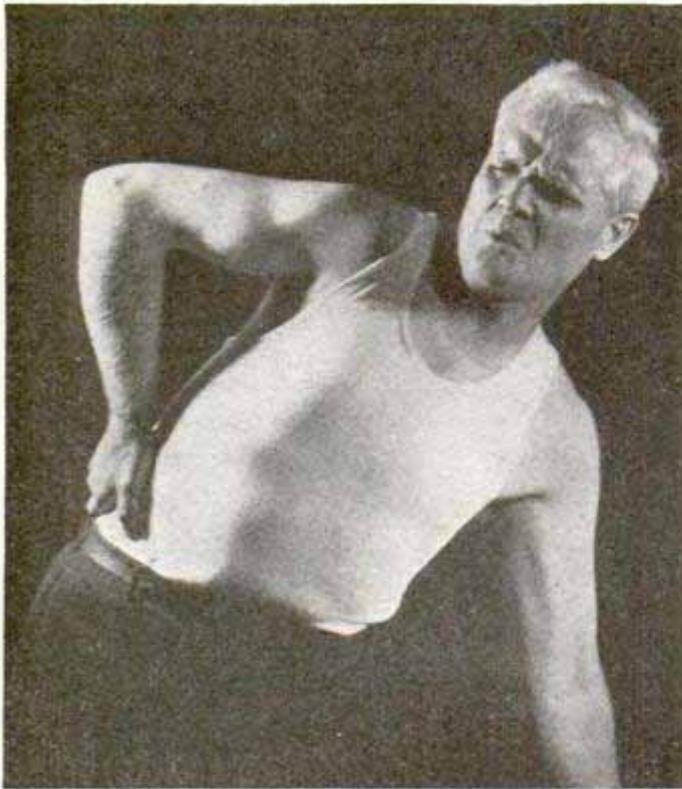

Aching Muscles? —Stiff joints?

A SUDDEN strain on a muscle. A quick severe twist of a joint. Sometimes overwork does it. Sometimes hard exercise. Later those dull, throbbing pains! That old stiffness and soreness! How much suffering they can cause us. We feel lame and stiff. It's hard to do any work.

DON'T put up with pain from muscles and joints. Sloan's Liniment eases the soreness quickly. *Warms the body like sunshine.* Drives away pain. Used in 13 million homes. Booklet of 16 tested treatments for aches and pains in every package. Get a *fresh* bottle from your druggist. 35 cents.

SLOAN'S Liniment

861 PRACTICAL IDEAS for REDUCING FARM LABOR and INCREASING INCOME

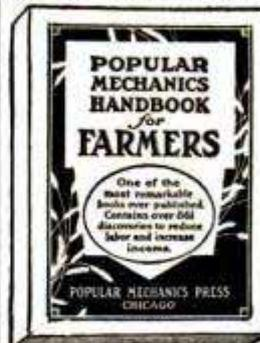

One farmer writes: "I would not take \$100 for my copy if I could not secure another."

The Handbook for Farmers contains: 138 ideas for the farm shop, 35 on fencing, 98 on auto, truck and tractor, 61 on farm buildings, 36 on field machines, 48 on concrete work, 22 on orchard work, 23 on painting, 15 on live stock, 34 on poultry, 54 on garden work, 25 on electrical work, 22 on farm tools, 16 on hunting, fishing and trapping, 140 household helps.

394 HELPFUL KINKS to LIGHTEN the LABOR of the FARMER'S WIFE

The Handbook for Women contains: 83 kitchen and dining room helps, 17 on garden and flowers, 19 on sewing and mending, 37 on furniture, pictures and fixtures, 38 on laundry and cleaning, 32 on house cleaning, 12 on music, 14 on sleeping rooms, 11 on care of children, 16 on lights, 9 on photography, 14 on clothing and shoes, 23 on house temperatures, 12 on water and drains, 10 on insect pests, and 47 miscellaneous.

SPECIAL OFFER BOTH for \$1

(Regular \$1.50 Value)

For a limited time you are offered both books for \$1 plus the postage. Pay postman when he delivers package. If outside U. S. send remittance and include 15 cents extra for postage.

POPULAR MECHANICS PRESS
Room 3, 200 E. Ontario St., Chicago

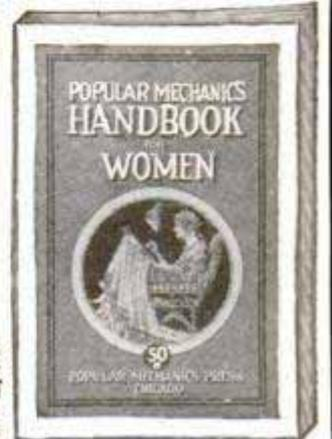

BLUEPRINT READING For the Building Trades

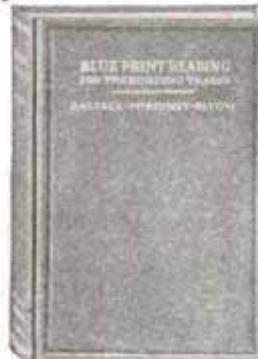

Every man who is ambitious to learn the last detail of blueprint reading will want this new book which is thorough, complete and up-to-the-minute. Written in a clear, non-technical manner. An ideal working tool for apprentices, teachers, students, carpenters, bricklayers, etc.

Over 100 pages—50 plans and illustrations.

Cloth—Price \$1.25 postpaid

Popular Mechanics Press
Room P 3
200 E. Ontario St. Chicago

What Do You Do When
You Cannot Find the

Book You Want ?

Don't give up in despair. Send for a copy of the unique catalog published by Popular Mechanics Press. It contains 5000 books listed alphabetically under 2000 main subjects and sub-headings—literally from A to Z—Abrasives Manufacture to Zoologist and everything in between.

FREE UPON REQUEST

Send for your copy today

POPULAR MECHANICS PRESS
200 E. Ontario Street, CHICAGO



AN ECONOMICAL MOTOR-BOAT STURDY AS A STEAMER

ECONOMY — speed — safety — and durability — you get these in an "Old Town" square-stern sponson powered with an outboard motor. She skims the water—shoots along as stoutly as the staunchest cruiser.

The extra-strong stern cares for the weight of the motor. Rigidity is wrought into the ribs . . . no vibration or shaking. This and the heavy, non-leak canvas means she won't "loosen up" and need soaking or caulking. An "Old Town" doesn't require going over for a long, long time.

Free catalog shows many outboard craft, including big, fast, seaworthy, all-wood family boats; dinghies; rowboats; speedy step-planes; and also all canoe types. Write today. Old Town Canoe Co., 1143 Middle St., Old Town, Maine.

"Old Town Boats"

ALL ABOUT Aviation FREE!

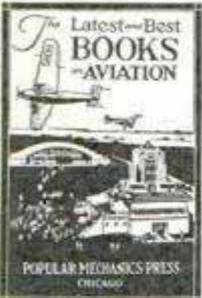

No matter what your interest in flying may be; whether that of student, instructor, pilot, executive, flying field mechanic, hangar or shop man, engineer, designer, draftsman, manufacturer or layman, you need the latest and best information obtainable.

First-Hand Knowledge for Prospective Students

The young prospective student of flying should have forcibly impressed upon him the advantages in getting all the first-hand knowledge possible of aircraft construction, flight, etc.

Survey of Transport Aviation Development

No business man who is looking to the future can afford to remain out of touch with the rapidly unfolding commercial development of transport aviation.

New Opportunities Constantly Opening

As an illustration of the many new calls for skilled craftsmen in the industry, the advent of all-metal ships has brought the trade of aircraft welding into prominence.

Consult the Best Authorities

For the best help on any and every phase of aeronautical science send for our special new 24-page illustrated catalog of aviation books. In this you are not only given the most complete descriptions of the important new books, but such well-known authorities as the Staff of the Daniel Guggenheim School of Aeronautics, New York University and Major R. W. Schroeder, pioneer Aviator and Aeronautical Engineer aid you by recommending the best books available on a big assortment of subjects.

Send for Your Copy Today

Popular Mechanics Press, 200 E. Ontario St., Chicago



Buy when you're convinced

We claim that, if you will accept our free 7-day shaving test, our chances are 86 in 100 it will win you. Will you take us up?

PALMOLIVE Shaving Cream, in a few short years, has become the fastest selling in the world. Millions of men who have sent for our free test have been won by it. 86% of those who try it never return to old methods.

Our problem is to convince you of the importance of making this test.

Our laboratories, for 68 years creating world leaders in the soap field, felt that olive oil in a shaving cream would do much, by its cosmetic emollience, to relieve the irritation and chafing of daily shaving.

Time and again they tried to make a shaving cream worthy of the name Palmolive. 129 formulas were rejected before success came. Then we offered men for a convincing test, a product which embodied 5 important improvements.

5 Features

- 1 *Multiplies itself in lather 250 times.*
- 2 *Softens the beard in one minute.*
- 3 *Maintains its creamy fullness for 10 minutes.*
- 4 *Strong bubbles hold the hairs erect.*
- 5 *Fine after-effects due to olive oil content.*



5189

7 SHAVES FREE

and a can of Palmolive After Shaving Talc

Simply insert your name and address and mail to Palmolive, Dept. M-835, P. O. Box 375, Grand Central Post Office, New York City.

(Please print your name and address)

Simplex Screw Jacks

For the Home, Workshop, or Manual Training

WITH this 500 lb. capacity Simplex Jack, you can straighten window or door frames and avoid planing or resetting locks—level radiators, plumbing, drain pipes, ice box—straighten or clamp glued work, radio cabinets, etc. This little—

“Jack in the Box”
is for the man who uses tools, or the boys interested in manual training or mechanical toys. It has hundreds of uses. Sturdily built, beautifully finished, and unconditionally guaranteed. Its purpose is to demonstrate and advertise the exclusive safety feature of the visible screw and power of the larger Simplex Jacks, and will be sent you prepaid for 35 cents—Canada 45 cents. Money refunded without question and instantly if not satisfied.

Templeton, Kenly & Co. 35¢
ESTABLISHED 1899
1020 So. Central Av. Chicago Ill. U.S.A. 130

Gentlemen: Please send me postpaid 1 Simplex Miniature Jack at 35 cents and at 35 cents each for my friends. A total of \$..... is enclosed.

Name.....
Street.....
City..... State.....
Mark color desired: Red, Blue, Green.

Ask Your Hardware Dealer for the Larger SIMPLEX Jacks

Make Big Money Laugh at Competition

AGENTS BUY DIRECT AT LOWEST MILL PRICES

Men's Latest Fancy Hose, doz. \$1.45 and \$2.10
Ladies' Pointex Silk Hosiery, doz. \$4.25—\$7.00
Satisfaction Guaranteed, Catalogue FREE. Act TODAY.
SUPERIOR KNITTING CO., Dept. 41, NEW HAVEN, CONN.

Ship Models with Electric Lights ONLY \$6.50



We furnish you with all the parts cut perfect. No trouble to fit them together and in a very little time you will have a beautiful ship model that you will be proud to own, placed on your radio or mantel and lighted with the electrical equipment that comes with each model. They give the effect of a ship at sea sailing along on the quest of adventure.

We have the following models, all parts cut to fit and ready to be put together, a complete diagram and instruction sheet numbered so that you cannot go wrong.

- Flying Cloud... 26 1/2" long, 7 1/2" wide, 19" high.
- Santa Maria... 27" long, 10" wide, 25" high.
- Mayflower..... 30" long, 10" wide, 26" high.
- La Pinta..... 27" long, 12" wide, 26" high.
- Constitution... 32" long, 10" wide, 30" high.

Every Model Guaranteed Money Back If You Want It

We will send you any of the above models C.O.D. anywhere in the United States. Money order or check must accompany all foreign orders.

All models shipped same day as order is received.

Model Woodworking Co. Dept. D-3 PERKASIE, PA.

PANTS MATCHED!

Why Throw Away That Coat and Vest? Save \$25 or more! Let us match your coat and vest with new trousers and save the price of a new suit. Each pair tailored to your measure. (Average price \$8.50). Over 100,000 patterns. Mail sample of suit, or your vest which will be returned together with FREE Sample for your approval.

Match Pants Co., Dept. 202, 20 W. Jackson Blvd. CHICAGO

\$7,346.00 in PRIZES! FIND THE MISTAKES!

Every year we spend over \$150,000.00 on prize offers like this to advertise and expand our business. Here is our latest offer with \$7,346.00 in prizes—a magnificent list of 24 breath-taking prizes! Any man, woman, boy or girl in U. S. A. outside of Chicago, Illinois, may submit an answer.

BE QUICK!

BE CAREFUL!

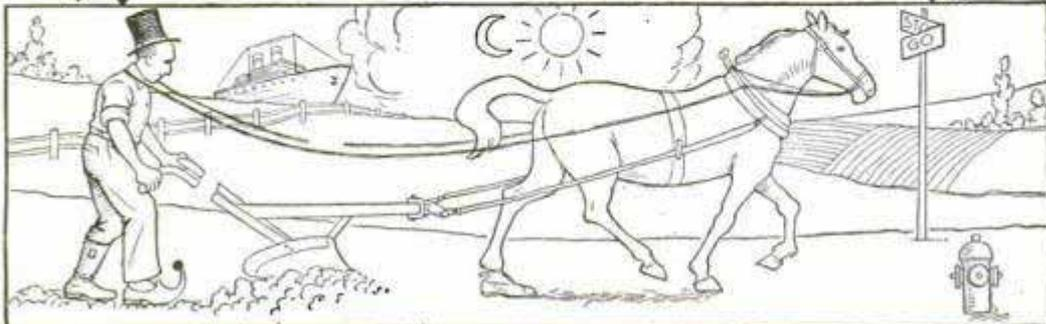

SEVEN BIG NEW SEDANS GIVEN

IN drawing the picture shown here, the artist made several mistakes on purpose—so don't be fooled! How many of these mistakes can you find? What objects are wrong, out of place, etc.? If you can find 7 mistakes you will qualify for this extraordinary opportunity. Mark the mistakes you find on the picture and send it to me, or write them down in a letter or on a post card.

You May Win Nash Sedan or \$1845.00

Imagine winning Nash Sedan or \$1845.00—first prize in this latest offer! And besides, 6 other big new Sedans for the next 6 prizes—beautiful new Oldsmobile, De Soto, Pontiac, Essex, Whippet, and Chevrolet. **ONLY THIS ONE PUZZLE TO SOLVE**, and you risk no money and don't have to

buy a thing to win. This is our way of advertising. Solve this puzzle and learn how you can win. Duplicate prizes paid in case of ties.

ADDITIONAL \$500.00 FOR PROMPTNESS

Hurry now! Solve the puzzle above correctly and receive at once the Certificate I will send, which will be good for \$500.00 if you are prompt and win first prize, making total first prize \$1845.00. Don't delay! We have given over 60 automobiles already, and you can win this time. It costs you nothing, so send your answer right now.

G. W. ALDERTON, DEPT. 592

510 N. DEARBORN STREET, CHICAGO, ILLINOIS

**For
Craftsmen
Who
Want
Something
More Than
a Toy!**

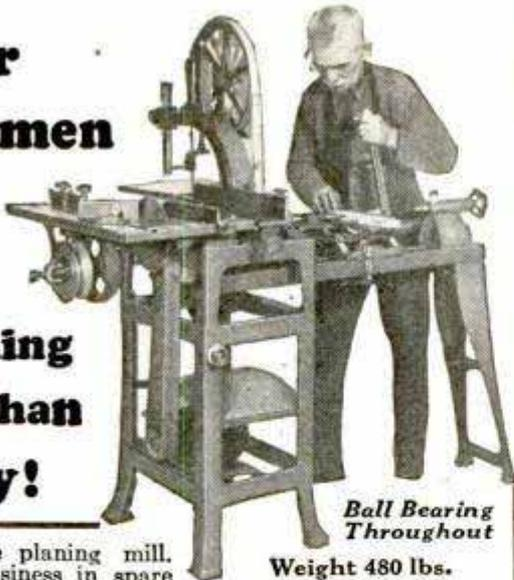

**Ball Bearing
Throughout**
Weight 480 lbs.

A complete planing mill. Build a business in spare time. Turn out accurate cabinet work. Ideal for the Home Craftsman. Saws 3 1/4" thick. Rips 12" wide. Lathe swings 10". Rugged cast-iron frame; no warping, twisting or vibration.

The Electric Carpenter

Runs from any Light Socket

\$65 deposit brings it to you for Free Trial.

A whole year to pay!

**7
Machines
in One**

- 8" Circular Saw
- 14" Band Saw
- 36" Lathe
- 10" Swing
- 4" Jointer
- Reversible Shaper
- 1/2" Hollow Chisel
- Mortiser
- Sander

Does 35 Woodworking Operations

Write today for New Folder P-99
We also build a complete line of single-purpose machines
THE WOODWORKING MACHINERY CO., INC.
Eleventh and Vine Sts., Philadelphia, Pa.

**PUNCTURE-PROOFS
TIRES in ONE minute**



**"SILVER STAR" EMULSIFIED
PURE RUBBER LATEX**

(A Viscous Pneumatic Cement—Not a Liquid)

Seals punctures instantly—the moment they occur—one application made in a minute without taking tire off wheel or rim—does the work. Seals slow leaks and porous tubes. Don't confuse with anything else you have ever seen or heard about. "Silver Star" is new—different and scientifically correct. Manufactured by a newly perfected process the result of over five years of intense chemical research. We invite you to—

Make This Test—Yourself

Hammer as many nails into a tire as you wish, pull them out or leave them in—just as you please—no air will escape—no pressure will be lost. We welcome you to subject "Silver Star" to the severest tests you can devise. The results produced by this new emulsified compound of Pure Rubber Latex will both astonish and amaze you.

AGENTS

We want live, energetic, wide awake distributors to introduce "Silver Star" to car owners, garages and filling stations. No talking—just hammer, seal and make the most powerful, attention compelling, self selling demonstration ever devised. You can't get rich in an hour but can make immediate, sure, steady profits that are amazing.

Exclusive Territory Rights—Powerful advertising Co-operation—A Straightforward Money Back Guarantee—Low Selling Price and Liberal Profit Margin all combine to make this the most attractive and profitable proposition in the direct selling field today. It will pay you to get the facts and get them NOW.

SEND TODAY! Write or wire now for complete information, stating territory wanted. Or, better still, for quick action, enclose \$2.50 and we will send you by return mail, postpaid, enough "Silver Star" for four ordinary size tires. Test it out in one of your tires and if you are not absolutely satisfied, send the balance back in 10 days and we will not only refund your money but pay you 50 cents extra for your time and trouble. Could a fairer offer be made? Territory is going fast—Don't delay—Send today.

VILO MFG. CO. 159 N. Michigan Avenue
Dept. 6 CHICAGO
Canadian Plant—Galt, Ontario.



**He's popular!
makes extra money!**



EASY » he learned in a few weeks
FUN » having the time of his life

This fellow gets the smiles worth while. Steps ahead socially and in business. Is popular—at gay parties, lodge, church, school, college. Makes friends. Earns money on the side. And he does it all with his Buescher Sax. . . . You can do what he is doing. Easy! You can learn in a few weeks. And you'll have the time of your life while you are doing it.

BUESCHER True-Tone Band Instruments

Unrivalled in easy playing. Unmatched in purity and sweetness of tone. Unexcelled in fine musical craftsmanship. Incomparable in beauty. Buescher Band Instruments share the illustrious name and fame of most of the great band, orchestra, stage and radio artists of today. There are no finer Band Instruments in all the world.

Pay as You Play!

Bueschers are easy to own. Just a little down, then pay as you play. There are 88 Buescher instruments. Fill out the coupon below so we will know which instrument you want; whether for band, orchestra, or home playing; what instrument you now play, if any; and your age. Then we'll send the correct Buescher Catalog-Folder and full details.



Buescher Band Instrument Co.
3044 Buescher Block
Elkhart, Indiana



Buescher Band Instrument Co.,
3044 Buescher Block, Elkhart, Ind.

Gentlemen:—Please send your Catalog-Folder. I am interested in a I want to play it in
I now play a My age is
Name
Street Address
Town State

Thank you for making it possible for me to own a **21 Jewel - Santa Fe Special**

Writes Thousands of Our Customers

The Nationally Popular Santa Fe Special sent to you for your approval. Wear 30 Days FREE!



Write for Watch Book and Diamond Book Buy Direct

Buy and Pay the Santa Fe Way

You must be pleased when you buy a "Santa Fe Special" Watch. That is why I will send for your approval one of these Standard Watches, guaranteed for a lifetime of satisfactory service, not only by the Santa Fe Watch Company, but by the Great Illinois Watch Factory. They are found in the pockets of men in the service on every railroad in this country. Senators, Congressmen, and Governors keep their official appointments by "Santa Fe Special" time, Army Officers and Privates carried them all through the Greatest War in history—thousands of these splendid watches are in use all over the World. If you want one on my liberal Buy and Pay the Santa Fe Way Plan—you had better write for my Free Watch Book today and make your selection. I will even let you wear the watch 30 days FREE, then sell it to you on a binding money back guarantee, and on easy monthly payments.

JUST OUT!—New "Santa Fe" Watch Book

Send coupon for our New Watch Book—just off the press. All the newest watch case designs in white or green gold, fancy shapes and thin models are shown. Read our easy payment offer. Wear the watch 30 days FREE. Nothing to risk. See the watch before you buy. Write for New Book Today—It's FREE. Select Your Watch NOW.

FREE A limited offer! With every Santa Fe Special, a beautiful gold chain or strand of exquisite pearls. Write today.

SANTA FE WATCH COMPANY
Dept. 36, Thomas Bldg., Topeka, Kansas

Send No Money
11 1/2 cents a day—
pays for any of
these Watches.
wear 30 days
free!

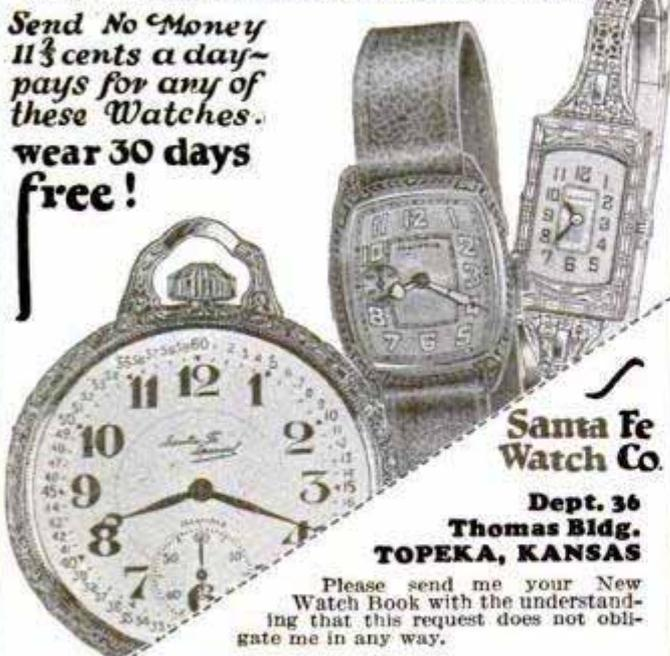

Santa Fe Watch Co.

Dept. 36
Thomas Bldg.
TOPEKA, KANSAS

Please send me your New Watch Book with the understanding that this request does not obligate me in any way.

Name.....
Address..... State.....



We Invite Men Past 40..
To Send For These Amazing Facts About Old Age!

The Truth About Rejuvenation—Prostate Trouble—and a New Home Treatment

EVERY man approaching or past middle age owes it to himself to read the astonishing book "Why Many Men Are Old at 40." Just as there are certain diseases common to childhood, so there are symptoms of debility and break-down that are likely to occur at or past the prime of life. Weakness—pains in the back, legs or feet—loss of mental or physical vigor—loss of sleep through frequent nightly rising—these are but a few of the danger signals often set by Nature to warn men of prostate trouble. The symptoms are many times falsely attributed to bladder or kidney trouble—but in fact they warn often of a different danger; a failing prostate gland.

But now an amazing scientific discovery, used by over 50,000 men, is bringing back health to many men who have reached that "dangerous age" when prostate trouble sets in. Without drugs, diets, exercises, or violet rays this treatment works quickly, and frequently restores the prostate gland to normal. Harmless and easy to use as a hot water bottle—yet many men report feeling ten years younger after using it a week. Not only frequently relieves swollen prostate and urinary discomfort but usually banishes immediately any chronic constipation.

If you have this gland trouble or any of the symptoms named you should have this free book "Why Many Men Are Old at 40." Not only tells you the things you need to know about your health, but explains our sweeping guarantee and tells you how you can make yourself feel ten years younger in six days or pay nothing. The present edition of the book is limited, so send for your free copy now.

THE ELECTRO THERMAL COMPANY
2127 Morris Ave. Steubenville, Ohio

Western Address, Dept. 21-D, 303 Van Nuys Bldg., Los Angeles, Calif.
In Canada, address The Electro Thermal Co., Desk 21-D, 53 Yonge St., Toronto, Ont., Can.

The Electro Thermal Company
2127 Morris Ave., Steubenville, Ohio
Please mail at once a FREE copy of the book "Why Many Men Are Old at 40," and illustrated details of the new treatment. I am not obligated in any way.
Name..... Age.....
Address.....
City..... State.....

PAINT EXPERTLY with ELECTRICITY

FACTORY 1/2 PRICE

SURE SPRAY

The ELECTRIC PAINT BRUSH

\$39⁵⁰

it can't clog

FREE
Write for large illustrated broadside giving every detail of the marvelous Electric Paint Brush and "Factory-to-You 30-day offer."

ALL-STEEL PRODUCTS CO.
DEPT. A-3
1245 Michigan Theatre Bldg., Detroit, Mich.

3 EXTRA PAINT CANS FREE



Lonely Hearts



WILBERT has a heart of gold. Will no one tell him what's the matter — why girls turn pale, and gracious matrons freeze at his approach? Yes, *we* will. This has gone far enough. Get a new pipe, Wilbert, and break it in gently, thoughtfully, with Sir Walter Raleigh's favorite smoking mixture. When the curling wisps of its fragrance surround you, everything will be changed, Wilbert.

How to Take Care of Your Pipe—(Hint No. 3)

To make your pipe sweet from top to heel, smoke *all* the pipe load when you break it in, or fill the bowl full the first few times so that the heel, and not merely the top, will be broken in. Send for our free booklet, "How to Take Care of Your Pipe." Brown & Williamson Tobacco Corporation, Louisville, Kentucky, Dept. 78.



SIR WALTER RALEIGH

Smoking

It's



Tobacco

milder

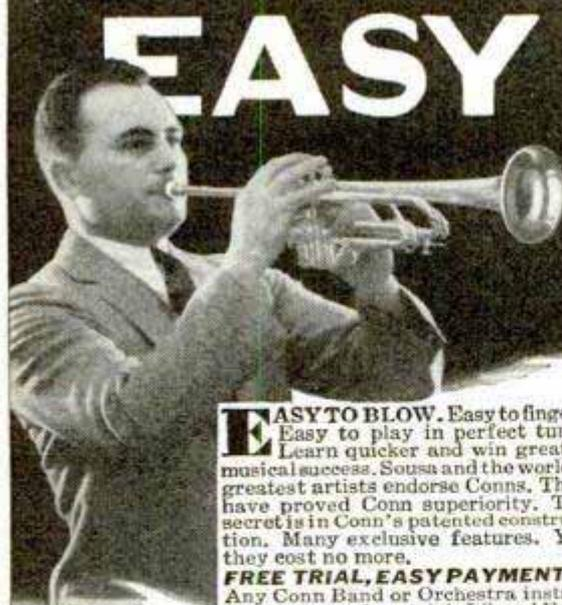

EASY

EASY TO BLOW. Easy to finger. Easy to play in perfect tune. Learn quicker and win greater musical success. Sousa and the world's greatest artists endorse Conns. They have proved Conn superiority. The secret is in Conn's patented construction. Many exclusive features. Yet they cost no more.

FREE TRIAL, EASY PAYMENTS. Any Conn Band or Orchestra instrument sent on free trial. Liberal Easy Payment Plan. Write for special offer. **Send For FREE BOOK.** Describes your favorite instrument. Gives history, place in band, points out money making opportunities. Illustrates newest models in natural colors. Mention instrument.

C. G. CONN, LTD.
331 Conn Bldg., Elkhart, Indiana

CONN
World's Largest
Manufacturers of
BAND INSTRUMENTS

Write for **FREE BOOK**

›› Mention Instrument ‹‹





Lend us a hand, men!

We want to borrow a hand—the hardest-to-clean hand that ever did a dirt-collecting job. In 58 seconds we'll give back that hand so clean that its owner and his wife won't know it. How will we clean it? With Lava Soap. That's all. But that's enough—because Lava is made to drag out grime and grease quicker than any other soap in the world—without hurting the skin. Lava contains pulverized Italian pumice ground almost as fine as flour. It makes a rich, fast-working lather—even in cold or hard water—a lather that gets the dirt and protects the skin. Lava costs only 6 cents or a dime—at any grocery or drug store.

George, the Lava Soap Man

IF YOU'VE NEVER TRIED LAVA SOAP
SEND FOR A FREE SAMPLE CAKE

Procter & Gamble, Dept. W-330
Cincinnati, Ohio

Send me a free sample cake of Lava Soap.

Name.....

Street or R. F. D. route.....

City.....State.....

THREAD CUTTING LATHE
A REAL Lathe. 9" swing; 30" between centers. Speedy and accurate. Special attachments and tools available. Write today for 12" BAND SAW Circular and Powerful, practical. Not a toy. Prices on these Has tilting table. Price \$30 and other machines. Rossbacher Machine Co., 1516 Fernwood Ave., TOLEDO, OHIO

SIMONDS SAWS
Best for every cutting purpose
SIMONDS SAW & STEEL CO., FITCHBURG, MASS.

SPORS GUARANTEED No. 1 FOUNTAIN PEN

SELLS FOR \$1.25

SEND ONLY

39¢

Sent Post-Paid

"Writes Like a \$7 Pen."

Use 60 Days

Money Back If Not Pleased



Write for Free Wholesale Catalog Showing Over 400 Articles.
AGENTS! CHANCE TO MAKE \$10 TO \$20 A DAY.
F. SPORS & CO., 130 Main Street, LESUEUR CENTER, MINN.

DIAMONDS WATCHES
CASH or CREDIT
Buy Your Bulova of Loftis!
EACH WATCH SENT IN *Buy Now!* ATTRACTIVE GIFT BOX

No. 911—*"Lone Eagle"* with dust-proof Bulova case. 15-Jewel-movement . . . \$37.50
No. 948—*"Miss Liberty,"* with dust-proof Bulova case. 6 sapphires. 15-Jewel-movement . . . \$37.50
\$3.75 Down; \$3.75 a Month \$3.75 Down; \$3.75 a Month

How to Order State article desired—name of employer—kind of work you do—how long in position—age—married—where live—how long there. **EVERYTHING IS CONFIDENTIAL.** Send first payment, OR goods sent for your FREE Examination on request. **WEAR WHILE YOU PAY.**

CREDIT TERMS: One-tenth down; balance weekly, semi-monthly or monthly at your convenience. Satisfaction Guaranteed Or Your Money Back. Order Now.

SEND FOR FREE CATALOG
Over 2,000 illustrations. Catalog explains everything.
Our References: Any Bank or Banker in U. S. A.

The Old Reliable Credit Jewelers **LOFTIS** BROS. & CO. 1858
Dept. L-894
108 N. State St.
Chicago, Illinois

Auto Seat Covers \$2.95
Special Price Offer

AGENTS Make \$20 a Day

Write orders fast for this excellent Quality line Auto Seat Covers. Amazing values—quick sales. Cash daily. We deliver. Write for handsome Free Leatherette Sample Outfit. **Quality Sales, 1834-36 North Ave., Dept. 316, Chicago**

World's Wonder Wrench
Banishes Old Style Wrenches!

New! Different! Never a nut wrench like "speednut" Chicago Auto Show sensation. Automatic! Ratchets! Can't slip! The harder it's pulled the tighter it grips!
A whole kit of wrenches in one. Has 23 wonder features. Priced low with big profits to you. Enormous demand. Special Demonstrator Offer starts you writing orders from tool users, car owners, factories, shops, part, full time. Collect pay daily. We deliver. **SPEEDNUT CORP., 190 N. State St., Dept. 79, Chicago**

Pays Agents Big Money

\$8.50 SUNLIGHT FOR HEALTH, NEW LIFE AND VIGOR

Special low price on Mann CARBON ARC Ultra Violet Lamp—complete with carbons, etc., only \$8.50. Produce genuine Ultra-Violet Rays in your home! Aids and maintains health, relieves pain, builds up vitality! Has automatic device and uses big 8mm carbons. Efficient, powerful and easy to use. Built extra strong and durable. 12 1/4 in. high.
SEND NO MONEY! Pay postman \$8.50 on arrival, plus postage. Try it! If not more than delighted with results, return it and your money will be promptly refunded. Descriptive literature free on request.
Ultra Mfg. Co., (Lamp Dept.) 121 N. Francisco Ave. CHICAGO

SILVER ACE Flying Models



Good News for 1930

THE world-wide approval of SILVER ACE models for beauty of design, performance and durability enables us to quote new prices on our de luxe, silk-covered, convertible cabin and Spirit of St. Louis models and sets. From one fuselage you can now build or fly six of these most famous of all aircraft models, merely by adding extra wings, pontoons or skis. Prices of our other models are unchanged.

New Prices	
Ready to Fly Monoplane.....	\$10.00
Partly Assembled.....	8.00
Knocked Down.....	6.00
Contest Set.....	4.50
Pair of Extra Wings.....	3.00
Pontoons.....	4.00
Skis.....	1.00

Add 50 cents for shipping if your dealer cannot supply you.

Complete catalog 10 cents.

AERO MODEL COMPANY

Dept. M-23

111 No. Wacker Drive
CHICAGO



CRESCENT SAW TABLES



Portable and heavy, 16 types and sizes. This No. 14 Portable is well built, highly efficient, and exceptionally convenient for light work. Tilting top; table raises and lowers, etc. 30 other Crescent wood-working machines include band saws, self feed rip saw, shapers, jointers, planers, planer and matcher, variety woodworker, disk grinder, cut-off table, swing cut-off saws, borers, hollow chisel mortisers, tenoners, universal woodworkers, universal variety saw.

THE CRESCENT MACHINE CO.
93 Columbia St. Leontonia, Ohio

Send for FREE BULLETINS



How to Obtain A Better Looking Nose!

Improve your personal appearance. My new Model 25 Nose Shaper is designed to improve the shape of the nose by remodeling the cartilage and fleshy parts, safely and painlessly. This is accomplished thru the very fine and precise adjustments which only my patented Model 25 possesses. Results are lasting. Can be worn at night, or during the day. Money refunded if not satisfied after thirty days' trial. Write for free booklet to

M. TRILETY, Pioneer Nose Shaping Specialist
Dept. 61 BINGHAMTON, N. Y.

Why WORRY ABOUT MONEY?

YOU CAN HAVE A **STEADY INCOME** and **EXTRA MONEY, too!**

FREE!
Sales
Outfit

Take Orders for America's Great SHIRT and TIE Values!

If MONEY is the question, here is your answer! We offer YOU an extraordinary opportunity for a steady, big income which will help you to really enjoy life and to save for that "rainy day."

Take orders, during ALL or SPARE Time for Howard Style-Tailored SHIRTS and TIES. More than 100 remarkable values. No Experience necessary!

DON'T SEND ONE PENNY! WRITE TODAY!

We will send you FREE, everything you need to start right out, take orders and EARN BIG PROFITS. Our Sales Outfit is yours without charge. Take it and STOP MONEY WORRIES!

HOWARD SHIRT CO., Dept. H-6
1213-19 W. Van Buren St. Chicago, Ill.



You never know when or where you may need **SMOOTH-ON NO. 1** so keep a can in the house

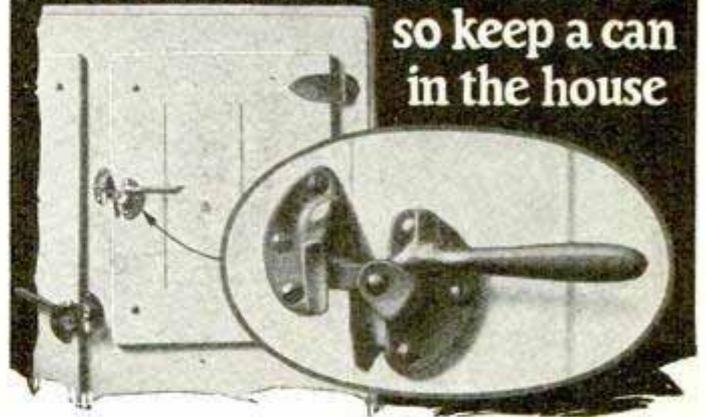

A 50-lb. block of ice dropped on this icebox handle, bent the lever, stripped the screws and splintered the wood. Larger screws could not be used and the lock could not be shifted. A new door seemed necessary. Instead the owner fitted the splinters back, filled the screw holes with about 5 cents worth of Smooth-On No. 1, and put back the screws. When the Smooth-On metallized, the lock became strong as new. The repair will last as long as the icebox.

Any handy man can make equally practical home and automobile repairs with Smooth-On No. 1 and avoid a repair bill every time. Use it to stop leaks

in steam, water, gas, oil or stove pipes, mend cracks, breaks or leaks in furnaces and boilers, radiators, tanks, sinks, pots and pails, make loose handles tight on umbrellas, knives, hammers, brushes, drawers, etc., tighten loose screws, hooks, locks, door knobs, etc.

Automobile repairs:—Making cracked water jackets and pumps good as new, stopping leaks in radiator, hose connections, gas tank and gas, oil and exhaust lines, making a fume-proof joint between exhaust pipe and tonneau heater, tightening loose headlight posts, keeping grease cups, hub caps and nuts from loosening and falling off, etc.

To get perfect results, write for and use the Smooth-On Repair Book.

Get Smooth-On No. 1 in 7-oz., 1-lb. or 5-lb. tins at any hardware store or if necessary direct from us.



Write for FREE BOOK

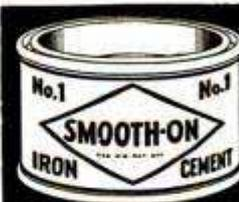

Do it with SMOOTH-ON

SMOOTH-ON MFG. CO., Dept. 37,
574 Communipaw Ave., Jersey City, N. J.

Please send the free Smooth-On Repair Book.

Name.....

Address.....

3-30.....

GIVES FACTORY FINISH JOB!



Painting Time Cut in Half with Haywood Improved Payntgun

It's a joy to put a perfect, smooth surface on your car, furniture, woodwork, etc., with the new Haywood Payntgun! No experience needed. Powerful spray designed for easy, sure control; sprays evenly lacquer, varnish, paint or enamel. Built for service. Fully guaranteed.

FREE Folder on Perfect Painting

Gives Valuable instructions on skillful home painting. Write for your copy now!

HAYWOOD EQUIPMENT CO.

2345-C Ogden Avenue, Chicago, Ill.



ARTISTIC ENLARGEMENTS

Size 16x20 inches

Surely you have a photo of some dear one, mother, dad, baby, or friend that would enlarge beautifully and bring out the lifelike features perhaps better than in the small picture. The usual price of this work is \$5.00, but our price is only 98c.

98c

SEND NO MONEY

Just mail photo or snap-shot any size, full figure, bust or group. Within a week you will have your enlargement, size 16 x 20, or smaller, if desired. Guaranteed fadeless. Pay postman 98c plus postage, or send \$1.00, and we pay postage. Money back, if not delighted.

FREE With each enlargement we send Free a hand tinted miniature reproduction of photograph. Take advantage of this amazing offer now. Send photo today.

ALTON ART STUDIO, 5654 West Lake St., Dept. 80, Chicago, Ill. Please send.....enlargements from enclosed photo. I will pay postman 98c plus postage for each enlargement. (If \$1.00 cash for each enlargement is enclosed with this order, we pay postage.)

Name.....
Address.....
Town.....State.....

- Check Size Wanted
- 16x20 in.
 - 10x16 in.
 - 11x14 in.
 - 8x10 in.



SIZE
23 1/2" Long, 22" High
10" Wide

Get this— Ship Model

True—"Santa Maria" only made in knocked down form with all parts carefully cut to fit, each part numbered so as to make the assembling to follow from drawing and instruction sheet furnished with each KIT, FREE.

Educational and interesting pastime. When completed you have a beautiful ornament for your Radio Cabinet or Mantel. Sails all painted with designs in colors \$5.48 Plus Mailed C.O.D. anywhere in U.S.A.

COLARK CO., INC.

2213 E. Susquehanna Ave., Phila., Pa.

BREAKFAST NOOK and 26 other splendid articles of Built-In Furniture in our new book on this subject. 198 pages. Illustrated. Price \$2.50 Postpaid.
POPULAR MECHANICS PRESS, 200 E. Ontario St., Chicago

BUICK 4door SEDAN

5 CARS GIVEN

Every year we spend over \$150,000.00 on prize offers to advertise our business. In this new offer, 150 Grand Prizes totaling \$6555.00 will be given to the fortunate ones who solve our puzzle and win. Here it is—

FIND THE "DIFFERENT" AUTO

The 16 cars in circle all look alike. 15 of them are exactly alike—but one is different from the rest. Find this "different" car if you can—and mark it. The differences may be in fenders, bumper, name plate, radiator or top. Careful—don't let this puzzle stump you, because winner must solve puzzle correctly first in order to

WIN BUICK SEDAN OR \$2000.00 CASH

Winner has choice of Buick Sedan or cash if preferred. No more puzzles to solve. Duplicate prizes in case of ties. All actively interested who have answered correctly and qualify will receive prizes or cash compensations. Nothing to buy, now, later or ever, so send no money.

\$705.00 For Promptness—Don't delay! Solve puzzle correctly and receive Certificate good for \$705.00 if you are prompt and win first prize, making total prize \$2000.00. Any man, woman, boy, or girl in U. S. A., outside of Chicago, may submit an answer. 150 of the people who take up this offer are going to win these splendid prizes. Be one of them. Send number of "different" auto in letter or postcard today. But act promptly!

**B. A. BLACK, Room 104,
504 North Dearborn Street
Chicago, Ill.**

Send No Money! Reply to-day!

\$705.00 for Promptness!

Polydyne 7-TUBE "250" Power Audio Sensational Radio



Value at

\$24⁵⁰

All Electric Radio—No Batteries

YOU—who have been looking for radio prices to drop—will find Millenium Value in this genuine Freshman POLYDYNE All Electric, 7-tube, "w50" Power Audio Set at \$24.50, less tubes. Complete with all accessories necessary for operation, except speaker, ONLY \$35.50.

Never before such a sensational value in radio merchandising. Only our million-dollar purchasing power makes it now possible. The retail value, complete, is actually \$110.

Finest Quality—Throughout

Designed to incorporate all the ultra-modern principles of scientific radio engineering, the Freshman POLYDYNE 7-250 reaches a new high-water mark for performance and reception. Constructed of finest quality materials by skilled workmen, it is sturdily built for long life.

Distinctive Metal Cabinet

Its all-metal cabinet is beautifully finished in brown and gold crackle effect. Designed for beauty and endurance, it gives a highly desirable decoration for any home. Length 18½", depth 9", height 9".

Unexcelled Performance—Wonderful Tone and Volume

The famous Freshman POLYDYNE 7-250 circuit consists of three tuned radio frequency amplification stages, detector, and two stages of audio frequency. The powerful new X250 power audio tube provides tremendous volume without distortion. Every note produced is mellow, true and vibrant with life. It is remarkably selective, sensitive, and powerful! Its reception is positively flawless.

Or this \$75 Value
only \$15⁹⁵

This Freshman POLYDYNE 5-Tube, all electric, modern Screen Grid Receiver, less tubes, for ONLY \$15.95; or complete, with tubes, \$23.95. Incorporates all latest improvements.

Use Coupon below for ordering set and equipment desired. Also ask for our new 196-page catalog or everything in radio at wholesale prices.

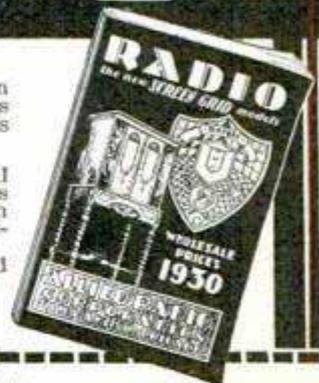

Allied Radio Corp.
707 W. Lake St., Chicago, Ill.

Date.....

Gentlemen: Enclosed please find \$..... 25% Deposit—Bal. C. O. D.
For which please send me Full payment

- Polydyne 7-250 less tubes \$24.50
- Polydyne 7-250 with tubes 35.50
- Polydyne 5- less tubes 15.95
- Polydyne 5- with tubes 23.95

Name.....

Address.....

City..... State.....

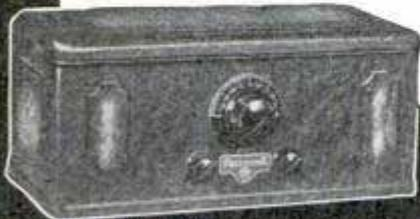

ALLIED RADIO CORPORATION

707 West Lake St.
CHICAGO, ILL.

Extra Money This Winter

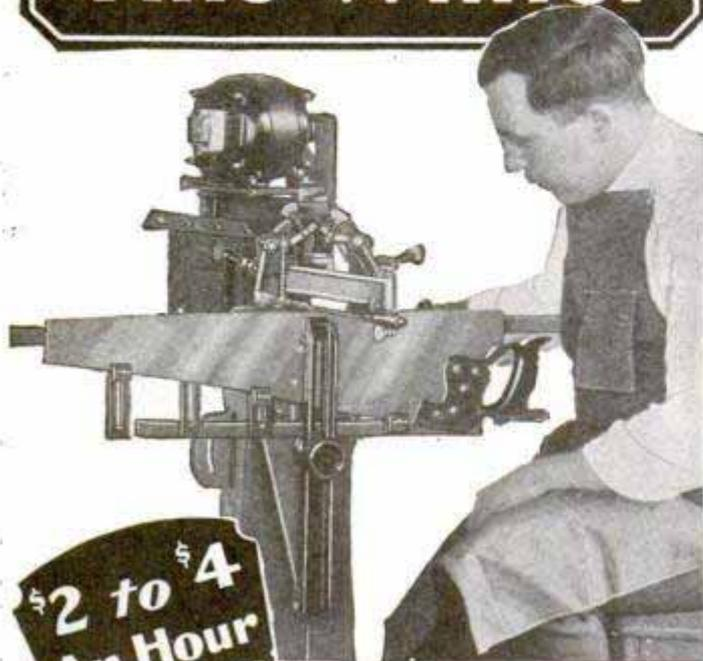

**\$2 to \$4
An Hour
In Spare
Time**

A Fine Paying Cash Business

Build a good, steady, permanent business of your own that will pay you a handsome income all year 'round, filing saws on the Foley Automatic Saw Filer. Very little capital required—buy on easy payments. Make money while starting. Paul J. Davidson, who does spare time filing, writes, "... have made as high as \$12 in one day. . . . My business is increasing all the time. Will soon be forced to devote my entire time to saw filing."

No Experience Necessary

It is easy to file all kinds of saws on the Foley. After saw is put in machine and simple adjustments made, it files *automatically*. E. D. Toulme writes, "Without any previous mechanical experience I operated my Foley guided by the instructions received with the machine."

Start Making Money At Once

You will get all the business you can handle just as soon as you let people know you have a Foley Filer. **No Canvassing.** Others are making big money with the Foley—YOU can too. Send coupon at once for Free Plan.

Foley Manufacturing Co.
247 Foley Bldg., 11 Main St. N. E.,
MINNEAPOLIS, MINNESOTA

Please send me complete information about the Foley Filer and Free Plan for getting business.

Name.....

Address.....

City.....State.....

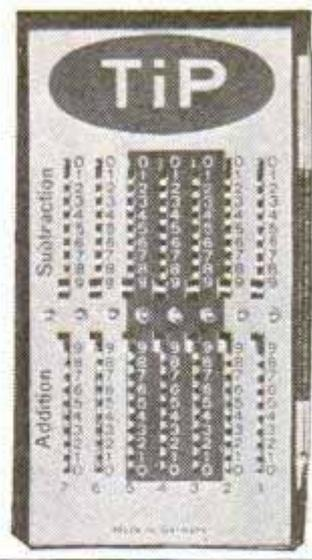

New German Adding Machine

Does Work of \$300 Machine
COSTS AGENTS ONLY \$1.90

Here is a wonderful little machine imported from Germany that adds and subtracts perfectly, yet so small it easily fits into the vest pocket.

FREE SAMPLE AND BIG MONEY OFFER

Everyone will buy on sight. You can make as much as \$5.00 to \$10.00 an hour in spare time. We want you to have a Tip machine to make demonstrations. Upon hearing from you we will send you one C.O.D. for \$1.90 plus a few cents postage, or if you send \$1.90 we will send the machine prepaid. On receipt of your first order as our agent we will credit you with the cost of this machine so actually it will cost you nothing. Or should you return it within 10 days your money will be refunded. **SEND TODAY.**

H. MARTIN

Dept. A-10 E. Erie St., Chicago, Illinois

GIVEN BIG MOVIE MACHINE

THIS Large Size Movie Machine operates on same principles as expensive professional models, uses standard size films same as big theatres. Imported double Convex Lenses show large, clear pictures. Complete outfit furnished—enough for a full hour's show, including Tom Mix film, etc. Easy to operate, guaranteed for life. Just send for 12 large Bottles *Salut D'Amour* Perfume that sells at 25 cents each. This is a real bottle size 3 1/2 inches. We also send 12 Perfume Novelties which you give away free of charge and Easy Plans for obtaining **MOVIE** Machine. Send no money. We trust you.
TREVAUX Perfume Co.
Dept. 7F78 CHICAGO



Best in the world. 10-year guarantee, lowest prices. FREE instruction, ask for FREE catalog. RUATTA, SERENELLI & CO., 1014 Blue Island Ave. Dept P, Chicago, Ill.

AGENTS

Sells for 50c—Costs Agent 17 1/2c

Every Home Wants Kitchen Tongs

\$10.00 a Day Easy!

No more burned fingers. Picks up hot things when cooking, feeds clothes to the wringer, grabs articles out of hot water—like a human hand. Made of lifetime metal. Strong, durable, good looking. 10 1/2 inches long. 5 sets packed in individual illustrated cartons sent post-paid to agents for \$1.

MICHIGAN METAL PRODUCTS COMPANY, Dept. K, Battle Creek, Mich.

Information on any book free. Write Popular Mechanics Press, Chicago, Ill.

A PRACTICAL COURSE IN MECHANICAL DRAWING

By WM. F. WILLARD

An ideal book for home study. Each exercise is clinched in the mind of the student by practical application to every day practice. 160 Pages. 157 Drawings. Cloth. Price \$1.00 Postpaid

POPULAR MECHANICS PRESS 200 E. Ontario St. CHICAGO

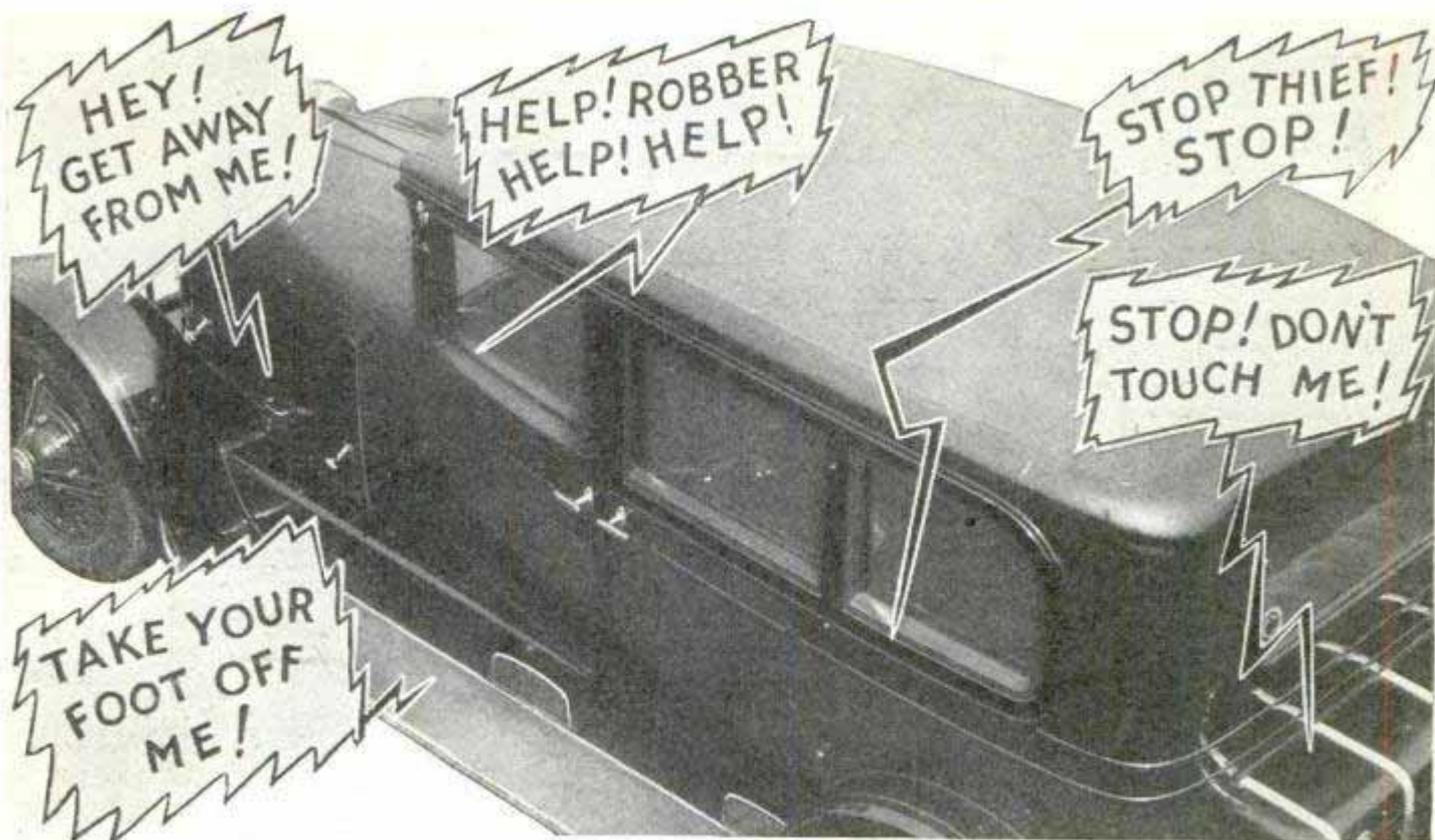

Astonishing Electrical Invention Protects Your Car from Thieves ...Automatically!

This unquestionably is the queerest, most incredible invention since the first discoveries of radio! A magical, shouting, automatic watchman that actually is far more than human! Never sleeps, rests or gets

tired! Stands guard over your entire car from spare tire to headlights and steering wheel! Endorsed by police! Approved by Motor Associations! Now offered on generous 5-day free test basis! The coupon brings full details.

A Startling Uncanny Money Maker For Agents

"WHAT makes it work?" "Where on earth did you get it?" "Bet you five dollars he's got some one hiding in there!" "It simply can't be true." A running fire of comment like this breaks out whenever and wherever this new invention is exhibited. And why not? When no one ever heard of such a startling, uncanny device before! In fact few people would even dare to dream there could be such a thing! So this, men, is something really NEW, something to grip the imagination of everyone, something that sells to every autoist on sheer novelty alone. Distributors, "star" salesmen, every man who wants to double and triple his present income should note carefully the following facts.

The Secret Of A Theft-Proof Car

Now in this amazing new way, every car can be protected from theft for 24 full hours a day. In the garage or parked on the street, if any thief so much as pulls at your spare tire or touches his foot to your running board—ZOWIE! A riot of noise starts instantly! And your car never shuts up till the thief leaves. And listen to this. Even if the thief is wise to what's up, you alone place the secret contr'l button anywhere you want it around the car. The thief can't possibly find it. If he wastes time looking for it—Bingo! He's caught and on his way to jail! This astonishing invention guards your spare-tire, head-lights and spot-lights as well as the car itself.

Installed In 10 Minutes—Costs Nothing To Operate

The inventor has asked the U. S. Government to protect his patent rights in this revolutionary discovery. Because of its uncanny powers and to distinguish it from everything else on earth this queer discovery is now

called "Devil Dog." Among its amazing features is the fact that it can be installed by anyone in 10 minutes or less. There is absolutely no cost for operation. It will last as long as the car. Fits any car from Ford to Rolls Royce without adjustment or fussing.

For introductory purposes a special 5-day test offer is now being made. If you are interested in learning about the most astonishing invention since the radio first came in, use the coupon at once. If your present income is less than \$75 a week, the profit possibilities as our agent will astonish you. The coupon brings details of all offers. Mail it now.



NORTHWEST ELECTRIC CORP.,

Dept. C-10,

Pukwana, So. Dakota

**AUTOMATIC
DEVIL DOG**

Northwest Electric Corp.,
Dept. C-10,
Pukwana, So. Dakota.
Rush details of your big 5-day test offer and big profits for agents.

Name.....
Address.....
Town..... State.....
 Check here if interested only in one for your own car and not in agents' money-making offer.

LUMINOUS PAINT

Make Your Watches, Clocks, Etc., Visible by Night

The very latest discovery in the scientific world. hitherto, practically unobtainable except at an exorbitant price, we have at last succeeded in producing this remarkable LUMINOUS PAINT, which, applied to the surface of any article, emits rays of white light, rendering it perfectly visible in the dark. THE DARKER THE NIGHT, THE MORE BRILLIANT IT SHINES. Quite simple to use. Anyone—you can do it. A little applied to the dial of your watch or clock will enable you to tell the time by night. You can coat the push buttons or switch plates of your electric lights, match boxes, and innumerable other articles; make your own Luminous Cigarettes, Luminous Rosaries, etc. Small bottle, price 25c, largest size, 50c and \$1 postpaid. JOHNSON SMITH & CO. Dept. 848 RACINE, WIS.



CIGARETTE MAKER

Roll your own and save money. Better and quicker; saves more than half. Use your favorite brand of tobacco. Neat, useful, handy. Pocket size, weighs 15 oz. Made entirely of metal, nickel plated. 25c, 3 for 65c postpaid anywhere.



Explosion Cigarettes

Box contains ten genuine cigarettes of excellent quality. They appear so real, but when each cigarette is about one-third smoked, the victim gets a very great surprise as it goes off with a loud BANG! A great mirth provoker yet entirely harmless. Price 25c box.

GOOD LUCK RING

Very striking, quaint and uncommon. Silver finish; skull and crossbones design, two brilliant, flashing gems sparkle out of the eyes. Said to bring good luck. Only 25c ppd.

NOVELTY BADGES



Kissing Permit 10c
Two very novel metal badges, nickel plated, that you can wear, giving you fun out of all proportion to their trifling cost. 10c, each badge, 3 for 25c, or 75c per doz. postpaid anywhere.

Garter Inspector 10c
Two very novel metal badges, nickel plated, that you can wear, giving you fun out of all proportion to their trifling cost. 10c, each badge, 3 for 25c, or 75c per doz. postpaid anywhere.

MIDGET BIBLE

GREAT CURIOSITY
Smallest Bible in the World. Size of a postage stamp. 200 Pages. Said to bring good luck to the owner. A genuine work of art. Must be seen to be appreciated. Make good money selling them to friends, church acquaintances, etc. PRICE 15c each, 3 for 40c, 12 for \$1.35, 100 for \$7.50. Also obtainable in Leather Binding, with gold edges. Price 50c each, 3 for \$1.25, \$4.50 per doz. Magnifying Glass for use with Midget Bible 15c.

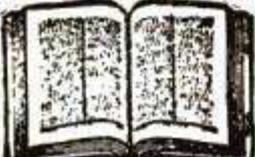

STAGE MONEY

With a bunch of these bills, it is easy for each person of limited means to appear prosperous by flashing a roll of these bills at the proper time and peeling off a genuine bill or two from the outside of the roll, the effect created will be found to be all that can be desired. Prices, postpaid: 40 Bills 20c, 120 for 50c, or \$3.50 thousand postpaid.

NOSE FLUTE

The Magic Nose Flute, or Humanstone, is a unique and novel musical instrument that is played with nose and mouth combined. There is just a little knack in playing it which, when once acquired after a little practice, will enable you to produce very sweet music that somewhat resembles a flute. There is no fingering, and once you have mastered it you can play all kinds of music with facility and ease. When played as an accompaniment to a piano or any other musical instrument, the effect is as charming as it is surprising.

Post Paid 10c

SURPRISE MATCHES

More fun than fighting with your wife. Look just like ordinary matches. Put up in boxes just like regular Safety Matches. As the victim tries to light one he gets quite a surprise. Price 10c per box, 3 boxes for 25c, 12 for 75c cents.

STAR TOY MAKER

Greatest boys' book written. Tells how to make a Pinhole Camera, a Canoe, model Railroad, a Telephone, Boomerang, Telegraph Instrument, Box Kite, Talking Machine, Microscope, Electric Motor, Electric Door Bell, a Dog Sled, Bird House, Rabbit Yard, etc. 64 pages. 150 illustrations. PRICE 10c. **AMATEUR ELECTRICIAN**, all about electricity in simple language. How to make batteries, dynamos, motors, telephones, bells, electric coils, engines, lights, etc. Price 10c.

BOOK ON ROPE SPlicing!

Useful Knots, Hitches, Splices, etc. How different knots are made and what they are used for, knots that are unsafe, etc. Over 130 illustrations. All about wire rope attachments, lashing blocks, tackles, etc. PRICE 20 CENTS.

Wonderful X-Ray Tube

A wonderful little instrument producing optical illusions both surprising and startling. With it you can see what is apparently the bones of your fingers, the lead in a lead pencil, the interior opening in a pipe stem, and many other similar illusions. Price 10c, 3 for 25c.

NOSE BLOWER

When some men blow their noses it sounds like a trombone. Now the **NOSE BLOWER** has come to torment us. It is a starter! It is ingeniously concealed in the handkerchief. Proceed to blow your nose and your friends will think they heard a steam engine or something. You can blame the hideous noise to your having a very loud cold and keep up the fun as long as you like. PRICE 10c, 5 for 25c, or 75c doz. postpaid.

Serpent's Eggs

Box contains 12 eggs. When lit with a match, each one gradually hatches itself into a snake several feet long, which curls and twists about in a most life-like manner. Price per box, 10c postpaid, 3 for 25c

BLANK CARTRIDGE PISTOL

Protection against Burglars, Tramps, & Dogs. Special Offer 1 Blank Cartridge Pistol, 100 Blank Cartridges, 1 550-page Novelty Catalog. ONLY \$1.50



Well made and effective, modified on latest type of Revolver; appearance alone is enough to scare a burglar. When loaded it may be as effective as a real revolver without danger to life. It takes standard 22 Cal. Blank Cartridge—obtainable everywhere. Special cash with order offers 1 Superior quality Blank Cartridge Pistol, 100 Blank Cartridges, and our new 550 page De Luxe Catalog of latest novelties; all for ONLY \$1.50. Shipped by Express only. Cannot go by parcel post. Extra Blank Cartridges 50c per 100. Special Holder (Cowboy Type) for pistol 50c. No C. O. D. shipments.

The Lot Shipped by Express Only Cash With Order Only

LOOK 35¢ LOOK Wonderful Instrument.



Greatest thing yet. Nine separate articles in one. Everybody delighted with it. Odd, Curious and interesting. Lots of pleasure as well as very useful. It is a double Microscope for examining the wonders of nature. It is also an Opera Glass, a Stereoscope, a Burning Lens, a Reading Glass, a Telescope, a Compass, a pocket Mirror, and a Laryngoscope—for examining eye, ear, nose and throat. It is worth all the cost to locate even one painful cinder in the eye. Folds flat and fits the pocket. Something great—you need one. Don't miss it. Sent by mail. Only 35c or 3 for \$1.00

Watch Charm Pistol \$1.00

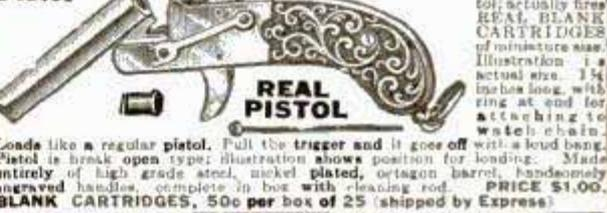

Exact reproduction of a real pistol; actually fires REAL BLANK CARTRIDGES of miniature size. Illustration shows actual size. 1 1/4 inches long, with ring at end for attaching to watch chain. Loads like a regular pistol. Pull the trigger and it goes off with a loud bang. Pistol is break open type; illustration shows position for loading. Made entirely of high grade steel, nickel plated, octagon barrel, handomely engraved handles, or metal in box with loading rod. PRICE \$1.00. BLANK CARTRIDGES, 50c per box of 25 (shipped by Express)

PISTOL CIGARETTE CASE

It looks like a deadly weapon, but it is merely a novel Cigarette Case. This clever contrivance has proved itself better than the real thing in many an awkward encounter. Great fun "sticking up" your friends. They squirm and protest it might be loaded. Pull the trigger and the slide flies open disclosing the cigarettes. Well made, light and compact. Weight only 2 ounces. PRICE POSTPAID 25c

MICROPHONE TRANSMITTER BUTTON



You can easily make a highly sensitive detector-telephone by using this Transmitter Button to collect the sound waves. You can build your own outfit without buying expensive equipment. It is simple and inexpensive. You can install an outfit in your home and hear conversations being held all over the house. You can connect up different rooms of a hotel. This outfit was used by secret service operatives during the war. It is being used on the stage. It is ultra-sensitive and is the greatest invention in microphones. You can mount the button almost anywhere—card board boxes, stove pipes, stiff calendars, on the wall behind a picture frame, etc. Button is so light and small it cannot be detected. Persons can be overheard without suspecting it. You can listen in on conversations in another room. A deaf person in the audience can hear the speaker. Connected to phonograph, piano or other musical instrument, music can be heard hundreds of feet away. Button may be used to renew telephone transmitters; often makes an old line "talk up" when nothing else will. The ideal microphone for radio use; carries heavy current and is extremely sensitive. It picks up radio signals. Countless other similar uses will suggest themselves. Experimenters find the button useful for hundreds of experiments along the lines of telephones, amplifiers, loud speakers, etc. Many fascinating stunts may be devised, such as holding the button against the throat or chest to reproduce speech without sound waves. PRICE \$1.00. JOHNSON SMITH & CO., Dept. 848, RACINE, WIS.

LATEST CATALOG

JOHNSON SMITH & CO.
Dept. 848 RACINE, WIS.

A De Luxe Edition of our new CATALOG mailed on receipt of 25c. Handsome binding. Bigger and better than ever. Only book of its kind in existence. Nearly 700 pages of all the latest and newest novelties, puzzles, games, sporting goods, rubber stamps, unusual interesting books, curiosities in seeds and plants, etc., unobtainable elsewhere. Remit by Coin, Money Order, Check or unused U. S., Canadian and Foreign Stamps for all articles listed above. See next page also.

BOYS! BOYS! BOYS! THROW YOUR VOICE



Into a trunk, under the bed, under a table, back of the door, into a desk at school, or anywhere. You get lots of fun fooling the teacher, policemen, peddlers, and surprise and fool all your friends besides.



The Ventrilo

is a little instrument that fits in the mouth out of sight. Cannot be detected. It is used in connection with the above, and with the aid of this wonderful DOUBLE THROAT, or VENTRILLO, you can imitate many kinds of birds, animals, etc. Remember you get everything for ONLY TEN CENTS—a booklet giving you full instructions how to become a ventriloquist and throw your voice, the Double Throat, or Ventrilo, and our big 600 page catalog of novelties, tricks, puzzles, masks, books, etc.,

All Sent Postpaid to Any Address for Only **10c**

INVISIBLE INK | Rubber Chewing Gum

The most confidential messages can be written with this ink, for the writing makes no mark. Cannot be seen unless you know the secret. Invaluable for many reasons. Keep your postals and other private memoranda away from prying eyes. Great fun for playing practical jokes. Only 15c a Bottle; 3 for 40c



It is just like a regular package of chewing gum and looks so real that it fools everybody. Of course no one suspects it is not genuine until they start to chew it. There's a world of fun in this rubber chewing gum — 3 sticks to the package. Price, 10c Pkg.; 3 for 25c; 12 for 75c postpaid.

Rubber Tacks Box 10c
Rubber Cigarettes. Price per Box. 20c
Rubber Cigars. Price Ea. 10c
Rubber Matches. Price per Pkg. 10c

U. S. BABY TANK

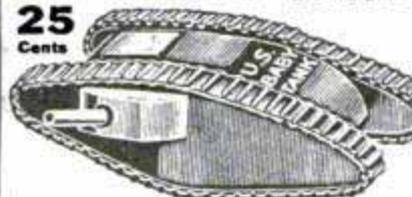

It goes with real Yankee Pep—by its own power

Most remarkable toy ever invented. By drawing the Tank backward, either with the hand or over the floor or table and then placing it down, it will crawl along, overcoming all obstacles, in the same life-like manner as the larger tank that proved so deadly in the great war. What makes it go is somewhat of a mystery, for there is no mechanism to wind up as is usually understood, with mechanical toys, yet this tank will keep plodding along ten times longer than the ordinary run of toys. It will perform dozens of the most wonderful stunts; 2 1/4 inches long. Price only 25c prepaid. Stamps accepted.

JOHNSON SMITH & CO.

\$250 ROLMONICA



AMouth Organ that Plays with a Music Roll
Any One Can Play It Without Practice
A Wide Selection of Rolls to Choose From
A Veritable Pocket Size Jazz-Band!

Rolmonica is an automatic harmonica, that plays a music roll just like a player piano. It is a whole brass band all in one—the biggest sensation of the musical world in the last few years. Anyone can play it, for all you have to do is to insert a roll, and turn the handle while you blow. That is all there is to it. Nothing could be simpler. Any child who can do these two simple things can play the Rolmonica. It is a veritable pocket size jazz-band, combining the principles of the harmonica and the player piano. It is an instrument of a thousand melodies; it plays the popular airs of the past, as well as the latest Broadway hits. There are hundreds of rolls to select from, such as My Blue Heaven, Home Sweet Home, America, Old Black Joe, Annie Laurie, Sidewalks of New York, Humoresque, Wild Irish Rose, Rosie O'Grady, Among My Souvenirs, Love's Old Sweet Song, Dixie, Mighty Lak' a Rose, Aloha Oe, Ramona, Juanita, Rose Marie, Onward Christian Soldiers, Sally of My Dreams, Carolina Moon, I Faw Down & Go Boom, Weary River, Over There, Ma Cherie, Long Way to Tipperary, Make Believe, Desert Song, La Paloma, Sweet Adeline, I've Got a Feeling, Pagan Love Song, When My Dreams Come True, Parade of Wooden Soldiers, Land of Sleepy Water, Turkey in the Straw, Hail the Gang's All Here, and hundreds of others. An unending source of amusement. You can delight your friends for hours and play tune after tune simply by changing rolls. Small in size, fitting your pocket, yet mighty in its finger-tinkling, toe-tinkling tune power. Not a toy, but a genuine musical instrument and the life of any party. Four Rolls free with each Rolmonica. Extra Rolls always obtainable; complete list with each instrument. New Rolls added each month. PRICE with 4 Rolls \$2.50; Extra Rolls 10c each, all postpaid.

Send remittance (Postage Stamps accepted) for all articles listed above, also in our other ad on previous page

CARD MIRACLES



Here is a combination box containing twelve of our best Card Tricks. Each trick is entirely different. With these Tricks you can put on a complete magic act, astonishing and mystifying everybody. Among the tricks included are the following: THREE CARD MONTE. Hide the Ace and no one can find it. This will fool them all. TIP-TOP CARD TRICK. You can name these cards without seeing the fronts. TWISTER CARD TRICK. The Ace of Spades and Ace of Diamonds change places while held in full view. TWO CARD MONTE. A good trick in magic that always produces a laugh. (N. B.—this trick will keep you supplied with free cigars for your friends.) PAPEL BLANCO CARD TRICK. Cards placed in a hat turn to blanks. Fine for stage or parlor use. PHANTOM CARD TRICK. Or two from five leaves nothing. Causes two big surprises. Positively the greatest card trick out. DISAPPEARING SPOTS. These cards change faces five times by simply breathing on them. One of the best of all card tricks. CINCH CARD TRICK. Four Queens when dropped into a borrowed hat disappear and change to other cards. CHANGING SPOTS. These cards change from eights to deuces, also from red to black. Splendid stage trick. ACE CARD TRICK. Ace placed in different piles will gather in one pile. SPOTTER OR EDUCATED DIE. Every time a die is cast it reveals the position of the Ace of Clubs. Each trick is complete in an envelope, with full instructions for performing. They are so simple that anybody can perform them, yet puzzle everybody. Price, Per Box of 12 Tricks, Postpaid..... **\$1.00**

MAGICIAN'S BOX OF TRICKS

Apparatus and Directions for a Number of Mysterious Tricks, Enough for an Entire Evening's Entertainment..... **\$1.00**

ANYONE CAN DO THEM

It is great fun mystifying your friends. Get this Conjuror's Cabinet, and you will be the cleverest fellow in your district. It contains the apparatus for ten first-class tricks, including THE MAGIC BALL AND VASE TRICK (a wooden ball is placed inside, and upon replacing the lid has disappeared and is found in someone else's pocket); THE HINDOO TRICK CARDS (can be made to change completely no less than five times); DISAPPEARING COIN BOX (a coin, placed in the wooden box, vanishes entirely or changes into a coin of another denomination); THE GLASS GOBLET TRICK (a coin is dropped into a glass of water and when the water is poured out the coin has vanished and is found somewhere else); THE RIBBON FACTORY FROM THE MOUTH TRICK (a seemingly endless supply of colored paper ribbons comes out of your mouth); the DISAPPEARING HANDEKERCHIEF (a handkerchief held in the hand mysteriously vanishes); the WIZARD'S RING COIN TRICK; the ENCHANTED BOTTLE (no one but yourself is able to make it lay down); the GREAT HAT AND DICE TRICK (a large die is placed on top of a hat, disappears, and is found underneath yet no one has touched the hat), and last, but not least, the GREAT PHANTOM CARD TRICK, or two from five leaves nothing. Full instructions are sent for performing each trick. In addition to the above, a number of other feats and illusions are fully explained for which you can easily make or procure the necessary apparatus. Price complete \$1.00 postpaid. JOHNSON SMITH & CO.



RESURRECTION PLANT

Great curiosity. Place in water, plant opens up and starts to grow in few minutes. Taken out it dries up and goes to sleep until put in water again. PRICE 10c, 3 for 25c. 75c dozer postpaid.



MAGIC MADE EASY 250 MAGIC TRICKS 10c

An excellent little book containing 250 Parlor Tricks, tricks with cards, coins, handkerchiefs, eggs, rings, glasses, etc. So simple that a child can perform them. Profusely illustrated. Sent postpaid to any address for only 10c, 3 copies for 25c.



Comical Motto Rings
Lots of harmless fun and amusement wearing these rings. Made in platinum finish (to resemble platinum), with wording on enameloid, as illustrated. Price only 25c Postpaid.

The "Little Giant" Typewriter



A First Class Writing Machine For \$1.50
A perfect little typewriter for \$1.50. There are thousands of persons who would like to use a typewriter but whose needs and business do not warrant the expense attached to the purchase and use of a fifty or seventy-five dollar machine. To such persons we confidently recommend our Little Giant. It is strongly made, but simple in construction, so that anyone can quickly learn to operate it, and write as rapidly as they would with pen and ink. The letters of the alphabet most frequently used are so grouped as to enable one to write rapidly, the numerals 1 to 10, and the punctuation marks being together. With this machine you can send your best girl typewritten love letters, address envelopes, make out bills, and do almost any kind of work not requiring a large, expensive machine. With each typewriter we send a tube of ink and full printed instructions for using the machine. Price complete \$1.50 by mail postpaid to any address in the world. Stamps accepted.

JOHNSON SMITH & CO. Dept. Racine, Wis. 848



“Getting Ahead”

“It’s the first time we’ve really been able to say that, John. More money in the bank—more to spend on the house and on ourselves—more for insurance. Yes, we’re *getting ahead!*”

“And it all dates from last year, when you enrolled for that course with the International Correspondence Schools. Before that we’d really been standing still. Remember how discouraged you were? Bills piling up, and no raises for three years?”

“Then you started studying at home in the evenings. Right away you had more interest in your job and more confidence, because you felt you were *going* somewhere. The chief heard about your progress from a report sent him by the I. C. S., and it wasn’t long before he gave you your chance. Now you’ve made good, John, and oh, but I’m proud of you!”

This every-day story of success can be *your* story if you make up your mind to quit standing still and *get ahead*. The International Correspondence Schools have trained thousands of men for better jobs and bigger pay—men who started with even less than you. In an hour a day of spare time you can gain the specialized knowledge of your work that will bring you promotion and a good salary. *Find out* what the I. C. S. can do for you. Mark and mail this coupon today!

INTERNATIONAL CORRESPONDENCE SCHOOLS Box 5672-F, Scranton, Penna.

Without cost or obligation, please send me a copy of your booklet, “Who Wins and Why,” and full particulars about the course before which I have marked X in the list below:

TECHNICAL AND INDUSTRIAL COURSES

- | | |
|--|---|
| <input type="checkbox"/> Architect | <input type="checkbox"/> Automobile Mechanic |
| <input type="checkbox"/> Architectural Draftsman | <input type="checkbox"/> Aviation Engines |
| <input type="checkbox"/> Building Foreman | <input type="checkbox"/> Plumber and Steam Fitter |
| <input type="checkbox"/> Concrete Builder | <input type="checkbox"/> Plumbing Inspector |
| <input type="checkbox"/> Contractor and Builder | <input type="checkbox"/> Foreman Plumber |
| <input type="checkbox"/> Structural Draftsman | <input type="checkbox"/> Heating and Ventilation |
| <input type="checkbox"/> Structural Engineer | <input type="checkbox"/> Sheet-Metal Worker |
| <input type="checkbox"/> Electrical Engineer | <input type="checkbox"/> Steam Engineer |
| <input type="checkbox"/> Electrical Contractor | <input type="checkbox"/> Marine Engineer |
| <input type="checkbox"/> Electric Wiring | <input type="checkbox"/> Refrigeration Engineer |
| <input type="checkbox"/> Electric Lighting | <input type="checkbox"/> R. R. Positions |
| <input type="checkbox"/> Reading Shop Blueprints | <input type="checkbox"/> Highway Engineer |
| <input type="checkbox"/> Telegraph Engineer | <input type="checkbox"/> Chemistry |
| <input type="checkbox"/> Telephone Work | <input type="checkbox"/> Pharmacy |
| <input type="checkbox"/> Mechanical Engineer | <input type="checkbox"/> Coal Mining Engineer |
| <input type="checkbox"/> Mechanical Draftsman | <input type="checkbox"/> Navigation <input type="checkbox"/> Assayer |
| <input type="checkbox"/> Machine Shop Practice | <input type="checkbox"/> Iron and Steel Worker |
| <input type="checkbox"/> Toolmaker | <input type="checkbox"/> Textile Overseer or Supt. |
| <input type="checkbox"/> Patternmaker | <input type="checkbox"/> Cotton Manufacturing |
| <input type="checkbox"/> Civil Engineer | <input type="checkbox"/> Woolen Manufacturing |
| <input type="checkbox"/> Surveying and Mapping | <input type="checkbox"/> Agriculture <input type="checkbox"/> Fruit Growing |
| <input type="checkbox"/> Bridge Engineer | <input type="checkbox"/> Poultry Farming |
| <input type="checkbox"/> Gas Engine Operating | <input type="checkbox"/> Mathematics <input type="checkbox"/> Radio |

BUSINESS TRAINING COURSES

- | | |
|--|---|
| <input type="checkbox"/> Business Management | <input type="checkbox"/> Business Correspondence |
| <input type="checkbox"/> Industrial Management | <input type="checkbox"/> Show Card and Sign Lettering |
| <input type="checkbox"/> Personnel Management | <input type="checkbox"/> Stenography and Typing |
| <input type="checkbox"/> Traffic Management | <input type="checkbox"/> English |
| <input type="checkbox"/> Accounting and
C. P. A. Coaching | <input type="checkbox"/> Civil Service |
| <input type="checkbox"/> Cost Accounting | <input type="checkbox"/> Railway Mail Clerk |
| <input type="checkbox"/> Bookkeeping | <input type="checkbox"/> Mail Carrier |
| <input type="checkbox"/> Secretarial Work | <input type="checkbox"/> Grade School Subjects |
| <input type="checkbox"/> Spanish <input type="checkbox"/> French | <input type="checkbox"/> High School Subjects |
| <input type="checkbox"/> Salesmanship | <input type="checkbox"/> Cartooning |
| <input type="checkbox"/> Advertising | <input type="checkbox"/> Illustrating |
| | <input type="checkbox"/> Lumber Dealer |

Name.....

Address.....

City..... State.....

Occupation.....

If you reside in Canada, send this coupon to the International Correspondence Schools Canadian, Limited, Montreal, Canada

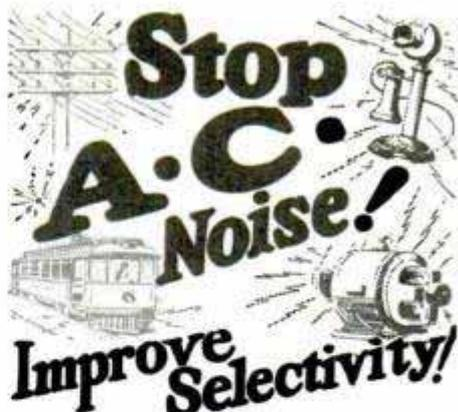

RADIO reception may be made much more enjoyable by plugging in a Falck Claroceptor between the light socket and your set. By blocking out the line interference noises, this wonderful device also helps selectivity and distance. Tested, proved. Thousands now in successful use all over America. No change required in your set. Only equipment of the kind. Compact size: 3½" x 5½" x 2½". Made by pioneer radio manufacturer. At radio parts dealers, or write us for new free folder.

Falck (With Cord and Plug) CLAROCEPTOR

Manufactured by ADVANCE ELECTRIC CO.
Dept. P M—1260 W. Second St., Los Angeles, Calif.
JOBBER AND DEALERS, GET OUR PROPOSITION

ELECTRIC LIGHTS ANYWHERE

110 Volt—complete plant with all Wiring, Fixtures and Lamps for 7 rooms \$147.50, Direct-To-You.

Ideal for Farms, Camps, Summer Homes.

Also runs Household Electrical Appliances. Install it yourself. Write for circular.

D. W. ONAN & SONS \$147.50
29 Royalston Ave.
Minneapolis, Minnesota.

C-A Sanding, Grinding, Polishing, Buffing KIT

\$4.95 Complete

Three 6" Wheels, Arbor and Sand Drum A Real Outfit For Real Jobs!

SANDING DRUM 3 inches by 2 inches. Interchangeable wheels of CLOTH, WIRE BRISTLES and EMERY, each 6 inches in diameter. Simply constructed ARBOR is sturdy, fool proof and will last for years. Outfit is for use in real shops, homes or schools in model making, floor sanding, refinishing furniture, smoothing metal, etc. Use with electric hand drill or motor. Easily worth double this price, complete \$4.95. MONEY BACK IF NOT SATISFIED!

Sander and Arbor Sold Separately
\$2.50

Write For Folder
ADJUSTABLE BEARING CO., Inc.
213 E. SOUTH ST. INDIANAPOLIS, IND. U. S. A.

No Trade to Learn No Books to Buy Pay for First Day and \$700 a Month

Nearly 2,000 Popular Mechanics readers have already grabbed this amazing opportunity to be independent and make Big Money at this new, easy work, in the modern trade of Flor-Kraft.

How You Can Do It

Clarke has perfected a low-cost machine for finishing floors by electricity. It does this high-pay work in a speedy profitable manner. It enables any man to do so much of this work every day in such an expert way, at such expert pay, that many Popular Mechanics readers are making \$25 to \$75 per day, in Flor-Kraft. In this work all you do is finish new and old floors to a velvety smoothness with this machine. You make the floors ready for varnishing or waxing. The Clarke Vacuum Portable Sander weighs only 31 lbs., and runs from any light socket. It handles like a vacuum cleaner, and works almost as easily.

Start at Once — No Delay

You don't have to study any course or buy any books. A few hours' practice with this machine gives you the skill of a veteran. The machine does the work—you merely guide it.

Why the Pay Is Big

This work was formerly done by hand or with slow cumbersome machines. That's why the rates are high—3c to 5c per sq. ft. on new floors, 7c to 15c per sq. ft. on old floors. The fast-cutting Clarke is guaranteed to do 900 to 2,200 sq. ft. of new, or 300 to 1,000 sq. ft. of old varnished floor, per 8 hour day. That's why with a Clarke you can make from \$25 to \$75 per day so easily in Flor-Kraft. You can make similar big profits in re-finishing store counters, desks, tables, cabinet-work or wood-work of any kind. There's all kinds of this ready work and ready money for you to go after. It's all inside work that the weather doesn't bother.

Get Started Today for Yourself

It takes only about \$100 to get started. You make big money right from the start. The Clarke quickly pays for itself. As boss of your own Flor-Kraft business you pocket all the profits. Many former clerks, mechanics, office workers, shop and handy men are making this big money. So can You! Send for the *guaranteed* facts and full details today. Use the coupon or write.

CLARKE SANDING MACHINE CO.

DEPT. T-33

3831 Cortland Street

CHICAGO, ILLINOIS

*Originators and, for 13 years, Manufacturers of
Portable Sanding Machines*



POWERFUL, PORTABLE, ECONOMY
CLARKE
VACUUM PORTABLE SANDER

CLARKE SANDING
MACHINE CO.,
Dept. T-33, 3831 Cortland St.,
Chicago, Illinois.

Gentlemen: Please send me, without obligation, full details on the Clarke Sander, and the money-making possibilities of Flor-Kraft.

Name.....

Address.....

City.....State.....

AUTO REPAIRMEN EARN GREATER PROFITS

Get your share of the big money being spent on automobile upkeep.

Put improved time, labor and money-saving ideas to work in your shop to-day. Take advantage of our special bargain offer and secure 3 valuable kink books at a reduced price.

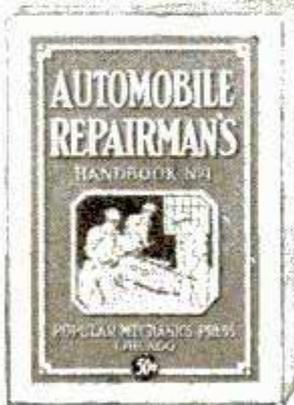

1. 334 Valuable Discoveries made by auto mechanics in our **Automobile Repairman's Handbook**. 337 Illustrations.

2. 301 Ways to use drills, drill presses, taps and dies more effectively in our **Drilling and Thread Cutting Handbook**. 298 Illustrations.

3. 259 Kinks furnished by the most expert Lathe Operators in our **Lathe Handbook**. 212 Illustrations.

Special Offer—These 3 books (regular price 50 cents each, \$1.50 value) are offered for a limited time for only 98 cents plus postage. Pay postman C. O. D. when he delivers or if outside U.S. send 98 cents and 15 cents extra for postage.



POPULAR MECHANICS PRESS

Room P 3

200 E. Ontario St.

CHICAGO

INVENTORS—Read the marvelous history of American Invention, the most impressive record in the annals of human achievement. A very limited edition of Waldemar Kaempfert's Popular History of American Invention in 2 vols. 1034 Pages. Over 500 Illustrations. Cloth. \$5 per set postpaid (just half price of original edition.)

Popular Mechanics Press, 200 E. Ontario St., Chicago

Information on any book free. Write Popular Mechanics Press, Chicago, Ill.

Build a BOAT How to Make 14 Kinds

If you want a boat, you can save several dollars by making it yourself. Or you can pick up money on the side making boats for your friends. Besides you'll have barrels of fun. Everything is made so simple and easy in Popular Mechanics Boat Book. Complete and simple directions and necessary illustrations for building these boats and canoes:

Rowboat suitable for outboard motor. Canoe. Whiz (14-ft. step hydroplane). Portable Canvas Boat. Fast 19-ft. Runabout Motorboat. Cabin Scow driven by auto engine. Long Island Scooter with aero-propeller. Portable Folding Boat. Convertible House Boat and Camp. Sea-Gull (sailing boat). Pile-Driver Punt. Inexpensive Motor Boat. Power-Driven Catamaran. Fishing Sleigh and Boat. In addition there are valuable instructions for calking, repairing, painting and making boats watertight, also articles on picking your canoe, handling and fitting outboard motors, laying up for winter and making a boat trailer and boathouse for small canoe club.

This book, together with its companion, Outdoor Sports (containing hundreds of practical plans and ideas on sports, games, tours and camping), will be sent to you C. O. D. if you live anywhere in the U. S.

Just send a note saying you want the Boat Book and Outdoor Sports. When they arrive, pay postman \$1.98 and the postage. If outside the U. S. remit when ordering and include 15 cents extra for postage.

POPULAR MECHANICS PRESS

Room P-3, 200 E. Ontario Street, CHICAGO, ILL.

**Build
Your
Own
Boat**

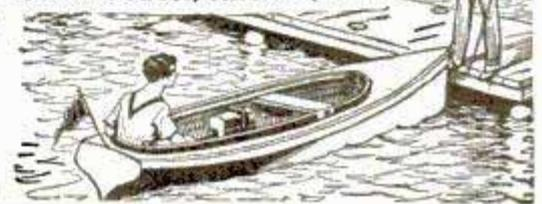

Outdoor Opportunities

How to raise rabbits, guinea pigs, milk goats, silver foxes, ferrets, white rats, white mice, dogs, cats, pigeons, pheasants, bantams, canaries, bees, frogs, mushrooms, ginseng and golden seal for profit. Practical 250-page book with 120 illustrations. Will be sent C. O. D. When postman hands you the package, pay him \$2 plus the postage.

POPULAR MECHANICS PRESS

Room 506

200 E. Ontario St.

CHICAGO

The man who studies gets ahead. Popular Mechanics Press will advise you what books to read to advance in your trade. 200 East Ontario Street, Chicago, Illinois.

Win a Nash Sedan or \$2750.00 in Cash

Someone who answers this ad and qualifies will receive a fully equipped 7-Passenger, Advanced Six Nash Sedan or its full value in cash (\$2,000.00) and \$750.00 in cash for promptness. We are also giving away a Dodge Sedan, a Brunswick Phonograph and many other valuable prizes—besides Hundreds of Dollars in Cash for advertising purposes to men, women and children who solve our puzzle and win our prizes. Over \$100,000 in Cash and Prizes already given! Mrs. Kate L. Needham won \$3,150.00; W. R. Eddington, \$3,050.00; Mrs. M. Iverson, \$2,320.00. This offer is guaranteed by a big reliable company with a reputation of many years of honest dealings, and is open to anyone living in the U. S. A. outside of Chicago.



Find the Twin Babies

There are eight babies in the picture at left. Two, and only two, are alike. These two are the twins. See if you can find them. The rest are different either in their clothes or in their eyes. When you find the twins, mark them with an "X," tear out the picture and send it to me together with your name and address.

\$750.00 Extra for Promptness

In addition to the many valuable prizes and Hundreds of Dollars in Cash we are also giving a Special Added Prize of \$750.00 Cash for Promptness to the winner of the Nash Sedan—making a total of \$2,750.00 in prizes or cash that you can win. In case of ties duplicate prizes will be awarded each one tying. Solve the puzzle and send it to me right away together with your name and address to qualify for an opportunity to share in the \$4,500.00 total Grand Prizes. EVERYBODY PROFITS—you may be the lucky first prize winner. It pays to be prompt.

JOHN T. ADAMS, Manager, Dept. 1773

323 South Peoria Street, Chicago, Illinois

Auto Owners Now Save Millions of Gallons of Gas

A new invention called the Whirlwind is actually saving millions of gallons of gasoline for automobile owners. Those who have installed this amazing device on their cars report almost unbelievable gasoline savings. They also report more speed and power, quicker starting and disappearance of carbon.

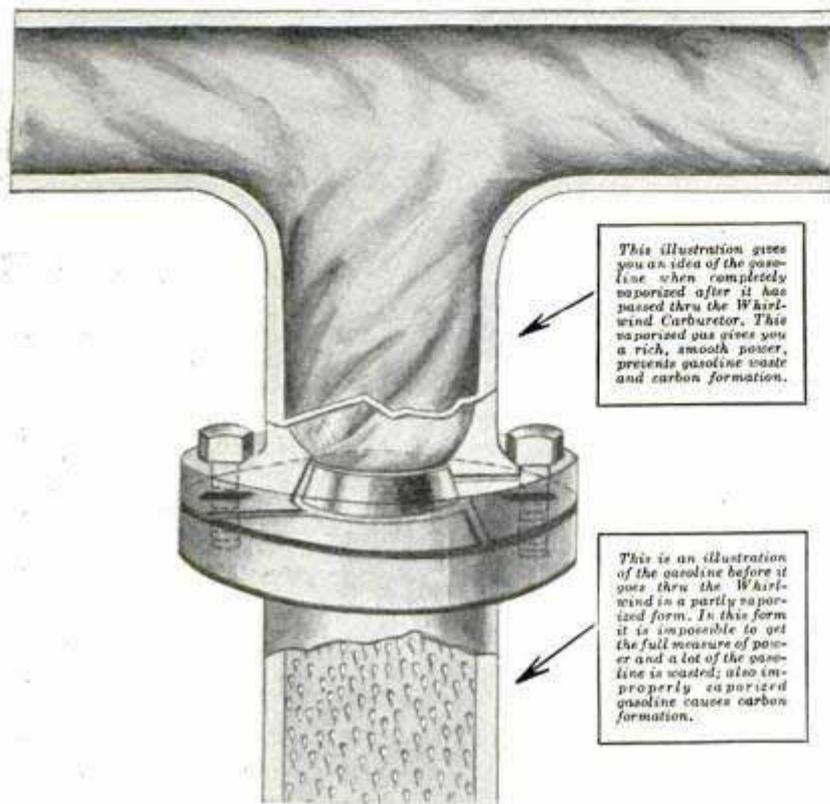

This illustration gives you an idea of the gasoline when completely vaporized after it has passed thru the Whirlwind Carburetor. This vaporized gas gives you a rich, smooth power, prevents gasoline waste and carbon formation.

This is an illustration of the gasoline before it goes thru the Whirlwind in a partly vaporized form. In this form it is impossible to get the full measure of power and a lot of the gasoline is wasted; also improperly vaporized gasoline causes carbon formation.

The marvelous thing about this Whirlwind is that it works as well on all makes of cars. Reports are received from owners of practically every known make of automobile from Fords to Lincolns and they are all equally enthusiastic in their praise.

FITS ALL CARS

In just a few minutes the Whirlwind can be installed on any make of car, truck or tractor. It's actually less work than changing your oil or putting water in the battery. No drilling, tapping or changes of any kind necessary. It is guaranteed to work perfectly on any make of car, truck or tractor, large or small, new model or old model. The more you drive the more you will save.

SALESMEN AND DISTRIBUTORS WANTED

FREE SAMPLE AND \$100.00 A WEEK OFFER

Whirlwind men are making big profits supplying this fast selling device that car owners cannot afford to be without.

Good territory still open. Free sample offer and full particulars sent on request. Just check the coupon.

GUARANTEE

No matter what kind of a car you have—no matter how big a gas eater it is—the Whirlwind will save you money. We absolutely guarantee that the Whirlwind will more than save its cost in gasoline alone within 30 days, or the trial will cost you nothing. We invite you to test it at our risk and expense. You are to be the sole judge.

WHIRLWIND MFG. CO.
DEPT. 999-200-A THIRD ST.
MILWAUKEE, WISCONSIN

Free Trial Coupon

Whirlwind Mfg. Co.,
999-200-A Third St., Milwaukee, Wis.

Gentlemen: You may send me full particulars of your Whirlwind Carbureting device and free trial offer. This does not obligate me in any way whatever.

NAME.....

ADDRESS.....

CITY.....

COUNTY..... STATE.....

Check here if you are interested in full or part time salesman position.

DIRECT FOREIGN RADIO RECEPTION

Without Dependence on Local Re-Broadcasting



WIDEN YOUR CIRCLE of ENTERTAINMENT

Your broadcast receiver is silent below 200 meters, but the Super-Wasp, swooping down to 14 meters and up to 500, unlocks a new world of trans-oceanic radio you never heard before! And you get it directly from the foreign station and not from a local re-broadcast.

PILOT SUPER-WASP

Short-wave and Broadcast Receiver, 14 to 500 Meters
In Kit Form for A.C. or Battery Operation.

CUSTOM SET BUILDERS' PRICES

KIT K-115—The A. C. Super-Wasp. Use your own ABC pack or Pilot K-111 at \$16.50, specially designed for the Super-Wasp. Power Pack and Tubes extra **\$34⁵⁰**

KIT K-110—The battery-operated Super-Wasp. Batteries and Tubes extra **\$29⁵⁰**

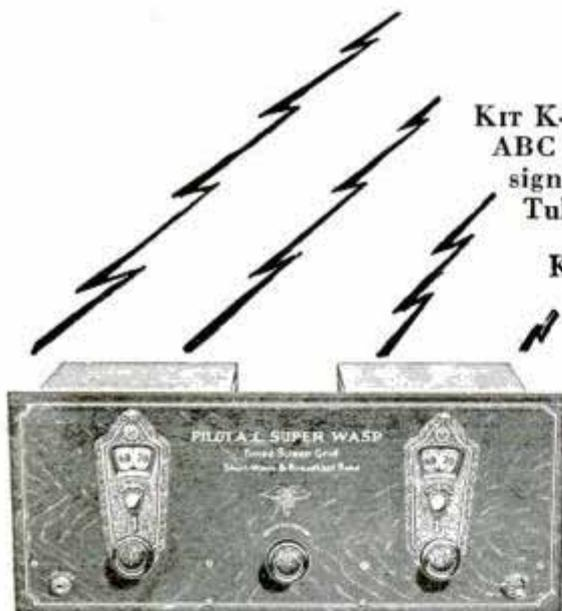

PILOT RADIO & TUBE CORP.

323 Berry Street, Brooklyn, N. Y.

234 So. Wells Street, Chicago, Ill.

1278 Mission St., San Francisco, Cal.



"F"

JOINING THE RADIO INTERNATIONAL GUILD

costs only 50c for a full year's membership, which includes lapel pin, certificate, and the Guild's Official Organ—"Radio Design" published quarterly. Enclose 50c coin or stamps with this coupon, and return to Radio International Guild, 103 Broadway, Brooklyn, N. Y.

Name

Address

City State.....



WORKACE Electric WOODWORKER

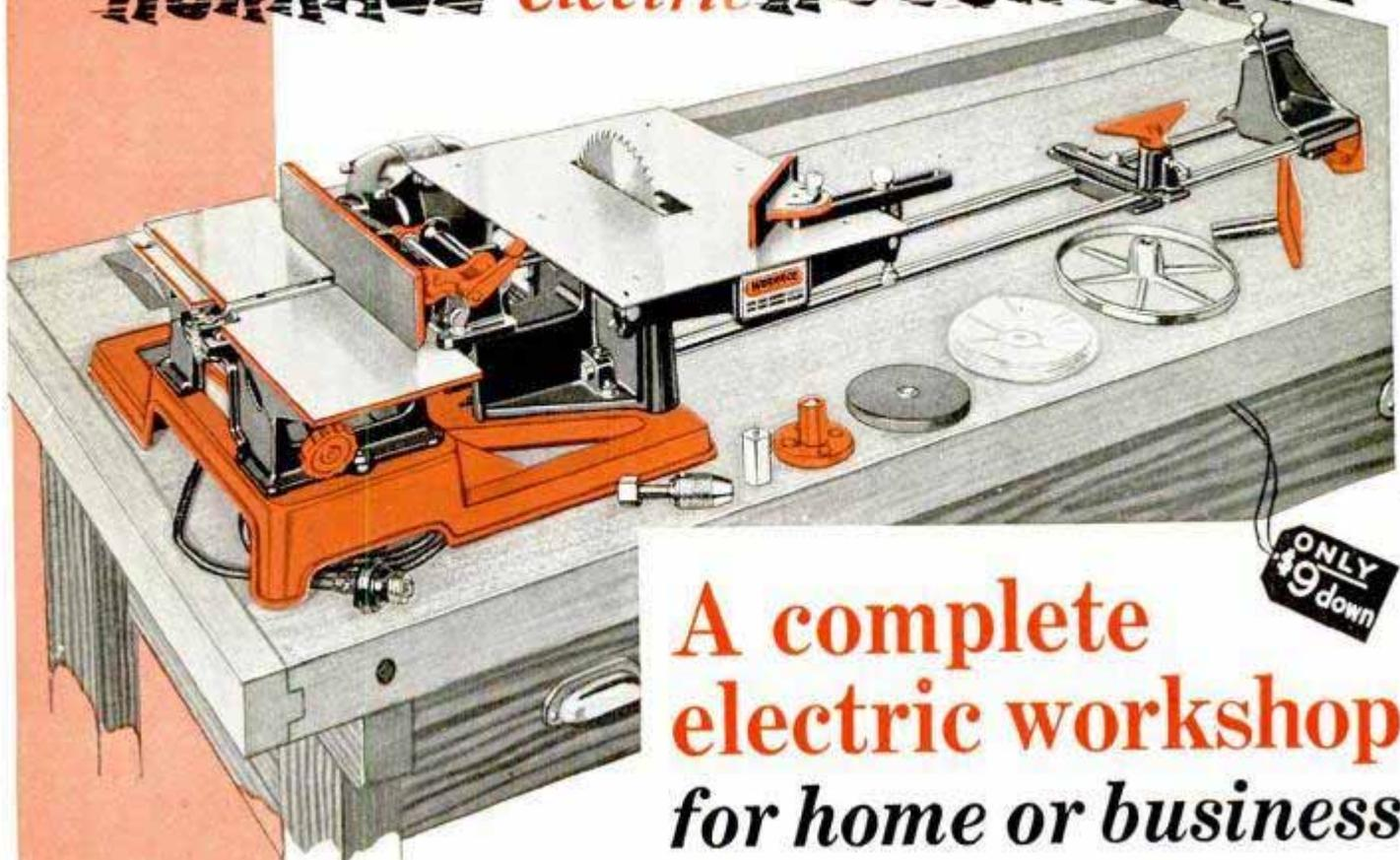

A complete electric workshop for home or business

EVERY man who has a workbench has often wished for a complete outfit of power driven woodworking machinery. Such a workshop is now as easy to possess as a radio set, and costs much less.

The Workace Electric Woodworker — a complete all-electric shop — costs but \$9.00 first payment and \$9.00 a month. This includes power driven tools for every woodworking operation.

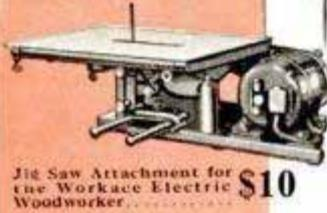

Jig Saw Attachment for the Workace Electric Woodworker..... \$10

Low Price \$89 Easy Terms

Here's a hobby that gives you relaxation from everyday cares — bringing pleasure and profit. Thousands of men and boys have adopted the Workace electric hobby. Make hundreds of things with the Workace Electric Woodworker. Under the magic of the whirring saw, planer, lathe, sander, drill, grinder and buffing wheel (all are included in the Workace Woodworker) raw lumber is easily converted into furniture, household necessities and countless other articles. Work out your own ideas with your own complete electric workshop. There's no better gift for the growing boy than Workace. It provides a wholesome man-building outlet for his energy and enthusiasm.

includes all this:

- 4" Planer
 - 8" Circular Saw
 - 6" x 36" Lathe
 - 8" Disc Sander
 - 6" Buffing Wheel
 - 5" Emery Grinder
 - 1/2" Drill Chuck
 - 1/2 H. P. G. E. Motor, 110-Volt, A. C., 60 Cycle
 - Endless V-Belt, 4" and 2 1/2" V-Stepped Pulleys, Cast Iron Sub Base and 10 ft. Cable with separable Plug.
- The Planer and Circular Saws are each complete units and may be purchased separately at the correspondingly low price of \$25.00 each.

A down payment of \$9.00 brings you the complete Workace All-Electric Woodworker ready to set up and use right away. The entire transaction is handled by one of your local hardware stores so that you will know the man you are dealing with and get his service and cooperation.

The Wallace Guarantee assures replacement of defective parts.

Large reproduction

For every coupon mailed in we will send a large picture of the entire outfit and a complete description of each item.

Send for full particulars and we will refer you to our dealer who is nearest to you.

MAIL THE COUPON TODAY

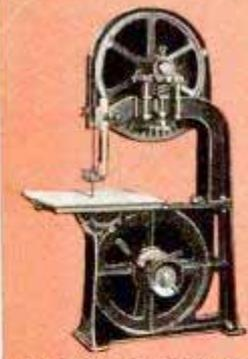

14" Workace Band Saw, fast, accurate, economical..... \$75

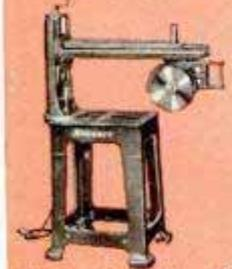

Workace Radial Saw, sets at any angle, Cast Iron Table \$10 Extra, Cast Iron Legs \$15 Extra..... \$140



Workace high speed, direct drive, portable electric Shaper..... \$95

J. D. WALLACE & COMPANY,
 Adams St. at California Ave., Chicago
 11 West 42nd Street, New York City
 268 Market Street, San Francisco

Please send me large size photograph and particulars about the Workace Electric Woodworker. Also interested in Jig Saw — Band Saw — Radial Saw — Shaper — Planer.

Name.....
 Firm.....
 Address.....
 Consult telephone directory for branch addresses in other cities



**WHEN CRITICAL SMOKERS
GET TOGETHER**

Their experience recognizes that Camel is indeed "a better cigarette":

Better in its quality of mellow, fragrant tobacco—

Better in the mildness and satisfying taste of the Camel blend—

When they learn the difference they flock to Camels.

CAMEL
CIGARETTES