

POPULAR MECHANICS

MAGAZINE

WRITTEN SO

REG'D. TRADE MARK, GREAT BRITAIN, NO. 40426

REG. U.S. PAT. OFF.



SEE PAGE 218



BRAND NEW

CORONA GENUINE Model #3

Lowest Price — Easiest Terms Ever Offered



HERE's your chance to own that *brand new* Genuine Model 3 Corona you've wanted — on the easiest terms ever offered — at **LOWEST PRICE** ever offered. Complete in every detail; back spacer, etc., *Manufacturer's Guarantee*. Recognized the world over as the finest, strongest, sturdiest portable built.

Yours for 10 DAYS FREE

Only a limited number of these splendid machines available. To get one, you must act now! Experience the joy this personal writing portable typewriter can give you! Use it ten days free! See how easy it is to run and the splendidly typed letters it turns out. Ideal for the office desk, home, traveling. Small, compact, light, convenient. Don't

send out letters, manuscripts, reports, bills in poor handwriting when you can have this Corona at such a low price on such easy terms. Remember these are *brand new* machines right out of the Corona factory.

Carrying Case FREE
If You Act Now!

Leatheroid carrying case, oiler, instructions free on this offer. Send no money — just the

coupon. Without delay or red tape we will send you the Corona. Try it 10 days. If you decide to keep it, send us only \$2 — then \$3 a month until our special price of \$39.90 is paid. Now is the time to buy. This offer may never be repeated.

Save Money — Use this Coupon

Smith Typewriter Sales Corp., (Corona Division)
469 E. Ohio St., Chicago, Ill. Dept. 32

Ship me the Corona, F.O.B. Chicago. On arrival I'll deposit \$2 with express agent. If I keep the machine, I'll send you \$3 a month until the \$37.90 balance of \$39.90 price is paid; the title to remain with you until then. I am to have 10 days to try the typewriter. If I decide not to keep it, I will repack and return to express agent, who will return my \$2. You are to give your standard guarantee.

Name _____

Address _____

Employed by _____

WHAT MAKES IT TICK?



*The boy takes his birthday watch apart to see what makes it tick. The man listens to the tick of the uranium electrons discharged into space—he actually **hears** the atoms of the metal disintegrate.*

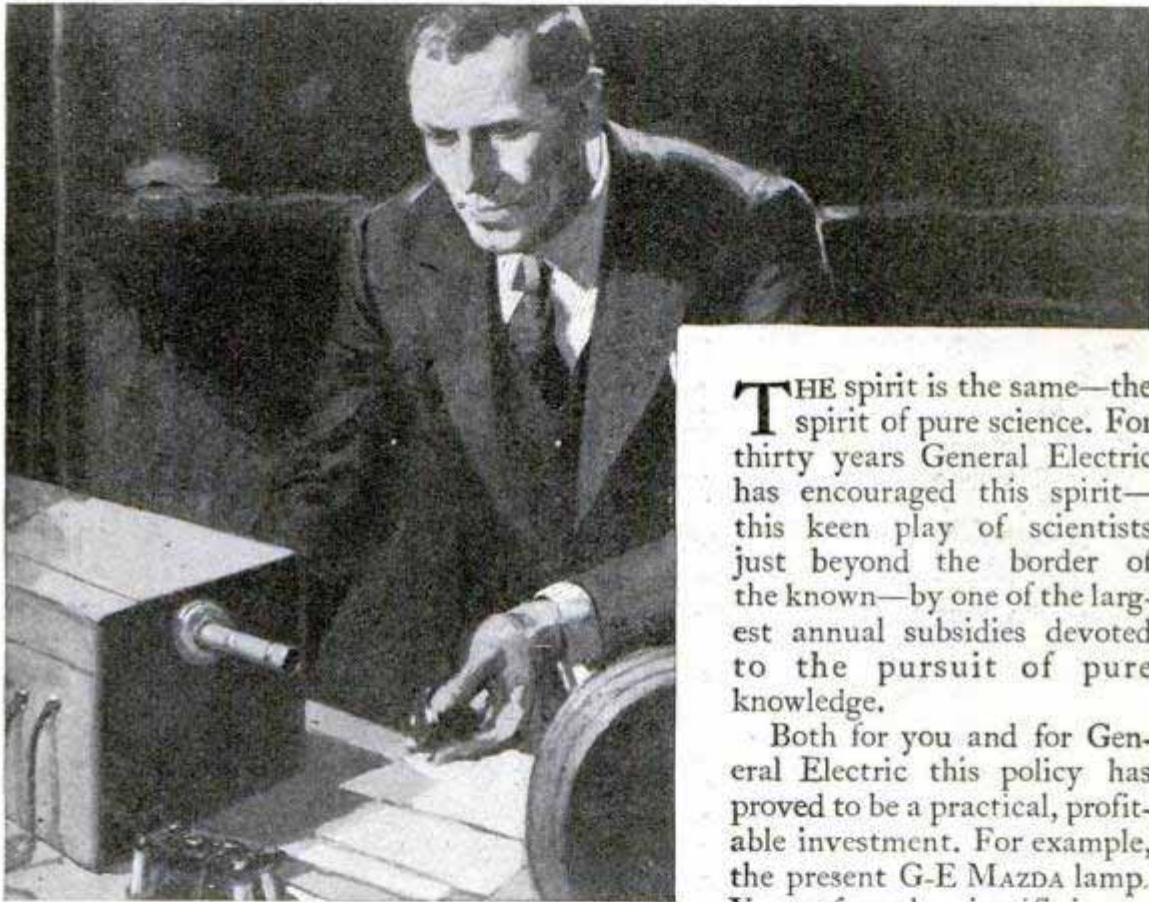

THE spirit is the same—the spirit of pure science. For thirty years General Electric has encouraged this spirit—this keen play of scientists just beyond the border of the known—by one of the largest annual subsidies devoted to the pursuit of pure knowledge.

Both for you and for General Electric this policy has proved to be a practical, profitable investment. For example, the present G-E MAZDA lamp. Years of purely scientific investigation

preceded this invention. And to-day, it saves the American people about a billion dollars a year in lighting bills.

The history of General Electric research is, in fact, crowded with such practical contributions to the comfort, health, and prosperity of us all, yet most of them owe their origin to the purely scientific curiosity which is the real dynamo of General Electric accomplishment. Because General Electric has pioneered this policy, and maintains it on a steadily increasing scale, the G-E monogram on any electric product—whether it is the little motor that runs your sewing machine or the turbines that drive the newest liners out to sea—is your assurance of electrical correctness and dependability.



JOIN US IN THE GENERAL ELECTRIC HOUR, BROADCAST EVERY SATURDAY AT 9 P.M.,
E.S.T. ON A NATION-WIDE N.B.C. NETWORK

GENERAL ELECTRIC

A Reduction in Long Distance Telephone Rates

*An Advertisement of the
American Telephone and Telegraph Company*

ON JANUARY 1, 1930, there is effective a reduction in various long distance telephone rates in the Bell System which on the present volume of calls means a saving of more than \$5,000,000 a year to the telephone-using public in the United States. This is the fourth reduction in long distance rates within a little more than three years. On October 1, 1926, they were reduced by \$3,000,000. On December 1, 1927, a reduction of \$1,500,000 went into effect. On February 1, 1929, there was a reduction of \$5,000,000.

THESE REDUCTIONS are in accordance with the aim of the Bell System to continue to furnish the best possible telephone service at the least cost to the public. Earnings must, of course, be sufficient to permit the best possible telephone service at all times and to provide a reasonable payment to stockholders with an adequate margin to insure financial safety. Earnings in excess of these requirements will either be spent for the enlargement and improvement of the service, or the rates for the service will be reduced. This is fundamental in the policy of the management.



Popular Mechanics Magazine

200 E. Ontario Street, Chicago, U. S. A.

H. H. WINDSOR, Founder

H. H. WINDSOR, Jr., Editor and Publisher

London: Hachette & Cie.,
16-17 King William Street, Charing Cross, W. C. 2

Paris: Hachette & Cie.,
111 Rue Reaumur

Melbourne: Gordon & Gotch
509-513 Little Collins St.

ISSUED MONTHLY

SUBSCRIPTION:

SINGLE COPY, 25 CENTS

In United States and its possessions, Canada, Cuba, Mexico, and all countries in the Pan-American Postal Union, per year, postpaid) \$2.50

To all other countries in the Postal Union 3.00

All subscriptions are discontinued at expiration. Please examine the date printed on your wrapper.

Entered as Second Class Matter Sept. 15, 1903, at the Post Office at Chicago, Illinois, under Act of March 3rd, 1879.

Entered as Second Class Matter at the Post Office Department, Canada.

Published monthly by POPULAR MECHANICS CO.

Copyright, 1930, by Popular Mechanics Co.

Copyright in Australia. Copyright in France

Vol. 53

Contents for February, 1930

No. 2

Special Features

The Passing of the Carrier Pigeon	194
The Magic Wand of the Opera	202
The Conquest of Fog	211
The Air Liners of the Future	218
What Your Tires Tell You	226
Sea Rovers Battle Derelicts	258
Air Riddles and the Answers	273
Dust---What It Does	281
Thrills in Hunting Birds' Eggs	290

Advertising—flexible mirror sign	232	Deafness	
Agriculture—extra light speeds growth of sugar-beet seeds	253	deaf hear "talkies" through sets on seats	201
Air-Mail—pilot's equipment costs thousand dollars	285	earphones for tabernacle	199
Airplanes		Dentistry—sterilizer for handpiece helps curb disease	280
fog dial on captive balloon to aid landings	288	Deodorizer—electric, kills smell of cooking	207
glider equipped motor	295	Desk—collapsible for child	251
gliders fitted with motors	263	Disease—electricity produces fever to fight	232
gyroscope pilots plane	278	Dogs—carried in covered rumble seat	215
heater for motor	198	Ducks—fly as fast as planes	256
helicopter plane passes successful tests	233	Earthquake—breaks cables	231
jet of steam aids take-off from ship	241	Educational Methods—blocks help teach foreign languages	240
Lindbergh's latest plane is built for speed	257	Electricity—revives infants by inducing breathing	265
pontoon turn small plane into a seaplane	280	Exercising Machine—like big tricycle	231
Astronomy—how to look at spots on sun	201	Filling Station—like plane	250
Automobiles—Accessories—forced-draft water heater	231	Fire Escape—fire victims slide to safety down tubular chute	289
Automobiles—Racing—auto body used as radiator in racing car	198	Fruit—packing frozen raw	215
Aviation		Furnace—made of fireplace	251
half of air deaths due to pilots' errors	208	Gloves—identification tags for soldiers	200
huge air sign aids high flyers	283	Gold medals for Canada	292
improved airport map	205	hog bristles in balls	193
landing field on long roof	264	larger and lighter ball	225
plane lookout built on Granite Peak	272	tee support provides target	262
Baby Carriage—resembling auto	254	Hats—sun hat held on shoulders	295
Boats and Boating—sailboat made of concrete	265	Heater—electric hot-water	288
Boxing—padded mask protects face	265	Highways—how motor highways are being beautified	255
Bridges—Ambassador, links Canada and United States	206	Household Devices	286
Camera—snaps electric spark	264	House Plan	352
Clocks		Humidifier—and radiator in one unit	285
giant dial of Westminster	193	Illumination—over hundred floodlights operated as one unit	278
operated by sunshine	233	Insects	
Cotton—picker cleans fluff and saves time	199	radio waves slay insects	295
Crime—glass bullets full of gas used by slayer	289	trapped by lights for hatchery	278

[Continued on Page 4]

Blood pressure, watermelon seed remedy for 265

BOOK! These NEW Books Will Help You MAKE MORE MONEY

ORDER ON 5-DAY TRIAL

The books listed below will perfect you in your chosen trade—pave the way to the big positions. Written in non-technical language—easy to read and understand. Every book covers its subject completely. An entire course of instruction condensed into one volume. Your choice sent postpaid—you benefit 5 days—money refunded in full if not entirely satisfactory. Order direct from this page.

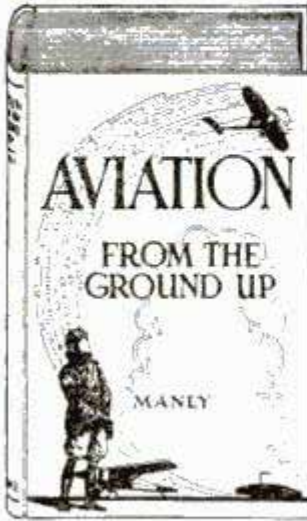

Aviation and Auto Books

- Aviation From the Ground Up... \$3.50
- Automobile Starting, Lighting and Ignition, by Manly... 700 pp. \$3.00
- Brookes' Automobile Handbook... \$2.00
- Ford Motor Car, Truck and Tractor, by Manly... Cloth \$1.50
- Auto and Radio Battery, Care and Repair, by Manly... Leatherette \$2.00
- Motorecycle Handbook, by Manly... \$1.50



Shop Practice Books

- Practical Heating Systems, Trouble Jobs and Ventilation... \$4.00
- Sheet Metal Workers' Manual... \$2.00
- Oxy-Acetylene Welding and Cutting... Cloth \$1.25
- Slide Rule and Logarithmic Tables... \$2.00
- Handbook for Millwrights... Cloth \$2.00
- Machine Shop Practice... Cloth \$2.00
- Mechanical Drawing and Machine Design... Cloth \$2.00

ORDER DIRECT FROM THIS PAGE — ON OUR MONEY-BACK PLAN

The books listed above are only a few of the many in our catalogue, which you will receive promptly after filling out and mailing us the attached coupon. For quick action order direct from this page—cross name of each book wanted and send in with price quoted. We prepay postage and send the books on our money-back plan.

FREDERICK J. DRAKE & CO.

Publishers

R508—179 No. Michigan Ave. CHICAGO

Drake Books Are For Sale at All Book Stores

Mail Coupon For Free Catalogue
Your Guide to Home Study

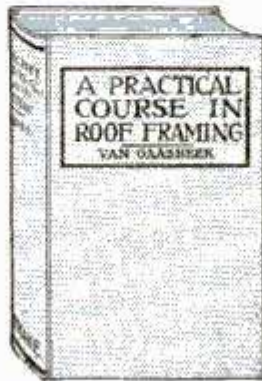

Carpentry Books

Cloth Binding

- Modern Carpentry, 2 vols... \$3.00
- The Steel Square, 2 vols... \$3.00
- Modern Estimator... \$1.50
- Timber Framing... \$2.00
- Builders' Architectural Drawing... \$2.00
- Concretes... \$1.50
- Practical Bungalows... \$1.00
- Roof Framing, by Van Gaasbeek... \$1.50

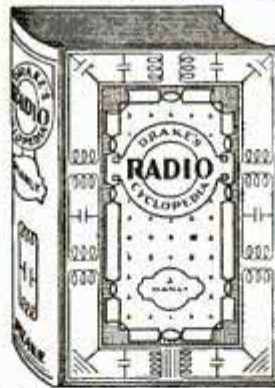

Drake's Radio Cyclopedia

By H. P. Manly 3rd Edition
1025 Pages, 1100 Illustrations, 1700 Subjects, arranged alphabetically. For Service and Repair Men, Dealers, Salesmen, Experimenters and Designers. Bound in Art Buckram. Price... \$6.00

By Prof. P. S. Allen, U. of Chicago
French without a Teacher... Cloth \$1.25
Spanish without a Teacher... Cloth \$1.25



Painting, Decorating and Art

- Lettering, Modern and Foreign, Welo \$5.00
- Silk Screen Process of Reproduction, Lea... \$5.00
- Modernistic Lettering and Design, (Portfolio)... \$2.00
- Modern Illustration... Cloth \$3.50
- The Lacquer System of Sign Painting... Cloth \$3.00
- Practical Estimating for Painters and Decorators... Cloth \$2.00
- How to Draw Funny Pictures—a Complete Course in Cartooning... Cloth \$3.00
- Layouts for Advertising... Lea... \$3.00
- Furniture, Furniture Finishing, Decoration and Patching... \$5.00
- Ross Crane Book of Home Furnishing and Decoration... Cloth \$3.00
- House Painting Methods... Cloth \$2.00
- Interior Wall Decoration, by Vanderwalker... Leatherette \$4.00
- The Mixing of Colors and Paints, by Vanderwalker... Cloth \$2.00
- Studio Handbook—Letter and Design... \$3.00
- A Show at Sho' Cards... Cloth \$4.00
- Sign Painting, by Atkinson... Cloth \$4.00
- Strong's Book of Designs, Leatherette \$4.00
- Modern Painters' Cyclopedia, Cloth \$2.00
- Automobile Painting... Cloth \$1.50
- Wood Finishing, Plain and Decorative... Cloth \$2.00

Steam Engineering

- Swingle's Handbook for Steam Engineers and Electricians... Leatherette \$4.00
- Examination Questions and Answers for Marine and Stationary Engineers... Leatherette \$2.00
- Steam Boilers... Leatherette \$2.00
- Swingle's Catechism of Steam, Gas and Electrical Engineering... Leatherette \$1.50

MODERN LANGUAGES

- German without a Teacher... Cloth \$1.25
- Everyday French... \$1.25
- Everyday Spanish... \$1.25

This One



1YNS-X6S-QETC

FREDERICK
R508—179 No
Chicago, Ill

GENTLEMEN
Illustrated catalogues
Mechanical Books for Home Study.

My name is

and my address

1930 1931 1932 1933 1934 1935 1936 1937 1938 1939



Will You Be Clerk or Manager Ten Years from Now?

SURELY, this could never happen to *me*," you say—"that I should be sitting at the same desk—be doing the same work, *for ten straight years!*"

But wait a minute—

Exactly the same thing is happening to thousands upon thousands of men thruout the country. It has probably happened to men right in the company you now are working for. *And—unless you deliberately fit yourself for a better job—there is a very good chance that it will happen to you!*

Unthinkable? That's what R. M. Whitney, of Rochester, N. Y., said to himself. Yet lack of training kept him slaving away at low wages for more than twenty years . . .

Trebled His Salary in Three Years

—For more than twenty years, till finally, at the age of 47, and still receiving only thirty dollars a week, R. M. Whitney resolved to be a bookkeeper no longer. He enrolled with LaSalle for training in Higher Accountancy, and completed the course. Almost immediately came the offer of a bigger job.

Less than three years later, the Davenport Machine Tool Company—the very company he had worked for as a clerk—invited him to come back. He returned as Auditor, at a salary-increase of better than 300 per cent.

Today, he is Treasurer of this great company: and in a letter to LaSalle, after commenting on the opportunities LaSalle affords to men in their forties or early fifties, he adds, "And for the young man, who is just getting a foothold in the business world, LaSalle Extension University training is the most profitable investment he could make."

Says Good-bye to Clerkship— Now Heads Successful Firm

We have told you about a man who *waited*—at a cost to himself of probably not less than \$100,000. Now consider the experience of a younger man—G. Roy Eshelman, of Decatur, Illinois—

Eshelman was occupying a subordinate position in the purchasing department of a manufacturing concern—salary \$16 a week. Visualizing the opportunities for skilled accountants, he enrolled with LaSalle for training in Higher Accountancy.

"Thru this training," writes Mr. Eshelman, "I became interested in the Auditing Department and often remained after working hours watching the Auditor at his work. Observing my interest, he soon placed me in his department at a 50% increase in pay, and as I progressed with my LaSalle work, I was shortly rewarded with an additional 40% increase.

"My studies rapidly equipped me to strike out for myself, and at present I have an extensive practice as a Public Accountant, employing four accountants. It is sufficient to say that my present income is *many, many times greater than when I enrolled.*"

Send For These Two Books and Start Toward Real Success

Need you hear more before you investigate the opportunities in Accountancy? Shall we tell you about Pentland—or Gray—or McDuffie—all of them commanding incomes better than \$10,000 a year and all of them still in their thirties?

Or will you face the problem of your future NOW—and send to LaSalle and get further facts and particulars?

Without cost or obligation, the coupon will bring you two books—one a 64-page book entitled, "Accountancy, the Profession that Pays;" the other, "Ten Years' Promotion in One."

How about those next ten years—will you wait, or will you START TODAY to realize the opportunities that lie ahead of you thru sound and practical home-study business training?

Measure your grit and ambition by what you do with this coupon—NOW.

— — — — — Find Yourself Through LaSalle — — — — —

LaSalle Extension University

The World's Largest Business Training Institution

Dept. 264-HR Chicago
Opportunities in Accountancy—Check below and we will send you copy of "Accountancy, the Profession that Pays," also copy of "Ten Years' Promotion in One," all without obligation.

Higher Accountancy:

Other LaSalle Opportunities: If more interested in one of the other fields of business indicated below, check here:

- | | |
|--------------------------------------------------|----------------------------------------------------|
| <input type="checkbox"/> Business Management | <input type="checkbox"/> Personnel Management |
| <input type="checkbox"/> Modern Salesmanship | <input type="checkbox"/> Expert Bookkeeping |
| <input type="checkbox"/> Traffic Management | <input type="checkbox"/> C. P. A. Coaching |
| <input type="checkbox"/> Railway Station Mgmt. | <input type="checkbox"/> Business English |
| <input type="checkbox"/> Law: Degree of LL. B. | <input type="checkbox"/> Commercial Spanish |
| <input type="checkbox"/> Commercial Law | <input type="checkbox"/> Effective Speaking |
| <input type="checkbox"/> Industrial Management | <input type="checkbox"/> Telegraphy |
| <input type="checkbox"/> Business Correspondence | <input type="checkbox"/> Stenotypy—Stenography |
| <input type="checkbox"/> Credit and Collection | <input type="checkbox"/> Railway Accounting |
| <input type="checkbox"/> Correspondence | <input type="checkbox"/> Paper Salesman's Training |
| <input type="checkbox"/> Banking and Finance | |
| <input type="checkbox"/> Modern Foremanship | |

Name.....

Present Position.....

Address.....

ELECTRIC WIRING CODE TRANSMISSION



We take pleasure in announcing: "AUDELS NEW ELECTRIC LIBRARY"

New and More Uses for Electricity that come up daily offer great opportunities to men who can handle this power correctly and accurately. Modern electrification of industry calls for trained men who know how to handle electricity.

Simple as A. B. C.—"Audels New Electric Library" gives latest, exact information from foundations of electrical practice to latest modern applications. This is a NEW practical and theoretical course in electricity for home study and ready reference.

Here are the answers to your questions, giving you the real dope that every electrician must know. They chart your knowledge, taking away the uncertainty of guess work.

NEW!

Beautiful, timely books for service—pocket size; completely illustrated with diagrams and charts; simplified, easy to read and understand. No electrical man can afford to pass up this opportunity. Extremely low price; buy on your own terms.

NEW!

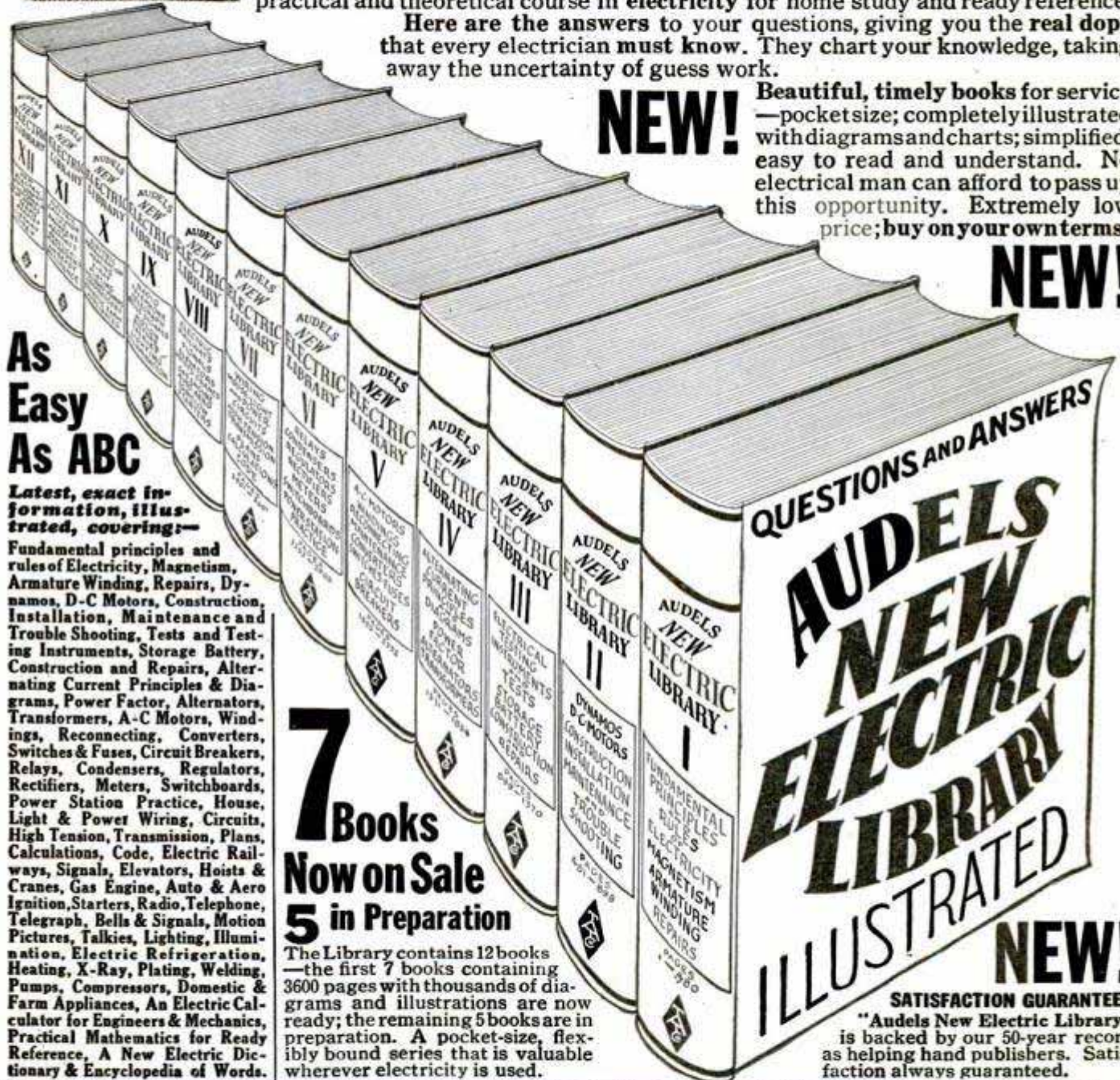

As Easy As ABC

Latest, exact information, illustrated, covering—

Fundamental principles and rules of Electricity, Magnetism, Armature Winding, Repairs, Dynamos, D-C Motors, Construction, Installation, Maintenance and Trouble Shooting, Tests and Testing Instruments, Storage Battery, Construction and Repairs, Alternating Current Principles & Diagrams, Power Factor, Alternators, Transformers, A-C Motors, Windings, Reconnecting, Converters, Switches & Fuses, Circuit Breakers, Relays, Condensers, Regulators, Rectifiers, Meters, Switchboards, Power Station Practice, House, Light & Power Wiring, Circuits, High Tension, Transmission, Plans, Calculations, Code, Electric Railways, Signals, Elevators, Hoists & Cranes, Gas Engine, Auto & Aero Ignition, Starters, Radio, Telephone, Telegraph, Bells & Signals, Motion Pictures, Talkies, Lighting, Illumination, Electric Refrigeration, Heating, X-Ray, Plating, Welding, Pumps, Compressors, Domestic & Farm Appliances, An Electric Calculator for Engineers & Mechanics, Practical Mathematics for Ready Reference, A New Electric Dictionary & Encyclopedia of Words.

7 Books Now on Sale 5 in Preparation

The Library contains 12 books—the first 7 books containing 3600 pages with thousands of diagrams and illustrations are now ready; the remaining 5 books are in preparation. A pocket-size, flexibly bound series that is valuable wherever electricity is used.

QUESTIONS AND ANSWERS
AUDELS NEW ELECTRIC LIBRARY ILLUSTRATED

NEW!

SATISFACTION GUARANTEED
"Audels New Electric Library" is backed by our 50-year record as helping hand publishers. Satisfaction always guaranteed.

BUY ON YOUR OWN TERMS

- PLAN 1—ONE BOOK A MONTH**
Please enter my subscription to "Audels New Electric Library" to consist of twelve volumes, price \$1.50 a volume (\$10.50 for the seven volumes now ready). Mail one volume each month and as they are received, I will mail you \$1.50 promptly.
- PLAN 2—PAY 50c OR MORE A WEEK**
Please ship me for one week's free trial the first seven volumes of "Audels New Electric Library," \$1.50 each (\$10.50 for the seven volumes now ready). The remaining five volumes to be mailed as issued at \$1.50 a volume. If satisfied, I will mail you 50c or more each week as payment for the first seven books and I will pay for the last five numbers as I receive them at \$1.50 each.
- PLAN 3—CASH PRICE \$9.98**
Please ship me postpaid "Audels New Electric Library" for which I enclose remittance \$9.98 in full payment for the seven volumes now ready. You are to ship me on one week's trial the remaining five volumes as they are issued for which I will either pay \$1.50 each as received or return to you. This price is based on 5% cash discount.

THEO. AUDEL & CO.,
65 West 23rd St., New York, N. Y.

Please ship me the NEW "Audels Electric Library" on the plan marked (X).

NAME

ADDRESS

OCCUPATION

EMPLOYED BY

BE AN AUTO EXPERT

EARN up to \$5000 A YEAR



Learn Autos
the new easy interesting
JOB-WAY



From \$30 a Week to \$90 a Week!

W. S. Yancy, Perla, Arkansas, was making only \$30 a week when he wrote for my Book. Today he's earning \$90 a week! You can get the same book FREE! Just clip the coupon — and mail it today!

Clip Coupon for Free Auto Book!

Say good-bye to low pay! Get into the Auto Business, where big pay — extra money — raises — come quick! A brilliant future awaits you in the World's Biggest Business.

LEARN AT HOME In Spare Time

If you're earning a cent less than \$50 a week, clip that coupon now. Learn how \$50—\$75—even \$100 a week is now possible for you. See how I train you, right at home, in every branch of Auto Work, quickly and easily. Find out about this Training which boosted Yancy's salary from \$30 a week to \$90 a week!

Experience, Education, Not Necessary!

All you need is common schooling—and it makes no difference if you never touched an auto before. Men from all walks of life who worked long, hard hours for low pay, are now becoming Garage Owners, Foremen and Superintendents. If you like autos, if you're between 15 and 65—get the facts now! "Job-

Way" Training covers everything about Autos — Mechanical and Electrical—everything you need to get in line for a Big Pay Job as an Auto Expert! It's the trained man who gets the good jobs and "Job-Way" is complete Training, yet so simple and so easy that you get it quick.

3 Testing and Repair Outfits also included FREE of extra cost — If You Act At Once!

Right now I am offering an Electrical Experimental Outfit, equipment for a Portable Electric Test Bench, and 381 Auto Wiring Diagram Charts to students. Send coupon now.

Auto Book FREE!

Send for this big new book. Take the first step to a Big Pay Job!



Read My Money-Back Agreement!

Learn about the 14 "Job-Way" Features shown in my big Free Auto Book. Also about my Money-Back Agreement. Be sure to get the book and see how easily you can get in line for a Job paying up to \$100 a week!

MAIL THIS COUPON!

MOTOR INSTITUTE OF AMERICA. B. W. COOKE, Dir. Engineer
Motor Institute Bldg., Dept. 3162, Evanston, Ill.
Send me your FREE Auto Book. Also proof that I can succeed in the Auto Business. Tell me about "Job-Way" Auto training — about your Employment Department, and about your 3 Testing and Repair Outfits and Aviation Course Offer. No obligation on my part whatever.

Name

Address

Town State

Age Occupation

Get Full Particulars of AVIATION

Find out how my Employment Department **Course Offer** helps you get a Good Job—Raises in Pay—and Promotions. Get all the details of my offer of a complete, ground-school Aviation Course which I am making to men who enroll.

Address me **B. W. COOKE** Directing
Personally **Engineer**

MOTOR INSTITUTE OF AMERICA

Motor Institute Bldg., Dept. 3162, Evanston, Ill.



HE PICKED IT UP IN THE ROAD...

AND INCREASED HIS WAGES 6 TIMES!



E. L. HOUSE was a day laborer in Baltimore when the wind blew a piece of paper toward him. He picked it up—read it. It was a circular about the International Correspondence Schools course in Mechanical Drawing.

"I didn't know what mechanical drawing was," says Mr. House, "and I wrote to the Schools at Scranton to find out. They wrote back, explaining just what I would be letting myself in for, and I did some thinking. It didn't look as if I'd ever amount to anything unless I worked with my head as well as my hands, and I had to get the old head ready. So I enrolled for that course in drawing when I didn't know what it was all about. It might have been clothes pressing!

"I was studying on that course three years and I graduated in it in 1917. Then I went to work

as a draftsman in the Bethlehem Plant at Sparrows Point. Jobs with other firms followed, each one an advancement, and today my wages are six times as much as at the time of my enrolment for that drafting course. The I. C. S. has done much for me, as it has for my brothers."

No matter how small your capital may be, or how limited your education, if you want to get ahead, the International Correspondence Schools can help you do it.

One hour a day of spare time, spent with the I. C. S. in the quiet of your own home, will train you for the position you want, in the work you like best. Put it up to us to prove it!

You don't have to wait for the wind to blow a circular your way. Clip this coupon, mark the subjects that interest you, and mail it—today.

INTERNATIONAL CORRESPONDENCE SCHOOLS, Box 5664-F, Scranton, Penna.

"The Universal University"

Without cost or obligation, please send me a copy of your booklet, "Who Wins and Why," and full particulars about the subject before which I have marked X in the list below:

BUSINESS TRAINING COURSES

- | | | | | |
|------------------------------------------------|------------------------------------------|------------------------------------------------------------------|-------------------------------------------------------------------------|---------------------------------------------------------------------------|
| <input type="checkbox"/> Business Management | <input type="checkbox"/> Cost Accounting | <input type="checkbox"/> Secretarial Work | <input type="checkbox"/> Business Correspondence | <input type="checkbox"/> Railway Mail Clerk |
| <input type="checkbox"/> Industrial Management | <input type="checkbox"/> Accounting and | <input type="checkbox"/> Spanish <input type="checkbox"/> French | <input type="checkbox"/> Show Card and Sign Lettering | <input type="checkbox"/> Grade School Subjects |
| <input type="checkbox"/> Personnel Management | <input type="checkbox"/> C.P.A. Coaching | <input type="checkbox"/> Salesmanship | <input type="checkbox"/> Stenography and Typing | <input type="checkbox"/> High School Subjects |
| <input type="checkbox"/> Traffic Management | <input type="checkbox"/> Bookkeeping | <input type="checkbox"/> Advertising | <input type="checkbox"/> English <input type="checkbox"/> Civil Service | <input type="checkbox"/> Illustrating <input type="checkbox"/> Cartooning |

TECHNICAL AND INDUSTRIAL COURSES

- | | | | | |
|-------------------------------------------------|------------------------------------------------|--------------------------------------------------|----------------------------------------------------------------------|-------------------------------------------|
| <input type="checkbox"/> Electrical Engineering | <input type="checkbox"/> Railroad Positions | <input type="checkbox"/> Steam Engineering | <input type="checkbox"/> Concrete Builder | <input type="checkbox"/> Aviation Engines |
| <input type="checkbox"/> Electric Lighting | <input type="checkbox"/> Gas Engine Operating | <input type="checkbox"/> Architect | <input type="checkbox"/> Structural Engineer | <input type="checkbox"/> Agriculture |
| <input type="checkbox"/> Mechanical Engineer | <input type="checkbox"/> Civil Engineer | <input type="checkbox"/> Architects' Blueprints | <input type="checkbox"/> Chemistry <input type="checkbox"/> Pharmacy | <input type="checkbox"/> Mathematics |
| <input type="checkbox"/> Mechanical Draftsman | <input type="checkbox"/> Surveying and Mapping | <input type="checkbox"/> Contractor and Builder | <input type="checkbox"/> Coal Mining | <input type="checkbox"/> Navigation |
| <input type="checkbox"/> Machine Shop Practice | <input type="checkbox"/> Plumbing and Heating | <input type="checkbox"/> Architectural Draftsman | <input type="checkbox"/> Automobile Work | <input type="checkbox"/> Radio |

Name..... Street Address.....

City..... State..... Occupation.....

Persons residing in Canada should send this coupon to the International Correspondence Schools Canadian, Limited, Montreal, Canada

4 of the 40 Easy Ways to Make \$3⁰⁰ an Hour

THE four plans shown are but a sample of the many ways in which our members are making \$3.00 an hour upwards, spare time and full time, *from the day they join the Association.* If you want to get into Radio, have a business of your own, make \$50 to \$75 weekly in your spare time, investigate the opportunities offered the inexperienced, ambitious man by the Association.

Our Members Earning Thousands of Dollars Weekly

The Association was formed to help men cash in on Radio. It makes past experience unnecessary. As a member of the Association you are trained in a quick, easy, practical way to install, service, repair, build and rebuild sets—given sure-fire money-making plans developed by us—helped to secure a position by our Employment Department. You earn while you learn, while you prepare yourself for a big-pay Radio position.

The Association will enable you to buy parts at wholesale, start in business without capital, help you get your share of the \$600,000,000 spent annually for Radio. As a result of the Association, men all over the country are opening stores, increasing their pay, passing licensed operator examinations, landing big-pay positions with Radio makers.



In Your Spare Time in RADIO

Below are a few reports from those cashing in on the "easy ways"

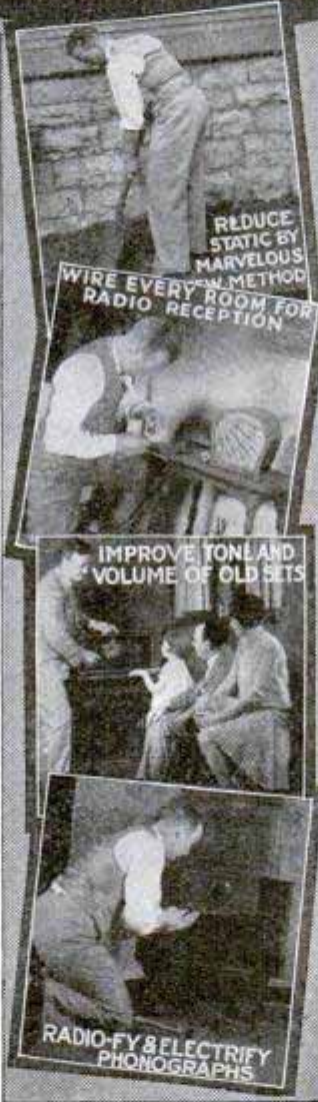

Clears \$3,000.00 Frank J. Deutch, Pa.—"Since joining the Association I have cleared nearly \$3,000.00. It is almost impossible for a young fellow to fail, no matter how little education he has, if he will follow your easy ways of making money."

\$1,100.00 in 6 Weeks J. R. Allen, Calif.—"Have done over \$1,100.00 worth of business in the last 6 weeks. Next month I am going to open up a store of my own. I never knew that money could come so fast and easy."

\$25.00 a Week Spare Time N. J. Friedrich, N. Y.—"I have averaged \$25.00 a week for the last 7 months even though I am not a graduate but just learning."

Training Lands Him Job R. C. Kirk, N. C.—"Your training has been very valuable to me. I landed a job with the big department store out here a few weeks ago because I had my membership card with me. There were a large bunch of applications ahead of me."

ACT NOW If You Wish NO-COST Membership

For a limited time we will give to the ambitious man a No-Cost Membership which need not—should not—cost you a cent. For the sake of making more money now, and having a better position in the future, mail coupon below *now*.

Mail Coupon for the FREE HANDBOOK

It is not only chock-full of absorbing information about Radio, but it shows you how easily you can increase your income in your spare time. Mailing the coupon can mean \$50 to \$75 a week more for you.

Radio Training Association of America
4513 Ravenswood Avenue Dept. PM-2 Chicago, Illinois

Radio Training Association of America
Dept. PM-2 4513 Ravenswood Ave., Chicago
Gentlemen: Please send me by return mail full details of your Special No-Cost Membership Plan, and also a copy of your Radio Handbook.

Name _____
Address _____
City _____ State _____

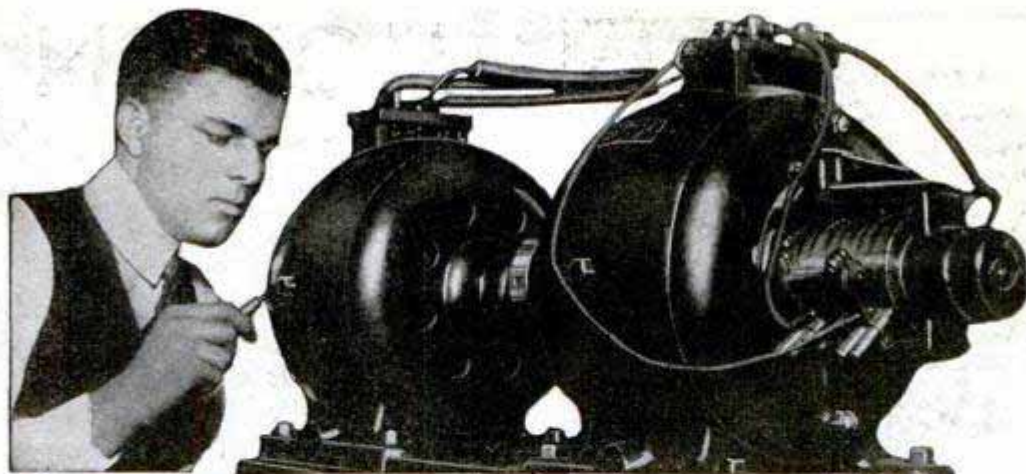

Amazingly Easy Way to get into ELECTRICITY

Don't spend your life waiting for \$5 raises, in a dull, hopeless job. Now... and forever... say good-bye to 25 and 35 dollars a week. Let me show you how to qualify for jobs leading to salaries of \$50, \$60 and up, a week, in Electricity—NOT by correspondence, but by an amazing way to teach, RIGHT HERE IN THE GREAT COYNE SHOPS. You become a practical Electrician in 90 days! Getting into Electricity is far easier than you imagine!

Learn Without Lessons in 90 DAYS By Actual Work—in the Great Shops of Coyne

Lack of experience—age, or advanced education bars no one. I don't care if you don't know an armature from an air brake—I don't expect you to! I don't care if you're 16 years old or 48—it makes no difference! Don't let lack of money stop you. Most of the men at Coyne have no more money than you have.

Railroad Fare Allowed

I will allow your railroad fare to Chicago, and if you should need part-time work I'll assist you to it. Then, in 12 brief weeks in the great roaring shops of Coyne, I train you as you never dreamed you could be trained... on a gigantic outlay of electrical apparatus... costing hundreds of thousands of dollars... real dynamos, engines, power plants, autos, switchboards, transmitting stations... everything from doorbells to farm power and lighting... full-sized... in full operation every day!



Prepare for Jobs Like These

Here are a few of hundreds of positions open to Coyne-trained men. Our free employment bureau gives you lifetime employment service.

Armature Expert	up to \$100 a Week
Substation Operator	\$60 a Week and up
Auto Electrician	\$110 a Week
Inventor	Unlimited
Maintenance Engineer	up to \$150 a Week
Service Station Owner	up to \$200 a Week
Radio Expert	up to \$100 a Week

etc., etc. That's a glimpse of how we make you a practical electrician in 90 days, teaching you far more than the average ordinary electrician ever knows and fitting you to step into jobs leading to big pay immediately after graduation. Here, in this world-famous *Parent school*—and nowhere else in the world—can you get this training!

Jobs, Pay, Future

Don't worry about a job, Coyne training settles the job question for life. Demand for Coyne men often exceeds the supply. Our employment bureau gives you a lifetime service. Two weeks after graduation Clyde F. Hart got a position as electrician for the Great Western Railroad at over \$100 a week. That's not unusual. We can point to Coyne men making up to \$600 a month. \$60 a week is only the beginning of your opportunity. You can go into radio, battery, or automotive electrical business for yourself and make up to \$15,000 a year.

Get the Facts

Coyne is your one great chance to get into electricity. Every obstacle is removed. This school is 30 years old—Coyne training is tested—proven beyond all doubt—endorsed by many large electrical concerns. You can find out everything absolutely free. Simply mail the coupon and let me send you the big, free Coyne book of 150 photographs... facts... jobs... salaries... opportunities. Tells you how many earn expenses while training and how we assist our graduates in the field. This does not obligate you. So act at once. Just mail coupon.

Get This Free Book



NO BOOKS

No Printed Lessons

No books, no baffling charts... all real actual work... right here in the great Coyne school... building real batteries... winding real armatures, operating real motors, dynamos and generators, wiring houses



NOW IN OUR

NEW HOME

This is our new fireproof, modern home wherein is installed thousands of dollars' worth of the newest and most modern Electrical equipment of all kinds. Every comfort and convenience has been arranged to make you happy and contented during your training.

COYNE ELECTRICAL SCHOOL
H. C. LEWIS, President
500 S. Paulina Street, Dept. 20-72 Chicago, Ill.

Mr. H. C. LEWIS, President
Coyne Electrical School, Dept. 20-72
500 S. Paulina Street, Chicago, Illinois

Dear Mr. Lewis:
Without obligation send me your big free catalog and all details of Railroad Fare to Chicago. Free Employment Service, Radio, Aviation Electricity, and Automotive Courses, and how I can "earn while learning."

Name

Address

City State



MODERN ART PAYS BIG MONEY

The amazing demand for art work of all kinds is creating hundreds of big-pay opportunities every year. Trained artists are needed. This is the Age of Color . . . of Design . . . of Art in everything. Manufacturers, decorators, publishers . . . all are seeking men and women with art training.

Through the Federal School of Illustrating many who drudged at small pay have found fascinating careers . . . large incomes. Hundreds of Federal students are now earning from \$2500 to \$6000 a year . . . many even more.

You can learn at home . . . in your spare time . . . the Federal way. Earn while you learn . . . most of our students do. The Federal Course is for practical artists who **MUST** make good. It aims at dollars and cents profit for every student.

More than fifty famous artists . . . masters of modern art . . . contribute exclusive lessons and drawings to the Federal Course. They tell you how they create new . . . striking . . . clever . . . art work. They give you their technical tricks in illustrating, cartooning, lettering, designing, etc.

Test Your Talent Free

Send for our Free Vocational Test Chart. It's simple to fill out. Our artists judge it for you and give you a definite guide to your probable talent and earning power in art. We will also send you, without charge, "A Road To Bigger Things," giving names of the famous Federal instructors . . . showing where the big money in art is . . . what others are making. Get this Book and the Test Chart. Write now.

THE FEDERAL SCHOOL of ILLUSTRATING

2130 FEDERAL SCHOOLS BUILDING

MINNEAPOLIS, MINNESOTA

Federal School of Illustrating

2130 Federal Schools Building, Minneapolis, Minnesota

Please send me free book, "A Road To Bigger Things," and Standard Art Test.

Name _____

Age _____ Occupation _____

Address _____



We have placed machinists, carpenters, masons, plumbers, railroad men, office clerks, farmers and even laborers in fine Drafting Jobs under this plan. Mail coupon for details of our remarkable offer.

Men Who Work With Their Hands Make the Best DRAFTSMEN



—and we'll back them with this EMPLOYMENT CONTRACT

We are looking for more ambitious young fellows with factory, building-trade or any other kind of mechanical experience to prepare for and help place in well-paid Drafting positions. Such men, we find, are unusually successful as Draftsmen, because they know how things are done, and that's a priceless asset to the man who makes the blueprint plans. Get in touch with me and I'll tell you how you can cash in on your entire past mechanical experience.

Drafting Is Logically Your Next Move!

Of course you realize the biggest handicap to mechanical work is that you're limited in earning capacity to the output of your two hands, as long as you live. Even the skilled mechanic earning \$50 to \$60 a week has reached his limit. He can never earn more and when he gets old he will earn less. So I don't blame any man for wanting to get away from this futureless outlook. For wanting to get into something where he can use his head as well as his hands—where he will be paid for what he knows, instead of only for what he does . . . You know enough about blueprints to understand that PLANS govern every move in factory and construction job. The Draftsman who makes them is several jumps ahead of the workman who follows them. And so I want you to know that DRAFTING is a logical, natural PROMOTION from mechanical and building work—better-paid, more interesting—just the kind of work you'd enjoy doing.

Get Our NO-RISK PLAN

The way to a fine Drafting job for you—is easier than you think. It takes no "artistic talent" or advanced education. Thousands of men no smarter than you, with no more education or ability, have learned it quickly and you can, too. With the co-operation of some of the biggest employers and engineers in the U. S., we have worked out a plan to prepare you for Drafting work in your spare time at home—then to help you get a fine position at increased pay. Mail the coupon and we'll be glad to tell you all about this lifetime chance to get into Drafting.

THE AMERICAN SCHOOL
Dept. D-247, Drexel Ave. and 58th St., Chicago, Ill.

American School

NOW! Jobs for students too!

1. WE GUARANTEE to prepare you for a good position in

DRAFTING and DESIGN by giving you thorough, complete, up-to-date, and simplified home-study training.

2. WE ALSO GUARANTEE that, when you have completed at least one-half of this training, our Employment Service will help you secure a good position, without extra charge.

3. WE FURTHER GUARANTEE to refund the entire amount you have paid for this training if, within 60 days after submitting your final examination, you inform us that, in your opinion, our Training and Employment Service has not been satisfactory.



R. J. Milligan
President

36-Page Drafting Book—FREE

Tells how easy Drafting is to learn—how interesting the work is—what remarkable opportunities are open for Draftsmen right now. Mail coupon for a copy—without cost or obligation.

AMERICAN SCHOOL, Dept. D-247, Drexel Ave. & 58th St., Chicago, Ill.

Please tell me, without cost or obligation, about your training and employment service in line marked X below.

DRAFTING

- Architecture
- Building
- Electrical Engineering
- Business Management
- Accounting
- Mechanical Engineering
- Shop Superintendent
- Foremanship
- High School in 2 years
- Structural Steel
- Civil Engineering
- Auto Engineering

Name _____

St. No. _____

City _____ State _____

Age _____ Occupation _____



"I have landed a job with the Pacific Tel. and Tel. Co. in Seattle, and I must say that I am greatly indebted to the American School for my success. You have done all that you promised in helping me obtain employment."

T. C. White
Seattle, Wash.



"I have obtained a position as a junior draftsman with the Muncie Oil Engine Co., and so far I like the work real well. I appreciate your aid in obtaining this position very much."

M. N. Bareham
Muncie, Ind.

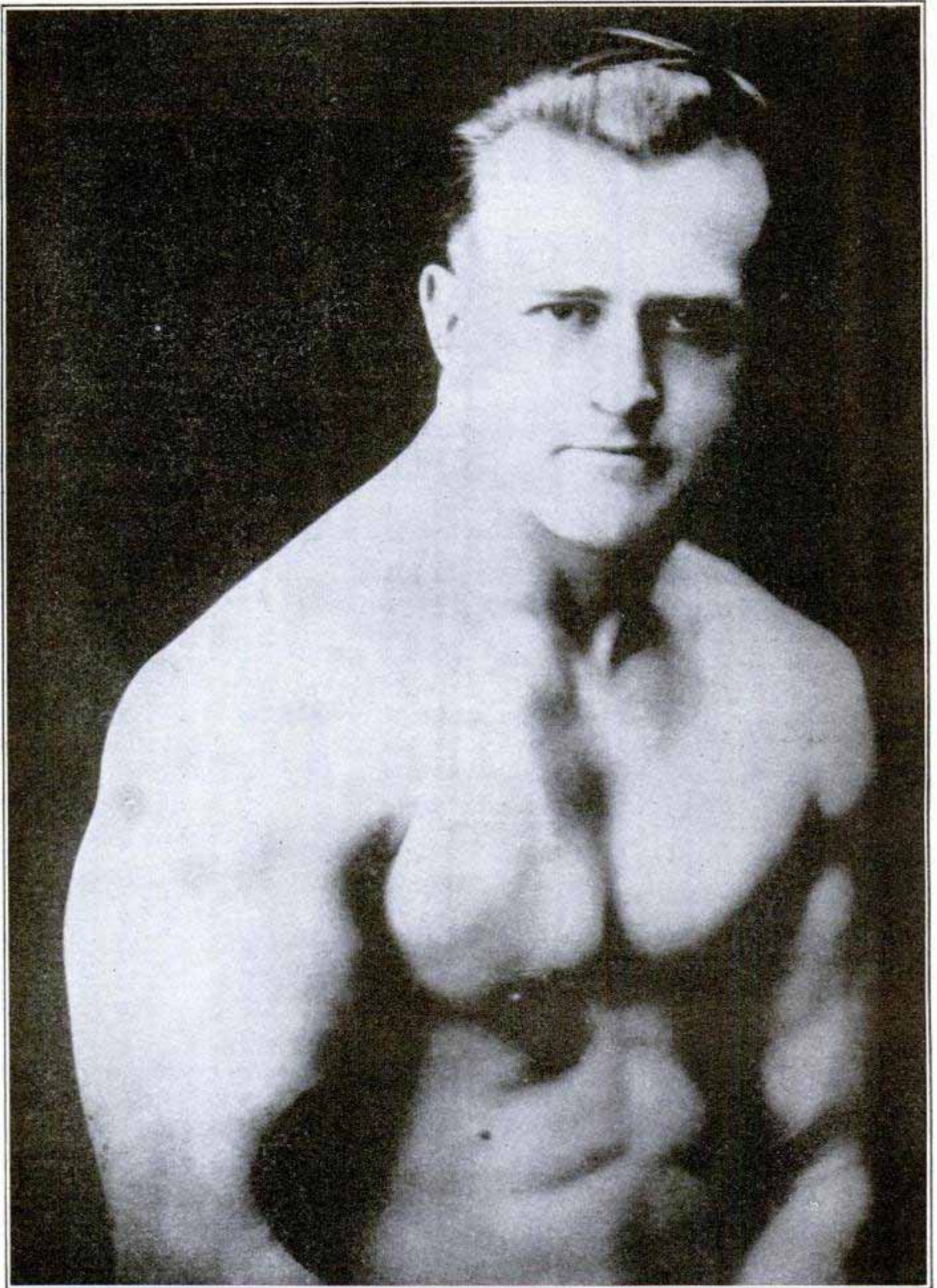

EARLE LIEDERMAN, *The Muscle Builder*

Author of "Science of Wrestling," "Muscle Building," "Secrets of Strength," "Here's Health," "Endurance," etc.

The Man I Pity Most

POOOR OLD JONES. I see him now, standing there, dejected, cringing, afraid of the world. No one had any use for him. No one respected him. Across his face I read one harsh word—FAILURE.

He just lived on. A poor worn out imitation of a man, doing his sorry best to get on in the world. If he had realized just one thing, he could have made good. He might have been a brilliant success.

There are thousands and thousands of men like Jones. They, too, could be happy, successful, respected and loved. But they can't seem to realize the one big fact—that practically everything worth while living for depends upon STRENGTH—upon live, red-blooded, he-man muscle.

Everything you do depends upon strength. No matter what your occupation, you need the health, vitality and clear thinking only big, strong, virile muscles can give you. When you are ill the strength in those big muscles pulls you through. At the office, in the farm fields, or on the tennis courts, you'll find your success generally depends upon your muscular development.

Here's a Short-Cut to Strength and Success

But, you say, "It takes years to build my body up to the point where it will equal those of athletic champions." It does if you go about it without any system, but there's a scientific short-cut. And that's where I come in.

30 Days Is All I Need

People call me the Muscle-Builder. In just 30 days I can do things with your body you never thought possible. With just a few minutes' work every morning, I will add one full inch of real, live muscle to each of your arms, and two whole inches across your chest. Many of my pupils have gained more than that, but I GUARANTEE to do at least that much for you in one short month. Your neck will grow shapely, your shoulders begin to broaden. Before you know it, you'll find people turning around when you pass. Women will want to know you. Your boss will treat you with a new respect. Your friends will wonder what has come over you. You'll look ten years younger, and you'll feel like it, too. Work will be easy. As for play, why, you'll realize then that you never knew what play really means.

I Strengthen Those Inner Organs Too

But I'm not through with you. I want ninety days in all to do the job right, and then all I ask is that you stand in front of your mirror and look yourself over.

What a marvelous change! Those great squared shoulders! That pair of huge, lithe arms! Those firm, shapely legs! Yes, sir. They are yours, and they are there to stay. You'll be just as fit inside as you are out, too, because I work on your heart, your liver—all of your inner organs, strengthening and exercising them. Yes indeed, life can give you a greater thrill than you ever dreamed. But, remember, the only sure road to health, strength and happiness always demands action. Fill out the coupon below and mail it today. Write now!

Send For My New
64 Page Book

"Muscular Development"
IT IS FREE

It contains forty-eight full-page photographs of myself and some of the many prize-winning pupils I have trained. Some of these came to me as pitiful weaklings, imploring me to help them. Look them over now and you will marvel at their present physiques. This book will prove an impetus and a real inspiration to you. It will thrill you through and through. This will not obligate you at all, but, for the sake of your future health and happiness, do not put it off. Send today—right now, before you turn this page.

EARLE LIEDERMAN

Dept. 2002, 305 Broadway, New York City

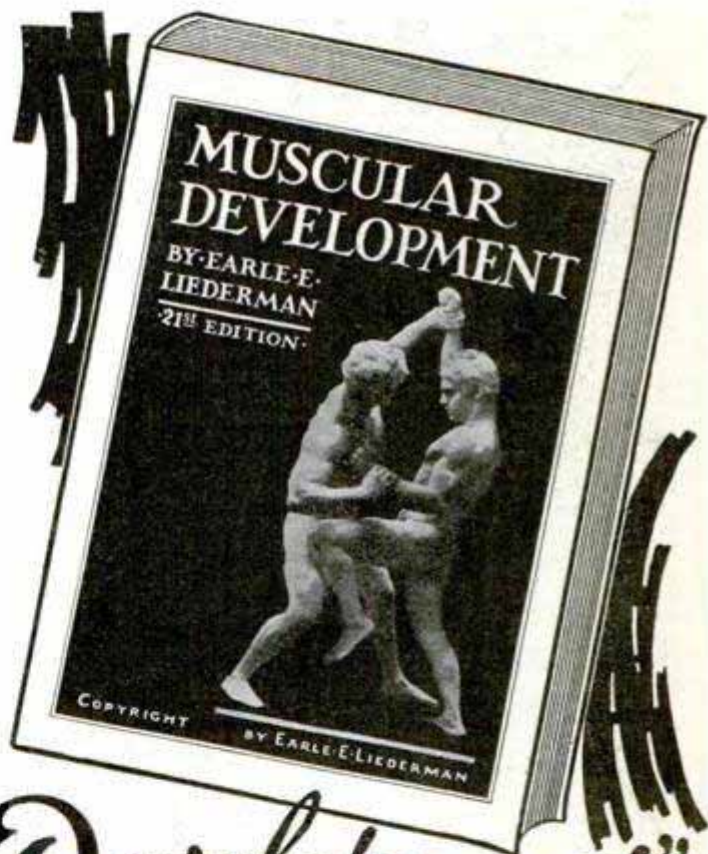

DON'T
SEND ONE
PENNY
—
YOUR
NAME AND
ADDRESS
ON A
POSTAL
WILL DO

EARLE LIEDERMAN
Dept. 2002, 305 Broadway, New York City

Dear Sir: Please send me, without any obligation on my part whatever, a copy of your latest book, "Muscular Development." (Please write or print plainly.)

Name.....Age.....

Street.....

City.....State.....

Lee Bullard has found his friends

BULLARD lives in Columbus, Ga. He wanted to step out from the crowd—get ahead personally, socially, financially. Read how he has **SUCCEEDED**. He writes: "I have so many appointments and invitations that I can't fill them all; more friends than I can keep in good humor! Everyone wants me to play my *Hawaiian Guitar*—and I just haven't time to get around to all the places I am wanted. Although I have not kept accurate account—I know I have made \$500 with my playing. I wouldn't trade my Guitar and knowledge gained through your Course for \$1,000!"

and he has made \$500

YOU Can Learn to Play the HAWAIIAN GUITAR Right at Home-1 to 3 Months



Lee Bullard is one of many who have shot ahead to Success, with the amazing Hawaiian Guitar Course of The New York Academy of Music. No previous musical training is necessary; most of our students don't know one note from another when they start. Nothing monotonous or dull, about our method either. Clear lessons, unmistakable pictures, actual phonograph records—all combine to teach YOU this marvelous music-maker and money-maker in as short as 1 to 3 months.

WE SEND YOU \$20 GUITAR and BIG OUTFIT

First lesson brings you a big, rich-toned, genuine Hawaiian Guitar worth \$20—Fabrikoid Case—famous Knobs—All and Master Chart—that make reading notes easy—tuner, picks, steel bar, etc.—Phonograph Records of every lesson in course. We supply EVERYTHING YOU NEED.

Have More Friends, More Fun, More MONEY—Easy!

Bid good-bye to the days of being a wall-flower—saying nothing, doing nothing and *having* nothing! Be the bright spot in your crowd—the most popular and the most *prosperous*. Spare-time playing can mean \$15 to \$35 a week extra in your pocket. Full-time playing pays as high as \$75 a week and up.

Some play and pay for their Courses while still learning! **TREMENDOUS DEMAND** for Hawaiian Guitarists as entertainers, with orchestras, on Radio.

Rush the Coupon NOW for your copy of "The Hawaiian Way to Popularity and Big Pay"—the FREE Book that has started others toward top positions in the professional and social worlds.

Send for FREE BOOK NOW!



Get FREE Book Quick

A. F. BLOCH, President
Hawaiian Studios 52020 of
NEW YORK ACADEMY OF MUSIC
100 Fifth Avenue, New York City

I want to read "The Hawaiian Way to Popularity and Big Pay" without delay and without obligation. Rush my copy by return mail.

Name.....

Address.....

City..... State.....

THE CHICAGO DAILY NEWS School and College Bureau

Offers You Its Specialized Services in Choosing a School

Last year the School and College Bureau of The Chicago Daily News saved many busy parents and questioning boys and girls both time and worry by sending them prompt, reliable information about just the kind of school they wanted—personal requirements as to location and tuition charges being considered in each individual case.

Again this year many young people will be perplexed by the problem of finding the right school. Why not let us help you?

The Chicago Daily News maintains this service absolutely free of charge to you. No need to hurriedly select a school on mere hearsay when expert advice can be obtained by telephoning Dearborn 1111, writing or calling for a personal interview at

THE CHICAGO DAILY NEWS School and College Bureau

Dept. K, Daily News Plaza, 400 W. Madison St., Chicago, Ill.

"The TRUTH about VOICE"

SENT FREE No Obligation to Buy
If you act quick!—we will send you postpaid—for 30 days free reading—new Voice Book disclosing startling FACTS that may save hundreds of dollars to every man or woman seeking a strong, rich voice for either singing or speaking. 30 days free reading—then send \$1. Otherwise, return it.



1810 Wilson Ave., Suite 29,
Prof. E. Feuchtinger, Dent. 13-52 Chicago, Ill.

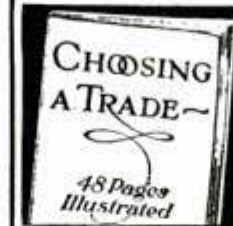

SENT ON REQUEST

Helpful discussion of this important problem and of fastest growing of Mechanical Trades—Mechanical Dentistry. Easily learned. Of interest to men of all ages. Send for Bulletin 2.

BODEE INSTITUTE

1756 Broadway, New York
1305 N. Broad St., Philadelphia
85 Court St., Brooklyn

GOV'T. POSITIONS \$35 TO \$75 WEEKLY

MEN - WOMEN	<input type="checkbox"/> Ry. Mail Clerk	<input type="checkbox"/> Steno-Typist	AGE 18 to 55
	<input type="checkbox"/> Prohibition Agent	<input type="checkbox"/> Immigrant Inspector	
	<input type="checkbox"/> R. F. D. Carrier	<input type="checkbox"/> Seamstress	
	<input type="checkbox"/> Special Agent (Investigator)	<input type="checkbox"/> Auditor	
	<input type="checkbox"/> City Mail Carrier	<input type="checkbox"/> U. S. Border Patrol	
	<input type="checkbox"/> Meat Inspector	<input type="checkbox"/> Chauffeur-Carrier	
	<input type="checkbox"/> P. O. Clerk	<input type="checkbox"/> Waterman	
	<input type="checkbox"/> File Clerk	<input type="checkbox"/> Skilled Laborer	
	<input type="checkbox"/> General Clerk	<input type="checkbox"/> Postmaster	
	<input type="checkbox"/> Matron	<input type="checkbox"/> Typist	

MENT INSTRUCTION BUREAU, 111 Arcade Bldg., St. Louis, Mo. Send me FREE particulars How To Qualify for positions marked "X". Salaries, locations, opportunities, etc. ALL SENT FREE.

NAME.....
ADDRESS.....

...Raised His Pay \$4800* After Reading This Amazing Book Which Is Now FREE!

*Based on the combined experiences of F. B. Englehardt, Chattanooga, Tenn., A. F. Thompson, Sioux City, Iowa, L. D. Mather, E. Cleveland, Ohio, and many others.



Caught in a Rut

I wonder I put up with it as long as I did! Every day was filled with nothing but deadly routine and monotonous detail. No freedom or independence. No chance to get out and meet people, travel, nor have interesting experiences. I was just like a cog in a big machine with poor prospects of ever being anything more.



Long, Tiresome Hours

Every hour of the day I was under somebody's supervision. The TIME-CLOCK constantly laid in wait for me—a monument to unfulfilled hopes and dying ambition. Four times a day, promptly on the dot, it hurled its silent challenge at my self-respect, reminding me how unimportant I was and how little I really COUN-
TED in the business and social world!



Low Pay

Paid just enough to keep going—but never enough to enjoy any of the GOOD things of life every man **DESERVES** for his family and himself. Always economizing and pinching pennies. Always wondering what I would do if I were laid off or lost my job. Always uncertain and apprehensive of the future.



Desperate

Happened to get a look at the payroll one day and was astonished to see what big salaries went to the sales force. Found that salesman Brown made \$200 a week—and Jenkins \$275! Would have given my right arm to make money that fast, but never dreamed I had any "gift" for salesmanship.



A Ray of Light

Stumbled across an article on salesmanship in a magazine that evening. Was surprised to discover that salesmen were made and not "born" as I had foolishly believed. Read about a former cowpuncher, Wm. Shore of California, making \$525 in one week after learning the ins-and-outs of scientific salesmanship. Decided that if HE could do it, so could I!



The Turning Point

My first step was to write for a certain little book which a famous business genius has called "The MOST AMAZING BOOK EVER PRINTED". It wasn't a very big book, but it certainly opened my eyes to things I had never dreamed of—and proved the turning point of my entire career!

What I Discovered



Between the pages of this remarkable volume, I discovered hundreds of little known facts and secrets that revealed the REAL TRUTH about the science of selling! It wasn't a bit as I had imagined. I found out that it was governed by simple rules and laws that almost ANY man can mas-

ter as easily as he learned the alphabet. I even learned how to go about getting into this "highest paid of all professions". I found out exactly how Mark Barichievich of San Francisco was enabled to quit his \$8 a week job as a restaurant-worker and start making \$125 a week as a salesman; and how C. W. Birmingham of Dayton, Ohio, jumped from \$15 a week to \$7500 a year—these and hundreds of others! It certainly was a revelation!

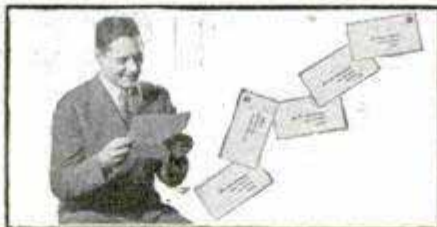

FREE Employment Service

Furthermore, I discovered that the National Salesmen's Training Association, which published the book, also operates a most effective employment service! Last year they received requests from all over the U. S. and Canada for more than 50,000 salesmen trained by their method. This service is FREE to both members and employers and thousands have secured positions this way!



Making Good At Last!

It didn't take me long to decide to cast my lot with N. S. T. A.—and after a few weeks I had mastered the secrets of Modern Salesmanship during spare time, without losing a day or a dollar from my old job. When I was ready, the employment manager found me over a dozen openings to choose from—I selected one which paid over \$70 a week to start.



Was It Worth It?

Today my salary is \$4800 greater than ever before! No more punching time-clocks or worrying over dimes and quarters! NOW my services are in REAL DEMAND with bigger prospects for the future than I ever dared HOPE for back in those days when I was just another "name" on a pay-roll!



Get Your Copy FREE

Right now the book—"The Key To Master Salesmanship,"—which banished all my fears and troubles and showed me how to get started on the road to success and independence—will be mailed as a gift to any ambitious man, absolutely FREE. And since there is no obligation, why not see for yourself what amazing facts it contains! Just mail the coupon now—for there is no better way in the world to invest a 2-cent stamp! I KNOW!

National Salesmen's Training Assn., Dept. B-102, N. S. T. A. Bldg., Chicago, Ill.
Without obligation, please send me a free copy of "The Key To Master Salesmanship."

Name.....Address.....

Town.....State.....

Age.....Occupation.....

Do You Make these Mistakes in ENGLISH?

MANY persons say "Did you hear from him today?" They should say "Have you heard from him today?" Some spell calendar "cal-ender" or "calander." Still others say "between you and I" instead of "between you and me." It is astonishing how often "who" is used for "whom," and how frequently the simplest words are mispronounced. Few know whether to spell certain words with one or two "c's" or "m's" or "r's," or with "ie" or "ei." Most persons use only common words—colorless, flat, ordinary. Their speech and their letters are lifeless, monotonous, humdrum.



Sherwin Cody

Every time you talk, every time you write, you show what you are. When you use the wrong word, when you mispronounce a word, when you punctuate incorrectly, when you use flat, ordinary words, you handicap yourself enormously. A striking command of English enables you to present your ideas clearly, forcefully, convincingly. If your language is incorrect it hurts you more than you will ever know, for people are too polite to tell you about your mistakes.

Wonderful New Invention

For many years Mr. Cody studied the problem of creating instinctive habits of using good English. After countless experiments he finally invented a simple method by which you can acquire a better command of the English language in only 15 minutes a day. Now you can stop making the mistakes which have been hurting you. Mr. Cody's students have secured more improvement in five weeks than previously had been obtained by other pupils in two years!

Under old methods rules are memorized, but correct habits are not formed. Finally the rules themselves are forgotten. The new Sherwin Cody method provides for the formation of correct habits by calling to your attention constantly only the **mistakes you make**—and then showing you the right way without asking you to memorize any rules.

One of the wonderful things about Mr. Cody's course is the speed with which these habit-forming practice drills can be carried out. You can write the answers to fifty questions in fifteen minutes and correct your work in five minutes more. The drudgery and work of copying have been ended by Mr. Cody! You concentrate always on your own mistakes until it becomes "second nature" to speak and write correctly.

FREE—Book on English

A command of polished and effective English denotes education and culture. It wins friends and makes a favorable impression upon those with whom you come in contact. In business as well as in social life correct English gives you added advantages and better opportunities, while poor English handicaps you more than you now realize.

A new book explaining Mr. Cody's remarkable method is ready. If you are ever embarrassed by mistakes in grammar, spelling, punctuation, pronunciation, or if you cannot instantly command the exact words with which to express your ideas, this new free book, "How You Can Master Good English—in 15 Minutes a Day," will prove a revelation to you. Merely mail the coupon or a letter or postal card for it now. **SHERWIN CODY SCHOOL OF ENGLISH, 52 Searle Building, Rochester, N. Y.**

**SHERWIN CODY SCHOOL OF ENGLISH,
52 Searle Building, Rochester, N. Y.**

Please send me your free book, "How You Can Master Good English—in 15 Minutes a Day."

Name.....
Address.....
.....

Increase Your Earning Power

Apply time and labor-saving kinks to your work. Your efficiency will soon be recognized and you will be in line for advancement.

If you do machine shop work of any kind, sheet-metal work, painting, carpentry, auto repairing, farming, concrete work, plumbing, electrical work, welding, building, glass work, general repairing, tool-making, poultry raising, masonry or home repair work, get this

LIBRARY OF 6000 TIME AND LABOR SAVING IDEAS FOR SHOPMEN AND HANDYMEN

JUST PUBLISHED

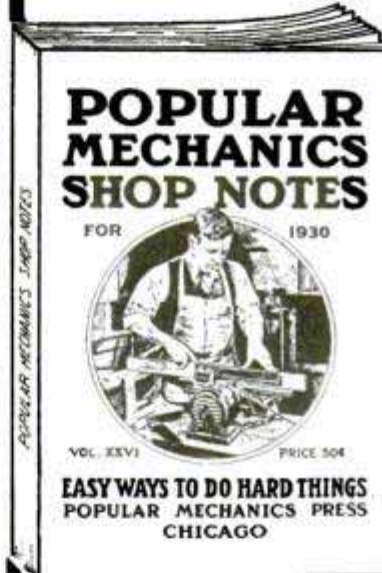

SHOP NOTES for 1930

192 Pages
415 Articles
377 Illustrations

See partial list of contents below

Including the new 1930 issue illustrated above, there are now 15 volumes in the Shop Notes Library of 6,000 easily understood short cuts to every-day jobs. Here are just a few of the subjects taken from the 415 articles in the latest issue.

- | | | |
|-----------------------------------------------------------------|-------------------------------------|---------------------------------------------------------|
| Animal Traps, Care of | Concrete Fountain Water, Cooler for | Bandaging on the Lathe |
| Barrel Method of Slings | Furniture, Refinishing Old | Saw Mount for Home Shop |
| Bench Light, Convenient | Furniture, Restoring | Saws, Keeping Fit |
| Bench Saw, Getting Most Out of | Haakaw, Power, for Small Shops | Scrollsaw, Ball-Bearing |
| Boatman's Chair Rigging | Hoist, Light and Strong | Speedboats, Automatic |
| Bookcase, Modern | Household Shortcuts | Switch for Stainless Steel, Soldering |
| Brass Fixtures, Cleaning | Ice Cutter, Engine-Driven | "Sugi" Finish, How to Apply |
| Builders' and Contractors' Kinks | Outboard Motor, Super-charger for | Summer House, Japanese |
| Cans Jig for Layout of Conveyor, Portable | Package Sealer, Home-made | Templates, Making Accurate |
| Speeds Loading | Pipe Holder, Hammered-Copper | Tinners, Paint Scraper for |
| Dadoing on Small Power Saws | Power Saw Made from Bufling Head | Toolrest, Sliding, for Emery Wheel |
| Decorating with Pastry Gun | Power Saws Made in Small Shop | Tools for Home Mechanics |
| Disk Sander Making Ellipse, How to Lay Out "Exercises" Electric | Sand Disk for Small Lathe | Towed Car Steered by Tow Bar |
| Farmers, Labor-Saving Kinks for "Flagstones", Making | | Wood, Plastic Filler for Workshop, Homemade Combination |

Each volume contains approximately 500 articles and 400 illustrations and has 224 Pages. At the regular price of 50 cents per single volume this library costs \$7.50, but for a limited period we will supply the 15 vols. when ordered at one time at the special reduced price of only \$4.50.

SPECIAL OFFER COUPON

**POPULAR MECHANICS PRESS,
200 E. Ontario St., Room P2, Chicago, Ill.**
Send me, as per your special offer, the following books. I will pay for books C.O.D. when they arrive. My money will be refunded if I am not satisfied. (Check what you want.)
 1930 Shop Notes and Lathe Handbook, both for 98c.
 Complete Shop Notes Library (15 vols.) \$4.50.
Name.....
Street and No.....
City..... State.....

NOW READY FOR YOU

The Education of the Great Universities

In the Simplest, Handiest Form yet devised

—Completely *NEW*

ENCYCLOPAEDIA BRITANNICA

NOW all the world's knowledge can be yours in the simplest, handiest form yet devised. *Simple* because all the searching and studying has been done for you. *Handy* because you can stay right in your own home and range through every subject known to man.

This completely *new* Britannica is a "new model", a \$2,000,000 work, new in plan and purpose. Never before has knowledge been made so accessible. Never before has it been presented in a form so convenient, so authoritative and yet so fascinating.

A New and Different University

The very men whose wisdom you would share at the great universities have written this newest, greatest Britannica.

Here is the learning and experience of 3,500 supreme authorities. Knowledge so *humanized*, so "live" and vivid, that it reads like a novel. It keeps you fascinated—hour after hour.

Latest Discoveries

It is education of a new type that the *new* Britannica gives you. Education brought right into your home for your everyday use.

Open any one of its 24 volumes. Here is the latest information in every field. The secrets of the laboratory, the newest discoveries of study and seminar, the world's remotest wonders—all are yours on the instant.

The 15,000 illustrations are an endless treasure of interest and education, a unique, colorful gallery of art and nature and science.

For All the Family

This is literally a book for every single member of the family. "It satisfies the needs of curious readers from eight to eighty," says James Harvey Robinson. It is a help-book indispensable for your children.

Not a question they can ask, not a point you can wonder about, but the *new* Britannica settles it at once, once and for all.

EXTREMELY LOW PRICE

YET the cost of this extraordinary knowledge book is extremely low. Mass production on a scale never before possible gives you this set

at less than a third of what it would otherwise cost.

Make sure of your *new* Britannica now—at the present low price. **Easy payments if desired.** An initial payment of only \$5 brings the set with mahogany bookcase to your home.

56-page BOOKLET FREE

It includes specimen pages, maps and color plates from the **NEW** Britannica. We will gladly send you your copy without the slightest obligation on your part.

NOW—while this page is here before you—tear out the coupon and send it in.

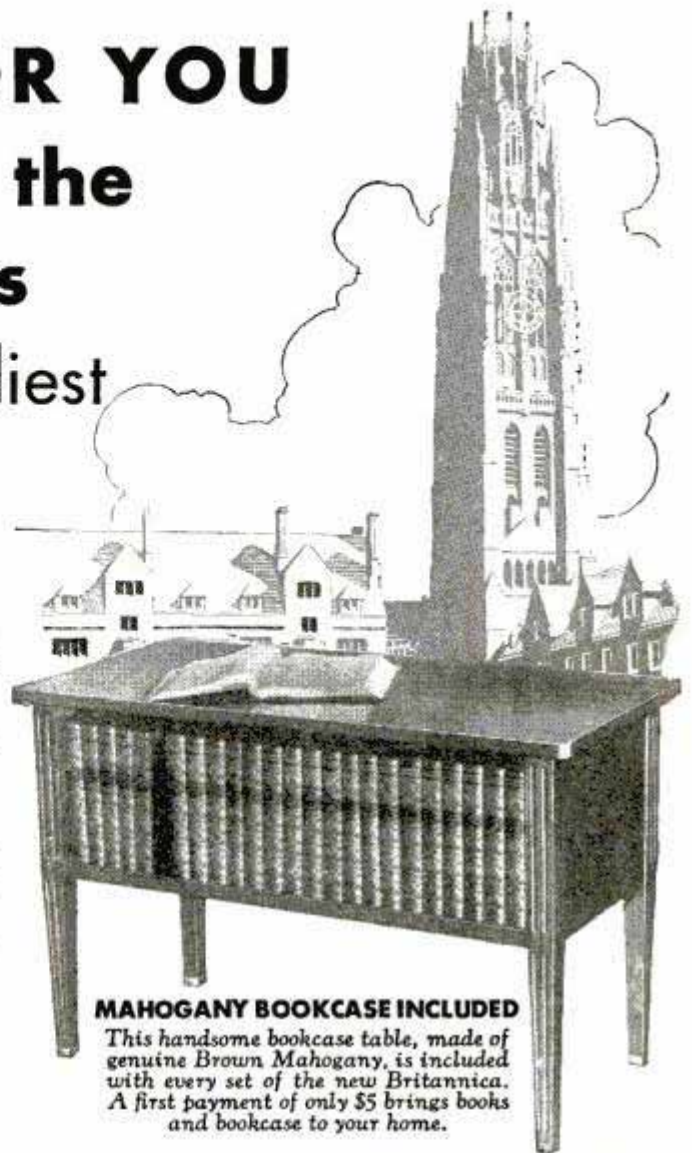

MAHOGANY BOOKCASE INCLUDED

This handsome bookcase table, made of genuine Brown Mahogany, is included with every set of the new Britannica. A first payment of only \$5 brings books and bookcase to your home.

SEND FOR FREE BOOKLET TODAY

ENCYCLOPAEDIA BRITANNICA, Inc.
342 Madison Avenue, New York P.M. 3-A1

Please send me by return mail, without any obligation, your 56-page illustrated booklet describing the *new* Britannica; also low price offer, etc.

Name.....

Address.....

City..... State.....



“There’s One Man We’re Going to Keep”

“Ed Wilson, there, is one of the most ambitious men in the plant. I notice that he never fools away his spare time. He studies his International Correspondence Schools course every chance he gets.

“It’s been the making of him too. He hasn’t been here nearly so long as Tom Downey, who was laid off yesterday, but he knows ten times as much about this business.

“I’m going to give him Tom’s job at a raise in salary. He’s the kind of man we want around here.”

How do you stand in your shop or office? Are you an Ed Wilson or a Tom Downey? Are you going up? Or down?

No matter where you live, the International Correspondence Schools will come to you. No matter what your handicaps or how small your means, we have a plan to meet your circumstances. No matter how limited your previous education, the simply-written, wonderfully-illustrated I. C. S. textbooks make it easy to learn.

This is all we ask: Without cost, without obligating yourself in any way, put it up to us to prove how we can help you. Just mark and mail this coupon.

INTERNATIONAL CORRESPONDENCE SCHOOLS Box 5668-F, Scranton, Penna.

Without cost or obligation, please send me a copy of your booklet, “Who Wins and Why,” and full particulars about the course before which I have marked X in the list below:

TECHNICAL AND INDUSTRIAL COURSES

- | | |
|--------------------------------------------------|-----------------------------------------------------------------------------|
| <input type="checkbox"/> Architect | <input type="checkbox"/> Automobile Mechanic |
| <input type="checkbox"/> Architectural Draftsman | <input type="checkbox"/> Aviation Engines |
| <input type="checkbox"/> Building Foreman | <input type="checkbox"/> Plumber and Steam Fitter |
| <input type="checkbox"/> Concrete Builder | <input type="checkbox"/> Plumbing Inspector |
| <input type="checkbox"/> Contractor and Builder | <input type="checkbox"/> Foreman Plumber |
| <input type="checkbox"/> Structural Draftsman | <input type="checkbox"/> Heating and Ventilation |
| <input type="checkbox"/> Structural Engineer | <input type="checkbox"/> Sheet-Metal Worker |
| <input type="checkbox"/> Electrical Engineer | <input type="checkbox"/> Steam Engineer |
| <input type="checkbox"/> Electrical Contractor | <input type="checkbox"/> Marine Engineer |
| <input type="checkbox"/> Electric Wiring | <input type="checkbox"/> Refrigeration Engineer |
| <input type="checkbox"/> Electric Lighting | <input type="checkbox"/> R. R. Positions |
| <input type="checkbox"/> Reading Shop Blueprints | <input type="checkbox"/> Highway Engineer |
| <input type="checkbox"/> Telegraph Engineer | <input type="checkbox"/> Chemistry |
| <input type="checkbox"/> Telephone Work | <input type="checkbox"/> Pharmacy |
| <input type="checkbox"/> Mechanical Engineer | <input type="checkbox"/> Coal Mining Engineer |
| <input type="checkbox"/> Mechanical Draftsman | <input type="checkbox"/> Navigation <input type="checkbox"/> Assayer |
| <input type="checkbox"/> Machine Shop Practice | <input type="checkbox"/> Iron and Steel Worker |
| <input type="checkbox"/> Toolmaker | <input type="checkbox"/> Textile Overseer or Supt. |
| <input type="checkbox"/> Patternmaker | <input type="checkbox"/> Cotton Manufacturing |
| <input type="checkbox"/> Civil Engineer | <input type="checkbox"/> Woolen Manufacturing |
| <input type="checkbox"/> Surveying and Mapping | <input type="checkbox"/> Agriculture <input type="checkbox"/> Fruit Growing |
| <input type="checkbox"/> Bridge Engineer | <input type="checkbox"/> Poultry Farming |
| <input type="checkbox"/> Gas Engine Operating | <input type="checkbox"/> Mathematics <input type="checkbox"/> Radio |

BUSINESS TRAINING COURSES

- | | |
|------------------------------------------------------------------|-------------------------------------------------------|
| <input type="checkbox"/> Business Management | <input type="checkbox"/> Business Correspondence |
| <input type="checkbox"/> Industrial Management | <input type="checkbox"/> Show Card and Sign Lettering |
| <input type="checkbox"/> Personnel Management | <input type="checkbox"/> Stenography and Typing |
| <input type="checkbox"/> Traffic Management | <input type="checkbox"/> English |
| <input type="checkbox"/> Accounting and C. P. A. Coaching | <input type="checkbox"/> Civil Service |
| <input type="checkbox"/> Cost Accounting | <input type="checkbox"/> Railway Mail Clerk |
| <input type="checkbox"/> Bookkeeping | <input type="checkbox"/> Mail Carrier |
| <input type="checkbox"/> Secretarial Work | <input type="checkbox"/> Grade School Subjects |
| <input type="checkbox"/> Spanish <input type="checkbox"/> French | <input type="checkbox"/> High School Subjects |
| <input type="checkbox"/> Salesmanship | <input type="checkbox"/> Cartooning |
| <input type="checkbox"/> Advertising | <input type="checkbox"/> Illustrating |
| | <input type="checkbox"/> Lumber Dealer |

Name.....
 Address.....
 City..... State.....
 Occupation.....

If you reside in Canada, send this coupon to the International Correspondence Schools Canadian, Limited, Montreal, Canada

34 Lesson Drawing Course \$2.98

The biggest value you ever saw advertised anywhere

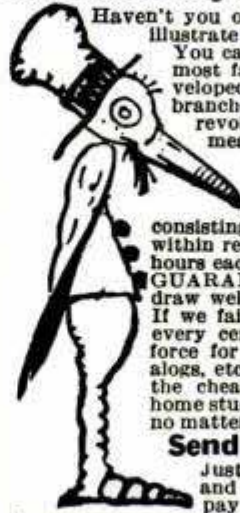

Haven't you often wished that you could draw cartoons, illustrate some idea, sketch some pretty face, etc.? You can do all of these things. One of America's most famous Cartoonists and illustrators has developed a great, simple system for success in all branches of Commercial Art. This system has revolutionized the entire theory of drawing. It means that drawing can be as easy for you as writing—much simpler than learning shorthand, bookkeeping or typewriting. We are now placing this original system for learning Drawing, Art and Cartooning, consisting of 34 lessons with over 500 illustrations, within reach of every one. If you will devote a few hours each week to the Course WE ABSOLUTELY GUARANTEE that you will learn to draw and draw well before you have half finished the Course. If we fail to make this claim good, we will refund every cent paid us. By eliminating a large office force for answering correspondence, expensive catalogs, etc., we are enabled to make a price of \$2.98, the cheapest price ever known for a high-grade, home study course. Learn to draw. It is a big asset, no matter what field you are in.

Send No Money

Just order the course and on arrival pay postman \$2.98

If you order the course at once, we will include a drawing outfit, consisting of artist's pencils, pens, paper, erasers, thumb tacks, etc., enabling you to go to work without any additional cost.

plus a few cents postage, payment in full for the entire Course and Drawing Outfit. If not entirely satisfied, return within five days and we will Refund Money. Address: LEDERER SCHOOL of DRAWING, Dept. 312-S, Chattanooga, Tenn. Orders from outside the U. S. A. are payable \$3.28 cash with order.

ELECTRICITY WELDING AUTOMOBILES

PRACTICAL TRAINING ON MASSIVE LAY-OUT OF ELECTRICAL EQUIPMENT Aircraft Oxy-Acetylene and Electric Welding, Armature Winding, Power Plants, Switchboards, Transformers, Motors, Generators, Batteries, Radio and Automobiles. Write now for Free Catalog. Coleman Electrical School, 1628 Main St., Kansas City, Mo.

MUSIC LESSONS IN YOUR HOME



You can play music like this quickly

Write today for our FREE BOOKLET. It tells how to learn to play Piano, Organ, Violin, Mandolin, Guitar, Banjo, etc. Beginners or advanced players. You pay as you learn. Costs only a few cents a day. Thousands of satisfied students.

AMERICAN SCHOOL of MUSIC, 51 Manhattan Bldg., CHICAGO

AIRPLANE DRAFTING

THOUSANDS OF MEN

will make fortunes in Aviation. Airplane Drafting and Designing are the biggest jobs ahead in this fastest growing industry. A new field of opportunity for you is opened in our improved method of training.

EASY TO LEARN. STUDY AT HOME. PAY AS YOU GO. EMPLOYMENT SERVICE.

Write for booklet outlining courses in Airplane Drafting and other aviation subjects, including the famous Weem's System of Navigation—endorsed by Col. Lindbergh, Commander Byrd, Lincoln Ellsworth, Admiral Moffett, etc.

Name.....

Address.....

City..... State.....

- AIRPLANE DRAFTING
 AIRPLANE MOTORS AIRPLANE MECHANICS

PACIFIC TECHNICAL UNIVERSITY SAN DIEGO CALIFORNIA

1000 Hotel Positions! Open!

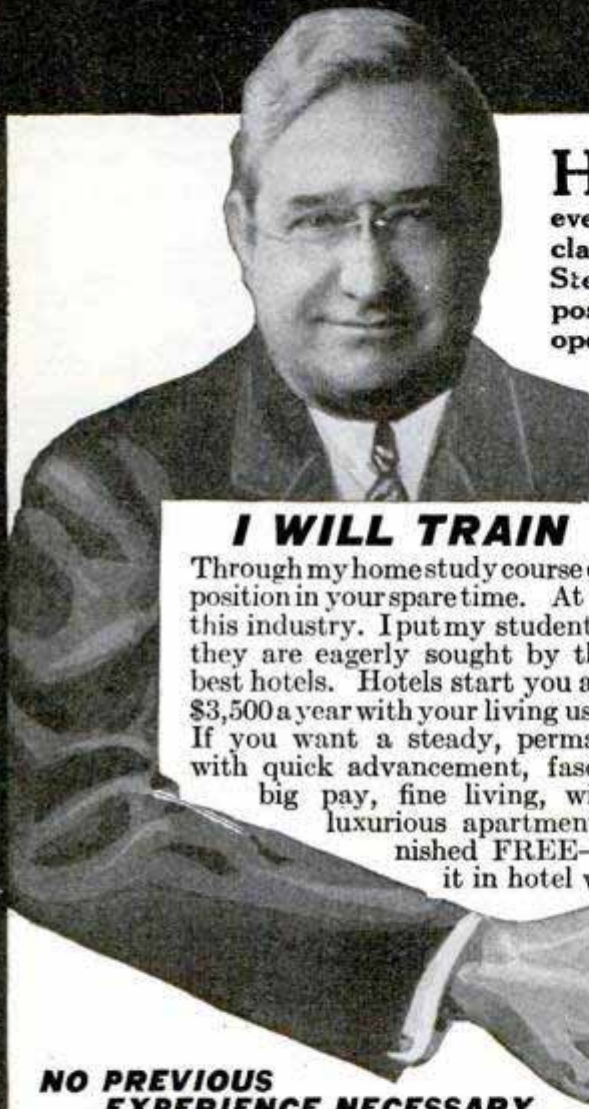

HOTELS, Restaurants, Clubs, Apartment Hotels, Institutions, Schools, Colleges, Hospitals, etc., everywhere need trained men. Over 70,000 high-class positions as Manager, Assistant Manager, Steward, Room Clerk and scores of other executive positions, paying from \$2,500 to \$10,000 a year, are open each year in the hotels of the United States alone. Nearly one and three-quarter billions of dollars' worth of new hotels, clubs, apartment hotels, restaurants and institutions being built this year will need over 200,000 trained men and women.

I WILL TRAIN YOU IN YOUR SPARE TIME

Through my homestudy course on hotel work you can quickly qualify for a well-paid position in your sparetime. At any time there are over 1,000 hotel positions open in this industry. I put my students in touch with positions. All over the United States they are eagerly sought by the biggest and best hotels. Hotels start you at salaries up to \$3,500 a year with your living usually included. If you want a steady, permanent position, with quick advancement, fascinating work, big pay, fine living, with meals and luxurious apartment usually furnished FREE—you can find it in hotel work.

Opportunity Coupon 1000 Hotel Positions Open!

Lewis Hotel Training Schools,
Room CB-310, Washington, D. C.
Send me without obligation the FREE BOOK,
"Your Big Opportunity," with details about
Registration in the Lewis National Employment
Bureau.

Name.....

Address.....

City..... State.....

NO PREVIOUS EXPERIENCE NECESSARY

We train you by mail in your spare time at home with the Lewis Simplified Home Study Plan and put you in touch with big opportunities. All of your training under the personal supervision of Clifford Lewis, former U. S. Government Hotel and Restaurant Expert, now Managing Consultant for over 300 hotels throughout the United States.

Through Lewis Training, Leroy L. Saunders became Assistant Manager of an \$8,000,000 Athletic Club. Frank Schrath, through the Lewis Course, became Steward of a large Restaurant, at double his previous salary! C. W. Ryder was appointed Purchasing Agent of a chain of hotels a few weeks after he received his diploma from the Lewis Schools.

FREE BOOK GIVES FULL DETAILS

No matter what your present occupation is—there are opportunities for you in this big-paying hotel industry. Many students have obtained splendid hotel positions paying as high as \$2,500 a year, even before they had finished the course. My Free Book—"Your Big Opportunity"—shows how you can do as well and explains how you are registered in our National Employment Bureau.

Mail the coupon at once for your free copy of "Your Big Opportunity," showing how we can train you for one of these splendid positions and explaining our Money-Back agreement. Send for it today—NOW—before you forget.

LEWIS HOTEL TRAINING SCHOOLS

ROOM CB-310

CLIFFORD LEWIS, Pres.

WASHINGTON, D. C.

The Original and Only School of Its Kind in the World



Freedom
from a
Small-Pay Job

Come to New York
the city of 100,000 jobs

ANY MAN who can read and write and use a pair of pliers can become an electrical expert and free himself forever from the long hours and drudgery of a small pay job.

And you can learn the **BIG PAY** profession of electricity right in New York City—the heart of the electrical world—the city of 100,000 jobs. At the same time you are learning the **BIG PAY** profession you can be enjoying the sights and wonders of New York, the modern Bagdad.

Be an Electrical Expert

Graduates of the **NEW YORK ELECTRICAL SCHOOL** are in demand by all the big electrical companies. Or, if you prefer the independence of a business of your own, there are thousands of opportunities for efficient, **dependable** men to become electrical contractors. When you are your own boss the money you can make is limited only by your own energy and ability.

Special Course in Mechanics and Electricity for Autos, Aeroplanes & Marine Engines.

Personal Instruction

The **NEW YORK ELECTRICAL SCHOOL** is not a correspondence school. You learn by doing—by personal instruction on full size standard electrical equipment under the personal supervision of trained instructors.

At **N. Y. E. S.** you train your hands and mind at the same time. You learn the theories of electricity—and then you are shown how to put the theories into actual practice by solving the problems with your own hands.

The man who has learned electricity by actually doing electrical work under intelligent personal instructors can go to any part of the world and be sure of a good living. There are **N. Y. E. S.** graduates in all the countries of the world.

Write today for the 48-page booklet giving full information about the **N. Y. E. S.** Course and showing pictures of the equipment available for your personal use in our two seven-story buildings. Mail coupon *now!* The **New York Electrical School, 44 W. 17th Street, New York.**

The New York Electrical School
44 W. 17th Street, New York

Please send me **FREE** your 48-page booklet. It is understood that this request puts me under no obligation.

Name.....

Address.....



Learn to Write

I Teach by Mail

I can make a good penman of you at your home during spare time, no matter where you live or how poorly you now write. My simplified system has shown thousands of others the way to good penmanship during the past thirty-five years—it can and **WILL** do the same for **YOU!**

Thos C. Swope
My signatures above and below show the wonderful improvement I've made in less than six months after beginning your course.
THOS C. SWOPE, Rt. 2, Gillespieville, O.

Thos C. Swope

Beautifully Illustrated Book
"HOW TO BECOME A GOOD PENMAN"
FREE!

It contains information, testimonials and beautiful specimens of penmanship, showing what others have accomplished by the Tamblin System. (Your name elegantly written on a card if you enclose stamp.) Write today, Address

F. W. TAMBLIN
418 Ridge Bldg., Kansas City, Mo., U. S. A.

F. W. Tamblin

Learn to PAINT SIGNS and SHOW CARDS

We quickly teach you by mail, or at school, in spare time. Enormous demand. Big future. Interesting work. Oldest and foremost school. **EARN \$50 TO \$200 WEEKLY**

Otto Wiegand, Md., home-study graduate, made \$12,000 from his business in one year. John Vassos, N.Y., gets \$25 for a show card. Crawford, D. C., writes: "Earned \$200 while taking course." Write for complete information.

DETROIT SCHOOL OF LETTERING
154 Stinson Ave. Est. 1899 Detroit, Mich.



LEARN WATCH REPAIRING



You can learn by our modern and original system of instruction every part of the **Watch Repairing Trade** at home as good or better than at a shop. You can earn money while learning and secure a well paying position or start in business after completing our course of instruction. Good watch repairers are always in demand and earn from \$50 to \$75 per week. For particulars apply to the **Wisconsin School of Watch Repairing** 166 Mason St., MILWAUKEE, WIS.

BIG PAY THRILLING WORK

BE A \$ \$ MOVIE OPERATOR

With Talking Equipment

Make big money in this easy and pleasant work. Big demand for trained operators.

Motion Picture Operators School
61 Sprout St. Detroit, Mich.

IF YOU STAMMER

Write for my free book "Millard's Advanced Natural Corrective Course" and a free copy of my speech magazine. 10,000 cases successfully treated. Est. 24 years. Largest school for stammerers in world. Millard Inst. of Normal Speech, 2317 Millard Bldg., Milwaukee, Wis.

Learn the Code with Teleplex!

Be an expert Morse or Continental code operator! **BIG PAY—TRAVEL—FUN—ADVENTURE.** After a few short weeks of practical study with Teleplex you will be an expert operator. This amazing instrument teaches you right in your own home. Works like a phonograph. No knowledge needed—beginners learn at once! **Not a school. Free 10 days' trial.** Write for free booklet J-10. **TELEPLEX COMPANY, 72 CORTLANDT ST., NEW YORK CITY**





Major R. L. Rockwell Says:
"I'll Train You at Home
and Until You Have an Aviation
Job Paying \$300 to \$400 a Month!"

Major Rockwell
World War Flyer
Who Will Teach You

Major Rockwell is a famous world war flyer, decorated with the Legion of Honor and the War Cross. He is now devoting himself to teaching Aviation, and he will train you for a position in this great new industry as only a Veteran World War Flyer can train you. Under Major Rockwell's guidance your future in Aviation is assured.

I make this amazing offer, for a short time and to a limited number, to supply the crying need for trained men. Here is your opportunity to get into this uncrowded, fascinating field with a definite certainty of your future.

In 12 Weeks!

Just devote about an hour a day to My Home Study Course, and in 12 weeks you can be mastering the principles of Ground Training

which are necessary before you take your place in any branch of Aviation. In a few short months I will give you practical aviation training and prepare you for one of the big pay, thrilling jobs open only to men thoroughly trained in Aviation.

No Advance Education Necessary or Experience Needed

You don't need to have a high school or college education to master my course. You do not even need to know anything about airplanes, motors or mechanics. My home course is thorough and complete. Everything is so clearly explained, with easy-to-understand text and pictures, that in a few short months you will be able to grasp every funda-

mental principle of Aviation ground work and you will be well on the road to qualify for any important aviation job paying \$300 to \$400 a month. My Home Study Course will give you all the knowledge necessary to pass the government's written examinations for mechanics' or pilots' licenses.

You Learn Principles of Aviation at Home
Then Choose Any One of 40 Ground Jobs.
—If You Want Actual Flying, My Home Study Course

teaches you the principles of flight. When you have completed the ground training I will arrange for you to take your flying instruction at any licensed airport near your home at special reduced rates. Or, if you want, you can come here to Dayton and get training at one of the finest and best equipped airports in America. No matter where you learn to fly you can qualify for a pilot's license and a high pay flying job in passenger lines, mail service, and other important branches of flying.



MY GROUND SCHOOL
Course Enabled Rickels
to solo in 7 hours—at a big
saving.

Dear Major: Your excellent advice prevented me from taking up Aviation the wrong way when I wanted to learn flying first. After I had completed your ground course, which thoroughly prepared me in the principles of flight, I was able to solo in 7 hours. I always will be glad to tell anyone that I am a Rockwell trained man.
 Sincerely, WM. C. RICKELS.

FORMER PHOTOGRAPHER NOW
MANAGER OF BIG COMPANY

Dear Major: The main thing about your individual method of instruction is that you not only gave me a thorough knowledge of Aviation, but you also showed me how to capitalize on what I learned. I am now General Manager for International Air Surveys and making three times what I ever earned before. I will always be a booster for your method of training.
 FLOYD PROTHERO.



Satisfaction or Money Back

I am so sure that you can learn Aviation with my help and step into a big aviation job that if you are not satisfied when you have finished my course, I agree to return every penny of your tuition. Act now while my special offer lasts. Rush this coupon to me for a copy of my famous free book.

MAJOR ROB'T L. ROCKWELL
THE DAYTON SCHOOL OF AVIATION
 Desk B-1 DAYTON, OHIO

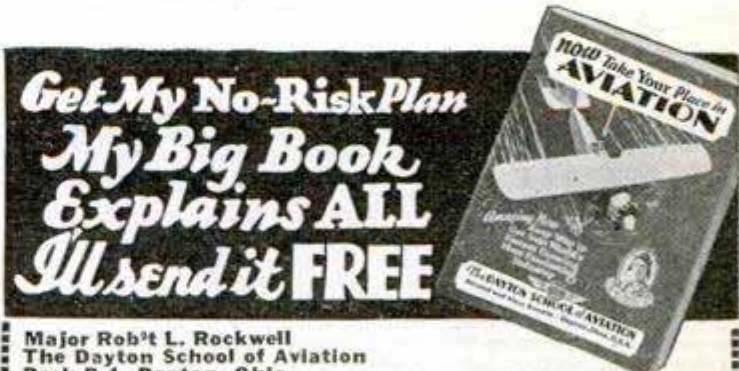

Get My No-Risk Plan
My Big Book
Explains ALL
I'll send it FREE

Major Rob't L. Rockwell
 The Dayton School of Aviation
 Desk B-1, Dayton, Ohio.

Dear Major:—Please send me FREE and without obligation a copy of your famous book on Aviation; also your special tuition and position offer.

Name.....

Address.....

Town..... State..... Age.....

Easy home method quickly teaches HAWAIIAN GUITAR



Play all the latest hits
just as the Hawaiians do!
Have good times aplenty!

Win fame—
friends—fortune!
Learn the
Hawaiian
Guitar!

Native Hawaiian expert directs you

You get expert instruction directed by a world-famous player and teacher, Prof. Walter Kolomoku. He quickly reveals to you the secrets of this fascinating instrument.

Only 4 Motions to learn. Then you can play any music—popular songs, classical, old-time melodies, native Hawaiian airs—or real jazz. You'll never be lonesome after you learn the Hawaiian Guitar.

Complete Course

52 lessons. Nothing omitted. Pictures explain every move. You are sure to learn—what we can do for others we can do for you. Over 50,000 successful students.

Payasyouplay

We make it easy for you. Start with small first payment—then pay while learning. Costs only few cents per lesson. You only pay the cost of instruction—we furnish everything.

Learn at home in spare time

Study in spare time at home. Even if you don't know a note our method is so simple, plain and easy, you begin a piece your first lesson. In half an hour you can play it!

GIVEN when you enroll

—with genuine seal grain Fabrikoid Cover and complete playing outfit—this beautiful sweet-toned

HAWAIIAN GUITAR

Reliable retailers ask \$18 to \$20 for a similar instrument and outfit without the fine Fabrikoid Case, which alone is worth \$3.50.

Instrument and outfit valued at **\$18 to \$20**

Other Courses (Banjo, Violin, Tiple, Tenor Guitar, Ukulele, Banjo Ukulele—well-known instructors.

FIRST HAWAIIAN CONSERVATORY OF MUSIC, Inc.
9th Floor, Woolworth Bldg., Dept. 648, New York

Approved as a Correspondence School Under the Laws of the State of New York

Member National Home Study Council

Send This Coupon for Liberal Offer!

FIRST HAWAIIAN CONSERVATORY OF MUSIC, Inc.
9th Floor, Woolworth Bldg., Dept. 648, New York, N.Y.
Please mail full information about your 52-lesson Hawaiian Guitar Course. I am not obliged to enroll unless I want to.

Name _____

Address _____

City _____ State _____

BEDFORD YMCA TRADE SCHOOL

Aviation Mechanic
Airplane Welding
Airplane Drafting
Auto Mechanic
Starting, Lighting, Ignition
Machine Shop. Electric Welding
Oxy-Acetylene Welding
Radio Mechanic. Battery Repair
Mechanical, Architectural Drawing
Blue Print Reading
Building Estimating
Sign Painting. Show Card Writing
Window Dressing
Commercial Art. Fine Art
DAY AND EVENING SESSIONS
Write for Catalog 50
Brooklyn Engineering Institute
(Operated by Bedford Y. M. C. A.)
1125 Bedford Avenue, Brooklyn
New York City

Electrical Engineering

Course for men of ambition and limited time. Over 5000 men trained. Condensed course in Theoretical and Practical Electrical Engineering including the closely related subjects of Mathematics and Mechanical Drawing.



Students construct motors, install wiring, test electrical machinery. Course designed to be completed in one college year. Prepare for your profession in the most interesting city in the world. Est. 1893. Catalog on request.

Bliss Electrical School

132 Takoma Ave., Washington, D. C.

You can be quickly cured, if you

STAMMER

Send 10 cents for 288-page book on Stammering and Stuttering. "Its Cause and Cure." It tells how I cured myself after stammering 20 yrs. B. N. Bogue, 11126 Bogue Bldg., 1147 N. Illinois St., Indianapolis.



Wonderful, new device, guides your hand; corrects your writing in a few days. Big improvement in three hours. No failures. Complete outline FREE. Write C. J. Ozment, Dept. 34, St. Louis, Mo.

Learn Watchwork, Jewelrywork and Engraving

A fine trade commanding a good salary, and your services always in demand. Address **Horological**, Dept. P, Bradley Institute, PEORIA, ILLINOIS, for our latest catalog.

Get Rid of COAL

NOW-OIL HEAT at Amazing Low Cost



Now—OIL HEAT is no longer a luxury for the rich. A wonderful invention—the LACO AUTOMATIC BURNER, burns AIR and OIL, and smashes fuel costs. Sold on EASY TERMS at a price so amazingly low, any home can easily afford it. Laco's patented indestructible mineral wick does it. Automatic temperature control. FITS ANY KIND OF FURNACE INSTANTLY. Complies with all ordinances. Safer than the ordinary kitchen gas range. Guaranteed. Built to last a lifetime. Write now for full information.

Instant Heat for Your Cook Stove

We also announce the new Laco power stove-burner. Fits easily into any coal stove or range. Two burners. Does away with coal or wood fires. Gives you clean heat fast as city gas, but safer, as you can go away and leave it on all night, but nothing will happen. Gives you convenience equal to city gas heat at a fraction of the cost.

WRITE for Information, Easy Terms
and SENSATIONAL PRICES

State if interested in burner for furnace or for coal stove—if furnace burner, what kind of furnace have you? SPECIAL INTRODUCTORY PRICES if you ACT NOW. DEALERS WANTED.

LACO OIL BURNER CO.

128 Union Street

GRISWOLD, IOWA.

Why good dancers are popular

Good dancers are good mixers. They create a favorable impression—have ease of manner, a pleasing assurance that wins. No wonder people find them interesting—seek their company!

By **ARTHUR MURRAY**,
World-Famous Dancing Authority

GOOD dancers are popular—sure of a good time wherever they go!

And dancing is great fun—wonderful exercise. Keeps you happy and healthy—on your toes and full of pep. Develops self-confidence, poise. Enables you to make friends easily—to be well-liked—and often opens the doors to important business and social contacts.

And it's so easy now to be a good dancer, able to do all the newest, smartest steps! It's so easy now to get some real fun out of life—to be a good mixer—to be popular, sought after, admired!

Amazing New Method

I have developed a remarkable new method which is so simple that *you can learn any of the latest steps in one evening*—right at home, in the privacy of your own room, without music or partner!

It makes no difference if you've never been on a dance floor in your life—my new method makes learning to dance *just as easy as taking one step after another!*

With my amazingly simple lessons you start right at the beginning and go through the entire field of social dancing. Nothing is omitted—nothing taken for granted. You learn to master every step from the simple waltz to the newest, smartest steps and all their variations.

Learn at Home Without Music or Partner

The best feature of my easy lessons is that you study them in the comfort of your own home whenever you find time. No one to watch and embarrass you. No private teacher—no partner—no music—just the lessons. Yet, almost before you realize it, you will be able to step on the floor with the best dancers of your set—and with as much ease and assurance as if you had been dancing for years!

If You Can Do This Step

Arthur Murray will make you a finished dancer in 10 days.



Posed by Jean Arthur, Famous Film Star, and Arthur Murray

Regular \$5.00 Course
NOW ONLY \$1.98 Five Days Free Trial

I have already taught over 400,000 men and women how to dance through this amazingly simple method. Thousands of folks everywhere who used to stay home and miss all the fun are now having the time of their lives.

And I'm so positive that you, too, can become a good dancer and get your full share of fun and popularity through my new, easy method that I'm willing to send you my *regular \$5.00 course for only \$1.98!*

Just mail the coupon below, and the regular \$5.00 course will be sent you immediately. When it arrives, pay the postman only \$1.98, plus few cents delivery charges. Then use it for five days—study it—practice the steps. See for yourself how easy it is to become a finished dancer—sought after, popular—the Arthur Murray way.

Remember—if you're not absolutely delighted with results, simply return the course within the five days FREE trial period, and *your money will be promptly refunded.*—Arthur Murray, Studio 975, 7 East 43rd St., New York.

**ARTHUR MURRAY, Studio 975,
7 East 43rd St., New York.**

To prove that I can learn to dance at home without music, partner, or teacher, you may send me your regular \$5.00 course for only \$1.98 C. O. D. I understand that if not delighted I may return the course within 5 days and my money will be refunded.

Name.....

Address.....

City..... State.....

NOTE: If apt to be out when postman calls, send \$2.00 with coupon and save C. O. D. postage.

Students at work on 1929 Packard Six, 8, Other 1929 Models include: Buick, Studebaker, Marmon, Auburn, Nash, Reo, Essex, DeSoto, Chev., Ford, Oakland—and 11 more chassis.

\$25,000 worth of 1929 cars for you to work on!

Learn Autos IN LOS ANGELES

and LEARN IT RIGHT!

1. NATIONAL—America's Best Equipped Auto School

NATIONAL is a Million Dollar institution—established in Los Angeles in 1905—recognized throughout the automotive industry as one of America's foremost trade schools. NATIONAL offers practical, intensive training in all automotive branches. No age limit. No previous experience necessary. You learn by "Actual-Shop" Methods. Life Scholarship privileges. Start any time of the year.

2. NATIONAL Qualifies YOU to Make Good

NATIONAL properly trains you in the Auto Trades in the short time of 4 to 6 months. Upon completing this Condensed Course you are fully qualified as a Practical, Competent Automobile man, and you have not risked your chances of employment because of inferior, incomplete instruction.

3. NATIONAL Guarantees YOU Efficient Employment Service

NATIONAL GUARANTEES to give unlimited and efficient Employment Service to students wishing to earn living expenses while learning; and to graduates getting started in the automobile field. This is the most any reputable school can be expected to do.

4. NATIONAL'S Training in Every Man's Reach

NATIONAL offers YOU the very best technical-practical training that money can buy at a cost within every man's reach. It does not offer to pay your railroad fare, room and board or other personal expenses, preferring to limit its activities to the PROPER TRAINING OF MEN FOR SUCCESS.

5. Come to LOS ANGELES—the Playground of America!

LOS ANGELES is the heart of the country's most prosperous automobile section—as well as the world's most ideal city in which to live and prepare for success in the auto game.

WRITE for FREE BOOK NOW!

National Automotive School

NATIONAL AUTOMOTIVE, Dept. 731, 4086 Figueroa St., Los Angeles, Calif.

Send me, absolutely free, your big illustrated catalog of Automotive Opportunities.

Name.....
Address.....
Age..... City..... State.....

Your Future assured!

National Automotive
LOS ANGELES

ENGINEERING — ELECTRICITY ARCHITECTURE — DRAFTING

Save time—enroll at this old established school of engineering. Enter any time, days or evenings. 1, 2 and 3 year courses. Diplomas and B. S. Degrees.



Special 4 months' practical course in Drafting. Others short courses. Low tuition—easy terms. Earn while you learn. Free employment bureau. Athletics. Successful graduates everywhere. Write for our free, illustrated 80 page "Blue Book." It gives you all the facts. Address the President, Charles W. Morey, B. S., M. E.

CHICAGO TECHNICAL COLLEGE
Dept. B-78 118 East 26th Street, Chicago, Ill.

COLLEGE COURSES

AT HOME



Carry on your education. Develop power to initiate and achieve. Earn credit toward a Bachelor degree or Teaching Certificate by correspondence. Select from 450 courses in 45 subjects, including English, Mathematics, History, Education, Psychology, Economics, the Languages, etc. Write for catalog.

The University of Chicago

427 ELLIS HALL

CHICAGO, ILL.

WORLD NEEDS PLUMBERS

Old style plumbers are fading like the horse and buggy. The world demands modern Plumbing and Skilled Trained Mechanics to do it. Unlimited, swift growing field. Make \$50 to \$100 a week or start own shop. We train you quick. Learn in 8 to 12 WEEKS to do any job with skill and science. Need no previous experience. Strictly tool using system. Opportunity knocks. Investigate today—amazing offer—low tuition. World's greatest school.



Write—

UNIVERSAL PLUMBING SCHOOL

2130 Troost Ave.

Kansas City, Mo.

Anyone CAN LEARN

No talent or experience necessary. Fascinating work. Pays Big Money. Complete instruction book tells about: Alphabets, Colors, How to Mix Paints, Show Cards, Window Board and Wall Signs. Ready made letters, Gilding, Tricks of the Trade, also gives 100 Alphabets and Designs. Book bound in flexible imt. leather-gold edges, and four ball bearing Show Card Pens. Sent postpaid \$3.00. (C.O.D.) 10c ex. Ogilvie Pub. Co., 57 Race St., Dept. 20, N.Y. City

EARN MONEY IMMEDIATELY— WE FURNISH EQUIPMENT TO START!!

SONG WRITERS!



SUBSTANTIAL ADVANCE ROYALTIES are paid on work found acceptable for publication. Anyone wishing to write either the words or music for songs may submit work for free examination and advice. Past experience unnecessary. New demand created by "Talking Pictures" fully described in our free book. Write for it Today. NEWCOMER ASSOCIATES

759 Earle Building, New York, N. Y.

HOT PIANO Ultra-modern Piano



Jazz taught by mail. Note or ear. Easy rapid lessons for adult beginners. Also Self-instruction system for advanced pianists. Learn 358 Bass Styles, 976 Jazz Breaks, hundreds of Trick Endings, Hot Rhythms, Sock, Stomp and Dirt Effects; Symphonic and Wicked Harmony in latest Radio and Record Style. Write for Free Booklet.

WATERMAN PIANO SCHOOL, 1826 W. Adams St., Los Angeles, Calif.

"Unaccustomed as I am—

"I . . . er, er . . . a
don't know just
what to say on the
subject."

"I wasn't expecting to
be called on to speak."

"Mr. Bell can tell you
more about the idea
than I can."

"Er . . . that is not
very clear, but that's
the best I can do."



...Yet 4 Weeks Later He Swept Them Off Their Feet!

IN a daze he slumped to his seat. Failure when a good impression before these men meant so much. Over the coffee next morning, his wife noticed his gloomy, preoccupied air.

"What's the trouble, dear?"
"Oh, nothing. I just fumbled my big chance last night, that's all!"
"John! You don't mean that your big idea didn't go over!"

"I don't think so. But, Great Scott, I didn't know they were going to let me do the explaining. I outlined it to Bell—he's the public speaker of our company! I thought he was going to do the talking!"

"But, dear, that was so foolish. It was your idea—why let Bell take all the credit? They'll never recognize your ability if you sit back all the time. You really ought to learn how to speak in public!"

"Well, I'm too old to go to school now. And, besides, I haven't got the time!"

"Say, I've got the answer to that. Where's that magazine?"

"Here—read this. Here's an internationally known institute that offers a home study course in effective speaking. They offer a free book entitled *How to Work Wonders With Words*, which tells how any man can develop his natural speaking ability. Why not send for it?"

He did. And a few minutes' reading of this amazing book changed the entire

course of John Harkness' business career. It showed him how a simple and easy method, in 20 minutes a day would train him to dominate one man or thousands—convince one man or many how to talk at business meetings, lodges, banquets and social affairs. It banished all the mystery and magic of effective speaking and revealed the natural Laws of Conversation that distinguish the powerful speaker from the man who never knows what to say.

Four weeks sped by quickly. His associates were mystified by the change in his attitude. He began for the first time to voice his opinions at business conferences. Fortunately, the opportunity to resubmit his plan occurred a few weeks later. But this time he was ready. "Go ahead with the plan," said the president, when Harkness had finished his talk. "I get your idea much more clearly now. And I'm creating a new place for you—there's room at the top in our organization for men who know how to talk!"

And his newly developed talent has created other advantages for him. He is a sought-after speaker for civic banquets and lodge affairs. Social leaders compete for his attendance at dinners because he is such an interesting talker. And he lays all the credit for his success to his wife's suggestion—and to the facts contained in this free book—*How to Work Wonders With Words*.

For fifteen years the North American Institute has been proving to men that ability to express one's self is the result of training, rather than a natural gift of a chosen few. Any man with a grammar school education can absorb and apply quickly the natural Laws of Conversation. With these laws in mind, the faults of timidity, self-consciousness, stage-fright and lack

of poise disappear; repressed ideas and thoughts come forth in words of fire.

Send for This Amazing Book

Have you an open mind? Then send for this free book *How to Work Wonders With Words*. Over 65,000 men in all walks of life—including many bankers, lawyers, politicians and other prominent men—have found in this book a key that has opened a veritable floodgate of natural speaking ability. See for yourself how you can become a popular and dominating speaker! Your copy is waiting for you—free—simply for the mailing of the coupon.

North American Institute
Dept. 1352, 3601 Michigan Ave., Chicago, Ill.

**Now
Sent
FREE**



North American Institute, Dept. 1352, 3601 Michigan Ave., Chicago. Please send me FREE and without obligation my copy of your inspiring booklet, *How to Work Wonders With Words*, and full information regarding your Course in Effective Speaking.

Name.....
Address.....
City..... State.....

An Expert Training that Leads to an Expert's Pay



The Croft Library of Practical Electricity

JUST OUT!
Newly Revised Edition

THIS is the electrical age, with unlimited opportunities for the man who has educated himself in the finer points of electrical practice. Fit yourself for a big-pay job by knowing electrical practice complete, including inside and outside work, central stations, and the whole subject. With the aid of the Croft books you can know electricity as experts know it and put yourself in line for an expert's pay.

Standard Electrical Training

The Croft Library is a complete electrical educator. It is founded on practice—on work as it is actually done. It is jammed from cover to cover with the kind of hard-headed facts you want. Written so that the beginner can easily understand it, yet so sound, so thorough, that it is the daily guide of 59,000 highly paid electrical workers and engineers. Croft tells you the things you need to know about motors, generators, armatures, commutators, transformers, circuits, switchboards, distribution systems—electrical machinery of every type—wiring for light and power—wiring of finished buildings—underwriters and municipal requirements—illumination in its every phase—the latest and most improved methods of lighting—lamps and lighting effects, etc.—how to do a complete job, from estimating it, to completion. Make no mistake about it—there are big jobs in electricity ready for you when you're ready for them. Thousands of men who have the Croft Library know that to be a fact. The Library itself, on a FREE TRIAL BASIS, will prove it to your own absolute satisfaction.

3000 Pages, 2100 Illustrations

In these volumes Croft teaches you electrical practice complete. He takes you in quick, easy steps from the simplest principles to the complete and economical operation of a great central station. He tells you all that he has learned in twenty years of shirt-sleeve practice. With these books at his elbow a man can learn as much about electricity in six months—good practical "bread and butter" stuff—as he would ordinarily learn in a lifetime of practice.

NO MONEY DOWN SMALL MONTHLY PAYMENTS

10 Days FREE TRIAL
Just Mail the Coupon

Fill in and mail the coupon attached and we will send you the entire set of eight volumes for ten days' Free Examination. We take all the risk—pay all charges. You assume no obligation—you pay nothing unless you decide to keep the books. Then \$1.50 in ten days and the balance at the rate of \$2.00 a month. Send the coupon NOW and see the books for yourself.

FREE EXAMINATION COUPON

McGraw-Hill Book Co., Inc., 370 Seventh Ave., New York

Send me for 10 days' free examination the Croft Library of Practical Electricity. If satisfactory I will send you \$1.50 in 10 days and \$2.00 monthly until the special price of \$19.50 is paid. If not wanted, I will return the books at your expense. (To insure prompt shipment write plainly and fill in all lines.)

Name.....
Address.....
City and State.....
Position.....
Company..... P. M. 2-30

RADIO PROFESSIONALS SERVICEMEN RADIOTRICIANS



RADIO-CRAFT is the spokesman of the professional radio guild. It publishes articles appealing to the man engaged in radio work. It helps him to a better understanding of his trade and shows him how to make more money from it. The magazine is published by the pioneers of radio editors.

On sale at all newsstands—25c the copy. Special subscription offer—One Dollar—for eight months.

RADIO-CRAFT
(A Gernsback Publication)
98 W. Park Place, N.Y.C.

Learn Photography at HOME

Make money taking pictures. Prepare quickly during spare time. Also earn while you learn. No experience necessary. New easy method. Nothing else like it. Send at once for free book, OPPORTUNITIES IN MODERN PHOTOGRAPHY and full particulars

AMERICAN SCHOOL OF PHOTOGRAPHY
Dept. 1352 3601 Michigan Ave. Chicago, U. S. A.

LEARN MECHANICAL DENTISTRY SEND FOR FREE BOOK *Your Success*

Earn Big Money—Steady Work
You can EARN WHILE LEARNING this modern money making business and become independent. Big demand. You learn by doing actual work in rubber and gold. Easy terms. Individual instruction. Day and night school. Railroad fare allowed—no extra cost. Write NOW for catalog P.

NEW YORK SCHOOL OF MECHANICAL DENTISTRY
147 W. 33rd Street NEW YORK

ASTROLOGY

What do the Stars foretell for 1930? Would you like to know? Our Special 15-page Astrological Reading gives predictions—month by month—with exact days, dates and happenings for 1930 based on your Sign of the Zodiac. Consult it before making any change in home or business affairs, signing papers, love, marriage, seeking employment, speculation, travel, friends, enemies, health, accidents, lucky days, etc. Absolutely scientific—unusually accurate. Send exact birthday with \$1.00 for complete reading.

FRANKLIN PUBLISHING COMPANY
800 N. Clark Street Dept. 1501 Chicago, Ill.

STAMMERING easily, permanently corrected. Win happiness and success. Ask for full information and special phonograph record. Send dime for postage

12972 Woodward Ave., LEWIS INSTITUTE, Detroit

See the Craters in the MOON!

Astronomical and Terrestrial TELESCOPE See Landscapes, Games, Ocean Scenes, Enlarged 30 Times!

Magnifies 30 Times

Own a genuine Astronomer's Telescope. See thousands of miles away. Make sun, moon, planets, stars your next door neighbors. Moon Craters, Sun Spots, Eclipses, Comets enlarged 30 times. Strange thrill!

Diameter 2 inches. Special friction adjustment for focusing. Adjustable bracket and clamp can be fastened to chair, fence, branch, etc. Finest materials. Will last lifetime.

5 Days' Free Trial
Rush only \$1.00 now. Pay balance (\$1.95 plus postage) when postman delivers. Keep 5 days. If not delighted, return telescope and money will be refunded.

R. R. SPECIALTY CO.
Dept. B-305
220 E. 3rd St. Cincinnati, Ohio

Price Only \$2.95

Hours of fun looking at scenery, games, bathing beauties. Great for trips and voyages. Made like telescopes used in observatories. Gerding wrote: "Moon seemed 10 yards away."

EARN \$10 A DAY
Charge 25c to look at the moon



"You folks must think I can't play!"

I cried, when they laughed at my offer

IT was the monthly get-together of our little group and the fun was at its height. Mabel had just finished singing a touching version of "Frankie and Johnnie" when I offered to play.

"Boy! This is going to be good! Did you folks hear that? Jim said he'd play for us!" cried Tom.

I pretended to be highly insulted. Drawing myself up with mock dignity, I said, "You folks must think I can't play! Why, the very idea!"

This caused a fresh explosion of laughter. "Can't play!" called someone. "Say, if I could play as well as you, I'd be digging ditches right now!"

Seating myself at the piano I held up my hand to command silence. Then, with a good many flourishes I opened "Swanee River," turned it upside down, and began to play.

And how! I traveled up and down that keyboard with my one good finger, as Tom called it, until the crowd howled for mercy. Finally I turned around and demanded,

"Now who says I can't play?"

"You win!" came from all sides. "Only please don't demonstrate any more, for the love of heaven!"

But instead of getting up from the piano, I suddenly swung into the haunting strains of "The Pagan Love Song." But with what a difference! This was not clowning, but real music. I played as I had always longed to—beautifully, effortlessly, with real skill and feeling.

No wonder the crowd could hardly believe their ears! The moment the piece was finished they overwhelmed me with questions. *Where had I learned to play? When*

had I studied? Who was my teacher? Why had I kept it a secret?

How I Taught Myself to Play

I told them the whole story. Ever since I was a child, I had been crazy about music. But, like most children, I hated to practice. That's why, after a few desultory attempts, my music lessons were given up, and I had to content myself with hearing others play.

But every time I pepped up a party with my one-finger clowning the longing to really play returned. However, I had no time now to take lessons and spend hours practicing, to say nothing of the expense of a private teacher. Then one day I happened to come across an ad of the U. S. School of Music.

"Why, that's a correspondence school, isn't it?" interrupted Tom.

"Yes," I told him. "The ad offered a Free Demonstration Lesson to prove how easy it is to learn to play at home, without a teacher, in one's spare time. I sent for it."

"It was great. I decided to take the course. I learned in my spare time, after work, and thoroughly enjoyed each lesson. For there are no long hours of practice—no tiresome scales—the U. S. School of Music way."

"Almost before I knew it, I was able to play all the pieces I had always longed to—Jazz, classical, anything. But I didn't want to tell you folks until I was sure of myself—you know, no clowning. . . ."

They were dumbfounded. But in a moment they eagerly demanded piece after piece—dance music, ballads, snappy songs. Now I'm never invited anywhere that I'm not practically

forced to entertain with my music. As Tom says, learning to really play has certainly made me popular!

No Talent Needed

This story is typical. People who once didn't know one note from another are good players today—thanks to the U. S. School of Music.

For the U. S. School course presents everything in such a concise, graphic way—so clear and simple—that a child could understand it. First you are told what to do—then a picture shows you how to do it—then you do it yourself and hear it. No private teacher could make it any clearer.

Send NOW for Free Book

We will be glad to send you our illustrated Free Book and Free Demonstration Lesson which explain all about this remarkable method whereby over half a million men and women have learned to play their favorite instruments *by note*.

If you really want to learn to play, take this opportunity to make your dreams come true. Sign the coupon below and send it Now! Instruments supplied when needed, cash or credit. U. S. SCHOOL OF MUSIC, 72 Brunswick Bldg., New York.

U. S. SCHOOL OF MUSIC,
72 Brunswick Bldg., New York

Please send me your free book, "Music Lessons in Your Own Home" with introduction by Dr. Frank Crane, Free Demonstration Lesson and particulars of your easy payment plan. I am interested in the following course:

Have you
..... instrument?.....

Name.....

Address.....

City..... State.....

PICK YOUR COURSE

- | | |
|-------------------------------------|-----------|
| Piano | Violin |
| Organ | Clarinet |
| Ukulele | Flute |
| Cornet | Saxophone |
| Trombone | Harp |
| Piccolo | Mandolin |
| Guitar | Cello |
| Hawaiian Steel Guitar | |
| Sight Singing | |
| Piano Accordion | |
| Italian and | |
| German Accordion | |
| Voice and Speech Culture | |
| Drums and Traps | |
| Automatic Finger Control | |
| Banjo (Plectrum, 5-String or Tenor) | |



I'll Teach You To Dance

—at home without music or a partner or the Trial is Free

YES—I'll teach you in a few hours—at home—in private—how to learn all the modern dances—Charleston, Black Bottom, Valencia, Canter, French Tango, St. Louis Hop, Latest Waltzes, Fox Trots, etc., or the trial costs you nothing. I'll train you to be an easy, confident dancer by a system so clear, so simple, so complete that you will soon start dancing gracefully—even though you've never danced before.

Dancing Made Simple as A-B-C

You will be surprised to see how easily you can learn to dance by our simple chart system. Every dance is explained step by step with charts and diagrams. You can't possibly go wrong. The directions are so easy to follow, and the pictures are so clear, that you'll be dancing before you know it.

It isn't necessary that you understand music or even have a piano, phonograph or radio. Our remarkable system teaches you a very simple system of timing yourself. It tells how to know by the music what kind of a dance is next, how to start on the right beat, how to follow the music, how to be graceful and feel at ease, how to get rhythm, how to lead or follow, how to stand correctly, how to gain confidence, how to become popular. In fact, in a short time this remarkable course should make you one of the best dancers in your set.

If you want to become a perfect dancer—if you want to be popular—learn to dance at home this new, easy way.

Think of the Good Times You Are Missing

Every time you turn down an invitation to a dance, you are missing hours of fun, enjoyment and pleasure. Dancing is the best of the social accomplishments. If you are a good dancer, you will be the most popular person in your set and get invitations to all the parties. Why not learn to dance and share the splendid times others are enjoying?

Try for 5 Days FREE

Just send your name and address and we'll send the complete course—323 pages, 49 illustrations, by return mail. When the postman hands you the book, pay him only \$1.98, plus the delivery charges. Try the course for 5 days. Then if not satisfied, return it and your money will be refunded. Mail your order now!

Franklin Publishing Co., Dept. 9424,
800 N. Clark St., Chicago

Please send me your complete course—"Dancing Made Easy"—323 pages, 49 illustrations. When the book arrives I'll pay the postman only \$1.98, plus delivery charges. If I am not satisfied after 5 days' trial, I may return the book and you are to refund my money.

Name.....

Street and No.....

Town.....State.....

If you are likely to be out when postman calls, send \$2.00 with coupon and we'll pay delivery charges. Customers outside U. S. must send cash with order.

Books on 65 Practical Subjects

Popular Mechanics Press specializes in supplying the outstanding best books on many subjects. As new books of merit appear, we will revise the list accordingly.

AIR NAVIGATION AND METEOROLOGY
Every flyer needs... \$3.00

AIRCRAFT ENGINES
Dyke's New Instructor
Best Engine Book... \$5.00

ARCHITECTURAL
Drawing and Lettering... \$2.00

ARMATURE WINDING
Excellent new book... \$2.00

AUTO ENCYCLOPEDIA
Dyke's. (Covers New Model A Ford)... \$6.00

AVIGATION
By Dead Reckoning... \$2.00

BIRD HOUSES
How to Make... \$1.00

BLUE PRINTS
How to Read... \$2.00

BOAT BUILDING
35 Craft, Popular Outboard Engine Type... \$3.00

BOY MECHANIC
Famous 4 Vol. Library, 4000 Things to Make... \$7.00

BUILT-IN FURNITURE
Complete Instructions... \$2.50

CARBURETORS
Excellent book on all makes... \$2.00

CARPENTRY
Hand book of 336 Kinks... \$1.50

CHEMISTRY
For Old and Young Beginners... \$2.50

CIVIL SERVICE
How to Prepare for... \$3.00

COLOR SIMPLIFIED
Practical new Book (for Color Users)... \$3.50

CONCRETE
173 Ways of Using New Edition (Cloth)... \$1.00

CONTRACTOR
Building Cost Estimator... \$2.00

DIESEL ENGINES
(New Work). Best Authority... \$5.00

DOGS
Care and Raising... \$2.00

ELECTRICIAN
214 Practical Kinks... \$1.50

ELECTROPLATING
Practical Results Easily Obtained... \$1.00

ENGLISH
Self-Improvement in... \$2.50

ETIQUETTE
New 560-Page Book. Only... \$1.00

FARMER'S BOOK
of 861 Kinks and Book for Farmers' Wives... \$1.00

FLIGHT TRAINING
Practical, new book, best on subject... \$5.00

FORD (HENRY)
His Philosophy of Industry... \$1.50

FORMULAS
10,000 Money Making... \$4.00

FURNITURE
Homemade (3 vols.)... \$3.00

HOME REPAIRS
Practical Book of... \$2.50

INTERIOR DECORATING
Best book of new methods... \$4.00

INVENTIONS (American)
Popular History of 2 vols. Reduced to... \$5.00

INVESTMENT
Policies that pay By Ray Vance... \$4.00

JOINT WIPING
(New Edition)... \$1.00

KITES THAT FLY
How to make... \$1.25

LANDSCAPING
Practical... \$2.50

LATHE WORK (METAL)
and Drilling and Thread Cutting... \$1.00

LETTER WRITING
Social and Business Only... \$1.00

MACHINIST
419 Kinks for... \$1.50

MAGIC
200 New Tricks for Amateurs... \$1.00

MAKING THINGS YOURSELF
900 Different Articles... \$3.00

MATHEMATICS
Made Easy for the Practical Man... \$1.50

MECHANICAL DRAWING
Practical Course in... \$1.00

MODEL AIRCRAFT
Building and Flying... \$2.25

MOVIE MAKING
for Amateurs... \$3.00

OUTDOOR OPPORTUNITIES
for Making a Living... \$2.00

OUTDOOR SPORTS
for All Year 'Round... \$1.50

PAINTING
House (Best Methods)... \$2.00

PETS
For Pleasure and Profit... \$2.00

PLUMBING
500 Plain Facts for Every Homeowner... \$1.50

POULTRY RAISING
for Profit... \$2.00

POWER WIRING (D. C.)
Electrical (Just Out)... \$3.50

PUZZLES
Amusing Mathematical... \$1.50

RADIO
Trouble Shooting. Covers All-Electric Sets and Television... \$3.00

ROPE SPINNING
Only Book on Subject... \$1.50

SHIP MODEL
Making... \$2.50

SHOP NOTES
15 Vols. of 6000 Valuable Kinks... \$4.50

STEEL SQUARE
Pocket Book, Practical... \$1.00

TAXIDERMY
Best Book of Methods... \$3.50

TENNIS
By Helen Wills... \$2.00

TOY MAKING
Complete instructions... \$1.50

WELDING
ENCYCLOPEDIA
All Methods... \$5.00

WIRING
House (New Book)... \$2.50

WOOD TURNING (LATHE)
Practical Course in... \$1.50

WOODCRAFT
Famous 590 Page Book by Ernest Thompson Seton; Only... \$1.00

Books sent C. O. D. anywhere in U.S.

Just check the books you want, write your name and address below, and mail the advertisement. It is your order blank. When postman hands you books, pay him the price and the postal charges. If outside the U. S. remit when ordering and include 10 cents per book extra for postage. We have many other books on these and 2,000 other subjects. Catalog free.

Name.....

City.....State.....

Address.....

Mail to Popular Mechanics Press,
Room P2—200 East Ontario St., Chicago, Ill.

ELECTRICITY

Learn **and in 90 Days
You Can Get a Big Pay Job**

Get into this profitable profession. Get into Electricity where there is always an insistent demand for your services at highest pay—\$50 to \$150 a week. Learn to master the magical "juice"—the power that puts and keeps the universe in motion. I will teach you by the simple, practical, personal instruction method. For many years I have been training men by this **Shop Plan System** which has proved to be the most successful method for making well trained electrical men. Many of my graduates are now earning \$50 to \$150 a week and if you will put your future in my hands I'll prepare you to earn that much.

No Books—You Learn on Actual Machines

You learn on real electrical equipment, with real tools. My special school shops are fitted with Switch Boards, Generators, Motors, etc. You get first hand knowledge of A. C. and D. C. Armature Winding, House Wiring, Splicing, in fact everything you need to know to become an Electrical Expert. I also give you complete instruction on Automobile, Aviation and Radio Electrical Systems and Batteries.



I'll Train You the McSweeney Way

I don't believe in books or printed lessons, or dry lectures. I believe in the practical shop way. I want every McSweeney Graduate to become an electrical expert, and that's what he is heading for when he finishes my course. Here I put you into the very heart of electricity. I teach you every phase from A to Z—alternating and direct currents. My course is complete—Installation, substation work, motor and generator repairing, telephone, telegraph, and radio electricity.

No Experience or Education Needed!

You don't have to have any special previous education or training, to grasp my simple method of instruction. You don't even need to know anything about electricity now. I don't care if you can't tell a motor from a horse-and-buggy this minute—I guarantee that when you have finished my course you will know electricity thoroughly and be qualified to fill a big pay job. And if you are not, I'll refund every penny of your tuition.

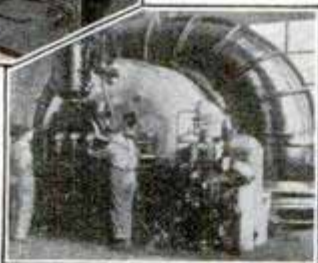

**Complete
Course
in
RADIO**



I GUARANTEE SATISFACTION

If, after completing my training you are not 100% satisfied and are not qualified to fill one of the big pay electrical jobs, I will refund every cent of your tuition.



**Mail
Coupon
for My
Big
FREE
Book
and
Special
Low
Tuition
Offer!**



Mail the Coupon

That's your next step right now. It will bring you my remarkable low tuition offer and also full details of how you can master this highly paid profession and in a few short weeks be ready to land a real job at real pay. Learn why you will like my school—why fellows say it's more fun than work to train the McSweeney Way. Start now to better yourself. Act at once. Mail this coupon for my famous Big Book—sent FREE. J. H. McSweeney, President.

(Write to Nearest School)

Mail This to Nearest School

Mr. J. H. McSweeney, Pres.,
McSweeney Electrical Shops,
Dept. E-11-S, 1815 E. 24th St., Cleveland, O.
Dept. E-11-S, 263 Madison St., Memphis, Tenn.
Dear Mac: Without obligation send me a copy of your big free book on ELECTRICITY; also details of remarkable tuition offer and complete Radio Course.

Name.....

Address.....

Town.....State.....

McSWEENEY

ELECTRICAL SCHOOLS

Dept. E-11-S, 1815 E. 24th St.,
Dept. E-11-S, 263 Madison St.,

Cleveland, Ohio, or
Memphis, Tenn.



"The Boss Was Stumped"

"He was trying to figure out a way to speed up the machines. I could see he was stumped and I asked him if he would let me try my hand at it.

"Go ahead," he said, "but I don't believe you can help much. Looks like an outside job to me."

"So I started right in and pretty soon I had the whole thing worked out. The boss was watching me and I could see he was surprised.

"How did you learn all that?" he asked in that quiet way of his. And then I told him I'd been studying at home nights through the International Correspondence Schools.

"He didn't say anything more and I thought he had forgotten all about it until he called me in his office a few weeks later and said he was going to make me foreman and increase my salary \$75 a month.

"Keep on studying," he told me, "and you'll get another promotion soon. You can't beat those International Correspondence Schools text-books for good, sound, practical knowledge."

That's a true story of what spare-time study has done for just one man. There are thousands of others. Why don't you take up a home-study course with the International Correspondence Schools and prepare yourself to earn more money? At least get the facts.

Mail the Coupon for Free Booklet

INTERNATIONAL CORRESPONDENCE SCHOOLS
Box 5665-F, Scranton, Penna.

Without cost or obligation, please send me a copy of your booklet, "Who Wins and Why," and full particulars about the course before which I have marked X in the list below:

TECHNICAL AND INDUSTRIAL COURSES

- | | |
|--------------------------------------------------|-----------------------------------------------------------------------------|
| <input type="checkbox"/> Architect | <input type="checkbox"/> Automobile Mechanic |
| <input type="checkbox"/> Architectural Draftsman | <input type="checkbox"/> Aviation Engines |
| <input type="checkbox"/> Building Foreman | <input type="checkbox"/> Plumber and Steam Fitter |
| <input type="checkbox"/> Concrete Builder | <input type="checkbox"/> Plumbing Inspector |
| <input type="checkbox"/> Contractor and Builder | <input type="checkbox"/> Foreman Plumber |
| <input type="checkbox"/> Structural Draftsman | <input type="checkbox"/> Heating and Ventilation |
| <input type="checkbox"/> Structural Engineer | <input type="checkbox"/> Sheet-Metal Worker |
| <input type="checkbox"/> Electrical Engineer | <input type="checkbox"/> Steam Engineer |
| <input type="checkbox"/> Electrical Contractor | <input type="checkbox"/> Marine Engineer |
| <input type="checkbox"/> Electric Wiring | <input type="checkbox"/> Refrigeration Engineer |
| <input type="checkbox"/> Electric Lighting | <input type="checkbox"/> R. R. Positions |
| <input type="checkbox"/> Reading Shop Blueprints | <input type="checkbox"/> Highway Engineer |
| <input type="checkbox"/> Telegraph Engineer | <input type="checkbox"/> Chemistry |
| <input type="checkbox"/> Telephone Work | <input type="checkbox"/> Pharmacy |
| <input type="checkbox"/> Mechanical Engineer | <input type="checkbox"/> Coal Mining Engineer |
| <input type="checkbox"/> Mechanical Draftsman | <input type="checkbox"/> Navigation <input type="checkbox"/> Assayer |
| <input type="checkbox"/> Machine Shop Practice | <input type="checkbox"/> Iron and Steel Worker |
| <input type="checkbox"/> Toolmaker | <input type="checkbox"/> Textile Overseer or Supt. |
| <input type="checkbox"/> Patternmaker | <input type="checkbox"/> Cotton Manufacturing |
| <input type="checkbox"/> Civil Engineer | <input type="checkbox"/> Woolen Manufacturing |
| <input type="checkbox"/> Surveying and Mapping | <input type="checkbox"/> Agriculture <input type="checkbox"/> Fruit Growing |
| <input type="checkbox"/> Bridge Engineer | <input type="checkbox"/> Poultry Farming |
| <input type="checkbox"/> Gas Engine Operating | <input type="checkbox"/> Mathematics <input type="checkbox"/> Radio |

BUSINESS TRAINING COURSES

- | | |
|------------------------------------------------------------------|-------------------------------------------------------|
| <input type="checkbox"/> Business Management | <input type="checkbox"/> Business Correspondence |
| <input type="checkbox"/> Industrial Management | <input type="checkbox"/> Show Card and Sign Lettering |
| <input type="checkbox"/> Personnel Management | <input type="checkbox"/> Stenography and Typing |
| <input type="checkbox"/> Traffic Management | <input type="checkbox"/> English |
| <input type="checkbox"/> Accounting and C. P. A. Coaching | <input type="checkbox"/> Civil Service |
| <input type="checkbox"/> Cost Accounting | <input type="checkbox"/> Railway Mail Clerk |
| <input type="checkbox"/> Bookkeeping | <input type="checkbox"/> Mail Carrier |
| <input type="checkbox"/> Secretarial Work | <input type="checkbox"/> Grade School Subjects |
| <input type="checkbox"/> Spanish <input type="checkbox"/> French | <input type="checkbox"/> High School Subjects |
| <input type="checkbox"/> Salesmanship | <input type="checkbox"/> Cartooning |
| <input type="checkbox"/> Advertising | <input type="checkbox"/> Illustrating |
| | <input type="checkbox"/> Lumber Dealer |

Name.....

Address.....

City..... State.....

Occupation.....

If you reside in Canada, send this coupon to the International Correspondence Schools Canadian, Limited, Montreal, Canada

BIG MONEY JOBS OPEN

IN ELECTRIC REFRIGERATION

HERE'S your chance to escape forever from crowded fields, poor pay and limited future! America's newest and fastest-growing industry — Electric Refrigeration—needs trained men to fill service, sales, factory and executive positions at salaries up to \$50 and \$250 a week. Amazing new easy training fits you quickly at home in spare time—endorsed and praised by Servel, Kelvinator, Copeland, Champion, Zerozone and others.

Earn As You Learn New Easy Way

Unlike ordinary schooling. Fascinating—simple as A.B.C. No textbooks. No study drudgery. Trained experts guide you step by step. Charts, diagrams and pictures help you master every principle and practice. Easy terms. Money-back agreement. Free employment service. Hundreds of satisfied students. Get big new book of facts—Rich Rewards in Electric Refrigeration. Sent FREE without obligation.

UTILITIES ENGINEERING INSTITUTE
Dept. 120, 4403 Sheridan Rd., Chicago, Ill.

FREE BOOK



"BECOME A LIGHTNING TRICK CARTOONIST"

Send \$1.00 for Laugh Producing Program of 23 Trick Drawings with Instructions. Catalog of Chalk Talk Supplies Free. BALDA ART SERVICE, Dept. 1, Oshkosh, Wis.

Learn Watchwork, Jewelrywork and Engraving

A fine trade commanding a good salary, and your services always in demand. Address **Horological**, Dept. P, Bradley Institute, PEORIA, ILLINOIS, for our latest catalog.

WHY NOT spend Spring, Summer and Fall gathering butterflies, insects? I buy hundreds of kinds for collections. Some worth \$1 to \$7 each. Simple outdoor work with my instructions, pictures, price-list. Send 10 cents (not stamps) for my illustrated Prospectus before sending butterflies. **MR. SINCLAIR, DEALER IN INSECTS,** Dept. 6, Box 1424, San Diego, Calif.

NERVES?

Are You Always Excited? Fatigued? Worried? Gloomy? Pessimistic? Constipation, indigestion, cold sweats, dizzy spells and bashfulness are caused by NERVE EXHAUSTION. Drugs, tonics and medicines cannot help weak, sick, nerves! Learn how to regain Vigor, Calmness and Self Confidence. Send 25c for this amazing book. **RICHARD BLACKSTONE, N-472** FLATIRON BUILDING, N. Y.

QUIT TOBACCO

Don't try to banish unaided the hold tobacco has upon you. Thousands of inveterate tobacco users have, with the aid of the Keeley Treatment, found it easy to quit.

KEELEY TREATMENT FOR TOBACCO HABIT Quickly banishes craving for tobacco. Successful for over 50 years. Write today for FREE BOOK and particulars of our MONEY-BACK GUARANTEE.

THE KEELEY INSTITUTE, Dept. A-930, Dwight, Ill. Home of the famous Keeley Treatment for Liquor and Drugs. Booklet Sent on Request. Correspondence Strictly Confidential.



ZIP-ZIP SHOOTER

THOUSANDS of boys are made happy with this wonderful Zip-Zip shooter, scientifically and practically made. If you like hunting and outdoor sports, get a Zip-Zip shooter with plenty of pep and force.

If your dealer happens not to have them, order from us. Zip-Zip shooter 35c or three for \$1.00; send stamps, coin or money order.

Automatic Rubber Co., Columbia, S. C.



A FRANTIC CALL FOR MEN WHO CAN READ BLUE PRINTS OF BUILDINGS

Leads Quickly to Jobs Paying up to \$12,000 a Year

See how easy it is to get in the building game. Nowhere else does such simple training count for so much. Nowhere else can a man make up to \$12,000 a year so quickly and so easily. Nowhere else are there so many countless thousands of openings as there are with contractors, builders, and real estate firms, who are constantly calling for men who can read blue prints. Six billion dollars a year is spent for building. Trained men are at a premium in this gigantic industry. Untold thousands are needed at steady salaries far above the scale wage.

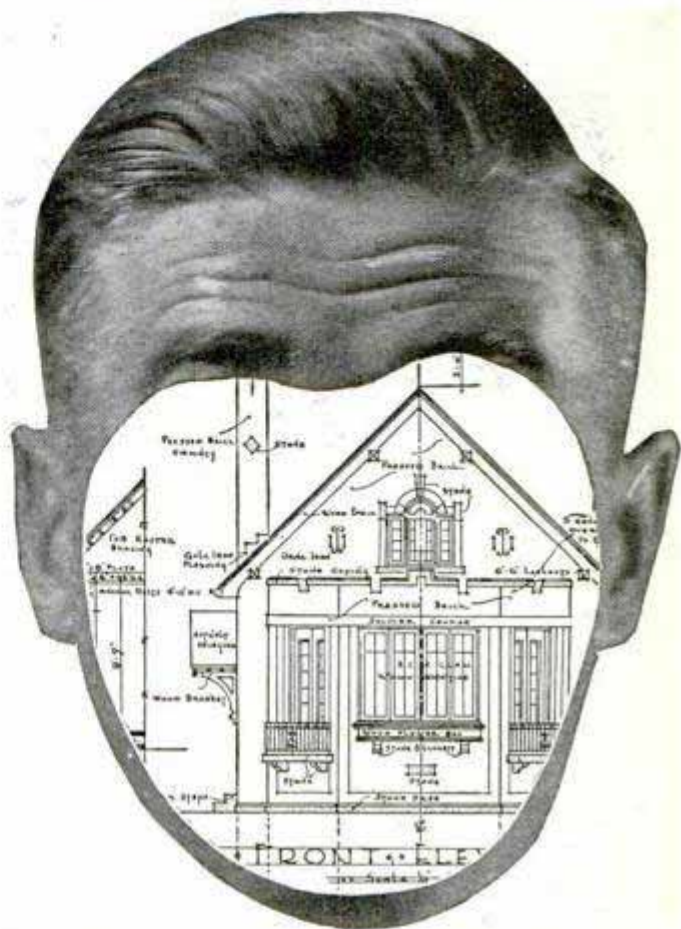

90 DAYS EASY TRAINING PUTS YOU IN THE 6 BILLION DOLLAR BUILDING FIELD

NO longer is it necessary to start at the bottom of the building trades and spend years to work up. Now you can get three years' training in three months. There are no barriers to your success in the great outdoor building field. You do not need more than a common school education. We train you at home, in spare time, by the fascinating blue-print method with lessons that are as easy to read as your newspaper.

These tested plans come to you from one of the oldest and largest schools of building construction and superintendence in the country. This course is endorsed by leading contractors and master builders. These tested, practical plans and lessons are the kind of training that puts men in high salaried jobs and in profitable building and contracting businesses of their own. You learn from actual blue print plans—from practical building experts—you learn how to read all the plans, estimate the costs and supervise the entire construction of a building—you learn everything a contractor has to know when he undertakes the construction of a building.

Amazing opportunities are open to you when you know blue prints, plans, estimating and construction. There is building superintending—the best outdoor profession on earth—that pays handsome salaries and often a bonus for efficient work. Clifford Scholl went from clerk to Asst. Superintendent at 49% increase in salary in 8 months. Thousands of builders and contractors need men like Clifford Scholl.

If you really want more money—if you hope to own a business of your own—get into the building business . . . no matter what your job is now. No overcrowding in this tremendous field—room for thousands every day. Why buck competition in crowded industries where only a few men can succeed?

Clerk or carpenter—office man or bricklayer—salesman or superintendent—it makes no difference. You can get into the building business quickly . . . easily. Or if you are in it at present, get this training now, that you must have for success.

FREE Book and Blue-Prints

Simply mail the coupon below for an intensely interesting free book "How to Read Blue Prints," and actual blue print plans. Get these facts before you. See what amazing opportunities open up for you in the Six Billion Dollar Building Field. Don't wait or delay. Act now. Simply mail the coupon below.



IF YOU LIVE IN OR NEAR CHICAGO

Visit our School for Builders, open day or evening. Thousand men attend each year. Enter any time. You can get the same training at home, by mail. Same plans; same lessons; same instructors. The Coupon brings all facts FREE.

Every Job Must Have a Contractor

The building field is wide open for men who want to go into business for themselves. Henry Mehl, Pa., a policeman, now owns his own contracting business. Burgert, Ill., stepped into a foremanship at 200% increase in salary. Busch, Kan., writes, "I have been offered \$300 a month several times." Boyes, Can., writes, "Your school has increased my wages 40% already." Patrick, Mich., says: "My salary has been increased 92%." Marchand, La., writes, "I am getting along fine. My salary is now increased 196%."

Chicago Technical SCHOOL for BUILDERS

Dept. B-143, 118 E. 26th Street, Chicago, Ill.

Chicago Technical School for Builders, Dept. B-143, 118 E. 26th Street, Chicago, Ill.

Send me, without obligation, your free book, "How to Read Blue Prints" and full details of the course and the opportunities in the Building Field. It is understood that no salesmen will call on me.

Name.....

Address.....

City..... State.....

Age..... Occupation.....

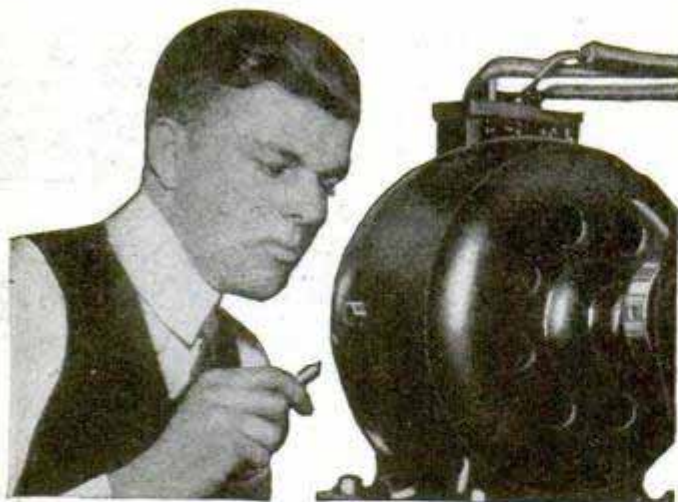

Amazingly Easy Way to Get Into ELECTRICITY

Don't spend your life waiting for \$5 raises in a dull, hopeless job. Now ... and forever ... say good-bye to 25 and 35 dollars a week. Let me teach you how to prepare for positions that lead to \$50, \$60, and on up to \$200 a week in Electricity — NOT by correspondence, but by an amazing way to teach right here in the **great Coyne Shops** that teaches you electricity in 90 days! Getting into electricity is far easier than you imagine!

LEARN WITHOUT BOOKS — In 90 Days

By Actual Work—in the Great Coyne Shops
I don't care if you don't know an armature from an air brake—I don't expect you to! It makes no difference! Don't let lack of money stop you. Most of the men at Coyne have no more money than you have. That's why I have worked out my astonishing offers.

Earn While Learning

If you need part-time work to help pay your living expenses I'll help you get it and when you graduate I'll give you lifetime employment service. And, in 12 brief weeks, in the **great roaring shops of Coyne**, I train you as you never dreamed you could be trained... on one of the greatest outlays of electrical apparatus ever assembled... real dynamos, engines, power plants, autos, switchboards, transmitting stations... everything from door bells to farm power and lighting... full sized... in full operation every day!

No Books — No Lessons

No dull books, no baffling charts, no classes, you get individual training... all real actual work... building real batteries... winding real armatures, operating real motors, dynamos and generators, wiring houses, etc.

GET THE FACTS Coyne is your one great chance to get into electricity. Every obstacle is removed. This school is 30 years old—Coyne training is tested—proven beyond all doubt—endorsed by many large electrical concerns. You can find out everything absolutely free. Simply mail the coupon and let me send you the big, free Coyne book of 150 photographs... facts... jobs... salaries... opportunities. Tells you how many earn expenses while training and how we assist our graduates in the field. This does not obligate you. So act at once. Just mail coupon.

BIG BOOK FREE!

Send for my big book containing 150 photographs telling complete story—absolutely FREE

COYNE ELECTRICAL SCHOOL
500 S. Paulina St., Dept. 20-72C, Chicago, Ill.

COYNE ELECTRICAL SCHOOL, H. C. Lewis, Pres.
500 S. Paulina Street, Dept. 20-72C, Chicago, Illinois

Dear Mr. Lewis: Without obligation send me your big, free catalog and all details of Free Employment Service, Radio, Airplane, and Automotive Electrical Courses, and how I may "earn while learning."

Name _____

Address _____

City _____ State _____

SENT FREE **ON THIS COUPON MAIL NOW**

THIS E-F ANGLE SCREWDRIVER—of tempered crucible Spring steel—has 7 powerful edges for large and small screws. Works under obstructions where others won't—101 uses. Carries like pen-knife—often more valuable.

(PRINT*)

Name _____

Route No., St. _____

P. O. City, St. _____

Interested in PlierRench Factory Repr. Proposition!

In User Literature: **THE FLASH SALES CORP**

PMB, 4809 N. Ashland Ave., CHICAGO, ILL.

Also FREE ON COUPON—A "\$5,000" CIRCULAR giving amazing 125-Picture story of

The "Pocket Machine Shop!"

Off they come!



Its GEAR gives Your Hands the 1-TON grip of 20 hands, that outgrips a 40-Lb. Vise!

An Automatic Lock-Grip Ratchet Wrench



Speed VISE Parallel PLIERS Plus

No. 1, Universal—for ALL Pliers, Clamp, Spring-making, Nut Wrench, Vise and Work, etc.

No. 2—for all Pipe work, "chewed" nuts in tight places, etc.

No. 3—For all Wire chain, spring-making, fence work, etc.

EIFEL-FLASH PLIERRENCH KIT

(Say "Eye-fel-Flash") "The T. N. T. of Tools"

A 1-Second change of Gear-Jaws gives you 1, 2 and 3, in this 24 oz. Master KIT—for the Price of 1 good tool. They DO the Work of 60-Lbs. of Best Other Tools costing \$50.00, and many things no other tools can do!

A GUARANTEED Super-Quality Gripping Machine that Pays for itself in the 4-Weeks' Trial Period.

A Half Million in Use 'round the World—Thousands in U. S. Army, Navy, Air Service, etc.—"horse-&-buggy" tools are being "junked."

A GREAT WINTER MONEY-MAKER

for PlierRench Factory Reprs.—Full or Part Time. Amazing Demonstration sells at sight—A Ga. Repr. made \$97 in 20-Min. Group Sale; a Mich. Repr. \$379 in 5 days. Everybody wants the Kit!

Mail Valuable Coupon Above Now!

Learn Advertising at HOME

Send your name and address for free booklet giving interesting information and vital facts about Advertising. Find out how we prepare you at home, in your spare time, for the opportunities open in this fascinating business. Practical work. No text books. Old established school. Successful graduates everywhere. Just the plan you have always wanted. Write today. No obligation.

PAGE-DAVIS SCHOOL OF ADVERTISING

Dept. 1352 3601 Michigan Ave. Chicago, U. S. A.

ALWAYS Ask for DENISON'S—54 Years of Hits

Comedy - Dramas, Farces, Musical Comedies, Revues, Musical Readings, Comedy Songs, Chalk Talks, Minstrels, Blackface Skits, Make-up Goods. Catalog FREE. T. S. DENISON & CO. 623 S. Wabash, Dept. 9 CHICAGO

10c NEW SCIENTIFIC WONDER

3 for 25c "X-RAY" CURIO



SILVER ONLY

BOYS You apparently see thru Clothes, Wood, Stone, any object. See Bones in Flesh. FREE-PIKG. RADIO BIG FUN PICTURE FILMS. Takes pictures without camera. "You'll like 'em." 1 pkg. with each 25c order.

MARVEL MFG. CO. Dept. 31 NEW HAVEN, CONN.

Is there a Job and a Future for Me in AVIATION?



"My Answer is YES!"

Walter Hinton

THERE'S more than that! There's a *better* job and a *better* future for you in Aviation than in any other industry.

The reason is this: Aviation is **just beginning** its period of *big growth*.

Aviation is going to be America's *next* gigantic industry. And if you get into it *now*—while it's still uncrowded—you can grow as *Aviation grows*.

A lot of men saw **their** opportunity in radio when it was young. They got in **early** and literally "cleaned up." Today thousands of those "early birds" of radio are wealthy.

The same was true of the automobile industry. It was the men who got in "on the ground floor" who made the biggest successes.

That's the **kind of a chance** you have in Aviation today. During the next few years Aviation is going to pick its bosses, its high priced specialists, its leaders and executives. And *you*—by *looking ahead* and *acting ahead*—can be one of them.

What is more, to fit yourself for an important place in AVIATION—it isn't necessary for you to leave your home, give up your present job or spend a lot of money.

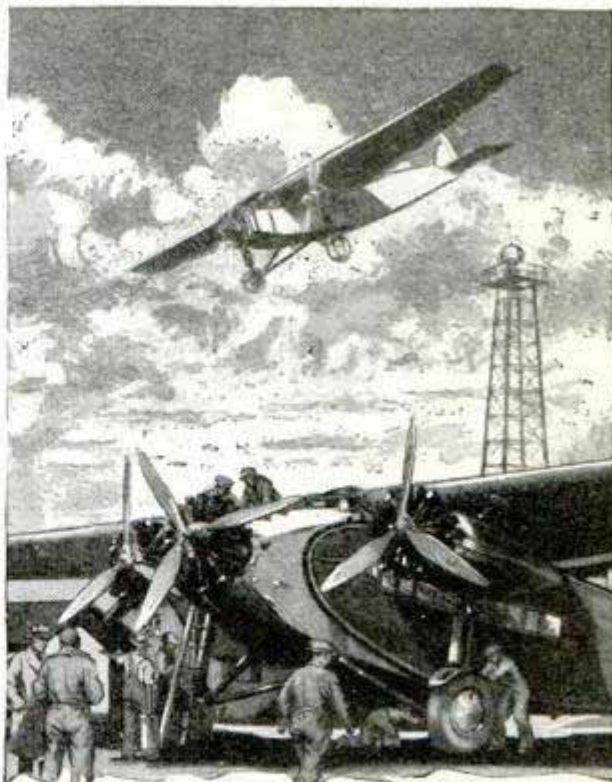

Instead, give me just a part of your spare time during the next few months, and I'll give you the kind of training that employers need and are paying *real cash* to get.

I'll do **even more!** I'll actually help you get a job. You will receive the free assistance of my Employment

Department. I'm getting calls from transport companies, airports, airplane manufacturers asking for trained men to fill "ground jobs" and "flying jobs" that pay *real money* and offer *real futures*.

Get My FREE Book!

I have an idea that the only reason I'm not training *you right now*—just as I'm training hundreds of other ambitious men who don't propose to let this chance of a life-time get away from them—is because you haven't begun to appreciate what a tremendous opportunity Aviation offers you.

If that's so, I want you to have a copy of my book, "Wings of Opportunity." You'll find it crammed with interesting facts, that are vital to *your future*.

Before you tell yourself that there isn't any sensible, practical, *easy* way for *you* to get into Commercial Aviation—read this book.

Before you decide to sit by and let Aviation grow up *without you*—clip that coupon and tell me where to send *your copy*.

Aviation Institute of U. S. A.

Walter Hinton, Pres.

1115 Connecticut Ave., Washington, D. C.

WALTER HINTON
was the pilot of the famous NC-4, the very first plane to fly across the Atlantic; he was first to fly from North to South America; first to fly over the head waters of the Amazon River. During the war he was one of the crack flying instructors for the U. S. Navy. Today, through a remarkable course of practical training which you take right at home, he gives you the knowledge you need to succeed in any branch of Aviation. If you are eighteen years of age, or older, send *now* for a free copy of his book.



Rush to Washington!

Walter Hinton, President,
Aviation Institute of U. S. A.,
1115 Connecticut Avenue, N. W.,
Washington, D. C.

301-D

Send my FREE copy of "Wings of Opportunity". I'd like to know what kind of a future Commercial Aviation offers ME.

Name.....

Address..... Age.....

(Must be over 18)

City..... State.....



SPARE TIME training

that leads to BIGGER PAY

DO you want a better position and a higher salary? You can have these if you can do the work. LaSalle experts will show you how, guide you step by step to success and help solve your personal business problems through the time-saving LaSalle Problem Method. Our *salary-increasing plan* enables you to prepare during your spare hours, without interference with your present duties. Simply mark on the coupon the field in which you desire success, and we will mail you a valuable book describing the opportunities in that field, together with an outline of our *salary-increasing plan*. Also copy of "Ten Years' Promotion in One." There is no cost or obligation. Find out how the *salary-increasing plan* starts average men and women on the high road to success and financial independence. Check and mail the coupon NOW.

----- Find Yourself Through LaSalle! -----

LaSalle Extension University

Dept. 264-R Chicago

Please send me full information regarding the course and service I have marked with an X below. Also a copy of "Ten Years' Promotion in One" all without obligation to me.



- Business Management:** Training for Official Managerial, Sales and Departmental Executive positions.
- Modern Salesmanship:** Training for position as Sales Executive, Salesman, Sales Trainer, Sales Promotion Manager, Manufacturers' Agent, and all positions in retail, wholesale or specialty selling.
- Higher Accountancy:** Training for position as Auditor, Comptroller, Certified Public Accountant, Cost Accountant, etc.
- Traffic Management:** Training for position as Railroad or Industrial Traffic Manager, Rate Expert, Freight Solicitor, etc.
- Law:** LL. B. Degree.
- Banking and Finance:** Training for executive positions in Banks and Financial Institutions.
- Modern Foremanship:** Training for positions in Shop Management, such as that of Superintendent, General Foreman, Foreman, Sub-Foreman, etc.
- Industrial Management:** Training for Works Management, Production Control, Industrial Engineering, etc.
- Personnel Management:** Training for Personnel Manager, Industrial Relations Manager, Employment Manager, and positions in Employee Service.
- Modern Business Correspondence:** Training for Sales or Collection Correspondent, Sales Promotion Manager, Mail Sales Manager, Secretary, etc.
- Stenography:** Training in the new superior machine shorthand, Stenotypy.
- Railway Station Management**
- Railway Accounting**
- Expert Bookkeeping**
- Business English**
- Commercial Law**
- Credit and Collection Correspondence**
- Paper Salesman's Training**
- Effective Speaking**
- C. P. A. Coaching**
- Commercial Spanish**
- Stenotypy—Stenography**
- Telegraphy**

Name..... Age.....
 Present Position.....
 Address.....

In Demand Oh, Boy!



They Want Me for Every Dance —and They Are Willing to Pay My Price, Too

I learned right at home—in odd half hours—that used to hang heavily on my hands. Easy? You bet. Right from the start I began to practice tunes. It was wonderful, playing catchy tunes—I liked learning better every lesson. Just some amazingly clear instructions and illustrations—real child's play. Why, I was playing like an old-timer before I realized it.

Pick Your Course!

- Piano
- Violin
- Banjo
- Flute
- Cornet
- Guitar
- Drums
- Mandolin
- Singing
- Ukulele
- Trombone
- Saxophone
- Voice and Speech Culture
- Automatic Finger Control
- and many others

Free Book and Demonstration Lesson

—Tells all about this marvelous new method, learned at home, that started thousands of skilled musicians. Ask about offer on tenor banjo course, now so popular. Or any instrument you prefer. See at once how to get popularity. Enjoy music and make money. Booklet absolutely free. Write at once.

U. S. School of Music
 72-A Brunswick Bldg., NEW YORK CITY

BIG Demand for Skilled Mechanics!

The entire country is calling for skilled mechanics! Good pay—steady work—good opportunities for advancement! Master this fascinating trade with the aid of the

AMERICAN MACHINISTS' LIBRARY

6 volumes—2,000 pages—2,500 illustrations

(A combined home-study course and reference library)

This library of machine shop practice was written for practical men. It gives you the best methods for every kind of machine shop work. It explains machine tools and their operation, tool work, gears and grinding, jigs and fixtures, automatic screw machines, their tools, punches, dies, etc. Plainly written—completely illustrated—the best kind of help to the machine-shop man who wants to advance himself.

Free TRIAL

No money down—only 7c a day

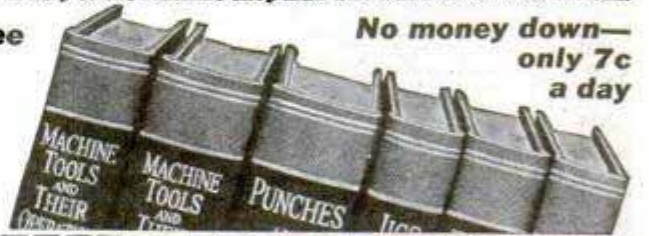

FREE EXAMINATION COUPON

McGraw-Hill Book Co., Inc., 370 Seventh Ave., New York
 Send me for 10 days' free examination the AMERICAN MACHINISTS' LIBRARY. If satisfactory, I will send \$1.50 in 10 days and \$2 monthly until the special price of \$17.50 is paid. If not wanted, I will return the books at your expense.

Signed.....
 Address.....
 City and State.....
 Position.....
 Company..... P. M. 2-30

3 BIG PAY FIELDS

Learn ELECTRICITY A BIG PAY JOB

Electricity and Radio now pays hundreds of trained men \$60, \$75, \$100, up to \$200 a week. The world's Greatest businesses. Billions—not millions—but billions of dollars are spent in them yearly. Now is the time to get away from low pay!

Learn in Only 3 Months in Great Greer Shops on Real Equipment

Mine is not a correspondence course. You start any day or any evening. It is practical, easy, quick, fascinating training. You learn on great, running live equipment in tremendous Greer Shops. Electricity is the fastest growing industry in the world—Radio a close second, and yet in its infancy, is a billion dollar industry. Trained men by scores needed for positions up to \$250 a week. Find out now about my great shops training.

You Get Real Help to Big Jobs

My big Employment Department gets jobs for Greer men. You get this help before and after graduation. Don't let money hold you back. Get my free book. Learn how I get you ready so Employers gladly pay you what you are worth.

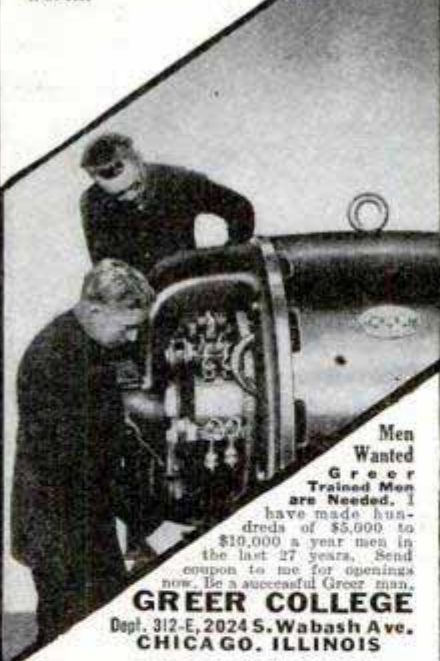

**Men Wanted
Greer Trained Men
are Needed.** I have made hundreds of \$5,000 to \$10,000 a year men in the last 27 years. Send coupon to me for openings now. Be a successful Greer man.

GREER COLLEGE
Dept. 312-E, 2024 S. Wabash Ave.
CHICAGO, ILLINOIS

Big Money in AUTOS OWN YOUR OWN BUSINESS

Be your own boss. Learn it all. Big men draw big money because they know the whole business. You can't make big money by just doing one single little thing. Factories pay a very ordinary salary to "Jones" who screws on nut number 39, because they can quickly teach someone else to do it just as well.

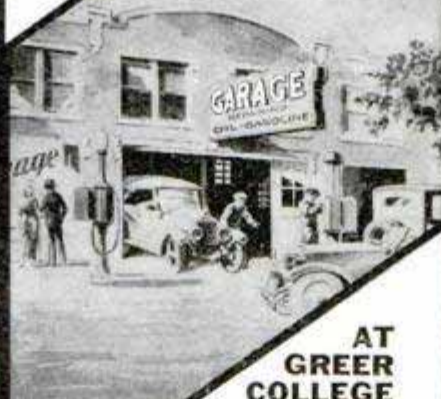

**AT
GREER
COLLEGE**

you learn how to boss the job.

**Quickest, Easiest of
Ways to Become Expert**

I'll allow your fare here free of extra cost, then help you to a job while learning. Then I not only fit you to get a big pay job, but I'll help you hold it. Young and old, educated and uneducated, experienced and inexperienced, have found Greer Shops training easy, fascinating and valuable. You learn on big, actual full size equipment like you will work on out on the big pay job. Coupon below brings details. Don't delay! Get my free book now!

GREER COLLEGE
Dept. 312-A, 2024 S. Wabash Ave.
CHICAGO, ILLINOIS

Get into AVIATION

You know the vast opportunities. Greer offers the way to get them. Now is the time.



You Learn to Fly by Flying

The 27 years' growth of Greer College, thru genuine service, speaks for itself. From 1902, to the present tremendous plant including three modern buildings and three airports in the Chicago area. Real endorsement by satisfied students and graduates have made this possible. Aviation enthusiasts come to marvel at the tremendous outlay of motors, planes, instruments, wood and metal working equipment, welding and ignition shops. Many more have come to consult our Chief Aviation Engineer, C. L. Laird, regarding airplane design and construction.

Get My Free Book "Winning Your Wings"

Learn how my students prepare for amazing opportunities in this most fascinating and alluring profession—Aviation. Learn about my great shop and field training. Rates are reasonably low because of our large enrollment. Mail the coupon below for full details of my free employment offer and the many ways I help you to pilot's and mechanic's license.

Now All Can Learn to Fly
My shop training plan equips you for any branch of Aviation. Get the details today.

GREER COLLEGE
Dept. 312, 2024 S. Wabash Ave.
CHICAGO, ILLINOIS

FREE Electrical Book

Erwin Greer, President,
Dept. 312-E, 2024 So. Wabash Ave.,
Chicago, Illinois.

Send Free Book and details of Special offer, without obligation to me.

Name.....
Address.....
State..... Age.....

FREE Auto Book

Erwin Greer, President,
Dept. 312-A, 2024 So. Wabash Ave.,
Chicago, Illinois.

Send Free Book and details of Special offer, without obligation to me.

Name.....
Address.....
State..... Age.....

FREE Aviation Book

Erwin Greer, President,
Dept. 312, 2024 So. Wabash Ave.,
Chicago, Illinois.

Send Free Book and details of Special offer, without obligation to me.

Name.....
Address.....
State..... Age.....



High School Course in Two Years!

You Want to Earn Big Money!

And you will not be satisfied unless you earn steady promotion. But are you prepared for the job ahead of you? Do you measure up to the standard that insures success? For a more responsible position a fairly good education is necessary. To write a sensible business letter, to prepare estimates, to figure cost and to compute interest, you must have a certain amount of preparation. All this you must be able to do before you will earn promotion. Many business houses hire no men whose general knowledge is not equal to a high school course. Why? Because big business refuses to burden itself with men who are barred from promotion by the lack of elementary education.

Can You Qualify for a Better Position

We have a plan whereby you can. We can give you a complete but simplified high school course in two years, giving you all the essentials that form the foundation of practical business. It will prepare you to hold your own where competition is keen and exacting. Do not doubt your ability, but make up your mind to it and you will soon have the requirements that will bring you success and big money. **YOU CAN DO IT.**

Let us show you how to get on the road to success. It will not cost you a single working hour. Write today. It costs you nothing but a stamp.

American School

Dept. H-247 Drexel Ave. and 58th St., Chicago

American School

Dept. H-247 Drexel Ave. and 58th St., Chicago

Send me full information on the subject checked and how you will help me win success.

- | | |
|------------------------------|----------------------------|
| Architect | Business Law |
| Building Contractor | Lawyer |
| Automobile Engineer | Machine Shop Practice |
| Automobile Repairman | Mechanical Engineer |
| Civil Engineer | Shop Superintendent |
| Structural Engineer | Employment Manager |
| Business Manager | Steam Engineer |
| Cert. Public Accountant | Foremanship |
| Accountant and Auditor | Sanitary Engineer |
| Bookkeeper | Surveyor (& Mapping) |
| Draftsman and Designer | Telephone Engineer |
| Electrical Engineer | Telegraph Engineer |
| Electric Light & Power | High School Graduate |
| General Education | Wireless Radio |
| Vocational Guidance | Undecided |

Name

Address

CARTOON & COMIC STRIP COURSE FOR \$2.98 ONLY COMPLETE



The Ace of Cartoon Courses

For fun and profit learn to draw cartoons and comic strips. Amazingly simple system developed by CARL ANDERSON, famous contributor to SATURDAY EVENING POST, COLLIER'S, LIFE, JUDGE, NEW YORK JOURNAL, NEW YORK WORLD and other leading publications, gives complete instructions in DRAWING, CARTOONING, COMIC STRIP AND ILLUSTRATION. These easy lessons make drawing as easy as writing. Spend only a few hours a week practicing and you will be able to draw and draw well in a very short time. 48 lessons, hundreds of illustrations, cost but \$2.98, the greatest bargain ever offered in a guaranteed drawing course. We

SEND NO MONEY
Just order course and pay postman \$2.98 plus postage on delivery.

positively **GUARANTEE MONEY BACK** if the course is not everything we claim. Order today—Address

THE CARL ANDERSON SCHOOL, MADISON, WIS.

Send \$3.28 cash with orders from outside U. S. A.

A Card Case Any MASON Would Be Proud To Own



Protects your lodge cards, \$1 auto license, passes, etc. under isinglass windows, **1** ready to be seen at a glance. A genuine leather, 5-window sturdy card case, extra pocket—snap button—gold corners, for only \$1.

Stamped with Masonic Emblem in heavy gold FREE—Same price without emblem. Name and other stamping 35c a line extra. Larger cases, 9 windows \$1.50, 13 windows \$2. Send for Catalogue.

- Masonic Books, Monitors, Jewelry.
- Lodge Supplies. [Check Choice]

REDDING MASONIC SUPPLY CO.
200 Fifth Ave., Dept. P.M., New York

Develop Your Talent!



Don't put off that urge to play! Be a musician! Learn to play for your own entertainment, for your friends, or even for a livelihood. More than that—broaden your own education and get the *real appreciation of life* that comes with the knowledge and understanding of music.

Violins • Violas • Cellos on Approval

You do not have to buy an instrument from us in order to try it. We will send what you want on approval. We want to see you satisfied with your choice *before* you buy.

30 Days Trial Examine our instruments in your own home. Try them yourself—show them to your friends. Then, at the end of 30 days, if you are not entirely satisfied, return what you ordered at no obligation whatever.

New Catalog Free The coupon brings full details of our special "on approval" offer, also our new catalog with 96 pages of interesting and valuable information for the student, teacher or professional. Send the coupon *now!*

Wm. Lewis & Son, Dept. 3372, 207 S. Wabash Av., Chicago, Ill.
Please send me entirely without obligation your new catalog on instruments of the violin family and details of your special offer.

Name

Address

City State

I play—want to play—a
(Music Teachers—enclose professional card.)

All you need is a little TRAINING to make a SUCCESS in RADIO

"YOUNG MAN, study radio!" That's what every ambitious young man of today is told by J. H. Barron, Radio Inspector of the U. S. Department of Commerce. Radio is crying for trained men. Experienced radio operators and service men are in great demand. A very serious shortage exists. Practically all of the seven thousand licensed commercial operators are now employed and the need is constantly increasing. Radio needs thousands of trained men. Are you prepared to take advantage of this big opportunity? Ships at sea, planes in the air, broadcasting stations, manufacturing plants, as well as dealers, require thousands of experienced radio men.

You Can Easily Learn Radio at Home Through This Course
Sponsored by the Radio Corporation of America

RCA sets the standards for the entire radio industry... And this RCA Institutes' Home Laboratory Training Course gives you the *real inside secrets* of radio *quickly and easily!* In your spare time, you can obtain all the information you require to make a success in radio. You study at the very source of all the latest, up-to-the-minute developments. This is the only radio course sponsored by RCA, the world's largest radio organization. This is the *real way* to study radio. Learn radio under the direction of RCA... under the men who actually made radio what it is today!



Radio
Mechanic
and
Inspector
\$1800 to
\$4000 a
Year.



Broadcast
Operators
\$1800 to
\$4800 a
Year.

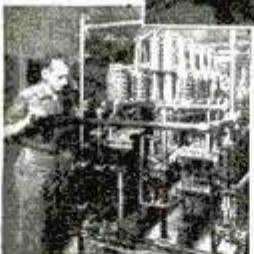

Broadcast
Station
Mechanic
\$1800 to
\$3600 a
Year.

For the added convenience of students who prefer a Resident Study Course, RCA Institutes, Inc., has established Resident Schools in the following cities:
New York . . . 326 Broadway
Boston, Mass. . . 899 Boylston St.
Philadelphia, Pa. 1211 Chestnut St.
Baltimore, Md. 1215 N. Charles St.
Newark, N. J. . . 560 Broad St.
Home Study graduates may also attend any one of our resident schools for post-graduate instruction at no extra charge.

Graduates Find It Easy To Secure Good-Pay Radio Jobs

You actually *train* for success. Every graduate of RCA Institutes has the ability and the confidence to hold a well-paid radio job. You learn radio by actual experience with the remarkable outlay of apparatus given to every student. Every radio problem, such as repairing, installing and servicing fine sets is covered in this course. Students of RCA Institutes get first-hand information and get it complete... That's why every graduate of RCA Institutes who desired a position has been able to get one. That's why they're always in big demand.

Step Out Towards Success in Radio Today!

Get out of the low-pay class. Make your first move towards a pleasant and profitable career in radio today by sending for this free book... "Radio... the Field of Unlimited Opportunity." Read these forty fascinating pages, packed with pictures and descriptions of the brilliant opportunities in radio. Learn all about the oldest commercial radio training organization in the world. See how you, too, can speed up your earning capacity in the fastest-growing industry of today. Others have done it and so can you!

Clip this Coupon NOW!

RCA INSTITUTES, Inc.

Formerly
Radio Institute
of America



RCA INSTITUTES, Inc.
Dept. PM-2, 326 Broadway,
New York, N. Y.

Gentlemen: Please send me your FREE 40-page book which illustrates the brilliant opportunities in Radio and describes your laboratory-method of instruction at home!

Name.....

Address.....



Learn Piano **JAZZ** Quickly by Ear

Beginners and advanced students learn quickly at home—in spare time. Wonderful Niagara Method clearly shows you how. Complete course 20 lessons. 10 years successful teaching.

By R. C. JAMES

How I used to wish that I could sit down at the piano and pour out the golden syncopation of American melody, like the jazz piano players I had heard. How I used to wish that I could be the popular one in every crowd. But I could not play a note.

Niagara Method Showed Me The Way

Then somewhere—just as you are reading this—I read of the Niagara Method which makes piano playing wonderfully simple. I sent for Director Wright's book "The Niagara Secret." I read the book, and I knew it was right.

I followed Director Wright's principles, and in no time I had caught on to his ideas.

So Simple—So Easy—So Delightful

And the best part of it all is that there is nothing hard about the Niagara Method. In a short time, by following Director Wright's principles and by devoting a part of my spare time to the practical application of his course, I soon learned to play.

No tiresome scales—no arpeggios to learn—no weary hours of practice—no do-re-mi—no meaningless exercises. If you know the Niagara Method, you can sit down and reel off any popular song which the high-priced orchestra leaders play in cabarets, clubs, hotels, dance halls, or theaters.

Clip Coupon Now—Play In Few Months

If you have never played a note, or if you do play—no matter how well—you too may become a master of jazz and melody by learning the simple, wonderful

FREE BOOK

Niagara Method. Don't wait another day. Send the coupon now for the "Niagara Secret." This book is yours absolutely FREE. If 10c (coin or stamps) is enclosed you also receive wonderful booklet "How to Entertain at Piano"



Ronald G. Wright, Director
Niagara School of Music
356 Cleveland Ave., Niagara Falls, N. Y.

CLIP THIS COUPON NOW!

NIAGARA SCHOOL OF MUSIC, 356 Cleveland Avenue
Niagara Falls, N. Y.

Without obligation mail me your book "The Niagara Secret." I enclose 10c for book "How to Entertain at Piano"

Name _____

Street _____

City _____ State _____

BE A RAILWAY TRAFFIC INSPECTOR

EARN UP TO

\$250

Earning
\$192 per
Month—and
Likes His Work

I am earning \$192.00 per month and I have the knowledge and satisfaction that my work is highly satisfactory to my superiors. I am far more than satisfied and received far more than I expected when I first subscribed for your course. Considering you the greatest benefactor that has come into my life,

I am
(Signed) JOE ETTLE

Many men are needed to fill existing vacancies in this fascinating railway work. Pays \$120 to \$150 monthly to start. Rapid advances to \$175, \$200, \$250. Travel, or remain near home.

For eleven years this school has trained men for Traffic Inspection and assisted them to positions upon completion of training. Railways look to us for men. We'll train you in a few weeks' spare time home instruction, and upon completion assist you to a position at a definite salary or refund your tuition. You take no risk.

per month
plus expenses

Send for Free Booklet

Learn complete details of this great uncrowded profession today. Our free booklet explains all about it—how we have

obtained positions for our graduates, and what we can do for you. Write today.

Standard Business Training Inst.
Div. 2, BUFFALO, NEW YORK

Government Positions

Census Clerks, Clerk Carriers, Rural Carriers, Railway Mail Clerks, Postmasters, Department Clerks, and many others. Splendid salaries, easy work, vacation with pay. Only common school education required. Examinations often. 37,976 appointed last year. Send for our Civil Service Catalog No. 6. **COLUMBIAN CORRESPONDENCE COLLEGE, Washington, D. C.**

LAW *Free Book*

Write today for FREE 64-page book, "THE LAW-TRAINED MAN", which shows how to learn law in spare time through the Blackstone home-study course prepared by 80 prominent legal authorities, including law school deans and U. S. Supreme Court justices. Combination text and case method of instruction used. All material necessary furnished with the course, including elaborate 25-volume law library, delivered immediately upon enrollment. Many successful attorneys among our graduates. LL. B. degree conferred. Moderate tuition, low monthly terms. Money-Back Agreement.

Write for free book today.

BLACKSTONE INSTITUTE, 307 N. Michigan Ave. Dept. 52 Chicago

CUTTING DOLLARS OUT OF MEAT

START
A
MEAT
MARKET
BIG
MONEY

Scientific meat buying, cutting, selling and serving rapidly coming to the front. HIGH SALARIED, PLEASANT, STEADY positions open everywhere. Splendid opportunities for trained meat specialists to connect with large markets, ships, hotels, clubs, etc. Let National train you. Oldest and most reliable school of its kind. Easy, inexpensive home-study course or come to industrial Toledo. Own your own market. Large enrollment. Many successful graduates. Write at once for large illustrated catalog and "PROOF OF OUR GRADUATES' SUCCESSSES." Mail coupon below today and get the NEW MEAT FACTS.



Plenty of
Jobs
for Trained Men

\$60.00
A WEEK
AND MORE

National S.O.M., Cutting,
604-C Summit, Toledo, Ohio.

Name _____
Address _____

- takes only 8 weeks to get a big job

and Earn
**\$50 to
\$125 Weekly**
as Auto
or Aviation
Expert

Learn the Automotive or Aviation business by the McSweeney system. Get ready to step out and hold a real job. Earn \$50 to \$125 a week. Or, you can open a garage and repair shop and clean up as high as \$10,000 a year. It's no idle dream—no fanciful goal—but actual accomplishments of many McSweeney graduates. The Automobile, Tractor, and Aviation Business needs Trained men. Opportunities are everywhere. Good openings galore. Eight weeks training with McSweeney fits you to open your own place or go with one of the many firms seeking trained men. Read what George Smith, C. E. Gillespie and D. M. Collins have done. And there are hundreds of other McSweeney trained men who can tell you just as interesting facts. Every month McSweeney graduates are supplanting the inexperienced, untrained men.

You Do Actual Work on Real Equipment

First we tell you, then show you, then you actually do the work yourself—you learn Mac's practical way—we use no books—no lessons—an education is not necessary. A green man works shoulder to shoulder with the man who has had years of experience. The McSweeney way is the real way to big pay. Learn a trade that can never be replaced by machinery. Automobile, Tractor and Aviation repair and maintenance can never be put on a production basis.

You Can Learn in Only 8 Weeks!

Yes sir—in only eight short weeks McSweeney will train you so you can qualify for a big pay job in the Auto, Tractor or Aviation fields. You don't need any advance education. In fact, very little schooling is necessary. Any man from 16 to 60 can easily learn and master the clear, concise, simple McSweeney Course. And think of it, in just 8 weeks you can do it. In only 8 weeks you will be ready to step into a big job paying \$50 to \$125 weekly. Why fool away your time with small pay jobs when it's so easy to make real money through McSweeney training? And you can do it in such a short time. You are protected in every way. Read the money-back guarantee below. You have every chance to win out in the biggest sort of way without risk. Take advantage of my Remarkable Limited Tuition Offer by mailing the coupon to me at once. No facilities for colored students.

What I Have Done For
Others, I Can Do For You

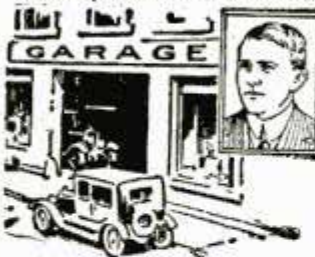

George Smith owns an agency and repair shop in West Alexandria, Ohio. He makes \$200 a week.

Learn on Real
Machines



C. E. Gillespie has charge of a fleet of trucks and tractors for the State Highway Commission, due to McSweeney training.



D. M. Collins, Williamsville, West Virginia, writes: "After finishing McSweeney training, I started as manager of a garage at \$300 a month."

AVIATION Course

Aviation, the big new field for ambitious men! But Aviation will pay tremendous incomes to trained men only. With McSweeney you learn all about airplane engines, airplane wings, airplane construction, under experienced instructors. Coupon brings full details. Don't miss this remarkable opportunity.

Write for Big FREE Book

Send coupon at once for this big, illustrated book. It tells you all about the McSweeney Schools and explains how you can enroll at once and save money. Besides, the sooner you start, the sooner you will be ready to earn big pay, or get into business for yourself. Don't delay. Mail coupon today sure. The book is Free to you!

McSWEENEY
Auto-Tractor and Aviation **SCHOOLS**

Chester at 30th St.,
Cleveland, Ohio

Dept. A-11-S

or

263 Madison St.,
Memphis, Tenn.

Money-Back Guarantee!

If, after completing my training, you are not satisfied, your tuition will be refunded. You yourself are the sole judge of McSweeney training. I want no dissatisfied students and I'm willing to go the limit to prove my sincerity and honesty. There is no catch to this, it's a straight forward, honest guarantee!

Address school nearest you.

Mail this Coupon Today

McSweeney Auto, Tractor and Aviation School,
Dept. A-11-S, Chester at 30th St., Cleveland, Ohio,
or 263 Madison, Memphis, Tennessee.

Without cost or obligation, send me your big, FREE book on Autos and Aviation, also full details of your special tuition offer.

Name

Street

Town State.....

There's Quicker, Bigger MONEY for YOU in POULTRY RAISING!



Wherever You Live—
Whatever You Do Now—
\$2,000 to \$5,000 a Year
Can Be Yours!



YOU Can Do What They Have Done

"Your Course on Poultry Raising is the most practical and complete in the country. You have opened up a pleasant and profitable way for me to gain an independent living."—S. Anderson, Barrington, R.I.

J. I. Mosher of Buffalo, N. Y., started at \$35 a week after 10th Lesson, F. O. Anderson of Phoenix, Ariz., writes: "Thanks to N. P. I. I got a job even before I finished your course!"

Spare Time or Full Time YOU Can Cash-In BIG

The Poultry Industry is growing by leaps and bounds. Eggs and Poultry meat are commanding high prices—prices that mean real profits on every bird you raise—every egg your flock produces. Thousands of my students have turned to Poultry Raising for parttime extra money or fulltime big pay. I'll show you how to start in a small way—in your own back yard—and make it pay—make your little investment multiply itself automatically. Or, if you want to work for someone else at a good salary—my FREE Employment Dept. will help place you in one of the thousands of splendid positions open to trained poultrymen. Why wait? I'll PROVE that I can put you among the big money makers QUICK!

My Proved Methods Assure Success Right from START

All the "mystery" all the "secrets" all the guesswork are taken out of Poultry Raising by my sure, tested, proved successful methods. I will teach them all to you. Nothing left out, nothing for you to have to figure yourself. I make it easy for you. It's fascinating, healthful, pleasant, profitable. You'll be your own boss—I'll show you how to make \$1.00 to \$3.00 for every hour of your spare time. What's more, I'll show you the way to a salary of \$5,000 a year AND UP! Start as small as you want; my methods will get the maximum profits out of your flock and make it grow automatically, into a sure source of steady big income for YOU.

FREE BOOK Shows Way to BIG PROFITS

My big new FREE book, "How to Raise Poultry for Profit," will amaze you! It brings evidence a-plenty—absolute proof—of what I have done for thousands of others. My forty years experience as Commercial Poultryman and former Senior Poultryman in the U. S. Dept. of Agriculture is yours for real Success and Independence. The Poultry Business needs you—and you need the profits that the poultry business brings. You need my book. Get in line for QUICKER, BIGGER MONEY. Do it this minute—don't delay a day. Get this coupon into the very next mail!



48 Pages of Money-making FACTS

Get this FREE Book NOW!

Harry M. Lamon, Pres.,
NATIONAL POULTRY INSTITUTE
Dept. 411-F, Washington, D. C.

Dear Mr. Lamon: Send me your FREE Book, "How to Raise Poultry for Profit." I want to know more about MY opportunity to make \$2,000 to \$5,000 a year, spare time or full time.

Name.....
Address.....
City.....State.....

Let Slamming Doors Pay You \$15 a Day

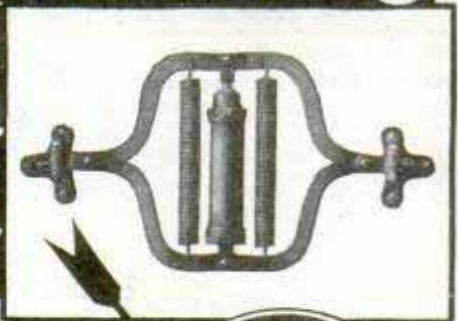

Amazing invention that ends all trouble, annoyance and expense of slamming doors and brings fortunes to agents. Just one look at this clever device and the sale is made. Can be installed in a few minutes with just a screw driver. Saves nerves, besides enormous loss through broken glass and wasted fuel. Every office, factory, store, institution or public building needs one for every noisy door.

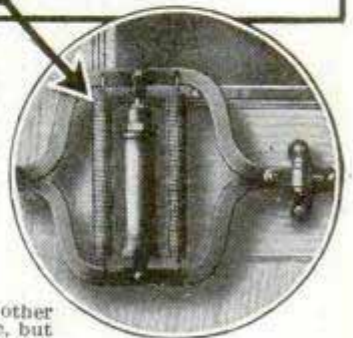

Entirely New Principle—Works in Oil

Kant-Slam is different from any other door control. It's not pneumatic, but is built on new oil principle, that controls door like human hand. Gives lifetime service without adjustments. Always efficient in any weather.

Low in Price

Kant-Slam is neat, compact, light in weight and is lowest priced control ever offered with a factory guarantee. Pays big commission that makes agents \$15 a day and more, easily, just showing it.

Clever Demonstrator Offered FREE

We furnish agents a full size sample mounted on a light weight easy-to-carry miniature door. Makes sales in a few minutes. WRITE FOR FREE OFFER!

KANT-SLAM DOOR CHECK CO.

Dept. X-5 **STRAIGHTLINE** Bloomfield, Ind.

Wrestling Book FREE

Learn at Home



Be an expert wrestler. Learn at home by mail. The greatest wrestlers of all, Frank Gotch and Farmer Burns, both world's champions have prepared the most wonderful course of lessons ever written on Physical Culture and Expert Wrestling. Be strong and healthy! Handle big men with ease. This great free book tells you how. Don't delay. Write now. State your age. Farmer Burns School, 3372 Ry. Exchange Bldg., Omaha, Neb.

ELECTRICAL ENGINEERING

Intensive, practical—technical courses. Engineering degree in 2 years. Diploma in 1 year. Also Special Short Courses in Practical Electricity—Power Plant Operation—Armature Winding—Radio—Electric Refrigeration—Aviation Electricity—Electric Welding. LOW TUITION RATES. Faculty of recognized experts. Extensive Laboratories. Free employment service for graduates. We help secure part-time work during training. 28th year. Write for catalog.



FINLAY ENGINEERING COLLEGE 1001-A Indiana Ave. Kansas City, Mo.



Minstrels

Unique First Parts for complete show with special songs and choruses. Make-up. Catalog Free.



T. S. Denison & Co., 623 S. Wabash, Dept. 19 Chicago

SHORTHAND IN 30 DAYS

Boyd, the wonderful easy system, 150 words a minute guaranteed. Send today for Catalog and sample lesson.

CHICAGO HOME STUDY SCHOOLS

801 Reaper Block Chicago, Ill.

VOICE!



NOW
you can
have the
VOICE
you want!

100% Improvement Guaranteed!

No matter how hopeless your case may seem—send for free Voice Book. Discloses startling voice facts that may save you hundreds of dollars. Tells all about marvelous new SILENT Method of Voice Training. Increases Range. Improves quality. Banish huskiness—hoarseness. 100 per cent improvement *guaranteed*—or money back. Mail coupon *at once* for free book—the greatest voice book ever written—sent FREE with no obligation!

No matter how hopeless your case may seem — send at once for FREE Voice Book.
Mail Coupon Now!

Perfect Voice Institute
Dept. 13-52, 1922 Sunnyside Ave., Chicago

Mail Coupon for Free Voice Book

Perfect Voice Institute, Dept. 13-52
1922 Sunnyside Ave., Chicago

Please send me FREE and without obligation, Prof. Feuchtinger's new book, "Physical Voice Culture." I have checked subject in which I am most interested.

Weak Voice Singing Stammering Speaking

Name

Address

City State

We Will Train You in a Few Months



Day and Night Schools in Chicago, Detroit, Cleveland, Boston, Phila.

No Books—No Classes—

Wonderful Future in this Uncrowded Field

Experts Earn Up To \$125 A WEEK

as MECHANICAL DENTISTS

We teach you to make rubber plates, crowns, bridge work, metal base dentures, etc., for dentists. After graduating you are ready for a job or can open your own laboratory. We assist you.



Big Demand for Men!

Mechanical Dentistry is the laboratory bench work which the dentist turns over to the laboratory worker. Master this profession and help meet the demand of 64,000 dentists for laboratory work. Every city and every town where dentists are located offers work to the mechanical dentist. We train you in a few months in day or night school for this uncrowded field—no classes—no books—no mechanical experience necessary. **No Educational Requirements.**

Work Your Way Thru School

We will help you find a job to meet your expenses while taking our training. And we will help you find satisfactory living quarters when you arrive

Schools located in Chicago, Detroit, Cleveland, Boston, Philadelphia. Day and night schools. We pay railroad fare of students who enroll.

INTERESTING FREE BOOK

Our illustrated free book on Mechanical Dentistry will acquaint you with some surprisingly interesting facts. It tells about the thriving profession of Mechanical Dentistry—the way to swift and certain success. And it tells about the progress of many of our graduates—men who have succeeded beyond their expectations, also full details of our liberal offers. Mail the coupon and find out more about this fascinating opportunity.

McCarrie School of Mechanical Dentistry
1338 S. Michigan Ave., Dept. 380, Chicago, Ill.

McCARRIE SCHOOL OF MECHANICAL DENTISTRY
1338 S. Michigan Ave., Dept. 380, Chicago.

Without cost or obligation, send me your illustrated book on Mechanical Dentistry, and complete information as to my opportunities in dental laboratory work.

Name.....

Address.....

Learn

In spare time, few hours weekly

SIGN and SHOW CARD WRITING

FREE
"Book of Facts"
—
Write For It

Fascinating profession. Big opportunity in this fast-growing trade. Earn while you learn the sign arts. No talent or experience required. Be your own boss or obtain a good position. Learn show cards, posters, bulletins, signs, advertising layouts and allied subjects. We teach by mail or at our school. Quick results—easy to learn.

EARN \$50 TO \$200 WEEKLY

Otto C. Wiegand, Md., home-study graduate, made \$12,000 from his business in one year. Many successful graduates. Oldest and foremost school. Don't delay. Write for complete information.

DETROIT SCHOOL OF LETTERING

193 Stimson Ave. Est. 1899 DETROIT, MICH.

CULTURED SPEECH

AT LAST! Something New!

Learn Cultured Speech and Correct Pronunciation quickly from phonograph records. Also increase your vocabulary this new easy way. Be a fluent talker—cultivated speech is a social and business asset of the first importance. This new "learn by listening" method highly recommended by leading educators. Records sent on free trial. Write for information and free Self Test. Neobigallon.



THE PRONUNCIPHONE INSTITUTE
3601 Michigan Ave., Dept. 1352, CHICAGO

WELDING—The Busy Big-Pay Trade

We teach ambitious men by actual welding practice. —**OXY-ACETYLENE and ELECTRIC ARC**—Pipe-line, Sheet Steel, Structural Steel, Aircraft, Cast-Iron, Aluminum and Commercial Welding. Cutting, Brazing and Plating. Splendidly Equipped to Teach You Right Rapidly and at Reasonable Rates

A Free Booklet for You—Write for it Now.
COLEMAN ELECTRICAL SCHOOL, 1628-X Main Street KANSAS CITY, MO.

AVIATION Information FREE

Send us your name and address for full information regarding the Aviation and Airplane business. Find out about the many great opportunities now open and how we prepare you at home, during spare time, to qualify. Our new book "Opportunities in the Airplane Industry" also sent free if you answer at once.

AMERICAN SCHOOL OF AVIATION
3601 Michigan Ave. Dept. 1352 CHICAGO

LEARN WATCHMAKING AND ENGRAVING

BY OUR PROFIT-SHARING PLAN OUR GRADUATES SUCCEED

One of our Iowa students started in a very small way—now doing over \$30,000 a year. Another in Wisconsin, over \$10,000 the first year. Day or night classes. Call or write for FREE BOOK.

Chicago School of Watchmaking, Dept. 6101, 549 W. Randolph St., CHICAGO

LAW HIGH-GRADE INSTRUCTION BY CORRESPONDENCE

College, Post Grad. and Bar Ex. Rev. Courses. Law has attracted more keen, brainy men than any other calling. Send today for catalog. Low cost, easy terms. Standard texts. Degrees.
Chicago School of Law Dept. 801, Reaper Block CHICAGO, ILL.

BASHFUL?

"Shame on you!" Are you nervous, embarrassed in company of the other sex? Stop being shy of strangers. Conquer the terrible fear of your superiors. Be cheerful and confident of your future! Our facile, easily overcome so you can enjoy life to the fullest. Send 25c for this amazing book.
RICHARD BLACKSTONE, B-472 Flatiron Bldg., N. Y.



Want a U. S. Government Job?

RAILWAY POSTAL CLERKS COMMENCE \$1900 YEAR

Many Other U. S. Government Jobs Open to Men and Women 18 Up

- POSTOFFICE CLERKS CITY MAIL CARRIERS
 RURAL CARRIERS GENERAL OFFICE CLERKS
 INSPECTORS OF CUSTOMS CENSUS CLERKS

These are steady positions. Strikes, poor business conditions, lockouts or politics will not affect them. U. S. Government employees get their pay for full twelve months every year. There is no such thing as "HARD TIMES" in the U. S. Government Service.

RAILWAY POSTAL CLERKS

Railway Postal Clerks now get \$1900 the first year regular, being paid on the first and fifteenth of each month. \$79.16 each pay day. Their pay is quickly increased, the maximum being \$2700 a year, \$112.50 each pay day. They get extra allowance for hotel expenses when away from home. We expect Spring examinations throughout the country.



PAID VACATIONS

Railway Postal Clerks, like all Government employees, are given a yearly vacation of 15 working days (about 18 days). On runs they usually work three days and have three days off duty or in the same proportion. During this off duty and vacation, their pay continues just as though they were working. When they grow old, they are retired with a pension. As Railway Postal Clerks are continually traveling, they have an excellent chance to see the country.

CITY MAIL CARRIERS—POST OFFICE CLERKS

Clerks and Carriers commence at \$1700 a year and automatically increase \$100 a year to \$2100 with further increase to \$2300. They also have 15 days vacation. Many February examinations will be held. City residence is unnecessary.

GENERAL CLERKS—CENSUS CLERKS

(Open to men or women 18 to 50)

Salary \$1260 and \$1440 to \$2100 a year. Pleasant clerical work in the census and other departments and offices at Washington, D. C., and throughout the country.

WHAT WILL YOU EARN FIVE YEARS FROM NOW?

Compare these conditions with your present or your prospective condition, perhaps changing positions frequently, kicking around from post to pillar, no chance in sight for PERMANENT employment; frequently out of a position and the year's average salary very low. Do YOU EARN \$1900 EVERY YEAR? HAVE YOU ANY ASSURANCE THAT A FEW YEARS FROM NOW YOU WILL GET \$2700 OR MORE A YEAR, EVERY YEAR?

GET FREE LIST OF POSITIONS

Fill out the coupon. Tear it off and mail it today—now, at once. DO IT NOW—This investment of two cents for a postage stamp may result in your getting a U. S. Government Job.



FRANKLIN INSTITUTE
 Dept. F-173
 ROCHESTER, N. Y.

Rush to me, entirely free of charge (1) a full description of the position checked below; (2) Free copy of illustrated 32-page book, "U. S. Government Positions and How to Get Them"; (3) Tell me how to get the position checked.

- Railway Postal Clerk.... (\$1900-\$2700)
- Post Office Clerk..... (\$1700-\$2300)
- City Mail Carrier..... (\$1700-\$2100)
- Rural Mail Carrier..... (\$2100-\$3300)
- General Clerk—Census Clerk.. (\$1260-\$2100)
- Inspector of Customs..... (\$2100 up)

Name

Address.....

Use This Coupon Before You Mislays It—Write or Print Plainly

MAIL COUPON TODAY

Learn AVIATION

AT LINCOLN
WHERE
LINDBERGH
LEARNED!

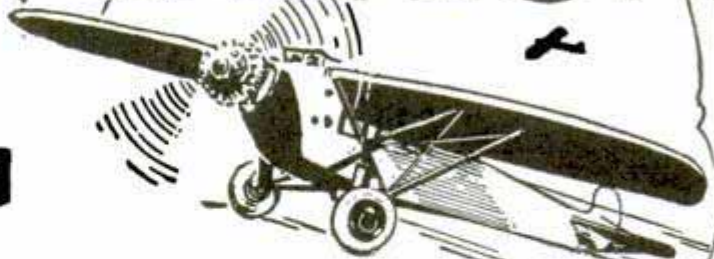

GET complete, intensive Aviation training! That's the key to success! Get it at Lincoln—where "Lindy" learned! Come to the famous Lincoln Airplane and Flying School now. This school is well-known in factories and airports throughout this country as the school that turns out better trained pilots and ground men.

Unusual Facilities—Take advantage of our exceptional facilities for training you. We have more than \$250,000.00 worth of buildings and equipment with large production airplane factory in connection. A modern 160 acre flying field. Plenty of new production, government-licensed open cockpit and cabin planes. Expert government-licensed pilots and airplane mechanic instructors teach you.

Practical Instruction—You work on ac-

tual airplanes and engines under real factory standards. Learn aerodynamics, meteorology, instruments and other important subjects. We train you for a private, limited commercial, industrial or transport pilot's license. Make you a safe, dependable pilot in the shortest possible time.

We Help You Get a Paying Position—The demand for Lincoln-trained men is great. We have placed graduates without delay. We will help you get a job!

LINCOLN AIRPLANE & FLYING SCHOOL
207 Aircraft Bldg. LINCOLN, NEBR.

FREE—
Aviation Book!

Get FREE Book, "Aviation Beckons You"—just off the press. Tells everything you want to know about Lincoln School, Low Tuition, etc. Tells about "Lindy" at Lincoln. Write today. Be sure you state your age.



PATENTS

Booklet Free Highest References
Promptness Assured Best Results

Send drawing or model for preliminary examination and advice.

ALL BUSINESS GIVEN PROMPT AND PROPER ATTENTION

Listed Patent Lawyer in the latest editions of the Rand-McNally Directory of Bankers and Bonded Attorneys, published by Rand-McNally & Co., Chicago, Ill.; The Baggott & Ryall Directory of Guaranteed Attorneys, published by Legal Directory Corporation, Boston, Mass.; Flugel's Law List, published by Legal Directory Publishing Co., St. Louis, Mo.; American Lawyers Annual, published in Cleveland, Ohio; Bankers Service Legal Directory, published by Bankers Service Co., Boston, Mass.; Eyre's Law List, 9 Park Place, New York City; Walters Legal Directory, Omaha, Nebraska, and the National Directory of Attorneys, Baltimore, Maryland.

WATSON E. COLEMAN,
REGISTERED PATENT LAWYER

Victor Building, 724 Ninth Street, N. W.
WASHINGTON, D. C.

Make \$50 to \$100 a Week

By **BEING TECHNICALLY TRAINED**

THIS THOROUGHWAY Only trained men rise to be bosses! They make the large, steady incomes! Are you ready for that? Now's the time to learn. Master a craft—your craft. Select the subjects you want to study from the list below. You can master them quickly, easily and thoroughly with the St. Louis Technical Institute's home study training. Learn right at home.

GET THE FACTS, FREE!

Our methods and lessons are so plainly and clearly defined that you'll be amazed how fast you master the work and get a raise in pay. Don't let anything stop you. Get ready for big things.

How soon will you be qualified for an increase? Write us today! Get complete information. Our big free book explains it all! Tells what you can learn.

Train at Home

CHECK THE COURSES YOU WANT TO STUDY, AND MAIL TODAY!

DO IT NOW!

Drafting (Architectural Machine)

- Heating & Ventilating Engineering
- Plumbing and Sanitary Engineering
- Sheet Metal Designing and Drafting
- Boiler Maker Laying Out & Inspection
- Steel Ship Laying Off & Plan Reading
- Contracting & Estimating
- Mathematics and Slide Rule Reading
- Aeronautical Drafting and Engineering



ST. LOUIS TECHNICAL INSTITUTE

4545 CLAYTON AVENUE, ST. LOUIS, MO.

Who Else Wants a Good



DRAFTING JOB?

Here's good news for the man who wants a \$50 or \$75 a week job—who knows it takes training to land it—and who has been holding back for fear he didn't have enough education to make good.

I want to tell you about DRAFTING, and show you that it offers you everything in pay and opportunity that you could hope for. I want to show you that a fine Drafting job is now easily within your reach. And I want to set before you an amazing plan which we have worked out with the co-operation of some of the biggest employers and engineers in America, to prepare you at home, in spare time, to help you get the job and increased pay—absolutely without risk of a penny on your part.

American School

Now—Jobs for students too!

1. WE GUARANTEE to prepare you for a good position in **DRAFTING and DESIGN** by giving you thorough, complete, up-to-date, and simplified home-study training.

2. WE ALSO GUARANTEE that when you have completed at least one-half of this training, our Employment Service will help you secure a good position, without extra charge.

3. WE FURTHER GUARANTEE to refund the entire amount you have paid for this training if, within 60 days after submitting your final examination, you inform us that, in your opinion, our Training and Employment Service has not been satisfactory.

R. L. Millif Pres.

Wonderful Opportunities for you in DRAFTING

During the past few months we have placed hundreds of men, not a bit smarter than you, with no more schooling or experience, in fine Drafting positions with Architects, Contractors and in big manufacturing plants. Most of these men were formerly clerks, mechanics, building and trade workers, some even beginners and laborers.

Over 75,000 good Drafting jobs have been advertised in the past year. Draftsmen are urgently needed in all building, construction, manufacturing, mechanical and engineering lines.

Get Our No-Risk Job and Raise Plan

I wish I had the room to tell you all about DRAFTING—how it has become the most important branch of every kind of manufacturing and building construction work—how fascinating the work is—the fine bunch of fellows you'll work with—the big salaries paid—the wonderful chances for advancement. All this inside dope takes a 36-page book to describe and we'll be glad to send you a copy free when you mail the coupon for our no-risk job and raise plan.

36 Page Drafting Book —FREE

Tells how easy Drafting is to learn—how interesting the work is—what remarkable opportunities are open for Draftsmen right now. Mail coupon for a copy—without cost or obligation.

AMERICAN SCHOOL, Dept. D-247A, Drexel Ave. & 58th St., Chicago, Ill.

Please send me, without cost or obligation, 36 page Drafting Book, and tell me about your training and employment service in line marked X below.

DRAFTING

- Architecture
- Building
- Structural Steel
- Civil Engineering
- Auto Engineering
- Electrical Engineering
- Business Management
- Accounting
- Mechanical Engineering
- Shop Superintendent
- Foremanship
- High School in 2 years

Name _____

St. No. _____

City _____ State _____

Age _____ Occupation _____



Starts at \$40 a Week
 "Thanks for helping me get a Drafting position with Slyker Co. starting at \$40 a week."
 OSKAR R. LUDWIG

Mr. Oskar Ludwig has been in our employ as Draftsman for about three months and to date we have found his work satisfactory.
 SLYKER, INC.
 Gary, Ind.



Now Junior Draftsman
 "I have obtained a position as a junior draftsman with the Muncie Oil Engine Co. I appreciate your aid in obtaining this position very much."
 M. N. BARAM,
 Muncie, Ind.

THE AMERICAN SCHOOL
 Dept. D-247A Drexel Ave. and 58th St., Chicago, Ill.

Learn Electricity IN LOS ANGELES

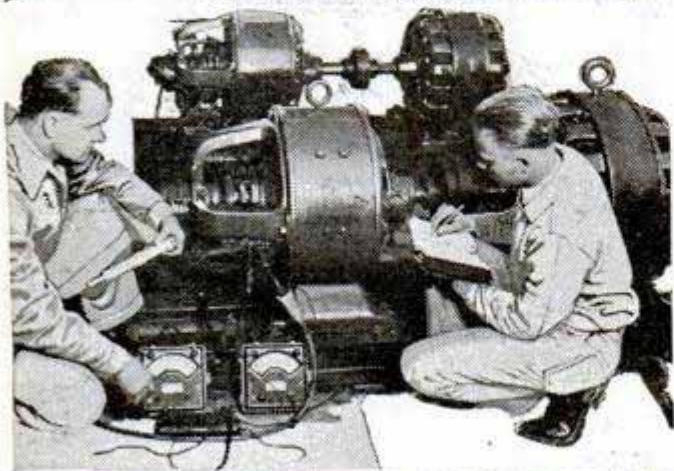

and LEARN IT RIGHT!

1. What Kind of a School Is NATIONAL?

NATIONAL is a Million Dollar institution—established in 1905—recognized throughout the electrical industry as one of America's foremost trade schools. NATIONAL offers practical, intensive training in all electrical branches. All technical essentials included. No age limit. No previous experience necessary. Life Scholarship privileges. Start any time of the year.

2. How Long to Learn Electricity?

NATIONAL properly trains you in the short time of 6 to 9 months. Upon completing this Condensed Course you are fully qualified as a Practical, Competent Electrician, and you have not risked your chances of employment because of inferior, incomplete instruction.

3. What Employment Service Does NATIONAL Guarantee?

NATIONAL GUARANTEES to give unlimited and efficient Employment Service to students wishing to earn living expenses while learning; and to graduates getting started in the electrical field. This is the most any reputable school can be expected to do.

4. What Inducements Does NATIONAL Offer?

NATIONAL offers YOU the very best technical-practical training that money can buy at a cost within every man's reach. It does not offer to pay your railroad fare, room and board or other personal expenses, preferring to limit its activities to the PROPER TRAINING OF MEN FOR SUCCESS.

5. Why You Should Come to LOS ANGELES!

LOS ANGELES is the heart of the country's most rapid electrical development—as well as the world's most ideal city in which to live and prepare for success in electricity

WRITE for FREE BOOK NOW!

NATIONAL Electrical School

Dept. 540, 4006 Figueroa St., Los Angeles, California.

Send me your big free illustrated catalog of Electrical Opportunities showing how I can learn quickly and get a Big-Pay Electrical Job.

Name.....

Address.....

Age..... City..... State.....

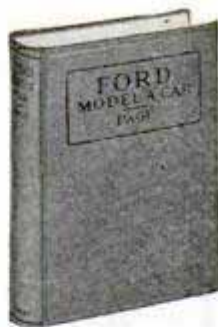

The NEW FORD

Explained Inside and Out

Construction, Operation and Repair

Every Part Described and Illustrated

**545 Pages
252 Diagrams
and Pictures**

100 Specially Posed Photographs
Ford Car, Parts and Functions
Model A Engine and Parts
Ford Engine Auxiliary Groups
Details Ford Model A Chassis Parts
Driving and Maintenance
Top Overhead Ford Model A Engine Parts
Troubles Ford Auxiliary Systems
Electrical System
Overhauling Clutch and Transmission
Front Axle and Steering Gear
Brakes and Rear Axle
Ford Body and Its Care

The book you have been waiting for! Everything you want to know about the new Ford, all in one compact, plainly written, lavishly illustrated, accurate book. Every detail of construction shown in exclusive pictures and diagrams. All repair processes illustrated and explained by more than 100 specially posed photographs. Everything is simply and fully described so that you can instantly understand it. Ford owners, repairmen, dealers, salesmen, drivers need this book, written by a recognized automobile authority.

Be An Expert On the New Ford Car

Be the New Ford expert of your community. Make big money as a trouble shooter. Save yourself dollars and miles by KNOWING your New Ford inside and out.

SEND TODAY No Money Needed

Send NOW for this greatest book on the New Ford. No money needed. Just deposit \$2.00 plus the few cents postal charges, with the postman when you receive the book. Or, if you prefer, enclose \$2.00 and we will pay postal charges. If, after 5 days' examination, you decide, for any reason, to return this book, we will refund your money in full. The edition is limited. Act NOW and be among the first to get this valuable work.

Trouble Shooting CHART

25x38 inches, sectional views of entire Model A Power Plant, showing location and causes of all common troubles. Every part illustrated. Send 35c (coin or stamps) for chart or tell us to send it when we send you book. Send \$2.25 for book and chart prepaid.

**Norman W. Henley Publishing Co., Dept. 42
2 West 45th Street NEW YORK CITY**

Building, repairing and servicing of modern radio receiving sets . . .

RADIO CONSTRUCTION LIBRARY

By JAMES A. MOYER, Director, University Extension, Massachusetts Department of Education and JOHN F. WOSTREL, Instructor, Radio Engineering, Massachusetts Department of Education

3 volumes, 993 pages, 6 x 9, 561 illustrations

Here is a set of books which covers the needs of the amateur as well as the commercial dealer and service man. The library embodies a thorough home-study course and a constant reference in daily radio problems. Step-by-step information is given on all types of hook-ups, wiring, trouble shooting, rebuilding, as well as the underlying principles of vacuum tubes. It is a library which should be in the hands of every serviceman, dealer and amateur who is genuinely interested in radio.

FREE TRIAL

No Money Down—
Pay in Small Monthly Sums



FREE EXAMINATION COUPON

McGraw-Hill Book Co., 370 Seventh Ave., New York

Send me the Radio Construction Library, three volumes, for 10 days' free examination. If satisfactory I will send \$1.50 in 10 days and \$2.00 a month until \$7.50 has been paid. Otherwise I will return the books.

Name.....

Home Address.....

City and State.....

Position.....

Name of Company..... P.M. 2-30

"I GAMBLED 2¢ and WON \$35,840 in 2 YEARS"

*A Story for Men and Women
who are dissatisfied with themselves*

THIS is the story of a gamble—a 2c risk—which paid me a profit of \$35,840 in two years. I am not, and never was, a gambler by nature; in all probability I never would have taken the chance if more money was involved. So even if you too are against gambling, you will feel like risking two cents after you've read my story.

Some people believe I was lucky. Others think I am brilliant. But the sort of luck I had everyone can have. My type of brilliance is that of any average man.

Almost any \$40-a-week wage earner has as complete a mental equipment as I had two years ago. And he feels today just about the way I did then. For two years ago I too was in the \$40-a-week rut. My earnings were \$2,080 per year!

I was discontented, unhappy. I was not getting ahead. There didn't seem to be much hope in the future. I wanted to earn more money—a lot more money. I wanted to wear better clothes and have a car, and travel. I wanted to be on a par with people I then looked up to. I wanted to feel equal to them mentally and financially.

But it all seemed hopeless. I was beset with fears. I was afraid of losing my job. I was afraid of the future. I could see nothing ahead for myself and my wife and baby but a hard struggle. I would live and work and die—just one of the millions who slaved their lives away. I was irritable, easily annoyed, discouraged, "sore" at my fate and at the world. I could not think clearly. My mind was in a constant whirl. I was "scatterbrained." I had a thousand half-baked ideas to make more money but acted on none of them.

The end of each year found me in about the same position as the beginning. The tiny increases in salary, grudgingly given to me, were just about enough to meet the rising cost of living. Rent was higher; clothes cost more; food was more expensive. It was absolutely necessary for me to earn more money. So once in a while I got a few dollars more. But



it wasn't because of any great change in my ability.

Today I have an income of \$20,000 a year. That's exactly \$17,920 more than it was two years ago. A difference of \$35,840 in two years. My family has everything it needs for its comfort and pleasure. My bank account is growing rapidly. I have my own home in the suburbs. I am respected by my neighbors, and I have won my wife and children's love as only the comforts and pleasures of life can do. When I am old I will not be a millstone around anyone's neck. My children will not have to support me.

I look forward to the future with confidence and without fear. I know that only improvement can come with the years. Once I wandered through life aimlessly, cringing, afraid. Today I have a definite goal and the will to reach it. I know I cannot be beaten. Once my discontent resulted in wishes. Today my slightest discontent results in action. Once I looked forward hopefully to a \$5 a week increase in salary. Today I look forward confidently to a \$100 a week increase in my earnings.

What magic was it that caused the change in my circumstances? How did I, a \$40-a-week clerk, change my whole life so remarkably? I can give you the answer in one word—Pelmanism. I gambled 2c on it. Yet without it, I

might have continued in my old \$40-a-week rut for the rest of my life.

Pelmanism taught me how to think straight and true. It crystallized my scattered ideas. It focussed my aim on one thing. It gave me the will power to carry out my ideas. It dispelled my fears. It improved my memory. It taught me how to concentrate—how to observe keenly. Initiative, resourcefulness, organizing ability, forcefulness, were a natural result. I stopped putting things off. Inertia disappeared. Mind-wandering and indecision were things of the past. With new allies on my side and old enemies beaten, there was nothing to hold me back.

I am writing this in appreciation of what Pelmanism did for me. I want other average men to gamble 2c as I did. For the cost of a postage stamp I sent for the booklet about Pelmanism, called "Scientific Mind Training." Reading that free book started me on my climb. I took no risk when I enrolled for the Course because of the Institute's guarantee. All I gambled was 2c and I am \$36,000 better off now than I would have been had I not written for the book about Pelmanism.

* * * * *

The Pelman Institute will be glad to send a copy of "Scientific Mind Training" to any interested individual. This book is free. It explains Pelmanism. It tells what it does to the mind. It tells what Pelmanism has meant to others. For over 25 years Pelmanism has been helping people to happiness. Over 700,000 others have studied this remarkable science. Among those who have praised it are such great world figures as Judge Ben B. Lindsey, Jerome K. Jerome, Sir Harry Lauder, T. P. O'Connor, Major-Gen. Sir Frederick Maurice, H. R. H. Prince Charles of Sweden, and many others. Your whole life may be altered as a result of reading "Scientific Mind Training." Send the coupon. You have nothing to lose. If Pelmanism does not help you it costs you nothing. There is no obligation in mailing the coupon. No salesman will call on you. Decide for yourself what to do after you read the free book about Pelmanism. Mail the coupon NOW.

The Pelman Institute of America,
71 West 45th St., Suite 62, New York

**THE PELMAN INSTITUTE OF
AMERICA,
71 West 45th St., Suite 62, N. Y. C.**

I want you to show me what Pelmanism has actually done for over 700,000 people. Please send me your free book "Scientific Mind Training." This places me under no obligation whatever.

Name.....

Address.....

City..... State.....

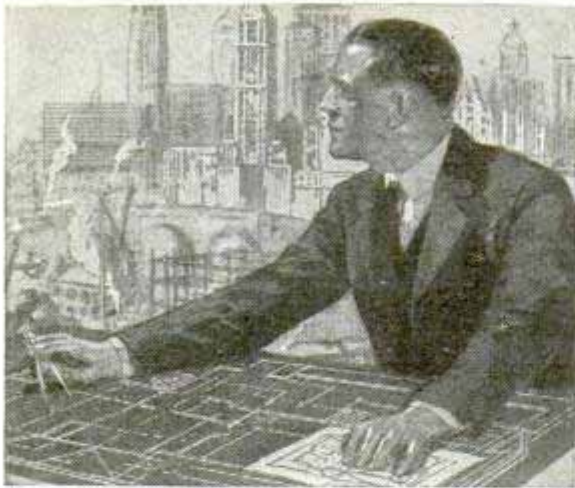

Former Plasterer Now Earning \$12,000 a Year

"When I enrolled with the International Correspondence Schools, I was a plasterer and I didn't know a thing about blueprints. Today I have my own contracting business and I am able to figure the most difficult jobs and execute them to the satisfaction of everyone concerned. My income is between \$12,000 and \$15,000 a year. It certainly was a lucky day for me when I sent in that I. C. S. coupon."

That's a true story of what just one student of the International Correspondence Schools has done. Every mail brings letters from other ambitious men and women telling of promotions and increases in salary due directly to spare-time study.

One hour a day spent with the I. C. S., in the quiet of your own home, will prepare you for success in the work you like best.

Mail Coupon for Free Booklet

INTERNATIONAL CORRESPONDENCE SCHOOLS Box 5666-F, Scranton, Penna.

Without cost or obligation, please send me a copy of your booklet, "Who Wins and Why," and full particulars about the course before which I have marked X in the list below:

TECHNICAL AND INDUSTRIAL COURSES

- | | |
|--------------------------------------------------|-----------------------------------------------------------------------------|
| <input type="checkbox"/> Architect | <input type="checkbox"/> Automobile Mechanic |
| <input type="checkbox"/> Architectural Draftsman | <input type="checkbox"/> Aviation Engines |
| <input type="checkbox"/> Building Foreman | <input type="checkbox"/> Plumber and Steam Fitter |
| <input type="checkbox"/> Concrete Builder | <input type="checkbox"/> Plumbing Inspector |
| <input type="checkbox"/> Contractor and Builder | <input type="checkbox"/> Foreman Plumber |
| <input type="checkbox"/> Structural Draftsman | <input type="checkbox"/> Heating and Ventilation |
| <input type="checkbox"/> Structural Engineer | <input type="checkbox"/> Sheet-Metal Worker |
| <input type="checkbox"/> Electrical Engineer | <input type="checkbox"/> Steam Engineer |
| <input type="checkbox"/> Electrical Contractor | <input type="checkbox"/> Marine Engineer |
| <input type="checkbox"/> Electric Wiring | <input type="checkbox"/> Refrigeration Engineer |
| <input type="checkbox"/> Electric Lighting | <input type="checkbox"/> R. R. Positions |
| <input type="checkbox"/> Reading Shop Blueprints | <input type="checkbox"/> Highway Engineer |
| <input type="checkbox"/> Telegraph Engineer | <input type="checkbox"/> Chemistry |
| <input type="checkbox"/> Telephone Work | <input type="checkbox"/> Pharmacy |
| <input type="checkbox"/> Mechanical Engineer | <input type="checkbox"/> Coal Mining Engineer |
| <input type="checkbox"/> Mechanical Draftsman | <input type="checkbox"/> Navigation <input type="checkbox"/> Assayer |
| <input type="checkbox"/> Machine Shop Practice | <input type="checkbox"/> Iron and Steel Worker |
| <input type="checkbox"/> Toolmaker | <input type="checkbox"/> Textile Overseer or Supt. |
| <input type="checkbox"/> Patternmaker | <input type="checkbox"/> Cotton Manufacturing |
| <input type="checkbox"/> Civil Engineer | <input type="checkbox"/> Woolen Manufacturing |
| <input type="checkbox"/> Surveying and Mapping | <input type="checkbox"/> Agriculture <input type="checkbox"/> Fruit Growing |
| <input type="checkbox"/> Bridge Engineer | <input type="checkbox"/> Poultry Farming |
| <input type="checkbox"/> Gas Engine Operating | <input type="checkbox"/> Mathematics <input type="checkbox"/> Radio |

BUSINESS TRAINING COURSES

- | | |
|------------------------------------------------------------------|-------------------------------------------------------|
| <input type="checkbox"/> Business Management | <input type="checkbox"/> Business Correspondence |
| <input type="checkbox"/> Industrial Management | <input type="checkbox"/> Show Card and Sign Lettering |
| <input type="checkbox"/> Personnel Management | <input type="checkbox"/> Stenography and Typing |
| <input type="checkbox"/> Traffic Management | <input type="checkbox"/> English |
| <input type="checkbox"/> Accounting and | <input type="checkbox"/> Civil Service |
| <input type="checkbox"/> C. P. A. Coaching | <input type="checkbox"/> Railway Mail Clerk |
| <input type="checkbox"/> Cost Accounting | <input type="checkbox"/> Mail Carrier |
| <input type="checkbox"/> Bookkeeping | <input type="checkbox"/> Grade School Subjects |
| <input type="checkbox"/> Secretarial Work | <input type="checkbox"/> High School Subjects |
| <input type="checkbox"/> Spanish <input type="checkbox"/> French | <input type="checkbox"/> Cartooning |
| <input type="checkbox"/> Salesmanship | <input type="checkbox"/> Illustrating |
| <input type="checkbox"/> Advertising | <input type="checkbox"/> Lumber Dealer |

Name.....

Address.....

City..... State.....

Occupation.....

If you reside in Canada, send this coupon to the International Correspondence Schools Canadian, Limited, Montreal, Canada

OPPORTUNITIES IN Traffic Management Become a Traffic Expert

The opportunities in traffic management are limited only by the boundaries of the business world. The trained traffic man is in demand by transportation systems and by industrial organizations.

Three Detroit Firms Pay Their Traffic Managers Over \$20,000 a Year

Prepare for this growing, profitable profession at home in your spare time under supervision of traffic experts. Low cost; easy terms. Thru the LaSalle Problem Method you learn by doing. Valuable 64-page booklet free. Send for it Now.

LaSalle Extension University, Dept. 264-T, Chicago



This Book
FREE!

PUBLIC SPEAKING SIMPLIFIED

Just published—an amazing new, practical and fascinating easy way to learn Public Speaking. With this Course you will gain immediate self-confidence, and start making talks or speeches. SEND NO MONEY. Pay Postman only \$5 plus few pennies postage. 5-day examination privilege. Also "How To Get Vocabulary You Want", \$1. You'll astonish your friends.

NIAGARA SCHOOL, Inc., Dept. P., B. L. E. Bldg., CLEVELAND, O.

Mrs. Gleason made \$23 one day with
GUARANTEED HOSIERY for men,
women and children. Ford Car and
Silk Hose offered producers. No experi-
ence. Wilkmit Hosiery, Dept. S-8431,
Greenfield, Ohio

AGENTS

Your
Chance for
\$10 a Day

How to Obtain A Better Looking Nose!

Improve your personal appearance
My new Model 25 Nose Shaper is designed to improve the shape of the nose by remoulding the cartilage and fleshy parts, safely and painlessly. This is accomplished thru the very fine and precise adjustments which only my patented Model 25 possesses. Results are lasting. Can be worn at night, or during the day. Money refunded if not satisfied after thirty days' trial. Write for free booklet to



M. TRILETY, Pioneer Nose Shaping Specialist
Dept. 61
BINGHAMTON, N. Y.

Big Money for You as an Automobile Mechanic

These four practical books, written by five well known teachers of automobile practice, will teach you right in your own home during your leisure time just what you need to know about automobile troubles and repair. They will teach you automobile construction, maintenance and repair as practiced by experts and will help you to earn an expert's pay.

Practical Automobile Library: Four Books—\$1.50 in 10 days and \$2 monthly for 6 months—only \$13.50 in all!

Hundreds of question-answering diagrams—hundreds of clearly-marked illustrations—make the books plain and readily understandable. All the explanations and descriptions are clear, simple, direct. Every chapter is packed with definite, step-by-step, how-to-do-it information. Here is your opportunity to enter a big-pay field.

FREE TRIAL

Send No Money
Mail the Coupon



FREE EXAMINATION COUPON

McGRAW-HILL BOOK CO., 370 Seventh Ave., New York

Send me for 10 days' free examination the New Practical Automobile Library. If satisfactory, I will send you \$1.50 in 10 days and \$2.00 monthly until the special price of \$13.50 is paid. If not wanted, I will return the books at your expense.

Signed.....

Address.....

City and State.....

Position.....

Employer..... P. M. 2-30

Start to Play Very First Day

This Year Give Yourself
Lifelong Fun
Profit and
Popularity



PARENTS!

What greater gift can you confer on your children this year than lifelong fun and entertainment?

Love of music means love of home, an appreciation of the finer things in life. Here is a chance to give your boy or girl that love without the tedious practice that most instruments require. The Xylorimba is easy to play. No teacher is needed. Practice is actually a joy.

Remember, the Xylorimba is the guaranteed product of a company established nearly half a century ago—a company that stands back of every promise it makes.

THINK of the best gift you have ever received. Multiply the pleasure it gave you by ten, and still you have only an idea of the joy you can give yourself right now if you act at once!

Start to Play the Very First Day!

Haven't you, like millions of others, envied the fellows who "bring down the house" with snappy xylophone or xylorimba numbers? Haven't you longed to create your own music, to be looked up to wherever you go, to be able to make real money in spare time? If you have, this ad spells O-p-p-o-r-t-u-n-i-t-y. The xylorimba—wonderful for home, in demand at dances and gatherings—is nevertheless the easiest of all instruments to play. In fact, on the very day you get yours you play simple melodies, even if you can't read a note of music right now. In a few weeks you astonish your friends and family. *All your life* you have the joy that comes to those who can entertain.

Plays 20 Minutes; Gets \$20!

Ralph Smith, Chicago, played twenty minutes at wedding; his "pay" was \$20. Altho only 12, Turk McBee, Jr., plays big-time vaudeville exclusively. Harry Breuer, New York, has

made thousands of friends thru his xylophone selections on the radio. L. E. Hallman, Reading, Pa., writes: "Made \$300 in 5 weeks—spare time."

And now J. C. Deagan, Inc., (world's largest manufacturer of xylophonic instruments) has made it so easy to own a xylorimba that nothing stands in your way. Sizes and styles to fit every age and pocketbook. A five-day free trial that eliminates risk. Free, easy lessons that make teacher unnecessary—and, best of all, such easy payments that they are hardly noticed.

Will You Investigate?

Everyone wants to be popular. Everyone wants to make extra money. Everyone wants to be center of attraction at gatherings. But these advantages don't come by themselves. Opportunities must be seized. This is *your* opportunity—will you pass it up without investigation? The accompanying coupon will bring our big FREE book to your door. It tells all about the Deagan line, the free trial, the easy payments. Remember, no cost or obligation! Simply fill in and mail the coupon—but do it before it slips your mind. Today is as good a day as any. Do it NOW!

YOUR
MAGIC

KEY

to Popularity

Send for
BIG FREE
Book!

Mail
Now!

Please send me full details on the Free Trial offer and easy payment plan of the Deagan Xylorimba.

J. C. DEAGAN, Inc.
Dept. 1452, 1770 Bertenu Avenue, Chicago

Name _____ Address _____
City _____ State _____

More Money



Be a Trained Radio Expert

If you're earning a penny less than \$50 a week, get my free book of information about the Radio business. Trained Radio Experts are needed in more than twenty different lines of this new and growing profession (three hundred thousand new openings created by the swift growth of Radio in past few years). Why go along at \$25 or \$35 or \$45 a week all your life? Study Radio and after only a short time land yourself a REAL job with a REAL future! Be a man who has money in his pocket and in the bank—don't scrimp and scrape for the rest of your days.

Salaries of \$50 Up to \$250 a Week Not Unusual in Radio

The good positions in Radio pay all the way from \$50 on up to \$150, \$200, and even \$250 a week. Suppose you don't climb to the very top but that you do advance to a position that pays you \$125 a week, year in and year out. Any chance to make that much where you are now? Then send for my free book, and learn about a field where there's some

Money Back If You Aren't Fully Satisfied

I'll give you all the training you need to get into any line of the Radio business. And I back up this training by a signed agreement to refund every penny you pay me if upon completion of my course you are not satisfied with the lessons and instruction service I give you.

real opportunity. Where good men, if they have the right training, can work their way into really big salaried jobs!

Get Book!

Find out for yourself about the bigger pay waiting for you in Radio! From \$2,000,000 in 1920 to \$1,000,000,000 in 1929—that's the record of the Radio industry! Plenty of big Radio jobs are waiting for the man who KNOWS. John Fetscher sent for my free book—now he's Chief Engineer at WEMC and designs and builds broadcast stations. T. M. Wilcox sent for the book—now he's in his own Radio business and reports profits as high as \$70 in one day! All information will be sent you free, without obligation—just mail coupon on opposite page.

Six Big Practical Outfits Given You To Help You Learn

I teach you both the "why" and the "how" of Radio. You learn to DO a thing, and you learn WHY it's done. I send you, WITHOUT EXTRA COST with your course, six big practical outfits of material to experiment and work with. These outfits are the real thing—not toys. The parts they contain will build approximately one hundred different Radio circuits. With all this material you do practical work from start to finish of your training. You get your hand in, and you get confidence in yourself. Then when you run into a Radio problem later, on the job, you KNOW you can do it because you've already done it with these six outfits of practical material. With me you don't learn to be a "paper Radio Expert"—you learn to be the kind of expert that shows his worth on the payroll. Full details in my big book—sent free.

Send For NEW Free Book of Information



Broadcasting and commercial Radio land station work appeal to a lot of men—it's a big, growing field and fascinating work. My course prepares you thoroughly to get into this field and make good.

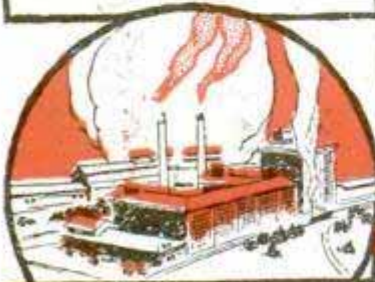

Radio manufacturing has grown faster in the last six years than any other big business ever did. It's two hundred and fifty times as big as it was. That means lots of good chances for the trained Radio Expert.

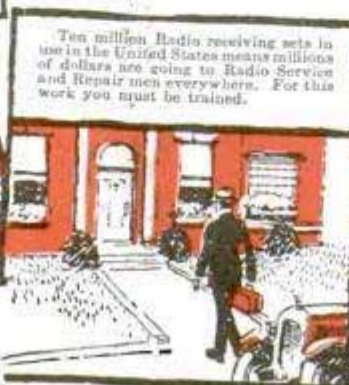

Ten million Radio receiving sets in use in the United States means millions of dollars are going to Radio Service and Repair men everywhere. For this work you must be trained.



Radio operators on board ship go everywhere—see everything. You sell the world over, all your expenses paid, and draw a good salary besides. It's the life of Kelly.

see
coupon
next
page



Learn Quickly, Easily Train at Home In Spare Minutes

Stay home! Hold your job! I'll bring your Radio training to you, and you can learn in your spare time after work. No need to go to a strange city and live for months on expense when you learn my way. You study in the quiet of your own home. As for this training—it's written just as I would talk—in straightforward, every day, understandable language. You'll get it, and you'll get it quickly—in a few months' spare time—because I've made it so clear and interesting! No particular education needed—lots of my successful students didn't finish the grades.

Many Earn \$10, \$20, \$25 Weekly Right Away "On the Side"

Delos Brown, South St., Foxboro, Mass., made \$1,000 from spare-time Radio jobs before he even finished my course. H. W. Coblenz, Washington, averaged \$45 a week; Leo Auchampaugh, 6432 Lakewood Ave., Chicago, made \$500 before graduation; Frank Toomey, Jr., Piermont, N. Y., made \$833 while taking the course. All this done IN SPARE TIME away from the regular job, while these fellows were still studying the course—and they're only a few of hundreds. As soon as you start this training I begin teaching you practical Radio work. Then a few weeks later, I show you how to make use of it in spare time, so you can be making \$10, \$20, \$25 a week "on the side," all the while you're learning.

NEW 64-Page Book Sent Free for the Asking

My big book of Radio information won't cost you a penny, and you won't be under any obligation by asking for it. It's put hundreds of fellows on the way to big pay and brighter futures. Sending for it has been the turning-point where many a man has made his start toward real success. Get it. See what it's going to mean to you. Send coupon TODAY!

Address: **J. E. SMITH, President**
National Radio Institute

Dept. OBP

Washington, D. C.

Hundreds of fine jobs opening in Radio every year

Radio needs more trained men to take care of its rapid growth. Every year there are many fine jobs for men with the right training in broadcasting stations, commercial land stations, Radio factories, with Radio dealers and jobbers, with shipping companies which offer worldwide travel and good pay. Besides there are countless opportunities to have a spare time or full time business of your own.

Talking movies, Television and many other new and recent developments in and uses for Radio are increasing the need for trained men continually. This is best proved by the fact that the Employment Department of the National Radio Institute is getting three times as many calls for our graduates this year as it did last.

Radio's \$5000 and \$10,000 year men of the future will be picked from those who get in now

Just as the men who got into the automobile business, the motion picture industry and others at the right time now have the key jobs, so those who get into Radio now, while it is growing fast, will have the first chance at the big jobs. The opportunities that make men rich in other fields are developing right before your eyes in Radio. I will give you the training you need to break in and have a firm foundation on which to build for a successful future.

Find out about my methods that have increased the earnings of so many others. Mail the coupon today



Send No Money

J. E. Smith, President,
National Radio Institute,
Dept. OBP, Washington, D. C.

Dear Mr. Smith: Kindly send me your big free book, "Rich Rewards in Radio," giving all information about the big-money opportunities in Radio and how you will train me to take advantage of them. I understand this places me under no obligation, and that no salesman will call on me.

Name

Address

Town State



This big 64-page book, printed in two colors, crammed with interesting facts and photos about money-making opportunities in Radio, sent free to everyone who clips the coupon. No obligation by sending for the book—it's absolutely free. One of the most valuable books about Radio ever written.

MEN

EARN \$100

While LEARNING BARBERING



The Simplest Work in the World to Learn
SHORT—PRACTICAL COURSE
Protecting Laws Make It the Best Profession in the Universe

ART STEFFEN paid his way through a two year course of Aviation by Barbering. He came to Moler's from an Automobile Job.

RALPH KUHLMAN has a Barber job on the Santa Fe running from Chicago to Los Angeles paying as high as \$60 a single trip. A short while ago he was a farm hand.

ARTHUR BAKER runs a shop in the exclusive great money district of Wall Street. He has accumulated a fortune. He learned at Moler's.

60,000 have done as well as these boys. It is better than the average man does and it is so easy.

GOODNESS !!! GRACIOUS !!!

anybody can barber and it's put within your easy reach. There is a school near you. Write to the nearest one and see.

Standardized Branches

Moler System of Colleges

- | | |
|-----------------------------------|-------------------------------------|
| 139 E. 23rd St., New York City. | 109 S. 15th St., Omaha, Nebr. |
| 512 N. State St., Chicago, Ill. | 501 E. Water St., Milwaukee, Wis. |
| 810 N. 6th St., St. Louis, Mo. | 81 Forsyth St., N. W., Atlanta, Ga. |
| 801 Main St., Kansas City, Mo. | 81 S. Second St., Memphis, Tenn. |
| 206 E. 4th St., Cincinnati, Ohio. | 912 Main St., Dallas, Texas. |
| 215 Huron Road, Cleveland, Ohio. | |
| 559 Michigan Ave., Detroit, Mich. | |

Address Nearest Branch

Please send me without obligation on my part your Booklet B telling how I may earn \$100 and my meals while learning barbering.

Name.....

Address.....

City.....State.....

RUPTURED



people praise this improved appliance

Forget about rupture pains and the need for constant care and watchfulness. Hold your rupture this secure, sanitary way. This perfected appliance retains rupture safely and with great comfort, and at the same time promotes healing. Out-of-door men praise this better way to hold their ruptures. It binds the separated muscle fibres together. It gives absolute freedom in body movement. Over 3,000,000 Brooks Appliances sold.

Write for our 10-day trial offer, and 28-page Rupture booklet. Sent in plain sealed envelope.
BROOKS APPLIANCE CO., 107C State St., Marshall, Mich.

DANDRUFF

Millions Use Lucky Tiger
for Hair and Scalp and Whyte-Fox (1 and 2)
 for skin ailments. Ask your barber for Whyte-Fox Medicated Massage. Valuable booklet free on request. Money-Back Guarantee.
At Barbers, Druggists, Beauty Parlors.
 Kansas City, Mo. **LUCKY TIGER REM. CO.**



BOW LEGS?

THIS GARTER (Pat'd)
Makes Trousers Hang Straight
If Legs Bend In or Out
 Free Booklet—Plain Sealed Envelope
THE T. GARTER CO., Dept. E
 South Bend, Ind.

RUPTURE IS NOT A TEAR

Your physician will tell you that hernia (rupture) is a muscular weakness in the abdominal wall.—Do not be satisfied with merely bracing these weakened muscles, with your condition probably growing worse every day!—Strike at the real cause of the trouble, and

WHEN—

- The weakened muscles recover their strength and elasticity, and—
- The unsightly, unnatural protrusion disappears, and—
- You recover your vim, vigor and vitality,—your strength and energy,—and you look and feel better in every way,—and your friends notice the difference,—

THEN—

- You'll know your rupture is gone, and
- You'll know why for almost a quarter of a century numerous sworn statements report complete recovery and freedom from uncomfortable mechanical supports, without delay from work.

SEND NO MONEY

A Test of the scientific self-treatment mentioned in coupon below is now available to you, whether you are young or old,—man or woman. It costs you nothing to make this test.—For your own good mail the coupon NOW—TODAY.

FREE TEST COUPON

Plapao Laboratories, 455 Stuart Bldg., St. Louis, Mo.

Send me a Free 10 day test supply of the remedial factor Plapao and 48-page illustrated book on Rupture; no charge for this now or later.

Name.....

Address.....

Be The Man Behind The Camera



Earn \$2,000 to \$12,000 a Year

ADVENTURE — thrills — more action in a week than the average man sees in a lifetime. When you're a motion picture cameraman the world is YOURS! You can travel, if you wish, or there are thrills galore close to home. As a news-cameraman you can be on the spot when things happen—there's no limit to the things you can see and do. Then, of course, there are the big picture studios where you come in daily contact with all the movie stars and actually take the pictures that millions of people see.

Adventure—sure—plenty of it—AND BIG PAY, TOO! Expert cameramen earn from \$60 to \$250 a week. Thousands of opportunities await the trained cameraman—opportunities offering fascinating work, big pay, and unlimited chances for advancement. Best of all, you need no previous experience to qualify for one of these well-paid positions—to train for the position of your choice.

Billion Dollar Photographic Field Needs You!

Motion picture photography is just one of the many big-paying branches of the billion dollar photographic industry. All over the country today there's a crying need for expert projectionists — for photo-finishers and trained commercial photographers. No

matter which branch of the work you select there are sure to be scores of positions awaiting you—positions paying \$2,000 to \$12,000 a year and offering unlimited opportunities for advancement.

We Train You at Home in Spare Time

Pick the branch of photographic work you like best—we'll train you for it, in your spare time. Previous experience unnecessary. Age or lack of education no obstacle. If you can read and write English we'll teach you, through our Simplified Home-Study

Method, all there is to know about Motion Picture Photography, Projection, Commercial Photography or Photo-Finishing. Our Employment Bureau helps you secure the position of your choice.

SEND TODAY FOR FREE BOOK

Let us tell you how you can quickly qualify as Motion Picture Cameraman, Projectionist, Commercial Photographer or Photo-Finisher. Our big FREE book gives details about this billion-dollar industry, and explains how you can easily step into a well-paid position. Fill in the coupon—check off the branch of photography you're most interested in, and mail it NOW! It means happiness—success for you!



NEW YORK INSTITUTE OF PHOTOGRAPHY

Dept. G-1423

10 WEST 33rd STREET

NEW YORK, N. Y.

**New York Institute of Photography,
Dept. G-1423, 10 West 33rd Street,
New York, N. Y.**

Without cost or obligation send me a copy of your FREE book and details about how I can qualify as:

- Motion Picture Cameraman
- Motion Picture Projectionist
- Commercial Photographer
- Photo-Finisher

Name.....

Address.....

City.....State.....

YOUR SUCCESS COUPON

AUTO BOOKS SENT FREE!

Mail the coupon and we'll send you a set of these remarkable auto books, just off the press. Whether you are mechanic or helper, expert or student, auto-owner or driver, if you're interested in autos, by all means take advantage of this opportunity to see the latest and most complete work on autos we have ever published. Built by eighteen of America's greatest automotive engineers. Simple enough for men with little schooling to understand, yet in daily use by hundreds of engineers, service station superintendents and foremen as an authoritative REFERENCE Cyclopedic.

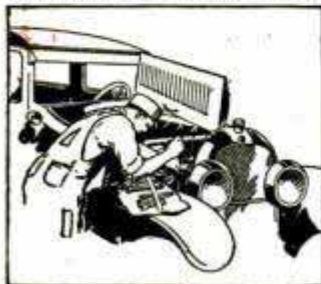

CAN YOU FIX IT?

Can you take out "play" in differential? Can you kill the "shimmy" in steering? Can you reset TIMING? Can you put your finger on engine trouble without guessing or tinkering? Can you pull the starter off and fix it? Can you adjust and repair transmission, engine, rear axle, bearing?

These Books Tell How

and they tell you how to do any and every auto job right the first time.

5 Big Volumes

2400 pages, over 2000 illustrations, wiring diagrams, equipment charts, etc. De Luxe edition with gold-stamped flexible binding. Sent FREE for 15 days' use. If not wanted return express collect. If kept, send only \$2 after 10 days, then \$3 a month until special advertising price, \$24.80, is paid.

Put the JIFFY INDEX to work for you!

The billion-dollar auto industry offers rich prizes to men with gumption enough to really learn all branches of automotive mechanics. A better job, bigger pay—a chance to go into business and get a share of the huge profits, are waiting for any man who even half tries to improve his ability to deliver service. And here's the shortest, easiest way: No tedious studying, no memorizing, no lessons or examinations. Just LOOK UP the facts you seek. You'll find the answer to any auto problem literally at your finger-tips, in the famous JIFFY INDEX.

"Was garage hand—now have shop of my own," writes W. Sidle of Toledo, O.
"I got a raise," says P. Ervin of Yorkmouth, N. S., shortly after getting his books.
And D. S. Reid of Siluria, Ala., was offered \$4000 for invention worked out with these Auto Books.



A Year's Consulting Membership FREE!

Privilege of consulting engineers of million-dollar American Technical Society on any automotive problem for one year without charge, if you mail coupon immediately.

American Technical Society

Dept. A-219, Drexel Ave. & 58th St. Chicago, Ill.

Don't Send a Penny!

AMERICAN TECHNICAL SOCIETY
Dept. A-219, Drexel Ave. & 58th St., Chicago, Ill.

I would like to see the new 5-volume edition of your AUTO BOOKS, but without obligating me to buy them. I will pay the few cents delivery charges only, but if I choose to, I will return them express collect. If after 10 days' use I prefer to keep them, I will send you \$2 and pay the balance at the rate of only \$3 a month, until \$24.80 is paid. Please include free membership offer above.

Your Name.....
Your Address.....
Employer's Name.....
Employer's Address.....

No Joke to be Bald



What I accomplished on my own head, pictured above, I believe I can do for you, provided you are under 45 years of age and loss of hair was not caused by burns or scars and the hair roots are not absolutely dead. Anyhow, I must succeed or you pay nothing. No apparatus—my home treatment is simple, quick and inexpensive.

Send No Money Just your name and address and I will mail you full information with PHOTOGRAPHS, NAMES and addresses of men and women who have successfully used my treatment for dandruff, falling and loss of hair. Write Now. A postal will do.

Vreeland's, 1352 Euclid-Windsor Bldg. CLEVELAND, OHIO

NO JOKE TO BE DEAF

—EVERY DEAF PERSON KNOWS THAT



I make myself hear; after being deaf for 25 years, with these Artificial Ear Drums. I wear them day and night. They stop head noises and ringing ears. They are perfectly comfortable. No one sees them. Write me and I will tell you a true story how I got deaf and how I make you hear. Address



GEO. P. WAY, Artificial Ear Drum Co. (Inc.)
80 Hoffman Bldg., Detroit, Mich.

\$10.00 PER MONTH BUYS Fibre-Life Limbs



NEXT TO NATURE. BRACES MADE TO ORDER. AGENTS WANTED. FREE FIBRE SAMPLE **WORMAN CO.** 252-P HENNEPIN AVE. MINNEAPOLIS, MINN.

WAISTLINE Too Big?

A new belt called Director gets at the cause of excess fat and quickly corrects the condition. With every movement of the body, during every working hour, Director acts as a massage on the abdomen and actually dissolves excess fat away. F. P. Cowan of Pinehurst, N. C., says, "Director is the finest thing I ever wore. I want another, but not so large, as I am 5 inches smaller around the waist now." Doctors endorse Director as the natural way to accomplish a permanent reduction.



SENT ON TRIAL

Let us prove our claims. We'll send a Director to you for free trial. If you don't get results you owe us nothing. You don't risk a penny. Write now for free trial offer, doctors' endorsements and letters from users. No obligation. Mail coupon.

Landon & Warner, Dept. C-42, 332 S. La Salle St., Chicago, Ill.

Landon & Warner, Dept. C-42, 332 S. La Salle, Chicago.

Tell me how I can reduce my waistline 4 to 6 inches with Director Belt. Send details of your trial offer. This places me under no obligation.

Name.....

Address.....

Aeroplane Drafting Room Blue Print

FREE!



**I Train
You In
Your Own
HOME**

Learn to be an aeroplane designer. I will train you **RIGHT IN YOUR OWN HOME**. Here's your opportunity to get into the big money earning branch of Aviation—Designing aeroplanes. Copy the aeroplane picture shown here and mail to me with coupon below. If I think you show talent for this work and really want to train for a big pay position in aviation, I will mail you direct from my drafting room an aeroplane blueprint in three views with all main parts named and explained.

GET INTO AVIATION
through the Front Door—the Drafting Room

LEARN AERO-DRAFTING

If you want to fit yourself for a start toward making big money in AVIATION—get into the creative end of this rapidly growing industry. There are good aeroplane designers today who get \$12,000 a year—*think of it—\$1,000 a month*. Let me train you in Aero-Drafting—and put you in line for a position like this—Remember, *you don't need flying or mechanical experience* to become an Aero-Draftsman.

Former Factory Helper Raises Income to \$7,000 a Year

A. H. Bernier of Detroit, Michigan—one of my students had a factory job at \$12.00 a week when he enrolled with me. After taking my course he was picked from 65 men, and made assistant Chief Draftsman.

My Training the Front Door To a Place in AVIATION

No matter what you are doing now—if you can read, write and understand plain simple English and want to get into Aero-Drafting, mail coupon today. Let me show you what I can do for you. See how I train you—at home—by my easy practical method—Learn about my employment service that is free to my students. Copy sketch and mail today!



Engineer Dobe

Mail This Coupon If You Earn Less Than \$70 a Week

Get my free books giving all the facts about Aero-Drafting and my training. Read my money back agreement which says you must be satisfied or your training costs you nothing. Make the start to big pay today. Mail sketch. Get Free Blue Print.

Engineer Dobe, Div. 13-52
1951 Lawrence Ave. Chicago, Ill.

**Aero Drafting Experts
In Big Demand**



**THESE
PAY-MAKING
TOOLS FOR
YOU!**

FREE → Pay-Raising Plan

Write today for this book which has started hundreds of men—many with but little education and no experience on the road to success. Learn about the drafting instruments I furnish my students without extra charge. And all the other features of my training. Write today.

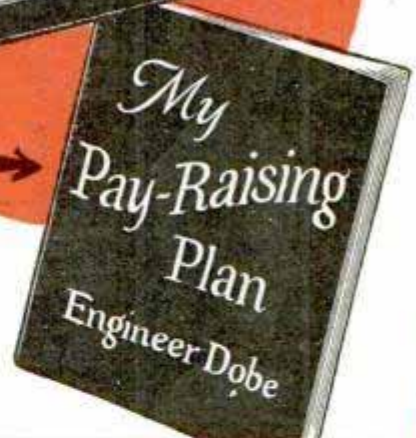

FREE Blue Print Coupon

ENGINEER DOBE, Div. 13-52

1951 Lawrence Ave., Chicago, Ill.

I want to get into Aviation through the Drafting Room. Here's my copy of Aeroplane sketch. Send me the blue print and your free books "Successful Draftsmanship" and "My Pay-Raising Plan," all Free to me.

Name _____ Age _____

Address _____

Town _____ State _____

LEARN CARTOONING

AT HOME DURING SPARE TIME

with the course that has trained HUNDREDS of beginners successfully. The Landon Picture Chart Method of teaching ORIGINAL drawing by mail makes cartooning easy to learn. This school is a Member of The National Home Study Council. Write today for sample picture chart to TEST YOUR ABILITY and examples of the work of successful students now earning from \$50 to \$200 and more per week. Enclose 6c in stamps and STATE YOUR AGE.

THE LANDON SCHOOL, 2838 National Bldg., Cleveland, Ohio



LAW

STUDY AT HOME

Become a lawyer. Legally trained men win high positions and big success in business and public life. Be independent. Greater opportunities now than ever before. Big corporations are headed by men with legal training. Earn

\$5,000 to \$10,000 Annually

We guide you step by step. You can train at home during spare time. Degree of LL.B. conferred. LaSalle students found among practicing attorneys of every state. We furnish all text material, including fourteen-volume Law Library. Low cost, easy terms. Get our valuable 64-page "Law Guide" and "Evidence" books FREE. Send for them NOW. LaSalle Extension University, Dept. 264-L, Chicago. The World's Largest Business Training Institution

2 YEARS TO ENGINEERING DEGREE!

Be a Civil, Electrical, Mechanical Administrative or Chemical ENGINEER in 96 weeks. No entrance examinations or high school diploma required. Low tuition expenses. Degrees conferred by State authority. Catalog FREE.

TRI-STATE COLLEGE

Box E-2113

Angola, Ind.

Learn Watchwork, Jewelrywork and Engraving

A fine trade commanding a good salary, and your services always in demand. Address **Horological**, Dept. P, Bradley Institute, PEORIA, ILLINOIS, for our latest catalog.

Win \$3,500.00



Many persons won from \$1800.00 to \$4245.00 each in our last offers by our unique advertising plan. A boy only fifteen years old won \$900.00. A man between sixty and seventy years old, unable to get work, with doctor and household bills to pay, won \$4245.00. A woman was surprised to win \$2500.00. Every age or sex has an equal chance to WIN. In next three or four months we will award thousands of dollars to fortunate men and women who solve our puzzles and join our contest. Here's our latest one:

Find the Twin Flyers

Here are sixteen pictures of a famous woman flyer. Now look closely. Don't make a mistake. All these pictures look alike, but they are not. Two, and only two, are exactly alike. They are the twin flyers! Can you find the two pictures that are alike in every way? Some are different in the collar, helmet, goggles, or tie. Each one is different from the rest except two. That's the challenge to you. Find them. Just send the numbers of the twin flyers on a post-card or letter today. If your answer is correct you will be qualified for this opportunity and learn how to win.

\$7160.00 In Prizes Given in This One Offer

Over 25 prizes this time, and duplicate prizes paid in case of ties. A wonderful prize list to fit almost every human desire. We have arranged so that if the winner chooses he or she can have either \$2875.00 in cash or a big new 90 H. P. Waco airplane with actual flying instruction. This prize will buy a home, an automobile. It's well worth while to try for.

Additional \$625.00 for Promptness

Act quick. Be prompt. It pays. If you solve this puzzle correctly, I will send Certificate which will be good for \$625.00 if you are prompt and win first prize, making your first prize \$3500.00.

NO MORE PUZZLES TO SOLVE. Any man, woman, boy or girl in the U. S. A.—it doesn't matter who or what you are or where you live—except residents of Chicago, Illinois, and former major prize winners. 25 of the people who take up this offer are going to win these wonderful prizes. Be one of them. Just send the numbers of the twin flyers. Send no money, but be prompt!

J. D. SNYDER, Publicity Director, Dept. 199
54 West Illinois St. Chicago, Ill.





















R. T. I. R. T. I. QUALIFIES YOU TO MAKE MONEY AND ITS SERVICE KEEPS YOU UP-TO-THE-MINUTE ON THE **R. T. I.**
 NEWEST DEVELOPMENTS IN RADIO, TELEVISION AND TALKING PICTURES

RADIO

CALLS FOR MORE TRAINED MEN

Big Money quick—the chance to more than double your salary—is offered to you now. RADIO has leaped from the experimental stage to a gigantic industry, employing many, many thousands and loudly calling for MORE TRAINED MEN to fill the Big-Pay jobs. TALKING PICTURES have taken the larger cities by storm and will sweep the entire country, opening up many new good jobs everywhere. TELEVISION now comes with even greater promise of a large number of good paying jobs and big profits for those who are prepared.

Big Money Now! More to Come

Here is an entirely new field of profitable employment—Big-Money Jobs—\$2500—\$3500—\$5000 and up, right now—lots of money easily made in spare time—increasing pay for you and more and more money as this new industry grows bigger and bigger.

ANSWER THE CALL—GET INTO THIS MONEY-MAKING INDUSTRY NOW!

The "R.T.I." famous "3 in 1" Home Training in Radio, Television and Talking Pictures makes it easy for men, young men and boys to get into this new field quickly. R. T. I. home training is practical and easy to understand. It trains your head and hands at the same time. Your opportunities for money-making are unlimited. Your age, amount of education, or experience make no difference. If you are interested and ambitious you can succeed. Are you willing to use a little spare time at home? That is all you need to quickly start making money with R.T.I. material and home training. You will be ready for a good job or profitable business of your own, even before you finish the training. Remember—you learn at home in your spare time on actual equipment included in fine, big outfits sent you. R.T.I. with all its connections in the industry, keeps you up-to-date and pushing forward all the time.

R. T. I. Wonderful Free Book Nothing Like It Ever Published

No one can fully realize the amazing size and future growth of the Radio, Television, and the Talking Picture industries unless they know all the facts revealed in this R.T.I. book. It will open your eyes to the vast number of new money-making jobs—enormous spare-time profits—all within easy reach of ambitious men.

Big R.T.I. Book Free—While They Last

LET F. H. SCHNELL AND THE R. T. I. ADVISORY BOARD HELP YOU.

20 years' Radio Experience. First to establish 2-way amateur communication with Europe. Former traffic Mgr. of Am. Radio Relay League. Lieut. Com. U. S. N. R. Inventor and Designer. Cons. Radio Engineer.

Assisting him is the R. T. I. Advisory Board, composed of men prominent in the Radio Industry—manufacturing, broadcasting, engineering and servicing. All these men know Radio and will help you succeed in their field.

RADIO & TELEVISION INSTITUTE
 Dept. 12, 4806 St. Anthony Ct., Chicago



Hasn't Finished the Course
 Your radio course enabled me to earn over \$500 in two months' spare time work.—J. Noffsinger, R. I. Box 37, Greenville, Ky.



\$80 a Week—Through R. T. I. Training
 I am earning \$60 per week and another \$20 a week in spare time Radio Work. Your Course was the best investment I ever made.—W. W. Mead, 915 W. 28th St., Indianapolis, Ind.



STEP UP QUICK TO A BIG-MONEY JOB THROUGH R.T.I. training in Broadcasting, Sales, Service, Manufacturing, Repairing, Ship and Station Operating, Installing, in business for yourself.

R. T. I. R. T. I. TRAINS YOU AT HOME FOR A GOOD JOB OR A PROFITABLE PART TIME OR FULL TIME BUSINESS OF YOUR OWN



RADIO & TELEVISION INSTITUTE
 Dept. 12, 4806 St. Anthony Court, Chicago

Send me Free and prepaid your BIG BOOK "Tune In On Big Pay" and full details of your three-in-one Home Training (without obligating me in any way.)

Name

Address

City State

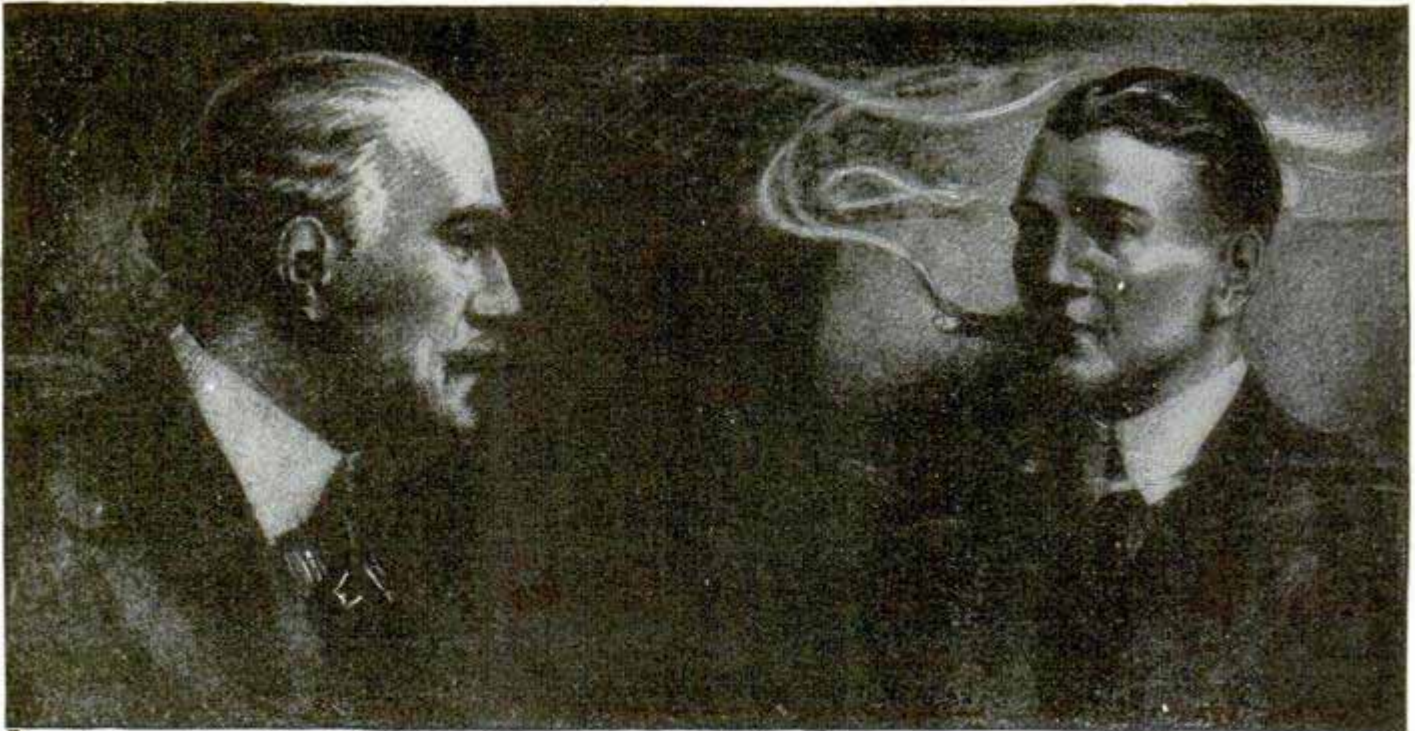

Is Tobacco Hurting You?

Look the facts square in the face, Mr. Tobacco User. You may think tobacco is not hurting you.

That is because you haven't as yet, perhaps, felt the effects of the nicotine poison in YOUR system. For you know that nicotine, as absorbed into the system through smoking and chewing tobacco, is a slow working poison. Slow, yes—but sure.

Tobacco lowers efficiency. It slows a man down. Makes it harder to concentrate the mind on work. Tobacco users seldom have the amount of "pep" and energy of those who do not use the weed. There's many a man older than you in years who is younger in energy, simply because he lets tobacco alone.

Some day, probably, you will realize to what an alarming extent tobacco does undermine the system.

When your hands begin to tremble—
and your appetite begins to fail—
and your heart seems to "skip a beat" now and then—
and slight exertion makes you short of breath—
then you have a right to suspect that
TOBACCO is getting the upper hand.

Any well-informed doctor will tell you that these are only a few of many symptoms of tobacco poisoning.

And YOU know that the use of tobacco in any form is an expensive, utterly useless habit. You know you ought to quit.

Tobacco Habit Banished In Many Cases—Let Us Help You

It doesn't make a particle of difference whether tobacco has been used for a single month or fifty years, or how much, or in what form—whether cigars, cigarettes, pipe, plug, fine cut, or snuff. In most cases, Tobacco Redeemer removes all craving for tobacco in any form in a very few days. Not the slightest shock to the nervous system. The tobacco craving will usually begin to decrease after the very first dose—there is no long waiting for results.

Tobacco Redeemer contains no habit-forming drugs of any kind and is quick, safe, pleasant and thoroughly reliable.

It is in no sense a substitute for tobacco. After finishing the treatment, there is usually no desire to use tobacco again or to continue the use of the remedy. It helps to quiet the nerves and makes one feel better in every way.

Results Guaranteed A single trial will convince you. Our legal, binding, money-back guarantee goes with each full treatment. We will refund every cent you pay for the treatment if, after taking it according to the easy-to-follow directions, it should fail to banish the tobacco habit completely.

SEND Coupon for Free Proof Let us send you our free booklet on the injurious effects of tobacco, together with testimonial letters from men all over the country telling how they have been absolutely freed from the tobacco habit by this simple home treatment. You could not ask for stronger proof that Tobacco Redeemer usually does do the work than the evidence we will gladly send on request. Just mail the coupon—or a postal will do.

NEWELL PHARMACAL CO.
Dept. 300 Clayton Station St. Louis, Mo.



Free Book Coupon

NEWELL PHARMACAL CO.

Dept. 300 Clayton Station St. Louis, Mo.

Please send, without obligating me in any way, your free booklet regarding the tobacco habit and proof that Tobacco Redeemer does positively relieve the tobacco habit in most cases. If it fails your money will be refunded.

Name.....

Street and No.....

Town..... State.....

Miracles Worked in Muscles!

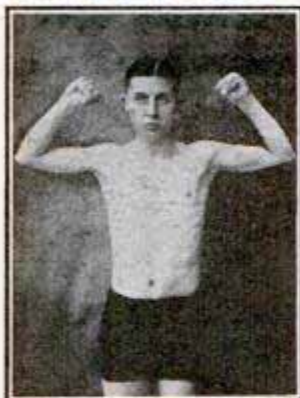

Is This YOU?

Don't be like that! Why be a puny, run-down, sickly weakling when it's so EASY to be strong? Don't be ashamed of your body—I'll build you one to be PROUD of.

From "PUNY"
to
PANTHER-MAN



A Titus-Built Body

Here's the man you were meant to be. Picture yourself with an arm like that, those big, powerful shoulders and that massive chest. That's the way Titus builds men—and YOU'RE NEXT!

READ THIS

AMAZING PROOF



Meredith Kirkpatrick had never wrestled before. Titus Training gave him the crushing strength to WIN.

WEAK men made strong! Puny, sickly chaps transformed into husky, broad-shouldered athletes! Man, if you've got an ounce of red blood in your veins you're going to find out about this wonderful way to get STRONG. All in a few minutes a day at home. My Free Book tells the whole amazing story. Send for it TODAY.

"Muscles seem to grow overnight"—that's what Walter Hollyoak of Victoria, B. C., says about the wonderful results of Titus Training. Harry Simonowich of New York writes—"I never put on muscles so fast in all my life!"

Wherever you live, I'll give YOU big muscles quick! Just read what Miguel Yeaza writes from the Philippine Islands: "I could hardly believe my own eyes at the great change you have made in me. My muscles grew as fast as the beanstalk in the story of 'the Giant-Killer.' I can hardly thank you for your great work; you have made a new man of me."



WEAR THIS MEDAL

Strong men all over the world wear it as a badge of manhood. Made of solid statuary bronze and given to you free.

Can You Do These Feats of Strength?

How would you like to amaze your friends by tearing a telephone book or deck of cards in two? Titus trained men do these feats and many others with ease.

Anthony Ottavio of Massillon, Ohio, is only 18—but what a MAN! He writes: "I can bend a light horseshoe with my hands. I can lift 200 lbs. with my left and right hands. I can lift 150 lbs. with one finger."

Adam Altman of Chicago, Ill., writes: "Before I took your course I could only chin myself eight times; now I can chin myself twenty-five."

Stanley Thompson, of Multnomah, Ore., writes: "I can tear a pack of cards in half, bend spikes, and do many other things which I could not do before. Titus-built men sure have the speed and power behind every punch."

A New Body in 20 Minutes a Day!

Just give me 20 minutes a day, that's all—and WATCH THOSE MUSCLES GROW! See the amazing change in 30 days. Man, won't you be PROUD of those big, rippling muscles! But don't get a swelled head when you hear the girl friends raving about your handsome, athletic build.

I don't just promise you all these good things—I GUARANTEE results. I Guarantee to put a solid inch of powerful muscle on your arms, a couple more on your legs—I Guarantee to develop every muscle in your body in proportion—I Guarantee to broaden your shoulders and add 5 inches to your chest—I Guarantee to strengthen your internal organs, too—I Guarantee you new pep, new energy, NEW LIFE.

SAXON World-Famous Strong Man Says:

"My feats of strength on the stage have brought me hundreds of inquiries asking how I developed such extraordinary strength. I tell them all to write to Titus; he'll show them how to develop physical power that will amaze them. Every red-blooded man should send for that marvelous book, 'MIRACLES IN MUSCLE.'"



William Lutz lifts 700 lbs. after taking Titus Training.



Titus-Trained men tear decks of cards in half and do other feats of strength with ease.

Let Me Make YOU Over

FREE BOOK Tells How



Come on, friend, you're next! I can't begin to tell you here what Titus Training has done for thousands of men—what it will do for you—but my great new book tells the whole amazing story. This book will give you the surprise of your life—read how weaklings have been changed into strong, brawny HEMEN—see actual photos of magnificent models of muscular manhood—discover how EASY it is for you to get strong. This glorious book is yours FREE. Mail that coupon NOW—no cost, no obligation, no salesman will bother you. There are no strings to this offer.

TITUS 853 Broadway
Dept. M-147, New York, N. Y.

TITUS, Dept. M-147
853 Broadway, New York, N. Y.

Dear Titus: Okay, send me that wonderful new book of yours "Miracles in Muscles." Get it to me by return mail without the slightest cost or obligation on my part.

Name.....
Address.....
Town.....State.....

Decorate these Giftwares and Make Money

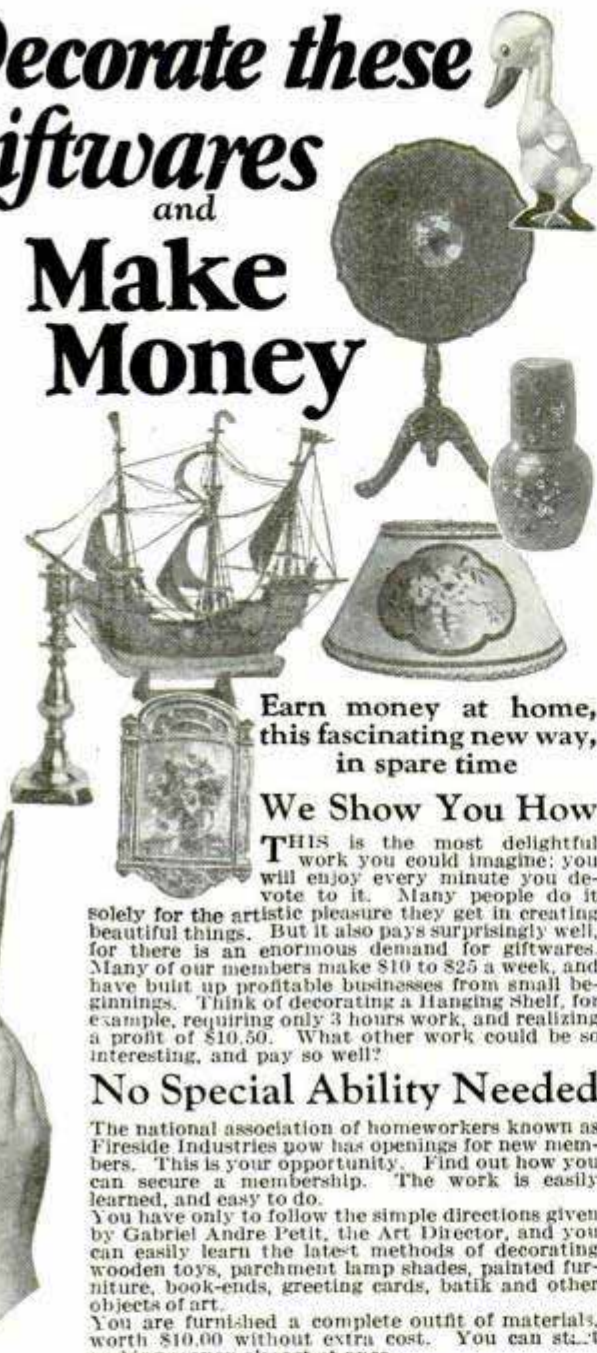

Earn money at home,
this fascinating new way,
in spare time

We Show You How

THIS is the most delightful work you could imagine; you will enjoy every minute you devote to it. Many people do it solely for the artistic pleasure they get in creating beautiful things. But it also pays surprisingly well, for there is an enormous demand for giftwares. Many of our members make \$10 to \$25 a week, and have built up profitable businesses from small beginnings. Think of decorating a Hanging Shelf, for example, requiring only 3 hours work, and realizing a profit of \$10.50. What other work could be so interesting, and pay so well?

No Special Ability Needed

The national association of homeworkers known as Fireside Industries now has openings for new members. This is your opportunity. Find out how you can secure a membership. The work is easily learned, and easy to do. You have only to follow the simple directions given by Gabriel Andre Pettit, the Art Director, and you can easily learn the latest methods of decorating wooden toys, parchment lamp shades, painted furniture, book-ends, greeting cards, batik and other objects of art. You are furnished a complete outfit of materials, worth \$10.00 without extra cost. You can start making money almost at once.

Money-Back Offer

What thousands of others are doing in Fireside Industries, you also can do. Be sure are we of your success in this fascinating work that we refund your money in full if, after completing your instructions, you are not entirely pleased. You take no risk whatever.

Beautiful Book FREE

The beautiful Book of Fireside Industries, illustrated in color, explains all about this new way to earn money at home. It will be sent you, absolutely FREE and without obligation. Just mail the coupon, or write, enclosing 2c stamp for postage. Put do this at once, while openings for new members are being offered.

FIRESIDE INDUSTRIES
Dept. 66-B, Adrian, Mich.

Fireside Industries, Dept. 66-B
Adrian, Michigan

Please send me, Free, the book on Fireside Industries, which explains how I may earn money at home. I enclose 2c stamp.

Name

Address

City..... State.....

(Write in pencil—ink will blot)

CAMPBELL'S INFRA-RED RAY LAMP Sent on Approval THIS MEANS NO MONEY DOWN



Have You Some Troublesome Ailment?

You will be greatly surprised when you learn how Infra-Red Rays relieve congestion or troubles causing aches and pains in the body. The Campbell Infra-Red Ray Lamp concentrates a mild beam of Infra-Red Rays upon any part of the body.

These rays penetrate deeply into the tissues. As they penetrate they create an active circulation of the blood. Most ailments are due to congestion—relieve the congestion and you relieve the ailment. Nature herself does the healing by active, normal blood circulation.

Why Suffer Needless Pain?

If you or someone in your home have a troublesome ailment, a lamp like this is a blessing. May be used safely by anyone.

Relieve Bronchial trouble, Neuralgia, Neuritis, Sinus trouble, Catarrh, Head Noises, Asthma, Ear trouble, Rheumatism, Hemorrhoids, Gall-Bladder, Tonsillitis, Lumbago and many other ailments with a soothing Infra-Red Rays.

Let Us Send You Our Book on Infra-Red Rays

We have an interesting book on the use of Infra-Red Rays which we shall be glad to send free to any reader upon request. Our book quotes leading authorities as well as users of our lamp. Full directions for use, how to order, our home trial offer, etc., are also explained.

Infra-Red Rays have brought such wonderful results for others you are sure to be interested. Write today for our book telling more about it.

THE WILLIAM CAMPBELL COMPANY
1040 Union Avenue Alliance, Ohio

DEAF? READ THIS

Vibraphones Reduce Head Noises

A new and scientific discovery stimulates the hearing processes by utilizing sound waves through small silver devices that fit the ears perfectly. The vibrators are built inside the sound chambers. The instruments are so small that your friends will seldom know you are wearing them. Comfortable, easily put in the ears or removed. No wires. No batteries. No head bands. Nothing like them. This new and scientific triumph produces marvelous results. Head noises are reduced. And hearing gradually improves. Don't be handicapped or embarrassed another day by deafness. Write for complete details.

VIBRAPHONE CO., Inc., Station 708
Central National Bank Bldg. St. Louis, Mo.

GREAT NEWS

If You Want a Real Pay Job

IN DRAFTING!

A New Easy Method Doubles The Earning Possibilities For Ambitious Men In This Great Field. Now—Right At Home—You Can Receive College Training in Drafting—From An Old Established College Known And Recognized Throughout The World—Chicago Tech. Yet The Cost Is Only A Fraction Of Ordinary College Training.

Chicago Tech Now Brings College Training in Drafting to You—At Home

HERE'S great news for every wide-awake man who wants to get into a big-money drafting job! An easy, practical home-study method has been developed which enables you to get the famous College-Training-In-Drafting as taught at Chicago Technical College—without leaving your home. This is the kind of training that employers are looking for in the men they hire. Training from a school that has real prestige wherever you go. Now you, too, can master professional drafting in your spare time and quickly prepare yourself for a position paying up to \$7,000 a year and more!

New Easy Practice Method

Realizing that many ambitious men cannot afford to go to college, this famous school, noted for its plain, practical, easily-mastered instruction, has worked out a plan whereby everyone can get actual College Drafting Training at home. As a result the top-notch jobs of this profitable profession are now within your easy reach. Think of it! The same fine drawing outfits, the same simple lessons and the same practical training as prepared and taught at the college!

Fascinating—Simple As A. B. C.

It's just like playing a fascinating game. No hard textbooks—no involved problems to solve. This astonishing new course is so different from ordinary "schooling" and so easy to master that you will be surprised and delighted with your progress.

Drawing Outfits FREE of Extra Cost

A full set of fine drawing instruments in handsome pocket case, special drawing table and valuable drawing outfit are included without extra cost. You are furnished with everything necessary to big-pay training.

Don't Delay—Act Now!

If you are sincere in your desire to get out of the rut and step into a high-salaried drafting position, investigate this new home-study method at once. The coupon brings free trial lesson and full details that will prove to you that here is just the certificated training you want. Mail it now—no obligation.

CHICAGO TECHNICAL COLLEGE

Dept. B-203, Home Study Division
118 E. 26th St. Chicago, Ill.

If you live nearby, visit the College. See how we train Draftsmen for Big Pay Jobs. More than 1000 attend every year.



NOW FREE
Sample Lesson and Book

If the news of this wonderful home study College Training in Drafting sounds too good to be true, mail the coupon below for free trial lesson and interesting literature. Convince yourself of the merits of this approved training that will prepare you for a top-notch drafting job in a short time. No obligation—no act at once.

Mail The Coupon



CHICAGO TECHNICAL COLLEGE,
Dept. B-203, Home Study Division,
118 E. 26th St., Chicago, Ill.

Please send me at once the sample lesson and complete facts about your new system that enables me to master College Drafting Training at home just as you teach it at College in Chicago. This does not obligate me in any way.

Name.....

Address.....

Town..... State.....

Age..... Occupation.....

() Check here only if you prefer to come to Chicago for our short course in Drafting at Chicago Tech. Opportunities to earn while learning.

You Fellows
Who Want

**BIG
PAY**

Get into

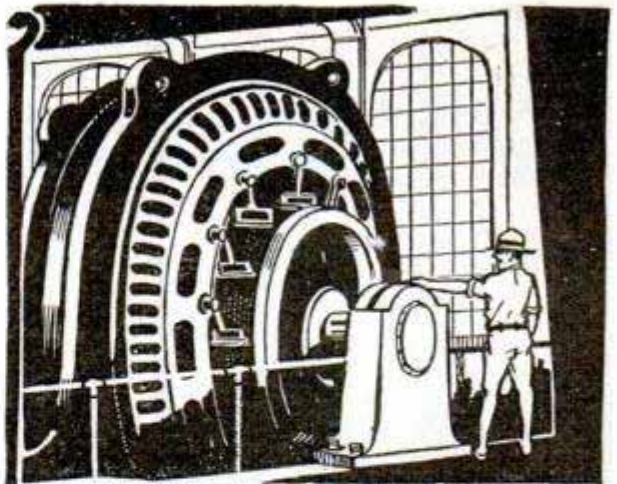

ELECTRICITY

*Hundreds of Men
I have trained
are now earning*

**\$60 to \$100
A WEEK!**

So Can You

**If you
earn less
than \$70
a week
INVESTIGATE
ACT
NOW**



I'll train you at home in a few short months.
L. L. COOKE

FREE BOOK COUPON

**L. L. COOKE, Chief Instruction Engineer,
Dept. 12, 2150 Lawrence Ave., Chicago, Ill.**

Send me FREE and prepaid, your Big Book "Secrets of Success in Electricity," with full details about your Home Study Course in Electricity.

Name _____
Address _____
City _____ State _____

Residents of Canada send coupon to L. A. Farrow, Special Representative, 7 Medbury Lane, East, Windsor, Ontario, Canada.

WHY earn \$15 or \$20 or \$30 a week, when in the same six days as an Electrical Expert, you can make \$60 to \$100 — and do it easier — not work half so hard. Why, then, remain in a small-pay, no-future job that offers no chance for big promotion — no chance for big income? Fit yourself for a real job. **Get into Electricity.** That's where the big money is being made, and always will be made.

Electricity — The Big Pay Field

Today even the ordinary Electrician — the "screw driver" kind — is making money — big money. But it's the trained man — the Electrical Expert, — who makes the really big money. — \$10 to \$20 a day — \$60 to \$100 a week. Be a Big-Pay man, yourself. Get in line, now, for one of these "Big-Pay" Jobs.

I'll Train You At Home

I'll train you at home, — in your spare time. You work just as you are working now — at your same job. My now famous "Work-Sheet and Job-Ticket" method, guarantees you simplified, practical training along work-shop lines. In a few short months you can step out of your old job into a new job — into electrical work where you can be a Big-Pay man in this Big-Pay field.

You Earn As You Learn

To learn Electricity my way you don't have to be a College man, or even a High School graduate. You can read. You can write. That's enough. With me, you get experience as you go along and make good money while learning. I'll show you how, — and I'll give you, without extra cost tools and apparatus to work with — 6 Pig Outfits in all.

Money Back If Not Satisfied

That's what I agree to do. And back of me in this agreement stands a \$2,000,000 Illinois Corporation. There's nothing like "Cooke" Training anywhere. It's the Training that big Electrical men are praising; it's the Training that employers recommend; it's the Training that one of our greatest Engineering societies has endorsed 100 per cent. **It's the training for you.**

If You're Earning Less Than \$70 A Week — Investigate

Don't wait a minute! Find out today why "The Cooke Trained Man is the Big-Pay Man", everywhere! Find out how "Cooke" Training will help you boost your pay! Mail coupon right now for my Big FREE Book of Facts. See the Six Big Working-Outfits I give you without extra charge. See the hundreds of pictures, the proofs, the Big-Pay letters of other "Cooke" Trained Men. Get this great free Book. Send for it today. Clip, sign, and mail coupon **RIGHT NOW!**

L. L. COOKE, Chief Instruction Engineer

**L. L. COOKE SCHOOL
OF ELECTRICITY**

Dept. 12

**2150 Lawrence Ave.
Chicago, Illinois**

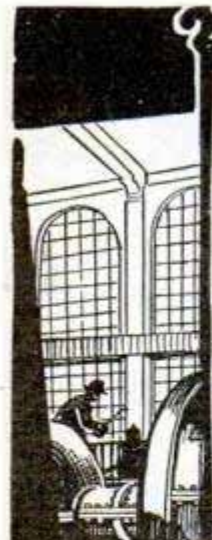

\$30 A DAY
Dear Mr. Cooke:
I was making \$25 a week when I enrolled. Now with my own Electrical Shop I make as high as \$30 a day. A. J. Daigneault, 225 Worcester, Southbridge, Mass.



\$1.50 AN HOUR
Dear Mr. Cooke:
I had to work like a slave for 45c an hour before I enrolled. Now, thanks to you, Mr. Cooke, I make \$1.50 an hour. G. W. Oprea, 4220 N. Meade Av. Chicago, Ill.

**6 BIG
OUTFITS
NO EXTRA
COST**

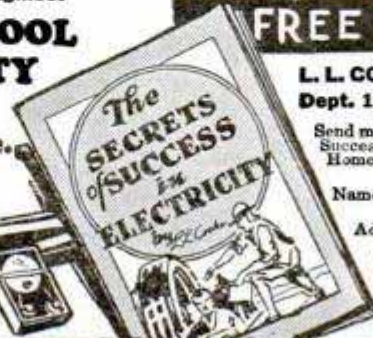

The "Cooke" Trained Man is the "Big Pay" Man

Classified Advertisements

WORLD'S BEST WANT AD MEDIUM

Advertisements in this section, 35 cents per word, each insertion, minimum 10 words, payable in advance. To be printed under proper classification in March issue, copy should be in our office January 18th

ADVERTISING AGENCIES

ADVERTISE—24 Leading Sunday newspapers, 24 words \$15.00. Excellent for obtaining help, salesmen, or business opportunities. Information 1,000 best paying dailies, mail-order weeklies, monthlies, mailing lists, everything. Free. Wade Agency, Great Northern Bldg., Chicago.

ADVERTISING: 24 Words 20 newspapers \$9; free list; magazines, farm. LeGrand Agency, 34 West 33rd St., New York.

BEFORE Advertising get our catalog. No charge. 25 years in business. The largest classified agency in the world. Ankrum Advertising Agency, 100 No. LaSalle St., Chicago, Ill.

GET Into advertising. Learn quickly at home. Experience unnecessary. New easy plan. No text books used. Practical work. Old established school. Send name and address for interesting free booklet. Page-Davis School of Advertising, Dept. 3432, 3601 Michigan, Chicago.

FREE—New 1930 Advertisers Rate Guide, 44 pages. Includes everything. Lowest rates. E. H. Brown Advertising Agency, 140 S. Dearborn, Chicago.

OBTAIN Canvassers, distributors through publication advertising. Martin, 276B West 43d, New York.

ADVERTISE In rural weeklies. Lists free. Meyer Agency, 4112 Hartford, St. Louis, Mo.

INCH Display advertisement 50 magazines year \$24. Wood's Popular Services, Atlantic City, N. J.

ADVERTISE 50 Magazines 3c word; \$3.00 inch; 5,000 country weeklies 1c line per paper; lists free. Evans King Co., 672P, Wilmington, Del.

TIME Counts in applying for patents. See pages 138 and 139. Clarence A. O'Brien, Registered Patent Attorney, Washington, D. C.

FOR ADVERTISERS

VARIETIES—Best advertising newspaper for goods in Colombia, South America. Carefully distributed in 880 towns. Big business field. Address Variedades, Box 425, Barranquilla, Colombia, S. A.

24 WORDS—87 Southeast weeklies, \$3.72. S. Stout, Warmsprings, Ga.

ADVERTISE 200 Country newspapers, 28 words \$7.50. Lists free. Roberts, Box 82, Monroe, Wis.

ADVERTISE 300 Country newspapers, 28 words, \$10. Business getter. Lists free. Keator, Hartford Bldg., Chicago.

SALES PROMOTION

\$50 TO \$50,000 Daily sales secured for our clients. Manufacturer sought new program to extend sales. Our recommendations embodied a \$5,000 expenditure for try-out. Sales produced at cost of less than 2%. Within two years sales under this same program expanded, climbed to \$800,000 in single month. 35 years' salesmanship-in-print experience back of our campaigns. Submit sales problems for free diagnosis. 10 years Sales Promotion Manager Larkin Co., James C. Johnson, 118A Woodbridge Ave., Buffalo.

LETTERS That talk—If you need sales letters that really sell. Mailing lists; form letters; any direct-mail advertising service. Write Omaha List & Letter Co., Box 1172, South Omaha, Nebr.

I SPECIALIZE Writing sales letters, advertisements and folders. Satisfaction guaranteed. Ray Thompson, 504 W. Glenaven, Youngstown, Ohio.

SALES Counsel—Personal, confidential service. Banning, Times Bldg., Watertown, N. Y.

MAILING LISTS

RURAL City, 1930 lists. D. Taylor, 287 Grant St., Youngstown, Ohio.

SEND \$1.00 For names of 1,000 rural buyers. Ill. Commercial Office, 5327 Cornell Ave., Box 301, Chicago, Ill.

AUTOMOBILES

TIME Counts in applying for patents. See pages 138 and 139. Clarence A. O'Brien, Registered Patent Attorney, Washington, D. C.

AUTOMOBILE SUPPLIES

YOU Are wanted to resilver mirrors at home. Immense profits plating autoparts, tableware, etc. Write Sprinkle, Plater, 77, Marion, Ind.

LUBRIKAID Is guaranteed to double the life of your oil; give you easy starting always. 50c postpaid. Agents wanted. The Lubrikaid Company, Box 949, Niagara Falls, N. Y.

I AUTO Gas saver sent. To introduce. All autos. Amazing mileage increases. Critchlow, RT-805, Wheaton, Ill.

AUTO Carburetor attachment greatly increasing power, speed, mileage. Immediate start anytime. No carbon. Applied wrench few minutes. Sample mailed \$1.25. Give make, year. Whirrigas Co., 816 Ford Bldg., Detroit.

SOLDERING And Brazing, by Yates, gives all the necessary "kinks" that will enable you to solder successfully. 90 pages, 64 illustrations. Delivered to your door C. O. D. Simply pay postman 75 cents and postage. Popular Mechanics Press, Room 801, 200 E. Ontario St., Chicago.

USED Air compressor, automatic, upright space saving, beltless. Reconditioned, guaranteed like new. Shipped on trial, easy terms. Few test stands, car washers, battery chargers, paint sprays. E. M. Connor, Box M-232, Troy, Ohio.

AUTO Parts new and used. Lowest prices. Bankrupt supplies, motors, wheels, radiators, transmissions, generators, gears, carburetors, touring tops complete \$15. Brakelining 50% off. Brightman, 2065 Main St., Hartford, Conn.

SPECIAL Introductory offer on Universal socket wrenches and time saving tools. Also liberal proposition to accessory salesmen. A. Frey, 2638 Greenview, Chicago.

DYKE'S Famous Automobile Encyclopedia—Latest edition. Fully revised to cover all latest facts regarding newest developments in automobile field, including new Model A Ford. Information given on repairing and adjusting every part of all motor cars. How to find trouble and fix it. 1,250 pages. 4,200 illus. Price, cloth, \$6. Flexible Morocco \$7.50. Pay postman price and postage when he delivers book. Popular Mechanics Press, Room 801, 200 E. Ontario St., Chicago.

AUTOMOBILE SERVICE EQUIPMENT

BIG Opportunity in 8-hour battery charging. Let me tell you how you can install equipment with practically no investment. Earn \$150 to \$300 monthly. Bargains in used outfits. Write today. Few reconditioned car washers, paint sprays, automatic compressors. I. C. Helmick, Box M-233, Troy, Ohio.

SIGNALS (Electric) for attendant to open garage doors, serve gas, oil. Automobile operates treads. Richardson, 4218 24th Place, Chicago.

SAVE Money—Garage equipment reconditioned guaranteed like new. Unusual bargains in test stands, car washers, battery chargers, air compressors. Shipped on trial, easy terms. What do you need to complete your equipment? E. C. Galbreath, Box M-234, Troy, Ohio.

HANDY Electrical kinks on all phases of practical electricity. 47 ideas on wiring, 45 on making electrical devices, 19 on lighting, 5 on transformers, 5 on motors, 8 on generators, 11 on switches, 22 on testing, 12 on repairing, 11 on battery manufacture and repair, 5 on telephones, and 9 on electricians' tools. 214 articles, 162 pictures. Send no money. Just write postal for "Electrical Kinks." Pay postman \$1.50 and postage. Popular Mechanics Press, Room 808, 200 E. Ontario St., Chicago, Ill.

FOR FORD OWNERS

FORD Generators exchanged \$3.50 with your old one. 30 days' guarantee. A. J. Hildebrand, 2903 S. Felton St., Philadelphia, Pa.

I AUTO Gas saver sent. To introduce. All autos. Amazing mileage increases. Critchlow, RU-805, Wheaton, Ill.

AURORA Underslung parts and 3.1 racing gears. Speedster bodies, headlights, hi compression head. See Sport Factories ad page 123.

MOTORCYCLES, BICYCLES AND SUPPLIES

MOTORCYCLE Bargains, lowest prices, bargain sheets for stamp, special aviators supplies, motorcycle accessories largest line in America, lowest prices. Largest motorcycle mail order house in the United States. Rochester Harley Davidson Corporation, 129 West Main St., Rochester, N. Y.

HARLEY-DAVIDSON Bargains at a tremendous sacrifice. All models and prices. Guaranteed. Send for our catalog, "Money Saving Motorcycle Bargains." Knuth's Harley-Davidson Agency, 2525 Fond du Lac Ave., Milwaukee, Wis.

USED Motorcycle parts half price or less. New parts, accessories, repairing. New and rebuilt Indians, Harleys, others. J. B. Dahl, 3661 Archer Ave., Chicago, Ill.

MOTORCYCLES, All makes, used, \$15 up, new tires \$8, used parts half price. Harley Davidson Company, 2910 Washington Ave., St. Louis, Mo.

USED Motorcycles \$5.00 down, \$2.00 per week. Indian club plan. Speedometer free. Send 15c for latest catalog. Indian Motorcycle Sales, Kansas City, Mo.

BICYCLE Reducing, exercising, training machines, tandem frames. McDougald, 5322 Windsor Ave., Chicago.

AVIATION

GET Into aviation! Earn \$35 to \$100 weekly. World's fastest growing industry. Factories and airports need trained men. Unlimited future. Learn in spare time. Amazing home study method qualifies you in few short weeks. Personal, practical help of veteran world-war flyer. Employment help free. You must be over 18. Rush name, address for special tuition offer and illustrated book, free. Write Major Rockwell, Dayton School of Aviation, Desk BC-1, Dayton, Ohio.

A MOTORCYCLE Motor as such will not fly your plane. To insure success to your airplane you need the famous Heath-Henderson motor. Six years of constant flying and refinement have developed this motor to perfection as an aircraft motor. Don't buy a worn out motorcycle motor and expect aircraft performance. 10c in stamps or coin brings illustrated booklet; describing this wonderful little motor. Heath Airplane Company, Chicago, Ill.

THE Success of your sled, boat or airplane depends on the propeller. Heath propellers are made to fit each individual case by engineers of 22 years' experience. Heath propellers are therefore guaranteed to give better results and the price is no more. 4c in stamps brings propeller catalog. Heath Airplane Company, Chicago, Ill.

PROPELLERS 4', \$6.00; 5', \$10.00; 6', \$14.00. Propellers for snow and ice sleds, boats, road speedsters, canoes, hydroplanes and airplanes. Special propellers built to order for all types of craft. We carry the largest stock of small propellers in the United States. Twenty years of propeller building plus mass production means better propellers for less money. We ship the same day. Write for our free price list. The Crawford Motor and Airplane Manufacturing, Inc., Seal Beach, Calif.

BUILD And fly your own 3-place OX-5 biplane. Reproduction of one of the world's most popular airplanes. Blue prints and most complete shop work drawing. Wing curve and fittings drawn to exact size; price \$9.50. Fort Wayne Aircraft Company, 1213 Jones St., Fort Wayne, Ind.

THE American School of Aviation announces a new correspondence course in mechanics of aviation. A thorough training in practical aeronautics. American School of Aviation, Dept. 1872, 3601 Michigan Ave., Chicago, Ill.

HEATH Super parasol, America's most popular sport plane can now be purchased in 11 progressive groups and still at \$199. \$12.00 will start you building this wonderful little plane. 10c in stamps or coin for large illustrated booklet. See our ad page 125. Heath Airplane Co., Chicago, Ill.

FINEST Propellers, 4', \$8.75; 5', \$13.25; 6', \$16.50; special Henderson propeller, \$15.00; "Aerodrive" sled or boat parts 50c each. Everything aeronautical. Ostergaard Aircraft, 4303 North Narragansett, Chicago.

"SKYWARD Ho!" Wonder book on aviation—32 pages, 150 illustrations. Shows you complete training for flying career, fame, fortune! Sent free. Write today! Parks Air College, 213 Mo. Theatre Bldg., St. Louis, Mo.

2c **POSTAGE Stamp** will bring you complete model airplane supplies price list. A. A. C. Model Aircrafters, 340 East 188th St., New York.

NEW Gnome engine \$85. Clerget \$125. Albert Latschaw, Clarion, Mich.

\$175 WILL Build our beautiful steel fuselage one place monoplane. Plans \$1. Sail planes performance guaranteed \$350. Plans \$1. Literature 10c. Barney Snyder, Rochester, Ind.

LIGHTPLANE Ribs 15 to 25 dollars; aluminum seat, \$2.50; eyebolt hinges 15c; if it is for lightplanes we have it; new circulars 20c. Kamm Aircraft Co., 524 12th, Oshkosh, Wis.

THE Sea plane parasol is the world's most practical light sea plane. 10c in stamps or coin brings large illustrated booklet. Heath Airplane Co., Chicago, Ill.

SEND For free 24-page illustrated catalog of all latest and best books on aviation. Special lists classified by subjects and recommended by well-known aviation authorities are a helpful feature of this catalog. Popular Mechanics Press, 200 E. Ontario St., Chicago.

FOR Sale—Three OX-5 Curtiss aviation motors, complete, in good condition, for \$150 each. Miller Corporation, New Brunswick Airport, New Brunswick, N. J.

BUILD Model airplanes that fly. 52 page catalog illustrates 26 flying and exhibiting models. Complete line of accessories and supplies. Send 10 cents for big catalog. U. S. Model Aircraft Corporation, 397F Bridge St., Brooklyn, N. Y.

TIME Counts in applying for patents. See pages 138 and 139. Clarence A. O'Brien, Registered Patent Attorney, Washington, D. C.

TAPER Wing J5 Waco. 130 hours, never damaged, \$5,500.00. Nell McCray, Fairview, Penna.

AIRMAN Soloplane material \$195.00, circular dime. Airman, 1610 Sutter, San Francisco, Calif.

SIMPLEX Air Model Co., Auburn, Mass. Send five cents for supply booklet.

FLYING Simplified—Just out. Here is a remarkable non-technical book for beginners, prospective or advanced students that teaches in an easily understood manner all you can need to know to master the art of flying. Will save you many dollars when you learn to fly. Pay postman only \$1 and postage when book is delivered at your door C. O. D. Popular Mechanics Press, Room 802, 200 E. Ontario St., Chicago.

MODEL Airplane Supply. Catalog free. Hoosier Aero Supply Shop, Lafayette, Ind.

SELLEY Champion, semi-constructed miniature airplanes and supplies. Most realistic models ever offered. Aluminum adjustable pitch propeller, 8 in. 60c, 10 in. 75c postpaid. Send 5c for catalog. Selley Co., 1405 Gates Ave., Brooklyn, N. Y.

CONVERSION Parts for Ford and motorcycle motors. Send 10c for price list. Heine Motor Works, Orwigsburg, Pa.

LEARN How to make aerial surveys. Course includes flying, photography and engineering. Write for particulars to Hamilton Maxwell, Inc., Springdale, Stamford, Conn.

AIRPLANES Motors and propellers bargains. Smith, Box 1343, Houston, Tex.

BOYS: Get a pursuit tractor kit complete 25c. No stamps. Send 5c for price list. W. & J. Aeroplane Shop, 200 Maple St., Wyandotte, Mich.

GET The latest sportplane constructor book. Full of blueprints, photographs, drawings, detail instructions, etc. Postpaid \$1.00. May save you hundreds. Circular free. Russell Aero, Box 455, Toledo, Ohio.

PROPELLERS For model aeroplanes. Semi carved, 6", 8", 10", 12" 10c each. Any size. Aero Shop, 3050 Huribut Ave., Detroit, Mich.

BOYS—Model airplanes supplies 2ft. Curtiss Hawk Flying Model Construction Set containing all necessary parts. \$2.50. Baby R. O. G. Kit, 50c. Send 5c for booklet. Hawthorne Model Aero Co., Hawthorne, N. J.

BIGGEST, Best catalog model airplanes; parts, supplies; 5c postpaid. Ideal Company, 19 West 18th St., New York.

VARIOUS Sizes wood, reeds, bamboo, rubber band, wheels, propeller, onion skin covering and other supplies. Big bundle for 25c, five for \$1.00. No stamps. Will also send circular on free three foot model. Aero Shop, 3050 Huribut Ave., Detroit, Mich.

BUILD And fly model aircraft. Complete instructions cover all types including tournament prize winners. Lindbergh's famous "Spirit of St. Louis" and others. Great sport and very instructive. Official handbook approved by leading flyers, government officials and others. Sent C. O. D. anywhere in U. S. Simply pay postman \$2.25 and postage when delivered. Sent postpaid to any address upon receipt of price. Popular Mechanics Press, Room 801, 200 E. Ontario St., Chicago.

BOOKS AND PERIODICALS

4TH EDITION, revised "Radio Theory and Operating," by Mary Texanna Loomis. The standard radio text and reference book of America. 992 pages, 800 illustrations, flexible binding. Price \$3.50 postage paid. For sale by hundreds of book dealers throughout America and many foreign countries. Or may be purchased direct from the publishers. Send check or money order to Loomis Publishing Company, Dept. 18, Washington, D. C.

INDUSTRIAL Alcohol. Complete directions for making. Fully illustrated. \$2.50. Spon & Chamberlain, 120 Liberty St., New York.

HYPNOTISM Easily learned. Lessons guaranteed. Postpaid \$1.10. Smith Pub. Co., Dept. 3, Springfield, Mass.

SCARLET Letter 1850; Uncle Tom's Cabin 1852; Huckleberry Finn 1885; Tom Sawyer 1876; Moby Dick 1851. Dunbar, 1613 Rowena St., Boston.

BOOKS—Aviation, automobiles, formulas, electricity, radio, model making, etc. Discount prices. Catalog. Manhattan Co., 333 W. Manhattan Blvd., Toledo, Ohio.

SEND For "A Billion Ideas"—our latest catalog of books just issued. Thousands of good books listed on almost every subject. Free upon request. Popular Mechanics Press, 200 E. Ontario St., Chicago.

HYPNOTISM Easily earned. Lessons guaranteed. Postpaid, \$1.10. Smith Pub. Co., Dept. 3, Springfield, Mass.

WELLS' Outline of History now only \$1. The complete, illustrated, 1,200-page edition that originally sold for \$5.00. One of the most popular books ever published. Can be read with profit by young or old. Pay postman \$1.00 plus postage when delivered to your door C. O. D. Popular Mechanics Press, Room 802, 200 E. Ontario St., Chicago.

BOOKS For everybody. Home study, entertainment, novelties; catalog free. Nation-Wide Pub. Co., P-746 So. Homan, Chicago.

BOOKS, Regular 75c, only 67c postpaid. Latest movies, romances, mysteries, detectives, etc. List free. Robert Mosher, 323 New Newark, N. J.

YOU Need a better grip on mathematics? Ask us to send you a copy of "Mathematics for the Practical Man," only \$1.50. By common sense methods it removes the mystery and difficulties so algebra and calculus are made simple. Assuming your knowledge is limited to arithmetic you quickly and easily gain a working knowledge of algebra, geometry, trigonometry and calculus. Simply pay postman when he hands you the package. Address Popular Mechanics Press, Room 802, 200 E. Ontario St., Chicago, Ill.

PICTURES AND POSTCARDS

BEAUTIFUL Postcards of the log cabin where Lincoln was born, printed at his birthplace, 10c each or three for quarter. Lincoln Agency, Box 557, West Tulsa, Okla.

ARTISTIC Alaska scenes, dogteams, reindeer, Eskimos, totempoles, glaciers, etc., on 4x5 linen finish double weight paper 12½c each, dozen \$1.25. Elmer Reed, Box 195, Juneau, Alaska.

CALIFORNIA Postals in rich colors. Mountains, beaches, Hollywood studios, old missions, ostrich farm, wild flowers, blooming cactus, 12 assorted, 25 cents. L. Armstrong, 401 So. Olive, Los Angeles, Calif.

ART Pictures—220 all different. 160 samples \$1.00. Particulars 10c. Howard Sales Co., Dept. 15, Box 529, San Francisco, Calif.

TEN Imported lovers photos with illustrated novelty catalog \$1.00. Money refunded if dissatisfied. Photo Sales Co., Box 744-R, Chicago, Ill.

IMPORTED French lovers photos. Love scenes of fellows and girls, taken from life poses. 12 for \$1.00. Carrano Novelty Co., (PM-J) West Haven, Conn.

GAMES, ENTERTAINMENTS AND PLAYS

PLAYS, Musical comedies and revues, minstrels, comedy and talking songs, black-face skits, vaudeville acts, monologs, dialogues, recitations, entertainments juvenile plays and songs, musical readings, make-up goods. Catalog free. T. S. Denison & Co., 623 So. Wabash, Dept. 11, Chicago.

MAGIC TRICKS, BOOKS AND JOKER NOVELTIES

AMAZING Magic. Dime placed in anybody's hand. They close tight. Dime vanishes instantly. Satisfaction guaranteed. Complete indestructible apparatus \$1.50. Easy. Free. 35 master card tricks, circular free, Teycer, Magician, Box 1275P, Chicago.

MAGIC Tricks, card tricks, coin tricks, Hindu magic, hypnotism, ventriloquism. Popular books 10c each. All six, 50c. Geo. Fenner, 2401 Jefferson, Louisville, Ky.

TRICKS With cards. Easy to do. Produce any card called for. Name any card drawn from pack. 6 tricks for 25 cents, including large catalog listing over 600 tricks. Wizard Magic Co., Dept. 15-J, Box 1055, Station "C," Los Angeles, Calif.

BOOKS, Magic, occult, imported perfumes, incenses, herbs, novelties. Catalog, sample 10c. Marrelle Company, 159 N. State, Chicago.

MAGIC—Tricks, Books and Supplies. For amateurs as well as the great professionals. Anyone can learn through our instructions. Feature Acts in Mind-Reading, Spiritualism, Rope Ties, etc. Large illustrated professional catalog, 20c. Chicago Magic Co., 140 So. Dearborn St., Dept. B, Chicago, Ill.

ELECTRIC Fun! Seventy stunts, 110 volts, \$1. Kutting Sons, Campbell, Calif.

"KNOCKOUT Card Trick" and catalog, 10c. Watson Bros., 24 N. May St., Chicago, Ill.

MAGIC Catalog 20c. Lynn's, 105 Beach, Dept. 3, Jersey City, N. J.

200 TRICKS You can do—Mystify your friends; have loads of fun. This collection of tricks has been selected by Thurston for the average person. Neither unusual skill nor elaborate apparatus are required. Send for this 200-page illustrated book. Pay postman \$1 plus postage when delivered. If outside U. S. remit when ordering. Popular Mechanics Press, Room 801, 200 E. Ontario St., Chicago.

CHALK TALKS

CHALK Talk and become popular. Make money. Program \$1.00. Big prize contest. Seaman Studios, 2104 Liberty Ave., Terre Haute, Ind.

100 CRAYON Stunts \$1. Sailor Chris, 2936 Garfield, Kansas City, Mo.

10 COLORED Chalk sketches. \$1.10 pre-paid. Satisfaction guaranteed. Reeves, 835 38th St., Milwaukee, Wis.

ENTERTAIN Lodges, clubs, schools with magical chalk talks, crayon, clay, sand, smoke pictures. Learn one evening. G. E. Hendrickson, Argyle, Wis.

LAUGH Producing program, \$1.00. Catalog free. Balda, The Cartoonist, Oshkosh, Wis.

CHALK-TALK Your way to popularity. Audiences at your feet if you learn how to entertain with a few simple pictures. Little artistic ability needed. "How to Chalk Talk" tells what to say and what to draw. Profusely illustrated. Make money giving chalk talks. Just order on a postal. Pay postman \$1.00 and postage when delivered. Popular Mechanics Press, Room 801, 200 E. Ontario St., Chicago, Ill.

RADIO SETS AND SUPPLIES

\$5 RADIOS All makes Atwater-Kent, Majestic, R. C. A., and others. Hundreds—world's best makes. Used, new and rebuilt. Going at \$5 to \$65. Many formerly priced at \$150 to \$300. Amazing bargains. Backed by responsible guarantee and 30 years' experience. Write for big free list today. Brown's Radio Exch., Dept. E, 3018 East 91st St., Chicago.

NEW 300-Mile "pocket" radio, \$3.50. Complete with special loud receiver. No tubes or batteries required. Order direct. Spencer Laboratories, 116 Atlas, Akron, Ohio.

LIFELONG Underground aerial, less static, better reception. No lightning danger, guaranteed for life. Only \$4.00 prepaid. Expert Radio Shop, 14236 Indiana, Detroit, Mich.

TIME Counts in applying for patents. See pages 138 and 139. Clarence A. O'Brien, Registered Patent Attorney, Washington, D. C.

STAMP COLLECTING

WRITE For our free illustrated price list. The illustrated Scott price list is the most complete offering of sets, packets, junior album packets, airmail and special packets, catalogs, albums, stock books and accessories ever made available to the stamp collector. It is beautifully illustrated throughout, and contains a wonderful range of offerings from 10c to hundreds of dollars. Free for the asking. Now on sale. Scott's Specialized United States catalog, 1930 edition. Pocket size \$2.00. Scott's Airmail catalog. A complete catalog of all airmail and semi-postal airmail stamps 15c. Scott Stamp and Coin Co., 1 West 47th St., New York, N. Y.

BOYS—Packets 5c each—5 Albania, 3 Barbados, 25 Bavaria, 10 Canada, 3 Carinthia, 4 Chad, 10 China, 25 Czechoslovakia, 8 Dutch Indies, 5 Estonia, 3 Georgia, 4 Gold Coast, 10 Greece, 25 Hungary, 10 India, 20 Italy, 18 Japan, 20 Liechtenstein, 10 Holland, 15 Poland, 20 Roumania, 17 Russia, 15 Switzerland, 5 South Africa, 10 Wurtemberg, 22 packets \$1.00 with fine premium free. No approvals. C. Reimers Co., 30 N. LaSalle, Chicago, Ill.

MYSTIC "Queer Country" Packet! Contains scarce stamps from the following strange lands: San Marino, Antioquia, Congo, Cyprus, Fiji Islands, Gwalior Hyderabad, Iceland, Jhind, Kenya, Uganda, Lebanon, Monaco, North Borneo, Nyassa, St. Thomas Prince, Eastern Roumelia, Siam, Sierra Leone, Tanganyika, Trinidad Tobago, Ubangi, Upper Volta, Wallis Futuna, Alaucauts. Get this wonderful packet of "freak countries" and make your friends envious! Price only 10c to approval applicants! Write today. Mystic Stamp Company (Dept. 8), Camden, N. Y.

FREE! Largest stamp in the world! Fine packet 65 different stamps from Cape Verde, Jamaica, Mozambique, Syria, etc., including dying soldier, beautiful women, ships, maps, savages, airplane, scenes, bird and animal stamps, for only 5c to approval applicants. Largest Stamp in the World (Rare China Wild Goose Special Delivery) given absolutely free with each order. Supply limited! Send your 5c today! Western Philatelists, 4021 Harper Ave., M2, Chicago.

THRILLING War scenes. A packet of all different stamps showing exciting scenes and records of nations at war. Includes siege guns; firing squad; mounted troops; prisoners of war; fire-pot hurlers; hand-to-hand bayonet struggle; bloody battle scenes; troop transport; red cross stamp; dying soldier; victory stamps, etc. Send for this thrilling "Big Parade" packet at once—limited supply. Only 10c to approval applicants. W. A. Rowell, 58 Cornhill, Boston, Mass.

500 DIFFERENT Stamps for 25c. Big collection from Bosnia, Crete, Epirus, Honduras, Iceland, Kenya, Liberia, Malta, Nyassa, Quelimane, Siam, Zambesia and other "hard" countries. Catalog value \$10. Price 25c to approval applicants! Bargains, 1,000 different 79c; 15 triangles 49c; 100 British colonies 30c; 100 French colonies 35c; 100 Portuguese colonies 50c. Five packets for \$2.00! Illustrated lists free. Loma Stamp Co., 4231 42d St., San Diego, Calif.

ANCHERS \$\$\$ Outfit—only 12c! Fine triangle stamp; set German stamps with (pre-war) value forty million dollars (interesting!); perforation gauge, mme scale; airmail set; scarce stamp from smallest republic on earth; newspaper set; packet good stamps and Travancore, Malay, Dutch Indies, etc. Entire outfit for 12c to approval applicants! (Nice pocket stock book, value 25c, with every order!) Ancher Stamp Co., Box 126, Rutherford, N. J.

A SNAP—300 Different foreign and 60 different U. S. stamps, including \$1 and \$2 revenues, all for only 25c. Free, with each order, our pamphlet which tells "How to Make a Stamp Collection Properly," together with our price lists of albums, supplies and hundreds of bargains in sets, packets, etc. Queen City Stamp & Coin Co., Room 36, 604 Race St., Cincinnati, Ohio.

CANADA Airmail stamp free, if you ask for approvals and send 15c for 25 different airmails or 30 different Canada and Newfoundland, both packets only 25c. We list 282 countries in our dime packets. Special bargains—500 different 25c; 1,000 different 75c; 2,000 different, \$2.50. Victoria Stamp Co., London, 4, Canada.

ZANZIBAR! Packet. Queer freakish stamps from Zanzibar, Hoikar, Antioquia, Congo, Hyderabad, Gold Coast, Newfoundland, British colonials, Souamericans. Don't delay! Don't wait! This whopping packet free for 5c postage. Gray Stampco, Toronto, Can.

SARAWAK 1871, Cat. 25c given with any 50c order of the following: 25 Australia 25c; 10 Bosnia 10c; 20 Luxembourg 15c; 10 Montenegro 10c; 4 Vatican City 10c; 20 Turkey 10c; 25 Spain 10c; 1,000 diff. 85c. Argonaut Stamp Company, Dept. 32, New Canaan, Conn.

POLYNESIA, Australasia, Oceania. 30 stamps from Sarawak, Wallis, Tasmania, Samoa, etc., 15c to applicants for our 50 to 70% approvals. Silvermine Stamps Company, Dept. 31, New Canaan, Conn.

LINDBERGH Stamped envelope with special Col. Roberto Fierro (Mexican) cancellation. Simco, San Jose, Costa Rica.

200 DIFFERENT Stamps 10c; 1,000 hinges 10c. R. H. Carlton, 382 West So. Temple, Salt Lake, Utah.

100 FOREIGN Stamps 3 cents. Lufbery Stamp Co., Branford, Conn.

STOP! Rare packet Confederate States "essays," Abyssinia, Heligoland, Monaco, etc. All for 10c to approval applicants. Diefenbach, 514 Mountain Ave., Westfield, N. J.

212 DIFFERENT Stamps including U. S. \$2, Dominica, Syria, etc. Catalog \$4.90, only 15c. Robert Haynes, Point Place, Toledo, Ohio.

U. S. Price List free. 50 diff. U. S., 25c. Stamp House, 38 Torrey, Dorchester, Mass.

ILLUSTRATED Descriptive U. S. list, price 50c; also our 1930 32-page price list free. Stanley Gibbons, 38P Park Row, New York City.

TRIANGLES, Ten different. 15 cents to approval applicants. Patapasco Company, Walbrook Station, Baltimore, Md.

FREE! Airmail packet with approvals. Aladdin, 1550 Carroll, St. Paul, Minn.

100 DIFFERENT, 10c. Tchad, Epirus, Abyssinia, etc., to approval applicants. Irvin Batson, Wolbrook, Baltimore, Md.

FREE Stamps packet with bargain Hsts, postage 2c. Rheume, 7748 Henri Julien, Montreal, Can.

5 TANNOU Touva 10c to approval applicants. Prospect Stamp, Elliot Place, Jamaica Plain, Mass.

50 SCANDINAVIAN 10c. Approval applicants. Olson, 456 Ross Ave., Winnipeg, Canada.

NET Approvals, 1c to 5c. French colonies specialty. References, Burgess, 206 Press Bldg., Binghamton, N. Y.

SEND 10c For Liechtenstein set cataloging 54c with approvals. King-Carroll, 202 Lewis St., Geneva, N. Y.

BIG 10c Bargain: Pair stamp tongs; water-mark detector; set scarce Greece Red Cross; fine packet 55 different British and French colonies, including Egypt, Newfoundland, birds, scenery, animals, map stamps, etc. All for 10c to approval applicants. Highland Stamp Co., 62 Woodcliffe Road, Newton Highlands, Mass.

APPROVALS ½ And 1c. References. Premium given. G. W. Engelter, 306 Bridge, Streator, Ill.

YOUR Stamp collection needs Walpole Approval Sheets! Sheets stocked by countries. Your application will be promptly filled from stock of over 20,000 varieties and will contain a free surprise packet. Walpole Stamp Company, Walpole, N. H.

CONFEDERATE (Essays), 14 different, 5c. Watermark detector free. Tatham Stamp Company, Mittineague, Mass.

TURKEY, Chili, Indo China and many others 5c to approval applicants for U. S. and foreign 50% sheets. Best hinges 10c. World Stamp Co., No. 2 Hillside Ave., Somerville, Mass.

FREE—French cover 1855—to applicants for sets at 60% discount. Charles Cleaveland, 806 North Humphrey Ave., Oak Park, Ill.

CONGO, Free, five fine to approval applicants. Bernard Karch, Bengies, Md.

SOUTH Central America, 40 different, 10 cents. Approvals. Croston, Box 25, Haverhill, Mass.

STAMP Collectors Magazine. Finest monthly stamp paper. Write for free sample copy. Philatelic Publishing Co., Inc., 15 John St., New York, N. Y.

FREE—25 Different old U. S. to approval applicants. Flister, 527 Hicks Bldg., San Antonio, Tex.

105 CHINA, Etc., 2c. Album (500 illustrations) 3c. Bullard, 446 Tremont, Boston.

5 DIFFERENT Tannou Touva 10c. Webster's Stamp Shoppe, 1377 Park, Plainfield, N. J.

AIRMAILS! 25 Different 10c. Splendid approvals 50%. Webster Stamp, Tremont Sta., Box 11, New York.

1,000 DIFFERENT Stamps, 90c; 500 different, 35c; 200 different, 12c; 1,000 mixed, 35c; 1,000 hinges, 10c. Evans, Box 366, Reading, Penna.

COREA. Two varieties, catalog 20c only 6c to approval applicants. Plymouth, 463 Cyrus Place, Bronx, N. Y.

FREE—20 Different Africa. Atlantic Stamp Co., Garden St., Springfield, Mass.

FREE Outfit! 52 stamps, hinges, pocket wallet. Postage 4c. Approvals. Milton Angle, South Berkeley, Calif.

25 LATIN America, 10c approvals. Dime list. Hollister, 3523 N. Seeley Ave., Chicago.

500 MIXED 25c. 55 Different U. S. and colony 25c. Glenwood Stamp Co., 30 Athol St., Springfield, Mass.

CONFEDERATE Essays 6c with approvals. References. Applebaum, 1258 Brook, New York.

SET 3 Rare Korea 10c. Approvals 50% off. Bargain list. Packets and sets 10c up. Evanston Stamp Shop, 2412 Noyes St., Evanston, Ill.

VALUABLE Premium given with each order for packet 60 different stamps from remote lands including rare Mauritius revenue, Iraq, Sudan, Trinidad, Tobago, Johore, Gold Coast, Travancore, Orange River colony, etc. Only 5c to approval applicants. Viking Stamp Co., P. O. Box 63, Sheephead Bay Station, Brooklyn, N. Y.

200 DIFFERENT 10c. 20 different Cuba 10c. Lists free. Premiums given. William Kolberg, Beverly, N. J.

200 DIFFERENT 8c. Lists free. Midwest Stamp Co., Kemper Bldg., Kansas City, Mo.

CANADIAN Commemorative, a complete set of 9 var. air mail, 5 beautiful picture stamps and 100 other stamps, all for 5c to collectors who ask for our approval sheets. Prices on approvals, ¼, ½, ¾ a 1c, etc. Lowest prices and best quality. Keigwin Stamp Co., P. M., Fernandina, Fla.

ONLY 5c. 33 Different stamps including scarce Latvian triangular airmail stamps, 10 airmail, 12 United States (early issues, commemoratives, etc.) and 10 Canada. Approvals and illustrated pricelist sent with each order. Curhan Stamp Company, Gloucester, Mass.

FIVE Specials—all different. 60 U. S., 60 Latin-Americans, 60 Africans, 60 Orientals, 300 Europeans, 25c each, all for \$1. Ohio Stamp Co., Box 249, Cleveland.

SPECIAL! 1,000 Different stamps, 72c; 100 U. S., 70c; to approval applicants. Cleveland Stamp Co., 408 Caxton Bldg., Cleveland.

FREE, 6 Different Luxemburg to approval applicants. E. D. Stamp Co., 3905 Forest Park Ave., Baltimore, Md.

10 WORTH White stamps, catalog value over \$5.00, all western hemisphere, consisting mostly of old Newfoundland, Canada, U. S., etc., for only 10c to approval applicants. We are the leading and most up-to-date approval house in America. As soon as you hear from us, you will realize that "it pays to deal with Globus." Globus Stamp Co., 214 Third Ave., New York.

FREE! Loose leaf postage stamp album at rate of 8 pages each month given with subscription to monthly journal. Send 2c stamp for prospectus. United Stamp Co., Marquette Bldg., Chicago, Ill.

BRITISH Colonials free with approvals 2c postage. Lightbowns, Southsea, England.

SEE Our latest price list. Lake Stamp Co., Paterson, N. J.

KOREA 3 Mint 1886 15c; 5 Liberia 10c; 9 Nyassa Triangles 20c; 20 Turkey 10c; 4 Vatican City 10c; 10 Montenegro 15c; 25 Italian Colonies 15c; Rumania Airmail 20c; 1,000 diff 85c; album, 85 stamps, hinges, gauge 12c. \$1 catalog stamp free with every 50c order. Argonaut Stamp Co., Dept. 98, New Canaan, Conn.

NEWFOUNDLAND Catalog, with air mail section. Free. Rev. Butler, St. Georges, Newfoundland.

55 DIFFERENT Including scarce countries to approval applicants 4c. Richard Lamrecht, Valparaiso, Ind.

BEST One cent approvals in America. F. Hand, 1117 So. 60th St., Phila., Pa.

MAGNIFICAROUS Packet free—Beauties from distant lands, many richly colored, unusual designs. 2c postage. Empire Stamp Co., Toronto, Can.

NICE Air-mail covers, list free. R. Laughlin, Retreat, Penna.

STAMPS—100 Varieties, Africa, Brazil, Peru, Cuba, Mexico, etc., 10c; 25 different U. S. 25c; 1,000 mixed, 40c; 1,000 hinges, 15c. C. Stegman, 5941 Cote Brillante, St. Louis, Mo.

FREE Stamps with approvals. 2c postage. Harvey Teeple, Decatur, Ind.

COVERTCO Packet, 200 different stamps 10 cents, with 60% discount approvals. Covert Stamp, 39 State, Rochester, N. Y.

STAMPS Sent on approval at 70% discount. Reference required. Emory Renoll, Hanover, Pa.

FREE—31 Different stamps to applicants for Royal approvals. 2c return postage. Royal Stamp Company, Bristol, Pa.

150 **GOOD** Mixed foreign stamps 3 cents. Stanton, Niantic, Conn.

FREE—\$1.00 U. S. postage old issue free. If you write for our 56 page price-list of U. S. and foreign stamps, 2,000 illustrations. Also fine but cheap stamps on approval. Hussman Stamp Co., 620-3 Olive St., St. Louis, Mo.

FREE—Canada (15 Var.) for new applicant of my 1c, 2c and 3c approval, and also my 50% discount. Chas. W. Schmidt, P. O. Box No. 4832, Frankford Sta., Phila, Penna.

110 **DIFFERENT** Stamps, many unused, high values, free to collectors requesting our net approvals. Postage 2 cents. Christensen, Milwaukee, Wis.

ATTRACTIVE Approvals at 50% discount and 25% discount. Noemus Stamp Co., 312 East 23rd St., New York.

PENNY Approvals that Satisfy. Neil Gronberg, Box 5441, Philadelphia, Pa.

FREE! 115 Different stamps to approval applicants, 2c postage. Paige Stamp Co., Oak Park, Ill.

110 **NEW** Europe All Different, a wonderful collection cataloguing several dollars, free to collectors requesting our Net Approvals. Postage 2 cents. Badger Stamp Co., Milwaukee, Wis.

COMPLETE Sets on approval. References necessary. Kenneth White, Rockville, Conn.

FREE! Triangles, airmail, Iceland and 50 others to approval applicants including 3c postage. Hawkeye Stamp Co., Cedar Rapids, 39, Iowa.

UNITED States—Send on approval. Send me your want list. Ref. please. M. Hanna, New Kensington, Pa.

STAMPS, 100 all different. Postage 2c. Lists free. P. M. Quaker Stamp Co., Toledo, Ohio.

24 **VARIETIES** Cuban stamps, 10 cents. List of 6,000 low-priced stamps free. Address Chambers Stamp Co., 111P, Nassau St., New York City, N. Y.

FREE—20 Different Argentine. Approvals. List. Send 4c today for postage, etc. Reuter, Santa Ana, Calif.

BARGAIN Lists. Send postcard. Imperial, Box 1089, Vancouver, B. C., Can.

118 **STAMPS** Free with approvals. L. W. Hudson, Plainfield, N. J.

UNITED States \$2 present issue (catalogs 50c) for ten cents to approval buyers. State size of collection. Leduc, Redlion, Penna.

SPECIAL Watermark detector, 25 watermark stamps, instructions for use, etc., all for fifteen cents. Lake Stamp Co., Toledo, Ohio.

100 **VARIETIES**, Foreign stamps 10c to honest collectors. C. Taylor, Cross St., Newport, R. I.

33 **1-3% COMMISSION**. Sell our stamps, sheet catalog value, \$4. Our price, \$2.00. Unsold stamps returnable. No investment required. References necessary. Lux Stamp Co., 805-C Fairmont Place, Bronx, New York.

40 **DIFFERENT** United States 12c. 60% approvals. Also precancels. Seidenberg, Baroda, Mich.

RARE COINS

UNITED States commemorative half dollars. Pilgrim 89c, Monroe 89c, Stone Mountain 79c, Lexington 89c, Lincoln \$1.19, Norse American \$1.19, California \$1.69, Huguenot \$1.69, Bennington \$1.29, Oregon \$1.29, Grant \$1.39, Trade Dollars \$1.19; 10 large cents 79c; 10 two cent pieces 79c; 10 three cent pieces 89c; old coin and bargain price list 16c. Arey, Box 483, Muskogee, Okla.

OLD Money wanted—Will pay fifty dollars for nickel of 1913 with Liberty head (no buffalo). We pay cash premiums for all rare coins. Send 4c for large coin folder. May mean much profit to you. Numismatic Co., Dent, H. Ft. Worth, Tex.

PANAMA Pacific gold dollar uncirculated \$3.50. Grant gold dollar uncirculated \$3.50. 40 old coins all different \$1.00. 100 different coins \$3.00. 300 different coins \$10.00. Claud Denney, Box 315, Dallas, Tex.

UNITED States half dollars 1810 to 1814, \$1 each. 1818 to 1822, 95 cents each. 1823 to 1829, 90 cents each. Gold dollars, \$2.75 each. Monroe, Bennington, Pilgrim half dollars, 90 cents each. G. T. Davis, Box 1791, Huntington, W. Va.

1930 **SPECIALS** 25 Dates, large cents, \$2.00; 12 1922 cents, \$1.00; 5 Confederate bills, 25c; 3 1893 Columbian exposition tickets, 50c; 50 different foreign coins, \$1.00. Price list 2c. Romanocoinshop, Springfield, Mass.

UNITED States. Large cent, two-cent bronze, three-cent nickel and bargain list, 25c. Thirteen dates large cents, \$1.00. George Coffin, Greenwood Mountain, Me.

15 **DIFFERENT** Coins 25c. 30 different 50c. 66 assorted coins \$1.00. Oddehon, Box 681, Kansas City, Mo.

\$2 TO \$500 Each paid for hundreds of old coins. Keep all old money, it may be very valuable. Send 10 cents for illustrated coin value book, 4x6. Prices guaranteed. Get posted. We buy and sell. Clarke's Coin Office, Box 5, Le Roy, N. Y.

RARE United States, foreign coins, war medals. Chinese coin and catalog 10c. Alexis Mengelle, Colorado Springs, Colo.

CALIFORNIA Gold—Quarter size, 27c; $\frac{1}{2}$ size, 53c; 3c piece and catalog, 10c. Norman Shultz, Box 746, Salt Lake, Utah.

GET Profit and pleasure in collecting old coins. Send 10c for large illustrated coin catalog. You'll be delighted with it. Send for it right now. B. Max Mehl, Numismatist, Mehl Bldg., Dept. P, Fort Worth, Tex. Largest Rare Coin Firm in the U. S.

OLD Coins, large fall selling catalog of coins for sale free to collectors only. Catalog quoting prices paid for coins, ten cents. William Hesslein, 101A Tremont St., Boston, Mass.

3 **DIFFERENT** Fine bronze or nickel coin, 2 large crisp bank notes and catalog 10c. George Best, Cedar Rapids, Iowa.

CALIFORNIA Gold quarter 25c, half 50c. Chester Brooks, Cuero, Tex.

FOR BOYS

"**BOYS** Handcraft Booklet," 50c (coin). Gene Ward, 4287 W. 204th St., Cleveland, Ohio.

CAMERAS AND PHOTO SUPPLIES

BARGAINS—A few practically new items taken from our bargain list issued free. 1A autographic special kodak, f:4.5 lens. Kodamatic shutter, \$39.50. Autographic Grafex $3\frac{1}{2} \times 5\frac{1}{2}$ with kodak f:4.5 lens, \$64.75, and many others. Secure your copy now. Everything guaranteed, money returned if not satisfied in ten days. Central Camera Co., 230 S. Wabash Ave., Chicago, Ill.

HAVE You a Camera? Write for Free sample of our big magazine, showing how to make better pictures and earn money. American Photography, 116 Camera House, Boston, 17, Mass.

TIME Counts in applying for patents. See pages 138 and 139. Clarence A. O'Brien, Registered Patent Attorney, Washington, D. C.

FILMS Developed. Special Trial Offer. Any Size Kodak film developed 5c, prints 3c each. Trial 6x10 Enlargement in handsome folder 40c. Overnight Service. Roanoke Photo Finishing Co., 209 Bell Ave., Roanoke, Va.

MAKE Money in photography. Learn quickly at home. Spare or full time. New plan. Nothing like it. Experience unnecessary. American School of Photography, Dept. 3431, 3601 Michigan Ave., Chicago.

KODAK Films developed 5c roll. Prints 3c each. Trial offer. 8x10 enlargement 25c. Young Photo Service, 405 Bertha St., Albany, N. Y.

GERMAN Cameras, Lenses, Baritro 237 $\frac{1}{2}$ S. Spring St., Los Angeles, Calif.

ENLARGEMENTS 8x10 50c. Colored \$1. Trial kodak film developed, 5c, prints 3c each. James McSorley, 1520 Ball St., Eau Claire, Wis.

SAMPLE Enlargement—dime, and negative (returned). Trial roll, glossy prints, 25c silver. Brown, Warsaw, N. C.

MOTION PICTURES

SOUND Motion pictures! You must order this great and only authoritative text book on the subject by James Cameron, world's foremost authority. 400 pages crammed full of information on photo cells, Vitaphone, Movietone, Photophone, methods of recording, maintenance. We are selling thousands of copies. Price, \$5.00 postpaid anywhere. Bass Bargaingram No. 199 just off the press. Red hot bargains in standard and 16 mm. motion picture cameras, projectors and accessories. Send 4c in stamps. Bass Camera Company, Motion Picture Headquarters, 179 West Madison St., Chicago, Ill.

FILMS—Standard size 250 ft., \$1.00. Full of action. J. Brink, 56 Melrose St., Boston, Mass.

300 **FEET** Film, 90 cents postpaid. Star Films, Allentown, Pa.

\$1.250 **FOR** Original photoplay story. Our sales department sold unknown author's first story for above amount. We revise, copy-right and market stories for both silent and talking pictures. Located in the heart of motion-picture industry. We know the demand. Established 1917. Free booklet. Universal Scenario Company, 206 Western and Santa Monica Bldg., Hollywood, Calif.

BARGAINS—Just a sample few, practically new 35mm., Sept combination motion and still picture camera, \$19.50; 16mm., Eastman Cine model B camera, \$61.50. For other bargains, refer to our bargain book issued free. Everything fully guaranteed and ten days trial allowed. Central Camera Co., 230 South Wabash Ave., Chicago, Ill.

BE A movie exhibitor. Big opportunity. Only moderate capital required. Complete equipment at remarkably low prices. Write Atlas Moving Picture Co., 825 So. Wabash, Chicago, Ill.

FILMS, New and slightly used, features and serials, \$2.50 to \$5.00 per reel, including advertising. Rosenthal Film Co., 3306 Olive St., St. Louis.

FILMS (New) natural color 50 ft. \$1.00. Worth \$12.50. Westerns, Indians, no lists. Hemenway Film Co., 37 Church St., Boston, Mass.

HOLLYWOOD Slangage. A snappy hip pocket movie dictionary. Over four hundred definitions, including the latest Hollywood slang. Just out, 35c. Studio Novelty Press, 1814 Irving St., San Francisco, Calif.

\$1.00 **POSTPAID** For motion pictures with the Baby Cine, the sensationally new Pathe automatic motion picture camera. Film completely developed for \$1.75. Big Pathe catalog free. Send \$1.00 today to Motion Picture Headquarters, Bass Camera Company, 179 W. Madison St., Chicago, Ill.

UNIVERSALS, Wilarts, DeVrys, Filmos, Pathex, Tripods, Screens, Lens. List for stamp. F. W. Buchanan, 320 Walnut St., Johnstown, Pa.

LEARN Theatre management as a business or profession. Theatre Managers Institute, Elmira, N. Y.

BOYS—You can save 10% on all your movie supplies. Fine big catalog on machines. Charles Chaplin films 'n' everything for 2-cent stamp. Scholefield, Jr., Film Dealer, 6801-03 Carpenter St., Chicago, Ill.

BARGAINS: Machines, films, supplies, stereopticons. National Equipment Company, Duluth, Minn.

TIME Counts in applying for patents. See pages 138 and 139. Clarence A. O'Brien, Registered Patent Attorney, Washington, D. C.

GOOD Film—300 feet \$1.00. Reels \$2.45. Samples, lists, particulars for stamp. Eastin Feature Films, Galesburg, Ill.

NEW And rebuilt projectors for theaters, schools, churches, traveling shows. Supplies and complete theater equipments. Bargain prices. Free catalog. Monarch Theatre Supply Co., Memphis, Tenn.

MOVIE Films, 1,000 ft. reels, \$2.50 each; shipped anywhere on receipt of remittance. Particulars on request. Independent Films, 177 Golden Gate Ave., San Francisco, Calif.

FILMS, Machines, Stamp for list. Box 255, Hickman Mills, Mo.

FILMS, 300 Ft. \$1.00, reels \$1.95. List. Edgeworth Sales, Box 155, Blue Island, Ill.

MOVIE Films. New list of big bargains free. Write Home Movies, Box 744, Minneapolis, Minn.

SPRING Motor 35m movie camera \$25; movie projector, \$35. Negative stock 2 cents foot. Pathex camera and projector, \$33. Bargains in 16m cameras, kodaks, typewriters. Ray, 266 W. 46th St., New York.

TRADE AND TECHNICAL SCHOOLS

OUR Extension course covers entire subject of radio. Graduates allowed three months finishing course free at the college. Tuition charge moderate. Have always placed graduates at pay ranging \$150 to \$300 monthly from the start. Write for catalog. Loomis Radio College, Dept. 7-A, Washington, D. C.

DRAFTSMEN! Be an expert. Our method trains you quickly. Books and tools furnished. Write for illustrated catalog. Columbia School, 2048 Drexel Bldg., Philadelphia.

BE A blue print reader. Men in your trade have succeeded. Write for facts. What's your trade? Carroll Rumsay, Drexel Bldg., Philadelphia.

LEARN Morse and wireless telegraphy. Big salaries. Tremendous demand. Expenses low, can earn part. Catalog free. Dodge's Institute, Fern St., Valparaiso, Ind.

HILES Watchmaking and engraving school. The largest and best equipped school in the west. 5330 Mission St., San Francisco, Calif.

BUSINESS OPPORTUNITIES

WITHOUT Exception most profitable opportunity ever offered. Unlimited possibilities—plan unique—unbelievable results; small investment for advertising matter only; no stock to carry; permanent income; no effort required; tremendous number buyers developed automatically. We warehouse and deliver for you. Anyone can succeed with this most profitable of all sales plans. For full particulars write The Finance Corporation, Desk K, 522 McKnight Bldg., Minneapolis, Minn.

LOIDLAC. Chemist's amazing new discovery. Forever ending automobile polishing and repainting! Instantly restores all colors, producing hard, brilliant lustre-finish. Guaranteed water, sun and weather-proof. You make Loidlac from my guaranteed exclusive copyright-protected formula for \$1.40 gallon, sell at \$14.00 a gallon profit! Write for exceptional offer. Miller, Chemist, 707 Jetton, Tampa, Fla.

PAINTERS And paint dealers: This is a plastic paint period. Earn good profits selling or applying Plastone, the finest plastic paint on the market. Beautiful colored texture effects are very simple to produce. Each order will bring dozens of others. Build a good business as plastic paint expert in your section. Write for full particulars or send \$2.00 for generous trial sample and color cards. Everlastone Products Corp., Everlastone Square, Baltimore, Md.

START A home manufactory. Ten "tested" manufacturer's formula processes 25c. Lewis Irons, Terre Haute, Ind.

250,000 ARTICLES At low wholesale prices. Directory 10c. W-Publishers, 4111 University, Des Moines, Iowa.

LEARN Marbleizing. The greatest discovery in cement composition. With our processes it can be brushed on like paint. Resembles polished marble, veined perfectly, flintlike hardness, veneers over any concrete products, wallboard, lumber. Inexpensive, anyone can do. 200% profits; wonderful opportunity. Address Cowell Institute, Grayling, Mich.

MAKE \$20.00 A day cleaning wallpaper with new invention. Write Superior Specialties, Springfield, Ill.

OPPORTUNITY Earn big pay, be your own boss, releveling butcher chopping blocks, machines cut any size or shape block, connects to light socket. Portable Block Leveling Machine Co., 210 Lafayette St., New York, N. Y.

"SCHEMER Magazine," Alliance, Ohio, prints big \$-getters. Subscribers report \$10,000 to \$50,000 from its schemes, tips, formulas. 32nd year. Only \$1.00; 3 months, 30c. Now subscribe!

START A Business. In your spare time make your own goods from our tested formulas. Quick sales and large profits. Information free. Bureau of Formulas, 1534 N. Milton Ave., Baltimore, Md.

START Your own mail order business. Write for free information. Box No. 1071, Knoxville, Tenn.

SMALL Capital starts profitable route peanut and gum vending machines. Particulars free. Robbins Corp., Dodworth St., Brooklyn, N. Y.

\$2,000 To \$5,000 Made yearly in real estate brokerage business. Learn how. Write to The Noel Land Agency, 821-A Equitable Bldg., Baltimore, Md.

"MAIL Order Selling" magazine. Contains new ideas each month. 3 months' subscription 25c. One year \$1.00. Mail Order Selling, Brookfield, Ill.

WE Sell new inlaid articles. Write for price list. Importer's Shop, 507 Tarrytown Road, Pleasantville, N. Y.

MIRRORS Resilvered at home. Costs near 5 cents per square foot; you charge 75 cents. Immense profits plating like new, brassy, worn-off autoparts, reflectors, tableware, stoves, etc. Outfits furnished. Details free. Sprinkle, Plater, 127, Marion, Ind.

24 MONEY-MAKING Plans \$1.00. Clarence Utrup, 248 Willard St., Toledo, Ohio.

DOLLARS For names. Complete instructions and where to sell, 25c. Mack, Box 124, Lowell, Mass.

MAKE Black, brown, white, Floragraph paintless show cards home first day. No hand lettering. Outfits \$2.00 up. Stores make own signs. Tested screen process included. Two 12x18 samples, 50c. Laird's Floragraphs, 5925 Eggleston, Chicago.

SCREW-HOLDING screw driver! New patented invention! Removes, inserts screws inaccessible places. Factories, garages, electricians, mechanics, auto, radio owners buy on sight! Two sizes. Your profit 75c each. Exclusive territory. Free trial offer. Jiffy, 1319 Winthrop Bldg., Boston.

NICKEL-SILVER Plate auto parts, silverware, jewelry, lighting fixtures. Free laboratory solutions. Big money evenings in basement or spare room. Send stamp for samples, data. Lincoln Engineering Company, 855-F South 37th, Lincoln, Nebr.

\$20.00 PER 100 Stamping keytags. Sample and instructions 25c. Ruth Tag Co., Wheelersburg, Ohio.

MAKE Money manufacturing building materials. Granite, marble, fire proof paint, flooring, roofing. No machinery. Cheap. Big profits. International School of Cement Arts, 443 E. Washington St., Portland, Ore.

FAST-SELLING Specialties: Make them yourself! Best formulas, processes; guaranteed. Gerard Research Laboratories, Wheeling, W. Va.

SUCCESS, Prosperity with our collection of business plans. Modern. New. Trade secrets. Formulas. Mail order. Can't be beat. Everything \$3.25. Commercial Educators, Desk A, 311 West 13th, Kansas City, Mo.

LATEST Business guide now ready. Modern, complete, dependable. Information free. Stamp appreciated. B. Wolf, 6618 Quimby, Cleveland, Ohio.

SIX Hours a week spare time and twelve numbered gum venders placed with good merchants will earn you \$500.00 monthly. Sample \$18.00. Write for territory. Sanders, Mfg. Co., Nashville, Tenn.

80c PROFIT On \$1.00 sale. Splendid cleaner for automobiles, furniture, metal and glass. Your name on labels. Exclusive territory. Sample 10c. Particulars free. Minute Kleen Laboratories, Dept. E, Evansville, Ind.

ARTIFICIAL Marble sanitary flooring, instructions covering wood or cement flooring 1/2 inch thick, fireproof, all colors, low cost. Ornamental casting, concrete, plaster, papier-mache decorations, garden furniture, statuary, flexible molds, particulars and illustrations free. Chris. Mahler, Huntington, N. Y.

CONCRETE Building block manufacturing, is your home town opportunity. Particulars free. Concrete Machine Co., 5 Main St., St. Louis, Mo.

MAKE Your own products. Employ agents yourself. Toilet articles, soap, extracts. We furnish everything. Valuable book free. National Scientific Laboratories, 1935W Broad, Richmond, Va.

MAKE Big profits with a fur farm in your backyard. Chinchilla rabbits, muskrat, mink. Write for facts. 252 Conrad's Ranch, Denver, Colo.

BIG Money awaits you here. 250 signs and pictures an hour without press, type or machinery. Samples and particulars 10c. Straco, 1013 Mulberry, Springfield, Ohio.

WE Start you in business, furnishing everything. Men and women, earn \$40 to \$100 weekly operating our original "New System Specialty Candy Factories." Begin home spare time. Unlimited opportunity. Valuable booklet free. W. Hillyer Ragsdale, Drawer 4, East Orange, N. J.

400% PROFIT Selling imported and American novelties. A \$5.00 investment will earn \$180.00. Valuable and useful samples. Complete information 25c. Northwestern Company, 543-M North Ashland, Chicago.

DON'T Sell for others—Employ agents yourself. Make your own products. Toilet articles, household specialties, etc. 500% profit. Valuable book free. National Scientific Laboratories, 1935W Broad, Richmond, Va.

"ODD-THINGS"—Money making Ideas! Schemes! Plans! Tips! Opportunities galore! New—different! Special three months' subscription, 10c postage. "Odd Things," 1516 Prospect, Cleveland, Ohio.

"IF You want to fly" let Alexander Klein, brilliant engineer, teach you. With great skill whole course of training has been simplified and made crystal clear. Remarkable book teaches in most practical and easily understood fashion. Recommended by skilled fliers. Sent C.O.D. anywhere in U. S. Simply pay postman \$2.50 and postage when delivered. Sent postpaid to any address upon receipt of price. Popular Mechanics Press, Room 801, 200 E. Ontario St., Chicago.

GUARANTEED Honest, workable money making propositions. Many lines. Little or no capital required. City or country. Send 10c for bulletin. Nebraska Technical Society, 801 Omaha National Bank Bldg., Omaha, Nebr.

RESPONSIBLE Manufacturer wants competent men open office, manage salesmen; \$200 to \$1,000 necessary. Will pay expenses to Baltimore if you qualify. Address Manager, 603 N. Eautaw St., Baltimore, Md.

AMATEUR Cartoonists: Sell your work. Write Smith's Service, PX1194, Wenatchee, Wash.

THAXLY Formulas produce perfect products. All lines. Catalog free. B. Thaxly Co., Washington, D. C.

UNPATENTED Ideas can be sold. I tell you how and help you make the sale. Free particulars (Copyrighted). Write W. T. Greene, 910 Barrister Bldg., Washington, D. C.

SIGNS And showcards easily painted. If you use Letter Patterns. Write for free samples. John Rahn, B2120 Neva Ave., Chicago.

SUCCEED With your own products. Make them yourself. Formulas, processes, trade-secrets. All lines. Catalog, circulars free. B. Thaxly Co., Washington, D. C.

CHEMICAL Expert will furnish formulas and trade secrets. All lines. Lists free. W. L. Cummings, Ph. D., 223 Gordon Ave., Syracuse, N. Y.

SELL By mail! Books, novelties, bargains! Large profits! Particulars Free! B-Elfco, 525 South Dearborn, Chicago.

DELAWARE Charters; fees small; free forms. Chas. G. Guyer, Wilmington, Del.

I MADE \$30 a week home. French bread-making. 15 years' experience; free booklet tells. Ashbrook 67, Marengo, Ohio.

FREE Book. Start your own little business anywhere, selling novelties by mail. My beginner's outfit contains everything required, novelties, circulars, instructions, etc. Descriptive book free. Hadwil, 3A-74 Cortlandt St., New York.

LEARN The collection business. Good income, quick results. Interesting booklet, "Skillful Collecting" free. National Collectors Assn., Long St., Newark, Ohio.

A BUSINESS Of your own making—Sparkling Glass Name and Number plates. Checkerboards, signs. Big book and sample free. E. Palmer, 540, Wooster, Ohio.

CHARTERS: Delaware; best, cheapest; free forms. Colonial Charter Co., Wilmington, Del.

KING System mail order, co-operative idea. It's different! Honest! Big profits! Details free. Evans P. King Co., Wilmington, Del.

FREE Booklet describes 67 plans for making \$20-\$100 weekly in home or office business of your own. Elite Co., 84 Elizabeth St., New York.

CAPITAL—For copy, the "Promoters' Hand Book," a leaflet on financing; an eye opener for capital seekers. Send \$1.00 to Amster Leonard, East Orange, N. J.

MAN in each town to plate auto parts, reflectors, bathroom fixtures, refinish beds, mirrors, chandeliers; by new method. No capital or experience required. Simple plan of manufacturing at home starts you in big money-making business. Outfit furnished. Free particulars and proofs. Gun Metal Co., Ave. H, Decatur, Ill.

CHEMICAL Expert furnishes manufacturing formulas with working directions. Individual services, charges reasonable. Correspondence solicited. Dr. Vanheeden, 2410 Congress St., Chicago.

YOU Want a mail-order business that will bring you large returns, with unlimited expansion? No competition, no manufacturing. Exceptional plan, samples with simple instructions. Send \$1.00; permanent income guaranteed. Dale Specialty Company, 1476 Broadway, New York.

10,000 MONEY-MAKING Formulas. Tells you how to make and sell almost everything under the sun; cosmetics, mucilage, anti-freeze solutions, battery solutions, beverages, cheese, chewing gum, cleaning preparations, extracts, hair preparations, inks, bluing, leather polish, mirrors, perfumes, polishes, typewriter ribbons, carbon paper, washing powders, liquid soap, and hundreds of other profitable articles. Send no money. Just write a postal for "Henley's 20th Century Book of Formulas." Pay postman postage and \$4. Popular Mechanics Press, 200 E. Ontario St., Room 802, Chicago.

BUSINESS Profession of your own and earn income in service fees. See Stephenson Laboratories, display ad page 137.

TIME Counts in applying for patents. See pages 138 and 139. Clarence A. O'Brien, Registered Patent Attorney, Washington, D. C.

MECHANICS, Painters, carpenters, start furniture refinishing, painting, handyman shop on nearly nothing; winning plan brings customers quickly. John Braceland, 1439 So. Ninth, Philadelphia, Pa.

TELEGRAPHY

LEARN Morse and wireless telegraphy. Big salaries. Tremendous demand. Expenses low, can earn part. Catalog free. Dodge's Institute, H St., Valparaiso, Ind.

CHEMISTRY

CATALOG Listing 2,500 illustrations chemists' supplies, 5,000 chemicals, 1,000 scientific books sent for 50c. Laboratory Materials Company, 643 E. 71st St., Chicago, Ill.

CHEMICAL Fun! Hundred home experiments \$1. Cutting Sons, Campbell, Calif.

"HANDBOOK For Chemical Experimenters." Hundreds of interesting experiments. Illustrated. Postpaid 50c. General Chemical Company, Box 397, Reading, Penna.

CHEMICAL Analysis, processes, technical information. Robert Henderson, Laboratory, Madison, Me.

YOUR Chemical problems solved and formula or process furnished for \$5.00. Write me, W. Stedman Richard, Industrial Chemist, Box 2402, Boston, Mass.

FORMULAS AND TRADE SECRETS

DON'T Buy spurious formulas! Write Dr. Owens, 1694 Martindale, Indianapolis.

FORMULAS, Processes; all lines. Moderate charges. Individual service. L. Clore, Industrial Chemist, Crawfordsville, Ind.

FORMULAS: Hardest glue for patterns, radio, home, shop, etc., 50c. 3506 Harrisburg Blvd., Houston, Tex.

NEWEST Tested formulas. Particulars, catalog free. Grinstead Laboratories, Oswego, Kans.

3,000 VALUABLE Formulas prepaid \$1.00. National Service, 3937 Marburg, Cincinnati, Ohio.

MAKE Imitation honey; send one dollar for formula. Frame, Rockland, Ohio.

15 TESTED Money making formulas \$1. Braun, 4012 83rd St., Elmhurst, N. Y.

\$4,223.00 PROFIT From a town lot in one year. H. Cecil Sheppard tells you his disastrous and profitable experiences in raising chickens from the start until in the sixth year he took the above net profit. He would have gladly paid \$100 for this information during the first years. Send for his book. Price only \$1. Pay postman when delivered, or, if outside U. S., remit when ordering. Popular Mechanics Press, Room 801, 200 E. Ontario St., Chicago.

DON'T Sell for others—Employ agents yourself. Make your own products. Toilet articles, household specialties, etc. 500% profit. Valuable book free. National Scientific Laboratories, 1935W Broad, Richmond, Va.

SUCCEED With your own products. Make them yourself. Formulas, processes, trade secrets. All lines. Catalog, circulars free. R. Thaxly Co., Washington, D. C.

GUARANTEED Formulas, best science can produce for making popular, biggest-selling specialties all lines. Don't buy formulas till you've received valuable eye-opening literature. Miller, Chemist, 706-F Jetton, Tampa, Fla.

500 FORMULAS And big illustrated catalog 25c. Ideal Book Shop, Park Ridge, Ill.

MAKE Your own products. Employ agents yourself. Toilet articles, soap, extracts. We furnish everything. Valuable book free. National Scientific Laboratories, 1935W Broad, Richmond, Va.

FORMULAS: Guaranteed, catalog free. Bestovall Laboratories, 6720 Oconto Ave., Chicago.

FREE Formula catalog. Latest money makers. Western Chemical, Salem, Ore.

FORMULAS All kinds. Catalog free. Clover Laboratories (P), Park Ridge, Ill.

RADIO Service and repair men, dealers, salesmen, experimenters and designers—you will find Drake's Radio Encyclopedia covering 1,700 subjects arranged especially for your use. 920 pages, 1,000 illustrations. Most comprehensive radio reference book published. Delivered to your door C. O. D. Simply pay postman \$6 and postage. Popular Mechanics Press, Room 801, 200 E. Ontario St., Chicago.

AGENTS WANTED

WANTED At once: More good men to introduce and retail Rawleigh's Good Health Products. Town and country. Wonderful opportunity. Get into business with backing of largest manufacturer its kind. Capital over 15 million dollars. Quick freight, express, parcels post service from 10 great factories and branches—one near you. Nothing new—no experimenting. No experience required. You simply follow the same old time-tested Rawleigh Methods which secure the most business everywhere and have given consumers best values and satisfaction for 40 years. 170 necessities frequently needed every home. Enormous demand. Annual sales now over 35 million products. Big free trial inducements. Quick easy sales. Repeat every 30-60 days. Enormous profits—\$200-\$400 month and more clear profits. Steady year around; no lay-off. No boss—you become sole owner and manager. Practically no capital required. We supply everything—stocks, outfit, sales and service methods. Big pay every day. Profits increase every month. "First come first served." For full particulars write W. T. Rawleigh Co., Dept. A-2PPM, Freeport, Ill.

GOODWEAR, Inc., announces sensational new profit-sharing plan. Write at once. Get full facts. Make no arrangements for spring until you get our announcement. Entirely new sensational plan. Every experienced tailoring salesman, specialty salesman, or new man ambitious to break into field should get in touch with us at once. Address Dept. 304, Goodwear, Inc., 844 West Adams St., Chicago.

AGENTS: Big chance to earn \$15 to \$25 daily, introducing new, patented, automatic safety ventilating window lock, for houses, stores, banks, garages, offices; 3 to 12 needed every house. Recommended by police, insurance people everywhere. No competition. Nothing like it on earth. Be first in your locality. Sample easily carried in pocket. Elmwood Mfg. Company, 1202 Elmwood Place, Cincinnati, Ohio.

EVERY Man needs a bill fold for the new size currency. Our line can't be beat in quality or price. Send one dollar for samples and wholesale prices. Your dollar refunded on first order. Boyer Specialty Co., Box 1186, Wichita Falls, Tex.

AGENTS—Up to \$72 weekly, introducing hosiery guaranteed 6 months or replaced. 126 styles, colors for men, women, children. Undersell stores. Auto and hose offered. Credit given. Outfit furnished. Willkit Hosiery, Dept. AC-8631, Greenfield, Ohio.

SENSATIONAL! New everywhere! San-Pro-Tex protects milk from filth, thieves; biggest-money-making sales proposition in America! Absolutely without competition! Wildfire demand! Write for facts! Convince yourself! Sanprotex, Shelby, N. C.

EARN More pay the Quaker way. Take orders, complete line men's shirts, ties, underwear, hosiery. Remarkable values. All quick sellers. Big commissions. Earn your shirts, ties, cash bonuses. Satisfaction guaranteed. Complete outfit free. Write today. Dept. S206, Quaker, 1107 Broadway, New York.

MEN Wanted—to demonstrate and take orders direct from motorists. Amazing magnetic trouble light. Sticks on metallic surfaces. Our men earn as high as \$75.00 weekly. Write for demonstrator. Magno, Beacon Bldg., Dept. 182, Boston, Mass.

AGENTS: Sell nursery stock. Free landscape service. Wonderful possibilities. Pay check weekly. Write for particulars. Perry Nurseries, R-2, Rochester, N. Y.

AGENTS—Make a dollar an hour. Sell new kind of sharpeners. Sharpens all knives and tools quickly. Demonstrating sample 10c. Premier Mfg. Co., Dept. 100, Detroit, Mich.

GOLDEN Opportunity for making money. No competition. Sells itself. Write today. Rudley Mfg. Co., Inc., 230 Market St., Philadelphia, Pa.

OH Hello! Why didn't I see this before? Christy's Iron Rust and Stain Remover sells like blazes. Write for free sample. Christy, Inc., 5067 Broadway, Newark, N. Y.

SHOE Salesmen—Sell garages, gasoline stations, etc. Our five months guaranteed shoes with special soles. Make \$50.00 weekly. Write Moench, 140 Beach, Boston, Mass.

AGENTS—\$10 Daily demonstrating amazing miracle tool. Gives hand one-ton power. Outgrips 40-lb. vise. Quick seller, shops, factories, garages, farms, homes. Big commissions. Free demonstrator offered. Flash Sales, PMCB, 4809 N. Ashland, Chicago, Ill.

WELLS Cleared \$620.00 in one month with Business Guide and free legal service. Write for free outfit. Prof. Nichols, Dept. 71, Naperville, Ill.

\$3 TO \$10 Hourly demonstrating amazing door check. Finger-touch shuts all doors silently. No slamming. No broken glass. Keeps doors open when wanted open. Low priced. Big commission. No competition. Quick demonstration sells several to almost every home, office, factory, public institution. Write! Kant-Siam, Dept. XC-5, Bloomfield, Ind.

UNUSUAL Income. Every community. Sell homes, shops, theatres, stores, banks, schools, etc., the new Fugo, world's simplest fire protection. No sales experience necessary; we teach you. Part or full time. Act quick! The National Formetal Co., 6547 Metta Ave., Cleveland.

NEW! Different! Milady's Novelty Clothes Brush. Rainbow colors create instant sales. Wadleigh made \$24 first day. Free sample. L. Jensen Co., 304 So. Dearborn, Chicago.

CHICAGO Expert valued \$3 stone at \$900. The diamond's only guaranteed rival! Greatest spare time side-line article ever known! Amazing profits. \$5 pocket sample case free. Write quick! Mexican Gem Company, Dept. PM, Monterey, Calif.

NEW, Profitable—Sell auto step mats. Quality rubber with owner's name molded white. Details free. Ebonite Products, B-80, 895 Main, Akron, Ohio.

NEW Startling seller. Rayon bedspread. Tremendous profits. Take orders. We deliver. Sample free. Bestever Co., 201 Irving Park Station, Chicago.

AGENTS 40 To 50% profit. Sell complete new line guaranteed hosiery. All colors, styles. Work all or part time. Free hose for your own use with your outfit. Write today. Fashion Silk Hosiery Co., Desk 231, Cincinnati, Ohio.

AGENTS—\$15 A day is easy with our wonderful new line of soaps. Biggest line on market. Highest quality. Beautiful packages. Large orders in every home. Steady repeat business. Write today for particulars. American Products Co., 4981 Monmouth, Cincinnati, Ohio.

MIRRORS Resilvered at home. Costs near 5 cents per square foot; you charge 75 cents. Immense profits plating autoparts, reflectors, tableware, stoves, refinishing metalware, etc. Outfits furnished. Details free. Write Sprinkle, Plater, 128, Marion, Ind.

SELL Changeable signs to stores. 3 colors, 6 lines, size 14x24. Costs 40c, sells for \$1.50. Two sample signs postpaid \$1.00. Particulars free. National Sign System, 215 So. Broadway, St. Louis, Mo.

400% PROFIT Selling perfumes. Melrose Works, Box 731, Chicago, Ill.

SELL Complete line household brushes. 100% profit. Free gift brushes furnished. Liberal territory allotment. Big sample case outfit now only \$10.00. Write for catalog. National Fibre Broom Co., St. Louis, Mo.

GREATEST Opportunity; newest proposition. Build continually paying business in your own name. Household, industrial, brushes, brooms, mops, dusters, fully guaranteed. New catalog, all net prices, no discounts to bother with. Make as high as 300 per cent and over. Write today. Wire Grip Sanitary Brush Corp., 41 East 11th St., New York.

DON'T Sell for others—Employ agents yourself. Make your own products. Toilet articles, household specialties, etc. 500% profit. Valuable book free. National Scientific Laboratories, 1935W Broad, Richmond, Va.

GENUINE Gold Leaf Letters anyone can put on store windows. Guaranteed to never tarnish. Large profits. Enormous demand. Free samples. Write today. Metallic Letter Co., 438-D North Clark, Chicago.

SALES Agency offered to ambitious men pays splendid income. Complete line men's shirts, ties, underwear, hosiery. No investment. We furnish everything, deliver, collect. Guarantee satisfaction. Earn shirts and ties. Cash bonuses. Write today. Dept. S2, Quaker Shirt, 1107 Broadway, New York.

TIME Counts in applying for patents. See pages 138 and 139. Clarence A. O'Brien, Registered Patent Attorney, Washington, D. C.

DON'T Sell for others—Employ agents yourself. Make your own products. Toilet articles, household specialties, etc. 500% profit. Valuable book free. National Scientific Laboratories, 1935W Broad, Richmond, Va.

BECOME An employer yourself. Establish a real, successful, highly profitable business of your own, in spare time, with little capital. Manufacture your own toilet articles, household, auto or medicinal specialties or we will supply everything and show you how to proceed. 25 years successful experience to guide and help you. Ruskin Company, 1501 Euclid, Cleveland.

AGENTS: Free catalog 200 household specialties, toilet preparations, food products, remedies, portraits, frames, photo pillows, medallions, religious gods, pictures, damask tablecloths. Credit. James C. Bailey Co., Station C1, Chicago.

NEW Invention. Cleans wallpaper. Make \$18.00 to \$30.00 a day. No selling. Write Superior Specialties, Springfield, Ill.

TAKE Orders for guaranteed boys' and youths' spring suits. Big commissions in advance. Experience unnecessary. Sample outfit free. Write Craige-Wilson, 688 Broadway, Dept. BC-14, New York.

PORTRAIT Men! Handle our portraits. They deliver. Satisfy. Finished beautifully. Likeness guaranteed. Lowest prices. Viking Portrait Studios, 60 West Washington, Chicago.

DISTRIBUTORS. Canvassers, hustlers, Millions want our hot seller, dandruff killer, gray hair vanishes. No dyes. Great repeater. Big proposition. Big sample. 95c postpaid. Write today. Graynomor Laboratories, Springfield, Mass.

SELL 10c Bow ties and 25c four-in-hands. Samples 25c. Emanuel, 148 Greene St., New York.

MAKE \$1,000 Monthly selling advertising space in "Big Chief" 8-foot thermometer, barometer, electric clock. Wire or write for particulars. Crystal Manufacturing Company, Dept. K, San Diego, Calif.

SELL Koehler's blue signs. Cost 34c, sells for 20c. Koehler, 717 N. Fourth, St. Louis, Mo.

AGENTS! 300% Profit! Build a permanent business selling giant transfers and permanent window letters in colors and gold to every retail store. Exclusive territory. Print-A-Sign, Akron, Ohio.

NATIONAL Manufacturer of guaranteed quality shoes for entire family, established 25 years, wants representatives. New territories now open. Big profits. Sales outfit, catalog, and valuable book sent free. Write Mason Shoe Mfg. Co., Dept. 21, Chippewa Falls, Wis.

AMAZING New plan gives you chance to earn \$10 daily. Pass out free food samples. Your own groceries half price. New Buick offered to workers. No investment or experience. Steady job. Harley Co., Dept. B-2016 Cleveland, Ohio.

AGENTS—Big opportunity. Beautiful Indian design rugs, for bathroom, bedroom, porches, washable chenille, reversible. Every home prospect. We deliver. \$15 daily opportunity. Pocket sample free. Chenille Corporation of America, 3922 Claremont, Chicago.

NEW Startling seller. Rayon bedspreads. Beautiful colors. Go like wildfire. Women buy instantly. Big profit. Take orders. We deliver. Samples free. Bestever Co., 178 Irving Park Station, Chicago.

MEN—Sell durable rubber name mats, either as side line or full time. Store dealers, banks, apartments, hotels, etc., all buy on sight. Your territory open and immediate acceptance of application will be sole representative in their city. Durable Rubber Co., 1140 Broadway, Dept. E, New York, N. Y.

\$10 DAILY; Amazing new iron cord holder clamps to board; keeps cord out of way; free sample offer. C. A. Myers Company, 6339 Woodlawn Ave., Chicago, Ill.

AMSCO Magnetic health belts, \$15; guaranteed; Ionacos, used, \$15; new, \$20. A-Amsco Mfgs., 721 18th St., Oakland, Calif.

BIGGEST Surprise offer ever made. Be sure to answer this ad. My line of soaps, coffee, tea, spices, toilet articles, household specialties, pays you bigger profits. M. G. Roth, President, 2833 Dodier, St. Louis, Mo.

I AUTO Gas saver sent. To introduce. All autos. Amazing mileage increases. Critchlow, RW-805, Wheaton, Ill.

PENNY A Day accident policy, \$15,000,000 company. Death \$5,000. Disability \$100 monthly. Liberal commissions. Renewals. Experience unnecessary. Druyand Underwriters, 192 North Clark, Chicago.

BIG Money for Bearden agents. A hundred needs for the home. Louis A. Bearden, Inc., (Englewood Station) Chicago, Ill.

AGENTS—Sell vanilla, perfume free, easy sales, big profits guaranteed. Box 71, Station W, Brooklyn, N. Y.

MAKE Big, steady income. Sell Rosecliff quality men's shirts, ties, underwear, direct from maker. Guaranteed full year. No substitutions. Free initials. Shirts and ties to producers. Effective sales helps, complete sample line free. Write today. Dept. P200 Rosecliff, 1237 Broadway, New York.

AN Opportunity to make \$100 weekly selling all wool, union made-to-measure suits and topsuits at \$23.50 and up. Build big repeat business. Big pay daily—monthly bonus extra. Large swatch samples free. W. Z. Gibson, Inc., 5008 Throop St., P-517, Chicago.

BE Independent. Make, sell your own goods. Immense profits. Catalog dependable formulas, special selected agents' best sellers free. R. Lustrro, 4211 Cottage Grove, Chicago.

PORTRAIT Men, you can make money anywhere selling our guaranteed portraits. Send for free frame catalog. Portrait Agents' Supply Co., Dept. F, LaPorte, Ind.

SELLING Like blazes! Beautiful toilet goods assortment at \$1.50 with 25-inch pearl necklace free to your customers. 100% profit! Davis Products Co., 238 North Ave., Dept. 530, Chicago.

MAKE \$2.00 Now every hour. Sell every home wonderful preparation; mends hosiery and clothing without sewing. Invisible. Results guaranteed. Send for free sample of work. Queen City Lab., PM-2, Cincinnati, Ohio.

DISTRICT Managers! Crew managers! General agents: Two sales daily will pay your saleswomen \$51 weekly and net you \$55 monthly overwriting. What have you? Write Daintymaid, J-708, Meriden, Conn.

EASY To sell groceries, paints, auto oils to customers. Steady, profitable work. Experience unnecessary. Credit given. Valuable outfit free. Loverin & Browne, 1602R So. State, Chicago.

AGENTS—Absolutely new! Our hand-colored popular-priced photo statuettes going big! Everyone wants them! \$10-\$25 daily earnings possible. Samples furnished! Cruser Mfg. Co., BS 2456 Jackson, Chicago.

MAKE \$20 Daily selling merchant's changeable letter show-window signs. Experience unnecessary. Send for free sample offer. Maze Company, 542 W. Washington, Chicago.

FREE Booklet describes 67 plans for making \$20-\$100 weekly in home or office business of your own. Elite Co., 84 Elizabeth St., New York.

AGENTS—Men, you can earn \$12 daily wearing fine felt hats and showing friends. Smartest styles. Latest shades. \$2 to \$5 saving on every hat. Samples free. Taylor Hat and Cap. Mfrs., Dept. BC-135, Cincinnati, Ohio.

BUILD Your own business. Sell shirts and ties. No investment needed. Big self-selling sales outfit free. Liberal commissions. Write Public Service Mills, 517CF 30th St., North Bergen, N. J.

MAKE Big, steady income. Sell Rosecliff quality men's shirts, ties, underwear, direct from maker. Guaranteed full year. No substitutions. Free initials. Shirts and ties to producers. Effective sales helps, complete sample line free. Write today. Dept. P2 Rosecliff, 1237 Broadway, New York.

OUR New style needle books and threaders are the fastest selling agents' articles on earth. Millions sold. Earn \$15 daily. Proof free. Samples 10c. Patey Needle Co., West Somerville, Mass.

ANTI-STEAM (Keeps steam, rain, snow off windshield) is proposition we regret we can't begin to outline in advertisement. Unprecedented possibilities. Request free sample and complete story. Walter S. Doe Co., Dept. E, Kent, Ohio.

\$30 TO \$40 Extra weekly for tailoring and other salesmen with amazing side line made-to-measure clothes. Five beautiful fabrics. Guaranteed full year. Big swatches and outfit free. Write Palmer Clothing Co., Dept. SC-110, Chattanooga, Tenn.

AN Opportunity to get brand new Ford sedan without cost, besides biggest commissions, taking orders for our fine all-wool, union-made, tailored-to-order suits at \$23.50 and up. We train the inexperienced. Handsome carrying case outfit of large real cloth samples furnished free. Spencer Mead Company, Harrison and Throop Sts., Dept. P-817, Chicago.

CASH Paid for Butterflies, Insects. See Sinclair Display Advertisement on page 32.

GOLD-LEAF Sign letters; copyrighted manufacturing instructions; profits 1,000%. Johnson Co., Quincy, Ill.

STRANGE New ironing cord! Prevents scorching. Saves electricity. Cannot kink or snarl. For telephones also. Up to \$25 daily. Samples furnished. Neverknot, Dept. 2-A, 4303 Ravenswood, Chicago.

AGENTS—Magic hot pads, fairly damask tablecovers, sponge rubber mats, and 50 other fast sellers. Write B. & G. Rubber Co., Dept. 427, Pittsburgh, Pa.

FLAVORING Extracts—Bottle yourself! Concentrated. Labels furnished. 600% profits! Whirlwind money-makers! Free offer! Thomas Manufacturing Company, Indianapolis, Ind.

SELL "Prevents Runs." Guaranteed to prevent runs in silk hosiery. Large profits. Particulars. Specialty Mfg., 127B S. Broadway, Los Angeles, Calif.

AGENTS And demonstrators. Big money selling Porfrey Face Clay and Odorless Hair Remover. Indorsed. Guaranteed and has national demand. Norman Products, Box 178, San Francisco, Calif.

HOT Water won't hurt it! Astounding new China cement sells on sight. Mends anything! 150% profit each 50c sale. Write Direct Home Sales, Inc., Morgantown, W. Va.

"LUSTREBAG" Improved auto refinish; not paint, polish or wax. Restores sparkling lustre instantly. Use on any color. Guaranteed not turn white. Sample 50c. Agents Donahoo, Hondo, Calif.

FLAVORING Extracts, whirlwind sellers. \$10 daily easy. Marvel Co., Box 684, Johnstown, Pa.

SOAP Agents to demonstrate and sell E-Z-Kleen hand soap to mechanics, garages. Removes grease from hands. Sure repeater. Free sample. Hamler Co., 3430 Pulford St., Detroit.

EARN \$15 Per day. Experience unnecessary. Start at home in spare time. Big profits. No capital. Write quick. Particulars free. Sales Manager, Box 244, Elwood, Ind.

\$100 WEEKLY Demonstrating famous DuPont launderless tablecloth. Also \$2.98 trench coats, and full line waterproof necessities. Samples free. American, 724D, Roosevelt, Chicago.

\$5.00 HOURLY. Mercerized damask scalloped table cloths, size 58x58", 73"! Tremendous demand. Other bargains. Big sample line free. American Braiding, GD-418 S. Wells, Chicago.

WONDER Hotpad invention paying \$18.00 daily. Banishes water bottle and electric pads. Sales helps. Experience unnecessary. Free sample offer. Applicator Corporation, 3357-C Cottage Grove, Chicago.

QUICK Easy sales. Small simple cleaning device. Average profit \$1.00. 15 to 20 sales per day. Experience unnecessary. Free sample offer. Old reliable organization. Mac Lead Co., Dept. PM2, 2640 Greenview, Chicago.

AGENTS. \$75.00 Weekly. New Sunbeam changeable letter electric sign selling fast. Every store buys. Excellent, profitable territory open. Write today for particulars. Sunbeam Sign Co., 5507 West Division St., Chicago, Ill.

MINUTES Pay dollars demonstrating wonderful three pound Calculator. Patented 1926. Retail \$15.00. Work equals \$300 machines. Adds, subtracts, multiplies, divides automatically. Five year guarantee. Big demand, large profits, experience unnecessary. Write quick for liberal trial offer and protected territory. Lightning Calculator Co., Dept. A, Grand Rapids, Mich.

AGENTS—Sell pure silk guaranteed hosiery direct to wearers. Unusual quality-values assure unlimited earnings. Lynx Knitting Co., 16 Hudson St., Dept. 1, New York.

RAZOR Blade stropper. New, fifty cents. Big commission. White, 544 Willis, Youngstown, Ohio.

AGENTS—100% Profit selling our low-priced, beautiful and attractive felt rugs. Perfect color combinations win instant admiration, insuring quick sales. Excellent opportunity to build substantial business. Eastern Mills, Everett, Mass.

WANT Distributing agent for Hanslick, powdered handsoap; removes anything from the hands without injury to skin; everybody a customer; great opportunity for hustler to get in business; sample free. Solar Products Co., J2144 So. Troy, Chicago.

BIG Money easy. Simply showing new Polly wrench. 10 wrenches in one. Guaranteed! Fast seller. Sample furnished. Gellman Mfg., Dept. 6-N, Rock Island, Ill.

JUST Put our chewing gum outfit in your pocket. Make daily expenses. Sell to stores. Popular flavors. Outfit furnished. Helmet Corp., Dept. 56, Cincinnati, Ohio.

SELL Self-blowing gasoline torches, sample 50c. Circular free. Modern Torch Works, 1040 Newton Ave., Erie, Pa.

MAKE Your own products. Employ agents yourself. Toilet articles, soap, extracts. We furnish everything. Valuable book free. National Scientific Laboratories, 1935W Broad, Richmond, Va.

80c PROFIT On \$1.00 sale. Splendid cleaner for automobiles, furniture, metal and glass. Your name on labels. Exclusive territory. Sample 10c. Particulars free. Minute Kleen Laboratories, Dept. E, Evansville, Ind.

\$50,000 PICTURE Man Friedman made canvassing. Beginners can make \$100.00 weekly with my sales talk. Experienced men make more. Free book "Profits in Portraits" explains. Sample free. Picture Man Friedman, Dept. 8, 109 West Austin, Chicago.

BIG Money weekly year round appointing agents. No canvassing, delivery or investment. Mother Hubbard Foods, 554U Congress, Chicago.

CALIFORNIA Perfumed beads selling like hot cakes. Agents coining money. Big profits. Catalog free. Mission Factory P. 2328 W. Pico, Los Angeles, Calif.

AGENTS Wanted to sell billfolds designed to beat the pickpocket. J. E. Oylar, 282 Adelaide, Detroit, Mich.

WE Start you without a dollar. Soaps, extracts, perfumes, toilet goods. Experience unnecessary. Carnation Co., 641, St. Louis, Mo.

\$200 MONTHLY Selling amazing new automobile trouble light. Sticks anywhere on car. Electro magnetic. It's also an everlasting flashlight. Send for demonstrator and prices. National Electric Corporation, 222 High St., Newark, N. J.

GET Our free sample case. Toilet articles, flavorings and specialties. Wonderfully profitable. LaDerma Co., Dept. A, St. Louis, Mo.

AGENTS—A hot one, new, for canvassers, men or women, store demonstrator or pitchmen. The Earl Specialty Co., 264 Myers Block, Anderson, Ind.

\$20.00 A DAY Easy installing lifelong underground asexuals. Only takes thirty minutes to make \$5.00. Particulars free. Expert Radio Shop, 14236 Indiana, Detroit, Mich.

\$60-200 A WEEK. Genuine gold letters for store windows. Easily applied. Free samples. Liberal offer to general agents. Metallic Letter Co., 438-B North Clark, Chicago.

AGENTS—Mosco Corn and Callous Remover will build you a steady repeat business. Send today for pocket-size trial outfit. The Moss Company, 504 Searle Bldg., Rochester, N. Y.

SHOE Creme cleans, polishes, all color shoes. Fred Heitmueller, 830-A Cherry, Jamestown, N. Y.

SIXTY Meritorious big-profit mailorder products, trade secrets, sales plans. Success assured. K. Home, 3949 Metropolitan, Chicago.

BIG Money and fast sales. Every owner buys gold initials for his auto. You charge \$1.50; make \$1.34. Ten orders daily easy. Write for particulars and free samples. American Monogram Co., Dept. 40, East Orange, N. J.

AGENTS To sell our metal polishing cloth, powdered hand soap, furniture and Duco polish. Sales Mgr., 1307 East Walnut, Des Moines, Iowa.

MAKE—Sell your own goods. We tell you how. Formula catalog free. Clover Laboratories (PM) Park Ridge, Ill.

AGENTS Everywhere. Big commission selling overcoats, sheep-lined coats, leather vests, flannel shirts; men's, women's underwear, sweaters, hosiery. Outfit free. May Co., Panceo Bldg., Chicago.

AGENTS Buy hosiery direct at lowest mill prices. Men's heavy silk and Rayon hose, doz. \$2.25-\$3.50; men's latest fancy hose, doz. \$1.45-\$2.10; ladies' Pointex silk hosiery, doz. \$4.25-\$7.00. Satisfaction guaranteed. Act today. Superior Knitting Company, Dept. 31, New Haven, Conn.

\$8.00 DAILY Selling lingerie. Exclusive designs. Fashioned at Naomi Shoppe, 1415 U St. N. W., Washington, D. C.

SELL Housewives something they want. A necessity. Reduces gas bills 25%. New in your territory. No competition with this guaranteed gas saving device. Exclusive sales rights. 400% profit. Box 18E, East San Diego, Calif.

AUTOMOBILE Specialties. Guaranteed formulas for all latest money makers. Lowest prices. Write for free lists. Murphy, Chemist, Tujunga, Calif.

START An honest-to-goodness, successful-paying business that's yours. Making world's greatest sellers! Investment small. Profits great. Start anywhere. Get my valuable "eye-opening" literature about specialty manufacturing—How you can easily make guaranteed exclusive automobile specialties, including wonderful LoidLac, finest household cleaners, best soaps, high-grade toilet preparations, modern insecticides, delicious food and beverage lines fastest-selling carded specialties. 32 years unequaled reliable service. Miller, Chemist, 706-J Chemical Building, Tampa, Fla.

NEW Kant Slip Plier just out. Sells on sight to mechanics, automobile owners. Different from all others. Make big money quick on the start. Orders rapidly repeat. Kant Slip Plier & Tool Co., 6036 Wentworth Ave., Chicago, Ill.

DON'T Sell for others—Employ agents yourself. Make your own products. Toilet articles, household specialties, etc. 500% profit. Valuable book free. National Scientific Laboratories, 1935W Broad, Richmond, Va.

FREE Booklet describes 67 plans for making \$20-\$100 weekly in home or office business of your own. Elite Co., 84 Elizabeth St., New York.

NO Dull times selling food. People must eat. Federal distributors make big money; many over \$3,000 yearly. No capital or experience needed; guaranteed sales; unsold goods may be returned. We furnish you with license, sample case and free samples for customers. Repeat orders sure; exclusive territory. Ask now! Federal Pure Food Co., A2307 Archer, Chicago.

ENGRAVED Name plates, signs, numbers, desk plates, store window signs, etc.; profits large. Brett Bros., Winthrop, Mass.

SELL Stores 5c candy specialties. 100% profit. Lorrac Products, Albany, N. Y.

PHOTO Medallion men and women, the largest line of photo novelties in the world. Lowest prices, quickest service. Send for catalog showing over 200 money makers. Photo medallions, photo medallion clocks, photo mirrors, photo fountain pens, photo powder compacts, photo jewelry and photo buttons. Gibson Photo Jewelry Co., 608-614 Gravesend Ave., Brooklyn, N. Y.

BIG Money applying gold initials on automobiles. Easiest thing today. No experience needed. \$1.45 profit every \$1.50 job. Free samples. "Ralco," X-1043 Washington, Boston, Mass.

MAKE Your own products. Employ agents yourself. Toilet articles, soap, extracts. We furnish everything. Valuable book free. National Scientific Laboratories, 1935W Broad, Richmond, Va.

SUCCEED With your own products. Make them yourself. Formulas, processes, trade secrets. All lines. Catalog, circulars free. B. Thaxly Co., Washington, D. C.

SELL Men's neckwear—wonderful proposition. Astor-M, 39 East 28th, New York.

REMNANT Store, Bethel, Ohio. Greatest Dry Goods Bargains on Earth. Agents and Dealers.

AGENTS—Make a dollar an hour. Sell Mendets, a patented patch for instantly mending leaks in all utensils. Sample package free. Collette Mfg. Co., Dept. 404, Amsterdam, N. Y.

GOLD-LEAF Window letters and script signs; no experience; 500% profit; samples free. Consolidated, 69-T West Van Buren, Chicago.

MAKE Your own products. Employ agents yourself. Toilet articles, soap, extracts. We furnish everything. Valuable book free. National Scientific Laboratories, 1935W Broad, Richmond, Va.

POLMET Polishing Cloth removes tarnish from metals without the use of liquid, paste or powder. Our agents say it sells like "hot cakes." Retail 25c; sample free. Gale & Co., Inc., 15 Edinboro St., Boston, Mass.

AGENTS—New shirt proposition. No capital or experience needed. Commissions in advance. Samples free. Madison Company, 566 Broadway, New York.

THAXLY Formulas produce perfect products. All lines. Catalog free. B. Thaxly Co., Washington, D. C.

AGENTS Wanted—On a fast selling 25c item for the kitchen, costs you \$1-3c. Sample sent parcel post prepaid for 10 cents. P. Seed Filter Mfg. Co., Inc., 353 Broadway, New York.

MAKE Your own products. Employ agents yourself. Toilet articles, soap, extracts. We furnish everything. Valuable book free. National Scientific Laboratories, 1935W Broad, Richmond, Va.

MAN In each town to plate auto parts, reflectors, bathroom fixtures, relinish beds, mirrors, chandeliers; by new method. No capital or experience required. Simple plan of manufacturing at home starts you in big money-making business. Outfit furnished. Free particulars and proofs. Gun Metal Co., Ave. H, Decatur, Ill.

A BUSINESS Of your own—Making sparkling glass name and number plates, check-boards signs. Big book and sample free. E. Palmer, 512, Wooster, Ohio.

\$12.00 DAILY Showing new table cloth. Looks like linen. Wash like oilcloth. No laundering. You just take orders. We deliver. Pay daily. Sample free. Bestever, 152 Irving Park Station, Chicago.

\$75 WEEKLY Up placing Aspirin. Notar-tar. Lighter Flints, Silk-Tone and other self-selling counter display cards with merchants, soda fountains, cigar stores, etc. Over 100% profit. Steady repeats. Sterling Company, F. Baltimore, Md.

AGENTS—Clever Invention! Inkspoon makes every pen a fountain pen. Fast office seller; big profit, demand increasing everywhere. Exclusive territory offered. Sample free. H. Marui Company, Tribune Bldg., New York, N. Y.

TWO Money makers for agents. "Francis" Pocket Adding Machine retails \$4.85. To you \$1.00. "Excellograph" Rotary Stencil Duplicator \$37.50 retail. Write Typewriter Supply, 102 Hersch Bldg., Pittsburgh, Pa.

BIG Profits! Fast sales! \$9.75 automatic washing machine. Guaranteed. Write Storm Royalty Co., 3601 Enright, St. Louis, Mo.

MONOGRAM Automobiles. \$1.35 Profit ten minutes' work; every owner wants them; millions without; particulars free. Motorists Accessories Co., Mansfield, Ohio.

HIGH GRADE SALESMEN WANTED

BIG Free printing line brings easy quick profits. Bigger commissions—up to 55%! Experience unnecessary. Now write orders with America's most profitable printing stationery line. Thousands of free cuts. Hundreds of standard items for every merchant and manufacturer: Letterheads, noteheads, envelopes, billheads, business cards, statements, garage forms, shipping, battery, dry cleaning, tire, storage, parking and hat cleaning tags; garage forms, blotters, gummed shipping, drug and advertising stickers. Sales books, duplicate forms, triplicate forms, etc. In fact, America's largest line. Lowest prices. Steady repeat orders. Ship everywhere. New free 1930 outfit ready. Write quick. Dept. 196, Box 498, Cincinnati, Ohio.

SPECIALTY Salesmen: If you have had experience in selling trade stimulators, premium coupon deals or business building plans to the retail merchants and can command over \$200 weekly, we can use you. Ours is a brand new, profit and money-back, proven sales builder that no shrewd merchant can afford to overlook, 10 minute demonstration with the only item in the world that never grows old. So simple, sells on sight. No competition. If not qualified along the lines mentioned above do not reply. We want go-getters who can stand prosperity. Write giving past experience. No investment. Manufacturers, 71 West 23rd St., Suite 1821, New York.

SALESMEN—Make \$5.00 an order, selling high-grade suits, topcoats, \$19.85. Fine materials; union made. Big repeat business. Free giant outfit. Write Metro Tailors, 132C Fifth Ave., New York.

SELL Nothing, earn up to \$170 weekly, empty handed. No samples to tote. Oldest and largest punchboard firm, established 20 years, rated \$500,000, announces amazing new plan. Salesmen cleaning up. No one invests a penny. We even pay express charges. Unsalable merchandise returnable. Big season now here. Full commission repeat business. Grab this quick. K&S Sales Co., 4316 Ravenswood, Chicago.

ABSOLUTELY Unequaled window attraction, used by thousands of merchants, offers exclusive permanent opportunity. Big commissions, dignified selling, unlimited prospects. Splendid sales materials free. The Illustranew, 511 Chapel St., New Haven, Conn.

SALESMEN—You make \$130 monthly selling only one \$10 accident-sickness policy a day! Policy pays \$10,000 death, \$25 weekly benefit. Full or spare time. Tremendous demand. \$100,000 guarantee with state. Leads furnished from our direct newspaper advertising campaign. Write quick for territory and special contract. Underwriters, 1002 Wallach Bldg., Newark, N. J.

SALESMEN—Make \$5.00 an order, selling high-grade suits, topcoats, \$19.85. Fine materials; union made. Big repeat business. Free grant outfit. Write Metro Tailors, 152B Fifth Ave., New York.

POOL Shooter; new, fascinating vending machine. Merchants everywhere buy! Splendid sideline. Big profit maker! Free pocket outfit! Specialty Mfg. Co., W817 W. Division, Chicago.

VENDING Machine men—Grab this! \$12.50 commission every call! New, different, low priced, whirlwind seller. Act quick. Postal Confection Mfg., 2033 W. Charleston, Chicago.

BUSINESS Stationery, largest line, highest quality, quickest delivery; biggest commissions, liberal bonuses. Free copyrighted cuts every business. Experience unnecessary. Instructions and outfit free. David Lionel Press, 312 S. Hamilton, Dept. 131, Chicago.

300% PROFIT Selling Mystery Gas Lighter, Retail 25c. Costs you \$1.00 doz. Sample free. Square Deal Mfg., Desk PM4, Bradford, Pa.

GREETING Card salesmen. Well established line. Everyday and holiday greeting cards selling retail merchants and printers. Liberal commission. Good territories open for 1930. Auburn Greeting Card Company, Auburn, Ind.

SALESMEN, Wonderful sideline. 40% commission paid daily. Sells all merchants. Pocket outfit free. Willens Co., Dept. 280, 2130 Gladys Ave., Chicago.

80% PROFIT On \$1.00 sale. Splendid cleaner for automobiles, furniture, metal and glass. Your name on labels. Exclusive territory. Sample 10c. Particulars free. Minute Kleen Laboratories, Dept. E, Evansville, Ind.

CAPABLE Salesman wanted to call on executives and professional men, who can close on first call. Possibilities \$60.00 to \$100.00 weekly. Give references. Geographical Pub. Co., 621 Plymouth Court, Chicago.

PUNCHBOARD Salesmen make big commissions, selling punchboards and vending machines. Reliable concern, established 20 years. Largest most complete catalog in colors, free. Best season now. Write today! Lincoln Sales, 116 S. Wells, Chicago, Dept. D.

MONEY Every minute every day. Anyone can sell printing with our elaborate free outfit. 106 fast-selling items. Free illustrations. Our prices beat competition. Big commissions paid daily. Sell every merchant, manufacturer, bank, doctor, etc. Full time or sideline. Write for details. All-Trades Printing Service, 111 Second, Rockford, Ill.

\$282.80 COMMISSION Possible on a \$10.50 original sale. Every merchant a prospect. Absolutely new and different. Exclusive territory. Sales Stimulators, 339 W. Madison, Chicago.

RELIABLE Man—Distribute and collect store route in county; nets up to \$60 weekly; permanent, profitable work. Full information. Write Peris Mfg. Co., Dept. 8, Florin, Pa.

TOOL Salesmen: Sell our fast-selling, big profit tools to mechanics, garages. Excel Tool Company, San Diego, Calif.

EARN \$10,000 Yearly. Easy. Sure. Sell Royal Policy Death Benefit \$5,000. Disability \$100 monthly. Sickness \$50.00 monthly. It sells for \$3.65. Everybody buys. Send your name, age, address, beneficiary's name, relationship, for 10 days free inspection of policy and proposition. American Peoples Life, Dept. 1512B, 134 N. LaSalle St., Chicago.

SELL Collection and goodwill stickers to merchants and manufacturers. Splendid variety, wonderful repeaters. Pocket samples, \$50.00 daily possible. Act today. E. L. Russell, 6 N. Michigan, Chicago, Ill.

DISTRICT Managers: Biggest overwriting in dress industry. Expansion program opens choice territories for ambitious, reliable men. Experience unnecessary. Earn up to \$7,800.00 year. Dresses and shirts, \$1.55 to \$12.95. Investigate. Detroit Frocks, 3334 Jefferson Ave., Detroit, Mich.

NEW And plenty different. Fast selling 5c-10c merchandise on attractive counter cards. 100% commission for you and dealers. Advertised by radio. No capital required. Catalog free. World's Products (Estab. 1921), 48 Central, Spencer, Ind.

AGENTS—Up to \$72 weekly. Introducing hosiery guaranteed 6 months or replaced, 126 styles, colors for men, women, children. Undersell stores. Auto and hose offered. Credit given. Outfit furnished. Wilknit Hosiery, Dept. SC-8631, Greenfield, Ohio.

SALESMEN: Here's a real job for a real man entire time. A-1 references but no security required for valuable samples. Sales to merchants on 90 days credit. Full commissions paid on acceptance of orders. Liberal advances on certain conditions. Practically every account a large repeater. Protected territory. Merchants National Co., 1565 Race, Philadelphia, Pa.

\$18 TO \$25 Daily; biggest selling line of 2-piece suits, \$9.95 and \$12.50; 3-piece wool suit, \$17.95 (regular \$28.00 value). All-wool overcoats \$18.50. Splendid raincoats, slickers and boys' suits. Biggest commission. Free outfits. "Jim" Foster, Inc., Dept. 22, 2250 S. Spaulding Ave., Chicago, Ill.

WONDERFUL Invention. Seals fifty envelopes minute. Sells on sight at \$2.25. Attractive trial offer. Square Deal. Bank references. Kendall Sealer Co., 440 Sansome, San Francisco, Dept. C-15.

GOODWEAR, Inc., announces sensational new profit-sharing plan. If you're now selling tailoring or any other line, write at once for the most sensational announcement ever made in the history of direct selling. Address Dept. 305, Goodwear, Inc., 844 West Adams St., Chicago.

IMMENSE Profit. Distribute the Silent Bathing Filler. Illustrated page 45 January issue. Sample outfit \$1.50. Ambitious direct salesmen and saleswomen answer! Rlesbeck & Co., Mfrs., 3525 No. Leavitt St., Chicago, Ill.

\$20 DAILY Showing \$2.98 trench coats and DuPont's launderless tablecloths. Samples free. American, 724-J Roosevelt, Chicago.

COVERALL Salesmen can make \$20 daily selling new \$3.50 improved coveralls, also service coats with customer's name embroidered on back. Unusual construction. Commission 75c! Wonderful advertising value. Lowest priced; highest commission. Free outfit. Amb. Co., FV-418 S. Wells, Chicago.

REPEAT Commissions. Patent automatic tag tackers. Absolute necessity shippers; shade, screen tackers, paper fasteners. Commissions repeat orders credited accounts. Agents fully protected. Possible income \$5,000 to \$10,000. J. B. Crofoot Co., Mount Prospect, Ill.

AUTOMOBILE Specialty tool salesmen. Wonderful new valve lifter and stem lock replacer. Quick sales, big commissions. Clark Mfg. Co., Ft. Morgan, Colo.

LIBERAL Proposition to salesmen with car. Establish independent business. New introductory offer. Mechanical or auto accessory experience. Daily cash orders and commissions. York Co., Dept. PM22, 2640 Greenview, Chicago.

DON'T Sell for others—employ agents yourself. Make your own products. Toilet articles, household specialties, etc. 500% profit. Valuable book free. National Scientific Laboratories, 1935W Broad, Richmond, Va.

SALESMEN: Reliable line disinfectants and paints, for merchants, schools, hospitals. Commercial Chemical Co., Marion, Ind.

COMMISSIONS Daily. Sell classy printing and personal "N-Grav-O" stationery. Commissions on customers' repeat business. Bonuses. Interested? Write United Specialty Printing Co., PM424 So. 2nd, Minneapolis, Minn.

EARN \$100.00 Weekly selling our \$1,500 accident and registration policy for \$1.00 per year. E. W. Shaw Company, Insurance Bldg., Denver, Colo.

OUR Men actually earn \$300 to \$500 selling our lines. Adelitte, the newcomer in electric window salesmen, is making a big hit. More for the money. Business posters for every line. Changeable letter system too. Permanent business for you working with us. Territory protected and repeats credited. Fat commissions. Full details prove very interesting. Display Products, Ltd., 409-A East 31st St., Kansas City, Mo.

SUCCESS Is no accident! You will fully understand this slogan when you examine our automatic credit and collection plan. Copyrighted, brand new, unusual. 250% on original sale. Half cash on repeats without callbacks. Commonwealth Publishing, 508 So. Dearborn, Chicago.

PUNCHBOARD Salesmen. \$10,000 yearly. New line. All fast sellers. Lowest prices. Full commission on repeat business. Catalog free. Hurry! Puritan Novelty Co., 1409 Jackson, Chicago.

MAKE Your own products. Employ agents yourself. Toilet articles, soap, extracts. We furnish everything. Valuable book free. National Scientific Laboratories, 1935W Broad, Richmond, Va.

PUNCHBOARD Salesman—Most gigantic line ever featured. Vending machines, all kinds. Make high as \$28.00 on single order. Repeat commissions. Beautiful colored catalog free. Lion Mfg., Dept. 8, 308 W. Erie, Chicago.

FREE Booklet describes 67 plans for making \$20-\$100 weekly in home or office business of your own. Elite Co., 84 Elizabeth St., New York.

SELL Goodyear raincoats; \$2.95 up. Goodyear Rainwear, 682 Sixth Ave., New York.

PUNCHBOARDS—Hottest, largest money-making line ever offered. Season starting. Best commissions. Nothing to carry. Catalog free. Act! M&L Sales, 301 W. Adams, Chicago.

ELECTRICAL Tool line selling to garages, mechanics and auto owners, wonderful demonstrators, big commissions. Salesmen, write Barker Specialties, Girard, Penna.

MAIN Or sideline. Sell auto tires and auto accessories to tire stores, garages, etc. Protected territory, liberal commission. Economy Rubber Products Co., 604 Burkhardt Ave., Dayton, Ohio.

WANTED District managers—Capable men to represent us in prosperous territories with direct home office contract. Our organization is the oldest of its kind in the health and accident business and offer exceptionally remunerative compensation. Write today for information. Dept. 18, Inter-State Business Men's Accident Association, Brown Bldg., Des Moines, Iowa.

SALESMEN—Four \$15.00 sales to merchants net you \$40.00 daily. Sayers Systems, 2813 Sheffield, Chicago, Ill.

SALESMEN—Become independent. Own your business; experience unnecessary. Selling our \$10,000 Accidental Death; \$50 Accident; \$25 Sick Weekly Benefits—\$16.00 yearly. Other amounts proportionate. Guaranteed steady income from renewals. \$20,000 deposited Insurance Department, Universal Policy Dept. A, 40 Clinton St., Newark, N. J.

GOLD-LEAF Window letters and script signs; no experience; 500% profit; samples free. Consolidated, 69-V West Van Buren, Chicago.

\$60-\$200 A WEEK. Genuine gold letters for store windows. Easily applied. Free samples. Liberal offer to general agents. Metallic Letter Co., 438-A North Clark, Chicago.

HELP WANTED

WANTED: Women who need quick money. "New idea" imported ladies' necessity sells on sight; everyone buys; representatives everywhere are cashing in big. Miss Ely has made \$1,900; Mrs. Hart \$2,200, without experience. New sales plan puts you in business for yourself. Sample free. Write Mary E. Coleman, Meriden, Conn.

DISTRIBUTORS—New automotive necessity. No competition. Should net you \$200-\$300 weekly. Motoscope locates motor troubles. Sell every garage, service station dealer. Write quick for details; territory; sample. Motoscope Corporation of America, 112 N. Franklin, Chicago.

MANUFACTURER Wants distributor for 300-mile \$2.00 "Pocket" radio. "Sells itself with music." Pays 100%. Spencer Radio, Dept. 10, Akron, Ohio.

WHERE To buy thousands of articles wholesale. New directory. Agents wanted. Pruitt, Brookfield, Ill.

MAKE Big profits silvering mirrors. Easily learned patented process. Plans free. Wear Mirror Works, Excelsior Springs, Mo.

ARE You tired of working long hours for small pay? Be your own boss! I'll show you how to make \$15 profit a day. Easy work. No capital needed. Albert Mills, 4982 Monmouth, Cincinnati, Ohio.

YOU Are wanted to resilver mirrors at home. Immense profits, plating autoparts, tableware, etc. Write Sprinkle, Plater, 287, Marion, Ind.

ARE You old at forty? See our advertisement on page 100 of this issue. The Electro Thermal Company, 2126 Morris Ave., Steubenville, Ohio.

CASH Paid for Butterflies, Insects. See Sinclair Display Advertisement on page 32.

EDUCATIONAL AND INSTRUCTION

WORK For "Uncle Sam." Postoffice clerks, carriers, railway postal clerks, \$1,700-\$2,700 year. Men 18-45. Sample free. Write immediately. Franklin Institute, Dept. F14, Rochester, N. Y.

FIRMEN, Brakemen, baggagemen (white or colored), sleeping car, train porters (colored), \$150-\$250 monthly. Experience unnecessary. 810 Railway Bureau, East St. Louis, Ill.

MEN-Women, 18 up. Want a government job? \$105.00 to \$280.00 month. Steady work. Short hours. Paid summer vacation. Common education sufficient. Experience usually unnecessary. We coach you without leaving home. 32-page book with full particulars and sample coaching free. Write immediately—today. Franklin Institute, Dept. F3, Rochester, N. Y.

LEARN Shoe repairing at home. Send dollar for instruction book. Shoe Makers College, Aurora, Ill.

LEARN Aircraft welding, auto mechanics, electricity. Big pay. Big demand. Low rates. Free catalog. Sterlison School, 2008 A Main, Kansas City, Mo.

PRACTICAL, Thorough, simplified home courses. House to house salesmanship, 50c. Memory course, 50c. B. Farbstain, Loupurex, Pa.

RADIO Announcing and performing taught successfully by mail. Particulars free. Alex. McQueen, Radio Educator, Box 724, Cincinnati, Ohio.

LEARN To figure twice as fast by studying Smith's "Higher Arithmetic" at home. Write for prospectus to F. A. Smith, 608 S. Dearborn St., Chicago.

PRIVATE School for boys and girls. Wilson Schools, Dayton, Ohio.

DOUBLE Entry bookkeeping 60 hours with 8 keys; guaranteed. (Diplomas.) International Bookkeeping Inst., 8 Springfield, Mo.

DON'T Prepare for any civil service examination without seeing our catalog. Free. Columbian Correspondence College, Washington, D. C.

BIG Demand for photoplay talking picture and magazine stories. We revise, develop and copyright. Sell on commission. Established 1917. Booklet free. Universal Scenario Company, 406 Western and Santa Monica Bldg., Hollywood, Calif.

BECOME A landscape architect. Uncrowded profession; wonderful opportunity for money-making. Easily mastered by mail. Earn while you learn. Est. 1916. Write for details. American Landscape School, 29 Plymouth Bldg., Des Moines, Iowa.

U. S. GOVERNMENT Wants men, \$1,700-\$1,900 and up at start. Railway mail clerk examination coming. Let our expert (former government examiner) prepare you for this and also rural carrier, post office, customs, internal revenue, and other branches. Write today for free booklet. Dept. 8, Patterson School, Rochester, N. Y.

WANTED Immediately, men-women, 18-55, qualify for permanent government positions, \$105-\$250 month; no government experience required. Paid vacations. Common education. Many needed soon. Write Ozment Inst., 101, St. Louis, Mo.

TYPEWRITERS AND SUPPLIES

TYPEWRITERS—All makes, guaranteed, \$6 to \$33. Catalog free. Dee Typewriter Exchange, Ada, Okla.

TYPEWRITERS—Factory rebuilt Royals, Remingtons, Underwoods, New Royal, Remington and Corona portables. New "Excelsior" Rotary Stencil Duplicator \$37.50. Catalog free. Pittsburgh Typewriter Supply, Dept. 945, Pittsburgh, Pa.

ADDING MACHINES

NEW \$3.50 Automatic adding machine. Adds, subtracts, multiplies, absolutely accurate. Capacity \$999,999.99. Fully guaranteed. 75,000 pleased users. Makes adding easy, positive, quick. Eliminates mistakes. Saves time. Postpaid \$3.50. Bassett Co., 1458-E. Hollywood Ave., Chicago.

PRINTING, ENGRAVING AND MULTI-GRAPHING

500 **LETTERHEADS** With envelopes, \$4.75. LaGrange News Press, LaGrange, Ga.

200 **LETTERHEADS** And 100 envelopes \$1.00. 200 letterheads, 8 1/4 x 11, 150 envelopes \$2.00. 250 cards \$1.00. Hoosier Print Shop, Portland, Ind.

5,000 **ENVELOPES** (Printed) \$2.75; letterheads, \$2.19 thousand; statements, \$1.79 thousand. Lawrence Company, 700 South Kedzie, Chicago.

1,000 **LETTERHEADS**, \$2.75. Emerson Print Shop, 309 Montgomery St., Jackson, Mich.

500 **BUSINESS** Cards, advertising cards, tickets, 2x3 1/2, \$1.00 postpaid. Samples 2c. Wm. Strdevan, Ravenna, Ohio.

200 **NOTE** Sheets, 100 envelopes, \$1.25. 500 business cards, \$1.40. Postpaid. Simms, 548 Balfourbridge St., Brooklyn, N. Y.

BATTLEFIELD Press, Gettysburg, Penna. Lowest printing prices anywhere. Free battlefield souvenir.

500 **LETTERHEADS** 8 1/2 x 11, 250 envelopes \$3.00 cash. Print anything. Process engraving. Catalog free. National Printing, Goshen, Ind.

POSTPAID—500 White envelopes, letterheads, tags, \$2.00, all \$5.50. A. Sturm, Stratford, Wis.

500 **BOND** Letterheads, envelopes or statements \$2.00. 48 hour service. Samples 2c. B. & M. Printing, 2243 Scranton, Cleveland, Ohio.

PARTICULAR? Near-Gravure Printed stationery. Samples. Solldlays, Knox, Ind.

1,000 **LETTERHEADS**, Envelopes, cards, circulars, \$2.75. Morganrice Press, Springfield, Mass.

500 \$1.10 **LETTERHEADS**, Envelopes. Free samples. Coyle & Kimballs, Newport, N. Y.

1,000 **LETTERHEADS**, Envelopes, billheads, statements, cards, \$3.45 each. Satisfaction. Samples. H. Curtis, 811 Hargigan, Kalamazoo, Mich.

WE Print stationery, booklets, catalogs, circulars. Samples. Commercial Press, Batavia, Ohio.

1,000 **BUSINESS** Cards \$2.75 postpaid. Samples free. John Miller, Montgomery Ave., Narberth, Pa.

QUALITY Printing! Reasonable Prices! Send for Free Standardized samples and prices. Folders, Circulars, Catalogs our specialty. Earnest Fantus, 525 South Dearborn, Chicago.

250 **BOND** Letterheads, Envelopes, Billheads, Cards, \$1.35 each. Economic Press, Leona, N. J.

200 **NOTE** Sheets and 100 envelopes \$1. Brown, Warsaw, N. C.

CIRCULARS, 5,000—5 1/2 x 8 1/2—\$11; 3 1/2 x 6—4-Page folders \$14. Big plant. Little prices. Garrison Press, Harrisonburg, Va.

PRINTING OUTFITS AND SUPPLIES

PRINT Your own cards, stationery, circulars, advertising, etc. Junior press \$5.90; job presses, \$11; rotary, \$149. Print for others; big profit. Easy rules furnished. Write for catalog presses, type, paper, etc. Kelsey Company, Q-11, Meriden, Conn.

MAKE Your own printing device. It's practical. Different! Particulars, specimens free. Grinstead Laboratories, Oswego, Kans.

PRINTING Outfits—Presses, type supplies, type novelties. Send stamp for catalog. Model Press, York, Penna.

GUMMED LABELS

1,000 **PRINTED**: Name, business, address 50c. JBS Company, Box 93, Holyoke, Mass.

500 **ADDRESS** Roll form, \$1.25. Stanley, 13 Kirkland St., Boston.

RUBBER STAMPS

RUBBER Stamps; name, address, 35 cents. Newman & Son, Auburn, Nebr.

DUPLICATORS AND DEVICES

YOU Can make 50 to 100 copies of a letter, notice, etc., at a cost of three cents on a Hever Quality Duplicator. Write for free trial offer. The Hever Duplicator Co., 909 Jackson Blvd., Chicago, Ill.

"**EXCELLOGRAPH**" Portable rotary stencil printing duplicators \$39. Terms. Description, testimonials, printed samples, free. Pittsburgh Typewriter Supply Co., Dept. 531, Pittsburgh, Pa.

FOR THE HOME

PECANS! Cracked, 5 lb., \$2; 1 lb., choice meats, \$1. Postpaid. Greenleaf Pecan Orchard, Okemah, Okla.

NEED Extra money? Home weaving pays. Free book. Union Looms, Boonville, N. Y.

CEDAR Chests only \$11.65—"Red-1-Kut" complete with rich copper trim—you assemble and save half—send for pictures. Kuempel Furniture Company, Guttenberg, Iowa.

IN Your home shop use our remarkable book called "Make It Yourself." Contains a great variety of 900 worth while things to make, all fully illustrated and explained. For the home mechanic, whether young or old. Delivered to your door C. O. D. Simply pay postman \$3 and postage. Popular Mechanics Press, Room 801, 200 E. Ontario St., Chicago.

PLUMBING Facts that will save you dollars—Get 500 plain facts worth knowing about the plumbing and heating systems in your home. Remarkable book enables you to save on plumbing bills. Money back if not satisfied. Pay postman \$1.50 plus postage when delivered. Popular Mechanics Press, Room 801, 200 E. Ontario St., Chicago.

FOR MECHANICS

A BIG Opportunity in 8-hour battery charging or 20 minute car washing. Let me tell you how you can install equipment with practically no investment. Earn \$150 to \$300 monthly. Bargains in used outfits. Few reconditioned buffers, grinders, air compressors, paint sprays, arc welders. Write today. Ken Byrum, Box M-235, Troy, Ohio.

ELECTRICAL Kinks on all phases of practical electricity. 47 ideas on wiring, 45 on making electrical devices, 19 on lighting, 5 on transformers, 5 on motors, 8 on generators, 11 on switches, 22 on testing, 12 on repairing, 11 on battery manufacture and repair, 5 on telephones, and 9 on electricians' tools. 214 articles, 162 pictures. Send no money. Just write postal for "Electrical Kinks." Pay postman \$1.50 and postage when book is delivered. Popular Mechanics Press, Room 801, 200 E. Ontario St., Chicago.

FOR SMOKERS

AUTOMATIC Cigaret making machines. Rolls, glues 50 for 10 cents; illustrated folder. Postpaid \$2.50. For home use. Automatic Cigaret Machine Works, 6247-51 Broadway, Chicago.

SMOKE On me free—I'll send you free big generous sample Old Green River pipe tobacco. Enjoy the mild mellow tasty natural tobacco flavor. See how smooth and satisfying. No obligation. Send today. Pete Moberly, Box 775, Owensboro, Ky.

RAZORS AND BLADES

NEW Gillette type razor blades, 30 for \$1.00. Every blade guaranteed. Superior Blade Co., Box 1516 Cincinnati, Ohio.

SHARPEN Razor blades. Build a business for yourself. Make a dollar per hour with our machines. Easy, light work. Ideal proposition for elderly men. Fully equipped machines \$175.00. Velvet Edger Mfg. Co., 725 West 59th Place, Los Angeles, Calif.

EAGLE Blades to fit Gillette safety razors. 10 blades to a package, 25c. 426 N. Colorado Ave., Indianapolis, Ind.

GILLETTE Razor blades honed and stropped, 1c each. Petter Wetterquist, Rockford, Ill.

ARCHERY

ARCHERY Raw materials. Geo. Brommers, Box 1164, San Pedro, Calif.

MAKE Your own archery equipment. We furnish highest grade materials and instructions for assembly. Build highest quality outfit for fourth cost of complete outfits. Letter brings catalog and prices. Sidney Archery Co., Box M-23, Sidney, Ohio.

ILLUSTRATED Bi-monthly archery magazine. Stories, articles on tackle making, sources supply raw materials, etc. Sample 20c. Year \$1.00. Sylvan Archer, Dept. J, Corvallis, Ore.

ANTIQUES, WAR RELICS AND INDIAN GOODS

5,000 **INDIAN** Arrows, 25 for \$3.00. 4 tiny bird points \$1.00. Battle axes \$2.50. Skinning knives, hammers, etc. Sent C. O. D. P. Heike, Pontiac, Ill.

MILITARY Medals for your collection. Illustrated catalog 10c. Craig Dore, 670 E. 42d, Brooklyn, N. Y.

SEND 5c For fine new list Indian relics, antique firearms, F. E. Ellis, Webster Groves, Mo.

BOATS AND LAUNCHES

BUILD Your own outboard racing boat, runabout or skiff. Complete drawings, specifications, patterns and knock down frames. Designed by Jas. B. Welch, designer of the original "Century Cyclone." Get plans or frames of the world's fastest outboard racing hydroplane. Jas. B. Welch, P. O. Box 928, Milwaukee, Wis.

MAKE 16' Rowboat. Blueprint. 30c. Weesho-Uco, 31st Office, Detroit, Mich.

BEST Books for \$1. All formerly sold for \$2.50 to \$5 each. Select from the following list of guaranteed bargains. All brand new books: Woodcraft by Seton, Book of Letter Writing by Crowther, Etiquette by Eichler, Creative Chemistry by Slosson, Lawn Tennis by Tilden, also Revolt in the Desert by Lawrence, Trader Horn, White Shadows in South Seas by O'Brien, Count Luckner (The Sea Devil) and Outline of History by Wells. Delivered at your door C. O. D. Simply pay postman \$1 each and postage. Popular Mechanics Press, Room 801, 200 E. Ontario St., Chicago.

BUILD Your own boat. Commence building now and be ready for next season. Use our ready cut semi assembled materials. 55 designs outboard speedsters, runabouts, cruisers, sail, etc. Send 10c for catalog. Brooks Boat Co., Box S. S., Saginaw West Side, Mich.

EIGHTEEN Foot outboard runabout, complete plans 50c. Free boatbuilding catalog. The Rudder, 15 Murray St., New York.

MAKE 12' Rowboat. Blueprint 30c. Weesho-Uco, 31st Office, Detroit, Mich.

16' CANVAS Canoe. Easily made. Blueprint, 30c. Weesho-Uco, 31st Office, Detroit, Mich.

SPEEDY Outboards—Many prize-winners. Complete instructions with blueprints for building 35 different boats. Pay postman only \$3 and postage when delivered. If outside U. S. remit when ordering. Popular Mechanics Press, Room 801, 200 E. Ontario St., Chicago.

PHONOGRAPHS AND RECORDS

EQUIP Your phonograph with a recording instrument. Makes and plays back records of voice, musical instrument or radio immediately. Easy to install. No skill required. Send for complete details. Talk Back Recorder Co., Dept. P, 315 W. Ninth St., Los Angeles, Calif.

BUILD Your own phonograph. Parts catalog with instruction mailed for 10c. American Phonograph Co., 3602 Wesley, Berwyn, Ill.

MUSIC AND MUSICAL INSTRUMENTS

SONG Poem writers, reliable proposition free. MacDonalds Song Service Bureau, 42 Keenan, Watertown, Mass.

FELLOWSHIP Songs, new book, 83 songs, words and music, and Salute the Flag sheet music, both 50c prepaid. Lutz Printing Co., York, Penna.

"BANJOS" Should interest all musicians on account of the popularity of the banjo, as it easily increases a player's income. Illus. catalog of 48 pages free. The Bacon Banjo Co., Inc., Groton, Conn., U. S. A.

COMPOSERS—Verse or music. Brilliant opportunity. Write VanBuren, 1939 McClurg Bldg., Chicago.

SONGS Professionally arranged for publication. Expert service. Submit poems. Brennan, 11660 Broadway, New York.

SONG Writers! Melody for words, one dollar. Frank Littig, Nipomo, Calif.

SONGWRITERS: Submit your song-poem or complete song! Will return it immediately if not acceptable! Chester A. Escher, Music Publisher, 125 West 45th St., New York City.

DUO-FLEX Reeds for saxophones and clarinets. Only invention improving tone quality. Special prices per dozen. Duo-Flex Reeds, 1204 First Ave., Evansville, Ind.

LON Healy's Arizona Rose, 40 cents. Feist or from composer. Liberty Theatre, Colorado Springs, Colo.

HOW To market your song. Send for free information. Song Writers Press, 3647 Bloomington Ave., Minneapolis, Minn.

FREE! Song Writers Guide. Beaver, 1257 Elm, Green Bay, Wis.

PLAY Piano by ear. A sound system. Particulars free. Boucher's Harmony Studio, Ottawa, Can.

SONGWRITERS—Arranging, composing. Free booklet. Tucker, 330 Wadsworth, New York.

SONG Poets, write Sequoia Songwriter Service, Sherman Branch, Los Angeles, Calif.

\$15.00 UP For a musical instrument. Catalog and complete details on request. Mention what instrument you are interested in. Carl Fischer, Inc., 58 Cooper Square, New York.

SONGWRITERS: Substantial advance royalties are paid on publisher's acceptance. New booklet, "Song Requirements of Talking Pictures," sent free. Newcomer Associates, 790 Earl Bldg., New York.

SONG Poem writers, "Real" proposition. Hibbler, Dl, 2104 N. Keystone, Chicago.

POEMS Wanted. Work guaranteed. We publish. Great Eastern Song Bureau, Dept. 27, Thomaston, Me.

SEND Song poems, 50-50 plan. Indiana Song Bureau, (Brookside), Salem, Ind.

VIOLINS, Deep, mellow, soulful—on credit. Easy terms for wonderful instrument. Get details today. Gustav F. Henning, 302 University Building, Seattle, Wash.

CORNETISTS—Trombonists—Saxophonists—Clarinetists. Get "Free Pointers." Name instrument. Virtuosi School, Buffalo, N. Y.

SONGWRITERS: Submit your song-poem or complete song. Will return it immediately if not acceptable! Chester A. Escher, Music Publisher, 125 West 45th St., New York City.

"MUSIC Composed" to words. Bauer Bros. (formerly of Sousa's Band), Oshkosh, Wis.

SONG Writers. Send for our "Publishing Agreement." McKinley Music Printers, 1501 E. 55th St., Chicago.

WRITE Songs. Big money and reputation. Write for information. J. Gordon Pub. Co., 201 N. Hoyne Ave., Chicago.

SONG Poems solicited. A different proposition. Richard Broughton, Sioux Falls, S. Dak.

PATENT ATTORNEYS

PATENTS Procured. Prompt, careful efficient service. Highest references. Moderate fees. Send sketch or model for actual search and advice. George P. Kimmel, Master of Patent Law, 54-B Legal Bldg., Washington, D. C.

IF You have a sound patent or pending patent for sale, write American Patents Corporation, Barrister Bldg., Washington, D. C.

TIME Counts in applying for patents. See pages 138 and 139. Clarence A. O'Brien, Registered Patent Attorney, Washington, D. C.

PATENTS—Write for our free book, "How to Obtain a Patent" and Record of Invention Blank. Send model or sketch of invention for inspection and instructions free. Terms reasonable. See advertisements on pages 140 and 141. Victor J. Evans & Co., 934 Ninth, Washington, D. C.

LACEY'S Patent Sense. Valuable book free. See ad page 143.

INVENTOR'S Adviser with mechanical movements sent free. Labiner, Five Park-row, New York.

INVENTORS Service Bureau will send booklet and give you free advice concerning the proper procedure for obtaining patents on easy payment plan and at least expense. Dept. B, Union Trust Bldg., Washington, D. C.

REGISTERED Patent attorney-engineer. Expert in chemical and mechanical patent matters. Former patent examiner. Correspondence invited. A. Ponack, 401 Homer Bldg., Washington, D. C.

SELL Your invention before patenting. Write for free particulars. W. T. Greene, 901 Barrister Bldg., Washington, D. C.

INVENTIONS Patented; confidential advice; inventions developed—representative for Blair Tool and Machine Corp.; trademarks registered. Edward Gottlieb, Patent Attorney, 5 Beekman St., New York.

PATENTS Procured; trade marks registered—preliminary advice furnished without charge. Booklet and form for disclosing idea free. Irving L. McCathran, 704 International Building, Washington, D. C.

UNPATENTED Ideas can be sold. I tell you how and help you make the sale. Free particulars (Copyrighted). Write W. T. Greene, 906 Barrister Bldg., Washington, D. C.

PATENTS, Trade-Marks, Designs. This firm has 27 years' experience and gives expert personal service at reasonable rates. We properly protect your invention. Write for free information and exact cost of procuring patent before proceeding. John B. Thomas & Co., 902 F St., N. W., Washington, D. C.

INVENTORS: Send for booklet telling how to patent and sell your inventions at lowest cost. Ralph Burch, Patent Lawyer, 900 F St., Washington, D. C.

ESTABLISHED 1864. Milo B. Stevens Company. Free booklet. Patents. Trade marks. Copyrights. Offices. Monadnock Block, Chicago; Barrister Building, Washington, D. C.

INVENTORS—Write for our Guide Book, "How to Get Your Patent," and Evidence of Invention Blank. Send model or sketch of your invention for our prompt examination and instructions free. Randolph & Co., Dept. 430, Washington, D. C.

PATENTS. Prompt personal service. Write for information. Albert E. Dieterich, Registered Patent Lawyer, 621½ Ouray Bldg., Washington, D. C.

PATENTS. Send sketch or model for advice. Free book: "How to Obtain a Patent." Established thirty years. Highest references. Prompt service. Reasonable charges. Chandlee & Chandlee, 910 F St., Washington, D. C.

PATENTS. Booklet free. Highest references. Best results. Promptness assured. Send model or drawing for preliminary examination. Watson E. Coleman, Patent Lawyer, 724 Ninth St., Washington, D. C.

LANCASTER and Allwine, 221 Ouray Bldg., Washington, D. C. "Originators of the Form Evidence of Conception." Before disclosing your invention to anyone send for blank form to be signed and witnessed. Form and patent information bulletin free.

"INVENTOR'S Guide," valuable information, free. Frank Ledermann, Registered Attorney-Engineer, 1712 Woolworth Bldg., New York.

PATENTS—Write for free instructions. Send drawing or model for examination. Carl Miller, Registered Patent Attorney (former Patent Office examiner), 259 McGill Bldg., Washington, D. C.

PERCY S. WEBSTER, 203 Saving and Loan Building, Stockton, Calif. Patent booklet free.

FOR INVENTORS

INVENTIONS Successfully marketed under modern plan. Booklet free to inventors. Chartered Institute of American Inventors, Barrister Bldg., Washington, D. C.

TIME Counts in applying for patents. See pages 138 and 139. Clarence A. O'Brien, Registered Patent Attorney, Washington, D. C.

INVENTIONS—Write for our free book "How to Obtain a Patent" and Record of Invention Blank. Send model or sketch of invention for inspection and instructions free. Terms reasonable. See advertisements on pages 140 and 141. Victor J. Evans & Co., 157 Ninth, Washington, D. C.

LACEY'S Patent Sense. Valuable book free. See ad page 143.

WE Sell patents by presenting them personally to manufacturers. Largest firm in U. S. Send description of patent or invention for examination. Harry G. Green & Company, 180 West Washington St., Chicago.

INVENTORS Notice: Your invention or improvement can be sold, or its commercial value can be determined, without the expense of first getting a patent, by using our new copyrighted Inventors Protection System. Write for full free particulars. Inventors Protection Bureau, Dept. A, 2032 Estes Ave., Chicago, Ill.

I SELL Patents. Established in 1900. A nationally-known service. Experienced, respected. Why take chances Charles A. Scott, 773PM Garson Ave., Rochester, N. Y.

INVENTIONS Wanted—Patented, unpatented. If you have an idea for sale write Hartley, Box 928, Bangor, Me.

LOW Cost manufacturing. Large plant completely equipped for blanking, drawing, stamping and wire forming in any finish. Can save you money on your product. Our figures will convince. Eastern States Products, Box 721, New Haven, Conn.

UNPATENTED Ideas can be sold. I tell you how and help you make the sale. Free particulars. (Copyrighted). Write W. T. Greene, 907 Barrister Bldg., Washington, D. C.

GET Your own patents. Legal blanks, complete instructions \$1. Cutting Sons, Campbell, Calif.

PATENTS Sold or commercialized. Arthur I. Zeiger, Plaza Bldg., Pittsburgh.

INVENTORS—Ideas developed and working models built. Electrical problems solved. Lowest charges and confidential service. Industro Electric Tools Co., Petersburg, Va.

SELL Your invention before patenting. Write for free particulars. W. T. Greene, 902 Barrister Bldg., Washington, D. C.

INVENTORS Universal - Educator—contains 900 mechanical movements; 50 perpetual motions. Tells how to obtain and sell patents. Suggests new ideas. Explains how to select your attorney and avoid patent sharks. Price (revised edition) \$1.00 postpaid. Albert E. Dieterich, 621 Ouray Bldg., Washington, D. C.

INVENTORS—Cash in on your invention now! Don't delay the sale any longer! Send for a free copy of our specially prepared booklet, "Turn Your Patent Into Money," today! It contains helpful information for all inventors. M. L. Rund, Mgr. Classified Advertising, Popular Mechanics Magazine, 200 E. Ontario St., Chicago, Ill.

PATENTS FOR SALE

PATENT 1,730,134 Outright or royalty. "Life saving device for all kinds of ships and submarine." Any ship's company equipped with these devices would not only save human lives but they would attract the public and improve their business. Nicola Grabich % Mr. Bozdan, 210 21st St., West New York, N. J.

UNIQUE Gymnast automaton doll, keen advertising attraction and toy. Sell patent 1,732,197. Snap. Need cash. Tadakuma, 3261 Folsom, Los Angeles, Calif.

ROYALTY—Cap and jar for preserves, jelly, jam, etc. Very practical and economical. Patent pending. Irving S. Thompson, St. James, Minn.

NEW Invention, child vehicle. Reasonably manufactured. Telreff, Bronx Apartments, Los Angeles, Calif.

OUTRIGHT, End "speed" wrench, ratchets, reverses, locks, for nuts, pipe. For particulars, Bert Eder, Route 1, Box 150, Portland, Ore.

WRIST Adding machine. Swinghead flash light. Twelve new inventions. E. R. Hanson Mfg., Redstone, Mont.

PATENT 1,721,355. Rotary band saw mower. F. E. Richards, Jackson, R. 2, Miss.

IF You want to make many thousands in a short time, then produce my small turned and very original woodtoy for boys and girls, young and old. Place patent pending on royalty. Guyot, 443 S. Virgil Ave., Los Angeles, Calif.

ILLUMINATED Level and plumb for dark days, night work. Hans Swanson, 7631 East End Ave., Chicago, Ill.

SAFETY Razor blade stropper. Small cylindrical casing, fitting traveler's toilet set. Cheap to manufacture. Dyktor, 6242 Southwood, St. Louis, Mo.

OUTRIGHT Recently patented improvements on steel point dividers. John M. Cusack, 1044 9th St., Muskegon Heights, Mich.

OUTRIGHT Or royalty. Patented brake drum cooling for automobile. Guarantee keep brakes from overheating; every automobile needs it. Peter Lasco, Forest City, Penna.

FOR Sale—Patent on lock for emergency brake lever; locks automatically, preventing automobiles from starting when parked on hill. Address John Damm, Brockton, Pa.

OUTRIGHT Or royalty smoking pipe takes apart, cleaned with cloth. Oscar Aspgren, 100 Kentucky, Amarillo, Tex.

DOOR Carrying device. Cash and royalty. Particularly adapted for freight cars or where swinging door not desired. Further information Viers and Sheldon, 204 Gibbons St., Toledo, Ohio.

AUTOMATIC Electric baby cradle and swing. Air cooled screened cradle. Mechanical music device, electric light. Patent pending. Cash and royalty. Emmett N. Newman, Box 295, Avella, Pa.

OUTRIGHT Or royalty. Combined lifting jack and rim tool. Canadian patent, 285,620; U. S. patent pending. Working model. Robert Clark, 24 Alwington Ave., Kingston, Ontario, Can.

PATENT For sale, or on royalty basis: Automobile mud chain fastener. Will not come unfastened. Simple to operate. Inexpensive to manufacture. Chas. E. Henderson, 1108 Missouri Ave., Chickasha, Okla.

SELL, Patented fountain pen. Chrystal McCue, Goodells, Mich.

PLASTERING Machine, United States, Canadian patents, newly invented. Royalty or cash. James Pages, 51 Willow Place, Brooklyn, N. Y.

CASH And Royalty. Patent pending. Anti skedd either side, wing row devices for motor vehicles. Zarries Bros., 17 Brattle St., Boston, Mass.

CASH And royalty. Patent pending. All in one spark plug, no points. Changeable radius area, electrodes, gas saver. Basile Georgias, 192 Fourth St., South Boston, Mass.

TIME Counts in applying for patents. See pages 138 and 139. Clarence A. O'Brien, Registered Patent Attorney, Washington, D. C.

FOR Sale one-third interest in patent No. 1,637,266. Price \$300.00. F. L. Perkins, Boise City, Okla.

PATENT On an excellent fly catcher superior to ordinary means. H. M. Linding, Ossining, N. Y.

PATENT For sale—Outright or royalty. New game, interesting toy for children and adults. James S. Nicholas, Akron, Ohio.

COMBINATION Motor truck, concrete and mortar mixer; establishing a new mixing principle and will prove a big money maker to manufacturer. Chas. Payne, 27 Fulton Ave., Waukegan, Ill., U. S. A.

INVENTORS—Cash in on your invention now! Don't delay the sale any longer! Send for a free copy of our specially prepared booklet, "Turn Your Patent Into Money," today! It contains helpful information for all inventors. M. L. Rund, Mgr. Classified Advertising, Popular Mechanics Magazine, 200 E. Ontario St., Chicago, Ill.

OUTRIGHT Seed pan attachment to mowers. T. H. Dalton, Water Valley, Miss.

MODELS AND MODEL SUPPLIES

PRODUCERS Of results. Mechanical and consulting engineers. Our specialty models in metal. Designing, developing, building special machinery, manufacturing, experimental work, patterns, castings and model supplies. Reasonable rates. Inventors see or write us. 25 years in this work. The Johns Engineering Co., 1382 E. 17th St., Cleveland, Ohio. Dept. F.

SCALE Model railroad supplies—not toys. For hobbies or railroad exhibition work. The first and only complete model railroad catalog in the country—35c with credit slip. Well illustrated, parts for five gauges. American Model Railway Company, New Rochelle, N. Y.

THE Modelmaker: An illustrated magazine devoted to practical model making. Sample 10c. Modelmaker, 122 Liberty St., New York.

TIME Counts in applying for patents. See pages 138 and 139. Clarence A. O'Brien, Registered Patent Attorney, Washington, D. C.

THEATRE Model—New. Fascinating. Imported puppet scenery in beautiful colors for 24 different stage settings, proscenium 19x32, to mount and cut out, with plans, \$3. Miniature Theatre Guild, Gary, Ind.

SPECIAL Machinery developed, designed and built. Patented or unpatented ideas developed, models made. Experimental work a specialty. Write Arthur Lansberry, Mechanical Engineer, 3009 Liberty St., Erie, Pa.

WORK With master machinist; 16 years experimental experience, well equipped shop. Albert Weiss, 161 W. 21st St., New York City.

SHIP Model fittings. Send dime for illustrated catalog No. 6. A. J. Fisher, 1002 Etowah Ave., Royal Oak, Mich.

LET Our experience be your guide. Models that are models; tools and equipment for economic manufg. Patterns of all types; manufacturing in all branches. Satisfaction guaranteed. United Machinery Company, Cincinnati, U. S. A.

WE Make working models for inventors and do experimental work and carry a complete stock of brass gears and model supplies. Send for catalog. The Pierce Model Works, Tinley Park, Ill.

SPECIAL Machine builders, tool and die makers, inventors' models production work of all kinds. Dept. L. Quality Hardware & Machine Corporation, Ravenswood and Thorndale Aves., Chicago, Ill.

MODEL Steam engines and boilers for miniature power boats. Boat and boiler fittings. New catalog 15c. Model Machine Shop, 212 Price St., Rahway, N. J.

MANUFACTURING

MANUFACTURING: Mechanical and electrical machinery, devices, parts, stampings. Birchall, Reading, Mass.

LOW Cost manufacturing. Large plant completely equipped for blanking, drawing, stamping and wire forming in any finish. Can save you money on your product. Our figures will convince. Eastern States Products, Box 721, New Haven, Conn.

MANUFACTURING Models, dies, stampings, brass work, one or thousands. Circular free. Baum's Metal Specialties, Kansas City, Mo.

SPECIAL Machinery or parts, dies, tools, metal specialties, models, special gears, stock gears and model supplies. Send for Catalogue. The Pierce Model Works, Tinley Park, Ill.

WIRE Goods made to order. Cooley Mfg. Co., 530 N. Western Ave., Chicago.

SPECIALTY Manufacturing. Stampings, wire products, patents developed and marketed. Safety Globe & Mfg. Co., Columbus, Ohio.

FOR MANUFACTURERS

WOODWORKING Plant. Complete modern equipment. Low cost quantity production. Additional wood specialties wanted. Address Manager, 515 Garfield Bldg., Detroit, Mich.

MACHINERY, TOOLS AND SUPPLIES

16"x5' VON WYCK Lathe, \$175.00; No. 1 1/2 Valley City plain milling machine, \$350.00; No. 60 Heald grinder, \$275.00; 24" Hندی shaper, \$250.00; 15" Smith & Mills crank shaper, \$225.00; 36"x18" Fifield lathe, \$750.00; 20" silver upright drill press, \$60.00; Quincy air compressor with tank, \$65.00; 10" bench drill press, new, \$23.00. Terms to suit. Write for catalog. Cincinnati Machinery & Supply Co., 27 West Second St., Cincinnati, Ohio.

FOR Sale: Small punch press. B. L. Nortwed, Mitchell, S. Dak.

START Business of your own, small investment required, doing nickel, copper and silver plating. This work in big demand. Information free. Electro Platers Supply Co., 28 W. Second St., Cincinnati, Ohio.

USED Arc welders, air compressors, buffers, grinders, reconditioned like new. Shipped on trial and easy terms. If you need good guaranteed equipment, write today to Bob Jones, Box M-236, Troy, Ohio.

BUILD Your own lathe. About 8" swing. 12 castings postpaid for \$3.00. Stuart Keneipp, Mt. Carmel, Ill.

CONCRETE Building block machines and molds. Easy payments. Catalog free. Concrete Machine Co., 5 North Main St., St. Louis, Mo.

LATEST And best House Wiring book—just published—This new book of over 250 pages and 600 illustrations represents 15 years of work in perfecting the material for the best House Wiring manual it is possible to produce. The work of two men high up in the fields of mechanical arts and electricity. Price \$2.50 postpaid. Sent C. O. D. anywhere in the U. S. or possessions. Popular Mechanics Press, Room 802, 200 E. Ontario St., Chicago, Ill.

ENGINES, MOTORS AND DYNAMOS

SEE Our big catalog on steam and gasoline engines, battery motors, dyna-motors, lathes, drill presses, gears, books, blue prints, pulleys, hangers, bench saws, display tables, model makers' supplies and materials. Sent postpaid for 20c to Canada. 25c refunded first order. Howard Engine & Mfg. Co., 2417 N. Ashland Ave., Chicago, Ill.

FOR Sale: One-sixth hp. elec. motors, 60 cycle, 110 volt, a.c. slightly used, first class running condition, \$1.50 each. Cash with order. Maytag-Chicago Co., 160 E. Illinois St., Chicago, Ill.

1/4 hp. BRIGGS-STRATTON Gasoline engines \$25.00. Harris Machinery Company, Minneapolis, Minn.

SAVE Money—Automatic air compressors, constant potential battery chargers, reconditioned and guaranteed like new. Unusual value—shipped on trial and easy terms. If can use, better write today to D. W. Baker, Box M-237, Troy, Ohio.

BARGAINS: Woodworking outfits \$14.50 complete, includes 6" circular saw, 31" lathe, sanding attachment, drill-chuck, face plate and attachments. Leitner Mfg. Co., 2216 Granville Ave., Chicago, Ill.

ELECTRIC Motor winding models and instructions. Gaines Bros., Gainesville, Tex.

FOR Sale, late model auto motors. Hudson 1929, Chrysler (65) 1929, Willys Knight (70) 1927, Buick Master Six 1924-25-26, Graham Paige 1928 Model 619, J. Trockman & Sons, Inc., 310-312 Lincoln Ave., Evansville, Ind.

GOVERNORS (Ours) will control any make of auto engine at any speed desired. Easy to install. \$10 C. O. D. Circulars. Candee-Smith Governor Co., 215 North Los Angeles St., Los Angeles.

TIME Counts in applying for patents. See pages 138 and 139. Clarence A. O'Brien, Registered Patent Attorney, Washington, D. C.

BRAND New motor bargains. 1/4 hp. a.c. \$7.50; 1-3 hp., \$10.50; 32v. motors, 1/2 hp., \$8.50; 1-3 hp., \$12.00; 1/2 hp., \$19.50. 32v. motors with emery and buffer \$6.00. Large stock motors and generators. Queen City Electric, 1736 Grand Ave., Chicago.

WHILE 100 Last; 1/4 horse alternating double shaft grinding and buffing motors with emery wheel, buff, cord and switch \$9.75. 1/4 horse motors, \$7.00. 1-3 horse \$10.50. Also generator bargains. Electrical Surplus Company, Dept. 12, 1911 Chicago Ave., Chicago.

EDISON Phonograph motors with speed governor. Universal, \$5.00 plus express 10 lb. Geo. Schulz, Calumet, Mich.

COMPRESSORS, Twin cylinder, for small tire shops. Duco spraying. J. Trockman & Sons, Inc., 310-312 Lincoln Ave., Evansville, Ind.

STEAM Engines—One h. p. \$18.00; 1/2, \$12.00. James Chambliss, Bessemer, Ala.

BENDING MACHINES

THE Famous Hossfeld "Wrenchless" Universal Iron Bender is the last word in bending machines. Bends metal, cold or hot, into most any conceivable shape, including Eye Bolts and Automobile Spring Eyes. Bends up to 1" bars or 1 1/2" pipe cold. Thousands in use by all classes of trade, from the smallest shops to the largest railway system. Write for circular and prices. Hossfeld Mfg. Co., Winona, Minn.

WELDING AND SOLDERING

START In highly profitable arc welding business, practically no expense. Our constant arc welder starts you on road to success. Easy monthly terms, liberal trial on money back guarantee. Write today. Hobart Industries, Box M-238, Troy, Ohio.

ELECTRICAL Trouble shooting on the motor car and airplane. Don't trust to luck or guess work. Learn to make every motion count in testing and repairing. Send for our standard 493-page book for electricians and mechanics. 300 diagrams. Hundreds of practical tests. Pay postman \$4.00 plus postage when delivered. If outside U. S. remit when ordering. Popular Mechanics Press, Room 801, 200 E. Ontario St., Chicago.

AIRPLANE Welding—Just out. Only book on new subject vital to all mechanics. Big demand for men thoroughly familiar with the work. Get into this big, new, unlimited field. Complete, illustrated book will be delivered to your door C. O. D. Simply pay postman \$3.50 plus postage. Popular Mechanics Press, Room 801, 200 E. Ontario St., Chicago.

SURVEYING INSTRUMENTS

COMPLETE Builders level outfit \$25.00; transits, \$35.00 up. Also guaranteed used instruments of all types. Wissler, 649 No. Broadway, St. Louis, Mo.

EXCEPTIONAL Bargains in transits and levels. All makes. Easy terms. Rebuilt and guaranteed by the manufacturers of "Sterling" surveying instruments. Write for descriptive list M-42, Warren-Knight Co., 136 N. 12th St., Philadelphia, Pa.

BOYS! Here's fun galore. Four large profusely illustrated books tell how to make almost everything you could want. Nearly 4,000 different articles are described (Think of it). Now \$2 per book or \$7 for the four if ordered at once. Just write a postal saying, "Send the Boy Mechanic Library." Pay postman \$7 and postage. For single books, specify either Book 1, 2, 3 or 4. Popular Mechanics Press, Room 801, 200 E. Ontario St., Chicago, Ill.

LUMBER

RARE Wood samples \$2.00 postpaid, uniform size and labeled. Free price list. Craftsman Wood Service, CP-717 E. 62nd St., Chicago.

FARM LANDS

CANADA Tax sale, seized and sold for axes. \$76.00 buys 250 feet lake front; \$153.00 buys 99 acres Ontario, \$180.00 buys 100 acres fur farm; \$202.00 buys 35 acres Muskoka lake front; \$396.00 buys 100 acres house and barn; \$450.00 buys 300 acres game preserve. These properties, with several hundred others, are offered at the prices stated, no mortgage, no further payments. Beautifully situated hunting camps and fishing lodges where there is real hunting and fishing. Summer cottage sites, heavily wooded acreages situated in Muskoka, Highlands of Ontario, and the New North; also farms in old Ontario, Quebec, Prairie Provinces and British Columbia. Our 13th annual list just issued in the form of a twenty-page illustrated booklet, describes these properties and gives full particulars. It is mailed free on application. Now is the time to invest in Canada's minerals, forests and farms. Don't delay. These properties won't last long at these prices. Send no money but send for booklet today, so you will have first choice. Tax Sale Service, Room 613, 72 Queen St. West, Toronto 2, Can.

LAND Opening—The Great Northern Railway serves an agricultural empire in Minnesota, North Dakota, Montana, Idaho, Washington and Oregon. These states abound in opportunities for small farmers or large operators to rent or purchase a farm at lowest prices and best terms of many years. Every kind of farming, grain, livestock, dairying, fruit, poultry; large acreage or small suburban tracts, rich cutover or high producing irrigated land. Write for free Zone of Plenty book with detailed information. Low homeseekers' rates. E. C. Leedy, Dept. 457, St. Paul, Minn.

OZARKS—20 Acres, poultry land, \$100, \$5 monthly. Fishing, hunting, trapping. Other bargains. Alvin Zimmerman, 1802 N. Fifth, Kansas City, Kans.

\$400 GETS Fruit-poultry farm—600 fruit trees, 49 acres near city, nice stream; attractive roomy home, new outbuildings alone worth price; only \$3,300 with \$400 down. Picture page 86. Free catalog. Strout Agency, 255-P Fourth Ave., New York City.

TO Sell, trade or buy property anywhere located write Fisher Realty Co., 108 Hannibal, Mo.

WANTED: Hear from owner having good farm for sale. Cash price, particulars. John Black, Chippewa Falls, Wis.

FARMS Wanted anywhere. Cash buyers waiting. National Brokers, 2515 Lakewood, Detroit, Mich.

LAND Sale, \$5 down, \$5 monthly, buys 40 acres Southern Missouri. Price \$200. Send for list. Box 22N, Kirkwood, Mo.

MONEY Made in Mich. potatoes. \$10 down now and easy terms buys land near markets, lakes, streams. Write today. Swiggart & Co., P-601, 32 N. State St. Bldg., Chicago, Ill.

PECAN-Orange-Fig groves "On the Gulf." Monthly payments. Guaranteed care. Big, quick returns. Suburban Orchards, Dept. M., Biloxi, Miss.

SELL Your property quickly for cash, no matter where located. Don't pay big commission. Particulars free. Real Estate Salesmen Co., Desk B, Lincoln, Nebr.

EASTERN Pennsylvania farms near Philadelphia. Write for bulletin giving prices, sizes and descriptions. Wilson George, Quakertown, Pa.

861 PRACTICAL Ways to Reduce Farm Labor and Expense and Increase Income. One farmer writes he would not part with this information for \$100, if he could not duplicate it. Nothing experimental. These ideas have all been put to test and proven practical. Send today for a copy of our Handbook for Farmers and get ready to put these ideas into operation for your own benefit. Pay postman only 98 cents and the postage when he hands you the package. Popular Mechanics Press, Room 801, 200 E. Ontario St., Chicago.

POULTRY

\$100.00 TO \$500.00 Profit spare time in back lot. Copyrighted booklet shows how. P. Heike, Pontiac, Ill.

OUTDOOR Opportunities. You can make a good living raising rabbits, guinea pigs, milk goats, silver foxes, ferrets, white rats, white mice, dogs, cats, pigeons, pheasants, bantams, canaries, bees, frogs, mushrooms, ginseng and golden seal on a small amount of land. Send for valuable book of instructions called "Outdoor Opportunities." Pay postman \$2 and postage. Popular Mechanics Press, Room 801, 200 E. Ontario St., Chicago, Ill.

DOGS AND PETS

COONHOUNDS, Combination fur hunters, squirrel and rabbit hounds, shipped on free trial. Illustrated catalog and book on "Night Hunting," 100 pages, illustrated, clothbound, 50c. Southern Farm Coonhound Kennels, Selmer, Tenn.

FOR Sale or exchange, pair of beagles. 46 Lorraine St., Plattsburg, N. Y.

COONHOUNDS, Combination fur hunters, foxhounds, beagle rabbit-hounds, cow-hide leather dog collars, name engraved, \$1.00. Texas steer blow horns, \$2.00. Running fits cure guaranteed \$1.00. Catalog. River-view Kennels, Ramsey, Ill.

ENGLISH Shepherds, fox terriers, collies, police. Ed Barnes, Fairfield, Nebr.

HUNDRED Hunting hounds cheap; trial; literature free. Dixie, A14, Herrick, Ill.

FOR Sale. Minks, squirrels, raccoons, foxes, ferrets, muskrats, ginseng, rabbits, skunks, wolf pups, opossums. B. Tippman, Caledonia, Minn.

WHITE Collies and other colors. Beautiful and useful. Dept. P, Shomont Kennels, Monticello, Iowa.

DOG Lovers—Every fact regarding every phase of dog training (all breeds) including psychology, obedience, guarding, swimming, rescue work, hunting, herding flocks, teaching tricks, finding lost articles, racing, war service, police dogs, sled dogs, etc., will be found in "Training the Dog," by Will Judy. Price only \$1.50. Pay postman when delivered or, if outside U. S., remit when ordering. Popular Mechanics Press, Room 809, 200 E. Ontario St., Chicago.

RABBITS

RAISE Rabbits, make money. Join our association of over 8,000 breeders. Send \$2.00 for membership. 250 page book free. American Rabbit & Cavy Breeders Association, Inc., 7408 Normal Ave., Chicago, Ill.

BIG Profits raising rabbits. We furnish stock and buy your increase. Free literature. Salesmen wanted. National Fur Farms, Osseo, Minn.

MAKE Big profit, chinchilla rabbits. Real money makers. Get the facts. Fox Farms, Inglewood, Calif.

RAISE LaSalle fur rabbits. Build big paying business. LaSalle Fur Co., Mt. Clemens, Mich.

MAKE Big profits with Chinchilla rabbits. Real moneymakers. Write for facts. 852 Conrad's Ranch, Denver, Colo.

MUSKRATS

WRITE For free literature concerning reliable quality stock. Muskrats, raccoon, silver badger, black opossum, etc. Reliance Fur Farms, Box 2345H, Denver, Colo.

TRAPPERS—"Eleven Box Traps." Complete blueprints, 30c. Weesho-Uco, 31st Office, Detroit, Mich.

MUSKRAT Farming—The greatest book on one of the greatest opportunities today. Tells of the opportunity in this business and how to do everything in connection with the raising and marketing of muskrats. Pay postman only \$2.25 and postage when delivered or, outside U. S., remit when ordering. Popular Mechanics Press, Room 809, 200 E. Ontario St., Chicago.

ROOTS AND HERBS

FREE! 96 Page "Medicine Man" book. Contains 250 valuable herb medicine preparations for home use. Botanics, 145 West 112th St., Chicago.

WANTED—MISCELLANEOUS

MAIL Us your discarded jewelry, gold, crowns and bridges, watches, diamonds, silver, platinum. Money promptly mailed. Goods returned if offer refused. United States Smelting Works (The Old Reliable), Dept. 71, Chicago.

WANT Outboard motors, boats, guns, piano accordion, Sousaphones, coins, stamp, egg collection, rare jewelry, sculpture, fur rugs, diamonds, rare birds and animals. John Redshaw, Granville, Ill.

CASH For false teeth, dental gold, discarded jewelry, old gold, diamonds, silver and platinum. Send to R. Uhler, 207 Jefferson Ave., Brooklyn, N. Y.

WE Buy gold teeth. Southwest Gold & Silver Co., Box 68, Fort Worth, Tex.

HUNDREDS Of people have sent their old gold, silver, platinum jewelry, dental work to me. Why not mail yours today? Highest prices paid. Satisfaction guaranteed or goods returned. F. Polcer, 2408 South Cicero Ave., Cicero, Ill.

WANTED—Back numbers of Popular Mechanics Magazine. We will pay 25c each for the following copies delivered to us in good condition: August, 1917; February, March, May, June, July, 1918; May, July, 1919; April, September, October, November 1920; December, 1922; November, 1923; August 1924; July 1925; January 1926. Send to Popular Mechanics Magazine, Room 408, 200 East Ontario St., Chicago.

REFRIGERATING Machine, homemade. Inexpensive to build. Gives better service than ice. This and 328 other practical articles in our book "Home Mechanics." Just ask for this and "Handbook for Women," containing 394 valuable household helps and pay postman 98 cents and postage for the two books. Popular Mechanics Press, Room 801, 200 E. Ontario St., Chicago, Ill.

FOR SALE—MISCELLANEOUS

WANT Guns, diamonds, coins, anything valuable. Offer guaranteed radios, musical instruments. Dept. A, State Bank Bldg., Granville, Ill.

HICKORY Handles for sale: First quality assorted hammer handles 12"-14", 84c per dozen, postpaid in U. S. Woot Keathley, Patterson, Mo.

ADDRESSOGRAPHS, Letter folders, multigraphs, envelope sealers, duplicators, less than half price. Guaranteed. Pruitt Co., 117 No. Wacker Drive, Chicago.

WATCHMAKERS Lathe for sale at a bargain. R. Jaegermann, 5815 Easton Ave., St. Louis, Mo.

15,000 PROFIT Making formulas. Following and many others: Accidents and emergencies, agriculture, alloys and amalgams, artist's materials, beverages, cements, glues, pastes, mullages, bleaching, renovating, coloring metals, dyeing, glass, heat treatment of metals, household formulas, ice cream, confectionery, chewing gum, lapidary work, exterminating vermin, lubricants, paints, varnishes, photography, condiments, canning formulas, rubber, soap, candies, soldering, toilet preparations, perfumes, waterproofing, fireproofing, writing materials. Just write for "Scientific American Encyclopedia of Formulas." When postman hands you book pay \$5.50 and postal charges. Popular Mechanics Press, Room 801, 200 E. Ontario St., Chicago, Ill.

BATTERY Shop—How to run. Most complete and authoritative information ever compiled on tools needed, shop equipment, charging methods, opening batteries, work on plates, jars, case, etc. Covers auto, radio and farm lighting batteries. Send for big 550-page book and pay postman \$5.00 plus postage when he delivers same. If outside U. S. remit when ordering. Popular Mechanics Press, Room 801, 200 E. Ontario St., Chicago.

GINSENG

BOOK On ginseng, goldenseal culture \$1, postpaid. Ginseng Gardens, Orma, W. Va.

PENMANSHIP SPECIALISTS

PENMANSHIP Courses by mail. Write today for free folder. Your signature written six beautiful styles if you enclose 10c. Meub, Penmanship Specialist, Box 194, Pasadena, Calif.

PERSONAL

HOLLYWOOD Starts another fad. Pig Latin is all the rage. Be in style and learn this wise-cracking language now so popular around the studios and as used by John Gilbert in the "Hollywood Revue." Send twenty cents and self-addressed envelope for code and one hundred easy examples. Wilkie Mahoney, author of "Hollywood Slangage," San Luis Obispo, Calif.

YOU Can have a New York office and address. You may establish a branch office at our address for \$3.00 per month. Mail forwarded promptly. Translation in all languages. National Business Service Bureau, Room 200, 10 East 23rd St., New York City.

RUPTURED? Amazing invention. Pneumatic pads. Hold like the hand. Satisfaction guaranteed. Peterson, 1906 San Pablo, Oakland, Calif.

HIGH Blood pressure inexpensively overcome, without drugs. Send address. Franklin Stokes, Mohawk, Fla.

FOR Health. Use Dr. Funk's Tongue Cleaner. Price \$1.00. 20 W. Jackson Blvd., Chicago.

ARE You old at forty? See our advertisement on page 100 of this issue. The Electro Thermal Company, 2126 Morris Ave., Steubenville, Ohio.

ADVICE. Information 25c coin up. Experience. Fred Klotz, Reading, Pa.

INGROWING Nail or bunion treatments on positive money back guarantee if not well satisfied. Write Eugene Eaton, D106, Bandon, Oreg.

TOBACCO Habit overcome or no pay. 500,000 used Superba to help stop cigarettes, cigars, chewing, pipe, snuff. Treatment sent on trial. Costs \$2.00 if successful. Superba Co., L81, Baltimore, Md.

MISCELLANEOUS

MIRRORS Resilvered at home. Cost near 5 cents per square foot; you charge 75 cents. Immense profits plating autoparts, reflectors, tableware, stoves, refinishing metalware, etc. Outfits furnished. Details free. Write Sprinkle, Plater, 288, Marion, Ind.

"INTERIOR Movie Lighting." Free book for amateurs, shows how. Write Westphalen, 438 Rush St., Chicago.

ARE You old at forty? See our advertisement on page 100 of this issue. The Electro Thermal Company, 2126 Morris Ave., Steubenville, Ohio.

WHO Owes you? Mail us your bills for collection. No collection; no charge. Bonded representatives everywhere. Ace Collection Syndicate, 824 Park Ave., Weehawken, N. J.

INVENTIONS—Have you conceived one? There is a long, winding road to travel before your vision of rewards can be realized. Send for the new book "Inventions and Patents, Their Development and Promotion" by an eminent authority. It is designed to guide the inventor on his way and help him avoid pitfalls. Will be sent C. O. D. Pay postman \$2.50 plus postage when he hands you the package. Popular Mechanics Press, Room 802, 200 E. Ontario St., Chicago.

CARTOONISTS. Sell your drawings. Proven plan. Castle Studios, Independence, Mo.

MEXICAN Made holsters, lariats, horsehair articles; rattlesnake belts. Send four cents for illustrated list. Tex-Mex Leather Co., 309 Esperson Bldg., Houston, Tex.

QUIT Tobacco easy. Harmless home remedy. Ni-Ko System, Ojai, Calif.

AMATEUR Cartoonists: Sell your work. Write Smith's Service, PW1194, Wenatchee, Wash.

CARTOON Of yourself, drawn from photo, for \$1.00, photo returned. Szarek's Studio, 4525 Pierce St., Philadelphia, Pa.

LETTERS Mailed from here for 10c. Heller, 509 Riverside Drive, New York.

CAN'T Slip belt. Belt watch chain, monogrammed; complete \$1.00. Black-Brown, McFlwain, Mays Landing, N. J.

TIME Counts in applying for patents. See pages 138 and 139. Clarence A. O'Brien, Registered Patent Attorney, Washington, D. C.

CASH Paid for Butterflies, Insects. See Sinclair Display Advertisement on page 32.

AMATEUR Cartoonists earn \$25.00 week, spare time, copying or tracing cartoons for advertisers. 12 months contracts. 3-M Syndicate, Argyle, Wis.

SHOP Notes for 1930. Get your copy now. Only a limited edition. Contains all the articles published in the Shop Notes department of Popular Mechanics Magazine during 1929. Send 50 cents. If you want the entire set of Shop Notes books consisting of 15 volumes including the 1930 number and 14 others issued previously we will send them C. O. D. at a special reduced price of \$4.50. Popular Mechanics Press, Room 802, 200 E. Ontario St., Chicago, Ill.

TATTOOING Outfits, supplies. Illustrated list free. "Waters," 965 Put-nam, Detroit.

"CARTOONING For Profit," cartoon hints, markets, contests, selling plans, \$1, postpaid. Smith's Service, 1194, Wenatchee, Wash.

HOMEOPATHIC And Biochemic preparations sent postpaid to all parts of the world. Manual and booklet free. Halsey Bros. Co., 5517 Ravenswood Ave., Chicago, Ill. Established 1855.

CUTS Anybody can make. Simple, cheap process, \$1.25. Specimens, particulars, 2c stamp. M. Day, Windfall, Ind.

TELL An army of 3,000,000 live readers all about your offer! If you have anything to sell, buy or exchange, or if you have any reasonable proposition, tell our readers all about it—they'll respond quickly. Our booklet "How to Create More Business" contains some very interesting, helpful facts. Write today for your copy—it's free. M. L. Rund, Manager Classified Advertising, Popular Mechanics Magazine, 200 E. Ontario St., Chicago, Ill.

PRACTICAL Flight Training is a splendid, thorough instruction book written by Lieut. Barrett Studley of the Naval Air Station at Pensacola. It is the official text book from which all U. S. naval flyers are trained. You can double the value of expensive instruction time in the air by a preliminary study of the subject from this book. Pay postman \$5 and postage when he delivers it to your door. Popular Mechanics Press, Room 802, 200 E. Ontario St., Chicago.

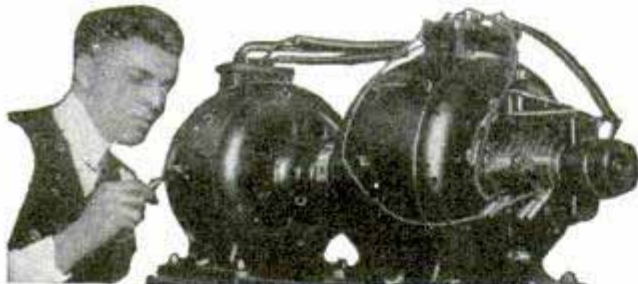

Amazingly Easy Way to get into ELECTRICITY

Don't spend your life waiting for \$5 raises in a dull, hopeless job. Now... and forever... say good-bye to 25 and 35 dollars a week. Let me teach you how to prepare for positions that lead to \$50, \$60 and up to \$200 a week in Electricity.

Learn Without Books or Lessons in 90 Days In the Great Coyne Shops

Lack of experience—age or advanced education bars no one. I don't care if you don't know an armature from an air brake—I don't expect you to. The secret of Coyne training is that it is ALL PRACTICAL WORK. No books—no dry lessons—YOU LEARN BY DOING on REAL ELECTRICAL MACHINERY. Everything from doorbells to power plants with instructors at your side at all times.

You can Earn while Learning, too

If you're short of money my Employment Department will help you FIND PART TIME WORK, and when you graduate they will help you get that BIG PAY ELECTRICAL JOB. I've done all this for thousands of others—I'll do the same for you.

AVIATION, RADIO AND AUTOMOBILE ELECTRICITY NOW

Right now I'm including my big new Aviation Electricity, Radio and Automobile Electricity courses at no extra cost.

COYNE ELECTRICAL SCHOOL
H. C. LEWIS, Pres. Established 1899
500 S. Paulina Street Dept. 20-74 Chicago, Ill.

GET THE FACTS

Coyne is your one great chance to get into Electricity. Every obstacle is removed. This school is 30 years old—COYNE training is tested—proven beyond all doubt—endorsed by many large electrical concerns. You can find out everything absolutely free. Simply mail the coupon and let me send you the big, free Coyne book of 150 photographs... facts... jobs... salaries... opportunities. This does not obligate you. So act at once. Just mail coupon. **GET THIS FREE BOOK.**

**BIG
PAY
FACTS**

H. C. LEWIS, President
COYNE ELECTRICAL SCHOOL, Dept. 20-74
500 S. Paulina St., Chicago, Ill.

Please send me your Free, Illustrated Book on Electricity and Coyne. No obligation. Give details of special offer too.

Name

Address

City.....State.....

These 2 Books Now FREE!



Be your own master—go in business for yourself—break out of the rut of small pay—escape the slavery of the time-clock—get some of the good things of life! These two FREE books show you how. Dr. Orison Swett Marden blazes the trail toward your independence—then I help you “follow through” to success! Send for these two FREE books today.

“It is yours to choose success or failure,” says Dr. Marden.

You can pull yourself out of the Mire of Mediocrity—you can climb the ladder of Leadership—you can make your big dream come true—if you are really in earnest, and will follow the advice given in these two free books.

Whether you are a youthful beginner, who has not yet made his mark in the world, or a dismayed and dissatisfied struggler who has met with rebuffs, discouragements and failures, Dr. Marden's book plants your feet with firmness upon the Path of Progress that leads straight to the Land of Opportunity and Achievement.

Here are a few of the important things you get in this brilliant little book—sure success—helps that spur you on to a better living and a bigger bank account: 1. Are You Just a Cog or a Complete Machine? 2. The Great Man-Developer. 3. Making Every Shot Tell. 4. Don't Be a Leased Man. 5. Your Right to Independence. 6. Planning to Reach the Top. 7. The Compelling Motive to Expand. 8. The Real Spur to Achievement. 9. Pilot Your Own Ship. 10. Don't Let Well Enough Alone.

Two million copies of Dr. Marden's books have been sold. They are printed in twenty different languages. They are endorsed by some of the world's most successful men.

So, get this little book by Dr. Marden. Read it—over and over again. I promise you that it will be the best success tonic you ever took—that it will give you the spirit and the power to interpret, understand and profit by your desires, your talents and your opportunities.

With the Marden book, you receive—also free—another book which tells how, with less than \$5 capital, I started in my spare time and built up a new kind of a real estate business that netted me more than \$100,000 in less than five years. And it tells how I have helped hundreds of men and women pull themselves out of the rut of hard work and small pay—build up independent businesses of their

own—make more money than they ever made before.

Here are just a few examples of what my book has done for others and what it can do for you:

R. J. Sanders, 55 years old, made \$1,057.50 his first four months in a small

What Big Men Say

John Wanamaker said: “I would, if it had been necessary, have been willing to have gone without one meal a day to buy one of the Marden Books.”

Charles M. Schwab said: “Dr. Marden's writings have had much to do with my success.”

J. C. Penney said: “I owe a great deal of my success and the success of the J. C. Penney Co., to Dr. Marden.”

Lord Northcliffe said: “I believe your writings will be of immense assistance to all ambitious men.”

Judge Ben B. Lindsey said: “Dr. Marden is one of the wonders of our time. I personally feel under a debt of obligation to him.”

Chauncey M. Depew said: “Your writings are of great value for the encouragement and instruction of men and women.”

Tennessee town of only 1,500 population. *E. G. Baum*, 50 year old bookkeeper, out of a job, got my free book, followed its advice, made \$8,000 his first year in my kind of a real estate business. *Mrs. McGinley* of Texas had an invalid husband, got my book, and made a fine profit on her first deal which was a \$35,000 sale. *Robert L. Abell*, former Illinois painter, followed my instructions and averaged monthly earnings of \$335 in his spare time only. *P. W. Budinik*, former Michigan barber, made \$950 his first six weeks—an average of \$158.33 a week. *A. V. Arnold*, a railroad man, started in a strange town and made \$1,500 his first two weeks. *Tony Maxwell*, former New Jersey barber, made \$4,133 in three months. And if you want to read about really big earnings, there's *Thomas E. Mone, Jr.*, insurance solicitor, who cleaned up \$40,000 in two years. And

think of *Gus Roeder* and his wife who ran a hot-dog stand! I started them in real estate and they say they have made \$150,000 in four years. And I have a letter on my desk from *Samuel Soifer*, who hits the highest record of all. He says that his second year in my kind of a real estate business netted him \$70,000.

These earnings may sound big to you, but they are all true. You can't ignore facts. You can't deny truth. And I have hundreds of such letters on file in my offices for inspection at a moment's notice.

There is no room here to tell you any more about the astounding success of men and women, of all ages from 21 to 79, and from all walks of life, who have changed their whole business lives through the reading of my free book.

So, get this book now. It is filled with money-making business facts and stories of business success that will amaze you. You don't have to take my word for this. You don't have to take anyone's word. Just get my free book of facts and proof. Then judge for yourself.

Mail the coupon today. Get these two books which have done so much for others. Remember, they do not cost you anything. But as soon as you read them you will realize that they can do more for your future business success than any other books you ever read.

Don't wait. Don't delay. Don't cheat yourself out of the good these two books contain. Get the facts. Learn the truth. Consider the proof. And do it now—before it is too late. Address President, American Business Builders, Inc., Dept. BB44, 205 East 42 Street, New York.

President, American Business Builders, Inc.
(Established 1917—Capital \$600,000)

Dept. BB44, 205 East 42 St., New York, N. Y.

Please send me—free of charge—Dr. Orison Swett Marden's book “Go in Business for Yourself” and your book “How to Become a Real Estate Specialist.”

Name.....
(Please Print or Write Plainly)

Address.....

City.....State.....

(The mailing of this coupon has brought business success to many. Let it do the same for you.)



-and they come from Everywhere to get SWEENEY-SYSTEM TRAINING and BIG-PAY JOBS!

Everyday they keep coming in to Sweeney's—from Japan, China, the Philippines, Cuba, Spain, France, England, Central America, South Africa—every country on the globe, as well as every state in the Union. For a quarter of a century Sweeney has been known and recognized the world over as the great pioneer auto and trade school—now sons of former students are coming, as well as a host of youngsters who have seen the success of Sweeney graduates and want to follow in their footsteps.

From Every Condition and Every Clime

Students come to Sweeney's from every walk of life—not only ambitious boys from the country, small towns and cities, from offices, factories, stores and mines, but also graduates from Yale, Harvard, Pennsylvania, California, Minnesota, Florida and practically every big college and university in the country have come to get the Sweeney System—so that they can go out fitted for success in the auto and aviation field. Over 80,000 young men have been trained here for high pay positions. Sweeney graduates all over the world are filling important jobs, garage and shop owners, auto and aero mechanics, welders, electrical experts and kindred lines. Sweeney training is success training—that's why our graduates are our greatest recommendation.

How "SWEENEY SYSTEM" Quickly Fits for Big Pay Jobs

If you are afraid of grease and dirt, don't come to Sweeney's, for here you "learn to do by doing"—you dig right in, get grease on your hands, but you learn thoroughly and fully from the ground up. If you are mechanically inclined, you'll like Sweeney Practical Training. No dull books to read. You work with tools on real engines and the most modern and complete gas engine, aviation, electrical and welding equipment in the country. In a few weeks you are trained to make big money in your chosen field.

Expert Auto Mechanics Now Wanted

Trained Mechanics make \$50 to \$100 a week. Drivers, repair men, tire men, welders, demonstrators, clean up. You can own your own shop and make handsome income. Learning to earn is easy by the Sweeney System of Practical Training. You jump right in, get grease on your hands, learn everything from the ground up.

Airplane Mechanics \$85 to \$125 a Week

Sweeney ground school gives you a thorough course in practical airplane mechanics on latest type equipment. All about plane construction and repairs, motors, recovering wings, etc. Everyone should have this work, before learning to fly. Airplane mechanics in five to one demand over flyers. Mechanics and engineers earn \$60 to \$150 a week. Riggers, \$50 to \$75. Steady, high pay, interesting work.

Big Demand for Welders \$12 a Day

Welding courses now popular as demand far exceeds supply. Oklahoma oil fields gobbling up Sweeney Trained men as fast as they qualify. Acetylene and electrical welding only one of high pay jobs we fit you for. You learn direct and alternating current, armature and field wiring, battery work, automotive electricity, starter and generator, radio, care and repair of electrical machinery—all by **practical operation** and actual experiences on complete equipment.

MAIL COUPON TODAY for FREE CATALOG and Special Offer

Get my amazing new book and also the special offer I am making for those who can act at once. Here's the chance of your lifetime! Clip and mail the coupon below. Find out about the amazing opportunities that await you. See how we have put our graduates into the best pay jobs the nation offers. Be independent, prosperous, a leader, do the work you like. See the world, make money, have a business of your own. Writing for this book is the first step. It will open your eyes, change your whole future. Do it today, NOW.

LEARN A TRADE

Sweeney

Automotive Electrical Aviation School
1615-AP GRAND AVE., KANSAS CITY, MO

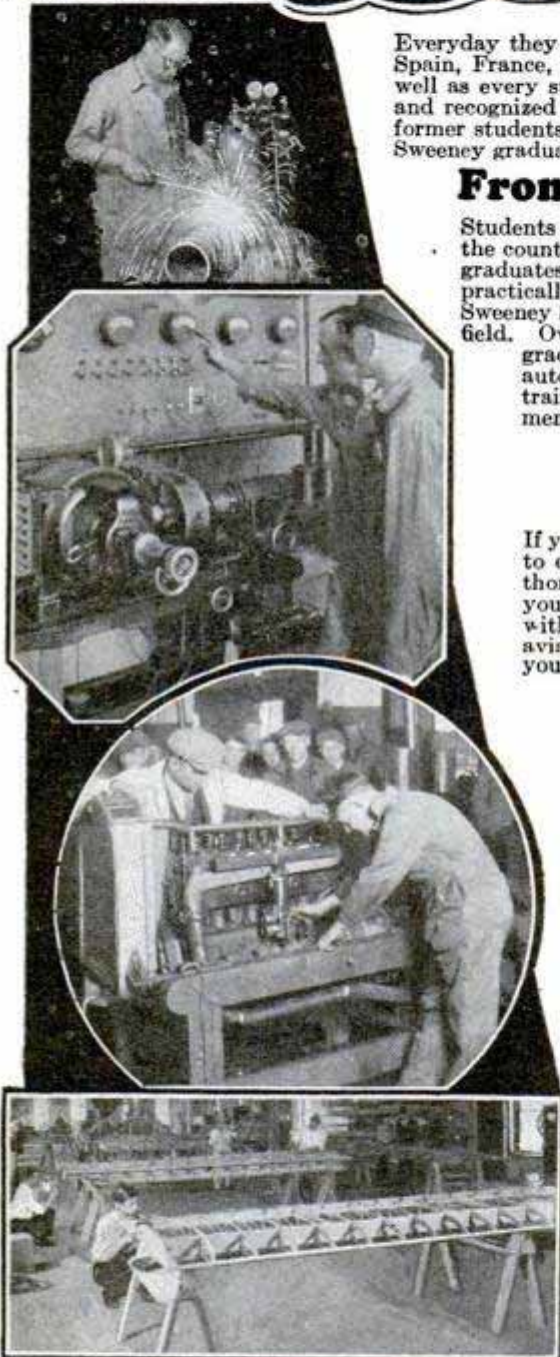

MAIL
COUPON



EMORY J.
SWEENEY,
President,
1615-AP Grand Ave.,
Kansas City, Mo.

Send me free, without any obligation, your catalog and Special Offer!

Name:
P. O.
State: Age:

ACCOUNTING

How to learn Accounting

THOUSANDS of ambitious men are earning more money today because they know Accounting. Send for our 80-page book, "How to Learn Accounting," and the first lesson. Both will be sent free.

International Accountants Society, Inc.
A Division of the
ALEXANDER HAMILTON INSTITUTE
Dept. 114, 3411 So. Michigan Ave., Chicago, Ill.

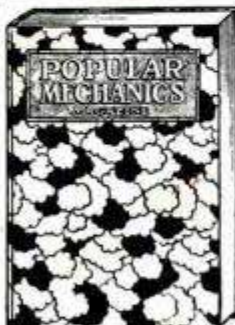

ATTRACTIVE NEW BINDERS

For Popular Mechanics Magazine
In your choice of colors; blue, green, brown, red or black. We recommend these beautiful and durable art binders to libraries, schools, reading rooms and our readers generally.

An Ornament To Any Reading Table

Price \$1.25 Each
Postpaid
Your name in gold on the front cover for 25 cents additional.
Address
Popular Mechanics Company, 200 E. Ontario St., Chicago

You will be delighted with the artistic waterproof covers in colors and other improved features.

Mechanical Toys

Ship Models, Colonial Brie-a-Brac, Leather and Celluloid articles and hundreds of other useful things are described in our new book, Make It Yourself. 460 Pages. Illustrated. Price 53 Postpaid.

POPULAR MECHANICS PRESS, 200 E. Ontario St., Chicago

BIG-PAY JOBS in ELECTRICITY

\$60⁰⁰
to
\$150⁰⁰
WEEKLY

Amazing new method. Trains you quicker and better. Motion Pictures in your own home make every point clear. Genuine DeVry motion picture projector at no extra cost. Thousands of feet of film furnished. We pledge to give you training and employment service necessary to secure a better job at bigger pay or refund money. Get full facts. No obligation. Write quick while offer lasts.

Motion Pictures Train You QUICK

MAIL THIS COUPON NOW!

National School of Visual Education. Dept. 22-BH
537 S. Dearborn St., Chicago, Ill.

Send book, "The Film Way to Bigger Pay," with facts about this new, easier way to master electricity.

Name.....Age.....

St. or R. F. D.....

City.....

State.....



Before Kenneth McCarty Mailed that Coupon He was an \$18⁰⁰ Clerk~

Today His Income is \$85⁰⁰ a Week



After completing the course he wrote us: "Yours is the finest course ever presented for the Tenor Banjo. Before I enrolled with you, I knew nothing whatever about music. I was earning \$18.00 weekly clerking in a store. Little did I realize the opportunity that had come. I took up the course just for fun. But here I am playing in one of the best orchestras in Western Michigan and making \$85.00 a week. Your course and your kind co-operation have made me a professional Tenor Banjoist."—
Kenneth McCarty, Parkview Hotel, South Haven, Mich.

Play for Fun or \$5,000 a Year

Whether a salary of \$65 to \$100 a week—or spare time playing at \$5, \$10, \$15 or more a night—interests you or not—think of the fun in store for you. In one to three months we can train you at home to play this marvelous, melodious instrument with a fine easy skill that will make you the envy of all other eyes. Think, too, of the pleasure of being able to express yourself musically when alone! You're passing up the best times of your life if you pass up an opportunity like this to learn at slight cost and with no inconvenience at all the world's most popular instrument. DON'T DO IT! Decide NOW to learn more about The Play-Way—the quickest, surest short-cut ever devised to social and professional success.

FREE Book Tells How

Send at once for "The Play-Way to Popularity and Big Pay." Learn all about our unique method of training you at home, about the big, professional size Tenor Banjo, Phonograph Records and complete Outfit that we send you along with your very first lesson. Undreamed of possibilities for pleasure, popularity and big pay are open to you the minute you "become good." The book below is your first step. Take it now. Clip the coupon while it's here before your eyes.

You Get Phonograph Records, Too

Every selection of the course, fifty-five in all—comes to you on a phonograph record. You hear the instructor's playing just as though he were right at your side. The Play-Way is different, interesting, FOOL-PROOF. Get the good news the coupon brings. SEND FOR IT NOW!



Get Big Free Book

A. F. Bloch, President,
NEW YORK ACADEMY OF MUSIC,
Studio 1020, 100 Fifth Avenue,
New York City.

Send me the book that started McCarty. No obligation whatsoever on my part, understand.

Name.....

Address.....



Send for this Gripping Secret Service BOOK

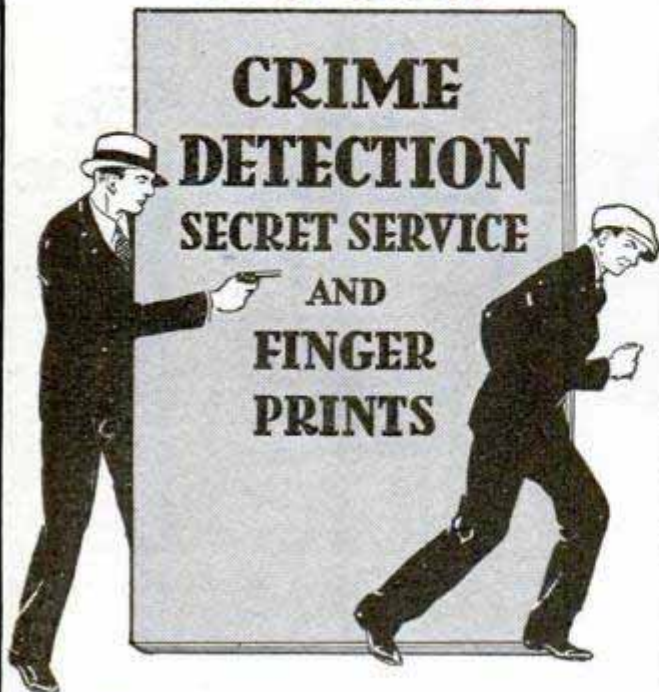

30 Days FREE Reading No Money Down

Here is one of the greatest books that has ever been written on Crime Detection, Secret Service and Finger Print Identification Work. Written by a well-known authority. Scores of gripping mystery cases. Actual crime cases—not fiction. You follow the operator straight through as he unravels some of the most baffling crime cases that have ever confronted officials. Nothing like it ever before.

Send for this unusual book TODAY. All you have to do now is merely mail the coupon below. Send no money. The book comes to you postpaid—for 30 Days Free Reading. Then, if you decide to keep it, you send me only \$1.00. If not—return it. That's all. You are not obligated to buy anything. Fill in, mail coupon now—before present limited supply is exhausted.

T. G. COOKE, Book Dept. 13-52
1920 Sunnyside Ave. Chicago, Illinois

T. G. COOKE, Book Dept. 13-52
1920 Sunnyside Ave., Chicago, Ill.

Send me at once—for 30 days free reading—with no obligation to buy, your "Crime Detection—Secret Service—Finger Print" Book. If after the free reading period I desire to keep the book I am to send you \$1.00. Otherwise I have the liberty to return it with no further obligation.

Name _____
 Address _____
 City _____ State _____

I'll Start You in a Big Paying Steady Repeat Business OF YOUR OWN OVERNIGHT!

You Collect Up to **\$20 a Day PROFITS**



Holds 6 Keys

Get Started at Once in This Big Paying Business!

A \$1.50 Investment Pays You \$1.75 Clear!

Send 25c for Sample Master Key Case or \$1.50 for sample card of 13 Master Key Cases. You make \$1.75 clear profit selling to consumers or use it to take orders from dealers.

I Guarantee You Sales—You Can't Lose!

I guarantee that you will sell these Key Cases and collect up to \$20.00 a day or refund your money absolutely. You will receive full details and selling plans with your order for single sample or sample display card of 13.

Act At Once And Reserve Your Territory!

GORDON MFG. CO.
Dept. KA-19,
110 E. 23rd St.,
New York, N. Y.

Yes up to \$20 a day every day—\$143.00 a week—clear profit. That's what you or any live wire can earn by simply placing these astonishing new "Automatic Sale-men" of newly patented Master Key Cases. The world's smallest and handiest Key Case. Works on a new principle; holds six keys on a clever screw-rod. Opens like a jack knife—each Key always in the same position. Comes in genuine Cowhide leather in attractive colors, packed 13 Key Cases to a beautiful display card. Notice, it retails for only 25c and you make 100% profit selling to dealers, and over 200% profit selling to consumers in full or spare time.

It Sells Everywhere—IT'S NEW!

Auto owners and everyone who has keys to carry BUY ON SIGHT. You can place the Master Key Case Display with automobile and auto accessory dealers, drug stores, hardware stores, grocers, novelty shops, cigar stores, men's furnishing stores—hundreds of different places where the dealer is glad to accept your unusual offer.

A LIFETIME OPPORTUNITY WITH THIS AUTOMATIC PROFIT MAKER!

Our amazing selling plans show you many ways of making big money selling to dealers outright or on consignment. You can easily place 20 cards with dealers every day — 60 cards every 3 days. Your cost in lots of 60 is only \$1.00 per card. Selling to dealers at \$2.00 per card, you make 100% profit or up to \$20.00 a day, and just think of the tremendous repeat business that you are building.



TELEGRAPHY

(More and Wireless) and RAILWAY ACCOUNTING, taught thoroughly. Big salaries. Tremendous demand. Oldest, largest school. Endorsed by Telegraph, Railway, Radio, and Government officials. Expenses low—opportunities to earn large portion. Catalog free. **DODGE INSTITUTE**, Jones St., Valparaiso, Ind.

If I Send You a Suit



made to your measure in the latest style, would you keep and wear it, show it to your friends, let them see our beautiful samples and splendid new styles? Could you use \$3.00 an hour for a little spare time? Just write a letter or postal or fill out and mail coupon below for my big new Swatch Line Sample Outfit and my new, special offer FREE. Even if you don't care to be agent, send anyway and learn how to get all your own clothes FREE. Fill out coupon and mail.

L. E. ASHER
BANNER TAILORING CO.
Dept. 404 Chicago, Ill.

Fill out coupon at side and mail

Name.....State.....
 St. & No.....
 Town.....

“Who else wants
BIG
MUSCLES
and a Handsome, Healthy Body
—my quick Dynamic-Tension way?”

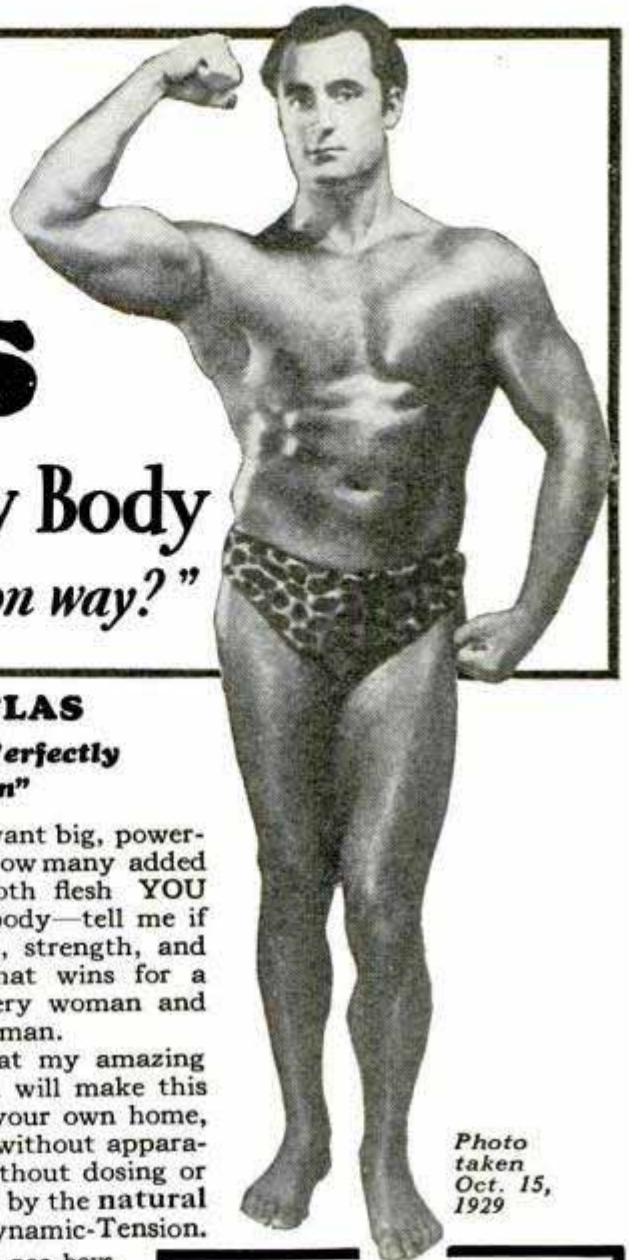

Photo taken Oct. 15, 1929

WHERE DO YOU WANT BIG MUSCLES LIKE THESE?



Want an arm like this? I'll show you the quick "Dynamic-Tension" way to get two of 'em!



Then we'll get at that chest and neck of yours. In "no time" you'll have to mark up a new set of measurements for yourself.



Imagine yourself with a broad powerful back like this—what or who couldn't you tackle? Let's go!

By CHAS. ATLAS
“The World's Most Perfectly Developed Man”

TELL me where YOU want big, powerful muscles—tell me how many added pounds of firm, smooth flesh YOU want distributed over your body—tell me if YOU want the vitality, pep, strength, and splendid bodily condition that wins for a fellow the admiration of every woman and the respect and envy of any man.

“Then let me PROVE that my amazing secret of Dynamic-Tension will make this new man of you—right in your own home, using just your leisure time, without apparatus, without special diets, without dosing or doctoring yourself, but purely by the natural methods of my system of Dynamic-Tension.

“I, too, was one of the *below par* boys. Then I developed and used these methods that I now offer to reveal to you. These self-same methods built me up from a 97-pound, flat-chested, skinny, no-muscle specimen to the figure of health, strength and powerful, balanced muscular development that you see in my new photographs.

“My discovery changed me from a near-wreck to the holder of the title—‘*The World's Most Perfectly Developed Man.*’ I won this title in open competition against every man who consented to appear against me. No one else in the world can claim this title. I am the Champion in my field just as the Heavy-weight Champion of the World is in his!

“OTHER fellows—scores, hundreds, thousands, of them, all over the world—have used my methods with success and now you can, too! What my methods did for me and these others they can do for you. You owe it to yourself to find out how these methods can help you—how you can build-up and tone-up, outside and inside, freeing yourself of shameful ailments such as constipation, poor digestion, bad breath, pimples, skin blotches and the others that rob you of the good times and the good things of life. Find out what I can do for YOU! Write to me—I'll send you a free copy of my new 48-page book that will show you the way out. But act! Mail at once the coupon that entitles you to a free copy of my book. Address me personally—CHARLES ATLAS, 171 Madison Avenue, (Dept. 82), New York City.”

Gamble a 2c Stamp

—for the biggest prize that anyone can win—a handsome, healthy, husky body. Send for YOUR free copy of my big new book.



CHARLES ATLAS
 (Dept. 82)
 171 Madison Ave.,
 New York City

I want the proof that your system of *Dynamic Tension* will give me, too, a healthy, husky body and big muscle development. Send me your free book, “Everlasting Health and Strength.”

Name.....
 Address.....
 City.....State.....
 (Please print or write plainly)



"Why, Bill—here's an extra \$20!"

"Yes, Betty, I've had another raise! Twenty dollars—think of it! That's a thousand more a year. We can have the new furniture now, dear, and save more than ever, besides. You certainly were right about that International Correspondence Schools Course. You said I'd make some headway, once I had the training. And studying at home in my spare time wasn't hard, either.

"Remember, I said the Boss had been talking to me about technical points, and that I was able to answer his questions? He told me today that the I. C. S. people had written him about my course. He's been watching my work, and he decided this week that I was ready for promotion.

"This is only the start, dear. Nobody can stop me now, for I've got the training to handle my job and the job ahead."

Thousands of I. C. S. students are earning promotion and increased pay through spare-time study. Your employer is watching you. If he sees you have the training for a bigger job, you'll get it.

One hour a day, spent with the I. C. S. in the quiet of your own home, will prepare you for success in the work you like best. Put it up to us to prove it.

Mail this Coupon for Free Booklet

INTERNATIONAL CORRESPONDENCE SCHOOLS
Box 5669-F, Scranton, Penna.

Without cost or obligation, please send me a copy of your booklet, "Who Wins and Why," and full particulars about the course before which I have marked X in the list below:

TECHNICAL AND INDUSTRIAL COURSES

- | | |
|--------------------------------------------------|-----------------------------------------------------------------------------|
| <input type="checkbox"/> Architect | <input type="checkbox"/> Automobile Mechanic |
| <input type="checkbox"/> Architectural Draftsman | <input type="checkbox"/> Aviation Engines |
| <input type="checkbox"/> Building Foreman | <input type="checkbox"/> Plumber and Steam Fitter |
| <input type="checkbox"/> Concrete Builder | <input type="checkbox"/> Plumbing Inspector |
| <input type="checkbox"/> Contractor and Builder | <input type="checkbox"/> Foreman Plumber |
| <input type="checkbox"/> Structural Draftsman | <input type="checkbox"/> Heating and Ventilation |
| <input type="checkbox"/> Structural Engineer | <input type="checkbox"/> Sheet-Metal Worker |
| <input type="checkbox"/> Electrical Engineer | <input type="checkbox"/> Steam Engineer |
| <input type="checkbox"/> Electrical Contractor | <input type="checkbox"/> Marine Engineer |
| <input type="checkbox"/> Electric Wiring | <input type="checkbox"/> Refrigeration Engineer |
| <input type="checkbox"/> Electric Lighting | <input type="checkbox"/> R. R. Positions |
| <input type="checkbox"/> Reading Shop Blueprints | <input type="checkbox"/> Highway Engineer |
| <input type="checkbox"/> Telegraph Engineer | <input type="checkbox"/> Chemistry |
| <input type="checkbox"/> Telephone Work | <input type="checkbox"/> Pharmacy |
| <input type="checkbox"/> Mechanical Engineer | <input type="checkbox"/> Coal Mining Engineer |
| <input type="checkbox"/> Mechanical Draftsman | <input type="checkbox"/> Navigation <input type="checkbox"/> Assayer |
| <input type="checkbox"/> Machine Shop Practice | <input type="checkbox"/> Iron and Steel Worker |
| <input type="checkbox"/> Toolmaker | <input type="checkbox"/> Textile Overseer or Supt. |
| <input type="checkbox"/> Patternmaker | <input type="checkbox"/> Cotton Manufacturing |
| <input type="checkbox"/> Civil Engineer | <input type="checkbox"/> Woolen Manufacturing |
| <input type="checkbox"/> Surveying and Mapping | <input type="checkbox"/> Agriculture <input type="checkbox"/> Fruit Growing |
| <input type="checkbox"/> Bridge Engineer | <input type="checkbox"/> Poultry Farming |
| <input type="checkbox"/> Gas Engine Operating | <input type="checkbox"/> Mathematics <input type="checkbox"/> Radio |

BUSINESS TRAINING COURSES

- | | |
|------------------------------------------------------------------|-------------------------------------------------------|
| <input type="checkbox"/> Business Management | <input type="checkbox"/> Business Correspondence |
| <input type="checkbox"/> Industrial Management | <input type="checkbox"/> Show Card and Sign Lettering |
| <input type="checkbox"/> Personnel Management | <input type="checkbox"/> Stenography and Typing |
| <input type="checkbox"/> Traffic Management | <input type="checkbox"/> English |
| <input type="checkbox"/> Accounting and | <input type="checkbox"/> Civil Service |
| <input type="checkbox"/> C. P. A. Coaching | <input type="checkbox"/> Railway Mail Clerk |
| <input type="checkbox"/> Cost Accounting | <input type="checkbox"/> Mail Carrier |
| <input type="checkbox"/> Bookkeeping | <input type="checkbox"/> Grade School Subjects |
| <input type="checkbox"/> Secretarial Work | <input type="checkbox"/> High School Subjects |
| <input type="checkbox"/> Spanish <input type="checkbox"/> French | <input type="checkbox"/> Cartooning |
| <input type="checkbox"/> Salesmanship | <input type="checkbox"/> Illustrating |
| <input type="checkbox"/> Advertising | <input type="checkbox"/> Lumber Dealer |

Name.....
 Address.....
 City..... State.....
 Occupation.....

If you reside in Canada, send this coupon to the International Correspondence Schools Canadian, Limited, Montreal, Canada

MAKE BIG MONEY

\$5 Down Charging Batteries Starts You



Let me show you how to make big money right from the start. I've prepared a FREE book, explaining all details. Ralph Miranda is making \$125.00 per week in his own business. You can get a good share of the battery charging business in your community with my Service Station Charger — it's years ahead of ordinary chargers—handles more batteries. I explain everything—start you in a business of your own and put you on the way to big money. Write for Free Book.



C. F. HOLMES, Chief Engineer, Dept. V
Independent Electric Works
4912 North Clark St. Chicago, Ill.



FREE BOOK—Just Out

AGENTS Make big earnings, taking orders for made-to-individual measure suits at less than ready-to-wear prices. Giant Chicago wholesale house makes world's greatest values at \$23.50 and \$29.50. Your profit \$4 and \$5 per sale in advance—we deliver and collect. No experience needed, work full or part time.

FREE OUTFIT Send no deposit. Write for details of our unique money-making plan. Nothing like it ever before offered. Act at once.

GENERAL TAILORING CO., DEPT. 2X 618 W. Jackson Blvd., Chicago

PAINT SHOW CARDS
and SIGNS. LEARN AT HOME IN SPARE TIME. WE TEACH YOU QUICKLY — FASCINATING WORK. \$75 WEEKLY. SEND 6c IN STAMPS FOR CIRCULAR.
Universal School of Lettering NEW HAVEN, CONN.

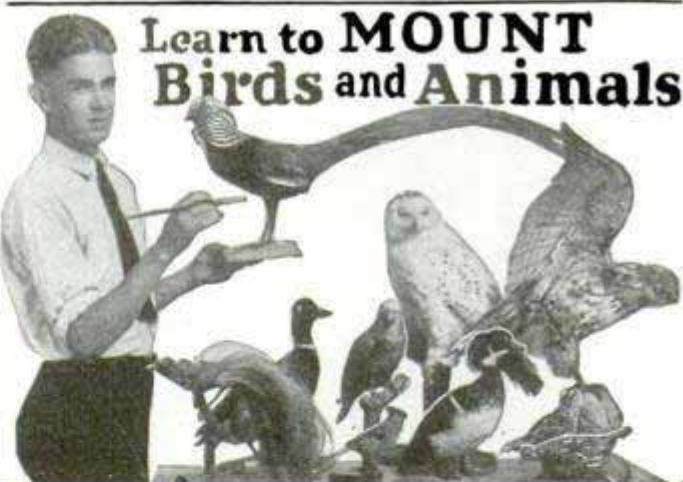

Learn at Home by Mail Be a taxidermist. Learn to mount BIRDS, ANIMALS, GAME HEADS, FISH. Wonderful fascinating new art. All secrets revealed. Easily, quickly learned by men, women and boys. Decorate home and den with nature's finest art. SPORTSMEN save your trophies. BIG PROFITS for spare time. Sell your mounted specimens and mount for others. Have a business of your own. Big demand, high prices. Learn from old reliable school, 20 years' experience.

FREE! Beautiful illustrated book, "How to Learn to Mount Game," with dozens of photos of mounted specimens. Yours for the asking—FREE—Write Today. Taxidermy is a NECESSITY for sportsmen and nature lovers—INVESTIGATE. Get this wonderful FREE BOOK NOW—no obligations. Send Coupon Today!

FREE BOOK COUPON
 Northwestern School of Taxidermy
 3372 Elwood Bldg. Omaha, Neb.
 Send me your free illustrated book "How to Mount Game." Also tell me how I may learn this fascinating art easily and quickly by mail. No obligation.
 Name.....
 Address.....

Say Goodbye to COLDS, Bronchitis, Catarrh

*At Last, Science Offers
Nature's Own Remedy*

IF you suffer from coughs and colds or from any form of catarrh, bronchitis, tonsilitis, sinus infection or other respiratory disease that is causing you misery, loss of time and wasted money, I want you to send me your name so I can tell you about a revolutionary discovery that has brought relief to more than 70,000 men and women.



JOHN F. CLASS

I suffered for years—was judged a hopeless case by doctors. Now, at 70, I never know an hour's pain or suffering. I'll give you my remedy. Just mail the coupon.

I don't care how bad your case is. I don't care how deep-seated or long standing. I don't care how many other treatments you have tried. I urge you not to give up hope until you have heard my story. I suffered untold misery myself for 13 years. My case was judged incurable. Yet, today, at 70, I never know a sick day or an ache or pain. I enjoy vigorous, robust health that is the envy of many a man in his thirties.

I Help the Worst Cases

My way is NATURE'S way.

It has worked wonders for thousands who despaired of ever being cured. It has acted like magic on many of the most difficult cases on record. I am so sure it will do the same for you that I am eager to *prove* it—entirely at my own risk and expense. If my method fails, you owe me nothing. It doesn't cost a penny to find out. That's all I ask. Just find out. If you turn away from a hand that reaches out to offer you relief from misery you may regret it all your

**NEW KIND OF BUSINESS PAYS \$5000
TO \$10,000 AND MORE A YEAR**

Amazing opportunity for service and profit now offered to ONE man or woman in each locality as director of local John F. Class Health Institution. More than 200 now in operation. If interested, mail coupon for particulars.



**30 Days
FREE Trial**
Mail Coupon

life. So mail the coupon now and get all of the facts.

No Drugs—No Medicines

You use no drugs with my method. You don't burn out your stomach with strong medicines. You don't have to go on a diet. There's no need of wasting time and money at sanitariums. You take the treatments right in the comfort and privacy of your own home as shown in the picture. People in the worst condition often find wonderful relief almost immediately. After a single treatment you feel that you have made a start toward recovery.

FREE TRIAL

I don't ask you to take my word for this. *Try it yourself and see for yourself.* If my method fails, you pay nothing. If it relieves you, then you will be thankful all your life that you accepted my offer. Immediately upon receipt of the coupon I will send you a book called "How I Found Nature's Way to Health." This book tells all about my system, explains my Free Trial Offer and tells how you can try my method in your own home for 30 days entirely at my expense. Don't lose a single day in getting these amazing new facts. Simply mail the coupon or write in detail about your case. All information held in strict confidence.

FREE TRIAL COUPON

Mr. John F. Class, NATIONAL HEADQUARTERS,
John F. Class Health Fume System,
R-10 W. First St., Dayton, Ohio.

Send me without cost or obligation information about your wonderful new NATURAL treatment for coughs, colds and other respiratory diseases. Also explain your 30 days Free Trial Offer.

Name.....

Address.....

Check here if interested in treatment for home use.

Check here if you are interested in conducting a John F. Class Health Fume Institution in your city.



Which Job do YOU Want

Lawyer



Auto Expert

Try for it This



Civil Engineer



Business Manager way

Men don't just fall into easy jobs of big pay positions—they prepare for the big chance before it comes. Make up your mind today what you want to be, then take the first step at once. You don't have to go to college to get ahead. Other men have gone there for you and have put the things they learned there and through years of practical experience into easily understood books which give you a short cut to a better and a bigger job.

We have picked 13 of the best paying professions and have published for your benefit new editions of the most practical, the most valuable books we have ever printed on the subjects covered.

JIFFY INDEX

Our new Jiffy Index makes each book a quick reference work—no time need be wasted in search or study—put your finger on the facts you want instantly.

Special Price List of Pay-Raising Books

Automobile Engineering, 5 volumes, over 2,000 pages.....	\$24.80
Civil Engineering, 9 volumes, 3,900 pages, 3,000 pictures..	34.80
Practical Business Administration, 12 volumes, 3,400 pages. (Extra volume containing self quiz reading course of 80 lessons included free).....	39.80
Electrical Engineering, 8 volumes, 4,300 pages, 3,200 illustrations.....	34.80
Modern Shop Practice, 7 volumes, 7,250 pages, 3,000 pictures.	29.80
American Law and Practice (with reading course), 13 volumes, 6,000 pages, illustrated.....	49.80
Telephony and Telegraphy, 4 volumes, 1,728 pages, 2,000 pictures.....	14.80
Sanitation, Heating and Ventilating, 4 volumes, 1,454 pages, 1,400 pictures.....	14.80
Drawing, 4 volumes, 1,578 pages, 1,000 pictures, blue prints, etc.....	14.80
Employment Management and Safety Engineering, 7 volumes, 1,800 pages, 540 illustrations, charts and diagrams.	24.80
Architecture, Carpentry and Building, 5 volumes, includes 58 beautiful architectural plates free.....	24.80

SHIPPED FREE

Words alone cannot describe the full value these books may be to you, so we ship Free for Examination. Pick the set you want, the price is plainly shown, but **Send No Money**; just your name and address, and the books will be sent promptly. Take fifteen full days to read, test and examine them. You'll realize at once what a tremendous force for a better future they can be. After fifteen days you send only \$2.00; then \$3.00 per month until the balance is paid. **There Are No Interest Charges of Any Kind**; the price shown is the total cost.

MEMBERSHIP FREE

Anyone who takes advantage now of this opportunity to "Raise his Pay" will be given absolutely free, a certificate of membership in the American Technical Society, which entitles him to full consultation privileges with our experts in his chosen field. This is good for a whole year and is of tremendous value in solving special problems.

American Technical Society, Dept. X219, Drexel Ave. at 58th St., Chicago, U. S. A.

Please send me set of.....

 for Fifteen Days' examination. I will examine the books thoroughly and if satisfied, will send \$2.00 within 15 days and \$3.00 each month until I have paid the special price of \$..... If I decide not to keep the books I will return them at your expense at end of 15 days.
 Name.....
 Address.....
 Reference.....

MOULDING A MIGHTY CHEST



Get a 46 Inch Chest Complete Course on Chest Building ONLY 25c

Learn the real secret of powerful chest building. Know all about the muscles that lift, widen and deepen the chest and broaden the shoulders. Practice the specialized exercises which will make YOUR chest massive and powerful. The greatest analysis of vital, vigorous chest development ever written. Learn the Hindoo religious system of exercises that makes their wrestlers and strong men invincible. A Hindoo strong man and wrestler threw Zybyso in two seconds. Many other methods unknown to the American body builder, are explained. Complete with anatomic illustrations on which are indicated the little known vital spots in creating vitalic internal strength. You can build for yourself a Herculean chest. The author, George F. Jowett, built his chest from 32 inches of weakness to 48 inches of colossal muscular strength. Develop your chest with straps of big steel muscle. Fill it full of unresisting vital strength energy.

WORTH ITS WEIGHT IN GOLD—GET IT TODAY

To each purchaser will be given a FREE COPY of THE THRILL OF BEING STRONG. It is a priceless book to the strength fan and muscle builder. Full of pictures of marvelous bodied men who tell you decisively how you can build symmetry and strength the equal of theirs.

REACH OUT—GRASP THIS SPECIAL OFFER

JOWETT INSTITUTE of PHYSICAL CULTURE

422 Poplar Street, Dept. 4-B, Scranton, Penna.

Dear Mr. Jowett: I am enclosing 25c. Please send me the course "MOULDING A MIGHTY CHEST" and a free copy of "THE THRILL OF BEING STRONG."

Name.....

Address.....

Learn AVIATION *The One and Only Right Way*



Your plane is Govt. licensed. Your instructor is a transport pilot.

Practical Experience Is All That Counts

To learn flying, you must actually fly. To learn aviation mechanics, you must actually work on planes and motors. In Universal Aviation Schools you get the practical training that counts as well as the theoretical instruction. Universal flight and ground courses are probably the strictest in the country. But they teach you what you need to know.



The Universal student gets practical work on modern type motors.

Universal Training Is Exceptionally Thorough

When you complete a Universal flying, mechanic's or welding course, you are immediately placed in a position to put yourself on a money-making basis. Universal graduates are making good on highly paid jobs all over the United States. Their thorough training prepared them to grasp big opportunities when offered.



The Universal graduate knows airplanes from "prop" to tail end.

Prepare Now for Next Spring's Opportunities

Year around training is available in Universal Aviation Schools. By starting your training at once you may become a full-fledged licensed pilot in the Spring. Or by beginning your ground school training now you may be ready to step into other branches of this fast growing industry early in the year. Take the first step toward getting into aviation by mailing the coupon below.

Get the Facts - Clip the Coupon

UNIVERSAL AVIATION SCHOOLS

Universal Flying School	St. Louis, Mo.	Universal Flying School	Memphis, Tenn.
Universal Flying School	Minneapolis, Minn.	Universal Flying School	Cleveland, Ohio
Universal Flying School	St. Paul, Minn.	Porterfield Flying School	Kansas City, Kansas

A Division of The Aviation Corporation

Universal Schools inspected and rated by U. S. Dept. of Commerce



Universal Aviation Schools
1047-56 Boatmen's Bank Bldg.
St. Louis, Mo. 2-39

Please send me at once your free book, "Aviation—What It Means To You." I am interested in:
 Flying Mechanics Business Course
 Extension Course

Name.....Age.....
 Address.....
 City.....State.....NR344

BOYS a Bicycle for You

You can earn it easily in YOUR spare time



Do you want this beautiful bicycle? This is just one of many prizes Crowell Junior Salesmen are given. They are a group of peppy go-getters who deliver The American Magazine, Woman's Home Companion and Collier's, The National Weekly.

You need no experience to start. We tell you how to locate readers of our magazines and furnish all material. Hundreds of boys are winning prizes and earning their own spending money. You can do the same—just mail the coupon now.

Mail this →

Mr. Jim Thayer's Dept. 136
The Crowell Publishing Company,
Springfield, Ohio.

Dear Mr. Jim:
I sure want one of your bicycles. Start me off as a salesman and send me full instructions.

My Name.....
 Address.....
 Town.....State.....

Read how

Crime is Solved in the Laboratory!

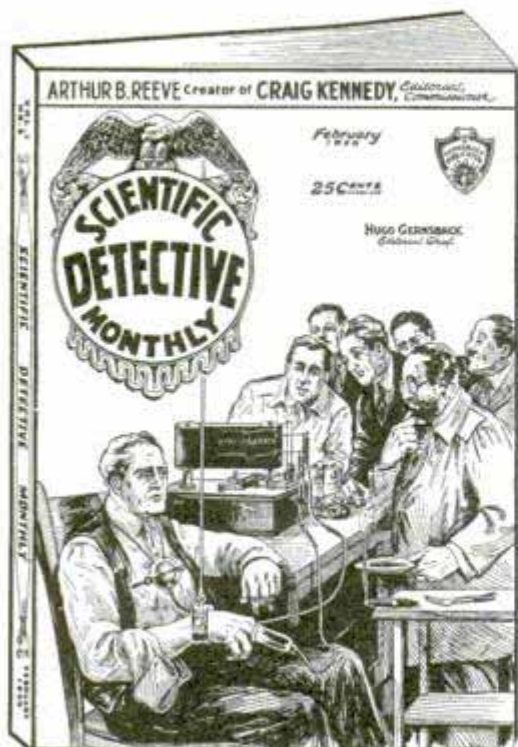

Now—for the first time, advanced thought on scientific crime detection is published in a profusely illustrated monthly magazine. SCIENTIFIC DETECTIVE MONTHLY is truly the most amazing publication ever issued and the most fascinating reading ever set into type. 100 pages—every one chock full of gripping revelations and stirring situations. All based on newly discovered scientific facts.

BEGIN WITH THE FEBRUARY ISSUE

Read about the astounding work of the "Bacteriological Detective" as told by Arthur B. Reeve, known the world over as the creator of "Craig Kennedy" the famous detective. Read "A Scientific Widowhood" by David H. Keller, M. D. Also, "The Man With the Silver Disc," "The Sealed Room," "A Denizen of the Underworld," "The Man Higher Up," and the great "Bishop Murder Case" by S. S. Van Dine. Vastly different and far more intriguing than any detective stories ever published before. Obtain your copy of SCIENTIFIC DETECTIVE MONTHLY from your news dealer—25c—**act now on our special 8 month trial subscription offer.**

8 MONTHS \$1 ONLY

The regular subscription price of this great new magazine is \$2.50 a year. We offer you an 8 months subscription for \$1.00. Think of it! 8 issues—800 pages of scientific Detective Fiction and Fact for only a dollar. Mail coupon today.

SCIENTIFIC DETECTIVE MONTHLY, Dept. P 2,
98 Park Place, New York, N. Y.

Dollar bill enclosed. Send me Scientific Detective Monthly for 8 months.

Name.....

Street.....

Town..... State.....

SCIENTIFIC DETECTIVE MONTHLY
98 Park Place, Dept. P 2, New York, N. Y.

**Only
50c**

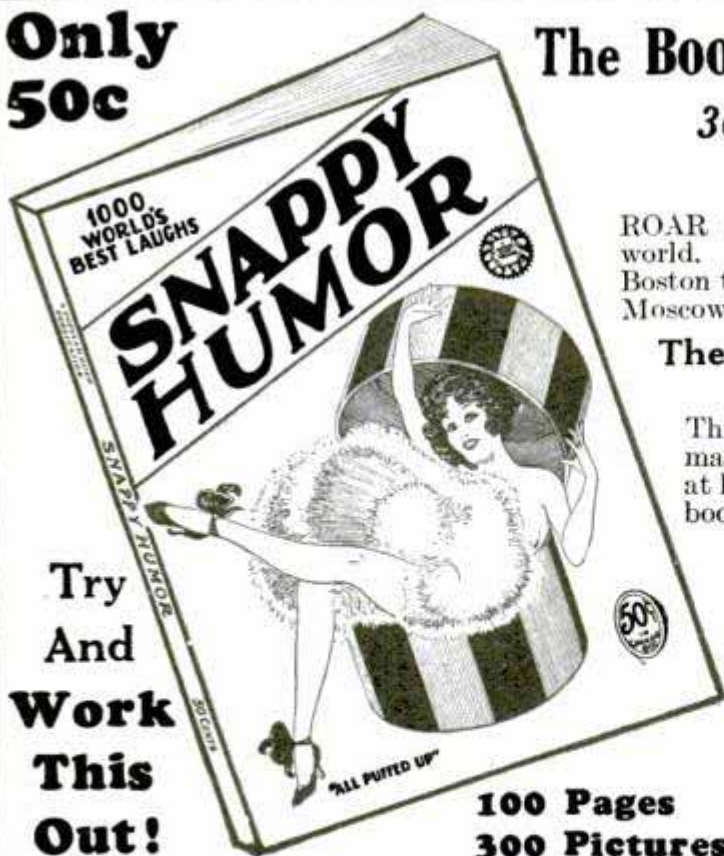

**Try
And
Work
This
Out!**



**100 Pages
300 Pictures
1,000 Laughs
50c a copy**

The Book of a Thousand Laughs

300 Snappy Pictures

Grin! Chuckle! Snort!

ROAR over these funny stories from all over the world. The best wit and humor of the year from Boston to Bombay, from Pernambuco to Panama, from Moscow to Madrid.

The Whole World Loves a Good Joke

One of the Popular Books

This is a regular two dollar book; bound like a magazine; and brought to you on the newsstands at lowest possible cost. Other Popular Book Co. books now on the newsstands are: "STRICTLY PRIVATE"—the intimate Diary of a Doctor; "HOW TO BUILD AND FLY GLIDERS"—an expert treatise for training in aviation, with scores of drawings and diagrams.

A Complete Popular Book

50c—While They Last—50c

GET YOUR COPY NOW!

At any of the larger newsstands. If they are sold out, or you can't find it easily, send your check, money order, cash, or stamps to

Popular Book Corp.

98 Park Place

New York City

**TRAIN
at
HOME
for**

Electricity

THE NEW Shop-Laboratory Way



**Big Shop
Laboratory
Worth \$60.00
without Extra
Cost**

Aviation, Talking Movies, Radio, Super-Power, Television, Refrigeration, Lighting

Need Electrically Trained Men

These new Electrical industries are sweeping the world. This is the Electrical Age! Big manufacturers are pleading for Electrically-trained men. Salaries of \$3,000 to \$7,500 a year are common! Wonderful opportunities for advancement. Here is the field for you. Now is the time to start on the road that leads to increased pay and SUCCESS!

Train the Practical Way

Theory or books alone can never make you a Practical Electro-technician. Our new Home Shop-Laboratory Method, with the patented Unit Board System brings the School right to your home. You learn by doing—by working on full-sized equipment that is yours without extra cost. Behind your training is a fully established college—not a mere correspondence school. Recognized by the U.S. Government. Established 26 years. Over 25,000 graduates holding important Electrical positions all over the world

Earn as You Learn

Cash in on your Electrical Training while you're learning. Many students report increased earnings, advancement, even while studying. Train in your spare time at home. Employment Service renders FREE aid for life. Lifetime Consultation Service. Many exclusive features available nowhere else. Mail the coupon today for full particulars.

**EXTENSION DIVISION
SCHOOL of ENGINEERING
MILWAUKEE, WISCONSIN**

**FREE
48-Page
Book**

Send Coupon TODAY for illustrated 48-Page Book "Practical Electricity—the Key to Success"—and full details of Extension Division Training.



**Exclusive Patented
Laboratory Equipment**

that cannot be secured elsewhere. Special Unit Board System makes fascinating sport of laboratory experiments. Amazingly easy to use.



Learn By Doing



No mere book on theoretical study—but PRACTICAL training on full-sized motor, switchboard, circuits, and electrical equipment.

Satisfaction Guaranteed

You can take \$ of E. Home Shop-Laboratory training without risking a penny. Guarantee Bond protects you.



RADIO CONTROLLED AVIATION



TALKING MOVIES

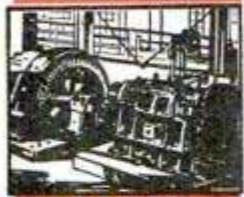

POWER



TELEVISION



RADIO

Extension Division, Dept. 35
SCHOOL OF ENGINEERING
Milwaukee, Wisconsin

Please send me, without obligation, FREE Illustrated 48-Page Book, "Practical Electricity—the Key to Success," and details of Extension Division training.

Name

Address



DRAW CARTOONS

**TURN
YOUR TALENT
INTO MONEY**



Cartoonists earn from \$50 to \$250 per week—some even more. Remarkable *Circle System of Drawing* teaches you in half the usual time. Students from all parts of the world are enrolling for this exceptional instruction. *Personal* criticism service and up-to-the-minute instruction make it easy for National students to attain success. Send for interesting **BOOKLET** and **SAMPLE LESSON PLATE** explaining full details of the Course and what National students are accomplishing. No salesman will call.

The National School of Cartooning, 623 Penton Bldg., Cleveland, Ohio

PLAY BANJO



LET the sweet-voiced, easy-playing Gibson banjo help you make your dreams come true. Gibson banjoists play everywhere—on the records, over the radio, on the stage, for dances and parties. The Gibson is easy to learn. Francis Henry, at left, with Guy Lombardo, plays a Gibson banjo. You learn to play a Gibson easily, quickly.

Gibson

FREE Trial, Easy Payments
Send the coupon for information and free book, "The Road to Happiness." Check the instrument desired.



GIBSON, INC., 203 Parsons Street, Kalamazoo, Michigan.
Gentlemen: Please send free book and complete information about
 BANJO GUITAR MANDOLIN

Name

St.

City



BOYS! Make Big Money

BUILD BIRD HOUSES

Here's a real money maker. With my simple instructions any boy can build and erect Grandpa Bird Houses. They sell at \$2 to \$9.50 each. \$2000 worth sold in Oak Park, Ill., in a year. Send \$1 for my big collection of work shop plans for boys who want to have fun and make money building my famous bird houses. Valuable information about song birds and tips and advice on making sales included **Free**.

GEO. J. BREIDERT, 1040 N. Elmwood Ave., Oak Park, Ill.

LEARN WATCHMAKING

and become independent. We help you secure a position. Easy to learn. Send for **FREE CATALOG**.

ST. LOUIS WATCHMAKING SCHOOL Dept. 5, ST. LOUIS, MO.



CODE TELEGRAPH ATHOME WITH THE AUTOMATIC Omnigraph

Leads quickly to big money jobs. The easy and cheap way. U. S. Gov't., Schools, etc., use it. THE WORLD'S Hobby. Mention Age. Catalog P6. **DO IT NOW.**
Omnigraph Mfg. Co., 810 E. 39th St., Brooklyn, N. Y.

NEW PRACTICAL

DIESEL ENGINE BOOK

The importance of the Diesel engine in its various applications to Marine, Locomotive, and Stationary operation can scarcely be overestimated. Every progressive engineer and student of mechanical engineering will realize the necessity of extending his knowledge into this field.

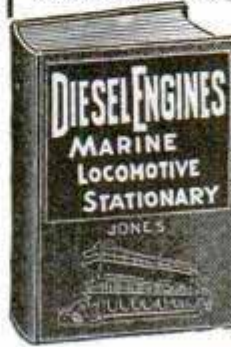

This up-to-the-minute book by D. L. Jones, Chief Machinist, U. S. Navy, is extremely practical, complete and in simplified language. Deals thoroughly with installation, operation and maintenance.

500 pages (6x9)—280 Illustrations.
Pay postman \$5.00 on delivery.

Popular Mechanics Press
200 E. Ontario St. CHICAGO

Handbook for Farmers

861 discoveries by practical farmers, telling how to make, repair or improve the various devices and machines used about a farm or garden. 683 illustrations. "The Most Remarkable Book Ever Published for Farmers," says one authority. **Send No Money.** When the postman delivers the book to you, hand him \$1 plus the few cents postage.

POPULAR MECHANICS PRESS
Popular Mechanics Building, Room 711, Chicago, Ill.

**What Do You Do When
You Cannot Find the**

Book You Want?

Don't give up in despair. Send for a copy of the unique catalog published by Popular Mechanics Press. It contains 5000 books listed alphabetically under 2000 main subjects and sub-headings—literally from A to Z—Abrasives Manufacture to Zoologist and everything in between.

FREE UPON REQUEST

Send for your copy today

POPULAR MECHANICS PRESS
200 E. Ontario Street, CHICAGO

TRAVEL—for 'UNCLE SAM'

RAILWAY POSTAL CLERKS

MAIL CARRIERS—POSTOFFICE CLERKS
GENERAL CLERKS—CUSTOMS INSPECTORS

\$1700 to \$3400 a Year for Life

No "lay-offs" because of strikes, poor business, etc.—sure pay—rapid advancement. Many other U. S. Government Jobs. City and country residents stand same chance. Common sense education usually sufficient.

STEADY WORK

Cut coupon and mail it before turning the page.

MEN—BOYS 18 to 45

Use Coupon Before You Lose It

COUPON

FRANKLIN INSTITUTE, Dept. F175, Rochester, N. Y.
Rush to me, free of charge, (1) A full description of the position checked below; (2) 32-page book, with list of positions obtainable; (3) Tell me how to get the position checked.

- Railway Postal Clerk (\$1900 to \$2700) General Clerk (\$1260 to \$2100)
 Postoffice Clerk (\$1700 to \$2300) Customs Inspector (\$2100 up)
 City Mail Carrier (\$1700 to \$2100) Rural Mail Carrier (\$2100 to \$3300)

Name

Address

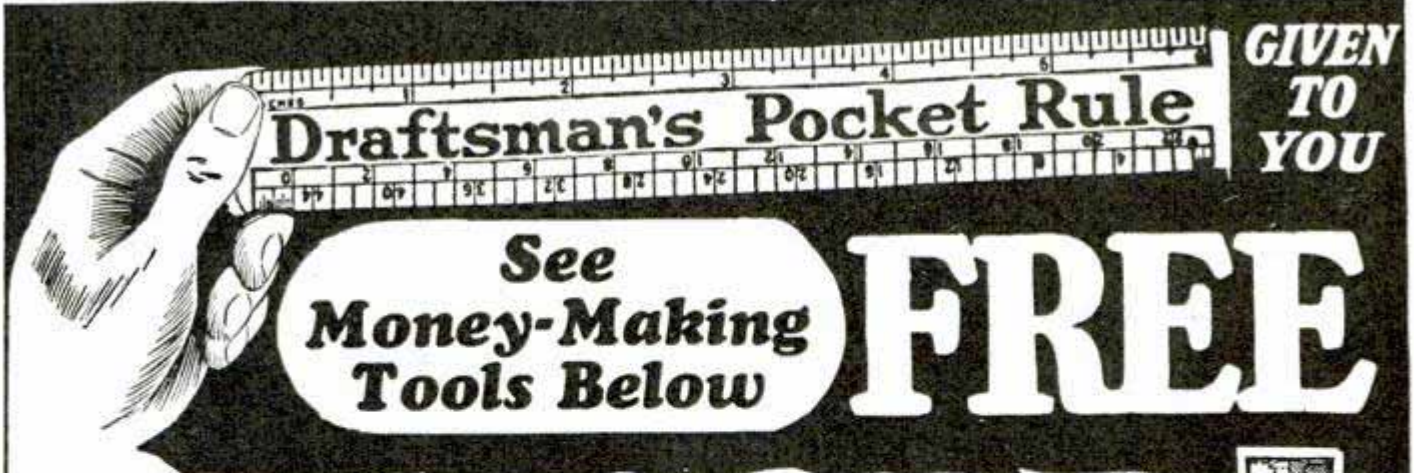

See Money-Making Tools Below

FREE

Just Copy This Jack Today!

If you are 16 or older and will copy jack shown at right and mail it to me I will send you a Draftsman's pocket rule, free.



NEW Pay-Raising Plan



Write to me. I will send you this new book. Not a catalog. My Pay-Raising Plan and Money Making Advice. I can prove that John Savadge, trained by me, makes \$300 a month. Earl J. Dupree, trained by me, refused \$600 a month because he makes more in his own business. A. H. Bernier, trained by me, earns \$7000 to \$9000 a year. Arthur Dewalt, trained by me, makes more than \$400 a month. D. C. Stroop, trained by me, makes \$475 a month. L. V. Broughten, trained by me, makes \$300 a month.

Now is the time to learn to be a draftsman. Get Free, "My Pay-Raising Plan." Send for it at once.

Let me tell you how some Dobe Draftsmen make \$250.00 to \$750 a month. Read this advertisement clear through. See for yourself how you can make real money as a draftsman. Read how much work there is for them.

Age or Lack of Education No Drawback

You do not need previous experience. You do not need to be a high school graduate. My practical, home study course gives you just the kind of training you need to become successful, during only your spare time.

I Train You at Home

My practical working method makes every step in learning drafting as clear as a moving picture. That's why I train you so fast to be a draftsman.

Money Back if Not Satisfied

I train you under a positive Money Back Agreement. If my training does not satisfy you after you have finished you get every penny back.

Earn While You Learn

You can start earning extra money a few weeks after beginning my training. I give you special work and tell you how to make money.



Money-Making Tools Furnished by Me

You get these fine quality, genuine, imported draftsman's tools, just as soon as you become my student. No finer tools made for practical drafting work.

Employment Service

After training you I help you to get a job without charging you a cent for this service. Employers of draftsmen come to me for men because they know that men I train make good.

Draftsmen Needed In: Auto Work

The automobile industry is one of the greatest in America. Thousands of draftsmen needed. I'll train you for the work.

Electricity

Electricity is the coming motive force of the world. Draftsmen are needed in every department of this fascinating work. I'll train you at home. Get a job here.

Aviation

Aviation is just in its infancy. It is bound to expand to enormous proportions. Draftsmen are essential to it. I'll train you quick at home for drafting position.

Motor Bus Work

Motor bus building and motor bus transportation have become leading world industries. Hundreds of draftsmen engaged in this work. I'll show you the way.

Building Work

There will always be building. No structure can be erected without plans drawn by draftsmen. I'll make you an architectural draftsman at home.



"If You Earn Less Than \$70 a Week Write Me Today! I Will Train You At Home"
Engineer Dobe

ACT NOW

Before You Put this Magazine Down. Let me send you my books "Successful Draftsmanship" and "My Pay Raising Plan". Remember Draftsmen are needed everywhere. That's the kind of profession to get into. Get started now. Get into a better position, paying a good straight salary the year around.

Engineer Dobe 1951 Lawrence Avenue Div. 93-52 Chicago, Ill.

Mail Sketch—Get Free Rule

ENGINEER DOBE

1951 Lawrence Ave., Div. 93-52 Chicago

Here's the sketch. Send me free rule; also send me free of all cost books "Successful Draftsmanship" and "My Pay-Raising Plan,"—how to earn money while learning and proof of big money paying positions.

Name..... Age.....
Address.....
Post Office..... State.....

The Marshall Trained Man



is

Flier, Executive and Mechanic

He gets the big jobs because he understands them.

Marshall Flying School training is more than mere flight instruction. It fits Marshall-trained men for big, executive jobs. Pilots, managers, technicians, and mechanics as well as executives are in constant demand.

Marshall Flying Instruction Is Complete

The Marshall Flying School offers complete Aviation training in regular courses based on departmentalized University Methods. Marshall students learn to fly under noted fliers in the Barling NB 3, all metal structured, low-wing monoplane, and other new production ships. Under splendid technicians you will receive instruction in flight theory, instrument flying, aero dynamics, meteorology, avigation and aircraft motors. You are taught how to DIRECT THE WORK OF OTHERS.

Be An Executive

At the Marshall Flying School you can learn airline operations, airport management, and supervision of field activities. The sale and distribution of airplanes and aircraft supplies is another important phase of executive training. There is a rich future for trained executives who can fly and who know Aviation thoroughly.

Mechanical and Engineering Courses

The best paying mechanical and engineering jobs are now offered in Aviation. Marshall offers instruction and ACTUAL EXPERIENCE, under factory conditions, in metal welding, fuselage construction, wing construction and rigging, wing covering, the principles of aircraft design, and the construction and correction of instruments.

COMPARE THESE PRICES

Special 10-hour Flying Course.....	\$200	Sportsman's Course.....	\$450
Primary Aviation Course (Solo flight)....	275	Professional Course.....	875
		Mechanic's Course.....	95
		Welding Course.....	135

MARSHALL FLYING SCHOOL
190 English Street, MARSHALL, MO.

Please send me all information on Marshall Flying School Courses.

Name..... Age.....

Address.....

LEARN TO PLAY

VIOLIN, TENOR BANJO, HAWAIIAN GUITAR, BANJO, CORNET, GUITAR, MANDOLIN, BANJO MANDOLIN, BANJO-GUITAR, SNARE DRUM, FIELD DRUM, PIANO or ORGAN quickly by note by our copyrighted easy to learn home-study method. No teacher or talent necessary. Lessons are so simplified and so easily mastered many pupils play by note after only 10 lessons. Thousands of men, women, boys and girls have learned to play quickly and proficiently by our system of teaching. Cost is less than 10c a day. Pay while you learn. Your opportunity to become popular and play for profit or pleasure. Write for Free Trial. Any instrument except PIANO and ORGAN furnished if desired at wholesale price.

CHICAGO CORRESPONDENCE SCHOOL OF MUSIC, INC.
1632 No. Halsted St., Dept. 40 Chicago, Ill.

Learn **MECHANICAL DENTISTRY** *in 10 Months!*



Men and Women can do this at home in their spare time. As much as \$100 weekly and even more is made by trained mechanical dentists. Steady work. Earn big money in a profession. Write for FREE particulars about our easy but complete Home Study Course.

AMERICAN SCHOOL OF MECHANICAL DENTISTRY
Dept. A 150 E. South Temple St., SALT LAKE CITY, UTAH

BE AN OIL EXPERT!

Trained geologists, drillers, refiners, salesmen are at a premium! New, easy, practical way to learn at home in spare time! Write Today! FREE Book!

PETROLEUM ENGINEERING UNIVERSITY, Dept. 222, FORT WAYNE, IND.

INVENTORS

— Read the marvelous history of American Invention, the most impressive record in the annals of human achievement. A very limited edition of Waldemar Kaempffert's Popular History of American Invention in 2 vols. 1034 Pages. Over 500 Illustrations. Cloth. \$5 per set postpaid (just half price of original edition.)

Popular Mechanics Press, 200 E. Ontario St., Chicago

DRAW for PLEASURE and PROFIT

C A Sharpen a soft pencil. Follow the simple lines in this amazing book, "Figure Construction," copy the illustrations several times — and PRESTO! you can sketch a head, a hand, a figure with the ease and grace of a real artist. It is a lot of fun to draw and sketch—there may be profit, too, from your sketches as you advance. Don't think you can't draw until you have tried the easy instructions of this excellent course—now in one handy, beautiful book.

AS EASY AS A B C

Every intelligent man or woman will find great satisfaction in being able to sketch a head, a figure, a landscape, easily and rapidly. It is so easy to follow the Foundation Line System as contained in this course that any one that can handle a pencil at all can make progress quickly. Even if you thought you "couldn't draw a straight line," you will get remarkable results from only 15 minutes' practice a day.

Beginner's Course \$2.50

Although a beginner's art class would cost a great deal in time, money and materials, you can obtain all the elements you need in this elegant course—book for only \$2.50. The book is 7" x 11", heavy, calendared paper; over 100 progressive illustrations to follow; full page plates; easy instructions. Who knows but what this valuable instructor may introduce you to the highly profitable field of commercial art?

Send No Money

Send the coupon below and deposit the purchase price of \$2.50 (and postage) with the postman when your "Figure Construction" book arrives. Money back if unsatisfactory.

GREGG PUBLISHING CO., 20 West 47th St., New York, N.Y.
Send me "Figure Construction." I will pay postman \$2.50 (and postage) on arrival. My money to be refunded at any time within 30 days, if I am not satisfied.

Name

Address..... PM1
(Postage free if the \$2.50 is sent with order.)



Auto Owners Now Save Millions of Gallons of Gas

A new invention called the Whirlwind is actually saving millions of gallons of gasoline for automobile owners. Those who have installed this amazing device on their cars report almost unbelievable gasoline savings. They also report more speed and power, quicker starting and disappearance of carbon.

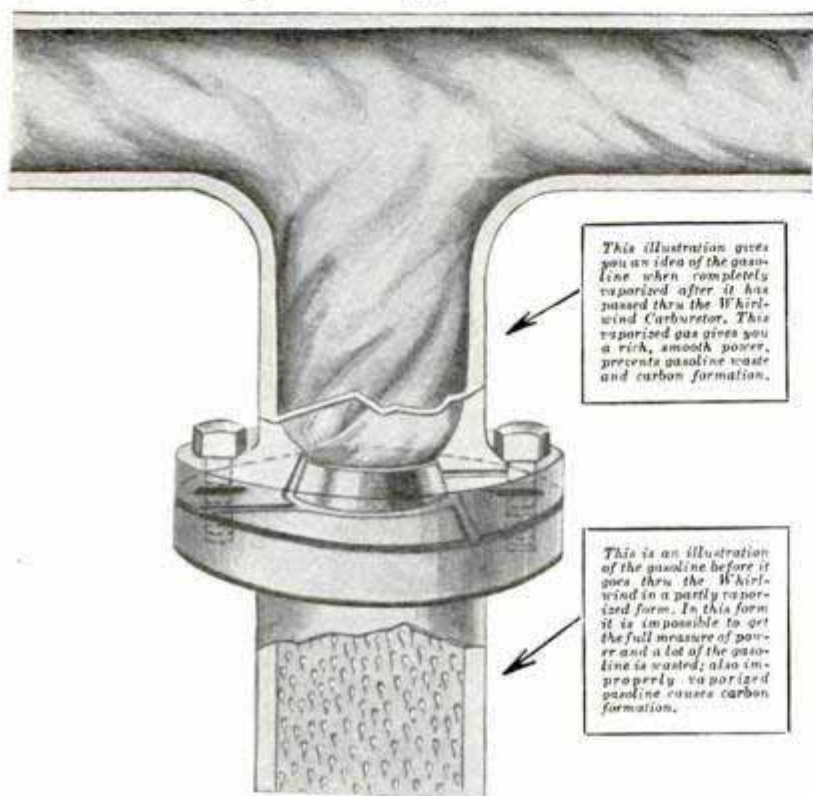

This illustration gives you an idea of the gasoline when completely vaporized after it has passed thru the Whirlwind Carburetor. This vaporized gas gives you a rich, smooth power, prevents gasoline waste and carbon formation.

This is an illustration of the gasoline before it goes thru the Whirlwind in a partly vaporized form. In this form it is impossible to get the full measure of power and a lot of the gasoline is wasted; also improperly vaporized gasoline causes carbon formation.

The marvelous thing about this Whirlwind is that it works as well on all makes of cars. Reports are received from owners of practically every known make of automobile from Fords to Lincolns and they are all equally enthusiastic in their praise.

FITS ALL CARS

In just a few minutes the Whirlwind can be installed on any make of car, truck or tractor. It's actually less work than changing your oil or putting water in the battery. No drilling, tapping or changes of any kind necessary. It is guaranteed to work perfectly on any make of car, truck or tractor, large or small, new model or old model. The more you drive the more you will save.

SALESMEN AND DISTRIBUTORS WANTED

FREE SAMPLE AND \$100.00 A WEEK OFFER

Whirlwind men are making big profits supplying this fast selling device that car owners cannot afford to be without.

Good territory still open. Free sample offer and full particulars sent on request. Just check the coupon.

GUARANTEE

No matter what kind of a car you have—no matter how big a gas eater it is—the Whirlwind will save you money. We absolutely guarantee that the Whirlwind will more than save its cost in gasoline alone within 30 days, or the trial will cost you nothing. We invite you to test it at our risk and expense. You are to be the sole judge.

WHIRLWIND MFG. CO.

DEPT. 999-147-A THIRD ST.

MILWAUKEE, WISCONSIN

Free Trial Coupon

Whirlwind Mfg. Co.,
999-147-A Third St., Milwaukee, Wis.

Gentlemen: You may send me full particulars of your Whirlwind Carbureting device and free trial offer. This does not obligate me in any way whatever.

NAME.....

ADDRESS.....

CITY.....

COUNTY..... STATE.....

Check here if you are interested in full or part time salesman position.

Be Vigorous — Manly Strongfort Tells How

You are blue, despondent and discouraged if you feel beaten in the game of life. You are giving in too easily.—Snap out of it—take a new grip on yourself. Join the big crowd of fellows all over the world who gave me a chance to talk things over with them confidentially and then took my advice and instruction and were led to joyous health, strength and courageous manhood.



LIONEL STRONGFORT
Specialist in
Health and Strength

Let Me Take Hold of You

Let me build up that body of yours into a fine, vigorous specimen of manhood. Let me eradicate all the taints and vitality-sapping ailments that come through excesses, a neglected body, over-work, or inherited weaknesses. I will build you up inch by inch until you are a real man inside and out—making you proud of your power, giving you confidence in your ability and filling you with eagerness for the physical and mental delights of life.

STRONGFORTISM Will Build You Up

Strongfortism has performed wonders for thousands of men all over the world. It is the basic science of health and strength—no doubt about it. For over 30 years I have demonstrated its value in body building.

Health in abundance will be yours—and dynamic energy will come with it—if you will listen to me and take up my Course in STRONGFORTISM. My unquestioned mastery of the human body, my proved ability to restore weakened men to health and strength by this system, qualifies me to diagnose your troubles and map out a Course that will speedily and certainly transform you.

Success Comes With Health

Without abundant health and dynamic strength you can't hope, in these speedy times, to score any success in life—to attract people to you, to win favor or affection or to get on in business. You can't expect advancement to the bigger jobs with higher pay. With a face radiating good cheer, backed by a peppy body full of energy and a mind chock full of ambition you can climb to any height—you can command success.

Pupils praise me as their teacher. They write letters full of thanks and joy for what I have done for them through STRONGFORTISM—just by following natural laws and giving their bodies a chance to help themselves as Nature intended.

SEND FOR MY NEW BOOK

"Life's Energy Through Strongfortism"

This book of many pages and pictures is a revelation of priceless secrets about the human body—a storehouse of facts that will show you what has been and can be done for weak, sickly and underdeveloped men. Get this book right away.

LIONEL STRONGFORT

PHYSICAL AND HEALTH SPECIALIST
FOR OVER 30 YEARS

Dept. 23 Newark, N. J., U. S. A.

.....SEND THIS COUPON.....

Free Confidential Consultation

Mr. Lionel Strongfort, Dept. 23, Newark, N. J.—Please send me absolutely free my copy of your book, "LIFE'S ENERGY THROUGH STRONGFORTISM." This does not place me under any obligation and no salesman is to call on me. I have marked (x) before the subjects in which I am most interested.

- | | | |
|---------------|-------------------|---------------------|
| .. Colds | .. Deformity | .. Weak Eyes |
| .. Catarrh | .. Insomnia | .. Falling Hair |
| .. Asthma | .. Heart Weakness | .. Poor Memory |
| .. Hay Fever | .. Short Wind | .. Rheumatism |
| .. Obesity | .. Flat Feet | .. Poor Circulation |
| .. Headache | .. Constipation | .. Skin Disorders |
| .. Thinness | .. Billousness | .. Despondency |
| .. Rupture | .. Torpid Liver | .. Round Shoulders |
| .. Neuritis | .. Indigestion | .. Lung Troubles |
| .. Neuralgia | .. Nervousness | .. Increased Height |
| .. Flat Chest | | |

Name.....

Age..... Occupation.....

Street.....

City..... State.....

ALL ABOUT Aviation FREE!

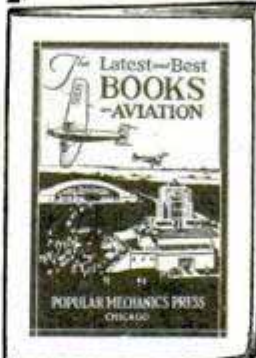

No matter what your interest in flying may be; whether that of student, instructor, pilot, executive, flying field mechanic, hangar or shop man, engineer, designer, draftsman, manufacturer or layman, you need the latest and best information obtainable.

First-Hand Knowledge for Prospective Students

The young prospective student of flying should have forcibly impressed upon him the advantages in getting all the first-hand knowledge possible of aircraft construction, flight, etc.

Survey of Transport Aviation Development

No business man who is looking to the future can afford to remain out of touch with the rapidly unfolding commercial development of transport aviation.

New Opportunities Constantly Opening

As an illustration of the many new calls for skilled craftsmen in the industry, the advent of all-metal ships has brought the trade of aircraft welding into prominence.

Consult the Best Authorities

For the best help on any and every phase of aeronautical science send for our special new 24-page illustrated catalog of aviation books. In this you are not only given the most complete descriptions of the important new books, but such well-known authorities as the Staff of the Daniel Guggenheim School of Aeronautics, New York University and Major R. W. Schroeder, pioneer Aviator and Aeronautical Engineer aid you by recommending the best books available on a big assortment of subjects.

Send for Your Copy Today

Popular Mechanics Press, 200 E. Ontario St., Chicago

861 PRACTICAL IDEAS for REDUCING FARM LABOR and INCREASING INCOME

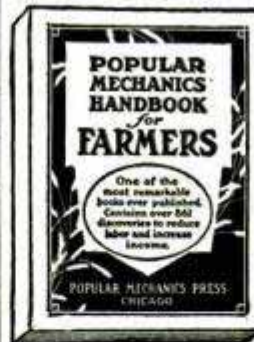

One farmer writes: "I would not take \$100 for my copy if I could not secure another."

The Handbook for Farmers contains: 138 ideas for the farm shop, 35 on fencing, 98 on auto, truck and tractor, 61 on farm buildings, 36 on field machines, 48 on concrete work, 22 on orchard work, 23 on painting, 15 on live stock, 34 on poultry, 54 on garden work, 25 on electrical work, 22 on farm tools, 16 on hunting, fishing and trapping, 140 household helps.

394 HELPFUL KINKS to LIGHTEN the LABOR of the FARMER'S WIFE

The Handbook for Women contains: 83 kitchen and dining room helps, 17 on garden and flowers, 19 on sewing and mending, 37 on furniture, pictures and fixtures, 38 on laundry and cleaning, 32 on house cleaning, 12 on music, 14 on sleeping rooms, 11 on care of children, 16 on lights, 9 on photography, 14 on clothing and shoes, 23 on house temperatures, 12 on water and drains, 10 on insect pests, and 47 miscellaneous.

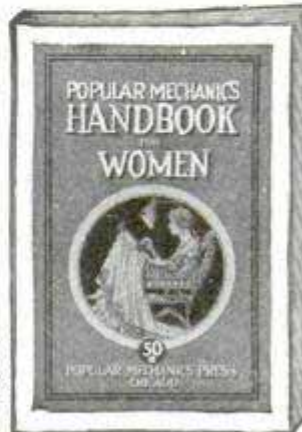

SPECIAL OFFER BOTH for \$1

(Regular \$1.50 Value)

For a limited time you are offered both books for \$1 plus the postage. Pay postman when he delivers package, if outside U. S. send remittance and include 15 cents extra for postage.

POPULAR MECHANICS PRESS
Room 2, 200 E. Ontario St., Chicago



Actual size of Magic Dot. The new system weighs only 4 ounces, yet holds rupture more securely than pounds of steel springs, and hard, gouging cushions.



Beware the Small Rupture THAT "DOESN'T BOTHER MUCH"

Yet... Holds Rupture!

Now—An Ohio Scientist Is Helping Nature Rescue Thousands Of Rupture Victims From The Eternal Horror Of Many Dangerous Cumbersome Trusses And Other Torturous, Harness-Like Contraptions. He Has Perfected A Tiny, Feather-Weight Magic Dot That Frequently Brings About Joyous Relief And New Comfort From The First Day. Countless Former Victims Everlastingly Thank This Interesting Discovery For Their New Happiness. Just Mail The Coupon For Free Material Sample If You, Too, Want New Freedom.

SCIENCE has at last developed a tiny, interesting device weighing less than 1/25 of an ounce, which has helped to free and amazed thousands of rupture sufferers and won the admiration of many doctors and scientists.

The New Science System makes utterly obsolete all painful trusses, gouging knobs, steel springs and unsanitary, cumbersome leg straps.

It "Breathes" Air

Magic Dot anchors a flesh-soft padlet composed of a newly perfected substance named Airtex. This is honey-combed with microscopic air cells that tend to "breathe" air with each movement of your body. It expands and contracts as easily as your own flesh. When you walk, run, bend or exercise it tends to squeeze itself—not the part of the body it rests against.

The appliance is so light—so comfortable—the wearer as a rule hardly knows he has it on. It does not produce that "hot spot" feeling. Sanitation is now more sure—because the padlet can be washed clean and sweet in a jiffy.

Immediate relief and new comfort are not the only things the New Science System should accomplish. Of far greater importance is the comfort you have dreamed of—the possibility of ultimate FREEDOM! This should be possible because this amazing new method gives nature a chance to heal the rupture automatically. This is not possible with gouging trusses that prevent free circulation.

Test Sample Free

Send no money. Just mail the coupon for Free Sample of remarkable Airtex. With it we send, without charge, latest copy of a very new and informative book on Rupture and Hernia that should open your eyes.

NEW SCIENCE INSTITUTE

2169 Clay Street

Stuebenville, Ohio

New Science Institute,
2169 Clay St., Stuebenville, Ohio.

Without obligation send me a no-cost Airtex sample with new book about rupture and hernia relief.

Name.....

Address.....

City.....State.....



FREE! Body Chart

If you will mail the coupon below, this Anatomical and Physiological Chart will be mailed to you without one cent of expense. It shows the location of the Organs, Bones of the Body, Muscles of the Body, Head and Vertebra Column and tells you how the nerves radiate from your spinal cord to all organs of the body. This chart should be in every home.

Where Is That PAIN?

It may be in the neck, back, hips, stomach, liver, legs or arms. Wherever it is, the chart will help to show you the location and cause of your ailment. For instance, this chart will help you locate verminiform appendix pains. Hundreds of lives might have been saved if people had known the location and character of the pain and had received proper attention.

Stop that Pain

By Relieving the Cause with

**Violet Ray - Vibration
Ozone - Medical Electricity**

The Four Greatest Curative Powers Generated by This

Great New Invention!



Elco Health Generators at last are ready for you! If you want more health—greater power to enjoy the pleasures and delights about you, or if more beauty is your desire—write! Ask for the book on these inventions which has just been prepared. It will be sent to you without cost. It tells you how Elco Health Generators aid you in leaving the lethargy and hopelessness of bad health and weakness behind forever. Re-vitalize yourself. Bring back energy. Be wholly alive. Write today!

Here's What Elco Users Say—

"Wouldn't take \$1000 for my Elco."
"Has done me more good in 2 weeks than doctors did in three years."



"Cured my Rheumatism." "My Eczema gone." "Cured my stomach trouble." "Cured my weakness." "Now I sleep soundly all night." "Thanks to Elco my strength and vigor are back." "No more pain." "Colds never bother me now." "Chronic Constipation banished."

These great new inventions generate Violet Ray, Vibration, Electricity and Ozone—combined or separate. They operate on the electric light in your home or on their own motive power at less than 50 cents per year. Elco Health Generators are positively the only instruments which can give you in one outfit Electricity, Violet Ray—Vibration and Ozone—the four greatest curative agents. Send the coupon below. Get the Free Book NOW!

MAIL COUPON for FREE BOOK

Do not put this paper down without sending the coupon. Don't go on as you are with pains and with almost no life and energy. You owe it to yourself to be a better man or woman. You were put here to enjoy life—not just to drag through it. So do not rest another day until you have put your name on the coupon here. That will bring the whole story of these great new inventions. Do it today—now.



Lindstrom & Co. [Makers of Therapeutic Apparatus since 1892.]
2322 Indiana Avenue Dept. 13-52 Chicago
Please send me your free book, "Health—Power—Beauty" and full information of your 10-day Free Trial Offer.

Name.....
Address.....

How To Secure A Government Position

Why worry about strikes, layoffs, hard times? Get a Government job! Increased salaries, steady work, travel, good pay. Examinations coming. I'll help you become a Custom House Clerk, Railway Postal Clerk, Post Office Clerk, City Mail Carrier, Rural Carrier—or get into any other Government job you want. I was a Secretary-Examiner of Civil Service Commission for 8 years. Have helped thousands.

Now FREE

My 32-page book tells about the jobs open—and how I can help you get one. Write TODAY. ARTHUR R. PATTERSON, Civil Service Expert, PATTERSON SCHOOL, 82 Winner Building, Rochester, N. Y.



\$100 to \$500 A Week Is Earned by Cartoonists Today

DO YOU LIKE TO DRAW?

Billy Hon's Famous Cartoon Book Will Teach You A Simple—Complete—Interesting Course in Cartooning. Consisting of 30 lessons illustrated with over 300 original drawings by one of America's famous cartoonists. Sent Post Paid for \$1.00, outside of U. S. \$1.20.

Satisfaction guaranteed.

Wasley Publishing Co., 210-P West 14th St., Los Angeles, Cal.



I POSITIVELY GUARANTEE

to increase your arms one-half inch in size, chest one full inch, strength 25%, health 100% in one week's time, by following my instructions and using my exerciser 10 minutes mornings and at night. Send \$1 for complete course and exercisers. Satisfaction guaranteed or \$1 refunded.

J. A. DRYER, Box 1850-P, Chicago, Ill



DRAFTING

BOOKS SENT FREE!

For Beginners

Written so you can understand every word, by 18 famous Engineers and Architects. Deluxe, flexible binding. 1750 pages, 1050 blue prints, charts and diagrams. Prepares you for a good Drafting job in mechanical or architectural lines. Sent for 10 days' free use, if you mail coupon immediately.

Only fifteen minutes a day with these WONDER BOOKS will prepare you for a good Drafting job in less than a year! Mechanical and Architectural Drafting from simple straight lines to important, complex plans, a step at a time! Built especially for beginners, for men with only grammar schooling. Drafting room practice plus engineering made easy and clear!

Big Field—Big Demand—Big Pay!

Competent Draftsmen are urgently needed right now in all building and manufacturing lines at \$50 to \$100 a week. That's just the beginning—for draftsmen have the best chances for advancement! Pleasant, fascinating work, easy to learn and do. Learn quick with these books—send coupon for a set FREE, and see for yourself!

[A year's Consulting Membership in the American Technical Society now given free to all readers of this famous Cyclopaedia of Drafting. Many say that's worth more than cost of books.]

American Technical Society Dept. D-219, 58th & Drexel Ave., Chicago

FREE If you send for these great Drafting Books NOW we will include without cost a complete volume "Blueprint Reading" containing 120 pages durably bound in cloth and also a complete portfolio of 58 plates covering the basic orders of architecture. These plates are drawn to scale and are very valuable.

American Technical Society
Dept. D-219, 58th & Drexel Ave., Chicago
Send for 10 days' free use 4-volume set of DRAFTING. In return for mailing this coupon promptly send absolutely FREE "Blueprint Reading" (Building) 120 pages, 69 illustrations, also a complete portfolio of 58 plates. I will pay the few cents delivery charges. If I wish I may return books in 10 days and owe you nothing. But if I prefer to keep them I will send \$1.50 after 10 days, then \$2.00 a month until \$14.80 (special reduced price) is paid.

Name.....
Address.....
Employed by.....
Address.....

Save \$20.00 with this OFFER. Send no money



Get Strong WITH These Improved Muscle Builders All for \$5.00



Why pay an extravagant price for strength—here's an opportunity to get all the equipment you require along with an excellent course of instructions for only \$5.00. Realize your ambition and develop muscles of a super-man. Get strong and amaze your friends. We show you how to easily master feats which now seem difficult—or if you just want physical culture for your health's sake, this equipment is just what you need. With this special offer you save at least \$20.00. We furnish a ten cable chest expander which is adjustable to give resistance up to 200 lbs. It is made of new live strength, springy rubber so as to assure long wear and give the resistance you need for real muscle development. You also get a pair of patented hand grips for developing powerful grip and forearms.

We include wall exercising parts which permits you to develop your back, arms and legs—a real muscle necessity. You know that business men and athletes, too, first show their age in their legs. Develop your leg muscles with the foot strap which we furnish. This will give you speed and endurance—but that isn't all that you get. In addition we include a specially written course which contains pictures and diagrams showing you how to develop any part of your body so that you will quickly get on with these exercises and gain the greatest advantage from their use. Act now while you can get in on this special offer. It might be withdrawn, so rush the coupon.

SEND NO MONEY

All of the items pictured on this page are included in this big special reduction offer. Sign your name and address to the coupon below and rush it to us. We will send you ten cable chest developer, the wall parts, a pair of hand grips, foot strap and the course by return mail. Pay the postman only \$5.00, plus the few cents postage on arrival. (If you desire to send check or money order in advance, we pay postage.)

GUARANTEE

All Crusader products are guaranteed to give entire satisfaction or money back.



Crusader Apparatus Co., Dept. 102, 44 Parker Ave., Maplewood, N. J.

I accept your offer. Send me everything described in your advertisement by return mail. I will pay postman \$5.00 plus postage on arrival. It is understood if I am not entirely satisfied after examination I can return the goods and you will refund my money.

Note:—No C.O.D. Orders to Foreign Countries or Canada

Name.....

Street.....

City..... State.....

Learn Aviation from these Famous Books



EVERYTHING you need to know! From fundamental ground work to advanced navigation. THOUSANDS of dollars' worth of accurate UP-TO-DATE information contained in these practical books, written in clear, understandable language, by outstanding authorities. Take your pick of these great NEW books, now used for instruction purposes in 200 schools and colleges. NEW and exclusive material—illustrations—photographs, charts, diagrams, tables, etc.

Beginners—Students—Pilots—Mechanics!

Let these famous books help you in your work. **EXAMINE ANY OF THEM 5 DAYS.** Learn Aviation quicker, with these standard books. Send coupon for your selection NOW.

MODERN AIRCRAFT by Major Victor W. Pagé. The standard for beginner and expert. All types of airships, airplanes, engines—design, construction, operation, maintenance. Includes: History Aviation; Airplane Fuselage; Landing Gear Construction; Airplane Parts and Functions; Air and Water Cooled Engines; Airplane and Engine Instruments; Propeller Construction and Action; Equilibrium and Control Principles; Inspection and Maintenance; Commercial Aviation; Aerial Navigation; Dictionary Aviation Terms, etc. 855 pages, 400 illustrations, 23 tables. Price, \$5.00.

MODERN AVIATION by Major Victor W. Pagé. Every type of aircraft motor described, explained, illustrated. NEW—up-to-date—authoritative. Each volume contains 1,000 pages; 500 illustrations. **Volume One** covers principles of engines, engine parts and functions; fuels; carburetion, aircraft superchargers, Diesel engines, ignition systems; magnetos, lubrication, cooling systems, cylinder construction, trouble shooting, etc. **Volume Two** covers all types of modern aircraft engines; Wright "Whirlwind" and "Cyclone"; Pratt and Whitney "Wasp" and "Hornet," Anzani, Cirrus Mark 11 and 111, Packard, Curtiss and Caminez, air and water-cooled types and accessories; Engine installation, instruments, propellers, reduction gears, starters, engine repair, etc. Price per volume, \$5.00. Both volumes, \$9.00.

AERIAL NAVIGATION AND METEOROLOGY by Capt. Lewis A. Yancey, Master Mariner (Unlimited), Famous Trans-Atlantic Navigator. Indispensable to transport pilots and those preparing for examinations. 350 pages practical information. Illustrations, colored plates. Numerous solved problems. Examples for practice. Chapters on Bearing, and Direction; Terrestrial Sphere; Charts and Maps; The Compass; Errors; Compensation; Correction of Courses—Cross-Country work; Meteorology; Air Commerce Regulations; Course Error and Conversion Tables; Variation Map of North America. Price, \$4.00.

EVERYBODY'S AVIATION by Major Victor W. Pagé. 600 Questions and Answers; complete information for U. S. Government license. Explains construction and navigation. Brief history of aeronautics, elementary aero-dynamics. Parts, functions, airplane fuselage forms, landing gears, wing forms, construction, engine types, propellers, equilibrium and control, etc. Price, \$2.00.

A B C OF AVIATION by Major W. Pagé. A readable, popular discussion of aviation and its history. Operating principles of various types of flying machines. Illustrated with diagrams of leading types of airplanes. Ideal for everyone approaching the study of aviation. Paper bound, 160 pages, 150 illustrations. Price, \$1.00.

EXAMINE ANY BOOKS 5 DAYS

Check coupon for whichever books you want. Examine them 5 days. Return if not satisfied, and your money will be refunded in full. You take no risk, SO MAIL THE COUPON NOW.

NORMAN W. HENLEY PUBLISHING CO. (Dept. 42A) 2 West 45th St., New York, N. Y.

MAIL THIS COUPON NOW

Norman W. Henley Publishing Co., Dept. 42A, 2 West 45th Street, New York, N. Y.

Please send books checked for examination. I enclose no money but will deposit price, plus postage, with postman on delivery. If, for any reason, I return the books within 5 days after receipt, you agree to refund my money in full. (If you enclose price, we pay postage. Same return privilege.)

Modern Aircraft, \$5.00
 Modern Aviation Engines
 1 vol., \$5.00
 2 vols., \$9.00

Aerial Navigation and Meteorology, \$4.00
 Everybody's Aviation Guide, \$2.00
 A B C of Aviation, \$1.00

NAME.....

ADDRESS.....

TOWN..... STATE.....

(Outside U. S. remit with order)

ENJOY THE FINEST AVIATION TRAINING

with
The School of
VON HOFFMANN
One of America's
Leading Schools
of **AVIATION**

United States Government
APPROVED SCHOOL for
Transport, Limited Commercial,
Private Pilot, Ground & Flying

There is money for you in aviation if you get thorough training now! Our courses will give you this training—they are taught under the direction of U. S. licensed transport pilots and mechanics and cover everything about planes, motors, their maintenance and construction. The training which the student receives at the School of Von Hoffmann is the exact training which he must have to qualify for immediate positions on the ground or in the air. Our equipment is new and of modern design, subject to U. S. Gov't inspection—the cost is low considering actual flying and thoroughness of ground instruction on latest modern type planes, Wright Whirlwind and other standard motors. No student bond required.



WORLD'S FAMOUS PILOTS TRAINED HERE

Our field is identified in the world of Aviation as an outstanding place to enjoy the best training—a place where conditions are ideal—from here was started the 'cross the Atlantic Flight that convinced the world what could be done and more recently the world endurance flight record was established here.

EASY MONTHLY PAYMENTS

It is easy to pay the Von Hoffmann way because small monthly payments are extended. Let us show you how you can start now and pay later, even after you have finished the course of training.

VON HOFFMANN AIRCRAFT SCHOOL
126 Lambert-St. Louis Flying Field
ST. LOUIS, MO.

VON HOFFMANN AIRCRAFT SCHOOL
126 Lambert-St. Louis Flying Field
St. Louis, Mo. MAIL TODAY

Please mail FREE information at once.

Name.....

Address.....

City..... State.....

Age..... I am interested in

FLYING COURSE GROUND COURSE
WELDING COURSE HOME STUDY

Make Furniture At Home



—either for your own pleasure or to sell. It is easy when you have the instructions supplied in Popular Mechanics Home Furniture Making Library. This library consists of the

following cloth-bound, profusely illustrated books of which many thousand have been sold to satisfied customers everywhere:
1. Mission Furniture—Part 1
2. Mission Furniture—Part 2
3. Mission Furniture—Part 3
These three practical, money-saving books contain full directions and drawings for the making of all sorts of furniture, including tables, chairs, stools, davenports, electric table lamps, and many other useful and beautiful articles of furniture. Crystal clear instructions in 3 handy books; 360 pages—186 illustrations. Just follow directions and you'll be amazed at your good results. Use the furniture in your own home or sell it. One man writes he



sold over \$1,000 worth of furniture made from these books. You can do the same.

Send No Money! Just write a postal asking that Popular Mechanics Home Furniture Making Library be sent you C. O. D. When the postman delivers the books, simply hand him \$2.98 plus the few cents postage. Money refunded if not delighted.

POPULAR MECHANICS PRESS
Popular Mechanics Bldg., Room 702, Chicago, Ill.

AUTO REPAIRMEN EARN GREATER PROFITS

Get your share of the big money being spent on automobile upkeep.

Put improved time, labor and money-saving ideas to work in your shop to-day. Take advantage of our special bargain offer and secure 3 valuable kink books at a reduced price.



1. 334 Valuable Discoveries made by auto mechanics in our Automobile Repairman's Handbook. 337 Illustrations.

2. 301 Ways to use drills, drill presses, taps and dies more effectively in our Drilling and Thread Cutting Handbook. 298 Illustrations.

3. 259 Kinks furnished by the most expert Lathe Operators in our Lathe Handbook. 212 Illustrations.

Special Offer—These 3 books (regular price 50 cents each, \$1.50 value) are offered for a limited time for only 98 cents plus postage. Pay postman C. O. D. when he delivers or if outside U.S. send 98 cents and 15 cents extra for postage.

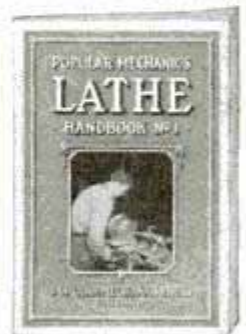

POPULAR MECHANICS PRESS
Room P 2
200 E. Ontario St. CHICAGO

NOW! A QUICKER SURER WAY *to* BIG PAY *through* DRAFTING



The L.L. COOKE PICTURE

NOW the wonderful Big Pay Opportunities that Drafting offers are open to you as never before. Now, with the amazing new L. L. COOKE "See it - Do it" Training, you can become a full-fledged Engineering Draftsman in a surprisingly short time - and you don't need artistic ability nor High School education to do it. Many fellows no smarter than you qualify in a few months for Big Pay Jobs this new quick way.

STEP BY STEP YOU SEE IT-

It's just as easy as it looks in the pictures here. You go along step by step. You SEE IT done - and you DO IT yourself. Pictures guide you - actual movie-photos of your instructor's hands doing drafting show you every move of pen or pencil. Yet it's not a mere copying course. (You can't learn by copying). The pictures show you HOW to do it, and the simple, interesting text explains WHY it's done. At the same time you learn all about mechanics, engineering, shop-practice and everything a draftsman must know. In other words, you learn **Drafting**, from A to Z!



AMAZING NEW METHOD-

Everyone knows that Drafting is the Open Door to the Big Pay Jobs in the Mechanical World - the jobs that pay \$60 to \$100 a week and up - the jobs you **can't** get unless you're a Draftsman. Why not get into this great work now that this Training has made it so easy - why put off any longer the success other fellows like you now enjoy - why don't you, too, jump into Drafting this quicker, surer way?

STEP BY STEP YOU DO IT!

Decide today to get ready for this Big Pay work. But don't sign up for any Drafting Course until you've found out all about this highly simplified "SEE IT - DO IT" Method. Get the Big FREE Book that explains all. Read about the wonderful big outfit of tools, instruments, drawing board, etc., furnished without extra cost. Read about the Nation-wide Job Service, the great Earn-while-Learning Plan, (the famous Money-Back-Agreement, and the brilliant future that awaits you in Drafting when you've learned Drafting this fascinating, thorough way. Mail the coupon NOW!

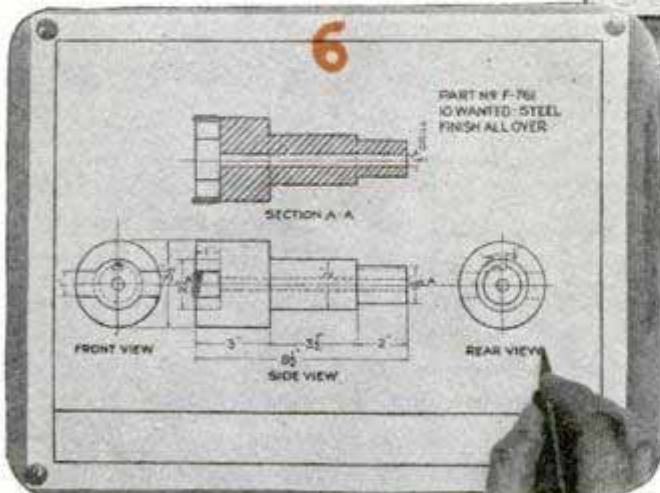

The illustrations here show only 6 of the 37 fine, instructive pictures and drawings contained in Job No. 13 of this great Training

Act today to increase your pay.



MAIL COUPON FOR FREE BOOK

K. M. Boyd, Chief Drafting Engineer
L. L. COOKE SCHOOL OF DRAFTING
 Dept. 12, 2132 Lawrence Avenue, Chicago, Illinois

Send me your book "Draw Big Pay in Drafting" and tell me more about your "See It - Do It" Method. This does not obligate me in any way.

Name

Address

City.....State..... Age.....



See How Easy You Can Learn HYPNOTISM

TRY FREE 5 DAYS!

SEE for yourself how easy it is to master the great science of Hypnotism—how quickly you can learn to bend people to your will—banish fear, worry and opposition—increase your earnings—and force others to give you the recognition, power, and admiration you deserve. I'll show you how to use this great force to help you master every situation or **The Five Day Trial is FREE!**

In just a few hours I'll teach you the hidden secrets of Hypnotism—the methods used by the great operators—the amazing things you can accomplish once you understand this mighty power. You can use it to overcome obstacles, achieve your fondest ambitions and become MASTER of yourself, friends and acquaintances—either sex. Now you can quit being just one of the crowd—now you need not be unpopular, lonesome or unhappy a minute longer. Through this strange power you can learn how to stand out—dominate—to make your life what you want it to be!

In his startling NEW book, *The Science of Hypnotism*, the world famous hypnotist—Prof. L. E. Young—reveals the most carefully guarded secrets of this fascinating subject. He not only explains the methods of noted hypnotists, step by step—but tells clearly all about the nine stages of Hypnotism, The Hypnotic Mirror, Mental Telepathy, how to select your subjects, magnetic healing, methods of hypnotizing, how to wake the subject, how to make money out of hypnotism!

**Try 5 Days FREE—
Send No Money**

So confident are we that Prof. Young and his great book will quickly teach you the science of Hypnotism, that we will send you a copy without one cent in advance! Simply clip and mail the coupon below. When the book arrives pay the postman the special low price of \$2.50 plus few cents postage. If not test the powers of Hypnotism 5 days! If not amazed and delighted, return the book and money will be refunded at once.

**FRANKLIN PUBLISHING CO.,
Dept. B-70, 800 No. Clark Street, Chicago, Illinois**

Mysteries of Hypnotism Revealed

- How to Hypnotize at a Glance
- Susceptible Subjects
- How to Hypnotize by Telephone
- How to Give an Entertainment
- How to Make Others Obey You
- Overcoming Bad Habits
- How to Do Dozens of Hypnotic Feats
- Use of Hypnotism in Operations

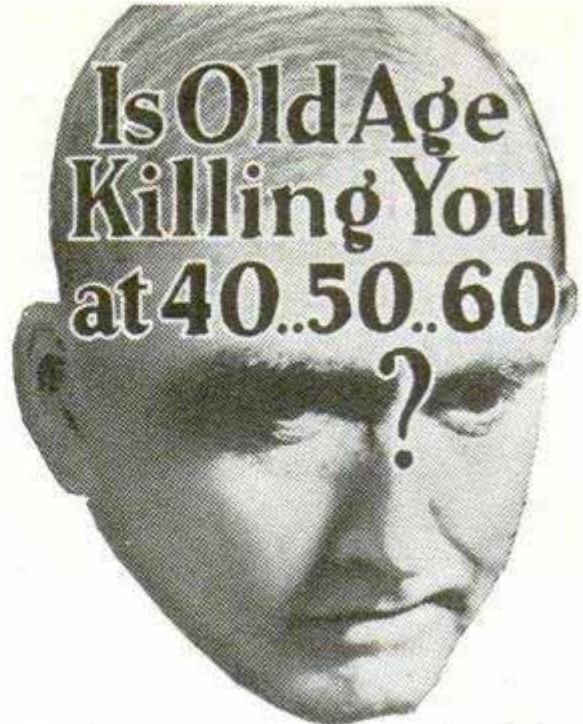
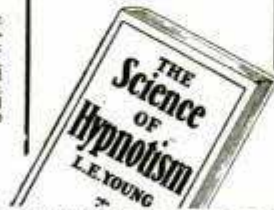

Is Old Age Killing You at 40..50..60?

Are you aging too soon . . . getting up 5 to 10 times at night . . . is vitality ebbing steadily away . . . are you definitely on the down grade, half-living, blue, depressed, subject to chronic constipation, chronic fatigue, back-ache, foot and leg pains? Then look to the vital prostate gland.

New Facts About the Prostate Gland

In men past 40, do you know that these symptoms are often the direct result of prostate gland failure? Are you aware that these symptoms frequently warn of the most critical period of a man's life, and that prostate trouble unchecked usually goes from bad to worse . . . that it frequently leads to years of fruitless treatment and even surgery . . . that it even threatens life itself?

FREE to Men Past 40

No man past 40 should go on blindly blaming old age for these distressing conditions. Know the true meaning of these symptoms. Send for a new, illustrated booklet, "Why Many Men are Old at 40," written by a well-known American Scientist, and see if these facts apply to you.

Natural Method

There is little or nothing that medicine can do for the prostate gland. Massage is annoying, expensive and not always effective. Now this scientist has perfected a totally different kind of treatment that you can use in your own home. It employs no drugs, medicine, or violet rays. It stimulates the vital prostate gland in a new natural way, and it is as harmless as brushing your hair. 50,000 men have used it with remarkable results.

Swift Natural Relief

Now physicians and surgeons in every part of the country are recommending this non-medical treatment. So directly does this new safe treatment go to the prostate gland that noticeable relief often follows overnight. So remarkable are the results that you can test it under a guarantee that unless you feel 10 years younger in 6 days you pay nothing.

Scientist's Book Free

Send now for this Scientist's free book and learn these new facts about the prostate gland and old age ailments.

Simply mail the coupon to **W. J. Kirk, president, 2126 Morris Ave., Steubenville, Ohio.**

If you live West of the Rockies, address The Electro Thermal Co., 303 Van Nuys Building, Dept. 21-C, Los Angeles, Calif. In Canada, address The Electro Thermal Co., Desk 21-C, 53 Yonge St., Toronto, Ont., Can.

W. J. Kirk, Pres., 2126 Morris Ave., Steubenville, Ohio.

Without obligation, kindly send me a free copy of "Why Many Men are Old at 40."

Name.....

Address.....

City..... State.....

Franklin Pub. Co., Dept. B-70,
800 No. Clark St., Chicago, Ill.

Please send me your amazing new book—*The Science of Hypnotism*—by Prof. Young. When book arrives, I'll pay the postman only \$2.50 plus postage. If I am not satisfied after 5 days' trial, I may return the book and you are to refund my money.

Name.....

Street and No.....

Town..... State.....

If you are likely to be out when postman calls, send \$2.50 with coupon and we'll pay delivery charges. Customers outside U. S. send cash with order.

Think of it! Genuine UNDERWOOD

Yours for 10 Days FREE

Yes—this world-famous Underwood is yours free for full 10 days. See for yourself the real bargain it is. See how beautiful and new it looks—compare its neat, perfect work—without obligation.

Buy Direct at Less Than 1/2 Mfg's Price



My unchallenged direct sale price and easy terms on this genuine Underwood No. 4 is the lowest ever offered. While they last—less than half (1/2) the manufacturer's regular price—and easy terms besides. Do not confuse this genuine late model Underwood with inferior or frail machines worth only one-half as much. This is the full sized standard Underwood with 4-row keyboard and late improvements, manufactured to sell for \$100. **Fully Guaranteed** in writing.

12 REASONS

Why this is the Greatest Value Ever Offered

- 1 Genuine Underwood Standard 4-row Keyboard
- 2 2-color Ribbon
- 3 Back Spacer Ribbon Reverse
- 4 Tabulator
- 5 Automatic Release Shift
- 6 Lock
- 7 Lowest Price
- 8 Easiest Terms
- 9 10-Day Free Trial
- 10 Fully Guaranteed

FREE Complete 9-piece Office Supply Set and Typewriting Course



We teach you speed type writing free. Complete Home Study Course of the Famous Van Sant Speed Typewriting System, fully illustrated, easily learned. We also give complete office supply set free during this sensational sale.

Easy Terms—Only 10c a Day

Think of it—a genuine late model Underwood reduced to \$39.90 (Cash). A saving of over \$60 by acting now. Send only \$1 deposit for a 10-day Free Trial. Then only 10c a day on my easy year-to-pay plan. And you use and enjoy your typewriter all the time. Remember this Underwood all rebuilt and refinished like new is without question the greatest value ever offered at this rock-bottom price. (See column to left for its many outstanding features and improvements.)

Limited Quantity—Act Now !!

This exceptional bargain offer is for a very limited time only. Remember, every typewriter is sent on 10-days' Free Trial and Fully Guaranteed.

International Typewriter Exchange, 231 West Monroe St., Chicago, Ill., Dept. 294.

Please send the Underwood No. 4 at the special reduced price for 10-day Free Trial. I am enclosing \$1.00 deposit with the understanding that if I am not perfectly satisfied I can return it Express Collect and get my deposit back. If I keep it I will pay \$3 a month until I have paid \$44.90 in full.

Name.....Age.....
 Address.....
 Town.....State.....

International Typewriter Exchange
 231 W. Monroe St. Chicago

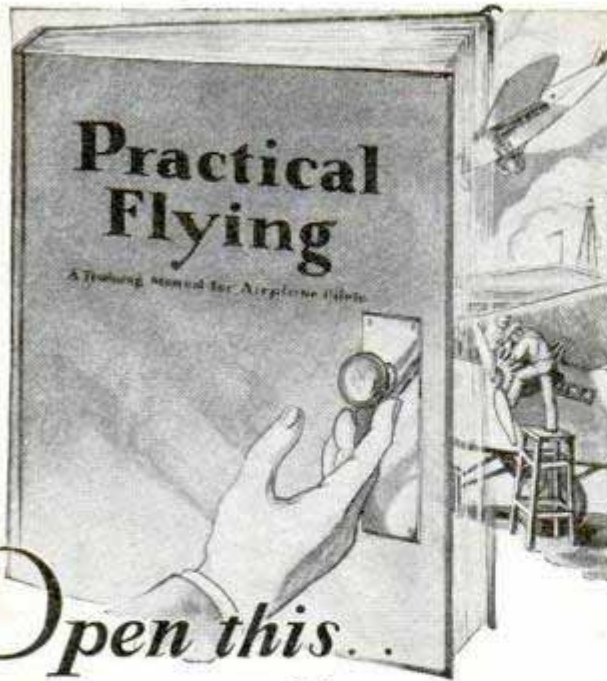

Open this... Door to Success

"FLYING is not a mysterious art for a chosen few. All you need is a proper understanding of airplanes"—and here, in this practical book, crammed full of vital flying facts, Major Jones, famous Army instructor, gives you that "proper understanding."

Thousands are entering Aviation through this famous book

To that question you've been asking—"Can I be a pilot?"—he answers, "Yes! and I'll show you how." He takes you over every part of a plane, inch by inch. He explains the puzzling language of Aviators. He shows you how to get the most out of your actual flight instruction—how to save time and money. He gives you a basic ground course that puts the facts of flying at your command—teaches you to talk like an old-timer—saves you from the embarrassment of asking foolish questions—prepares you for real flying work, right in the cockpit.

Air colleges use and endorse this famous book. Old-timers read it to improve their practical flying. It is giving thousands of men their start in Commercial Aviation.

The inside tricks of flying that Major Jones reveals can give you a head start on your career in the air. Get this book NOW, while opportunities in Aviation are at their best—get started on your training NOW while the demand for pilots is great, and salaries are mounting.



Send for FREE Examination

The Ronald Press Company,
15 E. 26th St., New York, Dept. M-281.

Rush my copy of "Practical Flying." Enclosed is \$3 to cover cost of book and mailing. I am privileged to return book at end of five days and receive money back if not satisfied.

Name.....

Address.....

City..... State.....

Car Washing now a PLEASURE!

GYRO WHIRLO BRUSH
washes CARS
CLEAN!

**WITHOUT
Chamois, Soap or Spray!
"WATER PRESSURE
MAKES IT WORK"**

Any Garden Hose Will Do



Useful Around the Home

Gyro saves many a painting job. Also cleans screens, windows, etc.



Nothing like Gyro anywhere. No fuss—no bother. Self-cleaning. Guaranteed for 1000 washings.

The days are gone when an autoist must "take a swim" to wash his car! No longer is car washing a process of "deep sea diving" with a splashy hose, a pound of soap and a slippery chamois.

Since the invention of the Gyro Whirlo Brush car washing has become a few moments of the easiest work imaginable. Chamois, soap and spray have been discarded as obsolete and unnecessary.

AUTO OWNERS WILD ABOUT THE GYRO!

Car owners everywhere recognized GYRO as the first real device to simplify auto cleaning. It cleans cars CLEAN in a jiffy. It works on the simple law of water pressure. Water from ordinary garden hose pours through center—making brushes whirl. These whirling brushes cut right through dirt and mud. They do all the work. You simply brush down the car. Every autoist will buy one.

100% PROFIT FOR AGENTS!

Live agents are needed everywhere to demonstrate this amazing invention, needed by auto owners, garages, service stations everywhere. 100% profit for spare or full time workers. No experience needed.

WRITE AT ONCE!

Send name and address for all particulars. Don't delay or you may lose territory. Even showing to friends will net you handsome profits. WRITE NOW!

**GY-ROBRUSH COMPANY
Dept. B-14 Ampere, N. J.**

Where will you Get in 1930?

A whole new year full of opportunities is waiting for you. Now is the time to decide. If you want to get ahead—get in the **BIG PAY Class!**

HERE'S YOUR OPPORTUNITY

Learn ELECTRICITY this amazing new way! Motion Pictures train you quicker, better. Right in your home, movies make every point clear. Simple, fascinating instruction teaches you thoroughly, easily.

Genuine DeVry motion picture projector at no extra cost. Thousands of feet of film furnished.

\$60.00 to \$150.00 Weekly

We pledge to give you the training and employment service necessary to secure a better job at bigger pay or refund money. Get full facts. No obligation. Write quick while offer lasts.

MAIL this Coupon

**NATIONAL SCHOOL OF VISUAL EDUCATION, Dept. 21-BH
537 S. Dearborn St., Chicago, Ill.**

Send book, "The Film Way to Bigger Pay" with facts about this new way to master ELECTRICITY.

Name..... Age.....

Street or R.F.D.....

City.....

State.....

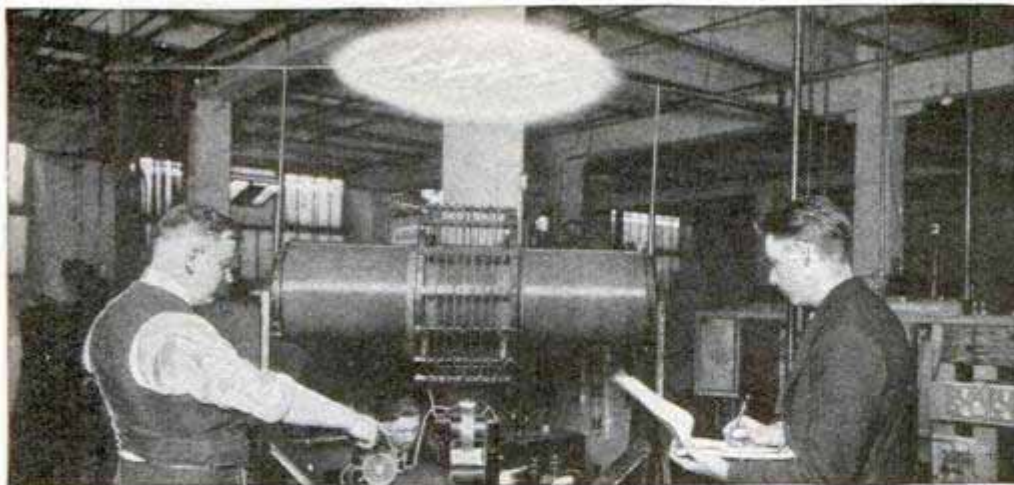

500,000 VOLTS

"Artificial lightning" being developed in COYNE School. Spark of 500,000 volts is shown jumping 30 inches. This gigantic Tesla coil is the same as that used by Steinmetz, absolutely harmless, because of high frequency.

LEARN ELECTRICITY Without Books or Lessons in 12 Weeks

By Actual Work - In the GREAT SHOPS of COYNE



Anyone who can see and understand the English language can learn Electricity in 90 days. I teach you on a gigantic outlay of electrical apparatus—30 foot control board—2-story transmitting stations—skeleton houses, huge motors of all kinds—dynamoes—sub-stations—automobiles—switchboards. In one department we generate enough electricity to supply a small city!

No Books—No Lessons—No Classes

ENTER ANYTIME. Experts teach you without books or classes. They guide you every step of the way with individual attention. You do the actual work on real full-size machinery in full operation. Take motors for instance. Instead of learning from books and charts—you actually build motors. You can't help but know all about them. Anyone can learn this fascinating way.

No Experience Necessary

That's how my methods make men learn electricity in 12 wonderful weeks. You don't need experience—Coyne training starts from the very beginning. You don't need advanced education—you learn by doing. Age is no handicap—Coyne students range from 16 to 40.

Triple Your Earning Power

I don't need to tell you about the opportunities in Electricity. They are too many and too amazing to mention. Ordinary jobs run from \$50—\$75—\$150 a week. And Coyne training leads to the biggest positions.

COYNE ELECTRICAL SCHOOL

H. C. LEWIS, President — ESTABLISHED 1899
500 S. Paulina St., Dept. 20-75, Chicago

Many Coyne men are making up to \$600 a month. Demand for Coyne men often exceeds the supply. Our Employment Bureau helps you secure position.

EARN WHILE YOU LEARN

We help many students to secure part-time jobs to earn a good part of living expenses while learning.

RAILROAD FARE to Chicago Allowed

Right now I am including railroad fare to Chicago and complete courses in Radio, Aviation, and Automotive Electricity without extra charge.

All Details Sent Free

This school is 30 years old—Coyne training is tested—proven beyond all doubt—endorsed by electrical industry. You can find out everything absolutely free. Simply mail the coupon and let me send you the big, free Coyne book of 150 photographs—facts—jobs—salaries—opportunities. See what Coyne training can do for you in just 90 days! This does not obligate you. So act at once. Just mail coupon.

Get this Free Book



H. C. LEWIS, President
COYNE ELECTRICAL SCHOOL, Dept. 20-75
500 S. Paulina St., Chicago, Ill.

Dear Mr. Lewis:
 Without obligation send me your big free catalog and all details of Railroad Fare to Chicago, Free Employment Service, Radio Aviation and Automotive Electrical Courses you are including and how many "earn while learning."

Name

Address

City.....State.....

3836

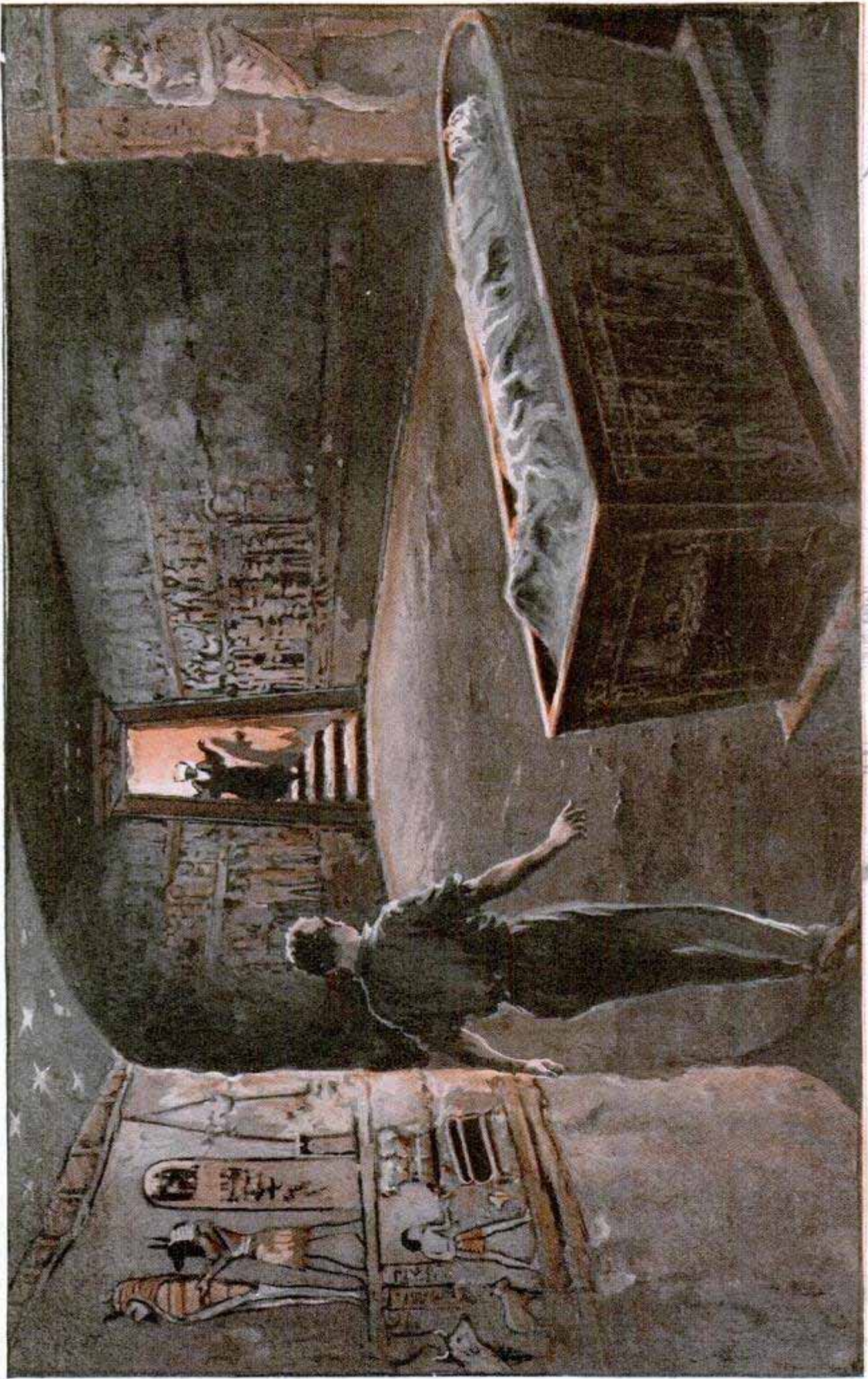

Artist's Drawing of an Egyptian Tomb Interior like That in Which the Mummy of Pharaoh Meneptah Was Found, Hacked by the Axes of Robbers and Bearing Evidence of a Serious Heart Disease, Curiously Suggesting the Old Testament Words, "And the Lord Hardened the Heart of Pharaoh".—See Page 184

Popular Mechanics Magazine

REGISTERED IN U. S. PATENT OFFICE

WRITTEN SO YOU CAN UNDERSTAND IT

Vol. 53

FEBRUARY, 1930

3878

No. 2

Flying Over Jungleland

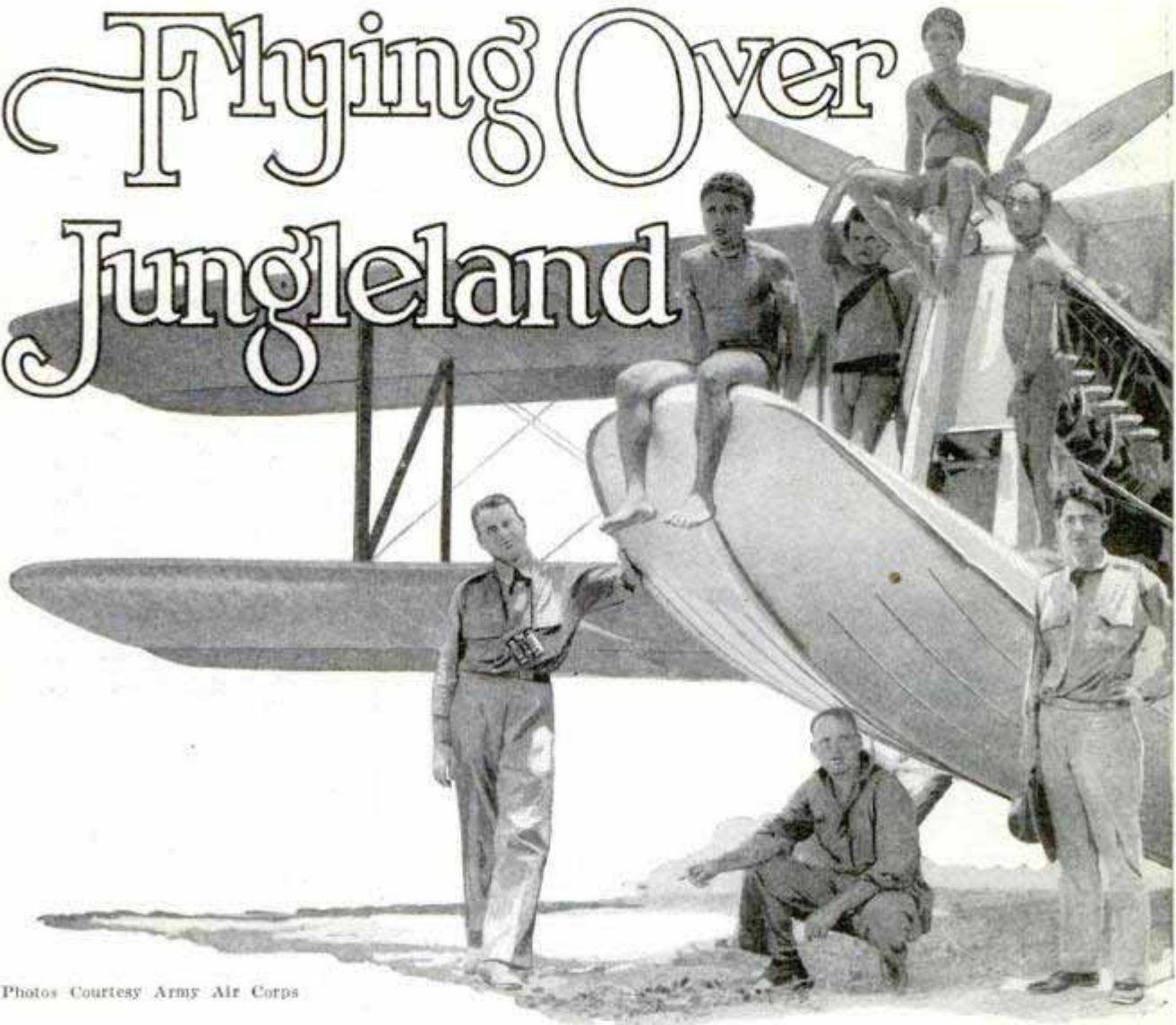

Photos Courtesy Army Air Corps

By LIEUT. GEORGE W. GODDARD, U. S. A. A. C.

AERIAL photography in the tropics is full of grief and thrills. In the Philippines it is necessary to use two planes which fly fairly close together so that, in case of a forced landing, one can return for assistance. The planes always carry arms, life preservers and emergency rations. Most of the cross-country flying is over shark-infested waters, swamps and flooded rice fields.

From 12,000 feet, the mountainous country of the Philippines appears very flat, carpeted a dark-green color with few landmarks, which were needed very badly

Rantoul Illenow
in laying out our lines of flight. It was suggested that we experiment in dropping white-cloth parachute markers on tree tops at desirable points. We found, however, that the wild Negrito tribe which inhabits the Bataan peninsula section stole them within twenty-four hours, presumably using them for G-strings. It was decided that the best time to locate these markers would be the same morning the pictures were being taken.

On our first important mapping expedition, Lieutenant Wells was flying the parachute plane and I flew the photo-

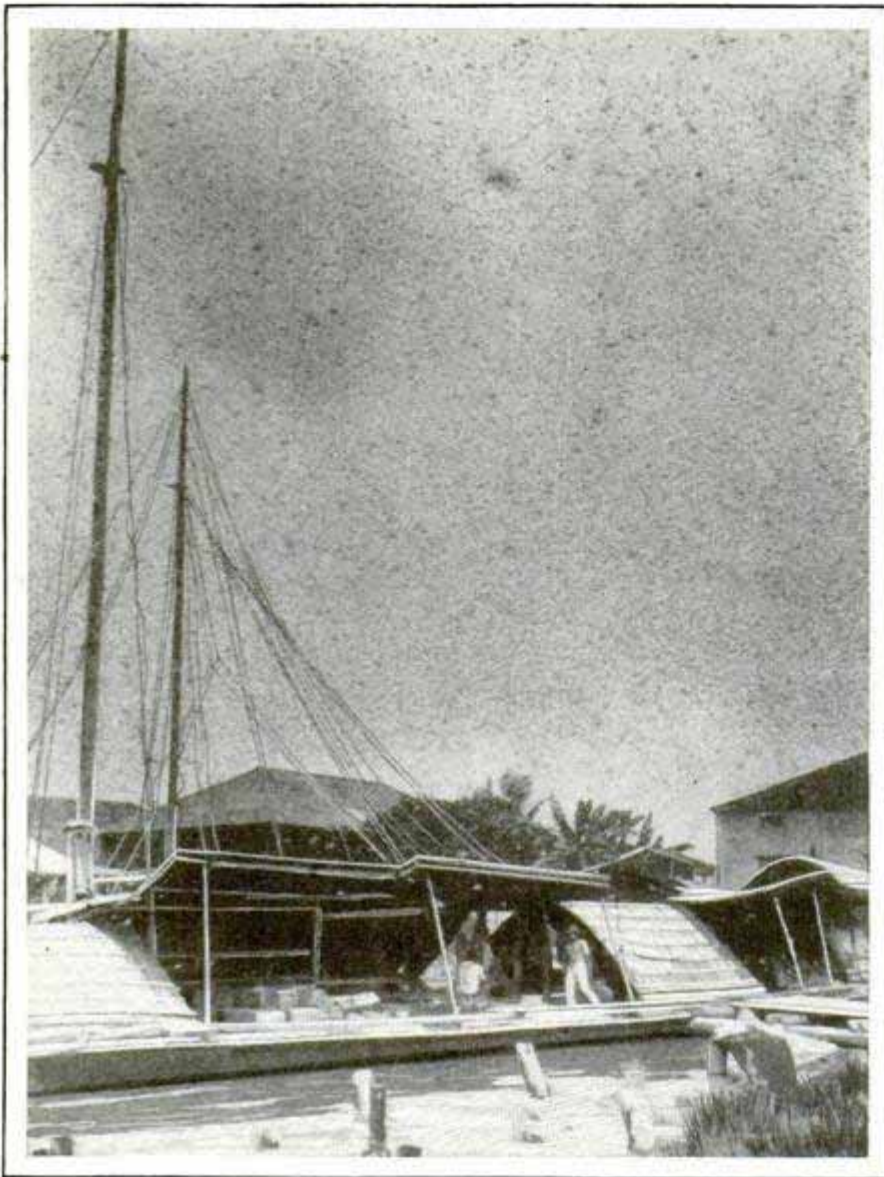

Swarm of Locusts near Landing Field in Northern Luzon; the Flyers at First Thought the Cloud Was a Dust Storm

graphic plane. From 12,000 feet, I could see the markers very plainly, but, after flying the second twenty-five-mile strip, I was unable to locate the next row, so I started looking for Wells' plane. Failing to locate it, I headed for the home air-drome. When I landed, Lieutenant Wells met me and described his narrow escape.

"Everything was going fine until I passed up a narrow canyon into the crater of an extinct volcano, but because of down currents of air and the fact that the rim of the crater was too high to climb over, I decided to turn around and fly back through the canyon. At a point about a thousand yards from the crater, I saw an enormous black cloud. It was not possible to turn around or climb over, so through I went, and oh, what a mess!

Bats! Thousands of them. How they thumped against the wires, wings, propeller and radiator. Water began to stream out from the sides of the radiator and so I started for home."

Another exciting incident took place one clear morning on what we believed was our last flight over an unexplored section of Luzon. Our two mapping planes became separated. We proceeded alone with single-lens work. While circling around to afford Sergeant Stockwell an opportunity to reload his film magazine, we were both startled to hear the motor begin missing.

It was fifty-fifty—pick the rock-bound Pacific with chances of rescue very remote or try to reach our base or one of the few openings in the jungle en route. We took the chance of reaching our base. It was evident that there was water in our main gas line and carburetor, because,

shortly after I had switched over to my emergency gravity tank, the motor functioned better and, after flying for about seventy-five miles with the gasoline hand pump going, the trouble disappeared.

As I was taxiing up to our tent, I noticed the natives pointing toward the east and discovered they were watching a swarm of locusts. Soon this black cloud was over the landing field and shortly after we heard the roar of Lieutenant Wells' motor overhead. We did not see his plane until he was part way through the swam of locusts, then suddenly his motor was run at full speed and the plane flew on and disappeared.

In a few minutes, the locusts settled and Lieutenant Wells landed. As his plane ran along the ground, the insects

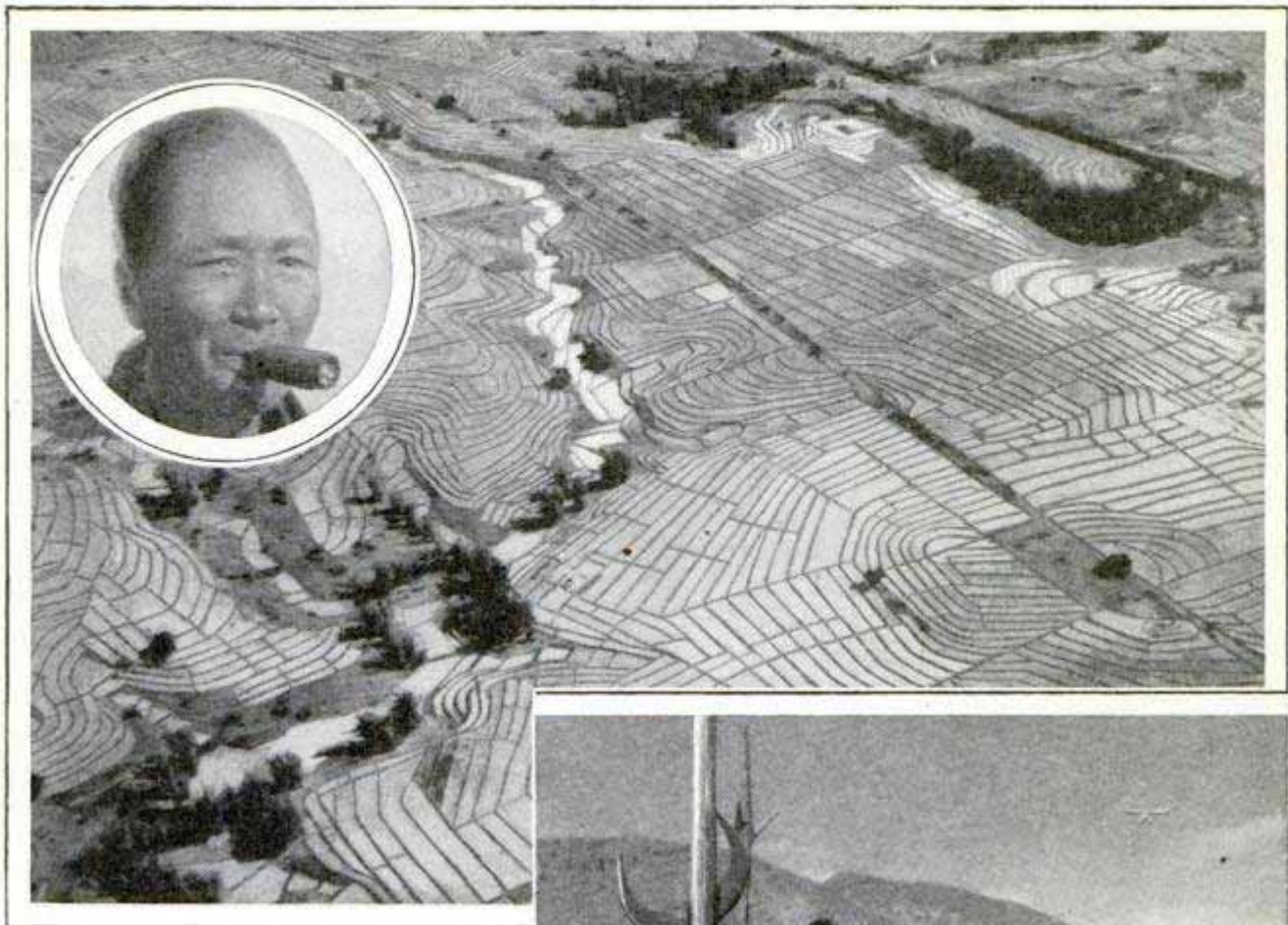

How Rice Fields Look from the Air; Inset, a Native Woman Enjoying Her Cigar, and, Below, Traveling and Watching for the "Big White Bird," the Army Airplane Used in Mapping

flew up, giving the appearance of dust raised by a fast automobile. Lieutenant Wells told us that he had received the surprise of his life when he arrived over the field. He thought that this strange phenomenon was caused by heat waves or a sand storm, but changed his mind when the locusts started flattening out on his face and windshield. It was not very long before the entire village was out to our camp with nets and burlap bags which they filled. That evening we watched the natives sitting in front of their huts roasting and eating locusts, which they consider a great delicacy.

One day, while using an amphibian, we landed in a small bay with an interpreter to find out what the natives thought of us. As we taxied up to the beach the natives scattered, hiding behind trees. Presently one old man with bow and arrow in hand mustered up courage to approach within fifty feet of the plane. Our interpreter

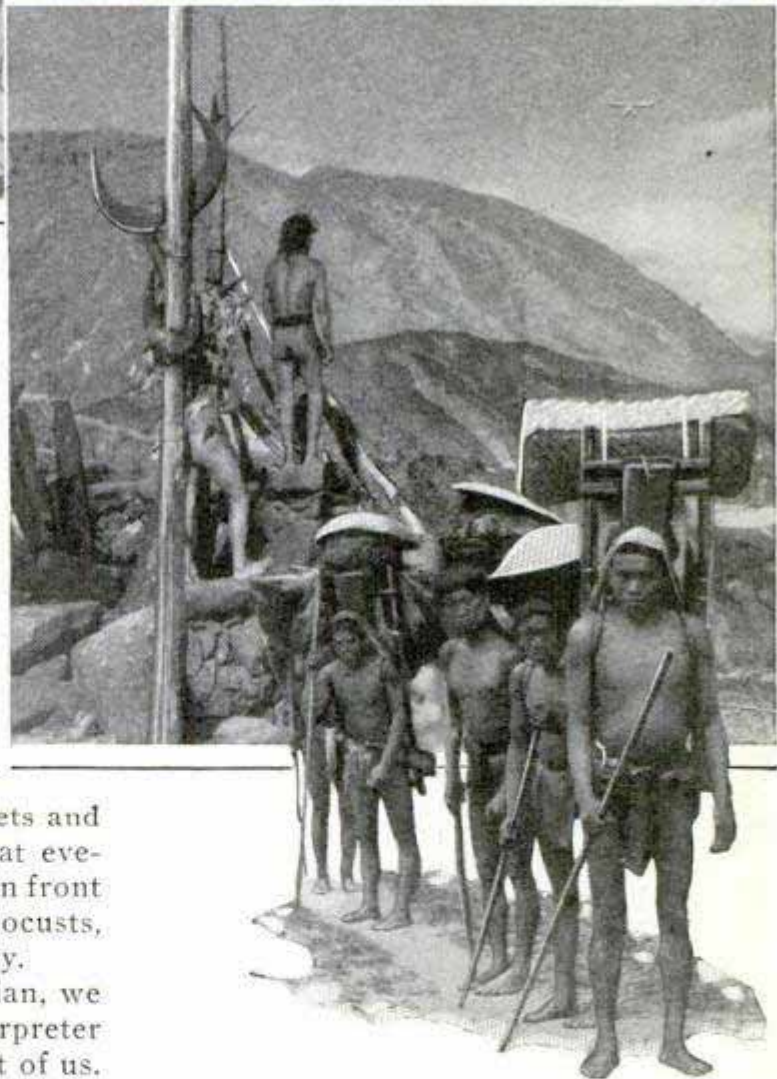

muttered a few words, and it was not very long before the natives lined up along the beach jabbering like a flock of magpies. After we were carried ashore, the interpreter informed us that we were the first

white men they had ever seen and that they had believed the airplane to be an enormously big white bird.

The last part of June, reports were being received in Manila that Mayon volcano was erupting and that the inhabitants of the villages near by were panic-stricken. The American Red Cross and the weather bureau were anxious to have aerial photographs taken of the crater and lava flow in order to show definitely the seriousness of the situation; so we started out.

The weather for 200 miles was ideal, but at a point approximately fifty miles from the volcano, we ran into a bad thunderstorm. We decided, however, to take a chance climbing over it instead of turning back, and for the next twenty minutes we gained our altitude and started milling through the passages between the clouds,

which, as we proceeded, towered to 16,000 or 17,000 feet.

Suddenly, our plane was thrown almost upside down. Cameras flew in all directions and we both felt a dry burning sensation in our throats. We knew we were close to Mayon. Before Lieutenant Corkille could right the plane, we were flying blindly in a cloud; minutes seemed like hours before we had worked our way out and were rewarded with our first glimpse of the volcano with about 500 feet of its cone above the clouds.

It was a magnificent sight to witness the flames, clouds of ashes and yellow smoke belching from the crater. In a few minutes, more of the volcano became visible and we could see the 300-foot stream of molten lava pouring out of the fire pit and running down the side. Our return was without further incident.

SOUND OCEAN FROM ZEPPELIN ON ARCTIC FLIGHT

Soundings of the water below and the air above, with automatic radio-equipped balloons, will be part of the program of scientific observation to be made by the dirigible "Graf Zeppelin" on its proposed flight over the arctic regions. The first ocean soundings to be made from a dirigible will be attempted as the ship sails over open lanes in the ice by means of the sonic depth finder. The instruments will be lowered to the water, and electrical connections between the float carrying the instruments and the dirigible will reveal the ocean's depth at any point. Aerial study will be made by ordinary sounding balloons equipped with automatic transmitters to report back to

the Zeppelin the conditions encountered according to the instruments carried by the balloons.

HOMEMADE TELESCOPE BUILT OF AUTO AXLE AND IRON

Utilizing an old automobile axle and some galvanized sheet iron, a Pennsylvania student of astronomy has constructed a six-foot ten-inch reflecting telescope on a four-foot concrete base at a cost of \$100. The telescope was designed from one of Isaac Newton's seventeenth century drawings and magnifies 288 times, making it possible to distinguish the hairs of a caterpillar on a church steeple three-quarters of a mile distant. The mirror is silverplated. Three months were required to build the instrument.



Homemade Telescope Constructed of Part of an Automobile Axle and Galvanized Sheet Iron

Science Service News Bulletin
454
12/7/29

38 58

3841

*Right under auspices
International Society for*

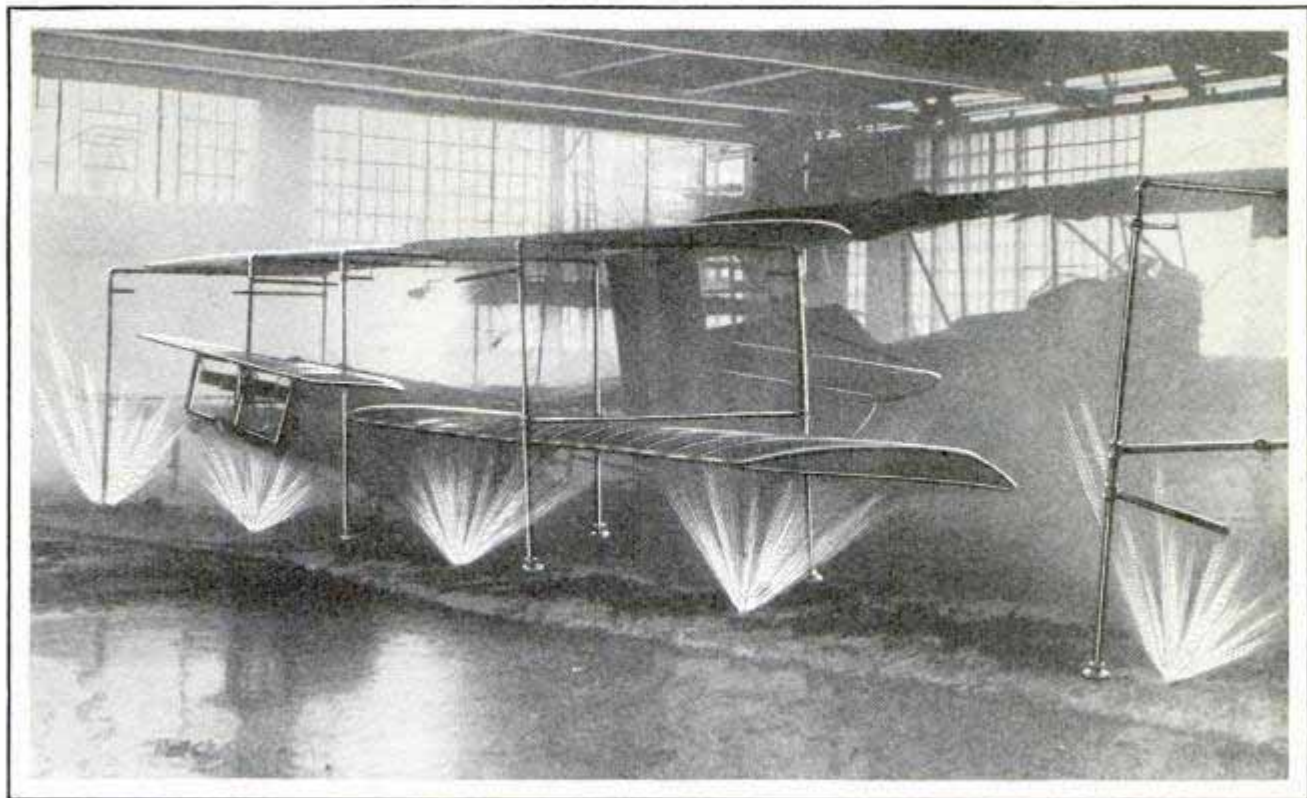

Hangar Equipped with Both Overhead and Ground Sprinklers for Protection of Planes; Heat Starts a Shower of Water from Above and Also Sends Powerful Sprays Upward

SPRINKLER SYSTEM IN HANGAR PROTECTS FROM FIRE

Complete fire protection is provided for the hangar and planes of the Colonial Airways at Newark, N. J., by an elaborate overhead-sprinkler system supplemented by a series of ground sprinklers. Heat from flames not only loosens the deluge of water from above, but also starts the ground sprinklers which throw water into the air from below. During recent tests, three planes were set afire in the hangar, and the flames were extinguished before any appreciable damage was done.

TRANSPARENT MAN LIKE GHOST SHOWS BONES AND ORGANS

Revealing every bone and organ of the human body in a state of perfect translucency, a transparent man on exhibition at a London health society has attracted much attention. The body was brought in sections from the museum of hygiene in Dresden. By a secret process the heart, skull, or any other organ or bone has been transformed into what appears a fragile, ghostlike model, crisscrossed by a delicate tracery of blue veins and red

arteries. The basis of the process is the removal of every particle of opaque material, the flesh being turned into a transparent gelatine, after which veins and arteries are injected with plaster of paris tinted blue or red. Similarly prepared bodies may be of aid to students of anatomy.

PAPER-BOX OPENER SAVES TIME IN UNPACKING CONTAINERS

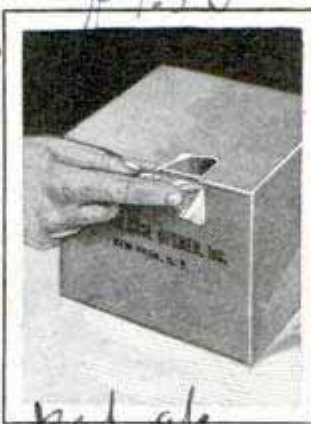

Equipped with a removable blade somewhat like those used in safety razors, a paper-box opener now is available for opening any kind of container from a cereal package to a heavy corrugated packing case. The blade is

adjustable for cutting boxes of various materials and is operated by slipping it into an edge of the box and running it along the surface. It safeguards the contents of the containers and makes possible their repeated use.

at Horticultural Hall Westminster & W. Eng

Municipal Airport

made 11/20/29

3930

3rd & 2nd St. Philadelphia

Premier Case Opener, Inc., 23 Beaver St.

581 Islewood
Kansas City, Mo

Netherlands and ten per cent to the country's arable soil at an estimated cost of \$200,000,000. Borings to test the soil under the sea were made, and only the best sections are being drained so that it is estimated that only eight per cent of the land will be sand. After dikes have been built and the water pumped out, the land will lie fallow for some time until rains have washed out the sea salt, but meanwhile it will be available for grazing. Across the mouth of the Zuyder Zee, a dike nineteen miles long is being erected, 112 yards thick at its base, made of sand and stiff clay and buttressed with brushwood weighted with stone. On this dike will be laid a double railroad track, a road for heavy motor and wagon traffic, and one for cyclists and pedestrians.

FROSTING OF GLASS IS STOPPED BY ELECTRIC HEATER 38 7 2

Good driving visibility under winter's most adverse conditions has been made possible by the development of an electric windshield heater for the automobile. It consists of a shallow steel frame with a glass back, wired for connection to the battery. The frame fits air-tight against the windshield, and between the glass back of the heater and the windshield stretch three wires which keep the air between the panes of glass at a constant temperature of from seventy-eight to eighty degrees when the heater is operating. This heat melts snow, sleet and ice on the outside and keeps the glass back of the shield dry at all times.

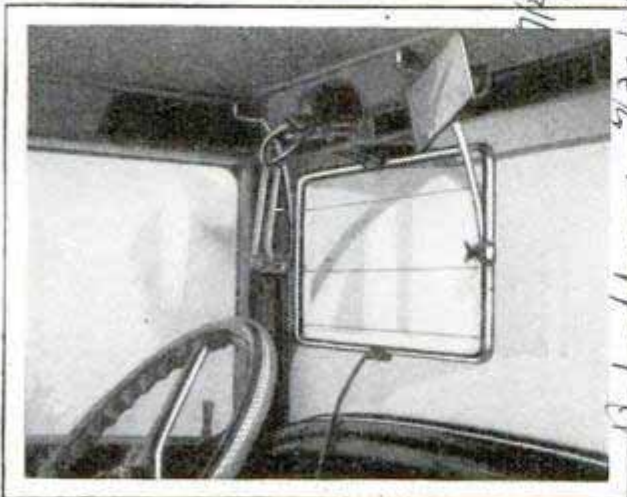

Electric Windshield Heater Which Warms Glass Sufficiently to Melt Snow and Sleet

Holzner Products Corp
6000 Blue Mountain Road

Globe of World Inside of Which Is Index and Gazetteer Containing over 200,000 Words

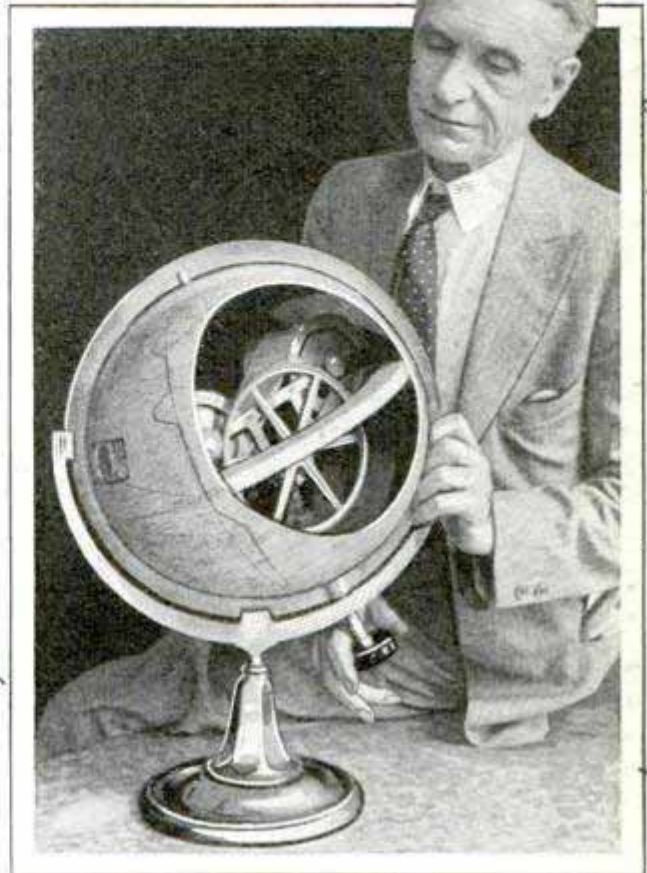

GLOBE OF WORLD HAS INDEX AND TINY GAZETTEER

Giving a combined index and gazetteer of approximately 200,000 words, a revolving globe of the world has been made by a Californian on the surface of which may be found 43,000 cities, towns, rivers, bays, mountains and other geographical features. The index and gazetteer is contained in a mechanism within the globe, the use of which makes it possible to locate many more positions than is possible with the ordinary globe. Outwardly, the appearance is much like that of any other globe, save that the surface is broken in two places for the insertion of magnifying lenses, through which the printing inside may be read. The paper is printed in a continuous roll and the type is microscopic, requiring a reading glass. Each strip in the globe, printed on a special press, is four inches wide and fifty-one feet long, containing twenty-eight lines of type to the inch. The strips are wound about a metal drum which is geared to a handle that turns the index-gazetteer to any desired name.

Williams - Prudhian - Under - Globe - Los Angeles - California
206 N. Los Angeles St.

Pat applied 7/23/1919

3030
Colombier 29 Bean Road
Dorset Beach, nr. London Eng

PHARAOH'S HEART

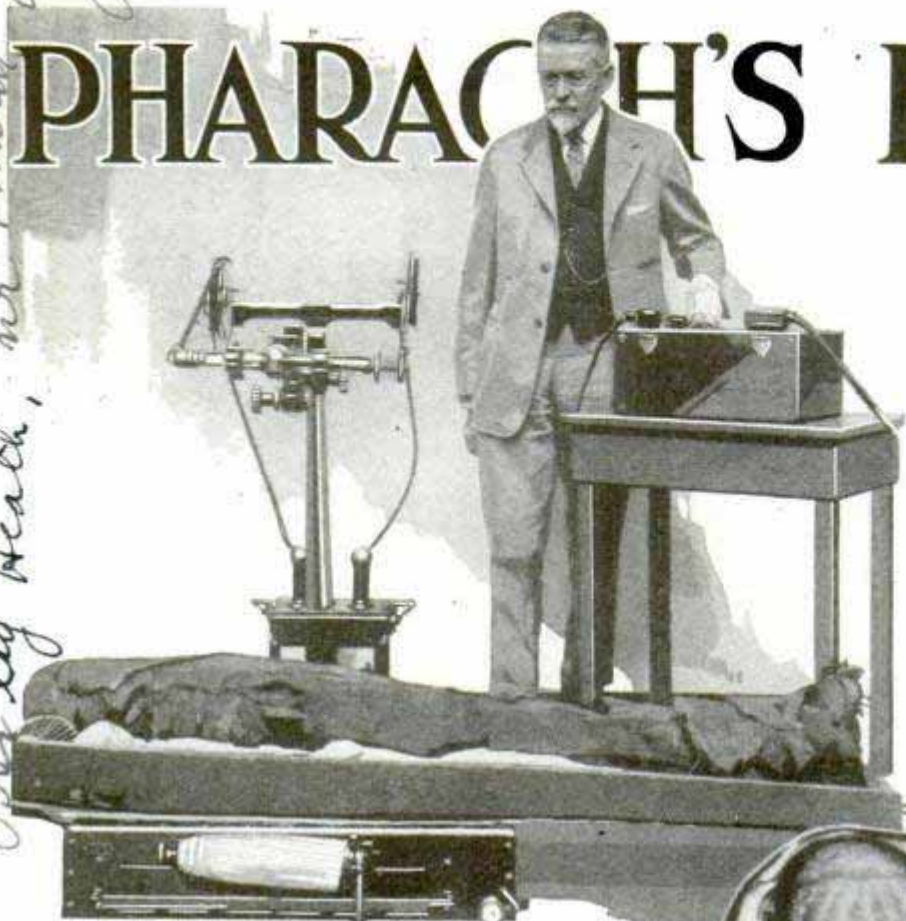

Courtesy Field Museum of Natural History

Dr. Ed. C. Jerman with X-Ray Outfit for Examining Mummies, and, at Right, Mummies of Boy and Girl

By HAROLD T. WILKINS

ONE night, about 4,000 years ago, in a range of lonely hills of western Thebes in the Nile valley, a band of robbers, hiding picks, axes and ropes under voluminous robes, were stealing across a hot and desolate waste of sand to the base of high cliffs of limestone.

Rounding a vast block of stone, which seemed to have fallen from above, but was a cunningly made screen, they saw a hole in the face of a cliff. They lowered themselves down a fifty-foot shaft, and groped their way in pitchy darkness along a tunnel, so low that they had to stoop to avoid hitting their heads against the roof. Now, they turned a corner, and descended a flight of rock-hewn steps deep into the bowels of the hill. They entered a vast hall where mummy cases were piled against the walls, and alabaster vases, ushabtiu statuettes and terra-cotta figures stood around. Along another corridor they went, and entered into the hall of dead pharaohs with gilded sarcophagi and mummy cases decorated with hiero-

glyphic pictures from the "Book of the Dead."

One of the intruders struck his ax at the swathed mummy of a king on whose linen shroud was written in hieratic characters the name "Meneptah." The ax cut right through the cloths from the chest to the spine. The robbers were impatient to strip the pharaoh of the gold, jewels, and precious stuffs and costly ivory and fur-

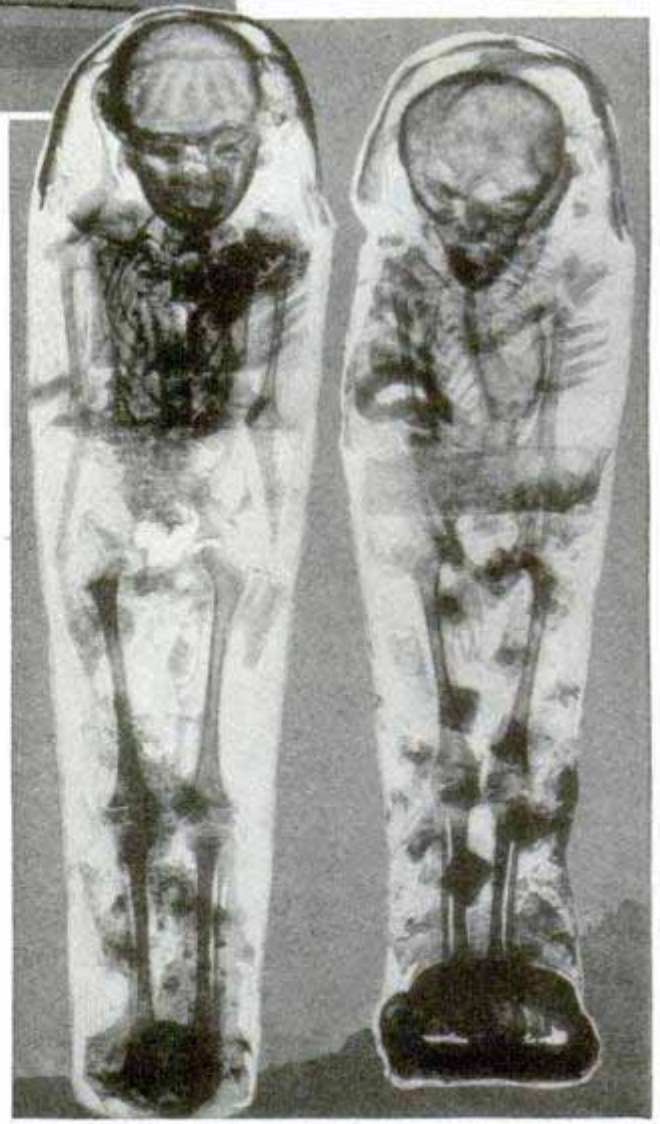

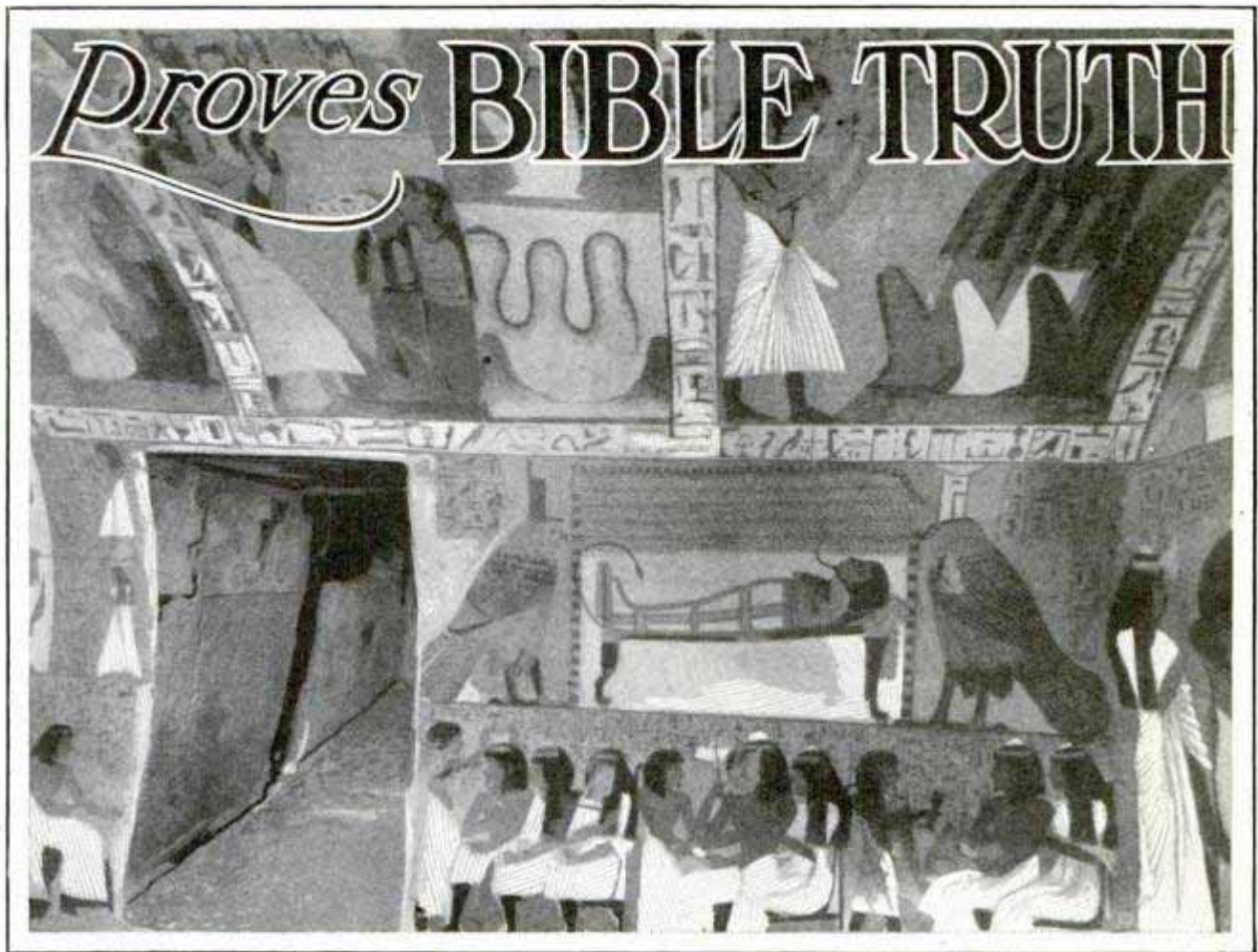

Courtesy Institut Francais d'Archeologie, Cairo

Interior of a Pharaoh's Tomb. Showing Mural Paintings Depicting Scenes from the Egyptian "Book of the Dead," Souls Being Judged or Awaiting Judgment in the After-World

niture buried when the priests hid the royal mummies in the Valley of the Kings. Collecting the plunder in feverish haste, they filed out quickly the way they came, lest dawn arrive or a chance watcher detect them at their work and inform the high priest or the descendants of the long-dead rulers.

Then the tomb was left to the mice, till, 4,000 years later, a famous French archaeologist, Gaston Maspero, was asked by some Arabs if he would buy some beautifully illuminated papyri.

"Where did you get them?" he asked.

The Arabs were evasive. Maspero's mind flashed to the conclusion that they were in some way related to tomb robbers who had discovered a royal burial chamber. He told a pasha, who had one of the men arrested, but with no success. Bribery won, however, and the royal mummies were once more brought to the light of day after their sleep of 6,000 and more years.

It was found that one of the mum-

mies was that of Pharaoh Menephtah, and it was recalled that a tradition among the Jews of Alexandria said that this was the Pharaoh of the Oppression who, with his host, was drowned in the Red Sea when the Israelites made their exodus from Egypt to the land of Goshen, somewhere in the peninsula of Sinai.

Professor Elliot-Smith, a famous medical scientist and ethnologist, was given the task of examining the mummies. "It is essential that we examine the mummy of Pharaoh Menephtah," he told Maspero, who replied, "Yes, we must invite the missionaries to be present at the unwrapping of it."

Professor Smith recently told the story of the unwrapping of Pharaoh Menephtah's mummy. "While I was removing the bandages, M. Maspero was busy telling the visitors of a tradition of the Alexandrian epoch that Menephtah was the Pharaoh of the Exodus who perished in the Red Sea. Hence, when the mummy was exposed, and I called attention to

36
186

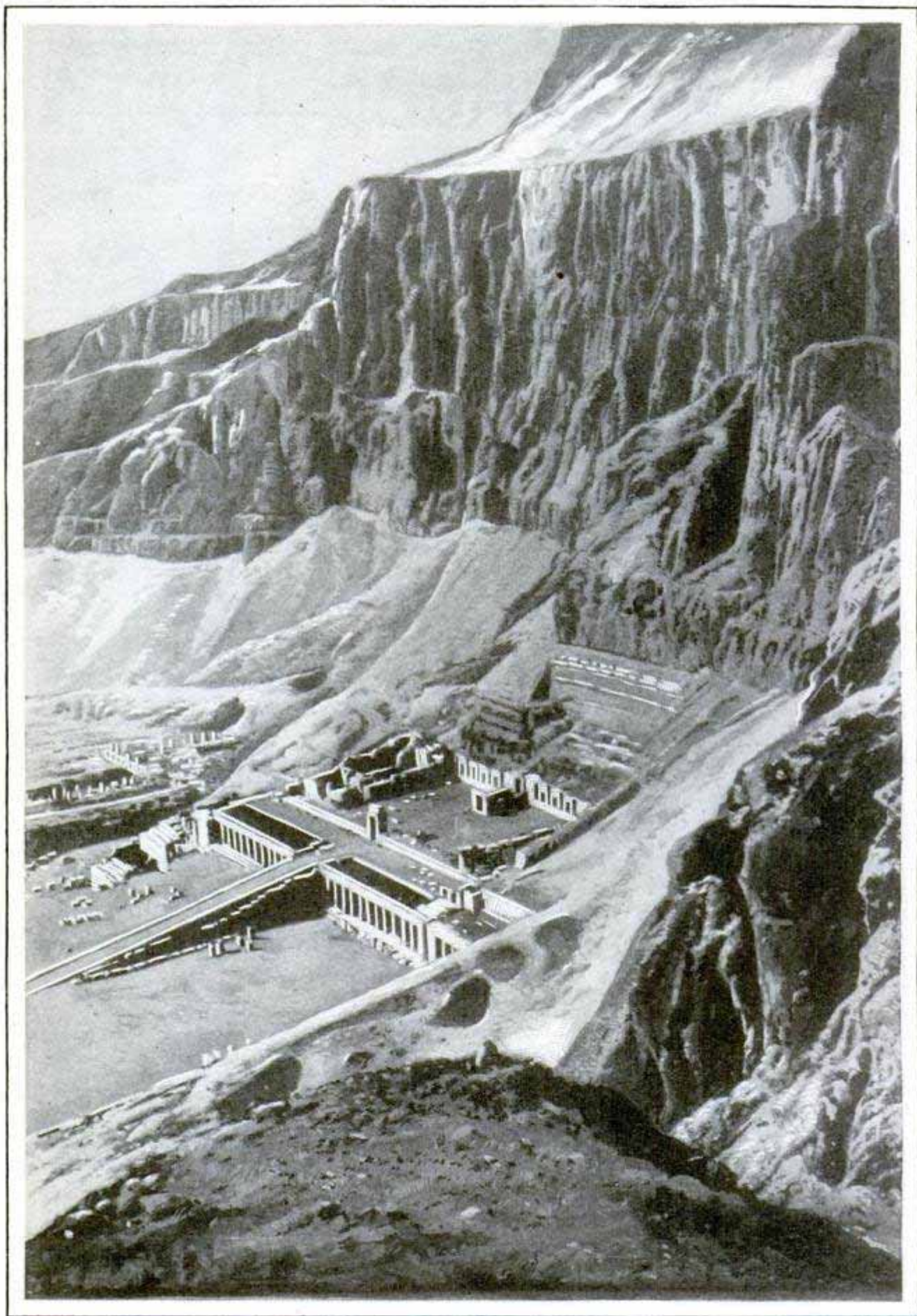

Tomb of Queen Hatshepsut, the Female Pharaoh, at Deir el Bahri; This District Has Proved Rich in Archaeological Treasures, the Mummies of Several Egyptian Kings Being Found near Here

the unique phenomenon of the incrustation of the body with crystals of common salt, M. Maspero at once turned to the missionaries and said: 'There you see the confirmation of the Red Sea episode.' And, when examining the body which ancient tomb robbers had hacked with an ax, I found calcified patches on the large vessel of the heart, M. Maspero at once added 'and you see his heart really was hardened.' One of the broken pieces of the damaged aorta M. Maspero allowed me to send to the late Professor Shattock of the Royal College of Surgeons.

"The tomb robbers inflicted very severe injuries on the corpse. The hands were placed in the position of grasping scepters, the thumbs being in the position reproduced in the bas-reliefs. The skin of the body was thickly encrusted with salt, which my colleague, Mr. W. M. Colles, has examined and found to be sodium chloride (common salt). The

Photo, Courtesy Sir Arthur Keith and Professor Elliot-Smith

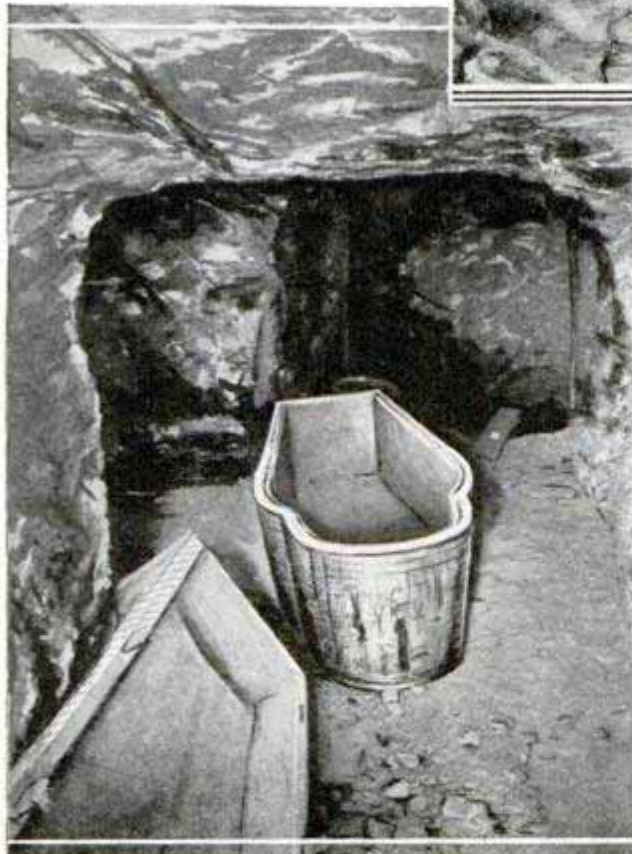

Top and Bottom Photos, Courtesy Metropolitan Museum of Art
Sphinx of Queen Hatshepsut; Head of Pharaoh Menepthah, Who Suffered from Hardened Heart, and Empty Coffin Found in Tomb



mummy of this pharaoh has been cut by a tomb robber's ax, and the throat and body gashed. On the back of the head there is a hole made by a sharp instrument. Whether this was due to the tomb robbers'

haste to remove the wrappings, or made for some occult reason (to allow evil spirits to escape, as Maspero suggested) is conjectural. The pharaoh was a man of great age. He had a prominent and high-bridged nose, and was rather corpulent."

Lord Moynihan, president of the Royal College of Surgeons, where the heart of the pharaoh was examined under a powerful microscope, declared: "We have ocular demonstration of the truth of the Old Testament words, 'And the Lord hardened the heart of Pharaoh, and he hearkened not unto them; as the Lord had spoken unto Moses.' His heart was really hardened. The large vessel springing from the heart was found in such well-preserved state that S. G. Shattock made sections of it and compared them with those made from a man recently dead. I have shown the two sections side by side on a lantern slide, and no pathologist can

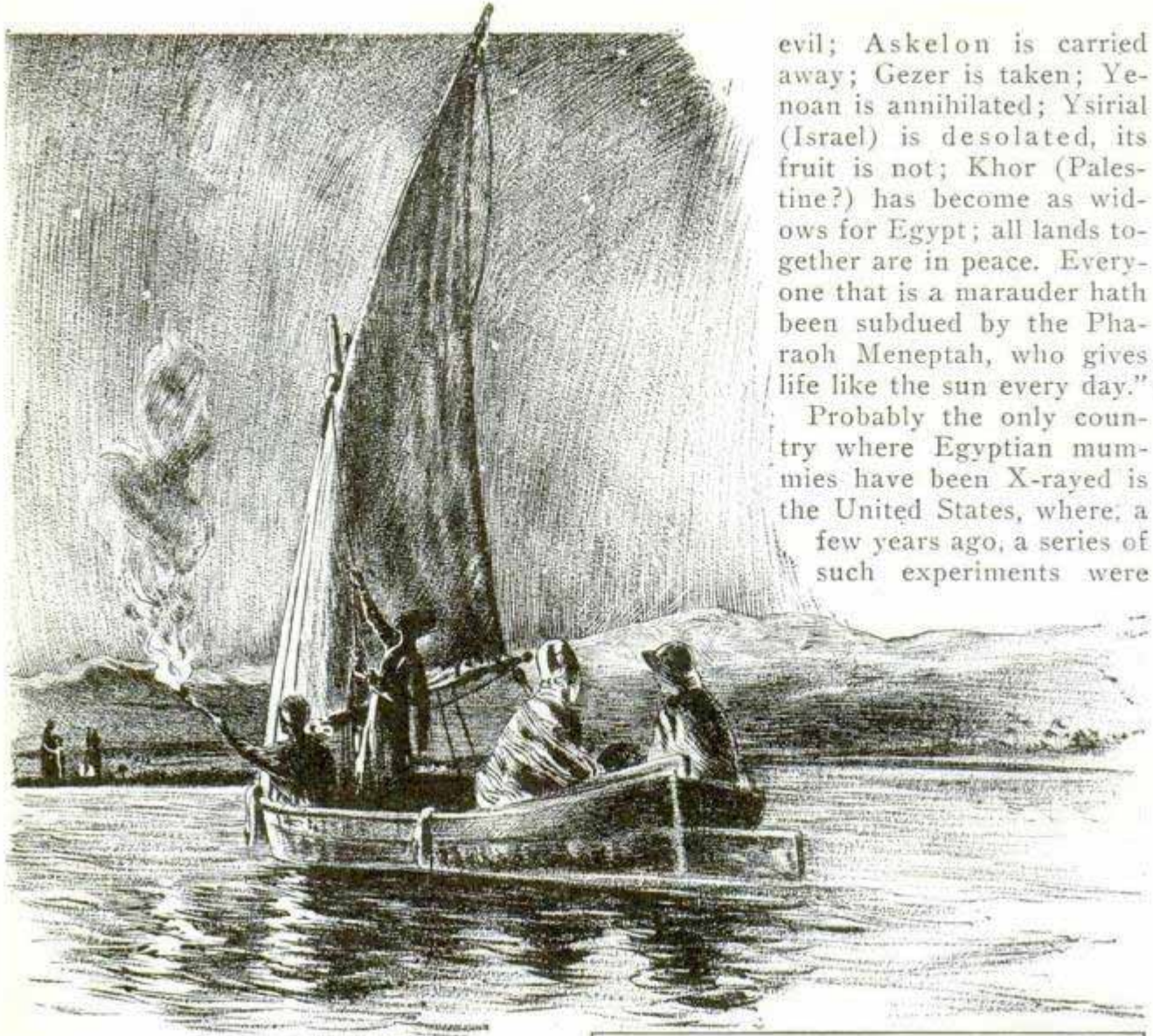

Sailing across the Nile at Night on a Visit to an Important Spot, Valley of the Kings

tell me which is the ancient and which the modern vessel. Both were attacked by the disease atheroma, a condition in which calcium salts are deposited in the walls of the vessel, making it rigid and inelastic. The vessel did not expand adequately to the stream of blood coming from the heart, so that this pharaoh suffered from high blood pressure." Menepthah left a stela with an inscription at Thebes, which was unearthed in 1896, and may refer to the Israelites:

"The villages are again settled. He who prepares his harvest will eat it. He is born for the purpose of avenging it—the King Menepthah. Chiefs are prostrate, saying 'Peace!' Not one of the nine bows (the barbarians) raises his head. Vanquished are the Tehennu (Libyans or desert marauders); the Khita (Hittites) are pacified; Canaan is prisoner in every

evil; Askelon is carried away; Gezer is taken; Yenoan is annihilated; Ysirial (Israel) is desolated, its fruit is not; Khor (Palestine?) has become as widows for Egypt; all lands together are in peace. Everyone that is a marauder hath been subdued by the Pharaoh Menepthah, who gives life like the sun every day."

Probably the only country where Egyptian mummies have been X-rayed is the United States, where, a few years ago, a series of such experiments were

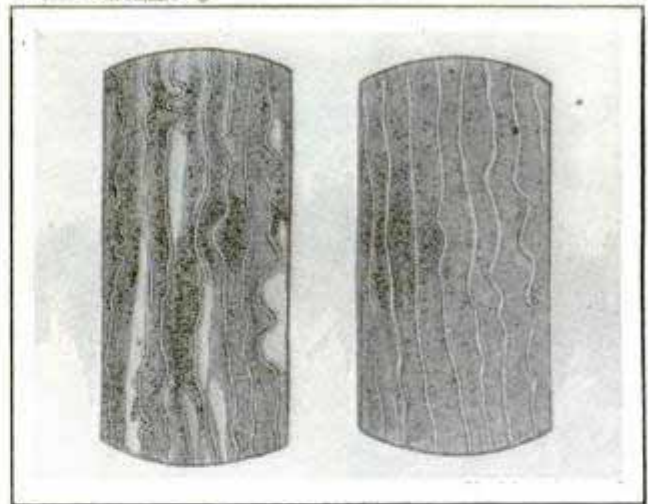

Courtesy Sir Arthur Keith

Magnified Section of Pharaoh's Heart, Left, Compared with Section of Same Organ of Modern Man, Both Showing Hardening

conducted. It was found that ancient Egyptians suffered from some very modern diseases, including chronic rheumatism, tuberculosis of the bones, caries and pyorrhea, and appendicitis.

Jan 20/29

11/20/29

3804

Box 407, Route 4, 189

Hayward Calif

DEEPEST BUILDING IS PLANNED IN JAPAN 3931

While other countries are contesting to build the world's tallest building, Japan is planning the world's deepest one, drawings having been made for constructing an underground "skyscraper," eighty stories deep at Tokyo. It is even planned so it can be made deeper from time to time as additional floor space is needed. The framework will be of steel, and the material will be concrete and stone. The building is to be cylindrical in form, 155 feet in diameter and 1,100 feet deep, with a ventilating shaft seventy-five feet in diameter running straight down through the center of the structure. It is to be equipped with modern conveniences, including electric lights, elevators, telephones, wireless and mirrors reflecting sunlight. It is estimated the building can be completed in less than one-third the time required to build a fifty-story skyscraper, and its cost is placed at about \$12,000,000, only a fraction of the cost of a skyscraper as tall.

WIPER BLADE HAS TEN EDGES TO CLEAN WINDSHIELD 389 7

Worn blades of windshield wipers now may be replaced with a refill which fits any kind of wiper and may be attached in little more than a minute. The wiper is composed of a wedge-shaped piece of solid rubber, having along each side five separate edges of rubber which clean the glass without smearing or collecting mud or snow. An adapter is provided for wipers having a crooked arm.

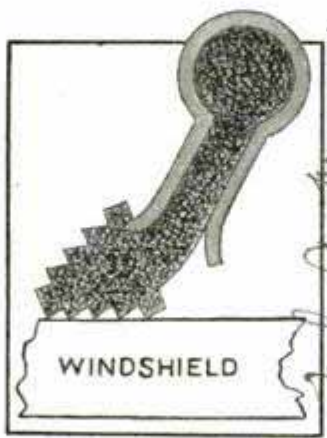

Tel. a. Friend Laboratories

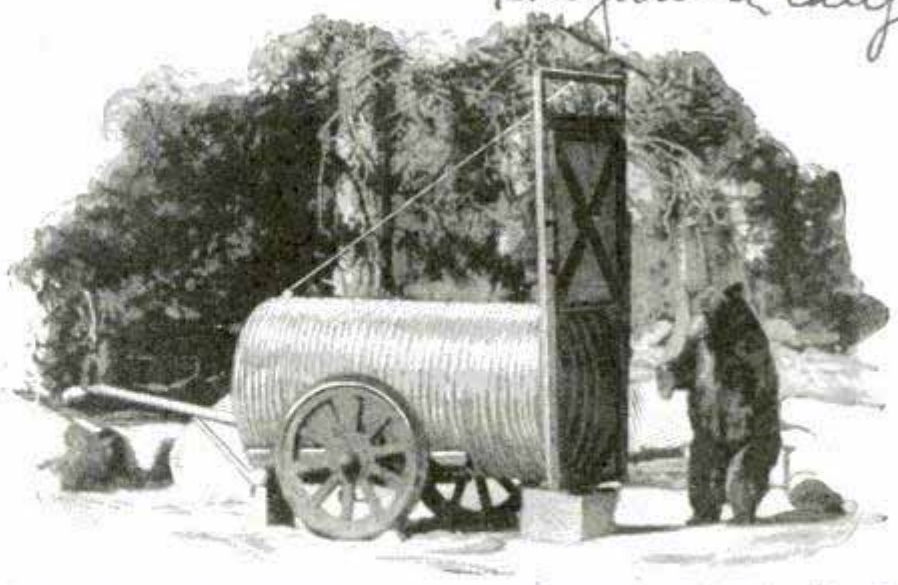

Bad Bears in Yosemite National Park Are Trapped in This Tubelike "Patrol Wagon" as a Preliminary Step to Banishment

PATROL WAGON FOR BAD BEARS IN YOSEMITE PARK

Unruly bears in Yosemite national park have their own patrol wagon for a ride to the "station." It consists of a corrugated pipe, sealed at one end and equipped at the other with a trapdoor. It is mounted on pneumatic wheels and attached to a truck. When a bear causes trouble, out goes the patrol wagon. It is detached from its wheels and a piece of meat placed inside. When bruin goes after the meat, the trapdoor catches him. The sentence, if the bear is found in the inhabited portion of the park, is banishment. It is marked with a daub of paint, and apparently this causes the animal to feel disgraced, for it is said it rarely causes further trouble.

BRAIN GROWS TILL SIXTY 3939

Belief that man's brain continues to grow until the age of sixty has been expressed in a report to the Brush Foundation for the Betterment of Human Stock. The report says it is doubtful if a part of the brain reaches its limits before sixty, but adds that the part which is the seat of imagination and originality shows its maximum growth between four and seven years. The part covering memory and experience begins to grow at seven years and continues until nineteen. Thereafter a part, called the silent area, shows possibilities of expansion in human beings alone until very late in life.

Prof. J. Wingate Todd, Western University

3844

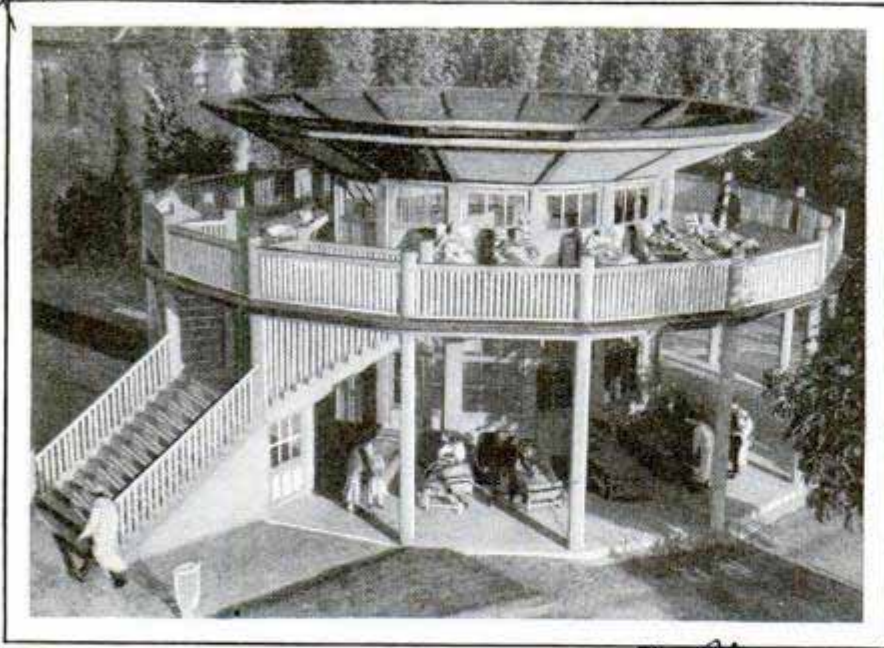

Solarium for Tubercular Patients in Hungary, Constructed Like a Roundhouse so It Catches the Sun's Rays from All Angles

SOLARIUM LIKE A ROUNDHOUSE CATCHES SUN'S RAYS

Resembling a roundhouse in construction and appearance, a combined solarium and fresh-air pavilion has been built for a tuberculosis sanitarium in Hungary. The center is glass-enclosed for protection from the elements.

Baja

HANDS RELATED TO TONGUE IN STUTTERING TEST

3892

Use of the hands and stuttering have a definite relationship, tests by Dr. Milton Metfessel, psychologist of the University of Southern California, have shown. A person physiologically left-handed, that is, born naturally to use the left hand in preference to the right, but who has cultivated a habit of using the right hand, often stutters, he found. The mental workings of such a person are so disturbed by the unnatural right-handedness that stuttering is induced. Use of the hands as na-



Tracing a Star with Both Hands Simultaneously, to Show if Patient Is Right or Left-Handed

ture intended often remedies the condition, and tests to determine the hand naturally used are given by having the patient trace a star in a mirror with both hands. The hand that is the fastest is the one which should be used normally.

FISH FIGHTS SPORT OF SIAMESE NATIVES

3933

A strange sport using fighting fish is one of the features of Bangkok, Siam, where these fish are bred specially for this purpose. A pair of males are taken to a hall and placed

in a glass globe, while crowds gather round to watch the fish fight until one kills the other. The crowd shows as much excitement as the spectators at a boxing ring in America or Europe. Many bets are made on the fights, as they are in progress. The fish change color while the fight is going on. When they close at the beginning, their bodies take on a

bright-pink hue, changing to intense purple, green and blue tints as the fight goes on. The fish are only two or three

inches long, but are fierce fighters, and in zoos have to be separated in the tanks by thick sheets of plate glass, to prevent them from tearing each other to pieces. The Siamese greatly prize these fish, and will wager all they possess on a fish of good fighting qualities. So fierce are the fights, that the winner is seldom able to fight again. It is used, however, for the purpose of breeding.

Wilkins

HUGE LAND PLANE CARRIES PASSENGERS IN WINGS

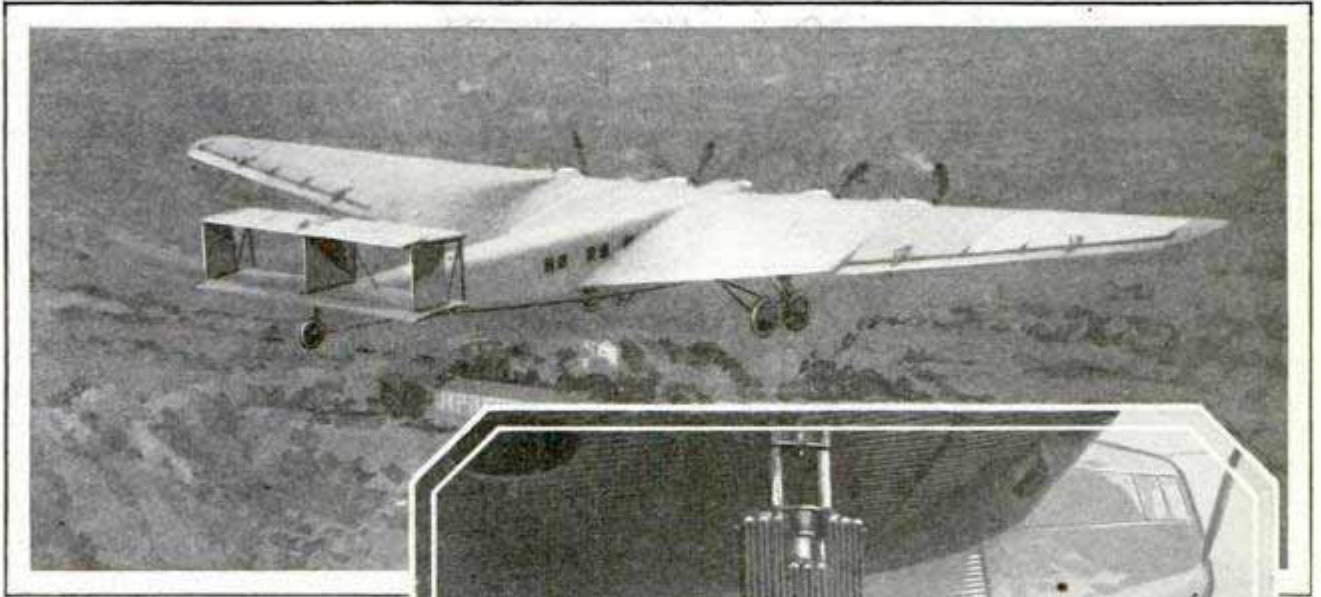

© P. & A.

The Junkers Plane "G-38" in Flight, and a Close View of the Landing Wheels, Which Are Five Feet in Diameter; the Ship Has Four Motors, Developing a Total of 2,400 Horsepower, and Carries Forty Persons

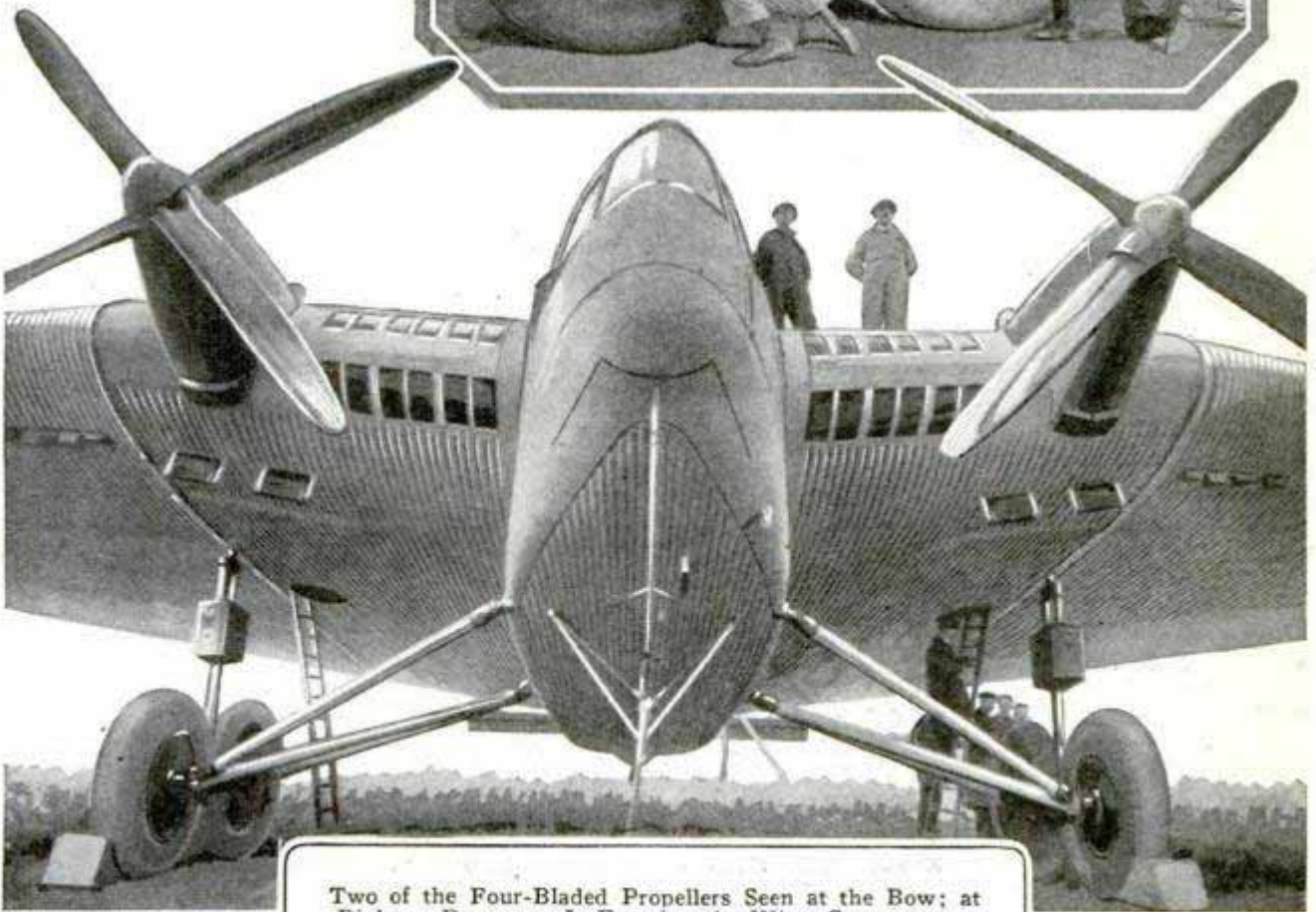
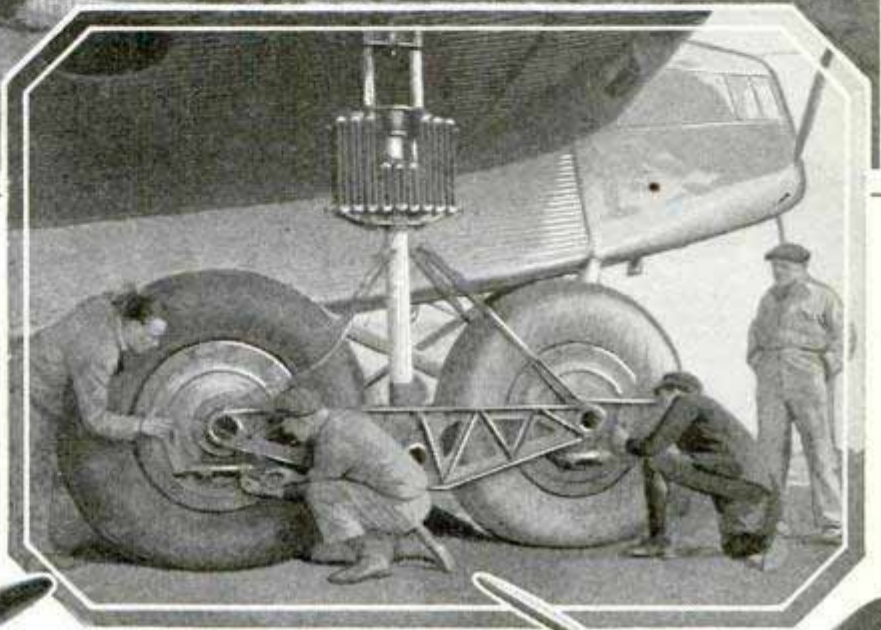

Two of the Four-Bladed Propellers Seen at the Bow; at Right, a Passenger Is Entering the Wing Compartment

announced by J. H. Hawkmark,

250 W. 57th

New York City

automotive sales and advertising engineer

3846
letter
retd
6/22/37



Vacuum Gear Shift for Auto Is Operated by a Throttle on the Wheel Instead of by a Lever

VACUUM GEAR SHIFT FOR AUTO ELIMINATES LEVER

Eliminating the gear-shift lever, and substituting finger control from the wheel of the automobile, a vacuum gear shift has been invented by a New York automotive engineer. The device makes use of the engine intake to create the necessary vacuum and may be installed on any car by removing the cover plate of the transmission box and applying a special one. An attachment is made to vacuum tubing running to two small cylinders at the rear of the transmission case, and a line extends to the motor intake pipe. The shift is operated by a throttle on the steering wheel.

RIFLE AND TOY BALLOON SOLVE ENGINEERING PROBLEM

How a sharpshooter with an idea and a toy balloon solved a difficult problem and saved several thousand dollars was related at an engineering society meeting. Due to an oversight, a 125-foot smoke-stack for one of the plants of the Southern California Edison company had been erected without the usual built-in steel

ladders on the outside, and when it became necessary to get at the top for repairs, the workmen found they would have to sprout wings or else build an expensive scaffolding to the top. Finally, the foreman of an "outside" construction gang of the Consolidated Steel corporation, whose plant adjoined that of the utility company, was called in consultation and hit upon a plan which, so far as engineering records show, is unique. Obtaining a rifle, he inflated a toy balloon to about four feet in diameter, attached a light string to it and staged a take-off inside the high stack. Taking his stand some distance from the chimney, he waited until the balloon floated high above the stack and then brought it down with a well-aimed shot from his rifle. The position from which he shot was on the side of the chimney so that the balloon

and string would fall outside the stack. To the string was attached a stout twine and when that had been hauled over the side, a rope was tied to the twine and pulled up. A cradle attached to the rope then took a repairman to the top.

PORTABLE LIGHT AND BATTERY FOR EMERGENCY WORK

Providing 300,000 candlepower, and capable of projecting a beam one mile, a portable electric searchlight, weighing only thirteen pounds, is now available for emergency work at night on overhead high-tension lines, in manholes or other dangerous positions where



sufficient light is essential to safety. Both beam and floodlight will burn from two and one-half to three and one-half hours. The battery is provided with an adjustable light bracket and the flood type of light will brilliantly illuminate 30,000 square feet at a distance of fifty feet.

3912

3912
Capt. Albert Boswell
Box 2231, Los Angeles

3916
PortaLite Co.
1109 Massachusetts Ave.

Clarence
11/30/29 *0.1068*

FEWER PERSONS RIDE ON TRAIN EACH SUCCESSIVE YEAR

Passenger business of the railroads, which has been dropping since 1920, still is on the decline, although the loss of 1929 was less than for any year since 1920, except 1925. All the loss occurred in day-coach business. Loss for the first eight months of 1929 was about one per cent as compared with six per cent in 1928, and passenger business was about thirty-four per cent less than in 1920. Part of the decline in passenger earnings, the smallest since 1917, is attributed to a slow but steady decline in the average passenger rate in addition to the decline in traffic.

3902

PHONOGRAPH IN AN END TABLE CONNECTS TO RADIO

Inclosed in an end-table cabinet, an electric phonograph, which may be connected to any radio receiver amplifier having a phonograph pick-up jack and played through the radio loud speaker, now is on the market. The cabinet has a compartment for records and may be placed beside a chair a considerable distance from the radio, the cabinet top forming a convenient table for books or other living-room accessories, when the phonograph is not in use.

3891



\$115.00

Phonograph Built into an End Table Intended for Connection with Electric Radio

Chicago - 9 S. Clinch

Continental Radio Corp
Fort Wayne Ind

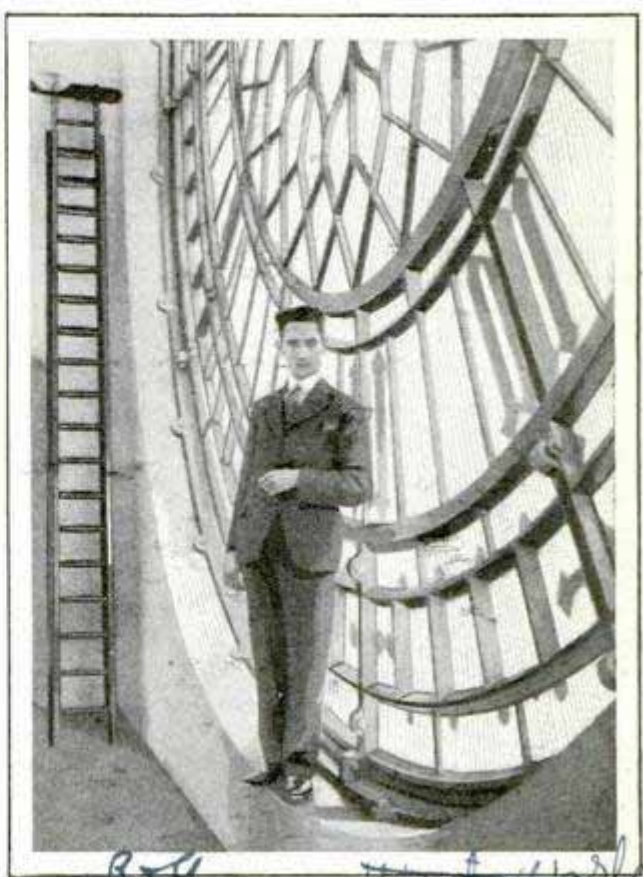

Close-Up of Part of One Dial of Big Ben, in Westminster, with Figure of Man for Comparison

MAN DWARFED BY GIANT DIAL OF WESTMINSTER CLOCK

Mere man is dwarfed in comparison with the giant dials of the most famous, and probably one of the most authoritative clocks in the world, "Big Ben," whose sonorous chimes sound hourly from the tower in Westminster, London. The figures on each of the four faces are two feet high and the minute hands are fourteen feet long.

HOG BRISTLES IN GOLF BALLS REPLACE RUBBER WINDING

Golf balls that depend on springy hog bristles for life instead of all-rubber cores, have been developed recently. Instead of the ordinary center of rubber bands wound over a core, a homogeneous mass of rubber and bristles is used, the standard cover being applied over it. Tests show the ball to be as lively as any other type, the bristles acting as tiny individual springs when the ball is struck. The mass of rubber and bristles does not change shape easily, and balls of this type can be produced much more cheaply than the wound type.

3902

Dr. Glenn H. Willis
Akron Ohio

and Walter B
Burton 1917 7 ponds are
Remove the skin of

326, Park Central Hotel, Washington, D.C.

The Passing of the

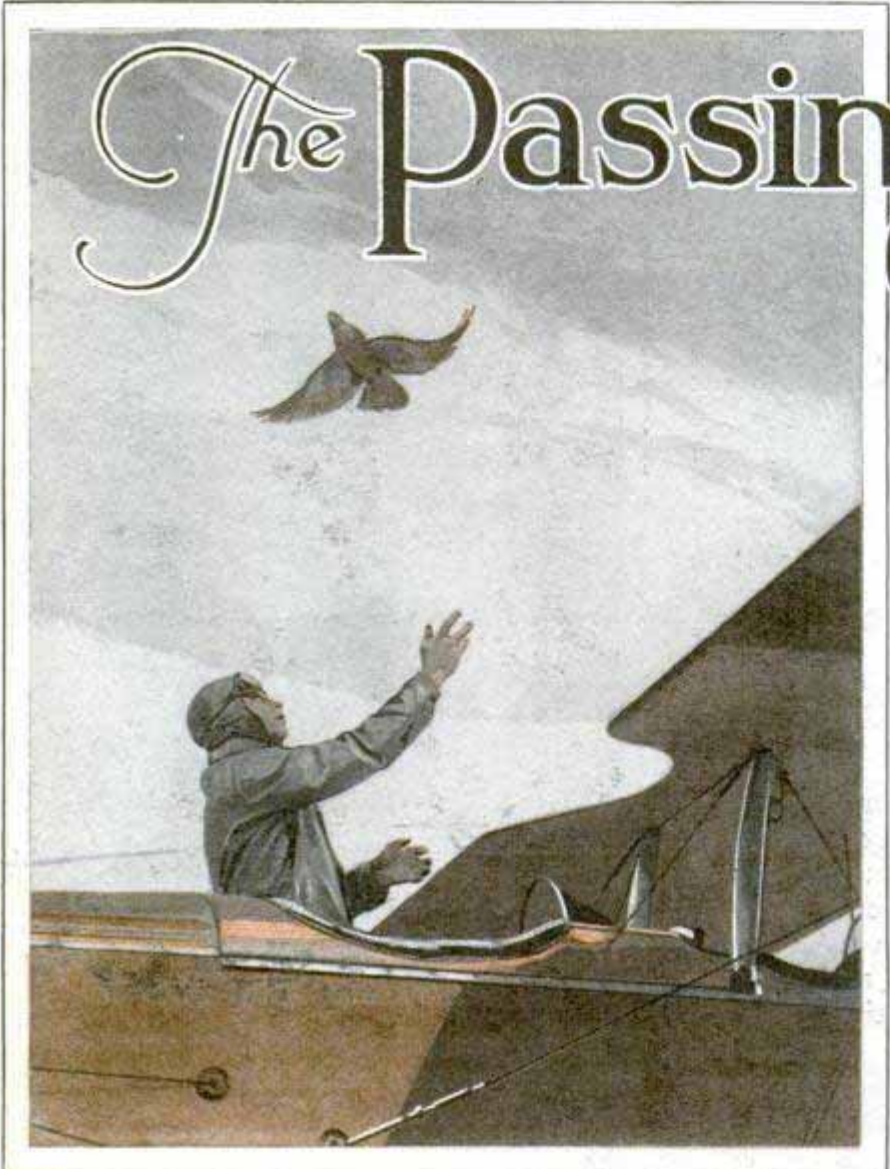

Aviator Demonstrating the Proper Method of Tossing a Carrier Pigeon, Bearing an Important Message, from a Speeding Airplane

By JAMES NEVIN MILLER

THE SWAN song of the carrier pigeon, internationally famous since the days of ancient Greece for bearing important war-time messages, has just been sung by the U. S. navy.

Advanced developments in aircraft radio have eliminated the bird's value as a messenger, according to official orders, with the result that eight of the ten lofts, maintained by the navy throughout American territory, will be abolished. Only lofts at Lakehurst, N. J., and Guam will be kept, and the number of birds retained, 400, is about half that used up to the present time.

"The greatest pal the fighting Yankee doughboy ever had," is the way the World War buddies like to speak of the carrier.

That this affectionately phrased opinion isn't far from the truth is indicated by the fact that the official records of the pigeon's valor are almost innumerable. Indeed, they form a chapter of the war that has never received due recognition.

Probably history has no record to compare with that achieved by the dauntless "Spike." Pigeon fanciers are still telling his story. Of uncertain pedigree and bred by American troops in France, he was a strong, aggressive, fast-flying bird with considerable vitality and unusual endurance. He is known to have delivered fifty-two messages all told without receiving the slightest injury.

Another famous war bird was "Cher Ami." He delivered twelve important messages from the Verdun front to his loft at Rampont, a distance of forty kilometers, in the remarkable time of forty-five minutes. Upon his return from the last trip it was found that one of his legs had been shot away and his breast pierced by a bullet. The message tube, containing the important message, was found intact, hanging by the ligaments of the torn leg. This valiant bird earned a place among the immortals, for when he died, in 1919, he was stuffed and mounted in the famous Smithsonian Institution.

Then there was "The Mocker." A dark-red bird, of doubtful breeding, his best-known feat took place early on the morn-

Carrier Pigeon

ing of Sept. 12, 1918. With one eye destroyed by a shell splinter, this game fellow raced home in splendid time from the vicinity of Beaumont front, St. Mihiel sector, bearing a message of great importance. Not only did the information thus sent give the location of certain heavy enemy batteries, but it enabled the Yank artillery to silence the rival guns within twenty minutes.

The pigeon section of

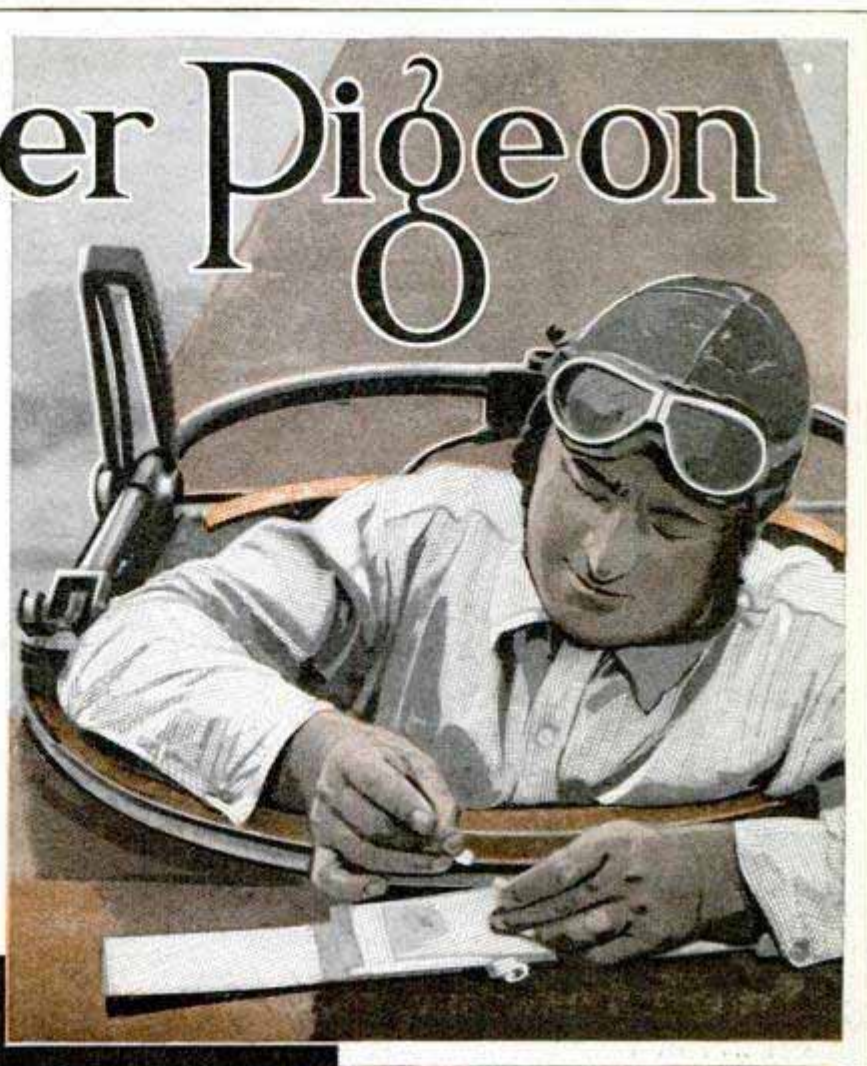

Top. Aviator Writing Message to Be Sent by Carrier Pigeon; Veteran of World War Which Carried Message Enabling Destruction of Enemy Battery after Being Wounded

tries had come to look upon the messenger pigeon as an important communication resort. When every other mode of contact had failed, the message was entrusted to a bird; and the fact that ninety per cent of these messages reached their destination after passing through every handicap imposed by battle conditions and unfair weather, will testify to the efficiency of pigeon liaison.

Germany had a very efficient and well-established pigeon service. It is a matter of record that they had established, throughout

the signal corps, U. S. army, had no existence prior to the entrance of the United States into the World War, and while many efforts were made previous to this time by interested observers to introduce carriers into the army, their value was not realized until after their performances had been observed in the European armies. Early in the war, the other coun-

England, lofts which were used for intercommunication purposes. This was made possible by maintaining flights between England and Germany before the war. Birds thus trained were simply held for release after hostilities had begun.

The commanding officer of the American expeditionary forces observed the wonderful work of the French and British

3650

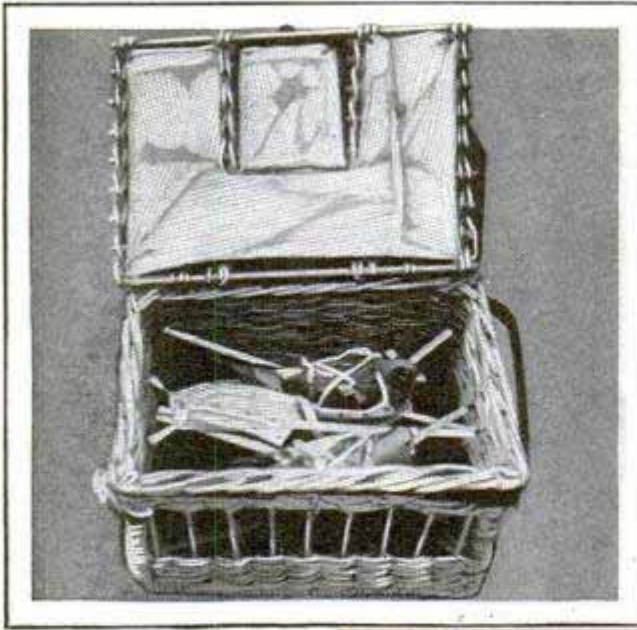

changing front line, difficulty was experienced in settling the birds, but a mobile loft, operating near the line, received seventy-eight important messages and 148 test messages in the active period extending from August 29 to September 11. Of the seventy-two birds used from this loft, not one failed to return.

In the St. Mihiel drive which followed, 567 carriers were available for the use of the American forces. Many of these birds were assigned to the tanks, and although their training had been very brief and prevailing fog and rain made flying difficult, ninety important messages were received, and of the 202 birds used in the tanks, only twenty-four were lost or killed in

action. Moreover, most of these losses were caused by long detention in small assault baskets and by inexperienced handling.

How the messenger pigeon is equipped by nature to perform its marvelous feats is described thus graphically in an official document of the navy: "The modern homing pigeon is capable of

birds and appreciated the necessity for a similar service within our forces. It was therefore upon his recommendation that the section was authorized in November, 1917, by the adjutant general of the army.

Immediate steps were taken to procure personnel and birds. When it is considered that homing pigeons bear the same relation to ordinary pigeons that a carefully bred, high-strung racing horse does to a drayhorse, it will be appreciated that the care and training of the messenger bird require considerable knowledge and experience. The physical condition of the bird is all-important, and a homer, no matter how carefully bred, must have a course of training before it will function efficiently.

The first extensive use of the birds by American troops in battle was made during the renowned Aisne-Marne offensive. Owing to the rapid advance of our forces and the constantly

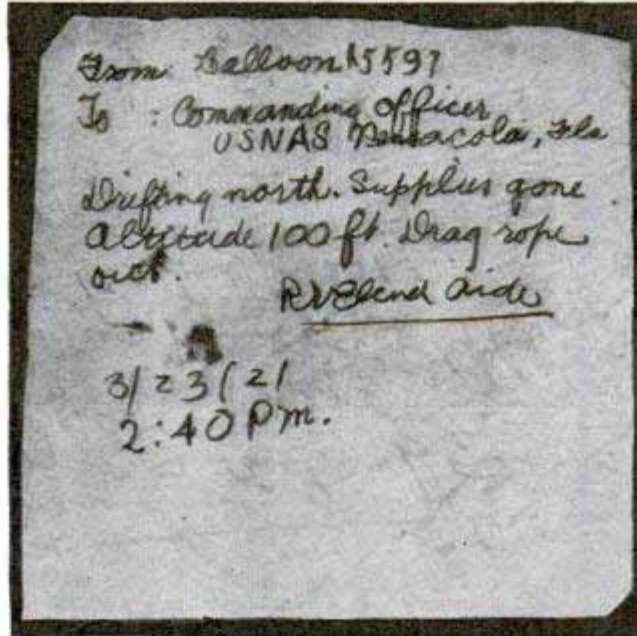

Top, Interior View of Pigeon Basket Carried by Doughboys; Center, Typical Message Sent by Pigeon; Below, Proper Way to Hold Bird in Attaching Message

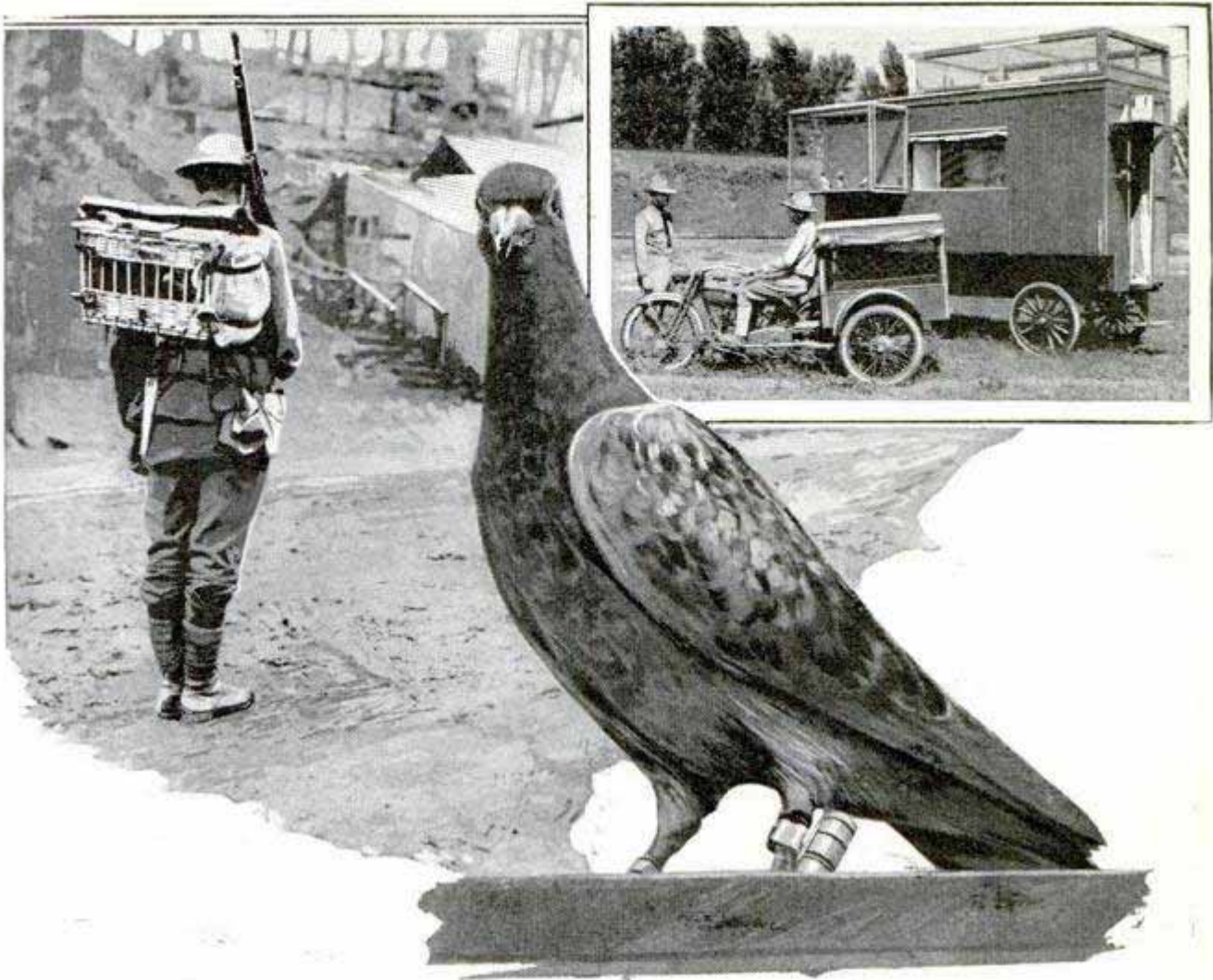

Soldier Carrying Homing Pigeons on Scouting Trip to Send Back Messages; Upper Right, Two War-Time Types of Mobile Pigeon Lofts; Below, Method of Attaching Aluminum Message Container

covering distances of 500 or 600 miles in a single day. The eye has great penetration of sight. The respiratory channels are wonderful, enabling a pigeon to fly without interruption for twelve to fifteen hours.

The ear appears to play an essential part in the sense of direction. It includes three semicircular canals, which appear to be the nerve conductors of orientation, and it is probable that their great sensitiveness enables the pigeons to perceive magnetic and other atmospheric disturbances, as experience has shown that any lesion of the canals destroys the sense of direction.

While the use of pigeons as a means of aircraft communication with the ground forces was utilized during the World War, it was really only an experiment. Since the war, however, it has become a genuine science. Night flying, for instance, has been utilized to a remarkable

degree. A striking case in point took place a couple of years ago. It seems that, around midnight, the launch "Crow," of the Panama canal department, with eleven persons aboard, left Balboa Heights for a trip to the Pearl islands. Eight pigeons were taken along, four day flyers and four night carriers. After a slight mishap, the trip to the islands was accomplished, but it was deemed advisable not to return at once. After a couple of days, however, the vessel started back. Very soon it became apparent that little headway could be made against a heavy sea and terrific wind. Whereupon two day birds were released with a message asking for a boat to be sent to tow the disabled craft to safety. No help came, so another message was dispatched at night. The following day, just as the craft, now completely disabled, was in bad straits against the tide, an airplane circled overhead and soon returned with a rescue launch.

Comr. William Thompson, Malden on Hudson

369 **MOSAIC SIDEWALKS IN LISBON
PORTRAY HISTORIC EVENTS**

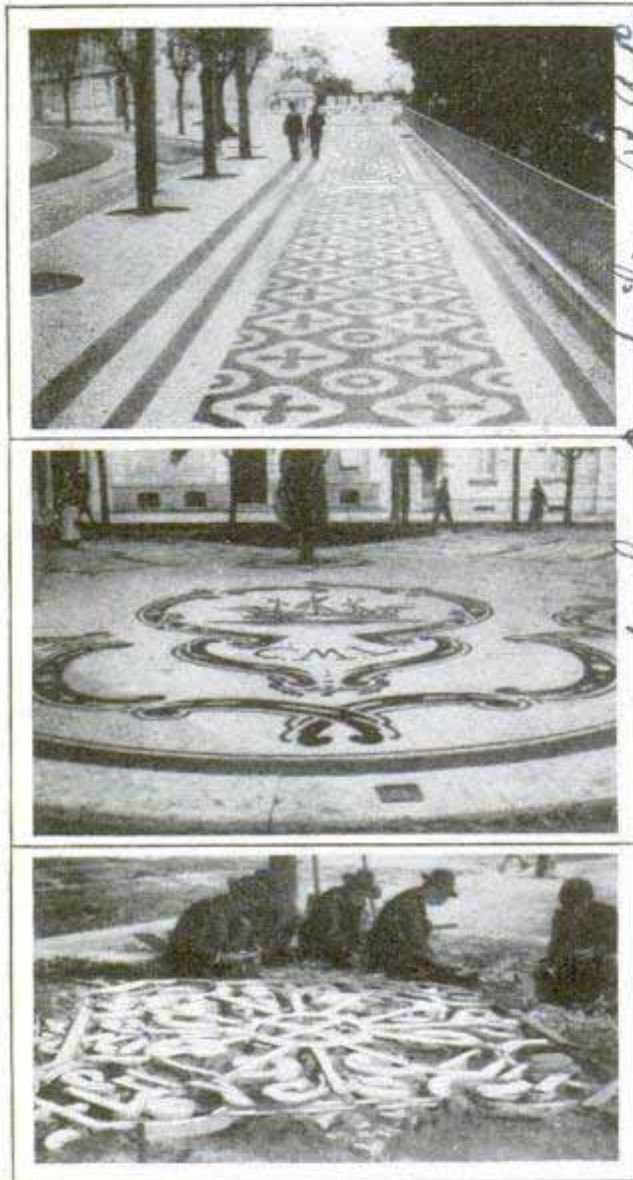

Sidewalks of Lisbon, Portugal, Laid in Intricate Mosaic Designs Depicting Local Legends

Probably the most unusual and most beautiful sidewalks in the world are found in Lisbon, Portugal, where skilled artisans lay the pavements in intricate mosaic designs, making the walks as decorative and costly as the floors of many great buildings. Some of the pavements represent historic episodes and local legends, and their construction takes much time.

**AUTO BODY USED AS RADIATOR
IN MIGHTY RACING CAR**

Using the body surface as a radiator, a racing car of novel design has been built for Kaye Don, British driver, and is to be brought to Daytona Beach to attack the world's speed record of 231 miles per hour

39/13
Sunbeam Motor Co.
W. Oberholster Eng.

made there by Sir Henry Seagrave. The body of the car is made up of two layers of thin metal between which cool water circulates, and the space between the wheels also has been inclosed by two layers of aluminum for circulating water. The auto, fitted with two engines of 2,000 horsepower each, has many safety features. For instance, if it should enter the sea, the shape of the bottom would enable it to skip over the surface for a considerable distance, or if the wheels should collapse, it would slide along the beach without overturning. In order to avoid jarring the driver from his seat, it is mounted on a pivot and counterbalanced by a weight equal to the driver's. The car was actually built to Mr. Don's body measurements. It weighs two and one-half tons, is only two and one-half feet wide, has a fifteen-foot wheelbase and an over-all height of three and one-half feet, allowing a little less than eight inches of ground clearance. In the engines, supercharged and mounted in tandem, nitralloy-steel cylinder liners have been used to increase the horsepower due to the glass-like surface of the metal. The drive is taken through a three-speed gear box, then by a separate propeller shaft to each rear wheel, duplication of propeller shafts allowing a much lower position for the driver, thus reducing head resistance.

Designed by Lane Crawford & Co. Ltd.

**HEATER FOR AIRPLANE MOTOR
FACILITATES STARTING**

Enlisted men of the army air corps at Selfridge flying field have developed a heater for airplane motors to facilitate starting in cold weather.

It consists of a coil of copper tubing heated by a set of three gasoline burners sheltered in a container small enough to fit into the cowl- ing of a plane be- neath the motor.

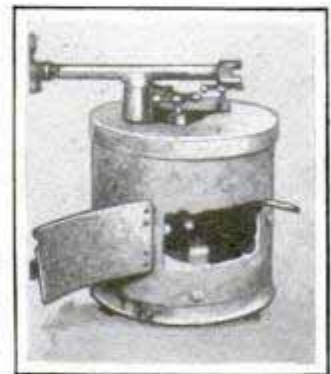

Gasoline is drawn from the ship's tank, and the coil is hooked to the cooling system. The heaters are connected so that the water of the cooling system may be

Comr. Walter Brenna
169 S. Esplanade Ave.

3866

directed through them or run through the usual piping. Ships standing outdoors in temperatures fifteen degrees below zero have been started as easily as during the summer months when the heaters have been allowed to run overnight.

EARPHONES FOR TABERNACLE ENABLE DEAF TO HEAR 3915

Mormons who are hard of hearing now have no difficulty in listening to the speakers in the famous Salt Lake tabernacle, the benches of which have been equipped with earphones. Wires connected to an amplifier are strung beneath the benches and a plug attached to the phones fits into a jack beneath the seat.

TELEVISION FOR MANY MADE POSSIBLE BY MIRROR 3843

Television for groups of persons is made possible by an invention of Dr. Vladimir Zworykin, research engineer of the Westinghouse Electric and Manufacturing company, who has developed a cathode-ray set. The effect is accomplished by projecting the images onto a mirror visible to the spectators.

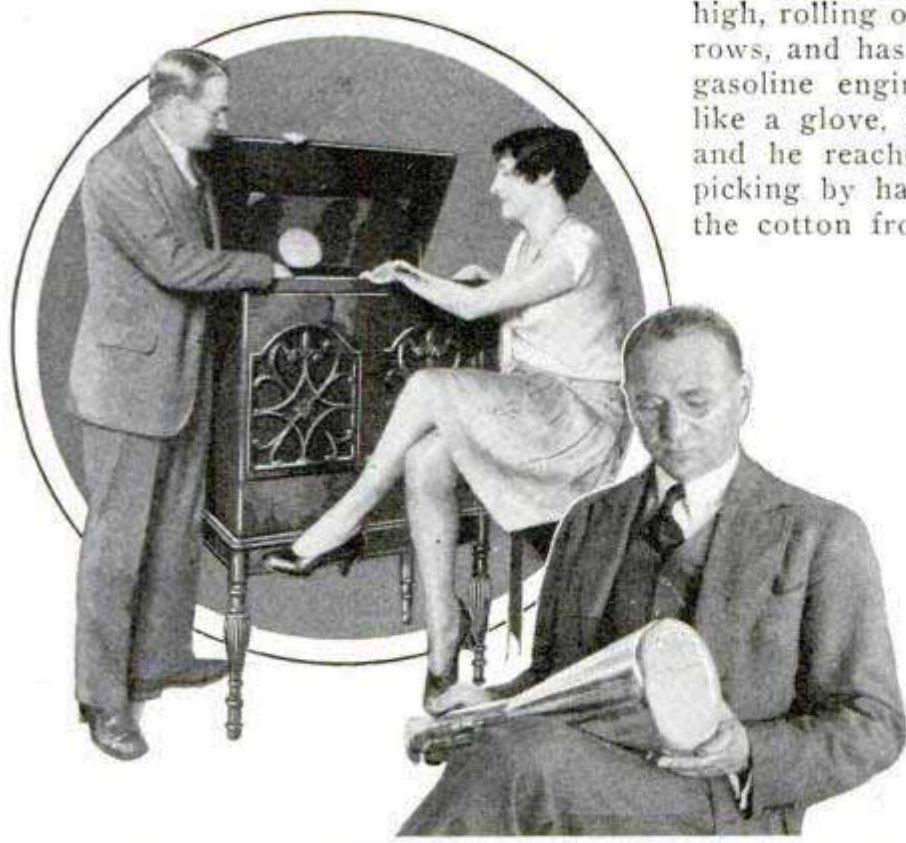

Television Receiver Which Throws Pictures on Mirror So Many May See, and Cathode-Ray Tube Which Casts the Image



Cotton Picker Moved and Operated by One Man, and Close-Up of Picker Head

COTTON PICKER CLEANS FLUFF AND SAVES TIME

One man is able to move and operate a light and compact cotton picker now on the market. - The machine weighs 300 pounds, is two feet wide, five and one-half feet long and four and one-half feet high, rolling on three wheels between the rows, and has a three-fourth horsepower gasoline engine. A picker head, worn like a glove, fits in the operator's hand and he reaches for the boll as though picking by hand. The picker head lifts the cotton from the boll, wipers fluffing out every lock, after which air currents convey it through a long tube and direct it against a wire screen, thus separating sand, dirt, moisture and other foreign matter. It is claimed the picker operates in damp weather when picking by hand is impossible, picks cleaner than is possible by hand, thus insuring a higher grade, and operates on about a gallon of gasoline daily. The engine is used to provide suction and actuate the parts of the picker head.

American Cottonpicker Corp., St. Louis, Mo. General Office 250 W. 57th St., New York

under \$500.00

13760

*Slemon
H. Walker*

*Barberton
Rubber Lace Co
made by
Berbering*

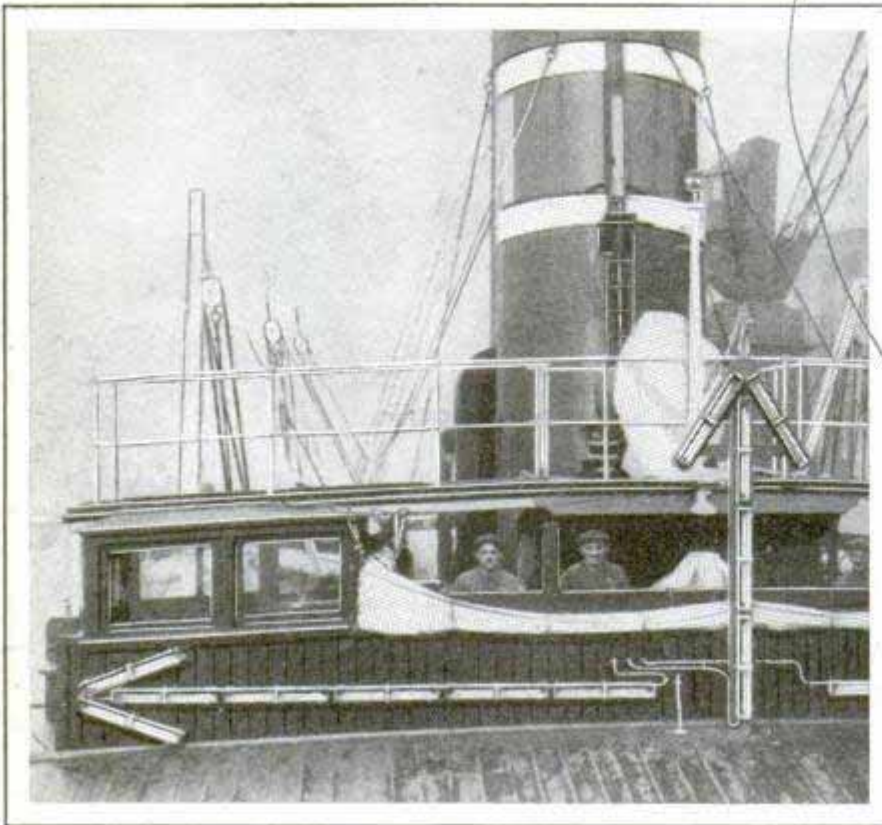

Electrically Illuminated Arrow on Dutch Ship Decreases Accidents by Pointing the Directions for Ships in Passing

ILLUMINATED ARROW ON SHIP DIRECTS OTHER VESSELS

To prevent collisions at sea, an electrically illuminated arrow has been installed across the bridge of the "Batavia V," a Dutch liner. The arrow is lighted to point the direction other vessels should take in passing.

NAME AND ADDRESS IN GLOVES FOR IDENTIFICATION

Identification tags for gloves, particularly helpful in case of accident or if the gloves are lost, now are being provided. The tag is glued to the inside of the wrist of the glove and the name and address are written on a small card which is placed inside a tiny envelope and sealed. The envelope contains instructions to break the seal

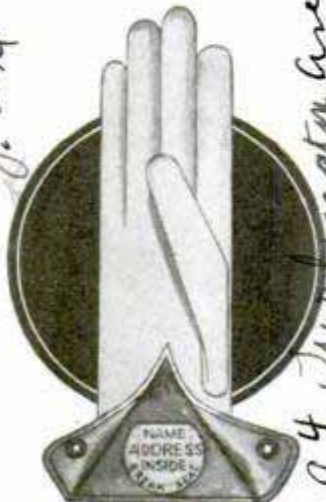

15304 Washington Ave

mold and curing it. The most intricate of expensive lace can be reproduced, the pieces being suitable for placing beneath flowerpots. Color combinations are also possible, and the pieces can be made either solid or with open meshes.

LACE DESIGNS ARE REPRODUCED IN RUBBER

Rubber lace, crochet work and tatting, almost identical with the originals, have been produced by a process evolved by an Akron inventor. First a mold is made by placing the article to be reproduced in contact with a hard rubber plate which is softened by heat, and then pressing the object into the surface. When the rubber hardens again, a durable impression of the pattern is left and duplicates are made by forcing rubber into the

STEEL TOE CAP FOR SKATERS LAIDS HOCKEY PLAYERS

Designed especially for hockey players, a steel cap attached to the skate, fits over the toe of the wearer's shoes, protecting him from the hardest blows. They are said also to assist in controlling the movements of the feet. The units are light in weight and permit wearing flexible, comfortable shoes.

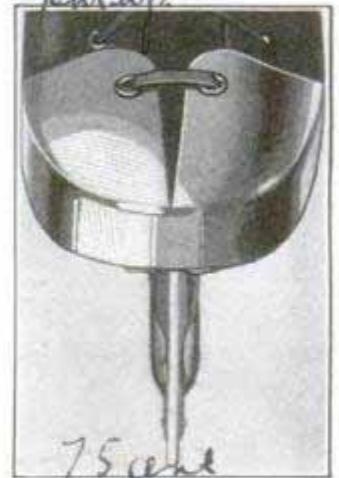

Whenever you find that you wish to know more about any article in this magazine, write our Bureau of Information,

*Nestor Johnson Mfg Co
1900 N. Springfield Ave*

*and J. Klein
Harvey d'Al
30*

San Francisco
Calif

WINDOW VENTILATOR-MUFFLER
KEEPS OUT NOISE 3914

Admitting fresh air, but keeping out street noises, a window ventilator which also serves as a noise muffler now is on the market. The muffler operates on the principle of the reflection of sound waves. Street sounds impinge on the outer member of the muffler and are reflected away from it. Some sound waves entering by reflection from masonry surrounding the window are caught by the inner reflector, and sound that otherwise would enter through the space between the sashes is kept out by a top barrier completely closing the gap between upper and lower sash. The result is that most of the noise that would enter through the opened window is kept out, although some noise enters by way of the glass when the window is closed, but this is deadened. The combination of reflectors with the sash between produces a valve used to regulate the air supply, and the shape of the inner reflector is such as to deflect air currents up into the room, thus preventing drafts.

POWER PLANT COOLING TOWER
LIKE BIG MILK BOTTLE 3915

Gigantic concrete cooling towers of the electric generating station at Liverpool, England, are a source of interest and wonder to all who see them for the first time. The huge towers, with their flaring bases, resemble nothing so much as the upper half of big milk bottles, or the straw-netted tops of cordial containers. They tower high above the near-by buildings.

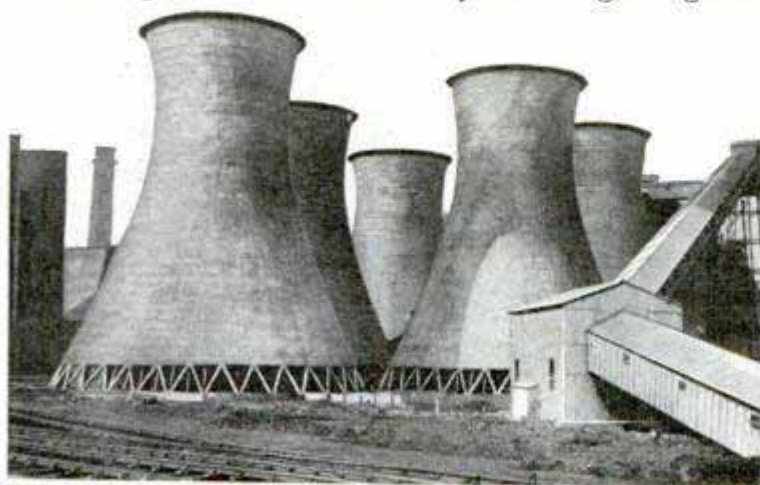

They Look Like Huge Milk Bottles, but These Concrete Structures Are Cooling Towers for an Electric Generating Station

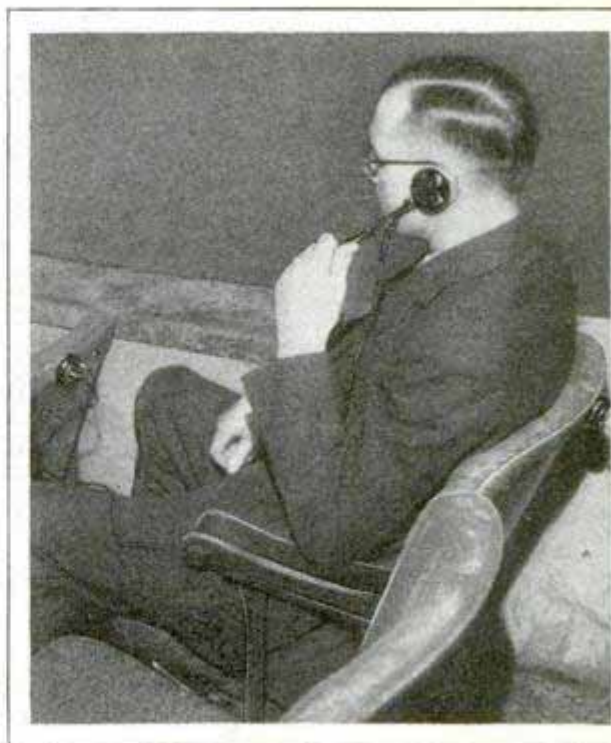

Theater Seat Equipped with Earphones to Enable Deaf Persons to Hear Talking Movies

DEAF PERSONS HEAR "TALKIES"
THROUGH SETS ON SEATS

To enable persons hard of hearing to understand the "talkies," a western theater manager has equipped the seats with special acoustic receivers. The listener plugs into one of the units and is able to hear the sound which is picked up by a microphone device near the loud speakers and relayed to all the receivers.

HOW TO LOOK AT SPOTS ON SUN 3917

Smoked glass, the old standby for sun gazers and those desiring to see eclipses and spots on the sun, is not as effective for this purpose as spoiled photographic negatives because it is difficult to smoke the glass densely enough. Two over-exposed negatives, placed one over the other, form an excellent shield through which to observe the spots. The film should be held close to the eye or close to the outer lens of binoculars. Look with one eye at a time to check against possible errors. Seeing a spot twice in the same place is evidence that the spot is on the sun, and not "in the eye."

Science Service
New Bulletin

Royal Theatre, San Francisco City, Calif.
S. C. Capepack, Manager

3445
Paddock

ing

John Clayton
Chicago Civic Opera
20 Wacker Drive



The Magic Wand of the Opera

ACHIEVEMENTS of this age of science lend a fresh enchantment to Chicago's new Civic Opera, the stage of which is the largest in America and the highest in the world. It could swallow a fourteen-story skyscraper and have a few feet to spare! This tremendous height as well as several other amazing features of the theater, innovations never introduced before in any playhouse, enable the staging of grand opera on new levels of mechanical and artistic perfection.

For the first time in theatrical history, the men who run the lights have left backstage and take their place alongside the

prompter in front of the curtain. For the first time, too, it is possible to effect instantaneous changes of lighting for entire scenes. Huge switchboards have been eliminated and in their stead there is a compact control set, as wonderful as Aladdin's lamp, for, at a touch of the hand, as much as 1,700 horsepower in the form of light can be made to produce sunsets, sudden thunderstorms and complex lighting combinations for the entire stage, all as simply and easily as the turning of a switch at home.

In the lofty wonderland behind the fifteen-ton steel curtain are other marvels.

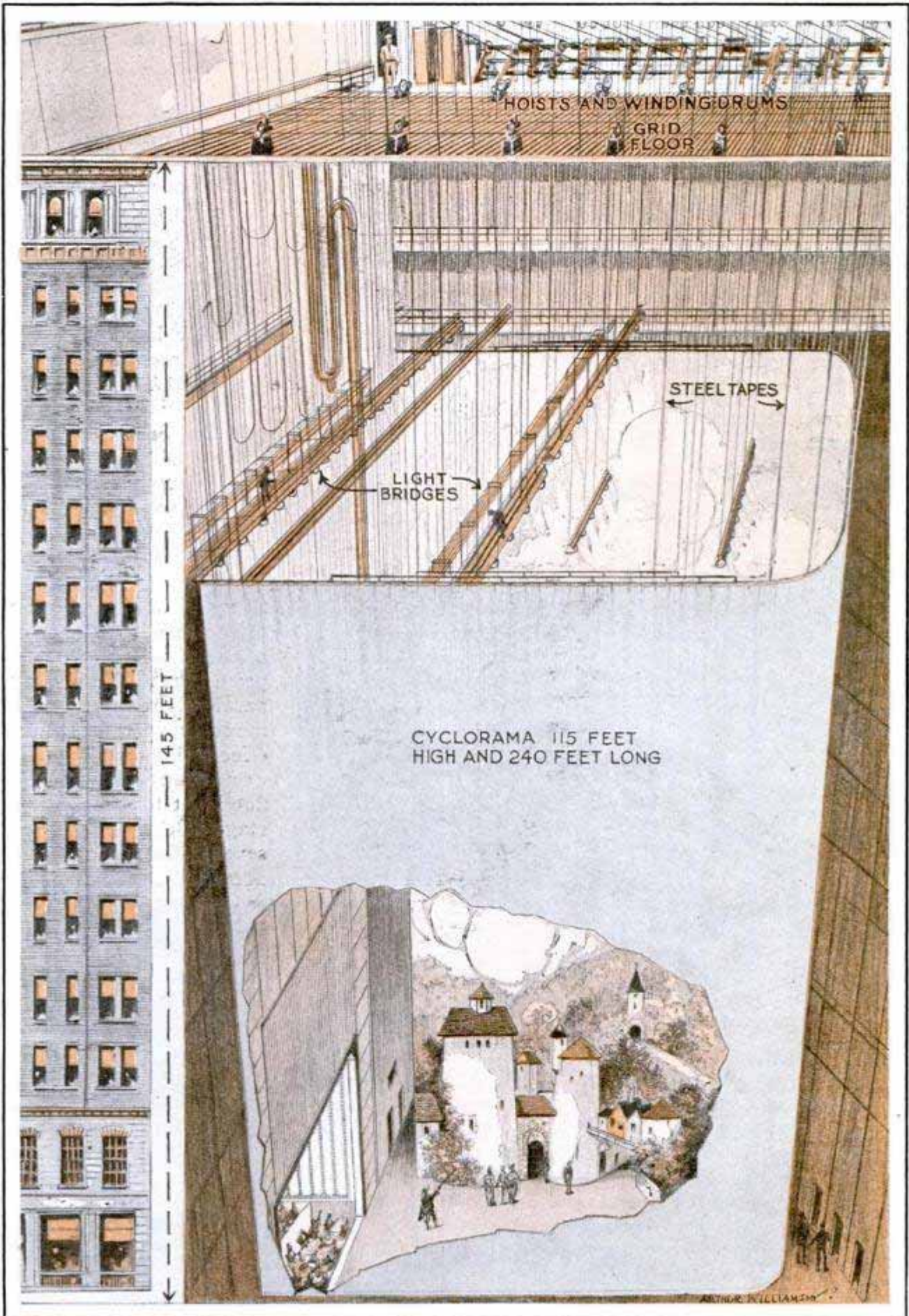

Artist's Drawing of the Lofty Wonderland Backstage in the Chicago Civic Opera House; the Space Is High Enough to Hold a Fourteen-Story Skyscraper

3745

Slender steel ribbons, razorlike in thinness and only two inches wide but capable of supporting four tons, replace heavy cable to lift and lower the huge cycloramas, the big curved curtain drops, 240 feet long and 115 feet high, that embrace three sides of the stage. This steel tape is a story in itself. Opera-company craftsmen and engineers developed it chiefly to save space in the lifting machinery room high above the stage. It winds up on narrow spools when the cycloramas are raised or lowered, whereas wide drums would have been necessary for the cables. There are three of these cycloramas, all controlled from the central station at the

theater's marvels, a portable aluminum station which the chief electrician wears over his shoulders while scenes are being shifted. He plugs a connecting wire into a socket, touches a button and a bunch light, floodlight, or one or all of the three huge light bridges, each of which carries 24,000 watts of current for spotlights and arcs, move up or down at his discretion.

The working stage, the portion visible from in front of the footlights, is divided into twenty sections, each of which may be raised twelve feet or lowered twelve feet or tilted in either direction at an angle of thirty-five degrees. This is accomplished by forty plungers, two for each section or trap. They are operated by hydraulic rams and are run from the central control station at the right of the stage. Each section has roll-away floors. This feature and the lift and drop flexibility of the different traps will permit the rapid and comparatively easy arrangement of complex scenic effects that could not be constructed on a flat floor. At the rear of the stage is the largest trap, seventy-five feet long and

Waller & Speck, 215 W. Congress, Chicago

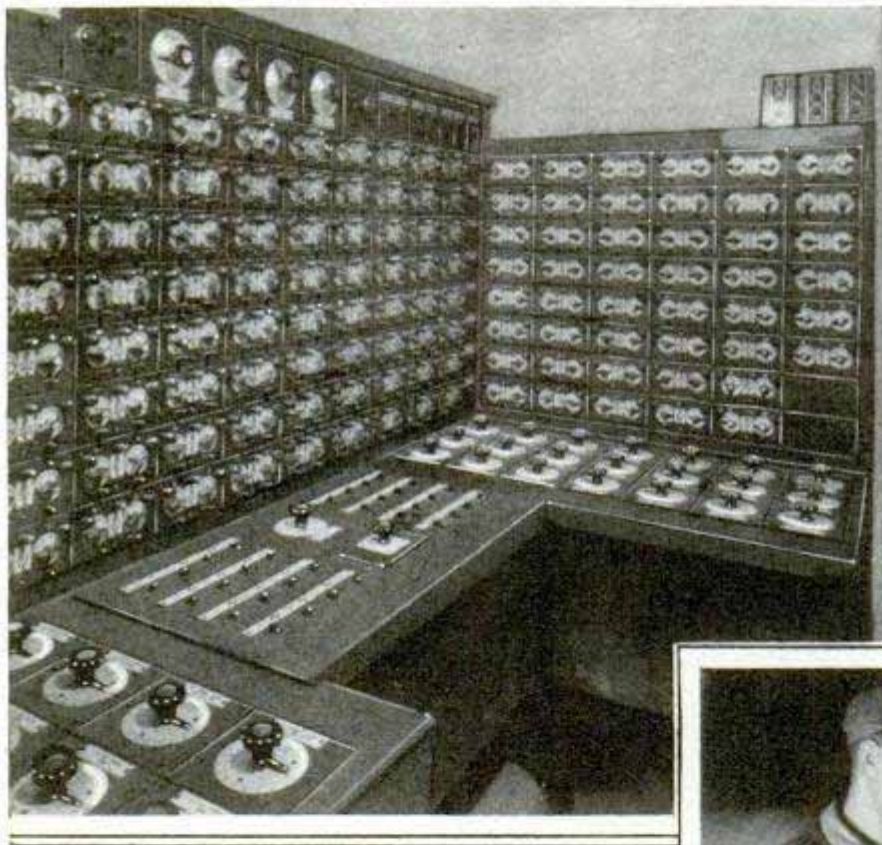

At the rear of the stage is the largest trap, seventy-five feet long and

right of the stage. Incidentally, the linen cloth for one of them cost \$7,000, and forty artists were employed simultaneously in painting it. With these huge backgrounds, interesting outdoor and other effects can be produced, and they eliminate the need of "tormentors," the curtains or flats at the sides of the stage.

Over 100 miles of rope, steel cable and steel tape and more than 100 hoisting machines are used in shifting and lowering the various drops, lights and other paraphernalia of the stage. Over half of this equipment is controlled from another of



Views of the Light-Control Boards and the Portable Station for Raising and Lowering Stage Units

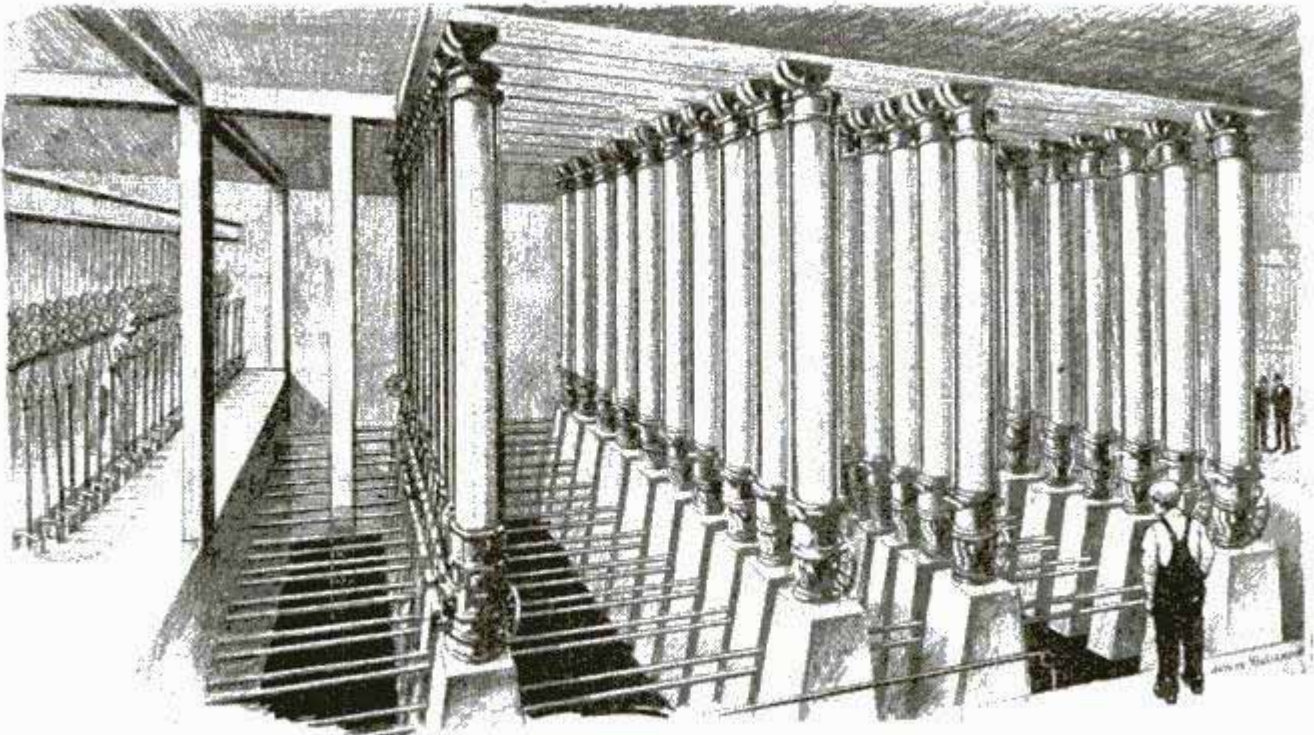

Drawing of the Forty Hydraulic Plungers That Raise or Lower the Twenty Stage Sections Above a Total Distance of Twenty-Four Feet to Make Possible Varied Setting Effects

five feet wide. It rises five feet above the level and descends thirty-five feet into a huge moisture-proof vault, where 2,000 drop curtains, all lettered and filed away according to the operas to which they belong, are stored. Drops for from three to ten operas may be hung at one time on the 106 scenery "pipes," each of which is seventy feet long and has a clear lift of 144 feet.

Back of the proscenium is a steam curtain for scenic effects and two fast-working curtains operated by horizontal hydraulic machinery, one for the drape curtain and the other for the act curtain. Both are controlled from the right side of the stage. In the pit is equipment for an orchestra of 200 pieces. The pipe-organ console is portable, so that it can be placed at different locations in the pit or on the stage. While the conductor is directing the orchestra, he can talk to persons backstage through a microphone connected to a loud speaker. To relay the time of the music to an off-stage group of singers or a band, it is no longer necessary for an assistant conductor to peer through a peephole and pick up the beat from the conductor. The assistant has a time beater which operates from a keyboard of four keys and controls four lights backstage.

All the lighting circuits are grouped

under the control of master knobs. In operation, the lighting supervisor may set in advance the illumination for a scene, and when the time comes for the performance, he cuts it into the circuit by means of a master switch. From his booth next to the prompter's, the lighting director is able to see all the lighting on the stage and also in the auditorium, although he is not visible from the audience.

At the rear of the theater is the radio room where opera performances will be broadcast with the latest equipment. The entire theater is provided with specially conditioned air so that even temperatures and humidity may be maintained, regardless of the weather outdoors. The opera house is constructed within a huge building which also contains a smaller "studio" theater adjoining the main auditorium.

3870

IMPROVED AIRPORT MAP

Location of the principal airports in large cities and a pictorial diagram of each landing field are shown on a condensed map that takes up but little space and can easily be interpreted by the pilot. It saves turning pages or handling a large chart. The diagrams of the fields give the position of runways, hangars, lights and obstructions as well as other information important to the flyer.

The Argus Maps Co
Barneswood

3795
206

Bridge Co,
Klime **POPULAR MECHANICS**
Detroit, Mich.

Federal Cement
Tile Co.
608 S. Dearborn
Chicago

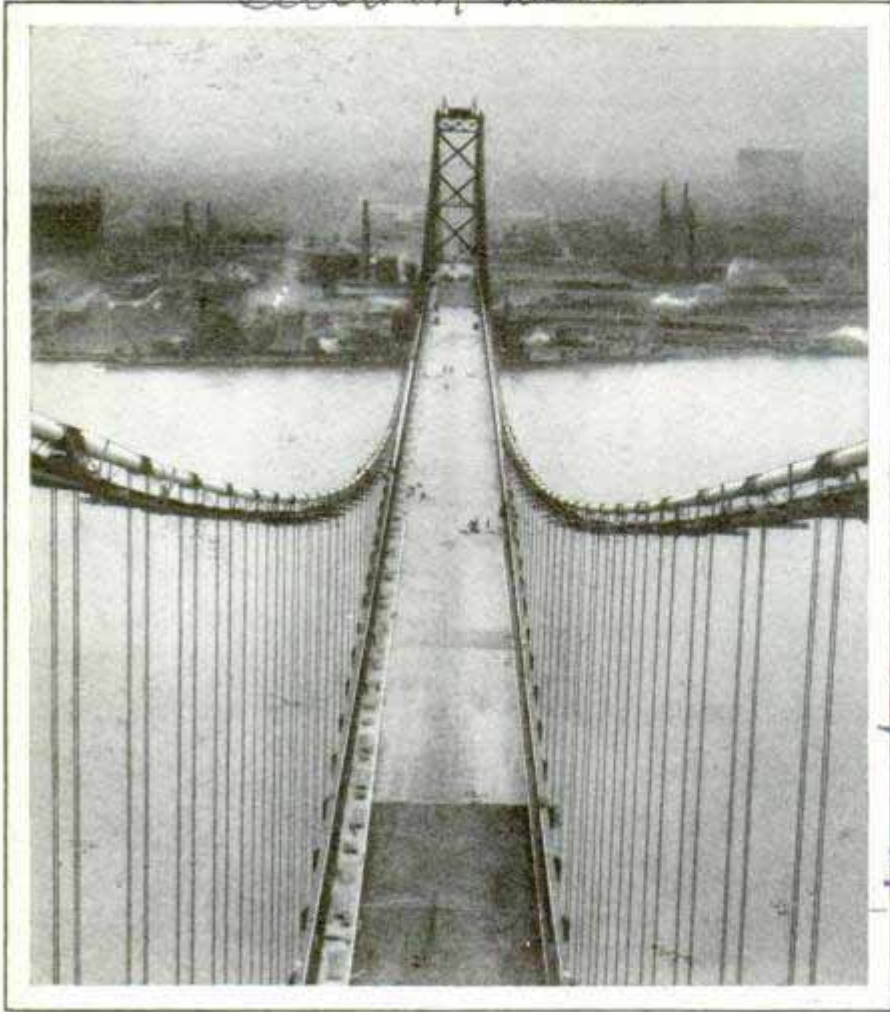

The 1,850-Foot Free Span of the "Good Will" Bridge between Canada and the United States, the World's Longest Suspension Span.

"GOOD WILL" BRIDGE TO CANADA HAS LONGEST SPAN

Linking Canada and the United States, the Ambassador bridge, recently dedicated, has a free span of 1,850 feet, 100 feet longer than that of the Philadelphia-Camden bridge which was the longest suspension viaduct before the completion of the huge structure at Detroit. The Ambassador represents the realization of a dream of thirty years ago, but it was completed in a little more than two years. It has an over-all length of about one and eight-tenths miles, and clears the Detroit river at a height of 152 feet in the center of the span, so that boats with tall masts can safely pass underneath it. Because of expansion and contraction during the heat and cold of

summer and winter, the length of the bridge varies thirty-two inches a year. It cost \$20,000,000.

FEATHERWEIGHT ROOF TILE IS CELLULAR

One-third lighter than ordinary concrete tile, a lightweight concrete roof tile, made of a material known as "haydite," has been placed on the market as a means of saving steel in roof construction. It requires no heavier steel design than any other form of roof covering and at the same time offers the advantages of permanence and fire safety. It is made from shale, ground and burned at a temperature of 2,000 degrees. In burning, oxidation of the carbon contents forms gases, causing the shale to expand into a light cellular structure. The material, a mass of trapped air cells the walls of which are vitrified fused shale, is crushed and used for mixing with concrete instead of the heavier sand and gravel. The cellular nature also gives the tile insulating value.

3894
Haydite

cellular structure. The material, a mass of trapped air cells the walls of which are vitrified fused shale, is crushed and used for mixing with concrete instead of the heavier sand and gravel. The cellular nature also gives the tile insulating value.

RADIO LIGHTNING ARRESTER DOES DOUBLE DUTY

Two lightning arresters are included in a single unit intended for use with the electric radio. One protects the set against lightning entering through outdoor antenna, and the other protects the radio against lightning entering through the light wires. The arrester also may be used as an indoor antenna. A filter between antenna and light circuit improves reception.

Chicago, Ill.

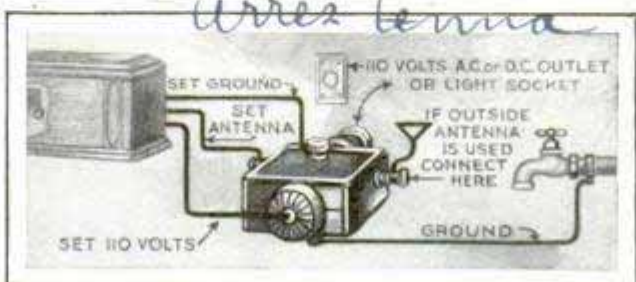

Lightning Arrester for Radio Which Protects from Charge through Antenna or Light Wires

L.S. Brachy Mfg Co.
129
Chicago, Ill.

*American...
Akron, Ohio*

**OAT HULLS AND HARD RUBBER
MAKE TOUGH MATERIAL**

Oat hulls and hard rubber, in equal parts, have been combined to produce a material of great toughness used in making silent gears and for other purposes where excessive wearing action from friction is a factor. The oat hulls, costing about \$38 a ton, are very durable, and when combined with the rubber, form a substance that will break only under great stress, and that takes a high polish. Because the hulls have a dulling action on tools, molding rather than machining is employed to fashion the material.

3901



\$19.50

3951

**LATEST OUTBOARD TWIN FIRES
ON ALTERNATING CYLINDERS**

Outboard motors have been developed with alternately firing twin cylinders, thereby producing two impulses per revolution instead of one, and increasing smoothness of power flow while decreasing pulsations. Full pivot steering is combined with underwater exhaust, something that has not been accomplished previously. Many of the features of the modern automobile engine are included in the outboard motors, particularly the carburetor

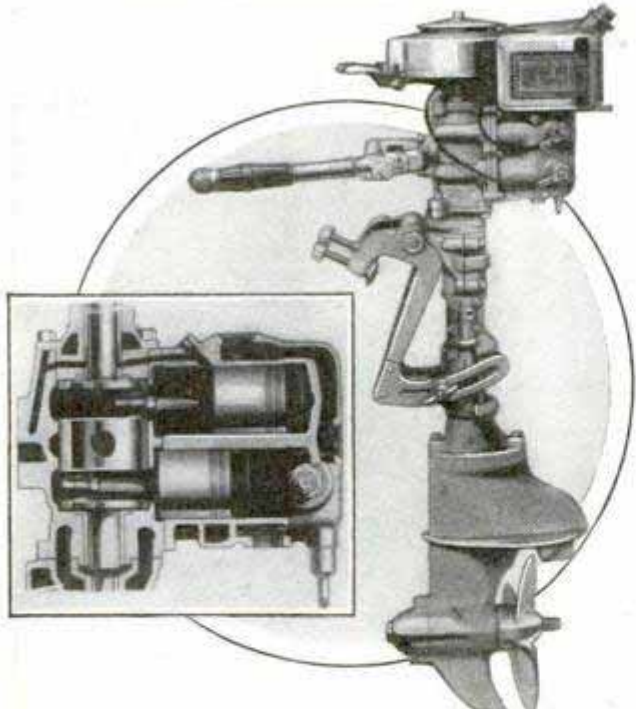

Outboard Motor with Alternately Firing Twin Cylinders, Producing Two Impulses Per Revolution

design. Another feature is an automatic back-pressure relief valve which closes at high speeds and opens at low speeds.

*Johnson Motor Co
Waukegan, Ill.*

Electric Deodorizer Which Kills Germs and Purifies the Air by Generating Ozone

**ELECTRIC DEODORIZER KILLS
SMELL OF COOKING**

Destroying the odor of cooking fish, cabbage or onions, and other unpleasant household smells, an electric deodorizer is now on the market. The apparatus, in a small cabinet resembling a jewel box, may be operated on any alternating-current 100-volt circuit and generates the concentrated and activated form of oxygen known as ozone, quite often noticeable in the atmosphere after a thunderstorm. It clears a room of tobacco smoke and also aids in purifying the air because the ozone tends to kill germs.

3898

SAFE "LISTENS" FOR BURGLARS

Mechanical ears are provided for a type of safe which "listens" for burglars and, on hearing them, sets off an alarm. Any noise, such as drilling, made in an attempt to open the safe when the alarm is on, sets up vibrations in the "ears" which cause the ringing of an alarm bell and the switching on of lights.

Ⓞ Military airplanes of all-steel construction are being built in France; equipped with 500-horsepower motors, they have a speed of 167 miles an hour in spite of their greater weight.

*Mal Radio Product Co
\$20.00 per unit
727 S. Michigan Ave
Chicago*

*St. Joseph News Press
11/2/29*

make ad given

3837

WALKING ON WATER MADE EASY WITH INFLATED SHOES



Shoes Attached to Inflated Cushions and an Inflated Staff Form Water-Walking Apparatus

Walking on water is made comparatively simple with a pair of inflated shoes and a staff with an inflated bottom, the invention of an Ohio man who hopes to walk across the English channel. The water-walking apparatus resembles a pair of shoes resting on cushions. The shoes are laced onto the walker's feet, the bottoms are inflated and a staff with an inflated end to preserve balance completes the equipment. The inventor believes the shoes will appeal to fishermen accustomed to standing in hip boots.

MORE THAN HALF OF AIR DEATHS DUE TO PILOTS' ERRORS

A study of all accidents in naval aviation during the last eight years shows that fifty-two per cent of the total number of crashes were due to pilots' errors. Power-plant failures caused but eighteen per cent of the accidents, and the weather but two per cent. Pilots were found to be responsible for three-fourths of the fatal accidents. The investigators also discovered that the infrequent flyer is the most dangerous pilot, the records reveal-

ing that men who quadruple their frequency of flying, approximately halve their accident hazard. The naval data show that the most dangerous period for the flyer is about his 200-hour mark. Then he is likely to become overconfident and, with the involved maneuvers he is likely to perform at this time, his chances for serious accidents are bound to increase, although the seasoned flyer was found to have only one-third as many accidents as the recent graduate from the flying school. Among the underlying causes of many crashes was the lack of appreciation on the part of the pilot of the definite limitations to which he should have held himself; in other words, a tendency to be careless. Among the accidents due to pilots, sixty-three per cent were caused by faulty flying technique and nineteen per cent by faulty judgment. Of the crashes due to power-plant failures, nearly half were caused by failure of the fuel system, thirteen per cent by the ignition and twelve per cent by the lubrication system. Nearly half of the fatal accidents followed the dreaded tail-spin, usually at a low altitude where recovery is difficult.

PLIERS GRIP WITHOUT SLIPPING ON ROUND SURFACE

Combining the principle of the cam, the fulcrum and the wedge, pliers that will not slip, even when gripping a round surface, now are on the market. The tool thereby performs work for which other appliances heretofore have been necessary. It eliminates the pin as a point of strain, the cam sliding the fulcrum to the correct position to wedge the work between the jaws in a viselike grip. It contains no screw adjustment and grips with the slightest pressure.

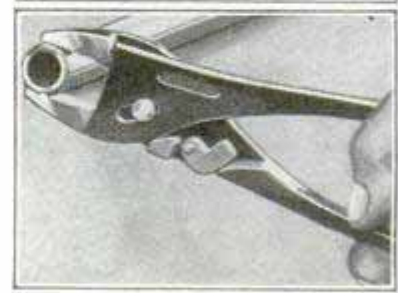
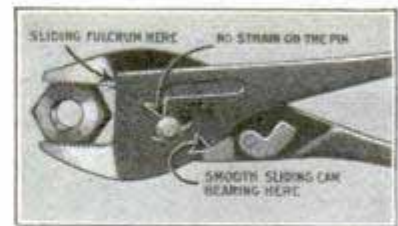

Kant Slip Plier + Tool Co. 6036 Pl.

Air Corps News Letter, issued by office of Chief of Air Corps 3909 War Dept, Washington

PLANE LAUNCHED FROM TOP OF SPEEDING AUTO

For the first time an airplane recently was launched into the air from the top of a speeding automobile during tests at Old Orchard beach, Maine. The car,



Upper Right, Airplane Resting on Frame on Top of Automobile from Which It Hopped, as Shown Below, When the Car Had Attained a Speed of Fifty-Two Miles an Hour

carrying the plane in a frame on its roof, gathered a speed of fifty-two miles an hour before the ship, which weighed more than 1,300 pounds, left the car top and proceeded under its own power. Both plane and car were standard stock models.

STUN FISH WITH ELECTRICITY TO LAND THEM EASILY

Tuna fishermen off the coast of Mexico are stunning the large fish with electricity to make the landing easier. The fish travel in schools according to size and cannot be caught in nets but only with poles and hooks. Fishermen running into a school averaging 100 pounds or more

each often were faced with difficulties in landing the catch. Now, however, many of the boats are equipped with 110-volt direct current. On one side of the circuit is a small steel plate which is thrown into the water. The other side of the circuit is carried to the steel hook with a small insulated wire. Once the fish is hooked, a switch is closed sending sufficient current through the fish to stun it. Swordfish, weighing from 300 to 1,000 pounds and requiring seven or eight hours to land, have been pulled in within five minutes after being stunned.

☐ A rocket-driven bicycle has been constructed by two German racers.

*Com. B. S. Harens
News Bureau General*

2655

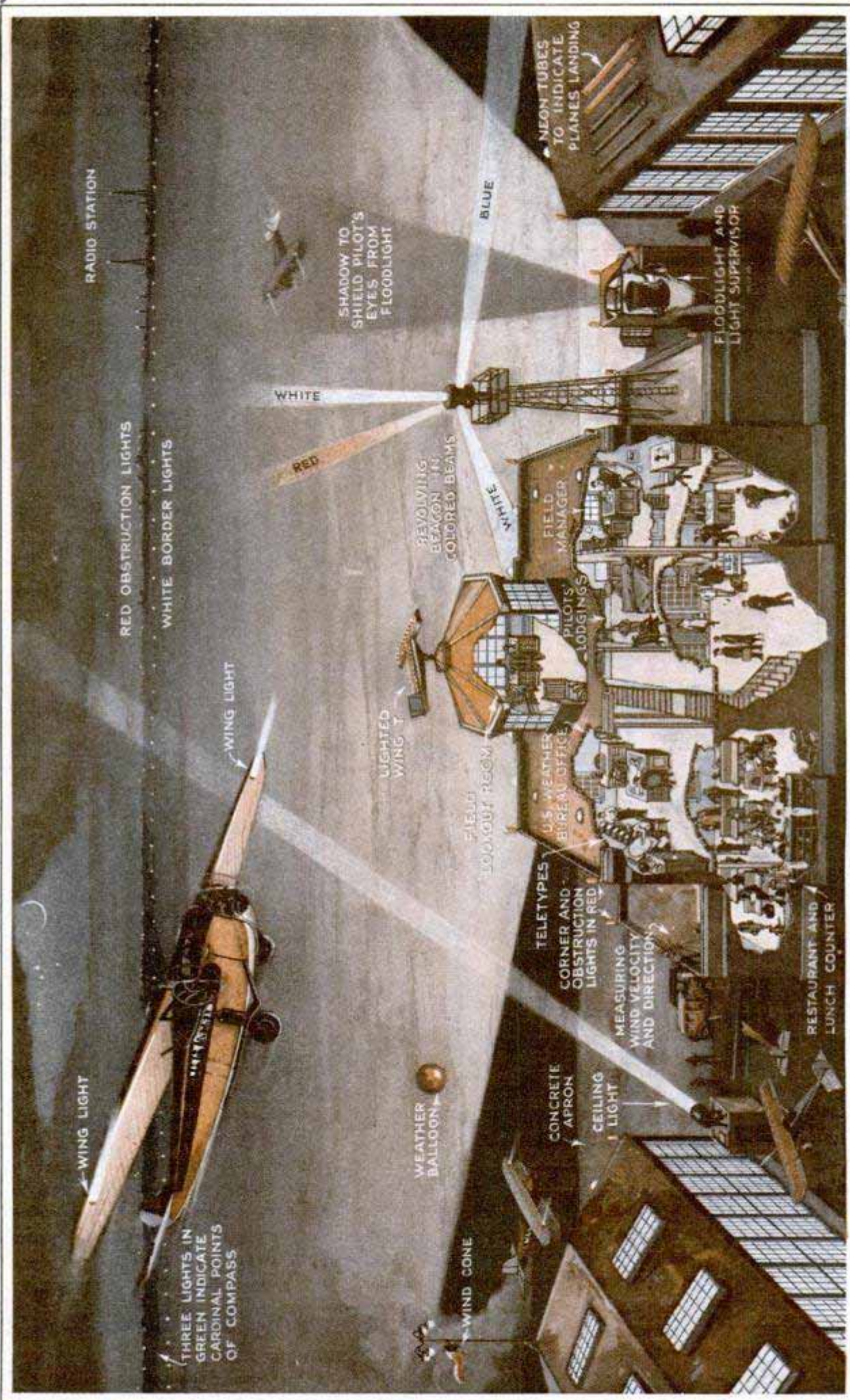

Some of the Important Details of a Modern Air Terminal; This Drawing, Based on the Cleveland Airport, Which Is One of the Best Equipped in the Country, Shows a Few of the Interesting Activities and Units Required for the Safe Operation of Planes at Night and during Times of Poor Visibility

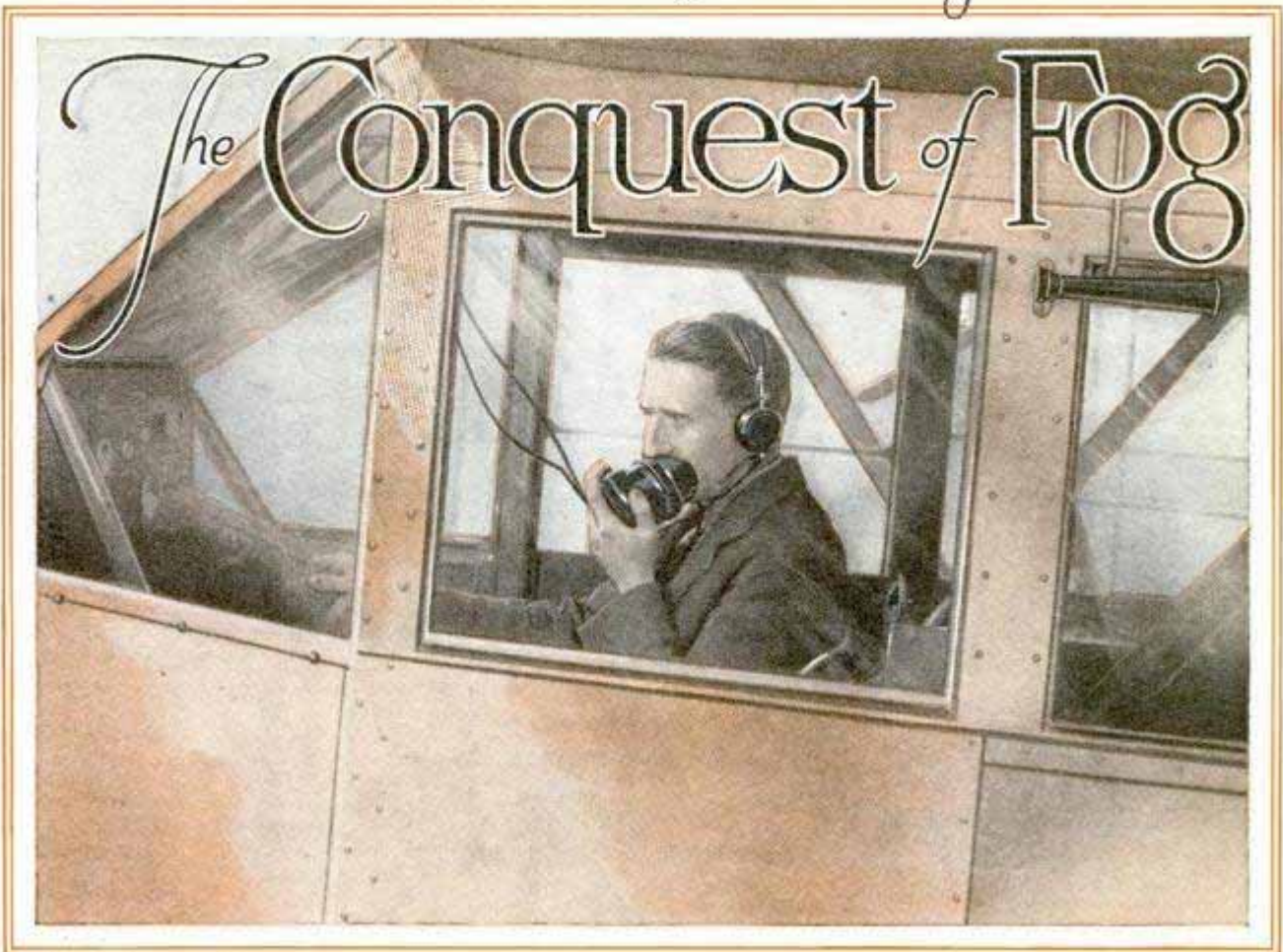

Pilot Using Special Phone Transmitter Developed by Bell Telephone Laboratories; Note How It Is Shaped to Keep Out the Plane's Noises and to Permit Easy Use

FOG, the last great bugbear of aviation, has been conquered.

The application of the conquest to commercial aviation remains to be brought about, but a year of experiments, just completed on Long Island, have evolved an instrument that seems to be the answer to the flyer's prayer. Lieut. "Jimmie" Doolittle, the army's flying ace, did the actual experimental work, and the Guggenheim Fund for the Promotion of Aeronautics, of which Colonel Lindbergh is a director, financed it, but behind them was the combined research departments of four great organizations: the Sperry Gyroscope company, the General Electric company, the Bell Telephone laboratories and the Bureau of Standards.

The solution they reached, with the combined inventive genius of several thousand trained scientists battling with the problem, is an adaptation of the sonic depth finder used on many big liners at sea. The aerial depth finder, however, is super-sonic, for it employs sounds of such extremely short wavelength and ex-

tremely high frequency that they are inaudible, not only to man, but to the highly sensitive ear of a cat.

These super-sonic sounds, at a frequency of some 26,000 cycles, will descend from the plane and send back an echo from the ground, while an electrical recorder automatically measures the elapsed time and translates fractions of a second into feet and hundreds of feet.

In its essence the plan differs but little from the experimental work done a year ago by the General Electric with a radio altitude finder, but that little difference represents the margin between failure and success.

The difference is merely the difference in speed of light or radio waves, and the speed of sound waves. Radio, like light, travels at 186,000 miles a second. Given an altitude of 5,000 feet, the radio wave, traveling that distance and back, would return in eighteen thousandths of a second, an extremely small lapse of time to be measured, and when the plane got down to 100 feet or so, where a fog altim-

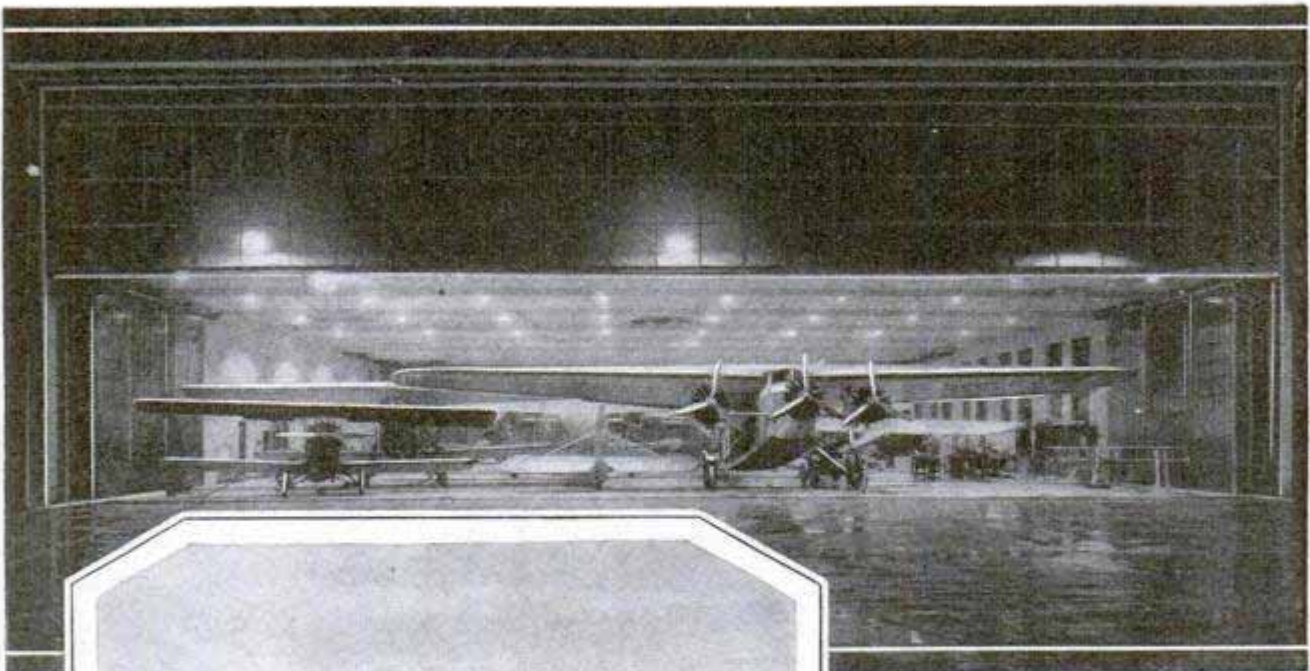

Night View of Interior of Universal Air Lines Hangar at the Cleveland Airport; Passengers Are Discharged on Concrete Platform in the Foreground; at Left, One of the Bell Telephone Company's Air Laboratories in Flight; the Radio Mast Is Now Commonly Seen on Many Transport and Mail Planes Since Wireless Has Proved So Efficient in Enabling Pilots to Guide Their Ships at Night and through Bad Weather

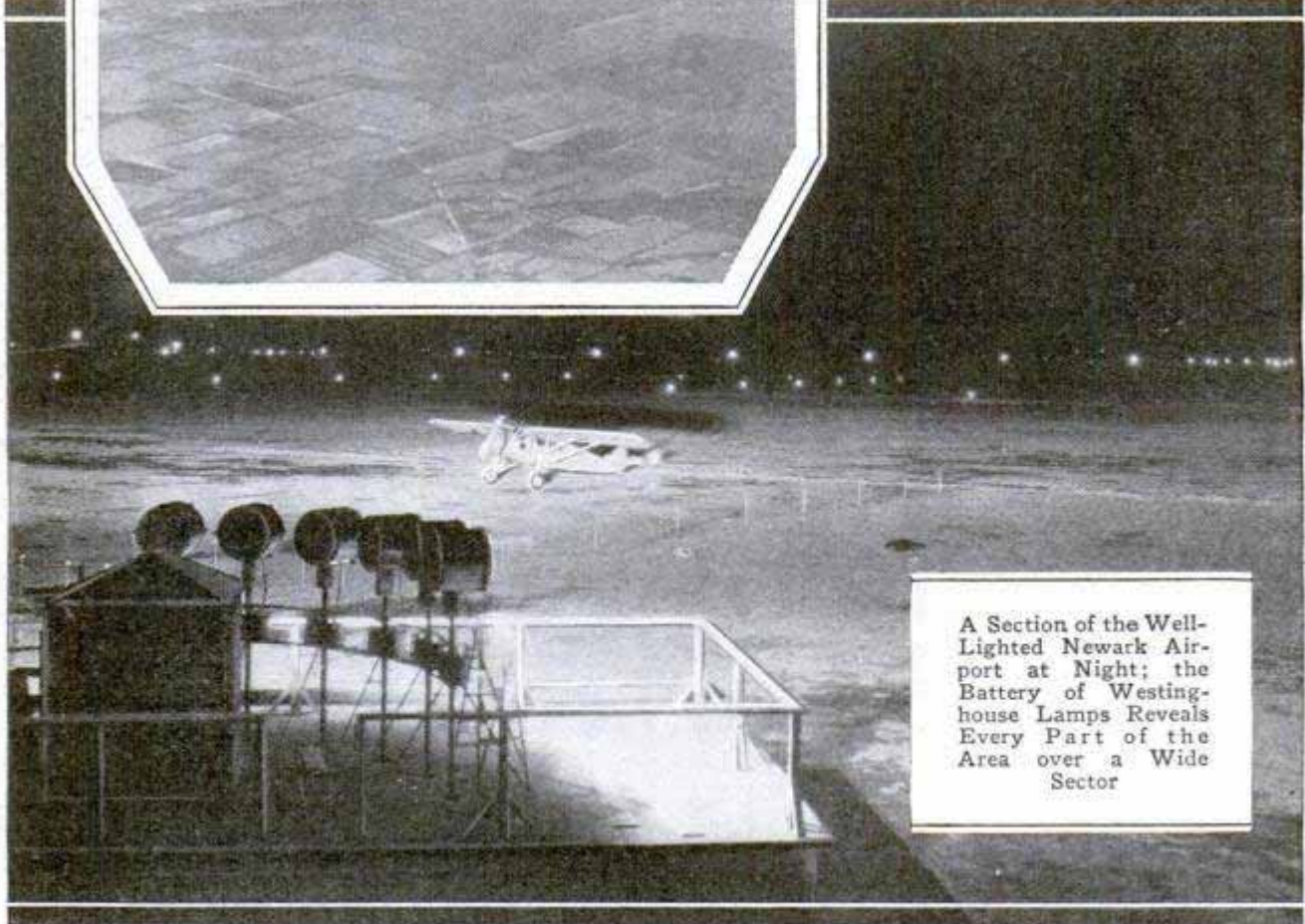

A Section of the Well-Lighted Newark Airport at Night; the Battery of Westinghouse Lamps Reveals Every Part of the Area over a Wide Sector

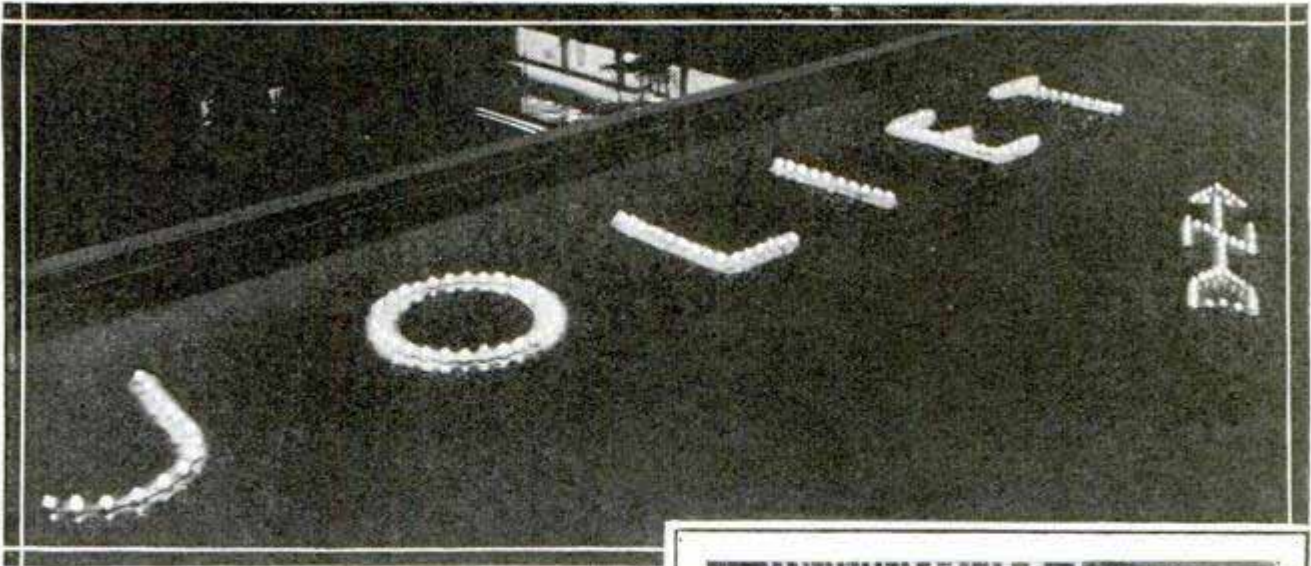

eter really is important, the speed of the radio wave is so great that accurate measurement becomes almost an impossibility.

But, compared with that, the speed of sound waves through the air is only 1,087 feet a second. Sonic depth finders at sea, because of the fairly slow speed of sound through water, can measure depths of a few fathoms, though sound travels 4,708 feet per second in this medium.

Moving at their relatively slow rate, sounds in the air can be broadcast from a plane, reflected back from the earth, and the time taken for the echo to return measured accurately when the plane is not more than thirty feet in the air. And as super-sonic waves, inaudible even to the family cat, are to be used, the widespread application of the device to thousands of planes will cause no annoyance on the ground.

One peculiarity of super-sonic waves is the enormous power required to project them any great distance. The air absorbs them rapidly.

"It takes," says Elmer Sperry, the famous inventor of the gyroscopic stabilizer, the gyro-compass and the high-intensity arc light, "twenty horsepower of energy to project super-sonic waves a half mile. However, as the flyer needs no warning of objects more than 1,000 feet distant, we can produce sufficient energy without too great weight of apparatus, using a battery and radio apparatus."

Details of the apparatus itself are being closely guarded, and will not be made public until the Guggenheim Foundation issues its formal report, probably some

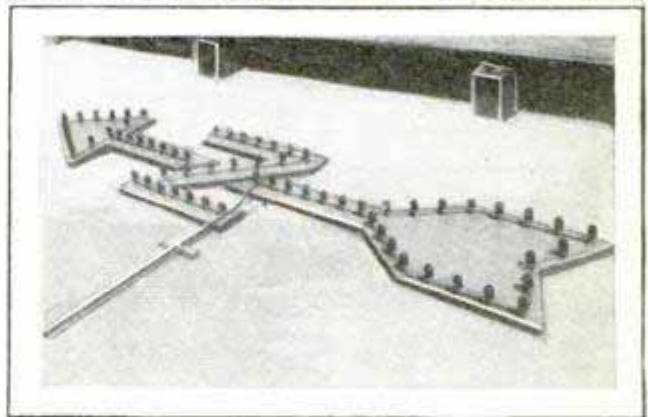
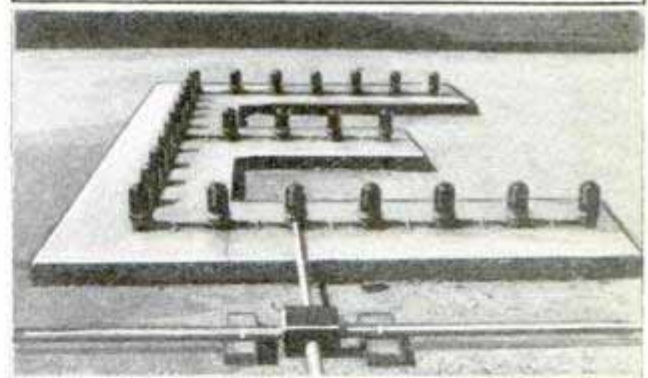
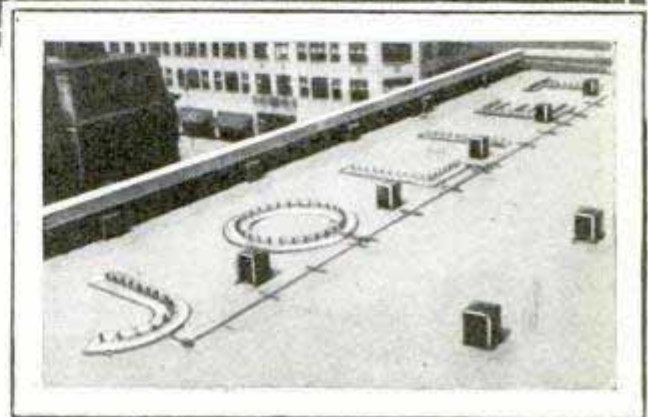

A Welcome Sign for the Airman; Joliet Says It in Lights with a Guiding Arrow

time during the winter. Nothing is known beyond the fact that a radio oscillator is used to produce the high-frequency waves, and an automatic electrical recorder to pick up the reflected sound and

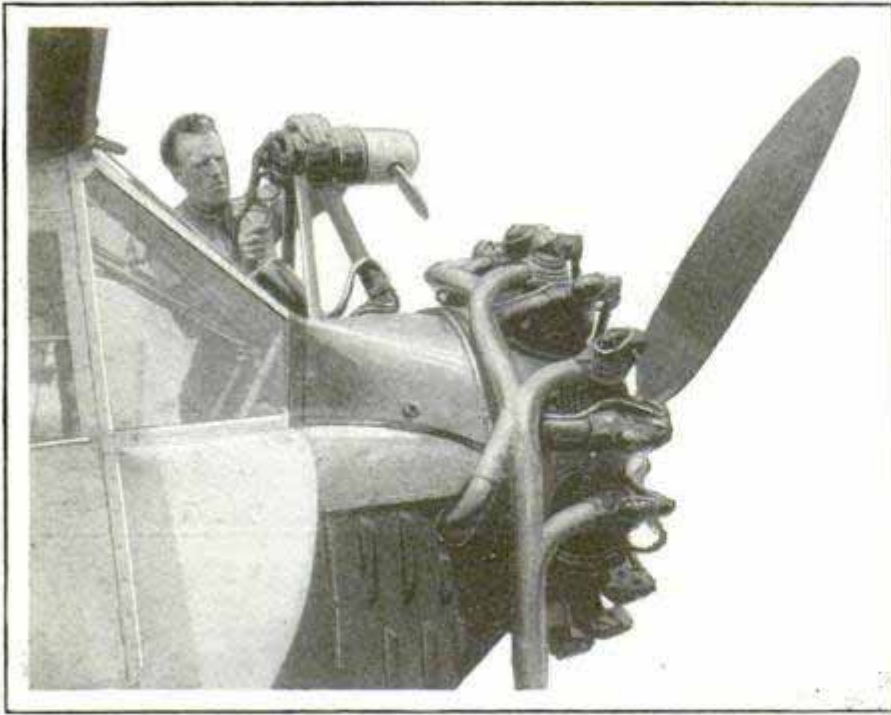

Wind-Driven Generator Which Supplies Filament and Plate Current for the Plane's Radio Transmitter and Receiver

lighter colors, as the terrain varies.

In the London experiments, a white sheet was tied to the top of an automobile, and the car driven past the Sperry offices, and then parked, thereby determining the altitudes at which moving and stationary objects could be seen in a dense fog.

The radio division of the lighthouse service, under which airway beacons, either radio or lights, come, has completed the installation of radio beacons from Boston to Des Moines, with intermediate plants at Hadley Field, N. J., Bel-

lefonte, Pa., Cleveland, Goshen, Ind., Chicago, and Sterling, Ill., while a ninth has been installed at Key West, for the Havana route. These are in addition to the army-controlled beacons at San Francisco and Hawaii.

Installation of fifty more radio beacons by the lighthouse service has been approved, and within two years it is expected that every important air route in the country will be fully protected by radio.

No two adjoining beacons use the same code letters, so the pilot flying from one beacon zone into the next has no trouble picking up the new signals. Each beacon transmits two sets of code signals, which, on the true course, blend to form a third signal. The standard radio alphabet signals for the letters "B" and "V" are used in one set of beacons, "D" and "U" in a second, and "A" and "N" in a third. If a flyer is on a course between the A and N-signals, for example, he hears the letter "T" in his headphones.

Although the radio beacons, with two antenna systems spaced at right angles, would normally send out signals in the same way, it is possible to correct them with additional apparatus so they can be sent in any desired direction, thus shifting each of the four available courses to mark a direct course to another city, re-

translate the elapsed time into a measurement in feet.

Supplementing the super-sonic altimeter, will eventually be two systems of radio beacons, one, nine stations of which have already been installed by the department of commerce, covering routes between airports, and the other, a purely local beacon, broadcasting down the best runway of the flying field. Whenever fog or storm conditions will make landing difficult, the latter beacon will be on.

An incoming plane, arriving over the airport on the long-range beacon, will tune to the wavelength of the local beacon and locate the direction and length of the runway from it, flying back and forth in the radio lane as he descends. The super-sonic altimeter will guard his descent down to a point where the ground below will be visible, even in the thickest fog.

Experiments, carried out by the London office of the Sperry company during England's famous "peasoup" fogs, proved that a moving object below was visible from as high as fourth-story windows, while one standing still could not be seen from the second floor. As everything below is moving, in relation to the plane, the pilot gets what Mr. Sperry describes as a "barber-pole effect," the ground flashing by in alternate stripes of darker and

ardless of its compass bearing in relation to the other three.

The radio receiver used in the airplane is a simple set, weighing, complete with batteries, but eighteen pounds. A vertical antenna, carried by a pole above the fuselage, is used instead of the now obsolete trailing wire.

In addition to the other devices already in use or projected, the department of commerce has approved short-range radio telephones for use at airports to direct planes about to land. All airports in the country will operate these transmitters on the same wavelength, so they are limited to a range of not more than five miles. The pilot of an approaching plane can get his landing directions from the airport manager through the same receiver used for the beacons, and, while he will not be able to talk back, unless a portable transmitter is installed on the plane, the ground crew, by listening to his motor, can give valuable advice and directions even in a dense fog.



Terminal Equipment for Plane-to-Ground Transmitter at Airport Weather Station

DOGS CARRIED IN RUMBLE SEAT COVERED WITH CANVAS

3842

Another use for the rumble seat has been found by a Pennsylvania dog fancier who hauls his prize winners about in the rear seat of his car which has been made into a kennel by fitting a strong canvas

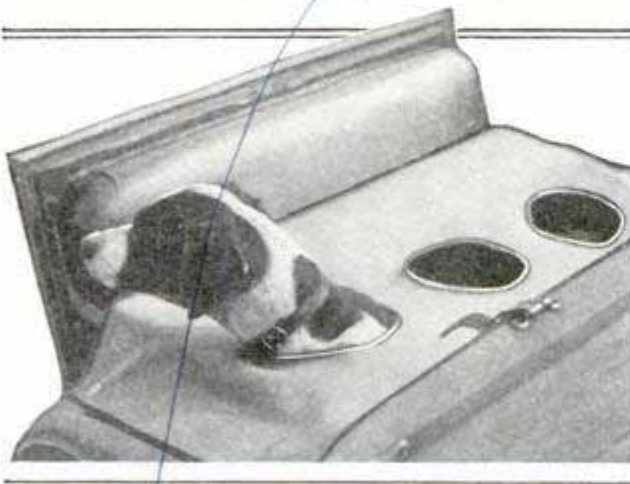

Rumble Seat Fitted with Cover and Ventilators for Carrying a Dog Fancier's Prize Winners

Pierce Archer
11 W. Newwood

cover over the opening around the rumble seat. The cover was attached with snap fasteners, and over the seat three holes were cut, to allow the dogs' heads to protrude. When traveling, the dogs may enjoy the fresh air without escaping, and when tired, they may curl up in the seat.

3864

PACKING FROZEN RAW FRUITS

Packing frozen raw fruits, berries and vegetables in small containers to preserve the original flavor of the fresh product is being studied by the department of agriculture. More than 10,000 cans have been packed by various freezing methods and placed in cold storage to determine the best method of preserving the fresh flavor, and at the same time keep the fruits from spoiling. The experiments are being conducted for the benefit of officials enforcing the pure food and drug act, and to supply packers with accurate information regarding the various processes.

U.S. Darty 11/22/29

LIGHTS RULE MOB SCENES IN TALKIES

Faced with the problem of directing a mob scene in a talking picture in which 5,000 persons participated, without having his voice picked up by the sensitive microphones, one

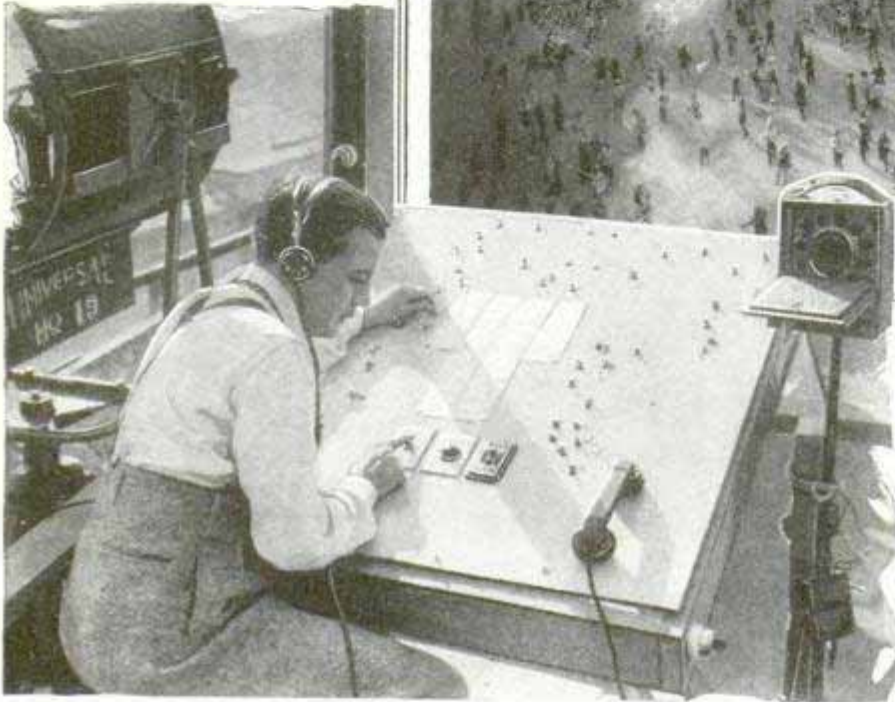

Mob Scene from Talking Movie Being Directed by Cue Lights; These Are Governed by the Director, Seated at the Switchboard

director solved the difficulty by using a system of light and flag cues, thereby enabling the photographing of sight and sound simultaneously. Heretofore mob scenes were shot in the silent way and the sound was supplied later by a crowd of extras. The director in charge of filming the talking-picture mob scene was perched on a building high above the scene and in front of him was a ground plan showing every entrance, window and door. On his layout were electric switches connecting with lights at each door, window and archway. He pressed a switch to start the cameras, then, by pressing cue lights, hidden from the cameras, gave the signal which started the first of the mob on the scene. Headphones gave the director the sounds exactly as they would reproduce and a hand phone connected him with the sound man so that he was able to govern

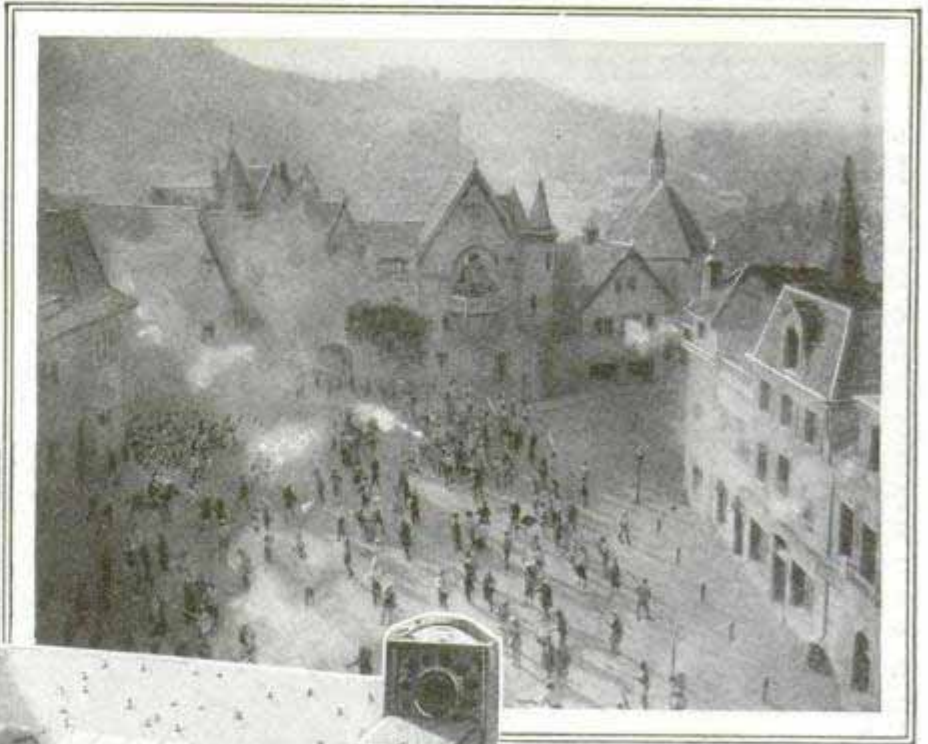

the volume. Switch after switch was pressed to release more of the hidden actors and, during a battle, a red flag above the director indicated to the actors that one section was to retreat slowly, and a white flag, run up after a master switch released all the cue lights and brought reserves, showed the thousands of actors

that the tide of battle had turned. The scene finished, the director pushed a button stopping the cameras and sounded a siren indicating to the actors that the cameras had ceased grinding. It has been suggested that a modified system of light and flag signals might be used to direct troops in battle.

AERIAL BOMBING OF PORPOISES PROTECTS FISHERIES

Airplanes equipped with bombs similar to those used in war time have come to the aid of the fishing industry along the lower St. Lawrence river, which was threatened with destruction by the voracious appetites of porpoises. The Quebec department of game and fisheries first employed expert marksmen, but they made no headway, so airplanes and depth bombs

Mr. Paul Fejos

3869

3918

1148 - 4th Ave. E. Canada
Aven Sound Out
Canada

POPULAR MECHANICS

U.S. No. 1
Clyde, Ohio
217

3848

were tried. The porpoises, however, are such swift swimmers they usually scattered as soon as the bombs hit the water, and the weapons then were changed to bombs that exploded as soon as they struck the surface. This proved the most effective method and several bombs dropped on a school kill many outright, injure others and send the survivors scurrying in all directions.

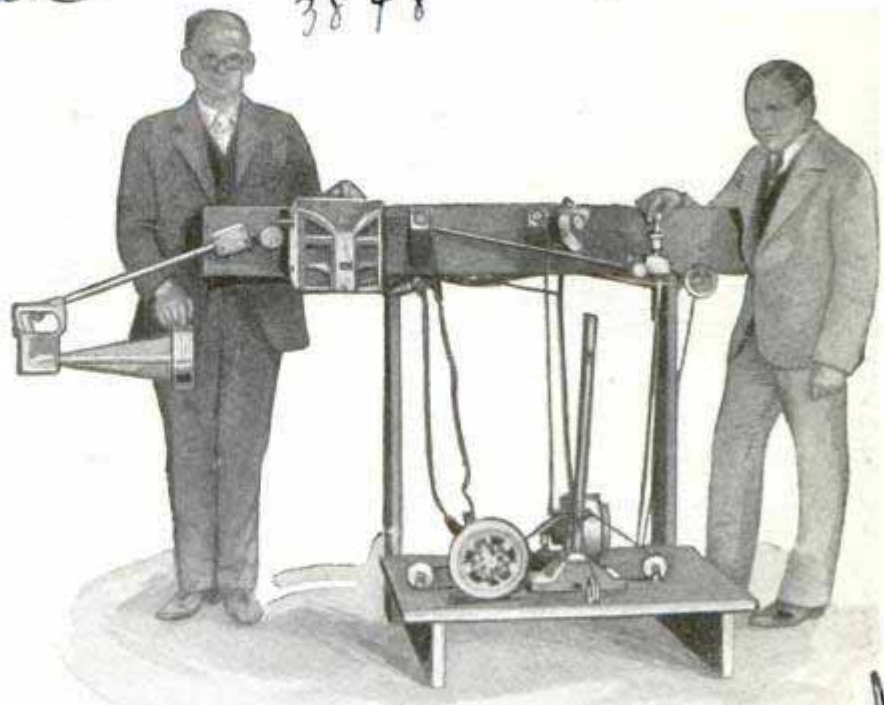

GLOBE OF RUBBER IS INFLATED LIKE BALL

Intended for use in the classroom and to allow children to absorb useful facts while playing, a rubber globe of the world that may be inflated like a basketball now is available. The globe inflates to twelve inches, is equipped with a folding stand, and may be obtained with colored maps on its surface, with the outlines of the maps for crayon coloring by children, or with a plain surface. The bladder inside the globe can be replaced at small cost.

Automatic Plane Stabilizer, Embodying the Principles of the Vane and Pendulum, to Keep the Ship in Level Flight Constantly.

March 1926
365

AUTOMATIC PLANE STABILIZER LIKE VANE AND PENDULUM

Combining the principles of the vane and pendulum, an Ohio inventor has made an instrument for automatically stabilizing an airplane in flight. The control reacts to any disturbance of the plane laterally or fore and aft, thus keeping it in level flight without the aid of the pilot. It maintains balance more evenly and acts more quickly than any human agency and is expected to be particularly valuable in night trips, bad-weather flights and emergency landings. It is also believed that it will greatly reduce the effect of "bumpy" air, and so prove helpful in passenger transports.

3875

12-in. \$3.75



Rubber Globe of the World Mounted on Folding Stand; the Globe is Inflated like a Football

FAN BLOWS POISON IN ANTHILL

Blowing poison into anthills with an outboard motor is one way of killing the ants. A resident of South America, unable to rid his premises of the pest by any other method, rigged up an exterminator consisting of a blower fan run by an ordinary outboard motor. With this equipment he was able to blow poison into the hills and kill the occupants instantly.

3917

Sea water contains 1,500 tons of solid matter per cubic mile.

Sarrigue Sloke Corp
49 W. 3rd

Johnson Motor Co,
Waukegan, Ill

3905
Capt. Walter E. Burton, 1922
Alameda Ave. Kenimore
Station, Akron, Ohio

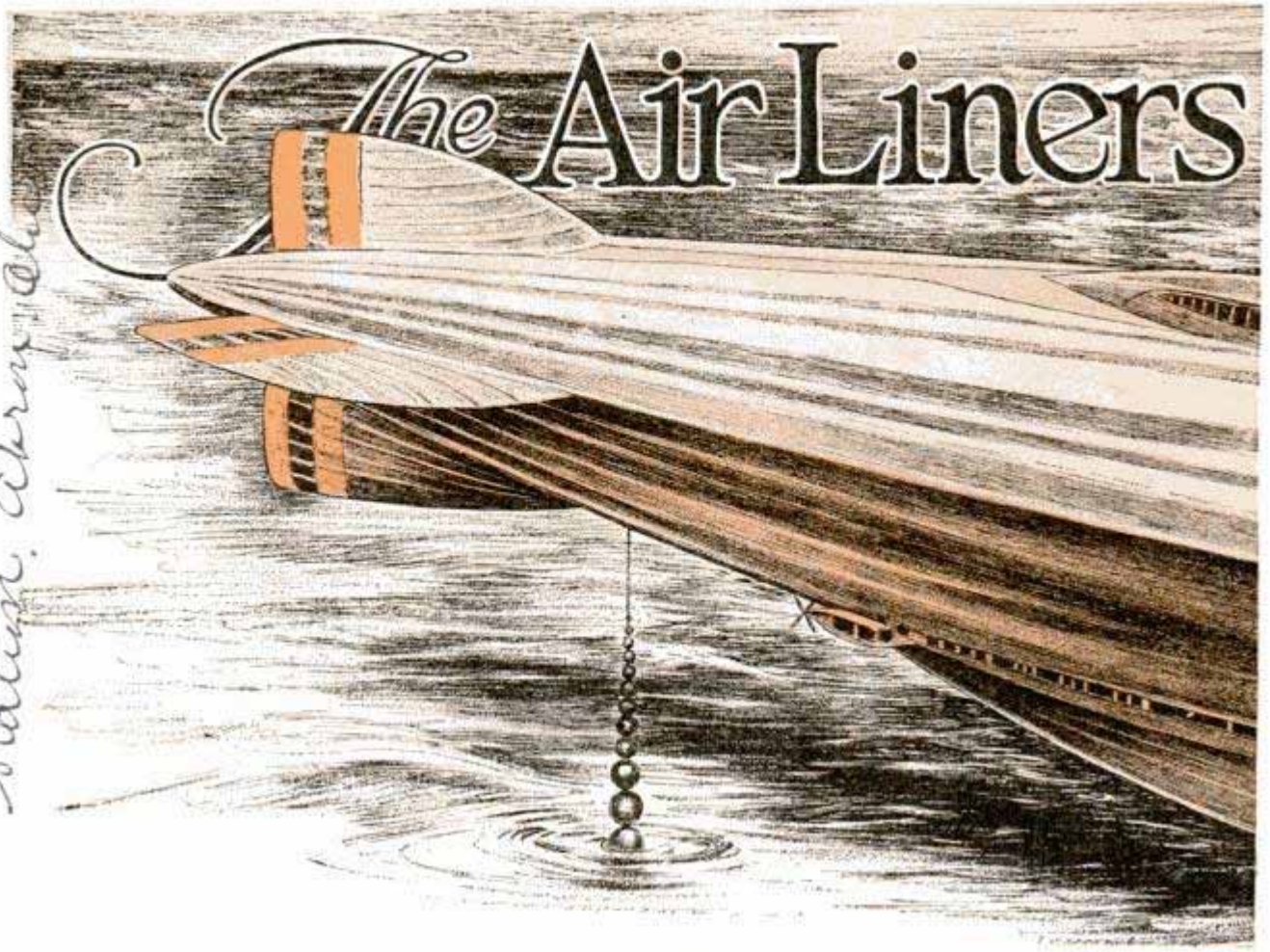

Artist's Conception of How Air Liner of the Future Might Be Anchored off Shore on a Special Landing Buoy in Regions Where Construction of Hangars Is Impractical

By JOHN DRAPER

THE DREAM of inventors who pictured the day when huge air liners that would bring Podunk within a few hours of Paris, seems about to be realized. Count Ferdinand von Zeppelin flew his first successful rigid airship in July, 1900, over Lake Constance on the German-Swiss border. Since then, there has been rapid development of this mode of travel. The World War helped tremendously, but it is only within the past year or two that the Zeppelin has become a transportation factor. The "Graf's" world trip was a realization of Count Zeppelin's dream wherein he saw all countries of the earth linked by huge swift-flying air liners. The voyages of the "Graf" demonstrated many things about airship navigation over long distances. That there is need for better methods of obtaining reliable weather reports is one of the most outstanding. Throughout the twenty-one-day world journey, Dr. Hugo Eckener had to rely largely on his own experience

and perception of conditions to determine the best courses. He received weather reports over Europe, America and the oceans, but this information was almost entirely lacking over Asia and left much to be desired at other points. Undoubtedly, when airship travel becomes an everyday matter, there will be a well-organized network of weather stations, radio transmitters, and like equipment, covering the earth. Then the condition of the weather will have only a limited effect on airship-line operation. Builders of the "Graf Zeppelin" had to make it to fit the only large hangar available in Germany. Therefore the ship is not of ideal proportions. Its steering mechanism is not entirely satisfactory, and its speed is too low. Doctor Eckener, following the world trip, declared that future long-distance airships ought to be fatter—have a lower ratio between length and diameter—than the "Graf." They also must be more powerful if they are to

of the Future

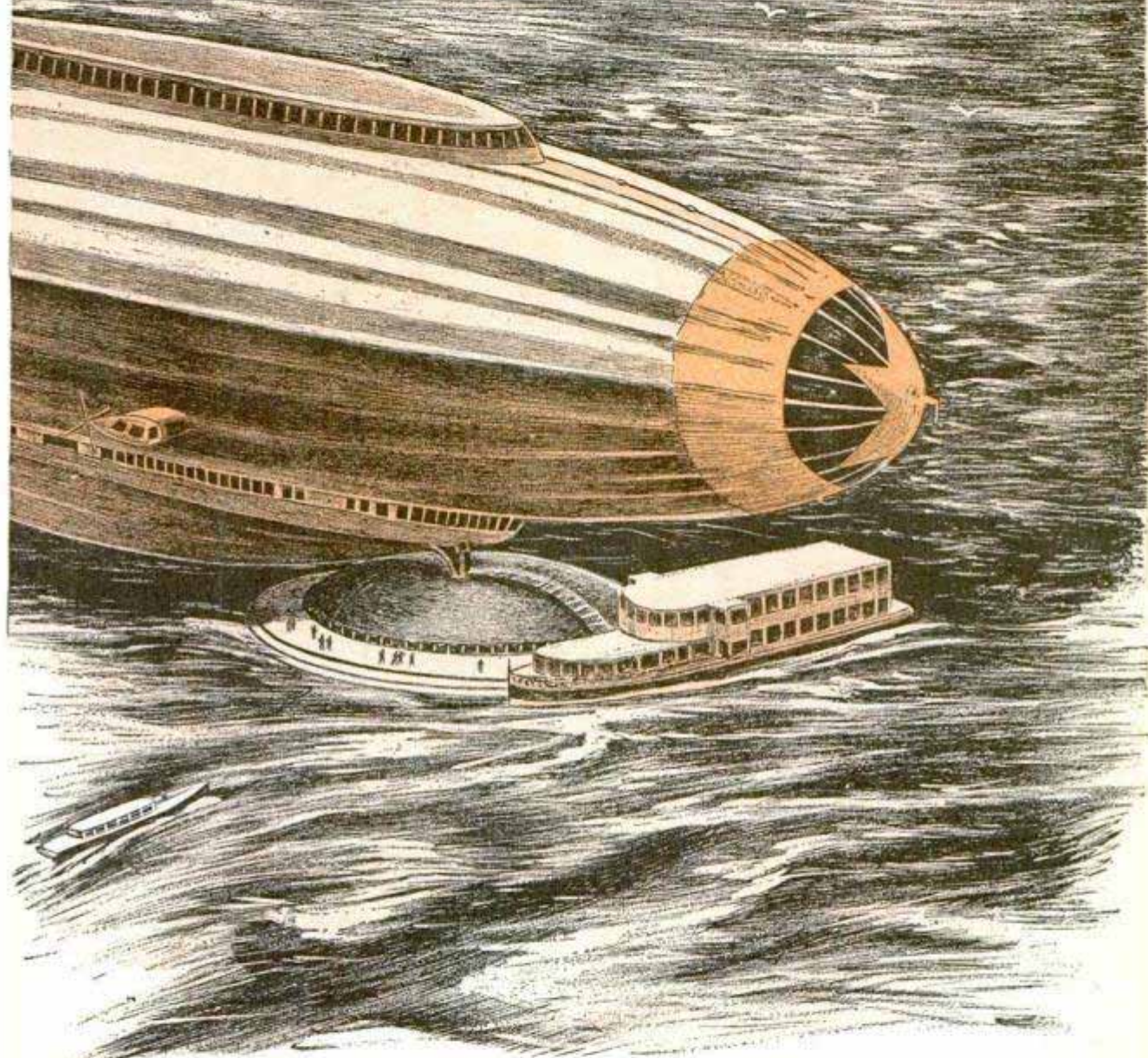

The "Landing Foot" of the Craft Slips into Slot of Buoy While Globelike Buckets That Fill with Water Are Lowered from the Rear to Serve as Anchors

maintain reliable schedules regardless of weather. The "Graf" also suffered from a kind of skin affliction. That is, its fabric covering became loosened in several places during a long flight. This was remedied by installing light reefing frames. In future ships, adjustable bars will be provided so that the fabric can be loosened or tightened as desired.

Many improvements which the "Graf" lacked are being embodied in the new German dirigible now under construction

at Friedrichshafen, the two British ships "R-100" and "R-101," and the United States navy airships "ZRS-4" and "ZRS-5," now being built at Akron, Ohio, by the Goodyear-Zeppelin corporation. The new German dirigible is thirty per cent larger than the "Graf"; has eight motors instead of five, and retains the outside motor gondolas because inflammable hydrogen gas will be used for lift. It will be completed in the spring of 1931. The "R-101," recently flown, is shorter than

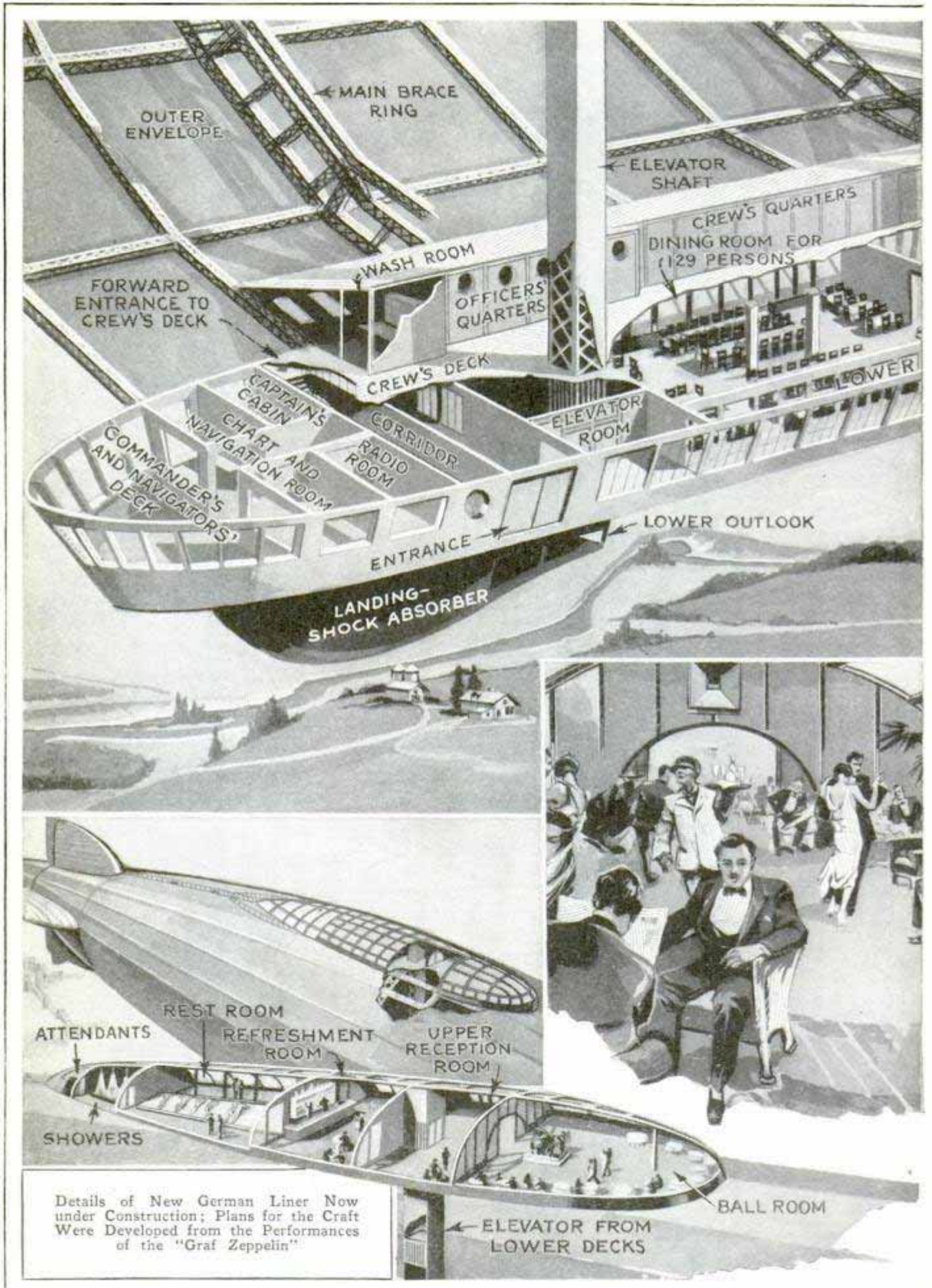

Details of New German Liner Now under Construction; Plans for the Craft Were Developed from the Performances of the "Graf Zeppelin"

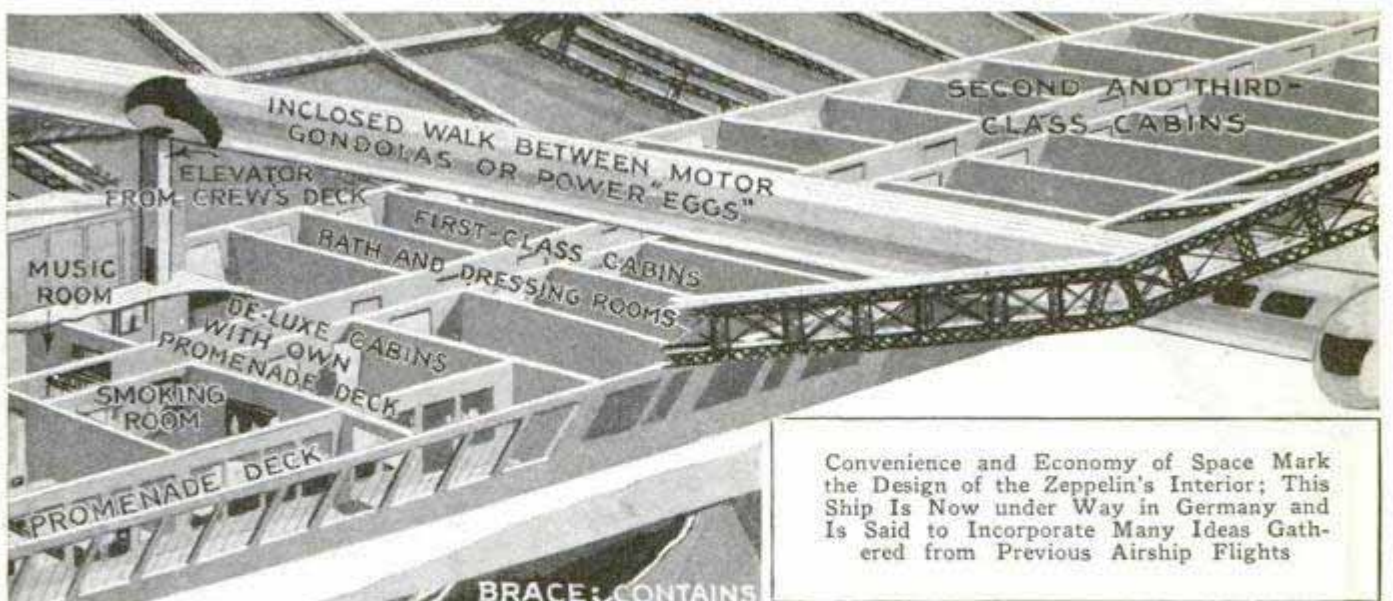

Convenience and Economy of Space Mark the Design of the Zeppelin's Interior; This Ship Is Now under Way in Germany and Is Said to Incorporate Many Ideas Gathered from Previous Airship Flights



Sketch of Motor Arrangement and Method of Attaching the "Egg" to the Body of the Ship; All Exterior Portions Are Streamlined



INTERIOR OF NEW TWIN-MOTOR POWER "EGG"

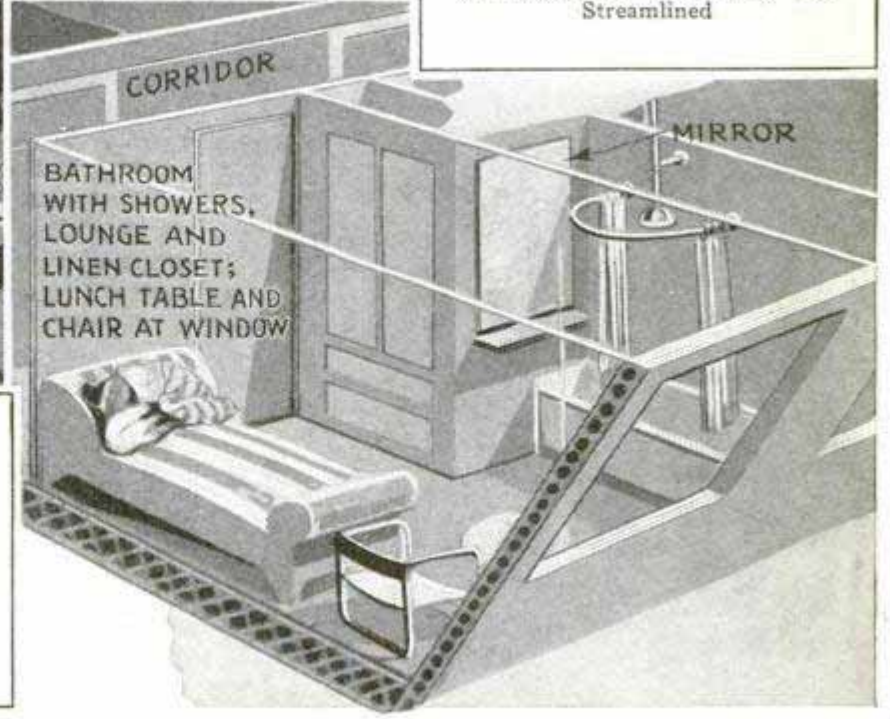

Luxuries like Those on Ocean Liners Will Be Common to the Big Craft of the Skies if Dirigible Traffic Fulfills the Hopes of Its Backers; a Brilliant Dining Room and Well-Appointed Bath Are Featured in These Sketches, Which Show Details of Craft Germans Are Building; the Race for Supremacy in Commerce Is Being Carried to the Skies

3705

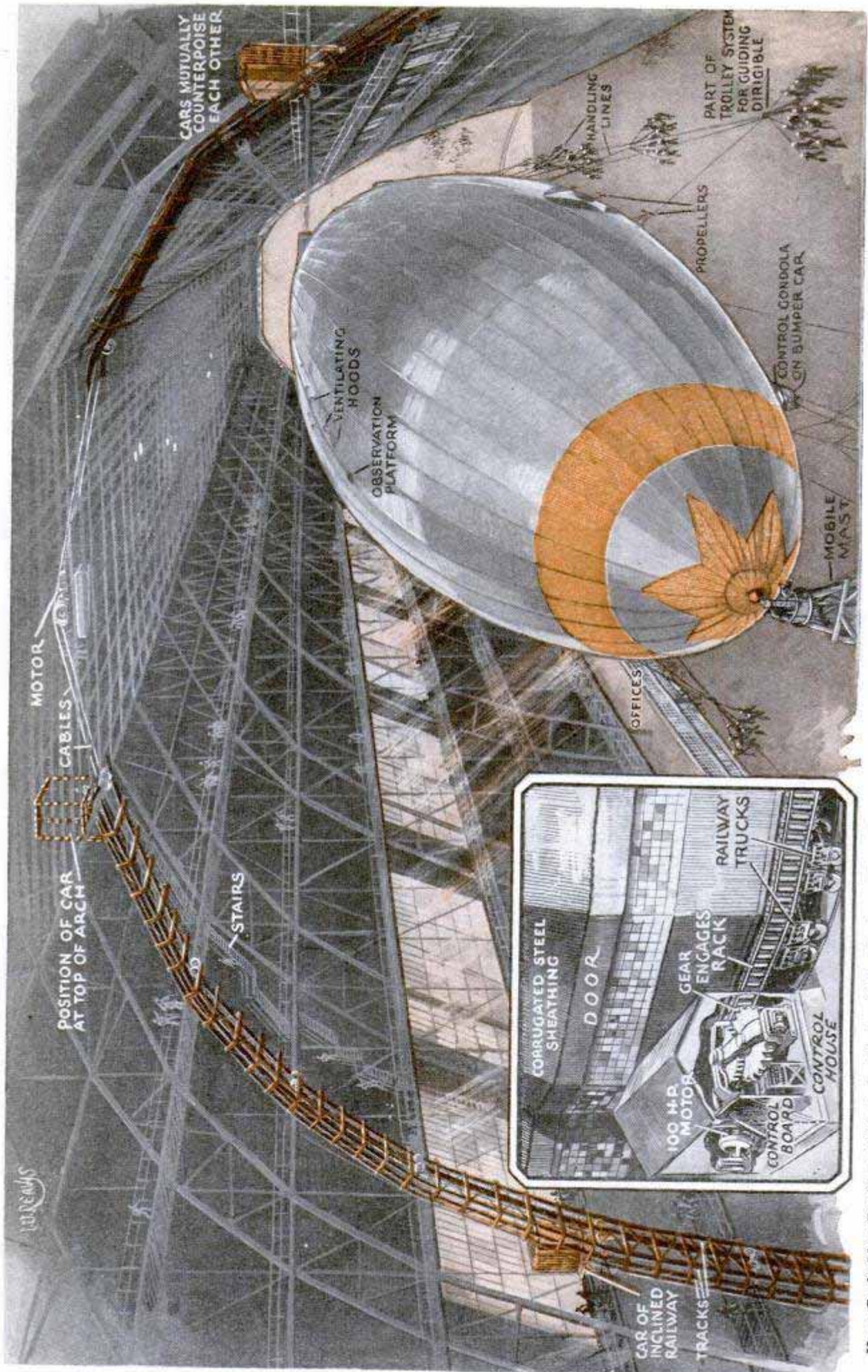

How Craft May Be Brought into the Dock of the Goodyear-Zeppelin Corporation at Akron, Ohio, and a Close View of the Operating Mechanism of the "Orange Peel" Doors; the First of Two Dirigibles for the Navy Is Now under Construction in This Huge Dock Which Was Completed Recently



the "Graf" but is fatter and therefore has a greater useful load. It departs from previous practice by using stainless-steel girders. Both the British and German ships hold approximately 5,000,000 cubic feet of hydrogen. The two new American ships are larger, being of 6,500,000-cubic-foot capacity, but the lift produced by the helium they will use will be about equal to that of a 5,000,000-cubic-foot hydrogen ship. Because helium will not burn, these ships will represent many innovations in design. Almost everything will be inside the hull, where wind resistance is nil. The propellers and their outriggers, control surfaces and control room will be practically the only protruding parts. Motor rooms, being inside the framework, can be larger and of stronger construction. Passenger and crew quarters will be more extensive than in any previous airship. Each ship will have three triangular keels. Corridors, staterooms and other compartments will be located inside these keels.

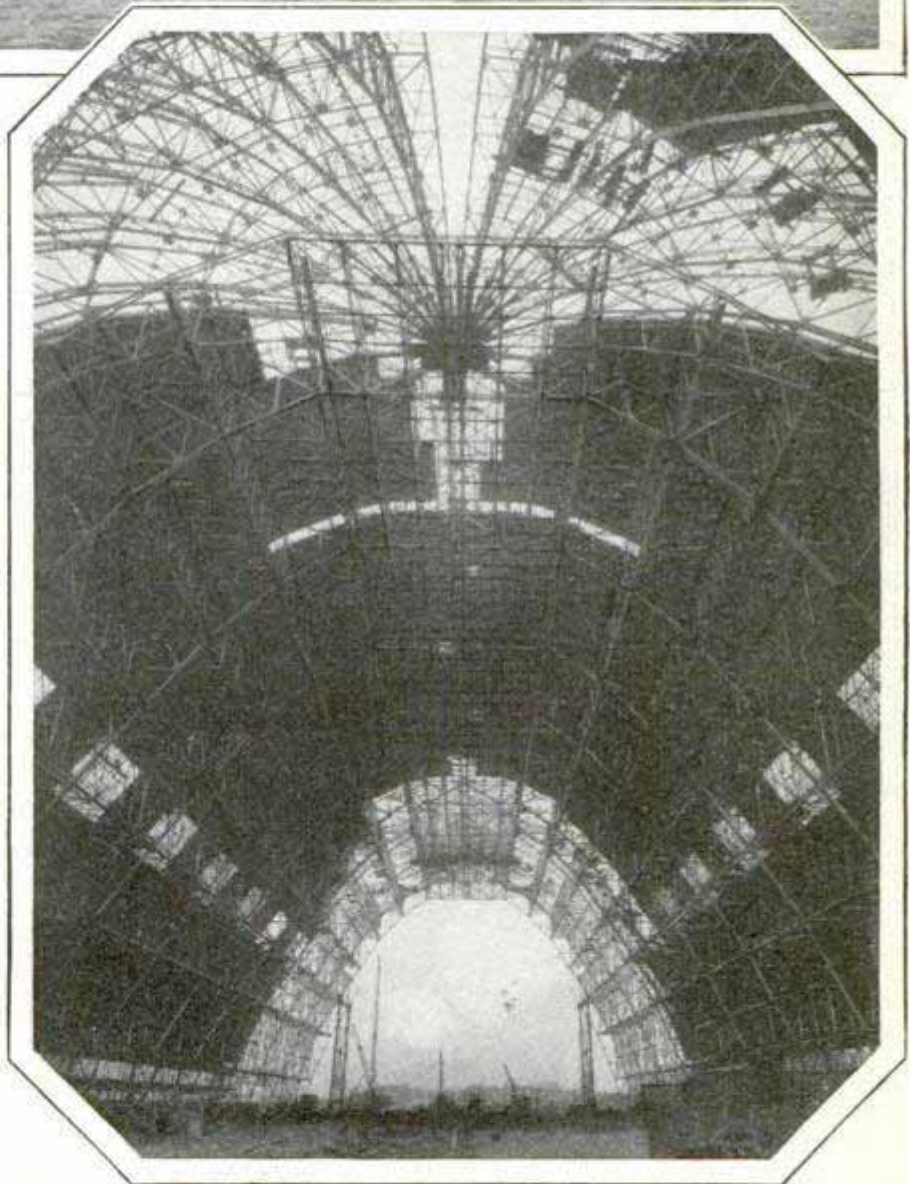

Composite Photo-Diagram to Show Size of the Dirigible Dock, and View of Interior When Structure Was about Three-Fourths Finished

Perhaps the most spectacular phase of the airship's growth is its recently acquired ability to carry airplanes. The new British ships, it is reported, are designed primarily as motherships for air-

planes, and are equipped so that the planes can be used as auxiliary power plants. The American Zeppelins will have compartments within the hull that will hold five to seven planes, depending on size.

It has been said that, whenever anything is built on a gigantic scale, something bigger must be made to house it. Before building the American airships, the Goodyear-Zeppelin corporation had to erect a factory and dock at Akron which is the world's largest building without interior supports. Ten football games could be played in this dock at one time, and there would be room for thousands of spectators. The Woolworth building and Washington monument could be laid down side by side, and there would be space to spare for a few dozen ten-room houses.

The dock is of steel and concrete construction. First, 1,300 concrete piles, averaging twenty-five feet long, were driven for the foundation. Then thirteen huge steel arches, each the shape of a

parabola, were erected. Only the center three arches are firmly attached to their foundations. The others are arranged so that they can move as the building expands and contracts. The building will change its length about five inches between extremes of temperature.

Doors that close the ends are the most interesting part of the dock. They are of the "orange-peel" type. That is, each section is the shape of the peel you would obtain by quartering one-half of an orange. Each door section weighs 600 tons.

When wind is blowing against one side of the building, a vacuum is created on the opposite side, often causing a pressure against the inside of the covering greater than that from the wind on the outside. Along each side, about a third of the distance from the top, are four dormerlike projections, with colored-glass windows. These are automatic louvers that open when pressure inside is ten pounds greater than that outside, preventing the steel plates from ripping off.

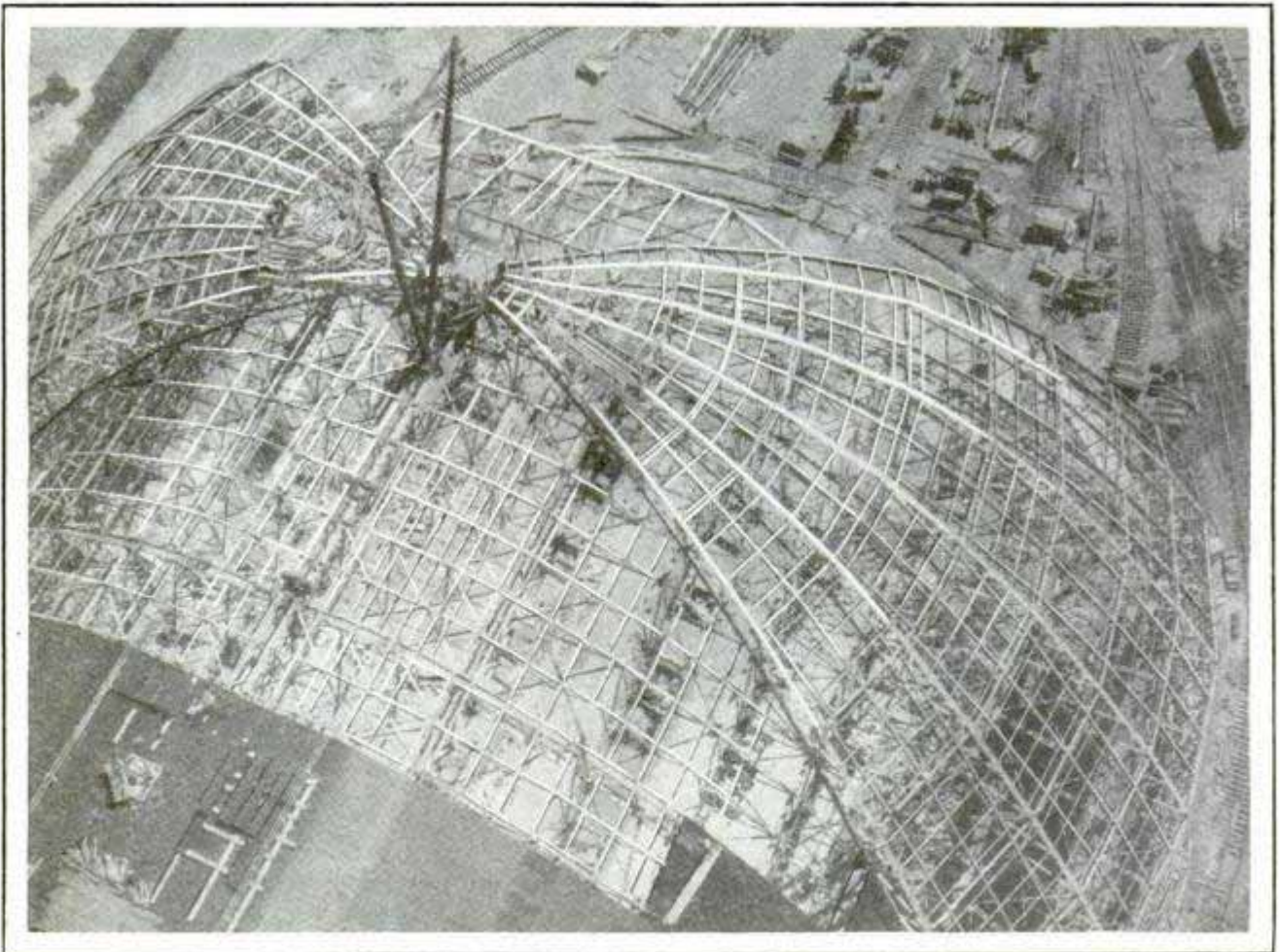

Looking Down on Southern End of the Dock from a Dirigible: There Are Several Men in This Photograph —but Try to Find Them

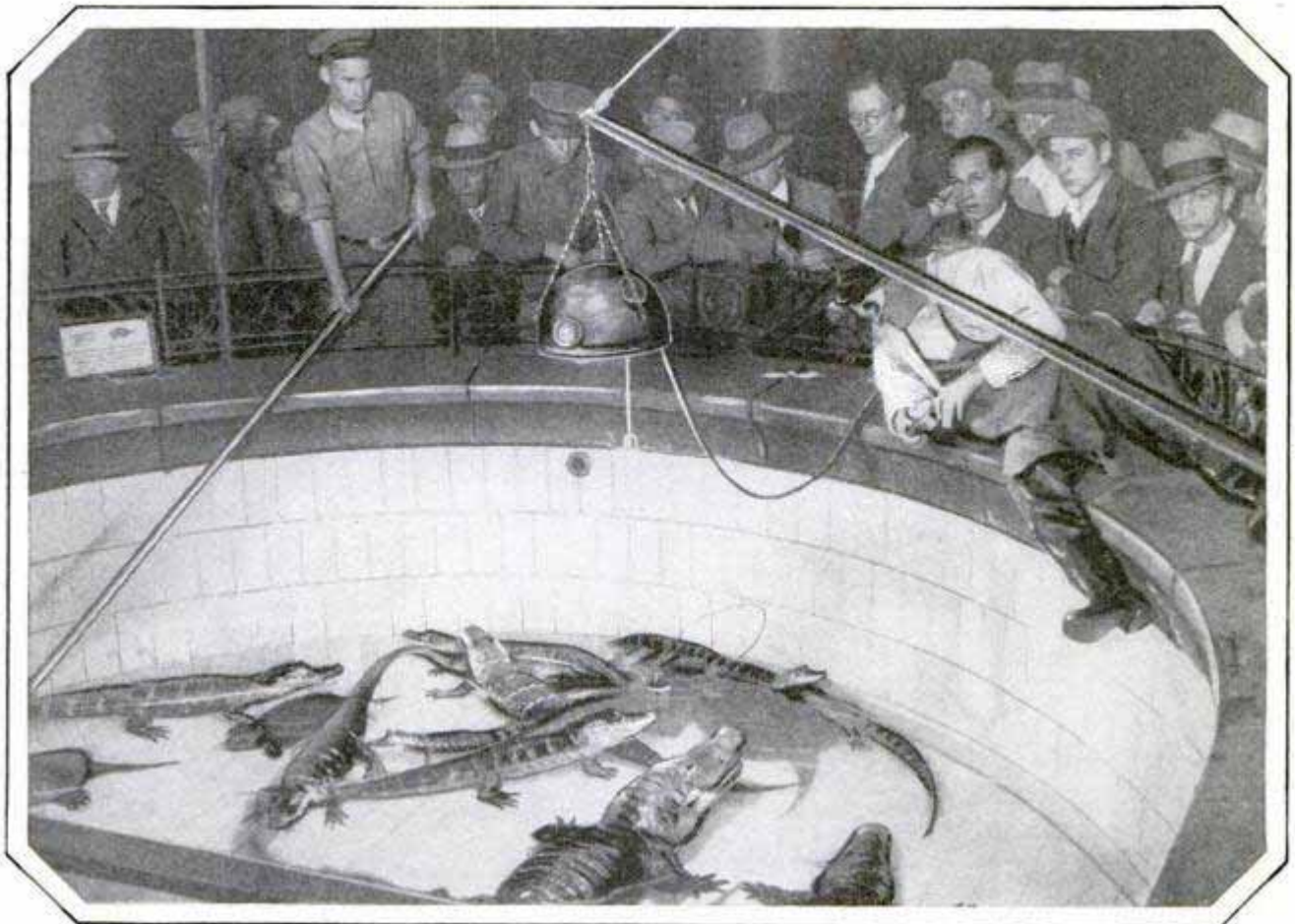

Artificial Tropic Sunlight Keeping Zoo Specimens in Good Health; Crocodiles, Alligators and Other Reptiles as Well as Animals, Used to Much Sun, Are Said to Be Benefited by the Lights

LIGHT RAYS FOR ZOO REPTILES PROLONG THEIR LIVES

Ultraviolet-ray treatments for turtles, crocodiles and other specimens have proved beneficial in preventing sickness among the zoo and aquarium families. Glass that permits the passage of the sun's helpful rays has been used to good advantage over the cages of monkeys and other tropical animals, and where it is not practical to employ such glass, special lamps are being sought for the artificial sunlight they produce.

LARGER, LIGHTER GOLF BALL TO IMPROVE GAME

Great interest is being shown among golf players in the proposed new ball, which is to be slightly lighter and larger than the old one. Some experts believe that it will be easier to hit, easier to stop on a green and more easily controlled on chip shots. On the other hand, it will roll less when it comes down. will not go so far and will not speed against the wind so well as the

present ball. While present plans are that the new ball is to be compulsory only during tournaments, it is believed that its use will become almost universal. One reason for the change is said to be that expert players of today are able to hit the ordinary ball so far that courses, once considered difficult, have become comparatively simple ones.

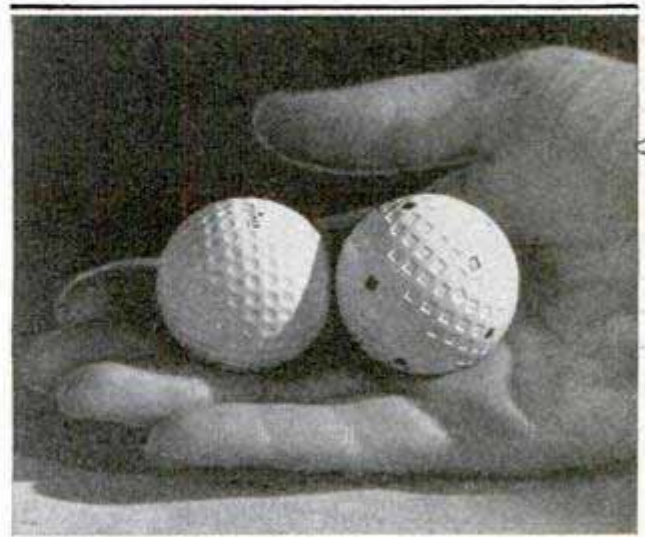

Slightly Larger Golf Ball on the Right as Compared with Old One; the New One Is Also Lighter

*Curt. R. Es Thackwell
Islen Eden Hotel, Chicago*

*newford
105
U.S. Spalding & Bros
masson*

3729

What Your Tires

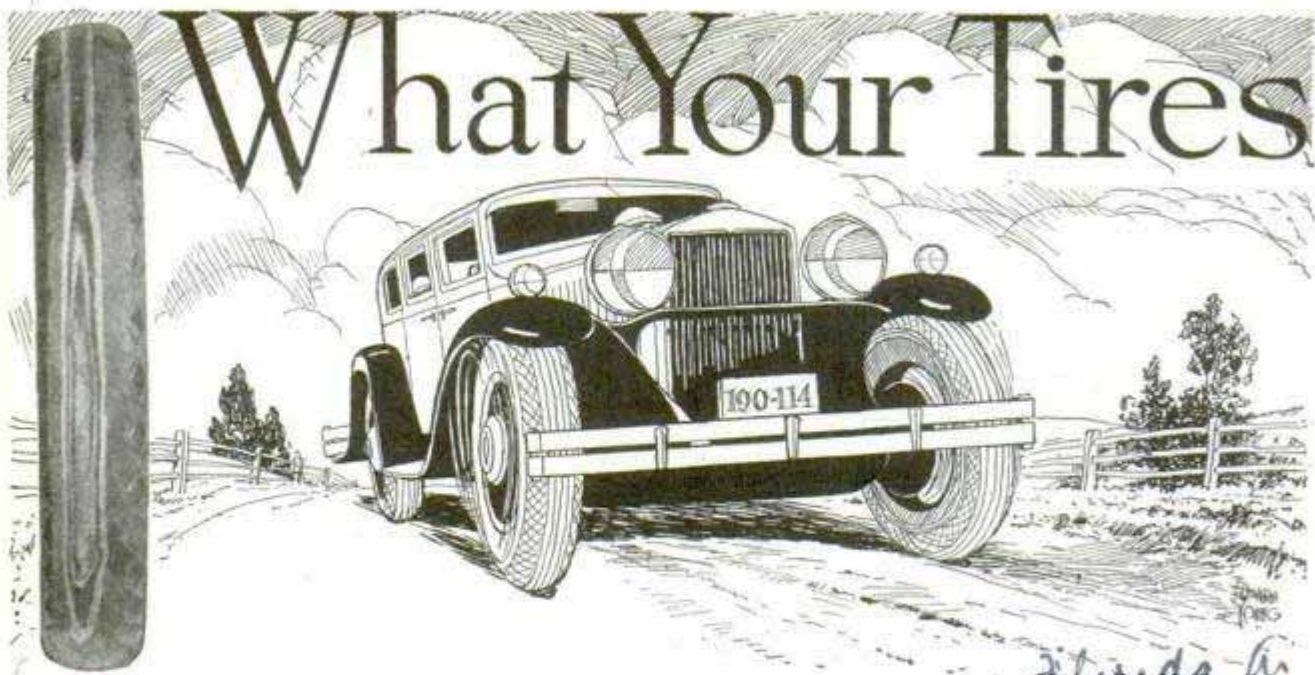

By WALTER E. BURTON

1922 Florida
Abramellis

AUTOMOBILE tires are much like criminals. If they are misbehaving, they frequently can be caught through a study of their fingerprints. There is the difference, however, that the real criminal frequently is not the tire, but the driver of the car on which it is used.

A tire's fingerprint is its track in the snow, mud or other surface over which it rolls. Because of the large size of tread details, it usually is easier to study the tire surface itself rather than the track. There are a number of human fingerprint classifications, each including one or more definite types of persons. With tires, the thing of greatest interest is tread wear; and there are several definite types of wear, each with its telltale fingerprint.

Suppose that, in examining the front tires of your car, you find the tread to be worn sideways across the surface of the casing. Closer examination reveals that one edge of the tread projections is worn round, while the opposite edge is feathered—has a little fringe of rubber all

around. This condition is produced by sliding of the tire sideways, and the sliding is a result of wheel misalignment.

Front wheels of most automobiles are toed in, the amount depending on the type of wheels, axle, and the like. That is, the measured distance between the two front-wheel tires is less in front of the axle than back of it. The difference generally is from nothing to one-eighth inch. The purpose of the toe-in is to bring the tires parallel when the car is in motion. They

normally have a tendency to move outward. If the toe-in is too little or too great, one or both of the tires will be subjected to a dragging or sliding action which rapidly wears away the tread. You can detect this condition by examining the tire surface closely. If the toe-in is too great, tread projections will be worn so that the outer edges are rounded, while the inner edges will be feathered—have little pieces of rubber projecting out like a fringe. If the toe-in is not sufficient or is negative, the wear is opposite, with rounded edges on the inner side.



Uneven Wear on Front Tire Due to Insufficient Camber of Wheel

Tell You

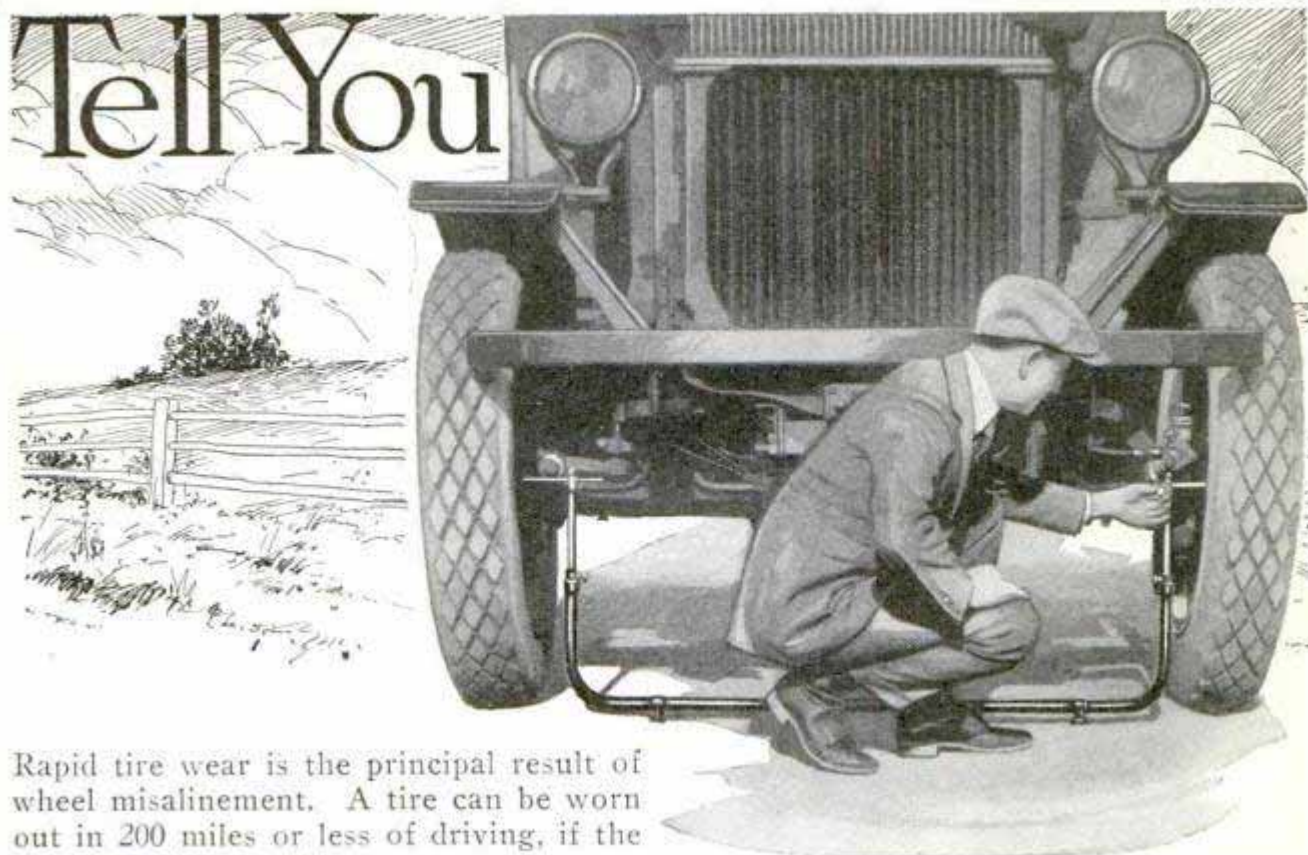

Rapid tire wear is the principal result of wheel misalignment. A tire can be worn out in 200 miles or less of driving, if the alignment is not right.

Now that you have found what tire makers consider one of the greatest criminals in tire wear, you can abolish him by having your wheels realigned. This should be done every three months, with normal driving. Accidents, rough roads, striking of wheels against curbs, and similar incidents will destroy alignment.

But suppose you find that your front-wheel tires are wearing faster on one side of the tread than the other, and that the wear is uneven. This indicates that the camber—the angle at which the wheels are tilted—is faulty. Normally, the tilt is such that the kingpin points approximately to the center of the tire when the latter is inflated to the correct pressure, although the tendency among manufacturers recently is to use less camber. If you think that the wear is too rapid, have your camber checked. But if the wear is moderate, do not worry much about it, because it probably is normal. By reversing your tires every few thousand miles, you can offset the effects of cam-

ber wear, and obtain maximum service from them.

If you suspect that some mechanical irregularity is causing rapid wear of your tires, it is a good plan first to consult your tire dealer and get his advice. Then take your machine to a garage which is equipped to remedy the trouble.

Your automobile is a four-fingered animal, and so there are four fingerprints to inspect. If, on comparing all four prints, you find that one tire is rapidly los-

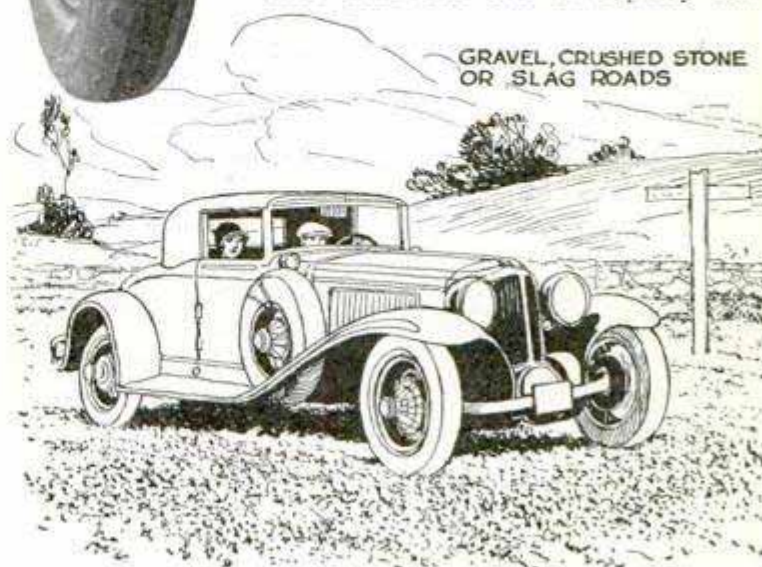

3429/228

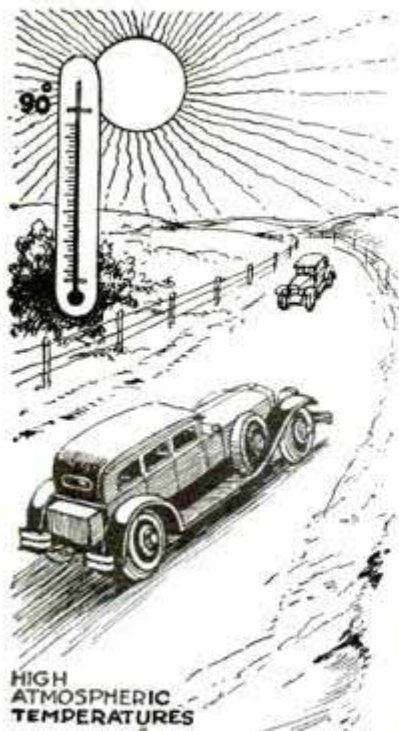

ing its ability to make tracks —is wearing rapidly, in other words— investigate your brakes. One of them probably is tighter than the others, causing the tire on that wheel to wear

stretches; and that you stop at the last possible moment. All of these things cause tires to wear quickly, but there are several more equally bad. They include high temperatures, driving on gravel, crushed stone, slag, broken hard-surface roads, or hilly and stony dirt roads. Of course, some of this wear is to be expected, but much of it can be avoided by exercise of a little care.

If your car tires exhibit uneven or cupping wear, indicated by spots along the tread area, your steering mechanism probably needs attention. The wheels

too fast. It is not necessary for a tire to slide to wear. When the brake is applied even moderately, the wheel is slowed down and a resistance is set up between the tire surface and the road. This causes little pieces of rubber to be torn from the tread. On cars having four-wheel brakes, wear caused by brake drag usually is even around the circumference of the tire. Sometimes, however, the driver finds that one of his tires is wearing in one or two spots, and that the wear is rapid. This indicates an egg-shaped brake drum, or one that has a high spot in it. Truing the drum in a lathe is the recommended remedy.

Perhaps an examination of your tires reveals that they all are wearing out more rapidly that you have reason to expect. The criminal in this case is yourself, or whoever else drives the car. If you analyze your driving, you will discover, more than likely, that you are the first to get under way when the traffic light flashes green, that you take turns at a fast clip, and "step on it" along the straight



EXCESSIVE TOE IN vs. HIGH CAMBRE

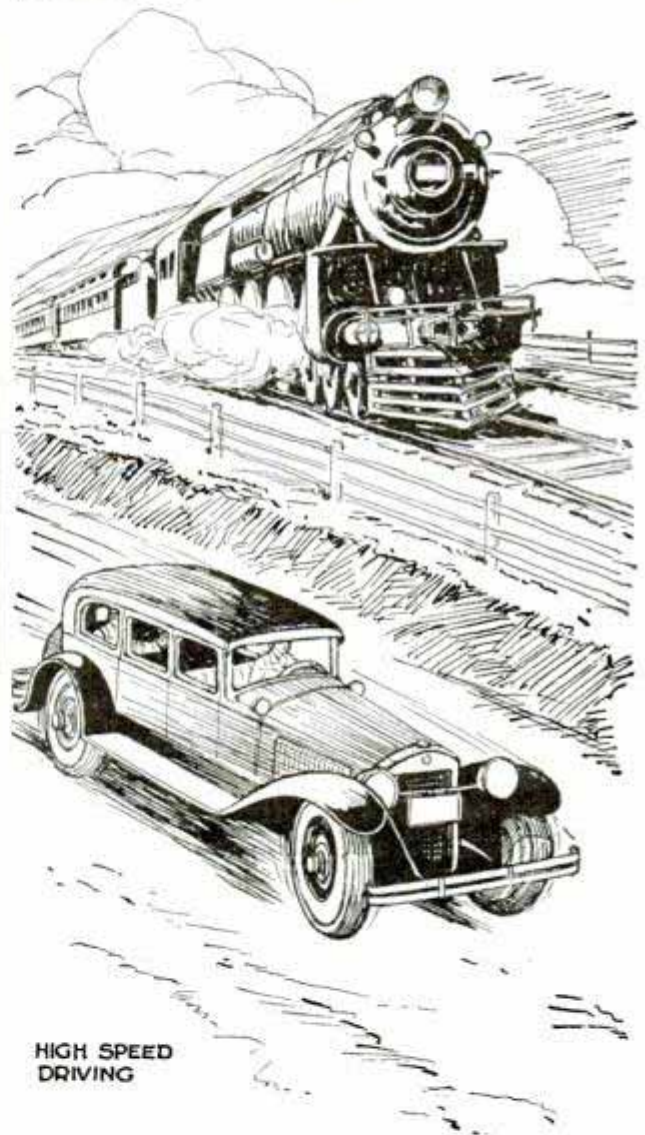

may be wobbly, and there is undoubtedly considerable play in the steering-assembly bearings and bushings. A complete overhaul will save you money.

If your tires wear evenly along both tread edges, but the centers stand up distinctly, you have found the fingerprints of one of the greatest tire enemies—un-

derinflation. Balloon tires are particularly sensitive about their air pressures. That is why car and tire manufacturers go out of their way to inform you of the correct number of pounds required. Use a reliable gauge to test your tires, and inflate them at least every week. Oftener will not hurt.

When a tube has less than the recommended poundage of air, the casing is bent excessively. This causes the edges of the tread to undergo a wiping action over the road surface, wearing away rubber. But inside the tire, where you cannot see it, is still other wear. The cotton cords that make up much of the carcass are chafed back and forth over each other, with the rubber between them acting as a lubricant, much like oil between the leaves of a spring. If this chafing is excessive, due to low air pressure, injury to the tire will result. Underinflation further renders your tires susceptible to injury if the wheel strikes the edge of a hole, a curbstone, brick or other projection. Frequently the cords are broken, or the inner tube ruptured.

Overinflation is almost as great an evil as its twin brother, but it is perhaps not so frequently encountered. Its fingerprints show even wear in the center of the tread, but comparatively little at the edges. The effect

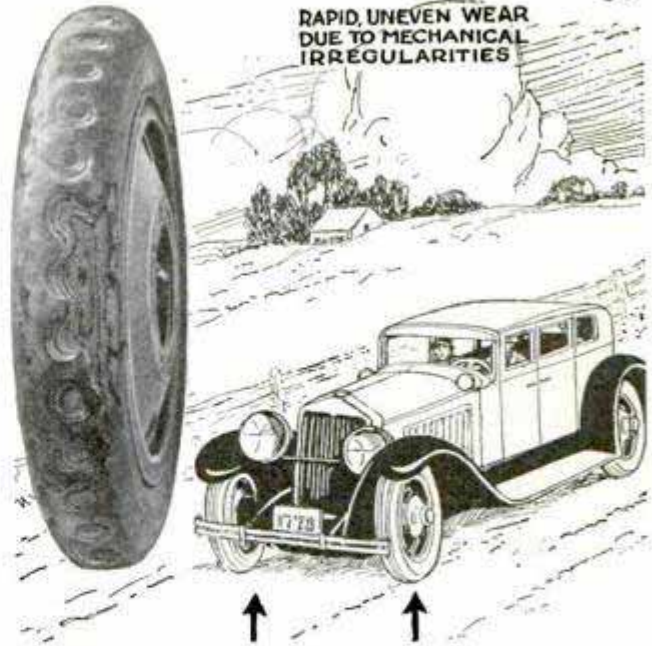

RAPID, UNEVEN WEAR DUE TO MECHANICAL IRREGULARITIES

of too much pressure is twofold. First, the center wears excessively. Second, the rear tires have a tendency to bounce and spin on rough roads, sometimes causing the car to hop to one side. If you don't hop into a ditch, you are fortunate, but your tires still are wearing far too rapidly, and your rear-axle assembly is not being benefited.

The principal classes of tire fingerprints mentioned are supplemented by a host of subdivisions. But only the most common need worry you. If you find a type of tread wear that proves puzzling, the best thing is to seek a reliable tire-service station at once.

In arriving at a conclusion

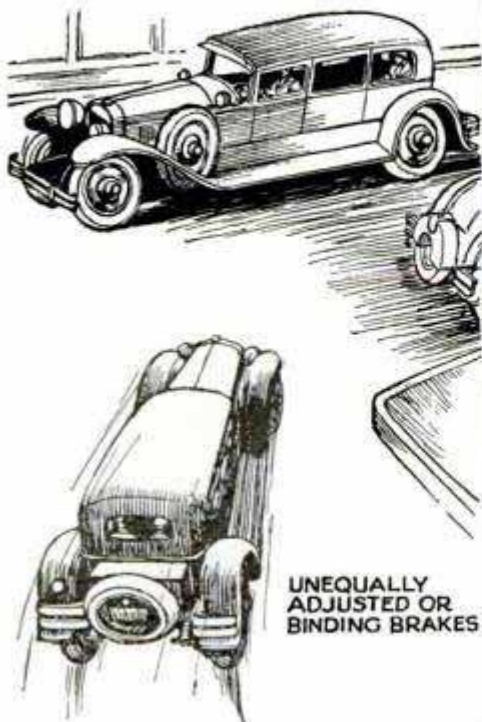

UNEQUALLY ADJUSTED OR BINDING BRAKES

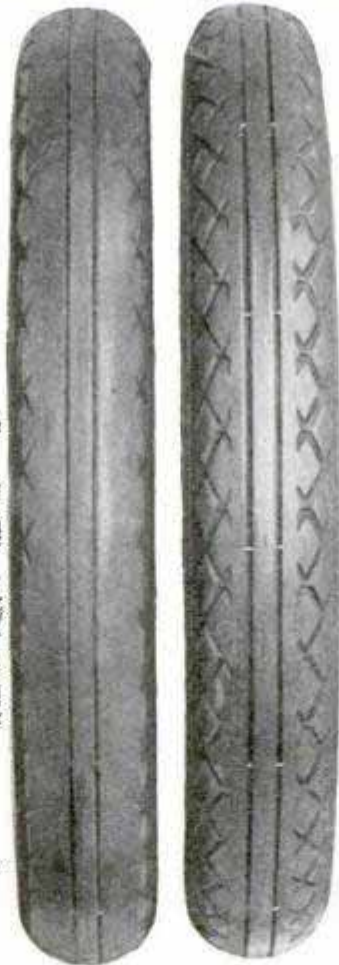

UNDER INFLATION VS. NORMAL CAMBRE

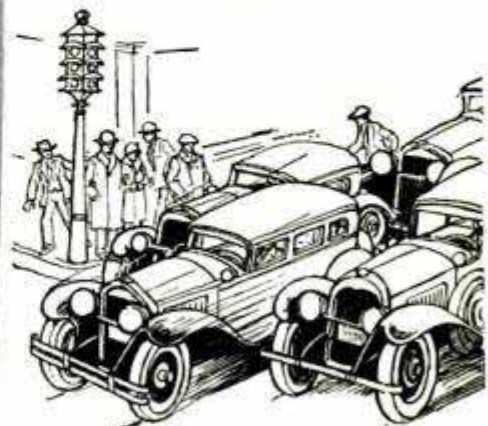

QUICK STARTING

about tire wear, take into account the conditions under which you drive. High speed, frequent use of brakes, rough, hilly country, traffic lights, stop streets, high tem-



BROKEN, HARD SURFACE ROADS



FAST DRIVING ON TURNS

chains do not bind and cut your tires, and to maintain proper air pressure.

Spotty or "scalloped" tread wear, indicated by a series of worn spots about the circumference of a tire, is usually

perature—all of these strive to bring your tires to an early grave, but it is to the credit of tire makers that tires today have much longer lives than those of yesterday.

Perhaps you have noticed that your tires wear very little in winter. Manufacturers have found that the rate of wear in summer is twice as great as in the winter. In fact, they consider it useless to operate test cars in winter in the north, because the wear on icy and snow-covered roads is not rapid enough. Wet pavements, too, do not wear tires rapidly because the water acts as a lubricant. About the only precautions to take in winter driving are to see that the



EXCESSIVE CAMBRE VS. NORMAL HIGH TOE IN

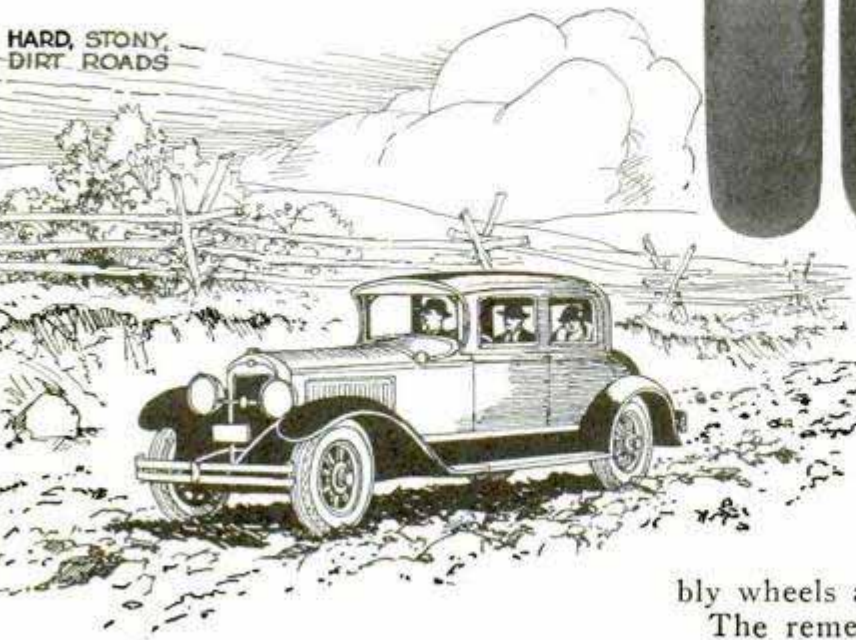

HARD, STONY, DIRT ROADS

caused by a number of factors working together. Underinflation usually starts it, and the trouble is aggravated by looseness in wheel bearings and steering mechanism. Wob-

bly wheels are sometimes the cause.

The remedy is threefold. First, check

*Agent of ...
N. H. Beck, in charge
of investigations in seismology*

your inflation when you notice this type of wear. Second, tighten wheel bearings, and bearings and joints in the steering equipment so that all play is removed. Third, switch the affected tires about so that they rotate in the opposite direction.

Spotty wear is a disease common to front wheels only, and the switching of front and rear tires sometimes is advisable, after the causes of the trouble have been removed.

3873

EARTHQUAKE BREAKS CABLES ON BOTTOM OF ATLANTIC

Undersea landslides, set in motion by the earthquake off the Atlantic coast on November 18, were blamed for breaks in the transatlantic cables by officials of the U. S. coast and geodetic survey. The quake is believed to have occurred deep under the ocean bed and to have spread over a large area. The ocean bottom where the tremors centered has a steep slope, and landslides down these submarine slopes snapped the cables, officials believe. The earth quivered sufficiently, it was estimated, to cause a perceptible shaking over 1,500,000 square miles of land and 200,000 square miles of sea.

FORCED-DRAFT WATER HEATER FOR REAR OF CAR *3781*

Providing clean, odorless heat circulated through the car by motor and blower, a forced-draft hot-water heater for the automobile now is on the market. Instead of bringing cold air from outside the car, the heater uses preheated air from inside the car, insuring quicker action and greater heat. It is designed for front or rear-compartment installation

\$30.00

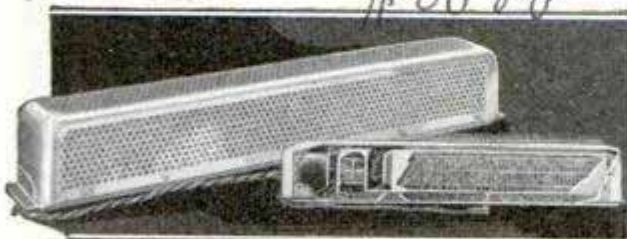

A Forced-Draft Hot-Water Heater for Either Front or Rear Compartment of the Automobile

and is placed on the floorboard so that it directs heat upward or along the floor of the car as desired.

*Chanson Ltd
Illinois Iron & Bolt Co
P.O. Bentonville Ill*

EXERCISER LIKE BIG TRICYCLE GIVES EFFECT OF ROWING

3831

Bellmobile



Exercising Machine, Resembling a Tricycle, Which Gives Effect of Rowing When Propelled

Somewhat resembling a huge tricycle, but giving much of the effect of rowing when in use, an exercising machine which brings all the muscles of the body into play now is on the market. The weight of the body and a slight downward pressure on the pedals keep the exerciser in motion on level ground, and between each up and down dip of the pedals, about seven inches, the machine travels approximately fifteen feet and a speed of twenty miles an hour is possible. The operator takes his position in the saddle, his body somewhat crouched and grips the handlebars, then exerts pressure on the pedals, at the same time raising the body and extending the legs while pulling on the handles. This action sends the vehicle forward, but the crank arrangement under the saddle automatically lowers the body, bringing it into position for the next propulsion. For indoor use, a stand is provided on which the machine rests, and while it is stationary, all the effects of the vehicle in motion are possible. A smaller model is made for children.

231
*Sold at 17th & Mission San Francisco, Calif.
568. 14th St. Oakland Calif.
836 S. Hill St. Los Angeles Calif.*

National Mirror Sign
 232 Co, 4425 N. POPULAR
 Racine Ave. Chicago

3878



Front of Cabinet Showing Effect of Motion, and Lid Raised to Illustrate How Display Is Arranged

FLEXIBLE MIRROR SIGN GIVES LIFE TO WINDOW DISPLAY

Pliers open and close, bottles become tall and then short, dolls dance and other mysterious things happen in an attractive window-display sign now on the market. It consists of a cabinet in which is a flexible metal mirror that bends by the rotation of eccentrics on a shaft driven by a small electric motor. The objects to be displayed are placed on a glass shelf at the top of the cabinet and are reflected by the moving mirror so that they appear to change size and position, although, in reality, they remain fixed. The mechanism, the shelf and the lights that illuminate the interior of the box are all invisible to the spectator, who sees nothing but the oddly moving group of objects or the sign, through the glass panel at the front of the cabinet. The box is suited to the display of a wide variety of articles and of pictures and drawings. To produce unusual backgrounds, colored papers or other materials are laid over the shelf at the top. A special feature of the outfit is that the letters may be made

Assem. by Dr. Edwin M. Cooke, supt. Western State Hospital,
 from interlocking metal stencils of the usual kind. The connections are invisible when the lights are turned on.

Edward Jensen and

ELECTRICITY PRODUCES FEVER TO FIGHT DISEASE

3850

Electricity has been used successfully in inducing an artificial fever in some patients suffering from ills which are combated by fever, notably paresis. The use of fever in treating certain diseases is based on the theory that fever is one of the major defensive measures of the body against invading organisms. Previously malaria had been used to produce fever but recently doctors have raised temperatures by using an electric current from a diathermy machine which was found to give better control of the degree and duration of the fever.

Mr. J. Cash King, Memphis

PHONOGRAPH UNIT FOR RADIO CHANGES OWN RECORDS

3810

Phonograph records are changed automatically and played through the radio loud speaker by an electrically operated unit now on the market. It is also a complete phonograph in itself, having its own power pack and speaker in a cabinet. It has a capacity of fifteen records and keeps playing and changing them without further attention after it is started.

Musichome

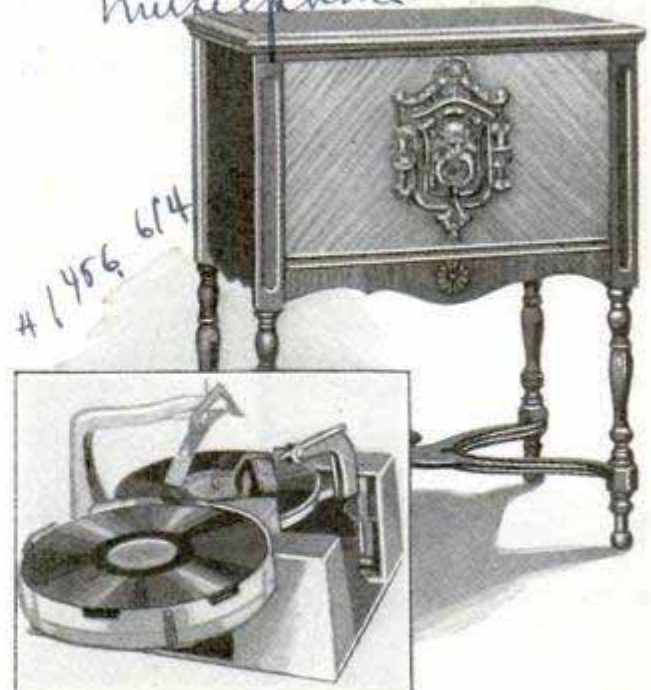

Close View of the Record Player, Which May Be Used with the Radio or as a Separate Instrument

*Krasberg Tools Mfg. Co.
 P.O. 811, 111 W. Jackson*

3804

Milwaukee, Wis

POPULAR MECHANICS
Unclap'd by Jesse Johnson, Detroit 233
Fla

HELICOPTER PLANE PASSES SUCCESSFUL TESTS

Man's dream of an airplane that will rise or descend vertically has expressed itself in many forms and one of the latest is an interesting all-metal plane with two twenty-foot propellers under the wing. They are driven by a 150-horsepower motor in the fuselage and revolve in a direction at right angles to that of

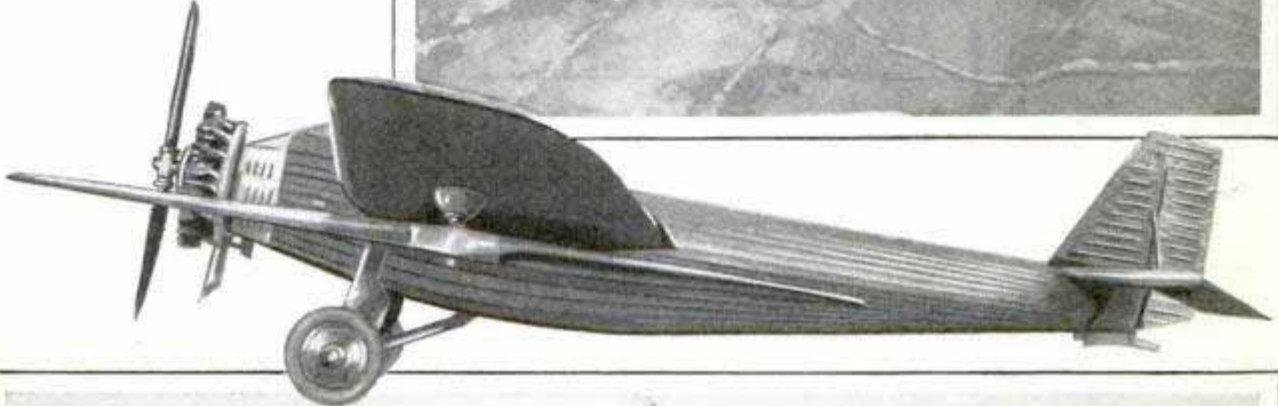

Helicopter Plane in Flight, Showing Position of the Propellers under the Wings, and Closer Views of the Craft; the Lifting Propellers Are Operated by a 150-Horsepower Motor in the Fuselage

the front propeller, which furnishes the forward power for the craft. On a test flight, the pilot was able to take the ship off after a run of but seventy-five feet, an unusual performance for a plane of this size and weight. He then quickly gained an altitude of 600 feet in short, steep climbs. At 6,000 feet, with both the under-wing propellers going at full speed, he found that the plane was under satisfactory control in all positions and under all conditions. The lifting propellers, giving an upward pull, also afforded greater stability, it was reported. The ship represents the results of more

than four years of experimenting and further improvements in it are being made.

CLOCK OPERATED BY SUNSHINE

In the observatory at Sydney, Australia, is a clock that apparently never can register incorrect time as long as the sun is shining on it, for the light from the sun operates it. Sunlight shining through a pinpoint falls on a scale which is geared to hands in such a manner that they register the time on the face of the clock to fractions of a minute. Several years of testing have revealed no inaccuracy.

385
Built by Prof. W. E. Cooke
former astronomer. New

3718

Jumping into

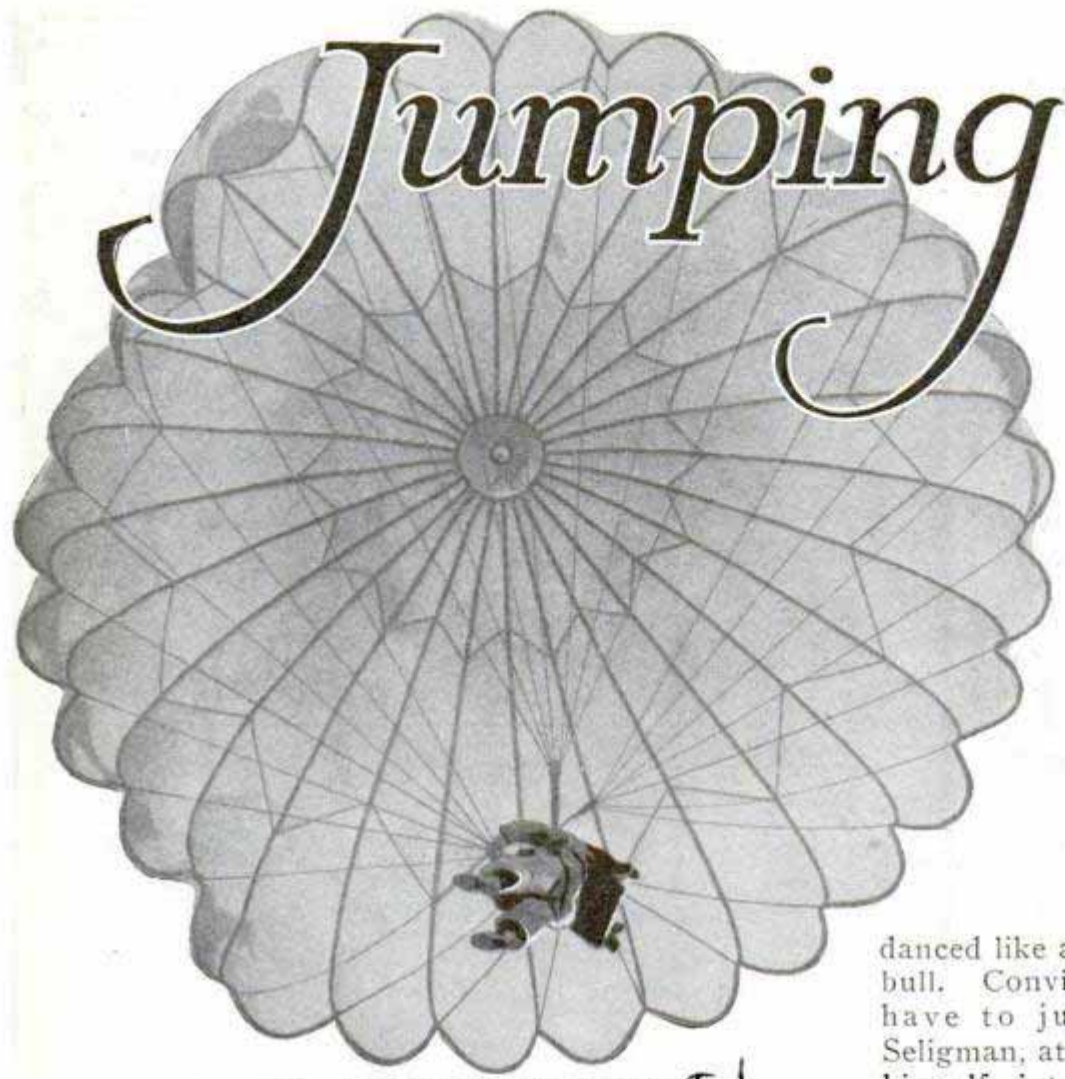

During the same month, Lieut. John Seligman was flying a Vought-Corsair near Freeport, Long Island, when the plane wheeled and started a tail-spin at about 8,000 feet. For 5,000 feet, Lieutenant Seligman fought with the controls, but the ship

danced like an uncontrollable bull. Convinced he would have to jump, Lieutenant Seligman, at 3,000 feet, threw himself into the void and landed about three miles from

the point where the wrecked ship fell.

A few months before Lieutenant Seligman's adventure, two naval flyers, Chief Radio Electrician O. E. Williams and Comm. O. W. Erickson, chief inspector at the naval aircraft factory, were drop-testing parachutes over Mustin field, near Philadelphia.

"We had made twenty-nine short flights," said Williams, "when things began to happen. Approaching the field, everything was functioning beautifully, and the fifty-ninth parachute was released. Less than four seconds later, one blade of the three-bladed metal propeller broke, causing excessive vibration of the whole plane, tearing the power unit from the barriers and dropping it into the field, burying itself under five feet of sod."

A blinding flash of fire and smoke rose before them. A dull muffled noise sounded as though someone had tried to smother the motor and propeller with a heavy blanket.

By DON GLASSMAN, 154
W. 80 St. N. New York

THE Caterpillar Club, that famous society of self-saved men and women, initiated about seventy-five persons during 1929. Membership toward the close of the year approximated 200.

Since the first two "Caterpillars," John A. Boettner and Henry Wacker, were initiated in 1919, this marks the tenth anniversary of the society's existence, although its official charter was not framed or the name conceived until 1922.

In October, 1929, Harry Sievers, pilot on the Cleveland-Pittsburgh air-mail express, left Bettis field, Pittsburgh, with an airworthy plane. Near Beaver Falls, his motor coughed, then stopped. He saw that he would be forced to abandon the ship, but he was loath to leave the mail where it might be consumed by fire. Seizing it with one hand, he dived into space, and pulled the rip-cord ring with the other. The chute boomed open. The conscientious mail pilot grounded safely and handed his pouch to the postal authorities.

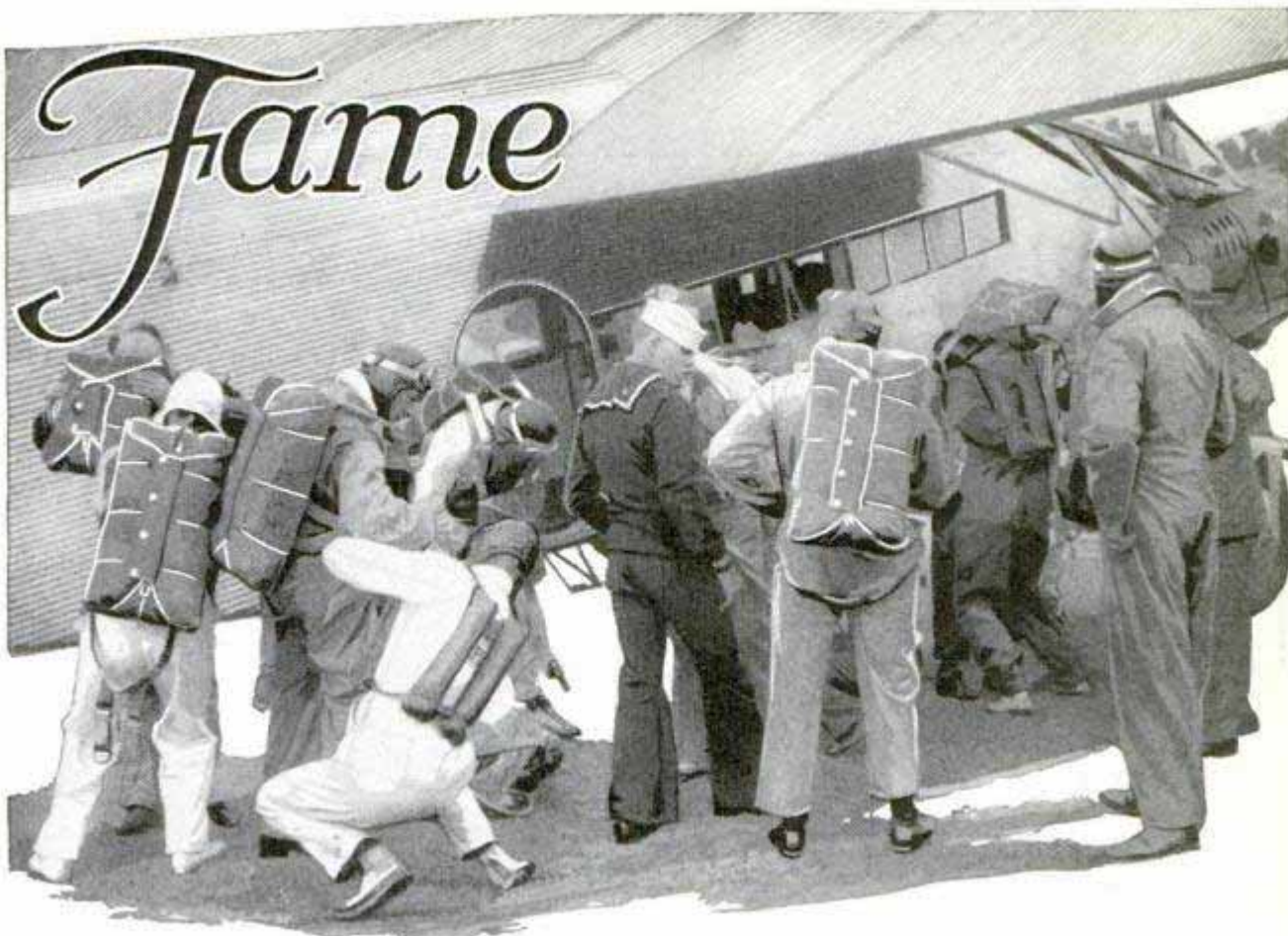

Twelve Officers and Enlisted Men of the Naval Air Station at Anacostia Boarding a Tri-Motored Ford Plane for a Demonstration Jump during Navy Day Celebration

"I first thought the plane had burst into flames, but only a moment elapsed before this condition cleared and the motor dropped out. The plane was thrown around ninety degrees to the right, and began to fall with the tail dangerously low. The adjustable stabilizer was all the way up, which increased our danger. At the time I jumped, Commander Erickson was making every possible effort to get the stabilizer down. Seeing that my weight on the tail jeopardized his efforts, and knowing the plane was starting to spin, I yelled, 'I am going to jump!' Noting the position of brace wires and the tail, I engineered my exit by sliding down the side of the fuselage with my hands—the altitude at this moment was a good 600 feet. Dropping clear, I waited for a good safe margin of ship clearance, then pulled the parachute rip cord. I experienced no unusual jerk or sensation. I landed on my heels in a field and gave way to a sitting position in order better to collapse the chute."

Commander Erickson's motto was, "Don't give up the ship." After Williams

had jumped, he managed to bring up the tail and piloted the motorless bomber to a safe landing.

Another recent jump was made near Islip, Long Island, by Lieut. Richard H. Magee, attached to Mitchell field. Lieut. William C. Thomas, pilot, and Magee, machine gunner, were pursuing a "sleeve" target towed by another airplane. Lieutenant Thomas suddenly felt torrid waves of heat coming from the engine. It was overheated and stalled.

"Jump!" the pilot commanded Magee, thinking he would be unable to make a safe landing. The altimeter registered 2,000 feet. Magee waited for about 500 feet before stepping off. The pilot remained at his controls and brought the "Falcon" biplane down in a swamp. Lieutenant Magee made a skillful water landing in Great Neck bay. Detached from his parachute, he managed to swim until he was rescued by a rowboat.

While flying an "F-3-B," Lieut. P. M. Clyde, navy flyer, lost control of his spinning plane and was forced to jump. Just as he opened his parachute, he received

3574

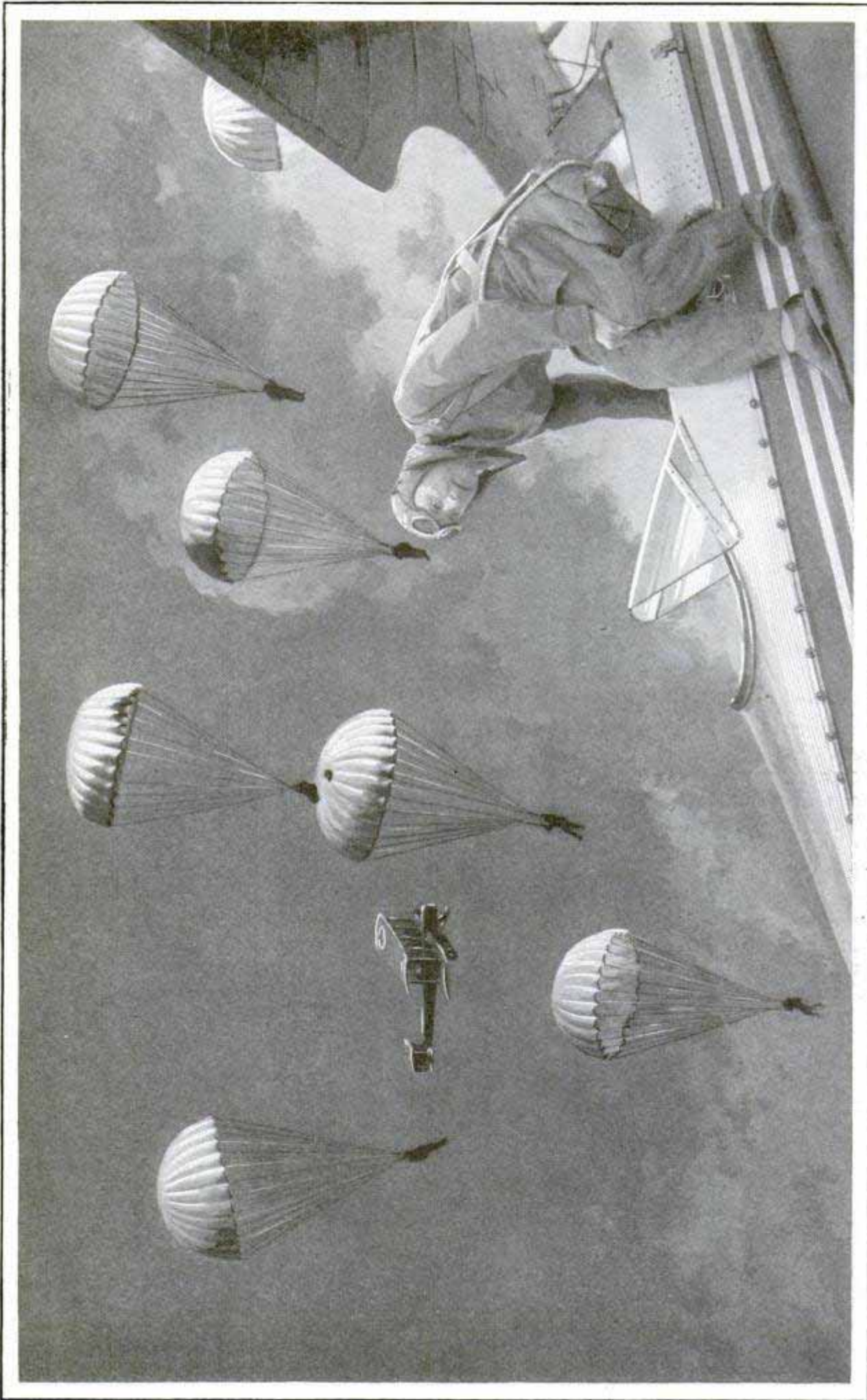

Composite Photograph Showing Six Jumpers in the Air at One Time. Members of the Royal Air Force in England Staging a Parachute Exhibition, and Close View of Flyer Showing How the Seat Pack Is Worn; Cases of Parachute Failures Are Now Almost Unknown

a vicious blow on the right shoulder from a wing. It disabled his right arm. Nine hundred feet below him lay the ocean, and while he dropped about sixteen feet per second, he managed to kick off his boots and unsnap his parachute harness before striking the water. He fell into the ocean about four miles off North Island and was picked out by a navy barge.

Richard Bowman, pilot for the Pacific Air Transport company, was flying his regular run between Los Angeles and points north. The night was dark and sticky. He saw the glimmering bulbs of the city fade in low-hanging mist until they resembled strands of lacework. The clouds were piled in thick layers as he headed for the Tehachapi range. He edged in between two canyons of mist and rushed down

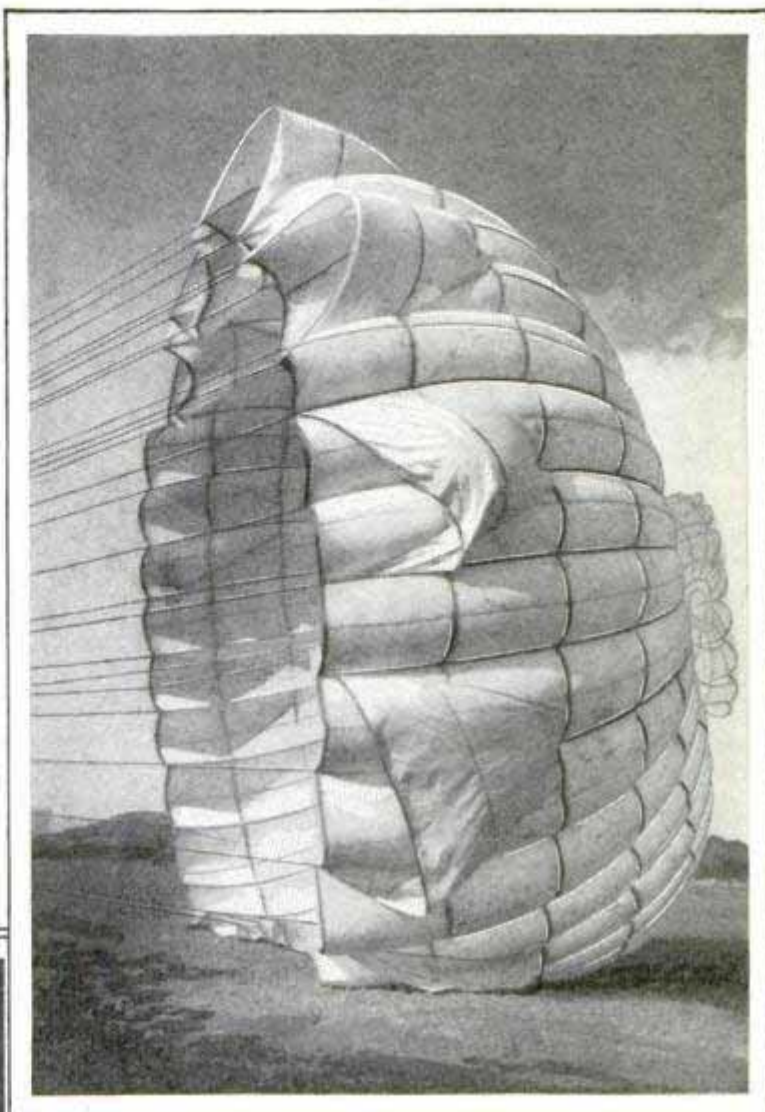

Big Chute for Supporting Airplanes Partly Inflated, and Young Woman Parachute Student with Hand on the Releasing Ring

a black corridor in the direction of Bakersfield.

For an hour, the pilot fought buffeting winds. The plane side-slipped and skidded. The propeller churned in soggy mist, and Bowman kept an even keel only by relying on his intuition and the illuminated dashboard.

When his instruments gave warning signals, he sensed that the ship had thrown a fit and was beginning to whirl into what seemed to be an outside spin. Not a light shone from earth. The transport did not show the slightest inclination of coming out of the spin.

Bowman could not describe the exact nature of the ship's maneuver, as he was thrown off by centrifugal force and thrust into the blackest of nights. His landing came surprisingly easy. He found himself on a mountain ledge, apparently the only place within ten miles where a parachutist could have grounded without injury. He built a fire and sat beside it

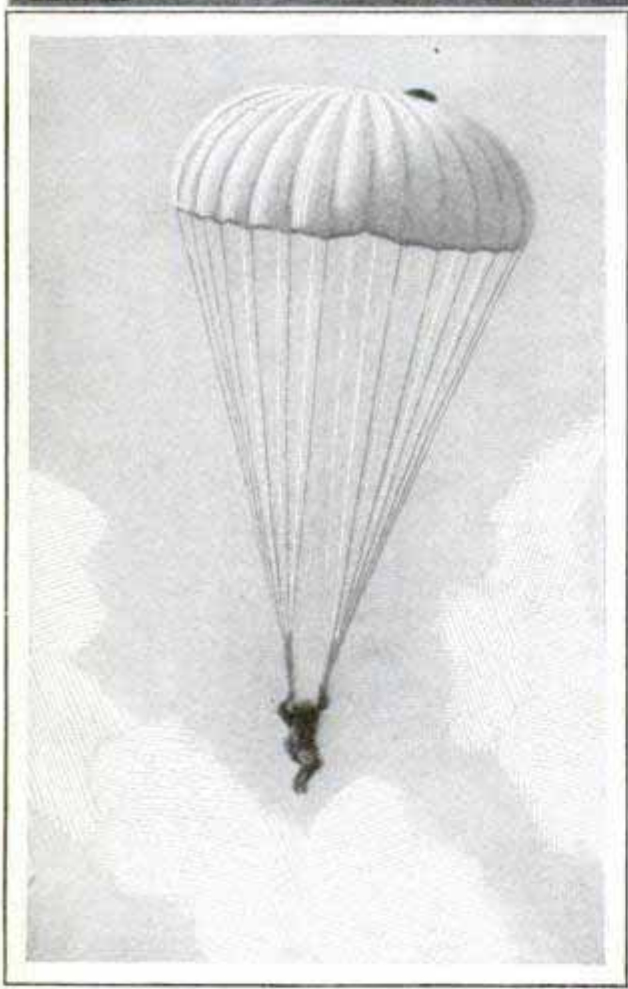
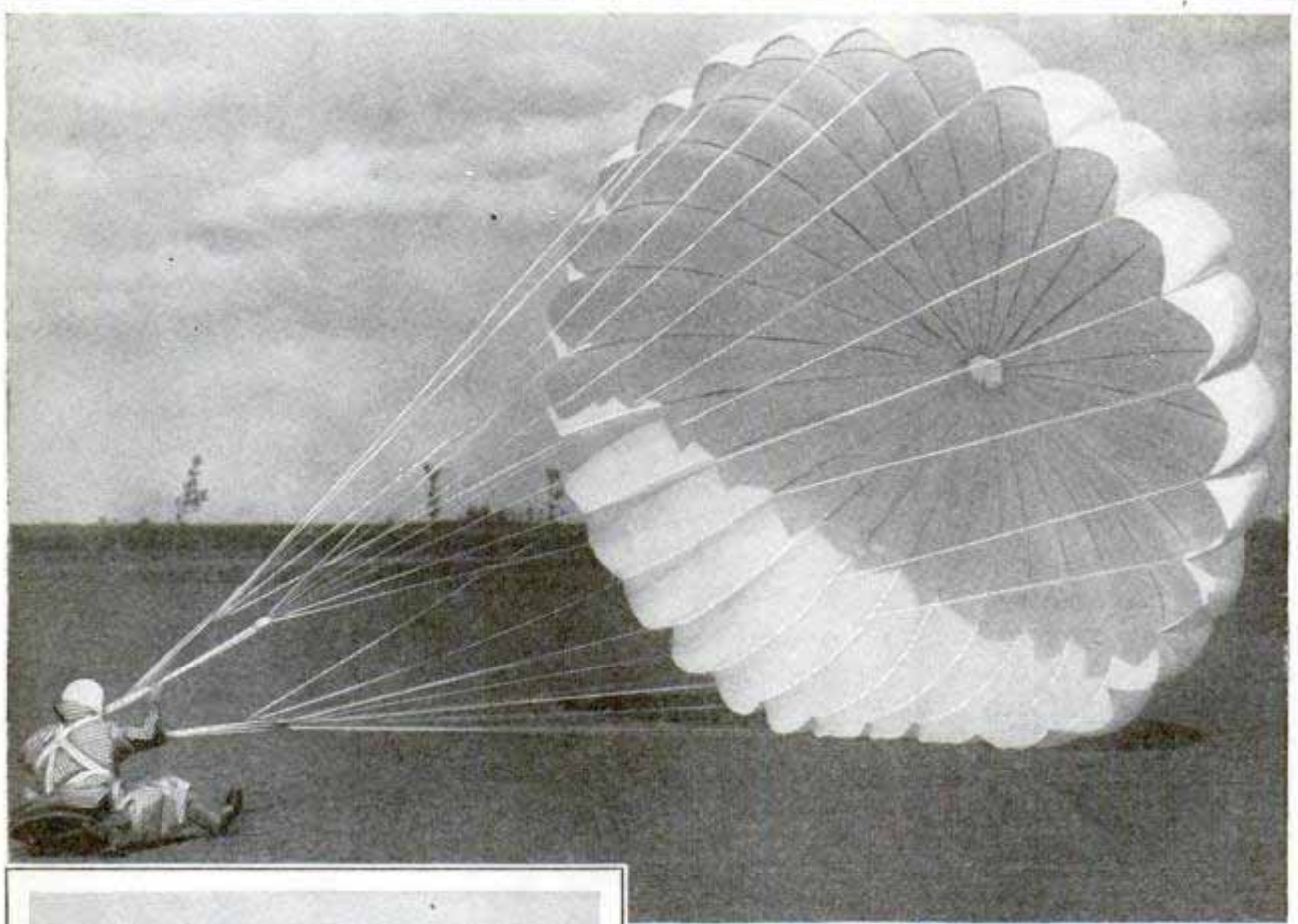

Landing after a Successful Test of an Automatic Parachute Release for Passengers, and Close View of an Easy Descent

until morning, when he slid and crawled over crags until he reached a road.

While testing a new monoplane near Alexandria, Va., Temple N. Joyce, purposely drove it into a left spin in order to learn its recovering characteristics. "After a few turns," said Joyce, "it became apparent that the plane would be difficult to recover. I immediately gave full opposite controls. Instead of responding, the attitude of the plane became increasingly flat. After 2,500 to 3,000 feet of spinning and several futile attempts to use the gun, I resolved to abandon the ship.

"The centrifugal force in a flat spin is generally very great and acts to rearward. In this spin, I was pinned so tightly against the back of the cockpit that the parachute caught under the leather padding of the cowl when I attempted to stand up. This delayed my exit for about 500 feet. Finally I abandoned this attempt and rolled over the left side, hoping to peel the parachute from under the padding.

"It worked.

"After clearing the plane and pulling the rip cord, the chute opened with little



One in the Air and Another on the Wing Ready for the Jump into Space; Navy Flyers Taking Parachute Tests, an Important Detail of the Army and Navy Flying Regulations

jar. I floated within seventy-five feet of the spinning plane—too close for comfort.

"A few moments later the plane crashed; I landed in a tree without bruise or injury.

"I think this is the first record of anyone jumping safely from a spinning plane, and I am sure it was the first time it was accomplished from a flat spin."

On April 14, 1929, Lieut. Shapley Gray and Capt. William Wimer left Jefferson City, Mo., headed for St. Louis.

"I was flying over the Missouri river, watching the shoreline over the right side to avoid the bluffs," said Captain Wimer, "when the motor quit. I turned to the right to get over land and yelled to Gray, 'Take to your chute!'

"Gray was up on the edge of the rear cockpit with one leg over the side; he paused long enough to pull off his gauntlets and throw them back into the ship.

"Then I got busy. By the time I had got out on the left wing, the ship had nosed down and lost considerable altitude. I sensed rather than gauged the distance between me and the approaching trees.

"I decided to trust a 'pull-off.' I held the center-section strut with my left hand and made a grab for the rip cord

with the right. I missed. I released my hold on the ship, grabbed the harness with my left hand and pulled it out in front of me so I could see the ring.

"I pulled it. The chute opened.

"I felt one oscillation only, and the next thing I knew I was suspended far above ground, between two trees, with my chute caught in the topmost branches of one of them. I could not reach either tree and I was afraid to swing myself over to one as I could not see how securely the chute was fastened. I had visions of the darn thing slipping and dropping.

"Finally, I managed to swing around. I touched a twig, and pulled myself, hand over hand, toward larger branches. I released the chute, and there I was fifty feet from ground, marooned like a squirrel.

"I began to slide down the trunk, and had traveled about thirty feet when I struck a knot in the tree which broke my hold. I fell the rest of the way. Luckily I landed on my seat in marshy ground overgrown with willows and cat-tails.

"I tried to locate my buddy, but he was not found until the next morning. His chute was still in the pack and the rip cord in its pocket."

Mr. H. J. ...
Thunderley,
Asses England

W. E. Ward,
Metropolitan Life Insurance Co
Madison Ave., N.Y.C.

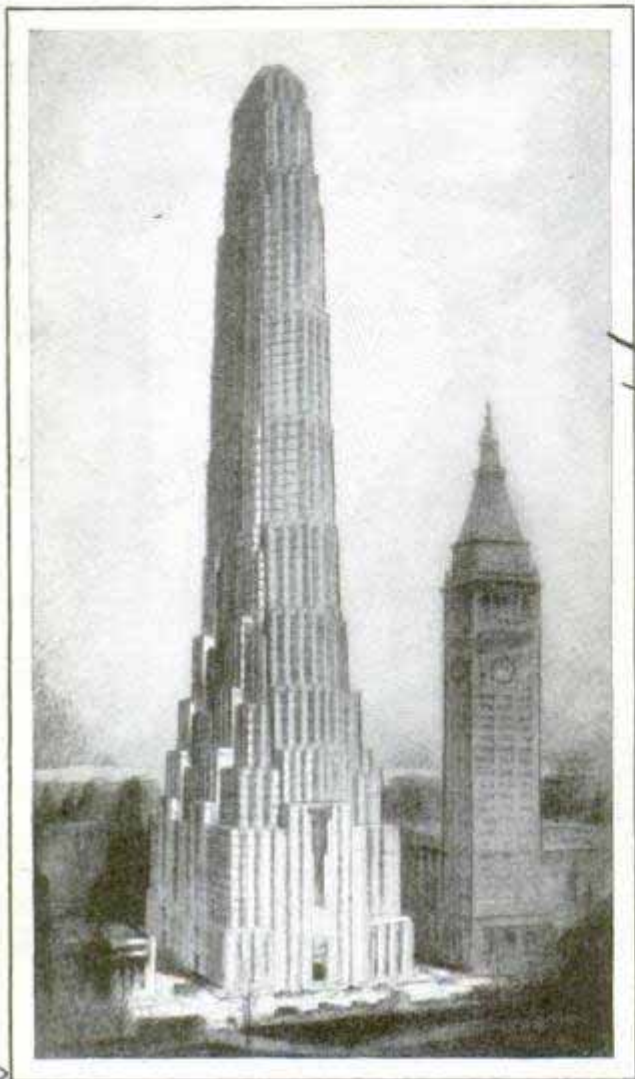

Architect's Drawing of World's Tallest Building, a 100-Story Skyscraper for New York

HUNDRED-STORY SKYSCRAPER TO BE SERIES OF TOWERS

Planned to dominate the entire city of New York when completed, the first one-hundred-story skyscraper is to be erected in Madison Square. The structure will consist of a series of set-back towers, piled one upon the other, and will be the world's tallest building. It will house the 30,000 employes of the Metropolitan Life Insurance company.

PROSPECTORS DISCARD METAL COSTLIER THAN GOLD

Three prospectors searching for gold in New Guinea recently threw away hundreds of pounds of a metal worth ten times more than the gold they sought, and were unable to recover the discarded fortune. While sluicing for gold, they found a quantity of blue-gray metal which appeared as heavy as the gold they were

name not known

hunting, but they did not recognize it and flung great quantities into a stream bed. Later a mining expert was taken to the scene, gathered up about three pounds of the metal and sent it to London for analysis. A cable came offering the miners a price ten times higher than that paid for gold for all the metal they could produce. It was osmiridium, a rare mineral containing the two closely related elements of osmium and iridium. It is among the heaviest and hardest metals known and is used for tipping fountain pens and for scientific instruments, being valued at from \$200 to \$300 an ounce in the crude state. The discarded fortune had been washed away by the waters except for a few scraps.

from not known

BLOCKS HELP TEACH CHILDREN FOREIGN LANGUAGES

Children are taught many of the words of foreign languages in an easy and interesting manner with the aid of a set of blocks now on the market. Each unit has different interchangeable words on the faces so that new combinations appear as the blocks are turned. With only four blocks, more than 200 variations are possible. The units are numbered and a vocabulary with translation is provided with each set in addition to a key for a guide to sentence formation. Another feature is that masculine words are printed in red and the feminine in blue, to aid the young student.



Sold by John Martin
300-4th Ave N.Y.C.
1-60 postpaid

McChes

Learning a Foreign Language with Aid of Blocks Painted with Interchangeable Words

Lucy M. ...
8. Arborway Court

5054 Cont. A. S. ...
 Colomberg, 29 Bean Road,
 Berley Heath, nr. London, Eng

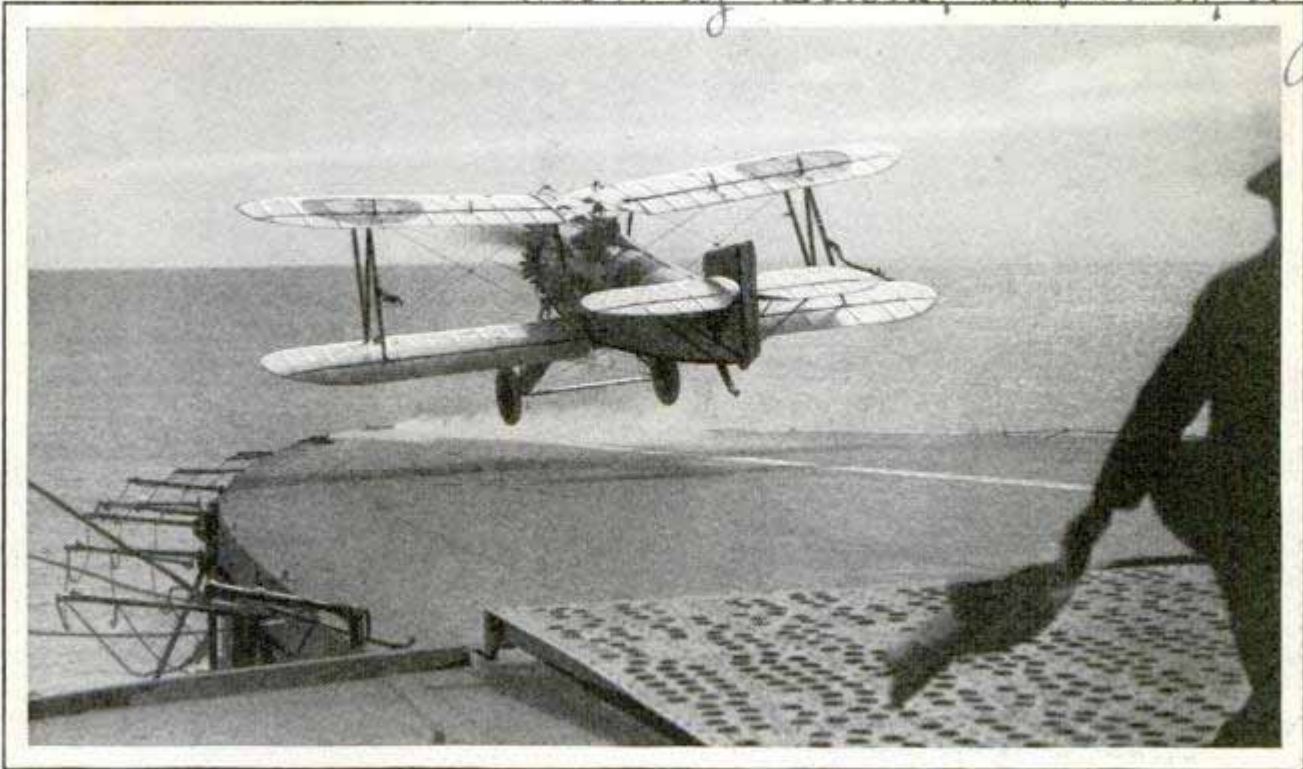

Photo by Central Press

Plane Leaving a Ship, Its Take-Off Aided by the Steam Jet in the Bows Which Indicates the Angle to Face the Wind When the Jet Coincides with the White Line the Plane Follows

JET OF STEAM AIDS AIRPLANE TAKE-OFF FROM SHIP

To show the correct angle for a sea-plane to take off from the deck of a British battleship, a steam jet was played along a white line on the deck during re-

cent maneuvers in the Mediterranean. The vessel first ran head into the wind, then from the bows the steam blew along the deck until it exactly coincided with the white line which the plane followed in leaving the ship, thus giving it the correct angle to face the wind.

MOTOR RUN BY WAVES OF SEA OFFERS CHEAP POWER

3827

Converting the motion of the waves of the sea into usable electrical energy is accomplished by an ocean-wave motor, a model of which has been demonstrated successfully by its inventor. The motor records every impulse of the water due to wave motion, including roll, weight of the water, tide and undertow from any direction. The apparatus consists of a float attached under water to two swinging arms. The waves rolling onto the flat top of the float force it down, and the motion thus created is translated into power

by mechanism all of which is above water. The float resets automatically for the next wave. The inventor claims that it is practicable to install batteries of these motors along the seashore to provide cheap power for all seaside communities.



Model of Ocean-Wave Motor Intended to Convert Wave Energy into Electric Power for Commercial Purposes

Dr. E. C. Shuler, Los Angeles
 Coronado St

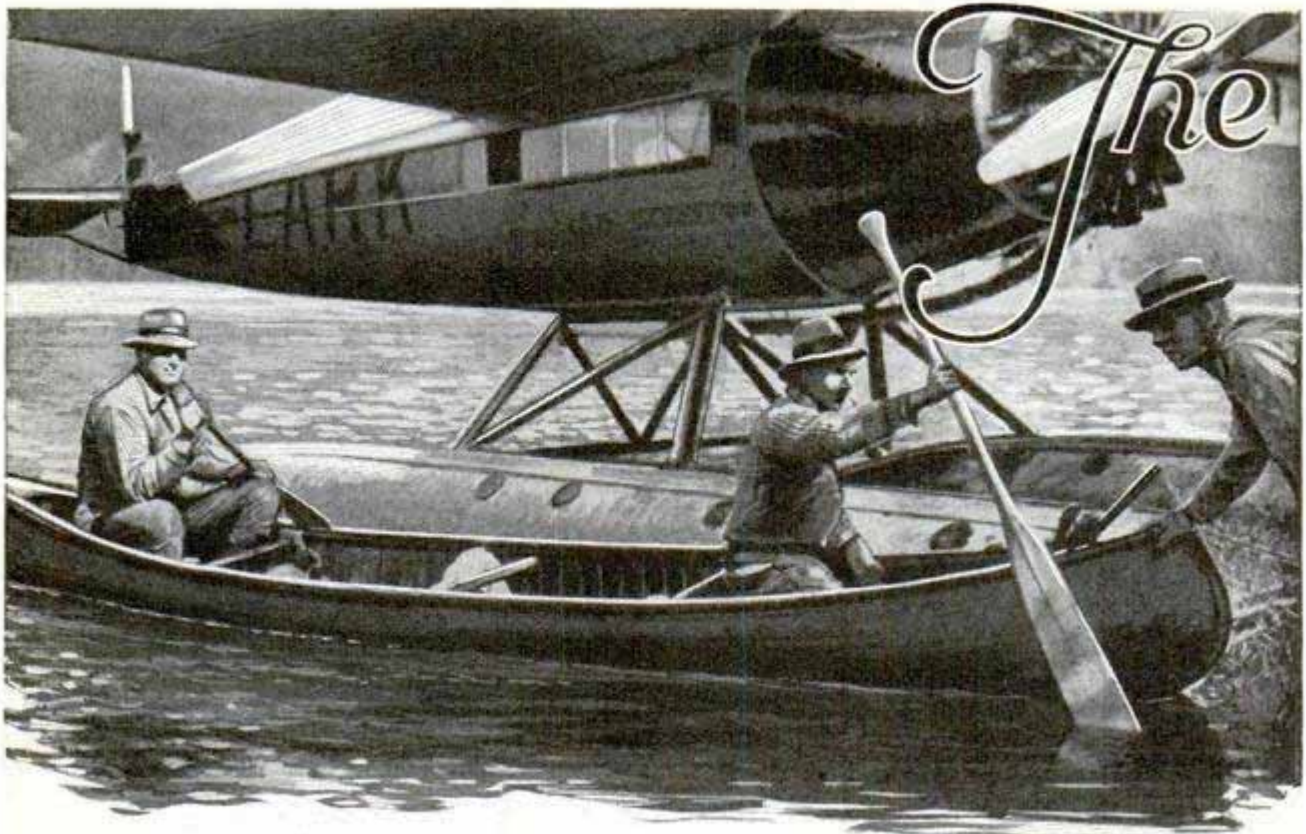

A Pair of Prospectors, Landed on an Unnamed Lake by Airplane, Ready to Start the Hunt for Gold; Two Weeks Later the Plane Returns to the Rendezvous to Pick Up Samples and Land Supplies

PART III

THE FIRST week in August a wireless message out of the land of the northern lights, sputtering in a dah-dah dit-dit-dah of dots and dashes, came from a little ship anchored in the northeastern arm of Bathurst inlet, at the eastern end of Coronation gulf, 200 miles east of the Coppermine river, and just south of Victoria island, in the Arctic sea.

Stations down along the rim of civilization picked it up, and relayed it back to a radio operator at Baker lake, far up in the Barren Lands, to make sure he had not missed it. The message read:

"Number Two Gas Cache Ready."

Three planes were waiting at Baker lake for just that word. Weeks before, the same radio chain had brought a similar message, with the word "One" instead of "Two," and sent from the mouth of the Coppermine, far to the east of Alaska. The three ships, a Loening amphibian, a Fokker and a Fairchild, the latter two on seaplane pontoons, had come in on the heels of the ice break-up, flying from Sioux Lookout, just north of Lake Superior, by way of the western shore of Hudson bay, past Fort Nelson and Fort

Churchill, Cape Eskimo to Fort Chesterfield, where they turned westward up Chesterfield inlet and out over the Barren Lands to Baker lake.

The next day, the three took off and winged northwest over 400 miles of unexplored and unmapped territory, assured that fuel and supplies were waiting them on the rim of the Arctic sea. At the controls of one ship was C. A. "Duke" Schiller, hero of the spectacular rescue of the "Bremen" flyers at Greenly island. J. D. Vance flew the Fokker and Tom Reid the Fairchild. All three were war-time pilots in France.

With them went the last frontier, moving back until it disappeared among the arctic islands. With two gasoline caches planted above the Barren Lands, every point in Canada, from the Ungava coast opposite Greenland to the Alaska border and from the United States to the polar sea is within two days of the end of steel.

From Bathurst inlet, the three flew on in company to the mouth of the Coppermine, where the supply ship, starting from Vancouver in the early spring, had put down the first cache and landed lumber

Last Frontier

and stores to establish a permanent camp, complete with houses and hangar.

Another party already was there, a group of mineral prospectors who had left steel at Waterways, north of Edmonton, Alta., sailed down the Athabasca to the lake of the same name, down the Slave river to Great Slave lake, out of it and down the Mackenzie past Forts Simpson, Wrigley, Norman and Good Hope, and so to the arctic, and from there east to Coronation gulf.

Their purpose, when the planes arrived to transport them, was to prospect the Coppermine river country and the adjacent lands in Victoria island, from which the Eskimos for untold time have ex-

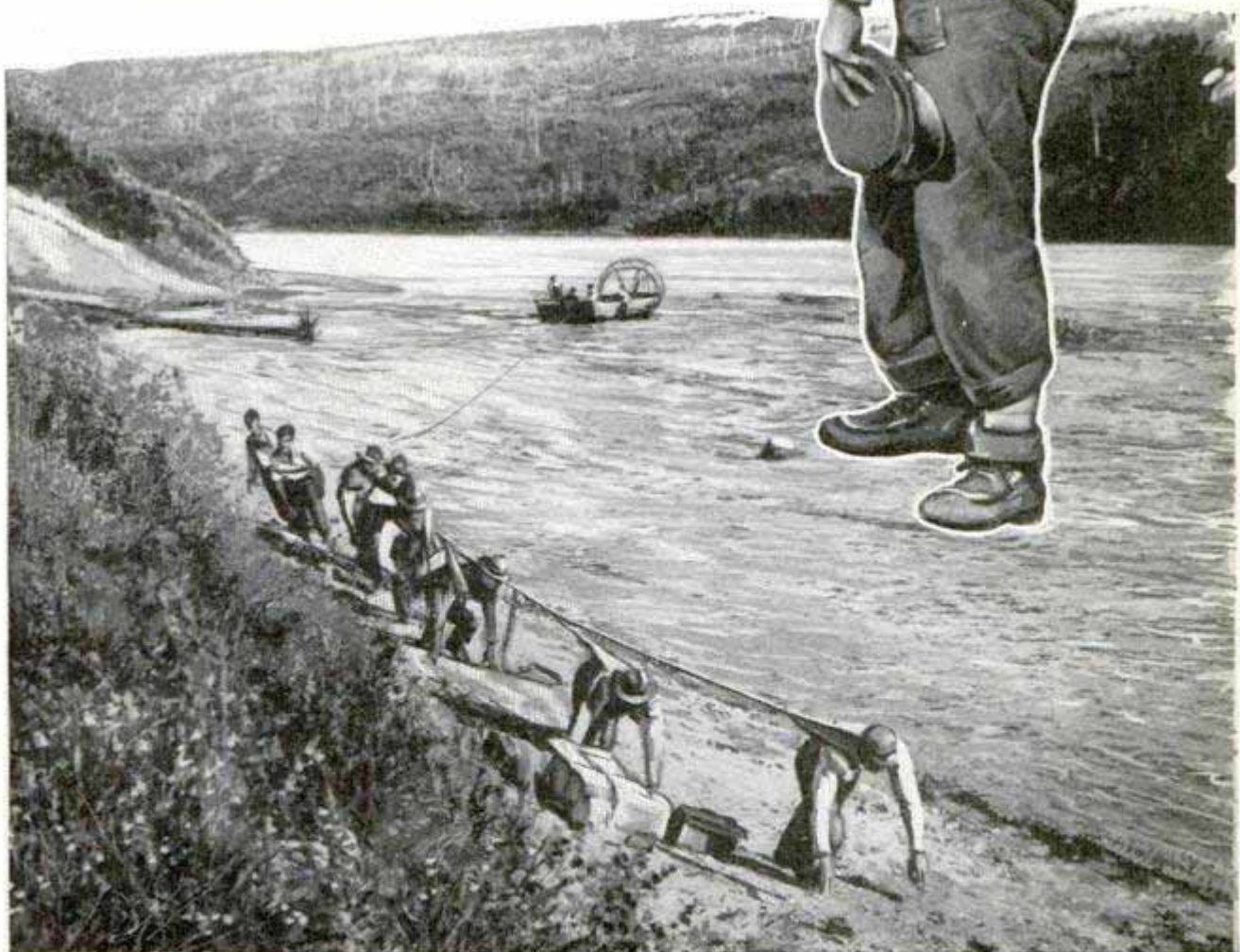

Airplanes Have Done Much to Take the Toil Out of Prospecting, Ending Scenes Like These; at the Top Is a Prospector Headed for Flin Flon, and, Below, Indians "Lining" a Barge up the Peace River Rapids



Men Have Carried 600-Pound Weights in the North, and Two Oil Barrels Are No Load for an Indian; Top, a Prospecting Party in the Bush

tracted vast quantities of virgin copper. Their hope was to uncover another great copper-mining center which would rival Calumet, in Michigan, and the Anaconda country, in Montana. If they succeed, plans are already being laid for a new arctic railroad, a road 400 miles long whose southern terminal, on Great Slave lake, at either Fort Rae or Fort Reliance, will be hundreds of miles north of the end of steel at Waterways. It will be a mining road linked with civilization by nearly a thousand miles of waterways.

Two or three years ago, the proponent of such a scheme would have been thought crazy; today, with all the north opened up by airplanes, anything is regarded as possible. Vast distances have ceased to terrify. Instead of being months away, the most distant points have been brought to just over the horizon. A week suffices to go to the mouth of the Coppermine and back, starting from New York or Chicago.

Show a big enough ore body to warrant it, and the railroads, both the Canadian Pacific and the Canadian National, are ready to push ahead almost any distance beyond their present ends of steel and furnish transportation. It has only been four or five years since depression was so general throughout Canada that

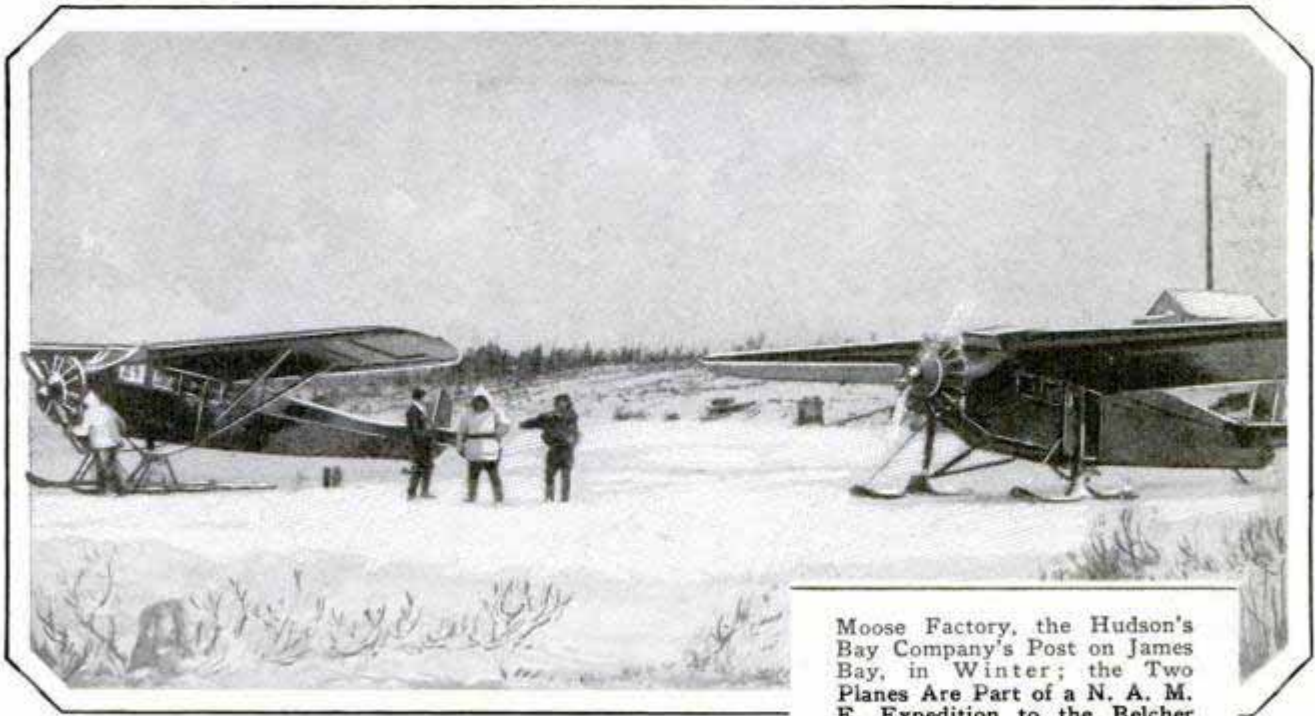

Moose Factory, the Hudson's Bay Company's Post on James Bay, in Winter; the Two Planes Are Part of a N. A. M. E. Expedition to the Belcher Islands, Where Rich Iron Claims Were Staked

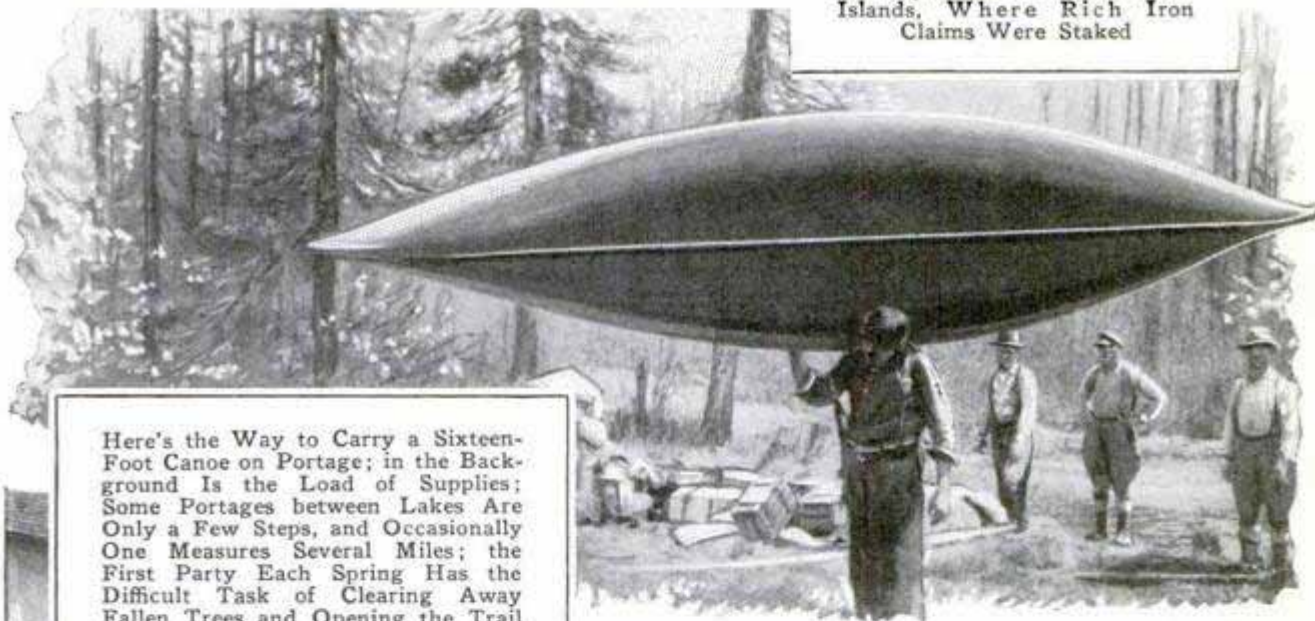

Here's the Way to Carry a Sixteen-Foot Canoe on Portage; in the Background Is the Load of Supplies; Some Portages between Lakes Are Only a Few Steps, and Occasionally One Measures Several Miles; the First Party Each Spring Has the Difficult Task of Clearing Away Fallen Trees and Opening the Trail

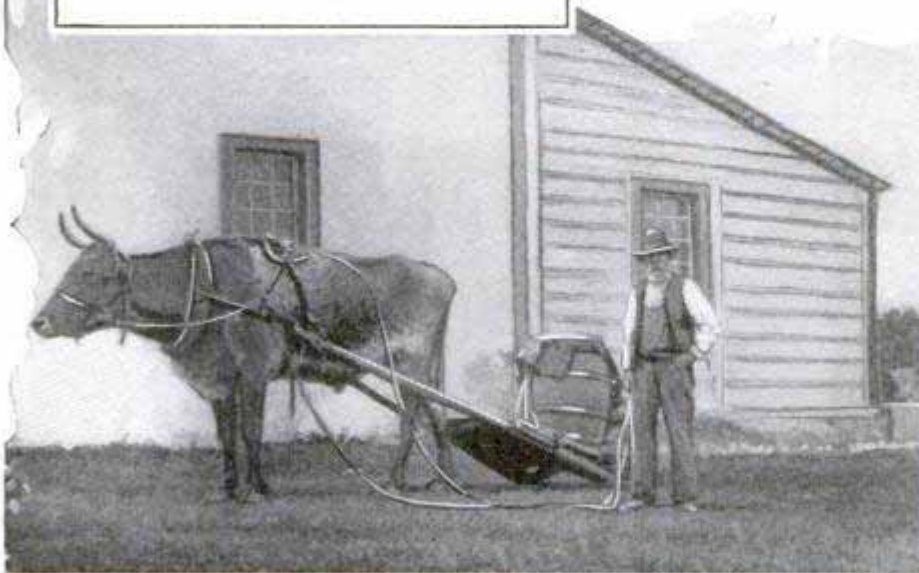

The Water Company of the North Requires No Pipe Lines or Pumping Plant; This Crude Drag, with Its Ox for Motive Power, Is the Hudson's Bay Company Waterworks at Cumberland House, a Famous Post West of The Pas in Saskatchewan

3392
246

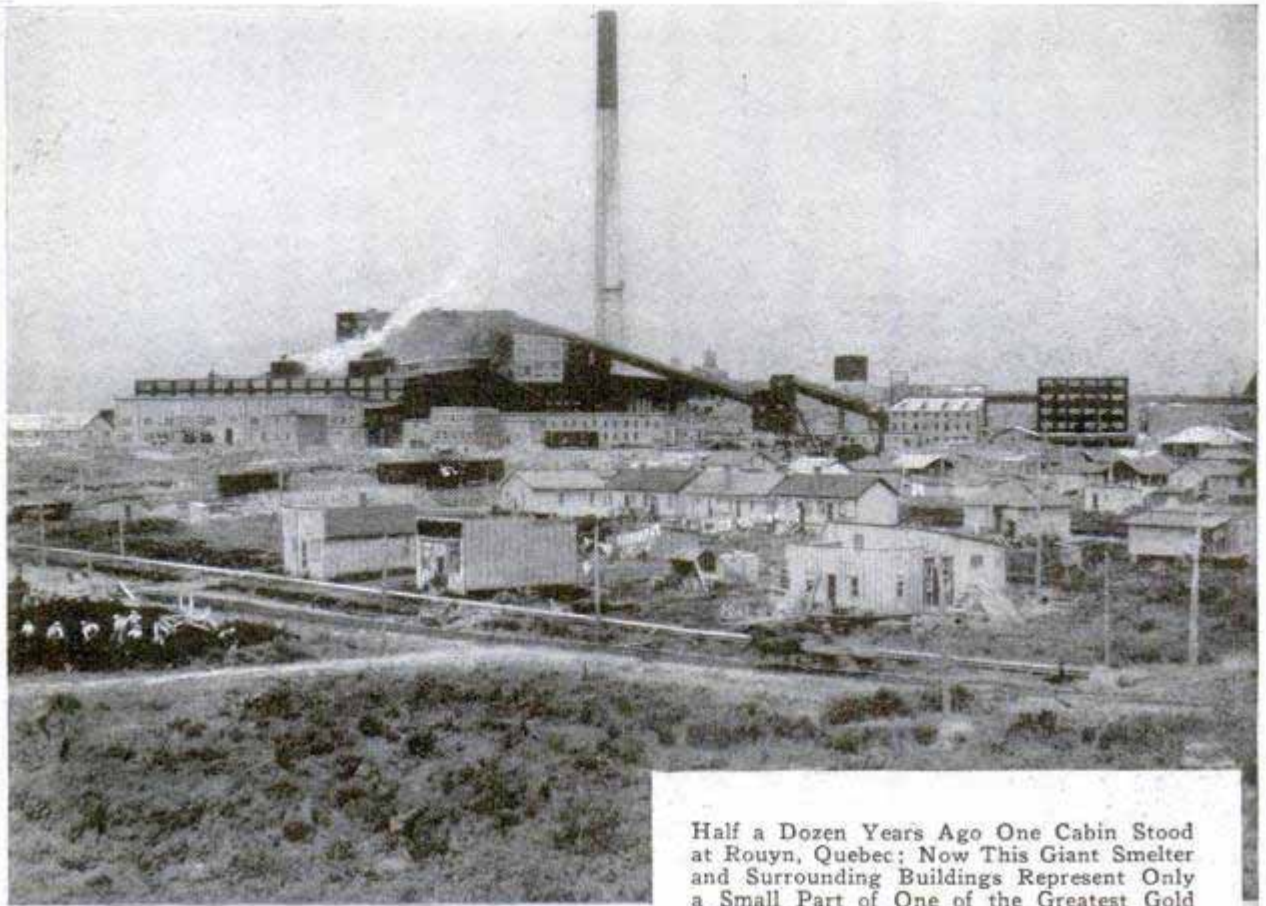

Half a Dozen Years Ago One Cabin Stood at Rouyn, Quebec; Now This Giant Smelter and Surrounding Buildings Represent Only a Small Part of One of the Greatest Gold Camps of Recent Years; the Railroad Has Pushed into Rouyn, Supplanting the First Aerial Gold-Mine Service; Below, the Second Busiest Airport in North America, Sioux Lookout, a Bush Village at the Gateway to the North

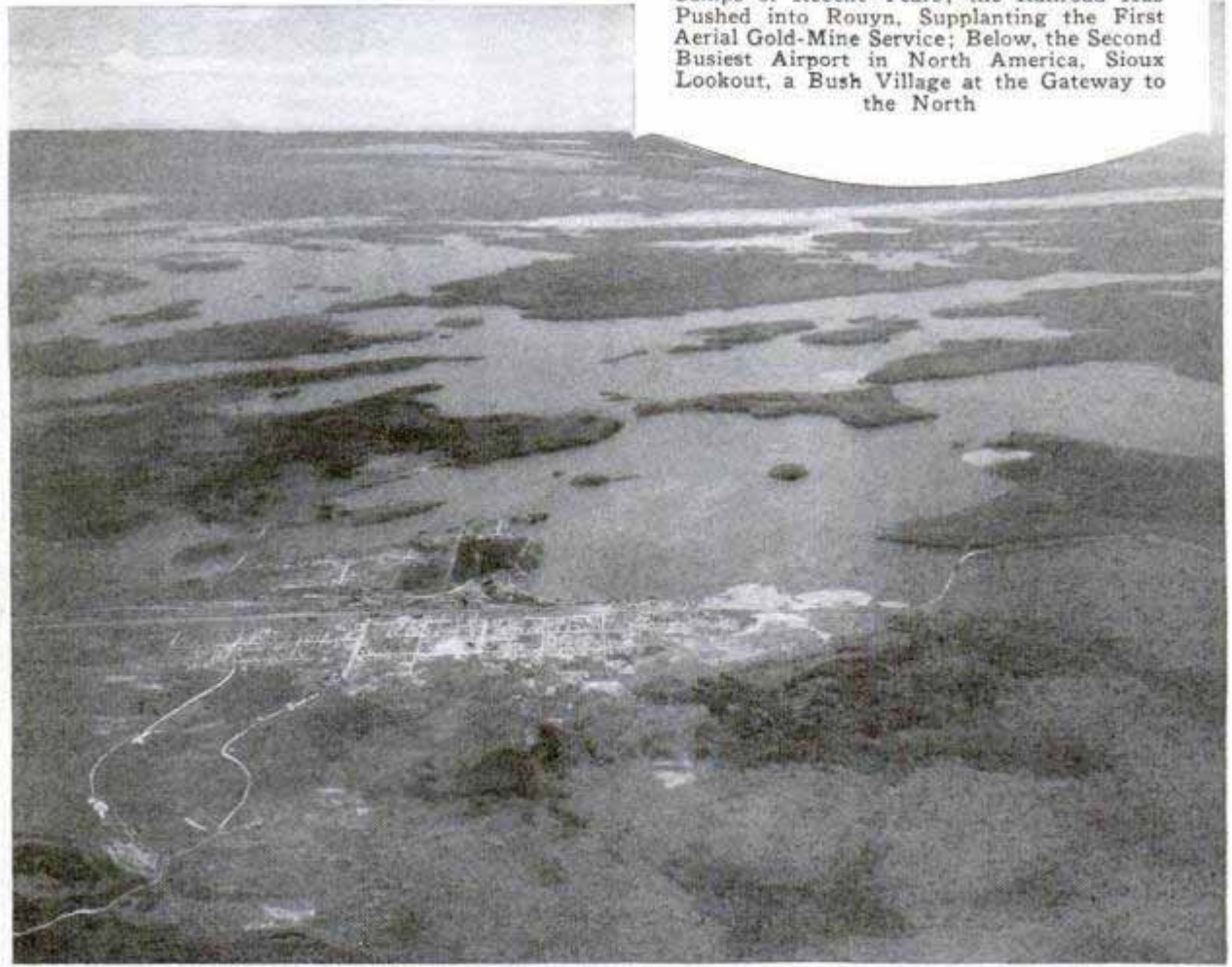

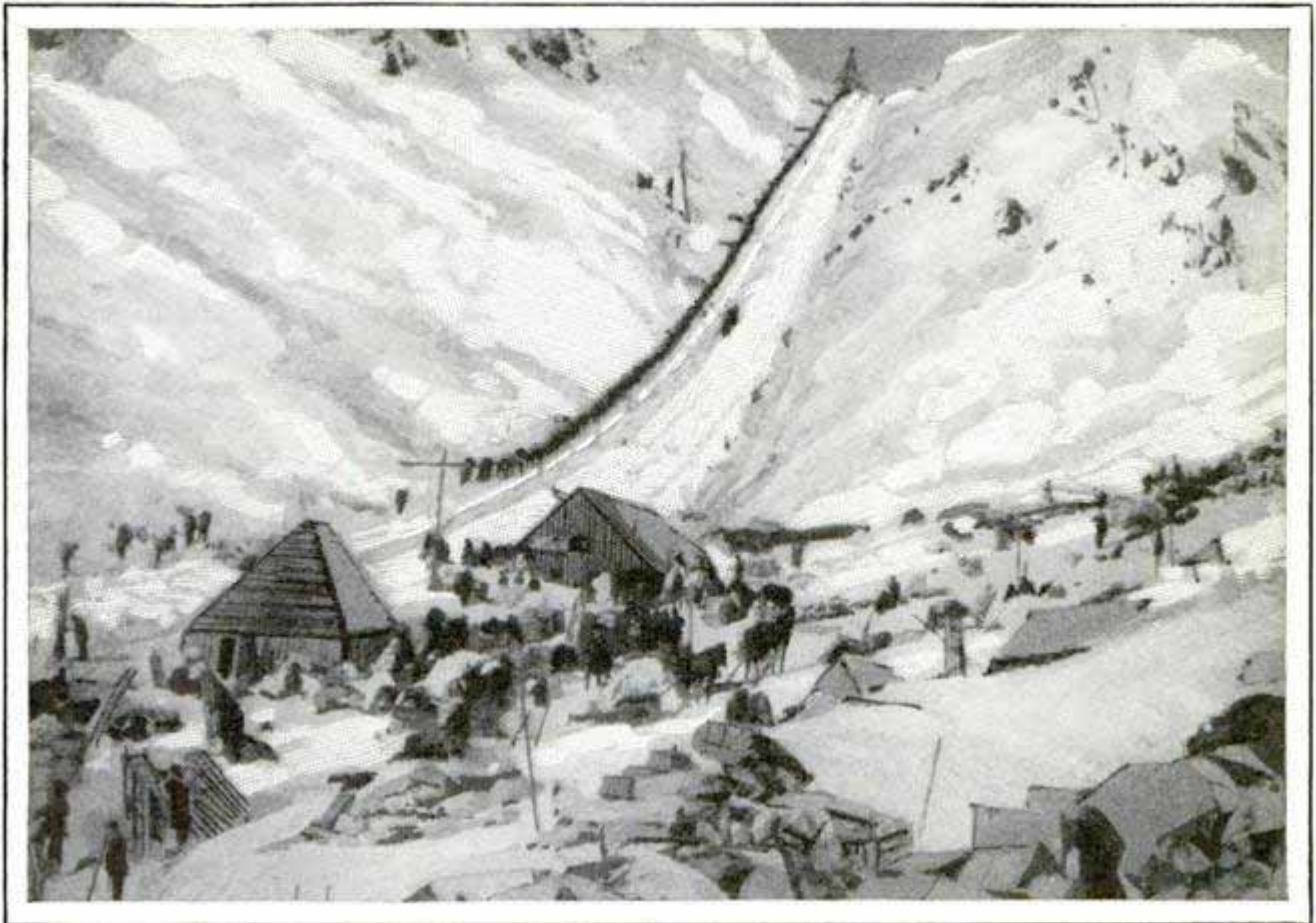

They Had No Space-Devouring Airplanes When This Black Ribbon of Men Toiled up Chilkoot Pass and Down into the Yukon on Their Way to Dawson and the Gold Camps; This Photo Was Taken in 1898

many Canadians themselves lacked confidence in the future of the country. All that is changed now, and both confidence and the money to back it are available to go any place and do anything.

As late as 1926, a rich group of claims, only a hundred miles or so northwest of The Pas, were allowed to lapse because no one saw any prospect of getting transportation, and without machinery to build a mill, the mines could not be worked. That group, restaked, now forms the Sheritt-Gordon mines, only a few miles beyond the end of the Flin Flon mining railroad branch, and within easy reach of track extension. Two million dollars already is being spent on development there, and when the railroad gets in, millions more will be invested.

Even without a railroad, it has been discovered, mines can be built and developed. The Howey mine at Red lake, the original discovery claim that started the stampede in the winter of 1925-26, will have its mill completed before this appears in print, will have power wired in from a hydroelectric plant which has been rushed to completion at a power site more than

sixty miles away, and had a shaft down a thousand feet last July. Marine railways across the portages made that possible, for the railway is still nearly 150 miles away, by boat, and 100 miles by air. The mill equipment went in by scows. At each portage, the marine railway hauled the scows out of the water, across the land bridge, and dropped them into the next lake.

In winter, when the lakes freeze, giant endless-tread tractors take the place of both scows and marine railways. Hauling six or eight tons on their own bodies and dragging long sled trains with forty to sixty tons more, they plow through snow and over the ice, hour after hour, on exact schedule, and transport supplies at costs easily comparable with railroad freight rates.

Tractor trains were first introduced in the north to get building material and food and supply caches strung along the right of way, so that work on the Flin Flon railroad could open promptly with the beginning of spring. They proved their worth and were tried on the Hudson Bay road, which was being pushed north to

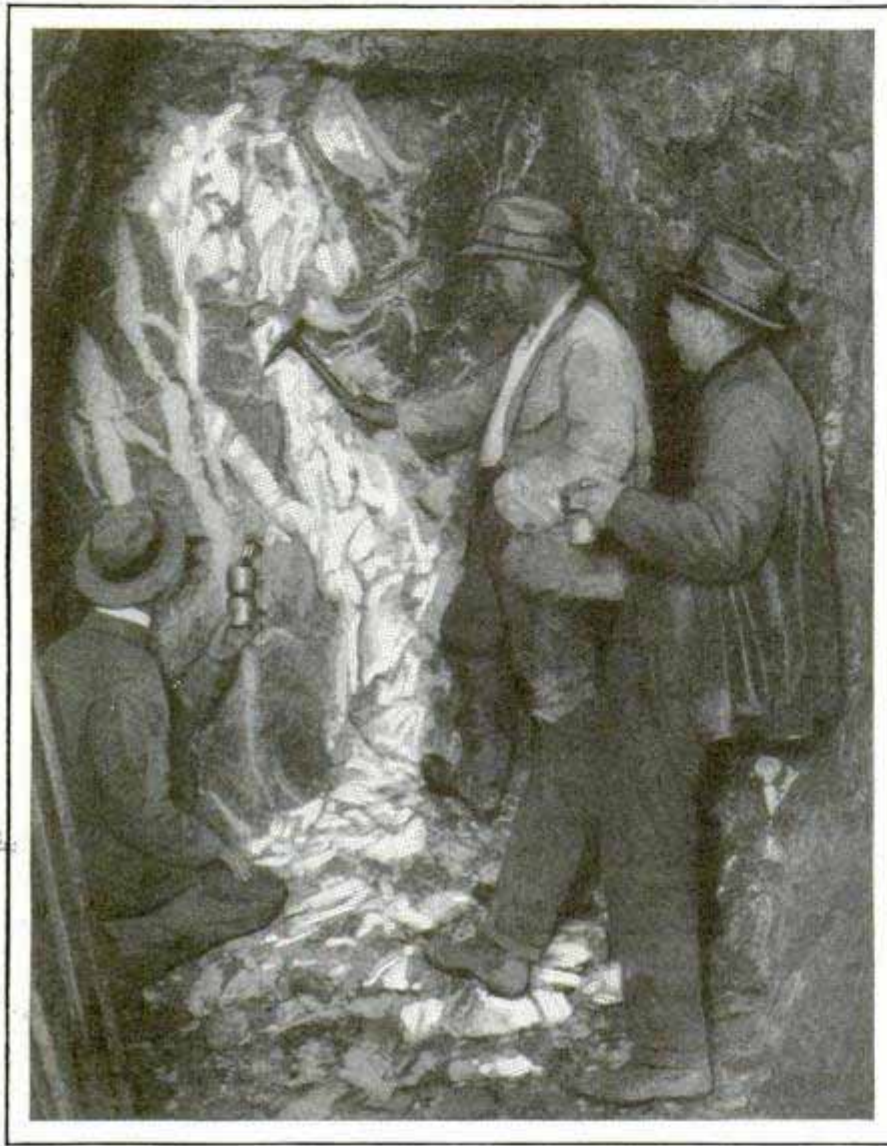

A Scene to Make a "High Grader" Happy; Rich Silver Vein on the 700-Foot Level of the Concarum Mine, at Schumaker, Ontario

other discoveries in the Yukon. The modern mining boom really started with the Cobalt field, a famous silver camp, in 1905. It has been claimed that only \$600 was invested in the original Cobalt discovery. Cobalt, Porcupine, Kirkland lake, Timmons, Rouyn, and now Red lake, Flin Flon, Cold lake and Rottenstone are largely responsible for putting mining third among Canadian industries, exceeded, in value of output, only by agriculture and forestry. The Dominion rates first among the nations of the world in the output of nickel and asbestos, second in cobalt, third in gold, third in silver, fourth in lead and copper, and sixth in zinc. The copper output is growing so rapidly that Canada is soon expected to be in third place, exceeding Africa and surpassed only by the United States and Chile.

Fort Churchill, and they were used to move a great part of the original projected railroad terminus at Fort Nelson north to the new site at Churchill.

Winter camps were established along the road to house the crews, and the tractors ran constantly, twenty-four hours a day, which prevented their engines freezing. Crews were changed every eight hours, but in some cases the engines themselves ran steadily for weeks without a halt. They made endurance records that set marks for later airplane pilots, with refueling contests, to shoot at.

The history of Canadian mining, while it goes back more than three-quarters of a century, is really concentrated, so far as the more precious minerals go and so far as quantity production is concerned, within the last quarter century, if you leave out of consideration the Klondike and

While the great camps and the famous mines, such as the Hollinger, at Timmons, and the Teck Hughes and McIntyre—the three biggest producers in the Dominion—are fairly limited, there are dozens of other camps in which transportation and money for development may produce names that will be as famous in the future.

Big business, with the advent of the airplane and modern methods, is displacing the old free-lance prospector and going at the conquest of the north in such a systematic manner that it is only a question of time until every square mile of possible mineral territory will have been examined.

Much of the romance of the north, with its canoe and dog-team trails, may pass with the aerial conquest, but at least the life in the bush has been made more pleasant, and more safe. Not a single pros-



Tractors Are Doing for the North What Airplanes Have Done in the Sky; Where Horses Cannot Live, They Solve the Ground Transportation Problem

pector was killed nor a pound of freight lost by any of the air lines in 1928 and the first half of 1929, while some forty prospectors were reported to have been drowned or lost on the trail during the same period. The perfect record for transportation of supplies is one thing that commends aerial progress to the miners, for, in shipping by canoe, it is customary to lose an average of one-fourth of all goods in the rapids and on portages.

Even the safety record of the airplanes, however, has not taken all the danger out of life in the far north. Two N. A. M. E. prospectors met with misfortune in the Barren Lands in October of 1928, one losing his life on the trail and the other being so badly frozen that both legs had to be amputated. The two had been prospecting northwest of Baker lake, and their plane was to return on a fixed date. That day a blizzard blew up, and for three days no planes could get into the air. Becoming alarmed, the two left their camp and started to walk out. One froze to death, and, after nine days' walking, the other reached the base camp with both legs frozen. The plane had flown in to their abandoned camp on the fourth day after the blizzard ended, and, if they had waited there, both would have been rescued.

The survivor, Tom Cowan, was a veteran of the north. Forty years ago he was a jockey on American tracks, but for more than a quarter of a century he has

roamed the bush in canoes and behind dog teams. Last August, with a pair of crutches to supplement his artificial legs, he had flown in to Sioux Lookout to inspect some claims in which he has an interest. As he climbed out of the ship on his return, his only remark was that he was the "first wooden-legged man to fly into the north."

It is men of that stamp that have pushed the frontier back until it has been lost in the polar seas.

The completion of the Hudson Bay railroad, in September, is expected to lend speed to the civilization of the arctic. Projected as a grain carrier, to move wheat from the prairie provinces to Fort Churchill, where steamers could take the load over a shorter route to Liverpool, the Hudson Bay road now promises to be so important to the mining industry that grain carrying will only be a side line.

Men of vision have all sorts of plans for its future use. N. A. M. E. last winter sent an expedition up the eastern side of Hudson bay as far as the Great Whale river and established camps and gas caches all along the route, then flew out over the bay and staked five miles of iron claims in the Belcher islands.

What anyone wanted with five miles of even fabulously rich iron claims on an isolated group of islands in icy Hudson Bay was a puzzle to many people, but, as a matter of fact, they are linked quite di-

33920
250

Refined Syrups due
72 Wall St. New York

rectly to the development of the Hudson bay railroad into Churchill, hundreds of miles away.

One of the unsolved problems of the bay railroad has been what the wheat boats could carry westward as return cargo from England. The only bulk cargo suggested has been Welsh coal, and if coal was brought, the only outlet would have been down through the prairie provinces, which are developing quite satisfactory coal mines of their own.

But it is possible that coal from Wales may be coked at Fort Churchill and used there to smelt Belcher island iron, brought across the bay by boat, and so turned into steel. With coal carried at a low rate as a return cargo, and the iron ore hauled a relatively short distance from the islands, Churchill may in time be a great northern steel-making center.

Canada has great plans for Churchill, and is proceeding carefully with their development. To avert a land rush and uncalled-for speculation in frozen town sites, settlers have been barred. As all the north country for hundreds of miles has not been surveyed and remains crown lands, corresponding to the government domain in the western United States, settlers are easily barred. It is probable that

Churchill may be developed as a government-owned town site, to keep speculators out and bring in only such people as are needed to work on the railroad, docks and warehouses, and to operate such stores as may be needed to supply their wants.

(To Be Continued Next Month)

RIVER OF LIQUID SUGAR FLOWS THROUGH PIPE LINES

To speed the time of delivery, sugar is now being distributed in liquid form through pipes instead of being handled in bags. At the refinery, a gravity pipe line conveys the liquid sugar to a tank car or truck and is hauled to the buyer's plant where it is again pumped to a distributing tank in any part of the building. The system is a result of the discovery of a carbon of high purifying quality, making possible the production of a white sirup, as refined as granulated sugar, directly from the raw material.

FILLING STATION LIKE PLANE ATTRACTS ATTENTION

Resembling a huge monoplane, a gasoline-filling station in Salt Lake City invariably attracts the attention of passing motorists. The cabin is used for the

Owners. E. L. Cheeney and J. W. Yeates. Located at 1st South and State Sts.

3808
End. Churchill
Refined Syrups due

W. all W. New York



Photo by Ewing Galloway

Automobile Filling Station in the Form of an Airplane with the Wing Affording Shelter for Cars and Attendants; the Design Utilizes a Narrow Lot in Practical Manner

and Mason 3767
(Finance)
Marshall
Maurice

3767

office and storage space, and the wings are built as a canopy over the drive on either side.

WILLOW BARK IS PEELED BY MACHINE 3828

Willow wands used in basket weaving now may be peeled by machinery with an apparatus recently demonstrated in the willow-growing section of England where women and girls for many years have done the task by hand. The machine consists of a rapidly revolving drum with small spring forks on its surface. The willows are fed onto the drum in bundles through an aperture, the forks dragging off the bark as the wands are moved to and fro by the operator. The machine operates about five times as fast as the most expert willow workers.

The daily price 11/6 per

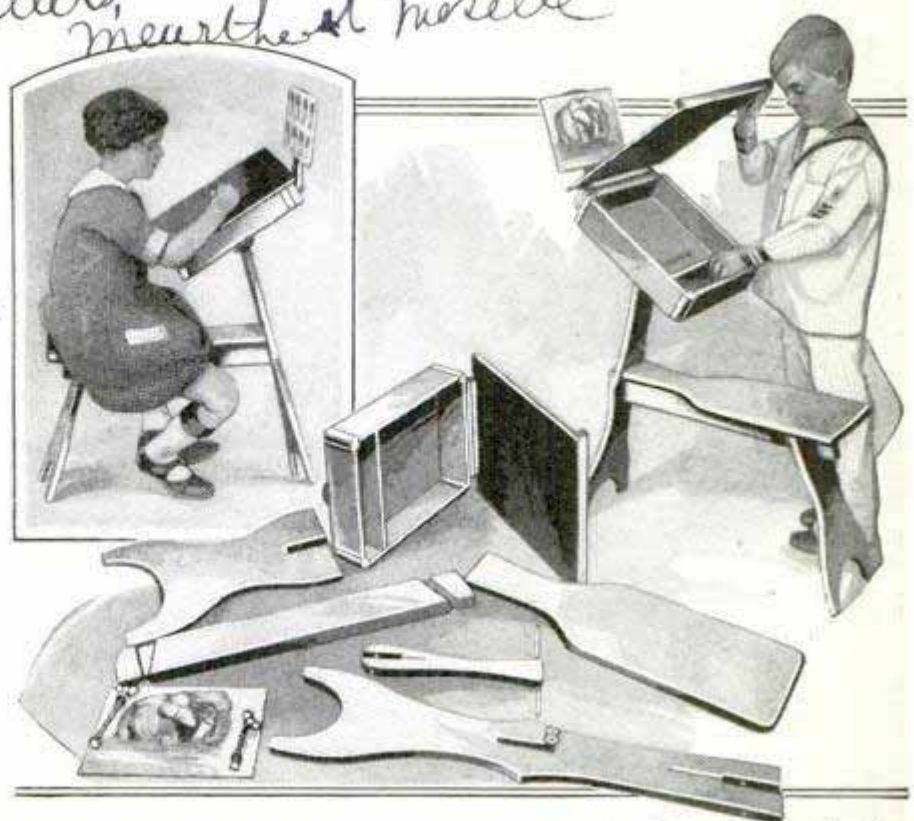

Collapsible Desk for the Classroom Consisting of a Drawer and Six Flat Pieces; Children Are Able to Assemble It in Two Minutes

COLLAPSIBLE DESK FOR CHILD IS ADJUSTED TO SIZE

Intended primarily for use in the classroom, a collapsible desk for children which the pupil is able to assemble or take apart in two or three minutes now is available. It is made of six pieces, all flat except the rectangular hinged top box which forms the working surface. It provides a seat, a working surface and a hinged drawer and may be adjusted to the size of the child. The top may be locked to form a hand case for carrying to and from school, and above the desk is a rack for placing material to be copied, while the surface may contain a built-in blackboard if desired. Two set-screws are all the equipment needed to set up the desk, which weighs about fifteen pounds. Use of the desks enables rapid clearing of the classroom for play or other work, which is an obvious advantage.

FURNACE MADE OF FIREPLACE TO HEAT ENTIRE HOUSE 3790

Transforming a fireplace into a furnace which heats the entire house instead of one room is accomplished with an apparatus employing an electric fan system below the floor on which the master fireplace is installed. The fireplace back is of corrugated iron and inclosed by a second metal jacket, leaving a space through which air is circulated by the fan. Radiating fins on the fire back project into the air space to speed heat absorption as cold air is forced over them. Distributing pipes below the floor convey heated air to registers in the various rooms.

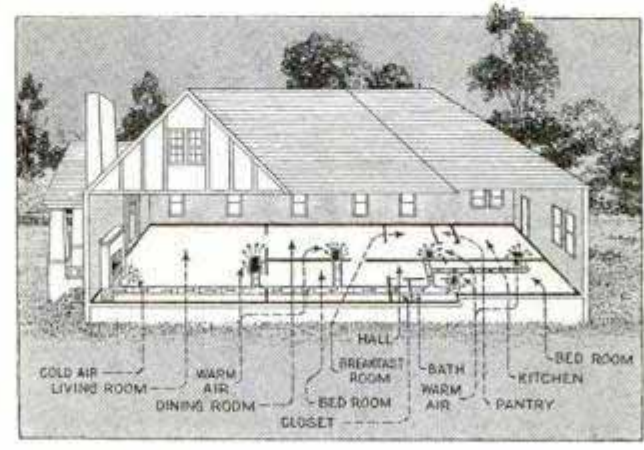

Diagram Showing How Heat from a Fireplace May Be Conveyed to Other Rooms of the House

Thermogone Mfg Co

Com. Shunn see letter

35 72

City of Detroit, Dept. of Street
Railways, Administration Bldg
Helfert, Inc.

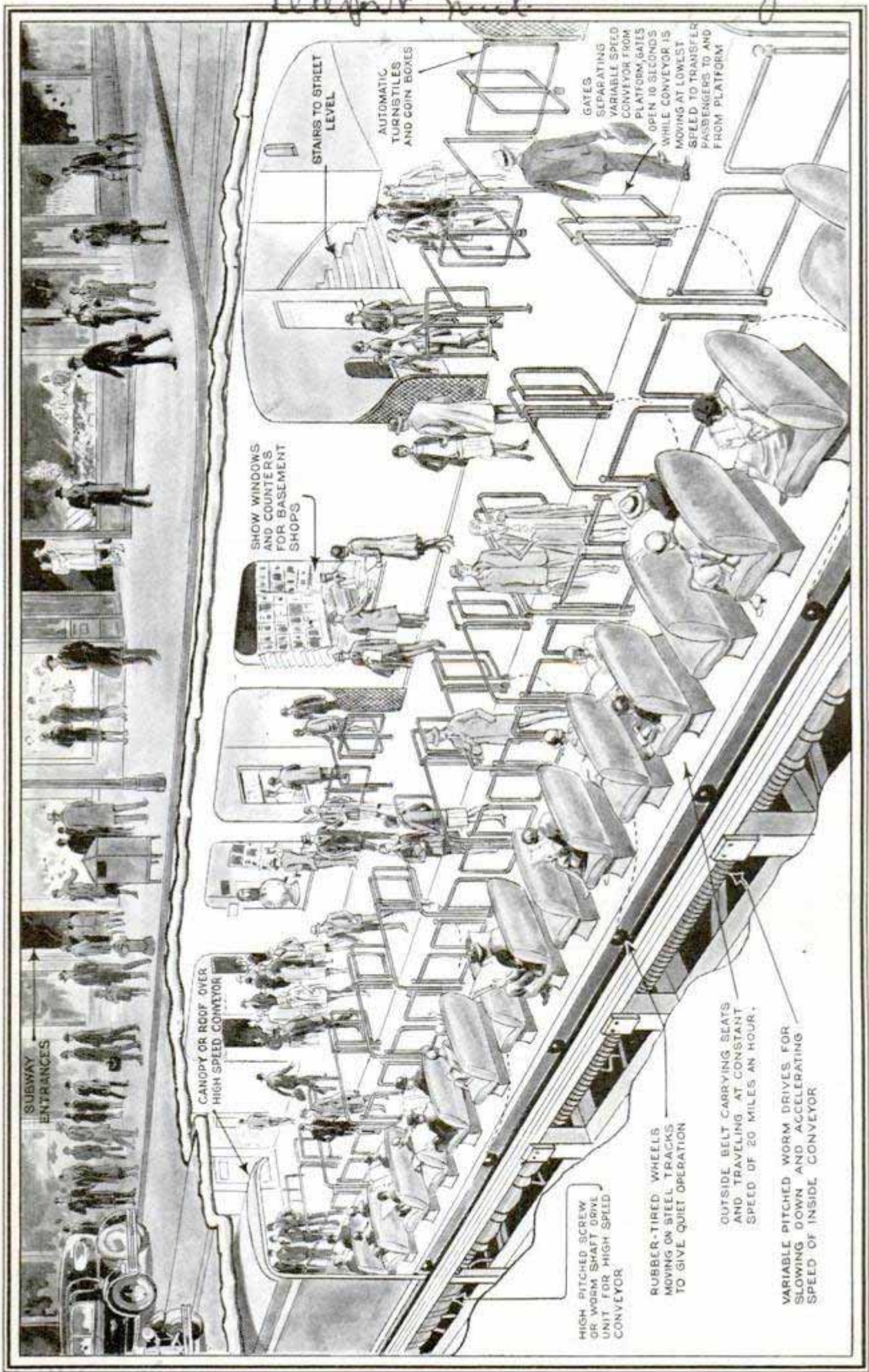

MOVING SIDEWALK MAY SOLVE RAPID-TRANSIT PROBLEMS

Possible solution of the rapid-transit problem of large cities is seen in a moving sidewalk, built on the principle of a belt conveyor, said to be capable of carrying 70,000 persons past a given point every hour at a speed of from twenty to twenty-five miles an hour. The sidewalk, either subway or elevated, makes no stops but enables passengers to alight with ease and safety. It is the invention of a Detroit man, and a model of the system now is in operation. It comprises two endless belts, one beside the other, each five feet wide and built in twelve-foot sections. Traveling on wheels and tracks, the sections are built as solidly as the modern trolley car, and fit into each other at the ends. The inner belt, separated from the outer by an endless succession of automatically controlled gates, moves uniformly at from twenty to twenty-five miles an hour, its outer edge forming an aisle and the inner containing seats. The outer belt consists of a platform separated from the stationary walk or platform by another succession of gates. This platform at intervals moves at a speed of less than a mile an hour, at which time the gates open to permit passengers to board it. In nine seconds it is accelerated to the same speed as the inner platform when the inner gates open to permit passengers to enter the constant-speed conveyance and take seats. The entire system would move in one direction on one side of a street, and in the opposite direction under the sidewalk on the other side. Construction and operation would be simpler and less expensive than a subway, it is claimed.

EXTRA LIGHT SPEEDS GROWTH OF SUGAR-BEET SEEDS

By the use of electric light, sugar-beet seeds can be produced in one year instead of the usual two, Prof. George Stewart, of the Utah agricultural experiment station, has discovered. He planted the seeds in greenhouses in November or early December and illuminated them after dark. The plants produced seed the same summer they were set out in the field.

38 00
Tempting the Insect-Eating Plant's Appetite with a Morsel of Meat; Note Cobralike Shape of Stems



PLANT THAT DEVOURS INSECTS TRAPS THEM WITH HONEY

One of nature's strangest products is a plant that represents a sort of cross between the vegetable and animal kingdoms. It contains honey-secreting cells which prove a lure to various insects, but as soon as they alight, the leaves close over them, and they are digested by the plant's juices. The blossom and stalk have a curious resemblance to the hooded cobra.

TONGUE CLEANER ON HANDLE OF TOOTHBRUSH



Cleaning the tongue as well as the teeth is made possible with a toothbrush which also contains a pad for brushing the tongue. This pad is on the end opposite the brush and consists of a spongy, round cushion which cleans by vacuum

and contact without injury to the nerves of taste in the tongue.

Science Service news
Bull. # 450-10

Mr. Link
29 11 Jackson Blvd

Washington
Pletcher plant

BABY BUGGY RESEMBLING AUTO AFFORDS PROTECTION

Baby Carriage Like an Automobile Body, Which Affords Complete Protection from the Weather



Affording complete protection from the weather to the youngster out for an airing, a baby carriage resembling an automobile body has made its appearance in London. The carriage is entirely inclosed, and has movable glass windows.

MEASURE FOR LIGHT IS FOUND AFTER TWENTY YEARS

For the first time in history, mankind has a way of measuring light with unvarying accuracy. Tomorrow all the artificial lights in the world could be destroyed, and the next day man could reproduce them to an exact standard. Yesterday, figuratively speaking, he could not have done so. He had no accurate means of measurement then. This remarkable contribution to man's constant trek away from darkness is the product of the bureau of standards after twenty years of research. The brilliance of pure platinum at the fusing point is the basis for the new standard which has supplanted the undependable comparison with a

group of standard electric lamps which the bureau has guarded for a score of years as the "international candle." All the time they were changing in brilliance and could not be reproduced when their efficiency was seriously impaired. The first method of measuring illumination was by the candle standard from which is derived the common term candlepower. It is a virtual impossibility to reproduce a candle with the precision that science demands and just as difficult to make it behave in the way its predecessor did. The oil-lamp standards succeeded that first elastic yardstick. Their performance was affected and subjected to a change by a host of factors. Then came the electric-lamp standard, which also was uncertain. Finally, Dr. E. Wichers perfected a process of refining platinum until it was chemically pure to within four parts in one million. Comparison of the brilliance of the platinum at the fusing point was then made with the lamp standard and a measurement established that for a time will remain unchangeable. A standard of measurement, Doctor Wensel, director of the experiments, declared, that is predicated on a natural phenomenon is the most precise. No standard of temperature, for example, can be as unvarying as the melting point of ice or the boiling point of water. Nature is far better than instruments, he added. In the case of instruments, one cannot be sure that the materials used in them always will be the same. The new standard parallels those of the above natural phenomena.

ELECTRIC SHEARS CUT CLOTH AND SHEET METAL

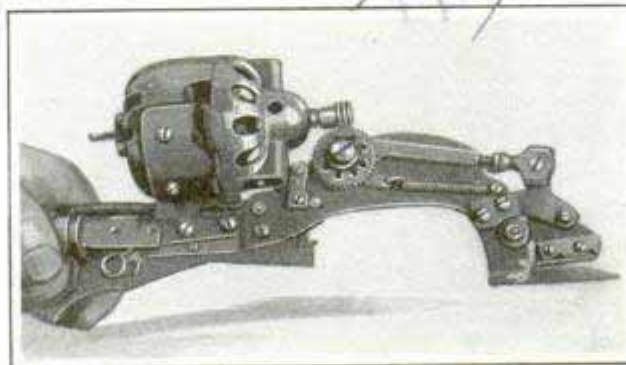

Pair of Shears Operated by Electric Motor for Cutting Many Layers of Cloth at Once

Run by a motor which delivers power through a series of gears to the cutting blades, electrically operated shears save much time and labor in cutting cloth and sheet metal. They cut several layers of heavy cloth in one operation.

3909
6.C. 3899
Carl William Allman,
Woodward Blvd. Washington,

International

3909

Carl Herfler
1087 Pennsylvania Ave.

54 Rubblesdale Road

POPULAR MECHANICS

Streatham, London

HOW MOTOR HIGHWAYS ARE BEING BEAUTIFIED

S.W. 16, Eng

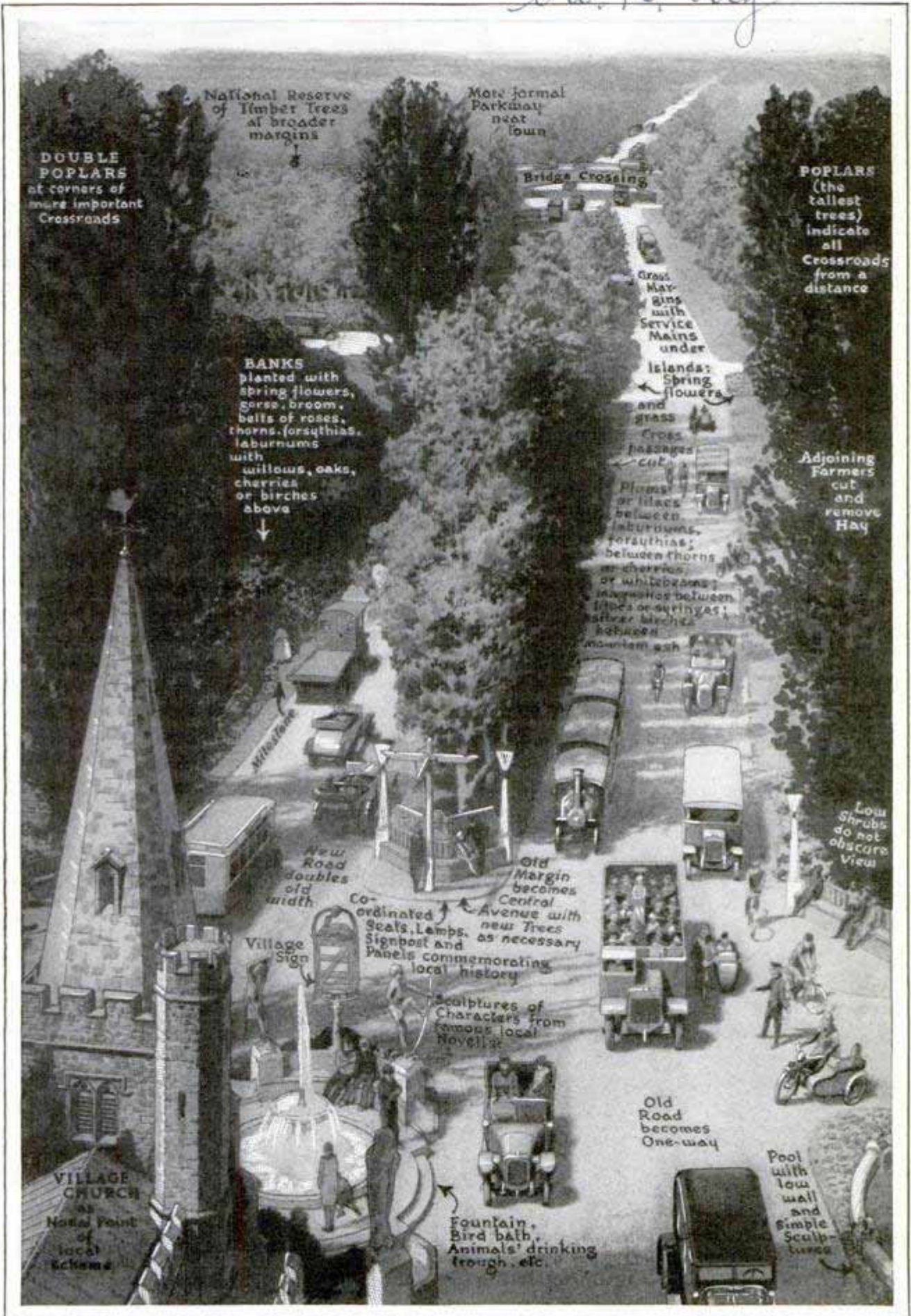

*Transfer
Dec 1929*

*3832.
Cmt. Walter E. Burton
1922 Florida City/Kennings Station
Arthur O. Austin*



Radio Tower Built in Insulated Sections for Better Reception; Insert, One of the Insulators

SECTIONAL TYPE RADIO TOWER GIVES BETTER RECEPTION

Instead of being one unit of steel supported on large insulators, the 200-foot antenna towers of radio station WHK, at Cleveland, have been broken up into five sections, each about forty feet long, with big porcelain insulators between the sections. This method, which gives more uniform and reliable reception, was developed by Arthur O. Austin, of Barberton, Ohio, internationally known authority on insulation. The ideal aerial is one that is suspended in the air in order to radiate energy in a circle, and the sectional tower is the nearest practical approach to this ideal. In one-piece towers it is often necessary to tune the tower to the frequency of the station because such masses of metal behave like one plate of a large condenser, the other terminal being the ground, and so have a natural period of oscillation. With the sectional towers, the frequency of the individual sections is so high that they do not interfere with station frequency. Ladders and hoisting system for raising or lowering the aerial

also are provided with gaps and insulated sections. Electric lights cannot be used because the wires interfere with insulation, and, instead, the top of the tower is lighted with acetylene, the gas being carried in copper tubing with porcelain insulation at each tower section.

3862

DUCKS FLY AS FAST AS PLANE

Ducks can approximate the flying speed of the ordinary passenger airplane, although the faster ships outrun them. The speediest duck is the canvasback which travels at an estimated rate of 145 feet per second, or nearly 100 miles an hour. Mallards and black ducks fly at an estimated speed of seventy-five feet per second or about fifty miles an hour, bluebills from 110 to 140 feet per second, redheads at 120 feet per second and the wild goose at 110 to 125 feet per second.

PRINTING STONE FROM CHINA TWO THOUSAND YEARS OLD

456

Weighing more than half a ton, a stone slab believed to have been one of the first crude printing machines has been brought to England from China, where it was found. The slab, more than 2,000 years old, has carvings of priests and animals on its surface. It is thought that a form of ink was applied to the face and that copies of the design were rolled off on silk. The stone is recognized as being of the Han period, which was 206 B. C.

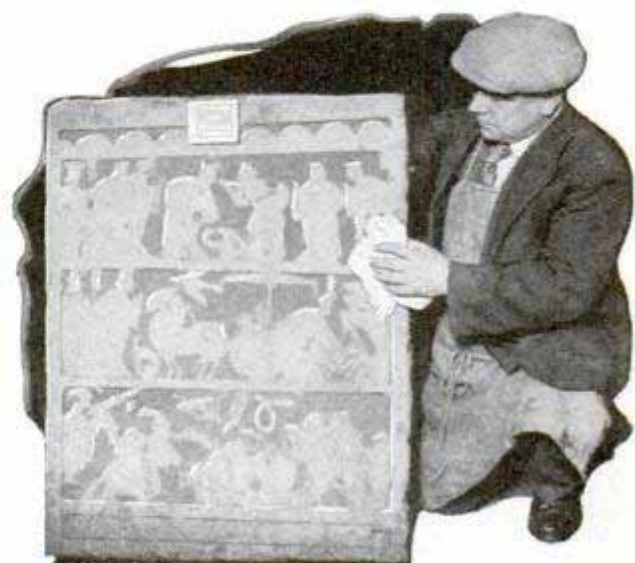

© P. & A.

Stone Slab, Found in China, Believed to Have Been Used for Printing 2,000 Years Ago

LINDBERGH'S LATEST PLANE IS BUILT FOR SPEED

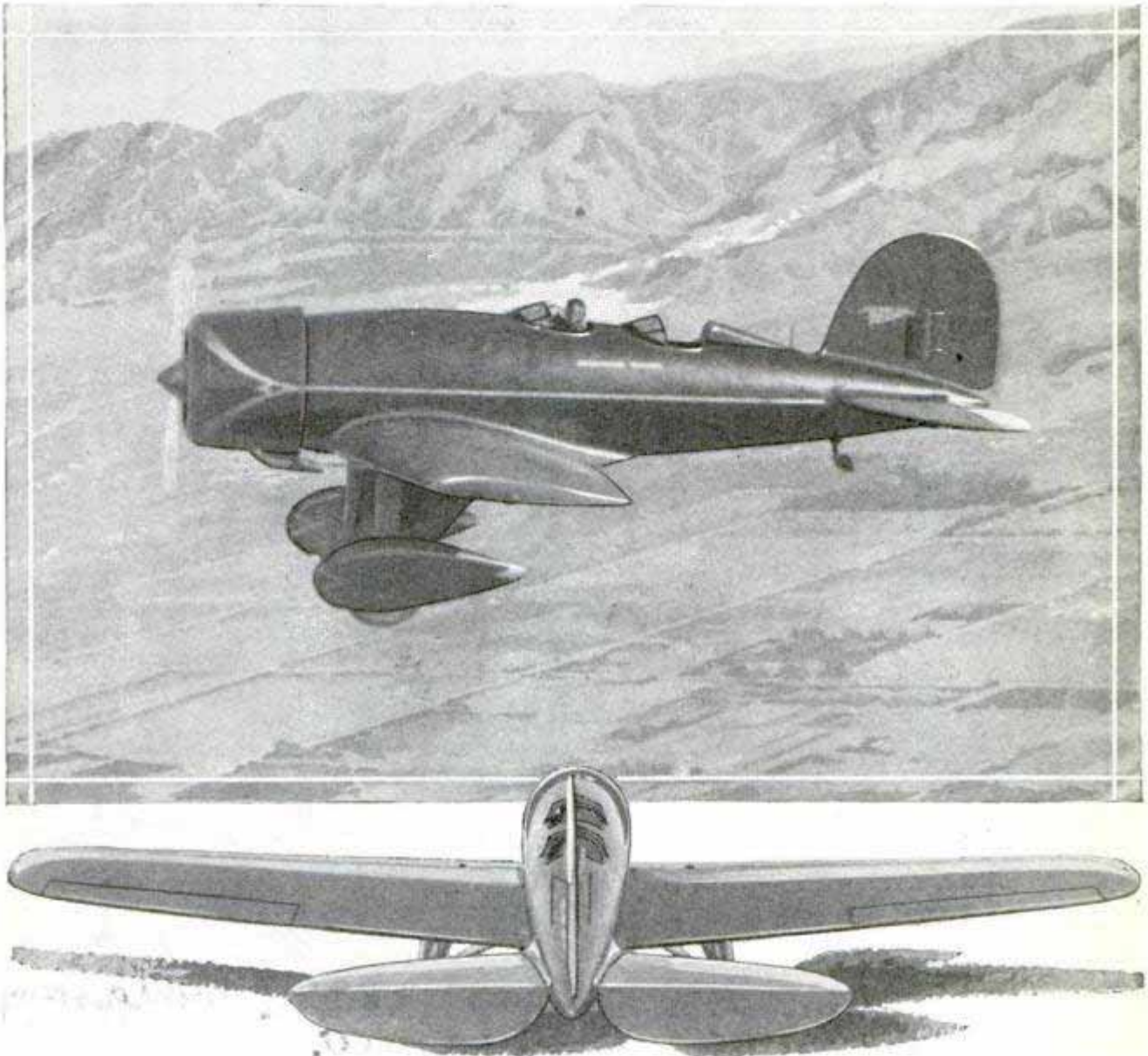

Two Views of the Low-Wing Lockheed Vega Monoplane Built for Col. Charles A. Lindbergh; the Two-Place Arrangement with Double Controls Was Designed So That Mrs. Lindbergh May Fly with Her Husband

Built to the order of Col. Charles A. Lindbergh, a Lockheed Vega monoplane that has a top speed of 180 miles an hour and a cruising speed of 150 miles, has been constructed at Burbank, Calif., and has passed successful trial flights. Several distinctive features, not found in the usual Lockheed ship, have been incorporated in this plane. The low wing is a departure from the usual style of ship of this make, there are dual controls, installed so that Mrs. Lindbergh, who already has made solo flights, can fly with her husband and there is fuel-storage space sufficient for 540 gallons of gasoline. It is estimated that the plane will be able to fly, with a full load of fuel, more than 4,000

miles without landing, and will have a normal cruising radius of 3,500 miles. The colonel is said to have suggested several of the ideas incorporated in the unusual streamline design of the plane. Motor cowling, shields over the landing wheels and other features have been employed to decrease wind resistance to an even greater extent than is possible with the ordinary Lockheed plane, which is one of the fastest in the skies. Mrs. Lindbergh is reported to have suggested the color scheme. The plane has a black body and vermilion wings.

☐ The pouch of the pelican is used as a scoop or dip net for fishing.

*Lockheed Aircraft Co.
Burbank Calif.*

3590

Sea Rovers Battle

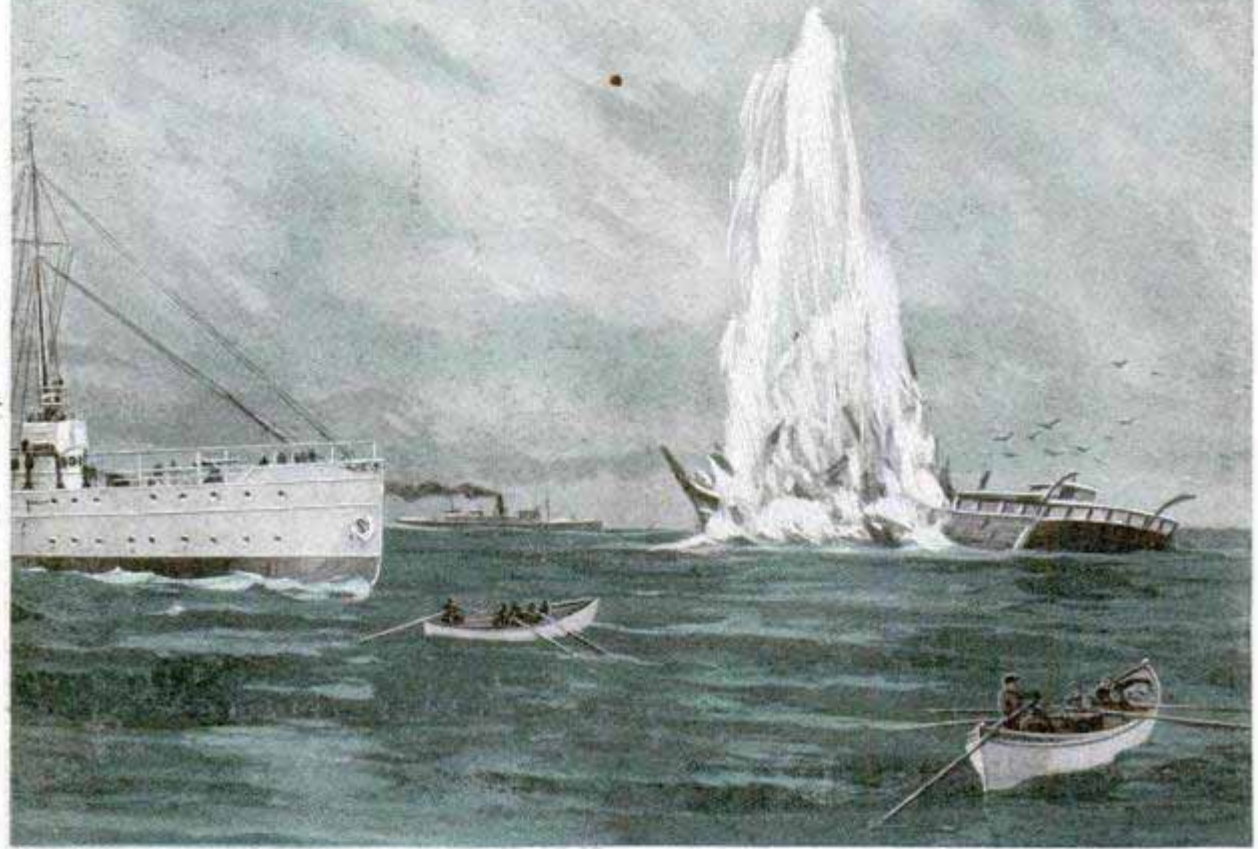

Coast Guard Derelict Destroyer "Seneca," Blowing Up Floating Wreckage of Old Vessel by Exploding Mines underneath the Craft; in Shallow Waters, Derelicts Are Usually Towed Ashore and Destroyed

By G. H. DACY, 4639 E. Montgomery
 Av. Bethesda, Md.

COMB the archives of sea lore and you will find recorded there the amazing wanderings of the "Fannie E. Wilson," the most famous derelict known to American shipping.

For three years, this three-masted schooner, which was wrecked off Cape Hatteras, floated erratically upon the ocean, driven by currents and shifting winds. Seasoned navigators estimate that the abandoned ship cruised 9,000 miles in this crewless voyage.

Uncle Sam's naval rovers who patrol our coastal waters and seek to minimize maritime dangers scouted time and again for the "mystery derelict," as she came to be known. Their quests were futile for they never solved the riddle. Man had no hand in the eventual sinking of that floating peril to shipping. The remains

of the "Fannie E. Wilson" were last seen several thousand miles from where her crew abandoned the wreck. Mariners believe that she finally broke to pieces on the rocks.

Currents and countercurrents, winds and crosswinds, fair weather and foul, singing gales and smooth seas drove the derelict on one course and another. After abandonment, she swept to sea under Gulf Stream and westerly-wind influences. She cruised to the domain of the latitudes where the northeasterly trades dictated her course. Later, westerly currents and winds brought her back to the Antilles and the region of the Gulf Stream. This cruise was repeated many times, wind and weather driving the derelict over a huge elliptical course.

The "Fred B. Taylor" was another his-

Derelicts

toric derelict, wrecked 400 miles east of New York harbor and subsequently reported forty-seven times, yet always eluding all attempts of the U. S. navy to find and sink that dangerous rover. In the course of time, the stem of this wreck, severed from the hull, was beached in a storm. The bow continued to imperil shipping and finally docked in the unknown harbor of missing ships and wreckage whence return is impossible.

The annals of the U. S. coast guard—its cutters have been engaged in derelict destruction since 1910—tell the strange story of the tank steamer "Oklahoma," a ship that defied the natural order of things by continuing to float for many days though water ran freely into her hull. After being rammed in a collision, the forward end of this ship, about 200 feet long, rode out a severe storm floating bottom up. The coast guards, when they finally found this stray hulk of iron and steel, discovered that the cause of the marine marvel was special air tanks which had buoyed up the wandering wreck. Attempt was made to destroy the derelict by mines placed six feet under the water against her sides. These mines were ineffective. It was not until the wreck was raked below the waterline by fifteen shells fired from six-pounders, that the hulk began to sink and disappeared in seventy minutes.

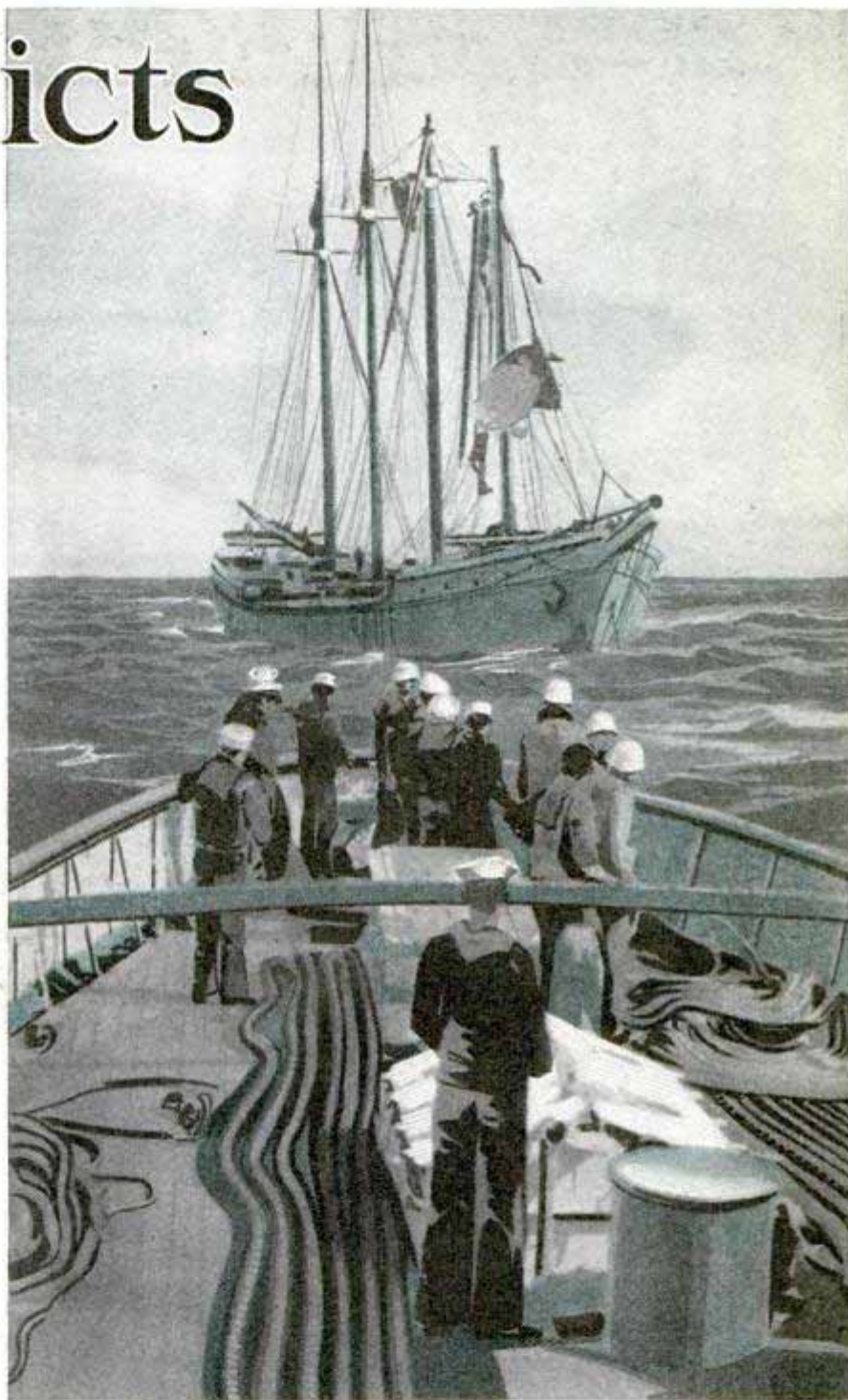

Four-Masted Schooner, Storm-Tossed and Partially Wrecked, Being Salvaged by Coast Guard Crew Before It Becomes a Derelict

Another metal ship which refused to sink for two weeks after being wrecked was the Russian bark "Dorothea." This waterlogged derelict, with headbooms, masts, deckhouses, hatches and bulwarks washed away, continued to ride tempestuous waves. The doomed hulk floated with one side of the deck awash and the other side three feet above the sea. The wreck was reported as occurring about halfway between New York and Bermuda. A

359 0260



sailors, officers and passengers. This job of searching for derelicts is often as difficult as ferreting out the mysteries of complicated crimes. Many hours or days usually elapse between the receipt of the radio report and the arrival of the "derelict destroyer" at the point where the floating wreck was last seen. The experienced hunters, familiar with the directions of currents, winds and tempest trends in that latitude, follow four systems of cruising after derelicts. The scout may be made by the zigzag system where the ship sails courses sixty degrees apart with the

vessel advancing somewhat and also beating to windward. Spiral scouting consists in the uniform and progressive circling of the suspected region, while in a triangular quest after a derelict, the pursuing ship steams over three courses sixty degrees apart in an ever-increasing triangular cruise. In rectangular hunting, the coast guard cutter cruises over four courses which con-

coast guard cutter spent ten days of scouting before it succeeded in locating the derelict one moonlight night when the visibility range was one and one-half miles. The "Dorothea," challenging the law of gravity, had been buoyed up by her cargo of yellow-pine lumber. Uncle Sam salvaged the wreck and cargo.

The British steamer "Erne" of steel construction also floated for days after a collision because of the buoyancy produced by her lumber cargo.

Derelicts discovered along steamship lanes and other marine routes run the gamut of most everything that will float, from whales to sails, spars and masts, from fragile hydroplanes to huge ships, docks, trees, logs and lumber. Three-fourths of the derelicts which jeopardize ocean travel are caused by storms. During the last twelve months, the U. S. coast guard destroyed 267 of these floating hazards of navigation as well as saving \$49,000,000 in ships and the lives of 4,375

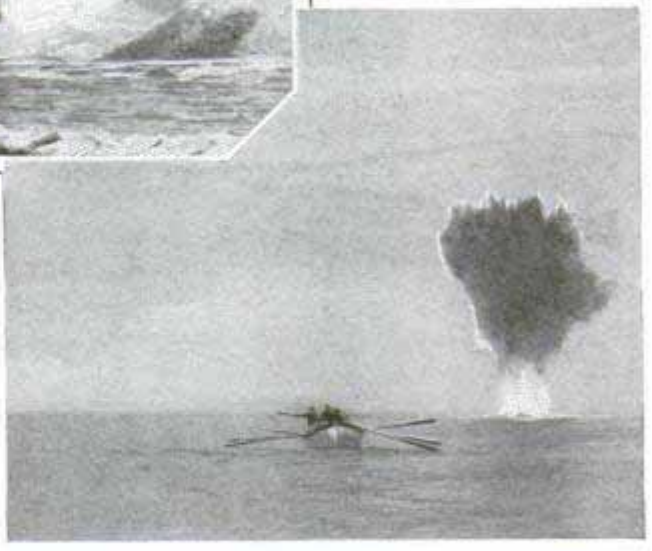

At the Top, Recovering Floating Masts; in Center, a Derelict in the Making, and, at the Bottom, Removing an Obstruction with T.N.T. Mine



If Mines Fail, Guns Are Sometimes Employed to Destroy the Derelicts; Expert Marksmen of the Coast Guard Show Their Skill in Hitting Difficult Targets

stitute a constantly increasing rectangle, and in all cases makes right-angle turns. This system of searching is used principally in offshore scouting.

You can well appreciate that the hunt may be as difficult as looking for the traditional needle in the haystack by the fact that the abandoned schooner, the "Frederick Roessner"—lumber-loaded—floated 285 miles from the scene of wreck in less than four days. The rate of drift of the derelict depends on the wind, sea, currents and whether or not the wreck is waterlogged. A waterlogged wreck without sails tends to lie in the trough of the sea and drift to leeward about one-half as fast as will a coast guard cutter with her engines stopped. One of these government ships will drift one-fourth of a mile an hour in a light breeze, one mile in a moderate breeze and two miles in a moderate gale.

Cape Hatteras, the Nantucket shoals and the Cape Cod region are the "graveyards of the Atlantic," where stately ships are transformed by storms, currents and shoals into wrecks that drift as derelicts until destroyed. The notable "graveyard

of the Pacific" is that tribute-taking stretch of water between Vancouver island, Cape Flattery and Puget sound. As many as three or four large vessels have gone on the rocks there in a single night. A curious fluctuating current on the coastal route between San Francisco and Seattle proves the undoing of foreign ships whose captains are unacquainted with the vagaries of those waters. During stormy, foggy weather, all these hatcheries of derelicts are fertile of potential menaces to other shipping.

"Mining" a wreck is not as simple as telling the tale about it. For example, one four-masted schooner, sunk in twenty-two feet of water, required the explosion of thirty-eight mines, costing about \$60 a piece, before the derelict was destroyed.

During clear weather, a derelict ship or other large wreckage is visible at sea from seven to ten miles. Small flotsam, such as rafts, trees, spars, logs, balks, and the like, are visible for from one to two miles under favorable conditions. On rare occasions, when the sea is like a mirror, the normal range of visibility is increased measurably.

Tested by navy

American Institute of Steel Construction

3825

off Newport, R.I.



Radio-Controlled Torpedo as It Is Fired from Ship; It Has a Firing Range of Six Miles

TORPEDO CONTROLLED BY RADIO AFTER STRIKING WATER

Controlled by radio after striking the water, the Hammond torpedo recently was tested by the navy, off Newport, R. I. The radio death missile costs \$12,000. Except for the fact that its course can be controlled by radio, it looks and fires like the torpedoes that have long been in use. The Hammond type has an effective range of about six miles.

ALARM WHEN PIPE FLOW FAILS PROTECTS MACHINERY

Sounding or flashing a warning when the flow of liquid or gas through a pipe stops for any reason is the purpose of an attachment that may be connected to any piping system to protect machinery from damage. The alarm may be attached to an oil-circulation system, to water circulation for condensers or water jackets,

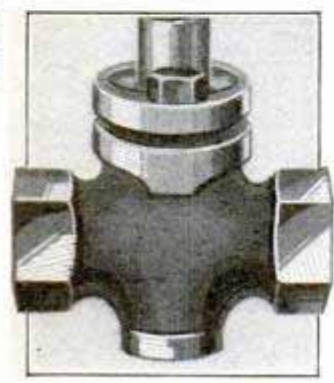

to the fuel supply of an internal-combustion engine, or to a steam, gas or ventilating system. The alarm takes the form of a bell or colored light, and may also be made to stop the engine.

STEEL FLOORS IN SKYSCRAPERS PERMIT TALLER BUILDINGS

Electrically welded steel flooring, which materially reduces the weight of a building while adding to its strength, recently was tested and hailed by architects as a means of erecting taller skyscrapers than have heretofore been possible. Known as the battledeck type of flooring, the material, consisting of steel plates and structural-steel beams, is "stitched" together with an automatic welding machine developed by the General Electric company. The flooring, when in place, resembles a solid steel deck which acts as a girder to prevent any distortion of the building if subjected to wind or earthquake action. The method may also be carried into the walls to provide standard construction to support the outside walls. Cost of the flooring, overlaid with cork tile, thus eliminating the necessity for any other covering, is estimated at less than the cost of the ordinary floor if covered with carpet. Its use is expected to permit an increase of twenty-five per cent in the height of the building or the number of floors of a structure without increasing the load on the foundations.

TEE SUPPORT PROVIDES TARGET TO PREVENT TOPPING

Golfers who are troubled with topping, hooking or slicing their ball now may be aided in correcting the faults by a tee which at the same time is a target.



The base of the tee is of rubber and on top of the base, just behind the tee, is a red disk which is the target at which the player aims. Using the base also protects sod and clubs. A circular opening in front of the tee allows the wooden peg to emerge when struck by the driver. Swinging the disk to either side of the tee helps to offset the tendency to hook or slice, while topping is corrected by aiming at the disk just behind the ball. This golf accessory also is found helpful in indoor practice.

M. V. Perry, Jr.
572 Page St.

3137 - E. Michisoni, A. d. met. P. T. Clithelder, Chevrolet Sales Sandler, Wakefield Eng

**ELECTRIC EYE MEASURES
 HAZE IN HOLLAND
 TUNNEL** 3895

Measuring the smoke and haze in the Holland tunnel under the Hudson river is the latest job for the photoelectric cell which has made television and talking pictures practicable. Above the main tube of the tunnel is an exhaust duct through which the gases formed in the tunnel are drawn. It is dark except for light admitted through air openings, and it is here that the photoelectric appliance to measure visibility is installed. A box contains a lamp and photoelectric cell in adjacent light-tight compartments, except for a lens at the front of each. The lens in front of the light makes a narrow beam shining on a mirror, 150 feet distant, from which it is reflected to a second mirror and back to the box where the other lens focuses the light on the cell. The current from the cell is amplified by vacuum tubes, and passes over wires to the recording apparatus in the tunnel office half a mile away. Here it controls the movement of a pencil over a moving strip of paper. When smoke increases, the intensity of the light decreases. The pencil indicates the fact, and, to remedy it, ventilating engineers turn on more fans.

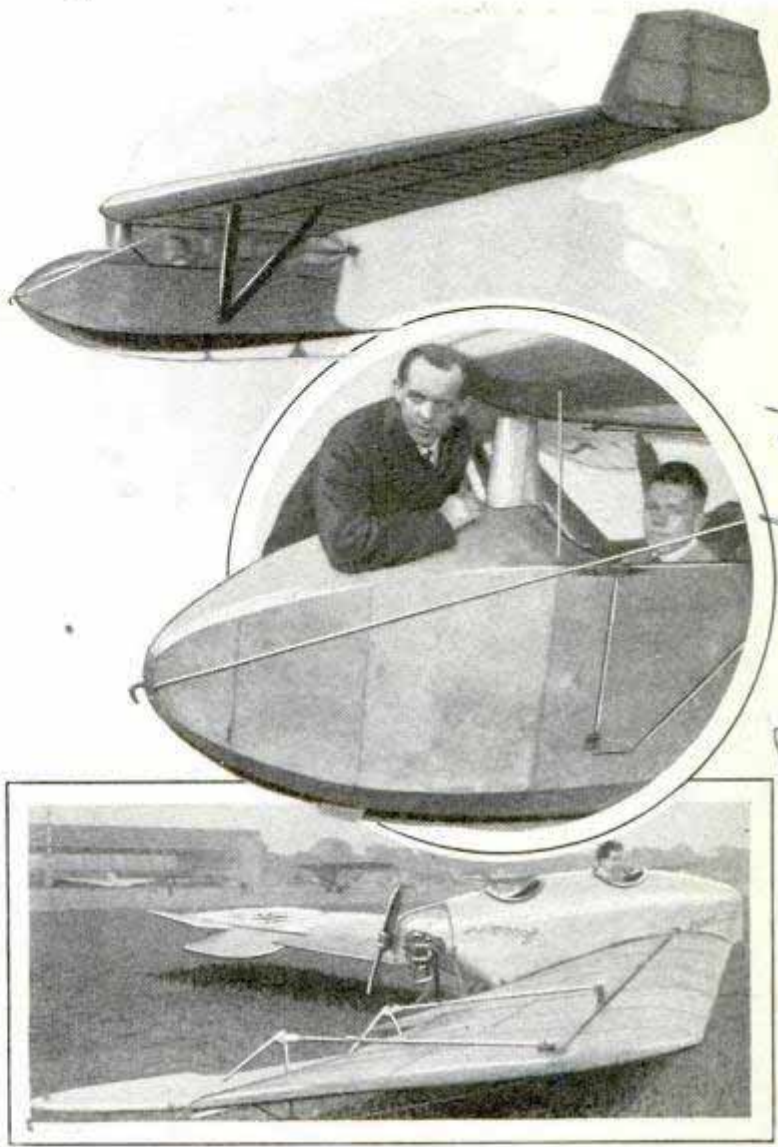

Views of the Motorized Tailless Gliders Tested in Germany; the Engine Is Seen behind Rear Cockpit in Lower Photograph

**GLIDERS FITTED WITH MOTORS
 TEST "TAILLESS" FLIGHT**

Eight-horsepower motors have been installed in two gliders in Germany and the craft flown to test certain advantages claimed for tailless airplanes. One was flown at a slow rate of speed and was landed at an angle much steeper than would have been possible with the usual plane, aviators declared. Steering is accomplished by rudders at the ends of the wing, and flaps at the rear edge serve as ailerons.

Wassen wird
 Fortschritt
 Wilhelmstrasse, 130. Berlin d. W. 49.
 Germany

**PUPPET SHOW FOR THE HOME
 IS EASILY ERECTED**

Miniature theater stages and settings for the home, school or studio are available in lithographed sheets to be mounted on cardboard and cut out. Based on the modern built-up principle, a great number of settings are obtainable.

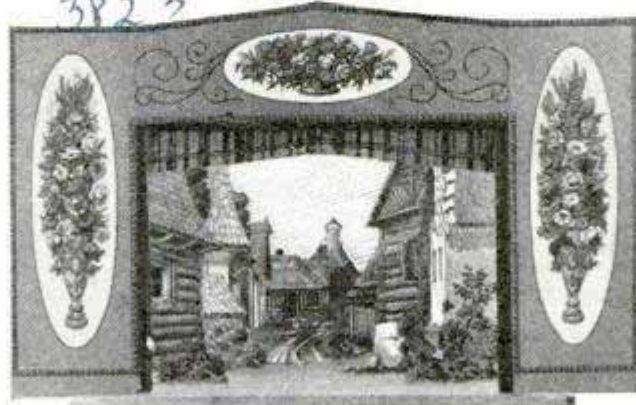

Front View of the Miniature Stage Designed for School Instruction or Home Amusement

Miniature Theatre
 Esyeld

John Rossiter
 Esplanade

*picture taken at
A. G. Galy*

3799

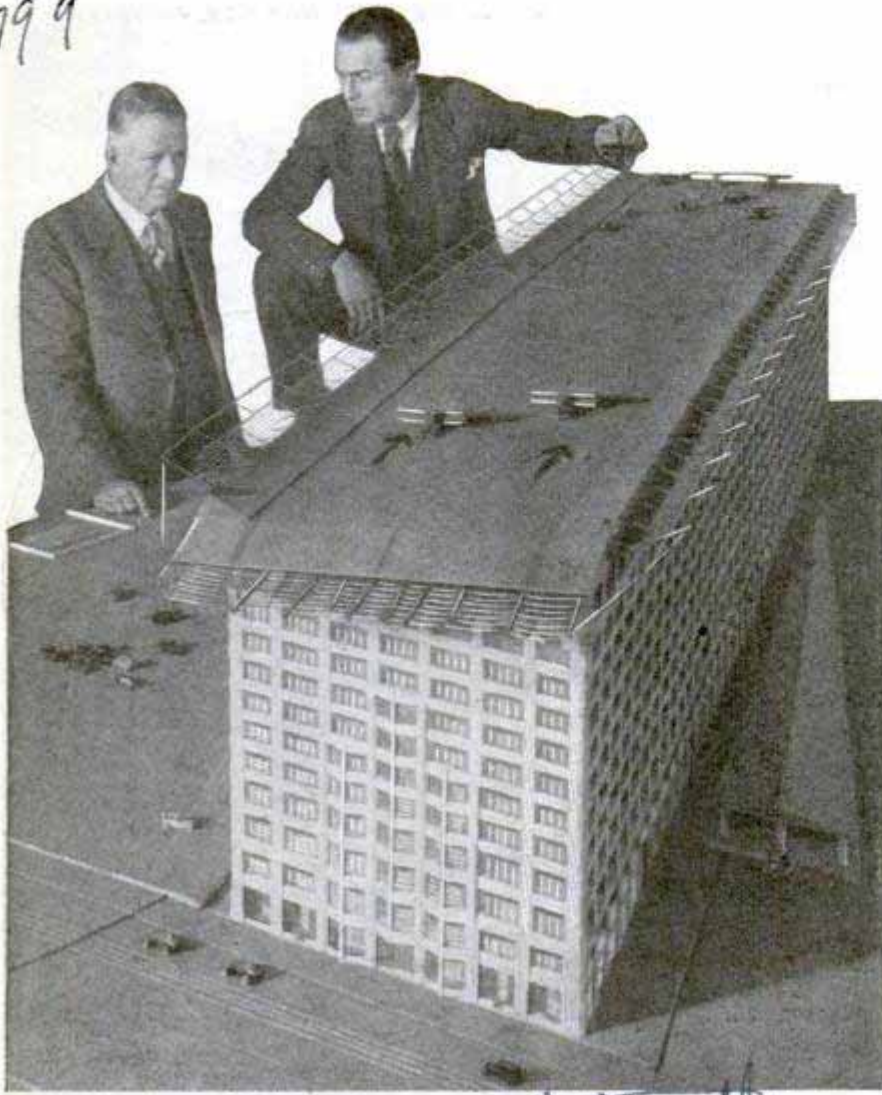

Model of Industrial Building, Planned for Los Angeles, with Landing Field for Airplanes on Its Long Roof

LANDING FIELD ON LONG ROOF TO SERVE BIG BUILDING

Anticipating the day when it will be practical to land aircraft on the top of buildings, the roof of a huge terminal structure, planned for Los Angeles, is to be fitted for the accommodation of airplanes and other ships. It will be 980 feet long and 152 feet wide.

El Fran

CAMERA SNAPS ELECTRIC SPARK IN BILLIONTH OF SECOND

By using a spectroscopic camera with a shutter operating in about one-billionth of a second, pictures have been taken of the action of light at various periods during the jump of an electric spark which lasts about one-hundred-thousandth second. Photographic evidence has shown that the magnetic field developed by the

about 186,000 miles a second and an infinitesimal part of a second later the light from the spark starts toward the camera at the same speed. It is a race between the spark current and the spark light, but by lengthening the wires between the spark gap and the camera, the light is allowed to arrive first, the current reaching the camera to close the shutter a fraction of a second later. By adjusting the wiring, the shutter can be made to close during any one-billionth of a second interval in the first four ten-millionths of a second of the spark's short life. The camera "shutter" consists of two Nicol prisms of Iceland spar, so arranged that under ordinary conditions the light coming from the spark is stopped by polarization and prevented from reaching the camera. Between the prisms, however, is a solution of chemicals which will depolarize the light and allow it to continue,

Internat

1 Herald Tribune 4/28/27

3880

*Experimental work done by Frank Es
Dunnington under direction of (next page)*

Camera developed by Mr. L. W.
POPULAR MECHANICS

His new
James P. Dy
265
New York.

Beams of Yale

the wires from the spark gap connecting with this solution, so that the current electrifies the solution for one-billionth of a second, thus removing the depolarizing effect and stopping the light passage, or, in other words, closing the shutter.

ELECTRICITY REVIVES INFANTS BY INDUCING BREATHING

Persons apparently dead from electric shock and seemingly still-born babies have been revived by an electrical method tested at the physiological laboratory of Bonn university in Germany. Dr. Fritz Israel, originator of the method, successfully treated six new-born infants by applying electrodes to both sides of either the neck or chest and passing a weak current through the body. By the first application a nerve leading to the diaphragm is excited, and by the second the diaphragm muscle itself is acted upon, forcing expansion of the lungs, or, in other words, artificial breathing. Doctor Zangger, professor of medical jurisprudence at Zurich, Switzerland, similarly revived a man apparently dead of electric shock.

SAILBOAT MADE OF CONCRETE WITH A KEEL OF IRON

Divided into four water-tight compartments, a sailing boat made of concrete has been constructed at the direction of a Stockholm sailing enthusiast. The concrete boat has a sail area of more than 360 square feet. The outside is unpainted and the keel is of iron.

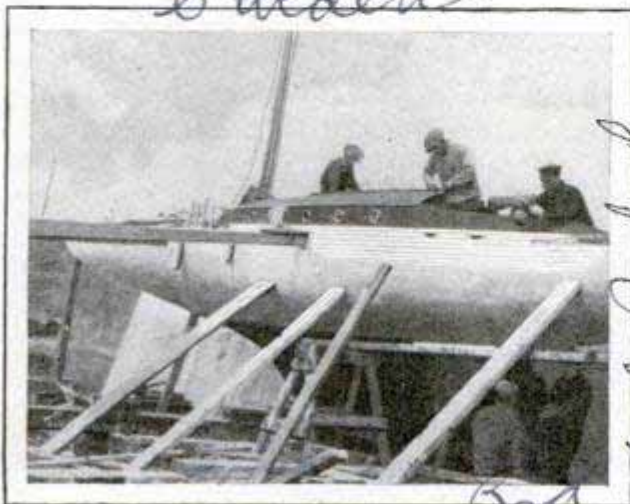

Sailboat of Concrete and Iron Which Is Divided into Four Water-Tight Compartments

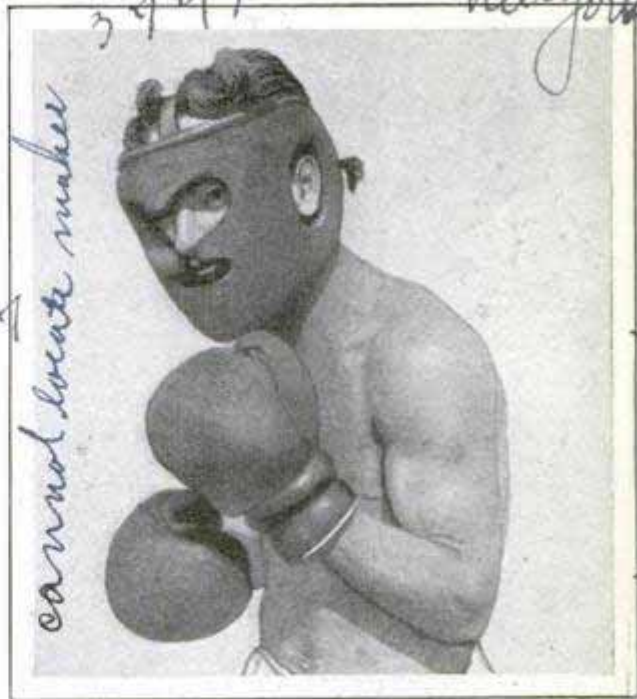

Padded Mask Which Protects Boxer's Face but Still Has Openings for Eyes, Ears and Nose

PADDED MASK PROTECTS FACE OF PRIZE FIGHTER

Covering almost the entire face of the boxer, a padded mask has been made to protect the features of the man who likes to box but does not want to be disfigured. Openings for ears, eyes and nose are provided, but even these are protected by the thickness of the mask so that the landing of a damaging blow is impossible.

WATERMELON SEED IS REMEDY FOR HIGH BLOOD PRESSURE

Following a series of experiments, physicians recently announced that an extract obtained from watermelon seeds has been found to offer dependable relief for many cases of high blood pressure. The extract has been named cucurbitacin and in the tests reduced the pressure of blood coming from the heart by more than ten millimeters in seventy-three per cent of the cases. Use of the extract afforded relief to eighty-two per cent of the cases in experiments with thirty-nine patients. The drug in most cases appeared to offer immediate relief, but better results were obtained with cases of short duration and with patients under fifty years of age. No untoward aftereffects were observed, but the tests indicated that the treatment should be used only in certain selected cases, and not as a general remedy.

Illustrations Technical 11/4/29 P. 46

390
378
Greenwell
Table Rock Laboratories

suggest one made by Genesee. Magniard & P. J. Thomsen N.Y.
Checked by Dr. J. L. Althausen and Dr. Wm. J. Kerr at G. & C. Calif.

Ed. Barksdale

3676

Sixteen Million

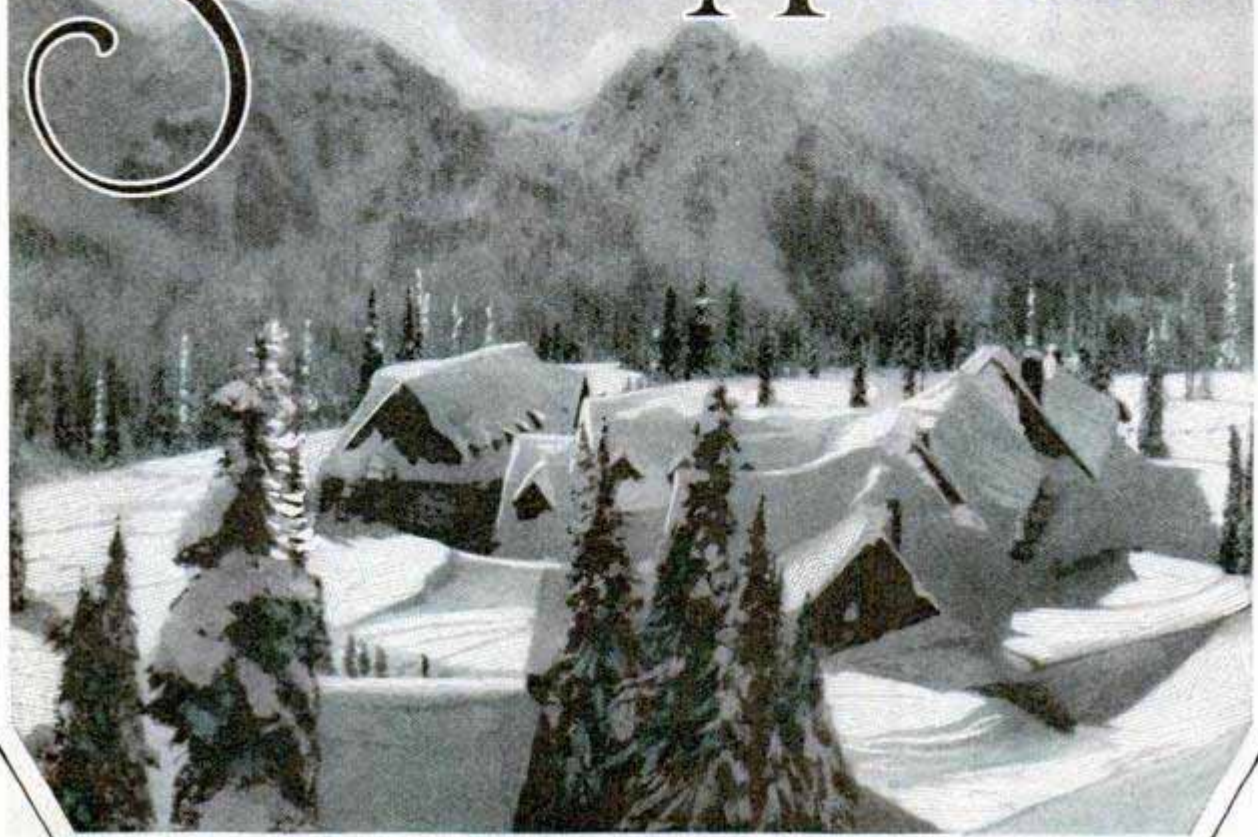

Paradise Inn, Mount Rainier, in Mid-Winter with Snow Lying Twenty-Two Feet Deep on the Level; the Snowfall in This Region Is Seldom Surpassed Anywhere in North America

By CALVIN FRAZER

c/o The Pictogram & Berlyo Washington, DC

TH**E**RE are two things in the economy of nature of which few people have any adequate conception. One is the amount of water that falls upon the earth in the form of rain and snow. The other is the amount that passes off into the air by evaporation.

The two amounts are, in the long run, exactly equal. For every ton of water that falls upon the globe a ton is returned, in gaseous form, to the atmosphere, though not, as a rule, at the same place where it fell. The oceans, lakes and rivers generally lose a good deal more water by evaporation than they receive directly from rainfall. The lands, for the most part, lose less, though a tract of land covered with luxuriant vegetation, especially with forests, vies with a corresponding area of water in the amount of moisture it supplies to the air.

How much water is involved in these processes? The records of precipitation

and evaporation for different parts of the world, as given in reference books, do not sound impressive. The reason is that both these things are measured and recorded in terms of depth rather than volume or weight. The unit used for such data in English-speaking countries is the inch, which seems an insignificant quantity until you learn that an inch of rainfall means 113 tons of water to the acre, or 72,320 tons to the square mile.

The amount of water that falls in a single widespread shower is often enormous. In the county of Norfolk, England, one day's rain brought down 670,720,000 tons of water—more than twice the amount contained in England's largest lake, Windermere. Much more remarkable downpours have occurred in tropical and subtropical countries. A few years ago rain fell over an area of about 10,000 square miles in India. The readings of numerous rain gauges within

Tons a Second

this area made it possible to determine with reasonable accuracy the total fall of water in the shower, which was found to be something like 7,000,000,000 tons!

Even with this figure in mind, the reader may be startled to learn that the amount of rain and snow falling on the entire surface of the earth averages about 16,000,000 tons a second.

Day after day, year after year and century after century, this prodigious deluge goes on, yet the oceans get no fuller, the land, as a whole, gets no damper, and the atmosphere, despite this tremendous drainage of its moisture, gets no drier. The reason for this paradoxical fact has already been stated—rainfall is exactly counterbalanced by evaporation.

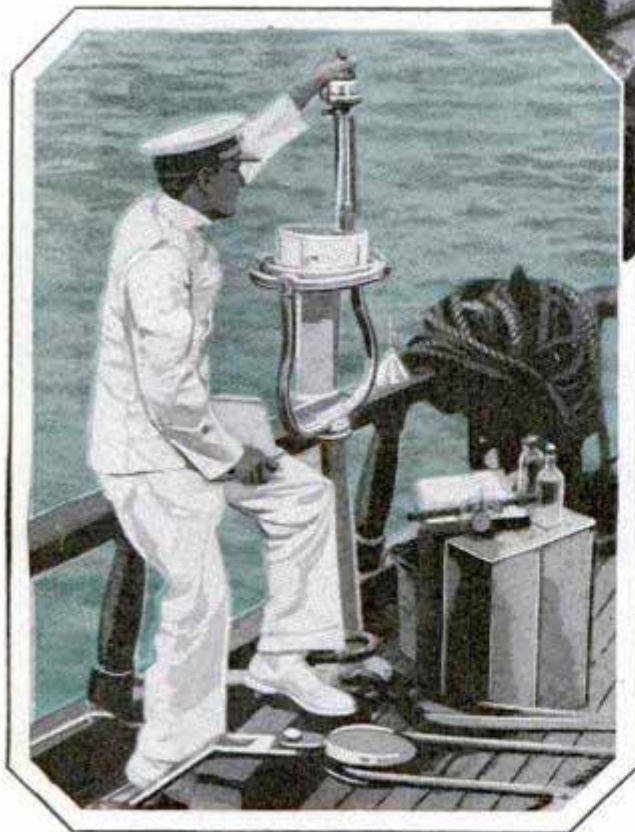

Courtesy Carnegie Institution

Top, Salt and Oil Gauge in Measuring Snow in Alps;
Below, Evaporation Gauge on Shipboard

Though the exchange of water between earth and air is unceasing, it is accomplished in an exceedingly irregular way. Moisture borne by the winds forms a constantly changing pattern of cloud distribution over the globe. The clouds affect moisture conditions on the earth beneath them by checking evaporation, even when they do not yield rain. When rain occurs, it is more or less uneven in its fall and often strikingly so, ranging from a cloudburst in one spot to a mere sprinkle in another. All these irregularities are reflected in the distribution of water in the soil, the flow of streams, the yield of springs and the depth of water in lakes and reservoirs.



tricts. In the United States, for example, the range is from a little over an inch and a half a year in Death Valley, California, to more than 130 inches a year in Tillamook county, Oregon. These geographical contrasts are only half the story of rainfall diversity. The other half is furnished by the variations that occur from time to time in any one locality. It is a remarkable and little known fact that almost the only parts of the world where people have no reason to worry about occasional drouths are the desert regions where drouth is a permanent condition.

A good illustration of the rainfall vicissitudes that the American farmer has to reckon with was recently reported. The village of Dresden, in northwestern Tennessee, lies in a region where the average

rainfall in June is about three and a half inches and that of July about three and three-fourths inches. In 1928, the weather bureau station at that place registered 18.67 inches of rain in

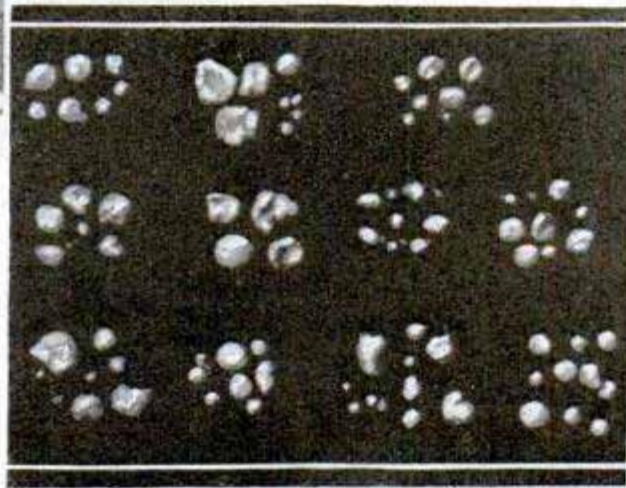

They are also reflected to an almost incalculable extent in the practical affairs of mankind. An overabundance of rain in the basin of the Mississippi in the spring of 1927

caused floods that cost the American people over \$350,000,000, besides entailing considerable loss of life. The recent frightful famine in China illustrates the calamitous effects of drouth. Though in most parts of the world drouth no longer takes toll of human life, its economic effects are often of immense importance. Drouths were exceptionally prevalent during the year 1929. The grain-growing districts of Argentina had one that lasted six months, and when it broke, in September, the price of wheat dropped four cents a bushel on the Chicago market.

Rainfall is the most variable and uncertain element of weather. Whoever examines for the first time a chart showing the normal distribution of this element over almost any large country cannot fail to be struck by the contrasts in the amounts indicated for different dis-



Measuring Stream Flow with Current Meter; Casts of Rain Drops, and Making a Snow Survey



A Result of Too Much Rain; an Air View along the Mississippi during the Flood of 1927, One of the Greatest in American History; Note Break in Levee at Top of Picture

June. During the whole of July only "traces" of rain fell; in other words, no day's rainfall was large enough to be measured.

The driest regions of the earth sometimes experience torrential downpours. At Yuma, Ariz., in 1921, there was a rainfall of 3.65 inches in twenty-four hours—more than the normal amount for the entire year at that place. The so-called "rainless" coast of Peru, where years go by without a shower, has had at rare intervals rains heavy enough to cause destructive floods.

Because of these endless variations of rainfall and their well-recognized importance to humanity, the measurement of rain has always been the biggest job of the meteorologists. So far as we know, it was first undertaken in India some centuries before the Christian era. Ancient Sanskrit texts give figures for the rainfall of different parts of that country, indicating the existence of rain gauges and their systematic use. Measurements of rainfall were made in Palestine in the first century after Christ.

At the present time, rain is measured

once a day or oftener at upward of 35,000 places throughout the world. The distribution of these places is, however, extremely uneven. The densest "network" of rainfall stations in the world is found in the island of Barbados, which, with an area of 166 square miles, has about 200 such stations. There are approximately 5,000 rainfall stations in the British isles—about the same number as in the immensely larger area of the United States. As compared with Britain's average of one rain gauge per nineteen square miles, we have in this country an average of one for each 595 square miles. Of course there are many countries in which rain gauges are far scarcer than in the United States. Though numerous measurements of rainfall have been made on shipboard, the statistics for the oceans are little better than rough estimates.

For certain practical purposes it is important to know not only how much rain falls from day to day, but also how fast it falls in individual showers. Records of excessive rates of rainfall are especially valuable to engineers in planning sewers, which must be made large enough to carry

off the "storm water" from the heaviest showers likely to occur in the locality; also in connection with the design of hydroelectric plants, irrigation systems, and the like. Such records can be obtained only from self-registering gauges. These instruments are costly, and the total number of them in the world is small compared with the number of ordinary rain gauges.

The fastest shower ever recorded with one of these automatic gauges occurred on April 5, 1926, at Opid's Camp, a mountain station in California maintained for the benefit of the Los Angeles county flood-control commission. By a lucky chance, two self-registering gauges of the "weighing" type had been set up side by side at this place, in order to compare their readings, when the shower occurred, and both showed a fall of 1.02 inches in one minute. The previous world record was 2.47 inches in three minutes at Porto Bello, Panama, Nov. 29, 1911.

Rain gauges are made in a great variety of forms, though certain principles are common to nearly all of them. An almost universal feature is a conical receiver with a small orifice intended to reduce evaporation. In the common American gauge, the rain falling into the receiver flows

into an inner tube of small diameter, so that the depth of water is magnified ten times. This is for the purpose of facilitating measurement, which is made by means of a stick graduated so that a depth of one inch in the tube reads one-tenth of an inch on the stick. In European gauges the same result is accomplished by pouring the water from the gauge into a measuring glass of much smaller diameter than the gauge, so that the depth of water is similarly magnified.

The automatic rain gauge most used by the weather bureau—known as the "tipping-bucket" gauge—is a remarkable combination of simplicity and ingenuity. The rain flows into a little metal trough divided by a central partition into two compartments and mounted on a central pivot. The alternate filling of the compartments causes the trough to tip back and forth. Each tip represents one-tenth inch of rainfall and is recorded by a pen on a moving sheet of paper, ruled to show the time of occurrence. This gauge has a distinguished ancestry. The first one operating on the same principle was constructed by the famous English architect, Sir Christopher Wren, about 1662.

In so-called weighing rain gauges, the water collects in a vessel resting on a

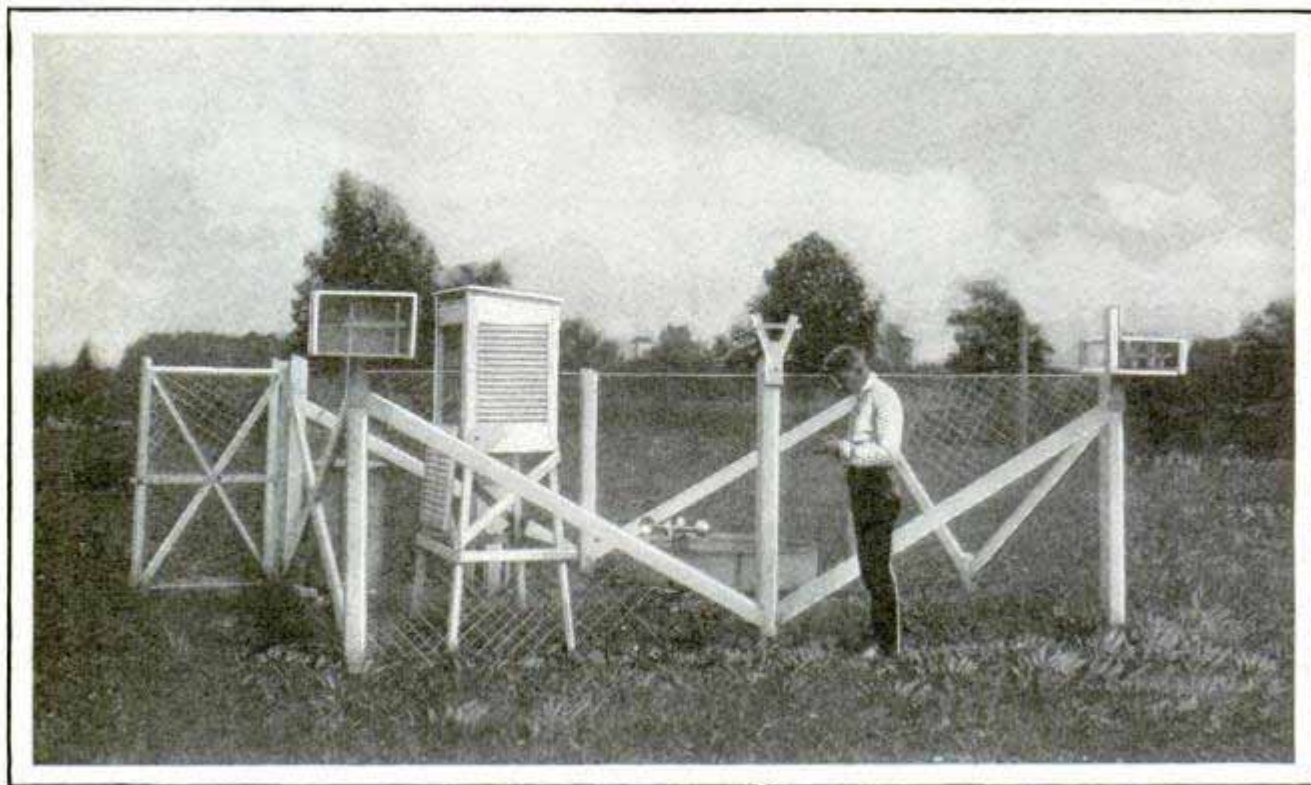

Evaporation Station of the United States Weather Bureau; the Pan Is Seen in the Middle of the Inclosure with the Wind, Rain and Other Gauges

coiled spring. As the water accumulates the vessel descends and its movement is registered by a pen. In still other types of automatic gauge, the recording pen is connected with a float, which rises as the depth of water increases. One of these, invented by Prof. C. F. Marvin, the present chief of the weather bureau, makes a week's record on a single sheet of paper.

In measuring rainfall as an element of climate, meteorologists include snowfall, but the actual depth of the snow must be reduced to its water equivalent before it can be combined with statistics of rain. One way of doing this is to melt the snow caught in the rain gauge before measuring its depth. Another plan is to weigh a sample of snow and compute the corresponding depth of water.

There are several

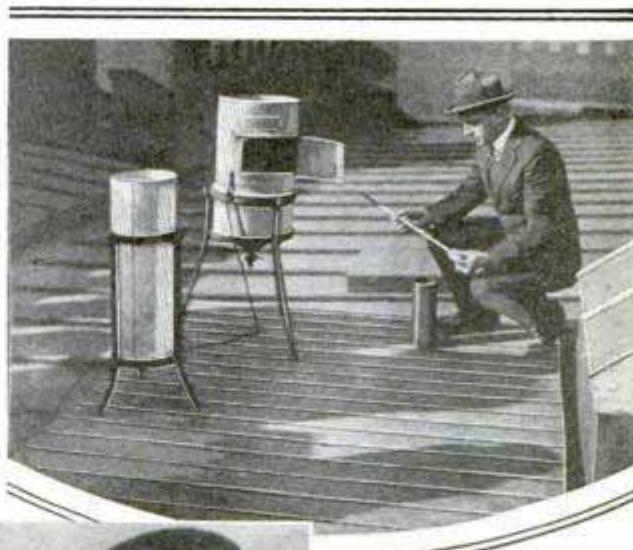

Special gauges used for such measurements catch and store a whole season's snowfall, while in some regions the depth of the snowfields is measured from time to time by means of snow stakes set permanently in the ground. The snow sampler is a long

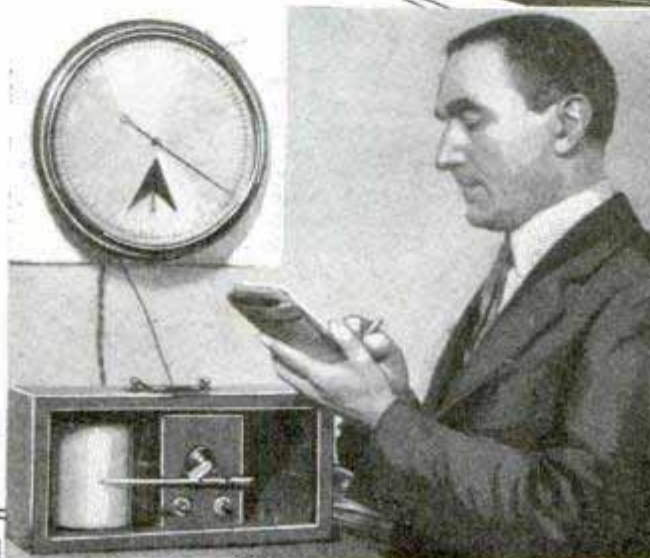

steel tube, with a sharp edge, by which cores of snow can be cut through a snowfield. The cores are weighed and the results of many such measurements furnish an indication of the prospective water supply.

Evaporation, like rainfall, is measured in terms of depth. The instruments employed are variously known as atmometers, atmidometers, evaporimeters, evaporating pans, and so on. Many attempts have been made to develop mathematical formulas by means of which the amount of evaporation might be computed, but this problem seems to be beyond solution, and reliable data can be obtained only by actual measurements.

The importance of evaporation in connection with irrigation may be judged from the fact that the total amount of water evaporated from the reservoirs of the U. S. reclamation service in the western United States is estimated at 1,000,000 acre-feet a year—enough water to irrigate an area of about 250,000 acres of land.

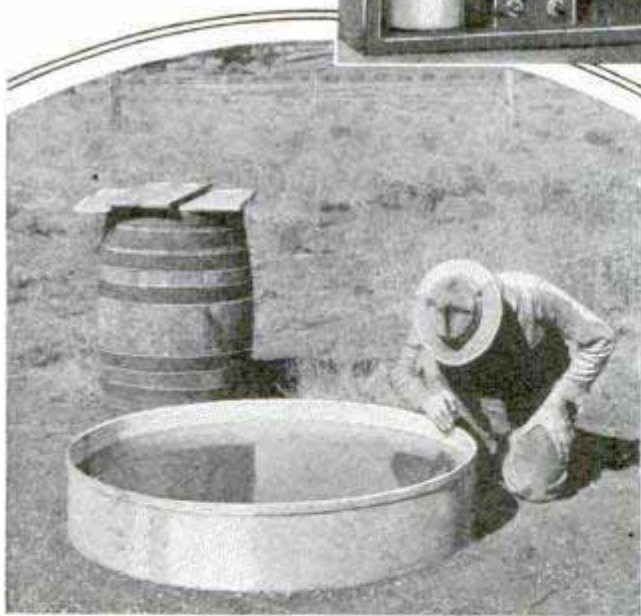

A Tipping-Bucket Rain Gauge; Gauging River at Distance, and Close View of an Evaporation Pan

devices for measuring mountain snowfall at places far from human habitation. Some of these measurements are made in connection with the study of glaciers; others in order to estimate the amount of water the melting of the snows will yield for adjacent power and irrigation projects.

*Prof Albert B. Newmay
Dept of Chem Eng at Cooper*

*Announced by Mr. Seorge Ellery Hale,
Honorary Director, Mt. Wilson Observatory
Chairman, Observatory Council*

3922

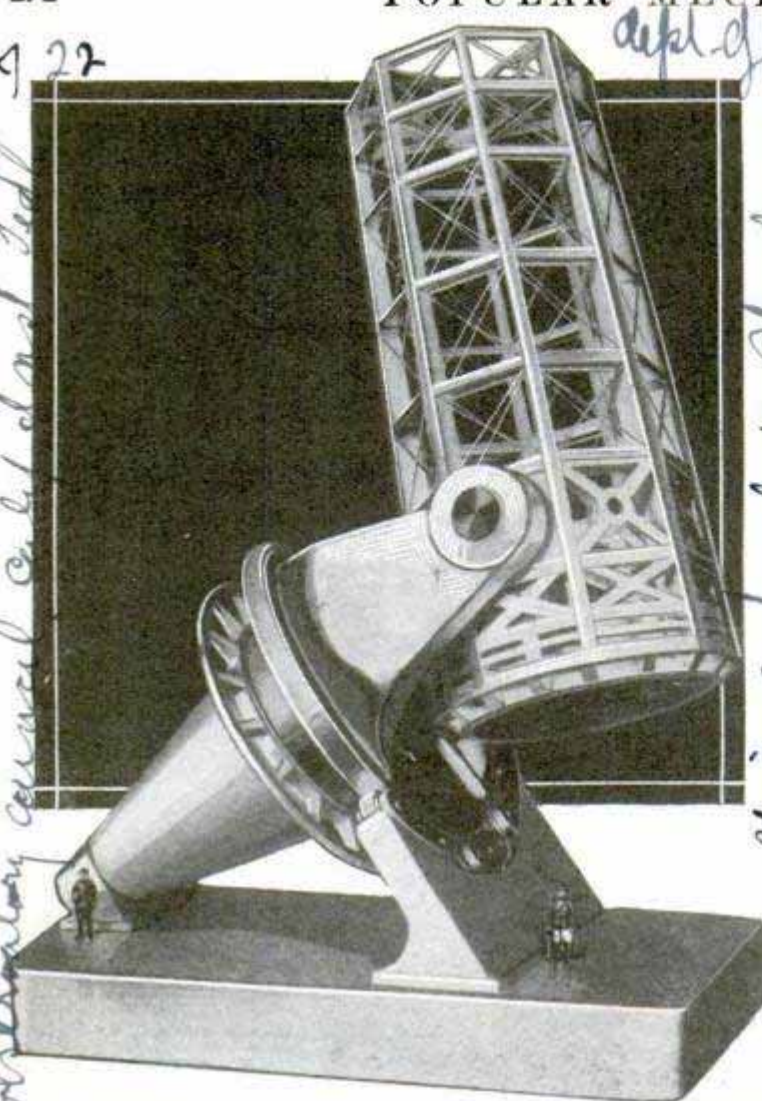

Model of World's Largest Reflecting Telescope Which Will Weigh Thirty Tons and Have a 200-Inch Mirror Disk

GIANT EYE TO PROBE SPACE WEIGHS THIRTY TONS

Equivalent in many respects to the human eye, but with a pupil seventeen feet in diameter, the largest reflecting telescope in the world is to be built in southern California or Arizona. It will have a mirror 200 inches in diameter weighing thirty tons, and it is hoped that it will penetrate more than three times as far into space as any existing instrument.

MURALS ARE SAVED FROM MOLD BY POISONING FUNGI

American chemists have succeeded in saving from destruction by mold the only official records of the construction period of the Panama canal, a series of five mural paintings in the administration building at Balboa. Presence of mold became apparent a year ago on the pictures, which cover 400 square feet and are attached to

Unim. Co of Wash. Mr. Charles

the walls so they could not be removed for laboratory treatment. The murals show features of the actual construction of the canal now hidden by fifty feet of water, and the circular walls of the rotunda which the paintings adorn made construction of a fumigation chamber almost impossible. Chemists finally removed the porous beeswax with which the murals were covered with turpentine and alcohol, then applied a liquid fungicide to kill the deep-seated spores of the mold. The dead fungi were removed by washing with ammonia, and a thin coat of paraffin and some of the fungicide were spread over the surface of the murals for future protection.

Chem. B. D. Wren of Chem.

PLANE LOOKOUT BUILT ON GRANITE PEAK

3837

At an elevation of 8,000 feet, a cottage has been built on a granite peak of the Sierra Nevada mountains by the United States department of airways which will serve as an airplane lookout. The attendant occupying

it takes care of beacon lights, forwards weather reports and keeps watch for planes in distress during bad weather. The cottage has a coal-burning furnace and electric lights from a near-by power line. It is anchored by cables to the solid rock to resist the wind.



House Anchored to a Granite Mountain Peak 8,000 Feet High, to Serve as Airplane Lookout

Emb. G. A. Feathers Br 206

Truchee, Nevada Co. Calif

will report tillahana Calif and Pers, Nev

3210

Air Riddles *and* the Answers

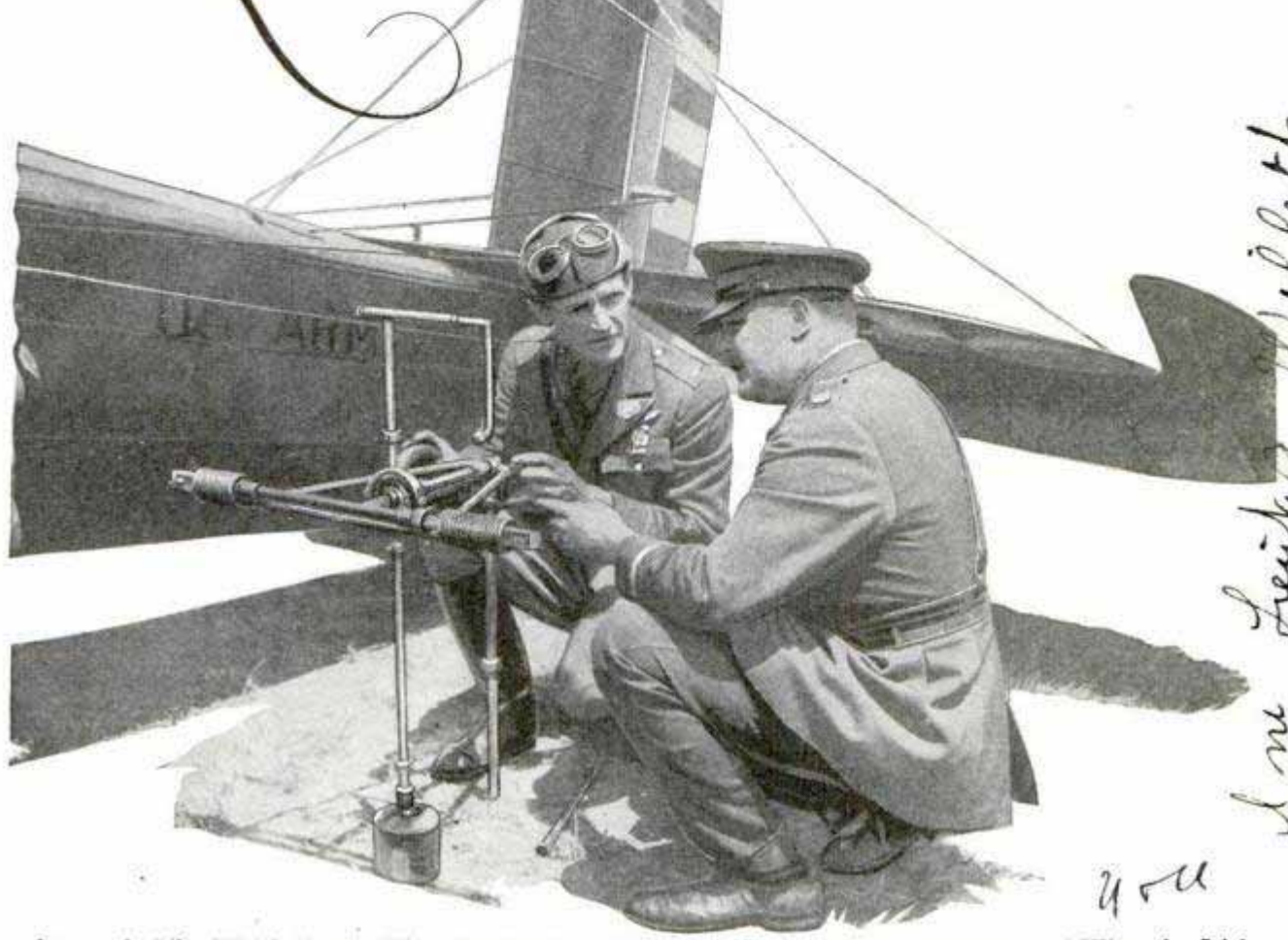

*I'm Leitch. Willett
Cressy Field, San Francisco
Delta net.*

you

Automatic Pilot Which Keeps a Plane Level in Any Weather; the Flying Robot Takes Control When the Stick Is Dropped, Preventing Dives or Spins and Making the Ship Fool-Proof

“WHAT,” a reader asked the other day, “is the difference between a radial and a rotary airplane engine, and to which class do the Wrights and the Wasps belong?”

The answer is that all the famous aircraft engines today of the air-cooled type, with cylinders arranged in a circle about the crankcase, are radials. And the difference between the radial and the rotary is that the cylinders of the first remain fixed in place, while the cylinders of the latter revolve.

It is doubtful whether there is a single rotary still in service today, for, since the Gnome motor of war-time days, the rotary has been dropped. Their one claim to worth—light weight per horsepower—has been surpassed by the more efficient radial engines.

The idea behind the Gnome was that the revolving cylinders would cool better than if they were stationary. Charles L.

Lawrance, designer of the Wright motor, proved that with proper cooling fins a radial motor with fixed cylinders would get plenty of cooling air when fixed to the nose of an airplane. The Gnome was interesting because it had a single valve, a fixed crankshaft and its moving cylinders. Gasoline and air were brought together in a mixing valve, and an exceptionally rich mixture fed, through passages in the cylinder walls, to the tops of the cylinders, where additional fresh air was drawn in to thin the mixture down to the proper combination. The crankshaft was rigidly attached to the nose of the plane and remained stationary, while the propeller was attached to the revolving crankcase carrying the cylinders.

The radial, on the other hand, combines lightness with the simplicity of gasoline, oil and electrical connections which its fixed cylinders make possible, removing all the chief objections of the rotary. The

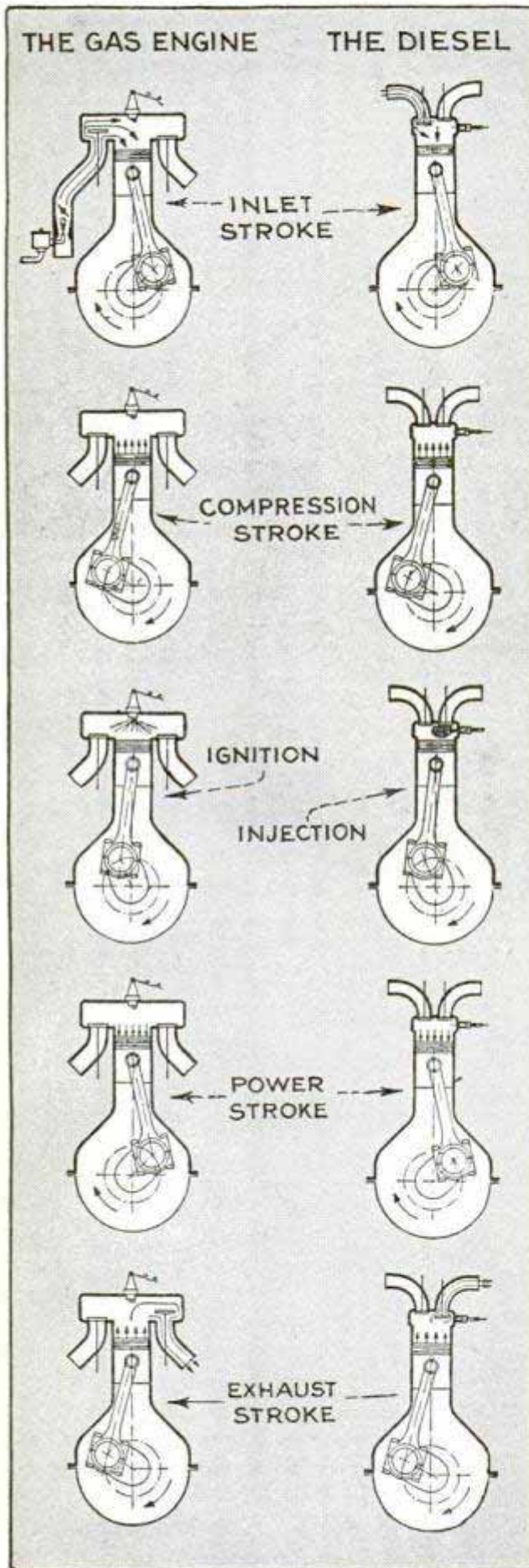

Drawing Illustrating Difference in Principle Between the Gas Engine and Diesel Engine; Absence of Ignition Is the Chief Characteristic of the Latter

arrangement of the cylinders in a circle makes possible a very short crankshaft with a single throw, eliminating the troubles experienced in the long shafts of conventional engines, built like the motors in automobiles. All the connecting rods are attached about the circumference of a single sleeve, fitting over the throw of the crank. The radial has one big disadvantage: Its broad spread of cylinders increases the frontal area of the plane, and therefore cuts down the speed, due to wind resistance. This is being largely overcome, however, as the result of the development of special cowling which, on a typical installation, increased the speed of a plane seventeen miles an hour, without any other change being made, and still admitted sufficient air to cool the cylinders properly.

"What happens to the engine when the plane does a loop?" another reader asks.

The answer is, nothing. The carburetor goes on functioning just as it did when the plane was right side up, the oil remains in the crankcase where it belongs; in fact, the engine performs as normally upside down at the top of a loop as it does right side up in level flight.

The reason is that centrifugal force maintains the status quo. That this is true is easily demonstrated by placing a glass of water on the floor of the cockpit before doing a loop. The glass will not fall out, nor will the water be spilled, any more than the contents of a bucket will spill when it is whirled over the head. The same force, in both cases, keeps the liquid in place.

However, if, instead of coming out of the loop, the pilot elects to fly along in level flight, upside down, things begin to happen at once. The carburetor float drops out of position, the carburetor drains, the engine stops, the oil in the crankcase flows past the pistons and fouls the plugs, and, if the engine is water-cooled, the water drains out of the radiator. For such "stunts," a double carburetor generally is used together with a radial motor which eliminates the oiling trouble.

Another question asked is how fast a propeller can turn before it begins to thrash the air and lose its effectiveness. No one knows a definite answer to that.

*Dr. W. ...
Los Angeles, Calif.*

Motorboat men discovered long ago that there is a point where what is called "cavitation" sets in, and the water becomes so disturbed that a further increase in revolutions produces no effect. That point, however, differs with each design of propeller, and outboard engines are being run today with propeller speeds that would have seemed fantastic only a year or so ago.

As a general thing, with standard types of propellers, efficiency seems to decrease when an airplane engine is geared up to more than 2,000 revolutions per minute, but a propeller speed of 3,200 revolutions per minute was used with a specially designed prop on the Bristol "Bullet," built by England for the Schneider cup races. Many of



Wide World

Electrically Heated Flying Suit, Helmet and Boot, Warmed by "Plugging In" on the Dash Control

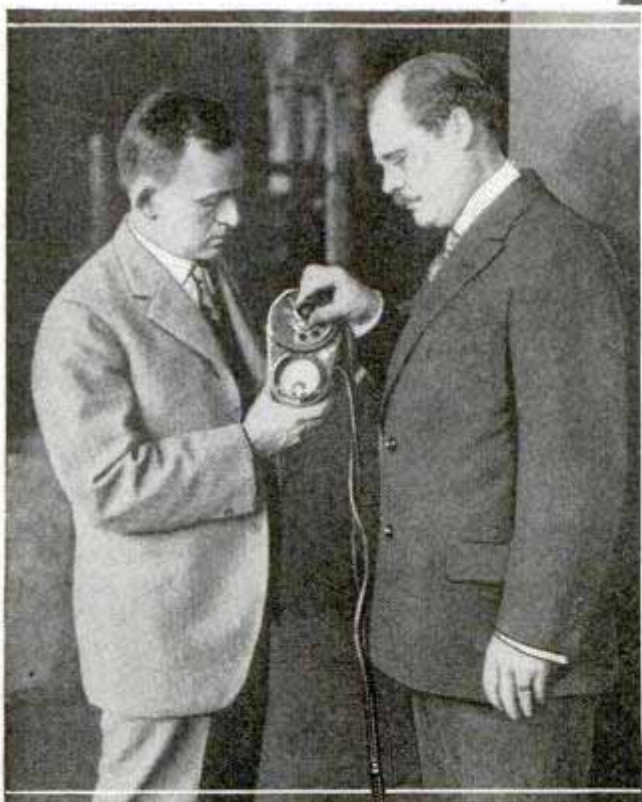

A Memory Meter for Depth Sounding from Planes; Lights Flash as the Ship Nears the Ground

the small fast racers are now being built with geared-down propellers, the engines turning over at speeds of 4,200 or more, and a two-to-one reduction gearing being used to cut the propeller speed in half. A

big slow-turning propeller is more effective as a load puller than a small high-speed prop, which explains why speeds of 1,400 to 1,600 revolutions per minute are in general use for aircraft engines.

Another interesting question deals with engine torque, and why the twisting effect of the engine turning over at high speed doesn't cause the plane itself to try to revolve in the same direction, turning on its longitudinal axis. The answer is that the immense spread of wings exerts too much resistance against the air to allow the plane to revolve. As a direct offshoot of its inability to turn, however, the engine imparts a force to the plane which makes it want to go off the course to one side.

Most modern ships correct that by setting the front edge of the vertical fin a trifle off center, so that the continual blast of air along one side of the fin will be just sufficient to overcome the engine twist and keep the nose on the course. In lieu

Dr. W. E. R. W. Anderson & Co

Schenectady, N.Y.

Wm. at Chicago by rail

*3210
name of maker unknown*

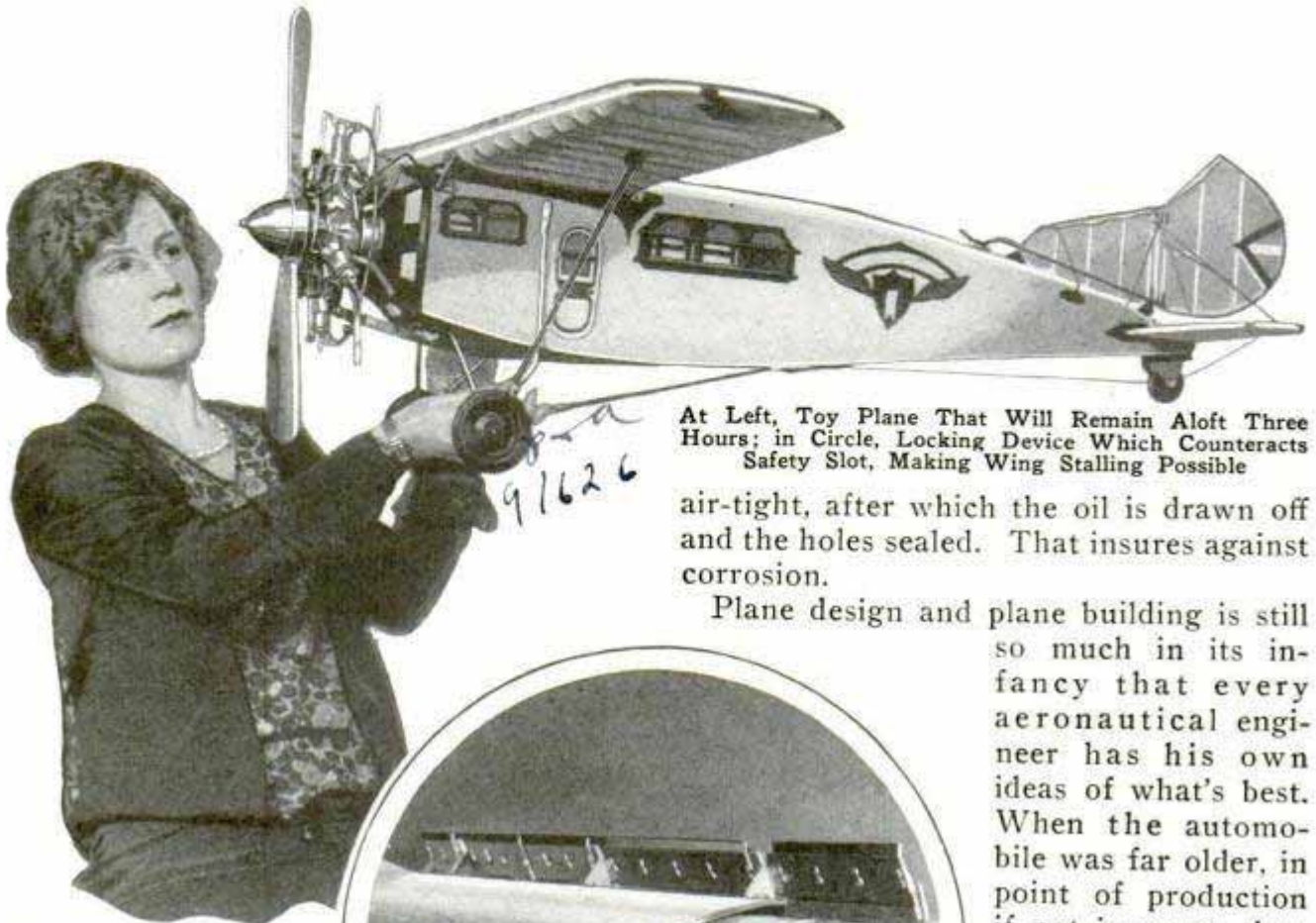

At Left, Toy Plane That Will Remain Aloft Three Hours; in Circle, Locking Device Which Counteracts Safety Slot, Making Wing Stalling Possible

air-tight, after which the oil is drawn off and the holes sealed. That insures against corrosion.

Plane design and plane building is still so much in its infancy that every aeronautical engineer has his own ideas of what's best. When the automobile was far older, in point of production if not in years, than the airplane is today, one maker used an air-cooled engine, while all others used water cooling, and the same maker used a wooden chassis

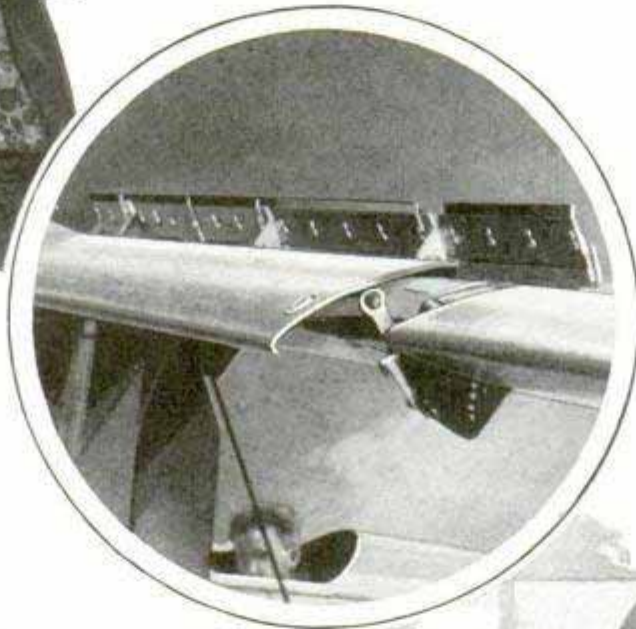

of that setting of the fin, the pilot must always carry a small amount of opposite rudder. If the ship has an engine revolving in the normal direction—to the right as you look forward

—the left rudder pedal is pushed forward a trifle.

Why, another questioner asks, does the Fokker use a wooden wing structure and a metal fuselage, while the Ford has duralumin wing and body, and other ships use either all wood or all metal, or in some cases combinations of the two. The battle of metal against wood is still raging. Some designers believe spruce spars and ribs build up a better cantilever structure than can be formed of metal; some insist that hollow tubing is in danger of hidden rusting on the inside. On at least one ship, the Fairchild, all tubes are connected by small holes, and then pumped full of boiling oil to make sure they are

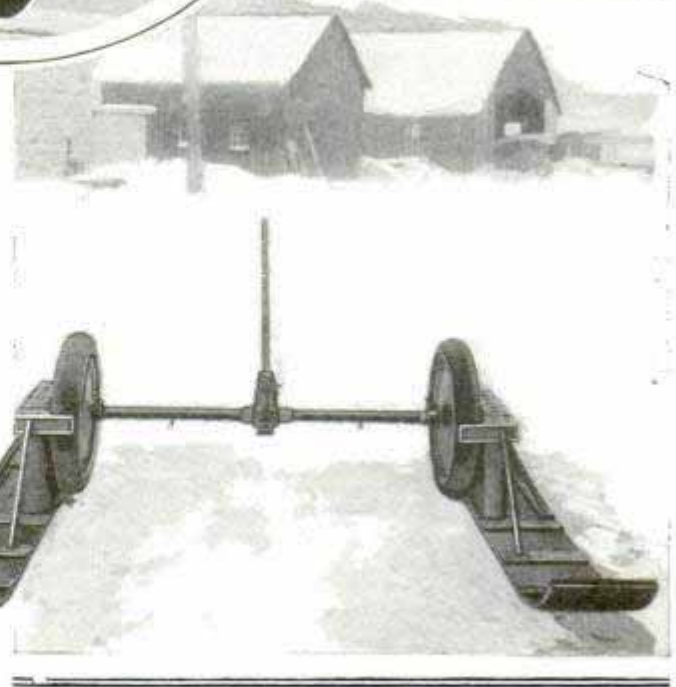

Combination Ski-Wheel Landing Gear for Alighting on Snow after Take-Off from Bare Ground

*Wm. H. S. Perry
Director, Ottawa Aeronautics Club*

Wenger - Dr. C. J. ...
Islandale Calif

Build for him by Kinner Airplane
& Motor Corp. Islandale
Calif



Monoplane Whose Wings Can Be Folded for Parking in a Garage; Below, Rear View with Wings Folded

when everybody else had settled on metal. And automobile engineers are still disagreed on the relative merits of square, round and elliptical tubing for chassis braces.

Even the many successful flights with air-cooled engines have not discouraged the proponents of water cooling. The army is tackling the question of eliminating some of its more obvious objections, which include the weight of radiator and cooling liquid and the fact that a water-cooled engine must operate below its most efficient temperature.

To that end successful experiments have been made with a new cooling solution, a chemical compound whose chief ingredient is the same glycerine offshoot used as an anti-freeze in automobile radiators. The compound has a boiling point more than 100 degrees above that of water, and, instead of operating the engine at a temperature of 180 to 200 degrees, as must be done with water cooling, it can be operated at around 300 degrees, which gives much better performance. Besides its higher boiling point, the new liquid requires less water for cooling, and therefore a smaller radiator, so weight is cut down, and also the frontal area of the radiator is reduced, with consequent reduction in air resis-

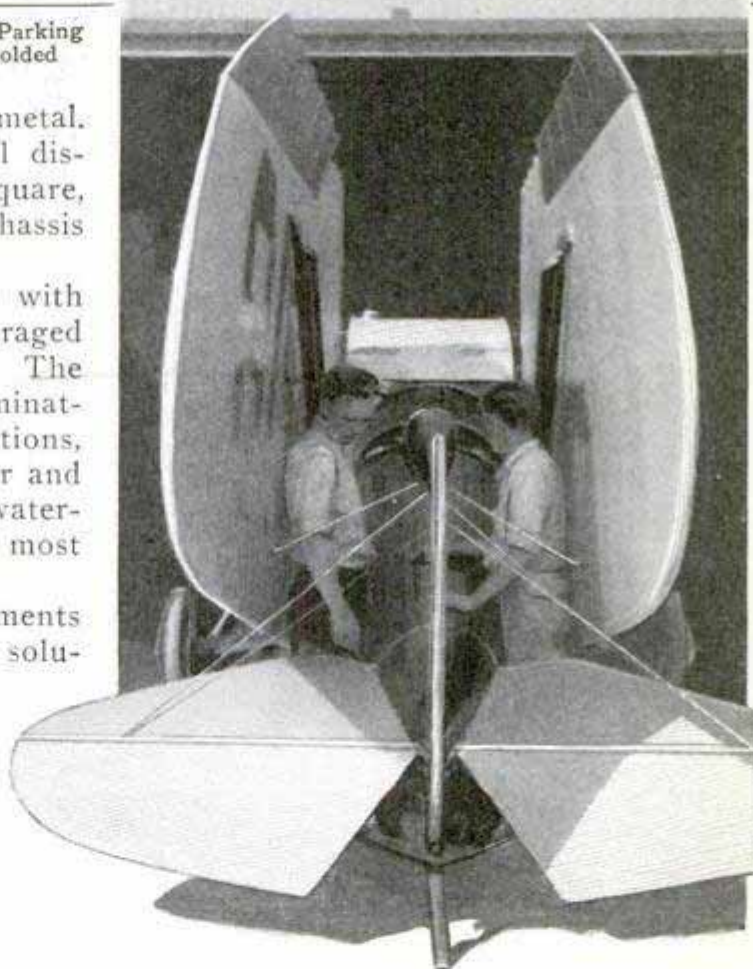

tance and increase in speed. The latest chemical-cooled plane introduced for army pursuit work is the Curtiss P-6 "Hawk." It has a high speed of 181 miles an hour, and the chemical solution permits a reduction of 125 pounds in weight.

☐ About 250 kinds of snakes are poisonous.

37 49 278

Mr. J. W. Bickel Co.,
25 Jefferson Apts.,
Jefferson + Daniels
Cincinnati Ohio

Sperry Gyroscope Co.
40 2nd Ave. East
Brooklyn NY

POPULAR MECHANICS

GYROSCOPE PILOTS AIRPLANE WITHOUT AID FROM MAN

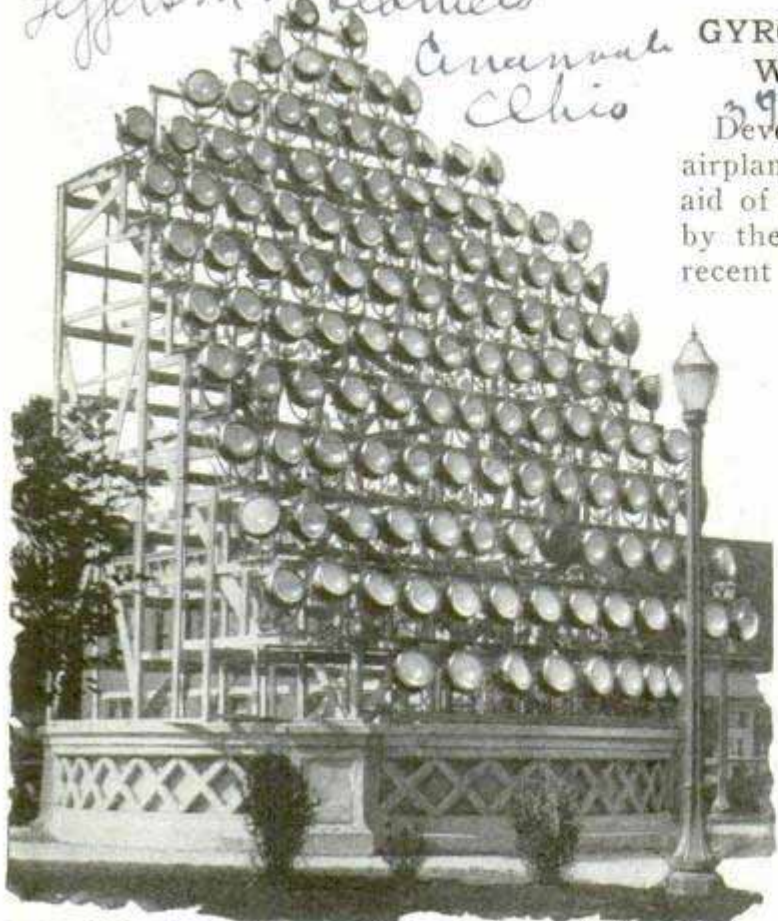

Bank of Floodlights for Exterior Illumination at Cincinnati; They Are Mounted on a Framework Thirty-Six Feet High

OVER HUNDRED FLOODLIGHTS OPERATED AS ONE UNIT

As a part of the decorative scheme for the Edison exposition held in Cincinnati, Ohio, a total of 127 floodlights for outdoor illumination were installed in one great bank, all the lights operating simultaneously. When all were lighted they drew a total of 82,000 watts, the equivalent of 110 horsepower. The framework for the unit extended into the air thirty-six feet.

Development of a gyroscope to keep airplanes on their courses without the aid of human hands has been announced by the war department as the result of recent tests. With this automatic pilot, the human flyer takes the plane off the ground, then turns it over to the robot pilot until the time comes for landing. The mechanical pilot will hold the plane straight and level, regardless of fog, rain or darkness. It is expected to be useful particularly in handling large planes and on long flights, relieving the pilot of much of the strain. The mechanical flyer weighs fifty pounds and occupies a space fourteen by fourteen by ten inches beneath the pilot's seat. Its action centers around two gyroscopes, one mounted vertically, the other horizontally. A series of electrical contacts actuate electromagnets, that in turn operate controls leading to rudder, elevators and ailerons. Power is obtained from a small wind-driven generator. So sensitive is the instrument that movement half a degree out of level flight is detected. The apparatus flew an army plane from Dayton to Detroit without direction from the pilot.

Apparatus Which Kept a Plane on Its Course without Aid from Pilot

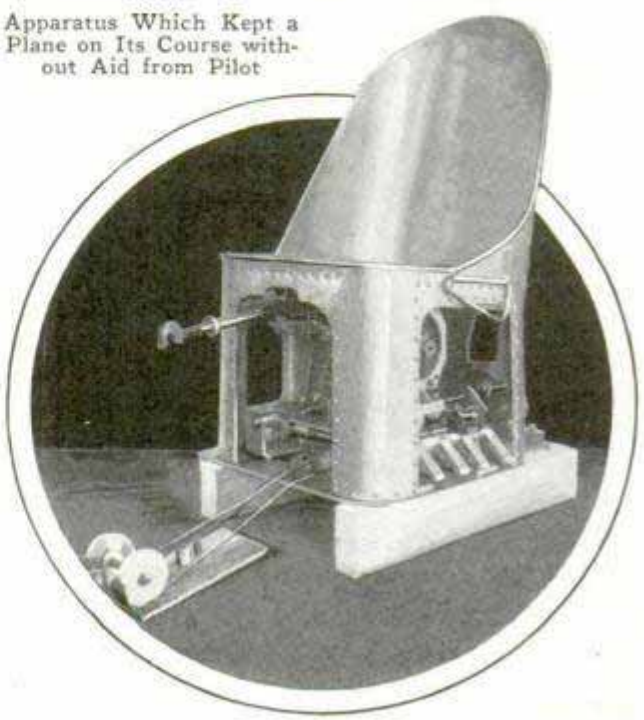

INSECTS TRAPPED BY LIGHTS TO FEED YOUNG TROUT

Liberal supplies of insects to feed young trout are obtained at a California hatchery with the aid of funnel-shaped cloth sacks and electric lights which are left burning all night. The insects, attracted by the glow, become enmeshed in the traps and are collected the next morning. By using a number of sacks, many pounds of flies and other insects were caught. These are supplemented with other foods to give the young trout a varied diet.

J. W. Bickel - sold
Creek Hatchery

Reported by California Dept of Natural

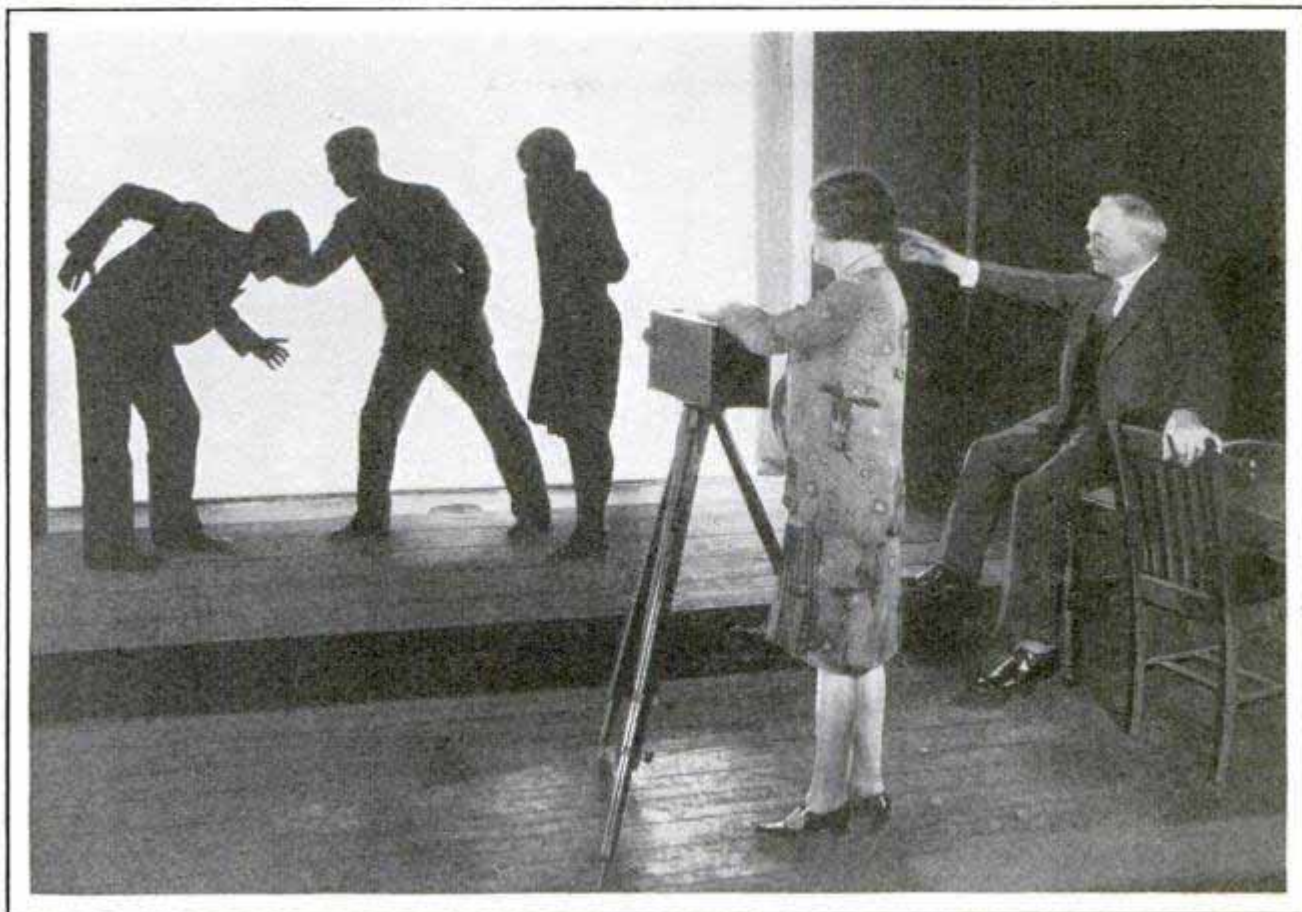

© U. & U.
 Making a Moving Picture for Transmission by Radio; Actors Are Shown in Silhouette, and Pictures Are Taken in That Manner as This Is the Form in Which They Are Received

MOVIES TAKEN IN SILHOUETTE FOR RADIO TRANSMISSION

Devoted exclusively to the production of motion pictures to be shown to an audience by radio, a studio has been opened in Washington by Dr. C. Francis Jenkins, inventor and television pioneer. The performers all are shown in silhouette.

NEW USES FOR PEANUTS FOUND IN MANY BY-PRODUCTS

Utilization of the peanut for many purposes besides food has stimulated their cultivation, particularly in Oklahoma, where 82,000 acres were planted to them last year, an increase of 1,200 per cent in the last five years. Chemists have discovered that almost every part of the peanut, the top, hulls, nuts, skins and germs, has value. When properly cured, the tops make nutritious hay, comparable with alfalfa, they say. Three tons of hulls are equal to a ton of coal in fuel value, and the hulls are also employed to absorb the palm oil on galvanized iron in its manu-

facture. Large quantities are used as filler in fertilizers, and in the manufacture of cellulose for fiberboard. They also contain a kind of sugar. The skin and germs, removed from the nuts, contain twenty to thirty per cent of oil which is sold for stock feed or for soap. A nutritious flour is manufactured from the peanut. It is said to contain four times as much protein, eight times as much fat and nine times as much mineral substance as white flour. One ton of nuts gives about 600 pounds of oil.

WINDOW VENTILATOR SCREEN KEEPS OUT DUST



To keep dust from the interior of the room, a window ventilator now on the market is fitted with a screen of fine mesh. It is shaped to lie closely against the sash and may be removed in a second or two for cleaning.

*Ans. Homer Sege
 581 Islandwood*

*J. Snyder.
 54 W. Lake*

3965
280

Death Airplane by the
1721 Sedgwick
POPULAR MECHANICS
Chicago

Edward
S. Parks

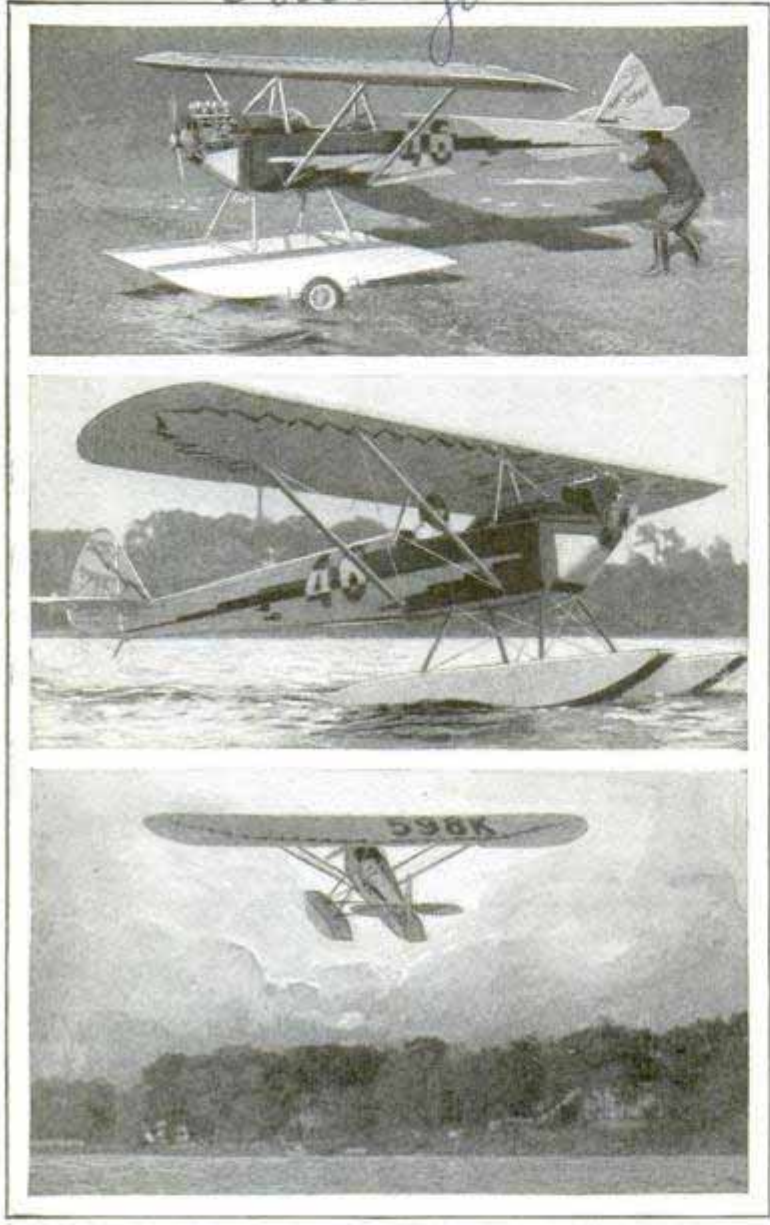

Three Views of an Airplane with Detachable Pontoons beside the Landing Gear to Transform It into a Seaplane

PONTOONS TURN SMALL PLANE INTO A WATER CRAFT

Transforming a small airplane into a seaplane within a few minutes may be accomplished by installing pontoons beside the wheels. Equipped for water flying, the craft weighs only 340 pounds, making it one of the smallest planes to take off on land or water. The lightness makes it possible to rise from or alight on a comparatively small area, the craft having an exceptionally low take-off and landing speed. The pontoons weigh thirty pounds each, are nine and one-half feet long, a foot deep and sixteen inches wide, and are placed a little more than four feet apart. Maneuverability of the craft apparently was not affected by installing the

pontoons, as it went through any stunt that was possible when equipped with landing gear. The little ship, with pontoons attached, in tests took off from the water in eight seconds in still air, and climbed 450 feet the first minute.

SHELLAC FROM OLD DERBIES

3840

Discarded derby hats and silk toppers are gathered in carload lots by a Fall River, Mass., merchant who puts them through a salvaging process to recover the shellac that provides the stiffness and constitutes one-third of the weight of such headgear. After the shellac is dissolved in a soda solution in which the hats are soaked, the remainder is baled and shipped to a fertilizer factory.

STERILIZER FOR DENTISTS' GRIP HELPS CURB DISEASE

3816

Easily attached to the wall or to the dentist's handpiece, a small sterilizer, charged with formalin gas, keeps the cap, angles and handpiece sanitary without injury to the instruments. These units, coming in contact with a patient's mouth, may be the means of spreading various diseases unless kept clean, and the gas chamber is offered as a simple and effective way to afford such sanitation.

\$15.00

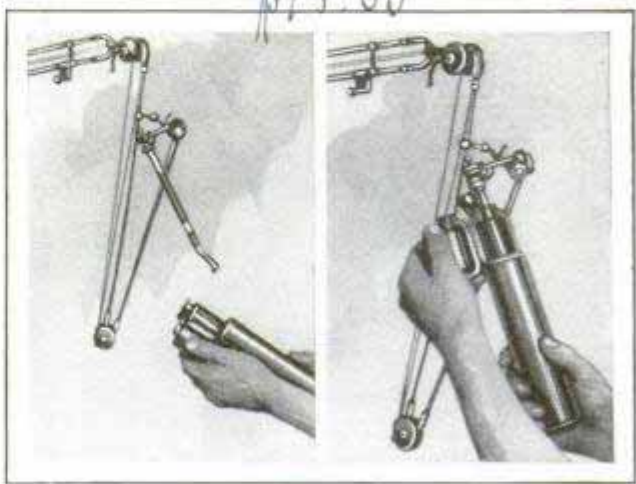

Sterilizer Attached to Dentist's Handpiece to Keep Instrument Free of Disease Germs

The Essential Sterilizer Co
1225 Broadway

307
Mr. Calvin ...
% The Pictogram Co.
Box 40, Washington, D.C.

DUST—What It Does

THE ENORMOUS amount of solid material contained at all times in the air is one of the startling revelations of modern science. Some measurements and analyses of atmospheric pollution have just been made in New York City. Though the air of Gotham is undoubtedly cleaner than that of many of the large manufacturing centers of the country, these studies show that, at any given moment, the solid matter suspended in the air of

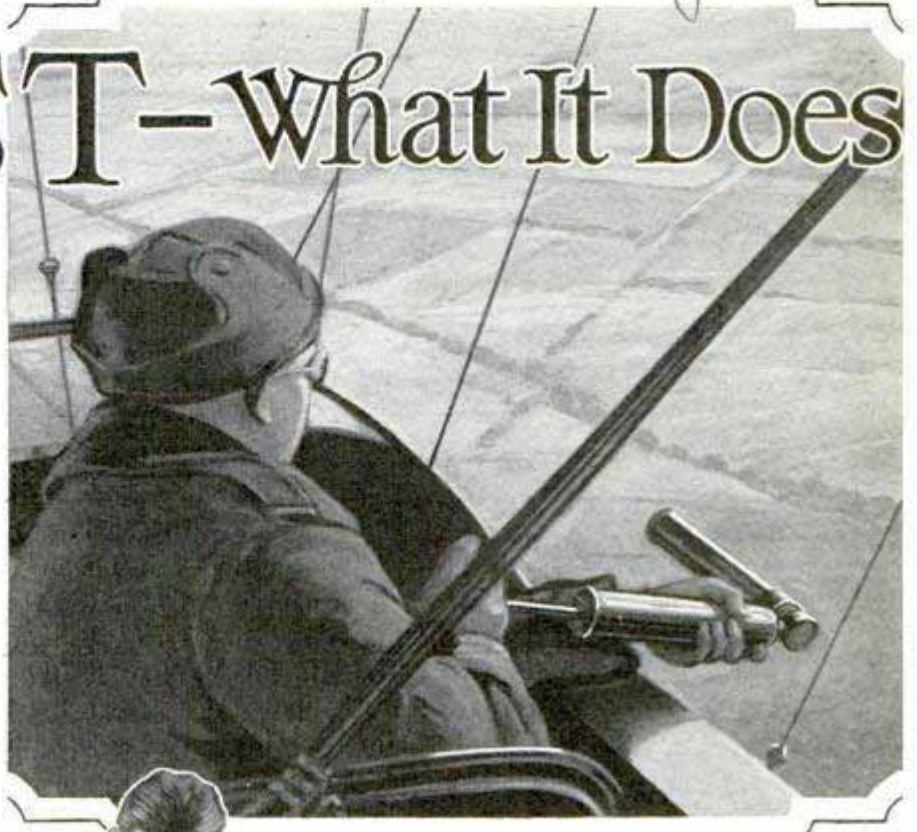

Making a Dust Count in Airplane over Washington, D. C., and Measuring Dust by "Paper Thimble"

the city up to a height of 200 feet above the ground weighs, under average weather conditions, 2,200 tons.

The composition of this dust is as interesting as its quantity. About sixty-five per cent is carbon, fifteen per cent mineral and ash, and twenty per cent or-

ganic material, including an immense variety of germs, pathogenic and otherwise. The large amount of carbon furnishes a striking example of industrial waste. It consists of unconsumed coal, gasoline, motor oils and other fuels. If this carbon could be collected and burned, it would suffice to operate the city's electric-light and power plants for six hours out of every twenty-four.

Even more remarkable figures bearing upon the dust content of the atmosphere are supplied by the records of "sootfall," and by the statistics of occasional showers of dust that have occurred over great areas of the earth's surface. The sootfall records usually represent the total deposit of solid impurities in districts where the chief cause of atmospheric pollution is the imperfect combustion of fuel. In Pittsburgh, before the smoke nuisance was partially abated, the annual sootfall averaged 1,031 tons per square mile. In Great Britain, where the atmosphere is notoriously smoky, sootfall is measured regularly with gauges of uniform pattern at about sixty places under the direction of the advisory committee on atmospheric pollution. In the heart of Glasgow, 820 tons of soot and dust per square mile is collected in an average year. London's



China vast areas are covered to a depth of hundreds or even thousands of feet with a fine yellowish material called "loess," which is believed to have been blown there by winds from the deserts of central Asia. Less extensive deposits of this wind-borne material are found in other parts of the world, including the Mississippi valley. Another effect of winds is the mixing of soils. There is a constant interchange of soil material between different regions, so that the composition of the soil on a particular farm, for instance, is not the same now as it was a few years ago or as it will be a few years hence.

average is 248 tons per square mile.

Individual showers of dust, known as "dustfalls," entail the temporary suspension of enormous quantities of dust in the air. One of these showers occurred in March, 1901. The dust was whirled aloft by cyclonic winds from the floor of the Sahara desert and was eventually deposited over most of western Europe to a distance of 2,500 miles from its place of origin. The fall on the European continent in four days was estimated at 1,800,000 tons. Much more fell over the Mediterranean, while on the African coast the deposit is supposed to have amounted to 150,000,000 tons. Europe has experienced many gigantic dustfalls coming from the Sahara, but in the latest great shower, that of April, 1928, the source of the dust was different. It was blown up from the dry soil of southern Russia north of the Black Sea and fell as far west as the Baltic. In Poland alone the deposit was estimated at 1,500,000 tons.

The transportation of dust by the winds is an agency in shaping the surface of the earth comparable in importance to the transportation of soil by water. Thus in

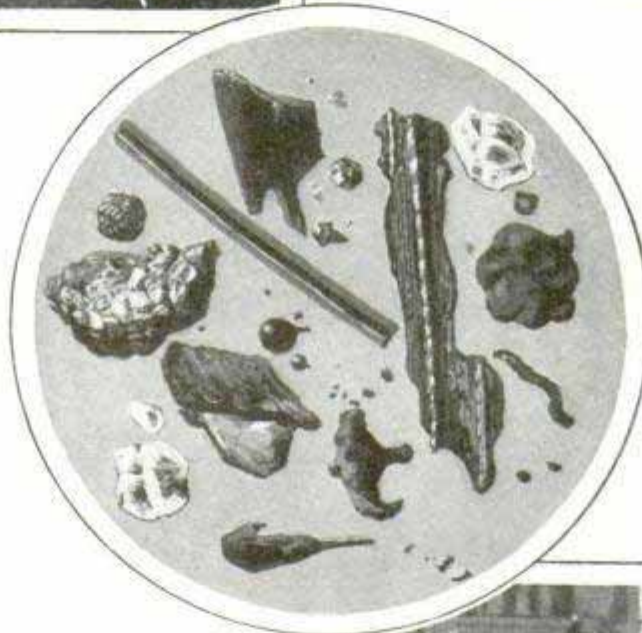

The greatest concentration of dust in the air ever occurring under natural conditions is probably that found in the midst of a desert dust storm, or sand storm, where, according to an estimate of Prof. J. A. Udden, it may reach 126,000 tons of suspended solid matter per cubic mile of air. Such storms are common



Direct-Vision Dust Counter; Dust Particles Magnified 100 Diameters, and Measuring Dustiness in Stone-Cutting Plant

in the southwestern United States, but the most spectacular examples are the "haboobs" of Egypt and the Sudan.

While the winds are the principal agency in charging the air with dust, there are several others. The countless meteors that enter the earth's atmosphere every day from outer space contribute their quota of dust, traces of which are found on the snowy summits of high mountains and on the polar ice fields. Forest fires, burning peat beds and other conflagrations on a large scale discharge great quantities of soot into the air. Cinders from the Chicago fire, in 1871, spread over a large part of the globe.

Another occasional cause of atmospheric dustiness is the eruption of volcanoes, especially those of an explosive character, which carry the dust up to levels where it cannot be washed out of the atmosphere by rain. The remarkable dry fog of 1783—the most famous in history—which covered the greater part of Europe and North America for three or four months—was due to the great eruptions of that year in Iceland and Japan.

A persistent veil of dust in the upper atmosphere is believed to have a marked effect in lowering terrestrial temperatures. The fine grains of dust reflect back into space much of the short-wave radiation coming from the sun, but do not bar the passage of long heat waves radiated outward from the earth, so that, when the dust is present, the earth loses heat much more rapidly than it receives it.

SIX-HUNDRED-FOOT AIR SIGN AID HIGH FLYERS

Aviators flying as high as 5,000 feet over Marysville, Kans., have little trouble in identifying the town, for the name is painted in letters over fifty feet high on the roof of a large building. The sign is 600 feet long and seventy-five feet wide. The boy scouts of the town were instrumental in having the huge marker painted.



How the Boy Scouts of Marysville, Kans., Have Helped Aviators; Huge Marker as Seen from the Air

*Cml. Frank S. Reynolds,
615 W. N. Ave. C.D.*

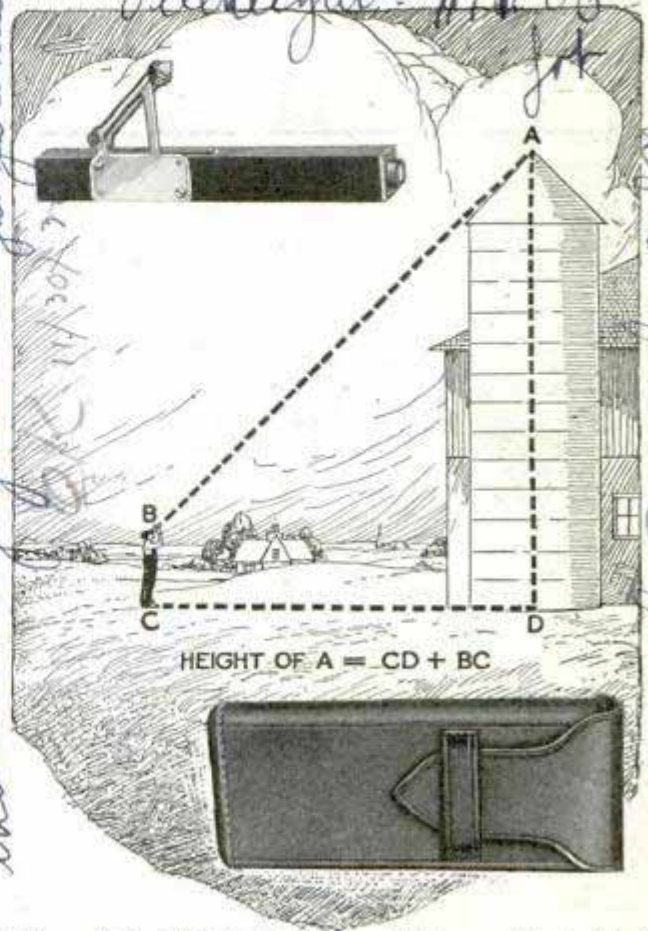

Views of the Height Finder, and Diagram Illustrating the Principle of Its Operation

HOW HIGH IS IT, ANSWERED AT SINGLE GLANCE

Simple and accurate in operation, a measuring instrument now is available which indicates the height of trees or poles from the ground, merely by sighting through it. The person operating the instrument stands away from the pole to be measured until a bubble and line in the device cross each other. The sum of the distance he stands from the pole and the height at which the instrument was held then will total the height of the pole. It is valuable to linemen and others who desire quickly to establish wire clearances, or heights of trees or buildings.

☐ We want our readers to write us whenever they wish additional details on articles in this magazine. Address Bureau of Information.

*390 W. N. Malheur
3922 Forest Park Ave
St. Louis 283
Teleheight
Chicago. H. L. Brueck, 9 S. Clinton
Rm 420, Madison Terminal Bldg*

3953
 ABANDONED TRETTLES TURNED INTO AUTO ROADS

Com. L. H. Wilson, Co. J. 1st
 morning Republican
 Fresno, Calif.

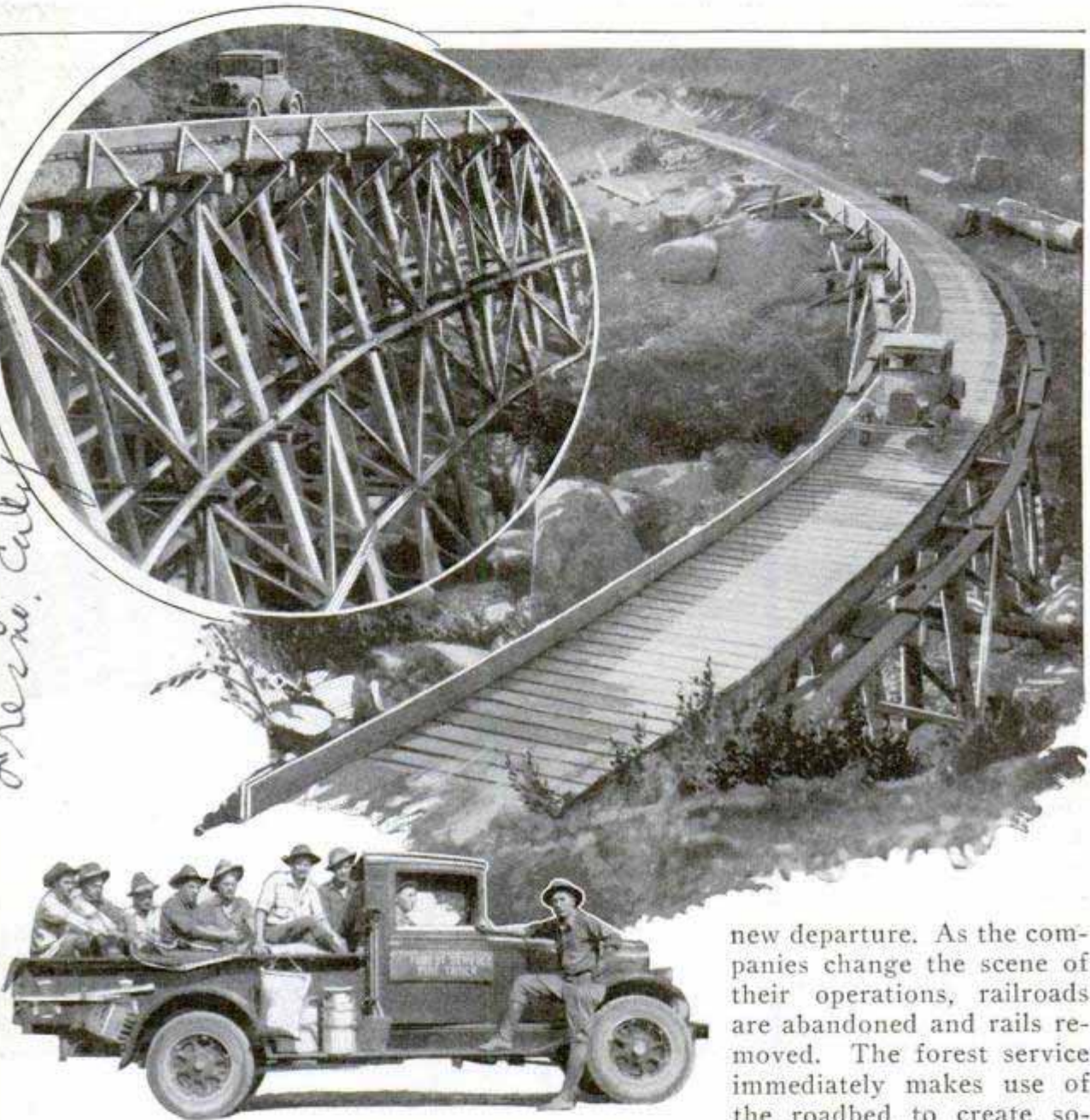

Above, Using an Abandoned Railroad Trestle and Roadbed as a Road for
 Forest-Fire Fighters; Below, One of the Fire-Suppression Crews

Ten thousand feet above the sea in the middle of a narrow trestle, where a twitch of the wheel to right or left means a plunge to death on the rocks and trees one hundred feet below; such is the place where you might find yourself if you set out to pursue the newly created suppression crew in its work of combating fires in the high country of the Sierra national forest in central California. The trestle is a vital part of one of the newest and most spectacular plans inaugurated for aiding in the quick control of forest fires. The work of two large lumber companies is being used to great advantage in this

new departure. As the companies change the scene of their operations, railroads are abandoned and rails removed. The forest service immediately makes use of the roadbed to create so-called light-duty roads. A crew of men quickly clears away old ties and debris. An ordinary road scraper then completes the job, leveling the earth into an automobile road. The trestles, of course, require more attention. Two-inch planks, long enough to give a clearance of from eighteen inches to two feet, are nailed closely across the trestles to form bridges. In general, no railings are placed on the bridges, the routes not being intended for general use because of the lack of funds for maintenance. Although the roads are not open to the public, they may be traveled with a special permit from the government or the lumber companies.

1645 Hennepin Ave. Minneapolis

A. 809. 537 S. Dearborn Chicago

HUMIDIFIER AND RADIATOR IN ONE UNIT

To provide the home or office interior with the proper moisture during the winter months, a combination radiator and humidifier has been introduced. Water is tapped from the house system and trickles down over the outside of the radiator, which is much like the usual article except that it consists of a series of troughs, giving a large evaporation surface. A valve prevents too much water from flowing out of the pipe and also insures a constant supply, so that no tanks or other containers have to be filled. Excess water runs off into the house drains.

The entire unit is covered with an attractive screen when in operation, is noiseless, requires no attention and is obtainable in various sizes. Engineers state that it evaporates sufficient water to insure a healthful humidity at all times.

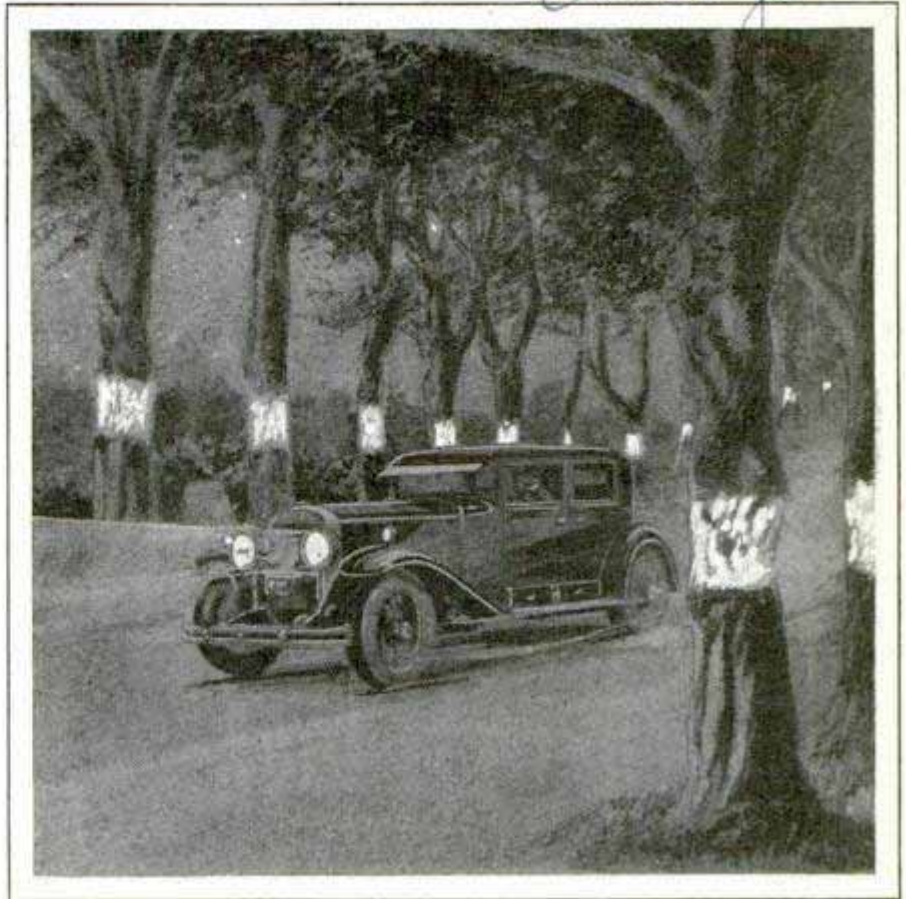

These Trees Bordering a Highway Are Painted with a Phosphorescent Band for the Protection of Motorists at Night

TREES THAT GLOW AT NIGHT TO STOP ACCIDENTS

In order to prevent numerous accidents that have befallen motorists along some of the tree-lined roads of the Rhine region, German officials are painting the trees bordering the highway with a band of phosphorescent paint. The trees glow at night, and the driver is able to see them far enough away to avoid swerving into them.

AIR-MAIL PILOT'S EQUIPMENT COSTS THOUSAND DOLLARS 3007

Clothing and safety devices worn by some of the western air-mail pilots cost nearly \$1,000. Wool shirt, boots and thick socks will total around \$100. An all-leather coat adds \$35 more; the flying suit itself often costs as much as \$250, as it is leather and wool-lined, while the parachute and harness are worth \$350. Moccasins, helmet and mittens cost \$55, and the revolver adds \$15. It takes some of the men as long as thirty minutes to get into the complete outfit.

*Capt. H. W. Fickler
5021-12th St*

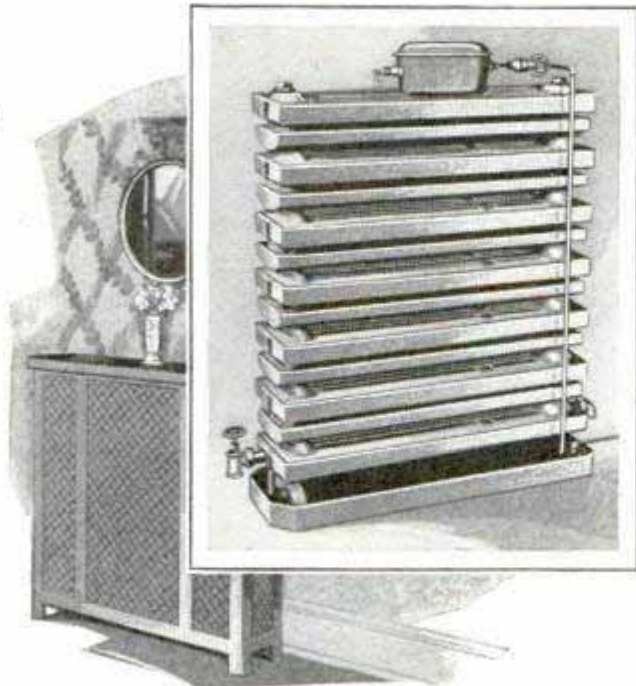

Combination Radiator and Humidifier Which Employs Running Water to Keep the Air Moist

3510

Easier Ways



Here Is an Electric Clothes Drier That Folds Up as Shown at the Right When Not in Use; It Circulates 2,500 Cubic Feet of Air per Minute, Helping to Ventilate the House and Remove Cooking Odors; It May Also Be Used for Drying the Hair after Washing, or to Cool Foods

Electric Food Mixer Stands Up Alone in Bowl or Other Dish and Has Wide Range of Speeds for Ingredients of Different Kinds

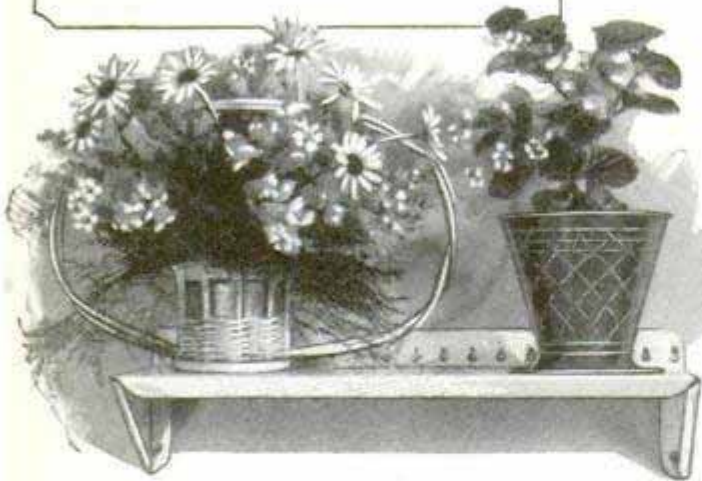

Above Is a Convenient Reversible Metal Shelf That Hangs on the Heads of Two Nails and Will Support as Much as 100-Pounds; at Right, a Warm Rug with an Interlocking Fastener to Keep the Baby Snug and Safe; It Is of Wool and Attractively Trimmed in Colors



of Doing It

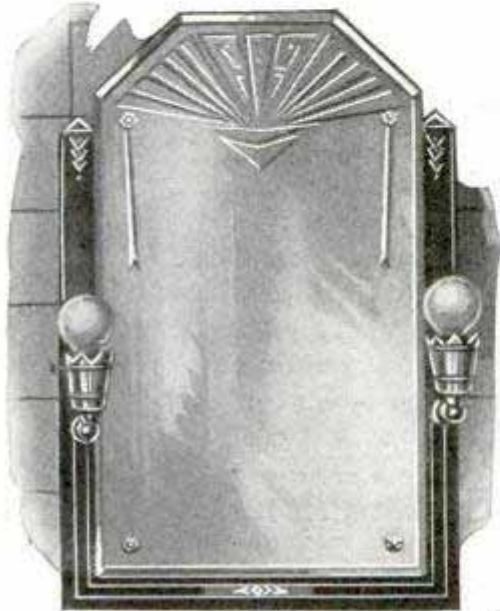

Easily Installed Mirror Cabinet for the Bathroom Has Edge Lights That May Be Moved to Various Positions along the Frame Simply by Pushing Them around the Slot; No Wires Are Exposed



© Keystone

This Baby Carriage Has a Specially Built-In Compartment for a Phonograph on Which Lullaby and Other Records May Be Played to Soothe or Amuse the Infant; a Cover Fits Tightly over the Instrument When Not in Use



When the Door Is Opened, the Broiler of This Gas Range Automatically Slides Out and Will Not Tip or Fall; It Has a Drain to Carry Off Drippings and Thus Prevent Fires



Here Is a Safety Strainer Kettle That Protects the Hands as Shown When Pouring Off Hot Liquids; the Lid Will Not Slide Off



The Summit Corp
 908 American
 288 POPULAR MECHANICS
 Bank Bldg. Liverpool
 ELECTRIC HOT WATER HEATER
 PLUGS INTO LIGHT SOCKET

Captn. Sumner G. Palmer
 San Francisco
 Calif

3732

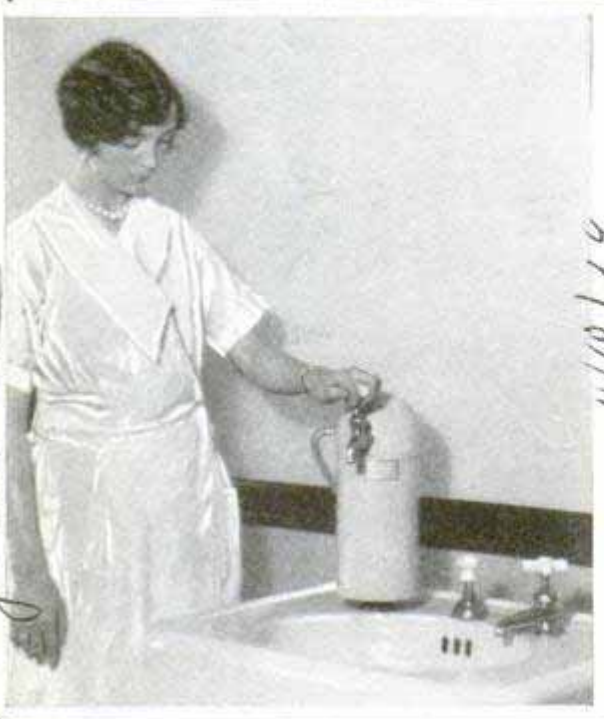

11/10/24

Herald Trans

802

375

pulp represents a good half day's work. The men gather the fuel and haul the water for the camp fires over which the juice from the pulp is boiled until it is reduced to a sirup, suitable for sealing in the jars. Preserves are also made from the cactus fruit and seeds left over are either ground into meal or kept for chicken feed.

FOG DIAL ON CAPTIVE BALLOON TO AID PLANE LANDINGS

To assist pilots in landing on fields blanketed with fog, a western inventor proposes to send up a captive balloon until it floats in clear air. Directly beneath it would be a gauge giving the height of the balloon, the depth of the fog bank below and the height of the ceiling as well as the direction of the wind.

CANNIBAL MICROBES IN WATER SHOWN BY MICROSCOPE

Magnifying a drop of water one million times reveals ferocious cannibal microbes which make vicious attacks on other less hardy breeds, or even set traps for the unwary ones. One of the species is a "savage rotifer" whose pincerlike jaws devour other microbes, and another is a "bladderwort," which, although a plant, is a "meat eater," setting netlike traps for itinerant microbes. At the New York Museum of Natural History, a glass device which enlarges microbe life has been installed. Four years of work was necessary to make the model of life in a drop of water, which was blown in glass.

Reported in Journal of Frank A. Thacker U.S. Dept. of Agriculture
 credited by 38/4

An Electric Hot-Water Heater for the Bathroom Which Plugs into a Light Socket

Plugging in at a light socket is all that is necessary to obtain hot water with an electric heater which is intended for installation in the bathroom. It may be mounted either under or above the wash-bowl, is completely insulated and is equipped with a temperature control. It heats only the measure of water wanted, an automatic arrangement shutting off the current when the faucet is turned off. It is particularly adapted for shaving and other home uses, but also may be utilized by doctors, dentists and barbers.

FRUIT OF GIANT CACTUS TREE RELISHED BY INDIANS

Indians of the Arizona desert country have a natural sugar supply in the fruit of the giant sahuaro cactus. It is used mainly in the preparation of a sirup which is sealed in clay jars and keeps for a year or more. Harvesting the sahuaro fruits is an annual event. The women knock the ripe, red fruits from the tops of the tall cacti with long poles made of spliced cactus ribs and fitted with hooks fashioned from the thorns. The pulp is extracted by slitting the skins with a slash of the thumb nail. Fourteen or fifteen quarts of

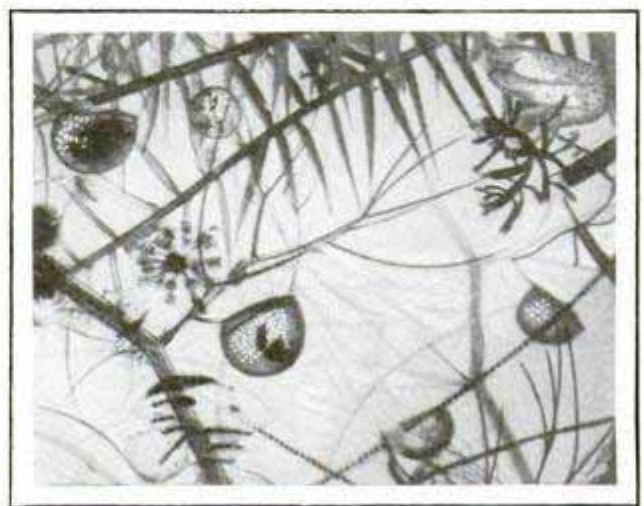

Some of the Cannibal Microbes Found in a Drop of Water Magnified One Million Times

work of Herman C

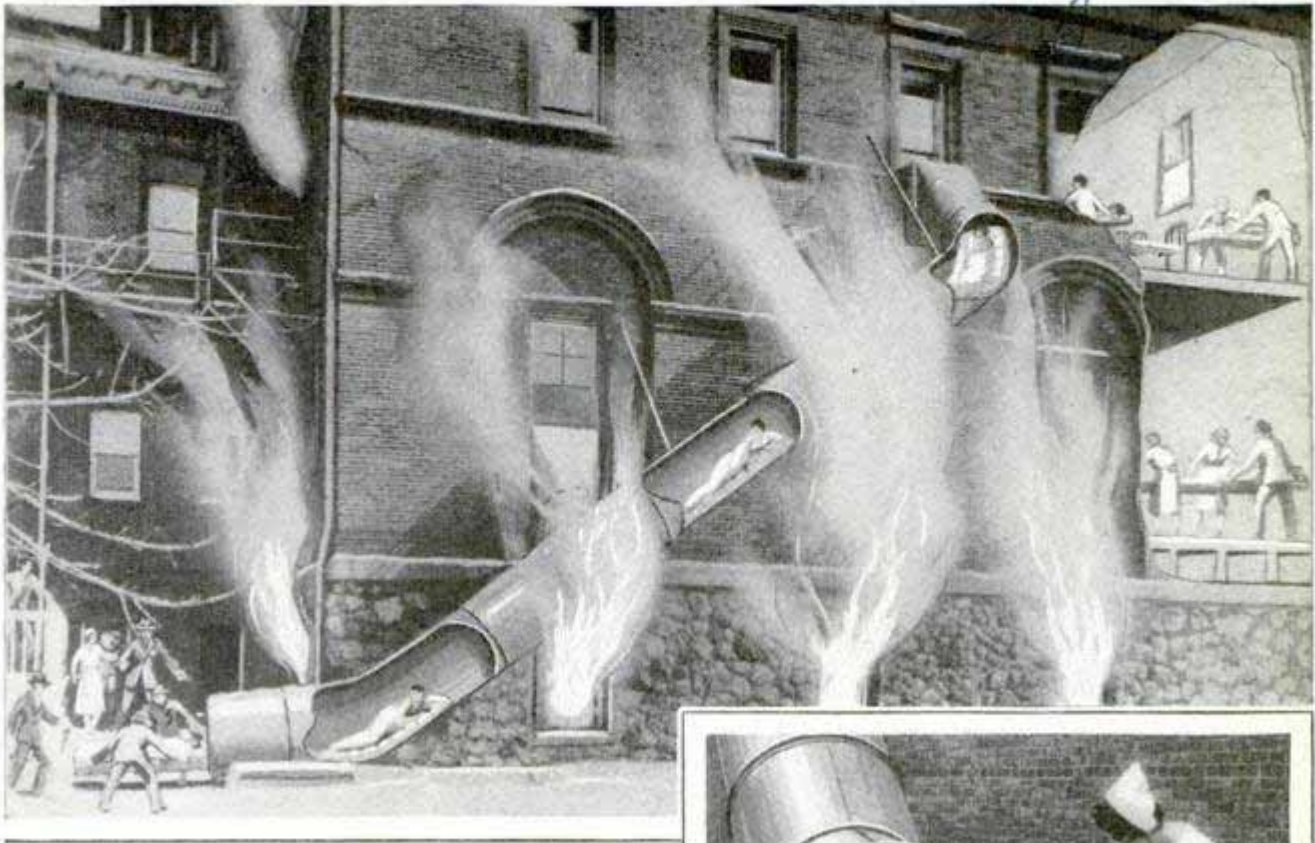

Tubular Fire Escape Which Protects from Fire, Water and Smoke; at Right, Hospital Patient Emerging from the Tube

FIRE VICTIMS SLIDE TO SAFETY DOWN TUBULAR CHUTE

Intended primarily for hospitals, schools and other buildings where fire constitutes more than the ordinary hazard against life, a tubular fire escape, like a huge chute, down which the victims slide to safety, now is available. The chute is of steel construction and those trapped by flames step into it from doors on each floor of the building. Hospital patients may be sent down on mattresses and at the bottom come to a stop, ready to step out or be lifted out of the opening. Others may go through the chute much faster than down ordinary fire escapes, and are protected during the descent from weather, smoke and water, as well as from fire.



GLASS BULLETS FULL OF GAS USED BY SLAYER 3786

Germany's police museum has acquired a pneumatic pistol used to fire glass bullets filled with deadly poison gas, the weapon used by a young Russian doctor to kill more than half a dozen victims, and finally himself. A woman first was

found slain, her purse empty, but the cause of death a mystery. Four other persons were found under similar circumstances within a week, but one of the four recovered and said he saw a man step from a doorway and raise his hand. The others died from poison. Three more murders followed, but beside one of the victims the police found splinters of a thin glass bulb and suspicion was directed to the Russian doctor who had become suddenly wealthy. A detective put on his track was killed by the poison and when other officers raided the doctor's rooms, he began hurling the glass bullets, killing himself and all but one of the raiders. The glass bullets fired in the weapon were filled with a gas so deadly that it killed as soon as released.

*Described in H Ashton. Wolfe's book.
 The Matter of Glass*

36/5

4351 Georgia St. San Diego Calif.

Thrills *in* Hunting



great strength, endurance, ingenuity and scientific zeal as any kind of big-game hunting.

Approximately 10,000 persons—aside from the wild tribes who gather them for food—in the world are interested in collecting birds' eggs. Of these, there are not less than 3,000 in the United States. Scores are employed by museums and by wealthy private collectors; others make their own collections, devoting their at-

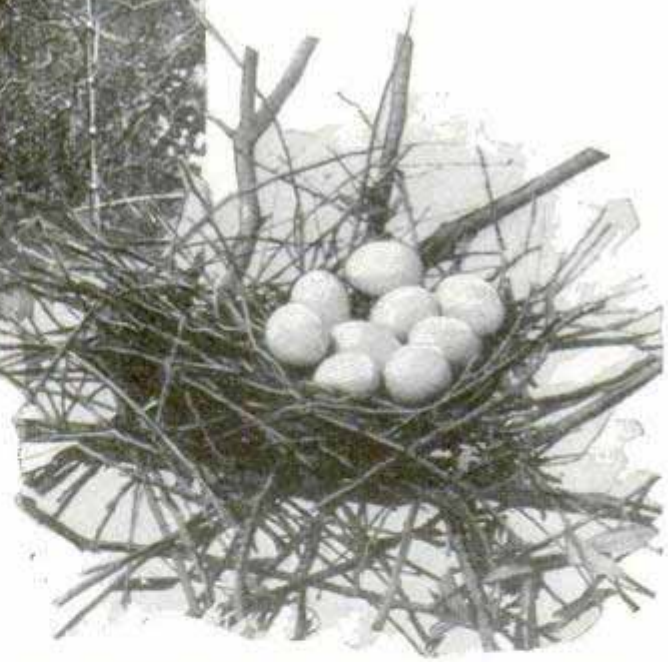

By H. H. DUNN

COMBINING the adventurous features of mountaineering, hunting and fishing with the necessity of varied knowledge of woodcraft, zoology and botany, and spiced with the danger of cliff and tree climbing, the collecting of birds' eggs, carried to its greatest development and value in the United States, offers a truly scientific sport. In desert and mountain regions, as well as on the islands off our coasts, the finding of birds' nests and the collection of their eggs require as

Rope Ladders Are Useful to the Egg Collectors; Right, Nest and Eggs of the Anthony Green Heron

tention largely to the birds of their own localities, counties or states. There are about 780 species of birds in the United States, and more than 10,000,000 of their eggs are in the public and private collections of this country. From a study of these eggs, and of the carefully kept notes

Birds' Eggs



Expedition from the San Diego Museum of Natural History on a 1,000-Mile Trip through Lower California Hunting for Birds' Eggs; Extensive Expeditions Are Sent Out by Various Museums Each Year

of the many men, and a few women, who collected them, a very considerable part of our knowledge of the bird life of North America has been accumulated.

From them we have learned of the floating nests of the grebes and coots, the palm-fiber cradles of the hooded orioles, the habit of one of the flycatchers of putting a bit of discarded snake skin in every nest, the preference of the red-tailed hawk for sycamore trees, the reason that the meadowlark puts a dome of woven grass over its nest, why the dipper (water ouzel) makes a hollow ball of moss to house its eggs, that the long-eared owl steals the nests of hawks and crows to rear its young, and so on, indefinitely.

As previous collectors, since the days of Audubon, have paid particular attention to the number of eggs laid by each species of bird, the modern collector knows how many should be in the nests of the commoner species. When he observes that a bird has commenced incubation on a smaller, or larger, number than normal, this is a note of scientific interest. If he finds that this smaller, or

larger, number persists over a considerable territory, the matter is of interest to evolutionists, who seek to learn the reason for the change in the normal "clutch" of this species of bird.

It is obvious that birds of prey have developed the habit of laying few eggs—two, three or four—because of the difficulty of providing fresh meat for a large family. But why do some of the ducks, notably the ruddy, deposit three to five more eggs than their bodies will cover? The condor, largest bird that flies, lays a solitary egg; the hummingbird, smallest of all the winged wanderers, lays only two, and sometimes one. The ostrich, largest of all birds of today, fills a hollow scraped in the sand with fifteen or more huge eggs; the common hobwhite, about the size of one toe of the ostrich, lays fifteen to twenty pure-white eggs. Who knows why?

Down precipitous cliffs, into caves, up towering wind-swayed trees, out on treacherous limbs, into quaking swamps, the egg collector goes to find his treasures, and, having found them, all he keeps is



the shell. As the eggs are taken from the nest, each is marked. Then, every egg is wrapped in cotton and placed carefully in specially devised collecting boxes which give the utmost insurance against breakage. Most of the museums, and many private collectors prefer to keep the eggs in the nests, as found, so the nests must be collected, too, by recently developed methods. When the collector has reached his camp, or his home, he drills a very small hole in the shell and with a curved blowpipe, forces out the contents.

When the eggs have been cleaned and dried, they are preserved in one of two ways: Either in sealed, glass-covered trays in large drawers, or in the original nests in which they were found. In the first method, square cardboard boxes, heavy enough to protect the eggs, are provided, lined with cotton. Then the glass top is sealed on with black adhesive tape, after a few grains of some insecticide, usually naphthalene, have been sprinkled inside. Almost microscopic insects of several kinds attack birds' eggs and skins, and preservation of the specimen from these pests is only one of the troubles of the collector.



The second method of preserving the eggs involves considerably more work, but the results are more interesting and far more valuable. Here the nest—whether it be that of a hummingbird, no larger than a silver half-dollar piece, or the 100-pound collection of coarse sticks assembled by an eagle—is collected with the eggs. The larger nests are sewn together, in their original shape, in the tree or on the cliff, before they are taken from their resting place. Arrived at the home of the collector, or in the museum, they are placed in closed tanks and thoroughly fumigated, to destroy the abundant insect life which usually is to be found in them.

In the case of many of the birds of prey, and other flyers which build large nests in trees, part of the branch on which the nest was made also is collected. This, too, must be fumigated with the nest.

When the nests have been prepared, the eggs, blown, dried and marked as previously described, are placed in them and the

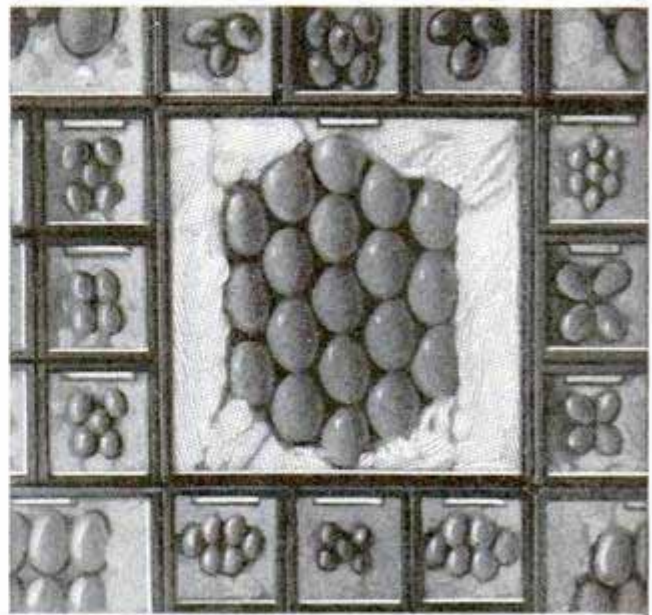

Top to Bottom, Raven's Nest and Eggs; a Female Snowy Heron on Her Nest, and Sample Egg Collection in Shallow Boxes

tops of the drawers either sealed on, or the standing or hanging nests left open. This method of preserving the eggs gives the student an opportunity to learn just what materials are used by various species of birds in building their nests, and how the only home builders in the world except man go about the construction of their temporary or permanent residences. A collection of eggs with the nests is about three times as valuable as the same collection would be without them. Smaller nests are collected with branches, clumps of brush, bunches of grass or reeds in which they are built. Woodpeckers' homes are preserved in the section of tree trunk which they have hollowed to suit their needs, and small doors are cut in the back of the trunk, to permit inspection of the eggs.

Most interesting of all is the method devised for the collection of the nests of some of the sea birds, such as gulls and terns, and some of the shorebirds, such as plovers, snipe, curlew, and others. These birds make little or no nest, merely scratching out a hollow in the sand, and lining it very rudely with bits of seaweed, moss or an occasional feather. The oyster catchers usually drag in a small shell or two with the eggs. Such birds trust to the protective coloration of their bodies and eggs to prevent discovery by enemies, and many of the terns and shorebirds will sit tight on their nests until almost trodden upon before taking to flight. Others fly away, run off with drooping wings, simulating injury, whenever man approaches, and it is almost impossible to see their sand-colored, brown-spotted eggs against the background of beach or sand spit.

When the collector finds one of these nests, however, he marks with a small twig a square around it, usually one foot to fifteen inches in each dimension, depending on the size of the nest hollow. Then he pours all over the sand on the inside of this square a quantity of very thin, colorless shellac, first having removed the eggs, but leaving nest, twigs, feathers and shells undisturbed. Marking the nest with a stick, so that he may find it again, and taking the eggs with him so that the bird will not again settle down on the nest, he leaves the shellac to soak into

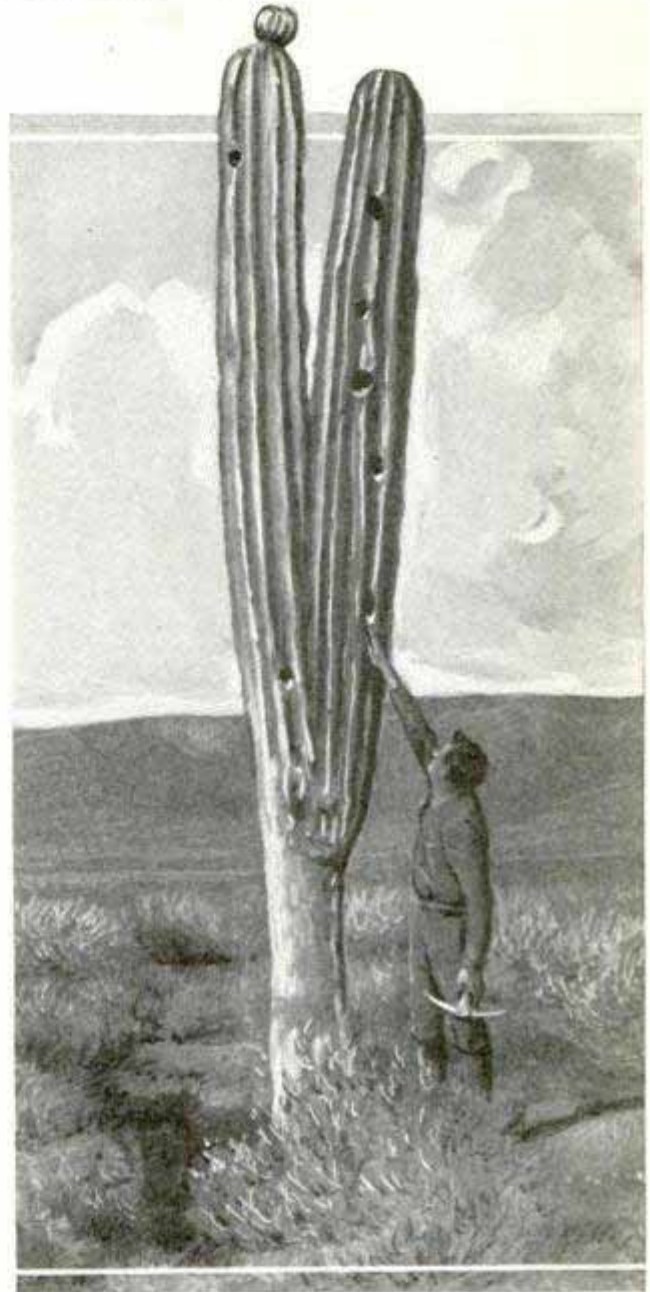

Woodpeckers Carve Safe and Comfortable Nests in the Giant Cactus; Several Birds Make Their Homes in This Large Specimen

the sand for two or three hours, while he locates and similarly prepares other nests.

On his return, he finds that the shellac-soaked sand inside the square has hardened, and he is able to lift out the whole nest in a neat square of imitation sandstone. Any and all insect pests of course have been destroyed, and the nest is quite ready to be placed in the collection. It remains only to prepare the eggs, write up the record, and seal the specimens in the proper drawer.

The egg collector calls on the fireman and the sailor for his equipment in reaching the high-hung nests of some of the birds. A. M. Ingersoll, of San Diego, who has been building up his own private col-

3615

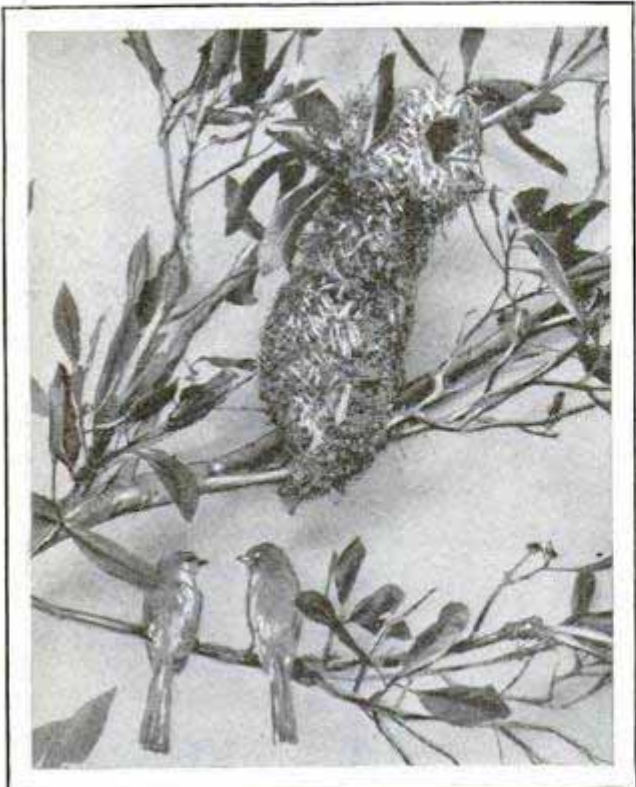

Beautiful and Elaborate Nest of the Bush Tit, a Small Bird That Builds a Home a Dozen Times Its Size

lection of eggs of the birds of southern California for nearly half a century, has devised a folding ladder, made of steel, with a full extension of sixty feet. He has had made, from his own designs, a quite stable rope ladder which reaches ninety feet. The former is used on cliffs, in getting eggs of eagles, condors, hawks, owls, ravens, rock wrens and swifts.

Saws, hammers, strong cords, stout thread, and preservatives for birds' skins, eggs and nests also are part of the equipment of the modern egg collector, who must prove he knows his eggs and be a real student of ornithology before he can obtain license from the state as a collector. Virtually all the states now protect the eggs, nests and lives of the great majority of their birds, with the exception of a few hawks and owls, so that wanton collecting of eggs, nests or skins is a thing of the past. Scientific collectors have proved that when one nest and set of eggs are taken, the birds almost invariably build another nest and lay another clutch. This is never disturbed by the true collector.

Many collectors exchange with others in different parts of the world; some buy eggs from other collections, and a number, including most museums, employ salaried collectors of unquestioned reli-

bility, to gather eggs and nests for them. Eliminating the eggs of extinct species, such as the great auk, Labrador duck and passenger pigeon, the highest-priced egg is that of the California vulture (condor), valued at \$1,000 cash, or \$2,000 in exchange for other eggs. At the other end of the scale lies the egg of the common English sparrow, placed at one cent. Rarity of species rather than difficulty of collecting sets the standard for these valuations.

Battles with condors, eagles and even some of the larger hawks, as well as with great horned owls, mark the lives of egg collectors. Climbing dizzy cliffs, creeping along narrow ledges, crawling into dark caves, sliding down hundreds of feet of rope, not knowing just how he will get back—all these are incidents in the scientific sport of gathering birds' eggs.

STREET CAR MOVED ON TRUCK WHEN AN AXLE BREAKS

Enabling two men to jack up a broken street-car axle and repair the damage sufficiently to allow the trolley car to proceed under its own power, an emergency truck for this form of trouble is in use in Cincinnati. The wheels of the truck are rolled into position on the track just in

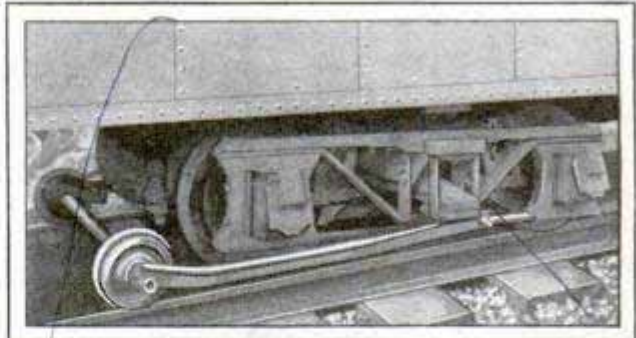

Truck Placed under Street Car with Broken Axle, Enabling It to Proceed under Own Power

front of the street-car wheels, and the car is lowered onto the emergency truck which weighs 445 pounds, while axle and wheels weigh 290 pounds. The outfit is carried in a motor truck to the scene of trouble and, when it is in place, a street car with broken axle can proceed at normal speed for several miles.

Whales are being killed off at the rate of 30,000 a year.

Designed by E. J. Jones.
Patent Pending

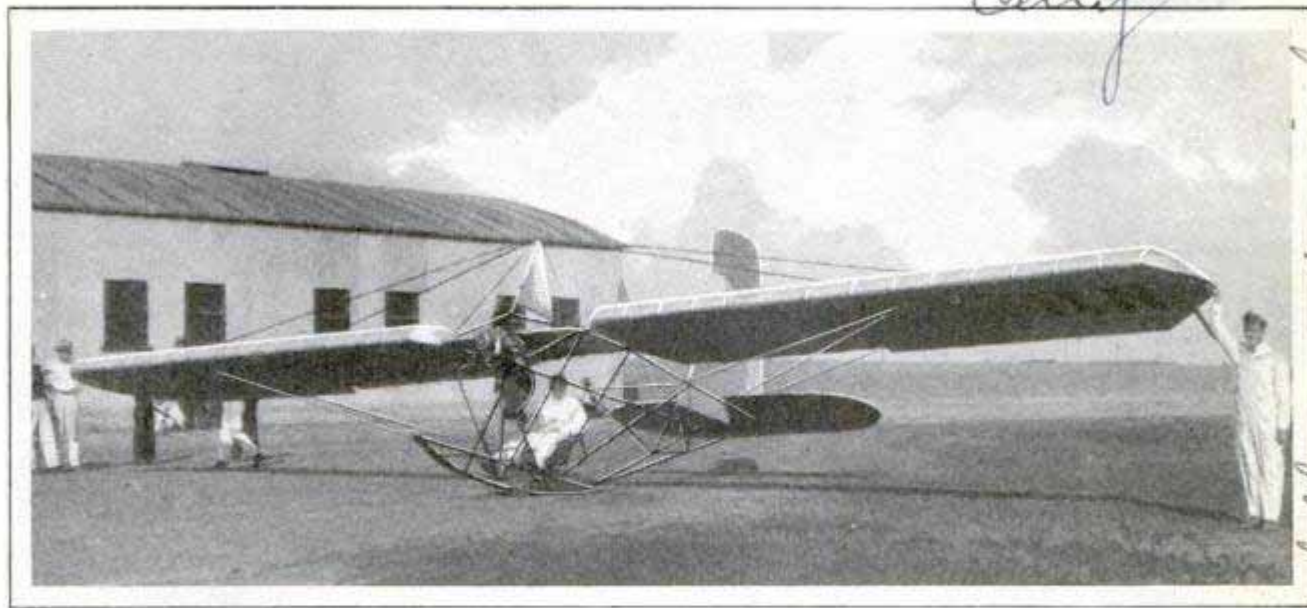

Glider Equipped with a Forty-Horsepower Motor Which Gets into the Air More Quickly Than an Airplane and Lands at a Safe Speed of About Fifteen Miles an Hour

Probably connected with Crawford Motors & Airplane Co. Seal Beach, Calif.

GLIDER EQUIPPED WITH MOTOR LANDS AT LOW SPEED

Propelled by a forty-horsepower motor, a glider recently underwent successful tests in California. The maker claims the craft, driven by its engine, will take off in one-fifth the time and distance required for an airplane, and will glide to a slow, safe landing at fifteen miles an hour after attaining an altitude of 10,000 feet.

The subjects became warm to the touch after a few moments' exposure to the radio. Scientists see a wide application of the system if the method followed in the preliminary laboratory tests can be applied to general use.

SUN HAT HELD ON SHOULDERS GIVES GREATER COMFORT

Permitting free circulation of air about head and shoulders, and at the same time affording protection from heat and sun, a hat made of wire and covered with cloth is attached to the wearer's body around the chest or waist by means of a belt. The light frame rests on the shoulders and interferes in no way with free movements. It is collapsible, the same springs that hold it in position when open, keeping it closed when pushed back over the head. Netting can be used with it to transform the hat into a bee helmet or protection against mosquitoes and other insects.

3931 Dallas

RADIO WAVES SLAY INSECTS LABORATORY TESTS SHOW

Victory over one of man's most dangerous and destructive enemies, the insect, and an important new use for radio are promised as a result of interesting tests with high-frequency radio waves at the New Jersey agricultural experiment station. Investigators found that such waves killed cockroaches, beetles, house flies and other insects in short order. The invisible impulses, emitted on a wavelength of about twenty-four meters and with a frequency of nearly 12,000,000 cycles a second, developed heat of a deadly degree within the bodies of the insects, producing death in a short time. The German cockroach proved to be the most difficult to defeat by this means, nearly two and one-half minutes being required before it was killed. Apparently, the tissues in the bodies of the insects reacted to the high-frequency waves in such a manner that heat was speedily generated.

newspaper 11/26/29 3817 papers on this subject



Sun Hat of Wire and Cloth, Which Rests on Shoulders, to Give Comfort to Wearer

Bldg. Valley Tex. Per J. Denton will market for m.o. Austin

N.Y. Herald Tribune 11/26/29

Mr. Thomas J. Headles and Robert C. Burdette

Mechanical Progress Co. 1010

Built-In Dynamic Uses Wall for Baffle

By Edwin M. Love

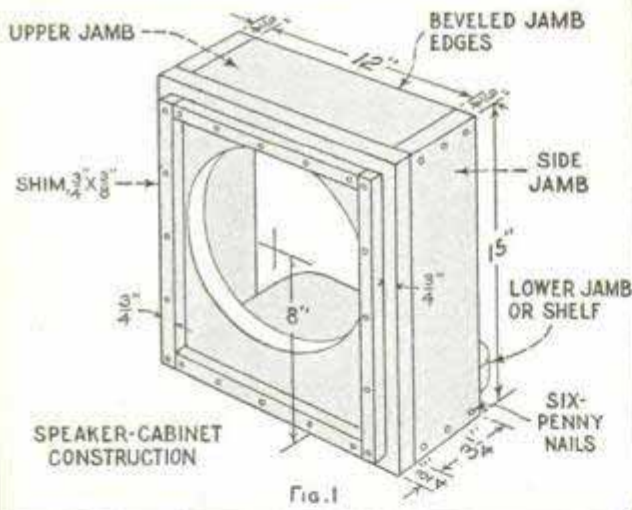
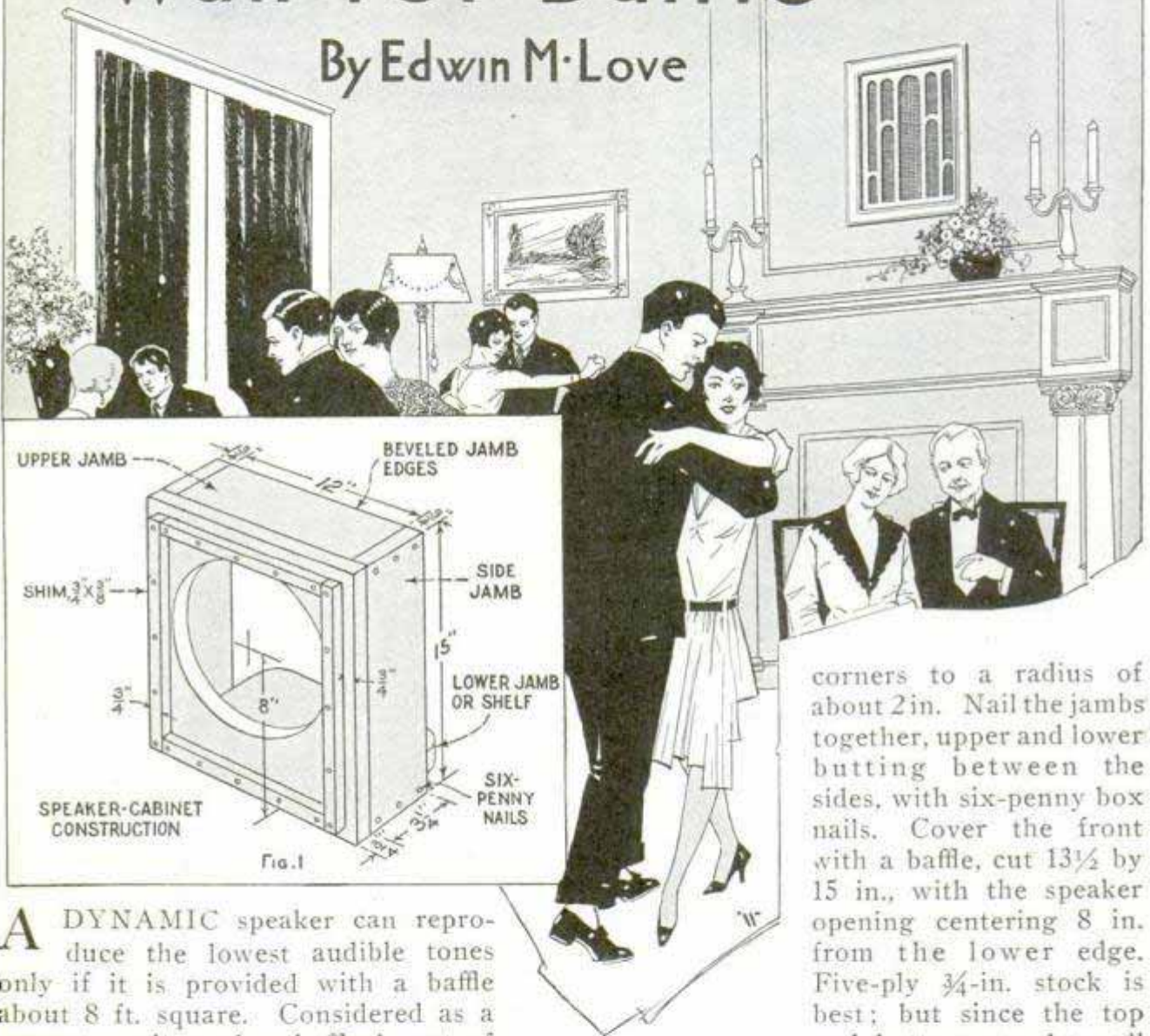

A DYNAMIC speaker can reproduce the lowest audible tones only if it is provided with a baffle about 8 ft. square. Considered as a separate unit, such a baffle is out of the question for the average house; but there is no reason why a wide partition space cannot be utilized for the purpose if the projection of the speaker back can be made into a closet, hall, or other room where it is not noticed.

Figure 1 illustrates a cabinet for holding speakers up to 10 in. in diameter. Smooth two pine side jambs, $\frac{3}{4}$ by $3\frac{1}{4}$ in. by 15 in., and an upper jamb, 12 in. long. The lower jamb must be of sufficient width to accommodate the base of the speaker. For neatness, round the outside

corners to a radius of about 2 in. Nail the jambs together, upper and lower butting between the sides, with six-penny box nails. Cover the front with a baffle, cut $13\frac{1}{2}$ by 15 in., with the speaker opening centering 8 in. from the lower edge. Five-ply $\frac{3}{4}$ -in. stock is best; but since the top and bottom can be well

nailed to the jambs, solid stock is fairly satisfactory.

This cabinet will fit between two studs in the wall, leaving a little side clearance for plumbing. For the best appearance in the wall, the grill should be noticeably above or below the center of the room height; but do not, on this account, reduce the effective size of the wall baffle. If the grill must be centered on the wall, a table or stand under the grill will make centering less noticeable.

Cut the plaster on the wall back first, lay-

ing $\frac{3}{8}$ -in. shims, or strips of any necessary thickness, to bring the face within $\frac{3}{8}$ in. of the plaster. Cover the joint with a casing of panel molding (Fig. 5), made by rabbeting a $\frac{3}{4}$ by $1\frac{1}{8}$ -in. strip $\frac{3}{8}$ by $\frac{3}{8}$ in. and rounding the corners.

Paint the wood to match the trim, and

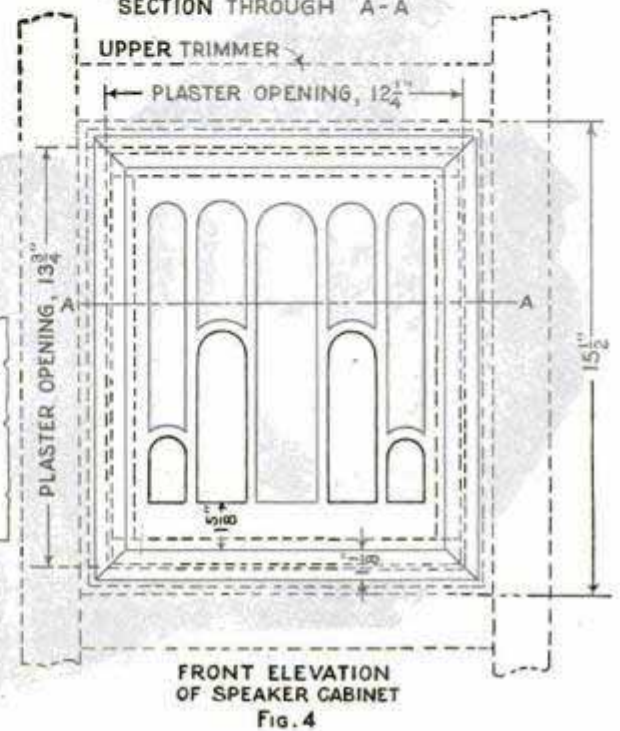
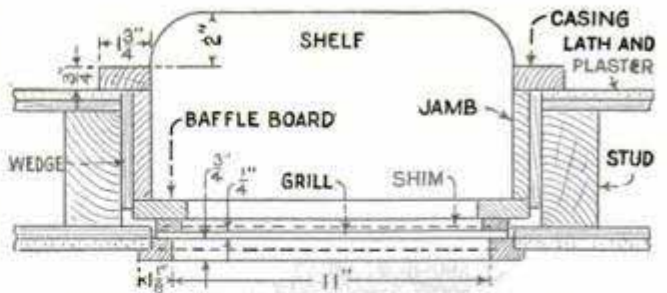
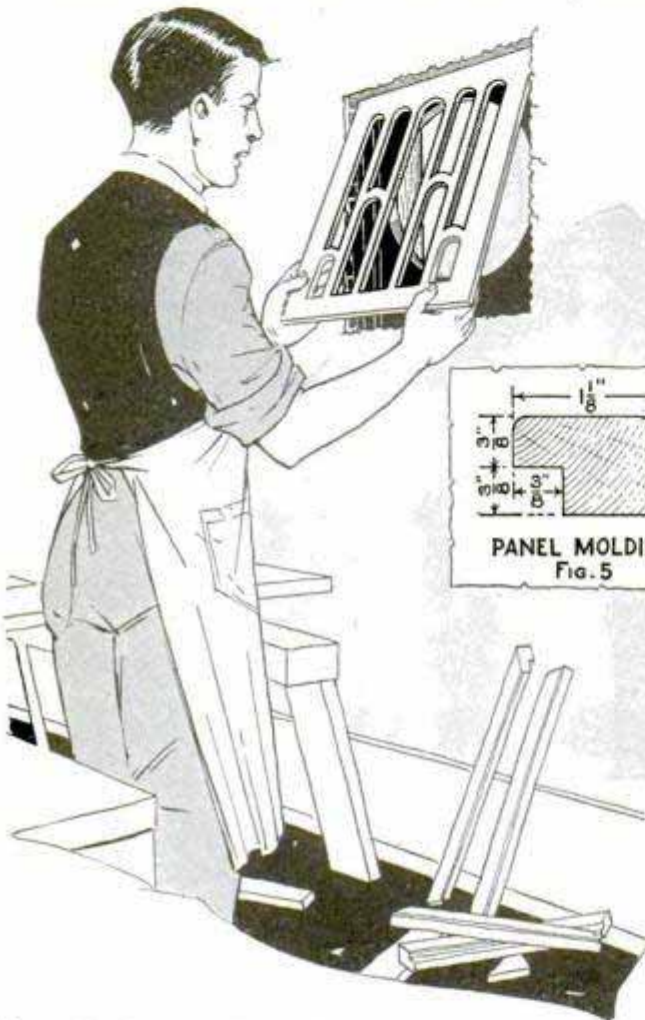

install the speaker. If it is desired to hide the back of the unit, hang a small curtain from a rod above.

Caring for Electrolytic B-Power Units

Many of the electrolytic B-power units are in use and it has been the experience of the writer that they perform in a very satisfactory manner when proper care is taken of them. Add distilled water to the jars occasionally to take the place of that which has evaporated and use a clean hydrometer, kept for this purpose only. This is important because if there is the slightest trace of battery acid added to the solution in certain types of power units, it will render the unit inoperative. When the solution becomes thick and filled with solid matter, it is time to discard it. Rinse

the jars with clean water and add new solution. Be sure to use the particular solution that is made for your unit. It is well to renew the electrodes at the same time. Remove only one electrode at a time so as to be sure to get the right kind in the same position. Replacement solution and electrodes can be obtained from the manufacturer of the unit or the dealer handling the device.

When testing the output voltage of any type of power unit, use only a high-resistance voltmeter (1,000 ohms per volt). They cost a little more than the common type but must be used in order to get a correct reading. The cheaper type will give a reading 5 or 10 volts below normal, owing to the greater current taken by the low-resistance meter. When working with any type of power unit, always disconnect it from the line-supply first. Check all binding posts to make sure that they are secure and free from corrosion, as a loose contact will cause noise and loss of power. When starting the unit in operation, adjust the detector and

*370. 7th Ave
New York 299*

amplifier voltages for best signal strength and quality of reproduction. After this adjustment is made, it is seldom necessary to change it, and the device is usually better left alone.—R. J. Plaisted, Cleveland, Ohio.

Soldering Iron Permanently Tinned

To tin a soldering iron permanently, take it to a jeweler and have him tin the point with silver solder. This has a higher melting point than lead solders and the point will stay tinned. It is best to let a jeweler do the job unless you are accustomed to using hard solder, and the cost is usually only about 50 cents.

New Screen-Grid Unit for Experimenter

A three-stage, high-gain screen-grid r.f. amplifier, completely assembled, wired and tested, is now available to the home constructor. The unit is designed for maximum r.f. amplification over the entire broadcast band and is said to be absolutely stable with consequent absence of regenerative distortion. It consists of a matched triple condenser of the "battleship" type in an aluminum shield; three sealed copper cans, each containing a high-gain r.f. transformer and a polarized r.f. choke; metallized gridleak and mica grid condenser. Pigtail leads are taken from the bottom of the unit for connections beneath the subpanel. The chokes used are

2439-a

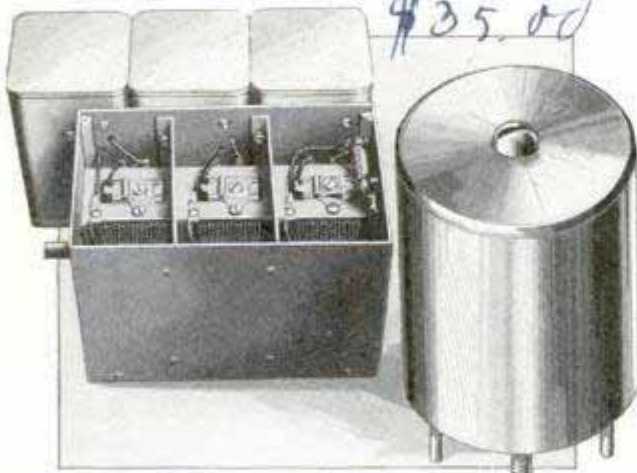

\$35.00

Three-Stage Screen-Grid Amplifier with Cover Removed from Triple Condenser Shield; Right, Shielded and Polarized R.F. Choke Coil

specially designed for screen-grid tube operation; they are thoroughly shielded in an aluminum shell and polarized.

*Hammarlund Mfg. Co.
424 W. 3rd St. 1st Fl.*

Portable Set Operates on Direct or Alternating Current

2436-R

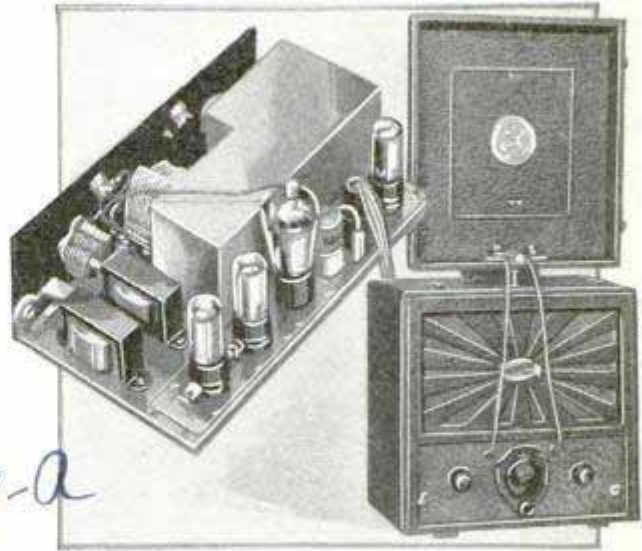

Left, Tubes in Position; Right, Complete Portable Receiver for Either A.C. or D.C. Operation

A portable receiver that will meet any current requirements is a departure from the usual portable, which depends entirely on batteries for its operation. The receiver shown in the accompanying illustration is one of three models which employ an efficient shielded circuit and a screen-grid tube. The power packs and batteries are interchangeable in all three models, so that the owner may use the set, regardless of location or power supply, by adapting it for either 110-volt alternating or direct current, or, where neither of these are available, by using batteries instead. The sets are of the four-tube type and employ one dial for tuning, with a small trimmer condenser provided for use in congested broadcast areas and for separating near-by stations on very close wavelengths. The small model is intended chiefly as a battery-operated set, but can be equipped with either of the power packs which come as separate equipment. Fully equipped, this small model weighs only 27 pounds. Type-199 tubes are employed for the first a.f. and detector stages, a screen-grid tube in the r.f. stage, and a type-120 tube in the last audio stage. The larger models are intended for use with a power tube in the last stage and for a.c. or d.c. operation. The speakers are considerably larger than the one used in the smaller model so as to handle the greater volume delivered by the more powerful audio system.

*Hammarlund Mfg. Co.
1818 Washington Ave. St. Louis, Mo.*

Jersey City, N.J.

Television at Low Cost Now Possible

2451-2

With the development of a simplified and relatively inexpensive television, the inauguration of regular sight broadcasting service from Jersey City, N. J., and Washington, D. C., and a production

Tests during the past six months have resulted in a television which combines a simplified scanning drum with a selector shutter, simpler, quieter and less expensive than the previous models. Far better detail in movies or silhouettes and very satisfactory half-tones are possible with

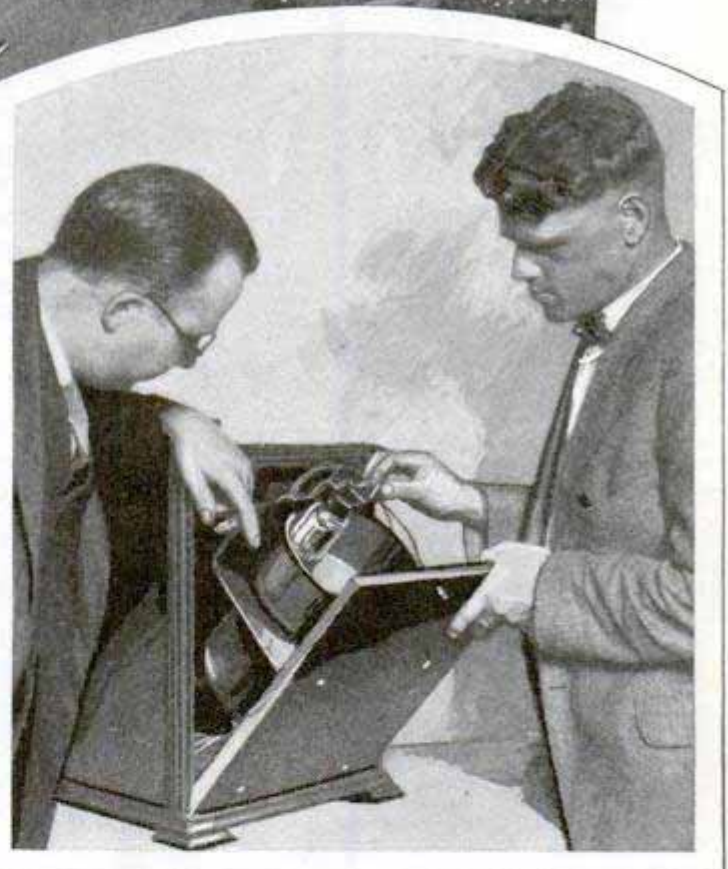
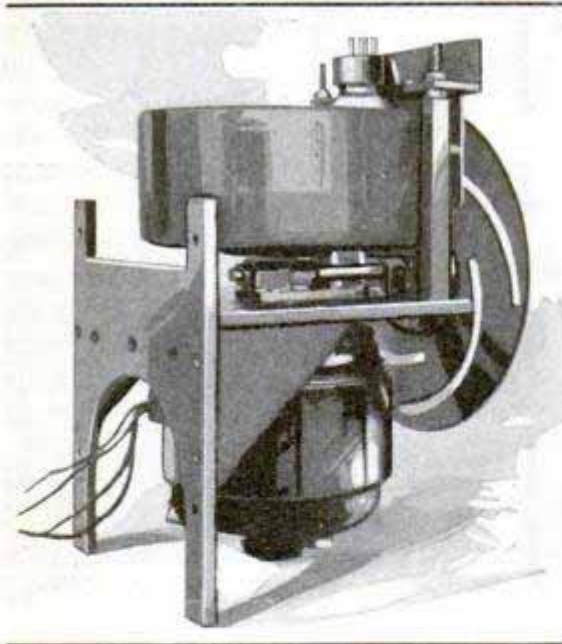

Television in the Home; Lower Left, Scanning Drum, Motor and Selector-Shutter Assembly; Right, Engineers Examining the Installation by Opening the Rear Door of the Cabinet

schedule well under way, an eastern television corporation is in a position to introduce television into the home. The apparatus is, of course, suitable for reception also from other stations using the same standard transmitting methods.

this new television. The scanning drum is mounted at the top of the receiver and contains a vertically mounted neon glow lamp; the synchronous motor is below the drum and the selector shutter is mounted at the front of the assembly.

The equipment is reduced to the simplest parts, yet the performance is remarkably improved.

A Corner Baffle for the Dynamic Speaker

Dynamic speakers now in vogue require a large baffleboard for maximum results. This means that the owner of a speaker of this type must either place it in a large cabinet or mount it behind a cumbersome and unsightly baffle. A simple solution of the problem is an ornamental baffleboard, carrying the speaker, mounted in a corner of the room as shown. All that is required is a suitable board with a small shelf at the rear to support the weight of the speaker. The baffle may consist of a nicely grained piece of hardwood, suitably stained, varnished and finished, or it may be a section of insulating lumber, on which plastic paint can be applied in any ornamental way. A suitable shape is the shield detailed in the diagram. The hole for the speaker may be cut in the form of a grill or a circle backed with silk or tapestry glued to the back of the baffle. The speaker is then mounted on the shelf which is supported with small brackets

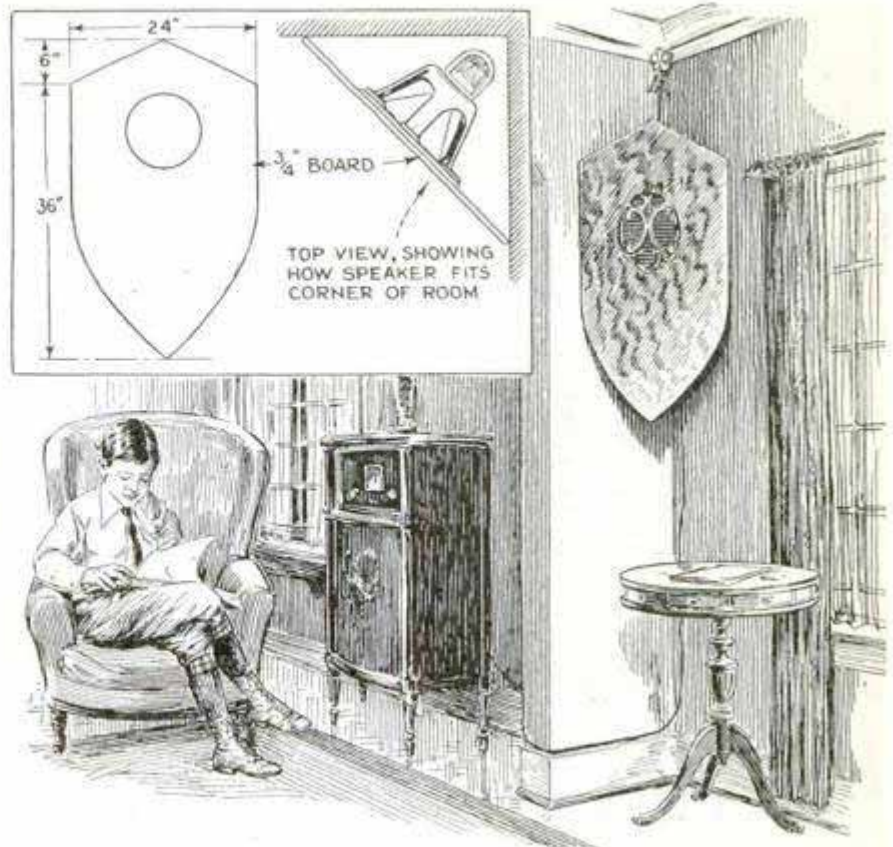

Upper Left, Construction Details of Baffle; Right, Completed Unit Showing Method of Installation

and screwed down in such position that the cone housing presses firmly against the baffle at the rear. A screw-eye at the upper end of the baffle is provided for a rosette suspension cord of the type used for hanging heavy pictures. The walls of the room diverging from the baffle have the effect of adding baffling surface and aid in bringing up the low notes, in which this type of speaker excels when properly installed.—Harry G. Schultz, Astoria, Long Island, N. Y.

New Unit Eliminates Line Noise

Crackling and sizzling noises, which may be caused by defective electrical apparatus in operation at some point distant from the receiver, are often communicated to the set by the lighting line which supplies power for both units. The instrument



shown in the illustration is designed to eliminate interference of this nature. The plug from the receiver to the power-supply line is removed from the wall outlet and the plug from the device substituted for it. The connection from the receiver is then made to a receptacle in the top of the interference eliminator, and the receiver operated in the regular manner. Should the interference still persist, an extra wire may be connected to the binding post on the front of the device and connected to the ground on the set.

Popular Mechanics radio department offers its information service free.

2316 R
 Ansulite Corp. of America
 78 Crossland New York

Across the



Left, for a Good Antenna Joint, Wrap Lead-In Wire as Shown, Leaving 2 In. Parallel to Horizontal Wire and Solder Together; Right, Aluminum Drinking Cup Makes Good Tube Shield



Left, a Handy Jack Assembly for Making Amplifier Unit in Broadcast Receiver Available for Use with Short-Wave Adapter or Phonograph Pick-Up; the Double-Circuit Jack Is Mounted at the Rear of Subpanel and the Diagram, Showing All Connections, Is Given Below

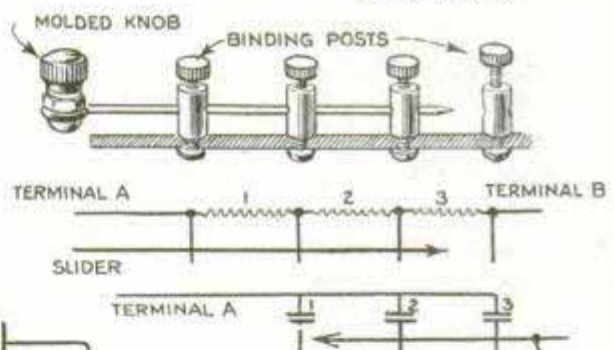
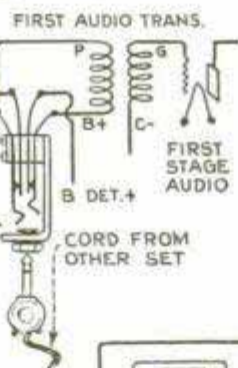
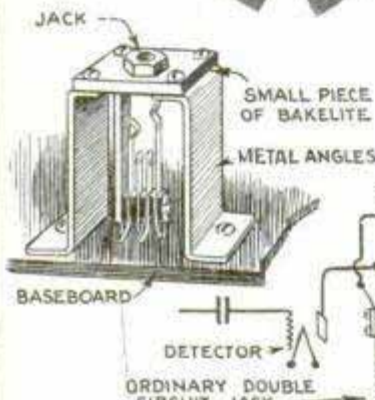

Above, Handy Kink for Cutting Resistors in Series and Condensers in Parallel In and Out of Experimental Hookups

Right, Buzzer Hookup for Alining Ganged Condensers; the Device Is Placed near the Set and Buzzer Signal Tuned In; if Tuning Is Broad, Move Device Away Until Sharp, Loosen Separate Rotors and Vary Them Until Signal Strength Is Maximum; Then Lock Rotor Plates in Position

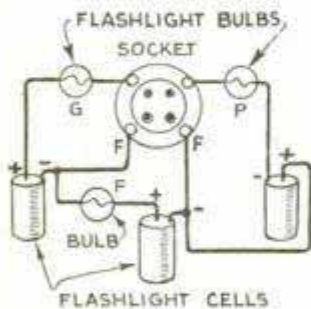
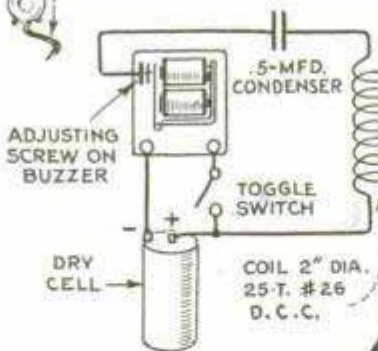

To Test Radio Tubes for Short Circuits, Insert Tube; if Bulb F Lights, Bulbs G and P Should Not Light; G Lighted Indicates Grid-Filament Short; P Lighted Shows Grid-Plate Short; to Clear Short in Either Case, Tap Tube, and if Lamp Continues to Burn Discard Tube; Many Elaborate Tube Testers Do Not Indicate Shorts

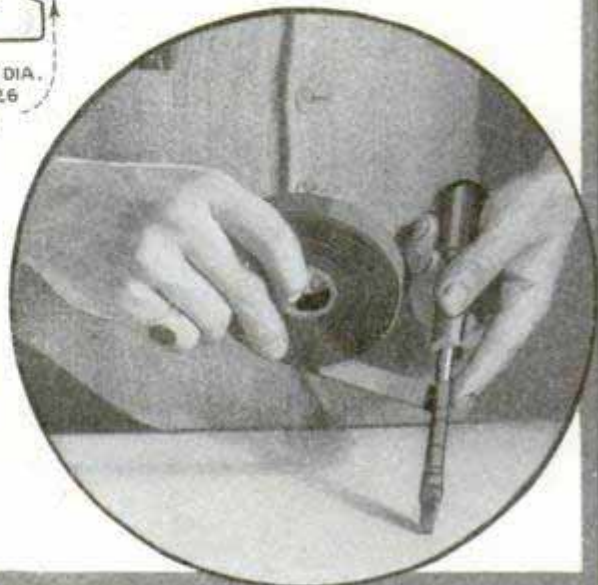

To Prevent Expensive Short Circuits When Making Adjustments in Receivers, Tape the Screwdriver as Shown in the Photo

Radio Bench

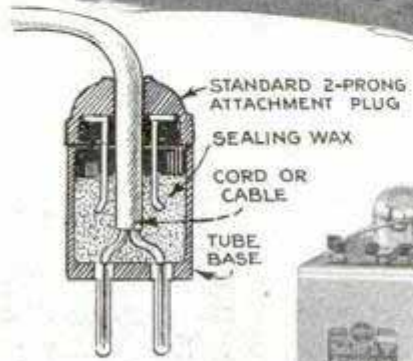

Connector Plug for Tube Testers or for Short-Wave Adapters

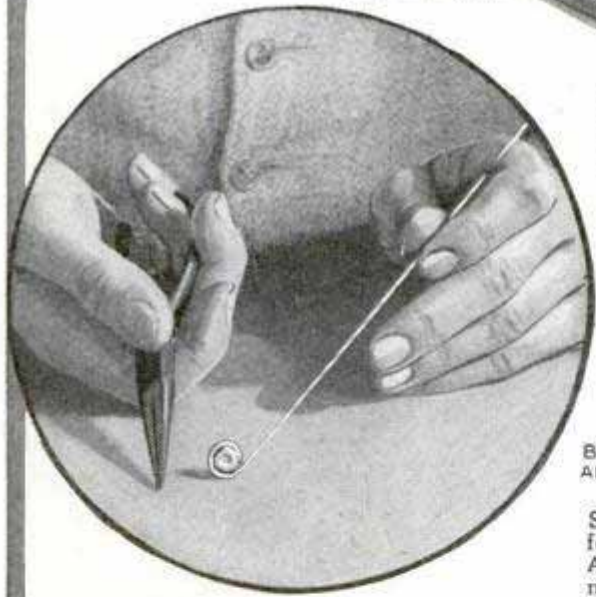

Threading Nuts behind Panels and under Instruments Is Simplified by Bending a Length of Busbar Wire to Hold the Nut

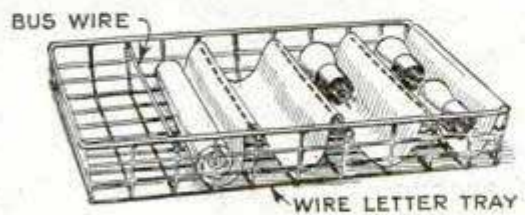

A Wire Letter Tray Converted into a Vacuum-Tube Holder; Busbar Wire Forms the Partitions and the Covering Material Is Felt or Woolen Cloth; the Holder Should Be Fastened to the Bench

To Check Audio Distortion, Connect an 0-50 Milliammeter in Negative-B' Lead, Tune in Strong Signal; if Pointer Pulsates Upward from Normal Position, There Is Excessive C-Bias; to Correct, Increase B-Voltage on Last Tube

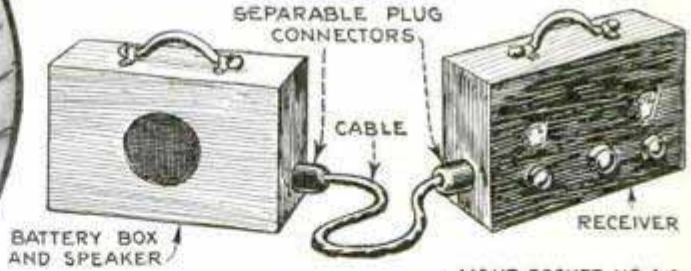

Suggested Two-Unit Installation for Portable Receiver; by This Arrangement a Good-Sized Magnetic Cone-Speaker Unit May Be Installed in the Battery Box without Crowding the Apparatus in the Receiver Proper

Right, a Simple Device for Correcting Low A.C. Line Voltage Conditions; the Bell-Ringing Transformer Is a Heavy-Duty Type and Boosts the Voltage by Steps of 6, 12 and, in Extreme Cases, 18 Volts; the D.P.D.T. Switch Controls the Set Voltage between Light and Heavy-Load Periods; When Load Is Light, as in Day-time, Throw Switch to Position R; When the Heavy Line Load Is On at Night, Throw the Switch to L; the Line Voltage Should Be Checked at Both Periods before Installing This Device

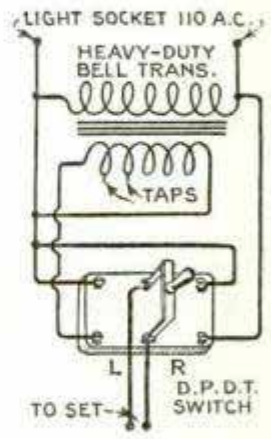

City 4 Westton Ave
Waverly Park Newark, N.J.

the hum disappears is easily found and the potentiometer is then left at this setting. In my case it was only necessary to use the center-tapped resistor across the filament of the detector tube.—Henry S. Laraby, New Haven, Conn.

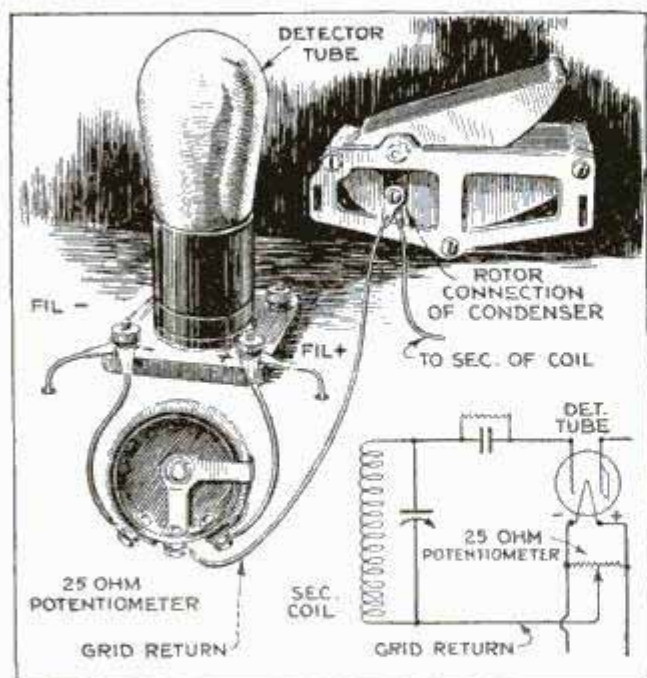

Left, Picture Diagram Showing All Connections; Right, Schematic Circuit Diagram

Stopping A-Eliminator Hum

The A-eliminators now in common use in adapting standard battery-operated sets for a.c. operation, in connection with B-eliminators, are practical and efficient and very little hum is present in the usual installation. In some circuits, however, the hum may be annoying, and in these cases there is a simple remedy which the writer has found effective. In this particular A-eliminator there were eight taps, so that, by means of a switch, a different tap could be used to compensate for line variations and also for different types of receivers. A slight hum could be heard when using the first tap and as the switch was advanced to the point for the correct operation of the receiver, the hum became more pronounced and annoying. To solve the problem, after trying a number of advised suggestions without avail, as a last resort I decided to try the system employed in a.c. sets; that is, connecting the grid return to the electrical center of the tube filaments as shown in the diagram and sketch. There are several types of strip resistors with variable center taps on the market that may be used for the purpose of balancing out this hum. In the writer's case a 25-ohm potentiometer was available and answered the purpose nicely. The center post is connected to the slider arm so that, by moving the slider from left to right, the electrical center where

Portable Instrument Makes Testing 2300 P. Easy for Service Man

A combination set tester can now be had contained in a rugged bakelite case provided with a carrying handle and a compartment for the set accessories and a few small tools. It has a removable snap-on cover, and the over-all size is 12 $\frac{3}{8}$ by 9 by 3 $\frac{1}{4}$ in. The weight is approximately 10 pounds. A UX and UY-socket are provided on the panel, the tester plug has four prongs, and an adapter is provided to change it to a five-prong plug. Rotary switches are used to make the various voltage ranges available and binding posts are supplied for external tests using flexible test leads which come with the set. Two binding posts and a 4 $\frac{1}{2}$ -volt C-battery are provided for use in making continuity tests with either a high or low-resistance voltmeter. The resistance is changed by means of a toggle switch, so that either 1,000 or 100 ohms' resistance per volt may be placed in the circuit.

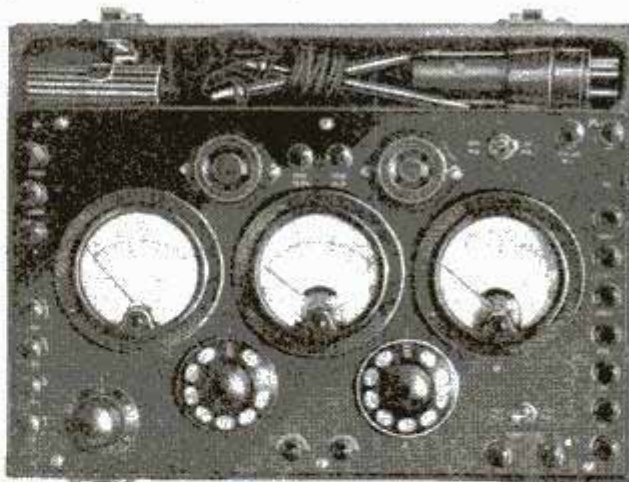

Combination A.C.-D.C. Set Tester for the Service and Repair Man

Simultaneous readings can be made of the heater voltages on the a.c. voltmeter and the plate current on the milliammeter, while plate, grid bias, cathode or screen voltages, or the grid, screen or rectifier currents are being measured on the d.c. volt-milliammeter.

Filament Supply from 32-Volt Source

Many homes in suburban and rural districts have 32-volt electric plants and in

1 1/4 amp. Referring to the first column of the resistor table we find that a set drain of 1 1/4 amp. requires a fixed resistor, No. 1, of 10 ohms and No. 2 of 5 ohms. Vari-

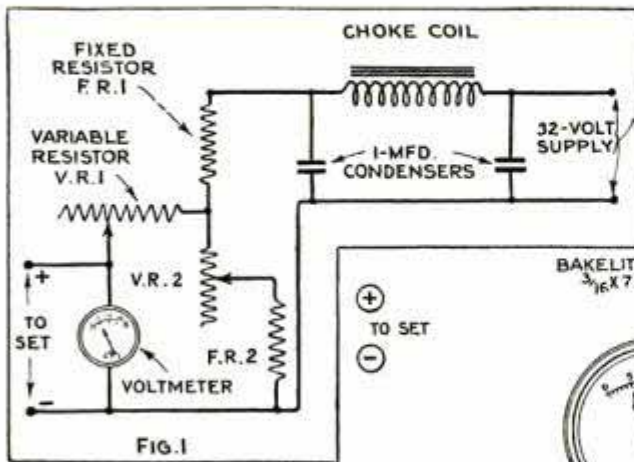

RECEIVER CURRENT DRAIN	F. R. 1	WATTAGE RATING	F. R. 2	WATTAGE RATING
.75	12.5	60	5	60
1.00	12.5	60	7	60
1.25	10.0	60	5	60
1.50	10.0	60	7	70
1.75	6.5	150	3.5	70
2.00	6.5	150	3.5	70
2.25	5.5	150	4.5	70
2.50	6.5	150	0.5	70

FIG. 3

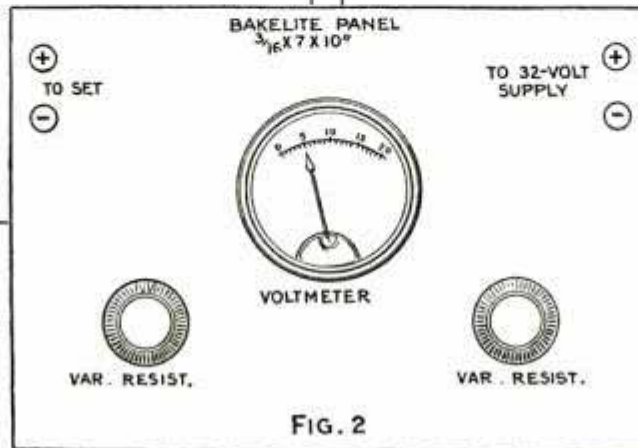

FIG. 2

able resistors Nos. 1 and 2 are of the 6-ohm type and are capable of carrying the total current of the receiver without overheating. If tubes of the 199-type are used, the fixed resistors No. 1 and No. 2 are 35 and 10 ohms re-

such localities, where battery-operated receivers are in use, an efficient method of obtaining the filament supply directly from the 32-volt outlet will be appreciated. The simple reducing unit shown in the sketch may be mounted on a small bakelite panel and baseboard and installed in a well ventilated receiver cabinet, doing away with a separate battery and the bother of charging. The current supplied by this type of electric plant is usually sufficiently constant to give a good quiet source of filament supply if a little filtering is afforded. In order to keep the noise at a minimum, a filter choke coil, made by winding 100 turns of 12 gauge, single-cotton enameled wire on a piece of iron pipe, 2 in. in diameter and 5 in. long, is connected in the line, as shown in Fig. 1. The 1-mfd. filter condensers are connected across the line on each side of the choke, and the remainder of the unit is the voltage-reducing device. The values of the fixed and variable voltage-reducing resistors will be determined by the current drawn by the particular receiver with which it is to be used. The table, Fig. 3, will enable one to select resistors for specific requirements, but, as the sets used in these localities, as a rule, are of the five-tube type, employing 201-A tubes, the writer has used a set of this type as an illustration. Employing five tubes drawing 1/4 amp. each, the full current load is

respectively, and the variable rheostats are 25 ohms each. When this device is installed, remove the ground wire from the receiver, as the set is already grounded at the light plant. If the set must be grounded for best results, use a 1-mfd. condenser in series with the set and ground, to prevent the possibility of a short circuit.—D. A. Brown, Marion, Ohio.

Connector Plug for Power Packs 2441 R.

This semi-soft rubber connector plug should appeal to the experimenter as well as the set manufacturer as an inexpensive yet effective method of connecting a chassis



or dynamic-speaker field to the power pack. The receptacle used is a standard tube socket, either four or five-prong. The plug will also lend itself to many other similar uses.

*National Radio Co
Malden Mass*

New Settings



same pattern and most of them look better on the dealer's floor than in the home.

The modern radio chassis is so compact that it offers almost unlimited opportunity for unusual treatment. For instance, the little end table illustrated in the head-piece to the left not only holds magazines and a full shelf of books, but houses a complete six-tube screen-grid radio, power pack, amplifier and dynamic speaker. The tuning controls are at the top. The set may also

THERE are some twenty million radio sets in use in America and they are all pretty much alike. To be sure, some are consoles, some table models and some cabinets, but whether they stand on floor or table, they are cut more or less to the

as shown on page 307. In this installation the panel, imitating a row of books, was made at a bookbinder's, and the set simply slid into place.

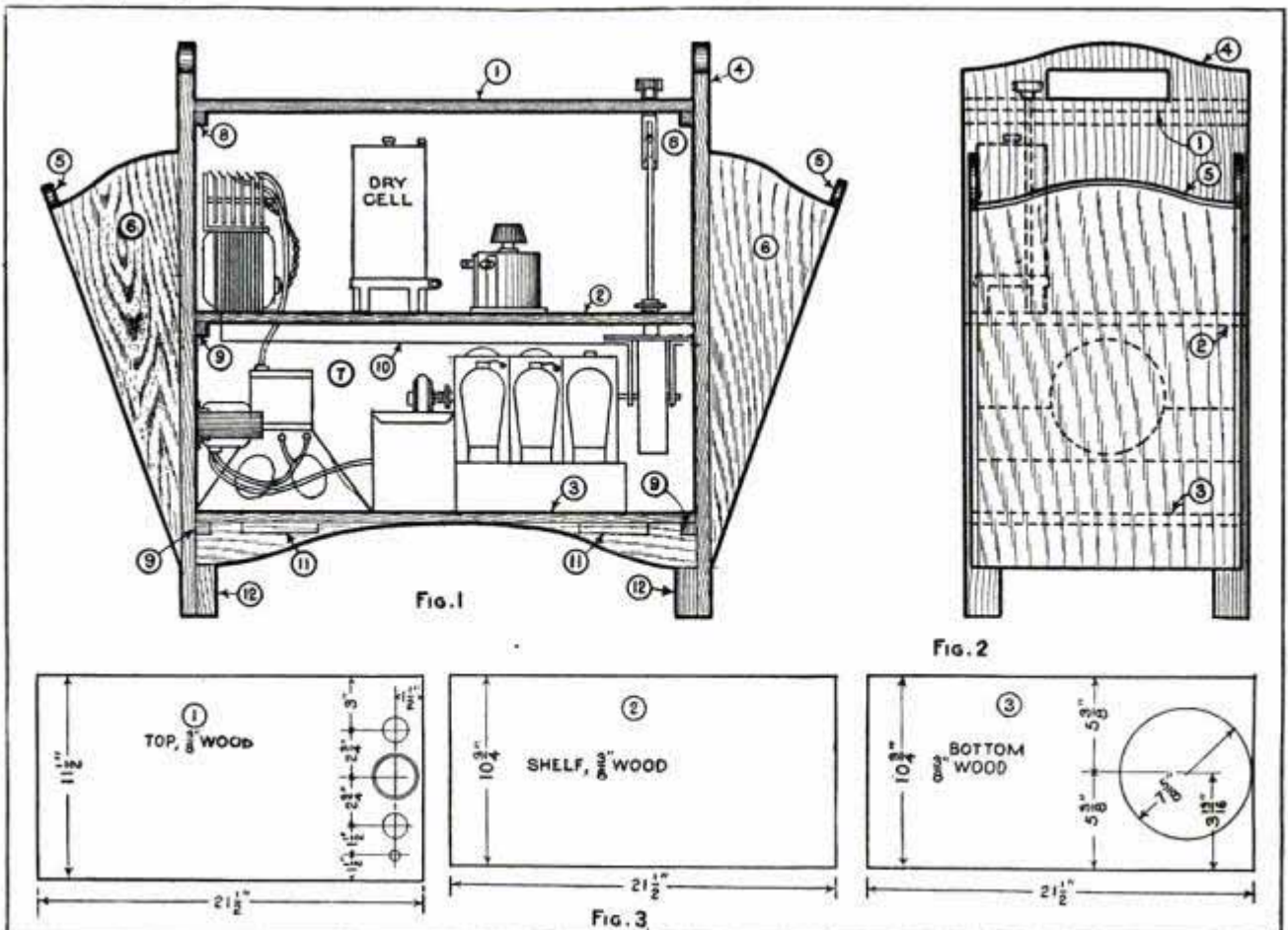

for Modern Receivers

By
GRAYDON SMITH

The magazine stand, Fig. 1, has been found very satisfactory, as well as easy to build. The two knobs at the top are the tuning and the volume controls. The meter between them shows the wavelength the set is tuned to. Very little space is allotted to the radio equipment, and it is absolutely necessary to know the exact size of the chassis you intend using before building the cabinet. The dimensions given in the drawing are for a chassis which, though clear and powerful, is exceptionally compact. This is shown in center photo, page 309.

The wood for the table should match the other furniture in the room as far as possible. Mahogany, walnut and gumwood are easy to work and finish well. Two pieces, 10 ft. long, 1 ft. wide, and $\frac{3}{8}$ in. thick, will be needed for the top and sides of the table. This does not include the door on the back, which is not visible and is made of cheap plywood, $\frac{3}{8}$ in. thick. Although the little pieces which complete the legs are shown $\frac{5}{8}$ in. thick, they may just as well be built up of scraps from the other pieces.

The pieces are laid out on the finished boards in pencil, then cut out with a key-hole saw, coping or jig saw. Most of the pieces are very easy to lay out, but a few words about 6, Fig. 1, may be of help. In laying out these pieces, first draw the straight line AB, Fig. 5, $17\frac{3}{8}$ in. long. Set a pair of compasses to this radius and draw an arc about point B. Then set the compasses to 6-in. radius and draw an arc about point A. These arcs intersect

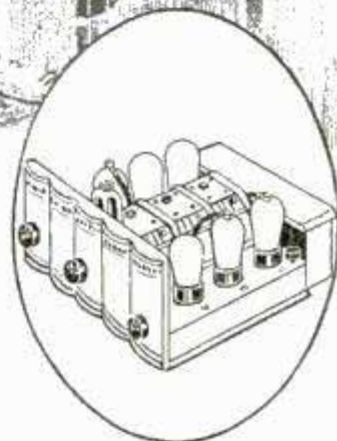
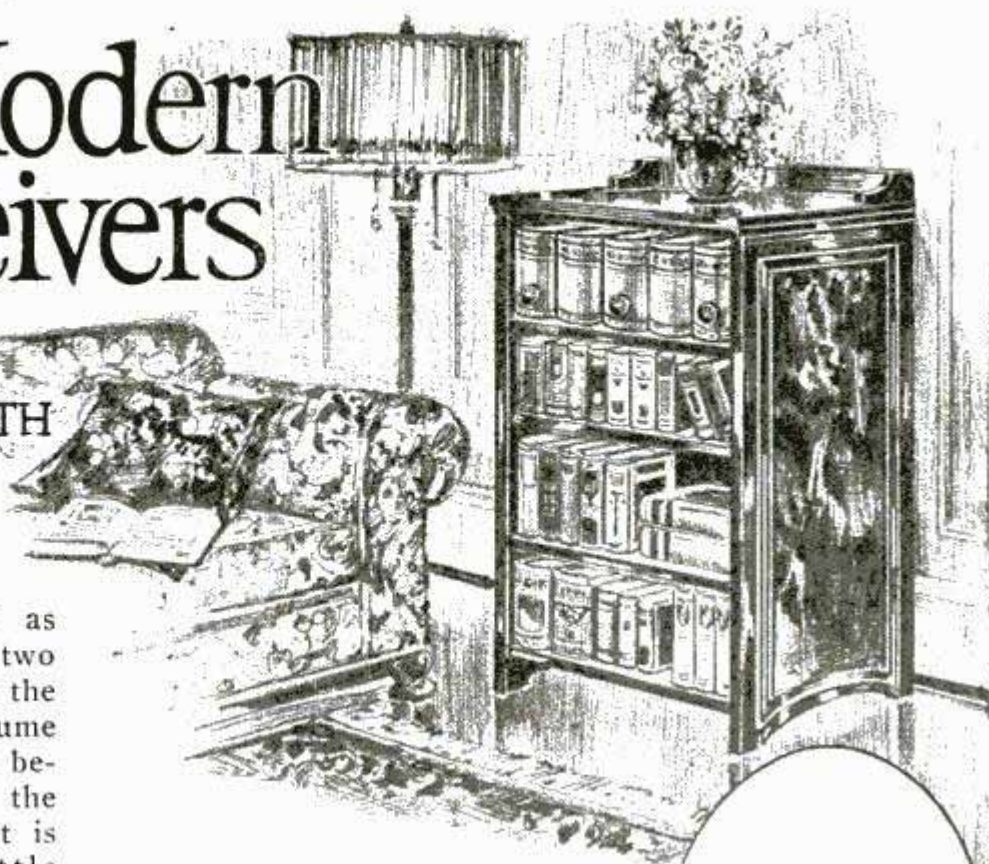

at point C. Draw a line from C to B. Two sides of the piece are now drawn. To complete the piece, locate D, 6 in. from A. With the compasses still set to 6 in., draw an arc about this point. And finally with the compasses set to 7 in. find a point on the line BC, about which a circle can be drawn that will join smoothly

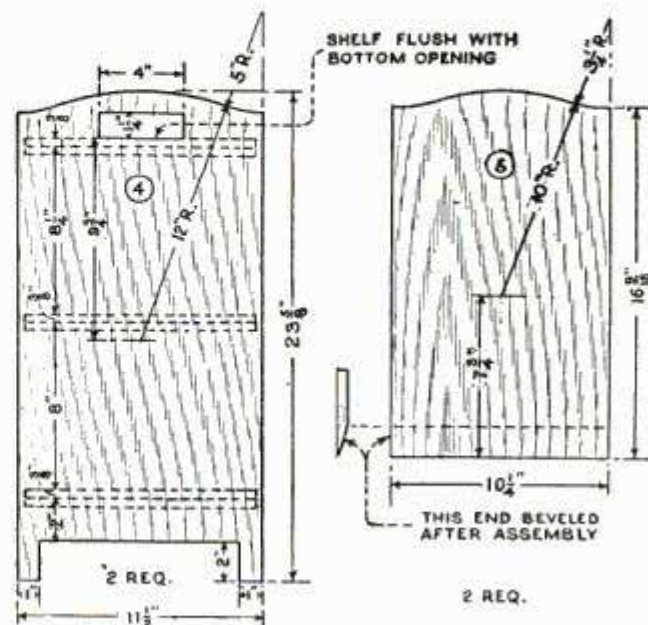

Fig. 4

mounting them in the ordinary manner. Fill the holes left by the heads of the brads with putty or plastic wood, but if dark wood is used for the table, a dark filler is required.

The table is now ready to be shellacked. It may be painted, of course, if color is desired. Use either enamel or lacquer for this. If the grain of the wood is desired rather than color, white shellac is best. Four coats, rubbed down after each application, give an excellent finish. Before each of the first three coats, go over the surface with No. 2-0 sandpaper, but do not take off all the shellac with it. After the third, rub down the finish with fine pumice, then coat with very thin shellac.

To mount the radio equipment, remove the base, rectifier and transformers from the dynamic speaker, first noting the connections. The transformers and the rectifier are mounted in the middle shelf behind the books as shown in the photographs. The stripped speaker is then pushed into place from the outside of the cabinet, and fastened in place with screws. When these units have been mounted, wire them up again immediately. The underside of the table should be covered with felt to prevent the sound from reverberating in the narrow space between the floor and the table.

The radio set itself is very easy to mount, the only difficulty being in driving the condenser gang from above. This is done by

mounting a drum dial on the end of the shaft with the knob pointing vertically. The escutcheon plate and the knob are removed, as only the mechanism is wanted. This, together with the radio chassis, will just slip into the allotted space beside the speaker. Mark on the middle shelf the spot exactly over the drive shaft on the dial. Then remove the chassis to avoid damaging it, and drill a 1-in. hole at this spot. The next step is to drill a 1/4-in.

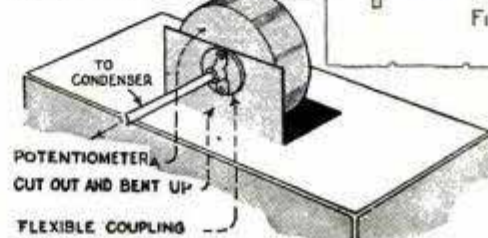
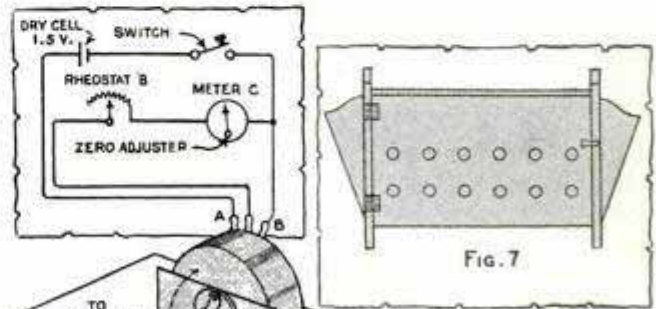

MILLIAMMETER C	RHEOSTAT B	POTENTIOMETER A
1 MILLIAMP. SCALE	1,000 OHMS	200 OHMS
5 "	200 "	100 "

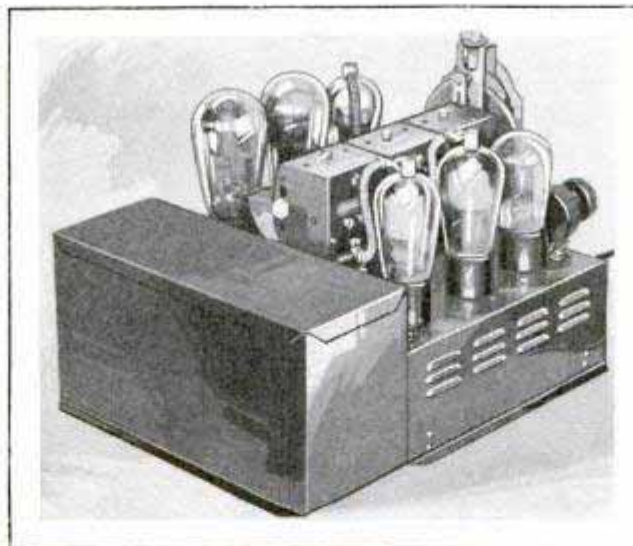

Top, Details of Tuning-Indicator Device; Center, Compact Six-Tube Chassis and Power Unit; Bottom, Magazine Stand with Rear Door Open, Showing Receiver Installation

hole exactly over the hole in the middle shelf. A 1/4-in. brass shaft extends through this hole to the drum dial below, to which it is fastened by a flexible coupler. A knob on the top completes the drive. The volume control and the switch are fastened to the chassis by flexible wires, consequently can be mounted anywhere. The only things now remaining are the connecting of the loud-speaker, plugging

in the speaker field in the outlet on the chassis, connecting aerial and ground, and plugging the set in on the 110-volt line.

Although the set now looks well and operates well, one thing is lacking: There is no indication of the condenser setting.

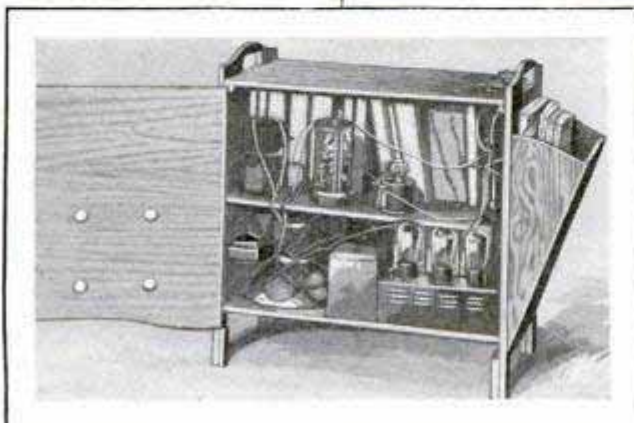

We have found by experiment that it is perfectly easy to tune a set this way. Merely turn the knob until a station comes in; it is as simple as turning on a light. However, the following paragraphs describe an easy way to provide an indicator for the condenser setting.

There is a small milliammeter between the two knobs on the top of the table. This meter is used to show either dial reading or wavelength. In the former case the dial should be removed and a new one, calibrated in wavelengths, substituted. The scale can be either 0-1 or 0-5 milliamp. but the lower range is better as it puts less drain on the cell. A potentiometer, mounted on the back cover of the radio chassis and coupled to the condenser gang, controls the meter. This is shown in more detail in Fig. 8. As the circuit diagram shows, current flows from the battery through the potentiometer. As the voltage drop is uniform along the potentiometer, the voltage between the slider and the battery will depend on the position of the drum dial. It is thus only necessary to measure this voltage in order to get the dial reading. To do this we use the milliammeter C with the rheostat B in series with it.

To adjust the meter, turn the condenser rotors until they are in mid-position, and cut in all the resistance of the rheostat B. Then connect the battery. The needle on the meter should swing upscale to the right; if it does not, reverse the leads on the battery. Now rotate the condenser shaft a little. The meter reading should increase as the condenser rotors slide into the stators; if it does not, reverse the leads A and B on the potentiometer. Next turn the rotors all the way out, then loosen the setscrew on the coupling between the condensers and the potentiometer and turn the slider until the meter reads as near to zero on the scale as possi-

ble. Tighten the setscrew again. If you cannot make the meter read zero this way, turn the "zero adjuster" until it does read zero. One other adjustment remains. Turn the condenser shaft so that the rotors are entirely within the stators. This corresponds to a full-scale reading on the indicator, so adjust rheostat B until the meter reads exactly full scale. The needle on the instrument will now indicate the dial reading smoothly and accurately.

To make the battery last as long as possible, it should be turned off when not in use. The best way to do this is to substitute a double-pole single-throw switch for the one supplied with the set. One side of the switch is then used to turn the radio off and on, while the other side switches the battery.

Receiver Employs New Methods

Viewed as revolutionary is the new circuit and vacuum tube invented by Dr. Alger S. Riggs, a South Carolina scientist. ~~From the antenna binding post to the output of the amplifier everything, it is claimed, is wholly new.~~ The circuit employs no negative grid bias, no tuned r.f., no neutralization, no gridleak and condenser, no reflexing, no C-battery and no secondary emission. The set is said not to squeal, oscillate or permit any ground noises, and the quality of reproduction is termed excellent. The new type

of vacuum tube, it is said, is the heart of the invention. "Threshold detection" is the name given to the method of signal detection employed. The advantages of this method lie in the fact that extraneous ground noises may be completely eliminated. The threshold detector is said to have the sensitivity of the grid leak and con-

denser, with the handling power and quality of the negative C-bias power detector.

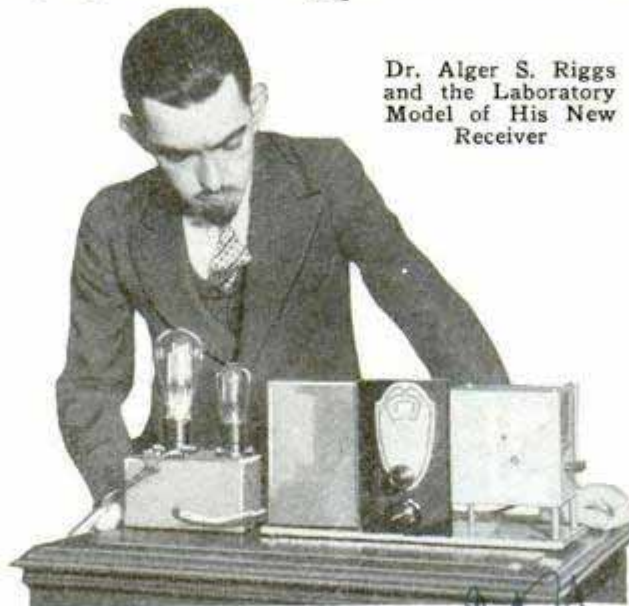

Dr. Alger S. Riggs
and the Laboratory
Model of His New
Receiver

136 Liberty St. New York City

2517. 02

AMATEUR MECHANICS



Make This Two-Propeller Helicopter

By HI SIBLEY

THIS little helicopter weighs slightly over 1 oz. and is a very able performer. The propellers rotate in opposite directions and the blades therefore should be made with less pitch than is the usual model-airplane practice for minimum interference.

At first glance the framework may appear very fragile to one experienced in model-airplane construction, but it must be borne in mind that all the motor strain comes on the central revolving frame. The outer triangular frame merely carries the small side wings and light tail.

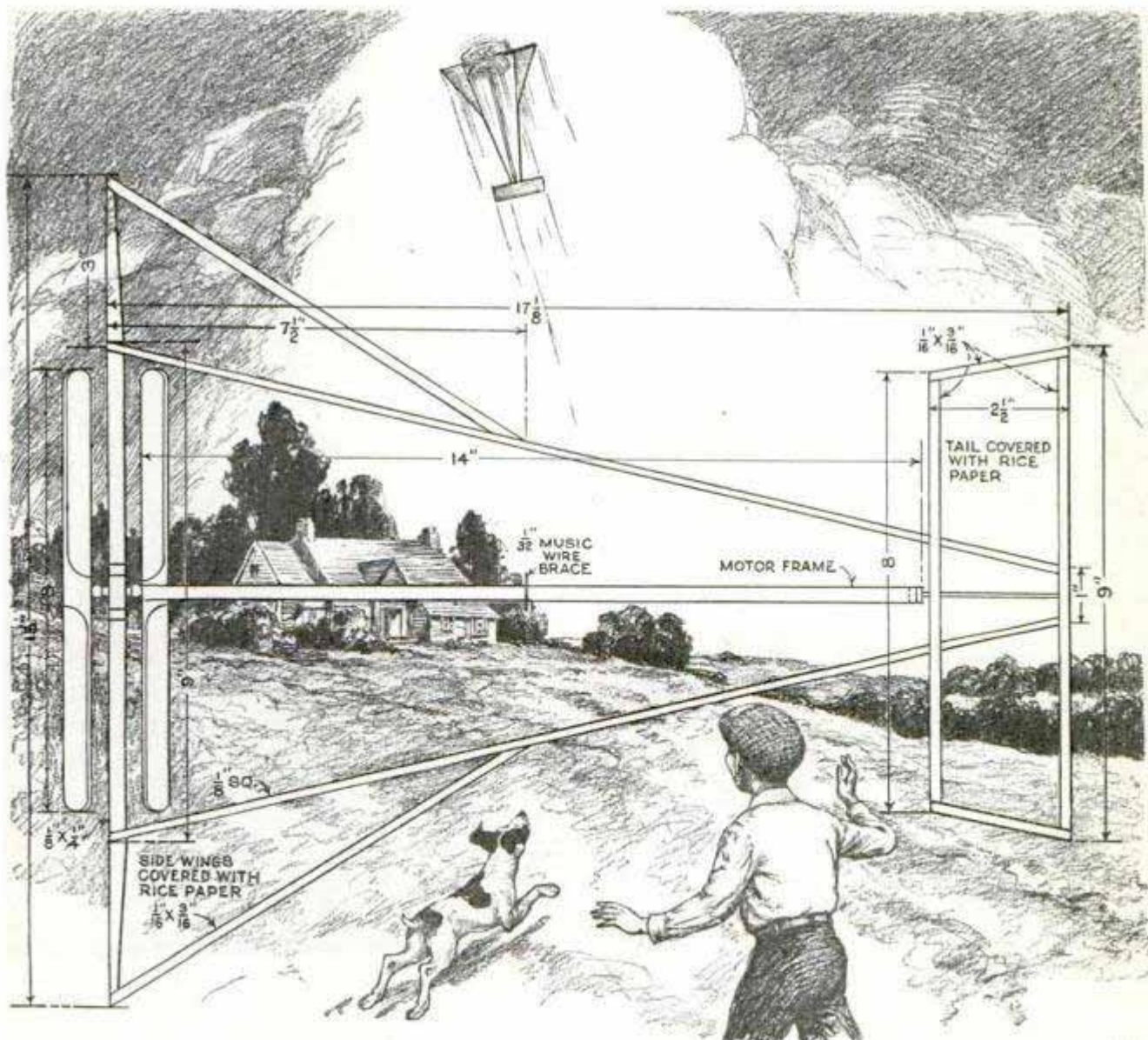

Make the propellers first, using soft balsa blocks, 8 in. long, $\frac{5}{8}$ in. thick and 1 in. wide, a size that will work into blades of moderate pitch. The hub of one of the propellers forms the front end of the motor frame and should have a short piece of aluminum tubing inserted through it. The other propeller is fixed on the music-wire shaft. Trim the blades down with jackknife and sandpaper to about $\frac{1}{16}$ -in.

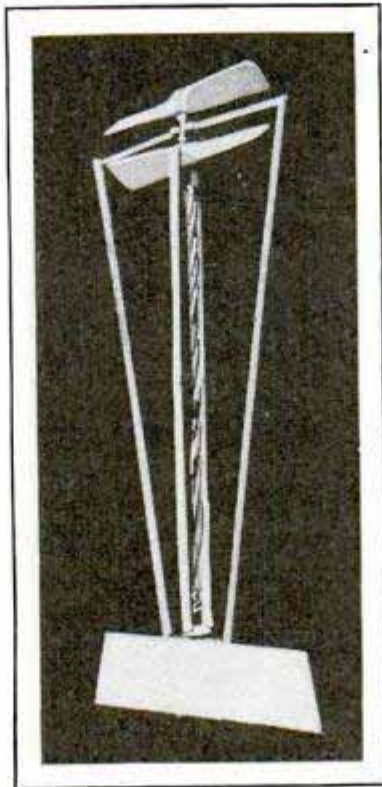

tubing from a tobacco pipe. There should be a glass-bead thrust bearing on each end of the main bearing.

Build up the outer frame from balsa, to the sizes indicated. Cement the joints and bind with thread. Always allow model-airplane

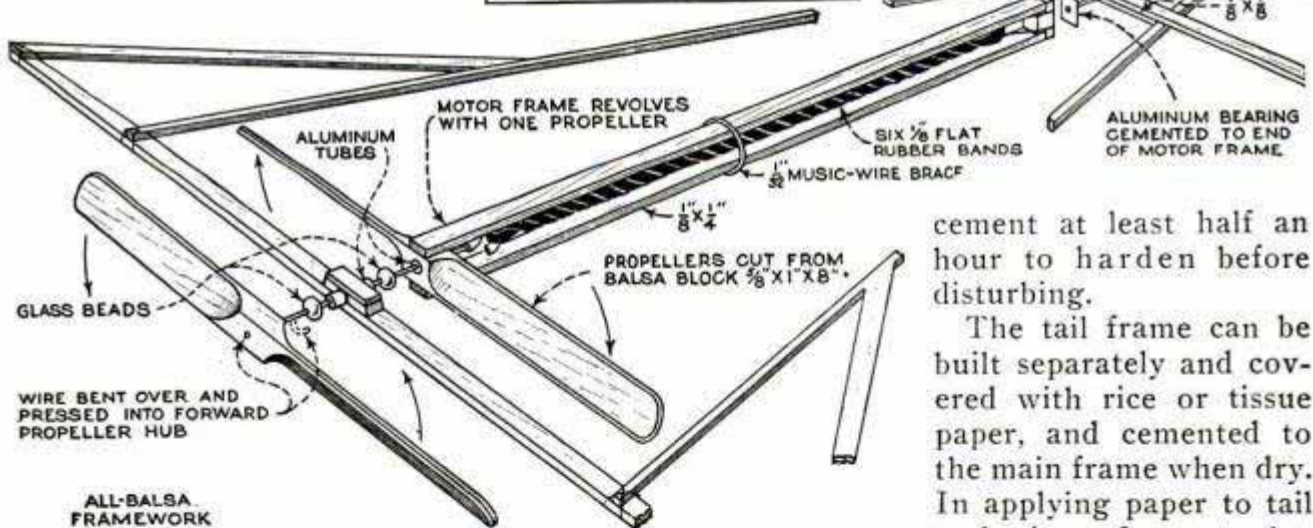
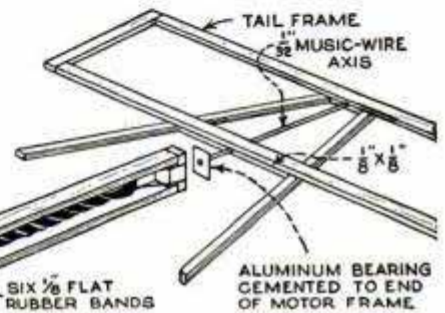
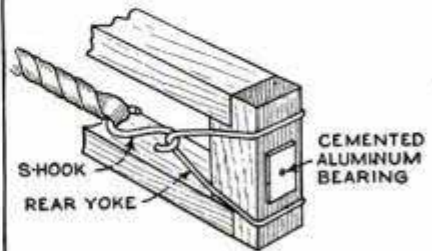
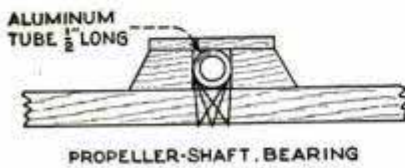

cement at least half an hour to harden before disturbing.

The tail frame can be built separately and covered with rice or tissue paper, and cemented to the main frame when dry. In applying paper to tail and wings, first put glue

thickness, and cut away as much of the hub as possible without lessening strength. The two side members of the motor frame should be of selected "hard" balsa, reinforced with a music-wire ring at the center, to prevent spreading when the rubbers are wound. The rear end of the side-pieces is secured with a $\frac{1}{4}$ by $\frac{1}{4}$ -in. balsa block, cut as shown. Cement a small piece of aluminum or tin to the end to serve as a bearing for the music-wire axle.

on the spars with the tip of a finger. This will work it well into the grain and also prevent a superfluous amount remaining. The merest film will hold the paper, which is stretched tightly and pressed down on the glued pieces.

In all cases use music wire about $\frac{1}{32}$ in. in diameter. This is sufficiently stiff for its purposes. Note that the propeller shaft turns in the rear propeller, through the aluminum tube. The main propeller-shaft bearing on the balsa cross frame is also aluminum tubing. The writer used

With all parts completed, insert the wire propeller shaft through the rear propeller-hub bearing, string on a bead, put the shaft through the main-shaft bearing (on the cross member), string on another bead, push the end through the outer propeller hub, bend it into a hook and press back into the hub over a short piece of bamboo or toothpick so it will not tear the balsa. Place a drop of cement on each side of the hub, where the wire enters, on the outer propeller.

When this has set, string on six strands of $\frac{1}{8}$ -in. flat rubber band so that they do not sag, and still are not stretched. You can wind the outer propeller by hand for 50 or 75 turns, but better results are secured with a mechanical winder. In the latter case, detach the S-hook at the rear and pull the rubbers out to about twice normal length while winding. It will be necessary to hold both propellers while doing this.

In launching, although the helicopter will rise straight up, it will go farther by sending it off at an angle of about 45° . Take care to head it for an open space or you may find yourself climbing a tree or house roof to retrieve it. The original model, shown in the photo on page 312, was built without side wings. The wings better the performance considerably.

Background for Fire Extinguisher

In order to make it easy to find fire extinguishers when needed, mount them against a background especially painted to call attention to their presence. A large circle, painted diagonally with broad



black-and-white strips, forms the center of a white square as shown in the photo. The fire extinguisher is mounted in the circle, and below, on the white surface, the type of liquid used in the extinguisher is painted in heavy type.—A. Mathieu, Chicago.

Preserving Paint

To keep a small quantity of left-over paint or lacquer in good condition for future use, replace the lid securely on the can and store the can upside down. If the cover fits tightly there will be no leakage, and the paint will form its own hermetic seal, preventing it from spoiling.—Wilfred J. Lennox, Warton, Can.

Light for the Rumble Seat

Often it is convenient to have a light in the rumble seat. The best light for this purpose is a dashboard type with a



Dashboard Lamp with Switch Incorporated Provides Light for Rumble-Seat Occupants

switch incorporated in it. It is connected by running one wire to the ammeter or headlight circuit and grounding the other, as indicated by the dotted lines in the illustration.—G. A. Luers, Washington, District of Columbia.

Wall Recess for Sillcock

Sillcocks in exposed positions may be broken off accidentally, particularly when they are located over or near a drive or platform. By making a square recess in the concrete wall at the time it is poured, and locating the sillcock inside of this recess, as shown in the photo, the trouble of breaking sillcocks will be overcome. The recess should be large enough to allow a hose to be attached and removed, and also to admit the top part of a bucket so that it can be filled.



Tracking dust and ashes from the basement can be overcome to a considerable extent by providing carpet mats on the lower treads of the basement stairs.



Clothespin Holder Arranged to Slide on the Line Is Always Open

Clothespin Holder Slides on Line

Every woman who has to hang the wash out will appreciate the novel clothespin holder shown in the illustration, as it is always open and can be pushed along the line as it is needed. It consists of a cloth sack hemmed at the top edge to take a No. 12 gauge galvanized-wire frame bent to an oblong shape to hold the bag open. At the ends of the bag the wire is bent upward to form a double hook by which it is hung on the line.—M. D. McFaddin, Winfield, Kans.

Sharpened Cotter Pin Is Useful Tool

For many small jobs which frequently arise when no tools of any kind are at hand, a useful device can be easily made of a $\frac{1}{8}$ by 2-in. cotter pin, which can be

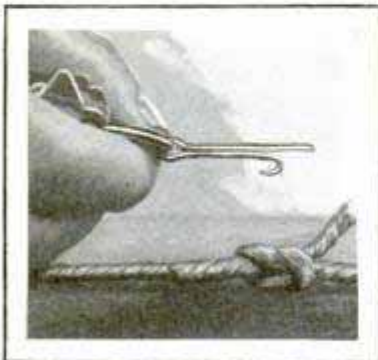

kept on the key ring where it is always available. File the legs to a fairly sharp point and bend one of them to form a hook. It is always ready for one

of those little jobs of digging, pulling, loosening, and many other purposes, for which the pocket knife is usually pressed

into service, not infrequently to the detriment of the blades.—Frank W. Bentley, Jr., Missouri Valley, Iowa.

Substitute for Wide-Angle Lens

Wide-angle effects, the inclusion of a larger field of vision within the photo, are dependent on the use of a short-focus lens, which is one that will operate very close to the plate holder and bring objects into clear focus. When the camera enthusiast graduates from a hand camera to a view camera, he begins to feel the need of a wide-angle lens. This is not supplied with a view camera and has to be purchased separately at a cost of from \$10 to \$50, or more, which one cannot always afford. In this case, you will find that a portrait attachment for amateur cameras serves the purpose well as a substitute, and costs less than a dollar.—H. Rossiter Snyder, Guilford, Conn.

Sink Stoppers for Wide-Mouth Bottles

Wide-mouth bottles are generally sealed with flat cork stoppers, which have to be pried out and are often broken or punctured when they are being removed. Similar corks are usually hard to find, but rubber sink stoppers, which can be had in various sizes at any hardware store, make good substitutes. They can be used over and over again on different bottles and fit more snugly than corks.—Herman G. Cuthbert, Newark, N. J.



Mirror for Amateur Movie Kit

One of the most useful additions to an amateur's movie outfit is a mirror. With this he can reflect light on a poorly illuminated subject or into a dark corner. It can also be used as a spotlight for making portraits, or for back-lighting effects, provided the projected beam does not shine into the lens.

Oilcan Spout Fills Shock Absorbers

Shock absorbers on model-A Ford cars need a small quantity of glycerine added from time to time. As there is not much space above the filler opening, it is rather difficult to use a bottle or oilcan. However, the spout of an oilcan may be used satisfactorily. It is filled with glycerine and one finger is held over the large end to prevent the liquid from running out until the spout has been inserted in the filler-plug opening. This procedure is repeated until the shock absorber is filled.

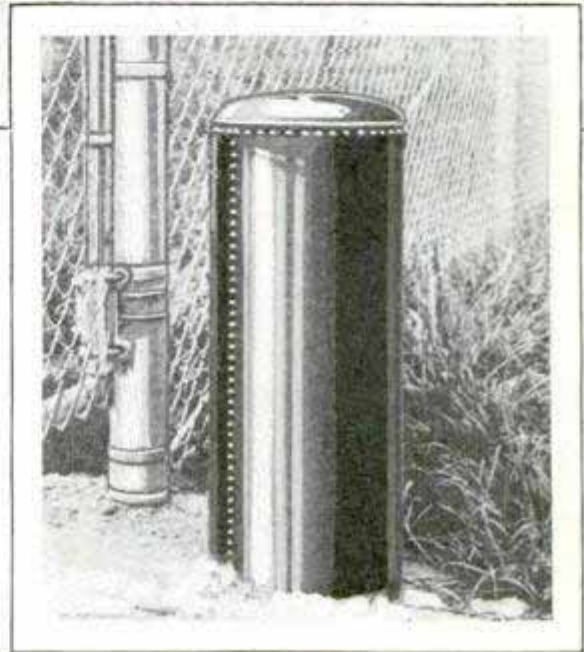
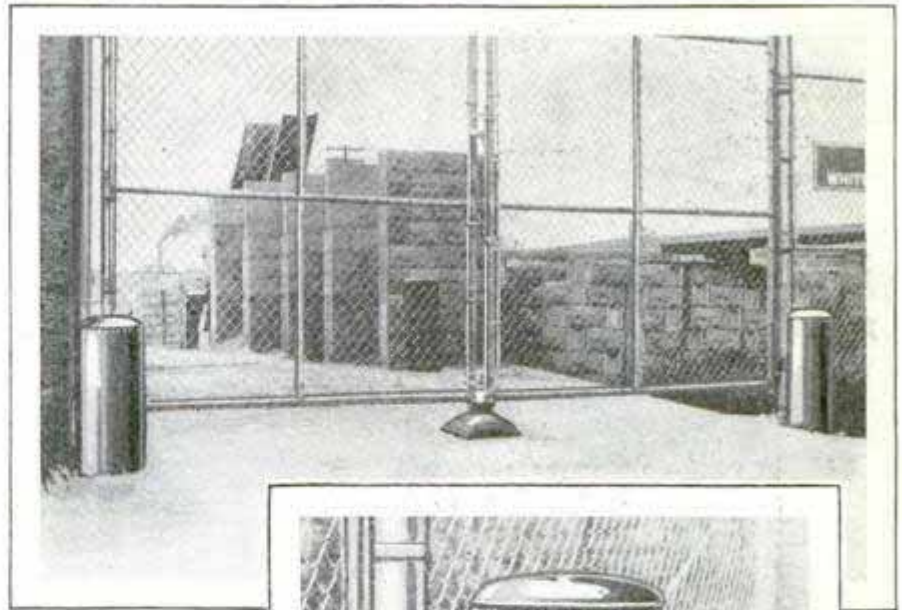

Old Hot-Water Tanks Filled with Concrete Make Good Baffle Posts to Protect Light Gate Supports

Vacuum Cleaner Fills Pillowcase

Filling pillowcases with feathers, which is ordinarily quite a messy job, can be done quickly and easily by using the method indicated. Clean the machine, attach the suction hose to a vacuum cleaner and substitute the pillowcase for the dust bag. Tie the open end of the pillowcase securely around the discharge opening of the cleaner. Start the motor and lower the suction hose into the feather container. The feathers will be drawn into the casing and few of them will be spilled.



Vacuum Cleaner Fills Pillowcases with Feathers, Eliminating the Usual Work and Mess

Old Water Tanks Make Good Baffle Posts

A simple and practical method of protecting light fence posts against being struck by trucks and wagons when making short turns, is shown in the photos. Two old hot-water tanks are filled with concrete and scrap iron. They are buried quite deeply in the earth and a liberal quantity of concrete is also poured around them so that they will be securely anchored. The steel shell nicely resists the nips of the wheel hubs and there is practically no denting owing to the concrete filling.

Repair for Shoe Linings

When your shoe lining is torn, trim the ragged edge and apply a piece of adhesive tape, pressing it firmly in position. Dust some powder on the tape so that the exposed surface will not be sticky.



How to Stipple



Right, Applying the Foundation Color to the Wall

THERE is nothing to which the home craftsman can turn his hand that will improve the interior of his home more, or add more to its value than the decoration of shabby walls and ceilings in richly textured paint-stippled treatments.

Painted wall decoration has been used for years in clubs, churches, theaters and residences, but, due to its high cost, has not until recently come into general use for home decoration. A word of explanation may be in order, as "painted walls" are thought of by many as fitting for kitchens, bathrooms, etc., where utility and easy cleaning, rather than beauty, are the prime requirements. However, the perfection of soft-toned, lusterless wall finishes, and the development of various decorative methods, such as stippling, mottling, glazing, scumbling, Tiffany, stenciling, etc., makes possible the decora-

tion of living room, dining room, bedrooms and other rooms in effects of artistic distinction. The glareless wall paints of today permit the tones of the decoration to be brought out at their full value, no matter from what angle or in what light they may be viewed. They are quite as washable as painted or varnished woodwork, non-fading and very durable.

These treatments are not intricate or complicated to produce. With a little practice work on

sheets of paper or wallboard, a degree of proficiency may be acquired that will insure good results.

In the use of paint for wall treatment, as with wallpaper, many prefer plain colors, without pattern, and there are also certain conditions where they are most desirable. For instance, if the furniture is unusually fine, plain walls will set it off to advantage. In some cases, also, decorative schemes are arranged for, in which color and interest are provided through draperies, furnishings and accessories, so that a pleasing effect is only possible through the use of a neutral background.

The application of wall paint in itself is a comparatively simple operation. The one important thing to keep in mind is that, where walls are of bare plaster,

Your Own Walls

by
Berton Elliot

never before painted, the first coat should be a sizing coat, to seal the absorbent surface and keep succeeding coats from soaking in. This is sometimes accomplished by mixing wall size (sold by all paint stores) with regular flat wall paint, about equal parts of each. There are also prepared wall primers which have the size already incorporated. Three coats are ordinarily required—two of straight wall paint over the sizing or priming coat—especially with light, delicate shades, although with the darker, denser colors, two coats will often produce a satisfactory job.

Where the walls have previously been in wallpaper, the paper, of course, should be removed before starting the paint decoration, which is not a difficult job if plenty of water is used to thoroughly saturate the paper, so that it may be readily scraped off in large furrows with a wide putty knife. Any cracks or other surface imperfections should be filled, before starting to apply the priming coat, with one of the prepared patching plasters or a mixture of plaster of paris and wall paint.

After the final coat, the use of a stencil border will add a most desirable finishing touch. If it is desired to keep the walls very unobtrusive, the border may be small and light, and in subdued tones.

The first thing to fix in mind, in taking up the processes of stipple-textured wall finishing, is that all of these treatments are produced by first applying a foundation color to the wall, on which the stip-

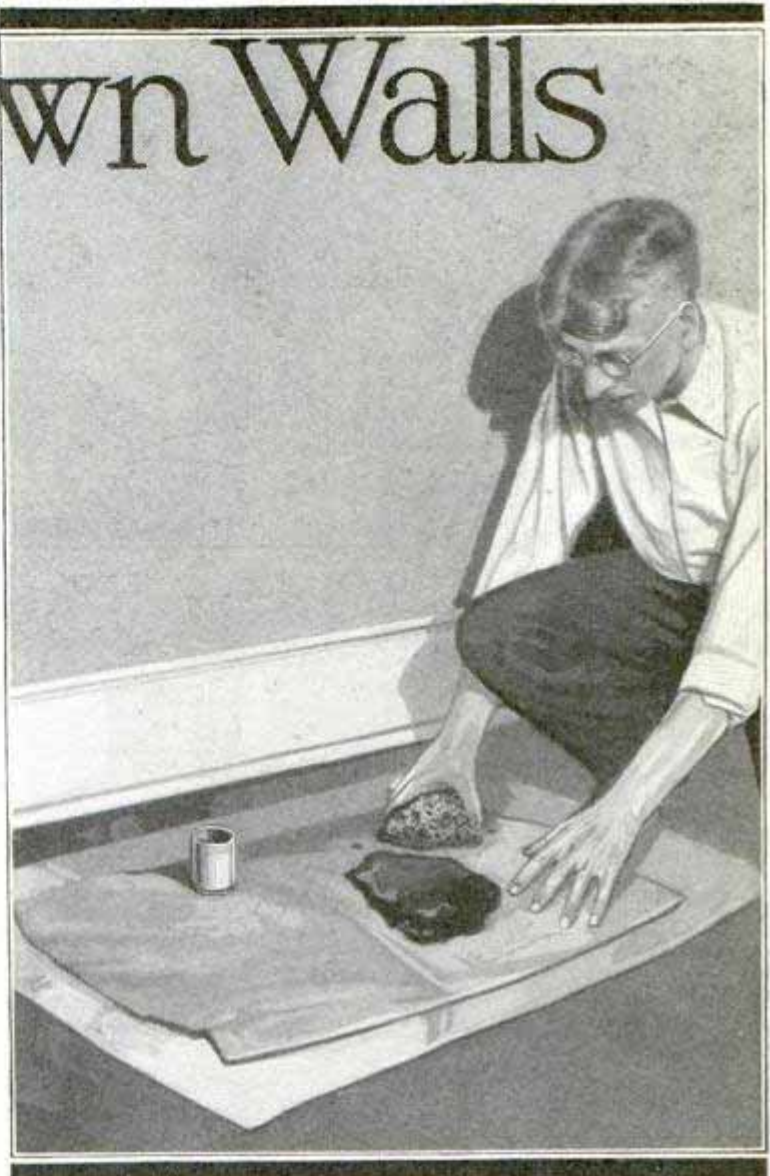

Filling the Sponge with Paint by Rubbing on a Cardboard Smeard with Paint

pled, mottled or figured effects are laid.

The foundation coating consists merely of brush coats of flat wall paint, applied in the regular way, just as if the wall was going to be left in plain color, except that two coats are ordinarily sufficient (one finishing coat over the sizing or priming coat on bare plaster walls), as it is not necessary to have as solid covering where the walls are to be stippled. The color used for the foundation coating, of course, will depend upon the effect desired.

Sponge stippling, one of the most interesting and beautiful treatments, is also one of the simplest to do. After the foundation coat has dried thoroughly, an all-over pattern is printed on the wall in one or more contrasting or harmonizing colors with a sponge. In selecting the sponge, get one that is of uniformly even

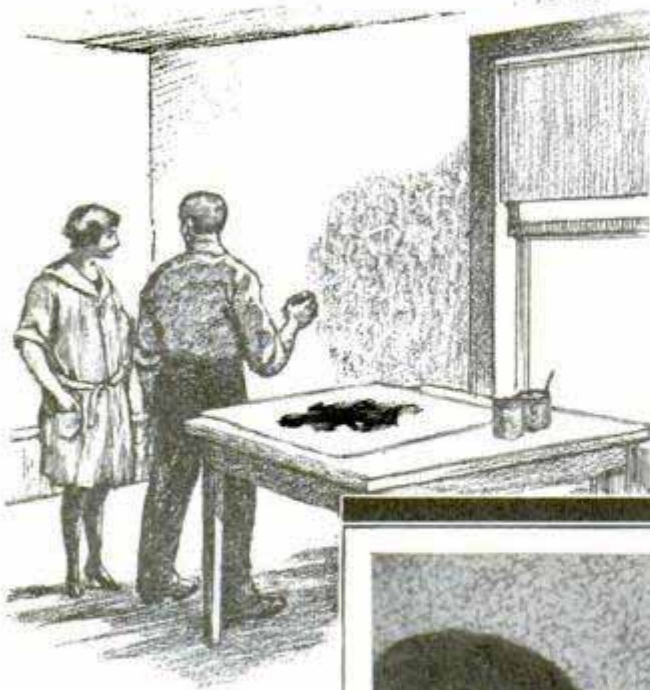

construction, without either large open spaces or solid stretches of side wall. It should be cut in two across the grain, to give a perfectly flat printing surface. If any spots are found to be a little high, they should be trimmed off with a pair of scissors, as one of the secrets of success in this work is to have an absolutely flat printing surface. This evening up can be most satisfactorily done when the sponge is wet.

We are now ready to start the stippling operation. Pour some of the stippling color onto a piece of tin, cardboard or folded wrapping paper. Regular flat wall paint of the desired color is ordinarily used for the purpose. The addition of a little varnish (about 10 per cent) makes the stipple color dry with a slight sheen, which gives a very pretty effect with the dead flat of the foundation color

peeking through the glistening stipple tones.

Immediately before starting, the sponge should be soaked in water and wrung out reasonably dry. Then rub the flat side into the stipple color, until the paint has thoroughly worked into the printing surface. Tap off any excess paint on a sheet of paper. At first, do some try-out work on a large sheet of wrapping paper spread out perfectly flat on a table or on the bare floor. If these try-out prints indicate that there are any high or low places in the sponge, so that the pattern is not

even, the sponge should be trimmed further with the scissors.

The method of stippling is as follows: Tap or pat the color-loaded sponge straight onto the surface you are decorating, without twisting or turning, which will imprint the pattern of the sponge in all its natural beauty onto the wall. Continue tapping over the entire surface, placing the prints

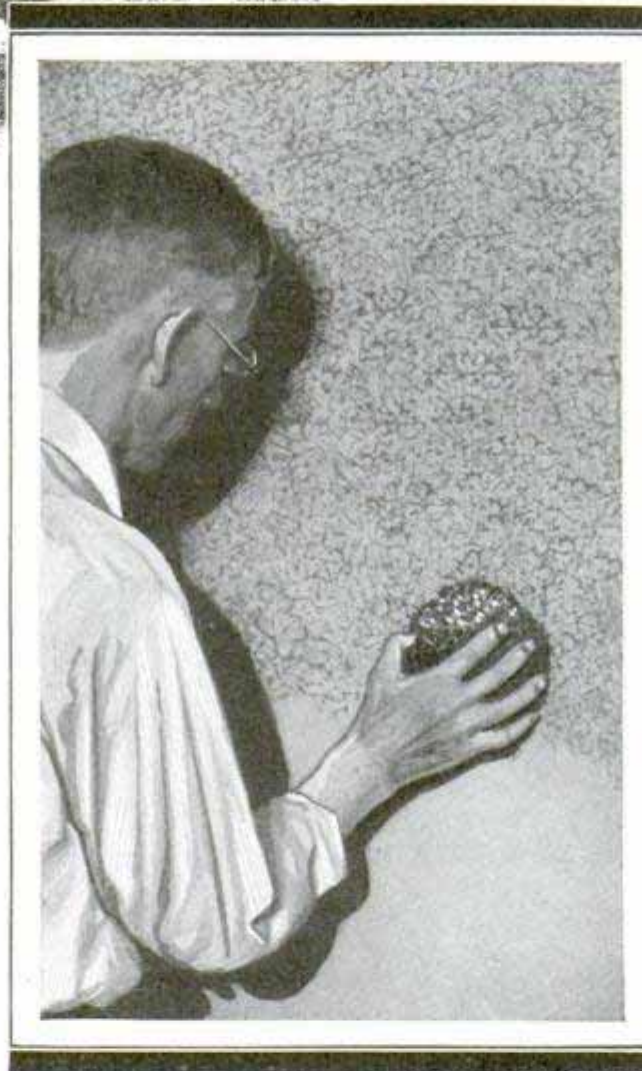

Above, Applying the First Stipple Color to the Wall

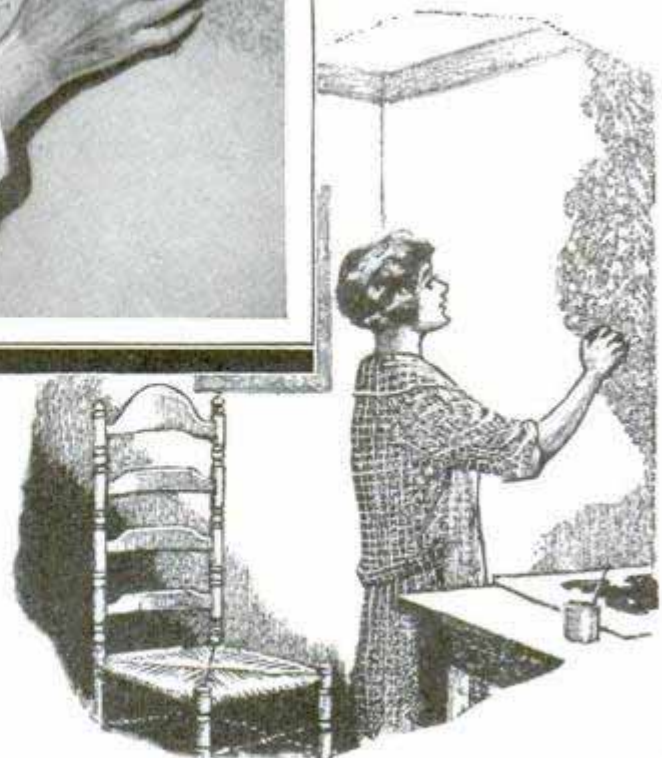

close together so there will be no intervening spaces to cause a break in the pattern, yet overlapping just as little as possible. Stagger the prints in irregular fashion, so they will not be in straight rows, otherwise the effect will be too monotonous, and will not be pleasing.

Two or more stipple colors may be applied by going all the way around the room with one color, then cleaning the sponge and (next day) going over the entire surface again with another color—and again, the following day, if desired, with a third color. While two-color and three-color effects are usually far more beautiful, they are really easier to do well than one-color stipples, for the reason that any little irregularities of workmanship in applying any of the stipple coats are rendered far less noticeable, and it is also practically impossible for any spaces of plain, unfigured background color to be left showing through in the finished effect.

Following are a few general suggestions which will help in obtaining good results: Use a small piece of sponge for getting up close to woodwork and moldings, into corners, etc. This may be a piece of the regular stippling sponge, cut from the side opposite the printing surface. A piece of tin or cardboard held against woodwork and moldings, when working up close to them, will prevent daubing them with the stippling color. Any paint that does get on woodwork or floors should be wiped off at once, before it has a chance to dry, with a cloth moistened with gasoline. In case any part of the work does not turn out satisfactorily, it may be wiped off with a cloth saturated with gasoline, although this should be very carefully done, so there will be no smeary places where the wiped-off space joins the satisfactory part of the work. After the stippling with any color has been completed, the sponge should be cleaned at once with a liberal quantity of gasoline, followed by a thorough washing in warm water and soap. This will make it as clean and soft as a new sponge.

One of the secrets of success in this work is the use of harmonious colors. A few good combinations are as follows: pink foundation, stippled with a mixture of part white and part pink; dark-blue

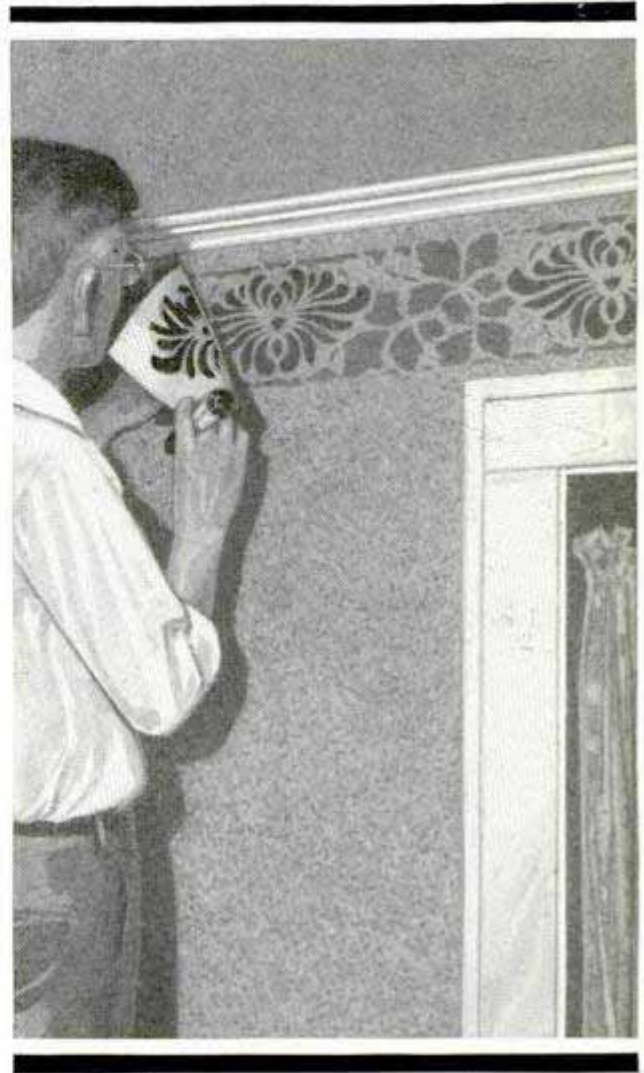

A Stencil Border Adds a Final Touch of Great Charm to the Stippled Wall

foundation, stippled with light blue; ivory foundation, stippled with buff; silver-gray foundation, with first stipple color pink, second stipple color ivory; sage-green foundation, with first stipple color buff, second stipple color ivory. Most paint stores also have samples of sponge stipple effects put out by paint manufacturers, which show just how various effects will look, together with specifications for producing them.

Outboard Motor Drives Small Lathe

The owner of a small outboard motor will be interested to know that it is capable of furnishing sufficient power to run a small lathe or circular saw. Transmission is provided for by a belt slipped over the flywheel or from a pulley on the propeller shaft. The motor can be conveniently held by clamping it to a board nailed to the bench or in a vise.—J. Lawrence Evans, Jr., Bauner House, N. Y.

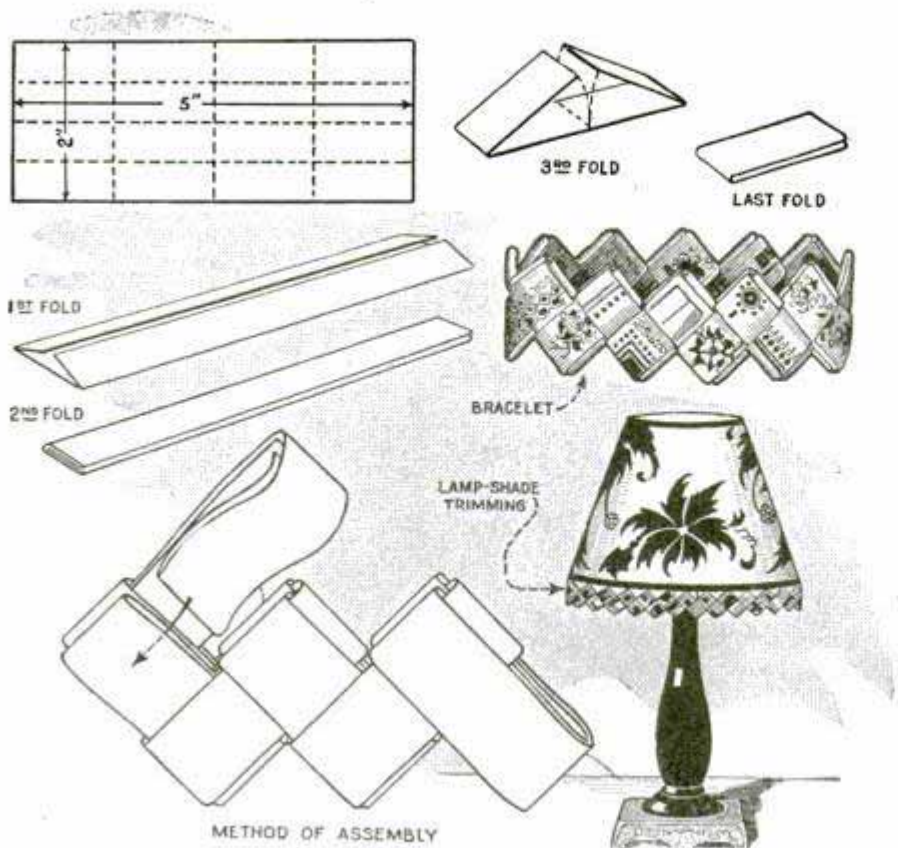

Colored Magazine Advertisements Are Used to Make Heavy Braid for Lamp Trimmings and Other Purposes

Braided Paper Trimming Made from Colored Ads

Colored advertisements in magazines furnish excellent material for making braided trimmings which may be used for many purposes. Cut strips 5 in. long and 2 in. wide. Fold them lengthwise, each side toward the center, until the edges meet; then fold the strip over lengthwise in the center, and lastly fold the ends toward the center as shown in the drawing. After two strips have been prepared in this way, the tips of one may be laced into the folded opening of the other. Vary the colors of the paper and continue placing one strip into the preceding one until the trimming is as long as desired. For parchment and paper lampshades, this trimming may serve as a binding for the top and bottom of the shade and may be treated with a coat of shellac the same as the shade. The joining of the strands is easy. The trimming may also be used by children for suspenders, tying the ends to the belts and crossing the strands at the back. Girls can use it for bracelets, necklaces and for trimming play hats. It will also do as a banding for work baskets, etc.—Sandra LaPlante, Washington, Ill.

A Handy Bench Vice for Rough Work

Where rapid action is not needed or the worker desires an odd vise for rough work, it is possible to make one from an ordinary iron vise screw as shown in the illustration. The usual method of construction is to allow the outer jaw to extend to the floor but this arrangement is not always convenient. Cut the outer jaw from a piece of 2 by 6-in. oak, or, better still, glue two pieces of 1-in. stock together, 5 in. wide and 10 in. long. Strengthen this piece further with screws and drill a $2\frac{1}{4}$ -in. recess with an expansion bit, 5 in. from the end, $3\frac{1}{4}$ in.

from the top and about $\frac{1}{2}$ in. deep, to take the collar on the screw. With the same center drill a hole for the screw. If the screw is 1 in. in diameter the hole should be $1\frac{1}{8}$ in. in order to prevent binding. Three inches from this hole, on either side and

on the same center line, drill a hole 1 in. in diameter, making sure that both are as true as possible. Plane the inner surface of the jaw carefully and sand it down so that it will not mar the work when tightened. Get a stout hickory or maple handle, 1 in. in

diameter throughout its length, and cut from it two 16-in. pieces. Smooth with sandpaper and drive them into the outer holes in glue. Drill a $\frac{1}{4}$ -in. hole up from the lower edge of the jaw and key the rods

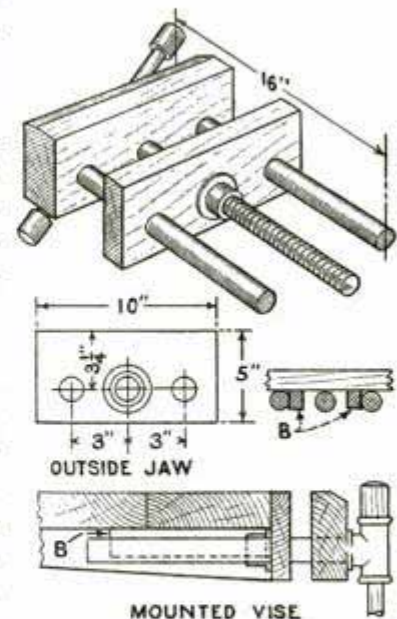

with dowels. Make the inner jaw of hardwood and fasten it to the bench with screws. Drill three corresponding holes to take the rods and screw, each $1\frac{1}{8}$ in. in diameter. Fasten the nut on the back of the inner jaw and after starting the screw, bring the jaws tightly together. Screw a piece of stock to the underside of the bench top just over the rods. This piece should be of such thickness that the rods will bear against it. Between the rod and the screw fasten a piece of 1-in. stock, making sure that the jaws are parallel before tightening them in place. Use two of these pieces and have them bear hard against each rod, as at B in the detail. This will hold the jaws parallel when tightened. Lastly bevel a piece of 2-in. stock and tighten it solidly to the bench top and the inner jaw of the vise. This makes a sound, serviceable vise that can be used for the roughest work.

Preventing Drain Cock from Freezing

During the winter we are troubled with the sink-drain trap freezing and bursting. Instead of removing the whole trap in order to empty it, I purchased a small cock of the kind used to drain Ford radiators. With this, the trap was emptied easily.—J. A. Tandy, Ghent, Ky.

Wooden Tweezers Easily Made

On repair jobs which require the handling of small parts, a pair of tweezers is a great convenience. If not at hand, it is easy to improvise a pair from two matches and a rubber band as shown in the photo. Break a short piece off the end of one match to use as a pivot or fulcrum; this is slipped between the matches, and the rubber band is then wound around the assembly, so that it forces the ends together. The ends, of course, should be whittled flat where they make contact in order to insure a tight grip.—Frank W. Bentley, Jr., Missouri Valley, Iowa.

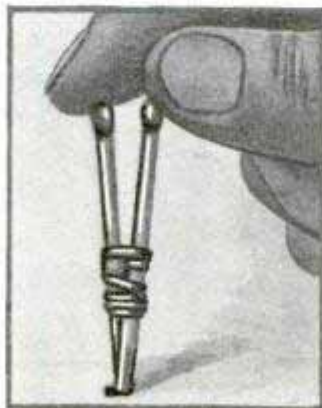

Folding Horse for Ironing Board

In the absence of a built-in or collapsible ironing board, it is quite customary to

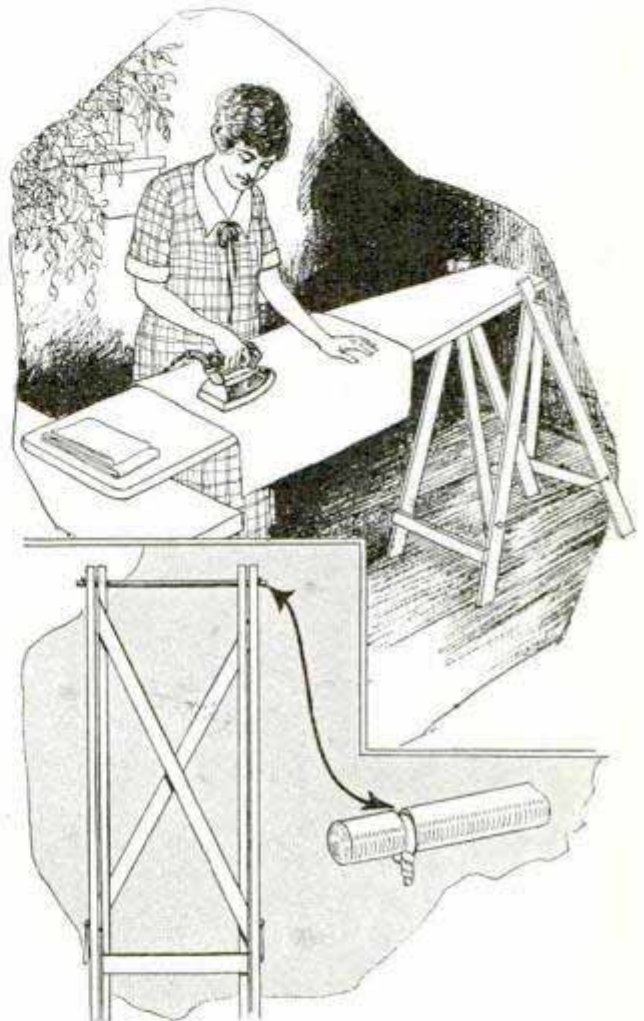

Lightweight Collapsible Wooden Horse Is Useful for Supporting the Ironing Board

place one end of it on the table and the other on the back of a chair. This method is not always satisfactory, as the chair may slip, and it is much better to provide a light folding horse to support the board. Make the legs of $\frac{3}{4}$ -in. square stock, each braced with one crosspiece and one diagonal. They hinge together on a $\frac{5}{16}$ -in. iron rod, such as a piece of baby-carriage axle, which is strong enough to hold the ironing board without bending. The ends of the rod are grooved as indicated, which can be done with a hacksaw. Heavy galvanized wire is wrapped in each groove so that the legs won't slip off.

☐ If a new cotton clothesline is boiled in water for a few minutes and allowed to dry before being used again, it will be thoroughly shrunk.



Illuminated Road Map, with Extension Cord Attached to the Car's Wiring System, Is an Improvement That Will Greatly Help Motorists

Illuminated Road-Map Holder

Reading a road map at night with only the dashlight to provide illumination is rather difficult. If you do considerable driving at night it is a good idea to make an illuminated map holder as shown in the drawing. It consists of a $\frac{1}{2}$ -in. board, about 8 in. wide and 10 in. long, having a tin hood tacked to the upper long edge, to serve as a shade and reflector for two small dashlight lamps. A toggle switch is mounted on the hood and a flexible cord fitted with two spring clips is provided for connection to the wiring system of the car, one being attached to the ammeter terminal and the other grounded. The map is held in place with rubber bands. On some cars it is possible to hang the holder on the crossrail above the instrument board by means of two L-hooks.—C. E. Packer, Chicago, Ill.

☞ Pure turpentine, dropped on a piece of white paper and exposed to the air, will leave no trace of foreign matter.

Easy Method of Making Ice

The farm icehouse can be filled in the winter without the trouble of taking the ice from a pond or lake and sawing it into cakes. Fill a number of paper boxes, about 1 by 2 by 2 ft. in dimensions, with clean water at night when the weather is cold enough to freeze it in a few hours. The resulting cakes are easy to handle and store. This method has been used successfully by a South Dakota farmer.—Ferdinand J. Wiener, Sauk Center, Minn.

Old Lawnmower Makes Good Truck

An old lawnmower can readily be converted into a serviceable truck for carrying barrels, boxes, etc., around the yard.

First remove the wheels and small gears inside of them. Loosen the frame in order to take out the rotary cutters and the wooden roller. The stationary blade is retained to form a rest for the load. A hook, made of heavy galvanized-iron wire, is attached to the handle with a woodscrew, to hold the upper end of a barrel against the handle.



Old Lawnmower Converted into a Small Truck for Carrying Barrels

Water Gardens for the Home

by W. E. Burton

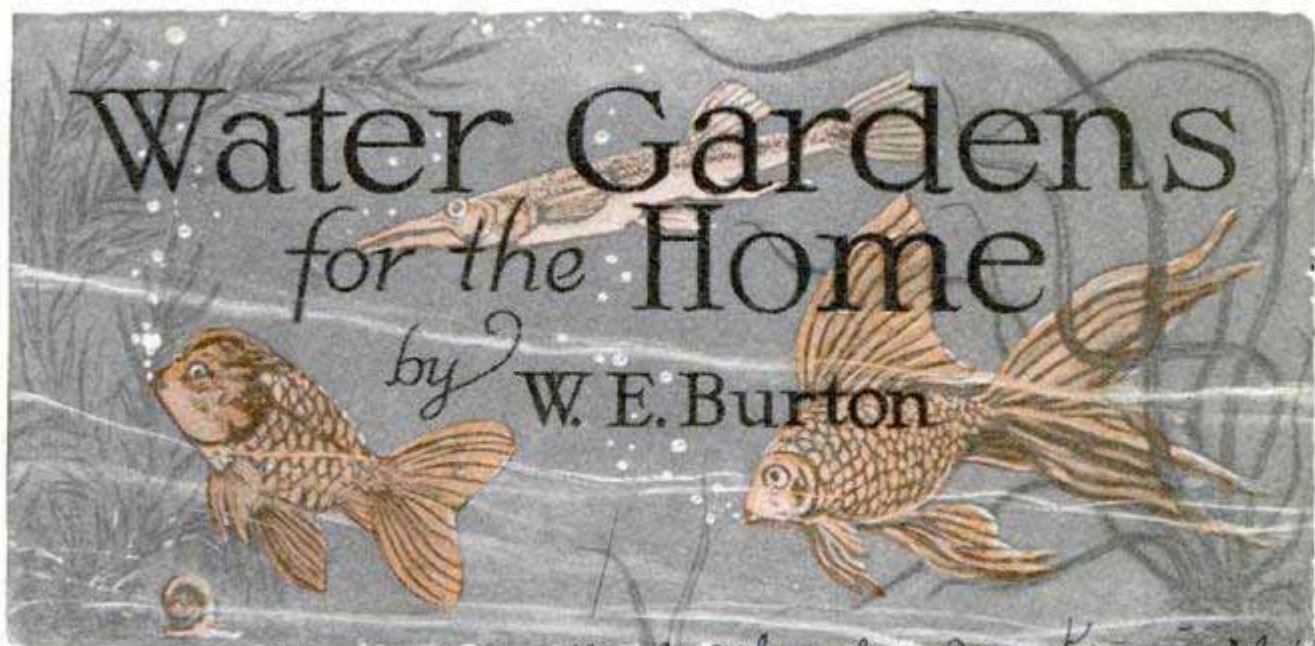

1922 Florida Ave. Kenmore Station
Akron Ohio

FISH are among the few pets that make no noise, produce no odor and are cleanly in their habits. For that reason, aquariums are becoming popular in homes, schools and even business offices. But many keepers of aquatic pets do not meet with success simply because they are not familiar with the habits of fishes.

If you want to keep goldfish or tropical fish, obtain an aquarium built of flat glass sides set in a metal frame, rather than a spherical bowl. A bowl is all right, provided it is large enough and that too many fish are not kept in it. But such bowls usually are sadly overcrowded, and oxygen-producing plants cannot be placed in them as well as in aquariums; they are then mere prisons to the fish. Besides, the curved sides distort the appearance of fish and plants. The tank with rectangular sides should be of such dimensions that as much water surface as possible is provided. This permits air, essential for the breathing of the fish, to penetrate the water. The depth of the water should be from 8 to 12 in.

There should be, roughly, 1 gal. of water or 20 sq. in. of water surface for every inch of fish, according to Dr. J. T.

Charleson, chemist for William Tricker, Inc., the largest raiser of fancy fish in the world. Thus, if you have an aquarium with a surface of 400 sq. in., you can keep twenty 1-in. fish, or five 4-in., and so on, in it.

An aquarium should be virtually a cubical section of a lake or pond. Therefore it should have plants, scavengers and sand, as well as fish. The sand preferably should be of the white or silicon variety, well washed; it is placed over the bottom to an average depth of from 1 to 2 in., and heaped up more at the back than in front. Aquatic plants are set in it, near the back and ends of the tank so that a clear view of the fishes is provided in front.

The plants have a purpose other than being ornamental. They grow and in so doing, absorb some of the waste matter from the fishes. But, more important, they liberate oxygen, which is necessary to fish and

also keeps the water fresh. There are five or six common water plants that give satisfaction in the home aquarium. Their names may mean little to you, but your aquarium-supply man will recognize them. Here they are: vallisneria, having long, grasslike leaves; saggitaria, similar to vallisneria, but with short rather stubby



Saddle River, N.J.
Independence, Ohio.



leaves; anacharis, a beautiful plant with short leaves radiating from a stem; Ludwigia, a highly ornamental plant with broad leaves; greenhouse spatterdock, a plant with large, broad, light-green leaves, which is better suited for the large tank; water poppy, the only practical flowering aquarium plant, and floating elodea, a good cover for young tropical fishes.

With proper plants, balanced aquariums have been kept in condition for two years, without change of water. Most of the plants mentioned have roots, and must be firmly fastened in the sand. Dead parts should be pinched off and removed from the water. If some of your plants mysteriously disappear, it is simply because the fish have eaten them.

There are certain creatures that you can put into your aquarium which will function as an efficient "street-cleaning department." Snails are the most common and suitable of these scavengers. Two to a gallon of water are about right. There are four preferable kinds of snails, Doctor Charleson points out. The largest is the Japanese snail which bears its young ones alive. Then there are Copenhagen reds, black ramshorns, and trumpet snails. The snails clean the glass and devour decaying vegetation. Among other scavengers are

salamanders and tadpoles, which remove excess food; weather fish, which cultivate the sand around the plants, and clams, which form natural filters for the water. So if you dislike changing water, provide your aquarium with a sufficiently large army of cleaners.

You have two general choices as to the fish themselves. You can have a collection of plain and fancy goldfish, or you can go in for the smaller, but perhaps more interesting, tropicals. But don't try to raise both kinds in the same tank, for their habits are different, and the larger goldfish sometimes become cannibals long enough to eat the others.

The names of popular gold-

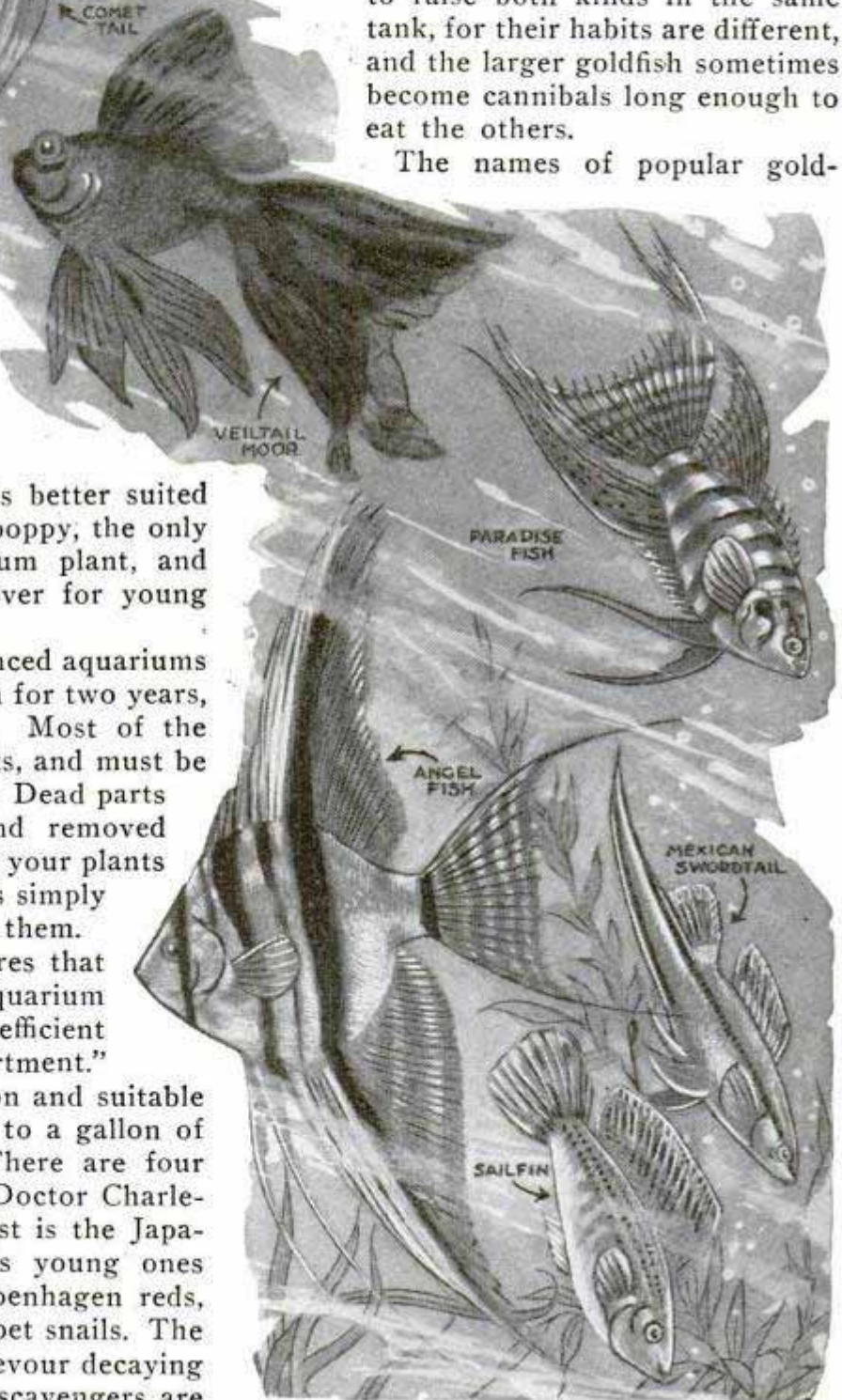

fishes frequently are descriptive. There are, for example, the Japanese calico fishes, calico fringetails, Japanese fringetails, Chinese telescopes with their protruding eyes, comet tails, lionheads, and the like.

Most people kill their goldfish by kindness, authorities claim. They feed them too much. The familiar wafer food is losing popularity, and is giving way to preparations containing necessary vitamins, proteins and other substances. A live fly or other insect now and then is excellent. Feeding should take place every day for tropical fish and every other day for goldfish, but only as much food as will be consumed in 5 minutes should be given adult goldfish. With small, young goldfish, as much as can be eaten in 15 minutes is permissible. A large fish will eat half its own weight in that time. If you miss a few days, the fish will not suffer much. Remove all uneaten food, as it contaminates the water. A feeding ring, consisting of a disk or square of tubing that floats on the water, will keep floating food from spreading.

Goldfish can stand fairly low temperatures, but be careful not to subject them to sudden changes. In renewing the aquarium water, let the fresh supply stand in

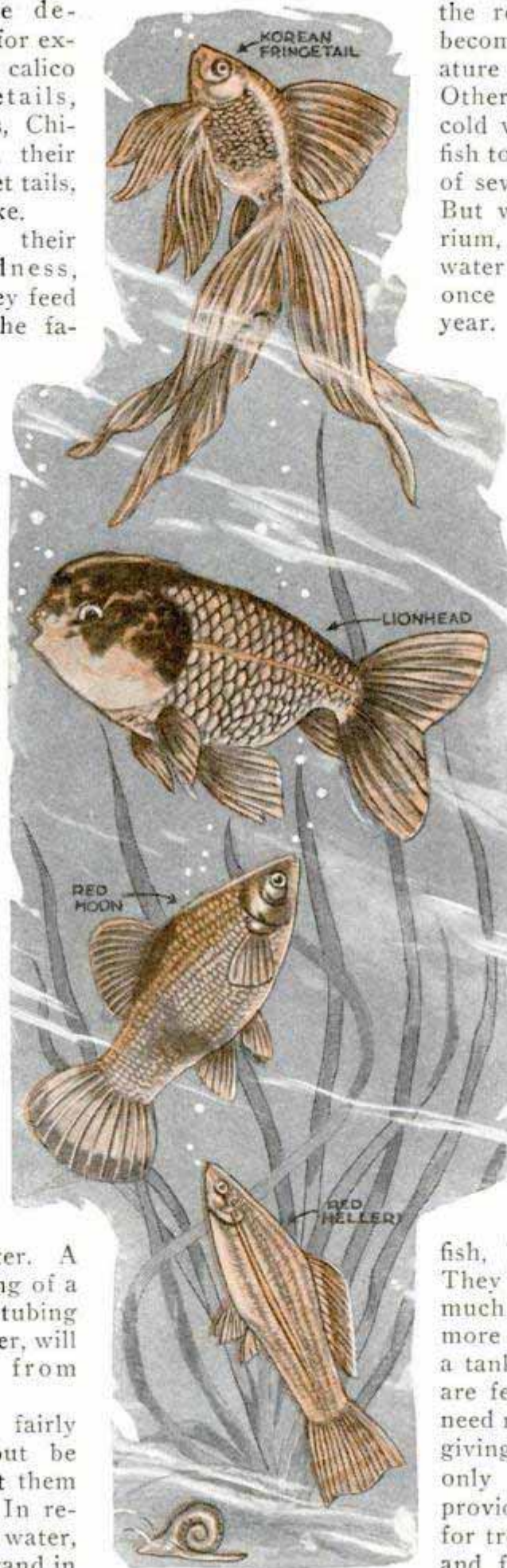

the room long enough to become of the same temperature as that in the tank. Otherwise, a sudden bath in cold water may cause your fish to become sick with one of several possible diseases. But with a balanced aquarium, you need not change water often—not more than once in six months or a year. From time to time,

waste matter that collects on the bottom should be siphoned out. Then fresh water, which has been allowed to stand for a few hours, must be added to compensate for this and for evaporation.

Tropical fishes are bringing new pleasures to thousands of aquarium owners. There are some 120 different varieties available. Some of these are importations from tropical waters, while others are the results of crossbreeding. But regardless of their source, the markings and habits of tropicals are always interesting.

These fish are, on the average, much smaller than goldfish, but are more hardy. They do not require as much oxygen, and therefore more of them can be kept in a tank of given size. They are fed every day, and you need not be so careful about giving them too much. The only disastrous result of providing too much food for tropicals is that it sours and fouls the water, often

killing the fish. As much as will be eaten in 15 minutes is the rule.

The only precaution to take with tropicls is to keep the temperature above 70°, but not over 82° F., although there are a few varieties that will exist in water as low as 45°. If your aquarium is in a place where it will become too cold overnight, a small electric bulb, partly immersed in the water, or a special electric heater obtainable for the purpose, can be used.

A cover of some kind is necessary for the tropical aquarium, for these little fish are so lively that they will jump out of the water. This might be all right for the Chinese walking fish, which can travel overland for half a mile, provided the land is damp; but it means "taps" for the others. Even goldfish sometimes become acrobatic and require a cover. A sheet of glass is all right, if it does not completely shut out the air. A screen of some non-corroding material, such as aluminum, is better.

Varieties of tropical fish are too numerous to be listed, but one of the most striking is the angel fish which, measured from fin tip to fin tip, is wider than it is long. The zebra fish is little but active. Many of the tropicls bear their young alive. Others, like the dwarf gourami, or the rainbow-colored Betta Trickeri, build bubble nests in which the eggs are laid. Some of the parents guard their young or eggs closely.

There are a few other hardy fishes that are neither tropicls nor goldfishes. The nest-building stickleback, which constructs a nest of twigs and plants, is one. The chætodon or "poor man's angel fish" is like the angel but minus the wings. It lives with goldfishes. So does the black bullhead, which is a jet-black fish with long, whiskerlike feelers. If you go in for breeding fish, there are many more interesting things that you should learn, and a visit to a large fish hatchery is advisable,

as being both educational and interesting.

Sometimes, in a large aquarium, you will have trouble with a small leak, especially after a complete changing of water. If very small, the leak frequently will heal itself, or a little mud introduced into the water will, upon settling, plug the hole.

But it is perhaps best to locate the hole, and then drain the water and apply aquarium cement. This is a preparation that you can purchase, and which adheres to the glass but remains somewhat soft and elastic so that it will not crack.

It is unwise to place an aquarium in the direct sunlight, without shading with paper or cloth. For one thing, the formation of a green scum of algæ on the glass will result. But there should be enough light for the plants. A north window is suitable. At night, the aquarium can be made a thing of surprising beauty by arranging a small electric lamp behind it, so that the light passes through the water, or the light can be placed at one end so a side illumination is provided. A 10 or 15-watt bulb, colored if you like, is about right.

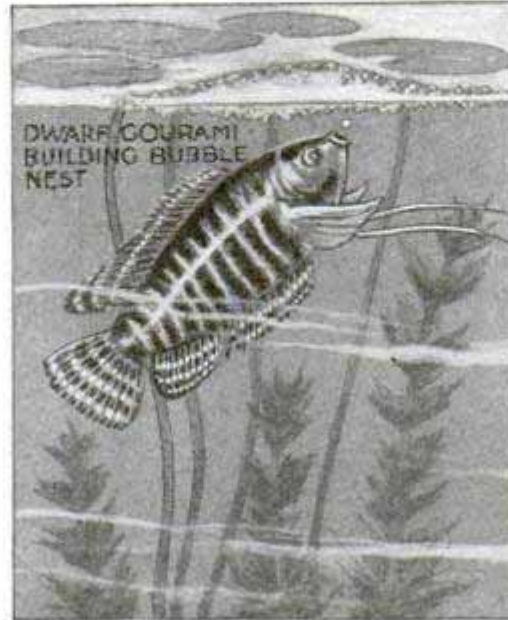

Whistles for Toy Steam Engines

Many whistles on toy steam engines do not work, owing to the fact that they are of the air-column type, and the frequency necessary for operating them is too high to maintain in the case of a toy steam engine. A good substitute whistle can often be made from a blow note of an old "harmonica" or mouth organ. With a hacksaw, cut out a rectangular piece containing the blow note, from the brass plate on which it is mounted. Make a tin or sheet-metal compartment about the same size as the hole in the wooden base of the harmonica, and fasten to this the blow-note plate. Fasten the whistle thus made above a valve. Be sure that you do not get a draw note. Sometimes the high-pitch reeds will work better on a small

boiler than the low-pitch reeds will do. If a tire valve has the flange cut off to just a little ring, and is mounted on the boiler, water can be forced into the latter with a bicycle pump when the supply becomes low, and the engine can be run continuously. The rubber on the valve wears out fast in this service. It is possible to use greased-cord packing instead of the rubber, but valves using this kind of packing are hard to keep tight.

Fireproofing Cloth

Cloth holders used around stoves, fire screens and the like, can be made fireproof by the following method: Mix equal quantities of alum, borax and vitriol (copper sulphate). Dissolve the mixture in boiling water or a thin size made by melting 1 oz. of glue or gum arabic in 1 gal. of water. Use no more water than necessary to dissolve the mixture thoroughly. Immerse the cloth in this preparation, and, when dry, it will be entirely fireproof.—William P. Mack, Chicago.

Old Carpet Useful on Boat Dock

Last year one of our neighbor's boys lost his life from blood poisoning caused by a sliver which entered his foot while playing on our boat dock. To prevent any similar occurrence, we have laid an old carpet runner on the dock. Besides preventing the danger of slivers, the carpet gives bathers a firm foothold when the dock is wet.—C. A. Gunn, Minneapolis, Minn.



Carpet Runner on Boat Dock Protects Bathers against Wood Slivers

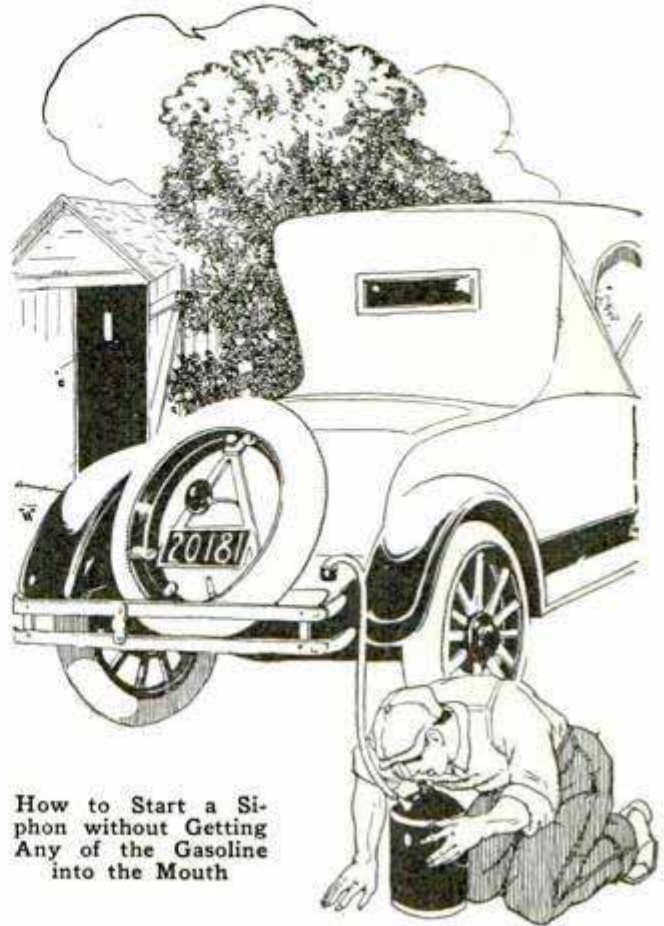

How to Start a Siphon without Getting Any of the Gasoline into the Mouth

Better Method of Siphoning Gasoline

When starting a siphon to obtain a small quantity of gasoline for an emergency, it is annoying to get some of the liquid into the mouth. To avoid this proceed as follows: Attach the hose to the spout of a gasoline can as indicated. It should fit tight in order to prevent the escape of air. Then remove the cap and suck the air out of the can at the top. The gasoline will then start flowing.—A. C. Wilson, Columbia Cross Roads, Pa.

Eraser for Cleaning Bone and Ivory

Small curios and oriental carvings in ivory and bone are often rather difficult to clean. An ordinary typewriter eraser, however, will do the work effectively. It should be trimmed to suitable shape with a knife so that it will reach inside of the small spaces. Fragments of the eraser that may stick to the article are removed with a soft brush.—Douglas Leechman, Ottawa, Can.

Photographic work in the dark room is greatly improved by the use of distilled water in the preparation of solutions.

*Blueprints discontinued.
Company supplying material
and business*

A Scale-Model Plane



by **Walter Bullock**

Pilot, Northwest Airways, Inc.

THE DOOR to the passenger compartment is cut from a piece of galvanized iron and covered with corrugated metal, leaving $\frac{1}{16}$ in. of the plain iron showing all around the edge. This narrow band later will be painted.

An exact scale template for the galvanized-iron base is shown in Fig. 23. Cut the door and file down the window opening to exact size. Lay the door on a piece of the corrugated metal, with the corrugations parallel to the top and bottom of the window, and mark around the edges. Cut out the corrugated covering, and then, with the shears, pare off $\frac{1}{16}$ in. all around the edge, giving you a corrugated cover of the right size. Sweat the cover to the door, being careful to keep the margin even all around. Cut out the window, using the opening in the iron as a guide. File the edges smooth. Any little inequalities in the margin around the corrugated cover can be smoothed out by running a file around the edge. The door goes on the right side of the fuselage,

looking forward from the tail, and fits over the rear cabin window, as shown in the picture of the completed model on page 331. Spot it in place with two or three drops of solder, taking care not to move the covering while the solder is soft.

The control sticks in the pilot compartment and the pilots' seats also are fitted before the wing is added. The Ford has dual controls of the Deperdussin wheel type. The wheels and columns are cut from a piece of three-ply veneer, $\frac{1}{16}$ in. thick, to the dimensions in Fig. 24.

Glue the wheels to the sticks, the latter reaching to the center of the wheel. Next cut two pieces of plain nicked brass, $\frac{3}{8}$ by $\frac{1}{2}$ in., clip off the corners, bend them around a length of $\frac{1}{16}$ -in. copper-coated iron wire, 3 or 4 in. long, insert the sticks, bend the brass over the "T" at the base of the stick and solder.

The seats are plain bucket type, made with a solid

wood block for seat and base, and a piece of plain nicked brass bent to form the back. The details and dimensions are

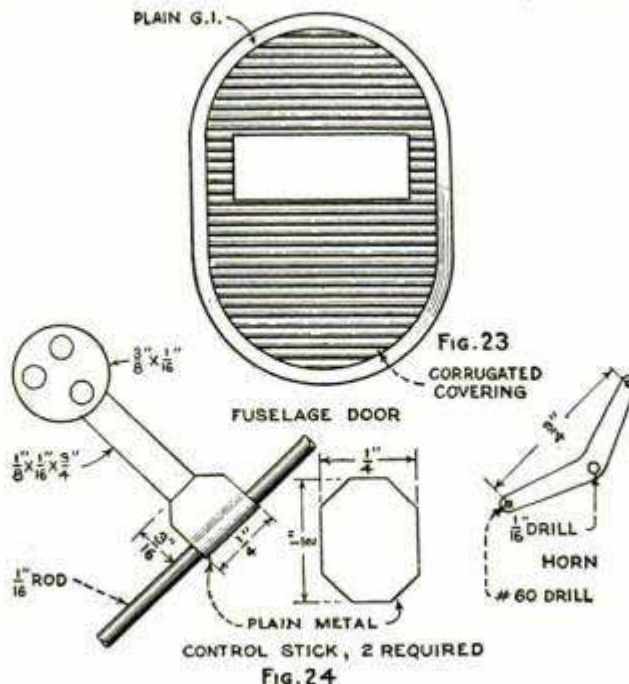

Is Easy To Build

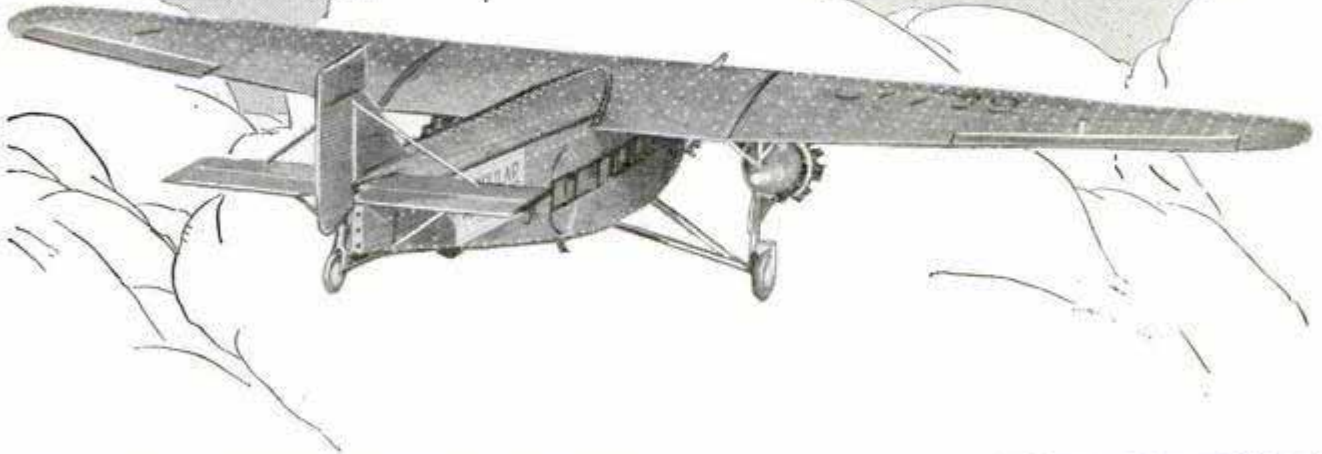

clearly shown in Fig. 25, and no other instructions are necessary. A metal seat may be soldered in to cover the top of the block. The two seats are glued to the floor, leaving an aisle between them. Next drill through the sides of the pilot compartment, $\frac{1}{8}$ in. above the floor and about halfway between the rear of the nose block and the front of the seats, using a $\frac{1}{16}$ -in. drill. Remove the controls from the wire, insert the latter through one side of the fuselage, string the control sticks on it, and push the rod on out through the other side. Center the wheels in front of the two seats and attach them to the wire with a drop of solder. Cut two elevator-control horns from galvanized iron, as shown in Fig. 24. Holding the wheels upright, solder the horns to either end of the rod at the angle shown in the photograph of the plane's nose, and cut off the excess rod, filing the ends down smooth with the horns.

Cabin seats are optional, but in a model of this size so little of them can be seen—only the tips of the backs—by even the closest inspection, that it is hardly worth while to put them in. If you do want cabin seats, however, only the backs need be made. The Ford of which this is a model is the 14-passenger ship, with 13 fixed chairs and one folding seat beside the door, in the rear corner of the cabin. An easy way of making chairs is to cut a strip of thin board the width and length of the cabin, make 7 equally spaced saw cuts across it, and in them stick 13 small

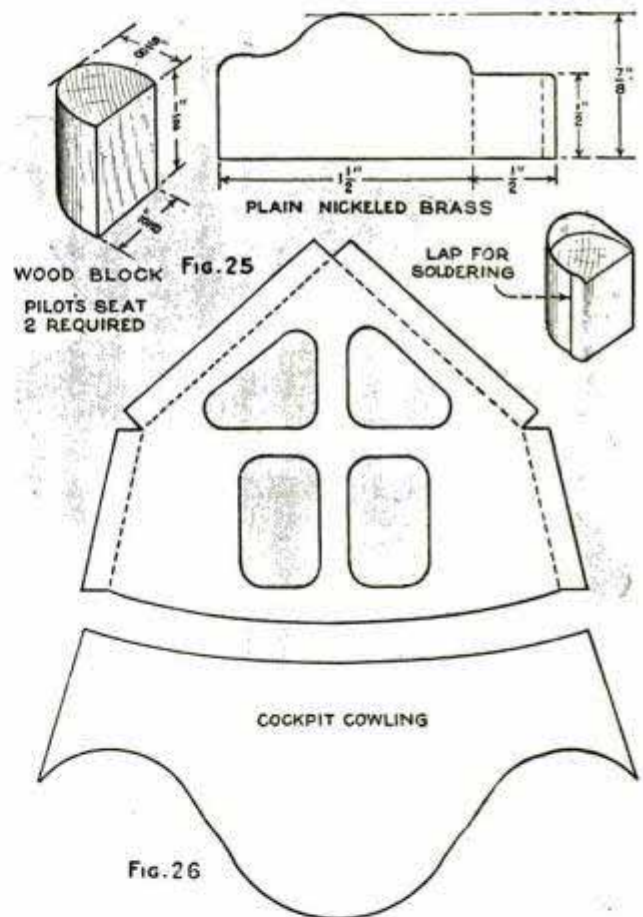

pieces taken from a berry box, painting the upper ends with aluminum paint. The small part that can be seen through the cabin windows is very effective.

You are ready now to attach the wing. Mark the exact center of the wing so that it can be lined up with the projecting tip on top of the fuselage. Starting near one tip, push the wing through the fuselage opening. If it sticks before reaching the center mark the places where the

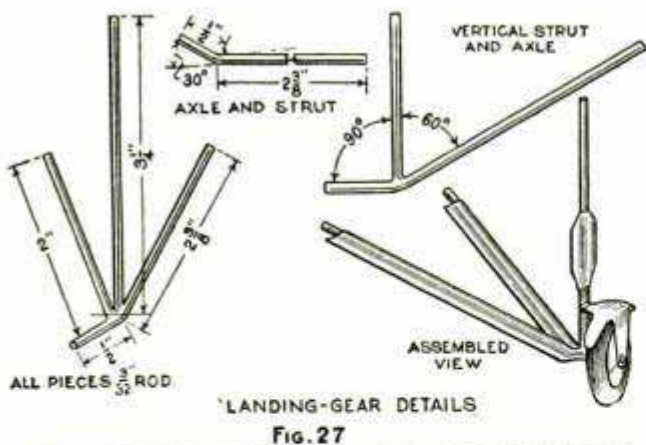

LANDING-GEAR DETAILS
FIG. 27

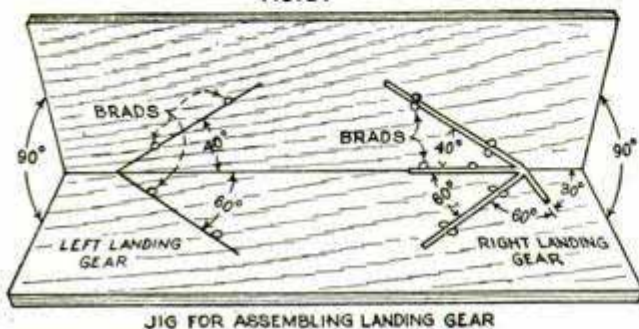

JIG FOR ASSEMBLING LANDING GEAR

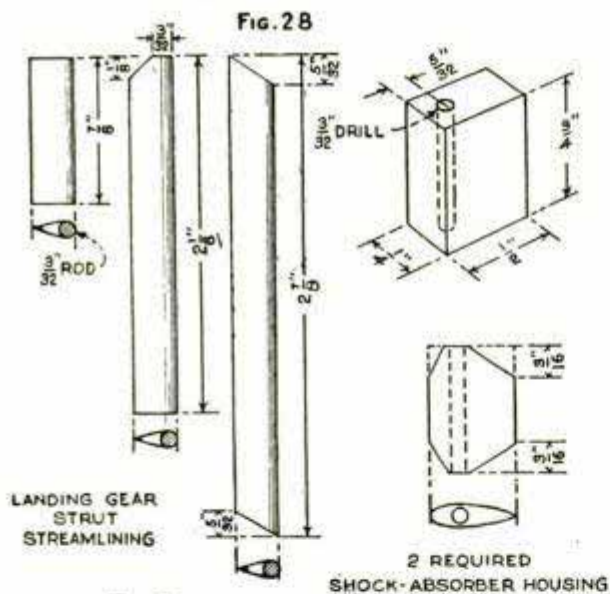
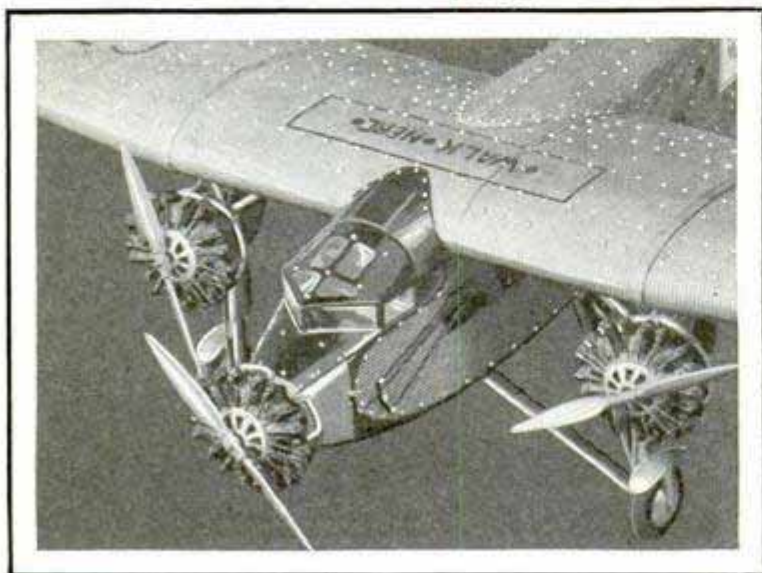

FIG. 29

2 REQUIRED
SHOCK-ABSORBER HOUSING
FIG. 30



metal on the fuselage is binding, remove the wing and file away the excess metal around the opening, and wood, too, if it is in the way. Continue until you can get the wing into its exact position. Using a T-square on the straight front edge of the center wing section, with the corrugations on top of the fuselage as a fore-and-aft line, adjust the wing to right angles with the fuselage, then secure it by removing a couple of the brads in the top of the fuselage and driving longer ones down through the wing.

Solder the wing to the metal covering of the fuselage, smooth down the solder joint, and then cut strips of plain nicked metal, $\frac{3}{16}$ in. wide, cup them slightly, and sweat them down over the joint, working all the way around, both on top of the wing and along the fuselage underneath.

The cowling over the pilots' cockpit comes next, and then you will be ready to start on landing gear and motors. The cowling is cut from galvanized iron, in two pieces, one of which contains four windows, to give the pilot a view above him. The exact sizes are shown in the two full-size templates in Fig. 26. The other piece projects up over the wing and fits down around its leading edge. Cut out the two, cut the windows with a cold chisel, file the edges straight and the corners round, and you are ready to bend them. As every model differs a trifle in size, it might be well to cut the cowling slightly oversize and trim it down to fit as you bend it into shape.

The piece containing the four windows has four soldering flanges which are bent down first. Then cup it to the shape shown in the photographs of the fuselage nose, fitting the soldering flanges on the outside of the windscreen which is already in place. The celluloid windows can be cut from an old photographic film, after soaking off the emulsion in hot water. Cut the film to the same size and shape as the cowling, place it underneath the metal, and it will naturally cup upward to a good fit. When you get an accurate fit, solder the two together. The other piece is bent and fitted in

the same way, taking care to get an accurate joint around the wing before soldering. Smooth the solder joint down with a small round file. All this cowling is later to be painted.

Now comes the landing

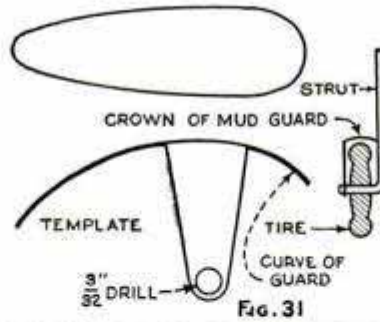

gear, fastening it with brads on both sides; place the other two rods in position, the longest on the 40° line and the shortest on the 60° mark, and secure them with brads on the side away from the line. When all

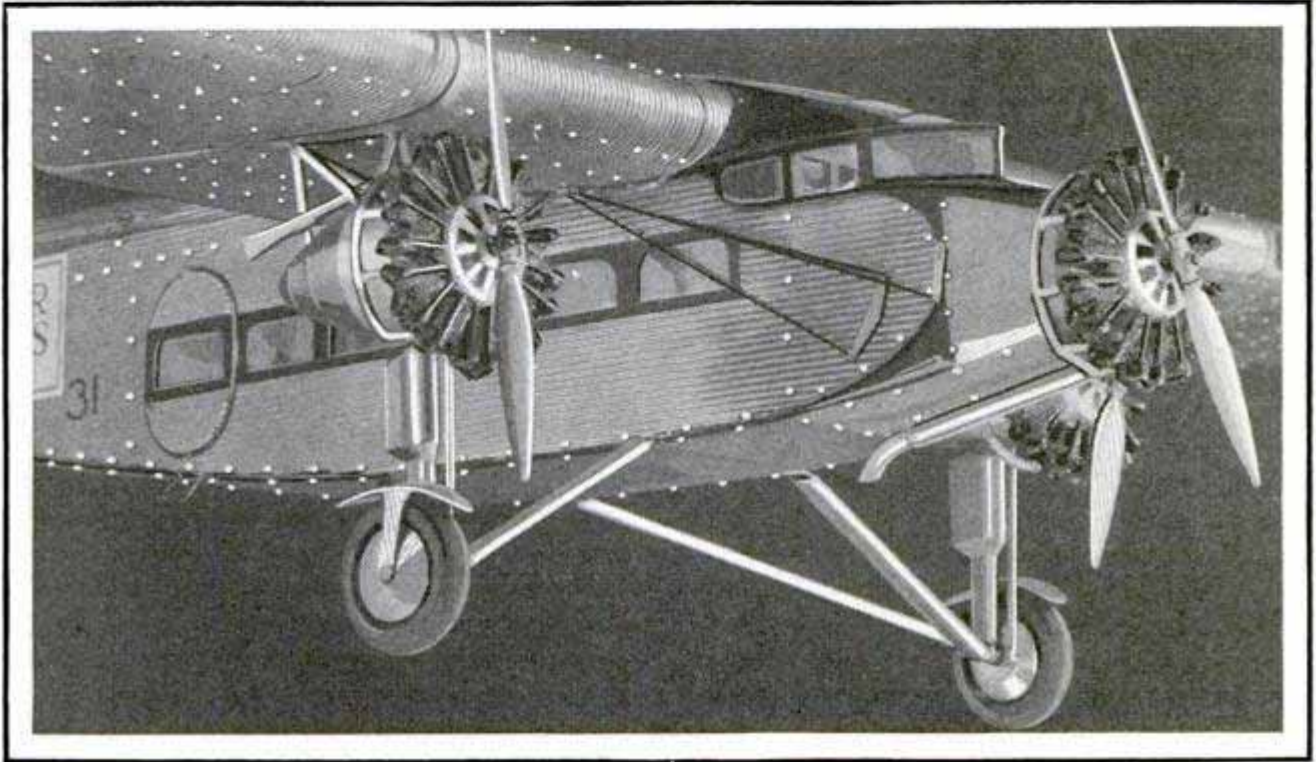

gear. It looks more difficult than it really is. Copper-coated iron wire, $\frac{3}{32}$ in. in diameter, is used for the struts and axles. Three pieces are required for each side. One is $2\frac{7}{8}$ in. long, one 2 in., and the third $3\frac{1}{4}$ in. All of the details of the landing gear are shown in Figs. 27 to 30. Start with the $2\frac{7}{8}$ -in. length and bend $\frac{1}{2}$ in. at a 30° angle to form the axle, as shown.

To assemble the three pieces and solder them together with accurate angles, you will need a jig, which can be made from two scraps of board nailed together at right angles. The jig is shown in Fig. 28. After nailing the boards together, lay out the two angles, one of 40 and the other of 60°, as shown. Drive two brads into each line, lay the bent rod in place with the bend at the point where the two angles

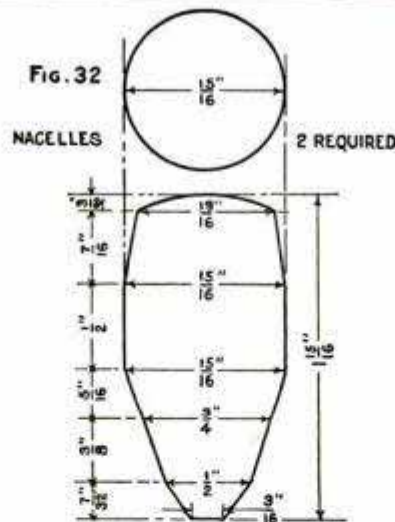

three are in place, with the bent axle lying flat against the board, run plenty of solder into the angle to hold them firmly.

To make the other side of the landing gear, a second jig must be laid out, with the angles pointed in the opposite direction, as shown in the jig sketch. This is necessary as one left and one right-hand gear are required, with the long strut

in each pointing to the rear. Smooth away the excess solder with a file, taking care not to cut away enough to weaken the joint and get the struts out of alignment.

The streamlining of the struts is made from plain nicked brass, and the streamlining of the shock absorber, on the short vertical strut, which later will be attached to the bottom of the wing motor nacelle,

is cut from wood and painted with aluminum paint, or, as described later, the wood itself may be nickelplated.

For the metal streamlining, cut strips of plain metal, $\frac{1}{2}$ in. wide. The lengths and other details of the three are shown in Fig. 29. Bend them down the center, over the edge of a board, then lay a length of the $\frac{3}{32}$ -in. rod in the bend, press the edges together and solder them. Cut the lower end of the $2\frac{1}{8}$ -in. piece as shown, and both ends of the longest one. Slip them onto the struts, and pare away the solder until they fit well down near the axle bend.



The shock-absorber housing, which goes on the vertical strut on top of the metal streamlining, can be cut from any soft wood, pine or poplar both being excellent. Cut two pieces to the dimensions shown in Fig. 30 and drill a $\frac{3}{32}$ -in. hole through each. With a knife, round off the front edge, and cut away the sides to a knife-edge at the rear, carrying out the same streamline form as in the metal parts. Bevel the corners, round off the front edge of the bevel, pare the sides down and carry the knife-edge of the back down to the drill hole. Smooth down the pieces with sandpaper and slip them into place on the short struts.

The metal streamlining on these struts has been cut somewhat longer than required. The over-all length from the bottom of the axle to the top of the wooden shock-absorber housing should be $1\frac{11}{16}$ in. Measure the length on your model, and cut off enough of the metal to bring it down to the required over-all length.

The long strut is the rear one. Be sure the streamline parts all point with the thin edge to the rear, and then solder them in position at the axle joint, taking care not to soften the previous solder enough to change the angle of the struts. Remove excess solder with knife and file.

Landing-gear wheels are $\frac{5}{8}$ in. in diam-

eter, $\frac{3}{8}$ in. thick, and are grooved to take a $\frac{7}{32}$ -in. rubber tire. Wheels and tires can be obtained ready-made for the model; suitable wheels and tires may be found on dime-store toys, or wooden wheels and tires may be turned, and the tires painted black. A tail wheel, $\frac{9}{16}$ by $\frac{1}{8}$ in., cast complete with tire, may be ob-

tained ready-made and the tire painted black, or a suitable wheel can be found at the dime store on some cheap toy automobile.

The landing-gear wheels are covered by mudguards, cut from galvanized iron. Exact-size templates for the two parts are

shown in Fig. 31. The fender is given a crown effect by bending it over a small dowel, a nailset or even a round pencil, then curved fore and aft, the forward half to about the same radius as the tire, and the tail left almost straight. The side is soldered on at right angles, after drilling a $\frac{3}{32}$ -in. hole, as shown, for the axle. Slip the mudguard on the end of the axle and solder it to the strut, with the side support vertical, in the same plane as the strut. Next solder the guard to the axle end, and file the axle down almost flush, the filing giving a slight burr to help hold the guard in place.

You are ready now for the nacelles, or "eggs," on which the two wing motors are mounted. They are turned from wood, the dimensions being shown in Fig. 32. Nacelles, ready-turned to size, can be obtained with other kit parts, if no lathe is available to make them. After the plane is completed, the nacelles and other motor and landing-gear parts may be painted with aluminum paint, or they can be nickelplated, as suggested before.

If you decide to have the nacelles and shock absorbers plated, the wood should be so treated before assembling, and, after the motors are completed, they can be returned to the plater for another coat of nickel, to cover the exhaust pipes and mounting struts.

(To Be Concluded Next Month)

Radiator Steam Softens Transmission Oil

Ordinarily the water in an automobile radiator should not be allowed to boil, but there are times when steam from the radiator can be used to advantage. As cold weather sets in, many motorists realize that the old thick grease in the transmission and differential should be cleaned out thoroughly and thinner grease substituted. Many service stations, especially those in the northern states, use steam to soften the old oil, which has been found better than any other method. The motorist can do this himself by connecting a 12 or 15-ft. length of garden hose to the filler opening of the radiator. The overflow pipe and the space around the hose should, of course, be packed tight with rags to prevent the escape of steam. Start the motor and run it at a moderate speed with the spark retarded, and place a newspaper in front of the radiator to cut down the circulation of air. Open the bottom drain of the transmission and push the open end of the hose inside. As steam comes out, the grease will soon be softened and will flow out. Leave the steam on for about 20 minutes so that the entire transmission unit will be sufficiently hot to dry itself after the hose is removed. The differential can be cleaned in a similar way.

Mailing Tube Removes Necktie Wrinkles

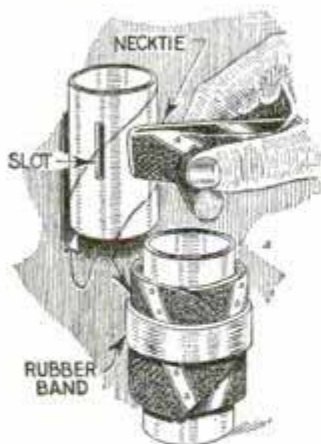

When looking about for some simple method of keeping my neckties in shape without the need of having them pressed so often, I discovered that if the ties were rolled up tightly on a short length of mailing tube, as shown in the drawing, and held in this position by means of a wide rubber band, the wrinkles would disappear. A slot is cut in the tube to receive the doubled narrow portion of the tie, after which the wide part is wrapped around the tube.—H. G. Schultz, Astoria, N. Y.



Satisfactory Support for the Camera Tripod on Snow Is Provided with Newspapers

Support for the Tripod on Snow

When the camera tripod is set up in snow-covered ground, difficulty is frequently experienced in adjusting it, as the legs sink into the snow and this prevents them from being moved about easily. It is too unhandy to take along pieces of light wood or heavy cardboard, but a few newspapers carried in one's pocket will serve as well. Folded and tied together as shown, they will make excellent supports.—Frank W. Bentley, Jr., Missouri Valley, Iowa.

Removing Scratches in Furniture

To remove light scratches in furniture, go over the surface with a soft rag dampened with kerosene, which will cause all the surface bruises to disappear. If the scratches or cracks are deep, melt a little beeswax and thin it with turpentine to the consistency of sirup. Apply it with a soft cloth and then polish with flannel or velveteen.—William P. Mack, Chicago.

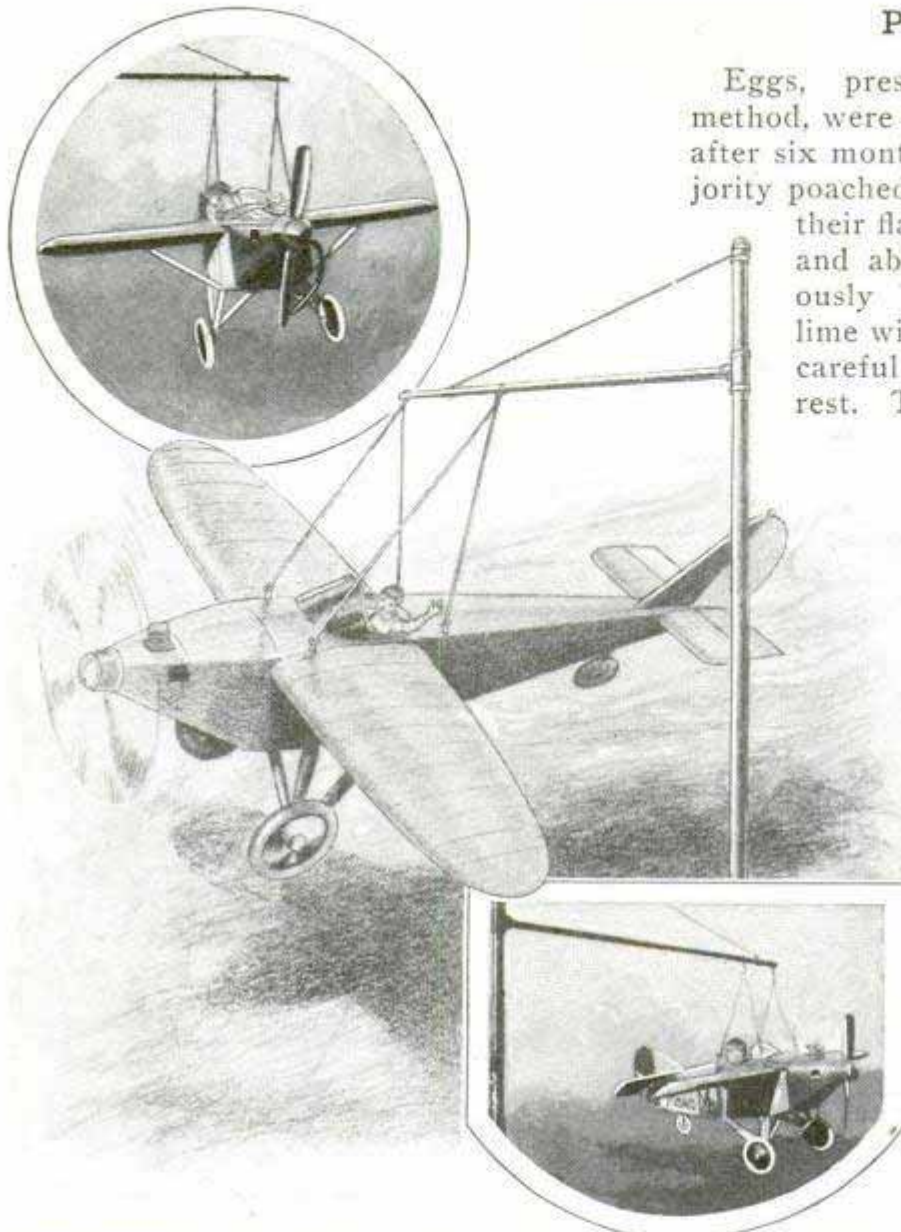

Child's Aeroplane Suspended from Swing Flies on Its Own Power, Making a 20-Ft. Circle in Three Seconds

Backyard Aeroplane Flies on Own Power

It took me a little over three weeks of spare time to complete the small plane shown in the photos. It is powered by a $\frac{1}{2}$ -hp. washing-machine motor, the shaft of which is extended to permit the attachment of a propeller. I found that the motor would pull the plane over a level floor at a good rate of speed. However, I made a swing for it so that it would sail in a circle 20 ft. in diameter. The swing is made of heavy pipe and fittings and securely imbedded in a concrete base. To reduce friction, it is advisable to use ball bearings. When traveling full speed, the plane makes a complete circle in about three seconds.—F. E. Engler, Pukwana, South Dakota.

Preserving Eggs

Eggs, preserved by the following method, were still in such good condition after six months of storage, that the majority poached very well, besides keeping their flavor. Get 2 lb. of fresh lime and about 5 gal. of water, previously boiled. After slaking the lime with 1 gal. of the water, being careful to avoid spattering, add the rest. The solution is stirred quite frequently, allowed to settle and then the clear part, or saturated lime solution, is taken off the top and poured over the eggs. This is better than water glass.

Clothespin Made into Razor-Blade Holder

For cutting stitches, scraping paint from glass, etc., an old razor blade will serve very well. A handy holder for it can be made from a clothespin of the spring type. As the pressure of the spring itself is not sufficient to hold the blade securely, a small wood screw is driven into one

lever as indicated, and the upper lever is cut off so that the stub end will serve as a thumb rest. This clamp will also be found to be very useful for holding brass and copper tubing, as it has a firm grip but will not mar the tube.—Durre Rockwell, Hollywood, California.



By moistening the buttonholes of starched clothing on the inside, buttons may be inserted easily without soiling or crumpling the area that surrounds the buttonhole.

SHOP NOTES



How to Make a Metal Kitchen Stool

By J. W. BOLLINGER

HERE is a real convenience that the lady of the house will appreciate having in the kitchen. It will enable her to sit down to do a lot of work which she would otherwise have to do standing up, and will in the run of a day save her more than enough energy to pay for the slight cost and effort of making it.

The stool is very simple and easy to make. You will need only the tools already in your kit, with the addition of a $\frac{3}{16}$ -in. drill for metal, to use in your brace or breast drill when making the rivet holes, and a center punch, which you can make yourself. For material, you will need 9 ft. of some $\frac{3}{16}$ by $\frac{3}{4}$ -in flat or strap

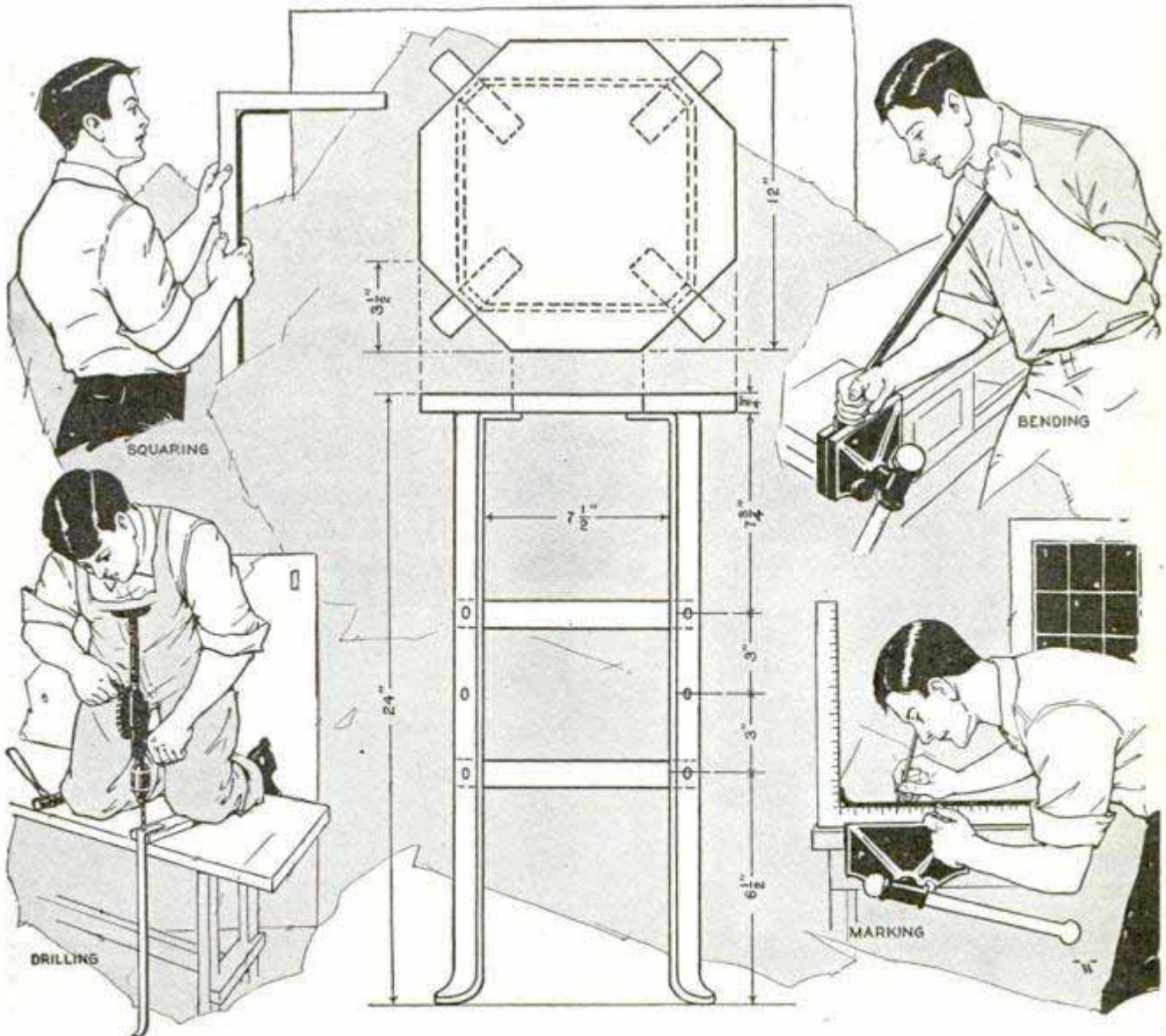

iron for the legs, 6 ft. of $\frac{1}{8}$ by $\frac{1}{2}$ -in. iron for the braces, and sixteen $\frac{3}{16}$ by $\frac{1}{2}$ -in. round-head iron rivets.

Cut the $\frac{3}{16}$ -in. iron 27 in. long for each leg. Grind or file the end for the feet round. To curve the foot end, clamp $\frac{1}{2}$ in. of that end of the iron in the vise, and bend the rest of the iron over. It may be necessary to strike it lightly with a hammer, but be careful not to dent it. Make the four feet as nearly alike as possible.

Lay the four legs on the bench with the feet resting against the wall and make a mark across all four pieces $23\frac{1}{4}$ in. from the bottom. This is where you are to make the bend for the part of the leg which fastens to the top. Make the bends as before, testing them for squareness with a carpenter's square. All four legs must be the same length, or the stool will not stand level.

Measure from the foot end of each leg first $6\frac{1}{2}$ in., then two intervals of 3 in., as in the drawing, for the holes. Be careful to get all four legs marked exactly alike. Make a center-punch mark on the center line of the leg at these places and drill the holes with the $\frac{3}{16}$ -in. drill. Also drill two or three holes in the part that fastens to the top.

Cut the iron for the braces into eight pieces, each 9 in. long. Clamp $\frac{3}{4}$ in. of each end of the pieces in the vise, and bend to an angle of 45° . Make a little wooden gauge for testing the bend, and use the same gauge to locate a hole in the center of this $\frac{3}{4}$ -in. length. All eight braces must be alike, and the holes should line up as accurately as possible.

Take two legs and two braces and rivet them together. Put the rivet through from the outside of the leg, lay the iron down so that the rivet head rests on a solid iron surface, saw on the vise or on a heavy hammer, and shape the head on

the inside. To round the head over, finish by striking around the edge of the rivet with the ball end of a machinists' hammer.

Rivet the other set of two legs and two braces together in the same way, then rivet the other braces in place. Note that the braces alternate on the sides. File the ends of the braces smooth, and test them with the square to see whether they are square with each other; also test the stool to see that it stands level, and that the top is level.

Choose a 12-in. square piece of some strong wood, preferably birch, for the top. You can saw the top out round, if you prefer, or you can make it eight-sided or octagon-shaped, by first squaring it up and then measuring $3\frac{1}{2}$ in. each way from each corner, as shown on the drawing.

Give the finished stool two coats of white undercoat, and two coats of white enamel, sanding each coat when dry with No. 4-0 sandpaper. Or, if you want a more modern finish, lacquer it in some pleasing color, to harmonize with the colored kitchen furnishings that are the latest trend. The kitchen stool in the illustration is finished in dark-green lacquer.

Border Slide Rack for Printers

In most printing offices equipped with linotype machines, border slides are kept loosely in a cigar box or similar container. A New Mexico printer keeps his slides in order in a homemade rack. It is made of a piece of 1 by 4-in. pine, about 2 ft. long, grooved laterally at intervals of about $\frac{1}{2}$ in. on the composing-room saw. The grooves should be made to hold a slide easily, and of such depth that, when a piece of heavy binder's board is bradded across the face and a strip of batting nailed firmly to the bottom, each groove forms a compartment sufficiently large



to hold a slide with enough of the latter projecting to facilitate easy removal. Proofs of borders are pulled and glued over corresponding compartments to aid in quick identification of the slide wanted.—Edgar Sherman, Tucumcari, N. Mex.

Repairing Leaky Storage Batteries

Leaky storage batteries can be repaired without removing either the plates or the jars. Simply pour the acid of the battery into a glass, stone, or rubber jar and dissolve in it one-third cupful of plain gelatine per cell. Allow the mixture to stand for approximately ten hours and then pour it back into the cells. The gelatine does not retard the chemical action of the electrolyte noticeably.

Roller Shade for the Skylight

At times it is desired to have a skylight shaded, which can be readily accomplished by installing a roller shade as shown in the drawing. The brackets supporting the shade are mounted at one end of the sash so that the shade will run lengthwise. A suitable length of cord, attached to the shade stick by means of a screw-eye, is run through a second screw-eye driven into the sash, in line with the first, and the cord is then passed over a pivoted pulley fitted on the sash frame. The cord is manipulated from below and must be taut when the shade is drawn away from the roller to prevent it from sagging. It will be found convenient to have a hook on the wall for fastening the cord. The

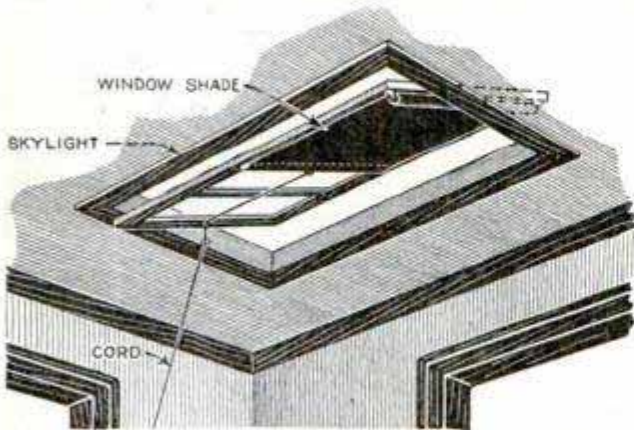

Roller Shade Arranged on a Skylight Can Be Adjusted from Below

shade can be drawn whether the window is closed or not.—Preston West, Headland, Ala.

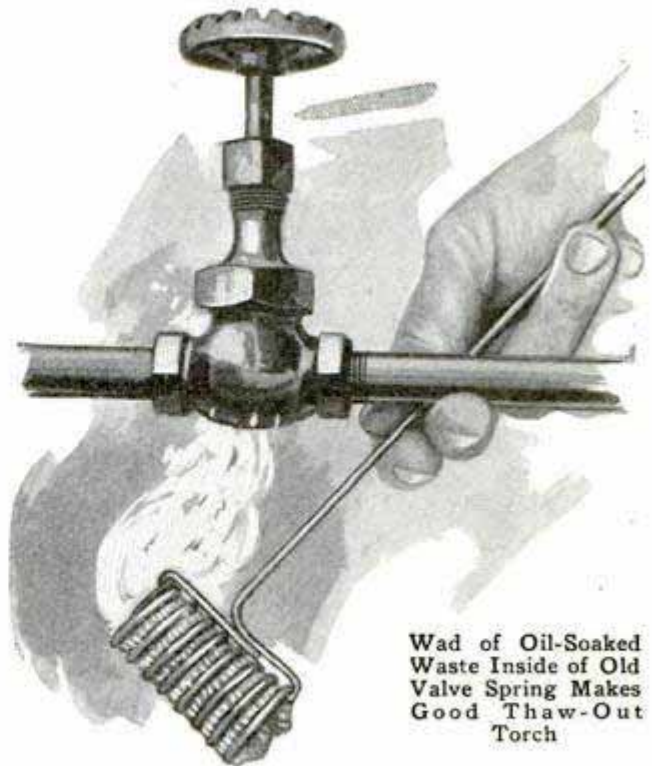

Wad of Oil-Soaked Waste Inside of Old Valve Spring Makes Good Thaw-Out Torch

Safe Thaw-Out Torch

Small thaw-out jobs, which are commonly done with a piece of oily waste hooked to the end of a length of wire, are not entirely safe, as the burning waste may drop off unnoticed with disastrous results. Furthermore, the flame of a loose piece of waste spreads out, and the heat is therefore not concentrated. A better torch can be made as follows: Take an old gas-engine valve spring and loop a fairly long piece of heavy wire through one side, clinching it down as shown in the photo. Pack some waste tightly inside of the spring and soak it in kerosene or other oil. When ignited, it will give a hot flame for a long time and no burning pieces of waste will drop off.—Frank W. Bentley, Jr., Missouri Valley, Iowa.

Photographing Silver Cups

When photographing presentation cups, "plate" trophies and other silverware, difficulty is usually experienced in preventing halation or "flare," which is caused by the reflected light from the bright surfaces of the metal. To overcome this trouble, place a piece of ice inside of the vessel just before photographing. The slight condensation formed on the outside surface dims it and enables the photo to be taken without halation.—Thomas Goudie, Rangoon, Burma.

Two Shafts Milled at One Set-Up

A small shop had a large quantity of 2-in. shafts on which keyways had to be

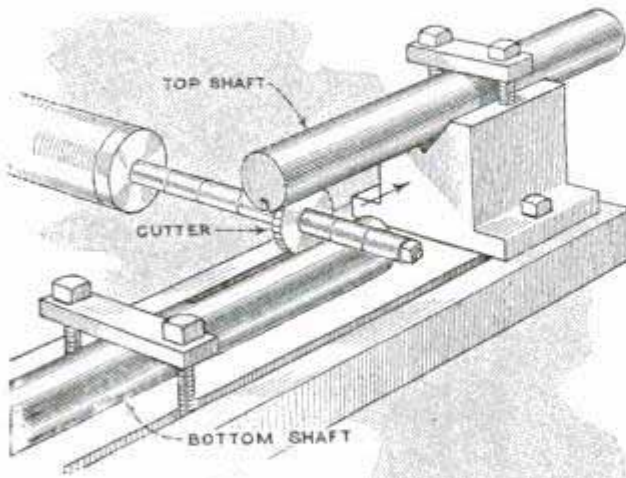

Milling Keyways in Two Shafts at One Set-Up Increased the Production Speed in a Small Shop

milled. As only one cutter was available, the work would have progressed very slowly had the workman not thought of the illustrated method of milling two shafts at one set-up. One shaft was strapped to a T-slot in the table and the other to a V-block suitably packed up on parallels. The cut was started by raising the table and sinking the cutter the required depth in the bottom shaft. The feed was then operated in the ordinary way. At the end of the cut the table was run back to the starting position and lowered to enable both shafts to be removed. By the use of this method, the output was nearly doubled.

Cotter-Pin Holder

When putting in cotter pins in difficult places, the illustrated device will be found useful. It is made by bending a piece of flat iron to the shape shown and slotting the end to hold the shank of the pin.

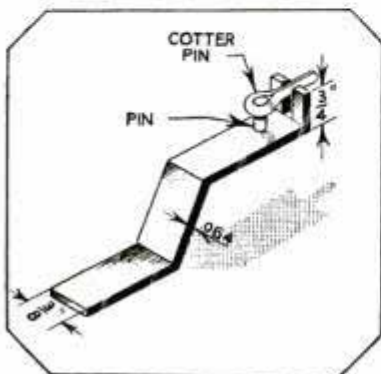

Drill a $\frac{1}{16}$ -in. hole, in line with this slot and about $\frac{1}{4}$ in. from it, and drive in a nail, making a tight fit. Cut off the nail so that a small pin is

formed which will fit in the eye of the cotter pin, holding it securely in position until the end is started in the hole, after which it is an easy matter to slip the tool off. The tool handle may be as long as desired.—Whitmal W. Hill, Philadelphia, Pennsylvania.

Durable Drill for Difficult Job

In drilling between rivet holes in two malleable-iron plates, it was found that small twist drills cut a clean hole but that a large percentage of the drills broke, as the sharp lips had a tendency to dig into the casting when striking the edge of the holes. It was then suggested to use a piece of drill rod several feet long. A new spindle for the drill was made of tool steel, and a hole, slightly larger than the drill, was bored entirely through it. The shaft was trued up to the hole in its center and a very fine thread was cut on the end. Beyond the thread, the shaft was relieved and finally tapered to a blunt point. Two slots were sawed at right angles to each

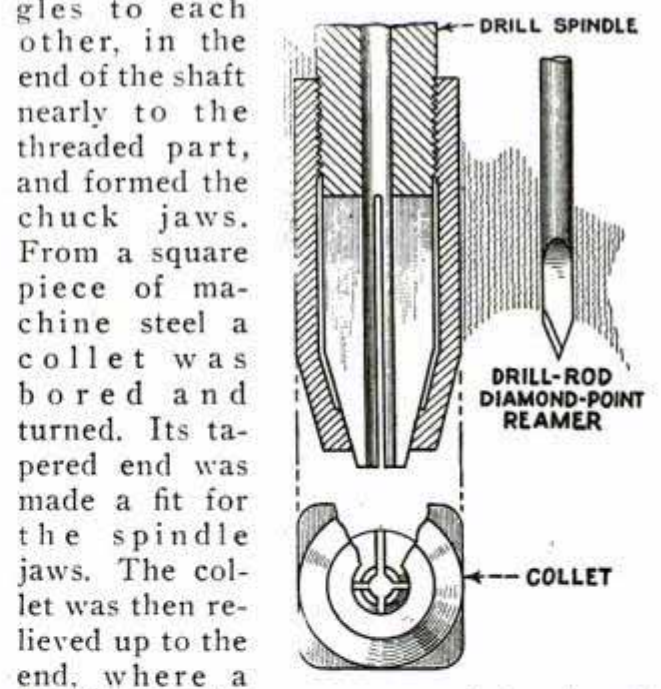

other, in the end of the shaft nearly to the threaded part, and formed the chuck jaws. From a square piece of machine steel a collet was bored and turned. Its tapered end was made a fit for the spindle jaws. The collet was then relieved up to the end, where a female thread was cut to match the thread on the spindle. The sharp corners of the collet were rounded off, leaving enough of the square to act as a nut for tightening the chuck. The pieces of drill rod used had the ends ground down to the shape of a diamond-point drill. These rods have enormous strength and will twist before they break. If the rod twists or the point breaks, the chuck is loosened

and the rod can then be driven out of the shaft by means of a smaller rod. A new diamond point is ground on the end and the drill put back into service.—Robert Althaus, Moline, Ill.

Knife for Tire Shops Made from Hacksaw

When cutting down tires for retreading, it is important to have a knife with a small surface, as the friction of the blade against rubber makes cutting difficult. Grind the back of a hacksaw blade to a knife-edge and then mount the blade in the saw frame upside down. This will not ruin the blade and will provide an excellent knife for the purpose.—Waldemar Engberg, San Francisco, Calif.

Holding Fence Wire Taut with Wagon Wheel

Holding fence wires taut is a simple matter if the method indicated in the illustration is followed. The end of the wire is tied around a 1-ft. length of 2 by 4-in. or other stock of equal strength, and the piece is slipped between two wagon spokes, the rear end of the wagon having been jacked up so that the wheel is off the ground. Let the wire to be stretched run under the hub and then turn the wheel. When the wire is as taut as desired, set a short piece of 2 by 4-in. stock on the ground and against one of the spokes to prevent the wheel from turning back under the strain of the taut wire. You can then let go of the wheel and staple the wire to the fence post.—A. S. Wurz, Jr., Rockyford, Can.

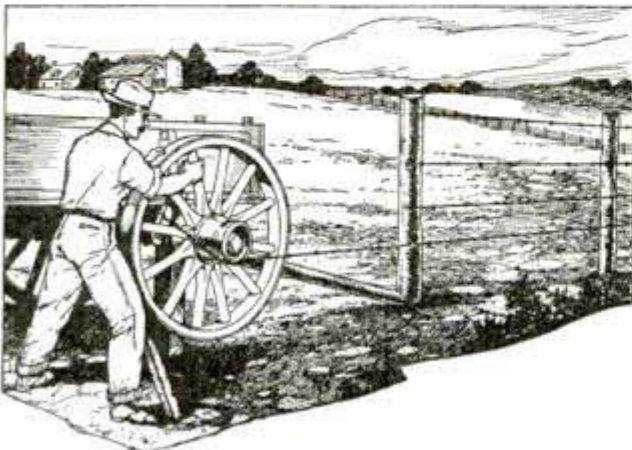

It Is an Easy Matter to Hold the Fence Wire Taut with a Wagon Wheel

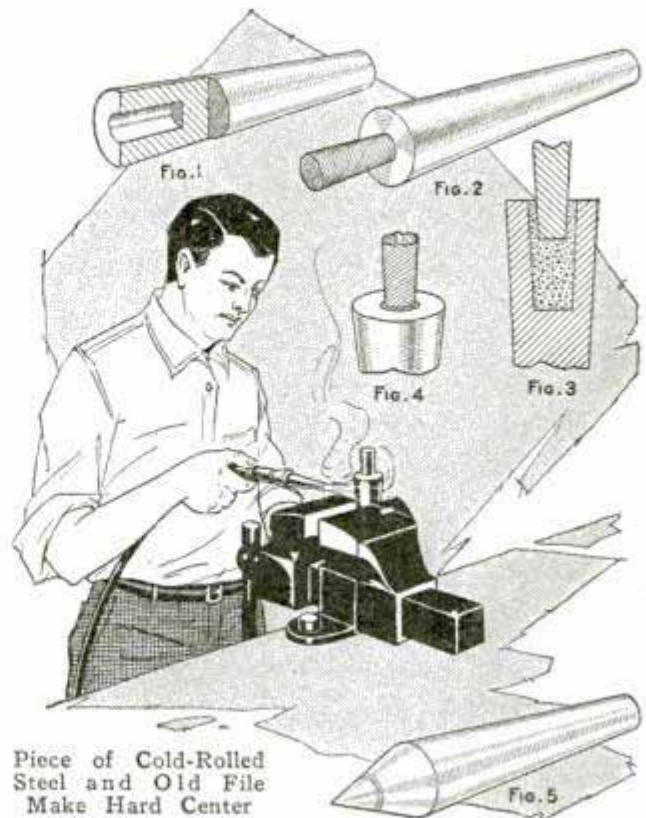

How to Make a Hard Tailstock Center

Turn down a piece of cold-rolled steel rod to the proper size and taper for the tailstock center; then drill a hole in the end to receive a piece of an old rat-tail file. The file is chucked in a brace and is revolved in the hole in the opposite direction to the spiral on the file, until the file fits snugly in the hole. When properly seated, grind down the teeth of the file and break a piece off, as shown in the illustration. Figs. 1 and 2 show the center before and after the piece of file is inserted. Put a quantity of brass or bronze filings and brazing flux into the hole of the center and set it in a vise vertically as in Fig. 3. Play the flame of an oxyacetylene torch against the body of the center until the brass filings melt, and then press the piece of file into position and hold it firmly in place until the metal sets. While still hot, plunge the end into water or oil. Grind the end to shape as shown in Fig. 5, and the tool is finished. Care must be taken to prevent the flame from coming in contact with the piece of file, as this would remove its hardness. I have found that centers made in this way wear much longer, without regrinding, than ordinary centers, and are not so apt to be scored.—C. R. Van Druff, McLouth, Kans.

How To Make Spiral

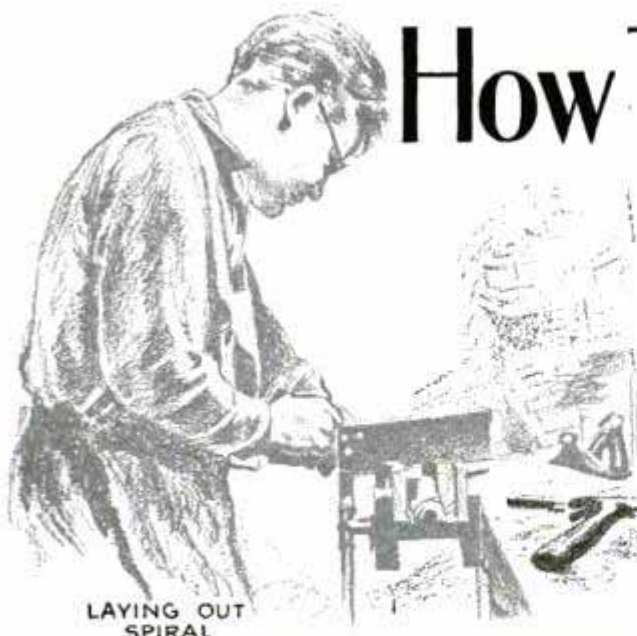

LAYING OUT SPIRAL

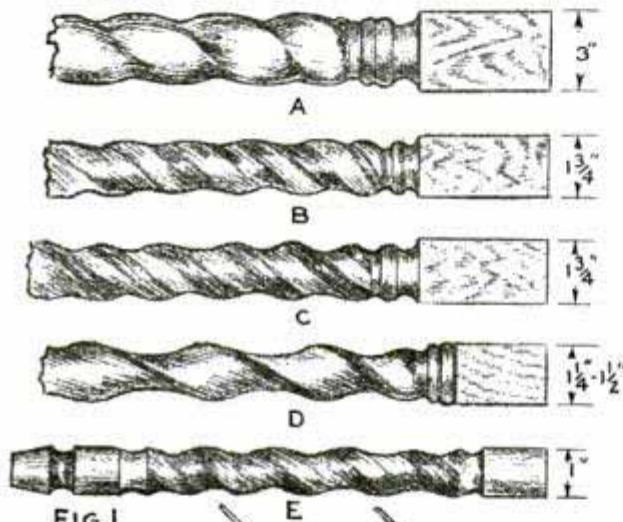

FIG. 1

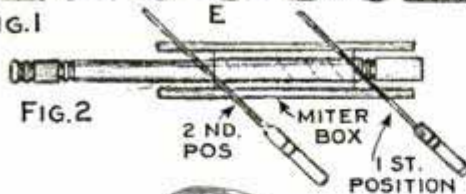

FIG. 2



LAYING OUT SHORT TURNING WITH COPING SAW

IT IS almost safe to say there is no branch of what might be termed "hand" woodworking that is so well adapted to the effort of the individual worker, and has in addition the feature of displaying the worker's skill to such excellent advantage as hand-made spiral turnings.

The first consideration is, of course, the design of which the spiral turnings are to be a part, and it must be remembered that considerable variation is possible in the form, size and pitch of the spiral itself. Several examples of the different forms of spiral turnings are shown in Fig. 1. The sizes given for the square end of the pieces in the first four designs are, of course, arbitrary. The first, A, looks well in a piece of massive proportions such as found in the older period designs. The next two forms, B and C, are suitable for a wider range of projects. Turning D is especially pleasing in a small stand or end table where the legs are close together on a secondary base, both ends of the turning in this case being left square. The last, E, is the simplest possible form, being turned from a length of 1-in. dowel rod. This is made wholly by hand and will appeal to those not possessing a bench lathe.

The turnings supporting the magazine rack pictured are made from two sizes of dowel rods, the legs of the same form, as at E in Fig. 1. The crosspieces and stretcher are made from a length of $\frac{3}{4}$ -in. rod, while the legs are 1 in. in diameter. The larger wall desk pictured on page 343 has the two legs and crosspieces of the form B, with the center stretcher of form D, turned on a piece of the same diameter as the legs. The two pieces illustrated are intended to be merely suggestions.

Taking as an example the turning of the form E, the first step is to cut the pieces for the upright posts or legs to length from the 1-in. dowel. Cut them all to the same length and square at the ends. Dowel stock of maple or beech is the best to use as it makes a strong assembly and can be dressed very smooth. Mark the location of the concave rings at the lower

Turnings

by W. Clyde Lammey

end of the leg in the same position on all pieces. This done, tighten the piece in the vise with the marked end projecting and run the ring about the circumference with a coarse wood rasp, using the convex side and cutting not quite as deep as the thickness of the tool. Do this with all four pieces, smoothing the cut with a fine rasp of the same size.

No elaborate layout is necessary to start the turning. Locate two points exactly opposite at one end on the circumference of that portion of the leg which is to be formed into the spiral. This may be done with dividers, or simply with the eye, which latter means will be accurate enough for the short lengths. Make a simple miter box by ripping out a bottom from ordinary stock to $1\frac{1}{8}$ in. in width and about 8 in. long. For the two sides, cut two pieces to the same length and rip to about $3\frac{1}{2}$ -in. width. Nail these to the bottom to form the box. Set the T-bevel to 45° and strike a line at this angle across the top edges of the sides and approximately in the center. Square down from this line on the outside and saw down the line with a small back or dovetail saw. Place the end of the leg in the miter box with one or the other of the marks directly under the saw. Start the saw cut on this mark, making the kerf not more than $\frac{1}{4}$ in. deep—less is better—and continue to saw with a light stroke, turning the leg slowly with the left hand. If this is done carefully, the cut will progress accurately about the circumference owing to the angle of the saw. The first cut finished, begin the second, starting on the opposite mark. It is necessary to be very careful not to cut over $\frac{1}{4}$ in. deep (about $\frac{1}{8}$ in. is better or the saw kerf is likely to show in the finished work). The principal use of the saw kerf is to aid in starting and guiding the rasp

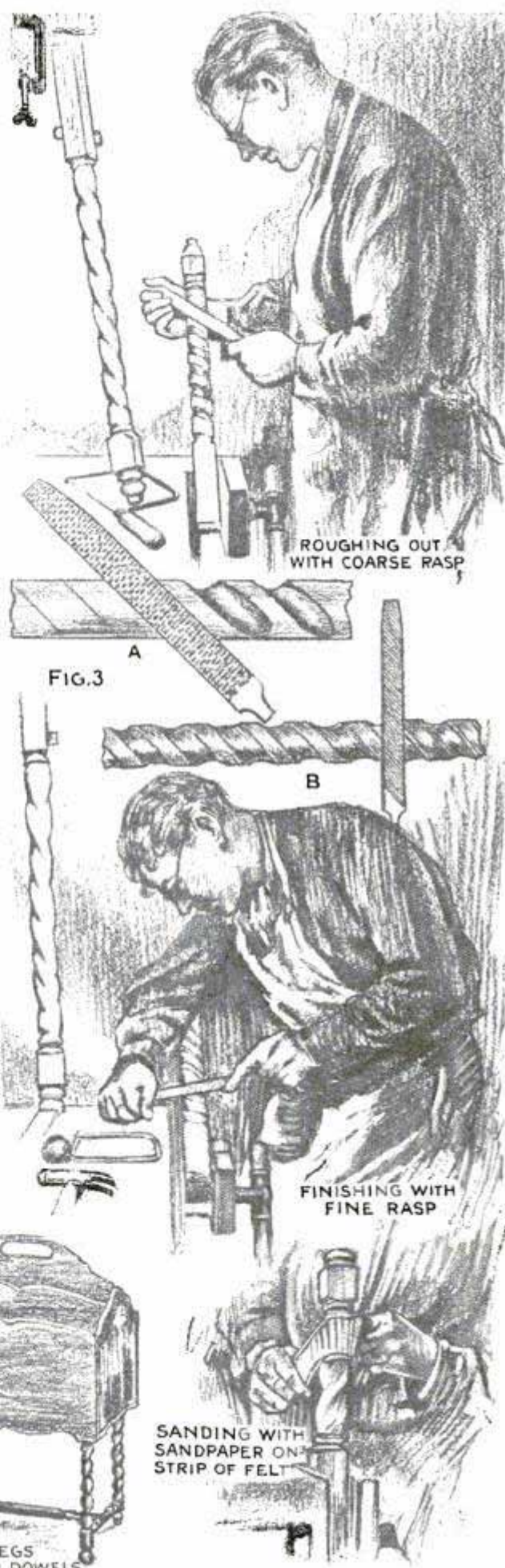

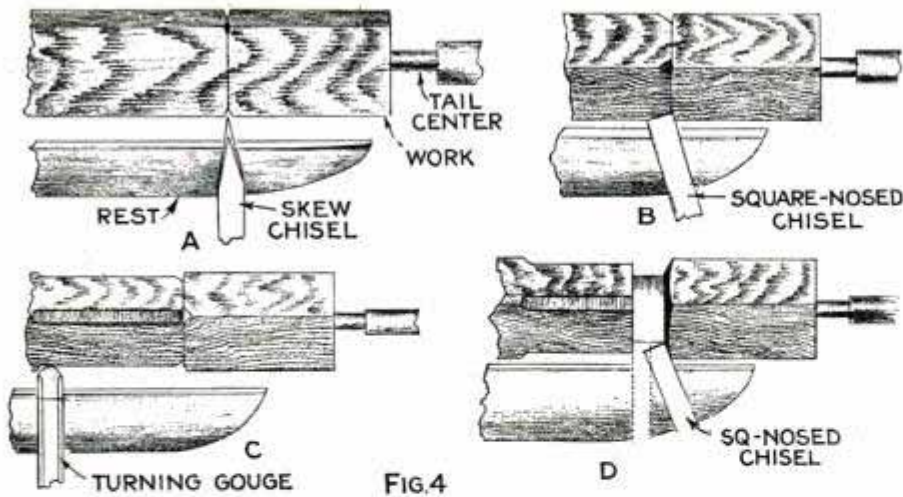

FIG. 4

and nothing is gained by cutting it deeper than necessary to form a guide when working out the spiral.

Next, tighten the piece in the vise at a convenient angle, and, using the coarse rasp first, begin on the saw mark at the end of the piece. Instead of following this single mark along the work, cut down to a trifle less depth than the thickness of the rasp and as far each way as handy, then move to the second kerf without shifting the piece. In this way, rasp out the several marks that appear on what is the top of the piece in this position. Now give the piece a quarter turn and proceed with the rasp in the same manner. This method will save much time and continued shifting of the work in the vise. Be careful to get the cuts as nearly even in depth as possible, and be very particular to keep on the line of the saw mark. Be careful at the end that the rasp does not mar or deface the portion of the leg that is to be left round.

With the spiral roughed out, the next step is the rounding of the flutes or ribs of the spiral and smoothing of the spaces. First use the fine rasp, following in the groove made by the first cut, and giving the tool a rolling motion by turning the handle slightly as the stroke is made. Take out all ridges and unevenness in the grooves, bringing them to a uniform depth, which, for this size of turning, should be about the thickness of the tool. To round the shoulders of the flutes, make the stroke in the groove as before, but hold the rasp very nearly at right angles to the piece, as in the illustration on page 341 showing this operation. Give the tool the same rolling motion during

the stroke as before and vary the angle slightly at the same time. With a little practice, this operation will round the shoulders very neatly and far more quickly than sanding or a lengthwise stroke of the tool along the shoulder. The method also prevents the edge of the tool from striking the bottom of the grooves and saves the continued shifting.

With the above operation completed, the work is ready for the final finish by sanding with fine sandpaper. Obtain several sheets of No. 1-0 garnet paper, and tear or cut them into 2-in. strips the long way of the sheet. From a piece of heavy cloth or canvas, cut several strips, 2 in. wide and about 18 in. long, and glue these to the strips of sandpaper, having the cloth on the back of the paper, of course, and allowing the ends of the cloth to project beyond the ends of the paper strip to afford a smooth, comfortable handhold. Tighten the turning in the vise and draw the sandpaper back and forth over the ribs of the spiral, using considerable pressure and holding the ends of the cloth close together beneath, as in the drawing on page 341. Finally rasp and sand the lower end of the leg to the form shown in Fig. 1, E. The above operations complete the single leg for the magazine rack and will apply in essentials to the making of any of the forms in Fig. 1.

The lathe work on larger sizes is worthy of careful consideration and as careful execution. Plain oak squares look best in the larger sizes. Walnut is also an excellent wood for the purpose and is easily worked with hand tools; among the cheaper grades, gum, birch, and hard maple are good. The latter three turn especially well, but are not so easy to work with the rasp as oak and walnut. Use only clean, seasoned stock, carefully planed and squared. Cut the pieces to be turned to exact and uniform length, using the miter box or power saw to insure a square cut at the ends. The lathe centers must be accurately located on the ends of the stock.

Sharp tools are absolutely essential to good work. Where the rounded center section on which the spiral is to be formed meets that portion of the end which is to be left square, the corners must be cut down neatly without splintering. While there are a number of ways of doing this, the method perhaps best suited to this particular work makes use of the skew chisel when doing the first scoring cut on the corners. Fig. 4 shows the principal operations on the shoulder, following the sequence indicated by the letter.

On most table-leg assemblies, and those like that on the wall desk illustrated, it will be seen that a portion must be left square at or near the lower

square ends of the front stretcher and this joins a square on each front leg, making a solid joint. The square portions of the legs and stretcher must be carefully laid out to exact measurement beforehand.

Most common designs of spiral turning feature beads at each end of the spiral, as in Fig. 1, with a concave rounding groove or ring between the beading and the ends of the spiral. This groove is essential where the spiral is worked out by hand as it allows room for handling the rasp when forming the ends of the turned work. It is best that the space between the end of the spiral and the square shoulder be not more than 2 in.

Owing to the square parts of the

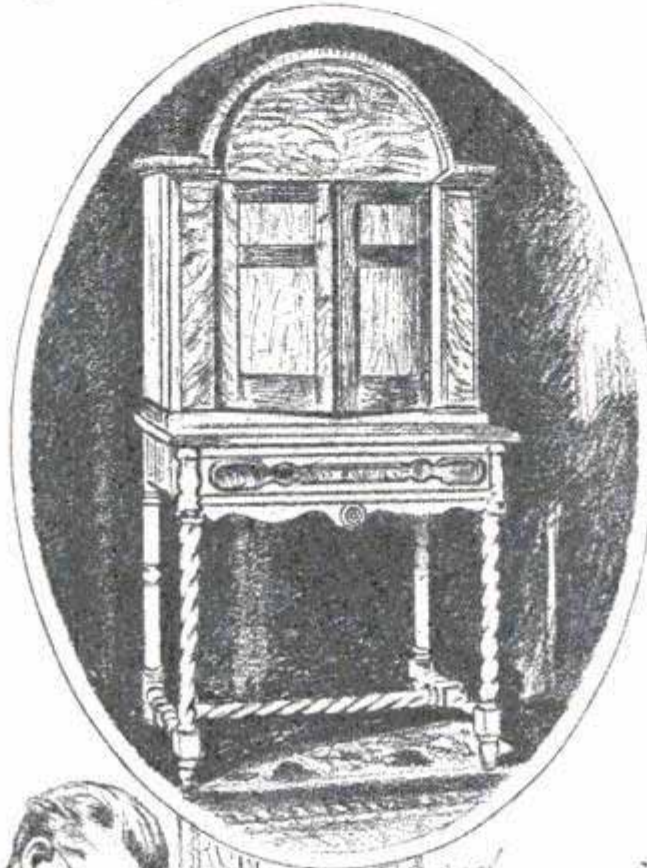

SANDING IN THE LATHE

end to present a square shoulder to the crosspiece or stretcher. This phase of the design should be given careful consideration. The design of the leg assembly in the wall desk pictured on this page is a common one for this particular size of turning. Where the size and type of the turning is like that shown in the drawing Fig. 1, A, the stretcher is usually placed between the two front legs and the short crosspieces and back legs are left square. A dowel is turned on the

leg, the laying out of the spiral by means of the saw as described before requires a miter box constructed as in Fig. 2, which may be made of any suitable odds and ends of stock. The principal consideration is the length of the box. If the spiral is to be 20 in. long the bottom of the box must be only 10 in. long, the two inner pieces forming the sides being the same length and the two outer pieces about 18 in. in length. The sides are then nailed securely to the bottom, the longer pieces



SPIRAL AFTER SANDING

on the outside, as in Fig. 2. For the average-size turning, the sides should be about 6 in. wide. The angle determining the pitch of the spiral may range from 30 to 60°, the lesser pitch being better for the larger sizes, and 45° for the medium size. A saw kerf is made at each end of the box as shown in Fig. 2, the angle in this case being 45 degrees.

The bottom of the box is ripped to a width about $\frac{1}{8}$ in. greater than the diameter of the turning. This is important, as the sides act as guides and determine the accuracy of the layout. Tighten the box in the vise and place the turning in the position shown in Fig. 2, with one of the marks, previously made opposite each other on the circumference, directly under the saw. When sawing, turn the work with one hand as the blade progresses, but do not push against it; the fact that the blade is running at an angle will cause it to advance the work of its own accord. Do not use any end pressure.

When the shoulder of the leg prevents its further travel, place the saw in the kerf at the other end (second position) and slide the work back until the blade engages the original cut, which may then be continued. The second laying-out cut is made in the same way, starting on the point opposite the first cut. If the work is carefully done, the layout will be accurate. After the layout is made, the turning is roughed out, finished up and sanded in the manner described before.

It will be noted from Fig. 1 that the first four designs all differ somewhat in form. That shown at B is the easiest to turn out by hand. When making the roughing cut with the coarse rasp on the form at A, instead of holding the rasp flat across the work as at A in Fig. 3, turn it more on edge and make the cut deeper and narrower. The other portion may then be easily rounded to the form shown. The pitch angle of form D, Fig. 1, is made about 60° and the greater part of the work

is done with the coarse rasp, after which it may be quickly sanded smooth and to form in the lathe, as in the illustration on page 343. Turn a cylinder of wood, 8 or 10 in. long, to such diameter that the arc will approximate that of the spiral groove, and tack a piece of medium-grit paper about this as a drum. Hold the work with the groove bearing on the revolving drum, turning the work slowly back and forth.

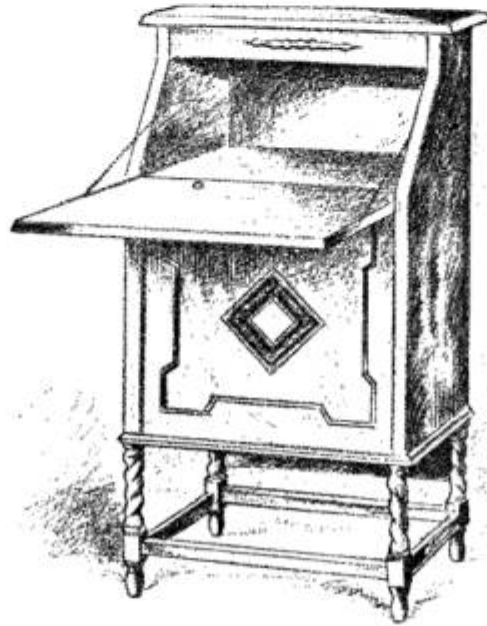

If the design of the project calls for a very short turning, the spiral being less than 10 or 12 in. in length, the layout of the spiral may be made accurately enough without a miter box. The drawing on page 340 shows how the laying out is done with the coping saw. With a little care a very accurate layout may be made in this simple way. Any slight irregularity is easily corrected when making the roughing cut. On the longer pieces always use the miter box.

As a rule, the turning should be finished before it is put in position on the project. In this way, the finishing is much more easily and effectively done. If the wood is walnut or oak it must be filled. Unless the oak is to be left in the natural, stain a prepared filler to the desired shade and thin it with turpentine until it will spread with a brush. Before filling, make sure that all rough spots have been cleaned up with the sandpaper or the fine rasp. Tighten the work in the vise and spread the filler on the spiral with the brush. Get a piece of heavy cloth, about 20 in. long, and fold it several times. When the filler begins to set, rub with the cloth, holding it at both ends and drawing it back and forth in the same manner as when sanding. On the first turning, it may take several applications to fill the cloth with the excess filler so that the rubbing fills the wood satisfactorily. Continue the operation on the first turning until the cloth has collected a coating of the filler. The pieces may then be coated with the filler and rubbed with the same cloth successively. Be par-

ticular to get the surface evenly filled, as only a good job of filling will produce a satisfactory finish on open-grained woods.

After the filling and staining have been done, and the work has been allowed to dry thoroughly, give the spiral two or three coats of rubbing varnish or clear lacquer. Allow this to become thoroughly hardened and then rub down with pumice-stone. Use a piece of cloth folded the same as in filling, soak this in rubbing oil or crude oil and sprinkle the pumice on the cloth. Be careful in rubbing down, for the pumice cuts very fast and is likely to cut through the finish film unless carefully watched.

If it is desired to have a fine finish, remove all traces of the pumice and follow with a clean cloth and rottenstone, the cloth being soaked in the oil as before and the powder sprinkled on the surface until the cloth collects a film of the abrasive. Clean up with turpentine and finally with a dry cloth.

Tin Chickens Decorate Farm Gate to Warn Motorists

The chickens shown in the photo are not flesh and blood but are made of tin. The farmer's purpose in doing this was, first, to prevent motorists, who had the habit of turning around in the driveway, from breaking the gate, which frequently occurred before the tin chickens were mounted on it. The "chickens," however, are so lifelike that motorists are now very careful of the gate. The second purpose was to advertise the product of the farm at the roadside and this method

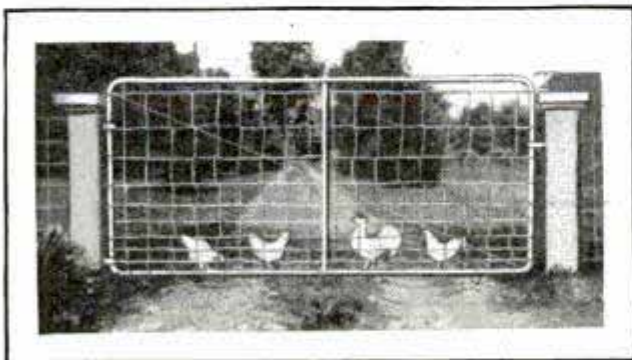

Tin Chickens, Carefully Painted to Make Them Appear Realistic, Mounted on Front Gate

proved highly effective, as the farmer is always sold out of eggs and broilers.—
J. L. Graff, Park Ridge, Ill.

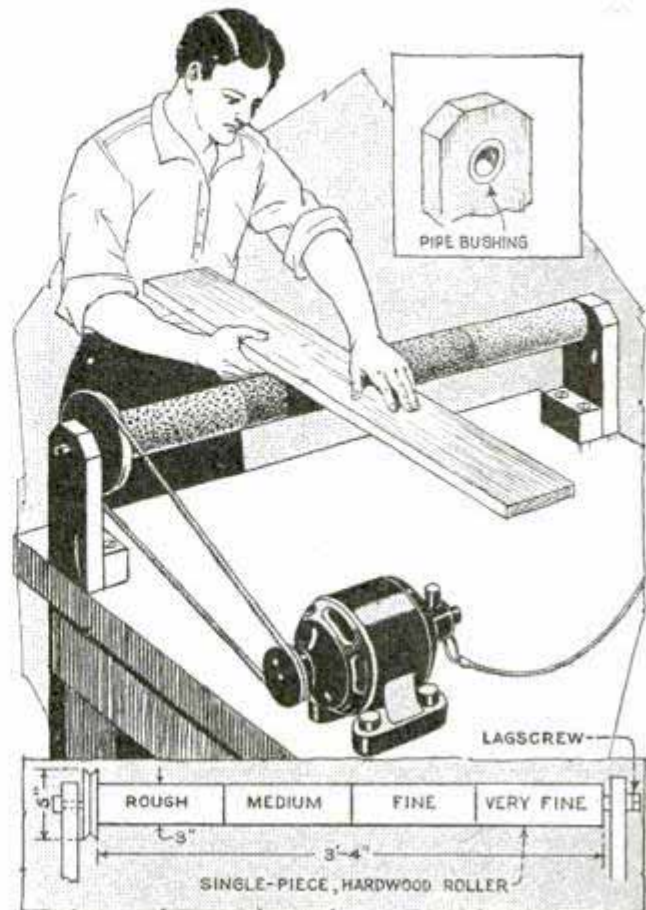

Four Different Grades of Sandpaper Are Mounted on This Cylindrical Sander

Simple Power Sander for the Workshop

Ordinarily one grade of sandpaper is used on a sander, but the cylindrical sander shown in the illustration is especially made to take four pieces, ranging from a very fine to a coarse grade. It consists of suitable endpieces securely mounted on a table or bench with holes drilled to receive bushings made of pipe, which serve as bearings. Lagscrews, fitting nicely in the bushings, are driven into the ends of a 40-in. length of 4 by 4-in. piece of clear-grain wood, turned to cylindrical shape.

Expanding Aluminum Piston for Insertion of Pin

Aluminum pistons of the type having tight wristpins and the upper end of the rod bushed, must be expanded by means of heat in order to insert the wristpin. This is often done with warm water, but a less troublesome method is to invert the piston and pour a little gasoline into it. The gasoline is ignited and allowed to burn out, expanding the piston sufficiently to permit insertion of the pin.

Turning on a Drill Press

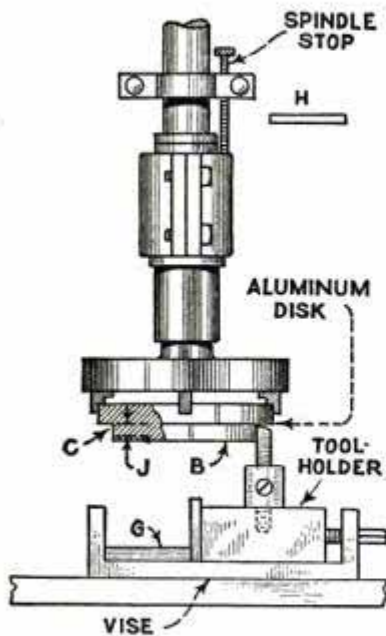

For turning a large quantity of aluminum disks, a small machine shop successfully uses a drill press, as shown in the illustration. The disks are faced off at B, and the shoulder C turned at one chucking. A vise and tool-holder are securely bolted to the drill-press table as indicated. For turning the shoulder C to its correct diameter, a piece of steel, G, is placed in the vise and acts as a positive stop. This piece is then removed and another piece of steel, H, is placed under the spindle stop, which raises the spindle the distance J, and a cut is then taken over B. Obviously the pieces H and G keep the work uniform. When a lathe is not available, this method is excellent.—C. Kugler, Philadelphia, Pa.

Oiled Twine Seals Corrugated-Iron Roofing Laps

Frequently the laps of corrugated-iron roofing allow rain and snow to enter. A successful remedy is to file a small V-notch in the top and bottom of the last ridge where the next piece will fit over it.



in place, allowing it to lap over the twine. A lap of only one corrugation is necessary.

Procure some heavy cord or twine, such as binder twine, and soak it in linseed oil. Cut off a length to fit between the notches, and then knot the ends so that the twine can be slipped through the notches and the knots will hold it taut on the ridge. Lay the next piece of roofing

Where a horizontal joint is made, the same method may be used.—Luther Stro-snyder, Onaga, Kans.

Starting Auto Motor in Cold Weather

Short-circuiting the resistance coil on the spark coil of a car in order to provide more current for the coil when the battery is low, or to assist in easy starting during cold weather, has been found effective. However, instead of mounting a switch on the instrument board for this purpose, it is better to make a connection to the starter terminal, so that the short circuit will be made automatically. This allows the coil to receive full voltage when it needs it most as is the case when a cold, stiff motor is being turned over.

Twin Pencils Save Time in Copying

A stock-room worker whose job consisted in supplying the factory with castings, was required to write two tags for each order, one to go with the material and the other for the files. As hundreds of these tags were issued each week it took a large part of his time to fill them out. To save time he tied two pencils together as shown and by this means could write both tags at once. After a little practice the tags could be written in approximately half the time formerly required.

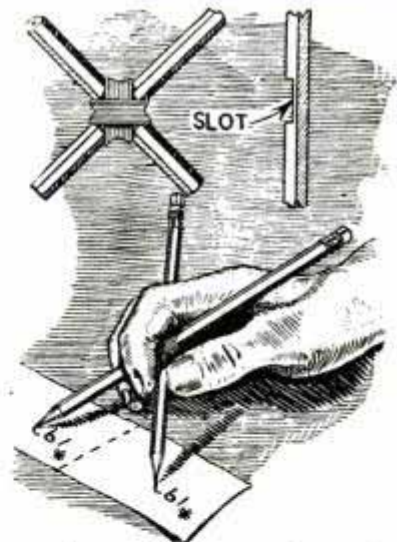

Drilling Hard Iron Castings

It was quite a problem, in a small machine shop, to drill some cast-iron valve bodies owing to their hardness; even drills hardened in acid had little effect on the work. It was a cold winter night and the stove was red-hot, which gave me an idea. I placed all the valve bodies into the stove on the hot coals. After they

had been heated sufficiently, I transferred them into another stove, which I had filled with ashes for slow cooling. The drilling was then accomplished with ease. Another job involved the truing of some large-diameter pulleys which were covered with a very hard scale. The cutting tool would not stand up when the lathe was revolving at full speed, so I did not start the lathe until I had turned it over several times by hand in order to remove the hard crust. Then the job was easy.—J. A. Homewood, Long Beach, Calif.

Removing a Tight Nut

After all of the usual methods had been tried, it was still found impossible to remove a nut on a 2-in. rod as it was firmly set by rust. At last, the following method was tried successfully: A small electric drill was used to make a row of 1/4-in. holes side by side across one flat side of the nut. Then a wrench was applied. As the nut was nearly cut through on one side and greatly weakened, the two halves pulled apart slightly under the twist of the wrench, and the nut was removed.

Guard Block Keeps Plow Free from Rubbish

A plow usually drags more or less rubbish in the crook of the beam just above the moldboard. By fitting a wooden block as shown in the drawing, this trouble can be entirely overcome. The block is shaped to fit the beam and is held in place securely by means of four nails, two on each side of the beam. A length of wire also is used to tie the block and beam together to obtain additional strength. The block should have a 3-in. face on the moldboard side.—Adolph Rieter, Marinette, Wis.

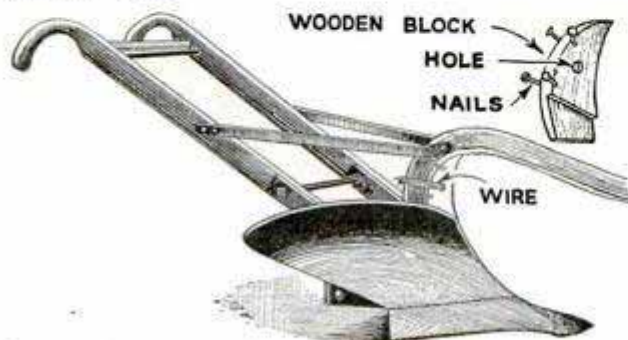

Wooden Guard Block Attached to Plow Beam Keeps It Free from Rubbish

Load-Binding Winch for the Truck

When hauling material for factory or farm, a motor truck becomes of greater

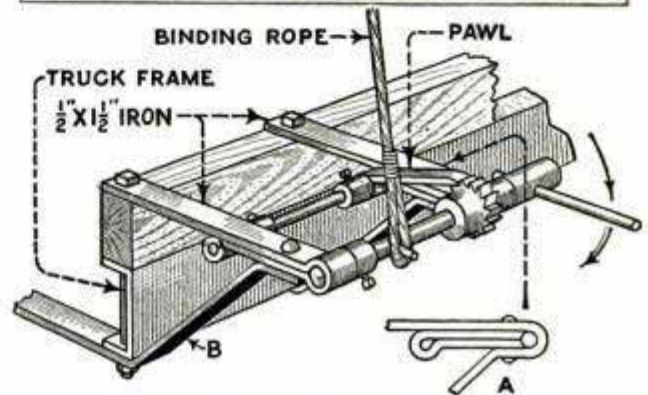
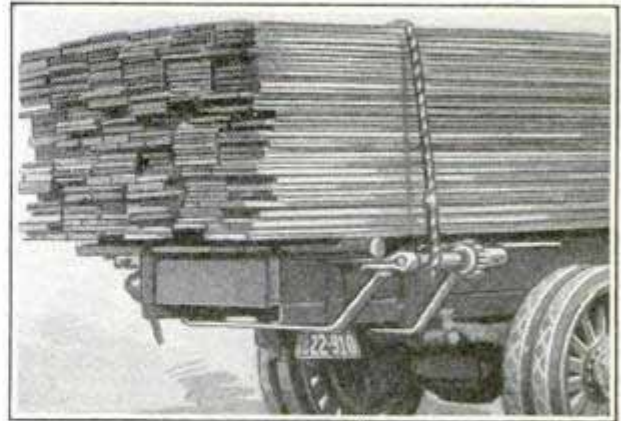

Winch Attached to Rear End of Truck for Holding Down Heavy Loads

service if some quick and efficient method of binding the load to the truck is used in order to prevent shifting. The illustration shows a winch that will serve this purpose well and can be attached to any truck. The shaft and ratchet wheel are made from the jackshaft of an old truck or auto transmission. The brackets supporting the winch are made of 1/2 by 1 1/2-in. flat steel. A suitable pawl is provided to engage the teeth of the wheel as the winch is turned. All details of construction are clearly shown, but where the material on hand is not exactly similar to that illustrated, it may be necessary to deviate from the method of construction to some extent. A rope is better than a cable for use in binding down a load as it does not cut the corners of lumber or wear through sacks, although it stretches somewhat, making it necessary to tighten the winch once or twice on a long trip.

☛ Steam-pipe drains should be provided at all points in the line where water is likely to accumulate.

Wind-Driven Auto Generator Makes Electric Power Plant

Those who wish to have a small electric power plant capable of furnishing sufficient electricity to light a few lamps, or to charge a battery, will find the apparatus

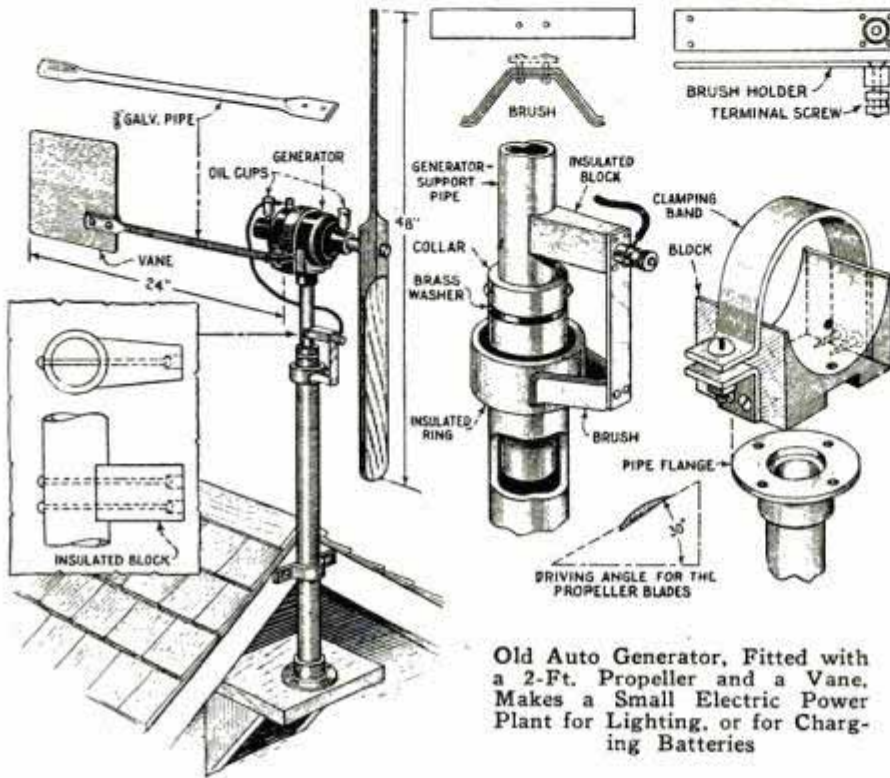

Old Auto Generator, Fitted with a 2-Ft. Propeller and a Vane. Makes a Small Electric Power Plant for Lighting, or for Charging Batteries

shown in the illustration entirely practical for the purpose. This device was built at a negligible cost and was put into successful use by a West Virginia farmer. It consists of a Ford generator arranged to pivot on a pipe support. The pipe should be long enough to project 2 or 3 ft. above the roof when set on a wooden shelf in the extreme upper part of the gable. The pipe is held on the shelf by means of a flange, and additional rigidity is obtained by clamping it to the edge of the roof with a strap. An insulated ring is fitted on the top of the pipe, which is done by driving a narrow brass or copper ring over an insulating bushing of fiber, rubber or similar material. Both ring and bushing should be a drive fit, so that they will not be dislodged easily. A short piece of shafting or pipe is fitted in the upper end of the support pipe and must be just loose enough to turn with minimum friction. If possible, it is better to provide a thrust bearing in the upper end of the support pipe, than to fit a collar on the shafting to ride on the edge of the pipe. The detail on

the right-hand side of the drawing shows the generator mounting, which is made from a block of hardwood. Strips of flat metal are bent to fit over the generator to clamp it securely on the block, being fastened to the latter by means of suitable wood screws. An insulating block is fastened to the shafting that

holds the generator, to carry a flat length of brass fitted with a brush for making contact with the insulated ring, and also a binding post to which connection is made from one terminal of the generator. The other side of the generator is grounded and the pipe support is used as a conductor. The output leads to the lights or battery (not shown in illustration) are connected to the insulated ring, and to the pipe support at some suitable point. Large oil cups are substituted for the small cups with which the generator is equipped. The

attachment of a light and well-balanced propeller and a vane to keep the propeller in the wind, complete the device. A 2-ft. wooden propeller, having two blades beveled at a 30° angle, was found highly satisfactory. However, for a high-speed generator, a propeller having four or six blades may be necessary. The vane is made of galvanized sheet iron, fastened to the generator by means of a length of 3/8-in. pipe, which is flattened, drilled and cut at the ends as shown.—G. A. Luers,

Washington, D. C. *2355 Ashmead Place N.W.*

Boat Paint Made from Dry-Cell Tops

Some time ago I acquired an old boat and did not feel justified in going to any great expense in painting it. Melted tar is not suitable for sealing cracks, as it gets brittle upon cooling and will break off. In looking around for a cheap substitute, I discovered a large number of old dry cells. I removed the black substance used to seal them and melted this, but as it was too thick and gummy for use,

Washington, D.C.

I proceeded to find a solvent to thin it. Ordinary paint oil would not mix well with it, but creosote was found highly satisfactory. I applied this "paint" to the boat hull and it sealed all the cracks effectively, drying in about 20 hours. In this case the mixture consisted of equal parts of melted cell tops and creosote. In the proportions of one part of melted cell tops and two parts of creosote, it proved satisfactory for furnaces and stoves. White lead mixed with this paint makes it yellow or brown, depending on the proportions. Yellow paint, made in this way, was used for the inside of the boat hull.—Sidney Cornell, Southport, Connecticut.

Towline Hook That Will Not Loosen

Most towline hooks have a tendency to get loose, but this can be overcome by using a worm hook as shown in the illustration. The hook has a large eye to receive the end of a steel cable, which is looped through it and tied securely. In

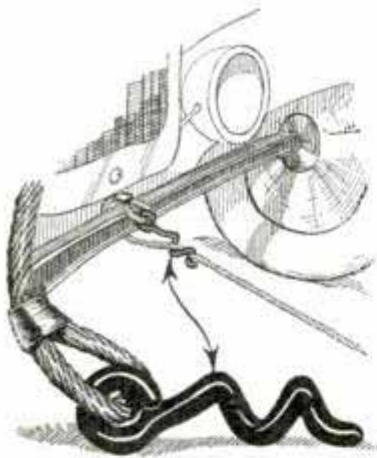

use, the hook and part of the cable are slipped around the axle of the car to be towed, and the cable is given a couple of twists so that it enters the cork-screw like turns of the hook, engaging with it firmly.—Joe Chmelar, St. Louis, Mo.

How to Preserve Fence Posts

Place the ends of thoroughly dried posts in lime water, about 1½ in. deep, for about 15 minutes. Then take them out and let them dry, after which paint them with a solution of sulphuric acid and water in the proportion of 1 to 6. The acid should always be poured into the water and this should be done slowly to avoid having the hands or clothing spattered with the liquid.—Vernon V. Johnson, Spokane, Washington.



Handle for Wire Solder Is Made of Pipe, and Remains Cool While Soldering

Handle for Holding Wire Solder

When in constant use, wire solder becomes uncomfortably hot. To avoid this, an electrician made the handle shown in the drawing. A short piece of ¼-in. pipe was drilled and split at one end and bent as indicated to form a reel holder. The wire was threaded through the pipe and a few inches of it drawn out of the end. As the solder is needed, it is pushed through the pipe and the handle remains cool, regardless of the amount of work.

Universal Diamond-Tool Holder

The diamond-tool holder shown in the drawing can be turned around to any position, so that a new edge will be brought in contact with the wheel. In addition, the turning of the diamond tends to produce new sharp edges. It is assumed that the shank is fitted in a holder that rests on a magnetic chuck. The ball is held tightly or loosely by turning the shell.—C. Kugler, Philadelphia, Pa.

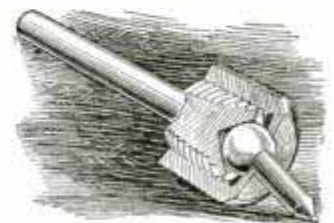

☐The small dust cap usually found on Ford tires will fit the grease-cup connection on the model-A Ford water pump.

Storm-Proof Door for Sheep Shed



Burlap Sack Partly Filled with Sand Keeps Doorway of Sheep Shed Closed against Wind and Snow

Shelters for sheep on many farms have open entrances so that the animals can run in and out. Although this freedom is said to be essential to the health of the flock, the high winds and drifting snow are a danger, often costly, at lambing time. A Wisconsin farmer, therefore, decided it would be profitable as well as humane, to provide a wind and storm-proof door for the shed. A small quantity of sand was poured into a large burlap sack, which was then nailed above the doorway to act as a curtain. The weight of the sand holds the curtain suspended so that the opening is closed against the strongest wind, yet the sheep may enter or leave without difficulty.

Cutter for Glass Tubing

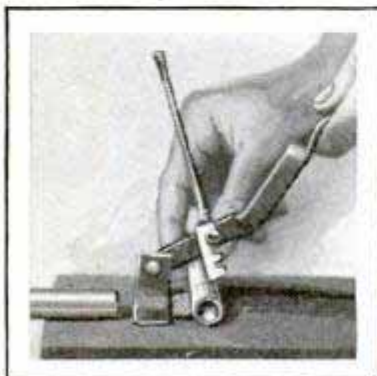

For cutting glass tubing of the smaller sizes the jig shown in the photo has been found practical. An old Ford door-latch handle and

part of the latch box were used to make the cutter holder. One side of the latch box was cut away and a portion of it having a screw hole was bent to form a foot, which was securely fastened to a block of wood with a heavy screw. A $\frac{7}{32}$ -in. hole was drilled through the handle to take a short $\frac{3}{16}$ -in. bolt fitted with a nut to hold the cutter. A small strip of wood was tacked to the block to hold the tubing under the cutter a little off center and away from the strip. In use, the tubing is rotated while the handle is pressed down.—Frank W. Bentley, Jr., Missouri Valley, Iowa.

Trench Used as Silo

Instead of a concrete silo, a Nevada farmer keeps ensilage in a trench dug in the ground. It is first covered with straw and then with dirt. The trench is 6 ft. wide and 100 ft. long.—G. Perrins, Ogden, Utah.

Tool for Cleaning Furnace

Removing hardened soot from the corrugations inside of a furnace radiator is a rather difficult task, as the small doors on each side of the fire door and at the back do not allow the hand and arm much space to work with a tool of large size. To circumvent the difficulty, get an old gas-tractor engine valve, heat it about an inch from the head and bend it at right angles as shown. Wrap the stem with a piece of an old inner tube and tie it on securely to form a handle. This improvised tool can be worked up and down the corrugations, no matter how cramped the quarters.



Method of Restoring Old Oil Paintings

The curator in an eastern museum uses the following method of restoring old faded oil paintings: He touches up the darkened lights of the picture with a small sable brush dipped in a mixture consisting of one part of dioxide of hydrogen and six or eight parts of water, by weight.

After this treatment, the original luster returns. It is necessary, of course, to wash the painting thoroughly with a clean sponge and water before applying the mixture.—Vernon V. Johnson, Spokane, Washington

Opening Locked Cars without Key

When the key to the auto door has been lost, it is sometimes necessary to open it by pushing up the floorboard and releasing the catch. It is not possible to reach the catch from below with the fingers and therefore a length of stiff wire must be used. A rifle-cleaning rod of the cheap wire sort, with a loop on the end, makes a good tool for this purpose, as it is straight and fairly stiff. Ford model-A closed cars can be opened by raising the hood and drilling a $\frac{3}{8}$ -in. hole through the dash, about 4 in. above and 1 in. to the outside of the steering column. This will allow a long stiff wire to be inserted. The hole may be closed by brazing on a patch, but this involves some risk of fire.

Blocks to Raise Photographed Objects

When making photos of machine parts, or other objects for catalog work, and the like, it often becomes necessary to raise or block up the piece in order to get the best view. In such cases the operator usually uses any small object that comes to hand, such as a match box, an empty spool, book, etc. This, of course, has to be blocked out in the finished negative, which requires both skill and time. The work can be greatly reduced or entirely eliminated by using small painted blocks of wood. They should be of various sizes, painted black on one end and two adjacent sides, and flat white on the other end and two remaining sides. The blocks are placed so as to present either black or white sides to the camera according to the color of the background.—Warren N. Crane, Brooklyn, N. Y.

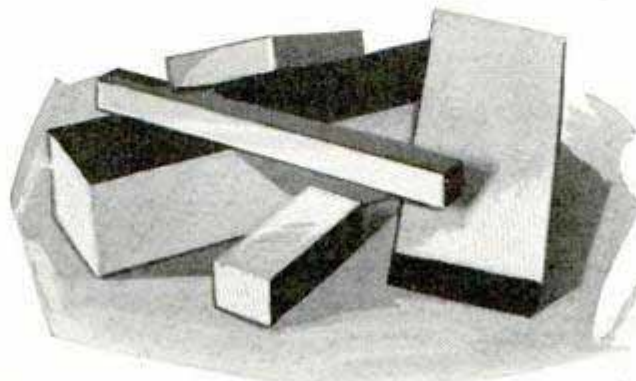

Black and White-Painted Blocks Aid Photographer in Adjusting Objects

Pedal Depressor for Adjusting Brakes

When adjusting brakes single-handed, the illustrated pedal depressor will be

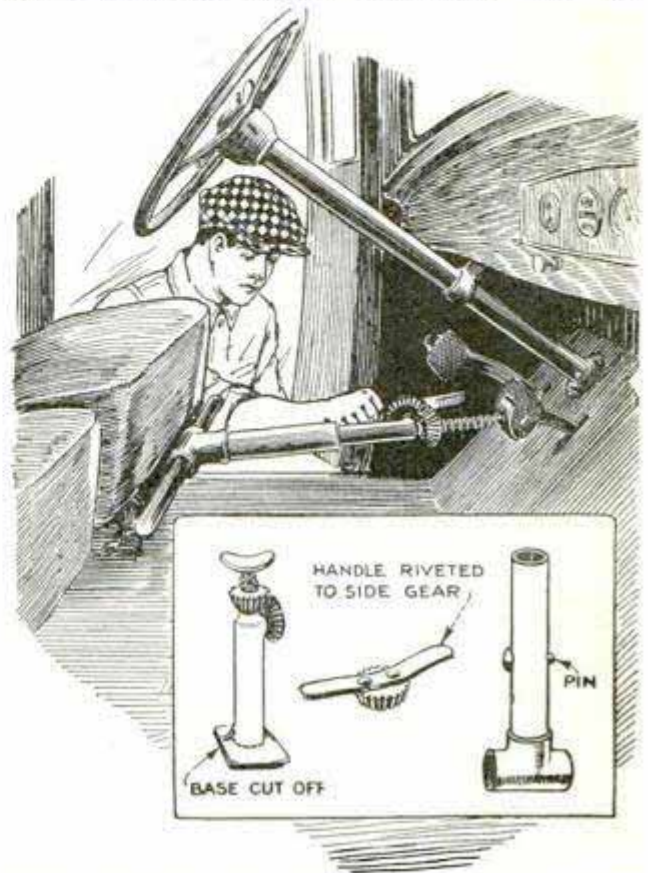

Pedal Depressor, Made from Old Auto Jack, Helps When Adjusting Brakes Single-Handed

found highly convenient, as it can be set to hold the brake down at any desired point. It is made from an old auto jack, the base is cut off, and a handle is riveted to the side gear. The body of the jack is slipped into a length of pipe fitted with a tee to take a length of hardwood or smaller pipe. The latter is placed across the hinged supports of the driver's seat when the car is of the coach type with individual front seats, but is not necessary on other cars. A pin is driven through the lower end of the pipe to serve as a stop for the jack. In use, the pedal is gradually depressed, and at each position of the pedal the brakes are adjusted so that they are perfectly equalized.—John A. Blaker, West Auburn, Massachusetts.

3x34

delay

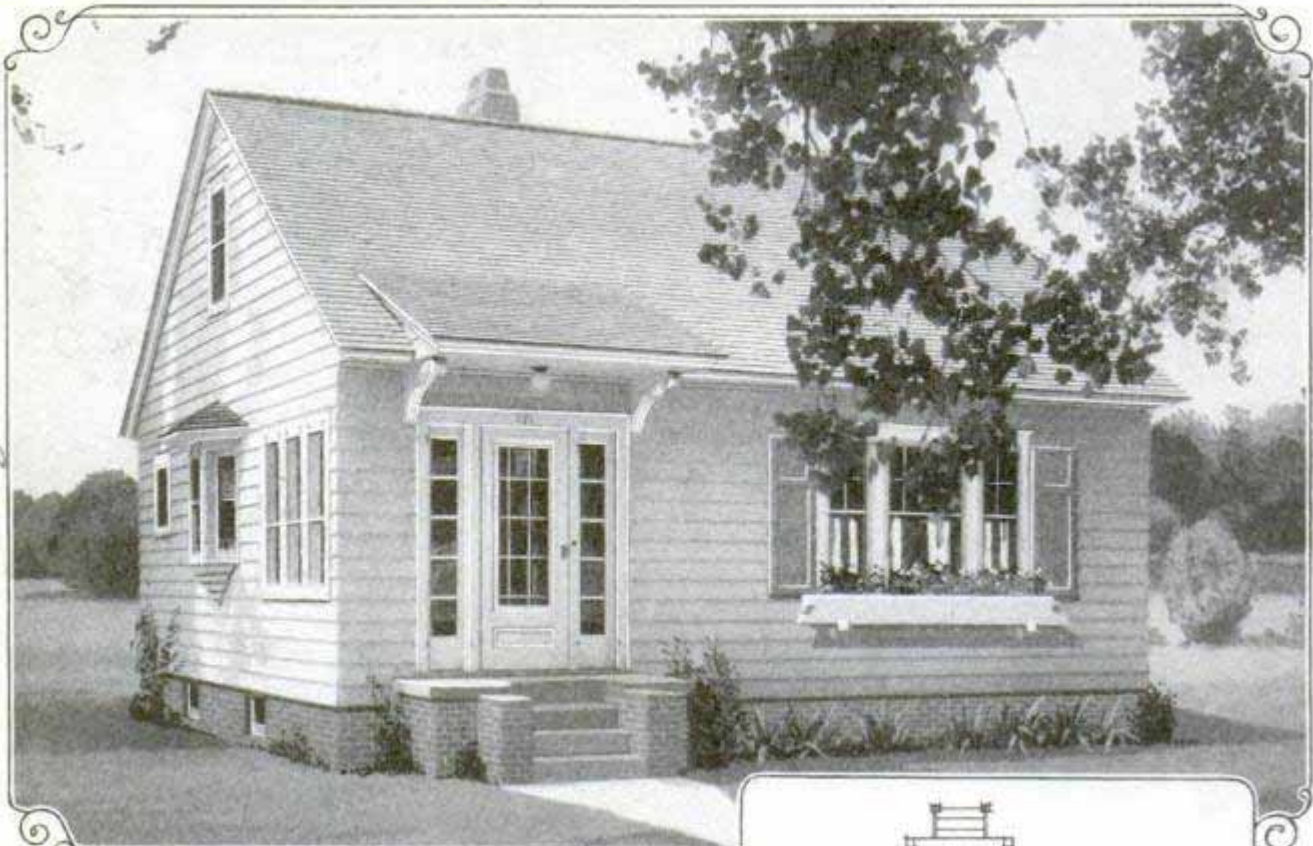

COPYRIGHT POPULAR MECHANICS PLAN 6-W-60

If You Are Long On Ambition and Short On Cash

"YOU'RE right, \$3,675.02 seems like a mighty low price for a well-built seven-room house. But here are the figures," said lumberman Robb, who recently built this colonial bungalow. "As a matter of fact, by careful planning and wise spending you can build a pretty fine house today at little more than before-the-war prices."

The total does not include an eighteen by eighteen-foot garage added later at a cost of about \$300. House and garage therefore amounted to \$3,975.02. The average cost of each room, and there are seven including the sun room, was \$525. This amount compares favorably with pre-war per-room costs. What is more, this house should be duplicated in most any average town, outside the large cities, for about the same money.

Let's look into the plan and equipment of this bungalow and see what you get for your money. The first floor is a complete bungalow. One bedroom may be all a family of two—newlyweds or old folks—require. Even so, there are two more bedrooms above.

Every inch of floor space does duty. The house is of frame construction with siding exterior and red-cedar edge-grain shingle roof. Insulation is obtained by use of patent lath.

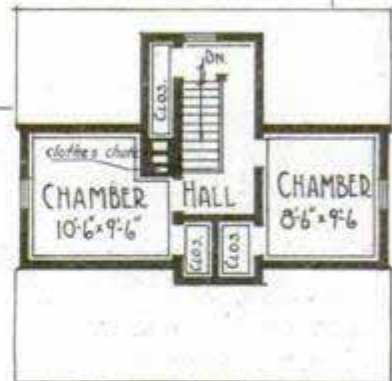

Popular Mechanics Magazine will supply readers a one-sheet blueprint of any house appearing in the magazine for \$1, and a new bungalow book will be sent for ten cents.

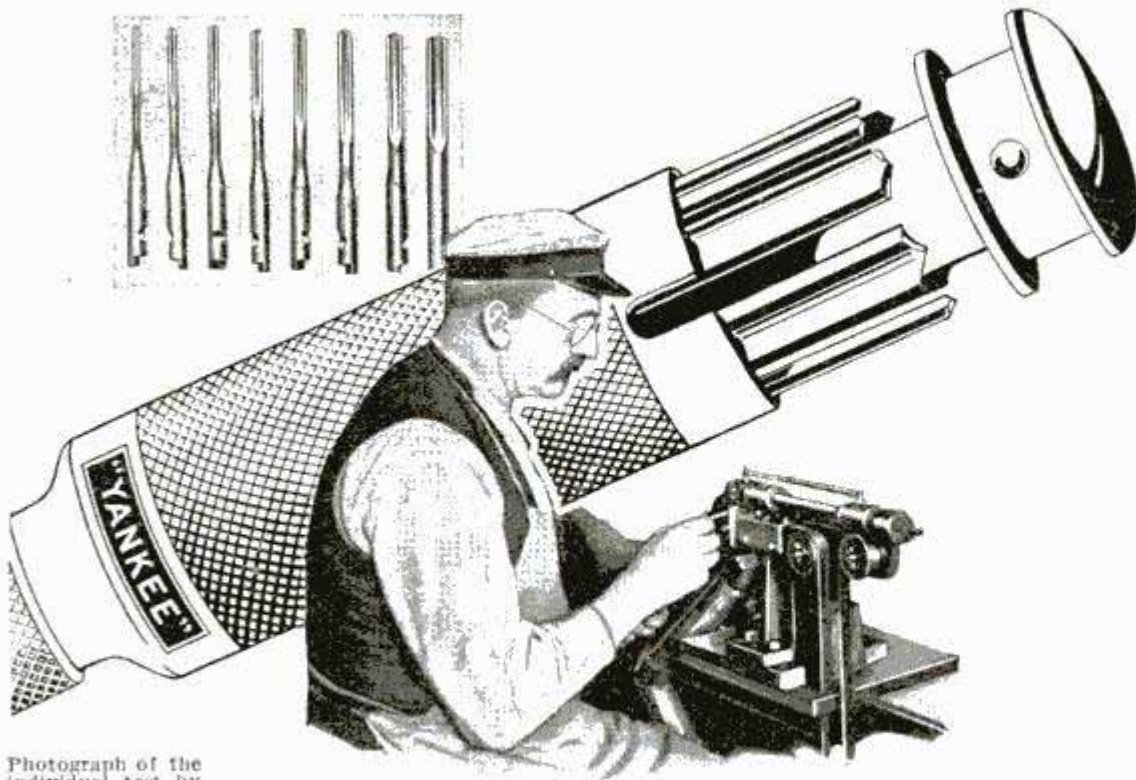

Photograph of the individual test by experts given to "Yankee" Drill-points—each and every one of the hundreds of thousands, made to be used in "Yankee" Push Drills and "Yankee" Spiral Screw-drivers.

... you get tested drill-points

IN the handle of the "Yankee" Automatic Push Drill you find a full set of eight drill-points for boring holes from $\frac{1}{16}$ up to $\frac{11}{64}$ inches:

ALSO,—you find each drill-point stamped with the name "YANKEE."

That means that every drill-point,—in the very tool you get, has been individually tested by "Yankee" tool-makers. It means that each drill-point, from the smallest to the largest, is right in temper and best suited for speed and efficiency in the work for which it is intended.

Every man who uses a screw-driver has need for a tool, to make holes for the screws he drives.

Like every "Yankee" Tool, for its particular job, the "Yankee" Automatic Push Drill will do its job of boring holes for screws—with large drills or small, in hard wood or soft, better than any other tool.

The name "Yankee" is a guarantee of quality in a tool. Look for "Yankee" when you buy a push drill.

"Yankee" Push Drills

No. 41.—Used by mechanics everywhere as the working mate of the "Yankee" Spiral Screw-driver. Price, \$2.60.

No. 44.—With adjustable tension to regulate pressure to suit kind of wood, size of drill, etc. Price, \$3.15.

- $\frac{1}{16}$
- $\frac{3}{32}$
- $\frac{1}{8}$
- $\frac{5}{32}$
- $\frac{3}{8}$
- $\frac{7}{16}$
- $\frac{1}{2}$
- $\frac{5}{8}$
- $\frac{3}{4}$
- $\frac{7}{8}$
- $\frac{11}{16}$

Holes bored in hard or soft wood without splitting. Drill-point is revolved by pressing on handle; spring brings handle back for next push.

"YANKEE" TOOLS

—TO HELP YOU MAKE THINGS—

North Bros. Mfg. Co., Lehigh Avenue, Philadelphia, U. S. A.

My idea is to save time and labor. Send me "Yankee" Tool Book, with action pictures showing new Two-speed (11-inch) Hand Drills, new Bit Braces with famous "Yankee" Ratchet, Quick-Return Spiral Screw-drivers, Adjustable Tension Push Drills, Ratchet Breast, Hand and Chain Drills, Automatic Bench Drills, Ratchet Tap Wrenches, Removable-base Vises, Etc.

Name.....Address.....(p m)



Used car shopping is simpler and surer on the



Pledge to the Public on Used Car Sales

- 1 Every used car is conspicuously marked with its lowest price in plain figures, and that price, just as the price of our new cars, is rigidly maintained.
- 2 All Studebaker automobiles which are sold as CERTIFIED CARS have been properly reconditioned, and carry a 30-day guarantee for replacement of defective parts and free service on adjustments.
- 3 Every purchaser of a used car may drive it for five days, and then, if not satisfied for any reason, turn it back and apply the money paid as a credit on the purchase of any other car in stock—new or used. (It is assumed that the car has not been damaged in the meantime.)

© 1931 The Studebaker Corporation of America

STUDEBAKER PLEDGE PLAN

... more than 150,000 buyers got Pledge protection last year

WHEN you enter the used car market, go direct to your nearest Studebaker dealer. Here used car shopping is simpler and surer.

You choose from Studebakers, Erskines and other makes of cars which have been carefully reconditioned—with new car beauty and performance, offered at bargain prices. You get five days' driving trial under the protection of the Studebaker Pledge. Every certified car carries a 30-day guarantee for free adjustments and replacement of defective parts. All prices are plainly marked—proof positive of fair and square dealing. Let this pledge point the way to used car satisfaction *for you!*

Invest 2c—you may save \$200



Mail the coupon below for this free booklet. A 2c stamp is an investment which may save you as much as \$200 in buying a car!

STUDEBAKER
Builder of Champions

THE STUDEBAKER CORPORATION OF AMERICA
Dept. 152, South Bend, Indiana
Please send me copy of "How to Judge a Used Car"

Name

Street

City State

New Book—"You Can Make It"

Showing How to Utilize Boxes and Odd Lumber, Sent Free

DISSTON, the world's foremost makers of saws, co-operates with the Department of Commerce to lessen waste of lumber. Millions of boxes, now thrown away, may be used to make useful articles for the home, garden trellises, bird houses, tool chests, toys, etc.

To promote better uses of odd pieces of lumber, now burned or thrown away, Disston will send

you the new book, "You Can Make It," issued by the National Committee on Wood Utilization—52 helpful pages, more than 100 drawings.

To make the useful articles shown in this valuable book you will, of course, want Disston Saws, Tools, and Files. No other steel is like Disston Steel; no other saw cuts like a Disston Hand Saw, "The Saw Most Carpenters Use."

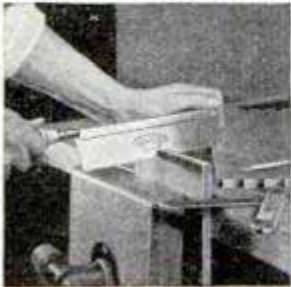

For Cutting Dovetails, etc.

Wherever the finest possible joint is needed, and for dovetailing, pattern making, etc., use a Disston No. 68 Dovetail Saw. Blade extra thin, with fine teeth. The 8" blade, 17 points to inch, is most popular. \$1.60.



For Finishing Wood Surfaces

For giving a fine finish to your work, removing paint, etc., use a Disston Acme Cabinet Scraper, made of Disston Saw Steel. Made in all needed sizes, 2½" and 2⅞" wide and 5" and 6" long being standard. 30c and up.



Files for the Wood Worker

Disston Cabinet Files (fine teeth) for smoothing and finishing wood surfaces, easing tight doors and drawers, etc. Disston Wood Rasps (coarse teeth) for rough and fast cutting, enlarging holes, etc. Half-round 8" Cabinet File, 65c. Flat 8" Wood Rasp, 50c.



THE amateur mechanic, always glad to get new ideas, plans and working drawings for making things in his home workshop, will want both the new book, "You Can Make It," and "The Disston Saw, Tool, and File Book."

"You Can Make It" tells *what* to make. "The Disston Saw, Tool and File Book" tells *what tools* to use for the job.

All Disston Saws are made of Disston Steel, from Disston's own steel furnaces. Disston Steel puts stamina, toughness and long cutting life into them. This better steel takes and holds a better temper: a *live* temper, which, while hard, is tough, yet readily filed and set. With this temper, a Disston saw takes and holds a keener cutting edge.

The new Disston Hand Saws are finer now than ever before—improved in every feature: Lighter blades, for easier cutting; narrower blades, saving strength; true-taper ground, faster cutting; thin, yet stiff, for true running; new weatherproof finish handles, larger hand holes.

They will run with less set, cut easier, and stay sharp longer than any other hand saws ever made. See them at your hardware merchant's. Ask for Disston! Hand Saws, of course, and also every other type of saw for hand or machine work; Disston Hack Saws, files, try squares, levels, and other tools made of Disston Steel.

And mail the coupon for the books that will help you in your home workshop.

DISSTON
Makers of "THE SAW MOST CARPENTERS USE"



"The Saw Most Carpenters Use"

The two handiest saws for the home work-shop are the 26-inch 8-point for cross-cutting, and the 26-inch 5½-point for ripping. You will need these on almost every job. The popular "D-8" Lightweights cost \$3.45.



Handiest of All Small Saws

The Back Saw, with fine teeth and stiff back, enables you to do smooth, accurate cutting of mitres, grooves, etc., for making furniture, picture frames, etc. Disston No. 4, 12" size, 3" under back, 14-point, costs \$3.00.

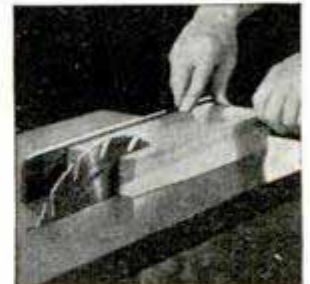

On Your Power Saw Outfit

With a Disston Circular Saw you can do better work. Disston Steel and Temper make a saw cut easier and stay sharp longer. There is a Disston Saw—cross-cut, rip or combination—for your outfit. If your dealer cannot supply you, write to us.



Every saw user will enjoy reading "You Can Make It" and "The Disston Saw, Tool, and File Book." Both contain valuable information for the man interested in making things. Sent free. Use coupon or write for them.



Henry Disston & Sons, Inc., Philadelphia.
(In Canada, Henry Disston & Sons, Ltd., Toronto)
Please send "You Can Make It" and "The Disston Saw, Tool and File Book"

Name and Address _____

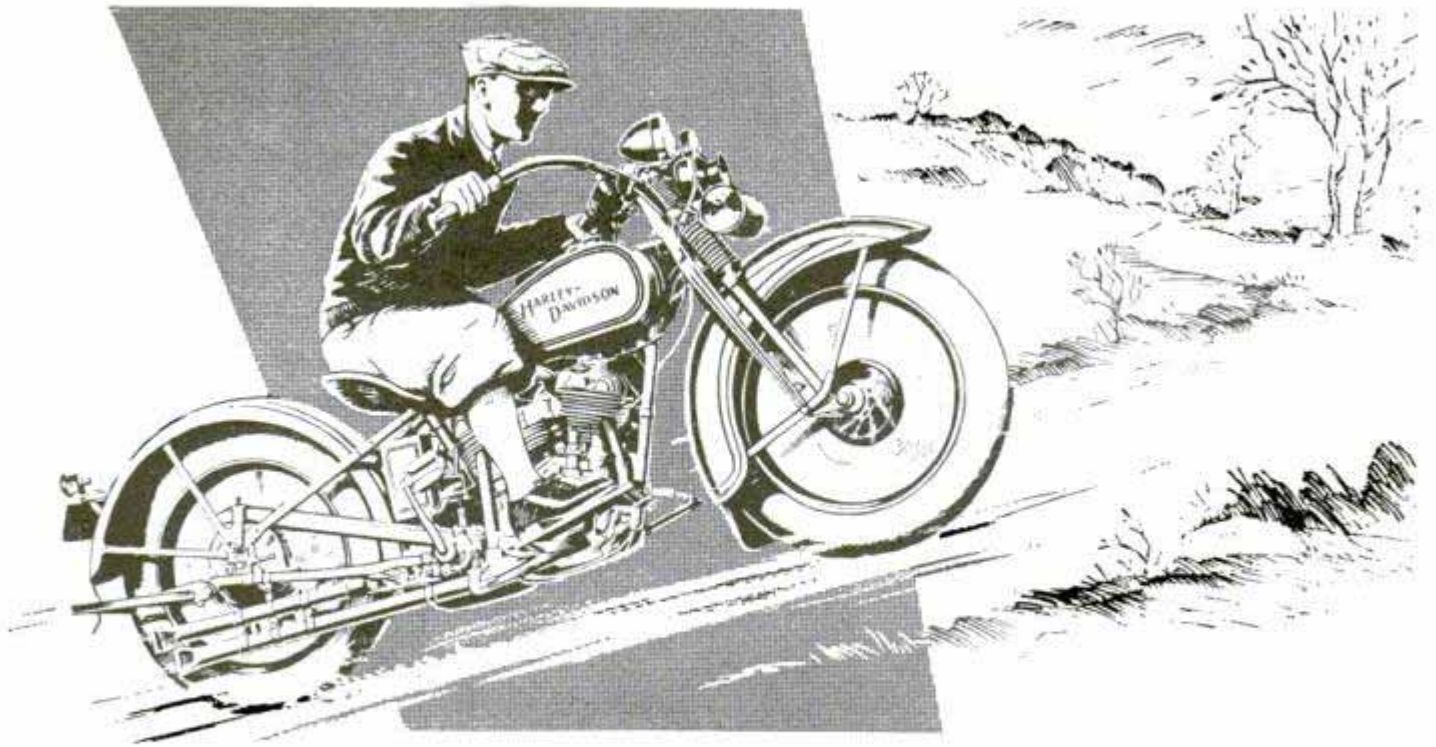

You Never Tire of It

EVERY MOTORCYCLE trip is a new adventure — every ride gives a new thrill — for motorcycling is one sport you never tire of. Ask any rider.

When you get a Harley-Davidson you give yourself *years* of enjoyment, *years* of delightful recreation in the open air, *years* of the "greatest sport on wheels".

And the cost is amazingly low. A Harley-Davidson "45" Twin costs little to buy and almost nothing to run.

Your local dealer has a Pay-As-You-Ride Plan that will interest you. Ask him about it — and look over the wonderful 1930 models.

Ride

a

HARLEY-DAVIDSON

Mail the Coupon!

for literature that shows the full line of Singles, Twins, and Sidecars. Motorcycle prices are as low as \$235 f. o. b. factory.

HARLEY-DAVIDSON MOTOR CO., Dept. P., Milwaukee, Wis.
Interested in your motorcycles. Send literature.

Name.....

Address.....

My age is 16-19 years, 20-30 years, 31 years and up, Under 16 years.
Check your age group.

While the weather man says "Cold!"

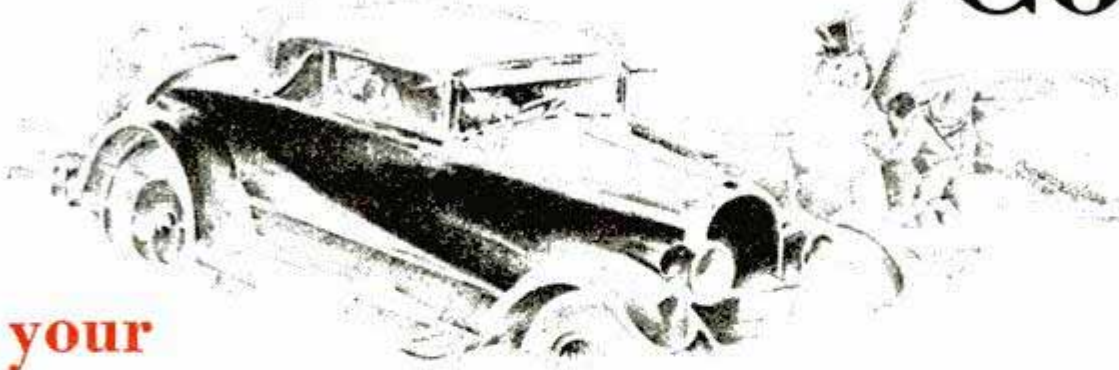

your
engine demands
the double-range protection

of Mobiloil Arctic

Two of the most dangerous enemies your battery and engine can have are "summer-oil-in-winter," or a winter oil which is so light that it lacks rich lubricating value.

With too heavy a lubricant the thick oil lies, stiffened by cold, in your crankcase. After standing in the cold, your engine strains to overcome the resistance of "dry" pistons, cylinder-walls and bearings. Your battery can waste hours of its life in those few moments of terrific effort.

With too light an oil in your crankcase you get easy starting—but when your engine heats up, such oil may show a serious lack of lubricating value.

The new Mobiloil Arctic will give efficient lubrication from the first turn.

In its ability to meet your two cold-

weather needs Mobiloil Arctic is unique.

1. Its correct body, and fluidity at zero assures easy starting and quick oil circulation.
2. It retains its rich lubricating value at your highest winter operating temperatures—thus assuring full protection no matter how fast or how far you drive.

Mobiloil Arctic has been tested and proved by millions of motorists in every cold country from Norway to Cape Horn.

When you change to Mobiloil Arctic you end every doubt about the correctness of your winter lubrication.

VACUUM OIL COMPANY

Makers of high quality lubricants
for all types of machinery

the New



Mobiloil

ARCTIC

The SPOT LIGHT'S on



the "SAX"

Today big orchestras everywhere feature the Sax. Besides, most famous orchestra leaders play the Sax. And it is the favorite instrument in many of the best radio programs.

BUESCHER

True-Tone Saxophone

Remember, the beginners of today will be the stage and radio artists of tomorrow. While you may not aspire to be a great saxophone soloist or orchestra leader, you do want the fun, the social advantage, the good friends, and the extra money that playing a saxophone will surely bring you. At parties or entertainments—at school or college—the Saxophone player is always in demand.

Easy to Play—Easy to Pay

The key arrangement of the Buescher is so simple your fingers fall into place naturally. That's why in only one hour you can learn to play the scale. A few weeks will find you playing the popular song hits. In 90 days many are ready to join an orchestra. The Buescher positive octave key and stationary hand position mean smooth, accurate playing and full, clear, true tones. Patented snap-on pads, also add to beauty of tone and mean easy replacement.

Easy to pay for the Buescher, too. Just a little down. Then you pay as you play—a little each month. In only a short time the instrument is yours—with its rich, clear, true tone—to play and enjoy for years to come.

Mail the Coupon for Free Catalog. Fully illustrated. Complete with prices, terms, 6 days' trial offer and all details. Mail it today!

Buescher Band Instrument Co.
3043 Buescher Block Elkhart, Indiana

BUESCHER BAND INSTRUMENT CO. (555)
3043 Buescher Block, Elkhart, Ind.

Gentlemen: Without obligating me in any way please send me your free catalog. I am interested in the instrument checked below: Saxophone Trumpet Cornet Trombone Clarinet Mention any other instrument in which you may be interested.

Name.....

Address.....

It's a BULOVA—Sent with a Mesh Band! For \$1.00

TAKE 12 MONTHS TO PAY

Send \$1.00 with order and tell us a little about yourself: (A) How long at present address, (B) Age, (C) Married or Single, (D) Name of Employer, (E) Position, (F) How long employed. All information held strictly confidential. We make no direct inquiries of anyone—not even from your employer.

10 Days Free Trial—Satisfaction Guaranteed
This genuine Bulova watch comes to you postage paid—no C.O.D. to pay on arrival. You take no risk—satisfaction guaranteed or money back.

Estab. 1895



\$2975
DG5—
15 jewel BULOVA gent's wrist watch, White Gold filled case; "dust-tite" protector; radium dial and hands; latest woven mesh wristband. Guaranteed \$1 now \$2.39 a mo. Nationally advertised cash price, no extra charge for credit.

Catalog FREE to Adults
New catalog of genuine diamonds, standard nationally advertised watches, fine jewelry. Write for it now.

ROYAL DIAMOND & WATCH CO.
ADDRESS DEPT. B-11 170 BROADWAY, N.Y.

NEW! CarryAll CarNet AGENTS MAKE \$15-\$25 A DAY



Suspends from top of your car. Carries papers, clothes, maps and other small articles in neat, safe, compact position. Meets instant approval of car owners everywhere. Takes 5 minutes to install. Agents wanted. Write for FREE TRIAL OFFER. THE GRACE COMPANY, 706 Grand, Des Moines, Iowa

MOVIES AT HOME LET US SEND OUR INTERESTING AND FREE CATALOGUE OF MOVIE MACHINES—AS LOW AS \$3.75 POSTPAID—USE STANDARD OR 16mm SIZE—COMPLETE LINE OF FILM SUBJECTS AVAILABLE WITH EXCHANGE SERVICE—LOWEST PRICES—DON'T DELAY—WRITE FOR FREE CATALOGUE

PARAMOUNT MFG. CO. NOW!
BOSTON DEPT. G-24 MASS.



RUN SHOWS EARN EXTRA MONEY!

FORD TriMotor MONOPLANE



Build Model Airplanes the IDEAL way!

Plans for Model Airplanes 25c each.

FORD MONOPLANE
Fokker Monoplane
New York-Paris Plane
Curtiss BiPlane
DeHAVILLAND BiPlane
NC-4 Naval Seaplane
Bleriot, Nieuport or Taube Monoplanes
Cecil Peoli Racer

Build this perfect, 3 ft. Flying Model of the famous FORD MONOPLANE in which Comm. Byrd flew over the South Pole. It is guaranteed to fly. The Ideal Construction Outfit contains everything needed; all materials with Plans and Instructions. Ask your Model Airplane dealer, or order direct. The price is \$8.50.

48-page Catalog of Model Airplanes, Parts, Materials and Supplies for Builders, 6c.

IDEAL AEROPLANE & SUPPLY COMPANY, Inc.
26 West 19th Street, New York City

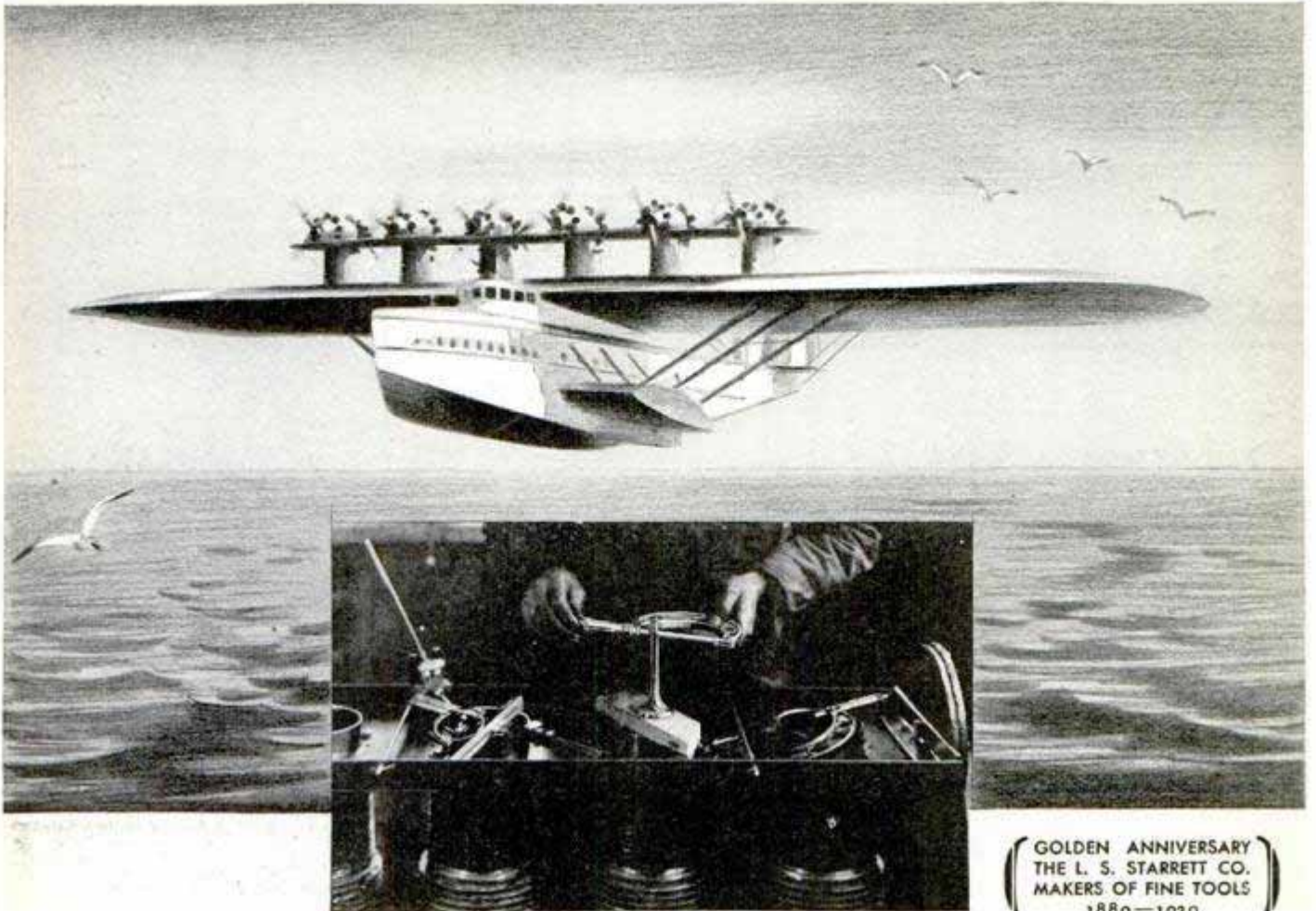

(GOLDEN ANNIVERSARY
THE L. S. STARRETT CO.
MAKERS OF FINE TOOLS
1880-1930)

A yacht takes wing

The air quakes with the phasing beats of twelve propellers . . . a roaring yacht lifts from the sea, takes wing.

A triumph of engineering skill? Yes . . . and a triumph of craftsmanship, a triumph of skilled hands and precision tools.

Real craftsmen the world over do their best work with the tools that offer them the most precise accuracy—with Starrett Tools. Whether you use fine tools in your serious work or as a hobby, your hands will borrow greater skill from the unfailing accuracy of Starrett Tools.

Let us send you the Starrett Catalog No. 24 "AP" which displays over 2500 Starrett Tools, Tapes and Hacksaws. It is free.

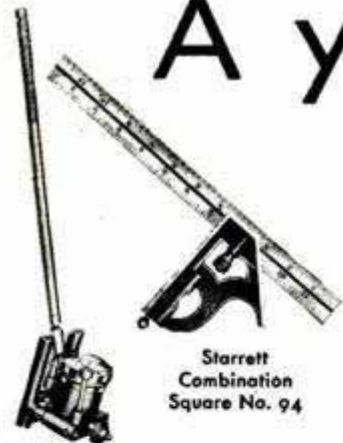

Starrett
Combination
Square No. 94



Starrett
Improved
Cylinder Gage
No. 45a B

Starrett
Micrometer
No. 224 AA

THE L. S. STARRETT CO.
World's Greatest Toolmakers
Manufacturers of Hacksaws Unexcelled
Steel Tapes—Standard for Accuracy
ATHOL, MASS., U. S. A.

Starrett
Dividers
No. 92



Starrett
Vernier
Calipers
No. 122



Starrett
Hacksaw
Frame No. 153



Use Starrett Tools



Here's

the

**EXTRA SMALL
Electric Drill**
*of a hundred
new uses*

Around corners or over your head? —it's easy with this little power tool. It weighs only about 3 pounds—snuggles into your hand like a well-balanced screw driver. Into so-called inaccessible spots? — why this handy drill is only 9 3/8" overall. And yet this Millers Falls 3/16" Drill will turn out matchless performance with powerful ball-bearing motor and a no-load speed of 3,000 R.P.M. The motor housing is "Racolite"—a non-conductor. The price of \$36.00 includes an auxiliary handle.

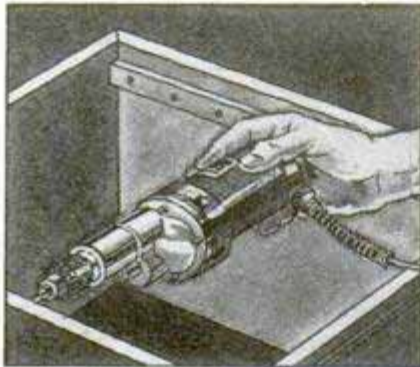

Use the coupon below for additional information on this new power tool. Don't forget either that Millers Falls makes a complete line of electric tools. MILLERS FALLS COMPANY, Millers Falls, Mass., New York: 28 Warren St., Chicago: 9 So. Clinton St. Cable address: MILLERFALL NEWYORK.

**MILLERS FALLS
ELECTRIC TOOLS**



MILLERS FALLS COMPANY
Millers Falls, Mass.

Send me additional data on the new 3/16" drill.

Name.....

Address.....

City..... State.....

PM2-30

**SILVER ACE
Flying Models**

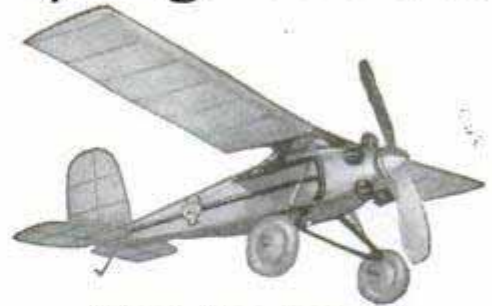

Silver Ace Pursuit

IN response to countless requests, we have designed a construction set to build this beautiful De Luxe monoplane. The pyralin fuselage, wheels, superstructure, propeller and landing gear are all made. All parts, silk covering, plans and rubber included. A fast flier indoors or out, and the most durable you ever owned.

Construction Set.....\$5.75
Ready to Fly..... 8.00
Add 50c for packing and shipping if ordered through us instead of through your dealer.

Catalog describing the renowned SILVER ACE SQUADRON of 18 flying models.

AERO MODEL COMPANY

Dept. M-22
111 North Wacker Drive
CHICAGO



Build a CLOCK for Pleasure or PROFIT!

FREE BOOK of Clock Making, Money Making ideas. Gives details, prices of movements, parts. Write NOW for copy!

Shows How YOU Can Make Fine Clocks Right at Home —for yourself, or to sell at Big Profits. We furnish instructions, parts. Works \$1.65 up; others with chimes, all prices. Make case or assemble parts. Cash-in on demand for Mantel, Banjo, Grandfather's Clocks. Write for Special Blue Print Offer, FREE Catalog.

AMERICAN CHIME CLOCK COMPANY
1670-S Ruffner St. Philadelphia, Pa.

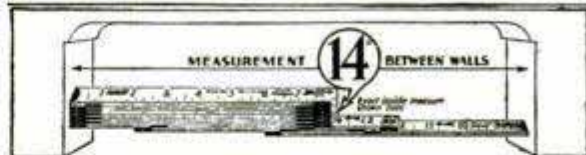

Ask the Dealer or send 20c each lineal foot.

MASTER INTERLOX SLIDE RULE Every kind of inside measurement. Just slide out the MASTER till it reaches from stop to stop. No guessing. Quick results. Locks rigid in use. Without equal for outside measure, too. Dealers and Agents Wanted. **MASTER RULE MFG. CO., Inc.** 21 E. 136th Street NEW YORK CITY

**SAVE 1/2 ON
PLUMBING
HEATING**

Any handy man can install his own plumbing or heating by our new easy cut-to-fit method. Low wholesale prices on highest quality Grade A goods enable you to save one-half!

WE SHOW YOU HOW—BOOK FREE Send for our new wholesale catalog. Save waste material and high labor costs. This book has saved money for home owners and builders for over 50 years.

Free Estimate—Send for Sketch Blank

MILLION DOLLAR BONDED GUARANTEE PROTECTS YOU

OVER 50 YEARS

HARDIN-LAVIN Co.

EST. 1876

122-32A West Pershing Road, Chicago, Ill.



New Model SOUTH BEND LATHES

BACK GEARED SCREW CUTTING LATHES

45,000 Lathes in Use in U. S. and 78 Foreign Countries

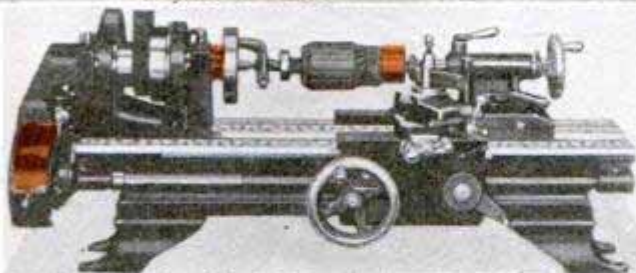

9" x 3' New Model South Bend Jr. Back Geared Screw Cutting Lathe (Weight 375 lbs.) Complete with Countershaft and \$169 Equipment shown only



FOR THE

Manufacturing Plant	Service Station Maintenance
Tool Room	Airport
General Repair Shop	Electrical Shop
Machine Shop	Engineering Shop and Laboratory
USED BY MANUFACTURERS OF	
Automobiles	and
Electrical Parts	Government Departments
Machinery	National and State
Aircraft	
Textile Machines	

Prices of 9-in. Junior Bench Lathes Including Lathe Equipment

Size of Lathe	Shipping Weight	Countershaft Drive	Horizontal Motor Drive
9" x 2 1/4'	350 lbs.	\$163.00	\$248.00
9" x 3'	375 lbs.	169.00	254.00
9" x 3 1/2'	400 lbs.	175.00	260.00
9" x 4'	425 lbs.	182.00	267.00

New FREE Catalog

Shows 96 Sizes from 9-in. to 18-in.

Write or send coupon today for the New South Bend Lathe Catalog. This complete book illustrates and describes 96 sizes and types of Countershaft Driven Lathes, Motor Driven Lathes, Quick Change Gear Lathes, Standard Change Gear Lathes, Tool Room Lathes, Gap Bed Lathes, Brake Drum Lathes and Bench Lathes. Investigate the New Model Lathe as it has all the latest improvements.

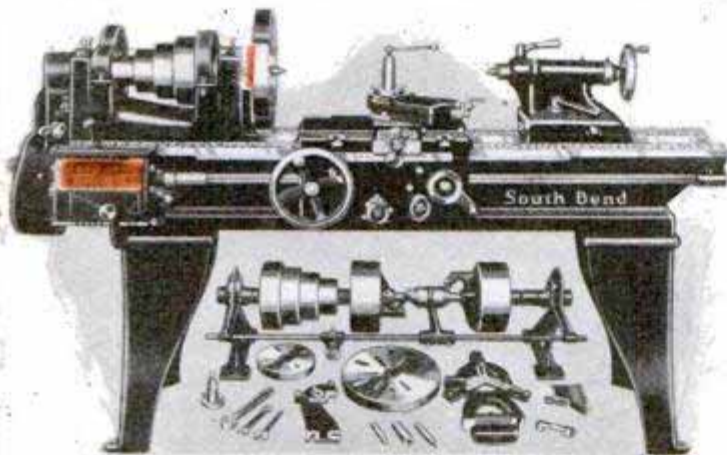

16" x 6' Quick Change Gear New Model South Bend Lathe - - - \$598

Prices of Popular Sizes of Quick Change Gear Lathes with Lathe Equipment

Size of Lathe	Shipping Weight	Countershaft Drive	Silent Chain Motor Drive
9" x 3'	490 lbs.	\$294.00	\$398.00
11" x 4'	725 lbs.	359.00	498.00
13" x 5'	1110 lbs.	443.00	602.00
15" x 6'	1550 lbs.	543.00	720.00
16" x 8'	2035 lbs.	638.00	817.00

Easy Payments

We ship any South Bend Lathe immediately upon receipt of only 20 percent of Catalog Price. Balance in 12 equal monthly payments. Write for Time Payment Catalog.

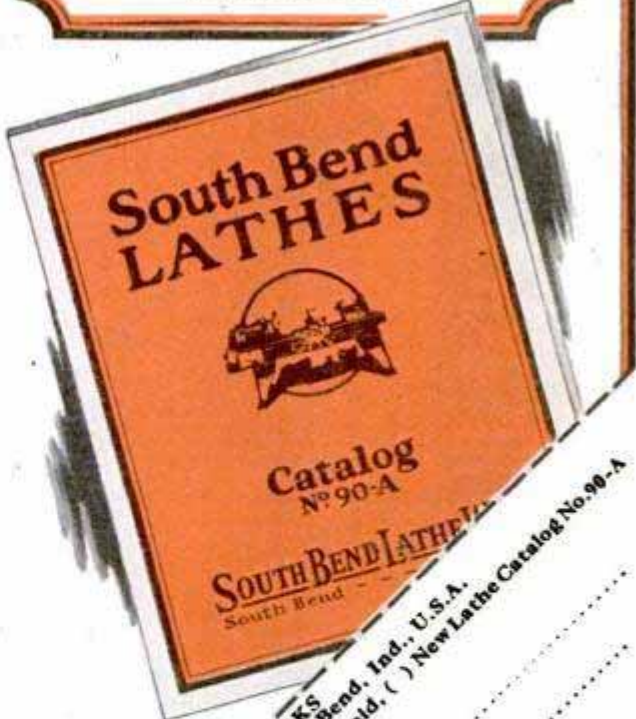

SOUTH BEND LATHE WORKS

618 E. Madison St., South Bend, Ind., U.S.A.

Lathe Builders for 23 Years

SOUTH BEND LATHE WORKS
618 E. Madison St., South Bend, Ind., U.S.A.
() Time Payment Catalog, () New Lathe Catalog No. 90-A

Name.....
Address.....
City.....
State.....

CONCEALED RADIO?

Here it is!

A modern, All-Electric 6-tube Chassis. For installation in any available square foot of space. Laboratory assembled with genuine National Company parts and National R.C.A. licensed Power-Amplifier.



The NJ-30 CHASSIS

3 Screen-Grid Tubes and three 245 Power tubes. Tune up to the most modern standards. List price, (less speaker and tubes) \$77.50. Wired and ready to use.

Send for descriptive folder, mentioning Popular Mechanics Magazine, when you write.

JACKSON RESEARCH LABORATORIES
Jackson Street, Malden, Mass.

20th Century Mail Order Corp.

RADIO APPARATUS
KIT SPECIALISTS
SPEEDY SERVICE

Send for **FREE** Catalog
238 South Wells Street, Chicago

TRUVOLT

The **SAFE** Resistance for
Eliminators and Power Packs

Patented TRUVOLT Air-cooled winding insures greater accuracy and longer life. TRUVOLT Variable has fine knob variation. Lasts longer due to endwise travel of contact over wire. 22 stock sizes, \$2.50 ea.

Fixed models have exclusive sliding clip for quick adjustment. All usual sizes.



U. S. Pat. 1676869
& Pats. Pend.
Write Dept. PM2
for TRUVOLT
literature

175 Varick St., New York, N.Y.
ELECTRAD
INC.

"HiQ-30"

Built From
**WORLD FAMOUS
PARTS**

JUST like adding two and two to get four—the result is inevitable when you combine a most efficient circuit with parts the whole radio world respects.

The "HiQ-30" Receiver is Hammarlund-designed and Hammarlund-built. That's all the insurance of quality you need. It is available as a complete kit or you may purchase any of its units separately.

Write Dept. PM2 for circular

HAMMARLUND MANUFACTURING CO.
424-438 W. 33rd St., New York, N. Y.

For Better Radio
Hammarlund
PRECISION
PRODUCTS

SOLDERALL

METAL IN PASTE FORM

The
Only
convenient
metal
solder



Every Electrical
Connection needs
Solderall for perfect reception
25¢
The **SOLDERALL CO., NEWARK, N.J.**

RADIO TONIC

No matter what set; no matter what skill; no matter what experience; no matter what trouble—there is just one way to make your set right—

CLAROSTAT

Ask your dealer about it. Better still, write for literature

CLAROSTAT MFG. CO., Inc.
286 N. 6th St. Brooklyn, N. Y.

FREE RADIO CATALOG

GREATEST OF ALL!
Nothing to compare with new 1930 Wholesale Radio Service catalog. Fully describes biggest bargains ever offered. Unparalleled dollar for dollar value. **VERY LATEST EQUIPMENT** Shows all standard equipment, kits, parts, batteries, accessories. Everything offered at substantial savings. **FREE RADIO ADVICE** and information.

WRITE TODAY FOR COPY

Get your copy of this great radio guide and catalog **ABSOLUTELY FREE**. Don't miss this offer! Simply send name and address. Postal will do. But you must act quick before supply is exhausted. Write today!

New perfected **LAFAYETTE A.C. Screen-Grid Receiver**, Humless, cathedral toned reception. 245 push pull audio. Gorgeous cabinets, consoles. Catalog describes all. **BARGAINS.**

**1930
RADIO
CATALOG**

WHOLESALE RADIO
SERVICE CO.

Dealers and Agents:
Lowest wholesale
prices offered on all
equipment. Confidential
price list.
Personal advice.
Write for our plan.

WHOLESALE RADIO SERVICE CO., INC.
36 VESEY ST. Dept. E-11 NEW YORK



THESE MEN KNOW TOOLS

THE carpenter, the builder, the industrial worker, the expert woodsman: *These men know tools.* They know that with all their skill they cannot do fine work with cheap ones.

Let their ripe experience and judgment guide your choice. Grip a Plumb Hammer and feel the difference in the balance; pull the slimmest headless brad with those nipper claws. You'll have more confidence... you'll do better work with a tool like that.

Try the Plumb Hatchet; it is balanced to control your blows. Sink it deep or slice a shaving; that keen edge goes where you aim it.

Or the Ball Pein—favorite of machinists; or the Plumb Chopping Axe—selected by expert woodsmen. Notice how many experts use Plumb—with the Red Handle and Black Head. Because they are easier to work with, turn out a better job, give longer life...

And the handles are always tight! Plumb's invention—the screw wedge—instantly takes up any shrinkage in the handle, just by a turn of the screw.

Your local hardware man will recommend Plumb. FAYETTE R. PLUMB, Inc., Philadelphia, U. S. A.



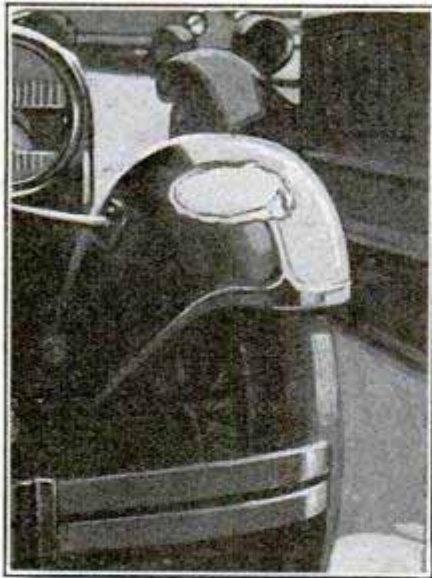

Here's a place for PLASTIC WOOD

[Reg. U. S. Pat. Off.]

A dent in your automobile fender or body—you can make the spot look as good as new with a careful application of Plastic Wood. It handles like putty, hardens into wood, and adheres lastingly to wood, steel, aluminum or other material.

Hammer out the dent as smoothly as possible, and scrape away all paint, rust and dirt. Then apply Plastic Wood in layers not over $\frac{1}{4}$ -inch thick, allowing each to harden, and build up slightly above the surrounding surface. Press it firmly against the metal around the edges. When hard sand to the surface and shape desired, and paint or lacquer to the color of the car.

Plastic Wood, too, is invaluable for filling enlarged screw holes, holding loose hardware, and for building up behind loose door bumpers. A can of Plastic Wood in your tool box may save many a repair bill at home or on the road.

Handles
Like
Putty



Hardens
Into
Wood

Tube, 25 cts. $\frac{1}{4}$ lb. can 35 cts.

1 lb. can \$1.00

At Hardware and Paint Stores

ADDISON-LESLIE CO., 424 Bolivar St., Canton, Mass.



ELECTRO-PLATING

This Easy, New,
Scientific Way...

With an ALADDIN Portable

You actually see the metal flow—gold, silver, brass, copper, nickel, etc.

NO EXPERIENCE REQUIRED

This Miraculous New Invention enables Anyone to successfully plate Anything, Anywhere, Instantly: Auto Parts; Bathroom, Kitchen, and Electric Fixtures; Faucets, Spoons, Forks, Knives, Silver Service, Tools; Restaurant and Soda Fountain Fixtures; Surgical and Dental Instruments... No interruption of Service... No Parts to be removed. Renew Worn plating or plate New work. Add this magic touch of prosperity to your home, shop, or office.

NICKEL
PLATING

INTRODUCTORY OUTFIT
\$6.50
PLUS POSTAGE
RETAIL PRICE \$19.50

SILVER
PLATING

Be Your Own Boss

Free

ELECTRO-
PLATING

Agents & Dealers
—WANTED—

NOT A TOY

but a practical, portable Electro-Plating Outfit with which Perfect and Durable Work can be done. Deposits the metal electrically. Easy, Simple, and Economical to Operate. Positively Guaranteed to do as we claim.

MAKE UP TO \$500 A WEEK

Be Your Own Boss! No Sales Experience required. Build up a Profitable ALADDIN Electro-plating Business of Your Own. Thousands in Service. A Big, Easy, Money-maker for Agents and Dealers. Take advantage of our Introductory, 30 day trial offer... \$6.50 for Master Outfit "A" to plate with Nickel. Order Today. Ask for FREE booklet and inspiring testimonials.

P. J. F. BATENBURG CO., Dept. 181, Racine, Wis.



CLASS PINS 35¢

FREE CATALOG SHOWING 200 DESIGNS

PIN SHOWN. SILVER PLATE 35¢ EA., 12 OR MORE, \$3.90
DOZ.; STERLING SILVER OR GOLD PLATE, 70¢ EA.
12 OR MORE \$6.50 DOZ. 1 OR 2 COLORS ENAMEL;
3 OR 4 LETTERS; DATES 1930-31-32-33.

45025 BASTIAN BROS. CO. 925 BASTIAN BLDG., ROCHESTER, N. Y.



Walsh Garden Tractor

and Power Mower

For Gardeners, Florists, Fruitmen, Suburbanites
Plows, Seeds, Cultivates, Mows Lawns & Hay
Single and Twin Engine-Belt Jobs-Walk and Ride

SPECIAL FACTORY PRICE

New Improved Models—CATALOG FREE

WALSH TRACTOR CO. Minneapolis, Minn.
3328 Talmage Av. SE



3 FOR ONLY 65¢

Boys—send 65c. *Big kit includes 3 famous SOLAR Detroit Model Airplane Fliers Club plans and complete instructions for building Biplane, Tractor and Pusher, plus all materials for making all 3—balsa blocks and sticks for blades, spars, ribs, fins; Japanese paper; rubber motor; wire; glue; banana oil—everything. Great fun to build; guaranteed to fly. Send money order TODAY (65c); no stamps.

COLLINS PLOW COMPANY, Dept. 102, Quincy, Ill.

Safety Saw Model N. Makes Anything

If woodworking is your living or your hobby, this precision machine will give you perfect results most economically. It is built for long and accurate service without attention. It is not a toy.

- RIPS...MITERS...
- CROSS-CUTS...
- BEVELS...DADOES...
- PLOUGHS...
- GROOVES...
- RABBETS...
- SANDS...
- BORES...
- GRINDS...
- POLISHES...ETC.

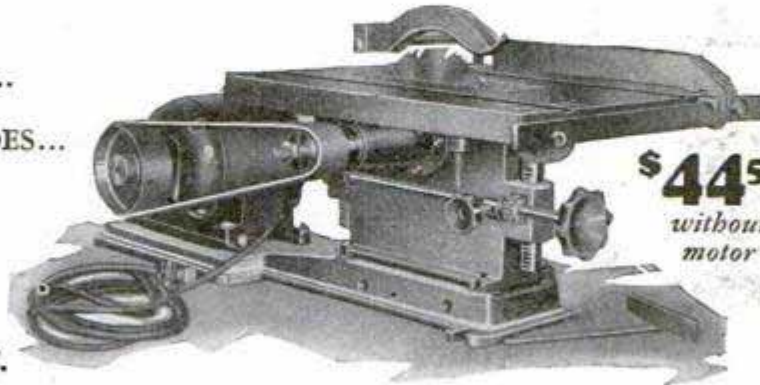

\$44.50
without motor

Easy to operate
Easy to own
BALL BEARING
Table Top 18" x 14"
Raises and lowers on a level.
Saw Arbor 3/4" Dia.
Cuts 2 1/2" Thick
Rips 12" Wide
Cross-cuts any width
Bevel Rips to 45°

Send Coupon
Now for Details,
Illustrations and
EASY TERMS

TRY THIS Safety-Saw AT OUR EXPENSE

Put this machine on your work bench . . . give it a thorough test . . . compare it with others . . . and then if you're not more than satisfied with it in every way . . . send it back and we'll return every cent of your down payment and pay the transportation charges both ways. You can't lose a nickel, but you can gain a lot. Don't buy any machine until you've read our FREE descriptive folder . . . It shows Bench Saws . . . Band Saws . . . Lathes . . . Jointers . . . and all equipment.

SAFE TOOL MFG. CO. • BRIDGEPORT, PA.

SAFE TOOL MFG. CO., Bridgeport, Pa.

Please send me full information about your woodworking machines.

Name.....

Address.....

GET DETAILS NOW!

Build and Fly America's Popular Sport Plane



\$199 brings complete kit to construct the Heath Super Parasol. Fly it from our Airport for \$975. Complete detailed shop prints at \$5 per set. 10c brings large illustrated booklet.

Heath Airplane Company 1721-29 Sedgwick Street, Dept. P-2, CHICAGO, ILL.

Make Your FORD Into The "ACE"

GET READY FOR SPRING—BUILD YOUR ACE NOW—

\$5.99 Red-I-Kut life size patterns Class—Snap

Famous sure-fit RED-I-KUT life-size patterns and picture instructions show how you can easily convert your Ford into this **Fast, Saucy, Sport-Car** as thousands have done with easily obtained materials. No need to lay up the car. Makes wonderful 4-passenger car. Send 10c coin for actual photo of sport car and new manual of distinctive sport car patterns from \$5.50 up—“EKO” Steel “Swing-Lo” irons, Tops, Windshields and many speed necessities. **ORDER RIGHT NOW and get a real thrill.**



38-inch Easy Riding Seat

KUEMPEL COMPANY, 117 Kuempel Bldg., GUTTENBERG, IOWA

SELL PIONEER All Wool Tailoring
Full or Part Time

\$4.50 to \$7.00 (WITH BONUS) PROFIT Per SUIT

An opportunity to make \$12 a day from the start, selling famous Pioneer tailored-to-measure, all-wool suits at \$25. Commissions paid in advance. **Chance for own clothes at no cost.** Striking Big Outfit of over 100 large swatches furnished free—other equally remarkable values at \$30 and \$35. We train the inexperienced. Men willing to work for success will write for this big money-making opportunity, today.

Cash Paid Daily

PIONEER TAILORING CO.
Congress and Throop Sts., Dept. P-1116, Chicago



LOFTIS BROS. & CO. F218

DIAMONDS WATCHES

CASH or CREDIT

Send for FREE Catalog!

HOW TO ORDER: Send first payment—state article desired—name of employer—kind of work you do—how long in position—age—married—where live—how long there. **STRICTLY CONFIDENTIAL.**

Satisfaction guaranteed or money back. Goods sent for your free examination on request. CREDIT TERMS: Pay one-tenth down; balance weekly, semi-monthly or monthly at your convenience. Goods delivered on first payment.



No. 882
\$100
\$2.50 a week



No. 27
\$50
\$1.25 a week



No. 918
\$37.50
\$1.00 a week



No. 925
\$50
\$1.25 a week



No. 927—Elgin "Legionnaire" for Men,
\$19; \$1.90 down; \$1.90 a month.

FIERY BLUE WHITE DIAMONDS Dept. K-834 108 North State Street, Chicago, Illinois **SOLID 18-K WHITE GOLD RINGS**

Stores in Leading Cities

HERE'S BIG MONEY



Selling NEW Specialty to Business and Professional Men!

Four \$15 Sales Daily Pay \$288 Weekly

Just what you've waited for! The world's largest firms—Bell Telephone Company, National Radio Company, LaSalle Extension University, Sears Roebuck and Company, and scores of others nationally known are among our customers. The smallest business can use it! A specialty that's irresistible! **GUARANTEED TO NET YOUR CUSTOMER TEN TIMES WHAT IT COSTS HIM!** He gets a signed certificate of guarantee protecting him, backed by a national organization. You get portfolio of dazzling letters from the world's most famous concerns. Show this amazing specialty, show the letters, take the order! 2 sizes—one costs \$2.50, sells \$7.50—your profit \$5.00; the other costs \$5.00, sells \$15.00, your profit \$10.00. Enormous repeat business; tremendous profits from sub-agents—write for proof of profits up to \$500 a week! You get profit on all mail-order business from your territory!

\$165 FIRST DAY

Made by Walker; \$1500 a month clear from M. L. Tardy; A. R. Almond nets \$6,000 first year and going better all the time; J. J. Schmidt in \$5,000 class for years; I. G. Waltz shows \$350 profit in spare time for one month! Just a limited number of openings. Hurry, boys—they won't be left long now! Write.

F. E. ARMSTRONG, President

Box 601-F MOBILE, ALA.

STRANGE INVENTION! PAYS YOU IMMENSE PROFITS NEW FIELD for AGENTS

Sell only device in the world that prevents kinking, snarling and tangling of telephone and electric iron cords. Housewives and business men buy 1 to 50.

NEW KIND OF CORD SET FREE

Every Neverknot Salesman is given FREE the complete Neverknot Switch Plug Cord Set pictured. This new kind of ironing cord automatically coils itself out of the way and a new kind of switch plug prevents scorching and saves electric bills. This set is a "gold mine" for house-to-house workers. It's different and it's yours free if you work for us. Don't delay! Send now for free offer.

NEVERKNOT CO. Dept. 2-V 4503 Ravenswood, Chicago

The Plug That Saves Electric Bills.

Vacuum Cleaner Men

Your selection of 30 leading makes, rightly rebuilt vacuum cleaners, from \$5.00 up. All fully guaranteed. Perfect in action and appearance. Any quantity desired. Biggest vac bargain ever offered.

Here's Real Money for You

Attachments, armatures, bags, belts, brushes, all other parts. Highest quality. Lowest prices.

World's Largest Factory Rebuilders

UNITED ENTERPRISES, Inc.
13024 ATHENS AVENUE CLEVELAND, U. S. A.
FREE Complete Catalogs

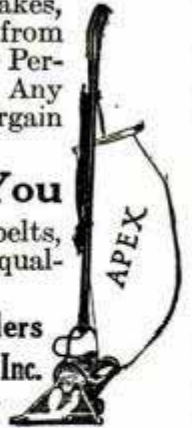

12-INCH SCALE MODEL

of Lindbergh's Spirit of St. Louis. Scientifically designed and very realistic. Rises from ground by own power and flies 40 ft. or more. Only flying scale model sold at this price. Easily built in 7 or 8 hours. No tools needed. Construction



set, with all parts and full directions, postpaid in U. S. and Canada, only 50c (no stamps). Satisfaction or money back. Send today and print your address plainly.
MANN & BENTON
Box D, Chillicothe, Ohio

SAMPLES OF 33 RARE WOODS

ALSO, 20 cabinet and 20 inlay, \$1.75 ONLY 25c —or your choice \$1.00. Sets labeled and postpaid. We carry WOODS of all kinds, including panels, veneers and inlay woods. Write for FREE Price list.

CRAFTSMAN WOOD SERVICE
PM-717 E. 62nd St., Chicago, Ill.

IDEAL SMOKER'S GIFT

Cleanest, safest, sanitary receiver made. Push top—ashes disappear—springs back, closes self tightly. No more ashes spilled on rugs—tables, etc. No cigar, cigarette, match ends in sight. Odorless—makes smoking no longer objectionable. Ideal for home—office. 5 in. wide—set anywhere. Attractive appearance. Soft red, green or blue finish. Handsome nickel top. Send no money, just name and address. Pay postman only \$1.29 and few cents postage when received.

\$1.29

L. A. RICKER, 2458 S. St. Louis Ave., CHICAGO, ILL.

SELL DRESS GOODS

Oh How Lovely!

Show finest silks, dress goods, wash fabrics, drapery materials. Special pattern service. Also hosiery, underwear, etc. Liberal commissions and bonuses. Repeat sales all year. Outfit free.

THE NATIONAL IMPORTING CO.
569 Broadway, Dept. A-39 New York

MOTORCYCLES

Direct to you at wholesale prices Send 10c today for the latest

Illustrated Bulletin and Confidential Price List of Guaranteed Indians Harleys Hendersons SuperX etc.

(Small Weekly Payments Now—Spring Delivery at Winter Prices)

CRANDALL CYCLE CO. 826-28 State St. Shipments to all parts of the world
Motorcycles Since 1905 Springfield, Mass.

WAD E AMATEUR MECHANICS, REPAIR SHOPS, INVENTORS, STUDENTS

BENCH LATHE

A real machine tool for the home work bench—capacity 4" dia. x 12" length For Metal—Wood—Composition materials. Turning—Facing—Boring—Drilling—Winding—Thread Cutting. Accurate—Strong—Quiet—Compact. Slide-rest has travel entire length of bed. Leadscrew inside bed. No. 1 Lathe, plain headstock, \$40.00. No. 2 Lathe, back-gear headstock, \$68.00. Extra for lathes with 18 inches between centers, \$7.00. Complete line of accessories at equally low prices. Write for free catalog.

THE GEROLD CO. Dept. P-60 120 Liberty St. New York

Cape Cod Chest of Drawers



LePage's Third Home Work Shop Book, only 10 Cents, Shows How to Make These 20 Projects

Cape Cod Chest of Drawers, Alexandria Nest of Tables, Old Salem Ship's Cupboard, Plymouth Built-In China Closet, Lady Washington Sewing Cabinet, Set-Back Book Shelves, Modernistic Desk, Modernistic Table, Modernistic Folding Screen, Modernistic Fire Screen, Chess and Checkers Table, Smoking Table, Caned Side Chair, China or Book Cabinet, Book Trough and Magazine Stand, Magazine Carrier, Vanity Case, Book Stand, Fernery Stand and Folding Sewing Screen.

Job Plans 10 cents each. Order by number as indicated in Coupon.

- 16 Sheraton Writing Desk
- 17 Sheraton Desk Chair
- 18 Colonial Hanging Book Shelves
- 19 Smoking and Reading Cabinet
- 20 Colonial Mirror
- 21 Tea Wagon
- 22 Telephone Cabinet
- 23 Stool for Telephone Cabinet
- 24 Manual Training Work Bench
- 25 Home Worker's Tool Cabinet
- 26 Spanish Galleon
- 27 Vanity Table



A handsome and useful piece that you can make yourself

Complete step-by-step directions and dimension drawings of all the parts are given on page 3 of LePage's Third Home Work Shop Book so clearly and simply that any man handy with tools can easily make this handsome and useful piece at little cost—or any of the other attractive, useful projects found in LePage's Third Home Work Shop Book or in LePage's Job Plans.

Expert Instruction

You have expert instruction to guide you. The designs, dimension drawings, photographs, step-by-step directions and the actual furniture itself were made by William W. Klenke, Instructor in Woodworking, Central Commercial and Manual Training High School, Newark, New Jersey. His experience as an expert gives assurance that each project and the di-

rections for making it are thoroughly practical. Look over the contents of LePage's book and the Job Plans available as shown in the column at the left. The price of the book is 10 cents. The Job Plans are 10 cents each and are for projects requiring more elaborate instructions than those shown in the Book. In all cases the instruction consists of printed step-by-step directions, dimension drawings of full-size patterns, and a photograph of the finished article.

Send 10 cents for LePage's Third Home Work Shop Book

Simply use the coupon below, sending it to us with 10 cents in coin or stamps, and we will at once send you a copy of this latest LePage's Book, postage paid.

LePage's Craft League
726 Essex Ave., Gloucester, Mass.

Gentlemen: Enclosed please find 10 cents (coin or stamps) in payment for LePage's New Third Home Work Shop Book. Please send a copy of this book to:

Name.....

Street.....

City..... State.....

Please also send the following Job Plans..... (indicate by number those you want. See column at left), for each of which I enclose an additional 10 cents.

Mail

This

Coupon

LE PAGE'S
GLUE
HANDIEST TOOL IN YOUR WORKSHOP

30 DAYS' FREE TRIAL



We Ship On Approval

and 30 days' trial direct from our factory. Select from 44 styles, colors and sizes.

Save \$10.00 to \$25.00 No extravagant selling expenses enter into the cost and selling prices of these bicycles. Factory-to-Rider saves you big money and assures you service.

EASY PAYMENTS if desired. Only \$5 down.

We allow 30 days for trial and test. If it does not suit—return at our expense. Do business direct with makers of Ranger—Pathfinder—Crusader bicycles.

TIRES, Lamps, Wheels, Equipment and Sundries at half usual prices.

RADIO—Musical Instruments. Complete line—exceptional prices and terms. Please mention which catalog you wish.

Write today for catalog and marvelous new price offers and terms.

Mead Cycle Co., Dept. D 110, Chicago

FREE New Book FACTORY PRICES

Save 1/3 to 1/2

New FREE book quotes **Reduced Factory Prices. Lower terms—year to pay.** Choice of 5 colors in New Porcelain Enamel Ranges. New Cabinet Heaters—

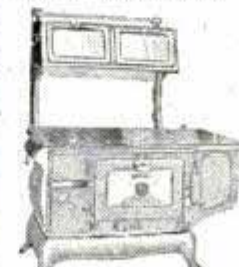

\$38.25 up. 200 styles and sizes. Cash or easy terms. 24-hour shipments. 30-day FREE trial. 360-day test. Satisfaction guaranteed. 29 years in business. 750,000 customers. Write today for FREE book.

Furnaces \$61.95 up

Ranges \$41.50 up

KALAMAZOO STOVE CO.
391 Rochester Ave.
Kalamazoo, Mich.

"A Kalamazoo Direct to You"
Trade Mark Registered

MOTORCYCLES



Price \$10 and up purchased through our Co-Operative Plan for as low as \$1.00 down and \$1.00 per week Indians Harley-Davidsons Ace Henderson and Clevalands

Send ten cents for Bulletin A. Motorcycles shipped to all parts of the world
WALKER-INDIAN CO., 1309 Boylston St., BOSTON, MASS.

SPORT BODIES FOR FORDS at FACTORY PRICES

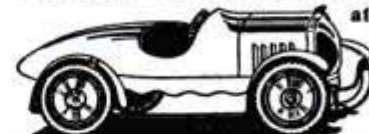

This Model in Grey Prime \$38.50

Hi-compression heads, underslung parts, 3:1 gears, headlights, cowlamps for Ford & Chev. Seat Covers for all cars.

Send 10c for catalog showing all models of bodies for Fords and other equipment. Also radio, boats, tents and camping outfits.

SPORT FACTORIES, Dept. A-2, AURORA, ILL.

Rotary Stencil Duplicator \$39



Print Bulletins, Circulars, Programs, Letters, with the Amazing "EXCELLOGRAPH"

Simple and easy. Just write, typewrite, draw or trace on dry stencil; place in position and print up to 1,000 copies per hour. All supplies and instructions furnished. Guaranteed 10 years. Prints any size from postcards to sheets 9x14. Does beautiful work.

SAVE MONEY—MAKE MONEY

Saves and makes money for Merchants, Ministers, Teachers, Offices, etc. Use it to build your business. Do work for others at big profits.

Write for Free Book—TODAY

Shipped at our risk. Positive MONEY-BACK GUARANTEE. Amazing value. Thousands in use. Get free book describing all details and easy payment plan.

Easy Terms

PITTSBURGH TYPEWRITER & SUPPLY COMPANY
Dept. M-4 339 Fifth Ave. Pittsburgh, Pa.

NEW VEST POCKET ADDING MACHINE

BABY CALCULATOR
CHICAGO U.S.A. PATENT APPLIED FOR

ADD, SUBTRACT, MULTIPLY, DIVIDE

ADDITION
SUBTRACTION
MULTIPLICATION
DIVISION

Guaranteed

ADDS, SUBTRACTS, MULTIPLIES, DIVIDES
Does work of \$300 machine. Guaranteed 5 years. NOT A TOY.
Made of steel and indestructible. Million dollar capacity. Fits in pocket. Will not make mistakes. So simple child can operate it. Instructions furnished. Everybody should carry one for figuring.

FREE TRIAL \$2.50 Total Cost

SEND NO MONEY—Just name and address. We will ship Calculator immediately. On delivery pay postman \$2.50 (Plus few cents Postage). (If outside U. S. send cash.) 10c additional in Leatherette Case. If not satisfied after 10 days trial you get your money back. THOUSANDS OF SATISFIED USERS.
This is lowest priced practical calculator made. "Why pay more for inferior imitations?" Order from this ad.

Mail Coupon Today

BABY CALCULATOR MACHINE CO., (MANUFACTURERS)

Dept. 41, P. O. Box 1118, CHICAGO, ILL., U. S. A.

I am enclosing \$2.50—send adding machine prepaid.

Send Adding Machine C. O. D. \$2.50 plus 18c postage. (10c additional in Leatherette Case)

Name.....

Address.....

City..... State.....

AGENTS

Write for big commission and territory proposition.

5 Ft. Workshop
INCLUDES
 4" Planer, 8" Circular Saw, 6" x 36" Lathe, 8" Disc Sander, 6" Buffer, 5" Grinder, 1/2" Drill Chuck, 1/2 H. P. G. E. Motor, 110 V., A. C., 60 Cycle, Endless V Belt, Two 2-step 4" and 2 1/2" Pulleys, Cast Iron Sub Base, 10 ft. Cable with separable Plug. Planer and Saw may be purchased separately — \$25.00 each.

HERE'S A Real Man's HOBBY



Operates from Electric Light Socket

WORKACE Electric WOODWORKER

HERE'S A HOBBY that offers relaxation from everyday cares—bringing pleasure and profit. Thousands of men have adopted the Workace hobby. Make hundreds of things with the Workace Electric Woodworker. Under the magic of the whirling saw, planer, lathe, sander, drill, grinder and buffing wheel (all included in the Workace Woodworker) raw lumber is easily converted into furniture, household necessities and countless other articles. Work out your ideas with your own complete electric workshop.

There's no better gift for the growing boy than Workace. It provides a wholesome man-building outlet for his energy and enthusiasm. Man or boy will appreciate Workace. \$9.00 down will bring it. Send coupon now for details.

J. D. WALLACE & COMPANY
 Adams Street at California Avenue, CHICAGO
 11 W. 42nd St., New York • 268 Market St., San Francisco
 Consult telephone directory for branch addresses in other cities

J. D. WALLACE & COMPANY,
 Adams St. at California Ave., Chicago, Ill.
 Please send me full information about the Workace Electric Woodworker and also the Workace Machines checked below.

Workace Jig Saw Workace Band Saw
 Workace Shaper Workace Planer Workace Radial Saw

Name.....
 Address.....
 City..... State.....

\$9.00 DOWN
\$89.00 COMPLETE

Mail Coupon Above

5 FEET

Jig Saw Attachment for the Workace Electric Woodworker... **\$10**

Workace Electric Shaper—high speed, direct drive, portable... **\$95**

14 in. Workace Band Saw, fast, accurate, economical... **\$75**

Workace Portable 4 in. Planer... **\$25**
 Complete with motor **\$60**

Workace Radial Saw. Saws at any angle... **\$140**
 Cast Iron Table **\$10 Extra**
 Cast Iron Legs **\$15 Extra**

New Men's Strap Watch

CUT PRICE SALE

\$3.99

Two years guaranteed with this jeweled Swiss watch. Choice in square, tonneau round or cushion shape—same price. Radium dial, accurate timekeeper. Satisfaction guaranteed. Rush order. Send no money. Pay postmaster \$3.99. **JENKINS, 685 Broadway, New York, Dept. 37-F-2.**

OLD MONEY and stamps WANTED

POST YOURSELF! It pays! I paid J. D. Martin, Virginia, \$200 for a single copper cent. Mr. Manning, New York, \$2,500 for one silver dollar. Mrs. G. P. Adams \$740 for a few old coins. I want all kinds of old coins, medals, bills and stamps. I pay big cash premiums.

WILL PAY \$100 FOR DIME
 1894 S. Mint; \$50 for 1913 Liberty Head Nickel (not buffalo) and hundreds of other amazing prices for coins. Get in touch with me. Send 4c for Large Illustrated Coin Folder. It may mean much profit to you. Write today to

NUMISMATIC COMPANY OF TEXAS
 Dept 187 FORT WORTH, TEXAS
 [Largest Rare Coin Establishment in U. S.]

TRICKS MAGIC JOKES FREE

SCIENTIFIC NOVELTY CO.
 98-B PARK PLACE, N.Y.C. CATALOG POSTAL BRINGS IT

Big Profits Can Be Made in Your Own Business

Start at Home In Spare Time



Sharpening lawn mowers on the Foley Electraken Lawn Mower Sharpener is a very profitable business. You can start at home in spare time in the basement, attic, garage or anywhere. Very little space required. No stock to carry.

Foley Electraken Lawn Mower Sharpener

Sharpens all kinds of lawn mowers perfectly in 15 to 20 minutes—and you get from \$1.25 to \$2.00 according to size. Figure the possibilities for yourself. Many have paid for the machine out of profits in a few weeks. Easy work and a steady, fine cash income.

No Experience Necessary

Easy and simple to operate. You can learn to turn out a perfect job in a short time. Get started now! Get some of this **Big Money** for yourself. Send coupon for information today.

READ THIS!

"I purchased a Foley Lawn Mower Sharpener 3 weeks ago and have already made enough money to pay for the machine and all expenses. . . ."
Walter Dambeck

"Last summer I made \$1,520.00 in five months."
Henry Morse

Foley Manufacturing Co.

1434 Foley Bldg., 11 Main St. N. E., Minneapolis, Minn.

Please tell me how I can make big money in my own business with the Foley Lawn Mower Sharpener.

Name.....

Address.....

City..... State.....

You can do it better with a Crescent Wrench

Your "shop" may be in the attic or the basement; maybe it's in the garage, but at any rate you need a dependable wrench—a **Crescent**. Crescent wrenches are made of special analysis steel—they are easily adjusted and they hold when set. They'll do the job easier and better.

The **CRESCENT—Smith & Hemenway** line includes a wide range of small tools, many with exclusive features, but all identified by their quality and workmanship. Crescent Tools are always sold under a satisfaction or money back guarantee.

CRESCENT TOOL CO.
210 Harrison St. Jamestown, N. Y.

Wrenches Chisels Snips
Pliers Punches Hacksaws
Screw Drivers Auger Bits
Nippers, Electricians' Tools



CRESCENT and Smith & Hemenway TOOLS



Lathes \$6.00 to \$75.00 Largest line of small lathes in America. Send six cents for 32 page catalog of lathes, drill presses, bench saws, jig saws, band saws, etc.

\$10⁰⁰ DOWN
Brings this Lathe to You

SYEPHER MANUFACTURING COMPANY
Dept. D-2 Toledo, Ohio

KINKADE GARDEN TRACTOR and Power Lawnmower

A Practical, Proven Power cultivator for Gardeners, Suburbanites, Truckers, Florists, Nurserymen, Fruit Growers.

New Low Prices—Easy Terms
AMERICAN FARM MACHINE COMPANY
1058, 33rd Av. SE. Minneapolis, Minn.



THE SKATE SHARPENER



sharpens the skate concave and lengthwise of the blade leaving a smooth, polished surface with no hollows.

WELLS MANUFACTURING COMPANY
Box 613
Greenfield, Massachusetts, U. S. A.

ELECTRIC LIGHTS ANYWHERE

Also runs Household Electrical Appliances. Install it yourself. Write for circular.

D. W. ONAN & SONS \$147⁵⁰
28 Royalston Ave. Minneapolis, Minnesota.

110 Volt—complete plant with all Wiring, Fixtures and Lamps for 7 rooms \$147.50, Direct-To-You.

Ideal for Farms, Camps, Summer Homes.



The FARRAND RAPID RULE

The most amazing tool invented in years. Coils easily in small cup, shoots out more rigid than wooden rule.



Compact,
Convenient,
Durable.

Made in eight
and six foot
lengths.

The Modern Craftsman Prefers
the Modern Tool

Ask Your Dealer or Write for Six
Inch Sample and Descriptive Folder

HIRAM A. FARRAND, Inc., BERLIN,
N. H.



Engines & Motors Big Catalog No. 30

Illustrating Electrical, Mechanical and Model Maker's Supplies, Small Steam & Gasoline Engines, Motors, Generators, Lathes, Drill

Presses, Bench and Band Saws, etc., 16-32 & 64 Watt Dyna-Motors, School Projects, Engine Castings, Motor Parts, etc., Books, Blue prints, Brass and Steel Tubing, Gears, Pulleys, Hangers, Experimental Material.

Send for Copy. Mailed anywhere for 20 cents, 45 cents Canada, refunded first order.

LOOMIS ELECTRIC & MFG. CO., 2822 N. CALIFORNIA AVE., CHICAGO, ILL.

PROTECT YOUR CAR National Carbon Company, Inc.
EVEREADY General Offices: New York, N. Y.
PRESTONE Branches: Chicago, Kansas City,
New York, San Francisco

for preparation of the perfect anti-freeze. Unit of Union Carbide and Carbon Corporation



Smooth Edges Quicker!

with Simonds
Planer Saws

If you could see how quickly and how easily a Simonds Planer Saw produces a smooth edge on any kind of wood—you'd want one for your home workshop... Simonds Planer Saws save lots of precious minutes...help you turn out a neater, better fitting job. Because they're made of high quality Simonds steel you can depend upon them for long service and genuine satisfaction. Ask your regular dealer to supply you, or write for prices and detailed information.

SIMONDS

SAWS FILES KNIVES STEEL

SIMONDS SAW AND STEEL CO.
FITCHBURG, MASS.

"The Saw Makers"

Established 1832

Branch Offices and Service Shops in Principal Cities

PARKS

WOODWORKING MACHINES

Cabinet Shop
Special No. 10

\$290

With Motor

You ought to have this handy Parks in your shop. Compact, complete machine designed like a big production outfit at 1/3 the cost. Floor space required only 42x72 in. Does any kind of cabinet and joinery work. Write for circular.

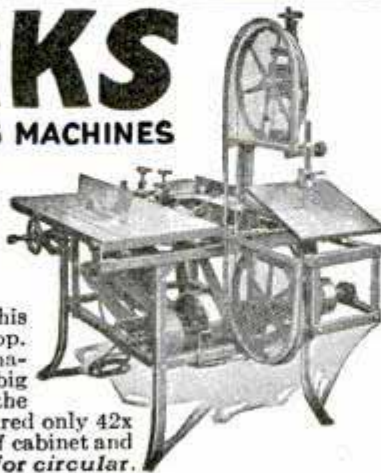

The Parks Woodworking Machine Co.

Builders of quality woodworking machines since 1887
1500-40 Knowlton St. Cincinnati, Ohio

Canadian Factory: 338 Notre Dame East, Montreal

Make big money from repair work



Practically every householder spends at least \$10.00 to \$50.00 each year and many spend several times that much on simple repairs that can be made *quickly, easily and well* with

Smooth-On No. 1

With a can of Smooth-On, you can save this money in your own home — and by doing similar repair work for others, you can make money.

No skill is required to make repairs and the amount of Smooth-On used on any one job seldom costs more than a few cents.

Typical repairs that can be made perfectly with Smooth-On:—Stopping leaks in steam, water, gas, oil or stove pipes, mending cracks, breaks or leaks in furnaces and boilers, radiators, tanks, sinks,

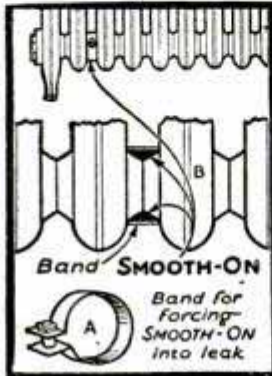

Leak at radiator joint stopped with Smooth-On

pots and pails, making loose handles tight on umbrellas, knives, hammers, brushes, drawers, etc., tightening loose screws, hooks, locks, door knobs, etc.

On the Automobile:—Making cracked water jackets and pumps good as new, stopping leaks in radiator, hose connections, gas tank and gas, oil and exhaust lines, making a fume-proof joint between exhaust pipe and tonneau heater, tightening loose headlight posts, keeping grease cups, hub caps and nuts from loosening and falling off, etc.

To get perfect results, write to us for and use the Smooth-On Repair Book. Free if you return the coupon.

Get Smooth-On No. 1 in 7-oz., 1-lb. or 5-lb. tins at any hardware store or if necessary direct from us.

SMOOTH-ON MFG. CO.
Dept. 37, 574 Communipaw Ave.
JERSEY CITY, N. J.



How to make HOME-AUTOMOBILE REPAIRS

Do it with SMOOTH-ON

Write for FREE BOOK



Do it with SMOOTH-ON

SMOOTH-ON MFG. CO., Dept. 37,
574 Communipaw Ave., Jersey City, N. J.

Please send the free Smooth-On Repair Book.

Name.....

Address.....

2-30

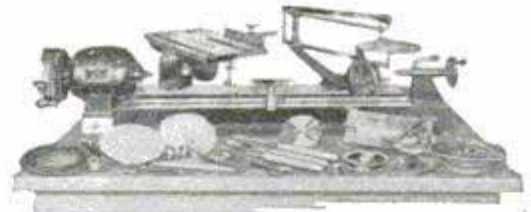

The Home Workshop for Quality Work

The Ar-Con Utilitool workshop is designed and built to provide the power, strength and accuracy essential to quality workmanship. The motor, for instance, is of the super-efficient repulsion-induction type, ball-bearing, and delivers full 1/2 HP at 1750 r.p.m. And all other units are built to the same high standards of quality in material and workmanship. Whatever the operation—turning, rip or crosscut sawing, scroll sawing, sanding, grinding, buffing, drilling—you can depend on Ar-Con Utilitool units always.

Free Trial! Easy Terms!

Write for fully illustrated circular, together with details of 10-day trial offer and liberal time payments applying to complete outfit or any unit or combination of units you may desire.

THE AR-CON TOOL COMPANY
500 Fassett Street - - - Toledo, Ohio

AIR-CON UTILITOL

THE KING OF THEM ALL

SALESMEN WANTED! SELL COX HOLDFAST SCREW DRIVERS

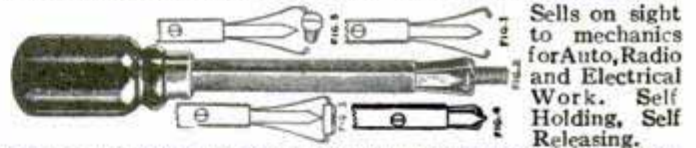

Sells on sight to mechanics for Auto, Radio and Electrical Work. Self Holding, Self Releasing.

Send 50c for sample and ask how to get Salesman's Outfit Free. S. J. COX Dept. F. FRANKLIN, PA.

BURN YOUR NAME ON TOOLS

WITH THE ARKOGRAF

PROTECT YOUR TOOLS FROM THEFT Write with electricity any name or design on the hardest and finest tools and instruments, or any metal, like writing on paper with pen or pencil. Complete Outfit \$3.50—Prepaid Anywhere Interesting illustrated circular free. Write today. Agents wanted. ARKOGRAF PEN CO., 1171 E. Stark St., Portland, Oregon

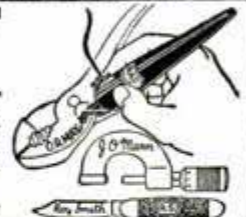

TOOLMAKERS and MACHINISTS FIND GERSTNER Tool Chests desirable. They keep tools in order and save them from loss and damage. *Catalog Free.*

Gerstner & Sons
74 Columbia Street, Dayton, Ohio

STANDARD GARDEN TRACTOR

Plows Seeds Cultivates Mows Hay and Lawns

A Powerful Tractor for Small Farms Gardeners, Florists, Nurseries, Fruit Growers and Poultrymen

DOES 4 MEN'S WORK
Walking & Riding Equipment
Free Catalog. Does Belt Work

STANDARD ENGINE COMPANY
3221 Como Ave. Minneapolis, Minn.

THIS STERLING HOME for \$1194



Big Special Discount for Cash!

Here's a modern 7-room home that you can build yourself and save money. We ship you the lumber cut-to-fit, freight paid to your station. Our simple plans and new system of cutting makes it easy for anyone to build a Sterling home. No skilled labor necessary. Our customers claim average savings of 47% over local builders' prices.

Rock-Bottom Prices!

Our large volume of sales enables us to quote rock-bottom prices and sell on time-payments without high interest or financing charges. Terms as low as \$8.10 per month. Send 25c today for beautiful Color Book of NEW Sterling Home Plans and learn how you can buy a home with your rent money.



International Mill & Timber Co.
324 S. Wenona Ave. Bay City, Mich.



ELECTRIC LAWN MOWER

Don't tire yourself out with an old style mower when you can get an electric at a price you can afford to pay. 110 volt A. C. or 32 volt farm plant. Write for particulars. Agent wanted.

Raun Lawn Mower Co.
Box 533 El Campo, Texas

BOYS! GET READY FOR NATIONAL MODEL AIRPLANE CONTEST



NATIONAL MODEL AIRPLANE CONTEST

Big Cash prizes are won yearly by contestants. Send 10c today for 48 page illustrated catalog and contest particulars. Hurry—no time to lose.

MICHIGAN MODEL AIRPLANE SUPPLY CO.
4758-F Grand River Ave. Detroit, Mich.

ATKINS SILVER STEEL SAWS



for YOUR Home WORKSHOP

It's FUN to Cut with these Saws

YOU'LL never know how much fun you can have in cutting wood or metal, until you use an ATKINS Silver Steel Saw. Then you'll realize why these famous Saws are the favorites with home craftsmen, as well as mechanics, factories and mills, the world over.

For cutting metal, the New ATKINS Silver Steel Blue-End Hack Saw Blades win every time. They cut TWICE as fast, and last SIX times longer, than OLD STYLE blades.

For cutting wood, there's a full line of ATKINS Saws, headed by the famous "400" Hand Saws.



ATKINS Circular Rip, Cross-Cut or Miter Saws for any outfit

They cut faster, run easier, stay sharp longer and out-last other saws! Dozens of other popular ATKINS hand saws, including the "Junior Mechanic" for boys.



ATKINS Narrow Band Saws in all sizes for small machines

For power sawing, ATKINS Circular Saws fit any outfit and do better work. Also, Band Saws for fine, fast sawing! Dado Heads for cutting grooves quicker!

Whatever other saws or cutting tools you need — Back Saws, Coping Saws, Compass Saws, Cabinet Scrapers, Files, Grinding Wheels, Saw Filers, Saw Sets, etc.—ask for "ATKINS" at your Hardware Store.

Four Saw Booklets FREE

CIRCULAR SAWS

DADO HEADS

SAWS IN THE HOME

SAW SENSE

E. C. ATKINS & CO.
Est. 1857 426 S. Illinois St.
Indianapolis, Ind.

Send "Saws in the Home," "Circular Saws," "Dado Heads," and "Saw Sense"; also information on your offer to pay \$10 for best home workshop photo.

Name.....

Address.....

My Dealer is.....

FUGO

FIRE EXTINGUISHER

EASY \$100 a Week

Unusual opening for live agents in every locality. Make \$5,000 or more a year—easily. Fugo—the instantaneous automatic fire extinguisher—is needed and wanted in every home, store, theatre, garage, shop, school, automobile, etc. Cheapest fire protection available today. Within reach of all.

1 Qt. Size \$5.00 2 Qt. Size \$7.50

Recharged in a Hify

Amazing 30-second demonstration clinches sale—each one sold sells others. Territory going fast. Write at once for wonderful proposition that will MAKE YOU BIG MONEY.

The National Formetal Co., 6535 Metta Ave., Cleveland, Ohio

10th Anniversary Offer

THIS great 10-tool kit at \$10 celebrates our 10th Anniversary. A Special CORNWELL Offer, the first ever made. Just the tools you need for daily use. Order this kit at once. Every tool of standard, genuine, CORNWELL Quality.



TEN "CORNWELL" TOOLS for TEN DOLLARS

HERE are the tools in the Anniversary Kit—10"x1" Flexible Wire Carbon Scraper, 3/4"x9" Flat Chisel, 10" Screw Driver, 3/8"x9/16" opening 7 1/2" length 12-Pt. Box Wrench, 5/8"x7" Flat Chisel, 3/8"x9" Drift Punch, Cornwell Nu-Thread Thread Restorer, 5/8"x3/4" USS Open End Wrench, 7" Combination Side Cutting Plier, 5/8"x3/8" SAE Open End Wrench. CORNWELL Tools have been on the market 10 years. Their marvel-

ous quality has made them the choice of mechanics everywhere. Millions are in use. Every tool is amazingly strong, being hand-made from Swedish Chrome Molybdenum Steel—hardened and heat-treated by our special CORNWELL process. CORNWELL Tools will stand severe tests and strains that no other tools can endure.

Order this special kit today or mail the coupon for catalogue of our complete line. Remember, there is no substitute for Cornwell Quality.

The Cornwell Quality Tools Co. Dept. T, Mogadore, O.

Send me new illustrated catalog with prices on full line of CORNWELL Hand-made Tools.

CORNWELL QUALITY TOOLS CO.

Mogadore, Ohio
Suburb of Akron

Name..... Where Employed.....

Address.....

City..... State.....



Andy Sannella Talks to Reed Players. Get this Free Book!

On the air tonight, and every night, Andy Sannella is earning a fabulous salary with his Selmer Sax. In his book of "Advice to Saxophone Players," he gives more valuable information than in ten private lessons. This book also contains Talks to Clarinetists by Alexandre Selmer. Send for free copy.

If you will mention the instrument you play, we will send also, free samples of our Alexandre Reeds. They Play!

Selmer

264 SELMER BUILDING, ELKHART, INDIANA
(In Canada: 516 Yonge St., Toronto)

Watch!
It
"Taxis"
"Takes
Off"

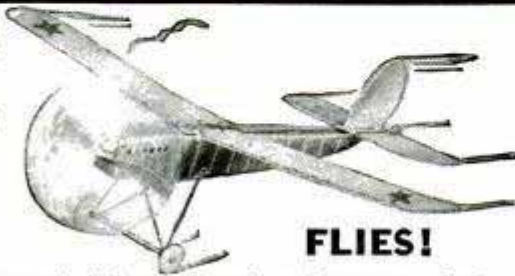

FLIES!

Boys! Picture a great airplane roaring down the runway—faster—faster—faster! Then, Z-O-O-M and she's up in the air. What a thrill! Well—now you can have a toy plane that has precisely the same flight action. Not a construction toy but a fully built plane. A few moments to assemble and she's ready for flight. Wings and body of light Balsam wood, reinforced with aluminum; aluminum propeller; powerful elastic motor, Model 21, Cabin Type, 22 in. wing spread, \$2.50. Racing Model No. 1, 18 in. wing spread, \$1; No. 2, 26 in. wing spread, \$2.00. (West of Miss. \$2.75—\$1.10—\$2.20.) Look for them at your dealer's. If not in stock we will ship direct. KINGSBURY MFG. CO., 83B Myrtle St., Keene, N. H.

Send 10c for a Kingsbury Disc Wheel, Balloon Tire Eraser.

KINGSBURY MOTOR DRIVEN TOYS

For
Craftsmen
Who
Want
Something
More Than
a Toy!

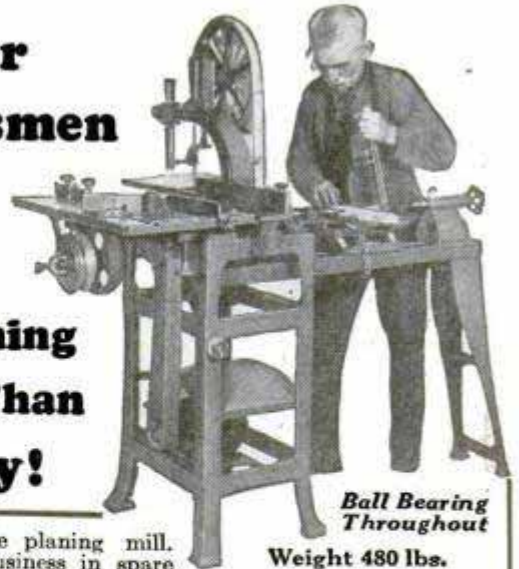

Ball Bearing Throughout

Weight 480 lbs.

A complete planing mill. Build a business in spare time. Turn out accurate cabinet work. Ideal for the Home Craftsman. Saws 3 1/4" thick. Rips 12" wide. Lathe swings 10". Rugged cast-iron frame; no warping, twisting or vibration.

The Electric Carpenter

Runs from any Light Socket

\$35 deposit brings it to you for Free Trial. A whole year to pay!

7 Machines in One

- 8" Circular Saw
- 14" Band Saw
- 36" Lathe
- 10" Swing
- 4" Jolnter
- Reversible Shaper
- 1/2" Hollow Chisel Mortiser
- Sander

Does 35 Woodworking Operations

Write today for New Folder P-99

We also build a complete line of single-purpose machines
THE WOODWORKING MACHINERY CO., INC.
Eleventh and Vine Sts., Philadelphia, Pa.

Learn to PAINT SIGNS and SHOW CARDS

We quickly teach you by mail, or at school, in spare time. Big demand. Big future. Interesting work. Oldest, foremost school. EARN \$50 TO \$200 WEEKLY

Otto Wiegand, Md., home-study graduate, made \$12,000 from his business in one year. John Vassos, N. Y., gets \$35 for a show card. Crawford, B. C., writes: "Earned \$200 while taking course." Write for complete information.

DETROIT SCHOOL OF LETTERING
150 Stimson Ave. Est. 1899 DETROIT, MICH.

OTTAWA LOG SAW

only \$39

GREATEST OFFER EVER MADE

PUTS THIS OTTAWA TO WORK FOR YOU

Make Money! Wood is valuable. Saw 15 to 20 cords a day. Does more than 10 men. Ottawa easily operated by man or boy. Falls trees—saws limbs. Use 4-hp. engine for other work. 30 DAYS TRIAL. Write today for FREE book. Shipped from factory or nearest of 6 branch houses.

OTTAWA MFG. CO., 1741-W Wood Street, Ottawa, Kansas

Photos ENLARGED

Size 16x20 inches
Same price for full length or bust form groups, landscapes, or pet animals, etc., enlargements of any part of group picture. Safe return of your own original photo guaranteed.

98c

SEND NO MONEY Just mail photo or snapshot (any size) and within a week you will receive your beautiful life-like enlargement size 16x20 in. guaranteed fadeless. Pay postman 98c plus postage or send \$1.00 with order and we pay postage. **SPECIAL** With each enlargement we will send FREE a hand-tinted miniature reproduction of photo sent. Take advantage now of this amazing offer—send your photo today!

UNITED PORTRAIT COMPANY
1652 Ogden Ave. Dept. B-360 Chicago, Ill.

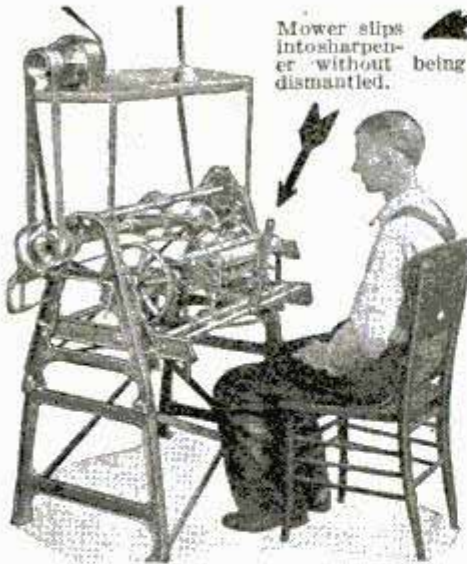

THIS MAN IS MAKING \$4.00 to \$6.00 an hour!

SHARPENING LAWNMOWERS in Spare Time With the "IDEAL" LAWNMOWER SHARPENER Man, Why Don't You Do That?

You've got the chance—the same chance as W. T. Moore, Twin Falls, Idaho, who made \$1200 net profits in 90 days—the same chance as Walter Wever, Middletown, N. Y., who made \$1000 in 4 months—the same chance as hundreds of others who have reaped rich rewards with this amazingly efficient lawnmower sharpener.

Use Your Spare Time. If you work at a trade, put an Ideal in your basement and earn \$4 to \$6 an hour evenings and Saturday afternoons. E. W. McCormick, Saginaw, Mich., writes: "Five years ago I bought an Ideal Sharpener on which I have ground over 5,000 lawnmowers. In the last few weeks I worked at my trade, machinist, full time 9 hours a day. I also ground 97 mowers which netted me \$114.10 clear gain."

Pays for itself and makes big profits: C. S. Coburn, Little Rock, Ark., writes that his "Ideal" Sharpener earned enough in 18 months to pay for itself and \$1857.00 worth of additional machinery.

Our Free Book Tells You How—these men and many others have made themselves independent—built substantial, permanent, BIG PAYING businesses with this Ideal Sharpener. Send for this book today—It's Free.

SIGN THIS AND MAIL TODAY

THE FATE-ROOT-HEATH CO.
918-944 Bell St., Plymouth, Ohio.

Send me the book that tells me how I can make my spare time worth \$4 to \$6.00 per hour.

Name.....

Address.....

FREE BOOK TELLS HOW OTHERS DO IT!

THE "IDEAL" LAWNMOWER SHARPENER is a wonderfully simple machine that sharpens all makes of mowers perfectly, scientifically, without taking the mowers apart. Just pick up the mower, set it in the "Ideal," make a few simple adjustments and proceed to sharpen. In 15 minutes the mower is ready for the lawn, and you have made \$1.50 to \$2.00—depending upon the charge you fix. No training required, and machine set up in a few minutes. Plug into light socket and start to sharpen. Hundreds of dull mowers in your locality are waiting to be sharpened. Owners are looking for a place to get them sharpened. Sharpens skates—all kinds—perfectly.



WANT TO MAKE

\$500?

I'll Show You a New, Pleasant Way to Do It!

If you want to make \$500—in spare time or full time—just send me your name. I have wonderful openings in every locality for both men and women. Earnings can start at once. Pleasant work. No experience or capital needed. I furnish everything and show you how.

\$83 PROFIT FIRST 5 DAYS

That's what Victor Baumann made as my Representative in his locality. Mrs. K. R. Roof, \$50 first week in spare time. Van Allen, \$125 in one week. Think of the possibilities! Hundreds of men and women making big money. Don't miss this chance. Vacancies being filled rapidly. Write today **SURE!**

ALBERT MILLS, Pres., 5504 Monmouth Ave., CINCINNATI, OHIO

QUIT TOBACCO

Don't try to banish unaided the hold tobacco has upon you. Thousands of inveterate tobacco users have, with the aid of the Keeley Treatment, found it easy to quit.

KEELEY TREATMENT FOR TOBACCO HABIT Quickly banishes craving for tobacco. Successful for over 50 years. Write today for **FREE BOOK** and particulars of our **MONEY-BACK GUARANTEE.**

THE KEELEY INSTITUTE, Dept. A-930, Dwight, Ill. Home of the famous Keeley Treatment for Liquor and Drugs. Booklet Sent on Request. Correspondence Strictly Confidential.



Makes Old Ford a Tractor

Now you can convert that old Ford car into a useful farm tractor without altering any Ford parts. We furnish the traction wheels, drive gears and auxiliary axle and mountings, ready to clamp on to the Ford frame. Pulls 16' plow.

We supply a Belt Pulley also



Write for Free Particulars. Shaw Mfg. Co., Dept. PM2, Galesburg, Kan.

Going to Build Remodel or Repair?

DON'T think of building a new home or repairing an old one without a copy of our free woodwork catalog.

To those who contemplate building or remodeling, this book is a valuable work of reference. In it are found the latest ideas and most advanced styles for everything in millwork. It illustrates and describes windows and sash of all kinds, including porch and storm sash, doors, frames, mouldings, screens, porchwork, stairwork, hardwood flooring, interior finish, cabinet work—in fact, practically everything in manufactured millwork.

Every article in the book shows a low money-saving price direct to you.

FREE ESTIMATES

Send us your lumber and millwork bills for a free estimate. Let us quote prices on your material and tell you the exact amount of freight. Then compare our prices with others. This service costs you nothing and places you under no obligation whatever.



CHICAGO MILLWORK SUPPLY CO., 1444 W. 37th St., Chicago, Ill.
PLEASE SEND ME YOUR FREE BOOK

Name _____
Town _____
State _____
Occupation _____
St. No. _____

Book is Free



Hand him this!

If you know a man who brings home a hand like this every night, you can do him a good turn—and make his wife happy, too—by telling him about Lava Soap. Tell him that Lava's rich lather is filled with Italian pumice that's ground as fine as flour. It gets the grimeiest hands clean in 58 seconds, without hurting the skin. And tell him that Lava works fast even in cold or very hard water.

George, the Lava Soap Man

A big cake of Lava Soap costs only a dime (or 6 cents for the medium size cake) at any grocery or drug store. But if you want to try it first at my expense, mail this coupon.

Procter & Gamble, Dept. W-230
Cincinnati, O.

George: Send me a free sample cake of Lava Soap.

Name.....

Street.....

City.....State.....

BIG MONEY MAKER



Selling Kit Furnished

"A great idea!"

Something different—an original idea—never before seen on the market. Every man and boy a prospect.

Hook-Fast Belt and Buckle made to individual order—no two alike. Every buckle with personal initials and emblems—according to individual taste. Splendid profits made easily—**HANDSOME SELLING OUTFIT FURNISHED**—contains actual samples.

Become the official representative of Hook-Fast Belt and Buckle in your locality—Make big money—Sells itself.

Belt made of genuine English cowhide—never wears out—Buckle made of attractive plated-croyd—lasts a life time, bright and untarnished—Specially patented Hook-Fast catch never slips.

Red-Hot selling proposition. Get in on it now! Write for free particulars.

NATIONAL CRAFTS COMPANY

20 West 27th Street, Dept. B-26

New York City

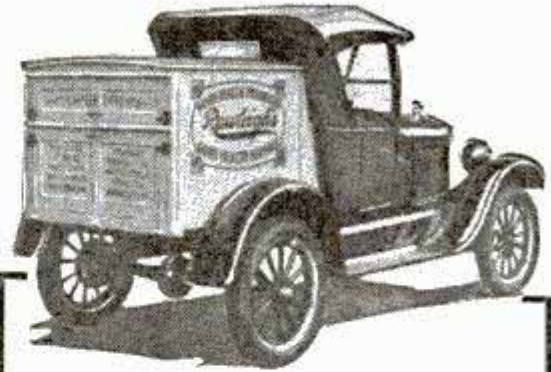

WANTED!

500 Dissatisfied Farmers and Sons to Stop Renting

And begin retailing Rawleigh's Good Health Products to Consumers. Start your own business. Make from \$100 to \$400 a month or more clear profit. Be your own boss. No selling experience required. We supply everything—Products, Outfit, Sales and Service Methods. Profits increase every month. No lay off. Steady year-round. Lowest prices. Best values. Most complete Service. Rawleigh Methods get the most business everywhere. For particulars write

THE W. T. RAWLEIGH CO.

DEPT. B-18PPM, FREEPORT, ILL.



SUNLIGHT FOR HEALTH, NEW LIFE AND VIGOR

Special low price on Mann CARBON ARC Ultra Violet Projector—complete with carbons, etc., only \$8.50. Produce concentrate Ultra-Violet Rays in your home! Aids and maintains health, relieves pain, builds up vitality! Has automatic device and uses big 8mm carbons. Efficient, powerful and easy to use. Built extra strong and durable. 12 1/2 in. high.

SEND NO MONEY! Pay postman \$8.50 on arrival, plus postage. Try it! If not more than delighted with results, return it and your money will be promptly refunded. Descriptive literature free on request.

Ultra Mfg. Co., (Lamp Dept.) 121 N. Francisco Ave. CHICAGO

Beautiful HOUSES \$900 and BUNGALOWS \$900

CAN BE BUILT FOR AND UP

This and many others in my new book, Building Plans for Modern Homes, will save you hundreds of dollars. One of the most complete and comprehensive books of plans ever published by any architect. New edition just off the press. Nearly 600 floor plans and photographs of Colonial houses, bungalows, etc., costing from \$200 up; gives sizes and cost to build. Sent postpaid for \$3.00.



FREDERICK H. GOWING ARCHITECT

101 Tremont St., BOSTON, MASS.

\$4.99 22 Cal. Blank Automatic

100 CART. RIDGES Free!

You need no license or permit to own this 6-shot blank Automatic. Use for fun, keeps away tramps, thieves, dogs, fool your friends. Same as an expensive automatic in construction, finish, appearance, durability; automatic magazine loading and ejection of cartridges, powerful report. Guaranteed absolutely safe. Send no money. Pay on delivery \$4.99. **JENKINS, 655 Broadway, New York, Dept. 37-J-2**



AGENTS: The DUO-PAC is a Whirlwind Seller



Duo-Pac holds package cigarettes, also regular book matches in special slides on side. Variety colors baked enamel also plated. Most convenient little article ever invented. A sale every time shown with big profit. Beautiful gift men and women. Nothing like it.

Write for full particulars MUTUAL SERVICE FACTORIES

Desk 22—522-24 McKnight Building Minneapolis, Minn.

Patents Pending SAMPLE 50c 3 for \$1.00

Everyone is Skiing!

Wherever snow flies, you'll see skiers on the hills. And 90% of the experts are using

Northland Skis

National Champions and World's Champion jumpers are 100% for these fast, finely-designed record-makers. The famous deerhead trademark identifies them.

Ask for booklet, "How to Ski".

Northland Ski Mfg. Co.

World's Largest Ski Mfrs.

95 Merriam Pl.
St. Paul,
Minn.



\$2.00 INKOGRAPH
PENCIL POINTED FOUNTAIN PEN

Writes with ink smooth as a lead pencil on cheapest or finest paper, without miss, skip or blur. Won't blot, scratch or leak. Makes 3 carbon copies at one time with original in ink. Any one can use your Inkograph—hard pressure cannot spread or injure its 14 Kt. gold point. Patent automatic feed prevents point from clogging. No complicated mechanism. Best material and workmanship. Fully Guaranteed.

Send No Money. Pay postman \$2.00 plus postage. Sent prepaid if remittance accompanies order. Money back if not satisfied within 10 days.

INKOGRAPH CO., Inc., 161-78 Centre St., New York City

FREE 10 DAYS TRIAL

THE WRITING HEMISPHERE

THAT BALL-LIKE 14 KT GOLD POINT

AGENTS Send for Inkograph or FREE sales plan booklet. Sells on sight, no investment, immediate commissions.

\$65.00 buys a genuine 4' Crescent bench jointer, complete with powerful universal motor, ball bearings and guard. Ask for circular giving complete description.

Other Crescent machines that will help turn out your wood work to advantage are band saws, saw tables, self feed rip saw, shapers, jointers, variety wood worker, planers, planer and matcher, disk grinder, cut off table, swing cut off saws, borers, hollow chisel mortisers, tenoners, universal cut-off saw, universal wood workers.

THE CRESCENT MACHINE CO.
93 Columbia St. Leontonia, Ohio

Send for FREE BULLETINS

AGENTS 500% PROFIT

GENUINE GOLD LEAF LETTERS

S guaranteed to never tarnish. Anyone can put them on stores and office windows. Enormous demand, large profits. Paul Clark says: Smallest day \$28.70. R. L. Reel made \$920 in two months. Write today for free sample and liberal offer to general agents.

METALLIC LETTER CO. 433-B N. Clark St., CHICAGO

DO YOU WANT a new business profession of your own, with all the trade you can attend to? Then become a foot correctionist, and in a few weeks earn big income in service fees,—not medical nor chiropody—easy terms for home training, no further capital needed, no goods to buy, no agency. Address

Stephenson Laboratory, 1 Back Bay, Boston, Mass.

AGENTS AND SIGN MEN
Now Making \$50.00 to \$100.00 and Up Per Week Selling Our

GOLD LEAF SIGN LETTERS

R For store and office windows, board signs, trucks and glass signs. We also make to order script signs and business emblems singly or by the thousands. A permanent business. No capital or experience required. Big demand in every city. *Samples and Literature Free.*

CONSOLIDATED SIGN LETTER CO. 71-X W. Van Buren CHICAGO, ILL.

Do Your PRINTING
Cards, stationery, circulars, tags, labels, advertising, etc. Save money. Print for Others, Big Profits. Junior Press, \$5.00. Job Presses \$11 up, Rotary \$140. Will do popular Raised Printing like Engraving. Easy rules sent. Send for catalog outfits. **THE KELSEY CO., S-37, Meriden, Conn.**

WURLITZER

Trade Mark Reg.

THE WORLD'S LARGEST MUSIC HOUSE



200 Years Ago in the little Saxon town of Schoeneck lived Hans Adam Wurlitzer, Master Violin Maker. His shop was a gathering place for musicians of the time, for he was a true craftsman.

When he died his shop passed into the hands of his eldest son, and for seven generations, down to the present day, the descendants of Hans Adam Wurlitzer have carried on his work.

Today in every Wurlitzer instrument you will find a quality, a character, that could not come from mere excellence of manufacture. It is the heritage of these seven generations of music craftsmanship.



Try any Wurlitzer Instrument in your Own Home

YOU may now have any Wurlitzer instrument for a generous free trial in your own home. Examine the instrument, show it to your friends, play it as much as you wish. No obligation to buy—no expense for the trial. We make this liberal offer because we want you to try for yourself these wonderful instruments, the result of 200 years' experience in musical instrument Building. Easy payments are arranged to suit your convenience. This is your opportunity to try a famous Wurlitzer instrument in your own home.

Send for New Catalog

The greatest musical catalog ever published. Over 3,000 articles—every known instrument described and illustrated; many of them shown in full colors. Gives you lowest prices and all details of Free Trial, Easy Payment plan. All sent FREE—no obligation.

Send this Coupon

THE RUDOLPH WURLITZER CO., Dept. 1772
117 E. 4th St., Cincinnati

Send me absolutely free, your new illustrated catalog, with prices and description of every known musical instrument. Also tell me how I may try any instrument in my own home and pay for it in small monthly sums. No obligation.

Name.....
Address.....
City.....State.....
Instrument.....
(State instrument in which you are interested)

PATENT

Protect Your Ideas

Take the First Step Today

If you have a useful, practical, novel idea for any new article or for an improvement on an old one, you should communicate with a competent Registered Patent Attorney AT ONCE. Every year thousands of applications for patents are filed in the U. S. Patent Office. Frequently two or more applications are made for the same or substantially the same idea (even though the inventors may live in different sections of the country and be entirely unknown to one another). In such a case, the burden of proof rests upon the last application filed. Delays of even a few days in filing the application sometimes mean the loss of a patent. So lose no time. Get in touch with me at once by mailing the coupon on the opposite page.

Prompt, Careful, Efficient Service

This large, experienced organization devotes its entire time and attention to patent and trade mark cases. Our offices are directly across the street from the U. S. Patent Office. We understand the technicalities of patent law. We know the rules and requirements of the Patent Office. We can proceed in the quickest, safest and best ways in preparing an application for a patent covering your idea. Our success has been built on the strength of careful, efficient, satisfactory service to inventors and trademark owners located in every state in the Union.

NO CHARGE for Information On How to Proceed

The booklet shown here contains valuable information relating to patent procedure that every inventor should have. And with it I will also send you my "Record of Invention" form on which you can sketch your idea and establish its date before a witness. Such evidence may later prove valuable to you. Simply mail the coupon and I will send you the booklet, and the "Record of Invention" form, together with detailed information on how to proceed and the costs involved. Do this NOW. No need to lose a minute's time. The coupon will bring you complete information entirely without charge or obligation.

My Patent Law Offices
Just Across
Street From
U.S. Pat. Office



Above is a view of my drafting and specification offices where a large staff of experienced experts are in my constant employ. All drawings and specifications are prepared under my personal supervision.

FIRST

Inventors
Write for these

**Free
Books**

Strict Secrécy Preserved

All communications, sketches, drawings, etc., are held in strictest confidence in strong, steel, fireproof files, which are accessible only to authorized members of my staff. Feel free to write me fully and frankly. It is probable that I can help you. Highest references. But **FIRST**—clip the coupon and get my free book. Do **THAT** right now.

Clarence A. O'Brien

*Registered Patent Attorney
& Attorney-at-Law*

Member of Bar of: Supreme Court of the United States; Court of Appeals, District of Columbia; Supreme Court, District of Columbia; United States Court of Claims. Practice confined exclusively to Patents, Trademarks and Copyrights

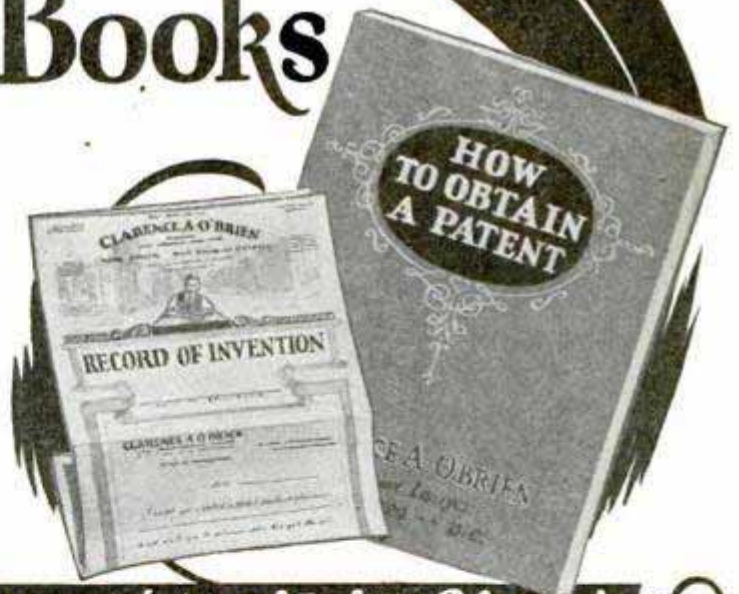

Clip this Coupon and Mail it Now!

CLARENCE A. O'BRIEN, *Registered Patent Attorney & Attorney-at-Law*

701 Security Savings and
Commercial Bank Bldg.,
Washington, D. C.

OR

Suite 1106 Woolworth Bldg.,
New York City

Please send me your free book, "How to Obtain a Patent," and your "Record of Invention" form without any cost or obligation on my part.

Name.....

Address.....

(Important—Write plainly and address office nearest you)

PATENTS TRADE MARKS COPYRIGHTS



Our New York Office
Suite 1007 Woolworth Bldg.



Our Philadelphia Office
828 Fidelity Phila. Trust Bldg.



VICTOR BUILDING
Our New Building Nearly Opposite U. S. Patent
Office Specially Erected by Us for Our Own Use



Have You An Idea?

Our Offer: FOR THE PROTECTION
OF YOUR INVENTION

YOUR FIRST STEP—The Inventor should write for our blank form "RECORD OF INVENTION." A sketch and description should be made on this Blank, signed, witnessed, then returned to us. We also give our opinion as to whether the invention comes within the Patent Office definition of a patentable invention. This "Record of Invention" will serve as "proof of conception." *There is no charge or obligation for this service.*

**Our Five Books Mailed
Free to Inventors**
Our Illustrated Guide BOOK

How to Obtain a Patent
Contains full instructions regarding U. S. Patents. Our Methods, Terms, and 100 Mechanical Movements illustrated and described.

Our Trade Mark Book
Shows value and necessity of Trade Mark Protection. Information regarding *Trade Marks and unfair competition in trade.*

Our Foreign Book
We have Direct Agencies in Foreign Countries, and secure Foreign Patents in shortest time and lowest cost.

Progress of Invention
Description of World's Most Pressing Problems by Leading Scientists and Inventors.

Payment of Fees in Installments
It is not necessary that the total cost for the preparation and prosecution of a patent be paid in one payment. Our custom is to permit our clients to pay for their applications in three installments as the preparation of the application progresses in our office. This plan makes the payments easy for the inventor.

We Regard a Satisfied Client as our best advertisement, and furnish anyone, upon request, lists of clients in any state for whom we have secured patents.

*Highest References—Prompt Service
—Reasonable Terms*

VICTOR J. EVANS & CO.

Patent Attorneys, Established in 1898
Main Offices: 789 9th St., N. W., Washington, D. C.
Nearly Opposite U. S. Patent Office

DELAYS ARE DANGEROUS IN PATENT MATTERS

IMPORTANT! To Avoid Delay!

YOU SHOULD HAVE YOUR CASE MADE SPECIAL IN OUR OFFICE to save correspondence, secure protection and early filing date in the Patent Office. To secure **special preparation** of your case send \$25.00 on account with model or sketch and description of invention.

ACT NOW—Often two or more inventors file applications for practically the same idea. In such cases the burden of proof rests upon the last application filed. Therefore, delays often cause the loss of a patent.



Our Chicago Office
Suite 1640-42 Conway Bldg.



Our Pittsburgh Office
Suite 514 Empire Building



Our San Francisco Office
Suite 1010 Hobart Building



MAIN OFFICE, VICTOR J. EVANS & CO.—VICTOR BUILDING, WASHINGTON, D. C.

Our Large, Comprehensive Organization has been established for 30 years and offers Prompt, Efficient and **Personal Service** by experienced Patent Lawyers and Draftsmen. Every case is in charge of a Specialist who has been selected for his knowledge and experience in certain lines of invention. Our Lawyers practice in all U. S. Courts and defend clients in suits involving Patents, Trademarks and Copyrights. All Communications, Sketches, Drawings, etc., preserved in fireproof Files, strictly **Secret and Confidential**. We shall be glad to have you consult us or to answer any questions in regard to Patents, Trademarks or Copyrights without charge or obligation.

**FREE
COUPON**

VICTOR J. EVANS & CO.
PATENT ATTORNEYS *Established in 1898*

NEW YORK OFFICES
1007 Woolworth Bldg.

CHICAGO OFFICES
Suite 1640-42 Conway Bldg.

PHILADELPHIA OFFICES
828 Fidelity Phila. Trust Bldg.

PITTSBURGH OFFICES
514 Empire Bldg.

SAN FRANCISCO OFFICES
1010 Hobart Bldg.

MAIN OFFICES: 789-9th Street, N. W., WASHINGTON, D. C.

Gentlemen: Please send me *Free of Charge* your books as described on preceding page.

Name.....

Address.....

PATENTS

Booklet Free Highest References
Promptness Assured Best Results

Send drawing or model for preliminary examination and advice.

ALL BUSINESS GIVEN PROMPT AND PROPER ATTENTION

Listed Patent Lawyer in the latest editions of the Rand-McNally Directory of Bankers and Bonded Attorneys, published by Rand-McNally & Co., Chicago, Ill.; The Baggott & Ryall Directory of Guaranteed Attorneys, published by Legal Directory Corporation, Boston, Mass.; Flugel's Law List, published by Legal Directory Publishing Co., St. Louis, Mo.; American Lawyers Annual, published in Cleveland, Ohio; Bankers Service Legal Directory, published by Bankers Service Co., Boston, Mass.; Eyre's Law List, 9 Park Place, New York City; Walters Legal Directory, Omaha, Nebraska, and the National Directory of Attorneys, Baltimore, Maryland.

WATSON E. COLEMAN,
REGISTERED PATENT LAWYER

Victor Building, 724 Ninth Street, N. W.
WASHINGTON, D. C.

PATENTS

PROTECT YOUR IDEAS

Write today for FREE INSTRUCTIONS—or send Drawing or Model of your Invention for Examination.

Promptness Assured with Best Results

CARL MILLER
REGISTERED PATENT ATTORNEY

Former Member Examining Corps U. S. Patent Office
255 McGill Building Washington, D. C.

PATENTS

To the Man with an Idea

PATENTS Procured. Trade Marks Registered.—A comprehensive, experienced, prompt service for the protection and development of your ideas. Preliminary advice gladly furnished without charge. Booklet of information and form for disclosing idea free on request.

IRVING L. McCATHRAN, Patent Lawyer
Formerly with and successor to RICHARD B. OWEN
704 International Bldg., Washington, D. C.
41-E Park Row, New York City

TRADE-MARKS
REGISTERED

PATENTS



Send us sketch or model for advice and exact cost of patent. Our book "How to Obtain a Patent" sent free. It tells how to apply for Patents, Trade Marks, Foreign Patents, Copyrights, etc.; gives information on Patent Procedure; tells what every inventor should know. Thousands of inventors, who are our clients, are our reference.

CHANDLEE & CHANDLEE, 25 Years' Experience
912 F Street Washington, D. C.

PATENTS

Trade Marks, Copyrights, Patent Litigation Handbook with illustrations, 100 mechanical movements. Sent free on request.

ALBERT E. DIETERICH
formerly member Examining Corps U. S. Patent Office

REGISTERED
PATENT LAWYER and SOLICITOR

621-A, Ouray Bldg.
30 Years' Experience Washington, D. C.

Information on any book free. Write Popular Mechanics Press, Chicago, Ill.

PATENT YOUR INVENTIONS

EDWARD GOTTLIEB

Attorney in Patent Causes

5 Beekman Street New York

Inventions Developed—Representatives for

BLAIR TOOL AND MACHINE CORP.

PATENTS

TRADE-MARKS

*Don't Lose Your Rights
To Patent Protection*

Before disclosing your invention to anyone send for blank form "EVIDENCE OF CONCEPTION" to be signed and witnessed.

LANCASTER & ALLWINE

480 Ouray Bldg. WASHINGTON, D. C.
Originators of forms "Evidence of Conception."

This Needed Invention Paid
\$135,000



a year. Beverage manufacturers immediately adopted this simple crimped tin cap. This invention would have made you independently

wealthy. Fortunes await inventors working along right lines. Concentrate on things that are NEEDED. Get Raymond Yates's new book

"1000 NEEDED INVENTIONS"

Costs only \$1.50 and may lead to a big idea. Find out what industry needs and the public wants. That's where the money is! Mr. Yates's book tells you what these things are. This revised 1929 edition contains valuable chapters on Aviation and Television. Send no money. Just write postal. Pay mail man \$1.50 plus postage when book arrives. Your money back if you want it. This offer limited. Write now and get on the right track. (Outside U. S. \$1.70 cash with order.)

Bureau of Inventive Science, 32 Wisner Bldg., Rochester, N. Y.

On your feet-
In a good Paying Business

We start you in the shoe and hosiery business. Inexperienced workers earn Big Money yearly. Direct-to-Wearer plan. Just show Tanners Famous Line of Footwear. We tell how and where to sell. Perfect fit through Patented System. Collect your pay daily. We furnish \$40.00 Sample Outfit of actual shoes and hosiery 83 styles. Send for free book "Getting Ahead" and full particulars. No obligation.

TANNERS SHOE CO.
 872 C Street, Boston, Mass.

MOTORCYCLES

WE WILL TRUST YOU
 Pay As Low As \$2.00 per Week
 Hendersons, Harley-Davidsons, Indians
 Slightly used and rebuilt. Hundreds to select from.
 Send 10c for list today.

MYEROW BROS. CO., 15 Berkeley St., Boston, Mass., U. S. A

BASHFUL?

"Shame on you!" Are you nervous, embarrassed in company of the other sex? Stop being shy of strangers. Conquer the terrible fear of your superiors. Be cheerful and confident of your future! Your faults easily overcome so you can enjoy life to the fullest. Send 25c for this amazing book.

RICHARD BLACKSTONE, BA-472 FLATIRON BLDG., NEW YORK

GEARS IN STOCK—
 immediate delivery

Gears, speed reducers, sprockets, thrust bearings, flexible couplings, pulleys, etc. A complete line is carried in our Chicago stock. Can also quote on special gears of any kind. Send us your blue-prints and inquiries. Write for catalog No. 10.

Chicago Gear Works
 769-773 W. Jackson Blvd., Chicago, Ill.

PATENTS

As one of the oldest patent firms in America we give inventors at lowest consistent charge, a service noted for results, evidenced by many well-known Patents of extraordinary value. Book, Patent-Sense, free.

Lacey & Lacey, 646 F St., Washington, D. C. Estab. 1869

SHOOT THE REAL THING!



Here is that famous genuine pump boys everywhere are turning to. Single stroke outshoots all others. Two to three strokes now give full shooting force. New rear peep sight, leak-proof valves, fully enclosed action. A beauty. Amazing accuracy. Full factory guarantee for one year. Uses regular air rifle lead shot. Photo shows flattening power at 30 ft. on steel target. The biggest money's worth in genuine air rifles ever offered.

"The Shooter's Art" FREE
 Tells how to hold, aim and handle rifles; helps you guide others in correct knowledge of guns. Gives facts that make crack shots. Contains safety and common sense instructions every parent and boy should have. Helps to make boys leaders. Your copy free. Write at once!

SEND TODAY!

\$5 at your dealer's or sent postpaid
NEW MODEL "G"

BENJAMIN
 Genuine Pump Air Rifle
 BENJAMIN AIR RIFLE & MFG. CO., 645 N. Broadway, St. Louis, Mo.

"LITTLE SAXO"
 Auto Clothes Hanger
 for Tourists



Handy as a wardrobe—Holds hats, coats, road maps, clothes, purses, anything—out of the way. Slips on window in a jiffy. Does not interfere with opening or closing—Wonderful souvenir. Send 15c for sample. Box 50 for \$4.00. Salesmen wanted everywhere.

FRANK SAXTON MFRS., 13 Adrian St., Blissfield, Mich.

INVENTORS PROTECT YOUR IDEAS

Write for our Guide Book, "HOW TO GET YOUR PATENT," and Evidence of Invention Blank, sent Free. Tells our terms, methods, etc. Send model or sketch and description of your invention for INSPECTION and INSTRUCTIONS FREE.

Terms Reasonable. Best References.

WRITE TODAY

RANDOLPH & COMPANY, Patent Attorneys
 301 VICTOR BUILDING, WASHINGTON, D. C.

Name

Address

Free this 140 Page Book of Record Keeping Forms

HERE'S a book that will help you with your record-keeping problems. Contains wide variety of life-size Bookkeeping forms, completely filled in, illustrating uses. For office or factory—business or profession—it shows you simplest and most efficient methods of accounting now being used by 300,000 leading firms. Send for your **FREE** copy today. No obligation!

JOHN C. MOORE CORP., Est. 1839
6052 Stone Street, Rochester, N. Y.

Merely Fill in Coupon and 140-page Book Will be Sent you **FREE**

Name _____
Business _____
City _____ State _____

Popular!

YOU will be doubly welcome everywhere when you learn to play a Conn. Chances to join a band or orchestra, to travel, to make extra money. Conns are the choice of Sousa and the world's greatest artists. Easiest to play. Recommended to beginners for quicker progress.

FREE TRIAL, EASY PAYMENTS on any Conn. No matter which band or orchestra instrument interests you most, Conn will send you a special booklet on that instrument giving valuable facts.

C. G. CONN, Ltd., 231 Conn Bldg. Elkhart, Ind.

CONN
World's Largest Manufacturers of
BAND INSTRUMENTS

Write for FREE BOOK
▶▶ Mention Instrument ◀◀

Thompson BEATS the World on BOATS

THOMPSON BOATS

CATALOG FREE!



OUTBOARD MOTOR BOATS—For Every Purpose and Every Purse— The very fastest and most seaworthy V Type, V Bottom and Sled Type Boats for family use, and a strictly up-to-date line of Step Plane Racing Models to choose from.

Rowboats \$48.00 and up—

The most complete line ever offered, at real money-saving prices.

Canoes \$50.00 and up—

Some all wood, others canvas covered. Light, swift, safe, strong and durable. Choice of many distinctive color combinations.

20 ft. Motor Boats—

With or without Engine. Fast, handsome six passenger craft at money-saving prices.

CATALOG FREE — SAVE MONEY — ORDER BY MAIL
Please state the kind of boat you are interested in (35)

THOMPSON BROS. BOAT MFG. CO.

213 Ann St.
PESHIGO
WISCONSIN

(Write to
Either Place)

113 Elm St.
CORTLAND
NEW YORK

FLY THIS COMBAT MONOPLANE!



This realistic copy of a military monoplane is an unusually graceful flyer. Wing-spread 18 in. Weight only 7/8 oz. Will take off by own power and fly over 80 ft. Markings in red and blue. Can be built in 2 hrs. without tools. Construction set includes 6-in. aluminum propeller with shaft, 3/4 in. disc wheels, wood struts, rubber band motor and all other parts, with clear directions. Complete set, packed in un-

breakable container, only \$1.00, postpaid in U. S. and Canada. Order today. Satisfaction or money refunded.

The MIDLAND MODEL WORKS, Chillicothe, Ohio
(We cannot make C.O.D. shipments. No retail catalogue issued.)

Catch Fish!

Eels, Mink, Muskrats with our new folding galvanized **STEEL WIRE TRAP.** Write for our **FREE TRAP OFFER** and Bargain Catalog. \$1 Box of our famous Fish Bait **FREE** to introduce our traps. **WALTON SUPPLY CO., 3502 JUNIATA AVE., ST. LOUIS, MO.**

Chemical Tricks for Boys



Surprise and puzzle your friends with magic chemical tricks; make ink; dye cloth, test water and soil, write secret letters with invisible ink; pour blue, brown and black liquid from a pitcher of water. All these and many more chemical stunts are easy with Chemcraft Junior. It's the best box of fun you ever had! Get yours now.

ONLY 25c POSTPAID

FREE Magazine

to every boy who writes for it now. Full of new ideas and chemical stunts. Ask for yours right away!

The Porter Chemical Co.
54 East Washington St.
Hagerstown, Md.



Build a Ship Model at Home

For Pastime and Pleasure



It is a wonderful fascination and a beautiful decoration for your mantel, radio cabinet or it may be used in any part of the home.

Santa Maria—Size—25" high, 10" wide, 27" long.....\$4.98
La Pinta—Size—26" high, 11" wide, 27" long.....\$4.98

Mayflower—Size—26" high, 10" wide, 30" long.....\$4.98
Constitution—Size—25" high, 8" wide, 29" long.....\$6.98
Flying Cloud—Size—27" high, 9" wide, 36" long.....\$6.98

These prices are f. o. b. Philadelphia, plus a few cents postage. These models are sold in knock-down form. All parts are cut to fit and ready to assemble. They will be sent anywhere in United States C. O. D.

Money order or check must accompany all foreign orders.

Write for free illustrated catalog

MINIATURE SHIP MODELS, Inc.

Dept. RT-2, 3216 BARING ST., PHILADELPHIA, PA.

NEW IMPROVED PAYNT GUN

LACQUERS CARS AND FURNITURE

Skillful painting easy for anyone this new simplified way. Exclusive Paynt-gun features cut painting time in half. Sturdy. Compact. Powerful spray.

Complete Outfit \$9.65

FREE Attractive folder on Perfect Painting ready for you. Write for it NOW!

HAYWOOD EQUIPMENT CO.
2345-B Ogden Ave., CHICAGO, ILL.

AGENTS WANTED

AGENTS

Every Home Wants Kitchen Tongs

Sells for 50c—Costs Agent 17½c

\$10.00 a Day Easy!

No more burned fingers. Picks up hot things when cooking, feeds clothes to the wringer, grabs articles out of hot water—like a human hand. Made of lifetime metal. Strong, durable, good looking. 10½ inches long. 5 sets packed in individual illustrated cartons sent post-paid to agents for \$1.

MICHIGAN METAL PRODUCTS COMPANY, Dept. K, Battle Creek, Mich.

NEW EDITION MODERN GASOLINE AUTOMOBILE

The type matter has been entirely reset for the thorough revision of this authoritative book by V. W. Page. With 1000 new illustrations this strictly modern work shows every recent improvement in automobiles and their component parts. This most complete and practical treatise describes every part of all types from light cars to heavy-duty trucks and road tractors.

The first book to devote many of its 1150 pages to a complete, illustrated description of the

NEW MODEL A FORD

Design, construction, operation and maintenance are the broad divisions of the text matter.

All latest developments are dealt with in minute detail.

Size, 6x9 in. Fabrikoid Binding
Price \$5

Will be sent C. O. D. in U. S. Pay postman price and postage.

Popular Mechanics Press
Room P-2
200 E. Ontario St. Chicago



"I Would Not Part with It for \$10,000!"

THE NATURAL BODY BRACE

SO writes one happy, grateful user of The Natural Body Brace. In like manner testify thousands who have benefitted from this wonderful aid to health, strength and regained vigor.

Men everywhere are finding new joy of living, are relieving pain and strain with The Natural Body Brace. Makes work and play a pleasure. Enables you to enjoy the invigorating life of the healthy, active man.

A wonderful Proved Aid for Rupture—Overcomes painful boring pressure. Brings wearer many general body benefits while holding rupture easily and comfortably.

Overcomes Weakness and Organic Ailments of Both MEN and WOMEN—Develops erect, graceful figure. Replaces and supports misplaced organs; supports enlarged abdomen; strengthens and straightens the back. Enables you to be active—do things—feel fit always!

Develops lungs, chest, bust. Corrects stooping shoulders. Relieves backache, curvatures, nervousness, constipation, after effects of Flu.

Made to fit individual measurements. Comfortable, easy to wear. Over 300,000 satisfied users!

TRY 30 DAYS

under our money-back guarantee of satisfaction. Know what it means to keep fit, be strong, graceful, active. Send coupon now for free illustrated booklet "Health, Strength and Perfect Figure," and details of our free Individual Health Service and liberal trial proposition.

THE NATURAL BODY BRACE CO.
205 Rash Bldg., SALINA, KANS.

Natural Body Brace Co., 205 Rash Bldg., Salina, Kans.

Please send me free illustrated booklet and further details about your free Individual Health Service and liberal trial proposition.

Name.....

Address.....

City.....State.....

STOMACHS THAT BULGE quickly reduced

Bulging waistlines are physical and social handicaps. Why have a conspicuous stomach when it's so easy now to control your girth with this marvelous belt of new patented weave.

Inches Off Instantly

Men of all sizes, in all walks of life, wear and praise the Inches OFF Abdominal Belt for its extraordinary reducing power. Will quickly cut your girth 4 to 6 inches. Wears down fat and fights accumulation by gentle massaging action. No other belt like it in body-shaped design, nor made of this marvelous-woven elastic of patented weave exclusively ours. Worn over shirt. Cool, comfortable, healthful. Approved by physicians. Always in place—can't creep up or down. Attaches to suspender buttons on inside of trousers if desired. Holds shirt and trousers perfectly in place. Guaranteed not to shrink or overstretch from washing. Will wear three times longer than any belt of other material. Ideal for golf, sports, business and full dress. Many influential business men wear an Inches OFF Belt continuously—never without one. Will make you look and feel ten years younger. Try one on approval—results will amaze you. Satisfaction guaranteed.

Wear One 10 Days On Trial

If your waist is bulging or getting bigger, this belt will work wonders at needed reduction. Our guarantee and responsibility backed by resources of over \$10,000,000. Write for all the facts and our 10-day approval offer. Address

THE SANDFELDER CO.

100 E. Ohio Street Dept. 116 Chicago

BRASS WAFER THERMOSTATS FOR TEMPERATURE CONTROLS



For Incubators, Brooders, Fire Alarms; any place that a wafer thermostat can be used. Single or double unit. Made of special tempered brass. Vacuum filled, sensitive, accurate, durable. Units separated by a solid post, gives double protection. Made in 3, 4, and 5 inch sizes.

RELIABLE INCUBATOR & BROODER CO.
2815 Chestnut St. Quincy, Illinois

LIFE-TIME DX AERIAL

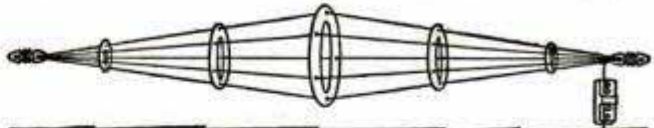

Guaranteed Double Volume and Sharper Tuning

BRINGS IN STATIONS! YOU NEVER HEARD BEFORE!

No. 30—LENGTH 30 FEET: Assembled ready to string up. Brings in volume of 150-ft. aerial but retains the selectivity of a 30-ft. aerial. Rings are heavy gauge solid zinc. Duplicates in design and non-corrosive materials the aerials used by most of largest Broadcasting Stations. Design permits using this powerful aerial in 30-ft. space (preferably outside). Sharpens tuning of any receiving set because of short length but has enormous pick-up because 150-ft. of No. 14 enamelled wire is used. Made for owners of fine radio sets who want great volume on distance without destroying sharp tuning. (Also used by many owners of short-wave outfits.) "Makes a good radio set better." We include with each aerial one lightning arrestor (approved by Insurance Underwriters). **PRICE \$10.00**

No. 60—LENGTH 60 FEET: Assembled—ready to string up. "BIG BOY" Size, (same description as above except that 300-ft. of wire is used making this the most efficient and powerful aerial possible to manufacture). **PRICE \$12.50**

Send in \$1.00—Balance C. O. D. If unable to buy at your dealer.

THOROLA RADIO PRODUCTS

1014 So. Michigan Blv'd., Chicago, Illinois

MAKES A COMPLETE MACHINE SHOP

\$1.75 UNITOOL ELECTRIC MOTOR ATTACHMENT

without chuck \$2.25 with chuck



Fastens directly on motor shaft, no pulleys or belts necessary. Holds grinders, buffs, saws, wire scratch brushes, drills, etc. Serves as pulley. Made to fit 3/8, 1/2 and 5/8 in. shafts. State size. Postage prepaid if remittance accompanies order.



United Electric Motor Co., 178 Centre St., Dept. C-2, New York

Let us recommend the best books to study on any subject. Popular Mechanics Press, Chicago, Illinois.

AMAZING NEW TABLECLOTH

LOOKS LIKE LINEN WASHES LIKE OILCLOTH



New material rivals Irish linen in appearance—washes without laundering. Stainproof. Does not crack, peel. Saves time, laundry bills. A five piece set given to all agents.

AGENTS
\$15 daily easy!
Write for Free Sample Offer and full details.

National Industries, 67 E. Lake, Dept. 15-g Chicago

The New Junior "Wonder" Workshop

A Greater Value Than Ever Before!

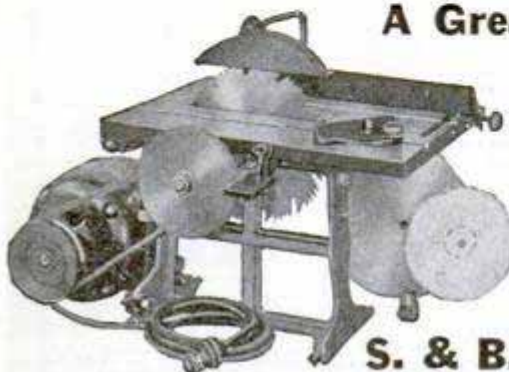

THE New No. 77 S. & B. 7-inch Combination Saw enables you to perform 18 operations. Will rip, cross-cut, bevel, mitre, mortise, drill, groove, grind, polish, etc. Complete with 1/4 H.P.-A.C. motor, costs only \$29.95. Planer attachment, \$5.00 extra. Shipped on approval at manufacturer's risk.

Bench Saw \$29.95

THE New S. & B. Scroll Saw is ideal for fine craftsmanship and hard usage. Made of cast iron and babbit bearings, the 4-inch model costs only \$4.95, the 8-inch model \$9.95, and the 12-inch model \$12.45. The 8-inch die cast model, with bronze bearings, costs \$15.00, complete with air compressor. Write immediately for descriptive circular.



Scroll Saw (4 models) \$4.95 and Up

S. & B. MFG. CO., 4601-B W. 20th St., CHICAGO, ILL.

The Model A Ford Car

is treated in a special supplement to the latest edition, the 15th, of

Dyke's Auto Encyclopedia

For 15 years "Dyke's" has been the one recognized and undisputed authority on the Automobile. Each succeeding edition has surpassed the last one. Now comes the greatest book of all—the wonderful 15th Edition—A. L. Dyke's crowning triumph—the super auto book of all times.

Some "High Spots" of the New Book!

1,249 pages covering every known auto fact.
4,200 Pictures, Plans, Diagrams and Charts.
15,000 lines of Index by which you can instantly locate any subject you want.
A new section of "Trouble Shooting" Charts in Colors to enable you to quickly locate any major or minor trouble on any car.
Special instructions on testing and adjusting every part of the automobile.
Specifications of Gasoline Passenger Cars, Trucks and Tractors.

Specifications for Replacements, Accessories, Interchangeable Parts and Equipment.

Large colored Combination Chart which shows the working principles of the Automobile.

Large Charts showing the working principles of Trucks and Tractors.

Cloth \$6.00; Limp American Morocco \$7.50

Sent postpaid upon receipt of price.

Will be sent C. O. D. if preferred to any address in the U. S.

POPULAR MECHANICS
PRESS
Room P-2
200 E. Ontario St.,
Chicago

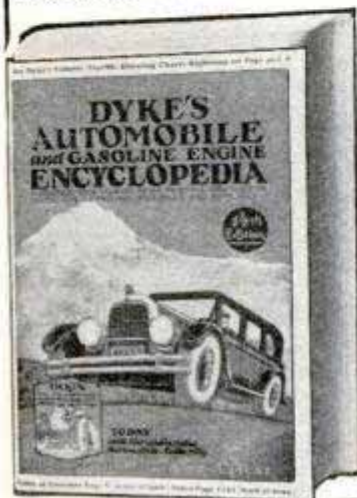

Build a BOAT

How to Make 14 Kinds

If you want a boat, you can save several dollars by making it yourself. Or you can pick up money on the side making boats for your friends. Besides you'll have barrels of fun. Everything is made so simple and easy in Popular Mechanics Boat Book. Complete and simple directions and necessary illustrations for building these boats and canoes:

Rowboat suitable for outboard motor, Canoe, Whiz (14-ft. step hydroplane), Portable Canvas Boat, Fast 19-ft. Runabout Motorboat, Cabin Scow driven by auto engine, Long Island Scooter with aero-propeller, Portable Folding Boat, Convertible House Boat and Camp, Sea-Gull (sailing boat), Pile-Driver Punt, Inexpensive Motor Boat, Power-Driven Catamaran, Fishing Sleigh and Boat. In addition there are valuable instructions for caulking, repairing, painting and making boats watertight, also articles on picking your canoe, handling and fitting outboard motors, laying up for winter and making a boat trailer and boathouse for small canoe club.

This book, together with its companion, Outdoor Sports (containing hundreds of practical plans and ideas on sports, games, tours and camping), will be sent to you C. O. D. if you live anywhere in the U. S.

Just send a note saying you want the Boat Book and Outdoor Sports. When they arrive, pay postman \$1.98 and the postage. If outside the U. S. remit when ordering and include 15 cents extra for postage.

POPULAR MECHANICS PRESS
Room P-2, 200 E. Ontario Street, CHICAGO, ILL.

Build
Your
Own
Boat



Hold Your Money

Until this test convinces you

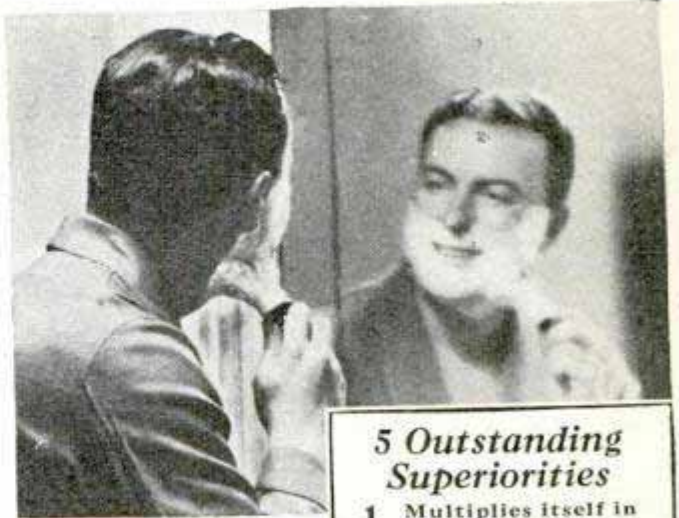

5 Outstanding Superiorities

- 1 Multiplies itself in lather 250 times.
- 2 Softens the beard in one minute.
- 3 Maintains its creamy fullness for 10 minutes on the face.
- 4 Strong bubbles hold the hairs erect for shaving.
- 5 Fine after-effects due to palm and olive oil content.

A sales policy that has won millions of friends. Try this remarkable cream 7 days at our expense before you make your decision.

GENTLEMEN: When we perfected our new shaving cream, we decided upon a daring course. Rather than attempt to force men into buying it through eloquence or printed argument, we staked our whole case on a trial.

We told men, as we tell you here: "Don't buy—yet. Let us prove our product's outstanding merit by sending you enough for a fair test at our risk. You be the judge."

Millions took us up and Palmolive Shaving

Cream is today the world's largest selling. For 86% of those who tested it found what they had long sought. They became wedded to this remarkable new shaving cream.

Please make our test

Now we ask you to mail the convenient coupon for your test. Even if you usually do not send coupons, please mail this one. We promise you great things. But we take the risk of convincing you. Clip it now.

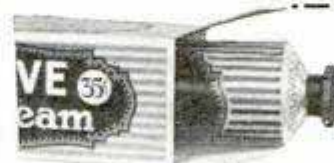

7 SHAVES FREE

and a can of Palmolive After Shaving Talc

Simply insert your name and address and mail to Palmolive, Dept. M-834, P. O. Box 375, Grand Central Post Office, New York City.

PALMOLIVE RADIO HOUR—Broadcast every Wednesday—from 9:30 to 10:30 p. m. Eastern time; 8:30 to 9:30 p. m. Central time; 7:30 to 8:30 p. m. Mountain time; 6:30 to 7:30 p. m. Pacific time—over station WEAJ and 39 stations associated with The National Broadcasting Co.

(Please print your name and address)

Free Quick— to ANY Worker Foreman President Executive

If you work on ANY product that is used by concerns that serve the public; or used in business or homes, (for utility, beauty, or luxury)—GET THE FACTS that are back of this Tidal Wave of new quick thinking in all industries. . . A Look AHEAD, in manufacturing, in methods, models, competition, costs, prices, Standards of Living. . . How—right NOW—articles and parts are being made, far easier, faster, at lower cost; and "righter."

Fact-Sheets of Industry

will give you a look AHEAD that will start you thinking; probably amaze you. Full CONTENTS OUTLINE is free; no obligation. Just state your name, address, company's name and products, and whether you want the Facts for self or company. Postal will do. Or margin of this page. Save this. Do not trust to find it again; write NOW. Address: Fact-Sheets of Industry; N V F Co., Dept. K-1, Wilmington, Del.

N V F

Offer is by NATIONAL VULCANIZED FIBRE Company; its Divisions and Associated Industries. Special working methods; special Phenolites; "righter" Bakelites; parts, materials, and ways; Material Handling; etc.; besides Vulcanized Fibre. Serving America's Industries, from Smallest to Greatest.

SELL STAR BOOK MATCHES!

—make \$15 to \$20 per day



Merchants, Banks, Hotels, etc. buy on sight!

STAR Salesmen are big money makers because they sell an article that instantly appeals to every merchant.

Star Book Matches cost less than business cards. That is why Star Salesmen easily average 4 to 6 orders a day—and they average \$4 per order. There is some good territory still open. If you are a "live Wire" write today.

STAR MATCH CO.

Dept. AR

314 N. Broadway, St. Louis, Mo.

Mail This Coupon—NOW!

STAR MATCH CO., Dept. AR
314 N. Broadway, St. Louis, Mo.

Gentlemen:

I am interested in increasing my income and would like to know more about your Star Book Match Plan. Please send complete details without obligation on my part.

Name.....
Address.....
City..... State.....
Territory desired.....

12 IN ONE TOOL! A Whole Tool Kit in One

A patented invention just presented to the trades. A valuable tool for carpenters, cabinet makers, millwrights, inventors and workmen in any trade. A handy tool in the shop or home. Folds to fit the pocket. Instantly adjustable—True-Precise.

Use it as a Tri-Square, T-Square, Mitre Gauge, Bevel Square, Inside-Rule, Extension Rule, 30, 45, 60 angles, Depth Gauge, Marking Gauge, Compass and Two Foot Rule. Has many uses. Price \$2.50.



Salesmen Making Over \$100 a Week

Send Money Order or will be sent C. O. D. in U. S. A. We pay delivery costs.

Read the editorial on page 191, August 1929 issue of Popular Mechanics.

Twelve in One Tool Co., Not Inc. 11 So. La Salle Street CHICAGO, ILL.

Do the Finest of Pattern or Cabinet Work



With This H & A JOINTER

A ball bearing motor-driven equipment of finest construction and absolute accuracy for all planing, jointing, bevelling and rabbeting operations. Plug into the nearest lamp socket. Reasonably priced. Write to HESTON & ANDERSON 602 Kirkwood Ave., Fairfield, Iowa

New Food Idea Pays Big Profits!

Men! Women! Investigate the wonderful NEW Brown Bobby GREASELESS Doughnut. Sells like wildfire! You can easily make \$50 week spare time; \$5000 to \$8000 year full time. Investment small. No experience needed. Write today for big special offer. Food Display Machine Corp., Dept. 32, 500-510 N. Dearborn St., Chicago

FOR THE RADIO BUILDER

The blueprints below include the best of Popular Mechanics tested circuits. When ordering, simply quote the numbers of blueprints desired and inclose proper amount addressed to Popular Mechanics Magazine, Radio Dept., 200 E. Ontario St., Chicago, Ill. Magazines containing full descriptions of the circuits can be obtained. Send 25 cents for each magazine desired, giving date of publication.

- No. 111, Homemade Tube Tester..... July 1926..25c
- No. 116, Three-Tube Loop Set..... Dec. 1926..25c
- No. 123, Economy-Nine Super-heterodyne..... Nov. 1927..50c
- No. 134, Edison Type B-Battery..... July 1928..25c
- No. 138, Screen-Grid Perfect-Tone Six Receiver..... Nov. 1928..25c
- No. 139, Simple Television Receiver.. Dec. 1928..25c
- No. 140, Power Amplifier and B-Supply for Television..... Jan. 1929..25c
- No. 142, Two-Tube Screen-Grid Short-Wave Adapter..... Mar. 1929..25c
- No. 143, Four-Tube Screen-Grid Receiver..... May 1929..25c
- No. 144, Three-Tube Self-Contained A.C. Receiver..... Oct. 1929..25c
- No. 145, One-Tube S-G Set for Beginners..... Nov. 1929..25c
- No. 146, Adjustable B-Eliminator... Nov. 1929..25c
- No. 147, A-Eliminator for Set and Dynamic Speaker..... Dec. 1929..25c
- No. 148, Adding Audio Stages to S. G. Receiver..... Dec. 1929..25c

Make BIG Money

GET into the profitable floor sanding business where your earnings may be bigger than you ever dreamed. No experience necessary. The only equipment needed is the—

American Handy Sander

This Electrical machine doing the work of four hand scrapers makes you money fast. It is LIGHT enough to carry anywhere in one hand—SPEEDY enough to produce quick results—POWERFUL enough to sand the worst kind of floors—RUGGED enough to stand up under severe operating conditions.

Easy Work

Just plug into any light socket and you're ready. Produces highest class sanding job on new and old floors. Ample large for dwelling and apartment house work—small enough for closets, narrow hallways, stair landings, etc.

The big demand for floor sanding makes this machine a big MONEY MAKER. Ask for the facts TODAY. There is no obligation. Just write to—

The American Floor Surfacing Machine Co.
523 South St. Clair St. Dept. B Toledo, Ohio



BUILT-IN FURNITURE

Adds Beauty and Convenience to Your Home



With the plans and directions given in this new book by Edwin M. Love any handy man will be able to build the various pieces of popular space-saving furniture.

These useful and ornamental cabinets are easily added to an old house and many are designed to be built into odd nooks and recesses. The construction is very simple as the walls offer support and no structural alteration of either floors or walls is necessary.

Stock sizes of material are specified in each instance. The home owner will be able to alter designs if necessary to suit available space.

That practically every adaptation of built-in furniture is covered by this book is shown by the following list of contents.

General Details of Construction—Portable Buffet—Recess Buffet—Corner China Closets—Clothes Closet Linen Cabinet—Furnishing a Clothes Closet—Bathroom Cabinet—Linen Closet—Mantel Shelves—Bookcases—Writing Desk—Seats—Indirect Lighting Fixtures—Sewing Cabinet—Corner Kitchen Cupboards—Breakfast Nook—Bathtubs—Laundry Porch Furnishings—Dining Table—Dressing Table—Radio Set—Phonograph—Safe—Shaving Cabinet—Cupboard and Drainboard Cabinet—Clothes Chute—Wood Box—Work Bench and Tool Cabinet—Mortise and Tenon and Dado Joints—Wood Dowels—Bending Small Moldings—Driving Nails and Screws—Care of Tools.

198 pages. Size 7x10 In. Fully illustrated. Price \$2.50 postpaid.

Popular Mechanics Press

Room P-2

200 E. Ontario St. Chicago, Ill.

You Can Easily
EARN \$150 to \$300
MONTHLY
Profits
COSTS
Only \$16
MONTHLY

30
DAYS
TRIAL

Pays for Itself—No Expense to You

Start a Money Making Business of your own. Mechanics, Filling Stations, Repair Shops, Garages and Battery Stations are all making BIG MONEY with HB 8 Hour Battery Service. Recommended by the leading car and battery makers. Constant Potential lets you give a better charge than the other fellow in one-third the time, and at a saving of 30% to 50% on current. Anyone can operate. Check coupon below for full information on how to get started in this money making work.

Shouldn't Cost You a Cent

Pays for Itself—Brings a Big Profit Besides

Only \$16 Monthly
30 DAYS' TRIAL AT OUR RISK



Largest Profits

The best paying work in automotive field today is 20 minute car washing. Puts you above competition—eliminates all drudgery! Users report \$100 weekly profits. Liberal trial, easy terms. Savings in labor and material over other methods will easily pay for it.

Earn 5 Men's Wages

Portable Paint Spray does the work of five brush painters. You get four men's wages as profit. Paints Cars, Houses, Garages, Barns, Furniture. No experience necessary to operate. Check coupon for trial offer and terms.



Air Service

Only \$12 Monthly



Free Air Service costs you only \$12 monthly for a few months. Fully Automatic day and night service will draw customers to your shop as well as operate your air tools. Check coupon for full details without obligation.



Hobart Brothers

Box M-23

TROY, OHIO

Tear off and Mail Today

Hobart Brothers, Box M-23, Troy, Ohio. Send me complete information on the items I've checked—your thirty-day trial offer—easy payment terms—information on how HB equipment will increase my earnings.

- HB 8 HOUR BATTERY CHARGER
- HB TEST BENCH
- HB PAINT SPRAY
- HB AIR SERVICE
- HB CAR WASHER

Name.....Address.....

ITALIAN ACCORDIONS

Best in the world. 10-year guarantee. lowest prices. FREE instruction. ask for FREE catalog. RUATTA, SERENELLI & CO., 1014 Blue Island Ave. Dept P, Chicago, Ill.

Stage Money



New Bills To Conform With Small Size Currency

With these bills it is easy for a person of limited means to appear prosperous by flashing a roll of them at the proper time. By peeling off a genuine bill or two from the outside of the roll, the effect created will be all that can be desired. Prices, postpaid: 50 bills \$1.40 for 50c, or \$3.00 thousand postpaid.

Fire-Eater

A great trick by which you appear to breathe fire from mouth. Quite harmless. All necessary apparatus sent complete for only 30c. postpaid.



Black Art

This book tells of the sciences of Magic, Witchcraft, Alchemy, Necromancy, Mesmerism, etc. It tells how to make persons think of you, how to charm those you love, etc. The book contains 122 pages. Price 30c prepaid.



Miller's American Poultry Guide FREE

Tells all about chick's-care, feeding and raising for profit. Also describes Hot Water & Electric "IDEAL" INCUBATORS - \$9.25 Up With Original Patented EGG TURNING TRAYS "IDEAL" BROODERS - - \$6.90 Up WE PREPAY POSTAGE--WE PREPAY FREIGHT Coal, Oil, and Electric Brooders, Poultry Supplies, Baby Chicks. Special LOW PRICES! Write Today! J. W. MILLER CO., Dept. 12, Rockford, Ill.



CONDON'S GIANT TOMATO EVERBEARING

"QUEEN OF THE MARKET." Big Money Maker. Large, solid fruit; excellent canner. To introduce to you our Northern Grown Live Seeds and Plants, we will mail you 125 seeds of Condon's Giant Everbearing Tomato and our Big 1930 Catalog of Seeds, Plants, Shrubs, 184-Page Book. Tells how, and when to plant. Send 2c stamp to cover postage. 1930 Prices Lower Than Ever. **CONDON BROS., Seedsmen** Rock River Valley Seed Farm BOX 156 ROCKFORD, ILLINOIS



OAKS' MASTER BOX OF TRICKS

Mystery and entertainment for every day in the year. Whole evening's entertainment complete for \$1.00. Without practice or experience, anyone can give a complete entertainment with these mechanical and self-working tricks so simple that a child can perform. Contains apparatus for 7 complete tricks. The Magic Ball and Vase Trick. Wooden ball is placed inside, and upon replacing the lid has disappeared and is found in someone else's pocket; Disappearing Spots. This trick consists of changing four Kings to four Aces, and then to blank cards; Magnetic Wand. Magician's Wand clings to fingers and floats about as if magnetized, yet falls when anyone else tries; Ribbon Factory from the Mouth Trick. A seemingly endless supply of colored paper ribbon comes out of the mouth; Disappearing Handkerchief. Handkerchief held in the mouth mysteriously vanishes; Enchanted Bottle. No one but yourself is able to make it lie down; Great Hat and Dice Trick. Large dice is placed on top of hat, disappears, and is found underneath, yet no one has touched the hat. Only \$1.00 for all.

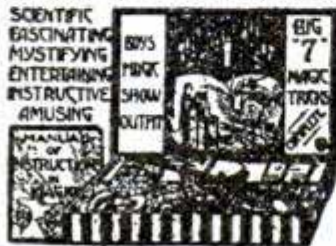

INCREASE YOUR POULTRY PROFITS!

By proper Breeding, Feeding, Housing, Culling and Marketing AMERICAN POULTRY JOURNAL tells how to do it, and in addition a series of **COLORED PICTURES** with explanatory text tell and show many things you should know. They are not just colored pictures of birds but pictures of an educational nature, something never before shown by a poultry paper. 12 issues of American Poultry Journal contain about 1000 pages—Price 25c a year—5 years \$1. AMERICAN POULTRY JOURNAL, 14-536 S. Clark St., CHICAGO



RAISE CHINCHILLA AND NEW ZEALAND WHITE FUR RABBITS

Make Big Money We Supply Stock and pay you following prices for all you raise; Chinchilla average \$3 each—New Zealand Whites \$2 each. 32-page illustrated book, catalog and contract, also copy of Fur Farming magazine, tells how to raise rabbits for big profits, all for 10c. Address **OUTDOOR ENTERPRISE CO., Box 1021 Holmes Park, Missouri**



OAKS' CARD MIRACLES



Complete box of our most popular card tricks. Easily performed with instructions for each trick. Box contains Disappearing Spots, Hindoo Cards, Phantom Cards, Pick It Out Cards, Satan Card Trick, Educated Card Dice Trick, Knockout Cards, Diminishing Card Trick and Wonderful Ace Trick. If purchased separately would cost \$1.00. Special complete, only 50c.

MULTIPLYING BILLIARD BALLS

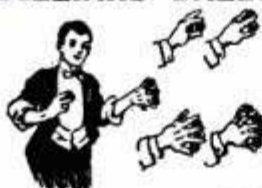

Magically producing a solid billiard ball, the conjurer simply moving his hand thru the air, causes a second ball of the same size to appear beside it. Everyone watching closely, a third appears in like manner. Then to the amazement of all, a fourth appears. Make them vanish singly until hand is empty. Per set, 35c. Larger sizes, \$1 and \$1.25.

RAISE PIGEONS AND RABBITS For Pleasure and Profit

OUR FREE BOOKLET TELLS YOU HOW. Over 20 varieties of Pigeons, Also Bantams. **W. V. MOORE, Box A, STERLING, ILL.**



74 BREEDS Valuable New Poultry Book Free—100 Pages

Fine Pure-bred Northern raised chickens, ducks, geese, turkeys, eggs, baby chicks. Best laying strains at lowest prices. America's great industry. My 48th year. **W. A. Weber, Box 28, Mankato, Minn.**



SQUAB BOOK FREE

Breed PR squabs for rich trade. Sold by millions for more than chickens. Write for free 48-page book telling how to do it and how to profit by new sales method. **PLYMOUTH ROCK SQUAB CO.** 634 H Street Melrose Highlands, Mass.



70 BREEDS Chickens, ducks, geese hardy, northern raised and most profitable. Fowls, eggs, baby chicks, incubators; low prices. America's great plant. 37th year. Valuable new 100 page Poultry book FREE.

R. F. NEUBERT Co., Box 878, Mankato, Minn.



Information on any book free. Write Popular Mechanics Press, Chicago, Ill.

Buddha's Money Mystery



With this contrivance it is apparently possible to change a blank piece of paper into a bill of any denomination. Can be performed easily by anyone. Only 25c.

Serpent's Eggs



When lit with a match each egg hatches itself into a snake several feet long, curling and twisting in life-like manner. Box of 12, 10c postpaid; 3 for 25c.

Send 10c in stamps or coin and our 1930 catalogue, DeLuxe Edition, containing 202 pages of all the latest tricks and novelties, will be sent to you. We are the largest dealers in tricks of all kinds in the world. Order from this advertisement or send for our catalogue today. FREE—Our large die box trick when you have sent in orders amounting to \$25 within one year.

OAKS MAGICAL COMPANY

Dept. 810 Oshkosh, Wisconsin

The man who studies gets ahead. Popular Mechanics Press will advise you what books to read to advance in your trade. 200 East Ontario Street, Chicago, Illinois.

SELL RADIO AND MAKE BIG MONEY

In 7 years we have shown 7100 men how to double their incomes selling radios during their spare time evenings. We can do the same for you. Send for free book, "The Will to Win," telling you how. No experience needed. Choice exclusive territory still open. Write **OZARKA, Inc.** 134 W. Austin Ave. CHICAGO, ILL.



Your NOSE Beautified

NO OPERATION—NO PAIN—30 DAY HOME TRIAL

Dr. Josephs Nose Corrector can make your nose beautiful by moulding flesh and cartilage to desired shape. Worn night or day in absolute comfort. Amazing and lasting results in shortest time. Free Booklet tells all. Write today.

DR. JOSEPHS, Inc. Dept. B-18 IRVINGTON, N. J.

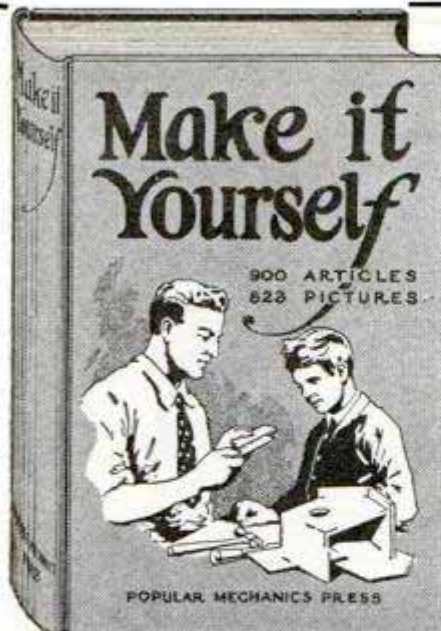

For Your Home Workshop

You should have a copy of this book recently published by Popular Mechanics entitled

Make It Yourself

The home mechanic, whether young or old, amateur or professional, will take pride and delight in making many of the things described therein.

Both father and son will find fascination and an association of interest in making useful and ornamental articles for mother to admire upon their completion.

900 Articles All Different

There are attractive ship models, a great variety of toys that operate themselves by means of an ingenious application of mechanical principles, novel amusement devices for indoors and outdoors, for both water and land, unique designs in furniture for children, scores of useful appliances for the home, things of beauty and utility for lawn and garden, etc.

Special articles instruct the amateur mechanic in the care and use of tools, special tools for special purposes, how to read and use plans, how to solder, the making of a handy work bench, cuts, joints and methods in woodworking, automobile repairing, installing radio equipment, house wiring, fixture hanging, working in glass, leather, metal, celluloid, lathe work, utilizing parts of old machines to make equipment that would be expensive to buy, etc.

Some of the Articles:

Tools for the Home Mechanic	Monorail Coaster
Ship Model Maker's Tools	Writing Cabinet
Build Your Own Ship Model	Workbench
Ship Model Plans	Tea Wagon
Water Sprite	Radio Apparatus
Puzzles	Lawn Canopy
Crazy Clown	Camp Car
Walking Wampus	California Cooler
Winter Toboggan Slide	Musical Instruments
Colonial Bric-a-Brac	Hedge Trimmer
Merry-Go-Twist	Homemade Baseball Game
Wiggling Pup	Small Turbine Motor
Black Cat Bench	Tools from Sewing Machines
Christmas Toys	Small Valves
Skating Whirligig	Bench Lathe
Venetian Swing	Auto Glare Shield
Bird Houses	Sesaw Merry-Go-Round
	Ferris Wheel

480 Pages — 823 Illustrations. Price \$3.00
Size 7x10x1 1/2 in. Cloth Binding

Mailed Postpaid upon receipt of price anywhere in the world. If you reside in U. S., Hawaii, Porto Rico, Alaska or Mexico, we will send the book by mail C. O. D. if you prefer. Simply pay postman when he delivers the package.

POPULAR MECHANICS PRESS (ROOM P-2)
200 East Ontario St. Chicago, Ill.



Follow this Man

Secret Service Operator 38 is on the job

FOLLOW him through all the excitement of his chase of the counterfeit gang. See how a crafty operator works. Telltale finger prints on the lamp stand in the murdered girl's room! The detective's cigarette case is handled by the unsuspecting gangster, and a great mystery is solved. Better than fiction. It's true, every word of it. No obligation. Just send the coupon and get—

FREE!

The Confidential Reports No. 38 Made to His Chief

And the best part of it all is this. It may open your eyes to the great future for YOU as a highly paid Finger Print Expert. More men are needed right now. This school has taken men just like you and trained them for high official positions. This is the kind of work you would like. Days full of excitement. Big salaries. Rewards.

Can you meet this test?

Can you read and write? Are you ambitious? Would you give 30 minutes a day of your spare time preparing yourself for this profession? Would you like a life of excitement, thrilling adventures and high pay? Answer "yes" and I'll show you how to attain all this.

Send the coupon and I'll send the Free Reports—also a wonderful illustrated book telling of the future awaiting you as a Finger Print Expert.

T. G. COOKE, Pres.

INSTITUTE OF APPLIED SCIENCE

1920 Sunnyside Ave., Dept. 93-52

Chicago, Ill.

Institute of Applied Science

1920 Sunnyside Ave., Dept. 93-52, Chicago, Ill.

Gentlemen:—Without any obligation whatever, send me the Reports of Operator No. 38, also your illustrated Free Book on Finger Prints and your low prices and Easy Terms Offer.

Name

Address

Age

"But, darling, Mr. Puff is such a *nice* man!"



IT isn't the pipe that causes these embarrassing moments, Mr. Puff. It's the tobacco. Isn't it time you discovered Sir Walter Raleigh—patron saint of pipe smokers, who discovered how good a pipe can be? His favorite smoking mixture really *is* milder. It really *is* just about the richest, mellowest, mildest blend of choice Burleys you have ever smoked.

(Hint No. 2) When breaking in a new pipe, smoke your first few pipefuls slowly. Don't let your pipe get hot. Fast burning discolors and burns the wood and bakes the oils in the tobacco before the pipe is properly "seasoned." Send for our free booklet, "How to Take Care of Your Pipe." Brown & Williamson Tobacco Corporation, Louisville, Ky. Dept. 77.



**SIR WALTER
RALEIGH**
Smoking Tobacco

It's



milder

A NEW HOUSE WIRING MANUAL

PRACTICAL — PLAINLY WRITTEN

BY J. G. WOLBER AND O. K. ROSE
Cass Technical H. S., Detroit, Mich.

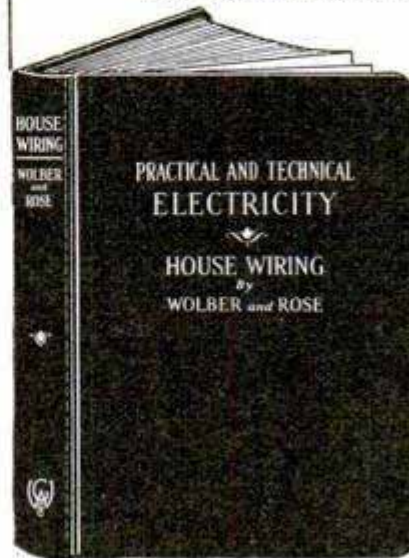

This book is the result of the author's fifteen years of industrial experience and of teaching. The material accumulated during this period of time has been worked over and over until in the author's opinion it was ready for publication.

320 Pages
662 Illustrations
Size 7½x5½ inches
Flexible Binding
Price \$2.50 Postpaid
Will be sent C. O. D. anywhere in U. S. or possessions.

POPULAR MECHANICS PRESS
Room P-2
200 E. Ontario St., Chicago

REAL ESTATE EDUCATOR

A most comprehensive yet concise arrangement of useful facts about buying, selling, leasing and sub-letting of Real Estate, contracting, for erection or repairs, mortgaging, transferring, insuring, etc.

New revised edition. 288 pp. Price \$2.00, postpaid.
POPULAR MECHANICS PRESS, 200 E. Ontario St., CHICAGO

NEED A BETTER GRIP ON MATHEMATICS?



SEND for a copy of "Mathematics for the Practical Man," only \$1.50. By common sense methods it removes the mystery and difficulties so that algebra and even calculus are made simple.

Assuming your knowledge is limited to arithmetic you quickly and easily gain a working knowledge of Algebra, Geometry, Trigonometry and Calculus. Simply pay postman price of book plus the postage when he hands you the package.

Popular Mechanics Press
Room P2
200 E. Ontario Street, Chicago

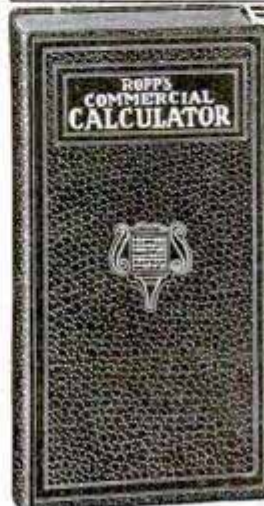

Mathematics Made Easy by ROPP'S CALCULATOR AND SHORT-CUT ARITHMETIC

Shows the Answer as Quickly as a Watch shows the Time to all Problems likely to occur in the Office, Store, Shop, Bank, Farm, or Factory.

Over 2,000,000 Sold
Explains and simplifies every principle in Arithmetic, Mechanics, and Mensuration.

PRICES POSTPAID
Desk Size, Flexible Keratol Binding \$2.00
Pocket Size, Art Leather Binding \$1.00
Pocket Size, Cloth Binding \$0.50

POPULAR MECHANICS PRESS
Room P-2 200 E. Ontario St. Chicago

Now-Observatory Time
 WITH
TOWNSEND
 Electric Clock



ONLY
\$5.95!

Just Plug into Light Socket and Forget It

It's here! The greatest new convenience of electrical science at the lowest price on record! The Townsend Electric Clock gives exact time always. No springs—you'll never have to wind it. Comes in beautiful dark walnut Bakelite case, as illustrated—a design that will grace the loveliest room in your home. 7 1/4 in. high, 3 1/4 in. silver finish dial. Convex crystal. Full sweep second hand points to the exact second.

Send Only \$1.00 deposit. Your Townsend Electric Clock will be sent immediately C. O. D. for \$4.95 and postage. The Townsend is guaranteed to be equal or superior to any clock, regardless of price. If you do not find it so—or if for any other reason not satisfied, return it and your money will be refunded. Order today!

Townsend Laboratories

715 Townsend St., Chicago, Ill.

NO SPRINGS
 NO WINDING

NEW SUPER-WASP AC & DC SHORT-WAVE RECEIVER

In Kit Form or Completely Constructed

1930 Catalog Free Set Builders! Write for your Short-Wave Supplies, standard parts and Accessories. **CHICAGO RADIO APPARATUS CO., Dept. PM 415 S. Dearborn St. Chicago, Ill.**

Cal. 30-40 Six Shot



KRAG CARBINE

Price
\$9.75

All the qualities of a high price rifle. In fine used condition, all working parts guaranteed for one year. Send today for our Free 60-page illustrated catalog of money saving values; Guns, Ammunition, Cutlery, Sports and Gov't goods. Deposit required on all orders. Money refunded if not satisfactory.

W. Stokes Kirk, Dept. P. M. 2, 1627 N. 10th St., Phila., Pa.



Ford Owner Stop that ruinous chatter on your car. **MAKE THIS TEST**—take out your floor boards, pull your emergency brake back and forth. If you notice play at the ball joint, you need Bredar's Bull Shim. Price \$1.50. Ask your Dealer or order direct. Demand Bredar's Shim.
NIC BREDAR'S SON MFG. CO., Rock Island, Ill.

FREE RADIO BARGAIN CATALOG
WHOLESALE PRICES!
 Send today for this big money saver.
 Buy from Radio's Oldest Mail Order House.
Radio Specialty Co.
 98E PARK PLACE
 NEW YORK CITY

Buy a Watch
 the Modern Way

This 21 Jewel Santa Fe Special

Sent You On-Approval
 Wear 30 days Free!



Thank you for making it possible for me to own a 21-jewel Santa Fe Special, writes thousands of our customers.

Buy Direct
 Our catalogue is our showroom. Any watch will be sent for you to see without one penny down. No obligation to buy.

Save 1/3 to 1/2

on the price you pay for a similar watch made by other Manufacturers. Most liberal offer. Our "Direct to You" offer and Extra Special Distribution Plan is fully explained in the New Santa Fe Special Booklet just off the press. The "Santa Fe Special" Plan means a big saving of money to you and you get the best watch value on the market today. Watch sent for you to see without one penny down.

**Railroad Accuracy
 Beauty Unsurpassed
 Life-long Dependability**

These watches are now in service on practically every railroad in the United States and in every branch of the Army and Naval service. Thousands of them are distributed around the world. You will never miss the few-cents a day that will make you own one of these watches.

Just Out! Send coupon for our New Watch Book—just off the press. All the newest watch case designs in white or green gold, fancy shapes and thin models are shown. Read our easy payment offer. Wear the watch 30 days FREE.

SANTA FE WATCH CO.

Dept. 26 Thomas Bldg. Topeka, Kans.

SANTA FE WATCH CO., Dept. 26, Thomas Bldg., Topeka, Kansas.

Please send me your New Watch Book with the understanding that this request does not obligate me in any way.

Name.....
 Address.....State.....



LUMINOUS PAINT

Make Your Watches, Clocks, Etc., Visible by Night

The very latest discovery in the scientific world. Hitherto, practically unobtainable except at an exorbitant price, we have at last succeeded in producing this remarkable LUMINOUS PAINT, which, applied to the surface of any article, emits rays of white light, rendering it perfectly visible in the dark. **THE DARKER THE NIGHT, THE MORE BRILLIANT IT SHINES.** Quite simple to use. Anyone can do it. A little applied to the dial of your watch or clock will enable you to tell the time by night. You can coat the push buttons or switch plates of your electric lights, match boxes, and innumerable other articles; make your own Luminous Crockets, Luminous Rosaries, etc. Small bottle, price 25c. Larger sizes, 50c and \$1.00 postpaid. **JOHNSON SMITH & CO., Dept. 847 RACINE, WIS.**



CIGARETTE MAKER

Roll your own and save money. Better and quicker; saves more than half. Use your favorite brand of tobacco. Neat, useful, handy. Pocket size, weighs 1/2 oz. Made entirely of metal, nickel plated. 25c, 3 for 65c postpaid anywhere.



GOOD LUCK RING

Very striking, quaint and uncommon. Silver finish; skull and crossbones design, two brilliant, flashing gems sparkle out of the eyes. Said to bring good luck. Only 25c ppd.



Exploding Cigarettes

Box contains ten genuine cigarettes of excellent quality. They appear so real, but when each cigarette is about one-third smoked, the victim gets a very great surprise as it goes off with a loud BANG! A great mirth provoker yet entirely harmless. Price 25c box.

NOVELTY BADGES



Permit 2 10c **Garter Inspector 10c**
Two very novel metal badges, nickel plated, that you can wear, giving you fun out of all proportion to their trifling cost. 10c, each badge, 3 for 25c, or 75c per doz. postpaid anywhere.

MIDGET BIBLE

GREAT CURIOSITY Smallest Bible in the World. Size of a postage stamp. 200 Pages. Said to bring good luck to the owner. A genuine work of art. Must be seen to be appreciated. Make good money selling them to friends, church acquaintances, etc. PRICE 15c each, 3 for 40c, 12 for \$1.35, 100 for \$7.50. Also obtainable in Leather Binding, with gold edges. Price 50c each, 3 for \$1.25, \$4.50 per doz. Magnifying Glass for use with Midget Bible. 15c.

STAGE MONEY

With a bunch of these bills, it is easy for each person of limited means to appear prosperous by flashing a roll of these bills at the proper time and peeling off a genuine bill or two from the outside of the roll, the effect created will be found to be all that can be desired. Prices, postpaid: 40 Bills 20c, 120 for 50c, or \$3.50 thousand postpaid.

NOSE FLUTE

The Magic Nose Flute, or Humanstone, is a unique and novel musical instrument that is played with nose and mouth combined. There is just a little knack in playing it which, when once acquired after a little practice, will enable you to produce very sweet music that somewhat resembles a flute. There is no fingering, and once you have mastered it you can play all kinds of music with facility and ease. When played as an accompaniment to a piano or any other musical instrument, the effect is as charming as it is surprising.

SURPRISE MATCHES

More fun than fighting with your wife. Look just like ordinary matches. Put up in boxes just like regular Safety Matches. As the victim tries to light one he gets quite a surprise. Price 10c per box, 3 boxes for 25c, 12 for 75c.

STAR TOY MAKER

Greatest boys' book written. Tells how to make a Pinhole Camera, a Canoe, model Railroad, a Telephone, Boomerang, Telegraph Instrument, Box Kite, Talking Machine, Microscope, Electric Motor, Electric Door Bell, Water Wheel, Paddle Raft, a pair of Skis, a Dog Sled, Bird House, Rabbit Yard, etc. 64 pages. 100 illustrations. PRICE 10c or 3 copies for 25c postpaid.

BOOK ON ROPE SPlicing

Useful Knots, Hitches, Splices, etc. How different knots are made and what they are used for, knots that are unsafe, etc. Over 100 illustrations. All about wire rope attachments, lashing, blocks, tackles, etc. PRICE 20 CENTS OR THREE COPIES, FOR 50 CENTS POSTPAID.

Wonderful X-Ray Tube

A wonderful little instrument producing optical illusions both surprising and startling. With it you can see what is apparently the bones of your fingers, the lead in a lead pencil, the interior opening in a pipe stem, and many other similar illusions. A mystery that no one has been able to satisfactorily explain. Price 10c, 3 for 25c, 1 dozen 75c. Johnson Smith & Co.

NOSE BLOWER

When some men blow their noses it sounds like a trombone. Now the NOSE BLOWER has come to torment us. It is a starter! It is ingeniously concealed in the handkerchief. Proceed to blow your nose and your friends will think they heard a steam engine or something. You can blame the hideous noise to your having a very bad cold and keep up the fun as long as you like. PRICE 10c, 3 for 25c, or 75c doz. postpaid.

Serpent's Eggs

Box contains 12 eggs. When lit with a match, each one gradually hatches itself into a snake several feet long, which curls and twists about in a most life-like manner. Price per box, 10c postpaid, 3 for 25c.

BLANK CARTRIDGE PISTOL

Protection against Burglars, Tramps, & Dogs. Special Offer: 1 Blank Cartridge Pistol, 100 Blank Cartridges, 1 500-page Novelty Catalog. **ONLY \$1.50**. The Lot Shipped by Express Only. Cash With Order Only. Well made and effective, modeled on latest type of Revolver; appearance alone is enough to scare a burglar. When loaded it may be as effective as a real revolver without danger to life. It takes standard 22 Cal. Blank Cartridge - obtainable everywhere. Special cash with order offer: 1 Superior quality Blank Cartridge Pistol, 100 Blank Cartridges, and our new 550 page De Luxe Catalog of latest novelties; all for **ONLY \$1.50**. Shipped by Express only. Cannot go by parcel post. Extra Blank Cartridges 50c per 100. Special Holder (Cowboy Type) for pistol 50c. No C.O.D. shipments.

LOOK 35c LOOK Wonderful Instrument.

Greatest thing yet. Nine separate articles in one. Everybody delighted with it. Odd, Curious and interesting. Lots of pleasure as well as very useful. It is a double Microscope for examining the wonders of nature. It is also an Opera Glass, a Stereoscope, a Burning Lens, a Reading Glass, a Telescope, a Compass, a pocket Mirror, and a Laryngoscope—for examining eye, ear, nose and throat. It is worth all the cost to locate even one painful cinder in the eye. Folds flat and fits the pocket. Something great—you need one. Don't miss it. Sent by mail. **Only 35c or 3 for \$1.00**

Watch Charm Pistol \$1.00

Exact reproduction of a real pistol; actually fires REAL BLANK CARTRIDGES of miniature size. Illustration is actual size. 1 1/2 inches long, with ring at end for attaching to watch chain. Loads like a regular pistol. Pull the trigger and it goes off with a loud bang. Pistol is break open type; illustration shows position for loading. Made entirely of high grade steel, nickel plated, octagon barrel, hand engraved handles, complete in box with cleaning rod. PRICE \$1.00, BLANK CARTRIDGES, 50c per box of 25 (shipped by Express)

PISTOL CIGARETTE CASE

It looks like a deadly weapon, but it is merely a novel Cigarette Case. This clever contrivance has proved itself better than the real thing in many an awkward encounter. Great fun "sticking up" your friends. They squirm and protest it might be loaded. Pull the trigger and the slide flies open disclosing the cigarettes. Well made, light and compact. Weight only 2 ounces. PRICE **POSTPAID 25c**

MICROPHONE TRANSMITTER BUTTON

You can easily make a highly sensitive telephone by using this Transmitter Button to collect the sound waves. You can build your own outfit without buying expensive equipment. It is simple and inexpensive. You can install an outfit in your home and hear conversations being held all over the house. You can connect up different rooms of a hotel. This outfit was used by secret service operatives during the war. It is being used on the stage. It is ultra-sensitive and is the greatest invention in microphones. You can mount the button almost anywhere—card board boxes, stove pipes, stiff cylinders, on the wall behind a picture frame, etc. Button is so light and small it cannot be detected. Persons can be overheard without suspecting it. You can listen in on conversations in another room. A deaf person in the audience can hear the speaker. Connected to phonograph, piano or other musical instrument, music can be heard hundreds of feet away. Button may be used to renew telephone transmitters; often makes an old line "talk up" when nothing else will. The ideal microphone for radio use; carries heavy current and is extremely sensitive. Amplifies radio signals. Countless other similar uses will suggest themselves. Experimenters find the button useful for hundreds of experiments along the lines of telephones, amplifiers, loud speakers, etc. Many fascinating stunts may be devised, such as holding the button against the throat or chest to reproduce speech without sound waves. PRICE \$1.00. **JOHNSON SMITH & CO., Dept. 847, RACINE, WIS.**

LATEST CATALOG

JOHNSON SMITH & CO.
Dept. 847 RACINE, WIS.
A De Luxe Edition of our new CATALOG mailed on receipt of 25c. Handsome binding. Bigger and better than ever. Only book of its kind in existence. Nearly 650 pages of all the latest tricks in magic, the newest interesting puzzles, games, sporting goods, rubber stamps, unusual and elsewhere. Remit by Coin, Money Order, Check or unused U.S., Canadian and Foreign Stamps for all articles listed above. See next page also.



BOYS! BOYS! BOYS! Throw Your Voice

Into a trunk, under the bed, under a table, back of the door, into a desk at school, or anywhere. You get lots of fun fooling the teacher, policemen, peddlers, and surprise and fool all your friends besides.

THE VENTRILO

is a little instrument that fits in the mouth out of sight. Cannot be detected. It is used in connection with the above, and with the aid of this wonderful DOUBLE



THROAT, or VENTRILO, you can imitate many kinds of birds, animals, etc. Remember you get everything for **ONLY TEN CENTS**—a booklet giving you full instructions how to become a ventriloquist and throw your voice, the **Double Throat, or Ventrilo**, and our big 600 page catalog of novelties, tricks, puzzles, masks, books, etc., **ALL SENT POSTPAID TO ANY ADDRESS FOR ONLY 10 cents**

INVISIBLE INK Rubber Cigarettes. Price per Box 20c

The most confidential messages can be written with this ink, for the writing makes no mark. Cannot be seen unless you know the secret. Invaluable for many reasons. Keep your posts and other private memorandums away from prying eyes. Great fun for playing practical jokes. Only 15c a bottle; 3 for 40c.



It is just like a regular package of chewing gum and looks so real that it fools everybody. Of course no one suspects it is not genuine until they start to chew it. There's a world of fun in this rubber chewing gum — 5 sticks to the package. Price, 10c Pkg.; 3 for 25c; 12 for 75c postpaid.



Rubber Tacks Box 10c
Rubber Cigs. Price Ea. 10c
Rubber Matches. Price per Pkg. 10c

MAGICIAN'S BOX OF TRICKS

Apparatus and Directions for a Number of Mysterious Tricks. Enough for an Entire Evening's Entertainment. \$1.00



ANYONE CAN DO THEM
It is great fun mystifying your friends. Get this Conjuror's Cabinet, and you will be the cleverest fellow in your district. It contains the apparatus for ten first-class tricks, including THE MAGIC BALL AND VASE TRICK (a wooden ball is placed inside, and upon replacing the lid has disappeared and is found in someone else's pocket); THE HINDOO TRICK CARDS (can be made to change completely no less than five times); DISAPPEARING COIN BOX (a coin, placed in the wooden box, vanishes entirely or changes into a coin of another denomination); THE GLASS GOBLET TRICK (a coin is dropped into a glass of water and when the water is poured out the coin has vanished and is found somewhere else); THE RIBBON FACTORY FROM THE MOUTH TRICK (a seemingly endless supply of colored paper ribbons comes out of your mouth); the DISAPPEARING HANDKERCHIEF (a handkerchief held in the hand mysteriously vanishes); THE WIZARD'S RING COIN TRICK; the ENCHANTED BOTTLE (no one but yourself is able to make it lay down); the GREAT HAT AND DICE TRICK (a large die is placed on top of a hat, disappears, and is found underneath yet no one has touched the hat), and last, but not least, the GREAT PHANTOM CARD TRICK, or two from five leaves nothing. Full instructions are sent for performing each trick. In addition to the above, a number of other feats and illusions are fully explained for which you can easily make or procure the necessary apparatus. Price complete \$1.00 postpaid. JOHNSON SMITH & CO.

U. S. BABY TANK



It goes with real Yankee Pep—by its own power
Most remarkable toy ever invented. By drawing the Tank backward, either with the hand or over the floor or table and then letting it down, it will crawl along, overcoming all obstacles, in the same life-like manner as the larger Tank that proved so deadly in the great war. What makes it go is somewhat of a mystery, for there is no mechanism to wind up as is usually understood with mechanical toys, yet this tank will keep plodding along ten times longer than the ordinary run of toys. It will perform dozens of the most wonderful stunts; 2 1/2 inches long. Price only 25c prepaid. Stamps accepted. JOHNSON SMITH & CO.

25 Cents

ROLMONICA

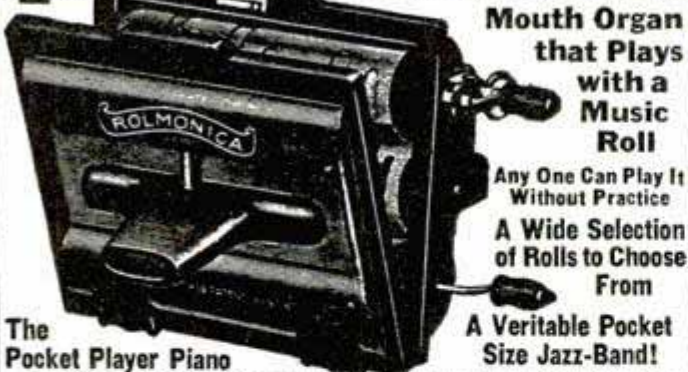

Mouth Organ that Plays with a Music Roll
Any One Can Play It Without Practice
A Wide Selection of Rolls to Choose From
A Veritable Pocket Size Jazz-Band!
The Pocket Player Piano
Rolmonica is an automatic harmonica, that plays a music roll just like a player piano. It is a whole brass band all in one—the biggest sensation of the musical world in the last few years. Anyone can play it, for all you have to do is to insert a roll, and turn the handle while you blow. That is all there is to it. Nothing could be simpler. Any child who can do these two simple things can play the Rolmonica. It is a veritable pocket size jazz-band, combining the principles of the harmonica and the player piano. It is an instrument of a thousand melodies, it plays the popular airs of the past, as well as the latest Broadway hits. There are hundreds of rolls to select from, such as My Blue Heaven, Home Sweet Home, America, Old Black Joe, Annie Laurie, Sidewalks of New York, Humoresque, Wild Irish Rose, Rosie O'Grady, Among My Souvenirs, Love's Old Sweet Song, Dixie, Mighty Lak' a Rose, Aloha Oe, Ramona, Juanita, Rose Marie, Onward Christian Soldiers, Sally of My Dreams, Carolina Moon, I Faw Down & Go Boom, Weary River, Over There, Ma Cherie, Luna Way to Tipperary, Make Believe, Desert Song, La Paloma, Sweet Adaline, I've Got a Feeling, Fagan Love Song, When My Dreaming Comes True, Parade of Wooden Soldiers, Land of Sleepy Water, Turkey in Straw, Hail the Gaiety's All Here, and hundreds of others. An unending source of amusement. You can delight your friends for hours and play tune after tune simply by changing rolls. Small in size, fitting your pocket, yet mighty in its finger-ticking, toe-tossing tune power. Not a toy, but a genuine musical instrument and the life of any party. Four Rolls free with each Rolmonica. Extra Rolls always obtainable; complete list with each instrument. New Rolls added each month. PRICE with 4 Rolls \$2.50; Extra Rolls 10c each, all postpaid.

RESURRECTION PLANT

Great curiosity. Place in water, plant opens up and starts to grow in few minutes. Taken out it dries up, and goes to sleep until put in water again. PRICE 10c, 3 for 25c. 75c dozen, postpaid.



MAGIC MADE EASY 250 MAGIC TRICKS 10c



An excellent little book containing 250 Parlor Tricks, tricks with cards, coins, handkerchiefs, eggs, rings, glasses, etc. So simple that a child can perform them. Profusely illus. Sent postpaid to any address for only 10c. 3 copies for 25c.

Comical Motto Rings
Lots of harmless fun and amusement wearing these rings. Made in platinumoid finish (to resemble platinum), with wording on enameloid, as illustrated. Price only 25c Postpaid.

The "Little Giant" Typewriter

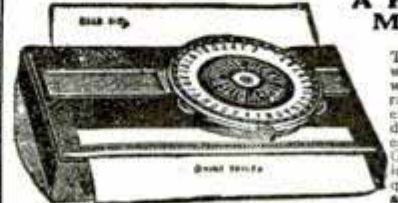

A First Class Writing Machine For \$1.50
A perfect little typewriter for \$1.50. There are thousands of persons who would like to use a typewriter but whose needs and business do not warrant the expense attached to the purchase and use of a fifty or seventy-five dollar machine. To such persons we confidently recommend our Little Giant. It is strongly made, but simple in construction, so that anyone can quickly learn to operate it, and write as rapidly as they would with pen and ink. The letters of the alphabet most frequently used are so grouped as to enable one to write rapidly, the numerals 1 to 10, and the punctuation marks being together. With this machine you can send your best girl typewritten love letters, address envelopes, make out bills, and do almost any kind of work not requiring a large, expensive machine. With each typewriter we send a tube of ink and full printed instructions for using the machine. Price complete \$1.50 by mail postpaid to any address in the world.

Own Your Own Big Money-Making Business

A NEW BUSINESS IN YOUR TOWN

A delightful, dignified and fascinating business. Make and sell Crispettes. Delicious confection. Young and old like them. Come again and again for more. Easy to make. I supply everything. Raw material plentiful and cheap. Profits big. No town too small. Start now.

QUICK SUCCESS POSSIBLE anywhere—cities, towns, villages, crowded streets; surging throngs at parks, carnivals, fairs, etc.; open a little retail store; or, begin at home; wholesale to stores, grocers, bakers, druggists, parks, baseball games, picnics, wayside stands.

EXCEPTIONAL (not average) PROFITS \$11,265 sales in 3 months reported by California man. New Jersey \$4,000 profits in less than 2 months. Revel of Michigan wrote: "Made \$25 on my first day". A. Leib of Montreal wrote: "My sales averaged \$400 per week".

WE START YOU IN BUSINESS for little money. Supply machines, secret formulas, and raw material. Little capital starts you. No experience needed.

WRITE FOR "BOOK OF FACTS"

—It's free, contains success letters from others—shows their places of business, tells how to start.



EAKINS CO.,
228 High St., Springfield, Ohio
Mail at once, your Book of Facts

AVERAGING \$3000.00
PROFIT FOR 3 SUMMER MONTHS
Report July 24 1929
E R NABOR
MASSACHUSETTS.

Name _____
Address _____

\$3000.00 PROFITS IN FOUR MONTHS
by Geo. Alexander, Pennsylvania.

AN EASIER Way to Popularity

PLAY your way to favor with a sweet-toned, easy-playing Pan-American. You learn popular music quickly. Fun, popularity, increased income! Choose any instrument—Pan-Americans are the only complete line of nationally advertised, factory guaranteed, moderately priced instruments made. **FREE TRIAL**; write for literature; mention instrument.

PAN-AMERICAN
Band Instrument and Case Co.
203 Pan-American Bldg., Elkhart, Ind.



ELECTRIC OR BATTERY **TRY IT 30 DAYS FREE BEFORE YOU BUY**

1 yr. guarantee
AC-7
\$39.85

9 Tube Screen Grid Steel Chassis
\$49.88



Factory to you. Save 50% on latest AC Electric or Battery Radio. Get 'Send No Money' Offer.

Big choice of cabinets

Lighted 1 dial **MIRACO**

Radio's most amazing bargains direct from big, old, reliable maker. Don't buy unless 30 days use proves entire outfit unbeatable at 2 to 3 times the price, for tone, selectivity, distance, volume.

Free Catalog and **BIG SPECIAL OFFER**
MIDWEST RADIO CORPORATION
10th Successful Year
407-GF Miraco Bldg., Cincinnati, O.



GET TWICE THE STATIONS Tune Scientifically



RADEX lists every station in America in the order in which they will come in on your dials. Thus you can identify programs the instant received and know where to set dials for any station you want even those never received before. . . . Only Correct Method of Tuning a Radio Set

RADIO IN DEX At Leading News Stands and Radio Stores or sent postpaid for **25c**
Complete hour-by-hour program of all chain features
THE RADEX PRESS, 1365 East 6th St., CLEVELAND, OHIO

BOYS: PRIZES! Write Quick!

BOYS: PRIZES! Write Quick!

SPORS GUARANTEED No. 10 FOUNTAIN PEN

SELLS FOR \$1.25 Use 60 Days **Ideal Xmas gift comes in**
SEND ONLY **Money Back If Not** **holly box**
39c "Writes Like a \$7 Pen."

39c Like a \$7 Pen.

[Sent Postpaid]



F. SPORS & CO., 1229 Main St., LESUEUR CENTER, MINN.

WRITE FOR FREE WHOLESALE CATALOG SHOWING OVER 400 ARTICLES

DIAMONDS

(Sent Free Examination)
here **60%** of Market Prices

10 large loan firms combined (world's oldest, largest association of its kind—rated over \$1,000,000.00), loans money on diamonds. A few such loans not repaid. Diamonds originally sold by outstanding jewelers. Of course we can loan but a fraction of real values. You get the advantage in Unpaid Loans at cash prices you can try to match at full 60% more. Every liberal privilege.—Examination free—No obligation to buy.

Free List of Unpaid Loan Diamond Bargains Every diamond accurately described. Radically low prices for any quality, any size. Written guaranteed amounts you can borrow (like Insurance Policy loan guarantee). Get full details of free examination offers. You don't risk a penny. 1/2 century old house (references: Bank of Pgh., Union Trust Co., 3rd Nat'l Bank). Lists limited—Send now. For **FREE LIST** write today to . . . **Jos. DeRoy & Sons, Opp. P. O. 1989 DeRoy Bldg., Pittsburgh, Pa.**



Unpaid Loans
Low as **\$60 per Carat**

The Rose Glen
5 Rooms, Bath
\$1449



BUILD YOUR OWN HOME at Mill Prices

Choose from 100 designs

Be Your Own Contractor and Save \$2,000

Here's your opportunity to own your own home. Let us tell you about the most liberal home plan in America! No speculative charges or extras.

Save \$500 to \$2,000 as you build! Our easy-to-follow instructions and correct architectural plans simplify building. Fully 80% of our customers do all or part of the actual work themselves. Any work you do is counted as cash. Earn as high as \$1.75 an hour on your own home! Get the facts. Since 1865 we have made it possible for 225,000 families to build profitably and safely.

Wholesale, mills-to-you prices. You get everything from our own building

material factories, lumber mills, huge warehouses and distributing yards. We furnish machine-sawed materials for a complete house; specially notched, and ready for exact fitting; saves 30% hand labor and 18% lumber waste.

Newest modern ideas: Oak floors throughout, linen closets, colorful deluxe kitchens, beautiful bathrooms, clothes chutes, fireplaces, solid bronze hardware, etc. Our Thermo-Sealed insulation saves 1/4 fuel cost. Finest lumber and millwork. Stanchest timbering construction. Proved engineering principles.

Satisfaction guaranteed. Before you buy or build, write for free facts.

Get Free Book—100 Plans and Secrets of Plan-Cut Savings



Gordon-Van Tine Co.
1414 Case St., Davenport, Iowa
Send me your Free Plan Book and Secrets of Plan-Cut Savings.

Name.....
Address.....

GARAGES
Easy to Build.
Plan-Cut.
From \$97.



Gordon-Van Tine

World's Largest Specialists in Homebuilding Since 1865

YOUR TREASURE SHIP!

Get this yellow book crammed with golden ideas. Follow a hobby that turns spare hours into money. True hand-carved ship models built from Hancock parts are readily sold. See Nancy Lee and Jumbo. Send 10c for copy right now.

ROY HANCOCK

323 Douglas Ave. Portsmouth, Va.

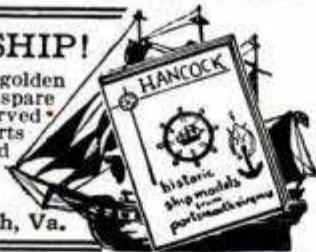

GET INTO THE VENDING MACHINE BUSINESS LARGE PROFITS BEING MADE!



You buy machines and place them in stores paying merchants 25% of receipts. Gum and peanuts used allow you from 100% to 200% profit! Start with small capital during spare time. A route of our machines will make you financially independent!

Write for catalog and full details *Today!*

D. ROBBINS & COMPANY 28-P DODD WORTH ST., BROOKLYN, N.Y.



Enjoy Building Things with These BOICE-CRANE Machines

Enjoy happy and profitable hours building handsome things for your wife, mother or the kiddies with this Boice-Crane home workshop that is just like a big woodworking plant. Connect to lamp socket and start work.

Turn Your Idle Hours into Gold

Have a woodworking plant of your own on a production basis. Use your spare time. You'll be delighted with the variety of accurate, intricate work you can do on Boice-Crane machines. The profits which will come from such a small investment and a few enjoyable hours will amaze you.

Boice-Crane Handi-Bench No. 5

(May Be Purchased Complete or in Separate Units)

- Universal Handi-Saw. Table 15"x17". Cuts 2 1/4" stock..... \$ 30.00
- Handi-Lathe 7"x40"..... 21.50
- 12" Handi-Band Saw..... 35.00
- Jig Saw. 10" Saw to frame. Cuts 1 1/4" stock..... 12.00
- 4" Handi-Jointer, Complete with guard..... 28.00
- Complete Handi-Bench including two 3/4 h.p. motors, belts, pulleys, switches and 3'x8' bench with steel legs 205.00

New 6" Handi-Jointer now ready for delivery. 36" long. Wt. 100 lbs. Constructed like our other well known jointers and moderately priced at\$75.00

Send 10c for 80-page catalog describing Boice Machines and Easy-Pay-Plan.

W. B. & J. E. BOICE
Dept. P.M. 2-F, TOLEDO, OHIO

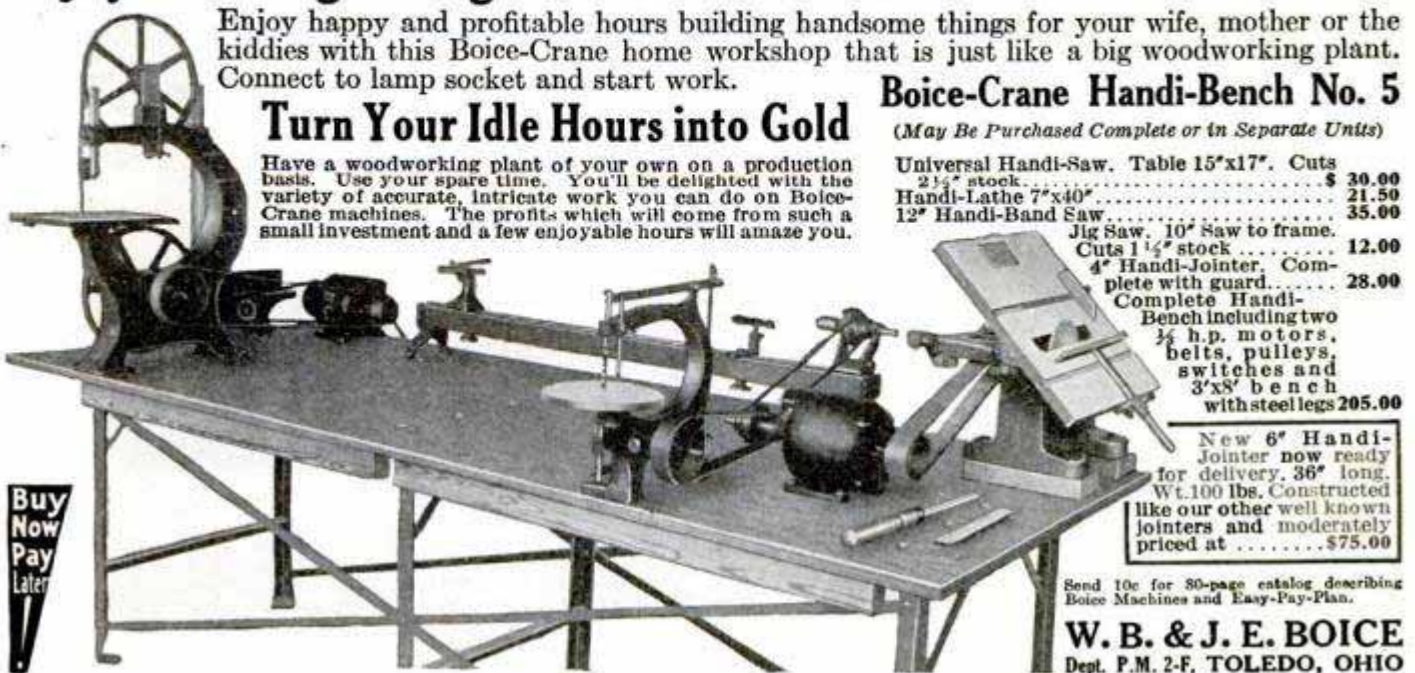

Buy Now
Pay Later

Soothes irritated eyes!

Men whose work exposes their eyes to irritation and strain will find *Murine* a godsend. Applied several times daily, it rids the eyes of irritating particles, relieves strain and prevents an unsightly bloodshot condition. This harmless lotion is a delight to use because of its cooling, soothing, strengthening effect. Write *Murine Co.*, 9 E. Ohio St., Chicago, for valuable free book on the care of the eyes.

MURINE FOR YOUR EYES

GOODELL PRATT 1500 GOOD TOOLS



Mr. Punch
The Hole Maker

This automatic drill carries eight sizes of drill points— $\frac{1}{16}$ " to $\frac{1}{4}$ ". Pick out the size you want, insert it in Mr. Punch's steel jaws, place point where you want the hole. You push. He twists. In goes the point and—presto, you have a clean smooth hole in any wood. Also can be used in plaster. Remember the name and look for Mr. Punch on the green-covered box.



To acquaint you with **GOODELL-PRATT** quality we make this Remarkable Offer!

SEND \$1.00 FOR HANDY POCKET SCREW DRIVER SET

Special low price. Ideal for repair work on radios, firearms, clocks, household appliances, etc. Contains three screw driver blades and reamer.



Goodell-Pratt Co., Greenfield, Mass.

Attached is one dollar for pocket screw driver set.

Name

Street

City..... State.....

My hardware dealer is

GET THIS SUIT

Big New
Outfit
FREE



To introduce our unbeatable values, classy styles and perfect tailoring, we make this introductory free suit offer—something different, better, bigger, more liberal than any offer ever made by a reliable house.

Splendid Opportunity for FREE Clothes Cash Commissions, Liberal Bonus

Earn \$45 a week and up, just showing our wonderful outfit and taking orders for our high-grade tailoring. Never before such low prices and beautiful styles.

NEW STYLE—of large real cloth samples—**OUTFIT** everything furnished **FREE**. Write **FREE** today for free suit offer and big money-making plans.
PROGRESS TAILORING COMPANY, Dept. P-216, CHICAGO

MODEL SHIPS



We can supply construction sets and all sorts of parts such as semi-finished hulls, blocks, dead-eyes, special flags, anchors, steering wheels, capstans, figureheads, blue prints, books, etc., for building real fine scale models of the Flying Cloud, Constitution, Spanish Galleon, Mississippi River Steamboat, Sovereign of the Seas, Mayflower and many others. Also special construction sets for racing sail boats, power boats, model steam engines, propellers, etc.; and fine tools for the model maker. Our large 48-page photographically illustrated booklet contains valuable information and hints for building ship models in addition to prices and full description of the above articles. Many people only slightly interested in models have become greatly enthused upon receiving this booklet. A copy will be sent postpaid upon receipt of 15 cts. (coin preferred).

Model Ship Supply Co., Dept. B, Mineola, N. Y.

"THE HOME MECHANIC" 1930 MODEL

Complete

\$14.50

Write for Details at Once



A
Real
Man-
Sized
Wood
Working
Outfit

LEITNER MFG. CO., 2214 Granville Ave., CHICAGO, ILL.

GO INTO BUSINESS AT HOME

Menor women, earn fine income in business of YOUR OWN operating "Specialty Candy Factory" --begin Home Spare Time, make BIG PROFITS First Week. We furnish Tools and Supplies--show you how to make and sell large line PURE, DELICIOUS Candies. Nothing else like it. Booklet FREE.
W. HILLIER RAGSDALE
Drawer 62
East Orange, N. J.

Boils 50 Gallons

In Less Than Hour

No Other Compares With This

Improved Oil Burner

Use Ordinary Kerosene or Coal Oil

[Burns Outdoors as Well as Indoors]

THE most remarkable Kerosene Burner ever built. Boils down apple cider, maple syrup, molasses, etc., in half the ordinary time. Ideal burner for dairies, butchers, indispensable on the farm.

**PRODUCES TERRIFIC HEAT WITH
SILENT BLUE FLAME**

**NO
NOISE
SMELL
SMOKE
SOOT**

So efficient it produces twice the amount of heat of City gas at half the cost. So simple anyone can install and operate. Double generator assures continuous operation without shut-downs. Nothing to wear out, starts in a jiffy, will last a life time. Every burner guaranteed fully. Write for special introductory price and free catalog of outdoor utility and kitchen stove oil burners.



HOME MFG. CO., Dept. 4013, 20 E. Kinzie St., CHICAGO



The WILBAR 12" BANDSAW \$57⁵⁰
 Complete as illustrated ready to operate from any light socket with 1/4 H. P., 110 V., 60 C., A. C., Motor and Extra Bandsaw Blade. Table Top will tilt from 0 to 45 degrees with Ball Bearing Guides. Shipping weight 155 lbs. \$47.50 without Motor F. O. B. Phila.

8" COMBINATION SAW OUTFIT \$45
 Complete F. O. B. PHILA. with Ball Bearings, 1/4 H. P. Double Shaft Motor. Base 28" long by 8" wide. Table Top 18" by 12". Will Rip, Crosscut, Bevel, Grind, Mitre, Groove, Sand, Mortise, Tenon and Polish. Everything complete ready to plug in any light socket. Same specifications without Ball Bearings, with 16" by 12" Motor \$30.00.

Table Top—\$35.00. Saw Table only with Combination Blade and 1/4 H. P. Motor \$30.00.

Catalog Free in which these outfits are clearly pictured. Also contains Bench Lathes, Complete Workshop and Hardware Specialties.

WILBAR CO., Inc., 2020 East Arizona Street, PHILA., PENNA.

ELECTRIFY YOUR RADIO FOR ONLY \$6⁸⁵ COMPLETE

Why discard your present good set when you can electrify it for only \$6.85, and banish the annoyance and expense of buying new "B" batteries?

Over 150,000 Townsend
 "B" POWER UNITS IN USE



Hooked up in a few minutes. Use same tubes—no changes. You'll be amazed at the improvement in reception and distance getting. Send name and address today for full details, proof and Free Trial Offer. TOWNSEND LABORATORIES, 715 Townsend St., Chicago, Ill.



CORRECT Your NOSE!

Improve your appearance with the ANITA NOSE ADJUSTER. Shapes flesh and cartilage—quickly, safely and painlessly, while you sleep. Results are lasting. Doctors praise it. 68,000 users. Write for 30-Day TRIAL OFFER and FREE BOOKLET.

ANITA INSTITUTE, 212, Anita Bldg., Newark, N. J.

Save Your Feet

When all else fails end your suffering with the flexible "no metal" Heefner ARCH SUPPORT



WRITE FOR FREE BOOKLET

HEEFNER ARCH SUPPORT CO., 673 M. E. TAYLOR BUILDING, LOUISVILLE, KY.

Agents!-Here's Something New



Make \$50 to \$90 A Week

Amazing new fast-selling invention—Crystal Home Filter for fruit juices and beverages. Patented. Nothing like it. Removes all sediment, pulp, fibres. Filters a gallon every 4 minutes. Perfect results guaranteed. Simple. Practical. Low priced. Every home a prospect. Big profits. Quick, easy sales.

Write Today for FREE Sample Offer
 500 more agents needed NOW. Make money fast. No experience needed. Write quick for Free Demonstrator and territory Offer. Send NOW. Home Filter Co., 422 Central Ave., Bay City, Mich.

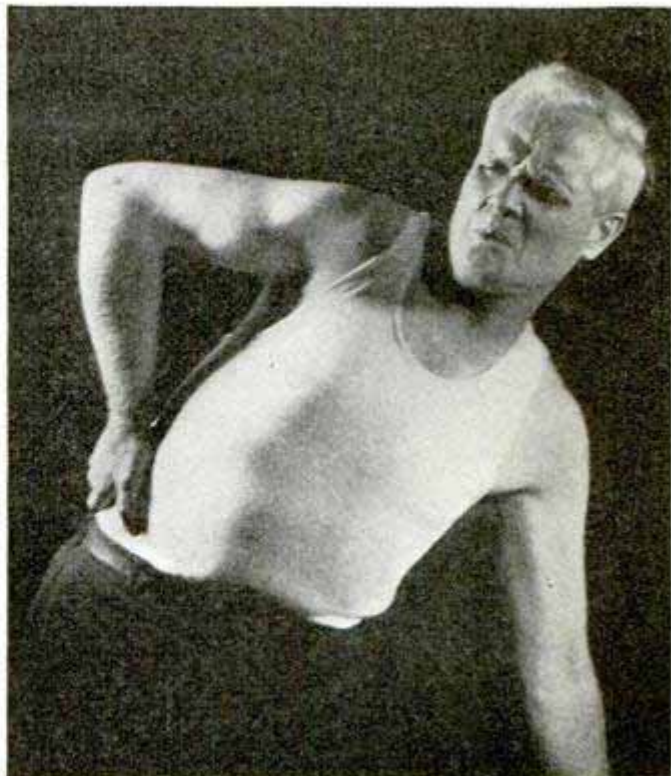

Aching Muscles?
—Stiff joints?

A SUDDEN strain on a muscle. A quick severe twist of a joint. Sometimes overwork does it. Sometimes hard exercise. Later those dull, throbbing pains! That old stiffness and soreness! How much suffering they can cause us. We feel lame and stiff. It's hard to do any work.

DON'T put up with pain from muscles and joints. Sloan's Liniment eases the soreness quickly. *Warms the body like sunshine.* Drives away pain. Used in 13 million homes. Booklet of 16 tested treatments for aches and pains in every package. Get a fresh bottle from your druggist. 35 cents.

SLOAN'S Liniment

Win Nash and \$500 or \$1,845 Cash

Seven Brand New 6-Cylinder Cars Given

For advertising purposes I am going to give absolutely free a brand new six-cylinder "Special Six" Nash four-door Sedan, an Oldsmobile two-door Sedan, a De Soto two-door Sedan, a Pontiac two-door Sedan, an Essex two-door Sedan, a Whippet two-door Sedan, and a Chevrolet two-door Sedan, all six-cylinder latest model Sedans; also 4 splendid new console type radios, a Victor Orthophonic Victrola and other valuable prizes. Any person living in the United States outside of Chicago may enter an answer to this puzzle except employees of the W. D. Boyce Company or members of their families, or winners of automobiles or first prizes in any of our previous offers, or members of their families.

SOLVE THIS TRAFFIC PUZZLE

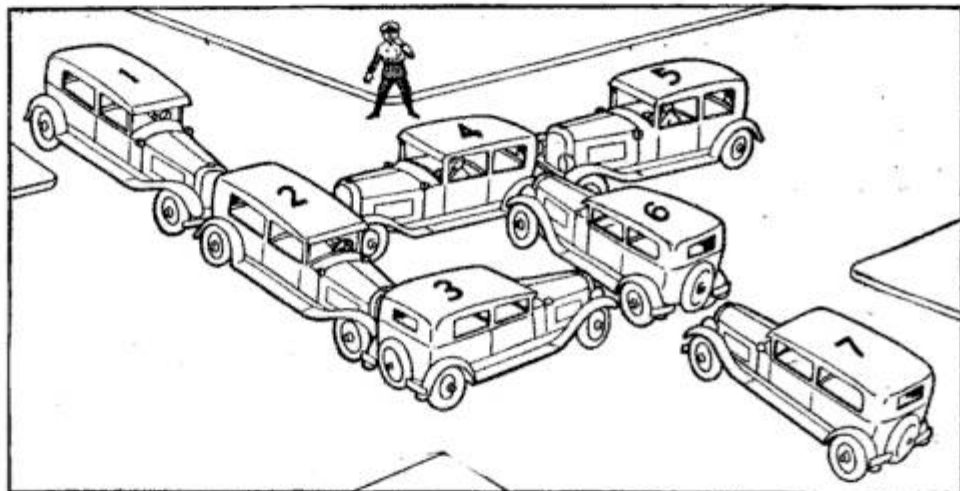

In the picture there are 7 cars in a bad traffic jam. None of them can move forward, for each car is blocked by the one in front of it. One of these cars will have to be backed out. Which one? The traffic policeman seems to be stumped. Can you straighten up this tangle for him? Only one car may be moved backward, and if you pick out the right one, you will see that it is not necessary to back up any of the others. Send the number of the car which when backed out will relieve this traffic tie-up, and if your answer is correct you will be qualified for this opportunity.

\$500.00 for Promptness

We are not only giving the Sedans, radios and so forth in our big prize list amounting to over \$6,800.00, but are also giving an additional \$500.00 in cash for promptness to the winner of first prize if he or she has been prompt. Thus, the first prize winner will receive the Nash Sedan and \$500.00 in cash, or \$1,845.00. Find the car which when backed out will relieve this traffic tangle and send the number of it in a letter or on a post card, or you can mark the car on the picture and send it to me. Be sure to write or print your name and address plainly. All who answer correctly will be told how they can share in the prizes or cash. Duplicate prizes paid in case of ties. ANSWER TODAY.

G. W. ALDERTON, Dept. 399 510 N. Dearborn St., Chicago, Ill.

Enjoy the Thrill of Making Things Quickly and Easily with the NEW 1930 Delta ELECTRIC Handi-Shop

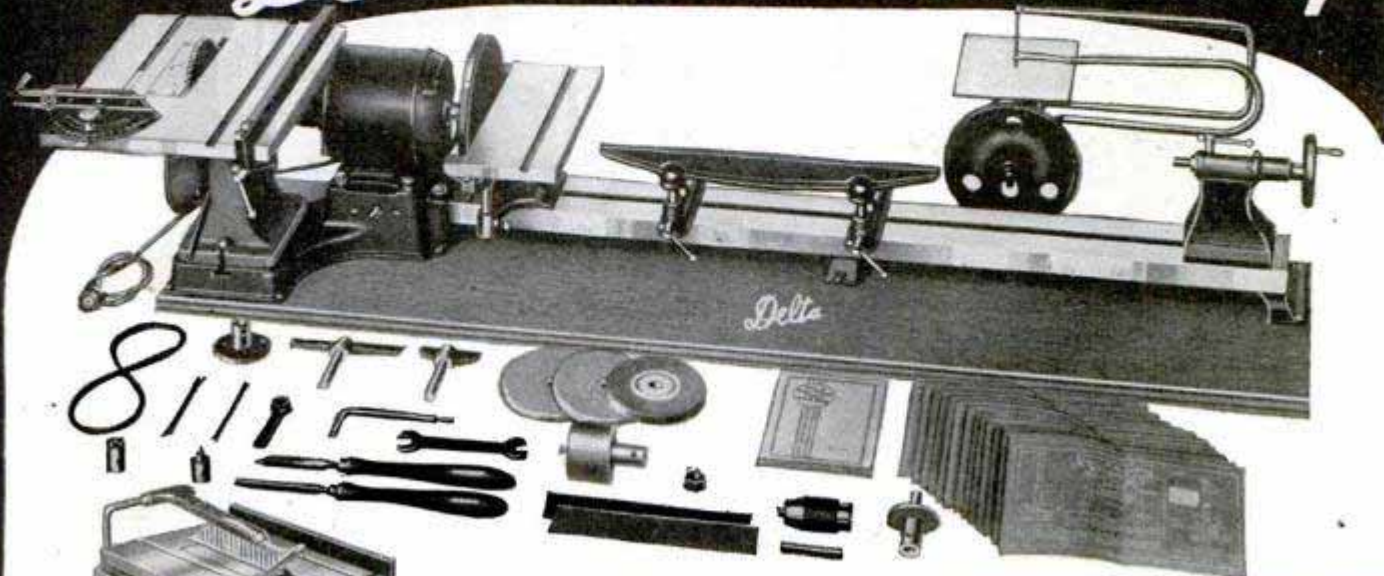

You will be delighted with the sturdy construction, splendid efficiency, and moderate cost of this Delta equipment. You will appreciate keenly in the "Handi-Shop" such exclusive constructional features as the Patented Tilting Tables, Automatically-Oiled Bronze Bearings, Heavy U-Shaped Lathe Bed, and Circular Saw Raising Lever. Send coupon for complete description of this remarkable workshop.

New Workworking Units

The Delta Jointer and Circular Saw Units mark a new era in moderate-priced woodworking equipment. Now, for the first time, are available sturdy, practical machines in compact, convenient form at price levels astonishingly low. The Combination Unit affords a compact, convenient arrangement which permits sawing and planing in one quick operation. Either Jointer or Saw can be operated separately or both together. Welded steel stand of convenient height. All three units are furnished with or without motor, as desired.

10-DAY TRIAL!

Easy Terms

For full description of the new 1930 Delta line, send coupon for FREE illustrated literature. Gives full details of 10-Day Trial Offer. Choice of three convenient payment plans. Mail coupon TODAY!

New "Delta" MOULDING CUTTER

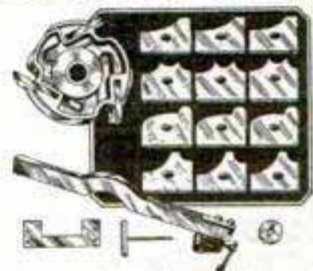

High speed blades produce over 10,000 cuts per minute at 3,500 R. P. M. Blades require no individual adjustment. Quickly and easily locked in position. Special guide fence. Unusually low price. Below are a few of the many shapes that can be made.

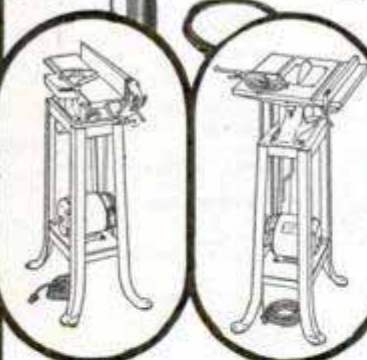
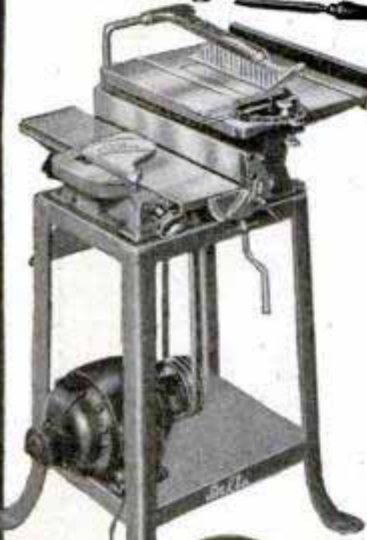

DELTA SPECIALTY CO.

Division of "Delta Manufacturing Co."

1661-67 Holton St., Dept. A-230, Milwaukee, Wis.

DELTA SPECIALTY COMPANY, Dept. A-230
Division of "Delta Manufacturing Co."
1661-67 Holton St., Milwaukee, Wis.

Please send me FREE, illustrated literature describing 1930 model "Delta" Woodworking Units. Also details of 10-Day Trial Offer and Easy Payment Plans. (Check special information desired.)

- Handi-Shop
- 4" Jointer Units
- Combination 4" Jointer and 8" Circular Saw
- I am interested particularly for home use
- I am interested for shop and professional use
- Moulding Cutter
- 8" Circular Saw Unit

Name.....

Address.....

A PRACTICAL COURSE IN MECHANICAL DRAWING

By WM. F. WILLARD

An ideal book for home study. Each exercise is clinched in the mind of the student by practical application to every day practice. 160 Pages. 157 Drawings. Cloth. Price \$1.00 Postpaid

POPULAR MECHANICS PRESS 200 E. Ontario St. CHICAGO

Outdoor Opportunities

How to raise rabbits, guinea pigs, milch goats, silver foxes, ferrets, white rats, white mice, dogs, cats, pigeons, pheasants, bantams, canaries, bees, frogs, mushrooms, ginseng and golden seal for profit. Practical 250-page book with 120 illustrations. Will be sent C. O. D. When postman hands you the package, pay him \$2 plus the postage.

POPULAR MECHANICS PRESS
Room 506 200 E. Ontario St. CHICAGO

**Stop
A.C.
Noise!**
**Improve
Selectivity!**

RADIO reception may be made much more enjoyable by plugging in a Falck Claroceptor between the light socket and your set. By blocking out the line interference noises, this wonderful device also helps selectivity and distance. Tested, proved. Thousands now in successful use all over America. No change required in your set. Only equipment of the kind. Compact size: 3 1/2" x 5 1/2" x 2 1/2". Made by pioneer radio manufacturer. At radio parts dealers, or write us for new free folder.

Falck \$7.50
(With Cord and Plug)
CLAROCEPTOR

Manufactured by ADVANCE ELECTRIC CO.
Dept. P M—1260 W. Second St., Los Angeles, Calif.
JOBBER AND DEALERS, GET OUR PROPOSITION

Simplex
**Screw
Jacks**
For the Home Workshop,
or Manual Training



WITH this 500 lb. capacity Simplex Jack, you can straighten window or door frames and avoid planing or re-setting locks—level radiators, plumbing, drain pipes, ice box—straighten or clamp glued work, radio cabinets, etc. This little—

"Jack in the Box"
is for the man who uses tools, or the boys interested in manual training or mechanical toys. It has hundreds of uses. Sturdily built, beautifully finished, and unconditionally guaranteed. Its purpose is to demonstrate and advertise the exclusive safety feature of the visible screw and power of the larger Simplex Jacks, and will be sent you prepaid for 35 cents—Canada 45 cents. Money refunded without question and instantly if not satisfied.

3 Inches High
When Closed
Capacity
500 lbs.



Templeton, Kenly & Co. 35¢
ESTABLISHED 1899
1020 So. Central Av. Chicago Ill. U.S.A. 120

Gentlemen: Please send me postpaid 1 Simplex Miniature Jack at 35 cents and at 35 cents each for my friends. A total of \$..... is enclosed.

Name.....
Street.....
City..... State.....
Mark color desired: Red, Blue, Green.

SURE SPRAY

The Electric Paint Brush

DIRECT FROM
FACTORY

1/2 Price

\$39.50



Built, designed and made to sell at half price direct from factory to you.

At last a perfect electric pump. Guaranteed to spray heavy enamel, lacquer, varnish, calcimine, anything in paint. A marvelous electric paint brush that works sure and steady. Now used by factories where continuous service is demanded. Portable. Sprays heavy enough to do good work. A touch on the thumb-control makes it paint a broadside or a fine line. Paints a house or very small articles. Pays for itself on one good job.

MEN—Go into business with an investment of only \$39.50 and paint automobiles. Do a perfect factory job. Vast opportunities for big profits.

Send for Free Information
This factory half-price offer good for 30 days only. Write at once for large full color broadside telling all, or send your order today.

All Steel Products Company
Dept. A
333 State St., Detroit, Mich.

3 EXTRA
COLOR
CANS
SUPPLIED!

Books on 32 Subjects

Popular Mechanics Press specializes in supplying books on any subject. Look over this list. Check the books you want, and mail this advertisement as your order blank. Catalog with lists on 2,000 subjects free.

- | | |
|--------------------------------------------------------------|----------------------------------------------------------------|
| AIRCRAFT (Modern)
Complete. Up-to-date. \$5.00 | FURNITURE REPAIRING
Finishing and Decoration. \$5.00 |
| ARTIST (Commercial)
Money-Making Art. \$5.00 | HYPNOTISM
A Reliable Treatise. \$2.00 |
| ATLAS (of World)
Modern. New Boundaries. \$3.00 | INVENTIONS
How to Make Pay. \$2.50 |
| AUTOMOBILE (Modern)
Gasoline. New Edition. \$5.00 | MAGIC
World's Best Book of. \$2.00 |
| BOOKKEEPING
Practical Handbook. \$1.00 | MIRRORS
Silvering. \$1.00 |
| BRICKLAYING
Plain and Fancy. \$1.50 | MODEL ENGINEERING
Very Interesting. \$4.00 |
| CARBURETORS (All Makes)
Only Book Covering. \$2.00 | PLASTERING
Best Instruction Manual. \$1.25 |
| CHALK TALK
and Crayon Presentation. \$1.25 | RADIO ENCYCLOPEDIA
Very Complete. \$6.00 |
| DRAWING
Freehand and Perspective. \$1.50 | REAL ESTATE
Educator. \$2.00 |
| DRY CLEANING (Practical)
and Dyer. \$3.00 | SHOW CARDS
Artistic. \$3.50 |
| ELECTRICAL SYSTEMS
Automobile. \$3.50 | SIGNS (Artistic)
How to Make. \$3.50 |
| FLOWER RAISING
1001 Questions Answered. \$2.00 | Steam Engineer's License
How to Obtain. \$2.00 |
| FLYING
A B C of. \$1.50 | STEEL SQUARE
How to Use. \$1.00 |
| FUNNY PICTURES
How to Draw (by Zim). \$3.00 | TELESCOPE (Amateur's)
How to Make. \$3.00 |
| FUR RAISING
For Profit. \$4.00 | TOOLS (Using)
Tinkering with Tools. \$2.00 |
| | TRICKS (200)
For the Amateur. \$1.00 |
| | WOOD FINISHING
Plain and Decorative. \$2.00 |

SEND NO MONEY

Just check the books you want, and mail the whole advertisement. It is your order blank. When postman hands you books, pay him the price and the postal charges. If outside the U. S. remit when ordering and include 10 cents per book extra for postage.
POPULAR MECHANICS PRESS, Room P2, 200 East Ontario St., Chicago, Ill.

\$483
BRINGS YOU

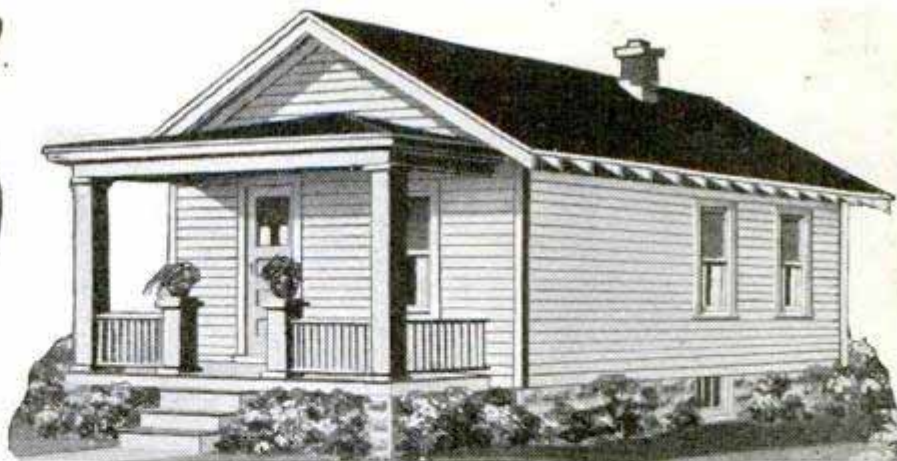

THIS 5-ROOM HOUSE WE PAY FREIGHT



The Biggest Home Values You'll Ever Find

SAVE 18% Lumber Waste 30% Labor Cost

Buy all the materials direct from the Aladdin Mills and make big savings. Price includes all lumber cut to fit millwork, hardware, glass, nails, paints, roofing and complete instructions. Build it yourself.

Homes-Summer Cottages-Garages

Aladdin's latest 1930 Catalog shows 100 plans of homes, summer cottages, and garages, at money-saving prices. Write nearest office **today** for your FREE copy. Ask for Catalog No. 259. No obligation.

The ALADDIN CO. Bay City, Michigan
Wilmington, N. C. Portland, Ore.



100 New Home Plans in Aladdin's Latest Catalog

"OLD TOWN CANOES"

glide forward at the slightest dip of the blade. Strong and sturdy, too. \$67 up. Free catalog gives full information on all models. Also shows big, fast, seaworthy outboard boats. Write, Old Town Canoe Co., 1142 Middle St., Old Town, Me.

BUCHSTEIN'S FIBRE LIMB

is soothing to your stump—strong, cool, neat, light. Easy payments. Braces for all deformities.
D. BUCHSTEIN CO.
610 3rd Ave., So.
MINNEAPOLIS, MINN.

Send for Catalog Today

Mac WORKSHOP
Electrically Operated
THE POPULAR MECHANIC

Sent on Approval

24 PLANS 25c

You Can Make It

Only 25c brings you these valuable plans, 24 separate sheets, with full particulars covering each operation. Collection includes Grandfather's Clock, Ship Model, Book Case, Table and many other useful and practical furniture objects, novelties and toys. Experience the thrill of building something that will last a lifetime. Don't miss this opportunity. Plans easily worth \$2.50—but while this special offer lasts—only 25c—ORDER NOW.

Write Today for Details

Send for particulars about MAC—THE POPULAR MECHANIC workshop and our Free Trial Offer. Here is an outfit that embraces everything necessary to gratify your creative instincts—and to earn big money, too. Even in unskilled hands results are surprising. MAC is a strong, sturdy, practical workshop—designed to perform the most difficult woodcraft operations. It is used in schools, carpenter shops, factories and in thousands of home workshops. We guarantee without reservation the highest degree of performance. **WRITE TODAY.**

MIDLAND APPLIANCE CORPORATION
225 N. Michigan Ave. Dept. 1410 Chicago, Ill.

Information on any book free. Write Popular Mechanics Press, Chicago, Ill.



ARTISTIC PORTRAIT ENLARGEMENTS
only **98¢ each**
FROM ANY PHOTO or SNAP-SHOT SIZE 16 x 20 INCH (or smaller if desired)

The usual price of this work is \$5.00 but by taking advantage of this Special offer you can get a beautiful life-like enlargement of that favorite picture of mother, dad, sweetheart, baby or any friend for only 98 cents.

SEND NO MONEY—Just mail us the photo—any size (Full figure, bust or group) and in about a week you will have your enlargement guaranteed never to fade. It comes to you C.O.D. On arrival pay postman 98c plus a few cents postage, or send one dollar cash with order and we pay postage. Money back if not delighted. You can send us your most treasured photograph, it will be returned to you unharmed.

FREE In order to advertise this remarkable offer we send free with every enlargement ordered, a Highly-Glazed Hand Painted miniature reproduction of the photo sent. These miniatures alone are worth the whole price charged for the enlargement. Take advantage of this really Amazing Offer and send your order today. **DO IT NOW.**

ALTON ART STUDIO, Dept. 46
5654 West Lake St., Chicago, Ill.

Please enlarge artistically the enclosed photo. Return enlargement and FREE Hand Painted miniature, C.O.D. 98c plus postage. (If \$1.00 is enclosed you are to send postage paid.)

Name _____

Address _____

Town _____ State _____

Check Size Wanted

16x20 in.

10x16 in.

11x14 in.

8x10 in.

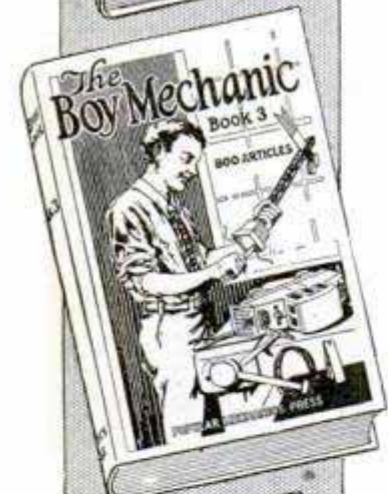
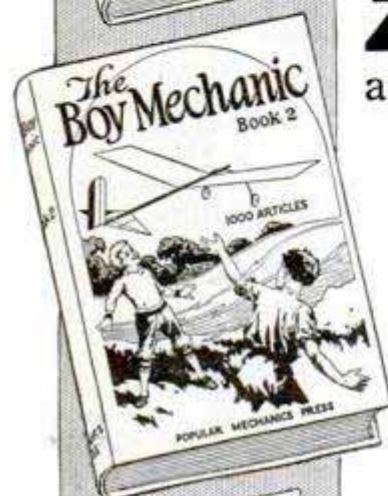

Boys! Here's Fun Galore

Zip! Here they come! Around a turn and down the home stretch to cross the finish line with a last furious burst of speed!

You want things that will "GO"—things you can race with—scooters, pushmobiles, small autos with motorcycle engines, wind wagons, etc.—Whether on spinning wheels or glistening runners—fast ice yachts, skis, toboggans, bobsleds, motor driven sleds and snow speedsters.

You air-minded boys enjoy gliders and model airplanes.

Turn your back yard into a regular amusement park with all these thrillers—ferris wheels, roller coasters, merry-go-round swings, etc.

How fascinating to imitate the big engineers and make small water wheels, pile drivers, aerial cableways and other things that "work."

When at camp or on the water you need plenty of ideas for new ways of having fun. Here are dozens such as water bicycles, push boats, water coasting toboggans, water games, etc.

On rainy days and other times when working in your home shop you have the hardest time finding interesting things to make. Here are any number such as electric locomotives, motion picture cameras, wood turning lathes, etc.

But why try to describe this great

Boy Mechanic Library

Boys, it simply cannot be done. You must actually have these books in your hands and see them before you can begin to realize that the four big volumes contain enough interesting things to last you until you are a grown-up man.

THINK OF IT!

4000 Worth While Things to Make and Do

Don't envy the other boys on account of the things they have. Be the boy in your neighborhood to make the others wonder where you get all your ideas—and it doesn't cost a lot of money, either. These wonderful books show you how to take parts from old cast-off things and perhaps get a few cents' worth of material from a hardware store—or have a blacksmith or shop man help you bend some iron, and thus make something that works just as well as though you had paid several dollars for it. Best of all—you get the thrill of having "Made It Yourself."

Everything is pictured out and made easy. Don't try to get along without these books any longer. Save or earn the money to buy them right away.

The complete library of 4 volumes, each book 7x10x1 1/2 inches and with 460 Pages.

Price \$7.00

or single volumes at \$2 each. Each volume complete in itself.

Books are numbered: 1, 2, 3 and 4. State the ones you want when ordering. Sent postpaid when remittance is sent with your order, or will be sent C. O. D. anywhere in the U. S. Pay postman price plus extra postage for this service.

Popular Mechanics Press, Room P 2 Chicago
200 E. Ontario St.

Get Busy

Like This Man and

Make \$700 a Month

This man got tired of low-pay, half-time work. He read and answered a Clarke advertisement just like this—now he is making \$700 per month. How? Through Flor-Kraft.

How You Can Do It

Clarke has perfected a low-cost machine for finishing floors by electricity. It does this high-pay work in a high-class speedy manner. It enables any man to do so much of this work every day in such an expert way, at such expert pay, that many Popular Mechanics readers are making \$25 to \$75 per day, in Flor-Kraft. In this work all you do is sandpaper new and old floors to a velvety smoothness with this machine. You make the floors ready for varnishing or waxing. The Clarke Vacuum Portable Sander weighs only 31 lbs., and runs from any light socket. It handles like a vacuum cleaner, and works almost as easily.

No Books To Study

You don't have to study any course or buy any books. A few hours' practice with this machine gives you the skill of a veteran. The machine does the work—you merely guide it.

Why This Big Pay

This work was formerly done by hand or with slow cumbersome machines—slower than an old ox. That's why the rates are high—3c to 5c per sq. ft. on new floors, 7c to 15c per sq. ft. on old floors. The fast-cutting Clarke is guaranteed to do 900 to 2,200 sq. ft. of new, or 300 to 1,000 sq. ft. of old varnished floor, per 8 hour day. That's why with a Clarke you can make from \$25 to \$75 per day so easily in Flor-Kraft. You can make similar big profits in re-finishing store counters, desks, tables, cabinet-work or wood-work of any kind. There's all kinds of this ready work and ready money for you to go after. It's all inside work that the weather doesn't bother.

The Quick Way To Independence

It takes only about \$100 to get started. You make this big money right from the start. The Clarke quickly pays for itself. As boss of your own Flor-Kraft business you pocket all the profits. Many former clerks, mechanics, office workers, shop and handy men are making this big money. So can You! Send for the guaranteed facts and full details today. Use the coupon.

CLARKE SANDING MACHINE CO.

DEPT. T-32

3831 Cortland Street

CHICAGO, ILLINOIS

*Originators and, for over 12 years, Manufacturers of
Portable Sanding Machines*

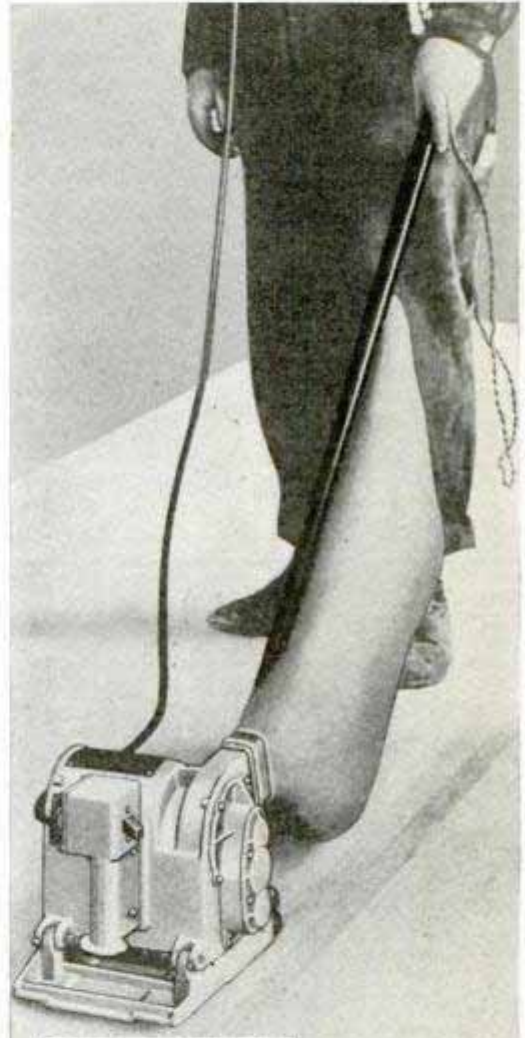

POWERFUL, FAST CUTTING
CLARKE
VACUUM PORTABLE SANDER

MAIL THIS COUPON

CLARKE SANDING
MACHINE CO.,
Dept. T-32, 3831 Cortland St.,
Chicago, Ill.

Gentlemen: Please send me, without obligation, full details on the Clarke Sander, and the money-making possibilities of Flor-Kraft.

Name.....

Address.....

City.....



"I'm going to raise his salary"

"I've had my eye on him for some time and I know he can handle bigger work."

"He studies those I. C. S. textbooks every chance he gets, and I want to tell you it has made him a valuable man for this business."

"I'm going to raise his salary and give him that new job we were talking about. I wish we had more men like him."

How do you stand when your employer checks up his men for promotion? Does he pass you by as just a routine worker, or does he think of you as a man who is ambitious to get ahead? Won't you be far more likely to get the promotion if he knows you are studying at home and are really preparing yourself to handle bigger work?

Think it over. Then act. It takes only a moment to mark and mail the coupon and find what the International Correspondence Schools can do for you, yet that one simple little step may be the means of changing your whole life. "Do it now."

Mail the Coupon for Free Booklet

INTERNATIONAL CORRESPONDENCE SCHOOLS Box 5667-F, Scranton, Penna.

Without cost or obligation, please send me a copy of your booklet, "Who Wins and Why," and full particulars about the course before which I have marked X in the list below:

TECHNICAL AND INDUSTRIAL COURSES

- | | |
|--------------------------------------------------|-----------------------------------------------------------------------------|
| <input type="checkbox"/> Architect | <input type="checkbox"/> Automobile Mechanic |
| <input type="checkbox"/> Architectural Draftsman | <input type="checkbox"/> Aviation Engines |
| <input type="checkbox"/> Building Foreman | <input type="checkbox"/> Plumber and Steam Fitter |
| <input type="checkbox"/> Concrete Builder | <input type="checkbox"/> Plumbing Inspector |
| <input type="checkbox"/> Contractor and Builder | <input type="checkbox"/> Foreman Plumber |
| <input type="checkbox"/> Structural Draftsman | <input type="checkbox"/> Heating and Ventilation |
| <input type="checkbox"/> Structural Engineer | <input type="checkbox"/> Sheet-Metal Worker |
| <input type="checkbox"/> Electrical Engineer | <input type="checkbox"/> Steam Engineer |
| <input type="checkbox"/> Electrical Contractor | <input type="checkbox"/> Marine Engineer |
| <input type="checkbox"/> Electric Wiring | <input type="checkbox"/> Refrigeration Engineer |
| <input type="checkbox"/> Electric Lighting | <input type="checkbox"/> R. R. Positions |
| <input type="checkbox"/> Reading Shop Blueprints | <input type="checkbox"/> Highway Engineer |
| <input type="checkbox"/> Telegraph Engineer | <input type="checkbox"/> Chemistry |
| <input type="checkbox"/> Telephone Work | <input type="checkbox"/> Pharmacy |
| <input type="checkbox"/> Mechanical Engineer | <input type="checkbox"/> Coal Mining Engineer |
| <input type="checkbox"/> Mechanical Draftsman | <input type="checkbox"/> Navigation <input type="checkbox"/> Assayer |
| <input type="checkbox"/> Machine Shop Practice | <input type="checkbox"/> Iron and Steel Worker |
| <input type="checkbox"/> Toolmaker | <input type="checkbox"/> Textile Overseer or Supt. |
| <input type="checkbox"/> Patternmaker | <input type="checkbox"/> Cotton Manufacturing |
| <input type="checkbox"/> Civil Engineer | <input type="checkbox"/> Woolen Manufacturing |
| <input type="checkbox"/> Surveying and Mapping | <input type="checkbox"/> Agriculture <input type="checkbox"/> Fruit Growing |
| <input type="checkbox"/> Bridge Engineer | <input type="checkbox"/> Poultry Farming |
| <input type="checkbox"/> Gas Engine Operating | <input type="checkbox"/> Mathematics <input type="checkbox"/> Radio |

BUSINESS TRAINING COURSES

- | | |
|------------------------------------------------------------------|-------------------------------------------------------|
| <input type="checkbox"/> Business Management | <input type="checkbox"/> Business Correspondence |
| <input type="checkbox"/> Industrial Management | <input type="checkbox"/> Show Card and Sign Lettering |
| <input type="checkbox"/> Personnel Management | <input type="checkbox"/> Stenography and Typing |
| <input type="checkbox"/> Traffic Management | <input type="checkbox"/> English |
| <input type="checkbox"/> Accounting and C. P. A. Coaching | <input type="checkbox"/> Civil Service |
| <input type="checkbox"/> Cost Accounting | <input type="checkbox"/> Railway Mail Clerk |
| <input type="checkbox"/> Bookkeeping | <input type="checkbox"/> Mail Carrier |
| <input type="checkbox"/> Secretarial Work | <input type="checkbox"/> Grade School Subjects |
| <input type="checkbox"/> Spanish <input type="checkbox"/> French | <input type="checkbox"/> High School Subjects |
| <input type="checkbox"/> Salesmanship | <input type="checkbox"/> Cartooning |
| <input type="checkbox"/> Advertising | <input type="checkbox"/> Illustrating |
| | <input type="checkbox"/> Lumber Dealer |

Name.....

Address.....

City.....State.....

Occupation.....

If you reside in Canada, send this coupon to the International Correspondence Schools Canadian, Limited, Montreal, Canada

A POPULAR AVIATION GUIDE at a Popular Price

Prepared to meet the demand for a simplified book on Aviation suitable for young people, beginners, and all persons desiring general information.

Everybody's Aviation Guide by V. W. Page, just published. 256 pages, 140 Illustrations, tells all about flying in simple, easily understood language.



Aviation terms, operating principles, elementary rules, forms of aircraft, functions of parts, types of power plants, machines, control systems and methods of flying. Learn now and prepare for the future. Price \$2

Will be sent C. O. D. in U. S. Pay postman price and postage.

POPULAR MECHANICS PRESS
Room P10, 200 E. Ontario St., Chicago

OUTDOOR SPORTS THE YEAR 'ROUND

Popular Mechanics Useful Book—Outdoor sports appeal to us all. But the fun is double when you make your own devices. There are 226 clearly written and concise articles telling how to make equipment for new and popular sports of many kinds in the Outdoor Sports book. There are clever devices for such sports as:

- | | | | |
|------------------|--------------|----------------------|--------------|
| Swimming | Trapping | Photography | Kite flying |
| Camping | Tobogganing | Tennis | Summer games |
| Football | Baseball | Outdoor winter games | Nutting |
| Swinging | Fishing | Skating | Pushmobiling |
| Trolley coasting | Golf | Boating | Racing |
| Roller skating | Boat sailing | Toy making | Skiing |

It is easy to make the devices described because there are 317 helpful illustrations. The articles are clear enough for boys, yet interesting enough for any man.

Send No Money Just write your name and address on a postal card and say that you want Outdoor Sports the Year 'Round. When the postman hands you the book, give him \$1.50 plus the few cents postage. That is all. If you live outside the U. S. or if you are not at home when the postman delivers the mail, then send \$1.50 with your order. Address your postal to

POPULAR MECHANICS PRESS Room 702, Popular Mechanics Bldg.
200 E. Ontario St., Chicago

BLUEPRINT READING For the Building Trades



Every man who is ambitious to learn the last detail of blueprint reading will want this new book which is thorough, complete and up-to-the-minute. Written in a clear, non-technical manner. An ideal working tool for apprentices, teachers, students, carpenters, bricklayers, etc.

Over 100 pages—50 plans and illustrations.

Cloth—Price \$1.25 postpaid

Popular Mechanics Press
Room P 2
200 E. Ontario St. Chicago

366 SHORT CUTS FOR

CARPENTRY WORK

Popular Mechanics Carpenter's Handbook is filled with illustrated short cuts and improved methods for doing all sorts of carpentry work and odd jobs. Each idea was discovered by a practical man in the course of his work. Each idea is practical, a time-saver, a money-saver. The 229 Pictures are so clear that in many cases, the picture itself explains the short cut. This new book is a book for professional carpenters, for amateurs, and for boys. It is destined to be just as popular as the many other handbooks published in recent months. This new book is beautifully bound in golden brown cloth, is a handy size, and sells for the remarkably low price of \$1.50.

Send No Money Simply write a postal saying that you want Popular Mechanics Carpenter's Handbook. It will be sent C. O. D. and you may pay the postman the price of the book and the few cents postage when he delivers the book to you. If you live outside the U. S. or if you are not at home when the postman delivers your mail, send \$1.50 with your order.

POPULAR MECHANICS PRESS
Room 702, Popular Mechanics Bldg., 200 E. Ontario Street, Chicago, Ill.

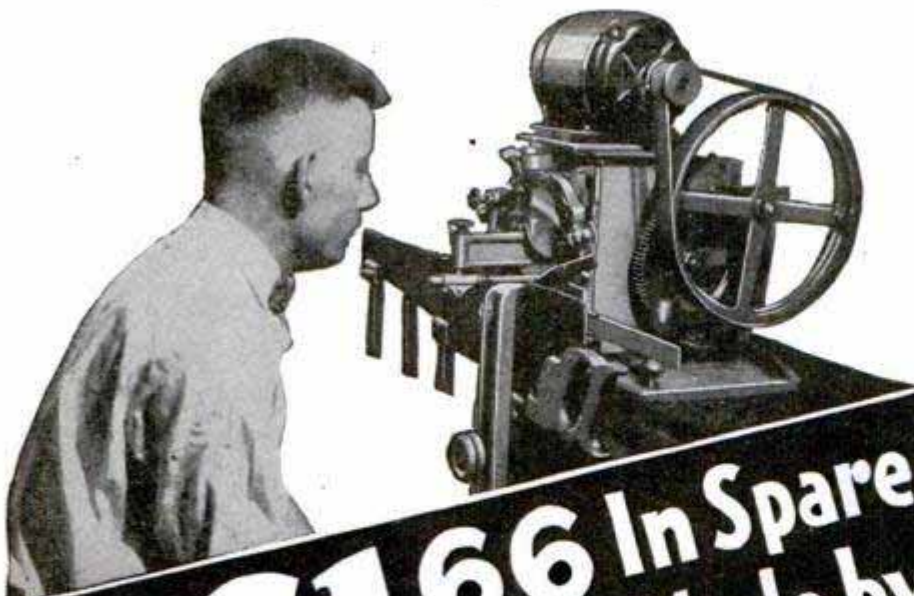

"... I did more business in September than I did in a year filing saws by hand. I banked \$161.66 which was accomplished in spare time and I can only attribute this new added success to my Foley because of its speed, which has enabled me to turn out four times more work. The accuracy of the Foley makes satisfied customers..."

EVERETT MYERS, INDIANA

\$161.66 In Spare Time 1 Month Made by Everett Myers

Start Your Own Cash Business At Home

Hundreds of men have started their own profitable business right at home in their spare time with the Foley Automatic Saw Filer. Many of them have had to give up their other job and devote all their time to saw filing because they got so much business they could not handle it all in spare time. Read what Brunick Serdinsky writes:

"I started business in my spare time and now have the best saw filing business in this community and have earned \$3000.00 in the past year... It is nothing for me to get saws to be filed from a customer 10 or 15 miles away..."

Start Earning Big Money At Once!

The Foley is so easy to operate, you can quickly learn to turn out perfect work by following the few simple instructions that come with the machine. NO CANVASSING. When people learn you file saws on the Foley they will bring you all the work you can handle. Average cost to file a saw is about 3c—you get 50c or more for every job—94c PROFIT OUT OF EVERY DOLLAR.

The Foley Model F-5 "3-Way" Automatic Saw Filer

This ONE MACHINE files all kinds of saws—cross-cut, rip, back, mitre and other hand saws, band saws and circular saws. It files better and more evenly than the best hand filing, making saws cut better and stay sharp longer. That is why saw users want Foley-filed saws. You satisfy every customer and they come back and bring you new customers.

Easy Payments

Very little capital needed to start. Pay out of profits in small monthly payments. No stock to carry. Operating expense almost nothing.

Act Now!

Get complete information about this money-maker at once. Send coupon below today.

Send Coupon for FREE Money Making Plan

Foley Manufacturing Co.,

248 Foley Bldg., 11 Main St. N. E.,
Minneapolis, Minnesota

Please send me Free Plan on how to start my own business in spare time with the Foley Saw Filer.

Name..... Present Occupation.....

Address.....



"I file saws in my spare time and make from \$10 to \$20 a week. Am now using my second Foley Filer."
GOTTFRID A. JOHNSON



"I get plenty of saw filing from all sources. I continue to keep my old customers and am adding new ones to my list continually."
T. P. WILSON



"I have made as much as \$5.00 a day working only in spare time. I have filed and retouched a large number of saws on the Foley."
M. M. RENN

Inside Measurements — any size



Quickly — Easily — Accurately

For measuring inside diameters of rings, cylinders, holes, widths of slots, recesses—anywhere that inside dimensions are required — there is a Brown & Sharpe Tool which will measure accurately and quickly. Here are some of the tools universally used by skilled mechanics.

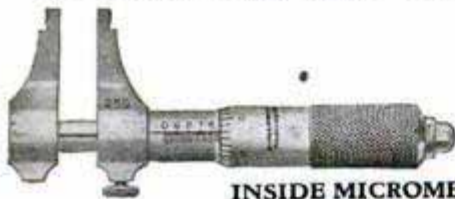

INSIDE MICROMETER CALIPER NO. 250
With a range .200" to 1" by thousandths of an inch, this micrometer is especially adapted for accurately measuring small internal dimensions.



INSIDE MICROMETER CALIPER NO. 252

Shape of the jaws makes it possible to take inside measurements over a flange or shoulder. Range $\frac{1}{2}$ " to $1\frac{1}{2}$ " by thousandths of an inch.

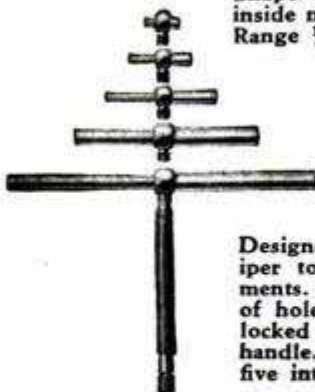

TELESCOPING GAUGES NO. 590

Designed to be used with a Micrometer Caliper to determine quickly internal measurements. Telescoping head expands to full size of hole or slot to be measured and is then locked by turn of knurled screw in end of handle. Range $\frac{1}{2}$ " to 6" is secured by using five interchangeable heads.



INSIDE MICROMETER NO. 264

With a range 2" to 8" by thousandths of an inch, this is truly a versatile tool for inside measuring. Clamp nut—an exclusive Brown & Sharpe feature—preserves the setting.



TUBULAR INSIDE MICROMETERS NO. 276

Takes long inside measurements by thousandths of an inch. There are three separate tools, with changeable anvils having a combined range of from 12" to 42". They are light, accurate tools, easy to handle.

VERNIER CALIPERS NO. 570

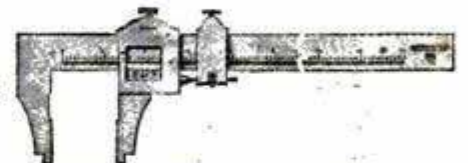

A versatile tool for both inside and outside measuring by thousandths of an inch. Graduated on one side for inside, and on other side for outside measurements, thus simplifying the reading. Made in four sizes: 6", 12", 24" and 36".

Other Brown & Sharpe Tools for inside measuring include: Thickness Gauges, Rules, Inside Calipers, Indicators, Vernier Height Gauges, Depth Gauges. All these tools are described in our Small Tool Catalog No. 31 which includes over 2300 useful tools. Send for a copy. Dept. P. M., Brown & Sharpe Mfg. Co., Providence, R. I., U. S. A.

Brown & Sharpe Tools

"WORLD'S STANDARD OF ACCURACY"



Shaves 5 YEARS with One Razor Blade!

AGENTS!

\$50 to \$200 in a Week

KRISS KROSS is so astonishingly effective in rejuvenating all makes of razor blades that any number of men are earning surprising sums by representing us in their territories. Even spare-time men, office and factory workers make as much as \$6-\$12 in a day extra, just showing KRISS KROSS to friends and fellow-employees. Jas. Tillotson paid entire expenses of a 30-day vacation trip with KRISS KROSS profits. One day he made \$114! H. King made \$66 in a day — R. Vanderhof sold 27 in 8½ hours—cleared over \$50! Emil Ham made \$200 his first four days, while S. Kantala made \$154 in 3 weeks, working just an hour or two each evening! Why not get your share of these easy profits? We furnish everything and back you to the limit. Check bottom line of coupon and get our big-profit plan at once!



"WHO says it costs a lot of money to operate a safety razor?" demands Mr. M. T. Main of Kenosha, Wisconsin. "Using KRISS KROSS stropper, I have been getting slick shaves out of one blade for five years, and from the looks of things, the blade will outlast me!" You men who think you are lucky if you get a week's service out of a blade—think that over! But don't waste time envying the man who is banking the money he used to throw away on razor blades! Join the army of KRISS KROSS shavers right now! You'll

never know real shaving comfort and economy until you do. For KRISS KROSS actually rejuvenates all makes of safety razor blades (except Durham). It makes them keener than new! Eleven seconds in a KRISS KROSS Stropper will actually make the oldest blade you own deliver a shave so cool and velvet-smooth that you won't believe your own eyes! That's because KRISS KROSS actually duplicates the diagonal stropping stroke of a master barber! No wonder more than a million men say KRISS KROSS has solved their shaving problem forever!

Amazing Offer Means... No More Razor Blades to Buy!

You can't possibly realize how KRISS KROSS will brighten your mornings and save your money until you have seen and tried it yourself. So don't fail to take advantage of our liberal trial offer which is now in effect. This offer includes an

amazing new kind of razor, now given Free to KRISS KROSS enthusiasts. Absolutely unique and different. Adjusts three ways in a jiffy. Requires no cleaning or assembling. Gives a sliding stroke that decreases beard resistance 45%! Comes with five new-process blades—probably the last you'll ever need to get!

Do not delay, for this unusual offer is limited and may be withdrawn at any time. Mail the coupon. It will bring full details without obligating you in any way.



Kriss Kross Corp., Dept. B-3714
1418 Pendleton Ave., St. Louis, Mo.

Send full details of KRISS KROSS and your Free razor offer. This request does not obligate me.

Name.....

Address.....

City.....State.....

Check if interested in making money as a KRISS KROSS Representative.

KRISS KROSS

KRISS KROSS CORP., Dept. B-3714
1418 Pendleton Avenue St. Louis, Mo.
World's Largest Manufacturers of Mechanical Stoppers



Makes \$18 First Day

"Received my first 24 Speedos yesterday; the entire lot is now delivered and more sold. In all my years of selling I never saw anything that met with such universal approval."
—W. H. Duncan, Mont.



\$5.00 His First Hour

"Received Speedo outfit April 1st. Left the house at 6:30 P. M. Returned just one hour later with 6 orders. Speedos are a necessity in every home."—W. W. Marshall, Ill.



Let These Twin Inventions Hand You

Double Profits...\$5 to \$11 IN AN HOUR!

Men, here's a proposition that's amazingly simple. Yet the profit possibilities are nothing short of startling! For now, an old, well-known manufacturer offers you direct, TWO unique, patented inventions. Items used every day in every home. Yet so revolutionary that they positively sell on sight! So just read the facts below. Then mail coupon for FREE OUTFIT and FREE TEST OFFERS.



Works Like a Charm

Just insert can in holder and turn crank. Top is cut completely out inside the rim. Juices can't spill out.



Food Pours Right Out

No fuss or muss. No scraping or "spooning." Even foods frozen in the can slip out easily.



No Jagged Edges

Speedo cuts the top out, smooth, slick, and clean. Ends danger of cut fingers.

EVERY man who has cut his eye teeth in the selling game knows this! The big clean-ups are always made by men who get in on the ground floor with something new and sensational. Think, then, what a doubly sensational chance to coin money is now yours! For here are offered you two unique devices—pronounced by experts everywhere to be absolutely revolutionary—approved by Good House-keeping Institute, Modern Priscilla, etc.—and real necessities in every home. In your wildest dreams, could you conjure up such an amazing opportunity for quick, easy profits?

A Real Million-Dollar Can Opener

Imagine an automatic machine that opens any can, round, square or oval, simply at the turn of a crank. Cuts the entire top out, slick, smooth and clean! No more stabbing and hacking with old-style can openers. No more fingers cut and infected on jagged tin-can edges. For Speedo holds the can—strips the top out—flips up the lid—all in a couple of seconds! No wonder women simply go wild over it. And no wonder 4 out of 5 buy on a 10-second demonstration!

The "Magic Groove" Sharpener

Women never saw anything even remotely like this other "twin" invention, the Speedo Sharpener. Just

demonstrate the "Magic Groove" and watch their eyes pop open with amazement. Now anyone can put a keen, smooth edge on everything that cuts. Even scissors! Every woman sees instantly that here is an end to the drudgery of dull knives and tools. That's why agents sometimes report as much as \$10 and \$12 in a single hour with Speedo sharpener alone!

Generous Co-operation

This company has been in business over 20 years. Speedos are made entirely in our own big factories, under exclusive patents. Each item is backed by a printed guarantee of 5 years' perfect service. We give you exclusive territory. Over 100% profit! We train you from A to Z, and supply you with a complete selling outfit FREE.

Mail the Coupon TODAY

Any ambitious man with just ordinary common sense can see the possibilities of the proposition at a glance. If you are that kind of a man, I want to send you my FREE OUTFIT and FREE TEST OFFERS. I want to show you what real big money means. Mail the coupon today. Then get set to test the fastest, dizziest profit makers of your life. Write me this minute!



Sharpens Like Magic

Just rest blade on Magic Groove, turn handle. Sharpens a ten-inch knife in six seconds. Puts a razor edge on everything that cuts.



Grinds Scissors Perfectly

Rest blade against guide, give handle a couple of turns—Presto! Scissors are sharp as new.

CENTRAL STATES MANUFACTURING CO.

Dept. B-703, 4500 Mary Avenue, St. Louis, Mo.

Central States Mfg. Co., Dept. B-703, 4500 Mary Ave., St. Louis, Mo.

Rush me details of your proposition and FREE TEST OFFER.

Name.....

Address.....

Town..... State.....

Check here if interested only in one for own home.