

NOVEMBER

25 CENTS

POPULAR MECHANICS

MAGAZINE

WRITTEN SO YOU CAN UNDERSTAND IT

REG'D TRADE MARK, GREAT BRITAIN NO. 410425

REG. U.S. PAT. OFF.

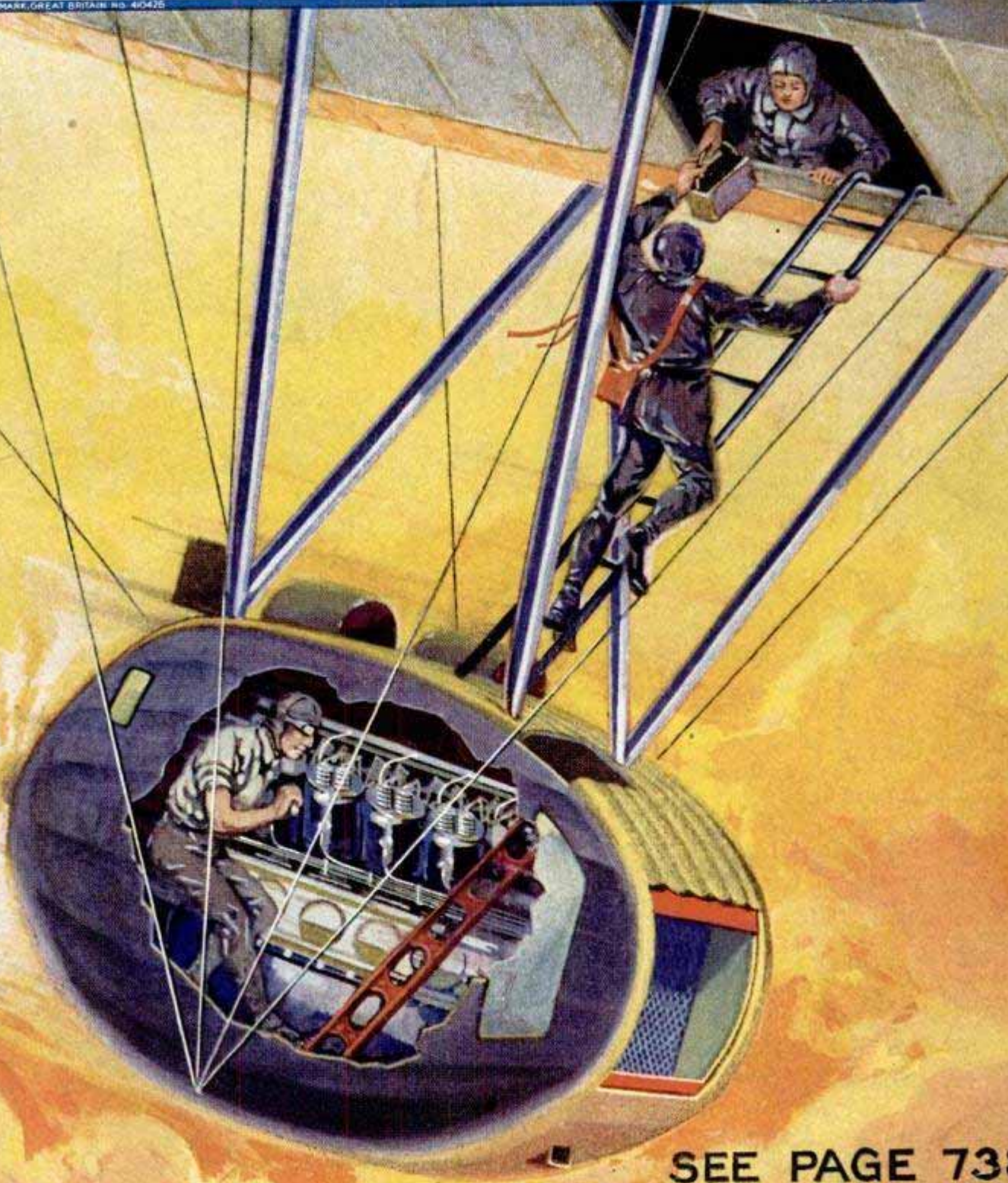

SEE PAGE 738

WINDYACH

On roaring speedway

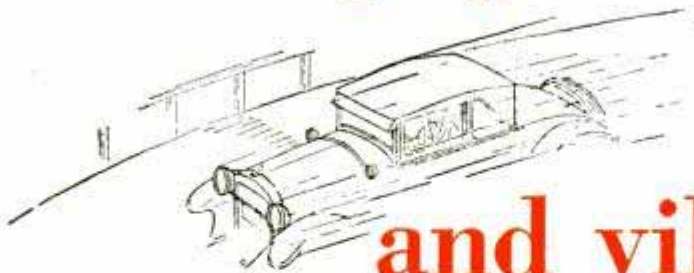

and village street

we found

the New Mobiloil

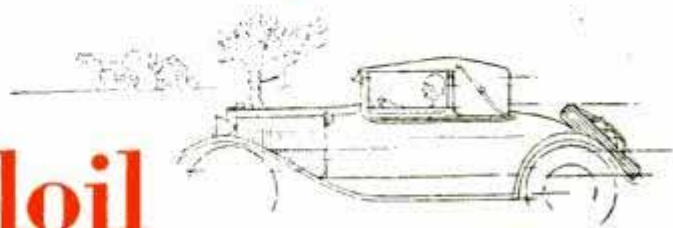

lasting longer

On the Atlantic City Speedway, with racing drivers at the wheel, we proved that the New Mobiloil lasted at least 20% longer than competing oils.

But we weren't satisfied to rest upon our own scientific tests—we wanted to find out how the New Mobiloil was serving *you*, the motorist. So we recently sent investigators into a wide territory to ask motorists which one fact about Mobiloil was most noticeable.

"Mobiloil lasts longer," was the answer of one motorist after another.

This fact about the New Mobiloil—longer life at modern high speeds—is the most significant fact in the testing of any oil. For,

in comparing oils of similar "body" engineers have proved that the oil which lasts longest, also lubricates best.

You can test the lasting power of the New Mobiloil in a simple and easy way. Have the Mobiloil dealer drain the old oil from your crankcase and refill with the grade of Mobiloil specified for your car on the Mobiloil chart. Then keep a record of your mileage and your speed. Notice how long it will be before you need to add more Mobiloil, whatever the driving conditions.

VACUUM OIL COMPANY

Makers of high quality lubricants for
all types of machinery

the New



Mobiloil

Keeps the first-year feel in your engine

This New VIX will SAVE $\frac{1}{4}$ to $\frac{1}{2}$ your GAS



New Moisture Humidifier & Carbon Eliminator

for all Makes of Cars, Trucks, Tractors and Engines

An amazing NEW Scientific Vapor Humidifier and GAS SAVER has been patented throughout the World that beats anything ever gotten out before. It makes engines run ALL THE TIME with the same wonderful efficiency they do on a cool moist night. It gives MORE pep and power—HIGHER topspeed—automatically ELIMINATES hard carbon from engine—and causes engine to give AMAZING MILEAGE RECORDS NEVER EQUALLED BEFORE.

ENTIRELY UNLIKE ANY OTHER DEVICE. This startling invention is radically different from every other kind. It uses MOISTURE from the radiator and makes the car run like on a damp cool night. It is GUARANTEED to save from $\frac{1}{4}$ to $\frac{1}{2}$ the gas and oil, stops boiling and steaming, makes engine start easier in all kinds of weather, and completely de-carbonizes the engine as you run.

This new principle device has been extensively tested out by Technical Engineers and Experts and found to give vastly more mileage, with largely increased power and pep from the engine. With it the engine used approximately 90% air, 6% moisture and ONLY 4% of gas.

Big Profits

to Man with Car Spare or Full Time

\$350 to \$1500 a month

1 man \$4,939.66 in 3 1/2 months
Another \$1,656.60 in 58 days
\$5,150.00 in 5 months to another. BIG MONEY can be—IS being made

Fitting Motors With Vix
One man sold 8 first morning
Another sells all 3 men can install

Another's profits as high as \$100.00 a day

VIX sells itself by 8 STARTLING demonstrations—BIG, STUNNING, ASTOUNDING DEMONSTRATIONS. Successful VIX men make MORE MONEY than they ever made before.

Free Trial TRY This New Principle Gas Saver AT MY RISK

Try this wonderful VIX Moisture Humidifier and Carbon Eliminator AT MY RISK on YOUR OWN CAR to prove that VAPOR MOISTURE (drawn from Radiator to Engine) gives you that wonderful night driving effect ALL THE TIME with MORE mileage from gas and oil—eliminates hard carbon accumulation—gives MORE power, a SNAPPY, PEPPY motor, FASTER acceleration, a SMOOTHER, QUIETER running engine and HIGHER top speed.

VIX will PROVE ITS MONEY SAVING MERIT on your own car by 8 DEMONSTRATIONS—conducted by yourself AT MY RISK—the most SENSATIONAL, most ASTOUNDING, most CONVINCING DEMONSTRATIONS you ever saw. If you don't find from your tests that it does MORE than I claim; return it and it COSTS YOU NOTHING. I want wide-awake hustling, County, State, Province and National Agencies everywhere, part or full time, to make \$350 to \$1500 per month filling the great DEMAND for this wonderful invention wherever introduced. Write for my FREE TRIAL and MONEY MAKING OFFER. Use coupon below.

WALTER CRITCHLOW

Inventor and Manufacturer, 805-V. 4 Street, WHEATON, ILL., U. S. A.

FREE VIX Mail Now offer

WALTER CRITCHLOW, INVENTOR and MANUFACTURER, 805-V.4 Street, Wheaton, Ill., U. S. A.

Please send me without obligation or charge your FREE TRIAL and MONEY MAKING VIX OFFER.

Name.....

Address.....

Town..... State.....



Pictures here and at top show Model "B" VIX attached to my own New Model A Ford. This car is wonderfully improved in performance with the VIX Moisture Humidifier. So is every Auto, Truck, Tractor, Taxi, Bus, Marine, Stationary and Aircraft Engine, both American and all Foreign makes.

GUARANTEED TO SAVE { $\frac{1}{4}$ to $\frac{1}{2}$ Gas
Carbon Cleaning
Engine Repairs
or Costs You Nothing

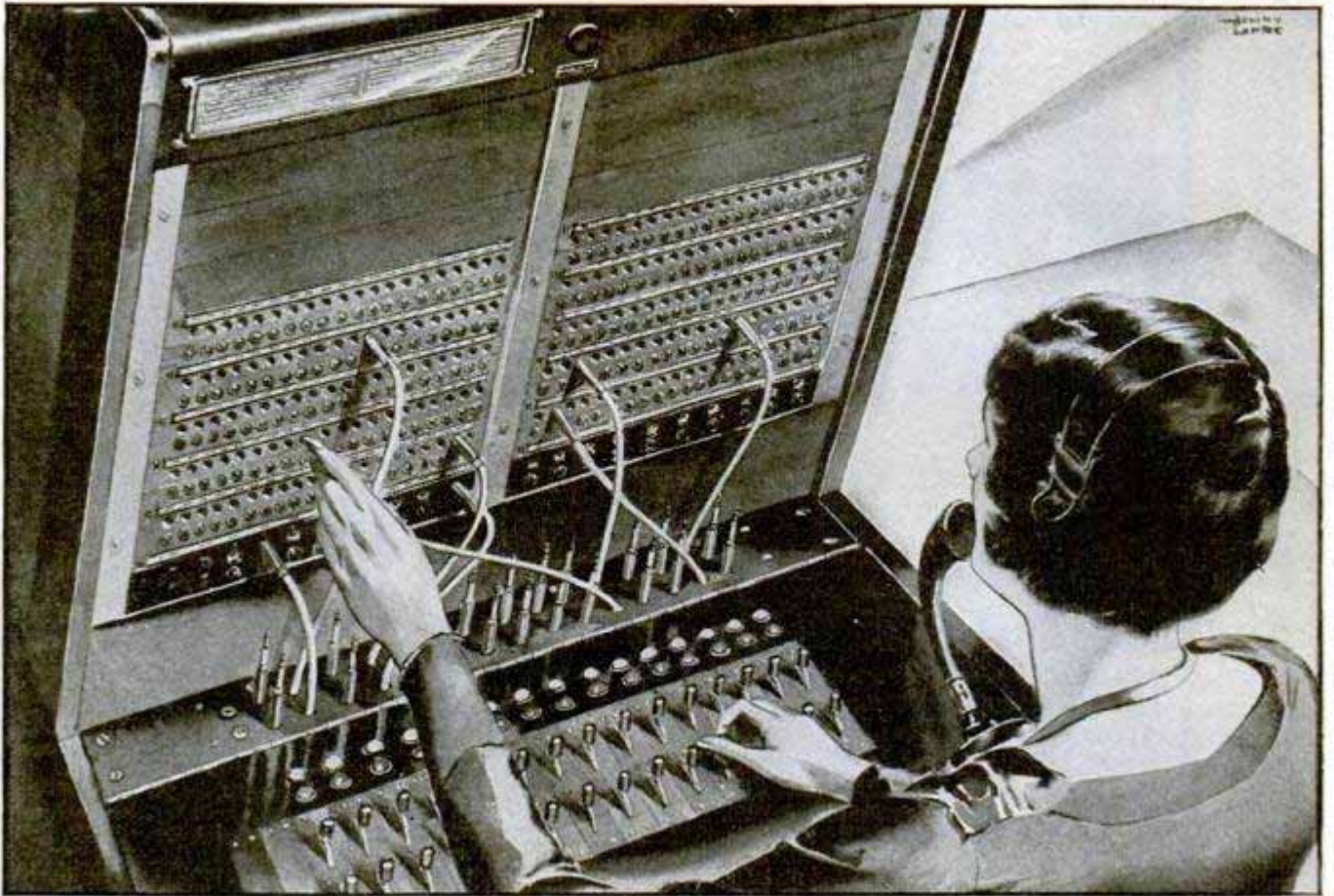

THE FAR FLUNG PARTS OF AN ORGANIZATION, ITS DEALERS AND ITS CUSTOMERS, ARE BROUGHT AS CLOSE AS INSTANT SPEECH

Great strides in invention, great expenditures . . .

*An Advertisement of the
American Telephone and Telegraph Company*

BUSINESS, using the telephone, eliminates space and time. The far-flung parts of an organization with its dealers and customers are brought together by instant speech. The home, like the office, reaches out over an ever-widening circle of neighbors.

The telephone is tireless and quick. It runs errands near and far, transacts business, keeps friendships alive. Telephones throughout the house save time and fatigue. They bring the comforts and conveniences of the office to the women in the home.



Keeping ahead of the new developments in American life calls for great strides in inventions, great expenditures in money. The Bell System's outlay this year for new plant and service improvements is more than 550 million dollars. This is one and one-half times the cost of the Panama Canal.

This program is part of the telephone ideal that anyone, anywhere, shall be able to talk quickly and at reasonable cost with anyone, anywhere else. There is no standing still in the Bell System.

Popular Mechanics Magazine

200 E. Ontario Street, Chicago, U. S. A.

H. H. WINDSOR, Founder

H. H. WINDSOR, Jr., Editor and Publisher

London: Hachette & Cie.,
16-17 King William Street, Charing Cross, W. C. 2

Paris: Hachette & Cie.,
111 Rue Reaumur

Melbourne: Gordon & Gotch
509-513 Little Collins St.

ISSUED MONTHLY

SUBSCRIPTION:

SINGLE COPY, 25 CENTS

In United States and its possessions, Canada, Cuba, Mexico, and all }
countries in the Pan-American Postal Union, per year, postpaid } \$2.50

To all other countries in the Postal Union 3.00

All subscriptions are discontinued at expiration. Please examine the date printed on your wrapper.

Entered as Second Class Matter Sept. 16, 1903, at the Post Office at Chicago, Illinois, under Act of March 3rd, 1879.
Entered as Second Class Matter at the Post Office Department, Canada.

Published monthly by POPULAR MECHANICS CO.

Copyright, 1929, by Popular Mechanics Co.

Copyright in Australia. Copyright in France

Vol. 52

Contents for November, 1929

No. 5

Special Features

Three Worlds Left to Explore	722
With the Ice-Plane Patrol	731
With the "Graf Zeppelin"	739
The Future of Air Travel	755
The Farmer Turns on the "Juice"	770
Fighting the Fiercest Fish	786
Sunrise on the Moon	794
The Romance of Crown Jewels	803
Can a Man Control the Weather?	818
Advertising—dummy reproduces writing at a distance	791
Air Mail—sorted aboard planes of flying post offices	799
Airplanes	
carry weed seeds	790
fly-it-yourself	800
how the ship is designed	778
new catapult drives plane from deck of liner	729
rockets may aid in taking off	810
seven thousand operate under license	736
tandem motors over wings add safety and power	793
without fuselage carries load in wings	802
Automobile Lighting—visor, lights placed on, to eliminate glare	790
Automobiles	
auto on seaplane pontoons	783
baby auto has packing-box garage	733
Automobiles—Accessories	
adjustable glare protector	775
hotter spark given by extra condenser	802
panoramic mirror shows whole road	776
time switch turns on parking lights	784
washer and tire pump get power from car	810
Automobiles—Parking	
chalk-marking parked cars aids traffic police	817
tower saves space and houses sixty cars	800
Aviation	
fog which solidifies into ice is peril to aviators	729
lighted streets guide flyers	799
plane is towed by dirigible after contact in air	737
races, pylons on destroyers are markers for	752
what makes a good pilot	733
Baking—breaking points of crackers	802
Balloon—captive, with motor converted into dirigible	811
Boats and Boating	
cranks replace oars to drive	728
detachable rack holds boat for hauling on auto	721
small ships sail around pool	721
what to do if boat tips over	730
Bread—ready-sliced loaf	733
Building Construction	
steel frame about building protects pedestrians	802
wire twister fastens forms for concrete walls	798
Camera, Aerial	
with pistol grip	769
world's largest tested	730
Camping—automobile trailer unfolds into a kitchen	728
Cards, Playing—round, easier to shuffle and deal	801
Cattle	
old license plates used as blinders	813
thrive on feed mixed with iron rust	752
Crime—colored bombs for police	801
Cushion—self-inflating air pillow	785
Deafness—flying no cure for	784
Dogs—modern medical science saves lives of pets	776
Electric Switch—time switch turns out light	799
Fish and Fishing	
devilfish relished as food	804
radium for fish bait	807
Glass—how to test antique	729
Household Devices	814
House Plan	879
Insects	
pistol shoots poison spray at	736
strange habits of revealed by scientist	769
Ladder—platform on top of serves as scaffold	777

[Continued on Page 4]

Canoe Outrigger

Camp and fan 768

703

768

fan and imp 768

Life-Saving—Navy's "lung" saves twenty-six men from sea	737
Lighting—diadem effect given palace by beams of light	792
Mail Box—automatic, weighs and stamps letter	823
Masks—for French convicts	775
Match—fireproof, is found safe and practical	800
Mine—artificial sunlight in	737
Money—lifted through hole underneath truck	823
Mop—self-wringing on reel also polishes floors	811
Motor, Outboard—is cooled by auxiliary pump	734
Moving Pictures—screen reflects rays without distortion	810
Office Supplies—holder for urgent messages aids memory	791
Operating Table—light for, is shadowless	817
Pencils	
leather holder for, buttons on shirt	783
writes three colors with interchangeable leads	752
Pests—cornstalks are cut low in war on borer	791
Piano—with three keyboards plays quarter tones	785
Pictures—in moss agate rival paintings	793
Psychology—faces vs. intelligence	721
Radiator—in baseboard heats from level of floor	798
Radio—tips from the radio laboratory	834
Radio—Aerials	
artistic indoor antenna	829
collapsible radio mast	833
combination lamp, antenna and world clock	832
Radio—Apparatus—marker for normal meter reading	827
Radio—Batteries—standard receivers operated from 32-volt supply	837
Radio—Broadcasting—atoms' noise heard on radio	808
Radio—Eliminator—B-C-eliminator is fully adjustable	830
Radio—Loud Speaker—the new inductor dynamic	827
Radio—Receiver	
beginner's set employs screen-grid tube	824
increasing volume in short-wave sets	829
new kit set has wide tuning range	828
new tuning system has remote control	836
Radio—Television—compact receiver for the home	838
Radio—Tubes	
discolored tubes should be discarded	828
handy clip for screen-grid	828
Railroads	
heat-proofed rail coaches	769
wireless on front of engine gives engineer warning	807
Rays, Infra-red—reveal more than the microscope	823
Robots—pugilistic, fight till one is knocked out	808
Safety Devices and Measures—semaphore "school" warning	823
Sawdust—mountain range reproduced in	784
Saws and Sawing—circular saw is lunch table	769
Scow—leaping, dumps itself	816
Screwdriver—is adapted for hard tasks	813
Seesaw—high, provides fun for four children	808
Ships and Shipping	
modern ships are made up of one-tenth copper	801
sounds made visible in fog to protect vessels	816
Smoke—instrument measures density of, to make air pure	792
Snow—steam pipes to melt from mountain pass	783
Stamps—palatable glue for, from sweet potatoes	775
Switch—air replaces oil in power	777
Telephone—phone language sought for international use	736
Tennis—machine gun serves balls to players	736
Theater—self-service for tickets	813
Trees	
Christmas tree farms	728
highest-priced bark	799
Trolley Wires—steel, possible with "sliding shoe"	791
Tunnel—Manhattan, provides sixth tier of traffic	784
Vending Machine—hot-dog sandwiches served by	806
Ventilation—water from artesian wells keeps theater cool	811
Vitamines—to be supplied by the sea	783
Volcanoes	
life history of Vesuvius	735
put salt in sea	774
spouts paint, ink and dyes	816
War Maneuvers	
paper "tanks" on bicycles used in	785
smoke screens guard flying battle fleet	809
Weather—kites and balloons give readings	812
Weed—wax from	798
Wood—treated to resist fire	727
X-rays—tracing by pantograph eliminates negatives	734

AMATEUR MECHANICS

Airplanes—one-man winder for model	859
Aluminum Ware—repairing	846
Apartment—changing large room to a small	843
Archery—animal target adds interest to practice	849
Automobiles, Radiator—splash guard protects finish	851
Automobiles, Repairing	
correcting front-wheel wobble on Ford	843
cure for wet distributor	861
Automobiles, Tires—removing old patches from inner tubes	847
Boats and Boating	
balsa cruiser develops high speed	839
extra propeller pins for outboard motor	862
lock for the outboard boat motor	847
patching dents in boat hulls	858
Camera—storm cover for	842
Camping	
canoe helps to make shelter	850
few camp-cooking kinks	844
Clock	
coin aids in winding alarm	844
how to clean works of	842
Door—rubber mat protects	849
Fish and Fishing—kink for the trout fisherman	848
Furnace	
air filter for the hot-air	861
emergency wood grate for	849
Furniture—sandpaper overlays for ornamenting novelty	848
Games—for your party	852
Hats—chest for men's	861
Hose Clamp—compressing	851
Hotbed—electric, easy to make	845
Lathe—revolving table for small	847
Light Socket—remote control for	848
Linotype—signal light aids operator	844
Lock—electric, thief-proof wiring for	858
Mortar—use of proper sand in	847
Photography—cleaning flash lamp	848
Plants—selecting house	850
Radiators—device for operating valves on overhead	842
Rifle—keep the barrel bright	861
Sander—for large surfaces	857
Springs—making and using coil	860
Stains—removing coffee and milk from clothing	861
Steam Box—for fomentations	862
Stove, Oil—water-heating installation for	858
Stump—vacuum cleaner forces draft for burning	846
Tool Box—locking handle	857
Tractor—old inner tubes used for hose	851

SHOP NOTES

Alcohol—test distinguishes wood and denatured	874
Automobiles, Repairing	
novel repair for cracked water jacket	877
sink plunger holds cylinders for lapping	877
Automobiles—test box for the automotive electrician	868
Blowtorch—adjustable gauge for acetylene	875
Bolts—convenient trays for bolts and rivets	874
Cloth—celluloid end strips keep bolts tidy	878
Conveyor—portable, speeds loading	868
Eccentrics—dial indicator facilitates turning and boring	877
Electric Bells—an improvement for, having small transformers	875
Fountain—cooler for water	866
Hay Hoist—old auto makes good	878
Lard Oil—keeping warm	875
Machinery—handles on	867
Nail Sack—attached to trouser cuff	869
Photography—ventilating dark room	876
Pipes	
cement-bandage repair on large	869
cement for joints	873
Plumb Bob—using in the wind	878
Radiators—valve for hot-water	869
Saws and Sawing	
hand guard for the bucksaw	869
keeping your saws fit	862
Screwdriver—anchoring shanks	875
Sheet Metal—cutting disks or rings accurately from	877
Templates—making accurate	867
Timbers—horse-drawn tool planes	874
Wheelbarrow—hinge legs make easy to load	876
Workbench—convenient light for	876
Workshop—a practical homemade combination	870

Try to
 of a cream and milk no gas refry 7/17

DRAKE'S PRACTICAL MECHANICAL BOOKS

THEY WILL RAISE YOUR PAY—

ORDER ON 5-DAY TRIAL

The books listed below will perfect you in your chosen trade—pave the way to the big positions. Written in non-technical language—easy to read and understand. Every book covers its subject completely. An entire course of instruction condensed into one volume. Your choice sent postpaid—you benefit 5 days—money refunded in full if not entirely satisfactory. Order direct from this page.

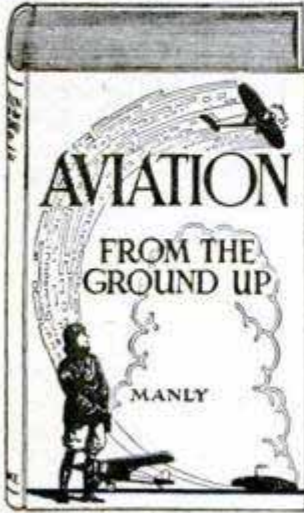

Aviation and Auto Books

- Aviation From the Ground Up... \$3.50
- Automobile Starting, Lighting and Ignition, by Manly... 700 pp. \$3.00
- Brookes' Automobile Handbook... \$2.00
- Ford Motor Car, Truck and Tractor, by Manly... Cloth \$1.50
- Auto and Radio Battery, Care and Repair, by Manly... Leatherette \$2.00
- Motorcycle Handbook, by Manly... \$1.50



Shop Practice Books

- Practical Heating Systems, Trouble Jobs and Ventilation... \$4.00
- Sheet Metal Workers' Manual... \$2.00
- Oxy-Acetylene Welding and Cutting... Cloth \$1.25
- Slide Rule and Logarithmic Tables... \$2.00
- Handbook for Millwrights... Cloth \$2.00
- Machine Shop Practice... Cloth \$2.00
- Mechanical Drawing and Machine Design... Cloth \$2.00

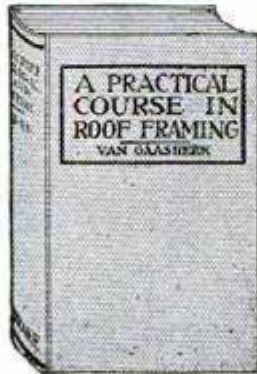

Carpentry Books

Cloth Binding

- Modern Carpentry, 2 vols... \$3.00
- The Steel Square, 2 vols... \$3.00
- Modern Estimator... \$1.50
- Timber Framing... \$2.00
- Builders' Architectural Drawing... \$2.00
- Concretes... \$1.50
- Practical Bungalows... \$1.00
- Roof Framing, by Van Gaasbeek... \$1.50

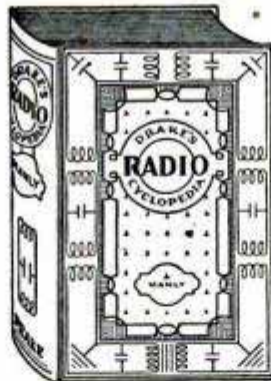

Drake's Radio Cyclopeda

By H. P. Manly

920 Pages, 1025 Illustrations, 1700 Subjects, arranged alphabetically. For Service and Repair Men, Dealers, Salesmen, Experimenters and Designers. Bound in Art Buckram. Price... \$6.00

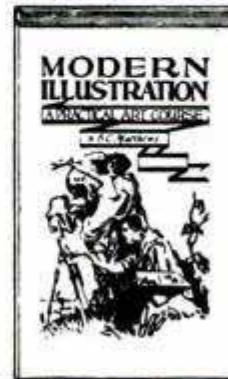

Painting and Decorating

- Modern Illustration... \$3.50
- The Lacquer System of Sign Painting... Cloth \$3.00
- Practical Estimating for Painters and Decorators... Cloth \$2.00
- How to Draw Funny Pictures—a Complete Course in Cartooning... Cloth \$3.00
- Layouts for Advertising... Lea. \$3.00
- Furniture, Furniture Finishing, Decoration and Patching... \$5.00
- Ross Crane Book of Home Furnishing and Decoration... Cloth \$3.00
- House Painting Methods... Cloth \$2.00
- Interior Wall Decoration, by Vanderwalker... Leatherette \$4.00
- The Mixing of Colors and Paints, by Vanderwalker... Cloth \$2.00
- Studio Handbook—Letter and Design... \$3.00
- A Show at Sho' Cards... Cloth \$4.00
- Sign Painting, by Atkinson... Cloth \$4.00
- Strong's Book of Designs, Leatherette \$4.00
- Modern Painters' Cyclopeda... Cloth \$2.00
- Automobile Painting... Cloth \$1.50
- Wood Finishing, Plain and Decorative... Cloth \$2.00

Steam Engineering

- Swingle's Handbook for Steam Engineers and Electricians... Leatherette \$4.00
- Examination Questions and Answers for Marine and Stationary Engineers... Leatherette \$2.00
- Steam Boilers... Leatherette \$2.00
- Swingle's Catechism of Steam, Gas and Electrical Engineering... Leatherette \$1.50

Modern Languages

- By Prof. P. S. Allen, U. of Chicago
- French without a Teacher... Cloth \$1.25
- Spanish without a Teacher... Cloth \$1.25
- German without a Teacher... Cloth \$1.25
- Everyday French... \$1.25
- Everyday Spanish... \$1.25

ORDER DIRECT FROM THIS PAGE—ON OUR MONEY-BACK PLAN

The books listed above are only a few of the many in our catalogue, which you will receive promptly after filling out and mailing us the attached coupon. For quick action order direct from this page—cross name of each book wanted and send in with price quoted. We repay postage and send the books on our money-back plan.

FREDERICK J. DRAKE & CO.

Publishers

R508—179 No. Michigan Ave. CHICAGO

Drake Books Are For Sale at All Book Stores

FREDERICK J. DRAKE & CO.
R508—179 No. Michigan Avenue
Chicago, Ill.

GENTLEMEN:—Please send me free, postage paid, your illustrated catalogue which lists and describes 200 Practical Mechanical Books for Home Study.

My name is

and my address

Mail Coupon For Free Catalogue
Your Guide to Home Study

Discontent

the First Step to Success!

IF you're contented—satisfied with your lot—merely hoping for things to come your way, the chances are you'll stay where you are.

If you're dissatisfied—discontented—studying over what the future holds and how you're going to get ahead—that can be your first step to success.

Be dissatisfied with yourself but don't stop there—let your dissatisfaction stir you to constructive action.

Analyze yourself and your ability, find out why you aren't going ahead, see what successful men have done to deserve success.

You'll find that there's an easy way out—a short cut to bigger ability and larger success—if you are really in earnest.

It lies through the field of specialized business training—that's where the big rewards are paid. That's where you should be.

Listen a moment to what other men who were in the same position you are today have done.

These are not unusual cases—similar reports come over our desks every day in the year.

For instance, W. A. Day wanted more money but he didn't wish to change employers—he made up his mind to get more money *right where he was*. That meant he must make himself worth more money to his employer, and that, in turn, meant *training*. LaSalle training was the answer—in two years, his salary increased 73.3%.

Mr. Paul F. Bourscheidt was Assistant Actuary of the Peoria Life Insurance Company. Eleven months after enrolling with LaSalle, he was promoted and his salary increased 30 per cent. Since then he has been made Assistant Secretary and Office Manager of this great company, and today he is being entrusted with larger and larger responsibilities.

These are men who grew without seeking new employment. On the other hand, you may want to be in business for yourself . . . In that case, consider W. R. MacNeal and J. H. Bryson.

Mr. Bryson was a young grocery clerk at \$40 a month. Today he is president of the Bryson Novelty Manufacturing Company, of Fayetteville, Tenn., doing a nation-wide business. Mr. MacNeal was a mature, successful executive, vice-president of an old established company. Today, he is owner, president and general manager of Knadler & Lucas of Louisville, Ky.

If you believe that your future success lies in a new field or with a different employer—



Read the experiences of C. J. Farris, of Tennessee, U. S. McIntyre of Alabama, Zura E. Bells of California.

Mr. Farris, at 45, was a Credit Manager at a small salary—now he is a Certified Public Accountant and head of a highly successful accounting firm. Mr. McIntyre was rate clerk for a western railroad—today he is operating a traffic bureau for three southern cities with an income increase of several hundred per cent. Mr. Bells was manager of a music goods store—now he is vice-president and sales manager of a prominent real estate firm and earning several times as much as when he enrolled with LaSalle.

* * *

We could cite hundreds and thousands of similar cases of discontent leading to success

through LaSalle training but these should be enough. What you need now is to *act*.

We have prepared a special, new 64-page book for you. It tells in detail about LaSalle spare time training under the LaSalle Problem Method. It analyzes and discusses your field of business in a very interesting, vital way. It will be valuable to you for that information alone—if, in addition, it leads you to take advantage of LaSalle training, only your future can ever measure its real value to you.

The coupon will bring this book, and another, "Ten Years' Promotion in One," to you quickly and without cost or obligation.

And—in your spare hours at home—at low cost and easy terms—you can turn discontent into success if you are the right man.

Measure the real meaning of your discontent by what you do with this coupon *NOW*.

----- Find Yourself Through La Salle! -----

LaSalle Extension University

The World's Largest Business Training Institution
Dept. 1164-R Chicago

I would welcome an outline of the LaSalle plan, together with a copy of "Ten Years' Promotion in One," all without obligation.

- | | |
|---|---|
| <input type="checkbox"/> Business Management | <input type="checkbox"/> Law—Degree of LL. B. |
| <input type="checkbox"/> Modern Salesmanship | <input type="checkbox"/> Commercial Law |
| <input type="checkbox"/> Higher Accountancy | <input type="checkbox"/> Credit and Collection Correspondence |
| <input type="checkbox"/> Traffic Management | <input type="checkbox"/> Industrial Management |
| <input type="checkbox"/> Railway Station Management | <input type="checkbox"/> Modern Foremanship |
| <input type="checkbox"/> Banking and Finance | <input type="checkbox"/> Personnel Management |
| <input type="checkbox"/> Modern Business Correspondence | <input type="checkbox"/> Expert Bookkeeping |
| <input type="checkbox"/> Business English | <input type="checkbox"/> Commercial Spanish |
| <input type="checkbox"/> Effective Speaking | <input type="checkbox"/> C. P. A. Coaching |
| <input type="checkbox"/> Telegraphy | <input type="checkbox"/> Stenography—Stenotypy |

Name.....

Present Position.....

Address.....

CARPENTRY PAYS



Here's inside trade information on Carpentry and Building. Short cuts, new ideas, plans and working methods that make the job easier, giving you better pay and results. With Audels Guides, apprentices learn the trade easily, journeymen become better mechanics; contractors earn more in less time—get ahead fast.

The 3700 diagrams and sketches show you just how to do the hardest jobs in the quickest, most approved way. Highly endorsed by thousands of successful carpenters and contractors.

Audels CARPENTERS & BUILDERS Guides

**4 Pocket-Size Guides—1600 Pages
3700 Sketches—Handsomely Bound**

An easy-to-read reference for all wood-workers. A complete, progressive, home-study course giving valuable inside information on: **How to use steel square; How to file and set saws; How to build furniture; How to use mitre box; How to use chalk line; How to use rules; How to make joints; Carpenters' arithmetic; Mensuration problems; Estimating strength of timbers; How to set girders and sills; How to frame houses and roofs; How to estimate costs; How to build houses, barns, garages, bungalows, etc.; How to read and draw plans; Drawing up specifications; How to excavate; How to use settings 12, 13 and 17 on the steel square; How to build hoists and scaffolds—skylights; How to build stairs; How to put on interior trim; How to hang doors; How to lath—lay floors; How to paint.**



4 Guides—\$6 Complete—\$1 A Month

Audels Carpenters and Builders Guides have 1,600 pages—3,700 trade illustrations. Pocket size, flexible covers, gold edges, clear type, strong white paper, easy to read and learn from, giving you valuable new ideas, methods and plans gained from the practical experiences of successful carpenters and builders. These Guides solve trade problems, eliminate mistakes, answer questions, saving you time, money and labor.

YOUR PENCIL IS A MAGIC WAND

Get a pencil. Use it here! In a few seconds, by filling in this coupon you can do more for your future than with a magic wand. This coupon brings you the means to advancement, better pay, progress—the position and things you have always wanted. Thousands of mechanics during three generations have been helped and advanced by Audels Guides. You, too, may share in the better times that this helping hand brings.

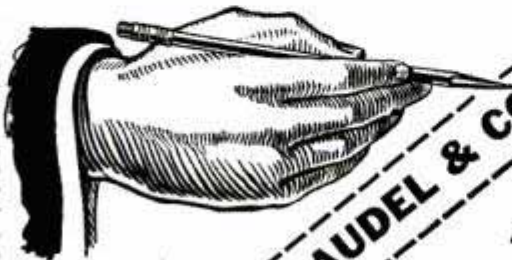

THEO. AUDEL & CO., 65 W. 23rd ST., NEW YORK CITY



Please mail me for free examination Audels Carpenters and Builders Guides—4 vols., \$6 complete. If I find them satisfactory I agree to mail you \$1 within 7 days and to mail \$1 monthly until I have paid \$6.

NAME.....

ADDRESS.....

OCCUPATION.....

EMPLOYED BY.....

Learn AUTOS



I Train You
At Home

up to **EARN**
\$5000
A YEAR

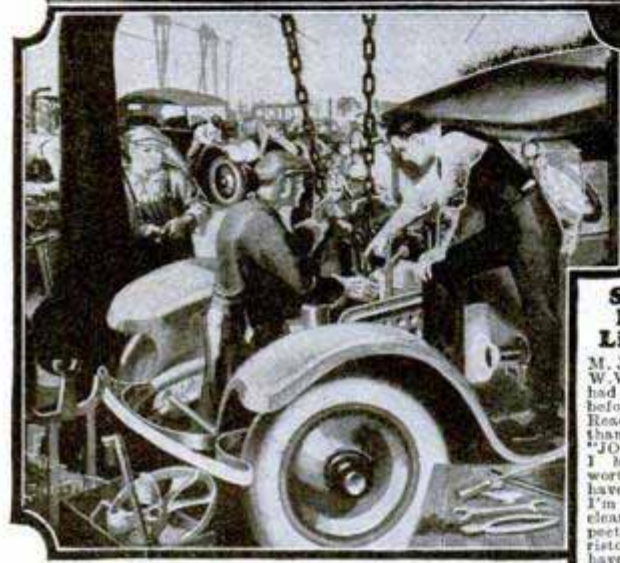

Start to Make Money Quick Like Morrision

M. J. Morrision, Parkersburg, W. Va. (photo at right), never had a day's experience on cars before starting my training. Read what he says when less than half-way through his "JOB-WAY" course. "What I have already learned is worth over \$500 to me. I have gone into business and I'm making over \$50 a week clear, with wonderful prospects." And what Mr. Morrision and hundreds of others have done I will help you to do!



M. J. MORRISON, Parkersburg, W. Va.

Clip this Coupon Now for my Big **FREE AUTO BOOK**

The World's biggest, most fascinating business needs you!

You needn't slave away at small wages another minute—mail coupon and I'll tell you how I train you at home in your spare time for positions paying up to \$150 a week. Unlimited opportunities for trained Electrical and Mechanical Auto Experts. Let me show you how my "JOB-WAY" training has prepared hundreds of men just like yourself for a quick, brilliant success in the Auto business.

Earn Up to \$150 a Week!

Don't sell your time for low pay! You don't need to when you have my "JOB-WAY" training. As Directing Engineer of this Institution I know what training you need to succeed. AND I GIVE YOU THAT TRAINING right in your own home. MASTER every branch of Auto, Truck and Tractor work. I train you with JOBS—not books. I bring the original "JOB-WAY" training TO YOUR HOME!

No Other "JOB-WAY" Training!

My training includes ALL Electrical work—Ignition, Starting, Lighting—ALL Mechanical end, Welding, Brazing, Vulcanizing—also Business Course—also Monthly Magazine, also 3 Testing and Repair Outfits. Nowhere else I know of, can you get ALL this. Six Billion dollars spent each year to repair 18 Million Autos, Trucks, Tractors—it's the world's biggest business. Amazing money opportunities everywhere for trained men. My Employment Service helps you to big jobs, and I help you to get into business for yourself.

Read My Agreement!

Ten agreements in my big free Auto Book. No. 1 is "I will refund every cent of your money if after receiving my training you are not absolutely satisfied." This and nine other wonderful agreements make my "JOB-WAY" course the training for you! Be sure to get my book and read all ten agreements.

Experience, Education Not Needed!

I don't care how little schooling you have. I will train you to become an Auto Mechanic or refund your money! Boys and men of all ages have become Garage owners and managers, Superintendents, Foremen, Auto Experts, BIG PAY executives, after completing Cooke "JOB-WAY" training. I prove to you that I will prepare you to take advantage of the many wonderful opportunities of the great auto business!

Get My Big Book Quick!

I will send it to you without one penny of cost. Read all the facts, find out about the demand for trained Auto Experts. Let me tell you how easily and quickly you, too, may become an Auto Expert. Splendid offer right now to ambitious men. Coupon brings complete information. Mail it today!

Address Me Personally **B. W. COOKE** DIRECTING ENGINEER
MOTOR INSTITUTE OF AMERICA

Formerly Chicago Motor Training Corporation
Motor Institute Bldg., Dept. 2168, Evanston, Ill.

AVIATION Training FREE of extra cost
Coupon brings full details of complete Aviation Training. I am offering FREE of extra charge. Send it now.



MAIL THIS COUPON NOW!

Free Auto Book

B. W. COOKE, Directing Engineer, Motor Institute of America Formerly Chicago Motor Training Corporation Motor Institute Bldg., Dept. 2168, Evanston, Ill. Send me FREE your Big Auto Book "Auto Facts" and proof that you will train me in spare time at home. Also reserve Complete Aviation Course and 3 Testing and Repair Outfits without obligating me.

Name.....
Address.....
City.....State.....
Age.....Occupation.....

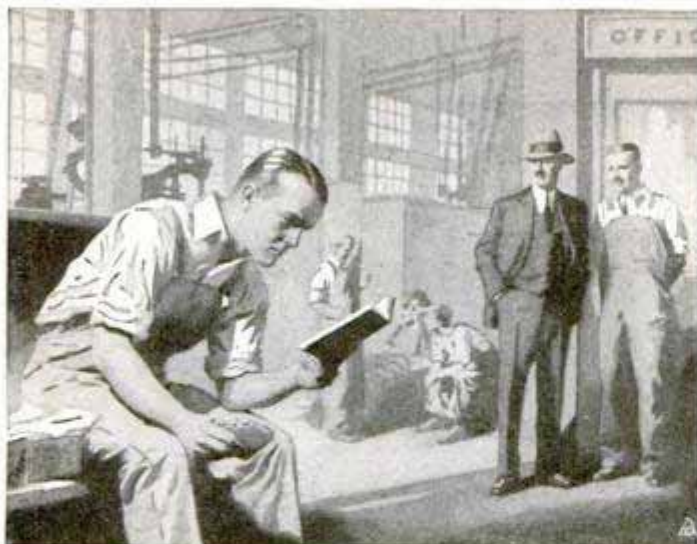

What Chance Have You Against This Man?

HE'S a clear-thinking chap. He realizes that he cannot count on accident to help him ahead. He knows that promotion comes only from preparation. He is studying earnestly and eagerly to fit himself for something better—using every extra moment that offers itself.

The International Correspondence Schools are helping him, guiding him, as they have thousands of other men and women.

Regular monthly reports, mailed to his superiors, have interested them in his progress. They are ready and anxious to recognize honest ambition—to promote any one who is equipped by training to handle increased responsibility.

Measure yourself by this man. Will advancement come first to him—or to you? . . . Why not increase your own chances? The coupon will help you.

Mark and Mail the Coupon Today

INTERNATIONAL CORRESPONDENCE SCHOOLS, Box 5645-F, Scranton, Penna.

"The Universal University"

Without cost or obligation on my part, please send me a copy of your 48-page booklet, "Who Wins and Why," and tell me how I can qualify for the position, or in the subject, before which I have marked an X:

BUSINESS TRAINING COURSES

- Business Management
- Industrial Management
- Personnel Management
- Traffic Management
- Accounting and
C. P. A. Coaching

- Cost Accounting
- Bookkeeping
- Secretarial Work
- Spanish French
- Salesmanship
- Advertising

- Business Correspondence
- Show Card and
Sign Lettering
- Stenography and Typing
- English
- Civil Service

- Mail Carrier
- Railway Mail Clerk
- High School Subjects
- Common School Subjects
- Illustrating Cartooning
- Lumber Dealer

TECHNICAL AND INDUSTRIAL COURSES

- Architect
- Architectural Draftsman
- Building Foreman
- Concrete Builder
- Contractor and Builder
- Structural Draftsman
- Structural Engineer
- Electrical Engineer
- Electrical Contractor
- Electric Wiring
- Electric Lighting
- Electric Car Running

- Telegraph Engineer
- Telephone Work
- Mechanical Engineer
- Mechanical Draftsman
- Machine Shop Practice
- Toolmaker
- Patternmaker
- Civil Engineer
- Surveying and Mapping
- Bridge Engineer
- Gas Engine Operating
- Automobile Work

- Airplane Engines
- Plumber and Steam Fitter
- Plumbing Inspector
- Foreman Plumber
- Heating and Ventilation
- Sheet-Metal Worker
- Steam Engineer
- Marine Engineer
- Refrigeration Engineer
- R. R. Positions
- Highway Engineer
- Chemistry

- Pharmacy
- Mining Engineer
- Navigation Assayer
- Iron and Steel Worker
- Textile Overseer or Supt.
- Cotton Manufacturing
- Woolen Manufacturing
- Agriculture
- Fruit Growing
- Poultry Farming
- Mathematics
- Radio

Name..... Street Address.....

City..... State..... Occupation.....

If you reside in Canada, send this coupon to the International Correspondence Schools Canadian, Limited, Montreal, Canada

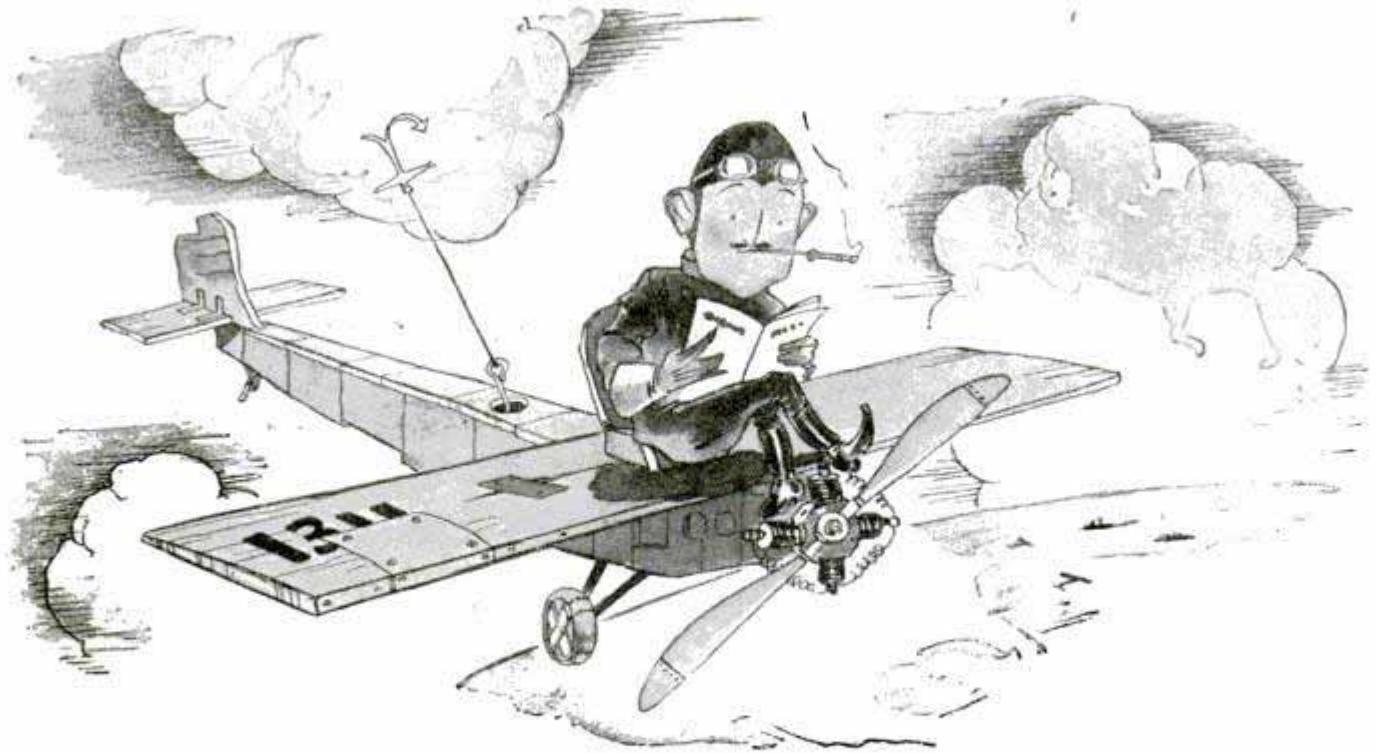

OUR flying friend, Willy McGurk,
 Had a plane that developed a quirk,
 So he threw out a Sky-hook,
 And read in his Fly-book—
 To see how to make a plane work!

NOBLE notion, that!—But not everyone has the foresight our William had when he took along the trusty old sky-hook for emergencies.

Most flyers prefer to take along a thorough knowledge of Aviation—they find that, in view of the present sky-hook shortage, it is a good idea to know beforehand what makes the plane work. Many successful flyers have found that a good way to get this “beforehand knowledge” is through Walter Hinton’s ground course.

And that goes for men in all other branches of Aviation, as well. Mechanics, Salesmen, Executives—men in all sorts of important ground jobs—have found this practical home-study course the sure way to promotion and pay.

This famous course gives a man the essential “ground-school” knowledge that employers demand. It teaches him the history of flight, the principles of flight, the materials of construction, the design and maintenance of engines, the influence of weather, the use of instruments, and a whole lot more—the specific, technical things an Aviation man must know.

It teaches him right at home, using specially prepared home-study textbooks, coupled up with a carefully adapted system of grading, marking, and personal supervision.

Then after he has finished his course, we have an energetic employment department that is placing our men right along, to help him get a job. Or if he wants to take up flying—we’ll arrange a reduced tuition rate at an accredited flying school.

Walter Hinton, President

AVIATION INSTITUTE OF U. S. A.
1115 Connecticut Ave., Washington, D. C.

301-A

I’m ready for the facts. Send your Free Book, “Wings of Opportunity.”

Name.....

Street..... Age.....

(Must be 18 or over)

City..... State.....

We Receive Many Letters Like These

“I have talked with some local pilots, and they tell me that Hinton’s course is the best way to get into Aviation. I fully agree with them, and each lesson makes me even more certain.” J. M. Grey, Wisconsin Rapids, Wis.

Proof!

“I went out to the Alliance Aircraft Co. I found the Employment Manager, who told me not to waste my breath, so I showed him your letter. The result was that I went to work that afternoon. If it were not for your splendid course and that letter of recommendation, I would still be on the outside looking in.” Earl D. Vaughn, Hartsville, Ohio.

Get This Free Book

“Wings of Opportunity” is a free book that will open your eyes. We know that Hinton’s course is practical—because it’s working. It’s getting results—CASH RESULTS—for hundreds of ambitious men all over the country. Find out why. Make the coupon bring complete information.



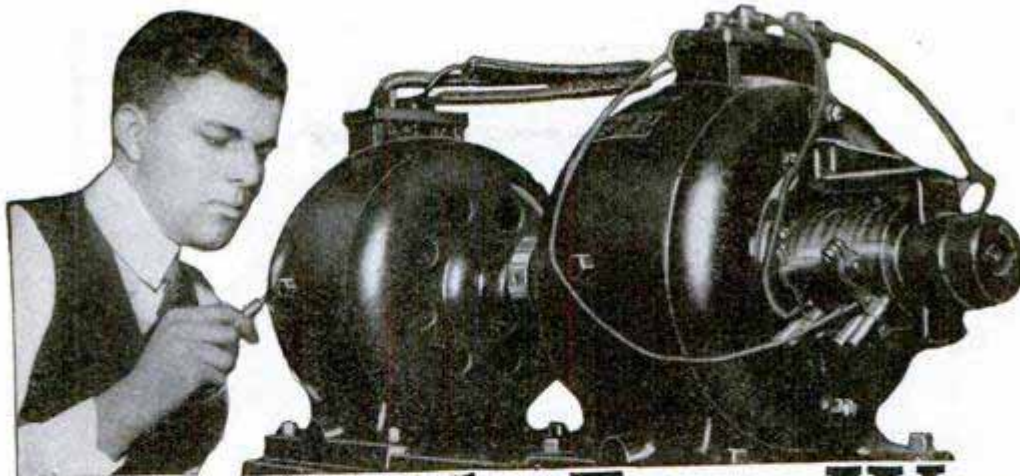

Amazingly Easy Way to get into ELECTRICITY

Don't spend your life waiting for \$5 raises, in a dull, hopeless job. Now . . . and . . . forever . . . say good-bye to 25 and 35 dollars a week. Let me show you how to qualify for jobs leading to salaries of \$50, \$60 and up, a week, in Electricity—NOT by correspondence, but by an amazingly way to teach, that teaches you Electricity in 90 days! Getting into Electricity is far easier than you imagine!

Learn Without Lessons in 90 DAYS

Lack of experience—age, or advanced education bars no one. I don't care if you don't know an armature from an air brake—I don't expect you to! I don't care if you're 16 years old or 48—it makes no difference! Don't let lack of money stop you. Most of the men at Coyne have no more money than you have.

Railroad Fare Allowed

I will allow your railroad fare to Chicago, and if you should need part-time work I'll assist you to it. Then, in 12 brief weeks in the great roaring shops of Coyne, I train you as you never dreamed you could be trained . . . on the greatest outlay of electrical apparatus ever assembled . . . costing hundreds of thousands of dollars . . . real dynamos, engines, power plants, autos, switchboards, transmitting stations . . . everything from doorbells to farm power and lighting . . . full-sized . . . in full operation every day!

NO BOOKS

No Printed Lessons

No books, no baffling charts . . . all real actual work . . . right here in the great Coyne school . . . building real batteries . . . winding real armatures, operating real motors, dynamos and generators, wiring houses

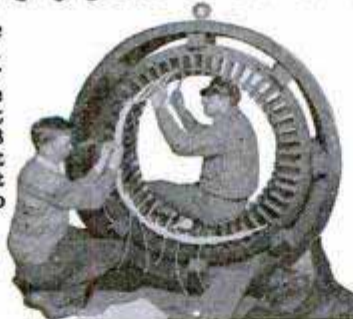

Prepare for Jobs Like These

Here are a few of hundreds of positions open to Coyne-trained men. Our free employment bureau gives you lifetime employment service.

- Armature Expert up to \$100 a Week
- Substation Operator \$60 a Week and up
- Auto Electrician \$110 a Week
- Inventor Unlimited
- Maintenance Engineer up to \$150 a Week
- Service Station Owner up to \$200 a Week
- Radio Expert up to \$100 a Week



NOW IN OUR NEW HOME

This is our new fireproof, modern home wherein is installed thousands of dollars worth of the newest and most modern Electrical equipment of all kinds. We now have the largest amount of floor space devoted to the exclusive teaching of practical electricity in the world. Every comfort and convenience has been arranged to make you happy and contented during your training.

etc., etc. That's a glimpse of how we make you a practical electrician in 90 days, teaching you far more than the average ordinary electrician ever knows and fitting you to step into jobs leading to big pay immediately after graduation. Here, in this world-famous Parent school—and nowhere else in the world—can you get this training!

Jobs, Pay, Future

Don't worry about a job. Coyne training settles the job question for life. Demand for Coyne men often exceeds the supply. Our employment bureau gives you a lifetime service. Two weeks after graduation Clyde F. Hart got a position as electrician for the Great Western Railroad at over \$100 a week. That's not unusual. We can point to Coyne men making up to \$600 a month. \$60 a week is only the beginning of your opportunity. You can go into radio, battery, or automotive electrical business for yourself and make up to \$15,000 a year.

Get the Facts

Coyne is your one great chance to get into electricity. Every obstacle is removed. This school is 30 years old—Coyne training is tested—proven beyond all doubt—endorsed by many large electrical concerns. You can find out everything absolutely free. Simply mail the coupon and let me send you the big, free Coyne book of 150 photographs . . . facts . . . jobs . . . salaries . . . opportunities. Tells you how many earn expenses while training and how we assist our graduates in the field. This does not obligate you. So act at once. Just mail coupon.

Get This Free Book



Mr. H. C. LEWIS, President
Coyne Electrical School, Dept. 89-72
500 S. Paulina Street, Chicago, Illinois

Dear Mr. Lewis:
Without obligation send me your big free catalog and all details of Railroad Fare to Chicago. Free Employment Service, Radio, Aviation Electricity, and Automotive Courses, and how I can "earn while learning."

Name

Address

City State

COYNE ELECTRICAL SCHOOL
H. C. LEWIS, President
500 S. Paulina Street, Dept. 89-72, Chicago, Ill.

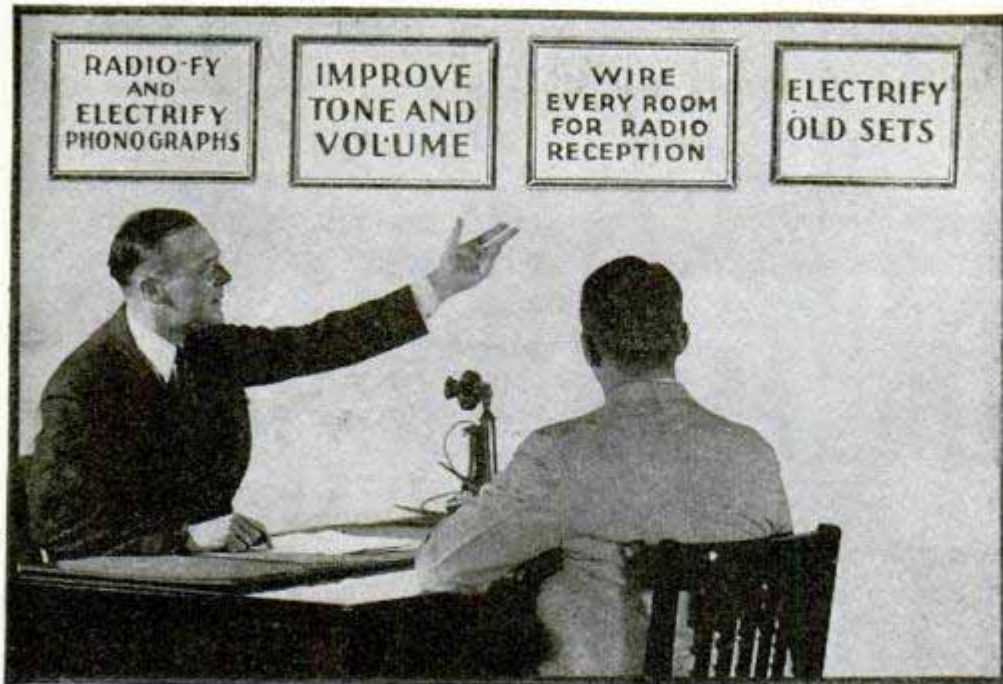

"That's But the Third of the 40 Easy Ways

— to make \$3⁰⁰ An Hour Spare Time In Radio"

Wiring rooms for Radio—as usual, our members are among the first to cash in on it, because the Association was on the job in advance of the trend, preparing its members for this newly developing easy way to make money in radio. It is but one of the many easy ways by which Association-trained men are making \$25 to \$75 a week in spare time, \$50 to \$200 a week full time—easy ways you, too, can follow.

Join With 100,000 Ambitious Men — Cash In on Radio Now

Join the Radio Training Association and take advantage of the proven ways by which you can make \$3.00 an hour upwards from the day you join. Our members are cleaning up on them and at the same time preparing for the \$10,000 to \$25,000 openings in Radio. The Association is helping men start businesses without capital, finance inventions, increase their pay, pass licensed operator's examinations, get better positions. No matter what you want out of Radio, the Association can help you get it easier and quicker. Learn what the Association has done for others and can do for you.

Act Now, for No-Cost Membership!

A limited number of these memberships now available! Write for one today! It need not—should not—cost you a cent. Write for the inspiring story of what the Association

has done for other ambitious men. Learn how it can help you make more money now and later. Fill out and mail in the coupon now—right now—without fail.

Radio Training Association of America
4513 Ravenswood Avenue ∴ Chicago, Illinois

Do You Know That—

- 20,000,000 sets are waiting to be modernized?
- over \$200,000,000 will be spent on them by their owners?
- every phonograph owner is a prospect for the services of an Association member?
- our Free Radio Handbook will open your eyes?

Mail
Coupon
for
FREE
Radio
Hand-
book



In 2 Months Made Factory Manager. 300% Pay Increase

H. L. Schweber, Ill.—"After graduating I secured a position with a large Radio manufacturer. In two months I was given complete charge of a factory. My income has increased 300% since I joined the Association.

Clears \$3,000.00

Frank J. Deutch, Pa.—"Since joining the Association I have cleared nearly \$3,000.00. I don't see how a man can fail, no matter how little education he has, if he follows your easy ways of making money."

\$1,100.00 in 6 Weeks

J. R. Allen, Calif.—"Have done over \$1,100.00 worth of business in the last 6 weeks. Next month I'm going to open a store. Never knew money could come so fast and easy."

\$32.00 In 2 Days

F. G. Gentner, Pa.—"I thought I was doing well last month in spare-time work, but the first two days of this month I have made \$32.00. Since joining I have started a bank account."

Radio Training Association of America
Dept. PM-11, 4513 Ravenswood Av., Chicago
Gentlemen: Please send me full details of your special No-Cost Membership Plan, and a copy of your Radio Handbook.

Name

Address

City

State

ASK

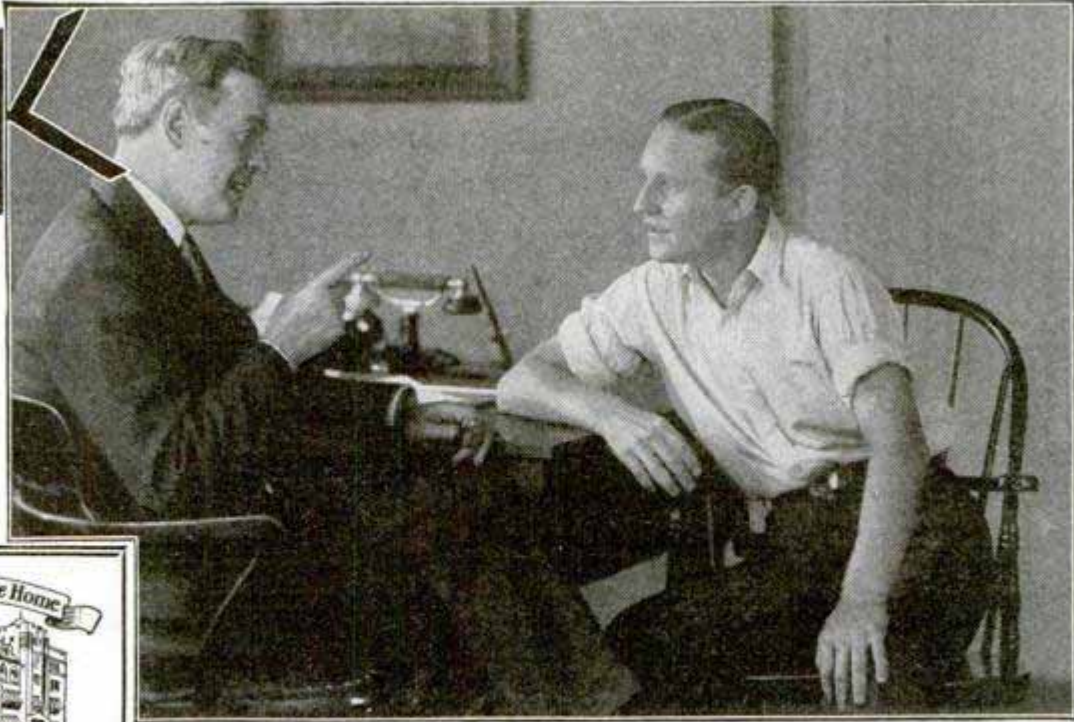

The American School UNIT PLAN

Employers have welcomed the Unit Plan because it enables their men to get just the training material they need to prepare them for the position immediately ahead.

And the Unit Plan appeals to the ambitious employee because it brings **INDIVIDUAL**, personal help when he goes after promotion. For every man has a different background of education and experience—every man has a different job ahead of him—and the Unit Plan permits him to fit his training to his immediate needs. Where in the past "complete" courses had to include everything thousands of men in a given industry might lack.

Now, instead of years of time, a UNIT takes only a few months. Now, instead of hundreds of dollars in cost, each unit costs around \$30. Simply because you take only the training you need for the position you seek.

FOR EXECUTIVE AND BEGINNER

Nearly 200 Units are now available, covering a wide range of business and engineering subjects. Here is help for executive or beginner—for college graduate or men with only grammar schooling.

Here in simplified, usable form is the life-long experience of big men from Westinghouse, Allis Chalmers, General Electric and other great corporations—of noted professors of Massachusetts Institute, Columbia University and many leading colleges. . . . The newest methods in office and factory.

All men ambitious enough to go after promotion, expect to continue to climb upwards year after year. Unless such a man secures real benefits from the first Unit he tries, he will not register for a second. That, in the belief of the American School, is convincing proof of the quality of their Units.

Your Employer how to get a \$5 Raise

The first chance you get to have a heart to heart talk with your "BOSS" ask him how YOU can get a \$3.00 or \$5.00 a week raise.

One of the surprising things he'll tell you is—the very existence of the business depends on promoting men now with the company, rather than "importing" executives from the outside. And that is why they are glad to tell YOU how to get ahead.

One Step Ahead at a Time

Advancement, your employer will frankly tell you, has become a matter of moving up **ONE STEP AT A TIME**. You can no longer expect to be promoted from Clerk to President or to jump from \$30.00 a week to \$5,000.00 a year.

He will tell you the company can't afford to pay you more money for the same work—if you want more money, you've got to learn to do work that *pays* more money.

There you have the employer's "formula" for promotion. The next question is where and how can you acquire the training which qualifies you for a better job?

How can the Clerk prepare for a Junior Executive position? How can the Mechanic get in line for a Foremanship? How can the Bookkeeper advance to Auditor and the Auditor become Assistant Treasurer? Where can the Carpenter quickly learn Drafting or a certain definite branch of building construction?

The new UNIT PLAN of the American

School, described briefly at the left, supplies exactly this need.

It helps you today by giving you the things you need today. As your circumstances change, you can now change your training, too. Extended contracts and long-drawn-out payments have been abolished—you register only for what you need, and pay only for what you get.



FREE UNIT PLAN BOOK

Send for booklet telling *ALL* about the UNIT PLAN, without cost or obligation. It will tell you *exactly* how to solve your immediate problem of getting your next \$5 raise.

**THE AMERICAN SCHOOL, Dept. U-847
Drexel Ave. & 58th St., Chicago**

Send me booklet about the Unit Plan without cost or obligation.

NAME.....

CITY.....

STATE.....

The American School

Dept. U-847, Drexel Ave. & 58th St., Chicago

Earn \$75 to \$100 a Week as AUTO MECHANIC—

In 8 Weeks You Can Have a Big-Pay Job as an Auto, Airplane or Tractor Mechanic

Eight short weeks of pleasant, fascinating, practical Auto, Airplane or Tractor work in my big shops—and then a real job paying \$75 to \$100 a week! You can step right out of low pay, long hours, and no future into the job of a high-salaried trained mechanic. Everywhere jobs are waiting for men trained as I train them. Change the whole course of your life in 8 weeks!

Learn on Real Machines—No Books

Come to my shops. I will make you a mechanic able to handle the hardest mechanic's job easily and quickly. I'll teach you to know Autos, Airplanes and Tractors inside out. You don't need education. You don't need previous experience. All you need is ambition. You learn by doing—by working on actual machines with real tools. This is not a correspondence course. (No facilities for colored students.)

Short Cut to Big Pay Learn how easy it is to get a steady, big pay job in the great Auto, Tractor and Aviation fields. Learn what other fellows like you have done with McSweeney training. Get special low tuition offer.

Special Aviation Course

AVIATION is paying tremendous incomes to trained men! Learn on real airplane engines under experienced instructors. Ask about special course in FLYING. Don't miss this remarkable opportunity.



McSweeney Auto, Tractor and Aviation Schools, Dept. A-18-L, Chester at 30th St., Cleveland, O., or 263 Madison St., Memphis, Tenn.

Without cost or obligation, send me your big FREE Book on Autos, Tractors and Aviation, also full details of your special tuition offer.

Name.....
Street.....
Town..... State.....

Mail Coupon for Book

Money Back Guarantee

If, after completing my training, you are not satisfied, if you are not qualified to accept a big-pay job, your tuition will be refunded.

McSWEENEY Auto, Tractor and Aviation SCHOOLS

Dept. A-18-L
Chester at 30th St., Cleveland, O. or 263 Madison St., Memphis, Tenn.

LEARN the BANJO at Home

under HARRY RESER

the World's Greatest Banjoist



The Famous Leader of the Widely Broadcasted **CLICQUOT CLUB ESKIMOS** offers an amazingly simple Banjo Course by mail which anyone, even without musical talent, can master at home in a few spare hours. Positions, fingering and chords thoroughly illustrated and explained. Students and Professionals heartily endorse this Simplified Home Method. Costs only few cents a day. Special Banjos for Students.

BE POPULAR—MAKE MONEY
At home, parties, or week-end gatherings, the banjo player has many friends. Also, the banjo is vitally essential in the dance orchestras of today. Banjoists make big money. Learn more about this inexpensive course.

Send for FREE ILLUSTRATED BOOKLET
Harry Reser's International Banjo Studio No. 23
148 West 46th Street, New York, N. Y.

Harry Reser famous radio entertainer, phonograph recording artist, teacher of Tenor Banjo, orchestra leader and composer of banjo music, guarantees your success or money back.

Learn the Code with Teleplex!

Be an expert Morse or Continental code operator! **BIG PAY—TRAVEL—FUN—ADVENTURE.** After a few short weeks of practical study with Teleplex you will be an expert operator. This amazing instrument teaches you right in your own home. Works like a photograph. No knowledge needed—beginners learn at once! Not a school. Free 10 days' trial. Write for free booklet F-10. TELEPLEX COMPANY, 72 CORTLANDT ST., NEW YORK CITY



WHY NOT spend Spring, Summer and Fall gathering butterflies, insects? I buy hundreds of kinds for collections. Some worth \$1 to \$7 each. Simple outdoor work with my instructions, pictures, price-list. Send 10 cents (not stamps) for my illustrated Prospectus before sending butterflies.

MR. SINCLAIR, DEALER IN INSECTS,
Dept. 6, Box 1424, San Diego, Calif.



"BECOME A LIGHTNING TRICK CARTOONIST"

Send \$1.00 for Laugh Producing Program of 23 Trick Drawings with Instructions. Catalog of Chalk Talk Supplies Free. BALDA ART SERVICE, Dept. 1, Oshkosh, Wis.



TECHNICAL TRAINING WILL HELP YOU GET A BIG SALARY!

It's your own fault if you don't earn more. Write today. Tell me which course you want to study. Technically trained men are leaders! You can be one, and enjoy the opportunities that come to them.

Let me show you that I can train you! Select the course or courses you are interested in and write today for complete information. I'll send a big free catalogue that clearly outlines everything we teach. You can see at a glance what we have for you. No obligation. course and write today.

Address O. W. KOTHE, Dir.
ST. LOUIS TECHNICAL INSTITUTE
4565 Clayton Avenue ST. LOUIS, MO.

Which Course Is Going to Raise Your Pay?

Drafting — Architectural, Machine—Heating & Ventilating Engineering — Plumbing & Sanitary Engineering — Sheet Metal Designing & Drafting — Boiler Maker Laying Out & Inspection — Steel Ship Laying Off & Plan Reading—Contracting & Estimating—Mathematics & Slide Rule Reading—Aeronautical Drafting & Engineering.

CHECK AND MAIL TODAY!



Check your HOME STUDY

NEW BODIES *in 24 hours*

HAVE you ever watched a magician pick wriggling rabbits out of a high hat? A wonderful trick, you say. Well, I'm a magician of a different sort—a magician that builds health and strength into your body in just 24 hours. And it is no trick. It took me 19 years of tireless planning and experimenting to be able to do it.

People call me the Muscle-Builder, because I take weak, run-down bodies and transform them into strong, virile, handsome bodies in double-quick time. *And I actually do it in 24 hours.*

In the Privacy of Your Own Room

By this I do not mean that you must exercise 24 hours continuously. My scientific short-cut to healthy, handsome, broad-shouldered bodies must be taken in short 15 minute doses. Because, if you exercise more than that in my high-pressure, quick development way, you would tear down more than I can build up. So all I ask of you is 15 minutes of your spare time each day for 90 days (actually only 22½ hours time) doing simple, easy exercises under my guidance. You can do them in the privacy of your room, if you wish, but you must do them every day to get the best results.

And What Results!

In the first 30 days I guarantee to add one whole inch of real, live muscle on each of your arms, and two whole inches of the same revitalizing strength across your chest. I'll take the kinks out of your back, strengthen and broaden your shoulders, give you a wrist of steel, and a fighting, peppy personality that just yells youth, vigor and vitality all over.

I Work Inside As Well As Out

Your heart, your liver, your kidneys, your lungs—all your internal organs get the jolt of their young lives when I start to work on them. And they settle down to an orderly, well-mannered existence that means a new kind of happiness for you—the joy of living that only a healthy, virile body can give you. And the headaches, constipation troubles, aches and pains that are always caused by weakened, flabby bodies somehow miraculously disappear.

You'll See It in Her Eyes

And will your friends notice the difference! Just watch that girl you love so dearly open her eyes, and *fight* to hold your attention! And the men in your crowd—they'll look up to you as a real leader. Instinctively they worship strength and leadership that must go with it. But let me tell you all about it. All you have to do is

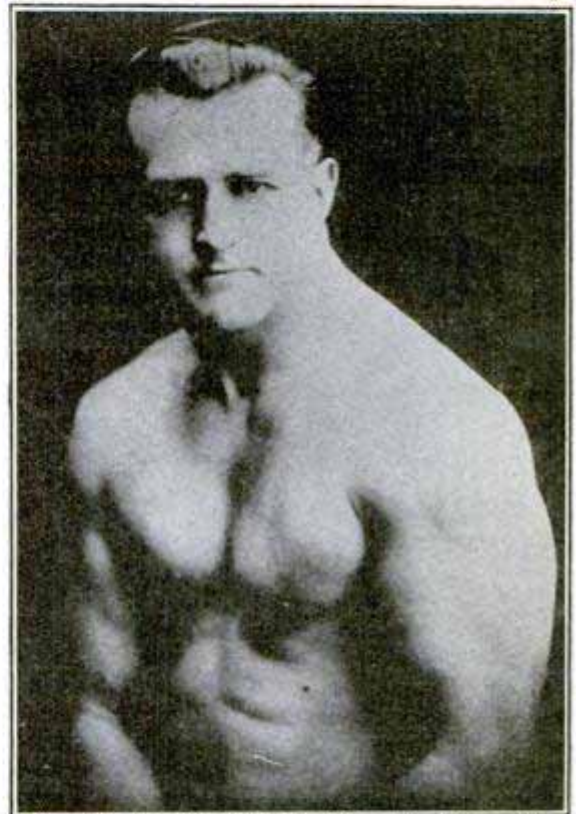

EARLE LIEDERMAN—The Muscle-Builder, Author of "Muscle Building," "Science of Wrestling," "Secrets of Strength," "Here's Health," "Endurance," etc.

Send For My New
64 Page Book

"Muscular Development"

IT IS FREE

The Earle Liederman System of Physical Education has been approved as a Correspondence School under the laws of the State of New York.

What do you think of that? I don't ask one cent. And it's the peppiest piece of reading you ever laid your eyes on. I swear you'll never blink an eyelash till you've turned the last cover. And there's 48 full-page photos of myself and some of my prize-winning pupils. This is the finest art gallery of strong men ever assembled. And every last one of them is shouting my praises. Look them over. If you don't get a kick out of this book, you had better roll over—you're dead. Come on, then. Take out the old pen or pencil and sign your name and address to the coupon. If you haven't a stamp, a postal will do. But snap into it. Do it *now*. Tomorrow you may forget. Remember, it's something for nothing and no strings attached, no obligation. *Grab it!*

EARLE LIEDERMAN

Dept. 2011, 305 Broadway, New York City

It Is F R E E	DON'T	EARLE LIEDERMAN
	SEND ONE	Dept. 2011, 305 Broadway, New York City
	PENNY	
	—	Dear Sir: Please send me, absolutely FREE and without any obligation on my part whatever, a copy of your latest book, "Muscular Development."
	YOUR	Name..... Age.....
	NAME AND	Street.....
ADDRESS	City..... State.....	
ON A	(Please write or print plainly)	
POSTAL		
WILL DO		

I Will Allow Your Railroad Fare to Chicago Without Extra Cost

This funny juice-

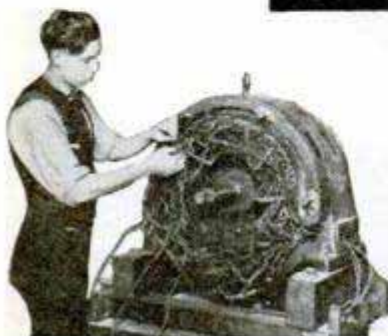

A 25 H. P. Motor for student practice

- helps to run automobiles
- makes radio possible
- makes your telephone work
- makes the wheels go round in thousands of factories
- illuminates homes, factories, office buildings and city streets
- toasts bread, percolates coffee and heats flat-irons
- runs street cars and fast trains

No one knows what it really is—it is called Electricity—but you can learn how to handle it.

—AND IT WILL PAY YOU

\$1⁰⁰ per Hour to \$5,000⁰⁰ per Year

IF you get a real "kick" out of this subject of Electricity you're crazy if you don't make it earn you real money. Pretty plain speaking—but I want to make you think. The world's greatest, most successful men were men who worked at things they liked. Work is fun if you like your job. If YOU like electricity, make it pay you real money.

Here's Your Chance

To get somewhere you've got to start, haven't you? It'll mean breaking away from home for about 12 weeks—but you and the family will be mighty glad you started and finished something. Especially something that pays so big. We'll take mighty good care of you here in the big Greer Electrical Shops. You'll be in company with hundreds of men temporarily away from home, like yourself. And you'll learn Electricity—oh man—how you'll learn it! You'll marvel at the way a subject apparently so mysterious is made so easy to understand. Just wait till we turn you loose among our hundreds of motors, rotary converters, generators, telephone and radio equipments. Competent, friendly instructors will show you

how to take 'em apart and put 'em together till you can do it in your sleep.

How to Get This Training

The coupon at the bottom of this page is the open door to pleasant work and big money in the Electrical Profession. We can't tell the whole story here because it takes a Book to tell it. The book is free. Mail the coupon, and be thankful the rest of your life for doing it. Delayed action never put money in the bank. DO IT NOW.

What About Automobiles?

Maybe automobiles interest you as much as electricity—or more. There's a lot of money in fixing autos, too. The well trained auto man is never out of a job. He's ready to go in business for himself. Would you like that kind of work? \$6 a day to \$20,000 a year is what it pays you. Then mark the coupon for the free book on our Automotive Course. We've helped make automobile experts out of thousands of men who didn't know a carburetor from a universal joint when they came to our big training shops. How much does it cost? You'll be surprised to learn how easily you can afford it. Mail the coupon NOW for complete information.



Using the "Weaver Crand" in the Automobile repair department. Here you learn about all up-to-date auto equipment — by actually using it. Real experience on all makes of cars, under supervision of an expert.

Greer College

Dept. 1101-E
2024 S. Wabash Ave., Chicago

FREE

Employment Service

Our employment department is ready to help you—while in training and for life. Day and evening classes. Low cost. Easy terms.

ERWIN GREER, President, Greer College
Dept. 1101-E, 2024 S. Wabash Ave., CHICAGO.

Please send me your FREE BOOK and offer for Electrical course
Automotive course
It is understood I am not obligated in any way

Name

Address



IT ISN'T SUCH A BUM WORLD AFTER ALL!!



WHEN YOU WORK UNDER A SIMON LEGREE STRAW BOSS WITH A TIME CLOCK STARING AT YOU ALL THE TIME—



AND YOU NEVER HAVE ANYTHING IN YOUR POCKETS EXCEPT A HOLE—



AND BILLS KEEP PILING UP ON YOU TILL YOU CAN'T SEE HOW IN THE SAM HILL YOU'RE EVER GOING TO GET OUT OF DEBT—



AND THEN YOU FIND IN A LITTLE BOOK THE KEY TO SECRETS WHICH HAVE MADE THOUSANDS COMFORTABLY WELL OFF AND EVEN RICH—



AND YOU START USING THOSE SECRETS YOURSELF AND LEARN WHAT IT IS TO REALLY MAKE BIG MONEY AS A SALESMAN—



'OH FELLERS IT ISN'T SUCH A BUM WORLD AFTER ALL

When Men Raise Their Pay \$3,000 to \$7,000 a Year ...After Reading This Little Free Book!

A MARVELOUS little free book is bringing vital news to thousands of men today and making momentous changes in their lives. Just sixty-four pages—about seven ounces of paper and printers' ink; but there are thousands of men holding down big-pay jobs all over the United States and Canada with earnings running up to \$10,000 a year, and even bigger, who started by reading this great book.

Take, for instance, Frank J. Walsh of Ludlow, Massachusetts. Just a few years ago, Walsh was struggling along on \$1,000 a year. In just one evening, reading this little free volume, he made the change in his life that raised his pay over 600%.

About the same time that Walsh was getting his start two other men—C. V. Champion of Danville, Illinois, and R. B. Hansen of Akron, Ohio—were reading it too. Both were factory hands at the time—but today both of them are presidents of prosperous and growing companies with incomes over \$10,000 a year! Just lately a California cowboy named William Shore spent an evening reading this book, in a ranchhouse. It wasn't many months later that he told us of one week when he made \$525 clear, as a salesman.

Men from all walks of life—men who never dreamed they could master the secrets of salesmanship—regular fellows just like anybody else, without any extra advantages of money or education—that's what these men are. This little book, and the marvelous N. S. T. A. Demonstration Method, are specially planned to help just that kind of men—ambitious average fellows. The N. S. T. A. does something which people said could not be done—it makes salesmen—successful high power earners, out of average men with normal every-day brains. It has proved that salesmen do not have to be "born." It teaches, in easy, yet thorough lessons, right

in your home, the secrets which great salesmen have spent years on the road to learn.

You can't keep a good man down—not if he really is a good man and will take advantage of his opportunities to rise in life. This book, "The Key to Master Salesmanship" brings ambitious men the chance they've all been looking for—the chance to get away from dull routine timeclock jobs at low pay. It shows them the way to a free employment service which gives N. S. T. A. members the pick of 50,000 high-pay jobs every year.

Right now this book, "The Key to Master Salesmanship," which showed these men how to get started on the road to success and independence, will be mailed as a gift to any ambitious man—absolutely free and without obligation. Why not see for yourself what amazing pay-raising secrets it contains? There is no better way to invest a two cent stamp! Simply fill out and mail the coupon to us today.

NATIONAL SALESMEN'S TRAINING ASSOCIATION

Dept. S-102, N. S. T. A. Bldg., Chicago, Illinois

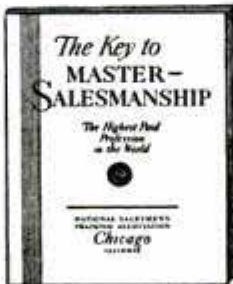

National Salesmen's Training Association, Dept. S-102, N. S. T. A. Bldg., Chicago, Ill.

Please send me free and without obligation my copy of "The Key to Master Salesmanship," and full details of your Free Employment Service and other special Earn While You Learn features.

Name.....
 Address.....
 City..... State.....
 Age..... Occupation.....

Want More Fun?



DO YOU want more good times—more invitations? Would you like to be right "in the spotlight," entertaining the others and having a lion's share of the fun at all the parties? Would you? If your answer is "Yes"—then you can't afford to say anything but "Yes" to the offer I'm going to make you—right on this very page!

—I asked Basil Glaze, of Germantown, Md. He answered "Yes!" and a few months later wrote me: "Though I started with no knowledge of music, your Course certainly taught me quickly. My playing has opened the doors to a new world of fun for me."

Want More Friends?

More Invitations - Good Times?

DO YOU want more real pals to fill your spare hours with enjoyment? Do you? Then I'll show you how to make them—more than you've ever dreamed of having. How? Easy! By teaching you to play an instrument that everyone loves—the Hawaiian Guitar! Even if you think you have no "talent"—don't worry. You don't need any talent or previous experience whatsoever, to learn at home by this simple method!

—I asked Pauline Hamrick, of Matthews, N. C. She, too, answered "Yes!" and soon wrote: "The very day I received my Guitar and first Lessons I began to have fun. Now my lonesome days are over. I make new friends almost every day—everywhere I go, with my playing."

Want More Money?

Extra Dollars Easily Earned

—I asked Ralph Prutzman of Lehighton, Pa. He also said "YES"—and I showed him the quickest, easiest way to make it. Now he writes: "I'm getting along fine. The Lessons are easy and interesting. Made \$16 the very first night I played professionally and I'm not even through the Course yet! I see lots of good money-making opportunities ahead and I'm making more friends and having a better time than ever before."

Big Hawaiian Guitar and Ouhli Come with Very First Lesson! We send you this fine, full-size Hawaiian Guitar, Phonograph Records of 55 selections and Complete Outfit. These are yours to keep. The Free Book explains everything. Get it NOW.

Learn the Hawaiian Guitar at Home—By Quick Easy Method

Ralph Prutzman didn't believe we could teach him—but he let us PROVE that we could! Never mind if you've never played a note in your life, either, this easy, simple method will teach you quick, just as it taught Ralph Prutzman, Basil Glaze, Pauline Hamrick and a thousand others. The Coupon below brings your copy of my big Free Book. It tells all about the Course and famous method. It tells, too, how I send you everything you need to learn. Get it quick! Clip and mail the Coupon today—right now—and I'll get your copy to you by return mail!



This Brings FREE Book

A. F. BLOCH, President,
Hawaiian Studios 52119 of
New York Academy of Music,
100 Fifth Avenue, New York City.

Send me the book that tells more about getting more FUN—more FRIENDS—More MONEY. No obligation to me, of course.

Name.....
Address.....
City..... State.....

THE CHICAGO DAILY NEWS School and College Bureau

Offers You Its Specialized Services in Choosing a School

Last year the School and College Bureau of The Chicago Daily News saved many busy parents and questioning boys and girls both time and worry by sending them prompt, reliable information about just the kind of school they wanted—personal requirements as to location and tuition charges being considered in each individual case.

Again this year many young people will be perplexed by the problem of finding the right school. Why not let us help you?

The Chicago Daily News maintains this service absolutely free of charge to you. No need to hurriedly select a school on mere hearsay when expert advice can be obtained by telephoning Dearborn 1111, writing or calling for a personal interview at

THE CHICAGO DAILY NEWS
School and College Bureau
Dept. K, Daily News Plaza, 400 W. Madison St., Chicago, Ill.

OPPORTUNITIES IN Traffic Management

Become a Traffic Expert

The opportunities in traffic management are limited only by the boundaries of the business world. The trained traffic man is in demand by transportation systems and by industrial organizations.

Three Detroit Firms Pay Their Traffic Managers Over \$20,000 a Year

Prepare for this growing, profitable profession at home in your spare time under supervision of traffic experts. Low cost; easy terms. Thru the LaSalle Problem Method you learn by doing. Valuable 64-page booklet free. Send for it Now.



This Book FREE!

LaSalle Extension University, Dept. 1164-T, Chicago

STAMMERING

easily, permanently corrected. Win happiness and success. Ask for full information and special phonograph record. Send dime for postage

12972 Woodward Ave., LEWIS INSTITUTE, Detroit

6 Ft. LONG



GIVEN!

Boys! Here's the great Navy model Airship. Large 6-foot air bag with inflators, parachute with automatic release and complete instructions for flying. Will fly for miles at height of 1000 feet. Great chance to study aerial navigation. Send name and we'll send 6 of our new art pictures to dispose of on special 25c offer. Send the \$1.50 you collect and as a reward for this service we will send this wonderful Airship with full instructions free.

C. M. Thomas, 337 W. Madison St., II-K-91, Chicago

JUST PUBLISHED!

Entirely New-14th Edition

Encyclopaedia Britannica

THERE has never been anything like it—never anything even remotely approaching this magnificent *new* Fourteenth Edition of the Encyclopaedia Britannica. Cast aside your old ideas of reference works and encyclopaedias, for here is something new, different, tremendously vital, alive.

“An unprecedented achievement,” is the verdict of foremost critics, a verdict that is sweeping the country. “The most exciting book of 1929,” says Henry Seidel Canby. “The last word in encyclopaedia perfection,” says a well-known librarian.

And so it goes, without a dissenting voice!

3,500 Contributors

The roster of contributors is a roll-call of the great and famous from the whole world—3,500 from fifty different countries.

No university could possess such a faculty, nowhere else can you find so complete a survey of the entire record of human thought and achievement.

Unique in Human Interest and Practical Value

The *new* Britannica is not only unique in scholarship. *It is unique in human interest and sheer practical value.*

It establishes the new principle that a wealth of learning can also be a treasure of fascinating reading. The amazing richness of illustration alone makes every subject easier and simpler to grasp, and at the same time ten times more interesting than ever before.



This handsome bookcase table, made of genuine Brown Mahogany, is included with every set of the new Britannica.

AN AMAZING WORK

35,000,000 Words

New from Cover to Cover

Cost More Than
\$2,000,000

15,000 Illustrations

Nearly 500,000
Index References

Remember—this is a new work! Only a small amount of text—material which could not be improved in any way—has been retained from previous editions.

This new Britannica brings to every American home the limitless possibilities of modern knowledge.

Astonishingly Low Price

The price of the *new* Britannica has been fixed so low that you

will marvel at this new evidence of modern printing efficiency.

In addition, you may own and enjoy it immediately on one of the easiest time payment plans ever devised. A deposit of only \$5 brings the complete set with its free bookcase table direct to your home.

Send For FREE Booklet

Learn about the *new* Britannica while it is still possible to get a set from the first printing at the low price that now prevails. Send for our handsome new 56-page booklet containing numerous color plates, maps, etc., from the new edition.

A free copy of this book is yours without the slightest obligation. Use the handy coupon below.

ENCYCLOPAEDIA BRITANNICA, INC.

342 Madison Avenue, New York City PM9-B2

Please send me by return mail, without any obligation on my part, your 56-page illustrated booklet describing the *new* Fourteenth Edition of the Britannica together with full information concerning bindings, low price offer, etc.

Name _____

Address _____

City _____ State _____

MAIL This Coupon TODAY



Here is Edwin McTeer (address on request) and some of his work. The crude pen drawing was made before he had any training and the striking story illustration (worth \$100) was made after he took the Federal Home Study Course.

He did it— Why don't you?

Edwin McTeer is only one of the hundreds of young men (and young women, too) who are succeeding in commercial art with the help of the practical training offered by the Federal Home Study Course. Well trained artists earn \$50, \$75, \$100, \$150 a week and more.

Success in Commercial Art

begins with a liking for drawing and the ambition to follow through with the right training. Mr. McTeer was thirty years old when he clipped a coupon like the one at the bottom of this ad, and took up the Federal Course. He progressed rapidly, increasing his earnings each year until, at the end of five years, he was making around \$10,000 a year. Read what he wrote us:

"I was not very talented when I entered this training with you people as you certainly know, and I had not even had high school training and I know any one with a love for work can accomplish even more than I if they will just let you people, the Federal Schools, help them. I suppose you remember I opened my own independent commercial art studio and to make a long story short, my earnings are now at the rate of over \$10,000.00 a year."

Send for "Your Future"

If you like to draw—send for book "Your Future" and find out what amazing progress you can make with the right art training. Use the coupon now, giving age and occupation.



Federal
School
of Commercial Designing

646 Federal Schools Bldg., Minneapolis, Minnesota.
Please send me your free book, "Your Future."

Name.....
Age..... Present Occupation.....
Address.....

BEDFORD YMCA TRADE SCHOOL

Auto Mechanic
Aviation Mechanic
Starting, Lighting, Ignition
Electric Welding, Airplane Welding
Oxy-Acetylene Welding
Wheel Alignment. Brake Testing
Machine Shop. Battery Repair
Electrical Course. Radio Mechanic
Mechanical, Architectural Drawing
Airplane Drafting
Blue Print Reading
Building Estimating
Sign Painting. Show Card Writing
Window Dressing
Commercial Art. Fine Art
Write for Catalog 50
Brooklyn Engineering Institute
(Operated by Bedford Y. M. C. A.)
1125 Bedford Avenue, Brooklyn
New York City

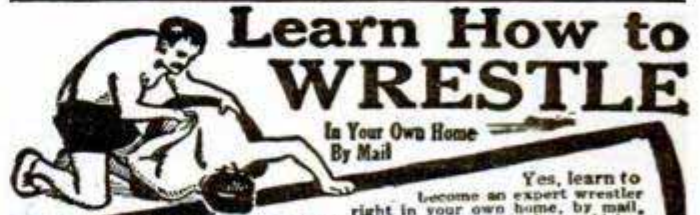

Yes, learn to become an expert wrestler right in your own home, by mail, from the greatest wrestlers the world has ever known. Be an athlete, be strong, be healthy. Learn how to throw and handle big men with ease. Learn to defend yourself. All taught in our course of lessons, and illustrated with hundreds of charts and actual photographs by

Farmer Burns and Frank Gotch

Farmer Burns, "the grand old man of the mat," taught Frank Gotch, the World's Champion, all he knew about wrestling, so Gotch said. He will now teach you Scientific Wrestling—Physical Culture—Jiu-Jitsu—Self Defense. Every man and boy in America, no difference what age, needs this wonderful course of lessons. Write today—your name, age and address on a postcard or letter brings you our fine book absolutely free, — no obligation of any kind. A splendid book on wrestling and physical culture. Write today stating your age.

Farmer Burns School of Wrestling 3378 Range Bldg., Omaha

This week long book FREE



Wonderful, new device, guides your hand; corrects your writing in a few days. Big improvement in three hours. No failures. Complete outline FREE. Write C. J. Ozment, Dept. 34, St. Louis, Mo.

Learn Advertising at HOME

Send your name and address for free booklet giving interesting information and vital facts about Advertising. Find out how we prepare you at home, in your spare time, for the opportunities open in this fascinating business. Practical work. No text books. Old established school. Successful graduates everywhere. Just the plan you have always wanted. Write today. No obligation.

PAGE-DAVIS SCHOOL OF ADVERTISING
Dept. 1358 3601 Michigan Ave. Chicago, U. S. A.

LEARN WATCH REPAIRING



You can learn by our modern and original system of instruction every part of the Watch Repairing Trade at home as good or better than at a shop. You can earn money while learning and secure a well paying position or start in business after completing our course of instruction. Good watch repairers are always in demand and earn from \$50 to \$75 per week. For particulars apply to the Wisconsin School of Watch Repairing 166 Mason St., MILWAUKEE, WIS.



ZIP-ZIP SHOOTER

THOUSANDS of boys are made happy with this wonderful Zip-Zip shooter, scientifically and practically made. If you like hunting and outdoor sports, get a Zip-Zip shooter with plenty of pep and force. If your dealer happens not to have them, order from us. Zip-Zip shooter 35c or three for \$1.00; send stamps, coin or money order.

Automatic Rubber Co., Columbia, S. C.



This New, Easy Blue Print Way Prepares You for These 9 Big Pay Jobs!

1 Building Superintendent \$5,000 to \$12,000

2 Building Inspector \$4,800 to \$8,000

3 Appraiser \$6,000 to \$10,000

4 Material Buyer \$5,000 to \$7,500

5 Material Salesmen \$5,000 to \$12,000

6 Building Estimator \$6,000 to \$10,000

7 Real Estate Expert \$5,500 to \$12,000

8 Construction Foreman \$4,500 to \$8,500

9 Contractor and Builder in Own Business \$5,000 to \$12,000

Make \$4,800 To \$12,000 A Year!

HAVE you ever stopped to consider what stands between you and a big-pay job? Simply a lack of training on the "Headwork" side of Building and Contracting—that's all! The men who command the high-salaried positions know how to read blue prints—how to lay out and run jobs.

There is no reason why you, too, can't bridge this narrow gap between you and the jobs that pay up to \$12,000 a year. You need only to equip yourself with this essential knowledge to win a better position or a business of your own. With the Building Trades calling frantically for practical men who can read blue prints—with this training so easily available to you the Chicago Tech "Blue Print Way"—the opportunity is yours to take NOW!

Get This Big-Pay Training

The day when a tradesman could get practical "headwork" training only on the job is gone forever. The records of thousands of Chicago Tech graduates have proved that the idea is no longer true. That it's easy to learn how to read blue prints by the Builders' Course, the "Blue Print Way To Big Pay." This practical method is quick, easy and it's certain. You learn right at home in your spare time with real blue prints and les-

sons as simple and easy to understand as a story book. Everything is explained in every day language and worked out by practical, experienced building experts. No text books. No grinding study. Simple as A. B. C.

Mastered In A Few Weeks

And the beauty of this wonderful course is that it teaches you plan reading in amazing short time. Yet this valuable knowledge is just what you need to equip yourself for one of the big indoor or outdoor jobs that yield \$4,800 to \$12,000 annually!

Take this positive, easy way to make your ambitions materialize. Simply mail the coupon at once. It brings a complete set of actual working blue prints and a valuable, instructive book, "How to Read Blue Prints" free, absolutely FREE! Get these true facts before you as soon as possible. See what fun it will be to learn the fascinating "Blue Print Way." Know what wonderful opportunities await you in the seven billion dollar building field! Don't delay!

If You Live Nearby

Visit our big day or evening school attended by over 1,000 builders. You get this training at home by mail—same plans, lessons and instructions.

FREE BLUE PRINTS AND BOOK

We will send you absolutely FREE a full set of practical working Blue Prints, also valuable book, "How to Read Blue Prints." We want you to see for yourself how easily and quickly you can now master blue print plan reading—the "Blue Print Way." Mail the coupon NOW—don't delay!



Chicago Technical School for Builders, Dept. P-142, Chicago Tech Bldg., 118 E. 26th St., Chicago, Ill.

Please send your Free Books and Blue Prints which I understand are mine to keep without obligation. It is also understood that no salesman will call on me.

Name.....
Address.....
City.....State.....

Chicago Technical SCHOOL for BUILDERS

Dept. P-142, 118 E. 26th St., Chicago, Ill.



\$25,000 worth of 1929 cars for you to work on!

Students at work on 1929 Packard Six, 5. Other 1929 Models include: Buick, Study, Marmon, Auburn, Nash, Hot, Essex, De Soto, Chev., Ford, Oakland—and 11 more chassis.

Learn Autos IN LOS ANGELES

and LEARN IT RIGHT!

1. NATIONAL—America's Best Equipped Auto School

NATIONAL is a Million Dollar institution—established in Los Angeles in 1905—recognized throughout the automotive industry as one of America's foremost trade schools. NATIONAL offers practical, intensive training in all automotive branches. No age limit. No previous experience necessary. You learn by "Actual-Shop" Methods. Life Scholarship privileges. Start any time of the year.

2. NATIONAL Qualifies YOU to Make Good

NATIONAL properly trains you in the Auto Trades in the short time of 4 to 6 months. Upon completing this Condensed Course you are fully qualified as a Practical, Competent Automobile man, and you have not risked your chances of employment because of inferior, incomplete instruction.

3. NATIONAL Guarantees YOU Efficient Employment Service

NATIONAL GUARANTEES to give unlimited and efficient Employment Service to students wishing to earn living expenses while learning; and to graduates getting started in the automobile field. This is the most any reputable school can be expected to do.

4. NATIONAL'S Training in Every Man's Reach

NATIONAL offers YOU the very best technical-practical training that money can buy at a cost within every man's reach. It does not offer to pay your railroad fare, room and board or other personal expenses, preferring to limit its activities to the PROPER TRAINING OF MEN FOR SUCCESS.

5. Come to LOS ANGELES—the Playground of America!

LOS ANGELES is the heart of the country's most prosperous automobile section—as well as the world's most ideal city in which to live and prepare for success in the auto game.

WRITE for FREE BOOK NOW!

National Automotive School

NATIONAL AUTOMOTIVE, Dept. 728, 4096 Figueroa St., Los Angeles, Calif.

Send me, absolutely free, your big illustrated catalog of Automotive Opportunities.

Name.....
Address.....
Age.....City.....State.....

Your Future assured!

National Automotive
LOS ANGELES

COLLEGE COURSES at Home

Carry on your education. Develop power to initiate and achieve. Earn credit toward a Bachelor degree or Teaching Certificate. Select from 450 courses in 45 subjects, including English, Mathematics, History, Education, Art, Psychology, Economics, the Sciences, the Languages, etc. Write for catalog.

The University of Chicago
427 ELLIS HALL CHICAGO, ILL.

MUSIC LESSONS IN YOUR HOME

You can read music like this quickly

Write today for our FREE BOOKLET. It tells how to learn to play Piano, Organ, Violin, Mandolin, Guitar, Banjo, etc. Beginners or advanced players. You pay as you learn. Costs only a few cents a day. Thousands of satisfied students.

AMERICAN SCHOOL of MUSIC, 51 Manhattan Bldg., CHICAGO

TELEGRAPHY

(Morse and Wireless) and RAILWAY ACCOUNTING, taught thoroughly. Big salaries. Tremendous demand. Oldest, largest school. Endorsed by Telegraph, Railway, Radio, and Government officials. Expenses low—opportunities to earn large portion. Catalog free. **DODGE INSTITUTE, Jones St., Valparaiso, Ind.**

10c NEW SCIENTIFIC WONDER

3 for 25c "X-RAY" CURIO

SILVER ONLY

BOYS You appreciate use thru Clothes, Wood, Stone, any object. See Bones in Flesh. FREE—PKG. RADIO BIG FUN

PICTURE FILMS. Takes pictures without camera. "You'll like 'em." 1 pkg. with each 25c order.

MARVEL MFG. CO. Dept. 31 NEW HAVEN, CONN.

FOREMEN!

FACTORY WORKERS AND ALL MECHANICS

\$1.98 (Worth \$25)

Lecture Course Complete in 1 Volume

SEND NO MONEY

Every foreman, factory worker, manager and ambitious mechanic will find a gold mine of inside information in "The Modern Foreman" by Robt. Grimshaw. The 28 chapters of this great work are shop talks pointing the way to success, efficiency, better pay and the job higher up. A complete study course in leadership; a handy, daily reference and guide.

SUBJECTS COVERED INCLUDE:—The Magic Wand of Efficiency, The New Type of Foreman, Teamwork, The Kicker, The Agitator, Bonus Plans, Self-Improvement, How to Handle Men, Hiring and Firing, Assigning Men to Jobs, How to Keep Records, How to Cut Out Waste of Time and Materials, New Inventions, Modern Methods, The Inspector, Health and Character Requirements, What the Foreman Should Know, Mathematics, Business Law, The Foreman as "Top Sergeant," Factors of Success, Leadership, What is "Labor"? Time and Idleness, Knowledge is Power, "Morale," The Value of Mistakes.

"The Modern Foreman" has 297 pages, quick reference index, many tables, diagrams, illustrations and forms; big type, easy to read and understand; rich binding, gold stamped. Size 6 x 9 x 1 1/4. Reg. price \$2.50. Our special sale price \$1.98. Send no money. Satisfaction guaranteed. Mail this coupon TODAY!

GREGG PUBLISHING CO., 20 W. 47 St., New York, N. Y.

Send me "The Modern Foreman." I will pay postman \$1.98 and postage on arrival. My money is to be refunded if I am not satisfied.

Name.....
Address.....

334



**Major Rockwell
World War Flyer
Who Will Teach You**

Major Rockwell is a famous world war flyer, decorated with the Legion of Honor and the War Cross. He is now devoting himself to teaching Aviation, and he will train you for a position in this great new industry as only a Veteran World War Flyer can train you. Under Major Rockwell's guidance your future in Aviation is assured.



Your Job Is Here

**Major Rockwell Says:
"I'll Train You at Home**

—and in 12 Weeks You Can Master Every Principle of Ground Training Which Is Necessary Before You Are Ready to Take Your Place in Any Branch of Aviation"

Of course you want to get into Aviation quickly! Every man, young and old, is eager to take his place and insure his future in this fastest growing industry which is paying big incomes to trained men. **Aviation is the only field in which manufacturers and airports are literally raid-**

ing each other for men with proper training! Now is the time for you to start! And my Home-Study Course is the easiest, quickest, least expensive way for you to make the start. Mail coupon for my fascinating book which gives all details.

**You Learn Aviation Ground Work at Home
—Then Choose Any of the 40 Ground Jobs**

Right in your own home, devoting about an hour a day, I teach you the essential Aviation fundamentals covering every phase of ground work, as well as the principles of flying and navigation. This is the same instruction that you would receive if you went away to a ground school. It makes no difference whether you intend to fly or to make your mark in Aviation as a designer, rigger, motor expert, repairer, inspector, builder or in any of the 40 big-pay ground jobs, **you must have this**

highly important ground work instruction to land any real good job in this new fast-growing industry. I will help you find your proper place in Aviation and start you on the right road to sure success. Manufacturers, Transport Companies and Airports prefer Rockwell trained men. Then if you want to go farther and take up actual flying, you can come here to Dayton where I'll see that you get your flying instructions at one of America's finest airports—**at my special reduced prices.**

- 40 Ground Jobs for Every Airplane**
- Every airplane in service means 40 men on the ground, all highly paid.
 - Riggers**
 - Designers**
 - Electricians**
 - Metal Workers**
 - Draughtsmen**
 - Plane Mechanics**
 - Motor Inspectors**
 - Air Port Managers**
 - Welders**
 - Transport Managers**
 - Etc., etc.**

No Advance Education or Experience Needed

You don't need to have any previous education to master my course. You do not even need to know anything about airplanes or mechanics. My home study course is thorough and complete. Everything is clearly explained with easy-to-understand text and pictures. In a few short months you will have grasped every

fundamental principle of aviation ground work and you will be well on the road to qualify for any important aviation job paying \$300 to \$400 a month. My Home Study Course will also give you all the knowledge necessary to pass the Government's written examinations for mechanics' or pilots' licenses.

Aviation Begging for Trained Men

Only TRAINED men can command the high salaries. Employers are glad to pay big money for men who know Aviation—builders, mechanics, service and maintenance men, and flyers. Let me prepare you for one of the many high salaried Aviation jobs open to the trained man. I will prepare you at home to take your place in the most fascinating, fastest growing industry in the world. Rush this coupon to me for a copy of my famous free book.

Money Back Guarantee

I am so certain of your success in Aviation that if you are not satisfied after completing my course, I will refund every cent of your tuition.

Employment Service

After you graduate I help you get a job without cost. There's a great demand for men with Rockwell training!

**MAJOR ROB'T L. ROCKWELL
THE DAYTON SCHOOL OF AVIATION
Desk R-1 DAYTON, OHIO**

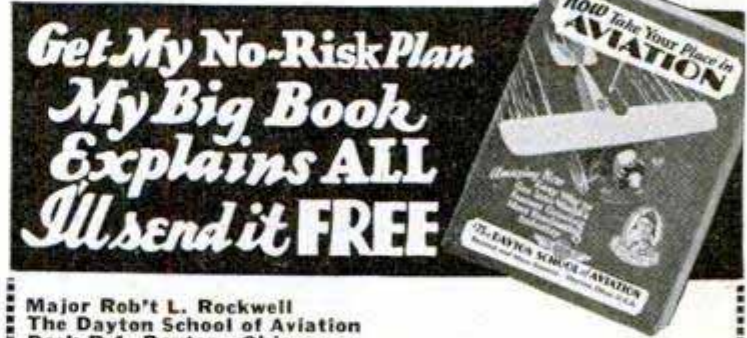

Major Rob't L. Rockwell
The Dayton School of Aviation
Desk R-1, Dayton, Ohio.

Dear Major:—Please send me FREE and without obligation a copy of your famous book on Aviation; also your special tuition and position offer.

Name.....
Address.....
Town..... State..... Age.....



There's the Man Who's Holding You Down

Yes, sir! There's the man! You see him every time you look in the mirror. His name isn't Brown or Smith or Jones but Y-O-U. He's your real boss. He's the man who decides whether your salary will be \$35 a week or \$100 or \$150.

If you want to get ahead there's just one sure way to do it—train yourself to do the day's work better than any other man in the office. Ability is bound to count. Your employer will be glad to pay you more money if you show him you deserve it.

A home-study course with the International Correspondence Schools will prepare YOU for the position you want in the work you like best. All it takes is an hour a day of the spare time that now goes to waste.

At least find out how by marking and mailing the coupon that has meant the difference between Failure and Success to so many other men. It doesn't obligate you in any way to fill in this coupon, yet it may be the means of changing your entire life. Do—it—now!

Write for Free Booklet

INTERNATIONAL CORRESPONDENCE SCHOOLS Box 5646-F, Scranton, Penna.

Without cost or obligation, please send me a copy of your booklet, "Who Wins and Why," and full particulars about the course before which I have marked X in the list below:

TECHNICAL AND INDUSTRIAL COURSES

- | | |
|--|---|
| <input type="checkbox"/> Architect | <input type="checkbox"/> Automobile Mechanic |
| <input type="checkbox"/> Architectural Draftsman | <input type="checkbox"/> Aviation Engines |
| <input type="checkbox"/> Building Foreman | <input type="checkbox"/> Plumber and Steam Fitter |
| <input type="checkbox"/> Concrete Builder | <input type="checkbox"/> Plumbing Inspector |
| <input type="checkbox"/> Contractor and Builder | <input type="checkbox"/> Foreman Plumber |
| <input type="checkbox"/> Structural Draftsman | <input type="checkbox"/> Heating and Ventilation |
| <input type="checkbox"/> Structural Engineer | <input type="checkbox"/> Sheet-Metal Worker |
| <input type="checkbox"/> Electrical Engineer | <input type="checkbox"/> Steam Engineer |
| <input type="checkbox"/> Electrical Contractor | <input type="checkbox"/> Marine Engineer |
| <input type="checkbox"/> Electric Wiring | <input type="checkbox"/> Refrigeration Engineer |
| <input type="checkbox"/> Electric Lighting | <input type="checkbox"/> R. R. Positions |
| <input type="checkbox"/> Reading Shop Blueprints | <input type="checkbox"/> Highway Engineer |
| <input type="checkbox"/> Telegraph Engineer | <input type="checkbox"/> Chemistry |
| <input type="checkbox"/> Telephone Work | <input type="checkbox"/> Pharmacy |
| <input type="checkbox"/> Mechanical Engineer | <input type="checkbox"/> Coal Mining Engineer |
| <input type="checkbox"/> Mechanical Draftsman | <input type="checkbox"/> Navigation <input type="checkbox"/> Assayer |
| <input type="checkbox"/> Machine Shop Practice | <input type="checkbox"/> Iron and Steel Worker |
| <input type="checkbox"/> Toolmaker | <input type="checkbox"/> Textile Overseer or Supt. |
| <input type="checkbox"/> Patternmaker | <input type="checkbox"/> Cotton Manufacturing |
| <input type="checkbox"/> Civil Engineer | <input type="checkbox"/> Woolen Manufacturing |
| <input type="checkbox"/> Surveying and Mapping | <input type="checkbox"/> Agriculture <input type="checkbox"/> Fruit Growing |
| <input type="checkbox"/> Bridge Engineer | <input type="checkbox"/> Poultry Farming |
| <input type="checkbox"/> Gas Engine Operating | <input type="checkbox"/> Mathematics <input type="checkbox"/> Radio |

BUSINESS TRAINING COURSES

- | | |
|--|---|
| <input type="checkbox"/> Business Management | <input type="checkbox"/> Business Correspondence |
| <input type="checkbox"/> Industrial Management | <input type="checkbox"/> Show Card and Sign Lettering |
| <input type="checkbox"/> Personnel Management | <input type="checkbox"/> Stenography and Typing |
| <input type="checkbox"/> Traffic Management | <input type="checkbox"/> English |
| <input type="checkbox"/> Accounting and C. P. A. Coaching | <input type="checkbox"/> Civil Service |
| <input type="checkbox"/> Cost Accounting | <input type="checkbox"/> Railway Mail Clerk |
| <input type="checkbox"/> Bookkeeping | <input type="checkbox"/> Mail Carrier |
| <input type="checkbox"/> Secretarial Work | <input type="checkbox"/> Grade School Subjects |
| <input type="checkbox"/> Spanish <input type="checkbox"/> French | <input type="checkbox"/> High School Subjects |
| <input type="checkbox"/> Salesmanship | <input type="checkbox"/> Cartooning |
| <input type="checkbox"/> Advertising | <input type="checkbox"/> Illustrating |
| | <input type="checkbox"/> Lumber Dealer |

Name.....

Address.....

City..... State.....

Occupation.....

If you reside in Canada, send this coupon to the International Correspondence Schools Canadian, Limited, Montreal, Canada



Learn to Write

I Teach by Mail

I CAN make a good penman of you at your home during spare time, no matter where you live or how poorly you now write. My simplified system has shown thousands of others the way to good penmanship during the past twenty years — it can and will do the same for YOU!

Beautifully Illustrated Book
"How to Become a Good Penman"

FREE!

It contains general information, with testimonials and beautiful specimens of penmanship showing what others have accomplished by the Tamblin System. (Your name elegantly written on a card if you enclose stamp for postage.) WRITE TODAY. Address

F. W. TAMBLIN
 418 Ridge Bldg., Kansas City, Mo., U. S. A.



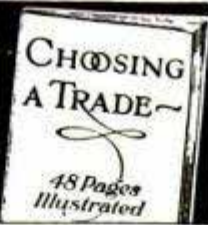

SENT ON REQUEST

Helpful discussion of this important problem and of fastest growing of Mechanical Trades—Mechanical Dentistry. Of interest to men of all ages. Send for Bulletin 2.

BODEE INSTITUTE
 1755 Broadway, New York
 1305 N. Broad St. Philadelphia
 85 Court St., Brooklyn



AIRPLANE DRAFTING



THOUSANDS OF MEN

will make fortunes in Aviation. Airplane Drafting and Designing are the biggest jobs ahead in this fastest growing industry. A new field of opportunity for you is opened in our improved method of training.

EASY TO LEARN. STUDY AT HOME. PAY AS YOU GO. EMPLOYMENT SERVICE.

Write for booklet outlining courses in Airplane Drafting and other aviation subjects, including the famous Weem's System of Navigation—endorsed by Col. Lindbergh, Commander Byrd, Lincoln Ellsworth, Admiral Moffett, etc.

Name.....

Address.....

City..... State.....

AIRPLANE DRAFTING
 AIRPLANE MOTORS
 AIRPLANE MECHANICS

PACIFIC TECHNICAL UNIVERSITY SAN DIEGO CALIFORNIA

A Challenge Made Me Popular!

"A BOX of cigars says you don't dare dance with her—Wall-flower!" That was the challenge they flung at me!

My sporting blood boiled! "All right, I accept!" I responded. And I started across the floor.

I NEVER was much of a dancer. But when our club gave this affair I couldn't stay away. Even now, I should have been sitting safely on the "sidelines"—if only the fellows hadn't made that sarcastic remark.

"Show them you can do it! Show them you can dance as well as they!" my pride whispered. And I would!

But halfway across the hall my courage died. I was nearly paralyzed with fright. There she was, waiting expectantly—Marion Blake, an exquisite dancer—graceful, poised, at ease. Suppose she should refuse? Suppose she should leave me in the center of the floor? Oh, wouldn't the fellows chuckle then!

The Unexpected Happens

"I'm—I'm sorry"—I stammered. "I guess——"

"Why, of course, I'll be glad to dance!" she interrupted. And before I realized it we were swallowed up in the dancing throng.

What a terrible ordeal it was for me! And twice as bad for her. I stumbled through the steps. I trod on her toes. I tried desperately to keep in time with the music. Yes, my dancing was inexorable—hopelessly out-of-date!

Suddenly she suggested that we sit out the rest of the number. I blushed furiously "Now, it's coming!" I thought. "Now, she is going to tell me what she thinks of my nerve!"

But I was in for the surprise of my life. "Jim," she began softly. "I'll be frank. You're not the best dancer in the world. But you're certainly not the worst. What you need is 'brushing up' on the latest steps. Why don't you get in touch with Arthur Murray?"

"Arthur Murray! Arthur Murray!" I repeated. "He teaches dancing by mail. You can't learn that way!"

"No?" and Marion arched her eyebrows. "The truth is, that's exactly the way I learned—even though no one *does* suspect it!"

Naturally I was astounded, but the next evening I found one of Arthur Murray's ads and mailed the coupon. If Marion could become a wonderful dancer that way it was certainly worth investigation—especially since I didn't risk a penny.

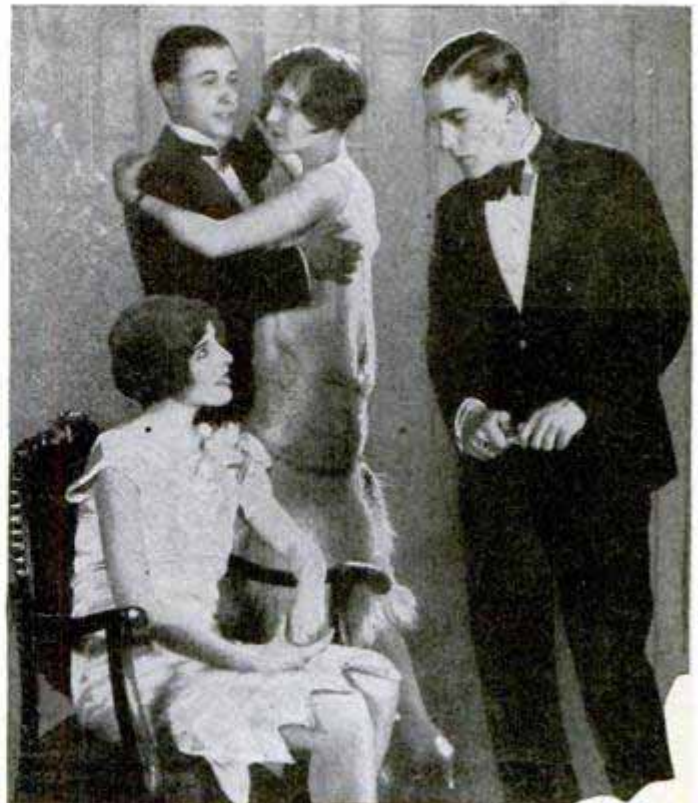

I was nearly paralyzed with fright. Suppose she should refuse? Suppose she should leave me in the center of the floor?

I Find the Secret!

The lessons came promptly. What a revelation! They showed me how many mistakes I had been making—how utterly ignorant I was of the modern style of dancing, yet in a few evenings I had learned the modern Waltz—the modern Fox Trot and many delightful variations of the very latest steps—without music, partner or teacher!

I Turn the Tables

A week later I attended a dance. The old crowd was there—"Here he is again!" they chorused. "Give him the cigars! He earned them!" Imagine how surprised they were when I asked Marion to dance! They stood open-mouthed as I glided around the floor like an expert! Now girls are always delighted to dance with me. I laugh when I think how scared I was that terrible evening—for everywhere I go I am welcomed as an accomplished dancer!

Regular \$5.00 Course NOW ONLY \$1.98

No matter how poorly you dance now, no matter if you've never been on a dance floor in your life—Arthur Murray's method makes you a finished dancer, right in your own home, without music, partner, or teacher—or you don't have to pay one cent. Over 400,000 people have already become good dancers the Arthur Murray way. To prove it, Mr. Murray will send you his famous dancing course *without one penny in advance*.

Simply mail the coupon below, and the regular \$5.00 course will be sent you immediately. When it arrives, pay the postman only \$1.98 plus few cents delivery charges. Then try the course for five days—*money back if not delighted*. Don't delay—you owe it to yourself to clip and mail coupon NOW—and surprise your friends by being a good dancer, sought after, popular, soon. Arthur Murray, Studio 958, 7 East 43rd Street, New York City.

**ARTHUR MURRAY, Studio 958
7 East 43rd St., New York**

To prove that I can learn to dance at home without music, partner, or teacher, you may send me your regular \$5.00 course for only \$1.98 C. O. D. I understand that if not delighted I may return the course within 5 days and my money will be refunded.

Name.....

Address.....

City..... State.....

NOTE: If apt to be out when postman calls, send \$2.00 with coupon and save C. O. D. postage.

Easy home method quickly teaches HAWAIIAN GUITAR



Play all the latest hits just as the Hawaiians do! Have good times aplenty!

Win fame—friends—fortune! Play the Hawaiian Guitar!

Native Hawaiian expert directs you

You get expert instruction directed by a world-famous player and teacher, Prof. Walter Kolomoku. He quickly reveals to you the secrets of this fascinating instrument.

Only 4 Motions to learn. Then you can play any music—popular songs, classical, old-time melodies, native Hawaiian airs—or real jazz. You'll never be lonesome after you learn the Hawaiian Guitar.

Complete Course

52 lessons. Nothing omitted. Pictures explain every move. You are sure to learn—what we can do for others we can do for you. Over 50,000 successful students.

Learn at home in spare time

Study in spare time at home. Even if you don't know a note our method is so simple, plain and easy, you begin a piece your first lesson. In half an hour you can play it!

Payasyouplay

We make it easy for you. Start with small first payment—then pay while learning. Costs only few cents per lesson. You only pay the cost of instruction—we furnish everything.

GIVEN when you enroll

—with genuine seal grain Fabrikoid Cover and complete playing outfit—this beautiful sweet-toned

HAWAIIAN GUITAR

Reliable retailers ask \$18 to \$20 for a similar instrument and outfit without the fine Fabrikoid Case, which alone is worth \$3.50.

Instrument and outfit valued at \$18 to \$20

Other Courses: Banjo, Violin, Tiple, Tenor Ukulele—well-known instructors.

FIRST HAWAIIAN CONSERVATORY OF MUSIC, Inc.
9th Floor, Woolworth Bldg.
Dept. 648, New York

Approved as a Correspondence School Under the Laws of the State of New York

Member National Home Study Council

Send This Coupon for Liberal Offer!

FIRST HAWAIIAN CONSERVATORY OF MUSIC, Inc.
9th Floor, Woolworth Bldg., Dept. 648, New York, N.Y.
Please mail full information about your 52-lesson Hawaiian Guitar Course. I am not obliged to enroll unless I want to.

Name _____

Address _____

City _____ State _____



PIN A DOLLAR BILL TO THIS

Get this genuine leather 5 window card case, with gold corners, Masonic emblem stamped in heavy gold. Your name or other stamping 35c extra, per line. Money back guarantee.



Please send catalogue

- No. 10. Books, Monitors, Jewelry
- No. 11. Lodge Supplies

Established 1859

Redding Masonic Supply Co.
200 Fifth Ave., Dept. P. M., New York

"Everything Masonic"

Electrical Engineering

Course for men of ambition and limited time. Over 5000 men trained. Condensed course in Theoretical and Practical Electrical Engineering including the closely related subjects of Mathematics and Mechanical Drawing.

Students construct motors, install wiring, test electrical machinery. Course designed to be completed in one college year. Prepare for your profession in the most interesting city in the world. Est. 1893. Catalog on request.



Bliss Electrical School

121 Takoma Ave., Washington, D. C.

Learn Photography at HOME

Make money taking pictures. Prepare quickly during spare time. Also earn while you learn. No experience necessary. New easy method. Nothing else like it. Send at once for free book, OPPORTUNITIES IN MODERN PHOTOGRAPHY and full particulars

AMERICAN SCHOOL OF PHOTOGRAPHY
Dept. 1358 3601 Michigan Ave. Chicago, U. S. A.

STAMMER

Write for my free book "Millard's Advanced Natural Corrective Course" and a free copy of my speech magazine. 10,000 cases successfully treated. Est. 24 years. Largest school for stammerers in world. Millard Inst. of Normal Speech, 2317 Millard Bldg., Milwaukee, Wis.

LEARN WATCHMAKING AND ENGRAVING

BY OUR PROFIT-SHARING PLAN OUR GRADUATES SUCCEED

One of our Iowa students started in a very small way—now doing over \$30,000 a year. Another in Wisconsin, over \$10,000 the first year. Day or night classes. Call or write for FREE BOOK.

Chicago School of Watchmaking, Dept. 5801, 549 W. Randolph St., CHICAGO

Learn MECHANICAL DENTISTRY

EARN BIG MONEY—Steady Work

WHY spend the best years of your life at uncertain jobs at small pay? You can EARN WHILE LEARNING this modern money making business and become independent. BIG DEMAND. You LEARN BY DOING PRACTICAL work. DAY AND NIGHT SCHOOL. INDIVIDUAL instructions. Easy terms. Railroad Fare Allowed—No Extra Cost. Address SECRETARY, N. Y. SCHOOL OF MECHANICAL DENTISTRY, 147 W. 33rd Street, NEW YORK, N. Y.

SEND FOR FREE BOOK



Write or Mail Coupon.

Name _____
Street _____
City _____ State _____

Do Unseen Hands Keep You Dumb.. When You Ought to Talk?



How often have you wanted to talk, but held back, silent, because you felt unequal to the other people present? How many times have you passed up, or avoided the chance to talk in public—before your business associates, your club or lodge, because of your fear of stage fright? Are you afraid of your own voice—instead of being able to use it as one of the greatest business and social assets in your possession? And yet you might be surprised to hear that many of the most brilliant public speakers we have today felt exactly this way—before they learned how to develop their "hidden knack" of powerful speech—a knack which authorities say seven men out of every ten actually possess. And the chances are that you, too, have in you the power of effective speech—which, if unloosed, would be almost priceless to you in a social or business way. Find out if you have this natural gift—read every word of the message below.

Discover These Easy Secrets of Effective Speech

PROBABLY you have never pictured yourself being able to sweep a giant audience off its feet—to win the applause of thousands. Yet, the men who are doing such things know that it is all astonishingly easy once you are in possession of the simple rules of effective speech.

Before you learn these secrets you may be appalled at the thought of even addressing a small audience. Still it all seems so ridiculously easy when you know how to banish stage fright, and exactly what to do and say to hold an audience of one or a thousand in the palm of your hand.

Yet what a change is brought about when a man learns to dominate others by the power of effective speech! Usually it means a quick increase in earnings. It means social popularity. You yourself know how the men who are interesting talkers seem to attract whomever they wish and name their own friends—men and women alike.

There is no magic, no trick, no mystery about becoming a powerful and convincing speaker—a brilliant, easy, fluent conversationalist. One of America's eminent

specialists in effective speech has developed a method that has already raised thousands from mediocre, narrow ruts to positions of greater prestige and wider influence. This new method is so delightfully simple and easy that by spending 20 minutes a day in the privacy of your own home you cannot fail to make rapid progress.

How you can use this method, how you can banish stage fright, self-consciousness, and bashfulness, quickly shaping yourself into an outstanding influential speaker, is told in an interesting book, *How to Work Wonders with Words*. Not

only men who have made millions but thousands of others have sent for this book and highly praise it. You can receive a copy absolutely free by simply mailing the coupon below. Act now to discover your priceless "hidden knack"—the natural gift within you. Fill out and mail the coupon at once.

NORTH AMERICAN INSTITUTE

Dept. 1358
3601 Michigan Ave. Chicago, Ill.

What 20 Minutes a Day Will Show You

How to address business meetings.
How to propose and respond to toasts.
How to make a political speech.
How to tell entertaining stories.
How to write better letters.
How to enlarge your vocabulary.
How to develop self-confidence.
How to acquire a winning personality.
How to strengthen your will power.
How to be the master of any situation.



FREE

"How to Work Wonders
With Words"

Mail Coupon Today

North American Institute,
3601 Michigan Ave., Dept. 1358,
Chicago, Illinois.

Please send me free and without obligation a copy of your inspiring booklet, *How to Work Wonders with Words*, and full information regarding your course in Effective Speaking.

Name.....

Address.....

City..... State.....



A giant plane dips and soars across the sky, leaving against the brilliant blue the one word
ELECTRICITY

Men stop and gaze at the huge letters written so gracefully thousands of feet above the earth. Somewhere an electrical expert has groomed the giant plane for its flawless flight . . . every wire tested . . . every electrical device in perfect running order.

Today industry is as dependent upon the expert electrician as the powerful plane tracing the magic name over countless cities and towns. To him come the profits of industry and commerce. You, too, can be an electrical expert. Write today for the 48-page booklet.

NEW YORK ELECTRICAL SCHOOL

44 West 17th St., NEW YORK

MAIL TODAY

THE NEW YORK ELECTRICAL SCHOOL
44 N. Y. E. S. BLDG., 17TH STREET, NEW YORK

Please send me **FREE** your 48-page booklet. It is understood that this request puts me under no obligation.

Name

Address

Books on 65 Practical Subjects

Popular Mechanics Press specializes in supplying the outstanding best books on many subjects. As new books of merit appear, we will revise the list accordingly.

- AIR NAVIGATION AND METEOROLOGY**
Every flyer needs . . . \$3.00
- AIRCRAFT ENGINES**
Dyke's New Instructor
Best Engine Book . . . \$5.00
- ARCHITECTURAL**
Drawing and Lettering \$2.00
- ARMATURE WINDING**
Excellent new book . . . \$2.00
- AUTO ENCYCLOPEDIA**
Dyke's. (Covers New Model A Ford) . . . \$6.00
- AVIGATION**
By Dead Reckoning . . . \$2.00
- BIRD HOUSES**
How to Make . . . \$1.00
- BLUE PRINTS**
How to Read . . . \$2.00
- BOAT BUILDING**
35 Craft, Popular Outboard Engined Type . . . \$3.00
- BOY MECHANIC**
Famous 4 Vol. Library, 4000 Things to Make. \$7.00
- BUILT-IN FURNITURE**
Complete Instructions. \$2.50
- CARBURETORS**
Excellent book on all makes . . . \$2.00
- CARPENTRY**
Hand book of 336 Kinks. \$1.50
- CHEMISTRY**
For Old and Young Beginners . . . \$2.50
- CIVIL SERVICE**
How to Prepare for . . . \$3.00
- COLOR SIMPLIFIED**
Practical new Book (for Color Users) . . . \$3.50
- CONCRETE**
173 Ways of Using New Edition (Cloth) \$1.00
- CONTRACTOR**
Building Cost Estimator. \$2.00
- DIESEL ENGINES**
(New Work). Best Authority . . . \$5.00
- DOGS**
Care and Raising . . . \$2.00
- ELECTRICIAN**
214 Practical Kinks . . . \$1.50
- ELECTROPLATING**
Practical Results Easily Obtained . . . \$1.00
- ENGLISH**
Self-Improvement in . . . \$2.50
- ETIQUETTE**
New 560-Page Book. Only . . . \$1.00
- FARMER'S BOOK**
of 861 Kinks and Book for Farmers' Wives. \$1.00
- FLIGHT TRAINING**
Practical, new book, best on subject . . . \$5.00
- FORD (HENRY)**
His Philosophy of Industry . . . \$1.50
- FORMULAS**
10,000 Money Making. \$4.00
- FURNITURE**
Homemade (3 vols.) . . . \$3.00
- HOME REPAIRS**
Practical Book of . . . \$2.50
- INTERIOR DECORATING**
Best book of new methods . . . \$4.00
- INVENTIONS (American)**
Popular History of 2 vols. Reduced to . . . \$5.00
- INVESTMENT**
Policies that pay By Ray Vance . . . \$4.00
- JOINT WIPING**
(New Edition) . . . \$1.00
- KITES THAT FLY**
How to make . . . \$1.25
- LANDSCAPING**
Practical . . . \$2.50
- LATHE WORK (METAL)**
and Drilling and Thread Cutting . . . \$1.00
- LETTER WRITING**
Social and Business Only . . . \$1.00
- MACHINIST**
419 Kinks for . . . \$1.50
- MAGIC**
200 New Tricks for Amateurs . . . \$1.00
- MAKING THINGS YOURSELF**
900 Different Articles. \$3.00
- MATHEMATICS**
Made Easy for the-Practical Man . . . \$1.50
- MECHANICAL DRAWING**
Practical Course in . . . \$1.00
- MODEL AIRCRAFT**
Building and Flying . . . \$2.25
- MOVIE MAKING**
for Amateurs . . . \$3.00
- OUTDOOR OPPORTUNITIES**
for Making a Living . . . \$2.00
- OUTDOOR SPORTS**
for All Year 'Round . . . \$1.50
- PAINTING**
House (Best Methods) . . . \$2.00
- PETS**
For Pleasure and Profit. \$2.00
- PLUMBING**
500 Plain Facts for Every Homeowner . . . \$1.50
- POULTRY RAISING**
for Profit . . . \$2.00
- POWER WIRING (D. C.)**
Electrical (Just Out) . . . \$3.50
- PUZZLES**
Amusing Mathematical. \$1.50
- RADIO**
Trouble Shooting. Covers All-Electric Sets and Television . . . \$3.00
- ROPE SPINNING**
Only Book on Subject. \$1.50
- SHIP MODEL**
Making . . . \$2.50
- SHOP NOTES**
15 Vols. of 6000 Valuable Kinks . . . \$4.50
- STEEL SQUARE**
Pocket Book, Practical. \$1.00
- TAXIDERMISTRY**
Best Book of Methods. \$3.50
- TENNIS**
By Helen Wills . . . \$2.00
- TOY MAKING**
Complete Instructions. \$1.50
- WELDING**
ENCYCLOPEDIA
All Methods . . . \$5.00
- WIRING**
House (New Book) . . . \$2.50
- WOOD TURNING (LATHE)**
Practical Course in . . . \$1.50
- WOODCRAFT**
Famous 590 Page Book by Ernest Thompson Seton; Only . . . \$1.00

Books sent C. O. D. anywhere in U.S.

Just check the books you want, write your name and address below, and mail the advertisement. It is your order blank. When post-man hands you books, pay him the price and the postal charges. If outside the U. S. remit when ordering and include 10 cents per book extra for postage. We have many other books on these and 2,000 other subjects. Catalog free.

Name

City State

Address

Mail to Popular Mechanics Press,
Room P11—200 East Ontario St., Chicago, Ill.

To those who think Learning Music is hard-

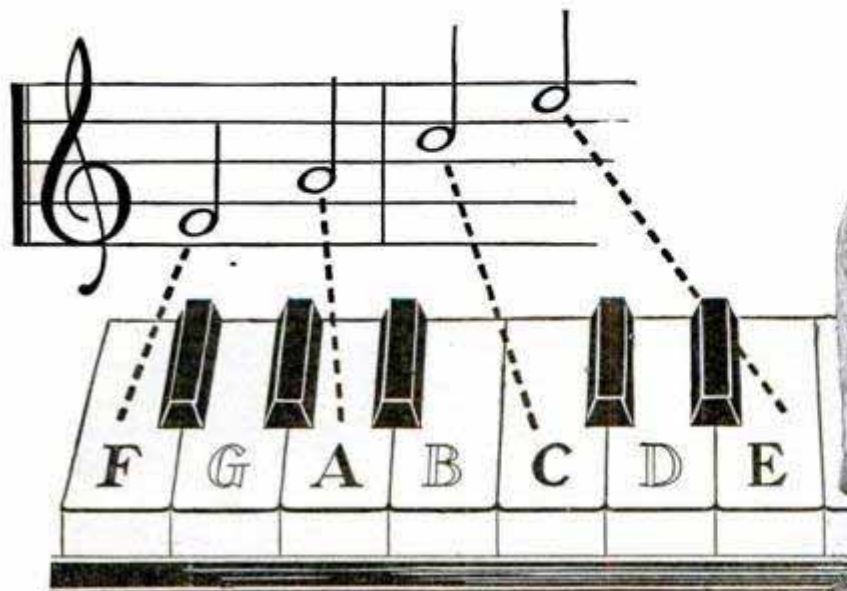

PERHAPS you think that taking music lessons is like taking a dose of medicine. It isn't any longer!

As far as you're concerned, the old days of long practice hours with their horrid scales, hard-work exercises, and expensive personal teachers' fees are over and done with.

You have no excuses—no alibis whatsoever for not making your start towards musical good times now!

For, through a method that removes the boredom and extravagance from musical lessons, you can now learn to play your favorite instrument entirely at home—without a private teacher—in half the usual time—at a fraction of the usual cost.

Just imagine . . . a method that has made the reading and playing of music so downright simple that you don't have to know one note from another to begin.

Do you wonder that this remarkable way of learning music has already been vouched for by over a half million people in all parts of the world.

Easy As Can Be

The lessons come to you by mail from the famous U. S. School of Music. They consist of complete printed instructions, diagrams, and all the music you need. You study with a smile. One week you are learning a dreamy waltz—the next you are mastering a stirring march. As the lessons continue they prove easier and easier. For instead of just scales you are always learning to play by *actual notes* the classic favorites and the

latest syncopation that formerly you only *listened* to.

And you're never in hot water. First, you are *told* how a thing is done. Then a picture *shows* you how, then you do it yourself and hear it. No private teacher could make it clearer or easier.

Soon when your friends say "please play something," you can surprise and entertain them with pleasing melodies on your favorite instrument. You'll find yourself in the spotlight—popular everywhere. Life at last will have its silver lining and lonely hours will vanish as you play the "blues" away.

New Friends—Better Times

If you're tired of doing the heavy looking-on at parties—if always listening to others play has almost spoiled the pleasure of music for you—if you've been envious because they could entertain their friends and family—if learning music has always been one of those never-to-come-true dreams, let the time-proven and tested home-study method of the U. S. School of Music come to your rescue.

Don't be afraid to begin your lessons

at once. Half a million people learned to play this modern way—and found it easy as A-B-C. Forget that old-fashioned idea that you need special "talent." Just read the list of instruments in the panel, decide which one you want to play, and the U. S. School will do the rest. And bear in mind no matter which instrument you choose, the cost in each case will average the same—just a few cents a day. No matter whether you are a mere beginner or already a good performer, you will be interested in learning about this new and wonderful method.

PICK YOUR INSTRUMENT

- | | |
|-------------------------------------|-----------|
| Piano | Violin |
| Organ | Clarinet |
| Ukulele | Flute |
| Cornet | Saxophone |
| Trombone | Harp |
| Piccolo | Mandolin |
| Guitar | 'Cello |
| Hawaiian Steel Guitar | |
| Sight Singing | |
| Piano Accordion | |
| Voice and | |
| Speech Culture | |
| Drums and Traps | |
| Automatic Finger Control | |
| Banjo (Plectrum, 5-String or Tenor) | |
| Italian and German Accordions | |

Send for Our Free Book and Demonstration Lesson

Our wonderful illustrated Free Book and our Free Demonstration Lesson explain all about this remarkable method. They prove just how anyone can learn to play his favorite instrument *by note* in almost no time and for just a fraction of what old slow methods cost. The booklet will also tell you all about the amazing new *Automatic Finger Control*.

Read the list of instruments to the left, decide which you want to play, and the U. S. School of Music will do the rest. Act NOW. Clip and mail this coupon today, and the fascinating Free Book and Free Demonstration Lesson will be sent to you at once. No obligation. Instruments supplied when needed, cash or credit. U. S. School of Music, 711 Brunswick Bldg., New York City.

U. S. SCHOOL OF MUSIC
711 Brunswick Bldg., New York City

Please send me your free book, "Music Lessons in Your Own Home," with introduction by Dr. Frank Crane, Free Demonstration Lesson and particulars of your easy payment plan. I am interested in the following course:

Have You
..... Instr?.....

Name.....

Address.....

City..... State.....

Step INTO A BIG-PAY HOTEL JOB



Earn \$2,500 to \$10,000 a Year

IN America's 3rd Largest Industry. Hotels, Clubs, Restaurants, Institutions, Schools, Hospitals, etc., are daily calling for Lewis Graduates. Over 70,000 high-class positions paying \$2,500 to \$10,000 a year open annually in hotels alone. Salaries up to \$3,500 to start. C. W. Ryder says:—"Shortly after completing your course I was appointed Purchasing Agent of a chain of hotels at a 100% increase in salary."

We Put You in Touch with Positions

Without cost let us show you how big pay, fascinating work, quick advancement can be yours in the great hotel industry. Age is no obstacle—young and old alike have equal chance for success. O. O. Miller, 55, qualified for a well-paid position thru the Lewis course. A common school education is all you need with the amazing Lewis System of Sparetime Training in Hotel Operation.

Previous Experience Unnecessary

Hundreds of Lewis students are winning success. Totally unacquainted with hotel work before taking the Lewis Course. N. Frank Hills is now Assistant Manager of a \$250,000 Apartment House. YOU can do as well. Low cost—easy terms—money back agreement. Write today for Free Book, "Your Big Opportunity," and complete details, mailed without obligation.

1000 HOTEL POSITIONS OPEN

**Lewis Hotel Training Schools
Room BT-339
Washington D. C.**



These Lewis Students "Made Good"

Charles A. Jones:—"I was chosen for the position of Manager. My success is due to Lewis Training."

Grant R. Jenkins:—"Mr. Jarow has just made me Steward and, as the business grows, he expects to give me full charge of the house. Just think, I haven't been in the work a year and yet I fully understand what will be required of me, thanks to Lewis Training."

Leroy L. Saunders:—"October 1st, our organization moves into the new \$5,000,000 club house. I am slated to become Assistant to the General Manager. Thank you for your cooperation."

Morris S. Johnston:—"I am Manager of the finest hotel of its kind in this city. Your course is essential to hotel work."

**LEWIS HOTEL TRAINING SCHOOLS,
Room BT-339, Washington, D. C.**

Send me the Free Book, "Your Big Opportunity," without obligation.

Name.....
Address.....
City..... State.....

OPPORTUNITY COUPON

AVIATION WANTS MEN

Learn Quickly to Earn BIG MONEY



Wonderful openings for pilots, mechanics and airport managers at big pay. Jobs opening up faster than we can supply trained men. Easy to learn aviation by our quick, thorough method. Step right out into a real job. Lowest pay for ground mechanics, \$150.00 per month. Trained men qualifying as transport pilots easily

Make Over \$500.00 a Month NOW!

The Consolidated system of instruction enables the average young man to master the principles of flying and airplane mechanics in the shortest time. No previous training required. You learn under direct supervision of veteran pilots and craftsmen, at the authorized school of the National Air Industries, a million dollar corporation. Instruction conforms with U. S. Gov't standards. Monthly records of all students will be kept preparatory to filing with the U. S. Dept. of Commerce.

We Pay Your Fare To Kansas City

Get the details of our offer to rebate your fare to Kansas City from anywhere in the U. S. Special low tuition rate now effective.

FREE Write today for fascinating new 64-page book, "Up to Fame and Fortune". Shows noted flyers, planes and shops. Tells about profits and opportunities in aviation. Explains step by step how you learn to fly. A vast fund of information. Don't miss it.



CONSOLIDATED AIR COLLEGE Inc.

536 Wyandotte Street
Kansas City, . . . Missouri

"STAMMERING Its Cause and Cure"

You can be quickly cured if you stammer. Send 10 cents coin, or stamps, for 288 page cloth bound book on Stammering and Stuttering. It tells how I cured myself after Stammering and Stuttering for 20 years. **BENJAMIN N. BOGUE**
11123 Bogue Building, 1147 N. Ill. St. Indianapolis

BASHFUL?

"Shame on you!" Are you nervous, embarrassed in company of the other sex? Stop being shy of strangers. Conquer the terrible fear of your superiors. Be cheerful and confident of your future! Your faults easily overcome so you can enjoy life to the fullest. Send 25c for this amazing book, **RICHARD BLACKSTONE, BA-4711 Flatiron Bldg., N. Y.**

GOV'T. POSITIONS \$35 TO \$75 WEEKLY

- | | | |
|--------------------|------------------------------|---------------------|
| MEN - WOMEN | Ry. Mail Clerk | Steno-Typist |
| | Prohibition Inv. | Immigrant Inspector |
| | R. F. D. Carrier | Seamstress |
| | Special Agent (Investigator) | Auditor |
| | City Mail Carrier | Steno-Secretary |
| | Meat Inspector | U. S. Border Patrol |
| | P. O. Clerk | Chaufeur-Carrier |
| | File Clerk | Watchman |
| | General Clerk | Skilled Laborer |
| | Matron | Postmaster |
| | Typist | |

AGE 18 to 55

GOVT. INSTRUCTION BUREAU, 111 Arcade Bldg., St. Louis, Mo. Send me FREE particulars How To Qualify for positions marked "X". Salaries, locations, opportunities, etc. ALL SENT FREE.

NAME.....
ADDRESS.....

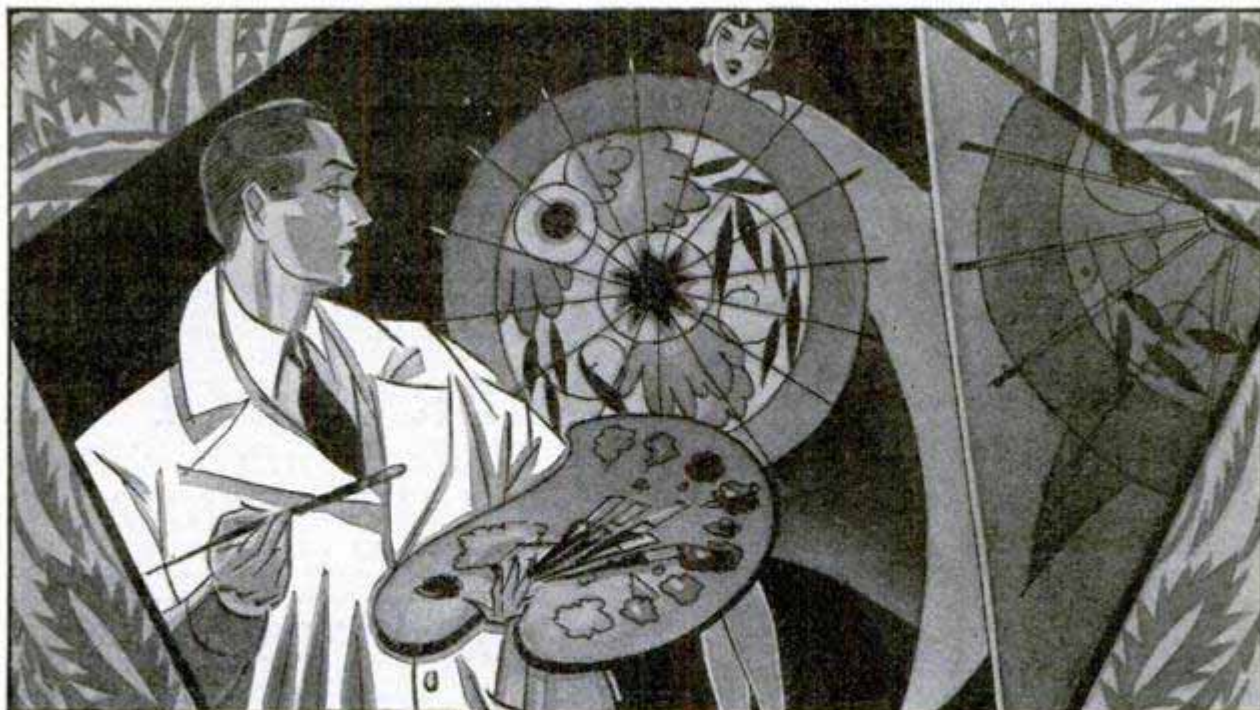

BE AN ARTIST

Earn a Big Name and a Fat Income

WHAT would you give to be this artist—earning a big income—enjoying studio life? He has learned the secret of forming simple lines into finished illustrations.

It was only a short time ago that this young artist filled out a coupon like the one below and mailed it to the Federal School of Illustrating. Now he is not only trained in modern art on which magazines are spending millions every year, but he has also had thorough instruction in all branches of illustration. Careful training by Federal Instructors has taught him to turn simple lines into dollars.

More than fifty famous artists—making big

incomes themselves—have contributed to the Federal Course. These successful men and women give you the benefit of their long experience in Illustrating, Cartooning, Lettering, Poster Designing and Window Card Writing. Careful training through the Federal Course teaches you to turn simple lines into dollars.

Why drudge at routine work? Opportunities for artists have never been better. Drawing is easy to learn the Federal Home Study way. Earn while you learn, if you wish. Many students find a market for their work after a comparatively short time of study.

Test Your Drawing Talent

If you like to draw, train your talent. Open the way to success and a fine income. Write your name, age and address on the coupon and get our Free Book, "A Road to Bigger Things," illustrated below. With it, you will receive our Free Vocational Art Test to find out your ability. Hundreds of successful artists got their start by sending for these. This is your opportunity—grasp it. **MAIL THE COUPON NOW.**

FEDERAL SCHOOL of ILLUSTRATING

11139 Federal Schools Bldg.
Minneapolis, Minnesota



FEDERAL
SCHOOL of
ILLUSTRATING

11139 Federal Schools Bldg.
Minneapolis, Minn.

Please send me free book "A ROAD TO
BIGGER THINGS" and Standard Art Test.

Name _____

Age _____ Occupation _____

Address _____

COUPON

\$85

**a Week for
McCarty**

Kenneth McCarty, South Haven, Mich. — former \$18 week clerk — now orchestra Tenor Banjoist coining \$85 weekly.



\$278

**Extra for
McGriff**

J. P. McGriff, Hawkinsville, Ga., playing for dances and movies, has already earned \$278 in spare-time.



\$100

**a month extra
for Abbott**

L. G. Abbott, Williston, N. D., "happiest fellow in town," cashing-in BIG every month.



You Can Make Real Cash Quick this Easy Fascinating Way

TENOR BANJO Pays Big!

McCarty, McGriff and Abbott are only three out of thousands of my students who have made more money and friends through my amazingly simple, rapid method of learning to play the Tenor Banjo. Most of them had never read a note or touched a string—but my clear, interesting instruction has made them top-notchers socially and financially. Now I'm ready to do the same thing for YOU!

Have Friends, Fun and EXTRA MONEY—Learn at Home in 1 to 3 Mos.

The Tenor Banjoist has all the friends, all the invitations, all the good times he wants. And he makes BIG MONEY — spare-time or full-time. Parties, dances, entertainments, orchestras — all of them want the melodious, snappy music of this favorite instrument. YOU can cash-in on such popularity; make yourself the most popular one in town; put plenty of good round dollars into your pocket too! And you can do it in 1 to 3 months' spare-time study at home—actually be playing your first tune within the first half hour!

Get this Big FREE Book Now—Tells How

"The Play-Way to Popularity and Big Pay" is the book that has started thousands toward popular, prosperous Success! It brings all the proof and facts about my astounding course — describes the wonderful Tenor Banjo and Outfit I send you—shows how you too can have more friends, fun and EXTRA CASH this easy way. Get this big book quick; no obligation. Don't put it off, don't delay. Mail the coupon at once!



This TENOR BANJO \$20

Complete Outfit and Phonograph Records Come with 1st Lesson

The same day I receive your "O. K."—telling me that you want to get in line quick for good times and good pay—I'll send you at no extra cost this splendid, professional size, full-tone Tenor Banjo worth \$20; Complete Outfit of pick, tuner, strings; Gain-time Chart; rapid progress lessons and instructions — and *Demonstration Phonograph Records* of every selection in the course, showing you exactly how to play each note, each tune. No long, tedious practicing or "seals." Instead, real fun—easy, fascinating! Get the FREE Book first — get the facts! Send coupon now!

Increase Your Earning Power

Apply time and labor-saving kinks to your work. Your efficiency will soon be recognized and you will be in line for advancement.

If you do machine shop work of any kind, sheet-metal work, painting, carpentry, auto repairing, farming, concrete work, plumbing, electrical work, welding, building, glass work, general repairing, tool-making, poultry raising, masonry or home repair work, get this

LIBRARY OF 6000 TIME AND LABOR SAVING IDEAS FOR SHOPMEN AND HANDYMEN

JUST PUBLISHED

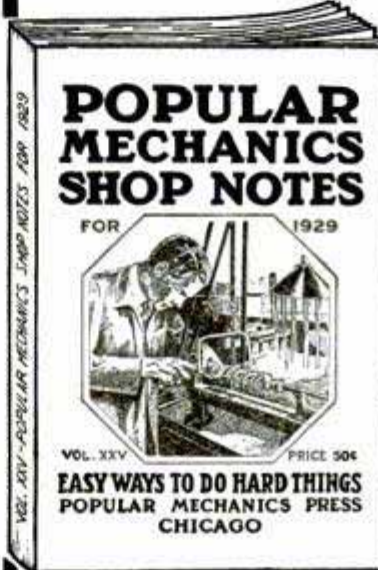

SHOP NOTES

for

1929

224 Pages

347 Articles

400 Illustrations

See partial list of contents below

Including the new 1929 issue illustrated above, there are now 15 volumes in the Shop Notes Library of 6,000 easily understood short cuts to every-day jobs. Here are just a few of the subjects taken from the 347 articles in the latest issue.

- | | | |
|-------------------------|---------------------------|---------------------------|
| Aluminum Mending | Drilling Kinks | Practical Mimeograph |
| Artistic Doorplates | Dumb Waiter | Reamer Holder |
| Artistic Plaques | Electric Crucible | Removing Roller Bearings |
| Attractive Lampshades | Furniture Designing | Renewing Old Pumps |
| Bird Bath in Concrete | Handy Workshop | Renovating Gaskets |
| Blowtorch Making | Homemade Jack | Repairing Laundry Tubs |
| Brass Pipe Handling | Homemade Silo | Rush or Fibre Seats |
| Build Your Own Garage | Insulating Hot Water Tank | Safe Folding Ladder |
| Burning Coke | Lathe Kinks | Six-Inch Bench Shaper |
| Burning Out Carbon | Long Narrow Photographs | Softening Leather Belting |
| Camera Exposure Meter | Machine for Making Rope | Tables in Art Moderne |
| Candlestick Making | Paint Removing | Tin Can Mechanics |
| Chute for Parcels | Piston Ring Compressor | Tractor for Light Work |
| Colonial Spinning Wheel | Pneumatic Soldering | |
| Crate for Small Garage | Plant | |
| Double Vise Press | | |
| Draft Regulator | | |

Each volume contains approximately 500 articles and 400 illustrations and has 224 Pages. At the regular price of 50 cents per single volume this library costs \$7.50, but for a limited period we will supply the 15 vols. when ordered at one time at the special reduced price of only \$4.50.

SPECIAL OFFER COUPON

POPULAR MECHANICS PRESS, 200 E. Ontario St., Room P11, Chicago, Ill.

Send me, as per your special offer, the following books. I will pay for books C. O. D. when they arrive. My money will be refunded if I am not satisfied. (Check what you want.)

- 1929 Shop Notes and Lathe Handbook, both for 98c.
- Complete Shop Notes Library (15 vols.) \$4.50.

Name.....

Street and No.....

City.....State.....

Clip-Sign-Send!

A. F. Bloch, President NEW YORK ACADEMY OF MUSIC Studio 1119, 100 Fifth Avenue, New York City.

Please send me FREE Book on Tenor Banjo Success—"The Play-Way to Popularity and Big Pay."

Name.....

Address.....



Learn AVIATION at GREER COLLEGE

Come into Aviation

Man's Dream Is Answered—Aviation Is Here

Transport Flyers will train you

Greer Air Transport supervises all flying instruction. Greer pilots have had long experience in instruction and transport flying. You are safe and will learn quickly with their expert help.

experience as a designer and builder, supervises all ground training. He has been in Aviation and actual flying since 1911.

Earn Big Money in a 4 Hour Day

What are a Flyer's hours? Four Hours—not work—but fun—nevertheless those are usually the hours for him.

And the pay! Many make \$300 on a single Sunday. My Free Book gives astonishing details. Send for it now!

Adventure—Prestige—Thrills—BIG PAY—Easy, Fascinating work—that IS Aviation.

C. L. Laird superintends ground training

C. L. Laird, with years of Aviation

I'll allow you railroad fare from any point in the United States

Come to Chicago. I'll pay your fare when you enroll. Here is the real hub of the Aviation Industry. The World's finest and biggest Airport is here. Get my Free Book — tells all remarkable facts.

LEARN DAYS OR EVES A Job while Learning

You can attend the Great Shops of Greer College and learn Aviation either days or evens. We even help get you a job so you earn as you learn—in short—what does this wonderful training cost? Nothing!



Erwin Greer

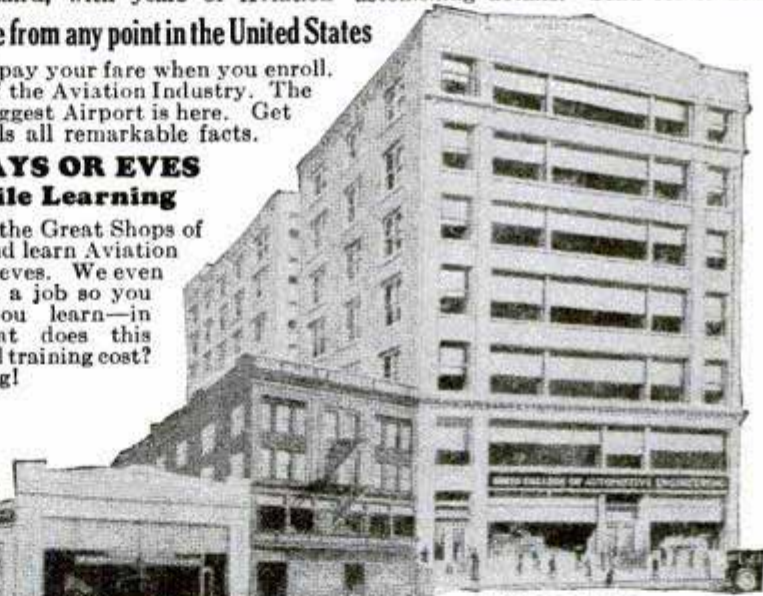

HOW!

I offer you a \$100 a week opportunity, perhaps more. But you must prepare. \$100 a week jobs mean nothing unless you can hold those jobs—so Prepare. I make it easy—26 years doing it—proves it, so when those jobs arrive—be ready—I'll help you get them—but be able to hold them.

SUCCESS

TODAY

Tomorrow is just a day—but think—is it to be a day wasted or a day rushing to success? Think of it. Tomorrow may be just the second day to your real triumph—but tomorrow can't possibly come before today. I ask you to do nothing but find out for yourself. My Book is Free. Look at it at least, it costs you nothing and it will help you if you enroll or don't.

Sincerely, ERWIN GREER, Pres.

GREER COLLEGE

Dept. 1101

2024 So. Wabash Ave.

CHICAGO



ERWIN GREER, President

Dept. 1101
2024 So. Wabash Avenue,
Chicago, Illinois

Send Free Book and details of Special offer, without obligation to me.

Name

Address..... Age.....



His Salary Was Raised while others were reduced

"Up to the time I enrolled for a course with the International Correspondence Schools, I had only a grade-school education. Since enrolling, I have advanced to a much better position, where my salary is nearly four times as much as I was making previously. I would not be able to hold my present position had I not taken your Course. Recently I received a nice increase in salary, while other men were being reduced."

There could be no better proof of the value of an I. C. S. course than that. It shows that the trained man is given preference over all others and paid more money, even in slack times, if his work deserves it. It shows that there are always bigger, better jobs open for men who have the foresight to prepare for them in spare time.

Why don't you study and get ready too? We'll be glad to help you if you will only make the start.

Choose the work you like best in the coupon below; then mark and mail it to the I. C. S. today. This doesn't obligate you in the least, but it will bring you information that will start you on a successful career. This is your opportunity.

Mail the Coupon for Free Booklet

INTERNATIONAL CORRESPONDENCE SCHOOLS
Box 5647-F, Scranton, Penna.

Without cost or obligation, please send me a copy of your booklet, "Who Wins and Why," and full particulars about the course before which I have marked X in the list below:

TECHNICAL AND INDUSTRIAL COURSES

- | | |
|--|---|
| <input type="checkbox"/> Architect | <input type="checkbox"/> Automobile Mechanic |
| <input type="checkbox"/> Architectural Draftsman | <input type="checkbox"/> Aviation Engines |
| <input type="checkbox"/> Building Foreman | <input type="checkbox"/> Plumber and Steam Fitter |
| <input type="checkbox"/> Concrete Builder | <input type="checkbox"/> Plumbing Inspector |
| <input type="checkbox"/> Contractor and Builder | <input type="checkbox"/> Foreman Plumber |
| <input type="checkbox"/> Structural Draftsman | <input type="checkbox"/> Heating and Ventilation |
| <input type="checkbox"/> Structural Engineer | <input type="checkbox"/> Sheet-Metal Worker |
| <input type="checkbox"/> Electrical Engineer | <input type="checkbox"/> Steam Engineer |
| <input type="checkbox"/> Electrical Contractor | <input type="checkbox"/> Marine Engineer |
| <input type="checkbox"/> Electric Wiring | <input type="checkbox"/> Refrigeration Engineer |
| <input type="checkbox"/> Electric Lighting | <input type="checkbox"/> R. R. Positions |
| <input type="checkbox"/> Reading Shop Blueprints | <input type="checkbox"/> Highway Engineer |
| <input type="checkbox"/> Telegraph Engineer | <input type="checkbox"/> Chemistry |
| <input type="checkbox"/> Telephone Work | <input type="checkbox"/> Pharmacy |
| <input type="checkbox"/> Mechanical Engineer | <input type="checkbox"/> Coal Mining Engineer |
| <input type="checkbox"/> Mechanical Draftsman | <input type="checkbox"/> Navigation <input type="checkbox"/> Assayer |
| <input type="checkbox"/> Machine Shop Practice | <input type="checkbox"/> Iron and Steel Worker |
| <input type="checkbox"/> Toolmaker | <input type="checkbox"/> Textile Overseer or Supt. |
| <input type="checkbox"/> Patternmaker | <input type="checkbox"/> Cotton Manufacturing |
| <input type="checkbox"/> Civil Engineer | <input type="checkbox"/> Woolen Manufacturing |
| <input type="checkbox"/> Surveying and Mapping | <input type="checkbox"/> Agriculture <input type="checkbox"/> Fruit Growing |
| <input type="checkbox"/> Bridge Engineer | <input type="checkbox"/> Poultry Farming |
| <input type="checkbox"/> Gas Engine Operating | <input type="checkbox"/> Mathematics <input type="checkbox"/> Radio |

BUSINESS TRAINING COURSES

- | | |
|--|---|
| <input type="checkbox"/> Business Management | <input type="checkbox"/> Business Correspondence |
| <input type="checkbox"/> Industrial Management | <input type="checkbox"/> Show Card and Sign Lettering |
| <input type="checkbox"/> Personnel Management | <input type="checkbox"/> Stenography and Typing |
| <input type="checkbox"/> Traffic Management | <input type="checkbox"/> English |
| <input type="checkbox"/> Accounting and | <input type="checkbox"/> Civil Service |
| C. P. A. Coaching | <input type="checkbox"/> Railway Mail Clerk |
| <input type="checkbox"/> Cost Accounting | <input type="checkbox"/> Mail Carrier |
| <input type="checkbox"/> Bookkeeping | <input type="checkbox"/> Grade School Subjects |
| <input type="checkbox"/> Secretarial Work | <input type="checkbox"/> High School Subjects |
| <input type="checkbox"/> Spanish <input type="checkbox"/> French | <input type="checkbox"/> Cartooning |
| <input type="checkbox"/> Salesmanship | <input type="checkbox"/> Illustrating |
| <input type="checkbox"/> Advertising | <input type="checkbox"/> Lumber Dealer |

Name.....

Address.....

City.....State.....

Occupation.....

If you reside in Canada, send this coupon to the International Correspondence Schools Canadian, Limited, Montreal, Canada



WIN QUICK POPULARITY—PLAY THE TENOR BANJO!

"I ALWAYS took my sister to parties. All the other girls turned me down. I never could figure it out until one day Jim Reid said to me, 'Bob, you're a nice chap—but you're "dead." Why don't you "pep up"?' You'll never get anywhere the way you are now!"

"Jim was right, nobody knew it better than I did. But what could I do about it? And then I saw an ad—'My Banjo Made Me Popular Over Night.' Here was my big chance. I sent for details . . . and well—"

"In almost no time, it seems, I was able to play even the most difficult pieces. I took my banjo to our next party. Everyone wanted to know what I was going to do with it. But their kidding turned to admiration when I started to play. Classical tunes, jazz, 'hot numbers,' they came as easy as rolling off a log. That night started me towards popularity—and has won me a better job and the sweetest girl in the world." Do you want to be popular? Do you want to win quick success and make money on the side, besides? Then take your first step towards popularity and success and send today, now, for details as to how you can learn to play the tenor banjo at home—easily—QUICKLY!

TENOR BANJO STUDIOS

Dept. B-102 9th Floor Woolworth Bldg. New York City

Engineering Degree in 2 Years

Be a Civil—Electrical—Mechanical or Chemical Engineer in 96 weeks. No entrance examinations or high school diploma required. Low tuition and expenses. Degrees conferred by State authority. Also 2 year Business Courses. Write for free catalog. State course you are interested in.

TRI-STATE COLLEGE, Box E-8113, Angola, Ind.

LAW Free Book

Write today for FREE 64-page book, "THE LAW-TRAINED MAN", which shows how to learn law in spare time through the Blackstone home-study course prepared by 80 prominent legal authorities, including law school deans, and U. S. Supreme Court justices. Combination text and case method of instruction used. All material necessary furnished with the course, including elaborate 25-volume law library, delivered immediately upon enrollment. Many successful attorneys among our graduates. LL. B. degree conferred. Moderate tuition, low monthly terms. Money-Back Agreement.

Write for free book today.

BLACKSTONE INSTITUTE, 307 N. Michigan Ave. Dept. 58 Chicago

ALWAYS Ask For DENISON'S — 53 Years of Hits

Comedy-Dramas,	Vaudeville Acts,
Farces, Musical	Monologs, Dialogs,
Comedies, Revues,	Entertainments,
Musical Readings,	Comedy Songs, Chalk Talk Books, Minstrels,
Blackface Skits, Make-up Goods.	Catalog FREE.

T. S. DENISON & CO., 623 S. Wabash, Dept. 9, CHICAGO

WORLD PLUMBERS NEEDS

Old style plumbers are fading like the horse and buggy. The world demands modern Plumbing and Skilled Trained Mechanics to do it. Unlimited, swift growing field. Make \$50 to \$100 a week or start own shop. We train you quick. Learn in 8 to 12 WEEKS to do any job with skill and science. Need no previous experience. Strictly tool using system. Opportunity knocks. Investigate today —amazing offer—low tuition. World's greatest school.

Write—

UNIVERSAL PLUMBING SCHOOL
2130 Troost Ave. Kansas City, Mo.

WANTED- for murder!



\$1,000 Reward

In a dirty, forlorn shack by the river's edge they found the mutilated body of Genevieve Martin. Her pretty face was swollen and distorted. Marks on the slender throat showed that the girl had been brutally choked to death. Who had committed this ghastly crime? No one had seen the girl and her assailant enter the cottage. No one had seen the murderer depart. How could he be brought to justice?

Crimes like this have been solved—are being solved every day by Finger Print Experts. Every day we read in the papers of their exploits, hear of the mysteries they solve, the criminals they identify, the rewards they win. Finger Print Experts are always in the thick of the excitement, the heroes of the hour.

Not Experienced Detectives Just Ordinary men

Within the past few years, scores of men, men with no police experience, men with just ordinary grade school educations, have become Finger Print Experts. You can become a Finger Print Expert, too. Can you imagine a more fascinating line of work than this? More trained men are needed. Here is a real opportunity for you.

Learn the Secrets of Identification

More and more the detection of crime resolves itself into a problem of identification. You can learn the methods of famous identification experts. You can learn the science of finger print identification—right at home in your spare time.

Send for the free book which tells how famous Finger Print Experts got their start in this fascinating work. Tells the stories of thirteen actual cases solved by Finger Print Experts. Tells how you can become a Finger Print Expert in an amazingly short time.

Rewards and How to Win Them!

This Coupon Brings Full Details

Also Confidential Report Operator No. 38 Made to His Chief
Men just like you have climbed to big success through Finger Print knowledge, gained at home in spare time. Get the thrilling book, telling in stories and pictures of the famous crimes solved by Finger Print Experts. This book is now FREE. Sent prepaid if you just mail the coupon AT ONCE!

Institute of Applied Science
Dept. 13-58 1920 Sunnyside Ave., Chicago, Ill.

Mail This NOW for Free Book

Institute of Applied Science,
1920 Sunnyside Avenue, Dept. 13-58 Chicago, Ill.

Without any obligation whatever, send me your new, fully illustrated, FREE book of authentic detective tales, "Finger Prints"; also Confidential Report Operator No. 38 Made to His Chief.

Name

Address

City and State Age

-takes only 8 weeks to get a big job



George Smith owns an agency and repair shop in West Alexandria, Ohio. He makes \$200 a week.

and Earn \$75 to \$125 a Week as Auto or Aviation Expert

Learn the auto and tractor business by the McSweeney method, then step out and get a good job at \$75 to \$125 a week or open your own repair shop and make up to \$10,000 a year. Trained men are needed everywhere. Opportunities galore! Eight weeks' training fits you to open repair shop or to go on with one of the big firms waiting for trained men. Read what George Smith and C. E. Gillespie have done. Hundreds of other McSweeney trained men can tell as interesting facts. Every month McSweeney men who complete their training are taking the place of half-trained and incompletely self-trained men.

Money Back Guarantee

If, after completing my training, you are not satisfied, if you are not qualified to accept a big-pay job, your tuition will be refunded.

AVIATION Course

AVIATION is paying tremendous incomes to trained men! Coupon brings complete details about complete course in Aviation. Learn on real airplane engines under experienced instructors. Ask about special course in FLYING. Don't miss this remarkable opportunity. Save by enrolling at once. The sooner you start the sooner you will be ready to earn big pay or set into business for yourself.

Learn in Only 8 Weeks

Simple, thorough, practical shop methods. You learn the "why" of everything you do, then learn to do it right. You do real work with real tools and real equipment. No book studying. Very little schooling necessary. Any man from 16 to 60 can learn. Write today for Big Special Limited Time Tuition Offer. No facilities for colored students. Write for Big Illustrated Book FREE!

Learn on Real Machines



C. E. Gillespie has charge of a fleet of trucks and tractors for the State Highway Commission, due to McSweeney training.

MAIL COUPON FOR FREE BOOK

McSweeney Auto, Tractor and Aviation School, Dept. A-11-L, Chester at 30th St., Cleveland, O., or 263 Madison St., Memphis, Tenn.

Without cost or obligation, send me your big FREE book on Autos and Aviation, also full details of your special tuition offer.

Name.....

Street.....

Town..... State.....



McSWEENEY Auto, Tractor and Aviation SCHOOLS

Dept. A-11-L
Chester at 30th St., Cleveland, O. or 263 Madison St., Memphis, Tenn.

SPORTSMEN

Read This Offer!

Send the COUPON and receive a magnificent Sportsmen's Book telling you how to learn to MOUNT GAME-HEADS, BIRDS and ANIMALS. You can NOW be your own Taxidermist. Our school has over 100,000 graduates throughout the world. You can now learn AT HOME in SPARE TIME.

Mount Your Own Trophies!

Hunting and Fishing have entered a new era. All true sportsmen now kill fewer specimens, but DOUBLE their interest by mounting their trophies. The secrets of Taxidermy (mounting birds and animals) are now revealed. YOU CAN NOW LEARN TAXIDERMY FOR YOURSELF! Be a Taxidermy artist. Mount birds, animals, game-heads, fishes, tan skins and make beautiful rugs and robes. Easily and quickly learned in your own home. Adorn your home and den with nature's finest ART. If you enjoy hunting—you will enjoy Taxidermy MORE.

Big Profits

Do you want to MAKE MORE MONEY? Then give your SPARE TIME to Taxidermy. Make \$50 to \$250 a month by mounting for others or selling your mounted specimens, or go into business—open a Taxidermy shop of your own, and earn \$3,000 to \$6,000 a year.

This Book FREE



Every Sportsman should have this marvelous book. You can right now, while this edition lasts, get a copy Free and prepaid by mailing the coupon NOW. Only limited number free—Send Today. Nothing like it. Just off the press. Contains 48 large pages and cover in brilliant colors. More than 100 photos of splendid game specimens and masterpieces of the National Museum at Washington. Brim full of interest to every sportsman. And think of it, this valuable unique and artistic book can be had now, by Sportsmen for the asking.

Mail the Coupon!

If you want to preserve your trophies; if you desire to make money from your spare time, if you are a nature lover—send the coupon and receive your copy by return mail.

N.W. School of Taxidermy, 3378 Elwood Bldg., Omaha, Neb.



N. W. School of Taxidermy

3378 Elwood Bldg., Omaha, Neb.

Send me your free illustrated book "Sportsmen and Their Trophies." Also tell me how I may learn this fascinating art easily and quickly by mail. No obligation.

Name.....

Address.....

GREAT NEWS

If You Want a Real Pay Job

IN DRAFTING!

A New Easy Method Doubles The Earning Possibilities For Ambitious Men In This Great Field. Now—Right At Home—You Can Receive College Training in Drafting—From An Old Established College Known And Recognized Throughout The World—Chicago Tech. Yet The Cost Is Only A Fraction Of Ordinary College Training.

Chicago Tech Now Brings College Training in Drafting to You—At Home

HERE'S great news for every wide-awake man who wants to get into a big-money drafting job! An easy, practical home-study method has been developed which enables you to get the famous College-Training-In-Drafting as taught at Chicago Technical College—without leaving your home. This is the kind of training that employers are looking for in the men they hire. Training from a school that has real prestige wherever you go. Now you, too, can master professional drafting in your spare time and quickly prepare yourself for a position paying \$5,000 to \$7,000 a year and more!

New Easy Practice Method

Realizing that many ambitious men cannot afford to go to college, this famous school, noted for its plain, practical, easily-mastered instruction, has worked out a plan whereby everyone can get actual College Drafting Training at home. As a result the top-notch jobs of this profitable profession are now within your easy reach. Think of it! The same fine drawing outfits, the same simple lessons and the same practical training as prepared and taught at the college!

Fascinating—Simple As A. B. C.

It's just like playing a fascinating game. No hard textbooks—no involved problems to solve. This astonishing new course is so different from ordinary "schooling" and so easy to master that you will be surprised and delighted with your progress.

Drawing Outfits FREE of Extra Cost

A full set of fine drawing instruments in handsome pocket case, special drawing table and valuable drawing outfit are included without extra cost. You are furnished with everything necessary to big-pay training.

Don't Delay—Act Now!

If you are sincere in your desire to get out of the rut and step into a high-salaried drafting position, investigate this new home-study method at once. The coupon brings free trial lesson and full details that will prove to you that here is just the certificated training you want. Mail it now—no obligation.

CHICAGO TECHNICAL COLLEGE

Dept. P-202, Home Study Division
118 E. 26th St. Chicago, Ill.

If you live nearby, visit the College. See how we train Draftsmen for Big Pay Jobs. More than 1000 attend every year.



NOW FREE
Sample Lesson and Book

If the news of this wonderful home study College Training in Drafting sounds too good to be true, mail the coupon below for free trial lesson and interesting literature. Convince yourself of the merits of this approved training that will prepare you for a top-notch drafting job in a short time. No obligation—so act at once.

Mail The Coupon



CHICAGO TECHNICAL COLLEGE,
Dept. P-202, Home Study Division,
118 E. 26th St., Chicago, Ill.

Please send me at once the sample lesson and complete facts about your new system that enables men to master College Drafting Training at home just as you teach it at College in Chicago. This does not obligate me in any way.

Name.....

Address.....

Town.....State.....

Age.....Occupation.....

() Check here only if you prefer to come to Chicago for our short course in Drafting at Chicago Tech. Opportunities to earn while learning.



Become an Expert Accountant

The Profession That Pays

The demand for skilled accountants—men who really know their business—is unceasing. Big corporations are in constant need of expert counsel in matters relating to Auditing, Cost Accounting, Business Law, Organization, Management, Finance. Men who prove their qualifications in this important branch of business are rapidly promoted to responsible executive positions—given an opportunity to earn real salaries. The range is from \$3,000 to \$15,000 a year—even to higher income-figures.

Send for Free Book—

“Accountancy, the Profession that Pays”

Why let the other fellow walk away with the better job, when right in your own home you can equip yourself for a splendid future in this profitable profession?

Preliminary knowledge of bookkeeping is unnecessary. Our free book on accountancy fully explains how we train you from the ground up, according to your individual needs. Low cost; easy terms.

The facts about LaSalle training in Accountancy and the opportunities in this highly profitable field are clearly outlined in a 64-page book which LaSalle will send you free.

The man in earnest to get ahead will find this coupon a most profitable aid to progress. If you have the urge and the will to increase your income, clip and mail the coupon NOW.

— Find Yourself Through LaSalle! —

LaSalle Extension University

The World's Largest Business Training Institution

Dept. 1164-HR

Chicago

I would welcome details of your salary-increasing plan, together with copy of “Accountancy, the Profession that Pays,” also a copy of “Ten Years’ Promotion in One,” all without obligation.

Higher Accountancy

Training for position as Auditor, Comptroller, Certified Public Accountant, Cost Accountant, etc.

Other LaSalle Opportunities:

LaSalle opens the way to success in every important field of business. If more interested in one of the fields indicated below, check and mail now.

- | | |
|---|---|
| <input type="checkbox"/> Business Management | <input type="checkbox"/> Law—Degree of LL.B. |
| <input type="checkbox"/> Modern Salesmanship | <input type="checkbox"/> Modern Business Correspondence |
| <input type="checkbox"/> Traffic Management | <input type="checkbox"/> Stenography—Stenotypy |
| <input type="checkbox"/> Railway Station Management | <input type="checkbox"/> Expert Bookkeeping |
| <input type="checkbox"/> Banking and Finance | <input type="checkbox"/> C. P. A. Coaching |
| <input type="checkbox"/> Commercial Law | <input type="checkbox"/> Business English |
| <input type="checkbox"/> Industrial Management | <input type="checkbox"/> Commercial Spanish |
| <input type="checkbox"/> Modern Foremanship | <input type="checkbox"/> Effective Speaking |
| <input type="checkbox"/> Personnel Management | <input type="checkbox"/> Telegraphy |
| <input type="checkbox"/> Credit and Collection Correspondence | |

Name.....

Present Position.....

Address.....



BE A RAILWAY TRAFFIC INSPECTOR

EARN UP TO

\$250

per month plus expenses

No Hunting for a Position after Completing your Training

Read what Dan M. Mack says: “I received my certificate on April 15, was on my way to take a position on the evening of April 16, and started to work on April 17. If this is not quick work, I don’t know what it is. I found the school very thorough.”

We assist you to a position paying \$120 to \$135 per month plus expenses, upon completion of a few weeks’ spare time home instruction, or refund your tuition. Rapid salary advances to \$175 and up with experience. Trained men are needed. Railways look to us for men. Unlimited opportunities. Report only to high officials. Traffic Inspectors travel, or remain near home. Healthful, outdoor work with regular hours.

Send for Free Booklet Now!
It tells all about Traffic Inspection—how we started hundreds of men to big pay jobs—what it can do for you—how we can assist you to a salaried position with rapid advancement. Send for it now. Don’t delay.

Standard Business Training Inst. Div. 2 BUFFALO, NEW YORK

Photos ENLARGED

Size 16x20 inches
Same price for full length or bust form groups, landscapes, or pet animals, etc., enlargements of any part of group picture. Safe return of your own original photo guaranteed.
98c
Just mail photo or snapshot (any size) and within a week you will receive your beautiful life-like enlargement size 16x20 in. guaranteed fadeless. Pay postman 98c plus postage or send \$1.00 with order and we pay postage. **SPECIAL** With each enlargement we will send FREE a hand-tinted miniature reproduction of photo sent. Take advantage now of this amazing offer—send your photo today!
UNITED PORTRAIT COMPANY
1652 Ogden Ave. Dept. P-369 Chicago, Ill.



LEARN WATCHMAKING

and become independent. We help you secure a position. Easy to learn. Send for FREE CATALOG.
ST. LOUIS WATCHMAKING SCHOOL Dept. 5, ST. LOUIS, MO.

Clever Device

Closes Doors Without a Slam

Kant-Slam Door Check is an amazing new invention that closes all doors silently and automatically. Operates on new oil principle. Low-priced. Everlasting. Easily installed in 3 minutes with screw driver and never needs attention.

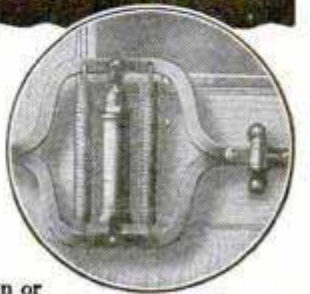

Agents \$15 a Day

Every office, factory, store, institution or public building needs one for every noisy door. You get orders quickly by actual sample demonstrator on miniature door. \$15 a day profits. Rush your name and address for full details.

FREE Trial Offer, Write!

KANT-SLAM DOOR CHECK CO. Dept. S-5 Bloomfield, Ind. STRAIGHT LINE



Radio Inspectors
\$2000 to \$4500,
a year.

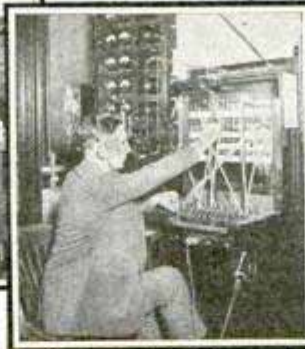

Radio Repair Mechanics
\$1800 to \$4000 a Year!



Radio Operators
\$90 to \$200
a month
(board free).

Open!

THOUSANDS OF

*Pick the job you want—
see what only 9 months
training will do!*

SEE how thousands of men just like you easily make big-money in Radio. It's a big pay business. Salaries from \$2,000 to \$25,000 a year are common.

Broadcasting stations and manufacturers are now eagerly seeking trained men . . . Thousands of ships require experienced operators . . . and now, new opportunities in nation-wide radiotelegraph service, telephony, television, and photoradiograms.

Easy to Learn at Home with this Magnificent Laboratory Outfit

The Radio Corporation of America sponsors this marvelous, simplified home training course . . . Prepare for success in every phase of Radio . . . By actual experience with apparatus given with this course . . .

learn to solve every Radio problem.

Only Course Backed by Radio Corporation of America
This gigantic organization sets the standards for the entire industry . . . and sponsors every lesson in the course. That's why graduates are posted in newest developments in Radio. That's why they are always in big demand.

Money Back if Not Satisfied
As a student you will receive an agreement signed by the president of this school assuring you of complete satisfaction upon completion of

your training—or your money refunded.

READ THIS FREE BOOK

Free . . . everything you want to know about Radio . . . 50 fascinating pages . . . packed with pictures and descriptions showing brilliant opportunities in this fast-growing profession. See for yourself why R.I.A. training has placed thousands of men in well paid positions—usually from 3 to 10 days after graduation. Mail this coupon now and receive your **FREE BOOK**.



RADIO INSTITUTE OF AMERICA,
Dept. PM-11, 326 Broadway,
New York, N. Y.

Gentlemen: Please send me your **FREE** 50-page book which illustrates the brilliant opportunities in Radio and describes your laboratory method of instruction at home.

Name

Address

BARBERING

Now One of the Highest Paid Professions! \$90 to \$150 Every Week!



Easy to Learn—Quick

to Earn! That's BARBERING for YOU! And the best part of it all is this—scientific barbering, as taught the modern MOLER way, makes YOU a Master Barber in a short course of intensive training, at small expense! You soon step out as your own Boss, if you wish, in your own Shop, which we will gladly help you equip.

MOLER Graduates are Always Busy! MOLER trained Men are always given the preference, for they alone possess the valuable, thorough MOLER training in the application of all the latest scientific Barbering methods, including the Electric hair cutter, the mechanical massage, and the latest vogue in ladies' hair bobbing. MOLER also gives special training in ladies' marcelling and an easy practical course in the treatment of skin diseases.

EARN WHILE LEARNING! "Where there's a Will there's a Way" to earn BIG pay! Write to the nearest MOLER College, there is one near you, and learn how you can earn while you learn the barber trade. Ask for the new FREE MOLER Barbering Booklet B. Find out HOW MOLER helps you help yourself AFTER you graduate, as well as BEFORE! Find out why MOLER Men are making DOUBLE the money others made last year, before Ladies' Shingle Bobbing became so popular. You're NEXT in line for big pay—the MOLER way. Send Coupon TODAY!

Standardized Branches

Moler System of Colleges

- | | |
|-----------------------------------|------------------------------------|
| 139 E. 23rd St., New York City. | 109 S. 15th St., Omaha, Nebr. |
| 512 N. State St., Chicago, Ill. | 501 E. Water St., Milwaukee, Wis. |
| 810 N. 6th St., St. Louis, Mo. | 81 Forsyth St., N.W., Atlanta, Ga. |
| 801 Main St., Kansas City, Mo. | 81 S. Second St., Memphis, Tenn. |
| 206 E. 4th St., Cincinnati, Ohio. | 912 Main St., Dallas, Texas. |
| 215 Huron Road, Cleveland, Ohio. | |
| 559 Michigan Ave., Detroit, Mich. | |

Address Nearest Branch

Please send me without obligation on my part your Booklet B.

Name.....
 Address.....
 City..... State.....

"The TRUTH about VOICE"

Sent FREE—No Obligation to Buy!

NO MONEY DOWN
 If you act quick!—we will send you, post-paid—for 30 days free reading—new Voice Book disclosing startling VOICE FACTS that may save hundreds of dollars to every man or woman seeking a strong, rich voice for either singing or speaking. A REVELATION! Know the truth about YOUR voice. Remember—sent for 30 days FREE reading. Then, if you keep it, send only \$1.00. Otherwise, just return it—that's all!

PROF. E. FEUCHTINGER Dept. 13-58 Suite 29, 1810 Wilson Ave., Chicago, Ill.



HOT PIANO

Ultra-modern Piano Jazz taught by mail. Note or ear. Easy rapid lessons for adult beginners. Also Self-instruction system for advanced pianists. Learn 358 Bass Styles, 976 Jazz Breaks, hundreds of Trick Endings, Hot Rhythms, Sock, Stomp and Dirt Effects; Symphonic and Wicked Harmony in latest Radio and Record Style. Write for Free Booklet.

WATERMAN PIANO SCHOOL, 1826 W. Adams St., Los Angeles, Calif.

Send for my Book STRONG ARMS and BROAD SHOULDERS

for 25c coin or 30c stamps
 Illustrated with 20 full-page half-tone cuts, showing exercises that will quickly develop, beautify and gain great strength in your shoulders, arms and hands, with-out any apparatus.
 Equal to a \$20.00 Course
Prof. ANTHONY BARKER
 1235 6th Avenue Studio F New York City

Air-Minded Men!

Heed the Call to...

Aviation.

Quickly Train at Home for BIG PAY

If you are seeking a big pay job, get into Aviation! Now—a complete, practical, EASY-TO-GRASP Course in Aviation fundamentals offered at a low price. We teach you—by Home Study—in the quickest possible time the necessary preliminary steps to qualify for position as Pilot, Mechanic, Designer, Motor Expert, Inspector, etc.
 You are taught every branch of Aviation: Motors, Wings, Assembly, Construction, Design, Nomenclature, Flight Principles, Air Rules, Meteorology, Navigation, How to Handle Ship in Air and on ground and 100 other fascinating subjects. Profusely illustrated with all necessary BLUE PRINTS, diagrams, charts, etc. Endorsed by Aviation experts. Accredited Diploma on graduation.
 All over America manufacturing, transport, air-port service and sales organizations are springing up—with valuable openings for high priced, skilled men. FREE Employment Service.
 Write today for your FREE copy of new book, "Aviation."



FREE Book Coupon
 National Aviation Training.
 Dept. 118, 1031 So. Broadway, Los Angeles, Calif.
 Send me, without obligation, the Free Book "Aviation."
 Name..... Age.....
 Address.....
 City..... State.....

IF —

you pledge yourself
to secrecy we will teach you the secrets
of Real Professional

Magic

For the first time in the history of Magic the age-old, sacredly guarded secrets of the Mystic Art are being revealed. Now at last you can learn to be a Real Professional Magician. Yes, and you can learn this wonderful art *easily and quickly AT HOME!—BY MAIL!* You are taught the mysterious *Principles* by which the Professional Magician works. You are taught everything from wonderful impromptu effects to massive stage illusions.



Dr. Harlan Tarbell
Master of Magic
who has mystified magicians
as well as laymen with his
marvelous tricks.

but

—before you can study, you must sign the Magician's Solemn Pledge of Secrecy. This means that you are getting the jealously *guarded secrets* of the Magic Profession. Think of that!

Earn \$250 to \$1000 a Month

There's a big demand for Magic entertainment. Magicians get big money. Dr. Tarbell gets as high as \$250 for a half hour's work. Unlimited opportunities for you!

WRITE for DETAILS

Mail coupon now for big free Magic circular telling all about the great Tarbell Course in Magic. Find out how you can learn to be a real magician—easily and quickly!—at home!—by mail! Learn what I have done for others—people just like yourself.

Tarbell System, Inc., Studio 13-58
1920 Sunnyside Ave. Chicago, Ill.

Tarbell System, Inc., Studio 13-58
1920 Sunnyside Avenue, Chicago, Ill.

Gentlemen: Without any obligation send me your free literature and information all about your wonderful "Tarbell Course in Magic." Also tell me about your low prices and Easy Payment Plan.

Name

Address

Age

Learn Electricity IN LOS ANGELES

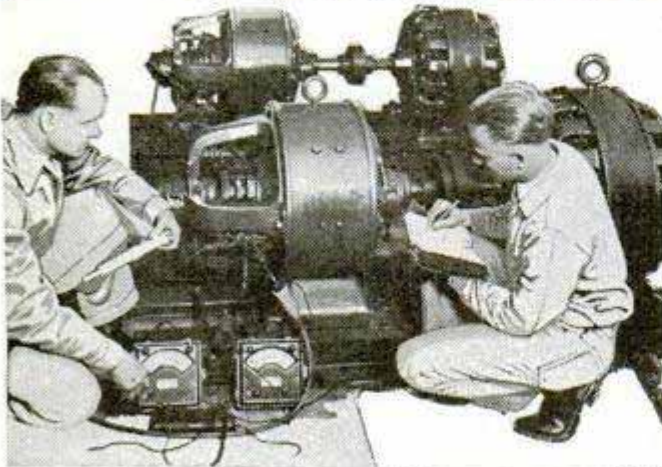

and LEARN IT RIGHT!

1. What Kind of a School Is NATIONAL?

NATIONAL is a Million Dollar institution—established in 1905—recognized throughout the electrical industry as one of America's foremost trade schools. NATIONAL offers practical, intensive training in all electrical branches. All technical essentials included. No age limit. No previous experience necessary. Life Scholarship privileges. Start any time of the year.

2. How Long to Learn Electricity?

NATIONAL properly trains you in the short time of 6 to 9 months. Upon completing this Condensed Course you are fully qualified as a Practical, Competent Electrician, and you have not risked your chances of employment because of inferior, incomplete instruction.

3. What Employment Service Does NATIONAL Guarantee?

NATIONAL GUARANTEES to give unlimited and efficient Employment Service to students wishing to earn living expenses while learning; and to graduates getting started in the electrical field. This is the most any reputable school can be expected to do.

4. What Inducements Does NATIONAL Offer?

NATIONAL offers YOU the very best technical-practical training that money can buy at a cost within every man's reach. It does not offer to pay your railroad fare, room and board or other personal expenses, preferring to limit its activities to the PROPER TRAINING OF MEN FOR SUCCESS.

5. Why You Should Come to LOS ANGELES!

LOS ANGELES is the heart of the country's most rapid electrical development—as well as the world's most ideal city in which to live and prepare for success in electricity

WRITE for FREE BOOK NOW!

NATIONAL Electrical School

Dept. 537, 4006 Figueroa St., Los Angeles, California.

Send me your big free illustrated catalog of Electrical Opportunities showing how I can learn quickly and get a Big-Pay Electrical Job.

Name.....
 Address.....
 Age..... City..... State.....



YOU PROBABLY NEED A DIFFERENT JOB

FREE TEST SENT

Thousands of men who depended on accident, chance, or guesswork in choosing an occupation today are square pegs in round holes, side-tracked away from success. Do you often feel you're cut out for better things, if you only knew which way to turn? For men in just your position there is now a tried scientific method of testing yourself at home, in strict privacy, to learn just what your own strongest abilities really are and what kind of work you're best fitted for. Every man is good in some things, poor in others. This test, which will be sent to you free on request, is not at all like a school examination. Can be taken by any man or woman with an ordinary education. A small fee if, after taking test, you decide to retain our professional services—otherwise no charge. To receive test and explanatory booklet, all free and without obligation to yourself, address NEW YORK VOCATIONAL INSTITUTE, Dept. E-27, 215 East 73rd St., NEW YORK.

ACCOUNTING

How to learn Accounting

THOUSANDS of ambitious men are earning more money today because they know Accounting. Send for our 80-page book, "How to Learn Accounting," and the first lesson. Both will be sent free.

International Accountants Society, Inc.
 A Division of the
 ALEXANDER HAMILTON INSTITUTE
 Dept. 96 3411 So. Michigan Ave., Chicago, Ill.

Anyone CAN LEARN

No talent or experience necessary. Fascinating work. Pays Big Money. Complete instruction book tells about: Alphabets, Colors, How to Make Patterns, Show Cards, Window Board and Wall Signs. Ready made letters, Gilding, Tricks of the Trade, also gives 100 Alphabets and Designs. Book bound in flexible int. leather-gold edges, and four ball bearing Show Card Pens. Sent postpaid \$3.00. (C.O.D.) 10c ex. Opeline Pub. Co., 57 Ross St., Dept. 20, N.Y. City

EARN MONEY IMMEDIATELY— WE FURNISH EQUIPMENT TO START !!

30 Days' Free Trial

New Models now ready for delivery direct from our factory. Astonishing low prices and terms. Do not buy until you get them.

RIDER AGENTS WANTED to ride and exhibit sample. Make big money. Many models \$21.50 up. Guaranteed \$1.50 each, wheels, lamps, horns, equipment at half usual prices. Send No Money. Write for our marvelous prices and terms on RANGER Bicycles.

Tires
Mead CYCLE CO. Dept. A110 CHICAGO



Strongfort Puts Pep Into the Weakling

STRONGFORTISM—The Science of Health and Strength—works wonders with run-down, weakly, skinny men. It builds them up to health through internal muscular development, then rounds them out into robust physical specimens, by bringing into play every muscle and making every muscle do its work as Nature intended. You'll be astonished how quickly you'll feel the benefits of this famous health and strength Course. You'll feel like a new man almost from the first day you start under my instructions. You'll be surprised at the lazy muscles you wake up when you begin, and they'll wake you up in turn. You'll quickly realize that a new day has dawned for you.

Send for MY FREE BOOK "Life's Energy Through Strongfortism"—a revelation of inside facts about the human body.

STRONGFORT INSTITUTE
 LIONEL STRONGFORT, DIRECTOR
 PHYSICAL AND HEALTH SPECIALIST

STRONGFORT Builder of Men DEPT. 961, NEWARK, NEW JERSEY, U.S.A.

Send this Consultation Coupon

MR. LIONEL STRONGFORT, STRONGFORT INSTITUTE, Dept. 961, Newark, N. J.

Please send me, without obligation, my copy of your book, "LIFE'S ENERGY THROUGH STRONGFORTISM." This does not place me under any obligation.

Name.....
 Age..... Occupation.....
 Street.....
 City..... State.....

From \$160 a Month to \$10,000 A Year!

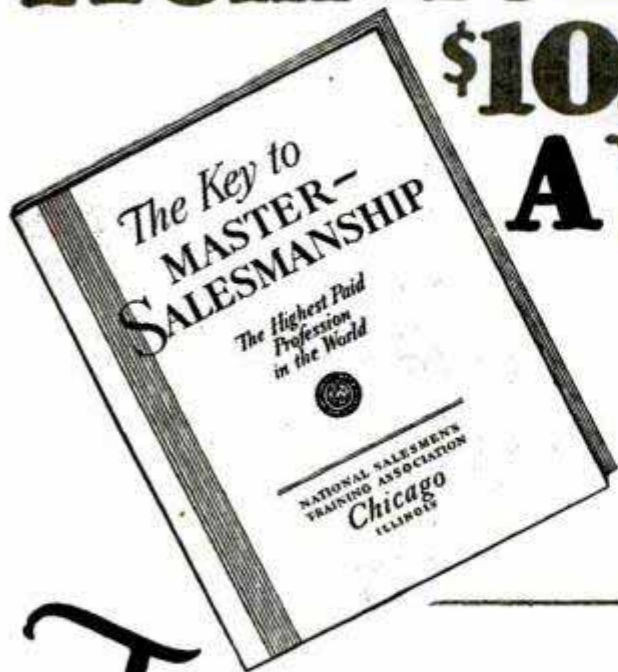

This Astonishing Book Showed Him How

How One Man Uncovered Hidden Possibilities He Never Suspected Within Himself and Raised His Yearly Income \$8,080! An Illuminating Message of Vital Interest to Every Man Who Ever Aspires to Earn \$10,000—\$20,000—or More a Year! SEE FOR YOURSELF This Remarkable Volume That Has Led So Many Men Into the Five-Figure Salary Class!

Where Shall We Send Your Copy . . . FREE?

TRUTH is stranger than fiction! And the true story that happened to R. B. Hansen proves it. His experience is not only intensely INTERESTING—but it will prove a revelation and positive inspiration to every ambitious man who reads this page.

Not long ago Hansen was working as a foreman in a rubber plant. His salary was \$160 a month. That meant skimping and petty economies that are bound to irk ANY ambitious man. Naturally he was keenly dissatisfied—but like so many other men caught in blind-alley jobs, he didn't know how to get out!

And then one day something happened! A certain book fell into his hands. Between its covers he discovered a certain force that eventually led him to rewards beyond his fondest expectations. Inspired to action and with his feet firmly guided to the first rungs of the ladder to Success, Hansen went into business for himself. And within a short time he had boosted his earnings to \$10,000 a year!

Salary Increases—200% to 900%!

A lucky accident? Not a bit of it! Hansen is not alone in his achievement of success after reading this remarkable book. OTHER men who have increased their salaries amazingly after reading these vital facts are numbered in the thousands! For example, C. W. Birmingham of Ohio read it and his salary raised from \$15 a week to \$7,500 a year. Wm. Shore of California made \$3,000 his first 5 months. L. D. Mather's salary jumped from \$35 a week to over \$7,200 a year after reading the amazing facts in this book.

How did they do it? What did the book show them? Just this:—Every one of these men realized that Salesmanship offers BIGGER rewards and delivers them QUICKER than any other line of work under the sun. This vital book, "The Key to Master Salesmanship," introduced them to hundreds of surprising and little-known facts about the highest paid of all professions—SALESMANSHIP. It blasted dozens of old theories, explained the science of selling in simple terms and told them exactly how the great sales records of nationally-known star salesmen had been achieved. And not only that, it outlined a simple plan that will enable almost

any man to master scientific salesmanship without spending years on the road—without losing a day or dollar from his present position.

Free to Every Man

If we were asking two or three dollars a copy for "The Key to Master Salesmanship" you might hesitate. But it is now FREE. We cannot urge you too strongly to take advantage of this opportunity to see for yourself what salesmanship has done for others—and what the National Salesmen's Training Association stands ready and willing to do for you. Find out exactly what the underlying principles of salesmanship are—and how you can put them to work for you.

No matter what your opinion is now, "The Key to Master Salesmanship" will give you a new insight into this fascinating and highly paid profession.

Mail the coupon now!

NATIONAL SALESMEN'S TRAINING ASSOCIATION

Dept. L-102 N. S. T. A. Bldg. Chicago, Ill.

National Salesmen's Training Ass'n
Dept. L-102, N. S. T. A. Bldg., Chicago, Illinois

Without cost or obligation, send me your free book, "The Key to Master Salesmanship." Also include full details of your training and free employment service.

Name

Address

City State

Age Occupation



High School Course in Two Years!

You Want to Earn Big Money!

And you will not be satisfied unless you earn steady promotion. But are you prepared for the job ahead of you? Do you measure up to the standard that insures success? For a more responsible position a fairly good education is necessary. To write a sensible business letter, to prepare estimates, to figure cost and to compute interest, you must have a certain amount of preparation. All this you must be able to do before you will earn promotion. Many business houses hire no men whose general knowledge is not equal to a high school course. Why? Because big business refuses to burden itself with men who are barred from promotion by the lack of elementary education.

Can You Qualify for a Better Position

We have a plan whereby you can. We can give you a complete but simplified high school course in two years, giving you all the essentials that form the foundation of practical business. It will prepare you to hold your own where competition is keen and exacting. Do not doubt your ability, but make up your mind to it and you will soon have the requirements that will bring you success and big money. YOU CAN DO IT.

Let us show you how to get on the road to success. It will not cost you a single working hour. Write today. It costs you nothing but a stamp.

American School

Dept. H-847 Drexel Ave. and 58th St., Chicago

American School

Dept. H-817 Drexel Ave. and 58th St., Chicago

Send me full information on the subject checked and how you will help me win success.

- | | |
|-----------------------------|---------------------------|
|Architect |Business Law |
|Building Contractor |Lawyer |
|Automobile Engineer |Machine Shop Practice |
|Automobile Repairman |Mechanical Engineer |
|Civil Engineer |Shop Superintendent |
|Structural Engineer |Employment Manager |
|Business Manager |Steam Engineer |
|Cert. Public Accountant |Foremanship |
|Accountant and Auditor |Sanitary Engineer |
|Bookkeeper |Surveyor (& Mapping) |
|Draftsman and Designer |Telephone Engineer |
|Electrical Engineer |Telegraph Engineer |
|Electric Light & Power |High School Graduate |
|General Education |Wireless Radio |
|Vocational Guidance |Undecided |

Name

Address

Learn ELECTRICITY

Earn \$50 to \$150 Weekly!

in
90
Days

You can do it easily and quickly in electricity. Come to my famous school where, in 12 short weeks, you will be qualified to fill one of the many high paid jobs in this interesting field.

Learn on Machines—No Books

You work with expert instructors on full size motors, generators, batteries, switchboards, telephone and telegraph systems. McSweeney Trained Men get the biggest pay jobs because they receive such complete and thorough training.

No Experience or Education Needed

It is easy to learn Electricity in my fascinating, practical workshop. No books to read. No dry lectures to listen to. You learn by doing. No matter how little you know about Electricity now, I guarantee that, when you graduate you'll know Electricity from "A" to "Z." And if you cannot fill a big pay job I'll refund every penny of your tuition.



SATISFACTION GUARANTEED

If you are not satisfied upon graduation your tuition will be refunded.



McSWEENEY
ELECTRICAL SCHOOL
Dept. E-10-L Cleveland, Ohio

BIG BOOK SENT FREE

Today — now, decide to get out of the low pay rut. Take the first step by sending for my big illustrated book on ELECTRICITY and special tuition offer.

BIG Demand for Skilled Mechanics!

The entire country is calling for skilled mechanics! Good pay—steady work—good opportunities for advancement! Master this fascinating trade with the aid of the

AMERICAN MACHINISTS' LIBRARY

6 volumes—2,000 pages—2,500 illustrations

(A combined home-study course and reference library)

This library of machine shop practice was written for practical men. It gives you the best methods for every kind of machine shop work. It explains machine tools and their operation, tool work, gears and grinding, jigs and fixtures, automatic screw machines, their tools, punches, dies, etc. Plainly written—completely illustrated—the best kind of help to the machine-shop man who wants to advance himself.

Free TRIAL No money down—only 7c a day

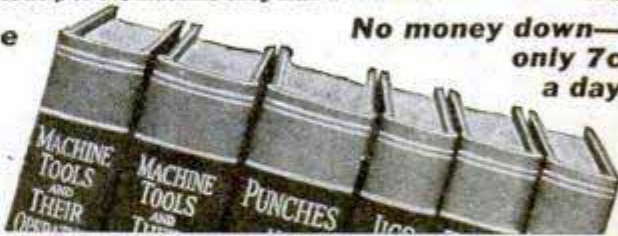

FREE EXAMINATION COUPON

McGraw-Hill Book Co., Inc., 370 Seventh Ave., New York
Send me for 10 days' free examination the AMERICAN MACHINISTS' LIBRARY. If satisfactory, I will send \$1.50 in 10 days and \$2 monthly until the special price of \$17.50 is paid. If not wanted, I will return the books at your expense.

Signed

Address

City and State

Position

Company

AUDELS ENGINEERS & MECHANICS GUIDES

EXAMINE FREE!

For Every

Engineer
Mechanic

Machinist
Electrician

Fireman; Oiler
Engineer Student



\$12
Complete
Set
8
Guides

THIS Master Set is a gold mine of daily, practical helps for workers in every branch of engineering. A self-educating study course for the student; the standard reference work for the chief. Thousands of rules, tables, calculations and diagrams make it easy to read and learn. Latest inside information on theory and practice of modern engineering for reference study and review. Thousands of new short-cuts that make the job easier. Examine free! Pay \$1 a month (less than 4c a day) if satisfied that this set will help you to a better job—or make your present job easier.

AUDELS STANDARD LIBRARY
With Questions and Answers That Solve Your Problems

EASY
TERMS

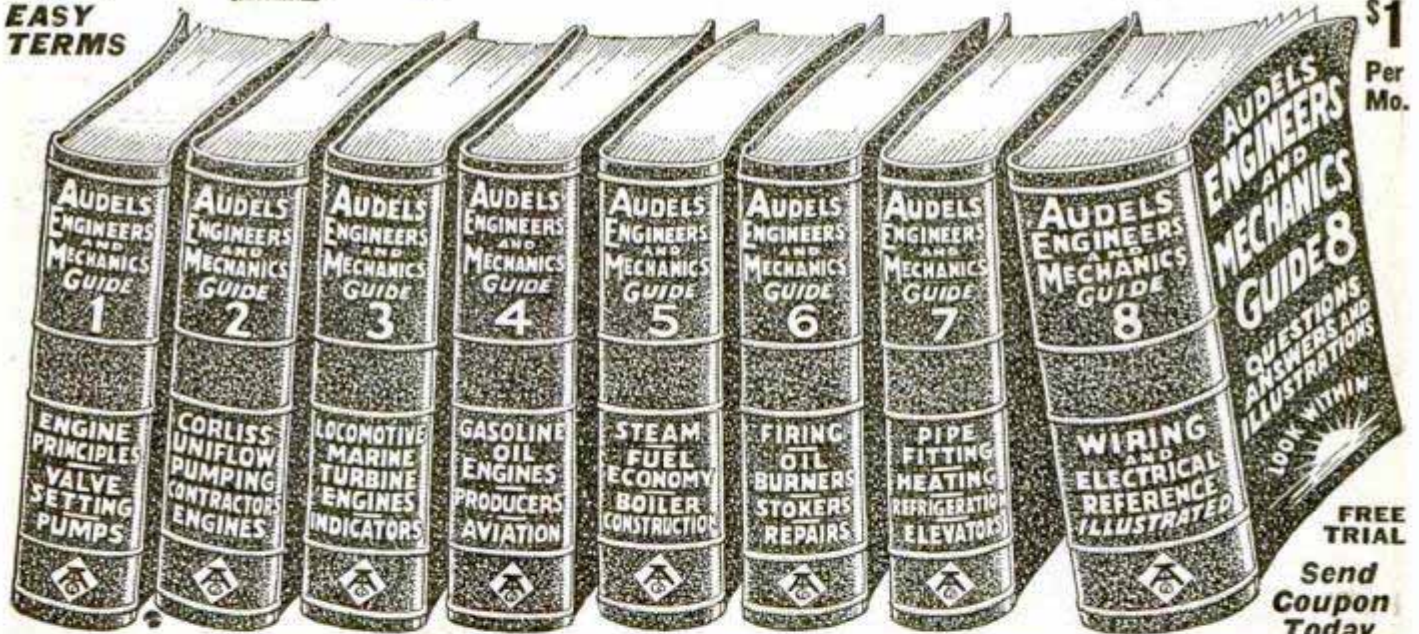

\$1
Per
Mo.

FREE TRIAL
Send
Coupon
Today

8 GUIDES 8754 PAGES — 4750 ILLUSTRATIONS — POCKET SIZE

8 Pocket numbers with Ready Reference Index. 8754 pages. 4750 illustrations. Easy to read. Highly endorsed. A good help in securing Engineer's License. Price \$12; terms, \$1 per month. Free Trial.

INFORMATION: — In A Handy Form. Answers to Your Questions and Problems. Here is a partial list of the subjects covered:— **Engine Principles, Valve Setting, Pumps, Corliss Engines, Uniflow Engines, Pumping Engines, Contractors Engines, Locomotives, Marine Engines, Turbine Engines, Gas Engines, Oil Engines, Indicators, Producers, Aviation, Steam, Fuel Economy, Boiler Construction, Firing, Oil Burners, Stokers, Boiler Repairs, Pipe Fitting, Heating, Refrigeration, Elevators, Dynamos, Motors, Lighting, Wiring, Electrical Diagrams, Radio, Electrical Reference and Calculations.**

FREE BOOK — FOR LIMITED TIME. While the edition lasts, "Audels Answers" will be included with each set of Audels Guides. Contains special information for those who want to go before the board to get a license. Makes Engineers' exams. easy. Send this coupon at once.

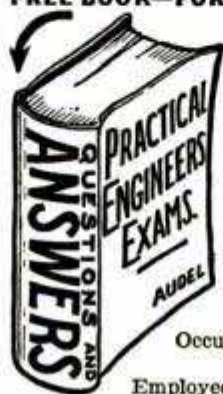

THEO. AUDEL & CO., 65 West 23rd St., New York City
Send me AUDELS ENGINEERS AND MECHANICS GUIDES, 8 numbers, \$12 and "Audels Answers" for free examination. If satisfactory, I will send you \$1 in 7 days, then \$1 monthly until \$12 is paid.

Name.....
Address.....
Occupation.....
Employed by.....

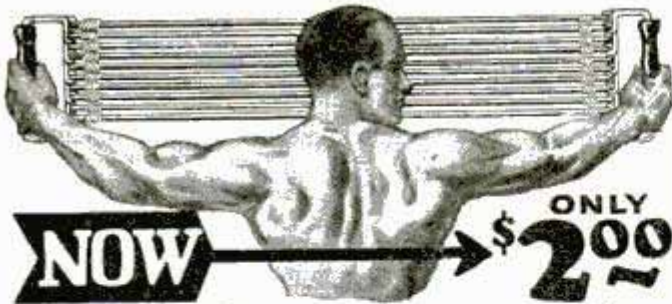

NOW → **ONLY \$2.00**
Giant Chest Expander

and

Progressive Exerciser

Be a muscular marvel. Have the muscles of a superman. Become strong for your health's sake or to astound your friends with extraordinary feats which only men of giant strength can do. In a few short weeks you will easily do stunts which now seem difficult—then real

Send No Money Use This Money Saving Coupon

muscles and strength will be yours—and yours to keep. If you want exercise to just keep in good shape you can reduce the strength of the Progressive Exerciser by eliminating as many cables as you wish. If you want great resistance so as to build up big solid muscles then use the full strength.

How the Giant Chest Expander and Progressive Exerciser is Made

The Giant Chest Expander and Progressive Exerciser is made with new live, springy rubber so as to give it long wearing and great resisting qualities. Do not pay more for an exerciser that has forty or less rubber strands to each cable. Get the best and most durable. The Giant Progressive Exerciser has 50 strands of the finest rubber procurable to each cable.

Free Instructions

We do not think it enough to send you an exerciser worth double what we ask, so for a limited time, we will also include instructions absolutely free. These instructions are interesting and simple to follow—they show you the short cut to health and strength. Order today before this wonderful offer is withdrawn.

Your Guarantee

The Giant Chest Expander is sold with a guarantee that you will say it is the finest you ever saw or your money back.

5 Cables or double 10 Cables for strength for \$2

\$4 The double strength exerciser has resistance of over 200 lbs.

How to Order—Send No Money

Sign your name and address to coupon below and get your Giant Exerciser at the present low introductory price by return mail. The price is made low because we want everyone to enjoy muscles and strength at the lowest possible cost. Don't pay more—order from us—get the most for your money. Use coupon now.

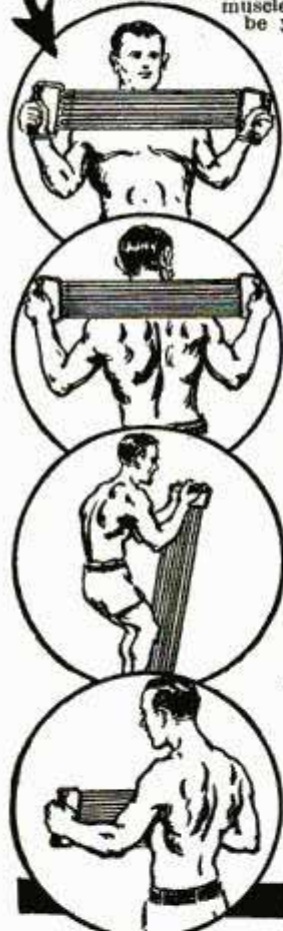

PROGRESSIVE EXERCISER CO.,
 4911 Langdon Bldg.,
 Broadway and Duane Street, New York

Please send Your 10 cable Progressive,
 Your 5 cable Exerciser.

Check the Exerciser you want, and it will be sent you by return mail. Pay postman introductory price, plus few cents postage on arrival. It is understood that if you are not entirely satisfied with your exerciser you may return it within 5 days and get your money back.

Name.....
 Street.....
 City..... State.....

If you live outside the United States, send cash with order.

RADIO PROFESSIONALS
SERVICEMEN
RADIOTRICIANS

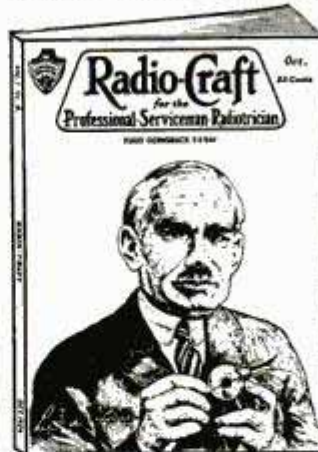

RADIO-CRAFT is the spokesman of the professional radio guild. It publishes articles appealing to the man engaged in radio work. It helps him to a better understanding of his trade and shows him how to make more money from it. The magazine is published by the pioneers of radio editors.

On sale at all newsstands—25c the copy. Special subscription offer—One Dollar—for eight months.

RADIO-CRAFT
 (A Gernsback Publication)
 98 W. Park Place, N. Y. C.



Be A Commercial Photographer

Earn \$2,000 to \$12,000 a Year

TREMENDOUS demand for trained Commercial Photographers. Fascinating, easy work—BIG PAY! Our home study course teaches you everything—you can quickly qualify in spare time. FREE booklet gives complete details—points out the way to high salaried positions. Send for it *Today*—NOW!

New York Institute of Photography
 Dept. C-1419, 4 West 33rd St., New York City

LEARN TO PLAY



VIOLIN, TENOR BANJO, HAWAIIAN GUITAR, BANJO, CORNET, UKULELE, BANJO UKULELE, GUITAR, BANJO MANDOLIN, BANJO GUITAR, MANDOLIN, SNARE DRUM, FIELD DRUM, PIANO OR ORGAN

at home, this new and "easy to learn" way. No teacher or talent required. Entirely different from any "chart" or "diagram" system. Lessons are so simplified and so easily mastered most pupils play by note after only 10 lessons. Thousands of men, women, boys and girls have learned to play quickly and proficiently by our Home Study method. Your opportunity to become popular and play for profit or pleasure. A few cents a day pays for lessons. Pay while you learn. Write to-day for full particulars and free trial. No obligation. Instruments except Piano and Organ furnished at cost if desired. **CHICAGO CORRESPONDENCE SCHOOL OF MUSIC, INC.** 1632 No. Halsted St., Dept. 15, Chicago, Ill.

BIG PAY THRILLING WORK **BE A \$ \$ \$ MOVIE OPERATOR**

Make big money in this easy and pleasant work. Big demand for trained operators. We help you earn while learning. Complete course in 5-10 weeks. Don't Wait. Write to-day.

MOVIE OPERATORS SCHOOL
 61 Sprout St. Detroit, Mich.

BART'S NEW CHALK TALK BOOK

"Their Best Stunts" from 25 chalk talk experienced artists. \$1.25 prepaid, 5-day trial. Also catalog "A," Art Supplies, or "S," Show Card Supplies.

BART SUPPLIES, 524 Eustis Bldg., Minneapolis, Minn.

6 FOOT MODEL ZEPPELIN
Flies For Miles

Large 6-foot air bag with inflators, parachute with automatic release and complete instructions for flying. Will fly for miles at height of 1000 feet. Send 25c for years' subscription to *Everyday Life* and 75c extra, \$1.00 in all and we will send you our magazine for one year and the ZEPPELIN Air Ship. All charges prepaid. A great offer to introduce.

EVERYDAY LIFE, Dept 91, A.S. 337 W. Madison St., CHICAGO



New!



Patented

Just A Twist Of The Wrist

Banishes Old-Style Can Openers to the Scrap Heap and
BRINGS AGENTS \$5 to \$12 IN AN HOUR

WOMEN universally detest the old-style can opener. Yet in every home in the land cans are being opened with it, often several times a day. Imagine how thankfully they welcome this new method—this automatic way of doing their most distasteful job. With the Speedo can opening machine you can just put the can in the machine, turn the handle, and almost instantly the job is done.

End This Waste and Danger

You undoubtedly know what a nasty, dangerous job it is to open cans with the old-fashioned can opener. You have

to hack your way along slowly—ripping a jagged furrow around the edge. Next thing you know, the can opener slips. Good night! You've torn a hole in your finger. As liable as not it will get infected and stay sore a long time. Perhaps even your life will be endangered from blood poisoning!

You may be lucky enough to get the can open without cutting yourself. But there's still the fact to consider that the ragged edge of tin left around the top makes it almost impossible to pour out all of the food. Yet now, all this trouble, waste and danger is ended. No

wonder salesmen everywhere are finding this invention a truly revolutionary money maker!

A "Million Dollar" Can Opener Machine

The Speedo holds the can—opens it—flips up the lid so you can grab it—and gives you back the can without a drop spilled, without any rough edges to snag your fingers—all in a couple of seconds! It's so easy even a 10-year-old child can do it in perfect safety! No wonder women—and men, too—simply go wild over it! No wonder Speedo salesmen often sell to every house in the block and make up to \$10 an hour.

Generous Free Test Offer

Frankly, men, I realize that the profit possibilities of this proposition as outlined briefly here may seem almost incredible to you. So I've worked out a plan by which you can examine the invention and test its profit without risking one penny. Get my free test offer while the territory you want is still open—I'll hold it for you while you make the test. I'll send you all the facts about \$75 to \$150 a week. I'll also tell you about another fast selling item that brings you two profits on every call. All you risk is a 2c stamp—so grab your pencil and shoot me the coupon right now.

CENTRAL STATES MFG. CO. Dept. P-703
4500 Mary Ave., (Est. over 20 years) St. Louis, Mo.



Central States Mfg. Co.
4500 Mary Ave., Dept. P-703
St. Louis, Mo.

Yes, rush me the facts and details of your FREE OFFER.

Name.....

Address.....

City..... State.....

Check here if interested only in one for your home.

AGENTS!



Full Time \$265 in a Week

"Here is my record for first 30 days with Speedo:
June 13, 60 Speedos;
June 20, 84 Speedos;
June 30, 192 Speedos;
July 6, 288 Speedos.
Speedo sells to 9 out of 10 prospects."

M. Ornoff, Va.

PART TIME

14 Sales in 2 Hours
J. J. Corwin, Ariz., says: "Send more order books. I sold first 14 orders in 2 hours."

SPARE TIME

Big Money Spare Time
Barb, W. Va., says: "Was only out a few evenings, and got 20 orders."

\$2,000.00 PRIZES

Now Being Given in Cash to Agents. Write for Details.

WANTED
A young man of executive ability and experience, thoroughly trained in business management. The salary is \$100 per week to start. The opportunity is unlimited. Address Box C. L. 842, listing qualifications and giving references.

DOING CEMENT
courses under the work: ... to responsible ... proving ability.

A REAL OP
See for ... ric. for ... cost.

1735 W

WOMEN
WAITRESSES
WATRESSES

HOUSEWORKERS GOVERNESSES
ONLY Highest wages. (1921)

CANVASERS—Sell newly patented auto invention. Tell-life always tells driver if lights are lit. prevents accidental projects in easily installed. Sell on sight for each producer; see it 1919 Broads.

How Would You Answer It?

THERE are advertisements in every issue of the great dailies that offer just as attractive openings as this. "The opportunity is unlimited" if you have the required knowledge. There is always room at the top for trained men.

Such advertisements will still be in the papers a year—two years—five years from now. If you have the foresight and the courage to prepare yourself, you can be ready to step into such a position when it is offered. Whatever your work may be today, you can start at once to train yourself for a bigger job, at a higher salary.

It doesn't cost you a cent or obligate you in any way to ask for our Free Booklets and complete information about the International Correspondence Schools. But that one simple act now may change the course of your whole life a few years hence.

INTERNATIONAL CORRESPONDENCE SCHOOLS

Box 5649-F, Scranton, Penna.

Without cost or obligation, please send me a copy of your booklet, "Who Wins and Why," and full particulars about the course before which I have marked X in the list below:

TECHNICAL AND INDUSTRIAL COURSES

- | | |
|--|---|
| <input type="checkbox"/> Architect | <input type="checkbox"/> Automobile Mechanic |
| <input type="checkbox"/> Architectural Draftsman | <input type="checkbox"/> Aviation Engines |
| <input type="checkbox"/> Building Foreman | <input type="checkbox"/> Plumber and Steam Fitter |
| <input type="checkbox"/> Concrete Builder | <input type="checkbox"/> Plumbing Inspector |
| <input type="checkbox"/> Contractor and Builder | <input type="checkbox"/> Foreman Plumber |
| <input type="checkbox"/> Structural Draftsman | <input type="checkbox"/> Heating and Ventilation |
| <input type="checkbox"/> Structural Engineer | <input type="checkbox"/> Sheet-Metal Worker |
| <input type="checkbox"/> Electrical Engineer | <input type="checkbox"/> Steam Engineer |
| <input type="checkbox"/> Electrical Contractor | <input type="checkbox"/> Marine Engineer |
| <input type="checkbox"/> Electric Wiring | <input type="checkbox"/> Refrigeration Engineer |
| <input type="checkbox"/> Electric Lighting | <input type="checkbox"/> R. R. Positions |
| <input type="checkbox"/> Reading Shop Blueprints | <input type="checkbox"/> Highway Engineer |
| <input type="checkbox"/> Telegraph Engineer | <input type="checkbox"/> Chemistry |
| <input type="checkbox"/> Telephone Work | <input type="checkbox"/> Pharmacy |
| <input type="checkbox"/> Mechanical Engineer | <input type="checkbox"/> Coal Mining Engineer |
| <input type="checkbox"/> Mechanical Draftsman | <input type="checkbox"/> Navigation <input type="checkbox"/> Assayer |
| <input type="checkbox"/> Machine Shop Practice | <input type="checkbox"/> Iron and Steel Worker |
| <input type="checkbox"/> Toolmaker | <input type="checkbox"/> Textile Overseer or Supt. |
| <input type="checkbox"/> Patternmaker | <input type="checkbox"/> Cotton Manufacturing |
| <input type="checkbox"/> Civil Engineer | <input type="checkbox"/> Woolen Manufacturing |
| <input type="checkbox"/> Surveying and Mapping | <input type="checkbox"/> Agriculture <input type="checkbox"/> Fruit Growing |
| <input type="checkbox"/> Bridge Engineer | <input type="checkbox"/> Poultry Farming |
| <input type="checkbox"/> Gas Engine Operating | <input type="checkbox"/> Mathematics <input type="checkbox"/> Radio |

BUSINESS TRAINING COURSES

- | | |
|--|---|
| <input type="checkbox"/> Business Management | <input type="checkbox"/> Business Correspondence |
| <input type="checkbox"/> Industrial Management | <input type="checkbox"/> Show Card and Sign Lettering |
| <input type="checkbox"/> Personnel Management | <input type="checkbox"/> Stenography and Typing |
| <input type="checkbox"/> Traffic Management | <input type="checkbox"/> English |
| <input type="checkbox"/> Accounting and C. P. A. Coaching | <input type="checkbox"/> Civil Service |
| <input type="checkbox"/> Cost Accounting | <input type="checkbox"/> Railway Mail Clerk |
| <input type="checkbox"/> Bookkeeping | <input type="checkbox"/> Mail Carrier |
| <input type="checkbox"/> Secretarial Work | <input type="checkbox"/> Grade School Subjects |
| <input type="checkbox"/> Spanish <input type="checkbox"/> French | <input type="checkbox"/> High School Subjects |
| <input type="checkbox"/> Salesmanship | <input type="checkbox"/> Cartooning |
| <input type="checkbox"/> Advertising | <input type="checkbox"/> Illustrating |
| | <input type="checkbox"/> Lumber Dealer |

Name.....

Address.....

City..... State.....

Occupation.....

If you reside in Canada, send this coupon to the International Correspondence Schools Canadian, Limited, Montreal, Canada

CULTURED SPEECH

AT LAST! Something New!

Learn Cultured Speech and Correct Pronunciation quickly from phonograph records. Also increase your vocabulary this new easy way. Be a fluent talker—cultivated speech is a social and business asset of the first importance. This new "learn by listening" method highly recommended by leading educators. Records sent on free trial. Write for information and free Self Test. No obligation.



THE PRONUNCIPHONE INSTITUTE
3601 Michigan Ave., Dept. 1358, CHICAGO

AVIATION Information FREE

Send us your name and address for full information regarding the Aviation and Airplane business. Find out about the many great opportunities now open and how we prepare you at home, during spare time, to qualify. Our new book "Opportunities in the Airplane Industry" also sent free if you answer at once.

AMERICAN SCHOOL OF AVIATION
3601 Michigan Ave. Dept. 1358 CHICAGO

BE AN OIL EXPERT!

Trained geologists, drillers, refiners, salesmen are at a premium! New, easy, practical way to learn at home in spare time! Write Today! FREE Book!

PETROLEUM ENGINEERING UNIVERSITY, Dept. 231, FORT WAYNE, IND.

SONG WRITERS!

SUBSTANTIAL ADVANCE ROYALTIES are paid on work found acceptable for publication. Anyone wishing to write either the words or music for songs may submit work for free examination and advice. Past experience unnecessary. New demand created by "Talking Pictures" fully described in our free book. Write for it Today. **NEWCOMER ASSOCIATES**
759 Earle Building, New York, N. Y.

HOW TO MAKE MONEY with INVENTIONS



Every mechanic and inventor needs this valuable work. Here you find just how to turn new ideas into money, how to protect yourself, what to invent. Billions are waiting to be paid to men with new ideas who know how to protect themselves.



How to Make Patents Pay

"Inventions and Patents" by Milton Wright, an editor of Scientific American, is a complete

up-to-date reference and helping hand—pointing the way to profit with questions and answers and clear instructions.

Highly Endorsed

It is a well-made special edition McGraw-Hill reference; 255 pages; usually sold at \$2.50. Use this coupon to secure it at the special bargain price.

98
SPECIAL BARGAIN PRICE

McGraw-Hill Book Co.

370-7th Ave., New York, N. Y.

Send me "Inventions and Patents." I will pay postman \$1.98 and postage on arrival. My money to be refunded if I am not satisfied.

Name.....

Address..... P.M. 11-29

Learn to PAINT SIGNS and SHOW CARDS

and YOUR FUTURE will be safe, secure, profitable and independent

ADVERTISING is the fastest growing profession in America today. COMMERCIAL LETTERING and its allied subjects, SIGNS, SHOW CARDS, THEATRICAL POSTERS, PICTORIAL BULLETINS, etc., constitute one of its most profitable branches. There is a far greater demand for competent letterers than the market can supply. The business has grown so fast, that trained men are commanding their own price for their services.

TALENT OR EXPERIENCE UNNECESSARY

While persons possessing natural talent for Art or drawing are attracted to this line of work, it is entirely unnecessary to possess any native ability or previous experience in order to become a successful craftsman. Indeed, some of our most successful graduates are those who had no natural ability in the beginning.

BE YOUR OWN BOSS AND EARN

BIG MONEY

Here is a profession you can learn in your spare time either at home—or here in our Studio—and fit yourself in a few weeks for work that pays trained men from \$3,000 to \$12,000 per year. No matter what your previous education or experience has been, we can teach you. The lessons are easy and the work fascinating. Strong's exclusive, practical studio method of instruction produces quick results.

DETROIT SCHOOL OF LETTERING

Box 44, 155 Stimson Avenue
DETROIT, MICHIGAN



Charles J. Strong

More than thirty years ago Charles J. Strong, then a master of his craft, conceived the idea of providing a direct and simple course that would teach any man the fundamentals and give him a groundwork to enable him to become a master of this highly paid business.

Do not fail to send for the "Book of Facts", which gives the history of this master craftsman and explains how the profession has grown since his simple and clear lessons were made available to others.

Our successful graduates come from every part of the globe. Below is part of a letter, typical of many, received from our graduates—

"MY EARNINGS RUN AS HIGH AS \$12,300 A YEAR"

It was a mighty lucky day when I started your course, "Believe me". The thorough training I received has enabled me to enjoy those luxuries of life which every man with ambition looks forward to. My earnings since completing this course have run as high as \$12,300.00 a year.

I have paid sign artists in my employ as high as \$100.00 per week. I know of no greater opportunity than the course in sign painting offered by your school" — U. Otto C. Wiegand, 37 E. Patrick, Frederick, Maryland.

LEARN WHILE YOU EARN

Both Home Study and Resident courses are conducted. The student may pursue the study of this fascinating and profitable profession either at home in spare time without interfering with present employment, or here in our Resident Studio, and complete the work in a few weeks.

The Detroit School of Lettering teaches ONLY ONE profession, Lettering and its allied subjects, and has been doing it successfully for more than three decades. Our entire efforts are devoted to the proper training of students to enter this remarkably pleasant and profitable business.

The attached coupon will bring you specimens of students' work, together with full information, telling how quickly and how easily this wonderful business may be mastered. TEAR IT OUT, FILL IT IN, and MAIL TO US TODAY. It costs you nothing.

It will be the means of bringing undreamed-of success to others. You can be one of them. Remember, there is no obligation. ACT NOW.

MAIL THIS COUPON TODAY

FREE

DETROIT SCHOOL OF LETTERING,
Box 44, 155 Stimson Ave., Detroit, Mich.

BOOK
of
FACTS

Gentlemen: Without cost or obligation on my part, please send me a copy of your Book of Facts, samples of students' work, and full information about your Lettering courses.

Name _____

R. F. D. or Street No. _____

City _____ State _____



A typical class-room scene in our Resident School

BIG MONEY IN ELECTRIC REFRIGERATION

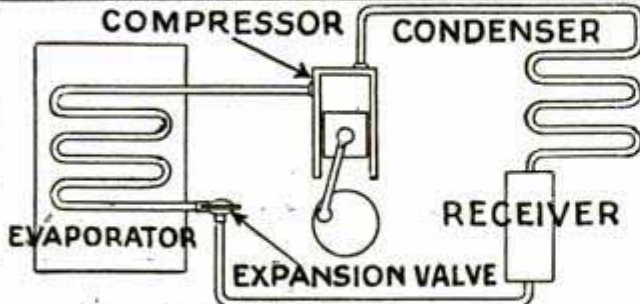

WHY look for big pay in over-crowded, limited industries? America's newest and fastest growing industry—Electric Refrigeration—needs practical men to fill jobs paying up to \$1,000 a month. Trained experts urgently needed in manufacture, installation, sales and service. Backed by the money powers of the country. Millions invested by General Motors, General Electric and others.

Now Easy to Learn at Home in Spare Time

And now a marvelous new easy method teaches you all the money-making secrets of refrigeration that quickly prepare you for the big jobs. Entirely practical—not like ordinary schooling. No textbooks. Trained experts teach you everything step by step. This amazing simplified training praised by Kelvinator, General Electric, Copeland, Servel, Zerozone, Champion and other leading manufacturers. Hundreds of satisfied students.

Practical—Simple as A. B. C.



"My salary has been increased 15% since I enrolled and another raise is in sight," writes S. C. Mathias, Penn. Geo. Zercher, N. Y., reports a job with

Frigidaire on the strength of his U. E. I. training. O. Born, Illinois, says: "Altho I am only half through with my training, I have already been called on to make small adjustments on refrigerators."

"Your Institute should be of great interest to young men wishing to get into the service and sales end of this business. It will be a pleasure to cooperate with you."
—Col. F. E. Smith, Pres., Servel, Inc.

VALUABLE BOOK SENT FREE

Mail coupon below. It brings you free without cost or obligation valuable new book, *Rich Rewards In Electric Refrigeration*. See how easy it is to quickly become a highly paid refrigeration expert.



UTILITIES ENGINEERING INSTITUTE
Dept. 1119 4403 Sheridan Road
CHICAGO, ILLINOIS

Utilities Engineering Institute,
Dept. 1119, 4403 Sheridan Rd., Chicago, Ill.

Send me at once without cost or obligation your free book, *Rich Rewards In Electric Refrigeration* and full details of your new easy training.

Name.....
Address.....
City..... State.....

DEALERS: We are referring our graduates to you as fast as they complete our training. Please write us your requirements as early as possible, for choice selection.

LEARN TO FLY~



WHERE LINDBERGH LEARNED!

GET the same complete, thorough, foundational training that Lindbergh received. Get it now—under greatly improved facilities—at the Lincoln Airplane School. Much better than when Lindbergh learned here. Get the best training now available. Here competent, experienced instructors teach you *practical* Flying and Ground Work. You go right up into the sky in our famous Lincoln Page Government Licensed Planes—with transport pilots. Learn on actual planes and motors supplied by the Lincoln Aircraft Factory. Write for full information today!

LINCOLN AIRPLANE SCHOOL
204 Aircraft Bldg., LINCOLN, NEBR.

CHICAGO TECH

FOUNDED 1903

ENGINEERING-ELECTRICITY ARCHITECTURE-DRAFTING

4 Fields of real opportunity. Big pay—a permanent position or a business of your own. 7 Billion dollars spent last year in one of these fields alone. Train here in Chicago, America's industrial center. 1, 2 and 3 year courses. Diplomas and B. S. Degrees. *Special 4 months' practical course in Drafting.* Other short courses. Earn while you learn. Enter any time. Day and evening classes. No time wasted. Free Employment Bureau. Low tuition—easy terms. Athletics. Successful graduates everywhere. Free 80-page "Blue Book." Address the President, **Chicago Technical College, Dept. P-77, 118 East 26th Street, Chicago, Ill.**

Learn Watchwork, Jewelrywork and Engraving

A fine trade commanding a good salary, and your services always in demand. Address **Horological, Dept. P, Bradley Institute, PEORIA, ILLINOIS**, for our latest catalog.

YOU CAN OIL PAINT

Amazing new method teaches men or women to earn after first lesson. **OIL PAINT** photos—portraits, landscapes or art subjects. Earn \$18 to \$50 and more a week. **OIL PAINT OUTPUT GIVEN.** Send now for free illustrated book. **PICTORIAL ART STUDIOS Inc., Dept. MP, 2926 Broadway, Chicago, Ill.**

PLAY BANJO

LET the sweet-voiced, easy-playing Gibson banjo help you make your dreams come true. Gibson banjoists play everywhere—on the records, over the radio, on the stage, for dances and parties. The Gibson is easy to learn. Francis Henry, at left, with Guy Lombardo, plays a Gibson banjo. You learn to play a Gibson easily, quickly.

Gibson

FREE Trial, Easy Payments
Send the coupon for information and free book, "The Road to Happiness." Check the instrument desired.

GIBSON, INC., 1103 Parsons Street, Kalamazoo, Michigan.
Gentlemen: Please send free book and complete information about
 BANJO GUITAR MANDOLIN

Name.....
St.....
City.....

I Will Train You at Home to Fill a Big-Pay Radio Job



If you are earning a penny less than \$50 a week, send for my book of information on the opportunities in Radio. It's FREE. Clip the coupon NOW. A flood of gold is pouring into Radio creating hundreds of big-pay jobs. Why go along at \$25, \$30 or \$45 a week when the good jobs in Radio pay \$50, \$75 and up to \$250 a week? "Rich Rewards in Radio" gives full information on these big jobs and explains how you can quickly learn Radio through my easy, practical home-study training.

Here's the PROOF



\$375 One Month in Spare Time

"Recently I made \$375 in one month in my spare time installing, servicing, selling Radio Sets." Earle Cummings, 18 Webster St., Haverhill, Mass.



\$450 a Month

"I work in what I believe to be the largest and best-equipped Radio shop in the Southwest and also operate KGFI. I am averaging \$450 a month."

Frank M. Jones, 922 Guadalupe St., San Angelo, Tex.

Salaries of \$50 to \$250 a Week Not Unusual

The amazing growth of Radio has astounded the world. In a few short years three hundred thousand jobs have been created. And the biggest growth is still to come. That's why salaries of \$50 to \$250 a week are not unusual. Radio simply hasn't got nearly the number of thoroughly trained men it needs.

You Can Learn Quickly and Easily in Spare Time

Hundreds of N. R. I. trained men are today making big money—holding down big jobs—in the Radio field. You, too, should get into Radio. You can stay home, hold your job, and learn in your spare time. Lack of high school education or Radio experience is no drawback.

Many Earn \$15, \$20, \$30 Weekly on the Side While Learning

I teach you to begin making money shortly after you enroll. My new practical method makes this possible. I give you SIX BIG OUTFITS of Radio parts and teach you to build practically every type of receiving set known. M. E. Sullivan, 412-73rd St., Brooklyn, N. Y., writes, "I made \$720 while studying." G. W. Page, 1807-21st Ave., S., Nashville, Tenn., "I picked up \$935 in my spare time while studying."

Your Money Back if Not Satisfied

My course fits you for all lines—manufacturing, selling, servicing sets, in business for yourself, operating on board ship or in a broadcasting station—and many others. I back up my training with a signed agreement to refund every penny of your money if, after completion, you are not satisfied with the lessons and instructions I give you.

Act NOW—64-Page Book Is FREE

Send for this big book of Radio information. It has put hundreds of fellows on the road to bigger pay and success. Get it. See what Radio offers you, and how my Employment Department helps you get into Radio after you graduate. Clip or tear out the coupon and mail it RIGHT NOW.

J. E. SMITH, President, Dept. 9YP, National Radio Institute, Washington, D. C.

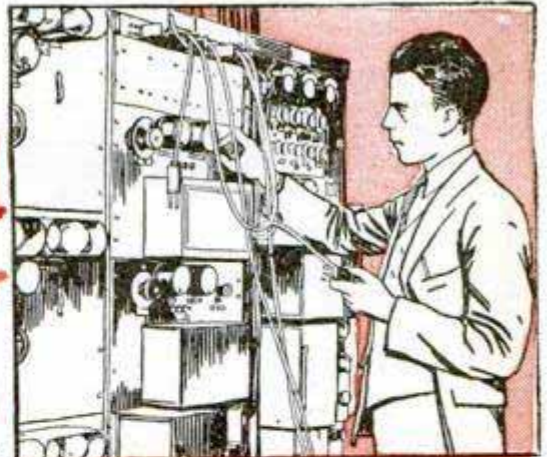

You can build 100 circuits with the six big outfits of Radio parts I give you

3 of the 100 you can build

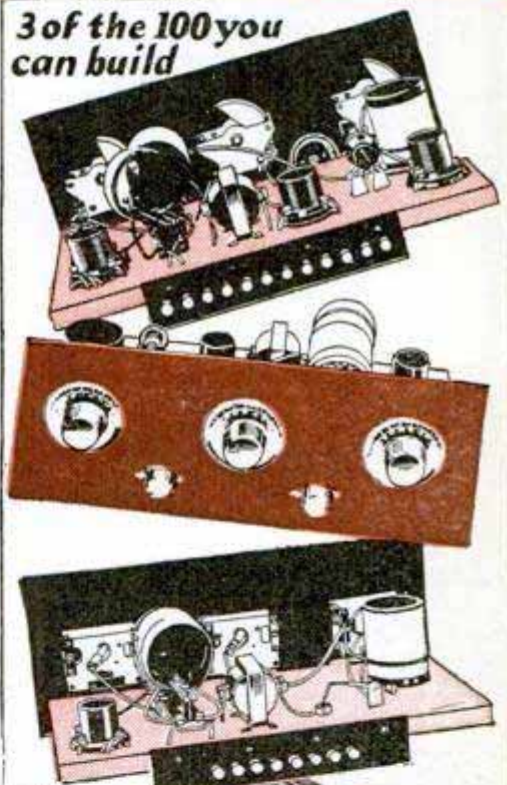

Find out quick about this practical way to big pay



Mail This FREE COUPON Today

J. E. Smith, President, Dept. 9YP, National Radio Institute, Washington, D. C.

Dear Mr. Smith: Send me your Free book "Rich Rewards in Radio" giving information on the big-money opportunities in Radio and your practical method of teaching with six Radio Outfits. I understand this places me under no obligation.

Name.....Age.....
 Address.....
 City.....State.....
 Occupation.....

Employment Service to all Graduates
Originators of Radio Home Study Training

You Can Learn ELECTRIC REFRIGERATION in 3 Months

EARN WHILE YOU LEARN

Men in Big Demand!

Hundreds of thousands of Electric refrigerators in use. Thousands being installed day after day. Trained service and installation men are in urgent need in this new, fast growing industry. Big money awaits men who master the principles of Electric Refrigeration in the School of Engineering of Milwaukee—America's greatest Electrical school.

COMPLETE PRACTICAL 90 DAYS COURSE

Includes Electric Refrigeration, Applied Electricity, Merchandising, and Practical Mathematics. Some of the topics are: Physics and Chemistry of Refrigeration, Heat and Heat Transfer, General Theory of Refrigeration, Systems of Refrigeration, Household Compression Systems, Refrigerants, Household Absorption Machines, Refrigeration Cabinets, Installation and Repair, Maintenance, Troubles and Their Cures, Sales and Merchandising. All instruction is thoroughly practical. Splendid equipment and laboratories.

WRITE FOR FREE BOOK TODAY

"Your Future in Electric Refrigeration," a fascinating book describing the School of Engineering course in Electric Refrigeration will be mailed free. Also contains details of "Earn While you Learn" plan, and facts about our employment service after you graduate. Unlimited money making opportunities are open in Electric Refrigeration. Write today!

New Class Organizing Now—Mail Coupon

SCHOOL of ENGINEERING

of Milwaukee

Founded 1903

163 East Wells Street P.M. 1129B MILWAUKEE, WIS.

School of Engineering of Milwaukee, P. M. 1129B, 163 East Wells St., Milwaukee, Wisconsin.
Send me FREE, with no obligations, a copy of "YOUR FUTURE IN ELECTRIC REFRIGERATION."

Name.....Age.....
 Address.....
 City.....State.....
 Education.....

Here is YOUR High School Education!

These fifteen wonderful books prepare you quickly at home for bigger pay, broader culture, social and business success. Every high school subject taught by fascinating "Question and Answer" method—English, French, Spanish, Latin; Ancient, Modern and American History; Literature, Biology, Physics, Algebra, Economics, Physiography, Geography, Spelling, Arithmetic and Grammar.



Greatest Bargain in Brain Power

Increase your earning power this easy way. Don't be held back by lack of education. Here is your chance to get your high school education in spare time at amazingly little cost and on easy monthly payments. These books are used in thousands of high schools. Qualify for High School Certificate this simple, inexpensive way.

Send for FREE Book Find out about this new method. Learn how a few cents a day can help you quickly to bigger pay and social culture. Just send your name and address for interesting FREE booklet "New Way to Get a High School Education at Home." No obligation.

High School Home-Study Bureau, Dept. 3378
31 Union Square, New York, N. Y.

Amazing Offer!

PHOTOS ENLARGED

Size 8x10 or 11x14 in.

Only **49c** each



At last your chance to get a life-like Bromide photo-enlargement at a small fraction of the regular price reproduced from any clear photograph, tintype or snapshot you mail us. No photo too large nor any snapshot too small. We guarantee return of your original photograph in the same condition as received. You run no risk. Send as many photos as you wish at the bargain price of 49c each.

Send No Money—Simply mail us the photo, with your name and address, and in about a week you will receive a beautiful enlargement that will never fade. We will also send with the enlargement an illustrated circular describing several of our most popular frames. From this circular you can choose the frame which we are giving FREE with every enlargement ordered in colors. On arrival of picture pay postman only 49c plus a few pennies postage or send 50c with order and we will prepay postage. If not delighted we will refund your money.

FREE BEAUTIFULLY CARVED FRAME—As a special inducement to acquaint you with the high quality of our work, we'll frame every enlargement done in **Partial Water Colors—ABSOLUTELY FREE**—during this sale only. **DON'T PUT IT OFF! MAIL YOUR PHOTO NOW!**

ARTWAY STUDIOS, Room 28 Cragin Bank, Chicago, Ill.		Check Size Wanted <input type="checkbox"/> 11 x 14 in. <input type="checkbox"/> 8 x 10 in.
Please send.....enlargements from enclosed photo. I will pay postman 49c plus postage for each enlargement. (If 50c cash for each enlargement is enclosed with this order, we pay postage.)		
Name.....		
Address.....		
Town.....		State.....



BRAND NEW

CORONA ^{GENUINE} Model #3

Lowest Price — Easiest Terms Ever Offered



HERE'S your chance to own that *brand new* Genuine Model 3 Corona you've wanted — on the easiest terms ever offered — at **LOWEST PRICE** ever offered. Complete in every detail; back spacer, etc., *Manufacturer's Guarantee*. Recognized the world over as the finest, strongest, sturdiest portable built.

Yours for 10 DAYS FREE

Only a limited number of these splendid machines available. To get one, you must act now! Experience the joy this personal writing portable typewriter can give you! Use it ten days free! See how easy it is to run and the splendidly typed letters it turns out. Ideal for the office desk, home, traveling. Small, compact, light, convenient. Don't

send out letters, manuscripts, reports, bills in poor handwriting when you can have this Corona at such a low price on such easy terms. Remember these are *brand new* machines right out of the Corona factory.

Carrying Case FREE
If You Act Now!

Leatheroid carrying case, oiler, instructions free on this offer. Send no money — just the

coupon. Without delay or red tape we will send you the Corona. Try it 10 days. If you decide to keep it, send us only \$2 — then \$3 a month until our special price of \$39.90 is paid. Now is the time to buy. This offer may never be repeated.

Save Money — Use this Coupon

Smith Typewriter Sales Corp., (Corona Division)
469 E. Ohio St., Chicago, Ill. Dept. B3

Ship me the Corona, F.O.B. Chicago. On arrival I'll deposit \$2 with express agent. If I keep the machine, I'll send you \$3 a month until the \$37.90 balance of \$39.90 price is paid; the title to remain with you until then. I am to have 10 days to try the typewriter. If I decide not to keep it, I will repack and return to express agent, who will return my \$2. You are to give your standard guarantee.

Name _____

Address _____

Employed by _____

We Will Train You in a Few Months



Day and Night Schools in Chicago, Detroit, Cleveland, Boston, Phila.

No Books—No Classes—

Wonderful Future in this Uncrowded Field

Experts Earn Up To \$125 A WEEK

as MECHANICAL DENTISTS

We teach you to make rubber plates, crowns, bridge work, metal base dentures, etc., for dentists. After graduating you are ready for a job or can open your own laboratory. We assist you.



Big Demand for Men!

Mechanical Dentistry is the laboratory bench work which the dentist turns over to the laboratory worker. Master this profession and help meet the demand of 64,000 dentists for laboratory work. Every city and every town where dentists are located offers work to the mechanical dentist. We train you in a few months in day or night school for this uncrowded field—no classes—no books—no mechanical experience necessary. **No Educational Requirements.**

Work Your Way Thru School

We will help you find a job to meet your expenses while taking our training. And we will help you find satisfactory living quarters when you arrive.

Schools located in Chicago, Detroit, Cleveland, Boston, Philadelphia. Day and night schools.

INTERESTING FREE BOOK

Our illustrated free book on Mechanical Dentistry will acquaint you with some surprisingly interesting facts. It tells about the thriving profession of Mechanical Dentistry—the way to swift and certain success. And it tells about the progress of many of our graduates—men who have succeeded beyond their expectations, also full details of our liberal offers. Mail the coupon and find out more about this fascinating opportunity.

McCarrie School of Mechanical Dentistry
1338 S. Michigan Ave., Dept. 353, Chicago, Ill.

McCARRIE SCHOOL OF MECHANICAL DENTISTRY
1338 S. Michigan Ave., Dept. 353, Chicago.

Without cost or obligation, send me your illustrated book on Mechanical Dentistry, and complete information as to my opportunities in dental laboratory work.

Name.....

Address.....

ELECTRICAL ENGINEERING

Intensive, practical—technical courses. Engineering degree in 2 years. Diploma in 1 year. Also Special Short Courses in Practical Electricity—Power Plant Operation—Armature Winding—Radio—Electric Refrigeration—Aviation Electricity—Electric Welding. **LOW TUITION RATES.** Faculty of recognized experts. Extensive Laboratories. Free employment service for graduates. We help secure part-time work during training, 28th year. Write for catalog. **FINLAY ENGINEERING COLLEGE** 1001-A Indiana Ave. Kansas City, Mo.



I POSITIVELY GUARANTEE

to increase your arms one-half inch in size, chest one full inch, strength 25%, health 100% in one week's time, by following my instructions and using my exerciser 10 minutes mornings and at night. Send \$1 for complete course and exercisers. Satisfaction guaranteed or \$1 refunded.

J. A. DRYER, Box 1850-P, Chicago, Ill.

Learn Watchwork, Jewelrywork and Engraving

A fine trade commanding a good salary, and your services always in demand. Address **Horological, Dept. P, Bradley Institute, PEORIA, ILLINOIS.** for our latest catalog.

MEN for RAILROADS

Nearest their homes—everywhere—to train for Firemen, Brakemen: Average wages \$150-\$200 monthly. Promoted to Conductor or Engineer—highest wages on railroads. Also clerks.

RAILWAY EDUCATIONAL ASSOCIATION. Dept. D-1, Brooklyn, N. Y.

ASK YOUR BARBER

FOR THE NEW MEDICATED MASSAGE

WHYTE-FOX



Doubles your pep. Heals as it cleanses. Those who know are "crazy" about it. Made and guaranteed by makers **Lucky Tiger Hair Tonic.** Ask for valuable free booklet.

Kansas Dept. A
City, Mo. **LUCKY TIGER REM. CO.**

Stop Using a Truss

STUART'S ADHESIF PLAPAO-PADS are entirely different—being mechanico-chemico applicators—made self-adhesive purposely to keep the muscle-tonic called "Plapao" continuously applied to the affected parts, and to minimize danger of slipping and painful friction. The fabric is soft as velvet, and being adhesive—clings closely

to the body without straps, buckles or springs. Easy to apply, comfortable, inexpensive.



Awarded Gold Medal



Awarded Grand Prix

For almost a quarter century stacks of sworn testimonials from many different countries report success—without delay from work. The epidermatic absorption of Plapao utilizing "mechanico-chemico" therapy tends toward a natural process of recovery, after which no further use for a truss.

MAIL COUPON BELOW TODAY

FREE TEST COUPON

PLAPAO CO., 193 Stuart Bldg., St. Louis, Mo.

Send me a FREE 10 day test supply of the remedial factor Plapao and 48-page illustrated book on Rupture; no charge for this now or later.

Name.....

Address.....

"The Von Hoffmann Graduate Qualifies"

Von Hoffmann Aircraft School

Will Give You a Thorough—Practical Training

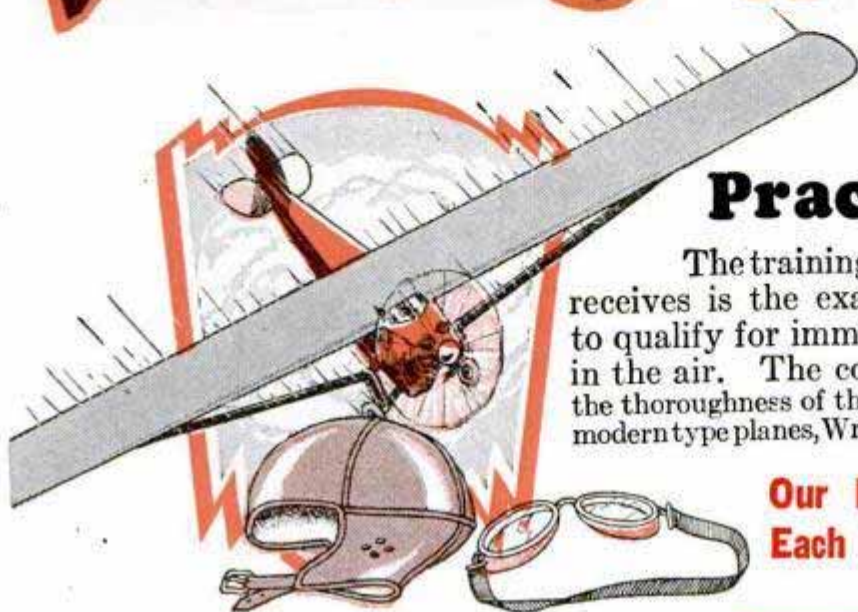

The training which the Von Hoffmann student receives is the exact training which he must have to qualify for immediate positions on the ground or in the air. The cost is low considering daily flying, the thoroughness of theoretical and ground instruction on latest modern type planes, Wright Whirlwind and other standard motors.

Our Instructors Are Ex-Army Pilots Each with Over 3000 Hours of Flying

Our School Registered, All Instructors and Airplanes Licensed by U. S. Government, Aeronautics Branch, Dept. of Commerce

All Airplanes used by us for both instruction and passenger service are planes licensed by the U. S. Government and our instructors are U. S. Licensed Transport Pilots and U. S. Licensed Mechanics. Our equipment is new and of modern design, subject to daily U. S. Government Inspection. (We have a resident U. S. Government Inspector on the field—think what this means to you.)

A Record to Be Proud Of

Our record to date shows that every Von Hoffmann graduate has received a U. S. Government License.



Ground Course



Easy Monthly Payments

It is easy to pay the Von Hoffmann way because small monthly payments are extended. Let us show you how you can start now and pay later, even after you have finished the course of training.

Von Hoffmann Aircraft School

123 Lambert-St. Louis Flying Field (Lindbergh's Own Field) St. Louis, Mo.

Flying Course

We teach you by actual flying and practical instruction; no long course needed. No student bond required.

Start NOW!

Free Information Coupon

Von Hoffmann Aircraft School, 123 Lambert-St. Louis Flying Field (Lindbergh's Own Field), St. Louis, Mo. Please mail FREE information at once.

Name Address Town State Age



"Last night I came home with great news!"

"I'D TELEPHONED Nora that I had a surprise for her and she could hardly wait for me to get home! You should have seen her face when I told her the Boss had given me a \$25 increase in salary.

"It's wonderful," she said, "just wonderful! Now we can pay some of those bills that have been worrying us and even put a little in the bank each week.

"Remember the night we saw that coupon and you decided to take up an I. C. S. course? It made a new man of you, Bob, and I knew it wouldn't be long before the firm would notice the difference.

"We certainly owe a lot to the International Correspondence Schools. You would never have received this increase if you hadn't studied at home and prepared yourself for bigger work."

How about you? Are you always going to work for a small salary? Are you going to waste your natural ability all your life? Or are you going to get ahead in a big way?

Don't let another precious hour pass before you find out what the I. C. S. can do for you. It doesn't cost you a penny or obligate you in any way to ask for full particulars, but that one simple little act may be the means of changing your entire life.

Mail Coupon for Free Booklet

INTERNATIONAL CORRESPONDENCE SCHOOLS

"The Universal University"
Box 5648-F, Scranton, Penna.

Without cost or obligation on my part, please send me a copy of your 48-page booklet, "Who Wins and Why," and tell me how I can qualify for the position, or in the subject, before which I have marked an X:

TECHNICAL AND INDUSTRIAL COURSES

- | | |
|--|---|
| <input type="checkbox"/> Architect | <input type="checkbox"/> Automobile Work |
| <input type="checkbox"/> Architectural Draftsman | <input type="checkbox"/> Aviation Engines |
| <input type="checkbox"/> Building Foreman | <input type="checkbox"/> Plumber and Steam Fitter |
| <input type="checkbox"/> Concrete Builder | <input type="checkbox"/> Plumbing Inspector |
| <input type="checkbox"/> Contractor and Builder | <input type="checkbox"/> Foreman Plumber |
| <input type="checkbox"/> Structural Draftsman | <input type="checkbox"/> Heating and Ventilation |
| <input type="checkbox"/> Structural Engineer | <input type="checkbox"/> Sheet-Metal Worker |
| <input type="checkbox"/> Electrical Engineer | <input type="checkbox"/> Steam Engineer |
| <input type="checkbox"/> Electrical Contractor | <input type="checkbox"/> Marine Engineer |
| <input type="checkbox"/> Electric Wiring | <input type="checkbox"/> Refrigeration Engineer |
| <input type="checkbox"/> Electric Lighting | <input type="checkbox"/> R. R. Positions |
| <input type="checkbox"/> Electric Car Running | <input type="checkbox"/> Highway Engineer |
| <input type="checkbox"/> Telegraph Engineer | <input type="checkbox"/> Chemistry |
| <input type="checkbox"/> Telephone Work | <input type="checkbox"/> Pharmacy |
| <input type="checkbox"/> Mechanical Engineer | <input type="checkbox"/> Coal Mining Engineer |
| <input type="checkbox"/> Mechanical Draftsman | <input type="checkbox"/> Navigation <input type="checkbox"/> Assayer |
| <input type="checkbox"/> Machine Shop Practice | <input type="checkbox"/> Iron and Steel Worker |
| <input type="checkbox"/> Toolmaker | <input type="checkbox"/> Textile Overseer or Supt. |
| <input type="checkbox"/> Patternmaker | <input type="checkbox"/> Cotton Manufacturing |
| <input type="checkbox"/> Civil Engineer | <input type="checkbox"/> Woolen Manufacturing |
| <input type="checkbox"/> Surveying and Mapping | <input type="checkbox"/> Agriculture <input type="checkbox"/> Fruit Growing |
| <input type="checkbox"/> Bridge Engineer | <input type="checkbox"/> Poultry Farming |
| <input type="checkbox"/> Gas Engine Operating | <input type="checkbox"/> Mathematics <input type="checkbox"/> Radio |

BUSINESS TRAINING COURSES

- | | |
|--|---|
| <input type="checkbox"/> Business Management | <input type="checkbox"/> Business Correspondence |
| <input type="checkbox"/> Industrial Management | <input type="checkbox"/> Show Card and Sign |
| <input type="checkbox"/> Personnel Management | <input type="checkbox"/> Lettering |
| <input type="checkbox"/> Traffic Management | <input type="checkbox"/> Stenography and Typing |
| <input type="checkbox"/> Accounting and C. P. A. Coaching | <input type="checkbox"/> English |
| <input type="checkbox"/> Cost Accounting | <input type="checkbox"/> Civil Service |
| <input type="checkbox"/> Bookkeeping | <input type="checkbox"/> Railway Mail Clerk |
| <input type="checkbox"/> Secretarial Work | <input type="checkbox"/> Mail Carrier |
| <input type="checkbox"/> Spanish <input type="checkbox"/> French | <input type="checkbox"/> Grade School Subjects |
| <input type="checkbox"/> Salesmanship | <input type="checkbox"/> High School Subjects |
| <input type="checkbox"/> Advertising | <input type="checkbox"/> Illustrating <input type="checkbox"/> Cartooning |
| | <input type="checkbox"/> Lumber Dealer |

Name.....
Street.....
Address.....

City..... State.....

Occupation.....
If you reside in Canada, send this coupon to the International Correspondence Schools Canadian, Limited, Montreal, Canada

ELECTRICITY WELDING AUTOMOBILES

PRACTICAL TRAINING ON MASSIVE LAY-OUT OF ELECTRICAL EQUIPMENT
Aircraft Oxy-Acetylene and Electric Welding, Armature Winding, Power Plants, Switchboards, Transformers, Motors, Generators, Batteries, Radio and Automobiles. Write now for Free Catalog.
Coleman Electrical School, 1628 Main St., Kansas City, Mo.

MINSTRELS Musical Comedies and Revues. Unique Minstrel First-Parts for complete show with special songs, opening choruses, etc. Full line of plays, stage songs, crossfire, monologues, afterpieces, vaudeville acts and make-up. CATALOGUE FREE.
T. S. DENISON & CO., 623 So. Wabash, Dept. 19, Chicago

QUIT TOBACCO

No man or woman can escape the harmful effects of tobacco. Don't try to banish unaided the hold tobacco has upon you. Join the thousands of inveterate tobacco users that have found it easy to quit with the aid of the Keeley Treatment.



KEELEY Treatment For Tobacco Habit Successful For Over 50 Years

Quickly banishes all craving for tobacco. Write today for Free Book telling how to quickly Free yourself from the tobacco habit and our Money Back Guarantee.

THE KEELEY INSTITUTE, Dept. A-927, Dwight, Illinois

PROTRUDING EARS?



PRIMSET, a simple and marvelous new method, will make them lay back to head at once and improve your appearance 100 per cent.

No mechanical appliance! **INVISIBLE, COMFORTABLE, HARMLESS.** Worn day or night. Use corrects deformity quickly with children, eventually with adults. Encouraged by physicians as best known method for straightening ears.

Thousands of enthusiastic users in Europe and America. Complete Outfit, guaranteed to do as claimed, sent for \$3.00 post-paid, or pay postman, plus postage. **THE PRIMSET SALES CO., Dept. 18, 2935 Ocean P'kway., Brooklyn, N. Y.**

NERVES?

Are You Always Excited? Fatigued? Worried? Gloomy? Pessimistic? Constipation, indigestion, cold sweats, dizzy spells and bashfulness are caused by **NERVE EXHAUSTION.** Drugs, tonics and medicines cannot help weak, sick, nerves! Learn how to regain Vigor, Calmness and Self Confidence. Send 25c for this amazing book. **RICHARD BLACKSTONE, N-4711 FLATIRON BUILDING, N. Y.**

NO JOKE TO BE DEAF - EVERY DEAF PERSON KNOWS THAT



I make myself hear, after being deaf for 25 years, with these Artificial Ear Drums. I wear them day and night. They stop head noises and ringing ears. They are perfectly comfortable. No one sees them. Write me and I will tell you a true story, how I got deaf and how I make you hear. Address **Medicated Ear Drum**



GEO. P. WAY, Artificial Ear Drum Co. (Inc.) 80 Hoffman Bldg., Detroit, Mich.



How to Obtain A Better Looking Nose!

Improve your personal appearance. My new Model 25 Nose Shaper is designed to improve the shape of the nose by remoulding the cartilage and fleshy parts, safely and painlessly. This is accomplished thru the very fine and precise adjustments which only my patented Model 25 possesses. Results are lasting. Can be worn at night, or during the day. Money refunded if not satisfied after thirty days' trial. Write for free booklet to

M. TRILETY, Pioneer Nose Shaping Specialist Dept. 61 BINGHAMTON, N. Y.



Railway Postal Clerks

\$158 Month First Year

Raise to Maximum of \$225 Month

Many Other U. S. Government Jobs Open to Men and Boys 18 Up
**POST OFFICE CLERKS RURAL MAIL CARRIERS CITY MAIL CARRIERS
 GENERAL CLERKS CUSTOMS INSPECTORS**

These are steady positions. Strikes, poor business conditions, lockouts or politics do not affect them. U. S. Government employees get their pay for full twelve months every year. There is no such thing as "HARD TIMES" in the U. S. Government Service.

ALLOWANCE FOR HOTEL EXPENSES

Railway Postal Clerks now get \$1900 the first year regular, being paid on the first and fifteenth of each month. \$79.16 each pay day. Their pay is increased \$100 and \$150 a year. The maximum is \$2700 a year. \$112.50 each pay day. They get extra allowance for hotel expenses when away from home.

PAID VACATIONS

Railway Postal Clerks, like all Government employees, are given a yearly vacation of 15 working days (about 18 days). When on runs they usually work 3 days and have 3 days off duty or in the same proportion. During this off duty and vacation, their pay continues just as though they were working. When they grow old, they are retired with a pension. As Railway Postal Clerks are continually traveling, they have an excellent chance to see the country. We expect Spring examinations.



CITY MAIL CARRIERS—POST OFFICE CLERKS

Clerks and Carriers get \$1700 the first year regular and automatically increase \$100 a year to \$2100 with further special increase to \$2300. They also have 15 days' vacation. Many February examinations will be held. City residence is unnecessary.

What Will You Earn 5 Years From Now?

Compare these conditions with your present or your prospective condition, perhaps changing positions frequently, kicking around from post to pillar, no chance in sight for PERMANENT employment; frequently out of a position and the year's average salary very low. **DO YOU EARN \$1900 EVERY YEAR? HAVE YOU ANY ASSURANCE THAT A FEW YEARS FROM NOW YOU WILL GET \$2700 OR MORE A YEAR, EVERY YEAR?**



FRANKLIN INSTITUTE
 Dept. C173
ROCHESTER, N. Y.

Rush to me entirely free of charge 32 page book with (1) a full description of the position checked below; (2) a list of U. S. Government jobs now obtainable; (3) tell me how to get the position checked.

- Railway Postal Clerk (\$1900-\$2700)
- Post Office Clerk (\$1700-\$2300)
- City Mail Carrier (\$1700-\$2100)
- Rural Mail Carrier (\$2100-\$3300)
- Clerk and File Clerks (\$1260-\$2500)
- Inspector of Customs (\$2100 up)

Get FREE List of Positions

Fill out the coupon. Tear it off and mail it today—now, at once. **DO IT NOW**—This investment of two cents for a postage stamp may result in you getting a U. S. Government Job.

Name.....

Address.....

Use This Coupon Before You Mislays It—Write or Print Plainly

MAIL COUPON TODAY

Swear Off Tobacco



Tobacco Tells on Nervous System



Tobacco Ruins Digestion



Tobacco Stunts Boy's Growth



Tobacco Robs Man of Vitality



Tobacco Steals from You the Pleasures, Comforts, Luxuries of Life

Tobacco Habit Banished Let Us Help You QUICK RESULTS

Trying to quit the tobacco habit unaided is often a losing fight against heavy odds, and may mean a distressing shock to the nervous system. So don't try it! Make the tobacco habit quit you. It does quit those who take **Tobacco Redeemer** according to directions.

It doesn't make a particle of difference whether tobacco has been used for a single month or fifty years, or how much, or in what form—whether it be cigars, cigarettes, pipe, plug, fine cut, or snuff. In most cases, **Tobacco Redeemer** removes all craving for tobacco in any form in a few days. Tobacco craving usually begins to decrease after the very first dose—there's no long waiting for results.

Tobacco Redeemer contains no habit-forming drugs of any kind and is safe, quick, pleasant, and thoroughly reliable.

Not a Substitute

Tobacco Redeemer is in no sense a substitute for tobacco, but is a radical, efficient treatment. After finishing the treatment, there is usually no desire to use tobacco again or to continue the use of the remedy. It helps to quiet the nerves, and makes one feel better in every way. If you really want to quit the tobacco habit—get rid of it so completely that when you see others using it, it will not awaken the slightest desire in you—you should at once begin a course of **Tobacco Redeemer** treatment for the habit.

Our Positive Guarantee

A single trial will convince the most skeptical. Our legal, binding, money back guarantee goes with each full treatment. If **Tobacco Redeemer** fails to banish the tobacco habit when taken according to the plain and easy directions, money will be cheerfully refunded upon request.

Let Us Send You Convincing Proof

If you are a slave of the tobacco habit and want to find a sure quick way of quitting "for keeps," you owe it to yourself and to your family to mail the coupon today or send your name and address on a postal, and receive our free booklet on the injurious effects of tobacco on the human system and positive proof that **Tobacco Redeemer** does quickly relieve the habit.

Newell Pharmacal Company
Dept. 300, Clayton Station, St. Louis, Mo.



Free Book Coupon

NEWELL PHARMACAL CO.
Dept. 300, Clayton Station St. Louis, Mo.

Please send, without obligating me in any way, your free booklet regarding the tobacco habit and proof that **Tobacco Redeemer** does positively relieve the tobacco habit or money refunded.

Name.....

Street and No.....

Town..... State.....

FREE

Get two wonderful books by mailing coupon below.

You get these Genuine High Quality, Imported Drawing Instruments, 14 Other Tools and a Drafting Table—all included in my Home Training Course.



These Two Books—
Mail Coupon!

Yes, Absolutely
FREE

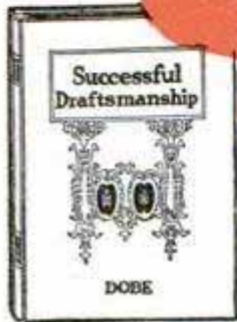

2
Books
FREE



Just Send the Coupon Below!

Money-Back Agreement

I train you at home under a positive Money - Back Agreement. If my training does not satisfy you after you have finished, you get every penny back.

Age or Lack of Education, No Drawback

Previous experience is not necessary. You do not need to be a college man or high school graduate.

Help As Long As You Need It

As my student you can write to me any time you want to and as often as you like and I will give you help on any subject pertaining to draftsmanship. I will advise you about jobs, extra work, fees and how to make extra money.

Jobs for Draftsmen in Great Industries—Learn At Home

Automobiles—Electricity—Motor Busses—Aviation—Building Construction.

There are jobs for Draftsmen in all of these industries and in hundreds of others.

Aviation is expanding to enormous proportions. Electricity is getting bigger every day.

Motor Bus building is becoming a leading world industry.

Building of stores, homes, factories and office buildings is going on all the time.

No structure can be erected without plans drawn by a draftsman. No machinery can be built without plans drawn by a draftsman.

I train you at home, in Drafting. Keep the job you have now while learning drafting.

I will train you in drafting right where you are in your spare time. I have trained men

who are making from \$3,500.00 to \$9,000.00 a year. There is a big future for draftsmen because you plan and supervise the work of others, or you go into business for yourself. Get started now toward a better position, paying a good, straight salary, the year around. Comfortable surroundings. Inside work.

Earn As You Learn

I tell you how to start earning extra money a few weeks after beginning my training.

Employment Service

After training you I help you to get a job without charging you a cent for this service. Employers of Draftsmen come to me for men because they know that Dobe Trained Men make good as they have learned drafting by actually doing the work themselves, in a practical way. Employers know they are not taking chances on men trained by me.

If You Earn Less Than \$70.00 a Week Ask for My 2 FREE Books



Mail this coupon, at once. Get "My Pay Raising Plan" and "Successful Draftsmanship". Both of them point the way to Success. You owe it to yourself to find out what a big opportunity there is in practically all industries, for Draftsmen. These two books are Free. They come to you post paid. Mail the Coupon for them TODAY.

ENGINEER DOBE

1951 Lawrence Ave., Div. 93-58 Chicago

FREE BOOK COUPON

ENGINEER DOBE

1951 Lawrence Ave., Div. 93-58 Chicago

Send me free of all cost your book, "Successful Draftsmanship", also plan to earn money while learning and proof of big money paying positions. Also your new book "My Pay-Raising Plan."

Name.....Age.....

Address.....

Post Office.....State.....

NAME THIS

This Offer Open to Every Reader of This Announcement

Have you sent a name? If not do so at once. It makes no difference who you are or where you live we want you to send us a name for our toothpaste. Whoever sends the most suitable name will win \$1000—nothing else to do.

Nothing To Buy—Nothing To Sell

You can use a coined word or a word made by combining two or more words, such as "Snow-White," "Gum-Strength," etc., or any other name you think would fit the high quality of this dental cream. There is nothing to buy or sell—simply the person sending the best and neatest suggestion for a name will receive \$1000 cash prize, or, if prompt, \$1100 in all.

Any Name May Win

No matter how simple you think your suggestion is you cannot afford to neglect sending it at once. Any name may win.

Win this \$1000 cash prize by a few moments' thought. How can you earn this amount of money easier or more quickly? Remember, there is no obligation! The person submitting the winning name will have nothing else to do to win the \$1000 and the extra \$100, if prompt.

In choosing a name bear in mind this dental cream is marvelous for teeth and gums. It is designed to sweeten the breath, beautify the teeth, cleanse cavities and promote teeth and gum health. The only thing necessary to win is to send the name we choose as the neatest and best suited for this dental cream. Only one name will be accepted from each contestant.

This unusual offer is only one of a number of offers embraced in our novel distribution plan whereby those taking part may win any one of twenty-odd prizes, the highest of which is \$3500 cash. By participating in our distribution plan the winner of the \$1100 cash prize may win an additional \$3500, making a total of \$4600. Everyone sending a name, regardless of whether it wins or not, will be given the same opportunity to win the \$3500 or one of the other cash prizes. Get busy with your suggestion at once—do not delay! Neglect may cost you thousands of dollars.

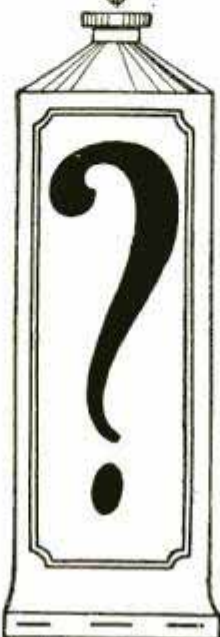

WIN

\$1000⁰⁰

Cash

\$100 EXTRA for PROMPTNESS

To get quick action I am going to pay the winner an extra \$100 for promptness, or \$1100 in all, so send your suggestion **AT ONCE!**

Contest Rules

This contest is open to everyone except members of this firm, its employees and relatives.

Each contestant may send only one name. Sending two or more names will cause all names submitted by that person to be thrown out.

Contest closes November 30, 1929. Duplicate prizes will be given in case of ties.

To win the promptness prize of \$100 extra, the winning name suggested must be mailed within three days after our announcement is read.

MR. H. E. RAY, *Contest Manager*
813 McCune Bldg., Des Moines, Iowa

Enclosed with this coupon on separate sheet is my suggestion for a name.

Date this announcement was read.....

Date my suggestion is mailed.....

Name.....

Address.....

NOTE: Being prompt qualifies you for the extra \$100 as outlined in this announcement.



**Cuts
Shave
Costs
83%**

**365
Keen Shaves
A Year
From The
Same Blade**

**KRISS-KROSS
Fits All Makes
of Blades**

AGENTS!

Make excellent money with Kriss Kross. H. King made \$66 in one day. N. C. Paige made \$104 in 3 days! Spare-time workers, Office and Factory men make up to \$6 and \$12 extra in a day showing Kriss Kross to friends and fellow employees. Get details at once. Check bottom of coupon and mail it tonight!

No More Razor Blades to Buy!

THINK of it! 365 keen, cool shaves a year from the same blade! That's what the revolutionary invention of a St. Louis man is doing for American shavers everywhere!

Kriss Kross marks the beginning of a new era in shaving comfort and economy. Its performance is so sensational that it seems hardly fair to call it a stropper. Rather it is a super-stropper or blade-rejuvenator! Almost literally, it makes a new blade out of an old one every day. No longer do you find that your blades "die" after five or six shaves. Kriss Kross "brings 'em to life" a surprising way, week after week and month after month—and endows them with a keenness that they seldom possess when brand-new!

Magic Diagonal Stroke

Kriss Kross employs the famous diagonal stroke, same as a master barber uses. Never before has anyone captured the secret of reproducing it automatically. Eight "lucky leather grooves" do the trick in 11

seconds with a precision it takes a master barber years to attain.

But that's not all. Kriss Kross embodies still another feature that has hitherto baffled mechanical reproduction. It stropps from heavy to light. It's absolutely uncanny the way the strokes start with strong pressure and grow lighter and lighter until an adjustable, automatic jig flies up and notifies you that your blade is ready—ready with the keenest cutting edge that steel can take!

Fits All Blades

Kriss Kross produces unbelievable sharpness and prolongs the life of any razor blade for months and even years. Fits all brands and makes except Durham. Eliminates 83% of shaving costs and ends all bother about remembering to buy new blades! No more "raking" and seraping with dull ones, either! Kriss Kross solves your blade problem for all time and gives you keen, velvet-smooth shaves forever!

New-Type Razor Blade FREE!



To introduce Kriss Kross stropper, we are including this month free samples of a revolution in razor blade construction. Made to fit your present razor. Guaranteed to last longer and shave better than any other. Expect a new shaving sensation.—Kriss Kross blades are made of a unique steel, made a new and better way. Send coupon today.

Rhodes' KRISS KROSS

**KRISS KROSS CORPORATION, Dept. S-3714
1418 Pendleton Ave., ST. LOUIS, MISSOURI**

Canadian Address:

**CANADIAN KRISS KROSS CO., 39 Wellington Street East, Toronto 2, Canada
Largest Manufacturers of Mechanical Stoppers in the World**

**Kriss Kross Corporation,
Dept. S-3714, 1418 Pendleton Ave.,
St. Louis, Mo.**

Send me details of Kriss Kross Stropper. Also send free sample of your new type razor blade for.....Razor.
(Fill in your make of razor.)

Name.....

Address.....

City.....State.....

() Check here for agents' money-making plan, full time or spare hours.

ANY BOY CAN WIN THESE PRIZES

Here are just a few of the attractive prizes selected from our Prize Book containing over 300 articles. You can easily have these and many more prizes . . . and besides earn your own spending money. Thousands of boys who are members of The Crowell Club of Junior Salesmen are doing this regularly. You are missing the time of your life if you don't get in with these fellows who spend part of their spare time delivering The American Magazine, Woman's Home Companion and Collier's The National Weekly to regular customers.



Here's smiling Bernard Korn, Ohio, with a few of the prizes he has won. How would you like to be as lucky as Bernard to have a good looking bicycle . . . a full chest of tools . . . a football . . . baseball glove . . . and a handsome set of silverware for Mother? Bernard will tell you that it's as easy as fun winning these prizes.

You Need No Experience to Start

If you want to win worth-while prizes, such as these shown, hurry and send your name and address on the coupon below. We will then start you as a Crowell Junior Salesman and tell you about the methods hundreds of boys are using to earn money and prizes.

SEND THIS COUPON NOW!

Mr Jim Thayer, Dept. 126
THE CROWELL PUBLISHING CO.,
Springfield, Ohio

Dear Jim: I want to earn money and prizes. Please start me off as a salesman.

My Name _____

Address _____

Town _____ State _____

CASH IN NOW WITH THESE! 2 BRAND NEW MONEY MAKERS!

LIFT-A-LITE ASH RECEIVER

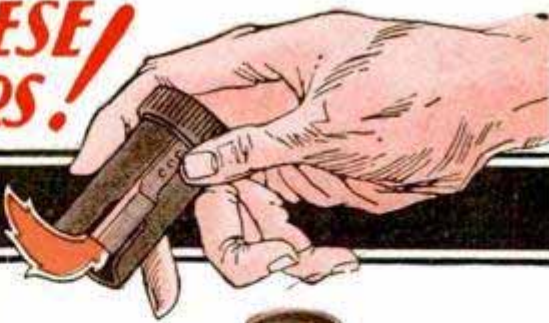

Here is the biggest hit brought out in recent years. A winning product—a sensational New Money Making Plan. On the right is pictured the new Lift-A-Lite Ash Receiver and Lighter Combination. No illustration can do justice to its real beauty and utility. It must be seen to be appreciated. It's a beauty to look at—the greatest convenience to use—takes but a snap to sell. The tray is deep and spacious, 6 inches long by 5 inches wide—the finest handiwork ever created. Made of durable Bakelite in lustrous colors and beautiful mottled effects in ONYX, RED, BLUEBLAZE, GREEN, MAHOGANY and WALNUT. The lighter works on an entirely new principle. Its exclusive patented features attract instant attention. By simply lifting the cap a light instantly appears. Replace the cap and enjoy your smoke with the tray handy to rest cigarette and hold ashes. The lighter has no springs or screws to adjust or any parts to get out of order. The working parts are fine gold finished. Every body is a prospect. Housewives, givers of gifts, club rooms, offices and business houses offer you tremendous sales and profits. Reap a harvest of the biggest profits you ever made in your life by getting behind this sensational big seller now. Our proven successful selling plans will show you how.

**JUST
LIFT CAP
FOR A
SURE LIGHT**

**\$5.00 VALUE
RETAILS FOR
\$3.45**

*Packed in
Gift Box*



Sensational Free Offer!

To get you started immediately we will send you a sample of the Lift-A-Lite Ash Receiver and De Luxe New Size Money Wallet and Lighter Set as illustrated here, both for the price of only one—\$3.45. With these samples in your hands we will prove to you that it is easy to earn \$2500.00 a month and more, or you may return the two samples and we will refund not \$3.45 but \$4.00 in cash. Mail coupon below!

**SAMPLES OF THESE \$3.45
2 BIG WINNERS for \$3.45
the price of only one**

Amazing New Advertising Imprint Plan Pays Tremendous Profits EVERY DEALER WORKS FOR YOU AS SUB-AGENT ONLY 25 ESTABLISHED DEALERS NET YOU \$2500 PER MONTH

We have originated an entirely new selling plan which will bring you big commissions in addition to the profits you make on the sale of this item to dealers. Lift-A-Lite Ash Tray makes a wonderful advertising gift and is designed to be imprinted with customer's ad. Twenty-five million dollars is spent annually in premium advertising. Every business and profession at one time or another—particularly during the holiday season—gives away advertising premiums to their customers or friends. You can cash in the profits on this business WITHOUT ACTUALLY DOING THE SELLING. The neighborhood dealer does that for you.

Here is How the Plan Works: We have designed a magnificent colorful display which automatically sells the consumer. At the same time a special message solicits orders from business men with their ads. The dealer is authorized to take orders at the list price furnished him and collect 25% deposit. This deposit the dealer retains as his profit and mails the order to us. We make shipment direct to the customer and collect the balance. Every order that the dealer sends in will show your name as our distributor. Out of this balance we pay you 25% commission. Advertising orders usually run in large quantities, ranging in lots of 100, 500 to several thousand. Estimating very conservatively, we will assume that a dealer will take orders for only 200 imprinted ash receivers per month amounting to \$500.00. On that basis he will collect 25% or \$125.00. Your commission is also 25% of the balance or \$100.00. If you have only twenty-five established dealers averaging 200 imprinted Lift-A-Lites per month, your commission will amount to \$2500.00. Before you appoint any dealer as your sub-agent for the imprinted lighters, it is necessary that he buy three or six assorted Lift-A-Lite Ash Receivers for resale and display over the counter. Your profit on the resale of Lift-A-Lites to 25 dealers will be \$108.00 in addition to the commission you will receive on all of their imprint orders. You can see at a glance what a money earner this proposition is. You simply can't miss a sale with this plan. Your earnings are only limited by the number of dealers you call on. BUT THIS IS NOT ALL.



NEW SIZE MONEY DE LUXE WALLET & LIGHTER SET

**\$5.00 VALUE
RETAILS FOR
\$3.45**

Here is our other winner, selling Big. The demand for the new size billfold is tremendous. This new combination of new money wallet and lighter to match is proving a whirlwind seller. Uncle Sam's recent change in the size of his paper currency means big money for you. Every man will want this De Luxe Set. The Wallet is smartly designed of genuine leather with handsomely embossed rose pattern. It is made to meet every requirement of the present day for a handy, convenient wallet to carry both the new size money and old large bills in separate compartments. There is a change and card purse and a compartment for identification and automobile license. The lighter is of the sure fire type with fine gold finished top and is covered with genuine leather embossed to match the wallet. Sells for only \$3.45. You make sales on sight every time you show it.

OUR SIX TESTED PROVEN SELLING PLANS LEAD YOU TO THE BIGGEST EARNINGS YOU EVER MADE

In addition to the advertising imprint plan briefly described above, we have five other plans that will prove big money makers for you. Briefly they are:—C. O. D. Plan. You take orders and collect your profit in advance. Initial and Emblem Plan, which brings instant sales and sells every prospect. Sales Board Plan—an extra profit maker. We show you how to build a steadily growing repeat business with dealers. Each and every one of these six plans will lead you to big earnings. Full details of all selling plans and selling aids will be sent with your samples.

Read This Extraordinary Guarantee

You take no risk. Send for these samples now and when they arrive if you are not satisfied it is the biggest opportunity ever offered for big sales and quick profits, return the samples and we will refund you not \$3.45 but \$4.00 in cash—50c extra for your trouble. YOU ABSOLUTELY TAKE NO RISK.

Rush Coupon Now for Special Offer

Fill out coupon below, enclose \$3.45 or \$1.00 deposit and we will ship C. O. D. for balance. You will receive one Lift-A-Lite Ash Receiver and one new size money De Luxe Wallet and Lighter Set—everything complete as illustrated here—with full details of all our amazing selling plans. There isn't another opportunity that compares with this. Exclusive territory to producers. Act now!

CLIP AND MAIL COUPON TODAY

GORDON MFG. CO. (Dept. CJ-19), 110 East 23rd St., New York, N. Y.

Your two big winners and selling plans interest me. I accept your special offer. Send me one Lift-A-Lite Ash Receiver and one De Luxe New Size Money Wallet Set.

Enclosed find () Full Remittance \$3.45

() \$1.00 deposit. (Will pay balance on delivery.)

It is understood you will refund \$4.00 if I return these samples.

Please include full details of all your selling plans.

Name.....

Address.....

City.....State.....



OLD SIZE BILLS

NEW SIZE BILLS

CHANGE AND CARD PURSE

IDENTIFICATION AND AUTO LICENSE

GORDON MFG. CO., Dept. CJ-19, 110 E. 23rd St., New York, N. Y.

Who Else Wants a **BIG PAY JOB** in **ELECTRICITY?**

Thousands of Cooke Trained Electrical Men are making \$3,000 to \$5,000 a year — \$60 to \$100 a week — some even more. They prepared for their fine jobs in **spare time only**. Now look at them — Big Pay Men, successful, independent, on the road to fortune. Who else wants quick success — who else wants Big Money in Electricity — who else wants to quickly say goodbye forever to hard work and small pay? Do YOU? Then act at once — mail the coupon today sure!



Jumps from \$25 to \$100

"From \$25 a week grocery clerk to \$100 a week electrical contractor is my record since enrolling." J. C. Kotheimer, 1808 So. 7th, Louisville, Ky.



Hubert Gets \$100 a Week

"I was a \$30 a week truck driver when I enrolled with you. Now I average \$90 to \$100 a week easy." C. H. Hubert, 460 Cherry St., New York.



Now Makes \$12 a Day

"A short time ago when I enrolled. I was a laborer at small pay. Now I make \$12 a day." Robert Korns, 203 S. Maple, Newkirk, Oklahoma.

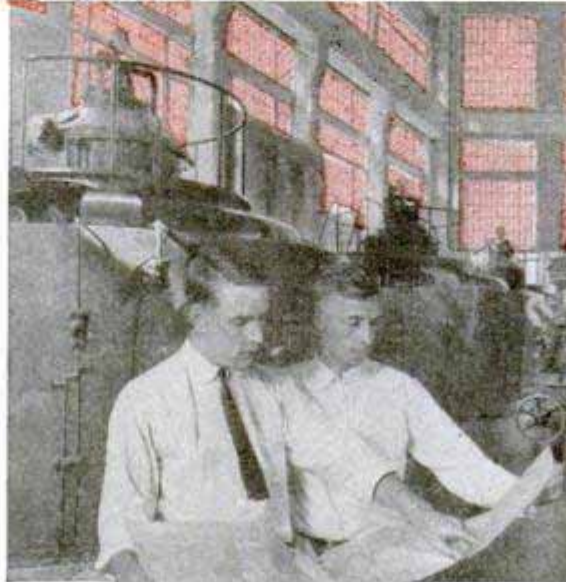

LEARN Electricity with the famous tried and proved "Work Sheet and Job Ticket" Method. It's just like actual shop experience. Yet it's all done right in your own home with a big complete outfit of apparatus given to you without extra cost. And it's done in your spare time — without quitting your present job or losing a single hour's pay.

You don't need previous experience or higher education. If you can read and write, that's enough. This famous training is as simple as A, B, C. Don't confuse it or compare it with any other Electrical course. There is nothing like "Cooke Training" anywhere. Big electrical men praise it — employers endorse it. That's why the "Cooke Trained Man is the Big Pay Man Everywhere and Always".

Electricity needs you, wants you, and will pay you well. Get ready now for a fine job in this Big Pay Field. Get started now under the famous Money Back Agreement with the same methods that have put thousands of men no smarter than you on Easy Street. Act today to get Big Pay. Mail coupon for my Big FREE BOOK "The Secrets of Success in Electricity", a brilliant story of Opportunity for you. Get it — mail the coupon NOW.

L. L. COOKE SCHOOL OF ELECTRICITY

The Cooke Trained Man is the Big Pay Man
Dept. 18, 2150 Lawrence Ave., Chicago, Ill.



Big Pay for Woelkers

"\$450 a month is what I now make with the help of L. L. Cooke's great electrical training." Leo Woelkers, 1332 Jefferson, Scranton, Pa.



Own Shop Pays Big Money

"You taught me all I know about Electricity. Last month I made \$675 in my new shop — I used to get \$15 a week." J. E. Ritch, Rt. No. 3, High Point, N. C.



\$80 a Month Increase

"In five months I boosted my earnings by over \$80 a month. I am \$1000 a year better off by taking your Course." Martin Herman, Box 598, Drumheller, Alta, Canada.



The MAN WITH 50,000 FRIENDS

This is L. L. Cooke, the man with 50,000 friends, because he has been so successful in training men for Big Pay Jobs in Electricity. In all the world there's no training like his. That's why his "boys" get the Big Jobs and Big Money. And now he wants to train YOU for a Big Pay Job too. Find out what he can do for you. Mail the coupon for his great book today.

L. L. COOKE, Chief Instruction Engineer,
Dept. 18, 2150 Lawrence Ave., Chicago, Illinois

You may send me, FREE and fully prepaid, your book "Secrets of Success in Electricity," with all particulars about your Home Study Course in Electricity.

Name _____

Address _____

City _____ State _____

Classified Advertisements

WORLD'S BEST WANT AD MEDIUM

Advertisements in this section, 30 cents per word, each insertion, minimum 10 words, payable in advance.

Rate starting January, 1930, issue 35 cents per word

To be inserted under proper classification in December issue, copy should be in our office October 18th

ADVERTISING AGENCIES

ADVERTISERS. Our 32 years mail order experience at your disposal. 68 page self-help guide, with United States map in colors, giving complete information best paying daily, weekly and monthly publications sent free. Frank W. Lenhoff Advertising Agency, 66 East Lake St., Chicago.

ADVERTISE In 24 big Sunday newspapers, 24 words \$15.00. Excellent for securing agents, salesmen and business opportunities. Catalog listing 1,000 leading dailies, weeklies, mail-order magazines, everything. Free. Wade Agency, Great Northern Bldg., Chicago.

GET Into Advertising. Learn quickly at home. Experience unnecessary. New easy plan. No text books used. Practical work. Old established school. Send name and address for interesting free booklet. Page-Davis School of Advertising, Dept. 3437, 3601 Michigan, Chicago.

ADVERTISERS. Publish your 24 word classified advertisement in 20 New York, Pennsylvania dailies, \$12.00. Campbell-McKay, Advertising, Box 123, Olean, N. Y.

ADVERTISE 50 Magazines 3c word; \$3.00 inch; 5,000 country weeklies 1c line per paper; lists free. Evans King Co., 672P, Wilmington, Del.

INCH Display Advertisement, 50 Magazines Year \$32. Wood's Services, Atlantic City, N. J.

ADVERTISING—Display or classified; placed anywhere; copy prepared; no additional charge. Newspaper, magazine, farm papers. List free. P. LeGrand Agency, 34 W. 33rd St., New York.

BEFORE Advertising get our catalog. No charge. 25 years in business. The largest classified agency in the world. Ankrum Advertising Agency, 100 No. LaSalle St., Chicago, Ill.

FREE—New 1929 Advertisers Rate Guide, 44 pages. Includes everything. Lowest rates. E. H. Brown Advertising Agency, 140 S. Dearborn, Chicago.

ADVERTISE in rural weeklies. Lists free. Meyer Agency, 4112 Hartford, St. Louis, Mo.

TIME Counts in applying for patents. See pages 140 and 141. Clarence A. O'Brien, Registered Patent Attorney, Washington, D. C.

FOR ADVERTISERS

ADVERTISE. 24 Words, 50 monthlies, 100 weeklies, \$4.50. List free. Allen, 234, Bound Brook, N. J.

"THE Master Letter Writer," including 500 successful letters, by Ad-Man Davison, world-famous letter expert; 704 pages, \$3. Circular sent. Opportunity Press, Westport, Conn.

ADVERTISE 300 Country newspapers, 28 words, \$10. Business getter. Lists free. Keator, Hartford Bldg., Chicago.

SALES PROMOTION

\$50 to \$50,000 Daily sales secured for our clients. This eastern client in fall 1927 had one product, but no distribution. Our counsel, plans, copy has now given him distribution in 26 states through 1200 outlets for 25 other products besides his original product. 85 years salesmanship-in-print experience back of our campaigns. Submit sales problems for free diagnosis. 10 years Sales Promotion, Manager Larkin Co. James C. Johnson, 118A Woodbridge Ave., Buffalo.

PRODUCTIVE Sales and advertising advice. Sales letters, slogans, advertisements, sales plans and copy prepared to fit your particular needs. P. A. Porter, Sales Counselor, 156 Fifth Ave., New York City.

LETTERS That talk—If you need sales letters that really sell. Mailing lists; form letters; any direct-mail advertising service. Write Omaha List & Letter Co., Box 1172, South Omaha, Nebr.

FORCEFUL advertising literature attractively prepared! Banning, Times Building, Watertown, N. Y.

AGENCIES WANTED

MANUFACTURERS Who have new patented specialties communicate with E. Temple, Box 737, Port Elizabeth. Mail canvassing organization whole South Africa. References furnished.

TYPING SERVICE

SEND Me your typing. Duplicate manuscripts 50c thousand words. 335 Rockwall, Tex.

MAILING LISTS

RURAL. City. Carefully selected. D. Taylor, 287 Grant St., Youngstown, Ohio.

BIG Free rate list describes 300,000 classified names. Many kinds; guaranteed correct; priced right. De Muth, 88-15 82nd Ave., Glendale, N. Y.

SEND \$1.00 For 3,000 rural women buyers names. Sheasgreen, PM1427 North Penn, Minneapolis, Minn.

AUTOMOBILES

STANLEY Steamers, please send address; free information; also sell Stanley Baker parts. 4826 Melrose Avenue, Los Angeles, Calif.

TIME Counts in applying for patents. See pages 140 and 141. Clarence A. O'Brien, Registered Patent Attorney, Washington, D. C.

AUTOMOBILE SUPPLIES

15 CENTS Stops the Rattle on all cars—the brake rods rattle unless you use Universal Antirattler. "Made of steel, tempered in oil." Western Auto Supply Stores and all dealers handling quality products have them. Ask for Universal Antirattler. New Ford A, new Chevrolet brake rod antirattler sets. Seat leg springs 75c pair. "Seeback" mirror \$3.90. 64 different antirattlers. For all cars. Universal Spring Co., 54 Grand Ave., Grand Rapids, Mich.

SAVE Money on auto and truck repairs. Gears, axles, bearings, motor and transmission parts at 50 to 75% off factory list prices. Satisfactory parts guaranteed. Prompt service. Price lists free. Century Parts Co., 1712 Lafayette Ave., St. Louis, Mo.

USED Air compressor, fully automatic, upright space saving type, beltless. Reconditioned and guaranteed like new. Shipped on trial and easy terms. Also a few test stands, car washers, battery chargers and paint sprays. E. M. Connor, Box M-1194, Troy, Ohio.

\$2,500.00 TO \$5,000.00 Plus satisfactory business experience and references secures state distribution for greatest safety and traffic automobile appliance ever placed on market. Investment covers stock supplies. Golden future for one qualifying. Gray Automotive Devices Co., Box 661, Houston, Tex.

YOU Are wanted to resilver mirrors at home. Immense profits plating auto parts, tableware, etc. Write Sprinkle, Plater, 77, Marion, Ind.

AUTO Parts new and used. Lowest prices. Bankrupt supplies, motors, wheels, radiators, transmissions, generators, gears, carburetors, touring tops complete \$15. Brakelining 50% off. Brightman, 2065 Main St., Hartford, Conn.

RADIATORS At wholesale prices. All standard makes. Satisfaction guaranteed. Send for prices, stating make and model. Independent Radiator Co., 1119 S. Wabash Ave., Chicago.

AMAZING New hub-cap wrench. 950,000 Chevrolet-Six owners. Agents wanted. Box 311, Apopka, R. I. Price \$1.25.

SET Eight spiral expansion reamers, \$11.95. Catalog. W. Barnitz, 203 Briggs, Harrisburg, Pa.

YOU Are wanted to resilver mirrors at home. Immense profits plating auto parts, tableware, etc. Write Sprinkle, Plater, 287, Marion, Ind.

AUTO SERVICE EQUIPMENT

BATTERY Chargers for service stations. Several makes. New and used bargains. Get price sheet. Adams-Barr, Columbus, Ohio.

BIG Opportunity in 8-hour battery charging. Let me tell you how you can install equipment with practically no investment. Earn \$150 to \$300 monthly from it. Bargains in used outfits. Write today. Also have a few reconditioned car washers, paint sprays, automatic air compressors. L. C. Helmick, Box M-1196, Troy, Ohio.

ECONOMIZER Transforms vibrating four cylinder Chevrolet or Ford to six cylinder smoothness, using vapor from radiator, removes carbon within few miles driving, increases gasoline mileage 50%, can be installed by anyone in ten minutes, will last the life of car. Send \$1.00 giving make and model, prepaid to any address. Positive guarantee. Economizer Manufacturing Company, Rome, Ga.

SAVE Money—Garage equipment reconditioned and guaranteed like new. Unusual bargains in test stands, car washers, battery chargers, air compressors, etc. Shipped on trial, easy terms. What do you need to complete your equipment? E. C. Galbreath, Box M-1195, Troy, Ohio.

FOR FORD OWNERS

SPECIAL Model A Ford heater. Low price. Write Broquist, Mfr., Chicago, City, Minnesota.

AURORA Underslung parts and 3.1 racing gears. Speedster bodies, headlights, hi compression head. See Sport Factories ad page 137.

FORD Generators exchanged \$3.50 with your old one, 30 days guarantee. A. J. Hildebrand, 2903 S. Fulton St., Philadelphia, Pa.

MOTORCYCLES, BICYCLES AND SUPPLIES

MOTORCYCLES \$25 To \$50. Easy terms. Tires \$2.50, frames \$3, forks \$3, tanks \$5, wheels \$4, chains \$2, saddles \$5, handle bars \$5, engines \$15, side cars \$25, transmissions \$12, belts \$6, airplane engines \$15, airplane wheels \$5, bicycle tires \$1.25, velocipedes \$7.50, bicycles \$9.50, new auto tires \$3, used auto tires \$2.50. Send 50c for catalogs. Price Cutter Deninger, Rochester, N. Y.

MOTORCYCLE Bargains, lowest prices, bargain sheets for stamp, special aviators supplies, motorcycle accessories largest line in America, lowest prices. Largest motorcycle mail order house in the United States. Rochester Harley Davidson Corporation, 129 West Main St., Rochester, N. Y.

HARLEY-DAVIDSON Bargains at a tremendous sacrifice. All models and prices. Guaranteed. Send for our catalog, "Money Saving Motorcycle Bargains." Knuth's Harley-Davidson Agency, 2525 Fond du Lac Ave., Milwaukee, Wis.

BARGAINS Used motorcycle parts for all makes. Goodyear balloon tires, \$8.25. J. B. Dahl, 3661-63 Archer Ave., Chicago, Ill.

AVIATION

LATEST. Best and up-to-date aviation books. Modern Aircraft, 900 pages, 500 engravings. Price \$5.00. Everybody's Aviation Guide, 256 pages, 140 illustrations. Price \$2.00. ABC of Aviation, 160 pages, 150 illustrations. Price \$1.00. Modern Aviation Engines, 2,000 pages, more than 1,000 engravings in two large volumes. Price \$9.00 for the set. All these books are written by Major Victor W. Page. Also the latest book on the subject of "Aerial Navigation and Meteorology," by Capt. Lewis A. Yancey, who made the famous flight from Old Orchard, Maine, to Rome, Italy; 350 pages, 102 illustrations. Price \$4.00. You make no mistake in ordering any of these books as they are all standard works, and some are used in 150 schools for instruction purposes. Any of these books sent prepaid on receipt of price, or just send us a card ordering book desired, and you can pay postman the price of book and postal charges when book is delivered. We publish books on more than 150 different subjects, and will send catalog on request. Norman W. Henley Publishing Company, 2 West 45th St., New York.

AIRPLANES Motors and propellers bargains. Smith, Box 1343, Houston, Tex.

ONCE Again the Heath Super Parasol, America's most popular sport plane won 1st and 2nd place at the national air races. Build this wonderful little plane for \$199. Complete bill of material. Less than \$40.00 will supply you with all the steel tubing and other parts to construct this modern plane. No cheap construction. Complete plane ready to fly \$975.00. Large detailed shop blue prints \$5.00. 10c in stamps or coin brings large illustrated booklet. Heath Airplane Co., Chicago, Ill.

BUILD A glider. Complete blue prints and plans for building. Get our three books, "Glider and Soaring," "Manual on Gliders and Soarers" and "Starting and Landing." Write for price list. Kenyon Press, Wauwatosa, Wis.

OX-6, Ox-5 motors for sale. JN. fuselage, rear half \$15. JN. parts 1/2 off. Ox-5 new cylinders \$20. Valves 50c. Turnbuckles 15c. Ox-6 propeller \$28. Quitting business. Pennsylvania Aero Service, 155 1/2 Dennick, Youngstown, Ohio.

SELLEY Champion, semi-constructed miniature airplanes and supplies. Most realistic models ever offered. Aluminum adjustable pitch propeller, 8 in. 60c. 10 in. 75c postpaid. Send 5c for catalog. Selley Co., 1465 Gates Ave., Brooklyn, N.Y.

AVIATION—Employment available now in Milwaukee for men who desire to earn while learning aviation. Training is in our shops, classrooms and on the airport. No experience necessary. Write for information without obligation. Aero Corporation of America, Employment Department MF, 63 Second Street, Milwaukee, Wis.

5c BRINGS You the biggest catalog of model airplane parts, supplies and construction sets in the country. Teaches building and flying models. Foster's Model Airplanes, 5503 Hudson Boulevard, North Bergen, N. J.

THE American School of Aviation announces a new correspondence course in Mechanics of Aviation. A thorough training in Practical Aeronautics. American School of Aviation, Dept. 1872, 3601 Michigan Ave., Chicago, Ill.

BUILD Model airplanes that fly. 52 page catalog illustrates 26 flying and exhibition models. Complete line of accessories and supplies. Send 10 cents for big catalog. U. S. Model Aircraft Corporation, 307F Bridge St., Brooklyn, N. Y.

HEATH Propellers for the aerial propulsion of sleds, boats or airplanes always give the best results. They are made to fit the particular conditions involved, accurately figured by men of 21 years' experience, specialized in air propulsion. 4c in stamps brings our propeller catalog. Heath Airplane Co., Chicago, Ill.

SEVENTEEN Inch Balsaplane, guaranteed flier, 50c. Catalog 5c. Marx Aircraft, 220 South Fourth East, Salt Lake, Utah.

DURALUMINUM Construction set, pursuit type single seater. Straightaway and stunt flyer \$1.25 postpaid. Send five cents for manual; teaches building and flying this plane. Foster's Model Airplanes, 5503 Hudson Boulevard, North Bergen, N. J.

MODEL Airplane supplies. 32 page catalog 5 cents. Curtiss Hawk construction set, \$3.00. National Model Aircraft Co., 29 P. North Ave., New Rochelle, N. Y.

PLANS For constructing sport monoplane. Use Ford or Chevrolet motor. Bergholt Aircraft Co., 143 East Lake St., Minneapolis, Minn.

PROPELLERS For airplanes, boats, hydroplanes, road speedsters, snow and ice sleds, canoes. Crawford Motor and Airplane Manufactory, Incorporated, Seal Beach, Calif.

WRITE For new free book, "Aviation." Tells you quickest way to get into aviation, money earned, etc. Also describes new method of home-study training that is preparing hundreds of men for big pay jobs. Address National Aviation Training, Dept. 119, 1031 South Broadway, Los Angeles.

TIME Counts in applying for patents. See pages 110 and 141. Clarence A. O'Brien, Registered Patent Attorney, Washington, D. C.

SIMPLEX Air Model Co., Auburn, Mass. Send five cents for supply booklet.

AIR Navigation and meteorology—New, simple, nontechnical book needed by every flyer. Nothing else on the subject like it. Written by Captain Duncan who has over 3,000 hours of flying to his credit. 225 pages. Flexibly bound. 80 pictures, maps, etc. Pay postman \$3.00 when he delivers book. Popular Mechanics Press, Room 804, 200 E. Ontario St., Chicago.

HEATH Henderson motors won at the national air races. It is the only dependable light plane motor in America. Due to low weight, 115, it is suitable for sleds, or boats as well as airplanes. Remanufactured motors may be had as low as \$190, or brand new for \$325. Send 10c in stamps or coin for large illustrated booklet. Heath Airplane Company, Chicago, Ill.

CONVERTED Henderson and Harley motors. Also propellers, hubs, motor mounts, etc. Let us convert your engine. Conversion work guaranteed. Send dime for booklet and prices. The Sensesch Brothers, Littitz, Pa.

3 FOOT Junkers flying-scale model, kit, complete with blueprints, \$3.50. Send 2c postage stamp for complete price list. A. A. C. Model Aircrafters, Dept. P-1, 340 East 188th St., New York.

ZEPPELINS! Boys! They're easy to build with our plans. Blue prints 3-foot models Los Angeles, Graf, Italia 50c a-piece. List free. Southern Aero Model Co., 1421 No. Washington Ave., Dallas, Tex.

TELESCOPIC Sights 26" long for airplane machine gun sacrifice at \$1.50. Air Transport Co., Garden City, N. Y.

PROPELLERS For model aeroplanes. Semi carved, 6", 8", 10", 12" 10c each. Any size. Aero Shop, 3050 Hurlbut Ave., Detroit, Mich.

NEW Model airplanes, supplies of finest obtainable materials, perfectly made. Catalog 10c. Dealers list 35c. Cleveland models, 1866P West 57th St., Cleveland, Ohio.

BOYS—Model airplanes supplies 2ft. Curtiss Hawk Flying Model Construction Set containing all necessary parts. \$2.50. Baby R. O. G. Kit, 50c. Send 5c for booklet. Hawthorne Model Aero Co., Hawthorne, N. J.

\$100 FLYING Course. Six hours, including solo. Only \$10 an hour for additional solo time. Allison Airplane Co., Lawrence, Kans.

SPORTPLANE—\$25 Payments. Buy the Alco Junior coupe monoplane. We deliver the knockdown parts to you express prepaid in eight convenient groups. Blueprints sold separately, \$2.50 per set of four big sheets. Allison Airplane Co., Lawrence, Kans.

BIGGEST, Best catalog model airplanes; parts, supplies; 5c postpaid. Ideal Company, 19 West 18th St., New York.

VARIOUS Sizes wood, reeds, bamboo, rubber band, wheels, propeller, onion skin covering and other supplies. Big bundle for 25c, five for \$1.00. No stamps. Will also send circular on free three foot model. Aero Shop, 3050 Hurlbut Ave., Detroit, Mich.

"SKYWARD HO!" Wonder book on aviation—32 pages, 150 illustrations. Shows you complete training for flying career, fame, fortune! Sent free. Write today! Parks Air College, 213 Mo. Theatre Bldg., St. Louis, Mo.

PROPELLERS—4", \$8.75; 5", \$13.25; 6", \$18.50; Special Henderson propeller, \$15.00; Aerodrive boat or sled blueprints, 50c each. Helmets, \$3.00; goggles, \$3.00, both only \$5.00. Engines, fuselages. Ostergaard Aircraft, 4303 North Narragansett, Chicago.

BOYS: Get a pursuit tractor kit complete 35c. No stamps. Send 5c for price list. W. & J. Aeroplane Shop, 200 Maple St., Wrandotte, Mich.

THE Age of the Air Is Here. For reliable information on both airplane building and flying we recommend "Aeroplane Construction and Operation," by Rathbun, a book used in government schools. All features of construction treated. Send no money. Pay postman \$2.50 and postage. Popular Mechanics Press, Room 806, 200 E. Ontario St., Chicago, Ill.

BOOKS AND PERIODICALS

4TH EDITION, revised "Radio Theory and Operating," by Mary Texanna Loomis. The standard radio text and reference book of America, 992 pages, 800 illustrations, flexible binding. Price \$3.50 postage paid. For sale by hundreds of book dealers throughout America and many foreign countries. Or may be purchased direct from the publishers. Send check or money order to Loomis Publishing Company, Dept. 18, Washington, D. C.

"CLEVER Ways to Save." "Clever Speeches for All Occasions." "Clever Songs to Sing." All 3 books 25c prepaid. Record Shop, Manitowoc, Wis.

CUT-RATE Books on money-making, sex, health, "flat money" of Europe, financial war relics. Lists gratis. Preatorius, 1629 Meyer Court, Chicago.

HYPNOTISM Easily learned. Lessons guaranteed. Postpaid, \$1.10. Smith Pub. Co., Dept. 3, Springfield, Mass.

"THE Personal Liberty Course"—A clever combination of mirth, information and instruction for quickly overcoming fear, bashfulness and physical complexes in men. No drugs, no gymnastics. Full particulars free, sealed. Harry J. Gardener, P. O. Box 607, Station C, Los Angeles, Calif.

INDUSTRIAL Alcohol. Wright's book. Full directions for making, fully illustrated, \$2.50. Spun & Chamberlain, 120 P.M. Liberty Street, New York, N. Y.

MONEY Making, worth while books, Catalog. Crown Supply, Box 241, Ottumwa, Iowa.

PRACTICAL Waterworks, power or electricity from stream having 3 feet fall or more. Plans for building \$1.00. Hansen, Box 809, San Francisco.

PICTURES AND POSTCARDS

OLD Mexico Spanish architecture masterpieces. Ten photographic postcards \$1 postpaid. Brown, Box 7062, Mexico City.

TEN Western views, 5x7, \$1.00. Fairchild, 125 West Main, Alhambra, Calif.

FRENCH Lovers photos. Love scenes of French girls and fellows. Taken from five poses. Imported direct from France, 12 for \$1.00. All different poses. Carrano Novelty Co., Dept. PM-N, West Haven, Conn.

ETCHING, Shrimp boat 25c coin. The Studio, 20 Aviles St., St. Augustine, Fla.

ART Pictures—226 all different. 160 samples \$1.00. Particulars 10c. Howard Sales Co., Dept. 15, Box 529, San Francisco, Calif.

TOYS, NOVELTIES AND CURIOS

ARTISTIC Double horseshoe picture frame. L. Baker, 810 6 North, Fort Dodge, Iowa.

TOM Mix comboy neckerchief, with Wonder Horse Tony, 15c. Clark, 46 Market St., Amsterdam, N. Y.

SNOOPER—The trick dog. He tickles the kiddies, 10 cents silver postpaid. Menon, 3502 South 54th St., Tacoma, Wash.

GAMES, ENTERTAINMENTS AND PLAYS

PLAYS, Musical comedies and revues, minstrels, comedy and talking songs, black-face skits, vaudeville acts, monologs, dialogues, recitations, entertainments juvenile plays and songs, musical readings, make-up goods. Catalog free. T. S. Denison & Co., 623 So. Wabash, Dept. 11, Chicago.

VENTRILOQUISM—Complete course, 50c Premier, 1980 Dorchester Ave., Dorchester, Mass.

VENTRILOQUISM By mail—small cost. 2c stamp brings particulars. Geo. W. Smith, Room 8-372, 125 N. Jefferson St., Peoria, Ill.

MAGIC TRICKS, BOOKS AND JOKER NOVELTIES

"THE Book of 1,000 Wonders" explains many mystifying tricks with coins, cards, handkerchiefs, etc. Also, contains complete catalog of magic tricks, jokes, puzzles, books, escapes, mind-reading acts, spiritualistic efforts, illusion plans, curios and imported novelties. Largest assortment, lowest prices. Amaze and mystify your friends! Send 10c today. Lyle Douglas, Station A-5, Dallas, Tex.

MAGIC—Tricks, Books and Supplies. For amateurs as well as the great professionals. Anyone can learn through our instructions. Feature Acts in Mind-Reading, Spiritualism, Rope Ties, etc. Large illustrated professional catalog, 20c. Chicago Magic Co., 140 So. Dearborn St., Dept. B, Chicago, Ill.

MAGIC Catalog 20c. Lynn's, 105 Beach, Dept. 3, Jersey City, N. J.

EIGHTEEN Magician's Tricks, \$1.00, including 29 pieces equipment, balls, dice, magiccards, etc., and wonderful performing secrets. Weber, 647—E-62nd, Chicago.

BUDDHA Money mystery. Lists, catalog 10c. Stringer, 3020 Sheffield, Chicago.

TRICKS With cards. Easy to do. Produce any card called for. Name any card drawn from pack. 6 tricks for 25 cents, including large catalog listing over 600 tricks. Wizard Magic Co., Dept. 15F, Box 1055, Station "C", Los Angeles, Calif.

BOOKS, Magic imported herbs, incenses, perfumes, gifts, novelties. 100-page catalog, sample 10c. Marelle Company, 160 N. LaSalle, Chicago.

FREE With \$25 order die box. Send 20c for our large catalog of tricks, wigs, sensational escapes. Oaks Magical Co., Dept. 548, Oshkosh, Wis.

MAGIC Tricks and novelties. Send 15c for illustrated catalog. E. Kay Magic Shop, 8822 Commercial Ave., Chicago, Ill.

SEVEN Magical Delusions and catalogs—25c. Gilmagico, Morgan Park, Ill.

ELECTRIC Fun! Seventy stunts, 110 volts, \$1. Kutting Sons, Campbell, Calif.

CHALK TALKS

LAUGH Producing program, \$1.00. Catalog free. Balda, The Cartoonist, Oshkosh, Wis.

MAKE 'Em laugh with magical cartoons. No talent needed. Entertain lodges, clubs and parties. G. E. Hendrickson, Argyle, Wis.

STAMP COLLECTING

MYSTIC "Queer Country" Packet! Contains scarce stamps from the following strange lands: San Marino, Antioquia, Congo, Cyprus, Fiji Islands, Gwalior Hyderabad, Iceland, Jhind, Kenya, Uganda, Lebanon, Monaco, North Borneo, Nyassa, St. Thomas Prince, Eastern Roumelia, Siam, Sierra Leone, Tanganyika, Trinidad Tobago, Ubangi, Upper Volta, Wallis Futuna, Alaouites. Get this wonderful packet of "freak countries" and make your friends envious! Price only 10c to approval applicants! Write today. Mystic Stamp Company (Dept. 8), Camden, N. Y.

500 DIFFERENT Stamps for 25c. Big collection from Bosnia, Crete, Epirus, Honduras, Iceland, Kenya, Liberia, Malta, Nyassa, Quelimane, Siam, Zambesia and other "hard" countries. Catalog value \$10. Price 25c to approval applicants! Bargains, 1,000 different 79c; 15 triangles 49c; 100 Africa 45c; 100 Asia 50c; 100 Balkans 35c; 100 British Colonies 30c; 100 French Colonies 35c; 100 Portuguese Colonies 50c. Eight packets for \$3.00! Illustrated lists free. Loma Stamp Co., 3926 32nd St., San Diego, Calif.

ANCHERS \$\$\$ Outfit—only 12c! Fine triangle stamp; set German stamps with (pre-war) value forty million dollars (interesting!); perforation gauge, mm scale; airmail set; scarce stamp from smallest republic on earth; newspaper set; packet good stamps and Travancore, Malay, Dutch Indies, etc. Entire outfit for 12c to approval applicants! (Nice pocket stock book, value 25c, with every order!) Ancher Stamp Co., Box 126, Rutherford, N. J.

FREE: Stamps from Bolivia, Roumania, Spain, Australia, to those sending 10c (coin) and 2c stamp for album with spaces for hundreds of stamps, free perforation gauge and packet of 80 different stamps, 150 diff. stamps 10c, 4 Vatican stamps 10c, 10 Persia 10c, 20 Turkey 10c, 12 Cape Verde 10c. Argonaut Stamp Company, Dept. 15, New Canaan, Conn.

SCOTT'S Standard catalog 1930 edition is on sale, Oct. 28. Lists, illustrates and describes every stamp ever issued to date of going to press. Prices used and unused, at which most of them may be bought. Cloth cover \$2.00, with thumb index, \$2.50, shipping weight 3 lbs., postage extra. Ask for a free copy of Scott's Monthly Journal when you order your catalog. It is the monthly catalog and the latest stamp magazine published. Scott Stamp and Coin Co., 1 West 47th St., New York, N. Y.

VIKING'S "Extraordinary" Packet! Contains 110 different stamps from Johore, Gold Coast, Mauritius, Cyprus, Travancore, Southern Rhodesia, Kenya Uganda, Sudan, Trinidad Tobago, etc. All for 5c to those requesting our excellent approvals. Useful premium free with each order. Viking Stamp Co., P. O. Box 63, Sheepshead Bay Station, Brooklyn, N. Y.

UNDERSTAND Your U. S. Stamps. Just what you need. Our U. S. Library (Illustrated) gives you full descriptions of all U. S. issues, Vol. 1—1847-69—50c; Vol. 2—Issues 1870-1893—50c; Vol. 3—Issues 1894-1900—50c; Vol. 4—1901-1929—\$1. Illustrated descriptive price list of U. S. and B. N. A. 50c. Our 32 page list of U. S. and B. N. A. free on request. Stanley Gibbons, Inc., 38P. Park Row, New York City, N. Y.

FREE—5 Portuguese Colonials, 50 diff. Foreign, 3 Triangles and 5 fine Liechtenstein—all free to new approval applicants. Regent Stamp Co., St. Albans, L. I., N. Y.

OLDENBURG Reprints. Set catalogs \$245.00—10c to approval applicants. Sheets and sets 60% discount. Charles Cleveland, 806 North Humphrey Ave., Oak Park, Ill.

NOVELTIES—Wonderful lot, 50 different Central American pictorials, only 25 cents. You'll come back for more. Chitraro, 500 W. 123rd St., New York City.

27 LIECHTENSTEIN 4c To approval applicants. Hagen, Box 129, Sioux Falls, S. Dak.

STAMPS—100 Varieties, Africa, Brazil, Peru, Cuba, Mexico, etc., 10c; 25 different U. S. 25c; 1,000 mixed, 40c; 1,000 hinges, 15c. C. Stegman, 5941 Cote Brillante, St. Louis, Mo.

100 DIFFERENT Foreign stamps from 100 different foreign countries, including Africa, Asia, Australia, Europe, West Indies, etc., for only 20c. Free with each order, our pamphlet which tells "How to Make a Stamp Collection Properly," together with our price lists of albums, supplies and hundreds of bargains in sets, packets, etc. Queen City Stamp & Coin Co., Room 36, 604 Race St., Cincinnati, Ohio.

CANADA Airmail stamp free, if you ask for approvals and send 15c for 25 different airmails or 30 different Canada and Newfoundland, both packets only 25c. We list 282 countries in our dime packets. Special bargains—500 different 25c; 1,000 different 75c; 2,000 different, \$2.50. Victoria Stamp Co., London, 4, Canada.

THOUSANDS Of stamps at 1c each—catalog values disregarded. Arrow Stamp Co., Winthrop Terrace, Meriden, Conn.

10 AIRMAIL And 100 other stamps 4c to approval applicants. John Alden, West Roxbury, Mass.

FREE Outfit! 52 stamps, hinges, pocket wallet. Postage 4c. Approvals. Milton Angle, South Berkeley, Calif.

FREE—Scarce two dollar postage stamp to purchasers of our superior British Colonial packet, only 10c to approval applicants. Globus Stamp Co., Dept. B, 214 Third Ave., New York.

PAR-A-WAY Land's packet, including Zanzibar, San Marino, Orange River Colony, Union South Africa, Southern Rhodesia, Hong Kong, Transvaal, Malay Tiger, Triangles, Air Mails, etc. Only 10c to approval applicants. McEwen, 755 Wilson, Columbus, Ohio.

ONE Dollar's worth of packets for fifty cents to purchasers of 1930 Scott's catalog. Lists free. Sunshine Stamp Co., 549 E. Maryland St., St. Paul, Minn.

CONGO, Free, five fine to approval applicants. Bernard Karch, Bengies, Md.

FREE, Large Greek pictorial set given free to approval applicants. Postage 2c. Hovey, 17384 Beaverland, Detroit, Mich.

25 VARIETIES Argentina, cat. \$1.00, for 25 cents to approval applicants. Bloedel, Hamlet, Ind.

1c, 2c APPROVALS, Discount. H. Peck, Langley Ave., Bedford, Ohio.

215 DIFFERENT, including triangle, birds, animals, Asia, Africa, Islands, 12c with approvals. Hollister, 3523 N. Seeley Ave., Chicago, Ill.

SOUTH Central America, 40 different, 10 cents. Approvals. Croston, Box 25, Haverhill, Mass.

PENNY Approvals. Premium. Schwaner, 9 Button St., New Haven, Conn.

EXCHANGING Movie stars' pictures for stamps from all over world results large accumulation. Selling as mixture: Large packet. Wonderful value, twenty-five cents postpaid. Tyson, 4816 Fountain, Hollywood, Calif.

200-200-200—ALL Different stamps; 200 hinges; approval sheet to hold 200 stamps; perforation gauge, millimeter scale and ruler; duplicate stamp container—all for only 15c to approval applicants. Edgewood Stamp Company, Milford, Conn.

NYASSA Triangle set complete (9 different) 20c to applicants for my new 1-5c net; Approvals. Paul Beyer, 269 Jewett Ave., Jersey City, N. J.

1,000 DIFFERENT Stamps (better grade) \$1.00. Hinges free with order. McKee, Norwood, N. J.

200 ALL Different stamps free. Postage 4c. Peabody Co., 3846 N. Dupont, Minneapolis, Minn.

400 VARIETIES 27c. Approvals at one-third. Hatch, 335-A Beverly Road, Milwaukee, Wis.

PACKETS, Sets, hinges, albums, etc. U. S., British and French colonies. Lists free. Carl Young, 1208 Chestnut St., Phila., Pa.

ALBUM 1,000 Hinges, 200 foreign, 25 Cuba, 25 Japan, 35c. Burtiss Company, Saratoga, N. Y.

ICELAND, 5 For 10c, 10 for 15c, 20 for 40c, 30 for 75c. Weber's Stamp Shoppe, 1377 Park Ave., Plainfield, N. J.

FREE! 5 Rare Siam to approval applicants. Winthrop Smith, 3611F, Cedardale Rd., Baltimore, Md.

UNITED States revenue, catalogs 50c, for 10c to approval buyers. State size of collection. Leduc, Redlion, Penna.

STAMPS Free. 12 large showy picture stamps, also 12 diff. British colonies for a request for my popular approvals at 50% discount. None better. Good supply of U. S. postage, 2c. P. F. Quinn, 1113 W. Nevada St., Philadelphia, Pa.

FREE! Largest stamp in the world! Fine packet 65 different stamps from Cape Verde, Jamaica, Mozambique, Syria, etc., including dying soldier, beautiful women, ships, maps, savages, airplane, scenes, bird and animal stamps, for only 5c to approval applicants. Largest Stamp in the World (Rare China Wild Goose Special Delivery) given absolutely free with each order. Supply limited! Send your 5c today! Western Philatelists, 6021 Harper Ave., M11, Chicago.

ATTRACTIVE Assortment, Central American with additional interesting unusual stamps, 2c postage only. Midland Stamp Company, Toronto, Can.

82 PAR Of countries only 10c—Inhabane, Travancore, Kouang Teheou, Syria, Liban and 77 other countries—82 different stamps; 82 different countries, 10 cents; approvals and illustrated lists with each order. Reimers, 29 Flatiron Bldg., Fort Worth, Tex.

25 DIFF., fine foreign coins, 55c, 12 diff. fine coins 25c. Willbert Bishoff, Ottawa, Kans.

5 ICELAND Free to approval applicants. Edward Hammond, Auburndale, Mass.

FOREIGN Stamps on approval. Napp, 413 Oak Grove, Beloit, Wis.

WHOLESALE: 50 Stamps, catalog \$5.00, for 25c. Alvin Johnson, Storm Lake, Iowa.

FREE! Bargain lists, scarce set Azerbaijan for 2c postage. Penna. Stamp Co., Greensburg, Pa.

SUMVALUE! 25 Airmails 10c; 8 Iceland, 10c. Choice approvals 50%. Webster Stamp, Box 11, Tremont Station, New York.

50% DISCOUNT United States and foreign. Palm Beach Stamp Shoppe, Box 2416, Palm Beach, Fla.

FREE—Bavaria 351-353 with approvals. C. Lacombe, 1800 W. Fayette, Syracuse, N. Y.

FREE Stamps with approvals. 2c postage. Harvey Teeple, Decatur, Ind.

FREE—20 Different African stamps, 60% approvals. Atlantic Stamp Co., 68 Garden St., Springfield, Mass.

REAL 1c Approvals. No junk. Howard G. Stuart, Gowanda, N. Y.

CANADIAN Commemoratives, Newfoundland 25 different. Illustrated lists 10 cents to approval applicants. Reid, 608 Yonge St., Toronto.

FREE! Stamps with approvals. Lists, 2 cents. Dundonald Stamp Company, Box 452, Station F, Toronto.

100 ALL Different British Colonies for 25 cents. To those asking for approval selections only. Lists free. United States and British colonies our specialty. Humber Stamp Co., 401 Quebec Ave., Toronto 9, Canada.

CHINA—25 Varieties. Free to approval applicants. Exchange? Target Stamp Shop, 6 Holland St., Binghamton, N. Y.

AFRICA, 25 Diff. for 5c to approval applicants. Hartjen, Dunning Station, Chicago, Ill.

WATERMARK Detector free! Approvals. Tatham Stamp Company, 49 Van-horn, West Springfield, Mass.

FREE 25 French colonies to approval applicants; postage 2c. Raymond Beall, 1209 Park Road, Washington, D. C.

AFGHANISTAN No. 501, cat. \$4.00, to approval applicants, 60c. J. M. Palmer, Jackson, Miss.

FREE—3 Triangles, 3 picture, 4 animals and 20 others to applicants for approvals. Hodgsons, 46 Olive Ave., Malden, Mass.

SELLING Out. 100 Barbados 40c. 100 British Guiana 35c. 100 Africa 30c. Craven Stamp Co., Thompsonville, Conn.

100 FOREIGN Stamps 3 cents. Lufbery Stamp Co., Branford, Conn.

FREE—Dandy packet with approvals. Monjar, 1551 Knox, Cincinnati, Ohio.

250 DIFFERENT Stamps, 10c. Approvals? Aladdin, 1550 Carroll, St. Paul, Minn.

FREE, 200 Diff. to approvals applicants. Postage 4c. A. Nosker, 4215 No. Dupont, Minneapolis, Minn.

75% APPROVALS 3c; 1,000 Stamps 20c; 4,000 75c; well mixed. Geo. Best, Cedar Rapids, Iowa.

STAMPS Cataloging over \$2 to approval buyers sending 2c postage. Ibis Stamp Company, Box 488, Miami Beach, Fla.

ONLY 5c! 10 Airmail stamps, including scarce Latvian triangle stamp, Portuguese Red Cross set and 8 different Latvian Occupation stamps. Approvals and free lists with each order. Curhan Stamp Company, Gloucester, Mass.

\$1.00 YELLOW Canadian (cata. 25c), a stock slip with U. S. and N. Y. \$2.00 stamps and 100 all different foreign free to approval applicants who send 5c for packing, etc. Stamps on approvals $\frac{1}{4}$, $\frac{1}{2}$, $\frac{3}{4}$, 1c, etc. Lowest prices and best quality. Kelgwin Stamp Co., P. M., Fernandina, Fla.

COVERTO Packet, 200 different stamps 10 cents, with 60% discount approvals. Covert Stamp, 39 State, Rochester, N. Y.

105 CHINA, Etc., 2c. Album (500 illustrations) 3c. Bullard, Sta. BB, Boston.

STAMPS Sent on approval at 70% discount. Reference required. Emory Renoll, Hanover, Pa.

33 1-3% COMMISSION. Sell our stamps, sheet catalog value, \$4. Our price, \$2.00. Unsold stamps returnable. No investment required. References necessary. Lux Stamp Co., 805-C Fairmont Place, Bronx, New York.

SIAM Airmail set of 4 weird stamps only 10c to applicants of our low-priced approvals. Lists free. E. P. Johnson, Box 692, San Jose, Calif.

ANNIVERSARY Offer! (15c) seven beautiful sets: "Airmail," "Commemorative," "Red Cross," "Occupation," "Charity," "Prisoners," "Pictorial," also three packets: (International) (Colonies) (Bulgaria), Approvals. G. W. Deering, 164 Albion, W. Somerville, Mass.

FREE—31 Different stamps to applicants for Royal approvals. 2c return postage. Royal Stamp Company, Bristol, Pa.

40 DIFFERENT United States with latest price list 12c. Approvals at 60% discount. Seidenberg, Baroda, Mich.

"NEWFOUNDLAND" Means "Rev. Butler." Collectors need my catalog (free). Rev. Butler, St. Georges, Newfoundland.

UNITED States stamps on approval. Reference essential. Stamp House, 38 Torrey, Dorchester, Mass.

BULGARIA—25 For 10c to approval applicants. Cleveland Stamp Co., Caxton Bldg., Cleveland.

SPECIAL 500 Different from all parts of the world, 25c to approval applicants. Ohio Stamp Co., Box 249, Cleveland.

SURPRISE Packet—Borneo, Congo, Malay, United States Commemoratives. Illustrated list, etc., to approval applicants 8c. Moseley, 4521 Parkview, St. Louis, Mo.

2,000 DIFFERENT Stamps \$2.65; 1,000, 80c; 500, 30c; 300, 20c. Maurice Michael, 942 So. 23rd, Bellwood, Ill.

FREE 6 Different Luxemburg to approval applicants. E. D. Stamp Co., 3905 Forest Park Ave., Baltimore, Md.

150 GOOD Mixed foreign stamps 3 cents. Stanton, Niantic, Conn.

FREE—\$1.00 U. S. postage old issue free. If you write for our 56 page price-list of U. S. and foreign stamps, 2,000 illustrations. Also fine but cheap stamps on approval. Hussman Stamp Co., 620-3 Olive St., St. Louis, Mo.

FREE—Canada (15 Var.) for new applicant of my 1c, 2c and 3c approval, and also my 50% discount. Chas. W. Schmidt, P. O. Box No. 4832, Frankford Sta., Phila., Penna.

1/2c APPROVALS, including Liberia, Nyassa, etc. Also 14,000 averaging 1 1/2c. References. Philatelic Exch., Huntington, W. Va.

ONLY 25c For a five months' subscription to The Stamp Collector, America's finest stamp magazine. 100 all different stamps given free to each subscriber. Money refunded if you are not more than pleased. The Stamp Collector, Dept. P. M., 515 Sedgwick Drive, Syracuse, N. Y.

25 SCANDINAVIAN 10c. M. Gustafson, 764 East, New Britain, Conn.

5c ONLY. 25 Different fine U. S. stamps; \$1.00 Canada postage; scarce Siam. Air mail with approvals. L. W. Hudson, Box 118, Plainfield, N. J.

ATTRACTIVE Approvals at 50% discount and 25% discount. Noemus Stamp Co., 312 East 23rd St., New York.

PENNY Approvals that Satisfy. Nell Gronberg, Box 5441, Philadelphia, Pa.

FREE! 115 Different stamps to approval applicants, 2c postage. Paige Stamp Co., Oak Park, Ill.

110 DIFFERENT Stamps, many unused, high values, free to collectors requesting our net approvals. Postage 2 cents. Christensen, Milwaukee, Wis.

FREE—100 Different stamps to applicants for our fine approvals. State Stamp Co., New Kensington, Pa.

AFRICA, 25 Diff. 5c to approval applicants only. Harry Brown Co., Elsmere, N. Y.

110 NEW Europe All Different, a wonderful collection cataloguing several dollars, free to collectors requesting our Net Approvals. Postage 2 cents. Badger Stamp Co., Milwaukee, Wis.

COMPLETE Sets on approval. References necessary. Kenneth White, Rockville, Conn.

FREE! Triangles, airmail, Iceland and 50 others to approval applicants inclosing 3c postage. Hawkeye Stamp Co., Cedar Rapids, 39, Iowa.

UNITED States—Send on approval. Send me your want list. Ref. please. M. Hanna, New Kensington, Pa.

200 DIFFERENT stamps 10c; 1,000 hinges 10c. R. H. Carlton, 380 W. So. Temple, Salt Lake, Utah.

STAMPS, 100 all different. Postage 2c. Lists free. P. M. Quaker Stamp Co., Toledo, Ohio.

24 VARIETIES Cuban stamps, 10 cents. List of 6,000 low-priced stamps free. Address Chambers Stamp Co., 111P, Nassau St., New York City, N. Y.

FREE 50 British Colonials, if approvals requested. Postage 4c. Berkeley Stamp Co., South Berkeley, Calif.

BEST One cent approvals in America. F. P. Hand, 1117 So. 60th St., Philadelphia, Pa.

101 STAMPS Free with approvals. Postage 2c. Johnson Stamp Co., (PM) Jamestown, N. Y.

111 DIFFERENT, Arabia, Azerbaijan, Zanzibar, etc., 10c to approval applicants. Floyd Marsh, 524 Hamilton Ave., Indianapolis, Ind.

BARREL Of foreign stamps while they last. 25c-1,000 or pound \$1.00 (over 4,000). Approvals sent. Hinges 3,000-25c. Elmer, 61 Court St., Boston.

FREE—20 Different Argentine. Approvals. List. Send 4c today for postage, etc. Reuter, Santa Ana, Calif.

STAMP Collectors' magazine. Finest monthly stamp paper. Write for free sample copy. Philatelic Publishing Co., Inc., 15 John St., New York, N. Y.

MAGNIFICENT Packet free—Beauties from distant lands, many richly colored, unusual designs. 2c postage. Empire Stamp Co., Toronto, Can.

RARE COINS

UNITED States commemorative half dollar, all uncirculated, Lincoln, Maine, Grant, Huguonot, Lexington and Oregon Trail \$1.25 each. 1920 and 21 Pilgrim, Monroe, Stone Mountain and Vermont 90c each. Isabella quarters \$1.25. 10 different dates, large cents, 90c. 10 old foreign coins, 50c. Postage extra. Ambrose Brown, Marblehead, Mass.

OLD Money wanted—Will pay fifty dollars for nickel of 1913 with Liberty head (no buffalo). We pay cash premiums for all rare coins. Send 4c for large coin folder. May mean much profit to you. Numismatic Co., Dep. H. Ft. Worth, Tex.

40 OLD Coins all different \$1.00; 100 different coins, \$3.00; 100 mixed foreign coins, \$1.00; 100 different Germany war-coins, \$2.00; Pilgrim half-dollar uncirculated, \$1.00. Claud Denney, Box 315, Dallas, Tex.

FINANCIAL War relics. Collectors derive lasting satisfaction from our free list. Preatorius, 1629 Meyer Court, Chicago.

30 DIFFERENT Coins 50c, 15 different, 25c. Oddehon, Kansas City, Mo.

CALIFORNIA Gold quarter 25c, half 50c. Chester Brooks, Cuero, Tex.

10,000,000 MARK Bill and list 10c. Greenclay, Box 2551, Denver, Colo.

5 DIFFERENT Foreign coins 25c, 5 different foreign paper money 25c. Price list and old coin 10c. Bob Cohen, Box 483, Muskogee, Okla.

UNITED States commemorative half dollars, Pilgrim 80c, Monroe 80c, Stone Mountain 70c, Lexington 80c, Lincoln \$1.19, Norse American \$1.19, California \$1.69, Bennington \$1.29. Old coin and bargain price list 10c. Arey, Box 483, Muskogee, Okla.

\$2 TO \$500 Each paid for hundreds of old coins. Keep all old money, it may be very valuable. Send 10 cents for illustrated coin value book, 4x6. Prices guaranteed. Get posted. We buy and sell. Clarke's Coin Office, Box 5, Le Roy, N. Y.

RARE United States, foreign coins, war medals, Chinese coin and catalog 10c. Alexis Mengelle, Colorado Springs, Colo.

AMERICAN Coins, bought, sold. Coin value booklet, 12c. Frank Saco, 735 45th St., Brooklyn, N. Y.

CALIFORNIA Gold—Quarter size, 27c; 3/4 size, 53c; 3c piece and catalog, 10c. Norman Shultz, Box 746, Salt Lake, Utah.

GET Profit and pleasure in collecting old coins. Send 10c for large illustrated coin catalog. You'll be delighted with it. Send for it right now. B. Max Mehl, Numismatist, Mehl Bldg., Dept. P, Fort Worth, Tex. Largest Rare Coin Firm in the U. S.

OLD Coins, large fall selling catalog of coins for sale free to collectors only. Catalog quoting prices paid for coins, ten cents. William Hesslein, 101A Tremont St., Boston, Mass.

3 DIFFERENT Fine bronze or nickel coin, 2 large crisp bank notes and catalog 10c. George Best, Cedar Rapids, Iowa.

UNITED States. Large cent, two-cent bronze, three-cent nickel and bargain list, 25c. Thirteen dates large cents, \$1.00. George Coffin, Greenwood Mountain, Me.

FOR BOYS

EARN Christmas money. Order 50 sets Christmas seals. Sell for 10c set. When sold return \$3.00, you keeping \$2.00. No work—just fun. St. Nicholas Seal Co., Dept. 43PM, Brooklyn, N. Y.

CAMERAS AND PHOTO SUPPLIES

BARGAINS In cameras, kodaks and lenses as well as supplies of every description are listed in our bargain book offered to you free. A few sample bargains: 3 1/4 x 4 1/4 Auto Graflex Camera, Goerz color f:4.5 lens \$46.75. Eastman Kodak 3 1/4 x 5 1/4 with f: 6.3 Anastigmat lens in Universal Shutter \$24.75. Send for your copy today. Central Camera Co., Dept. 11c, 230 S. Wabash Ave., Chicago, Ill.

FILM Developed, 6 glossy artistic border prints, 25c. Samples free. Glazo Co., 421 New Nelson Bldg., Kansas City, Mo.

KODAK Films developed 5c roll. Prints 3c each. Trial offer. 8x10 enlargement 25c. Sample holiday greeting card from your own negative 10c. Young Photo Service, 405 Bertha St., Albany, N. Y.

TIME Counts in applying for patents. See pages 140 and 141. Clarence A. O'Brien, Registered Patent Attorney, Washington, D. C.

NEW \$30 Camera, F6.3 lens, \$17.50 cash or trade. K. Spring, Lebanon, N. H.

EARN Big money with your camera in your spare time, using Halldorson Home Portrait Lamp. Write for booklet "Home Portrait Photography" and catalog—both free. The Halldorson Company, 4748 N. Western Ave., Chicago.

MAKE Money in photography. Learn quickly at home. Spare or full time. New plan. Nothing like it. Experience unnecessary. American School of Photography, Dept. 3432, 3601 Michigan Ave., Chicago.

HAVE You a Camera? Write for Free sample of our big magazine, showing how to make better pictures and earn money. American Photography, 116 Camera House, Boston, 17, Mass.

FILMS Developed. Special Trial Offer. Any Size Kodak film developed 5c, prints 3c each. Trial 6x10 Enlargement in handsome folder 40c. Overnight Service. Roanoke Photo Finishing Co., 209 Bell Ave., Roanoke, Va.

SAMPLE Enlargement—dime, and negative (returned). Trial roll, glossy prints, 25c silver. Brown, Warsaw, N. C.

GERMAN Cameras, Lenses, Baritro, 129 W 3rd St., Los Angeles, Calif.

MOTION PICTURES

SOUND Motion Pictures! The great and only authoritative text book on this subject by James Cameron, world's foremost authority. 400 pages complete information on all systems—Vitaphone, Movietone, Phototone. Methods of reording, maintenance of equipment. Complete information for projectionists and all interested. Thousands sold. Send for your copy, \$5.00 postpaid. Bass Camera Company, Motion Picture Headquarters, 179 W. Madison St., Chicago, Ill.

\$1,250 FOR Original photoplay story. Our sales department sold unknown author's first story for above amount. We revise, copy-right and market stories for both silent and talking pictures. Located in the heart of motion-picture industry. We know the demand. Established 1917. Free booklet. Universal Scenario Company, 206 Western and Santa Monica Bldg., Hollywood, Calif.

325 FEET \$1.10. New lists. Hoffman Film Service, 57 Broad, Albany, N. Y.

AGENTS Wanted, all cities, to sell RWK All-Movie Cabinets. Must own 16 m/m outfit. Write for proposition. National All-Movie Sales Co., 333 N. Michigan Ave., Room 605, Chicago, Ill.

"PROFESSIONAL Movie Tricks for Amateurs," 130 page book tells everything. Price 50 cents. Also "Making Money with Amateur Movies," 25 cents. Box L, Hollywood, Calif.

THE Bass Bargaingram No. 198 hot off the press, culminating twenty years of success with a tremendous offering of bargains in rebuilt standard and amateur Motion Picture Cameras, Projectors, Accessories, Text Books. The great bargaingram will be sent to you for 4c in stamps. Send for your copy today. Bass Camera Company, Motion Picture Headquarters, 179 West Madison St., Chicago, Ill.

YOU will save 25 to 60% on our used bargains. It will pay you to secure a copy of our bargain book offered to you free. A few sample motion picture camera bargains: 35mm., Institute Motion Picture Camera with f:5 lens 200 foot capacity \$79.50. Universal 35mm., M. P. Camera with Ultra f:1.9 Anastigmat lens 3 magazines and case \$295.00. Everything guaranteed. Central Camera Co., 230 S. Washburn Ave., Dept. PM-11c, Chicago, Ill.

MAKE Money writing photoplays for silent and talking pictures and magazine stories. Send for writing analysis chart and start on the road to successful authorship. No cost or obligation. Hollywood Photoplay & Fiction Institute, 105 Western & Santa Monica Bldg., Hollywood, Calif.

BARGAINS Excellent films, talking equipment, projectors. Marshall Films, Rome, Ga.

FILMS, 200 Feet \$1.00. Reels \$2.50. Lst. Edgeworth Sales, Box 155, Blue Island, Ill.

TIME Counts in applying for patents. See pages 140 and 141. Clarence A. O'Brien, Registered Patent Attorney, Washington, D. C.

FILM Bargain (new) theatre size, natural color, Indians, cowboys, scenes, big stars, 3 1/2 foot; sample 10c; no lists. Horizon Film Co., 37 Church St., Boston, Mass.

GOOD Film—300 feet \$1.00. Reels \$2.45. Samples, lists, particulars for stamp. Eastin Feature Films, Galesburg, Ill.

BE A Movie exhibitor. Big opportunity. Only moderate capital required. Complete equipment at remarkably low prices. Write Atlas Moving Picture Co., 624 South Michigan Ave., Chicago, Ill.

NEW And rebuilt projectors for theaters, schools, churches, traveling shows. Supplies and complete theater equipments. Bargain prices. Free catalog. Monarch Theatre Supply Co., Memphis, Tenn.

MOVIE Films, 1,000 ft. reels, \$2.50 each; shipped anywhere on receipt of remittance. Particulars on request. Independent Films, 177 Golden Gate Ave., San Francisco, Calif.

LEARN—Modern theatre management. Big opportunities. Free particulars. Theatre Managers Institute, 307 Washington, Elmira, N. Y.

RADIO SETS AND SUPPLIES

\$5 RADIOS All makes Atwater-Kent, Majestic, R. C. A., and others. Hundreds—world's best makes. Used, new and rebuilt. Going at \$5 to \$65. Many formerly priced at \$150 to \$300. Amazing bargains. Backed by responsible guarantee and 30 years' experience. Write for big free list today. Brown's Radio Exch., Dept. E, 3018 East 91st St., Chicago.

NEW 300-Mile "pocket" radio, \$3.50. Complete with special loud receiver. No tubes or batteries required. Order direct. Spencer Laboratories, 116 Atlas, Akron, Ohio.

GENUINE Grebe \$35.00 cone speakers. 22 inch, brand new, factory sealed, \$10.00 plus express. 18 pounds. Geo. Schulz, Calumet, Mich.

RADIO World, America's only national illustrated radio weekly. All stands. 15c copy; \$6 yearly. Special: Send \$1 trial subscription 8 weeks and "A" battery tester free. 145 W. 45th St., New York.

ALL Makes, latest models, bargain prices. Radloman, Lake, N. Y.

TIME Counts in applying for patents. See pages 140 and 141. Clarence A. O'Brien, Registered Patent Attorney, Washington, D. C.

RADIO Trouble Shooting—Covers all-electric sets and television. Greatest book ever published from the point of view of assisting the repairman as well as showing how the radio owner can do his own repairing. 328 pages. Over 300 illustrations. Flexible. Pay postman price \$3 and postage when he delivers it. Popular Mechanics Press, Room 808, 200 E. Ontario St., Chicago, Ill.

TRADE AND TECHNICAL SCHOOLS

LEARN Morse and wireless telegraphy. Big salaries. Tremendous demand. Expenses low, can earn part. Catalog free. Dodge's Institute, Fern St., Valparaiso, Ind.

OUR Commercial radio operating and junior engineering course pays our graduates \$150 to \$300 monthly from start. Rapid advancement. Fall term begins in September. Write for catalog of course including Extension Course. Loomis Radio College, Dept. 5-E, Washington, D. C.

BE A blue print reader. Write for facts. See how men in your trade got to the top. What's your trade? Carroll Ramsey, Drexel Bldg., Philadelphia.

HILES Watchmaking and engraving school. The largest and best equipped school in the west. 5330 Mission St., San Francisco, Calif.

DRAFTSMEN! Be an expert. By our method we train you quickly. Books and tools furnished. Write for illustrated catalog. Columbia School, 204P Drexel Bldg., Philadelphia.

BUSINESS OPPORTUNITIES

BIG Free printing line brings easy quick profits. Union label. Bigger commissions—up to 55%! Experience unnecessary. Now write orders with America's most profitable printing stationery line. Thousands of free cuts. Over 150 standard items covering every business need: letterheads, noteheads, envelopes, billheads, business cards, statements, garage forms—shipping, battery, dry cleaning, tire, storage, parking and hat-cleaning tags; repair forms; blotters, gummed shipping, drug, advertising stickers, etc. Lowest prices. Steady repeat orders. Ship everywhere. New free outfit just off press. Write quick. Dept. 163, Box 498, Cincinnati, Ohio.

READ The Mail Order News—America's pioneer mail trade journal. Quarter century old. Approximately 600 pages yearly of valuable information for beginners and established mail-order houses. Analyzes mail-order business, its opportunities. Practical mail-order ideas, legitimate money-making schemes, instructive articles. Tells how to start, what to sell. Published monthly. Subscription \$3.00 yearly. Send 25c for sample copy. None free. Mail Order News, 500 Fifth Ave., New York.

WITHOUT Exception most profitable opportunity ever offered. Unlimited possibilities—plan unique—unbelievable results; small investment for advertising matter only; no stock to carry; permanent income; no effort required; tremendous number buyers developed automatically. We warehouse and deliver for you. Anyone can succeed with this most profitable of all sales plans. For full particulars write The Finance Corporation, Desk K, 522 McKnight Bldg., Minneapolis, Minn.

IF Ever there was an opportunity offered you, to get into a highly profitable specialty manufacturing business, here it is. My free booklet "Keystone of Success" describes a new way to get started, on a liberal plan, under actual, successful, experienced guidance. If ambitious to succeed with your own products, send for it. C. Ruskin, 1501 Euclid Ave., Cleveland.

LOIDLAC. Chemist's amazing new discovery. Forever ending automobile polishing and repainting! Instantly restores all colors, producing hard, brilliant lustrous finish. Guaranteed water, sun and weather-proof. You make Loidlac from my guaranteed exclusive copyright-protected formula for \$1.40 gallon, sell at \$14.00 a gallon profit! Write for exceptional offer. Miller, Chemist, 707 Jetton, Tampa, Fla.

ARTIFICIAL Marble sanitary flooring instructions, covering wood or cement flooring 1/2 inch thick, fireproof, waterproof, all colors, low cost. Ornamental casting, concrete, plaster, papier-mache decorations, garden furniture, statuary, flexible molds. 18 years instructing the public; particulars and illustrations free. Chris. Mahler, Huntington, N. Y.

MAIL Order business your opportunity. Breniser's famous hand books by expert 28 years' experience show how to start selling articles you make or buy—all or part time—small capital. Fascinating, profitable. Set eleven books, \$3.25. Breniser Company, 1607 P. Sanson, Philadelphia. Sample book, 25c, pay \$3 for other ten if satisfied.

YOUR Winter opportunity, big demand and fast sales for chillblain remedy. Instant relief, easy and cheaply manufactured. Formula 50c. C. Beaumont, R2, Box 55, Yucalpa, Calif.

FOR Sale—Poultry farms and hatcheries. Wonderful opportunities. Melwood Company, 1805 Superior, Toledo, Ohio.

KING System mail order, co-operative idea. It's different! Honest! Big profits! Details free. Evans P. King Co., Wilmington, Del.

WIN Money! Subscribe to Current Contests, Sayville, N. Y. \$2 a year.

BUILD A Business of your own. Subscribe to The Income Increaser, the only magazine edited by Edward C. Barroll, the well known advertising man and mail order writer. This 40 page magazine filled with the latest ideas, plans, schemes, pointers and suggestions comes to you monthly for only one dollar per year. Sample copy 10c. Income Increaser, 88 Pearl St., Boston, Mass.

"ODD-THINGS"—Money making ideas! Schemes! Plans! Tips! Opportunities galore! New—different! Special three months' subscription, 10c postage. "Odd Things," 1516 Prospect, Cleveland, Ohio.

"HOLD-TITE Rug Sizing" prevents rugs from slipping. Something new. No competition. Big profits. Enormous demand. Sample can, 75c postpaid. Hold-Tite Products Co., 1847 Market St., San Francisco, Calif.

STEPSAVER Kitchen drawer is your opportunity. Sell them for us. Excellent profits. Reward Mfg. Co., 385 45th St., Milwaukee, Wis.

EARN Money decorating Christmas cards; new easy method. Send 10c for samples and full particulars. Walter Sharp, 5255 So. Broadway, Los Angeles, Calif.

START Something. A business of your own. Several successful plans, \$1.00. J. Tillberg, Proctor, Vt.

SIX Hours a week spare time and twelve numbered gum venders placed with good merchants will earn you \$500.00 monthly. Sample \$18.00. Write for territory. Sanders Mfg. Co., Nashville, Tenn.

"MAIL Order Selling," 48-page magazine. New ideas each month. Three months trial subscription 25c. One year with valuable premium \$1.00. Mail Order Selling, Brookfield, Ill.

INDIVIDUAL Mailings from over 400 firms 25c. Box 307, Vancouver, Wash.

MIRRORS Resilvered at home. Costs near 5 cents per square foot; you charge 75 cents. Immense profits plating like new brass, worn-off auto parts, reflectors, tableware, stoves, etc. Outfits furnished. Details Free. Sprinkle, Plater, 127, Marion, Ind.

CORRESPONDENCE Solicited any kind on second hand or low priced articles. Burke, 94 King, Northampton, Mass.

MECHANICS, Painters, carpenters, start furniture refinishing, painting, handyman shop on nearly nothing; winning plan brings customers quickly. John Braceland, 1439 So. Ninth, Philadelphia, Pa.

LEARN Marbleizing, and stone enameling concrete products, to resemble polished marble. How to veneer concrete slabs, tile, table tops, etc.; also to enamel wall boards or wood. How to make granite grave markers. How to make your own molds for all uses. Membership inexpensive. Send dime for samples and literature. The Cowell Institute, Grayling, Mich.

START A little factory in your home; big profits, small investment. Louis Irons, Terre Haute, Ind.

\$2,500.00 TO \$5,000.00 Plus satisfactory business experience and references secures state distribution for greatest safety and traffic automobile appliance ever placed on market. Investment covers stock supplies. Golden future for one qualifying. Gray Automotive Devices Co., Box 661, Houston, Tex.

NATIONALLY Known chemist will start you in highly specialized, money making business. Free information. J. C. Hertzstein, 46 Grand Ave., Grand Rapids, Mich.

FUNDS For expanding your present business or starting new one. We specialize in helping you; show you how. Interesting details free. Write George H. Cole, Pres. Tower Bldg., Syracuse, N. Y.

BIG Profits in making auto top dressing. Complete formula and instructions, all for \$1.00. Turvey's Rubber Prod. Co., 2020 E. Third, Dayton, Ohio.

10,000 FORMULAS. A real gold mine of money-making ideas. Tells how to make almost everything under the sun. You can make and sell cosmetics, murlage, anti-freeze solutions, battery solutions, beverages, cheese, chewing gum, cleaning preparations, extracts, hair preparations, inks, bluing, leather polish, mirrors, perfumes, polishes, typewriter ribbons, carbon paper, washing powders, liquid soap, and hundreds of other profitable articles. Send no money. Just write a postal for "Henley's 20th Century Book of Formulas." Pay postman postage and \$1. Popular Mechanics Press, 200 E. Ontario St., Room 811, Chicago, Ill.

WE Start you in business, furnishing everything. Men and women, earn \$40 to \$100 weekly operating our original "New System Specialty Candy Factories." Begin home spare time. Unlimited opportunity. Valuable booklet free. W. Hillyer Ragsdale, Drawer 4, East Orange, N. J.

OUR New income-producing system will place anyone into a good paying business. Write Brown Specialty Co., 30 Magnolia Ave., Jersey City, N. J.

AMAZING Screwdriving screw driver! Factories, garages, workers buy on sight! Profit 75c each. Exclusive territory. Free trial offer. Jiffy, 1242 Winthrop Bldg., Boston, Mass.

FOR Sale, copyrights to two books. Reasonable. Good mail order. Strong appeal to homeowners. Opportunity for somebody. Write Geo. L. Brockman, Laporte, Ind.

SMALL Capital starts profitable route peanut and gum vending machines. Particulars free. Robbins Corp., Dodworth St., Brooklyn, N. Y.

DON'T Sell for others—Employ agents yourself. Make your own products. Toilet articles, household specialties, etc. 500% profit. Valuable book free. National Scientific Laboratories, 1984W Broad, Richmond, Va.

START Your own business, making newest household specialties, toilet preparations, foods, remedies, motorist's necessities, etc. Our formulas and instructions teach you. Particulars, catalog free. Grinstead's Manufacturer's Laboratories, Oswego, Kans.

BUSINESS Profession of your own and earn income in service fees. See Stephenson Laboratories, display ad page 132.

TIME Counts in applying for patents. See pages 140 and 141. Clarence A. O'Brien, Registered Patent Attorney, Washington, D. C.

GIGANTIC Mail. Send me 25c (coin or stamps) for one pound of mail. Edward Armour, 136 East 28th St., New York.

FLORAGRAPH Show cards, paintless, clean, paying, home business, mastered first day. No hand lettering. Learn today, earn tomorrow. Ideal for ladies. Two gorgeous, tubed samples, 50c ductible. Laird's Floragraphs, 5925m Eggleston, Chicago.

FREE Booklet describes 67 plans for making \$20-\$100 weekly in home or office business of your own. Elite Co., 84 Elizabeth St., N. Y.

ASSOCIATED Chemists, Indianapolis, Ind. Write for formula lists latest household toilet, automobile and medical specialties. Long profits easily made. Analysis.

RESPONSIBLE Manufacturer wants competent men open office, manage salesmen; \$200 to \$1,000 necessary. Will pay expenses to Baltimore if you qualify. Address Manager, 603 N. Eutaw St., Baltimore, Md.

CAPITAL—An experienced dependable broker will aid in financing projects of merit. Amster Leonard, East Orange, N. J.

THAXLY Formulas produce perfect products. All lines. Catalog free. B. Thaxly Co., Washington, D. C.

UNPATENTED Ideas can be sold. I tell you how and help you make the sale. Free particulars (Copyrighted). Write W. T. Greene, 910 Barrister Bldg., Washington, D. C.

SIGNS And showcards easily painted. If you use Letter Patterns. Write for free samples. John Rahn, B2120 Nava Ave., Chicago.

SUCCEED With your own products. Make them yourself. Formulas, processes, trade-secrets. All lines. Catalog, circulars free. B. Thaxly Co., Washington, D. C.

CHEMICAL Expert will furnish formulas and trade secrets. All lines. Lists free. W. L. Cummings, Ph. D., 228 Gordon Ave., Syracuse, N. Y.

SELL By mail! Books, novelties, bargains! Large profits! Particulars Free! B-Elfec, 525 South Dearborn, Chicago.

AGENTS, Dealers, handle our line of Mexican curios, Indian novelties, jewelry, feather cards. Uncontested field. Liberal discounts. Samples fifty cents. None free. G. Medina, 78-P La-Rosa St., Mexico City, Mex.

DELAWARE Charters; fees small; free forms. Chas. G. Guyer, Wilmington, Del.

SIXTY Meritorious big-profit mailorder products, trade secrets, sales plans. Success assured. K. Home, 3949 Metropolitan, Chicago.

MAKE Big profits with a fur farm in your backyard! Chinchilla rabbits, muskrat, mink. Write for facts. 252 Conrad's Ranch, Denver, Colo.

MAKE Your own products. Employ agents yourself. Toilet articles, soap, extracts. We furnish everything. Valuable book free. National Scientific Laboratories, 1984W Broad, Richmond, Va.

"SCHEMER" Subscribers surely succeed. One reports \$50,000 from one tip; another \$25,000 from three Schemes; another \$10,000 from one formula. Try your luck! Year, \$1.00; three months, 30c. Patterson, Publisher, Alliance, Ohio.

FREE Book. Start your own little business anywhere, selling novelties by mail. My beginner's outfit contains everything required, novelties, circulars, instructions, etc. Descriptive book free. Hadwil, 3A-74 Cortlandt St., New York.

LEARN The collection business. Good income, quick results. Interesting booklet, "Skillful Collecting" free. National Collectors Assn., Long St., Newark, Ohio.

A BUSINESS Of your own making—Sparkling Glass Name and Number plates. Checkboards, signs. Big book and sample free. E. Palmer, 540, Wooster, Ohio.

CHARTERS; Delaware; best, cheapest; free forms. Colonial Charter Co., Wilmington, Del.

COMPOSITION Floor making earns industrious men \$12 and more daily if used as trade. Or make business of it with profits up to \$10,000 yearly. Openings everywhere. Semi-Tile, Box 43, Hollis, N. Y.

MAN In each town to plate auto parts, reflectors, bathroom fixtures, refinish beds, mirrors, chandeliers; by new method. No capital or experience required. Simple plan of manufacturing at home starts you in big money-making business. Outfit furnished. Free particulars and proofs. Gun Metal Co., Ave. H, Decatur, Ill.

AGENTS, Opportunity seekers. Make amazing profits. Write, Empire, Shawano, Wis.

AN Honest circular mailer looking for business. Make up a package, key them, inclose what you think a fair price and I guarantee to mail every piece to live prospects. No nude pictures or etc. Edward Armour, 136 East 28th St., New York.

MANUFACTURING Concrete building blocks is your home town opportunity. Particulars free. Concrete Machine Co., 5 Main, St. Louis, Mo.

I MADE \$30 a week home. French bread-making. 15 years' experience; free booklet tells. Ashbrook 67, Marengo, Ohio.

AMATEUR Cartoonists; Sell your cartoons. New plan. Smith's Service, PA-1194, Wenatchee, Wash.

TELEGRAPHY

LEARN Morse and wireless telegraphy. Big salaries. Tremendous demand. Expenses low, can earn part. Catalog free. Dodge's Institute, H St., Valparaiso, Ind.

CHEMISTRY

YOUR Chemical problems solved and formula or process furnished for \$5.00. Write me. W. Stedman Richard, Industrial Chemist, Box 2402, Boston, Mass.

BOOKLET Of experiments and chemical catalog 15c. General Chemical Company, Box 397, Reading, Penna.

CHEMICAL Analysis, processes, technical information. Robert Henderson, Laboratory, Madison, Me.

FORMULAS AND TRADE SECRETS

INDUSTRIAL Chemist furnishes formulas, processes; all lines. Moderate charges. Individual service. All inquiries answered personally. L. Clore, Industrial Chemist, Crawfordsville, Ind.

ANY Formula, 50c. Catalog free. Bernard Wells, Room 305, 852 George, Chicago.

ANY Formula, 50c. List free. 10 free with every 10 purchased. Weaver Mfg. Co., Altoona, Pa.

FREE Formula catalog. Agents Pitchen specialties. Western Chemical, Salem, Ore.

NEWEST Tested formulas. Particulars, catalog free. Grinstead Laboratories, Oswego, Kans.

DON'T Sell for others—Employ agents yourself. Make your own products. Toilet articles, household specialties, etc. 500% profit. Valuable book free. National Scientific Laboratories, 1984W Broad, Richmond, Va.

RELIABLE Formulas for newest fast sellers. All lines. Sources for fine labels—containers. Start right. Free literature. Manufacturer's Bureau, R17, 3937 Tracy, Kansas City, Mo.

509 FORMULAS And big illustrated catalog 25c. Ideal Book Shop, Park Ridge, Ill.

MOST Sensational formula bargain ever offered. Latest, best sellers. List free. Specialty Mfg. Service, 801 So. Farragut, Bay City, Mich.

GUARANTEED Formulas, best science can produce for making popular, biggest-selling specialties all lines. Don't buy formulas till you've received valuable eye-opening literature. Miller, Chemist, 706-F Jetton, Tampa, Fla.

MAKE Your own products. Employ agents yourself. Toilet articles, soap, extracts. We furnish everything. Valuable book free. National Scientific Laboratories, 1984W Broad, Richmond, Va.

FORMULAS; Guaranteed, catalog free. Bestoval Laboratories, 6720 Oconto Ave., Chicago.

SUCCEED With your own products. Make them yourself. Formulas, processes, trade-secrets. All lines. Catalog, circulars free. B. Thaxly Co., Washington, D. C.

15,000 PROFIT Making formulas. Following and many others: Accidents and emergencies, agriculture, alloys and amalgams, artist's materials, beverages, cements, glues, pastes, mullages, bleaching, renovating, coloring metals, dyeing, glass, heat treatment of metals, household formulas, ice cream, confectionery, chewing gum, lapidary work, exterminating vermin, lubricants, paints, varnishes, photography, condiments, canning formulas, rubber, soap, candles, soldering, toilet preparations, perfumes, waterproofing, fireproofing, writing materials. Just write for "Scientific American Encyclopedia of Formulas." When postman hands you book pay \$5.50 and postal charges. Popular Mechanics Press, Room 808, 200 E. Ontario St., Chicago, Ill.

AGENTS WANTED

WANTED At once: More good men to introduce and retail Rawleigh's Good Health Products. Town and country. Wonderful opportunity. Get into business with backing of largest manufacturer its kind. Capital over 15 million dollars. Quick freight, express, parcels post service from 10 great factories and branches—one near you. Nothing new—no experimenting. No experience required. You simply follow the same old time-tested Rawleigh Methods which secure the most business everywhere and have given consumers best values and satisfaction for 40 years. 170 necessities frequently needed every home. Enormous demand. Annual sales now over 35 million products. Big free trial inducements. Quick easy sales. Repeat every 30-60 days. Enormous profits—\$200-\$400 month and more clear profits. Steady year around; no lay-off. No boss—you become sole owner and manager. Practically no capital required. We supply everything—stocks, outfit, sales and service methods. Big pay every day. Profits increase every month. "First come first served." For full particulars write W. T. Rawleigh Co., Dept. A-11PPM, Freeport, Ill.

AGENTS Wanted to sell greatest household invention of a century. A necessity in every kitchen. Housewives have been waiting years for it. One agent made 9 sales out of 10 calls. You demonstrate how it works. Then it sells itself. Both full time and spare time agents wanted. Write for descriptive circular and special big money making proposition. Jiffy Appliance Co., Sta. 1, 1020 Central National Bk. Bldg., St. Louis, Mo.

AGENTS Buy hosiery direct at lowest mill prices. Men's heavy silk and Rayon hose, doz. pairs, \$2.25-\$3.50; men's latest fancy hose, doz. \$1.45-\$2.10; ladies' Pointex silk hosiery, \$1.25-\$7.25-\$9.50. Satisfaction guaranteed. Act today. Superior Knitting Company, Dept. 31, New Haven, Conn.

AGENTS—Just out, extremely novel aluminum; elephant head keyholder (carried on belt). A speedy 35-cent seller. Fran Mfg. Co., Wilmerding, Penna.

MARVELOUS New invention. Hot and cold massager. Easy to sell. Profit 200%. Write today. Mystic Massager Co., Dept. K, Box 834, Toledo, Ohio.

SOMETHING Different! Fountain pen with check protecting device. Protects checks against check-raisers who steal thousands. Works like expensive checkwriters. Earn \$10 to \$20 daily. Free outfit offer. Securograph Pens, RC-55, Securograph Bldg., Oakland City, Ind.

AGENTS, \$240 Month. Dri-KleanIt removes dirt, grease, tar all one operation. Cleans car for 10c. No soap or water used. Car looks like new. Wonderful seller. Free sample. American Accessories Co., Desk 5831, Cincinnati, Ohio.

TWO Snappy 50c articles, sell year around, to everybody. Large profit. Circulars free. Benedict Mfg. Co., Dallas, Tex.

AGENTS, \$6 day made by our sales agents. Sell finest line guaranteed hosiery you ever saw. All styles, colors. Finest silks. Commission earned daily. Spare time satisfactory. Ford car given to producers when earned. Earn your own silk hose. Write for samples. Wilkoff Hosiery Co., Dept. 8031, Greenfield, Ohio.

MAKE Extra money quickly, easily and pleasantly by distributing our beautiful Scripture-Text Art Calendars for Christmas. Ever home is a real prospect. Liberal commissions. Send 25c for a sample copy and full details. Church Service Bureau, Collingswood, N. J.

CORNS, Callouses removed entirely without harmful results, money back guarantee. Price 35c. Agents wanted. Joyner's Special Laboratory, 625 N. 3rd St., Richmond, Va.

ARTICLES Of merit. Repeat sellers. Big profits. For information write Lightning Products Co., 616 W. Kinzie St., Chicago.

ARE You old at forty? See our advertisement on page 96 of this issue. The Electro Thermal Company, 2123 Morris Ave., Steubenville, Ohio.

\$2.45—RAINCOATS, All colors. Trenchcoats, tweeds, alligators, leatherettes. Sample coat and bonus to workers. Beautiful outfit free. Bradley, Dept. AB-11, 230 S. Wells, Chicago.

SELL Holiday Greeting Checks. Something different. 200% profit. Sample free. 3330 Telegraph, Oakland, Calif.

BIG Ohio corporation wants county manager. Opportunity \$50 to \$75 weekly. Earnings start immediately. Good for \$5,000 yearly. We furnish everything, deliver and collect. Capital or experience unnecessary. Fyr-Fyter Co., 1905-N Fyr-Fyter Bldg., Dayton, Ohio.

EMBOSSED Signs. Something new. Going big. Ten cents for two samples. Signs. 3328A Telegraph, Oakland, Calif.

MIRRORS Resilvered at home. Costs near 5 cents per square foot; you charge 75 cents. Immense profits plating auto parts, reflectors, tableware, stores, refinishing metalware, etc. Outfits furnished. Details free. Write, Sprinkle, Plater, 128, Marion, Ind.

AGENTS—Housewives want articles that save time, work and money. Our new line is chock full of such products. Help us introduce them in your territory. Quality goods, fully guaranteed. Highest commissions. Steady repeat sales. Write quick for particulars. American Products Co., 3945 Monmouth, Cincinnati, O.

RED Witch—Stain remover (ink, rust, iodine); grease remover (both wet and dry cleaning for entire garment). Truly complete cleaning plant in one bottle. Not just a spot remover. Why play around with slow seller. It's a whiz! Get our proof. G. & R. Household Chemical Co., Manning, Iowa.

AGENTS—New fast-selling golf specialty. "Scotch Caddie," the practice drive with self-returning ball, improves game 10 strokes and offers same enjoyment in back yard or basement as playing on golf course. Write for full information; send \$2.00 if you want sample. Arnold B. Enaley, 715 Stevens Bldg., Detroit, Mich.

AUTOMATIC Gas lighters sell on demonstration. Retail 25 cents; costs you \$8 gross. Gives \$28 profit. Rapid Manufacturing Company, 2772 Pitkin Ave., Brooklyn, N. Y.

BIG Line Xmas card assortments, boxes, packs. Our 17th season. Liberal profits. Samples three leading sellers \$1.00. Send quickly for free details, price list. Ufert, 100 West 21st, New York.

WOMEN Go wild over gorgeously beautiful Rayon silk bedspreads! Original! Different! New everywhere! Wildfire seller! Gorgeous full size swatches free! Baker Company, Salisbury, N. C.

SELL Nail polish; sample free. DeFrees, 1034 W. 90th St., Los Angeles, Calif.

NEW Item. Every home buys. 200% profit. International Ink Works, 3004 Eastwood Ave., Chicago.

AGENTS Wanted to sell billfolds designed to beat the pickpockets. Sells like wildfire. Write J. F. Oyer, 304 Adelaide Detroit, Mich.

AGENTS—Speed filter. Guaranteed filter beverages crystal clear, one gallon minute; new invention. Sparkler Mfg. Co., 448 West Grand, Chicago.

AGENTS, Housewives buy our dollar ironing-board cover and unburnable pad. Tremendous demand; high commissions assure unlimited earnings. Full—spare time. Mardo Co., 105 Wooster St., Dept. 1011, New York.

DON'T Sell for others—Employ agents yourself. Make your own products. Toilet articles, household specialties, etc. 700% profit. Valuable book free. National Scientific Laboratories, 1984W Broad, Richmond, Va.

STOP! 400 Fast selling specialties from many parts of world. Write for free wholesale catalog. Sports, Dept. PM, Leveur Center, Minn.

SELL Changeable signs to stores, 3 colors, 6 lines, size 14x24. Costs 40c, sells for \$1.50. National Sign System, 215 So. Broadway, St. Louis, Mo.

NEW "Hire-Fire" Two-in-One spark plug. Just out—reversible—one end cleans other—fires 11,000 volts—for cars, trucks, tractors. Free sample offer, write for open territory. Hire Mfg., Peoria, Ill.

STRANGE New electric iron cord! Prevents scorching. Saves electricity. Cannot kink or snarl. Used on telephones also. \$25 daily. Samples free. Neverknot, Dept. 11-A, 4303 Ravenswood, Chicago.

EARN Big Money with manufacturer of shoes and complete line of leather goods. No experience necessary. Big catalog and information sent free. Address Consolidated Shoe System, Dept. 20, Eau Claire, Wis.

MAKE \$8.5 Weekly. Amazing one-year guarantee sells Roseliff shirts fast. 24 hour shipments. No substitutions. Big advance commissions. Customer gets free initials. Earn your own shirts. Get free outfit including ties. Write today. Dept. P011, Roseliff Shirts, 1237 Broadway, New York.

SELL Beautiful "Style Tailored" shirts, lumberjacks and neckties direct to wearer at factory prices. Many beginners earn \$50 first week in spare time. \$100 weekly full time easy. Selling Outfit Free. Howard Shirts, 1213 Van Buren, Factory 251, Chicago.

MAKE Big money every day. Sell finest work pants and breeches. Every man buys 1 pair \$1.95, 3 pair for \$5.50, your commission \$1.00. Customer's satisfaction guaranteed. Largest, finest sales outfit free. Write today. Dept. LPM11, Longwear, 489 Broome St., New York.

BIGGEST Money maker tailoring line pays \$1.00 to \$7.00 order. Cash bonuses. Earn your own suits. Quality worsteds. All wool serges, cassimeres, top coats, heavy weight overcoats. Giant outfit. 1/4 yd. samples free. Dept. PM11, Olympic, 5th Ave., at 19th St., New York.

IMPORT Your own goods. German export magazine published in English, offers numerous bargains latest novelties; opportunity for obtaining profitable agencies. Copy 60c. Square Deal Supply, P-246 Fifth Ave., New York.

BIG Money weekly year round appointing agents. No canvassing, delivering or investment. Mother Hubbard Foods, 554U Congress, Chicago.

MAKE More Money; sell Public Service ties and shirts direct from mill; exceptional values; ironclad guarantee; liberal commissions. Selling outfit and sales helps free. Producers earn own shirts and ties. Write today. Public Service Mills, 4943CF Hudson Blvd., North Bergen, N. J.

SELL Biggest Xmas card value ever offered. Beautiful box 21 large cards and folders. All envelopes tissue lined. 3 gift cards free. \$2.75 value. Costs you 50c postpaid. Sample portfolio furnished. Lee Co., Canal Station, Chicago.

SELL Rhinestone Initial Belt Buckles, etc. Fastest Xmas sellers. Big commission daily. We deliver. Pocket outfit free. Chaton, 608 Blue Island, Chicago.

MAKE More money selling most complete line Raincoats, Sportcoats, Sheeplined coats. Leather Jackets and Tablecloths. Latest styles. Lowest prices. Biggest commissions. 7x5 swatch line free. Jeffrey, over St., Boston, Mass.

AGENTS Say Magic Metal Polishing Cloths sell like hot cakes. Send for sample free. Universal Laboratories, 193 Hanover St., Boston, Mass.

AGENTS Earn \$8 day. Bonus besides. Sell finest line guaranteed hosiery. All styles. Credit given. Spare time satisfactory. Auto furnished agents when earned. Write for sales plan. Reiterkmit Hosiery Co., Desk 5231, Columbus, Ohio.

\$3 TO \$10 Hourly demonstrating amazing door check. Finger-touch shuts all doors silently. No slamming. No broken glass. Keeps doors open when wanted open. Low priced. Big commission. No competition. Quick demonstration sells several to almost every home, office, factory, public institution. Write! Kant-Slam, Dept. SC-5, Bloomfield, Ind.

MEN Wanted—to demonstrate and take orders direct from motorists. Amazing magnetic trouble light. Sticks on metallic surfaces. Our men earn as high as \$75.00 weekly. Write for demonstrator. Magno, Beacon Bldg., Dept. 168, Boston, Mass.

MYSTERY Polishing cloth in tin cans sell like hot cakes. Write free sample. Mohler, Box 453JH, Chicago.

MAKE Your own products. Employ agents yourself. Toilet articles, soap, extracts. We furnish everything. Valuable book free. National Scientific Laboratories, 1984W Broad, Richmond, Va.

AGENTS—Absolutely new! Our hand-colored popular-priced photo statuettes going big! Everyone wants them! Agents making \$10-\$25 daily! Samples furnished! Cruser Mfg. Co., LS2456 Jackson, Chicago.

SELLING Like blazes! Beautiful toilet goods assortment at \$1.50 with 24-inch pearl necklace free to your customers. 100% profit. E. M. Davis, 234 North Ave., Dept. 550, Chicago.

SURE! Big money for you. Amazing new window washer. Sells for only 75c. Over 100% profit for you. Beats every window washer on market. Every housewife, store, auto owner prospect. Send 50c for sample. Details free. Write Advance Metal Specialties Co., 184 W. Washington, Dept. S-10, Chicago.

A REAL Money-maker. Sells everywhere. Metal polish in tubes. Trial tube free. P. M. Reid, 1619 Clark, St. Louis, Mo.

BECOME Your home town leading business man. Sell full line of groceries, motor oils, paints. Everybody a customer. No capital or experience necessary. Selling outfit free. Write Loverin & Browne, 1602L So. State, Chicago.

GREATEST Opportunity; newest proposition. Build continually paying business in your own name. Household, industrial, brushes, brooms, mops, dusters, fully guaranteed. New catalog, all net prices, no discounts to bother with. Make as high as 300 per cent and over. Write today. Wire Grip Sanitary Brush Corp., 41 East 11th Street, New York.

SPLendid Money selling our boxed assortments of Christmas cards. Crackerjack proposition. Samples. Write quickly. Patterson Co., 4111 University, Des Moines, Iowa.

AGENTS, Distributors, make \$75.00 to \$100.00 weekly selling newly patented electric computing scale lighting device. Transforms old-type scales into electric. No competition, pays for itself, quickly applied, guaranteed. Massey Mfg. Co., 2481 Detroit Ave., Toledo, Oo.

AGENTS Wanted—Practical and most used necessity of the present day. Sold on a money back guarantee. The Es-Ton Company, La Salle, Ill.

WINDOW Shades are fastest sellers. Men wanted for profitable sales work. Very large commissions. Free demonstrating outfit furnished. Write for yours today. Kasan, 1481 Nostrand Avenue, Dept. A-14, Brooklyn, N. Y.

SELL Koehler's blue signs. Nothing like them for profit. Koehler, 717 N. Fourth, St. Louis, Mo.

400% PROFIT Selling imported and American novelties. A \$5.00 investment will earn \$180.00. Valuable and useful samples. Complete information 2c silver. Northwestern Co., 543-P North Ashland, Chicago.

SELL Everclean sparkplugs, sample 25c. Garage drop cord sets complete. Sample \$1.70. Guaranteed. American Equipment Company, 5558 Washington, Chicago.

100% CLEAR Profit! Men and women! Enormous profits can be made selling new \$2 patented pinless curtain stretcher. Miniature demonstrator furnished. Article sells itself. Exclusive territories available to first applicants. Western Newell Mfg. Co., Freeport, Ill.

\$10-\$25 DAILY Simply showing new Polly wrench. 10 wrenches in one. Guaranteed seller. Sample free. Gellman Mfg. Co., Dept. 6K, Rock Island, Ill.

EXPENSIVE Silk dresses; Slightly handled showroom samples sold cheap for cash. Peddlers, storekeepers, write Dress Jobbers, P-65 Times Square, New York.

DAMASK Tablecloths, no laundering. New futuristic design, cheapest price and largest commissions. Samples free. Gorden Mfg. Co., 6 N. Clark St., Chicago, Ill.

MEN! Get the new sensational Gitsknife counterdard. Good for \$20.00 daily. Free offer! Gits Co., E5419 Chicago Ave., Chicago.

AGENTS. Salesmen and exclusive distributors for auto accessory (to be nationally advertised immediately). Just opening state territories. Large profits to distributors. Pacific Coast Sales & Specialty Co., Dept. 1, 518 Hibernian Bldg., Los Angeles, Calif.

\$5.00 HOURLY. Mercerized damask scalloped table cloths, size 58x58", 75c! Tremendous demand. Other bargains. Big sample line free. American Braiding, Y-418 S. Wells, Chicago.

WELLS Cleared \$620.00 in one month with Business Guide and free legal service. Write for free outfit. Prof. Nichols, Dept. 62, Naperville, Ill.

MAKE \$20 Daily selling merchants changeable-letter show-window signs. Experience unnecessary. Send for free sample offer. Maze Company, 542 W. Washington, Chicago.

PATENTED Invention cuts gas bills 25%. Housewives delighted. My positive guarantee sells them. No competition. Starting stock free if you're a hustler. Box 18E, East San Diego, Calif.

GET Winter line now. Big season on. Sheep-lined coats, leather vests, flannel shirts, underwear, overcoats, sweaters, hosiery. Outfit free. Northern Sales, 101 So. Wells, Chicago.

JUST Out—New kind of electric lamp. 101 lamps in one. So beautiful women can't resist. So useful men buy instantly. Wonderful spare or full time proposition. Sell C.O.D. or deliver as you sell. Big profits daily. Write for money-making plan. Falcon Mfg. Co., Dept. P-251, 2550 Sullivan, St. Louis, Mo.

CHICAGO Expert valued \$3 stone at \$900. The diamond's only guaranteed rival! Greatest spare time side-line article ever known! Amazing profits. \$5 pocket sample case free. Write quick! Mexican Gem Company, Dept. PM, Monterey, Calif.

AGENTS—Men, you can earn \$12 daily wearing fine felt hats and show friends. Smartest styles. Latest shades. \$2 to \$5 saving on every hat. Samples free. Taylor Hat and Cap Mfrs., Dept. SC-135, Cincinnati, Ohio.

MAKE Steady money. Amazing one-year guarantee sells Rosecliff shirts fast. 24 hour shipments. No substitutions. Big advance commissions. Customer gets free initials. Earn your own shirts. Get free outfit including ties. Write today Dept. ME11, Rosecliff Shirts, 1237 Broadway, New York.

AGENTS Earn \$7 in one day. Sell new line guaranteed hosiery. Latest styles. Big sellers. Commission earned daily. Guarantee bond protects customers. Earn silk hose for your own use. Write quick. Silknet Hosiery Co., Dept. 1431, Dayton, Ohio.

AGENTS—Make a dollar an hour. Sell new kind of sharpeners. Sharpens all knives and tools quickly. Demonstrating sample 10c. Premier Mfg. Co., Dept. 97, Detroit, Mich.

BIG Money selling shirts and ties! Wonderful values. Finest line now ready. 54 latest New York styles. Big outfit and special samples. Everything free. Pioneer Mills, 1225 Broadway, Dept. D16, New York.

AGENTS: Free catalog 200 household specialties, toilet preparations, food products, portraits, frames, photo pillows, medallions, religious goods, pictures. Credit. James C. Bailey Co., Station C-11, Chicago.

AGENTS: Sell nursery stock. Free landscape service. Wonderful possibilities. Pay check weekly. Write for particulars. Perry Nurseries, R-11, Rochester, N. Y.

JUST Out—New patented apron. No strings or straps—\$20.00 a day every day; over 100% profit; commissions daily. Write for free outfit. Sta-Put Co., Dept. 211, St. Louis, Mo.

BIG Profits taking orders for ties and shirts. Latest styles. Made in our own big mills. Sell on sight at factory prices. Liberal commissions. Write for free selling outfit. Supra Value Shirt Co., 4927-M, Hudson Blvd., No. Bergen, N. J.

BIG Profits. Sell our holiday poultry banners to meat markets until Thanksgiving and then our Christmas window display cards, to every store, until Christmas. Both banners and cards are sold day or evening, alone or as a side line. Cash sales; no order taking. Great for crews of canvassers. Write today for free literature. Consolidated, 65-Q West Van Buren St., Chicago.

SALESMEN—Earn \$100 weekly taking orders for dazzler and rainbow glow electric signs. Big commission. Exclusive territory. High grade proposition. Write Chicago Sign Sales Co., Dept. 82, Charlotte, N. C.

NO Dull times selling food. People must eat. Federal distributors make big money; many over \$3,000 yearly. No capital or experience needed; guaranteed sales; unsold goods may be returned. We furnish you with license, sample case and free samples for customers. Repeat orders sure; exclusive territory. Ask now! Federal Pure Food Co., A2307 Archer, Chicago.

GUARANTEED Household article selling under 50c, sold to homes and stores. 100% profit. Exclusive territory. DE-ZPM, 601 East 3rd St., Dayton, Ohio.

FREE Listing in Agent's Directory. H. Wolf, 6618 Quimby, Cleveland, Ohio.

GENUINE Alligator and coconut electric lamps. Joseph Fleischman, Tampa, Fla.

\$20 DAILY. Showing \$2.98 trench coats, also DuPont's launderless tablecloths; garment bags. Samples free. American, 726-LX Roosevelt, Chicago.

GET Next to 101 new, easy-selling items you can make yourself. Novelties, toys, foods, preparations. Profits aplenty. Manufacturer's Bureau, R18, 3937 Tracy, Kansas City, Mo.

MADE-TO-ORDER Greeting Cards. Sensational values. Half usual price for less attractive cards. No extra charge for name, monogram, or fancy lined envelopes. Commissions daily. No experience necessary. If already soliciting orders for cards, show our samples where you fail to sell your regular line. Sample book furnished without deposit. Write Orleans Card Company, Orleans, Vt.

AGENTS—Sterling's "Anti-Freeze" keeps frost off windshield. Sample 50c. Sterling Laboratories, Cedar Rapids, Iowa.

FAST Seller—Big profits. Every housewife, automobile owner, etc., will buy "Kwik Kleen" for windows, mirrors, furniture, store fixtures. Sample 35c. Sales plan free. Sterling Laboratories, Cedar Rapids, Iowa.

MAKE \$20 To \$35 a day selling Imprint Book Matches, spare or full time. Big repeat business—no investment—every merchant a prospect. Send 50c for selling outfit which includes complete samples. Imprint Book Match, Dept. 118, 877 Meigs St. Rochester, N. Y.

AGENTS—To sell electric water heater for \$2.75. New invention. Heats water almost instantly. Real moneymaker. Write Lux-Visel Company, Dept. N, Elkhart, Ind.

BIG Money monogramming automobiles. \$1.40 profit on \$1.50 sale. Particulars and samples free. Evans Products Company, Midian Ave., Windsor, Conn.

SANITARY Rubber goods—Agents and distributors wanted. Factory prices. Send for price list. Knickerbocker, 32 Union Square, New York.

NEW, Patented, most useful 50c necessity. Homes, stores, offices buy several on sight. Repeats. Sole Mfrs. Carney & Nestle, 852 Belmont Ave., Chicago.

WRITE Sponge Nozzle Auto Washer Co., 3780 Clairmont, Detroit, Mich.

SELL Foot specialties. Complete line. Big demand. Strictly legitimate. Dignified. Make good living. Have enviable business of your own. Men or women. Write at once. Health Opedic Company, 210 St. Clair Ave., N. W., Cleveland, Ohio.

AGENTS "Strike a gold mine" selling Nulustre cloths at 25c; cleans, polishes all metals; the duller the metal, brighter it shines. One agent sells 102 boxes in 116 calls. Write for free samples, particulars. Shef Mfg. Co., 20 Shef Bldg., Weehawken, N. J.

TIME Counts in applying for patents. See pages 140 and 141. Clarence A. O'Brien, Registered Patent Attorney, Washington, D. C.

CASH Paid for Butterflies, Insects. See Sinclair Display Advertisement on page 14.

SNAPPY Shirt line ready! Season's best values. Agents cash in big. Nothing to invest. Get free outfit and handsome samples. Special features. Gracett, Dept. 711, 504 Sixth Ave., New York.

GOOD Men always wanted! I can use more men to distribute Hoyt groceries, toilet goods, extracts, home remedies. Only one to a town. Big pay for hard workers. Spare time or full time. Free auto for own use if you succeed. Handsome sample case furnished. Get my free proposition at once. Dan Hoyt, Hoyt Brothers, Inc., Dept. C-27, Newark, N. J.

GENUINE Gold Leaf Letters anyone can put on store windows. Guaranteed to never tarnish. Large profits. Enormous demand. Free samples. Write today. Metallic Letter Co., 438-D North Clark, Chicago.

DON'T Sell for others—Employ agents yourself. Make your own products. Toilet articles household specialties, etc. 500% profit. Valuable book free. National Scientific Laboratories, 1984W Broad, Richmond, Va.

EARN 40 To 50% commission. Box assortments and personal cards. Write today. Full or part time. Artistic Card Co., Dept. 12, Elmira, N. Y.

ENGRAVED Name plates, signs, numbers, desk plates, store window signs, etc.; profits large. Brett Bros., Winthrop, Mass.

SELL Stores 5c candy specialties. 100% profit. Lorrac Products, Albany, N. Y.

NEW Style needle books pay \$22.00 daily profit. Free clever threader invention creates eager buyers. Sweeping country. One billion Paty needles sold. Proof free. Four different samples 25c. Paty Needle Co., West Somerville, Mass.

AGENTS—The Gyro-Whirl Brush washes an automobile in fifteen minutes without splash or spray! Every owner and garage-man a prospect; every user satisfied. Attaches to ordinary garden hose. Takes labor out of car washing. We help you sell and make money—\$15-\$30 daily. Write Gyro Brush Co., Dept. C, Ampere, N. J.

PORTRAIT Men: Why not Pasco portraits; we refund your money for all you cannot deliver. Frame catalog free. Portrait Agent's Supply Co., Dept. F, LaPorte, Ind.

WISE Agents. No canvassing. Pleasant work. No delivering. Big money. No investment. Appointing agents. Welcome Foods, Harvey, Ill.

BE independent; make, sell your own goods. Immense profits. Catalog dependable formulas, special selected agents' best sellers, free. R. Lustrò, 4211 Cottage Grove, Chicago.

WANT Distributing agent for Hanslick, powdered handsoap; removes anything from the hands without injury to skin; everybody a customer; great opportunity for hustler to get in business; sample free. Solar Products Co., J2144 So. Troy, Chicago.

FREE Booklet describes 67 plans for making \$20-\$100 weekly in home or office business of your own. Elite Co., 84 Elizabeth St., N. Y.

BIG Money daily, selling shirts of all kinds, lumberjackets, underwear, hosiery, sweaters, playsuits, overalls, pants, raincoats, leather coats! Outfit free! Experience unnecessary. Nimrod Co., Dept. 8, 4922-23 Lincoln Ave., Chicago.

BIG List of Christmas sellers! Greeting cards, combination toilet sets, perfumes. More than 400 items. Details free. Write! Togstad Co., 30 Pulton St., Kokomo, Ind.

SELL Complete line household brushes. Send for free catalog and sample case offer. National Brushes, St. Louis, Mo.

PHOTO Medallion men and women, the largest line of photo novelties in the world. Lowest prices, quickest service. Send for catalog showing over 200 money makers. Photo medallions, photo medallion clocks, photo mirrors, photo fountain pens, photo powder compacts, photo jewelry and photo buttons. Gibson Photo Jewelry Co., 608-611 Gravesend Ave., Brooklyn, N. Y.

AGENTS—Mosco Corn and Callous Remover will build you a steady repeat business. Send today for pocket-size trial outfit. The Moss Company, 442 Searle Bldg., Rochester, N. Y.

BIG Money applying gold initials on automobiles. Easiest thing today. No experience needed. \$1.45 profit every \$1.50 job. Free samples. "Ralco," X-1043 Washington, Boston, Mass.

SENSATIONAL Pencil, writes four different colors. Instantly interchangeable. Wonderful item for agents, distributors or side line. Splendid profit. American Sales, Tribune Annex, Minneapolis, Minn.

BIGGEST Surprise offer ever made. Be sure to answer this ad. My line of soaps, coffee, tea, spices, toilet articles, household specialties, pays you bigger profits. M. G. Roth, President, 2716 Dodder, St. Louis, Mo.

FREE Booklet describes 67 plans for making \$20-\$100 weekly in home or office business of your own. Elite Co., 84 Elizabeth St., N. Y.

TACKLE That concrete job. Don't be afraid of not getting good results. With the instructions found in Popular Mechanics Concrete Handbook you can easily make 173 articles of utility and beauty ranging from ordinary steps to garden furniture. This book will be sent for only 98c plus postage C. O. D. Send your order to Popular Mechanics Press, Room 808, 200 E. Ontario St., Chicago, Ill.

START An honest-to-goodness, successful-paying business that's yours. Making world's greatest sellers! Investment small. Profits great. Start anywhere. Get my valuable "eye-opening" literature about specialty manufacturing—How you can easily make guaranteed exclusive automobile specialties, including wonderful Loidlac, finest household cleaners, best soaps, high-grade toilet preparations, modern insecticides, delicious food and beverage lines fastest-selling carded specialties. 32 years unequalled reliable service. Miller, Chemist, 706-J Chemical Building, Tampa, Fla.

"HOW To Secure Agents," a specially prepared booklet, tells of one of the most inexpensive methods in which to secure good live producing agents. It is free; write for your copy today! M. L. Rund, Mgr. Classified Advertising, Popular Mechanics Magazine, 200 E. Ontario St., Chicago, Ill.

ADDING Pencil. Adds mechanically, almost human. Make big money daily. Get sample and territory now. Add-O-Graph Co., Dept. 25, Saltville, Miss.

DON'T Sell for others—Employ agents yourself. Make your own products. Toilet articles, household specialties, etc. 500% profit. Valuable book free. National Scientific Laboratories, 1984W Broad, Richmond, Va.

SELL "Prevents Runs." Guaranteed to prevent runs in silk hosiery. Large profits. Particulars. Specialty Mfg., 307A West First, Los Angeles, Calif.

AGENTS—Make a dollar an hour. Sell Mendels, a patented patch for instantly mending leaks in all utensils. Sample package free. Collette Mfg. Co., Dept. 404, Amsterdam, N. Y.

HOSIERY—Real money selling Montgomery hosiery. Great satisfaction in selling better quality for less. Catalog free. Montgomery Hosiery Co., Dept. 101, Trenton, N. J.

FAST-SELLING Specialties—Make them yourself! Appoint agents. List free. Girard Research Laboratories, Wheeling, W. Va.

THAXLY Formulas produce perfect products. All lines. Catalog free. B. Thaxly Co., Washington, D. C.

POLMET Polishing Cloth removes tarnish from metals without the use of liquid, paste or powder. Our agents say it sells like "hot cakes." Retails 25c; sample free. Gale & Co., Inc., 15 Edinboro St., Boston, Mass.

AGENTS—Here's a new one. "Bestever Powdered Hand Soap." Sells like wildfire. Marvelous discovery. Removes grease, paint, ink, oil, in fact anything from hands. Cannot harm skin. 150% profit. Great repeater. Agents simply coin money. "Free Samples Get the Business." Write immediately. Bestever Products Co., 4315W Irving Park, Chicago.

SUCCEED With your own products. Make them yourself. Formulas, processes, trade-secrets. All lines. Catalog, circulars free. B. Thaxly Co., Washington, D. C.

SELL Men's neckwear—wonderful proposition. Astor-M. 39 East 28th, New York.

REMNANT Store, Bethel, Ohio. Greatest Dry Goods Bargains on Earth. Agents and Dealers.

MONOGRAM Automobiles, \$1.35 Profit ten minutes' work; every owner wants them; millions without; particulars free. Motorists Accessories Co., Mansfield, Ohio.

GOLD-LEAF Window letters and script signs; no experience; 500% profit; samples free. Consolidated, 69-T West Van Buren, Chicago.

GET Our free sample case—Toilet articles, flavoring and specialties. Wonderfully profitable. LaDerma Co., Dept. A, St. Louis, Mo.

AGENTS: Stamping names on pocket-key protectors. Sample check with your name and address, 25c. Stamping outfits. Emblem checks, check-fobs, name plates. Hart Mfg. Co., Desk 2, 303 Degraw St., Brooklyn, N. Y.

AGENTS. Our cigar lighters, musical novelties and salesboards sell quick. Large wholesale catalog free. Joseph Sales Company, 223 Madison St., Chicago.

HOMEOPATHIC And Biochemie preparations sent postpaid to all parts of the world. Manual and booklet free. Halsey Bros. Co., 5547 Ravenswood Ave., Chicago, Ill. Established 1855. Agents wanted.

MEN, Women, make big money selling Amity greeting cards for Christmas and all occasions. Biggest deal on market. Write for catalogs 10 and 11 giving all particulars. Splendid opportunity for a business of your own. Amity Greeting Cards, 1104 So. Wabash, Chicago.

\$200 MONTHLY Selling amazing new automobile trouble light. Sticks anywhere on car. Electro magnetic. It's also an everlasting flashlight. Send for demonstrator and prices. National Electric Corporation, 222 High St., Newark, N. J.

MAKE \$100 Week placing electric advertising cigar lighters and fans on dealer's counter. Flashing colored advertisements. Write Drake Mfg. Company, Dept. M, Milwaukee, Wis.

32 SECONDS Complete tire change by Detmer, Ohio, with Morey Quick Action Rim Tool. Sold, singly, 49 three days cleared \$100. Anderson, Mont., sold 1,400 in 14 weeks. Get details for good territory. Harvest time now. M. Morey Rim Tool, Buffalo, N. Y.

MAKE Your own products. Employ agents yourself. Toilet articles, soap, extracts. We furnish everything. Valuable book free. National Scientific Laboratories, 1984W Broad, Richmond, Va.

NO Matter what you are selling postal addressed to Excello Sales Co., Shreveport, La., will bring best money making offer you ever received.

AGENTS—New shirt proposition. No capital or experience needed. Commissions in advance. Samples free. Madison Company, 566 Broadway, New York.

RIM Tool—Complete tire change 24 seconds. Exclusive territory. Victory Tire Rim Tool Co., Santa Monica, Calif. 1516 Pico Blvd.

\$12.00 DAILY Showing new table cloth. Looks like linen. Wash like oilcloth. No laundering. You just take orders. We deliver. Pay daily. Sample free. Bestever, 152 Irving Park Station, Chicago.

\$75 WEEKLY Up placing Aspirin, Notar-tar, Lighter Films, Silk-Tone and other self-selling counter display cards with merchants, soda fountains, cigar stores, etc. Over 100% profit. Steady repeats. Sterling Company, F. Baltimore, Md.

A BUSINESS of your own—Making sparkling glass name and number plates, check-boards signs. Big book and sample free. E. Palmer, 512, Wooster, Ohio.

AGENTS Wanted—On a fast selling 25c item for the kitchen, costs you 8 1/2c. Sample sent parcel post prepaid for 10 cents. P. Seed Filter Mfg. Co., Inc., 353 Broadway, New York.

AUTOMOBILE Specialties. Guaranteed formulas for all latest money makers. Lowest prices. Write for free lists. Murphy, Chemist, Tubunga, Calif.

FLAVORING Extracts—Bottle yourself! Concentrated! Free labels. 600% profit! Whirlwind moneymaking proposition! Write Thomas Manufacturing Company, Indianapolis, Ind.

MAN in each town to plate auto parts, reflectors, bathroom fixtures, refinish beds, mirrors, chandeliers; by new method. No capital or experience required. Simple plan of manufacturing at home starts you in big money-making business. Outfit furnished. Free particulars and proofs. Gun Metal Co., Ave. H, Decatur, Ill.

REPLATE Brass worn-off automobile parts, reflectors, bath room fixtures, worn spoons, forks, etc., with pure silver. Looks like new. Use U-Kan-Plate Polish. Positively no mercury. \$1.00 half pints. Post paid. Satisfaction guaranteed. Agents wanted. Dept. A, U-Kan-Plate Co., Philadelphia.

MAKE Your own products. Employ agents yourself. Toilet articles, soap, extracts. We furnish everything. Valuable book free. National Scientific Laboratories, 1984W Broad, Richmond, Va.

AGENTS—Clever Invention! Inkspoon makes every pen a fountain pen. Fast office seller; big profit, demand increasing everywhere. Exclusive territory offered. Sample free. H. Marul Company, Tribune Bldg., New York, N. Y.

TWO Money makers for agents. "Francis" Pocket Adding Machine retails \$4.85. To you \$1.00. "Excellograph" Rotary Stencil Duplicator \$37.50 retail. Write Typewriter Supply, 102 Hersch Bldg., Pittsburgh, Pa.

WE Start you without a dollar. Soaps, extracts, perfumes, toilet goods. Experience unnecessary. Carnation Co., 641, St. Louis, Mo.

ALL-ELECTRIC Radio Sets—First book on subject—just out. Kenneth A. Hathaway, well known radio adviser of the Chicago Daily News has written this clear, interesting and non-technical book. It covers dynamic speakers also. 120 pages. Illustrated. Pay postman only \$1.50 plus postage upon delivery. Popular Mechanics Press, Room 808, 200 E. Ontario St., Chicago.

CALIFORNIA Perfumed beads selling like hot cakes. Agents coin money. Big profits. Catalog free. Mission Factory 1, 2328 W. Pico, Los Angeles, Calif.

BIG Profits! Fast sales! \$9.75 automatic washing machine. Guaranteed. Write Storm Royalty Co., 3601 Enright, St. Louis, Mo.

\$60-200 A WEEK. Genuine gold letters for store windows. Easily applied. Free samples. Liberal offer to general agents. Metallic Letter Co., 438-B North Clark, Chicago.

MEN With autos sell Koehler signs. 717 North Fourth, St. Louis, Mo.

MAKE Your own products. Employ agents yourself. Toilet articles, soap, extracts. We furnish everything. Valuable book free. National Scientific Laboratories, 1984W Broad, Richmond, Va.

HIGH GRADE SALESMEN WANTED

A SPLENDID Side line—We sell pace books, check covers, coin bags, etc., mainly to banks. They are centrally located and do business quickly. Little time is lost. Our samples are light, compact, easily carried. Sales run into money, items repeat well, commission is liberal, and all paid immediately. We also have an excellent line of advertising novelties for merchants. Our quality is good, the variety extensive, the styles interesting. Line is big enough to devote your whole time if you wish. We are manufacturers, own our buildings, been in business fifteen years, make thirteen thousand sales a year, ship to every state. You could work wherever you happen to be. Correspondence invited. Continental Bank-Supply Co., Mexico, Mo.

BIG Free printing line brings easy quick profits. Union label. Bigger commissions—up to 55%! Experience unnecessary. Now write orders with America's most profitable printing stationery line. Thousands of free cuts. Over 150 standard items covering every business need: letterheads, noteheads, envelopes, billheads, business cards, statements, garage forms—shipping, battery, dry cleaning, tire, storage, parking and hat-cleaning tags; repair forms, blotters, gummed shipping, drug, advertising stickers, etc. Lowest prices. Steady repeat orders. Ship everywhere. New free outfit just off press. Write quick. Dept. 162, Box 498, Cincinnati, Ohio.

OUR Men actually earn \$300 to \$500 monthly selling our lines. Adelite, the newcomer in electric window salesmen, is making a big hit. More for the money than anybody gives. Business posters for every line. Changeable letter system, too. Permanent business for you working with us. Territory protected and repeats credited. Fat commissions. Full details will prove very interesting. Display Products, Ltd., 409-A East 31st St., Kansas City, Mo.

SALESMEN, Dealers, service men investigate this new radio device. First time advertised. Doubles volume and distance. Can demonstrate coast to coast in summer. Brings in stations never heard on set before. Territories to producers. Write W. H. Laferty, Sales Agr., 279 Richey Ave., Detroit, Mich.

SALESMEN—Easy to make \$50 weekly selling our attractive advertising novelties and premiums to dealer trade. United Specialties Co., Dept. PM, Fort Wayne, Ind.

WANTED Salesmen to sell the latest business stimulators and premiums to dealer trade. Farr Manufacturing Co., Dept. PM, Fort Wayne, Ind.

RIGHT Now! Wonderful chance to represent big shirt manufacturer. Best season coming. Easy work. Commission in advance. Outfit given free. Write Graecit Company, Dept. 711-A, 504 Sixth Ave., New York.

A SIDELINE That pays 40% advanced commissions. Biggest line illustrated printing for all businesses. No experience needed. Selling outfit free. Hillside, 1217 Van-Buren, Dept. 23, Chicago.

WANTED—Salesmen to sell merchants our latest fast selling line. \$60 weekly easy. Guy-Ray Products Co., Lafayette, Ind.

PUNCHBOARDS—Hottest, largest money-making line ever offered. Season starting. Best commissions. Nothing to carry. Catalog free. Act! M&L Sales, 301 W. Adams, Chicago.

POOL Shooter. New, fascinating vending machine. Merchants everywhere buy! Splendid side line—big profit maker! Free pocket outfit! Specialty Mfg. Co., W617 W. Division, Chicago.

SELL Christmas cards. Start now. Be the first in the field. Samples free. Windermere Press, 6702 Dorchester Ave., Chicago.

PAYING Position open. I'll put you in the shoe and hosiery business. Permanent income, protected territory, full commission on repeats. Experience not necessary. Handsome sample outfit, literature—everything you need to become a successful shoe merchant. Send for free booklet "Getting Ahead." Wm. J. Mishel, Tanners Shoe Mfg. Co., M. 20011 C St., Boston, Mass.

\$18 TO \$25 Daily; biggest selling line of 2-piece suits, \$9.95 and \$12.50; 3-piece wool suit, \$17.95 (regular \$28.00 value). All-wool overcoats \$18.50. Splendid raincoats, slickers and boys' suits. Biggest commission. Free outfits. "Jim" Foster, Inc., Dept. 211, 2250 S. Spaulding Ave., Chicago, Ill.

HOW About this winter? Does your present connection offer you the money you want to earn this winter? We can show you how to earn \$50 to \$100.00 weekly. Are you interested? Write Geographical Pub. Co., 621 Plymouth Court, Chicago.

SELL "Union Label" business stationery. Lowest prices. 72-hour delivery. Big commissions advanced. Amazing bonus. Cuts furnished for every business. Experience unnecessary. Outfit free. Northwestern, 2002 Division, Chicago.

WHILE Others talk, our salesmen actually clean up. \$8.50 commission on ten-minute sale at \$18.50. Original Electric Hot Dog Machine. Write for available territory. Leonard E. Dickerson, Manufacturer, Dept. E-18, Springfield, Mo.

SALESMEN To sell Sales Builders. A time-tested result producing flexible plan of direct advertising for retailers. Big earnings for high grade men. Write A. D. Bradley, 500 South 4th Street, Minneapolis, Minn.

EARN \$20 A Day. Establish income for life selling for \$1 a year, \$1,500 accident policy. Write W. C. Stone, 11 So. LaSalle, Chicago.

PUNCHBOARD Salesmen—Four average orders daily pay \$96.00 weekly. 90 complete deals. Slot machines of all kinds. The most gigantic line ever featured. Repeat commissions. Big beautiful 4-color catalog free. Lion Mfg. Co., Dept. 8, 308 W. Erie, Chicago.

SALESMEN. Wonderful side line. 40% commission paid daily. Sells all merchants. Pocket outfit free. David Lionel Press, 312 S. Hamilton, Dept. 104, Chicago.

BUSINESS Stationery—Largest line—highest quality—quickest delivery—biggest commissions—liberal bonuses—free copyrighted cuts every business. Experience unnecessary. Instructions and outfit free. Willens Co., Dept. 261, 2130 Gladys Ave., Chicago.

AUTOMOBILE Specialty tool salesmen—Wonderful new valve lifter for all latest motors. Quick sales, big commissions. Clark Feather Mfg. Co., Ft. Morgan, Colo.

MOST Unusual chemical development. New product for all autoists. Prevents steam, rain and snow from blurring windshield. Exceptional opportunity for distributors and salesmen. Exclusive territories open. Retail 50c. Send 25c for full size product, and details. Walter S. Doe Co., Manufacturing Chemists, Dept. 25, Kent, Ohio.

AMAZING Screwholding screw driver! Factories, garages, workers buy on sight! Profit 75c each. Exclusive territory. Free trial offer. Jiffy, 1233 Winthrop Bldg., Boston.

VEST Pocket basket ball. New! Legal! Thrilling! Also four other sure-fire winners! \$125-\$200 weekly. Pocket sample free. Katz Sales, J-4332 Harrison, Chicago.

COVERALL Salesmen—Make \$20 daily selling new \$3.50 improved coveralls also service coats with customers name embroidered on back. Unusual construction. Commission 75c! Wonderful advertising value. Lowest priced; highest commission. Free outfit. Am. B. Co., AD-418 S. Wells, Chicago.

RESURRECTION Plant—Unique novelty; miracle of nature. Money maker for salesmen. Cost low. Write C. E. Locke, 10 Rio St., Mesilla, New Mexico.

DON'T Sell for others—Employ agents yourself. Make your own products. Toilet articles, household specialties, etc. 500% profit. Valuable book free. National Scientific Laboratories, 1984W Broad, Richmond, Va.

WONDERFUL Invention. Seals fifty envelopes minute. Sells on sight at \$2.25. Attractive trial offer. Square deal. Bank references. Kendal Sealer Co., 410 Sansome St., San Francisco, Dept. 14.

EXPERIENCED Salesman, as distributor for Whitlock Products direct to consumer. No competition, protected territory. Good reputation and ability to create opportunities essential. Opportunity for advancement. Replies confidential. Whitlock Products, 6895 S. Halsted, Chicago.

SALESMEN: To sell direct to consumers, factories, garages, schools, railroads, institutions, etc. High grade line of brooms, brushes and mops, for Chicago manufacturer. Sideline men considered. Write today. Frank Holub Mfrs., 1645 Blue Island Ave., Chicago, Ill.

\$250 TO \$400 Monthly for salesmen. Our goods sell quickly to factories, hotels, garages, public institutions, etc. Large profits. Year around repeat business. Exclusive territory. Free samples. Vasco Products, Elmira, N. Y.

\$50,000 PICTURE Man Friedman made canvassing. Beginners can make \$100.00 weekly with my sales talk. Experienced men make more. Free book "Profits in Portraits" explains. Sample free. Picture Man Friedman, Dept. 8, 109 West Austin, Chicago.

BIG Money and Fast Sales. Every owner buys Gold Initials for his auto. You charge \$1.50; make \$1.34. Ten orders daily easy. Write for particulars and free samples. American Monogram Co., Dept. 40, East Orange, N. J.

BIG Money daily, selling shirts of all kinds, lumberjackets, underwear, hosiery, sweaters, playsuits, overalls, pants, raincoats, leather coats! Outfit free! Experience unnecessary. Nimrod Co., Dept. 65, 4922-28 Lincoln Ave., Chicago.

AUTO Seat covers. Full or slip coverage all cars. Every autoist prospect. Selection and prices beat competition. \$3.00 commission advanced per set. Earn additional \$3.00 installation optional. Outfit free. Coverall, Inc., Lakewood, Ohio.

ELECTRICAL Tool line selling to garages, mechanics and auto owners, wonderful demonstrators, big commissions. Salesmen, write Barker Specialties, Girard, Penna.

PUNCHBOARD Salesmen, \$10,000 yearly. New line. All fast sellers. Lowest prices. Full commission on repeat business. Catalog free. Hurry! Puritan Novelty Co., 1409 Jackson, Chicago.

SELL Popcorn poppers. Low prices, big commissions. Northsides Co., 1306 5th, Des Moines, Iowa.

SALESMEN—America's leading collection service wants you to help doctors, merchants collect their bad accounts. You list them; we collect. Hustlers actually make \$75-\$100 weekly. Pleasant work, increasing profits. Get the facts. Arrow Service, 29 Jay St., Schenectady, N. Y.

SALESMEN—Become independent. Own your business; experience unnecessary. Selling our \$10,000 Accidental Death; \$50 Accident; \$25 Sick Weekly Benefits—\$10.00 yearly. Other amounts proportionate. Guaranteed steady income from renewals. \$250,000 deposited Insurance Department, Universal Policy Dept. A, 40 Clinton St., Newark, N. J.

SELL Goodyear raincoats; \$2.95 up. Goodyear Rainwear, 682 Sixth Ave., New York.

A MONEY Making sideline. A new quick seller to merchants and banks everywhere. Sales outfit free. Comm. paid daily. Carroll Co., Carroll & Albany Aves., Dept. 206, Chicago.

ADVERTISING Pencils cheaper than greeting cards. New Christmas designs appeal to all lines business. Fast sideline for hustlers. Cash in now. Northern Pencil Works, 126 S. Clinton, Chicago.

MAIN Or sideline. Sell auto tires and auto accessories to tire stores, garages, etc. Protected territory. Liberal commission. Economy Rubber Products Co., 604 Burkhardt Ave., Dayton, Ohio.

35% COMMISSION. Liberal repeats. New sales-producing service increases business 20% to 50%. Every retailer live prospect. Sales Stimulators, 339 W. Madison, Chicago.

SALESMEN! Sell Bostonian Shirts. Direct to wearer. Start in a money-making business of your own without a penny of capital. No experience necessary. Wonderful complete selling outfit free with everything you need to start collecting your profits at once. Write today, sure! Bostonian Mfg. Co., 106 Bleckford St., Boston, Mass. Est. 1863.

NEW Invention—Sell every business. Four \$15 sales daily pay \$288 weekly. Walker made \$145 first day. Exclusive territory. Adjustment Service, Dept. PM, Mobile, Ala.

WANTED District managers—Capable men to represent us in prosperous territories with direct home office contract. Our organization is the oldest of its kind in the health and accident business and offer exceptionally remunerative compensation. Write today for information. Dept. 18, Inter-State Business Men's Accident Association, Brown Bldg., Des Moines, Iowa.

GOLD-LEAF Window letters and script signs; no experience; 500% profit; samples free. Consolidated, 69-V West Van Buren, Chicago.

SUCCESS is no accident! You will fully understand this slogan when you examine our automatic credit and collection plan. Copyrighted, brand new, unusual. You make 250% on original sale. Half cash on repeats without call-backs. Commonwealth J. Publishing Company, 508 So. Dearborn St., Chicago, Ill.

SALESMEN—Four \$15.00 sales to merchants net you \$40.00 daily. Sayers Systems, 2813 Sheffield, Chicago, Ill.

TO Market 3A garage door holders, simple automatic action, quickly installed, instantly attracts garage owners, builders, dealers. Write for exclusive territory proposition. Knowlson-Stevenson Co., 1118 Packard, Ann Arbor, Mich.

PUNCHBOARD Salesmen make \$200.00 weekly selling punchboards and vending machines. Big repeat commissions. Beautiful 3-color catalog free. Best season now. Write today. Old reliable company, established 20 years. Lincoln Sales, 116 S. Wells, Chicago, Dept. D.

MAKE Your own products. Employ agents yourself. Toilet articles, soap, extracts. We furnish everything. Valuable book free. National Scientific Laboratories, 1984W Broad, Richmond, Va.

\$60-\$200 A WEEK. Genuine gold letters for store windows. Easily applied. Free samples. Liberal offer to general agents. Metallic Letter Co., 428-A North Clark, Chicago.

HELP WANTED

NO Dull times selling food. People must eat. Federal distributors make big money; many over \$3,000 yearly. No capital or experience needed; guaranteed sales; unsold goods may be returned. We furnish you with license, sample case and free samples for customers. Repeat orders sure; exclusive territory. Ask now! Federal Pure Food Co., C2307 Archer, Chicago.

DO You need \$500? I'll show you a new, easy way to make it as my local representative. No experience or capital required. Immediate earnings. Albert Mills, 3946 Monmouth, Cincinnati, Ohio.

OBTAIN Employment desired, quickly, anywhere. Learn how. Write Box 39-202, Station K, New York.

ARE You old at forty? See our advertisement on page 96 of this issue. The Electro Thermal Company, 2123 Morris Ave., Steubenville, Ohio.

MAKE Big profits silvering mirrors. Easily learned patented process. Plans free. Wear Mirror Works, Excelsior Springs, Mo.

BIG Wages in Canada, construction work, all trades! Write for list of positions, stamp appreciated. A. Allard, 4724 Des Erables, Montreal, Can.

CASH Paid for Butterflies, Insects. See Sinclair Display Advertisement on page 14.

"WHERE To buy thousands of articles wholesale." New directory. Agents wanted. Pruitt, Brookfield, Ill.

"IF You want to fly" let Alexander Klein, brilliant engineer, teach you. With great skill whole course of training has been simplified and made crystal clear. Remarkable book teaches in most practical and easily understood fashion. Recommended by skilled flyers. Sent C.O.D. anywhere in U. S. Simply pay postman \$2.50 and postage when delivered. Sent postpaid to any address upon receipt of \$2.50. Popular Mechanics Press, Room 803, 200 E. Ontario St., Chicago.

EDUCATIONAL AND INSTRUCTION

STUDY Mechanical dentistry and earn up to \$125 per week. Learn at home in spare time to make crowns, inlays, etc. Write for information. Modern Dental Institute, 49 South Main St., Salt Lake City, Utah.

200 TRICKS You can do—Mystify your friends; have loads of fun. This collection of tricks has been selected by Thurston for the average person. Neither unusual skill nor elaborate apparatus are required. Send for this 200-page illustrated book. Pay postman \$1 plus postage when delivered. If outside U. S. remit when ordering. Popular Mechanics Press, Room 803, 200 E. Ontario St., Chicago.

LEARN Aircraft welding, auto mechanics, electricity, Magnetos, radio. Big pay. Big demand. Low rates. Free catalog. Stevenson School, 2068A Main, Kansas City, Mo.

WANTED Immediately, men-women, 18-35, qualify for permanent government positions. \$105-\$250 month; no gov't experience required; paid vacations; common education; many needed soon. Write Ozment Inst., 101, St. Louis, Mo.

BECOME A landscape architect. Uncrowded profession; wonderful opportunity for money-making. Easily mastered by mail. Earn while you learn. Est. 1916. Write for details. American Landscape School, 29 Plymouth Bldg., Des Moines, Iowa.

U. S. GOVERNMENT Wants men, \$1,700-\$1,900 and up at start. Railway mail clerk examination coming. Let our expert (former government examiner) prepare you for this and also rural carrier, post office, customs, internal revenue, and other branches. Write today for free booklet. Dept. 8, Patterson School, Rochester, N. Y.

BOATING—Send for free list of best books on all places of pleasure boating, building, handling, fitting out, navigation, seamanship, where to cruise, etc. Popular Mechanics Press, 200 E. Ontario St., Chicago.

AMATEUR Cartoonists: Sell your cartoons. New market. Smith's Service, PR-1194, Wenatchee, Wash.

LEARN Linotype—Pays good salary; home or college course; small cost; free catalog. Linotype School, Maumee, Ohio.

DOUBLE Entry bookkeeping 60 hours with 8 keys; guaranteed. (Diplomas.) International Bookkeeping Inst., 8 Springfield, Mo.

DON'T Prepare for any civil service examination without seeing our catalog. Free. Columbian Correspondence College, Washington, D. C.

BIG Demand for photoplay talking picture and magazine stories. We revise, develop and copyright. Sell on commission. Established 1917. Booklet free. Universal Scenario Company, 406 Western and Santa Monica Bldg., Hollywood, Calif.

AIR Navigation and meteorology—New, simple, non-technical book needed by every flyer. Nothing else on the subject like it. Written by Captain Duncan who has over 3,000 hours of flying to his credit. 225 pages. Flexibly bound. 80 pictures, maps, etc. Pay postman \$3.00 when he delivers book. Popular Mechanics Press, Room 808, 200 E. Ontario St., Chicago, Ill.

STENOGRAPHY, 25c. Self-instructive books, 100 subjects, trades, etc. Will Marr, B605, Nashville, Tenn.

DISSATISFIED Working for somebody else? Want your own business? Want to be your own boss? Start a distributing bureau. Easy. Profitable. No selling. No experience. Start immediately. Opportunities everywhere. Complete instructions one dollar. Particulars free. Wagner, Box 457, Palo Alto, Calif.

PRIVATE School for boys and girls. Wilson Schools, Dayton, Ohio.

MEN, Women, 18 up, want a government job? \$105.00 to \$280.00 month. Steady work. Short hours. Paid summer vacation. Common education usually sufficient. Experience usually unnecessary. We coach you without leaving home. 32-page book with full particulars and sample coaching free. Write immediately. Franklin Institute, Dept. C3, Rochester, N. Y.

WRITERS, Authors: Criticism is essential; learn by exchanging Ms. with other writers. Get analytical test questionnaire. Send copy (not original) of story with \$1 to M. L. Smith, 87 Coleman St., Dorchester, Mass.

FIREMEN, Brakemen, baggagemen (white or colored), sleeping car, train porters (colored), \$150-\$250 monthly. Experience unnecessary. 810 Railway Bureau, East St. Louis, Ill.

MAIL Carriers, post office clerks, \$1700-\$2300 year. Steady work. Men 18-45. Frequent examinations. Common education. Particulars free. Write immediately. Franklin Institute, Dept. C14, Rochester, N. Y.

10,000 MONEY-MAKING Formulas. Tells you how to make and sell almost everything under the sun; cosmetics, mucilage, anti-freeze solutions, battery solutions, beverages, cheese, chewing gum, cleaning preparations, extracts, hair preparations, inks, bluing, leather polish, mirrors, perfumes, polishes, typewriter ribbons, carbon paper, washing powders, liquid soap, and hundreds of other profitable articles. Send No Money. Just write a postal for "Hensley's 20th Century Book of Formulas." Pay postman postage and \$4. Popular Mechanics Press, 200 E. Ontario St., Room 808, Chicago, Ill.

TYPEWRITERS AND SUPPLIES

TYPEWRITERS—Factory rebuilt Royals, Remingtons, Underwoods, New Royal, Remington and Corona portables. New "Excellograph" Rotary Stencil Duplicator \$37.50. Catalog free. Pittsburgh Typewriter Supply, Dept. 945, Pittsburgh, Penna.

TYPEWRITERS, All standard makes, \$10 up. Fully guaranteed. Free trial. Write for complete illustrated lists. Northwestern Typewriter Exchange, 121 N. Francisco Ave., Chicago.

TYPEWRITERS—All makes, \$6 to \$32. Fully guaranteed. Dee Typewriter Exchange, Ada, Okla.

ADDING MACHINES

NEW \$3.50 Automatic adding machine. Adds, subtracts, multiplies, absolutely accurate. Capacity \$999,999.99. Fully guaranteed. 75,000 pleased users. Makes adding easy, positive, quick. Eliminates mistakes. Saves time. Postpaid \$3.50. Bassett Co., 1458-D, Hollywood Ave., Chicago.

"MARVELOUS" 999,999,999. Calculator. Eliminates mistakes automatically. Postpaid \$2.75. Calculator Company, 721-G Magoffin St., Lexington, Ky.

PRINTING, ENGRAVING AND MULTIGRAPHING

BIG Free printing line brings easy quick profits. Union label. Bigger commissions—up to 55%! Experience unnecessary. Now write orders with America's most profitable printing stationery line. Thousands of free cuts. Over 150 standard items covering every business need: letterheads, noteheads, envelopes, billheads, business cards, statements, garage forms—shipping, battery, dry cleaning, tire, storage, parking and hat-cleaning tags; repair forms; blotters, gummed shipping, drug, advertising stickers, etc. Lowest prices. Steady repeat orders. Ship everywhere. New free outfit just off press. Write quick. Dept. 161, Box 498, Cincinnati, Ohio.

200 8 1/2 x 11 HAMMERMILL Bond letterheads, envelopes or business cards \$1.00 postpaid. Race Printing Company, Hudson, N. Y.

1,000 LETTERHEADS, Envelopes or statements \$3.50. Publishers, Box 2535, South Bend, Ind.

250 BOND Letterheads or envelopes, \$1.25. W. E. Moyer Supply House, Milton, Penna.

PRUITT Pays postage on all printing orders. Satisfied customers in every state. Free samples. Pruitt, Brookfield, Ill.

CIRCULARS, 5,000—5 1/2 x 8 1/2—\$11; 3 1/2 x 6—4-Page folders \$14. Big plant, little prices. Garrison Press, Harrisonburg, Va.

\$2.00 1,000 LETTERHEADS, Noteheads, envelopes, cards, billheads, tags, postcards. Samples free. Coyle & Kimbells, Newport, N. Y.

5,000 5 1/2 x 8 TINTED Enamel folders, \$13.75; 5,000 catchy envelope slips, \$5.00; 5,000 5 1/2 x 8 1/2 elegant circulars, \$10.00. Prompt delivery. Additional automatic press installed. 50,000-100,000 lots solicited. Samples. Estimates free. Goodprint, Harrisonburg, Va.

GUMMED Labels, sales slips, advertising devices, rubber stamps. Request samples—it pays. McPherson Printing Works, Middletown, Conn.

EMBOSS Your own stationery with name or initials. Samples free. Hazzard Company, Vanderveer Station, Brooklyn, N. Y.

WINDOW Envelopes and "One Fold Statements" save time and errors. Sample. Burket Printing Company, Roaring Spring, Pa. Ask about holiday printing.

200 MIMEOGRAPHED Letters, 8 1/2 x 11, \$1.25. Samples. Dougherty, B-74 Phillipsburg, N. J.

\$2.95 1,000 BOND Letterheads. Ewan, 224 Innes Road, Woodridge, N. J.

IF Particular, "Neogravure"—Special 500 8 1/2 x 11 letterheads, 250 envelopes \$4.44 postpaid. Samples. Soliday, Knox, Ind.

500 BUSINESS Cards \$1.10, 500 letterheads, envelopes \$1.98, 2,000 6 x 9 circulars \$2.50. Wm. Stridevan, Ravenna, Ohio.

500 BUSINESS Cards \$1.25 postpaid. Other printing reasonable. Samples free. Hanzer's, 1039 S. Cleveland, Phila., Pa.

100 8 1/2 x 11 HAMMERMILL 20lb. Letterheads and envelopes, \$1.25 postpaid. 200 noteheads, half letter size, \$1.00. Lowest prices on other printing. Lincoln Printshop, 225 Whitney, Hamden, Conn.

CLASSY Two-color letterheads or envelopes \$2.95, 500; \$4.95, 1,000. Beard Printing, 1360 E. 62d St., Chicago.

SAMPLES Raised letter printing with special prices free. LaClyde Service, Westfield, Mass.

1,000 Hammermill Letterheads or envelopes \$3.25. Cards, statements, billheads, 5 1/2 x 8 1/2 letterheads, \$2.50 cash delivered. The B. & M. Press, "Printers Extraordinary," Dawson, Okla.

MULTIGRAPHING Business correspondence two dollars thousand. Hammermill letterheads, four dollars; inexpensive quality, three dollars. Miscellaneous printing. Mayera Corporation, Monmouth, Ill.

PRINTING—Low prices, fine work. New price list and samples. Stationery, circulars, folders, booklets, catalogs, ruled forms. Sell direct, large or small orders. Large modern plant in small town, low operating cost. Shenandoah Publishing House, Inc., Box 1150, Strasburg, Virginia.

WE Print stationery, booklets, catalogs, circulars. Samples. Commercial Press, Batavia, Ohio.

200 LETTERHEADS And 100 envelopes \$1.00. 200 letterheads, 8 1/2 x 11, 150 envelopes \$2.00. 250 cards \$1.00. Hoosier Print Shop, Portland, Ind.

CIRCULARS \$3.00; Letterheads, \$3.50; envelopes, \$2.95 thousand. Fine printing. Battleground Press, Gettysburg, Penna. Free battleground souvenir.

QUALITY Printing! Reasonable Prices! Send for Free Standardized samples and prices. Folders, Circulars, Catalogs our specialty. Earnest Fantus, 525 South Dearborn, Chicago.

250 BOND Letterheads, Envelopes, Billheads, Cards, \$1.35 each. Economic Press, Leonia, N. J.

PRINTING OUTFITS AND SUPPLIES

PRINT Your own cards, stationery, circulars, advertising, etc. Junior press \$5.90; job presses, \$11; rotary, \$149. Print for others; big profit. Easy rules furnished. Write for catalog presses, type, paper, etc. Kelsey Company, Q-11, Meriden, Conn.

MAKE Your own printing device. It's practical—Different! Particulars, specimens free. Grinstead Laboratories, Oswego, Kans.

PRINTING OUTFITS—Presses, type supplies, type novelties. Send stamp for catalog. Model Press, York, Penna.

GUMMED LABELS

GUMMED Labels, 500 2 lines, 35c; 3, 55c, cash. Label catalog. Eastern Label Co., C. Clintonville, Conn.

RUBBER STAMPS

RUBBER Stamps! Name, address, two lines 25c; three lines 35c. DeLuxe Stamp Works, B572M, Auburn, Nebr.

DUPLICATORS AND DEVICES

YOU Can make 50 to 100 copies of a letter, notice, etc., at a cost of three cents on a Hoyer Quality Duplicator. Write for free trial offer. The Hoyer Duplicator Co., 309 Jackson Blvd., Chicago, Ill.

"EXCELOGRAPH" Portable rotary stencil printing duplicators \$39. Terms. Description, testimonials, printed samples, free. Pittsburgh Typewriter Supply Co., Dept. 531, Pittsburgh, Pa.

FOR THE HOME

DOOR Knockers, solid brass \$1.00 each postpaid. Nice Christmas gift. M. Lenor Esste, Newark, Ohio.

HOME Economy oil burners, stoves or furnaces, \$20.00, prepaid. Cheaper than coal. M. E. Page Sales Co., Watkins Glen, N. Y. Dept. "A."

CEDAR Chests only \$11.65—"Red-1-Kut" complete with rich copper trim—you assemble and save half—send for pictures. Kuempel Furniture Company, Guttenberg, Iowa.

753 TIME, Labor and Money Saving Ideas for all who own, drive or repair autos. These practical kinks are based upon the actual experiences of hundreds of owners and repairmen. Three books, Auto Owners', Auto Repairman's and Auto Tourists' Handbooks, regular \$1.50 value will be supplied at 98c plus the postage C. O. D. for a limited time only. Send your order today to Popular Mechanics Press, Room 808, 200 E. Ontario St., Chicago.

FOR MECHANICS

A BIG Opportunity in 8-hour battery charging or 20 minute car washing. Let me tell you how you can install equipment with practically no investment. Earn \$150 to \$300 monthly. Bargains in used outfits. Also a few reconditioned buffers, grinders, air compressors, paint sprays, air welders. Write today. Ken Byrum, Box M-1197, Troy, Ohio.

FOR Your Home Workshop—Great big book of 900 different things to make called "Make It Yourself." Big variety to suit all tastes. 823 illustrations. 480 pages. Clear instructions easily followed. Send to us at once for a copy and pay postman \$3.00 and postage when delivered. Popular Mechanics Press, Room 898, 200 E. Ontario St., Chicago.

FAMOUS Dyke's Automobile Encyclopedia—Latest 15th edition. Fully revised to cover all latest facts regarding newest developments, including new Model A Ford. Information given on repairing and adjusting every part of all motor cars. How to find trouble and fix it. 1,259 Pages. 4,200 illus. Price, cloth, \$6. Flexible Morocco \$7.50. Will be sent C. O. D. anywhere in U. S. Pay postman price and postage when he delivers book. Popular Mechanics Press, Room 806, 200 E. Ontario St., Chicago.

FOR SMOKERS

MACHINE Made cigarettes, 40c hundred, postpaid. Everyone guaranteed or money cheerfully refunded. Altman Co., 3635 Cote Brillante, St. Louis, Mo.

SMOKE On me—I'll send you free a generous sample of Kentucky nature flavored pipe tobacco. Enjoy the tasty natural tobacco flavor—the mild mellowness—the freedom from bite. See how cool, restful and enjoyable tobacco can be. Send today. Pete Moberly, Box 629, Owensboro, Ky.

RAZORS AND BLADES

GILLETTE Razor blades sharpened to perfection, 1c each. Pettet Wetterquist, Rockford, Ill.

SHARPEN Razor blades. Build a business for yourself. Make a dollar per hour with our machines. Easy, light work. Ideal proposition for elderly men. Fully equipped machines \$175.00. Velvet Edger Mfg. Co., 725 West 59th Place, Los Angeles, Calif.

NEW Gillette type razor blades. 30 for \$1.00. Every blade guaranteed. Superior Blade Co., Box 1516 Cincinnati, Ohio.

GILLETTE Blades sharpened good as new, 1c each. V. Swedberg, R. 1, Box 64, Harris, Minn.

BOATS AND LAUNCHES

MAKE 16' Rowboat. Blueprint 30c. Weesho-Uco, 31st Office, Detroit, Mich.

BUILD Your own boat using our ready cut semi assembled materials. 55 designs. Outboard speedsters, cruisers, runabouts, launches, sail, row. Send 10c for catalog. Hurry if for this season's use. Brooks Boat Co., Inc., Saginaw, Mich., Box NN.

HUBBELL Marine Coolers convert Ford engine into marine motors. Booklet free. Ford speedboat easily built, large blueprint and directions one dollar. C. C. Hubbell, Perry Ave., Norwalk, Conn.

COMPLETE Plans 155 sq. ft. and 350 sq. ft. iceboats \$1.00. Free boatbuilding catalog. The Rudder, 15 Murray St., New York.

NEW Boat Book telling how to make 21 kinds of boats. Also many other helpful ideas on boating. Profusely illustrated. With this we include the big book, "Outdoor Sports the Year Round." Directions for making all sorts of devices for outdoor recreation. Send no money. Simply pay the postman \$1.98, plus postage when books are delivered. Popular Mechanics Press, Room 806, 200 E. Ontario St., Chicago, Ill.

GUNS, SPORTING GOODS AND FISHING TACKLE

ARE You a rotten shot? Hunting season now open. Our shotgun peep-sight makes you a good shot, \$2.50 postpaid. Booklet "Wing Shooting Made Easy," 10 cents. Wilbur Gun Sight, Box 185, Times Square, New York City.

HUNTERS And trappers: See and try the "Screw-Bug," a mechanical ferret for routing rabbits, skunk and other burrowing animals. Sold by mail, allowing five days' trial with an absolute money-back guarantee. Price \$4.00 each, with order prepaid, or C. O. D. plus postage. Free circulars and testimonials. The Grabow Co., Dept. A, Franklin Square, L. I., New York.

HUNTERS, Remington autoloading shot guns, \$47.00. Ithaca field grade, \$33.00; Fox Sterlingworth, \$33.00. Low prices on all shot guns and rifles. List free. Pulver Sporting Goods, Hudson, N. Y.

FIELD GLASSES, TELESCOPES AND MICROSCOPES

WE Are closing out our stock of field glasses and binoculars at reduced rates. Send for our catalog and special close-out prices. Geneva Optical Company, 41 Linden St., Geneva, N. Y.

C-FAR Field Glasses \$2. Consists of two rounded lenses in neat leather case, slips into vest pocket, weighs only 1½ ounces. Gives 4 diameters magnification. Money back if not satisfied. Send \$2 today to Buffalo Optical Co., Dept. PM-1, 559 Main St., Buffalo, N. Y.

ARCHERY

MAKE Your own archery equipment. We furnish complete line highest grade materials and complete instructions for assembly. Can easily build highest quality outfit for fourth cost of complete outfits. Letter brings complete catalog and prices. Sidney Archery Co., Box M119, Sidney, Ohio.

ARCHERY—How to shoot accurately with the bow and arrow. Target shooting exclusively. New book "Modern Archery" by A. W. Lambert, champion shot, just what every enthusiast needs. Fully illustrated. Pay postman \$3 and postage when delivered, or if outside U. S., remit when ordering. Popular Mechanics Press, Room 806, 200 E. Ontario St., Chicago.

ANTIQUES, WAR RELICS AND INDIAN GOODS

German Iron Cross \$1.00. Dare, 670 East 42nd, Brooklyn, N. Y.

FINANCIAL War relics. Collectors find rich material for den or office in our free list. Praetorius, 1629 Meyer Court, Chicago.

GENUINE Indian goods direct from an Indian trader. Navajo blankets, rugs, pottery, basket, silver work. Price list Southwest Indian Crafts, Box M-247, Gallup, N. Mex.

700 ARROWS, 25 for \$3.00; tiny bird point 4 for \$1.00, battle axes \$2.00, skinning knives \$1.50, hammer stones \$1.50. Robert Helke, Pontiac, Ill.

SEND 5c For fine new list Indian relics, antique firearms. F. E. Ellis, Webster Groves, Mo.

MINERALS, PRECIOUS AND SEMI-PRECIOUS STONES

TOPAZ, The birthstone for November. White topaz, smoky topaz, direct from the mine and guaranteed to please anyone wanting a genuine stone at bargain. Inspect this stone 3 days and if you are not satisfied return it and your money will be returned. \$12.50, 1 carat, \$18.50, 2 carat. Have some wonderful bargains in rings. Write your wants to R. A. Garner, Box 188, Lancaster, Pa.

PHONOGRAPHS AND RECORDS

BUILD Your own phonograph. Parts catalog and instructions to build new horn, mailed for 10c. American Phonograph Co., 4116 West 24th Place, Chicago.

MUSIC AND MUSICAL INSTRUMENTS

SONG-POETS—"Your Best Bet." Healy, Liberty Theater, Colorado Springs, Colo.

COMPOSERS—Verse or music. Brilliant opportunity. Write Van Buren, 1893 McClurg Bldg., Chicago.

HEY-HEY! All musicians! Get "How to Play Hot in 1 Hour" (Shows the 6 big secrets). Guaranteed to make you hotter'n the devil's kitchen! Sent free to get acquainted. No cost, no obligation. Act now! State Instrument, Artists' Music School, Tyrone, Pa.

SONGWRITERS: Substantial advance royalties are paid on publisher's acceptance. New booklet, "Song Requirements of Talking Pictures," sent free. Newcomer Associates, 790 Earl Bldg., New York.

PROFESSIONAL Player's Jew-harp, kind heard over radio, \$1. McFerran, Box 44B, Mt. Morris, Ill.

SONG Poems arranged for publication. Submit poems for examination. Brennan, L1652½ Bway, N. Y.

SONG Poem writers, "Real" proposition. Hubbel, D1, 2104 N. Keystone, Chicago.

SONGWRITERS: Submit your song-poem of complete song. Quick decision on availability for publication—unacceptable manuscript returned. Chester A. Escher, Music Publisher, 125 W. 45th St., New York City.

VIOLINS—Hand-made masterpieces. John Lehto, 925 14th San Pedro, Calif.

FREE! Song Writers Guide. Beaver, 1257 Elm, Green Bay, Wis.

POEMS Wanted. Work guaranteed. We publish. Great Eastern Song Bureau, Dept. 27, Thomaston, Me.

SEND Song poems, 50-50 plan. Indiana Song Bureau, (Brookside), Salem, Ind.

SONG Poem writers. Write Sequoia Songwriters' Service, Sherman Branch, Los Angeles, Calif.

VIOLINS, Deep, mellow, soulful—on credit. Easy terms for wonderful instrument. Get details today. Gustav F. Henning, 302 University Building, Seattle, Wash.

CORNETISTS—Trumpeters—Saxophonists—Clarinetists. Get "Free Pofinters." Name instrument. Virtuosi School, Buffalo, N. Y.

PLAY Piano by ear. A sound system. Booklet free. Boucher's Harmony Studio, Ottawa, Can.

"MUSIC Composed" to words. Bauer Bros. (formerly of Sousa's Band), Oshkosh, Wis.

SONG Writers. Send for our "Publishing Agreement." McKinley Music Printers, 1501 E. 55th St., Chicago.

WRITE Songs. Big money and reputation. Write for information. J. Gordon Pub. Co., 201 N. Hoyne Ave., Chicago.

SONG Poems solicited. A different proposition. Richard Broughton, Sioux Falls, S. Dak.

PATENT ATTORNEYS

INVENTIONS Patented; confidential advice; inventions developed—representative for Blair Tool and Machine Corp.; trademarks registered. Edward Gottlieb, Patent Attorney, 5 Beekman St., New York.

JOHN PATTEN DUFFIE, Registered patent attorney, Victor Bldg., Washington, D. C. Reasonable rates. Advice free. Booklet. Prompt personal service.

IF You have a good patent or pending patent for sale, write promptly. American Patents Corporation, Barrister Bldg., Washington, D. C.

INVENTORS' Service Bureau will send booklet and give you free advice concerning the proper procedure for obtaining patents, arranging payments on time to assure immediate protection. Dent, B. Union Trust Building, Washington, D. C.

PATENTS Procured. Prompt, careful and efficient service. Highest references. Moderate fees. Send sketch or model for actual search and advice. George P. Kimmel, Master of Patent Law, 54-K Legal Bldg., Washington, D. C.

PATENTS Procured under my easy payment plan. See ad page 145, M. S. Cayne.

LACEY'S Patent Sense. Valuable book free. See ad page 145.

PATENTS—Write for our free book, "How to Obtain a Patent" and Record of Invention Blank. Send model or sketch of invention for inspection and instructions free. Terms reasonable. See advertisements on pages 142 and 143. Victor J. Evans & Co., 934 Ninth, Washington, D. C.

TIME Counts in applying for patents. See pages 140 and 141. Clarence A. O'Brien, Registered Patent Attorney, Washington, D. C.

PATENTS Procured; easy terms; practical inventions submitted direct to manufacturers; describe. H. Sanders, 7 Rand McNally Bldg., Chicago, Ill.

EDWARD C. SASNETT, 516 McGinn Bldg., Washington, D. C. Ex-principal examiner United States patent office, attorney at law, registered patent attorney. I offer to inventors and manufacturers a strictly personal service.

PATENTS Procured; trade marks registered—preliminary advice furnished without charge. Booklet and form for disclosing idea free. Irving L. McCathran, 704 International Building, Washington, D. C.

UNPATENTED Ideas can be sold. I tell you how and help you make the sale. Free particulars (Copyrighted). Write W. T. Greene, 906 Barrister Bldg., Washington, D. C.

SELL Your invention before patenting. Write for free particulars. W. T. Greene, 901 Barrister Bldg., Washington, D. C.

PATENTS, Trade-Marks, Designs. This firm has 27 years' experience and gives expert personal service at reasonable rates. We properly protect your invention. Write for free information and exact cost of procuring patent before proceeding. John B. Thomas & Co., 902 F St., N. W., Washington, D. C.

MONROE E. MILLER, Ouray Bldg., Washington, D. C., Patent Lawyer; Mechanical, Electrical Expert. Booklet and Priority Record blank gratis.

INVENTORS: Send for booklet telling how to patent and sell your inventions at lowest cost. Ralph Burch, Patent Lawyer, 900 F St., Washington, D. C.

ESTABLISHED 1864. Milo B. Stevens Company. Free booklet. Patents. Trade marks. Copyrights. Offices, Monadnock Block, Chicago; Barrister Building, Washington, D. C.

INVENTORS—Write for our Guide Book, "How to Get Your Patent," and Evidence of Invention Blank. Send model or sketch of your invention for our prompt examination and instructions free. Randolph & Co., Dept. 430, Washington, D. C.

PATENTS. Prompt personal service. Write for information. Albert E. Dieterich, Registered Patent Lawyer, 621½ Ouray Bldg., Washington, D. C.

LANCASTER and Allwine, 221 Ouray Bldg., Washington, D. C. "Originators of the Form Evidence of Conception." Before disclosing your invention to anyone send for blank form to be signed and witnessed. Form and patent information bulletin free.

PATENTS. Send sketch or model for advice. Free book: "How to Obtain a Patent." Established thirty years. Highest references. Prompt service. Reasonable charges. Chandlee & Chandlee, 910 F St., Washington, D. C.

INVENTOR'S Adviser with mechanical movements sent free. Labiner, Three Park-row, New York.

PATENTS. Booklet free. Highest references. Best results. Promptness assured. Send model or drawing for preliminary examination. Watson E. Coleman, Patent Lawyer, 724 Ninth St., Washington, D. C.

"**INVENTOR'S** Guide," valuable information, free. Frank Ledermann, Registered Attorney-Engineer, 1712 Woolworth Bldg., New York.

PATENTS—Write for free instructions. Send drawing or model for examination. Carl Miller, Registered Patent Attorney (former Patent Office examiner), 259 McGill Bldg., Washington, D. C.

PERCY S. WEBSTER, 203 Saving and Loan Building, Stockton, Calif. Patent booklet free.

FOR INVENTORS

PATENTS. If you have an invention which you wish to patent you can write fully and freely to Munn & Co., for advice in regard to the best way of obtaining protection. Please send sketches, or a model of your invention and a description of the device, explaining its operation. All communications are strictly confidential. Our Hand-Book on Patents is sent free on request. This explains our methods, terms, etc., in regard to patents, trade marks, foreign patents, etc. "Scientific American" contains patent office notes, decisions of interest to inventors and particulars of recently patented inventions. Munn & Company, Solicitors of Patents, 524 Scientific American Bldg., Washington, D. C.; 1523 Scientific American Bldg., 24 W. 40th St., New York City; 1313 Tower Bldg., Chicago, Ill.; 666 Hobart Bldg., San Francisco, Calif.; 521 Van Nuys Bldg., Los Angeles, Calif.

UNPATENTED Ideas can be sold. I tell you how and help you make the sale. Free particulars. (Copyrighted). Write W. T. Greene, 907 Barrister Bldg., Washington, D. C.

LOW Cost manufacturing. Large plant completely equipped for blanking, drawing, stamping and wire forming in any finish. Can save you money on your product. Our figures will convince. Eastern States Products, Box 421, New Haven, Conn.

INVENTORS—Ideas developed and working models built. Electrical problems solved. Lowest charges and confidential service. Industrial Electric Tools Co., Petersburg, Va.

If you have a good patent or pending patent for sale, write promptly. American Patents Corporation, Barrister Bldg., Washington, D. C.

LACEY'S Patent Sense. Valuable book free. See ad page 145.

INVENTORS—Write for our free book "How to Obtain a Patent" and Record of Invention Blank. Send model or sketch of invention for inspection and instructions free. Terms reasonable. See advertisements on pages 142 and 143. Victor J. Evans & Co., 157 Ninth, Washington, D. C.

TIME Counts in applying for patents. See pages 140 and 141. Clarence A. O'Brien, Registered Patent Attorney, Washington, D. C.

INVENTORS! Working drawings made of new inventions, patented ideas, perfected ideas. Write M. S. Opsata, 1917 Vienna Ave., Milwaukee, Wis.

\$800 SAVED By me on one invention, by applying direct through these foreign residential attorneys in England, France, Germany, Italy, Japan. Their names, addresses \$1.00. Ole Peterson, Turner, Oreg.

SELL Your invention before patenting. Write for free particulars. W. T. Greene, 902 Barrister Bldg., Washington, D. C.

I SELL Patents. Established in 1900. A nationally-known service. Experienced, respected. Why take chances? Charles A. Scott, 773PM Garson Ave., Rochester, N. Y.

INVENTORS—Cash in on your invention now! Don't delay the sale any longer! Send for a free copy of our specially prepared booklet, "Turn Your Patent Into Money," today! It contains helpful information for all inventors. M. L. Rund, Mgr. Classified Advertising, Popular Mechanics Magazine, 200 E. Ontario St., Chicago, Ill.

INVENTORS, Manufacturers. If you have a specialty of real merit suitable for national distribution write The Plomo Specialty Mfg. Co., Cleveland, Ohio.

INVENTORS Opportunities, a bulletin of ideas revised quarterly by an experienced industrial engineer. 50 cents. Beandbe Engineering Co., Midland, Mich.

WANTED—Article to manufacture and sell. All or some part of which must be consumed and thus be a repeater. Give full particulars and price. Address G. L. P., Room 514, 1240 South Main Street, Los Angeles.

INVENTIONS Wanted—Patented, unpatented. If you have an idea for sale, write Hartley, Box 928, Bangor, Me.

GET Your own patents. Legal blanks, complete instructions \$1. Cutting Soas, Campbell, Calif.

INVENTORS Universal - Educator - contains 900 mechanical movements; 50 perpetual motions. Tells how to obtain and sell patents. Suggests new ideas. Explains how to select your attorney and avoid patent sharks. Price (revised edition) \$1.00 postpaid. Albert E. Dieterich, 621 Ouray Bldg., Washington, D. C.

PATENTS FOR SALE

CASH And royalty doorkeeper prevents entry. Operated by foot. Manufactured at low cost. Stargardt, 278 Connors Ave., Detroit.

FOR Sale or royalty basis? Automobile automatic safety signal, approved of by the government road supervisor at the Detroit Automobile Show, through 1½ years' test, ready for production. Working prints, specifications and model furnished. Jordan & Penka, 3851 Edwin St., Detroit, Mich.

FOR Sale or royalty? Patent No. 1,720,427, on fire fighting appliance. J. T. Mulroy, 53 Johnson St., Brooklyn, N. Y.

RING-TOOL, Made by press. Mar 1, 925 Parkland, Flint, Mich.

OUTRIGHT Or royalty. Combination garden, lawn and sidewalk tool. L. Baker, 810-6 North, Fort Dodge, Iowa.

WIND-STORM Hat retainer. Every man a prospect. Louis Pichler, 670 E. 102d, Cleveland, Ohio.

OUTRIGHT Or royalty—Egg poacher, new, convenient; no waste; low cost; packs closely. Inventor, 1090 E. 21st Ave., Vancouver, Can.

OUTRIGHT — Full vision illuminated radio dial. Highest offer accepted. Lee, 118 W. State St., Rockford, Ill.

FOR Sale—Rubber tobacco humidifier. Patent pending. New novel device. Essential for smokers. Self-paying advertising medium for tobacco or rubber manufacturers. Wm. J. Engel, R. D. 6, Amsterdam, N. Y.

HINGED Clevis every farmer must have. Patent for sale and royalty. Have set of dies for manufacturing clevis. H. H. Schlueter, Canistota, S. Dak.

HEAT Regulating device for furnaces, boilers or stoves; hot water free; cash or royalty. Valgene Howard, 4047 Grant St., Flint, Mich.

WILL Sell for best offer: Patent small bottle and jar washing machine; big demand. Manufactured cheap. Carl Kallenbach, Sykesville, Md.

OUTRIGHT Or royalty. Automobile or truck tire gauge. Gauges mounted on instrument board. Patented August 15, 1929. Everett McKinney, Pawnee, Ill.

FOR Sale—Patent on electric train order hoop, permits delivering orders to trains without reducing speed. Clear vision of orders to trainmen at night. New, safety. Fred Foltz, Box 38, Shreve, Ohio.

753 TIME, Labor and Money Saving Ideas for all who own, drive or repair autos. These practical kinks are based upon the actual experiences of hundreds of owners and repairmen. Three books, "Auto Owners", "Auto Repairman's" and "Auto Tourists'" Handbooks, regular \$1.50 value will be supplied at 98¢ plus the postage C. O. D. for a limited time only. Send your order today to Popular Mechanics Press, Room 810, 200 E. Ontario St., Chicago.

OUTRIGHT Or royalty, Patent 1,730,511. Adjustable rubber hose clamp. Fred Johnson, 3111 Hawthorne Ave., Franklin Park, Ill.

OUTRIGHT Or royalty. Spoke tenoning machine. J. M. Taylor, Crawley, La.

FOR Sale—Patent on sanitary washer and sterilizer. To be used in every household and soda fountains. Will sell outright or royalty. H. K. McManus, 920 Speed St., Vicksburg, Miss.

INVENTOR Of winged ocean liner hawking model patent for sale. Write Frank Massie, Park Station, Wayneboro, Va.

FOUNTAIN Pen manufacturers write Payne 1263 Pacific St., Brooklyn, N. Y.

PATENTS For sale. Canada No. 216,021 and U. S. patent No. 1,397,670 on new and useful improvements on garment holders. D. W. York, 3 Temple St., N. Abington, Mass.

TIME Counts in applying for patents. See pages 140 and 141. Clarence A. O'Brien, Registered Patent Attorney, Washington, D. C.

AUTOMOBILE Inner-tube tester, test tubes under pressure. \$5,000.00 outright, Samples \$8.00. Geo. E. Mancos, Libbie and Monumental Aves., Richmond, Va.

COMBINATION Motor truck, concrete and mortar mixer; establishing a new mixing principle and will prove a big money maker to manufacturer. Chas. Payne, 27 Fulton Ave., Waukegan, Ill., U. S. A.

OUTRIGHT Or royalty—Patented keyless automatic door lock. Jay Westcott, 163 Wilmore Pl., Syracuse, N. Y.

INVENTORS—Cash in on your invention now! Don't delay the sale any longer! Send for a free copy of our specially prepared booklet, "Turn Your Patent Into Money," today! It contains helpful information for all inventors. M. L. Rund, Mgr. Classified Advertising, Popular Mechanics Magazine, 200 E. Ontario St., Chicago, Ill.

ELECTRICAL

ELECTRICIAN'S 1929 Code book free with each set questions, answers. Learn the rules. Make your jobs easy. Send dollar or stamps. Hinman, 2938 West Hancock, Detroit, Mich.

MODELS AND MODEL SUPPLIES

\$4.95 IS All you will have to pay for a C-A sanding, grinding, buffing and polishing kit, invaluable to model builders, consisting of: 2½" drum sander, 6" grinding wheel, 6" wire buffing wheel, 6" sewed polishing wheel, stick of polishing compound, an arbor which will fit any small motor with a ½" shaft. A real he-man outfit for hard work. Easily worth \$10.00. Guaranteed—"Your money back if not entirely satisfied." Adjustable Bearing Co., Inc., Indianapolis, Ind. Dept. A.

THEATRE Model—New, fascinating. Imported puppet scenery in beautiful colors for 24 different stage settings, 14x19, proscenium to mount and cut out, with plans, \$3. Miniature Theatre Guild, Gary, Ind.

INVENTORS—We build models. Send us your rough idea. Our master mechanic will develop it for you into a practical working model. Thirty years successful experience, doing this very thing. Confidential service guaranteed. Bank references furnished. Send for free booklet "The Road To Success." Crescent Tool Co., Dept. A, Cincinnati, Ohio.

BOXWOOD Blocks, deadeyes, 25¢ per dozen. Doubles 35¢. G. Anderson, 26 Red Deer Ave., Toronto, Ont.

MODEL Steam locomotives, castings, materials. Catalog 15¢. Birch, 131 Eliza Avenue, Hazel-Park, Mich.

POWER Models for modelmakers. Steam and gasoline engines, boilers. Ship, railway and steam fittings. Modelmakers' supplies, metals. Catalog 20¢. Chas. Cole, 1355 Church St., Ventura, Calif.

TIME Counts in applying for patents. See pages 140 and 141. Clarence A. O'Brien, Registered Patent Attorney, Washington, D. C.

SHIP Model Fittings: Send dime for booklet. A. J. Fisher, 1002 Etowah Ave., Royal Oak, Mich.

LET Our experience be your guide. Models that are models; tools and equipment for economic manufg. Patterns of all types; manufacturing in all branches. Satisfaction guaranteed. United Machinery Company, Cincinnati, U. S. A.

THREE Ship model plans for \$1. Catalog 6 cents. Richter's, 3217 Walnut St., Milwaukee, Wis.

READ The Model Yacht! The only national magazine in America devoted to the interests of the model yacht sailor. Published monthly. \$1.50 the year, 15c the copy. Yachting, Inc., 215 East 42nd St., New York.

WORK With master machinist; 15 years experimental experience, well equipped shop. Albert Weiss, 161 W. 21st St., New York City.

THE Modelmaker, a magazine for all interested in making working models, boats, etc. Sample 10c. Modelmaker, 123 Liberty St., New York.

WE Make working models for inventors and do experimental work and carry a complete stock of brass gears and model supplies. Send for catalog. The Pierce Model Works, Tinley Park, Ill.

SPECIAL Machine builders, tool and die makers, inventors' models production work of all kinds. Dept. L. Quality Hardware & Machine Corporation, Ravenswood and Thorndale Aves., Chicago, Ill.

MODEL Steam engines and boilers for miniature power boats. Boat and boiler fittings. New catalog 15c. Model Machine Shop, 212 Price St., Rahway, N. J.

MANUFACTURING

LARGE Factory exceptionally well equipped to manufacture your product complete, warehouse it and ship to your instructions. Dies, stampings, casting, screw machine, wire products, plating, enameling, assembling, cartons and printing. Quantity production. Estimates promptly furnished. A reliable and efficient organization. Maestle Products Mfg. Company, Box 877, Chicago.

LOW Cost manufacturing. Large plant completely equipped for blanking, drawing, stamping and wire forming in any finish. Can save you money on your product. Our figures will convince. Eastern States Products, Box 721, New Haven, Conn.

MANUFACTURING Models, dies, stampings, brass work, one or thousands. Circular free. Baum's Metal Specialties, Kansas City, Mo.

SPECIAL Machinery or parts, dies, tools, metal specialties, models, special gears, stock gears and model supplies. Send for Catalogue. The Pierce Model Works, Tinley Park, Ill.

WIRE Goods made to order. Cooley Mfg. Co., 530 N. Western Ave., Chicago.

SPECIALTY Manufacturing. Stampings, wire products, patents developed and marketed. Safety Globe & Mfg. Co., Columbus, Ohio.

MANUFACTURING: Small machines, parts, dies, stampings. Write Birchall, Reading, Mass.

DIES, Stampings, machine work. B. L. Nortwed, Mitchell, S. Dak.

HOME WORK SHOP

GOOD Used hand-saws, jig-saws, wood craftsman's lathes, drills at special low prices. Waco Tool Works, 5212 West Kinzie St., Chicago.

MACHINERY, TOOLS AND SUPPLIES

NO. 3 CINCINNATI Universal Milling Machine with dividing heads, \$550.00; 14 in. x 6 ft. Von Wyck lathe, \$140.00; No. 60 Hand Grinder, \$275.00; 20 in. Hedy Shaper, \$225.00; 24 in. Steptoe Back Geared Crank Shaper \$550.00, 36 in. x 18 ft. Niles Lathe, \$775.00; 20 in. Barnes Drill Press, complete, \$65.00; Quincy Air Compressor with tank and hose, \$65.00; 10 in. Bench Drill Press, \$23.00. Terms to suit. Write for catalog. Cincinnati Machinery & Supply Co., 27 West Second St., Cincinnati, Ohio.

500 BRAND New Westinghouse 1/4 hp. 110 volt, a.c. electric motors, price \$8.00 each. While they last. Botwinik Brothers, Inc., 67 Water St., New Haven, Conn.

BENCHLATHES, Real working miniature precision machines. 2 inch swing, 6 inch between centers and above. Set of detailed blueprints and directions 50 cents, complete castings \$3. Dzubay, 609 Avery St., Pittsburgh, Pa.

USED Arc welders, air compressors, buffers, grinders, reconditioned and guaranteed like new. Shipped on trial and easy terms. If you're in need of good guaranteed equipment, write today to Bob Jones, Box M-1198, Troy, Ohio.

LATHE, 16x9 Screwcutting \$75; drill presses \$25; screw machines \$75; disc grinders \$63. All real values. Klauber Machinery Co., 320 South Third St., St. Louis, Mo.

CONCRETE Building block machines and molds. Easy payments. Catalog free. Concrete Machine Co., 5 North Main St., St. Louis, Mo.

START Business of your own, small investment required, doing nickel, copper and silver plating. This work in big demand. Information free. Electro Platers Supply Co., 28 W. Second St., Cincinnati, Ohio.

ALINONE Belt dressing preserves leather belts. Reduces friction. Increases traction. Fifty cents prepaid. Home Mill Specialties Co., Box 1092B, Station A, Cleveland, Ohio.

FOR Sale—Handle machinery outfit for \$280. Joe Freeman, Wamsley, O.

ENGINES, MOTORS AND DYNAMOS

BARGAINS—Elec. drills, \$11.95; bench saw outfit \$7.35; elec. bench grinders \$13.20; combination lathe, \$8.15; scroll saw, \$5.60; motors, generators, farm plant equipment; flexible shafts; 100 other bargains. Send for special bargain bulletin. Acme Tool Co., 627 W. Washington, Chicago.

FOR Sale: One-sixth hp. elec. motors, 60 cycle, 110 volt, a.c. slightly used, first class running condition, \$1.50 each. Cash with order. Also some 1/2 hp. gasoline engines with magneto fly wheel at \$12.00 each and some electric motors not running at \$1.50 each. Maytag-Chicago Co., 160 E. Illinois St., Chicago, Ill.

NEW 1-3 Horse Westinghouse 110 volt alternating current motors, \$10.50. 1/4 horse, \$7.00. 32 and 110 volt 500 watt generators, \$18.50. All with pulleys. Hundreds of other bargains. Electrical Surplus Company, Dept. 12, 1911 Chicago Ave., Chicago.

TIME Counts in applying for patents. See pages 119 and 141. Clarence A. O'Brien, Registered Patent Attorney, Washington, D. C.

SAVE Money—Automatic air compressors, constant potential battery chargers, reconditioned and guaranteed like new. Unusual value—shipped on trial and easy terms. If can use, better write today to D. W. Baker, Box M-1199, Troy, Ohio.

NEW 10v. 5 Ampere battery charging generators \$6.50; a.c. 110v. 1/4 hp. motors, \$7.50; 1/2 hp., \$16.50; 32v. motors, 1/2 hp., \$19.50; 1/3 hp., \$12.50; 1/4 hp., \$8.50; 32v. motors with emery, buffer, drill chuck, \$8.00. Large stock motors and generators. Queen City Electric, 1736 Grand Ave., Chicago.

EDISON Phonograph motors with speed governor. Westinghouse dictaphone motors, both universal, \$5.00 plus express 10 lb. Geo. Schulz, Calumet, Mich.

STEAM Engines one hp. \$18, 1/2 \$12. James Chambliss, Bessemer, Ala.

WELDING AND SOLDERING

START In highly profitable arc welding business with practically no expense. Our constant arc welder starts you on road to success. Easy monthly terms, liberal trial on money back guarantee. Write today. Hobart Industries, Box M-1190, Troy, Ohio.

BENDING MACHINES

THE Famous Hossfeld "Wrenchless" Universal Iron Bender is the last word in bending machines. Bends metal, cold or hot, into most any conceivable shape, including Eye Bolts and Automobile Spring Eyes. Bends up to 1" bars or 1 1/2" pipe cold. Thousands in use by all classes of trade, from the smallest shops to the largest railway system. Write for circular and prices. Hossfeld Mfg. Co., Winona, Minn.

SURVEYING INSTRUMENTS

BARGAINS In rebuilt transits and levels. All kinds and makes. Guaranteed. Terms if desired. Write today for descriptive list M-311. Warren-Knight Company (Makers of "Sterling" Transits and Levels), 136 N. 12th St., Philadelphia, Pa.

COMPLETE Farm level outfit \$25.00. Combination transit \$45.00. Sent prepaid for cash. Money back guarantee. Wisler, 639 No. Broadway, St. Louis, Mo.

LUMBER

KNOW Your wood. 33 samples rare woods \$2.00. 20 cabinet and 20 inlay \$1.75, choice \$1.00. Sets postpaid and labeled. Send for catalog. Craftsman Wood Service, L-715 East 62nd St., Chicago.

FARM LANDS

LAND Opening—The Great Northern Railway serves an agricultural empire in Minnesota, North Dakota, Montana, Idaho, Washington and Oregon. These states abound in opportunities for small farmers or large operators to rent or purchase a farm at lowest prices and best terms of many years. Every kind of farming, grain, livestock, dairying, fruit, poultry; large acreage or small suburban tracts, rich cutover or high producing irrigated land. Write for free Zone of Plenty book with detailed information. Low home-seekers' rates. E. C. Leedy, Dept. 457, St. Paul, Minn.

NEW Catalog, 1,000 bargains, \$300 down, lovely furnished home, large plot on cement highway, 3 miles city 50,000; fine 7-room bungalow, concrete porch, fireplace, electricity available. \$2,000 value at \$900, third cash. Picture page 48. Write today. Strout Agency, 255-P Fourth Ave., New York City.

REACH Many prospective buyers for your property: Farm, business or residence, no matter where located. Information free. International Realty Co., Ford Bldg., Detroit.

LAND Sale, \$5 down, \$5 monthly, buys 40 acres Southern Missouri. Price \$200. Send for list. Box 22N, Kirkwood, Mo.

OZARKS—40 Acres, Missouri; \$5 month; own a home. Jarrell, Mt. Vernon, Ill.

WINTER Home in Florida. Lots \$1 down, \$1 a week. On Dixie Highway, close to Tampa. Ask for prospectus. P. O. Box 374, Tampa, Fla.

WANTED: Hear from owner having good farm for sale. Cash price, particulars. John Black, Chippewa Falls, Wis.

NORTHWEST Arkansas 20 acre tracts only \$150, \$5 down, \$5 monthly; easy driving distance university city of 10,000. H. W. Stanford, Fayetteville, Ark.

GET Quick cash sale for your property anywhere located. Details free. Write Fisher Realty Co., Hannibal, Mo.

PECAN-Orange-Fig groves "On the Gulf." Monthly payments. Guaranteed care. Big, quick returns. Suburban Orchards, Dept. M., Biloxi, Miss.

SELL Your property quickly for cash, no matter where located. Don't pay big commission. Particulars free. Real Estate Salesmen Co., Desk B, Lincoln, Nebr.

MONEY Made in Mich. potatoes, \$10 down now and easy terms buys land near markets, lakes, streams. Write today. Swiggart & Co., P-601, 32 N. State St. Bldg., Chicago, Ill.

EASTERN Pennsylvania farms near Philadelphia. Write for bulletin giving prices, sizes and descriptions. Wilson George, Quakertown, Pa.

OZARKS—10 Acres near White river and proposed power dam, \$100, \$5 monthly. Alvin Zimmerman, 1802 N. 5th, Kansas City, Kan.

DOGS AND PETS

ST. BERNARD For Christmas gift! Rare, beautiful thoroughbred puppies, photos submitted, delivery guaranteed. Helvetia Kennels, 181-P McKenna Ave., Montreal, Que.

ARKANSAS Coon-hounds, high class coon-hounds \$75.00, high class combination hounds \$40.00, coonhound pups \$10.00 each, champion rabbit hounds \$20.00. Allow ten day trial. T. J. Bradley, Alma, Ark.

SALISBURY'S Pedigree records for dogs and rabbits, 100, \$1.00. Grant Press, 634 North Western Ave., Los Angeles, Calif.

FOR Sale Minks, squirrels, raccoons, foxes, ferrets, muskrats, ginseng, rabbits, skunks, wolf pups, opossums. B. Tippman, Caledonia, Minn.

SHEPHERDS, Collies, fox terriers shipped on approval. Bicketts Farm, Kincaid, Kans.

FOR Sale—One four-year-old well-known coon and opossum hound. On 60-day trial. R. L. McCuan, Brownsville, Tennessee.

CANARIES—Supplies. We guarantee health, song, plumage. Tonic 30c. Canary Breeders, LaGrange, Ill.

GREEN Mexican, double yellow head parrots, \$10.00 each. Hand raised, real talkers, make interesting pets. Cash with order. Carl Johnson, Box 257, Dixon, Ill.

POULTRY

250 READY To lay White Leghorn pullets \$1.48, Ancona \$1.58, Minorra \$1.80, 12 weeks old \$1.13 each. Robert Heike, Pontiac, Ill.

RABBITS

MAKE Big profits with Chinchilla rabbits. Real money-makers. Write for facts. 852 Conrad's Ranch, Denver, Colo.

RAISE Rabbits. Build independent income on small capital. Send ten cents for Bulletin D, LaSalle Fur Co., Mt. Clemens, Mich.

WANTED—MISCELLANEOUS

WE Buy gold teeth. Southwest Gold & Silver Co., Box 68, Ft. Worth, Tex.

HUNDREDS Of people have sent their old gold, silver, platinum jewelry, dental work to me. Why not mail yours today? Highest prices paid. Satisfaction guaranteed or goods returned. F. Polcer, 2408 South Cicero Ave., Cicero, Ill.

MAIL Us your discarded jewelry, gold, crowns and bridges, watches, diamonds, silver, platinum. Money promptly mailed. Goods returned if offer refused. United States Smelting Works (The Old Reliable), Dept. 71, Chicago.

FOR SALE—MISCELLANEOUS

ADDRESSOGRAPHS. Letter folders, multi-graphs, envelope sealers, duplicators, less than half price. Guaranteed. Pruitt Co., 117 No. Wacker Drive, Chicago.

WATCHMAKERS Lathe for sale at a bargain. R. Jaegermann, 5815 Easton Ave., St. Louis, Mo.

ROOTS AND HERBS

HERB Doctor book—10 cents. 250 recipes for making herb medicines. Hazzard Company, Box 1, Vanderveer Park, Brooklyn, N. Y.

HERBS, Roots, barks, seeds. All kinds, 25c box. Lists free. Botanic, 145 West 112th St., Chicago.

PERSONAL

HIGH Blood pressure inexpensively overcome, without drugs. Send address. Franklyn Stokes, Mohawk, Fla.

YOUR Name artistically written in genuine gold ink, 25c. T. Kromer, 553 Almyra Ave., Youngstown, Ohio.

STOP Fingernail biting habit. Guaranteed cure \$2.00. M. W. McIntire, Wilmington, N. C.

SECRET of Popularity—Brings amazing results: \$1. Campbell, 7338 Jeffery Ave., Chicago, Ill.

LEARN to Hypnotize. Instructive book on hypnotism, 10c. Geo. Fenner, 2401 Jefferson, Louisville, Ky.

INFORMATION Any subject. Chicago, World's Fair, Germany; supply sources, employment. Classified questionnaire free. Pretorius, 1629 Meyer Court, Chicago.

YOUR Photo, 20, \$1.00. Confidential. Send photo. Pop-Goo, Box 471, New York.

TOBACCO Or snuff habit cured or no pay. \$1.50 if cured. Remedy sent on trial. Superba Co., N3, Baltimore, Md.

ADVICE. Information, any subject, 25c coin. References. Fred Klotz, Reading, Pa.

MISCELLANEOUS

MAKE Money with magical cartoons. Learned in one evening. Entertain lodges, clubs and parties. Hendrickson's Chalk Talks, Argyle, Wis.

MIRRORS Resilvered at home. Costs near 5 cents per square foot; you charge 75 cents. Immense profits plating auto parts, reflectors, tableware, stoves, refinishing metalware, etc. Outfits furnished. Details free. Write Sprinkle, Plater, 288, Marion, Ind.

COMIC Pen and ink sketch made from your photo for \$1.00. Send snapshot and state hobby. Photo returned uninjured. Address 4525 Pierce St., Phila., Pa.

QUIT Tobacco habit easy. Harmless home treatment. Ni-Ko System, Ojal, Calif.

MOST Appropriate Christmas gift. Brought from Holy Land. New, fascinating, thrilling. Details free. Write League, \$15 Longacre Bldg., New York City.

MEXICAN Made holsters, lariats, horse-hair articles; rattlesnake belts. Send four cents for illustrated list. Tex-Mex Leather Co., 309 Esperson Bldg., Houston, Tex.

GENEROUS Sample containing real oil of Pennsylvania oil sand from two thousand foot well. Invaluable to students schools, etc. Mailed anywhere on receipt of one dollar, no stamps accepted. Custer City Oil Co., Dept. A-10, Custer City, Pa.

WANTED—Exclusive distributorship for Pacific coast on new invention or specialty. Pacific Coast Sales & Specialty Co., 518 Hibernian Bldg., Los Angeles, Calif.

MONEY Making, worthwhile books. Catalog. Crown Supply, Box 241, Ottumwa, Iowa.

CARTOONISTS—Publish your work. New magazine tells you how. Send 25 cents for copy or \$2 for year. Cartoon Stories, Clifton, N. J.

CASH Paid for Butterflies, Insects. See Sinclair Display Advertisement on page 14.

GOOD Running bicycles, cheap for \$18; free price list. Young, 819 Ga. Ave., Chattanooga, Tenn.

INDIAN Methods—World's greatest trapping secrets exposed for first time. Best "weatherproof" Fox—Coyote—Mink sets on earth. Methods \$1.00—worth hundreds. Cecil Atkinson, 446-T, Mandan, N. Dak.

ARTISTS And art students are printing 250 signs or pictures an hour without machinery. Sample and particulars 10c. Straco, 1013 Mulberry, Springfield, Ohio.

AMATEUR Cartoonists: Sell your cartoons. New market. Smith's Service, PN-1194, Wenatchee, Wash.

CUTS Anybody can make. Simple, cheap process, \$1.25. Specimens, particulars. 25 stamp. M. Day, Windfall, Ind.

CARTOONISTS: Sell your drawings. Proven plan. Castle Studios, Independence, Missouri.

BATTERY Shop—How to run. Most complete and authoritative information ever compiled on tools needed, shop equipment, charging methods, opening batteries, work on plates, jars, case, etc. Covers auto, radio and farm lighting batteries. Send for big 550-page book and pay postman \$5.00 plus postage when he delivers same. If outside U. S. remit when ordering. Popular Mechanics Press, Room 809, 200 E. Ontario St., Chicago.

WEEDS—Cut them with cutter bar on Shaw Garden Tractor. Also plows, cultivators and runs belt machinery. Low prices. Immediate delivery. Shaw Manufacturing Company, Dept. C, Galesburg, Kans.

ADVERTISING Illustrations, trade marks and designs, patent drawings. Grout, P. O. Box 162, Denver, Colo.

TATTOOING Outfits, supplies. Illustrated list free. "Waters," 965 Put-nam, Detroit.

TELL An army of 3,000,000 line readers all about your offer! If you have anything to sell, buy or exchange, or if you have any reasonable proposition, tell our readers all about it—they'll respond quickly. Our booklet "How to Create More Business" contains some very interesting, helpful facts. Write today for your copy—it's free. M. L. Rund, Manager Classified Advertising, Popular Mechanics Magazine, 200 E. Ontario St., Chicago, Ill.

New Kind of Can Opener

"Works Like Magic"

Brings Agents Up To \$8 and \$10 In An Hour!

IMAGINE having a little automatic machine to open cans! Why, to women everywhere, the very idea is revolutionary as well as amazing! No more fuss, muss or bother. And danger absolutely banished! No wonder agents who demonstrate this astonishing invention have made almost incredible sums. E. T. Barclay, N. Y., cleaned up \$117 in a day and a half. Mrs. M. Bridges, Me., made over \$300 in a couple of months' spare time. O. C. Gregg, Wyo., made part time profits of \$20 in 3 hours. And why not?

The "Million-Dollar" Can Opener

This wonder-working little machine holds the can for you so you don't need to touch it. Then spins the can quickly around. Next the lid pops up so you can take hold of it. Entire top is cut out sleek, smooth and clean. Opens round, square and oval cans. Approved by Good Housekeeping Inst. Guaranteed for 5 full years. If your present income is less than \$75 a week write quick for details of Territory Reservation, Complete Sales Outfit and Free Test Offers.

CENTRAL STATES MANUFACTURING CO.
Dept. P-2673, 4500 Mary Ave., St. Louis, Missouri

Central States Mfg. Co., Dept. P-2673,
4500 Mary Ave., St. Louis, Mo.

Rush your FREE TEST OFFER, and big money making plan.

Name.....

Address.....

Town..... State.....

Check here if interested only in one for your home.



NO MORE DANGER

Every woman knows how dangerous the old-style can opener is. Almost daily the newspapers tell of blood-poison, amputations, even death, that sometimes follow the very tiniest "can opener scratches." Now all danger is banished forever. No wonder almost 9 out of 10 will buy on sight!

Every day sees new accomplishments which point toward a tremendous future growth in the aeronautical industry.

Why Should Young Men Learn Aviation?



AVIATION promises soon to become as great an industry as the railroad, the automobile or the radio. These industries that have made fortunes for those who entered them early and grew as they grew. So will aviation richly reward those who enter this new field now and build for the future. Aviation is the big opportunity for the young man of today.

To Learn Aviation—Fly

If you are physically and financially able, learn now to fly. Not that your future activities will be confined to flying. But the man who can fly will always have the advantage, just as the pilot today has the advantage over others.

How and Where to Start

Mail the coupon below for the interesting book, "Aviation—What It Means To You." It describes the various flight courses offered by this national system of schools and, in addition, the various mechanical and business courses available.

Let Others Dream While You Act

Get into aviation now while the industry is young and the chances are big. Don't be a dreamer. Get busy today and mail the coupon for this interesting free book.

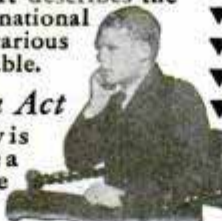

Universal Aviation Schools

A Division of the Universal Aviation Corporation

Universal Flying School	St. Louis, Mo.
Universal Flying School	Minneapolis, Minn.
Universal Flying School	Marion, Ill.
Universal Flying School	Oklahoma City, Okla.
Universal Flying School	Rochester, Minn.
Universal Flying School	St. Paul, Minn.
Universal Flying School	Memphis, Tenn.
Universal Flying School	Cleveland, Ohio
Universal Flying School	Wichita, Kansas
Porterfield Flying School	Kansas City, Kansas



UNIVERSAL AVIATION SCHOOLS
Suite 1047-56 Boatmen's Bk. Bldg., St. Louis

Please send me at once your free book, "Aviation—What It Means To You." I am interested in:

- Flying Course Business Course
 Aviation Mechanic's Course

Name.....Age.....

Address.....

City.....State.....

N321R93



Universal Aviation Schools are inspected and rated by the U. S. Government.

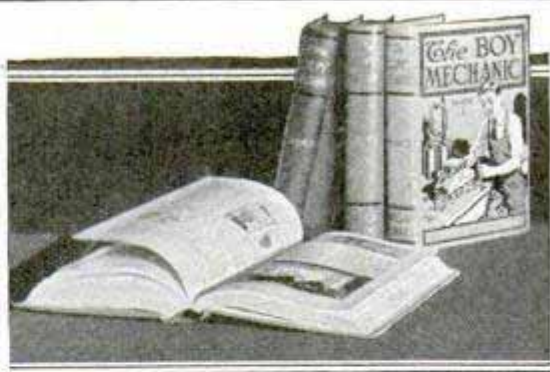

BOYS

It's Fun to Make Things

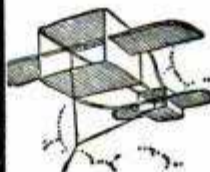

Let the other boys wonder how you can make so many interesting things. Make your own automobile. Make your own radio. Make your own kites and gliders. You can learn how to make almost anything that any boy could want by following the pictures and the simple directions in

The Boy Mechanic Library

And just think of it, there are nearly 4,000 separate articles in the four beautiful volumes! Some of the most fascinating subjects are listed below:

How to Make Things

- | | |
|-------------------|-----------------------|
| Boats | China painting |
| Winter sports | Decorative metal work |
| Camping | Furniture making |
| Ice boats | Farming |
| Water sports | Poultry |
| Toboggans | Models |
| Tents | Laboratory helps |
| Skis | Household helps |
| Indian snowshoes | Wood working |
| Skating | Electrical devices |
| Gymnasium | Photography |
| Wind wagons | Music |
| Motor sleds | Outdoor games |
| Radio | Stoves |
| Magic | Furnaces |
| Trapping | Wireless |
| Pets | Tricks |
| Leather work | Puzzles |
| Carpentry | Bicycle |
| Painting | Flowers |
| Toys | Hunting |
| Fishing | Kites |
| Fruit growing | Metal working tools |
| Entertainments | Secret locks |
| Automobile | Swings |
| House decorations | Sleds |
| Drafting | Power devices |

Buy the complete library, including Book 1, Book 2, Book 3 and Book 4, for \$7, thus saving \$1 as single volumes are \$2. If you want individual books at \$2 each order by number 1, 2, 3 or 4.

When the postman delivers the books to your door, pay him the price of the books and the postage. That is all. If outside U. S. remit when ordering and include 28 cents per volume extra for postage.

POPULAR MECHANICS PRESS
200 E. Ontario St.
Room 711 CHICAGO, ILL.

How \$5 Grew to \$100,000 In This Amazing Business

Let me send you my free book. It tells how, starting with a \$5 bill, I made \$100,000 in less than 5 years as a real estate specialist. I had no experience, little education, was in poor health, and had no influence. But I did have a system of my own which worked! And it is working today for many others who are making more money than they ever dreamed they would! My book tells their stories, too. Mail the coupon for your free copy.

I STARTED with \$5—and an idea. My friends laughed and said, "it's a fool idea."

But I was doing work I was not fitted for and which I thoroughly disliked, so I decided to "take a chance," especially since I had nothing to lose.

I was living in a gloomy boarding house, wearing cheap clothes, striving to keep out of debt, and getting mighty few of the good things of life.

In less than two years after I started to specialize in real estate, I was making nearly *one thousand dollars a month*. And in less than five years I cleaned up a net profit of *over one hundred thousand dollars*.

You, too, can make big money MY WAY. You can start in your own home, in your spare time. I don't care how old or how young you are or how discouraged you may be. I don't care how little education or influence you may have. I don't care how little business experience you may have had. You can make big money if you follow my methods—and when I say big money I MEAN it.

Amazing Earnings

The first step is for you to write for my free book.

Read my own story. Then read how W. E. Shoop, a former weaver, made \$6,000 on his first sale; how



Mrs. Evalynn Balster, a widowed schoolteacher, made \$5,500 commission on her first sale; how Eugene Walfrath, formerly in the clothing business, cleared \$17,000 on one deal; how Thomas E. Mone, Jr., a former insurance man, made \$40,000 in 2 years, using my method. How Chas. F. Worthen, formerly a salesman, made \$8,500 in 17 weeks by following my method. How H. G. Stewart earned \$14,400 in commissions in 6 months. How Earl Beam earned \$910 in spare time after supper in a few months with my system. How Anthony C. Maurell made \$4,133 in 3 months. How Al West made \$3,200 in 15 days. How A. D. Perkins, formerly in the furniture business, made

\$2,556 in 2½ months. How F. B. Bennett made \$435 on his first day. They all did it in this amazing business, using my methods.

My free book tells all about these wonderful successes. It tells how when I started in real estate I tossed overboard all the hit-or-miss, haphazard, rule-of-thumb methods of the past and put into operation my system which is as superior to the old way as the modern ocean liner is superior to the old sailing vessel.

A Wonderful Business

Real estate—conducted my way—is a great business. It is as permanent as the earth itself. It is getting bigger and bigger as the country grows. It doesn't require years of study to learn like most other businesses and professions. It offers enormous earnings to ambitious men and women. Users of my system report earnings of \$1,000—\$5,000—\$10,000—on single deals—as much as the average man gets for months and years of hard work. And the business is practically unlimited. Ten million properties are now on the market for rent, sale or exchange. And you can start without capital or experience—right at home—in your spare time. I did. So did others. So can you. My free book tells you how.

Get Free Book Now

My big, new illustrated book is filled with fascinating facts about my kind of a real estate business—what I did—what others are doing—what you can do.

Mail coupon right now and get this valuable, money-making information free. It doesn't cost you a nickel to find out what this book can do for you. So, act at once. You will never forgive yourself if you turn your back on this unusual chance to win big business success. Address PRESIDENT, American Business Builders, Inc., Dept. L-44, 205 East 42 St., New York.

Mail Coupon

→
for FREE Book

President, American Business Builders, Inc.
(Established 1917—Capital, \$500,000)
Dept. L-44, 205 East 42 St., New York, N. Y.

Mail me your free book telling how you made \$100,000 in a new kind of real estate business—how others are making big money and how I can do the same.

Name.....
(Please print or write plainly)

Address.....

City..... State.....

TRAVEL - for 'UNCLE SAM'

RAILWAY POSTAL CLERKS
MAIL CARRIERS—POSTOFFICE CLERKS
GENERAL CLERKS—CUSTOMS INSPECTORS

\$1700 to \$3400 a Year for Life

No "lay-offs" because of strikes, poor business, etc.—sure pay—rapid advancement. Many other U. S. Government Jobs. City and country residents stand same chance. Common sense education usually sufficient.

STEADY WORK

Cut coupon and mail it before turning the page.



MEN—BOYS 18 to 45

Use Coupon Before You Lose It



COUPON

FRANKLIN INSTITUTE, Dept. C175, Rochester, N. Y.
 Rush to me, free of charge, (1) A full description of the position checked below; (2) 32-page book, with list of positions obtainable; (3) Tell me how to get the position checked.
 Railway Postal Clerk (\$1900 to \$2700) General Clerk (\$1260 to \$2100)
 Postoffice Clerk (\$1700 to \$2300) Customs Inspector (\$2100 up)
 City Mail Carrier (\$1700 to \$2100) Rural Mail Carrier (\$2100 to \$3300)

Name

Address



DRAW CARTOONS

TURN YOUR TALENT INTO MONEY

Cartoonists earn from \$50 to \$250 per week—some even more. Remarkable *Circle System of Drawing* teaches you in half the usual time. Students from all parts of the world are enrolling for this exceptional instruction. *Personal* criticism service and up-to-the-minute instruction make it easy for National students to attain success. Send for interesting **BOOKLET** and **SAMPLE LESSON PLATE** explaining full details of the Course and what National students are accomplishing. No salesman will call.

The National School of Cartooning, 623 Penton Bldg., Cleveland, Ohio



Does Your English Help or Hurt You?

Wonderful new way to improve your English. No rules to learn. No hard study. Grammar, spelling, punctuation, and expression, taught in 15 minutes a day—at home. Self-correcting feature makes it fascinating as a game. Write today for free book "How to Speak and Write Masterly English." Address



SHERWIN CODY SCHOOL OF ENGLISH
 511 Searle Building Rochester, N. Y.

HB PAINT SPRAY

"DOES THE WORK OF FIVE MEN"



EASY TERMS
 30 DAYS TRIAL
 QUICKLY PAYS FOR ITSELF

QUICK, EASY PROFITS!

Practically no investment. Small space required. Steady demand and **BIG PROFITS** refinishing autos, furniture—painting house and barns with HB quick spray method. One man does the work of five with brushes. Pays for itself on easy monthly payments. 30 DAYS TRIAL. Write today for details.

HOBART BROS. CO.
 Box M-1191, Troy, Ohio

FREE!

of extra cost—send the coupon for details of our amazing new plan. It tells you how to get a big assortment of beautiful gifts that you can paint.



This Magic Box Turns Spare Time Into Money!

We show you how and give you the complete outfit illustrated above. Also we give you our Free Idea Book which has started hundreds making easy money! Mrs. H. L., Illinois, says: "I made \$100.00 on furniture in one week." Mrs. A. K., Virginia—"My sales were \$500.00 for five weeks. This is my first year." R. M. P., Illinois—"I did \$3,500 worth of business last year and over \$12,000 worth this year." D. W., New Mexico—"I would not take \$1000 for my course." A real desire to make money is all you have to have to make a big success at Fireside work.—No tiresome study—You learn by doing. It is fun decorating beautiful gifts and furniture—the most fascinating pastime you can imagine. You make good money practically from the start. Our FREE book tells you how. Send the coupon for it!

No Experience Needed

You need no experience or business ability to succeed at Fireside work and make excellent
FIRESIDE INDUSTRIES
 Dept. 66-S Adrian, Mich.

money. We help you and show you how. You can join now on the easiest plan ever offered. Get full details today. Coupon brings everything.

FREE Book on Decoration

Mail the coupon NOW for the beautiful new book on home decoration and money making. It's FREE! A new plan for starting you at good money at once will also be included. Do this at once—while there are openings for new members!

Fireside Industries
 Dept. 66-S, Adrian, Mich.

Send me FREE book on decoration and details of your new plan. Also how to get the big artist's outfit.



Name.....
 Address.....
 City.....State.....

You Can Be a "Registered" Radio Technician in 90 Days!

Tremendous Opportunities For Trained Men in This Fast Growing Industry

The School of Engineering of Milwaukee, home of broadcasting station WISN and amateur station W9SO, now offers a complete practical 90 days' course in radio to ambitious men. This great electrical school is helping to supply the great shortage of trained radio technicians by giving the most practical training ever before attempted in the radio industry.

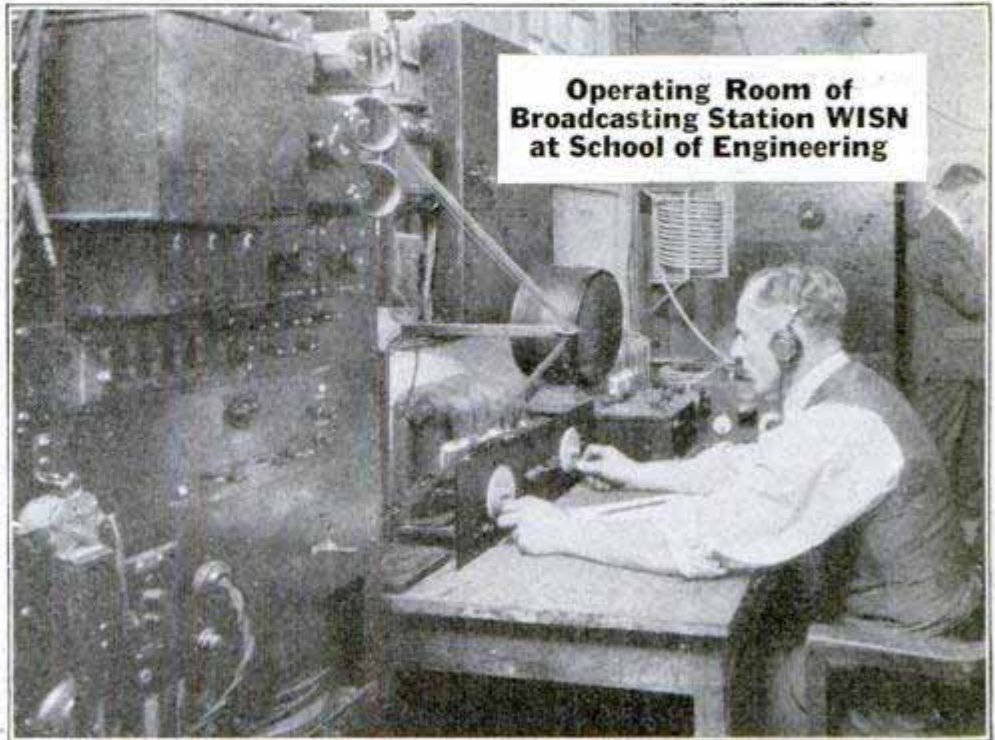

Federated Radio Trade Association Endorses S. of E. Radio Graduates



Read this letter from Michael Ert, Past Pres. of Wis. Radio Trade Ass'n, and now Pres. of the Federated Radio Trade Ass'n:

"We have investigated your Radio and Broadcast Course now being given at the School of Engineering of Milwaukee, and are acquainted with the high quality of educational work you have been doing for years.

Therefore, the Wisconsin Radio Trades Association hereby authorizes you to prepare men to receive Radio Serviceman's Registration Cards, classes A, B or C, of the Wisconsin Radio Trades Association."

The Wisconsin Radio Trades Ass'n now compels every radio service man to pass severe examinations and become registered. Dealers are tired of untrained, incompetent help. Radio trade associations the country over are planning to follow Wisconsin's example. The School of Engineering is the only institution in the country whose course is approved by a radio trade association. Graduates of the S. of E. are "registered."—14 S. of E. men successfully employed by Radio Corp. of America Photophone, Inc.

Most Thorough, Practical Radio Course in America

Here in this big splendidly equipped electrical school (from which Station WISN is operated) you can secure in three months the most thorough, the most compact, practical radio training offered anywhere. Covers entire field of radio! Complete course includes Radio Laboratory Practice, Radio Telephony Theory, Radio Transmission, Code Instruction, Electrical Mathematics, Service and Installation, Radio Sales and Merchandising. Daily broadcasting from WISN. All training is 100% practical. You learn in three short months!

Part-Time Job While You Learn

If you can finance your tuition we will assist you in getting part-time work to help pay living expenses while at school.



Towers of Broadcasting Station WISN on School of Engineering building. This station now being operated by School of Engineering.

Television Included

Complete Radio Course also includes study of fundamentals of Television and latest developments in that gigantic new field. Enables anyone to keep up with progress of this new industry.

FREE BOOK Mail coupon today for copy of catalog describing the S. of E. 90 days' Radio Course and our Earn-While-You-Learn plan. Writenow! Classes Now Organizing.

SCHOOL of ENGINEERING of Milwaukee

Founded 1903 Dept. P. M. 1129, Milwaukee, Wis.

School of Engineering, Milwaukee, Wis., Dept. P. M. 1129.

I am interested in your 90 days' Radio-technician Course. Send me, without obligation, FREE BOOK describing course in detail, also particulars about "Earn While Learning" plan.

Name Age

Address

City State

At Last

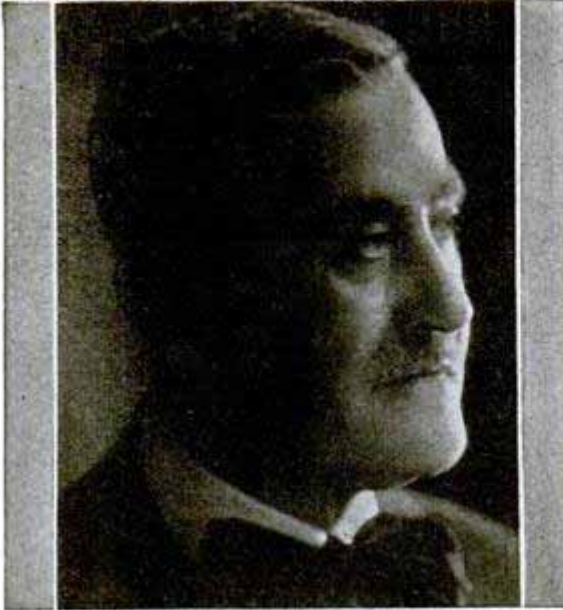

Eugene Feuchtinger, A. M.

Voice Teacher Who Actually Guarantees Results!

NOW!—YOU can be sure of possessing a rich, strong, beautiful, magnetic voice! Prof. Feuchtinger, descendant of a long line of European musicians, guarantees to improve any normal voice at least 100% or refund every penny.

Eugene Feuchtinger does not merely teach you how to sing. He actually develops the voice! No monotonous, tiresome scale work. He teaches you to build up the strength and elasticity of your vocal organ by scientific muscular exercise—*silent exercises!*—which you may practice in the privacy of your home. Thousands of men and women have been astonished to see how their voices have been *marvelously* improved—even when other methods have failed.

No matter how hopeless your case may seem, send for this

Physical Voice Culture Book

FREE Your voice has marvelous possibilities that you may not even suspect. "Physical Voice Culture" will reveal them to you. Send for this great book. Read the astounding true stories of what others have done. Learn how to build up a rich, strong, beautiful, magnetic voice and all about Prof. Feuchtinger's wonderful guarantee offer to improve your voice at least 100%—or refund every penny!

Perfect Voice Institute

1922 Sunnyside Avenue, Studio 13-58 Chicago

MAIL COUPON NOW!

Perfect Voice Institute, Studio 13-58
1922 Sunnyside Ave., Chicago, Ill.

Please send me, FREE and without any obligation, Prof. Feuchtinger's new book, "Physical Voice Culture." I have checked the subject in which I am most interested.

- Weak Voice
- Singing
- Stammering
- Speaking

Name

Address

City

30 DAYS TO TRY FREE Mead Ranger RADIO

—10 Months to Pay
SAVE \$25 TO \$100

All Electric With Dynamic Speaker Screen Grid Tubes

The Ranger Radio is a result of 7 years' development. It is to-day fast becoming the most favorably known radio—now leading the field, as its predecessor, the Ranger Bicycle, has for 30 years.

The Screen-Grid Tube Ranger Neutrodyne (with 9 tubes) with 2 No. 245 tubes in "Push-Pull" is licensed by R. C. A. Ranger assures you of selective reception from near and distant stations.

You may now own one of these distinctive Rangers with Dynamic Speaker in a DeLuxe Console by paying as low as \$10.00 down and balance in 10 months. Table models as low as \$40.00.

Rangers come all ready to use—simply insert tubes and plug into your electric light socket—no more trouble than to connect an electric floor lamp.



Write today for big catalog

CYCLE CO.
Mead

MEAD has been known for Ranger Precision Products for 30 Years.
Write for marvelous new Introductory offer—easy terms
DEPT. E173 CHICAGO

GET INTO BIG PROFIT WORK



Garages, filling stations, auto mechanics can easily get into profitable welding business with equipment that's sure to earn tremendous profits—with lower current costs. HB Constant Arc Welder starts you on the road to success with practically no experience on your part.

COSTS ONLY \$30 MONTHLY

Liberal trial on money back guarantee to prove its worth. Write today to
HOBART BROTHERS, Box M 1193, TROY, OHIO



INCREASE YOUR POULTRY PROFITS!

By proper Breeding, Feeding, Housing, Culling and Marketing AMERICAN POULTRY JOURNAL tells how to do it, and in addition a series of

COLORED PICTURES

with explanatory text tell and show many things you should know. They are not just colored pictures of birds but pictures of an educational nature, something never before shown by a poultry paper. 12 issues of American Poultry Journal contain about 1000 pages—

Price 25c a year—5 years \$1.
AMERICAN POULTRY JOURNAL, 14-536 S. Clark St., CHICAGO



RAISE CHINCHILLA

AND NEW ZEALAND WHITE FUR RABBITS

Make Big Money We Supply Stock and pay you following prices for all you raise: Chinchillas average \$3 each—New Zealand Whites \$2 each. 32-page illustrated book, catalog and contract, also copy of Fur Farming magazine, tells how to raise rabbits for big profits, all for 10c. Address
OUTDOOR ENTERPRISE CO., Box 1021 Holmes Park, Missouri



SQUAB BOOK FREE

Breed squabs and make money. Sold by millions at higher prices than chickens. Write at once for free 48-page book beautifully printed in colors telling how to do it. You will be surprised.
PLYMOUTH ROCK SQUAB CO., 634 H Street, Melrose Highlands, Mass.

Books on all subjects are sold by Popular Mechanics Press, 200 East Ontario Street, Chicago, Illinois.

Complete Course

Complete Course in BOXING

Jiu-Jitsu & Wrestling

\$2.97

Plus Postage

Complete course in Boxing, for only \$2.97. Our scientific methods cut time of learning in half. Teaches the blows used by professionals—Dempsy's Triple, Fitzsimmons' Shift, etc. Every blow illustrated. Also Wrestling, Jiu-Jitsu and History of Boxers. Six big books—hundreds of pages. Send no money—see coupon.

Marshall Stillman Association, Dept. 11-M, 247 Park Avenue, New York.

Send on 10 day approval complete Self-Defense course. I will deposit \$2.97 plus postage, with postman. I will return course in 10 days if not satisfactory and money will be refunded. (Outside U. S. A.—Cash with order.)

Name

Street and City

**MICHIGAN STATE
AUTO SCHOOL
AND
GREER COLLEGE
AMERICA'S GREATEST
TRAINING SHOPS
NOW UNDER MANAGEMENT
OF
ERWIN GREER**



LEARN AUTOS

Seven Billion Dollars are spent each year to repair Twenty-four Million Autos, Trucks and Tractors. Tinkering Mechanics are losing out. EXPERTS, trained on Big Equipment, by EXPERT TEACHERS are demanded at Big Pay. Thousands of Garage owners make up to \$15,000 a year.

New Purchase of Big School Gives Me Big Advantage

I recently bought the famous Michigan State Auto School, formerly of Detroit. NOWHERE ELSE I know of, is there NOW such Auto TRAINING SHOPS as GREER COLLEGE, where you get practical training on a world of equipment.

Up to \$15,000 a Year

Clip coupon below for Free Auto Book. Learn how I fit you for Big Jobs. I have trained thousands to earn over \$100 a week. Ninety Thousand men, in 26 years, have started their Auto careers at Greer College. Welding, Ignition, Starting, Lighting—EVERYTHING—I teach you. MY TRAINING IS COMPLETE—no dull books or deep theory.

A Job for You While Learning

My Free Book shows how you DON'T NEED a lot of MONEY or EDUCATION, and how I PAY YOUR FARE HERE—how I HELP GET YOU A JOB WHILE LEARNING, to help pay your living expenses and tuition—also another one at graduation. Send for this great book today.

Only 3 Months—Then Big Pay

It takes me ONLY THREE MONTHS to fit you for big pay. In this great seven story building (shown above) which is filled with machinery and training equipment, I fit you for every branch of the auto business. There are AMAZING OPPORTUNITIES for Foremen, Garage Owners, Auto Specialists the country over. Let my Free Book show you.

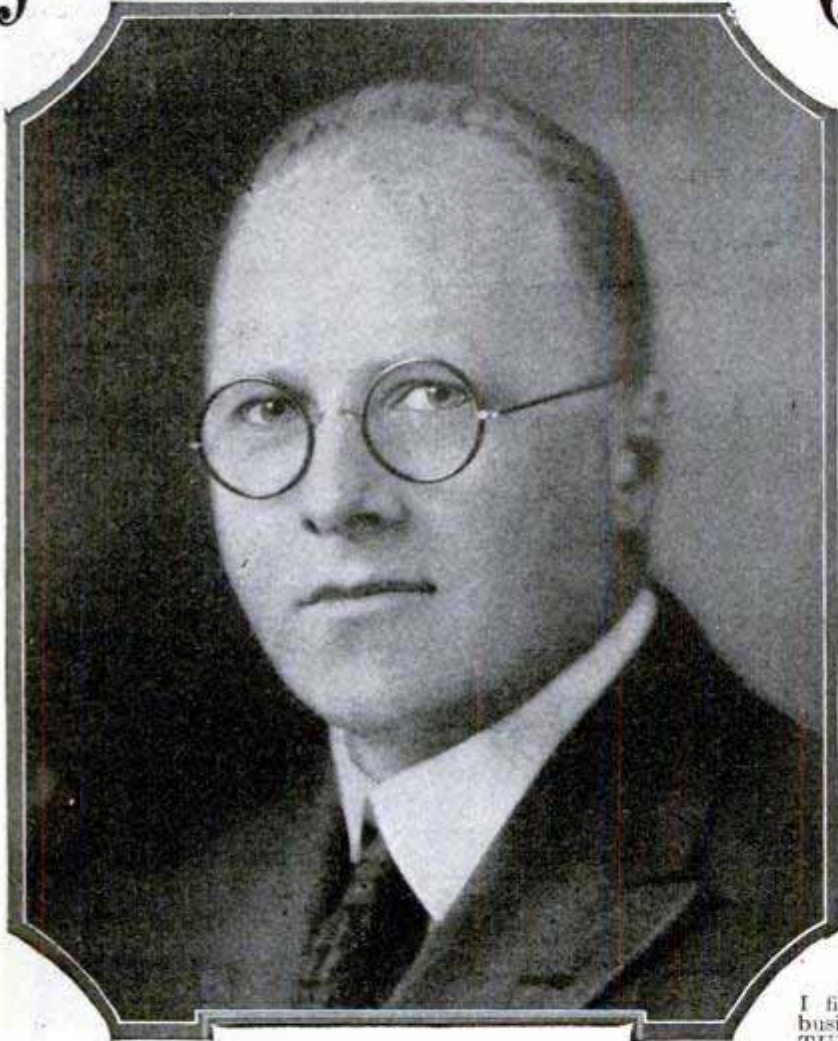

ERWIN GREER, President

LET ME HELP You to the Sunny Side of Life

My Free Auto Book will tell you about these remarkable GREER COLLEGE FEATURES: Railroad Fare included from any point of the United States—Easy Terms—Big Equipment—Help you get a Job while learning—Man's size income and YOUR FUTURE as a trained AUTO EXPERT. I will and can solve your life's money-making problem. While your fine ambition is urging you on—ACT—SEND FOR MY FREE AUTO BOOK.

**ERWIN GREER, President
GREER COLLEGE
Dept. 1101-A.T.
2024 Wabash Ave., Chicago, Illinois**

If unable to come to Chicago now for resident course, write for information about Home Study Course!

SCISSORS FOR SUCCESS BOOK

**ERWIN GREER, Pres.
GREER COLLEGE,
2024 Wabash Avenue,
Dept. 1101-A.T.,
Chicago, Ill.**

Dear Sir:
Send me your Big Auto Book—Free of Charge and without obligation to me.

Name.....

Street and No.....

City.....State.....



FREE! Body Chart

If you will mail the coupon below, this Anatomical and Physiological Chart will be mailed to you without one cent of expense. It shows the location of the Organs, Bones of the Body, Muscles of the Body, Head and Vertebra Column and tells you how the nerves radiate from your spinal cord to all organs of the body. This chart should be in every home.

Where Is That PAIN?

It may be in the neck, back, hips, stomach, liver, legs or arms. Wherever it is, the chart will help to show you the location and cause of your ailment. For instance, this chart will help you locate vermiform appendix pains. Hundreds of lives might have been saved if people had known the location and character of the pain and had received proper attention.

Stop that Pain

By Relieving the Cause with

**Violet Ray - Vibration
Ozone - Medical Electricity**

The Four Greatest Curative Powers Generated by This

Great New Invention!



Elco Health Generators at last are ready for you! If you want more health—greater power to enjoy the pleasures and delights about you, or if more beauty is your desire—write! Ask for the book on these inventions which has just been prepared. It will be sent to you without cost. It tells you how Elco Health Generators aid you in leaving the lethargy and hopelessness of bad health and weakness behind forever. Re-vitalize yourself. Bring back energy. Be wholly alive. Write today!

Here's What Elco Users Say—

"Wouldn't take \$1000 for my Elco."
"Has done me more good in 2 weeks than doctors did in three years."



"Cured my Rheumatism." "My Eczema gone." "Cured my stomach trouble." "Cured my weakness." "Now I sleep soundly all night." "Thanks to Elco my strength and vigor are back." "No more pain." "Colds never bother me now." "Chronic Constipation banished."
These great new inventions generate Violet Ray, Vibration, Electricity and Ozone—combined or separate. They operate on the electric light in your home or on their own motive power at less than 50 cents per year. Elco Health Generators are positively the only instruments which can give you in one outfit Electricity, Violet Ray—Vibration and Ozone—the four greatest curative agents. Send the coupon below. Get the Free Book NOW!

MAIL COUPON for FREE BOOK

Do not put this paper down without sending the coupon. Don't go on as you are with pains and with almost no life and energy. You owe it to yourself to be a better man or woman. You were put here to enjoy life—not just to drag through it. So do not rest another day until you have put your name on the coupon here. That will bring the whole story of these great new inventions. Do it today—now.



Lindstrom & Co. [Makers of Therapeutic Apparatus since 1892.]
2322 Indiana Avenue Dept. 13-58 Chicago
Please send me your free book, "Health—Power—Beauty" and full information of your 10-day Free Trial Offer.
Name.....
Address.....

How To Secure A Government Position

Why worry about strikes, layoffs, hard times? Get a Government job! Increased salaries, steady work, travel, good pay. I'll help you become a Custom House Clerk, Railway Postal Clerk, Post Office Clerk, City Mail Carrier, Rural Carrier—or any other Government job you want. I was a Secretary-Examiner of Civil Service Commission for 8 years. Have helped thousands.

Now FREE

My 32-page book tells about the jobs open—and how I can help you get one. Write TODAY. ARTHUR R. PATTERSON, Civil Service Expert, PATTERSON SCHOOL, 811 Wisner Building, Rochester, N. Y.



ALL ABOUT Aviation FREE!

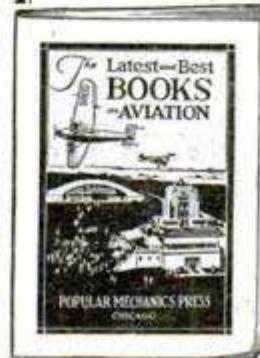

No matter whether your interest is that of student, instructor, pilot, executive, flying field mechanic, hangar or shop man, engineer, designer, draftsman, manufacturer or layman, you will find this comprehensive, 24-page catalog a great aid in the selection of the most helpful books on any and every phase of aeronautical science.

Sent Free Upon Request

POPULAR MECHANICS PRESS
200 E. Ontario Street, CHICAGO

Put Yourself
in this
Man's Place

Friends—
Fun—Extra
Money—
YOUR
Chance to
Be a
DRUMMER

**5 days trial
Easy Terms
FREE..
LESSONS**

Every day is a happy day when you learn to play the drums. Every party is a gala affair, every evening a new adventure in pleasure. The piano selections of wife, sister or sweetheart become orchestra music when you accompany them. Radio and phonograph take on a new joy. Good drummers easily earn \$3 to \$25 for an evening of fun!

If you can clap your hands or tap your feet in time with music you have born into you the ability to play the drum. No musical knowledge needed—free, easy lessons take you step by step from the very beginning to the most expert stages of drumming. Like Robert L. Richardson, you begin to play "right off the reel!"

Would you like to know more about Ludwig's 5-day trial offer, simple lessons, easy payments and wonderful opportunity drumming offers to those who want more fun and more profit out of life. It only costs a postage stamp to get the free details. Simply mail the coupon.

LUDWIG & LUDWIG, Dept. 8-11, 1611 N. Lincoln St., Chicago
Send me without obligation, full information on Ludwig Drums.

Name.....
Address.....
City..... State.....

Money Making Tools

ALL
are Regular
Draftsman's
Tools
SENT AT
ONCE

Sent to
YOU
Become a
BIG PAY MAN
with My Help

COMPLETE OUTFIT

ALSO DRAFTING TABLE

Earn as You Learn

I tell you how to start earning extra money a few weeks after beginning my training.



Copy me and get Iorine Rule Free.—Jack

Copy this Jack and
Get this Draftsman's Rule

FREE

Automobiles—Electricity—Motor Busses—Aviation—Building Construction. There are jobs for Draftsmen in all of these industries and in hundreds of others. Aviation is expanding to enormous proportions. Electricity is getting bigger every day. Motor Bus Building is becoming a leading world industry. Building of stores, homes, factories and office buildings is going on all the time. No structure can be erected without plans drawn by a draftsman. No machinery can be built without plans drawn by a draftsman. I train you at home, in Drafting. Keep the job you have now while learning drafting. I will train you in drafting right where you are in your spare time. I have trained men who are making from \$3,500 to \$9,000 a year. There is a big future for draftsmen because you plan and supervise the work of others, or you go into business for yourself. Get started now toward a better position, paying a good, straight salary, the year around. Comfortable surroundings. Inside work.

Employment Service After training you I help you to get a job without charging you a cent for this service. Employers of Draftsmen come to me for men because they know that Dobe Trained Men make good as they have learned drafting by actually doing the work themselves, in a practical way. Employers know they are not taking chances on men trained by me.

Money-Back Agreement

I train you at home under a positive Money-Back Agreement. If my training does not satisfy you after you have finished, you get every penny back.

Age or Lack of Education

No Drawback

Previous experience is not necessary. You do not need to be a college man or high school graduate.

Get My Pay-Raising Plan —also FREE

If you will mail sketch at once I'll send you also FREE "My Pay-Raising Plan"



I'll train you at home.—Engineer Dobe

If You Earn Less Than \$70 a Week—Write Me Today!

Mail this coupon, at once with copy of Jack. Get "My Pay-Raising Plan" and "Successful Draftsmanship." Both of them point the way to Success. You owe it to yourself to find out what a big opportunity there is in practically all industries, for Draftsmen. These two books are Free. They come to you post-paid. Mail the Coupon for them TODAY.

Engineer Dobe, 1951 Lawrence Ave. Div. 13-58, Chicago

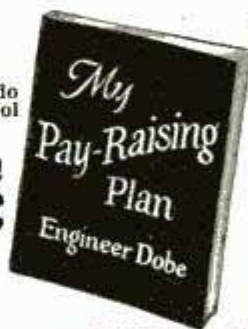

MONEY-MAKING TOOLS COUPON

ENGINEER DOBE, 1951 Lawrence Ave., Div. 13-58 Chicago

Here's my copy of Jack. Send me free of all cost your book, "Successful Draftsmanship," also plan to earn money while learning and proof of big money paying positions. Also your new book "My Pay-Raising Plan." Also tell me about your Money-Making Tools which you furnish. Send the free Pocket Rule.

Name..... Age.....
Address.....
Post Office..... State.....

The ONE Aviation Book You Need



A Complete Course!

"One thousand dollars' worth of aeronautical information." — Thos. L. Hill, Pres. Am. Society for Promotion of Aviation.

MODERN AIRCRAFT

Design—Construction—Operation—Repair
By Major Victor W. Page, Air Corps, U. S. R.

855 Pages
Over 500
Engravings
and Diagrams
Partial
Contents

Types of Aircraft—
Design—Airplane
Wings—Fuselage
and Landing Gear
Construction—
Airplane Power
Plants—Engines,
Air-cooled and
water-cooled—
Engine Auxiliaries—
Propeller Construction
and Action—
Equilibrium and
Control—Setting
up Airplane—In-
spection and Main-
tenance—Sea-
planes, Flying
Boats, Amphibians
and Other Aircraft
—Commercial Aviation
—Instru-
ments and Naviga-
tion—Standard
Nomenclature.

SAVE yourself months of ground work! Learn every-
thing about the construction, operation and repair of
all types of aircraft from this one great volume. Pre-
pared by an internationally recognized expert with the
cooperation of the Army and Navy, this is the STAND-
ARD book in the field. It is used in more than 200
schools and colleges. Thousands of pilots, mechanics,
students find it invaluable.

855 pages of solid information; everything you want
to know, from elementary principles to advanced prob-
lems of navigation. Simple—understandable—com-
plete. No one interested in any phase of aviation can
do without it. MORE THAN 500 ILLUSTRATIONS
make every detail clear. How and why air-
planes fly; latest engines, air and water cooled; airplane
instruments; aerial navigation; commercial possibilities
of aircraft; latest types and developments—every
detail of operation and construction of every type of
lighter and heavier-than-air craft fully described.

SEND NO MONEY

Examine this wonderful book for yourself. Let
us send it to you on approval. See how clear, how
complete, how up-to-date it is. Study the hundreds
of illustrations. Judge how much it will help you in
your aviation career.

Major Victor W. Page has trained thousands of
pilots and mechanics, including some of the best of the
A. E. F. He was Chief Aeronautical Engineer at the
world's largest aviation instruction center, in France.
Now let this famous authority teach you. In this one
great volume he gives you a complete course of instruc-
tion.

Mail the coupon now. You need send no money in
advance. Simply deposit the small price of \$5.00, plus
postal charges, with the postman when he delivers your
copy of MODERN AIRCRAFT. If you want to return
the book in 5 days, you get your money back in full.

Norman W. Henley Publishing Co.

Dept. 411 2 West 45th Street New York, N. Y.

Mail This Coupon

Norman W. Henley Publishing Co., Dept. 411, 2 West 45th St., New York

Mark X
Please send me MODERN AIRCRAFT, by Major Victor W. Page, for 5 days' examination. I enclose no money but will deposit price of \$5 plus postal charges with postman on delivery. My money back if I decide to return book in 5 days after receipt. (If you prefer, enclose \$5 and we will pay postage. Same return privilege.)

Name.....

Address.....

Town..... State.....

Mark X for Any of These Other Great Books.

Modern Aviation Engines, by Major Victor W. Page. Explains design, construction, installation and repair of all types of domestic and foreign aeronautical engines. Most complete work on subject. Two volumes, 2,000 pages, 1,000 illustrations. Price per vol., \$5.00; both volumes \$9.00.

Aerial Navigation and Meteorology, by Captain Lewis A. Yancey, Master Mariner, Unlimited, world-famous Navigator of the PATHFINDER on its historic flight to Rome. This monumental new book tells how to fly your course with precision. Invaluable for pilots, students and for reference—indispensable in preparing for Transport Pilot Examination. 350 pages, 102 illustrations and color plates. Price \$4.00.

Everybody's Aviation Guide, by Major Victor W. Page. Newest and most popular book on aviation. 600 questions and answers about airplanes and dirigibles, their construction and how they navigate the air. 256 pages, 140 illustrations. Price, \$2.00.

Wouldn't You Like to Get into Amateur Radio?

Imagine the thrill of building and operating your own private short-wave transmitter and receiver, and talking with other amateurs all over the world!

Talk with the Byrd Expedition at the South Pole! Chat with other expeditions in the far corners of the earth! Gossip with Frenchmen, South Africans, Chinese, Australians, or fellow-Americans thousands of miles away. Or, if you wish, listen in on concerts direct from London, Holland and Australia! You can do it for less than the price of your broadcast receiver and

Here Is a Book That Tells You How!

THE RADIO AMATEUR'S HANDBOOK

It explains everything about amateur radio and short-wave work from A to Z. Tells you how to build short-wave receivers from the simplest to the most complicated, that will bring you signals from all over the world; how to learn the code; how to get your licenses; how to build simple transmitters; how to build better transmitters; how to adjust and operate your set.

232 pages 6 1/2 x 9 1/2 188 illustrations

Over 60,000 copies in use

Sent postpaid anywhere in the world for

\$1

American Radio Relay League
Hartford, Connecticut, U. S. A.



DRAFTING

BOOKS SENT FREE!

For Beginners

Written so you can understand every word, by 18 famous Engineers and Architects. Deluxe, flexible binding. 1750 pages, 1050 blue prints, charts and diagrams. Prepares you for a good Drafting job in mechanical or architectural lines. Sent for 15 days' free use, if you mail coupon immediately.

Only fifteen minutes a day with these WONDER BOOKS will prepare you for a good Drafting job in less than a year! Mechanical and Architectural Drafting from simple straight lines to important, complex plans, a step at a time! Built especially for beginners, for men with only grammar schooling. Drafting room practice plus engineering made easy and clear!

Big Field—Big Demand—Big Pay!

Competent Draftsmen are urgently needed right now in all building and manufacturing lines at \$50 to \$100 a week. That's just the beginning—for drafters have the best chance for advancement! Pleasant, fascinating work, easy to learn and do. Learn quick with these books—send coupon for a set FREE, and see for yourself!

A year's Consulting Membership in the American Technical Society now given free to all readers of this famous Cyclo-pedia of Drafting. Many say that's worth more than cost of books.

American Technical Society
Dept. D819, 58th & Drexel Ave., Chicago



Modern American Homes FREE!

American Technical Society
Dept. D819, 58th & Drexel Ave., Chicago

Send for 15 days' free use 4-volume set of DRAFTING. In return for mailing this coupon promptly send absolutely FREE "Modern American Homes," 112 plates, exteriors, interiors and plans. I will pay the few cents delivery charges. If I wish I may return books in 15 days and owe you nothing. But if I prefer to keep them I will send \$1.50 after 15 days, then \$2.00 a month until \$14.50 (special reduced price) is paid.

Name.....

Address.....

Employed by.....

Address.....

The Wonder-Book of the English Language!

NEW STANDARD DICTIONARY

(Vocabulary Is Unabridged in This Edition)

Right Up to the Minute

In its all-embracing vocabulary of 455,000 terms are included all words of recent coinage, those that came into the language during the war, and the latest technical terms.

Typical of these are:

audiometer	radioamplifier
coagulen	bloc
electron	daylight saving
Hooverize	activism
intelligentsia	flair
milline	cocose
parsec	Philathea
rayon	empennage
rodeo	blurb
television	groceteria
topepo	acerbent
soviet	trotyl
chéka	blimp
radio-compass	paravane
radio-regener- ative	radiobroadcaster
plus fours	Bolsheviki
thermion	ambrine
	camouflage

Superb Illustrations

More than 7,000 illustrations serve to make clear the definitions, many of them full-page in colors or in black-and-white reproductions from photographs. All have been specially selected with a view to their helpfulness in supplementing the printed definitions. Fascinating full-page plates of Birds, Butterflies and Moths, Leaves, Flags, Modern Steel Construction, War-ships, Diamonds and Pearls, Flowers, Fire-fighting Appliances, Bacteria, the Spectrum, etc., are included.

Accurate Etymologies

A most careful and concise system of recording etymologies has been followed throughout, the Arabic, Greek, Latin, and Hebrew letters being transliterated into their English equivalents for the benefit of those not familiar with these languages.

Other Helpful and Exclusive Features

In addition, this great dictionary gives *word-finding lists*, under the names of arts, handicrafts, fruits, coins, weights, measures, stars, games, trades, etc., by which terms related to each word are brought out in the fullest possible way; a consensus of authoritative opinions on *disputed pronunciations* furnishes a guide to correct speaking; a complete list of *national songs* of leading countries of the world, with music, original words, and an English translation; many *tables* of a scientific character; exact *dates of all births and deaths* of men and women whose names occur in the vocabulary; the location, chapter and verse of all *Bible names*; latest *population records*.

It Answers a Million Questions!

W. H. P. Faunce, D.D., LL.D., *Pres. Brown Univ.*: "I am really astonished at the amount of information compressed into one volume. You have given us a biographical dictionary, a geographical gazetteer, and an encyclopedia under the guise of an English dictionary."

Every home and office should have this complete modern dictionary. In the home, especially where there are children, it will prove the greatest and friendliest of all teachers. There is constant need for it in business and professional offices.

455,000 Words
Spelled, Pronounced,
Defined

Cost Over
\$1,500,000



Nearly
3,000 pages;
handsome
sheepskin binding;
size 12½ x 9½ x 5¼
inches.

Absolutely Authoritative

More than 380 specialists and editors, each an expert in his own particular branch of learning, were employed in making the New Standard Dictionary.

One Vocabulary Order

The entire content of the dictionary is arranged alphabetically in *one vocabulary*, so that there is one place and one only in which to look for any required word. All place, personal, and other proper names are included, thus avoiding the necessity of referring to any one of several special departments for the information sought.

Two Pronunciation Keys

Two keys are used in respelling for pronunciation, the Revised Scientific Alphabet and the old Text-book Key.

Common Meaning First

The common, present-day meaning of every word is given first, where it can be most easily found. Then follow the rare and obsolete meanings, for which there is less call.

Definitions That Define

Definitions are made by definitive statement, not by synonyms. They are profusely illustrated by apt quotations, every one of which is located as to author and publication.

Synonyms and Antonyms

More than 23,500 synonyms are carefully discussed in special treatments, bringing out the fine shades of difference in the meaning of allied words and giving many explanatory sentences. 7,500 synonym lists and 5,000 antonyms are included in these treatments.

See It—Buy It—All Bookstores

If a Bookstore is inaccessible, or out of stock,
Order from Publishers

Use This Easy-Payment Coupon

FUNK & WAGNALLS COMPANY, 354-360 Fourth Ave., New York.

I enclose \$2.75 (75 cents is for carriage charge) as first payment for the New Standard Dictionary, unabridged Vocabulary, nearly 3,000 pages, beautifully bound in genuine sheepskin, richly stamped, marbled edges, handy thumb index. You are to ship the volume to me carriage paid. I will afterwards send you \$2.00 each month for nine months, otherwise I will return the volume to you within ten days at your expense and you will refund my first payment of \$2.75 and I will owe you nothing. Pop. Mec'h. 11-29

Name.....

Address.....

City.....State.....



"I will give you nerves of steel and muscles like iron"

George F. Jowett.
CHAMPION OF CHAMPIONS

I WAS once a weakling. But I craved to be strong. I increased my chest from a puny 32 inches to 47 inches. I built up my weight to 200 pounds; my neck to 18¾; my biceps to 18; forearms to 15½; wrists to 8¼; thighs to 26; my calves to 17.

Famous Athletes Indorse My Methods

My methods are indorsed by physicians and by Herman Gorner, the strongest man in the world; Arthur Dandurand, the Canadian Sandow; Arthur Gay, winner of the first prize in America's Most Perfect Man Contest; and Jim Londos, the famous wrestler.

Ask any of these men about my system and they will tell you there is no bunk about it. They will tell you that George F. Jowett plays the game square. I value that reputation more than all my medals—more than all my records and cups.

Pair of Dumbbells Free

To every person who takes my course I will give a pair of the patented Jowett Progressive Disk Dumbbells. They cannot be equaled for workmanship and muscle building. Here's another point—my course is laid out personally for each pupil. Every week you receive a new set of exercises in order of progression. You get Twelve Courses covering the Twelve Principles of Life and on conclusion of your course receive an emblem as a graduate of the Jowett Institute of Physical Culture. I guarantee to build you over in 90 days or return every penny you have paid me. My easy payment plan provides a way for every person to be a Jowett Pupil.

Get My Big Free Book

All I ask is this. Send for my big free book, "The Thrill of Being Strong." You'll get a real kick out of it because of the photographs and because it shows how easily you, too, can have nerves of steel and muscles of iron. Snap to it, buddy, and get that coupon into the mail before another day goes by. Remember, the book is FREE.

JOWETT INSTITUTE OF PHYSICAL CULTURE

Dept. 4-Y
 422 Poplar St., Scranton, Pa.

Dear Mr. Jowett:
 Without cost or obligation, please send me a copy of your illustrated booklet, "The Thrill of Being Strong."

Name.....

Address.....

FOR YOUR HOME WORKSHOP

If you like to make things, you will enjoy this new book just published by Popular Mechanics entitled

Make It Yourself

The home mechanic, whether young or old, amateur or professional, will take pride and delight in making many of the things described therein.

Both father and son will find fascination and an association of interest in making useful and ornamental articles for mother to admire upon their completion.

900 Articles All Different

There are attractive ship models, a great variety of toys that operate themselves by means of an ingenious application of mechanical principles, novel amusement devices for indoors and outdoors, for both water and land, unique designs in furniture for children, scores of useful appliances for the home, things of beauty and utility for lawn and garden, etc.

Special articles instruct the amateur mechanic in the care and use of tools, special tools for special purposes, how to read and use plans, how to solder, the making of a handy work bench, cuts, joints and methods in woodworking, automobile repairing, installing radio equipment, house wiring, fixture hanging, working in glass, leather, metal, celluloid, lathe work, utilizing parts of old machines to make equipment that would be expensive to buy, etc.

480 Pages—823 Illustrations.
 Size 7x10x1½ in. Cloth Binding

Price \$3.00

Mailed Postpaid upon receipt of price anywhere in the world. If you reside in U. S., Hawaii, Porto Rico, Alaska or Mexico, we will send the book by mail C. O. D. if you prefer.

POPULAR MECHANICS PRESS (ROOM-P-111)
 200 East Ontario St. Chicago, Ill.

Don't Be Afraid To Tackle That Concrete Job!

With the instructions found in the new, revised edition of Popular Mechanics Concrete Handbook you can make any of the following useful articles:



Garden Seats—Fountain and Basin—Flower Boxes and Vases—Pedestals and Bird Baths—Ornamental Pools—Sanitary Drinking Fountain—Gateposts—Auto Driveway—Sidewalks—Boat Landings and Docks—Entrance and Garden Walks—Sidewalk Flaggings—Narrow Curb Walks—Curbs and Gutters—Wall Coping—Steps—Garage Floor—Basement Floor—Fence Posts—Lawn Roller—Cistern—Chimney Cap—Refuse Burner—Culvert—Benches for Greenhouses—Tile—Retaining Walls—Foundation Supports—Engine Foundations—Septic Tank—Toy Blocks—Forge—Fireproof Safe—Ice House—Watering Troughs—Milk House—Smokehouse—Silo—Horse Stalls—Hitching Post—Rural Mail Box Post—Cyclone Cellar.

Build With Ease for Permanence and Beauty

This is a book of practical plans for using concrete about the home, farm or shop. For amateurs as well as contractors. In addition to making all the articles mentioned above the making of good concrete mixtures for various classes of construction is given; mechanical mixers and homemade tools are dealt with. All necessary form and mold making are covered as well as many other valuable pointers too numerous to mention here.

Simply write and ask us to send you this book. When postman hands you the package pay him \$1.00 plus the postage. If outside U. S. remit when ordering and include 15 cents extra for mailing.

POPULAR MECHANICS PRESS
 Room P11 200 E. Ontario Street CHICAGO



"I might say that I have netted \$950.00 with your charging outfit during the past five weeks."—Trego.



"I made \$425.00 the first eighteen days with your charger. The equipment cannot be licked."—Whalen.



"Jumped my earnings to \$85.00 a week. Know there is lots more in sight. Am tickled pink."—McDermott.



"Am now averaging \$110.00 a week. This is what you might call some boost in my earnings."—Fox.

New Kind of Business Offers You \$5,000 to \$10,000 a Year

Here's your chance, fellows, to get into something that is more than a job. And there's no weary months of studying before you start to clean up a real he-man's earnings.

You start to make money the day you uncrate the marvelous new Service Station Charger—an invention that saves 40% to 60% on current and one that handles

50% to 70% more batteries than similar outfits.

START AT HOME Experience Unnecessary

I don't care what you are now doing I guarantee you can start right to expertly operate my amazing Charger. Keep your present job for a while and make \$15 to \$20 a day on the side. Just hook up the batteries in the morning and they will be loaded when you come home.



I Pledge You My Word that you can make good right from the start. I'll stand back of you as far as humanly possible—help you with advertising, etc. Ask any of the boys who have put their future in my hands.

If you are the kind of a chap who wants to step into big pay then I am the kind of a fellow who will see that you do it. Take my word for it you'll have my personal attention. Let's go!

C. F. Holmes.

TREMENDOUS PROFITS

Think of it—you net nearly one dollar on each battery charged. And with thousands of batteries needing charging daily in all sections you don't have to solicit orders—they come to you.

Hundreds Now Cleaning Up

Our files are full of real stories of success from men who have joined with me in this business. But look what the four men above have to say. Real money! And how!

C. F. HOLMES, Dept. B, 4912 North Clark St., Chicago, Ill.

EXTRA EQUIPMENT INCLUDED

for Quick Action

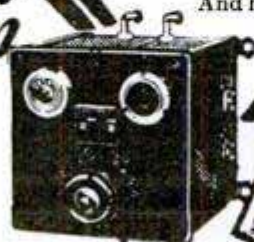

Clip Coupon Quick

C. F. Holmes, Dept. B, 4912 North Clark St., Chicago, Ill.

No obligation, but I am interested. Shoot along the free book and all details.

Name.....

Address.....

City..... State.....

If you are earning less than \$90.00 a week mail Coupon

MEN of ACTION!



U. S. Gov't asks S. of E. to test this huge Elec. generating Unit, built for Panama Canal.

Learn Electrical Engineering

Electricity seeks men of action! Jobs up to \$10,000 a year are open to men who have received special training such as is given in the School of Engineering of Milwaukee—one of the foremost and best equipped Electrical schools in America. If you have 14 high school credits or equivalent, you can become an electrical engineer with Bachelor of Science degree. Lacking credits can be made up in our short special course.



B. S. DEGREE IN 3 YEARS

Complete, Practical Electrical Education

Learn by the thorough, approved scientific methods which our 26 years of specializing enable us to give you. In addition to Electrical Engineering, the following complete courses are given: A. C. and D. C. Armature Winding—Wiring and Testing—Commercial Electrical Engineering—Automotive Electricity—Radio Sales Service and Broadcasting—Electrical Refrigeration.

EARN WHILE YOU LEARN

Cooperation with large Milwaukee Electrical industries enables us to help place students in part time jobs to help their way while learning. Low tuition. Board and room reasonable. Daily broadcasting. School orchestra. Fraternities.

Send Coupon for Free Catalog
NEW TERM BEGINS NOW

SCHOOL of ENGINEERING of Milwaukee

SCHOOL OF ENGINEERING OF MILWAUKEE
Dept. P. M. 1129A E. Wells & Jackson, Milwaukee, Wis.

Without obligating me in any way please mail free illustrated book "Rise to Success Through Electricity," and particulars regarding the course I have marked with an X.

RESIDENT COURSES

..... Electrical Engineering, B. S. Degree, (3 Years)

..... Commercial Elec. Engineering, (H. S. Graduates 1 yr.—others 1½ yrs.)

..... Armature Winding.

..... Light Motor Wiring and Testing.

..... Electrical Refrigeration.

..... Master Electrician.

..... Radio Sales Service and Broadcasting.

..... Home Laboratory Service. (Home Study Course.)

..... I am interested in your "Earn While You Learn" plan.

..... Day..... Evening Classes.

Name..... Age.....

Address.....

City..... State.....

Education.....

Learn How to BOX



\$2.98 brings you the famous boxing course by mail of Jimmy DeForest, World's Greatest Trainer and Maker of Champions, the system that trained Dempsey and great champions. Covers everything in scientific boxing from fundamentals to ring generalship. Twenty weeks makes you a finished DeForest trained boxer. Hundreds of DeForest trained men are making good in the ring today. Complete course sent you one mailing. Send \$2.98 or C. O. D. order paying postman \$2.98 plus actual postage.

JIMMY DEFOREST BOXING COURSE
347 Madison Ave., Box 137-A, NEW YORK CITY

Mysterious Power of Pelmanism

Let us send you a free copy of "Scientific Mind Training." An instructive book which explains an amazing system of mind training already used by more than 650,000 people. It will show you how and why Pelmanism is the *only* system of teaching for developing all the mental powers at the same time. Endorsed by such distinguished men as Judge Ben B. Lindsey, Sir Harry Lauder, Jerome K. Jerome, Prince Charles of Sweden and hundreds of others. Write TODAY to

THE PELMAN INSTITUTE OF AMERICA
71 WEST 45th STREET DEPT. 611 NEW YORK CITY

Learn Watchwork, Jewelrywork and Engraving A fine trade commanding a good salary, and your services always in demand. Address **Horological**, Dept. P, Bradley Institute, PEORIA, ILLINOIS, for our latest catalog.

Government Positions

Census Clerks, Clerk Carriers, Rural Carriers, Railway Mail Clerks, Postmasters, Department Clerks, and many others. Splendid salaries, easy work, vacation with pay. Only common school education required. Examinations often. 37,976 appointed last year. Send for our Civil Service Catalog No. 6. **COLUMBIAN CORRESPONDENCE COLLEGE**, Washington, D. C.

There's Quicker, Bigger MONEY for YOU - in POULTRY

Earn \$2,000 to \$5,000 a Year or Have a Business of Your Own!



Whether you want a job at good pay or a highly profitable business of your own—the Poultry Industry offers you more than any other. There's a shortage of poultry meat and eggs—a shortage of trained poultrymen. I'll train you quickly at home—to fill a good job in Poultry—and our FREE Students' Employment Dept. will help you get one!

Spare Time or Full Time YOU Can Cash-in BIG

No matter where you live—city, town or country—or what you do now, my proved methods will assure your success right from the start. I'll help you make from \$2,000 to \$5,000 a year and UP! And, if you choose to start your own business, I'll show you how to make your tiny investment multiply itself automatically. What I've done for thousands of others—I can do for you.

FREE Book Shows Way to Big Pay and BIG Profits

Mail coupon below TODAY—for my Big NEW FREE Book, "How to Raise Poultry for Profit." My forty years of experience are yours. The Poultry Industry needs YOU. You need my book. Get it—and get in line for the BIG Money that's waiting for you in POULTRY.

Mail NOW for FREE Book

NATIONAL POULTRY INSTITUTE, Dept. 411-C
Washington, D. C., Attn: Harry M. Lamon, Pres.

Dear Mr. Lamon: Send me your FREE Book, "How to Raise Poultry for Profit." I want to know more about my opportunity to make \$2000 to \$5000 a year, spare or full time.

Name.....

Address.....

Fuel Costs Smashed

The **SMALLEST HOME**



CAN AFFORD A LACO!

WONDERFUL INVENTION BURNS OIL NEW WAY

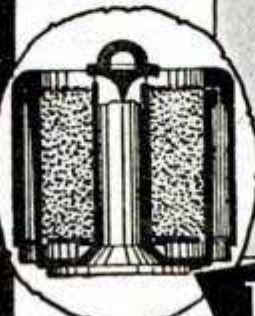

The **MINERAL WICK**

Solves Greatest Problem of the Oil Burner Industry!

Fits Any Furnace or Stove

In one minute, the LACO turns your hot-air furnace, hot-water or steam heat plant, parlor stove, or kitchen range, etc., into an up-to-date heating system!



Now oil heat is no longer a luxury for the rich. The remarkable invention of a foremost American engineer solves the oil burner industry's greatest problem—to produce a burner every home can easily afford—which **SAVES MONEY** on the fuel bill—and eliminates dirt, soot and grease!

OIL HEAT WITHOUT SMOKE SOOT or GREASE at SAVING in FUEL COST



Fully Automatic
Thermostat control—as much heat as you want, **WHEN** you want it. Operates quietly. Nothing to adjust. Designed to last a lifetime. Guaranteed. Complies with all ordinances. Actually **SAFER** than the ordinary kitchen gas range!

Sold on Easy Terms

Our **EASY PAYMENT PLAN** enables you to enjoy oil heat *this very year!* Now, resolve to end your slavery to King Coal—carrying dirty, heavy coal and ashes, chopping, shoveling, smoke, odor. No more getting up early on cold mornings to start stubborn fires—install a LACO and forget about your furnace!

DEALERS WANTED

We want rated men—preferably—but also the man who will invest a small amount in demonstrators—then get out and **SELL**. If this description fits you, we will offer you an opportunity *big enough for any man!*

LACO OIL BURNER CO.
125 Union St., Griswold, Iowa

The new way of burning oil—patented and found only on the Laco Oil Burner, results in tremendous economies. Other power burners, by means of air pressure, convert the liquid oil into a spray and burn oil in spray form. The surplus air pressure thus required blows a large part of the spray upward, out of the smokestack, wasting heat, increasing fuel expense. Contrast this with the LACO, which by means of the indestructible **MINERAL WICK**, converts the oil into hydro-carbon **GAS**, the most perfect medium for creating heat known to man—because **ALL** of it burns and **WASTE IS ELIMINATED!**

New Convenience—New Cleanliness

The spray form method of burning oil means waste oil and that means smoke, soot, grease. The LACO does away with all this! The LACO by burning **ALL** of the oil in **GAS** form eliminates waste, thus providing **CLEAN HEAT**, free from dirt or grease.

Mail Coupon for Introductory Low Price Offer!

Tell type of heating system you now have. Get our easy terms and special low price offer. Mail the convenient coupon **NOW!**

MAIL FOR INFORMATION & SPECIAL LOW PRICE OFFER

LACO OIL BURNER CO.,
125 Union St.
Griswold, Iowa

Send facts about your burner, the New Mineral Wick, and Special Low-Price Offer.

Name.....
St. or Rt.....
Town..... State.....
Kind of heating system I now have.....

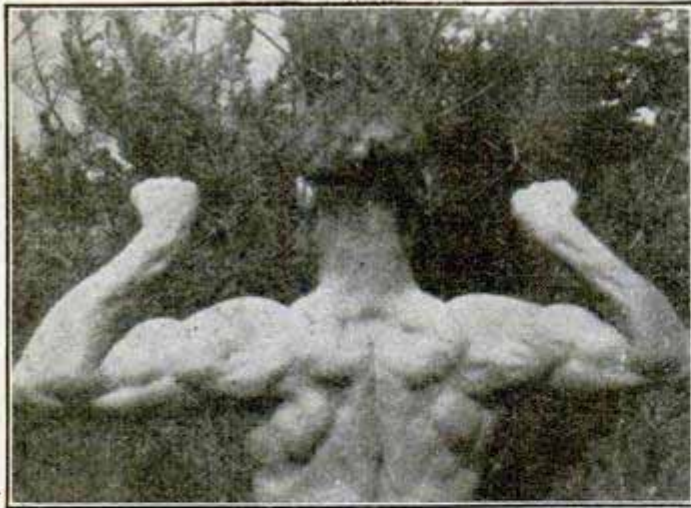

MARTY LEE

I'll Make You his
"MUSCLE TWIN"
—or No Pay!

Charles Atlas

LOOK him over, boys! What muscles! Wow! Can't you just FEEL the POWER in them? No chance of any wise guy getting funny around this fellow! Yes sir! He's the "house of muscle" that I built. Marty Lee is his name. And he's only one of my swell muscle jobs. I do it regularly. I'll turn the same trick for you when you give the high sign. I'll broaden your shoulders—make that head of yours sit pretty on a fine, sturdy neck. I'll pep up your internal organs, put NEW LIFE into them. I'll develop every square inch of your body into superb proportions. Your whole system will tick like a clock. You'll have the old "ambish"—eager to work, to fight, to love as a HE-man should! And if you don't fill the bill to your own satisfaction—I don't want a penny of your money!

HERE'S HOW!



CHARLES ATLAS

My methods work seeming miracles because they are based upon natural principles of "Dynamic-Tension." These principles I myself followed in transforming my body from a flat-chested, run-down weakling at 17 to my present tremendous physique—the identical principles through which fellows all over the country are becoming muscular marvels my way. I don't care whether you now look like a bag of bones or a sack of flour tied in the middle—just follow my simple exercises 15 minutes a day in your own home and watch results! No theory—no wasted effort—every exercise practical. Easy—real fun—and FAST.

You'll get a body that will put to shame the "half-dome" jobs that ordinary physical instructors develop, with apparatus. For my method of "Dynamic-Tension" says "Nothing doing!" to artificial muscle-makers. It utilizes instead the DORMANT muscle-power in your own God-given body—shows you how to make every unconscious movement, even walking, build up rugged sinews double-quick. I heap on the real wide-awake muscles with the PUNCH that STAYS with you. Let me PROVE it—at my risk.

FREE BOOK

"Everlasting Health and Strength"

Send for this red-hot, "down-to-earth" book about MUSCLES THAT SPEAK OUT! It's filled with smashing pictures of my red-blooded pupils—shows you how to get speed, stamina and tireless endurance plus all-around Samson measurements. No obligation. Be a winner my way. Send for this free book TODAY. CHARLES ATLAS, Dept. P. M. 811, 171 Madison Ave., New York City.

CHARLES ATLAS,
Dept. P. M. 811, 171 Madison Ave., New York City.

Dear Sir: I'm willing to be convinced about "Dynamic Tension." Send me without obligation a copy of your latest book, "EVER-LASTING HEALTH AND STRENGTH."

Name.....
Address.....
City.....

(Please print plainly)

Books on 32 Subjects

Popular Mechanics Press specializes in supplying books on any subject. Look over this list. Check the books you want, and mail this advertisement as your order blank. Catalog with lists on 2,000 subjects free.

- | | |
|--|---|
| AIRCRAFT (Modern)
Complete. Up-to-date... \$5.00 | FURNITURE REPAIRING
Finishing and Decora-
tion..... \$5.00 |
| ARTIST (Commercial)
Money-Making Art... \$5.00 | HYPNOTISM
A Reliable Treatise... \$2.00 |
| ATLAS (of World)
Modern. New Bound-
aries..... \$3.00 | INVENTIONS
How to Make Pay... \$2.50 |
| AUTOMOBILE (Modern)
Gasoline. New Edition... \$5.00 | MAGIC
World's Best Book of... \$2.00 |
| BOOKKEEPING
Practical Handbook... \$1.00 | MIRRORS
Silvering..... \$1.00 |
| BRICKLAYING
Plain and Fancy..... \$1.50 | MODEL ENGINEERING
Very Interesting..... \$4.00 |
| CARBURETORS (All Makes)
Only Book Covering... \$2.00 | PLASTERING
Best Instruction Man-
ual..... \$1.25 |
| CHALK TALK
and Crayon Presenta-
tion..... \$1.25 | RADIO ENCYCLOPEDIA
Very Complete..... \$6.00 |
| DRAWING
Freehand and Perspec-
tive..... \$1.50 | REAL ESTATE
Educator..... \$2.00 |
| DRY CLEANING (Practical)
and Dyer..... \$3.00 | SHOW CARDS
Artistic..... \$3.50 |
| ELECTRICAL SYSTEMS
Automobile..... \$3.50 | SIGNS (Artistic)
How to Make..... \$3.50 |
| FLOWER RAISING
1001 Questions
Answered..... \$2.00 | Steam Engineer's License
How to Obtain..... \$2.00 |
| FLYING
A B C of..... \$1.50 | STEEL SQUARE
How to Use..... \$1.00 |
| FUNNY PICTURES
How to Draw
(by Zim)..... \$3.00 | TELESCOPE (Amateur's)
How to Make..... \$3.00 |
| FUR RAISING
For Profit..... \$4.00 | TOOLS (Using)
Tinkering with Tools... \$2.00 |
| | TRICKS (200)
For the Amateur..... \$1.00 |
| | WOOD FINISHING
Plain and Decorative... \$2.00 |

SEND NO MONEY

Just check the books you want, and mail the whole advertisement. It is your order blank. When postman hands you books, pay him the price and the postal charges. If outside the U. S. remit when ordering and include 10 cents per book extra for postage. POPULAR MECHANICS PRESS, Room P11, 200 East Ontario St., Chicago, Ill.

NEED A BETTER GRIP ON MATHEMATICS?



SEND for a copy of "Mathematics for the Practical Man," only \$1.50. By common sense methods it removes the mystery and difficulties so that algebra and even calculus are made simple.

Assuming your knowledge is limited to arithmetic you quickly and easily gain a working knowledge of Algebra, Geometry, Trigonometry and Calculus. Simply pay postman price of book plus the postage when he hands you the package.

Popular Mechanics Press
Room P11
200 E. Ontario Street, Chicago

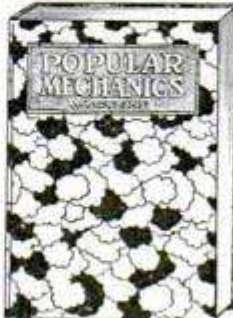

ATTRACTIVE NEW BINDERS

For Popular Mechanics Magazine In your choice of colors; blue, green, brown, red or black. We recommend these beautiful and durable art binders to libraries, schools, reading rooms and our readers generally.

An Ornament To Any Reading Table

Price \$1.25 Each
Postpaid
Your name in gold on the front cover for 25 cents additional.
Address

You will be delighted with the artistic waterproof covers in colors and other improved features.

Popular Mechanics Company, 200 E. Ontario St., Chicago

Movies teach You ELECTRICITY



Amazing New Method Paves the Way To BIGGER PAY

NOW there's an *easier* way to learn ELECTRICITY. Right in your own home you can *quickly* prepare yourself for a **BIG PAY JOB**. This new way takes away the drudgery. MOVING PICTURES train you, that's the *secret*. Every principle demonstrated before your eyes.

You *see* the currents flow. You *see* generators, dynamos, switchboards and all standard electrical apparatus in action. Fascinating as a news reel. Movie machine furnished *at no extra cost*. Hook it up to any electric connection. See the movies on your own screen. Repeat them as often as you wish. Thousands of feet of film furnished. The best colleges use MOTION PICTURE training. Now you can get it at home. Gives you advantage of home study training *plus* residence school experience. All at *much lower cost*.

Endorsed by Engineers and Educators

With the help of such practical engineers and educators as Bruce A. Rogers, M. S., Western Electric Co., J. A. Shimek, M. E., E. E., Engineer DeVry Corporation; A. P. Hollis, formerly Director Visual Education University of North Dakota; F. S. Wythe, Director Neighborhood Motion Picture School Film Service, and W. N. Littlewood, formerly instructor University of Wisconsin, *who will have personal charge of your training*, you will soon be ready for big pay jobs in Aviation Electricity, Radio, Switchboard Work, Sub-Station and Power Plant Operation, Automotive Electricity, Wiring, Contracting, Merchandising, Etc.

This Money-Back Pledge Protects You

You take *no chances* when you learn electricity this modern way. We are so sure of your success that we pledge *in writing* to give you training and employment service necessary to get you a *better job at bigger pay* or refund every cent.

This pledge protects you. It is your assurance that our MOTION PICTURE training will *increase your paycheck*. \$60.00 to \$150.00 a week is common in ELECTRICITY. Many make much more. Thousands of men are needed. Work is easy and steady. Here's your chance to say good-bye to long hours and low pay. Prove it to your own satisfaction **TODAY**.

Write Now for Get the money making facts. Our big book, "*The Film Way to Bigger Pay*,"

Big FREE Book explains the marvelous

opportunities now open in Electricity. The coupon will bring it FREE. There's no obligation. Write **NOW** while special introductory offer lasts.

**Mail
Coupon**



**ENGINEER SAYS NEW WAY
IS BEST**

Charles L. Fitz, M.E., E.E., a practicing engineer, formerly associated with Steinmetz of General Electric, says: "I am amazed at how clearly and simply you explain the facts about electricity and electrical work. You show the principles in these motion pictures and animated diagrams better than we can even in the laboratory. Your whole course seems to me by far the best method of getting thorough preparation for practical electrical work."

**The NATIONAL SCHOOL of
VISUAL EDUCATION**

"The Film Way to Bigger Pay"

The NATIONAL SCHOOL of VISUAL EDUCATION

537 S. Dearborn St., Chicago, U. S. A. Dept. 11 H. A.

Send book, "*The Film Way to Bigger Pay*," with facts about this new, easier way to master electricity.

Name.....Age.....

St. or R. F. D.....

City.....

State.....

LEARN CARTOONING

AT HOME DURING SPARE TIME

with the course that has trained HUNDREDS of beginners successfully. The Landon Picture Chart Method of teaching ORIGINAL drawing by mail makes cartooning easy to learn. This school is a Member of The National Home Study Council. Write today for sample picture chart to TEST YOUR ABILITY and examples of the work of successful students now earning from \$50 to \$200 and more per week. Enclose 6c in stamps and STATE YOUR AGE.

THE LANDON SCHOOL, 2838 National Bldg., Cleveland, Ohio



Be a MEAT CUTTER

Harry Holtzer stepped into \$50 a week job as Meat Cutter through NATIONAL training. You, too, can do the same. Previous experience not necessary. We teach you through our Home-Instruction Course. Don't get by—get ahead. Write today.

FREE book, "Big Pay the NATIONAL Way."

National School of Meat Cutting, Inc.
Dept. D Toledo, Ohio

INVENTORS— Read the marvelous history of American Invention, the most impressive record in the annals of human achievement. A very limited edition of Waldemar Kaempfert's Popular History of American Invention in 2 vols. 1034 Pages. Over 500 Illustrations. Cloth. \$5 per set postpaid (just half price of original edition.)

Popular Mechanics Press, 200 E. Ontario St., Chicago



Must Men Suffer *after 40?*

A WELL-KNOWN scientist's new book about old age reveals facts which to many men will be amazing. Did you know that two-thirds of all men past middle age are said to have a certain seldom mentioned disorder? Do you know the frequent cause of this decline in vitality?

Common "Old-Age" Symptoms

Medical men know this condition as hypertrophy of the prostate gland. Science now reveals that this swollen gland—painless in itself—not only often cheats men of vitality, but also bears on the bladder and is often directly responsible for sciatica, backache, pains in the legs and feet, and dizziness. When allowed to run on it is frequently the cause of cystitis, severe bladder inflammation.

65% Are Said to Have This Gland Disorder

Prostate trouble is now reached immediately by a new kind of safe home hygiene that goes directly to the gland itself, without drugs, medicine, massage, or application of electricity. Absolutely safe. 50,000 men have used it to restore the prostate gland to normal functioning. The principle involved is recommended by many physicians. Amazing recoveries often made in six days. Another grateful effect is usually the immediate disappearance of chronic constipation. Usually the entire body

is toned up. Either you feel ten years younger in six days or the treatment costs nothing.

Send for FREE Book

If you have gland trouble, or any of the symptoms mentioned, write today for scientist's free book, "Why Many Men Are Old at Forty." You can ask yourself certain frank questions that may reveal your true condition. Every man past 40 should make this test, as insidious prostate disorder often leads to surgery. This book is absolutely free, but mail coupon immediately, as the edition is limited. Address

THE ELECTRO THERMAL CO.
2123 Morris Ave. Steubenville, Ohio

If you live West of the Rockies, address The Electro Thermal Co., 303 Van Nuys Building, Dept. 21-Z, Los Angeles, Calif. In Canada, address The Electro Thermal Co., Desk 21-Z, 53 Yonge St., Toronto, Can.

The Electro Thermal Company,
2123 Morris Ave., Steubenville, Ohio

Please send me Free, and without obligation, a copy of your booklet, "Why Many Men Are Old at 40." Mail in plain wrapper.

Name.....
Address.....
City..... State.....

Ruptured 20 Years Ago...

Now Carries 12 Tons of Ice!

Thanks to Amazing Invention

He was ruptured at the age of one. For 20 years the victim of cruel, cumbersome trusses, barred from strenuous exercise and many of the things that every healthy man and boy wants to do. But now Wilbur Taylor of Lake Worth, Florida, finds himself carrying 12 tons of ice every day. A strenuous occupation even for one who had never been ruptured. But he does it. In his own words "with safety and comfort."

SAMPLE SENT FREE

IS the case of Wilbur Taylor a miracle? No! He is merely one of the thousands of ruptured people who have experienced the benefits brought about by the amazing discovery of an Eastern scientist.

Clinging Finger Ends Needless Rupture Torture

This scientist long knew that many of the hard, pressing cruel trusses actually prohibited the cure of rupture instead of helping. So he set out to develop a really scientific way, a device that would not only hold rupture securely and safely but that would not inhibit Nature's natural healing powers, as so many of the old fashioned devices have done. Now, after many years of research and experiment, after actual trial by thousands of ruptured persons, this new rupture discovery is offered to the public.

This new device can not be compared with any ordinary truss. It is something appealingly new. It works on the principle of the human finger. It flexes as your body does, increasing or decreasing its hold as necessary. It actually "breathes" air. It is as soft as your

hand. No rubber elastic is used. The tiny anchors are so small they can be concealed in the palm of your hand. Whole outfit weighs less than the contents of one of your pockets.

Coupon Brings Free Sample

So anxious is the scientist-discoverer of the new "Millionair" device, as he calls this discovery, that he wants to send a free sample of Finger Tip material to every ruptured person who will write. This discovery means a new day for ruptured. You will not want to lose an instant in finding out full details of the system and seeing this sample. No obligation. Just send your name and address on the coupon below. But act immediately while this offer is being made.

NEW SCIENCE INSTITUTE
2166 Clay St. Steubenville, Ohio

New Science Institute,
2166 Clay St., Steubenville, Ohio.

(We use plain unmarked packages.)
Yes, send me free sample as above mentioned of the "Millionair" and full details of your painless rupture appliance.

Name.....

Address.....

City..... State.....

Please be sure to print or write very plainly.





See How Easy You Can Learn HYPNOTISM

TRY FREE 5 DAYS!

SEE for yourself how easy it is to master the great science of Hypnotism—how quickly you can learn to bend people to your will—banish fear, worry and opposition—Increase your earnings—and force others to give you the recognition, power, and admiration you deserve. I'll show you how to use this great force to help you master every situation or **The Five Day Trial is FREE!**

In just a few hours I'll teach you the hidden secrets of Hypnotism—the methods used by the great operators—the amazing things you can accomplish once you understand this mighty power. You can use it to overcome obstacles, achieve your fondest ambitions and become **MASTER** of yourself, friends and acquaintances—either sex. Now you can quit being just one of the crowd—now you need not be unpopular, lonesome or unhappy a minute longer. Through this strange power you can learn how to stand out—dominate—to make your life what you want it to be!

In his startling **NEW** book, *The Science of Hypnotism*, the world famous hypnotist—Prof. L. E. Young—reveals the most carefully guarded secrets of this fascinating subject. He not only explains the methods of noted hypnotists, step by step—but tells clearly all about the nine stages of Hypnotism, *The Hypnotic Mirror*, Mental Telepathy, how to select your subjects, magnetic healing, methods of hypnotizing, how to wake the subject, how to make money out of hypnotism!

**Try 5 Days FREE—
Send No Money**

So confident are we that Prof. Young and his great book will quickly teach you the science of Hypnotism, that we will send you a copy without one cent in advance! Simply clip and mail the coupon below. When the book arrives pay the postman the special low price of \$2.50 plus few cents postage. Then test the powers of Hypnotism 5 days! If not amazed and delighted, return the book and money will be refunded at once.

**FRANKLIN PUBLISHING CO.,
Dept. P-70, 800 No. Clark Street, Chicago, Illinois**

Mysteries of Hypnotism Revealed

- How to Hypnotize at a Glance
- Susceptible Subjects
- How to Hypnotize by Telephone
- How to Give an Entertainment
- How to Make Others Obey You
- Overcoming Bad Habits
- How to Do Dozens of Hypnotic Feats.
- Use of Hypnotism in Operations

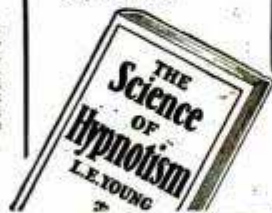

Franklin Pub. Co., Dept. P-70,
800 No. Clark St., Chicago, Ill.

Please send me your amazing new book—*The Science of Hypnotism*—by Prof. Young. When book arrives, I'll pay the postman only \$2.50 plus postage. If I am not satisfied after 5 days' trial, I may return the book and you are to refund my money.

Name

Street and No.

Town

If you are likely to be out when postman calls, send \$2.50 with coupon and we'll pay delivery charges. Customers outside U. S. send cash with order.

Fat Men!

This new self-massaging belt not only makes you look thinner **INSTANTLY**—but quickly takes off rolls of excess fat.

DIET is weakening—drugs are dangerous—strenuous reducing exercises are liable to strain your heart. The only safe method of reducing is massage. This method sets up a vigorous circulation that seems to melt away the surplus fat. The **Weil Reducing Belt**, made of special reducing rubber, produces exactly the same results as a skilled masseur, only quicker and cheaper. Every move you make causes the **Weil Belt** to gently massage your abdomen. Results are rapid because this belt works for you every second.

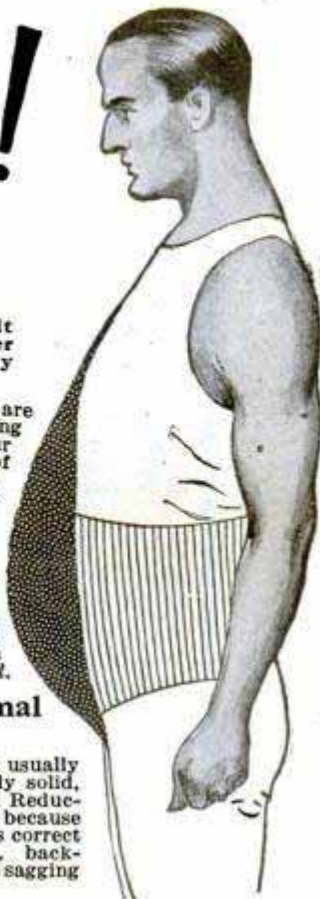

Fat Replaced by Normal Tissue

From 4 to 6 inches of flabby fat usually vanish in just a few weeks. Only solid, normal tissue remains. The **Weil Reducing Belt** is endorsed by physicians because it not only takes off fat, but helps correct stomach disorders, constipation, back-ache, shortness of breath, and puts sagging internal organs back into place.

Special 10-Day Trial Offer

Send no money. Write at once for detailed description, testimonials from delighted users and special 10-day trial offer. **The Weil Co., 911 Hill Street, New Haven, Connecticut.**



CODE TELEGRAPH

Morse or Radio
AT HOME WITH THE **Omnigraph**

Lends quickly to big money jobs. The easy and cheap way. U. S. Gov't., Schools, etc., use it. **THE WORLD'S Hobby.** Mention Age. Catalog—**Omnigraph Mfg. Co., P3-810 E. 39th St., Brooklyn, N. Y.**



BOW LEGS?

THIS GARTER (Pat'd)
Makes Trousers Hang Straight
If Legs Bend In or Out

Free Booklet—Plain Scaled Envelope

THE T. GARTER CO., Dept. B
South Bend, Ind.

HEALTH BEAUTY VIGOR

quickly won by using violet rays. No medicine. Very simple and easy to use. Give quick relief from pain and disease. **VIOLETTA** is endorsed and used by thousands of hospitals, sanitariums and physicians. Send for free book telling of the magical curative power of this marvelous discovery by Nikola Tesla, great electrical wizard. Testimonials by satisfied users. Write for it now. **VI-REX COMPANY, Dept. 1131, 2304 Warren Ave., Chicago.**

No Better Christmas Present for \$2.50

than a year's subscription to

Popular Mechanics Magazine

Containing 3600 Pictures and 3600 Articles

Much of it Interests Everybody
Most of it Interests Anybody
All of it Interests Somebody

Order through your Newsdealer or address the Publisher
POPULAR MECHANICS COMPANY
200 East Ontario Street, CHICAGO, ILL.

Let Me Make YOU OVER!

Big Muscles Quick!

LOOK at those two pictures! Which are YOU? A puny run-down weakling, scorned by your fellow-men, avoided by the fair sex, ashamed to show yourself in a bathing suit? Snap out of it, friend! Take a look at that big boy at the right and cheer up. That's the way TITUS builds men. And YOU'RE NEXT.

It's So EASY to Be Strong

Just give me 30 days and see the amazing change. New health—new strength—new energy—all in a few minutes a day! Why be a weakling when it's so EASY to be strong? One man writes me: "I never put on muscles so fast in all my life!" Another says: "I never thought that I could ever improve like I have." Still another writes that muscles "seem to grow overnight." Hundreds of letters like these PROVE that you, too, can be strong. Remember, I don't just promise you muscles, I GUARANTEE them.

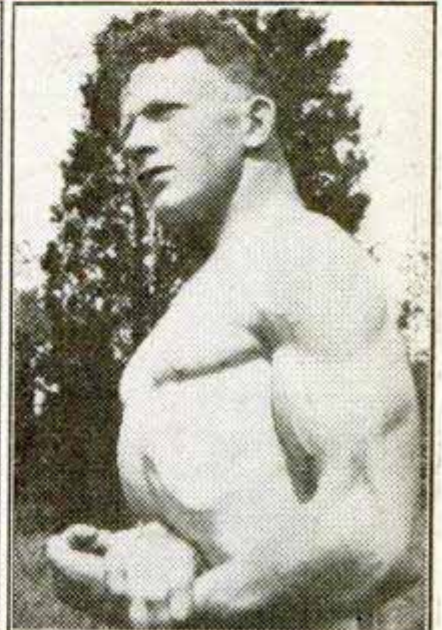
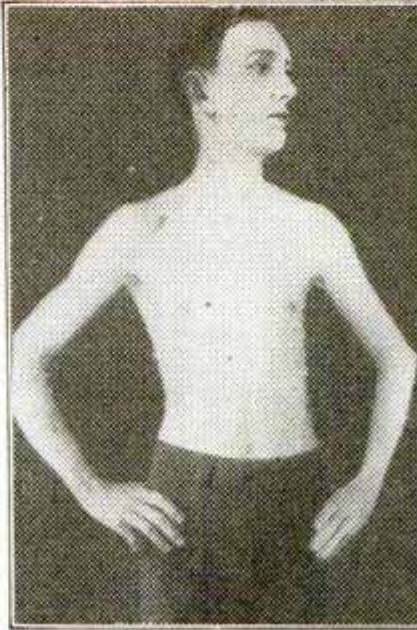

A Titus Built Body for YOU

I'm going to broaden your shoulders and fill out your chest. I'm going to build layers of powerful muscles. Not beef, not lumps of lead—but beautiful long rippling muscles that are ALIVE with speed and strength—PANTHER muscles! Just watch those mighty sinews GROW—on your arms, your legs, your back. I'm going to develop EVERY muscle in your body. And I'll not only work on you **outside**, but **inside**, too. I'll strengthen your internal organs, fill you full of glorious pep and energy. Man, you'll feel like shouting for the sheer joy of living. Shoot that coupon to me TODAY. Get your FREE copy of my big book "Miracles in Muscles." It's filled with Titus's own secrets for making muscles grow!



Get Your FREE Copy of My Amazing Book NOW

Is your body worth a 2c stamp? Then tear off that coupon and shoot it in the mail TODAY. By return mail you'll get my big, illustrated book — one of the most inspiring, most amazing books you've read. Chock-full of muscle-building facts, packed with pictures of men rebuilt. Read how, in just a few minutes a day at home, YOU can develop MIGHTY MUSCLES OF STEEL. No cost, no obligation, no salesman will call. RUSH the coupon.



TITUS
853 Broadway
NEW YORK CITY

WEAR THIS MEDAL

Strong men all over the world wear it as a badge of manhood. Made of solid statuary bronze and given to you free.



TITUS, Dept. M-144,
853 Broadway, New York, N. Y.

Dear Titus: Okay, send that wonderful, big illustrated book of yours, "MIRACLES IN MUSCLES." Get it to me by return mail, without the slightest cost or obligation on my part.

Name.....
Address.....
Town..... State.....

2½ Tons Heats 6 Rooms!

"With our Bulldog Furnace we use about 2½ tons of coal a winter on the average, and it is cozy all the time. We have only a 6-room house so we just use a third of the grate. Three cheers for the 'Bulldog!'"
— Frank H. Taylor, Dunning, Nebr.

More Heat with Half the Coal

"I had a hot air furnace in our house before I got the Bulldog and our 7-room house was always cold. With the Bulldog it only takes half as much coal and we had weather below zero, and the house was nice and warm in the morning when we got up. We never have the draft on more than a half hour at a time, and it has the place red hot." Jess. T. Conrad, Shamokin, Pa.

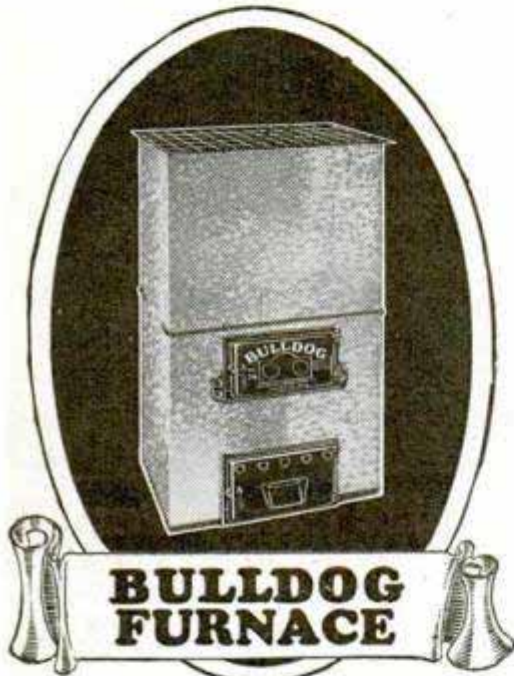

**BULLDOG
FURNACE**

If you are even thinking of a pipeless furnace, or any furnace, write for our free catalog. The Bulldog is one furnace you MUST investigate. Comes completely erected. Fits any height of basement and you install it yourself.

No Money Down

Small Monthly Payments

The Bulldog is sent for free inspection. Then, if satisfied, you make only small monthly payments at our amazingly low price. Factory connections in both East and West. We ship from nearest point. Write at once for our special offer and our free catalog together with the wonderful record of Bulldog success. Mail this coupon today.

Bulldog Furnace Co.

19th & California Ave., Dept. 13-58 Chicago

Without obligating me, please send me your free catalog and special offer on the Bulldog Furnace.

Have you a basement? Yes No

Name

Street Address

Town

County

State

GET INTO AVIATION

**BE A
PILOT**



Fly your own plane. Know engine and airplane mechanics. Study meteorology, air navigation. Our ground work and flying courses lead to adventure and success. This school endorsed by America's Ace, **Eddie Rickenbacker**, "**Eddie**" Stinson and other real flying experts. The old reliable Michigan State, at Detroit, the Aviation Center, is the logical place to study aviation. Practical experience guaranteed. **GARAGE MECHANICS**—can qualify quickly for new airfield jobs and bigger opportunities. 20 trained service men needed for every flyer. Learn at America's big school. 19 years' experience in training men. **WE WANT** only sincere, earnest men and women students. We are not looking for easy marks and do not "give" free railroad tickets or special discounts.

Send for Illustrated Catalog

MICHIGAN STATE AVIATION SCHOOL
4466 Woodward Ave. Detroit, Mich.

LEARN ADVERTISING MAKE BIG MONEY

ADVERTISING is a well-paid profession. Skilled writers of advertising command salaries of \$5000 to \$25,000 a year, and many executives of advertising agencies make far more.

Have you ever thought to yourself, "I could write an advertisement as good as that"? The advertising business is looking for men with ambition and imagination. You need the proper training in the scientific side of the subject, and the International Correspondence Schools Course in Advertising can give you that. It covers the writing of copy, layout and illustration, plans, markets and media, direct-mail, street car and outdoor advertising, department store advertising and many other necessary subjects.

These courses are complete and up to date, prepared by expert authorities. Right at home, in your spare hours, they will give you the practical knowledge you need to enter the advertising business.

It costs you nothing to find out the full details. Write for our free booklets, and learn what advertising has to offer you as a career. Mail the coupon today!

INTERNATIONAL CORRESPONDENCE SCHOOLS
Box 5651-F, Scranton, Penna.

Without cost or obligation, please send me full details of your home-study course in

ADVERTISING

Name

Address

20 YEARS OF SHIRT-SLEEVE PRACTICE IN *ELECTRICITY*



**NEWLY
REVISED
UP TO THE
MINUTE**

The Croft Library of PRACTICAL ELECTRICITY

The **STANDARD** Study Course

**FREE
TRIAL**

This is the electrical age, with unlimited opportunities for the man who has educated himself in the finer points of electrical practice. Fit yourself for a big-pay job by knowing electrical practice complete, including inside and outside work, central stations, and the whole subject. With the aid of the Croft books you can know electricity as experts know it and put yourself in line for an expert's pay.

The Croft Library is a complete electrical educator. It is founded on practice—on work as it is actually done. It is jammed from cover to cover with the kind of hard-headed facts you want. Written so that the beginner can easily understand it, yet so sound, so thorough, that it is the daily guide of 59,000 highly paid electrical workers and engineers. Croft tells you the things you need to know about motors, generators, armatures, commutators, transformers, circuits, switchboards, distribution systems—electrical machinery of every type—wiring for light and power—wiring of finished buildings—underwriters and municipal requirements—illumination in its every phase—the latest and most improved methods of lighting—lamps and lighting effects, etc.—how to do a complete job, from estimating it, to completion. Make no mistake about it—there are big jobs in electricity ready for you when you're ready for them. Thousands of men who have the Croft Library know that to be a fact. The Library itself, on a **FREE TRIAL BASIS**, will prove it to your own absolute satisfaction.

A reference library and self-training course in eight volumes. 3000 pages—2100 illustrations. In these volumes Croft teaches you electrical practice complete. He takes you in quick, easy steps from the simplest principles to the complete and economical operation of a great central station. He tells you all that he has learned in twenty years of shirt-sleeve practice.

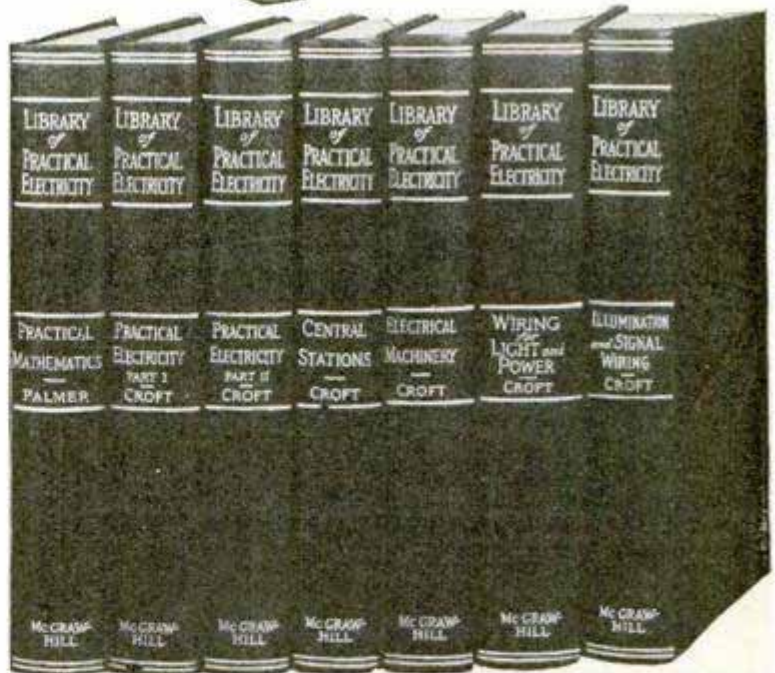

KNOW ELECTRICITY as the EXPERTS KNOW IT



With these books at his elbow a man can learn as much about electricity in six months—good practical "bread and butter" stuff—as he would ordinarily learn in a lifetime of practice.

NO MONEY DOWN

Small Monthly Payments

**10 Days
FREE
TRIAL
Just Mail
the
Coupon!**

Fill in and mail the coupon attached and we will send you the entire set of eight volumes for ten days' Free Examination. We take all the risk—pay all charges. You assume no obligation—you pay nothing unless you decide to keep the books. Then \$1.50 in ten days and the balance at the rate of \$2.00 a month. Send the coupon NOW and see the books for yourself.

FREE EXAMINATION COUPON

McGraw-Hill Book Co., Inc., 370 Seventh Ave., New York

Send me for 10 days' free examination the Croft Library of Practical Electricity. If satisfactory I will send you \$1.50 in 10 days and \$2.00 monthly until the special price of \$19.50 is paid. If not wanted, I will return the books at your expense. (To insure prompt shipment write plainly and fill in all lines.)

Name.....
Address.....
City and State.....
Position.....
Company.....

Save \$20.00 with this OFFER
Send no money



Get Strong WITH These Improved Muscle Builders All for \$5.00



Why pay an extravagant price for strength—here's an opportunity to get all the equipment you require along with an excellent course of instructions for only \$5.00. Realize your ambition and develop muscles of a super-man. Get strong and amaze your friends. We show you how to easily master feats which now seem difficult—or if you just want physical culture for your health's sake, this equipment is just what you need. With this special offer you save at least \$20.00. We furnish a ten cable chest expander which is adjustable to give resistance up to 200 lbs. It is made of new live extra strength, springy rubber so as to assure long wear and give the resistance you need for real muscle development. You also get a pair of patented hand grips for developing powerful grip and forearms.

We include wall exercising parts which permits you to develop your back, arms and legs—a real muscle necessity. You know that business men and athletes, too, first show their age in their legs. Develop your leg muscles with the foot strap which we furnish. This will give you speed and endurance—but that isn't all that you get. In addition we include a specially written course which contains pictures and diagrams showing you how to develop any part of your body so that you will quickly get on with these exercises and gain the greatest advantage from their use. Act now while you can get in on this special offer. It might be withdrawn, so rush the coupon.

SEND NO MONEY

All of the items pictured on this page are included in this big special reduction offer. Sign your name and address to the coupon below and rush it to us. We will send you ten cable chest developer, the wall parts, a pair of hand grips, foot strap and the course by return mail. Pay the postman only \$5.00, plus the few cents postage on arrival. (If you desire to send check or money order in advance, we pay postage.)

GUARANTEE

All Crusader products are guaranteed to give entire satisfaction or money back.



Crusader Apparatus Co., Dept. 111, 44 Parker Ave., Maplewood, N. J.

I accept your offer. Send me everything described in your advertisement by return mail. I will pay postman \$5.00 plus postage on arrival. It is understood if I am not entirely satisfied after examination I can return the goods and you will refund my money.

Name.....

Street.....

City..... State.....

Drawing Course \$2.98

The biggest value you ever saw advertised anywhere



Haven't you often wished that you could draw cartoons, illustrate some idea, sketch some pretty face, etc.? You can do all of these things. One of America's most famous Cartoonists and Illustrators has developed a great, simple system for success in all branches of Commercial Art. This system has revolutionized the entire theory of drawing. It means that drawing can be as easy for you as writing—much simpler than learning shorthand, bookkeeping or typewriting. We are now placing this original system for learning Drawing, Art and Cartooning, consisting of 34 lessons with over 500 illustrations, within reach of every one. If you will devote a few hours each week to the Course WE ABSOLUTELY GUARANTEE that you will learn to draw and draw well before you have half finished the Course. If we fail to make this claim good, we will refund every cent paid us. By eliminating a large office force for answering correspondence, expensive catalogs, etc., we are enabled to make a price of \$2.98, the cheapest price ever known for a high-grade, home study course. Learn to draw. It is a big asset, no matter what field you are in.

Send No Money

Just order the course and on arrival \$2.98 pay postman

If you order the course at once, we will include a drawing outfit, consisting of artist's pencils, pens, paper, erasers, thumb tacks, etc., enabling you to go to work without any additional cost.

plus a few cents postage, payment in full for the entire Course and Drawing Outfit. If not entirely satisfied, return within five days and we will Refund Money. Address: **LEDERER SCHOOL of DRAWING, Dept. 159-B, Chattanooga, Tenn.** Orders from outside the U. S. A. are payable \$3.28 cash with order.

Now You Can Get Into AVIATION Quickly

Train yourself NOW to qualify for one of thousands of jobs crying for men. My course trains you at home, and I help you find job upon graduation. Amazing new plan. No education or experience needed. Anyone over 18 can qualify.

FREE BOOK Explains All

Rush name and address for big FREE BOOK on Aviation. Get my special tuition offer, and money back agreement. State your age. **Major R. L. Rockwell, DAYTON SCHOOL OF AVIATION, Desk R-28, Dayton, Ohio.**



PAINT SHOW CARDS

and SIGNS. LEARN AT HOME IN SPARE TIME. WE TEACH YOU QUICKLY—FASCINATING WORK. \$75 WEEKLY. SEND 6c IN STAMPS FOR CIRCULAR. **Universal School of Lettering NEW HAVEN, CONN.**

NEW EDITION MODERN GASOLINE AUTOMOBILE

The type matter has been entirely reset for the thorough revision of this authoritative book by V. W. Page. With 1000 new illustrations this strictly modern work shows every recent improvement in automobiles and their component parts. This most complete and practical treatise describes every part of all types from light cars to heavy-duty trucks and road tractors.

The first book to devote many of its 1150 pages to a complete, illustrated description of the

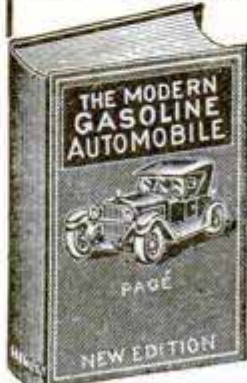

NEW MODEL A FORD

Design, construction, operation and maintenance are the broad divisions of the text matter.

All latest developments are dealt with in minute detail.

Size, 6x9 in. Fabrikoid Binding Price \$5

Will be sent C. O. D. in U. S. Pay postman price and postage.

Popular Mechanics Press
Room P 11

200 E. Ontario St. Chicago

Fix

that

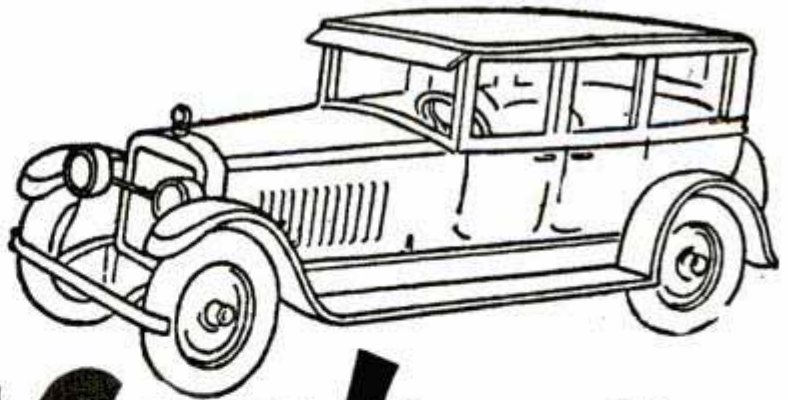

Car! Learn How-Easily



JIFFY INDEX in These Five New Big Auto Books Makes All Facts Instantly Available. Find Anything You Want To Know in a Moment in This Latest Edition

All Shipped Free

Don't miss a word of our free shipment offer. You don't have to pay us a cent—we ship without receiving one penny.

Learn All About Autos

Get these five big books on this liberal offer and learn all the things you want to know about autos—carburetors, engines, springs and spring suspension, brakes, 4-wheel drive, lubricating system—all are fully covered. These complete and comprehensive books are yours if you want them on this easy plan. Send for a set now. Fill in the coupon.

Repair any auto fault, learn how now. You can do it easily in this new simple way. These five big automobile books are the most interesting, the most practical books we have ever published on automobile construction, operation and repairs. Brimful of facts, photographs and explanations so easy to understand that anyone can learn how to repair auto faults in almost no time. Over 2,000 pages full of diagrams, data sheets and everything else needed to make anyone an authority on automobiles. Whether you want to qualify as garage owner, auto repair expert or merely wish to know how to keep your own car 100% efficient, you will recognize the amazing value of these five big books, especially on our

No Money Offer

A very liberal plan of distribution brings these books to you for examination without one cent of payment to us. We don't ask a cent of you, but ship the books free. Look them over, read them as much as you want to, note the splendid photographs and drawings, and then if you decide you want them, send only \$2.00 and then \$3.00 a month until only \$24.80 is paid. That is all. Nothing more to pay us. There is no further obligation.

REPAIR ANY AUTO FAULT

With these books you don't have to worry about autotroubles. Illustrations are so clear and explanations are so simple that anyone can understand them. All phases of automobile engineering fully covered. Engines, chassis, carburetors, ignition systems, transmissions, differentials—in fact every part of a modern automobile explained from the standpoint of theory and practice.

FIND FACTS QUICKLY

One of the best things about these money making books is the Jiffy Index, which puts vital facts at your finger tips. You don't have to read the books through; you don't have to spend long hours over them. This Index enables you to put your finger on the information wanted in a jiffy.

DON'T HESITATE

There are no strings to this offer—it means just what it says. Send name and address on the coupon and all of the five big books—the complete set—will be sent you for examination. Remember, one fact alone which you can find in these books may save you an expensive repair, or help you to a better job.

FOR FREE OFFER USE COUPON

American Technical Society, Dept. A819
Drexel Ave. at 58th St., Chicago, Ill.

I would like to look at the five big auto books—send them on your free offer. I will pay the few cents delivery charges. If I like them, I will send you \$2.00 when I have had the books fifteen days, and then \$3.00 a month until the special price of only \$24.80 is paid. Otherwise I will return the books at your expense. You are to include, without charge, free consulting membership certificate in the American Technical Society.

Name.....
Address.....
Employer's Name.....
Employer's Address.....

American Technical Society Membership Free

Yes, we include a certificate of membership in the American Technical Society, which entitles you to free consultation on any subject relating to automobile engineering. We have over a million dollars of resources enabling us to get co-operation of the largest automobile manufacturers and dealers who have furnished us plans and photographs. This membership, which you get for an entire year free, entitles you to consultation with 18 automobile experts, any of whom will be ready to help you at all times. You can write or wire any time for special information. Answers will be sent promptly without cost.

TRAIN
at **HOME**
for

Electricity

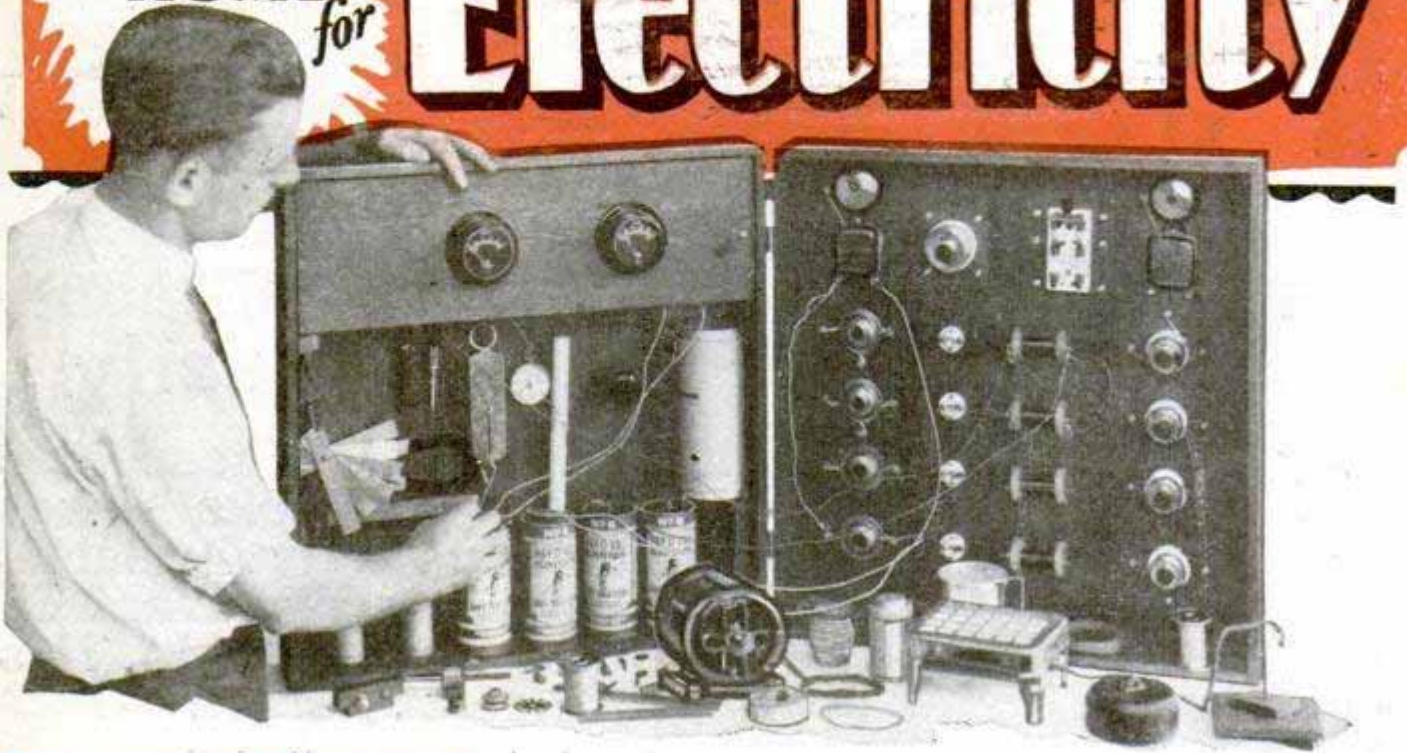

**Brings the School
Right to Your Home!**



Complete Shop-Laboratory enables you to train for Electricity the **PRACTICAL WAY** without leaving your home.

**Exclusive Patented
Laboratory Equipment**

that cannot be secured elsewhere. Special Unit Board System makes fascinating sport of laboratory experiments. Amazingly easy to use.



Learn By Doing



No mere book on theoretical study—but **PRACTICAL** training on full-sized motor, switchboard, circuits, and electrical equipment.

Satisfaction Guaranteed

You can take S. of E. Home Shop-Laboratory training without risking a penny. Guarantee Bond protects you.



**This Big Shop-Laboratory
Yours Without Extra Cost!**

Now comes the new way to learn Practical Electricity—the Home Shop-Laboratory Method. The big full-sized equipment (worth \$60.00) here illustrated makes your home training thorough, complete, **PRACTICAL**. Through this fascinating new method, important facts are driven home in a manner impossible with books alone. You learn by working on practical equipment—and enjoy it! This Shop-Laboratory is the most complete ever offered with a home course in Electricity—and is the only one to incorporate the patented Unit Board System that makes home training a pleasure instead of a task.

**America's Great Electrical School
Stands Back of Your Training**

And behind your training stands the Extension Division of the world-famous School of Engineering of Milwaukee. Not a mere correspondence school, but a fully-established college specializing in Electricity, chartered by the State of Wisconsin, and recognized by the United States Government. Established 26 years ago, with 26,000 graduates occupying important positions in Electrical Industries throughout the world. Through the Extension Division you get the same methods, the same course, the same faculty of skilled engineers that have made the School of Engineering internationally renowned.

**Broadcasting Station
WISN is operated from the
School of Engineering; also
amateur station W9SO.**

**Extension Division, Dept. 32
School of Engineering
Milwaukee, Wis.**

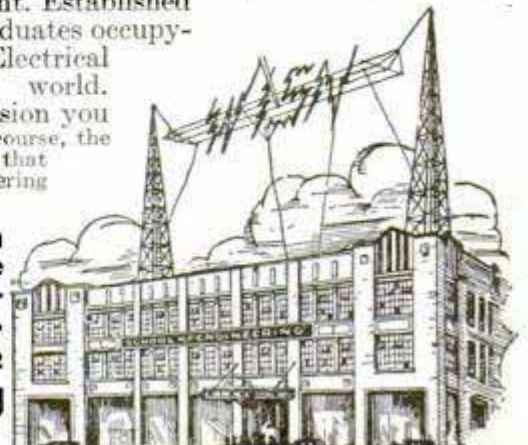

This NEW Shop Laboratory Way

Here is your opportunity to enter the big field of **ELECTRICITY**, crowded with opportunities, without leaving your home. Now you can train the **PRACTICAL WAY**, not by the ordinary correspondence course, but by the unique Shop-Laboratory Method. Enables you to become an Electro-Technician in surprisingly short time.

Radio, Aviation, Talking Movies, Television, Power, Refrigeration **Need Electrically Trained Men**

This is an Electrical Age. The new Electrical Industries are sweeping the world. Electricity is in the midst of gigantic developments. Radio's mushroom growth is familiar to all. Aviation's future depends upon Electricity. Television for every home is just around the corner. Talking movies are taking the world by storm. Electric refrigeration is a household necessity. Super-power transmission has made great headway.

No wonder big manufacturers are pleading for Electrically Trained men. Salaries of \$3,000 to \$7,500 a year are common. Wonderful opportunities for advancement. Here is the field for you. Now is the time to start on the road that leads to increased pay and **SUCCESS**.



RADIO

48-Page Illustrated Book FREE!

Just clip the coupon and mail it to-day for the **FREE** 48-page illustrated Book "Practical Electricity—The Key to Success," and full details of Shop-Laboratory Method of Training.

EXTENSION DIVISION
SCHOOL of ENGINEERING
 MILWAUKEE, WISCONSIN
 Dept. 32



RADIO CONTROLLED AVIATION



TALKING MOVIES

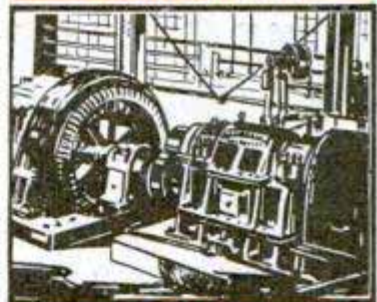

POWER

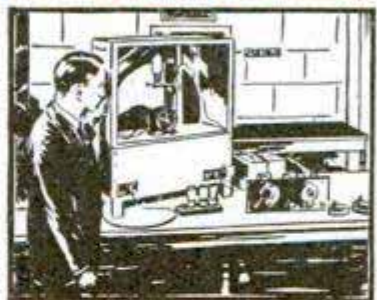

TELEVISION

**Extension Division, Dept. 32,
 SCHOOL OF ENGINEERING,
 Milwaukee, Wisconsin.**

Please send me, without obligation, **FREE** illustrated 48-page book, "Practical Electricity—the Key to Success," and details of Extension Division training.

Name

Address

Genuine
UNDERWOOD
Below 1/2 Price



Now Only **\$1 DOWN**

Standard 4-Row Keyboard

Think of it! Only \$1.00 brings the World's most famous Underwood Typewriter for 10 days' free trial. Lowest price and easiest terms ever offered. Pay only 10c a day on easy monthly payment plan. This is the full size standard Underwood 4-row keyboard typewriter, manufactured to sell for \$100.00.

Do not confuse this 4-row standard office model Underwood with other frail machines originally costing only one-half as much.

Lowest Price — 10-Day Free Trial

FREE!!
Nothing Else to Buy
 We teach you free. Complete Home Study Course of the famous Van Sant Speed Typewriting System, fully illustrated, easily learned, used in schools, business offices, everywhere.

This late model Underwood, specially priced at \$39.90 cash, is the lowest price ever quoted; has modern improvements including 4-row keyboard, two-color ribbon, back spacer, ribbon reverse, tabulator, release, shift lock and many other improvements. Beautifully refinished and renewed. Looks and operates like brand new.

International Typewriter Exchange,
 231 West Monroe Street, Chicago, Ill., Dept. 1194.
 I enclose \$1 deposit. Send Underwood No. 4 at once for 10-day Free Trial. If I am not perfectly satisfied I can return it Express Collect and get my deposit back. If I keep it I will pay \$3 a month until I have paid \$44.90 (term price) in full.

Name.....Age.....
 Address.....
 Town.....State.....

Aircraft Drafting
Now taught at home!

The demand for trained Aeronautical Draftsmen is so great that the famous old Columbia School of Drafting now offers a special Aeronautical Course. Under the new home study plan, non-resident students get the same instruction as those who come to Washington, and all receive the free services of Columbia's active employment service. The coupon will bring you our message to wide-awake men, "Drafting and Its Opportunities." Send for it today!



Columbia School of Drafting & Engineering
 All Branches of Drafting
 13th and E. Sts., N. W., Washington, D. C.

P. M.-11

Please send me my copy of your Free Book, showing how I can learn Aeronautical Drafting right at home.

Name.....
 Address.....

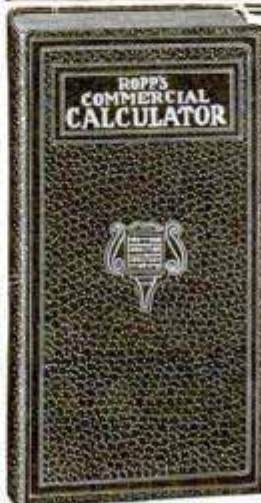

Mathematics Made Easy by
ROPP'S CALCULATOR
AND SHORT-CUT ARITHMETIC

Shows the Answer as Quickly as a Watch shows the Time to all Problems likely to occur in the Office, Store, Shop, Bank, Farm, or Factory.

Over 2,000,000 Sold
 Explains and simplifies every principle in Arithmetic, Mechanics, and Mensuration.

PRICES POSTPAID
 Desk Size, Flexible Keratol Binding.....\$2.00
 Pocket Size, Art Leather Binding.....\$1.00
 Pocket Size, Cloth Binding.....\$0.50

POPULAR MECHANICS PRESS
 Room P-11 200 E. Ontario St. Chicago

BUILT-IN FURNITURE
Adds Beauty and Convenience
to Your Home



With the plans and directions given in this new book by Edwin M. Love any handy man will be able to build the various pieces of popular space-saving furniture.

These useful and ornamental cabinets are easily added to an old house and many are designed to be built into odd nooks and recesses.

The construction is very simple as the walls offer support and no structural alteration of either floors or walls is necessary.

Stock sizes of material are specified in each instance. The home owner will be able to alter designs if necessary to suit available space.

That practically every adaptation of built-in furniture is covered by this book is shown by the following list of contents.

- General Details of Construction—Recess Buffet—Corner China Closets—Clothes Closet Linen Cabinet—Furnishing a Clothes Closet—Bathroom Cabinet—Linen Closet—Mantel Shelves—Bookcases—Writing Desk—Seats—Indirect Lighting Fixtures—Sewing Cabinet—Corner Kitchen Cupboards—Breakfast Nook—Bathtubs—Laundry Porch Furnishings—Dining Table—Dressing Table—Radio Set—Phonograph—Safe—Shaving Cabinet—Cupboard and Drainboard Cabinet—Clothes Chute—Wood Box—Work Bench and Tool Cabinet—Mortise and Tenon and Dado Joints—Wood Dowels—Bending Small Mouldings—Driving Nails and Screws—Care of Tools.

198 pages. Size 7x10 In. Fully illustrated. Price \$2.50 postpaid.

Popular Mechanics Press
 Room P-111
 200 E. Ontario St. Chicago, Ill.

This Singular Book Wields a Strange Power Over Its Readers

—showing them how to magnetize their personality *almost at once!*

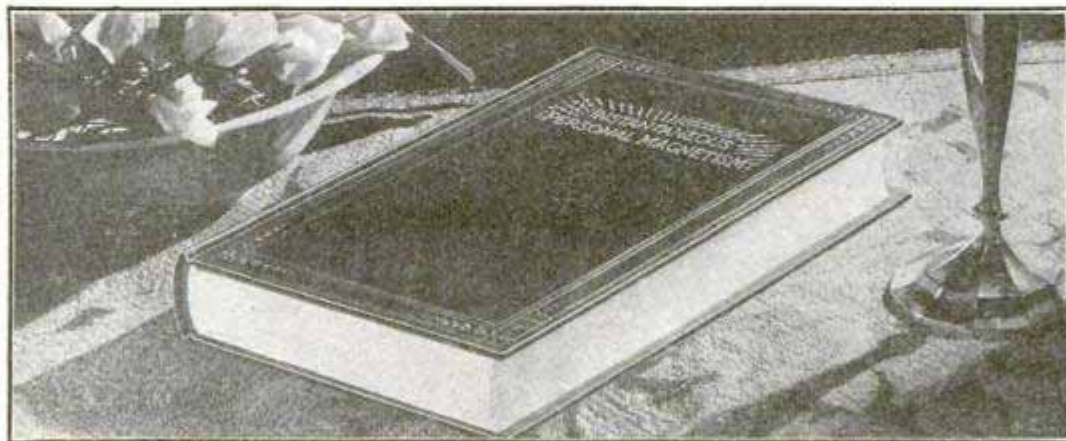

Will You Read It 5 Days FREE—to Prove It Can Help Multiply Your Present Income?

A STRANGE book! A book that almost seems to cast a spell over every person who turns its pages!

A copy of this book was left lying on a hotel table for a few weeks. To quote the author, "Nearly 400 people saw it—read a few pages—and then *sent for a copy!*"

In another case, the author reported that a physician placed a copy in his waiting room where more than 200 patients saw the book—read part of it—and then *ordered copies for themselves!*

Why are men and women so profoundly affected by this book?—so anxious to get a copy? The answer is simple. The book reveals to them how any man or woman—young or old—can develop a Magnetic Personality! It explains how to develop the personal charm that attracts friends—the self-confidence that helps insure success in any business or profession.

It tells how to draw people to you—how to be popular—how to overcome timidity and self-consciousness—how to be well-liked wherever you go.

Best of all—it tells you how to accomplish these results quickly and easily!

Whence Comes This Uncanny Volume

Forty years ago, Edmund Shaftesbury, famous student of the human mind, set out to discover the secret of Personal Magnetism. He applied his discoveries to his friends. Results were astonishing! His methods seemed to transform people into *entirely new beings!*

Shaftesbury's fame spread. Great men came to him. Among his students and friends were Gladstone, Queen Victoria, Edwin Booth, Henry Ward Beecher and Cardinal Gibbons.

Until recently, Shaftesbury's teachings have been available only to people who could pay \$25 to \$50 each for instruction books. Now, some of his most important teachings have been collected in a single volume, at a price *within the reach of all!* Furthermore, in this volume are revealed hundreds of Shaftesbury's discoveries never before put into print.

BOOK TELLS YOU

How to develop a magnetic personality.
How to gain nerve control.
How to read people's feelings by watching their mouths.
How to end awkwardness and timidity.
How to utilize your subconscious mind.
How to get ahead in your business or profession—and dozens of other vital topics.

Strange Effect on Readers

Readers of this book quickly learn the secret of attracting others—of influencing the men and women around them. Not by force—not by loud argument—but rather by applying certain simple, scientific rules that enable them to play on

people's feelings just as a skilled violinist plays upon a violin.

Is it any wonder that thousands of men and women say they are overjoyed with the results they have received? One enthusiast said of this volume, "Things I have read there I would never have dreamed of." Another wrote, "I would not give up what Shaftesbury has taught me for \$100,000!"

In your everyday life—in social life—and especially in business, you will find this book of immense value. It will help you to attract new friends and to gain the promotion and increased income which seems to come so easily to men and women who have developed MAGNETIC PERSONALITY!

Read This Book 5 Days FREE

Merely mail coupon below and this remarkable volume, with cover in handsome dark burgundy cloth, gold embossed, will be sent you for free examination. If you aren't stirred and inspired in the 5 day free period, return it and pay us nothing. Otherwise keep it as your own and remit the special price of only \$3 in full payment.

You are the sole judge. You do not pay unless you are absolutely delighted. And then only \$3. Don't delay! Clip and mail the coupon NOW. Ralston University Press, Dept. 13-T, Meriden, Conn.

RALSTON UNIVERSITY PRESS,
Dept. 13-T, Meriden, Conn.

All right—I'll be the judge. You may send me the volume "Instantaneous Personal Magnetism" for 5 days FREE EXAMINATION in my home. Within the 5 days, I will either remit the special low price of only \$3 or return the book without cost or obligation.

Name.....

Address.....

City..... State.....

Special cash price \$2.00 if payment accompanies coupon. This saves heavy bookkeeping and clerical expense. Money refunded if dissatisfied and book is returned within five days.

STEAM ENGINE FREE!

Here's our special "Little Hercules" Steam Engine. Made by "Weeden," world's leading maker. Fine quality and high finish. Has heavy fly-wheel, pulley-wheel, easy acting piston, and heavy cylinder. Strong boiler and fittings. Has fire box. Runs by alcohol or canned heat. Will run mechanical toys like Erector, Meccano. A big, high quality steam engine—powerful—just what you have been waiting for and you can have it FREE.



The Magazine of Thrills
The Open Road for Boys magazine has fifty pages crammed with thrilling, breath-taking stories that will hold you spell-bound. Tense stories of high adventure on land, on sea and in the air. Deep mystery. Suspense. "The Street of Dreadful Silence," the most thrilling mystery serial smash in ten years, now starting. Regular subscription price alone \$1.00 a year. We'll send you The Open Road for Boys

Magazine for a whole year for \$1.00 and this dandy steam engine FREE! Wow! What a bargain.

BOTH TOGETHER \$1



MAIL COUPON TO-DAY.

Canadian postage 25c extra. Foreign 50c extra.

The Open Road for Boys
Department W.P.M.
130 Newbury Street
Boston, Mass.

You bet I'll grab that bargain. Here's my \$1.00. Rush the Steam Engine right out to me and put me down for a year's subscription to The Open Road for Boys Magazine.

Name.....
Street.....
City..... State.....



The NEW FORD Explained Inside and Out Construction, Operation and Repair Every Part Described and Illustrated

545 Pages
252 Diagrams and Pictures

- 100 Specially Posed Photographs
- Ford Car, Parts and Functions
- Model A Engine and Parts
- Ford Engine Auxiliary Groups
- Details Ford Model A Chassis Parts
- Driving and Maintenance
- Top Overhead Ford Model A Engine Parts
- Troubles Ford Auxiliary Systems
- Electrical System
- Overhauling Clutch and Transmission
- Front Axle and Steering Gear
- Brakes and Rear Axle
- Ford Body and Its Care

The book you have been waiting for! Everything you want to know about the new Ford, all in one compact, plainly written, lavishly illustrated, accurate book. Every detail of construction shown in exclusive pictures and diagrams. All repair processes illustrated and explained by more than 100 specially posed photographs. Everything is simply and fully described so that you can instantly understand it. Ford owners, repairmen, dealers, salesmen, drivers need this book, written by a recognized automobile authority.

Be An Expert On the New Ford Car
Be the New Ford expert of your community. Make big money as a trouble shooter. Save yourself dollars and miles by KNOWING your New Ford inside and out.

SEND TODAY No Money Needed
Send NOW for this greatest book on the New Ford. No money needed. Just deposit \$2.00 plus the few cents postal charges, with the postman when you receive the book. Or, if you prefer, enclose \$2.00 and we will pay postal charges. If, after 5 days' examination, you decide, for any reason, to return this book, we will refund your money in full. The edition is limited. Act NOW and be among the first to get this valuable work.

Trouble Shooting CHART

25x38 inches, sectional views of entire Model A Power Plant, showing location and causes of all common troubles. Every part illustrated. Send 35c (coin or stamps) for chart or tell us to send it when we send you book. Send \$2.25 for book and chart prepaid.

Norman W. Henley Publishing Co., Dept. 411
2 West 45th Street NEW YORK CITY

MORE MONEY for Mechanics



Smart men look for ways to make more money and any mechanic will find many money-making secrets in these 7 big NEW books.

All These Books Shipped FREE
Yes, the whole set—7 books, over 2600 pages with nearly 3,000 illustrations will be shipped free to convince you that they are brimful of money-making facts which every shop man should know. Right up to the minute; just off the press, these 7 big books edited by 33 of the country's best known experts give you a complete library of practical money-making facts and, best of all, we ask you to



The new Jiffy Index puts facts at your finger tips; no need to hunt or study.

Send No Money

On our great offer you send only your name and address with the name of your employer or other reference just as an evidence of good faith and we send you all of the books without charge or obligation. Examine them; look them over carefully; find out anything you want to know and then if you want to keep them send only \$2, then \$3 a month until the wholesale price of only \$29.80 has been paid. If you are not more than satisfied with this free examination, send the books back and you owe us nothing.

Modern Shop Practice

This new 7 volume 1929-1930 edition of Modern Shop Practice is bound in flexible binding, gold stamped and each book is choiceful of facts and machine shop work—mechanical drawing, metallurgy, forging, shop mathematics, tool making pattern making and hundreds and hundreds of other similar subjects which will make any man a better and more valuable mechanic. Written in simple language, these books should be worth 10 times their price to anybody from mechanic to superintendent.

Send Coupon NOW

American Technical Society, Dept. 8819,
Drexel Ave. at 58th St., Chicago, Ill.
Send on your free offer 7 volumes "Modern Shop Practice." If I like the books I will send you \$2 and after that \$3 a month until the wholesale price of only \$29.80 is paid. Otherwise I will return the books and owe you nothing. Include free the special booklet outlined of reading course and also a certificate entitling me to membership in the American Technical Society with full consultation privileges with 18 experts for one year.

Name.....
Address.....
Employer's Name.....
Employer's Address.....

Answer This Ad!

If You Want Quick Success and Big Pay In AUTOS

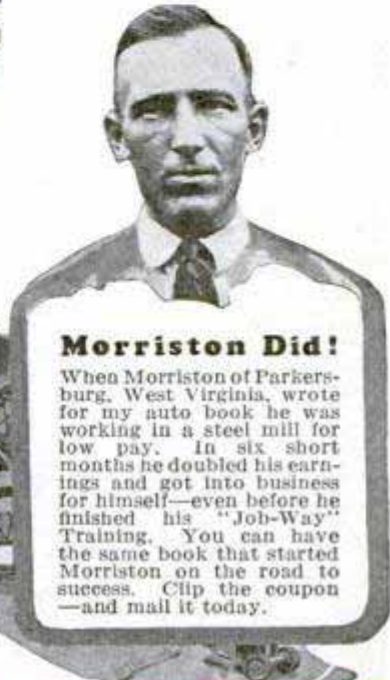

Morrison Did!

When Morrison of Parkersburg, West Virginia, wrote for my auto book he was working in a steel mill for low pay. In six short months he doubled his earnings and got into business for himself—even before he finished his "Job-Way" Training. You can have the same book that started Morrison on the road to success. Clip the coupon—and mail it today.

Earn Up to \$100 a Week

Get YOUR share of the \$7,000,000,000 spent every year on auto upkeep. Just think of it—more than 25,000,000 autos in the U. S. No wonder there are so many big pay jobs! Get into this fascinating game, now. Don't put it off another day. Get the facts. Mail coupon for big, FREE auto book. Learn of the countless opportunities in the World's Biggest Business where real jobs and big pay come quick. See how \$50—\$75—\$100 a week is possible for you now. Learn how "Job-Way" Training has brought big money—promotion—shops of their own to scores of men. Find out about my Employment Department—how it helps you get a good job in the auto business.

3 Working Outfits
also included FREE of extra charge if you act quick!

Learn at Home in Spare Time

"Job-Way" Training is the short cut to Auto Success. No need to quit your present job—no need to leave home—just use your spare time to prepare for a brilliant future—a real job paying up to \$100 a week. All you need is common schooling. I don't care if you never touched an auto before, I can train you at home. You should be able to make extra money quick—a few weeks after starting. Men from all walks of life who worked

long, hard hours for low pay are becoming garage owners, foremen and superintendents. If you like autos—if you're between 15 and 55—get the facts now. "Job-Way" Training covers everything about autos—Mechanical and Electrical Work, Starting, Lighting, Ignition, Welding, Vulcanizing, etc.—Everything you need to get in line for a big money job as an Electrical and Mechanical Auto Expert.

It's the trained man who gets the good jobs and "Job-Way" Training is COMPLETE yet so simple, so easy that you get it quick.

Send Coupon for FREE Auto Book

Get my FREE Auto Book. Learn how "Job-Way" Training has brought success to hundreds. See what it can do for you. Find out how my Employment Department helps you get a good job—about the three big outfits you get. Read my money-back agreement, my aviation course offer and many other features.

B. W. Cooke, Directing Engineer
Motor Institute of America
Motor Institute Bldg. Dept. 9168
EVANSTON, ILLINOIS
(Chicago's Largest Suburb)



Do It NOW!

Don't delay another day. Clip the coupon before you turn this page. Take the first step to a big-pay auto job. Now.

**B. W. Cooke, Directing Engineer,
MOTOR INSTITUTE OF AMERICA,
Motor Institute Bldg., Dept. 9168, Evanston, Ill.**

Send me your free auto book. I want to succeed in the auto business. Tell me about "Job-Way" Training—about your Employment Department and your 3 testing and repair outfits offer. No obligation on my part whatever.

Name.....
Address.....
Town..... State.....
Age..... Occupation.....

**Don't Say You Never
Had a Chance to
Get an Education!**

Here's Your Chance!

The Quickest, Surest, Easiest Way

Don't hobble along through life taking the short end of things and letting other men get the good jobs, the comforts and pleasures of life, away from you just because they have the advantage of education! You can have as good an education as they—quickly and easily—and you don't have to go to high school or college for it! More money, power, popularity are at your command just as soon as you give yourself the education that wins them. *And here's the quickest, easiest way—*

**A Liberal Education for You
In One Fascinating Volume**

Here is the knowledge that gives real education—all organized in a single volume. It is really SIX books in ONE offering in simple, clear, fascinating style the understanding you need of *History, Science, Literature, Art, Philosophy, Religion*—the six great branches of knowledge, an understanding of which will give you the education that brings **SUCCESS** and **LEADERSHIP**. Here is the easiest, the most practical, the most interesting method of self-education as thousands of men already have found out—all in this one famous book—



The Outline of Man's Knowledge

Written by Clement Wood with such success that the Pittsburgh *Sun-Telegraph* calls it "A University in itself"; and the Philadelphia *Public Ledger* says it is "The ONE book to read and know." Here is the whole scope of modern education in one thrilling narrative of 700 sparkling pages—the cream of the world's knowledge for quick and easy self-improvement.

Read It FREE

Here is a remarkable opportunity to secure this thrilling book without cost or obligation for a week's free examination. Send no money. The coupon below will bring your copy of the book. If you are not convinced that it is the biggest value for the money you have ever seen, send the book back and owe nothing. If you decide to keep it, pay the remarkably low price on the easy terms shown in the coupon. Don't delay.

**Mail This
Coupon Today**

LEWIS COPELAND COMPANY, Dept. 538
119 West 57th St., New York City

Kindly send me THE OUTLINE OF MAN'S KNOWLEDGE, by Clement Wood, 700 pages, illustrated, handsomely bound. Within 7 days I will either return the book or remit \$1.50 as first payment, and then \$2.00 per month for two months, a total of \$5.50. (Ten per cent discount for cash with order. Same return privilege.)

Name.....

Address.....

City..... State.....

If outside continental U. S., send \$5.50 with order

AUTO REPAIRMEN EARN GREATER PROFITS

Get your share of the big money being spent on automobile upkeep.

Put improved time, labor and money-saving ideas to work in your shop to-day. Take advantage of our special bargain offer and secure 3 valuable kink books at a reduced price.

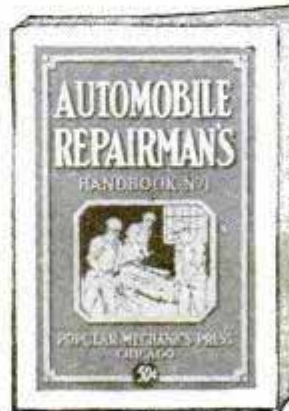

1. 334 Valuable Discoveries made by auto mechanics in our **Automobile Repairman's Handbook**. 337 Illustrations.

2. 301 Ways to use drills, drill presses, taps and dies more effectively in our **Drilling and Thread Cutting Handbook**. 298 Illustrations.

3. 259 Kinks furnished by the most expert Lathe Operators in our **Lathe Handbook**. 212 Illustrations.

Special Offer—These 3 books (regular price 50 cents each, \$1.50 value) are offered for a limited time for only 98 cents plus postage. Pay postman C. O. D. when he delivers or if outside U. S. send 98 cents and 15 cents extra for postage.



POPULAR MECHANICS PRESS

Room P 11

200 E. Ontario St.

CHICAGO

Build a BOAT How to Make 14 Kinds

If you want a boat, you can save several dollars by making it yourself. Or you can pick up money on the side making boats for your friends. Besides you'll have barrels of fun. Everything is made so simple and easy in Popular Mechanics Boat Book. Complete and simple directions and necessary illustrations for building these boats and canoes:

Rowboat suitable for outboard motor, Canoe, Whiz (14-ft. step hydroplane), Portable Canvas Boat, Fast 19-ft. Runabout Motorboat, Cabin Scow driven by auto engine, Long Island Scooter with aero-propeller, Portable Folding Boat, Convertible House Boat and Camp, Sea-Gull (sailing boat), Pile-Driver Punt, Inexpensive Motor Boat, Power-Driven Catamaran, Fishing Sleigh and Boat. In addition there are valuable instructions for caulking, repairing, painting and making boats watertight, also articles on picking your canoe, handling and fitting outboard motors, laying up for winter and making a boat trailer and boathouse for small canoe club.

This book, together with its companion, Outdoor Sports (containing hundreds of practical plans and ideas on sports, games, tours and camping), will be sent to you C. O. D. if you live anywhere in the U. S.

Just send a note saying you want the Boat Book and Outdoor Sports. When they arrive, pay postman \$1.98 and the postage. If outside the U. S. when ordering and include 15 cents extra for postage.

POPULAR MECHANICS PRESS

Room P11, 200 E. Ontario Street, CHICAGO, ILL.

**Build
Your
Own
Boat**



Be A RADIO Expert



Seldom Under \$100 a Week

"My earnings in Radio are many times greater than I ever anticipated they would be when I enrolled. They seldom fall under \$100 a week. My profits for the past three months were \$577, \$645, \$465. If your course cost 4 or 5 times more I would still consider it a good investment. You give a man more for his money than anybody else."

E. E. WINBORNE,
1414 W. 48th St., Norfolk, Va.



Making \$400 a Month

"I really believe that every man should take your course in Radio. If he has anything in him at all there is every chance for him to get some place. The field hasn't been scratched and it is getting bigger and better every day. A man just can't go wrong. I was making good money but could see the opportunities in Radio. Believe me, I am not sorry, as I have made more money than ever before. I have made more than \$400 each month."

J. G. DAHLSTEAD,
1484 So. 15th St., Salt Lake City, Utah.

Many make \$50 to \$200 a week

I GIVE YOU THE RADIO PARTS FOR A HOME EXPERIMENTAL LABORATORY

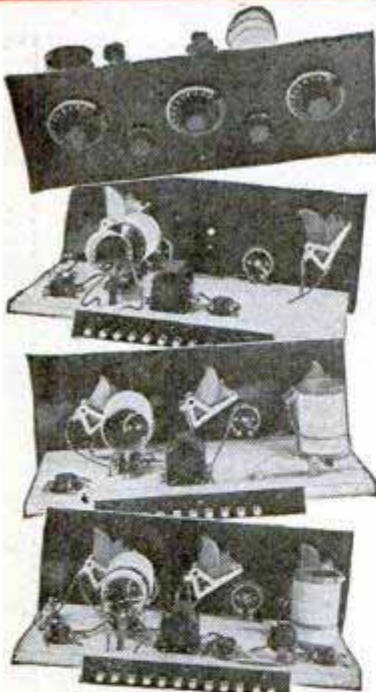

WITH THEM YOU CAN BUILD 100 CIRCUITS. 4 YOU BUILD ARE SHOWN HERE MY BOOK EXPLAINS THIS PRACTICAL, FASCINATING WAY OF LEARNING RADIO AT HOME

This is Radio's Biggest Year

Don't slave your life away for \$25, \$35 and \$40 a week in a no-future job. You're foolish to be satisfied with less than \$50, \$60 or \$75 a week for more than the short time it takes to get ready for Radio. That is what the good Radio jobs pay. And \$50 to \$75 a week is only the beginning. Many lead to as high as \$200 to \$250 a week.

Big Growth Making Hundreds of Fine Jobs Yearly

Over 300,000 jobs have already been made by Radio's amazing growth. It continues to grow and expand fast. This big growth can put you ahead fast. I have doubled and tripled salaries. I have shown hundreds how to make much more money in Radio than they were making in other fields. Let me show you what I can do for you.

Many Make \$5 to \$25 Extra A Week Almost at Once

The day you start I will show you how to do 10 Radio jobs most common in every neighborhood so you can begin making extra money. Frank Golden, 329 Walnut St., Newark, N. J., says, "I made over \$900 in my spare time in about 10 months." This is the world-famous course that pays for itself.

I Will Train You at Home In Your Spare Time

Hold your job. My 50-50 method of training—one-half from lesson books and one-half from practical experiments using Six Big Outfits of Parts given without extra charge, makes learning at home easy, fascinating. It is unequalled. It gives you practical Radio

experience while learning. You don't have to be a high school or college graduate. Many of my most successful graduates didn't finish the grades.

Your Money Back if Not Satisfied

My training is right up-to-the-minute with Radio's latest developments. Television, Talking Movies, Radio in Aviation, Screen Grid Tubes, A.C. Sets are included. It fits you for Radio factories, broadcasting stations, a spare-time or full-time business of your own, operating on board ship which gives you world-wide travel without expense, commercial land stations, research laboratories and many more branches. Every penny will be returned if after completion you are not satisfied with the lessons and instruction service.

FREE Book Tells What Radio Offers You

"Rich Rewards in Radio" gives you the facts about Radio, what your prospects are for the future, how you can get in without delay, what you can make. It explains our lifetime Employment Service after graduation and many other fine features. Get a copy AT ONCE.

J. E. SMITH, Pres.,
Dept. 9YPP
National Radio Institute
Washington, D.C.

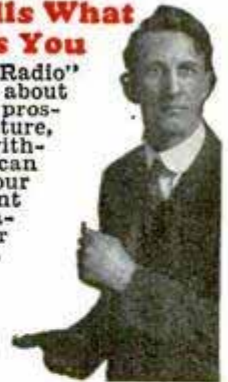

J. E. SMITH

Jumps From \$35 to \$100 a Week



"It is certainly great sport to do Radio work and a profitable one too. I had the pleasure of earning \$110 last week servicing and selling sets. I have made as high as \$241 in two weeks. Before I entered Radio I was making \$35 a week. You started me off on the right foot by giving me the knowledge every man should have to succeed in Radio."

J. A. VAUGHN,
4202 Arsenal St., St. Louis, Mo.

Mail this Coupon at Once

J. E. Smith, President,
National Radio Institute,
Dept. 9YPP
Washington, D. C.

Dear Mr. Smith: Without obligating me, send "Rich Rewards in Radio," your book on Radio's opportunities for big success.

Name _____
Address _____ Age _____
City _____ State _____



3373

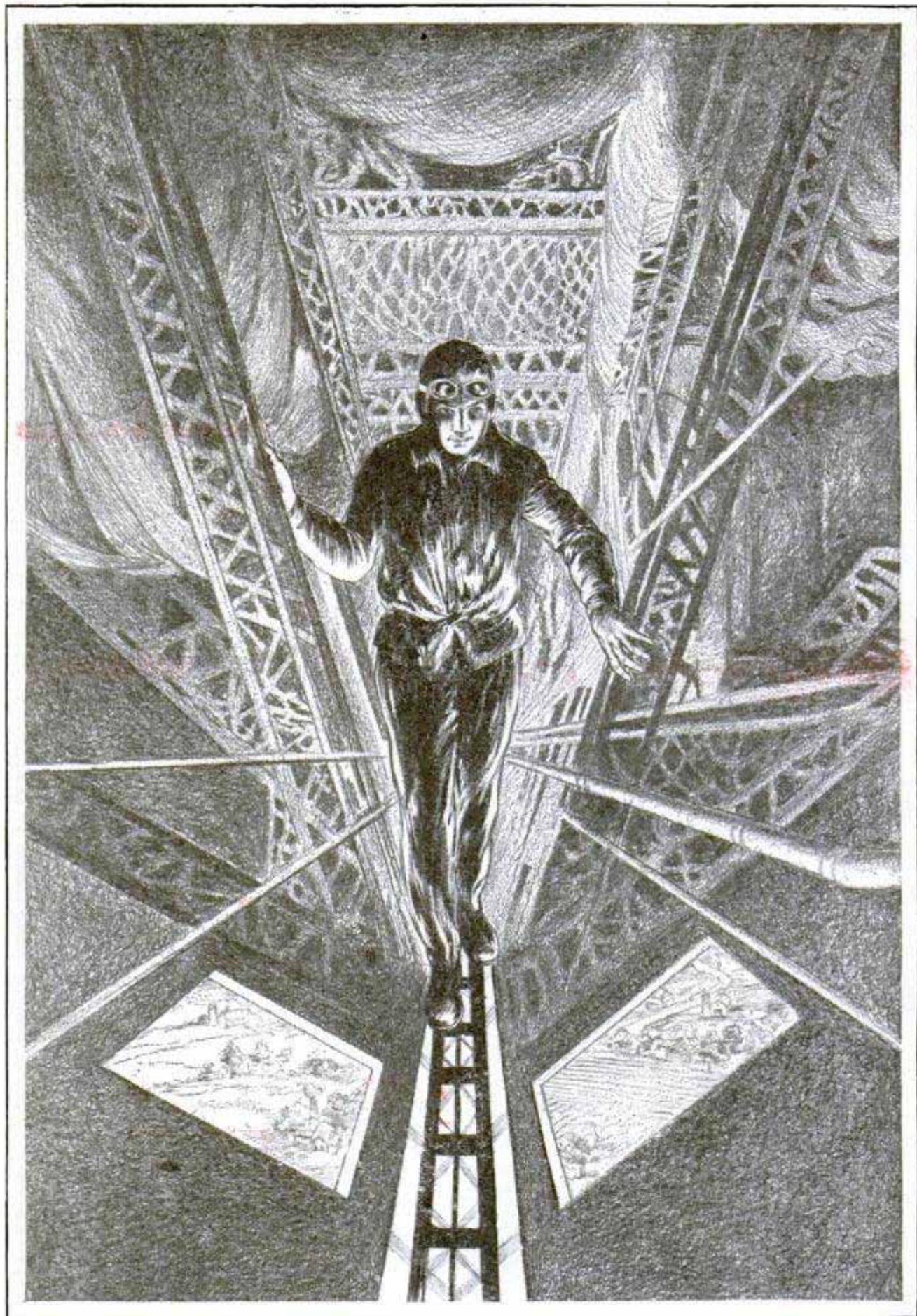

A Drawing Depicting a Member of the Crew of the Zeppelin on the Catwalk Leading through the Inside of the Dirigible to the Various Quarters and Compartments—See Page 738

Henry Miller News Picture Service
519-13 1/2 St. N.W.
Washington D.C.

Popular Mechanics Magazine

REGISTERED IN U. S. PATENT OFFICE

WRITTEN SO YOU CAN UNDERSTAND IT

Vol. 52

NOVEMBER, 1929

No. 5

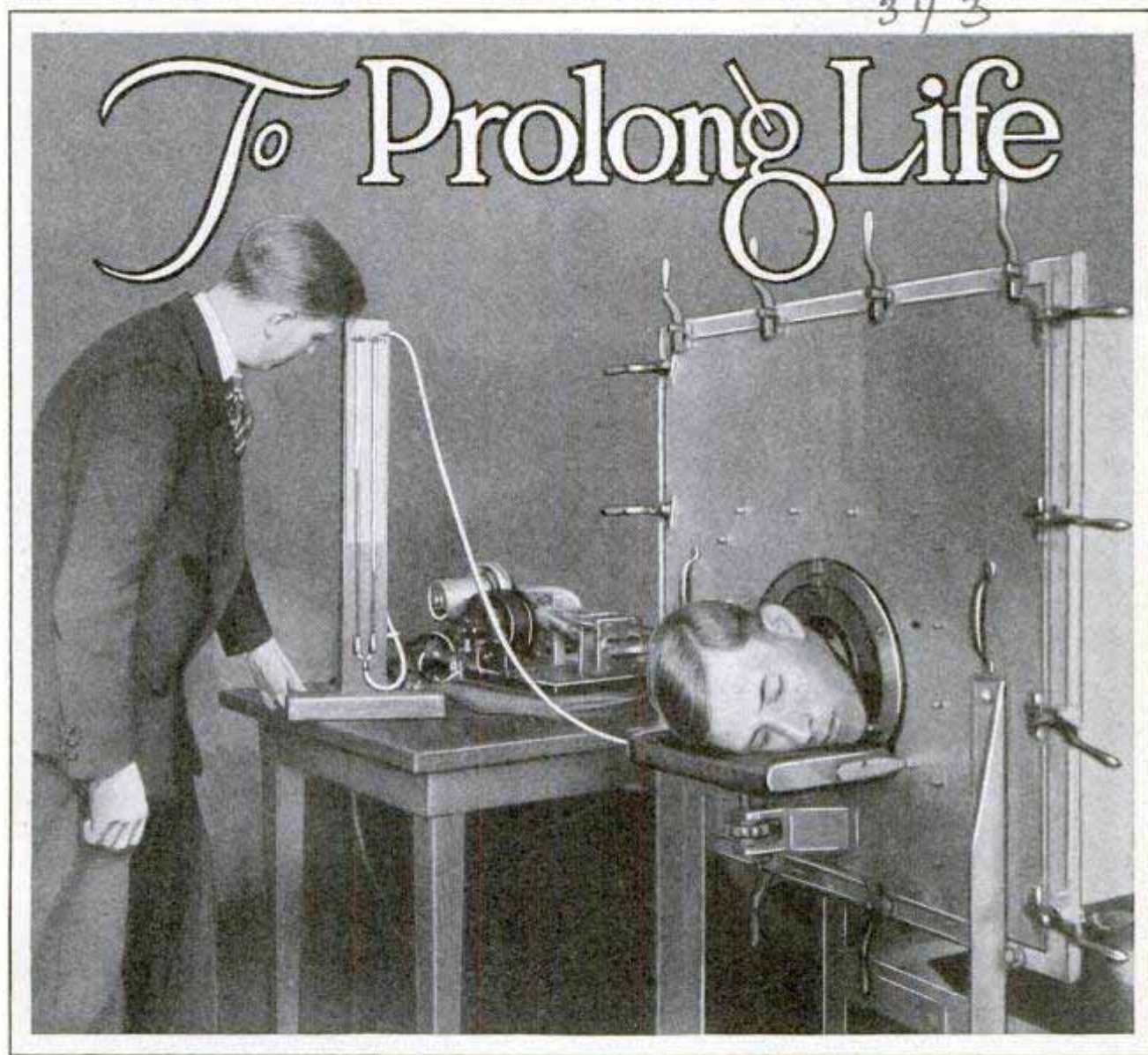

A Mechanical Breather, in Which the Patient Is Sealed and by Means of Positive and Negative Pressure Is Forced to Breathe, Even Though Asleep; the Tube Connects to a Blood-Pressure Gauge

By ANTHONY WAYNE

MEDICAL science is finding in mechanical contrivances a close and useful ally in the saving of life. When, through accident and disease, it is impossible to breathe properly, to sleep or eat, the mechanically inclined physicians have stepped forward with new inventions that will save many lives and make for health.

The new science of mechanical aids for man is based on the theory that the body is made up of many parts even as the automobile is put together by the use

of bolts, rings, valves and other devices. Suppose the heart fails. If injections are given to prevent blood coagulation, adrenalin, a powerful stimulant, will force the heart to function again. Without such injections, the individual must certainly be considered dead, and not many years ago would have been gone past recovery. Now he may live again.

The new science says that even if a man stops breathing in a normal way, he may be aided to keep on living. The

W. H. Vincent Wilcox
International Bldg
705

343
706

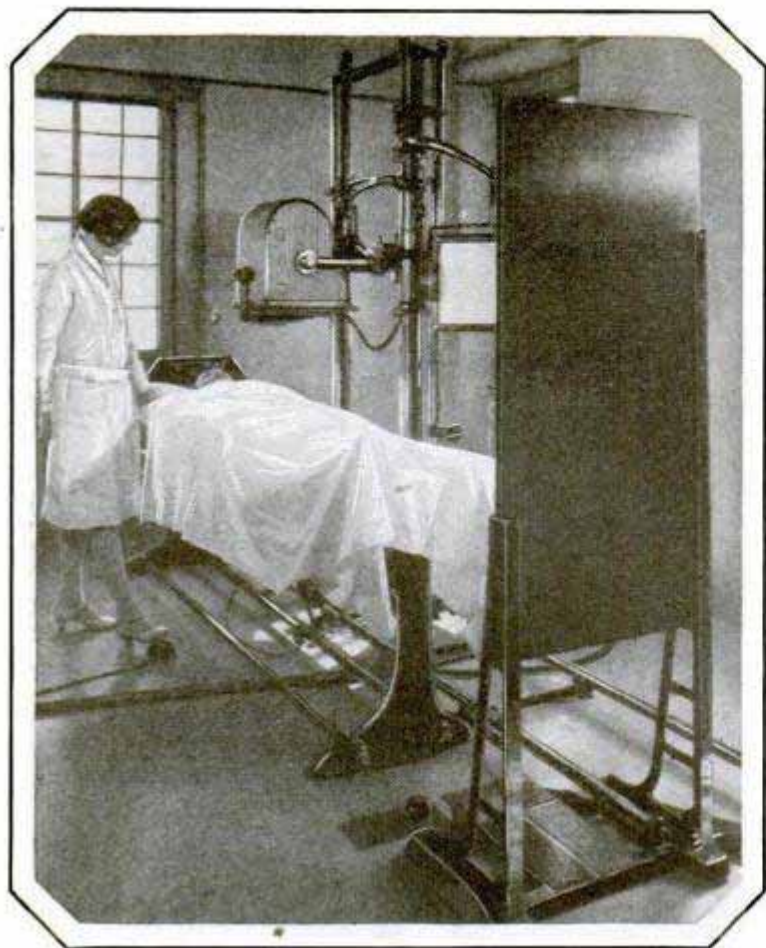

An Oil-Immersed X-Ray Apparatus Gives Protection from Shock and Its Capacity of Helping People Is Increased

principle is the same as with the loss of a spark plug in a machine or the short-circuiting of the ignition system. The whole automobile is not discarded nor is it necessarily worn out.

Not long ago Dr. O. S. Gibbs, of Dalhousie University, was able to keep cats alive over long periods with a rubber pump substituted for a heart. If the lack of a true heart can be considered as death, then certainly these cats were dead although they were capable of movement. Their artificial hearts worked as well as the hearts which nature gave them.

In Bellevue hospital, New York, there has recently been installed a machine that supplies the necessary stimulus to the individual who needs help in breathing. The manual system of producing artificial respiration has done wonders, but the latest apparatus for this purpose will do much more and revive many who might certainly have been considered dead according to past experience. The method is specially applicable in cases of electric shock, concussion, gas poisoning, smoke or drowning and industrial accidents.

In this, the newest of the artificial aids developed for man, the patient is placed in a hermetically sealed tube, his head protruding through an air-tight rubber collar. Respiration is brought about by rhythmically increasing and decreasing the pressure in the chamber. The degree of pressure can be closely watched and the change and the temperature in the cabinet may be controlled from the outside. A blood-pressure gauge also is used. If oxygen is to be given, a hood is placed over the individual's head. By such purely mechanical means is restoration to normal conditions possible.

Recently, Dr. S. S. Brunkhanenko was able to revive a detached dog's head by supplying it with an artificial heart, with a blood substitute composed of salts of blood and adrenalin. "The severed head opened its eyes, rejected acids with the tongue and swallowed a piece of cheese laid on the tongue. For more than

three hours every test showed that the dog's head was alive," the doctor stated. This is along the same line as the method used to make a frog's leg muscles move by means of the application of a high-voltage electric current. The nerves are still capable of reacting to the stimulus, even though the animal ceases to function as a whole.

The mechanical respirator, which was perfected by Philip Drinker and Louis A. Shaw, of Harvard University, is so designed that the patient lies on a mattress placed on a trunk which is attached to the lid of the tank. The head and neck extend through a rubber collar. The lid and trunk of the tank can be quickly pulled in and out with ease to permit occasional examination.

By means of electrically driven blowers, alternate positive and negative pressures are applied. A little girl was placed in the mechanical breather because certain of her muscles were paralyzed, and her life was preserved although ordinarily she could have lived but a few hours. In this strange machine she lived and even slept.

Continued (in Sept. 1929)

SEISMOGRAPHS TO HELP BETTER HIGHWAYS

3440

To study the effects of passing vehicles on roads of various kinds, a western company has installed a number of seismographs, ordinarily employed to register earthquakes along the highways. The instruments are said to record simultaneously the extent of the vertical and horizontal earth movements, thus furnishing important data to help in determining the best sort of road surface for long wear under operating conditions. Seismographs were used during the war to determine the range of enemy batteries.

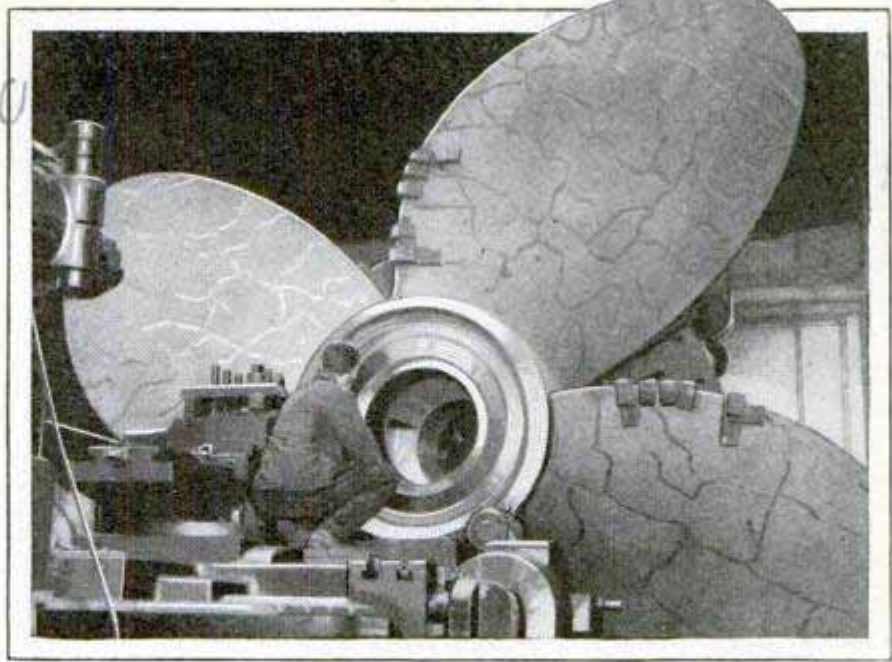

Twenty-Ton Bronze Propeller for the "Empress of Japan"; Figure of Man Emphasizes Its Enormous Size

BIG SHIP'S BRONZE PROPELLER WEIGHS TWENTY TONS

What is said to be the largest bronze propeller in the world has been made for the new Canadian Pacific liner "Empress of Japan." It weighs twenty tons and required a cast weighing fifteen tons more during its construction.

MINIATURE PLANES ON WHEELS FOR CHILDREN'S CONTEST

3446

Children of France are becoming air-minded, and engaging in airplane races on the beach at La Baule is their latest sport. Miniature planes mounted on three wheels, two forward and one at the tail, provide the craft for the contestants and pedals furnish the power.



French Children Race in These "Airplanes" Equipped with Three Wheels, While Pedals Furnish the Motive Power

SPRAYER DRIES FOOD EXTRACTS

3456

Drying fruit juices, milk and milk products, chocolate, margarine, beverage extracts and rubber latex is accomplished with an atomizer made by a Danish concern. The atomizer is adjustable for thin or thick liquids and is capable of producing uniform particles of large or small size. Evaporation from such particles is extremely rapid, which means that the moist product is subjected to heat for a shorter period, giving quick desiccation at a low temperature, so that none of the products to be dried is damaged. The process retains the vitamine content.

W. S. Lyngbyvej, Hurs, Sted, 11

Denmark

California Condor
San Diego Calif

Volado
Ohio

3444

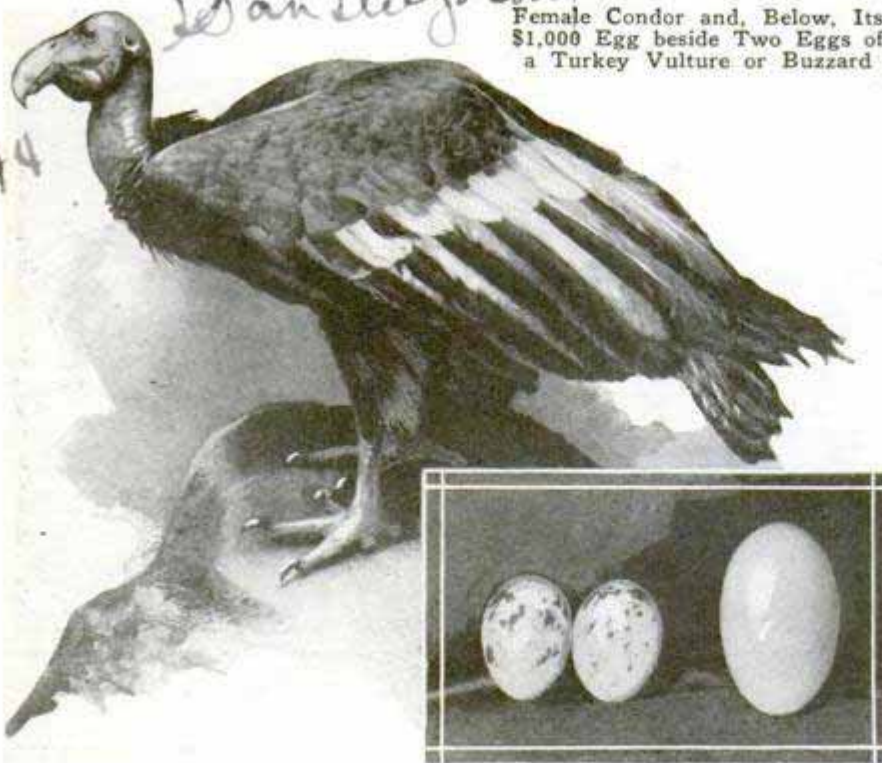

Female Condor and, Below, Its \$1,000 Egg beside Two Eggs of a Turkey Vulture or Buzzard

year, occasionally only one egg every two years, and the young birds remain for two or three years with their parents. The nest is a mere hollow, scooped in the sand and dust of the floor of some inaccessible cave in the face of a cliff far back in the mountains. Distance and time are of no importance to birds of such power and speed of flight, so that the nest is often fifty to one hundred miles from the feeding grounds. The condor egg is approximately four and one-half inches long by two and one-half inches in diameter at the widest part,

YOUTH FIGHTS CONDOR TO WIN THOUSAND-DOLLAR EGG

An egg of the almost extinct California condor has been found in a cave some fifty miles back of Ensenada, Lower California, by Carlos R. Lume, a young hunter and trapper. This egg, valued at \$1,000 in cash, or \$2,000 in exchange for other zoological specimens, is the fifteenth known to be in museums and private collections, and the first to be collected since 1915. Lume battled more than an hour with the two parent condors before he was able to escape with the egg. The California condor is the largest of the vultures, and also the largest bird that flies, individuals having been taken which exceeded in size the condor of the Andes, supposed to have been the original of the fabled Roc. The wingspread of the California condor is eight and one-half to nine and one-half feet, and the weight from forty-five to sixty pounds. In spite of its great size, the speed of the condor is estimated at sixty miles an hour, and the soaring range at 3,000 to 4,000 feet, whence, naturalists believe, the great vulture discovers its food by sight rather than by smell. Ornithologists assert that California condors do not mate until they are four years old and remain mated for life. Each pair produces but one egg a

equal-ended and olive-drab in color, paling in some instances almost to white.

LIGHTER STRIKES LIKE A MATCH SAVING WEAR ON THUMB

Springs, wheels and other units are not necessary on a cigar lighter operated like a match. A scratcher pin near the wick is drawn across a flint just as a match is ignited on a box. The lighter is then used, put back in the holder and is ready for another operation. A light, quick stroke ignites the wick, and there is nothing to get out of order.

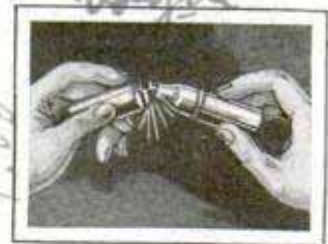

ACIDS MADE FROM SAWDUST

Acetic acid, the active principle in vinegar, and lactic acid, the substance that makes milk sour, have been prepared from sawdust and the process promises commercial returns, chemists at the recent meeting of the American Chemical society were told. The sawdust is first turned into sugar, then treated with a substance contained in malt sprouts and the acid is obtained by adding a micro-organism that ferments the sugars.

Prof. W. H. Peterson
R. J. Algerier
all

3443
Blade for spray
445
never used

University of Wisconsin

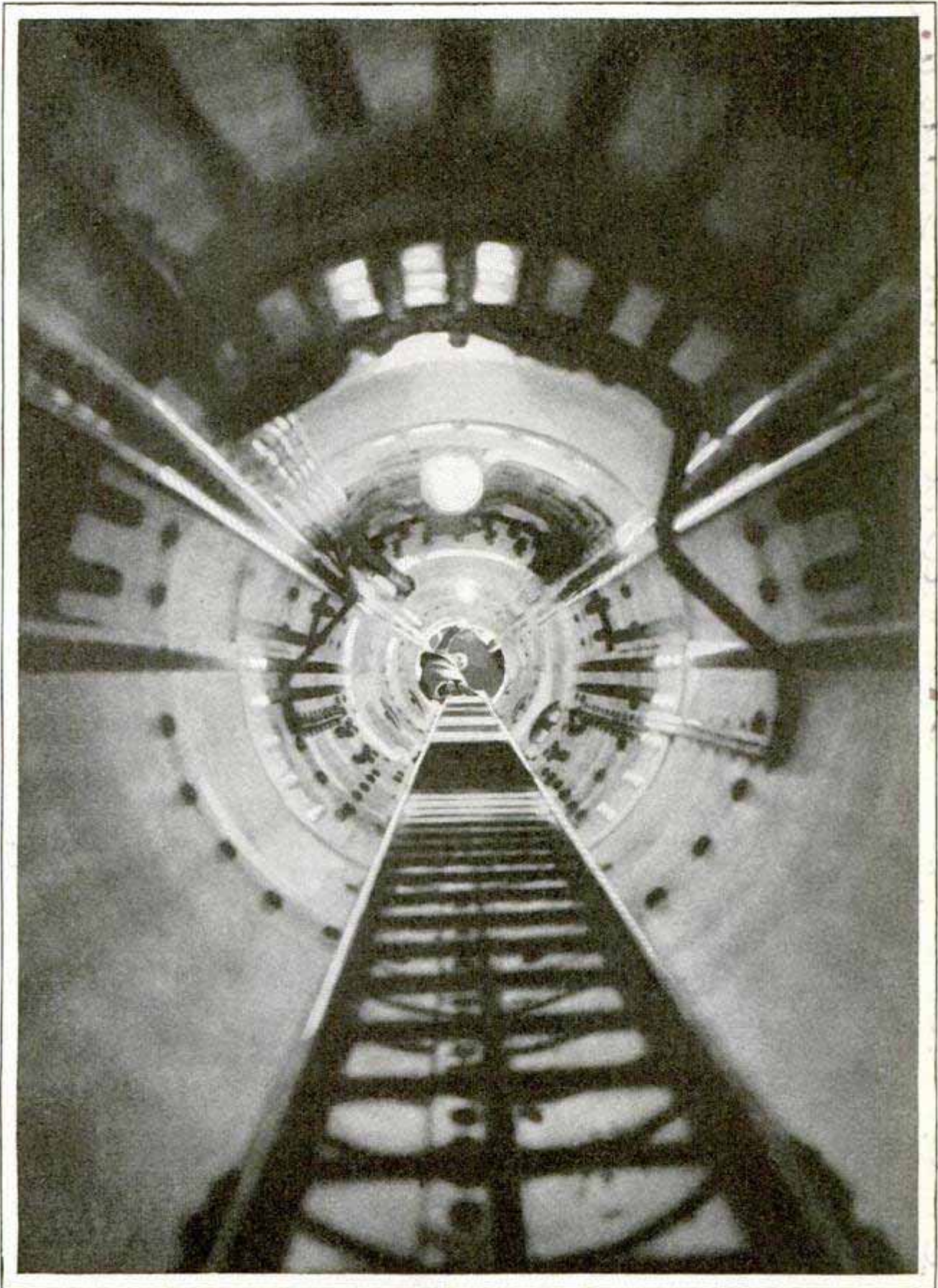
P. 241 8/10/29
"LOOKING-UPWARD" VIEW AT LINER'S CROW'S NEST

Looking Upward inside the Hollow Mast of the German Liner, "Bremen," Which Set a Transatlantic Speed Record; At the Top Is the Crow's Nest Reached by the Ladder inside the Mast; the Hollow Mast Enables the Lookout to Reach the Crow's Nest without Being Exposed to the Elements, and in Some Ships They Also Are Employed as Ventilating Shafts or to House Engine-Room Exhaust Vents

Boeing Engine

*any R. Cousins
A.M.T.C.E.
M.T.A.E.*



One Engine and Part of the Cabin of an Eighteen-Passenger Plane to Be Used on the Chicago-San Francisco Route

EIGHTEEN-PASSENGER PLANE WEIGHS OVER EIGHT TONS

One of the largest commercial airplanes ever produced in the United States is the Boeing tri-motored eighteen-passenger transport, which will follow a twenty-hour schedule from the Golden Gate to Chicago. Twelve similar ships are being built to be placed in this service. They have a wing span of eighty feet, weigh eight and one-half tons when fully loaded, are more than fifteen feet high and can carry a ton and a half of fuel.

CURRENT CONTROL ON BULBS TO CUT LIGHT BILLS

Electricity is "rationed" to the light bulbs in sufficient amount to keep them running at full efficiency while preventing waste of current, by means of an auto-

matic temperature control being tested in England. These are the claims for the unit, and reports of an actual test in London stated that the control apparatus effected a saving of more than twenty-eight per cent in current without any decrease in light, over bulbs not so equipped. Just as an electric range is not run for long at full heat, the current being turned down when the oven has been warmed sufficiently, so the new bulb device cuts down the supply, allowing just enough to keep the lights burning with full strength. It is a well-known fact that only a fraction of the current passing the meter is converted into light.

LION'S HEAD IS PICTURED IN STAMPS

Using only postage stamps for his materials, a French painter has made a life-size picture of a lion's head. Stamps of many different countries were used and 3,000 hours were required to complete the picture, which contains 50,000 stamps.



The Picture of the Lion's Head Was Made from 50,000 Postage Stamps of Different Countries

*Boeing Airplane Co. Boeing
Georgebeton Station, Wash. D.C.
Cant A.C. Packard
Vaneuil Square
Trancions, London W.1
449
Peldorine
Isolder Larry Road
11/21/23*

N. F. Fieret

McPherson

DIAMONDS MADE FROM CARBON AND METAL

Greater success in the production of synthetic diamonds is reported from McPherson College, where Prof. J. Willard Hershey, applying methods that were originated about thirty years ago and developing new ones, has made what he believes are the largest synthetic diamonds on record. He melts pure carbon with the filings of various metals in an electric furnace, then plunges the white-hot mass into an ice-cold saturated salt solution. The cooled material is treated further with chemicals and tested for diamond particles. Doctor Hershey believes that "the difficulties preventing preparation of large and beautiful stones are only technical."

ARMY SHOES AS FLOWERPOTS FEATURE NOVEL GARDEN

An English gardener has added a novel touch to his landscaping by reproducing



Gardener Tending His Old-Shoe Plantings; the Shoes Make Good Substitutes for Ordinary Flowerpots

scenes from the surrounding country in miniature. He also makes use of old army shoes to grow some kinds of flowers. The discarded shoes are partly filled with earth and employed as pots. They have the advantage of being unbreakable and the leather retains moisture for a long time.

H. Hatfield near Steyning



Servicing Tri-Motor Plane from the Special Truck Equipped with Electric Pump and Air Compressor for Inflating Tires

PLANE-SERVICE TRUCK FILLS TANKS BY MOTOR PUMP

Electricity replaces hand power in a service station on wheels to refuel airplanes. At a touch of a button on the dash control, gasoline is pumped into the airplane's tank at the rate of thirty gallons a minute. The truck holds 1,150 gallons of fuel and the pump is operated from storage batteries charged by a generator, run from a power take-off from the drive shaft. The outfit was developed especially for aviation purposes, and one of its earliest applications was in filling the plane that tended the "Question Mark" during its historic endurance flight.

FLAME FROM ALUMINUM DUST HOTTER THAN GAS

By employing powdered aluminum instead of hydrogen or acetylene gas, Dr. Frank M. Strong, of Syracuse University has produced a flame so hot that it will melt its way through any known solid when used in a blowpipe. The dust is fed from the bottom of a hopper by means of a screw conveyor. At the end of a brass pipe, it is met by a swift cross stream of oxygen. After being ignited, the two produce an intensely hot flame because free oxygen is yielded rapidly and the heat is concentrated on a small area.

☐ Slightly underripe fruits make the best pickles, Cornell experts advise.

Cleveland, Ohio

Ward by Richfield Bldg Los Angeles

Electric Service

Ohio

3250

Nursemaiding

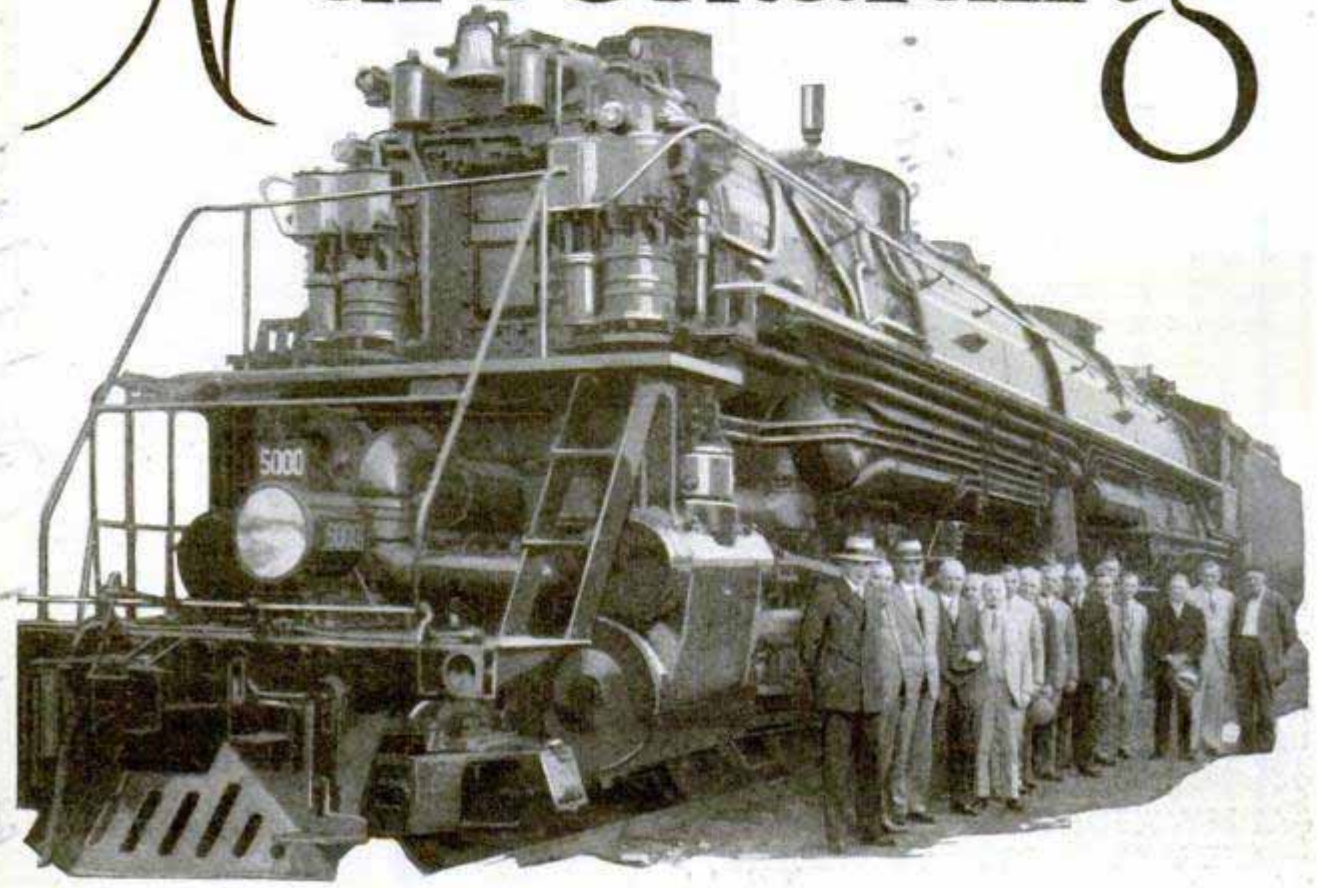

Officials of the Northern Pacific Railway and Associates with No. 5000, Gigantic Steam Locomotive Which Is 125 Feet Long and Operates between Glendive, Mont., and Mandan, N. D.

By EARL CHAPIN MAY *Sharon, Conn*

A GROUP of firemen and engineers were swapping stories of trouble met while on the line.

"I was running a fast eastbound passenger," one volunteered, "and was just coming into Westboro, Mass. The station platform was filled with people and my engine was shooting past when my right side rod broke. Before I could slap on the air, the left rod buckled and snapped off the main pin. Both sides of that engine were sure torn up."

"What happened then?" inquired a bystander.

"Oh, nothing much," the big fellow replied. "I just stayed with the engine on the track until an engine from a local freight dragged me onto a siding and then took my train into Boston. After that the wrecking crew turned up."

"About the only trouble I have these days," chimed in another locomotive cap-

tain, "is when my driving wheels slip going up a grade. These darned new engines are so heavy they spin on wet rails in spite of sand, until I cut in my booster engine."

"Why don't you send for a wrecker, Joe?" a veteran demanded. "About all you youngsters seem to know is to holler for help from the wrecking crew. When I began handling an engine throttle I was taught to take care of it myself. I carried the tools to do it, too. About all you fellows take out with you is a monkey wrench and a pick."

"That's about right," the first speaker admitted, "but we can't be experts on all the jewelry on the latest model locomotive—and carry a machine shop with us, too."

"Superintendents of motive power, master mechanics and their men are just naturally nursemaiding our iron horses,"

*used on first engine
Darlington. Stockton 1825*

the Iron Horses

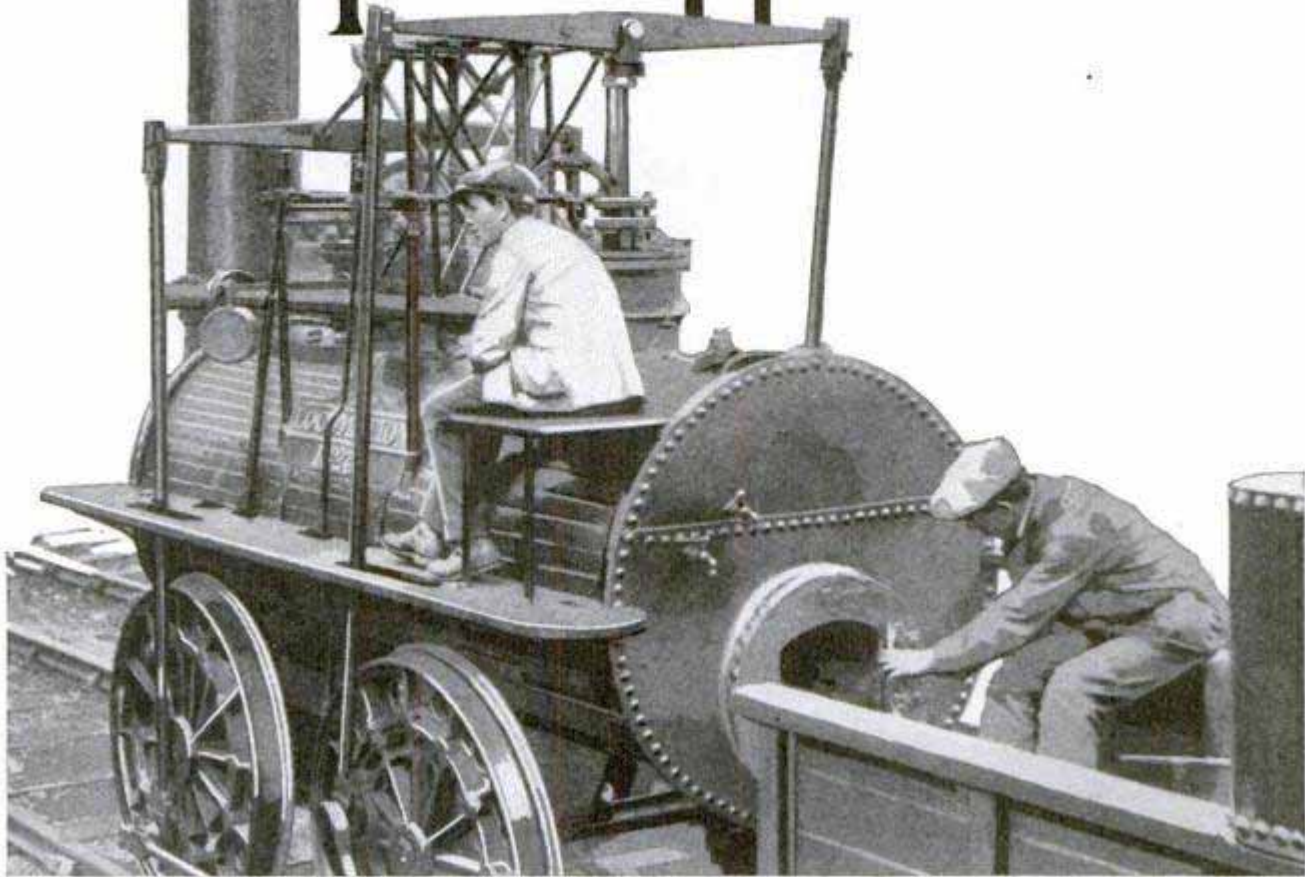

Historically Important in British Railroading, the Locomotive No. 1, Built by George Stephenson in 1825; the Engineer Had an Outdoor Seat on the Left Side, While the Fireman Rode in the Tender

added another denim-clad engineman. "That's why they get so much service out of engines—through modern methods of handling them."

The last speaker voiced a principle of the policy prevailing on all Class-1 railroads. This policy is in sharp contrast to that pursued years ago. Then engine crews wrestled with breakdowns while passengers paced around the stalled train impatiently. Enginemen in charge of railroad motive power now are expected to "take it out and bring it in again." Because of the increasing intricacy of steam engines, their crews have much more responsibility than did the enginemen of twenty or forty years ago, but they operate on a much larger margin of safety. For most of the trouble shooting is done by shopmen before the engines leave the terminal.

Twenty years ago a first-class passenger engine weighed in the neighborhood of

190,000 pounds and cost approximately \$30,000, while the best freight engines of that period cost a little more and weighed about 215,000 pounds. Today the famous Hudson type of motive-power unit weighs 351,000 pounds, and a Mohawk or Berkshire type of freight engine weighs 15,000 pounds more. Each costs about \$90,000. These weights are exclusive of the tender.

Once these great iron horses have been completed, and accepted after road tests by traveling or foreman engineers, they go into service. But after fifteen days of hauling freight or passenger trains on schedule, they go back into the shops for a "washout." A washout on the line is an accident which may result in a disaster. Invariably it is expensive. A washout in the shops is plain insurance, through maintenance of maximum pulling power.

There are seven distinct operations in an engine terminal washout. Not only is the boiler cleared of sediment by running

3250714

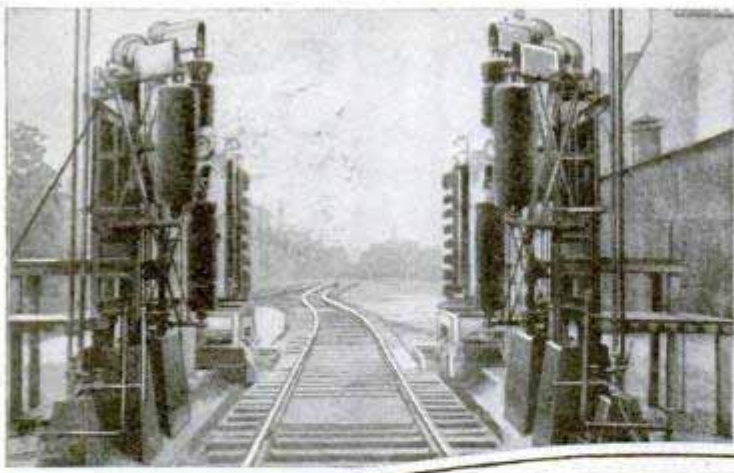

dered coal through the mechanical stoker are held by hook bolts. If the bolts are loose they must be tightened, if the jets are worn they must be renewed. At the same time the stoker's distributing plate is examined and must be replaced if it has been burned. The front end of each main rod, running from the pistons to the driving wheels, must be taken down and the rod examined with a magnifying mirror for checks,

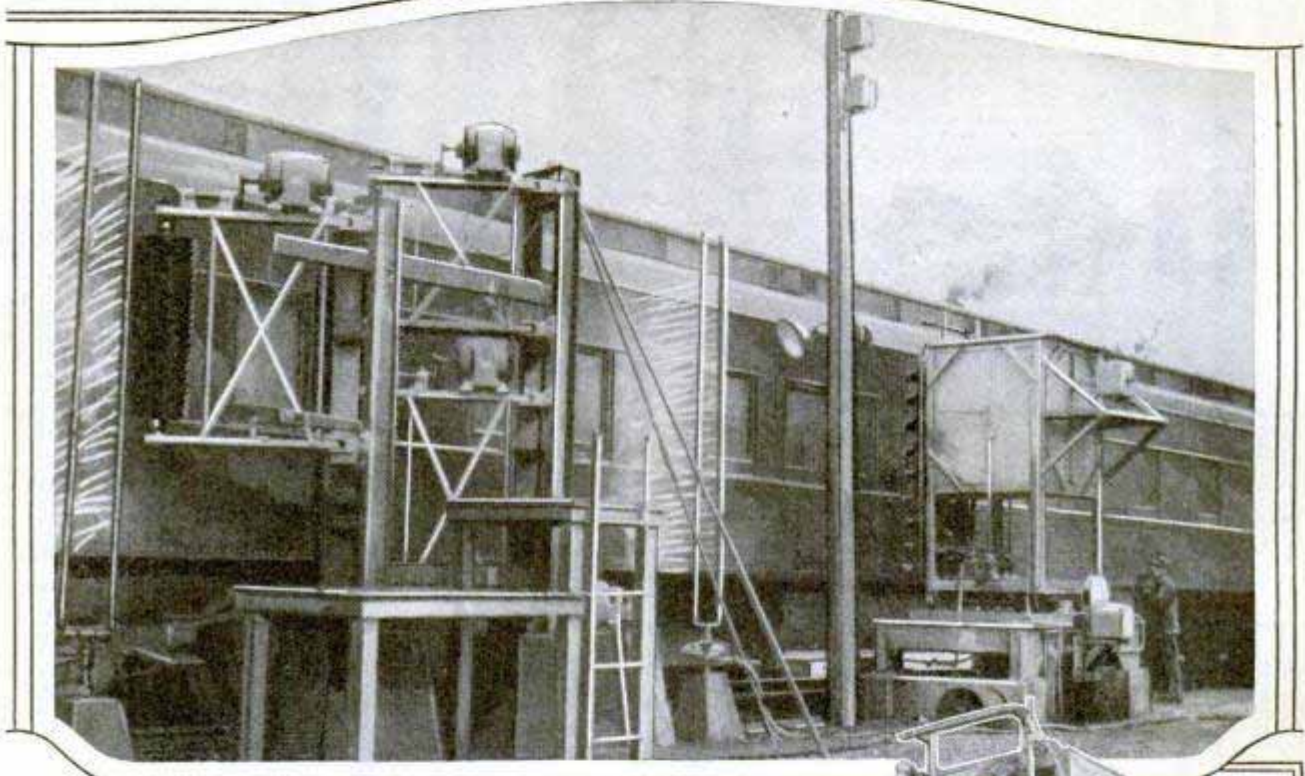

warm water from the top of the boiler out through the mud ring at the bottom, thus avoiding inside "blistering," but strainers, feed-water lines, tank valves and tank are cleaned. The cold-water sprinkler inside the tank and tender, and all pipe connections with that tank, are tested and examined carefully. The exhaust nozzle on the little booster engine, which acts as an accelerator when an engine starts or has trouble with a heavy load going over a hilltop, is cleared of accumulated dust or grease. The exhaust-nozzle bridge, which splits the forced draft in the smoke box and thus increases temperature, is renewed, if necessary, that is, if it is worn and hence does not function properly.

The air jets which distribute the pow-

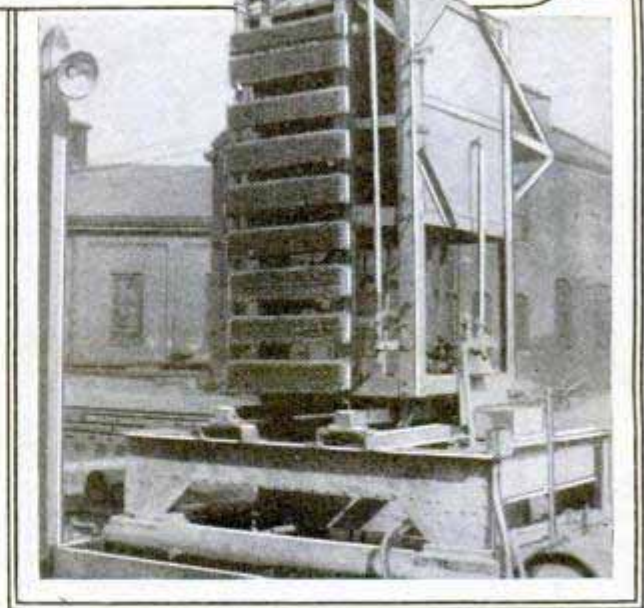

Views of a Modern Car-Scrubbing Installation, Showing, from Top to Bottom, the Brushes, Water Jets and Oxalic-Acid Pipes

Developed by Baltimore and Ohio

cracks or other evidences of weakness. Grease compound must be applied to the rods before they are again put in place. The three-piece brasses on the bearing surfaces of the main rods must be examined, binders tightened and shoes and

Replica of Rocket Locomotive of 100 Years Ago beside Modern British Engine

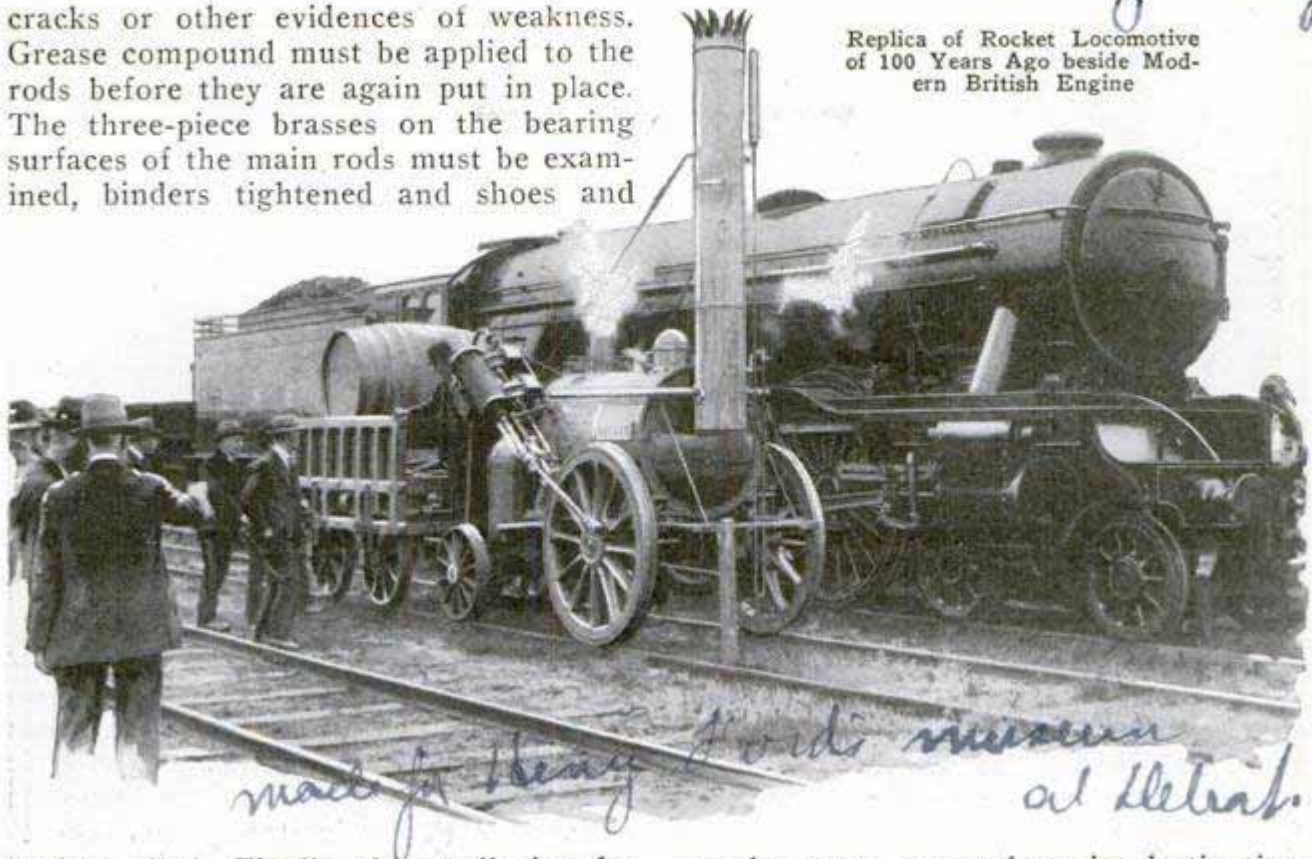

wedges oiled. Finally, the small pipe descending from the boiler top to within three inches of the crown sheet of the fire-box must be cleaned, because, when water gets low enough in the boiler to expose the bottom of that pipe, steam rushes up it and blows a whistle. This low-water alarm tells the engineer to start his pumps before the crown sheet is uncovered—unless he wants the boiler to explode.

In the old days, when 160 pounds of pressure was high, boiler explosions were not infrequent, though the engineer could determine the height of water by testing with hand gauges or by watching the water glass. Now, with 250 pounds of pressure, he may ignore the boiler's gauges and the special alarm whistle will give him timely warning.

In the more picturesque but less practical days of years ago, the same engine crew took out the same engine and no other crew ever sat in its cab. Now, engines are turned out in types and are distinguished by numbers, and each is handled by many crews, a kind of mass production in motive power. These engines are on duty all the time they are not under shop inspection. On long, high-speed runs of crack passenger locomotives, a crew will leave the engine at each 150 or 200 miles, but the iron steed, guided by

another crew, proceeds to its destination. It is a poor iron horse in this day and age which cannot cover 10,000 miles a month in passenger service or 5,000 miles a month while hauling freight.

Major troubles are rather rare. Although big engines on our roads carry 250 pounds of steam, a locomotive boiler seldom "lets go." Boiler explosions are almost unheard of in modern engines, because the builders know how to insure strength and stability, mechanical superintendents know how to keep the boilers in form, and the most careless of engineers cannot ignore the low-water alarm steam whistle.

The breaking of a side rod or a main rod is exceptional, because long testing has shown that the maximum of strength for weight is attained by fluting a main rod and that side rods should be plain or rectangular. Moreover, pounding or vibration is reduced by use of a three-piece floating bushing for the driving rods instead of the old-style stiff split brass held in place by adjusting keys. The new-style bushing is better lubricated and does not bind if it becomes warm enough to expand; hence it does not overheat the main pin, for example, and leave the engine helpless on the rails.

To the efficiency of the airbrake has

3250
716

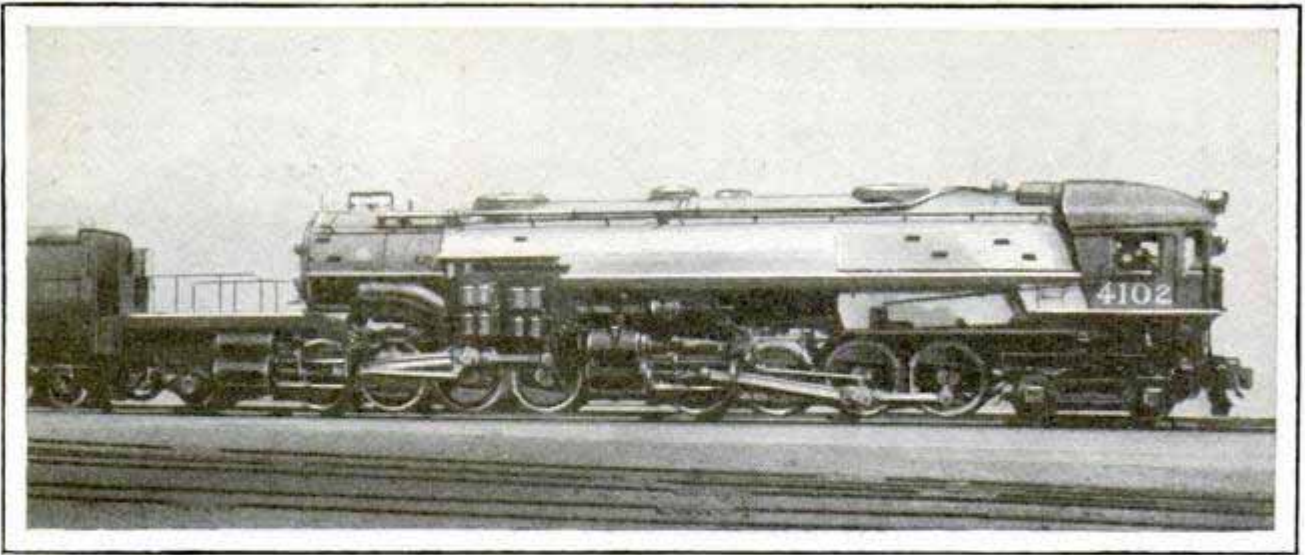

Burning Oil and Weighing, with Its Tender, over 900,000 Pounds, This Cab-in-Front Locomotive Is One of a Fleet of Ten Delivered for Mountain Service over the Southern Pacific Lines

been added the automatic train stop which, if the engineer runs past a stop or caution signal, applies the air automatically, so the train is under control, no matter what happens to the enginemen. In the larger latest engines, the mechanical stoker has relieved the fireman of handling 5,000 pounds of coal per hour. Now the coal travels from the tender to the firebox along a revolving horizontal spiral, which has a series of three crushers, and is sprayed onto the fire.

The lame-backed fireman of pre-stoker days would have welcomed the modern feed-water heater which heats the water from the tender before it enters the boiler, by subjecting it to exhaust steam. He would also have welcomed the modern superheater which increases the expansive power of the boiler steam, and the

devices which ring the engine bell by air and sand the rails almost automatically.

Instead of a dim kerosene lamp in front of the smokestack, a brilliant electric light, with its own power plant, supplies energy for the train stop. The old heroic days are past when a traditional Casey Jones, in order to avoid a head-on collision, flexed his biceps and pulled back on his reverse lever. There were giants in those days but they could not turn a trick of that character today. The locomotive's machinery is too heavy for mere man power. The engineer of this year's iron horse reverses it by spinning a small metal wheel actuated by steam or air pressure. This process is slower than the old lever, but is less laborious.

Engineers and firemen have it soft as far as using muscle is concerned, but life for two men in each cab is so complicated by mechanical appliances that they might be frequently in trouble if the mechanical executives and their assistants were not functioning so skillfully.

The difference between yesterday and today in American railroading is a difference in favor of modern methods and records, due to respect for rules laid down by federal and state commissions, enforced by railroad executives.

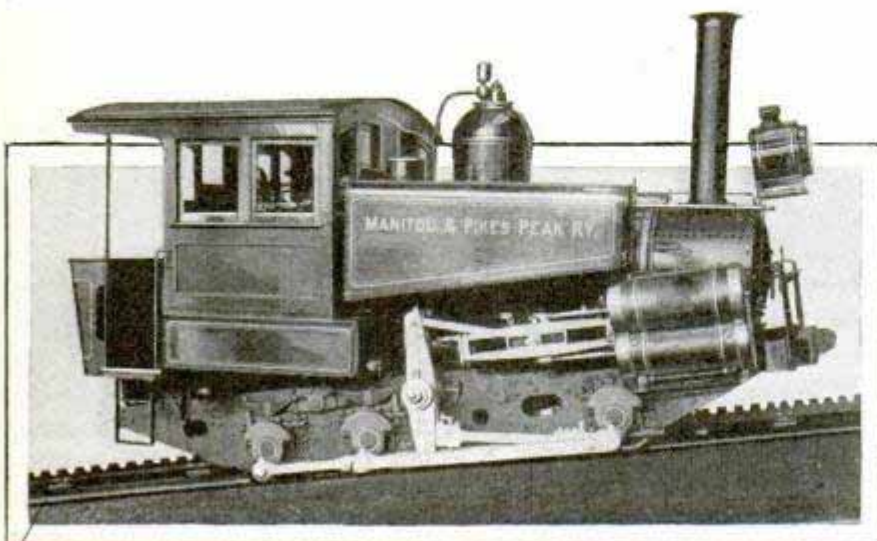

Tiny but Powerful; Special Locomotive Built for the Cog Line of the Manitou and Pikes Peak Railway

*Baldwin Locomotive Works
123 S. Broad St. Phila*

cannot locate maker 3426

GAS REFRIGERATOR FOR ICE-CREAM TRUCK

Ice-cream and milk-delivery trucks are being equipped with gas-burning refrigerating apparatus as a substitute for salt and ice. The plan is more effective and cleaner and is also said to be cheaper, particularly because the maintenance and service costs are greatly reduced. Successful operation of these refrigeration plants promises more extensive shipment of perishable goods by auto truck, owners point out.

see April 1930-6-44

"MYSTERY" PLANE'S SECRET IS THE COOLING SYSTEM

One of the principal secrets of the "mystery" plane which the navy is testing is the novel cooling system of the engine. It is modified to permit the use of "prestone," the high-efficiency cooling liquid. As a result small radiators can be used, and these are mounted on each side of the fuselage, thus reducing the air resistance.

3470

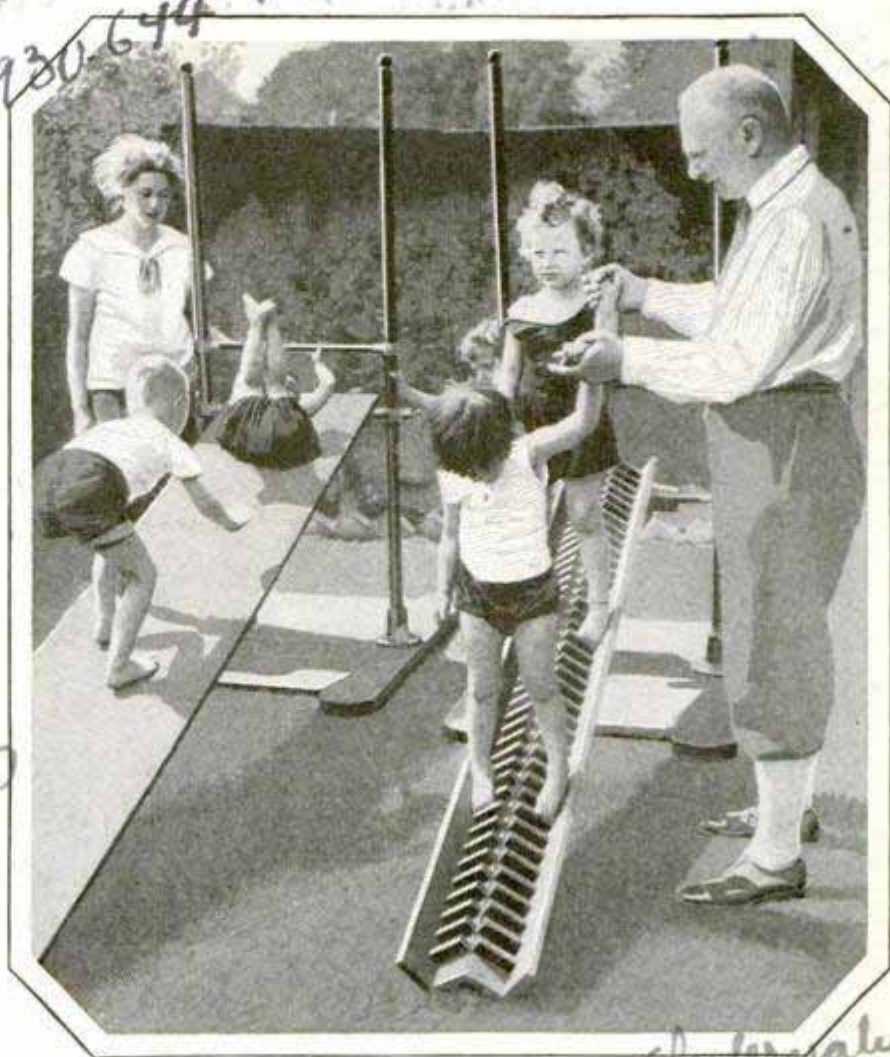

Youngsters Exercising in a Berlin Outdoor Gymnasium; the Foot Ladder Is of Special Benefit in Cases Needing Corrective Aid

International

CHILDREN'S FOOT GYMNASIUM CORRECTS DEFECTS

Extensive gymnastic training for young and old is being encouraged in Germany, and, at some of the schools and recreation grounds, special attention is paid to the children. In Berlin, for instance, one outdoor gymnasium has an inclined walk on which wooden blocks are set at angles. As the child steps over them in bare feet, the muscles of legs and arms are strengthened and minor foot defects are remedied.

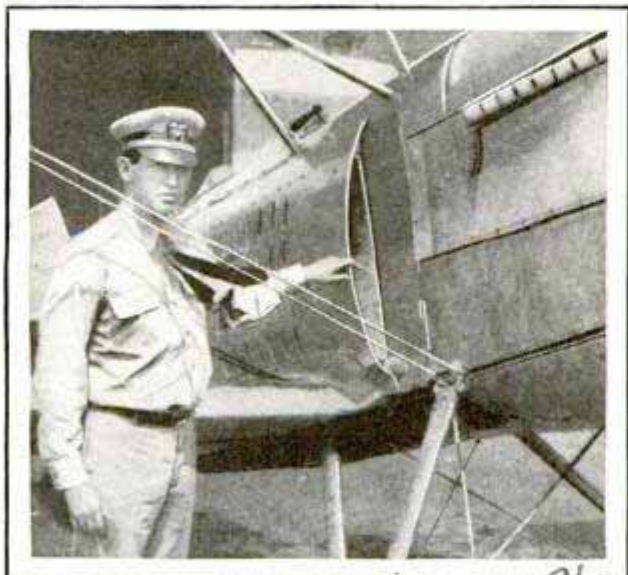

Copyright, Underwood and Underwood
This Small Radiator on the Navy's "Mystery" Plane Uses a High-Efficiency Cooling Liquid

PIT TO STOP SMUGGLERS 3438

At the American approach to the Ambassador bridge, between Detroit and Windsor, to be opened next year, an inspection pit for automobiles, similar to service-station pits, has been constructed. Automobiles suspected of smuggling liquor will be required to run onto the pit, where custom officers will make a quick search for compartments under the floor.

*Lieut. J. Clark
Naval Air Station*

34/4
718

(No reply & letter)
7/10/30 July, 1930.
20



Motorboating and Flying Are Combined in This Racing Craft Equipped with an Outboard Motor Which at Times Causes the Craft to Leap into the Air and Fly Short Distances

OUTBOARD-MOTOR BOAT "FLIES" FOR SHORT DISTANCES

Motorboating and flying are combined in an outboard racing boat which at times actually leaps into the air and flies for

short distances. The boat is owned by Harrison Fraser, former holder of the outboard speed record, and he made the "fuselage" of his modern Pegasus of a racer to which he attached a twin-cylinder sixteen-horsepower outboard motor.

April 1931-588 probably. Austral
Ste. Ame. des Cycles Austral.
1 de la Republique 1923
France

HUNDRED-DOLLAR "BABY" AUTO DEVELOPS HIGH SPEED

Not much larger than a toy, a small automobile, said to be well fitted for



For a Limited Purse and Service in Heavy Traffic; the Hundred-Dollar "Baby" Auto

serviceable duty especially in the cities, has appeared in Paris. It costs but \$100,

is powered with a two and one-half horsepower motor and yet develops a speed of over twenty miles an hour. It was exhibited at a recent auto show.

STALKING BIG GAME BY PLANE

Twentieth-century marksmen are taking to airplanes to stalk big game in Africa. Guns, ammunition, portable film cameras, etc., constitute the outfit employed by the flying hunters and three or four hundred miles is an average trip, because the flyers do not care to run the risk of a forced landing in the jungle. Antelopes and other boldly colored creatures may be easily located from the sky, but the natural camouflage that characterizes the giraffe, leopard and other timid animals makes shooting them from above difficult. Only when large herds of animals move together across the prairies is there any certainty of shooting them from the air.

at auto show

Erig. Orenting
Johannesburg

payee note
San Francisco Chronicle

and
M. C. Elrick

AVIATION INDUSTRY'S GROWTH CALLS FOR MANY MEN

Nearly 25,000 persons are directly employed in the manufacture of airplanes and airplane motors in the United States, according to the department of labor. The industry has demanded special materials, metals, wood, cloth and rubber with a consequent increase in the number of workers; schools teaching aviation need instructors, hundreds of mechanics are employed, and the necessary distribution of gasoline to supply the airplanes has required more men. The department considers the development of any new industry, such as aviation, of special importance at the present time for the reason that it offers employment for many workers who have been forced out of older activities due to the adoption of machinery in those lines.

drawn age 9/15/19



The Instrument Indicated Is an "Hourometer," Which Shows a Plane's Actual Time in the Air

PLANE'S ACTUAL TIME ALOFT SHOWN BY "HOUROMETER"

Indicating the actual time of an airplane in the air in hours and minutes is the purpose of an instrument designed by two Oakland inventors and called an "hourometer." A device near the landing gear electrically connects or disconnects as the plane rises or lands. It is expected to prove helpful in assisting pilots to keep accurate logs in endurance flights, etc.

TROLLEY CAR TILTED ON SIDE SO REPAIRMEN MAY WORK

Picking up a street car and turning it over on its side to give repairmen easy access to the bottom or top from the floor level of the shop, then tilting it back in an upright position, is accomplished by a

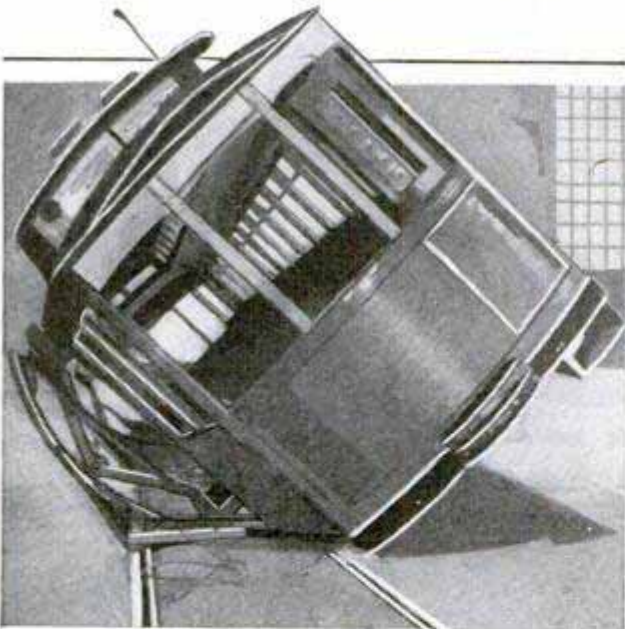

A Truck Which Tilts Trolley Cars into Convenient Positions for Repairmen

truck used by the Cincinnati street railway. The truck operates on the railway tracks on small wheels and has levers and cranks which hold the body of the car.

PHOTOGRAPH NOISES ON SHIPS TO END ANNOYING SOUNDS

Annoying sounds on ships are being eliminated by a process of sound photography. Prof. A. M. Low, British scientist, is conducting the campaign by stopping or rendering the noise harmless to comfort. Phonographs are used to record many of the noises, and in other cases an audiometer. This is an instrument by means of which sound waves are collected by a trumpet, projected onto a diaphragm, thinner than a soap bubble and carrying a mirror on which the collected waves are projected as a beam of light. The oscillations of this beam are recorded on a film which forms the noise picture. The means to stop the sound is judged by its intensity on the photograph. After locating the noise, sound absorbers are placed about the source.

Winton's shop

Winton's shop 7129

341 720

*Designed by William Beardmore
Glasgow Scotland*

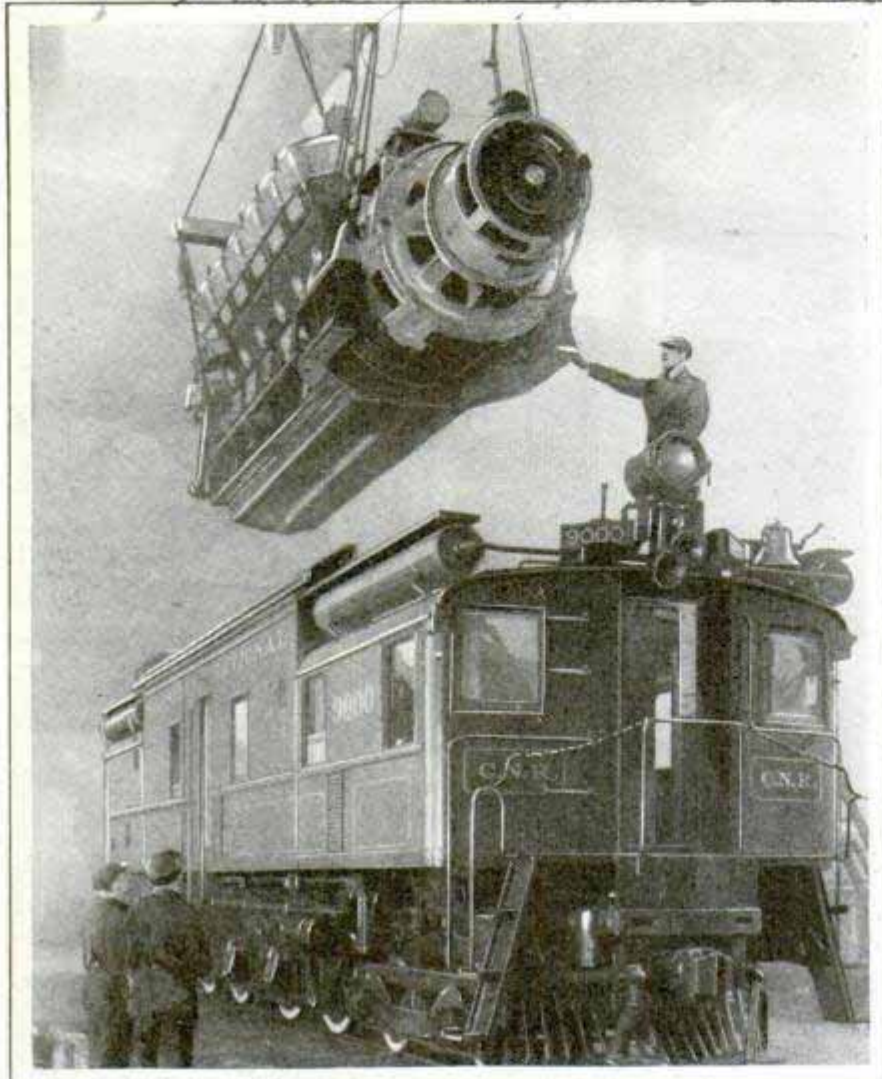

Huge Cables Were Used to Lower This 50,000-Pound Diesel Engine into Position to Operate Oil-Electric Locomotive

is a Diesel engine of mammoth size driving an electric generator, to supply current for the actual driving motors. Built in two units, the 9,000-class weighs 650,000 pounds, of which 480,000 pounds are carried on the sixteen drivewheels. Each unit consists of an oil-engine generator set mounted on the locomotive frame, boiler equipment to provide steam heat for standard passenger coaches and Pullmans, four traction motors, air brakes and other auxiliary equipment. Although electricity would be available for heating the coaches, steam was necessary as all existing coaches have been built for that type of heating.

3405
LONGEST LIGHTED AIRWAY CHICAGO TO PACIFIC

OIL-ELECTRIC GIANT OF RAILS BRINGS NEW ERA

Heralded as the most unusual departure yet made in the application of motive power, locomotive No. 9,000 has been given its inaugural run by the Canadian National railways. The new locomotive is unlike anything ever seen on a railroad, for it combines the electric drive with the heavy-oil Diesel engines which are rapidly driving steam off the seas. The result

Oakland-San Francisco air-mail, express and passenger route bears the distinction of being the longest lighted airway in the world. It extends over 2,000 miles with emergency landing fields every twenty miles for night flying, a revolving beacon every ten miles to keep planes on their course, and a flashing blinker every three miles. The route also contains the highest beacon in the world, that just west of Cheyenne, Wyo., which is 10,000 feet above sea level.

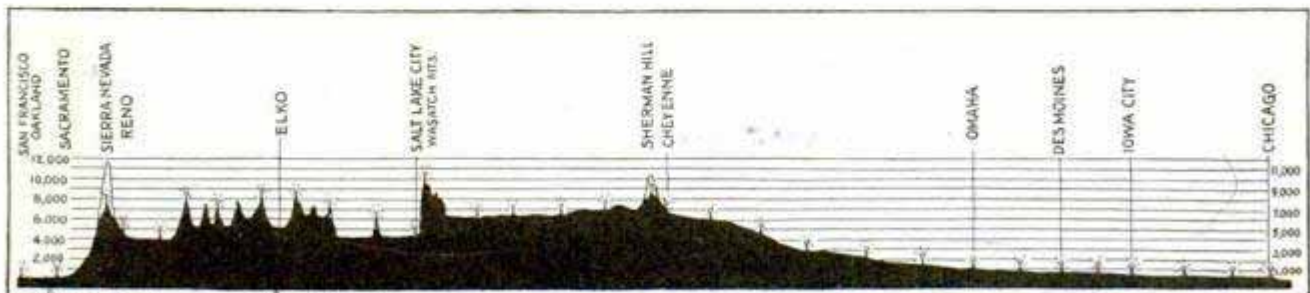

The Drawing Shows the Longest Lighted Airway Which at Night Guides Airplanes from Chicago to San Francisco; the Route Contains the Highest Beacon, 10,000 Feet Above Sea Level

Boeing systems

+40 76 8/21/29

2575

3435 San Diego St

San Diego Calif

FACES VS. INTELLIGENCE ARE STUDIED BY PSYCHOLOGIST

The photographer's stock warning, "Look pleasant, please," is sound advice, especially if the photograph is to be used in applying for a position or in any sort of competition, for a pleasant, alert expression improves your chances of appearing intelligent. This, at least, is the inference to be drawn from an experiment in which 600 men and women judged the intelligence of twelve photographed faces. Reporting the experiment before the International Congress of Psychology, Dr. R. S. Uhrbrock, of Cornell University, said that six of the twelve faces in the photograph represented men of high intelligence. The other six were men of lower mentality. Eight of the twelve faces were classified correctly by the judges, on the whole. But there were pictures of two men, both of whom had exactly the same high intelligence ratings. One face showed a drooping mouth, a snarl and averted eyes. More than three-fourths of the estimates said this man was a dullard. The other man looked the camera in the eye, with a pleased, agreeable expression. Three-fourths of the judges called this man bright. The investigation raises questions worthy of being pursued further, Doctor Uhrbrock said. It may be that certain facial characteristics are constantly associated with high or low intelligence in most people's minds. If these facial characteristics can be controlled, an individual may have himself photographed so as to put his best features foremost, or he may be able to select the one in a set of his own photographs that most accurately represents his intellectual level.



Small Pool Where Tiny Boats Sail in Calm and Windy Weather as Well; They Are Moved by a Concealed Wheel

SMALL SHIPS SAIL ROUND POOL REGARDLESS OF WIND

Small sailing ships in a San Diego pool sail around constantly regardless of wind direction to the mystification of visitors. Their motion is controlled from a lighthouse in the center of the pool which conceals an axle with a hub to which is attached a spoke for each vessel. The outer end of each spoke is bent upward and fastened under the ship. From whichever direction the wind blows there is always a filled sail to move one boat into the wind, keeping all in motion.

DETACHABLE RACK HOLDS BOAT FOR HAULING ON AUTO

For carrying a small power boat on an automobile, a detachable rack has been made which consists of two sections, the front one being a crosspiece of wood supported by two iron pipes bolted to the running boards. The rear-section supports are bolted to the frame of the car, being reinforced by rods leading to the ends of the springs to take up the shocks and eliminate topheaviness. The outboard motor may be clamped to a cross-piece at the rear.

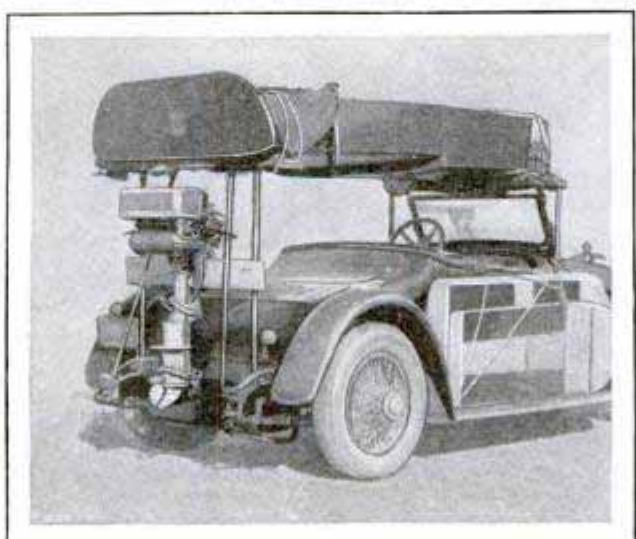

Detachable Rack for Hauling Boat and Outboard Motor by Auto; It Is Quickly Adjusted

3210
Ureigner. Lawrence J. Cornstock.
Ocean Park, Calif.

3000

Three Worlds

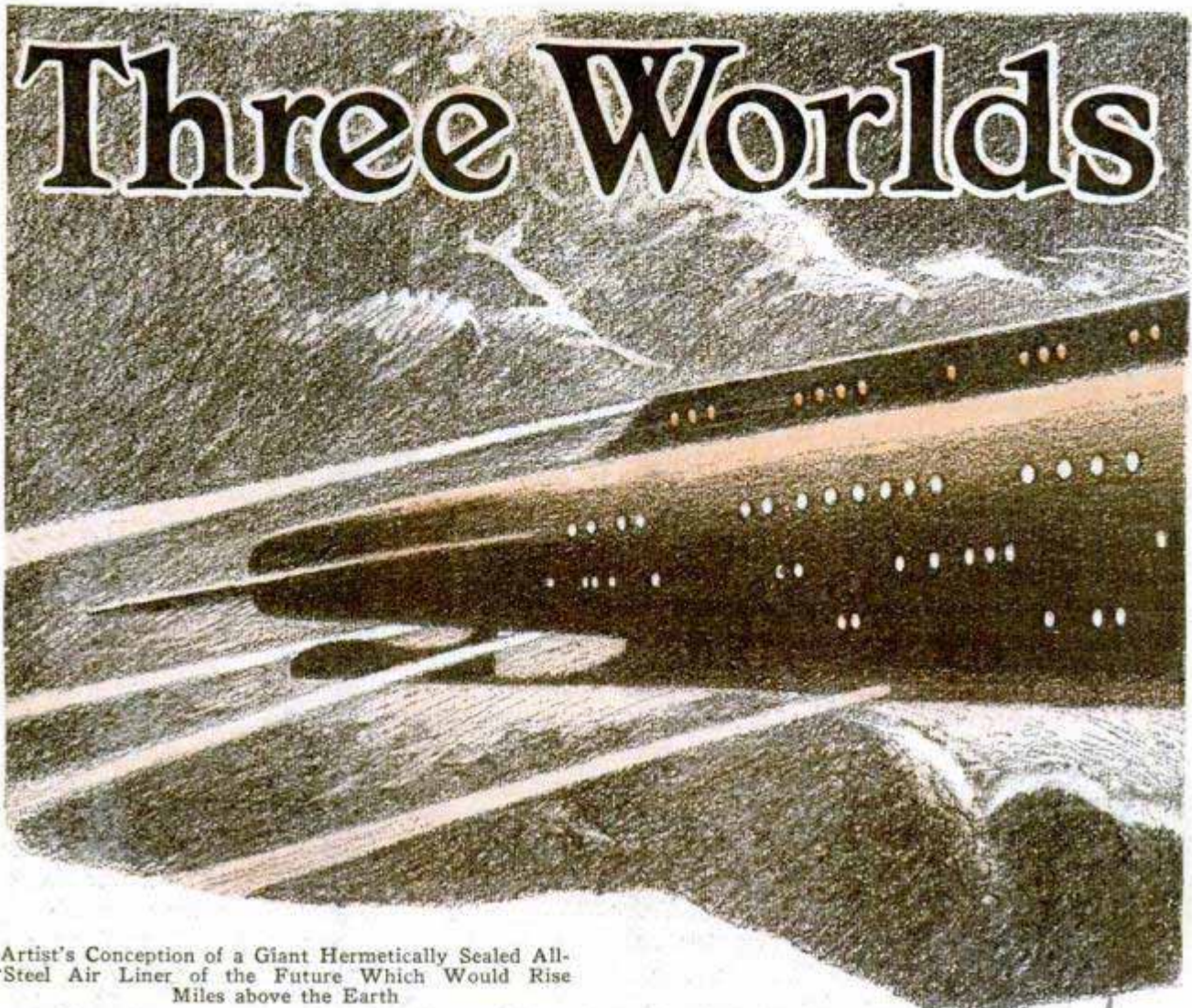

Artist's Conception of a Giant Hermetically Sealed All-Steel Air Liner of the Future Which Would Rise Miles above the Earth

By DON GLASSMAN

545 W. 111 St. New York

THE EARTH flings man a challenge. It offers three new worlds.

Lying outside the boundaries of latitude and longitude, these mysterious realms harbor strange creatures. The worlds of rock, water and gas need exploration.

The rock world invites men to search its porous crust for life that extends indefinitely toward the center.

The water world covers three-fourths of the globe's area, conceals vanished continents and supports a vast pageant of life.

The gas world is the sky sea. By volume stupendous, its life is both visible and invisible. Higher than we have ever believed, thrives a dominion of microscopic animals sustained by the sparsest air and enjoying frigid climate.

The most remote fastnesses on this earth have been reached by men independent of modern inventions. Columbus found a continent, Peary and Amundsen discovered the poles using simply sailing vessels

and dog teams. But the new age of discovery will be exalted by invention of a high order. In fact, inventors will share equal honors with explorers; for whithersoever a quest leads, the investigators will need tools, conveyances, instruments and machines.

Pressure and gravity are the forces the new explorer must overcome. He needs assistance, and the inventor fortifies him with the armor of his genius. So it is, the challenge flung to explorers concerns inventors also.

Just two years ago, when Dr. E. S. Bastin, of the University of Chicago, discovered a new subterranean realm, prevailing notions that life fifty feet beneath the surface of the earth was impossible were shattered, even though bacteria had already been found living in solid ice and boiling water.

How was subterranean life found? The story has its beginning in 1895, when two

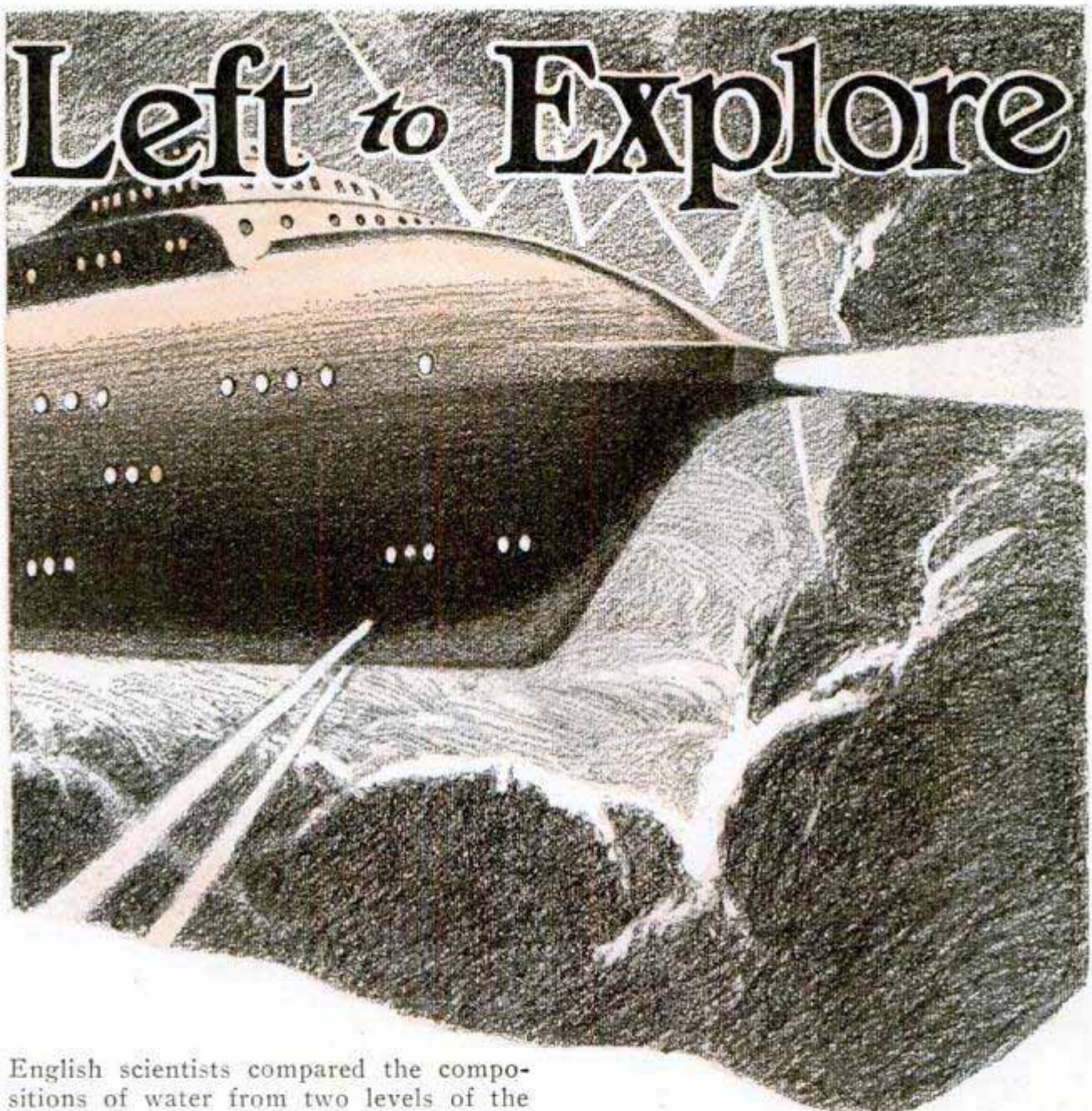

English scientists compared the compositions of water from two levels of the ocean, one from the blue muds at a depth of 17,400 feet, the other from a shallow shelf, and found that shallow water is rich in sulphate and poor in lime, while water drained from the deep blue muds is rich in lime and poor in sulphate.

Then came a Russian scientist, Issatchenko. He dredged the Black sea bottom and raised mud samples from a depth of 6,300 feet and identified living bacteria. He found a whole tribe of "sulphate eaters."

"These bacteria eat sulphates in the deep sea bottoms," he said, "and that explains why shallow ocean water is rich in sulphates."

Like many others, Doctor Bastin pondered over the mysterious role of sulphate eaters. Now, in his work as a geologist

he had often wondered about the disappearance of sulphur-bearing minerals. "Were sulphate eaters responsible here?" he asked himself, repeating the old question, "Does life extend far below the surface?"

When a geologist thinks of mud he recalls oil, too. For oil is fatefully linked with mud, being secreted on the sea bottom by marine animals and sealed in a natural reservoir by mud. That is the fuel we tap today.

Where but to an oil well would one go for evidence of life, for oil is rich in sulphate? If sulphate eaters could withstand a pressure of 3,000 pounds a square inch at the bottom of the Black sea, why couldn't they withstand twice as much,

3000
724

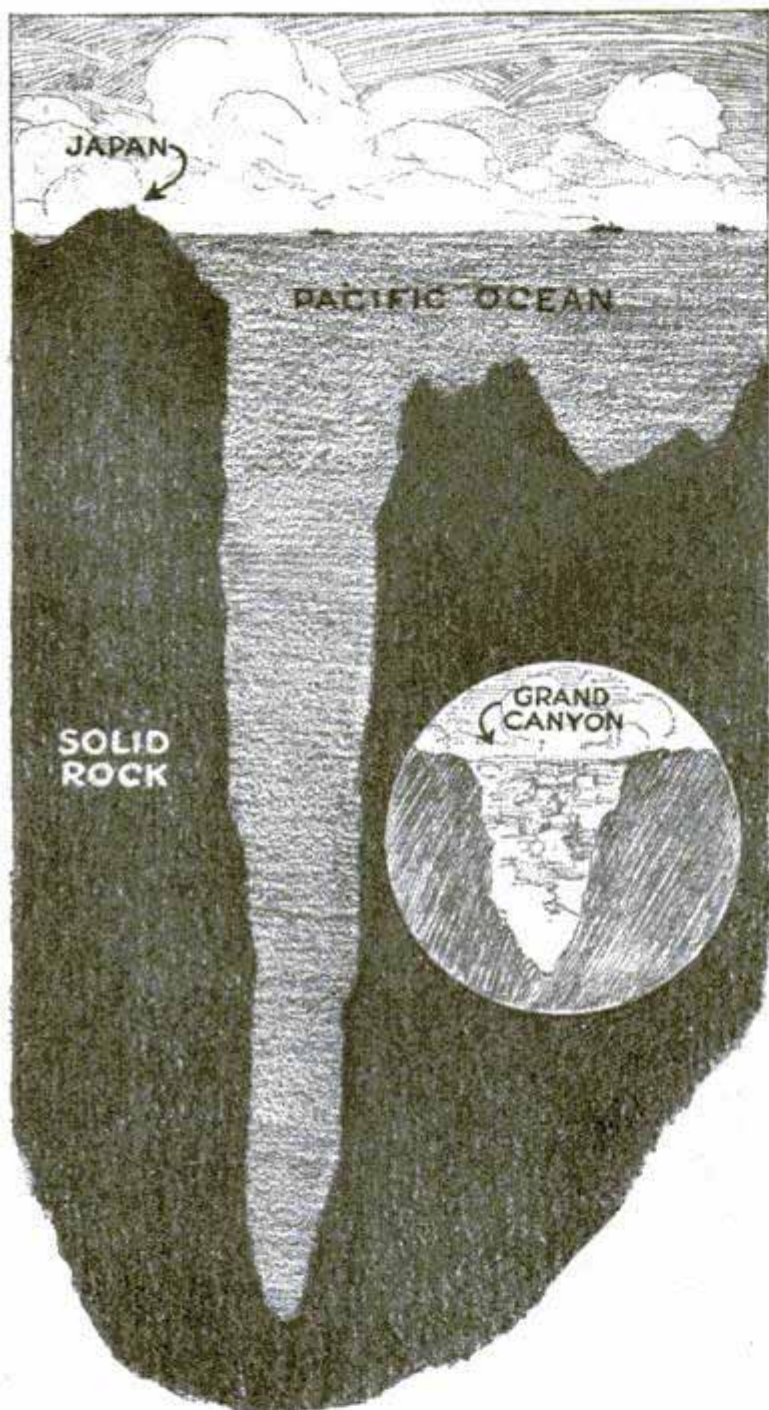

Drawing Showing Comparison between Grand Canyon and a Gulch in the Pacific Floor Five Times Deeper

certain ore deposits; and the laws of a universal cosmos of life govern this globe.

The Submarine World

Actually, we have seen very little of what composes the ocean bottoms. No man has stood on the brink of the canyon described by George W. Littlehales, of the U. S. Navy.

"A stupendous trough fronts the eastern borders of Japan," he said. "Five times deeper than the Grand Canyon of the Colorado! Twelve hundred miles long and its sides unbelievably steep. This submarine gash is 100 miles wide. No natural or artificial feature on the surface of the earth compares with its overpowering grandeur."

At the bottom of Submarina, there is frigid darkness. The water is colder than ice. Never a ray of light leaks through. Who prowls here? Shark-nosed demons, fantastic and ghostly, attacking with saw teeth and tentacles. Their shapes and variety are infinite. They swim on a forage, driven by ravenous hunger.

Dr. Austin H. Clark, of the Smithsonian Institution, a veteran of many deep-sea expeditions, contends that our present knowledge does not permit us to explore the ocean bottoms. "A diver's descent of 360 feet is nothing," says Doctor Clark, "when you consider that the

such as obtains under one mile of rock?

Doctor Bastin obtained samples of brine waters that flowed from oil wells bored to 3,000 feet, and was amazed to see bacterial cultures grow overnight. Subterranean life was abundant at almost a mile below the surface, reaching down indefinitely.

To explore the land of sulphate eaters, expeditions of diggers, borers and dynamiters are needed. For long, man has wanted to drive a shaft into the heart of the planet. Possibly he will find that life had much to do with the enrichment of

ocean basins are almost as deep as Mt. Everest is high.

"At a depth of one mile, our protective armor would have to be much thicker than at shallower levels. Under huge pressure water can penetrate microscopic crevices. For instance, in dredging operations, I attach glass balls to my nets. When these hollow spheres come up they are more or less filled with water. Yet near the surface, these balls are perfectly impervious and never leak.

"The maximum descent of submarines is less than 1,000 feet. The zone of ef-

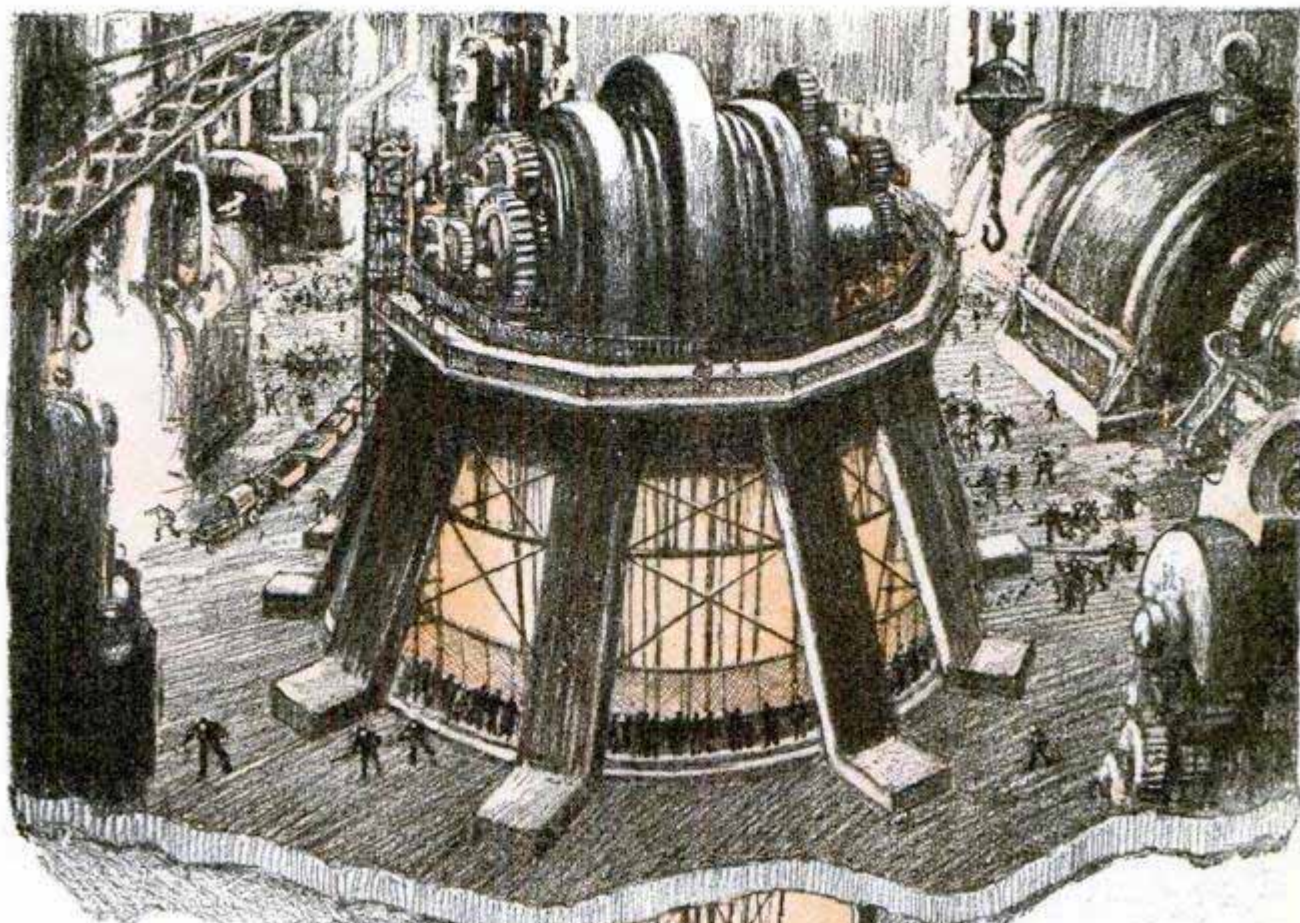

An Artist's Idea of the Machine That Would Bore a Shaft 5,000 Feet Deep to Explore Rock Formations

fective illumination is but 600 feet. Man has not even reached the preliminary abyss. Below 600 feet, the 'twilight zone' is similar to pale moonlight."

The Atmospheric World

The gaseous realm excites the imagination. It was the first of the three to intrigue man.

In 1927, Capt. Hawthorne C. Gray, army air corps, ascended 42,470 feet in a balloon. He sailed uncharted sky seas where the temperature is frigid, yet constant. That was the limit of human endurance.

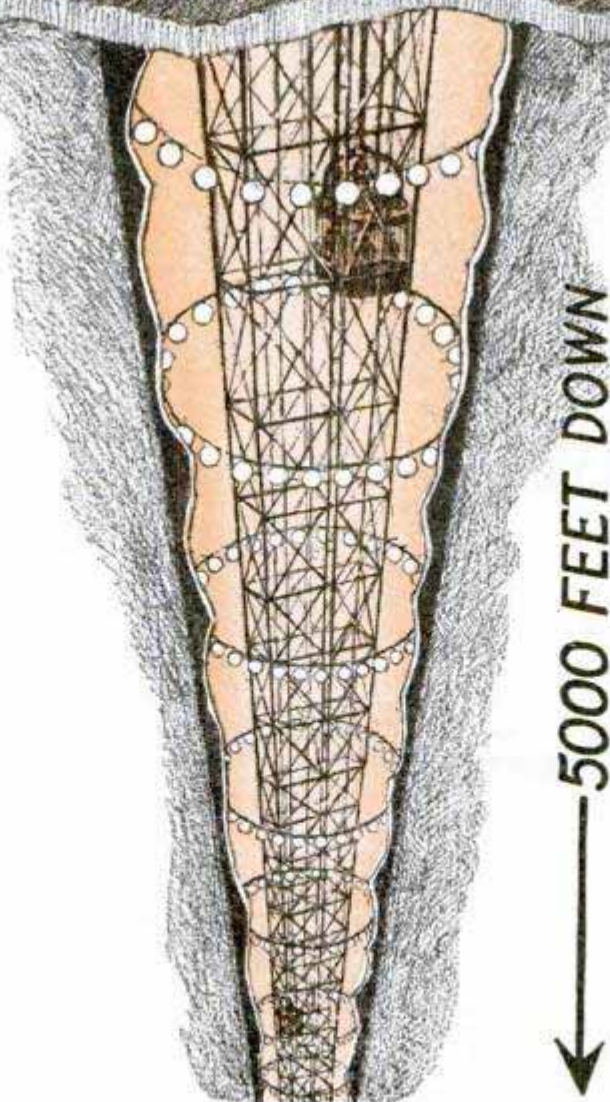

Commercial-aviation operators say they cannot compete with cheaper surface conveyances unless their aircraft attain a minimum speed of 200 miles per hour. Will air lines be driven to higher altitudes where resistance is lessened? If so, they need new equipment and knowledge.

Then there are clues to a realm of the earth higher than aircraft can travel. In the last five years we have learned startling facts about the tenacity of life. Maj. R. W. G. Hingston, naturalist of the Mt. Everest expedi-

3000

tion of 1924, exclaims, "How relentless is the force of nature to spread into every corner of the earth!

"On the Tibetan plateau I saw wild sheep and mountain hares struggle up barren slopes at 17,000 feet, bees, moths and butterflies at 21,000 feet and choughs at 27,000 feet. I saw life thriving in ice pools, glacial crevasses and rockbound mountain passes."

That arouses speculation on how high life can exist. Organisms can withstand intense heat, cold and pressure. They can eat mineral foods. What is the ceiling of existence? Sparse air extends out about 300 miles.

W. D. Verschoyle, an English scientist, predicts aerial navigation at an altitude of 100,000 feet within the next century. Jules Verne intimated such travel in the "Moon Voyage." Verschoyle describes a hermetically sealed wingless flying machine, shaped like a bullet, whose ability to ascend twenty miles and remain there, stationary, relative to the earth's center,

will result in a mean velocity equal to the speed of the earth's rotation, about 1,000 miles per hour. The machine could fly in continuous sunlight.

That sounds impossible to Dr. W.

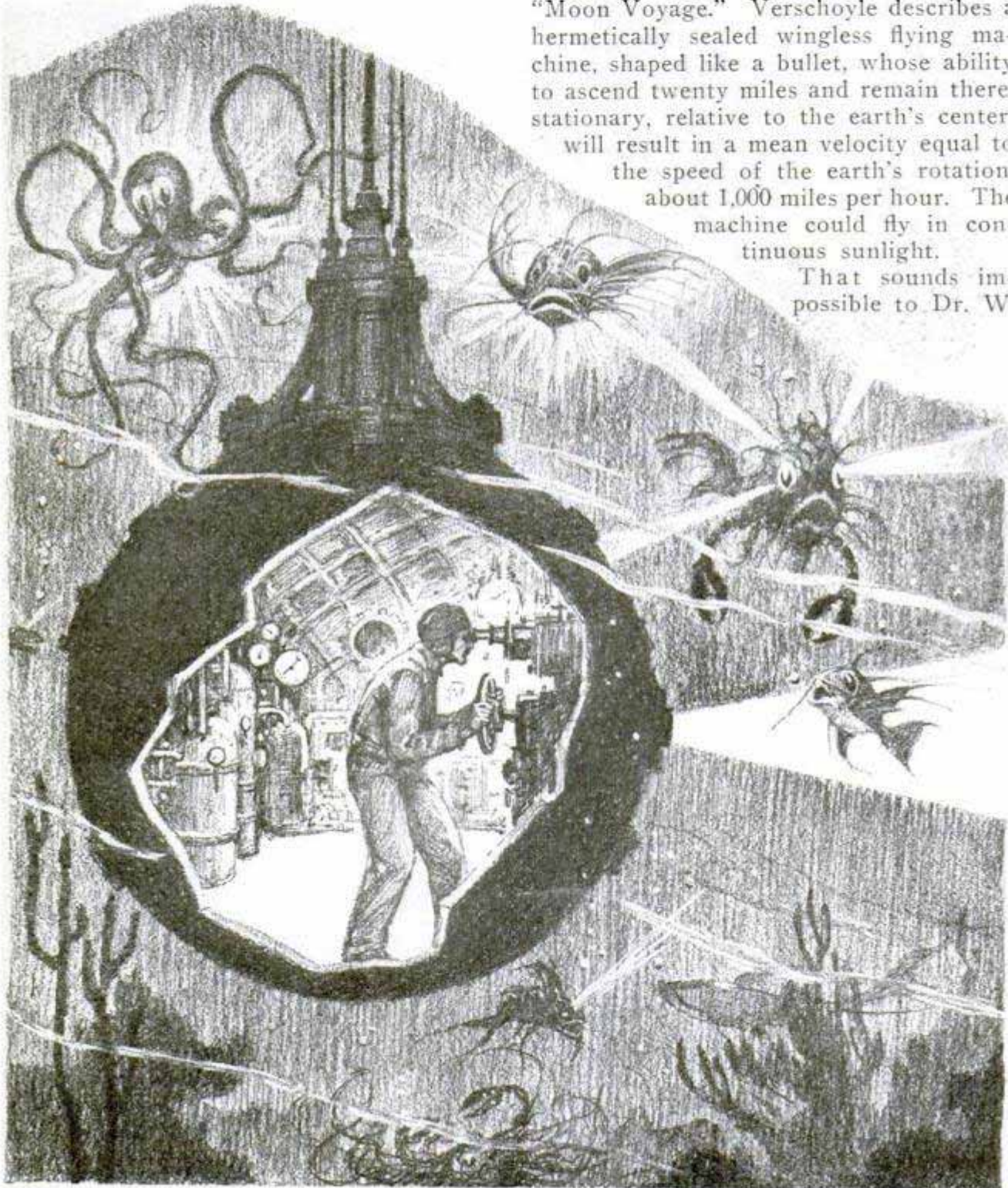

Drawing Depicting the Hollow Metal Sphere from the Inside of Which Explorers Equipped with Telescopes and Powerful Searchlights Might View Deep-Sea Life at Lower Depths Than Ever Before Attempted

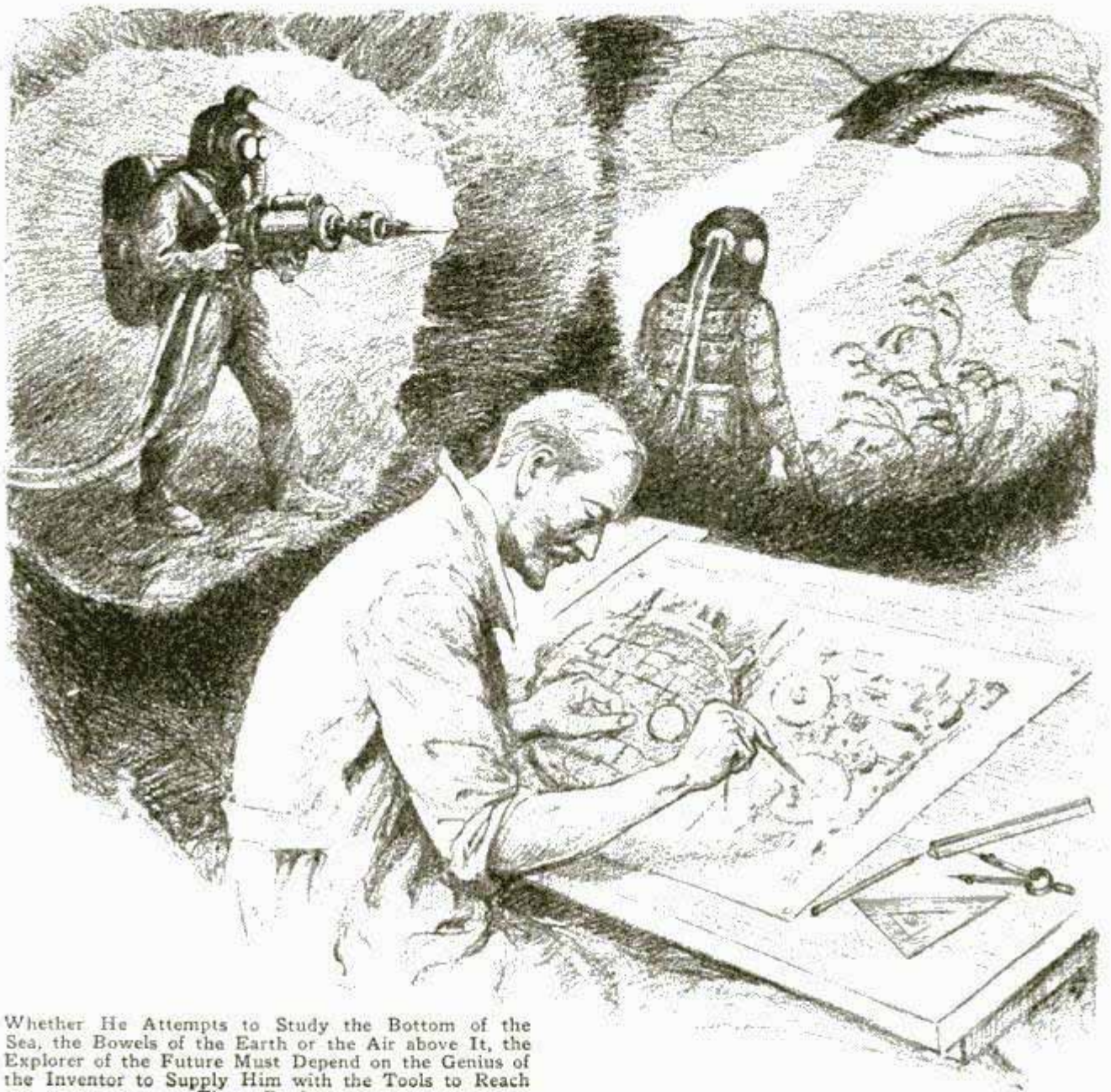

Whether He Attempts to Study the Bottom of the Sea, the Bowels of the Earth or the Air above It, the Explorer of the Future Must Depend on the Genius of the Inventor to Supply Him with the Tools to Reach These Regions

J. Humphreys, of the U. S. weather bureau. He says:

"At an altitude of 50,000 feet the air is extremely thin and propellers would gasp for something to pull against.

"By sending up balloons to about 100,000 feet, roughly twenty miles, we have recently learned that the mercury stops falling at about 35,000 feet as one ascends. Above that level is the constant temperature zone, whose temperature is about minus 60 degrees Fahrenheit."

So we see the opening scenes of an operatic mystery, replete with heroism and adventure, poignancy and thrill. It reveals how living substance crawled, swam and flew to new realms. The careers of a million nameless species that sprang up

and spawned their kind. Finally, the grand wonder of birth and the grim tragedy of death.

3115

WOOD TREATED TO RESIST FIRE

Tests at the University of Wisconsin have demonstrated that wood used for trim may be made fire-resisting, while fire-proof wood is a possibility. The research workers said the tests consisted largely in treating wood with a diammonium-phosphate solution, with similar results obtained by the use of zinc chloride. By charring the specimens so treated, it was definitely determined that the wood had exceptional fire-resisting qualities, although not entirely fireproof.

Mr. J. W. Truax,
Forest Products Laboratory

at meeting of American Society for Testing Materials

338 3

maker not known



This Auto Trailer for Campers Unfolds into Kitchen and Dinette, but Packs into Small Space for Transportation

AUTOMOBILE CAMPING TRAILER UNFOLDS INTO A KITCHEN

English campers are using a compact auto trailer instead of a tent to provide "home comforts" during a tour. The trailer unfolds by sections to provide plenty of room for cooking and eating, but when not in use the sections can be packed so compactly that they take up but small space for hauling.

CHRISTMAS TREE FARMS GROW MOST OF HOLIDAY SUPPLY

Most of the holiday supply of spruce and evergreen is grown on Christmas tree farms, an industry concerning which little is heard. One Ohio nursery has over 400,000 trees growing on seventy-five acres of land, ranging in size from tiny year-old Norway spruce seedlings to trees thirty feet tall. All of the trees come from seeds, and when the seedlings are two or three inches high, they are planted in beds, being arranged two inches apart in rows one foot from each other. There they remain for two or

Bushier's Independence 3 This nurseries, Independence 3

three years, when they are transplanted to fields where they have more room to develop. An average tree requires five years to reach a height of from four to six feet. Instead of cutting the trees, thousands of trees now are being dug up, and the roots wrapped in burlap with moist sod for shipment. After the tree has served its Christmas purpose, it may be transplanted into the yard where it usually lives and flourishes as a lawn evergreen, and may even be dug up and brought into the house the following year. Most

people want "fat" trees for Christmas, believing they are better-looking, but growers claim a slim tree can be more tastefully decorated and does not look overburdened when full of toys.

CRANKS REPLACE OARS TO DRIVE A SMALL BOAT

Operating a rowboat by hand without the necessity of rowing has been accomplished by an English army officer who made such a craft for his wife's use. Two cranks are attached to the gunwales of the boat in front of the passenger and by turning the handles two propellers in the rear are revolved thus furnishing the motive power.

now market



A Rowboat without Oars, Run by Turning the Cranks in Front of the Passenger, Thus Revolving Two Propellers in the Rear

official at Aldershot

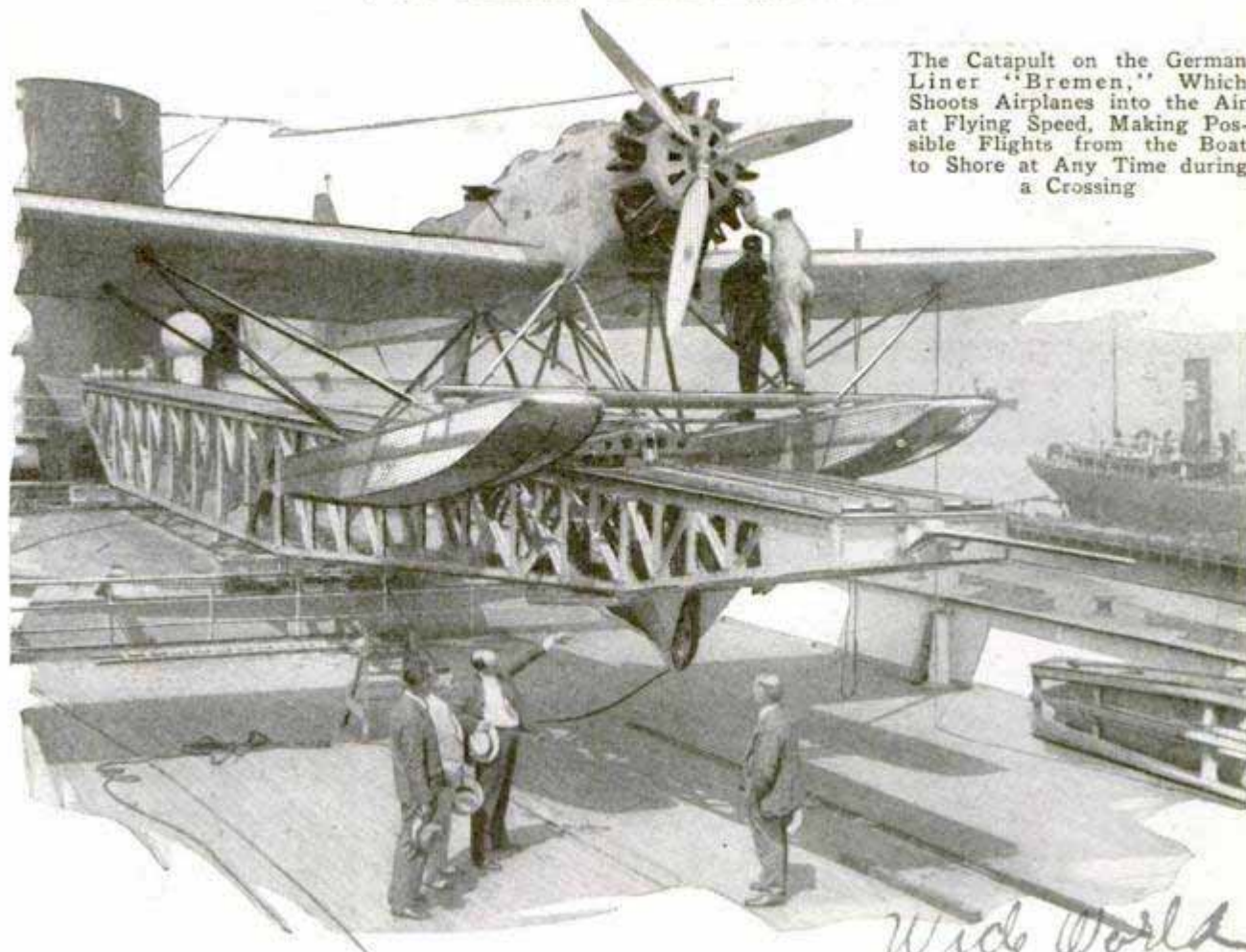

The Catapult on the German Liner "Bremen," Which Shoots Airplanes into the Air at Flying Speed, Making Possible Flights from the Boat to Shore at Any Time during a Crossing

Wide World

NEW CATAPULT DRIVES PLANE FROM DECK OF LINER

Shooting an airplane into the air from the deck of the German liner "Bremen," which recently established transatlantic speed records, is made possible by a catapult designed to launch the plane at flying speed. The catapult makes possible a flight from the ship to land with mail, express or passengers at any time during a crossing.

HOW TO TEST ANTIQUE GLASS

Collectors of antique glass are advised by an English glass expert to shine the article before completing the purchase because it should be clear and colorless as water unless sold as colored or tinted. The faintest trace of color indicates that lead, iron or magnesium is present, all these metals being injurious to its lasting qualities. Minute air bubbles appearing in glass when it is held to the light are an indication that it was not sufficiently worked in its melted state and has a tendency to become opaque or to crack when

exposed to sunlight. Glass which is slightly turbid suffers from "mattress," a defect which causes it to devitrify, losing its luster.

FOG WHICH SOLIDIFIES INTO ICE IS PERIL TO AVIATORS

Three meteorological conditions cause the peril of ice forming on aircraft, says Dr. Alexander McAdie of Harvard University. These are sleet, glaze and subcooled fog, the latter being most dangerous. Subcooling means that the tiny vapor particles are actually slightly colder than the freezing point, although still water, the condition occurring when the air is clear of dust upon which the droplets might solidify. Immediately upon contact with aircraft these particles of fog become a layer of ice. The best way to escape it is to watch thermometers closely and seek levels where the temperature is higher. Glaze occurs when raindrops fall upon a surface which is much colder and freeze to it, while real sleet is due to raindrops falling through a layer of air below freezing and solidifying as they fall.

Serge H. Holden.

39
 39
 4
 39
 4
 39
 4

*Bureau of Meteorological
Aviation*

8396



These Young Men Show What to Do When a Boat Capsizes: Straddle It, Use the Oars as Floats or Hang to Bottom of Boat

WHAT TO DO IF BOAT TIPS OVER AND YOU CANNOT SWIM

Keeping afloat when the canoe or row-boat upsets, even though unable to swim, is not difficult if the victim does not become panic-stricken when plunged into the water. In case of a rowboat capsizing, the two oars, or even one oar, placed under the arms will keep an inexpert swimmer afloat until he can paddle toward shore or summon aid. When one member of a

canoe party cannot swim, he may keep afloat by straddling the craft while the swimmers shove it ashore, or if all are unable to swim, each may hang onto the bottom of the overturned canoe with one hand, using the free hand to paddle.

WORLD'S LARGEST AIR CAMERA

3429 TESTED

The world's largest aerial camera, weighing 130 pounds and measuring about half the height of an average man, has just been tested successfully by the army air corps. The camera was developed to take widespread ground areas from high altitudes, and is the result of five years of experimentation. The pictures taken are nine by eighteen inches and the roll of film carried is 150 feet long. The camera's most important feature is that its operation is fully automatic, possessing a registering device whereby the elevation of the plane, the time, date, and the number of the negative are noted on one corner of the film. The device is electrically heated so that it will function at

the very low temperatures found at altitudes exceeding 40,000 feet. Ordinarily the camera is suspended through a hole in a section of the ship's bottom. While the picture is being taken, the plane moves at a speed of about eighty-five miles an hour. The completion of an exposure, including the automatic setting and winding of the shutter, the rolling of the film and the shooting of the picture, takes only fifteen seconds. During these operations the photographer has little to do.

Army Air Corps
Wright Field

3285
Com. H. O. W. ...
Columberie, 29 Beau Aog
Berley Heath, nr London,
Eng

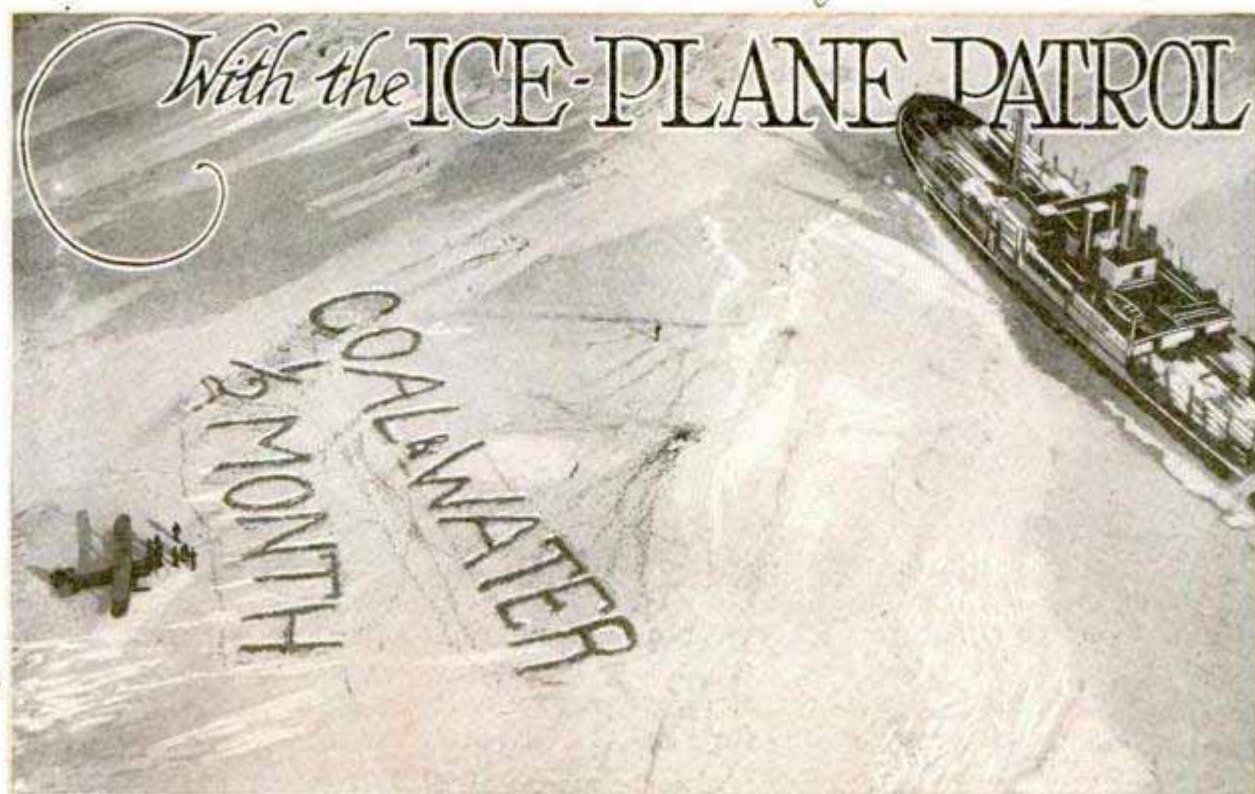

The Crew of This English Steamer, Frozen In in the Baltic Sea, Have Written in Coal Dust on the Ice That They Need Coal and Water, and the Airplane Has Arrived with Supplies

IN PORTS all round the Baltic sea, the German radio last winter was crackling an SOS telling of suffering and danger hundreds of miles distant, where many steamers of all nations were caught fast in the ice, their crews starving, their bunker coal running low, while drifting fog and lee-shore icefloes made it practically impossible for the most powerful of ice breakers to reach them.

Two of the most up-to-date of Germany's cruisers, the "Elsass" and the "Schleswig-Holstein," were converted into ice breakers and sent post-haste from Kiel harbor to the rescue of the nearest of the imprisoned steamers, whose radio announced that she was ice-bound off the island of Fehmern, some seventy miles east. A grey fog came over the sea and almost blotted out the surroundings by the time the navigators calculated they were about the position whose latitude and longitude had been radioed in the SOS. The cruiser sounded her siren and sent out radios, but there was no response.

Then came a wireless from Kiel, ordering the ship to return to port at once, and co-operate with spotting airplanes of the Luft Hansa, one of Germany's biggest air lines.

Back at Kiel, the ice breaker prepared for a new life-saving hunt in the cold and fog, while her consort, the "Schleswig-Holstein," steamed out of harbor under the convoy of an airplane in a search for two marooned steamers. After a brief flight, the plane reported spotting the two ice-locked ships which were invisible to the keen-sighted observer scanning the sea from the cruiser's fighting top. Later the plane reported several other steamers fast in the ice. Some of them were displaying flag signals. One read: "I am in great danger. I want coal." Another signaled: "I must have food! Down to our last biscuit, after days in the ice. Hurry, please!" A third ship had written in coal dust on the ice the one word: "Water!"

The plane had not found the ships on the first flight! At the outset, the position of the SOS steamers was a matter of mere guesswork. Systematic flights had to be made before each ship could be located. Each bay and arm of the sea was thoroughly scanned, and in weather in which the visibility was bad, the planes zigzagged in the air in order to hit on clear spaces of sufficient width. The job of the cruisers was to rescue the crews

of the ships; the problem of the spotting planes was to find and feed their crews.

This problem was made none the easier, owing to the fact that the seadromes were all frozen up, and a service of land planes had to be hastily improvised. From all ports of the German shores of the Baltic sea, from Kiel in the west to Lubeck, Stettin and far-away Danzig, the East Prussian timber port, fleets of fast planes took short flights to get a rapid bird's-eye view of the ice conditions in the waters below. The east-bound planes radioed back that the steamship lanes in their waters were pretty clear of ice; but the west-bound planes reported to the airport bases that a knife-edged east wind could be seen drifting the floes and the locked-in steamers farther away. From the shores of Denmark, the airplane observers made out fresh drifting floes threatening the imprisoned steamers with further perils of crushed hulls and broken screws.

When the planes spotted the frozen

steamships, it was impossible to land on the floes without running great risks. Under pressure, big chunks break off the floes, and fissures or open leads of thawed water endanger landing and take-off. By ingenious methods, the ice-locked crews were victualed with bread, peas, meat, potatoes and bacon, while drinking water, in the form of ice blocks, was dropped on the floes along with chocolate, cigarets and newspapers. Sacks of coal were actually sent down by the airplanes hovering over sailing ships with fireless galleys.

Parachutes to float down the food and necessaries could not be used, owing to the raging wind, which would have blown them far out of the reach of the starving crews. So the food and fuel was strongly packed in small sacks, incased in wood fiber, and dropped from the airplane, flying at a height of from 150 to 190 feet. Later, it was found that hardly one sack of peas and coal had burst open on contact with the floe's surface.



Photos Courtesy Deutsche Luft Hansa

This Picture, Taken from an Ice-Plane Patrol, Shows a German Ice Breaker Standing by a Frozen-In Cargo Steamer, While an Airplane Has Dropped Packages of Coal on the Ice

*James Martin
Martin Aeroklane Co*

Gliding quite closely above the nearest steamship, the airplane threw down the 112-pound food and coal containers, and flew on to the next ship to unload another cargo. The airmen could see the crews leaping from the decks onto the ice and dragging the provisions aboard. Where the ships had no radio, a code of flags was arranged between planes and vessels. One captain hit on the method of writing his wants in coal dust on the new-fallen snow.

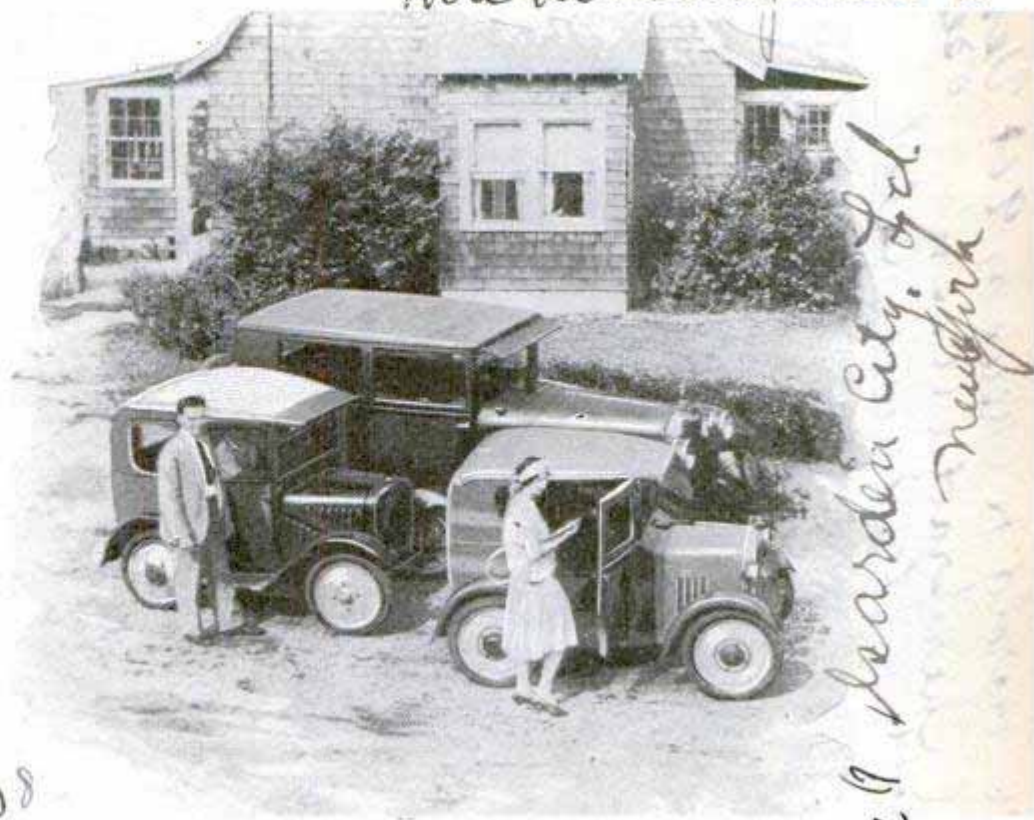

Four Wheels and a Body Containing an Engine Constitute These Baby Autos, Which Have Neither Chassis Nor Chassis Frame

WHAT MAKES A GOOD PILOT? 3308

What is the most desired characteristic in the student pilot? A. F. Arcier, vice president of the General Airplanes corporation, says an infinite capacity for detail plus unlimited patience are the most essential needs. Natural flying instinct is merely the unification of the several characteristics. The student who knows no limit in the study of every detail of aeronautical science, offers in his vigilance and attention to duties the best formula for flying safety, and is to be preferred to the man who learns to fly more quickly, but with a careless disregard of the fundamentals of operation. Impatience, carelessness and lack of knowledge of the fundamentals of flying were blamed for the majority of air accidents due to man failure rather than machine failure.

3148

READY-SLICED LOAF OF BREAD

Ready-sliced loaves of bread, coming to the housewife evenly cut and packed in a pasteboard tray wrapped in waxed paper, are now on the market. The bread is sliced automatically as it comes from the oven, the operation enabling it still to retain its flavor and moisture. The sliced bread saves time, particularly in making toast and sandwiches.

*Schulze Baking Co
408 Eschfeld Blvd*

BABY AUTO WITH NO CHASSIS HAS PACKING-BOX GARAGE

Weighing only 600 pounds, and with a sixty-inch wheelbase, a baby automobile, constructed by a New York man, is to be placed on the market at a price around \$200 and probably will be distributed through a mail-order house. The tiny car is unique in construction, consisting essentially of a body with an engine in it and four wheels. There is no chassis or chassis frame, each wheel being independently mounted on the body. In place of springs, rubber "aviation cord," such as is used in the landing gear of airplanes, is used. There is little rebound from bumps despite the lightness, because each wheel acts independently. The car is fitted with a four-cylinder engine and has an electric starter and other necessary instruments. It comfortably seats two persons, and the maker claims it will travel fifty miles on a gallon of gasoline. It is planned to ship it in a weatherproof packing case with hinged door which will also serve as a garage. A man of ordinary strength can lift one corner of the car and shove it in or out of the box.

*Warden City, Ind.
New York
not being marketed*

4/21/36

Reuss, 918

Temie Blvd. Calif

of Automobile Engineering

Cleveland Ohio

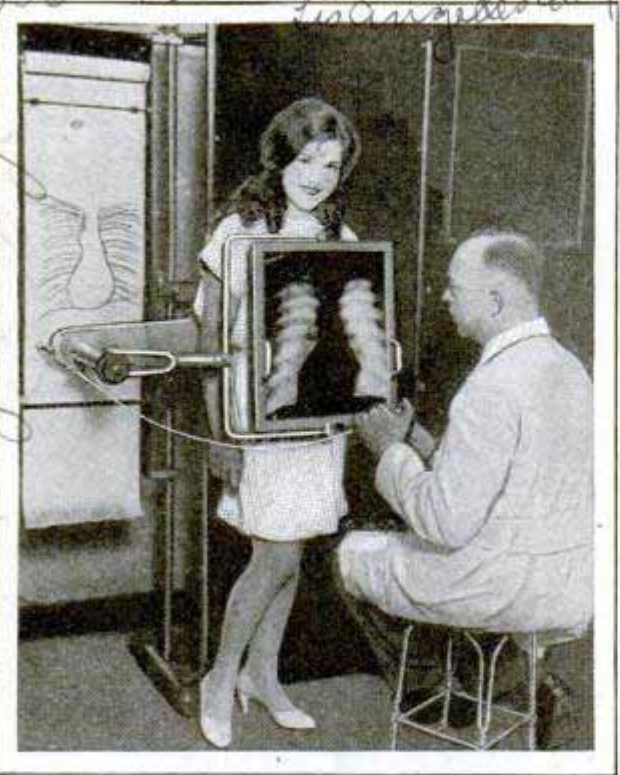

Combining the X-Ray and Pantograph, as Shown, Eliminates the Negative in X-Ray Photography

X-RAY TRACING BY PANTOGRAPH ELIMINATES NEGATIVES

Combining an X-ray machine with pantographic principles, a scientist has obtained tracings of organs or bones without using a negative, sensitive plate or film of any kind. The operation is known as an orthodiagraphic examination, and the appliance that makes the tracing is termed an orthodiagraph. The patient stands in front of the X-ray which brings out bone and tissue on a visible plate. The operator traces the outlines thus revealed on a near-by sheet of paper by the pantographic method.

VARIABLE PROPELLERS SEEN AS AIRCRAFT NEED

Airplane propellers that can be adjusted as to pitch while the plane is flying, are being developed and their successful adaptation will greatly increase the efficiency of sky craft, in the opinion of engineers. They point out that the propeller acts in the air as a screw does in wood. Its pitch is comparable to the pitch of a screw, that is, it is the distance the screw will advance when turned once. In a propeller, the practical pitch is somewhat less than it would be theoretically,

since the air is a less substantial medium than wood and a pitch that will produce the greatest efficiency at top-speed level flying, for instance, is not the best for climbing, starting or other maneuvers. If the pitch of the blades can be changed at will, the pilot will be able to achieve for his plane somewhat the same flexibility as the motorist accomplishes with his car by means of the gear shift. Various methods have been tried for controlling the blades. What some engineers regard as the most promising is a small electric motor, operated by a storage battery, geared to the propeller and enabling the pilot to change the pitch of the blades. One of the drawbacks to the control systems already introduced is that the apparatus adds too much to the weight of the ship. It is believed, however, that the electric-motor plan can be developed without great increase in weight, and what added burden there is will be more than offset by the great advantage of the adjustable blades. On heavy transport planes, the gearing of propellers to decrease the speed of the engine as applied to the propeller, is expected to come into extensive use where more than one motor is employed.

OUTBOARD MOTOR IS COOLED BY AUXILIARY PUMP

For use on a lightweight high-speed outboard motor recently placed on the market, there is provided an auxiliary plunger pump which can be quickly attached and provides a steady stream of water for cooling the cylinders at slowest



trolling speeds. A bronze cam is attached to the propeller shaft in place of the customary acorn nut and the auxiliary pump fastens on the pressure-flow scoop with a pin and has a gland fitting into an ordinary water gland. With only a scoop to provide circulation of water through action of the propeller, sufficient water to keep the motor cool was supplied only at fast speeds, it was found.

Tryed out by Dr. Harold H. Reuss, 918 Temie Blvd. Temie, Calif. National Chiropractic Assoc. Convention in Los Angeles Calif. J.P. Wright and W.A. Turnbull } Engineers. Curtis Aeroplane Motor Co. 572

Frank W. Caldwell, Chief Engineer

Coile Motor Co., 6240- 2nd Blvd.

LIFE HISTORY OF WORLD'S MOST NOTED VOLCANO

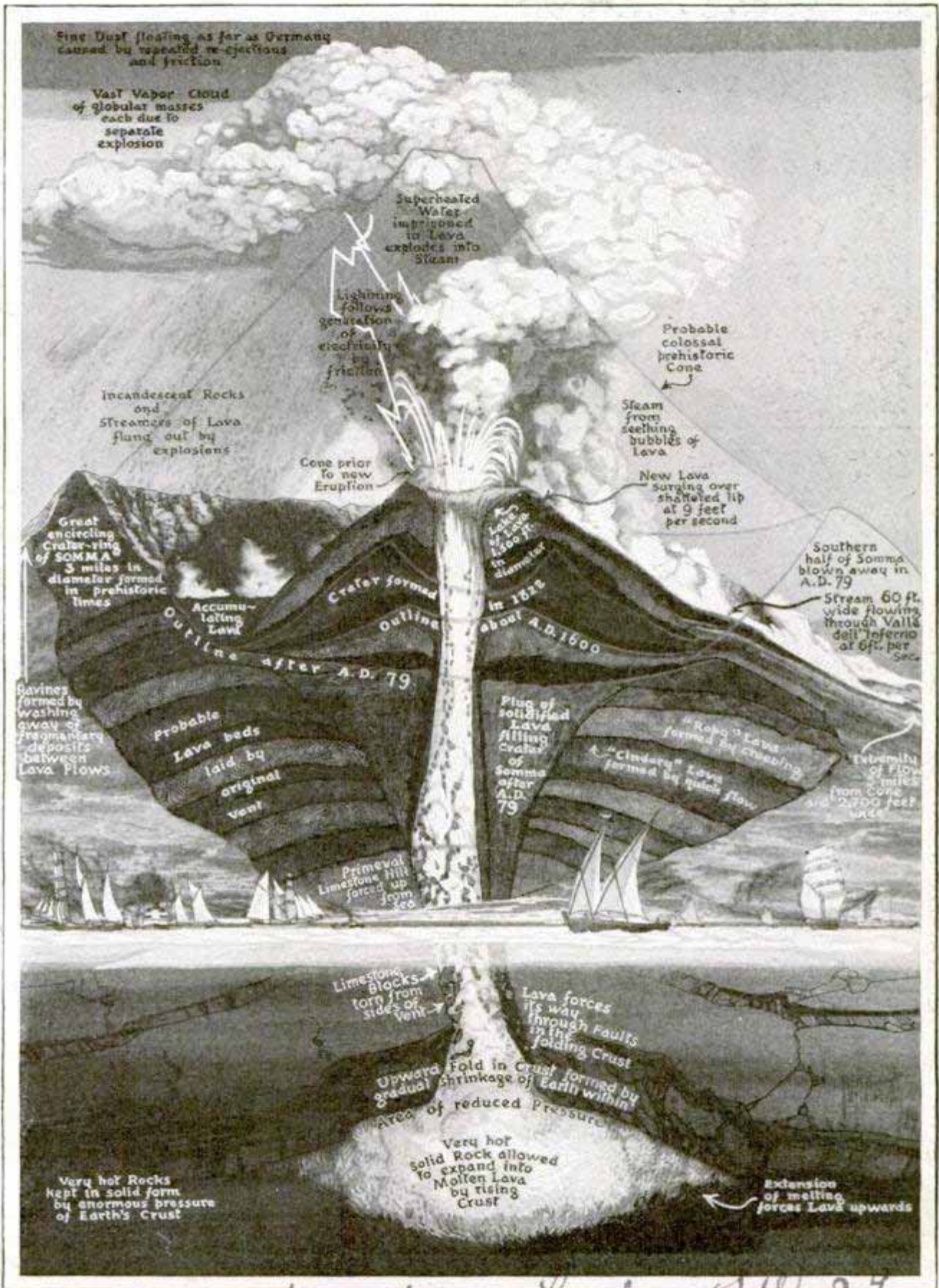

© S. W. Clatworthy, 916 Tulse Hill, London, N.W. 2, Eng.
 Diagram Illustrating the Life History of Vesuvius, Which Owe Its Splendid Shape Largely to the Fact That the Great Vent Has Remained Practically Unmoved Throughout the Ages

3356

3401

see April 1929. 6/16.
Dunlop
Siro & Rubber Co
West Road, Buffalo, N.Y.



Practicing Service Shots with the Aid of "Machine Gun" That Fires Tennis Balls at Player at Twelve Different Speeds

MACHINE GUN SERVES TENNIS BALLS TO PLAYERS

To aid tennis players in strengthening their returns on services, a machine gun to serve the balls has been developed. The gun holds a load of thirty-six balls and can be adjusted to fire them at the player at twelve different speeds.

PHONE LANGUAGE IS SOUGHT FOR INTERNATIONAL USE

What is the best language to use for international communication by telephone? Interesting facts have been revealed as the result of experiments with the various tongues. Italian is the most easily understood with German, English and French next in the order named. On the other hand, it is important to have a language in which the most can be said in the shortest time. From this standpoint, French ranked first, then came English, German and Italian. In general, the longer words are better understood, while short words have the advantage of speed.

3418
Edwin E. Slosson
in Colliers.

tered, 4,232 are licensed and 2,885 bear identification numbers. Computed on the basis of 1928 population estimates, California is the most "air-minded," with one plane for every 8,778 persons, while the District of Columbia ranks second with one for 9,200 persons. The market for open land biplanes is the largest in numbers with 2,991 such craft licensed, and cabin land monoplanes are next in favor with 1,093 licensed. Three states have less than five planes licensed or identified. Nevada has two, New Mexico, three, and Maine, four. Nineteen of the states have more than fifty each.

PISTOL SHOTS POISON SPRAY AT FLIES AND MOSQUITOES

Artillery, in the form of a toy pistol which fires a charge of poison at insects, is the latest weapon against flies, mosquitoes, spiders and other pests. The gun fires the concentrated poison spray on the insect, which expires in a few seconds. It is cocked by pressing the handle and fired by a trigger.



Spray Gun That Fires a Stream of Poison to Kill Insects. It Is Cocked by Pressing the Handle

Edw. Walter B. Kirten
549 E 80th Seattle Wash

8/26/29

3419

3400

NAVY'S LUNG SAVES TWENTY - SIX FROM SEA

Using the artificial "lung" recently developed for rescue work when men are trapped in submarines, twenty-six officers and bluejackets of the navy safely ascended from the after hatch of the reconstructed submarine "S-4" far below the surface during a successful test a few weeks ago. In some respects the lung resembles a gas mask. It consists of an oxygen bag with a container of soda lime in one corner. A tube leads from the oxygen compartment and from the lime canister to a mouthpiece, and the entire lung is strapped loosely about the neck and body. A nose clamp is provided to keep from drawing in salt water through the nostrils. The feature of the mouthpiece is the rubber flange which fits inside the lips and against the teeth and gums to form a firm and water-tight grip. In conducting the rescue tests with the device, use was made of a newly developed telephone set by which persons on the pier could talk clearly to the men in the submerged submarine.

Co-1st Lieut. C. B. Morris

Philadelphia Navy Yard

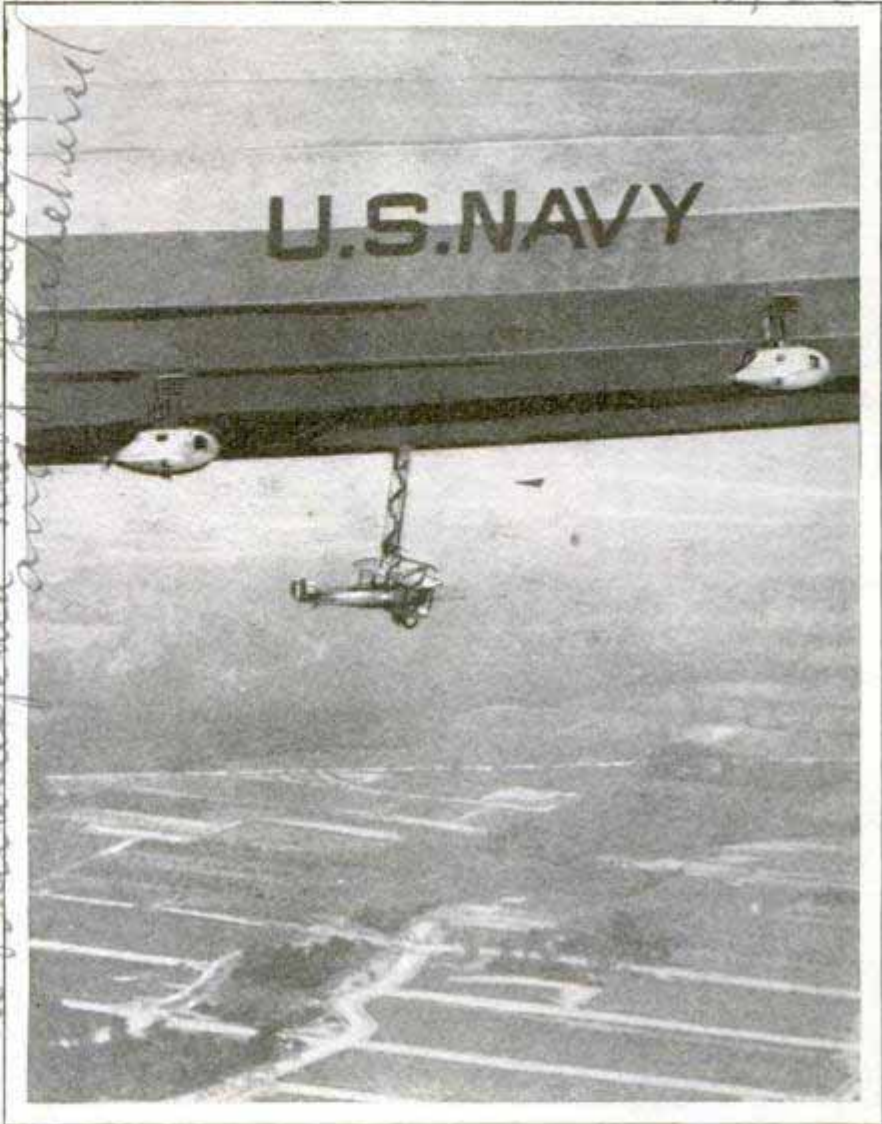

Plane Safely Hooked to the "Los Angeles"; Engineers Predict This System Will Be Used to Transfer Passengers

PLANE IS TOWED BY DIRIGIBLE AFTER CONTACT IN AIR

That passengers may be transferred between dirigibles and airplanes while both craft are in motion was demonstrated successfully at the air races in Cleveland when a plane made contact with the "Los Angeles"; a man climbed down into the cockpit from the big bag and was soon flying away in the plane. The dirigible is fitted with a ladder arrangement that is lowered from about the middle of the underside of the ship to provide a grip for

the airplane's hook. This latter unit is so arranged that it does not interfere with the usual operations of the plane and is raised in contact position simply by pulling a cord near the pilot's seat. Great skill is needed on the part of the plane's pilot and the operators of the dirigible in making a contact of this kind and the weather conditions must be suitable.

ARTIFICIAL SUNLIGHT IN MINE

Workers in a large western mine, deprived of sunlight because they labor far below the ground, are henceforth to be provided with artificial sunshine. An ultraviolet-ray solarium, capable of treating 150 persons an hour, is to be installed in the "dry" room of the plant. It is expected to aid greatly in keeping the workmen in good health.

Walloo, ddah

San Francisco California
Mining & Concentration

3373 Henry Miller News Picture,
Service, Inc. 519-13th St NW, Washington, DC

Remarkable Aerial Photograph of the "Graf Zeppelin," as it Appeared Soaring over Chicago's Near North Side on Its Flight Eastward from Los Angeles to Lakehurst; the Cross-Country Journey Was a Triumphant Climax to the "Fastest Voyage by Any Man-Made Mechanism over the Greatest of the World's Oceans"; the Graf Flew over the Pacific in Sixty-Eight Hours; before Reaching Lakehurst, Dr. Hugo Eckener and Companions Caught a Searchlight Glimpse of Another Famous Dirigible, the "Los Angeles," Moored at Cleveland for the Air Races Going on There

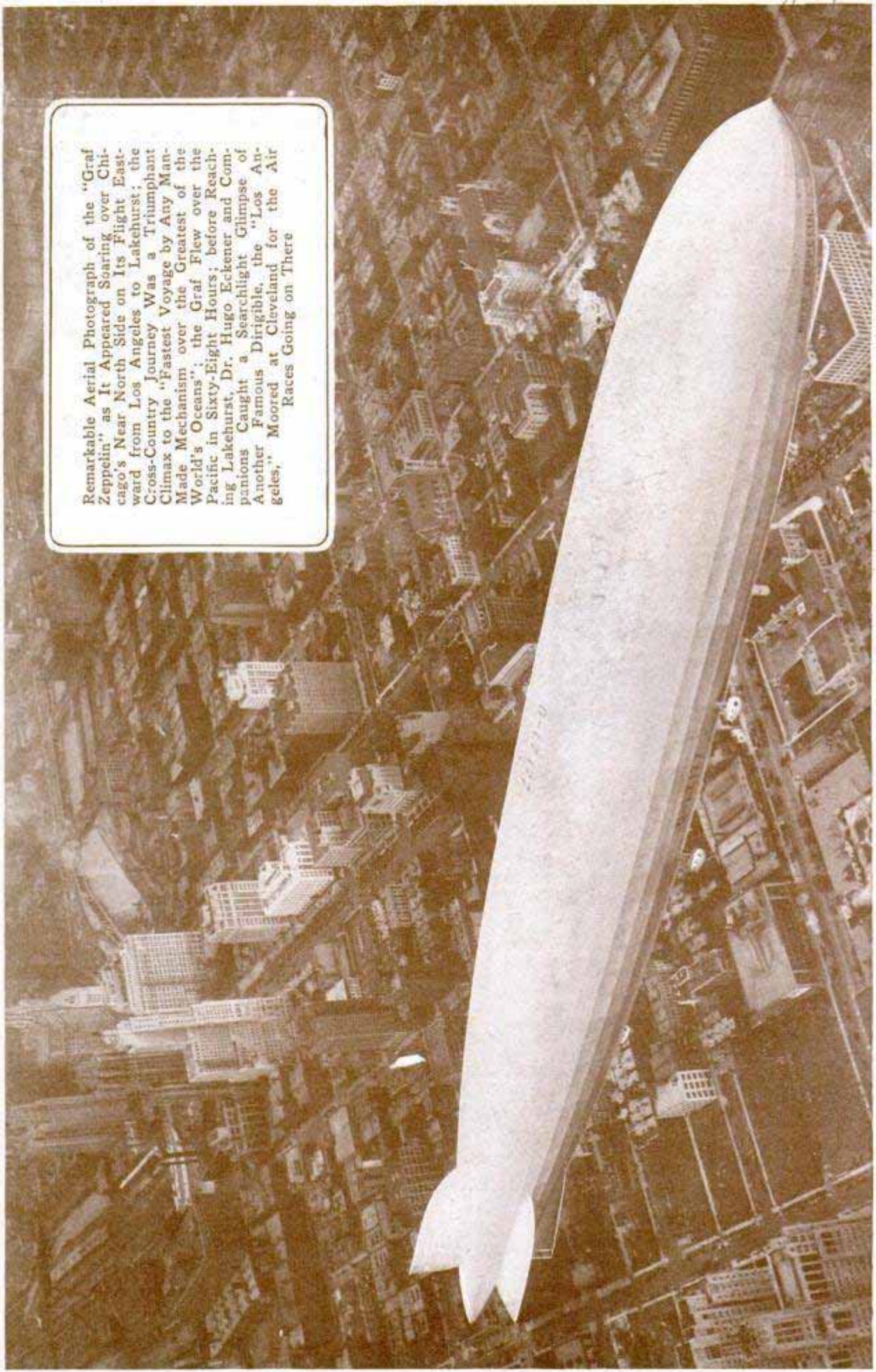

This picture

332 Michigan

With the Graf Zeppelin

Looking Up at One of the Streamlined Motor "Eggs," and Below, Evidence of a Near Tragedy; the Damage Was Done When the Graf Scraped High-Tension Wires at Los Angeles during Difficulty in Ascent

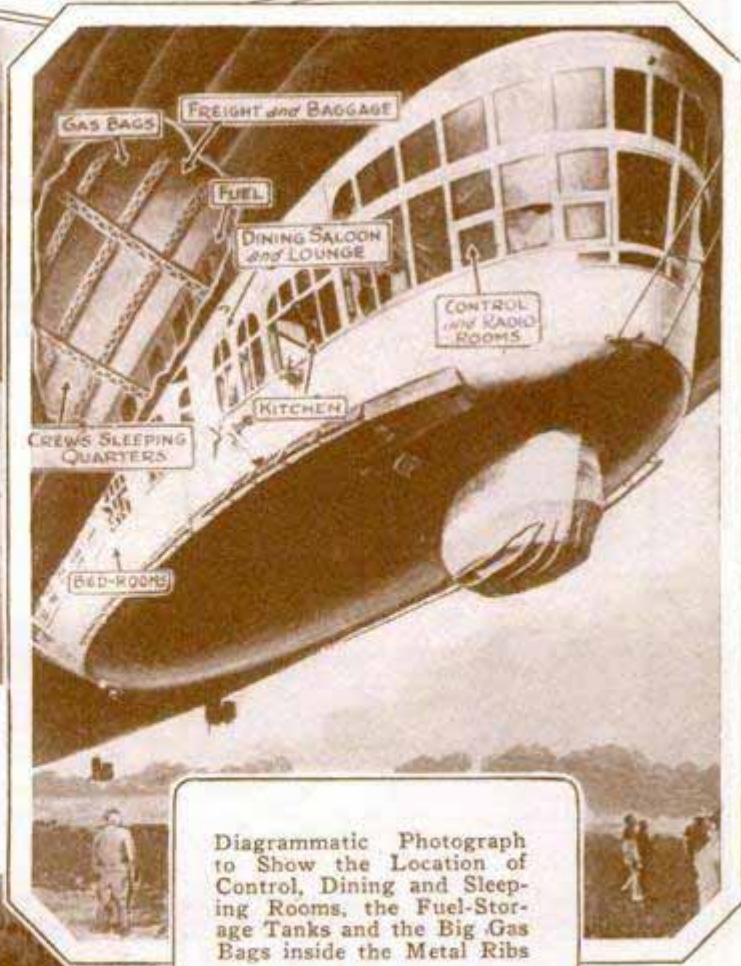

Diagrammatic Photograph to Show the Location of Control, Dining and Sleeping Rooms, the Fuel-Storage Tanks and the Big Gas Bags inside the Metal Ribs

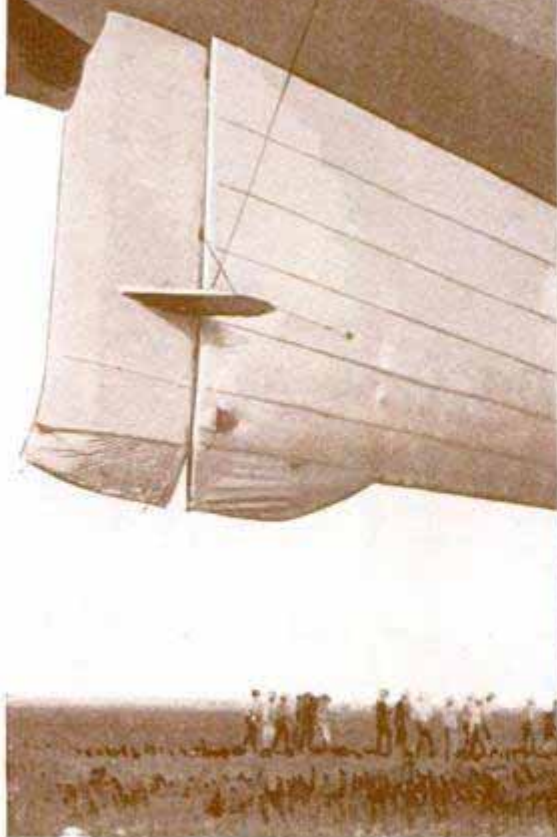

33 73
740

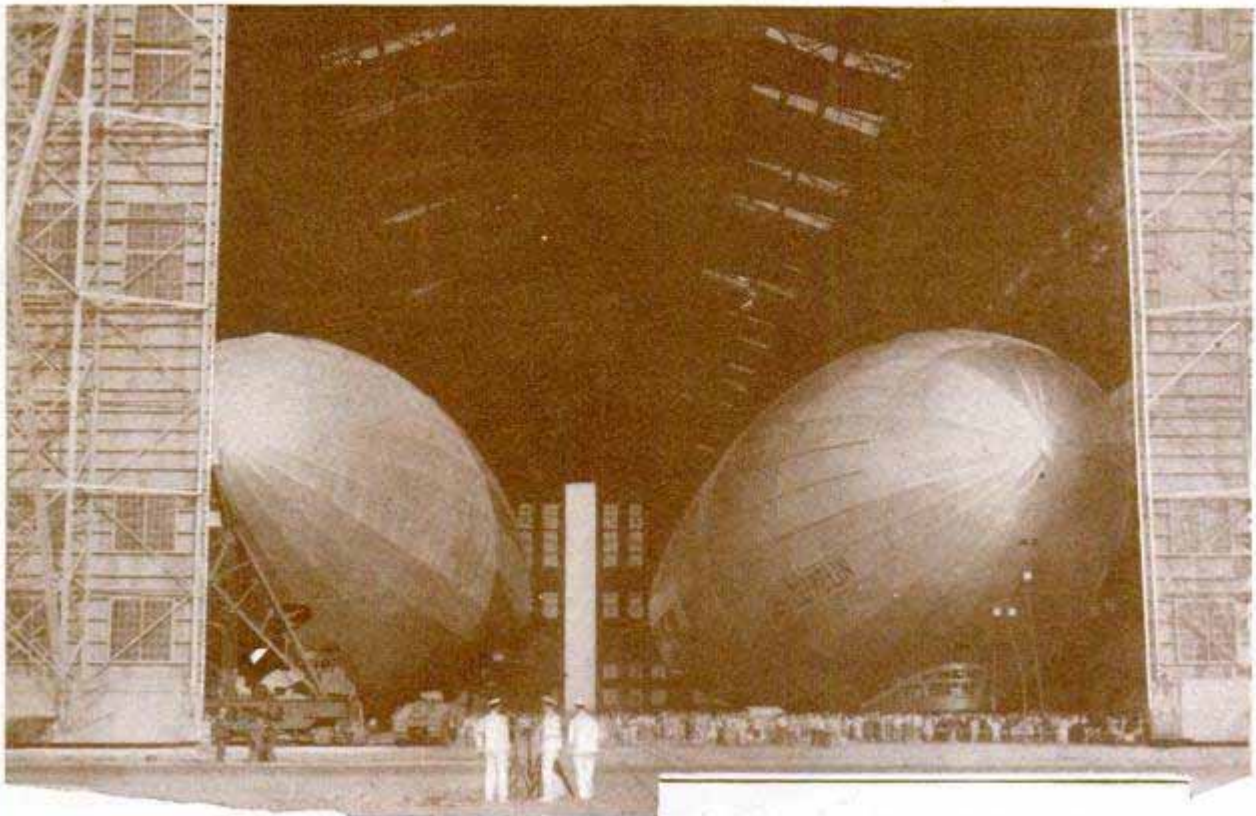

Above, the Navy Dirigible "Los Angeles" at the Left, and the "Graf Zeppelin" at the Right, as They Appeared in the Hangar at Lakehurst Before the German Ship Started on Its Round-the-World Flight; Below, Workmen Busy about the Gondola of the "Graf Zeppelin" Preparing the Air Liner for the Start of Its Globe-Circling Journey from Lakehurst.

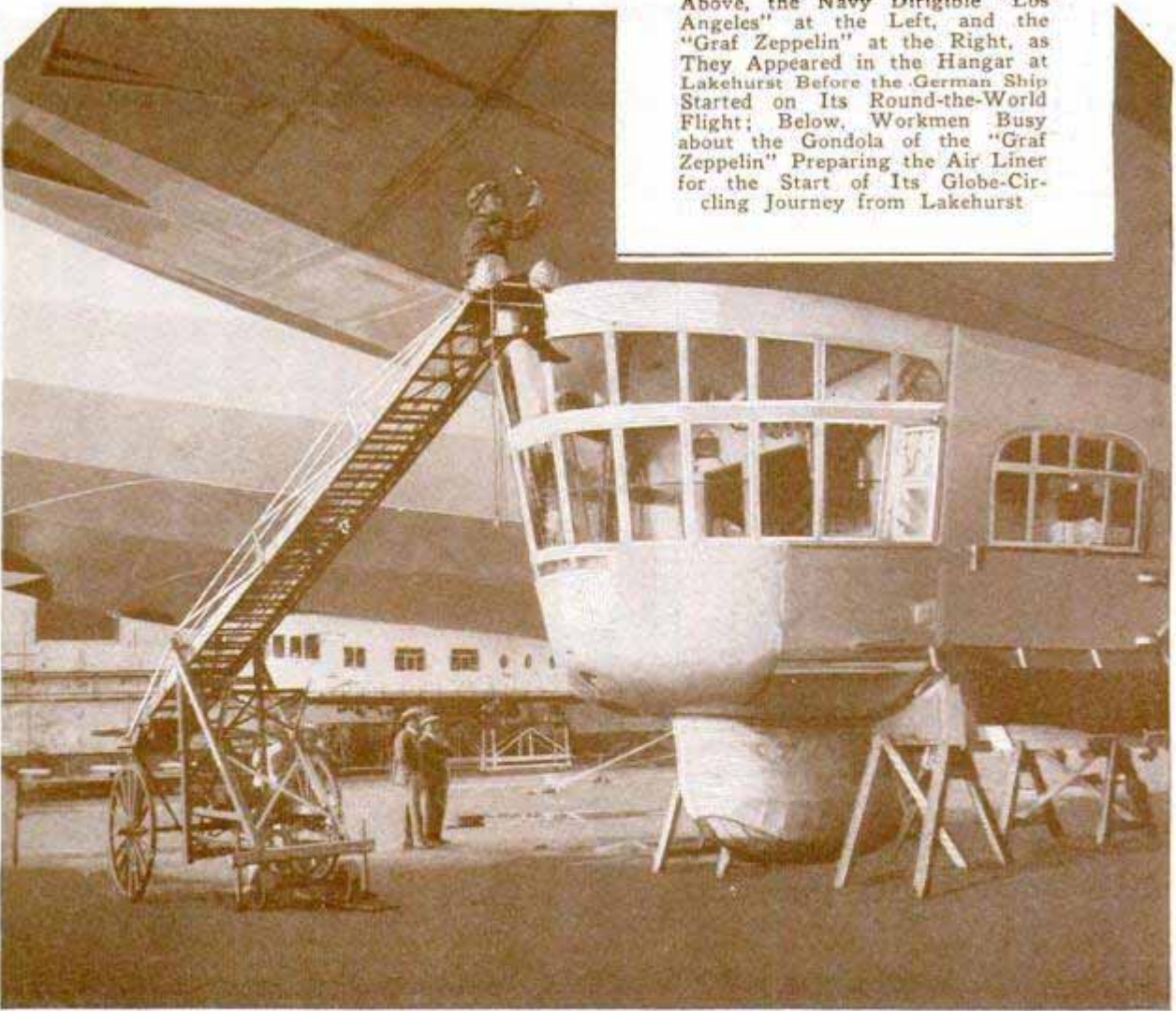

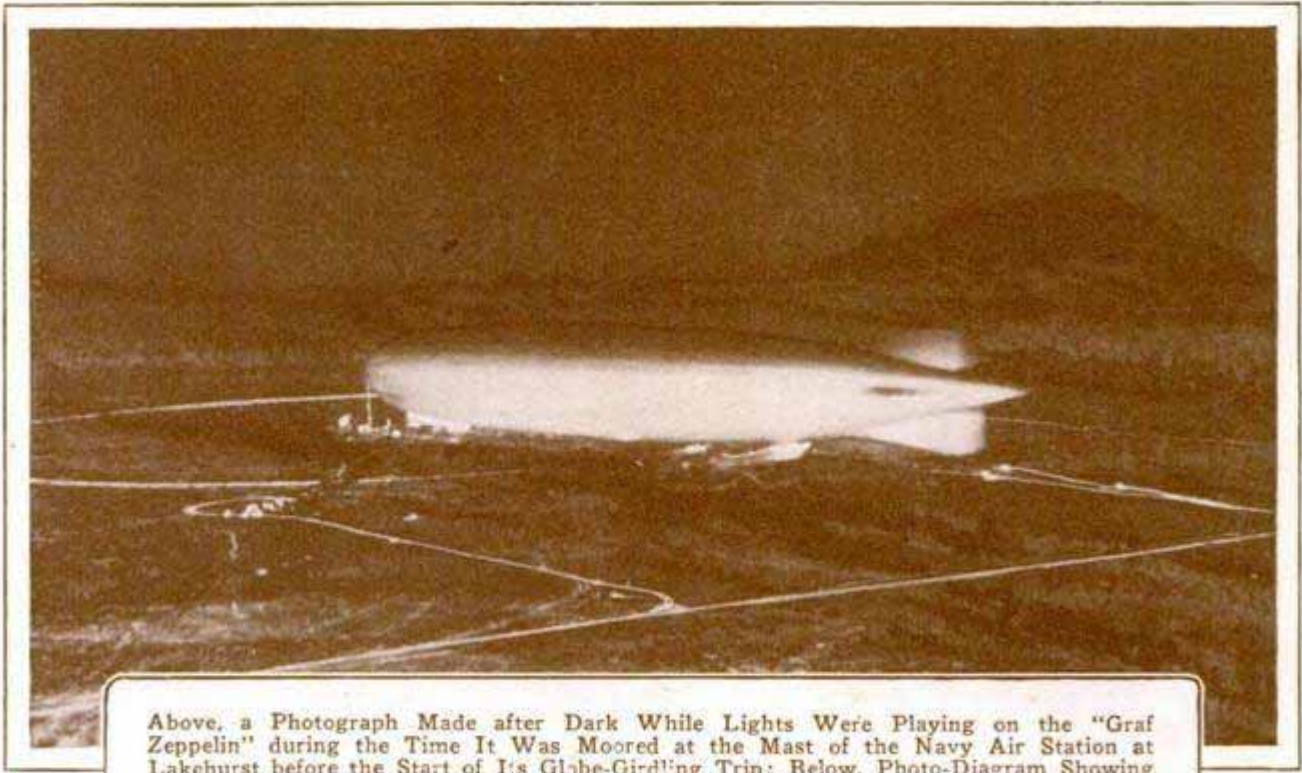

Above, a Photograph Made after Dark While Lights Were Playing on the "Graf Zeppelin" during the Time It Was Moored at the Mast of the Navy Air Station at Lakehurst before the Start of Its Globe-Girdling Trip; Below, Photo-Diagram Showing How the "Zeppelin" Was Refueled at Los Angeles and Other Stops

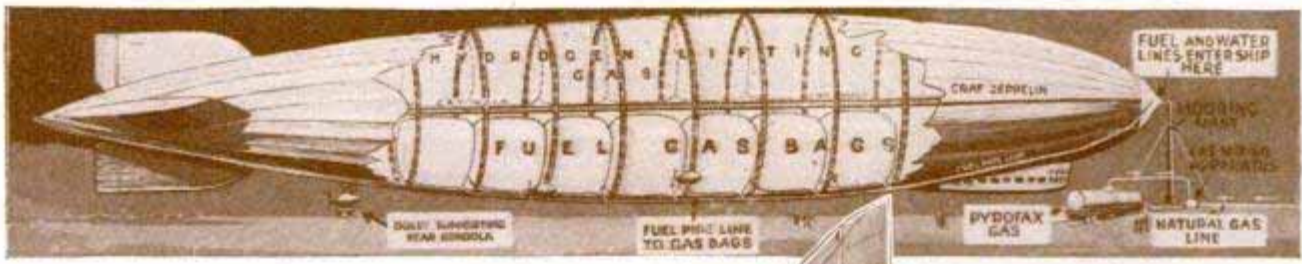

This Photograph, Taken at the "Graf Zeppelin's" Home Port, Friedrichshafen, Germany, Shows a Stern View of the Giant Dirigible with the Huge Fins and Rudders, as the Ship Was About to Take Off on Its First Test Flights over Lake Constance; the Initial Flights Were Most Successful, Dispelling the Doubts of Many Experts Concerning the Possibilities of the Craft

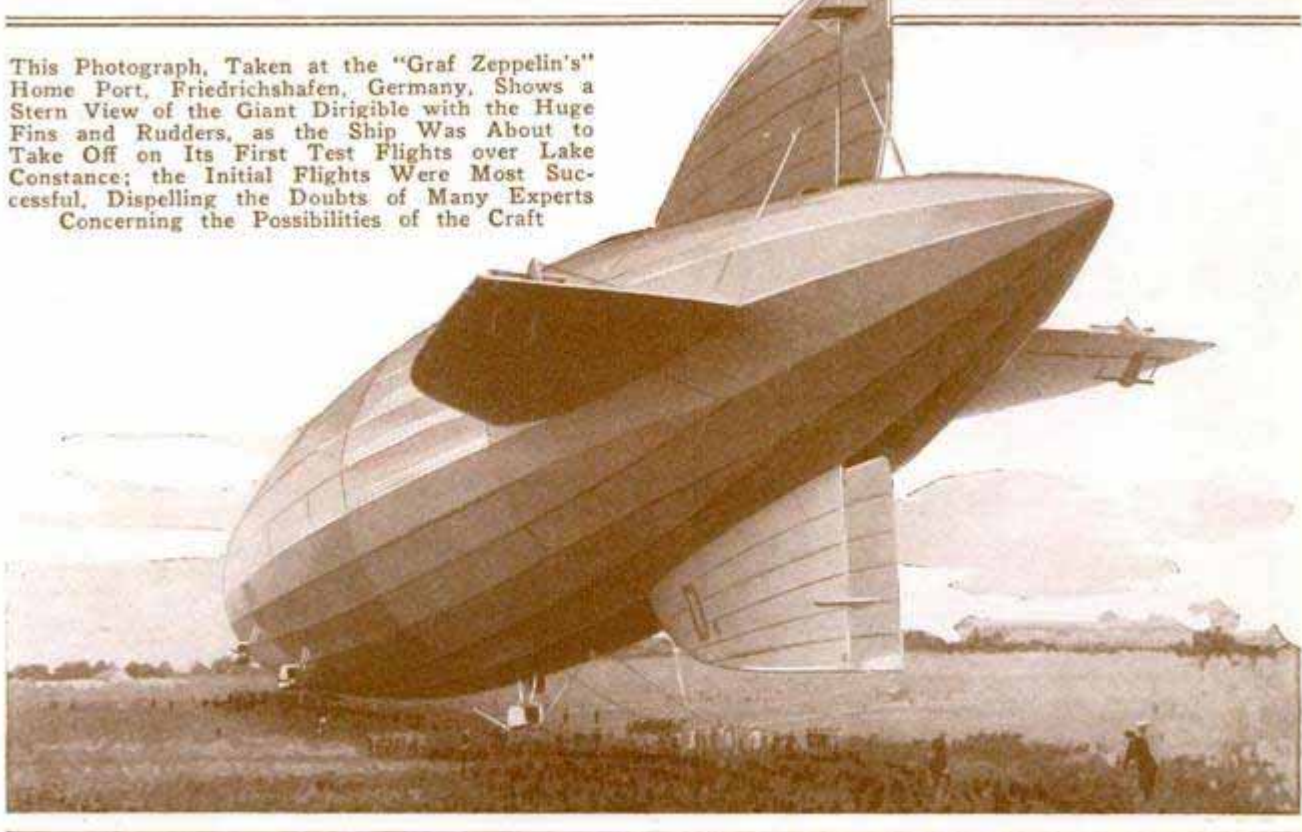

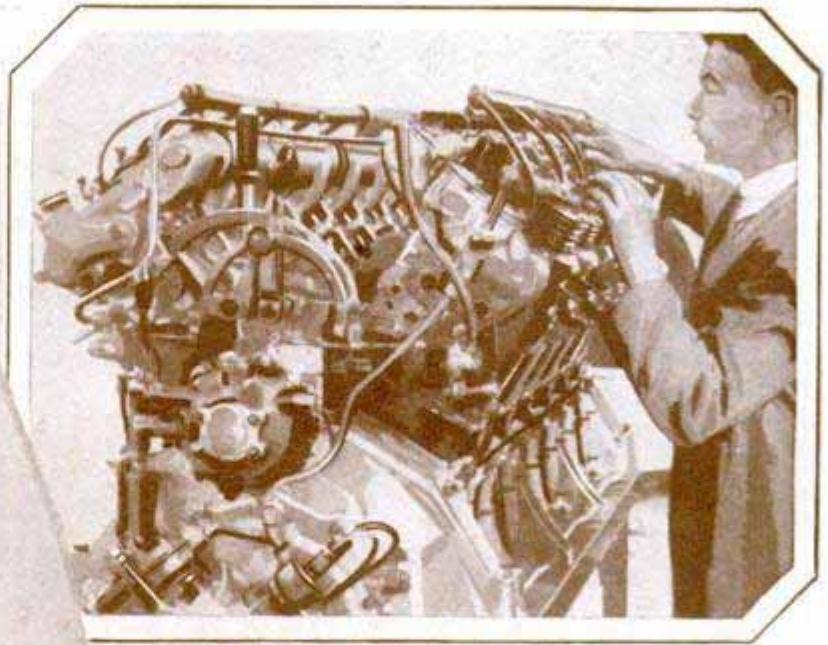

Above, Inspecting One of the Five 520-Horsepower Rohrbach Engines Which Carried the "Graf Zeppelin" around the World; Left, Lady Drummond Hay, English Noblewoman and Newspaper Writer, Who Was the Only Woman Passenger on the Round-the-World Trip, and, Below, One of the Powerful Engines Being Hoisted into Its Gondola as the Dirigible Was Nearing Completion; the Airship Has a Capacity of 3,750,000 Cubic Feet and Uses for Fuel a Gas Having Approximately the Same Specific Gravity as Air; It Has Accommodations for Fifteen Passengers with a Lounge, Dining Room and Ten Double Bedrooms for Their Comfort, and Easily Carries a Load of Fifteen Tons; a Kitchen with the Latest Electrical Equipment Provides the Meals, and the Dining Rooms Seat Forty Persons While a Crew of Two Score or More Operates the Great Ship

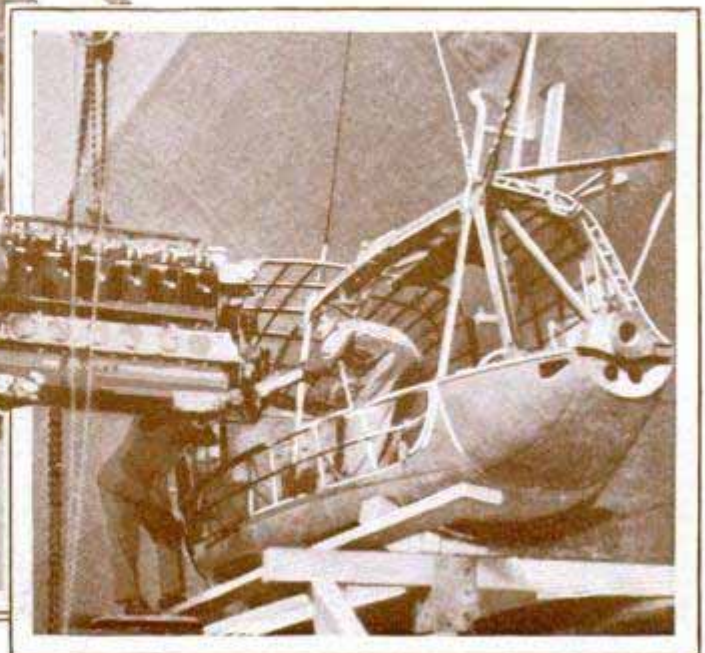

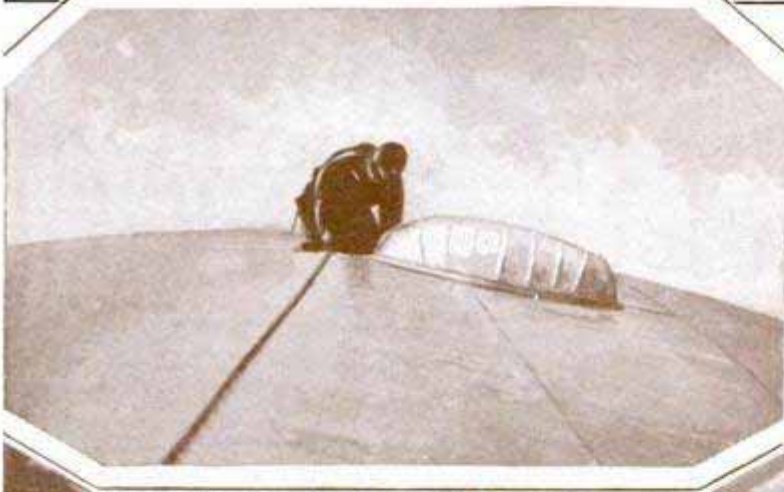

Above, Three of the "Zeppelin" Crew Who Previously Brought the "ZR-3," Now the "Los Angeles," to the United States; Left to Right, Anton Wittmann, Navigator; Capt. E. A. Lehman, First Officer, and H. Von Schiller, Navigator; at Left, a Member of the Crew Climbing Up through a Hatchway to Make an Inspection of the Dirigible's Fabric; This Picture Was Taken from Another Hatchway



Mount Fuji, Seventy Miles from Tokyo, and a Sacred Beauty Spot of Japan, Is Pictured Above; over This and Other Such Scenes the Zeppelin Passed on Its Tour around the World

3393

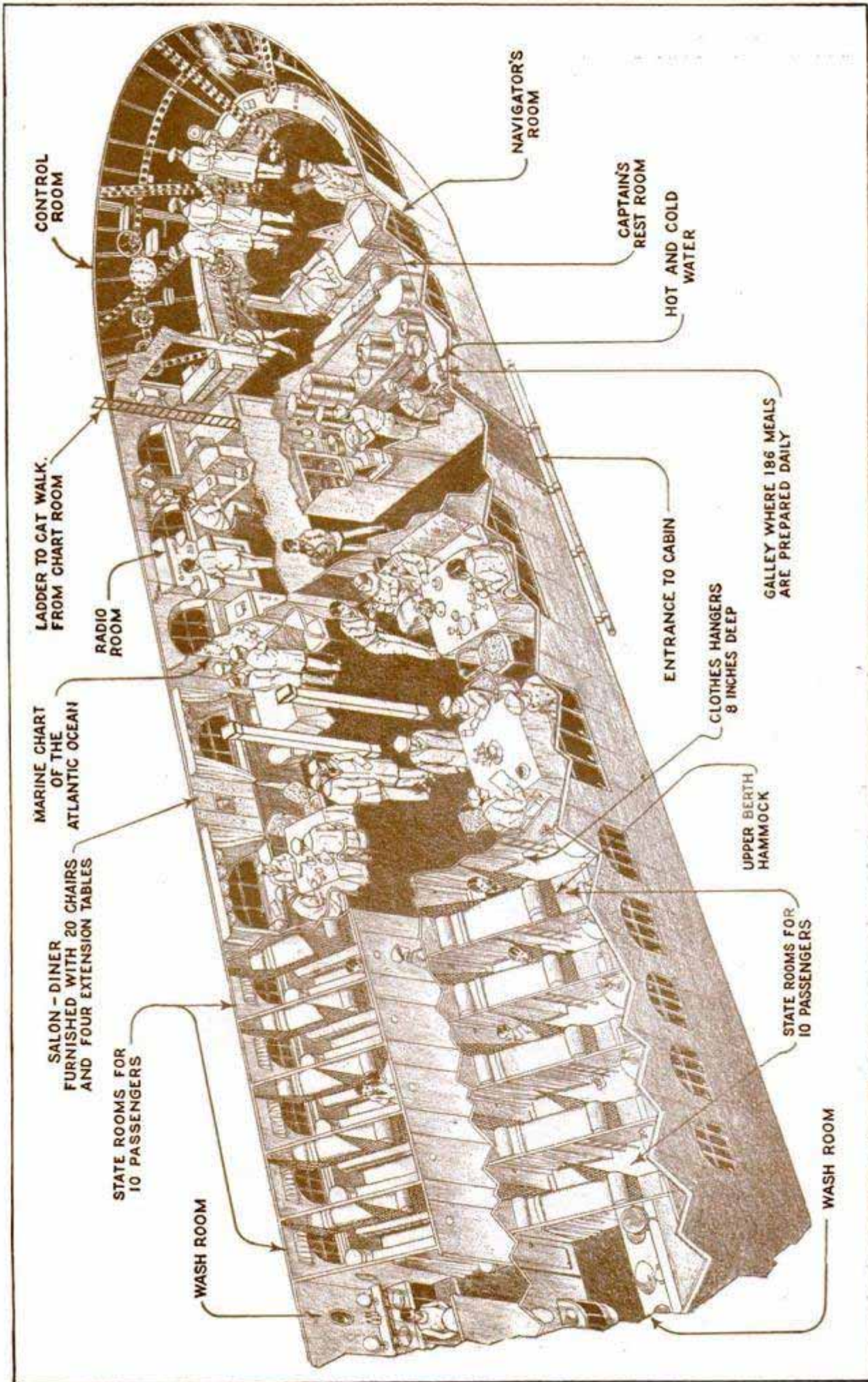

Above Is an Artist's Drawing of the Interior of the Zeppelin's Luxurious Gondola, Showing the Arrangement of State Rooms for Passengers, the Dining Salon, Chart Room, Radio Room, the Captain's Quarters, the Control Room and the Navigator's Quarters.

3373

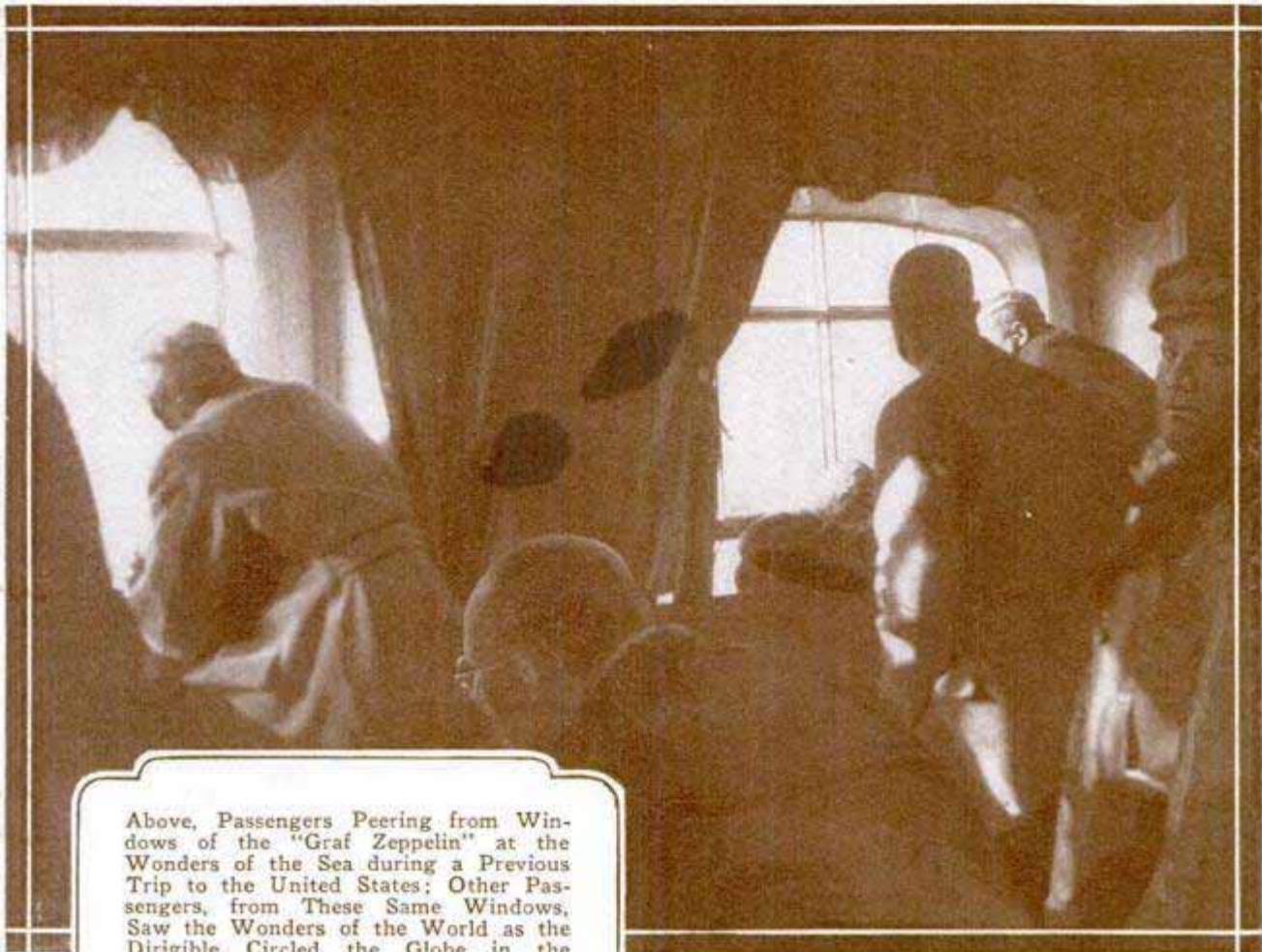

Above, Passengers Peering from Windows of the "Graf Zeppelin" at the Wonders of the Sea during a Previous Trip to the United States; Other Passengers, from These Same Windows, Saw the Wonders of the World as the Dirigible Circled the Globe in the Shortest Time Ever Consumed by Land, Sea or Air Craft; Three Weeks from the Time the Ship Left Lakehurst, It Landed There Again and Its Elapsed Time for the Trip Was About Thirteen Days; Below, Potsdamer Place, Berlin, One of the Busiest Sections, with Its Traffic Tower in the Center; It Was above Such Scenes That the Balloon Soared on Its Start for America

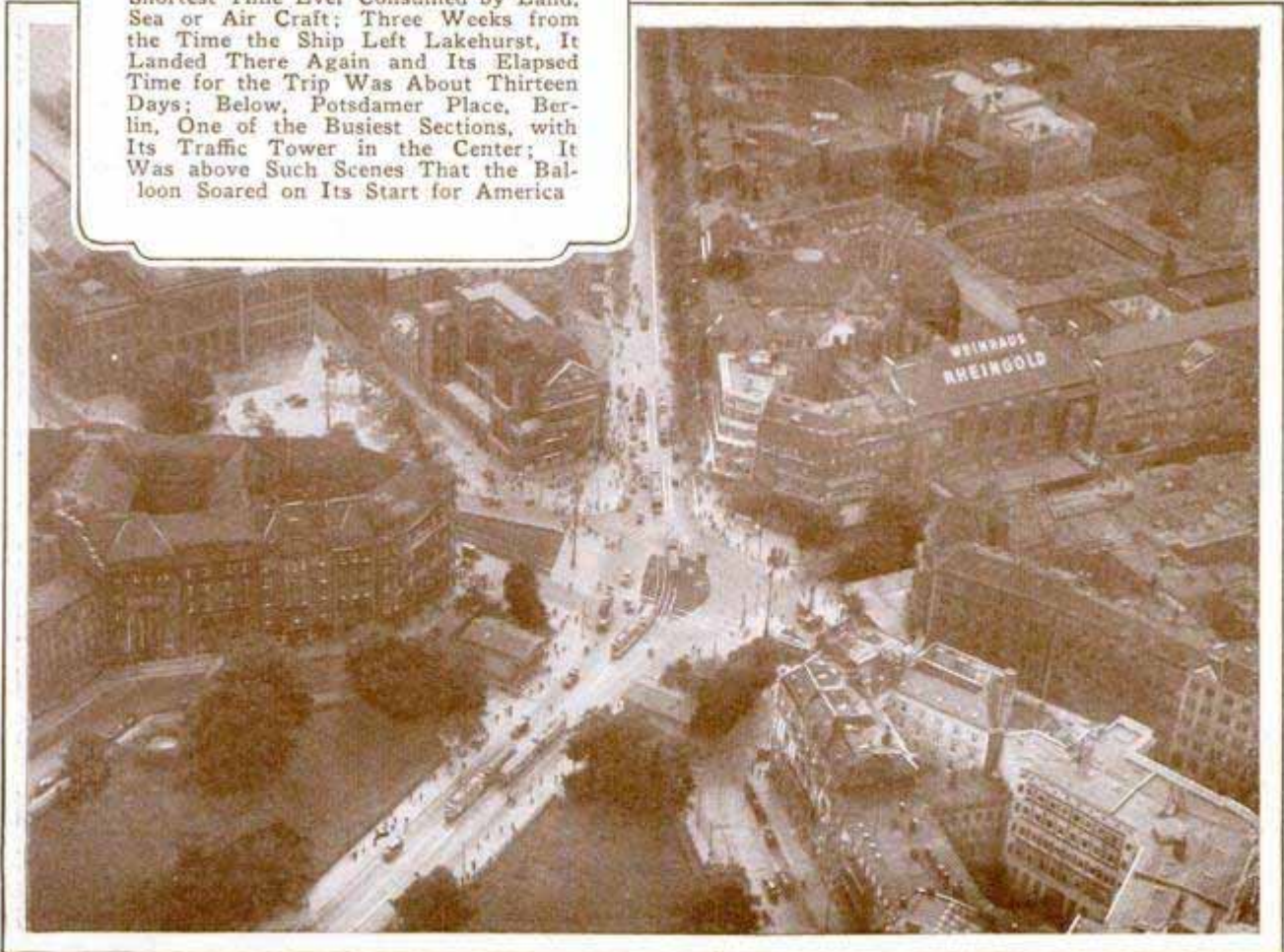

3343
746

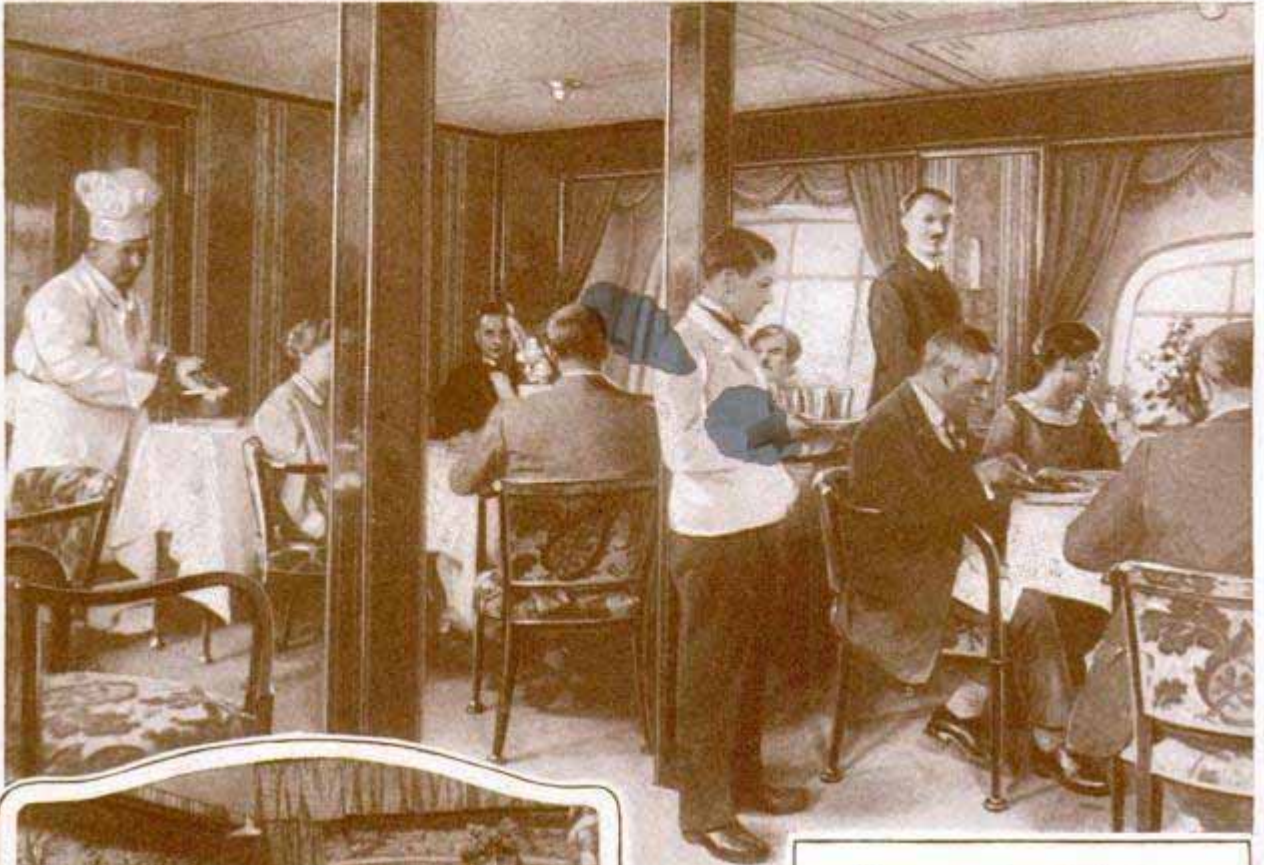

Above, a View of the Luxurious Zeppelin Dining Room, Showing How Passengers Were Served Their Meals on the World Flight, and, at Left, One of the Sleeping Rooms for Passengers, Which Is Equipped with Every Luxury to Be Found in the Cabin of a Modern Liner

At the Right Is Shown an Interesting View of the Tiny Kitchen in Which Was Prepared All the Food Served to the Passengers and Crew of Sixty Persons during the World Tour; the Kitchen Is a Model of Efficiency and Is Equipped with Every Kind of Electrical Device Which Would Save Time and Space in Preparing the Meals

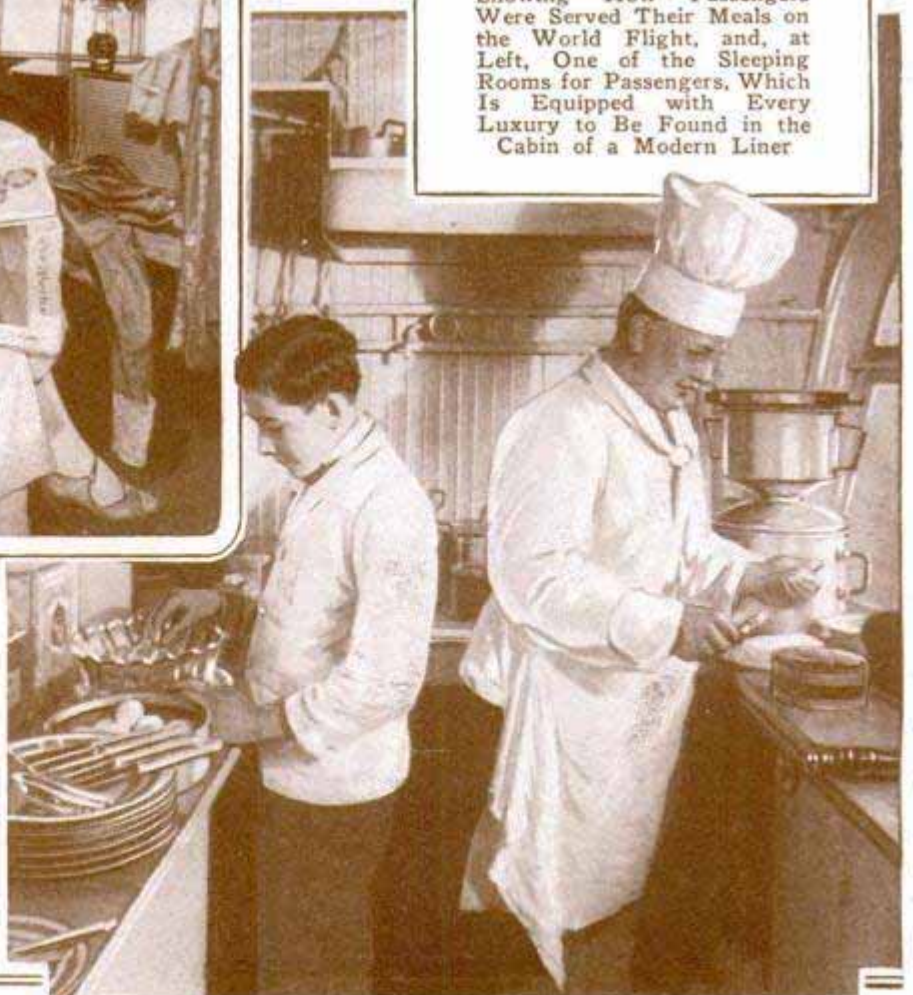

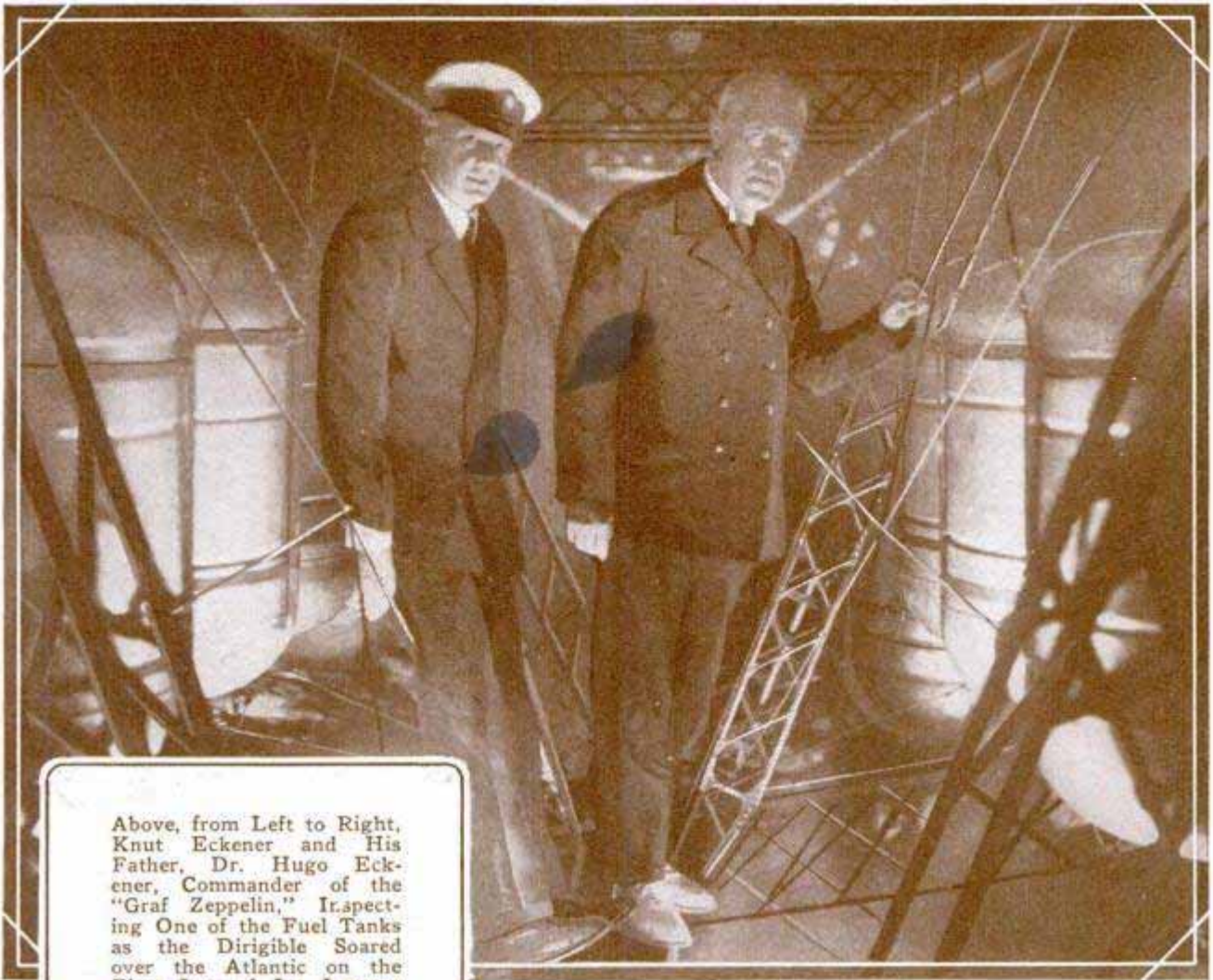

Above, from Left to Right, Knut Eckener and His Father, Dr. Hugo Eckener, Commander of the "Graf Zeppelin." Inspecting One of the Fuel Tanks as the Dirigible Soared over the Atlantic on the First Leg of Its Journey around the World; It Was the Son Who Risked His Life to Repair Damage to the Ship during Its First Trip to America in 1928; Below, Lady Drummond Hay and Other Passengers Getting Their First View of the United States



3313

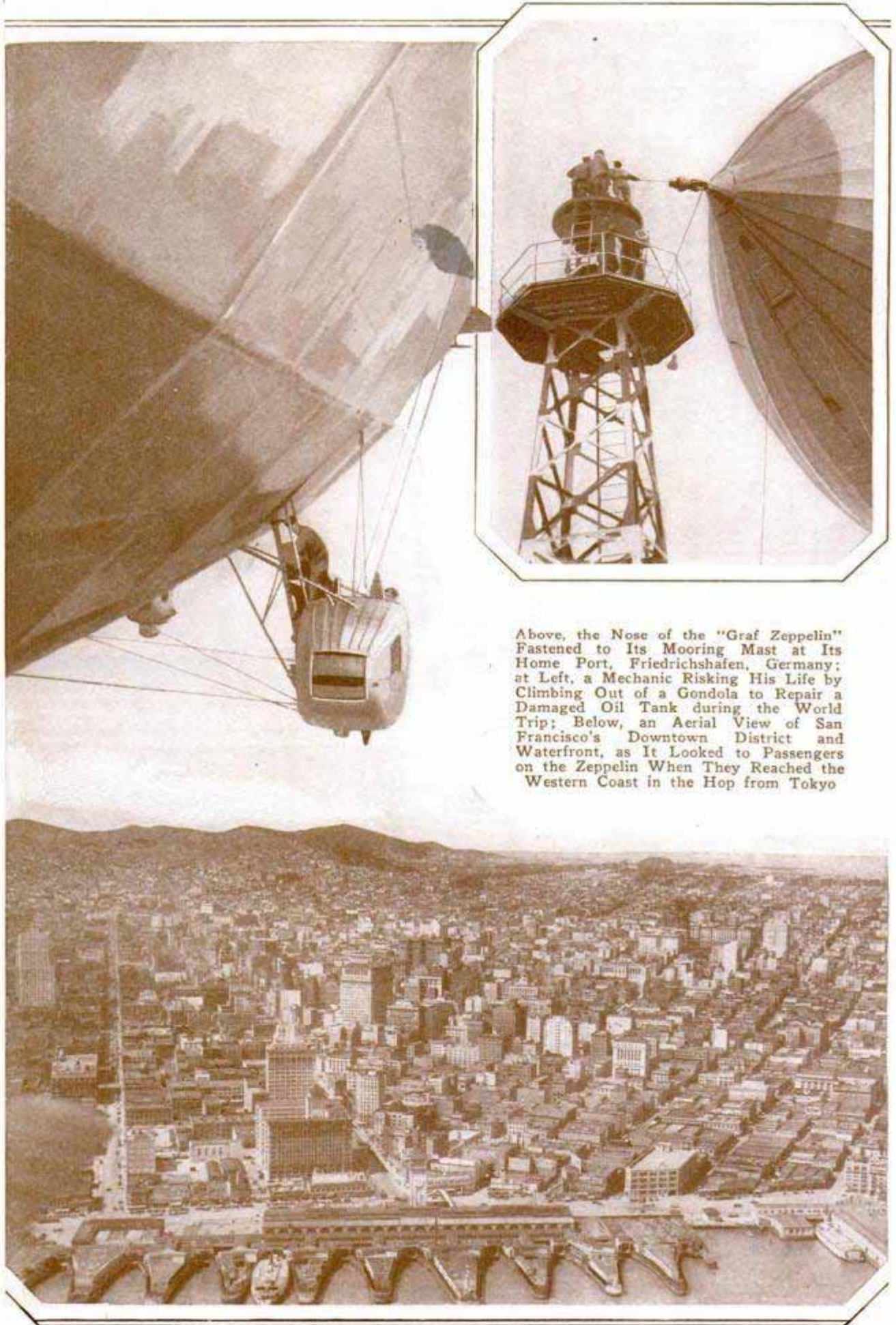

Above, the Nose of the "Graf Zeppelin" Fastened to Its Mooring Mast at Its Home Port, Friedrichshafen, Germany; at Left, a Mechanic Risking His Life by Climbing Out of a Gondola to Repair a Damaged Oil Tank during the World Trip; Below, an Aerial View of San Francisco's Downtown District and Waterfront, as It Looked to Passengers on the Zeppelin When They Reached the Western Coast in the Hop from Tokyo

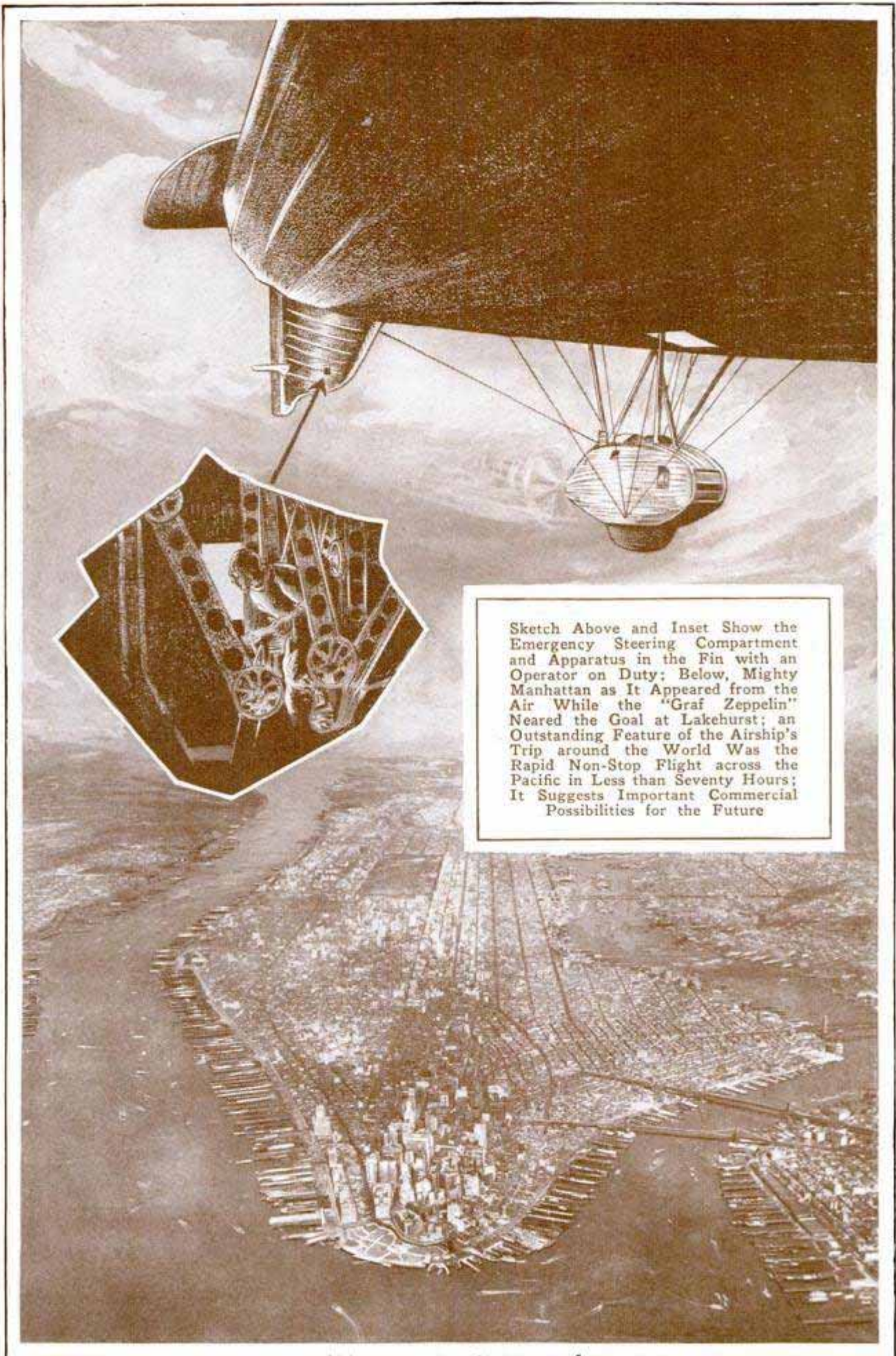

3393

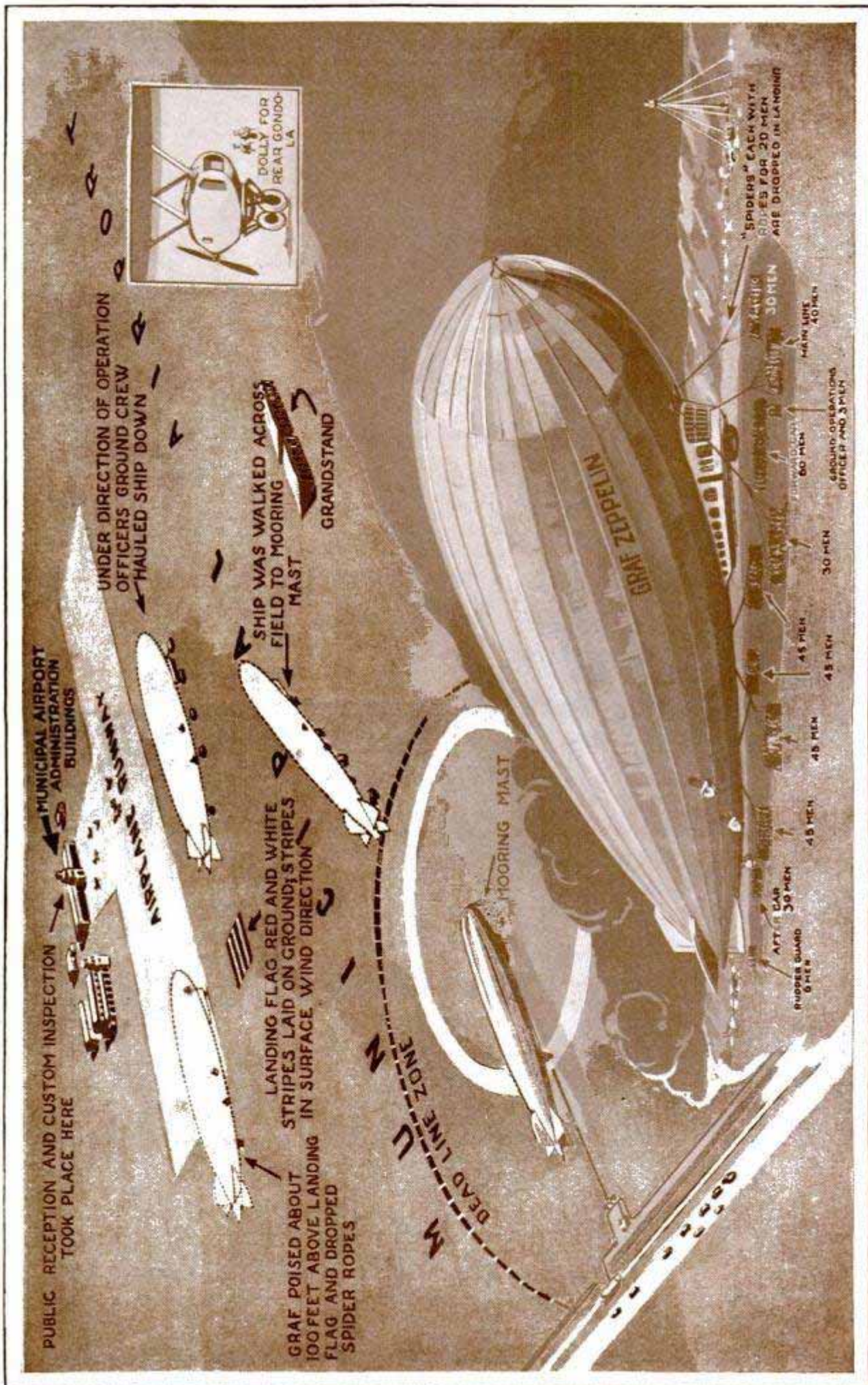

How the Graf Was Moored at Mines Field, Los Angeles, After It Had Been Halted a Moment before the Administration Building on the Airport: Note the Number and Position of the Squads of Men Needed to Handle the Big Craft and Walk It Safely to the Mast

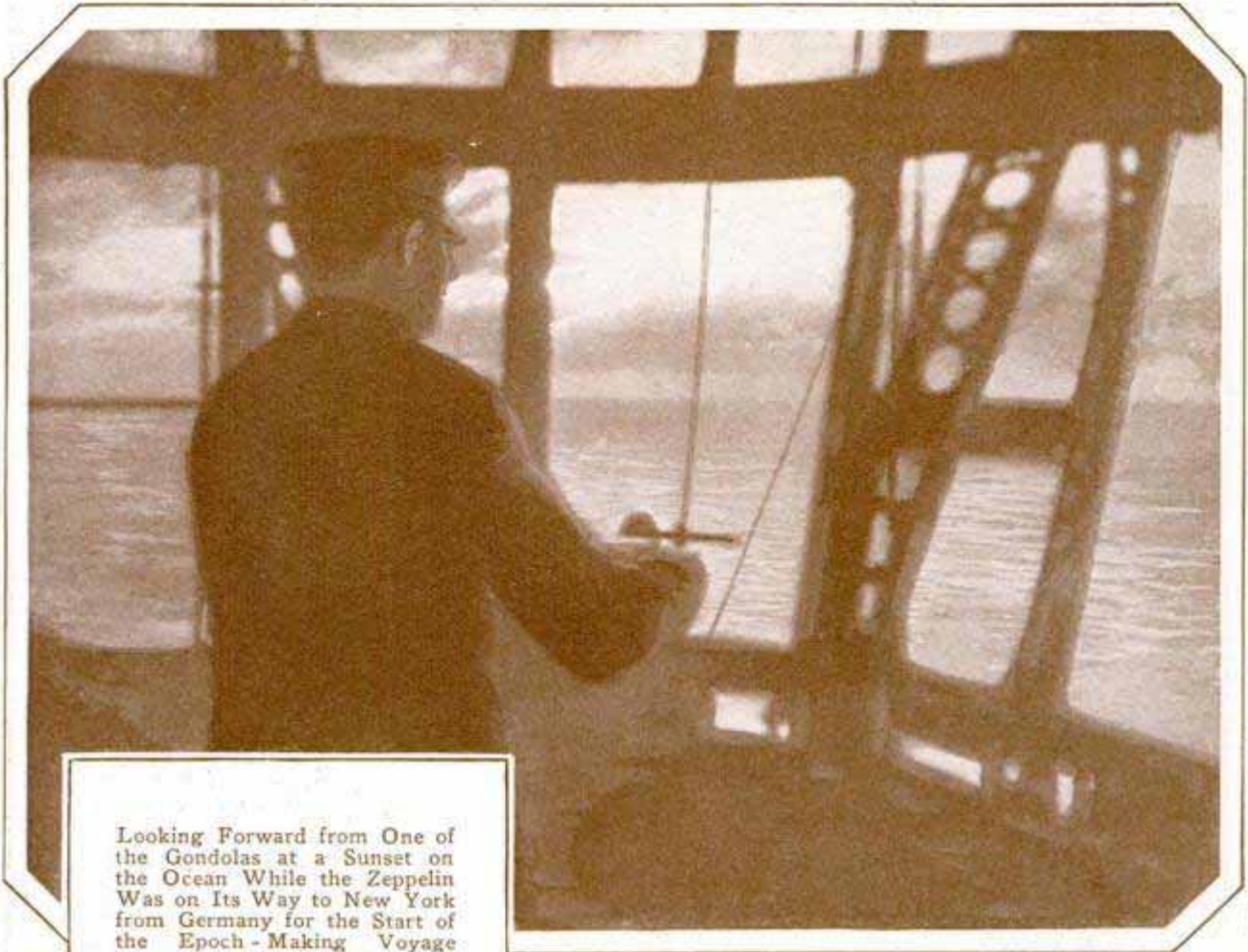

Looking Forward from One of the Gondolas at a Sunset on the Ocean While the Zeppelin Was on Its Way to New York from Germany for the Start of the Epoch - Making Voyage around the World

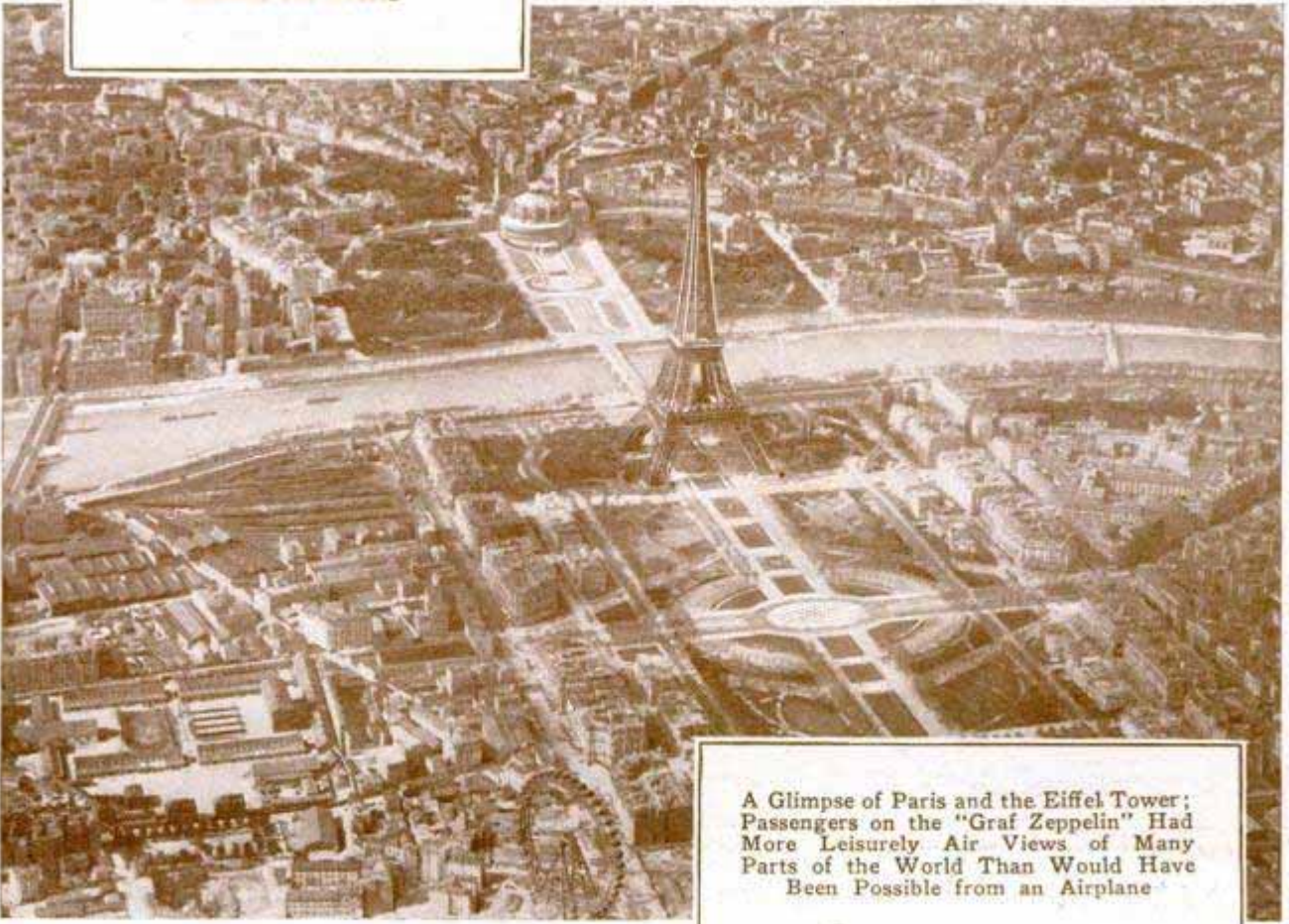

A Glimpse of Paris and the Eiffel Tower; Passengers on the "Graf Zeppelin" Had More Leisurely Air Views of Many Parts of the World Than Would Have Been Possible from an Airplane

3404

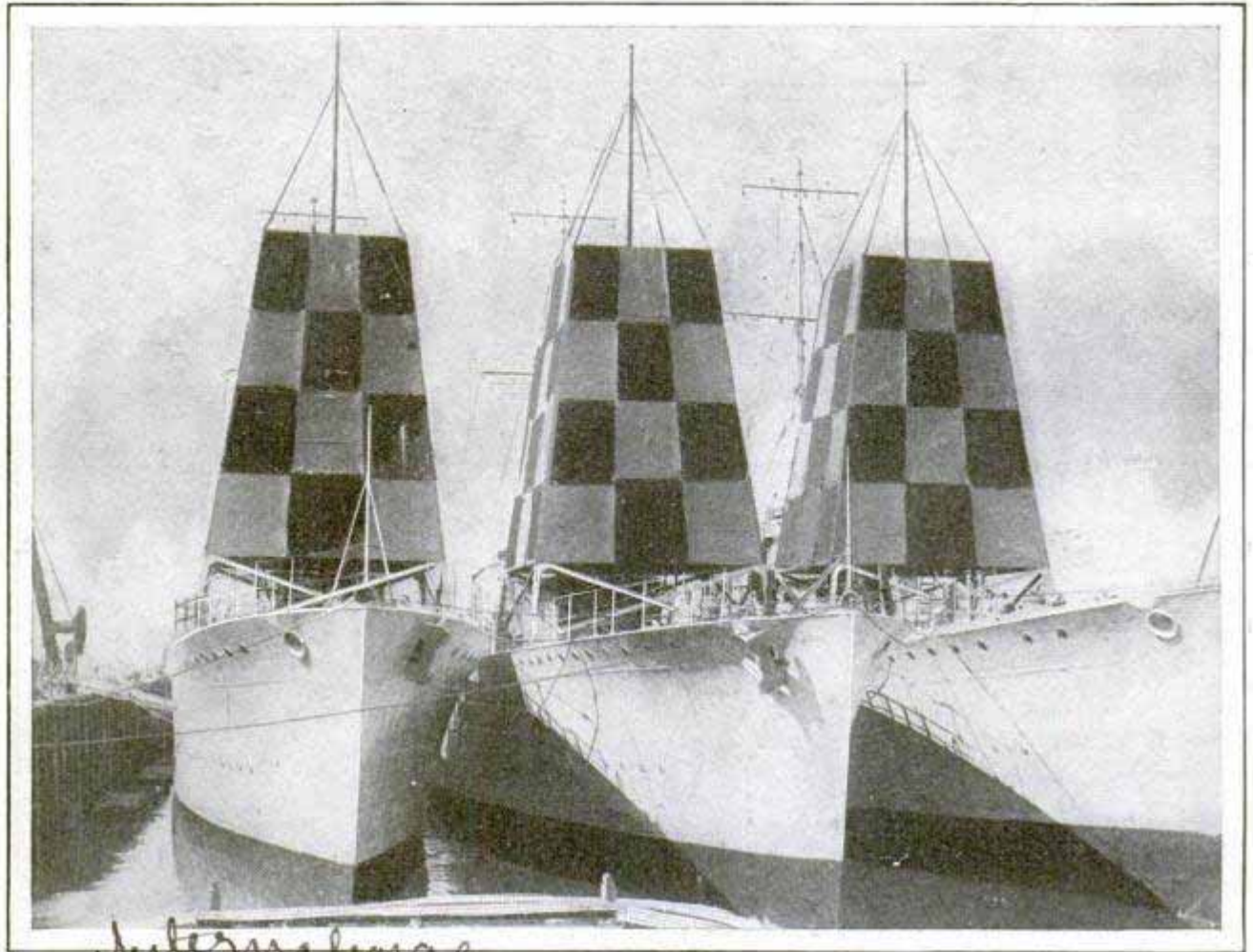

Destroyers Fitted to Serve as Markers in the Schneider Cup Races; the Distinctive Pattern and Colors of the Pylons Make Them Visible for a Considerable Distance

PYLONS BORNE ON DESTROYERS ARE AIR-RACE MARKERS

Three British destroyers were outfitted with pyramid-shaped pylons mounted on their forward decks, to serve as markers in the Schneider cup races. The pylons carried on the ships marked the turning points for the competing planes.

PENCIL WRITES THREE COLORS WITH INTERCHANGING LEADS

Capable of writing in any one of three colors by simply pressing a button, a handy pencil which saves the time of artists, designers and draftsmen is now on the market. The pencil carries black, blue



Sectional View of the "Magazine" Pencil That Holds Leads of Different Colors

and red leads, any one of which may be drawn out of position and another in-

serted by pressure of the finger. The pencil also may be fitted with yellow, green or indelible leads, and comes in a variety of exterior colors.

CATTLE THRIVE ON IRON RUST MIXED IN FEED

By the addition of common iron rust to the diet of cattle tested at Iowa State college, beneficial results have been obtained in recent experiments. For eight months several groups of cattle were fed different rations, and at the end of the period, it was found that those which had the rust added to their rations had gained almost one-third more in weight than those which had been given the normal plain feed. An ounce of rust was given daily to each of the animals.

Ten per cent of the areas of the national parks will be open to travel when the present ten-year road-building program is completed.

Empire. Archer, Gray

Internationale

Ames Iowa

Chicago J. H. Steady 46/88 46/61

Tri-Kolor

nardi Mfg Co U.S. Canada

3421

3402

\$2.00 - \$3.50

Research Assn. for Woolen and
Worsted Industries

3362

TESTER FOR FABRIC SHOWS DEFECTS IN WEAVING

Knitted fabrics of various kinds are automatically tested with an interesting apparatus developed by a British inventor. It reveals irregularities in the finished textiles and also enables the inspectors to trace and correct the cause of defects, such as result from improper variation in the tension on the threads during the knitting operation.

FLEXIBLE SHAFT IS COUPLING FOR SHOP TOOLS

Increasing the usefulness of the average workshop, a flexible-shaft assembly is on the market that can be fastened to the shaft of an electric motor while the other end is equipped with attachments for various kinds of work. The assembly consists of an outer flexible steel casing, inside of which a shaft made of layers of piano wire rotates. Threaded ends permit fastening of a drive coupling to one end, and to the other adapters for a drill chuck, polishing and grinding wheels, small saws, groovers, routing cutters, wire scratch wheels and a carbon-removing brush.



A Canoe Made into a Sailboat by Adding Outrigger Beams and Stabilizers; an Engine Also May Be Attached

OUTRIGGER CANOE A SAFE BOAT FOR SAIL OR MOTOR

Canoeing has not only been made safe, but the thrills of sailing and motor-boating have been added to it, with the provision of outrigger beams to which stabilizers are attached. Two flexible spruce outrigger beams are used, metal air-tight stabilizers being attached to each end, making capsizing virtually impossible. With this arrangement, the canoe also may be equipped either with sails or with an outboard motor. In the latter case, a full canopy over the boat is provided. The equipment may be attached to any canoe in a few minutes without marring the craft, and one of its principal advantages is that it has a draft of only a few inches, and thus the boat may be used in very shallow water.

The Popular Mechanics' Bureau of Information offers its free service to all readers of our magazine. Names and addresses of manufacturers and dealers in articles described, and any other details in our possession, will be promptly furnished by addressing the bureau.

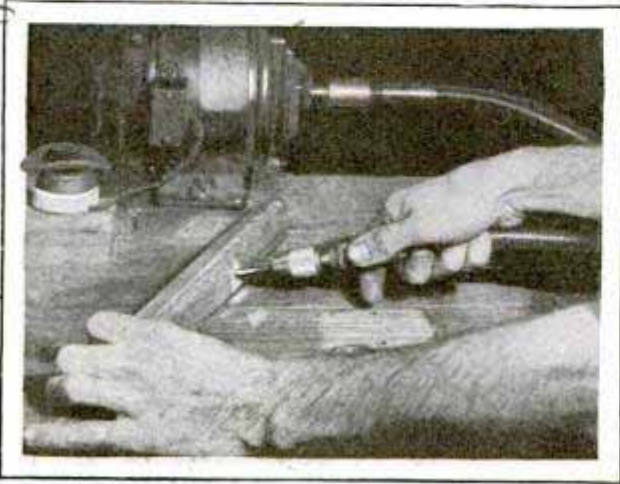

Flexible Shaft Which Provides a Coupling between a Portable Motor and Workshop Tools

Marketed through S.S. Kresge Co.

Torrington
Headingley
Leeds, Eng.

Park St. \$3.75.00 Job Factory
Laird & Sons
Norwich

Wagner & Co. Green City Mo. 66 Park St

3145

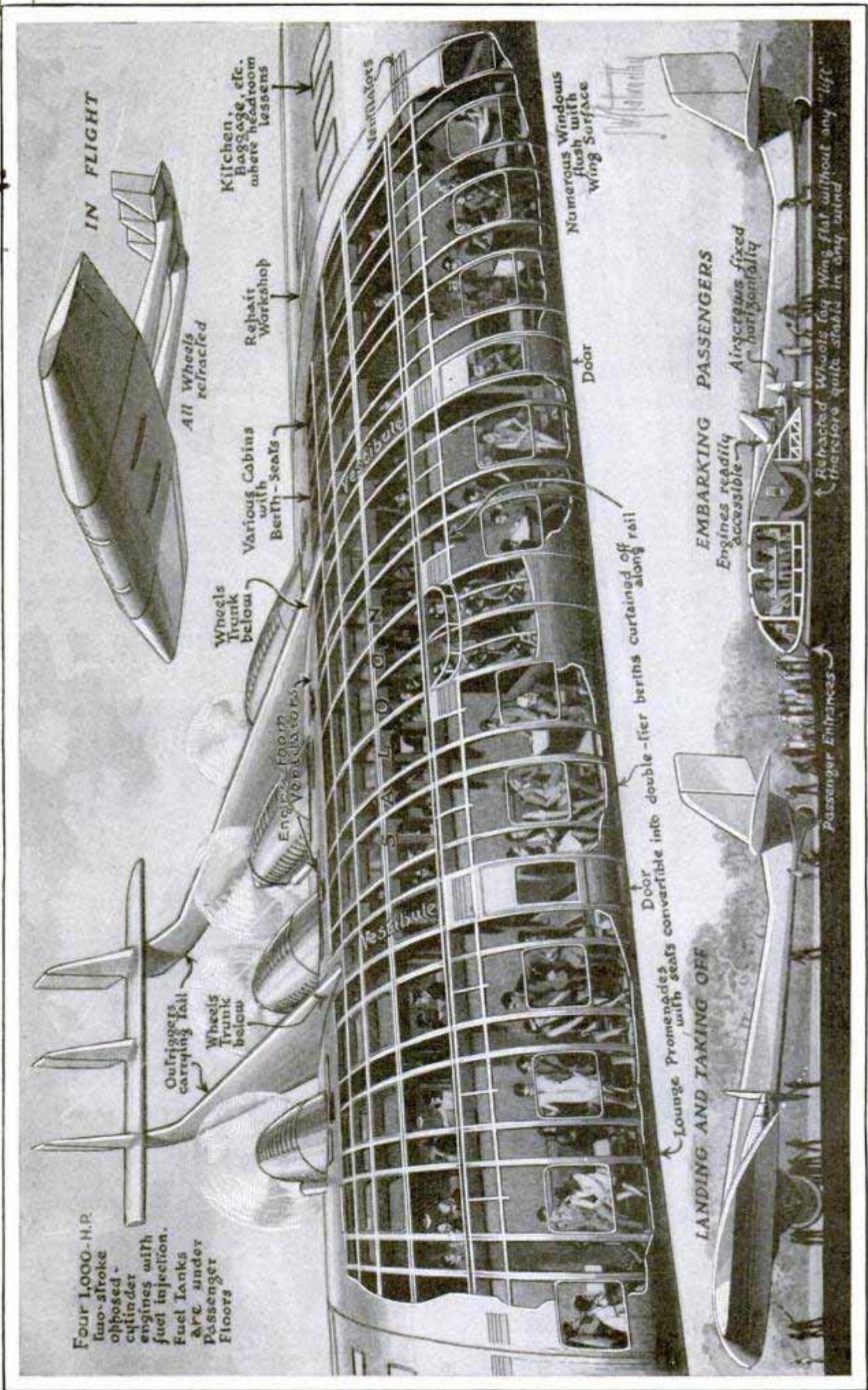

Four 1,000-H.P. two-stroke opposed-cylinder engines with fuel injection. Fuel tanks are under passenger floors

Drawing of the Junkers Ship Which, It Is Planned, Will Be Driven by Four 1,000-Horsepower Engines and Will Carry 100 Passengers in Huge Wings, Nine Feet Thick and with a 240-Foot Span; There Is No Fuselage, Everybody and Everything Being Contained in the Wings

A. ...
R. W. Schroeder

3143

The Future of Air Travel

RECENT altitude flights, the development of the variable-pitch propeller, better fuels and more efficient planes have awakened new interest in the practical side of high flying. Engineers assert that aviators will be reaching 75,000 feet in the near future. At 30,000 to 45,000 feet, where the stratosphere begins, with its favorable constant winds, a ship, it is believed, might skim from Los Angeles to New York in eight hours. Several thousand feet higher, even greater speeds could be made. Such heights will not be attained with present equipment, but

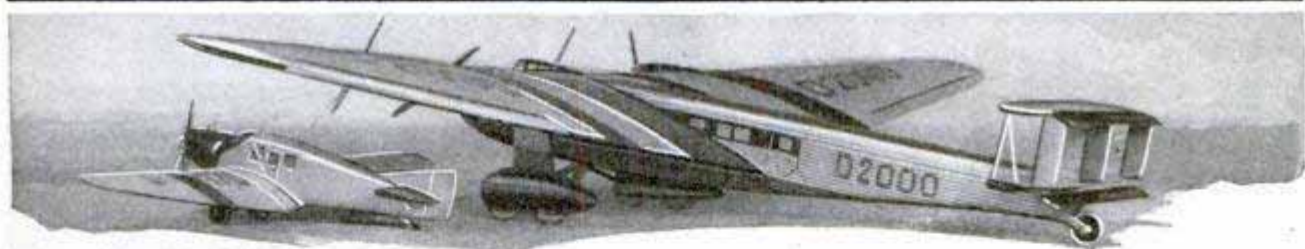

Above, Fur-Lined Suit, and Oxygen Mask and Tank for Flying in Rarefied Air; Below, Model of Forty-Passenger, Twenty-Ton Junkers Ship, Compared with an Ordinary Four-Passenger Plane

authorities declare that the utilization of the upper altitudes, the speedways of the skies, is the next step in flying, and they confidently predict that what is considered a daring altitude "stunt" today, will be an everyday occurrence tomorrow.

High flights are constantly revealing secrets of the skies. Several important developments in flying progress are directly due to the "Columbuses of the upper air," who have been confident that, high over our heads, lie faster and therefore shorter routes to distant lands. It is a fact not generally known that some of the improved gasolines widely enjoyed in motoring and in aviation today, are the outcome of a better fuel prepared especially

for Maj. R. W. Schroeder, pioneer altitude flyer, for his record-breaking flights of ten years ago. The flow meter, a valuable instrument to tell how much gasoline per hour the engine consumes in flying, was originated by Major Schroeder and developed by engineers under his direction. Altitude flying has given impetus to the development of the variable-pitch propeller, promised for practical use almost any day. With this device, on which the blades can be changed in pitch to give the ship greater efficiency on take-offs and at cruising speeds, airplanes will be given something of the flexibility and added power attained by the gear-ratio arrangement in an automobile.

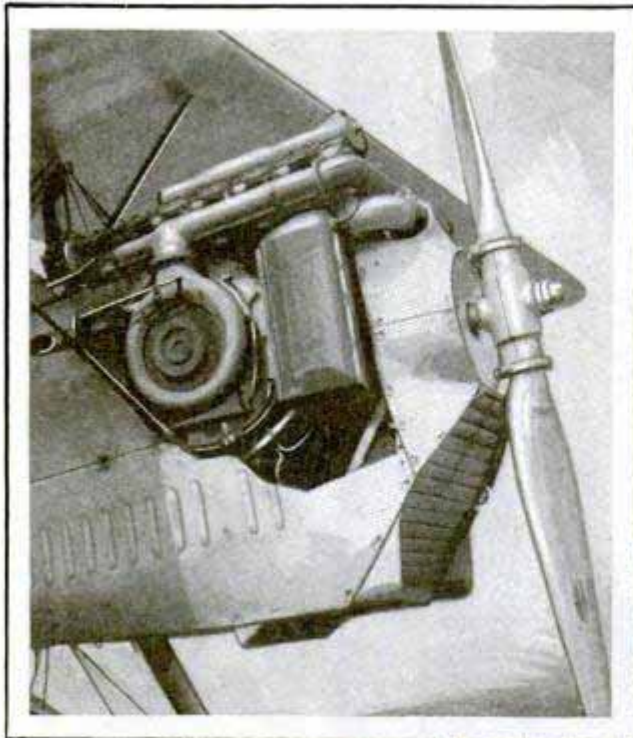

tion. Compressed by the supercharger and by the pistons of the motor, it would burn and supply power for flight. "If a plane were powerful enough to reach such a height, it could remain there for an indefinite length of time and could cover any distance at a speed of 3,000 miles an hour, using the atmosphere as a fuel," declares B. V. Korvin-Kroukovsky, aeronautical engineer, in a recent article in *Aviation*. "To be able to do so, however, it must possess about forty times the minimum power it requires for horizontal flight at sea level."

High flights have led to many improvements in aerial photography and in flying instruments. To keep clockwork mechanisms on barographs and other instruments from stopping, due to thickening of oil at high altitudes, engineers have learned to substitute a few grains of graphite for ordinary lubricants. Heated flying suits and cameras, their shutters

kept warm so that they will not become brittle and fly to pieces in the cold air, improved goggles and better breathing apparatus are a few other developments contributed by altitude flying. However, much of this pioneer equipment will not be needed in the future, for aviators will ride the high levels in air-tight cabin planes. They will breathe air at sea-level pressure all the way, through the operation of a supercharger similar to that used to supply the engine. Since Major Schroeder made the first flights at high altitudes with a supercharger, this instrument has been greatly improved, until now one is visioned, capable of supplying a plane at an altitude of 200,000 feet. At such a height, the mixture of hydrogen and oxygen in the air is right for combus-

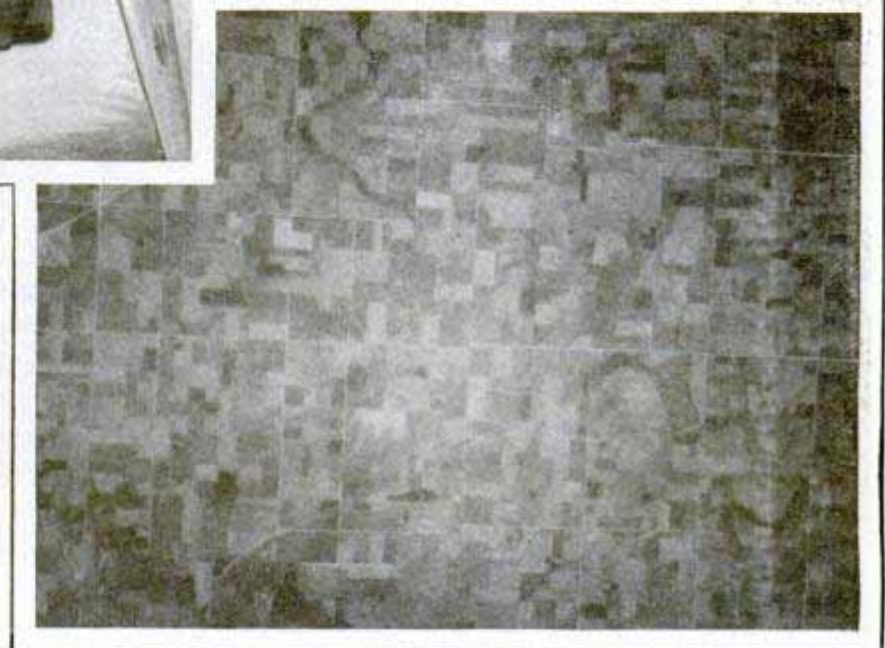

Above, Plane Equipped with Supercharger for Attaining Great Altitudes; Below, a Photograph of Indiana Landscape from 39,250 Feet

Such extreme altitudes probably will not be attained in the immediate future, but man will soon be sailing along the lower stratosphere where there are no clouds, no fogs, no disturbing air currents, only constant conditions favorable to progress.

According to Major Schroeder, whose official altitude record of 33,113 feet stood for several years, man will sail the upper air for the chief reason that there lies the greatest speed, and speed is the supreme aim in aviation.

"Picture an automobile road eight miles from your city, a road that is traveling 100 miles an hour in the direction you want to go," he said in talking over some phases of altitude flying. "Suppose your automobile makes 100 miles an hour. In



Here Is an Airplane Constructed Especially for Attaining High Altitudes; Experiments with Such Ships Are Considered Important Because Great Sky Liners of the Future Expect to Utilize the Upper Air Strata

order to enjoy extra-rapid progress toward your destination, you naturally would drive upon this traveling road. Now, tip this magic highway eight miles up in the sky and you have a fair idea of the great speedway that is up there waiting for us. We probably know more about the bottom of the ocean than we do of the extreme upper air, so that this region is one of mystery, but we do know that it is suited to flying in spite of its extreme cold and the rare atmosphere. In some ways, it is an ideal region, for conditions are constant. There are no storms or fogs. The air is so dry that when frost forms on the plane, it quickly drifts or is blown off.

"Present improvements in superchargers, propellers, engines and planes, all point to the practicability of further exploration and use of the higher altitudes. An air-tight cabin plane will have to be built. Before leaving the army, I had started construction on such a cabin. Occupants of the plane will be comfortably

supplied with air at sea-level pressure from a supercharger. A man needs only 300 cubic feet of fresh air per hour while a 425-horsepower engine requires more than 42,000 cubic feet of air an hour, so it ought not to be difficult to keep passengers and crew breathing under sea-level conditions.

"Planes for these high altitudes will be specially constructed. With the present type of ship and propellers, it takes too long to reach high altitudes. The fast express air liner of the upper lanes will have broad wings for steep climbing, a variable-pitch propeller and a reliable supercharger. The supercharger is intended to keep the carburetor supplied with air at sea-level pressure, no matter how rare the surrounding atmosphere may be. This is extremely important, for, at little more than 20,000 feet, the air is only half as dense as it is at sea level and, at about 80,000 feet, its density is reduced twenty-five times. Without a supercharger, a motor loses more than half of its original

horsepower at an altitude of 20,000 feet, while, at 45,000 feet, only about ten per cent of the original power is available.

"We do not know much about the winds in the stratosphere, but what little we have discovered shows that they probably will be of great aid. There are dependable currents from the west at 30,000 feet and higher. Speeds of 300 miles an hour from Los Angeles or San Francisco to New York will be common because of these winds at high altitudes, so that I regard non-stop flights of eight hours between the coasts, from west to east, as a practical certainty just as soon as the proper planes are constructed."

One of the chief instruments the high flyer of the future will use, says Major Schroeder, is the ordinary thermometer. When it ceases to register any lower temperatures, the aviator will know that he has reached the stratosphere and can level off with the constant anti-trade winds in his favor. This low temperature probably prevails for a considerable altitude above the troposphere, or lower level of the atmosphere, at a comparatively constant point around seventy degrees

below zero. From observations taken by means of weather balloons, at a station near the equator, at an altitude of 15,000 to 45,000 feet, southwest counter trade winds are found. From 45,000 feet to 60,000 feet is a level of upper easterly winds which change to westerly at levels between 60,000 feet and 75,000 feet, while the section between 75,000 and 90,000 feet is swept by easterly winds. Aviators therefore would be able to take advantage of the various wind directions at different elevations when extreme altitudes are accessible.

One of the interesting developments in high flying is the relative ease with which a high altitude is attained now as compared with the time when Major Schroeder battled his way to a height where his eyeballs froze and he was compelled to descend when exhaust fumes from the motor poured into the cockpit with blinding and suffocating results. His barograph later showed that when he lost consciousness, he fell from the peak of his flight, 38,180 feet, to about 1,500 feet in two minutes and eleven seconds. Not long ago, Lieut. Apollo Soucek, of the navy, climbed

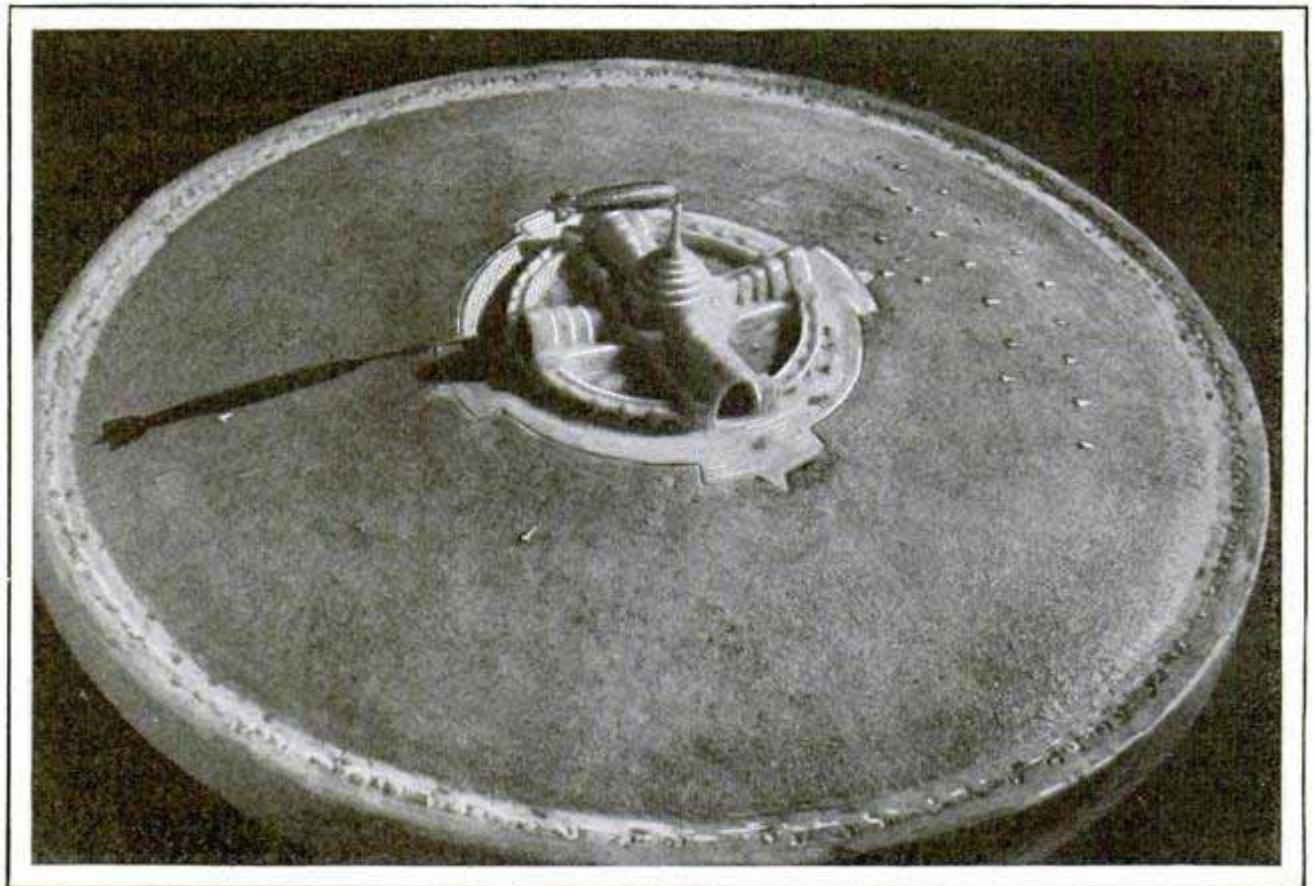

A Model, Done in Soap, of a "Beehive" Airport, Including, in the Center, an 850-Foot Hotel with a Dirigible Mooring Mast, and, Below the Surface, Tunnels for Autos, Subways and Railroads

to 39,140 feet with nothing more unpleasant than a feeling of weakness and dizziness and eyes that pained him in the extreme cold. A few days later, he made a world's record in the same plane, fitted with pontoons.

Capt. St. Clair Streett and A. W. Stevens, of the army, reached a height of 40,220 feet, by their altimeter, after a grind of an hour and twenty minutes. They had six quarts of liquid oxygen and suffered relatively little discomfort, although the throttle was frozen and they had to descend carefully to 34,000 feet where the throttle thawed out. The plane's gasoline was exhausted and they landed. In the early days of flying, heights of a few hundred feet were considered remarkable, and experts predicted that planes would meet their chief drawbacks in the form of land obstacles. Having learned to fly in the roughest and stormiest air, man is now directing his attention to the quiet altitudes nearer the stars.



This House, Constructed to Look Like a Pensive White Puppy, Serves to Advertise a Roadside Hot-Dog Stand in California

**HOUSE LOOKING LIKE PUP
ADVERTISES HOT DOGS**

Constructed to resemble a pensive white puppy, a house in California serves to advertise the hot-dog stand of the owner. The dog house is located near Los Angeles and attracts much attention from passing tourists.

**ALARM CLOCK STARTS MUSIC
TO AWAKEN SLEEPER**

Music replaces the shrill ringing of a bell to awaken the sleeper in a combined alarm clock and phonograph now on the market. The clock is set for the rising time when it starts the record playing.



Alarm Clock Attached to a Phonograph Awakens You with Your Favorite Record

BABY TROUT EAT HORSE MEAT

Ground horse meat is the diet on which baby trout thrive at a fish farm in Beaver Crossing, Nebr. Elimination of freshwater algæ, well aerated water, clean pools and the horse meat were found to be the principal requirements of a successful fish hatchery. The small fry are hatched on the premises in wooden troughs filled with water from artesian wells which flows over aerators. When the fish are four inches long, they are moved to concrete pools which are painted with lime to keep down the growth of algæ. The fish grow to a length of eight or nine inches in less than a year, at which time they are worth about a quarter each and weigh three to the pound.

Goldfish sometimes live for thirty years.

J. Elmer Young, 25-A, Great New Street, London, E.C.4, Eng.

Letter returned.
2/20/31

*and many more
leading London.*

3363

613 Spreckels Theatre Bldg
San Diego Calif

THREE PLANES TIED TOGETHER LOOP THE LOOP AT ONCE

Such great flying skill has been developed by fighting squadron No. 1 of the

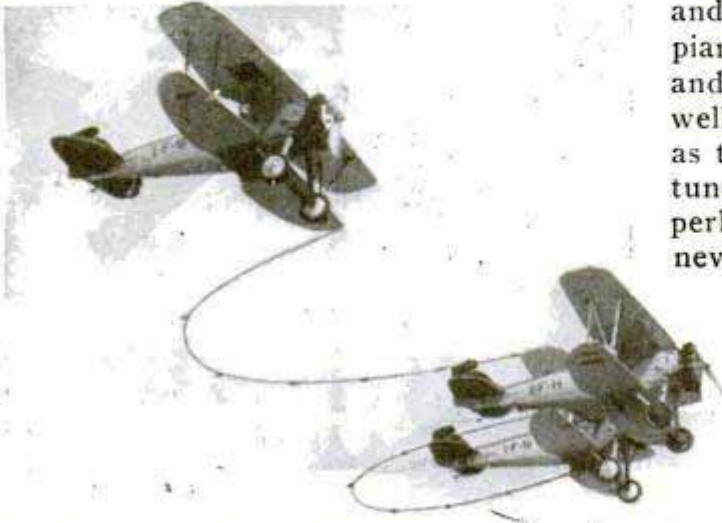

Navy Planes, Bound to Each Other with Ropes in Groups of Three Are Looping the Loop Together

U. S. S. "Saratoga" that the nine-plane formation loop the loop together, each group of three ships being tied to each other by ropes forty feet long. The navy does not permit stunting, so the flyers call the feat "aerobatics leading to flight proficiency." In flying these dangerous formations, the wing tips of the various groups are only fifteen feet apart. The planes take off in three sections known as the "Vee of Vee's," move into a nine-plane "V," shift into what is known as an echelon of echelons, then loop the loop in three-plane formations without breaking the lines.

3379

JARS OF WATER INSIDE PIANO REDUCE HEAT DAMAGE

To counteract the effects of hot, dry air upon his piano during the winter, E. J. Disler, expert tuner of Tiffin, Ohio, has had success in placing six fruit jars, filled with water, inside the cabinet of the upright. He is careful to keep the containers filled and to adjust them so that they will not touch strings or sounding board. The jars are removed in the spring. "An ideal temperature for a piano would be about sixty-five degrees Fahrenheit the year around," Mr. Disler declared. "Such conditions cannot be secured in the

average home, hence every effort should be made to prevent the piano from being damaged by hot air that has too little moisture. The heart of the piano is the sounding board. Since this is made of wood, it naturally is affected by moisture and temperature. Remember, when a piano gets out of tune, that its volume and tone quality are greatly impaired as well as its pitch. There is no general rule as to how often an instrument should be tuned in a year, two times at a minimum, perhaps. The old idea that a piano should never be placed against an outside wall has gone by the boards with the advent of modern heating. In winter when the house is likely to be overheated,

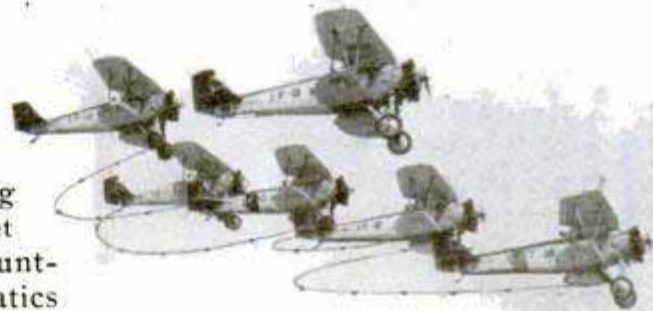

an outside wall is often the best place for the piano. Put the instrument in the coolest place in the house in winter; any spot where the piano is not directly exposed to a draft from between two windows." One of the chief reasons why pianos get out of tune, Mr. Disler explained, is that the hot, dry air causes the sounding board to shrink, resulting in a change in the tension of the strings.

336

WHALES TO BE ELECTROCUTED WITH CHARGED HARPOONS

Whales in future will be electrocuted, if an invention which has been tested is taken up by whaling companies. Norwegian engineers have devised a method of killing them instantly with electric currents in the harpoons. Three whales were killed in this manner in tests off the Faroe islands. The invention is considered of great value, because the number of whaling vessels could be reduced.

Weekly Express
8/10/29

CANCER CURE FOR RATS FOUND BUT UNTRIED BY HUMANS

Discovery of a compound that dissolved and apparently cured cancer in 1,000 rats and mice in a few days has been announced to the International Physiological congress, although the treatment has not been tried on human beings as yet. It is injected hypodermically into the cancer and its effect literally is to cause the malignant cells to breathe themselves to death. The process is termed oxidation, and means the abnormal cells get more oxygen than would filter through to them from breathing. Instead of trying to poison the cancer, the treatment consists of speeding up the natural activities of the body cells, thus working it to death. A young Russian who evolved the process said his attention was arrested by the fact that in humans suffering from cancer the cortex of the suprarenal glands showed effects apparently traceable to the cancer. An extract of these glands in their healthy state is the basis of his compound. To this extract, called corferrol, is added iron and pyrrol blue, a coal-tar product.

VENTILATOR IN REAR WINDOW OF AUTOMOBILE

Ventilation of closed automobiles without creating heavy draft is made possible by the use of a rear-window ventilator that takes the place of the usual stationary back window. It consists of two glass plates, each in a metal frame attached to a rod, by means of which the ventilator may be tilted inward or outward. The operation is similar to the

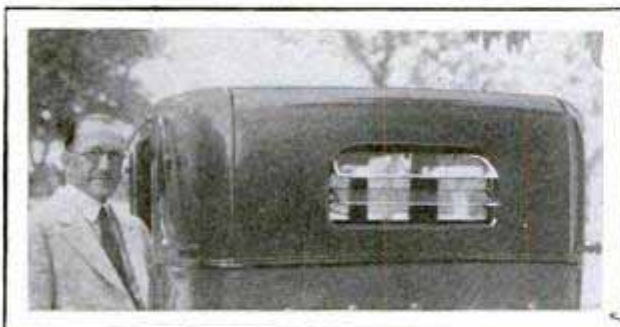

Rear-Window Ventilator for the Auto, Operated Like the Transom over an Ordinary Door

transom above doors and the ventilator is used particularly in cold weather when opening windows would cause a draft.

Dr. David H. Taylor
 1211 Medical Arts Bldg



These Accomplished Stilt Walkers Are Employed in Training Vines in an English Hop Garden

WORKERS ARE PUT ON STILTS TO TRAIN HOPS

Employees in the hop gardens of Kent, England, are accomplished stilt walkers. The workmen are equipped with long stilts which serve instead of ladders when they train the young hops over the tops of poles and give other care to the vines.

TIRE DUST CAUSE OF SKIDDING

Rubber dust is blamed for skidding in dry weather by an official of a British automobile club who has conducted tests in an effort to determine the cause. Dust from the constant wear of thousands of rubber tires, when mixed with ordinary dust and water, he said, forms a particularly virulent form of grease. This, he believes, accounts for slippery roads after a long period of dry weather.

British Ministry of Transport
 advised in

Wick World
 335
 Natural Physical Laboratory

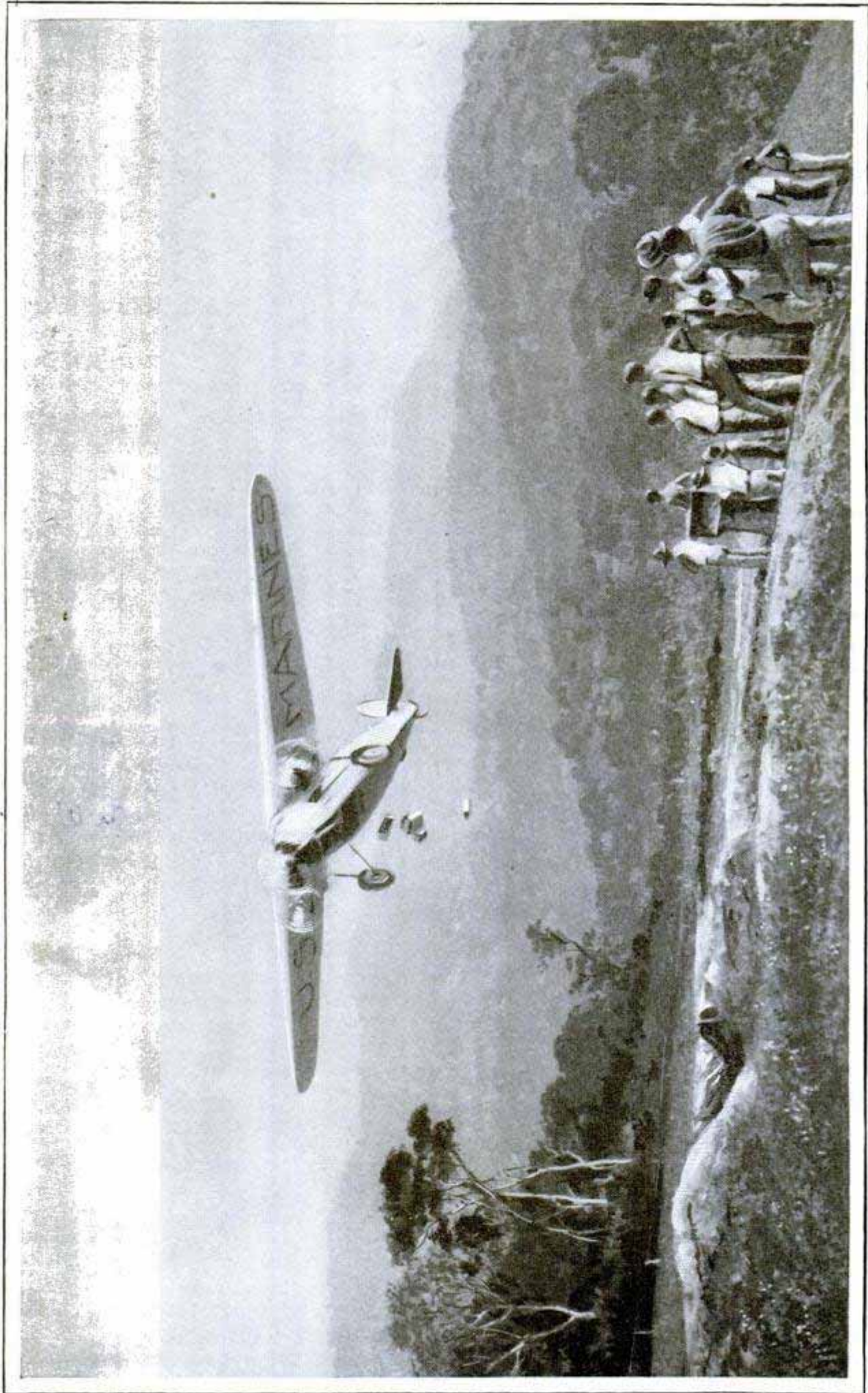

Swooping Close to the Ground in a Tri-Motor Plane, Marine Corps Flyers Toss Out Supplies to a Detachment in Nicaragua

Help *from the* Skies



Rushing Serums and Other Disease Preventives to Stricken Areas Is an Important Part of the Pilots' Business in Times of Flood and Other Serious Disasters

By K. M. PAINTER

MANNA from the clouds seems almost fantastic to the logical-minded twentieth century, yet the inhabitants of southeastern Alabama and western Florida were fed in this manner when the spring floods cut them off from civilization. Science has furnished the angel of mercy with wings, and hope is written in the skies.

In the early stages of the recent disaster, aircraft afforded the only means of reaching the flooded regions, and 3,000 loaves of bread, sixty cases of canned goods, twenty bushels of potatoes, twenty-five bundles of children's clothes, 100 blankets, and 1,500 newspapers were among the supplies distributed in this novel manner. Navy planes from the air station at Pensacola, Fla., were recruited, and made 113 flights totaling 15,000 miles. Registered mail valued at \$1,000,000 was dropped from the planes, and 5,000 pounds of ordinary mail winged its way to the refugees.

Although the flood was not as widespread as the Mississippi disaster of 1927,

nor as sudden as the New England flood of the same year, it will be remembered as the first disaster in which the air-ground message code, recently perfected by the Red Cross in co-operation with the army air corps, was used effectively over a large area. What to deliver and how much, so as to avoid waste and secure the proper distribution of supplies to the points where they were most needed, was ascertained by the flyers by means of the newly developed code. There was, however, an original difficulty which presented itself. How were the marooned flood victims, anxious to signal for those supplies which would stave off starvation, exposure, and disease, to do so. They did not know the code. The difficulty was overcome when special editions of a newspaper, carrying the entire code, were taken by the airplanes and dropped to the stranded people.

During the six days when the flood was at its highest, planes from Maxwell field, Ala., made 296 flights, an average of almost fifty each day, to deliver supplies and

ascertain the wants of the population, which was completely cut off from the outside world by means other than the air-ground code. In addition to food and medical stores, an outboard motor was dropped by parachute to a relief party along the bank of the river at Elba, Ala., in order to expedite the removal of inhabitants from roofs and tops of buildings. That rescue workers as well as flood victims may need help against the elements, was the discovery of Lieut. W. H. Higgins and Corporal Woodward of Langley field, who had been ordered to the flood area for duty. While they were patrolling a part of the inundated district, the motor of the airplane developed trouble and they were forced to land in the flood waters.

"I was scouting at about 100 feet, and we had just passed over several marooned people," recounted Lieutenant Higgins. "We still had our full load of 400 pounds of relief supplies, when suddenly the motor started violent vibration and the power dwindled to nothing. My first inclination was to jump, but knowing we were too low for that, I tried to make the open water in the stream of the Conecuh river. We lacked altitude for this, so I headed for an open space in the backwater. On account of the load, I was able to slow the machine down before striking the water. This was fortunate as I had no time to perform all the stabilizer-rolling busi-

ness necessary for normal landings with an 'O-11.'

"We hit the water at only about sixty miles an hour, I heard something break about the time we hit, and no sooner had we touched than the plane whipped over on its back. This threw Corporal Woodward out and clear of the ship, but I was trapped in the cockpit with my parachute. I didn't know I could work as fast as I did, but somehow I got my safety belt unclasped and my parachute partly unfastened and got from under the machine. The parachute floated me to the top.

"Corporal Woodward had floated to a log jammed against some pine trees by the time I got up. I floated to him with my parachute. Then we ripped the pads from the parachutes to use as floats. That is what pads are for, but I had never used one before. When we got fixed up with 'life preservers,' we started out through the water for the river. I told Corporal Woodward to stay as close to the shore as possible. The current, however, bore him out into midstream and he soon outdistanced me. After swimming and floating downstream for about half a mile, I saw an old house sticking out of the water. I maneuvered to it, caught a part of the roof, and climbed inside. I found myself in the attic, surrounded by quilts and old clothes. This was quite agreeable, for I was cold and shivering, and decided that a change into dry clothes was in order.

"Some men in a boat came along, and I joined them. Together we went in search of Corporal Woodward, and found him in the top of a pine tree. He had managed to get out of the main current and was swept, by a cross current, among the trees. The corporal was much disturbed as he had to fight with a polecat over his perch. Good, comfortable tree tops were scarce in that vicinity, and the polecat would not release its squatter rights without a struggle."



Submerged Sawmill and Town of Brewton, Ala.; the Mill Was Used as a Landmark by Rescue Pilots

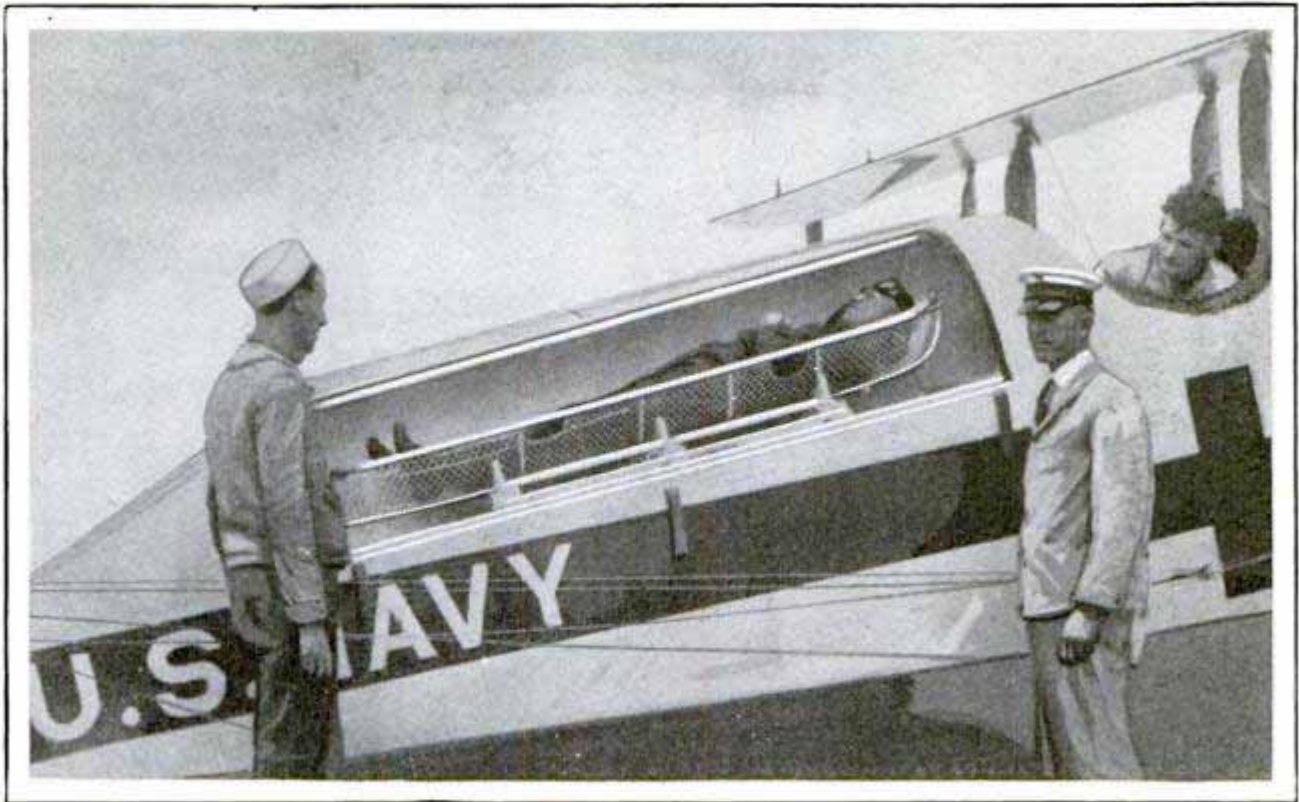

An Ambulance of the Clouds; the U. S. Navy's New Hospital Plane, Which Affords Patients More Comfort and Much Greater Speed Than Would Be Possible in a Vehicle

But experiences like Lieutenant Higgins' are, fortunately, not everyday occurrences, else 90,000 miles could not have been covered by airplanes when they were recruited to combat the onslaught of water that flooded 20,000 square miles of the Mississippi valley two years ago. On hundreds of little spots of high ground, behind the broken levees, the half million refugees huddled in search of safety. To assemble a fleet of boats sufficiently large to comb this area would have required weeks, but the planes met the crisis. It was not uncommon for an aviator to rush into the relief headquarters with a story of 500 or 1,000 refugees stranded on a levee with the water rising rapidly about them. A radio would begin sputtering directions to a rescue ship, and a few hours later, the half-clothed, starving, weary refugees would sight the ship battling the currents to get them.

While transportation by boat was necessary in rescue work, it was slow and tedious. In emergencies, airplanes were called into service, carrying medical supplies and doctors to outposts of the relief headquarters. From Arkansas City, Ark., came a radiogram to the Memphis headquarters: "Serious epidemic of dysentery. No medicine. Rush supplies." Immedi-

ately a plane was dispatched, and an hour and a half later delivered her precious cargo—thirty-five hours under boat time.

After the Florida hurricane disaster, when 6,281 injured persons were in danger of typhoid fever, Lieutenant Bissel flew from Langley field, Va., to Miami, Fla., carrying typhoid antitoxin. When death rode the mighty torrent that swept down on Winooski valley, Vt., airplanes provided advantageous lookout towers, but because seaplanes were not obtainable, it was impossible for the pilots to land in the devastated area. As a result of the New England experiences, the first airplane-relief signal code was devised by the army air corps detachment. Afterward it was enlarged and adopted by the Red Cross, and first put into service in the recent Florida-Alabama flood disaster. The code employs the simplest form of visual signals, somewhat like those for use between ground troops and co-operating aircraft in war, in which those on the ground signal the plane with strips of white cloth laid flat upon the ground, and the plane signals with engine blasts caused by opening the throttle.

The use of the air ambulance by the French forces in Morocco, as well as elsewhere, has been common and has resulted



Aviators Are Doing Much to Curb Fires in Our National Forests; Flying at High Altitudes, They Have Wide Vision and Can Quickly Summon Aid

in the saving of life and elimination of much suffering, especially during the severe fighting on the Wargla front in Morocco, when the smaller monoplane machines went to the actual front line and brought back wounded to a relay post twenty to thirty kilometers behind the battle line, from which they were taken in larger Breguet planes to surgical hospitals more than 100 kilometers away.

A recent report from Vice Consul Ellis A. Johnson tells of effective transportation service furnished by airplanes during the extremely severe ice-bound and snow-bound conditions in Denmark. All other methods of transportation had failed, and every available plane in the country—of army, navy, and private flying companies—was pressed into service. Emergency calls for additional planes brought Dutch, German and Swedish airplanes to Denmark. Ice-bound ships, islands, and forts were supplied with food and medicines dropped from sixty airplanes which were operated daily during the entire period without a single accident.

But the airplane's rescue activities are not confined to the spectacular. Nearly every day brings with it disaster that calls for emergency relief. Not long ago, during a rebel uprising, women were rescued by airplane from a besieged legation on the Indian frontier; to the vigilant eye of the airplane, the Bering sea yielded up an ice-bound vessel given up for lost. The eyes and wings of mercy have, since their

debut in the new role, effected varied rescues. Quite recently an isolated lightship keeper off one of the Virginia capes had good reason to be thankful when he was stricken with acute appendicitis. By radio he requested assistance and a patrol boat was rushed from the naval air station at Hampton Roads, Va. Less than half an hour later he was in a Norfolk hospital.

Such rescues, bordering on the miraculous, are making more and more air converts of skeptics; little wonder that air-mindedness is on the upward trend.

3066
**ADJUSTABLE LIGHT FOR PLANES
MAKES LANDING SAFER**

To promote safety in landing and taking off, an adjustable searchlight for airplanes is mounted in a streamlined body in gimbals like a compass, so that it has



an adjustability range of thirty degrees in all directions. It is operated from the pilot's seat by pull wires and counteracting springs.

For small planes the lights are under each wing tip, but for larger craft, fixed lights are at each wing tip and the adjustable light in the center. The lamps provide from 35,000 to 70,000 candlepower and give strong illumination even at a height of 1,000 feet.

Vertical text on the left side of the page, possibly a page number or reference: 122

*Carl Fein Fein
Germany
485 5th Ave. New York*

daily mail 07/1/27

AIR POLICE USE SMOKE BOMBS TO SIGNAL ARRESTS 3361

France has established an air-police patrol to operate over that country to control the movement of the large number of planes, particularly touring ships, that pass above French territory daily. Pilots failing to observe international air regulations face heavy fines. Police airplanes warn erring pilots by firing smoke bombs, all aircraft addressed in this manner being required to follow the police ship to the ground and land alongside it.

George A. Rosner, Los Angeles, Calif.

AIR IS NOT SO LIGHT 3346

Similes such as "light as air" and "thin as air" are incorrect, as it would require an exceptionally strong person to carry a roomful of air any considerable distance if it were compressed into a suit case. One thousand cubic feet of air weighs seventy-five pounds and a room twenty feet long, ten feet wide and twelve feet high contains 180 pounds of air, a weight the carrying of which would prove a burden.

Perhaps a revolution, Waterbury, Mass.

THERMOMETER FOR THE BLIND HAS RAISED FIGURES 3333



Blind workers at a St. Joseph, Mo., craft shop are enabled to take temperature readings with an indicator which has the degrees marked in raised figures and also employs the Braille system of lettering. A blind person may make a reading by touching the metal hand and following it to the gauge where his fingers reveal the temperature.

HOW GREATEST BRIDGE SPAN IS MADE SAFE 3365

Measuring the exact capacity of the load that can be borne with safety by the longest bridge span in the world before it is constructed, has been made possible by erecting an exact miniature model of the steel arch that will be a part of the

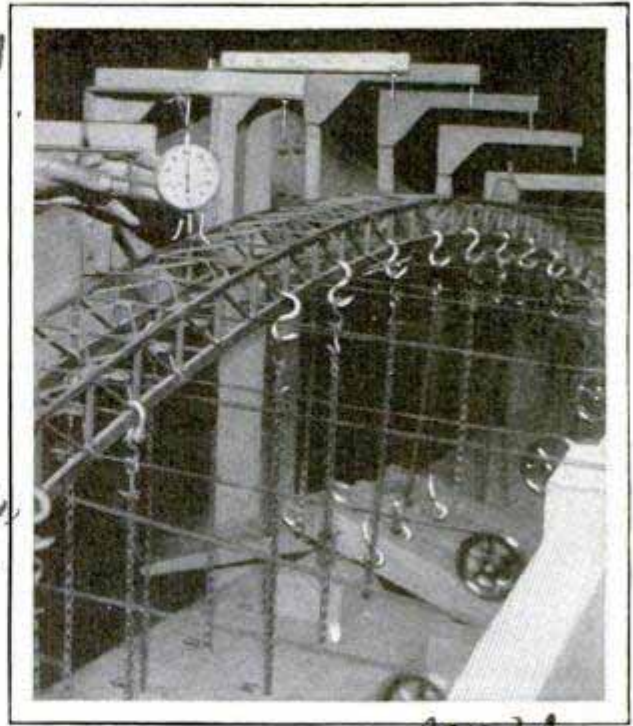

Model of Longest Bridge Span Tested with Weights, to Determine Capacity of the Real Arch

Kill van Kull bridge which is to connect Staten island with the mainland of New York by way of New Jersey. The bridge and approaches will have a total length of 8,075 feet and will cost \$18,000,000. The span of the great arch will be 1,675 feet, and the structure, exclusive of approaches, is to contain 34,500,000 pounds of steel. It will have a clearance for vessels of 150 feet and the rise of the arch will be about 275 feet, the depth of the crown fifty-seven and one-half feet, and the two arch trusses will be seventy-five feet apart. The span is designed to carry four lanes of traffic, two rapid-transit tracks and two sidewalks, all on one deck. The dead load of the main arch is 28,000 pounds per linear foot and the weight of the traffic is estimated at 6,000 pounds per linear foot of the whole bridge. Gauges placed on the model registered the bending of the structure even to thousandths of an inch when weights were applied. When the maximum load was applied at one end, the opposite end was raised as was the case with Brooklyn bridge a few years ago when the cables at one end snapped.

Accidents cost the United States a minimum of \$960,000,000 last year, of which automobile accidents accounted for about \$275,000,000.

Amusement Machine Co. 421 E. Washington St. Los Angeles, Calif.

Q 15 3-36

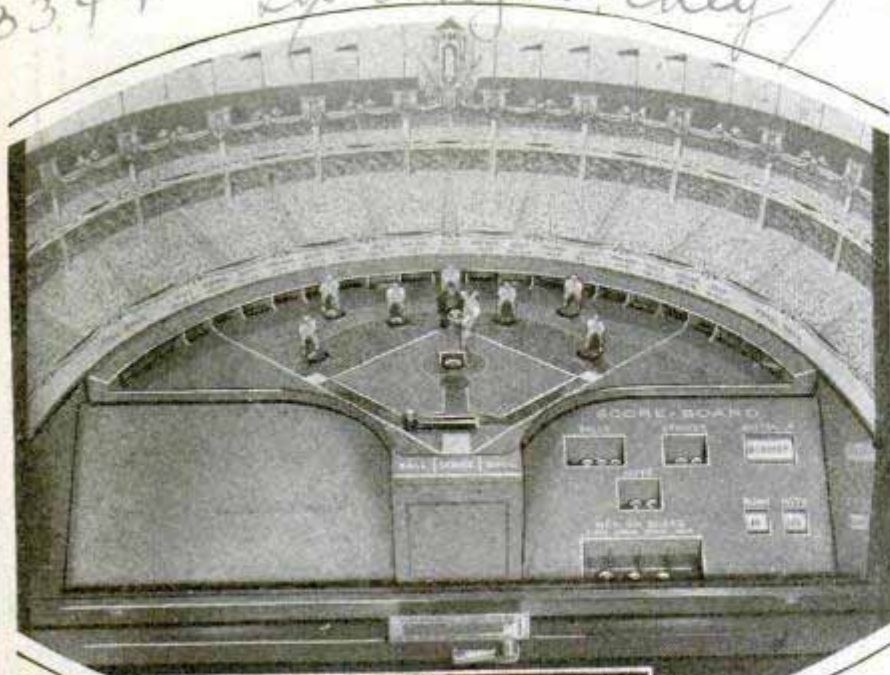

Two Views of a Coin-in-the-Slot Baseball Game, Which Is Operated by Two Players

COIN-IN-SLOT BASEBALL GAME TESTS PLAYERS' SKILL

One of the latest coin-in-the-slot amusement devices is an automatic baseball game, a complete inning of which is played for five cents, enabling two persons to represent rival teams and affording many of the thrills of a real game. The diamond and players, with a realistic background representing a crowded grandstand, are inclosed in an attractive cabinet, and upon the insertion of a coin in the slot, the game begins, electricity and gravity being the principal factors in the mechanical operation. A small steel ball pops up from the umpire, falls into

a socket in the tiny pitcher's hand and speeds forward as the pitcher is snapped toward the bat. This is operated by the human player, who swings it simply by pressing a small lever near the coin slot. The pitcher's position changes slightly, giving a variety of deliveries. Balls, strikes, outs, the position of the men on bases, in fact, a complete record of the game, play by play, are automatically registered by balls and moving signs on the scoring board at the right. Considerable skill is required to bring

in a big score, as much depends upon striking the ball at exactly the right moment. Since the game continues on paying only one nickel until there are three men out, a skillful player can prolong his amusement. Ten runs in a single inning is considered a good score. There are but few electrical parts to the cabinet, insuring little likelihood of breakdowns. Much of the automatic operation of the device is accomplished by the weight of the balls falling into the proper compartments.

Illustration Technique #13 & Aug 8/1929

ELECTRIC DESK LAMP AND FAN COMBINED IN ONE

Electric lamp and fan are combined in one article of desk furniture produced in Germany. The fan differs from the common type in that its blades, rotating on a vertical shaft, are arranged to form a conical surface parallel to the underside of the lamp shade.

This directs the air stream upward so that papers on the desk are left undisturbed and the air does not strike the head of the person using the desk, while cigar smoke is dispersed and ventilation accomplished.



insect life

STRANGE HABITS OF INSECTS REVEALED BY SCIENTIST

While many kinds of flies, including the mosquito which is a member of the fly family, prey on man or animals or crops useful to man, it is unfair to conclude that they are utterly useless, says C. H. Curran, of the American Museum of Natural History. This group of insects also preys on major insect pests. For the most part parasitic flies attack caterpillars, beetles and beetle larvæ. Their methods are often most ingenious. In some cases the flies deposit thousands of eggs on low plants and grasses, depending on a caterpillar to come along and eat the leaf, swallowing the eggs along with it. When the egg hatches the maggot feeds on the cutworm which swallowed it. Mosquitoes are partly controlled by nature itself.

3331

CIRCULAR SAW IS LUNCH TABLE FOR EIGHTEEN PERSONS

Eighteen persons were comfortably seated recently around luncheon tables, the tops of which were circular saws, 108 inches in diameter and weighing 795 pounds each, made by a saw-manufacturing company for a lumbermill at Longview, Wash. The saws are used in cutting giant logs, each having more than 150 removable teeth. They were utilized as tables at the opening of a branch factory at Portland, Oreg.

Long View

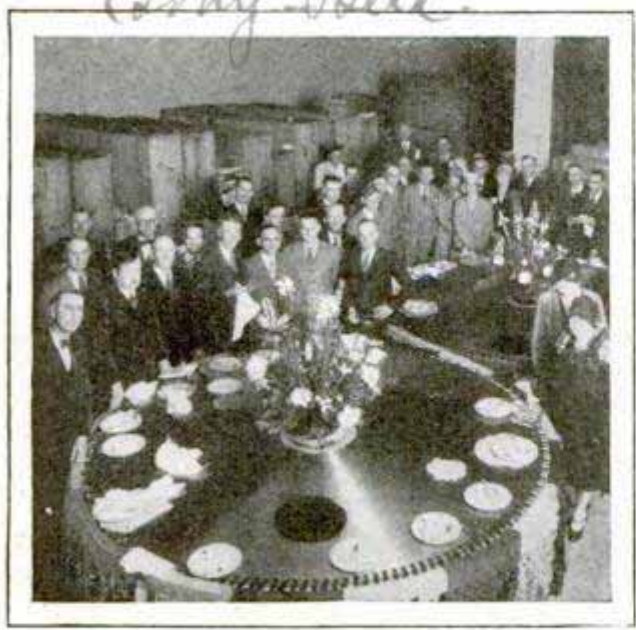

Circular Saws, Intended for Cutting Giant Logs, Here Are Employed as Luncheon Tables

Beaver Lumber Co. & Sons, Tacoma, Wash.



One Hand Only Is Required to Operate This Aerial Camera with Its Pistol Grip and Trigger

AIR CAMERA WITH PISTOL GRIP WORKED WITH ONE HAND

Fitted with a pistol grip, an aircraft camera intended particularly for the owner-pilot, may be operated with one hand. The exposures are made by pressing a trigger similar to that of a revolver. The camera weighs a little over three pounds and takes pictures three and one-quarter by two and one-quarter inches, a standard size for films, thus making the cost of plates and other equipment low. The body is of aluminum and the shutter has instantaneous speeds up to one-hundredth of a second. The camera will not take roll films, but plate holders, film-pack adapter or focusing screen may be used.

HEAT-PROOFED RAIL COACHES SUCCESSFUL IN TESTS

3369

Summer passengers on trains of a western road may travel in greater comfort if recent tests in treating the coaches with heat-resisting materials are as successful as indicated. Aluminum paint and actinic glass are used. The paint for heat absorption has been known previously, but it had not been used on railroad equipment. The special window glass, heretofore used in India and Africa, cuts off about eighty per cent of the heat, while admitting about sixty-five per cent of the light. It is green in color and soothing to the eyes. The paint keeps out about twenty-five per cent of the heat radiated from the sun.

Ⓞ A large redwood tree may contain enough lumber to build twenty average-size houses.

Gettman, America

3133

The Farmer Turns



Electricity Adds Beauty to Model Farm; Shearing Sheep the Modern Way

By H. H. SLAWSON

Dearborn, Chicago

LIFE on the farm is not what it used to be. The farmer has found a new hired man, through whose help drudgery has been banished, with much weary, back-breaking toil.

In the change, the farmer's wife has also benefited, and so have his children, to say nothing of the cows, the poultry, the pigs and other inhabitants of the barnyard.

The explanation is easy. Electricity is this new chore boy which is changing the age-long habits of earth's oldest industry. Farmers are enjoying the advantages of the electric fan in the cow barn, electric

lights in the haymow, electric radiant heat in the pigpen, and electrically driven implements from grindstones to threshing machines. And they even make hay now while it rains—with the help of electricity.

An authoritative count reveals 227 profitable uses for electricity on the farm. These range from A-battery eliminators, animal groomers and six other uses under "A," to bull tamers and twenty-one others under "B," down through twenty letters of the alphabet, to wood sawing at the bottom of the list. Electricity pumps the water, shreds the fodder, husks the corn, separates the milk, grinds bones, feed, fertilizer and sausage, cleans, bags and hoists grain into the bins, dries, bales and elevates hay, heats water, hotbeds and incubators, helps ventilation in the house and the stock barns, and also traps insects in the orchard and garden or thieves in the henhouse.

It cools or warms, sterilizes or pasteurizes, and bottles the milk. It hulls oats or sprouts them. It stimulates plant growth and furnishes refrigeration. It shears sheep and sprays whitewash and insecticides. In the farmhouse it does everything that electricity can do in the city home, including operation of the player piano.

In 1924, there were, in the state of

Washington

motor General Electric

On the "Juice"

Illinois, all told, only 2,201 farms provided with central-station service. But on Jan. 1, 1929, there were 13,284 electrified Illinois farms. Indiana has 15,163 farms getting such service.

California farmers claim to be the heaviest users of electric energy, as there are 55,000 electrified farms in that state. Altogether more than 500,000 farms in the United States are served by electric-light and power companies.

But there is a tremendous problem to be solved before rural America can be completely electrified. In Indiana, according to the 1925 federal farm census, there are 195,000 farms, the value of which is almost one and three-quarters billion dollars. On the basis of three to the mile, a rough estimate would call for 65,000 miles of power lines to serve these farms, and on the basis of construction costs of \$1,000 per mile, this would mean an expenditure of \$65,000,000 for lines alone. A like sum would be required to wire and equip the farm buildings, making the total installation cost almost ten per cent of the value of the industry in Indiana.

Electricity, to make its way on the farm, thus has to justify itself from an economic standpoint. In this regard, one of the state committees on the relation of electricity to agriculture submits the following. Ten cents spent for electricity will perform one of the following tasks: Cook for two persons for one day; do the family washing for one week; run the vacuum cleaner ten hours; operate the milking machine one hour and twenty minutes; separate 1,500 pounds of milk; heat a 150-

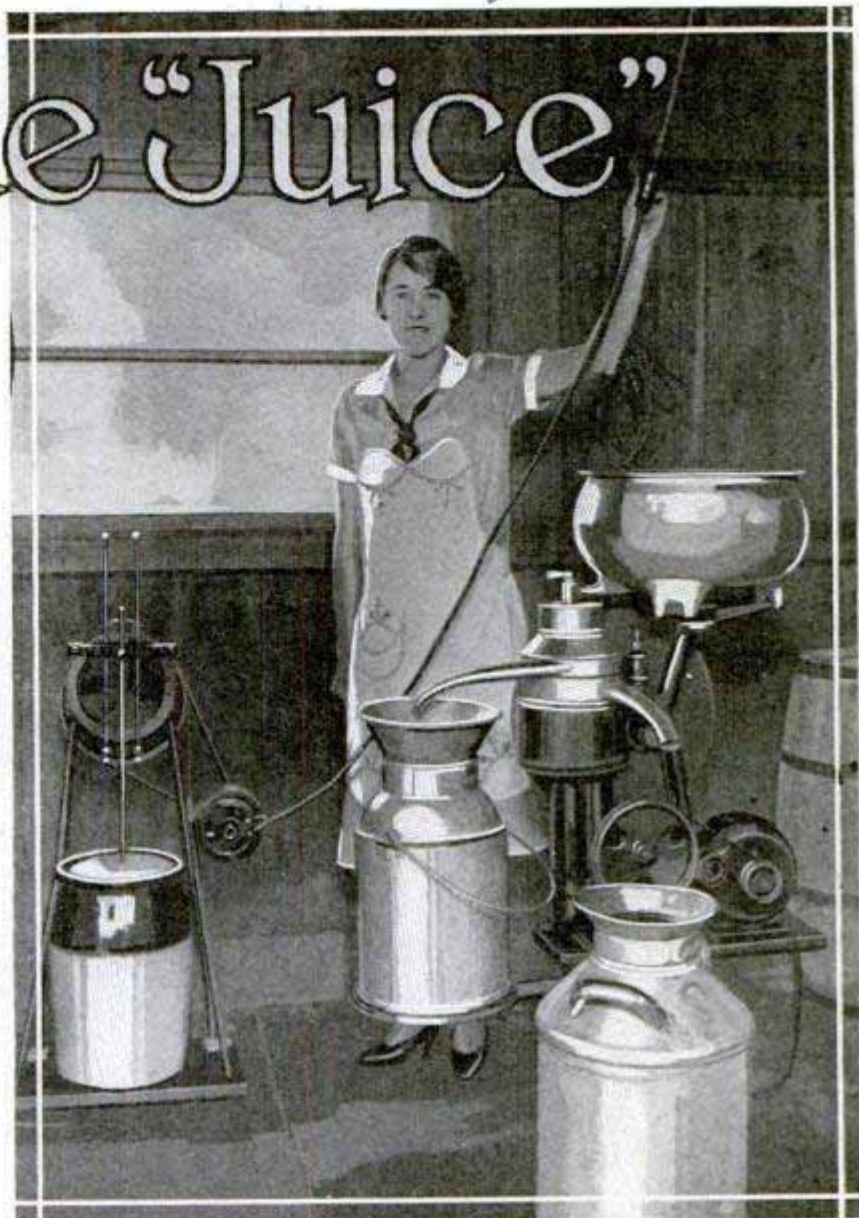

With Cream Separator and Churn Operated by Electricity, Much of the Drudgery of the Farm Dairy Is Eliminated

egg incubator for two days; saw one and two-thirds cords of wood; pump 500 gallons of water; run a fanning mill three hours, or cool a refrigerator for twelve hours.

Electricity is used on one model farm to light the barn, cow yard, washroom and milk-storage room. It does the milking, pumps ice water through the milk coolers and refrigerates the storage tank. It elevates grain to overhead bins, grinds feed, clips and grooms the cows. In the retail dairy, it turns the separator, drives the bottling equipment and operates the bottle-washing brushes. Some dairymen also pasteurize milk by running a current of electricity through it. One farmer in Wisconsin has rigged an endless-chain device with wooden crossbars, driven by

*Edison Electric Appliance Co. 771
5600 W. Taylor, Chicago*

3/33 772

Master Electric Co

POPULAR MECHANICS

Dayton, Ohio



but the electricians have fixed all that. When the lunch hour is ended, out go the lights, all but one faint pilot lamp away up in a distant corner, operated by a dimmer device which simulates sunset.

Electricity also is used to provide heat for sprouting oats, whose green tips supply the necessary vitamins for the health of the baby chick. Ultraviolet treatments have also been found of advantage as a

means of promoting healthy growth and lowering mortality. Electric heat is provided for the brooders and electric incubators are operated with greatly reduced costs and increase in results.

Many unusual adaptations of electricity to agriculture have been devised. At the New York college of ag-

electricity, for cleaning the gutters behind the cows in his barn.

The electromagnetic milking machine is the newest of many devices available to the dairy farmer. And the next adaptation of electricity to dairying is a device which takes the milk from the cow, through a pasteurizer and a refrigerator into a container, without exposing it to the air.

"It is probable," says one authority, "that the milk so produced could be kept sweet a month. Its bacterial count would be low."

The poultry house has also benefited by electricity. Almost everybody has heard how "biddy" can be fooled into believing day has dawned long before its actual advent. An alarm clock, attached to an electric switch, automatically turns the lights on, early in the morning, so biddy can hop down from her roost and begin scratching around. Many poultrymen set the alarm clock so she wakes up for a midnight lunch, which means more strength to the layers and more profits to the owner. You might think that after waking the chickens at midnight they wouldn't be inclined to go back to roost,

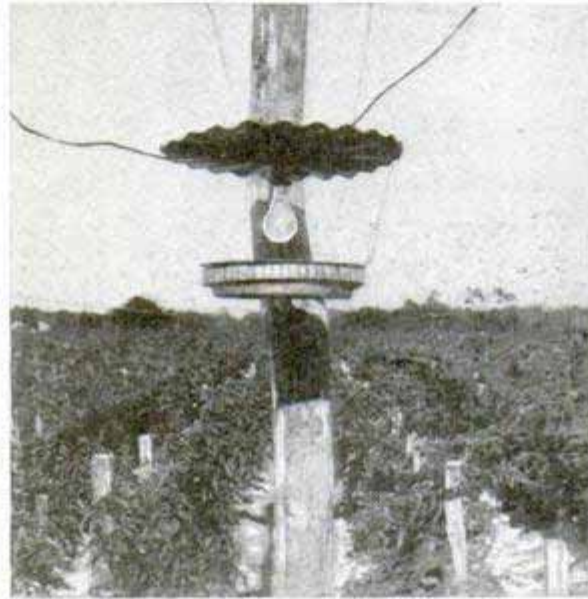

Motorized Grindstones, Light-Bulb Insect Traps, and Electric Cow Cleaners Mark the Modern Farm

American Radiator & Supply Co
820 S Michigan
Chicago

riculture, an electric screen door was constructed to electrocute flies around the dairy barn. As many as 2,500 flies, with other insects, were killed daily when they came in contact with the fine charged screen.

An electrical animal groomer is a convenience much favored by many farmers, especially for the dairy barn. It thoroughly removes dirt and hair without permitting it to escape into the stable air.

Electric lights are used by truck gardeners for insect control. Flying to the bright light, the moth or beetle drops into a pan of kerosene fastened below the globe. An Alabama farmer

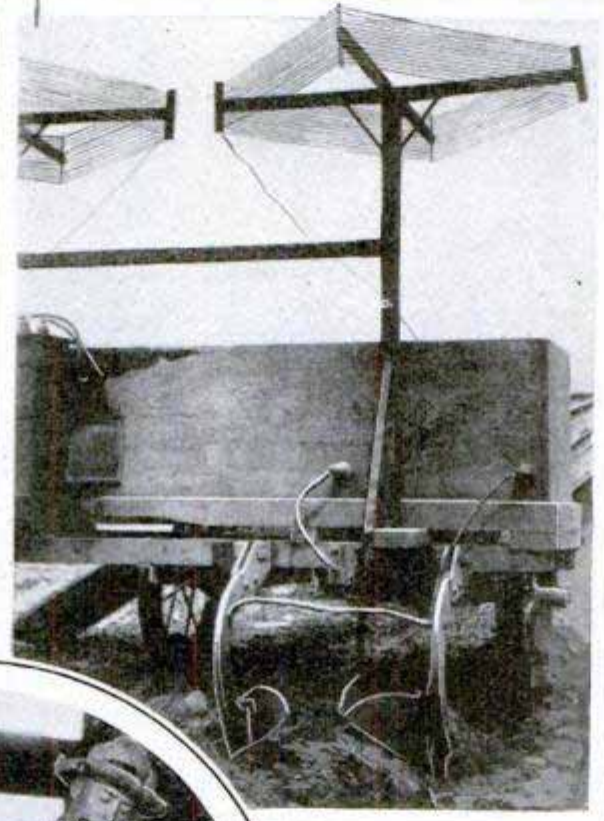
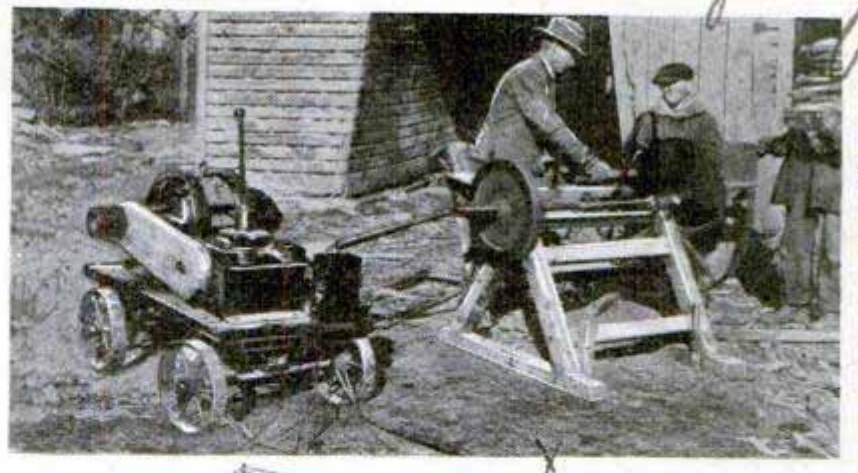

who used lights to trap insects over a tomato patch, reports that his losses from bugs were negligible, while on an unlighted plot the loss ran from thirty-five to fifty per cent of the crop.

At Cornell University, a study has been made of the problem of using electricity to dry damp hay. The hay is stacked over a shallow trench into which the mouth of a blower pipe is inserted. This is operated by a motor which drives

hot, dry air into the trench and allows it to percolate upward through the loosely stacked hay.

With such a device, the farmer no longer is obliged to make hay while the sun shines. He can cut it in a downpour of rain, if he wishes, stack it up, turn on the switch that puts the blower to work and electricity does the rest. The same principle has also been used to hasten the curing of tobacco.

An electrically driven vegetable-tying machine is among the novelties recently appearing on the market. Truck gardeners find it of use in tying onions, radishes, celery, etc. It will handle as many as 150 dozen bunches of celery in an hour.

Electro-culture, even in its present im-



Sawing Wood in the Up-To-Date Way; a Plow That Electrifies the Soil, and Electric Fanning Mill

cannot locate - Felius Tying Machine 1194-14th St
 elec. vegetable washer Milwaukee food power machine.

Porto. Portable Power Tool Co
 Chicago

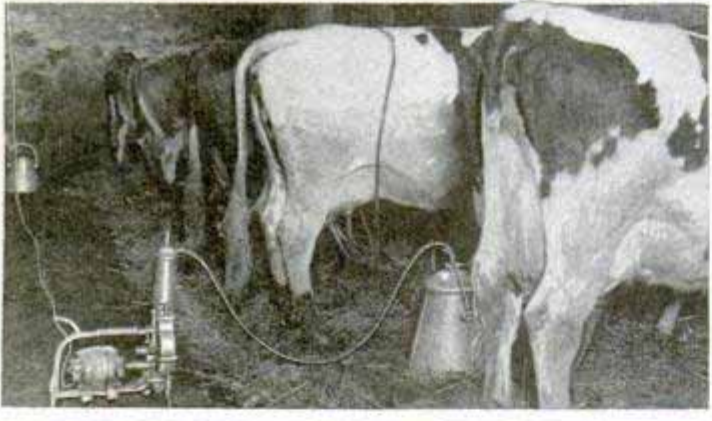

Electric Beauty Aid of "Dobbin"; Drying Wet Hay with Motor Blower, and Portable Electric Milking Outfit

maturity, has fascinating possibilities. At Purdue University an investigation has been under way for three years into an apparatus that consists of a wooden pole with projecting prongs, through which, it is claimed, electricity is sprayed into the air over the field with beneficial results. No scientific conclusions have yet been announced as to the standing of this device.

At the National Rural Electric Project laboratory at College Park, Md., George W. Kable, the director, has been carrying on a study of the results claimed for a high-voltage high-frequency electric plow devised by Hamilton L. Roe, of Leroy, N. Y. The inventor claims that the elec-

tric charge, passing through the soil, makes the plant food in it more readily available and eliminates the need for fertilizer. It also kills weeds and pests and makes plants less susceptible to drouths.

In test plots, quack grass was killed outright, which is considered remarkable as the roots of this plant are very hard to kill. Buckwheat and potatoes, on soil treated with the Roe plow, were freer from weeds than were check plots. The potatoes were also free from potato bugs and blight without spraying, which was not true of other parts of the field.

"I am not sure," said Mr. Kable to me recently, "that the time will never come when the farmer can dispense with plowing. Since the dawn of history, when a crooked stick was first used to turn the soil, farmers have clung to the plow as the indispensable foundation of husbandry. I do not know just what method may be devised to get away from this age-old practice. I do know that some crops can be grown without the traditional preliminary use of a plow. To me it seems that the possibilities in this direction are unlimited."

"In the medical profession," said Mr. Kable, "much knowledge is being developed regarding the use of the X-ray and the ultra-

violet ray on human beings. To some extent this knowledge is being applied to agricultural problems. The field has, however, barely been scratched.

"Electrical research work in one direction has resulted in such mechanical marvels as the radio and television. There is no reason why, if directed intensively to agriculture, research should not also prove correspondingly fruitful of achievements in this field."

That is the vision which rises before the farmer when he presses the button that turns on the "juice."

☐ American cities have 4,778 structures ten or more stories in height.

Milner - 26 Laval Separator Co, 165 Broadway, New York

3/3

PALATABLE GLUE FOR STAMPS FROM SWEET POTATOES

3366

Stamps with glue to suit the individual taste may be on the market soon as a result of researches by the bureau of chemistry and soils which has found a high quality of starch is obtainable from sweet potatoes. From the starch, dextrin of pleasant taste has been produced and this is being tested to determine its suitability as glue for stamps and stationery. A method of economical commercial production is being attempted with the fall crop of sweet potatoes. Tapioca is the present source of most stamp and stationery glue, but if manufacturers can use cull sweet potatoes for the purpose, a market will have been found for part of the 80,000,000 bushels of culls produced each year, which in the past have been fed to cattle. Six pounds of the sweet potatoes make one pound of starch.

ADJUSTABLE GLARE PROTECTOR SAVES MOTORISTS' EYES

3282

Fitting above the windshield, inside the automobile, an adjustable shield is intended to protect the eyes of the motorist against sun glare and the lights of approaching cars. The shield is of a material that diffuses the sun's rays, and is mounted on a flexible arm adjustable to any position. It is held from five to seven inches from the windshield when in use, and when not in use, may be raised to the

8 2.50

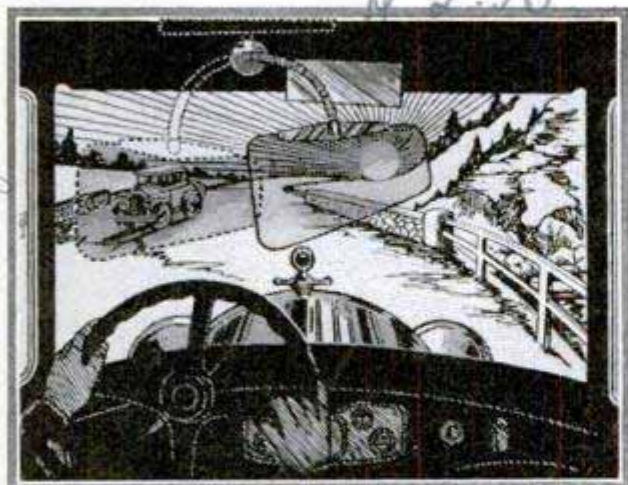

An Adjustable Glare Protector on a Flexible Shaft Which Shields the Eyes of Motorists

top of the car, leaving an unobstructed view ahead.

*Aaron's Mfg. Co.
Tulsa, Okla.*



Web World

French Convicts Wear These Masks to Prevent Them from Becoming Acquainted and from Plotting

MASKS FOR FRENCH CONVICTS TO PREVENT PLOTTING

Prisoners in the model French-prison at Fresnes, near Paris, are garbed in masks covering head and shoulders on their rare emergence from solitary confinement, to make it impossible for the convicts to recognize other inmates and plot with them. The wearer can breathe freely through the loose mesh of the mask and is able to see everything except the face of another prisoner dressed the same way.

VOLCANOES PUT SALT IN SEA

8233

What makes the sea salt? Dr. Thomas A. Jaggar, director of the Hawaiian volcano observatory, believes the salt is deposited in the sea by the 485 known volcanoes of the world which annually discharge more than 100,000,000 tons of hydrochloric acid, thus supplying the chlorine that keeps the ocean salty. Even though the amount of hydrochloric acid gas in steam from volcanoes is almost negligible, the ceaseless emission of the steam puts the gas in the air, and thence into the rain, he believes.

*Science Service
Bulletin 434*

MODERN MEDICAL SCIENCE SAVES LIVES OF PETS

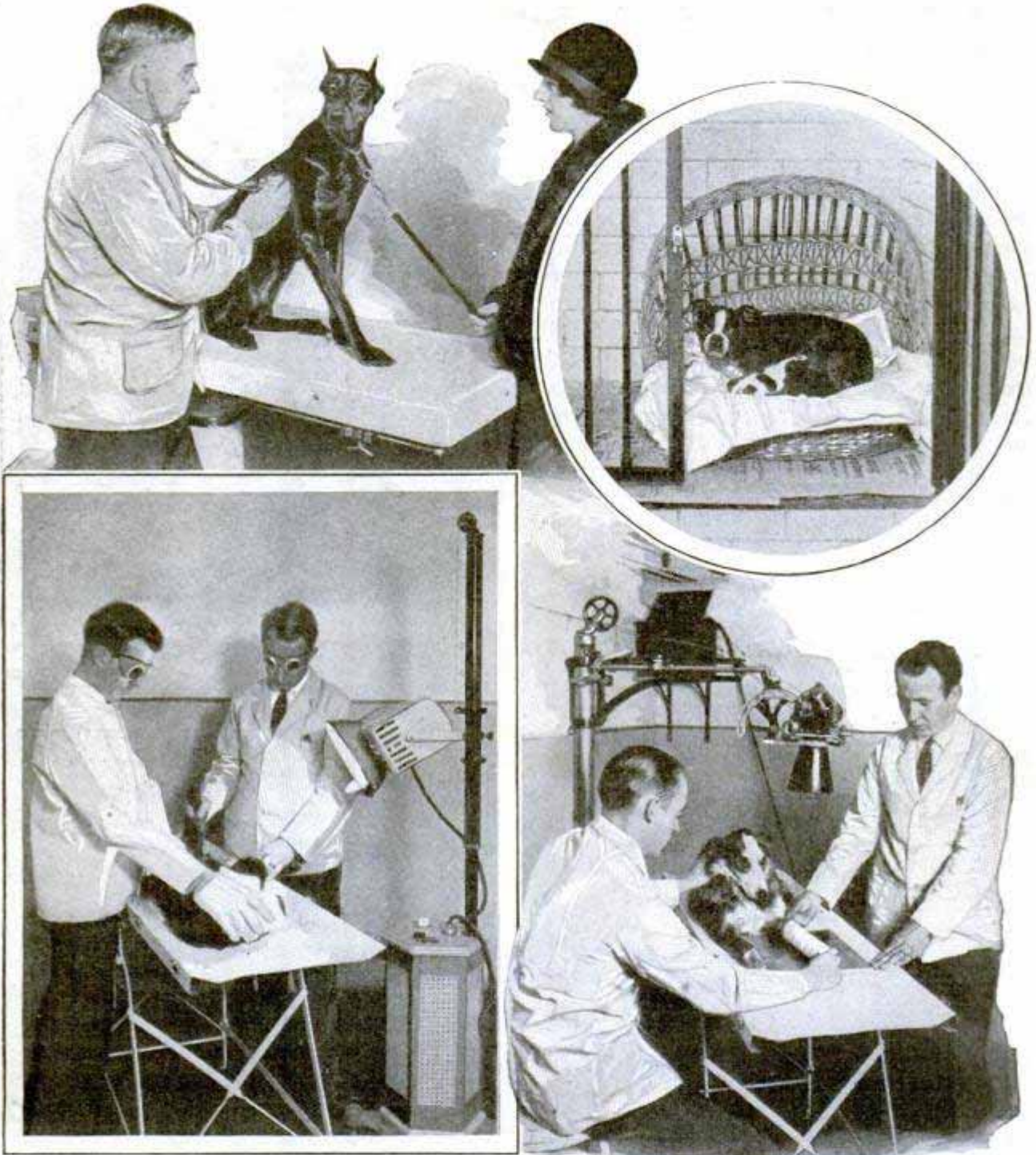

Where Dogs and Other Pets Receive Scientific Care; Glimpses inside the North Shore Animal Hospital, Showing How Dumb Patients Are Treated with the Aid of X-rays, Ultraviolet Light and Other Modern Means

Dogs and other domestic pets receive medical treatment embodying some of the latest scientific discoveries at the North Shore Animal hospital in Evanston, Ill. X-rays, ultraviolet light, special wards for animals suffering from communicable diseases and elaborately equipped operating rooms, are among the institution's unusual features. A motor ambulance calls for patients, food is prepared

under highly exacting conditions, constant record is kept of each patient's progress; in fact, the general procedure, from the time the animal is admitted, receives its physical examination and is assigned to its proper department, until it is released, is much the same as in a hospital for human beings. Dr. J. V. Lacroix, head of the hospital, talks about dogs and their care, as a family doctor would talk

Dr. J. V. Lacroix

to a mother about her children. "The lifetime of a dog is about one-seventh that of a man," he said. "Discipline is as necessary with these pets as it is in a human family, and this is especially true in regard to the diet. Largely because of his long association with men, a dog has learned to eat practically anything that a man will eat. Meat is the basis of its diet, but meat alone is not advisable. Some fibrous food is necessary. This is furnished by bran, steamed carrots and other vegetables that contain much cellulose. White bread, rice or potatoes contain the necessary starch. Raw meat once a week is desirable. Raw liver is a good laxative. The meat need not be cut fine. Milk is an important article of the diet, but it does not agree with all dogs. The animals should not have highly seasoned foods, and should not be given large quantities of candy, ice cream or cake any more than children should. Living in a small apartment is unnatural for a large dog and much care is needed in its feeding and exercising. A kitchenette apartment is no more a place for it than for a concert grand piano." Visitors are admitted to the hospital daily between the hours of two and four o'clock in the afternoon. The dogs, especially, seem to appreciate the careful treatment they are accorded, and in one or two instances, after being patients there, dogs have voluntarily reappeared to be treated for an injury.

PANORAMIC MIRROR FOR AUTO SHOWS WHOLE ROAD

Giving the motorist a full view of the road behind, a panoramic rear-view mirror has been placed on the market. Looking in it gives the driver the same effect as looking out of all the windows at once and shows the cars approaching from



Panoramic Rear-View Mirror for Auto Giving a Complete View of Whole Road Behind

each side and from the rear. The glass diffuses light in all directions, obviating the glare of headlights from the rear.

PLATFORM ON TOP OF LADDER SERVES AS SCAFFOLD



This Platform, Attached to an Ordinary Ladder, Serves as a Scaffold for One-Man Jobs

Eliminating necessity for a scaffold for one-man work, a ladder platform is on the market which may be attached to the top of any ladder. On long ladders, two such platforms, one above the other, may be used, providing space for two men to work. The platform is nearly a yard wide and the end resting against the building is provided with rubber bumpers to prevent its sliding sideways. Safety clamps also are used.

AIR REPLACES OIL IN SWITCH

Switches for high-tension electric-power plants in which compressed air takes the place of the usual oil filling, have been invented and are now being placed on the market in Germany. Advantages claimed for the switches include economy in size, safety of operation and a large range of capacities.

Chicago 2054 Parkway

826 W. Ave. 61
Cedar Rapids, Iowa

3337
3360
Frankfurt a. M.
Allgemeine Elektrizitäts
Gesellschaft
W. H. ...
1966 8 66th
M. ...

3080

How *the* Ship

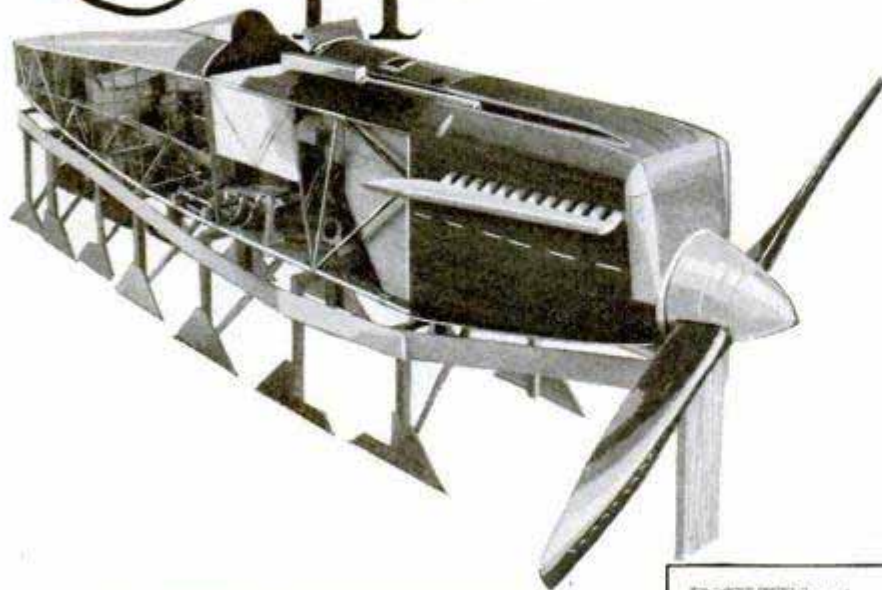

failures in flight have become very rare, but new designs are occasionally found to be unsatisfactory due to such weaknesses as lack of necessary performance or stability; and as such mistakes are likely to be very costly to the manufacturer of the plane, they must be very carefully guarded against.

By **EDWARD CAMPBELL**

Projection Engineer Boeing Airplane Co.

SUCCESSFUL airplane design consists mainly of profiting by the knowledge now available as a result of the thousands of planes that have been built and tested to date, and of incorporating this knowledge into a practical airplane, through the application of sound engineering principles.

Our successful airplanes of today are the result of a process of evolution, beginning with man's first attempt at flight, and in which the well-known trial-and-error system has necessarily played an important though sometimes expensive part. Painstaking theoretical and wind-tunnel research have gone hand in hand with actual flight testing, but the latter is always the final criterion. Each new design must be an improvement over what has gone before in order to be a success, so original ideas are constantly being developed. However, if precedent is completely ignored, the designer may as well be back in the pioneering days of aviation.

Accordingly, when the design of a new airplane is to be undertaken, the designer's first step must be thoroughly to familiarize himself with what has already been done with that particular class of plane, in order to avoid mistakes already made. Such serious consequences as structural

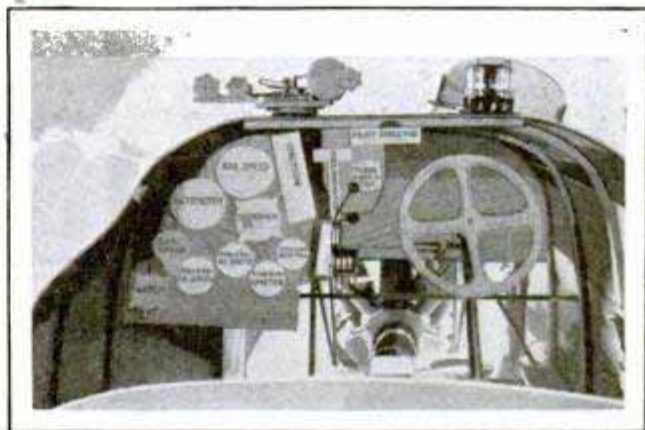

The "Mock-Up" or Full-Size Wooden Model of Part of a Plane, and Cockpit of Model

The design of an airplane necessarily starts with the formulation of the specification. This includes such characteristics as the type, that is whether it is to be a monoplane or biplane, single or multi-motored; useful load, or amount of cargo, fuel and oil to be carried; performance to be attained, which includes speed, climb and ceiling; type of engine to be used; the wing section; pounds per square foot of wing load; structural strength; degree of stability and maneuverability; and such considerations as type of construction, first cost and ease of maintenance.

Often the designer has little given him in the way of a specification other than the purpose for which the plane is to be used. With that as a basis, he must determine the above characteristics and should adhere to them as closely as pos-

is Designed

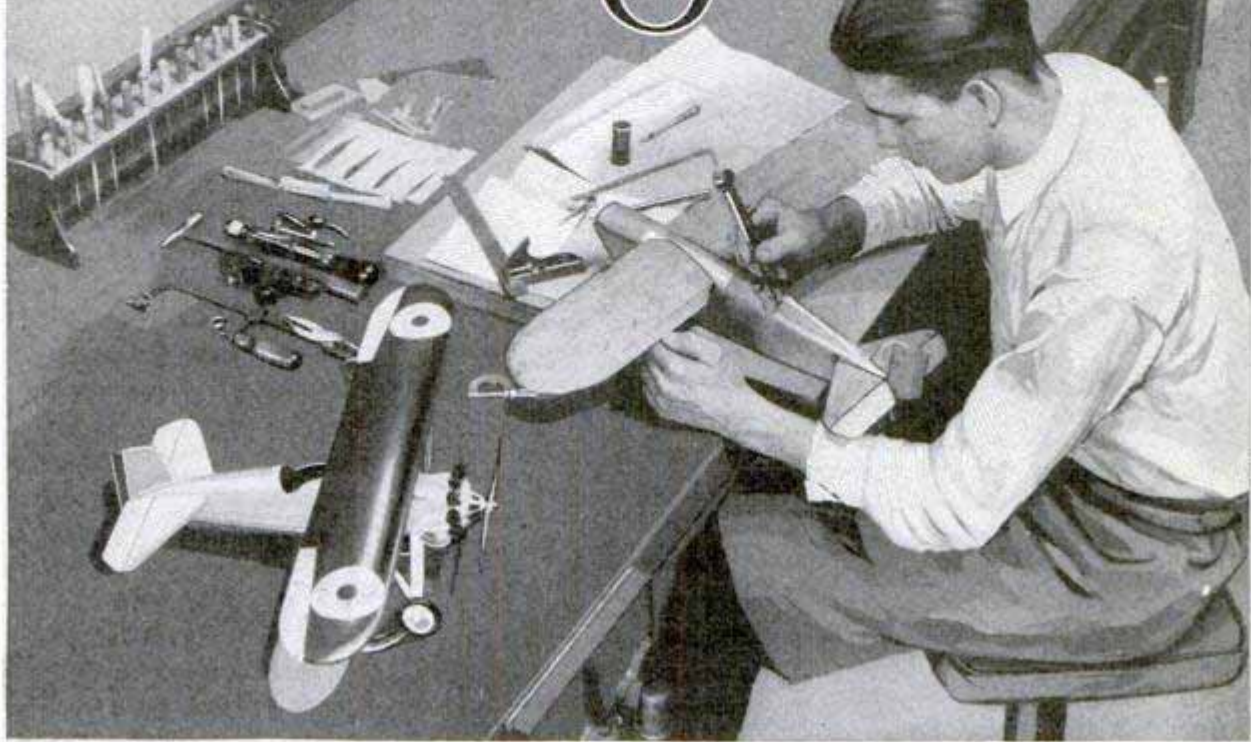

Photos Courtesy Boeing

Through His Skill in Making Models during a National Contest, Othello Dickert Landed a Job in the Boeing Factories; Some of His Models Are Valued at \$1,000 Each

sible throughout the design of the plane.

The next step is the preliminary weight estimate. One of the secrets of successful airplane design is the ability to make a reasonable weight estimate to begin with, and to hold the weight of the finished plane down to that figure. This takes a great deal of experience and very careful supervision of detail design and construction, as a plane will inevitably tend to gain steadily in weight up to the time of its completion. Overweight with resulting decreased performance has been the cause of failure of many otherwise promising designs.

For the preliminary weight estimate it is customary to divide the plane into a number of parts, such as wing group, tail group, body group, power plant, and useful load; and these are then further subdivided, as found convenient.

The weights of certain parts, such as engine, instruments, and useful load may be definitely known, while the weight of such

items as the wings, fuselage and tail surfaces must be estimated on the basis of experience with similar types of construction in planes already built. As the design progresses, the detail weights can be computed quite accurately. However, the scales are the final criterion, and the saying "it always weighs more" is too often found to be true.

It is important that the preliminary estimate be as close to the final weights as possible, as it is upon the former that the wing area and general proportions of the ship must be based. After a preliminary design of the wings has been made, the detail design of the ship begins with a scale drawing showing the side view of the fuselage. For this, it is best to locate first the most important items, such as engine, fuel and crew, in their desired relative positions. The less important items are then located, and the outline of the fuselage determined.

By locating the center of gravity of the

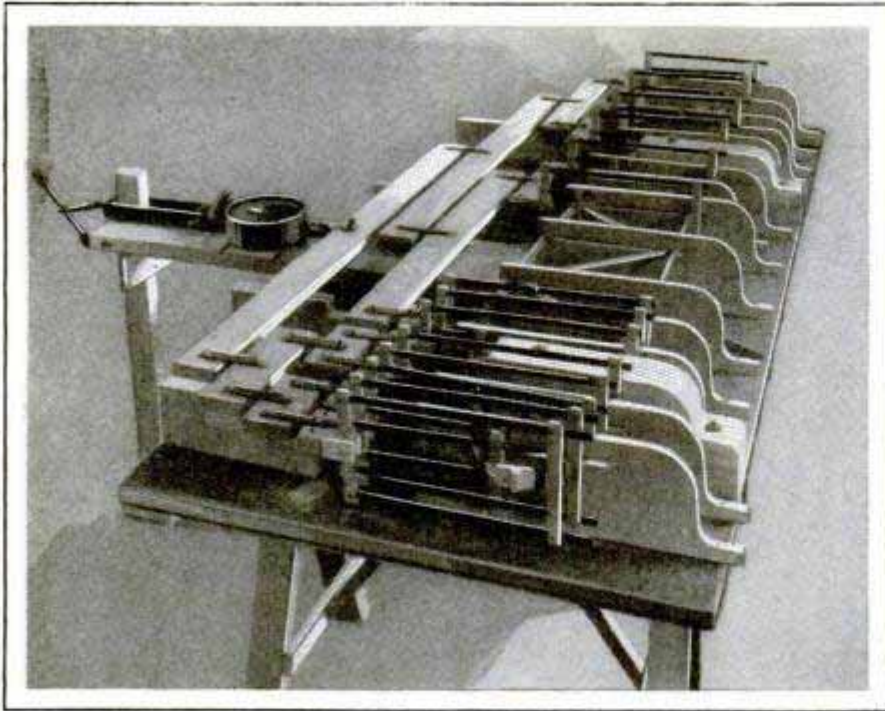

Testing the Wing Ribs of a New Design, to Be Sure They Have Sufficient Strength in Service

various parts and using their estimated weights, the center of gravity of the whole fuselage is next calculated, and this determines the location of the wings and landing gear. The location of the center of gravity of the complete plane with relation to the wings is so important that, if it should come out only a few inches forward or aft of the designed location, it might easily result in the ship's being totally unmanageable. The wheels must be located far enough ahead of the center of gravity to prevent the plane from nosing over in bad fields, but not far enough to put too much weight on the tail. Insuring the proper final location of the center of gravity of the complete airplane is one of the designer's greatest problems, and it can only be accomplished by careful preliminary design and constant checking of weights as the construction of the ship progresses.

With the side view completed, front and plan-view drawings are made, and the performance and stability characteristics are then calculated. By means of theoretical computations based on data obtained from flight tests of existing planes of similar type, an experienced designer can determine these characteristics quite accurately before the plane has passed the paper stage. If the design in question is at all radical, or if the more accurate determination of per-

formance and stability is considered advisable, a small but very accurate model is made and tested in a wind tunnel. These models are very expensive to build, but the information obtainable from such tests will often show up weak points in a design which would have proved very costly if not discovered until the flight tests were made. While performance calculations and wind-tunnel tests may not give strictly accurate results as compared with the final flight tests, they are particularly valuable for comparing the relative merits of two or

more designs under consideration.

If satisfactory performance is indicated for the general design, a full-size "mock-up" is usually built before the detailed design progresses too far for changes in arrangement to be readily made. A mock-up is a full-size reproduction of a portion of a finished plane. It is usually built of wood, and includes enough of the plane so that such considerations as the degree of visibility and comfort that the pilot and passengers will have can be determined.

The actual engine is often installed in its relative location and portions of the wings are reproduced in order to determine to what extent they will interfere with the vision of the pilot and passengers. The pilot's cockpit is usually finished in considerable detail with instruments and controls installed in place. Thus the need for important changes in design can often be discovered at a time when they can be made without much trouble. Visibility and comfort are characteristics which are difficult to determine from drawings, and when the plane is completed, it is usually too late to make the desired changes.

At this point, it is usually advisable to make a large-scale layout or profile, as it is called, of the fuselage in side elevation. This is usually made one-quarter size and shows all items to be installed, such

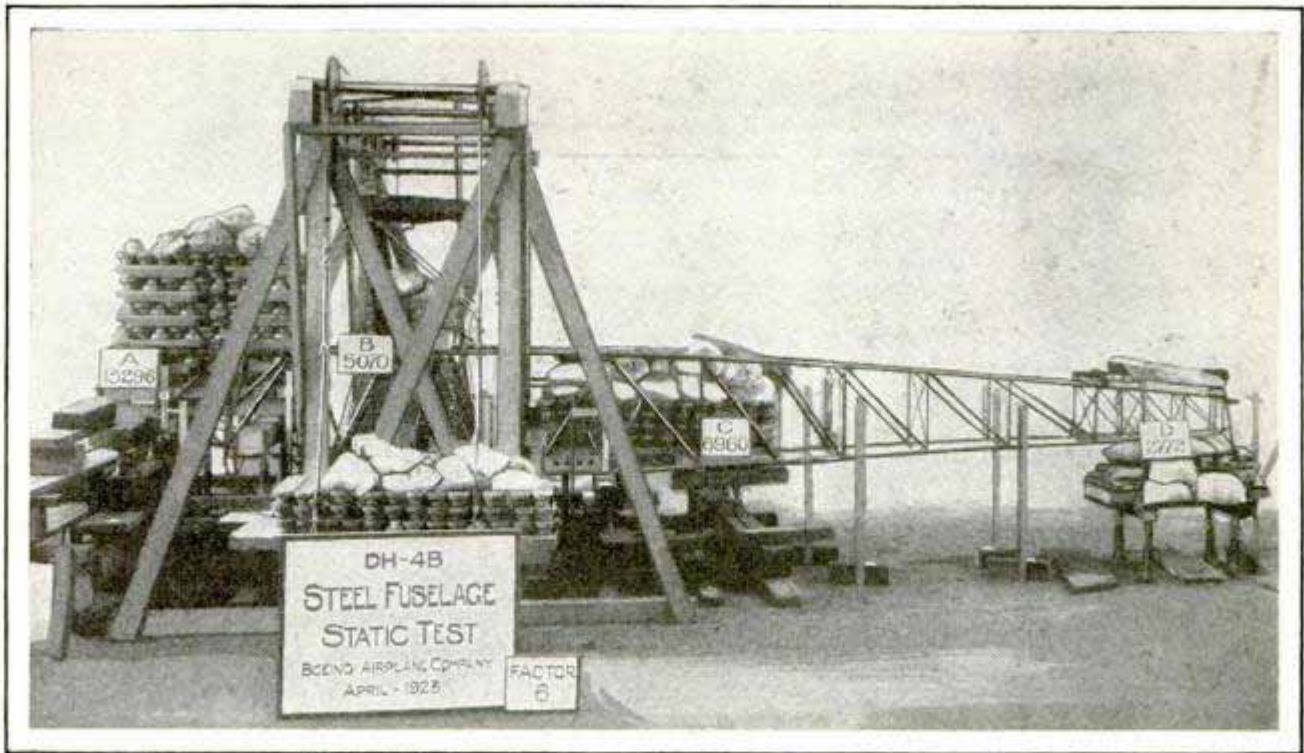

Testing the Complete Fuselage or Frame of an Airplane; the Loads, Carefully Measured, Are Applied in Such a Way as to Approximate Flight and Landing Conditions

as instruments, piping and controls. Its chief purpose is to prevent the possibility of unforeseen interferences, and it usually looks like a Chinese puzzle by the time it is finished, due to the complex installations necessary in a modern airplane. When time for such a drawing is not taken, it has been known to happen at the time of final assembly of the airplane, that the designer finds, to his dismay, that he is faced with the necessity of passing a structural member of the fuselage through the carburetor, or of running a rudder-control wire through the fire extinguisher.

By this time, the principal dimensions of the ship are definitely determined and the stress analysis can be carried out. This is a lengthy process, since the structure of an airplane is called upon to carry many types of loading in the course of normal operations. The stress in a given strut or wire may vary between wide limits, depending, for instance, upon whether the plane is flying at high speed, pulling out of a dive, or landing. An airplane structure must be analyzed for some six or seven distinct types of loading, approximating as many actual conditions encountered in service operation. This work is usually divided between three or four men, and requires considerable time.

With the stress analysis completed, the

greatest load which each strut and wire will be called upon to carry is known, and the detail design of the hundreds of different parts which go to make up the airplane can then be carried out. As each part must be designed to carry the required loads and must be drawn up in detail, several hundred drawings are required. This work is generally divided among a number of men whose work must be co-ordinated by the engineer in charge of the project.

When a part is difficult to analyze for strength, or when there is any question about its being capable of carrying the required loads, a sample is made and tested to destruction. Wing ribs are tested by applying loads to them through systems of lever arms which duplicate actual flight conditions as nearly as possible. Complete wing structures, tail assemblies and fuselages are frequently set up and tested by means of properly distributed sand loads, while small fittings are commonly tested in standard testing machines.

The process of designing and building an airplane is usually accompanied from the very beginning by a seemingly endless series of changes. These cause many complications and much extra work, but are inevitable since all progress and im-

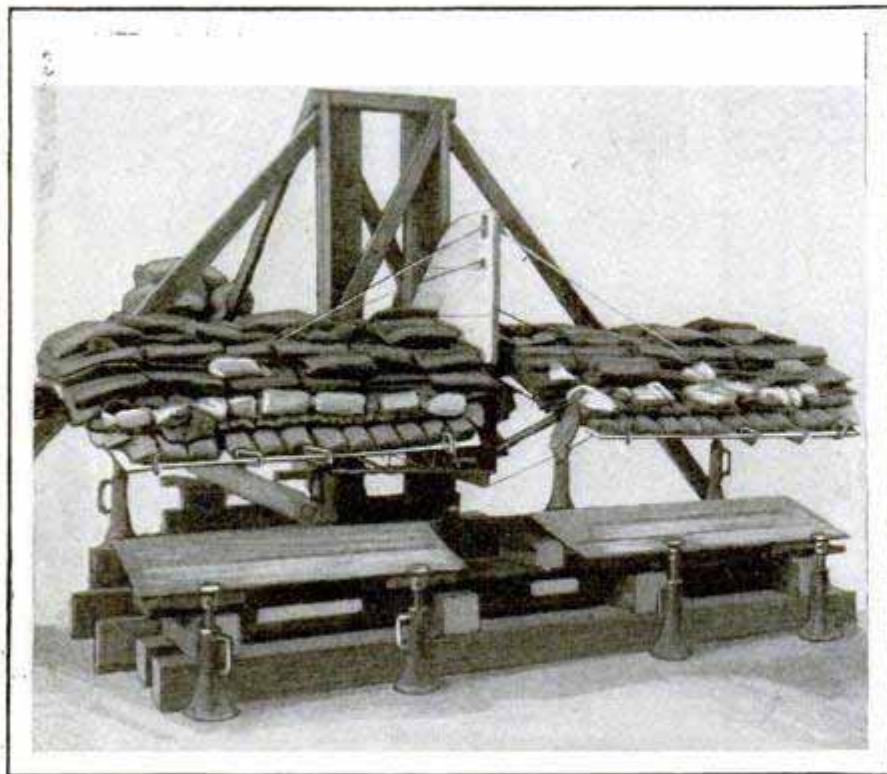

Bags of Lead Shot Are Piled on the Tail Assembly of a New Design, to Determine Its Strength

provement is necessarily based on change.

When the plane is finally completed and ready for flight, the highly interesting moment for the designer arrives when the final weight and center-of-gravity location are to be determined, and it is a case where the fate of the airplane really hangs in the balance. The total weight is usually pretty well known at this time, but if the center of gravity is found to be too far forward or too far back, the plane will not be safe to fly. This occasionally happens as a result of unforeseen changes in weight or location of certain parts of the plane, and some means must be found to shift the center of gravity to its designed location. If it is too far forward, a little added weight in the tail may bring about the desired result, as it is located a considerable distance from the center of gravity. If it is located too far back, however, nothing less than a change in the engine mount, so as to move the engine forward, will usually suffice, and this will require corresponding changes in the engine control and cowling.

After the balance is checked and found correct, the engine is usually run on the ground for several hours to test the engine installation, and if this is found to be satisfactory, the ship is ready for its

first flight. The moment when the first plane of a new design takes off on its trial flight is always an interesting one for everyone concerned, particularly the designer and test pilot. In the pioneering days of aviation, the information that was sought at the trial flight related to whether the plane would fly at all and, if so, whether it could be controlled and would hold together when landed. Now, however, airplane design has reached the point where there is little cause to question the airworthiness of a new plane before its first flight, unless it happens to be a very radical de-

sign. The first flight and the following routine test flights of a modern plane are made primarily for the purpose of determining whether it has the necessary performance, ease of control and stability required to suit it to the purpose for which it was designed. In the flight tests, such characteristics as speed, rate of climb, ceiling, fuel consumption, and degree of stability are determined; and it is often found desirable to try out several types of tail surfaces, propellers, and even engines.

When these tests are satisfactorily completed, the final step is to redesign the plane to the extent of incorporating in it the many changes which are inevitably found to be desirable during the designing and building of an airplane. Then the process of replacing preliminary drawings and sketches with complete and final drawings begins, and when this is finished, the design is at last complete and is ready to go into production.

☞ Popular Mechanics Magazine does not publish the name of the maker or seller of any device described in its pages, but this information is kept on file and will be furnished free upon application to our Bureau of Information.

4-564 Egin Ave.

VITAMINES TO BE SUPPLIED BY THE SEA

Wash News 8/22/29

Science is looking to the sea to supply needed vitamins and food resources of the future, particularly if a time of overpopulation should arrive. Experiments of the bureau of fisheries show the value of foods of marine animal origin, indirectly or immediately, for human consumption. These tests indicate that the benefits will be as great whether man eats marine life or animals that are fed fish products. Cows' milk, deficient under ordinary conditions in vitamins C, D and E, iron and iodine, was found to increase in vitamine content as well as iron and iodine when fish meal or other marine food was included in the diet.

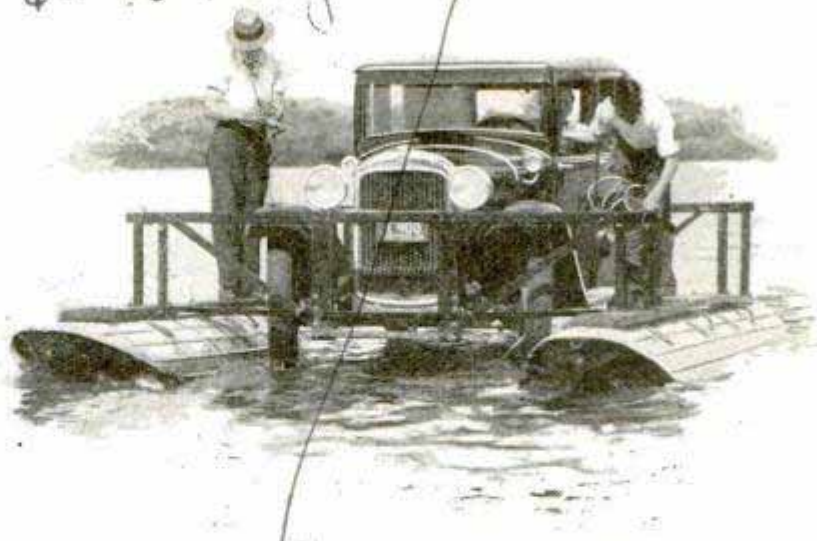

This Automobile, Equipped with Seaplane Pontoons and a Marine Propeller Shaft, Travels by Water as Well as by Land

AUTO ON SEAPLANE PONTOONS TRAVELS BY WATER

Using a pair of seaplane pontoons, a Manitoba, Canada, Winnipeg man makes trips by water in his automobile, and recently completed a 120-mile voyage without mishap. The propeller shaft of the car is disconnected at the universal joint, and a marine propeller shaft, rigged on the framework between the two floats, is connected. Thus equipped, the car cruises at a speed of about fifteen miles an hour.

LEATHER HOLDER FOR PENCILS BUTTONS ON SHIRT

Persons who have no place to carry pencils when they lay aside vests, now may use a leather pencil scabbard which buttons onto the shirt. The holder is essentially a sheath which fastens to the shirt at an angle and has room for half a dozen pencils in a position where they are always handy for use.

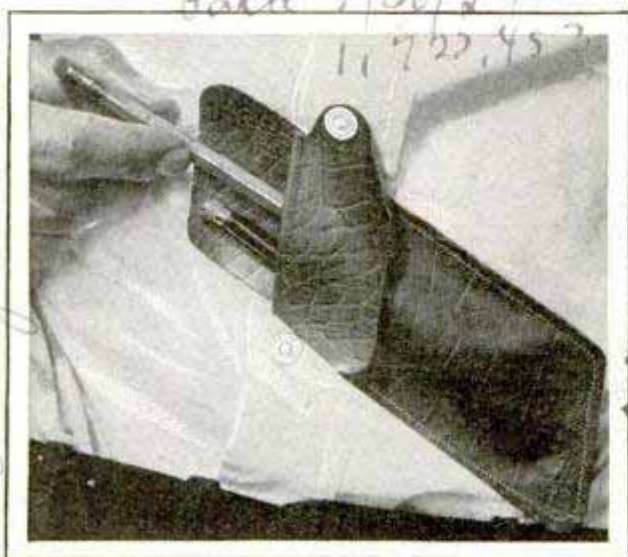

A Leather Scabbard for Carrying Pencils Which Buttons onto the Front of the Shirt

STEAM PIPES TO MELT SNOW FROM MOUNTAIN PASS

Steam pipes are being employed to conquer the snowdrifts that pile up each winter in the Berthoud pass over the Continental divide. This pass, 11,300 feet above sea level, often is blocked by snow from late October to May or June. Shoveling out the snow is an almost impossible task for about a mile and a half and it is in this section that steam pipes are to be used. Buried a few inches underground, no great heat is required as it will be necessary to keep the ground only a few degrees above freezing so the snow will melt and the water will drain off. During severe cold in the middle of winter or during light snowfall in early autumn or late spring the steam will not be used, but it is expected that it will keep the pass open several months longer than is possible at present.

Handwritten notes at the bottom of the page, including '25 and', 'University', and other illegible scribbles.

3249

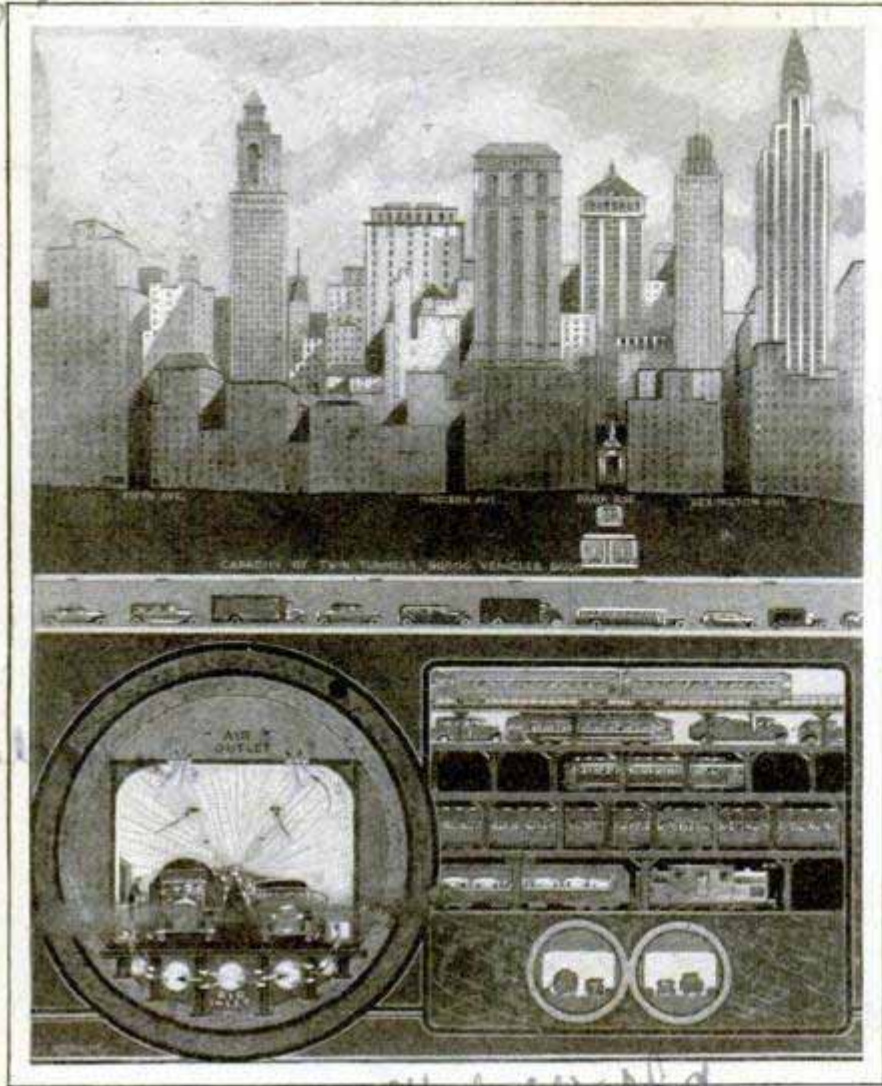

Above, Location of Contemplated Manhattan Tunnel, and, Below, Cross Sections Showing the Bore and Six Tiers of Traffic

MANHATTAN TUNNEL PROVIDES SIXTH TIER OF TRAFFIC

Six tiers of traffic, piled one on top of the other, part underground, some at the surface, and others above the surface, will be provided for certain sections of New York with completion of a proposed tunnel under Manhattan island and the East river to the boroughs of Brooklyn and Queens. Above the projected double-decked tubes with two roadways, each accommodating two lines of traffic, would be the Pennsylvania and New York Central railroads, Interborough Rapid Transit, the subway, the under-surface street-car lines in Madison avenue, the street level and the elevated railroad. Total length of the tri-borough tunnel is estimated at 22,600 feet. Under the river, two tubes are to be driven and the ultimate cost of the bore is estimated at about \$103,000,000.

W. J. ...

FLYING NO CURE FOR DEAFNESS

Stories of deaf persons having their hearing restored by taking airplane rides are ridiculed by Dr. L. H. Bauer, of the department of commerce. Instead, flying is likely to make deafness even worse by contracting the eardrums. In very rare cases, said Doctor Bauer, there are instances of hysterical deafness caused by some great emotional strain, and in such a case, a breathtaking dive in an airplane, or some other equal thrill, might restore lost hearing.

Portland Ore

MOUNTAIN RANGE REPRODUCED IN SAWDUST

Sculptured into a resemblance of parts of the Cascade range, the world's largest sawdust pile offers interest to tourists and residents of Portland, Ore. The pile is estimated at 240,000,000 sacks, and the sawdust is used to provide electric power to a city of 350,000 people. Its size, coupled with the exactness of the reproduction, lends an air of reality to its appearance.

Portland Ore

TIME SWITCH FOR AUTOMOBILE TURNS ON PARKING LIGHTS

Motorists who must turn on parking lamps when leaving their cars before dark, or return to switch them on later, have this worry eliminated by a time switch which may be set to light parking lamps at any designated

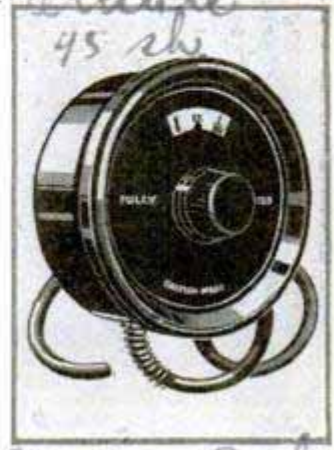

Stabilite 45 rh

Electric Co. Ltd. Sphinx House

Am. J. Francis, 40 Canadian, Rue de Valenciennes, Paris, France

M. U. 2 ch...

Pocket Corp...

20 22 nd St New York

time. The switch may be fitted to any car and is regulated by turning a knob to the time lights are to be switched on when the car is parked. The instrument consumes no current.

PIANO WITH THREE KEYBOARDS PLAYS QUARTER TONES

Distinguished musicians gathered in a small room in Paris recently to hear a triple-keyboard piano that plays quarter-tone notes. The instrument is the invention of a young Russian and is of German manufacture. It produces twenty-four separate pitches and was devised especially for the rendition of chamber music, and a symphony composed by the inventor. The pieces have quarter-sharps, quarter-flats, three-quarter sharps and three-quarter flats that cannot be played on an ordinary piano. Modern composers have said that the quarter-tone piano and similar instruments that give a division of tones may restore to music its "fluid quality," which has been lost somewhat in the present notation system.

PAPER "TANKS" ON BICYCLES USED IN MANEUVERS

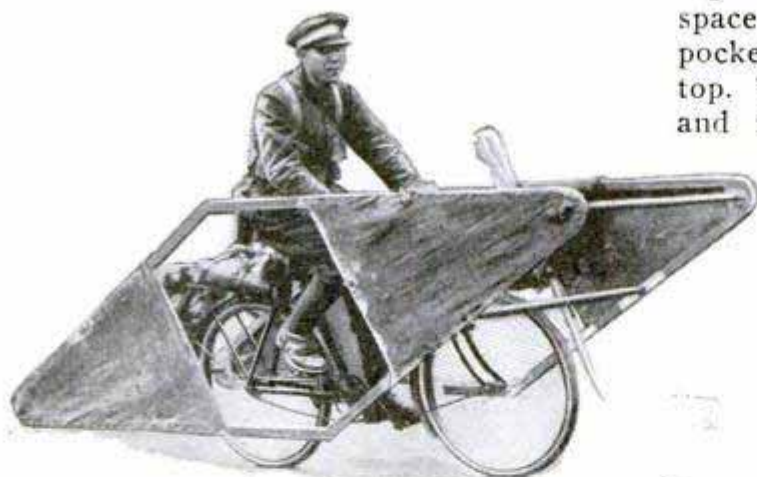

"Tanks" Used in British Army Maneuvers Were Made of Cardboard Frames like the Above, and Mounted on Bicycles

Cardboard frames, made to resemble lumbering tanks and mounted on bicycles, were used as one-man war machines in recent maneuvers conducted by the English army near Aldershot. Thousands of troops participated in the various battle formations in which the cardboard tanks played an important part.

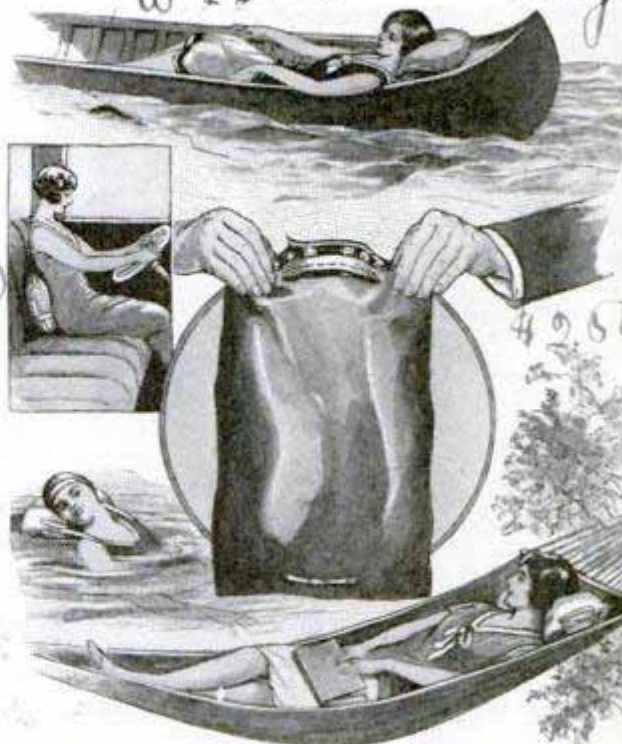

An Air Pillow Which Inflates Itself Adds Comfort to Swimming, Boating and Motoring

SELF-INFLATING AIR PILLOW ADDS COMFORT TO SPORTS

Affording comfort at the beach, while motoring, or engaged in other sport, a self-inflating air pillow may be transformed from a pillow to a bag for carrying wet bathing suits, or compressed into space permitting it to be carried in the pocket merely by opening a clasp at the top. The bag is twelve by seventeen inches and made of khaki cloth and rubber.

The clasp has rubber-lined edges, making the bag air and water-tight when the clasp is locked. Aside from its uses as a pillow and bag, the convenience also may take the place of water wings for swimming or of a canoe cushion, and has been used in emergency as a hot-water or ice bag. The outside of the pillow is decorated in a variety of contrasting colors to suit individual tastes.

The U. S. navy leads the world in airplane catapults, with two each fitted or building for eighteen battleships, and two each on ten cruisers built and eight others being built, a total of seventy-two, while Japan has but one, and England and France a couple each.

3147

Fighting the



By G. H. DACY

Montgomery Ave. Bethesda Md 4639
FISHING fables such as might be conjured out of the realm of fancy are enacted in real life in the waters of the Gulf Stream near the Florida keys.

These fishing grounds annually attract anglers from everywhere. Some 600 varieties of game and food fish live in these waters and, no matter how inexperienced the fisherman may be, he never returns with an empty creel.

The Gulf Stream, which tempers the climate of both Atlantic shores, is 1,000 miles wide at some points, but narrows to fifty miles off the Florida keys. This results in the relative congestion of warm-water fish in that stretch of salt water. Small wonder, under such conditions, that the largest pleasure-fishing fleet in the world, valued at more than \$12,000,000, centers at Miami ready for angling expeditions after silver tarpon, sailfish, marlin swordfish, sunfish, trunk-back turtles, whiplays, jewfish, whales, sharks and other denizens of the deep blue sea.



Below, Hammerhead Shark, Sighted from an Airplane and Later Harpooned from a Fishing Boat

Fiercest Fish

Capt. Charlie Thompson, dean of big-game fishing in south Florida waters, easily wins world honors as narrator of the champion fishing story. And just to prove that his experience was founded on fact instead of fiction, Captain Thompson towed ashore the giant of the ocean which gave him the fiercest fight of his life. Thompson won the battle, which lasted forty hours, but he lost exactly sixteen pounds in weight during the contest.

"Two fishermen had chartered my boat for a week's cruise," Captain Thompson said. "When the lookout sighted the monster, I ordered our thirty-one-foot motor tender lowered. The boat was outfitted with fish-fighting equipment. One seaman accompanied me. As soon as our boat was in range, I began firing at the mammoth with a high-powered rifle. Most of the bullets found the target but, apparently, made little impression.

"Finally, we approached close enough for me to throw a harpoon into the floundering giant. Quickly, I fastened the line to the prow of the boat. Enraged, the mammoth began a blind flight, towing our boat as though it were nothing at all. From then on, for the next two days and a night, it was a mad, exciting battle. Our fishing yacht followed us as the monster towed the small boat several hundred miles. The big boat could not get close enough to offer much assistance, and our supplies of food and water were soon ex-

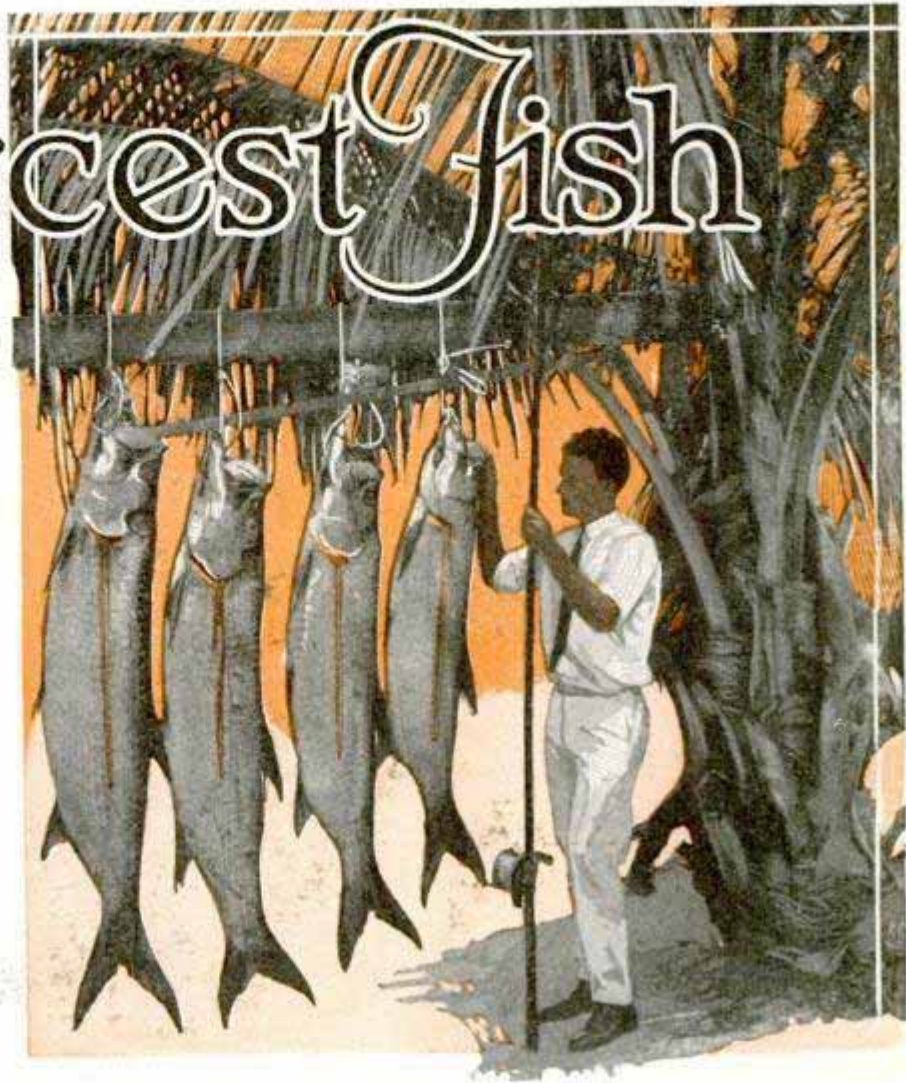

Silver Tarpon Caught in South Florida Waters; They Sometimes Leap Eight Feet High in an Effort to Free Themselves from the Hook

hausted. Our condition was becoming desperate, while the monster, as it became more infuriated, seemed to gain strength.

"Finally, when our ammunition was exhausted and all of the harpoons were seated in the mammoth, we signaled to the pursuing yacht. In desperation, the fishermen launched a rowboat and tried to bring us food and more fighting supplies. The monster, sensing the presence of the boat, made a wild charge and smashed the frail craft. Just when my companion and I had about resigned ourselves to a terrible death, the frantic efforts of the monster to break free from the five harpoons became feebler. And, almost before we comprehended what had happened, it was floating like a derelict on the ocean. The mammoth was forty-five feet long, weighed 30,000 pounds, and its body circumference was twenty-three feet."

Down in the latitude where Captain

3143



Thompson experienced the greatest thriller of his life, the modern "hook-and-liners" recently have taken to the air; that is to say, the airplanes are now being used successfully in locating schools of fish in order to advise amateur and professional anglers. Harry Rogers, an aviator, fishes directly from his homemade amphibian plane. He knows the waters below almost as well as the ocean of air above the sea. Airplanes are also being used by amateur sportsmen in their quest for huge rays and other harpoon fish. The land planes are employed merely as scouts in sighting the fish. The information is then either signaled or radioed to the sportsmen in an accompanying yacht.

Even elephant hunting in Africa now has its counterpart in "spear fishing." The goliaths of salt water are every bit as courageous, fierce and defiant as the challenging jungle beasts. The great ray, some of which measure thirty feet across the back, better known as the devilfish, is often encountered.

Harpooning hammerhead, shovel-nose, leopard, nurse and mackerel sharks is thrilling sport. These fish pirates usually are short-time fighters, but infuriated and fierce adversaries while their strength lasts. A giant sawfish has been known to tow a thirty-eight-foot motorboat for six hours.

One fishing party from Miami captured a sailfish that was ten and a half feet in length and weighed 152½ pounds, last winter. A thirty-five-foot sperm whale, weighing about twenty tons, was harpooned early one morning, but did not succumb until sundown. This fighter towed the boat more than seventy-five miles while the fishermen bombarded it with powerful rifle bullets and bombs. Once during that thrilling afternoon, a bomb dislodged the harpoon and the wounded whale disappeared in the school of which it was a member, but was speared a second time when,

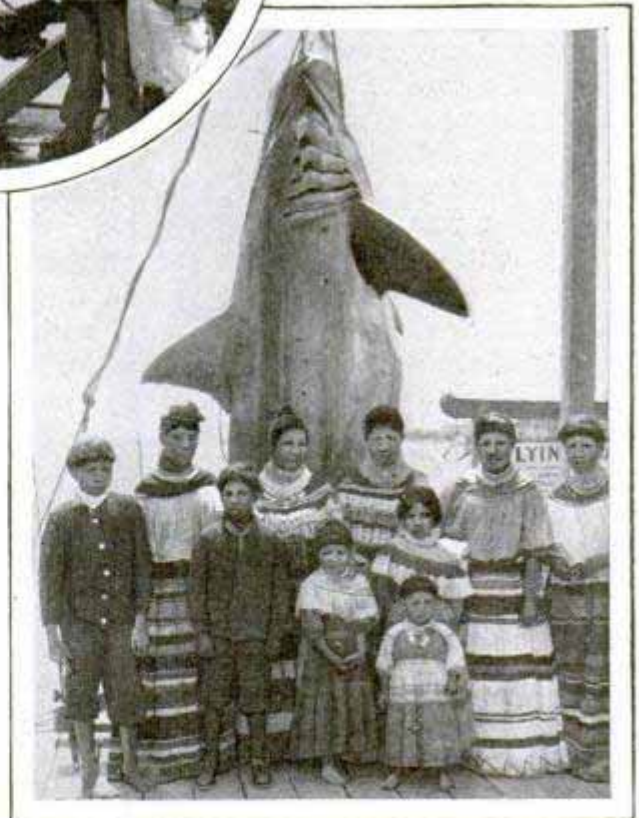
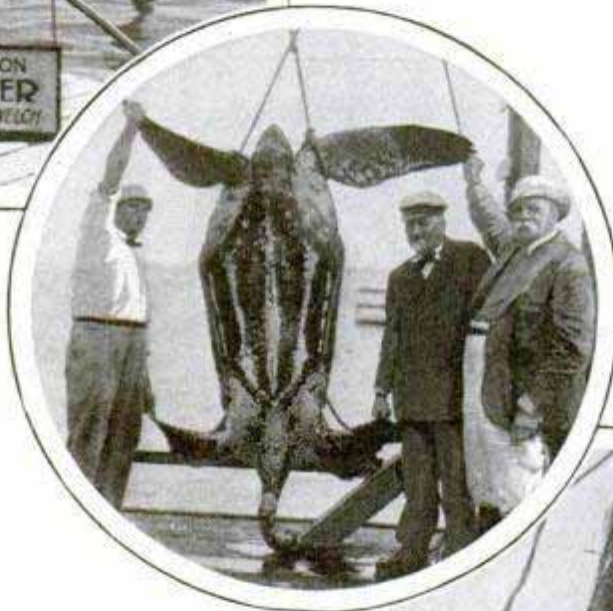

Devilfish, a Huge Trunk-Back Turtle Weighing 1,200 Pounds, and a Man-Eating Shark

due to ebbing vitality, it lagged behind its mates.

The experienced anglers of the Gulf Stream believe in giving the game fish a good fighting chance. Hence, the majority use light tackle, which consists of a nine-thread line with a breaking strength of eighteen pounds. It is then an odds-even fight between the fish and the fishermen. The skill of the anglers is depicted by the facts that the following record catches have been made in the South Atlantic ocean and Gulf Stream with such tackle: amberjack, sixty-two pounds; marlin swordfish, eighty-eight pounds; sailfish, eighty-nine and a half pounds; tarpon, 112 pounds; barracuda, fifty-five pounds; grouper, fifty-six pounds, and wahoo, sixteen and a half pounds.

Correspondingly larger fish have been caught by south Florida an-



glers and their guests who have fished with heavy tackle, using twenty-one-thread line with a breaking strength of forty-two pounds. Among their masterly catches are a 208-pound tarpon, 118-pound marlin, 107-pound sailfish, 104-pound amberjack, ninety-two-pound grouper and fifty-eight-pound

kingfish, not to forget the 150-pound tuna which was caught last winter near Miami.

A New York fisherman established a marathon fight record when he recently fought a tuna for eleven hours and twenty minutes before angling skill finally conquered. William Arnold, of Miami, an angler of seasoned skill, brought to gaff a jewfish weighing 412 pounds after an eight-and-a-half-hour fight, another proof of the fighting excellence of heavy tackle. In fact, it is a moot question among the hook-and-liners how large a fish can be yanked expertly from Davy Jones' locker on a twenty-one-thread line. The chances are that a one-half ton tarpon, if this species of valiant fighting fish grew that big, could be landed with such tackle, for the tarpon, in its charges and countercharges, leaps, dives and wears itself out.

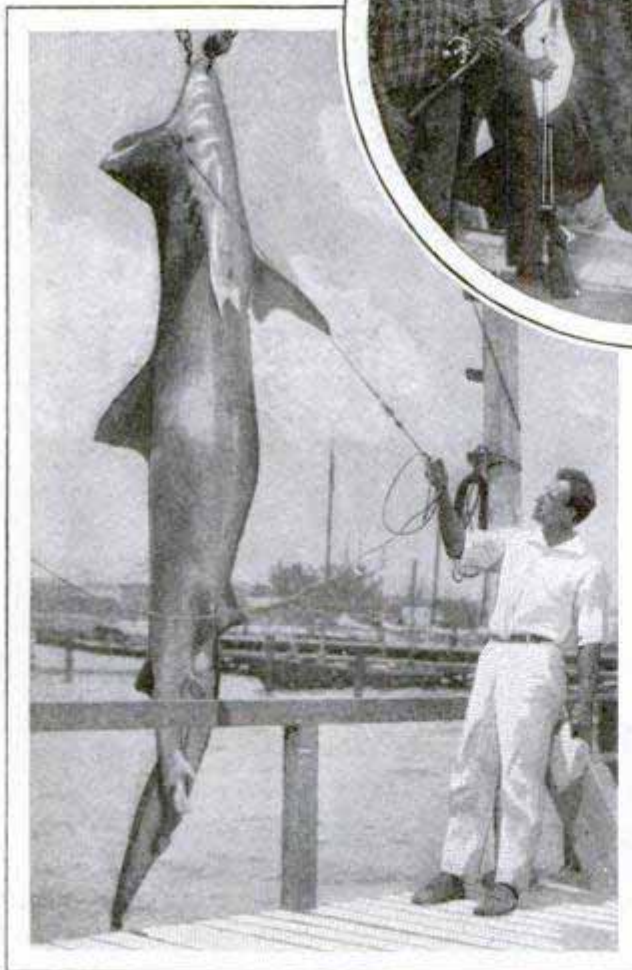

Spine Fish That Blows Up in Time of Danger; a 1,350-Pound Sunfish and a Hammerhead Shark

3143
790

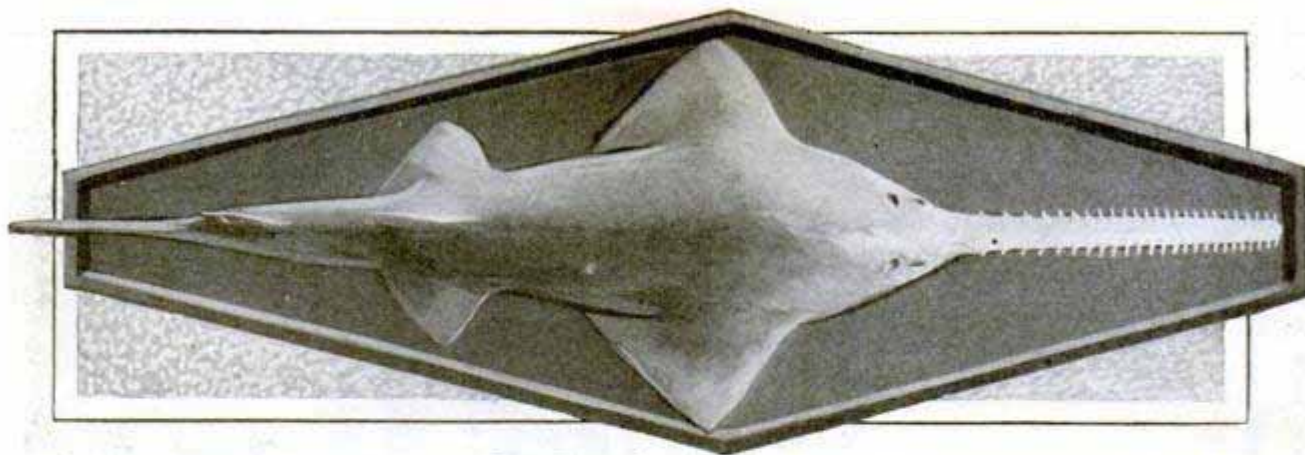

This Huge Sawfish, One of the Terrors of the Deep, Caught near Miami, Weighed 400 Pounds Before It Was Stuffed and Mounted as a Museum Specimen

A shark, on the other hand, hangs on the hook somewhat like a lump of lead and conserves his strength for the final crucial struggle for mastery.

The size of the fish is not always a true measure of its fighting ability when hooked. The bonefish, which weighs considerably less than ten pounds, is the fastest game fish that swims, and is a dauntless, intrepid fighter. The spectacular sailfish is a surface battler that runs helter-skelter and leaps with amazing force from the water. The tarpon is the peer of high jumpers among the hurdling fish and comes out of the water with a modified roar and thunder, leaping seven to eight feet into the air while it shakes its head vigorously, seeking to throw the hook.

The marlin, like the sailfish, is a surface fighter. The barracuda, a wolf of the sea, is nomadic, a dweller of the deep, and specializes in stealing fish from the fisherman as he is bringing his catch to gaff. The broadbill swordfish now ranks unrivaled as the most savage fighter in Florida waters. This species migrates to the Gulf Stream from the north Atlantic during July and August and every angler who has encountered one will remember the contest as long as he lives.

AIRPLANES CARRY WEED SEEDS

3100 Tumbleweeds and similar pests have taken to airplane travel, recent tests show. Inspection of 110 planes revealed that ten of them had in their tires the spines of puncture vine burrs, one of the most troublesome weeds of the southwest. This weed holds to a tire tread and works its way in like a tack. It is being fought by

*Horticultural Inspector
H. H. Hooper*

highway officials, who have become alarmed by the new trick of the weed to become started in fresh fields by way of airplane rides.

AUTO LIGHTS PLACED ON VISOR TO ELIMINATE GLARE

3350 Headlights for the automobile have been made to fit on the regular visor of the car top in order to eliminate the glare from lights in the ordinary position. Being above the eyes and shining directly on the road, makers of the visor lights say, the angle of illumination prevents the glare which results when ordinary lights shine partly on the road and partly in the air in front of the car. The lights on the visor shine over the radiator cap, illuminating the front of the car so that an ap-

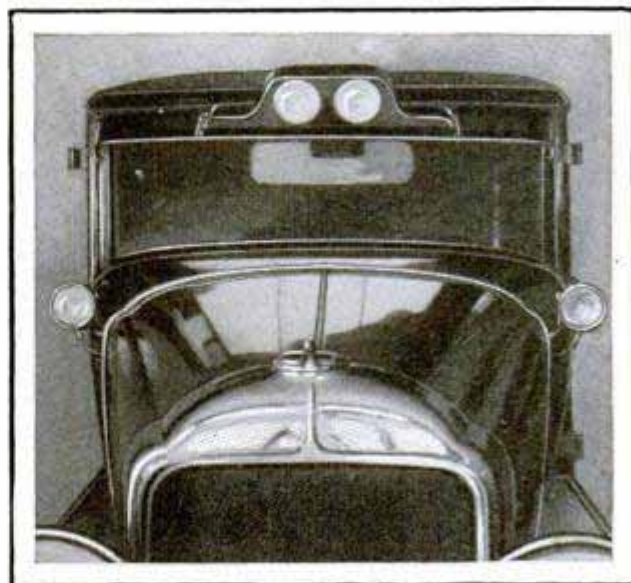

Headlights Placed on the Visor of the Car in Order to Eliminate Glare and Eye Strain

proaching motorist is able to gauge the distance between the cars more easily.

*Chas. W. Byron & Co.
S. H. Henshaw*

Asst. Trade Commissioner 3409

Arnold W. ... 3409

STEEL TROLLEY WIRES SEEN WITH "SLIDING SHOE"

Use of a "sliding shoe" instead of the usual wheel, to make contact with the trolley wire, may permit the installation of steel in place of the more costly copper wire engineers report after a series of tests with the shoe on street-car lines in Toronto. The shoe is twenty-five inches long and is thickly covered with grease which is expected to prevent the formation of sleet in the winter and to reduce the pitting and arcking of the wire. A pressure of from twenty-five to thirty pounds is required to keep the present trolley wheel against the wire, but only twelve pounds is needed with the shoe. This reduces wear and will allow the welding of wires instead of the usual frog at intersections, engineers believe. The shoe has been developed in Europe.

URGENT-MESSAGE HOLDER AIDS BUSINESSMAN'S MEMORY

Businessmen who find themselves forgetting important appointments and tasks are visibly reminded of them by an urgent-message holder intended for the desk.

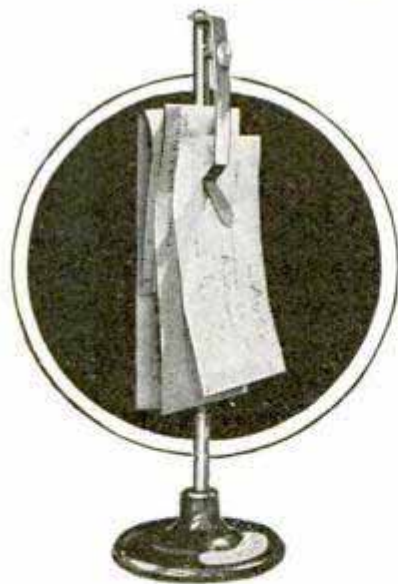

The holder consists of a base and a tall standard, at the top of which notes calling attention to urgent business may be inserted in a clip. The standard is of such height that the eye cannot fail to see the message as the businessman seats himself at his desk.

Popular Mechanics Magazine does not publish the name of the maker or seller of any device described in its pages, but this information is kept on file and will be furnished free upon application to our Bureau of Information.

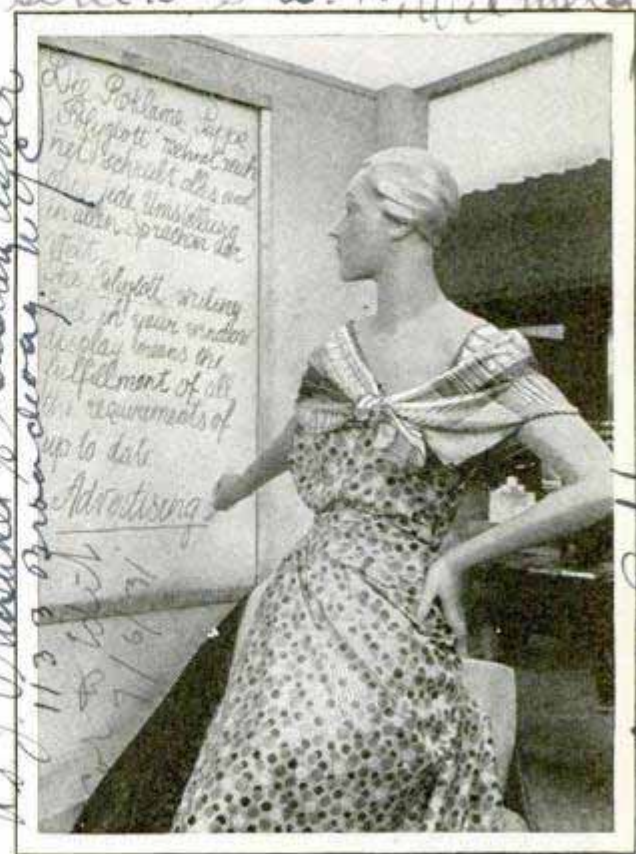

© Presse Photo
An Attractive Advertising Dummy; It Reproduces Handwriting through a Sending Mechanism

DUMMY REPRODUCES WRITING AT A DISTANCE

Copying the handwriting of a person who may be situated a considerable distance from it, a dummy developed in Berlin has attracted considerable attention. The writing robot faithfully copies, line for line and word for word, the handwriting of the sender who writes on a device which transmits the impulses to the dummy, which in turn transfers these impulses to a blackboard or chart. The dummy is used for advertising purposes.

CORNSTALKS ARE CUT LOW IN WAR ON BORER

War against the corn borer is aided by cutting off all stalks at the ground and shredding, ensiling or burning them, but the standard corn binder leaves a five or six-inch stubble. The department of agriculture has developed devices for four makes of binders which will cut the stalks at the surface, and has also made a low-cutting hand hoe for the same purpose. Most of the parts for such an implement can be made in the farm shop.

3409
30.
maker. Polygraph Typing Verbiel.
Geell Schaft. Geerfui w. 9
Soldanmer, 9. Germany

Hutchinson + Co. Clinton Chicago
Miscellaneous Publ
no 56 7w

3351
792

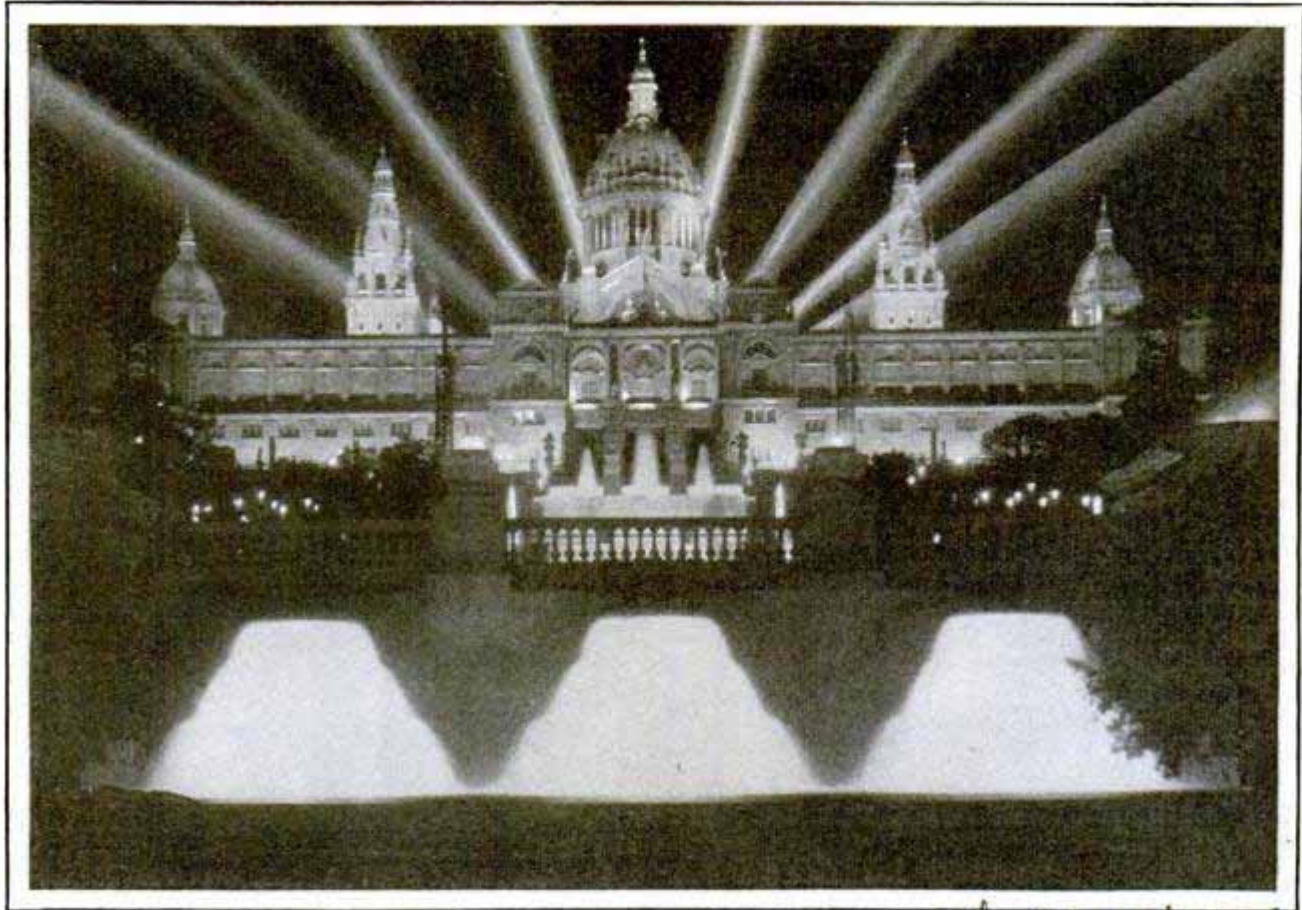

The National Palace at Barcelona, Spain, Pictured Above, Was Given the Effect of Wearing a Diadem by Eight Powerful Beams of Light Used to Illuminate It for an Exposition

DIADEM EFFECT GIVEN PALACE BY BEAMS OF LIGHT

Eight powerful beams of light were employed to help illuminate the national palace for the exposition at Barcelona, Spain. The beams, aside from lighting the heavens and being visible for miles, gave the palace itself the effect of wearing a diadem. In the center section and flowing down from the palace, were several cascades of water supplying a great fountain spraying water 200 feet high.

DENSITY OF SMOKE MEASURED TO MAKE CITY AIR PURE

New York's smoke abatement campaign is being aided by an instrument which measures accurately the density of smoke in the air. The appliance is used to determine the amount



of smoke issuing from stacks at any given time. It has been estimated that soot costs the city \$96,000,000 a year. The instrument is called an "umbrascope."

CRYSTAL REPLACES PENDULUM TO CONTROL CLOCK

Quartz crystals, similar to those used in radio stations to keep the wavelength constant, are being employed to provide more accurate clocks. Experiments have shown that crystals may be used instead of the ordinary pendulum, and when so used, compare well in accuracy with the observatory clocks. Since a pendulum is not required, the crystal clock does not need the firm base on which observatory timepieces must be mounted, and so could be used in tall buildings, on shipboard, or even in aircraft. When a quartz crystal, properly cut, is placed between two metal plates and a vibrating electric current applied to them, the crystal can be made to oscillate at a certain rate with great accuracy. Crystals vibrating 100,000 times a second are used for the clock, and the alternating electric current thus estab-

3384

Science Service

Health Dept. inspectors

at West Tele. Lab. Laboratory at Wash. D.C.

*made by a
Mabison*

3358

Dayton Aircraft Corp

Dayton Ohio

lished is made the basis of power to operate a motor geared to the clock face in such a way that it keeps correct time when the crystal vibrates accurately. Such a time-piece has been shown to vary within one one-hundredth of a second a day. This compares with the best clocks of late years, but a still more accurate timepiece has been developed in England.



Tandem Motors on This Plane Are Mounted above the Wings to Give an Unobstructed View and Add to the Power

PICTURES IN MOSS AGATE RIVAL PAINTINGS *3336*

Gathering pieces of moss agate bearing designs of unusual beauty, is the interesting hobby of a western man who collects most of his specimens from the bed of the Yellowstone river in Montana. After being cut and polished, the fragments display their unusual markings in striking manner. Miniature forests, lakes, islands and other scenes in soft colors are seen in the transparent stones, some of the effects being so realistic that it is difficult to believe they have been formed by nature. A rotating iron disk is the principal implement used in cutting the rough stones.

TANDEM MOTORS OVER WINGS ADD SAFETY AND POWER

Successful tests have been concluded of a large monoplane with its two motors mounted in tandem fashion, one behind the other, on top of the plane above the wings. It is the first time motors have been placed over the wings of a land plane, and the arrangement gives the pilot an unobstructed view from his compartment in the nose, eliminates the danger of persons walking into the whirling propeller blades, decreases the noise from the engines and adds power by giving an unobstructed draft over the top of the wings and non-interference with the air stream that strikes the underside. The radial-type engines are of 525 horsepower each, the front one having a two-blade propeller and the rear a three-blade of the pusher type. Either motor can carry the plane, which is fifty-three feet long, has a wing spread of sixty-seven feet, provides room for six passengers, pilot and observer, and weighs 9,000 pounds fully loaded. The ship has a maximum speed of 160 miles an hour and a cruising speed of 140 miles.



Pieces of Moss Agate Which, When Polished, Often Resemble Miniature Forests and Lakes

☞ To warn motorists against parking near a fire hydrant, a bright red mark is painted on the curbstone in a mid-western city.

*J. H. Monroe
address unknown*

32219

Sunrise on the

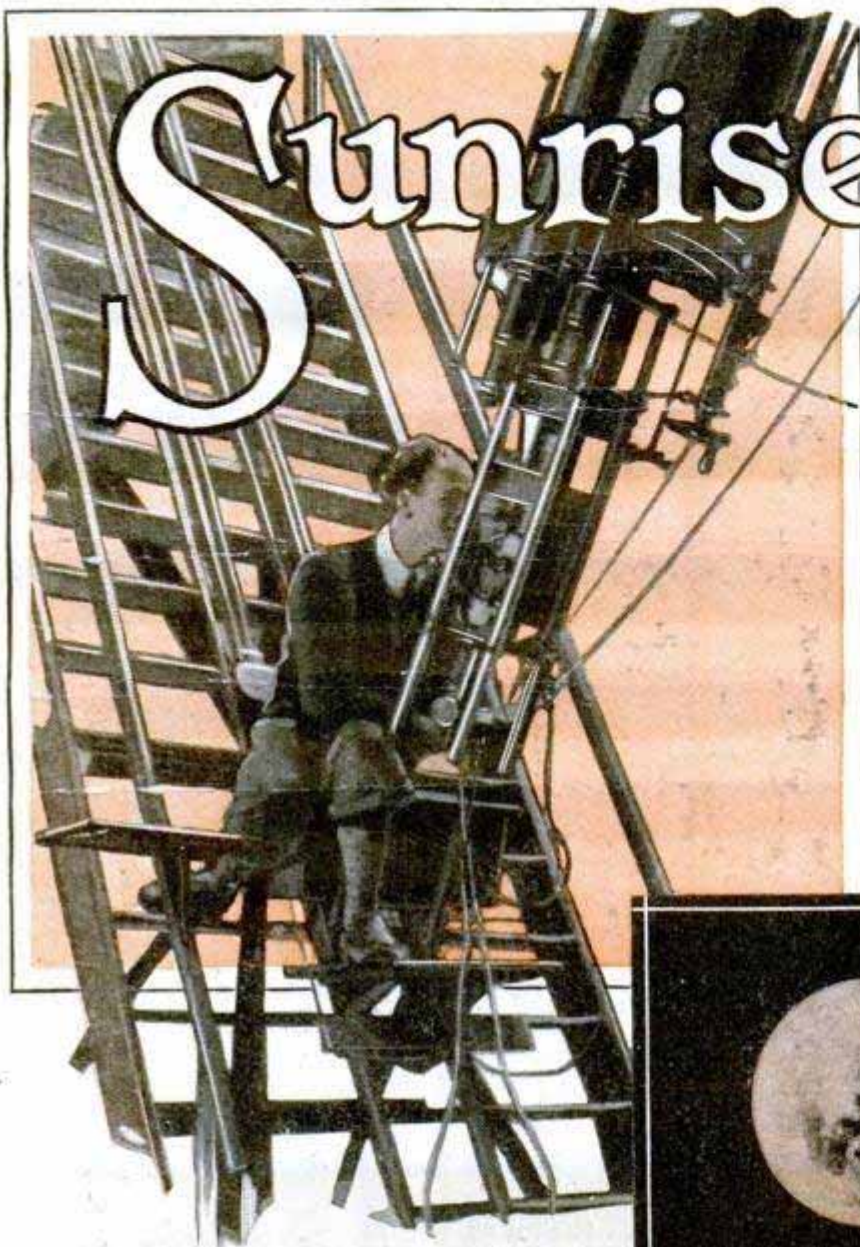

first peeks above the horizon of Luna to gild the lofty summit of Copernicus, burnishing the rim of the vast crater of this extinct volcano, at length wiping out the dense shadow in the crater's depths, and moving on to thrust back the darkness beyond.

It is as though we looked on at this from an airship a mere thousand miles away from the moon, so do the optical instruments of today annihilate distance in space, instead of

By J. OLIN HOWE 3224

Grand Camera
SUNRISE on the moon! Thrilling intimacy with the great orb which rules our nights is in the first motion pictures to be made of the moon, filmed by a graduate student at Princeton University. Astronomers long have been able to watch through their telescopes as the sun dispelled the black darkness of lunar night across the scarred and pitted face of our nearest neighbor in the heavens. Now the rest of us may share this rare privilege.

Mount Copernicus, perhaps the most magnificent of the moon's mighty peaks, and certainly one of the most fascinating, is featured in this first film of the moon. Upon the screen we see the brilliance of Old Sol's rays as he

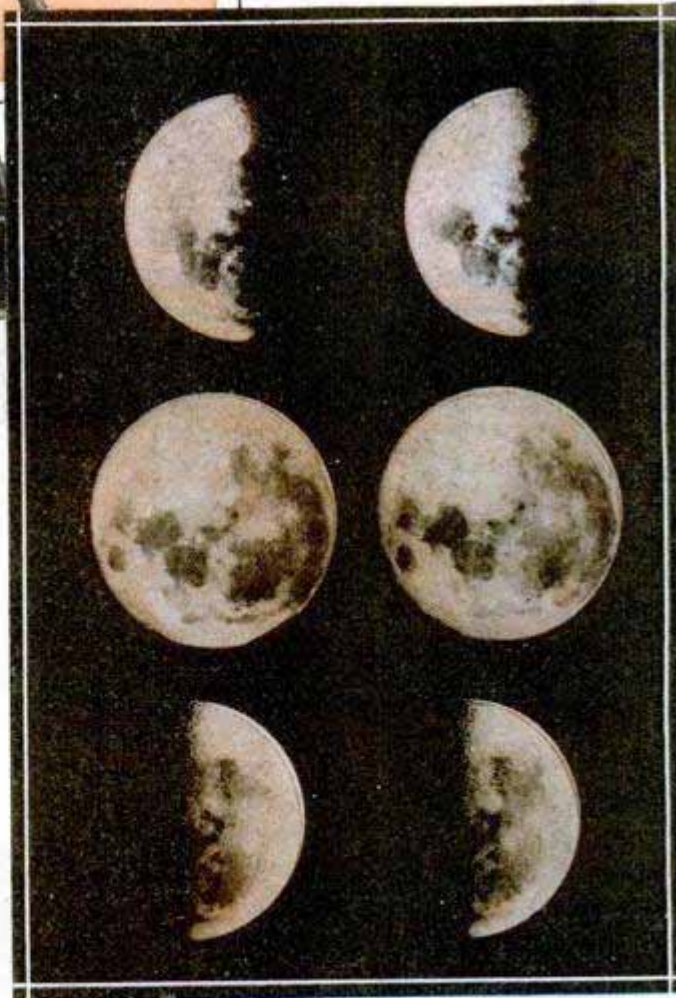

Prof. John Quincy Stewart, of Princeton University, Operating Movie Camera Attached to Big Telescope; Below, Moon Photographs

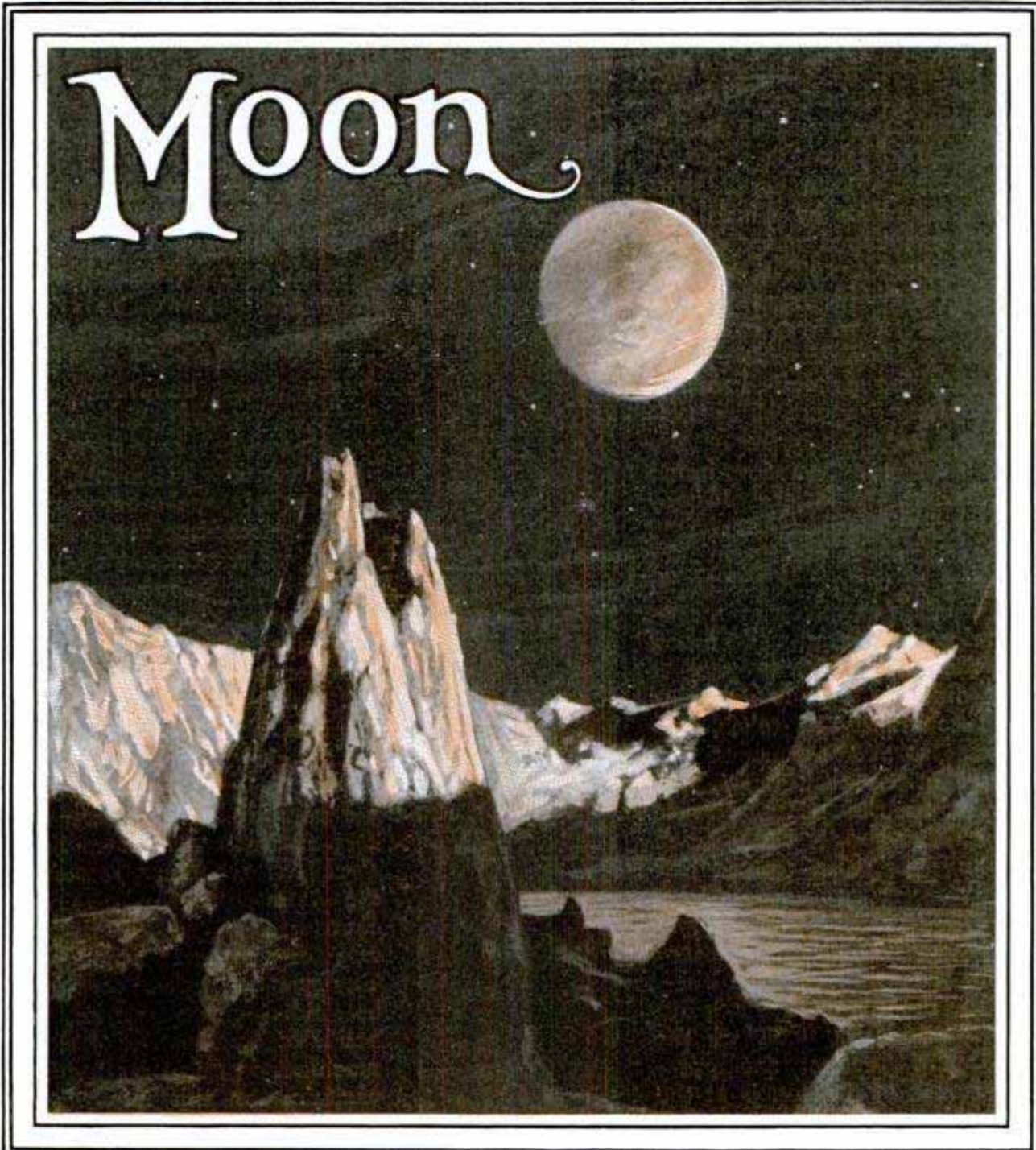

Courtesy The American Museum of Natural History

Imaginative Conception of a Moon Landscape and the Earth as Seen from the Moon, from an Oil Painting by Howard Russell Butler, N. A., in the American Museum of Natural History

the camera's being on the earth, 240,000 miles distant from its objective. And the motion picture which results discloses in a few short minutes changes on the face of the moon which really require twice as many hours to take place, hours of tireless observation on the part of the diligent astronomer.

Motion pictures of the lunar dawn are the idea of Edward G. F. Arnott, Princeton '28, now a graduate student at the university, and of Prof. John Quincy

Stewart, of the Princeton department of astronomy. This was worked out with the co-operation of the former's father, Robert Fleming Arnott, of Upper Montclair, N. J., and of Arthur L. Bennett, of Williamson, N. Y., also a graduate student at Princeton, who has had considerable experience in lunar photography at Lowell observatory, Flagstaff, Ariz.

Bennett made only still photographs there, however. No one ever made a motion picture of the moon until Arnott

conceived his plan of attaching a motion-picture camera to the big telescope in Princeton observatory and having its powerful lens, twenty-three inches in diameter, take the place of the camera's own small lens. The mechanism by which this was accomplished was designed by the elder Arnott, a consulting engineer with experience almost as world-wide as President Hoover's. And the whole affair is under the general direction of Professor Stewart. The camera is a popular make of the type now common for home use, its film the familiar 16-millimeter size. An aluminum frame holds it firmly in position at the eye end of the great telescope, and the film is driven by a special electric motor. The moon and the earth whirl in space at very different speeds and this must constantly be taken into account, as well as the continual change in the position of each relative to the other, minute though these are to the unaided human eye. The moon's day is roughly thirty times as long as ours—from our first glimpse of the new moon's slim crescent to the last vestige of the old—and the moon's diameter is but about a quarter that of the earth. On the moon, the apparent motion of the sun is at the rate of somewhere about nine miles an hour, while it rushes across the surface of the earth at the comparatively high speed of 1,000 miles an hour.

Picture, then, the astronomical cameraman in Princeton observatory in the still watches of night. He and his companions have climbed long flights of steep stairs into the tower, the machinery has rolled back the desired section of its dome, and the operator sits on the suspended seat adjustable to such position as he wishes up or down much steeper steps back of the small end of the great telescope. He is looking at the moon



Movie-Film Strip of Moon at Early Morn.

through an eyepiece which stands out at right angles to the telescope itself, and he sees exactly that portion of the lunar landscape which registers on the film.

Forty per cent of the light which comes through the big lens is diverted to this guide lens, so that the operator may know precisely what he is doing. You see, in each hundred feet of this film there are 4,000 separate pictures, one taken every six seconds, and after each exposure the operator must make two distinct adjustments, independent of each other and absolutely necessary, for the "hour angle," as astronomers term it, and for the moon's declination as it crosses the night sky. The exposure each time occupies but four seconds, camera wide open, full shutter, the remaining two seconds being the operator's.

The clockwork on the telescope, designed to compensate the rotation of the earth and keep the instrument steadily directed at whatever section of the firmament the observer chooses, is not sufficiently accurate for photographic purposes. The great spyglass must now be guided within finer limits by hand, or by electrically driven machinery guided by hand. A variation on this film of even a few thousandths of an inch is a serious matter, to be magnified to a noticeable distortion on the screen.

Hence the operator sits, eye glued to the eyepiece, and with an electrically connected push button in either hand makes his two different adjustments ten times in every minute during

those two seconds while the camera shutter is closed each time. Speaking generally, these are horizontal and vertical moves, and neither may be more than one-half of one-hundredth of an inch! Else it will show on the film.

Hour after hour of the night he who

films the moon is as fully occupied as an aviator flying with no other resource than the dials on his instrument board. It requires nearly seven hours of painstaking application to the job to make a hundred feet of this picture.

Nor will a single night suffice to take the full lighting up by the sun's rays of even this one mountain, except possibly one of our longest winter nights. And even then the camera would have to catch it just right. These moon craters are huge affairs. On earth we have no mountain craters over six or seven miles across; the moon has many craters fifty and sixty miles in diameter, and 100 miles in width

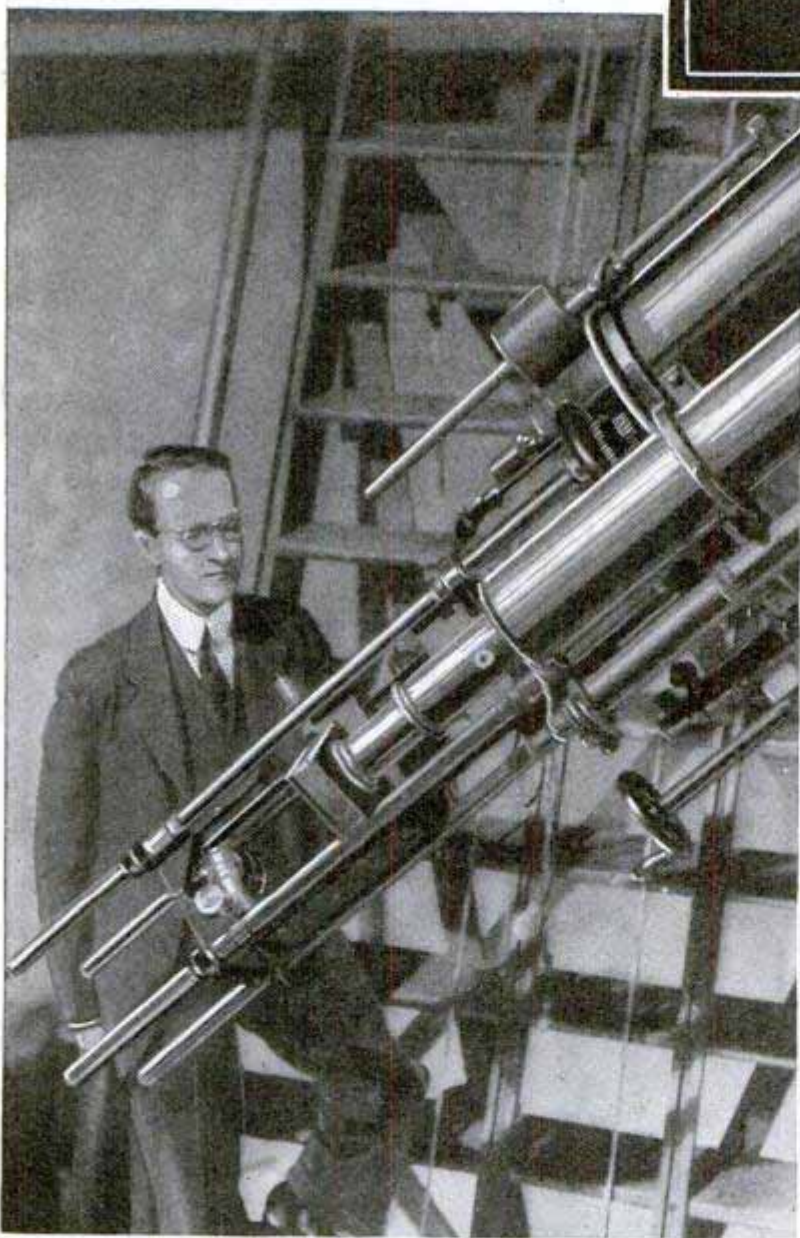
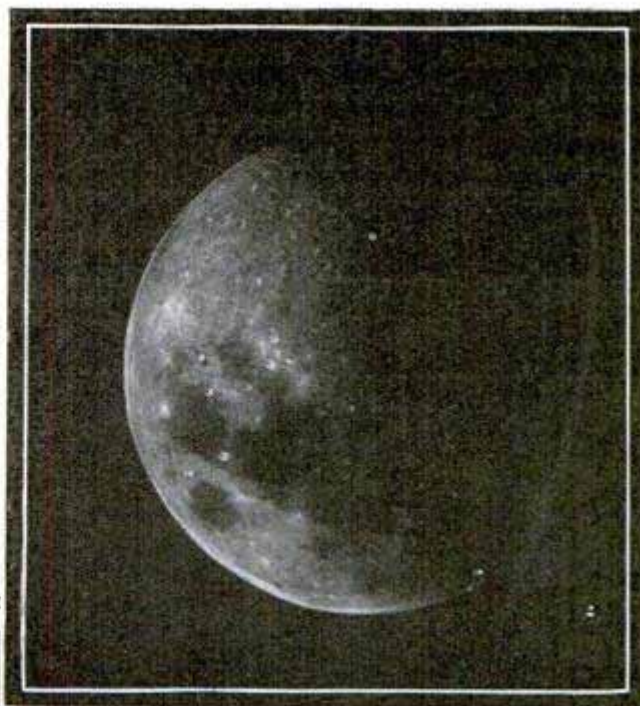

is by no means unknown there. The circlet of peaks which forms the crater of Copernicus is fifty-six miles across. By the time shadows were fully gone from its deepest depths the moon would have sunk beneath our western horizon, very likely.

The photographer cannot pick up his task and go ahead the following night, either; twenty hours will have made a great difference in the situation on any part of the moon. He must await conditions similar to those of his first night in the next month and hope for good luck. It took three months for Mr. Arnott to carry the lunar sunshine halfway across the crater of Copernicus and he felt himself especially fortunate to get two nights suited to his purpose in so short a time.

No rose tints paint the mountaintops at dawn on Luna, for the moon has no atmosphere. There are no gradations between darkness and light such as we have; no twilight band interposes between night and day. Before the sun comes, there is blank, black

Above, Photograph of Sunrise on the Moon Just Before Sun Reached Crater of Mount Copernicus, and, Below, Robert Fleming Arnott, Designer of the Moon Movie Apparatus

darkness such as we on this planet can hardly realize. On its arrival, almost instantly the first peaks to catch its rays stand out in full definition in a harsh, untempered glare in sharpest contrast to the dense blackness which obscures near-

by terrain where it is still night. And so slowly does the sun creep across the face of the moon that the tallest upthrust of her mountains is fully illuminated hours ere the shadows recede from neighboring plains.

WIRE TWISTER FASTENS FORMS FOR CONCRETE WALLS



Wire Twister Operated like an Auger, to Tighten the Wires on Concrete Forms

Tying together the forms for concrete walls with tightly twisted wire has been simplified by a tool which eliminates hand twisting, often a slow and dangerous process. By using the twister, the forms may be built in large units, instead of a board at a time, and the wire tightened after the units are placed on the footing. The twister has a handle like an auger and an extension shaft is provided so that it is unnecessary for the person operating it to descend into a narrow form to use it.

WAX FROM A WEED

A weed known by the Spanish name candelilla, growing in profusion on the mountain slopes of western Texas and

northern Mexico, is the source of a wax suitable for the manufacture of phonograph records, floor polishes, linoleum, and for various other uses. Small wax factories in remote localities in the mountains of Texas and Mexico extract the wax in a crude form from this weed and ship it east to be refined and converted to a useful purpose in industry. The little plants in the mountains are usually isolated where automobile or wagon travel is impossible. So, the raw material in the shape of weeds is generally brought to the plants on burros, and the crude product of the factories then transported to the outside in the same manner.

BASEBOARD RADIATOR HEATS FROM LEVEL OF FLOOR

Projecting its heat from the floor level where it is most efficient, a radiator is on the market which is so compact that it projects only a few inches from the wall when exposed, or it may be installed so that it is recessed partly or entirely in the baseboard. The radiator, made in eighteen and thirty-six-inch lengths, may extend straight along the wall, or make a right-angle turn. When recessed, valve connections and traps are incased for concealment. The heating device, only eight inches high and three and one-half inches deep, operates on any two-pipe steam, vapor or vacuum system, and on a hot-water plant of either forced or overhead circulation, sending its heat forth at the floor line where it is most required.



Floor-Level Radiator Installed, Showing How Closely It Fits to the Wall to Save Space

Richmond Radiator Co. Inc. 1480 Broadway

Cont. S. V. Lindau 315 Roseborough Ave.

San Antonio, Texas

3388

88.00

3408

Mar. H. Keller Champagne, Ill.

Myr-

Chicago, Ill. H. H. Mehegan, Dec. 10, 1910

3432

440 - 7. 8/31/29

3338

Boeing airplane 799

Cinnamomum POPULAR MECHANICS Cassia

International Land and Livestock Exchange

HIGHEST-PRICED TREE BARK

3431

To be the highest-priced bark in the world is the distinction claimed for a variety of cinnamon tree that grows in the province of Thanh Hoa, French Indo-China. The tree reaches a height of thirty or thirty-five feet, and bears a white-spotted bark. When the tree is stripped, the bark is divided into three parts. That from the upper portion of the trunk is esteemed most highly, and that from the base the least. The king claims two-thirds of the bark from the upper two-thirds of the tree as his own; the rest is auctioned off. The bark of a single tree brings as much as 100,000 francs which even at post-war exchange rates means \$4,000. The Chinese and Annamese native doctors supply an avid market for this bark, as it is regarded as a cure-all.

see Agricultural File

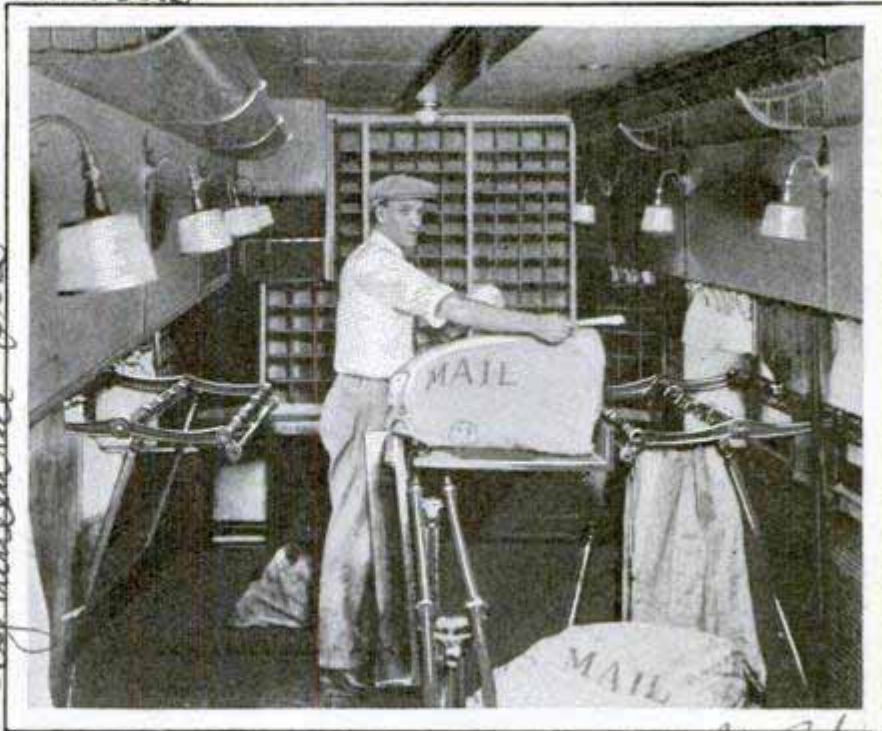

Inside the Mail Plane, Fitted Up like Railroad Car; the Clerk Sorts the Letters as the Ship Flies

MAIL SORTED ABOARD PLANES OF FLYING POST OFFICES

Airplanes which will serve as flying post offices when Uncle Sam decides to use them, much as railway post offices are now, are being built by the Boeing air transport, which handles mail contracts. By placing mail clerks aboard to sort letters in transit, officials estimate that about three hours can be saved on the run between Chicago and San Francisco. A fleet of eighteen-passenger transports now under construction can be converted without trouble into aerial post offices. The cabins are more than nineteen feet long and seven feet high, and the planes can carry three and one-half tons. The clerks may have their meals aboard, as the planes are equipped with a small buffet.

ELECTRIC-LIGHT TIME SWITCH TURNS OFF CURRENT

3395

Electric-light current is saved by a time switch which may be attached to any socket and which will turn off the light at a given time. The device consists of a coupling between which is a clock, wound by pulling the cord which turns on the light. The clock may be set at any number of minutes and when it runs down the light goes out. It may be fixed for any period from three to ten minutes, and the switch is intended particularly for stock rooms or warehouses where light generally is needed for only a few minutes at a time.

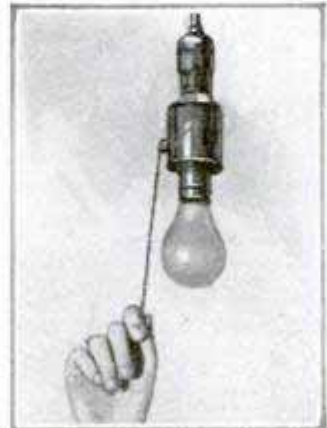

LIGHTED STREETS GUIDE FLYERS

3398

Two converging streets in Cheney, Wash., which form an arrowhead pointing to the airport at Spokane, at night become a guide for aviators hunting the landing field. The two streets have been equipped with sixty-two standards carrying brilliant lights which serve the double purpose of illuminating the thoroughfares and pointing to the airway, the lights from the air resembling a huge arrow.

Uni. John E. Shoemaker Westinghouse Elec. Mfg. Co. 208 Colorado Bldg. E. J. Pittman

117W J. G. Gordon
30800 - 1 - 2nd - 10th - 10th - 10th
Cincinnati, Ohio

Chicago Daily News
8/16/29

POPULAR MECHANICS

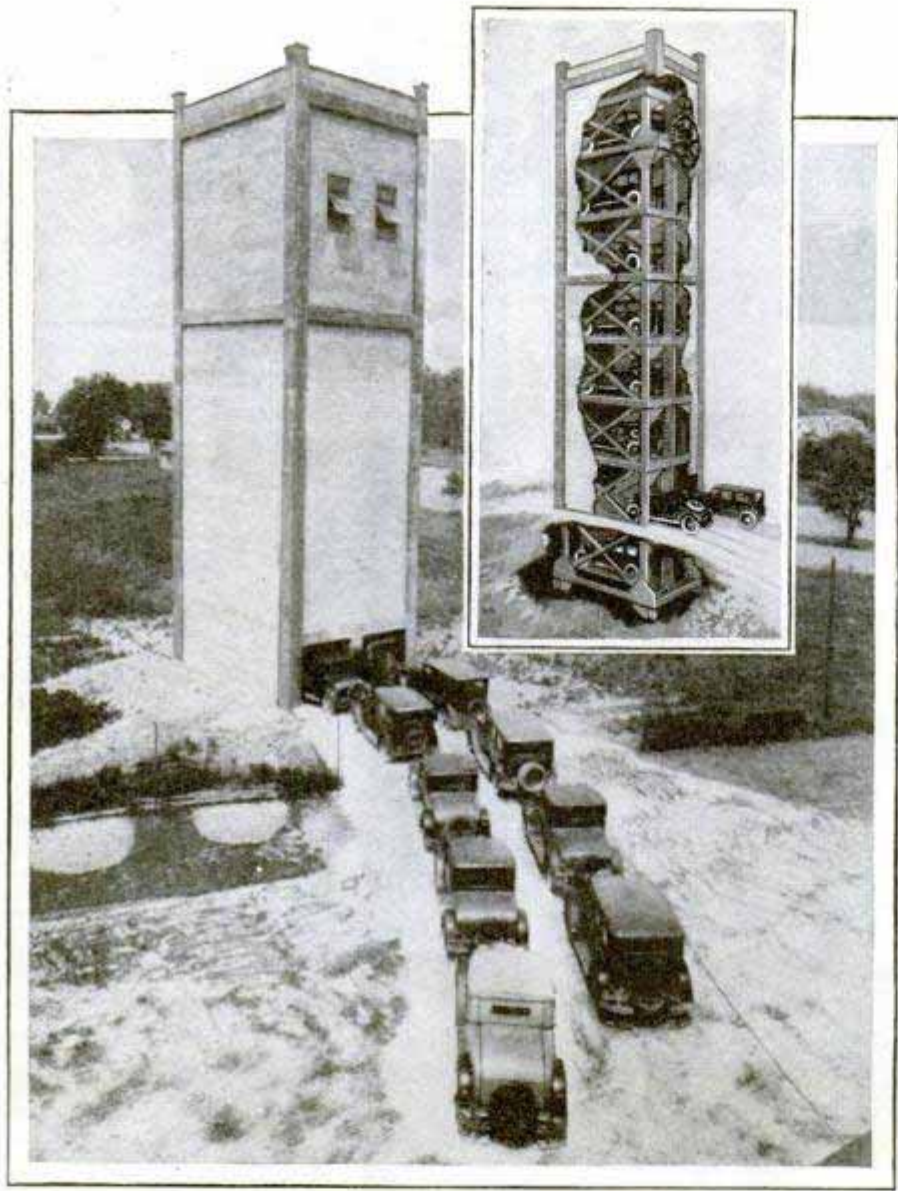

This Parking Tower Occupies No More Ground Space Than a Two-Car Garage, but Houses a Dozen Automobiles

PARKING TOWER SAVES SPACE AND HOUSES SIXTY CARS

Parking towers, built on plots of ground no larger than necessary to erect a two-car garage, but rising to heights allowing the housing of up to sixty autos, are being erected to relieve city-traffic congestion where space is at a premium. The tower is made of concrete with platforms of steel for the automobiles, which are moved up and down on an endless chain operated by an electric motor.

FIREPROOF MATCH IS FOUND SAFE AND PRACTICAL

Self-extinguishing cigarets and fireproof matches have been developed by the United States bureau of standards to re-

duce fire hazards. The fire-protection factor of the safety cigaret lies in an inch-long tip lined with water glass, air-excluding sodium silicate. The match is coated with water glass within half an inch of its head. Tossed aside as a fag end, the cigaret went out quickly enough to reduce fire hazards from this cause by ninety per cent, while possibilities of accidental fires were reduced about one-third by the fireproof matches. The annual fire loss from carelessness of smokers has been estimated at \$90,000,000. Investigators, after studying cigaret stubs in highways, byways and building corridors, learned that the stub usually discarded is one and one-fourth inches long. Cigaretts, taking into consideration total national consumption, were found to have a forty-to-one fire hazard as compared with cigars. Through tests, it was found that five seconds usually is taken to light cigarettes and ten seconds for cigars and pipes. The matches were coated with the water glass to allow them to burn for the longer period.

FLY-IT-YOURSELF AIRPLANE

Persons who have a pilot's license, but do not own a plane, now may rent a ship, just as they rent an automobile. A Kansas City company which operates motor-car rental agencies in sixty-five cities has formed a fly-it-yourself company and ordered 100 two-seater sport planes to rent to persons who find it too expensive to buy their own. The rental charge is between \$15 and \$20 an hour and a pilot also may be obtained by a person who wants to rent an airplane but does not have a pilot's license.

3302
3302
I am interested in it. Yours.

MODERN SHIPS ARE MADE UP OF ONE-TENTH COPPER

About one-tenth of a modern 30,000-ton ship is copper, according to the Copper and Brass Research association. The bronze propellers of such a vessel may contain 53,500 pounds of copper, shaft sleeves 53,000 pounds, main propelling machinery 200,000 pounds, electrical gear and wiring 3,000,000 pounds, and even such installations as speaking tubes about 100,000 pounds of copper. Prospective building programs of the world's merchant marines and navies are estimated at 3,000,000 gross tons of shipping a year, the yearly increase in world tonnage being about 1,000,000 tons.

DEVILFISH RELISHED AS FOOD ON NEW YORK'S EAST SIDE

One of the food delicacies of aliens on New York's lower east side is the baby octopus, or devilfish, which, when grown up, becomes the fearsome sea monster with long tentacles reputed to attack swimmers. A small octopus, weighing four or five pounds, is dried, and the purchaser soaks it for forty-eight hours before cooking, after which those who relish it say the meat develops a fine flavor.



Dried Baby Devilfish Which Is Considered a Food Delicacy by Some New York Foreigners



Round Playing Cards Which Those Who Have Used Them Say Are Easier to Shuffle and Deal

ROUND PLAYING CARDS EASIER TO SHUFFLE AND DEAL

Round playing cards are being produced by a British manufacturer who claims these cards, representing the first change in shape to be made in many years, are easier to shuffle and deal. The cards have six spots and numbers distributed around the rims so that numbers and suits are easily read in any position.

COLORED BOMBS FOR POLICE

London police are experimenting with color bombs, enabling them to deal more effectively with thieves who make their get-away in automobiles. The bombs are about the size of a tennis ball, made of thin metal and filled with a liquid described as quick-drying, viscous and luminous. A policeman, seeing the escape of a car containing thieves, throws the bomb at the fleeing auto. When it bursts it spreads a penetrating odor and spatters the machine with the quick-drying enamel, thus "spotting" it so that the next officer seeing it would arrest the occupants.

☉ Clouds are sometimes ten miles thick.

New York City
U. S. Columbia
mfg Co

258-5th Ave

3313
2298
Chicago

John Washington the
108 Albion Road Stoke
Newington
London

3321

Clouds are sometimes ten miles thick

327 4 11 20



The Steel Frame about This Building under Repair Protects Both Pedestrians and Workmen

STEEL FRAME ABOUT BUILDING PROTECTS PEDESTRIANS

Pedestrians and workers are protected from accidents by a huge steel frame that has been erected about the Collegiate Church of St. Nicholas on a busy New York street while the edifice is under repair. The steel scaffolds, which give the building the appearance of a big honeycomb, are fireproof and built to prevent a blaze such as started from wooden scaffolding and destroyed the old Rockefeller church in New York some time ago.

Anthony Hadimez

BREAKING POINT OF CRACKERS

Bakers are measuring the breaking point of cookies and crackers to determine the best "shortening" to obtain as tender a product as possible, which will at the same time withstand handling and shipping. The breaking strength varies

with the kind of flour and type and quantity of fatty matter used. The cracker is placed across two parallel rails and a pressure rod placed on it. Lead shot are poured into a cup at the top of the pressure rod until the cracker breaks, after which the weight of the shot is recorded.

HOTTER SPARK FOR AUTO GIVEN BY EXTRA CONDENSER

Protecting the ignition, increasing the intensity of the spark and preserving the distributor points, a condenser is on the market for automobiles with battery ignition. It helps overcome trouble caused by pumping cylinders, gives a hot spark, enabling the use of heavier oil and a weaker mixture of gas, thus saving fuel. It facilitates starting and gives added power for heavy pulls, the makers say.

AIRPLANE WITHOUT FUSELAGE CARRIES LOAD IN WINGS

Capable of carrying a large cargo and from ten to twenty passengers, an airplane without the present cumbersome fuselage is being built in Los Angeles. The designer claims the elimination of the fuselage not only reduces structural weight but diminishes complications, thereby lessening the cost of construction. The plane has a landing wheel in the center under the wings and ground hooks at the rear, and its wings are thickened at the center to carry passengers.

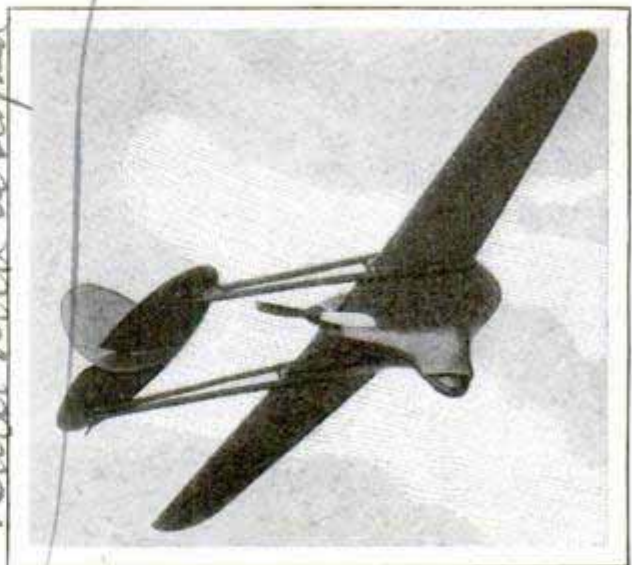

Model of Airplane without Fuselage Which Carries Its Load in the Thickened Wings

Anthony Hadimez

Calif. alt. Gym. Co. 127-0
Los Angeles, Cal. reprints

29 Beavis Road,
Over Sea by Beach on Sunday
Am

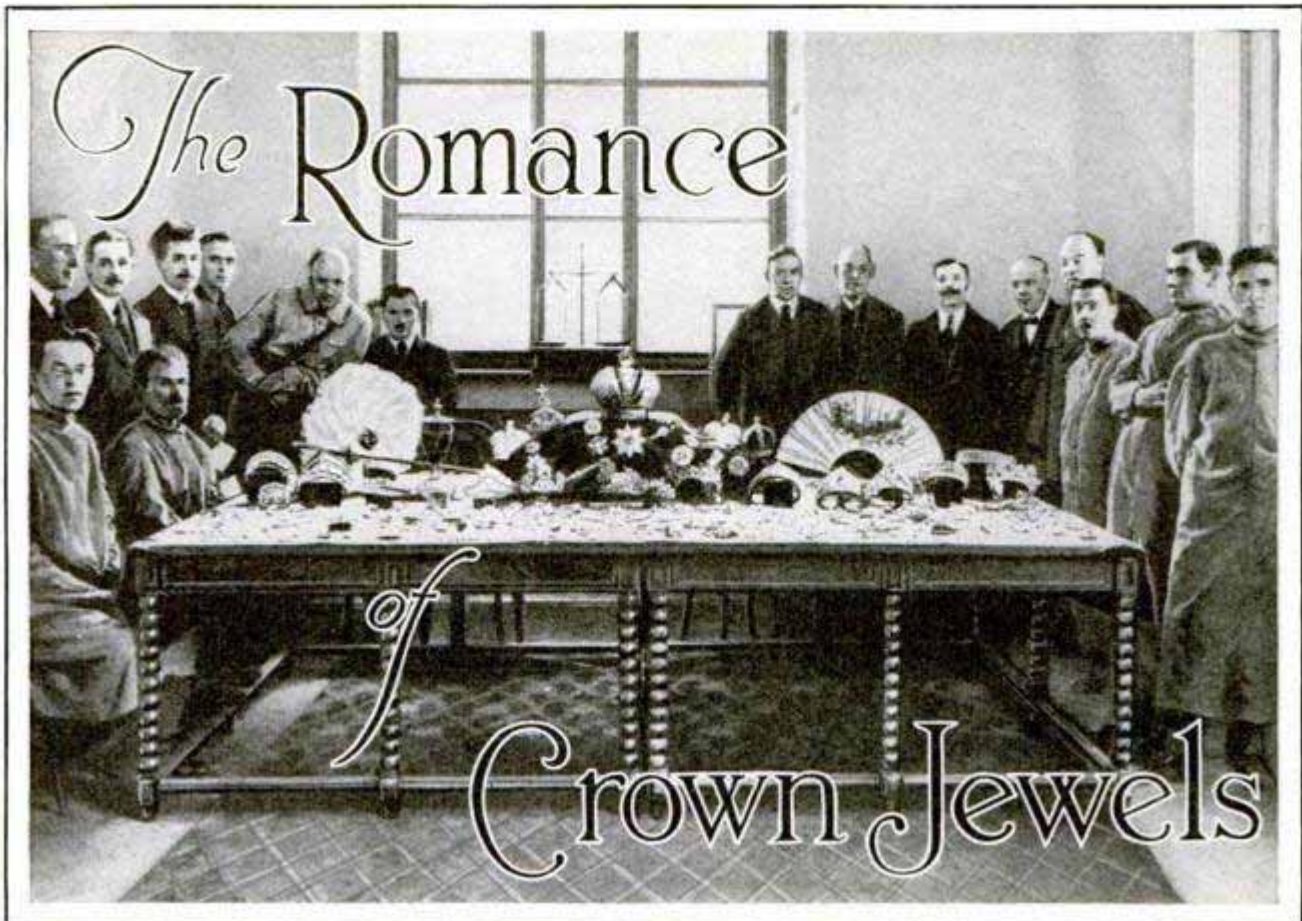

Photograph of the Russian Crown Jewels; Their Value Has Been Estimated at Seventy-Five Billion Dollars; Part of the Collection Has Been Sold by the Soviet Government

By HAROLD T. WILKINS, *208 Colombarie,*

TASTE and fashion in gems are as fickle as style in dress. At one time the rage is all for color, then the vogue passes on to white stones.

The ruby, "lord of gems," as the Orientals say, has from time out of mind burned in the crowns of kings or on the forehead of an idol in a Hindu temple, flaming redly from the jeweled breast-plates or sparkling from the gold symbols of priests of the oldest and most mysterious of Asiatic faiths. European royalties have always favored colored stones. Princess Mary, Viscountess Lascelles, of England, chose an emerald engagement ring and among the Russian crown jewels are the world's finest rubies. Today, a vivid pigeon-blood ruby costs ten times as much as the finest rose Kimberley diamond of the same size.

From the beginning of history, the world's finest rubies have come from a region of dense forest jungle, rising on ranges of hills above Mogok, and the mines of Mandalay, 400 feet above sea level in Upper Burma.

Millions of years ago, a white-hot flame and molten rock, belching out of the interior of the earth, came in contact with white limestone. The limestone crystallized into calcite and the impurities became the ruby, or corundum.

Hundreds of years ago, a Burman came to Mogok selling tamarinds. He exchanged his fruit for a red stone, which he gave to the king of Ava, who was so fascinated with the gem that he bought the land from which it had come. The ruby became what it still is—an object of worship throughout the East. No white man, in the old days, was allowed to approach the Burmese ruby mines, which were guarded by soldiers. The king of Burma took all the stones, and only a few fine ones were smuggled, at the risk of painful death, out of Burma. When a fine large ruby was found, a procession of grandees and elephants, escorted by soldiers, was sent out to take the gem to the royal treasure house. The king of Burma was called "Lord of the Rubies."

The old kings of England fancied rubies

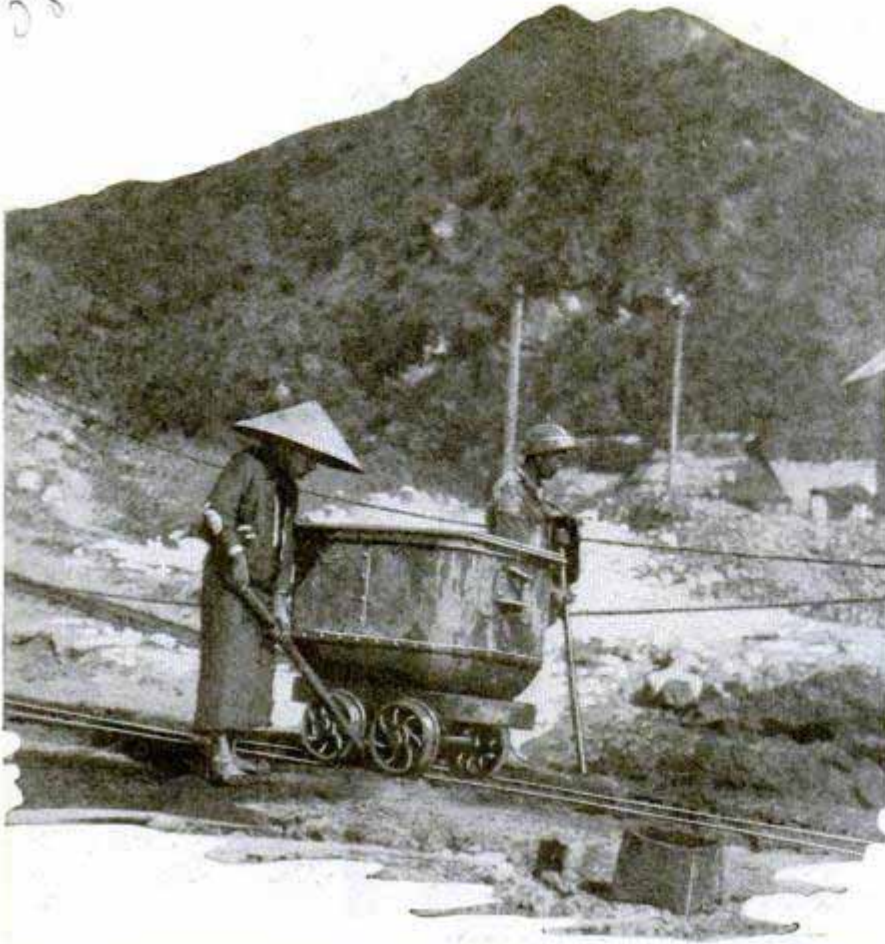

Natives with Truck Used in Hauling Ruby Earth: the Carrier, Attached to an Endless Rope, Is Pulled to the Washing House

in their crowns and regalias. When the coffin of Edward the Confessor was opened in Westminster Abbey, searchers found a fine gold crucifix suspended from a gold chain. The crucifix was fastened by a massive locket of gold gemmed with large stones, one of them a splendid ruby. King George V has a coronation ring of plain gold set with a large violet table ruby. In the crown of England is a fine large cherry-colored balas ruby, which came from the mountains of Baluchistan, India, more than 600 years ago. It was given to the Black Prince of England for helping Pedro of Castile in his wars. This ruby blazed on the helmet of Henry V at the battle of Agincourt. It is likely that it was stolen by some crusader at the sack of a Saracen city in the days of the great Sultan Saladin. The crusader perhaps brought it to Europe on his return and the gem drifted into the hands of the queen of France, who willed it to her brother, the Emperor Rudolph of Austria.

Gems such as these have pedigrees far more ancient than those of any living European monarch.

In Paris, there is an old building known as the Mont de Piete, which could tell some strange tales of the secrets of modern European kings. It was set up by the French king Louis XVI, in 1777, and at one time had in its vaults no fewer than forty barrels of gold watches. It loaned money on the security of jewels and valuables and the amount of money lent in the course of a year amounted to \$40,000,000. Many of the jewels were rubies of priceless value.

A mysterious robbery of the French crown jewels which has never been cleared up occurred at the Garde Meuble, Paris. The Garde Meuble had in its vaults and cellars the jewels and regalia of the old kings of

France. Before the time of the revolution, the public could see the regalia but the commune of Paris sealed up the vaults containing the cases holding the crown, scepter and hand of justice, and a golden shrine richly jeweled with rubies and diamonds which had been given by Cardinal Richelieu to Louis XIII. This "chapel" or shrine, weighed more than fifty-six pounds. All of these jewels were stolen during the revolution, but the famous Regent diamond, pawned by Napoleon with the Batavian government, to raise funds for a war, was recovered later.

Kings' jewels sometimes fall into private hands in ways unknown. The old court jeweler of the kings of France, de Berquem, tells of a man of rank in Paris who mysteriously acquired three magnificent rubies which had belonged to French kings and queens. One of the rubies had been set in a gold crown covered with gems with which Pope Stephen II had crowned Louis le Debonnaire in Rheims cathedral. The gem was lozenge-shaped and weighed $123\frac{1}{2}$ carats.

The magnificent rubies, which the mad

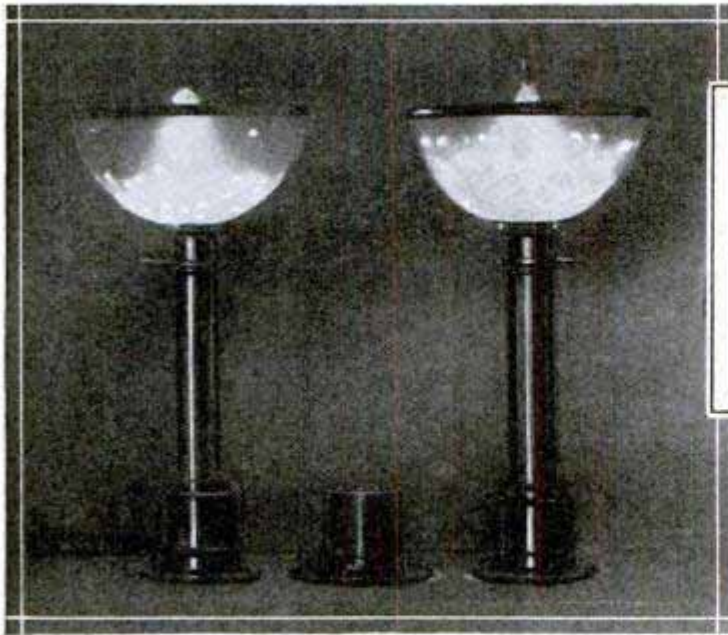

Profusion of Air Bubbles Reveals That This Is a Synthetic Sapphire

Photograph of the "Brilliantoscope" Taken in the Dark; This Instrument Was Developed by the Head of an Institute in Berlin Where Gems Are Tested; a White Sapphire at the Left and a Diamond at Right Are under Examination; the Laboratory, First Used for Private Tests, Has Been Taken over by the German Government for the Jewelry Industry



Above, Stratified Form of Genuine Pearl, and, at Left, Genuine Ruby Revealed by Angular Lines and Absence of Bubbles

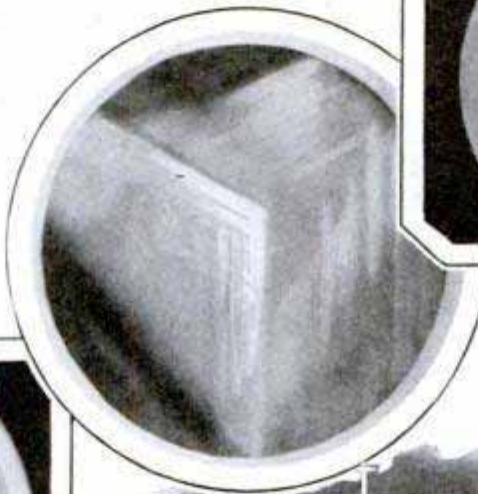

Above, Slice of a Cultured Pearl, and, at Right, Testing Pearl at the Berlin Laboratory; the Pearl, Suspended from a Thin Glass Rod, Comes within an Electromagnetic Field When the Operator Presses a Button; If the Pearl Remains Steady, It Is Genuine; If It Oscillates, It Is a Cultured Product



empress Charlotte saved after the execution of the emperor Maximilian in Mexico are known to be lying along with other

Austrian crown jewels in the strong rooms of the American liner "Merida," which sank in a collision during a fog off

Cape Charles, Virginia, in 1911. Several attempts have been made by syndicates of American salvors to fish up these jewels, but without success.

Now and again, the London auction rooms glow and glitter with splendid rubies, crudely cut, sent there for sale by some financially straitened Oriental potentate whose ancestors have worn the gems for hundreds of years. The Persian Shah has a throne of gold—the Takdis—standing on feet of rubies. It was a Persian shah who showed a Venetian ambassador a handkerchief filled with beautiful blood-red rubies, including a splendid table-cut balas ruby of a finger's breadth and weighing two and a half ounces, with other gems.

"What price would you ask for this exquisite ruby?" asked the Italian.

"A kingdom would scarcely buy it!" was the answer.

Runjeet Singh, the Indian ruler of the Punjab, had a ruby weighing half an ounce, engraved with the names of famous Indian emperors and kings who at one time owned the gem. Kingdoms were pawned and subjects and their property put in pledge to buy one of these splendid gems. Flowers made of the finest gems,

and roses made of rubies with leaves of glistening emeralds, glittering with diamond spray, were set by Shah Jehan on the wonderfully beautiful tomb of his wife in the Taj Mahal, near Agra, India. A screen of marble, carved like delicate lace, enriches this tomb, and lilies, tulips, and roses of rich white and red gems are inlaid in the marble.

The gem faker has, of course, tried his hands on the ruby. A case of a skillful imitation which deceived even experts occurred in England a short time ago. A society woman had a very large ruby which she sold in her lifetime, and replaced with an imitation which a jeweler, who valued the imitation for probate duty, said was worth \$50,000. The legatee paid a large tax on the imitation before he found it was a fake.

Some of the world's wildest fakers are to be found in the East. A passenger on a liner calling at Colombo, Ceylon, will be accosted by a handsome Singhalese, who has rubies for sale. The natives of Ceylon dig shallow pits in ruby grounds or wash the gems out of the sands of rivers. When genuine, the Ceylon ruby is a fine, pale rose-colored stone. The Singhalese shows the white traveler what seems a

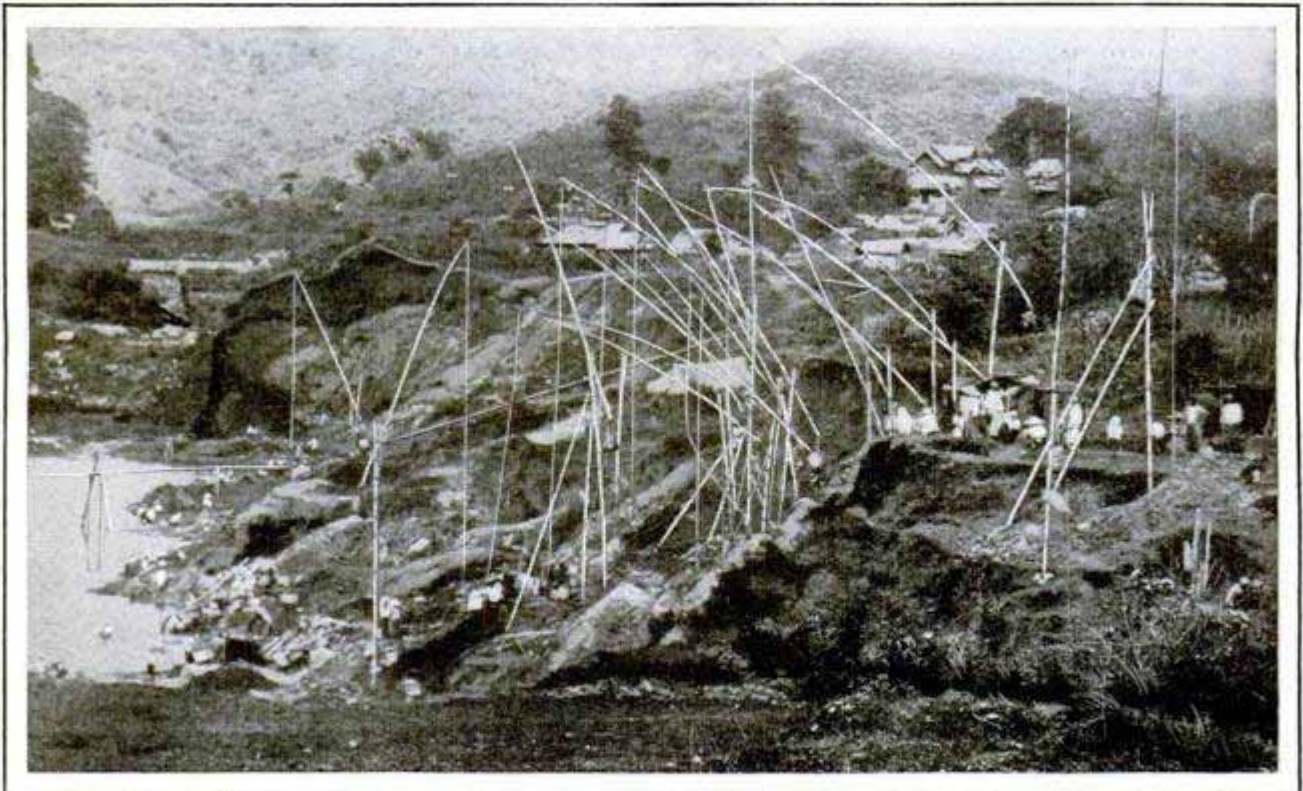

Courtesy Eric Ramsay

Native Burmese Village near Ruby Grounds; Water Is Raised by the Primitive Hoists to Wash Out the Gems Dug Up by the Native Miners

genuine ruby. Really it is a fake, called a "doublet" or half-stone. The top of this stone is genuine, but the under part is glass joined cleverly with cement. When set, these doublets are hard to detect. If the underpart is glass, a file will show it. Colored foil is used to enhance the effect, but gems "set open," or "azir," are faked by painting or enameling the interior of the setting to throw a color tint into the gem.

What makes the ruby red? This is unknown, but may be a mysterious property of the oxide of alumina. Rubies are really only bits of transmuted clay. Only a diamond is hard enough to scratch a ruby. The most valuable of all rubies is the imperfect gem called the "Star ruby." This star is formed by a silky imperfection in the gem, and shines when held up to the sunlight or artificial light, showing with great distinctness a six-pointed star across the crystal. A fine colored star ruby is very costly. Jewelers take care to get the center of the star as nearly as possible in the middle of the gem.

Red gems for brunettes and white for blondes—that is the fashion rule. Superstitious folk say the ruby keeps the wearer in good health and cheers the mind. If the wearer is threatened with danger, the ruby is supposed to blacken and not regain its color till the danger is gone.

WIRELESS ON FRONT OF ENGINE GIVES ENGINEER WARNING

German railway and air-service engineers and mechanics are making a determined effort to eliminate accidents in the air and on land by creating devices to give warning of danger. One of the appliances is a wireless installation on the front of the boiler of the railroad engine, intended to convey wireless messages to the engineer in the cab concerning the operation of his train or of danger ahead.



Werk



A German Vending Machine Which Serves Hot Sausage, Bread and Mustard for a Sandwich

HOT-DOG SANDWICHES SERVED BY VENDING MACHINE

Germany, famed for its sausage sandwiches, has introduced a hot-frankfurter slot machine which dispenses hot dogs automatically. For ten pfennig, about two cents, the hungry obtains fresh sausage, bread and mustard.

RADIUM FOR FISH BAIT

Radium has been employed by scientists as a lure for fish in obtaining deep-sea specimens off the coast of Bermuda. William Beebe, New York naturalist, used the radium for coating hooks attached to sounding wires about a mile long, which were lowered to depths where no light exists. Among the specimens that bit on the radium-coated hooks was a squid, member of the octopus family; a fish equipped with a rod, line, bait and three hooks and an ability to cast the hooks much as an angler does, and other fish with many patterns of phosphorescent light in blue, yellow and red. One fish observed through a microscope had a stomach so elastic it was able to swallow another fish three times its size.

No information

3287

3295

Chicago Tribune 8/6/29

Senator French C. ...

3121

105. Veronida
and
Veronida



Russian Children Are Finding Fun by Combining Two Old Sports, the Seesaw Board and the High Swing

HIGH SEESAW PROVIDES FUN FOR FOUR CHILDREN

Combining a swing with a seesaw board, children of soviet Russia have found new thrills in an old sport. Tall poles support the swing and a long plank, to the ends of which ropes are attached, provides the seesaw arrangement on which four children are accommodated.

PUGILISTIC ROBOTS FIGHT TILL ONE IS KNOCKED OUT

Pugilistic robots, mechanical men who box each other with blows twice as heavy as their human models, have been made

by two Pasadena mechanical experts, and are able to put on an excellent fight until one or the other is knocked out. When first constructed, the robots started fighting when a switch was pressed, but to give spectators some part, the control apparatus was connected with a wheel, like the steering wheel of an auto, and some distance from the mechanical men. Pushing the wheel moves the fighters toward or away from each other, a turn pivots them to right or left, and control buttons on the wheel enable the operator to govern arm movements. The fighters were fashioned after a human skeleton, with a framework of iron tubing and aluminum castings. When one robot has been hit squarely on the chin and again on the chest, it falls to the floor. During a battle they even converse in hoarse tones, Each fighter is capable of eight separate movements singly or simultaneously, these movements being governed by

a "brain" consisting of a hollow fiber sphere on whose inner walls are electrical contacts connected to the parts that produce the action. Only decided impulses may be trasmitted to the "muscles."

ATOMS' NOISE HEARD ON RADIO

Making a sound like hail pattering against a windowpane, the noise of atoms recently was broadcast by radio. The sound produced was that of helium atoms leaving the radioactive metal uranium, and bombarding a small piece of metal. A piece of uranium no larger than a nickel was used, the atoms leaving it faster than the fire of a machine gun.

Carl James Sizer
581 Glenwood
New York City, N.Y.

General Electric Co
Schenectady, N.Y.

3037

SMOKE SCREENS GUARD FLYING BATTLE FLEET

San Diego, Calif



When the "Lexington" and "Saratoga" Carry Their Broods of Airplanes, They Are Given Not Only Big-Gun Protection by the Fleet and Aerial Safety by Aircraft Squadrons, but Also Are Shielded by Dense Smoke Screens to Hide Their Movements from an Enemy; in the Photograph Above, the "Lexington" Is Emerging from a Smoke Screen Laid Down during Maneuvers on the Pacific Coast; Note the Planes on the Bow Ready to Take Off; at the Right, a Remarkable View, Looking Down on the "Saratoga" and Her Flock of Planes; One Has Just Risen from the Deck into the Air; the Carrier Steams into the Wind at a Speed of Twenty Knots or So, and, After a Remarkably Short Run, the Planes Are Able to Soar Away; Below, One of the Navy's "PN-12" Seaplanes in Flight; These Craft Are So Large That the Aviators Are Able to Leave Their Seats and Walk About between the Cockpits on the Wings, as This Photograph Shows

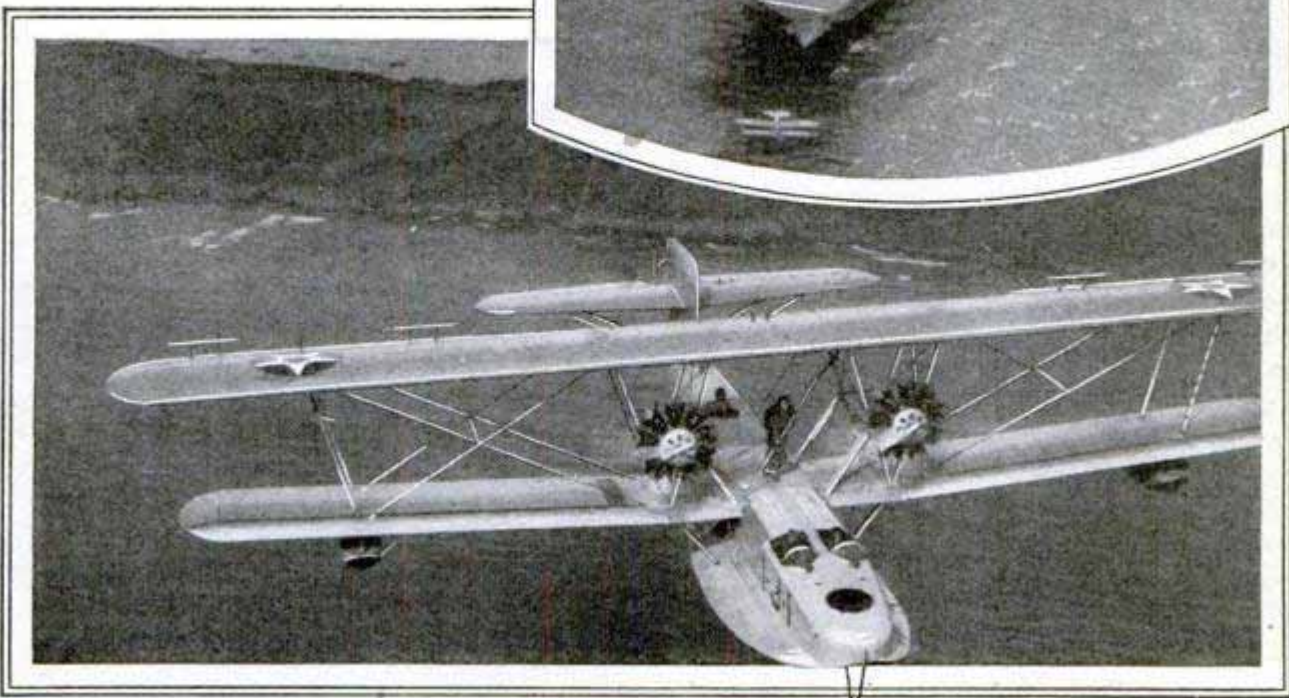
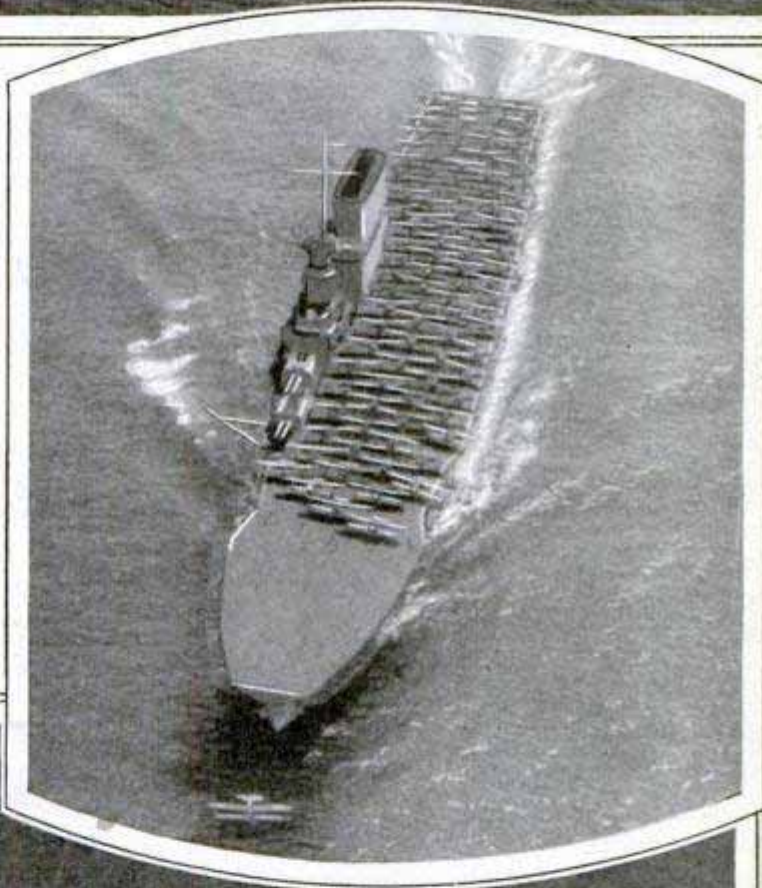

Saratoga

U. M. Charles A. Harrison Boston, Mass

Curt Wilbur

331/
Sarason's Screen & Boston
80

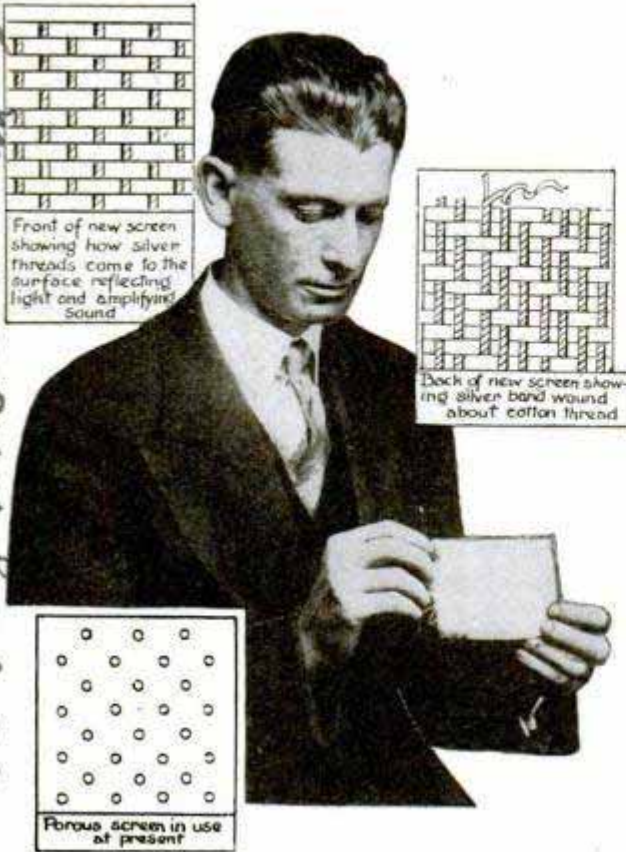

Drawings of Movie-Screen Sections Formed by Winding a Silver Wire about a Cotton Thread

MOVIE SCREEN REFLECTS RAYS WITHOUT DISTORTION

A new talking-picture screen that may revolutionize the projection end of the movie business has been invented. It is said to be the only reflecting, seamless screen that can be made in the new width of forty feet, which soon may be the standard size used for the showing of sound pictures. The inventor's first efforts went toward the perfecting of a process of applying aluminum paint to the existing screens. Then he tried making a screen of glass beads and found that it would work beautifully but could not be manufactured or used practically. His next venture consisted in threading a silver-coated wire at regular intervals through a cotton body, or filling. The talking pictures arrived at this juncture and, when the curtain was tried, it was found to distort the sound. He overcame this difficulty by making his silver-coated wire into a tiny coil wound longitudinally about a cotton thread. He then discovered various interesting features. He had not only a strongly reflective screen but one that added considerable amplification to the sound sent through

it from the big horns. In use, the screen amplifies the sound and casts a brilliant picture, equally clear in the first row of the orchestra and in the balcony.

ROCKETS MAY AID AIRPLANES

3314 IN TAKING OFF

Rocket propulsion, not in actual flight but to give airplanes and heavily loaded seaplanes an increase of motive power at the instant of take-off, is the subject of experiments by the German Junkers aircraft makers. The rocket auxiliary propulsion is intended to reduce the length of the run before the take-off, and to aid the planes to rise regardless of the load. The idea was secretly used by the British admiralty during the World War to propel submarines in a hurry to escape an enemy cruiser.

AUTO WASHER AND TIRE PUMP GET POWER FROM CAR

3272
The automobile itself furnishes the water pressure of a car washer and the air pressure for a tire inflator in two motor appliances operating on a similar principle and being marketed by a British company. On connecting either instrument in the place of one of the spark plugs, the reciprocal action of the engine piston is followed by pulsations of a diaphragm in the device. When the diaphragm is drawn in one direction by suction, it creates a partial vacuum, causing the chamber on the other side to become filled with air or water. When the diaphragm moves in the opposite direction, it displaces the air or water and this is driven past a valve into the delivery hose and emerges under considerable pressure.

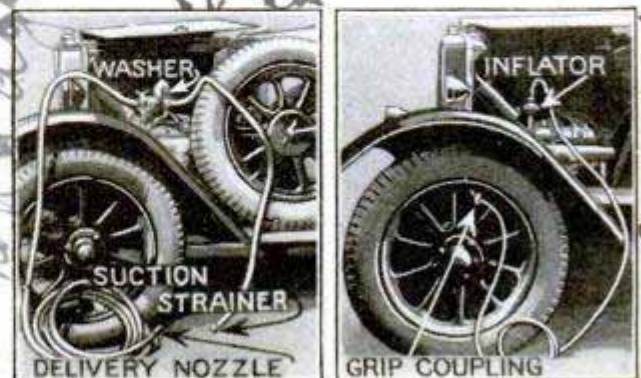

An Auto Washer and Tire Pump, Both of Which Are Operated by the Engine of the Car

Reads Campbell, Ltd
75 Victoria St. Weston

Prove - 15 pulses large inflator

*Designed by August Riedinger
Augsburg, Germany*

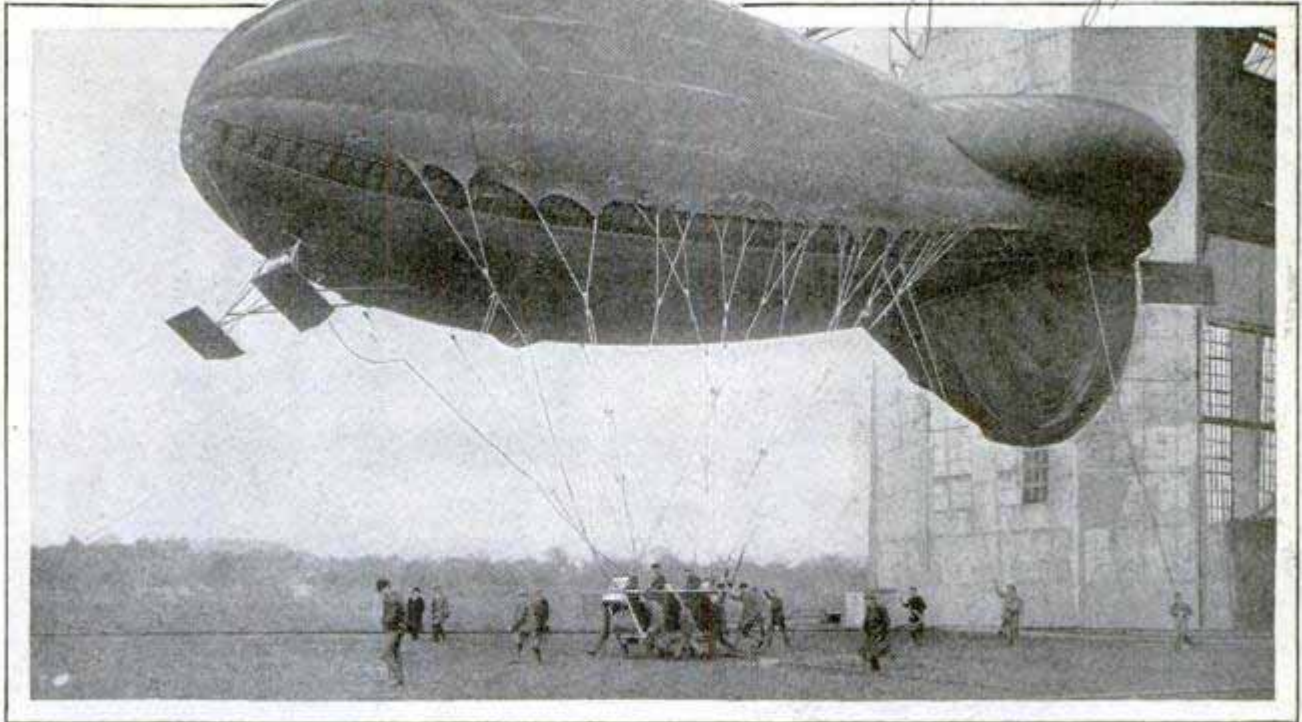

This Captive Balloon Is Equipped with a Motor Enabling It to Be Converted into a Dirigible Airship; Three Steering Bags Are Used as Stabilizers for the Convertible Blimp

CAPTIVE BALLOON WITH MOTOR CONVERTED INTO DIRIGIBLE

German engineers have developed a captive balloon equipped with an engine which allows it to be converted into a dirigible airship in only half an hour. Three steering bags are used as stabilizers, two lateral ones being filled with gas, and the lowermost one containing air. The rigging for holding the balloon captive attaches to a belt ending on one extremity at the observer's basket, and on the other, at a cross-rope pulley and below the belt, is an elastic section responding to variation in gas pressure. By removing the fastening cable and basket, a motor and vertical and horizontal rudders may be attached, enabling the balloon to be run at moderate speed.

fan draws the air to be used for ventilation. After being washed and cooled, the air is sucked through a drying room, where the humidity is lowered to normal and where warm air may be passed into the stream if necessary to regulate the temperature. A large saving is effected by the system, because the necessity for artificial refrigeration is eliminated.

SELF-WRINGING MOP ON REEL ALSO POLISHES FLOORS

Becoming in turn a mop, a long-handled scrub brush or a floor polisher, a reel mop containing a self-wringing attachment now is on the market. A crank turns the mop against a roller for wringing and the mop may be fastened against the roller in any position. When unrolled, it serves as an ordinary mop, when partly rolled it may be used for scrubbing, and when wrung dry, rolled up and covered with cheesecloth, the mop becomes a floor polisher.

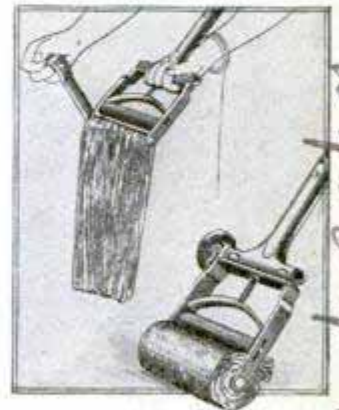

WATER FROM ARTESIAN WELLS KEEPS THEATER COOL

Nature's own cooling system has been harnessed by a Portland, Oreg., theater which drilled artesian wells tapping subterranean lakes 150 feet beneath the surface, to obtain a supply of water which is consistently fifty-two degrees. This naturally cooled water supply is pumped through three banks of sprays through which a

Patent owned by American Blower Corp. } Detroit

*3284
Minnneapolis, Minn*

Reel Mop Corp. 301 S. 9th St.

3343

KITES AND BALLOONS GIVE WEATHER READINGS

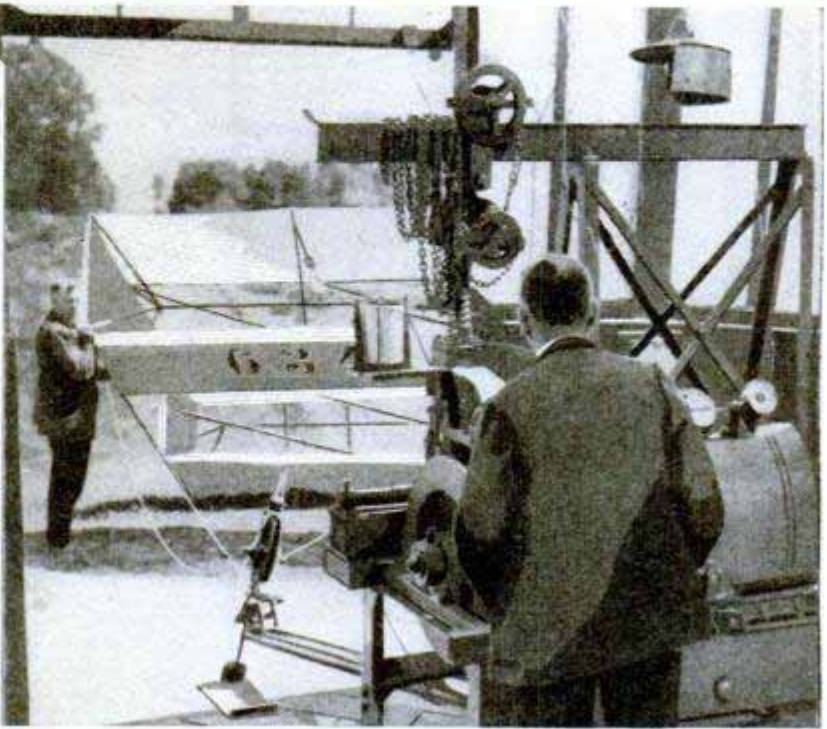
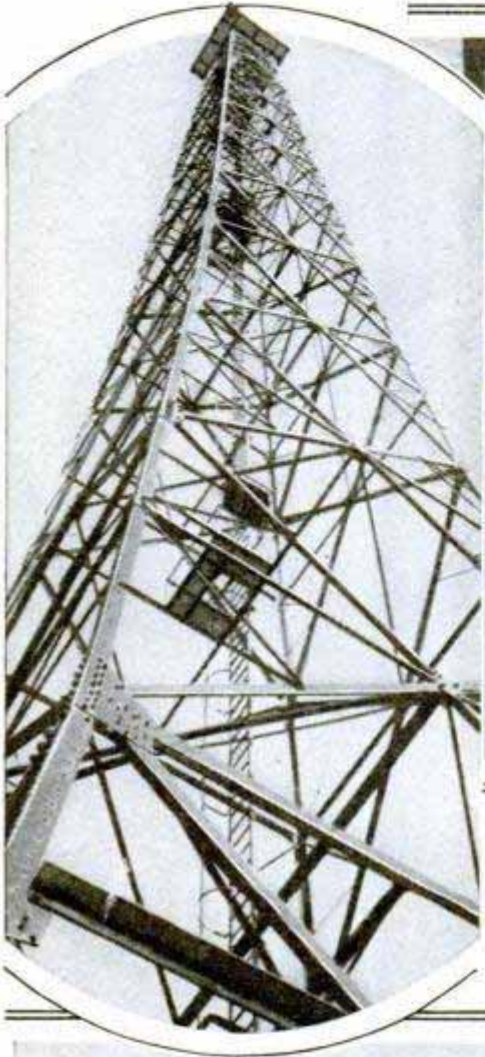

European Airports Receive Weather Reports from the Great Lindenburg Observatory near Berlin, Where Instruments Attached to Observation Kites and Balloons Are Sent Aloft to Obtain Atmospheric Pressure, Temperature and Humidity at Various Altitudes, the Readings Being Recorded on Paper Cylinders Attached to the Instruments; Above Is Shown an Observation Kite Ready to Be Sent Aloft by an Electrical Windlass, and, at Left, the 295-Foot Radio Tower of the Observatory

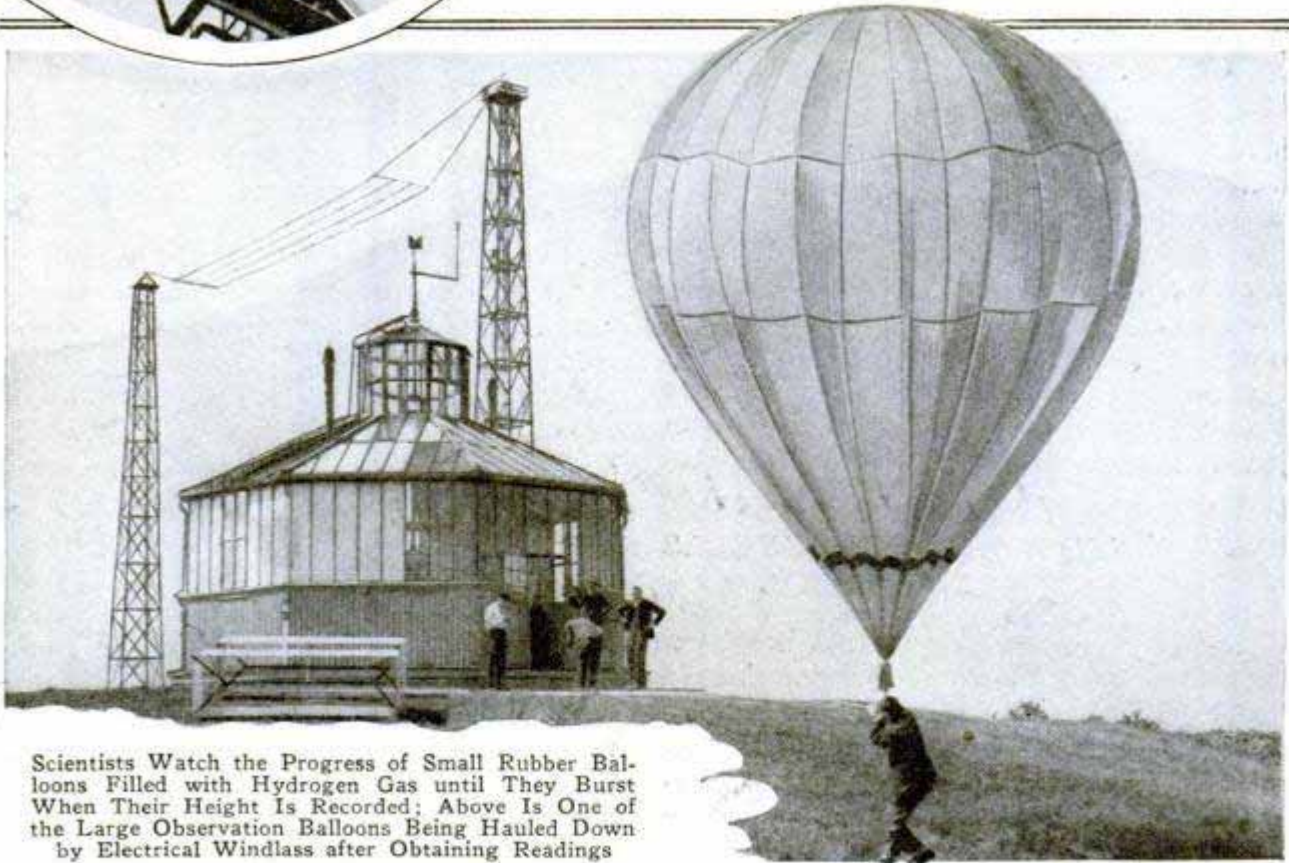

Scientists Watch the Progress of Small Rubber Balloons Filled with Hydrogen Gas until They Burst When Their Height Is Recorded; Above Is One of the Large Observation Balloons Being Hauled Down by Electrical Windlass after Obtaining Readings

Tip - use magnetic

SCREWDRIVER IS ADAPTED FOR HARD TASKS

3306

Fitting screws in positions not easily accessible is simplified with a screwdriver which firmly holds the screw on its end while it is being inserted and driven. The tool may be operated with one hand, the blade being slotted to accommodate a steel lever pivoted in the blade by a small pin. At the upper end of the lever is a cam, above which is a knurled sleeve. Pushing down this sleeve; just below the handle, forces the lower end of the lever outward, causing it to grip the screw tightly in the slot, and pulling up the knurled slide releases the lever. The implement may be used as an ordinary screwdriver when the holder is not needed.

\$ 1.50

OLD LICENSE PLATES OF AUTOS USED AS CATTLE BLINDERS

Discarded automobile license plates are used by a New York farmer to keep unruly cattle from tearing down pasture fences. A ring is placed in the nose and small chains run from it to the tip of each horn, where small holes have been drilled for fastening. The plate is hung on the chains directly before the eyes, preventing the animal from seeing objects in front of it, but still enabling it to feed. It seems to eliminate the roaming proclivities and the animals become quite tractable.



Cattle That Jump or Tear Down Fences Are Curbed by Blinders Made from Old Auto License Tags

near Schuylerville

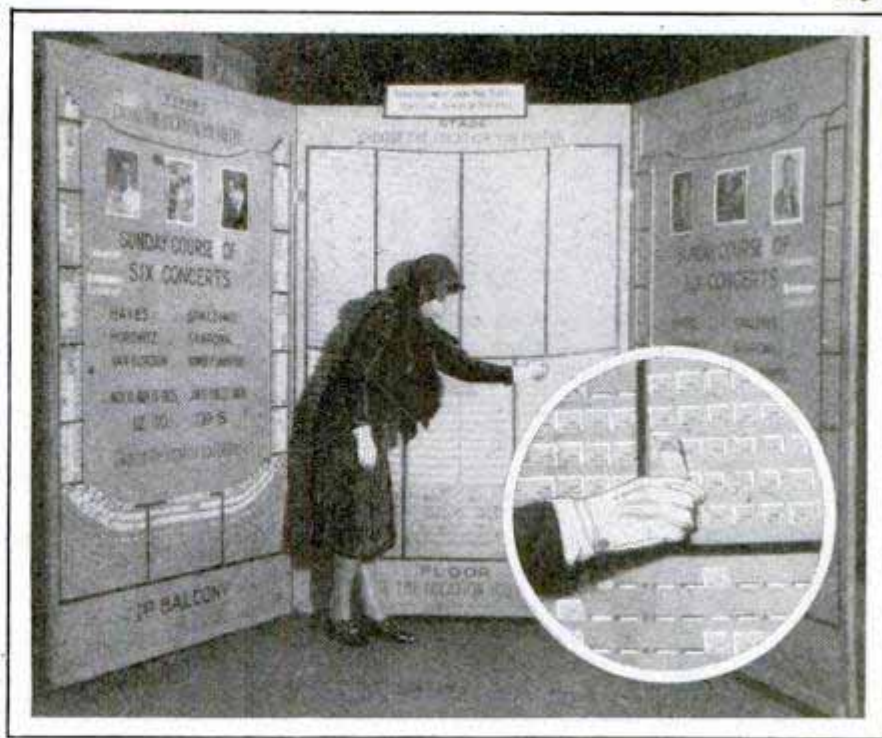

Courtesy The Christian Monitor

A Self-Serving Rack Enables Theater Patrons to Pick Their Own Seats without Referring to the Box Office

SELF-SERVICE FOR TICKETS ADOPTED BY THEATER

Persons attending concerts at Boston symphony hall choose their own seats from a portable automatic subscription rack, otherwise known as a ticket "cafeteria," placed in the lobby for their convenience. The rack shows a floor plan of the theater and in each seat location is an application blank looking like the ticket itself as it projects from its pocket. The prospective purchaser goes to the rack, surveys the floor plan, observes what tickets are yet unsold and chooses for himself. All the box-office man does is to accept the reservations. The top half of the projecting pasteboard looks like a ticket stub, but the lower section contains the application for the reservation.

Some frogs lay as many as 8,000 eggs.

814 3095

Easier Ways



Automatic Electric Toaster Browns Bread on Both Sides at Once; When the Piece Is Done, the Rack Is Ejected from the Oven; the Time Is Regulated by Setting a Small Lever at the Side

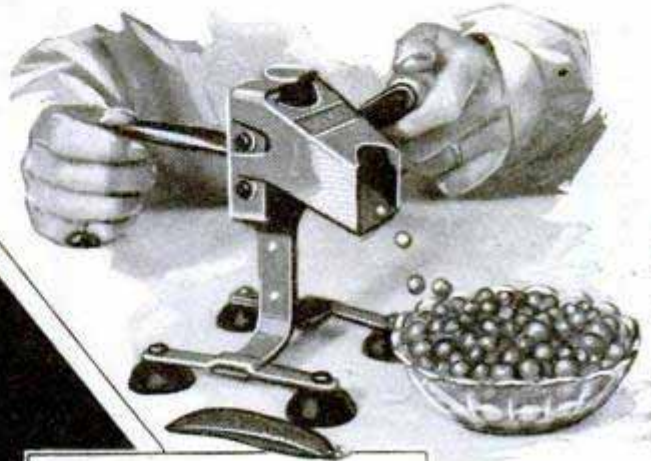

It Shells Peas or Lima Beans at the Rate of a Pound in About Four Minutes, Saving the Fingers; Fastens with Suction Grips

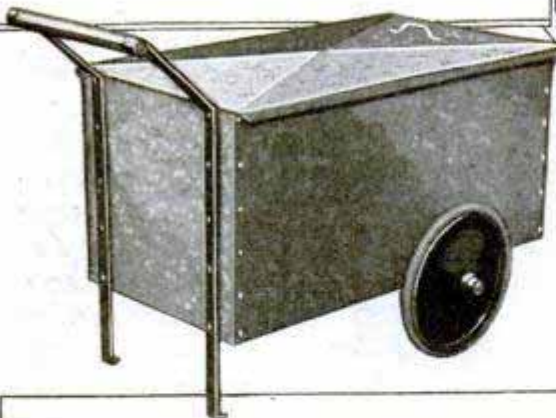

Handy Cart for the Garbage Can Is Supplied with a Box of Crystals That Help Reduce Objectionable Odors; at Right, Is an All-Metal Wired Table on Wheels with Two Electric Sockets for Percolator, Waffle Iron or Other Conveniences; It Saves Handling Annoying Wires at the Table and Is Especially Adapted for Luncheons and Parties; the Wheels Move on Ball Bearings and Respond to a Touch



7 E

of Doing It

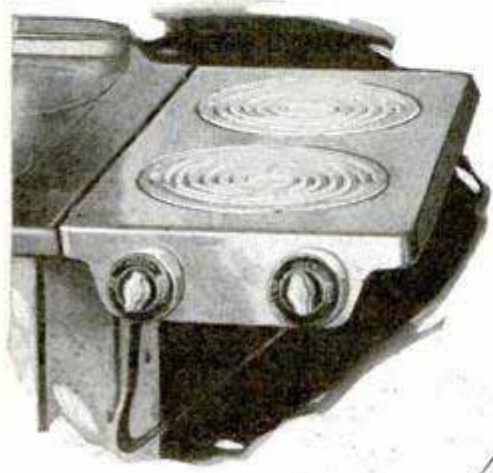

Convenient Electric End Shelf for Attachment to the Ordinary Stove Gives the Benefits of Electric Cooking at Little Cost; Current Is Controlled by a Three-Heat Switch; the Shelf Is Made of Cast Aluminum, Which Is Highly Polished



Play Room and Bassinet Combined Give the Baby Comfort and Safety; the Hood and Screen Are Easily Removed for Laundering by Undoing Straps above the Hood

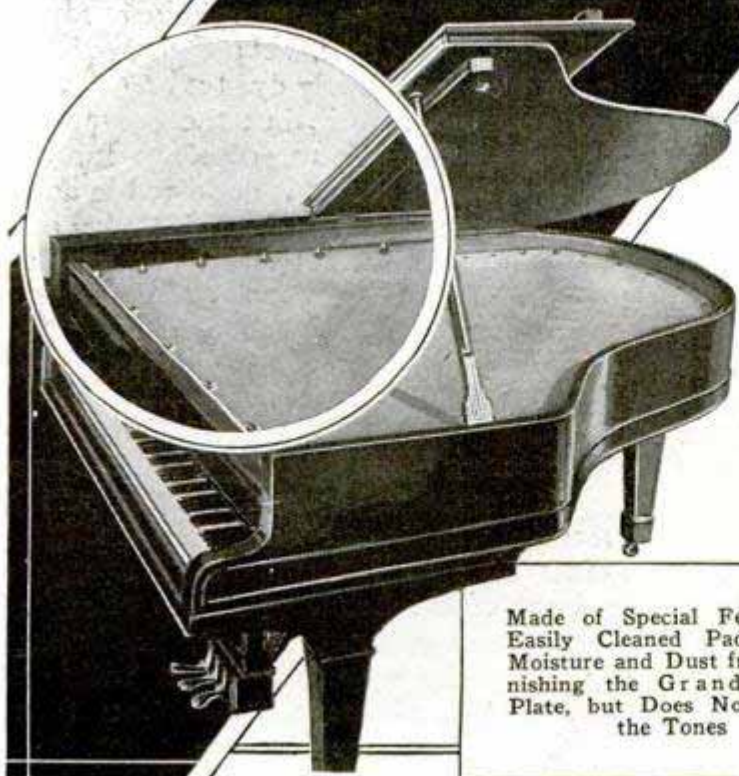

Made of Special Felt, This Easily Cleaned Pad Keeps Moisture and Dust from Tarnishing the Grand Piano Plate, but Does Not Muffle the Tones

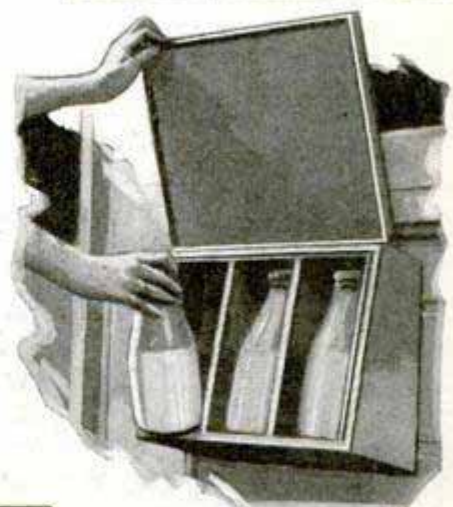

Milk-Bottle Holder Has Compartment for Each Bottle, Keeps Dust from the Caps and Is Insulated against Heat and Cold

Wm. W. A. Suckell,
Managing Director

POPULAR MECHANICS

Cont. H. B. Crane,
Route 4, Box 407,
Hayward Calif.

VOLCANO SPOOTS
PAINT, INK AND
DYES

Cont H Webster, 316 3rd St
New Westminster B.C.

816
3278

Coast Quarries Ltd
837 Hasling St W
Vancouver B.C.

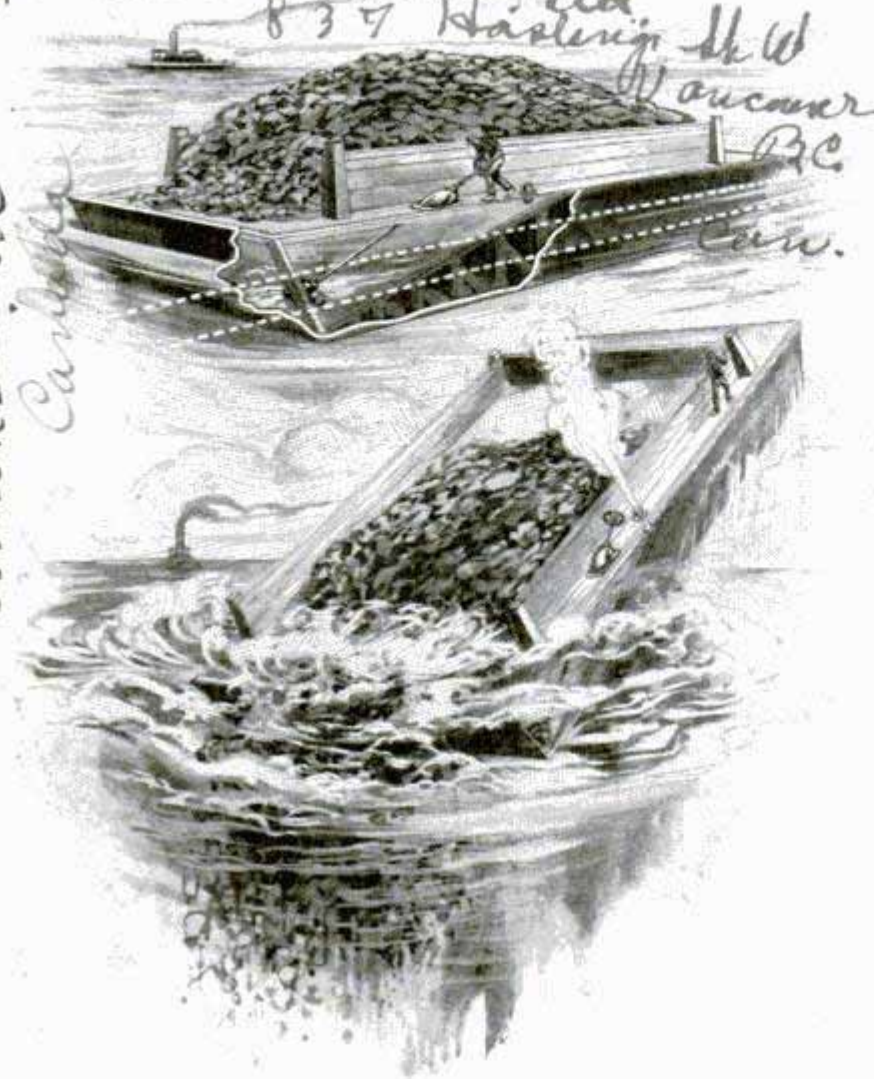

This Self-Dumping Scow Leaps on End to Empty Itself When an Air Compartment Is Flooded by the Man Aboard

LEAPING SCOW DUMPS ITSELF WITH MAN ABOARD

Doing in ten minutes work that formerly took eight hours, a self-dumping scow that leaps on end to empty itself with a man aboard, then is righted automatically, is being used in dredging operations at the mouth of the Fraser river in British Columbia. When the inlet valve at one end of the loaded scow is opened by the man aboard, water pours into the flood compartment until that end sinks below the surface, the rear end leaping into the air as the load slides along the deck and into the water. With the load gone, the front end bobs to the surface, bringing the inlet above the water line, and the flooded compartment drains itself, after which the valve is closed and it is ready for another load.

day, it had been partly dyed a bright blue. The vest was ruined, but the prospector abandoned the sulphur diggings for the new project. The soil is dissolved in acid-treated water in a series of tanks and subjected to a second treatment to give the desired coloring.

SOUNDS MADE VISIBLE IN FOG TO PROTECT VESSELS

Protecting ships in a fog is aided by an apparatus making sounds visible which recently was tested on a British ship. Points of light are thrown on a screen in front of the helmsman, the device being much more sensitive than the human ear. It picks up every sound within a wide radius, shows the direction from which it comes, the distance it has traveled and its character. Even the faintest

Cont. H. B. Crane
316 3rd St
New Westminster B.C.

Cont. H. B. Crane, Eng.

3319
490
West End Ave
New York City.

noise is screened, and it is possible for the helmsman to see a signal from a steamer in dense fog or from a regular fog-sounding station. A modified form of the instrument is being tested for use in airplanes when they are caught in fog. It weighs only a few pounds and shows sounds which otherwise would be drowned by the noise of the motors. The apparatus also is being tried to locate distant gunfire and sunken ships, and may be helpful in the locality of strange "blind spots" on the ocean where, it is said, fog signals cannot be heard by the ear.

CHALK-MARKING PARKED CARS AID TRAFFIC POLICE

In a recent campaign against abuse of the parking ordinances, Detroit police saved considerable time and work by using a bamboo stick, to which was attached a piece of chalk, to mark cars left too long at the curb. As the police automobile was driven along the street, an officer made a mark on one of the tires of the parked vehicle. An hour later, tow cars were sent over the route to pull to the pound all automobiles bearing the chalk mark. It was found that eleven police automobiles and one man on foot could make the rounds of the downtown district as quickly as fifty men on foot.



Chalk-Marking Parked Cars from Police Automobile Saved Detroit Traffic Officers Time and Trouble



A Shadowless Light for the Operating Table Formed by Focusing Eight Beams from Various Angles

LIGHT FOR OPERATING TABLE IS SHADOWLESS

Giving complete illumination of all parts of the field of operation, and leaving no dark or shaded portions, a virtually shadowless light has been invented for the hospital operating room. The light is suspended from the ceiling, and illumination is derived from eight widely separated direct light sources, each projecting an intense beam. The eight beams are converged simultaneously to any desired focal point by a single control handle, and are superimposed, forming an eightfold patch of light, eighteen inches in diameter. The light is without glare and produces very little heat.

During the fiscal year 1929, the federal government co-operated with the states in the improvement of 7,022 miles of road.

Sold by Connecticut Telephone & Electric Co.

1501 Paramount Bldg
Trinity Square New York

3215



Hopi Rain-Making Ceremony; Weird Rites Such as These Have Been Practiced by Savages for Centuries in an Effort to Produce Favorable Weather Conditions at Will

By CALVIN FRAZER

The Pictogram
Box 140, Washington DC

THE ARTIFICIAL control of weather is far from being a mere dream of the future. It is already accomplished to a vast extent in all parts of the world.

One of the most familiar methods of achieving this miracle is the wearing of clothes. Everybody except the savage of the tropics carries an artificial climate around with him for the comfort of his body. The interior of a heated house in winter is a man-made torrid zone. That of the up-to-date motion-picture palace in summer sometimes comes uncomfortably near being a man-made north pole. Air-conditioning engineers regulate to a nicety the humidity of the atmosphere in factories. Fruit growers warm up acres of air outdoors in order to circumvent Jack Frost. Farmers produce extensive areas of artificial calm by growing wind-breaks around their fields.

Partly by the control of his atmospheric environment and partly in other ways, civilized man tends to become more and

more independent of weather. The introduction of our modern system of weather forecasts and storm warnings, dating from the middle of the last century, was an important step in this direction. Information flashed by radio enables the mariner to dodge storms at sea, and their effects on land are greatly mitigated by storm warnings, storm-proof construction, insurance and the organized relief measures that follow every great weather disaster.

One of the most striking illustrations of our present-day independence of weather is the fact that winter has been robbed of the terrors that it had for our ancestors. Once it was proverbial for gloom and discomfort, but now it is generally regarded, in civilized communities, as the gayest and most enjoyable season of the year. Its cold and darkness and the embargo that its snow and ice formerly laid out upon travel and human intercourse have all been abolished.

the Weather?

Still greater independence of weather will probably be attained in the future, regardless of the progress that may be made in the taming of the atmosphere to man's will. For example, in the course of the next century, or less, the production of foods will probably be shifted to a large extent from the field to the factory, and will thus be removed from weather influences. Not long ago most of the leading dye-stuffs, such as madder and indigo, were obtained entirely by agricultural methods, but now man has learned how to produce them by means of synthetic chemistry, and it seems likely that most foods will eventually be produced in the same manner.

At the present time, however, the world has something like 1,500,000,000 acres of food crops and other agricultural crops subject to damage by drouth, excessive rains, frost and hail, and the like, and this fact alone, even if no other interests were at stake, would justify the intense desire of mankind to obtain further control over the weather. A single drouth in South Africa recently cost \$80,000,000—nearly as much as that country contributed to the World War. Is it strange that, in a region thus afflicted, people take a great deal of interest in doubtful but not demonstrably impossible schemes for making rain?

Hail is another costly scourge that humanity has eagerly sought means to avert. The world's annual hail bill is estimated

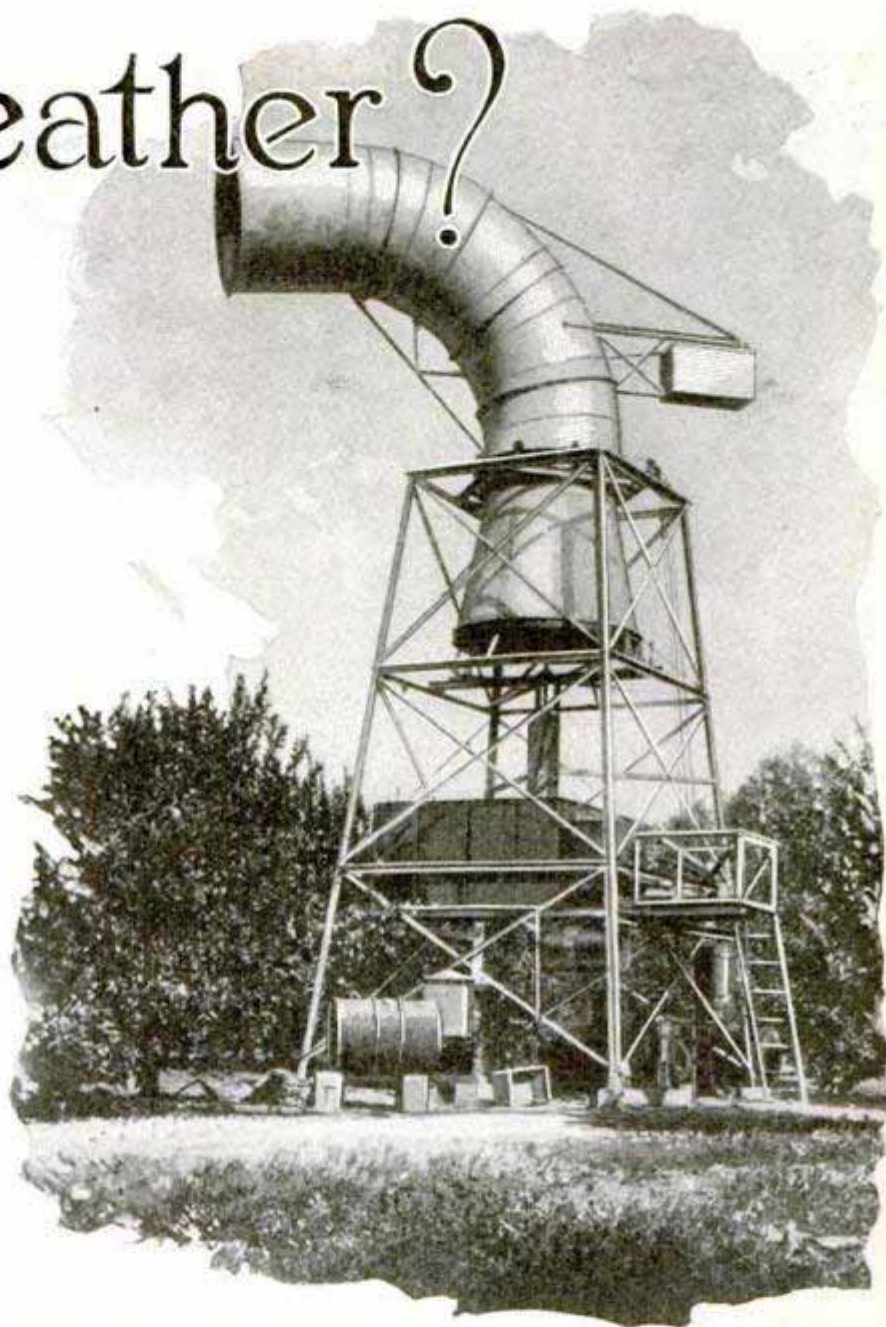

Huge Blower That Distributes a Stream of Warmed Air to Guard Orchard against Frost on Cold Nights

at upward of \$200,000,000, and in proportion to the area affected, the heaviest losses are borne by the vine-growing districts of southern Europe, which have consequently been, since early times, the proving ground for all sorts of attempts to combat hailstorms. Originally these undertakings were purely superstitious. Bells were rung, horns were blown and firearms were discharged in the hope of frightening away the demons of the storm. Sometimes bullets marked with pious crosses were fired at the clouds.

The most interesting fact about these superstitious undertakings in hail prevention is that they have been revived in a

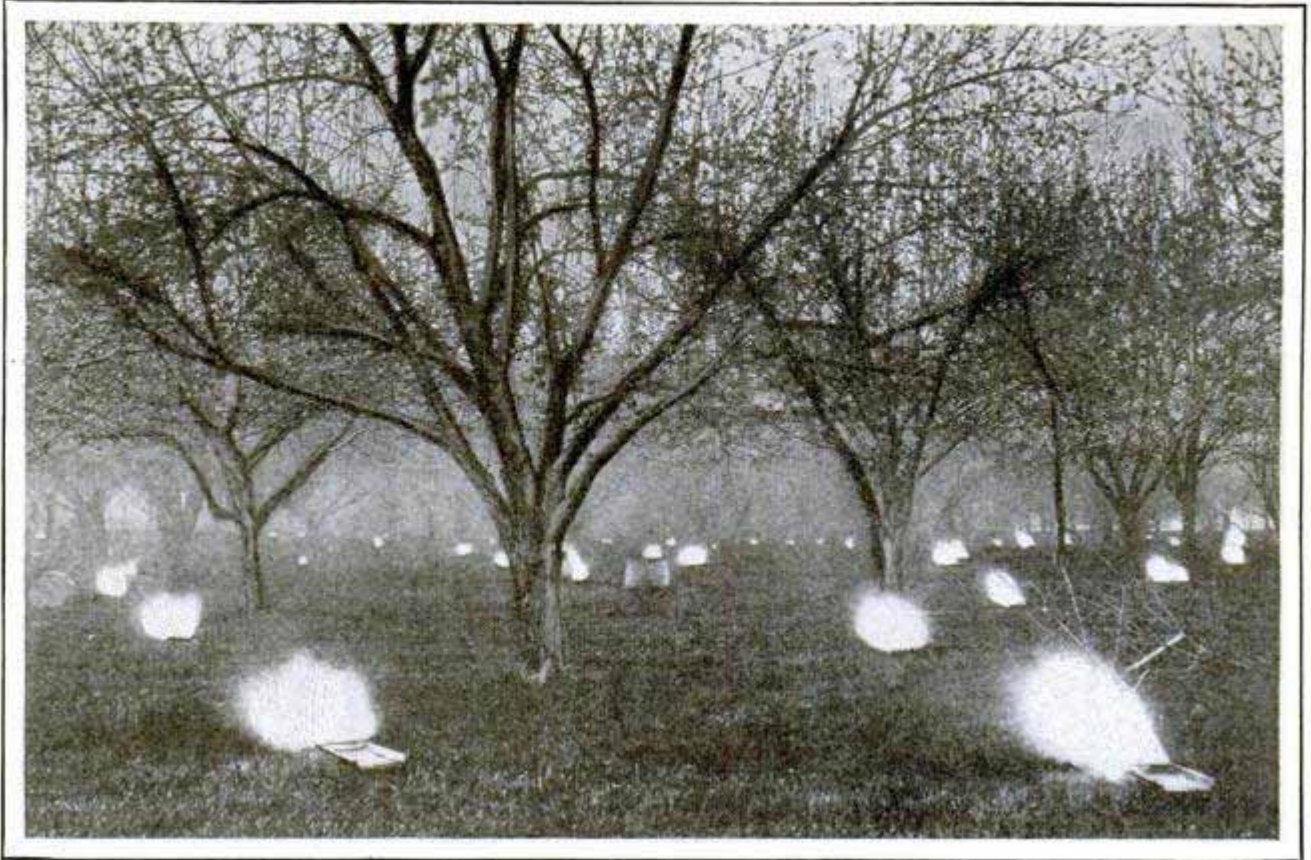

Another Weapon against Frosts to Protect Fruit Trees and Their Crops; Fire and Smudge Pots Do Control the Weather Effectively in Such Emergencies, Saving Huge Fruit Losses

modernized form and on a vast scale in our own times. The noise-making processes of long ago furnished the inspiration for the gigantic "hail shooting" craze that broke out in Austria at the close of the nineteenth century and soon spread to neighboring countries. Special forms of mortars which discharged smoke rings instead of projectiles, were used in these exploits, which cost millions of dollars and were the subject of elaborate scientific investigations.

Various attempts were made to dispel fog even before this problem became of vast practical importance on account of the rise of aviation, which now loses, in time and damaged planes, millions of dollars a year, besides a good many lives, on account of this weather handicap. Sir Oliver Lodge tried electrical precipitation in England many years ago. A little later the similar Cottrell process, which is so successfully applied to treating industrial dusts and fumes, was used on the fogs along the California coast under the auspices of the Smithsonian Institution. The army and navy air services in this country and the royal air force in Great Britain have tried the effects of sprinkling various

dusts in the air, and electrified sand has been similarly employed in the United States. Some of these experiments had in view the possibility of rain making as well as the dispersal of fogs and clouds.

Probably the most ambitious efforts to dispel fog were those that were in progress until about a year ago at the Naval Aircraft factory in Philadelphia, where elaborate machines were constructed for spraying electrified water drops into foggy air in order to cause the fog particles to coalesce and fall to the ground. Lastly, the process of coating the surface of a river with oil to check evaporation and prevent troublesome fogs from forming was tried at Lyons, France, just before the World War, and at Pittsburgh, in this country, about six years ago. In several of the undertakings above mentioned some success was attained, but no process seems yet to have justified itself on financial grounds.

Many of the most striking experiments in weather control have only been carried out on paper. These include the plan, for which a patent was once issued, to break up tornadoes by explosions, set off by the storm itself, and the more magnif-

icent proposal, submitted to the weather bureau by a university professor after the West India hurricane in 1928, to prevent the great tempests of the tropics from getting a good start by blowing them up with explosives at their breeding places.

What, now, do all these plans, experiments and partial successes amount to? What can be done toward conquering the weather? Undoubtedly a great deal, if people were willing and able to pay the price. If the air of an orchard can be warmed a few degrees through a frosty night by the burning of oil heaters, the air over an entire county or state might be kept warm indefinitely by a similar process, though of course the expense would be colossal.

Rain making on a fairly large scale is also feasible, by known methods, when atmospheric conditions are favorable, but not

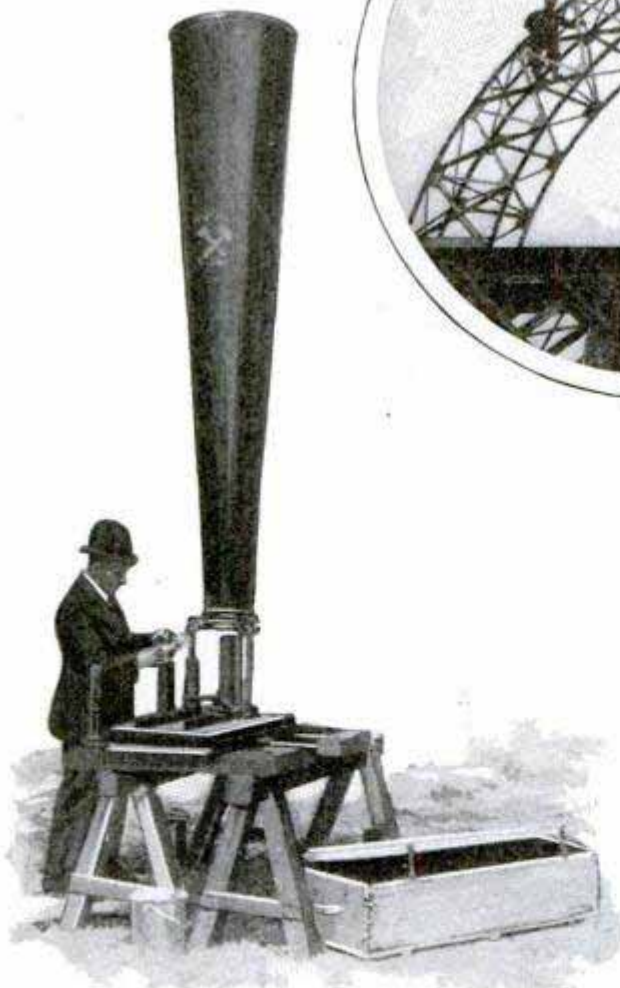
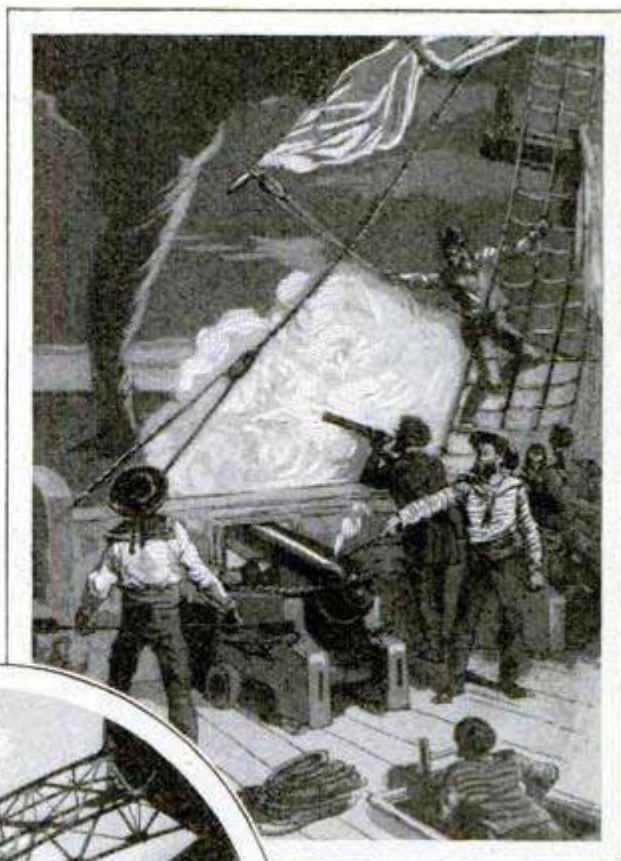

otherwise. It can then be accomplished by building a big fire. On a calm summer afternoon, when the atmosphere is well charged with invisible moisture, the column of warm air rising from a

burning forest or a burning city eventually becomes capped with a cumulus cloud, and in some cases this has been observed to grow into a thunderhead, from which fell enough rain to put out the fire that produced it.

Of course human beings could imitate this process—as they have probably sometimes done by accident—and fires big enough for the purpose could be built without sacrificing either a forest or a city; but until some new and revolutionary method of generating heat at low cost is discovered, the expense of making rain in this manner will remain prohibitive. If we had unlimited supplies of heat at our disposal, we could perform other sensational feats in weather making besides producing rain. It is the heat of the sun that keeps the entire machinery of winds

Top, Shooting at a Waterspout; Center, Futile "Hail Rods" on the Eiffel Tower, and, Bottom, Equally Useless Hail Cannon

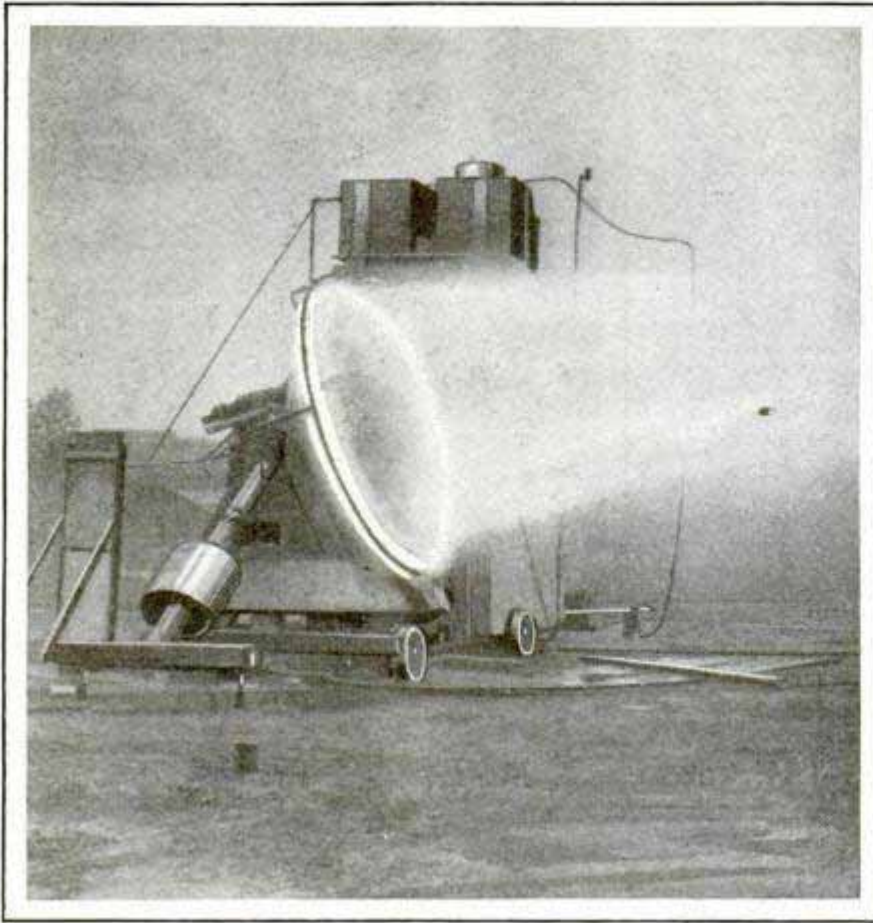

Experimenting against Fog; This Apparatus, Tested by the Navy, Sprays Electrified Water Drops in an Effort to Dissipate Mists

and weather in motion, so that when man can rival Old Sol as a fireman, he will also be able to rival him as a weather maker.

Rain cannot be made and fogs cannot be dispelled by concussion. As Prof. Simon Newcomb pointed out years ago, if we stand in the steam escaping from a teakettle and clap our hands we do not produce a shower, though we jostle the water drops much more than does a violent explosion at the distance of a few hundred yards.

The water vapor in humid air can be easily condensed by a little cooling, and we can cause condensation in such air by adding a little water vapor without changing the temperature—as happens when the moisture from the motor of an aeroplane leaves a long trail of cloud behind the plane that might be mistaken for “sky writing.” Condensation can likewise often be induced locally by charging the air with dusts, but most of the substances hitherto proposed or used for this purpose in weather-making experiments are quite costly, and some, such as sulphuric acid, are not desirable to sprinkle over

people's property. Moreover, the problem of the rain maker is not merely to form drops in the air, but to make them big enough to fall as rain; and, likewise, in most attempts to dissipate fog, the aim has been to cause the tiny drops of the fog to unite and form raindrops. It is now generally recognized that drops floating in the air do not readily coalesce unless some of them are electrified. An electric discharge between neighboring drops tends to break down the cushion of air that separates them and permit them to flow together. The best results in rain making and fog dispersal are obtained by electrifying some drops positively and some negatively, by means of alter-

nating currents, either sent into the air in the form of a brush discharge or carried by electrified spray or sand.

These electrical methods are now practicable within narrow limits. In time of war, when money is spent without stint, they might be employed rather extensively for clearing fog from landing fields, and in time of peace, the sprinkling of thin clouds with electrified sand, or some similar process, might save a costly eclipse expedition from spending its time and money in vain. The prospects of general application to rain making and fog prevention do not seem bright at present, but the interests at stake are so enormous that experiments in these and other lines certainly should be continued. After all, who can prescribe limits to the achievements of science and invention? The “impossibilities” of one generation become the commonplace accomplished facts of the next.

☛The longest air line on the American continent has been opened between Los Angeles and Guatemala City, 2,700 miles.

Bertrand 12

3345

Justin - Besancon

INFRA-RED RAYS REVEAL MORE THAN THE MICROSCOPE

Infra-red rays, the invisible light with which the camera peers into dense fog, have been used to bring to view tiny, living objects that the microscope has been unable to disclose. Use of the rays in medical photography was described before the International Physiological congress. Infra-red is a longer wavelength than red, and an intervening step between light and heat. Because of the extra length of these rays, they are enabled to penetrate into and reveal some of the outer portions of living cells when all visible light is excluded from the photographic plate. The rays in a kidney study showed organisms entirely missing in the microscopic examinations.

Al Howard Medical School 3349

MONEY LIFTED THROUGH HOLE UNDERNEATH TRUCK

To reduce the expense for guards necessary to watch money transported through the streets from one bank to another, a banker has suggested that a bullet-proof truck be equipped with a steel cylinder to be lowered through the floor of the truck directly into the receiving room of the bank. The cylinder would be bullet-proof and large enough for a man to go through, and banks or industrial concerns making use of the appliance would have turrets or receiving cylinders extending from the pavement into their vaults.

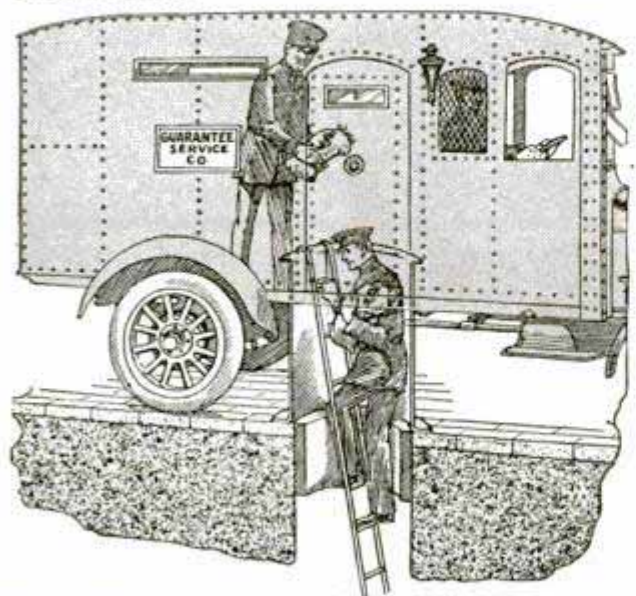

Taking Money from an Armored Truck down a Cylinder and Directly into a Bank Vault

Ans. Miller



A Semaphore School Warning Which Is Placed in Position While Pupils Are Departing

SEMAPHORE "SCHOOL" WARNING PROTECTS CHILDREN

Semaphore school warnings for motorists are being installed along Oregon highways, instead of the usual stationary signs, after tests indicated automobile drivers paid more attention to the semaphore. When school is dismissed, the semaphore board with the sign "School" and the speed warning is swung into place, remaining in position until the children have departed.

AUTOMATIC MAIL BOX WEIGHS AND STAMPS LETTERS

Unstamped letters or cards are handled automatically in a letter box made by a Cologne inventor. The mail is dropped through a slit and falls on a weighing apparatus, a device at the top of the box registering amount of postage required. The sender then places the proper coins in slots and these bring into action a paid-stamp mechanism which marks the missive and dumps it into a container below.

Ans. Carlton Perovak 311
Comingsupally Caley
are

Lyman
H. W. I.
Ans. G. C. Ospeball
of 1111 1/2
Square
Madison

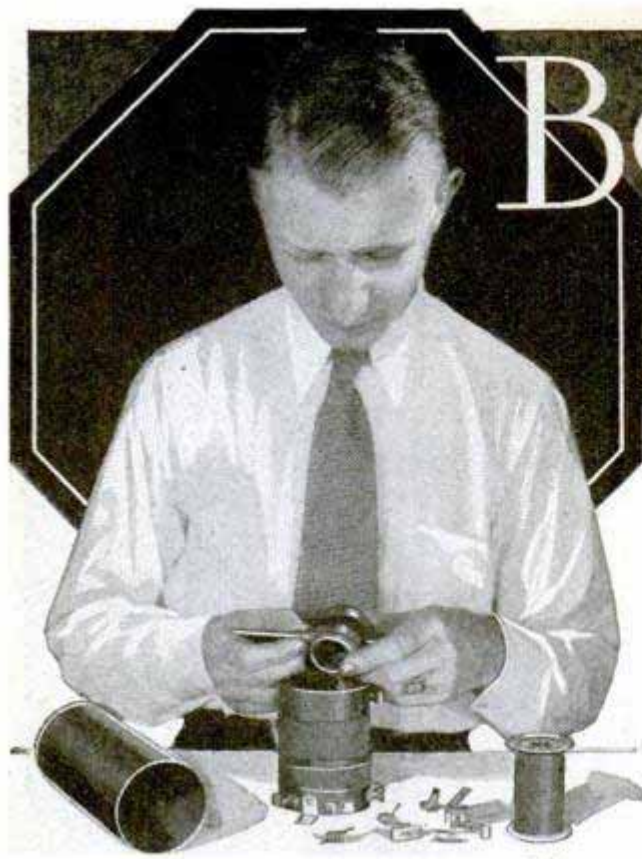

Inserting Shaft in Variable Primary Coil

Beginner's Screen-

A FEW years ago, when the beginner started out with a crystal receiver, tubes and parts were relatively expensive, and the novice was satisfied if he could hear a few strong locals. Tubes are now comparatively cheap and there is no reason why a good tube set for the beginner cannot be built at a cost but little more than that of the crystal receiver. The object of this article is to show the beginner how to build such a set in the simplest form. Next month, we will describe how to add one or two stages of audio amplification without the use of any additional batteries, for loud-speaker operation.

As a one-tube outfit this set has all the volume that can be received in comfort with a pair of headphones, and the range with the screen-grid tube is much greater than would be possible with any former type of tube. The method of using the screen-grid tube, while differing slightly from standard practice, is very simple, and necessitates the fewest possible parts.

The baseboard and instrument panel need not be changed to accommodate the audio stages that are to be added later. The only instrument to be added on the front panel will be a rheostat and there is ample room on the baseboard at the left

of the variable condenser for two resistance-coupled audio stages, as will be noted in the lower photo on page 826. All A, B and C-batteries are placed at the rear on the baseboard as shown in the photo at the top on page 825, making the receiver a self-contained unit.

The front panel is $\frac{7}{16}$ by 7 by 18 in., and the baseboard $\frac{3}{4}$ by 10 by 17 in. The template for drilling the former is given on page 826. Drill the panel from front to back and enlarge the holes with a reamer to pass the shafts of the various instruments.

As there is no coil on the market suitable for this circuit it will be necessary for the builder to make his own or change a standard three-circuit tuning coil to conform to the specifications. The input from the antenna is through the rotary coil; this, the primary coil, may be the rotor of a three-circuit tuner, the secondary being tuned with a variable condenser in the usual manner. The plate coil, however, must have more turns on it than would be necessary in a standard coil of this type. For this plate coil, remove the small primary winding on the standard three-circuit tuner and substitute a 30-turn winding as shown in the diagram. If the tube is not long enough for the 30 turns, wind the coil in a double layer.

The simplest and least expensive method is to wind your own tuning coil exactly like the one used in the model and shown in the diagrams. All that is necessary is two short sections of mailing tube of the diameter and length shown, a piece of brass rod, $5\frac{1}{4}$ in. long, a few Fahnestock clips, a small spool of No. 24 d.s.c. magnet wire and a short length of round busbar wire.

The mailing tubes should be thoroughly dry, and it is a good idea to place them in

Set Employs Grid Tube

by F.L. Brittin

a slow oven for a short time before winding the coils. Also drill holes in the tubing to just pass the shaft, and punch small holes at the points indicated for the start and finish of each winding. This, too, should be done before winding. Start the windings from the inside of both tubes so that the terminals will be inside the tubing. Be sure to leave a sufficient length of wire to reach the terminals, and in the case of the rotating primary coil, the leads should be long enough to allow the coil to be turned freely on the shaft. Insert the wire in and out of the starting and finishing holes so as to hold it tightly in position, to prevent the coils from loosening on the form. Note that all windings are in the same direction.

When the coils are completed, insert the shaft in the small primary coil as shown in the photo on page 824. Short pieces of round busbar wire are then coiled around the shaft at front and rear, as shown on page 826, to act as spacers holding the rotor coil in the center of the large tube. The sketch clearly illustrates the idea, and it will be noted that the ends of the spacers pressing against the tube are pushed through the tubing at front and rear above and below the rod. As the coiled wire and tube fit tightly on the shaft, the primary coil

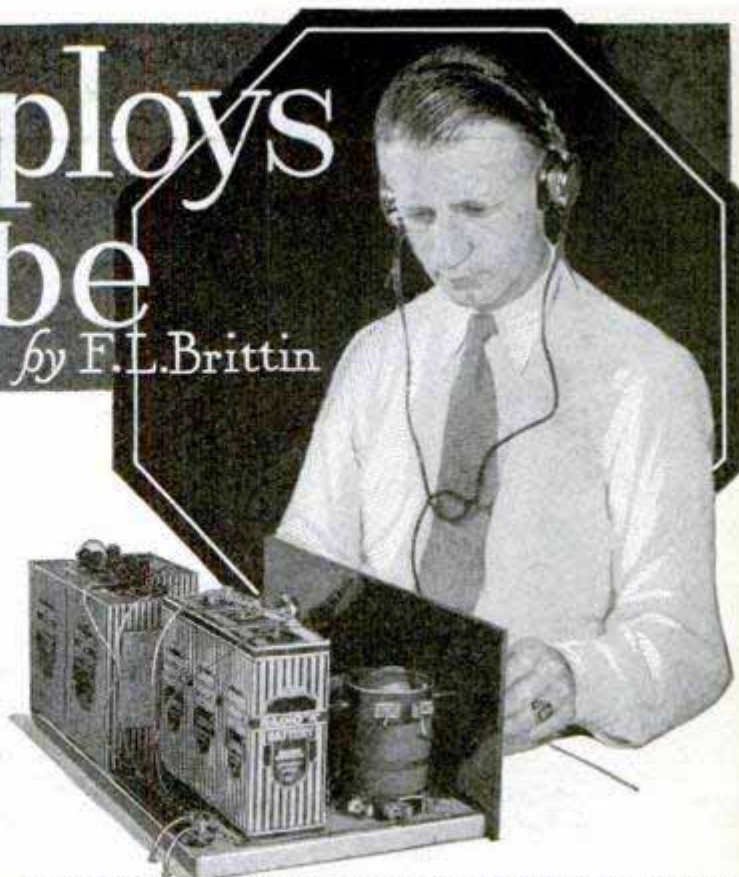

Completed Receiver Showing Compact Arrangement of Batteries on Baseboard

will turn with the latter. The Fahnestock clips are now mounted on the large tube by means of short 6-32 machine screws and hexagon nuts. This completes the tuning unit, which now may be mounted in the position indicated on the baseboard.

The variable condenser is mounted directly on the subpanel. The tube socket,

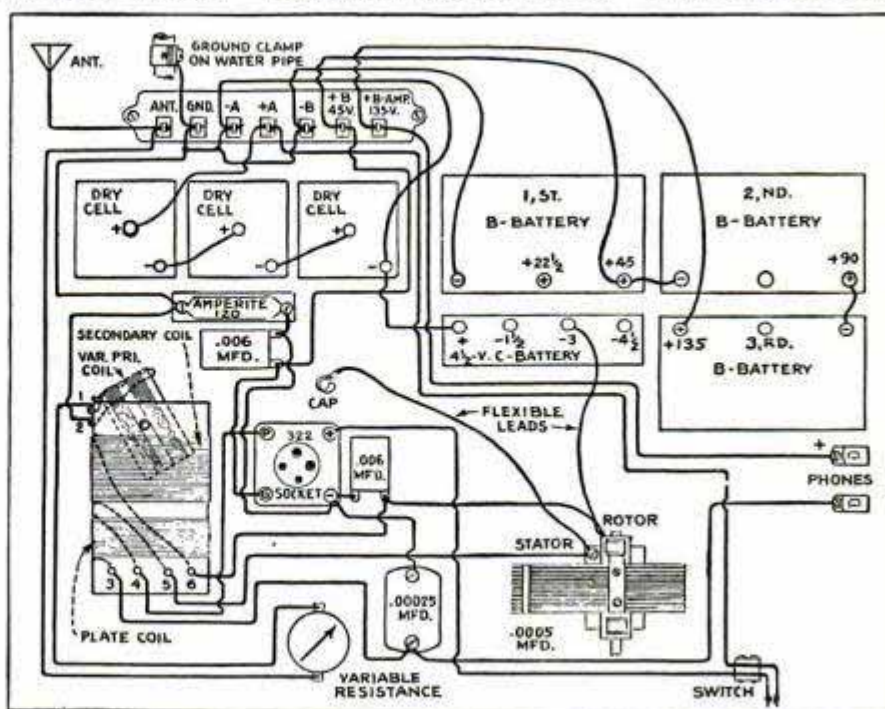

Simplified Wiring Diagram, Showing the Various Instruments in Their Relative Positions

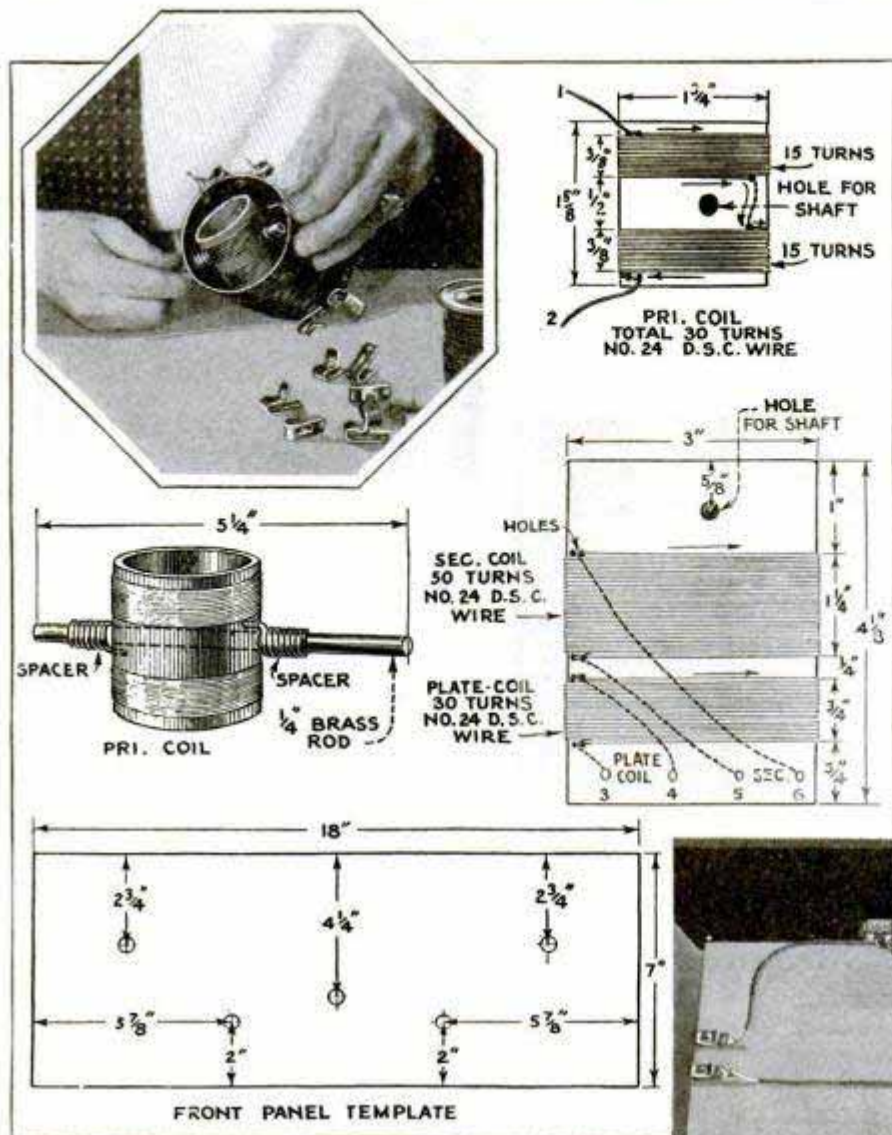

Upper Left, Mounting Variable Primary Coil; Below, Coil-Construction Details and Front-Panel Template; Right, Rear View of Completed Receiver with Batteries Removed

which is a spring-suspended variety, and the automatic filament-control unit for the tube are next mounted in the position shown. The terminal strip at the rear is a complete unit with the various clips mounted on a bakelite strip, although the Fahnestock clips may be mounted directly on the baseboard by means of short wood screws, if desired.

The controls on the front panel consist of a small black knob for the shaft of the primary coil, a dial for the shaft of the variable condenser, a knob for the variable resistance for controlling volume, and the switch for the dry-cell A-battery. The variable resistance employed in series with the antenna for controlling volume is an easily obtained device called a volume-control clarostat. This will be found useful in reducing the volume of strong local stations, which would otherwise interfere

with the reception of distant stations.

The wiring is clearly shown in the simplified diagram on page 825, and in this diagram the various instruments are shown in their relative positions. Use No. 18 tinned-copper wire covered with spaghetti tubing for all leads except for the battery connections and the lead to the control grid cap at the top of the screen-grid tube. These leads should be of flexible, rubber-covered, stranded hook-up wire. The lead to the tube cap may be of the type covered with a

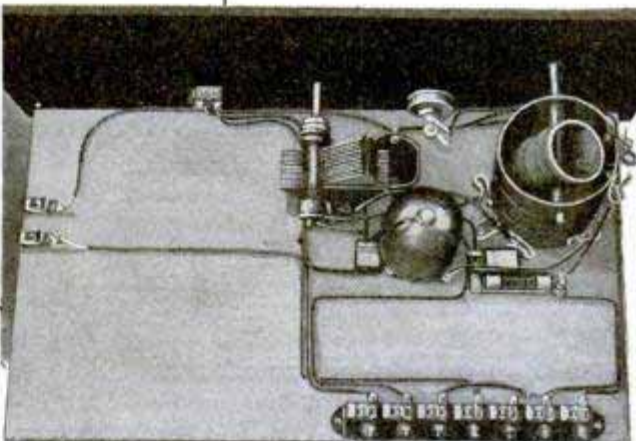

woven metal sheath if desired. If such a lead is used, the metal sheath should not touch the terminal connection at either end and it should be grounded to the negative A-battery terminal.

There are several types of tube shields that may be used, such as the one shown in the lower photo on this page, and, when so shielded, the efficiency of the tube is greatly increased. This tube shield should also be grounded to negative-A as in the case of the metal sheath on the control-grid lead. A short piece of fine flexible wire, soldered to the shield and connected to the A-negative post, will answer in both cases. The .006-mfd. fixed condenser is mounted as shown, directly in front of the tube socket. The two Fahnestock clips at the extreme left of the baseboard are for the phones.

The New Inductor Dynamic Speaker

Loud speakers now in common use are either of the magnetic or dynamic type.

Connect all batteries as shown, and the set is ready for test. Place the tube in the socket and connect the antenna and ground, turn on the filament switch and turn the volume-control knob to the left as far as it will go. Now slowly turn the tuning dial on the variable condenser until a station is heard in the phones. Turn the knob on the rotor-coil shaft until the signals come in at maximum volume and clarity, after which reduce the volume to the strength desired by turning the volume-control knob to the right. The average negative C-bias will be about 3 volts; this value may differ with certain tubes and the condition of the batteries, however, and may be best at 1½ volts. With the correct C-bias, regeneration will be obtained, and on the amount of regeneration will depend the selectivity of the receiver.

If there are any points not clear to the reader, or if further information is desired, write to the Radio Department; there is no charge for this service. A large blueprint of the layout and wiring diagrams, together with detailed sketches that will aid the builder and a material list of the parts used in the model, may be obtained for 25 cents to cover cost and mailing. The material list will be sent free to those who do not wish the blueprint. Address your blueprint orders and inquiries to Popular Mechanics Magazine.

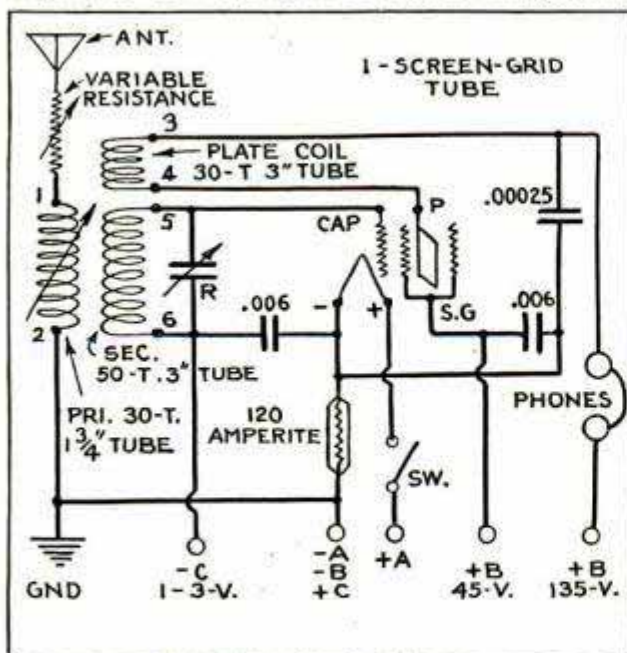

Schematic Circuit Diagram

Radio Department, 200 E. Ontario St., Chicago. Specify blueprint No. 145.

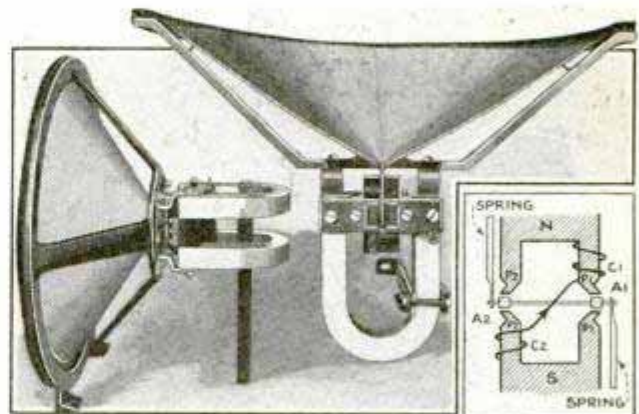

Left, Assembly Ready to Install in Cabinet or Baffle; Right, Cut-Away View Showing the Parts

The former, while inexpensive and simple to operate, is limited in volume and tone range, and the latter, while costly in comparison, has remarkable volume and tone. A new inductor dynamic speaker, so called because of its resemblance in principle to the conventional a.c. induction motor, is a compromise between the two types. The conventional diagram in the insert shows the armature riding freely between the pole pieces P₁ and P₂. The opposite forces on the two armature bars cause it to rest in a position which may be called a magnetic center. The flow of voice current in the coils causes this magnetic center to shift, moving the armature with it. The inductor dynamic speaker needs no separate field-exciting current as in the case of the standard dynamic speaker, although an output transformer or choke-and-condenser combination is required to keep the d.c. high-voltage current of the B-power supply out of the speaker windings. If the new speaker is to be used with a push-pull amplifier, a third lead may be taken from the windings at the point where the two coils are joined and used as the midpoint.

Marker for Normal Meter Reading

On any apparatus where there is a multiplicity of indicators it is a good idea to mark the normal reading of the most important ones with a small brush dipped in a quick-drying lacquer.—R. J. Plaisted, Cleveland, Ohio.

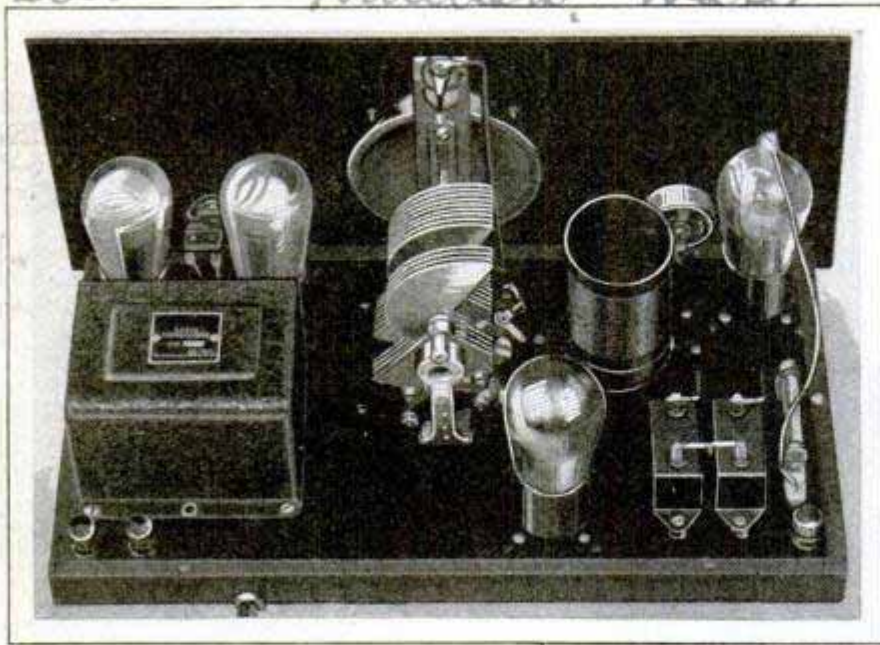

Top, Simple Layout of Parts; Right, Cover Opened to Show the Socket Storage Arrangement for the Coils

New Kit Set Has Wide Tuning Range

The screen-grid short-wave tuner shown in the photos has been designed for the home builder in response to the demand for a short-wave set capable of receiving the full short-wave range from 15 to 175 meters, and which at the same time would give good loud-speaker operation on the broadcast band. Previous difficulties in the satisfactory design of a set of this kind have been overcome by the use of a special two-section tuning condenser. At the touch of a switch, a large-capacity section for broadcast waves is thrown in or out. Six interchangeable coils are kept in special storage sockets in

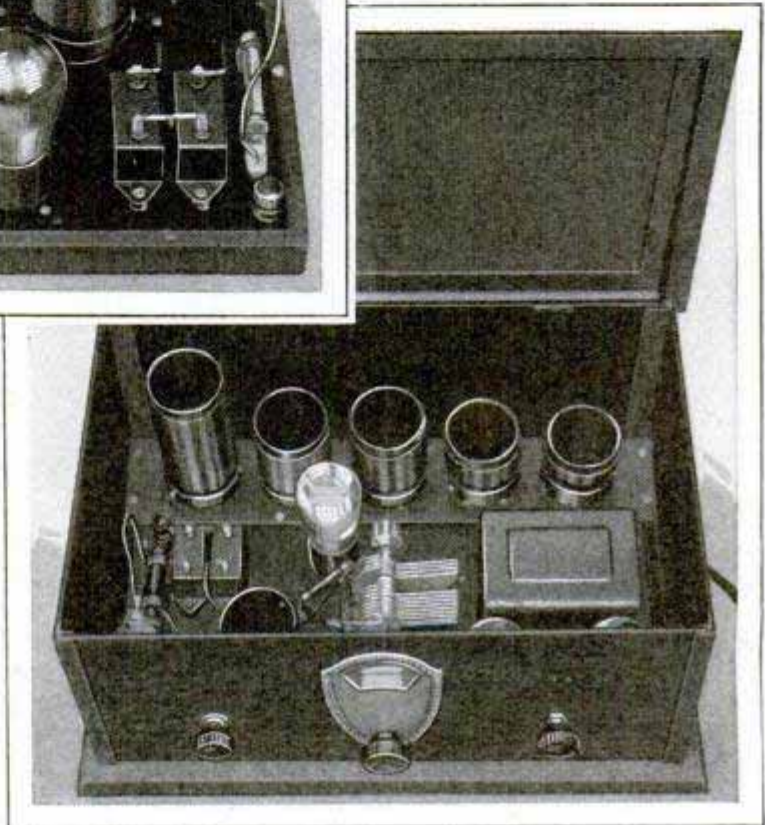

the rear of the metal cabinet, protected from dust and always ready for use. The screen-grid tube in the first stage provides good sensitivity and prevents radiation. The two audio units are placed in

one case for compactness and greater simplicity of wiring. The entire set is easy to assemble, compact, light and has a low drain on batteries. The set requires the following tubes: one each CX-322, 300-A, 340 and 371-A. The cabinet is made of sheet metal.

2365-62

Handy Clip for Screen-Grid Tube

A Fahnestock spring clip combined with a cap and soldering lug provides a handy connection to the control-grid post at the top of a screen-grid tube, as shown in the illustration. This device provides for either soldering the wire to



the cap or using the quick method of fastening the wire in the spring clip. The top fits tightly over the post.

Discolored Tubes Should Be Discarded

If a tube becomes purplish or shows a blue haze while in operation, it is an indication that an excess of plate voltage is being applied to it. Defective tubes, not properly evacuated, will sometimes produce the same effect and should be discarded immediately.

*Fahnestock Electric Co.
Long Island City, N.Y.*

Increasing Volume in Short-Wave Sets

The idea illustrated herewith will increase the volume of the short-wave receiver and at the same time improve tuning qualities and aid in eliminating "dead spots" within the various bands. A hard-rubber or wood rod, $\frac{3}{4}$ in. in diameter and $2\frac{1}{2}$ in. long, is used as the coil form. A hole slightly over $\frac{1}{8}$ in. in diameter is drilled through it to pass a $\frac{1}{8}$ -in. brass rod, upon which the coil may be slid back and forth. Thirty turns of No. 25 s.c.c. wire is wound on the form and anchored at each end. Leads are then extended to reach the antenna-tuning condenser at front and the antenna post at the rear of the set. The brass rod is then inserted in the form and mounted as shown so that the coil will be very near the plug-in coil and at right angles to it. The brass rod can be held rigidly on brackets, or by force-fitting in holes drilled in the front panel and rear of the cabinet. The original lead from the antenna post to the antenna tuning condenser is removed and the coil inserted instead. It is not neces-

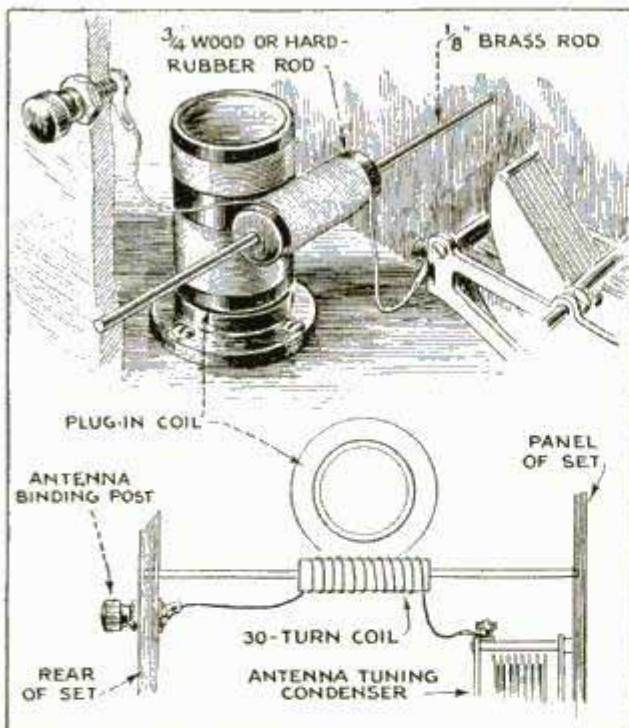

Detailed Sketch and Wiring Diagram for Variable Antenna Inductance

sary to have the rod run through the front panel for external coil adjustments, as, when once set by hand for best results, it requires no further adjustment.—C. A. Reberger, Daytona Beach, Fla.

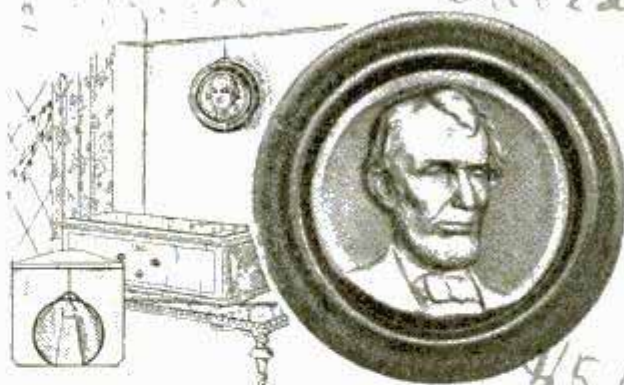

Right, Artistic Indoor Antenna; Left, Two Methods of Installation

Artistic Indoor Antenna

A Lincoln or Washington head, molded in bold relief in either copper or platinum effect and framed in period style, provides a container for an efficient indoor antenna. The winding is tapped for either short or long antenna effect, and is said to reduce static and local interference as well as improve the selectivity of the receiver. The device may either be hung on the wall, placed on the cabinet or on a table where it is supported by the easel shown in the rear-view sketch. The frame is finished in black and the unit is $10\frac{1}{2}$ in. in diameter.

FOR THE RADIO BUILDER

The blueprints below include the best of Popular Mechanics tested circuits. When ordering, simply quote numbers of blueprints desired and inclose proper amount addressed to Popular Mechanics Magazine, Radio Dept., 200 E. Ontario St., Chicago, Ill. Magazines containing full descriptions of the circuits can be obtained. Send 25 cents for each magazine desired, giving date of publication.

- No. 111, Homemade Tube Tester July 1926 . 25c
- No. 115, 15 to 550-Meter Three-Tube Receiver Nov. 1926 . 25c
- No. 116, Three-Tube Loop Set Dec. 1926 . 25c
- No. 123, Economy-Nine Super-heterodyne Nov. 1927 . 50c
- No. 130, One-Tube Short-Wave Adapter Mar. 1928 . 25c
- No. 134, Edison Type B-Battery July 1928 . 25c
- No. 138, Screen-Grid Perfect-Tone Six Receiver Nov. 1928 . 25c
- No. 139, Simple Television Receiver Dec. 1928 . 25c
- No. 140, Power Amplifier and B-supply for Television Jan. 1929 . 25c
- No. 142, Two-Tube Screen-Grid Short-Wave Adapter Mar. 1929 . 25c
- No. 143, Four-Tube Screen-Grid Receiver May 1929 . 25c
- No. 144, Three-Tube Self-Contained A.C. Receiver Oct. 1929 . 25c
- No. 145, One-Tube S-G Set for Beginners Nov. 1929 . 25c
- No. 146, Adjustable B-Eliminator Nov. 1929 . 25c

B and C ELIMINATOR



Voltage-Divider Unit Showing Control Knobs; Below, Wiring Diagram of Power Supply

UNLIKE the usual B-eliminator, in that the output voltages are variable instead of fixed, this very simple and efficient B and C socket-power unit leaves little to be desired. When properly adjusted, it will supply ample B and C power for any receiver employing up to eight or nine tubes, including the usual power stage, which may be of either the 112-A or 171-A type. It may be used in connection with any of the standard A-battery eliminators for the complete socket-power operation of any d.c. set not employing power tubes larger than the 171-A type. It is also suitable for operating any of the a.c. receivers recently described in Popular Mechanics

it easy to use the unit with a large variety of receivers without making any changes in the unit itself. The compact nature of the various instruments employed greatly simplifies the wiring, and the entire output may be assembled in an hour or two. An eliminator of this type is ideal for the beginner as the manufacturers of the various parts have co-operated in designing the instruments, so that the terminals have been arranged to permit the shortest possible wiring.

The main parts have been combined into three major units; the first, shown at the left in the photo on page 832, is the power compact. This unit consists of the power transformer, choke coils and small buffer condensers between C and H as shown in the wiring diagram within the dotted lines. The second is the condenser block No. 1, the individual condensers of which are indicated in the diagram at B; the smaller block No. 2 contains three 1-mfd. condensers and is placed immediately in front of block No. 1. The third major unit is the Truvolt voltage divider which is mounted at the front end of the baseboard by means of a small metal bracket that is supplied with it. This is a universal voltage separator, which greatly simplifies the construction of any B-eliminator. The

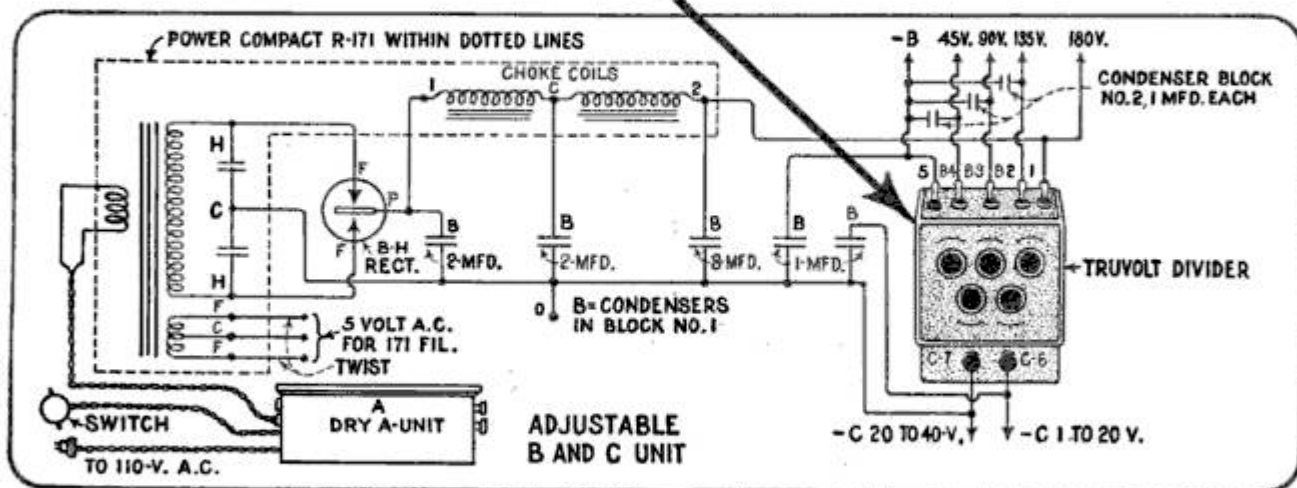

Magazine, or any other a.c. set within the limits stated.

The adjustable B and C-voltages make

maximum fixed voltage is 180 volts; the 135, 90 and 45-volt outputs are adjustable and, with the conventional re-

IS FULLY ADJUSTABLE

ceiver, may be varied at least 15 volts above and below the mean voltage. The two grid-bias taps are also variable; the intermediate grid tap will supply a grid bias from 1 to 20 volts negative, and the maximum bias tap will supply a bias voltage from 20 to 40 volts negative.

Connecting the voltage divider is quite simple as soldering lugs are provided on each tap, and the unit is shown in complete detail in the wiring diagram. This instrument provides the front panel of the completed assembly with the control knobs and binding posts for the power unit, which has no other controls. The various parts are mounted on the baseboard with wood screws. The exact size of the baseboard is optional, but one $\frac{3}{4}$ by 7 by 11 in. in dimensions was used in the model.

The rectifier tube employed is a Raytheon type B-H, and the socket for this tube is mounted directly back of the voltage divider in the center of the baseboard. This tube has long life and is designed so that the single tube utilizes both halves of the alternating current for rectification.

The parts are screwed to the baseboard in the order shown in the lower photo on this page. Mount the power compact so that the terminals on the top are nearest the condenser block No. 1. The unit is now ready for wiring. Use nothing but heavy-duty rubber-covered wire for the various leads or, if this is not available, busbar wire covered with a good grade of spaghetti tubing. Use soldering lugs under all terminals

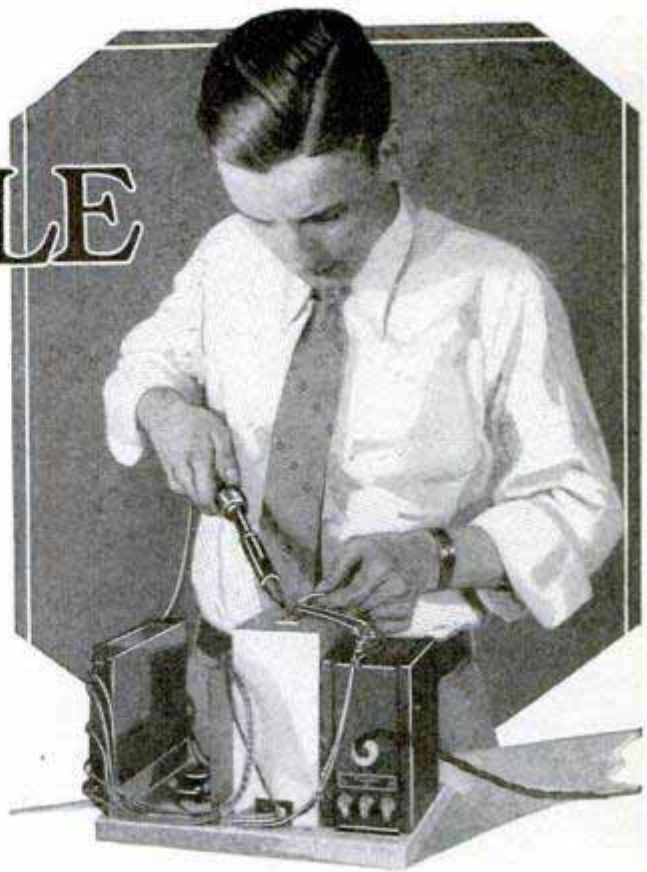

Soldering Leads from Power Compact to Condenser Block No. 1; Below, Units Screwed to Baseboard

and solder each connection carefully. When connecting the tube socket note that posts F, F, and P are used, and post C is left blank.

The 5-volt filament terminals, F and F, on the power compact for the power tubes, supply raw a.c. voltage; the center tap C is left open. This center tap is normally used in connection with a resistor and by-pass condenser to supply the necessary grid bias for the power tube. In this power unit the C-bias is already taken care of in the voltage divider, so this tap is not used. The filament leads, F and F, should be twisted together between the transformer and the power-tube socket terminals.

To put the power unit in operation, connect the various B and C leads to the set; if there is a positive-C post in the

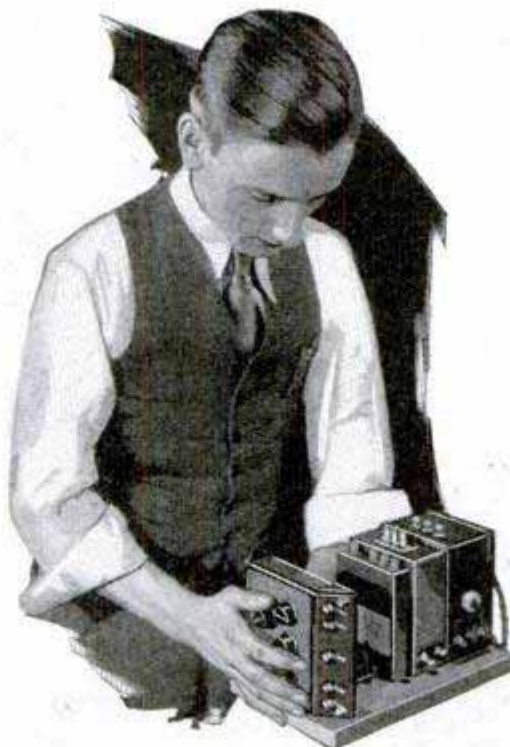

*Verbal & Visual
Screen Day, Wis*

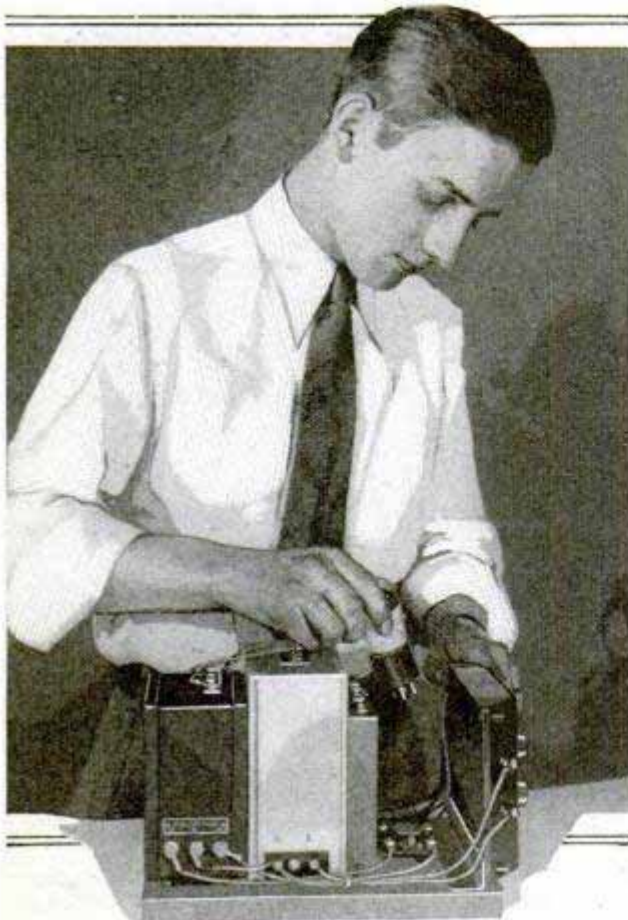

Inserting the Rectifier Tube in the Socket

receiver, this post is left open as the C-positive is already wired into the power-unit circuit. Place the rectifier tube in the socket and turn the filament switch on the panel of the receiver to the "on" position before plugging in the B-power supply. This is important, and the B-supply should also be turned off before the set switch is turned off. Now, with the set in operation, measure the output voltages at the voltage divider with a B-eliminator voltmeter and adjust the knobs for the necessary voltages to operate the set at maximum efficiency.

The switching operation may be simplified by the use of a standard power-control relay, which may be connected in series with either the positive or negative A-battery lead to the receiver. In case the power unit is used with an a.c. set, this relay switch will of course not be necessary.

This compact power unit takes up little space and will fit into any modern console, but do not attempt to inclose it in a metal container as plenty of air circulation is necessary. When installed in a console cabinet, holes should be bored

in the rear of the cabinet to permit ventilation.

Blueprint No. 146, describing in greater detail the construction of this power unit, may be obtained for 25 cents together with a complete list of the parts used. The list of parts will be mailed free to readers who do not desire the blueprint.

2298-22
Combination Lamp, Antenna and World Clock

A decorative miniature lamp is combined with an efficient light-socket antenna and, for the benefit of the short-wave fans, a well designed world-time clock to top off the device. A wire is connected to the antenna post on the set and to a post mounted on the base of the unit. The light-socket plug is then inserted in the house-lighting supply. The clock gives the exact time in one-half the world, from Berlin in the east to the Hawaiian islands in the west. A calibrated dial, which moves with the hour hand, indicates the corresponding time in the various parts of the world.

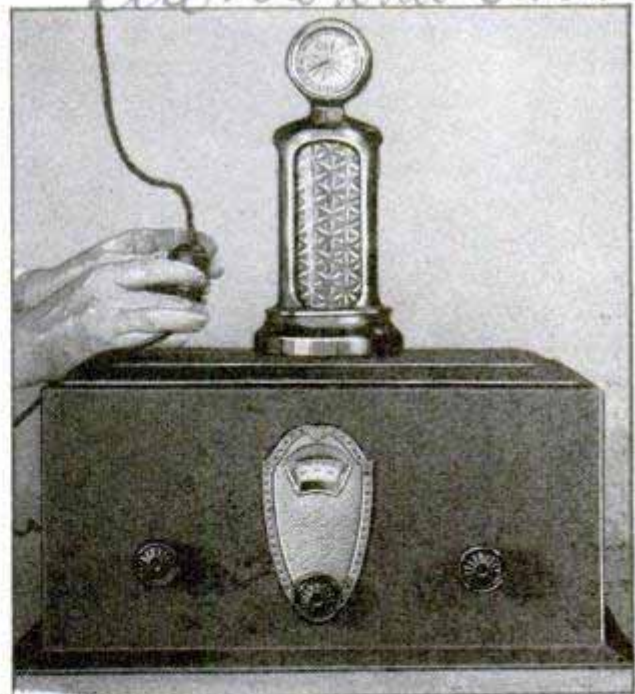

Plugging Combination Lamp, Antenna and World Clock into House-Lighting Circuit

Popular Mechanics' radio department offers its information service free to all readers of our magazine. We will be glad to help you with your problems, and will promptly answer all inquiries.

Collapsible Radio Mast

The radio antenna must be fastened to a firm support at its outer end. This discounts the use of trees, and neighboring houses are not always available. Some sort of mast is therefore often necessary, and to construct one is a problem for many. The mast shown here is sim-

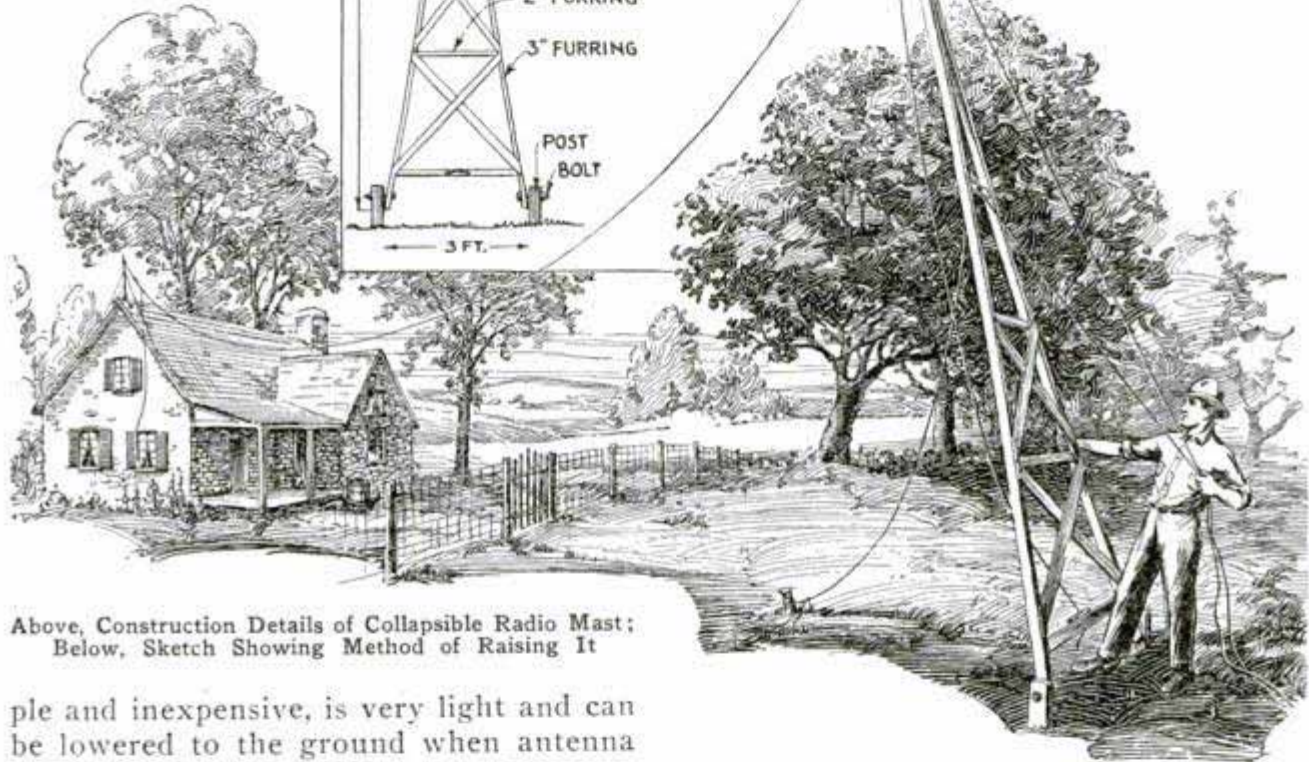
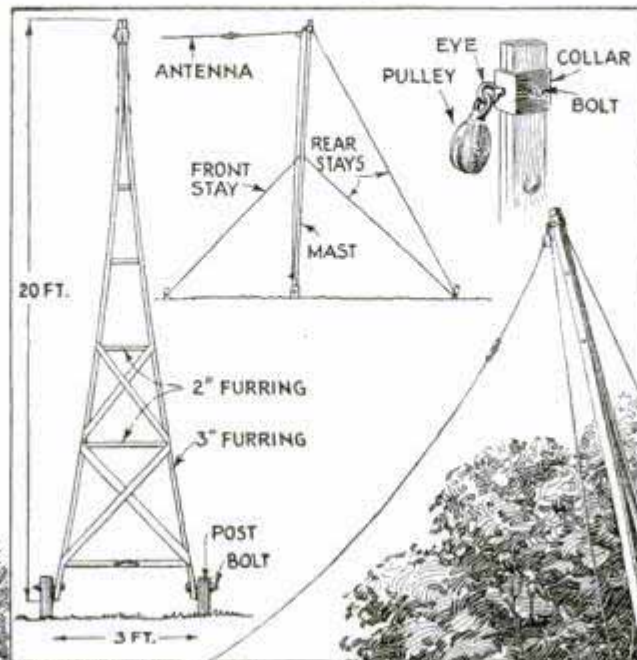

Above, Construction Details of Collapsible Radio Mast;
Below, Sketch Showing Method of Raising It

ple and inexpensive, is very light and can be lowered to the ground when antenna adjustments are to be made. The two uprights are 20-ft. lengths of 3-in. furring, that can be bought at any lumber yard. Select straight-grained material, as free from knots as possible. Lay them together and bore three holes through one end about 1 ft. apart, starting the uppermost hole only a few inches from the top. Have a collar made at the blacksmith shop or garage, of heavy sheet iron, with an eye in one of the narrow faces. A hole should be drilled also through each of the wide faces. The collar is rectangular, measuring about 3 by 1½ in. Drive it over the tip of the mast and bolt through the upper hole. Then draw the uprights together with two bolts below. Spread the uprights 3 ft. apart at the bottom and reinforce the structure with cross and

diagonal braces up half its length and with two or three crossbraces above. Set two posts in the ground, slightly farther apart than the width of the foot of the mast, bolt the latter inside the posts with loose-fitting bolts, so the mast will pivot on them. Fasten the back stays to the tip and center of the mast, and a front stay to the middle. Attach a

pulley to the eye in the collar and reeve the antenna halyard through it. The latter is fastened to a cleat on the bottom spreader.

When the mast has been raised, fasten the stays to posts in the ground so it will incline slightly back from the vertical. The antenna pull will keep it taut against the back stays. To lower it, simply release the halyard and unfasten the front stay, and the mast can be quickly dropped flat on the ground. It will be found to be practically free from side sway, and the stays keep it perfectly rigid fore and aft. A couple of coats of white paint will give it a nice appearance and also prevent it from weathering, so that it will last longer.—L. B. Robbins, Harwich, Conn.



TIPS from the

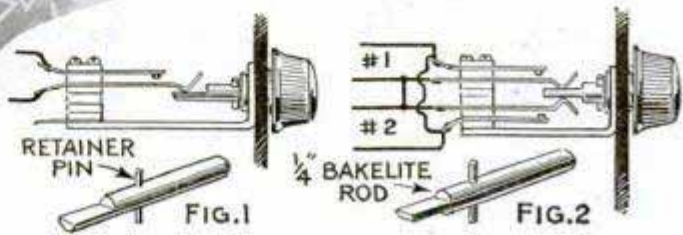

Above, Testing By-Pass Condensers for Short Circuit; Phones Are Connected in Series with B-Battery and Condenser; When Condenser Terminals Are First Touched Loud Click Is Heard; Immediate Succeeding Contacts Should Produce No Clicks Unless Defective

Panel-Mounting Battery Switches Made from Phone Jacks; Fig. 1, Single-Circuit Jack Altered to Open and Close Circuit When Knob Is Turned; Fig. 2, Double-Circuit Jack Wired in Parallel to Double Current-Carrying Capacity

Right, Small Single-Strand Flexible Leads, Stitched in Tape for Long Speaker Connection, Will Lie Flat under the Rug

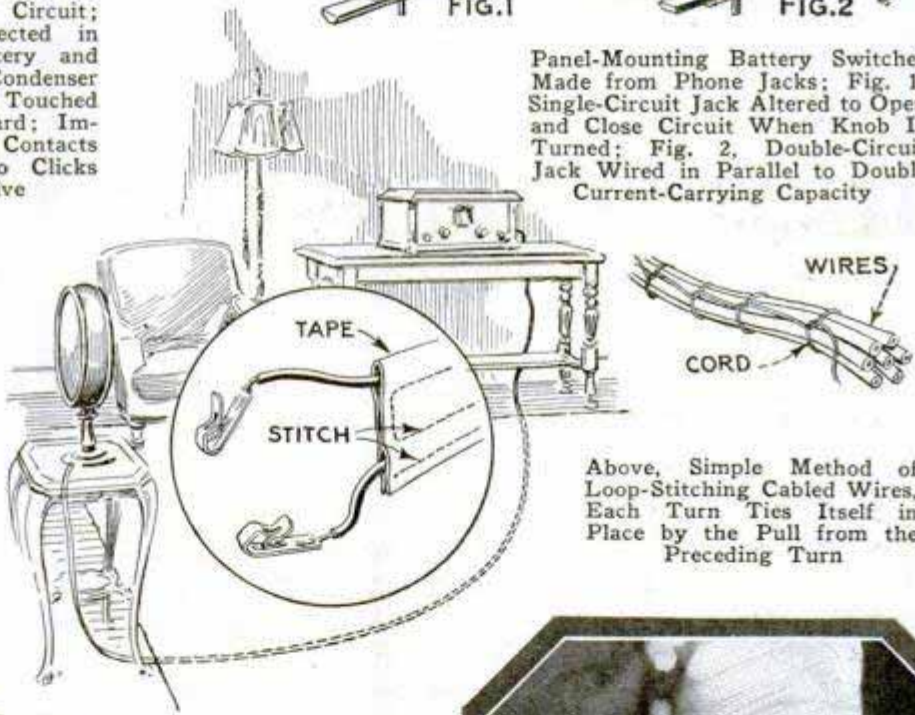

Above, Simple Method of Loop-Stitching Cabled Wires, Each Turn Ties Itself in Place by the Pull from the Preceding Turn

PIECE OF PURE COPPER SCREEN

THUMB TACKS

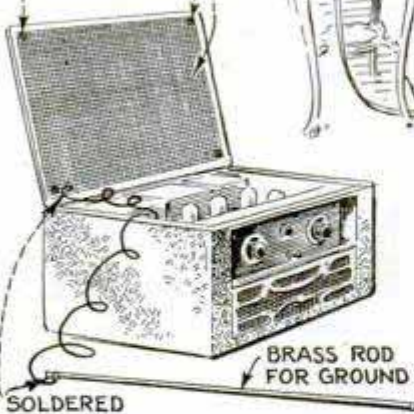

Right, Fahnestock Clips on Transformers, Rheostats and Tube Sockets Make Handy Terminal Connections for Experimental Hookups Which May Be Quickly Dismantled

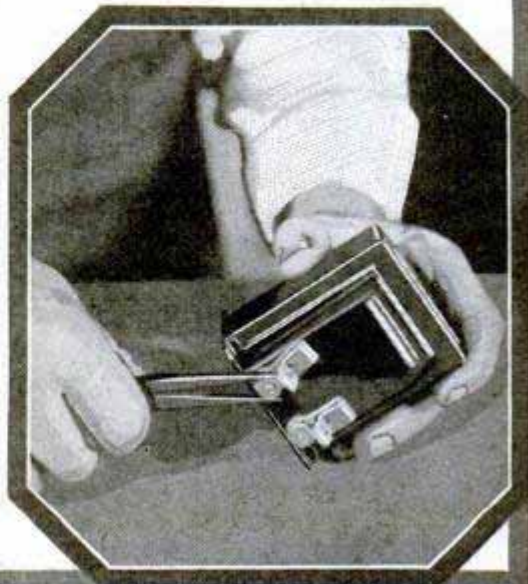

Above, a Field Antenna for a Portable Short-Wave Receiver May Be Made from a Piece of Copper Screen Cut to Fit inside the Cabinet Lid and Held in Position with Thumbtacks as Shown; a Flexible Lead from One Corner Is Connected to the Antenna Post

RADIO LAB.

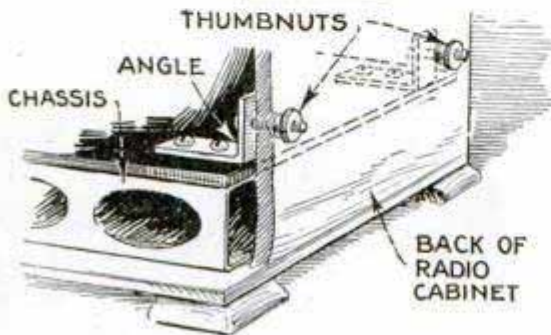
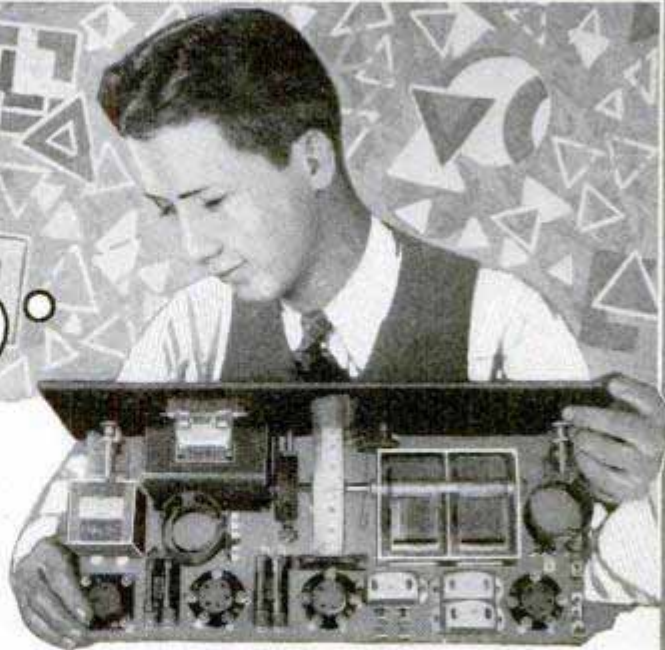

Convenient Method of Securing Chassis in Radio Cabinet; Machine Screws through Angles, and Thumbnuts, Hold Chassis Firmly to Rear of Cabinet

Experimental Layout of the Semi-Breadboard Type, Showing Method of Mounting Ganged Condensers and General Arrangement of the Parts; Such Layouts Are Easily Wired and Tested, and Can Then Be Torn Down and Rebuilt on a Metal Chassis and the Various Stages Shielded to Obtain Best Results

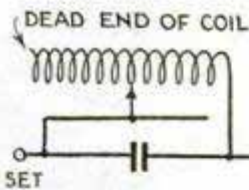

An Auxiliary Antenna Coil Which Will Aid in Adjusting the Length of the Antenna for Best Results on Short or Long Waves; Fixed Condenser Is .0005 Mfd.

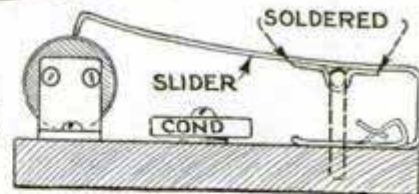
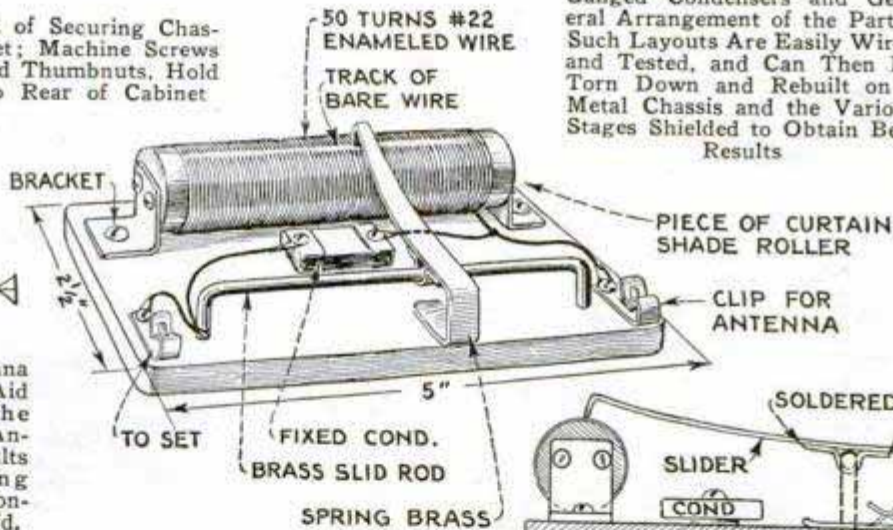

SIDE VIEW

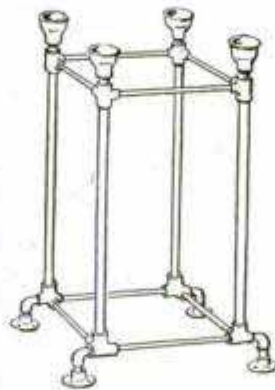

Left, a Handy Movable Stand for Any Table-Type Receiver May Be Made at Small Cost; the Frame Is of Standard Galvanized Pipe and Fittings and the Height, Including the Casters, Is 30 Inches; the Reducers at the Top Are Reamed Out to Take the Rubber Feet on the Bottom of the Cabinet; for Stationary Use, the Ball-Bearing Casters Are Left Off; Galvanized Pipe Is Used to Prevent Rust, and, When Completed, the Stand May Be Sprayed with Lacquer or Decorated to Suit the Builder; the Speaker Shelf Is Made of $\frac{3}{4}$ -Inch Veneer, the Corners of Which Are Cut Out to Fit the Bottom Couplings

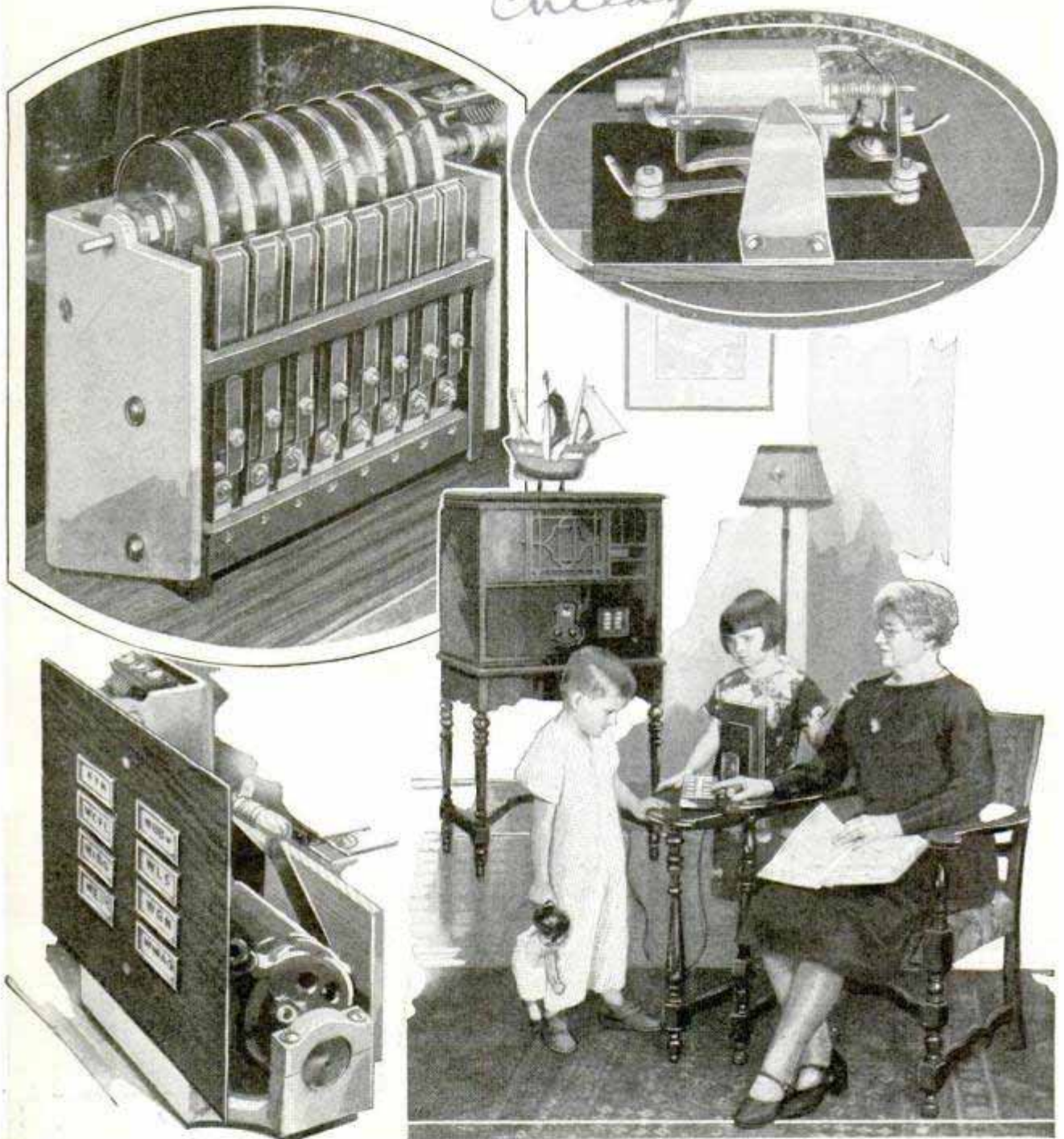

New Tuning System Has Remote Control

Push a button, snap!—there's your favorite station, and you need not leave your chair to do it. In fact, you may be almost anywhere in the house if you are equipped with a new remote control. The station selector, shown at the lower left and again shown fitted in the front panel of the complete receiver, is made up of a number of little tabs which are also push buttons. The station-call letters are inscribed on these transparent celluloid tabs, which fit into metal frames and are illuminated from the rear. A slight pres-

sure on the tabs sets the automatic tuner, shown at the upper left, into operation, tuning the set to the desired station. Any number of tabs may be employed, limited only by the space available. The same selector unit appears in the remote control operated by the lady seated in the chair. The automatic tuner consists of a number of slotted drums with a like number of contact segments or "fingers." This assembly is fastened to one side of the condenser gang of the receiver. It "finds" your station for you, after you have made the selection by pressing the button on the selector. The power for the auto-

matic electric tuner is supplied by a tiny motor which takes its current from the receiver supply and does not interfere in any way with the efficient operation of the receiver. The last unit of the automatic tuner is the relay switch, shown in the upper right-hand photo. This unit is required only when one or more remote controls are installed. Any number of control boxes may be used. They may be semi-portable with exposed cables running to the set, or permanently installed with concealed wiring. The remote control consists of a complete selector unit mounted in a metal box, on which is located a combination on-and-off switch and volume control. Any number of the remote-control units may be connected in parallel with that unit which is built into the receiver.

type of the receiver. The instrument shown in photo No. 3 is a specially designed charger for storage batteries, suitable for either radio or auto batteries, and the third unit for d.c.-set operation is the power unit shown in photo No. 4, which replaces the usual dry B-batteries. This unit provides a constant flow of high-voltage current from the low-voltage source. It is composed of a group of cells of the Edison type, and the cost of operation is said not to exceed five cents a month, even with a large radio receiver. For the operation of any standard a.c. receiver of the self-contained type, where all power is derived from the 110-volt 60-cycle a.c. line, only one of the above instruments is necessary, namely the unit shown in photo No. 2. This is perhaps the most interesting unit in the group as it converts the 32-volt d.c. farm lighting supply to the necessary 110-volt a.c. at low current consumption. The output is carefully filtered and as far as the operation of a.c. receivers is concerned it is a practical proposition. The converter is compact and sturdily built; it may be installed in a near-by closet or an adjoining room.

Standard Receivers Operated from 32-Volt Supply

The owner of a 32-volt farm-lighting plant is no longer limited as to the type of radio receiver he must use. A group of power units specially designed for use

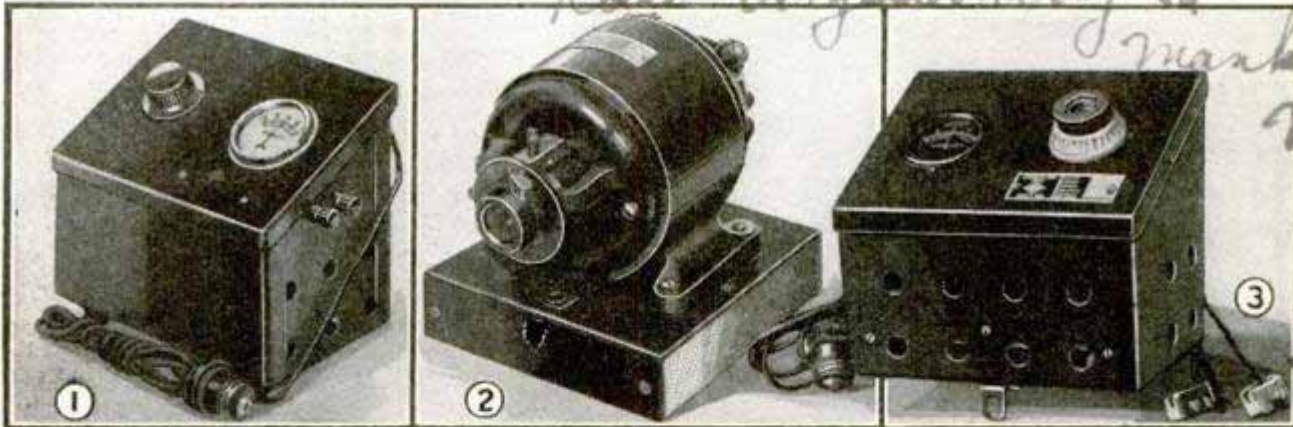

with this supply makes possible the operation of any standard a.c. or d.c. receiver on the farm, with the same efficiency as with a 60-cycle 110-volt a.c. current. For the standard battery-operated sets, the instrument shown in photo No. 1 is an A-battery eliminator which reduces the 32-volt current to the desired voltage for the tubes, regardless of the size or



Kato Engineering Co.
Manhato, Minn.
32 or 110 volt set

2367-21
838

Jenkins Television Corp
POPULAR MECHANICS
Jersey City, N.J.

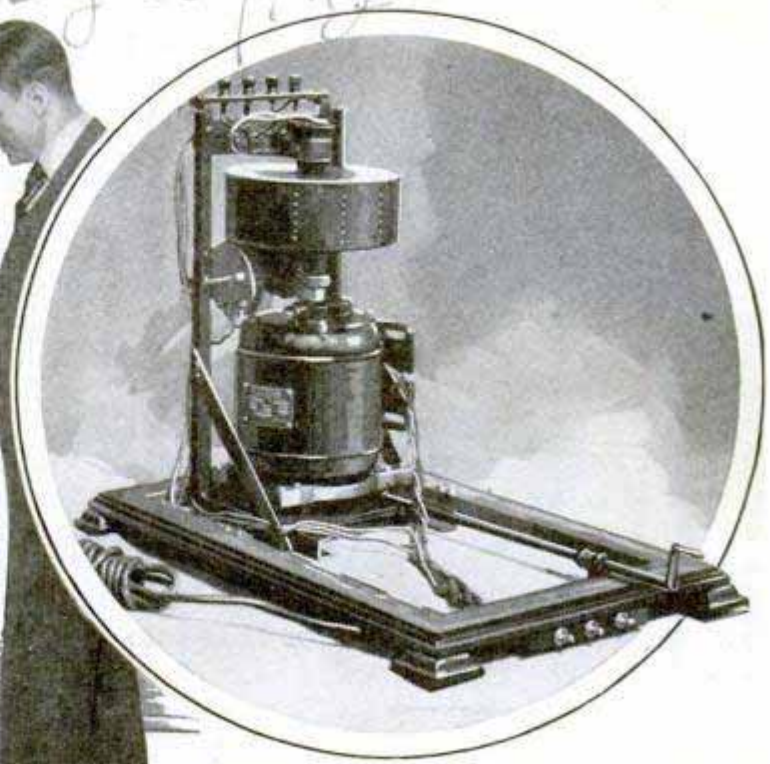

Televisor for Home Use, Showing the Toggle Switches and Framing Crank; Above, the Instrument Removed from the Cabinet, Showing the Simple Mechanism for Rotating the Entire Motor and Scanning Drum to Bring the Pictures in Phase with the Signals

Compact Television Receiver for the Home

What is generally regarded as the simplest and most practical television receiver yet proposed for home use, has recently been demonstrated by the Jenkins Television corporation. This simplified and compact instrument, shown in the photos, is housed in a neat walnut cabinet, 18 by 18 by 24 in. in size. The front of the cabinet contains a recessed opening or "shadow box," leading to a large and powerful magnifying lens through which the radio movies are viewed, together with three toggle switches and a framing crank. The operation of the new televisor is simplicity itself. The first toggle switch turns on the neon glow lamp; a standard short-wave radio receiver, employed in conjunction with the televisor, is then tuned in the usual manner, until the characteristic buzz-saw note of the television signal is at maximum in the loud speaker. The second switch cuts off the loud speaker and switches the set output to the neon lamp. The third switch turns on the motor and also serves to bring the scanning drum in step with the

picture. The crank is then turned so as to frame the picture from left to right. The synchronous motor and scanning drum are mounted vertically and supported by an angle-iron frame. A special form of distributor serves to flash the four neon-lamp plates in succession, illuminating the four quarters of the scanning drum in four successive revolutions. The scanning-drum holes are viewed through the magnifying lens, giving an apparent screen size of 6 in. square, or sufficient for the simultaneous entertainment of six to eight persons. As for the nature of the entertainment, only the simplest subjects are being broadcast at this time. Instead of attempting very crude halftone pictures, the Jenkins engineers are endeavoring to transmit and receive silhouette or black-and-white movies with a fair degree of accuracy. The demonstration of a thrilling boxing contest in silhouette form can be readily followed on the televisor screen. Complete silhouette pictures and animated cartoons are to be transmitted on a regular schedule by the Jenkins television stations in Jersey City and in Montgomery county, Maryland, near Washington, D. C., shortly.

Balsa Ambroid or a deal airplane Co 19 W. 11th. New York

AMATEUR MECHANICS



Balsa Cruiser Develops High Speed

WITH all the balsa and ambroid the model-airplane craftsmen are bringing home these days, there is opportunity to apply these remarkable materials in other fields. For light, swift model boats balsa is unexcelled, and ambroid, which does not dissolve in water like glue, makes it possible to use very thin pieces.

Made according to the drawings, the little express cruiser weighs slightly over four ounces and tears over the water at surprising

speed. Its draft is so slight that the propeller shaft needs no tube above the waterline. In fact, it could almost come right through the bottom without causing a leak. The entire hull is literally built around a triangular motor-stick assembly, somewhat sim-

ilar to that used in model airplanes, which forms the backbone of the craft and carries all the load. This is made of clear spruce, and is supported at the bow by the stem piece; at the stern it is bound to the keel and propeller-shaft block.

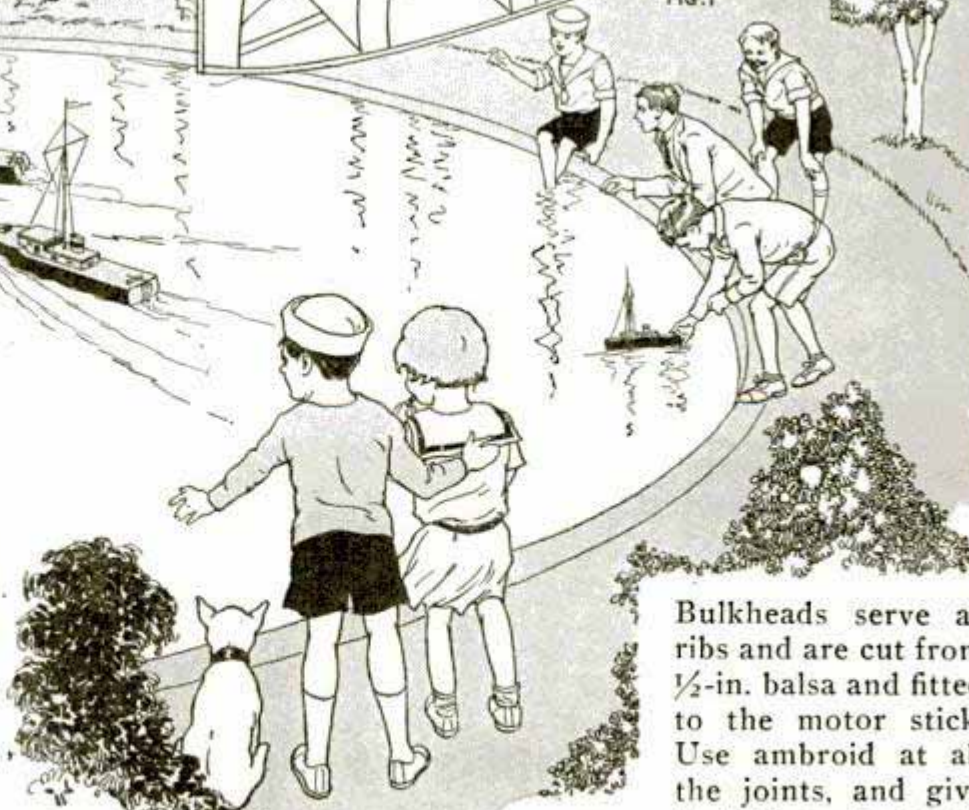
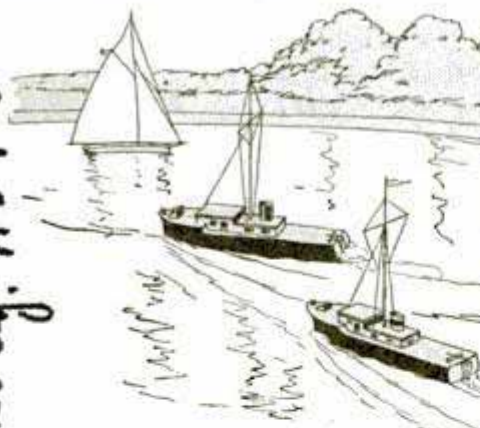
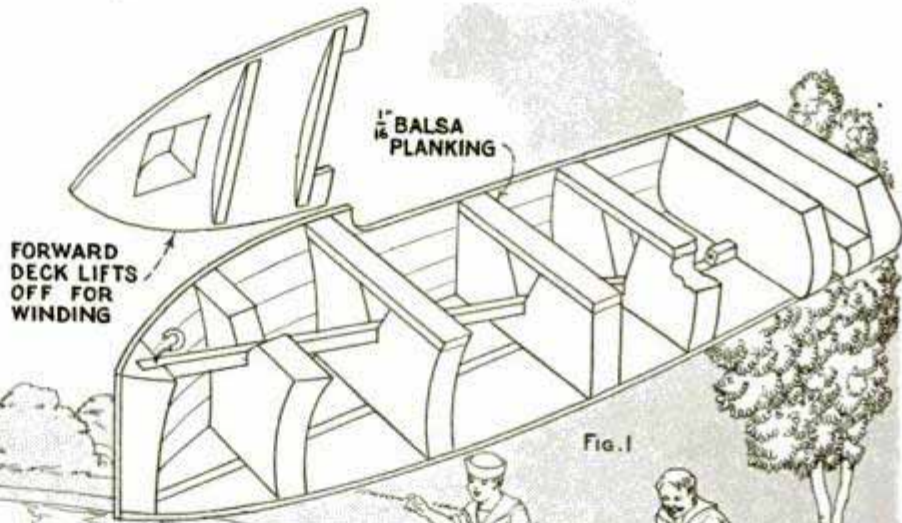

speed. Its draft is so slight that the propeller shaft needs no tube above the waterline. In fact, it could almost come right through the bottom without causing a leak.

The entire hull is literally built around a triangular motor-stick assembly, somewhat sim-

Bulkheads serve as ribs and are cut from 1/2-in. balsa and fitted to the motor stick. Use ambroid at all the joints, and give it half an hour to

*Balsa-International Engineering 839
Westway Bldg. Washington D.C.*

Had I only 1954 Brugden, Pasadena, Calif.

J. H. Moulton Co. 202 Lewis St. New York

harden before applying other parts. See Fig. 1 for details of ribs, and Fig. 2 for motor-stick, keel and stem assembly.

Fit the bottom planks of $\frac{1}{16}$ -in. balsa first and work toward the top. As each plank is fitted, ambroid it to the stern block and central bulkheads first, and let the ambroid harden before bending around the curve of the bow. By sandpapering the bow end of the planks, they will bend more readily. Or you can steam them over a teakettle and bend over a form. But they should be thoroughly dry when installed on the hull frame. Fitting the bow portion will require skill and patience because of the flare or inward curve of the ribs.

The propeller is very easily made from a piece of tin, galvanized sheet or brass. Make the two blades as generous as possible with a $1\frac{3}{4}$ -in. diameter, and give them considerable pitch. Your rubber motor will then unwind more slowly and keep the craft running longer. Before

bending the blades, however, solder the propeller to a short hub, such as the battery nut shown in Fig. 3, and to the wire propeller shaft. Stiff music wire or Bessemer steel rod is good for this purpose, but should be made as straight as possible. Ambroid a washer to the rear end of the propeller-shaft block to take the thrust. The hook for rubber bands must be bent after the shaft is inserted in the block. In case you wish your craft to carry a load or ballast that brings it well down in the water, stuff a quantity of oil-soaked cotton in the hole around the shaft. Fig. 4 shows how the propeller shaft is brought through the stern. It will be noted that two balsa blocks are ambroided together to form the stern block or transom, and that this permits a semicircular cut-out to be made to clear the propeller. This figure also shows the "shaft log," as the part carrying the propeller shaft is called, projecting through the bottom of the craft, as well as the

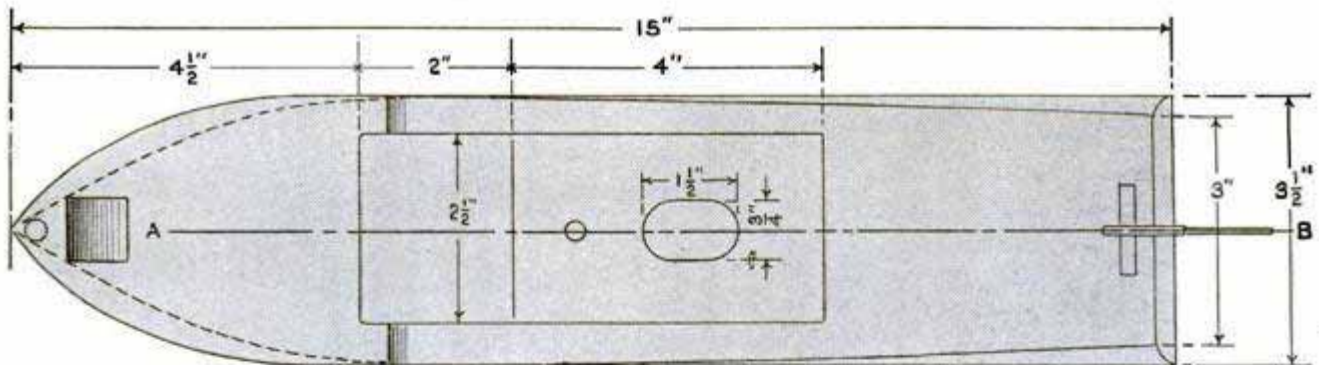

TOP VIEW
Fig. 5

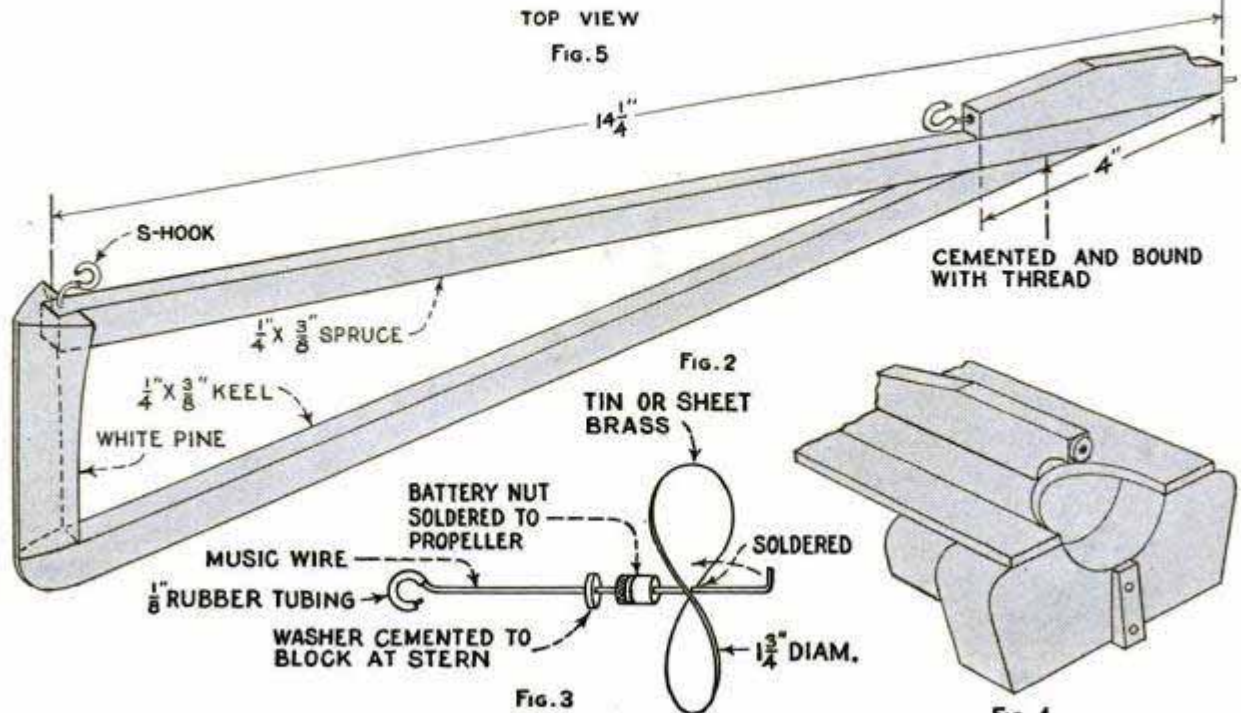
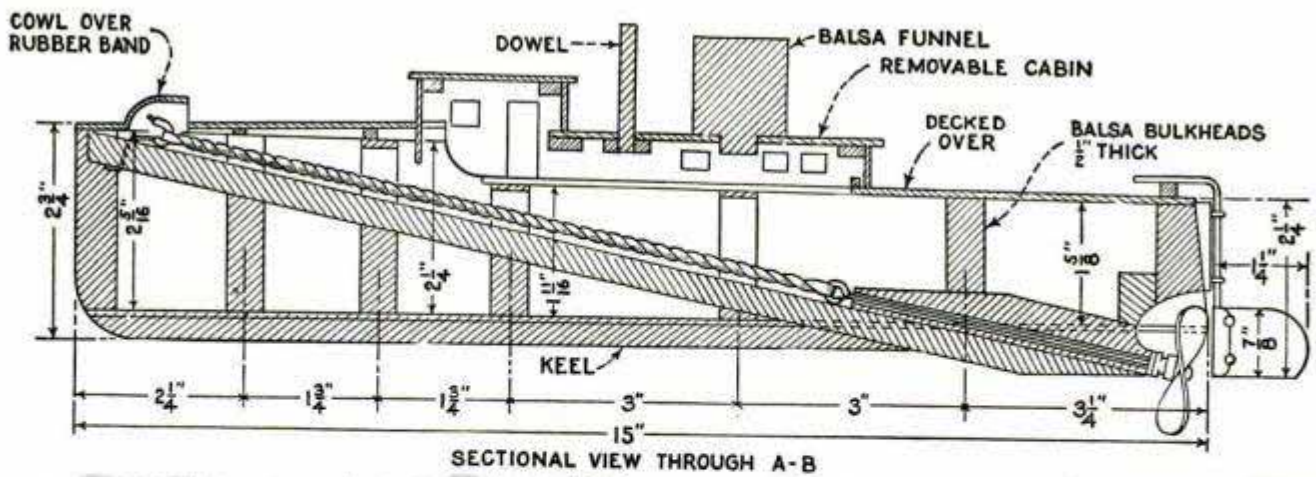

Fig. 3

Fig. 4



SECTIONAL VIEW THROUGH A-B

FIG. 6

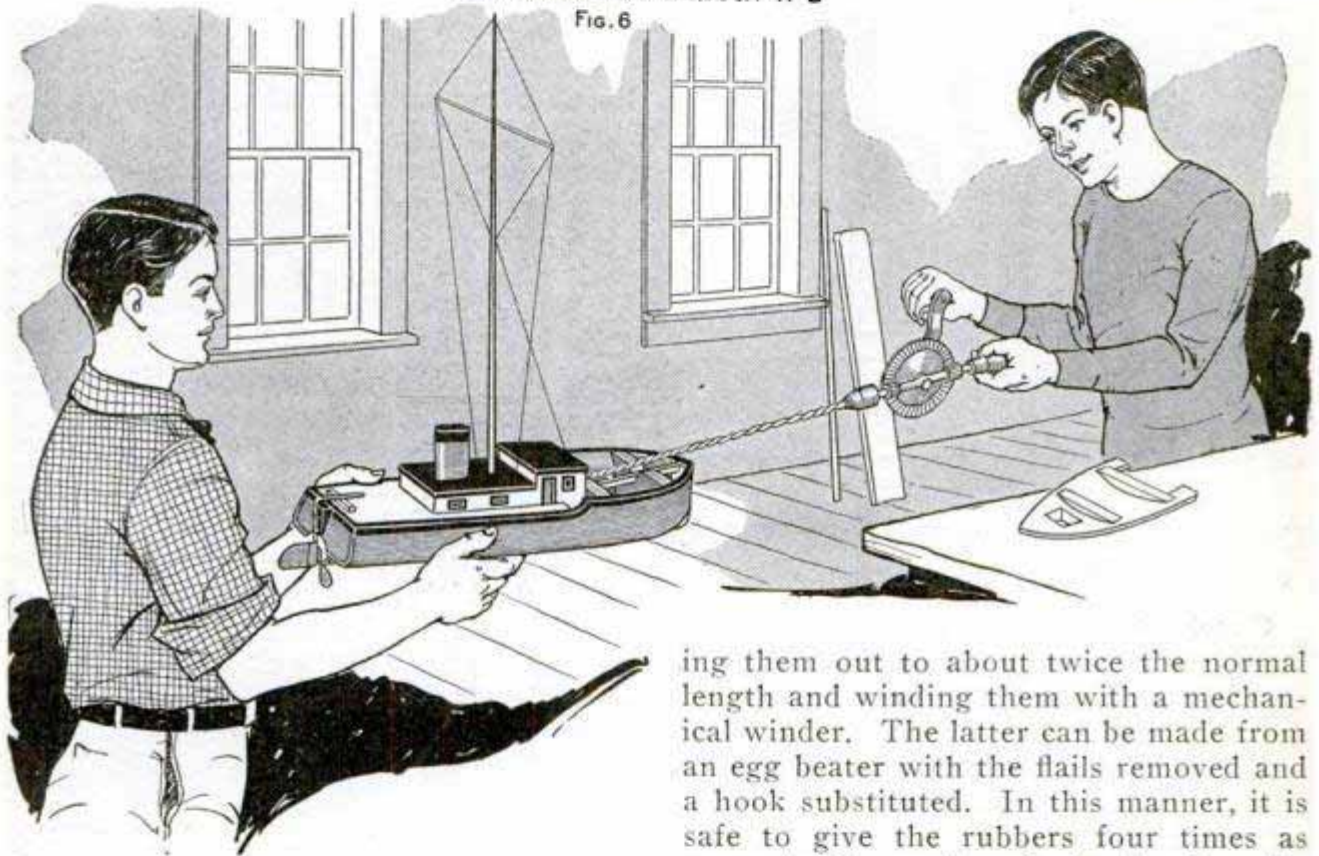

little wedge-shaped piece of balsa that is pinned and cemented to the transom to make the rudder stand vertical.

Make the rudder of tin, soldered to a length of brass wire and secured to the stern by means of small wire eyes. A balsa strip on the after deck holds the tiller in position.

Give the cruiser a trial run before putting on the afterdeck and cabin, and be sure to sandpaper it smoothly and give it two or three coats of paint and one of spar varnish before setting it in the water.

Use four strands of $\frac{1}{8}$ -in. model airplane rubber adjusted so that it is neither loose nor stretched. Best results will be achieved by detaching the S-hook carrying the forward end of the rubbers, pull-

ing them out to about twice the normal length and winding them with a mechanical winder. The latter can be made from an egg beater with the flails removed and a hook substituted. In this manner, it is safe to give the rubbers four times as many twists as by simply turning the propeller. Bear in mind, however, that the average egg beater is geared up to 4 to 1, so that in turning the crank 100 times you have twisted the rubbers 400 times. At first, do not attempt more than 75 turns at the most, either by winder or directly on the propeller.

Now make the forward deck and cabin. The former is crowned, a result achieved by supporting it on curved battens. This forward deck is so mounted that it can be lifted off for winding. The cowl over the opening for the hook is optional.

The first model we made like the diagrams fairly jumped out of our hand when released in a pool, and you can feel safe in entering your swift craft in any speed contest for this class.

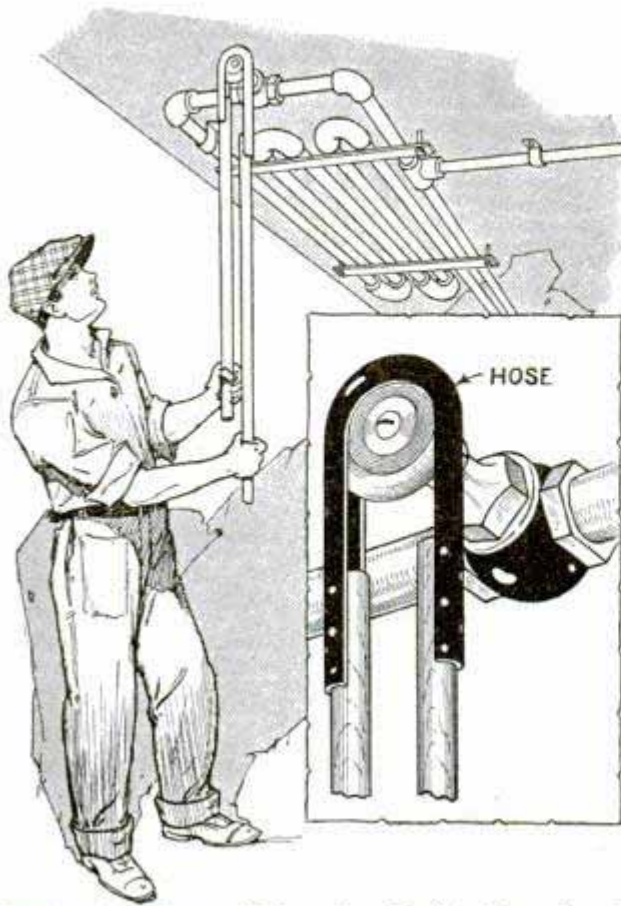

Overhead Radiator Valves Are Easily Opened and Closed with This Extension Grip

Convenient Device for Operating Valves on Overhead Radiators

Overhead radiators in shops and basements are ordinarily rather difficult to get at, but if they have round wooden valve handles it is an easy matter to open and close them by means of the device shown in the drawing. It consists of a 12 or 18-in. length of rubber garden hose, cut in half as indicated and tacked to the ends of two wooden handles. In use, the section of hose is slipped over the edge of the radiator-valve handle, and it is then an easy matter to turn the valve either way.—Carl G. Langland, Minneapolis, Minnesota.

How to Clean the Works of a Clock

To clean the works of a cheap clock, saturate a cloth or pad of cotton with kerosene and lay it inside of the case on a small disk to prevent the wood from absorbing the oil. The fumes caused by the evaporation of the oil will loosen dust and dirt in the works and cause it to drop. Lubrication is also accomplished to some extent in this way.

Storm Cover for a Hand Camera

When using an unprotected hand camera during stormy weather, rain and snow will soon dampen the bellows and lens front, covering the lens with a film of moisture which spoils the definition of the image. The storm cover shown in the drawing has been found an effective remedy for these troubles. It was made for a particular type of camera, but with a few minor changes, such a cover can be used on any similar type. The material is a cardboard box, cut as indicated and covered with oilcloth, imitation leather or other kind of waterproof fabric. Some linen or cotton tape, about $\frac{1}{2}$ in. wide, is used for "ties." After the individual pieces have been cut out, they are laid next to each other, with $\frac{1}{16}$ -in. space between them to facilitate folding. Coat with glue and press the fabric covering on firmly. Where the fabric covers the holes cut in the cardboard, it is carefully removed with a sharp razor blade. The cover can be folded when not in use and kept in the camera case. A $\frac{1}{2}$ -in. slot, about $\frac{1}{2}$ in. from the end, is cut in the two pieces forming the sides of the cover to receive two 12-in. lengths of tape, the ends of which are glued to the inside of the box. These lengths of tape are tied around the body of the camera to hold the cover in place securely.

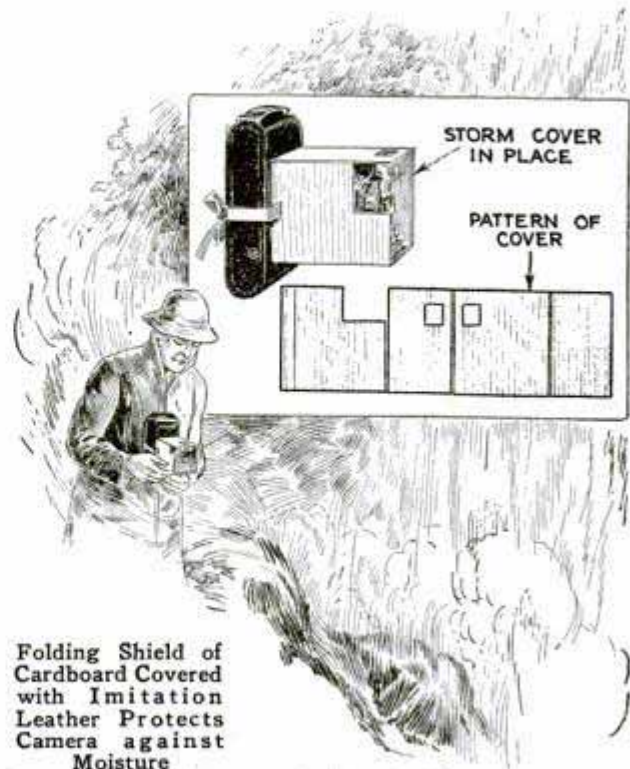

Folding Shield of Cardboard Covered with Imitation Leather Protects Camera against Moisture

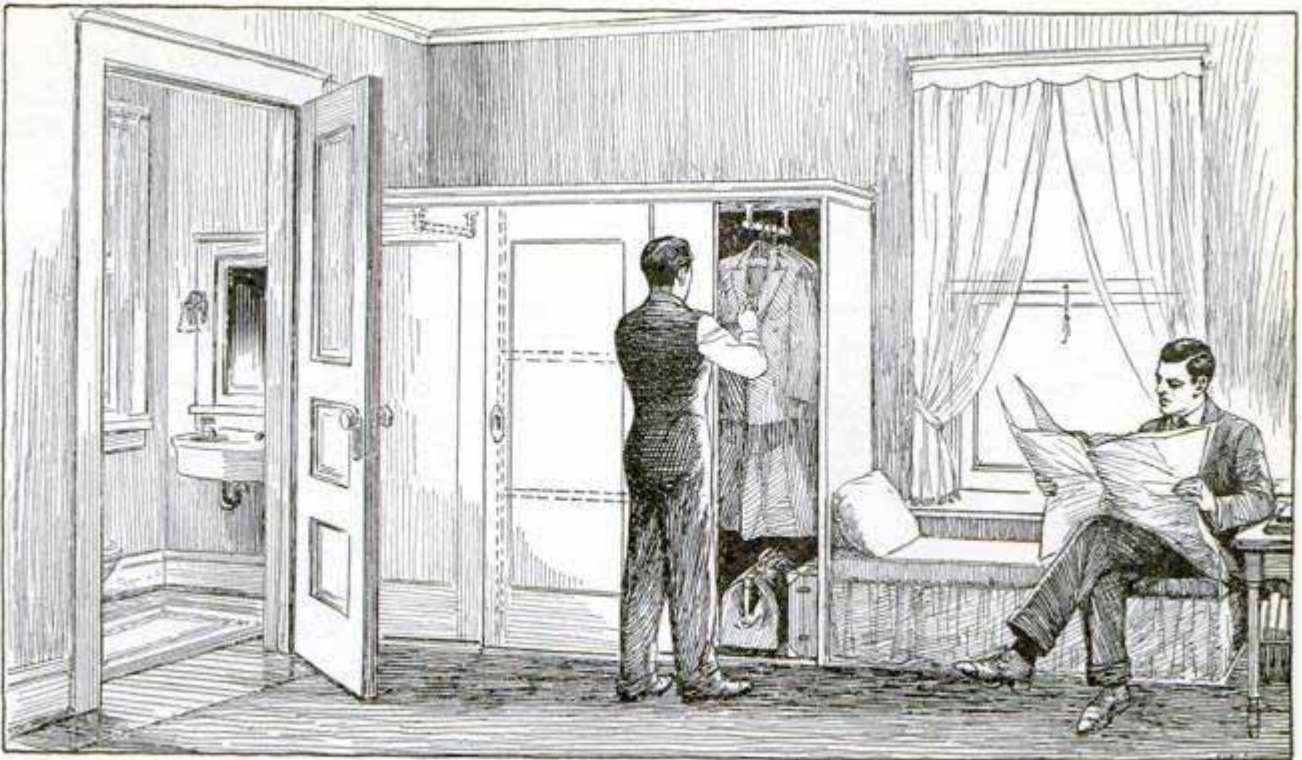

By Substituting a Wardrobe for the Clothes Closet, and Remodeling the Latter into a Small Bathroom, a Large Room Was Changed to a Small Apartment

Changing a Large Room to a Small Apartment

One home owner who rented out some rooms changed one of the large rooms to a small apartment with very little trouble and expense. The room had an extra-large closet which was remodeled into a bathroom. As a substitute for the closet, a wardrobe, provided with sliding doors, was built in one corner as shown. Thus, at the comparatively low cost of the plumbing, electric wiring and wood for the wardrobe, the income from the room was increased considerably.—Lester G. Herbert, Auburn, N. Y.

Correcting Front-Wheel Wobble on Ford Cars

Wabbling front wheels is a recurring fault in Ford model-T cars and involves a certain amount of danger. Tightening the bolts and spring perches or renewing bushings will not remedy the trouble if the front axle is incorrectly tilted. On the other hand, if the axle is correctly tilted, lost motion or looseness in the parts will not cause a wobble unless the lost motion is excessive. The drawing shows a method of correcting the axle tilt. A wooden square is made, slightly

longer than the axle is high. On the upper end of the square a block is added to serve as a gauge, projecting $\frac{3}{8}$ in. This gauge is used at the forked end where the wheel spindle is placed. By means of a long lever, shown in the lower detail, or a heavy wrench fitted with a pipe extension, the front axle is forced either upward or backward, until the gauge shows the upper end of the fork to be just $\frac{3}{8}$ in. behind the bottom end.

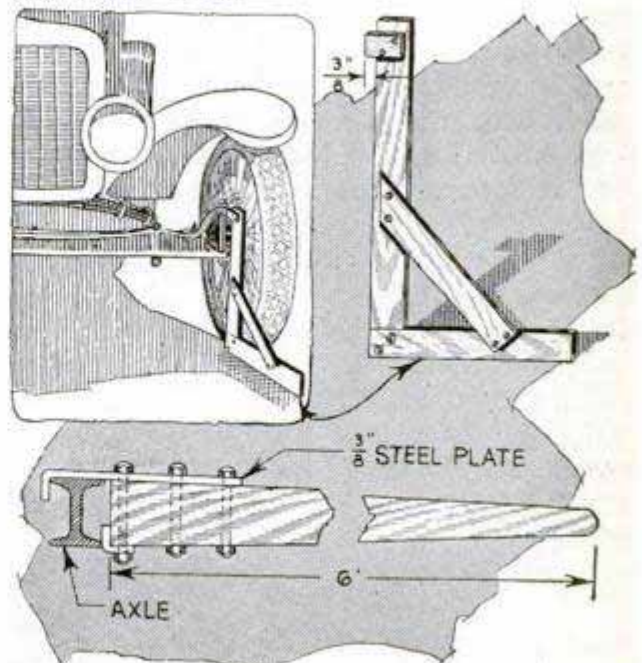

Wooden Square Used as Gauge to Correct Wrong Axle Tilt Which Causes Wabbling

A Few Camp-Cooking Kinks

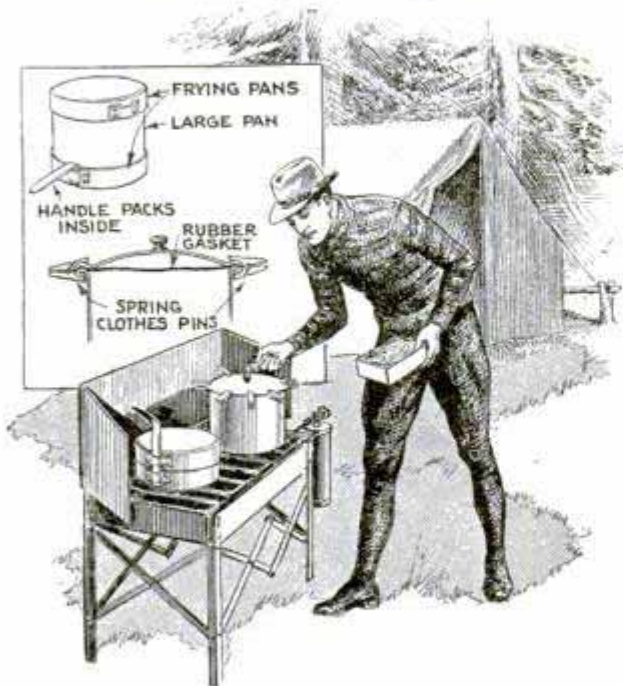

Tightly Sealed Lid on Cooking Vessel Hastens Boiling in High Altitudes

A compact "nesting" set of cooking utensils is always part of the experienced camper's equipment. The large frying pan of such a set usually fits over the largest pot when the set is packed. Smaller pots, a small frying pan and a coffeepot fit within the large pot. The purchase of a second large frying pan will add greatly to the utility of the set. This pan will fit over the bottom of the set when packed, without adding much to the bulk. The two frying pans can then be placed together on the stove, as shown at the left, to make a good Dutch oven. The upper pan is preheated over the burner of the stove before it is placed in position. At high altitudes, as in most of our western national parks, potatoes and other vegetables take a much longer time to boil, owing to the lessened atmospheric pressure. A remedy for this condition is to place a rubber disk, cut from an old inner tube, between the lid and the pot. A number of spring clothespins are then used to clamp the lid firmly on the pot. This sealing will slightly increase

the pressure within the pot and raise the boiling point of the water, so that potatoes can be boiled 10 to 15 minutes quicker than otherwise.—Retta Conley, Los Angeles, Calif.

Coin Aids in Winding Alarm Clock

The small size alarm clock is rather difficult to wind owing to the short and small winding keys, and one is likely to pinch a finger between the keys and the hand-setting stem. The doubled finger-holds of the winding keys were pried apart just enough to allow the insertion of a small coin, and it was found that, with this extension, the trouble was entirely eliminated.—John B. Ingram, Mansfield, Massachusetts.

Linotype Signal Light Aids Operator

When a linotype operator has considerable type to set and arrange around cuts and panels, the simple signal device shown in the drawing can be used to tell him when the necessary depth in picas of each measure has been set. A $\frac{1}{4}$ -in. rod is bent, one end to fit on the front galley-rack bracket, and the other end flattened and attached to the other support. The rod is graduated in picas so that a stop, drilled to fit the rod, can be set at any point. A small clamp, consisting of fiber and brass, is clamped on the first linotype slug, or held between the first two slugs, the brass strip at the top being insulated from them. As the slugs travel along toward the stop on the rod, the brass clamp is carried with them. Electrical connections are made as indicated, two small flashlight cells and a red lamp being used in the circuit. As soon as the clamp touches the stop, the lamp lights, indicating that the desired depth has been reached.

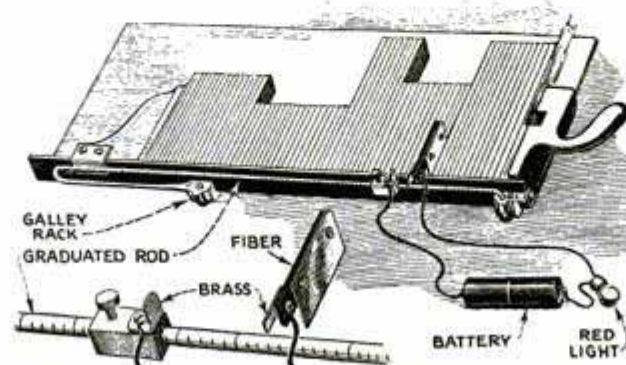

Small Red Lamp on Linotype Galley Rack Helps in Arranging Type around Cuts

¶ If a rock is too large to handle, put a couple of sticks of dynamite on top of it, seal with wet clay, and detonate; the rock will break.

Electric Hotbed Easy to Make

By M. E. BRIDSTON

THE GARDENER or nurseryman who has electricity available would do well to consider the use of electric current in furnishing bottom heat in the hotbed. This has many advantages over the use of manure and is entirely practical, as has been demonstrated by Glen Cushing of Puyallup, Wash. Nurserymen have found it especially valuable, for with the electric hotbed it is possible to start and root plants in three months that took two years by the old method. All manner of plants are being rooted with electric heat, soft rosewood cuttings being ready in three weeks.

The hotbed is so simple that anyone can make it, the only equipment necessary being electric coils to furnish bottom heat instead of manure. The propagator, having absolute control over the heat, is enabled to force the root growth just when the cuttings require warmth, and this puts within the reach of the small nurseryman the opportunity of rooting those cuttings which are difficult to secure on the market. Every season sees a shortage of lining out plants in certain varieties after

the lists are out. The man with the heat box, however, scans the lists for his needs and proceeds to root those not otherwise obtainable.

This electric frame is also of great value to the farmer and gardener in starting all kinds of garden plants where bottom heat is necessary. The heat can be controlled to any degree desired, which is very difficult when horse manure supplies the heat.

The electrically heated frames may be constructed in any size, from the window box, 8 by 18 in., to boxes many feet in dimensions. The housewife wishing to root her geraniums, or the plant lover desiring to obtain rare specimens, can also do so more easily with the electric frame. A small box, heated from the electric-light outlet, may be run at a cost of a few cents per month, and even the cost of the larger boxes is relatively low.

The first experimental frame constructed by Mr. Cushing was 2½ by 4 ft., and the heat supplied from an outlet on an electric range. The cost of heating this frame is about \$1 per month. The accompanying sketches give all the neces-

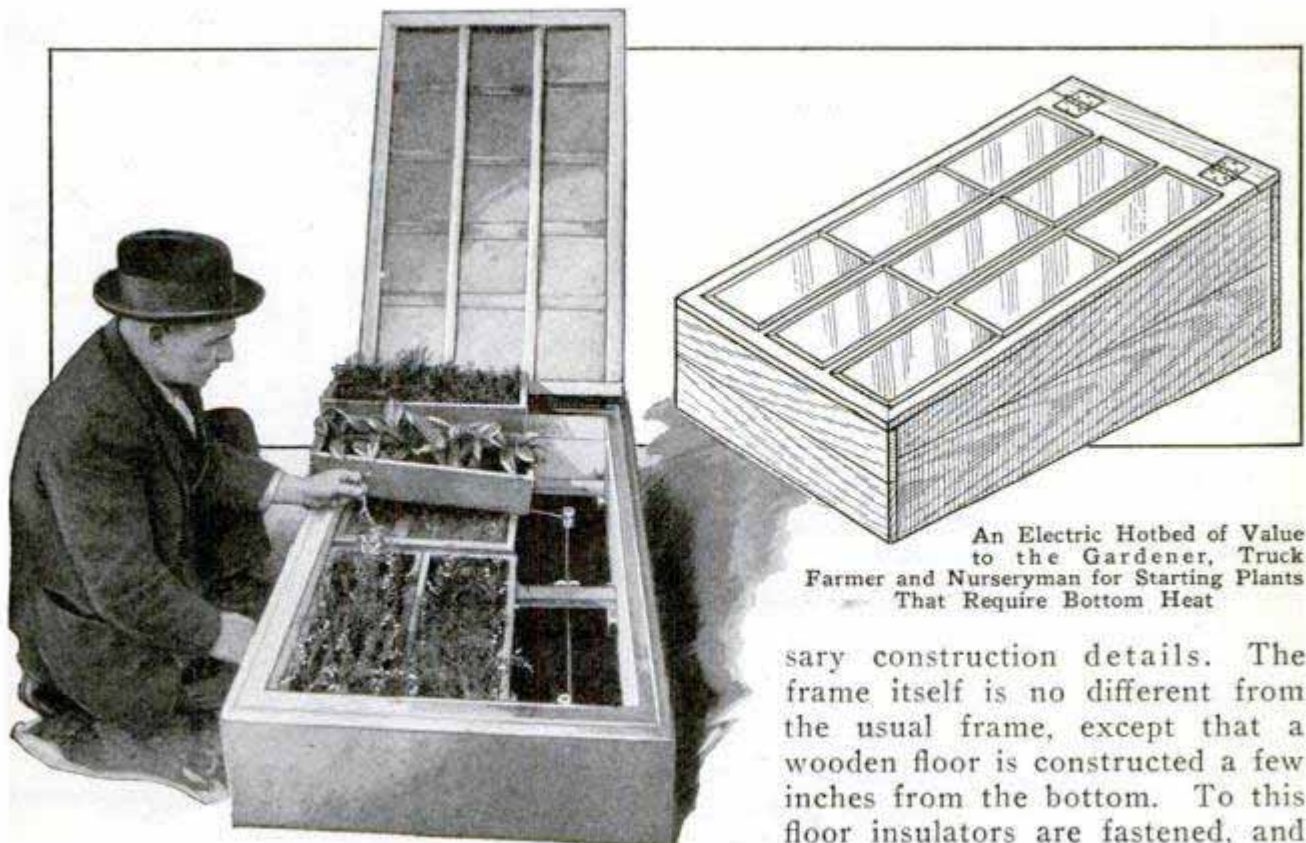

An Electric Hotbed of Value to the Gardener, Truck Farmer and Nurseryman for Starting Plants That Require Bottom Heat

sary construction details. The frame itself is no different from the usual frame, except that a wooden floor is constructed a few inches from the bottom. To this floor insulators are fastened, and

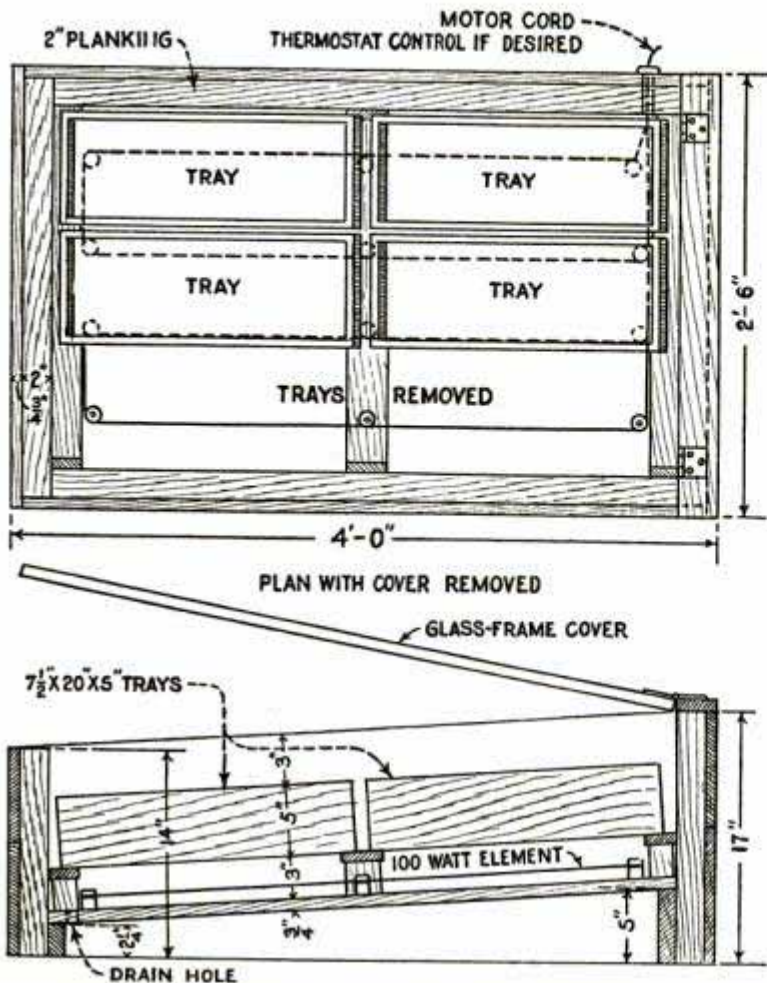

to these are attached the 100-watt heating elements. The floor should be sloping to provide drainage, with drainage holes at the lower end, or a metal plate may be placed between the seed trays and the heating elements to catch the drippings incidental to watering the plants. However, this precaution is not essential, for the coils are never hot enough to be damaged by the dripping water. The heating elements may be obtained through the local electrician. The seed boxes or trays rest on a frame rack and are removable.

At times there may be a slight advantage in having thermostatic control of the heat, although this is not essential. However, any cheap thermostat will serve the purpose, and thus the propagator will be assured of an even temperature that need not vary over a few degrees.

Repairing Aluminum Ware

To mend a hole in an aluminum vessel, get some solid wire rosin (not the kind having a rosin core) and cut off a piece about $\frac{1}{8}$ in. long. Ream out the hole in

the vessel to the exact diameter of the solder, which is then inserted in the hole and the projecting ends peined down with a hammer. The result will be a water-tight job and one that will last. If the hole is so large that a single rivet is found insufficient to close it, use two next to each other and run them together with a hot soldering bit.—F. A. Wilhelm, Mullica Hill, N. J.

Vacuum Cleaner Forces Draft for Stump Burning

Successful use has been made of an ordinary vacuum cleaner for stump burning by R. N. Miller, of the Washington state college extension department. A number of lengths of hose are attached to a fitting connected to the blower opening of the cleaner, and short pieces of iron pipe, serving as nozzles, are slipped into the ends of the hose. Several holes, about 4 in. deep, are bored in the roots of the stump, near the ground, and fires are started in the openings. The nozzles are then inserted in the holes and the vacuum cleaner is started to provide draft. After the blaze is well started, the nozzles may be removed.



Stump Burning Made Easier by Draft Supplied by Vacuum Cleaner

Removing Old Cold Patches from Auto Inner Tubes

In the repair of auto inner tubes, there is usually some difficulty encountered in removing an old cold patch that leaks or is close to a hole. It can be removed very easily, however, by application of heat. Light a match and hold the flame to the old patch until it gets hot all over. It will then come off easily without tearing the tube.—Wilton Elwick, Collinsville, Ill.

Lock for the Outboard Motor

Because of its market value and ready portability, an outboard motor is tempting loot for the sneak thief. A simple and effective locking device to foil him can be made as shown in the drawing. The clamping wingnuts on most motors have holes drilled in them. Get a steel rod of such diameter that it can just be slipped through the holes, and about 4 or 5 in. longer than the distance from the center of one wingnut to the other. The rod is bent over at right angles near one end and an eye formed, of about the same size as the wingnut hole and alining with

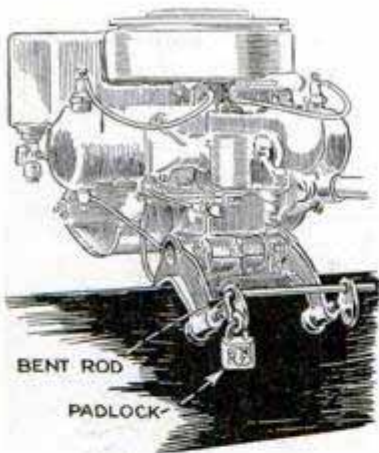

one wingnut hole, so that a padlock can be inserted through both. Besides making it nearly impossible to remove the motor from the boat, if the clamps are securely tightened, the

rod will prevent the clamps from loosening by the vibration of the motor.

Use of Proper Sand in Mortar

In brickwork, the thickness of the layer of mortar determines to a great extent the size of sand to be used. Customarily the thickness of mortar between bricks in standard bricklaying practice is from $\frac{1}{4}$ to $\frac{3}{8}$ in., and the sand used should pass through a No. 12 sieve. Finer or coarser sand is used for thinner and thicker joints.

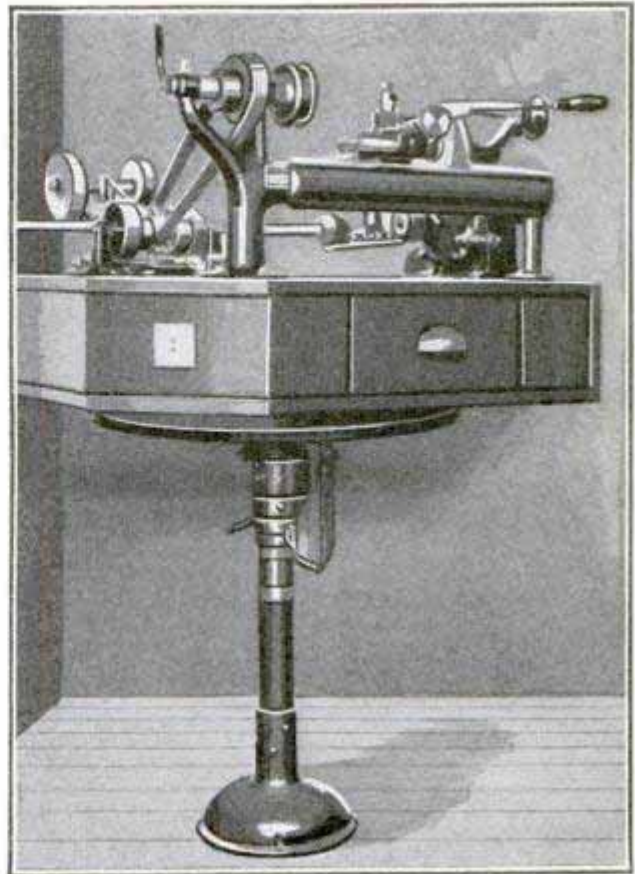
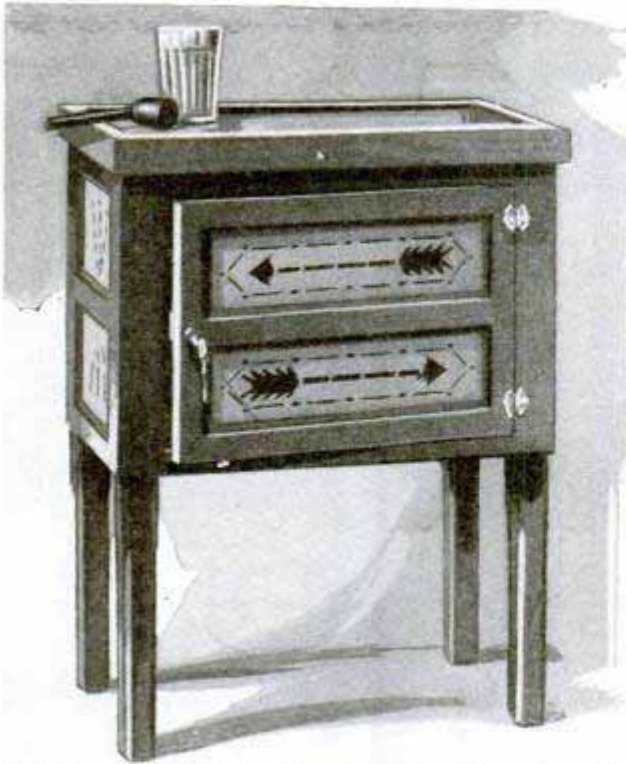

Table Holding Small Lathe, Grinder and Buffer Can Be Rotated to Obtain Good Light

Revolving Table for Small Lathe

My small lathe, grinder and buffer are mounted on a revolving table, permitting the tools to be turned around in any position in order to get the best light possible when working with them. The table top on which the tools are conveniently mounted is about 6 in. high and is fitted with several drawers. The revolving base on which the table is set consists of a rear-axle housing of an auto securely bolted to the floor, and a 24-in. wooden disk arranged to revolve on the top but fastened so that it will sustain considerable weight. The table holding the tools is then set on the disk and balanced, after which it is bolted down. Very little effort is necessary to turn the table in any desired position. In this particular instance no separate cord was run to the motor on the table, but a commutator arrangement was used to make constant contact while the table is being turned.—Richard Ton, Inglewood, Calif.

When cutting threads on wrought iron or steel, either in the lathe or with a die, use plenty of lard oil as a lubricant.



Old Pieces of Furniture Can Be Made Like New with Sandpaper Overlays

Sandpaper Overlays for Ornamenting Novelty Furniture

There are various objects of novelty furniture and cabinetwork whose appearance can be greatly improved by sandpaper overlays applied to the surface. A sample of such work is shown in the photo. Coarse sandpaper is used and designs are cut out to make the paper resemble a stencil. The surface of the wood under the cut-out sections is first painted or lacquered in suitable colors, which can be made highly glossy for contrast, and the sandpaper is then glued on with the rough side exposed. Molding, which can be obtained in all kinds of shapes and sizes, is used to cover the edges of the paper. This method of ornament is especially useful on furniture made of cheap wood, or old pieces of which the surface is marred beyond refinishing. The sandpaper itself can be painted or lacquered also.—Claude West, Chicago.

Kink for the Trout Fisherman

The trout fisherman will save himself many a ducking and an occasional bruise by wrapping a length of chain, having small pressed links, around the feet of his fishing boots. The chain will prevent slipping on wet, moss-covered rocks.

Cleaning Photographer's Flash Lamp

A photographic flash lamp will function properly only when it is kept clean and free from burned-powder residue. The cleaning is usually rather difficult because the powder clings like paint. An easy method of doing it is to submerge the lamp in boiling water, remove it while still hot and immediately sink it in cold water. The sudden expansion and contraction of the metal will instantly loosen the burned powder. This method is quite effective and will not injure the lamp.

Remote Control for Light Socket

When a long cord is used as a remote control on a chain-pull socket, an installation often found in hallways and stairways, the cord is usually passed through one or more screweyes to a convenient location. The objection to the usual installation, where the cord must make right-angle turns, is that there is quite a bit of friction between the cord and the screweyes, which wears out the cord quickly and also makes it rather difficult to turn on the light. A better installation is shown in the drawing. In this case it was necessary to make two right-angle turns with the cord. Three separate lengths of cord are used. One length is tied to the socket chain and to a screw-eye, where the first turn must be made; the second length is tied to the first cord and second screw-eye, while the third length is tied to the second near the second screw-eye, as indicated in the drawing. In this way a side pull is exerted on each cord, this having

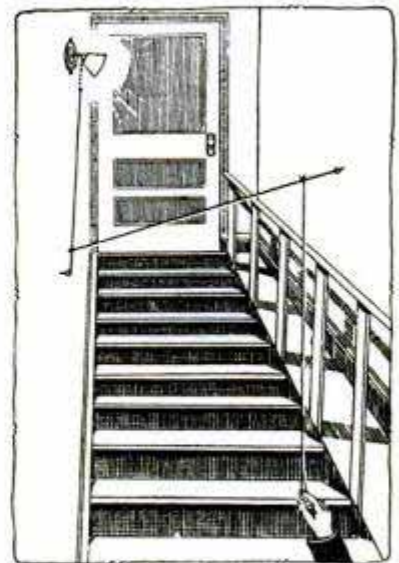

the same effect as an end pull without the objectionable feature. The drawing, of course, is merely illustrative.—Carl G. Langland, Minneapolis, Minn.

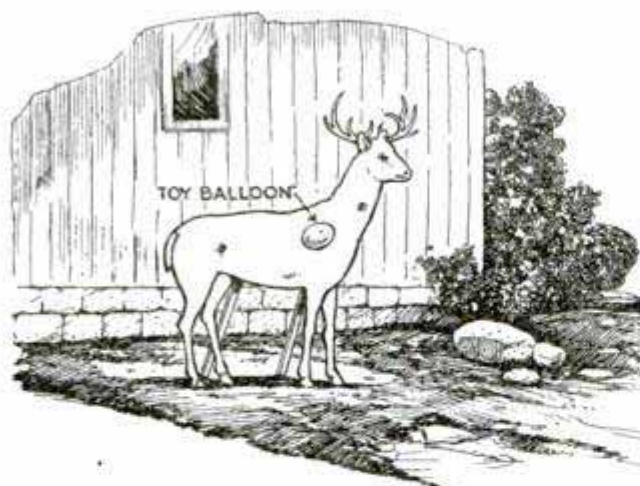

Archery Practice Is Made Much More Interesting If Wooden Figures of Animals Are Used as Targets

Animal Target Adds Interest to Archery Practice

Much more enjoyment can be derived from archery practice if there is something to shoot at besides the conventional round target. With very little expense and work, realistic-looking animals can be cut from $\frac{3}{8}$ -in. plywood, a material that is very strong and able to stand considerable abuse from the arrows. After being cut, the figures are painted in natural colors both for the sake of appearance and for protection against moisture, which otherwise would loosen and warp the plywood in a short time. Narrow parts, such as the neck and legs, should be reinforced with 1-in. strips on the back. Braces, made of 1-in. stock, are hinged to the top

of the figure, and when these are pulled out, the target rests against them at a slight angle to the ground, preventing an ordi-



nary breeze from blowing it over. The vital spots of the animal may be marked in order to add extra zest to the game. In one case, a toy balloon was blown up and pushed into a hole cut in the figure to represent the heart. Upon being struck with an arrow, the balloon burst with a bang.—C. Homewood, Hollywood, Calif.

Emergency Wood Grate for the Furnace

When coal cannot be obtained, or it is desired to burn wood for any other reason, the grate bars of the furnace must be sufficiently close together to prevent the burning embers from falling through into the ashbox. In my coal-burning furnace, the grate bars were too far apart, and, to remedy this condition, I cut a circular piece of heavy galvanized screen, the kind used for ash sifters, making it slightly smaller in diameter than the diameter of the firepot just

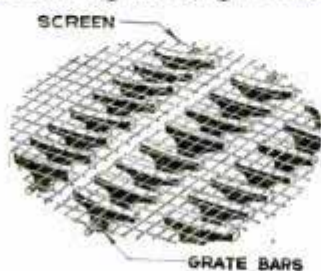

above the grates. After cutting the piece in half, so that it could be passed through the furnace door, I laid it on the grates as shown in the drawing, and found that it kept the wood embers from sifting through, and at the same time permitted the necessary draft.—L. B. Robbins, Harwich, Mass.

Rubber Mat Protects Door

Children often kick against doors when opening them, which mars the finish. To prevent this, a neat rubber mat can be tacked on the bottom of the door. The mat can be obtained from a five and ten-cent store, and will not spoil the appearance of the door.—Chas. Latour, Jr., Plattsburg, N. Y.

Camper's Canoe Helps to Make Shelter

Any canoe, set bottomsides up and covered with a large piece of canvas, as shown in the drawing, can be used to make a sturdy and

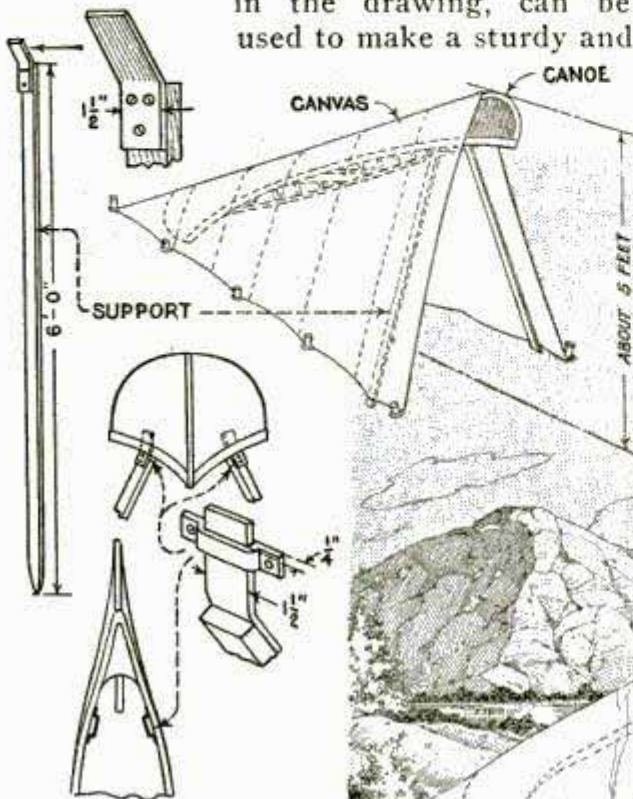

roomy shelter, eliminating the necessity of carrying a separate tent and thus reducing the weight of the camping outfit considerably. Two 6-ft. poles of $\frac{3}{4}$ by $1\frac{1}{2}$ -in. stock, preferably

hardwood, are used to raise one end of the canoe about 5 ft. above the ground. The lower ends of the supporting sticks are pointed. To the top ends $\frac{1}{4}$ -in. flat-iron tongues are attached; these fit into brackets made of the same material, and screwed to the inside of the gunwale or

rail near one end of the canoe. The tongues should be a sliding fit in the brackets so that they can readily be inserted and removed and they must be slightly bent so that the supports will spread about 5 ft. apart at the ground. After this adjustment has been made, a heavy screw-eye is driven into each support, near the top,

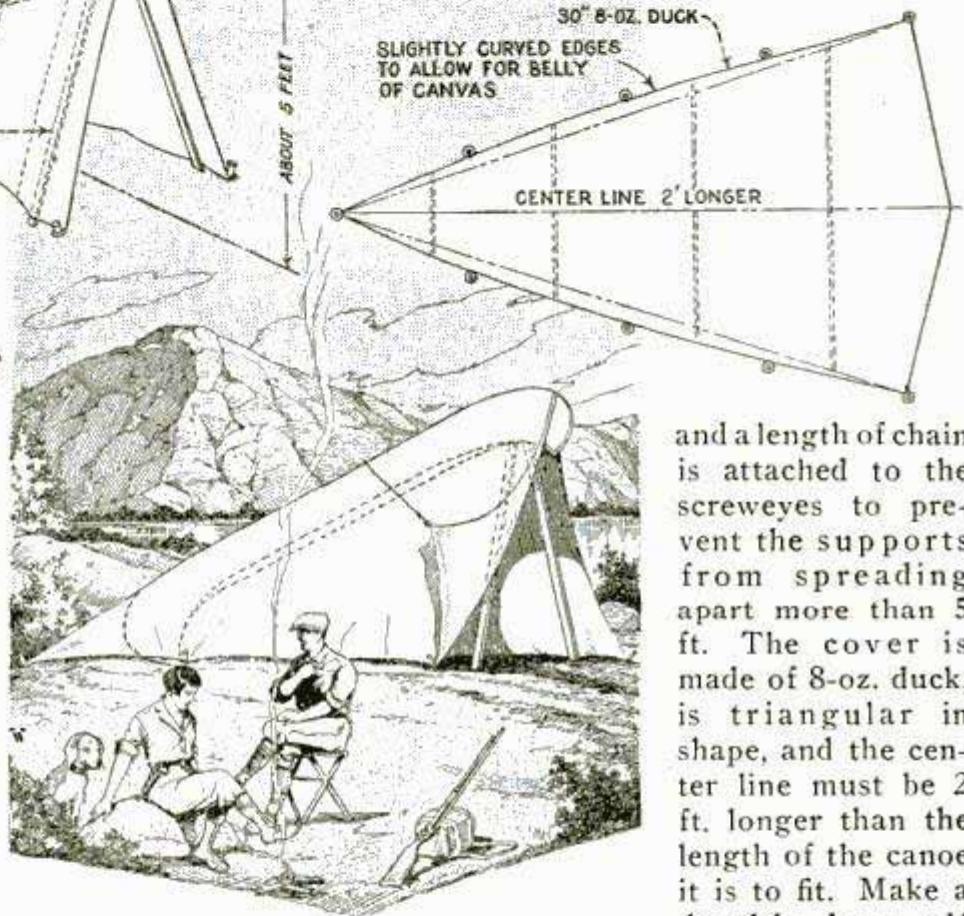

Large, Triangular Piece of Canvas Staked Down over a Canoe, Makes a Sturdy and Roomy Shelter for the Camper and Eliminates the Need of a Separate Tent

and a length of chain is attached to the screw-eyes to prevent the supports from spreading apart more than 5 ft. The cover is made of 8-oz. duck, is triangular in shape, and the center line must be 2 ft. longer than the length of the canoe it is to fit. Make a double hem all around the edge and sew in four

rope loops on each side, spacing them apart at equal intervals. Throw the canvas over the canoe and stake down as shown. Nothing short of a real hard gale will blow this shelter over, and the occupants will be kept entirely dry.—L. B. Robbins, Harwich, Mass.

Selecting House Plants

House plants, like pets, undoubtedly do much to keep the home more cheerful during the winter months, but they have to be chosen with regard to their ability to withstand indoor conditions. These, in modern homes and apartments, are none too good for humans, and pretty hard on

plants. The best method of meeting the situation is to choose plants that can stand draft and, if possible, also endure having their roots flooded and deprived of air occasionally. Some of the old favorites, like geraniums and oleanders, are of this kind. The native home of the oleander is in Mesopotamia, where it is accustomed to standing with its roots in

river mud and its leaves in air that would discourage anything short of cactus. In general, you can guess whether or not a prospective house plant possesses this kind of hardiness by looking at its leaves. If they are well covered with hairs, like the leaves of a geranium, or if they are thick, hard and have a polished waxy or horny surface, like the leaf of an oleander, they can probably endure the conditions found in our homes and apartments. Primulas and some of the begonias belong to the former class, while the Jerusalem cherry, and the Boston fern belong to the latter. Their leaves hold out against drouth because they save the water in the plant by cutting down the evaporation loss. Another of nature's methods of reducing evaporation is to limit the number of leaves. The cactus does away with leaves altogether, and the Christmas thorn and the poinsettia, both of them desert-dwelling euphorbias, develop leaves but sparingly. The century plant and aloe keep their leaves but make them thick and stemlike, and at the same time build up water-storing pulp, cactus-fashion, within them. Other plants meet the water-shortage peril by storing the indispensable fluid in their bulbs or corns, calla lilies, amaryllis, tulips, narcissi and jonquils being examples of this group.

Compressing Hose Clamps

For compressing hose clamps in order to enter the screw, a simple jig can be made from a common strap hinge. It is bent to the shape shown in the photo so that the ends will have a viselike grip on the clamp. A small notch is filed on each edge to keep a rubber band in position, the band serving to hold the jig in position against the hose clamp. The hinge is then placed in a vise which is used to compress it. It takes only a few minutes to make this device which will be of considerable utility.—F. W. Bentley, Jr., Missouri Valley, Iowa.

Ordinary Strap Hinge Bent to Make a Device for Holding Hose Clamps

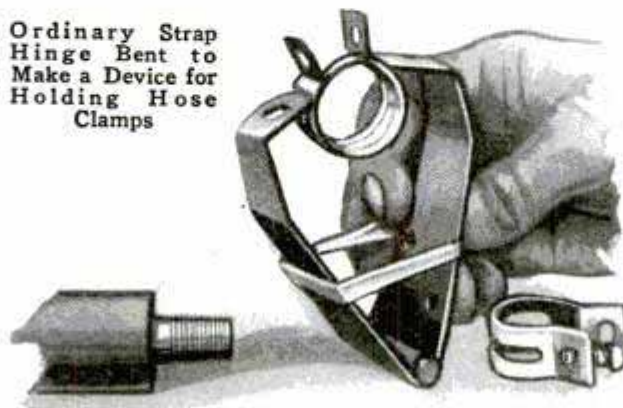

Section of Old Inner Tube on Radiator Spout Protects Finish

Splash Guard Protects Auto Finish

Lacquer finishes on auto radiators are quickly attacked by anti-freeze solutions containing alcohol. To prevent damage from such liquids, provide a rubber splash guard cut from an old inner tube. It should be a square piece, as large as possible, with a small hole that will fit tightly over the filling spout of the radiator, as shown in the illustration. The natural curl of the section of inner tube forms a sort of trough which will guide any liquid spilled and allow it to drip off on the ground.—G. A. Luers, Washington, D. C.

Old Inner Tubes Used for Tractor Hose

During the harvest season, the water hose of our tractor became so badly rotted that it was impossible to retain water in the cooling system. To make a quick repair, we cut the hose in two about midway between the ends and slipped a length of 3-in. inner tube over the cut to form a sleeve. Twine was wrapped around the ends, and the improvised repair held out the entire season without any leak.—Geo. G. McVicker, North Bend, Nebr.

Stunts for



"YEAH, but who goes to parties?" The answer is: "Everybody." It may be a full-dress affair with all the trimmings, or maybe just a quiet foursome in Joe's back room, but everybody goes to parties. The only fellow who is a total abstainer is the wooden cigar-store Indian, and, today, "there ain't no sech animal!"

Try this one: It's quite simple; you merely kick at a matchbox. And how! Mark a line out on the floor. Take a matchbox and place it in front of you, on the floor, just exactly three lengths of your foot from this chalked line, as shown in Fig. 2. Now, toeing this line, and standing on one foot, can you kick the box of matches with the toe of the other foot, as in Fig. 1? Maybe you can do it, maybe not!

①

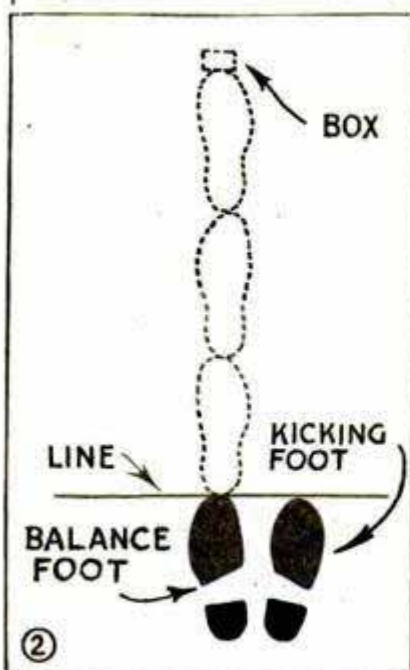

Diagram of Box-Kicking Stunt

Rules for this stunt do not allow you to score if you lose your balance; neither do you score if you change the position of the balancing foot. Try it! If the next morning finds you with a crick in your back, forget it. You ought to be in better shape, anyhow.

After the bridge game breaks up, try this little stunt of "In your hat." Here's the idea: You place a hat, open side up, on the floor several feet distant from where you sit. The trick is to toss the cards into the hat, as pictured in Fig. 4. At first sight, this may look like a simple little bit of byplay, but, get the bunch started and watch the fun. Score is kept by counting the number of cards "hatted" by each player, and the low-score man is "permitted" to pick up the cards at the completion of each round. Here's a tip: If you will hold the card by the upper left-hand corner between your first and second fingers, as shown in Fig. 3, you will find your aim considerably improved.

Your Party

by
SAM BROWN

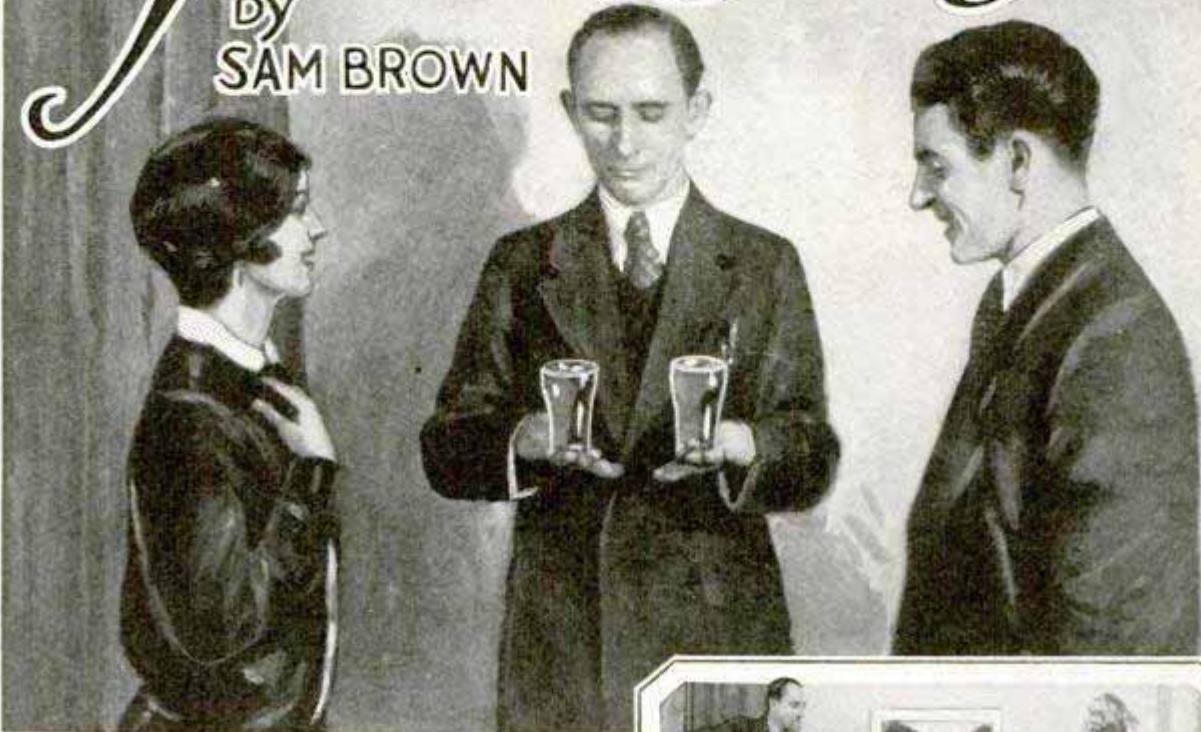

If at any party there comes the "felleh" you would gladly push into the river if nobody were looking, try to inveigle him into this: Tell him you can tell whether he is of the same dominating type as Jack Dempsey, Lindbergh, or Barney Google (thumbs down and take your choice) by a very simple expedient. This expedient calls for two glasses of water. Ask the friendly enemy to hold out his hands, fingers extending and palms down. Now, place the two glasses of water on the back of his fingers, one on each hand, as shown in Fig. 5. Tell him he must look very serious for ten seconds and look into the glasses.

Of course, he does this easily and smiles at you triumphantly. But, it's a short-lived grin! It rapidly changes into a sickly smile and then a look of utter dismay as he becomes aware that everyone is withdrawing from his vicinity, leaving him to wonder "how in heck" he is going to put the glasses down. His dilemma furnishes considerable amusement for everybody. Of course there is a way in which he can set down the glasses. But figure it out for yourself!

The next one is a "chestnut." In fact, it's so old that it is practically unknown to the younger generation.

Here's the layout: Get a bottle and place it, on its side, on a table. Put a cork in the mouth of the

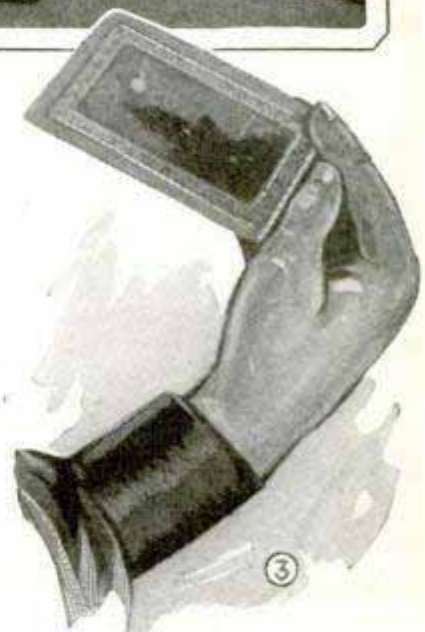

Best Way of Holding Card

bottle, this cork being considerably smaller than the bottle's mouth. Wager anyone that he cannot blow the cork into the bottle by blowing from his mouth directly upon the end of the cork, as pictured in Fig. 6. "Zat so?" he grunts, and the fun begins.

Actually, the stunt is an impossibility to anyone not in the know. It will be found that the cork stubbornly refuses to enter the bottle, and instead, flies out with some force into the face of the blower. This is due to the pressure of the air from



the inside of the bottle, which cannot escape around the cork owing to the external pressure of air caused by blowing. Well, then, how ya gonna blow the dern thing in? Simple! Merely take a soda straw, or roll a piece of paper to form a tube, and with this tube direct your breath so that it strikes the exact center of the cork, as shown in Fig. 7. It will then be found that the cork will be forced into the bottle, the displaced air escaping without obstruction.

The next little conceit is pretty rough business. At least they think so in the army. Get a curtain ring and tie it up somewhere with a piece of string. Hand a spectator a cane, yardstick, or what have

you, and ask him if he can advance steadily on the ring from a distance of about ten feet and run the end of the stick through the ring. Believe it or not, it takes a good eye. What's that? Oh, yes, in the army they do it with a long lance, and on horseback, and the ring is a large hoop, and they ride full tilt. If that makes any difference.

Can you do this one? Look at Fig. 9. You see a matchbox cover on top of a matchbox drawer. The thing is: Can you change the relative positions of these two parts of the matchbox, that is, place the drawer on top of the cover, and all this by using the thumb and forefinger of one hand only? Think it over. Give up? All right: Merely bend over, and place your mouth squarely over the end of the matchbox cover, as shown in Fig. 10. Inhale sharply. The resulting vacuum will cause the drawer to cling to the cover with sufficient tenacity to enable you to quickly raise it to an upright position, as shown in Fig. 11. In this position, you take the cover with the thumb and forefinger of your right hand—one hand only, mind

you—and then triumphantly return it to its place on the table. It's as simple as all that!

Here's something else: Tie a small ball, ring, or anything else that is handy, onto the end of a piece of string.



This should be done beforehand so that you can take the equipment from your pocket and announce, very gravely, that this key and string is possessed of a very magical property. This magical property has to do with the detection of males and females. The whole procedure calls for the subject taking a sitting position on a chair. He (or she) is then requested to look up at the key, which the performer holds suspended directly above her nose, as in Fig. 13. If the key swings backward and forward, it is "talking" to indicate that the subject is a lady; if the key swings from side to side, the subject is a gentleman. There is no visible movement of the performer's hand, and the divination is absorbingly mysterious.

As for the secret—there isn't any! The key actually swings the way you want it to! You merely think "backward and forward," running your eye from one end to the other of an imaginary line in this direction, and the key, slowly at first and then with increasing momentum, will swing in unison with your



lecting aces, deuces, treys, etc. Two people play the game and each has one set of five cards. The first player places a counter, which may be a poker chip, a coin or anything else that is handy, on one card, say the four. This scores 4. The second player places his counter on any card of his set, let's say the 5. This is added to the first figure, making

the second player's score 9. The first player then moves his counter to another card, the 1, and this is added to the 9, making the total score, so far, 10. The big scramble is this: The player who first scores 40, or who forces his opponent to score more than 40, wins the game.

thoughts. There is no visible movement of your hand—it is apparently made of iron—yet the unconscious muscular vibrations are of sufficient strength to sway the magic pendulum.

Here is one kind of game that everybody likes to play—you can win every time! Place two sets of five cards on the table, each set numbered from one to five. Ordinary playing cards will answer, se-

Now, for the big swindle. How can you win every time? Like this: You start the game, always playing the 4. The key numbers that you must plan to reach after the initial play are 10, 16, 22, 28, 34 and 40, which are all multiples of 3, plus 1. You may let your opponent start, if he or she insists, but as soon as possible you should make your play so that your score, when added to the previous total, will fall on

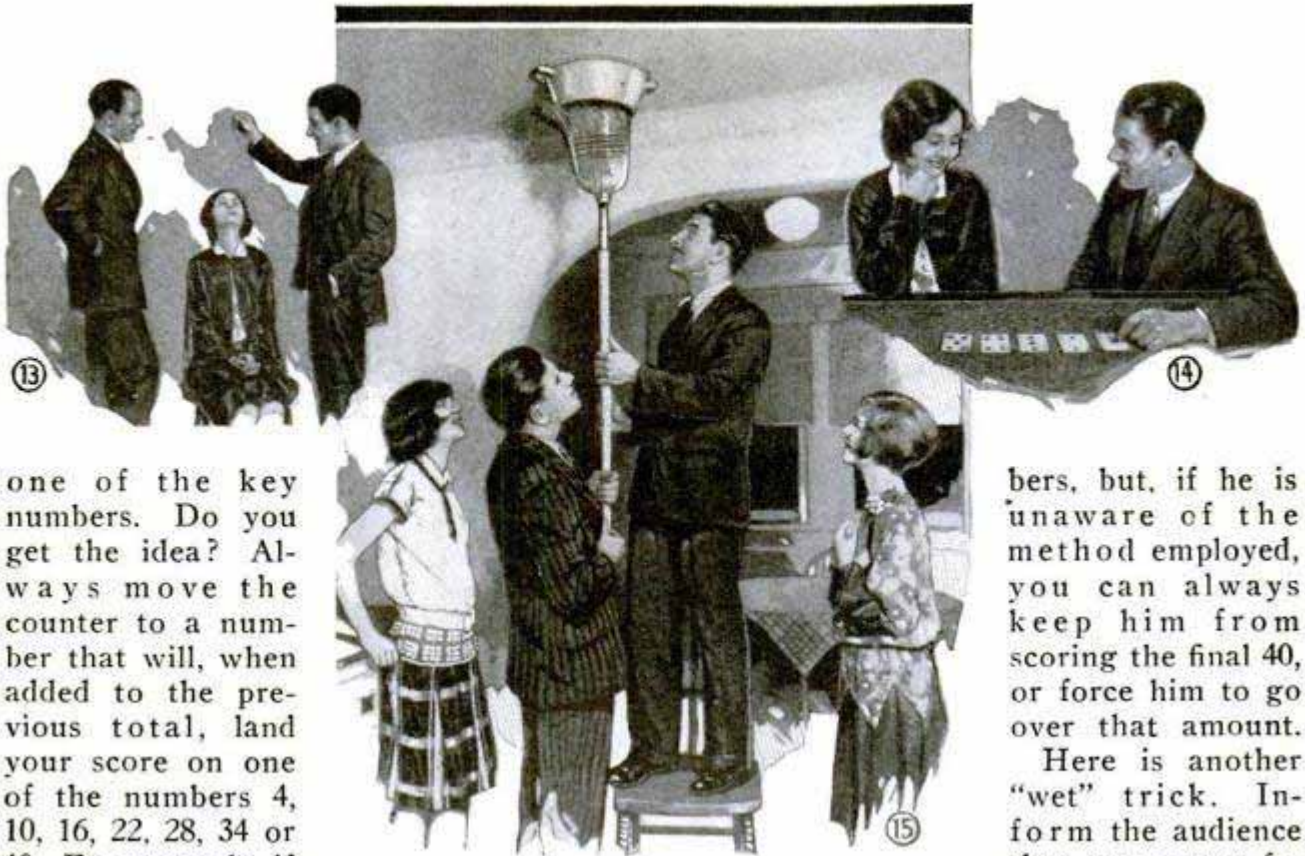

one of the key numbers. Do you get the idea? Always move the counter to a number that will, when added to the previous total, land your score on one of the numbers 4, 10, 16, 22, 28, 34 or 40. For example, if he starts with 5, you play 5 also, and your score will be 10. If he, in his haste to reach the final score, plays the 4 (the counter must be moved for every play), making his score 14, then you play a 2 and land on the 16. Your opponent may beat you to a possible two out of the key num-

bers, but, if he is unaware of the method employed, you can always keep him from scoring the final 40, or force him to go over that amount.

Here is another "wet" trick. Inform the audience that you are a famous juggler. You'll get nothing but shouts of "prove it!" Take a mental note of the "felleh" who hisses the loudest; it comes in handy later. Now, what you propose to do is to balance a basin of water on the end of a broom handle. To get this difficult maneuver under way, you take a chair, and, standing on this, press the basin of water to the ceiling of the room. The broom handle is then centered squarely against the bottom of the pan, so as to hold it against the ceiling, as shown in Fig. 15. The performer then asks a spectator (remember that fellow who hissed the loudest?) to hold the stick while he gets down from the chair. This is done, and the chair is removed.

And there you are! A certain party gradually becomes aware of the fact that everyone is watching him intently. This "certain party" is the man holding the stick—with the pan of water at the other end. He may think this absorbed attention rather strange at first (he isn't doing this juggle, is he?) and then, suddenly, he realizes that without help he cannot get the pan down from the ceiling.

Believe it or not, his facial expression is worth watching. Of course, someone may eventually come to the holder's assistance. Needless to say, this is not ab-



solutely essential. It makes a magnificent trick the other way. After the water is spilled, somebody mops it up good-naturedly, and all is well again. Very few murderers are convicted, in any case. Somebody suggests that you do the stunt in the kitchen!

A Locking Tool-Box Handle

A handle for the tool box, which will save considerable time, can be made of heavy flat iron, as shown in the illustration. It can be made of two separate lengths with a wooden grip between them as indicated, or if desired, it can be made of one length of flat iron bent to a U-shape. The sides of the handle are drilled and slotted as shown and are pivoted on two screws driven into opposite edges of the lid, so that, when the lid is swung back, the handle goes with it as in the lower detail. Notches, filed lengthwise in the ends of the handle, allow it to be slipped over another pair of screws, also driven into the edge of the lid. In this position, the handle is used for opening and closing the lid. When it is necessary to use the handle to carry the box, the lid is closed and the handle is disengaged from the screws just mentioned, after which it is brought to a vertical position. This action causes



two notches, which are filed half way across the width of the handle and at a slight angle, to engage with a third pair of screws driven into the sides of the box at a point in line with the notches. The handle always clamps the lid securely down on the box when the box is carried, preventing the loss of tools and equipment.—G. A. R. Peterson, Alma, Kansas.

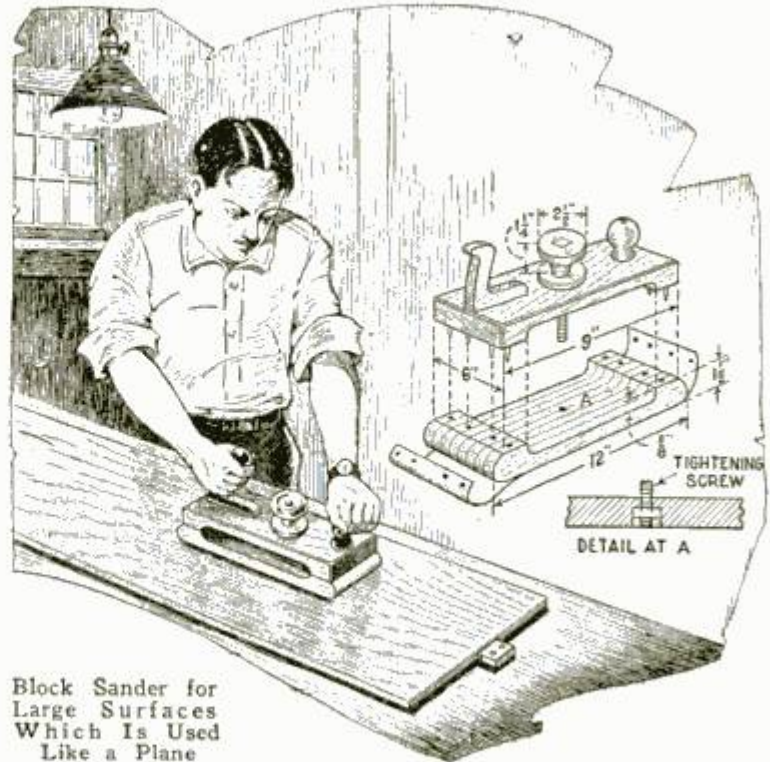

Block Sander for Large Surfaces Which Is Used Like a Plane

Sanding Block for Large Surfaces

Using a piece of sandpaper on an ordinary block of wood is rather inconvenient as one must hold the paper against the edges of the block, and must exert a downward pressure at the same time. Anyone who has to sand large surfaces occasionally will therefore appreciate the sandpaper plane shown in the illustration. It consists of two sections between which the paper is clamped securely. The lower section is made up of a number of pieces of 1-in. material, preferably maple, nailed and glued together, or it can be made from a piece of 2 by 6-in. stock. The upper section is made the same size, the dimensions being given in the drawing. To insure a tight grip on the sandpaper, a number of nails are driven through the upper piece in a row, near each end as indicated, so that they will project on the underside about $\frac{1}{4}$ in. The two sections of the sander are then pressed together and tapped with a hammer to drive the nail ends into the lower part, a piece of sandpaper being inserted between them. A tightening screw is provided in the center and regular plane handles are attached to the top piece. The old paper can be removed and a new one inserted in a few seconds.—W. Clyde Lamme, Downers Grove, Ill.

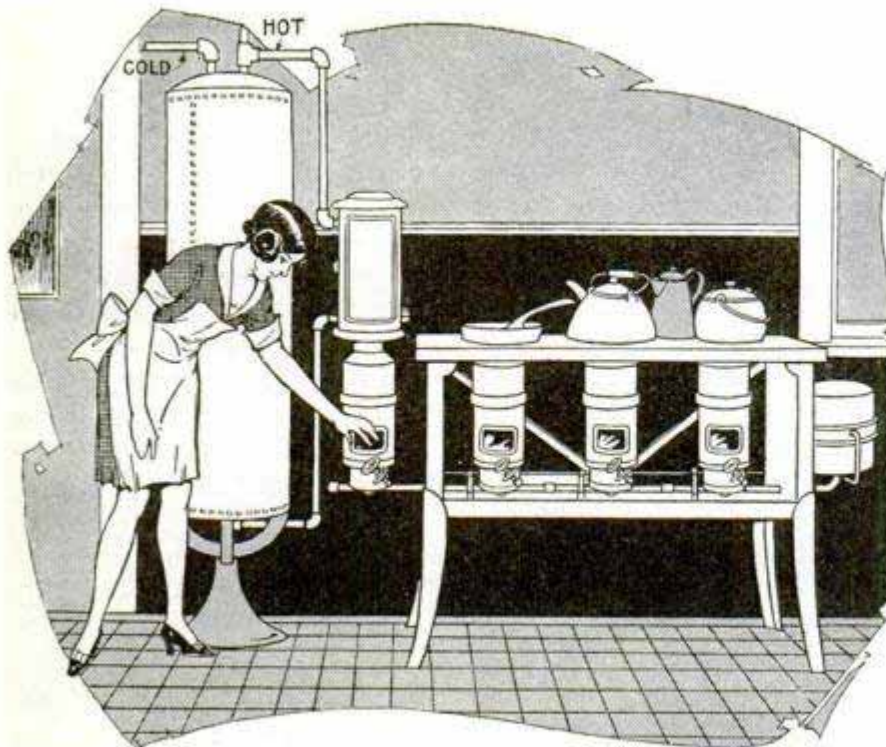

Extra Burner on an Oil Stove Used to Heat Water Coil in the Range Tank during the Summer

Water-Heating Installation for Oil Stove

In our home we have running water but no gas. The kitchen-range boiler has always given plenty of hot water during the winter, when the range was in use, but until we connected a heating coil to it and installed an extra burner on the oil stove to heat the coil, it was entirely useless during the summer. The oil stove was placed so that the extra burner would be located directly under the heating coil. The effect is the same as a gas heater, except that it is slower. It is an easy matter to attach an extra burner to the stove: Remove the cap from the pipe, substitute a coupling and then screw in a section of pipe taken from a discarded burner. The pipe is cut and threaded to fit and the cap is replaced on the new end. A suitable method of bracing the extra burner is also easy to improvise, if braces are needed. —A. C. Dayton, Cheshire, Conn.

Patching Dents in Boat Hulls

Red lead and Portland cement mixed, half and half, with oil to a putty consistency, form an excellent patching material for holes, up to the size of a silver dollar, in boat bottoms. The edge of the hole should be dry, rough, and pegged with small galvanized nails, projecting slightly to reinforce the cement. The patch hardens very slowly, hence it is best to do this work in winter, or while the boat is out of commission. For a quick repair, cement and water is fairly satis-

factory. It is then unnecessary to have the wood dry, and the boat can be put to use again, without danger to the patch, in about two days.

Thief-Proof Wiring Arrangement for Electric Lock

The diagram shows a wiring system for operating an electric lock by means of a block of push buttons, three of which, wired in series, open the lock, while all the others will ring an alarm bell when depressed. One not familiar with the key will not tamper with the switches, as the bell indicates his presence and causes him to depart before the owner appears. The switches should be arranged on a hardwood, metal or slate panel attached to a wall, both panel and wall being drilled for the wires so they cannot be tampered with and the panel bolted through the wall, if possible.—W. J. Murrow, Macon, Ga.

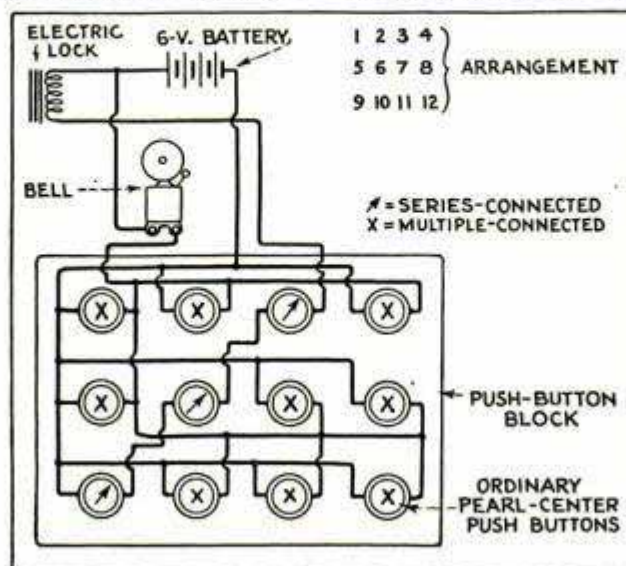

Wiring Arrangement for Operating an Electric Door Lock and Alarm Bell

One-Man Winder for Model Planes

By HI SIBLEY

THE ONLY proper method of putting power in a model airplane is with a mechanical winder, but this requires an assistant. There are, therefore, some disadvantages in that. Sometimes the experimenter wishes to try out a new model alone; again, assistants are not always available, especially in the early morning when air conditions are good.

The simply made winding frame described here will enable one pair of hands to do a more uniform job of winding than two, and should be a part of the amateur's regular equipment. A glance will show how easily it is made.

Start with the main frame member, Fig. 1, using material about $\frac{3}{4}$ by 1-in. wide. The length depends entirely upon the size of the plane you expect to use. We will assume we are building the frame for a standard commercial type with a 30-in. fuselage. In this case, the long frame

same width as the piece it rides on. Guides made of sheet metal, screwed to the top, allow it to slide along the main frame.

At the front end of the carriage, attach a slotted piece of flat iron, bent in the manner shown, to support the propeller when winding. This carries all the load, a V-block supporting the rear of the fuselage merely to keep it in line. There is no strain whatever on the fuselage. Note that the V-block, detailed in Fig. 2, is slightly offset so that rubber strands will clear the tail structure while winding.

In a convenient position for the thumb of the left hand, which holds the frame, install a brake for the cord shown. This brake is simply a piece of hardwood cut to the shape indicated in Fig. 2. A rubber band acts as a spring to keep it free when not required, and a slight pressure of the thumb clamps the wood against the cord. For the latter, use a stout cord

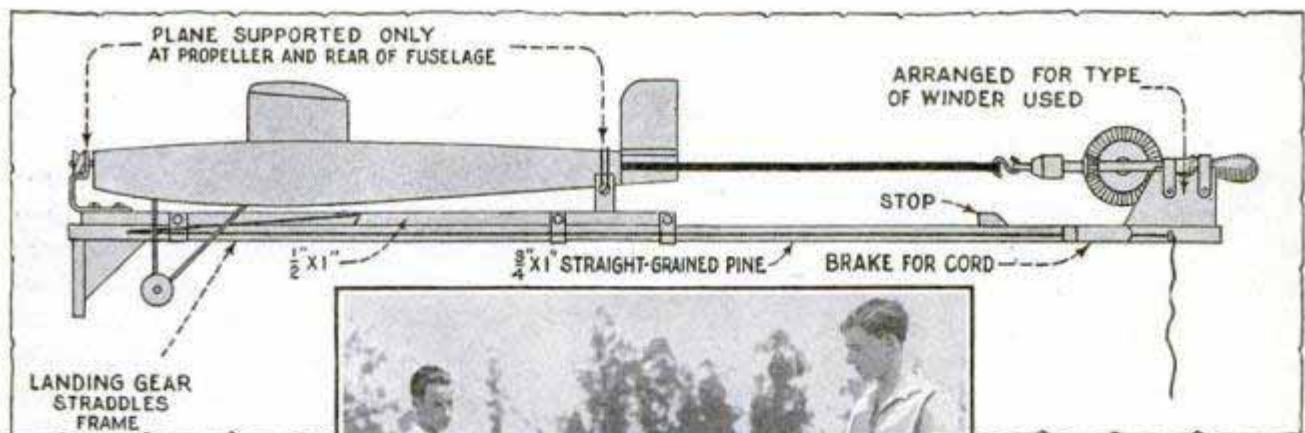

Fig. 1

piece should be about 6 ft. 10 in. in length, so that the rubbers can be stretched about two and a half times their normal length in winding. A straight-grained piece of spruce or pine is ideal for this. The carriage for the plane should be about the same length as the fuselage and need be only $\frac{1}{2}$ in. thick, but the



The Simple Mechanism in Fig. 1 Enables Builder to Wind Motor Single-Handed

similar to a mason's chalk line. Lead the cord from a screw-eye in the carriage, forward through one in the frame, then back to the rear and under the brake.

If a hand drill is used in connection with this frame, the shape of the block shown will serve to hold it in position. For the egg-beater winder the block must be altered a little

This Drawing Shows How the Model Winder Is Operated; the Plane Is Allowed to Move toward the Operator as the Motor Is Wound Up

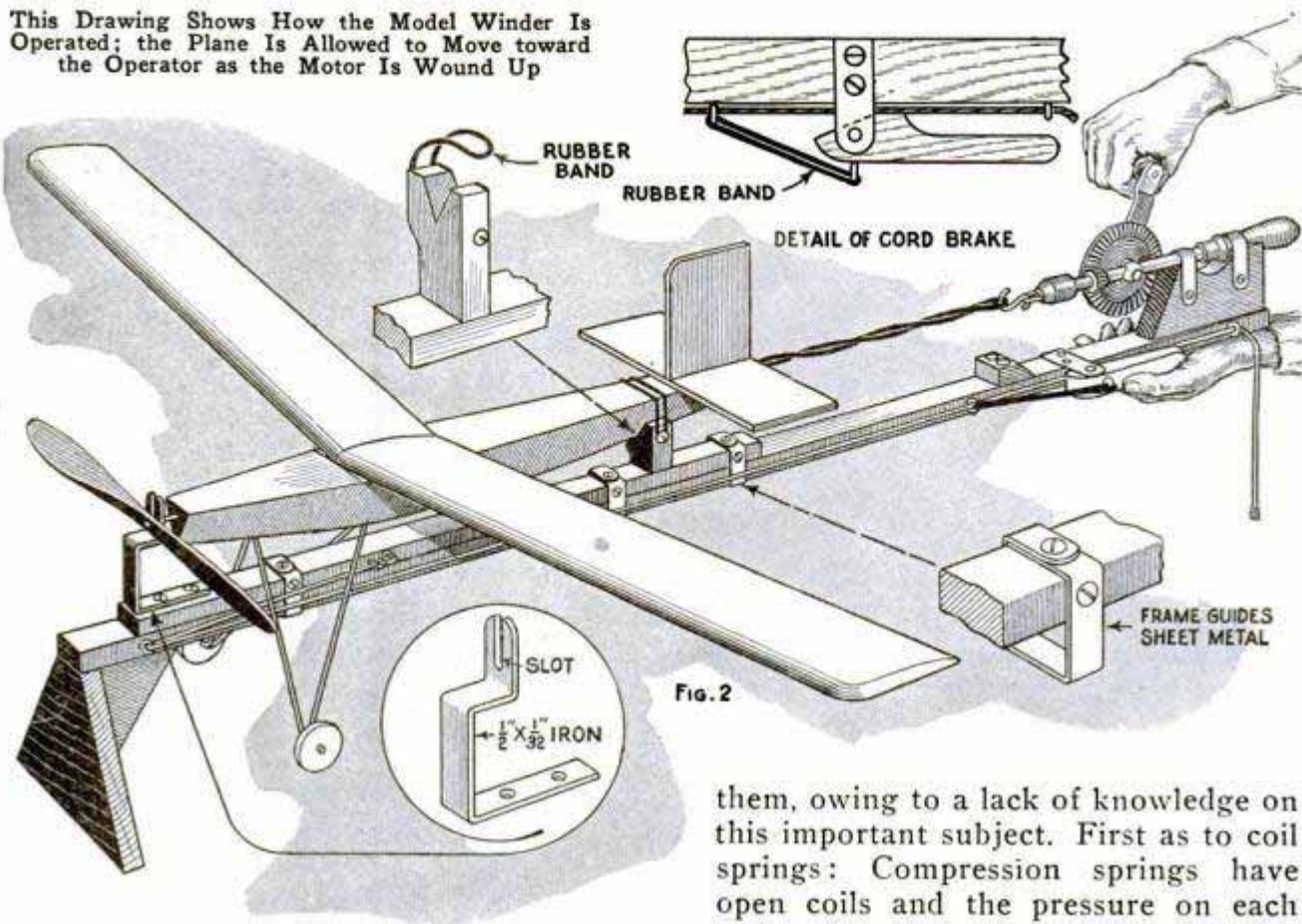

Fig. 2

in size and shape. A triangular block under the front end of the main frame rests on the ground when not in use and eliminates tendency to twist sideways.

To wind the motor, slip the propeller shaft into the slotted support and secure the fuselage by drawing a rubber band over the V-block, before detaching the S-hook. Now adjust the distance between winder and tail to your satisfaction, clamping it in the position temporarily by giving the loose end of the cord a couple of twists around the end of the frame. Next attach the S-hook to the winder, press the left thumb on the brake and begin winding, at the same time gradually paying out the cord by pressing so that the plane moves toward you. This will insure a more uniform job than could be done with the aid of an assistant. A stop on the frame keeps the tail of the plane from striking the winder when the carriage is back all the way.

Making and Using Coil Springs

The experimenter or mechanic often spends time trying out springs that could not possibly do the work expected of

them, owing to a lack of knowledge on this important subject. First as to coil springs: Compression springs have open coils and the pressure on each end is toward the center. Tension springs have their coils wound close together; the working pressure on their ends is away from the center. A compression spring of greater strength is made by increasing the size of the wire; making fewer coils per inch of length, or decreasing the outside diameter of the coils. When this kind of spring is compressed, its outside diameter is slightly increased. Where a spring fits in a hole, this should be allowed for. A given weight will compress a long spring more than a short spring, otherwise of the same dimensions. In building a mechanism with a spring that is to be compressed, see that in the extreme closed position there is room left for the spring itself. A stronger tension spring is made by increasing the size of the wire, or by decreasing the outside diameter of the coils; and a weaker one by changes in the opposite direction. A compression spring of fair quality may be made from a tension spring by spreading the coils with a screwdriver. The loop on the end of a tension spring can be made, with pliers, from the end of the spring wire. Springs may be coiled from spring wire, brass or steel, or from piano wire. Spring wire comes an-

nealed or tempered; if the former is used, the spring has to be tempered after it has been coiled.

Chest for Men's Hats

Usually a man's hat is laid on a shelf or hung on a hook in the closet where it is exposed to dust and where it is likely to be knocked down, which results in soiling it and getting it out of shape. A chest of four or five drawers, each just large enough to take one hat, can readily be made by anyone handy with tools, or if desired, can be ordered from a cabinet-maker. The chest provides an excellent place for storing hats not in use. It keeps them out of the way but easily accessible whenever needed. Com-
modes of this type are supplied by one New York hat retailer, as a



convenience for his customers.—D. P. Hill, Long Island, N. Y.

Packard Woodside
Cure for Wet Distributor

An oilcan filled with gasoline is a simple cure when a wet distributor will not permit a car to start. The gasoline, squirted over the wires at the top of the distributor, spreads over them and the bakelite surface, displacing or insulating the moisture particles that do the harm. A very small amount is sufficient.—A. Stenson, Gardena, Calif.

Removing Coffee and Milk Stains from Clothing

To remove coffee and milk stains from clothing, proceed as follows: Make a solution consisting of glycerine, 1 part, ammonia, 1/2 part, and water, 9 parts. Apply it to the spot, using a small brush, and then immerse the stained part of the clothing in the solution for 8 to 10 hours.

Keep the Rifle Barrel Bright

One of the best methods of keeping a rifle barrel well oiled is shown in the drawing. Get a length of sash cord a trifle longer than the barrel. Tie a knot at one end and wrap several turns of silk thread around the other end, after which a small screw can be driven into this end. To the screw head tie a stout cord. Soak the sash cord in a good grade of oil and pull it through the barrel by means of the smaller cord. The sash cord should fit snugly in the barrel and will keep it in good condition even if not used for long periods of time.—Dale R. Van Horn, Lincoln, Nebr.

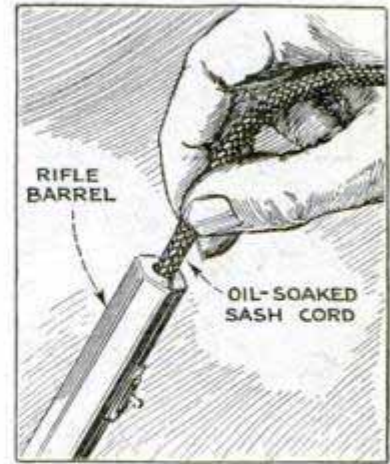

Air Filter for the Hot-Air Furnace

In some localities in cities where there is considerable smoke and soot, the illustrated air filter for the hot-air furnace will be found beneficial. This arrangement applies only to cases where the air is taken from the outside. All that is necessary is the provision of three screens, the frames being made of 1 by 2-in. strips of wood, and fitted with cheesecloth. Besides keeping out soot and dust, the screens will check excessive draft. They are slid in grooves made by nailing two slats parallel on each side of the fresh-air intake pipe, which is usually square and of wood. L. H. Georger, Buffalo.

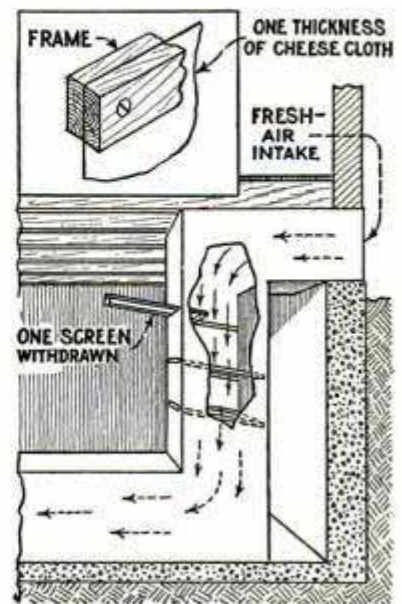

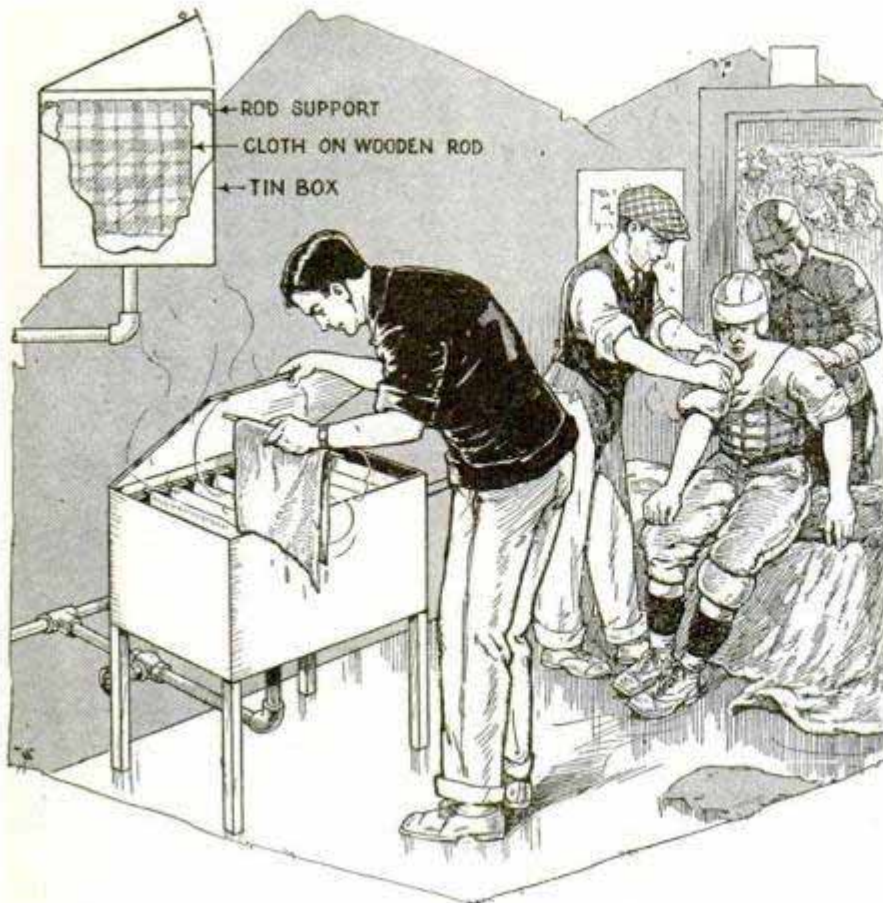

This Sheet-Metal Steam Box, Handy for the Preparation of Packs, Was Installed in the Football Training Quarters of the Wisconsin University

Steam Box for Fomentations

For the preparation of fomentations or packs used by football and hockey squads, the illustrated steam box has been used and is highly recommended by "Bill" Fallon, head trainer of the University of Wisconsin football and hockey teams. It is a sheet-metal box about the size of an ordinary cedar chest, set on a suitable stand made of angle iron, and connected to the steam-heating system as shown, a valve being provided to control the steam flow into the box. Wooden cleats are provided inside of the box to hold a number of wooden rods, cut from dowel stock. In use, woolen or flannel cloths are hung over the rods and the cover is tightly closed. When packs are

needed, steam is turned on and in a few moments the lid is lifted off, permitting the removal of a hot cloth ready to be applied to a sore muscle or stiff joint. The cost of making and installing such a box is less than \$10.00, and the operating cost is negligible.—Theodore S. Holstein, Madison, Wis.

Extra Propeller Pins for Outboard Motor

It is highly annoying to an outboard-motor enthusiast to have a propeller pin sheared off and then find that he has no spare pins with him. The shearing of propeller pins is a common occurrence, as the pins are purposely made of softer metal than

other parts of the propeller assembly so that they will shear off when the propeller hits an obstruction, thus avoiding damage to other parts. The installation of a new pin is only a moment's work, provided an extra is at hand. A convenient method of carrying a number of them is shown in the drawing. A small holder is made of sheet copper or galvanized sheet iron, cut and bent to the shape shown, so

as to form a number of cylindrical pockets, and soldered to the side of the fuel tank. The lugs are bent over to retain the propeller pins which are placed inside.—Dick Cole, Los Angeles, Calif.

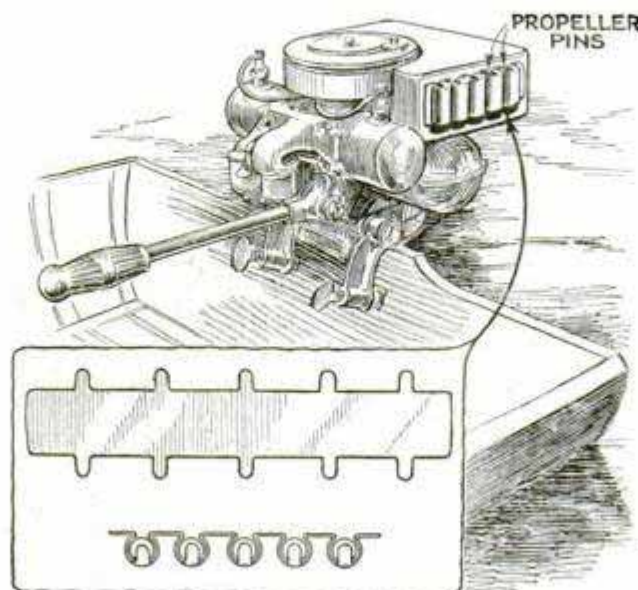

Container for Extra Propeller Pins Is Soldered to the Fuel Tank of Outboard Motor

ⓘ Instead of coiling the garden hose in the usual way, lay it down in the shape of the figure 8, and turn each successive coil the same way.

SHOP NOTES



All Shop Notes published in 1928, in book form—Fifty Cents—from our Book Department

Keeping Your Saws Fit

By W. CLYDE LAMMEY

ON MOST of the popular workshop saws, a combination rip and crosscut blade is regularly furnished. However, many owners still prefer separate blades for ripping and crosscutting, and it is true that the common ripping blade is considerably faster in the cut. Another excellent saw is that known as the "planer" blade, which is hollow-ground

and runs without set. While slow, it cuts extremely smooth and clean in either rip or crosscut. It is especially fine for trimming end grain and eliminates much hand work. While the essentials of filing the blades apply to the various styles of saw blades, there are certain exceptions to be observed in each particular case, such as the angle of the file, the coarseness of the

set, etc. As it is impossible to give rules covering all cases of saw filing, the amateur should give his blade a careful examination before he attempts to file it. In this way he will, if a keen observer, learn much about the method of sharpening the blade he has in hand. The form of the teeth, before they have been filed, is the best guide,

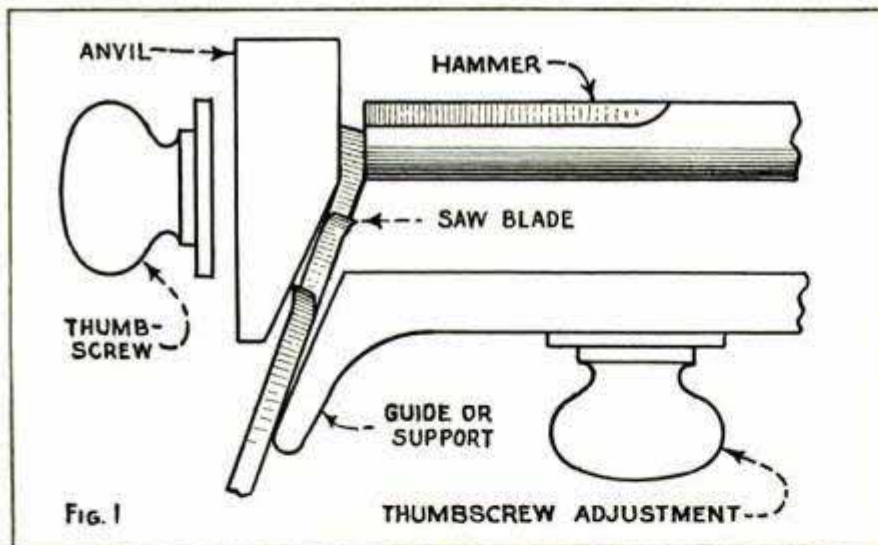
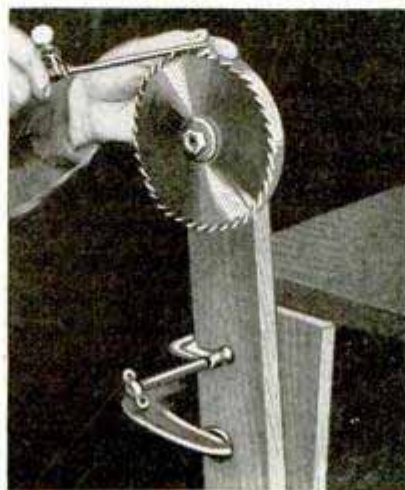

Fig. 1 Shows the Three Parts of Setter Used for Circular Saws; Photos Show, Left, Holder for Saws While Filing; Right, a Setter in Use



Saw set - E. C. Atkins Co
402 S. Illinois, Indianapolis, Ind.

and the aim of the filer should be to preserve this original form.

First you must remember that the three principal operations, namely, setting, jointing and filing, all contribute equally to the success of the job. If any of them is omitted or carelessly executed, you will have an ill-running saw, no matter how painstaking you are with the other two. First examine the set of the teeth. Unless they have been damaged by striking a nail or other metal, the form of the set can be easily seen. On small blades, the teeth are almost invariably set by bending them and the bent portion is generally one-third of the length, unless it has been set for special uses. The teeth of the ripping blade are filed square across, while those of the crosscut blade are filed at an angle with the blade both vertically and horizontally. If the teeth are merely dulled by long use, they must always be set before jointing or filing. If damaged, they should first be jointed, then brought to a point, after which they are again jointed off lightly, repointed by light filing, and the gullets cut down to give the proper clearance. The set should be put in after the preliminary jointing and pointing. In any case, the set is a major consideration, and as a rule it should be done first.

Fig. 1 shows the three principal parts of a saw set adapted to setting a circular saw. It will be seen from this that any adjustment of either the anvil or guide will change the form and coarseness of the set. With the better makes of saw sets, it is possible to adjust them very accurately to any depth desired. The set is best adjusted by placing the tool over the teeth while the blade is on the arbor. Make a trial adjustment and set several successive teeth, bending them in the same direction as before. Sight across the teeth edgewise to best determine what has happened. Remember that the power-driven saw does not require the same amount of set as the handsaw. Fig. 2, detail A, shows the correct medium set for a ripping blade. Where the blade is to be used almost exclusively in soft wood, the depth of the set, that is with relation to

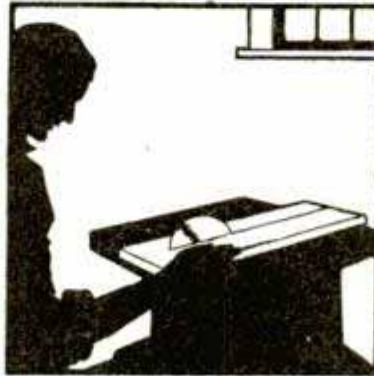

the length of the tooth, may be slightly greater, but the width across the points should never be as great as that shown at B, where a "valley" appears between two adjacent teeth. The formation of a valley must be carefully avoided, as this will cause the ripping blade to vibrate excessively and "run" in the cut with greatly lessened capacity. Any discrepancy of this kind may be taken out by resetting the blade with the tool properly adjusted.

For all ordinary purposes, the coarseness of the set should never exceed that shown in the detail A of Fig. 2. If the saw is to be used mostly for hardwood, the set may even be less. After checking over the setting, bend each alternate tooth in the same direction, so that two adjacent teeth will be set on opposite sides of the blade. Be sure to reset the teeth on which the trial setting was made so that they will be uniform with the rest. After every second tooth has been set on one side, reverse the set or the blade, whichever is most convenient, and finish the remaining teeth. Two precautions must be carefully observed, namely, that the adjustment of the tool does not shift while setting, and also, that the tool does not slip when the pressure is applied, causing the hammer or plunger of the tool to pinch off the points of the teeth. Always hold the tool firmly, with the guide bearing against the blade when setting each tooth. When setting a combination blade, omit setting the cleaner tooth.

After setting, the blade must be jointed. Although this is easy to do, it is nevertheless of considerable importance, as it determines to a great extent the behavior of the blade while in the wood. This is even more true of the circular saw than of the handsaw. Fig. 4 shows a simple method of accurately jointing a small circular saw on the arbor. Get two narrow strips of wood the length of the saw table and clamp them down, one on either side of the blade. Put the blade on the arbor so that it will run backward. Raise the table until the teeth are just below the top edges of the strips. Hold a carborundum stone, coarse side down, on the

strips directly over the blade and start the motor. Lower the table slowly with the handscrew until the teeth of the saw strike the stone. Give the handwheel an additional half turn, then stop the motor and examine the saw. This operation strikes the teeth off evenly so that they will run in the same arc. Carefully continue this procedure until each tooth comes in contact with the stone, which will be sufficient. Never take off more than is necessary to even the teeth. On a table without an elevating screw, revolve the saw blade by pulling the belt by hand while adjusting the height.

The blade is now ready for filing. It is better to use new files. Never attempt to sharpen a blade with a file clogged with an accumulation of dirt and grease. Make a support for the blade as shown in some of the photos. Saw out a disk of wood, about $\frac{1}{2}$ in. less in diameter than the blade, and if the hole in the blade is $\frac{1}{2}$ in., drill a hole of equal size in the center of the disk. Get a length of 1 by 4-in. stock and drill a $\frac{1}{2}$ -in. hole near one end. Put a short $\frac{1}{2}$ -in. bolt through the hole, place the disk over this and tighten the blade to the disk. Clamp the support to a table or bench with a suitable clamp or hold it in a vise. Never attempt to hold the saw itself in a vise when filing, for even though the jaws of the vise are of wood, the set is likely to be altered or taken out altogether in places, mak-

ing it necessary to reset the entire blade.

When sharpening the ripping blade, the file stroke must be made straight across, with the file held at right angles to the blade. Take care to bring each tooth to a point and keep the original form. When filing crosscut teeth, the file must be held at an angle with the blade both vertically and horizontally, so that the teeth will be shaped at an angle, as shown in details A and B, Fig. 3. Detail B shows the medium form of the crosscut tooth on the combination blade, and detail A the common form of the tooth on the crosscut blade. Note that the angle of the cutting edge in detail B is slightly greater than in detail A. The common crosscut tooth is sharpened with the file held more nearly square with the blade than in the case of the combination blade. A deeper valley on the combination cutting teeth will make the blade cut faster in a ripping cut and be in no way a hindrance when cross-cutting. This deeper valley allows the

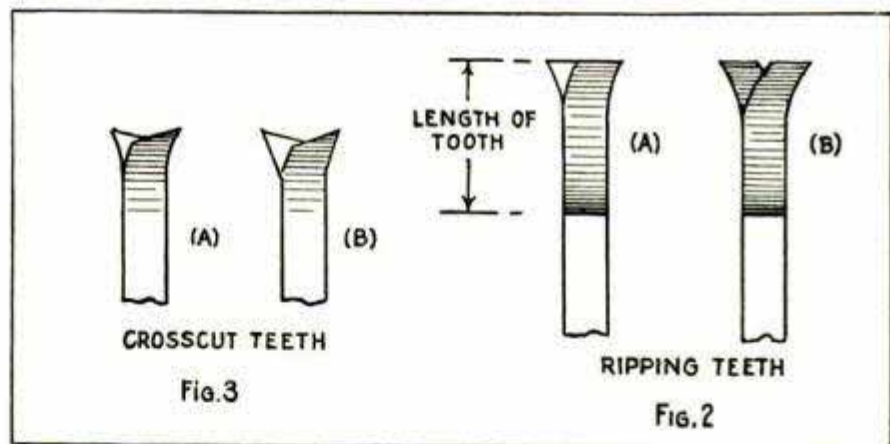

Figs. 2 and 3, Proper Set and Tooth Shape of Crosscut and Ripsaws; Center, How Sides of Filed Teeth Are Dressed Down Evenly and, Below, How Saw Table Is Let Down Slowly When Jointing

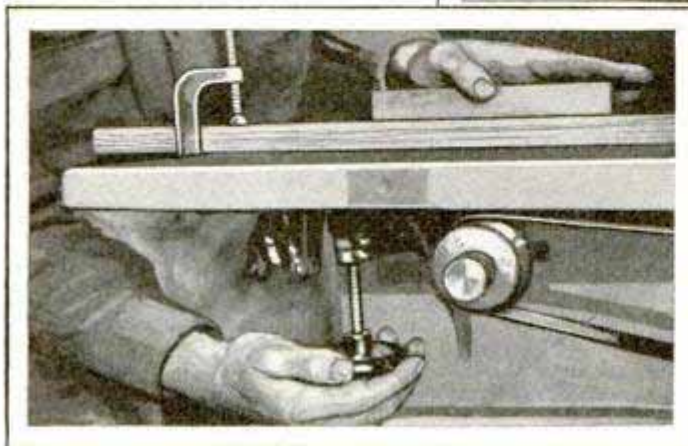

cleaner teeth to sever the lengthwise fibers of the wood when making the ripping cut.

When filing the cross-cutting teeth, run the file cut down into the gullet to keep the original form of the teeth and to prevent the formation of a shoulder in subsequent filings. Although it takes longer, the best method of filing accurately is to disregard

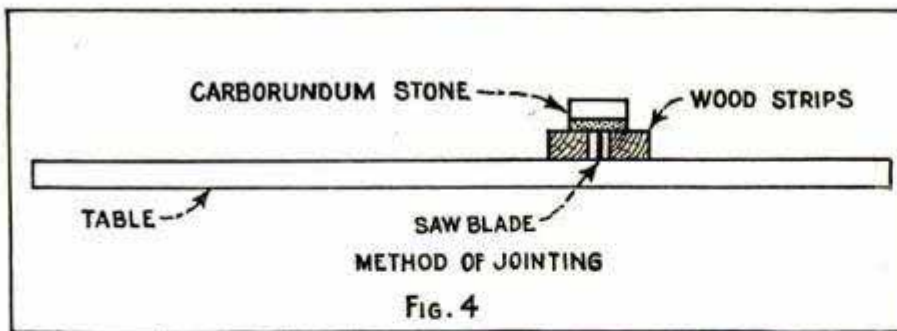

Fig. 4 Shows How Wood Strips and Carborundum Stone Are Used for Jointing and the Photos Show Side-Dressing and Filing Operations

the pointing of each individual tooth and adopt a uniform stroke of the file. For instance, give each alternate tooth two one-way strokes with as uniform a pressure as possible. Continue this until one complete set of teeth have been given two strokes of the file. Turn the blade around and repeat with the other set. In this sense the word "set" indicates all the teeth bent one way on the same blade. When finished, turn the blade back again and bring the teeth very carefully to a point, taking care not to alter their shape. Bring the other set to a point in the same manner. This makes four operations, and while it is not always done, owing to the time required, this method enables one to turn out as nearly perfect a job of saw filing as is possible by hand methods. While filing, it is essential to have the blade in the very best available light so that the result of each stroke may be seen readily, especially when pointing the teeth. Always use a flat file when sharpening the cleaner teeth of the combination and planer blades and make the stroke straight across as in filing the ripping tooth. Give the cleaner teeth one extra stroke with the file after bringing to an edge. This will bring the cutting edge to the correct position, which should be very slightly less than the arc of the cutting teeth.

It will perhaps be well to add a word concerning what is commonly known as "gumming." This operation consists in filing the round gullets between ripping teeth, to obtain maximum tooth clearance and prevent breakage. After the first two filings of a ripping blade, the



gullets should be filed with a small round file of suitable diameter. The stroke is made straight across, and it is best done before setting and jointing. Two strokes of the file in each gullet should be sufficient at each filing of the saw. The cutting teeth of combination, crosscut and planer blades are more or less automatically gummed by each filing, owing to the slightly rounded corners of the file used, and as a rule need no further attention on the smaller blades.

After the filing is finished, the teeth will need to be dressed, to bring the cutting points in line so that the saw will cut clean and smooth. To do this, tighten the blade on the arbor, running the right way, and bring up the rip guide. Lay the carborundum stone against the guide, with the edge up and the fine side next the saw. Do not allow the stone to strike the upcoming teeth but only those going down. Leave the guide free so that it may be easily moved by hand. Start the motor and bring the stone against the teeth very lightly, allowing it to touch only the sides of the points. Keep the stone flat against the guide. Repeat the operation on the other side of the blade. Be very careful not to take off too much.

Grind down just enough to even the points and bring them in line. Where the rip-guide assembly will not permit this procedure, lay the blade on a flat surface and rub the teeth lightly with the fine side of the stone, as shown.

A small dado head may be accurately jointed and filed by using practically the same method as for the saw blade. To joint the head, use the strips clamped to the saw table as before, and assemble all the separate cutters on the arbor so that they run backward. Use the coarse side of the stone, as before, in jointing. If this is done carefully, no harm will result to the stone either in this operation or in that of jointing the saw blade, if both are run backward. Remove the head and carefully file the two outside cutters. Note the shape of the cutting teeth and take care not to alter their shape. Remember that the original form of the tooth is the very best guide in filing it. When the filing is complete, give each cleaner tooth an additional stroke with the flat file, as on the combination and planer blades. Assemble all the inside cutters on the arbor, running backward, and joint them again very lightly. Remove and file the top of each tooth straight across, just back of the cutting edge, to remove the rounded portion caused by jointing. Carefully done, these simple operations will put the small dado head in excellent shape.

Making Accurate Templates

A flat piece of window glass simplifies the usually difficult job of making accurate templates. As the glass is transparent, the inaccuracies can be readily seen and corrected while the work is held flat by the glass. If other methods are used, it is almost impossible to hold the work properly and at the same time see the errors.—C. Kugler, Philadelphia, Pa.

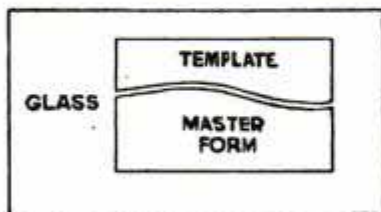

Handles on machinery are usually set so that a clockwise movement actuates the part controlled forward, and the reverse, backward.

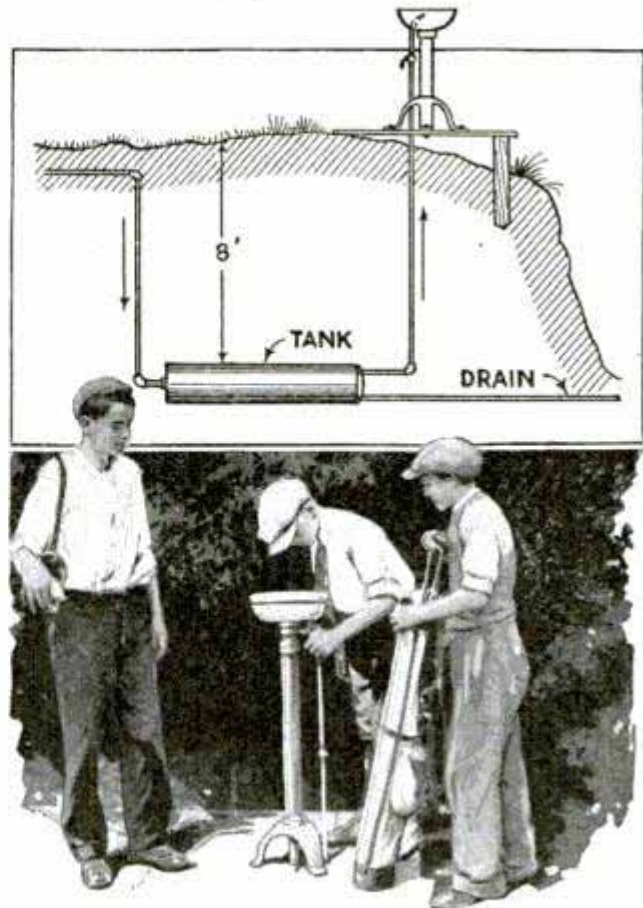

Cool Drinking Water from Fountain Obtained by Passing Water through a Buried Tank

Cooler for Fountain Water

Coolers of the kind shown in the drawing are used on a golf course near Akron, Ohio. The system consists of a galvanized-iron tank, such as a hot-water heater for the home, about 30 ft. of pipe and a fountain. The tank is buried in a horizontal position and at least 8 ft. under the ground. The feed pipe from the water supply is fitted to one end and a second pipe leads from the other end of the tank to the fountain above. In this particular case, a drain pipe was also provided to permit cleaning the tank or emptying it during cold weather. Of course, if it is desired to install a drain pipe, it is necessary to place the tank near a bank, as indicated. The fountain recommended for the purpose is of the angle-flow type, which is sanitary, and it is advisable to locate it in the shade. It was found that water in the pipes laid near the surface of the golf course often become hot, while that taken from the fountain had an average temperature of from 50 to 60°. The same system can be used wherever it is desired to have cool drinking water.—Walter E. Burton, Kenmore, Ohio.

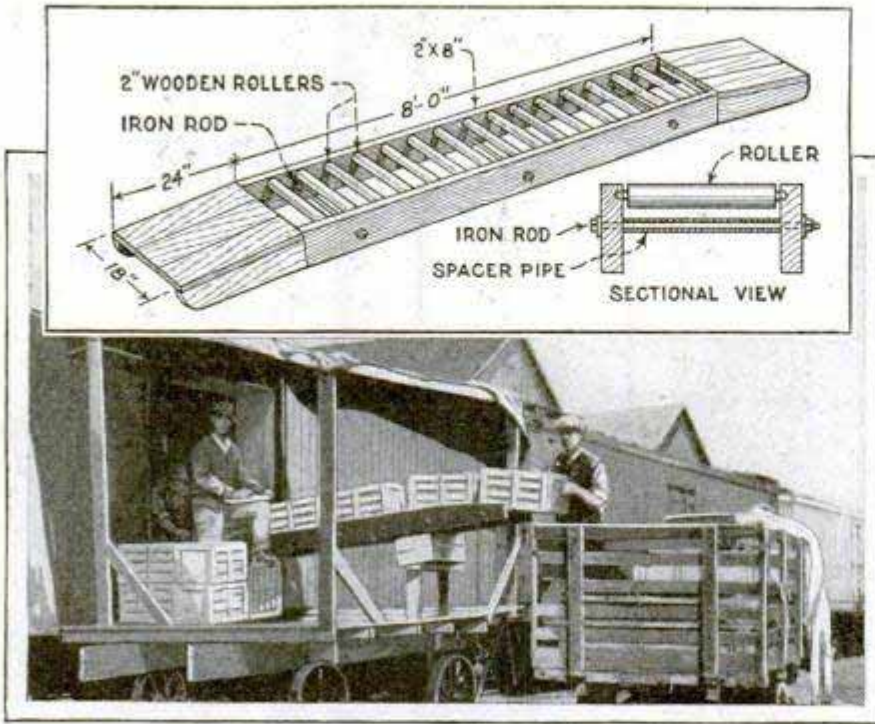

Portable Loading Shed with Roller Conveyor Enables Quick Transfer of Perishable Fruit from Farmers' Wagons into Refrigerator Cars

Portable Conveyor Speeds Loading

Quick action is necessary when loading strawberries, grapes and other perishable fruits into refrigerator cars. Under the old system, which is still generally in use, wagons containing the fruit are unloaded at sheds beside the railroad tracks, the crates handled over the tables for inspection, after which they are picked up and carried into the car. Hence, it is usually necessary to move the cars to points most convenient for loading them. To increase the speed of loading, a portable shed, equipped with a roller conveyor, was designed by Ira Graham, general manager of the Berry Growers' association, of Springdale, Ark., and it was highly successful. The shed can be moved from one car to the next in a few moments without waiting for a switch engine. The fruit is transferred directly from the farmers' wagons onto the roller conveyor in the shed, where it is examined and then pushed into the car.—Ira D. Mullinax, St. Louis, Mo.

Test Box for the Automotive Electrician

For testing the electrical systems of cars, the illustrated box, which holds a number of dry cells and has a voltmeter, ammeter, condenser and a number of

tapped switches, will be found of great utility. The box can be made any suitable size. A pocket of heavy fabric is attached to the back to carry two testing leads, which are fitted with test points at one end and small battery clips at the other for quick attachment to the parts to be tested. The switch contacts are made from No. 22 gauge rifle shells, and the connecting wires soldered to them, whereupon they are pushed into holes drilled in the panel. The switch lever can be obtained from a radio shop. The test condenser was made from

an old Ford-coil condenser, wrapped with tape and with leads soldered to the terminals. The dry cells are connected in series, and the negative end is connected to a terminal on the panel, while taps are taken to the switch points. In order to test ignition coils, the voltmeter must be connected in series with the dry cells, using 6 volts to test the secondary winding of the coil, in which case the voltmeter should read from 2 to 3 volts, owing to the resistance of the coil winding. A short circuit causes a high reading, while

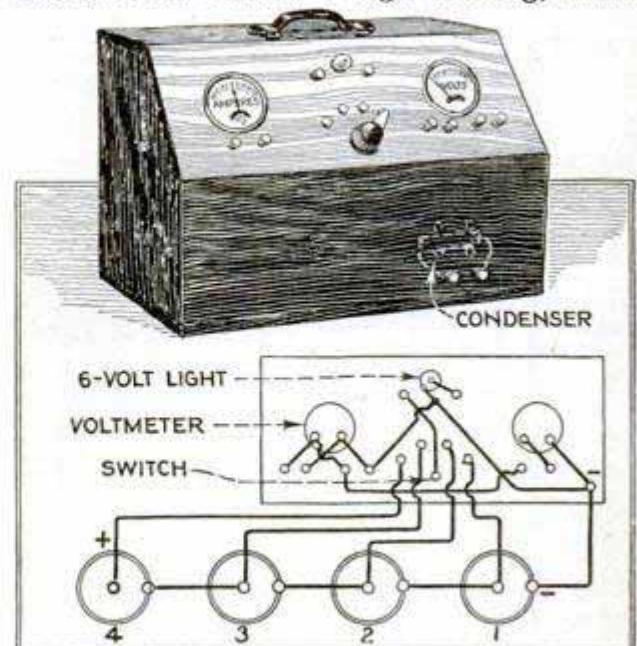

Portable Test Box for the Auto Electrician Contains Dry Cells and Is Equipped with Meters

an open circuit gives no reading at all.—
Harold L. Flinn, Arnold, Pa.

Cement-Bandage Repair on Large Pipes or Cylinders

For mending leaks in irrigating pipes, cracked pumps or cylinders, steam-heating pipes, etc., a bandage of cement and cloth makes a good job. Mix Portland cement and water to a paste; next take a long strip of loose-woven cloth, burlap, or cheesecloth, 3 in. wide, and roll it into a roll like a surgeon's bandage. Work the loose end full of the mortar, and wind it around the leak, taking a handful of the cement mortar and working it well into the cloth, at each round. Continue until the bandage is 1 in. thick; then finish over the surface with the mortar, and let it stand for 48 hours, well protected from wind and sun. It will then be ready for use. If there is a heavy pressure in the pipes, wrap wire mesh around to reinforce it. Leaks in 8-in. irrigating pipe have been mended by this method.

Valve for Hot-Water Radiator

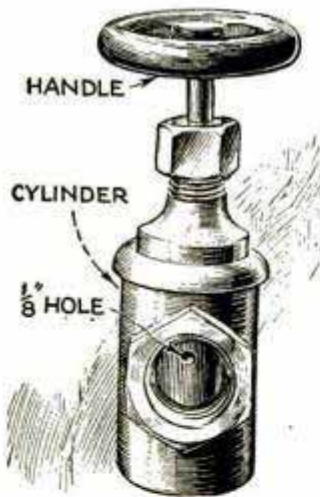

Hot-water radiators are often ruined by freezing. Usually this happens when people shut the valve and neglect opening it until too late to prevent the damage. Such damage can, however, be overcome by slightly altering the inside of the valve. If it is of

the revolving-cylinder type, as shown in the drawing, or a flat-surfaced gate valve, drill a $\frac{1}{8}$ -in. hole through it. If it is a flat-seated disk valve, cut a small groove across the face of the disk. This treatment will allow enough water to pass the valve to prevent its freezing as long as there is any fire in the furnace. At the same time, the flow of water is so slight that to all appearances the radiator is entirely closed.—James E. Noble, Toronto, Canada.



Extended Cuff on Carpenter's Trousers Makes Handy Nail Sack When Laying Flooring

Handy Carpenter's Nail Sack Attached to Trouser Cuff

When a carpenter is laying flooring he will find a nail sack attached to his left trouser cuff a great timesaver. The sack may be either separate, having strings to tie it around the ankle, or it can be made a permanent part of the trouser or overalls by merely extending the cuff. The latter method is preferable as it is always in place when needed.—H. H. Siegele, Emporia, Kans.

Hand Guard for the Bucksaw

Anyone who has grasped the handle of a bucksaw quickly and felt the teeth dig into his fingers, or has smashed his knuckles against the wood when making the forward stroke, will appreciate the illustrated guard to prevent such injuries. It consists of a strip of galvanized sheet iron bent to a U-shape and screwed to the handle of the saw as indicated.



The saw is used in the customary manner with the fore or index finger fitting inside of the guard.—Raymond B. Wailes, Bethesda, Md.

Bearsville. Water County, New York City

1111 Power, Cleveland, Ohio

A Practical Home Made

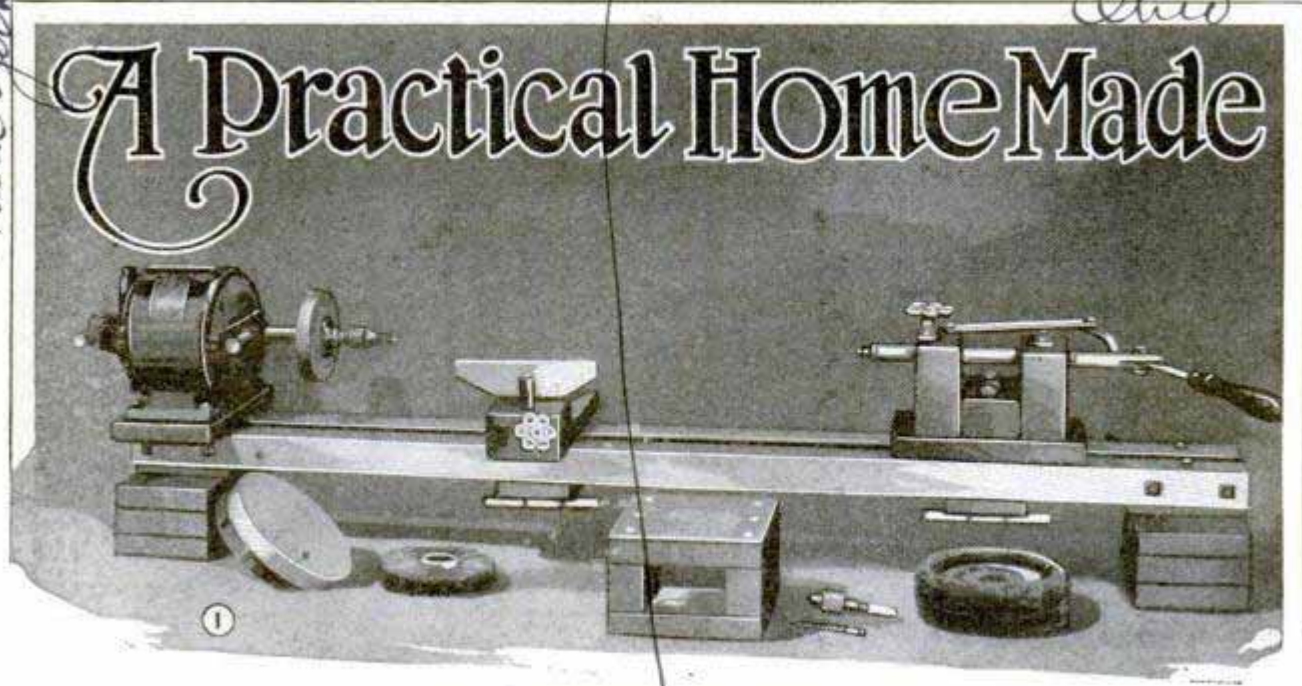

By EDWARD THATCHER

A THOROUGHLY practical combination workshop for turning, drilling, grinding, polishing, sanding and planing may be very easily built at home without the use of machine tools, ordinary hand tools, such as form part of the equipment of the average amateur's shop, being used throughout. The machine is inexpensive to build, runs smoothly and quietly, and will do quite as good work as its commercial counterparts, which it closely resembles both in appearance and results.

The writer has a well-equipped workshop for experimental and practical work, most of the machines being driven from a main shaft belted to the gasoline engine that drives his light plant. Several small motors are used, and the one shown on the lathe in the accompanying illustrations was formerly used to drive a small circular saw. For this I had purchased a motor-shaft attachment to hold an emery wheel, drill chuck, etc., and I found this exceedingly convenient, but it had one disadvantage: When in use on the motor, the saw table was always in the way. One day I picked up some pieces of angle iron from an old bedstead, and this gave me the idea of constructing the combination machine, as the angle stock, being rigid, straight and true, seemed to be ideal material for a lathe bed. I proceeded to build up the unit, using scrap pieces of iron, blocks of wood, bolts, handwheels from an old oil stove, etc. When it was finished, I was enabled to do a great deal of work that was formerly impossible; I had added a practical lathe to my equipment, and all my turning, grinding, polishing, etc., could be done on the combination unit without starting up the gasoline engine.

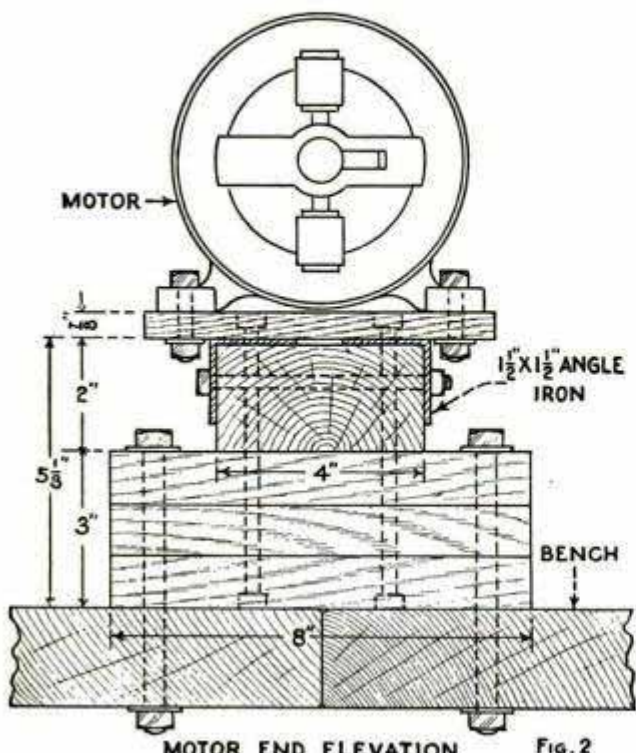

MOTOR END ELEVATION Fig. 2

Combination Workshop

ning at 1,750 r.p.m. will be ample for most work. New motors of this size can be obtained at prices ranging from \$7.50 to \$15, while secondhand motors, in good condition, can often be picked up for very much less. There is no reason why a ½-hp. motor could not be used for heavier work in the same way, as motor-shaft attachments can be purchased, fitting shafts up to 5/8 in. in diameter.

The angle-iron bed of the lathe can also be made heavier or longer if desired for special purposes, although, if this is done, the bed should be braced, at about 30-in. intervals, with auxiliary legs. The angles used for this lathe were 1½ in. wide and 1/8 in. thick. Angles, 3/16 or even 1/4 in. thick, would be still better for longer beds. The bed on the original is 4 ft. long, accommodating work 26 in. long and of 8-in. swing. It is a simple matter to increase the swing merely by increasing the height of the blocking under the motor, and making the tailstock and other parts to suit.

The shaft of my motor is ½ in., so this was the size of the shaft attachment purchased. The attachment consists of a sleeve bored to fit the motor shaft and locked in place with two setscrews, the outer end being threaded to accommodate the drill chuck, collars for emery and polishing wheels and the nut. This end is ½ in. in diameter, a good size, as it per-

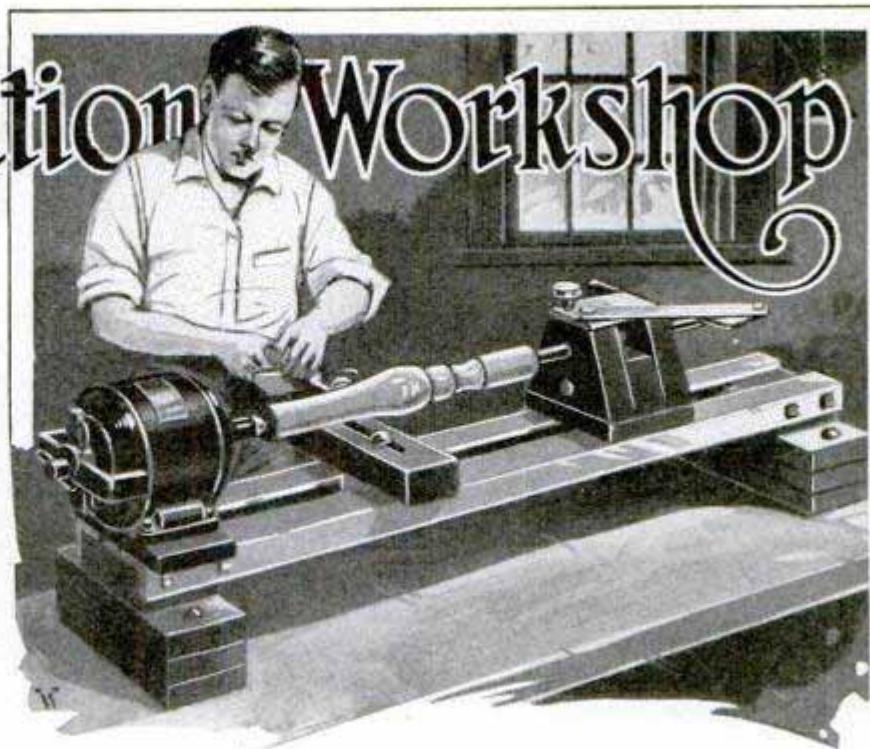

mits the use of a number of inexpensive lathe-head attachments of other makes. Such attachments may be purchased at from \$1 to \$2.50 each. It is important to see that the motor shaft runs true in the first instance, and that the attachment, when fitted, also runs true and straight.

The angle irons forming the bed of the lathe are bolted to the wooden blocks forming the legs or supports, as shown in Figs. 1 and 2. The blocks are preferably of hardwood, although soft wood may be used if hardwood is unobtainable. A clear straight-grained piece of 2 by 4-in. stuff is bolted between the angle irons at each end, spreading the angles and thus forming the slot in the bed. The piece at the motor end is as long as the bed of the motor. A piece of clear maple is bolted on top of the angles to form the motor base, the bolts running down through the spacing block and the supports. The slots in the frame of the motor permit a certain

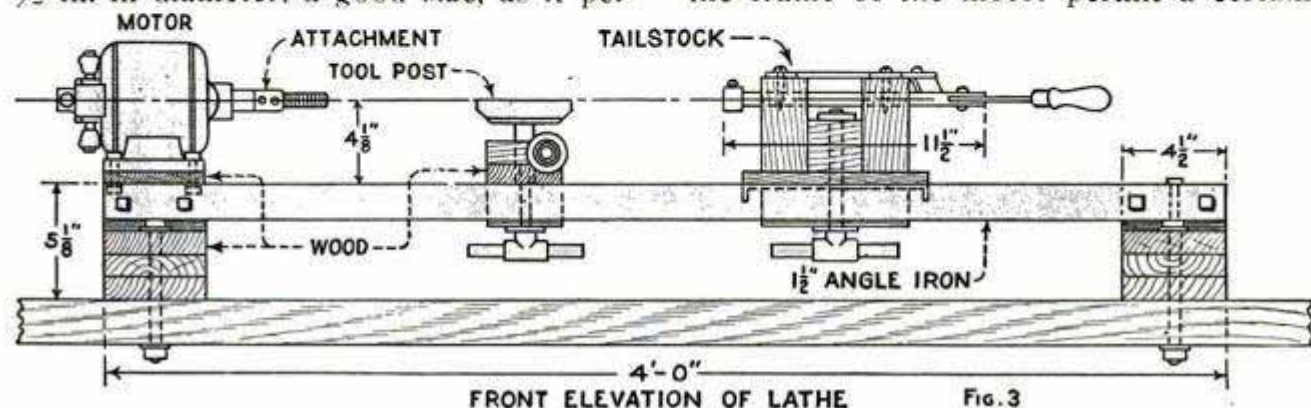

amount of side adjustment when lining up the lathe. The support blocks are bolted to the bench. Care should be taken to keep the lathe bed as level as possible, and, of course, the spindle of the motor should be kept parallel to the bed.

The tailstock, Figs. 3 and 4, is built up of hardwood blocks, preferably beech, maple or some similar hardwood of fine, even grain. The spindle is made of conduit, 1/2 in. in inside diameter. To strengthen this on the end where the centers are fitted, it is threaded, and a coupling is

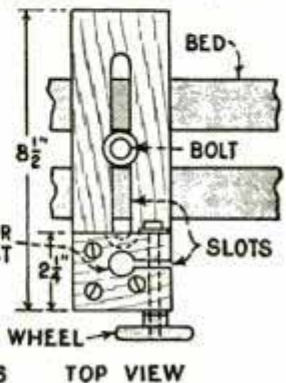
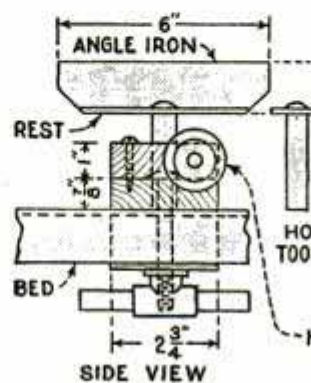
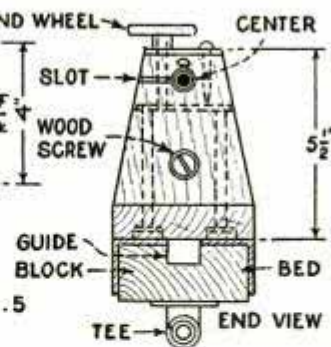
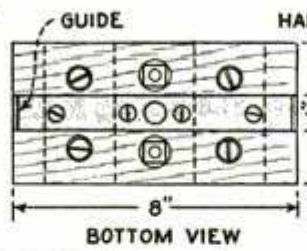
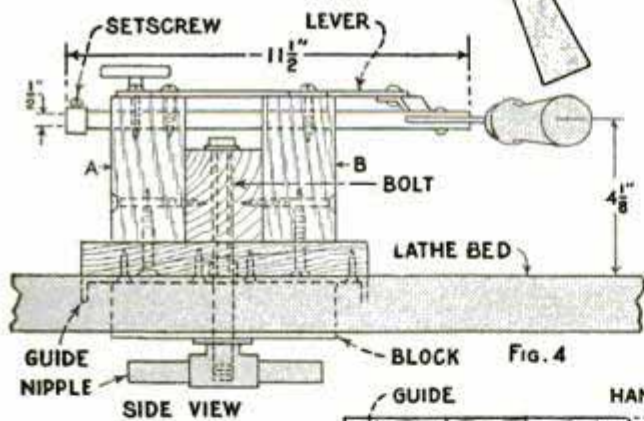
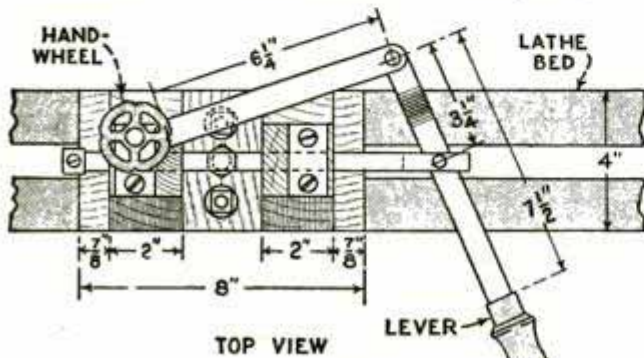

screwed on, after which the coupling is filed or turned off even with the end of the spindle, and made square. A hole is drilled through the coupling and spindle and tapped for a setscrew, which holds centers or a drill chuck with 1/2-in. shanks. The other end of the spindle is slotted with the hack-saw to take the lever feed.

The body of the tailstock is built up as shown in Fig. 4, using heavy wood screws to hold the blocks together. Underneath the flat block that rides on the lathe bed is screwed a length of 1-in. flat iron. The ends of this are bent down to fit in the slot of the lathe bed and form a guide for the tailstock. This piece must

be a good sliding fit in the slot, as it must keep the tailstock in line with the motor. Build up the body completely, but do not drill it for the spindle. See that it slides evenly and truly on the bed and that it may be clamped firmly in position. Mount the drill chuck on the motor shaft, and, with a 1/8-in. twist drill, drill through the blocks A and B on the tailstock body, moving the body up to the drill, while keeping it pressed down on the lathe bed. It will be necessary, after drilling block A, to reverse the tailstock to drill B. This small hole marks the exact height of the lathe centers, and forms a guide for an auger bit, of the right size for the tailstock spindle used. Remove the blocks and bore halfway through each block from each side, with the drilled holes as guides. A 3/16-in. bit was just right for the 1/2-in. conduit used on the original. The spindle, in any event, should be a good sliding fit in the blocks, and should center accurately with the headstock spindle. It should also be parallel to the bed.

Block A is slotted on one side of the spindle hole, as shown in Fig. 5, to permit clamping the spindle. Halfway between the spindle hole and the back of the block, bore a hole that will allow a 1/2-in. bolt to be screwed tightly into it. Enlarge the hole above the slot so that it will not bind on the bolt, cut off the bolt long enough to screw firmly down into

the lower hole, and still allow enough thread to project above the block to take the handwheel. Drill a clearance hole for the bolt in a piece of flat iron, and screw this to the top of the block (Figs. 4 and 5) to

take the pressure of the handwheel and to prevent marring or splitting the wood. If a handwheel to fit the bolt is not available, a common nut may be used to clamp the spindle. The construction of the lever feed is quite simple, and is perfectly clear from the drawings. This type of feed is very handy for drilling, and is decidedly easier to make than the screw feed.

The tool post and tool rest are shown in Fig. 6. The base, which rests on the

bed, is made of a slotted length of hardwood; the part that clamps the tool rest is made from another block, attached to the first with three screws, as indicated. The inner portion of the second block, beyond the saw slot, is not screwed down, as the bolt draws this in on the shank of the tool rest, making the rest adjustable for height. In this case, the clamp bolt goes right through the block, with its head toward the bed of the lathe. The rest itself is made of a length of angle iron, riveted to a shouldered post or shank. The offset thus given the angle makes it possible to set the rest close to small work. The rest, of course, may be made any desirable length.

The faceplate, Fig. 7, is made by first sawing out a wooden disk $\frac{7}{8}$ in. thick and 6 in. in diameter. Another disk, $1\frac{1}{2}$ to 2 in. thick and 3 in. in diameter, is glued and screwed to the first, to serve as a hub. Drill a hole through them slightly smaller in diameter than the threaded headstock spindle, screw the plate in place and turn to shape and size.

The table for use with the faceplate, when sanding, is made up of wood, as in Fig. 7. It is clamped to the lathe bed in the same manner as the tailstock and tool post. The table should be at right angles to the faceplate. The table can be made adjustable, to permit work to be sanded at a bevel, by hinging the front edge, and providing supports for the table when raised. Fig. 8 shows the table and face-

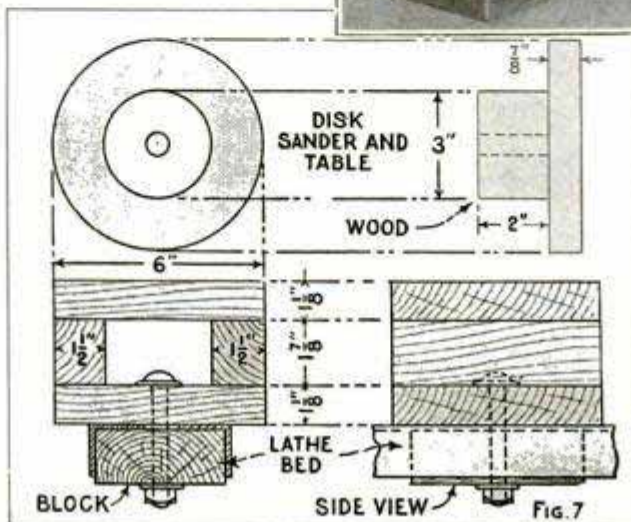
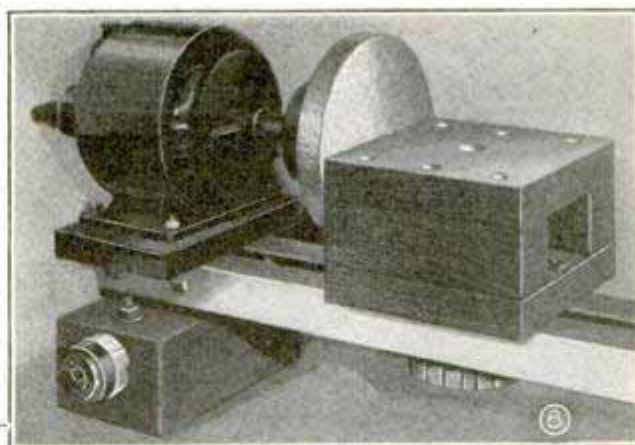

plate in position on the lathe. Note the conveniently placed snap switch for starting and stopping the machine. The clamping wheels for the various attachments may be made up of old valve wheels, drilled out and threaded to fit the

clamp bolts. Even wheels taken from old toys will sometimes serve the purpose. In the absence of wheels, clamp nuts may be made up of pipe and fittings, as indicated in Figs. 3, 4 and 6. A $\frac{1}{4}$ -in. tee and two nipples make a good clamp, the side outlet being tapped to fit the bolt.

(To Be Continued)

Cements for Pipe Joints

Cement for making screw joints in pipes steam-tight may be made from graphite and heavy cylinder oil. Just enough oil is mixed with the graphite to form a thick paste. A good cement for both water and steam pipes has this composition: whiting, 4 lb.; fine yellow ocher, 10 lb.; ground litharge, 4 lb.; and $\frac{1}{2}$ lb. of hemp cut into fine particles. These ingredients are mixed thoroughly with linseed oil to form a paste, which is applied on the threads of the pipes and fittings. For ammonia piping, a cement made of litharge and glycerin is used. Sufficient glycerin is added to the litharge to form a putty. Only enough of this cement should be mixed to serve immediate needs, as it sets quickly.

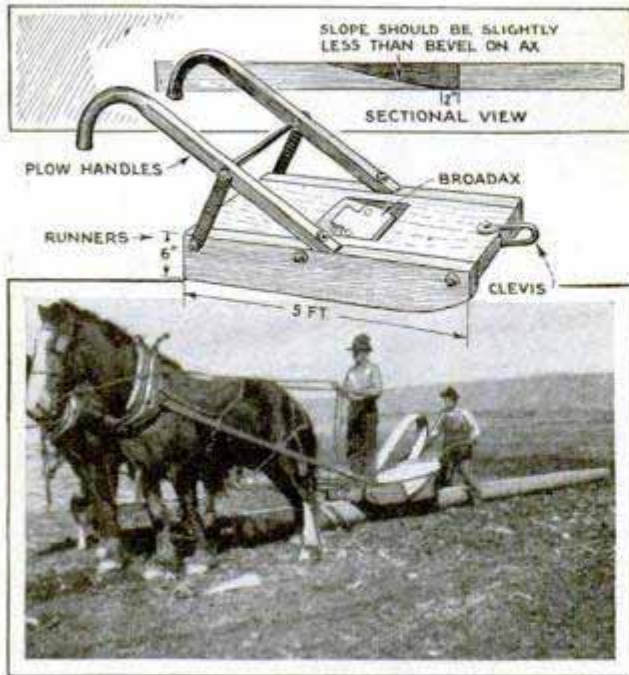

With This Horse-Drawn Plane Thick Slices Can Be Removed from Huge Logs

Horse-Drawn Tool Planes Timbers

Anyone who has to deal with timber will find the horse-drawn plane shown in the illustration a great labor saver. It consists of a wooden frame made by using 4 by 6-in. planks for runners 5 ft. long, a 4-in. top piece, fastened to the runner with $\frac{3}{4}$ -in. bolts through holes in both runner and top, and a broadax, set in the top piece as shown, a section of the top being cut out for this purpose. The broadax is securely bolted to the sloping edge of the top, the angle of which should be slightly less than the bevel of the ax. It is necessary to countersink the screw or bolt-heads which fasten the broadax, especially if it is desired to cut wood for making shingles. A pair of plow handles and a clevis complete the tool. The logs should be set against a stop to prevent them from sliding when a heavy cut is made. A stout post driven into the ground, so that only 6 in. projects makes a good stop for this purpose. For ordinary planing, a $\frac{1}{4}$ -in. bite should be taken, and a heavier cut for shingles. When cutting shingles, make cross saw cuts in the log, every 16 or 18 in., to within 2 in. of the heart.—Eden W. Robinson, Grand Haven, Can.

☐ When soldering, if there is any suspicion of grease or oil on the surface, clean off with carbon tetrachloride before applying the flux.

Simple Test Distinguishes Wood and Denatural Alcohols

It is often difficult to tell the difference between refined poisonous wood alcohol and denatured alcohol. A thin piece of celluloid, if put in a vial of the alcohol in question, will quickly reveal its nature. Wood alcohol will dissolve the celluloid, while denatured alcohol will have no other effect in 12 hours than to remove the polish. In handling these chemicals it should be borne in mind that wood alcohol is not only a deadly poison if taken internally, but that one may be poisoned by breathing its fumes or by absorption through the skin.

Convenient Bolt and Rivet Trays

In a large Denver machine shop, a number of bolt and rivet trays have been put in use and found entirely satisfactory. The frame consists of four 30-in. lengths of 2-in. pipe, flattened at one end and bent at right angles to form feet, and two siderails, flattened and drilled as indicated, for attachment to the top of the legs. Three sheet-metal troughs, ranging from 8 to 14 in. in width, and as long as the frame, with one partition across the center, are welded between the legs at suitable heights for the easy filling of the trays and handy removal of the contents. When not in use, the outfit is kept near the sup-



Rack of Sheet-Metal Trays on Pipe Frame Used for Holding Bolts in Machine Shop

ply bins, so that they can be quickly loaded up when required and carried to the job.—Jos. C. Coyle, Denver, Colo.

Keeping Lard Oil Warm

To keep lard oil warm during cold weather so that it will run easily, get an extension cord, a small lamp, a pipe coupling that will fit around the lamp, and a tin can which will allow both lamp and coupling to fit inside of it, as shown in the drawing. Cut a hole in the center of the bottom of the tin can just large enough for the neck of the lamp to pass through. Punch a hole through the side

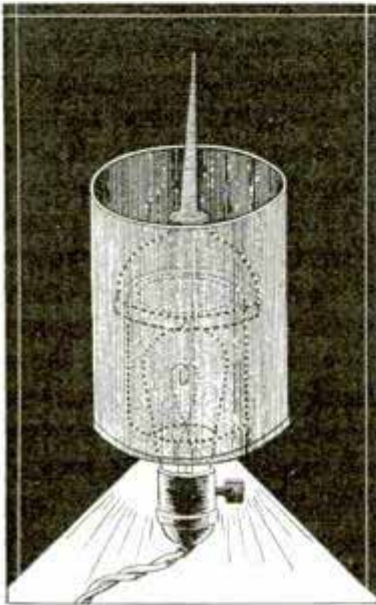

of the can and screw it to the wall. Place the coupling around the lamp so that it will extend above it, as shown. It will then serve as a grate for holding the oil can, as indicated, thus preventing the latter from coming in contact

with the lamp.—W. W. Parker, Lead, South Dakota.

An Improvement for Electric Bells Having Small Transformers

In electric-bell installations, dry cells are being superseded to a considerable extent by small transformers. This source of power is usually stronger than a battery current. For this reason the contacts are likely to occasion trouble, a particularly important consideration in view of the almost prohibitive cost of platinum. Ordinarily, there is no need for a loud signal, and in offices, and similar places, a quiet buzzer is desirable. Under these conditions the make-and-break system of contacts was disconnected, and the magnetic coils connected directly with the circuit. As the transformer current is of the alternating type, a good signal is obtained by adjusting the vibrating armature closely at the screw contact. When so arranged, a vibration of 120 per second is obtained on the 60-cycle current.

Adjustable Gauge for Acetylene Blowtorch

The sharpness of the cut made with an acetylene blowtorch depends to a great extent on the steadiness and regularity with which the torch can be moved along. With the aid of the adjustable gauge shown in the drawing, it

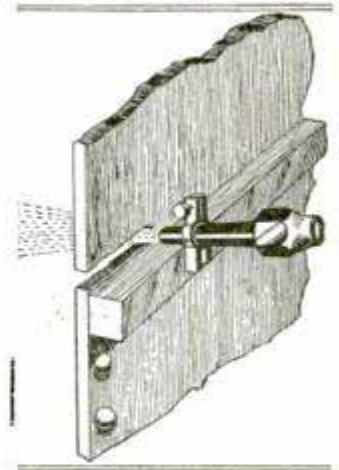

is easy to make a neat, narrow cut, both edges of which will be sharp and the lower one almost free from oxide. The gauge consists of a clamp fitted with a thumbscrew allowing it to be opened or closed on the nozzle of the torch in various positions. The body of the gauge is set at right angles to the nozzle so that it can be slid along a guide strip.

Anchoring Screwdriver Shanks

Screwdriver shanks can be securely anchored in a wooden handle without any risk of splitting by merely making a slit in the shank with a hacksaw and filing the edges to sharp points, as shown in the accompanying illustration. When the shank thus cut

and filed is driven down into the handle the sharpened edges will spread, providing excellent anchorage, and preventing the blade from turning, no matter how much force is applied in using the screwdriver. In fact, the handle will break before the shank will turn.—John A. Blaker, West Auburn, Mass.

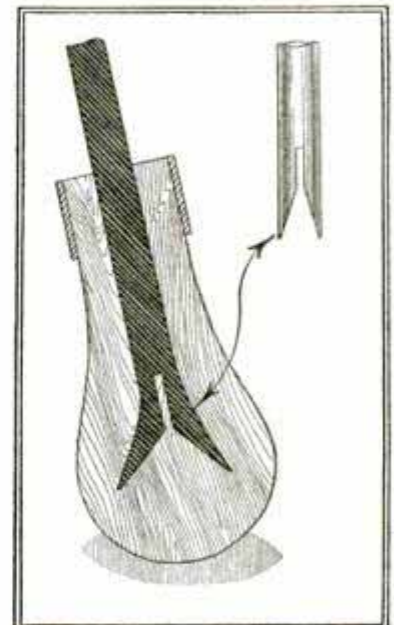

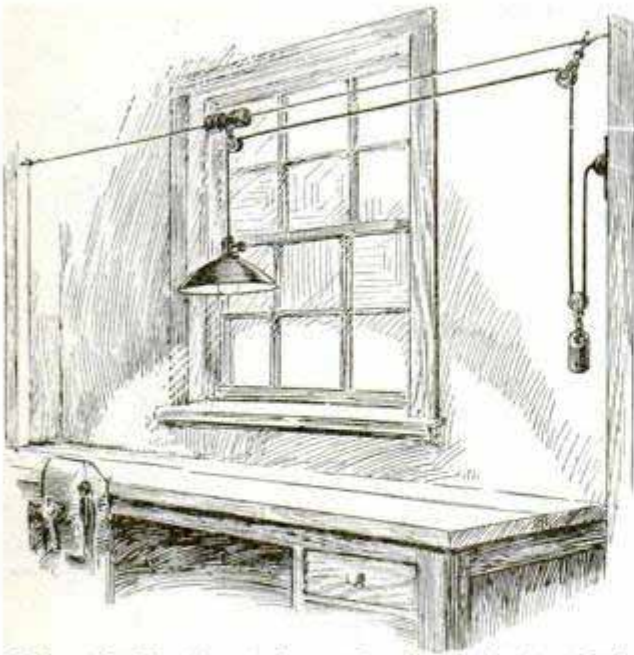

Adjustable Workbench Lamp Can Be Set in Any Position and Height Desired

A Convenient Bench Light

Where it is necessary to move a light over a workbench to various positions, the method of suspension shown in the drawing will be found highly satisfactory, as it allows the lamp to be moved about with the least effort, and it always stays just where it is put. A stout steel wire is stretched taut between two screwhooks driven into the wall at each end of the bench. A porcelain insulator used in electric wiring is slipped over the wire and a small pulley is attached to the knob. An extension cord is slipped over the pulley and over a similar pulley held by one of the screwhooks at the end. A third pulley with a small weight attached serves as a counterweight and is slipped over the cord at the plug end. A cleat receptacle or a wall receptacle should be installed in line with the wire and cord as indicated. The double advantage of this installation is that the bench light can be slid to any point

along the wire and it can also be adjusted to any desired height.—Hal Kramer, Allston, Mass.

Ventilating Photographic Dark Room

Photographic dark rooms should, of course, be light-proof, and in an effort to obtain this condition, the question of ventilation is often neglected. Good air is necessary for the comfort of the operator, and is especially essential in summer, to reduce the room temperature. A hot dark room means poor photographic results. The best method of securing ventilation is to force air into the room. This cannot be done handily by an electric fan in a direct opening in the wall, because of the admission of light. A wooden conduit, 12 in. high, 14 in. wide, and 8 ft. or more long, solved the problem. It was built to permit cool, fresh air to enter the room near the floor, and suitable provision was made for the exit of the warm air, near the ceiling. The air was blown into the room by an electric fan placed at the opening. The factory photographer who devised the arrangement found it indispensable.

Hinged Legs Make Barrow Easy to Load

Anyone who has loaded barrels of oil or other heavy material on a wheelbarrow knows what a job it is, and will therefore appreciate the type of barrow shown in

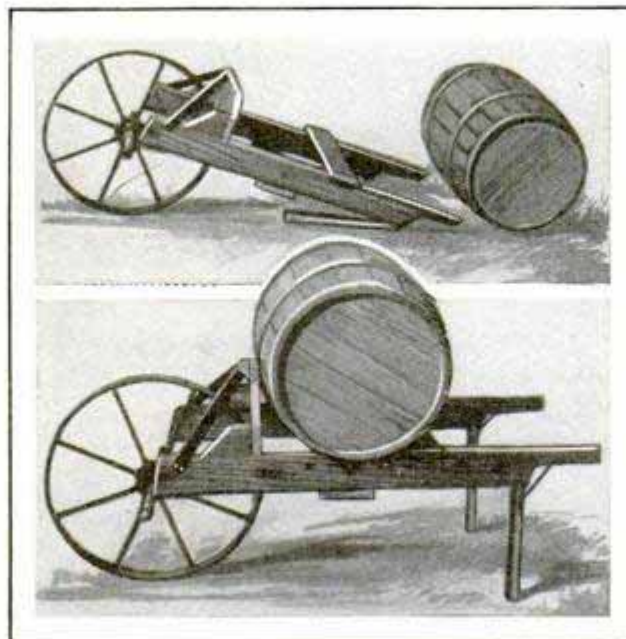

Folding Legs on Homemade Wheelbarrow Make It Easy to Load Heavy Barrels

the drawing. It has folding legs, which permit the handle end to rest on the ground so that the barrel can be rolled onto it. The whole barrow is homemade. The legs are hinged so that they will drop in place when the barrow is lifted. Hooks are attached to the underside of the handles to engage with screweyes driven into the legs in order to lock them securely when they are in use.

Cutting Disks or Rings Accurately from Sheet Metal

It is difficult to hold a piece of sheet metal to the faceplate of a lathe without boring holes in it. This is a difficulty that may be readily overcome by proceeding as follows: Warm the piece of sheet metal slightly and place upon it a piece of paraffin, sufficient to spread out and cover the surface when melted. Remove the faceplate and set it, face down, upon the paraffined surface of the metal. When the paraffin has hardened, the metal will be held against the faceplate firmly, permitting accurate cutting of disks or rings, if care is used.

Dial Indicator Facilitates Turning and Boring Eccentrics

A quick method of gauging an exact throw or "cam" by turning is to use a dial indicator as shown in the drawing. A recent turning job required a shaft that would give a reciprocating movement of

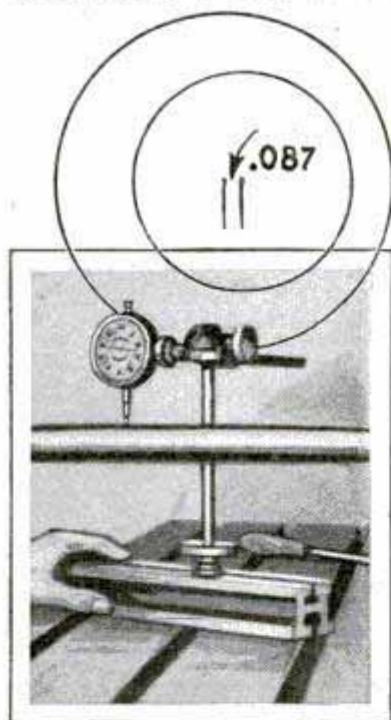

.087 in. to a plunger. The shaft was first laid in V-blocks, and lines were drawn on the two ends, one on center, the other approximately .087 in. out of center. Light prick-punch marks were then made, the shaft placed between centers, and the dial indicator was fed up to indicate the low spot on the shaft's diameter. While taking a reading of the dial, the shaft was turned one complete revolution to determine if the difference between the low and high reading on the dial was .087 in. By noting the readings, the prick-punch marks could be shifted so that the throw would be exactly .087 in.—J. McIntyre, Hartford, Conn.

A Sink Plunger Is a Convenient Handle for Lapping Oversize Pistons

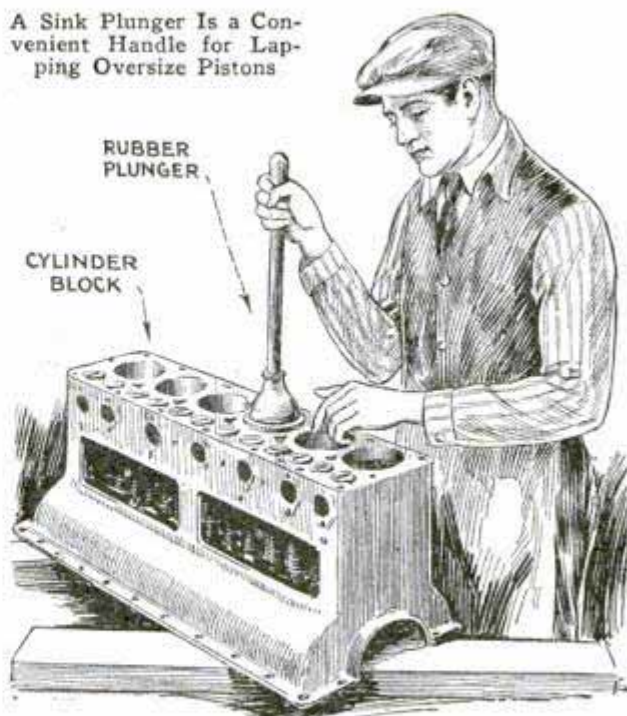

Sink Plunger Holds Cylinders for Lapping

Usually, during the process of fitting oversize pistons in an auto engine, the lapping of the pistons and rings is done by putting the piston in the cylinder upside down, so that the connecting rod can be used as a handle. This practice does not give very accurate results owing to the taper of the bore, which is caused by wear. The lapping of the piston should be done in its normal position in order to avoid compression leakage and oil pumping. To do this, a sink plunger will be found convenient, as it can be pressed on the top of the piston firmly and will retain its grip unless the suction cup is defective.

Novel Repair for Cracked Water Jacket on Engine

A cracked water jacket may be repaired satisfactorily as follows: Drill and tap a small hole at the end of the crack. Thread in a copper wire, or rod, and cut it off flush. Next drill another hole beside the first one, and close enough to it, so that the threads of the plug, screwed into it, will lap into the first plug. This process is repeated until the crack is filled. The heads of the plugs are then riveted, to close the small intervening spaces. With careful workmanship, this method will provide a water-tight repair that will give indefinite service.

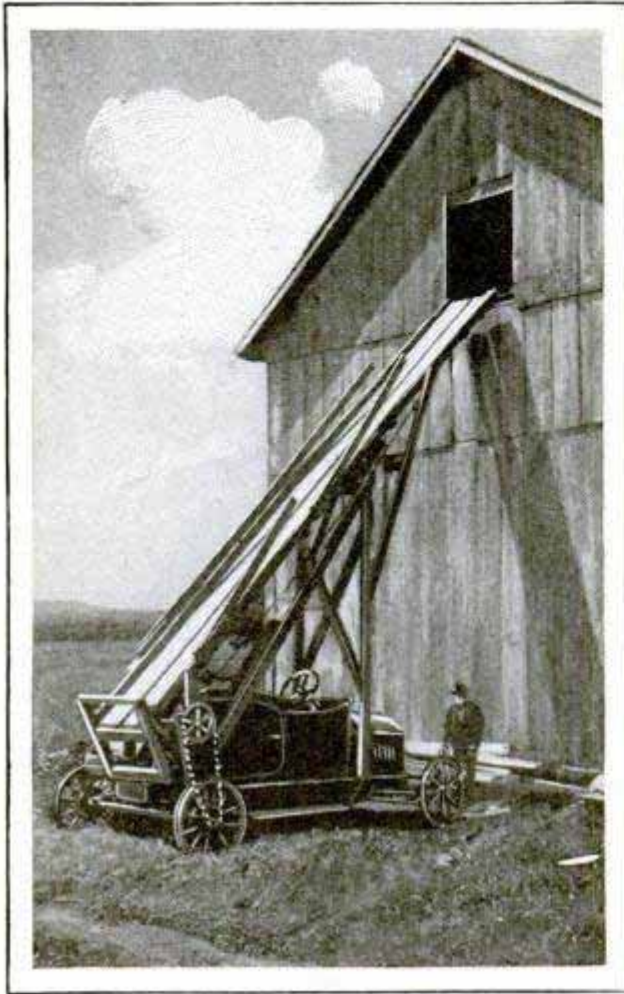

Homemade Baled-Hay Hoist Built on and Powered by an Old Auto

Old Auto Makes Good Hay Hoist

The photo shows a convenient baled-hay hoist built on and powered by an old auto. This contrivance was used with much success on the farm of Russell Brothers, of Winfield, Kans. It consists of a wooden slide extending from the auto at an angle to reach the hay door of the barn. The slide is slotted in the center from the bottom to the top. A hoisting chain, equipped with corn-binder lugs, runs directly under the slot so that the lugs project upward through the slot and engage with the bales that are placed on the slide. The hoisting chain is driven indirectly by means of three sprockets and a second chain, which engages with a sprocket attached to one of the drive wheels of the auto. An adjustable idler sprocket mounted under the slide keeps the chain tight. After a bale of hay is placed on the slide, the first lug that comes along catches the bale and pulls it up. Four wooden spars, mounted over the slide, catch any bale that happens to slip

back and hold it on the slide until the next lug again engages with the bale and carries it up. While the hoist is being operated it is, of course, necessary to jack up the car wheel, to which the driving sprocket is attached. The hoisting speed can be varied by using the gear shift of the car in various positions, and by adjusting the throttle. The hoist shown in the photo raises the bales 20 ft., but it is obvious that a hoist of any practical height can be built and operated in the same way. —Stanley Russell, Winfield, Kans.

Using Plumb Bob in the Wind

When the wind is blowing, accurate measurements with a plumb bob are impossible. The difficulty can be remedied by placing a pail of water so that the bob will be submerged in it. A thin, light line or fine wire should be used for suspending the bob to decrease the wind resistance.—Miss Cleo Conley, Los Angeles, Calif.

Celluloid End Strips Keep Bolts of Cloth Tidy in Store

Dealers in bolts of cloth know the necessity of keeping the bolts tidy. A grimy appearance of the bolt ends can readily be prevented by pieces of white celluloid, cut a trifle shorter and narrower than the bolt boards and attached to the latter with bright-headed thumbtacks as indicated. The bolts are neatly stacked in piles, all at the same angle. It is easy to clean the celluloid ends with a moistened cloth.



Celluloid Endpieces on Bolts of Cloth Eliminate Grimy Appearance

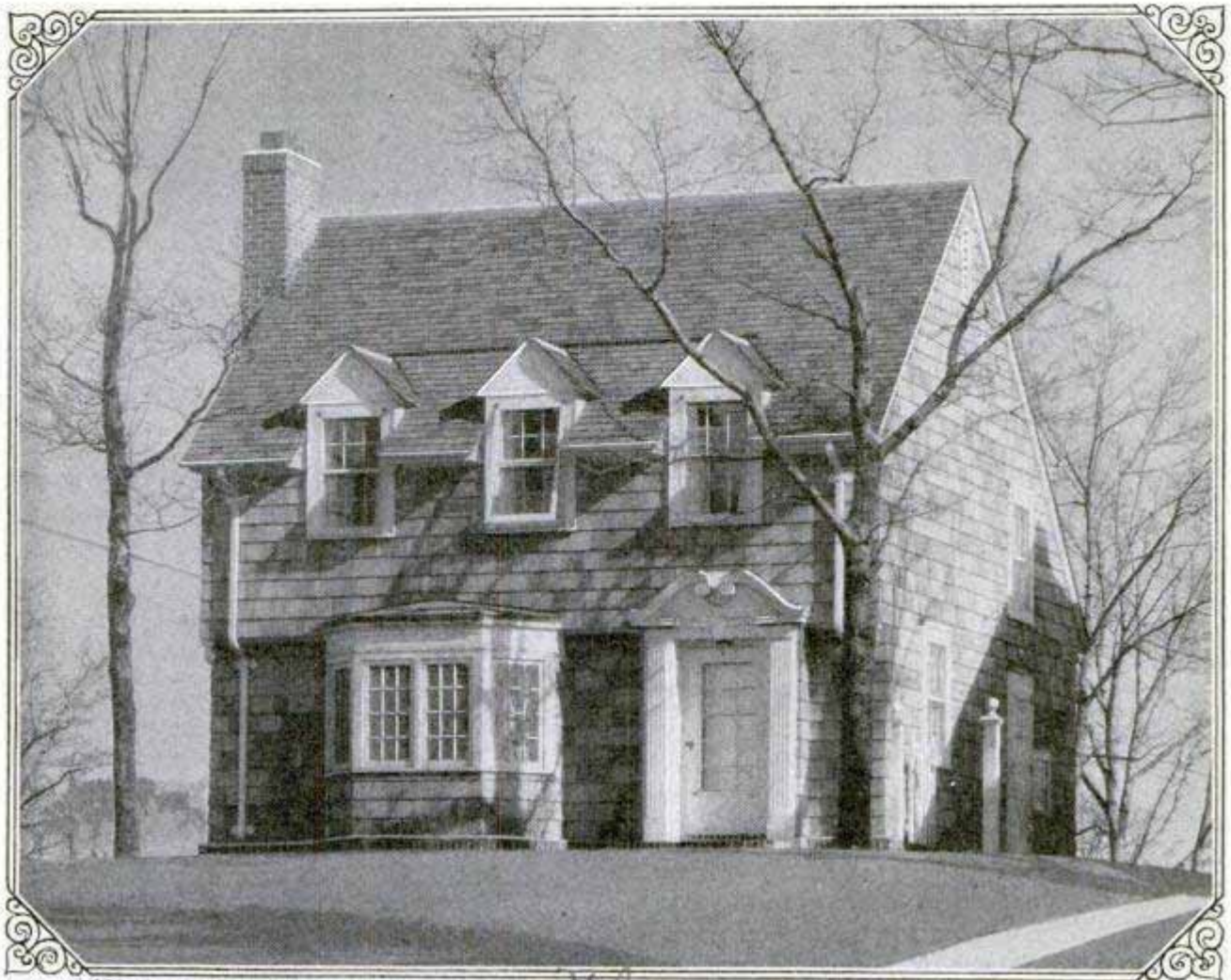

COPYRIGHT POPULAR MECHANICS

PLAN NO. 5-W-14

M. Lagg.

A Style That Never Grows Old

STYLES in houses come and go like styles in cars. You buy a car in the latest style and after you have driven it a little while, it's out of date because the makers have changed the body lines.

When building or buying a house, remember that style is an important factor in protecting your investment. It may be the determining factor in establishing good resale value for your house ten or fifteen years hence. It pays to build in a style as liquid in public approval as a Liberty bond at a bank. Colonial is such a style. Three reasons for its enduring popularity are these: First, in plan and construction colonial is the outgrowth of simple, honest housing

requirements of our forefathers—requirements which in many ways have not changed greatly since the days when Thomas Jefferson built Monticello and Washington lived at Mt. Vernon. Second, colonial is economical to build due to its simplicity in plan and freedom from over-ornamentation; third, it has good proportions.

The early colonial houses were for the most part built of wood, though brick was also used. The house illustrated this month therefore follows tradition. It is patterned after Cape Cod colonial with slight variations here and there that give it the touch of smartness typical of modern tendencies.

HOW TO GET A BLUEPRINT

To help our readers get started on one of life's most glorious experiences—building and owning a home—Popular Mechanics Magazine will supply readers a one-sheet blueprint of any house appearing in the magazine for \$1. This blueprint does away with the necessity of first purchasing a complete set of plans to find out whether you can afford to build. It contains floor plans, elevations, a section detail, size of joists, studs, etc., and also a brief specification. Submit it to tradesmen and dealers for building estimates.

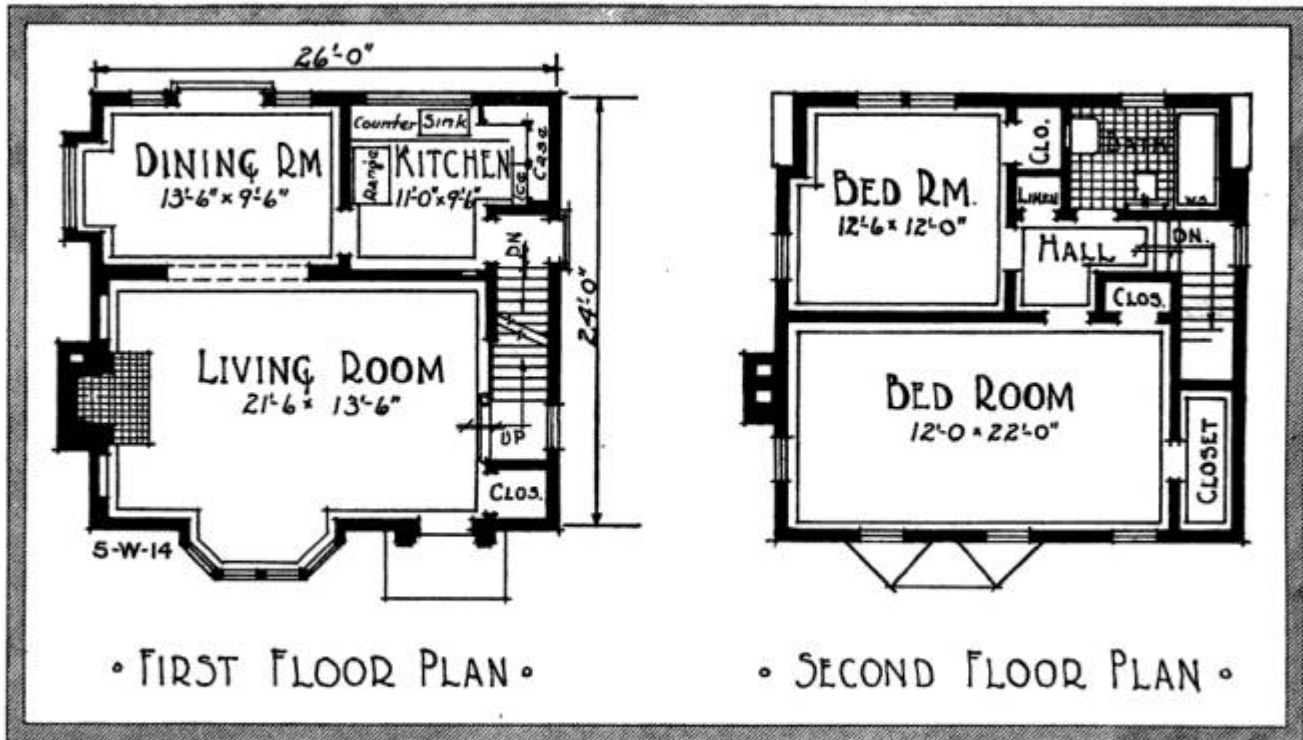

Shingle sidewalls were used extensively in pioneer days. They were called shakes and were hand-made. Modern machine-made shingles are not as crude as the early variety. Today, numerous shingle stains have added color to houses as well as a preservative for the shingles. There are three rules to remember when selecting wood shingles for your house: First, buy edge-grain shingles; second, lay them with rust-resisting nails; third, on the sidewalls of the house expose as much of the shingle as you can pay for.

There are two kinds of wood shingles. One is cut flatwise of a log like a board is cut. These are the less expensive shingles. Others are cut so the surface radiates toward the center of the tree. You will notice lines or ribs running lengthwise of the shingle. When these are used and well nailed, they lie flat and will not curl. The thick butts or ends cast shadows on the sidewall of a house and produce a texture much admired by architects. These shadows form horizontal or parallel lines and have a tendency to make a house appear lower and nearer the ground, melting into and out of the landscape, so to speak.

The colonial house above is a five-room affair planned for a forty-foot lot and a model house in many ways. If you want a third bedroom on the second floor, this may be had by slight rearrangement of

the large bedroom into two somewhat smaller sleeping rooms.

The house is of frame construction, fully insulated, has a full basement and attic space. Both roof and sidewalls are edge-grain red-cedar shingles.

The colonial doorway can be obtained from standard stocks made by various mills, or can be built up to order, and the same is true of other millwork in the house. Trim assembled from standard parts saves the cost of preparing new cutting knives for special orders, and therefore is much cheaper, as a rule.

Here you have a small house in a style that does not grow old and one that should make your dollars buy safe investment as long as the house stands. In round numbers, this is a \$6,000 house complete. Costs, however, will vary, depending upon where you build and the materials you use. The house would look well built of brick, either in skintled pattern or face-brick veneer. It would be difficult to plan a more roomy arrangement in so compact a floor area. Study the plan. It has many excellent qualities.

PLAN BOOK FOR READERS

A NEW BUNGALOW BOOK: Sixteen selected low-cost bungalows in popular styles, at prices ranging from \$5,000 down to \$2,000. Each house fully described and illustrated. Send ten cents in stamps to cover mailing.

"Even expert mechanics," says a tool dealer, "have little idea how fine a hand tool can be made, until they see the new 'Yankee' Bit Brace."

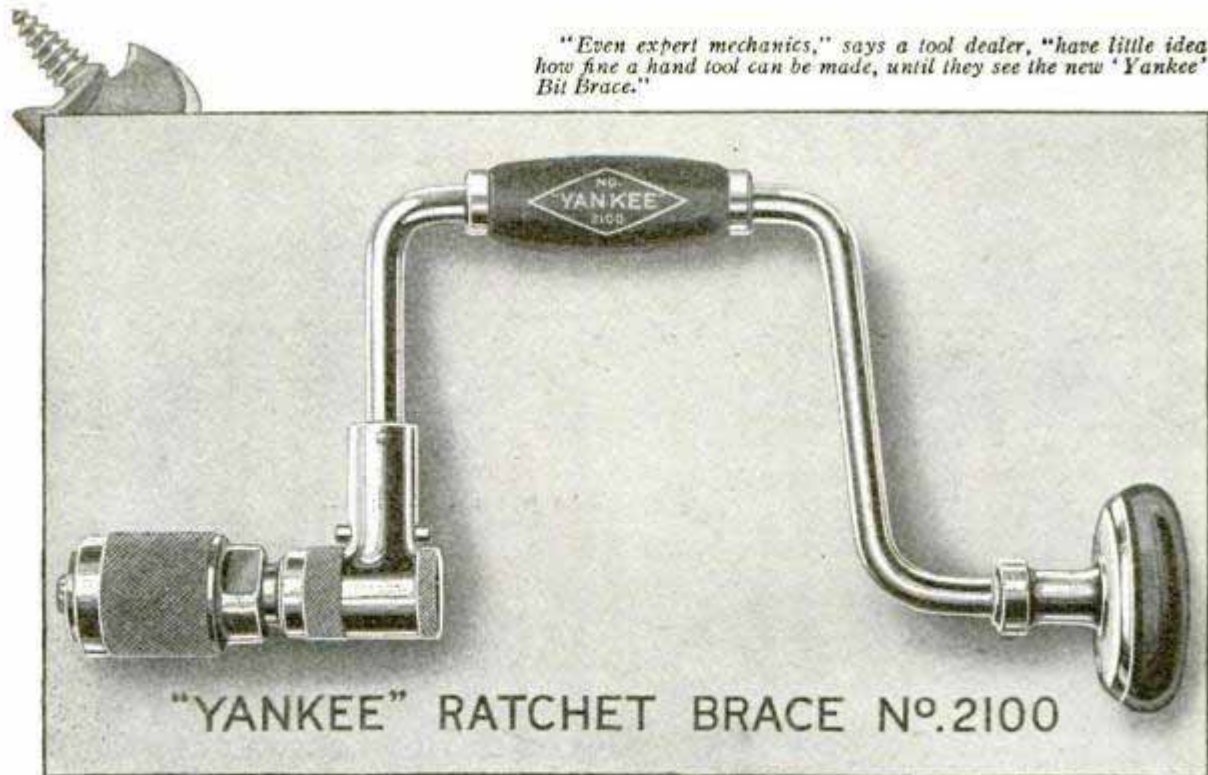

"YANKEE" RATCHET BRACE No. 2100

With famous "Yankee" Ratchet and "Yankee" Chuck

NO NEED to hold chuck to keep from turning back: "Yankee" Ratchet is smooth, silent, powerful. Adjustment is instant, positive, and *visible*. A glance tells how ratchet is set; a finger-touch changes it. Bronze encased—against dust and moisture.

"Yankee" Chuck centers bits accurately; locks and releases instantly. Holds any shape—round, square, any taper; and will not loosen in work.

"Yankee" Hard Rubber Handles (both top and side) do not warp, crack, shrink or bind.

Ask dealer to let you try the "Yankee" Brace. See for yourself the economy of owning the finest tool of its kind. Four sizes: 8, 10, 12, 14 inches. Price, 10-inch sweep, \$8.20.

"YANKEE" Two-jaw chuck
 1/2" round
 3/8" square
 (across corners)

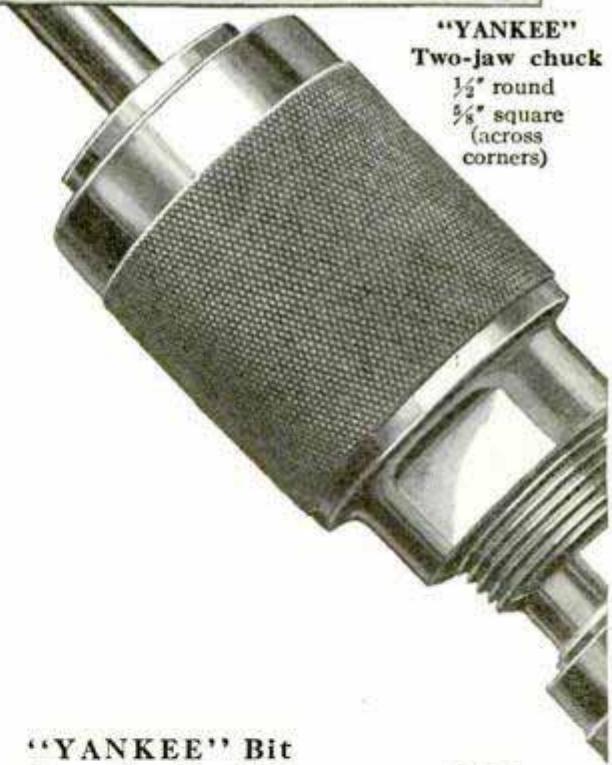

"YANKEE" Bit Extension No. 2150

No jaws. It holds bit in socket! No loosening and pulling out of bit in work. Can't jam. Fits any brace. Follows through. Stands abuse. Four lengths: 15, 18, 21, 24 inches. Prices, \$2.25 to \$2.40.

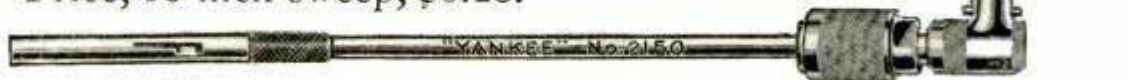

"YANKEE" on the tool you buy means utmost in quality, efficiency and durability.

North Bros. Mfg. Co., Lehigh Avenue, Philadelphia, U. S. A.

Saving time is important to me. You may send book showing *action pictures* of famous "Yankee" Ratchet tools: such as Ratchet Screw-drivers, Spiral Ratchet Screw-drivers, Ratchet Push Drills, Ratchet Push Braces, Ratchet Breast and Hand Drills, Ratchet Chain and Bench Drills, Ratchet Tap Wrenches, Etc.

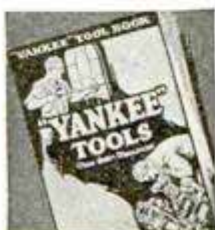

Name.....
 Address..... (pm)

Why wait...

to enjoy a better car?

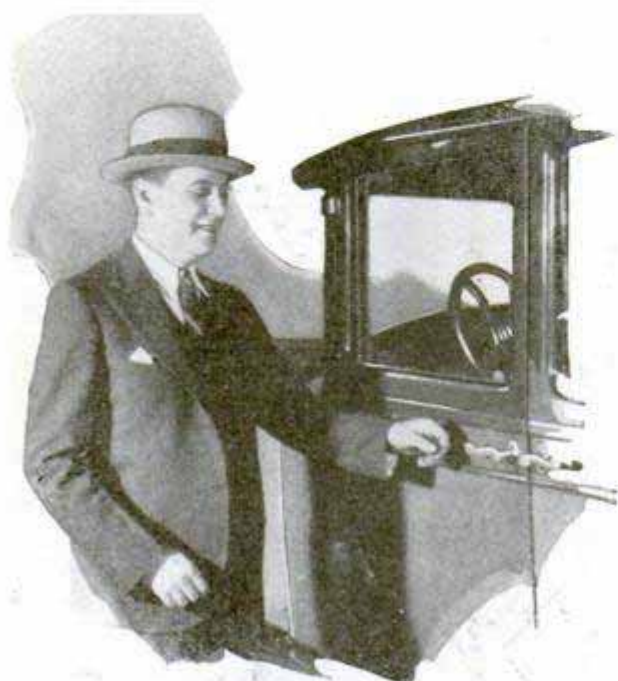

MANY fine quality cars with thousands of unused miles await you at reduced prices. You miss the first and greatest depreciation when you buy a good used car.

Let this free booklet, "How to Judge a Used Car," help you pick the right motor car at the right price. Read this booklet—then buy your used car where you get the full protection of the famous Studebaker Pledge. This Pledge provides five days driving trial with the used car of your choice. Certified cars carry a 30-day guarantee. All prices are marked in plain figures. The Studebaker Pledge is your greatest guarantee of complete satisfaction with the used car you buy.

Don't let false pride or fear of high prices keep you from enjoying a better car. Send for this free booklet *now*—learn what it can teach you—buy your used car under the terms of the Studebaker Pledge—you'll be pleased! Mail the coupon—*now*!



Pledge to the Public on Used Car Sales

- 1 Every used car is conspicuously marked with its lowest price in plain figures, and that price, just as the price of our new cars, is rigidly maintained.
- 2 All Studebaker automobiles which are sold as CERTIFIED CARS have been properly reconditioned, and carry a 30-day guarantee for replacement of defective parts and free service on adjustments.
- 3 Every purchaser of a used car may drive it for five days, and then, if not satisfied for any reason, turn it back and apply the money paid as a credit on the purchase of any other car in stock—new or used. (It is assumed that the car has not been damaged in the meantime.)

© 1924 The Studebaker Corporation of America

THE STUDEBAKER CORPORATION OF AMERICA
Dept. 1511, South Bend, Indiana
Please send me copy of "How to Judge a Used Car"

Name.....

Street.....

City..... State.....

STUDEBAKER

Builder of Champions

How to Use Your Hand Saws

Told by the Makers of "The Saw Most Carpenters Use"

FOR better work, you need Disston Hand Saws, made with Disston skill from Disston Steel: the world's great cutting steel, produced only by Disston in Disston's own steel furnaces. The new Disston Hand Saws are finer now than ever before—improved in every feature. Lighter blades, for easier cutting; narrower blades save user's strength; true-taper ground,

faster cutting; thin, yet stiff; true running; new weatherproof-finish handles; better balanced. They will run with less set, cut faster, cut easier and stay sharp longer, than any other hand saws ever made.

Ask your hardware merchant for Disston Hand Saws! Not only hand saws, but every other type of saws for bench or machine work.



Files for the Metal Worker

Every kind, size and style. A Disston 8-inch Mill File, bastard cut, is fine for sharpening axes, lawn mowers, garden tools, and general work in the home and shop. Excellent for finishing metal surfaces. 25 cents each.



Hints on Using a Hack Saw

For cutting pipes, bolts, nails, curtain rods, etc. Strain blade tight. Cut on forward stroke. Disston No. 36½ Hack Saw Frame takes 8" to 12" blades. \$2.10. Blades, 8", 55c doz.; 10", 65c doz.; 12", 75c doz.



For Finishing Wood Surfaces

For giving a fine finish to your work, removing paint, etc., use a Disston Acme Cabinet Scraper, made of Disston Saw Steel. Made in all needed sizes, 2½" and 2⅞" wide and 5" and 6" long being standard. 30c and up.



USE the right type of saw for the work: a Disston cross-cut saw for cutting across the grain of the wood, and a rip saw for cutting with the grain. The teeth are shaped differently, and work differently. For all-around work, use a cross-cut saw with 8 points to the inch, and a rip saw with 5½ points to the inch.

Keep your saws sharp and set properly. To start the cut, rest blade on waste side of line, support side of blade with left thumb, and draw saw toward you a few times until a slight groove is formed; then cut straight.

In cross-cutting, it is best to maintain an angle of 45° between edge of saw and face of work. Stand so saw, arm and shoulder are in line with cut. In ripping, keep angle of 60° between saw and work. (See illustrations.)

Take long, easy strokes. Don't twist or force blade in the cut. Raise work high enough to keep blade from striking floor. Remember that a Disston saw is a fine tool: do not throw it around. Keep your saw oiled and hung up when not in use.

Good hardware merchants everywhere sell Disston Saws. "The Disston Saw, Tool and File Book," sent free, tells you how to use them most efficiently. Write to us for it.

DISSTON
Makers of "THE SAW MOST CARPENTERS USE"



Teeth of cross-cut saw and proper sawing angle



Teeth of rip saw and proper sawing angle



"The Saw Most Carpenters Use"

The two handiest saws for the home work-shop are the 26-inch 8-point for cross-cutting, and the 26-inch 5½-point for ripping. You will need these on almost every job. The popular "D-S" Lightweights cost \$3.45.



Handiest of All Small Saws

The Back Saw, with fine teeth and stiff back, enables you to do smooth, accurate cutting of mitres, grooves, etc., for making furniture, picture frames, etc. Disston No. 4, 12" size, 3" under back, 14-point, costs \$3.00.



On Your Power Saw Outfit

With a Disston Circular Saw you can do better work. Disston Steel and Temper make a saw cut easier and stay sharp longer. There is a Disston Saw—cross-cut, rip or combination—for your outfit. Made in all sizes.



Every saw user will enjoy reading "The Disston Saw, Tool and File Book," an illustrated manual on the selection, care, and use of tools. It tells how to file and set saws and contains much other helpful information. Sent free. Use the coupon, or write for it.



Henry Disston & Sons, Inc., Philadelphia
(In Canada, address Henry Disston & Sons, Ltd., Toronto)

Please send me "The Disston Saw, Tool and File Book."

Name and Address.....

Your face knows it's winter..

*And so does your
Gillette Blade, for it
has extra work to do*

THE biting winds of winter contract your skin, make it rough—hard to shave. Your razor then has a far more difficult job to do than it has in summer.

Yet you can always get a comfortable shave, no matter what the weather does to your face. Why?

Because your smooth, sure Gillette Blade never changes, under *any* conditions. It can't. Machines, accurate to one ten-thousandth of an inch, ensure its even precision.

Four out of every nine employees in the Gillette blade department are skilled inspectors who actually receive a bonus for every blade they discard.

You may not wear the same face in November that you do in May, but count on Gillette Blades to shave you smoothly, swiftly, surely. They keep your face feeling young, and looking it. Gillette Safety Razor Co., Boston, U. S. A.

★ Gillette ★

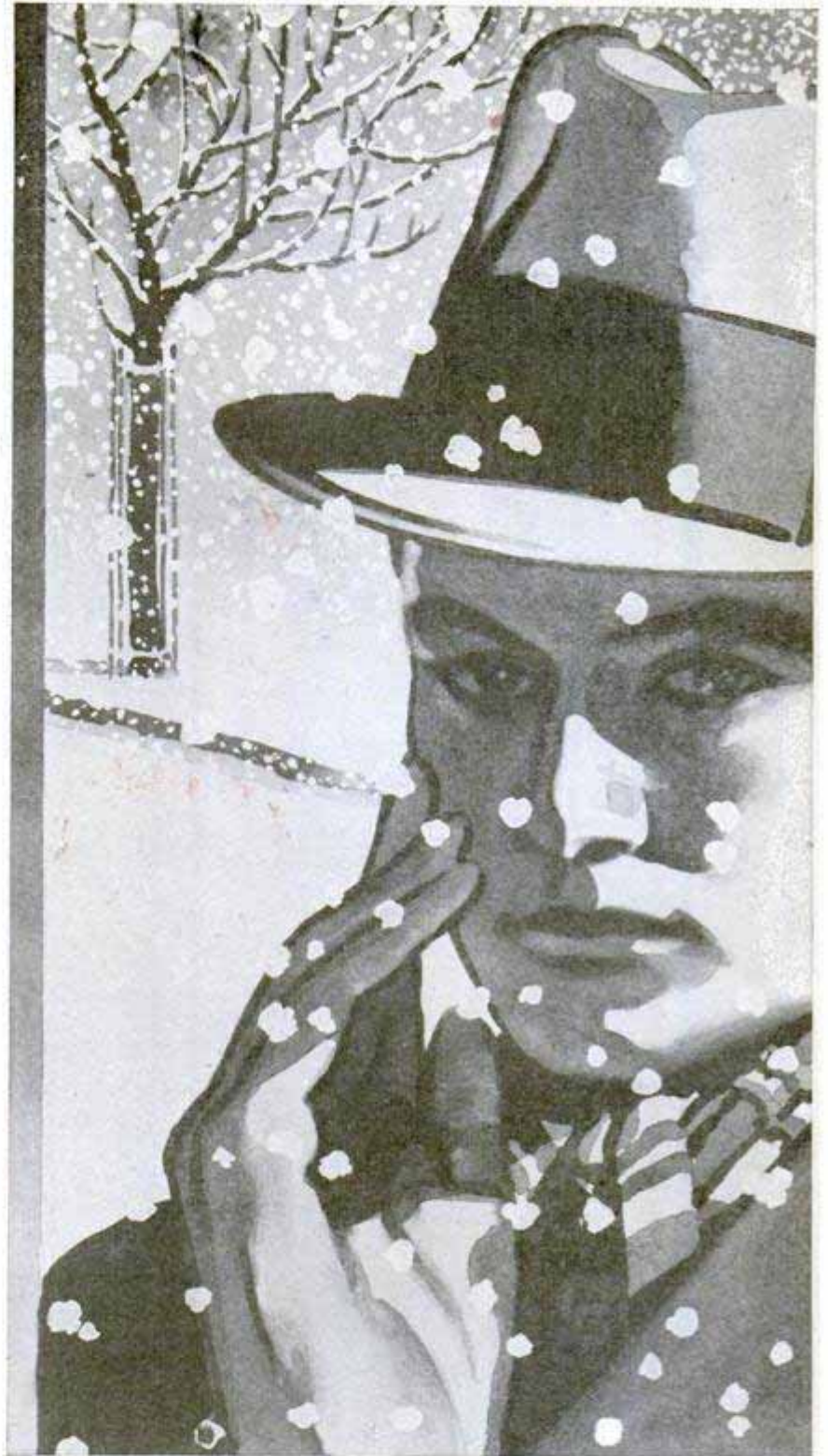

There's a lot of difference between the cold, wind-stiffened skin of late autumn and the tanned, freely perspiring face of July — and it makes a lot of difference in shaving. Yet it's easy to enjoy shaving comfort all the year round. Simply take ample time to soften your beard. And use a *fresh* Gillette Blade frequently.



King C. Gillette

THE only individual in history, ancient or modern, whose picture and signature are found in every city and town, in every country in the world, is King C. Gillette.

This picture and signature are universal sign-language for a perfect shave.

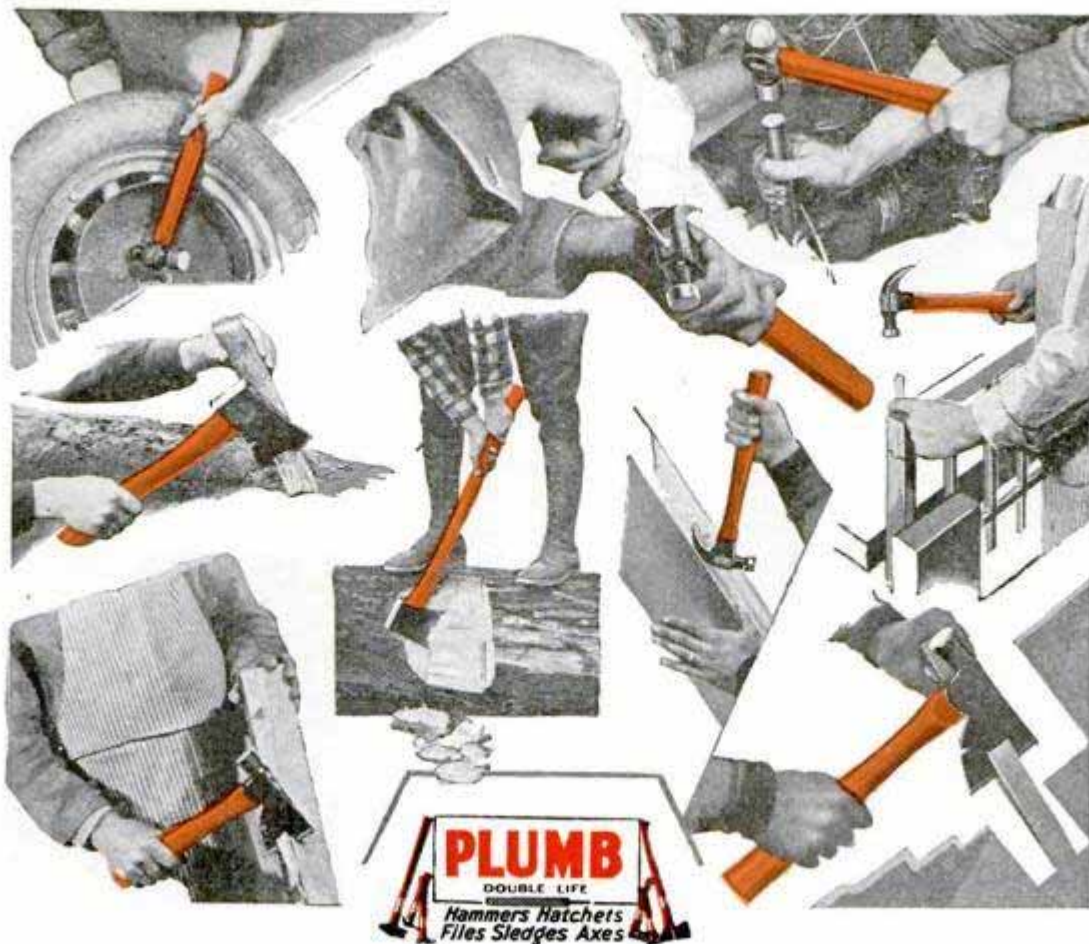

When expert hands need the finest tools...

WHEN the expert, with the skilled hand and exacting eye, acquired through years of training—needs the finest tools... How can the handy-man or amateur afford to waste time and bungle work with cheap ones?

There's a rhythm in working with fine tools. The long, easy swing of a Plumb Tool is perfectly balanced with your arm; gives you a feeling of confidence; adds a zest to your job.

There's the Plumb Hammer—the tool of expert carpenters. Its balanced head controls your blows; its knifelike claws grip and pull even a headless brad.

Or the Plumb Axe—used exclusively by Peter McLaren, Champion Chopper of America, because its sharp blade cuts faster and holds a keen edge longer than any other axe.

Or Plumb's Scout Axe—adopted as *Official* by The Boy Scouts of America. A fine tool for chopping and pounding for scouts, motorists, campers and home craftsmen.

Or the Plumb Hatchet and Ball Pein Hammer, favorites of carpenters, machinists and auto mechanics.

Fine tools—for expert or amateur. Their gleaming Red Handles and Polished Black Heads reflect the judgment of tool users everywhere.

They last a lifetime—and the handles are always tight: Plumb's invention—the screw-wedge takes up any shrinkage in the handle, just by a turn of the screw.

Your hardware man is a tool expert. Ask him about the Plumb Tools you should own.

Special Offer to readers of Popular Mechanics

Peter McLaren, America's Champion Chopper, will autograph personally a copy of his book—*The Axe Manual of Peter McLaren*—for every reader mailing the coupon with the regular price of 25c. An amazing book revealing secrets of axe care and use which every man who uses tools should have. 84 pages, well bound and illustrated. Thousands sold to scouts, woodsmen and mechanics.



FAYETTE R. PLUMB, Inc., Phila., U. S. A.

Enclosed find 25c. Send me a copy of the *Axe Manual* of Peter McLaren—autographed personally by the author.

Name

Address

WHOOPEE on Wheels!

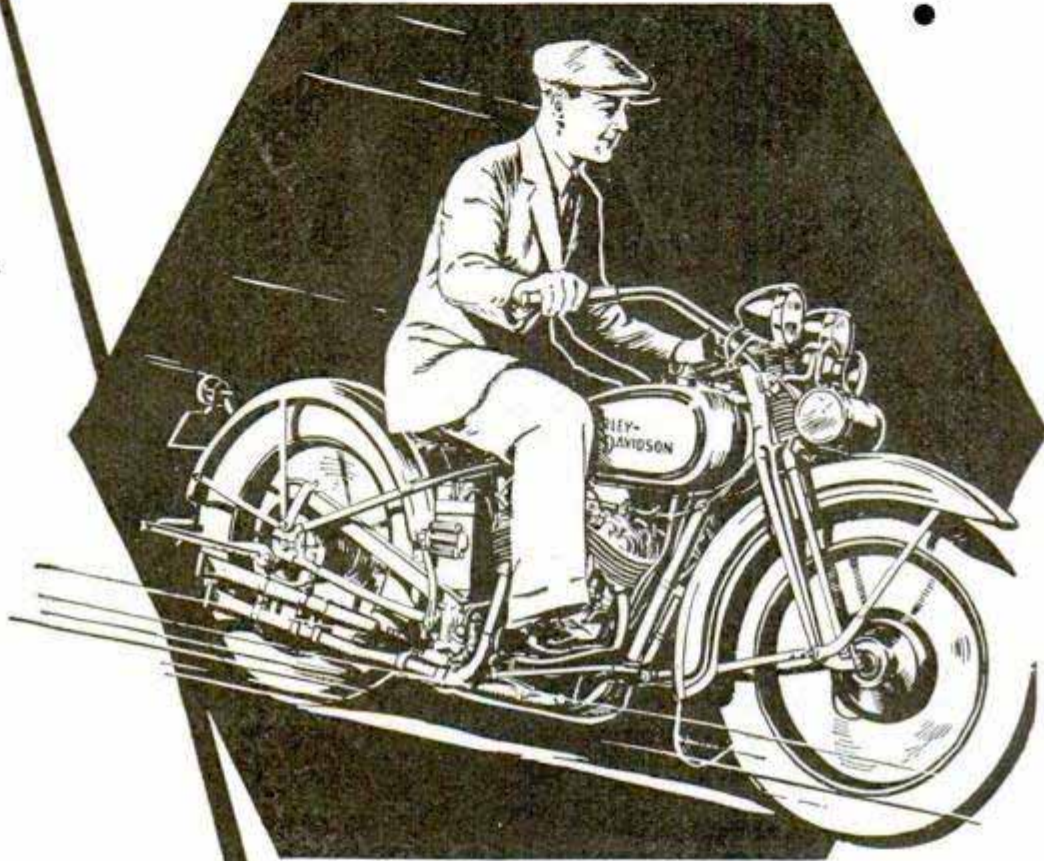

6
Important
Improvements
for 1930

WHOOOPEE that's healthful — motor-
cycling, sport of a thousand thrills!
Whirling wheels on a winding road—motor that
purrs when it's working hard, and whispers at
racing speed!

Ride away on a "45" Twin, 1930 model, and
revel in motorcycling at its best. On long tour or
short ride, you'll enjoy every mile — and the
miles will cost you almost nothing.

*Your dealer wants to show you the
1930 models. See him today—ask
about his Pay-As-You-Ride Plan.*

HARLEY-DAVIDSON Motorcycles

*Mail this
Coupon!*

—for literature show-
ing our Singles and
Twins for 1930.

HARLEY-DAVIDSON MOTOR CO. Dept. P., Milwaukee, Wis.
Interested in your motorcycles. Send literature.

Name.....

Address.....

My age is 12-15 years 16-19 years 20-30 years 31
years and up. Check your age group.

What is that "KNOCK"?

This is what happens in the cylinder of a gasoline engine when it is running smoothly. The pressure gradually increases after ignition until the mixture is nearly all burned. Then it grows less and less.

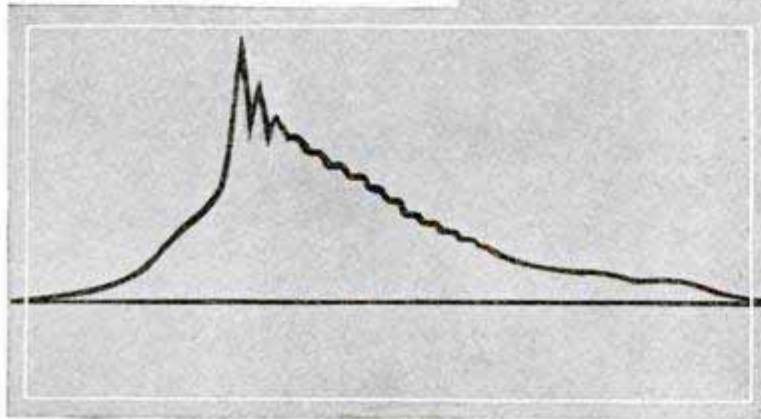
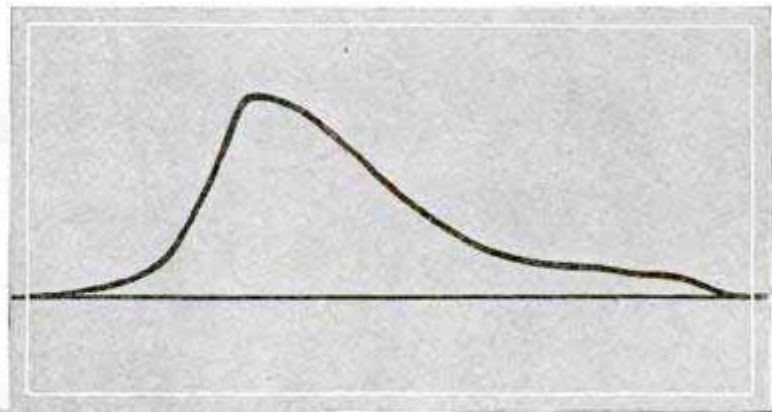

But when the gasoline is causing the engine to "knock," just see what happens. Is it any wonder that the engine loses power? Ethyl Gasoline prevents that jagged saw-tooth by "knocking out that knock."



THE "knock" was a mystery in the automotive world until the scientists in General Motors Research Laboratories started on its trail. Before they finished they not only found what that elusive "knock" was, but were actually able to take a picture of it! This was made possible by the development of the Midgley Indicator, which records the pressure inside the cylinder of a gasoline engine.

It showed that gasoline, when compressed beyond certain limits, explodes too fast—that is, "knocks" and loses power. Then the problem was to find something to mix with gasoline to control its combustion rate as

compression was raised. After years of research it was found that Ethyl fluid, containing tetraethyl lead, was the solution.

Today leading oil companies mix Ethyl fluid with their gasoline to form Ethyl Gasoline. Ethyl made possible the engines of higher compression now on the market. By eliminating "knock" in engines of average compression it brings out additional power, gives them a new resiliency and nimbleness impossible to obtain with ordinary gasoline. Ride with Ethyl today.

ETHYL GASOLINE CORPORATION, 25 Broadway, N. Y. C.
56 Church St., Toronto, Can., 36 Queen Anne's Gate, London, Eng.

ETHYL

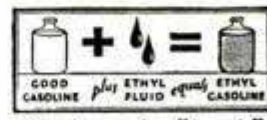

GASOLINE

FIRST FOR 62 YEARS

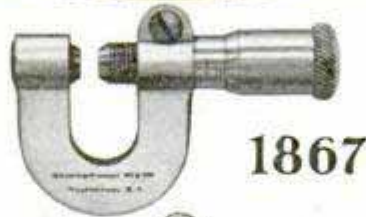

1867



1877

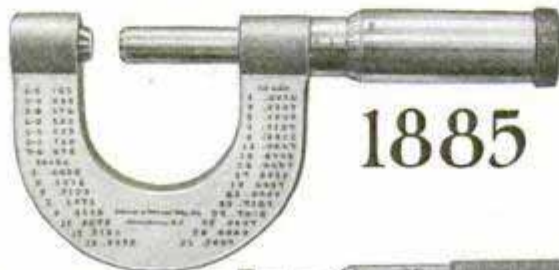

1885



1929

THE FIRST Brown & Sharpe Micrometer Caliper was made in 1867. At that time it was received as an important contribution to the science of accurate measurement.

Since that time constant improvements and new models have kept up with the demands for closer limits of accuracy.

Today, the Brown & Sharpe line of micrometers includes a variety of models and sizes to fit every requirement. Many of these meas-

ure to ten-thousandths of an inch. The preference for Brown & Sharpe Tools by skilled mechanics the world over has been built upon years of satisfactory use on every conceivable kind of precision work.

Our new Small Tool Catalog No. 31 illustrates over 2300 useful tools, including over 400 different micrometers. Ask your hardware dealer for a copy or write to us. Address Dept. P. M., Brown & Sharpe Mfg. Co., Providence, R. I. U. S. A.



"WORLD'S STANDARD OF ACCURACY"

BROWN & SHARPE TOOLS

Compare its mechanical features with those of any other low-priced six

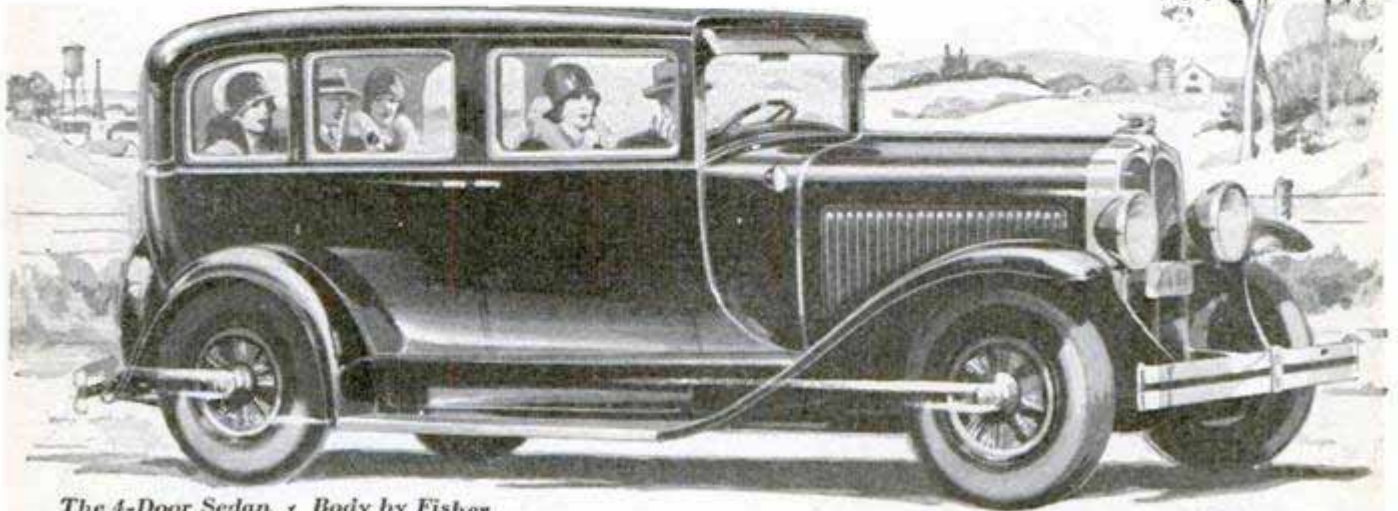

The 4-Door Sedan / Body by Fisher

1. A 200-cubic-inch L-head engine.
2. The Harmonic Balancer.
3. The G-M-R cylinder head.
4. The cross-flow radiator.
5. Automatic temperature control.
6. Fully counter-weighted crankshaft.
7. Airplane type interchangeable bronze-backed main bearings.
8. A 1 $\frac{1}{4}$ -inch carburetor with internal economizer and accelerating pump.
9. Gasoline pump, introduced by Oakland.
10. Patented expansion-type piston pins.
11. Full-pressure lubrication.
12. Crankcase ventilating system.
13. Internal-expanding four-wheel service brakes of the most efficient type.
14. Special moulded, brake bands. Positively no squeaking when stopping.
15. Coincidental ignition and transmission lock.
16. Individually mounted instruments, including gasoline gauge.
17. Foot-controlled headlights.
18. Small wheels with ten massive spokes.

A most convincing method of testing Pontiac's value is to compare the mechanical features of the Pontiac Big Six with those of other cars in its price field. Here are 18 of these features—each one an important factor in Pontiac's long life, dependability and big car performance. Put them side by side with the mechanical features of any car selling for less than \$1100. The more familiar you are with automobiles and their construction, the more quickly will such a comparison cause you to recognize the exceptional value offered by the Pontiac Big Six at \$745.

Ask your Oakland-Pontiac dealer about Pontiac's many other unusual features—particularly about those responsible for its wonderfully low cost of maintenance and operation. And let him appraise the car you are driving. You will be surprised when you see the actual figures and learn how economically and conveniently you can own and enjoy the Pontiac Big Six.

Pontiac Big Six, \$745 to \$895, f. o. b. Pontiac, Michigan, plus delivery charges.

OAKLAND MOTOR CAR CO., PONTIAC, MICH.

PONTIAC

BIG SIX

PRODUCT OF
GENERAL MOTORS

\$745
2-DOOR SEDAN
F. O. B. PONTIAC, MICH.

Announcing— The NEW 1930 Models

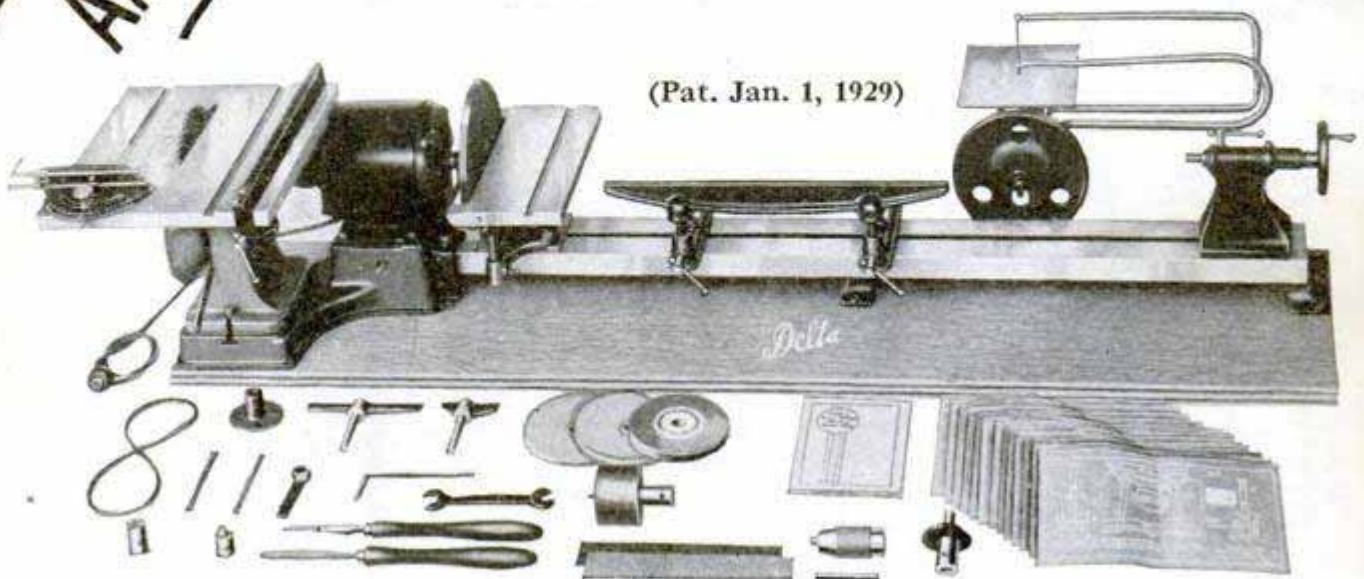

"Delta" Electric Handi-Shop

A complete motorized workshop for craftsmen including all necessary equipment for Circular Sawing, Wood Turning, Scroll Sawing, Sanding, Drilling, Grinding and Buffing. Full instructions and blue prints furnished.

New "DELTA" Moulding Cutter

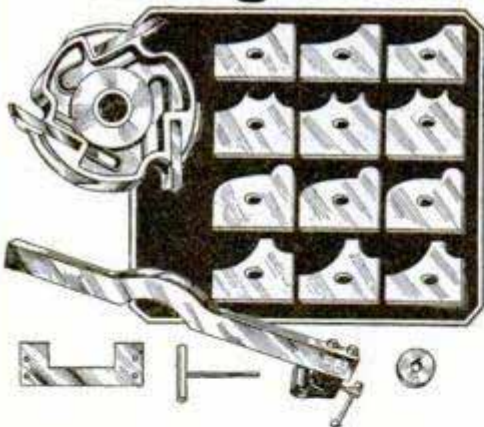

Cuts Over 50 Moulding Shapes With Only 4 Sets of Blades

Interchangeable high speed blades produce over 10,000 cuts per minute at 3500 RPM. Blades require no individual adjustment. Quickly and easily locked in position. Special guide fence. Unusually low price. Below are a few of the many attractive mouldings that can be made with this Delta Moulding Cutter.



Practical Design—Dependable Quality Plus Many Exclusive Features

that's what you find in every woodworking unit bearing the Delta trademark. Craftsmen, artisans, farmers, mechanics—all who use wood in their daily labors or spare-time hobbies—are delighted with the sturdy construction, splendid efficiency and moderate cost of Delta equipment. They appreciate keenly such practical constructional features in the Handi-Shop as:

1. Two-shaft motor that permits carrying on two important operations at one time without continually dismantling set-up.
2. Heavy U-shaped Lathe Bed (no rods) guaranteed not to chatter.
3. Automatically Oiled Bronze Bearings.
4. Patented Tilting-Tables.
5. Circular-Saw Raising lever.
6. Absence of interference when sawing large pieces of lumber; and many other important improvements found only in Delta products.

10-DAY TRIAL EASY TERMS

For complete details and full description of the new 1930 Delta line, send coupon for FREE illustrated literature. You will learn also how you can try any Delta equipment for 10 days under actual working conditions at our risk. Your choice of three convenient payment plans. Mail coupon on opposite page today. It describes numerous items of interest to those who work with wood.

Delta SPECIALTY Co.

Delta Woodworking Units

for HOME CRAFTSMEN, FACTORIES,
SHOPS, CONTRACTORS AND FARMERS

The introduction of the Delta Jointer and Circular Saw Units marks a new era in moderate-priced woodworking equipment. Now, for the first time, are available sturdy, practical machines in compact, convenient form at price levels astonishingly low. The new Delta Units include:

Combination 4-Inch Jointer 8-Inch Circular Saw Motor Driven

A convenient, efficient combination. Permits sawing, sizing, and smoothing in one quick operation. Both Jointer and Circular Saw are run from the same motor with separate belts. Neither Unit interferes with other. Can be operated together or separately. Mounted on sturdy welded steel stand of convenient height. A rugged portable outfit at an attractive low price. Furnished with or without motor as desired.

4-Inch Jointer Unit

Consists of new Delta 4-inch Jointer mounted on separate welded steel stand. Produces smoothly finished work in surprisingly short time. Built to give years of satisfactory dependable service on production work. Incorporates numerous exclusive features such as Self-Aligning Fence with accurate graduations permitting fence to be set quickly at any angle from 0°-45°; Fool-proof guard; Automatically-oiled bronzed bearings; Non-slipping V-belt drive. Furnished with or without motor.

8-Inch Circular Saw Unit

Consists of new Delta 8-inch circular saw on gracefully designed welded steel stand. Practical design and sturdy construction make it ideal for steady production work. Has Automatically-oiled bronze bearings; Patented tilting table; practical Miter-gage and Rip gage; Raising and Lowering Crank Screw permitting micrometer-like adjustment; V-belt drive. Furnished with or without motor.



4-Inch
Jointer
Unit

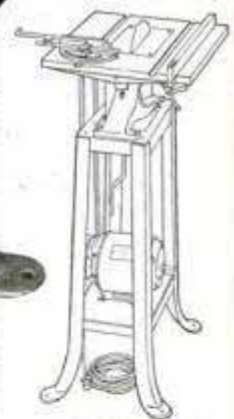

8-Inch
Circular
Saw Unit

"DELTA"
Means Quality in
Every Detail

Send coupon today for FREE Illustrated Literature showing many items of interest to those who work with wood.

Dept. A.119

Division of Delta Manufacturing Co.
1661-67 HOLTON ST. MILWAUKEE, WIS.

Delta Specialty Co., Dept. A.119
Division of "Delta Manufacturing Co."
1661-67 Holton St., Milwaukee, Wis.

Please send me without obligation, FREE illustrated literature showing new 1930 Delta line. Also full details of your 10 day trial offer and easy terms.

(Check proper square)

- I am particularly interested in Delta Electric Handi-Shop.
 I am interested in new Delta Woodworking Units.

Name.....

Address.....



Where's the can of PLASTIC WOOD?

(Reg. U. S. Pat. Off.)

The leg has split and the caster is off—it's hard on floors, furniture and tempers. But Plastic Wood, forced into the split and the socket, will hold the caster firm again. This amazing product—that Handles like Putty and Hardens into Wood—also holds fast to metal, plaster, fabric, tile, porcelain or glass! It is ideal for filling in furniture dents and gouges, too, and can be stained, painted or lacquered to any desired color. Waterproof and greaseproof.

Waterproof Tile Cement

For the bathroom, when tile or porcelain splits, cracks open up around the tiles, or a wall fixture comes loose, Plastic Wood White Waterproof Tile Cement is of immediate value. It will hold broken pieces, seal cracks, is impervious to water, and dries to a hard flat white. At the same prices as Plastic Wood.

Plastic Wood Solvent

Plastic Wood dries rapidly, and often when using it becomes necessary to soften or thin it. Plastic Wood Solvent will renew the wood that has started to dry or will clean tools after using. In 25 and 50-cent cans at your dealer's.

Handles
Like
Putty



Hardens
Into
Wood

1 lb. can \$1.00

¼ lb. can 35 cts.

At Hardware and Paint Stores

ADDISON-LESLIE CO., 421 Bolivar St., Canton, Mass.

PAINT with ELECTRICITY

the New and EASY WAY

THE Paint-O-Mister

THE EVEN PRESSURE SPRAYING MACHINE

The latest development in an electric cup gun spraying machine—The Paint-O-Mister. Made by the makers of the Atomaster. A larger, more powerful, more durable machine. Maintains an air pressure of 25 to 30 pounds.

Sprays paint, lacquer, varnish, disinfectants, insecticides. For use in the home, factory, garage, dairy, farm, sign shop, boat yard, greenhouse, etc.

Write for Booklet **\$39.50 complete**
At your dealer's—or from us.

THE ATOMISTER CORPORATION
32 Hamilton St., Rahway, N. J.

YOU Can Stage This Thrilling Race

Picture a giant aeroplane roaring through space in a race with Major Seagrave's world's record-breaking monster racing car—the "Golden Arrow!"

You Can Stage a Race Like This With Toys

You can have the Kingsbury "Golden Arrow," a 21-inch exact copy in shape, color, all the details—even genuine rubber tires—made by Dunlop. Beautifully built, all of steel, equipped with extra powerful clock-spring racing motor, \$3. (West of Mississippi, \$3.30.)

And you can have the Kingsbury "Silver Arrow"—the most sensational flying plane in years. It may be launched by hand and it "takes off" from the ground. See it speed away over the rooftops, banking, diving and dipping on a long continuous flight. Not a construction toy but a fully built plane. A few moments to assemble and it's ready to fly. Wings and body of Balsa wood, reinforced with aluminum braces; aluminum propeller; strong elastic motor. (Two Models: No. 1, Racing Type, 18 in. wing spread, \$1; No. 2, Racing Type, 24 in. wing spread, \$2. (West of Miss., \$1.10 and \$2.20.) If your dealer hasn't these thrilling Kingsbury toys, order direct. Kingsbury Mfg. Co., 331 Myrtle St., Keene, N. H.

KINGSBURY MOTOR DRIVEN TOYS

Send 10c for unique eraser. A disc wheel from a Kingsbury toy.



With "balloon" tire of fine eraser rubber. Toy Catalog Free.



LePage's Third Home Work Shop Book, only 10 cents, Shows How to Make These 20 Projects

Cape Cod Chest of Drawers, Alexandria Nest of Tables, Old Salem Ship's Cupboard, Plymouth Built-In China Closet, Lady Washington Sewing Cabinet, Set-Back Book Shelves, Modernistic Desk, Modernistic Table, Modernistic Folding Screen, Modernistic Fire Screen, Chess and Checkers Table, Smoking Table, Caned Side Chair, China or Book Cabinet, Book Trough and Magazine Stand, Magazine Carrier, Vanity Case, Book Stand, Fernery Stand and Folding Sewing Screen.

Job Plans 10 cents each. Order by Number as indicated in Coupon.

- 16 Sheraton Writing Desk
- 17 Sheraton Desk Chair
- 18 Colonial Hanging Book Shelves
- 19 Smoking and Reading Cabinet
- 20 Colonial Mirror
- 21 Tea Wagon
- 22 Telephone Cabinet
- 23 Stool for Telephone Cabinet
- 24 Manual Training Work Bench
- 25 Home Worker's Tool Cabinet
- 26 Spanish Galleon
- 27 Vanity Table



Smoking-Reading Cabinet

LePage's Complete Plans and Instructions Show You How to Make it Yourself

Rolled beside a comfortable chair this handsome, convenient cabinet brings your favorite books and magazines and favorite smoking things in easy reach for an evening of solid comfort. It even holds your book for you. The door of the smoking compartment when open becomes an adjustable book rest. And you can make it yourself—easily—by following the instructions in LePage's Job Plan No. 19.

Expert Instructions

You have expert instruction to guide you. The design, dimension drawing, photograph, step-by-step directions and the actual furniture itself was made by William W. Klenke, Instructor in Woodworking, Central Commercial and Manual Training High School, Newark, New Jersey. His experience as an expert gives assurance that this project and the directions

for making it are thoroughly practical.

To make the Cabinet as shown in the illustration, order LePage's Job Plan No. 19 at 10 cents. Look over the contents of LePage's book and the Job Plans available as shown in the column at the left. The price of the book is 10 cents. The Job Plans are 10 cents each and are for projects requiring more elaborate instructions than those shown in the Book. In all cases the instruction consists of printed step-by-step directions, dimension drawings or full-size patterns, and a photograph of the finished article.

Send 10 cents for LePage's Third Home Work Shop Book

Simply use the coupon below, sending it to us with 10 cents in coin or stamps, and we will at once send you a copy of this latest LePage's Book, postage paid.

**Mail
This
Coupon**

**LE PAGE'S
GLUE**
HANDIEST TOOL IN YOUR WORKSHOP

LEPAGE'S CRAFT LEAGUE

723 Essex Ave., Gloucester, Mass.

Gentlemen: Enclosed please find 10 cents (coin or stamps) in payment for LePage's New Third Home Work Shop Book. Please send a copy of this book to:

Name.....

Street.....

City..... State.....

Please also send the following Job Plans.....(indicate by number those you want. See column at left), for each of which I enclose an additional 10 cents.

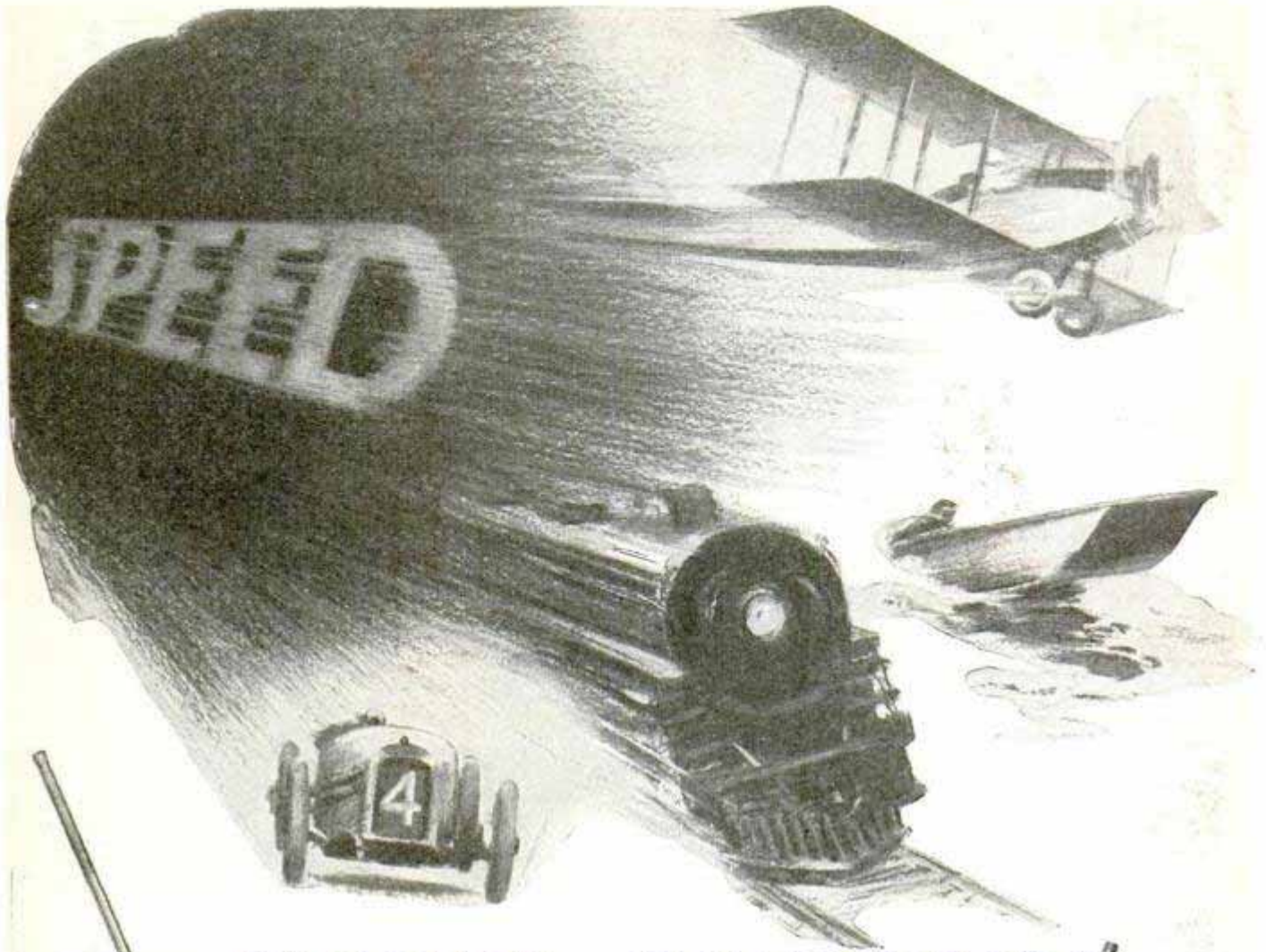

— means accuracy

Starrett Cylinder Gage No. 452B



Starrett Tools offer you the same swift, sure results that have made them the standard wherever accurate work is done.

For your work — on the job or at home — if you want the genuine, ask your dealer for Starrett Tools.

Send for Catalog No. 24 "AP" free on request.

THE L. S. STARRETT CO.

World's Greatest Toolmakers
Manufacturers of Hacksaws Unexcelled
Steel Tapes—Standard for Accuracy
ATHOL, MASS., U. S. A.

Starrett Combination Square No. 94



Starrett High Speed Hacksaw Blades

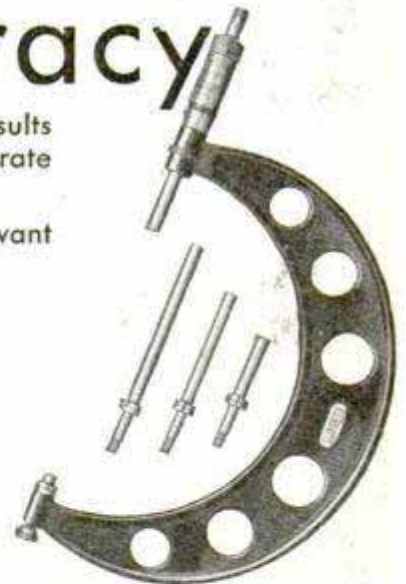

Starrett Micrometer No 224AA



Use Starrett Tools

The New 1930 Waco Red Jacket

INVITES YOU TO BE A REAL CRAFTSMAN

Enjoy the thrill of your new skill in making things this modern motorized way!

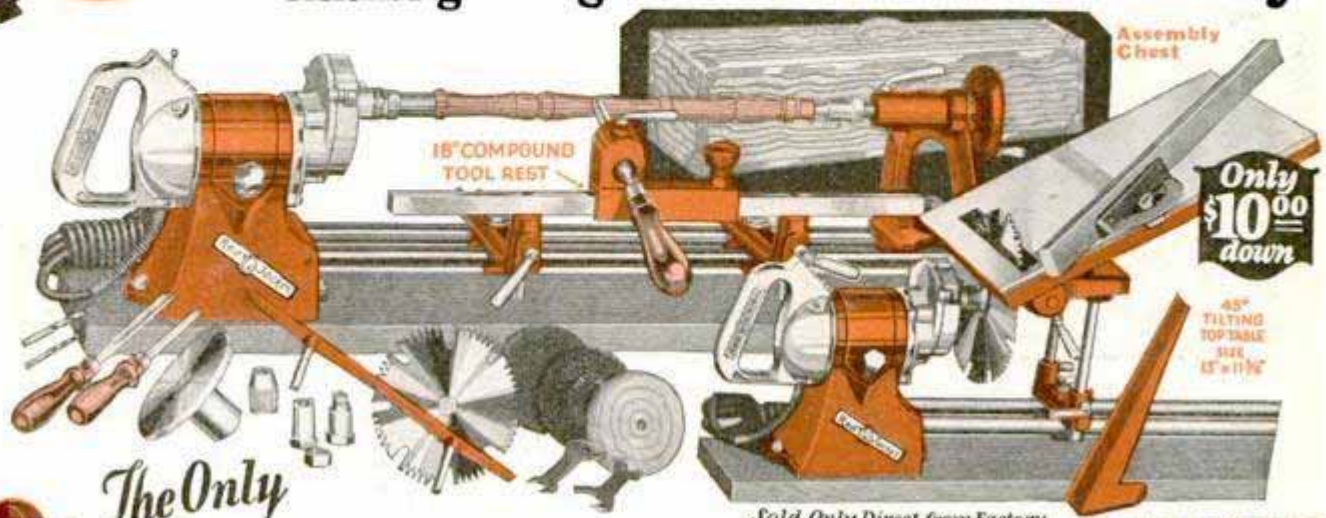

Assembly Chest

18" COMPOUND TOOL REST

Only \$10.00 down

45° TILTING TOP TABLE SIZE 15" x 11 1/2"

Sold Only Direct from Factory

The Only

Complete Interchangeable Power Shop - Improved Features - Exclusive Advantages

The right kind of tool-equipment is even more necessary than your own ability and desire. Now, you can do the things you long have wanted to—at home in your own modern motorized work shop—with this new, improved Waco Red Jacket Wonder-Shop. No other compares with it in its complete, interchangeable, power features, efficiency, exclusive advantages and quality.

Join the Happy Family of Waco Wonder-Shop Workers

Red Jacket Equipment is designed, tested, approved and guaranteed by Wm. L. Aylward, a nationally known craftsman and manufacturer who has developed his own life's hobby into a cooperative association of thousands of amateur and professional craftsmen. He invites you to join. He will instruct, guide and help you. A new zest in doing things awaits you.

The new 1930 Red Jacket Combination brings you the powerful Red Jacket Master Drill Motor with direct drive to the Waco Craftsman's Wood Turning Lathe (capacity 9" x 36"), Compound and 18" Rests, Tilting Top Mitre Saw with both depth and side gauges, Sander Disk, Scroll and Jig Saw, improved Band Saw, and all accessories for both portable and stationary power drilling, buffing, grinding and cleaning. Attaches to light socket. Converts your work bench into a complete private tool and machine shop—a complete chest full of electrically driven tools for your own private use.

Add New Special Equipment Any Time as Desired

Take your choice of four different assemblies to fit your present ideas and uses. Any time you wish to expand or add new special equipment you can do so. The Waco Red Jacket Assortment is the most complete available anywhere. Avoid Imitations! Waco Red Jacket is the pioneer—foremost in the field—sold only direct from the factory; not through stores.

Professional Quality and Efficiency

The choice of professional as well as home craftsmen. Red Jacket Shops are making money for their owners all over the country. You can be one of the Red Jacket Guild chain and market your products if you want under our new plan.

Buy It NOW On Easy Terms

Only \$10 down. Easy monthly payments. Liberal discount for cash. No hardship to own a Waco Red Jacket. You can make it more than pay its way in profits if you want, as well as in the pleasure of doing things for yourself.

Send NOW This Coupon for Interesting Literature

FREE Detailed descriptions and specifications. You will be surprised and fascinated by the possibilities afforded. Just see what you can make and do. Fill in and MAIL TODAY.

WACO TOOL WORKS, Inc. 5216 W. Kinzie St., Chicago, Ill. Manager, Dept. 111: Please send me all free information and literature on Red Jacket Assemblies and FREE Services.

Name.....
Address.....
City and State.....

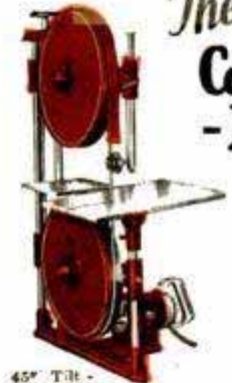

45° Tilt - Top Table Band Saw

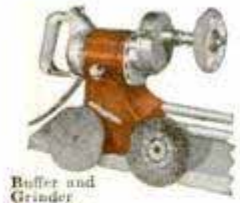

Buffer and Grinder Assembly



Belt Drive Jig Saw

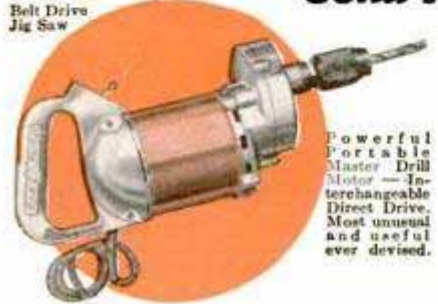

Powerful Portable Master Drill Motor — Interchangeable Direct Drive. Most unusual and useful ever devised.



Auxiliary Head Stock—For any kind of power hook-up.

Make Them Yourself!



Special Craft Course FREE

All there is to know about handicraft methods, raw materials, carving, turning, sawing, designing, etc., etc., is taught you by correspondence.

FREE Blue Prints

The WACO GUARANTEE

If it is not what you want when you get it — send it back.

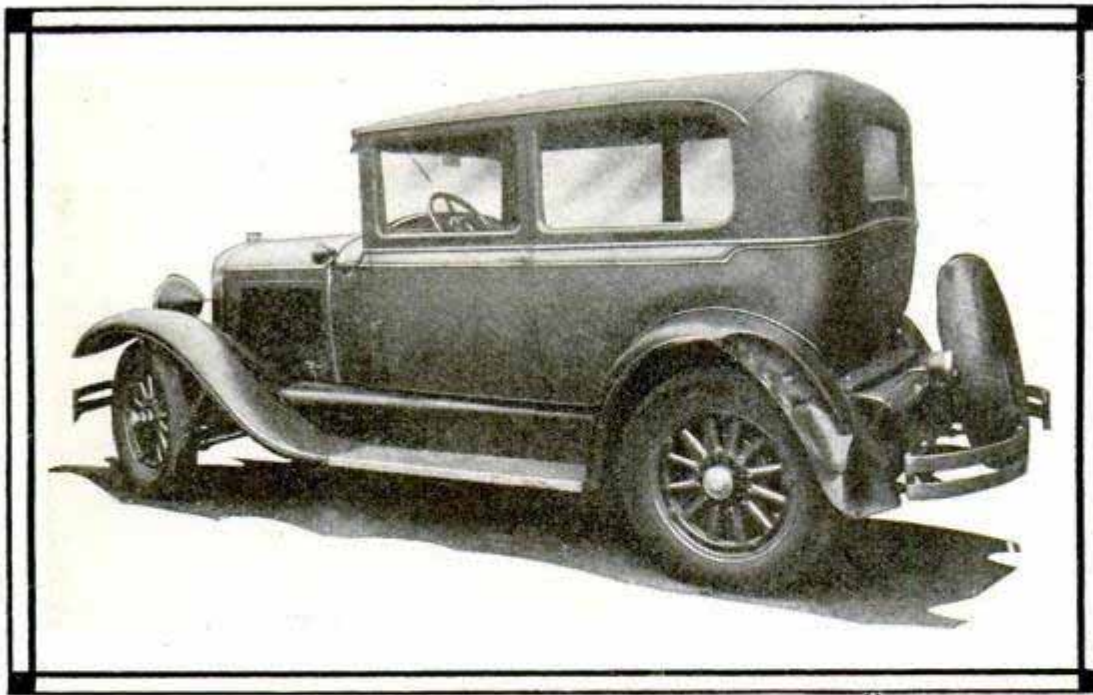

“A 45 Minute Job”

TODAY, a battered fender is a common occurrence. A few minutes in an up-to-date service shop will often make it as good as new. Almost every garage offers this body and fender repair service.

To take care of these mishaps, Stanley has designed a complete line of Body and Fender Repair Tools to fit every place in automobile bodies and fenders.

Mechanics—if you aren't already equipped to render this body and fender service here is your opportunity to start a real Body and Fender repair department. Our new catalog No. 26 shows many new tools which have been added to simplify your work. Send for an up-to-date copy.

THE STANLEY RULE & LEVEL PLANT
New Britain, Conn.



“The Choice of Most Mechanics”

STANLEY TOOLS



Set No. BX 600 F

Only \$11⁸³ a month

For This 9" x 3' New Model South Bend Back Geared Screw Cutting Precision Bench Lathe

Weights
375 lbs.
Price
\$169

Here is the greatest Lathe Value ever offered. A Universal Tool of highest quality and accuracy—one that will work metals of all kinds—cast iron, wrought iron, steel, aluminum, brass, bronze, copper, monometal—also fibre, hard rubber, and wood in pattern making.

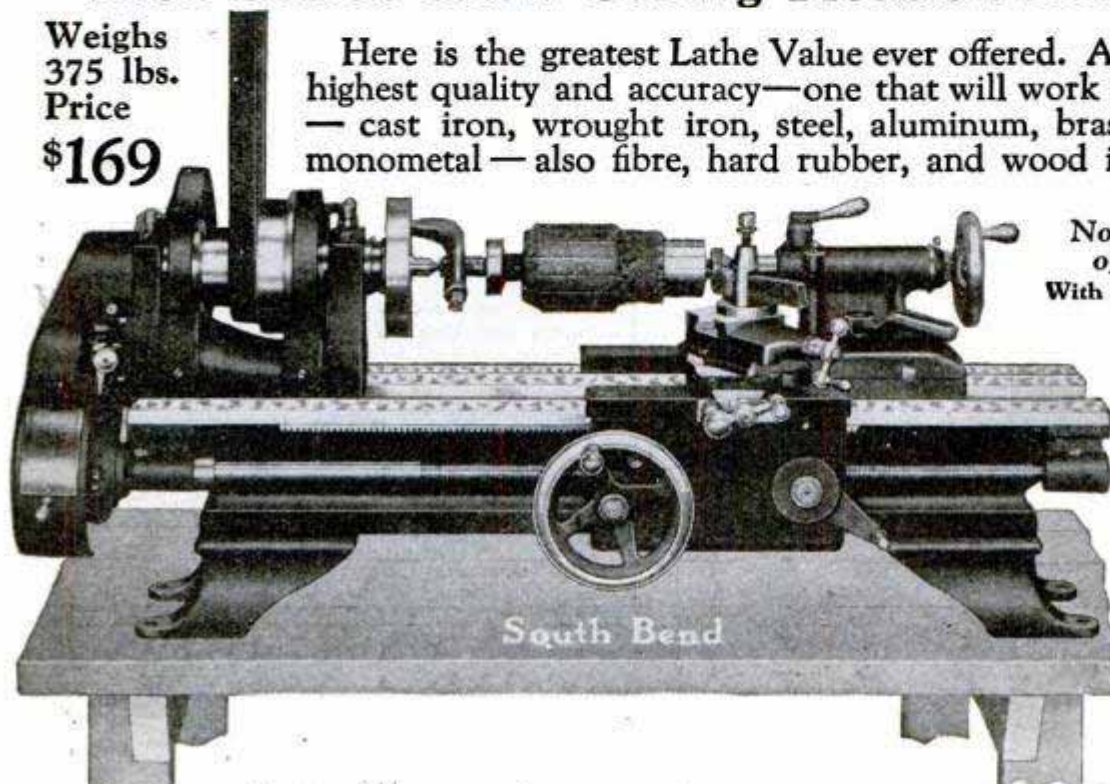

Note the Many Kinds
of Work It Will Do
With this Lathe you can:

- Machine Armatures
- Make Bushings
- Reface Valves
- Machine Pistons
- Undercut Mica
- Cut Threads
- Bore, File, Drill, Turn, Face, Grind, Polish, and do hundreds of other jobs.

Specifications

9 $\frac{1}{4}$ " x 3' Back Geared Screw Cutting, swing over bed, 9 $\frac{1}{4}$ "; distance between centers, 18"; width of belt cone drive, 1"; length of bed, 3 ft. Power required, $\frac{1}{4}$ H.P., shipping weight, 375 lbs.

FREE with Each Lathe!

Complete Book of Instructions, Countershaft and Equipment

It is as easy to learn how to run a Lathe as to learn to run a car. The operator soon becomes proficient, especially if mechanically inclined. With each South Bend Lathe, we send most complete book of instructions, telling just how to do all kinds of work on the Lathe.

Prices of Other Sizes of 9" Junior Lathes

Size	Distance Between Centers	Weight	Price	Down Payment	Monthly Payment
9" x 2 $\frac{1}{2}$ '	11 in.	350 lbs.	\$163.00	\$32.60	\$11.41
9" x 3 $\frac{1}{2}$ '	23 in.	400 lbs.	175.00	35.00	12.25
9" x 4'	29 in.	425 lbs.	182.00	36.40	12.74
9" x 4 $\frac{1}{2}$ '	36 in.	450 lbs.	190.00	38.00	13.30

Write for FREE CATALOG and Booklet No. 22

Booklet No. 22 tells all about this unusual South Bend Lathe now priced at only \$169. Also shows same Lathe with 2 $\frac{1}{2}$, 3 $\frac{1}{2}$, 4 and 4 $\frac{1}{2}$ ft. beds in bench and floor leg types. Free Catalog shows 96 types and sizes of New Model South Bend Lathes from the 9" swing to 24" swing.

SOUTH BEND LATHE WORKS
611 E. Madison St., South Bend, Ind., U. S. A.

Lathe Builders for Twenty-Two Years
—45,000 South Bend Lathes in Use.

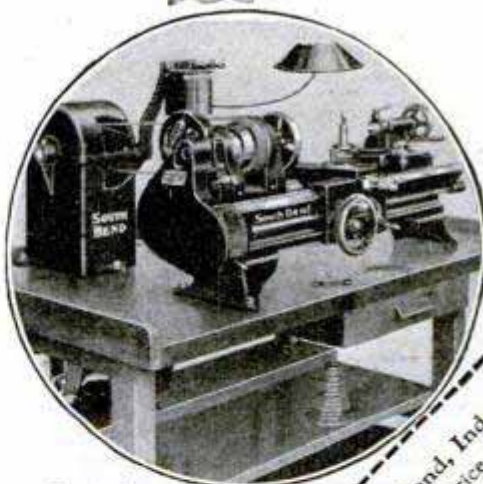

Illustration above shows New Model South Bend Junior Lathe, equipped with Horizontal Motor Drive. Connects to any ordinary light socket for power. Price, with Motor, \$254. Easy Payments. \$17.78 a month.

SOUTH BEND LATHE WORKS
611 E. Madison Street, South Bend, Ind., U. S. A.

Gentlemen: I would like your net factory price on a Screw Cutting Lathe size _____

Manufacturing Machine Shop Garage Work

Please send Free Catalog No. 22

Name _____

Address _____

City _____

State _____

FREE!
A whole week's better shaves. Just mail the coupon below.



How to feel Clean-Shaven Longer!

Now a closer shave because of extra efficiency of small-bubble lather.

MEN who use Colgate's do not worry around five o'clock as to whether to shave again . . . or to try and "get by." Such men know the superiority of Colgate's small-bubble lather—that it gives a longer-lasting shave—one that makes you feel comfortable and clean-faced.

Just Plain Reasoning

The minute you lather up with Colgate's small-bubble lather, two things happen: 1. The soap in the lather breaks up the oil film that covers each hair. 2. Billions of tiny, moisture-laden bubbles seep down through your beard . . . crowd around each whisker—soak it soft with water.

Instantly your beard gets moist . . . easier to cut . . . scientifically softened right down at the base.



COLGATE, Dept. B-1783, P. O. Box 375, Grand Central Post Office, New York.

Please send me, FREE, the seven-day trial tube of Colgate's Rapid Shave Cream; also a sample bottle of "After-Shave."

Name

Address

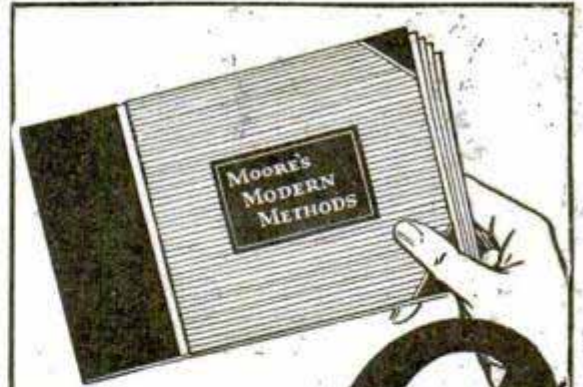

140-Page Book of record-keeping forms, filled in to show you their uses. It answers problems of accounting for office, factory and professions. This Free Book describes and illustrates Moore's Security 4-Post Binders, the simplest, easiest handled on the market. To insert or remove sheets takes but a moment. Low in cost—long in life. Moore's Binders are Different.

Write on your business stationery for this Free Book on up-to-date Loose-Leaf equipment



A great help toward simple and accurate record-keeping

Write for it today!

JOHN C. MOORE CORP. Est. 1839
 6038 STONE STREET ROCHESTER, N. Y.



The International Motor Saw

does every sawing job from straight cutting to intricate scroll and design work; crosscuts, rips, miters, bevels; inside and outside jig sawing and scroll cutting. One saw instead of several.

Write for full description. Dept. S, The International Stamping Co., 400 N. Leavitt St., Chicago, Ill.

Beautiful HOUSES \$900 and BUNGALOWS CAN BE BUILT FOR AND UP

This and many others in my new book, Building Plans for Modern Homes, will save you hundreds of dollars. One of the most complete and comprehensive books of plans ever published by any architect. New edition just off the press. Nearly 600 floor plans and photographs of Colonial houses, bungalows, etc., costing from \$200 up; gives sizes and cost to build. Sent postpaid for \$3.00.



FREDERICK H. GOWING ARCHITECT
 101 Tremont St., BOSTON, MASS.



Andy Sannella Talks to Reed Players. Get this Free Book!

On the air tonight, and every night, Andy Sannella is earning a fabulous salary with his Selmer Sax. In his book of "Advice to Saxophone Players" he gives more valuable information than in ten private lessons. This book is free to all reed players. Send a postal today for your copy. No obligation.

If you will mention the instrument you play, we will send also, free sample of our Alexandre Reeds. They Play!

Selmer

58 SELMER BUILDING, ELKHART, INDIANA
 In Canada: 516 Yonge St., Toronto

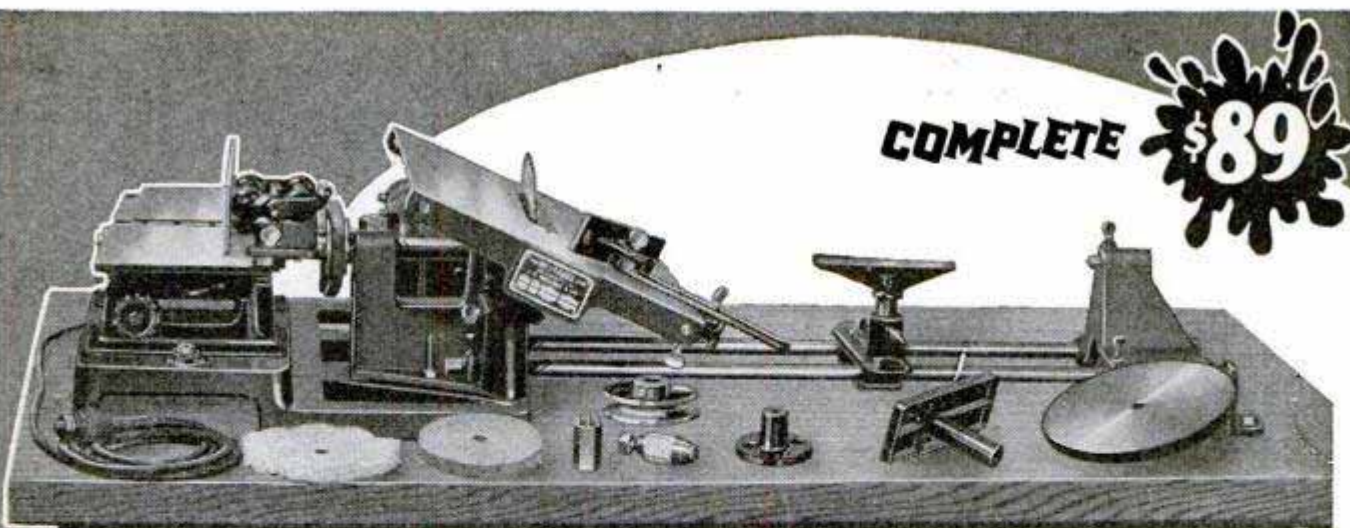

WORKACE Electric WOODWORKER

Recognized everywhere as the standard outfit for home and commercial use!



Jig Saw Attachment for the Workace Electric Woodworker..... **\$10**



14" Workace Band Saw, fast, accurate, economical..... **\$75**

The most complete all-electric wood-working shop made. It's guaranteed for one year against defective parts and you can have it for only \$9 down. The Workace is fast, accurate, powerful and easy to work with; can be made to pay for itself either as a hobby or as commercial woodworking equipment. Nothing like it sold or advertised. Send for complete illustrated description of the Woodworker and other portable machines.

Low Price

includes all this:

- 4" Planer
 - 8" Circular Saw
 - 6"x36" Lathe
 - 8" Disc Sander
 - 6" Buffing Wheel
 - 5" Emery Grinder
 - 1/4" Drill Chuck
 - 1/4 H. P. G. E. Motor, 110-Volt, A.C., 60 Cycle.
 - Endless V-Belt, two 4" and one 2 1/4" V-Belt Pulleys, Cast Iron Sub Base and 10 ft. Cable with separable Plug.
- The Planer and Circular Saws are each complete units and may be purchased separately at the correspondingly low price of \$25.00 each.

J. D. WALLACE & COMPANY
ADAMS STREET AT CALIFORNIA AVENUE
CHICAGO

11 WEST 42nd STREET, NEW YORK CITY
268 MARKET STREET, SAN FRANCISCO

Consult telephone directory for branch addresses in other cities

EASY TERMS

\$9 down

\$9 per month

MAIL THIS COUPON



Workace Radial Saw quickly set at any angle..... **\$140**
Cast Iron Table \$10 Extra
Cast Iron Legs \$15 Extra



Workace high speed, direct drive, portable Electric Shaper **\$95**

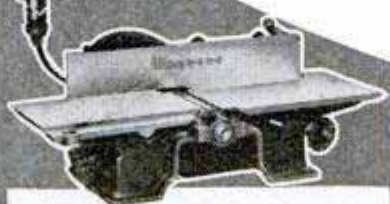

Workace Portable 4" Planer..... **\$25**
Complete with motor \$60.

J. D. WALLACE & COMPANY,
Adams St. at California Avenue,
Chicago, Illinois

I want to know all about the Workace Electric Woodworker. Also interested in Jig Saw Band Saw Radial Saw Shaper Planer

Name.....

Address.....

PYORRHEA

usually starts from tender
BLEEDING GUMS

GUMS that bleed easily—are tender or soft—warn that pyorrhea may be developing. Pyorrhea's infection attacks the periodontal membrane in the root sockets that hold the teeth in place.



Extraction of the teeth is often necessary, no matter how perfect they may be. Your teeth are not safe unless the gums are firm, pink and healthy.

Pyroside Powder was formulated for the special purpose of stimulating and hardening the gums. It is medicated with Dentinol, used for many years by thousands of dentists. The wide use of Pyroside for gum protection is largely the result of dentists' prescriptions. While Pyroside is a superior tooth cleanser, it should be brushed on the gums daily, no matter what other tooth preparation is habitually used.

Your druggist can supply Pyroside. Its regular use costs only 4c a week. Mail coupon below or a post card for free sample.

FREE SAMPLE

The Dentinol & Pyroside Co., Inc. (Sole Distributors)
Dept. O-9, 1480 Broadway, New York City.
Mail free sample of Pyroside Powder and booklet on care of the gums.

Name.....

Address.....

PYROZIDE POWDER

MOVIES AT HOME

Many models of genuine MOVIE MACHINES, some as low as \$3.75, all using standard size big theatre films. Our stock of films is the most complete and lowest in price—with an exchange service. Films of leading stars and religious subjects are available. **DON'T DELAY. WRITE FOR FREE INTERESTING CATALOGUE NOW!**



PARAMOUNT MFG. CO.

Dent. G-21 BOSTON, MASS.

FREE New Book FACTORY PRICES

Save $\frac{1}{3}$ to $\frac{1}{2}$

New FREE book quotes **Reduced Factory Prices. Lower terms—year to pay.** Choice of 5 colors in New Porcelain Enamel Ranges. New Circulating Heaters—



\$34.75 up. 200 styles and sizes. Cash or easy terms. 24-hour shipments. 30-day FREE trial. 360-day test. Satisfaction guaranteed. 29 years in business. 750,000 customers. Write today for FREE book.

Furnaces \$59⁰⁰ up

KALAMAZOO STOVE CO.
391 Rochester Ave.
Kalamazoo, Mich.

Ranges \$37⁷⁵ up

"A Kalamazoo Direct to You"
Trade Mark Registered

DO YOU

WANT a new business profession of your own, with all the trade you can attend to? Then become a foot correctionist, and in a few weeks earn big income in service fees,—not medical nor chiropody—easy terms for home training, no further capital needed, no goods to buy, no agency. Address

Stephenson Laboratory, 1 Back Bay, Boston, Mass.



12-INCH SCALE MODEL

of Lindbergh's Spirit of St. Louis. Scientifically designed and very realistic. Rises from ground by own power and flies 40 ft. or more. Only flying scale model sold at this price. Easily built in 2 or 3 hours. No tools needed. Construction

set, with all parts and full directions, postpaid in U. S. and Canada, only 50c (no stamps). Satisfaction or money back. Send today and print your address plainly.

MANN & BENTON
Box D, Chillicothe, Ohio



Now! Do Your Own Electric Nickel Plating

Introductory Offer

ONLY \$6.50 Plus Postage

For Plating Nickel, Brass, Copper, Silver, Gold, etc.



Make \$150 to \$500 a Week

NO EXPERIENCE REQUIRED. DO YOUR OWN Electro-Plating in Your Home, Garage, Office or Place of Business. Electrically Deposit Metal—Nickel, Brass, Copper, Silver, or Gold. You can Successfully do all the plating on your Automobile, Electric Fixtures, Faucets, Spoons, Forks, Chandeliers, Tools, Coffee Urns, Surgical and Dental Instruments, Utensils; large or small, Iron Stoves, Music Instruments; recondition worn plating or plate New Work; do it Instantly without interrupting the Service or without removing the parts to be plated with the

ALADDIN PORTABLE ELECTRO-PLATER

Simple and Economical to operate. Not a toy, but a practical Plating Outfit with which Perfect and Durable Work can be done. Positively Guaranteed to do as we claim. **BE YOUR OWN BOSS!** Build up a Profitable Aladdin Electro-Plating Business of your Own. This offers wonderful **ECONOMY** to users and **BIG MONEY-MAKING** possibilities to **AGENTS**. Thousands in Service since 1924. Write for **FREE** Booklet and Testimonials and **30 Day Trial Offer Today.**

P. J. F. BATENBURG, Dept. 117, RACINE, WISCONSIN

—AGENTS— WANTED EVERYWHERE

Go INTO BUSINESS AT HOME FOR YOURSELF!



We Set You Up in Business

Don't waste your time working for others. Get into a profitable business for yourself. You can earn good money making and selling toilet articles, perfumes, soaps, flavoring extracts, household specialties, etc. No experience necessary. We furnish everything and show you how. Wonderful opportunity for both men and women to make money at once!

Send for Free Booklet Today

Write immediately for free booklet explaining our proposition. This is your opportunity to become independent and have a profitable business absolutely your own. Don't delay. There is no obligation, so write for booklet NOW.

National Scientific Labs. 1927 W. Broad St. Richmond, Va.

SAVE 1/2 ON PLUMBING HEATING

Cut-to-fit Heating System

New Easy method enables any man to install his own PLUMBING and HEATING. Lowest wholesale prices on Highest Quality Grade A goods.

WE SHOW YOU HOW

Send for our new free catalog telling how you save waste material and high labor costs by being your own plumber. This book has saved money for builders, home-owners, farmers and mechanics for over 50 years. Send for your copy today.



MILLION DOLLAR BONDED GUARANTEE PROTECTS YOU

OVER 50 YEARS **HARDIN-LAVIN CO.** EST. 1876
122-32A West Pershing Road, Chicago, Ill.

AGENTS 500% PROFIT GENUINE GOLD LEAF LETTERS

S guaranteed to never tarnish. Anyone can put them on stores and office windows. Enormous demand, large profits. Paul Clark says: Smallest day \$28.70. R. L. Reel made \$920 in two months. Write today for free sample and liberal offer to general agents. METALLIC LETTER CO. 433-B N. Clark St., CHICAGO



The Musical Sensation ACCORDEON Played by Music Rolls

Without any knowledge of Music or Notes, you play in a few minutes, as perfect as an Artist, latest hits, songs and dances. Every instrument guaranteed. Circular No. C and roll list mailed free.

TREASURE SALES CO. 1690 Boston Road New York



YOU, Too, Can be Playing— Before Xmas!

Surprise all your friends, make new ones, sure popularity before Christmas by learning to play a Pan-American saxophone, trumpet, clarinet, or any band instrument. Only a few lessons, and you can play any popular air—so easy to learn.

Moderately Priced

Sent on free trial. Easy time payments. Only moderately priced band instrument, factory guaranteed. Recommended by professionals and band masters everywhere. Write today for free illustrated catalog.



PAN-AMERICAN BAND INSTRUMENT & CASE CO. 1103 Pan-American Bldg. Elkhart, Ind.

Make big money from repair work



Practically every householder spends at least \$10.00 to \$50.00 each year and many spend several times that much on simple repairs that can be made *quickly, easily* and *well* with

Smooth-On No. 1

With a can of Smooth-On, you can save this money in your own home — and by doing similar repair work for others, you can make money.

No skill is required to make repairs and the amount of Smooth-On used on any one job seldom costs more than a few cents.

Typical repairs that can be made perfectly with Smooth-On:—Stopping leaks in steam, water, gas, oil or stove pipes, mending cracks, breaks or leaks in furnaces and boilers, radiators, tanks, sinks,



Leak at radiator joint stopped with Smooth-On

pots and pails, making loose handles tight on umbrellas, knives, hammers, brushes, drawers, etc., tightening loose screws, hooks, locks, door knobs, etc.

On the Automobile:—Making cracked water jackets and pumps good as new, stopping leaks in radiators, hose connections, gas tanks and gas, oil and exhaust lines, making a fume-proof joint between exhaust pipe and tonneau heater, tightening loose headlight posts, keeping grease cups, hub caps, and nuts from loosening and falling off, etc.



How to make HOME-AUTOMOBILE REPAIRS

Do it with SMOOTH-ON

Write for FREE BOOK



To get perfect results, write to us for and use the Smooth-On Repair Book. Free if you return the coupon.

Get Smooth-On No. 1 in 7-oz., 1-lb. or 5-lb. tins at any hardware store or if necessary direct from us.

Do it with SMOOTH-ON

SMOOTH-ON MFG. CO., Dept. 37, 574 Communipaw Ave., Jersey City, N. J.

Please send the free Smooth-On Repair Book.

Name.....

Address.....

11-29.....

HERE IT IS, BOYS



FREE

The Greatest Railroad Planning Book Ever Published for Boys—46 Pages in Full Color—Send for Your Copy Today.

BOYS!—don't delay—the new LIONEL Railroad Planning Book is now off the press and thousands of copies will quickly be mailed. Get yours now! Don't wait.

It is full of surprises—a marvelous book chock full of pictures in color showing many ways to construct the world's finest model railroads.

See in it for the first time the new Lionel "Giant of Rails"—the new 22½ inch long Lionel "Steam Type" Locomotive—electrically driven, powered by the famous Lionel "Distant Control" "Bild-a-Loco" motor that can be taken apart and reassembled in a jiffy.

See the new, swift, powerful Big "Bild-a-Loco" Models—the most extraordinary electric locomotives and trains ever built. You will want the latest news of Lionel's new bridges, switches, derrick, freight cars and other accessories. It is the greatest model railroad planning book ever published. Free to every boy. Write today.

THE LIONEL CORPORATION, Dept. C.
15-17-19 East 26th Street, New York City

LIONEL
ELECTRIC TRAINS

SHOOT THE REAL THING!

Here is that famous genuine pump boys everywhere are turning to. Single stroke outshoots all others. Two to three strokes now give full shooting force. New rear peep sight, leak-proof valves, fully enclosed action. A beauty. Amazing accuracy. Full factory guarantee for one year. Uses regular air rifle lead shot. Photo shows flattening power at 30 ft. on steel target. The biggest money's worth in genuine air rifles ever offered.

"The Shooter's Art" FREE
Tells how to hold, aim and handle rifles; helps you guide others in correct knowledge of guns. Gives facts that make crack shots. Contains safety and common sense instructions every parent and boy should have. Helps to make boys leaders. Your copy free. Write at once!



\$5 at your dealer's or sent postpaid
NEW MODEL "G"
BENJAMIN
Genuine Pump Air Rifle
BENJAMIN AIR RIFLE & MFG. CO., 645 N. Broadway, St. Louis, Mo.

MOTORCYCLES

WE WILL TRUST YOU
Pay As Low As \$2.00 per Week
Hendersons, Harley-Davidsons, Indians
Slightly used and rebuilt. Hundreds to select from.
Send 10c for list today.
MYEROW BROS. CO., 15 Berkeley St., Boston, Mass., U. S. A.

30 Days' Free Trial
New Models now ready for delivery direct from our factory. Astonishing low prices and terms. Do not buy until you get them.
RIDER AGENTS WANTED to ride and exhibit sample. Make big money. Many models \$21.50 up. Guaranteed \$1.50 each, wheels, lamps, horns, equipment at half usual prices. Send No Money. Write for our marvelous prices and terms on RANGER Bicycles.
Mead CYCLE CO. Dept. A110 CHICAGO

MAKE YOUR FORD Into The "ACE"
\$599 Red-i-Kut life size patterns Class—Snap
Famous sure-fit RED-I-KUT life-size patterns and picture instructions show how you can easily convert your Ford into this **Fast, Saucy, Sport-Car** as thousands have done with easily obtained materials. No need to lay up the car. Makes wonderful 4-passenger car. Send 10c coin for actual photo of sport car and new manual of distinctive sport car patterns from \$3.50 up—"RKO" Steel "Sving-Lo" Irons. Tops, Windshields and many speed necessities. **ORDER RIGHT NOW and get a real thrill.**
KUEMPEL COMPANY, 114 Kuempel Bldg., GUTTENBERG, IOWA

MOTORCYCLES
Direct to you at wholesale prices. Send 10c today for the latest Illustrated Bulletin and Confidential Price List of Guaranteed Indians Harleys Hendersons SuperX etc. (Sold on easy terms if desired)

CRANDALL CYCLE CO. 826-28 State St. Shipments to all parts of the world
Springfield, Mass. Motorcycles Since 1905

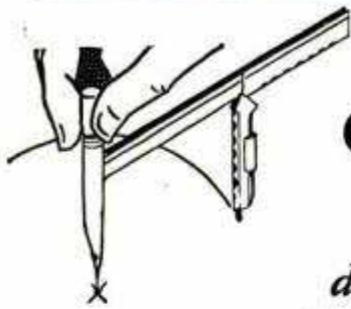

NEW COMPASS

makes accurate drafting work easy!

THERE are dozens of jobs on which you need a good compass—radio hook-up diagrams, lighting outlets—no end to its workroom uses!

Now you can have an accurate compass without buying a set of cumbersome, expensive drafting instruments! This **ESTERBROOK COMPASS** is so small that it seems like a toy. It is very inexpensive, yet amazingly precise.

It works on an ingenious

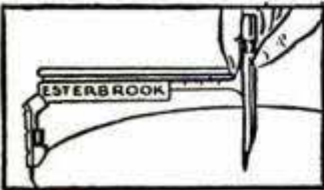

Above: Slide adjusted for long radius.

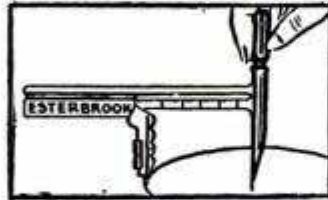

Above: Slide at the short radius.

new principle which prevents wobbling or slipping. Center-pin and pencil-lead are always parallel and vertical. Radius shown clearly and correctly on the beam, in inches or centimeters. Makes true circles from $\frac{1}{8}$ " to 8" diameters. With slide reversed radius is exactly 2" greater than scale reading.

50¢ at all stationers—or send direct to Esterbrook Pen Co., Camden, N. J. We mail postpaid.

JOY TO FORD OWNERS

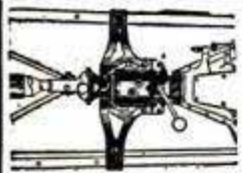

Attachments to install a Chevrolet gearshift priced extremely low.

Write for catalog. Dept. 3

Hollingsworth Mfg. Co.
Marshalltown Iowa

MOTORCYCLES



Price \$10 and up purchased through our Co-Operative Plan for as low as \$1.00 down and \$1.00 per week
Indians Harley-Davidsons Ace Henderson and Clevelands
Send ten cents for Bulletin A.
Motorcycles shipped to all parts of the world

WALKER-INDIAN CO., 78 Brookline Ave., BOSTON

Super Elto Quad

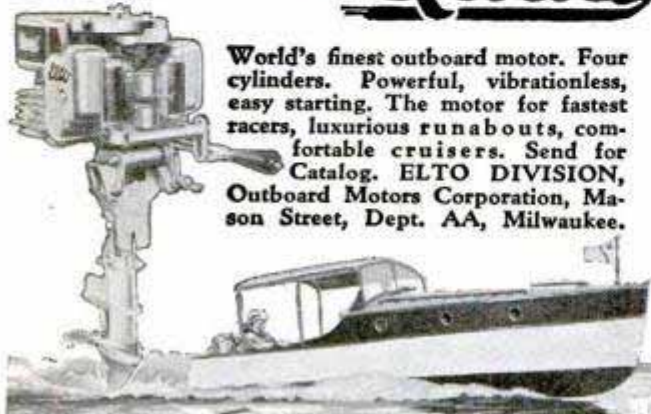

World's finest outboard motor. Four cylinders. Powerful, vibrationless, easy starting. The motor for fastest racers, luxurious runabouts, comfortable cruisers. Send for Catalog. **ELTO DIVISION, Outboard Motors Corporation, Mason Street, Dept. AA, Milwaukee.**



7 SHAVES FREE

and a can of Palmolive After ShavingTale
Simply insert your name and address and mail to Palmolive, Dept. B-3112, P. O. Box 375, Grand Central Post Office, New York City.

(Please print your name and address)

This Coupon is our ad

Words, we know, will never win you. So we stand or fall on 7-days' trial. Yet this simple test has made Palmolive Shaving Cream a leader quickly

GENTLEMEN: All any advertising can accomplish is to secure a trial of the product. After that the article itself must do its own selling.

So great is our confidence in Palmolive Shaving Cream that we do not ask you to buy; rather, to try it at our expense. For we find that 86% of men who try it, buy it. And its great success is based on the fact that it sells itself every time you use it.

So we print our coupon conspicuously, for your convenience. When you mail it to us, half our job is done. Will you send it now?

5 remarkable features

1. Multiplies itself in lather 250 times.
2. Softens the beard in one minute.
3. Maintains its creamy fullness for 10 minutes on the face.
4. Strong bubbles hold the hairs erect for cutting.
5. Fine after-effects due to palm and olive oil content.

Now a trial, please.

You stand to win—at least, you take no risk. Please mail the coupon.

PALMOLIVE RADIO HOUR—Broadcast every Wednesday night—from 9:30 to 10:30 p. m., Eastern time; 8:30 to 9:30 p. m., Central time; 7:30 to 8:30 p. m., Mountain time; 6:30 to 7:30 p. m., Pacific Coast time—over station WEAJ and 39 stations associated with The National Broadcasting Company.



4721

With the new unbreakable Bakelite top

DOES \$35.00 per day interest YOU?



That's what you can earn as a DENNIS Weather Strip Contractor

No experience necessary. No special tools. Quick cash profits on strips and labor. We furnish free working models and teach you how to get contracts. Patented "S" shape provides snug weatherproof seal that is self-adjusting and SAVES $\frac{1}{2}$ FUEL. Quick application and low price enables you to double volume of contracts. No grooving or removing of sash or doors — saves labor, time and expense.

Comes in convenient Window and Door sets, and bulk. Easily Installed in New or Old Buildings. Every property owner can be sold DENNIS metal strip at wood strip prices. A proven success endorsed by Contractors, Builders, Architects and Owners. Write now for details.

Mail Coupon Today

DENNIS

ONE PIECE - DOUBLE CUSHION
BRONZE WEATHERSTRIP

W. J. Dennis & Co., 2116 W. Lake St., Chicago, Ill.

- Send Money-Making Plan for Contractors
 Send.....Sample Window Sets at \$1.75 each postpaid
 Send.....Sample Door Sets at \$2.00 each, postpaid
- Name.....
 Street.....
 City..... State.....

Hotter than Coal

~ and no dirt



A New
Invention

Do away forever with the drudgery of wood or coal. The most simple and economical invention on the market is now giving perfect satisfaction to enthusiastic users everywhere.

Burns 96% Air—4% Cheap Oil

The International Oil Burner fits in the fire box of your furnace or stove. Installed in a few minutes. No noisy motors or complicated parts.

Costs only a Few Dollars

Heats any stove or furnace just as well as a \$400 or \$500 oil burner without electricity or gas. Simply turn one valve and have all the heat you want. Cleaner and better for heating and cooking. Approved by engineers everywhere. Over 100,000 in use.

30 Days FREE Trial Offer

Try this wonderful International Oil Burner right in your own home at our risk. Act quickly and get our special low introductory price. Sold under absolute money-back guarantee. Write at once for our free booklet on home heating and free burner offer.

AGENTS—Our men are making big money introducing International Oil Burners. The demand is enormous. We want spare or full

time workers immediately. If \$500 a month and more interests you, write or wire us for our protected territory offer.

INTERNATIONAL HEATING CO.

Spring and Park Ave., St. Louis, Mo., Dept. O-4

Send your free booklet and free details on home heating for stove furnace . Also free burner offer.

Name.....

Address.....

Check if interested in making money as an International representative with protected territory.

New
1929
Second
Edition

WHOLESALE PRICES

WRITE FOR
FREE CATALOG

Build your own with Rasco parts.
Positively lowest prices in the country.

Radio Specialty Company
98E Park Place NEW YORK, N. Y.

Choice of 1200 Newest RADIO VALUES

SEND for our 1930 catalog. Filled with amazing values in screen grid radios, push pull audio, console, kits, parts. All standard makes and guaranteed merchandise.

FREE

WESTERN RADIO MFG. CO.
126 W. LAKE ST. CHICAGO ILL.

THE WRITING
HEMISPHERE

THAT BALL-
LIKE 14 KT
GOLD POINT

\$1.50

INKOGRAPH
PENCIL POINTED PEN

Writes with ink smooth as a lead pencil on cheapest or finest paper, without miss, skip or blur. Won't blot, scratch or leak.

Makes 3 carbon copies at one time with original in ink. Anyone can use your Inkograph — hard pressure cannot spread or injure its 14 Kt. gold point. Patent automatic feed prevents point from clogging. No complicated mechanism. Best material and workmanship. Fully Guaranteed.

Send No Money. Pay postman \$1.50 plus postage. Sent prepaid if remittance accompanies order. Money back if not satisfied within 10 days.

INKOGRAPH CO., 161-76 Centre St., NEW YORK

AGENTS Send for Inkograph or FREE sales plan booklet. Sells on sight, no investment, immediate commissions.

Keds
RED U.S. PAT. OFF.

At \$1.00, \$1.25, \$1.50,
\$1.75 and up to \$4.00.

United States Rubber Company

New Complete "Wonder" Workshop

Outfit
saves you
\$15.00



A COMPLETE LINE

Bench Saw
Band Saw
Scroll Saw
Bench Drill
Jointer
3-Speed Lathe
Motor-Driven Lathe
Grinder

Dealers Wanted

Now you can have this new, amazing 8-in.

Combination Saw (18 tools in one) shipped on 15 days' approval, at manufacturer's risk. A complete ideal machine shop for factory, workshop or home; will rip, cross cut, bevel, miter, mortise, drill, groove, tenon, grind, rabbet, buff and polish. $\frac{1}{2}$ H. P.-A. C. motor included with all attachments.

Write quick for special 10 day offer.

S. & B. Mfg. Co., 4601-K, W. 20th St., Chicago

AGENTS \$6 A DAY

And Your Groceries AT WHOLESALE

Send me your name, QUICK, and I'll tell you how to get \$6 to \$9 a day easily and pleasantly. I'll supply you with your own groceries at rock-bottom, wholesale prices. I show you how Van Allen made profits of more than \$100 a week. Tyler, \$30 to \$35 in one day. Karnath, \$20.35 first 5 hours.



New Ford Tudor Sedan GIVEN

No experience, no capital needed. You simply act as my Representative and look after my interests in your locality. Send your name for my remarkable offer. I'll tell you how to get a new Ford Tudor Sedan without cost. Write today—SURE.

Albert Mills, Pres., 6799 Monmouth Ave., Cincinnati, Ohio

EASY \$100 a Week

FUGO FIRE EXTINGUISHER



Unusual opening for live agents in every locality. Make \$5000 or more a year—easily. Fugo—the instantaneous automatic fire extinguisher—is needed and wanted in every home, store, theatre, garage, shop, school, automobile, etc. Cheapest fire protection available today. Within reach of all.

1 Qt. Size \$5.00 2 Qt. Size \$7.50

Recharged in a jiffy

Amazing 30-second demonstration clinches sale—each one sold sells others. Territory going fast. Write at once for wonderful proposition that will make you big money.

THE NATIONAL FORMALT CO.
6535 Metta Ave., N. E. Cleveland, Ohio

FLY THIS COMBAT MONOPLANE!



This realistic copy of a military monoplane is an unusually graceful flyer. Wing-spread 18 in. Weight only 7/8 oz. Will take off by own power and fly over 80 ft. Markings in red and blue. Can be built in 2 hrs. without tools. Construction set includes 6-in. aluminum propeller with shaft, 4 in. disc wheels, wood struts, rubber band motor and all other parts, with clear directions. Complete set, packed in unbreakable container, only \$1.00, postpaid in U. S. and Canada. Order today. Satisfaction or money refunded.

The MIDLAND MODEL WORKS, Chillicothe, Ohio
(We cannot make C.O.D. shipments, No retail catalogue issued.)

RACING AND SPORT EQUIPMENT

Direct from Manufacturers

Bodies for Ford and Chevrolet \$18.75 and up

Hi-Compression Heads, under-slung Parts, Racing Gears, Cowling Lamps, Roadlites, Seat covers. Also Boats, Canoes, Portable Radio, Bicycles, and Camping Outfits. Send 10c for Catalog showing bodies of rare beauty and complete equipment.



Build a Real Auto from Used Chassis
Dept. K-2 AURORA, ILL.

SPORT FACTORIES

SALESMEN WANTED

For new invention. Sells every business and professional man. Used by Bell Telephone Co., Armour & Co., etc. Four \$15 sales daily pay \$288 weekly. Walker made \$165 first day. Write at once.

F. E. Armstrong, Dept. PM, Mobile, Ala.

DOUBLE ACTION AUTOMATIC

Pull the Trigger—Out Pops a Cigarette



Patented \$1.79

Protect yourself against hold-up, rowdies, etc. with this clever cigarette case of light weight metal. Looks like genuine automatic! Pull the trigger and out shoots a cigarette through the muzzle. Holds nearly a full pack of cigarettes. Handsome gun metal finish. Double action. Lots of fun scaring friends and a great protection. Order one to-day. When your friends ask for a cigarette, shoot one to them and enjoy a big laugh. Either enclose money order for \$1.79 or pay postman \$1.79, plus postage on arrival. Money back if not satisfied.

PATHFINDER CO., Dept. 811, 200 Hudson St., New York

Thank you for making it possible for me to own a 21 Jewel—Santa Fe Special

Writes Thousands of Our Customers



The Nationally Popular Santa Fe Special sent to you for your approval Wear 30 Days FREE!

Write for Watch Book and Diamond Book **Buy Direct**

Buy and Pay the Santa Fe Way

You must be pleased when you buy a "Santa Fe Special" Watch. That is why I will send for your approval one of these Standard Watches, guaranteed for a lifetime of satisfactory service, not only by the Santa Fe Watch Company, but by the Great Illinois Watch Factory. They are found in the pockets of men in the service on every railroad in this country. Senators, Congressmen, and Governors keep their official appointments by "Santa Fe Special" time. Army Officers and Privates carried them all through the Greatest War in history—thousands of these splendid watches are in use all over the World. If you want one on my liberal Buy and Pay the Santa Fe Way Plan—you had better write for my Free Watch Book today and make your selection. I will even let you wear the watch 30 days FREE, then sell it to you on a binding money back guarantee, and on easy monthly payments.

JUST OUT!—New "Santa Fe" Watch Book

Send coupon for our New Watch Book—just off the press. All the newest watch case designs in white or green gold, fancy shapes and thin models are shown. Read our easy payment offer. Wear the watch 30 days FREE. Nothing to risk. See the watch before you buy. Write for New Book Today—It's FREE. Select Your Watch NOW.

FREE A limited offer! With every Santa Fe Special, a beautiful gold chain or strand of exquisite pearls. Write today.

SANTA FE WATCH COMPANY
Dept. B-6 Thomas Bldg., Topeka, Kansas

Send No Money 11 1/2 cents a day—pays for any of these Watches. wear 30 days free!



Santa Fe Watch Co.
Dept. B-6 Thomas Bldg. TOPEKA, KANSAS

Please send me your New Watch Book with the understanding that this request does not obligate me in any way.

Name.....
Address..... State.....



Hands Up!

If you're one of those fellows who think that work-stained hands can't be cleaned, I'll bet you've never tried Lava Soap.

For more than 30 years men with jobs like yours have been using Lava Soap . . . because it gets the grimeiest, greasiest hands clean in 58 seconds, without hurting the skin . . . because it makes a lather rich as cream in the hardest water.

Here's the secret of Lava's speed, thoroughness and gentleness. In addition to pure vegetable oils, Lava contains pulverized Italian pumice. That's what makes dirt and grease disappear so quickly, without harm to the skin.

Get a cake or two tonight and see if I'm not right.

George, the Lava Soap Man

Lava costs a dime (or 6c for the medium size cake) at any drug or grocery store. But if you want to try it at our expense, mail this coupon.

Procter & Gamble, Dept. W-1129, Cincinnati, Ohio

George: I want a free sample cake of your Lava Soap.

Name.....

Street.....

City.....State.....



BOYS! Make Big Money

BUILD BIRD HOUSES

Boys! Here's a real money maker. With my simple instructions any boy can build and erect Grandpa Bird Houses. They sell at \$2 to \$97.50 each. \$2 000 worth sold in Oak Park, Ill., in one year. Send \$1 for 16 Blue Print Drawings showing correct building plans so you can build my famous bird houses. Valuable book on song birds with tips and advice on making sales included free. Get busy — act Now — Today.

GEO. J. BREIDERT, 1040 N. Elmwood Ave., Oak Park, Ill.

GAS HEAT ANYWHERE
1 1/2¢ an hour



38 Below Zero is not too cold when you have a **Sunshine Radiant Heater**. Makes and burns its own gas. Gives you clean, safe, healthful heat in 60 seconds from cold start. No piping, no installation costs. Easy to carry from room to room while in operation.

15-Day Trial

We'll send you the **SUNSHINE** on 15-day trial. Use it in your own home or store. Prove to yourself how easy it does away with dirt, ashes, smoke and odor. Sunshine is bringing cheery comfort to thousands of homes, now.

FREE Startling low offer on new, beautiful 1929 Model—and book, how new heater brings comfort and ease. Get your copy. Write today. **SUNSHINE SAFETY LAMP CO.** 337 Factory Bldg., Kansas City, Mo.

AGENTS

BIG MONEY—easy sales on part or full time. **WRITE!**

Build a CLOCK *for Pleasure or PROFIT!*

FREE BOOK shows how YOU can Make Fine Clocks Right at Home

Check full of Clock-Making and Money-Making ideas. Gives full details, descriptions, prices of movements and parts. Write NOW for your copy.

THOUSANDS of men have built our Clocks. For their own use—or to sell at money-making prices. It's easy, fascinating. Only ordinary tools needed. We furnish plans, instructions, parts. Works all assembled, ready to install, as low as \$1.65; others with chimes at all prices. You make the case, or simply assemble knock-down parts. Cash-in on the demand for craftsmen-built Mantel Clocks, Banjo Clocks, Grandfather's Clocks. Here's a hobby that PAYS—in pleasure, in ownership and in spare-time or full-time PROFITS!

Write for FREE Catalog and Special Blue Print Offer

American Chime Clock Company
1670-M Ruffner St., Philadelphia, Pa.

SPRIT OF TIME BANJO CLOCK

Do your own Printing!



Cards, stationery, circulars, tags, labels, advertising, book, menus, etc. Save money and time, cut cost in half. Easy rules furnished with every outfit.

Print for Others BIG PROFITS

A big opportunity to turn your spare time into cash, or develop a full time business of your own at small cost. **New and popular Raised Printing like Engraving** done with any of our presses. **Junior Press \$5.90**, Job presses \$11, \$29; Rotary \$149.

Write for catalog No. 737 of presses, type, cards, paper, supplies and full information.

The Kelsey Co., Meriden, Conn.

Photos ENLARGED

Size 16x20 inches Same price for full length or bust form groups, landscapes, or pet animals, etc., enlargements of any part of group picture. Safe return of your own original photo guaranteed. **SEND NO MONEY** just mail photo or snapshot (any size) and within a week you will receive your beautiful life-like enlargement size 16x20 in. guaranteed fadeless. Pay postman 98c plus postage or send \$1.00 with order and we pay postage. **SPECIAL FREE OFFER** reproduction of photo sent. Take advantage now of this amazing offer — send your photo today! **UNITED PORTRAIT COMPANY** 1652 Ogden Ave. Dept. P-1019 Chicago, Ill.



AGENTS WANTED \$50 TO \$100 WEEKLY! Take orders from Motorists for Electro Magnetic Trouble Light! Sticks to any part of car. Both Hands Free to Work. Amazing demonstration. Send for demonstrator and particulars. **WONDERLITE**, Industrial Trust Bldg. Dept. PM, Providence, R. I.

Agents! - Here's Something New



Make \$50 to \$90 A Week

Amazing new fast-selling invention—Crystal Home Filter for fruit juices and beverages. Patented. Nothing like it. Removes all sediment, pulp, fibres. Filters a gallon every 4 minutes. Perfect results guaranteed. Simple. Practical. Low priced. Every home a prospect. Big profits. Quick, easy sales.

Write Today for FREE Sample Offer

500 more agents needed NOW. Make money fast. No experience needed. Write **quick** for Free Demonstrator and territory Offer. Send NOW. **Home Filter Co., 431 Central Ave., Bay City, Mich.**

WANTED! Man with Car

To Run Store On Wheels

Sell the largest, finest quality line of daily necessities from your car. No experience necessary.



Hundreds now making **\$200 TO \$500 A MONTH**

Our proposition is entirely different from all others. Our advertising half sells the goods for you. Premiums, samples and gifts all make business come your way. Business is permanent, pleasant and profitable.

BE A DOUBLE MONEY MAKER

Two entirely different lines, 241 items, a sale at every home. Two lines mean two profits. We will give you liberal credit. Write for details about our new proposition.

FURST-McNESS CO., Dept. 450 Freeport, Ill.



only **\$1.00**
DOWN
10 Day FREE Trial

You can have a genuine L. C. Smith (the world's only ball bearing typewriter) for \$1 down. Lowest price ever offered! Easiest terms. All the 1928 operating attachments. Re-noved. **GUARANTEED FOR FIVE YEARS.** \$1 down and we ship. No delay. No red tape. 10 day Free Trial. Free Typewriter Course, Tools, Waterproof Cover if you act now. Write for \$1 down offer and free manual.

Smith Typewriter Sales Corp., 11B-469 E. Ohio St., Chicago, Ill.



MOULDS

For Making Toy Soldiers,
Indians, Cowboys, Animals, etc.

With one Mould you can make many HUNDREDS OF CASTINGS, whole Armies. Outfits, including material for casting, enamel paints and everything complete. \$4.50. Easy enough for any boy to make and great fun for grown-ups. Sport for the whole family. Write for illustrations of dozens of patterns you can make.

MAKE-A-TOY COMPANY, Dept. E, 1696 Boston Road, N. Y. CITY

TELESCOPE GIVEN & SCOUT KNIFE GIVEN



Three brass section telescope with set-in compass and 4 bladed Scout Knife all given for selling only 16 packages Gold-Eyed Needles and Magic Needle Threaders at 15c per package. The Magic Needle Threader makes it sell on sight. **Send no Money - We trust you.**
KING-HILL CO., Dept. T815 105 N. Talman Av., Chicago, Ill.

Catch Fish!

Eels, Mink, Muskrats with our new folding galvanized **STEEL WIRE TRAP.** Write for our **FREE TRAP OFFER** and Bargain Catalog. \$1 Box of our famous Fish Bait **FREE** to introduce our traps.
WALTON SUPPLY CO., 3502 JUNIATA AVE., ST. LOUIS, MO.

DENINGER WILL TRUST YOU

SEND 50c INSTAMPS FOR CATALOGUES
BIG MONEY SAVING FOR YOU

Used and rebuilt motorcycles \$25 to \$100, used bicycles \$9.50, tandems \$29.
All machines fully guaranteed. New bicycles and motorcycles at factory prices, save dealers' profits. Motorcycle and automobile tires \$3. Complete wire frames, engines, supplies.

DENINGER PRICE CUTTER, ROCHESTER, N. Y.

PAY AS YOU RIDE

Suppose You Were Offered- Diamonds at 60% of Market Price



Suppose a reason you rarely think of makes possible here radically **low prices, even for finest quality diamonds.** Thousands of representative people, bankers, lawyers, merchants, others—continually reap this real advantage. Everything sent for Free Examination. This 3/4 century, oldest, largest diamond banking institution in the world, rated over \$1,000,000.00,—converts into cash the diamonds on which money was loaned and not repaid. Loan values, a fraction of market values, are the price basis. Diamonds too from big cash deals direct with European cutters. **Must sell now!**

Why Pay Full Prices

When Much Less Buys the Same See this 70 hundredths ct., snappy solitaire for \$69.50. Try to match at \$115.00. Examine free any bargain at our risk. Startling, legitimate offers here of diamonds at 60% of market price. Send now for full details. Diamonds of unusual qualities (also watches) from unpaid loans, offered at radically low prices based on mere loan values. Then, too, we have hundreds of diamonds from big, cash, European deals with diamond cutters, who sacrificed these gems away under the market. Send now for our latest offers of this internationally known cash headquarters.



Unpaid Loan Listings Ready

As low as \$60 a Carat

Radically different from a catalog. List accurately describes every diamond in full detail with guaranteed exact weight, color, quality, etc. Explains **Guaranteed Cash—like Insurance Policy Loan guarantee.** Also **Unlimited Exchange** privilege at price paid us. Gives full details of free examination offers. Don't wait, the very diamond you want may be in this very list at a price that will amaze you. Costs nothing to see. Write today. A postal will do, or—**Mail Coupon NOW!**



**Command Recognition
a DIAMOND Does It**

JOS. DE ROY & SONS
Only Opposite Postoffice
1986 De Roy Bldg., Pittsburgh, Pa.

Without obligation to buy, send me free, in plain envelope, your Latest Bargain List of Diamonds, Watches, and other Jewels.

Name _____
Address _____
City _____ State _____

References by Permission:—Bank of Pittsburgh, Third National Bank; Union Trust Co., Pittsburgh, Pa. Your bank can look us up in the mercantile agencies.

NEW VEST POCKET ADDING MACHINE

ADDS, SUBTRACTS, MULTIPLIES, DIVIDES
Does work of \$300 machine. Guaranteed 5 years. **NOT A TOY.** Made of steel and indestructible. Million dollar capacity. Fits in pocket. Will not make mistakes. So simple child can operate it. Instructions furnished. Everybody should carry one for figuring.

FREE \$2.50 TRIAL Total Cost

SEND NO MONEY—Just name and address. We will ship Calculator immediately. On delivery pay postman \$2.50 (Plus few cents Postage). (If outside U. S. send cash.) 10c additional in Leatherette Case. If not satisfied after 10 days trial you get your money back. **THOUSANDS OF SATISFIED USERS.**

Guaranteed This is lowest priced practical calculator made. "Why pay more for inferior imitations!" Order from this ad.

----- Mail Coupon Today -----

BABY CALCULATOR MACHINE CO., (MANUFACTURERS)
Dept. 41, P. O. Box 1118, CHICAGO, ILL., U. S. A.

I am enclosing \$2.50—send adding machine prepaid.
 Send Adding Machine C. O. D. \$2.50 plus 18c postage. (10c additional in Leatherette Case)

Name.....
Address.....
City..... State.....

AGENTS Write for big commission and territory proposition.

PATENT

Protect Your Ideas

Take the First Step Today

If you have a useful, practical, novel idea for any new article or for an improvement on an old one, you should communicate with a competent Registered Patent Attorney AT ONCE. Every year thousands of applications for patents are filed in the U. S. Patent Office. Frequently two or more applications are made for the same or substantially the same idea (even though the inventors may live in different sections of the country and be entirely unknown to one another). In such a case, the burden of proof rests upon the last application filed. Delays of even a few days in filing the application sometimes mean the loss of a patent. So lose no time. Get in touch with me at once by mailing the coupon on the opposite page.

Prompt, Careful, Efficient Service

This large, experienced organization devotes its entire time and attention to patent and trade mark cases. Our offices are directly across the street from the U. S. Patent Office. We understand the technicalities of patent law. We know the rules and requirements of the Patent Office. We can proceed in the quickest, safest and best ways in preparing an application for a patent covering your idea. Our success has been built on the strength of careful, efficient, satisfactory service to inventors and trademark owners located in every state in the Union.

NO CHARGE for Information On How to Proceed

The booklet shown here contains valuable information relating to patent procedure that every inventor should have. And with it I will also send you my "Record of Invention" form on which you can sketch your idea and establish its date before a witness. Such evidence may later prove valuable to you. Simply mail the coupon and I will send you the booklet, and the "Record of Invention" form, together with detailed information on how to proceed and the costs involved. Do this NOW. No need to lose a minute's time. The coupon will bring you complete information entirely without charge or obligation.

My Patent Law Offices
Just Across
Street From
U.S. Pat. Office

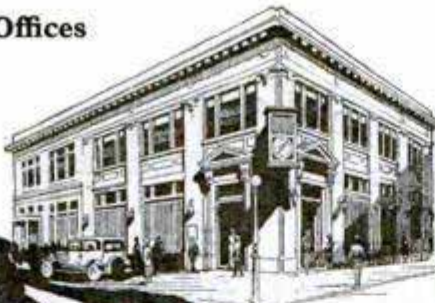

Above is a view of my drafting and specification offices where a large staff of experienced experts are in my constant employ. All drawings and specifications are prepared under my personal supervision.

NEWS

*Inventors
Write for these*

**Free
Books**

Strict Secrecy Preserved

All communications, sketches, drawings, etc., are held in strictest confidence in strong, steel, fireproof files, which are accessible only to authorized members of my staff. Feel free to write me fully and frankly. It is probable that I can help you. Highest references. But **FIRST**—clip the coupon and get my free book. Do **THAT** right now.

Clarence A. O'Brien

*Registered Patent Attorney
& Attorney-at-Law*

Member of Bar of: Supreme Court of the United States; Court of Appeals, District of Columbia; Supreme Court, District of Columbia; United States Court of Claims. Practice confined exclusively to Patents, Trademarks and Copyrights

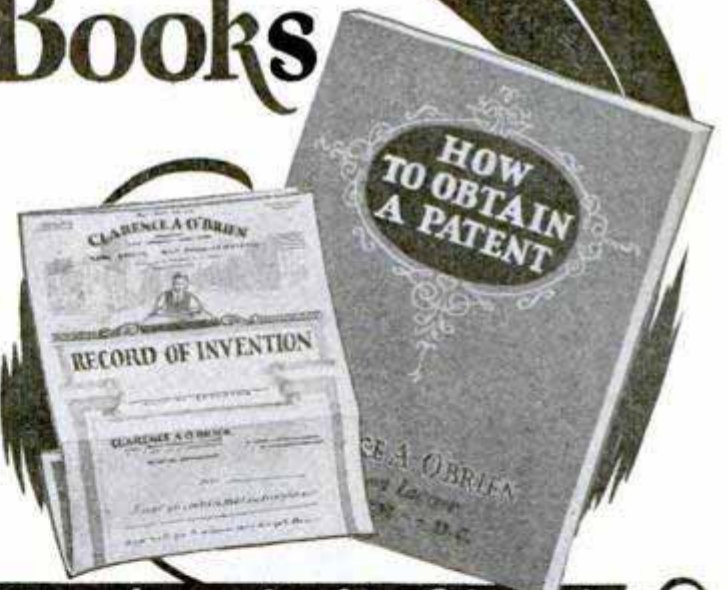

Clip this Coupon and Mail it Now!

CLARENCE A. O'BRIEN, *Registered Patent Attorney & Attorney-at-Law*

70-X Security Savings and
Commercial Bank Bldg.,
Washington, D. C.

OR

Suite 1106 Woolworth Bldg.,
New York City

Please send me your free book, "How to Obtain a Patent," and your "Record of Invention" form without any cost or obligation on my part.

Name.....

Address.....

(Important—Write plainly and address office nearest you)

PATENTS TRADE MARKS COPYRIGHTS

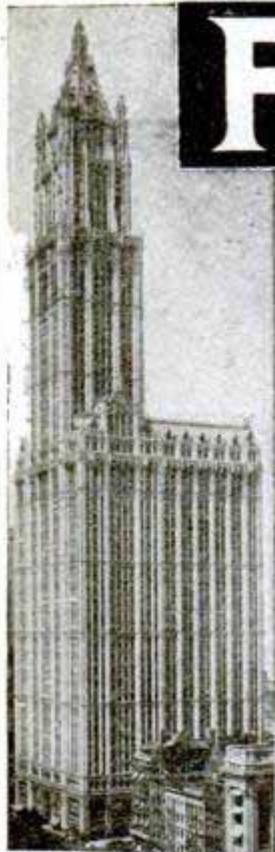

Our New York Office
Suite 1007 Woolworth Bldg.



Our Philadelphia Office
828 Fidelity Phila. Trust Bldg.



VICTOR BUILDING
Our New Building Nearly Opposite U. S. Patent
Office Specially Erected by Us for Our Own Use



Have You An Idea?

Our Offer: FOR THE PROTECTION OF YOUR INVENTION

YOUR FIRST STEP

The inventor should write for our blank form

"RECORD of INVENTION"

This should be signed and witnessed and returned to us together with model or sketch and description of the invention for

INSPECTION AND ADVICE

No Charge for the Above Information

Our Five Books Mailed

Free to Inventors

Our Illustrated Guide BOOK

How to Obtain a Patent

Contains full instructions regarding U. S. Patents. Our Methods, Terms, and 100 Mechanical Movements illustrated and described.

Our Trade Mark Book

Shows value and necessity of Trade Mark Protection. Information regarding *Trade Marks and unfair competition in trade.*

Our Foreign Book

We have Direct Agencies in Foreign Countries, and secure Foreign Patents in shortest time and lowest cost.

Progress of Invention

Description of World's Most Pressing Problems by Leading Scientists and Inventors.

Payment of Fees in Installments

It is not necessary that the total cost for the preparation and prosecution of a patent be paid in one payment. Our custom is to permit our clients to pay for their applications in three installments as the preparation of the application progresses in our office. This plan makes the payments easy for the inventor.

We Regard a Satisfied Client as our best advertisement, and furnish anyone, upon request, lists of clients in any state for whom we have secured patents.

**Highest References—Prompt Service
—Reasonable Terms**

VICTOR J. EVANS & CO.

Patent Attorneys, Established in 1898

Main Offices: 789 9th St., N. W., Washington, D. C.

Nearly Opposite U. S. Patent Office

DELAYS ARE DANGEROUS IN PATENT MATTERS

IMPORTANT! To Avoid Delay!

YOU SHOULD HAVE YOUR CASE MADE SPECIAL IN OUR OFFICE to save correspondence, secure protection and early filing date in the Patent Office. To secure **special preparation** of your case send \$25.00 on account with model or sketch and description of invention.

ACT NOW—Often two or more inventors file applications for practically the same idea. In such cases the burden of proof rests upon the last application filed. Therefore, delays often cause the loss of a patent.

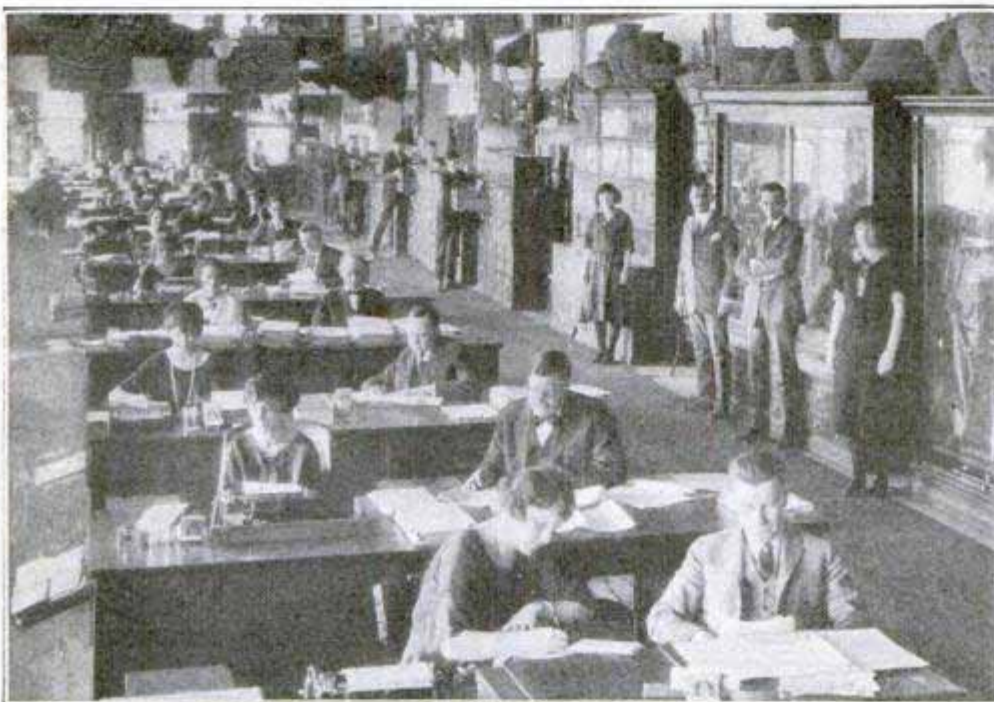

MAIN OFFICE, VICTOR J. EVANS & CO.—VICTOR BUILDING, WASHINGTON, D. C.

Our Large, Comprehensive Organization has been established for 30 years and offers Prompt, Efficient and **Personal Service** by experienced Patent Lawyers and Draftsmen. Every case is in charge of a Specialist who has been selected for his knowledge and experience in certain lines of invention. Our Lawyers practice in all U. S. Courts and defend clients in suits involving Patents, Trademarks and Copyrights. **All Communications and Data** strictly Secret and Confidential. We shall be glad to have you consult us or to answer any questions in regard to Patents, Trademarks or Copyrights without charge or obligation.

**FREE
COUPON**

VICTOR J. EVANS & CO.
PATENT ATTORNEYS *Established in 1898*

NEW YORK OFFICES
1007 Woolworth Bldg.

CHICAGO OFFICES
Suite 1640-42 Conway Bldg.

PHILADELPHIA OFFICES
828 Fidelity Phila. Trust Bldg.

PITTSBURGH OFFICES
514 Empire Bldg.

SAN FRANCISCO OFFICES
1010 Hobart Bldg.

MAIN OFFICES: 789-9th Street, N. W., WASHINGTON, D. C.

Gentlemen: Please send me *Free of Charge* your books as described on preceding page.

Name

Address



Our Chicago Office
Suite 1640-42 Conway Bldg.



Our Pittsburgh Office
Suite 514 Empire Building



Our San Francisco Office
Suite 1010 Hobart Building

PATENTS

Booklet Free

Highest References

Promptness Assured

Best Results

Send drawing or model for preliminary examination and advice.

ALL BUSINESS GIVEN PROMPT AND PROPER ATTENTION

Listed Patent Lawyer in the latest editions of the Rand-McNally Directory of Bankers and Bonded Attorneys, published by Rand-McNally & Co., Chicago, Ill.; The Baggott & Ryall Directory of Guaranteed Attorneys, published by Legal Directory Corporation, Boston, Mass.; Flugel's Law List, published by Legal Directory Publishing Co., St. Louis, Mo.; American Lawyers Annual, published in Cleveland, Ohio; Bankers Service Legal Directory, published by Bankers Service Co., Boston, Mass.; Eyre's Law List, 9 Park Place, New York City; Walters Legal Directory, Omaha, Nebraska, and the National Directory of Attorneys, Baltimore, Maryland.

WATSON E. COLEMAN,
REGISTERED PATENT LAWYER

Victor Building, 724 Ninth Street, N. W.
WASHINGTON, D. C.

PATENTS

To the Man with an Idea

PATENTS Procured. Trade Marks Registered. —A comprehensive, experienced, prompt service for the protection and development of your ideas. Preliminary advice gladly furnished without charge. Booklet of information and form for disclosing idea free on request.

IRVING L. McCATHRAN, Patent Lawyer
Formerly with and successor to **RICHARD B. OWEN**
704 International Bldg., Washington, D. C.
41-E Park Row, New York City

TRADE-MARKS REGISTERED

Information on any book free. Write Popular Mechanics Press, Chicago, Ill.

PATENT YOUR INVENTIONS

EDWARD GOTTLIEB

Attorney in Patent Causes

5 Beekman Street

New York

Inventions Developed—Representative for
BLAIR TOOL AND MACHINE CORP.

PATENTS

PROTECT YOUR IDEAS

Write today for FREE INSTRUCTIONS—or send Drawing or Model of your Invention for Examination.

Promptness Assured with Best Results

CARL MILLER
REGISTERED PATENT ATTORNEY

Former Member Examining Corps U. S. Patent Office
255 McGill Building Washington, D. C.



PATENTS TRADE-MARKS

*Don't Lose Your Rights
To Patent Protection*

Before disclosing your invention to anyone send for blank form "EVIDENCE OF CONCEPTION" to be signed and witnessed.

LANCASTER & ALLWINE
480 Ouray Bldg. WASHINGTON, D. C.
Originators of forms "Evidence of Conception."

INVENTORS PROTECT YOUR IDEAS

Write for our Guide Book, "HOW TO GET YOUR PATENT," and Evidence of Invention Blank, sent Free. Tells our terms, methods, etc. Send model or sketch and description of your invention for INSPECTION and INSTRUCTIONS FREE. Terms Reasonable. Best References.

.....WRITE TODAY.....

RANDOLPH & COMPANY, Patent Attorneys
301 VICTOR BUILDING, WASHINGTON, D. C.

Name

Address

PATENTS

TRADE-MARKS • DESIGNS
FOREIGN PATENTS

MUNN & CO.
PATENT ATTORNEYS

Associated since 1846 with the Scientific American

SCIENTIFIC AMERICAN BUILDING
625 F Street, Washington, D. C.

1303 TOWER BUILDING
Corner of Michigan Blvd. and Madison St.
Chicago, Ill.

1551 SCIENTIFIC AMERICAN BUILDING
21 West 40th Street, New York City

HOBART BUILDING
582 Market Street
San Francisco, Calif.

511 VAN NUYS BUILDING
Spring and Seventh Streets, Los Angeles, Calif.



Books and Information on Patents and Trade-Marks by Request.
Associates in All Foreign Countries.

PATENTS

Trade Marks, Copyrights, Patent Litigation Handbook with illustrations, 100 mechanical movements. Sent free on request.

ALBERT E. DIETERICH
formerly member Examining Corps U. S. Patent Office

REGISTERED
PATENT LAWYER and SOLICITOR
621-A, Ouray Bldg.

30 Years' Experience Washington, D. C.

INVENTORS

who derive largest profits know and heed certain simple but vital facts before applying for Patents. Our book *Patent-Sense* gives those facts; sent free. Write **LACEY & LACEY**, 646 F St., Washington, D. C. Established 1869.

BUCHSTEIN'S FIBRE LIMB



Send for Catalog Today

is soothing to your stump—strong, cool, neat, light. Easy payments. Braces for all deformities. **D. BUCHSTEIN CO.** 610 3rd Ave., So. MINNEAPOLIS, MINN.

PATENTS ON EASY PAYMENTS

Don't let lack of ready money keep you from protecting the idea which may prove the turning point in your life.

FORMER ASSISTANT EXAMINER OF U. S. PATENT OFFICE

will now handle your patent matters on easy payments. Write today for free information and particulars.

M. S. CAYNE

(Registered Patent Attorney)

Main Offices

BANKERS BLDG., 105 W. Adams St., CHICAGO

(With Offices in Washington, D. C.)

\$300,000 For This Simple Invention



That's what Eastman Kodak paid for the Autographic idea. Other simple inventions have brought fortunes to their inventors. The crimped tin cap paid \$135,000; the inventor of "Kiddie Cars" made \$165,000; King C. Gillette and Waterman have become millionaires many times over. Thousands of other inventions are needed and offer enormous opportunities for earning fortunes. If you are of an inventive turn of mind, why not concentrate on things that are really NEEDED? Even one practical IDEA—a little thing like the humped hair-pin, the pencil eraser, the paper clip and other money makers—and you're MADE! Get Raymond Yates' new book.

1,000 Needed Inventions

Costs only \$1.50 and may start you thinking on what the industries need and what the public wants. Hundreds of people have the imagination and ability to create some startling invention—yet don't realize it. Mr. Yates' book is the very thing to bring out your "inventive knack." It tells the ten most needed inventions and suggests what inventions are needed in the Radio, Chemical, Electrical, Marine, Automotive and Mechanical fields. Contains important chapters on Aviation and Television.

Send No Money

Just write postal. When postman arrives deposit with him \$1.50 plus postage. Examine the book for 10 days. If not delighted, return it and get your money back. Remember—not a cent now—and even after you have paid deposit it is still your money, if you want it. This offer limited. Write TODAY and discover your hidden "inventive knack." (Outside U. S., \$1.70 cash with order.) Address

Bureau of Inventive Science 311 Wisner Bldg. Rochester, N. Y.

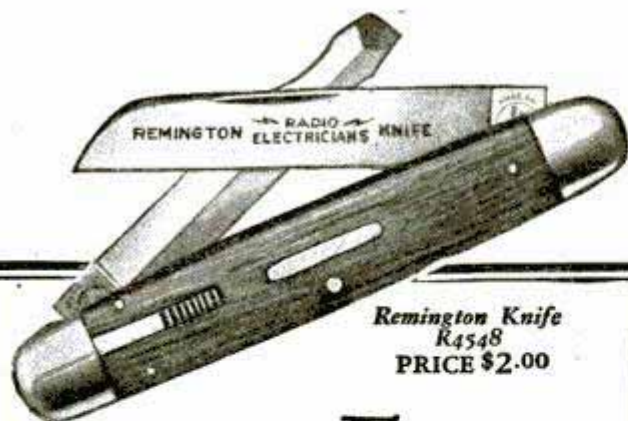

Remington Knife
R4548
PRICE \$2.00

▲▲ For the Radio-electrician

THE Remington Pocket Knife R4548 is manufactured expressly for Radio and Electrical use and makes a special appeal to all members of the wiring fraternity, professional or amateur.

Equipped with two forged steel blades of the finest quality, a 2 1/2" sheepfoot blade, and a combination of wire-stripper and screwdriver, locked in place by safety-catch when open, it readily adapts itself to many practical uses in tinkering with radio sets or installing general electric equipment.

Blades—are tempered and hardened to take a keen edge and retain it, and are hand-honed to razor sharpness at the factory.

Handle—is Genuine English Cocobolo with bolsters of nickel silver, light in weight but durable.

A strongly made and finely finished knife. An ideal pocket-companion for the man or boy who wishes to "build his own."

Ask your dealer to show you the Remington R4548. If he hasn't it in stock, send his name with \$2.00 to Remington Cutlery Works, Bridgeport, Conn. and it will be forwarded promptly.

REMINGTON ARMS COMPANY, Inc.
Originators of Kleanbore Ammunition
25 Broadway New York City

Remington

© 1929 R. A. Co.

3112



"Mind my words—Today I'm buying a **Farrand Rule**"

THE FARRAND RAPID RULE

is no bundle of flimsy sticks—yet it is more rigid than a wooden rule. It is not a limp tape—yet it measures around curves with equal facility. Thousands of carpenters and mechanics all over the world are buying the

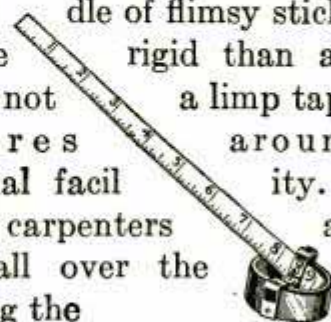

Modern Tool for Modern Craftsmen

which coils in a small holder of vest-pocket size. Made in six and eight foot lengths.

Write today for descriptive folder and six inch sample of rule strip.

Manufactured by

HIRAM A. FARRAND, Inc., BERLIN, N. H.

INVENTORS

May now arrange to obtain **PATENTS**

and pay for them on the basis of

DEFERRED PAYMENTS

INVENTORS SERVICE BUREAU

Dept. B, Union Trust Building, Washington, D. C.



VICAM STANDARD

MOVIE CAMERA

Make your own action movies of events, trips, parades, etc. Takes 25 feet of standard film. Equipped with F.5 universal lens. Loads in daylight. Films developed free. Film can be projected from any standard projector. All-Metal Camera \$18.50. An ideal gift for Christmas for any member of the family.

\$13⁵⁰
F.O.B. Phila.

Order today C. O. D. or send 10c in stamps for illustrated booklet.
VICAM PHOTO CO. 1222 Belmont Ave. PHILA., PA.

SAVE \$2,000 ON A HOME

15 Years to Pay

Send for FREE Book of 100 Home Plans

GORDON-VAN TINE 1401 CASE ST. DAVENPORT, IA.

AMAZING NEW TABLECLOTH

LOOKS LIKE LINEN
WASHES LIKE OILCLOTH



New material rivals Irish linen in appearance—washes without laundering. Stainproof. Does not crack, peel. Saves time, laundry bills. A five piece set given to all agents.

AGENTS
\$15 daily easy!
Write for Free
Sample Offer
and full details.

National Industries, 67 E. Lake, Dept. 15-K, Chicago

Your BRAINS and this machine can make anything

Why waste your time and money on toy machines when you can get this real rig at such a low price?

The SAFETY-SAW MODEL N

- RIPS... MITERS...
- CROSS-CUTS...
- BEVELS... DADOES...
- PLOUGHS...
- GROOVES...
- RABBETS...
- SANDS...
- BORES...
- GRINDS...
- POLISHES... ETC.

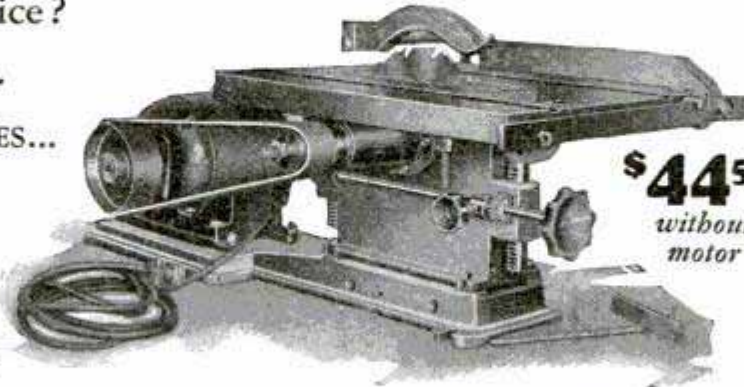

\$44⁵⁰
without motor

Easy to operate
Easy to own
BALL BEARING
Table Top 18" x 14"
Raises and lowers on a level.
Saw Arbor 3/4" Dia.
Cuts 2 1/2" Thick
Rips 12" Wide
Cross-cuts any width
Bevel Rips to 45°

Send Coupon Now for Details, Illustrations and EASY TERMS

GET DETAILS NOW!

TRY THIS Safety-Saw AT OUR EXPENSE

Put this machine on your work bench . . . give it a thorough test . . . compare it with others . . . and then if you're not more than satisfied with it in every way . . . send it back and we'll return every cent of your down payment and pay the transportation charges both ways. You can't lose a nickel, but you can gain a lot. Don't buy any machine until you've read our FREE descriptive folder . . . It shows Bench Saws . . . Band Saws . . . Lathes . . . Jointers . . . and all equipment.

SAFE TOOL MFG. CO. • BRIDGEPORT, PA.

SAFE TOOL MFG. CO., Bridgeport, Pa.

Please send me full information about your woodworking machines.

Name.....

Address.....

WOOD Samples of 33 rare woods \$2.00.
20 cabinet and 20 inlay \$1.75,
or your choice \$1.00
OF ALL KINDS Sets labeled and postpaid. Send for catalog
CRAFTSMAN WOOD SERVICE, K-717 E. 62nd St., Chicago

SALESMEN WANTED!

SELL COX HOLDFAST SCREW DRIVERS

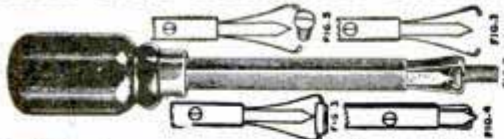

Sells on sight to mechanics for Auto, Radio and Electrical Work. Self Holding, Self Releasing.

Send 50c for sample and ask how to get Salesman's Outfit Free.
S. J. COX Dept. F. FRANKLIN, PA.

CORNWELL

forged Socket Wrenches

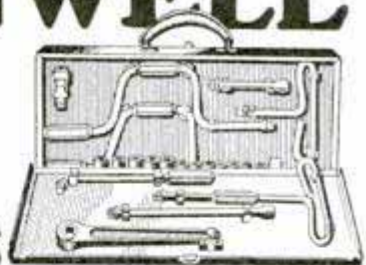

THE strongest and most durable socket wrenches made. They are forged from our special formula Chrome Molybdenum Alloy. Individually hardened and heat treated. Walls are very thin, permitting use in very close places. They are of amazing strength and durability. Sold in convenient kits or separately as required.

There Is No Substitute for Cornwell Quality

The long record of CORNWELL tools for strength and durability, for utility and practicability, and for amazing performance under the severest difficulties has convinced tool users of their absolute quality. No other tools are like them. A trial order will convince you.



This Catalog Sent-FREE

The Cornwell Quality Tools Co.,
Dept. P, Mogadore, Ohio.
(Suburb of Akron)

Send me new illustrated catalog with prices on full line of CORNWELL Handmade Tools.

..... Where employed
Name.....
Address.....
City..... State.....

WITTE ENGINES

LIFETIME GUARANTEE
ALL SIZES AND STYLES
MAGNETO EQUIPPED

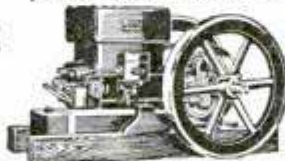

300,000 in Use All Over the World

Since 1870 inventive genius has been on the alert to maintain the leadership and mechanical perfection enjoyed by Witte engines the world over. No other Units afford such inexpensive reliable—all purpose power—for the farm, home, shop or mill.

Ask your dealer or write us for free catalog

WITTE ENGINE WORKS Kansas City, Mo.

ENGINE BUILDERS SINCE 1870

ATKINS SILVER STEEL SAWS



ATKINS Silver Steel Circular saws are needed in every well-equipped

Saws, Hack Saws and Hand Saws home shop.

Start a Home Workshop!

THINK of all the useful things you could build in spare time . . . the dozens of repair jobs you could do . . . the dollars you could save and the fun you could have . . . if you had a workshop and a set of good tools.

Start a home workshop now! Select the tools you need at your hardware store. Saws to cut wood or metal are your most important tools, so buy the best. Your dealer can show you a full line of ATKINS Saws, made of the world-famous "Silver Steel" that cuts faster, easier, holds its edge longer and outlasts any other saw steel.

You can get ATKINS Hand Saws for cross-cutting or ripping! Circular Cross Cut or Rip Saws in sizes to fit any power sawing outfit! Back Saws to do fine work in cutting mitres, etc.! Dado Heads to cut smooth grooves quickly! Hack Saw Frames with Blades that cut metal twice as fast and last six times longer! Narrow Band Saws for scroll work, etc.! Machine Knives for small planers! Cabinet Scrapers, Grinding Wheels and Files. Saw Filers, Saw Sets and hundreds of other fine tools for home craftsmen.

Send coupon below for helpful booklets every tool user should have.

4 Saw Booklets Sent FREE



E. C. ATKINS & CO.
Est. 1857 426 S. Illinois St.
Indianapolis, Ind.

Send "Saws in the Home," "Circular Saws," "Dado Heads," and "Saw Sense"; also information on your offer of \$10 for best home workshop photo.

Name

Address

My Dealer is

WIN \$10
for Best Photo of a Home Workshop!

CRESCENT SCREW DRIVERS Stand this test!



The new Crescent Screwdrivers will stand the abuse which this tool usually gets. Spring tempered shanks of forged alloy steel spring back into shape and the rigid handles will not turn. Crescent blades have a gently tapered point which "hangs" to screw slot and increases the turning power. At your hardware dealers.

CRESCENT TOOL COMPANY

210 Harrison St.,
Jamestown, N. Y.

No. 214
2 to 12 inch
\$.20 to \$.65



CRESCENT and Smith & Hemenway TOOLS

Catalog on Request



Engines & Motors Big Catalog No. 30

Illustrating Electrical, Mechanical and Model Maker's Supplies, Small Steam & Gasoline Engines, Motors, Generators, Lathes, Drill Presses, Bench and Band Saws, etc., 16-32 & 64 Watt Dyna-Motors, School Projects, Engine Castings, Motor Parts, etc., Books, Blue Prints, Brass and Steel Tubing, Gears, Pulleys, Hangers, Experimental Material. Send for Copy. Mailed anywhere for 20 cents, 25 cents Canada, refunded first order. **LOOMIS ELECTRIC & MFG. CO., 2822 N. CALIFORNIA AVE., CHICAGO, ILL.**

GEARS IN STOCK—immediate delivery

Gears, speed reducers, sprockets, thrust bearings, flexible couplings, pulleys, etc. A complete line is carried in our Chicago stock. Can also quote on special gears of any kind. Send us your blue-prints and inquiries. Write for catalog No. 10.

Chicago Stock Gear Works
769-773 W. Jackson Blvd., Chicago, Ill.

Makes Old Ford a Tractor

Now you can convert that old Ford car into a useful farm tractor without altering any Ford parts. We furnish the traction wheels, drive gears and auxiliary axle and mountings, ready to clamp on to the Ford frame. Pulls 16" plow.



Write for Free Particulars. Shaw Mfg. Co., Dept. PM11, Galesburg, Kan.

SOLDERALL METAL IN PASTE FORM

The only convenient metal solder. Every Electrical Connection needs Solderall for perfect reception. **25¢**
The SOLDERALL CO., NEWARK, N.J.



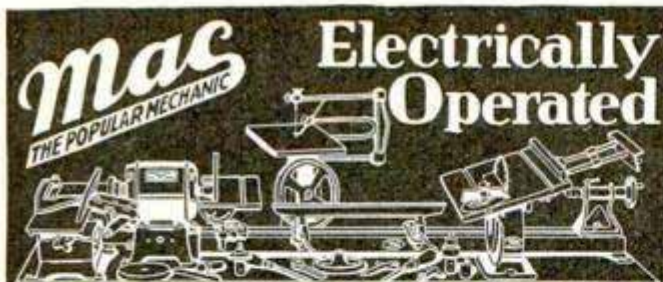

Amazingly Better Work Shop!

Home Mechanics, Inventors, Model Makers, Craftsmen! Now you can expect new things—amazing improvements, new easy ways to make and repair a thousand and one different articles right in your own home. Here is everything you need to gratify your creative instincts—and to make big money, too. Even in unskilled hands results are surprising. MAC is a strong, sturdy, practical workshop—designed to perform the most difficult feats of woodcraft.

Now Sent on 10 Days' FREE TRIAL!

We'll gladly send you this superb craftsman's shop on approval for 10 days' FREE TRIAL. Embraces everything necessary for a complete motorized workshop. 1-3 H. P. Motor; 8-inch Circular Saw; 36-inch Lathe; 4-in. Jointer; Sturdy Jig Saw and complete accessories for all woodworking operations. Guaranteed to give the highest degree of service. Never before has machinery of this character and quality been offered at such amazingly low prices.

Small Monthly Payments

Complete outfit shipped to you on approval, 10 days' Free Trial. Then convenient monthly terms if you decide to keep it—as low as \$5.94 per month. The things you make will be worth many times the small monthly payments.

Plans and Instructions Given

We'll help you to develop your mechanical talents. A complete service, including instructions and plans, is given. It is simple to master the art of wood turning. In a short time you can become an expert cabinet maker.

Write Today for Complete Details!

Send us your name and address and we will mail literature illustrating and describing MAC—The POPULAR MECHANIC Workshop—and details of our Free Trial offer and liberal monthly terms. Write today!

MIDLAND APPLIANCE CORPORATION
Dept. 1110, 225 N. Michigan Ave., Chicago, Ill.

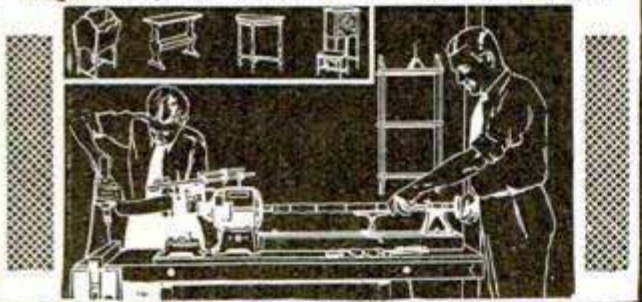

CALCULATIONS

in Office, School, Store and Shop can be instantly made with the Midget Slide Rule. It gives the answer to any problem involving fractions, mixed numbers, decimals, whole numbers, roots, powers, Logs and Trig. Functions. Thousands of these rules are used by Accountants, Engineers, Clerks, Students, etc. It is the most versatile calculator ever invented. If you have any figuring to do, order a Midget Slide Rule on trial. Made of aluminum with figures on white celluloid. Size 4". Price with Instruction Book \$1.50. Fabrikoid Case, 50c extra. Catalogue Free. Sent C. O. D. if desired. Your money back if you are not satisfied.

GILSON SLIDE RULE CO., Stuart, Fla.



BURN YOUR NAME ON TOOLS

WITH THE ARKOGRAF

PROTECT YOUR TOOLS FROM THEFT

Write with electricity your name or design on the hardest and finest tools and instruments, or any metal, like writing on paper with pen or pencil. Complete Outfit \$3.50—Prepaid Anywhere. Interesting illustrated circular free. Write today. Agents wanted.

ARKOGRAF PEN CO., 1171 E. Stark St., Portland, Oregon

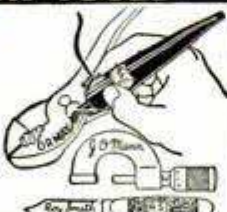

ONE-MAN SAW MILL

Makes lumber, shingles, cross ties, fence posts, laths, fruit and vegetable crates and boxes, dimension blanks for furniture, etc. Splits blocks into firewood. Needed by farmers, timber owners, contractors.

Pays for itself in a week, or on one job. Guaranteed. Sold direct from factory. Write today for Special Offer and Free Book "How To Make Lumber."

BELSAW MACHINERY CO.
BOX 104-D PLEASANT HILL, MO.

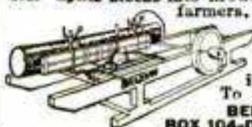

\$39
BRINGS IT TO YOU

LIKE A
Flash
"RED STREAK"
comes to ease
your cutting labor

"Red Streak" all hard and hard edge Hack Saws brilliantly identify Hack Saw Perfection.

SIMONDS, known for nearly a century as makers of the best cutting tools, now introduce "Red Streak" Hack Saw Blades—the new blades with important improvements in design and construction.

It pays to choose hack saws with the same care given to other tool purchases. The brilliant red end on all "Red Streak" Hack Saw Blades is your best guide. You'll recognize it instantly.

Furthermore, the red end on "Red Streak" tells you, first glance, the proper way to use "Red Streak" Blades . . . Put the red end forward and push toward the red! Look for the red end on "Red Streak" Hack Saw Blades. It's your protection in buying.

SIMONDS

SAW AND STEEL COMPANY
FITCHBURG, MASS.

"RED STREAKS" "The Saw Makers"
Established 1832 **cut like lightning!**

Branch Offices and Service Shops in Principal Cities

RUSH-ABSOLUTELY FREE!

THIS E-F ANGLE SCREWDRIVER—of tempered crucible Spring steel—has 7 powerful edges for large & small screws. Works under obstructions where others won't—101 other uses. Carries like pen-knife—often more valuable. Sent Free on Receipt of Coupon.

Name _____
 Route No., St. _____
 P. O. City, St't. _____

Interested in Factory Representative Proposition!
 In User Literature! **THE FLASH SALES CORPN**
 JPM - 4809 N. Ashland Ave., CHICAGO, ILL.

CLIP HERE—MAIL TO

Also FREE ON COUPON—the "\$5,000" CIRCULAR giving amazing 125-Picture story of **The "Pocket Machine Shop!"**

with its 1-TON POWER-GEAR It Outgrips a 40-Lb. Visel



The "hand-grip" of a tiny Rubber handholds the Hardest-to-Hold thing known against a 300-Pound Pull!

Its 10-to-1 ratio Power-Gear-Transmission gives YOUR hands the 1-TON GRIP of 20 Hands, yet — YOU CAN GRIP A HAIR.

An Automatic Lock-Grip Ratchet Wrench

Speed VISE
 Parallel PLIERS
 Plus



No. 3—for all Wire, chain, spring-making, fence work, etc.
 No. 2—for all Pipe work, "chewed" nuts in tight places, etc.
 No. 1, Universal—for ALL Pliers, Nut Wrench, Vise and Clamp, Spring-making Work, etc.

EIPEL-FLASH PIERRENCH KIT

(Say "Eye-fel-Flash") "The T.N.T. of Tools!"

You get the amazingly Quicker, Better, Easier, Universal Tool Service of Nos. 1, 2 & 3—Convertible in 1/5 second—in this new 24-Ounce Master Tool Kit—for the Price of One Good Tool; yet it Does the Work of the best other tools Weighing 60 pounds and Costing \$50.00!

Hundreds of Thousands of Men and Women are using these wonder Kits to make Homes and Estates more comfortable—Farms, Shops, etc., more profitable; to get more and better service from Auto's and all mechanical devices with a huge saving in money, time and energy! Used by the U. S. Army and Navy. Just try a Plierench Kit Once, and you'd no more go back to other tools than to the ancient Ox-cart!

With each Kit a 64-page Manual of Mechanics
A GUARANTEED SUPER-QUALITY PRODUCT (©'28 J.E.)

ALSO BIG FALL AND WINTER MONEY-MAKER for Plierench Factory Representatives—Full or Part Time. Amazing Demonstr'n sells at sight—makes \$75-\$200 weekly all year 'round. Seasonal Demand Doubles Profits. A Ga. Repr. made \$97 in 20-Min. Group Sale; a Mich. Repr. \$368 in 12 days; another \$379 in 5 days. Everybody wants the KH!

Mail Valuable Coupon Above NOW!

\$15 Electric Drill



1/2 in. Steel Chuck, key operated. Universal Motor. A sturdy tool for wood or metal. Fully guaranteed. Postage paid.

GEO. M. STUDEBAKER, Jr., B, South Bend, Ind.
 512 Citizens Bank Building

BIG MONEY

easily made by floor surfacing contractors who average \$40 per day. The New "American High Production" Machine does the work—makes you the money and builds you a business of your own. No dull seasons—no large capital nor experience required. Complete information free without obligation—write today.

THE AMERICAN FLOOR SURFACING MACHINE COMPANY
 253 So. St. Clair St. TOLEDO, OHIO

PARKS

WOODWORKING MACHINES

Cabinet Shop Special No. 10

\$290

With Motor



You ought to have this handy Parks in your shop. Compact, complete machine designed like a big production outfit at 1/2 the cost. Floor space required only 42x72 in. Does any kind of cabinet and joinery work. Write for circular.

The Parks Woodworking Machine Co.
 Builders of quality woodworking machines since 1887
 1500-40 Knowlton St. Cincinnati, Ohio
 Canadian Factory: 338 Notre Dame East, Montreal

MARVELOUS NEW PATENTED SCREW-HOLDING SCREW DRIVER

Non-magnetic. Holds screws any material tight! Removes and inserts them INSTANTLY from inaccessible places. Factories, garages, radio, electricians, machinists, auto owners, etc., buy on sight! Indispensable for all who ever use tools. Price \$1.50 only. (Sent postpaid receipt money order.)

DISTRIBUTORS: Genuine opportunity, earn big money. Exclusive territory closing fast. Write or wire quick for full details.

JIFFY-TITE MFG. CO., 1248 Water St. Boston, Mass.

A Genuine Robbins & Myers

1/4 H. P. Electric Motor



for 110 V., 60 Cycle light circuit at the low cost of \$10.70 net. A tool that will lighten your chores, connected to your lathe, grinder, pump, washer, etc. Always ready for service.

ROBBINS & MYERS, Inc.
 Department A, Springfield, Ohio

High Quality Tool Chests at Right Prices



Every GERSTNER Chest for Machinists and Toolmakers is built for many years of service. Many sizes in a variety of styles. Free Catalog.

Gerstner & Sons
 471 Columbia Street, Dayton, Ohio

ELECTRIC LIGHTS ANYWHERE

110 Volt—complete plant with all Wiring, Fixtures and Lamps for 7 rooms \$147.50, Direct-To-You.

Ideal for Farms, Camps, Summer Homes.

Also runs Household Electrical Appliances. Install it yourself. Write for circular.

D. W. ONAN & SONS \$147.50
 25 Royalston Ave. Minneapolis, Minnesota.



Information on any book free. Write Popular Mechanics Press, Chicago, Ill.

\$4.99 22 Cal. Blank Automatic



WITH 100 CARTRIDGES GIVEN! You need no license or permit to own this 6 shot Automatic. Use for fun or self-defense. Keeps away traps, frightens thieves, scares away dogs—A real home protector. Fool your friends. Same as an expensive automatic in construction, finish, appearance, durability; automatic magazine loading and ejection of cartridges, instant and powerful report. Guaranteed absolutely safe. Send no money. Pay on delivery \$4.99 plus shipping charges. 100 cartridges.

JENKINS, 683 Broadway, New York, Dept. 11-J-23

NO PERMIT REQUIRED

6 SHOT

INVIGORATE face, body, hair and scalp BY MASSAGE

NOW everyone can afford good health. The Hamilton Beach vibrator—now only \$13.50 and GUARANTEED—relieves fatigue, headaches, rheumatism, lumbago, cramp, excess fat, nervousness, and other ailments aided by invigorated circulation. Stimulating blood flow carries off unhealthy waste material, giving nature a chance to bring back health. This vibrator is equally effective for a facial massage or to invigorate the skin and scalp. It stops falling hair and dandruff. A few minutes' application gives you a new vigor. Sold at stores.



Free Book Send today, no obligation for FREE 117 page book "Health and How to Get It."

HAMILTON BEACH MFG. CO.
V-6098, H. B. BLDG., RACINE, WIS.



Scalp



Lumbago



Excess Fat



Rheumatism

Easy

A FEW weeks of pleasurable practice gives you command of the Conn saxophone which enables you to entertain yourself and friends. Be popular, increase your income if you wish! Start now with an easy-playing Conn. Choice of world's foremost artists—and costs no more. Free Trial, Easy Payments on any Conn. Write for Free Book, details. C. G. Conn, *Inc.*, 1131 Conn Bldg., Elkhart, Ind.

CONN

BAND INSTRUMENTS

Chesterfield

The MILD cigarette that SATISFIES

CLASS PINS 35¢

FREE CATALOG SHOWING 200 DESIGNS

EITHER DESIGN SHOWN. SILVER PLATE 35¢ EA. 12 OR MORE \$3.50 DOZ. STERLING SILVER OR GOLD PLATE. 50¢ EA. 12 OR MORE \$5.00 DOZ. 1 OR 2 COLORS ENAMEL. ANY 3 LETTERS AND DATE.

BASTIAN BROS. CO. 925 BASTIAN BLDG. ROCHESTER, N. Y.

Lighter and Pencil Combined

PENCILITE

It Lights and It Writes

It's irresistible! No. 5 Bullet Style PENCILITE—a serviceable pencil and sure-fire cigar lighter. Sells on attractive display cards to all stores, soda fountains, cigar stands, etc. Extra big profits to salesmen. Big repeater. Get sample! Protect territory now!

Uses any lighter fluid. Does work of \$5 lighter or pencil. Sells on sight! Write for special offer!

Sample 25c Prepaid
THE LYCO COMPANY
701 E. 40th St., Dept. 805-P, Chicago, Ill.

\$2 to \$4
An Hour
In Spare
Time

It's Easy for You To Start Your Own CASH BUSINESS

Be your own boss! You can get started in a fine paying, permanent business of your own in spare time, with very little capital. No selling—no stock to carry. Hundred of men are making big profits filing saws on the Foley Automatic Saw Filer.

\$52 in Spare Time One Week

"Saw filing is coming beyond all my expectations," says E. V. Harper. "I started as a hobby in my spare time. Filed \$52 worth in one week. Instead of a playtime hobby, it has gotten to be a regular business." See the Foley at the Power Show, Grand Central Palace, New York, Dec.

Easy to Operate

You don't have to be a mechanic to make big money on a Foley. No experience is necessary. Michael Brinza writes, "Learned to operate the Foley Filer in a few hours." It works automatically—you simply adjust the saw in the machine and turn on the power. No eye strain.

Get This Easy Business

There's big profits filing saws on the Foley, and you can get plenty of business. J. E. Allen writes, "I am doing a good business filing saws for contractors, carpenters and also for manual training schools. All are highly pleased with the work done on their saws with the Foley Automatic Saw Filer."

Better Saw Filing on the Foley

The Foley files all kinds of saws better than by hand, and they stay sharp longer. "People are coming from all directions to have their saws filed on my Foley Filer, and they pay me more than anyone else in the city," says Louis Christensen.

There is a big opportunity for YOU to make big money in your own cash business. Don't delay—send the coupon NOW and get started.

This Plan FREE

FOLEY MFG. CO., 245 Foley Bldg., 11 Main St. N. E., Minneapolis, Minn.

Please send me your FREE PLAN and tell me how I can start my own cash business in spare time and make big money with the Foley Filer.

Name.....

Address.....

City..... State.....

Fastest Cutting

Saws Fifteen Cords a Day!



Men—
Let Me Send You My
Greatest LOG SAW Offer!

ONLY
\$39

Puts the OTTAWA Working for YOU!



It's easier now than ever before to own this fastest-cutting, easiest-moved, most powerful Log Saw. Now, you can make big money sawing firewood, stave-bolts, ice, shingle timber, etc. Write today for full details of this most wonderful offer. Know how easy it is to make big money sawing fifteen cords of wood a day with no hard work.

350 Saw Cuts a Minute —

nearly six each second. Just think of it—take any size log—in a few seconds it's all sawed up into lengths you can use—without any hard work! The OTTAWA has balanced crank shaft, power force feed, friction clutch.

Make BIG MONEY—

Wood selling at \$3 a cord brings owner \$45 a day. Saw your own wood—go into the wood business. Don't let the lack of ready money stop you. Remember, we sell on very easy terms. More in use than all others combined.

"I average \$20 profit a day with my OTTAWA."—J. Schill, New York. "My OTTAWA has earned \$700 for me."—S. Graham, Wisconsin. "I can make more money with the OTTAWA than by farming."—D. Goff, Missouri.

OTTAWA 4 H.P. LOG SAW

30 Days to Try—one whole month to use the OTTAWA at your own sawing. Shipped on trial—backed by 10-year guarantee. Prove to yourself how easy you can saw 15 cords or

more a day—at a cost of 1 1/4 c a cord. To Save You Freight—and get your machine to you a few days after your order, I ship from factory or nearest to you of four branch houses.

FREE Send me your name and address on postcard today so I can send you my wonderful new edition of the "Wood Sawing Encyclopedia." Educational, instructive. Be sure to investigate—will help you to make big money.

C. E. WARNER, Pres. OTTAWA MFG. CO.
1742-P Wood Street OTTAWA, KANS.



One Year

No. A169 — \$62
\$2 Deposit — \$1.25 a Week

Seven fine quality, genuine blue-white diamonds are set in a **SOLID PLATINUM** disk shaped like a solitaire. The diamond platinum cluster looks like \$600 solitaire and is set in the latest style, handsomely engraved 18 Karat solid white gold mounting. Two dark sapphires add to its attractiveness.

Guaranteed

IB K SOLID - GOLD

To Pay

No Red Tape

10 Days Trial

SEND NO MONEY When you get the ring, pay only \$2.00 to the postman. If you keep it, pay only \$1.25 a week for one whole year. All credit dealings kept strictly confidential—No orders accepted from persons under 20 years of age.

PRICE CUT TO \$62.00—WORTH \$100.00

You can now buy this gorgeous ring at the wholesale price. Compare it with similar rings at \$100. We guarantee it to stand any test or comparison. Greatest bargain offered by any Diamond Importer. We allow 8% annual increase in exchange for a larger diamond ring.

Write for FREE Illustrated Catalog

It brings our large Jewelry Store right into your home. Gives weights, grades and complete description so you can buy diamonds like an expert. Gives you information other jewelers dare not tell.

Genuine Blue-White Diamonds as low as \$197.00 a Carat.

AGENTS WANTED—EARN \$100 WEEK. Write for details.

STERLING DIAMOND & WATCH CO. INC.
DIAMOND IMPORTERS—\$1,000,000 STOCK—ESTABLISHED 1879
1540 BROADWAY DEPT. 2660 NEW YORK

Complete Your HOME WORKSHOP EQUIPMENT with the
H & A BALL BEARING SHAPER

Turn out moldings, beading, matching—every conceivable millwork job—at a fraction of the usual cost. The first time that a practical heavy-duty Shaper has ever come within the price range of the average home shop. Also used in hundreds of woodworking and industrial shops. Portable; electric. Write for catalog.

HESTON & ANDERSON
611 Market Street FAIRFIELD, IOWA

AGENTS AND SIGN MEN
Now Making \$50.00 to \$100.00 and Up Per Week Selling Our **GOLD LEAF SIGN LETTERS**

R For store and office windows, board signs, trucks and glass signs. We also make to order script signs and business emblems singly or by the thousands. A permanent business. No capital or experience required. Big demand in every city. *Samples and Literature Free.*

CONSOLIDATED SIGN LETTER CO. 71-X W. Van Buren CHICAGO, ILL.

BASHFUL?

"Shame on you!" Are you nervous, embarrassed in company of the other sex? Stop being shy of strangers. Conquer the terrible fear of your superiors. Be cheerful and confident of your future! Your faults easily overcome so you can enjoy life to the fullest. Send 25c for this amazing book, **RICHARD BLACKSTONE, B-4711 FLATIRON BLDG., NEW YORK**

Enormous Profits **Manufacturing SPECIALTY CANDIES**

Men and women, earn \$35 to \$100 weekly operating our Original "New System Specialty Candy Factories." Start at home with a few dollars. We teach you the work complete, furnish tools and everything ready for immediate production. **QUICK RETURNS and a PERMANENT BUSINESS OF YOUR OWN.** Big FREE Book tells you how. Write for it today.

W. HILLYER RAGSDALE, Drawer 59, East Orange, N.J.

Easy to Make
\$25⁰⁰
a Day

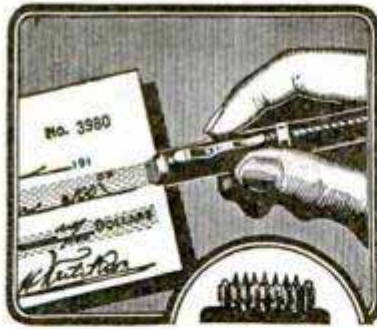

Sell Security Pens

Agents make three out of five sales on the spot! Hundreds making over \$600 a month! Others pocket \$5 an hour spare time. You, too, can make big money with this "wonder" 2 in 1 Security Pen—the most amazing pen on the market. Every man and woman with a checking account buys.

Check Protector and Pen Combined

Show both ends of Security Pen, demonstrate the sturdy, perfect writing, fountain pen. Then show the other end—the patented CHECK PROTECTOR which protects checks from crooks, who, every year, steal over \$250,000,000 raising checks. No other pen has this wonderful feature. No competition. A five-minute demonstration closes sale, pays you almost 100% clear profit at once. No experience necessary. Make big money.

Amazing New Plan

Entirely new selling plan to introduce this sensational novelty. Write now for details and while exclusive territories are open. No obligation.

DISTRICT MANAGERS:—If you have an organization or can form one we can make you an associate offer.

SECUROGRAPH PEN CO.

R-55 Securograph Bldg. **STRAIGHTLINE** Oakland City, Ind.

Sample Offer!

Learn how you can get a Security Pen sample outfit **ABSOLUTELY FREE.**

AMAZING PROFITS
for AGENTS
Make \$25⁰⁰
a Day—Easy!

Selling this Superb
HOT-RAY
Electric Portable
Radiant Heater



SENSATIONAL Money-Maker! Marvelous, new, electric portable heater taking the country by storm. **Beats anything you ever saw. Act fast! Get in on it now!**

Gives Lots of Heat—Portable

Efficient. Economical. Gives abundant heat. Small, compact, 14 in. high, 11 1/2 in. wide. Carry by handle. Weighs only 9 lbs. Complete with 6 ft. cord. No flue, no odor, no fumes.

Marvelously Beautiful and Efficient—
An Astounding Money-Making Opportunity
for Fall and Winter



Strong, iron-clad guarantee. Heater will last a lifetime. Durable, cast-iron construction, finished in charming green Vitreous Porcelain Enamel. Safety guard in front. Strikingly beautiful when lit. **Makes instant appeal. Price extremely low.**

Sell One for Every
Room in the Home

For bathrooms, bedrooms, dining rooms, living rooms, sun parlors, etc. Astounding, quick, profitable sales winner for Fall and Winter.

Quickly Demonstrated

Just connect to any light socket. Gets hot in a few seconds. Costs but little to operate. Sells quick on demonstration. You can make big money, fast.

Get Free Trial Offer
and Exclusive Territory

Don't delay! Mail coupon or write or wire for details. Free Trial Offer will convince you of this amazing, easy money-making plan at our risk.



MAIL THIS COUPON TODAY!

Lawson Mfg. Co., Dept. A, Pittsburgh, Pa.

Send full particulars and Free Trial Offer telling me how to make \$25 a day this Fall and Winter.

Name.....

Address.....

City..... State.....

PANTS MATCHED!
Why Throw Away That Coat and Vest?
Save \$25 or more! Let us match your coat and vest with new trousers and save the price of a new suit. Each pair tailored to your measure. (Average price \$8.50). Over 100,000 patterns. Mail sample of suit, or your vest which will be returned together with FREE Sample for your approval.
MATCH PANTS CO., Dept. 85, CHICAGO
20 W. Jackson Blvd.

Originators and Largest Pants Matchers

Cal. 30-40 Six Shot
KRAG CARBINE
All the qualities of a high price rifle. In fine used condition, all working parts guaranteed for one year. Send today for our Free 50-page illustrated catalog of money saving values; Guns, Ammunition, Cutlery, Sports and Gov't goods. Terms Cash. No C. O. D.
Price \$9⁷⁵
W. Stokes Kirk, Dept. P.M. 11, 1627 N. 10th St., Philadelphia, Pa.

BURNING CIGARETTES
BLAZE NEW PROFIT RECORDS

HERBERT TAREYTON
CAMEL CHESTERFIELD
LUCKY STRIKE CLOWN
HELMAR RALEIGH
MURAD PALLMALL
RALEIGH SALOME
CLOWN TURKISH
FATIMA TROPHY
SWEET THREE
CAPORAL KINGS
HASSON EGYPTIAN
BULL DOG DEITY
HOME R. SPUD
MELACHRINO OMAR
OLD GOLD PIEDMONT

NOW—let cigarette smokers pay you royally. Unheard of profits! Help us meet the demand for CIGARETTINE—and pocket \$25 daily. **POPULAR OVERNIGHT CIGARETTINE** puts kick in smokes. One drop on cigarette (any brand) cools throat, clears head, sweetens breath. Delightful sensation. Smokers wild about it. 25c bottle flavors 500 cigarettes. Perfume flavor for women.
FREE TRAINING
No experience needed—we train you. Free display cards. New plan guarantees success.
Rush Application for Territory.
THE VICTOR PRODUCTS CO.
Dept. G-9 Cincinnati, Ohio

\$25 DAILY

For the Modern Housewife
This New, Convenient
BURGESS
KITCHEN MEMORANDA

Paper and pencil handy all the time for recipes, shopping lists, phone calls, notes for the household, etc. Complete with beautiful enameled base, permanent place for pencil and 2 rolls of memo paper, enough for 15 months use. Size 4x12 inches.
Hangs on Wall—Matches Kitchen
Hang on kitchen cabinet or wall. Choice of six rich colors—Apple Green, China Blue, White, Orange, Red or Yellow. Give one for bridge prize, shower gift or Christmas present.
Lasts a Lifetime—Only \$1.00
A hundred daily uses—new paper easily procured at any stationery store. Mailed complete, postpaid anywhere U. S. or Canada for \$1—bill, stamps, money-order or check. Mention color. Money back if not satisfied.
BURGESS MANUFACTURING CO.
Dept. P-1 Beaver Falls, Pa.



ARTISTIC PORTRAIT ENLARGEMENTS

only **98¢** each

FROM ANY PHOTO
or SNAP-SHOT~
SIZE 16 x 20 INCH

(or smaller if desired)
The usual price of this work
is \$5.00 but by taking advan-
tage of this Special

Offer you can get a beautiful life-like enlarge-
ment of that favorite picture of mother, dad,
sweetheart, baby or any friend for only 98 cents.

SEND NO MONEY—Just mail us the photo—any size (Full
figure, bust or group) and in about a week you will have your
enlargement guaranteed never to fade. It comes to you
C.O.D. On arrival pay postman 98c plus a few cents postage,
or send one dollar cash with order and we pay postage. Money
back if not delighted. You can send us your most treasured
photograph, it will be returned to you unharmed.

FREE In order to advertise this remarkable offer we send free
with every enlargement ordered, a Highly-Glazed
Hand Painted miniature reproduction of the photo sent. These
miniatures alone are worth the whole price charged for the enlarge-
ment. Take advantage of this really Amazing Offer and send
your order today. **DO IT NOW.**

ALTON ART STUDIO, Dept. 46
5654 West Lake St., Chicago, Ill.

Please enlarge artistically the enclosed photo,
Return enlargement and FREE Hand Painted
miniature, C.O.D. 98c plus postage. (If \$1.00
is enclosed you are to send postage paid.)

Name _____

Address _____

Town _____

State _____

Check Size
Wanted

- 16x20 in.
- 10x 16 in.
- 11x 14 in.
- 8 x 10 in.



Why Not Start Welding Shop Of Your Own?

- Welding Outfits.....\$25.00 Up
- Lead Burning Outfits... 18.00 Up
- Soldering Outfits..... 8.00
- Paint Sprayers..... 14.00 Up
- Regulators and Gauges... 9.50 Up
- Lead Burning Torches... 6.00 Up
- Welding Torches..... 10.50 Up
- Cutting Torches..... 30.00 Up

Write for catalog—also our
payment plan.

SUPERIOR OXY-ACETYLENE MACH. CO., P. O. Box 285, Hamilton, Ohio

A BIG MACHINE at LOW PRICE!

DOES 20 DISTINCT WOODWORKING OPERATIONS

TURN YOUR HOBBY
INTO INCOME!

No trick at all
with this amaz-
ingly low price
Woodworker,
which you may try,
and pay for, on
terms, to turn idle hours
into profit. Does 20 wood-
working operations. Ideal
size, capacity for shop,
home or the job. Econo-
mical to operate. The best
buy in the market!

Just
\$25.00
BRINGS IT
TO YOU
FREE TRIAL



COMES COMPLETELY EQUIPPED!

Comes complete with 8-in. Cross
Cut, 8-in. Rip Saw; 12 in. Band
Saw; Jointer, Lathe, Borer, Sander,
Guides,
Electric Motor. Investigate it!

FREE Working Drawings
with Saw of Items You
Can Make

SEND FOR FULL DETAILS!

A. S. ALOE CO.
1831 Olive St.,
St. Louis, Mo.

Without obligation, send
me details on the Woodworker,
and the Free Trial and Easy Terms Plan.

NAME.....

ADDRESS.....

STRANGE NEW IRONING CORD

NEW FIELD FOR AGENTS

**Can't Kink or Snarl—
Prevents Scorching—
Saves Electricity!**

THIS CORD SET FREE

Every Neverknot Salesman is given FREE the complete Neverknot Cord Set pictured. This new type Cord Set automatically coils itself out of the way yet every inch is available. A new kind of plug prevents scorching and saves electric bills. It is a "gold mine" for house-to-house workers.

Big Companies Equip Phones

This unique Patented invention sells readily to phone users as it abolishes kinks, snarls and disconnects. Now used on phone cords of Fed. Res. Bk., Gen. Elec. Co., Mellon Nat. Bk., The Tex. Co., and many others.

There is only one Neverknot. It is protected by U. S. Patent. Get territory with free cord set NOW!

NEVERKNOT COMPANY
Dept. 11-V, 4503 Ravenswood, Chicago

MAKE \$90 A WEEK

3 FOR ONLY 65¢

Boys—send 65c. Big kit includes 3 famous SOLAR Detroit Model Airplane Fliers Club plans and complete instructions for building Biplane, Tractor and Pusher, plus all materials for making all 3—balsa blocks and sticks for blades, spars, ribs, fins; Japanese paper; rubber motor; wire; glue; banana oil—everything. Great fun to build; guaranteed to fly. Send money order TODAY (65c); no stamps.

COLLINS PLOW COMPANY, Dept. 102, Quincy, Ill.

AUTOMATIC WINDOW WASHER

Price \$1.95

**Washes, Cleans, Dries
Polishes in One
Quick Operation**

Amazing new invention.
**CARRIES OWN WATER
SUPPLY!** Eliminates all
drudgery and splashing! 5 times
as fast as old methods. Patented
features: **No pail. No brush. No
sponge. No chamois.** Can be used with
or without a pole. **\$90-\$150 weekly
easy for agents.** Sells on sight. Sen-
sational demonstration! Every housewife,
autoist, store-owner a prospect. Write for our
Free Sample Offer and big money-making
proposition. Be first.

NATIONAL INDUSTRIES, 67 E. Lake St., Dept. 1511, Chicago

NEW 8 DAY Strap Watch

\$7.49

**LATEST
INVENTION**

Something entirely new in wrist
watches. Runs eight days on one
winding. Guaranteed 6 jewel movement,
accurate timekeeper. 2 adjustments. Radium
dial. A real watch for those who can afford the
best. Made by one of the best known watch fac-
tories in the world. Nickel case. Our two years'
written guarantee protects you. Send no money.
Pay on delivery \$7.49 and postage.

JENKINS CORP., 683 Broadway, New York, Dept. 11-2-23

Your Opportunity!

**Sell
ALL-WOOL
Suits
\$25.00**

Show our all-wool union-made tailored-
to-measure suits and take orders. Col-
lect your big profits daily besides liberal
extra bonus. Largest commissions in
field. Supreme values—smartest styles.
Makes order-taking easy.

FREE OUTFIT—Nearly 200 large
swatches; complete instructions.
Reserve territory. **no money or ex-
perience required.** **Pioneer Tailor-
ing Co., Congress and Throop
Sts., Dept. L-1116, Chicago, Ill.**

**Make
\$95.00
Weekly**

MOTOR BARGAINS

Heavy starting duty, 110 Volts, 60 Cycle Single Phase, 1725 Speed, General Electric Repulsion Induction MOTORS in original cartons.

1/4 H. P. only \$13.50

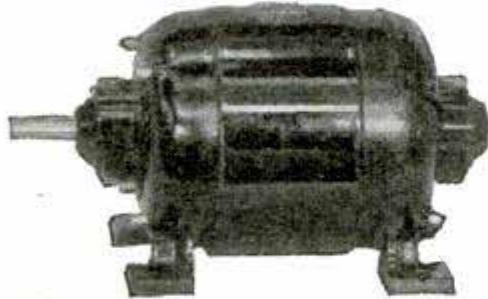

**1/6 H. P.
\$12.50**

**1/3 H. P.
\$15.00**

These motors were built by the G. E. Co., for a concern that failed before delivery could be made. We purchased 1500 of them at a very low price. You can buy one or more at prices quoted above until stock is exhausted. Furnished with feet or rubber cushion base. Shaft diameter 5/8 inch. Pulleys 75c extra. Grinding and buffing attachment spindle \$1.95. Six inch by 5/8 grind wheel \$1.75. Cotton Buffing Wheel 60c.

OTHER MOTOR BARGAINS

We have a large stock of new and rebuilt motors. Write us your requirements. We can save you money on any type and size motor.

NORTHWESTERN ELECTRIC CO.
410 So. Hoyne Ave. CHICAGO, ILL.



Gasoline Engines, Steam Engines, Motors, Dyna-Motors, Lathes, Drills, Gears, Books, Blueprints, Pulleys, Hangers, Bench Saws, Display Tables, Model Makers' Materials and Supplies.

Catalog sent postpaid 20c, refunded first order

HOWARD ENGINE & MFG. CO.
2417 N. Ashland Ave. CHICAGO, ILL.

MASTER INTERLOX SLIDE RULE

For Any INSIDE or OUTSIDE MEASURE

Every inside measurement at a glance. Just slide out the Master till it reaches from stop to stop. (Runs outlike tape—does not fold.) Exact measure figured for you. No guessing. Quick results. Other side for outside measure. Locks rigid in use.

Ask Dealer, or send 20c each lineal foot.

MASTER RULE MFG. CO., INC. 821 East 136th St., N.Y. C.
DEALERS AND AGENTS WANTED

Build a Ship Model at Home

For Pastime and Pleasure



It is a wonderful fascination and a beautiful decoration for your mantel, radio cabinet or it may be used in any part of the home.

Santa Maria—Size—25' high, 10' wide, 27' long.....\$4.98
La Pinta—Size—26' high, 11' wide, 27' long.....\$4.98

Mayflower—Size—26' high, 10' wide, 30' long.....\$4.98
Constitution—Size—25' high, 8' wide, 29' long.....\$6.98
Flying Cloud—Size—27' high, 9' wide, 36' long.....\$6.98

These prices are f.o.b. Philadelphia, plus a few cents postage. These models are sold in knock-down form. All parts are cut to fit and ready to assemble. They will be sent anywhere in United States C.O.D.

Money order or check must accompany all foreign orders.

Write for free illustrated catalog

MINIATURE SHIP MODELS, Inc.
3216 BARING STREET PHILADELPHIA, PA.



U. S. Pat.
1676869
& Pats. Pend.

TRUVOLT Resistance Reliability for Battery Eliminators

Effective performance of radio battery eliminators and power packs depend directly upon the reliability of their resistances. They must be able to stand long, hard use without overheating or corroding. Their value must remain constant.

Into TRUVOLTS, ELECTRAD has built the quality and stamina which enables them to pass the acid test of hard usage. Cooler operation and longer life, due to patented method of winding. An outstanding *exclusive* feature is the sliding clip for exact adjustment.

VARIABLE TRUVOLTS have a smoothly variable knob control and one-hole mounting. They last longer owing to endwise travel of contact over the resistance wire. 22 stock sizes—\$2.50 each at your dealer.

Super-Tonatrol



Licensed by Technidyne Corp.
U. S. Pats.
1034103-04
& Pats.
Pend.

A new high voltage volume control with unusually long life. Ideal for the new A. C. Receivers! Metal construction for cool operation. Pure silver floating contact. Delightfully smooth. Specially developed long-wearing resistance unit. \$2.40 to \$3.50 at your dealer.

ELECTRAD INC.

ELECTRAD INC., Dept. PM11, 175 Varick Street, New York, N. Y.

Please send data on TRUVOLTS Super-TONATROL

Name.....
Address.....



J. H. Clark

Startling New Screen Grid Radio

J. H. Clark, pioneer radio engineer, has developed a revolutionary 7 tube AC screen grid radio that amazes all who hear it. At last screen grid tubes have been conquered and put to work. Two years in advance, declare all who hear it.

A precision instrument of finest materials at a moderate price. Exceptional distance, tone and selectivity. Distant stations with tone quality of locals. Beautiful hand-rubbed cabinet of solid walnut and mahogany.

Agents Wanted

Rare opportunity for full time men. Exclusive territory to men who make good. Real chance for part time men to handsomely increase their incomes. Experience not necessary but will help. Big discounts.

Write or telegraph at once for full information.

CLARK RADIO CO.
205 W. Wacker Drive
Chicago, Ill.



Enjoy the Thrill of Electrified RADIO at Small Cost!



Make Good Reception Easy

Thousands of users marvel at the difference in reception with a Townsend "B" Power Unit. Full, sweet tone, clarity, volume and greater distance are among the many advantages reported daily



Townsend "B" Power Unit

Hooked up in a few minutes; just plug into the light socket and forget it. Delivers up to 100 volts on any set—D.C. or A.C.—any cycle.

Approved and Passed by the rigid laboratory tests of "Popular Radio" and "Radio News."

Over 150,000 Now in Use

There's no longer any reason for putting up with the expense and undependable performance of "B" Batteries—when you can own a good "B" Power Unit for \$6.85. Over 150,000 Townsend "B" Power Units now in use—a substantial proof of satisfaction.

TRY IT FREE!

We are so sure the Townsend will do all we claim for it, we give you the privilege of trying it ten days at our risk. A new joy in radio reception awaits you. Write for complete details today!

"Results Equal to 180 Volt Power Unit!"

I have used my Eliminator for a year and it is giving just as good service now as the time I bought it. I am using it on a Spaldorf 6 tube set that calls for 180 volts, and I noticed no difference when I connected the set to a 180 volt M—"B" Eliminator than when I used your 90 volt one.

Harry Metz,
Ben Avon, Pittsburgh, Pa.

TOWNSEND LABORATORIES

715 Townsend Street

Chicago, Illinois



FREE

RADIO CATALOG

The New SCREEN GRID models

Write for latest catalog just off the press—148-page book offering hundreds of radio bargains—New Humless Screen

Grid, A. C., all-electric and battery operated sets—beautiful consoles, accessories, parts and kits—

all at wholesale prices. **\$15.95**
Complete sets as low as

Chicago Salvage Stock Store
509 So. State St., Dept. 110, Chicago

CRESCENT \$65.00 buys a genuine 4" Crescent bench jointer, complete with powerful universal motor, ball bearings and guard. Ask for circular giving complete description.



Other Crescent machines that will help turn out your wood work to advantage are band saws, saw tables, self feed rip saw, shapers, jointers, variety wood worker, planer, planer and matcher, disk grinder, cut off table, swing cut off saws, borers, hollow chisel mortisers, tenoners, universal cut-off saw, universal wood workers.

THE CRESCENT MACHINE CO.
93 Columbia St. Leontia, Ohio

Send for FREE BULLETINS

RADIO FREE CATALOG

NEW SCREEN GRID SETS Wholesale Prices

Everything in radio at wholesale prices—New, Screen Grid, A. C. Humless All Electric Sets—Standard A. C. Sets—battery operated sets—

Priced as Low as \$15.95

Also an attractive array of beautiful consoles—accessories, parts, kits.

Most complete catalog in radio—196 pages of unusual price values. Write for it today!



ALLIED RADIO CORPORATION

711 W. LAKE ST. DEPT. 66 CHICAGO

Only 10¢ to Bald Men



Clayt Vreeland—as I am today. See my head of hair.

One Sample Ampoule of amazing Hairerbs fluid which I discovered myself and which grew hair on my head.

This Ampoule is mailed to you at the bare cost of material, postage and packing so that I may have an opportunity to show you the fluid with which I grew hair on my own and other men's heads. Merely mail the coupon below and enclose 10c in stamps.

Here Is How I Used to Look

I was just as bald as this picture. It is a true photograph without any tampering or retouching. It is exactly as I used to look. Then look at the full head of hair I have in the picture on the left! . . . As I have stated so often, I don't know whether I am the first man who discovered this great secret, but I do know I have it, that I grew my own hair and that I am growing hair on the heads of other men.



Bald Headed Clayt Vreeland as he used to be. Ugh!

Bald Men

IT'S NO JOKE TO BE BALD!

What I accomplished on my own head and on other heads I believe I can do for you, provided you are under

45 years of age and loss of hair was not brought about by burns or scars or other causes leading to absolutely dead hair roots. Anyhow, I must succeed or your money is refunded in strict accordance with my guarantee. No apparatus. My home treatment is simple, and easily applied,

Mail This 10c Coupon!

Mail the coupon today—enclosing 10c and I will send you, immediately, one full Ampoule of my marvelous Hairerbs fluid which I discovered, of which I hold the secret and which grew my own hair on my own bald head.

Besides the Ampoule of fluid, I will send photographs, names, addresses of men and women who successfully used my Hairerbs Fluid for dandruff, falling and loss of hair,

VREELAND

1358 Euclid-Windsor Building, Cleveland, Ohio



These are exact untouched photographs of Miss Augustina Raimondo, 2530 E. 25th St., Cleveland, who was almost entirely bald and who had to wear a net covering in the school room. She was a very unhappy young lady. Physicians, hospitals and clinics told her that she would be bald for life. She saw one of our advertisements, became interested and began taking treatments with Hairerbs. The growth of hair was surprisingly fast. A hairy fuzz began to appear after twelve treatments. More hair came steadily until today Miss Raimondo has a full head of hair which is daily becoming more luxuriant. The case is open to investigation by anyone.

10c COUPON

VREELAND 1358 Euclid-Windsor Bldg. CLEVELAND, OHIO

Please send me, one Ampoule of the same Wonderful Hairerbs Fluid which grew your hair. 10c enclosed.

My Name.....

My Address.....

State.....

LUMINOUS PAINT

Make Your Watches, Clocks, Etc., Visible by Night

The very latest discovery in the scientific world. Hitherto, practically unobtainable except at an exorbitant price, we have at last succeeded in producing this remarkable LUMINOUS PAINT, which, applied to the surface of any article, emits rays of white light, rendering it perfectly visible in the dark. THE DARKER THE NIGHT, THE MORE BRILLIANT IT SHINES. Quite simple to use. Anyone—you can do it. A little applied to the dial of your watch or clock will enable you to tell the time by night. You can coat the push buttons or switch plates of your electric lights, match boxes, and innumerable other articles; make your own Luminous Crucifera, Luminous Rosaries, etc. Small bottle, price 25c. Larger size, 50c and \$1 postpaid. JOHNSON SMITH & CO. Dept. 844 RACINE, WIS.



CIGARETTE MAKER

Roll your own and save money. Better and quicker; saves more than half. Use your favorite brand of tobacco. Neat, useful, handy. Pocket size, weighs 3/8 oz. Made entirely of metal, nickel plated. 25c, 3 for 65c postpaid anywhere.



GOOD LUCK RING

Very striking, quaint and uncommon. Silver finish; skull and crossbones design; two brilliant flashing gems sparkle out of the eyes. Said to bring good luck. Only 25c postpaid.



Explosion Cigarettes

JUST LIKE ORDINARY CIGARETTES. BUT SUCH REAL STARTLERS! The box contains ten genuine cigarettes of excellent quality. They appear so real, but when each cigarette is about one-third smoked, the victim gets a very great surprise as it goes off with a loud BANG! A great mirth provoker yet entirely harmless. Price 25c box.

NOVELTY BADGES



Kissing Permit 10c **Garter Inspector 10c**
Two very novel metal badges, nickel plated, that you can wear, giving you fun out of all proportion to their trifling cost. 10c, each badge, 3 for 25c, or 75c per doz. postpaid anywhere.

MIDGET BIBLE

GREAT CURIOSITY
Smallest Bible in the World. Size of a postage stamp. 200 Pages. Said to bring good luck to the owner. A genuine work of art. Must be seen to be appreciated. Make good money selling them to friends, church acquaintances, etc. PRICE 10c each, 3 for 40c, 12 for \$1.35, 100 for \$7.50. Also obtainable in Leather Binding with gold edges. Price 50c each, 3 for \$1.25, \$4.50 per doz. Magnifying Glass for use with Midget Bible 15c.



STAGE MONEY

With a bunch of these bills, it is easy for each person of limited means to appear prosperous by flashing a roll of these bills at the proper time and peeling off a genuine bill or two from the outside of the roll, the effect created will be found to be all that can be desired. Prices, postpaid: 40 Bills 20c, 120 for 50c, or \$3.50 thousand postpaid.

MAGIC NOSE FLUTE

The Magic Nose Flute, or Humantone, is a unique and novel musical instrument that is played with nose and mouth combined. There is just a little knack in playing it which, when once acquired after a little practice, will enable you to produce very sweet music that somewhat resembles a flute. There is no fingering, and once you have mastered it you can play all kinds of music with facility and ease. When played as an accompaniment to a piano or any other musical instrument, the effect is as charming as it is surprising.

Post Paid 10c

JOHNSON SMITH & CO.

Dept. 844 RACINE, WIS.

A De Luxe Edition of our new CATALOG mailed on receipt of 25c. Handsome binding. Bigger and better than ever. Only book of its kind in existence. Nearly 650 pages of all the latest tricks in magic, the newest novelties, puzzles, games, sporting goods, rubber stamps, unusual and interesting books, curiosities in seeds and plants, etc., unobtainable elsewhere. Remit by Coin, Money Order, Check or unused U. S., Canadian and Foreign Stamps for all articles listed above.

BLANK CARTRIDGE PISTOL

Protection against Burglars, Tramps, & Dogs



Well made and effective, modelled on latest type of Revolver; appearance since is enough to scare a burglar. When loaded it may be as effective as a real revolver without danger to life. It takes standard .22 Cal. Blank Cartridge—obtainable everywhere. Special cash with order offers 1 Superior quality Blank Cartridge Pistol, 100 Blank Cartridges, and our new 550 page De Luxe Catalog of latest novelties; all for ONLY \$1.50. Shipped by Express only. Cannot go by parcel post. Extra Blank Cartridges 50c per 100. Special Holster (Cowboy Type) for pistol 50c. No C. O. D. shipments.

Special Offer
1 Blank Cartridge Pistol
100 Blank Cartridges
1 550-page Novelty Catalog
ONLY \$1.50
The Lot Shipped by Express Only Cash With Order Only

LOOK 35¢ LOOK Wonderful Instrument.

Greatest thing yet. Nine separate articles in one. Everybody delighted with it. Odd, Curious and interesting. Lots of pleasure as well as very useful. It is a double Microscope for examining the wonders of nature. It is also an Opera Glass, a Stereoscope, a Burning Lens, a Reading Glass, a Telescope, a Compass, a pocket Mirror, and a Laryngoscope—for examining eye, ear, nose and throat. It is worth all the cost to locate even one painful cinder in the eye. Folds flat and fits the pocket. Something great—you need one. Don't miss it. Sent by mail. Only 35c or 3 for \$1.00. JOHNSON SMITH & CO., DEPT. 844, RACINE, WIS.

INVISIBLE INK Rubber Chewing Gum

The most confidential messages can be written with this ink, for the writing makes no mark. Cannot be won unless you know the secret. Invaluable for many reasons. Keep your postals and other private memorandums away from prying eyes. Great fun for playing practical jokes. Only 15c a Bottle; 3 for 40c.



It is just like a regular package of chewing gum and looks so real that it fools everybody. Of course no one suspects it is not genuine until they start to chew it. There's a world of fun in this rubber chewing gum — 5 sticks to the package. Price, 10c Pkg.; 3 for 25c; 12 for 75c postpaid. JOHNSON SMITH & Co., Dept. 844, Racine, Wis.

SURPRISE MATCHES

More fun than fighting with your wife. Look just like ordinary matches. Put up in boxes just like regular Safety Matches. As the victim tries to light one he gets quite a surprise. Price 10c per box, 3 boxes for 25c, 12 for 75 cents.



STAR TOY MAKER

Greatest boys' book written. Tells how to make a Pinhole Camera, a Canoe, model Railroad, a Telephone, Boomerang, Telegraph Instrument, Box Kite, Talking Machine, Microscope, Electric Motor, Electric Door Bell, Water Wheel, Paddle Raft, a pair of Skis, a Dog Sled, Bird House, Rabbit Yard, etc. 64 pages. 100 Illustrations. PRICE 10c postpaid.

Wonderful X-Ray Tube

A wonderful little instrument producing optical illusions both surprising and startling. With it you can see what is apparently the bones of your fingers, the lead in a lead pencil, the interior opening in a pipe stem, and many other similar illusions. A mystery that no one has been able to satisfactorily explain. Price 10c, 3 for 25c, 1 dozen 75c. JOHNSON SMITH & Co.

NOSE BLOWER

When some men blow their noses it sounds like a trombone. Now the NOSE BLOWER has come to torment us. It is a starter! It is ingeniously concealed in the handkerchief. Proceed to blow your nose and your friends will think they heard a steam engine or something. You can blame the hideous noise to your having a very bad cold and keep up the fun as long as you like. PRICE 10c, 5 for 50c, or 75c doz. postpaid

Serpent's Eggs

Box contains 12 eggs. When lit with a match, each one gradually hatches itself into a snake several feet long, which curls and twists about in a most life-like manner. Price per box, 10c postpaid, 3 for 25c

Watch Charm Pistol \$1.75

Exact reproduction of a real pistol; actually fires REAL BLANK CARTRIDGES of miniature size. Illustration is actual size. 1 1/4 inches long, with ring at end for attaching to watch chain. Loads like a regular pistol. Pull the trigger and it goes off with a loud bang. Pistols break open type; illustration shows position for loading. Made entirely of high grade steel, nickel plated, octagon barrel, handsomely engraved handles, complete in box with cleaning rod. PRICE \$1.75. Also furnished with pearl handles, \$2.50. BLANK CARTRIDGES, 50c per box of 25. JOHNSON SMITH & CO., DEPT. 844, RACINE, WIS.

MICROPHONE TRANSMITTER BUTTON



You can easily make a highly sensitive telephone by using this Transmitter Button to collect the sound waves. You can build your own outfit without buying expensive equipment. It is simple and inexpensive. You can install an outfit in your home and hear conversations being held all over the house. This outfit was used by secret service operatives during the war. It is being used on the stage. It is ultra-sensitive and is the greatest invention in microphones. You can mount the button almost anywhere—card board boxes, stove pipes, stiff calendars, on the wall behind a picture frame, etc. Button is so light and small it cannot be detected. Persons can be overheard without suspecting it. You can listen in on conversations in another room. A deaf person in the audience can hear the speaker. Connected to phonograph, piano or other musical instrument, music can be heard hundreds of feet away. Button may be used to renew telephone transmitters; often makes an old line "talk up" when nothing else will. The ideal microphone for radio use; carries heavy current and is extremely sensitive. Amplifies radio signals. Countless other similar uses will suggest themselves. Experimenters find the button useful for hundreds of experiments along the lines of telephones, amplifiers, loud speakers, etc. Many fascinating stunts may be devised, such as holding the button against the throat or chest to reproduce speech without sound waves. PRICE \$1.00. JOHNSON SMITH & CO., DEPT. 844, RACINE, WIS.



BOYS! BOYS! BOYS! Throw Your Voice

Into a trunk, under the bed, under a table, back of the door, into a desk at school, or anywhere. You get lots of fun fooling the teacher, policemen, peddlers, and surprise and fool all your friends besides.

THE VENTRILO

is a little instrument that fits in the mouth out of sight. Cannot be detected. It is used in connection with the above, and with the aid of this wonderful **DOUBLE**

THROAT, or **VENTRILO**, you can imitate many kinds of birds, animals, etc. Remember you get everything for **ONLY TEN CENTS**—a booklet giving you full instructions how to become a ventriloquist and throw your voice, the **Double Throat**, or **Ventrilo**, and our big 600 page catalog of novelties, tricks, puzzles, masks, books, etc., **10 cents**
ALL SENT POSTPAID TO ANY ADDRESS FOR ONLY **10 cents**



MEXICAN JUMPING BEANS

Scientists are unable to give a reasonable explanation for what purpose nature created these curious **Jumping Beans**. They are found growing on small trees in the high mountainous regions of Mexico. The Beans Wiggle, Move, Jump, Flop Over, Etc. It is amazing to see them keep up this endless activity. Send for a few of these great curiosities. Three Sample Beans sent for 25c, 12 for 75c, or One Gross (144) for \$7.50 Postpaid.



U. S. BABY TANK
25 Cents



It goes with real Yankee Pep—by its own power. Most remarkable toy ever invented. By drawing the Tank backward, either with the hand or over the floor or table and then placing it down, it will crawl along, overcoming all obstacles, in the same life-like manner as the larger Tank that proved so deadly in the great war. What makes it go is somewhat of a mystery, for there is no mechanism to wind up as is usually understood with mechanical toys, yet this tank will keep plodding along ten times longer than the ordinary run of toys. It will perform dozens of the most wonderful stunts; 2 1/2 inches long. Price only 25c prepaid. Stamps accepted. JOHNSON SMITH & CO.

MAGICIAN'S BOX OF TRICKS

Apparatus and Directions for a Number of Mysterious Tricks, Enough for an Entire Evening. \$1.00 Entertainment. ANYONE CAN DO THEM

It is great fun mystifying your friends. Get this Conjuror's Cabinet, and you will be the cleverest fellow in your district. It contains the apparatus for ten first-class tricks, including THE MAGIC BALL AND VASE TRICK (a wooden ball is placed inside, and upon replacing the lid has disappeared and is found in someone else's pocket); THE HINDOO TRICK CARDS (can be made to change completely no less than five times); DISAPPEARING COIN BOX (a coin, placed in the wooden box, vanishes entirely or changes into a coin of another denomination); THE GLASS GOBLET TRICK (a coin is dropped into a glass of water and when the water is poured out the coin has vanished and is found somewhere else); THE RIBBON FACTORY FROM THE MOUTH TRICK (a seemingly endless supply of colored paper ribbons comes out of your mouth); the DISAPPEARING HANKERCHIEF (a handkerchief held in the hand mysteriously vanishes); THE WIZARD'S RING COIN TRICK; the ENCHANTED BOTTLE (no one but yourself is able to make it lay down); THE GREAT HAT AND DICE TRICK (a large dice is placed on top of a hat, disappears, and is found underneath yet no one has touched the hat), and last, but not least, the GREAT PHANTOM CARD TRICK, or two from five leaves nothing. Full instructions are sent for performing each trick. In addition to the above, a number of other feats and illusions are fully explained for which you can easily make or procure the necessary apparatus. Price complete \$1.00 postpaid. JOHNSON SMITH & CO.



THE NEW POTATO PISTOL



This is surely the most ingenious of all air pistols. For ammunition ALL YOU NEED IS AN ORDINARY POTATO, and that isn't hard to get. Merely place the point of the barrel of the pistol into a potato, as shown in the illustration, withdraw the pistol and fire. Nothing could be simpler. It fires quite a distance, goes off with a report like all air guns, and there is absolutely no danger. Well and made entirely of metal. Price Postpaid. Only 35c.

RESURRECTION PLANT

Great curiosity. Place in water, plant opens up and starts to grow in few minutes. Taken out it dries up and goes to sleep until put in water again. PRICE 10c, 3 for 25c, 75c dozen, postpaid.



250 Magic Tricks 10c

An excellent little book containing 250 Parlor Tricks, tricks with cards, coins, handkerchiefs, eggs, rings, glasses, etc. So simple that a child can perform them. Profusely illus. Sent postpd. to any address for only 10c., 3 copies for 25c.



Comical Motto Rings

Lots of harmless fun and amusement wearing these rings. Made in platinumoid finish (to resemble platinum), with wording on enameloid, as illustrated. Price only 25c Postpaid.

Great Fire Eater

A great trick by which you can apparently breathe fire from mouth, to the horror and consternation of all. Quite harmless. All apparatus necessary sent complete in box for ONLY 30c, p. pd. JOHNSON SMITH



SQUIRT ROSE

25c
A REAL STARTLER. This is the most popular of all squirt tricks. The flower in your coat looks so fresh and sweet that everyone is tempted to inhale the delightful perfume. Then is the moment to press the bulb. Geewhilkens. Don't they jump? There is a very long rubber tube that easily reaches to the pocket of your coat or trousers, and the bulb is large enough to make a dozen shots with one loading. PRICE 25c each, or 3 for 65c postpaid.



SEEBACKROSCOPE

Place this clever instrument to your eye, you see what is going on behind your back. Very interesting things sometimes occur when no one thinks you are looking. Just like having eyes at the back of your head. PRICE 25c POSTPAID



The "Little Giant" Typewriter

A First Class Writing Machine For \$1.50

A perfect little typewriter for \$1.50. There are thousands of persons who would like to use a typewriter but whose needs and business do not warrant the expense attached to the purchase and use of a fifty or seventy-five dollar machine. To such persons we confidently recommend our Little Giant. It is strongly made, but simple in construction, so that anyone can quickly learn to operate it, and write as rapidly as they would with pen and ink. The letters of the alphabet most frequently used are so grouped as to enable one to write rapidly, the numerals 1 to 10, and the punctuation marks being together. With this machine you can send your best girl typewriters love letters, address envelopes, make out bills, and do almost any kind of work not requiring a large, expensive machine. With each typewriter, we send a tube of ink and full printed instructions for using the machine. Price complete \$1.50 by mail postpaid to any address in the world.

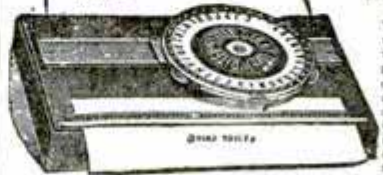

**Campbell's
Infra-Red
Ray Lamp**

**Relieves
Pain
Quickly**

**Write for
Factory
Price**

**30 Days
Home
Trial**

Relieve That Troublesome Ailment

Write at once and let me tell you how to relieve that troublesome ailment with Infra-Red treatments in your own home. The Campbell Infra-Red Ray Lamp throws out mild beams of Infra-Red Rays which penetrate deeply into the tissues and bring a soothing *internal heat*—best, because it works where the congestion is, and restores active blood circulation. Medical authorities say most ailments are due to congestion—relieve the congestion and you relieve the ailment because nature itself does the healing through active, normal blood circulation.

Why Suffer Needless Pain?

Are you troubled with Sinus Irritation, Sore Throat, Neuralgia, Bronchitis, Rheumatism, Neuritis, Lumbago, Tonsillitis, Catarrh, Ear Trouble, Gall Bladder trouble or similar ailments? Just let me send you this wonderful lamp on approval. Use thirty days according to directions and see if it does not bring you wonderful results.

Harmless You or anyone in your home can use the lamp on instant notice. It is on an adjustable stand—easily carried to any room—easily placed in any position. Leading health authorities recommend it. Letters from satisfied users everywhere tell of wonderful results. Just a few treatments will surprise you. First cost only cost. Connect with any electric light socket.

Easy Payments Shipped by parcel post or express direct to you from factory at lowest cost. Don't delay—if you or some friend have some troublesome ailment. Write and let me send it at once.

Get Our Book on Infra-Red Rays

This book quotes leading medical authorities and hundreds of users. Mention your ailment when writing and we will send you free valuable suggestions on how to treat it with Infra-Red Rays. Thirty day trial period.

WILLIAM CAMPBELL CO.

Dept. 1040

ALLIANCE, OHIO

KEYVENIENT • 50¢



CLOSED



OPEN

Here's the handiest little key carrier you ever saw. It carries 6 keys. Three are held by post binders on each end with a button snap in the center to prevent jangling and pocket wear. Made from handsome genuine pebble grain black and brown calf skin. Send 50c—stamps or money.

AGENTS:

Drug stores buy Keyvenient by the dozen in our attractive display card. We need representatives in some territories. Send 50c for sample and sales details.

OLIVER MFG. COMPANY

420 So. 7th Street
Minneapolis, Minn.



MODEL SHIPS

We can supply construction sets and all sorts of parts such as semi-finished hulls, blocks, dead-eyes, special flags, anchors, steering wheels, capstans, figureheads, blue prints, books, etc., for building a Flying Cloud, Constitution, Spanish Galleon, Mississippi River Steamboat, Sovereign of the Seas, Mayflower and many others. Also special construction sets for racing sail boats, power boats, model steam engines, propellers, etc., and fine tools for the model maker. Our large 48-page photographically illustrated booklet contains valuable information and hints for building ship models in addition to prices and full description of the above articles. Many people only slightly interested in models have become greatly enthused upon receiving this booklet. A copy will be sent postpaid upon receipt of 15 cts. (coin preferred).

Model Ship Supply Co., Dept. H, Mineola, N. Y.



ALL GIVEN

10 year guar. Watch with chain and ring, large Eastman Roll Film Camera or 22 cal. Hamilton Rifle, yours for introducing finest assorted liquid perfume at 15c a bottle. Send for 20 bottles and choose gift as per offer in our catalog. We trust you—just write to **BELL PERFUME CO., Dep. 8153, Chicago, Ill.**

22 CAL. RIFLE



"The KING of them all"

AIR-CON
UTILITool

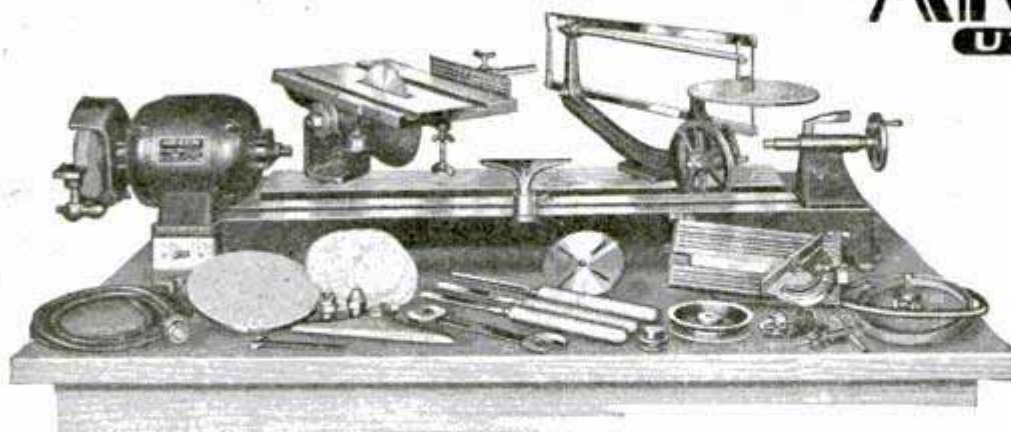

**Free Trial!
Easy Terms!**

Mail the coupon now for fully illustrated descriptive circular, together with details of our 10-day free trial offer and liberal time payments applying to the complete outfit or any unit or combination of units you may desire.

A Practical Shop—for Practical Use

Even though you want a shop just for the "fun of making things," you want one that will not "lay down on the job."

That's why you will get more satisfaction per dollar invested out of the Ar-Con Utilitool than any other workshop on the market. It has the strength and rigidity in every unit to insure accuracy under either light or heavy loads. And it is the only outfit equipped

with the super-efficient, non-radio-interfering, repulsion-induction type motor—full ½ HP, ball-bearing, and practically wear and trouble-proof. Consisting of heavy cast-iron-bed lathe, circular saw table, jig and scroll saw, sanding disc and table, grinding wheel, cotton buffs, drill chuck, turning tools, and full accessory equipment, the Ar-Con Utilitool comprises a complete workshop that will do what you want it to do, in the way you want it done.

The Ar-Con Tool Co.
500 Fassett St., Toledo, O.

Mail me complete information, prices and terms on Ar-Con Utilitool with details of your free trial offer.

Name.....
Street.....
City and State.....

THE AR-CON TOOL CO., Toledo, Ohio

ITALIAN ACCORDIONS
Best in the world. 10-year guarantee. lowest prices. FREE instruction, ask for FREE catalog. RUATTA, SERENELLI & CO., 1014 Blue Island Ave Dept P, Chicago, Ill.

TRIMETTE SAFETY Hair Cutter
Cut & Trim Your Own Hair for Men Women Children
Just as easy as combing your hair. Cuts evenly. Trims back of neck, sides and front. Perfect for men, women's bobs, and children's hair. Economical, sanitary, adjustable. Try it. Trimette, attached to Gillette Razor and Blade, complete; sent on receipt of \$1 postpaid. 10 days' satisfactory trial or money refunded. Trimette Co., Inc., 3 E. 44th Street, Dept. P-11, N. Y. C.
Agents Wanted (1) Check if interested in agency.

FREE GILLETTE SAFETY RAZOR with every TRIMETTE

NEW IMPROVED PAYNTGUN LACQUERS CARS AND FURNITURE
Skillful painting easy for anyone this new simplified way. Exclusive Payntgun features cut painting time in half. Sturdy. Compact. Powerful spray.
Complete Outfit \$9.65
FREE Attractive folder on Perfect Painting ready for you. Write for it NOW!
HAYWOOD EQUIPMENT CO. AGENTS WANTED
2345-R Ogden Ave., CHICAGO, ILL.

Let us recommend the best books to study on any subject. Popular Mechanics Press, Chicago, Illinois

Amazing New Step-Stool



Sells Easily!
Every Housewife Wants It
Big Profits
Wonderful Sales Plan

THIS Handy Monarch Step-Stool is one of the fastest selling household Specialties known today. Makes it easy to reach high shelves—hang curtains and a thousand other difficult tasks. The patented Step swings neatly under stool and locks in position. Feet are flattened to prevent marking of floor coverings. Special cork pad on seat and step prevents slipping and protects finish. Available in five different colors to harmonize with any kitchen color scheme.
Big commissions paid daily. No delivery or collecting to handle. Elaborate sales portfolio furnished free! Write today for our attractive proposition—it's a real opportunity to make big money—quick! Act now!

HARSTAN MFG. CO.
Dept. 700 Goshen, Indiana

Simplex SCREW JACKS

for the Home work shop or Manual Training

CAPACITY 500 LBS.

WITH it, you can force door and window frames back to their original position and avoid having sash or doors planed or locks reset. You can raise the end of a radiator, kitchen sink, lee box or piano—or clamp or straighten glued furniture, drawers, radio cabinets, and hundreds of other jobs. It's called

"JACK-IN-THE-BOX"

For the man who uses tools, or the boys interested in manual training, mechanical toys, erecto sets, etc., this little Jack is permanently useful and instructive.

Capacity, 500 pounds. Sturdily built — beautifully finished in red, blue or green Duco. A practical reproduction of the larger Simplex Screw Jacks. Built by the world's largest manufacturers of Screw and Lever Jacks, and unconditionally guaranteed.

Its purpose is to demonstrate and advertise the safety feature and power of the larger Simplex Jacks, and it will be sent you postpaid for 35 cents. Money refunded instantly and without question if not satisfied.

Templeton, Kenly & Co.
Manufacturers of the Simplex Jacks
1020 South Central Ave.
CHICAGO



MAIL THIS TODAY →

35c

Gentlemen:

Please send me postpaid one Simplex Miniature Jack at 35 cents and at 35 cents each for my friends. A total of \$..... is enclosed.

Name.....

Street..... City..... State.....

Underline color desired: Red Blue Green

Check here if you would like to receive a catalog of Simplex Jacks.

MAKES A COMPLETE MACHINE SHOP

\$1.75 without UNITOOL ELECTRIC MOTOR ATTACHMENT

chuck

\$2.35

with

chuck



Fastens directly on motor shaft, no pulleys or belts necessary. Holds grindstones, buffs, saws, wire scratch brushes, drills, etc. Serves as pulley. Made to fit 3-8, 1-2 and 5-8 inch shafts. State size. Postage prepaid if remittance accompanies order.



United Electric Motor Co., 178 Centre St., Dept. C-11, New York

PRINT YOUR OWN

Bulletins, Circulars, Programs, Letters, etc.—with this Amazing New "EXCELLOGRAPH"



Simple and easy. Prints anything written with pencil or typewriter. Just make stencil and print 1,000 copies per hour. Wonderful for illustrations drawn or traced. All supplies and instructions furnished. Guaranteed 10 years. Prints any size from postcards to sheets 9x14. Does beautiful work.

SAVE MONEY—MAKE MONEY

Saves and makes money for Merchants, Ministers, Teachers, Offices, etc. Use it to build your business. Do work for others at big profits.

Write for Free Book — Today

Shipped at our risk. Positive money-back guarantee. Amazing value. Thousands in use. Get free book describing all details and easy payment plan.

Only \$39.00 Easy Terms

PITTSBURGH TYPEWRITER & SUPPLY COMPANY
Dept. MI—339 Fifth Avenue Pittsburgh, Pa.



HOUDINI

known as the "hand-cuff" king, for his amazing ability to extricate himself from chains, ropes, etc.

The "Houdini Chain Escape" is in set No. 2; the "Master Rope Escape" is in set No. 3.



Mystify your friends

with these tricks of famous Magicians

Just think how your friends will envy you; giving magic shows just like the great stage wizards. Black magic, secret magic, real magic that has only been known by few. You will find it all in the Knapp Master Magic Sets!

These tricks are as easy as ABC to do. It's just knowing how—that's all, and the instruction booklet "Secrets of Master Magic" in each set tell you how. No hard sleight of hand tricks taking months of practice to learn. Everything fixed so that you can't go wrong.

This is your one big chance to be the Master Magician of your neighborhood. Get the sets at your local dealer now! or if he hasn't them, write us direct.

Send for free booklet "P"

KNAPP ELECTRIC, INC.

3029 East Washington St. Indianapolis, Ind.

Master Magic

LOOK FOR THIS TRADE MARK ON ALL KNAPP MASTER MAGIC SETS

861 PRACTICAL IDEAS for REDUCING FARM LABOR and INCREASING INCOME

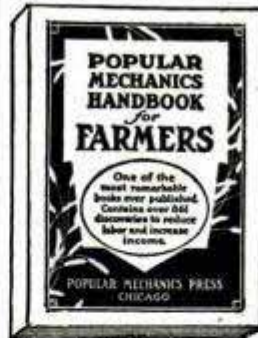

One farmer writes: "I would not take \$100 for my copy if I could not secure another."

The Handbook for Farmers contains: 138 ideas for the farm shop, 35 on fencing, 98 on auto, truck and tractor, 61 on farm buildings, 36 on field machines, 48 on concrete work, 22 on orchard work, 23 on painting, 15 on live stock, 34 on poultry, 54 on garden work, 25 on electrical work, 22 on farm tools, 16 on hunting, fishing and trapping, 140 household helps.

394 HELPFUL KINKS to LIGHTEN

the LABOR of the FARMER'S WIFE

The Handbook for Women contains: 83 kitchen and dining room helps, 17 on garden and flowers, 19 on sewing and mending, 37 on furniture, pictures and fixtures, 38 on laundry and cleaning, 32 on house cleaning, 12 on music, 14 on sleeping rooms, 11 on care of children, 16 on lights, 9 on photography, 14 on clothing and shoes, 23 on house temperatures, 12 on water and drains, 10 on insect pests, and 47 miscellaneous.

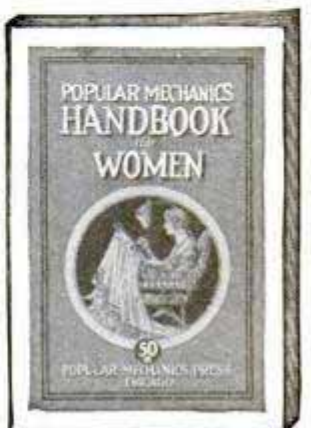

SPECIAL OFFER BOTH for \$1

(Regular \$1.50 Value)

For a limited time you are offered both books for \$1 plus the postage. Pay postman when he delivers package. If outside U. S. send remittance and include 15 cents extra for postage.

POPULAR MECHANICS PRESS Room 711, 200 E. Ontario St., Chicago

THE LATEST—THE BEST—THE LOWEST PRICED!

For 25 years the management of this firm has sold merchandise by mail. This is our guarantee to you—"We promise courteous treatment and prompt shipments."

Order Direct From this Page

WE PREPAY ALL ORDERS ABOVE 50 CENTS.
(Remit Five Cents extra postage for all orders below 50c)

Money Refunded If Goods Unsatisfactory

Remit by check, money order or U. S. Postage stamps. Canadian and foreign stamps not accepted.

Floroscope



This is a fine imported combination microscope. Really two instruments in one. One end used for high magnification, such as seeing bacteria in milk or water. Other end to see parts of insects, flower specimens, etc. Finished in gold brass. Magnifies about 25 diameters.
No. 8518 Floroscope 65c Prepaid

Microscope



Here is a real high power imported microscope for instruction and laboratory work. Has regulation rotating light mirror. Has adjustable lens for correct focusing. With it come 3 specimen slides. Entirely brass. Packed in neat leatherette box. Magnifies about 50 diameters.
No. 8517 Microscope \$1.90 Prepaid

Magnifier



This fine folding pocket magnifying glass, also called linen tester, is made entirely of gold lacquer brass. Has powerful lens that magnifies everything 10 times. Has fixed focus. Just open it and it is ready. When folded this magnifier occupies a space about as large as a quarter and twice as thick.
No. 8516 Magnifier 35c Prepaid

Ooh-La-La Ring



Handomely carved gold filled ring. Looks just like any other ring. But, oh boy, wait till you look through the "VIEW." Strong magnifying glass shows French actress when viewed against light. Ring has large imitation diamond. When ordering enclose a strip of paper giving size of your finger.
No. 8511 Surprise Ring. Prepaid 35c

Periscope

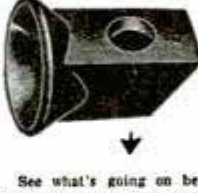

See what's going on behind your back with this Seebacoscope. Used like a magnifying glass. No one knows you're watching them. Gives you "eyes in your back." This article is made in molded bakelite and its size is 2"x1 1/2".
No. 8506 Periscope 25c Prepaid

Microscope



A real high-powered imported pocket microscope for instruction and laboratory work. Has adjustable and automatic lens for correct focusing. Comes with 1 prepared subject and three specimen glass slides. Entirely made of lacquered brass. Packed in a neat leatherette box. Magnifies 40 diameters.
No. 8517 Microscope \$1.40 Price

Wonderscopes

NEW! Greatest pocket microscope invented. Looks like a fountain pen and ACTUALLY MAGNIFIES 25 TIMES. Hair looks as big as a rope. See the pores in your skin. Has slide adjustable from home, laboratory or shop. Full lens. Made in three models for use in home, office, laboratory.
No. 8503. Wonderscope A—95c Prepaid
No. 8502. Wonderscope B—Same as above but adjustable to the amount of light \$1.35 available. Prepaid

Microscopes

A REAL laboratory microscope that stands 6" high, comes complete with forceps, 2 prepared specimen slides and two blank glass slides, all packed in a cherry wood box with brass hinges and fittings. Made entirely of lacquered brass, with powerful lenses. Entirely demountable to facilitate cleaning. Have arcade (open both sides) frame and rotary reflecting mirror. Made in three models for use in home, office, laboratory.
No. 8545. Microscope. Magnifies 50 diameters. Prepaid \$3.75
No. 8546. Microscope. Magnifies 70 diameters. Prepaid \$5.50
No. 8547. Microscope. Magnifies 90 diameters. Prepaid \$6.75

Telescopes

We carry only high grade imported French telescopes. All come in gold brass lacquer. The most powerful telescopes made. No. 8559 is covered with black Morocco leather. Brings object nearer ten times. This number has also brass dust cap and automatic eyepiece piece. Comes in imitation leather carrying case.
No. 8554. Telescope. One draw. 6 1/2". Prepaid 98c
No. 8548. Telescope. Two draw. 9 1/2". Prepaid \$2.00
No. 8549. Telescope. Three draw. 12 1/2". Prepaid \$3.50
No. 8550. Special telescope. 4 Sections. 13 1/2" long. Prepaid \$4.95

Luminous Paint



Make your own luminous articles. Paint watch and clock hands, electric light switches, push buttons, keyholes, house numbers, etc. 1,000 uses. Articles treated stand out brilliantly in dark. The darker the room, the more brilliancy.
No. 8508 Luminous Paint 25c Prepaid
No. 8508-A Large Size \$1.00

Big Magic Set



A chest of magical apparatus and directions for performing TWELVE AMAZING MAGICAL FEATS. An entire evening's entertainment can be given with them. Includes the Magic Vanisher, Cigarette Vanisher, How Coins Master Memory, Beads on String, Obeying Ball, Vanishing Watch, and many others. Biggest value ever offered, worth double the price we ask.
No. 8713. Big Magic Set. Prepaid \$1.00

Nose Blower



The real article! Conceal nose blower in your handkerchief and blow into instrument while you pretend to blow your nose. Everyone stops and looks at you. There never was a terrible noise like it. Keep it up as long as you like.
No. 8510 Noseblower 10c Prepaid

Bluffgun



Bluff your friends with this gun. Made of composition metal handomely nickelled. Exactly same size, weight and shape as real article. Fine to bluff burglars. Used also as desk paper weight. Size of this gun is 6 1/4" long and 3" wide.
No. 8505 Bluffgun 60c Prepaid

Real Pistol

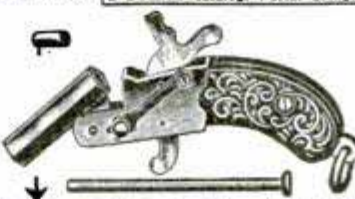

Here's a real pistol, yet small enough to be used as a watch charm. Illustration is full size. Imported, best European workmanship. Excellent reproduction of standard pistol. Cut shows pistol broken open to load blank cartridge. When trigger is pulled, cartridge goes off with a loud BANG that can be heard for a block. Pistol entirely made of steel, nickel plated. Handle is beautifully engraved. Octagonal barrel. Comes in box, with cleaning rod and 25 blank cartridges AT NO EXTRA CHARGE. (As explosives are prohibited to go by mail, pistol is sent express collect).
No. 8509 Pistol \$1.20
No. 8509A Set of 25 Cartridges, by exp. collect .25

Imp in the Bottle



A real Cartesian diver—Can you explain how it works? A little glass imp placed in a bottle of plain water and sealed with special rubber cap dances up and down in the liquid at your will. Will perform unique antics. An interesting, amazing and scientific novelty.
Bottle 4 inches high.
No. 8573. Imp in Bottle. 35c Prepaid

Opera Glass Charms

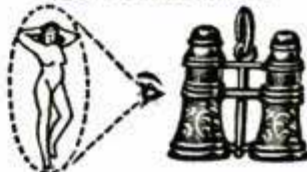

A pretty and unique watch charm. 3/4" x 1". Exact duplicate of real Opera Glasses. Powerful lenses that clearly magnify the view. Assorted views, scenic and French actresses. Fitted with ring to attach to watch chain. 2 VIEWS to each charm.
No. 8585. Bone Opera Glass Charm. Prepaid 25c
No. 8586. Relied Gold Opera Glass Charm. Prepaid 75c

Cigaret Gun

NEW! Actually shoots cigarettes. New improved double action model. Press the trigger—goes lightly—press it again, back fires the lid revealing it a cigarette case. Looks like a real automatic. Made entirely of metal, with oxidized stocks, barrel and fittings. The same sizes as the real article, and weighs but 12 ounces.
No. 8618. Automatic Cigarette Gun. Prepaid \$1.79

TELEGRAPH CODES

NEW!! Telegraph 25c

For the astonishing small sum of 25c you can now learn telegraphy. Any wide awake boy or girl can learn the telegraph codes with this little outfit within from 20 to 60 days. Gives loud signals perfectly—nothing to wear out. No batteries. The instrument consists of hard fiber base, mechanical sounder and telegraph key knob. Screw to table or carry it in pocket. Guaranteed to give exact reproduction of telegraph sounds just like regulation sets. We also furnish free a set of telegraph codes as shown, and full instructions of how to learn telegraphy.
No. 8525. Telegraph Set 25c Prepaid

INVISIBLE INK
A fluid in which you can write love letters, confidential messages, etc. without fear of detection. Remains entirely invisible until paper is heated. Used extensively by secret service operatives, detectives, etc.
No. 1528. Invisible ink.—Par bottle, prepaid 15c (3 for 40c)

NEW!! Spintharoscope
Positively the most astounding scientific instrument ever developed. This instrument formerly sold from \$1.00 to \$50.00 upwards. Now it is possible to get it for a small sum. Witness actual destruction of thousands of Worlds by simply looking through the lens of the instrument. Actual radium is disintegrated before your eyes. You see the atomic bombardment plainly. Instrument is guaranteed to contain a minute quantity of radium. There is no more enthralling sight in the whole world. Nothing to wear out. Lasts forever.
No. 8524—Spintharoscope complete with instruction. Prepaid 65c

Blackstone's Magic
A big 98-page book, every trick illustrated. Instructions for over 50 MAGICAL TRICKS—25 MATCH TRICKS—7 OPTICAL ILLUSIONS and MANY OTHER interesting diversions. No skill needed—no practice—no special apparatus. Written by the famous magician, Harry Blackstone. Neatly bound with highly lithographed cover. Most astonishing value ever offered.
No. 8561. Book of Magic. 25c Prepaid

Humanatone
Anyone can play the Humanatone. A unique and novel musical instrument played with nose and mouth combined. Produces sweet, toned music similar to a flute. No fingering—no lessons. A little practice and you'll get the knack. Made entirely of metal. Nothing to get out of order or wear out.
No. 8537. Humanatone. 10c Prepaid

SCIENTIFIC NOVELTY COMPANY, - - 245A Greenwich St., New York City
FREE. Send for our new fall catalog. Postal brings it.



UNTIL you learn to play, you have no idea of the rich joy, the vibrant fun, the big money that lie in the creation of music. And until you actually try out the Deagan Xylorimba in your own home, you have no idea how easy this fascinating instrument is to play!

Just think! No tiresome practice. No finger or lip exercises. No teacher. On the first day you play simple melodies. Soon you thrill friends and family with snappy fox trots, dreamy waltzes. Before you realize it, you are ready to appear in public. Xylorimbists are always in demand. The pep of any party, the spice of any band or orchestra. \$5 to \$25 for a night of "play!"

BIG BOOK FREE—Deagan Xylorimbis are sold on a 5-day FREE TRIAL basis. Models to suit every pocketbook. Surprisingly easy terms. You owe it to yourself to write today for the BIG FREE BOOK. No cost or obligation. Simply fill in and mail the coupon.

J. C. Deagan, Inc., Dept. A-1458, 1770 Berteau Ave., Chicago
Please send me full details of the Five-Day Trial offer and easy payment plan of the Deagan Xylorimba.

Name.....

Address.....

Let us recommend the best books to study on any subject. Popular Mechanics Press, Chicago, Illinois.

8" COMBINATION SAW OUTFIT \$35 F.O.B. Phila.

ABSOLUTELY the best Saw Outfit Buy on the market. We invite you to make thorough comparisons before you place your order, particularly check on these specifications:

Our outfit includes 3/4rd H.P. Double Extension Shaft Motor; table tilts to 45 degree angle, and may be raised or lowered to cut any depth from 0" to 2 3/4". We also include necessary attachments to Rip, Crosscut, Bevel, Grind, Mitre, Groove, Sand, Mortise, Tenon and Polish.

Everything is complete, ready to plug in any light socket. Note base which holds Saw and Motor. It is Portable. Same specifications, but with Ball Bearings, and 12" by 18" table top—\$45.00. **Catalog Free** in which this Saw Outfit is more clearly pictured. It also contains Bench Lathes, 12" Band Saw, Complete Work Shop and Hardware Specialties.

WILBAR CO., INC., 2020 E. Arizona St., PHILA., PA.

FREE!

This RADIO BARGAIN BOOK

Send Today for this Wholesale Catalog!

Dealers, Agents, Set Builders, Radio Service and Repair Men

Save money on latest radio sets, kits, parts, and supplies. Everything guaranteed by this 17 year old house. Our cash resources and great volume enable us to buy at lowest prices and save money for you on

Everything in Radio

A. C. Electric sets, Battery sets for unwired homes, Nationally advertised Kits, Tubes, Dynamic Speakers, etc. Everything in radio at rock bottom wholesale prices.

Send For **FREE Book—Now!**

Dealers, agents, service and repair men cannot afford to be without this money saving catalog of Radio Sets and Supplies.

Catalog contains full line of tires, tubes, auto supplies, sporting goods. Write on business stationery.

NEW ENGLAND MILLS CO.
851 Washington Blvd., Dept. 31, Chicago, Ill.

THE HEATH SUPER PARASOL WON

1st and 2nd at the National Air Races. 10c in stamps or coin brings large booklet.

Heath Airplane Company 1721-29 Sedgwick Street, Dept. P-11, CHICAGO, ILL.

JENKINS Watch-Lighter \$4.97

Guaranteed 6 Jewel watch and new design elegant quality lighter in one. Watch is of excellent Swiss make, tested and adjusted. Two years' written guarantee. Radium dial—tells time in dark. Lighter is of sturdy construction and can be opened with one hand. Gives instant flame. Large fluid capacity. Easily replaceable flints. Elegant covered case. **SEND NO MONEY.** Pay on delivery \$4.97 plus postage. Satisfaction guaranteed.

JENKINS, 683 Broadway, New York, Dept. 11-A-23.

\$50 and up Weekly

Making Amazing Demonstration

Commission checks for all money due mailed every Saturday to our men. Work full or spare time making amazing demonstration that will save prospects thousands of dollars.

Demonstrator Furnished

We will furnish outfit for sensational demonstration. No investment for stock—no deliveries or collections. Every one a prospect. Show in homes, stores, garages, schools, offices, and to farmers, etc. Many of our men now making \$300 to \$600 a month. Write at once to

FYR-FYTER COMPANY
90-Y Fyr-Fyter Bldg., Dayton, Ohio

IN ONE MINUTE

Ten of these sensational demonstrations a day should pay you \$50 a week. No experience necessary—we show you how.

BOYS-LEARN TO FLY

MODEL AIRPLANES

Join the CLINTON JUNIOR AVIATORS

The Greatest Dollar Value Ever Offered to Junior Aviators

At left are a few of the many model designs you will make under this Club Plan.

A. B. Clinton, 2nd, Senior Aviator and designer of successful model aircraft for over 10 years, invites you to join with thousands of other boys whom he has helped instruct.

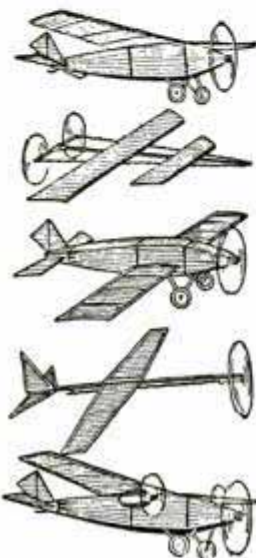

Only \$1.00 to Join

MODEL BUILDERS—If you really want to learn how to build all types of model airplanes, here is the greatest proposition ever offered. Join the Clinton Junior Aviators. The total membership cost to you is One Dollar (\$1.00) a year, and this is what we send you.

1. Twelve plans (regular price 25c each, \$3.00 total value)—one each month for 12 months—each plan different, new, advanced in design, with full instructions for making and flying. We also enclose a news sheet with valuable information for model builders, pictures, instructions, news, etc.
2. A year's membership card—entitling you to full club privileges and the prize opportunities offered in regular bulletins.
3. A Discount Sheet with 12 coupons, good for 10% discount on all material and parts purchased through the club.
4. Monthly prizes of \$5 to \$100 for the best models, best flights, photos and news, securing new members, etc. Under this club plan you can build more and better models at great savings in cost.

Can you imagine any greater value or any similar plan at any price that helps you to really study Aviation. Send in your membership right now and receive by return mail Plan No. 1—Junior Aviator Special Duration Scale Model, one of the neatest designs ever offered. Easy to construct. 20 in. wing, built-up 14 in. fuselage. Stays in the air for a minute and a half or more. Fine for flying either indoors or outdoors. Very light—weighs less than 1 oz. This plane is a wonder—you will rave about it.

Just fill in the coupon below—enclose \$1.00 (check, bill or money order) and we do the rest. Let's get off to a flying start.

SPECIAL COUPON

Clinton Junior Aviators, c/o Clinton Toy Corp., North Haven, Conn., Dept. J1

Dear Mr. Clinton:

I sure want to join your Junior Aviators Club. Here is my dollar. Put me down for a year's membership and rush me Plan No. 1 at once!

(Signed)

RADIO BARGAINS!

Brand New 7 tube A. C. sets \$36.75 guaranteed. Used radios as low as \$9.90. Power Transformers and chokes; No. 1003 Sec. 600 V. 7½ V. C. T. to first choke. 7½ V. C. T. 2.5 V. C. T. to case 1½ V. 3 chokes. Four one 281, one 250, one 227, four 226; Price \$5.00. No. 875 Secondary 375 volts—375 volts, 5, 5, 2½, 1½ and 1½. High and low primary and 2 chokes. For 280, two 171A, five 226, and one 227. Price \$4.25. Complete list upon request.

CHAS. HOODWIN CO., Dept. M2, 4240 Lincoln Ave., Chicago
Dealers in Bankrupt Radio Stocks

The man who studies gets ahead. Popular Mechanics Press will advise you what books to read to advance in your trade. 200 East Ontario Street, Chicago, Illinois.

30 DAYS TO TRY FREE MEAD Ranger RADIO

—10 Months to Pay
SAVE \$25 TO \$100

All Electric With Dynamic Speaker Screen Grid Tubes

The Ranger Radio is a result of 7 years' development. It is to-day fast becoming the most favorably known radio—now leading the field, as its predecessor, the Ranger Bicycle, has for 30 years.

The Screen-Grid Tube Ranger Neutrodyne (with 9 tubes) with 2 No. 245 tubes in "Push-Pull" is licensed by R. C. A.

Ranger assures you of selective reception from near and distant stations.

You may now own one of these distinctive Rangers with Dynamic Speaker in a DeLuxe Console by paying as low as \$10.00 down and balance in 10 months. Table models as low as \$40.00.

Rangers come all ready to use—simply insert tubes and plug into your electric light socket—no more trouble than to connect an electric floor lamp.



Write today for big catalog

MEAD has been known for Ranger Precision Products for 30 Years.

Write for marvelous new introductory offer—easy terms
DEPT. E173 CHICAGO

Mead
CYCLE CO.

Develop Your Talent!



Don't put off that urge to play! Be a musician! Learn to play for your own entertainment, for your friends, or even for a livelihood. More than that—broaden your own education and get the real appreciation of life that comes with the knowledge and understanding of music.

Stringed Instruments on Approval

You do not have to buy an instrument from us in order to try it. We will send what you want on approval. We want to see you satisfied with your choice before you buy.

30 Days Trial Examine our instruments in your own home. Try them yourself—show them to your friends. Then, at the end of 30 days, if you are not entirely satisfied, return what you ordered at no obligation whatever.

New Catalog Free The coupon brings full details of our special "on approval" offer, also our new catalog with 96 pages of interesting and valuable information for the student, teacher or professional. Send the coupon now!

Wm. Lewis & Son, Dept. 3378, 207 S. Wabash Av., Chicago, Ill.
Please send me entirely without obligation your new catalog on stringed instruments and details of your special offer.

Name

Address

City State

I play—want to play—a
(Music Teachers—enclose professional card.)

« THROUGH THE SKYWAYS ON THE HIGHWAYS » AT THE BOTTOM OF THE WORLD

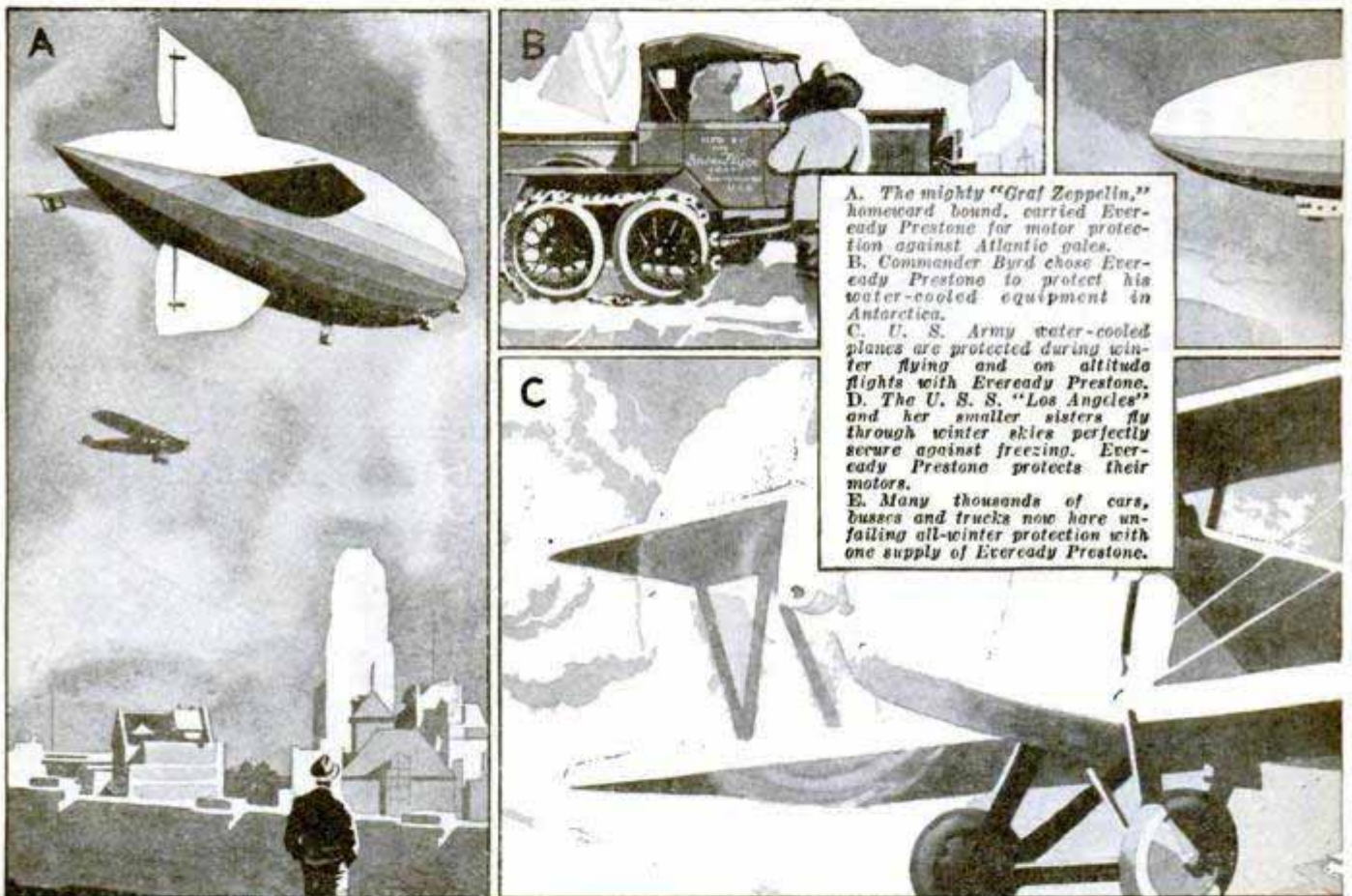

A. The mighty "Graf Zeppelin," homeward bound, carried Eveready Prestone for motor protection against Atlantic gales.
 B. Commander Byrd chose Eveready Prestone to protect his water-cooled equipment in Antarctica.
 C. U. S. Army water-cooled planes are protected during winter flying and on altitude flights with Eveready Prestone.
 D. The U. S. S. "Los Angeles" and her smaller sisters fly through winter skies perfectly secure against freezing. Eveready Prestone protects their motors.
 E. Many thousands of cars, busses and trucks now have un-failing all-winter protection with one supply of Eveready Prestone.

THE unfailing, harmless protection against frozen motors provided by one supply of Eveready Prestone has won for this perfect anti-freeze the highest endorsement wherever it has been used. When giant dirigibles take the air in winter weather, when a water-cooled Army plane ventures into frigid altitudes, when motors must operate in the intense Antarctic cold, Eveready Prestone is the first thought for protection. It possesses *all* the properties which the National Bureau of Standards has pointed out as essential for an anti-freeze.

Safest, most economical

The discovery of Eveready Prestone has given every motorist the opportunity to discard freezing worries. One supply of this perfect anti-freeze will keep his car in complete safety, *all winter*, no matter how soon it is put in the car or how long winter lasts.

Prepare your car

It is time now to have Eveready Prestone in your automobile. Before you add anti-freeze, however, be sure your car is ready for winter. Cold-weather driving demands free-flowing, winter-grade lubricants in

« EVERYWHERE THAT MOTORS OPERATE IN FREEZING TEMPERATURES YOU WILL FIND THIS PERMANENT, TRUSTWORTHY PROTECTION »»

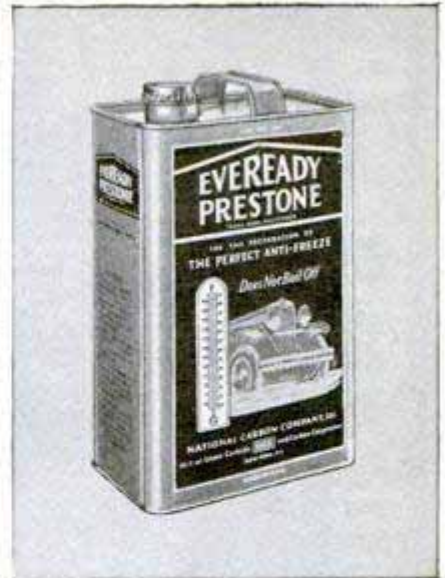

Eveready Prestone does not contain any alcohol or glycerine.

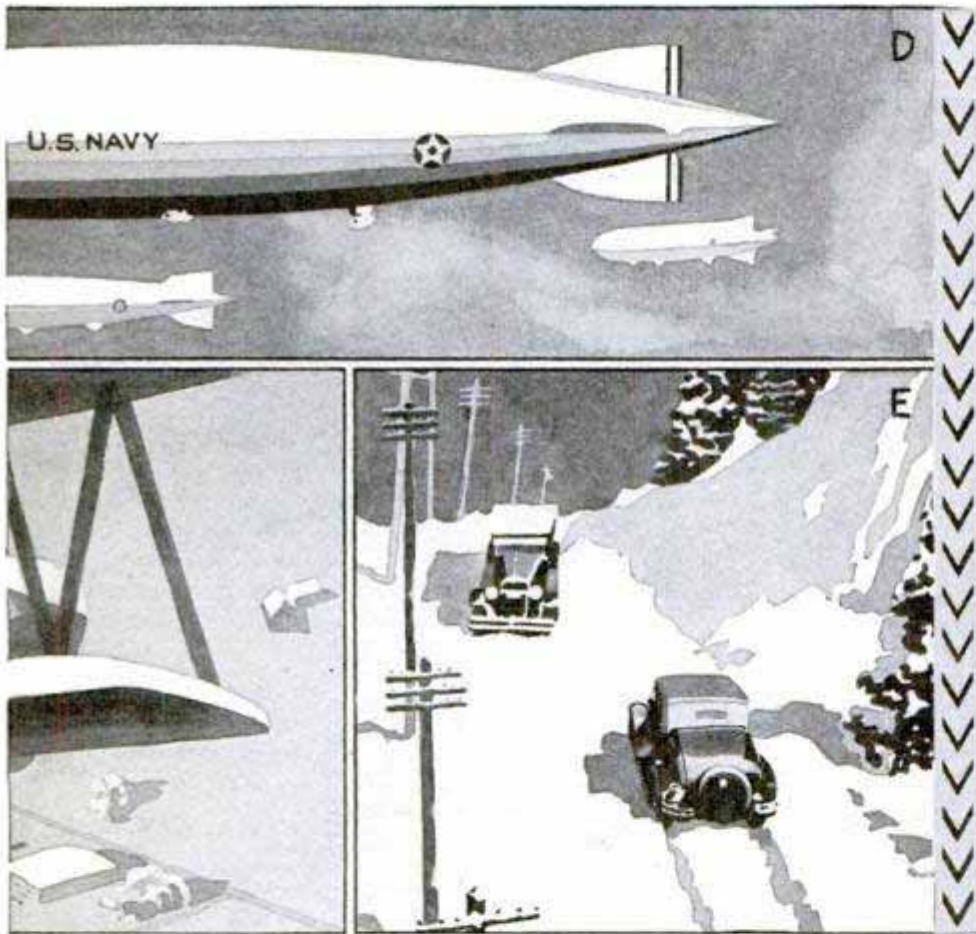

9 POINTS OF SUPERIORITY

- 1 Gives complete protection.
- 2 Does not boil off.
- 3 Positively will not damage cooling system.
- 4 Will not heat up a motor.
- 5 Circulates freely at the lowest operating temperatures.
- 6 Will not affect paint, varnish or lacquer finishes.
- 7 Non-inflammable.
- 8 Odorless.
- 9 Economical—one filling lasts all winter.



Thoroughly tested and 100% approved by the American Automobile Association.

EVEREADY PRESTONE

FOR PREPARATION OF THE PERFECT ANTI-FREEZE

crankcase, transmission and differential. Battery, spark plugs and ignition cables ought to be at their best. The all-important cooling system should be in perfect order. Have the radiator and water-jacket *clean and tight*—see that all of last summer's collection of scale and rust is flushed out. Vibration and jar tend to loosen joints and hose connections. Make certain that these and all pump parts, gaskets, drain cocks and radiator are absolutely free from leaks. Then add water and one purchase of Eveready Prestone, and your car will be ready for all winter.

Your car needs this simple preparation and a supply of Eveready Prestone *right now*. Don't put it off until freezing weather forces you to find protection.

You can get Eveready Prestone at any garage, filling station, automotive supply store, or hardware store. See about it today.

NATIONAL CARBON COMPANY, INC.

General Offices: New York, N. Y.

Branches: Chicago Kansas City New York
San Francisco

Unit of  and Carbon Corporation

DIAMONDS

The Old Reliable Original Credit Jewelers
Largest in the World

LOFTIS

BROS. & CO. 1858

Address: Dept. F-894, 108 N. State St., Chicago, Ill.

WATCHES



No. 918
\$37.50
\$1.00 a week



No. 913
\$1.00
\$3.75 a week



No. 917
\$50
\$1.25 a week

Genuine Diamonds Guaranteed—CASH or CREDIT

Give a Diamond for Christmas! Buy from Loftis, the Direct Importer, and be sure of highest quality and most value for your money. Our ring mountings are the latest creations in solid 18-k white gold, elaborately carved and pierced. Set with sparkling blue white Diamonds, radiantly beautiful. Satisfaction guaranteed, or money back. Goods sent for your free examination on request.

CREDIT TERMS: Pay one-tenth down; balance weekly, semi-monthly, or monthly at your convenience. All goods delivered on first payment.

Christmas Catalog FREE!

Write for big free book of 2000 illustrations and descriptions of Diamond Rings in Platinum and Solid Gold, Dinner Rings, Pins, Brooches, All Standard Makes of Pocket Watches, Pearls, Dresser Sets, Silverware, Clocks, Kodaks, Leather Goods. Write for Catalog TODAY.



Wrist Watch No. 866—14-k white gold. High grade 15-Jewel movement. Fancy corners; \$15. \$1.50 down & \$1.50 a mo.



Standard Railroad Watches on Credit at Cash Prices. Guaranteed to stand inspection. NO CARRYING CHARGE.



No. 897—Elgin "Legionnaire". New Elgin for men with white or green gold-filled case and raised figured dial, \$25.00—\$2.50 down and \$2.50 a month.



No. 916
\$100
\$2.50 a week



No. 919
\$120
\$3.25 a week



No. 907
\$100
\$2.50 a week

Our References: Any Bank or Banker in the U. S. A.



BARGAIN!

ONLY 39¢

GUARANTEED RADIO TUBES

Get guaranteed 201A type Barawik tubes for only 39¢ each. Send check or money order. These and thousands of other bargains are shown in Barawik's Big Radio Guide. Newest radio sets, speakers, parts, short wave and television supplies, etc.—all at lowest prices. Send for free copy today—NOW!

BARAWIK CO., 109-B Canal Sta., Chicago, U. S. A.
Mail This Coupon Now for Free Radio Guide

LATEST RADIO GUIDE

Name: _____
Address: _____

NEW AUTO LIGHT STICKS ANYWHERE

GRIP-LITE has magnetized base. Stick tight to any metallic surface. Ideal Auto "Trouble Light." Leaves both hands free! Attached in 5 seconds by clips. No batteries to wear out. Gives powerful shielded light. Protected bulb. Also serves as emergency headlight, tail light, or camping light.



AGENTS MAKE \$50 TO \$100 WEEKLY

Sells at sight. Every autoist, garage man, repair man a prospect. Sells at only \$3.00. W. Miller: "Sold 6 in one hour!" C. H. Streater: "Selling 90 a week easy!" Many cleaning up.

10 Day Trial

Send for sample at special Agents price of \$2.00 C.O.D. 10 Day trial. Also details of money-making plan. State make and year of car. Satisfaction guaranteed or money back.

MAGNO CO., 6 Beacon St., Dept. 168A Boston, Mass.

CLAROSTAT

Not just the name of a product, but the name of a service dedicated to better radio results. CLAROSTAT stands for variable and fixed resistors, volume controls, automatic line voltage ballasts, socket antennas, etc. Write for literature.

CLAROSTAT MFG. CO.

286 North 6th Street
Brooklyn, N. Y.

BUILD "FLYING CLOUD"

Send for quality parts and clear blueprints of 20' model. Readily made in spare hours as hull fully shaped and sanded. Set includes anchor, bell, capstan, dead eyes, wheel, rigging line, etc. Complete for \$11. Postage 5 lbs. White metal figure-head 50c. Send 10c today for catalog and folder on clipper ships.

R. E. HANCOCK

323 Douglas Ave.
Portsmouth, Va.

Buy Now Pay Later

Get Boice Prices Before You Buy!

Boice offers you greater values at lower prices with a positive money-back guarantee. Whatever you build, there's a Boice-Crane bench machine to do your work; Circular Saws, Band Saws, Lathes and Jointers. Send 10c for catalog, prices and Boice "E-Z" Pay Plan.



4" Handi-Jointer

Tables 20-inch. Planes 1/4-inch x 4 inches. Fence tilts 45 deg. both ways. Bronze bearings. Improved rabet arm. Safety guard \$3. \$25



12" Band Saw

Table 10 inches x 12 inches tilts 45 deg. Cuts 4 1/2 inches deep. Bronze bearings. Sturdy. Guards \$8. Without motor or guards, \$35



Handisaw

Universal. Table 15 inches x 17 inches tilts 45 deg. 8 inch saw cuts 2 inches. Elevates for dadoing. Attachments for dadoing, jointing, disc and drum sanding, boring, planing, grinding, \$30



Jig Saw

Table 8-inch dia. Tilts 45 degrees. Stroke 1 1/2 inches. Capacity 10 in. to frame. 600 R. P. M. 6 sizes of blades \$12

W. B. & J. E. BOICE, Dept. P.M. 11-E, TOLEDO, OHIO

Every Latest Feature for Performance and Quality

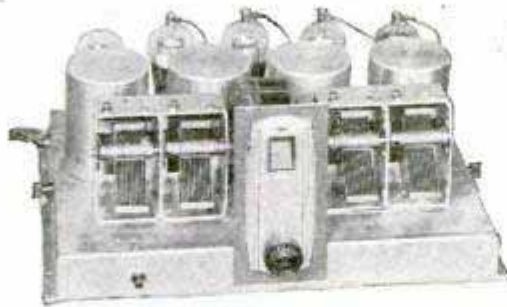

This new National MB-29 has every latest feature for performance and quality. *Four Screen Grid Tubes* for utmost sensitiveness—*Band Filter* tuning for selectivity without cutting of sidebands—*Power Detection* is for securing maximum results from the new type high percentage broadcast modulation—*Power Audio Amplification* with two 245's in push-pull—beautifully finished, rugged shielded aluminum chassis with precision matched coils and condensers—*New National Projector Dial*. These are just the high spots. The New National MB-29 is simply full of new and ingenious features for your convenience and pleasure.

A selection of beautiful types of consoles available for housing the MB-29, in popular combinations.

Write us today for full particulars and prices, mentioning *Popular Mechanics Magazine*.

NATIONAL CO. INC., Malden, Mass.

Est. 1914

NATIONAL SCREEN-GRID - MB-29

BOYS A real sensation. The newest development in AVIATION
"The Eaglet"
Only \$1.00



A Genuine Duration
Scale Model

Specifications: Built up model—wood frame. 20 inch wing spread. Fuselage 14 inches. WEIGHS ONLY SEVEN-EIGHTHS OF AN OUNCE. This remarkable light weight has never before been achieved in any commercially built scale model of this size. Practically CRASH PROOF and has flying qualities galore. The record to date is 92 SECONDS.

You will get new thrills with this newest and finest type model plane. Wonderful results indoors as well as outdoors. Such a light weight, long flying, real scale model will be a revelation to you.

"Win Five Dollars in Gold"

We are offering semi-monthly prizes of five dollars in gold to the boy or girl who sends in the best flight record obtained with this model. Full instructions and prize entry blanks are included with every eagle model. Get yours now.

Send check or money order. No stamps or C. O. D. The price is low—order your model now and compete for the prize awards. CONSTRUCTION SET—Complete with all parts, plans, instructions and prize entry blanks. Postage free. \$1.00.

Homer Mulo of Grantville, Mass., won last month's prize with flight of 400 feet distance and 92 seconds duration. Can you beat it?



**EAGLE MODEL
AIRPLANE CO.**

DEPT. P11 NORTH-HAVEN-CONN

New
AUTO LIGHT
Amazes Motorists!



Great!
New!

SEE

**THIS
MAGNETIZED BASE**
It's one of the really novel features. Convenient, too, because it makes BRITE-LITE useful as headlight or parking light in emergency.

**BRITE-LITE
Sticks ANYWHERE**
Besides this handy innovation, BRITE-LITE can be used as an ever ready flashlight. Camps, tourists, and others find it a truly convenient accessory.

**A BOON TO
MOTORISTS!**

BRITE-LITE startles autoists! They actually gasp with astonishment when they see how this sensational new product works. A single demonstration—hardly two minutes work—often sells 4 or 5 lamps on the spot.

STICK IT ANYWHERE—Presto—IT LIGHTS!
This clever emergency lamp has a magnetized base. Therefore it sticks like iron to any metal. Simply connect one clip to the battery or ammeter line, another to a ground lead-in. **FRESTO!**—It lights! Then, for convenience, stick it anywhere on the car. Leaves both hands free to work.

AGENTS—CLEAN UP!

Agents—do you see what a wonderful seller this remarkable product is? Every auto owner is not only astounded and pleased with your demonstration, but he realizes at once how positively useful this article will be. For any kind of auto trouble—tires, motor, smash-up—BRITE-LITE is a real saviour.

WRITE FOR DEMONSTRATOR

Try this yourself. Write for demonstrator. It will start you taking orders at once. **BIG PROFITS ARE CERTAIN. ACT TODAY!** Clip coupon, sign and mail before you forget. Don't delay. Reserve territory at once!

ACT TODAY!

MAIL THIS COUPON NOW!

National Electric Corp.
216 High Street, Dept. 104, Newark, N. J.
Send me a BRITE-LITE as a demonstrator. If my territory is open send all details of your offer, with full sales information.

Name.....
Address.....
Town.....State.....
Territory wanted.....

SAVE YOUR BODY

Conserve Your Health and Efficiency First

"I Would Not Part with it for \$10,000"

So writes an enthusiastic, grateful customer. "Worth more than a farm," says another. In like manner testify over 100,000 people who have worn it.

The Natural Body Brace

Overcomes WEAKNESS and ORGANIC AILMENTS of WOMEN AND MEN. Develops erect, graceful figure.

Brings restful relief, comfort, ability to do things, health and strength.

Wear It 30 Days Free at Our Expense

Does away with the strain and pain of standing and walking; replaces and supports misplaced internal organs; reduces enlarged abdomen; straightens and strengthens the back; corrects stooping shoulders; develops lungs, chest and bust; relieves backache, curvatures, nervousness, ruptures, constipation, after effects of flu. Comfortable and easy to wear.

Keep Yourself Fit Write today for illustrated booklet, measurement blank, etc., and read our very liberal proposition.

HOWARD C. RASH, Pres. Natural Body Brace Co.
123 Rash Building SALINA, KANSAS



For Boys and Girls Also



HUNDRED HUNTING HOUNDS
Cheap. Fur Finders. Money Makers. Dog Feed. Remedies, Collars, Hunting, Fishing, Camping Equipment. Agents Wanted. *Catalog.*

KASKASKIA, M-144, Herrick, Ill.

Make Decorative Metal Articles

Pictures and instructions for making: book ends, desk sets, jewelry, desk clocks, drawer pulls, hinges, bookmarks, stationery rack, candlestick, letter holder, whisk broom holder, and many similar articles. Send no money. Just write a postal for "Metal Work and Etching", our 88-page book. Pay postage and 98c to postman.

Popular Mechanics Press, Room 710, 200 E. Ontario St., Chicago, Ill.

GASOLINE AT HALF COST? AGENTS WANTED

Big money demonstrating, and selling Aerostat, first real improvement in carburetion in 20 years. Absolutely new! Patented! Positively gives 25% to 50% more mileage! Saves car owners hundreds of gallons of gas! Entirely new principle, tested and approved by automotive engineers. AN AMAZING SELLER! Guaranteed. Fits all cars! EXCLUSIVE TERRITORY GIVEN! Get in on the BIG MONEY NOW!

FREE TRIAL! Test Aerostat at our risk! Send no money! Simply send name and address for FREE OFFER!

AEROSTAT MFG. CO., Dept. H-25
3601 Violet Street MILWAUKEE, WIS.



WRITE TODAY!

Auto Tourist's Handbook tells how to make equipment for inexpensive touring with Auto Owner's Handbook, 98c. Send No Money. Just write a postal. Pay postman postage and price. Popular Mechanics Press, Room 707, Chicago, Ill.

Outdoor Opportunities

How to raise rabbits, guinea pigs, milch goats, silver foxes, ferrets, white rats, white mice, dogs, cats, pigeons, pheasants, bantams, canaries, bees, frogs, mushrooms, ginseng and golden seal for profit. Practical 250-page book with 120 illustrations. Will be sent C. O. D. When postman hands you the package, pay him \$2 plus the postage.

POPULAR MECHANICS PRESS
Room 506 200 E. Ontario St. CHICAGO



The NEW FOUR-in-ONE SPARK PLUG

Amazing spark plug combines four separate sparking points. More power; will not carbonize; never misses; cannot foul and has a great advantage over any spark plug on the market. Will last for years.

FREE OFFER

to agents who show eager motorists, machinists, mechanics, garagemen, etc., this astounding spark plug. Make up to \$100 a week in this new field. No competition. The finest, most satisfactory plug on the market. Write at once for FREE offer.

WETZIG MFG. CO.
Dept. W, 2600 Fletcher St., CHICAGO, ILL.

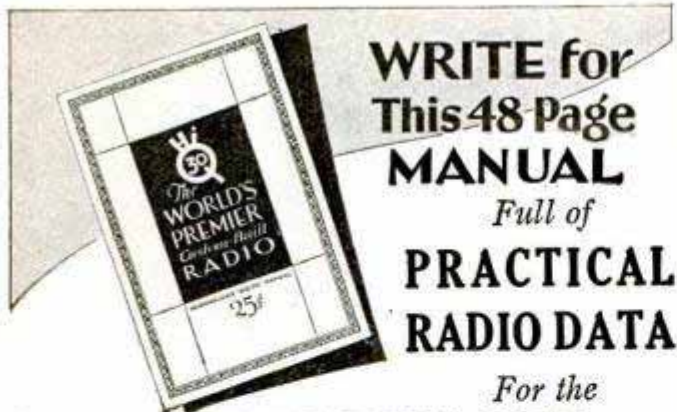

**WRITE for
This 48 Page
MANUAL**
Full of
**PRACTICAL
RADIO DATA**

For the
**CUSTOM-BUILDER
and ADVANCED FAN**

Describes the newest and finest **BAND-FILTER TUNING SYSTEM—SCREEN-GRID AMPLIFIER—PUSH-PULL AUDIO AMPLIFIER—POWER PACK—UNIT CONSTRUCTION SYSTEM—EFFECTIVE SHIELDING—SPEAKERS—CABINETS—INSTALLATION—SERVICING.**

It will make money for you; it will save money for you.

Write for it today.

Use the convenient coupon.

Hammarlund-Roberts, Inc. Dept. PM11, 424-438 W. 33rd St., New York
Enclosed 25c (stamps or coins) for "HI-Q-30" Manual.

Name..... Address.....



\$100 WEEKLY WASHING CARS

20 minute car washing is highly profitable with new HB Double Action Car Washer. Quickly builds paying business for you in garage, filling station or parking space—saves on labor, material, time. Throws more water per minute at high pressure than other makes.

ONLY \$20 MONTHLY

Easily paid out of profits. Users report profits of \$100 and over weekly. You try it 30 days at our risk on money back guarantee. Write today for details. **Hebert Brothers, Box M1192, Troy, Ohio.**



Ford Owner Stop that ruinous chatter on your car. **MAKE THIS TEST**—take out your floor boards, pull your emergency brake back and forth. If you notice play at the ball joint, you need Bredar's Ball Shim. Price \$.50. Ask your Dealer or order direct. Demand Bredar's Shim.

NIC BREDAR'S SON MFG. CO., Rock Island, Ill.



New Food Idea Pays Big Profits!
Men! Women! Investigate the wonderful **NEW Brown Bobby GREASELESS Doughnut.** Sells like wildfire! You can easily make \$50 week spare time; \$5000 to \$8000 year full time. Investment small. No experience needed. Write today for big special offer.

Food Display Machine Corp., Dept. 3-S, 500-510 N. Dearborn St., Chicago

IT PAYS BIG AND YOU OWN IT!

You make money in large gobs instead of small ones. You deal with real people, selling something substantial, not a cheap specialty. Pyramid's new Weatherstrip Products interest every householder—bigger improvements, easier installation, larger profits, and you deal with factory direct. Very small investment, very big returns, very live men only need apply. New Booklet, "The Weatherstrip Way to Wealth," sent FREE. Your copy is waiting.

**Just address Opportunity Division
PYRAMID METALS COMPANY
2014 Wabansia Ave. CHICAGO**

**Be the Tom Brown
of Your
Town**



Everyone has heard of Tom Brown, leader of the famous Tom Brown's Clown Band, one of the highest priced musical acts that has appeared all over the world.

If you have not seen them, you have probably heard them play on Victor Records.

First-Class Saxophonists make big money and the work is easy and pleasant. You might easily become a wizard like Tom Brown, or a great record-maker like Clyde Doerr or Bennie Krueger or Joseph Smith. \$100 to \$500 weekly is not unusual for such musicians to earn.



True Tone Saxophone



Only a Buescher gives you all these features:

Patented Snap-on Pads—the greatest improvement for beauty of tone — easy to replace — no more cementing. Found only on the Buescher.
Patented Automatic Octave Key—always positive.
Perfect scale accuracy—every tone always full, clear and true.

Hands never moved from one playing position.

Convenient key arrangement, simplifies fingering of rapid passages.

6 Days' Trial

in your own home on any Buescher Saxophone, Cornet, Trumpet, Trombone or other instrument. Fill out and mail coupon for full information. Mention instrument in which you are interested.

BUESCHER BAND INSTRUMENT CO.
2926 Buescher Block Elkhart, Ind.

BUESCHER BAND INSTRUMENT CO. (498)
2926 Buescher Block, Elkhart, Ind.

Gentlemen: Without obligating me in any way please send me your free literature.

I am interested in the following instrument.....Age.....

Name.....

Address.....

SMART-MODERN FINE JEWELRY Sent For \$1.00

DL31 27⁵⁰
Nationally known **ELGIN** or **WALTHAM!** Handsomely engraved new style case. Guaranteed Elgin or Waltham movement. **Warranted 14K White or Green Gold filled 25-year case.** Latest style flexible mesh wrist band to match. \$2.21 a mo.

DL1 50
Butterfly design 18K Solid White Gold engagement ring. Genuine, blue-white diamond. \$1 now, \$4.00 a mo.

DL12 48⁵⁰
Dazzling cluster, 7 genuine blue-white diamonds. 18K Solid White Gold ring. Looks like a \$750 solitaire. \$1 with order, \$3.95 a mo.

DL3-14K 37⁵⁰
Solid White Gold engraved case; 2 diamonds; 8 emeralds or sapphires. Guaranteed 15 jewel movement. Flexible bracelet, with sapphires or emeralds. \$1 with order, \$3.04 a mo.

NEW CATALOG FREE TO ADULTS
New catalog of genuine diamonds, standard advertised watches, fine jewelry. Write for it now.

ROYAL DIAMOND & WATCH CO.
ADDRESS DEPT. 11-Y, 170 BROADWAY, N.Y.

Steady Income from your Spare Time Hobby

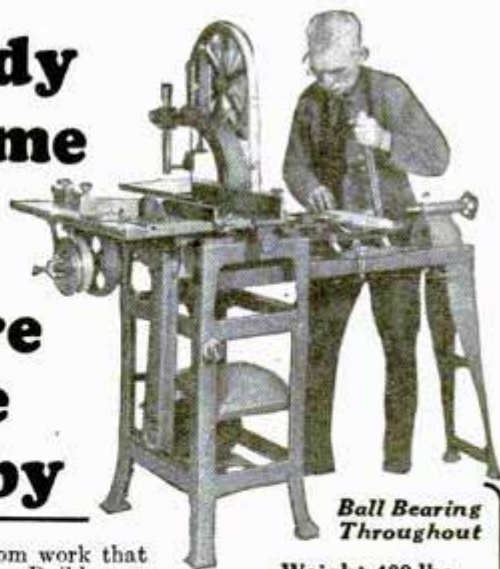

Ball Bearing Throughout

Weight 480 lbs.

\$35

Big profits from work that is really play. Build your own business. Make storm sash, porch enclosures, kitchen cabinets, radio tables, novelties, toys, furniture, jobbing carpenter work, etc.

THE ELECTRIC CARPENTER deposit brings it to you for Free Trial. **6 Months to Pay!**

Does 35 Woodworking Operations. Runs from any light socket.

7 MACHINES IN ONE 8" Circular Saw, 14" Band Saw, 36" Lathe with 10" Swing, 4" Jointer, Reversible Shaper, 1/2" Hollow Chisel Mortiser, Sander.

Write Today for New Illustrated Folder

THE WOODWORKING MACHINERY CO., INC.
Eleventh and Vine Sts., Philadelphia, Pa.

FOR THE RADIO BUILDER

The blueprints below include the best of Popular Mechanics tested circuits. When ordering, simply quote the numbers of blueprints desired and inclose proper amount addressed to Popular Mechanics Magazine, Radio Dept., 200 E. Ontario St., Chicago, Ill. Magazines containing full descriptions of the circuits can be obtained. Send 25 cents for each magazine desired, giving date of publication.

- No. 111, Homemade Tube Tester..... July 1926..25c
- No. 115, 15 to 550-Meter Three-Tube Receiver..... Nov. 1926..25c
- No. 116, Three-Tube Loop Set..... Dec. 1926..25c
- No. 123, Economy-Nine Super-heterodyne..... Nov. 1927..50c
- No. 130, One-Tube Short-Wave Adapter..... Mar. 1928..25c
- No. 134, Edison Type B-Battery..... July 1928..25c
- No. 138, Screen-Grid Perfect-Tone Six Receiver..... Nov. 1928..25c
- No. 139, Simple Television Receiver.. Dec. 1928..25c
- No. 140, Power Amplifier and B-Supply for Television..... Jan. 1929..25c
- No. 142, Two-Tube Screen-Grid Short-Wave Adapter..... Mar. 1929..25c
- No. 143, Four-Tube Screen-Grid Receiver..... May 1929..25c
- No. 144, Three-Tube Self-Contained A.C. Receiver..... Oct. 1929..25c
- No. 145, One-Tube S-G Set for Beginners..... Nov. 1929..25c
- No. 146, Adjustable B-Eliminator... Nov. 1929..25c
- No. 147, A-Eliminator for Set and Dynamic Speaker..... Dec. 1929..25c
- No. 148, Adding Audio Stages to S. G. Receiver..... Dec. 1929..25c

START to PLAY Very First Day!

Pleasant, Easy Lessons Show You How!



Extra Money—Hosts of Friends—Loads of Fun Within Your Reach

HAPPY DAYS are in store for you if you will only act on this suggestion! Cheery evenings playing catchy music alone or with sweetheart, wife or sister; proud moments as center of interest at gatherings; nights of joy making \$5 to \$25 for work that is "play."

The Deagan Xylorimba is your opportunity! Wonderful for home, in demand at dances and entertainments, yet easiest of all instruments to play. No teacher necessary—you actually play simple melodies the very first day even if you cannot read a note of music right now!

Earns \$60 a Week—Ralph Smith, Chicago, says: "Played 20 minutes at wedding. Received \$20." L. E. Hallmann, Reading, Pa., writes: "Made \$300 in 6 weeks, spare time. Had never played instrument before."

Send for Big Free Book! Our new book tells all about the delightful lessons furnished with each instrument. No obligation—simply fill in and mail the coupon.

J. C. Deagan, Inc., Dept. 1458, 1770 Bertkau Avenue, Chicago
Send me, without obligation, full details of Free Trial offer and easy-payment plan of the Deagan Xylorimba.

Name.....
Address.....



Here's the Newest Idea in Model Airplanes: — **The "American Eagle"**

Wing Span: 26 in. Weight: 3 3/4 oz.

An entirely new, light-weight, strong, fast-flying Model with IDEAL'S twenty years experience behind it, and months of dependable service before it. New in construction, unique in design. A wonderful flyer. Fuselage and tail assembly of balsawood; aluminum bulkheads; built-up wings with ready formed ribs; indestructible landing gear; special pitch propeller. Beautiful color scheme. Construction is simplicity itself; any boy can build this Model. Get one for Christmas!

Complete Construction Set containing all parts and full instructions **\$2.50**

Also furnished Completely Assembled and ready for immediate flight, with special silk-covered wings **\$5.00**

Build a 3 ft. Flying Model of the FORD Transcontinental MONOPLANE



A perfect, scale-model of the giant airplanes now in use for coast-to-coast passenger transportation. Any boy can build it; the IDEAL Complete Construction Outfit contains all parts, fittings and materials, with complete plans, diagrams and building-flying instructions. The Model is guaranteed to fly when correctly built. Complete Construction Outfit..... **\$8.50**

IDEAL Model Airplanes, Parts and Supplies are sold by Toy, Sporting Goods and Hardware Stores. If unobtainable in your locality, your order will be filled from the factory upon receipt of price.

All prices above are 10% higher West of Denver, Colo. and in Canada

Plans for Model Airplanes — 25c

Complete, accurate, 1/2-size Plans, with Building-Flying Instructions, for any one of the following Models, sent postpaid for 25c: FORD MONOPLANE; New York-Paris Monoplane; FOKKER MONOPLANE; Curtiss BiPlane; DELHAVILLAND BiPlane; NC-4 Naval Seaplane; Bleriot, Taube or Newport Monoplanes; Cecil Peoli Hacer. Catalogue included free with plans.

64-page Catalogue of Models, Parts and Supplies for Builders..... **5c**

IDEAL AEROPLANE & SUPPLY CO., Inc.
 "The Safest Name in Model Airplanes for 20 Years"
 26 West 19th Street, NEW YORK CITY



Earn \$150 to \$300 MONTHLY

COSTS ONLY \$16 MONTHLY 30 DAY TRIAL

8-Hour Charger Test Bench

Mechanics, filling stations, tire stores and garages are increasing profits, without expense to themselves, through use of HB service equipment. Start for yourself in this profitable work with HB 8-Hour Battery Service—Starting, Lighting, Ignition Service—Car Washing—Spray Painting. HB guarantees bigger profits, lets you do better work, at less expense to you.

ONLY \$16 MONTHLY

—a small part of your increased profits.

8-Hour Battery Service

Gives you edge on competitors. Saves 30 to 50% on electric bills over rectifiers—eliminates bulb cost and turns out work in 1/2 time. Recommended by leading car and battery makers.

Test Bench

Tests starting, lighting, ignition systems. Brings you this work from other shops. Does more than outfits priced \$100 to \$150 higher.

Car Washer

Easily washes complete car in 20 minutes. Eliminates all drudgery. Doubles your business. Users report \$100 weekly profits. Liberal trial, easy terms. Savings in labor and materials will easily pay for it.

Paint Spray

One man and an HB can earn five men's wages painting cars, houses, furniture. Paint Spray contractors earn big profits yet charge less than brush painters. Gas engine for country, electric for town. Liberal trial and easy terms.

Free Air

Only \$10 monthly lets you have this business pulling air service. Its automatic, ball bearing, two cylinder, compact spiral drive eliminates breaking belts. It's the best buy on the market. Liberal trial and easy terms.

Car Washer



30-Day Trial —at our risk



Hobart Brothers
 "Successful Manufacturers since 1893"

Box M 119 Troy, Ohio

TEAR HERE - MAIL TODAY

Hobart Brothers, Box M 119, Troy, Ohio.
 Without obligation send me complete information on the items I've checked together with your 30-day trial offer and liberal terms. Tell me how HB will increase my earnings, without expense to me.

8-Hour Battery Service HB Electrical Service
 HB Car Washer HB Paint Spray
 HB Air Service

Name.....
 Address.....

EVERY FLYER NEEDS

Practical Air Navigation and Meteorology: the new, simplified, non-technical treatise by Capt. Richard Duncan, who has over 3000 hours of flying to his credit. No subject is of greater importance to the flyer. 243 Pages. 70 Illustrations, Maps, Charts, etc. \$3 postpaid.

Popular Mechanics Press, 200 E. Ontario St., Chicago



CHI-RAD RADIO COMPLETE WITH DE FOREST AUDIONS. Eight years selling \$139.50
 quality radio equipment—now we've made an all AC set of our own, "The Chi-Rad". Has all the latest features: Power detection, Thordarson Audio Trans., push-pull amp. with new 245 power tubes, Magnavox Dynamic Speaker, walnut console, etc. Unusual guarantee.
 Agents We have an attractive selling proposition for you. Write today for details.
 Set Builders Write for Money-Saving Catalog
CHICAGO RADIO APPARATUS CO., Dept. P.M.
 415 S. Dearborn St. Chicago, Ill.

Own Your Own Big Money-Making Business

A NEW BUSINESS IN YOUR TOWN

A delightful, dignified and fascinating business. Make and sell Crispettes. Delicious confection. Young and old like them. Come again and again for more. Easy to make. I supply everything. Raw material plentiful and cheap. Profits big. No town too small. Start now.

QUICK SUCCESS POSSIBLE anywhere—cities, towns, villages, crowded streets; surging throngs at parks, carnivals, fairs, etc.; open a little retail store; or, begin at home; wholesale to stores, grocers, bakers, druggists, parks, baseball games, picnics, wayside stands.

EXCEPTIONAL (not average) PROFITS \$11,265 sales in 3 months reported by California man. New Jersey \$4,000 profits in less than 2 months. Revel of Michigan wrote: "Made \$25 on my first day". A. Leib of Montreal wrote: "My sales averaged \$400 per week".

WE START YOU IN BUSINESS for little money. Supply machines, secret formulas, and raw material. Little capital starts you. No experience needed.

WRITE FOR "BOOK OF FACTS"

—It's free, contains success letters from others—shows their places of business, tells how to start.



SALES \$606.81
One Week Ending July 20 1929.
W. H. ADAMS
OHIO

AVERAGING \$3000.00
PROFIT FOR 3 SUMMER MONTHS
Report July 24 1929
E R NABOR
MASSACHUSETTS

EAKINS CO.,
1128 High St., Springfield, Ohio
Mail at once, your Book of Facts

\$640.00
ESTIMATED OUTPUT
10 HOURS
CRISPETTE MACHINE

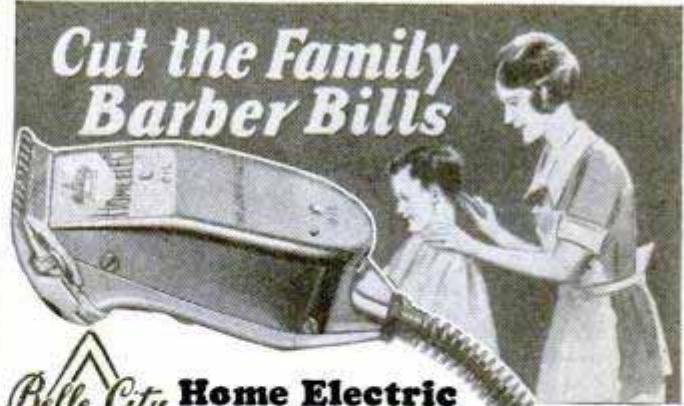

Belle City Home Electric Hair Clipper

Anyone can trim or bob hair, shorten bangs, clip neck or underarms in a shape almost impossible with hand clippers or shears. Operates on direct and alternating current. Will not clog or cut the skin, and cuts as cleanly as a razor. Thousands in use. Rigidly guaranteed.

TEN DAYS' FREE TRIAL
If your hardware or electrical dealer can't supply you, write for interesting booklet, or order from this ad. Send no money—pay postman \$8.75. Return it in ten days if not satisfactory. State whether 110, 220 or 32 volt current is used.
Dealers and Representatives Wanted
Belle City Appliance Co., 1022 12th St., Racine, Wis.

Fits Any Light Socket

\$5 BRINGS YOU THIS COMPLETE MOTORIZED SAW UNIT

GUARANTEED 10 DAYS' FREE TRIAL
This big, sturdy, powerful 8" Saw with 1/8 H. P. Motor—shipped to you on approval for only \$5.00. 10 Days' Free Trial. Then convenient monthly terms if you keep it. Send for complete facts on this offer and details on Lathes, Circular and Jig Saws, Jointers and complete portable work shop. Write today.
MIDLAND APPLIANCE CORPORATION
Dept. 1115 225 N. Michigan Avenue CHICAGO

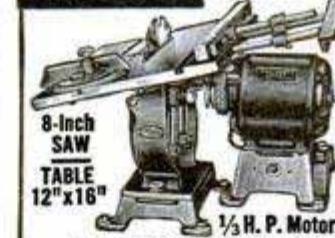

Name _____

Address _____



Concertina Plays by Roll
Pamphlets Free

PITTLER CO., Dept. 6, NEW BEDFORD, MASS.
Information on any book free. Write Popular Mechanics Press, Chicago, Ill.

Write Today for details
Establish a Good Future
ONLY \$50.00
DOWN AND \$4.00 Weekly
Starts a business of your own—No experience necessary. Instructions furnished. The only key machine that cuts ALL types of keys. No hand-filing. Make first keys by number of lock without taking lock apart.

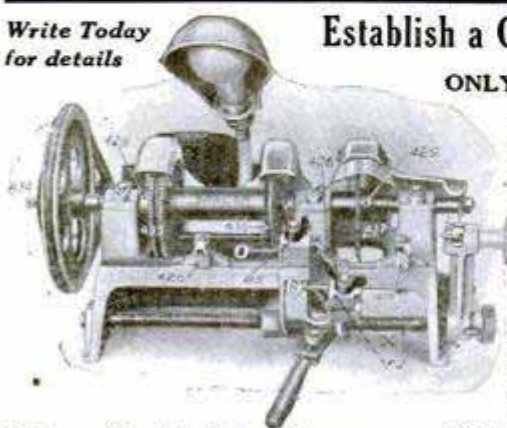

Beisser Key Machine Company 407 Fort St. East
Detroit, Mich., U. S. A.

SUPER OIL BURNER

BOILS 100 GALLONS OR MORE IN LESS THAN HOUR

TERRIFIC HEAT
NO SOOT NOISE SMELL SMOKE
MOST REMARKABLE GIANT BLUE FLAME BURNER BUILT. Ideal for gas fired boilers, heating large vats and tanks for factory, farm, agricultural and many other uses. (Burns outdoors as well as indoors.) Develops heat for 20 Horsepower gas fired boiler. Easy to install and operate.
DOUBLE HEAT AT HALF COST

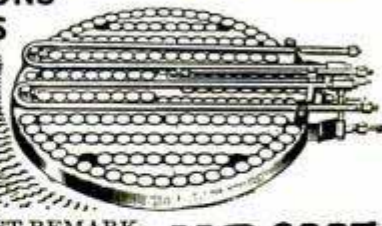

Improved generators, convert ordinary kerosene oil into rarefied superheated gas, producing intensely hot blue flame capable of boiling from 100 to 500 gallons of water or other liquid. Double generators assure continuous performance without shut downs. 150 lava flame discs intensifies heat. Equipped with all accessories. Nothing to buy.
QUICK STARTING—PERFECT FLAME CONTROL
Equipped with pilot light for quick starting. Improved valve control, regulates heat to any degree desired same as city or natural gas. For heavy or light duty this super-pressure oil burner gives entire satisfaction. Write for Catalog of Giant Therm-o-gas Burners, also smaller general utility burners for cook stoves, heaters, pressing machines, etc.
HOME MFG. CO., Dept. 3713, 20 E. Kinzie St., Chicago, Ill.

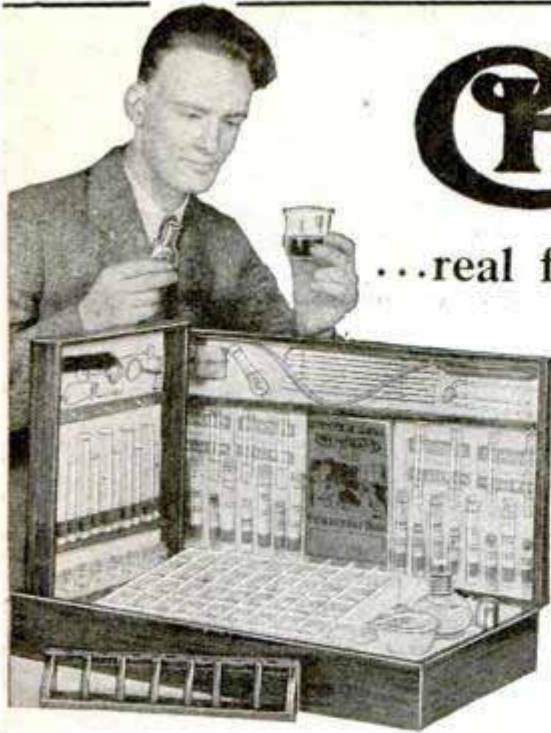

CHEMCRAFT

REGISTERED TRADE MARK
THE CHEMICAL OUTFIT

...real fun with the wonders of chemistry!

Get one of these new Chemcraft Chemical Outfits! Work hundreds of interesting and useful chemical experiments that will show you the wonders of chemical science; perform lots of mysterious chemical tricks. It's the finest fun you ever had. These are the original chemistry outfits; they have more chemicals and apparatus; better experiments and offer better value.

Six Different Sets to Choose From:

(No. 15 Illustrated at Left)

No. 1—\$1.00	No. 5—\$ 5.00	No. 15—\$15.00
No. 3—\$3.00	No. 10—\$10.00	No. 25—\$25.00

(Nos. 5, 10, 15 and 25 come in Wooden Cabinets)

Sold by all Toy Departments, Ask for them by name—
CHEMCRAFT CHEMICAL SETS

Try Chemistry for 25c

Get CHEMCRAFT Junior, the set for boys who want to see if they like chemistry. Sent postpaid for only 25 cents.

Free Magazine for Boys

CHEMCRAFT Chemist Club Magazine: full of fine ideas, stories and chemical stunts for everybody. Write for your free copy.

THE TELEPHONE BOOK with THE MAGIC MICROPHONE



Build your own Electric Telephone!

"THE TELEPHONE BOOK" tells the inside story of the telephone; explains how it works and how you can make a real, electric broadcasting telephone of your own. Also gives instructions for making a Super-sensitive Microphone, a Detectophone, a Stethoscope and other sound-detecting instruments. You can have great fun experimenting in telephonic and microphonic science—the science of sound transmission. All parts, wiring and other apparatus are included; everything packed in a unique Book-Box. Price\$5.00

Ask for "THE TELEPHONE BOOK" at Toy Departments and Book Shops. If unobtainable, we will send yours, prepaid, upon receipt of price.

FREE MAGAZINE FOR BOYS

Full of ideas on sound detection, woodworking and chemistry. Write for your free copy at once.

WoodCraft The Boy's Home Workshop

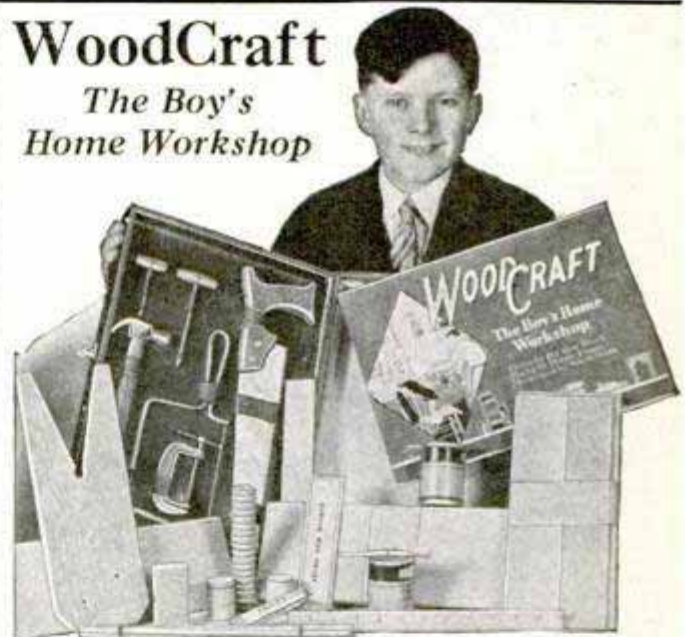

Design and Make Useful Articles of Wood!

"WOODCRAFT" will introduce you to the Art of Woodworking; show you how to plan, construct and decorate many practical things. Each set contains blueprint plans and instructions for making many useful articles such as bookracks, necktie holders, broom holders and others; also materials and supplies to make and decorate them; and good tools, specially selected for boys, to do the work. "WOODCRAFT" is a complete home workshop, designed for boys. It's more than a tool box because these sets show you what to do and how to do it. Made in two different sizes:

No. 5—\$5.00 No. 10—\$10.00

Each in strong, wooden cabinet, with snap lock.

(West of Denver, Colo., prices are 10% higher)

Look for "WOODCRAFT" in the Toy Department. If unobtainable, we will send your set, prepaid, upon receipt of price.

FREE MAGAZINE FOR BOYS

Full of fine ideas on woodworking, chemistry and telephony. Write for your free copy at once.

THE scientific outfits for boys described above are manufactured by The PORTER CHEMICAL COMPANY, 54 East Washington Street, Hagerstown, Maryland. Address all inquiries to this address, and if the outfits are unobtainable in your locality, send your orders direct to the company.

Stage Money



New Bills To Conform With Small Size Currency

With these bills it is easy for a person of limited means to appear prosperous by faking a roll of them at the proper time. By peeling off a genuine bill or two from the outside of the roll, the effect created will be all that can be desired. Prices, postpaid: 40 bills 20c, 120 for 50c, or \$3.50 thousand postpaid.

Serpent's Eggs



When lit with a match each egg hatches itself into a snake several feet long, curling and twisting in life-like manner. Box of 12, 10c postpaid, 3 for 25c.



an attractive box with full instructions. Each box contains six tricks as follows: Phantom Cards, Pick It Out Trick, Saton Card Trick, Fade Away Card Trick, Card to Match box, and The Encanted Magic Book. These tricks if purchased separate would cost 90c. Price complete 40c.

Nose Blower



It is concealed in the handkerchief. Proceed to blow your nose and your friends will think they heard a steam engine or something. You can blame the noise on a very bad cold and keep up the fun as long as you like. Price 10c, 3 for 25c, or 75c doz. postpaid.



Seebackroscope

With this instrument to your eye you can see what is going on behind your back. Many times things occur when no one thinks you are looking. Just like having eyes at the back of your head. Price 25c postpaid.



Magic Nose Flute

Is a unique and novel musical instrument played with nose and mouth combined. Just a little knack required to enable you to produce sweet music that resembles a flute. No fingering. Effect is charming when played as an accompaniment to piano or other musical instrument. Price 10c postpaid.

Black Art

This book tells of the sciences of Magic, Witchcraft, Alchemy, Necromancy, Mesmerism, etc. It tells how to make persons think of you, how to charm those you love, etc. The book contains 122 pages. Price 30c prepaid.



Exploding Cigarettes

JUST LIKE ORDINARY CIGARETTES, BUT SUCH REAL STARTLERS! The box contains ten genuine cigarettes of excellent quality. They appear so real, but when each cigarette is about one-third smoked, the victim gets a very great surprise as it goes off with a loud BANG! A great mirth provoker yet entirely harmless. Price 25c box.

Fire-Eater

A great trick by which you appear to breathe fire from mouth. Quite harmless. All necessary apparatus sent complete for only 30c, postpaid.



OAKS BOX OF POPULAR TRICKS

At the request of many of our customers we have made up a box of our most popular tricks. These tricks are all easily performed and are put up in

Silver Ace Flying Models



Convertible Cabin Model. Partly Assembled, \$9.00.
Wing Span, 20 inches. Complete by Knobs, \$7.00. (50c extra if shipped by us.)
Weight, 3 3/4 ounces. Ready to Fly, \$12.50

MODEL BUILDERS all over the world have learned the vast superiority of SILVER ACE MODELS, Construction Sets and Supplies. You save time, money and disappointment when you select a Silver Ace. With half the effort needed for assembling mere toy sets you can build a real little plane with the beautiful appearance and professional finish of the big ship.

Their amazing durability means money well spent. Their performance brings thrilling reports of prizes won.

Designed by aeronautical experts to meet all degrees of personal skill and every pocket book. Ready to fly, partly assembled, completely knocked down, or as contest sets. Prices from \$1.50 to \$30.00.

Sail Planes, Monoplanes, Biplanes, Seaplanes Faithful miniatures of the famous big ships. Fairchild—Stinson—Fokker—Ryan—Cessna—Curtiss types.

Sold by thousand reputable dealers. If your dealer cannot furnish SILVER ACES, we will ship your order direct. Send 10 cents for our photographic catalogue, describing 18 modern items and a complete list of real Silver Ace supplies.

AERO MODEL COMPANY

Dept. M11 111 North Wacker Drive CHICAGO

New Kind of Phonograph Has Amazing "Dynamic" Tone



"Bluebird" Portable has new scientific tone system. Reproduces electrical records with astonishing naturalness. Has deep, rich tone, thrillingly life-like, and tremendous volume. Sold direct from manufacturer at

Startling Low Price

never before equalled. Beautiful in appearance. Fully guaranteed. Ideal for homes, outings and radio amplification.

AGENTS

"Bluebirds" sell on sight. Agents make big money—even on part time. Write for sample offer and quick money making proposition.

SAUL DISTRIBUTORS 430 S. Wabash Ave. Room 1511 Chicago, Ill.

\$9.95

Retail Price

Plays All Standard Records

The man who studies gets ahead. Popular Mechanics Press will advise you what books to read to advance in your trade. 200 East Ontario Street, Chicago, Illinois.

SPORS GUARANTEED No. 10 FOUNTAIN PEN-PENCIL WITH COMPASS

PRICE \$1.25 SEND ONLY

MANY ATTRACTIVE COLORS GUARANTEED 2 YEARS MONEY BACK IF NOT PLEASED

"WRITES LIKE A \$7 PEN" AGENTS WANTED

39¢

(Sent Postpaid)



WRITE FOR FREE WHOLESALE CATALOG LISTING OVER 300 DIFFERENT ARTICLES

F. SPORS & CO., 929 Main St., LESUEUR CENTER, MINN.

New Model SOUTH BEND LATHES

BACK GEARED SCREW CUTTING LATHES

for the
Manufacturing Plant
Tool Room
General Repair Shop
Machine Shop
Service Station
Electrical Shop
Engineering Shop and Laboratory

Used by
Manufacturers of
Automobiles
Electrical Parts
Machinery
Aircraft
Textile Machines and Government Departments National and State

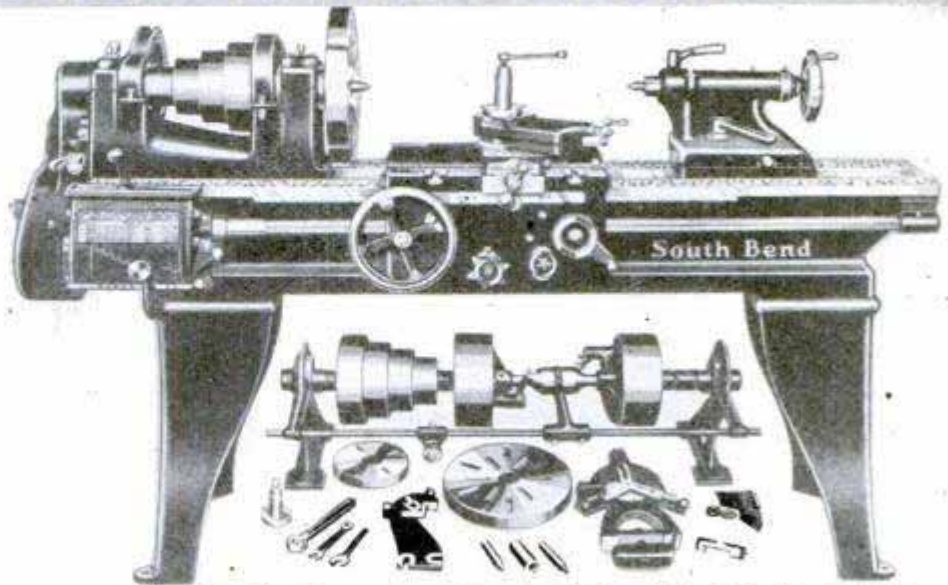

16" x 6' Quick Change Gear New Model South Bend Lathe, \$598

Prices of Popular Sizes of Quick Change Gear Lathes with Lathe Equipment

Size of Lathe	Shipping Weight	Countershaft Drive	Silent Chain Motor Drive
9" x 3' (Junior Bench Lathe)	375 lbs.	\$169.00	\$273.00
9" x 3'	490 lbs.	294.00	398.00
11" x 4'	725 lbs.	359.00	498.00
13" x 5'	1110 lbs.	443.00	602.00
15" x 6'	1550 lbs.	543.00	720.00
16" x 8'	2035 lbs.*	638.00	817.00



New Free Catalog Shows 96 Sizes from 9" to 18"

Write or send coupon today for the New South Bend Lathe Catalog. This complete book illustrates and describes 96 sizes and types of Countershaft Driven Lathes, Motor Driven Lathes, Quick Change Gear Lathes, Standard Change Gear Lathes, Tool Room Lathes, Gap Bed Lathes, Brake Drum Lathes and Bench Lathes.

Investigate the New Model Lathe as it has all the latest improvements.

Easy Payments

We ship any South Bend Lathe immediately upon receipt of only 20 per cent of Catalog Price. Balance in 12 equal monthly payments. Write for Time Payment Catalog.

SOUTH BEND LATHE WORKS

615 E. Madison St., South Bend, Ind., U.S.A.

Lathe Builders for 23 Years—44,000 Users

South Bend Lathes are carried in Stock by these Jobbers:

New York City: J. E. Beggs Co.
 Boston, Mass.: Lynd-Farquhar Co.
 Bridgeport, Conn.: A. C. Bisgood
 Cleveland, Ohio: Hess-Sebenck Co.
 Dayton, Ohio: C. H. Gosiger Mch. Co.
 Detroit, Mich.: Lee Mch. Co., Inc.
 Philadelphia, Pa.: Delta Equipment Co.

Chicago, Ill.: C. B. Burns Mch. Co.
 Pittsburgh, Pa.: Reliance Mch. Sales Co.
 Plainville, Conn.: Ideal Mch. Co.
 Providence, R.I.: The E. A. Eddy Mch. Co.
 St. Louis, Mo.: Colcord-Wright Mch. & Sup. Co.
 San Francisco, Cal.: Herberts-Moore Mch. Co.
 Seattle, Wash.: West Coast Mch. Co., Inc.
 Los Angeles, Cal.: Eccles & Davies Mch. Co., Inc.

Milwaukee, Wis.: Badger-Packard Mch. Co.
 Montreal, Que., Can.: The Canadian Fairbanks-Morse Co., Ltd.
 Newark, N.J.: Cassell Mch. Co.
 Syracuse, N.Y.: The H. A. Smith Mch. Co.
 Toronto, Ont., Can.: The A. R. Williams Mch. Co., Ltd.

SOUTH BEND LATHE WORKS, South Bend, Ind., U.S.A.
 615 E. Madison St., South Bend, Ind., U.S.A.
 Gentlemen: Send free postpaid, New Lathe Catalog.
 No. 90-A. () Time Payment Catalog.

Name.....
 Address.....
 City.....
 State.....

**"Mr.
Punch"**

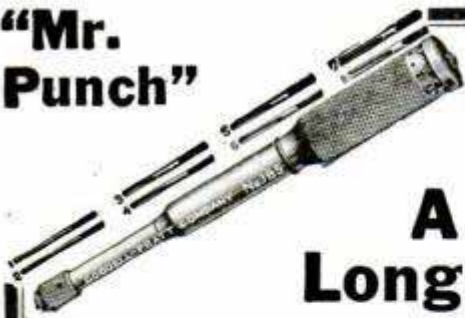

\$2.50
List
**A Life-
Long Tool**

Here is an automatic drill that is known the world over for its exclusive and super design. It possesses the small refinements which differentiates it from the ordinary tool.

A tool that should be in every home. Drills eight different size holes very rapidly in hard or soft wood, plaster wall board, etc., without splitting or cracking.

Ask your dealer to show the original "Mr. Punch" to you—accept no substitute. If he does not have them in stock, write to

Goodell-Pratt Company,
Greenfield, Mass. U. S. A.

Chicago Office New York Office London Office
38 N. Clinton St. 107 Lafayette St. 127 Queen Victoria St.

**GOODELL
PRATT**

1500 GOOD TOOLS

factory prices!

on Nationally Popular
21-JEWEL—Thin Model

STUDEBAKER

The Insured Watch

**The only high-grade watch
sold direct from factory!**

Imagine being able to purchase these magnificent thin model watches at lowest factory prices on easy payments out of your income, or for cash! Let us send you one of these marvelous watches—you are under no obligation to keep it. You'll agree it is the world's greatest watch value. Write for free 6-color book and learn the true facts!

FREE
6-Color Book

If you write at once we will send beautiful style book, showing lowest factory prices on these lifetime insured watches. Thousands save money this way. Write today!

WRITE!

Luxurious strap and bracelet watches at remarkably low prices! Write for free style book TODAY!

STUDEBAKER WATCH COMPANY

Directed by the Studebaker Family—known for
Three-quarters of a century of fair dealing

Dept. NY-103 South Bend, Indiana

Canadian Address: Windsor, Ont.



The New H. F. L. MASTERTONE

Laboratory Made RECEIVER

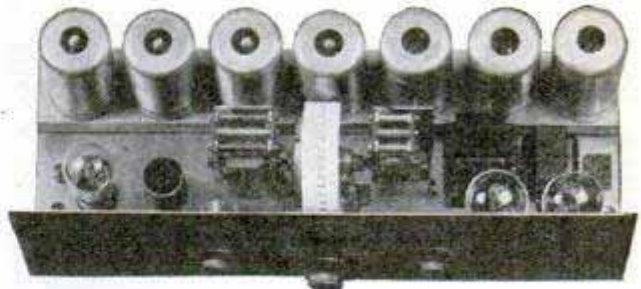

Built and Assembled by H. F. L. Engineers—Shipped Ready to Operate!

After two years of tireless research and tests under all conditions, H. F. L. engineers have perfected *the Mastertone*—a radio that sets an entirely new standard of performance.

Such startling realism! Such unflinching accuracy. Its great power and sweet tone will thrill you. Its keen sensitivity and positive 10 Kilocycle selectivity will amaze you. With only a wire screen or metal base aerial built in the cabinet, *the Mastertone* gets distant stations sharply, clearly and distinctly over entire musical scale, with magnetic, dynamic or horn speakers, and without a bit of hum.

THE MASTERTONE in Detail

All metal completely shielded chassis: 7x21x7½ inch. Fits nearly all consoles. 11 tubes operating at peak efficiency (5-224; 3-227; 2-245; 1-280). Single dial positive one-spot tuning; Humless AC Operation; Uses 5 Screen-Grid tubes, 5 Tuned R. F. Circuits; High Power Screen-Grid Detector, with 175 volts impressed on plate; Automatic line voltage control inbuilt holds voltage against fluctuating; 100-volt DC dynamic field supply incorporated; 3-stage phonographic amplifier; Finest quality precision made parts.

Built by Hand—Yet Low Priced

Quality—not quantity—the H. F. L. Mastertone standard. One demonstration will convince you that it's the master receiver of all times. Fully guaranteed.



**H.F.L.
Power Master**

Not an ordinary power pack, but a specially developed unit of the Mastertone, built separately to simplify installation. Has oversized transformer, full wave type 280 rectifier tube.

**Write Today for Complete Description
and Price**

HIGH FREQUENCY LABORATORIES

28 N. Sheldon St. Dept. 40 Chicago, Ill.

GET GOING!

Low pay, long hours, no future—more than 1700 Popular Mechanics readers have licked them through answering an ad just like this. They are Clarke FlorKraftsmen now. They're members of a real and new profession. They've learned how to earn \$500 to \$700 a month.

Are you facing a tough proposition to make the money you need? Do you want to get out of the wage struggle—to some day own a home and a new car that's all paid for and have money in the bank? If you do then mail in the coupon at the foot of this ad, for that's how these others have started toward financial independence. There's not a bit of cost or obligation to getting these facts this coupon brings.

No Books to Study

You don't need to buy or study any books to be a FlorKraftsman. A few hours practice with the Clarke Sander teaches you to sand a velvet surface onto new floors, or to remove the old varnish and make beautifully smooth old floors in houses already built.

That's the science of Clarke FlorKraftsmanship. It lets you earn money right from the start. And here's what it pays you.

**\$25 to \$75
per Day**

You can surface 900 to 2200 square feet of new floor in 8 hours. The pay ranges from 3 to 5 cents per square foot—or \$27 to over \$75 per day.

Surfacing old floors takes more time, but

CLARKE SANDING MACHINE COMPANY,

Dept. T-211, 3831 Cortland St., CHICAGO, ILL.

*Originators and, for over 12 years,
Manufacturers of Portable Sanding Machines.*



the pay is bigger. 300 to 1000 square feet a day and 7 to 15 cents a square foot are the figures. That's \$21 to over \$100 a day.

You don't have to open an office or make any heavy investment to become a FlorKraftsman. About \$100 is all you need to get started. And you earn you big pay *right from the start*. No long training period to eat up your time and money.

Maybe you've read one of these ads we've been running here in Popular Mechanics. If you have, just stop and figure that every month other men no smarter than you have started from these ads and are now earning this big money.

What they've done you can do. Why waste one more month in which you can be earning \$25 and up per day?

Do what these other Popular Mechanics readers did. Tear out this coupon and mail it. It doesn't obligate you to become a FlorKraftsman or to spend one penny. But it does bring you the full facts about how other men are earning \$500 to \$700 a month.

Clarke Sanding Machine Co.,
Dept. T- 211,
3831 Cortland St.,
Chicago, Ill.
Gentlemen: Please send me, without obligation, full details on the Clarke Sander, and the money-making possibilities of FlorKraftsmanship.

Name

Address

City State

MAIL THIS COUPON



SALES KIT WORTH \$15.25

Set Yourself Up In Business For Only \$4.75

BE our special sales representative, full or part time. Enjoy pleasant work taking orders for one of America's largest leather goods concerns. Sell quick-moving, fine-quality genuine leather articles suitable for gifts and personal use. *Big commissions!* Call on your friends, business people, lodge brothers. Every article in extensive line made by the owners of the Famous Halvorsen Patents. This guarantees the quality.

Order the kit now; receive excellent assortment of sample articles at cost, \$4.75: Halvorfold Calfskin Billfold (Value \$5.00), Halvor-Key Case of Pin Seal (Value \$3.75), Halvor-Card Case of Steer Hide, laced and embossed (Value \$3.75), Morocco Letter Case (Value \$2.75), all articles cornered in gold. Also handsome pocket kit case for carrying outfit, with your name in 23K Gold across cover. Order book and price list included. Retail value \$15.25.

Remember, \$4.75 sets you up in business. Act now! Whether you work full or part time you'll make big commissions. Get complete information. Send coupon at once! The gift season is on! Get in on the profits that are easily yours.

Dept. PM, U.S. LEATHER GOODS CO. 564 W. Monroe St., Chicago, Illinois I want to be your special sales representative and am enclosing \$4.75, cost price of complete kit as described. Send full sales equipment. My name as below to appear on kit in 23K Gold. I am to receive liberal commission. If not satisfied in any particular, I will return outfit and my money will be refunded immediately.

Name _____
Name to appear in 23K Gold

Address _____

\$125 per Week in YOUR OWN Business!

Many men are earning \$125 to \$200 per week with the H-B Rug-Washer. C. B. Taylor, Philadelphia, writes: "I alone have often earned \$75 in a day with my H-B Rug-Washer." C. J. White, Louisville, says: "\$100 worth of business in 6 days—never a complaint." C. H. Williams, Joliet, writes: "Gave up a railroad job to buy H-B cleaner. \$390 worth of work last month and business is increasing." Frank Diedrich writes: "I started business with one H-B Rug-Washer. Today I own large Milwaukee store with 4 machines." Thousands earning quick, easy profits. Electricity does the work. Finishes rugs like new, on customer's floor. Write today for booklet.

EASY TERMS Inexpensive equipment. No shop necessary. Hundreds of customers in your vicinity and in nearby towns—residences, hotels, offices, schools, clubs, theaters. Backed by \$33,000,000 Company. Used by the United States Government.

FREE Book Send today (no obligation) for booklet illustrating Rug-Washer and telling how you can earn large profits at prices below other methods; how you can build a permanent year around business; and how you can pay on easy terms. Enjoy a larger income. Mail a postcard or letter today—NOW. H-B Co., W-6098 H. B. Bldg., Racine, Wis.

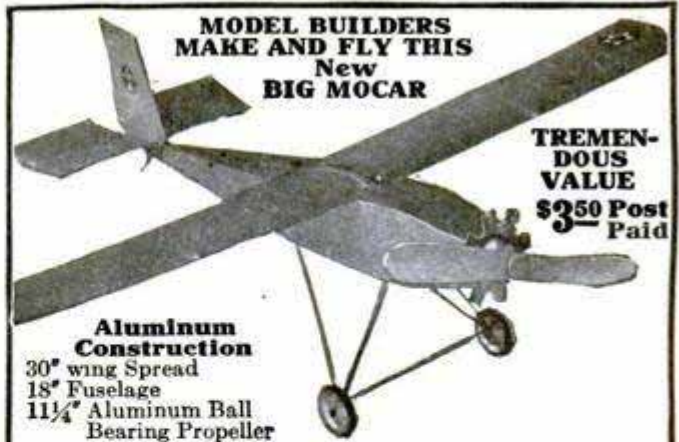

MODEL BUILDERS MAKE AND FLY THIS New BIG MOCAR

TREME-DOUS VALUE \$250 Post Paid

Aluminum Construction
30" wing Spread
18" Fuselage
11 1/4" Aluminum Ball Bearing Propeller

A GREAT CONSTRUCTION OUTFIT A SWEET FLYING JOB

Boys—Never in your life have you seen such a wonderful buy as this Big Mocar aluminum construction model plane! Just think—a real aluminum construction outfit—with 2 1/2 ft. wing spread and 18 in. fuselage—and how it does fly! Many special features, cambered wing construction, the big 1 1/4 in. ball-bearing propeller, with a powerful long-running motor that carries this plane soaring and zooming, won't break up even after many flights.

It is a real scale model—great fun to make—wonderful to fly. It will be your pride and joy. And you can fly it, too. It is made to stand the shocks. The Big Mocar construction outfit M-200 is complete with full instructions, mounted on board with all parts marked for easy assembly, rubber-tired wheels, covering material, cement and colors. Pliers only tool necessary.

Don't let a day pass without sending for this. You won't be disappointed. It's the greatest value and finest flying model ever offered at a popular price. It's yours for only \$3.50 postpaid. Model M made up ready to fly \$5.00 postpaid. Catalog showing many model planes from 75c to \$5.00 (glider given with catalog) 10c.

The American Model Aircraft Co., Dept. P-11, New Haven, Conn.



Beautify your NOSE to shapely proportions—while you sleep!



Gold Medal Won 1923

ANITA NOSE ADJUSTER is SAFE, painless, comfortable. Speedy, permanent results guaranteed. Doctors praise it. No metal to harm you. Small cost. Write for FREE BOOKLET



ANITA INSTITUTE, M-12, Anita Bldg., Newark, N. J.

FREE RADIO CATALOG

GREATEST OF ALL! Nothing to compare with new 1930 Wholesale Radio Service catalog. Fully describes biggest bargains ever offered. Unequaled dollar-for-dollar value. **VERY LATEST EQUIPMENT** Shows all standard equipment, kits, parts, batteries, accessories. Everything offered at substantial savings. **FREE RADIO ADVICE** and information.

WRITE TODAY FOR COPY Get your copy of this great radio guide and catalog **ABSOLUTELY FREE**. Don't miss this offer! Simply send name and address. Postal will do. But you must act quick before supply is exhausted. Write today!

1930 RADIO CATALOG
WHOLESALE RADIO SERVICE CO.

Dealers and Agents: Lowest wholesale prices offered on all equipment. Confidential price list. Personal advice. Write for our plan.

WHOLESALE RADIO SERVICE CO., INC.
36 VESEY ST. Dept. B-11 NEW YORK

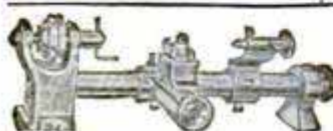

WADE AMATEUR MECHANICS, REPAIR SHOPS, INVENTORS, STUDENTS BENCH LATHE
A real machine tool for the home work bench—capacity 4" dia. x 12" length. For Metal—Wood—Composition materials. Turning—Facing—Boring—Drilling—Winding—Thread Cutting. Accurate—Strong—Quiet—Compact. Slide rest has travel entire length of bed. Leadscrew inside bed. No. 1 Lathe, plain headstock, \$40.00. No. 2 Lathe, back-geared headstock, \$58.00. Extra for lathes with 18 inches between centers, \$7.00. Complete line of accessories at equally low prices. Write for free catalog.
THE GEROLD CO. Dept. P-57 120 Liberty St. New York

"AC" RADIO

**6 TUBES
SCREEN
GRID**

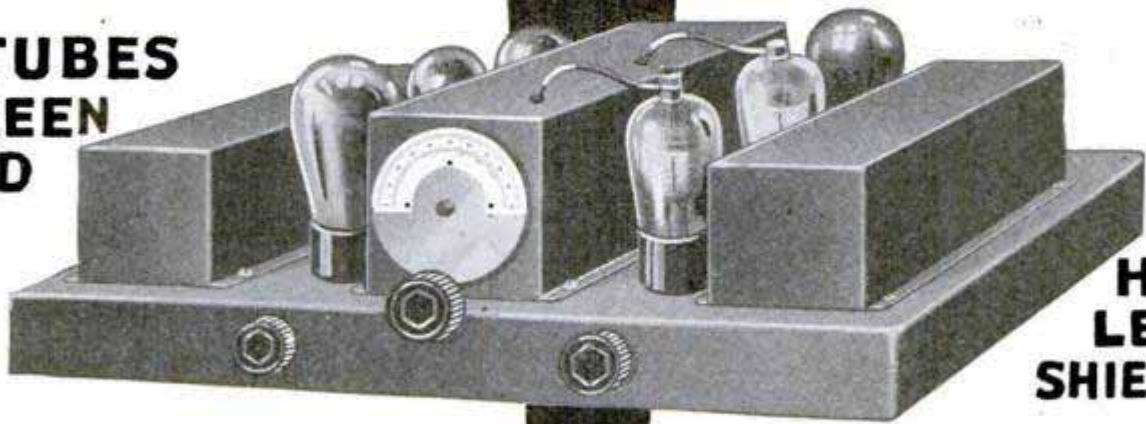

**HUM-
LESS
SHIELDED**

**AGENTS
WANTED**

Here at last is the radio everybody has been waiting for! A high-powered, long distance, 6 tube set with 2 stages of screen grid. No "AC" hum. Illuminated single dial drum control. Plenty of volume to operate power dynamic speaker. Beautiful clear tone, equal to high-priced sets. Guaranteed to give years of perfect satisfaction. All for the unheard of low price of \$24.00! No wonder it has become an overnight sensation! No wonder it is going like wildfire—selling itself almost at sight! And no wonder our agents are cleaning up \$60 to \$75.—yes, even up to \$200 a week during spare time—evenings!

**BIG PROFITS, QUICK
Choice, Exclusive
Territories Still Open**

This is your opportunity to tune in on station S-U-C-C-E-S-S! All you need is a sample ELGIN to find out what you really can do. Try it. Compare it with others for results. Demonstrate the ELGIN to your friends. When they hear its marvelous performance

**ONLY
\$24**

**ACT QUICK for
Exclusive
Territory**

**Live wires are tying up
choice territories on ex-
clusive contract. You
can do the same in your
territory if still open.**

**EXCLUSIVE
TERRITORY**

and the astonishingly low price—it's a sure sale nine times out of ten. The more people you see, the more you sell and the more money you make.

**START MAKING \$60 A WEEK
But You Must Act NOW!**

Today, without quitting your job, you can begin making real money, supplying the big demand for the new ELGIN. Work a few hours every evening—and before you know it, you have a profitable business of your own.

No miracles. No luck in this deal. Just plain facts. It's being done every day by our enthusiastic, successful band of Elgin agents. You can, too. No experience necessary. All we ask is your willingness to work—to get out and demonstrate the great new ELGIN. Now is the time to start. Fill in and mail the coupon today and you're all set to make money—yes, sir, *real* money—if your territory is still open. Find out now. Don't delay. Mail coupon or, better still, wire! **Be sure to give your county.**

DON'T LET A 2c STAMP STAND BETWEEN YOU AND SUCCESS!

ELGIN RADIO COMPANY, 4953 North Crawford Ave., Chicago. (Be sure to give your county.)

Please let me know immediately if the opportunity of cashing in on the new low-priced Elgin Radio is still open in my territory.

Name.....

Address..... County.....

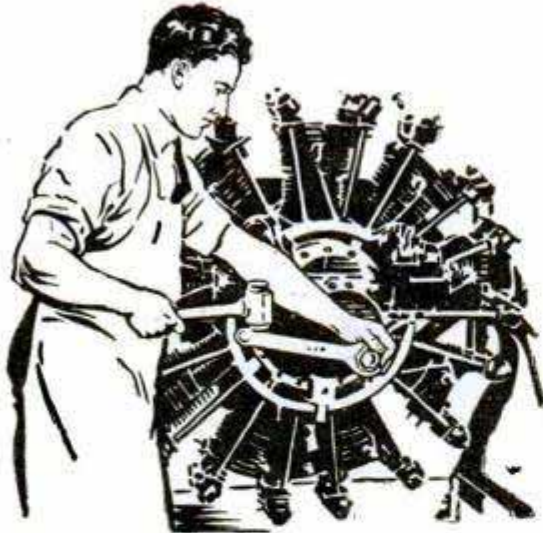

Do you want a career in Aviation?

A GENERATION AGO, when the automobile business was just beginning to grow, a group of young men determined to make it their career. To get the mechanical training they needed for success, they studied at night with the International Correspondence Schools. You know their names. Many of them are leaders in the motor world. Walter P. Chrysler, President of the Chrysler Motor Corporation; Jesse G. Vincent, Vice-president of the Packard Motor Car Co.; Hiram Walker, Chief Engineer of the Chandler Motor Car Co., and John Moore, designer of the famous Ansted Motor, are among them.

The same marvelous opportunity is yours, today, in the newer field of Aviation! Months of time and thousands of dollars have been put into the preparation of a great new I.C.S. Course in Aviation Engines, specially adapted to your needs.

You don't have to have experience, or a large amount of capital. You don't have to give up your present job. At home, in your spare time, you can quickly gain the knowledge of aviation motors that will qualify you as an expert mechanic.

The course is thoroughly modern and complete. It gives you a working knowledge of every up-to-date type of aviation engine—principles, construction, operation, maintenance and repair. It has been prepared by nationally known experts—such men as Lieut. Commander D. M. Carpenter, U.S.N., formerly in charge of ground training at the Pensacola Naval Air Station.

Find out today, without cost or obligation, just what this course offers and what opportunities it will bring you. Mark the coupon and mail it, *right now!*

INTERNATIONAL CORRESPONDENCE SCHOOLS
 "The Universal University"
 Box 5650-F, Scranton, Penna.

Without cost or obligation on my part, tell me how I can qualify for the position, or in the subject, before which I have marked an X.

AVIATION ENGINES

- | | |
|---|--|
| <input type="checkbox"/> Complete Automobile Course | <input type="checkbox"/> Gas Engine Operating |
| <input type="checkbox"/> Automobile Electric Equipment | <input type="checkbox"/> Complete Gas Engine Course |
| <input type="checkbox"/> Electrical Engineering | <input type="checkbox"/> Architect |
| <input type="checkbox"/> Electric Lighting | <input type="checkbox"/> Architects' Blueprints |
| <input type="checkbox"/> Mechanical Engineer | <input type="checkbox"/> Contractor and Builder |
| <input type="checkbox"/> Mechanical Draftsman | <input type="checkbox"/> Architectural Draftsman |
| <input type="checkbox"/> Railroad Positions | <input type="checkbox"/> Concrete Builder |
| <input type="checkbox"/> Machine Shop Practice | <input type="checkbox"/> Structural Engineer |
| <input type="checkbox"/> Civil Engineer <input type="checkbox"/> Mining | <input type="checkbox"/> Chemistry <input type="checkbox"/> Pharmacy |
| <input type="checkbox"/> Surveying and Mapping | <input type="checkbox"/> Agriculture |
| <input type="checkbox"/> Plumbing and Heating | <input type="checkbox"/> Navigation |
| <input type="checkbox"/> Steam Engineering | <input type="checkbox"/> Mathematics <input type="checkbox"/> Radio |

BUSINESS TRAINING COURSES

- | | |
|---|---|
| <input type="checkbox"/> Business Management | <input type="checkbox"/> Salesmanship |
| <input type="checkbox"/> Industrial Management | <input type="checkbox"/> Advertising |
| <input type="checkbox"/> Personnel Management | <input type="checkbox"/> Business Correspondence |
| <input type="checkbox"/> Traffic Management | <input type="checkbox"/> Show Card and Sign Lettering |
| <input type="checkbox"/> Accounting and C.P.A. Coaching | <input type="checkbox"/> Stenography and Typing |
| <input type="checkbox"/> Cost Accounting | <input type="checkbox"/> English <input type="checkbox"/> Civil Service |
| <input type="checkbox"/> Bookkeeping | <input type="checkbox"/> Railway Mail Clerk |
| <input type="checkbox"/> Secretarial Work | <input type="checkbox"/> Common School Subjects |
| <input type="checkbox"/> Spanish | <input type="checkbox"/> High School Subjects |
| <input type="checkbox"/> French | <input type="checkbox"/> Illustrating |
| | <input type="checkbox"/> Cartooning |

Name.....
 Street Address.....
 City..... State.....
 Occupation.....

If you reside in Canada, send this coupon to the International Correspondence Schools Canadian, Limited, Montreal



The Real Sport of Out-board Motor Boating Is to Build Your Own Boat **\$98⁰⁰** F. O. B. Factory

The famous Bossert Pirate Kid may be bought unassembled and built by any amateur—any boy with only ordinary knowledge of every-day tools can build one.

This is the boat that is breaking all records with B, C, and D motors.

World's Champions such as Malcolm Pope, Jack Kerr and many others are now driving Bossert Pirate Kids in all their stunts and races. They know good boats when they see them.

Walter Peterssen built his own boat and has won many big races as well as broken records in time trials in the boat he built himself.

Ask Pop to let you build your own—a lot of fun and you surely will like it much better than if you bought your boat all completed.

Many boys have already built their own Bossert Pirate Kid—A wonderful model.

The price is \$98.00 F.O.B. factory and the freight will average less than \$5.00 most any place in the U. S. Send in your order now.

You can also earn one of these boats for nothing for after you purchase your boat you are listed with us as an agent and then from every order you get for us you receive a bonus of 10% so you see if you are able to induce only 10 other boys to join you get your own boat free.

Write now for order blank and further particulars.

LOUIS BOSSERT & SONS, INC.

1350 Grand Street

BROOKLYN, N. Y.

The Model A Ford Car is treated in a special supplement to the latest edition, the 15th, of Dyke's Auto Encyclopedia

For 15 years "Dyke's" has been the one recognized and undisputed authority on the Automobile. Each succeeding edition has surpassed the last one. Now comes the greatest book of all—the wonderful 15th Edition—A. L. Dyke's crowning triumph—the super auto book of all times.

Some "High Spots" of the New Book!

- 1,249 pages covering every known auto fact.
- 4,200 Pictures, Plans, Diagrams and Charts.
- 15,000 lines of Index by which you can instantly locate any subject you want.
- A new section of "Trouble Shooting" Charts in Colors to enable you to quickly locate any major or minor trouble on any car.
- Special instructions on testing and adjusting every part of the automobile.
- Specifications of Gasoline Passenger Cars, Trucks and Tractors.

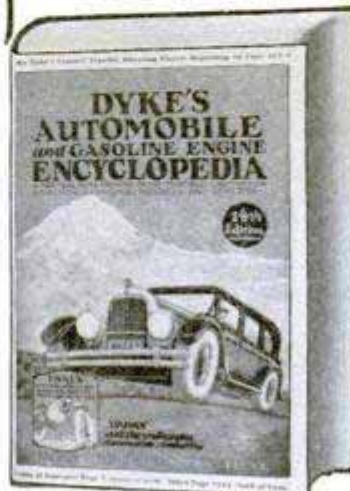

Specifications for Replacements, Accessories, Interchangeable Parts and Equipment.

Large colored Combination Chart which shows the working principles of the Automobile.

Large Charts showing the working principles of Trucks and Tractors.

Cloth \$6.00; Limp American Morocco \$7.50

Sent postpaid upon receipt of price.

Will be sent C. O. D. if preferred to any address in the U. S.

POPULAR MECHANICS PRESS
 Room P-11
 200 E. Ontario St., Chicago

The Power of the Whirlwind

Stops Gas Waste

Gasoline in a liquid state will not give power. Touch a match to a spoonful of liquid gasoline and it will burn, leaving carbon, but will not explode. Take another spoonful of gas, shake it in a can, thoroughly mixing it with air and it will explode immediately when touched with a match. The more thoroughly the gas is vaporized, the greater will be the explosion. Carbon also disappears when complete combustion occurs. The principle of the Whirlwind is to turn the otherwise wasted gasoline into power-giving added mileage and a saving to you. Figure up your gas bills for the year and the amount you are spending will surprise you. You are paying for a Whirlwind every day whether you have one or not. **PUT ONE ON YOUR CAR NOW AND LET IT BEGIN PAYING YOU DIVIDENDS.**

FITS ALL CARS

In just a few minutes a Whirlwind can be installed on any make of car, truck or tractor. It is actually less work than changing your oil or putting water in the battery. No drilling, tapping or changes of any kind necessary. It is guaranteed to work perfectly on any make of car, truck or tractor, large or small, new model or old model. **THE MORE YOU DRIVE THE MORE YOU WILL SAVE.**

Power in Gas | GUARANTEE

Automotive engineers claim that just a portion of the power in gasoline is being used. The

No matter what kind of a car you have—no

power is in the gas—it is merely the question of utilizing it by more complete vaporization. The Whirlwind utilizes a portion of this waste, turning it into power, and more miles to the gallon.

A Whirlwind on your car will give you 100% driving pleasure. You can instantly feel the smooth flow of power and quick pick-up.

Predicts an Increase in Gasoline Mileage

Detroit—C. F. Kettering, president, General Motors Research Corporation, predicts that mechanical perfection of automobiles will soon allow twice as much efficiency from fuel supply as is now received.

Mr. Kettering says that there is enough energy in a gallon of gasoline, if converted 100 per cent to mechanical energy, to run a small 4-cylinder car 450 miles.

Automobile manufacturers have made considerable progress, he says, but there remains a great deal to make automobile driving economical and efficient.

matter how big a gas eater it is—the Whirlwind will save you money. We absolutely guarantee that the Whirlwind will more than pay its cost in gasoline saving alone within thirty days or the trial will cost you nothing. **WE INVITE YOU TO TEST IT AT OUR RISK AND EXPENSE.** You are to be the sole judge.

From nature the Whirlwind secures a scientific principle, and with it DEVELOPS AMAZING POWER FROM ORDINARY GASOLINE. Just as a Whirlwind lifts and lowers, twists and twirls, scatters and tears apart things within its reach, so the Whirlwind carbureting device whirls and churns the liquid particles of gasoline into a vaporized gas that give added power and increased mileage. Anyone who has seen a Whirlwind with its spiral twisting action will quickly grasp the principle used in the Whirlwind.

SAVES MOTORISTS Millions Yearly

Car owners all over the world are saving money every day with the Whirlwind, besides having better operating motors. Gasoline saving is simply a matter of properly vaporizing gasoline—to thoroughly break down the liquid particles into a dry power-giving gas that eliminates waste and stops unnecessary wear to motor parts. The Whirlwind accomplishes this saving by three different proven and acknowledged principles of vaporization ALL COMBINED IN ONE SIMPLE DEVICE. Besides the big saving in gasoline, the Whirlwind also saves by aiding in quick starting. It also minimizes oil dilution by keeping the unvaporized gasoline out of the crank case oil. By giving your motor properly vaporized gas you save carbon cleaning costs, eliminate spark plug trouble, save on repairs by having a well lubricated efficient motor and save excessive depreciation by giving your motor long life.

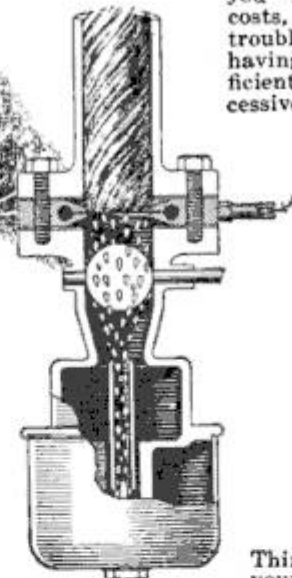

I have had my Whirlwind for three years, winter and summer it gives the same perfect service, instant starting, smoother running and what I have saved in gasoline these last few years has bought other luxuries.

A. W. Scott.

Think what this means on your own car. Figure up your savings—enough for a radio—a bank account—added pleasures. Why let the oil companies profit by your waste? Find out about this amazing device that will pay for itself every few weeks.

Free Trial Coupon

WHIRLWIND MANUFACTURING CO.
999-33-A Third Street, Milwaukee, Wis.

Please send me full particulars of the Whirlwind and your free trial offer.

Name

Address

City State

Agents and Salesmen Wanted

Whirlwind men are making big profits supplying this fast-selling device that car owners cannot afford to be without. Good territory is still open. Free sample offer and full particulars sent on request. Just mail the coupon.



Now PILOT'S ELECTRIC SUPER-WASP

Short Wave
PLUS Screen Grid
PLUS A. C. Operation



10,000 Mile Range
—Covers all bands
14 to 500 Meters

Employs Super-Sensitive Screen Grid Tube and New 227 PILOTRON especially developed for A. C. Super-Wasp

Now you can enjoy the thrill of international short-wave radio from your electric light socket! Utterly uncanny is the A. C. Super-Wasp's ability to jump 10,000 miles, "pulling in" novel short-wave broadcasts from all over Europe, Central and South America, Canada, South Africa and Australia! Easily assembled in single evening.

The Pilotron 227 used as detector is a new type tube developed especially for the critical requirements of short-wave reception! Precisely because of this it is an eminently superior tube for any broadcast receiver!



A. C. Operated SUPER-WASP

(Catalog No. K-115)

Custom
Set-Builder's
Price in U. S. A.

\$34⁵⁰

*Slightly Higher West
of the Rockies*

Power Pack extra
(Pilot K-111 ABC Power
Pack is recommended)



Battery-Operated SUPER-WASP

(Catalog No. K-110)

Custom
Set-Builder's
Price **\$29⁵⁰**
in U.S.A.

*Slightly Higher West of the
Rockies.*

**Special Notice to
Owners of
BATTERY-OPERATED
SUPER-WASPS**

Some S. W. fans will continue to prefer a battery-operated Super-Wasp. However those who desire to change over to A. C. operation, will find full details in Pilot's Special Data Sheet, obtainable free from your Pilot dealer or direct from the factory.

Join the Guild!

50c brings you four quarterly issues Radio Design, official organ of Radio International Guild. Subscription also includes one year's Guild membership with membership pin and certificate furnished without charge. Timely construction articles include full story on new A. C. Super-Wasp. Radio Design, Department 6, 103 Broadway, Brooklyn, New York.

Qualified Dealers!

Financially responsible and technically informed dealers are invited to secure details of Pilot's authorized Agency Plan.

PILOT RADIO & TUBE CORP.

WORLD'S LARGEST RADIO PARTS PLANT — ESTABLISHED 1908

323 BERRY ST.

BROOKLYN, N. Y.

Trade Mark



Registered

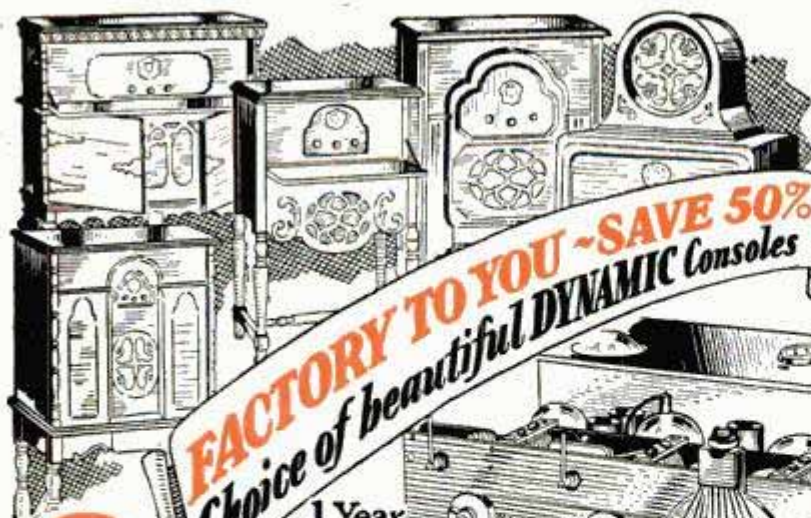

TRY IT 30 DAYS FREE BEFORE YOU BUY

FACTORY TO YOU - SAVE 50%
Choice of beautiful DYNAMIC Consoles
1 Year Guarantee



9

tube-perfected
SCREEN GRID, PUSH-PULL

MIRACO
 TRADE MARK REGISTERED

\$49⁸⁸ only
COMPLETELY ASSEMBLED

CATHEDRAL TONED, SUPER SELECTIVE, POWERFUL DISTANCE GETTER

Compare with costliest sets before you buy!

You needn't send us a cent! America's big, old, reliable Radio Factory springs its 10th Anniversary Surprise in high-grade full-year guaranteed sets at history's lowest prices! With its latest perfected Screen-Grid, push-pull, super-powered and hum-free AC electric Miraco's—you are guaranteed satisfaction, values and savings unsurpassed.

At our risk compare a Miraco with highest priced radios, for 30 days in your home. Surprise and entertain your friends—get their opinions. Unless 100% delighted, don't buy! Your decision is final—no argument!

Only marvelously fine radios, of latest perfected type, at rock-bottom prices, can back up such a guarantee. Send postal or coupon for Amazing Special Factory Offer!

Don't Confuse with Cheap Radios
 With Miraco's rich, clear cathedral tone, quiet operation, razor-sharp separation

of nearby stations, tremendous "kick" on distant stations and latest improvements—you'll be the envy of many who pay 2 or 3 times as much!

Send for proof that delighted thousands of Miraco users cut through locals, get coast to coast, with tone and power of costly sets. Miraco's are custom-built of finest parts—product of 10 years' successful experience. Approved by Radio's highest authorities.

DEAL DIRECT WITH BIG FACTORY

Miraco outfits reach you splendidly packed, rigidly tested with everything in place ready to plug in! No assembling! Entertain yourself 30 days—then decide. Liberal year's guarantee on each set. Play safe, save lots of money, insure satisfaction—deal direct with Radio's old, reliable builders of fine sets—10th successful year. SEND POSTAL OR COUPON NOW!

MIDWEST RADIO CORP., 407-EN Miraco Bldg., Cincinnati, O.

Get our Send No Money 10th Anniversary Offer

Dealers Write! - mail coupon right Now!



BEAUTIFULLY ILLUSTRATED LITERATURE

Free! Amazing Special Factory Offer
 All the proof you want—of our honesty, fairness, size, financial integrity, radio experience and the performance of our sets—including Amazing Factory Offer—sent without obligation!

User Agents Wanted! Exclusive Territory

DEMONSTRATOR SENT GET OUR PROPOSITION

Excels \$425 Outfit
 My 30 days trial on my Miraco AC-9 is up and if you would offer me \$200 extra for it back, I would tell you nothing doing. We had some very expensive sets in our home, one a \$425 9-tube AC set. Thanks to you I have a set that gets any and all stations. I have got stations in 45 states, also Cuba and Canada. It is beyond words to tell you what we think of our wonderful bargain. I will always praise Miraco's to everyone. J. W. LAUDERBACK, Barberton, Ohio.
 Coupon brings proof like this from people in YOUR locality, too.

SPECIAL ELECTRIC AC-7 \$39.85 BATTERY SET \$29.50

THIS COUPON IS NOT AN ORDER

MIDWEST RADIO CORPORATION
 10th Successful Year
 407-EN Miraco Bldg., Cincinnati, Ohio
 WITHOUT OBLIGATION send latest literature, AMAZING SPECIAL FREE TRIAL OFFER, testimony of nearby users, etc.
 User Agent Dealer
 Check here if interested in an EXCLUSIVE TERRITORY PROPOSITION.
 Name.....
 Address.....

WURLITZER

TRADE MARK REGISTERED

THE WORLD'S LARGEST MUSIC HOUSE



Try Any Wurlitzer Instrument in Your Own Home

EXAMINE it, show it to your friends, play it as much as you wish. An ample free trial—no obligation to buy. We make this liberal offer because we want you to see for yourself this superior quality of Wurlitzer instruments, the result of 200 years' experience. Noted musicians praise them for unusual tone quality, artistic workmanship and ease of playing. They are used in the finest bands and orchestras throughout the country.

Easy Payments

If you decide to buy, payments are arranged in small monthly sums. A few cents a day pays for your instrument. Special offers on complete musical outfits. Buy direct from Wurlitzer and save money.

SEND FOR New Catalog

The greatest musical catalog ever published! Over 3,000 articles—every known instrument described and illustrated; many of them shown in full colors. Gives you lowest prices and all details of Free Trial, Easy Payment plan. All sent FREE—no obligation. Just clip coupon and mail today.

Clip and Mail

THE RUDOLPH WURLITZER CO.

Dept. 1778

117 E. 4th St., Cincinnati

Send me, absolutely free, new illustrated catalog, with prices and details of Free Trial Easy Payment plan. No obligation.

Name.....

Address.....

City..... State.....

Instrument.....
(State instrument in which you are interested)