

POPULAR MECHANICS

MAGAZINE

WRITTEN SO YOU CAN UNDERSTAND IT

REG'D. TRADE MARK, GREAT BRITAIN, No. 410425

REG. U.S. PAT. OFF.



SEE PAGE 573

NEWS *for the owners of*

Hupmobile

Auburn 8

Graham-Paige

Buick

Nash

We have proved in thousands of miles of test driving on highways and the Atlantic City Speedway, and in hundreds of laboratory tests, that the New Mobiloil "BB" gives the greatest summer protection and power with the lowest oil consumption to Buick (1929, 1928, 1927 models), Nash (Advanced and Special Six 1929, 1928, 1927 models), Hupmobile (All 1929 and 1928 models), Graham-Paige (All 1929 and 1928 models), and Auburn 8's (1929, 1928, 1927 models). If you own one of these cars remember to *ask for Mobiloil "BB."* The price is 35¢ a quart, and there is always a Mobiloil dealer nearby.

VACUUM OIL COMPANY

Makers of high-quality lubricants for all types of machinery

the new



Mobiloil "BB"

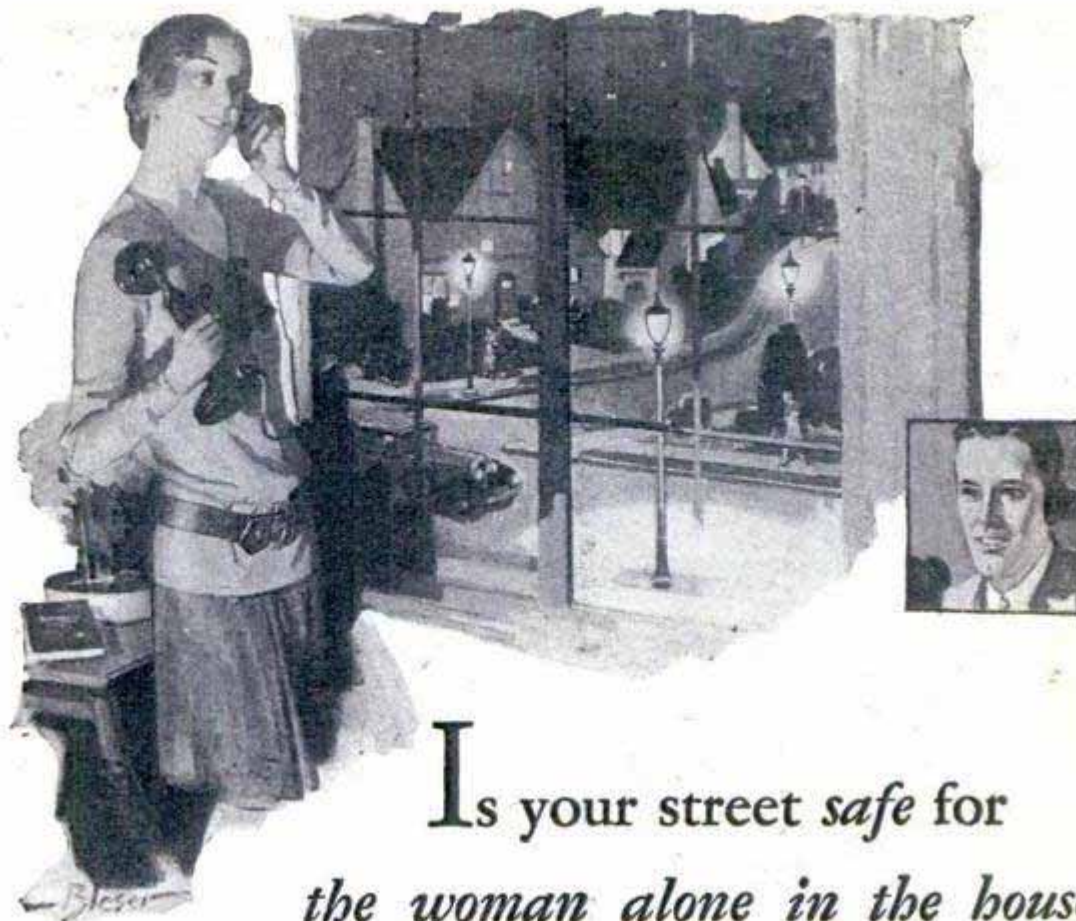

Is your street *safe* for
the woman alone in the house?

AN evening conference, an unexpected business trip—perhaps your wife's frightened voice over the telephone expresses a terror quite unwarranted. Why not summon Policeman Light to banish *fear*—and definitely reduce the chances of burglary? Isn't it time your community gave serious consideration to street lighting as a tried and proved investment, yielding rich returns both in civic progress and in public safety?

General Electric lighting specialists, working with your local power company, are ready at all times to aid in solving your community's lighting problems, and the G-E monogram is your assurance of quality in the materials and equipment installed. This same monogram appears on a multitude of electric appliances for home, office, and factory. It is an unflinching guide to electrical correctness and dependability.

JOIN US IN THE GENERAL ELECTRIC HOUR, BROADCAST EVERY SATURDAY AT 8 P.M., E.S.T. ON A NATION-WIDE N.B.C. NETWORK

95-649C

GENERAL ELECTRIC





... IT CONTRIBUTES TO THE PROSPERITY OF THE PEOPLE AND TO THE COMFORT AND CONVENIENCE OF LIVING

The telephone grows with the country

*An Advertisement of the
American Telephone and Telegraph Company*

THE Bell System must march a pace ahead of the new civilization on this continent, a civilization of better opportunity for the average man. The telephone contributes to the prosperity of the people and adds to the comfort and convenience of living.

It is used by the many. The time and money it saves are as important to the small business as to the large. The humblest home depends on it for aid in emergency, to run errands, maintain friendships. It is the aim of the Bell System to keep telephone service so good and so cheap that it will be used universally to make life richer and better. It seeks to



lead the way in social and business growth. It is raising buildings this year in more than two hundred cities, adding vast mileage to the expanding network of cable, and installing new telephones by the hundreds of thousands.

It is spending more than 550 million dollars this year—one and one-half times the cost of the Panama Canal—for new plant and service improvements. This program is part of the telephone ideal that anyone, anywhere, shall be able to talk quickly and at reasonable cost with anyone, anywhere else. There is no standing still in the Bell System.

Popular Mechanics Magazine

200 E. Ontario Street, Chicago, U. S. A.

H. H. WINDSOR, Founder

H. H. WINDSOR, Jr., Editor and Publisher

London: Hachette & Cie.,
16-17 King William Street, Charing Cross, W. C. 2

Paris: Hachette & Cie.,
111 Rue Reaumur

Melbourne: Gordon & Gotch
509-513 Little Collins St.

ISSUED MONTHLY

SUBSCRIPTION:

SINGLE COPY, 25 CENTS

In United States and its possessions, also Canada, Cuba, and Mexico, per year, postpaid - \$2.50

To all other countries in the Postal Union - 3.00

All subscriptions are discontinued at expiration. Please examine the date printed on your wrapper.

Entered as Second Class Matter Sept. 15, 1903, at the Post Office at Chicago, Illinois, under Act of March 3rd, 1879.

Entered as Second Class Matter at the Post Office Department, Canada.

Published monthly by POPULAR MECHANICS CO.

Copyright, 1929, by Popular Mechanics Co.

Copyright in Australia. Copyright in France

Vol. 52

Contents for October, 1929

No. 4

Special Features

Gliding on the Wings of the Wind	546
Chasing Chinese Pirates	554
With the Iceberg Patrol	579
Flying an Air Liner	586
On the Trail of Poison Mysteries	594
A Thunderbolt Factory	601
Salvage from the Sea	605
Wings for the Fishing Fleet	610
The Mystery of Stonehenge	618
Winged Kings of a Bird Empire	626
"Blacklight" Spots Planes	633
Making Crown Jewels for Movies	643
Agricultural Implements—hay drier removes moisture in forty seconds	635
Agriculture	
imported peas improve soil	545
meadow mice destroy crops	607
pheasants kill crop pests	603
Airplanes	
all-metal amphibian to cruise long distances	630
detachable cabin for safety and privacy	646
glider fitted with pontoons	642
maze of controls in cockpit of Australian plane	553
model plane has parachute jumpers	599
plane glides up canvas runway onto steamer	592
propeller like huge barrel	632
siren warns pilot of stalling danger	614
steam turbine for	577
talks to London while flying over New Jersey	623
upkeep of a small, same as that of auto	578
why tailspin is so often fatal	558
Airships	
gas is stubborn prisoner aboard	640
inflating "R-101" takes six weeks	576
Alaska—vast glacial tract in, remains unexplored	552
Aluminum—hardened will not stain or tarnish	600
Animals—luminous cloth lures coons	590
Architecture—crosslines on building give unique effect	635
Art—students have classes on skyscraper roof	609
Automobiles	
roller coaster gives motorists thrills	552
side sway remedied by control	609
single-cylinder has motor in rear	583
Automobiles, Accessories	
battery indicator checks power and water	607
campers' bed on top of auto	617
hub plates for Fords	640
Automobiles, (Driving—punching bag for autoists	604
Automobiles, Fuel—waste from autos filtered for oil burner	642
Aviation	
record breakers of the air age	562
the pay of air pilots	603
wind direction indicated by landing-field lights	636
Bank—uses vending machine to attract savers	603
Barbecue—automatic roaster saves meat	576
Blindness—mathematics taught blind by touch system	647
Boats and Boating—self-dumping scow	560
Books—aluminum covers for	545
Building Construction—steel house frame gives sky-scraper strength	608
Buildings—washing faces of, is made easy	593
Camera, Aerial—shows details of ground from aloft	583
Candy—helps working girls resist fatigue	599
Cattle	
brand with squeezer	560
prickly pears as stock feed	615
Clothesline—without pins	617
Concrete—sand tester shows quality of mixture	600
Cotton—seed "fuzz" valuable	646
Currency—reduced size bank notes cuts printing bill	636
Customs—dyed goose feathers puzzle custom chemists	592
Earthquakes—pulsating earth may change	553
Education—college travels on wheels	604
Envelopes—moistener seals and closes flaps	624
Eyes—are you right or left-eyed?	582
Fires, Forest—plane smokers start	583
Fish and Fishing	
anglers see beneath waves with a water scope	593
bait bucket with spring top	591
Floodlighting—dome's outside illuminated by inside lights	616

[Continued on Page 4]

Dancehall, White

Lipson, 541

[Contents—Continued]

Notes recorded on wire 600

Notes recorded on wire two

Food—keeping dry	593
Fruit—electric sunbaths for	591
Fruit Fly—war on waged in Florida	624
Furniture—armchair and bed in one	607
Golf—bag container for car attached on running board	581
Highway—balanced rock is preserved by rerouting	615
Horse Racing—betting machine on wheels	577
Horses, Race—heart tested by light-ray machine	585
Hose, Garden—combination hose reel and coal chute door	646
Household Devices	638
House Plan	703
Ice—dry, cause of injuries	585
Insulation—invisible walls shield home from heat and cold	604
Kettle—automatic electric	598
Lake—deepest fresh-water	557
Language—finds symbol for word "the"	609
Lawn Mower—run by current from light socket	632
Library—plan films of books to conserve space	625
Life Saving—rifle and rocket shoot line to swimmers	603
Lock—casement, is burglar-proof	578
Locomotive—model, hauls sixteen persons	647
Markets—drive-in, help solve traffic problem	584
Monument—forgotten story of ancients told by	624
Motorcycle—"wall of death" latest thriller	637
Moving Pictures—make-up tried out on modeled faces	640
Navy, French—world's fastest war ship	553
Navy, U. S.—ship chart shows position of naval vessels	578
Noise—city noises tire strangers	630
Oil Well—movie wind machine snuffs out oil fires	641
Organ—eleventh finger improves tone effect	576
Paints and Painting—black fence post turns white	560
Pavement	
prevent skidding by designs in	631
tar shaved from, by tractor rake	545
Piling—tide employed to save from marine borers	599
Plaster—steel mesh with fiber coat makes base for	617
Radio—helpful hints from the lab	658
Radio, Aerial—new device eliminates antenna	657
Radio—Apparatus	
electrolytic rectifier replaces tube	655
station selector replaces tuning knob	653
Radio—Application	
radio aids music students to hear own voices	600
switch clock is designed for fruit growers	662
Radio—Coils—disk coils for the experimenter	654
Radio—Condensers—locating defective, in power units	661
Radio—Loud Speakers	
new rectifier for dynamic	653
deeper tones from	662
Radio—Receivers	
a de-luxe receiver of unit design	656
combination hookup for the experimenter	660
cost of operating a.c. sets	653
self-contained a.c. three	648
tuner employs four screen-grid tubes	661
Radio—Reception—interference from flashers under control	662
Radio—Transformer—improving the audio amplifier	653
Radio—Tubes	
inexpensive fixed resistors	657
salvaging charger bulbs	653
Railroads	
box car with removable top	559
inter-car telephone system	591
Rammer—for paving blocks	615
Rugs—three tests for old	559
Saws and Sawing—round saw to cut plaster	585
Sea Elephant—four hundred pounds of fish daily meal	545
Ships and Shipping	
old warship turned into floating club	625
rudder shape secret of great liner's speed	582
shipbuilders vie for Atlantic record	616
Smokers' Accessories—cigar extinguisher combined with ash receiver	637
Statuary—forged, is detected by violet rays	585
Submarine	
blown to surface in tests	624
escape from, aided by breathing apparatus	632
Swimming—old theaters-remodeled into pools	634
Telephone—wire on ground helps guard forests	631
Tennis—ball sealed from air until ready to use	585
Theater—stage on wheels moves on rails	561
Thunderstorm—lowest place is the safest in a	615
Tornadoes—In action pictured by daring photographer	591
Tracing—frames for stencils	625
Truck	
self-loading, handles ten tons of steel	636
vanishing top changes from closed to open van	631
Weather—portable bureau on wheels	647

Wires—kept off floor with baseboard clips	623
Wood Shaper—for the small shop is portable	577
Zoo—penguins live in ice box	637

AMATEUR MECHANICS

Airplanes	
cornstalk makes model fuselage	674
this model plane flew forty-one minutes	676
Andirons—made from old anchors	667
Aquaplaner—safeguard for the outboard	673
Automobiles	
keeping free from rust	683
Automobiles, Accessories	
an electric radiator heater	665
comfortable auto seat for baby	686
dashboard watch holder	674
Automobiles, Repairing—repair for the timer roller	667
Automobiles, Tires—repairing inner tubes	686
Boats and Boating—make this speedy skimmer	684
Bottle—holder for the baby's	665
Cart—equipped with old auto tires	684
Coffee Bottle—old, decorated in modern style	686
Drilling—"strait-jacket" for drills prevents breakage	684
Fish and Fishing	
preserving fishing-rod grips	673
wax covers barb on fishing hook	681
Glass—cutting kink	666
Grommet—film-spool ends make good	682
Hallowe'en—stunts for your party	668
Heating—heat cafe with excess heat from range	683
Knife—emergency sharpener	683
Lawnmower—repairing	666
Lawn Seat—concrete, and tree guard	681
Onions—peeling	665
Paints and Painting—sealing-wax lacquer	675
Photography—drying negatives quickly	682
Rodents—gassing	666
Soldering—tinning bits	674
Stairway—folding, to the attic	675
Stovepipe—cleaner	673
Vaporizer—inexpensive electric	667
Windmill—old favorites in new forms	663

SHOP NOTES

593

Agricultural Implements	
covering rows of seed with dirt	698
weight on mower lightens tongue	689
Automobiles, Repairing—hydrometer syringe used to test oil line	698
Automobiles, Truck—half of large tank used for body	697
Automobiles, Wheel—forked tool helps mount disk	689
Barrel—simple method of slinging a	691
Batteries—tool for removing terminals	697
Belts—how to eliminate static electricity from moving	700
Bench Saw—handle for the	695
Brush—holder for artists'	688
Cans—metal, testing for leaks	702
Cleaning—removing tar and asphalt spots	689
Doors	
brace keeps from sagging	695
how to set and level a door jamb	698
Electric Light—saving in the stock room	701
Emery Wheel—sliding tool rest for	699
Floor—cement, covering to prevent dust	696
Furniture—restoring damaged	692
Gutter—repairing leaky	695
Hardening—can for local	691
Lathe—double parting tool	689
Lumber—roller helps load in box cars	701
Machine Screw—templates for drawing angles of heads	696
Measuring—diameter of flanged holes	690
Photography—quick method of making photo solutions	690
Printing	
feeding paper on job press	696
how to prevent "offset" in	690
Riveting—adjusting the air bucker-up	701
Saws and Sawing	
bands for bandsaw wheels	695
efficient guard for a saw trimmer	702
holding the work in the sawbuck	696
Screwdriver—two kinks worth knowing	696
Tapping—soft materials	701
Threading—cutting threads without a die	691
Tools—device to pick up articles	700
Tractor—canvas top for the	702
Wood	
expansion and contraction of	702
how to apply the "sugi" finish	687

593
ill-scope, water

DRAKE'S PRACTICAL MECHANICAL BOOKS

THEY WILL RAISE YOUR PAY

ORDER ON 5-DAY TRIAL

The books listed below will perfect you in your chosen trade—pay big positions. Written in non-technical language—easy to read. Every book covers its subject completely. An entire course condensed into one volume. Your choice sent postpaid days—money refunded in full if not entirely satisfactory. Order direct

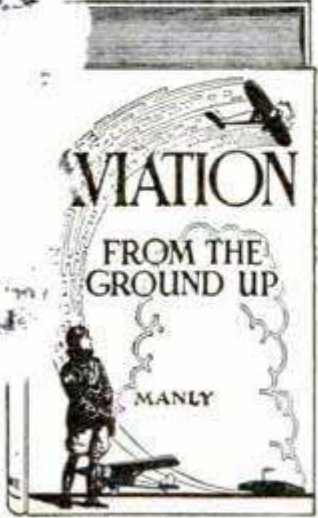

Aviation and Auto Books

- Aviation From the Ground Up... \$3.50
- Automobile Starting, Lighting and Ignition, by Manly... 700 pp. \$3.00
- Brookes' Automobile Handbook... \$2.00
- Ford Motor Car, Truck and Tractor, by Manly... Cloth \$1.50
- Auto and Radio Battery, Care and Repair, by Manly... Leatherette \$2.00
- Motorecycle Handbook, by Manly... \$1.50



Shop Practice Books

- Practical Heating Systems, Trouble Jobs and Ventilation... \$4.00
- Sheet Metal Workers' Manual... \$2.00
- Oxy-Acetylene Welding and Cutting... Cloth \$1.25
- Slide Rule and Logarithmic Tables... \$2.00
- Handbook for Millwrights... Cloth \$2.00
- Machine Shop Practice... Cloth \$2.00
- Mechanical Drawing and Machine Design... Cloth \$2.00

ORDER DIRECT FROM THIS PAGE — ON OUR MONEY-BACK PLAN

The books listed above are only a few of the many in our catalogue, which you will receive promptly after filling out and mailing us the attached coupon. For quick action order direct from this page—cross name of each book wanted and send in with price quoted. We prepay postage and send the books on our money-back plan.

FREDERICK J. DRAKE & CO.

Publishers

R508—179 No. Michigan Ave. CHICAGO

Drake Books Are For Sale at All Book Stores

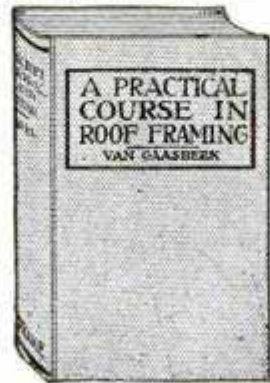

Carpentry Books

Cloth Binding

- Modern Carpentry, 2 vols... \$3.00
- The Steel Square, 2 vols... \$3.00
- Modern Estimator... \$1.50
- Timber Framing... \$2.00
- Builders' Architectural Drawing... \$2.00
- Concretes... \$1.50
- Practical Bungalows... \$1.00
- Roof Framing, by Van Gaasbeek... \$1.50

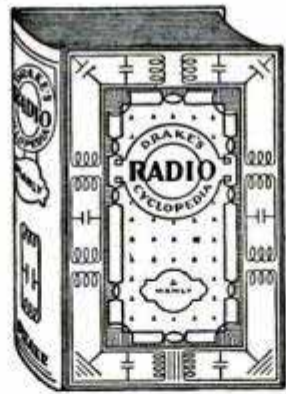

Drake's Radio Cyclopaedia

By H. P. Manly

920 Pages, 1025 Illustrations, 1700 Subjects, arranged alphabetically. For Service and Repair Men, Dealers, Salesmen, Experimenters and Designers. Bound in Art Buckram. Price... \$6.00



Painting and Deco-

- Modern Illustration... \$6.00
- The Lacquer System of Signaling... \$2.00
- Practical Estimating for Painters and Decorators... Cloth \$2.00
- How to Draw Funny Pictures—a Complete Course in Cartooning... Cloth \$3.00
- Layouts for Advertising... Lea. \$3.00
- Furniture, Furniture Finishing, Decoration and Patching... \$5.00
- Ross Crane Book of Home Furnishing and Decoration... Cloth \$3.00
- House Painting Methods... Cloth \$2.00
- Interior Wall Decoration, by Vanderwalker... Leatherette \$4.00
- The Mixing of Colors and Paints, by Vanderwalker... Cloth \$2.00
- Studio Handbook—Letter and Design... \$3.00
- A Show at Sho' Cards... Cloth \$4.00
- Sign Painting, by Atkinson... Cloth \$4.00
- Strong's Book of Designs, Leatherette \$4.00
- Modern Painters' Cyclopaedia... Cloth \$2.00
- Automobile Painting... Cloth \$1.50
- Wood Finishing, Plain and Decorative... Cloth \$2.00

Steam Engineering

- Swingle's Handbook for Steam Engineers and Electricians... Leatherette \$4.00
- Examination Questions and Answers for Marine and Stationary Engineers... Leatherette \$2.00
- Steam Boilers... Leatherette \$2.00
- Swingle's Catechism of Steam, Gas and Electrical Engineering... Leatherette \$1.50

Modern Languages

- By Prof. P. S. Allen, U. of Chicago
- French without a Teacher... Cloth \$1.25
- Spanish without a Teacher... Cloth \$1.25
- German without a Teacher... Cloth \$1.25
- Everyday French... \$1.25
- Everyday Spanish... \$1.25

Mail Coupon For Free Catalogue
Your Guide to Home Study

FREDERICK J. DRAKE & CO.
R508—179 No. Michigan Avenue
Chicago, Ill.

GENTLEMEN:—Please send me free, postage paid, your illustrated catalogue which lists and describes 200 Practical Mechanical Books for Home Study.

My name is _____

and my ac _____

.....

This One

TUES-P7H-2K1W

Your Next Raise —

Will it be a small one—grudgingly given? Or a big one, made unasked, because the firm wants to keep you satisfied?

You can compel the raise you want—fairly and squarely



When and Why?

YOU don't start home nights with your eyes closed—stumbling and groping—and expect to get there.

Then why are you stumbling blindly along, hoping and waiting for your next raise, praying that it may be more than a few dollars a week and knowing you'll probably be disappointed.

Common sense—your own experience—tells you that while modest raises may be given for loyalty and long service, the *big* ones come only as rewards for *increased ability*—greater value to your employer.

What's the answer?—It's simple if you're serious.

If you want to get to the place where salaries are substantial and raises come unasked instead of as a form of business charity, you must prepare. You must make yourself an unusual man—you must *train* yourself out of the masses into the classes.

Look—if you want to know *exactly* what we mean—here are three cases. There are over fifty thousand in our files.

What Home-Study Training Did for a College Man

He had a college education, but he had not been able to climb higher than a mechanic's job in a little Ohio garage—working long hours for a pittance—until he learned three years ago from a LaSalle representative about our home-study training in Modern Salesmanship.

Two years later, he was manager and his pay check was large in proportion.

"Fired" Into a Bigger Job

You would have thought that when paved roads and motor trucks wrought havoc with the freight business of this western electric railway, our graduate—then in charge as Traffic Manager—would have found himself out of a job.

And he might have—but for the fact that his training with LaSalle in Traffic Management had made him so valuable as an executive that he was retained in a different capacity and steadily promoted.

"Good-Bye, Bench, I'm Superintendent Now"

"A year ago the third of March, I was a tool and metal pattern maker. I was that day made a foreman, and soon afterward I took up LaSalle training in Industrial Management. On May 24 of the following year—due largely to the application of the

efficiency principles laid down in your training—I was made superintendent of the factory. During this time I made a reduction in my department overhead of about 6 per cent and an actual labor-cost reduction of 25 per cent."

So writes another LaSalle member after only 15 months of spare-time study.

Are You Really in Earnest?

You probably are saying right now, "But aren't those exceptional cases?" The best answer to that question is to give actual facts.

In our LaSalle 100 Per Cent Club—composed only of men and women who have doubled their salaries through LaSalle home-study training—are thousands of members. Many of these report increases of 500, 1,000, 2,000 per cent. Not yet in this club, but climbing fast toward it, are scores of thousands of others who can boast 10, 20, 50, 75 per cent increases.

You can do the same—if you will.

Would you like to know more about the special training LaSalle offers in the field you'd like to be in, about the way you can fit it into your evenings and apply it in your daily work? The coupon below, filled out and mailed, will bring you this detailed information, without cost or obligation, quickly and in interesting form.

Spend sixty seconds and a two-cent stamp. It may change your entire future. Get the coupon in the mail—quick.

----- Find Yourself Through LaSalle! ----- LaSalle Extension University

The World's Largest Business Training Institution
Dept. 1064-R Chicago

I would welcome an outline of the LaSalle plan, together with a copy of "Ten Years' Promotion in One," all without obligation.

- | | |
|---------------------------------------------------------|---------------------------------------------------------------|
| <input type="checkbox"/> Business Management | <input type="checkbox"/> Law—Degree of LL. B. |
| <input type="checkbox"/> Modern Salesmanship | <input type="checkbox"/> Commercial Law |
| <input type="checkbox"/> Higher Accountancy | <input type="checkbox"/> Credit and Collection Correspondence |
| <input type="checkbox"/> Traffic Management | <input type="checkbox"/> Industrial Management |
| <input type="checkbox"/> Railway Station Management | <input type="checkbox"/> Modern Foremanship |
| <input type="checkbox"/> Banking and Finance | <input type="checkbox"/> Personnel Management |
| <input type="checkbox"/> Modern Business Correspondence | <input type="checkbox"/> Expert Bookkeeping |
| <input type="checkbox"/> Business English | <input type="checkbox"/> Commercial Spanish |
| <input type="checkbox"/> Effective Speaking | <input type="checkbox"/> C. P. A. Coaching |
| <input type="checkbox"/> Telegraphy | <input type="checkbox"/> Stenography—Stenotypy |
| | <input type="checkbox"/> Railway Accounting |

Name.....

Present Position.....

Address.....

POCKET EDUCATORS

For all BUILDERS AND MECHANICS



Read Audels Pocket Educators for advancement and profit in your work. Every mechanic in the building trades should have this inside trade information at his fingers' ends. Learn the scope and possibilities of your profession. Any job can be done better if you are well informed. To earn more, learn more.



4 Vols. \$6

AUDELS CARPENTERS AND BUILDERS GUIDES—4 VOLS. \$6

Inside Information for Carpenters, Builders, Joiners, Building Mechanics—all Woodworkers. **1600 pages; 3700 diagrams; flexible; pocket size.** Short-cut instructions, new methods, ideas, solutions, plans, systems—money saving suggestions. An easy progressive course for the apprentice. A practical daily helper and Quick Reference for the master worker. A Helping Hand to Easier and Better Work and Better Pay. To get this aid for yourself, simply fill in and mail the FREE COUPON below.

INSIDE TRADE INFORMATION ON:

How to use steel square; How to file and set saws; How to build furniture; How to use mitre box; How to use chalk line; How to use rules; How to make joints; Carpenters' arithmetic; Mensuration problems; Estimating strength of timbers; How to set girders and sills; How to frame houses and roofs; How to estimate costs; How to build houses, barns, garages, bungalows, etc.; How to read and draw plans; Drawing up specifications; How to excavate; How to use settings 12, 13 and 17 on the steel square; How to build holts and scaffolds—skylights; How to build stairs; How to put on interior trim; How to hang doors; How to lath—lay floors; How to paint.

"Audels Guides worth four times their price—handy too as I carry them in pocket for reference." W. J. Bates, Knoxville, Pa.



4 Vols. \$6

AUDELS PLUMBERS AND STEAMFITTERS GUIDES—4 VOLS. \$6

A new set—just out! A practical, illustrated, Reference Library and Study-Course for Master Plumbers, Journeymen and Apprentice Steamfitters, Gas Fitters and Helpers, Sheet Metal Workers, Draughtsmen, Master Builders, Engineers and all Building Trade Students. **1670 pages; 3642 diagrams; flexible; pocket size.** Guides explain all the principles, advances and short cuts of the Plumbing and Heating trade. Contains instructions on how to figure and estimate jobs. Use FREE COUPON below to examine, without obligation, this valuable work.

INSIDE TRADE INFORMATION ON:

Soldering, tinning, joint wiping, bending, beating. Pipe—iron—steel, threading. Mathematics, tables, physics. Materials—iron, steel, copper, brass, lead, tin, antimony. Sheet metal—galvanized—plate. Sanitation, syphonage, tanks. Drainage, sewage, purification. Fixtures—bath—kitchen. Pipe fittings, soil pipe, tools. Laying out work. Roughing, screwed fittings, flanges, joints. Pipe bending, examples. Elbows, Heating, ventilation, refrigeration. Water supply, mains, wells, tanks. Gas-fittings. Underwriters. Sheet metal work, problems, methods, brazing, heating, lead burning. Welding, various welds, methods. Blacksmithing, forges, tools.

"Audels Guides are practical, easy to understand, reliable. Cover the field in plain language." W. J. Arminger, Annapolis, Md.



4 Vols. \$6

AUDELS MASONS AND BUILDERS GUIDES—4 VOLS. \$6

A new, complete, illustrated trade reference library, for Bricklayers, Cement Workers, Plasterers, Tile Setters and Stone Masons, including a practical outline of Steel Construction. **1100 pages; 2067 diagrams; flexible; pocket size.** A practical Trade Assistant explaining modern methods of masonry construction. Easy to understand and apply. A reliable and authentic reference work and study-course for Master Journeyman and Young Mechanic. Use FREE COUPON below and find out for yourself, without obligation, whether this set will benefit you.

INSIDE TRADE INFORMATION ON:

Bricklaying, tools, materials; Brick designs, patterns, bonds; Setting frames and foundations; Mortars, scaffolds, estimating; Mortars and mortar mixing; Tile setting, mosaic, hollow tile; Straight edge test, trowelling; How to figure brick work; Safe loads, piers, chimneys; Boiler settings, anchors, fire stops; Labor tables; Concrete, forms; How to figure concrete work; Stucco—on old and new buildings; Plastering—wood lath—metal; Plasterers agreement; Plastering on various surfaces; Stonemasonry; Cutting, finishing, estimating stone; Derricks, rigging; Steel construction; Fire proof; How to read blue prints.

"Audels Masons Guides are the best books on the subject. Have laid brick 12 years and am able to judge." H. A. Sonnett, Cortis, Pa.

PRACTICAL ELECTRICITY — 1 VOL. \$4

Audels Handy Book of Practical Electricity is a simplified Ready Reference and Study Course in one pocket size, leather bound volume—for Engineers, Professional Electricians and Students. **1040 pages; 2600 diagrams; flexible red leather bound.** A reliable authority and handy helper for every electrical worker. Contains important and valuable wiring diagrams, calculations, machine sketches, helps on maintenance and repair. Use this FREE COUPON today and find out, without obligation, how this handy book will help you in your daily work.

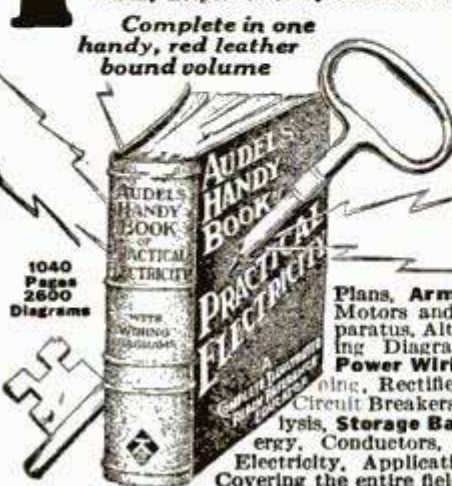

Complete in one handy, red leather bound volume

1040 Pages 2600 Diagrams

INSIDE TRADE INFORMATION ON:

Electro-Therapeutics, X-Rays, Shocks, Welding, Brazing, Radio Hook-ups, Motion Pictures, Telephone, Telegraph, Cranes, Bells, Elevators, Pumps, Tools, Ship Drive, Railways, Vehicles, Automobile Electric Systems, Ignition, Generation, Lighting, Plant Management, Power Plans, Armature Winding, Repairing, A. C. Motors and Apparatus, D. C. Motors and Apparatus, Alternator Construction, Dynamos, Wiring Diagrams, Sign Flashers, Cable Splicing, Power Wiring, Outside Wiring, Switches, Lighting, Rectifiers, Converters, Transformers, Fuses, Circuit Breakers, Rheostats, Electro Plating, Electrolysis, Storage Batteries, Magnetism, Electrical Energy, Conductors, Insulators, Static, Dynamic, Radio Electricity, Applications, Ready Reference and Index Covering the entire field of Modern Electricity.

Learn More and You Will Earn More!

Know your job and you'll never be without one. The skilled man is always in demand. Knowledge is power. Learn your trade thoroughly by easy reading. This coupon is your opportunity for advancement and better pay. You risk nothing in sending for Audels Guides for free examination. Send it NOW!

FREE EXAMINATION COUPON

THEO. AUDEL & CO., 65 W. 23 ST., NEW YORK CITY

Please mail me for free examination the books marked (x) below. If I find them satisfactory, I agree to mail \$1 in 7 days, on each set ordered, and to further mail \$1 monthly on each set until I have paid the purchase price.

4 CARPENTERS GUIDES \$6 | 4 PLUMBERS GUIDES \$6

4 MASONS GUIDES \$6 | 1 ELECTRICIANS HANDY BOOK \$4

NAME

ADDRESS

OCCUPATION

EMPLOYED BY..... 10T30

Answer This Ad!

If You Want Quick Success and Big Pay In **AUTOS**

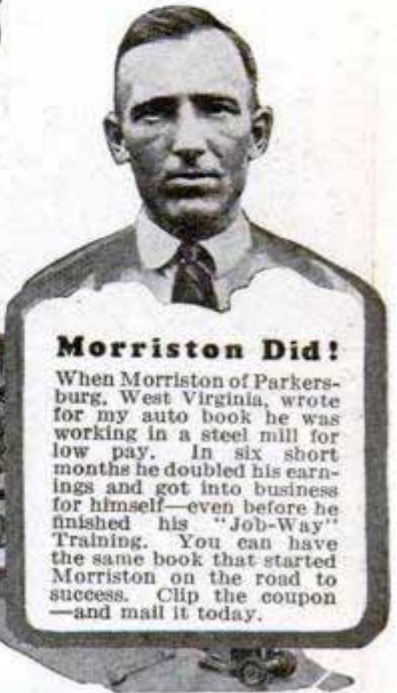

Morriston Did!

When Morriston of Parkersburg, West Virginia, wrote for my auto book he was working in a steel mill for low pay. In six short months he doubled his earnings and got into business for himself—even before he finished his "Job-Way" Training. You can have the same book that started Morriston on the road to success. Clip the coupon—and mail it today.

Earn Up to \$100 a Week

Get YOUR share of the \$7,000,000,000 spent every year on auto upkeep. Just think of it—more than 25,000,000 autos in the U. S. No wonder there are so many big pay jobs! Get into this fascinating game, now. Don't put it off another day. Get the facts. Mail coupon for big, FREE auto book. Learn of the countless opportunities in the World's Biggest Business where real jobs and big pay come quick. See how \$50—\$75—\$100 a week is possible for you now. Learn how "Job-Way" Training has brought big money—promotion—shops of their own to scores of men. Find out about my Employment Department—how it helps you get a good job in the auto business.

3 Working Outfits
also included FREE of extra charge if you act quick!

Learn at Home in Spare Time

"Job-Way" Training is the short cut to Auto Success. No need to quit your present job—no need to leave home—just use your spare time to prepare for a brilliant future—a real job paying up to \$100 a week. All you need is common schooling. I don't care if you never touched an auto before, I can train you at home. You should be able to make extra money quick—a few weeks after starting. Men from all walks of life who worked

long, hard hours for low pay are becoming garage owners, foremen and superintendents. If you like autos—if you're between 15 and 55—get the facts now. "Job-Way" Training covers everything about autos—Mechanical and Electrical Work, Starting, Lighting, Ignition, Welding, Vulcanizing, etc.—Everything you need to get in line for a big money job as an Electrical and Mechanical Auto Expert.

It's the trained man who gets the good jobs and "Job-Way" Training is COMPLETE yet so simple, so easy that you get it quick.

Send Coupon for FREE Auto Book

Get my FREE Auto Book. Learn how "Job-Way" Training has brought success to hundreds. See what it can do for you. Find out how my Employment Department helps you get a good job—about the three big outfits you get. Read my money-back agreement, my aviation course offer and many other features.

B. W. Cooke, Directing Engineer
Motor Institute of America
Motor Institute Bldg. Dept. 2167
EVANSTON, ILLINOIS
(Chicago's Largest Suburb)

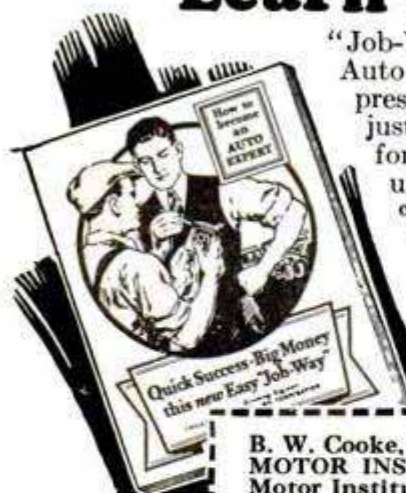

Do It NOW!

Don't delay another day. Clip the coupon before you turn this page. Take the first step to a big-pay auto job. Now.

B. W. Cooke, Directing Engineer,
MOTOR INSTITUTE OF AMERICA,
Motor Institute Bldg., Dept. 2167, Evanston, Ill.

Send me your free auto book. I want to succeed in the auto business. Tell me about "Job-Way" Training—about your Employment Department and your 3 testing and repair outfits offer. No obligation on my part whatever.

Name.....
Address.....
Town..... State.....
Age..... Occupation.....



Salary increased from \$112 to \$400 a month

"MY I. C. S. course in Cost Accounting was of great practical help in enabling me to install a cost system in a plant having somewhat unusual problems. It also helped me to get my B. C. S. degree from a resident commercial school and in preparing for the C. P. A. examination. My salary was \$112 a month when I enrolled. It is now \$400 a month, with a generous allowance for traveling expenses."

That's a true story of what spare-time study has done for just one man. There are thousands of others. Why don't *you* take up a home-study course with the International Correspondence Schools and prepare yourself to earn more money? You can do it if you really try.

It doesn't cost you a penny or obligate you in any way to mark and mail the coupon, but that one simple step will bring you information that will help you to get out of the rut and make good in a big way.

Mark and Mail the Coupon Today

INTERNATIONAL CORRESPONDENCE SCHOOLS, Box 5639-F, Scranton, Penna.
"The Universal University"

Without cost or obligation on my part, please send me a copy of your 48-page booklet, "Who Wins and Why," and tell me how I can qualify for the position, or in the subject, before which I have marked an X:

BUSINESS TRAINING COURSES

- | | | | |
|-----------------------------------------------------------|------------------------------------------------------------------|-------------------------------------------------------|---------------------------------------------------------------------------|
| <input type="checkbox"/> Business Management | <input type="checkbox"/> Cost Accounting | <input type="checkbox"/> Business Correspondence | <input type="checkbox"/> Mail Carrier |
| <input type="checkbox"/> Industrial Management | <input type="checkbox"/> Bookkeeping | <input type="checkbox"/> Show Card and Sign Lettering | <input type="checkbox"/> Railway Mail Clerk |
| <input type="checkbox"/> Personnel Management | <input type="checkbox"/> Secretarial Work | <input type="checkbox"/> Stenography and Typing | <input type="checkbox"/> High School Subjects |
| <input type="checkbox"/> Traffic Management | <input type="checkbox"/> Spanish <input type="checkbox"/> French | <input type="checkbox"/> English | <input type="checkbox"/> Common School Subjects |
| <input type="checkbox"/> Accounting and C. P. A. Coaching | <input type="checkbox"/> Salesmanship | <input type="checkbox"/> Civil Service | <input type="checkbox"/> Illustrating <input type="checkbox"/> Cartooning |
| | <input type="checkbox"/> Advertising | | <input type="checkbox"/> Lumber Dealer |

TECHNICAL AND INDUSTRIAL COURSES

- | | | | |
|--------------------------------------------------|------------------------------------------------|---------------------------------------------------|----------------------------------------------------------------------|
| <input type="checkbox"/> Architect | <input type="checkbox"/> Telegraph Engineer | <input type="checkbox"/> Airplane Engines | <input type="checkbox"/> Pharmacy |
| <input type="checkbox"/> Architectural Draftsman | <input type="checkbox"/> Telephone Work | <input type="checkbox"/> Plumber and Steam Fitter | <input type="checkbox"/> Mining Engineer |
| <input type="checkbox"/> Building Foreman | <input type="checkbox"/> Mechanical Engineer | <input type="checkbox"/> Plumbing Inspector | <input type="checkbox"/> Navigation <input type="checkbox"/> Assayer |
| <input type="checkbox"/> Concrete Builder | <input type="checkbox"/> Mechanical Draftsman | <input type="checkbox"/> Foreman Plumber | <input type="checkbox"/> Iron and Steel Worker |
| <input type="checkbox"/> Contractor and Builder | <input type="checkbox"/> Machine Shop Practice | <input type="checkbox"/> Heating and Ventilation | <input type="checkbox"/> Textile Overseer or Supt. |
| <input type="checkbox"/> Structural Draftsman | <input type="checkbox"/> Toolmaker | <input type="checkbox"/> Sheet-Metal Worker | <input type="checkbox"/> Cotton Manufacturing |
| <input type="checkbox"/> Structural Engineer | <input type="checkbox"/> Patternmaker | <input type="checkbox"/> Steam Engineer | <input type="checkbox"/> Agriculture |
| <input type="checkbox"/> Electrical Engineer | <input type="checkbox"/> Civil Engineer | <input type="checkbox"/> Marine Engineer | <input type="checkbox"/> Woolen Manufacturing |
| <input type="checkbox"/> Electrical Contractor | <input type="checkbox"/> Surveying and Mapping | <input type="checkbox"/> Refrigeration Engineer | <input type="checkbox"/> Fruit Growing |
| <input type="checkbox"/> Electric Wiring | <input type="checkbox"/> Bridge Engineer | <input type="checkbox"/> R. R. Positions | <input type="checkbox"/> Poultry Farming |
| <input type="checkbox"/> Electric Lighting | <input type="checkbox"/> Gas Engine Operating | <input type="checkbox"/> Highway Engineer | <input type="checkbox"/> Mathematics |
| <input type="checkbox"/> Electric Car Running | <input type="checkbox"/> Automobile Work | <input type="checkbox"/> Chemistry | <input type="checkbox"/> Radio |

Name..... Street Address.....

City..... State..... Occupation.....

If you reside in Canada, send this coupon to the International Correspondence Schools Canadian, Limited, Montreal, Canada

See Life
Win Applause...Thrills
Big Money



Get Into Aviation!

SEIZE the biggest thrill ever offered to man—the biggest adventure since time began—smash into Aviation—the game for men with sporting blood! Step into a life of excitement, daring and big money—away from a tame, narrow, humdrum existence.

Think what Aviation offers you. Thrills such as you never had before! The praise and plaudits of the multitude. And a chance to get in on the ground floor where rewards will be unlimited!

Amazing Opportunities

Aviation is growing so swiftly that one can hardly keep track of all the astonishing new developments. Air mail routes have just been extended to form a vast aerial network over the entire U. S. Airlines and airplane factories are springing up all over the country. Men like Henry Ford are investing millions in the future of commercial aviation in America! The possibilities are so tremendous that they stagger imagination!

Everything is set for the greatest boom in history. Big fortunes came out of the automobile industry and out of motion pictures. Big fortunes will also come out of Aviation. The development of Aviation as an industry is bringing with it a call for trained men. The opportunities open cannot be over-estimated. Those who qualify quickly should find themselves on the road to undreamed of money—success—popularity—and prominence.

Easy to Get Into Aviation by This Home Study Method

Get into this thrilling business at once while the field is new and uncrowded. Now—by a unique new plan—you can quickly secure at home, during spare time, the preliminary training necessary to get a start in the Aviation Industry. Experts will teach you the secrets—give you the inside facts that are essential to your success. And the study of Aviation

by our method is almost as fascinating as the actual work itself. Every lesson is chockful of interest—and so absorbing that you actually forget you are studying. But best of all are the ultimate rewards you are fitting yourself to gain.

Send for FREE Book

Send the coupon for our new, free book, just out—*Opportunities in the Airplane Industry*. It is unusually interesting, reads like a romance, and gives vital facts about Aviation you never even dreamed of. You owe it to yourself to at least read it. We offer you a free copy now. No obligation. Mail the coupon for yours today.

FREE—



PICK YOUR JOB!

Get Ready Now for One of These Positions

Flying
 Airplane Repairman
 Airplane Mechanician
 Airplane Inspector
 Airplane Salesman
 Airplane Assembler
 Airplane Builder
 Airplane Pilot
 Airplane Instructor
 Airplane Contractor
 Airplane Engineer
 Aerial Photography
 Aerial Advertising

AMERICAN SCHOOL OF AVIATION

Dept. 1357 3601 Michigan Ave. Chicago, Ill.

American School of Aviation,
 Dept. 1357, 3601 Michigan Ave.,
 Chicago, Ill.

Without obligation, please send me your FREE Book, *Opportunities in the Airplane Industry*. Also information about your Home Study Course in Practical Aviation.

Name.....Age.....

Address.....

City.....State.....

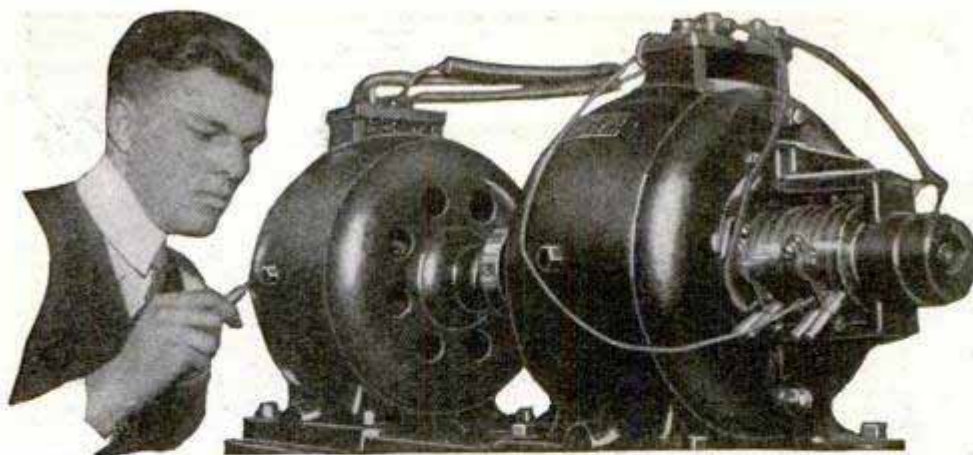

LEARN A TRADE!

If you haven't a Trade you are never sure of a job. You may, through loyal service with some concern, eventually work up to a half way decent salary. But then if that concern should go out of business or discharge you for some reason, you're left high and dry. Why? Because the work you have been doing was only something that could be applied to that particular concern. This is not so if you know a Trade. A man with a Trade can always get a good job at good wages.

Don't be a slave to an untrained job. Don't let the years ahead find you working for any old salary they want to pay you. Suppose you lose your job tomorrow—even worse yet, suppose you lose it 5, 10 or 15 years from now, when you are older and have a family to support. What will you do then. What CAN you do? There is just one way to make sure that such a thing cannot happen to you—to make sure of a good job as long as you live. That one way is to LEARN A TRADE.

Amazingly Easy Way to get into ELECTRICITY

Now ELECTRICITY is your one best bet. Here is one industry that is crying for trained men, men who have been trained thoroughly. And getting into Electricity is far easier than you imagine. Let me teach you here at my school, not by correspondence and not by books, but on actual electrical machinery. I'll train you for jobs leading to salaries of \$60 a week and up, and I'll do it in the quickest, most interesting way you ever imagined.

Learn by Doing in 90 Days

You need no advanced education or previous experience. Nor do you need to spend 12 months, 6 months, nor even 4 months, in learning. Just 3 months—90 days—is all the time I ask. Spend 90 days here working on the Big Electrical Equipment in my \$2,000,000 Shops, and I'll teach you the very best Trade of all—A Trade that will assure you a GOOD JOB AS LONG AS YOU LIVE.



COYNE ELECTRICAL SCHOOL
H. C. LEWIS, President
500 S. Paulina St., Dept. 79-72 • Chicago, Illinois

Free Employment Service Earn While Learning

Through my big Employment Department I am in constant touch with Electrical Employers all over the country, and will give you every assistance in locating just the job you want. Also, if you need part-time work to help pay your expenses while at School, I'll help you find that, too.

Special Aviation Offer

And if you will act QUICKLY, I will give you along with my regular course, and at no extra expense, a complete special training in AVIATION ELECTRICITY, as well as in Radio and Auto Ignition. Also, I'll agree to refund every cent of your railroad fare to Chicago. But to take advantage of these special offers, you must act at once. So clip the coupon and send it in today. Find out how QUICKLY and EASILY you can learn the Electrical Trade. Get my Big Free Book. It costs you nothing to investigate.

H. C. LEWIS, President
COYNE ELECTRICAL SCHOOL, Dept. 79-72
500 S. Paulina Street, Chicago, Illinois

Dear Mr. Lewis:—Without obligation send me your big free catalog and all details of Free Employment Service, Aviation Electricity, Radio and Automotive Courses without extra cost, and how I can "earn while learning." I understand I will not be bothered by any salesman.

Name.....

Address.....

City..... State.....

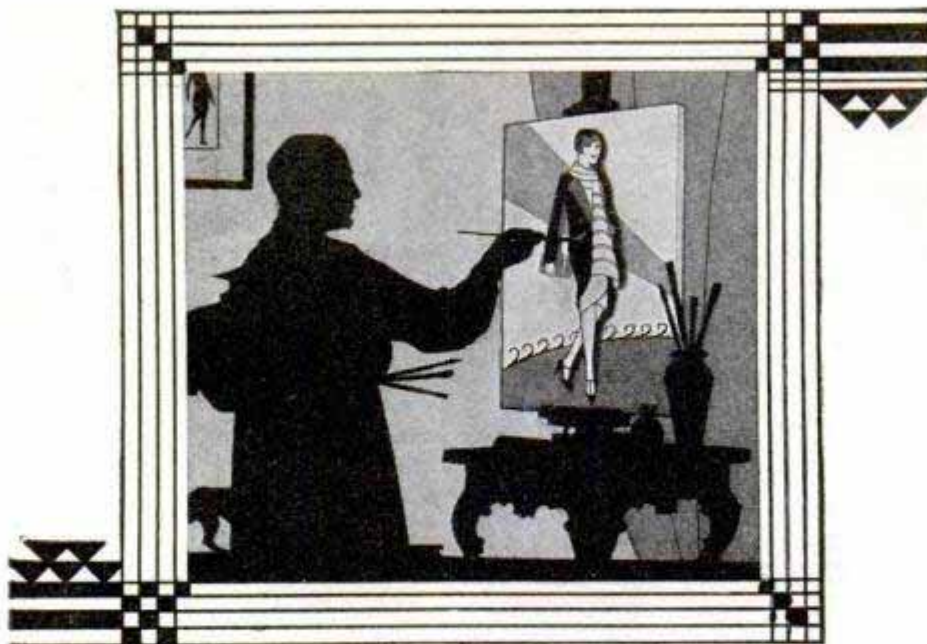

ARTISTS EARN MORE

WHILE you are dreaming of making money . . . enjoying life . . . why not train your talent for drawing? A fortune may be at your finger tips if you train them now. Many people do not realize they have artistic ability. Through art, you may find the way to a famous name and a large income.

Artists are paid more today than ever before. Since the war, rates for art work have increased tremendously. Advertisers and publishers are paying millions of dollars annually to those who are trained in Modern Art.

Think of the money paid to artists for the illustrations in this magazine alone. Hundreds of successful students of the Federal School of Illustrating are now making from \$2500 to \$6000 a year and some are making even larger incomes.

More than fifty famous artists . . . earning big money themselves . . . have contributed

their drawing secrets to the Federal Course. Clare Briggs, Neysa McMein, Sid Smith, Norman Rockwell and many others know the way to make money through art. The Federal Course teaches you their methods of Illustrating, Cartooning, Lettering, Poster Designing, Window Card Illustrating, etc. Through this course you can learn at home during your spare time.

TEST YOUR TALENT FREE

Why be content with a small income at routine work when art training offers such possibilities? Write your name, age and address on the coupon and get the Free Book, "A Road To Bigger Things" illustrated below. It gives details about how famous artists of today started their careers and shows examples of our students drawings. With it, you will receive our Free Vocational Art Test. Clip and sign this coupon now. It may be the beginning of an art career which will enable you to clip bond coupons and sign big checks later.

FEDERAL SCHOOL OF ILLUSTRATING

10139 Federal Schools Building



Minneapolis, Minnesota



Federal School of Illustrating,
10139 Federal Schools Building,
Minneapolis, Minnesota.

Please send me free book "A Road to Bigger Things" and Standard Art Test.

Name _____ Age _____ Occupation _____
Address _____



"I think that the letter that you sent to my employer had great weight in his decision to employ me. I like the position that I have very well."
William L. Olenak, Shawnee, Kansas

"Thank you very much for your assistance, which enabled me to secure a position as draftsman with the Mississippi Valley Power Company."
Lowell Perry, Fort Smith, Ark.

"I am very well satisfied with the results of your and my efforts to get me a job in the drafting rooms of the Michelmann Steel Construction Co., Quincy. The gentleman there spoke highly of your correspondence courses."
Marcus Linse, Danvers, Ill.

"I have obtained a position as a junior draftsman with the Muncie Oil Engine Co. I appreciate your aid in obtaining this position very much."
Maurice N. Bareham, Muncie, Ind.

Who Else wants a good Drafting Job?

DURING the past few months we have placed HUNDREDS of former clerks, mechanics and beginners in fine positions—with Contractors, Architects, and in big manufacturing plants. (Read a few typical letters above.)

These men came to us because they were dissatisfied with their earnings and with their future prospects. Now they are doing work they like—making good money—and have a real chance to advance still farther.

If you are trying to solve a similar personal problem, we invite you to get in touch with us. We'll be glad to tell you how you, too, can get a well-paid Drafting job—without risking a penny of your money.

Why we recommend DRAFTING

We believe it will pay you to investigate Drafting. Many of our most successful Contractors and Engineers STARTED in the Drafting room. That opportunity to get to the top—to meet big men—to take charge of important projects is the best feature of Drafting.

The work is interesting and pleasant. The hours are easy. You work with a wonderful bunch of fellows. Salaries range from \$35 to \$50 a week for beginners, up to \$100 and more a week for experienced Draftsmen.

One man puts it this way: "I really didn't know exactly what Drafting was. I thought it required artistic talent and a high school or college education. I was much surprised to find it wasn't any harder to learn than my former trade of plastering."



Promotion for office and factory workers

If you're a shop man you can realize that the man who **makes** the plans is a step above the workman who **follows** the blue-print. If you're a clerk you know that copying figures all day cannot compare in salary or responsibility with creating designs and plans of buildings, machinery, or the products of industry.

How are you going to get away from routine work—how can you even get a \$10 a week increase in pay—how can you get into a line where there is a real future? Let us show you that Drafting offers you all these things—in less time, and with less effort than any other line.

FREE--Drafting Book

Over 70,000 fine Drafting positions have been advertised in the past year. Electrical, Architectural, Mechanical, Structural and Automotive lines, all need Draftsmen. Here is one of the biggest fields you can get into. Get our free 36-page book and see how easily you can learn and how we help you get a well-paid position as soon as you are ready for it.

NOW — Jobs for STUDENTS !

For the past five years the American School has provided a free Employment service for all who **completed** this home-training in Drafting. Now we have found a way to help place all **STUDENTS** when only half-way through the course. Mail coupon for complete information of this remarkable service.

**The American School Dept. D-747
Drexel Ave. & 58th St., Chicago**

Please send **FREE** and without obligation 36-page Drafting Book and your offer to help me get a Drafting job when only half-way through the course.

Name Age

St. No.

City State



Dept. D-747, Drexel Ave. & 58th St., Chicago, Ill.

"Must have had a Big Raise eh, Bill?"



NO WONDER ED, the Receiving Teller down at the National Bank, was curious. This was the fifth Monday in succession I had made a big EXTRA deposit. By "big" I mean \$20 to \$25 more than I usually banked each week. And Ed noticed that I was dressed better, too!

He wondered where I was getting all the Extra Money

"You bet I had a big raise," I answered. "In fact I gave myself one!" "What do you mean," asked Ed, still puzzled. "Just this, Ed, I'm a professional TENOR BANJOIST three nights a week—playing in Harry Smith's Dance Orchestra, at \$10 a night! Believe me, it's the easiest money I ever earned, too." "You, a paid musician!" exclaimed Ed. "Why, I didn't know you ever touched a string!"



Six Months ago I was Lonely—Six Months ago I was Poor!

"Well," I said, "one night I was sitting at home feeling lonely and blue—wishing for more good times and more money to spend. Picking up a magazine I just happened upon an ad about a new way of learning the TENOR BANJO at home. It said anyone who could read English could learn to play. I had no idea I could — always thought those things were just for a few 'talented' folks. But I was sick and tired of being 'on the outside,' so I said to myself, 'I'll

send for their Free Book, anyway.' Guess you can tell from my face and my bank book that I'm mighty glad I did, Ed! That Course sure taught me quick. Then Harry Smith heard me playing one night at a party. It was only two months after I started, but right away he offered me a spare-time job with his Orchestra. And he'll soon be able to use me steady, six nights a week—at \$70 a week. That's twice what I'm making down at the Freight Office. I can't really call playing the TENOR BANJO 'work.' It's FUN!—every minute of it. And it's better than having a rich uncle."

The Same Opportunity is Yours—Right Now!

Never mind if you've never played a note in your life. This new method can make you a popular, high-paid Tenor Banjoist in a few short weeks. The Coupon below brings your Free copy of my book, "The Play-Way to Popularity and Big Pay." It tells how thousands of others have succeeded, just as Bill did—just as YOU CAN! Send for it right NOW—today!

Big Tenor Banjo and Outfit comes with 1st Lesson



Clip-Sign-Send

A. F. BLOCH, President,
New York Academy of Music,
Studio 1109, 100 Fifth Avenue,
New York City.

Send me the book that started Bill. No obligation on my part, of course.

Name.....

Address.....

City..... State.....

Learn **ELECTRICITY** in **90 Days**
Earn **\$50 to \$150 Weekly!**

You can do it easily and quickly in electricity. Come to my famous school where, in 12 short weeks, you will be qualified to fill one of the many high paid jobs in this interesting field.

Learn on Machines—No Books

You work with expert instructors on full size motors, generators, batteries, switchboards, telephone and telegraph systems. McSweeney Trained Men get the biggest pay jobs because they receive such complete and thorough training.

No Experience or Education Needed

It is easy to learn Electricity in my fascinating, practical workshop. No books to read. No dry lectures to listen to. You learn by doing. No matter how little you know about Electricity now, I guarantee that, when you graduate you'll know Electricity from "A" to "Z." And if you cannot fill a big pay job I'll refund every penny of your tuition.

McSWEENEY
ELECTRICAL SCHOOL
Dept. E-10-K Cleveland, Oh:o



SATISFACTION GUARANTEED

If you are not satisfied upon graduation your tuition will be refunded.



BIG BOOK SENT FREE

Today — now, decide to get out of the low pay rut. Take the first step by sending for my big illustrated book on **ELECTRICITY** and special tuition offer.

FOREMEN!

FACTORY WORKERS AND ALL MECHANICS



\$1.98 (Worth \$25)

Lecture Course Complete in 1 Volume

SEND NO MONEY

Every foreman, factory worker, manager and ambitious mechanic will find a gold mine of inside information in "The Modern Foreman" by Robt. Grimshaw. The 28 chapters of this great work are shop talks pointing the way to success, efficiency, better pay and the job higher up. A complete study course in leadership; a handy, daily reference and guide.

SUBJECTS COVERED INCLUDE:—The Magic Wand of Efficiency. The New Type of Foreman, Teamwork, The Kicker, The Agitator, Bonus Plans, Self-Improvement, How to Handle Men, Hiring and Firing, Assigning Men to Jobs, How to Keep Records, How to Cut Out Waste of Time and Materials, New Inventions, Modern Methods, The Inspector, Health and Character Requirements, What the Foreman Should Know, Mathematics, Business Law, The Foreman as "Top Sergeant," Factors of Success, Leadership, What is "Labor"? Time and Idleness, Knowledge is Power, "Morale," The Value of Mistakes.

"The Modern Foreman" has 297 pages, quick reference index, many tables, diagrams, illustrations and forms; big type, easy to read and understand; rich binding, gold stamped. Size 6 x 9 x 1 1/4. Reg. price \$2.50. Our special sale price \$1.98. Send no money. Satisfaction guaranteed. Mail this coupon TODAY!

GREGG PUBLISHING CO., 20 W. 47 St., New York, N. Y.

Send me "The Modern Foreman." I will pay postman \$1.98 and postage on arrival. My money is to be refunded if I am not satisfied.

Name.....

Address.....

Muscles 5¢ apiece!

WOULDNT it be great if we could buy muscles by the bag—take them home and paste them on our shoulders? Then our rich friends with money to buy them, sure would be socking us all over the lots.

But they don't come that easy, fellows. If you want muscle you have to work for it. That's the reason why the lazy fellow never can hope to be strong. So if you're lazy and don't want to work—you had better quit right here. This talk was never meant for you.

I Want Live Ones

I've been making big men out of little ones for over fifteen years. I've made pretty near as many strong men as Heinz has made pickles. My system never fails. That's why I guarantee my works to do the trick. That's why they gave me the name of "The Muscle Builder."

I have the surest bet that you ever heard of. Eugen Sandow himself said that my system is the shortest and surest that America ever had to offer.

Follow me closely now and I'll tell you a few things I'm going to do for you.

Here's What I Guarantee to Do For You

In just 30 days I'm going to increase your arm one full inch. Yes, and add two inches to your chest in the same length of time. But that's nothing. I've only started; get this—I'm going to put knobs of muscles on your shoulders like baseballs. I'm going to deepen your chest so that you will double your lung capacity. Each breath you take will flood every crevice of your pulmonary cavity with oxygen. This will load your blood with red corpuscles, shooting life and vitality throughout your entire system. I'm going to give you arms and legs like pillars. I'm going to work on every inner muscle as well, toning up your liver, your heart, etc. You'll have a snap to your step and a flash to your eye. You'll feel the real pep shooting up and down your old backbone.

You'll stretch out your big brawny arms and crave for a chance to crush everything before you. You'll just bubble over with vim and animation.

Sounds pretty good, what? You can bet your old ukulele it's good. It's wonderful. And don't forget, fellow—I'm not just promising all this—I guarantee it. Well, let's get busy, I want some action—So do you.

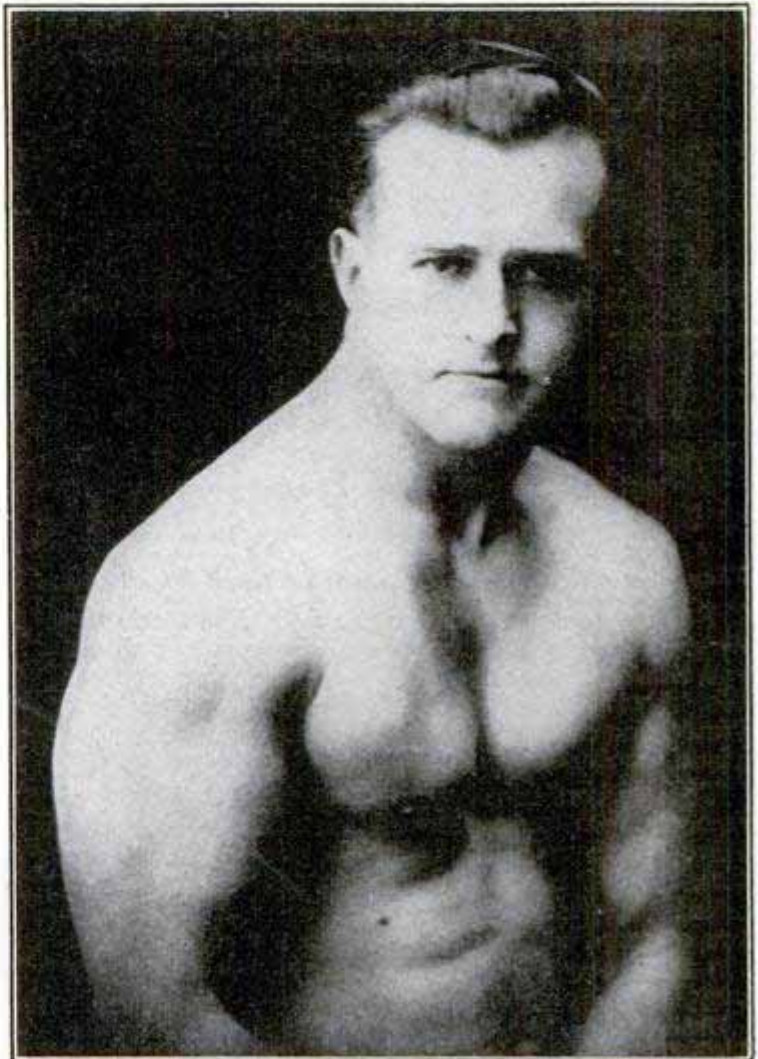

EARLE LIEDERMAN, The Muscle Builder

Author of "Muscle Building," "Science of Wrestling," and "Jiu Jitsu," "Secrets of Strength," "Here's Health," "Endurance," Etc.

Send for My New
64 Page Book

"Muscular Development"

IT IS FREE

Do you get that? It's free. I don't ask a cent. It's yours with my compliments. Take it and read it. It's the peppiest piece of literature you ever flashed your glimmers on. And 48 full-page photos of myself and some of my numerous prize-winning pupils. This is the finest collection of strong men ever assembled into one book—look them over—doctors, lawyers, merchants, mechanics and every line of trade you can think of. I swear you'll never let this book get out of your mitts again. And just think—you're getting it for nothing. Don't hesitate—no strings attached to it. Grab it.

Take your pen or pencil and fill out the coupon, or even your name and address on a postal will do—do it now before you turn this page.

Earle Liederman
Dept. 2010, 305 Broadway, New York City

EARLE LIEDERMAN

Dept. 2010, 305 Broadway, New York City

Dear Sir:—Please send me, absolutely free and without any obligation on my part whatsoever, a copy of your latest book, "Muscular Development." (Please write or print plainly.)

Name..... Age.....

Street.....

City..... State.....

"I aint" "He don't"
 "It's me!" "You was?"
 "Can't hardly"



What Are YOUR Mistakes in English?

They may offend others as much as these offend you

IF some one you met for the first time made the mistakes in English shown above, what would you think of him? Would he inspire your respect? Would you be inclined to make a friend of him? Would you care to introduce him to others as a close friend of yours?

These errors are easy for you to see. Perhaps, however, you make different mistakes which offend other people as much as these would offend you. How do you know that you do not mispronounce certain words; are you always sure that the things you say and write are grammatically correct? To you they may seem correct, but others may know they are wrong.

Unfortunately, people will not correct you when you make mistakes; all they do is to make a mental reservation about you. "He is ignorant and uncultured," they think. So you really have no way of telling when your English offends others.

FREE Book on English

Sherwin Cody, perhaps the best known teacher of practical English, has perfected and patented a remarkable device which will quickly find and correct mistakes you unconsciously make. Correct English soon becomes a HABIT.

If you are efficient in English, it will give you greater confidence; if you are deficient, you surely want to know it, so that you can correct your mistakes.

Mr. Cody's remarkable new invention, the 100% Self-Correcting Method, has already improved the English of more than 50,000 people. No useless rules, no tedious copying, no hard study. Only 15 minutes a day required. You learn by creating the HABIT of using correct English. Nothing like Mr. Cody's method has ever been used before!

A new book, "How to Speak and Write Masterly English," is ready. It explains Mr. Cody's surprisingly easy method. Get a copy free and learn how to stop making embarrassing errors. You do not want others to judge you unfairly. Merely mail the coupon or a postal card. SHERWIN CODY SCHOOL OF ENGLISH, 510 Searle Building, Rochester, N. Y.

SHERWIN CODY SCHOOL OF ENGLISH

510 Searle Building, Rochester, N. Y.

Please send me your free book, "How to Speak and Write Masterly English."

Name.....

Address.....

.....

THE CHICAGO DAILY NEWS School and College Bureau

Offers You Its Specialized Services in Choosing a School

Last year the School and College Bureau of The Chicago Daily News saved many busy parents and questioning boys and girls both time and worry by sending them prompt, reliable information about just the kind of school they wanted—personal requirements as to location and tuition charges being considered in each individual case.

Again this year many young people will be perplexed by the problem of finding the right school. Why not let us help you?

The Chicago Daily News maintains this service absolutely free of charge to you. No need to hurriedly select a school on mere hearsay when expert advice can be obtained by telephoning Dearborn 1111, writing or calling for a personal interview at

THE CHICAGO DAILY NEWS School and College Bureau

Dept. K, Daily News Plaza, 400 W. Madison St., Chicago, Ill.

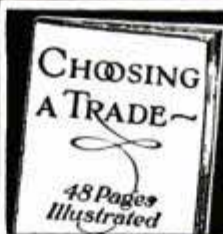

SENT ON REQUEST

Helpful discussion of this important problem and of fastest growing of Mechanical Trades—Mechanical Dentistry. Of interest to men of all ages. Send for Bulletin 2.

BODEE INSTITUTE

1755 Broadway, New York
 1305 N. Broad St., Philadelphia
 85 Court St., Brooklyn

AIRPLANE DRAFTING THOUSANDS OF MEN

will make fortunes in Aviation. Airplane Drafting and Designing are the biggest jobs ahead in this fastest growing industry. A new field of opportunity for you is opened in our improved method of training.

EASY TO LEARN. STUDY AT HOME. PAY AS YOU GO. EMPLOYMENT SERVICE.

Write for booklet outlining courses in Airplane Drafting and other aviation subjects, including the famous Weem's System of Navigation—endorsed by Col. Lindbergh, Commander Byrd, Lincoln Ellsworth, Admiral Moffett, etc.

Name.....

Address.....

City.....State.....

- AIRPLANE DRAFTING
- AIRPLANE MOTORS
- AIRPLANE MECHANICS

PACIFIC TECHNICAL UNIVERSITY SAN DIEGO CALIFORNIA

...Raised His Pay \$4800* After Reading This Amazing Book Which Is Now **FREE!**

* Based on the combined experiences of F. B. Englehardt, Chattanooga, Tenn., A. F. Thompson, Sioux City, Iowa, L. D. Mather, E. Cleveland, Ohio, and many others.



Caught in a Rut

I wonder I put up with it as long as I did! Every day was filled with nothing but deadly routine and monotonous detail. No freedom or independence. No chance to get out and meet people, travel, nor have interesting experiences. I was just like a cog in a big machine with poor prospects of ever being anything more.



Long, Tiresome Hours

Every hour of the day I was under somebody's supervision. The **TIME-CLOCK** constantly laid in wait for me—a monument to unfulfilled hopes and dying ambition. Four times a day, promptly on the dot, it hurled its silent challenge at my self-respect, reminding me how unimportant I was and how little I really **COUNTED** in the business and social world!



Low Pay

Paid just enough to keep going—but never enough to enjoy any of the **GOOD** things of life every man **DESERVES** for his family and himself. Always economizing and pinching pennies. Always wondering what I would do if I were laid off or lost my job. Always uncertain and apprehensive of the future.



Desperate

Happened to get a look at the payroll one day and was astonished to see what big salaries went to the sales force. Found that salesman Brown made \$200 a week—and Jenkins \$275! Would have given my right arm to make money that fast, but never dreamed I had any "gift" for salesmanship.



A Ray of Light

Stumbled across an article on salesmanship in a magazine that evening. Was surprised to discover that salesmen were made and not "born" as I had foolishly believed. Read about a former cowpuncher, Wm. Shore of California, making \$525 in one week after learning the ins-and-outs of scientific salesmanship. Decided that if **HE** could do it, so could I!



The Turning Point

My first step was to write for a certain little book which a famous business genius has called "**THE MOST AMAZING BOOK EVER PRINTED**". It wasn't a very **big** book, but it certainly opened my eyes to things I had never dreamed of—and proved the turning point of my entire career!

What I Discovered



Between the pages of this remarkable volume, I discovered hundreds of little known facts and secrets that revealed the **REAL TRUTH** about the science of selling! It wasn't a bit as I had imagined. I found out that it was governed by simple rules and laws that almost **ANY** man can master as easily as he learned the alphabet. I even learned how to go about getting into this "highest paid of all professions". I found out exactly how Mark Barichievich of San Francisco was enabled to quit his \$8 a week job as a restaurant-worker and start making \$125 a week as a salesman; and how C. W. Birmingham of Dayton, Ohio, jumped from \$15 a week to \$7500 a year—these and **hundreds** of others! It certainly was a revelation!

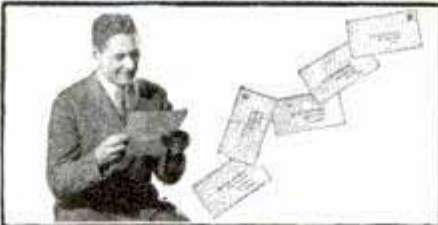

FREE Employment Service

Furthermore, I discovered that the National Salesmen's Training Association, which published the book, also operates a most effective employment service! Last year they received requests from all over the U. S. and Canada for more than 50,000 salesmen trained by their method. This service is **FREE** to both members and employers and thousands have secured positions this way!



Making Good At Last!

It didn't take me long to decide to cast my lot with N. S. T. A.—and after a few weeks I had mastered the secrets of Modern Salesmanship during spare time, without losing a day or a dollar from my old job. When I was ready, the Employment Manager found me over a dozen good openings to choose from—and I selected one which paid me over \$70 a week to start.



Was It Worth It?

Today my salary is \$4800 greater than ever before! No more punching time-clocks or worrying over dimes and quarters! **NOW** my services are in **REAL DEMAND** with bigger prospects for the future than I ever dared **HOPE** for back in those days when I was just another "name" on a pay-roll!



Get Your Copy **FREE**

Right now the book—"The Secrets of Modern Dynamic Salesmanship"—which banished all my fears and troubles and showed me how to get started on the road to success and independence—will be mailed as a gift to any ambitious man, absolutely **FREE**. And since there is no obligation, why not see for yourself what amazing facts it contains! Just mail the coupon now—for there is no better way in the world to invest a 2-cent stamp! **I KNOW!**

National Salesmen's Training Assn., Dept. R-102, N. S. T. A. Bldg., Chicago, Ill.

Without obligation, please send me a free copy of "The Secrets of Modern Dynamic Salesmanship."

Name Address

Town State

Age Occupation

Now First

A Completely New

ENCYCLOPAEDIA

BRITANNICA

NEW in plan and purpose—entirely recast from cover to cover—the *new* Fourteenth Edition of the Encyclopaedia Britannica is ready. This is the superb “humanized” Britannica which has captured the attention of the whole civilized world.

Three years of intensive effort—the co-operation of 3,500 of the world’s foremost authorities—the expenditure of more than \$2,000,000 before a single volume was printed—these are merely a few high lights in the preparation of the *new* Fourteenth Edition.

The Last Word in Encyclopaedia Perfection

This *new* Britannica immediately takes its place as the one pre-eminent American work of reference—the last word in encyclopaedia perfection.

Never has there been assembled together in one enterprise such a wealth of learning as is represented by the 3,500 builders of this great temple of knowledge. *All* the universities, *all* the learned professions, *all* the great industries, *all* the pastimes have contributed to the mighty sum.

Knowledge for All

It is a law library for the lawyer, a medical digest for the doctor, a universal history for the historian, a commercial university for the

Note these facts

**Cost More Than
\$2,000,000**

Over 15,000

Superb Illustrations

**Greatest Knowledge
Book Ever Produced**

**Written by 3,500 of
the World’s Most
Eminent Authorities**

Remember—this is a new book. Only a small amount of text—material which could not be improved in any way—has been retained from previous editions.

business man—and a compendium of all the arts and sciences for the average reader.

Here is “the cosmos between covers.” The whole whirling universe is brought within your grasp, obedient to your hand.

Nothing is too profound to baffle it, and nothing too familiar to escape its informing touch. And on every subject it speaks with the same finality and authority.

All the World’s Treasures of Art and Illustration

Among the many new features that will astonish and delight everyone who turns

these pages is the wealth and beauty of the il-

FILL OUT AND

Published!

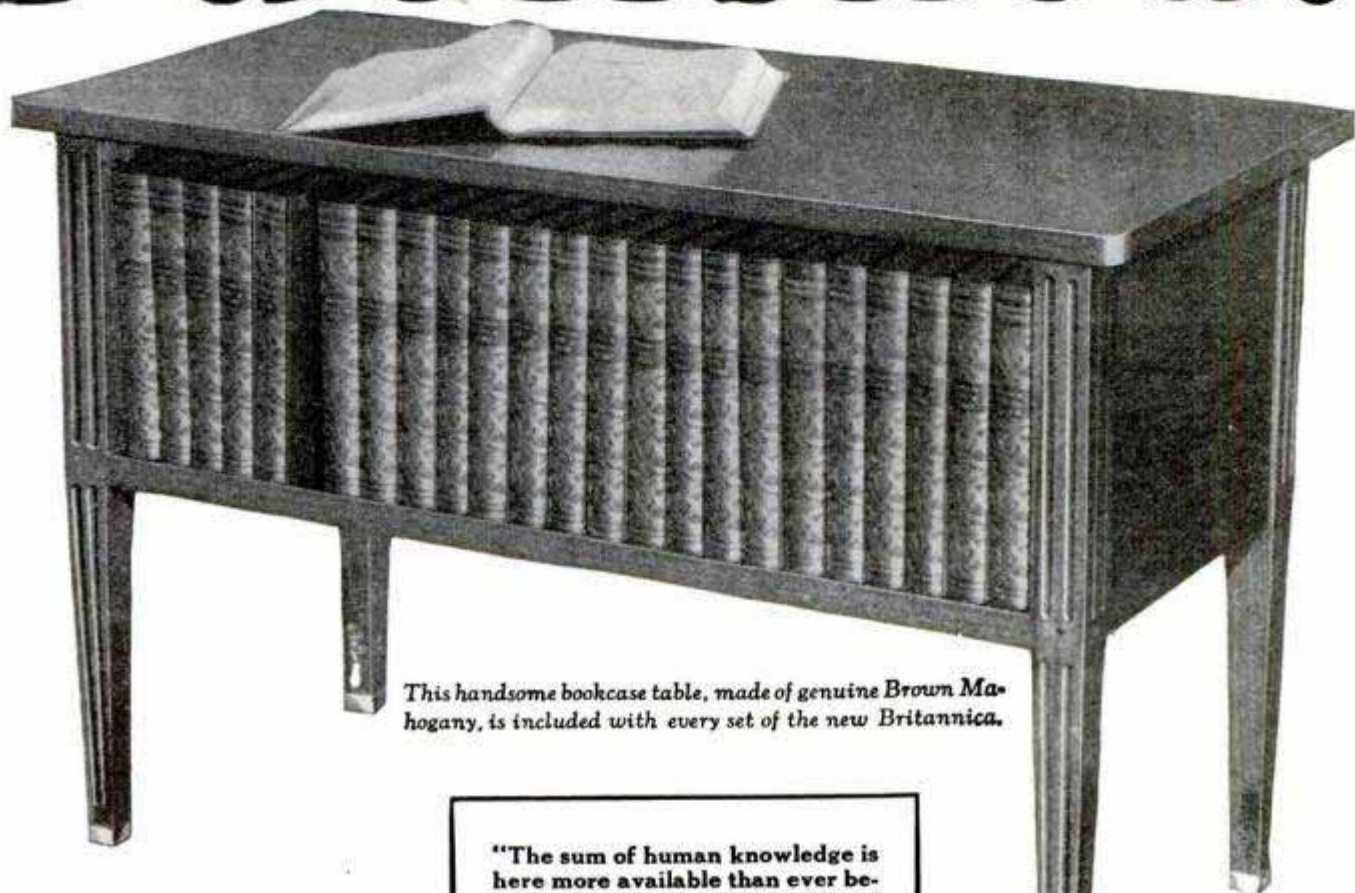

This handsome bookcase table, made of genuine Brown Mahogany, is included with every set of the new Britannica.

illustrations. This feature alone marks a tremendous advance. All the world's treasures of art and photography have been laid under tribute to illuminate the text.

"The most exciting book of 1929," asserts a leading critic, and the whole world is echoing that verdict.

This is a Britannica year! Here is your opportunity to join the thousands who will buy this new edition, now, while it is new—fresh from the presses. You owe it to yourself to learn further details regarding this magnificent series of volumes.

Extremely Low Price

And due to the economies of mass production, the price is extremely low—the lowest in fact at which a completely new edition has been offered for two generations! Easy payments, if desired—a deposit of only \$5 brings the complete set with bookcase table to your home.

"The sum of human knowledge is here more available than ever before. It contains a multitude of subjects of practical importance."

J. ARTHUR THOMSON
Editor The Outline of Science

"There is no question but that the best minds in science have contributed to this great Encyclopaedia."

ALBERT G. INGALLS
*Associate Editor
The Scientific American*

"If I were wrecked on a desert island I can conceive nothing more to be desired than to be washed ashore with a set of your new work"

WILLIAM BEEBE

Send for FREE Booklet

We have just prepared a handsome new 56-page booklet containing numerous color plates, maps, etc., from the new edition and giving full information about it, together with full details of bindings, the present low prices and easy payment plan. We want you to have a copy free and without the slightest obligation. The demand is great—you should act promptly if you are interested in owning a set of the

first printing on the present favorable terms. Just fill in the handy coupon and mail it today.

ENCYCLOPAEDIA BRITANNICA, Inc. PM9-A1
342 Madison Avenue, New York City.

Please send me by return mail, without any obligation on my part, your 56-page illustrated booklet describing the new Fourteenth Edition of the Britannica together with low price offer and easy terms of payments.

Name

Address

City State

MAIL this coupon TODAY

See the World FREE!



Taste Romance and Adventure In the Far Lands of the Earth.

How often you've longed to see for yourself the awe of Egypt's pyramids—the beauties of the gorgeous Mediterranean sunset—the squalor of China's ancient cities!

Spend a few years, or the rest of your life, tasting high adventure on the seven seas and in all the world's great ports—roving the earth's highways and byways! You can do it FREE—all your expenses paid—and earn a good salary besides!

Only one profession will carry you around the world at will, traveling like a gentleman, but that's the most interesting and pleasant work there is—Radio Operating! Easily and quickly learned, there's no other profession like it for the man who wants the experiences and pleasures of world-travel. Radio operators are needed—all sea-going ships like the one shown here must carry from one to half a dozen or more.



Take a Look Beyond the Skyline Without a Penny's Expense

Radio operators aboard ocean liners live luxuriously—they rank as officers of the ship. Meals, a private cabin, all other living needs are furnished free, and besides the operator draws a good salary. You can learn quickly and easily at home in your spare time to be a Radio operator through our practical training methods. Take a look at the FREE BOOK which tells how—mail coupon below.

This U. S. Government-recognized school has been training successful operators since 1914. Our graduates are all over the world. We maintain an Employment Department to help put you on your own ship. The famous NACOMETER, a patented home code teacher, given our students, is recognized as the best and easiest way to learn the Radio code at home. A few short months, with the aid of the famous Nacometer and our quick home training, and you too can be a fully qualified Radio operator, sitting in your cabin like the one shown above, bound out for Liverpool or Nagasaki!

Read the Free Book that tells all about this fascinating profession and our practical Government-recognized methods of training you for it. Send coupon TODAY—no obligation. Special tuition offer now on, includes the Nacometer, famous code teaching machine. Find out what Radio offers you. Act at once. Mail the Coupon.

NATIONAL RADIO INSTITUTE

Dept. 9XPA

WASHINGTON, D. C.

SPECIAL OFFER COUPON

National Radio Institute,
Dept. 9XPA, Washington, D. C.

Gentlemen: Without obligating me in any way send me your free book and information about your Nacometer, the Home Code teaching machine given with your course.

Name.....

Address.....

Occupation.....

Learn to Write

I Teach by Mail

I CAN make a good penman of you at your home during spare time, no matter where you live or how poorly you now write. My simplified system has shown thousands of others the way to good penmanship during the past twenty years—it can and will do the same for YOU!

Beautifully Illustrated Book
"How to Become a Good Penman" **FREE!**

It contains general information, with testimonials and beautiful specimens of penmanship showing what others have accomplished by the Tamblin System. (Your name elegantly written on a card if you enclose stamp for postage.) WRITE TODAY. Address

F. W. TAMBLIN

418 Ridge Bldg., Kansas City, Mo., U. S. A.



The BIG MONEY is in the AIR!

COME INTO AVIATION

Now!

A 2 1/4 Year College Course

Aviation offers ambitious men the same amazing opportunity found in the Automotive industry 25 years ago. But now the prizes go to men with College training in Aeronautical Engineering.

BETTER TRAINING AT LESS COST

Come to TRI-STATE for a regular technical College course cut down to 108 interesting weeks. All frills omitted—we concentrate on Science, Field Work, Laboratory, Mathematics, Aerostatics, Aeroplane and Engine Design, Aerodynamics and theory of flight—made easy by competent instructors.



B. Sc. (Bachelor of Science) degrees, conferred by authority of State of Indiana in all branches of Engineering listed below.

NO ENTRANCE EXAMINATIONS

And if you haven't a H. S. diploma, we'll teach you essential subjects. Fine equipment. For 45 years, TRI-STATE College has been the choice of men from all over the world, who are short on time, money and education, but who are strong in ambition. Called "the College of Successful Graduates" because our Alumni go to the top quickly.

LOW COST TRAINING

Tuition about half. Board and room at Angola as low as \$5.50 a week. No fees except chemical "lab." Wonderful bunch of students. Beautiful Campus. Healthy climate.

TRI-STATE COLLEGE, Box AE-7113 Angola, Ind.

Send for Catalog—Mail Coupon

Tri-State College, Box AE-7113, Angola, Ind.

Administrative Business Course Aeronautical
 Electrical Civil Mechanical Chemical

Please send your free catalog on checked (x) subjects.

Name.....

Address.....

"I GAMBLED 2¢ and WON \$35,840 in 2 YEARS"

*A Story for Men and Women
who are dissatisfied with themselves*

THIS is the story of a gamble—a 2c risk—which paid me a profit of \$35,840 in two years. I am not, and never was, a gambler by nature; in all probability I never would have taken the chance if more money was involved. So even if you too are against gambling, you will feel like risking two cents after you've read my story.

Some people believe I was lucky. Others think I am brilliant. But the sort of luck I had everyone can have. My type of brilliance is that of any average man.

Almost any \$40-a-week wage earner has as complete a mental equipment as I had two years ago. And he feels today just about the way I did then. For two years ago I too was in the \$40-a-week rut. My earnings were \$2,080 per year!

I was discontented, unhappy. I was not getting ahead. There didn't seem to be much hope in the future. I wanted to earn more money—a lot more money. I wanted to wear better clothes and have a car, and travel. I wanted to be on a par with people I then looked up to. I wanted to feel equal to them mentally and financially.

But it all seemed hopeless. I was beset with fears. I was afraid of losing my job. I was afraid of the future. I could see nothing ahead for myself and my wife and baby but a hard struggle. I would live and work and die—just one of the millions who slaved their lives away. I was irritable, easily annoyed, discouraged, "sore" at my fate and at the world. I could not think clearly. My mind was in a constant whirl. I was "scatterbrained." I had a thousand half-baked ideas to make more money but acted on none of them.

The end of each year found me in about the same position as the beginning. The tiny increases in salary, grudgingly given to me, were just about enough to meet the rising cost of living. Rent was higher; clothes cost more; food was more expensive. It was absolutely necessary for me to earn more money. So once in a while I got a few

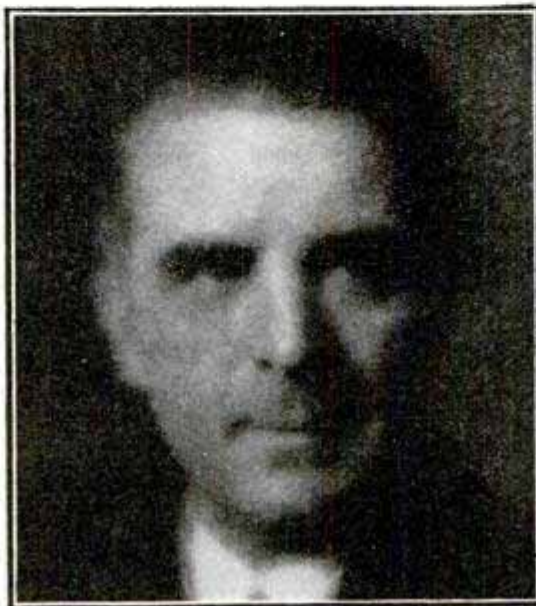

dollars more. But it wasn't because of any great change in my ability.

Today I have an income of \$20,000 a year. That's exactly \$17,920 more than it was two years ago. A difference of \$35,840 in two years. My family has everything it needs for its comfort and pleasure. My bank account is growing rapidly. I have my own home in the suburbs. I am respected by my neighbors, and I have won my wife and children's love as only the comforts and pleasures of life can do. When I am old I will not be a millstone around anyone's neck. My children will not have to support me.

I look forward to the future with confidence and without fear. I know that only improvement can come with the years. Once I wandered through life aimlessly, cringing, afraid. Today I have a definite goal and the will to reach it. I know I cannot be beaten. Once my discontent resulted in wishes. Today my slightest discontent results in action. Once I looked forward hopefully to a \$5 a week increase in salary. Today I look forward confidently to a \$100 a week increase in my earnings.

What magic was it that caused the change in my circumstances? How did I, a \$40-a-week clerk, change my whole life so remarkably? I can give you the answer in one word—Pelmanism. I gambled 2c on it. Yet without it, I

might have continued in my old \$40-a-week rut for the rest of my life.

Pelmanism taught me how to think straight and true. It crystallized my scattered ideas. It focussed my aim on one thing. It gave me the will power to carry out my ideas. It dispelled my fears. It improved my memory. It taught me how to concentrate—how to observe keenly. Initiative, resourcefulness, organizing ability, forcefulness were a natural result. I stopped putting things off. Inertia disappeared. Mind-wandering and indecision were things of the past. With new allies on my side and old enemies beaten, there was nothing to hold me back.

I am writing this in appreciation of what Pelmanism did for me. I want other average men to gamble 2c as I did. For the cost of a postage stamp I sent for the booklet about Pelmanism, called "Scientific Mind Training." Reading that free book started me on my climb. I took no risk when I enrolled for the Course because of the Institute's guarantee. All I gambled was 2c and I am \$36,000 better off now than I would have been had I not written for the book about Pelmanism.

* * * * *

The Pelman Institute will be glad to send a copy of "Scientific Mind Training" to any interested individual. This book is free. It explains Pelmanism. It tells what it does to the mind. It tells what Pelmanism has meant to others. For over 25 years Pelmanism has been helping people to happiness. Over 700,000 others have studied this remarkable science. Among those who have praised it are such great world figures as Judge Ben B. Lindsey, Jerome K. Jerome, Sir Harry Lauder, T. P. O'Connor, Major-Gen. Sir Frederick Maurice, H. R. H. Prince Charles of Sweden, and many others. Your whole life may be altered as a result of reading "Scientific Mind Training." Send the coupon. You have nothing to lose. If Pelmanism does not help you it costs you nothing. There is no obligation in mailing the coupon. No salesman will call on you. Decide for yourself what to do after you read the free book about Pelmanism. Mail the coupon NOW.

The Pelman Institute of America,
71 West 45th St., Suite 610, New York.

**THE PELMAN INSTITUTE OF AMERICA,
71 West 45th St., Suite 610, N. Y. C.**

I want you to show me what Pelmanism has actually done for over 700,000 people. Please send me your free book "Scientific Mind Training." This places me under no obligation whatever.

Name.....

Address.....

City.....State.....

Easy home method quickly teaches HAWAIIAN GUITAR



Play all the latest hits just as the Hawaiians do! Have good times aplenty!

Win fame—friends—fortune! Play the Hawaiian Guitar!

Native Hawaiian expert directs you

You get expert instruction directed by a world-famous player and teacher, Prof. Walter Kolomoku. He quickly reveals to you the secrets of this fascinating instrument.

Only 4 Motions to learn. Then you can play any music—popular songs, classical, old-time melodies, native Hawaiian airs—or real jazz. You'll never be lonesome after you learn the Hawaiian Guitar.

Complete Course

52 lessons. Nothing omitted. Pictures explain every move. You are sure to learn—what we can do for others we can do for you. Over 50,000 successful students.

Learn at home in spare time

Study in spare time at home. Even if you don't know a note our method is so simple, plain and easy, you begin a piece your first lesson. In half an hour you can play it!

Payasyouplay

We make it easy for you. Start with small first payment—then pay while learning. Costs only few cents per lesson. You only pay the cost of instruction—we furnish everything.

GIVEN when you enroll

—with genuine seal grain Fabrikoid Cover and complete playing outfit—this beautiful sweet-toned

HAWAIIAN GUITAR

Reliable retailers ask \$18 to \$20 for a similar instrument and outfit without the fine Fabrikoid Case, which alone is worth \$3.50

Instrument and outfit valued at **\$18 to \$20**

Other Courses { Banjo, Violin, Tiple, Tenor Guitar, Ukulele, Banjo Ukulele—well-known instructors.

FIRST HAWAIIAN CONSERVATORY OF MUSIC, Inc.
9th Floor, Woolworth Bldg., Dept. 648, New York

Approved as a Correspondence School Under the Laws of the State of New York

Member National Home Study Council

Send This Coupon for Liberal Offer!

FIRST HAWAIIAN CONSERVATORY OF MUSIC, Inc.
9th Floor, Woolworth Bldg., Dept. 648, New York, N.Y.
Please mail full information about your 52-lesson Hawaiian Guitar Course. I am not obliged to enroll unless I want to.

Name _____
Address _____
City _____ State _____



Young outdoor men wanted



To a few sturdy young men—lovers of fresh air and sunshine—who want to get away from the grind of indoor work—John Davey's national organization, The Davey Tree Expert Company, offers an exceptional opportunity. Steady expansion is creating a limited number of openings. Those young men selected will be thoroughly trained by the Company and given a permanent position if they make good. If you are single, between 20 and 30 years of age, free to travel, healthy, industrious, having a good practical education, and able to furnish satisfactory references, you have a good chance to qualify. Pay is good at start, advancement assured on merit. We want only men who desire permanent employment in a growing organization and will accept only clean, sturdy young men, thorough Americans, not afraid of vigorous outdoor work. Write for additional information and qualification blank to serve in place of personal interview. The Davey Tree Expert Co., Inc., 310 Federal Bldg., Kent, Ohio.

STAMMER

Write for my free book "Millard's Advanced Natural Corrective Course" and a free copy of my speech magazine. 10,000 cases successfully treated. Est. 24 years. Largest school for stammerers in world. Millard Inst. of Normal Speech, 2317 Millard Bldg., Milwaukee, Wis.

TRAVEL for "Uncle Sam"



New Bandit Proof Railway Mail Car

U.S. GOVERNMENT JOBS \$1260 TO \$3400 YEAR

Men—Boys, 18 Up
Steady Work
Paid Vacations
Common Education
Usually Sufficient
Mail Coupon
—Today SURE

FRANKLIN INSTITUTE
Dept. B171, Rochester, N. Y.

Gentlemen: Rush to me without charge 32-page book with list of U. S. Government big paid positions obtainable. Advise me regarding the salaries, hours, duties, vacations and full particulars.

--- COUPON ---
Name _____
Address _____



Get into

AVIATION

**Major Rockwell
World War Flyer
Who Will Teach You**

Major Rockwell is a famous world war flyer, decorated with the Legion of Honor and the War Cross. He is now devoting himself to teaching Aviation, and he will train you for a position in this great new industry as only a Veteran World War Flyer can train you. Under Major Rockwell's guidance your future in Aviation is assured.



Your Job Is Here

Only Trained Men Can Qualify in Aviation

The big money in Aviation does not go to the novice or apprentice. Only TRAINED men can command the high salaries. Employers are glad to pay big money for men who know Aviation—builders, mechanics, service and maintenance men, and flyers. Let me prepare you for one of the many high salaried Aviation jobs open to the trained man. I will prepare you to take your place in the most fascinating, fastest growing industry in the world. Act now while my special offer lasts. Rush this coupon to me for a copy of my famous free book.

Satisfaction or Money Back

I am so sure that you can learn Aviation with my help and step into a big aviation job that if you are not satisfied when you have finished my course, I agree to return every penny of your tuition.

MAJOR ROB'T L. ROCKWELL

THE DAYTON SCHOOL OF AVIATION
Desk M-1 DAYTON, OHIO

Major Rockwell, U.S.R. Air Corps, Says:
"I'll Train You at Home
and Until You Have an Aviation!
Job Paying \$300 to \$400 a Month!"

I make this amazing offer, for a short time and to a limited number, to supply the crying need for trained men. Here is your opportunity to get into this uncrowded, fascinating field with a definite certainty of your future.

In 12 Weeks!

Just devote about an hour a day to My Home Study Course, and in 12 weeks you can be mastering the principles of Ground Training

No Advance Education Necessary or Experience Needed

You don't need to have a high school or college education to master my course. You do not even need to know anything about airplanes, motors or mechanics. My home course is thorough and complete. Everything is so clearly explained, with easy-to-understand text and pictures, that in a few short months you will be able to grasp every funda-

mental principle of Aviation ground work and you will be well on the road to qualify for any important aviation job paying \$300 to \$400 a month. My Home Study Course will give you all the knowledge necessary to pass the government's written examinations for mechanics' or pilots' licenses.

You Learn Principles of Aviation at Home
Then Choose Any One of 40 Ground Jobs
— If You Want Actual Flying, My Home Study Course

teaches you the principles of flight. When you have completed the ground training come to Dayton—the birthplace of Aviation and the home of the Wright Brothers. You come here and get training at one of the finest and best equipped air ports

in America. Here, where we can work hand in hand, you can qualify for a pilot's license and a high pay flying job in passenger lines, mail service and other important branches of flying.

Employment Service

After you graduate I assist you in getting a job without any cost to you. Right now the demand for trained men is greater than the supply. A place is ready for you!

Get My No-Risk Plan
My Big Book
Explains ALL
I'll send it FREE



Major Rob't L. Rockwell
The Dayton School of Aviation
Desk M-1, Dayton, Ohio.

Dear Major:—Please send me FREE and without obligation a copy of your famous book on Aviation; also your special tuition and position offer.

Name.....

Address.....

Town..... State..... Age.....



Are you afraid you will be fired?

ARE you sitting on the anxious bench wondering what will happen to you if business slacks up? Are you one of the many small-salaried, untrained workers who are always the first to go when employers start cutting the salary list?

Why have this spectre of unemployment hanging over you all the time? Why not decide today that you are going to make yourself so valuable to your employer that he can't get along without you?

You can do it if you really want to, right at home in spare time, through the International Correspondence Schools. In just an hour a day you can get the special training that you must have if you are ever going to get—and keep—a real job at a real salary.

You're ambitious, aren't you? And you want to get ahead? Then don't turn this page until you have clipped the coupon, marked the line of work you want to follow and mailed it to Scranton for full particulars.

Surely it is worth at least a two-cent stamp to find out all about the I. C. S. and what it can do for you.

Mail the Coupon for Free Booklet that has helped thousands of men to win success.

INTERNATIONAL CORRESPONDENCE SCHOOLS "The Universal University" Box 5643-F, Scranton, Penna.

Without cost or obligation, please send me a copy of your booklet, "Who Wins and Why," and full particulars about the subject before which I have marked X in the list below:

TECHNICAL AND INDUSTRIAL COURSES

- | | |
|------------------------------------------------------------------------------|--------------------------------------------------------------------------|
| <input type="checkbox"/> Electrical Engineering | <input type="checkbox"/> Architect |
| <input type="checkbox"/> Electric Lighting | <input type="checkbox"/> Architects' Blueprints |
| <input type="checkbox"/> Mechanical Engineer | <input type="checkbox"/> Contractor and Builder |
| <input type="checkbox"/> Mechanical Draftsman | <input type="checkbox"/> Architectural Draftsman |
| <input type="checkbox"/> Machine Shop Practice | <input type="checkbox"/> Structural Draftsman |
| <input type="checkbox"/> Railroad Positions | <input type="checkbox"/> Concrete Builder |
| <input type="checkbox"/> Gas Engine Operating | <input type="checkbox"/> Structural Engineer |
| <input type="checkbox"/> Civil Engineer <input type="checkbox"/> Coal Mining | <input type="checkbox"/> Chemistry <input type="checkbox"/> Pharmacy |
| <input type="checkbox"/> Surveying and Mapping | <input type="checkbox"/> Automobile Work |
| <input type="checkbox"/> Plumbing and Heating | <input type="checkbox"/> Aviation Engines |
| <input type="checkbox"/> Steam Engineering | <input type="checkbox"/> Agriculture <input type="checkbox"/> Navigation |
| | <input type="checkbox"/> Mathematics <input type="checkbox"/> Radio |

BUSINESS TRAINING COURSES

- | | |
|------------------------------------------------------------------|---------------------------------------------------------------------------|
| <input type="checkbox"/> Business Management | <input type="checkbox"/> Salesmanship |
| <input type="checkbox"/> Industrial Management | <input type="checkbox"/> Advertising |
| <input type="checkbox"/> Personnel Management | <input type="checkbox"/> Business Correspondence |
| <input type="checkbox"/> Traffic Management | <input type="checkbox"/> Show Card and Sign Lettering |
| <input type="checkbox"/> Accounting and C. P. A. Coaching | <input type="checkbox"/> Stenography and Typing |
| <input type="checkbox"/> Cost Accounting | <input type="checkbox"/> English <input type="checkbox"/> Civil Service |
| <input type="checkbox"/> Bookkeeping | <input type="checkbox"/> Railway Mail Clerk |
| <input type="checkbox"/> Secretarial Work | <input type="checkbox"/> Grade School Subjects |
| <input type="checkbox"/> Spanish <input type="checkbox"/> French | <input type="checkbox"/> High School Subjects |
| | <input type="checkbox"/> Illustrating <input type="checkbox"/> Cartooning |

Name.....
Street Address.....
City..... State.....
Occupation.....
Persons residing in Canada should send this coupon to the International Correspondence Schools Canadian, Limited, Montreal, Canada

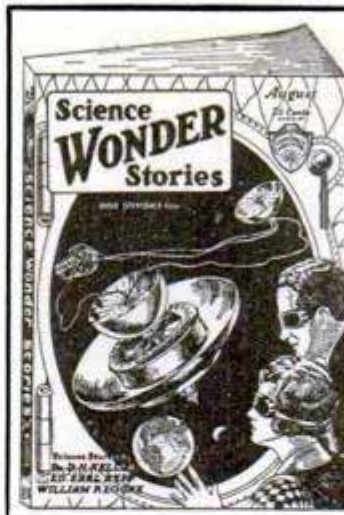

Dramatized Mechanics Fiction Stories

of a startling Nature with a Scientific Background. Contributions by the world's most brilliant authors.

On Sale at all news-stands 25c the copy. Special subscription offer—One Dollar—eight months.

Stellar Publishing Co.
98 W. Park Place, N. Y. C.

ELECTRICAL ENGINEERING

Intensive, practical—technical courses. Engineering degree in 2 years. Diploma in 1 year. Also Special Short Courses in Practical Electricity—Power Plant Operation—Armature Winding—Radio—Electric Refrigeration—Aviation Electricity—Electric Welding. LOW TUITION RATES. Faculty of recognized experts. Extensive Laboratories. Free employment service for graduates. We help secure part-time work during training. 28th year. Write for catalog.

FINLAY ENGINEERING COLLEGE 1001-A Indiana Ave. Kansas City, Mo.



HOT PIANO Ultra-modern Piano

Jazz taught by mail. Note or ear. Easy rapid lessons for adult beginners. Also Self-instruction system for advanced pianists. Learn 358 Bass Styles, 976 Jazz Breaks, hundreds of Trick Endings, Hot Rhythms, Sock, Stomp and Dirt Effects; Symphonic and Wicked Harmony in latest Radio and Record Style. Write for Free Booklet.

WATERMAN PIANO SCHOOL, 1826 W. Adams St., Los Angeles, Calif.



1,000 Hotel Positions Open!

HOTELS, restaurants, clubs, apartments, hospitals, institutions, schools and colleges everywhere need trained men and women. Over 70,000 high-class positions paying \$2,500 to \$10,000 a year open annually in the hotels of the United States. Nearly one and three-quarter billions of dollars' worth of NEW HOTELS, CLUBS AND INSTITUTIONS being built this year will need over 200,000 trained men and women. Hotels start you at salaries up to \$3,500 a year, with living usually included. At any time there are over 1,000 hotel positions open.

Previous Experience Unnecessary

You can have one of these fascinating, big-pay positions. Thru our Simplified Study Plan we give you the valuable knowledge that it has taken some of the most successful hotel men years to obtain. Age is no obstacle—young and old alike have equal chance for success. Past experience absolutely unnecessary. A common school education is all you need. We train you in your spare time and put you in touch with big opportunities. All of your training under the personal supervision of Clifford Lewis, who has been appointed Managing Consultant by over 300 hotels thruout the United States. Our students employed by leading hotels everywhere. Send coupon today for Free Book, "Your Big Opportunity," showing how we can train you for one of these splendid positions, and explaining our Money-Back Agreement.

FREE BOOK COUPON

**LEWIS HOTEL TRAINING SCHOOLS,
Room BS-385, Washington, D. C.**

Send me without obligation the Free Book, "Your Big Opportunity."

Name.....
Address.....
City..... State.....

Why toil for small wages?

RADIO

offers you **BIG PAY!**



**FREE Book Tells How to
Fill the Job You Want
.. Many Do It in
only 9 Months**

*Only Training Course Backed by
Radio Corporation of America*

Graduates of this school are always in big demand. The progress of Radio is measured by the accomplishments of the Radio Corporation of America. This gigantic corporation sets the standards for the entire industry... and sponsors every lesson in the course.

Money Back If Not Satisfied

As a student, you will receive an agreement signed by the president of this school assuring you of complete satisfaction upon completion

of your training—or your money will be instantly refunded.

Free!

This fascinating book on Radio's glorious FREE opportunities... written by one of America's well-known radio experts.



RADIO INSTITUTE
of AMERICA, Dept. PM-10,
326 Broadway, New York, N. Y.

Gentlemen: Please send me your
FREE 50-page book which illustrates the
brilliant opportunities in Radio and describes your
laboratory-method of instruction at home.

Name

Address



Broadcast operators earn from \$1,800 to \$4,800 a year. Radio inspectors \$2,000 to \$4,500 a year.

Become a radio operator—\$90 to \$200 a month (board free).

MAKE more money than you ever made before... in Radio—the big-money business of today. Hundreds of men just like you earn from \$2,000 to \$25,000 a year.

Astounding World-Wide Opportunities Beckon To You

Get in on the ground floor of this big-money industry. Broadcasting stations and manufacturers are eagerly seeking capable graduates.

*Magnificent Laboratory Outfit
Makes It Easy To Learn At Home*

By means of this marvelous, simplified home-training course, sponsored by the Radio Corporation of America... you can now prepare for success in every phase of Radio. The remarkable outlay of apparatus given to you with this course... enables you to learn by actual practice how to solve every problem in Radio work.

SPONSORED BY

RADIO INSTITUTE OF AMERICA



\$25 Extra Each Week for YOU—Easy



Make BIG MONEY—Spare-Time or Full-Time—with Hawaiian Guitar

Be the life of every party—be paid big for your spare-time hours! Dances, parties, orchestras—all pay REAL CASH for the sweet melodious music of the Hawaiian (Steel) Guitar. YOU can make \$25 a week and up extra; or \$65 to \$100 a week full-time pay!

No Musical Knowledge Needed; Learn Quick Right at Home in 1 to 3 Months. My easy method explains everything. No hard practice, no tiresome "scales" to learn. You play real tunes from the very first! And in only 1 to 3 short months you can actually be playing for pay. I'll prove it to you without cost; get my FREE Book with Coupon below.

PROOF

"Had learned only a few chords when I was asked to play at a dance. Received sixteen dollars (\$16) for one night's playing."—R. A. Prutzman, Leighton, Pa.
 "Only quarter way through course and already playing 3 evenings a week, spare-time, for \$10."—J. Kruticki, Kitchener, Ont., Can.
 "Have made almost \$200 with my Hawaiian Guitar in spare-time."—John T. McMullin, Cadet, Mo.

PHONOGRAPH RECORDS and Complete Outfit at No Extra Cost
 In addition to a beautiful Hawaiian Guitar — Complete Outfit — easy lessons and instructions — you receive clear, correct, fool-proof Demonstration Phonograph Records of every selection in the course. And NOT ONE CENT OF EXTRA COST to you!

FREE BOOK Shows You How
 I train you at home quickly to play Hawaiian Guitar; it shows how you risk absolutely nothing to learn; how I send you everything you need. Get your copy without one day's delay. Clip the coupon and send it today. NOW!

This Genuine
HAWAIIAN
 Guitar Comes with 1st Lesson

MAIL now!

A. F. Bioch, President, Hawaiian Studios 52109 of New York Academy of Music, 100 Fifth Avenue, New York City.
 Without obligation, send me FREE Book "How to Learn Hawaiian Guitar," with facts on how I can make BIG MONEY, spare-time or full-time.

Name.....
 Address.....
 City.....



PIN A DOLLAR BILL TO THIS

Get this genuine leather 5 window card case, with gold corners, Masonic emblem stamped in heavy gold. Your name or other stamping 35c extra, per line. Money back guarantee.



Please send catalogue

- No. 10. Books, Monitors, Jewelry
- No. 11. Lodge Supplies

Established 1859

Redding Masonic Supply Co.
 200 Fifth Ave., Dept. P. M., New York

"Everything Masonic"

Electrical Engineering

Course for men of ambition and limited time. Over 5000 men trained. Condensed course in Theoretical and Practical Electrical Engineering including the closely related subjects of Mathematics and Mechanical Drawing.

Students construct motors, install wiring, test electrical machinery. Course designed to be completed in one college year. Prepare for your profession in the most interesting city in the world. Est. 1893. Catalog on request.



Bliss Electrical School

120 Takoma Ave., Washington, D. C.

BE AN ARTIST

WE CAN TEACH YOU DRAWING in your own home during your spare time. Twenty-five years of successful teaching proves our ability. Artists receive large salaries.



Write Today for Art Year Book

SCHOOL OF APPLIED ART
 ROOM NO. 2 BATTLE CREEK MICH.



Wonderful, new device, guides your hand; corrects your writing in a few days. Big improvement in three hours. No failures. Complete outline FREE. Write C. J. Ozment, Dept. 34, St. Louis, Mo.

Learn Watchwork, Jewelrywork and Engraving

A fine trade commanding a good salary, and your services always in demand. Address **Horological**, Dept. P, Bradley Institute, PEORIA, ILLINOIS, for our latest catalog.

Learn MECHANICAL DENTISTRY

EARN BIG MONEY—Steady Work

WHY spend the best years of your life at uncertain jobs at small pay? You can EARN WHILE LEARNING this modern money making business and become independent. **BIG DEMAND.** You LEARN BY DOING PRACTICAL work. DAY AND NIGHT SCHOOL. INDIVIDUAL instructions. Easy terms. Railroad Fare Allowed — No Extra Cost. Address SECRETARY, N. Y. SCHOOL OF MECHANICAL DENTISTRY, 147 W. 33rd Street, NEW YORK, N. Y.



SEND FOR FREE BOOK



Write or Mail Coupon.
 Name.....
 Street.....
 City.....State.....



They Jeered at Me - But I Made Them Applaud Me Three Weeks Later!

I HAD never been called on to speak before. But the chairman had said: "Oh, it's easy, you won't have a bit of trouble. Just talk naturally." The minute I was on my feet I began to realize that speaking was a lot more difficult than I had expected. Everyone appeared to be bored and hostile. Suddenly I noticed two of the members whispering and laughing. For an instant I almost lost control of myself and wanted to slink out of that room like a whipped cur. But I pulled myself together and made a fresh attempt to get started when someone in the audience said, "Louder and funnier!" Everyone laughed. I stammered a few words and sat down.

And that was the way it always was—I was always trying to impress others with my ability—in business, in social life, in club work—and always failing miserably. Why couldn't I talk easily and fluently like other men talked? Often I saw men who were not half so thorough nor so hard working promoted to positions where they made a brilliant showing—not through hard work, but through their ability to talk cleverly and convincingly—

to give the appearance of being efficient and skillful.

In 20 Minutes a Day

And then suddenly I discovered a new easy method which made me a forceful speaker almost over night. I learned how to dominate one man or an audience of thousands. At the next meeting, just three weeks later, I got up and made the same speech I had tried to make before—but presented so forcefully, so convincingly that when I had finished they actually applauded me.

Soon I had won salary increases, promotion, popularity, power. Today I always have a ready flow of speech at my command. I am able to rise to any occasion, to meet any emergency with just the right words. And I accomplished all this by developing the natural power of speech possessed by everyone, but cultivated by so few—by simply spending 20 minutes a day in the privacy of my own home, on this most fascinating subject.

There is no magic, no trick, no mystery about becoming a powerful and convincing talker. You, too, can conquer timidity, stage fright, self-consciousness and bashfulness. Today business demands for the big,

important high-salaried jobs, men who can dominate others—men who can make others do as they wish.

Send for This Amazing Book

This new method of training is fully described in a very informative free booklet called, *How to Work Wonders with Words*. You are told how to bring out and develop your priceless natural gift—which will win for you advancement in position and salary, popularity, social standing, power and real success. Absolutely free. Mail this coupon.

Now
Sent
FREE



North American Institute
3601 Michigan Ave., Dept. 1357, Chicago, Ill.

North American Institute, Dept. 1357,
3601 Michigan Ave., Chicago, Ill.

Please send me FREE and without obligation my copy of your inspiring booklet, *How to Work Wonders with Words*, and full information regarding your Course in Effective Speaking.

Name.....

Address.....

City..... State.....

What 20 Minutes a Day Will Show You

How to talk before your club or lodge
How to propose and respond to toasts
How to address board meetings
How to make a political speech
How to tell entertaining stories
How to make after-dinner speeches
How to converse interestingly
How to write letters
How to sell more goods
How to train your memory
How to enlarge your vocabulary
How to develop self-confidence
How to acquire a winning personality

\$25,000 worth of 1929 cars for you to work on!

Students of work on 1929 Packard Str. 8. Other 1929 Models include: Buick, Study, Marmon, Auburn, Nash, Reo, Essex, De Soto, Chev., Ford, Oakland—and 11 more chassis.

Learn Autos IN LOS ANGELES

and LEARN IT RIGHT!

1. NATIONAL—America's Best Equipped Auto School

NATIONAL is a Million Dollar institution—established in Los Angeles in 1905—recognized throughout the automotive industry as one of America's foremost trade schools. NATIONAL offers practical, intensive training in all automotive branches. No age limit. No previous experience necessary. You learn by "Actual-Shop" Methods. Life Scholarship privileges. Start any time of the year.

2. NATIONAL Qualifies YOU to Make Good

NATIONAL properly trains you in the Auto Trades in the short time of 4 to 6 months. Upon completing this Condensed Course you are fully qualified as a Practical, Competent Automobile man, and you have not risked your chances of employment because of inferior, incomplete instruction.

3. NATIONAL Guarantees YOU Efficient Employment Service

NATIONAL GUARANTEES to give unlimited and efficient Employment Service to students wishing to earn living expenses while learning; and to graduates getting started in the automobile field. This is the most any reputable school can be expected to do.

4. NATIONAL'S Training in Every Man's Reach

NATIONAL offers YOU the very best technical-practical training that money can buy at a cost within every man's reach. It does not offer to pay your railroad fare, room and board or other personal expenses, preferring to limit its activities to the PROPER TRAINING OF MEN FOR SUCCESS.

5. Come to LOS ANGELES—the Playground of America!

LOS ANGELES is the heart of the country's most prosperous automobile section—as well as the world's most ideal city in which to live and prepare for success in the auto game.

WRITE for FREE BOOK NOW!

National Automotive School

NATIONAL AUTOMOTIVE, Dept. 727, 4686 Figueroa St., Los Angeles, Calif.

Send me, absolutely free, your big illustrated catalog of Automotive Opportunities.

Name.....
Address.....
Age..... City..... State.....

Your future assured!

National Automotive
LOS ANGELES

AVIATION WANTS MEN

Learn Quickly to Earn BIG MONEY

Wonderful openings for pilots, mechanics and airport managers at big pay. Jobs opening up faster than we can supply trained men. Easy to learn aviation by our quick, thorough method. Step right out into a real job. Lowest pay for ground mechanics, \$150.00 per month. Trained men qualifying as transport pilots easily

Make Over \$500.00 a Month NOW! The Consolidated system of instruction enables the average young man to master the principles of flying and airplane mechanics in the shortest time. No previous training required. You learn under direct supervision of veteran pilots and craftsmen, at the authorized school of the National Air Industries, a million dollar corporation. Instruction conforms with U. S. Gov't standards. Monthly records of all students will be kept preparatory to filing with the U. S. Dept. of Commerce.

We Pay Your Fare To Kansas City

Get the details of our offer to rebate your fare to Kansas City from anywhere in the U. S. Special low tuition rate now effective.

FREE Write today for fascinating new 64-page book, "Up to Fame and Fortune". Shows noted flyers, planes and shops. Tells about profits and opportunities in aviation. Explains step by step how you learn to fly. A vast fund of information. Don't miss it.

CONSOLIDATED AIR COLLEGE Inc.

536 Wyandotte Street
Kansas City, . . . Missouri!

Learn Advertising at HOME

Send your name and address for free booklet giving interesting information and vital facts about Advertising. Find out how we prepare you at home, in your spare time, for the opportunities open in this fascinating business. Practical work. No text books. Old established school. Successful graduates everywhere. Just the plan you have always wanted. Write today. No obligation.

PAGE-DAVIS SCHOOL OF ADVERTISING
Dept. 1357 3601 Michigan Ave. Chicago, U. S. A.

Learn Photography at HOME

Make money taking pictures. Prepare quickly during spare time. Also earn while you learn. No experience necessary. New easy method. Nothing else like it. Send at once for free book, OPPORTUNITIES IN MODERN PHOTOGRAPHY and full particulars

AMERICAN SCHOOL OF PHOTOGRAPHY
Dept. 1357 3601 Michigan Ave. Chicago, U. S. A.

12 FEMALE

31 MALE

WHY NOT spend Spring, Summer and Fall gathering butterflies, insects? I buy hundreds of kinds for collections. Some worth \$1 to \$7 each. Simple outdoor work with my instructions, pictures, price-list. Send 10 cents (not stamps) for my illustrated Prospectus before sending butterflies.

MR. SINCLAIR, DEALER IN INSECTS.
Dept. 6. Box 1424. San Diego, Calif.

"STAMMERING Its Cause and Cure"

You can be quickly cured if you stammer. Send 10 cents coin, or stamps, for 288 page cloth bound book on Stammering and Stuttering. It tells how I cured myself after Stammering and Stuttering for 20 years. **BENJAMIN N. BOGUE**

11122 Bogue Building, 1147 N. 111. St. Indianapolis

They dared Officer Kane to play

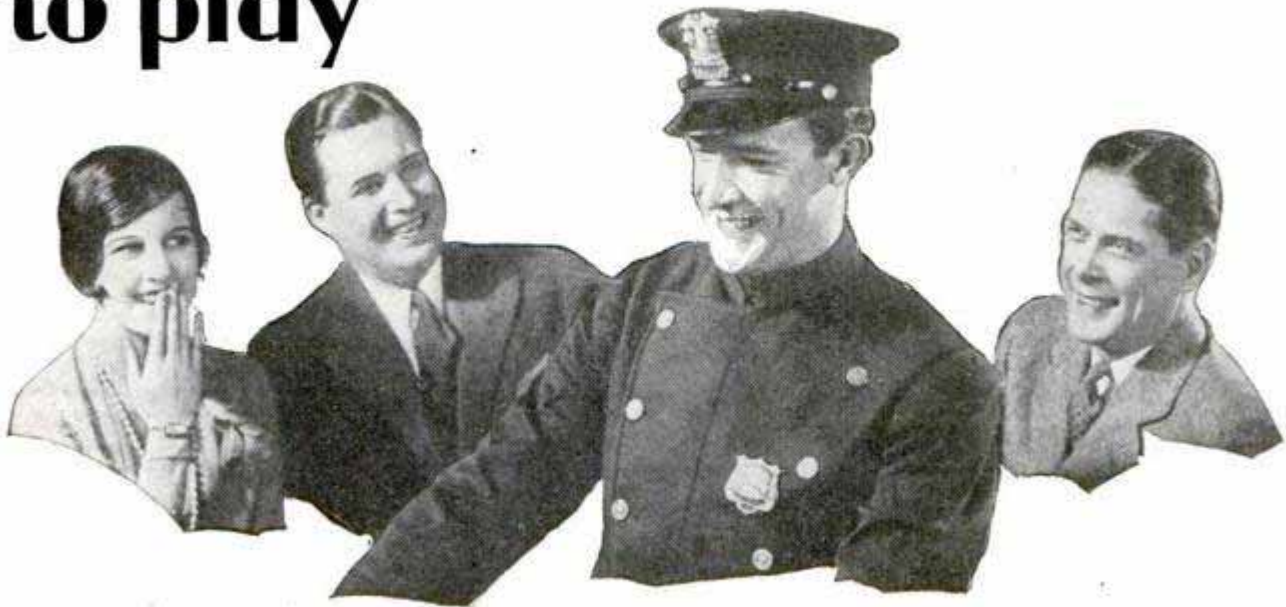

.. and his music held them spellbound

ETHEL'S house party was at its height—when suddenly there came an ominous knocking at the door. Ethel ran to open it and—there stood Police Officer Kane.

"I want to see the man of the house," thundered Kane.

"I'm sorry," stammered Ethel nervously, "but my father is not at home."

"Well, what's goin' on in here anyway?" continued the officer sternly. "Every one on the block is complainin' of the noise. I've a good mind to arrest the lot of you."

Ethel was mortified—what a disgrace! "Oh please," pleaded Ethel, "please don't do anything like that."

Then Kane burst out laughing. "Don't worry lassie—you were all havin' such a fine time I couldn't help droppin' in," he explained.

"Oh," sighed Ethel, "how you frightened me. Won't you join us?"

Kane Joins the Party

"Ha," laughed Kane, as the Victrola started again, "why must you play that canned music—can't any of you play this beautiful piano? Sure, I'd like to give you a tune myself."

"I dare you to play for us," shouted Ted Strong.

"I'm afraid I'll have to be goin'," stammered Kane, embarrassed.

"Mr. Kane, I think you might play for me after the fright you gave me," smiled Ethel.

"Well, b'gorry, maybe I will," agreed the officer. And as he sat down at the piano everyone laughed. But the noise stopped when he struck the first rollicking notes of the famous "Song of the Vagabonds."

"More—more.."

"That's great—play another," they all shouted as the last notes of that snappy march song died away. Kane then started that stirring old soldier song "On the Road to Mandalay," following it with song hits from the latest shows.



"Well," he laughed, as they finally let him get up from the piano, "I'll have to be on my way now."

"Thank you for your lovely music," said Ethel. "You must be playing a good many years?"

"Sure and I haven't been playin' long at all." Then the questions came thick and fast, "How did you ever learn so quickly?" "When do you find time to practice?" "Who was your teacher?"

PICK YOUR INSTRUMENT

Piano	Violin
Organ	Clarinet
Ukulele	Flute
Cornet	Saxophone
Trombone	Harp
Piccolo	Mandolin
Guitar	Cello
Hawaiian Steel Guitar	
Sight Singing	
Piano Accordion	
Voice and Speech Culture	
Drums and Traps	
Automatic Finger Control	
Banjo (Plectrum, 5-String or Tenor)	

Kane Tells His Story

"Well, to tell you the truth I had no teacher. I've always loved music but I couldn't take regular lessons on account of my duties as a policeman. Then one evenin' I saw a U. S. School of Music advertisement, tellin' of a new way of learnin' to play. I didn't believe it myself but I sent

for their Free Demonstration Lesson that showed me how easy it was, so I wrote for the whole course.

"There were no tiresome scales or tedious exercises. I played real pieces almost from the start. Now I'm playin' classical numbers or jazz, havin' the time of my life."

This is not the story of just one isolated case. Over half a million people have learned to play by this simple method. You can, too. Even if you don't know one note from another you'll grasp it in no time. First it tells you how to do a thing—then it shows you how in pictures—then you do it yourself and hear it.

You teach yourself—right at home—without any uninteresting finger exercises, tedious scales or other humdrum methods.

Free Booklet and Demonstration Lesson

To prove how practical this course is, the U. S. School of Music has arranged a typical demonstration lesson and explanatory booklet which you may have Free. They show how anyone can learn to play his favorite instrument by note in less than half the time and at a fraction of the cost of old slow methods. The Booklet will also tell you all about the amazing new *Automatic Finger Control*.

Don't delay—act at once—fill in and mail the coupon below today—no obligation whatever.

(Instrument supplied if desired, cash or credit.) U. S. School of Music, 710 Brunswick Bldg., New York City.

U. S. School of Music
710 Brunswick Bldg., New York City

Please send me your free book, "Music Lessons in Your Own Home," with introduction by Dr. Frank Crane, Free Demonstration Lesson and particulars of your easy payment plan. I am interested in the following course:

Have You
..... Instrument?

Name.....

Address.....

City.....State.....



A giant plane dips and soars across the sky, leaving against the brilliant blue the one word
ELECTRICITY

Men stop and gaze at the huge letters written so gracefully thousands of feet above the earth. Somewhere an electrical expert has groomed the giant plane for its flawless flight . . . every wire tested . . . every electrical device in perfect running order.

Today industry is as dependent upon the expert electrician as the powerful plane tracing the magic name over countless cities and towns. To him come the profits of industry and commerce. You, too, can be an electrical expert. Write today for the 48-page booklet.

NEW YORK ELECTRICAL SCHOOL
44 West 17th St.
NEW YORK



BEDFORD YMCA TRADE SCHOOL

Auto Mechanic
Aviation Mechanic
Starting, Lighting, Ignition
Electric Welding, Airplane Welding
Oxy-Acetylene Welding
Wheel Alignment. Brake Testing
Machine Shop. Battery Repair
Electrical Course. Radio Mechanic
Mechanical, Architectural Drawing
Airplane Drafting
Blue Print Reading
Building Estimating
Sign Painting. Show Card Writing
Window Dressing
Commercial Art. Fine Art
Write for Catalog 50
Brooklyn Engineering Institute
(Operated by Bedford Y. M. C. A.)
1125 Bedford Avenue, Brooklyn
New York City

COLLEGE COURSES

at Home



Carry on your education. Develop power to initiate and achieve. Earn credit toward a Bachelor degree or Teaching Certificate. Select from 450 courses in 45 subjects, including English, Mathematics, History, Education, Art, Psychology, Economics, the Sciences, the Languages, etc. Write for catalog.

The University of Chicago
427 ELLIS HALL CHICAGO, ILL.

WORLD NEEDS PLUMBERS

Old style plumbers are fading like the horse and buggy. The world demands modern Plumbing and Skilled Trained Mechanics to do it. Unlimited, swift growing field. Make \$50 to \$100 a week or start own shop. We train you quick. Learn in 8 to 12 WEEKS to do any job with skill and science. Need no previous experience. Strictly tool using system. Opportunity knocks. Investigate today—amazing offer—low tuition. World's greatest school.



Write—
UNIVERSAL PLUMBING SCHOOL
2130 Troost Ave. Kansas City, Mo.

LEARN WATCH REPAIRING



You can learn by our modern and original system of instruction every part of the **Watch Repairing Trade** at home as good or better than at a shop. You can earn money while learning and secure a well paying position or start in business after completing our course of instruction. Good watch repairers are always in demand and earn from \$50 to \$75 per week. For particulars apply to the **Wisconsin School of Watch Repairing** 166 Mason St., MILWAUKEE, WIS.



"BECOME A LIGHTNING TRICK CARTOONIST"

Send \$1.00 for Laugh Producing Program of 23 Trick Drawings with Instructions. Catalog of Chalk Talk Supplies Free. **BALDA ART SERVICE, Dept. 1, Oshkosh, Wis.**

GOV'T. POSITIONS

\$35 TO \$75 WEEKLY

MEN - WOMEN

- () Ry. Mail Clerk
- () Prohibition Inv.
- () R. F. D. Carrier
- () Special Agent (Investigator)
- () City Mail Carrier
- () Meat Inspector
- () P. O. Clerk
- () File Clerk
- () General Clerk
- () Matron
- () Steno-Typist
- () Immigrant Inspector
- () Seamstress
- () Auditor
- () Steno-Secretary
- () U. S. Border Patrol
- () Chauffeur-Carrier
- () Watchman
- () Skilled Laborer
- () Postmaster
- () Typist

AGE 18 to 55

GOVERNMENT INSTRUCTION BUREAU, 111 Arcade Bldg., St. Louis, Mo. Send me FREE particulars How To Qualify for positions marked "X". Salaries, locations, opportunities, etc. ALL SENT FREE.

NAME.....
ADDRESS.....

NOW You Can Be A College-Trained Draftsman Without College Cost!



Wonderful New Easy Method Now Brings College Training In Drafting To You At Your Home, In Spare Time. Quickly Fits You For Positions Paying Up to \$150 a Week. Yet The Cost Is Only a Fraction Of College Training. Get FREE Lesson And Facts At Once Without Obligation!

**THIS VALUABLE
DRAWING
OUTFIT
FURNISHED**

Learn Professional Drafting While You Earn . . . This Easy, Fascinating Way!

Here's great news for every ambitious man who wants a real pay job in Drafting! As a result of a marvelous, practical home-study method developed by Chicago Tech, you can now become a College Trained Draftsman and prepare yourself for a big-money drafting job right at home in your spare time!

**Entirely Different . . .
Simple as A.B.C.**

Just the kind of practical training that employers are looking for in the men they hire! Training from an old-established College known and recognized the world over.

Unlike ordinary schooling. Think of

it—no hard text-books to master—no involved problems to solve! Easy and practical throughout. You get the same fine drawing outfit, the same interesting lessons prepared by trained experts and the same practical instruction as prepared and taught right at the College. In a few short weeks you master all the big-money principles you need to qualify you for a fine drafting position!

Drawing Outfits FREE of Extra Cost

A full set of fine drawing instruments in handsome pocket case, special drawing table and high-grade drawing outfit included without extra cost. Everything you need furnished!

You owe it to yourself to at least investigate this astonishing College-Training-In-Drafting-At-Home at once! The Coupon brings full convincing facts and valuable lesson FREE! Mail it this very minute!

FREE!

Send no Money. Just fill in and mail the coupon below NOW! You will at once receive absolutely free a trial lesson that shows you how remarkably easy and fascinating it is to learn College Drafting right in your own home, without leaving your job. It will pay you to investigate at once, if you want a real pay job in drafting!

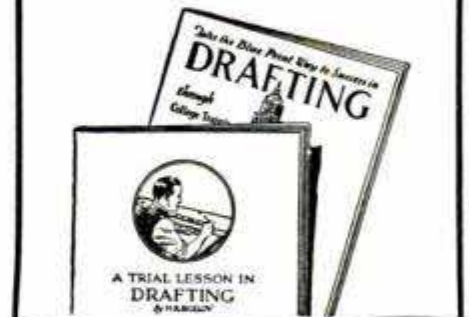

CHICAGO TECHNICAL COLLEGE

Dept. N-202, Home Study Division
118 E. 26th St., Chicago, Ill.

If you live nearby, visit the College. See how we train Draftsmen for big pay jobs. More than 1,000 attend every year.



Chicago Technical College,
Dept. N-202, Home Study Division,
118 E. 26th St., Chicago, Ill.

Send me at once the FREE sample lesson and complete facts about your new easy system that enables men to master College Drafting Training at home just as you teach it at the College in Chicago. This does not obligate me in any way.

Name.....

Address.....

Town..... State.....

Age..... Occupation.....

Check here if you prefer to come to Chicago for our short course in drafting. Opportunities to earn while you learn.

- takes only 8 weeks to get a big job



George Smith owns an agency and repair shop in West Alexandria, Ohio. He makes \$200 a week.

and Earn \$75 to \$125 a Week as Auto or Aviation Expert

Learn the auto and tractor business by the McSweeney method, then step out and get a good job at \$75 to \$125 a week or open your own repair shop and make up to \$10,000 a year. Trained men are needed everywhere. Opportunities galore! Eight weeks' training fits you to open repair shop or to go on with one of the big firms waiting for trained men. Read what George Smith and C. E. Gillespie have done. Hundreds of other McSweeney trained men can tell as interesting facts. Every month McSweeney men who complete their training are taking the place of half-trained and incompletely self-trained men.

Money Back Guarantee

If, after completing my training, you are not satisfied, if you are not qualified to accept a big-pay job, your tuition will be refunded.

AVIATION Course

AVIATION is paying tremendous incomes to trained men! Coupon brings complete details about complete course in Aviation. Learn on real airplane engines under experienced instructors. Ask about special course in FLYING. Don't miss this remarkable opportunity. Save by enrolling at once. The sooner you start the sooner you will be ready to earn big pay or get into business for yourself.

Learn in Only 8 Weeks

Simple, thorough, practical shop methods. You learn the "why" of everything you do, then learn to do it right. You do real work with real tools and real equipment. No book studying. Very little schooling necessary. Any man from 16 to 60 can learn. Write today for Big Special Limited Time Tuition Offer. No facilities for colored students. Write for Big, Illustrated Book FREE!



Learn on Real Machines

C. E. Gillespie has charge of a fleet of trucks and tractors for the State Highway Commission, due to McSweeney training.

MAIL COUPON FOR FREE BOOK

McSweeney Auto, Tractor and Aviation School, Dept. A-11-K, Chester at 30th St., Cleveland, O., #263 Madison St., Memphis, Tenn.

Without cost or obligation, send me your big FREE book on Autos and Aviation, also full details of your special tuition offer.

Name.....
Street.....
Town..... State.....



McSWEENEY

Auto, Tractor and Aviation SCHOOLS

Dept. A-11-K
Chester at 30th St., Cleveland, O. or 263 Madison St., Memphis, Tenn.

Learn How to Make \$50 to \$100 a Week

By BEING TECHNICALLY TRAINED THIS THOROUGH WAY

Only trained men rise to be bosses! They make the large, steady incomes! Are you ready for that? Now's the time to learn. Master a craft—your craft. Select the subjects you want to study from the list below.

You can master them quickly, easily and thoroughly with the St. Louis Technical Institute's homestudy teaching. **Get Started Today** Our methods and lessons are so plainly and clearly defined that

you'll be amazed how fast you master the work. How soon will you be qualified for an increase? Write us today! Get complete information. Our big free book explains it all!

Check Which Courses You Want to Learn!

- Drafting (Architectural Machine)
- Sheet Metal Designing and Drafting
- Contracting & Estimating
- Heating & Ventilating Engineering
- Boiler Maker Laying Out & Inspection
- Mathematics and Slide Rule Reading
- Plumbing and Sanitary Engineering
- Steel Ship Laying Off & Plan Reading
- Aeronautical Drafting and Engineering

ST. LOUIS TECHNICAL INSTITUTE, 4545 CLAYTON AVENUE ST. LOUIS, MO.

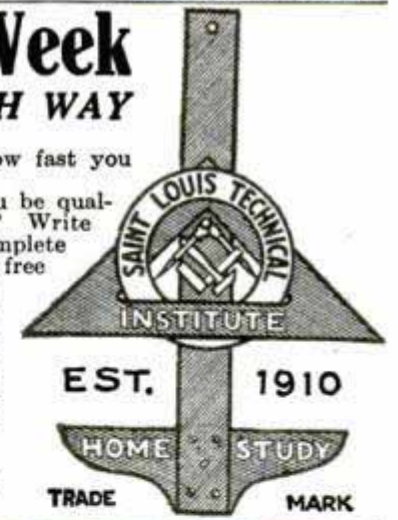

TRAVEL - for 'UNCLE SAM'

RAILWAY POSTAL CLERKS

MAIL CARRIERS—POSTOFFICE CLERKS
GENERAL CLERKS—FILE CLERKS

\$1700 to \$3400 a Year for Life

No "lay-offs" because of strikes, poor business, etc.—sure pay—rapid advancement. Many other U. S. Government Jobs. City and country residents stand same chance. Common sense education usually sufficient

STEADY WORK

Cut coupon and mail it before turning the page.

MEN—BOYS

18 to 45

Use Coupon Before You Lose It

COUPON

FRANKLIN INSTITUTE, Dept. B173, Rochester, N. Y. Rush to me, free of charge, (1) A full description of the position checked below; (2) 32-page book, with list of positions obtainable; (3) Tell me how to get the position checked.

- Railway Postal Clerk (\$1900 to \$2700)
- General Clerk (\$1260 to \$2100)
- Postoffice Clerk (\$1700 to \$2300)
- File Clerk (\$1260 to \$2500)
- City Mail Carrier (\$1700 to \$2100)
- Rural Mail Carrier (\$2100 to \$3300)

Name.....
Address.....



**"Possessed
of the
Devil?"**

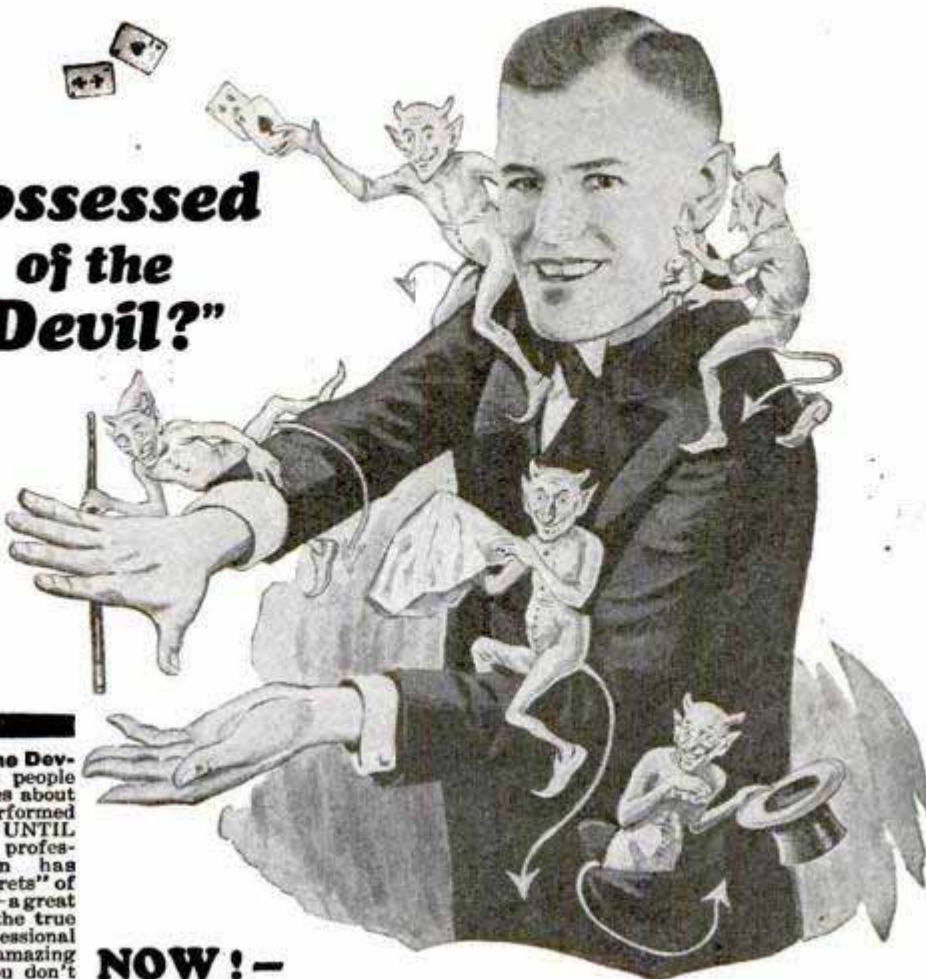

"Possessed of the Devil?"—that's what people said in olden times about the man who performed tricks of Magic. UNTIL NOW—only the professional magician has KNOWN the "Secrets" of Magic. BUT NOW—a great Magician reveals the true long-guarded professional "Secrets" in an amazing NEW Course. You don't need to be "possessed of the devil" to perform these seemingly impossible feats.

**NOW!—
YOU CAN—**

Learn MAGIC

At Home—by Mail

Mail coupon below and learn how the great Magician, Dr. Harlan Tarbell, NOW makes it possible for you to learn Magic—real professional Magic—quickly and easily—**AT HOME—BY MAIL—and at a very nominal cost!**

If you will pledge yourself to secrecy, Dr. Tarbell, internationally known magician and teacher of some of the world's greatest magicians, will reveal to you the long-guarded secrets of the magic profession. He reveals these secrets in an amazing NEW and elaborately illustrated

Course. Never before disclosed Secrets of the Orient, Mysteries from Europe, India, China and Japan—as well as a massive array of card tricks, parlor tricks, and sleight-of-hand feats—**ARE NOW YOURS** to learn easily and quickly—**BY MAIL—AT HOME**—during your spare time.

Mail coupon now for free Magic Book telling all about this amazing NEW Magic course that makes even the most super-human feats of the skilled magician as simple as "abc"!

Earn \$250 to \$1000 a Month

The NEW Tarbell Course in Magic will give YOU that magnetic popularity that will make you the center of any crowd. Business and social success is *assured* when you can perform Magic Feats. Without even giving up your present position, you can earn big money on the

side. Clubs, Lodges, Charity and Social Affairs—all pay high fees to the man who knows Magic. Magicians make from \$250.00 to \$1000.00 a month. You have everything to gain. You can't lose. Mail the coupon NOW—before you forget it—and learn all that is in store for YOU.

Write for Details

Money-Back Guarantee Protects You

The great NEW Tarbell Course in Magic is backed by an Iron Clad Money-back GUARANTEE. You get your money back if YOU are not entirely satisfied. You risk nothing.

Mail this coupon NOW—and without cost or obligation on your part—we will send you free literature telling all about this marvelous NEW Tarbell Course in Magic. Learn at home by mail—Real PROFESSIONAL MAGIC.

TARBELL SYSTEM, Inc.,
1926 Sunnyside Avenue Studio 13-57 Chicago, Illinois

Mail This NOW!

**TARBELL SYSTEM, Inc. Studio 13-57
1926 Sunnyside Ave., Chicago**

Tell me all about Dr. Tarbell's new and simple system by which I can learn the secrets of MAGIC. Also tell me about your Low Prices and Easy Payment Plan. No obligation on my part.

Name.....

Address.....

Age.....

Learn Electricity IN LOS ANGELES

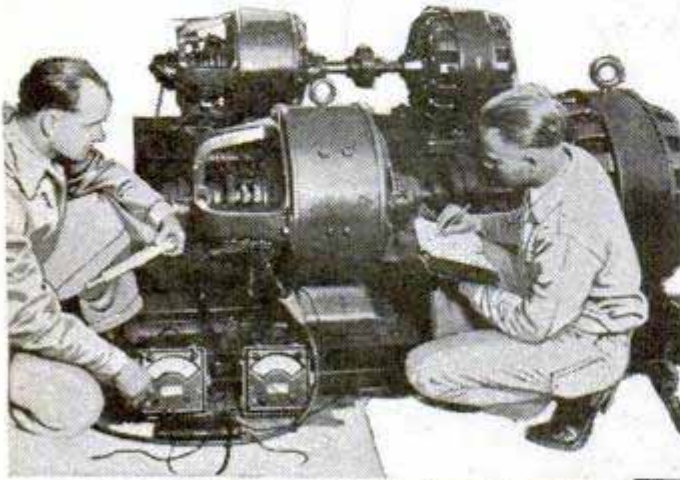

and LEARN IT RIGHT!

1. What Kind of a School Is NATIONAL?

NATIONAL is a Million Dollar institution—established in 1905—recognized throughout the electrical industry as one of America's foremost trade schools. NATIONAL offers practical, intensive training in all electrical branches. All technical essentials included. No age limit. No previous experience necessary. Life Scholarship privileges. Start any time of the year.

2. How Long to Learn Electricity?

NATIONAL properly trains you in the short time of 6 to 9 months. Upon completing this Condensed Course you are fully qualified as a Practical, Competent Electrician, and you have not risked your chances of employment because of inferior, incomplete instruction.

3. What Employment Service Does NATIONAL Guarantee?

NATIONAL GUARANTEES to give unlimited and efficient Employment Service to students wishing to earn living expenses while learning; and to graduates getting started in the electrical field. This is the most any reputable school can be expected to do.

4. What Inducements Does NATIONAL Offer?

NATIONAL offers YOU the very best technical-practical training that money can buy at a cost within every man's reach. It does not offer to pay your railroad fare, room and board or other personal expenses, preferring to limit its activities to the PROPER TRAINING OF MEN FOR SUCCESS.

5. Why You Should Come to LOS ANGELES!

LOS ANGELES is the heart of the country's most rapid electrical development—as well as the world's most ideal city in which to live and prepare for success in electricity

WRITE for FREE BOOK NOW!

NATIONAL Electrical School

Dept. 536, 4006 Figueroa St.,
Los Angeles, California.

Send me your big free illustrated catalog of
Electrical Opportunities showing how I can learn
quickly and get a Big-Pay Electrical Job.

Name.....

Address.....

Age..... City..... State.....



Increase Your Earning Power

Apply time and labor-saving kinks to your work. Your efficiency will soon be recognized and you will be in line for advancement.

If you do machine shop work of any kind, sheet-metal work, painting, carpentry, auto repairing, farming, concrete work, plumbing, electrical work, welding, building, glass work, general repairing, tool-making, poultry raising, masonry or home repair work, get this

LIBRARY OF 6000 TIME AND LABOR SAVING IDEAS FOR SHOPMEN AND HANDYMEN

JUST PUBLISHED

SHOP NOTES for 1929

224 Pages
347 Articles
400 Illustrations

See partial list
of
contents below

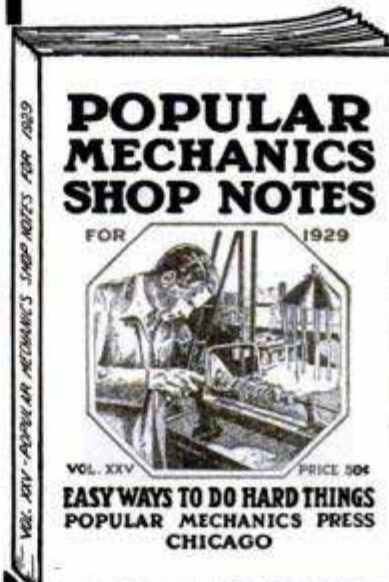

Including the new 1929 issue illustrated above, there are now 15 volumes in the Shop Notes Library of 6,000 easily understood short cuts to every-day jobs. Here are just a few of the subjects taken from the 347 articles in the latest issue.

Aluminum Mending	Drilling Kinks	Practical Mimeograph
Artistic Doorplates	Dumb Waiter	Reamer Holder
Artistic Plaques	Electric Crucible	Removing Roller Bearings
Attractive Lampshades	Furniture Designing	Renewing Old Pumps
Bird Bath in Concrete	Handy Workshop	Renovating Gaskets
Blowtorch Making	Homemade Jack	Repairing Laundry Tube
Brass Pipe Handling	Homemade Sile	Rush or Fibre Seats
Build Your Own Garage	Insulating Hot Water	Safe Folding Ladder
Burning Coke	Tank	Six-Inch Bench Shaper
Burning Out Carbon	Lathe Kinks	Softening Leather Belt-
Camera Exposure Meter	Long Narrow Photo-	ing
Candlestick Making	graphs	Tables in Art Moderne
Chute for Parcels	Machine for Making Rope	Tin Can Mechanics
Colonial Spinning Wheel	Paint Removing	Tractor for Light Work
Crane for Small Garage	Piston Ring Compressor	
Double Vise Press	Pneumatic Soldering	
Draft Regulator	Plant	

Each volume contains approximately 500 articles and 400 illustrations and has 224 Pages. At the regular price of 50 cents per single volume this library costs \$7.50, but for a limited period we will supply the 15 vols. when ordered at one time at the special reduced price of only \$4.50.

SPECIAL OFFER COUPON

POPULAR MECHANICS PRESS,
200 E. Ontario St., Room P10, Chicago, Ill.

Send me, as per your special offer, the following books. I will pay for books C. O. D. when they arrive. My money will be refunded if I am not satisfied. (Check what you want.)

- 1929 Shop Notes and Lathe Handbook, both for 98c.
 Complete Shop Notes Library (15 vols.) \$4.50.

Name.....

Street and No.....

City..... State.....

In this FREE BOOK

a World-Famous Flier shows
how YOU can get into

AVIATION

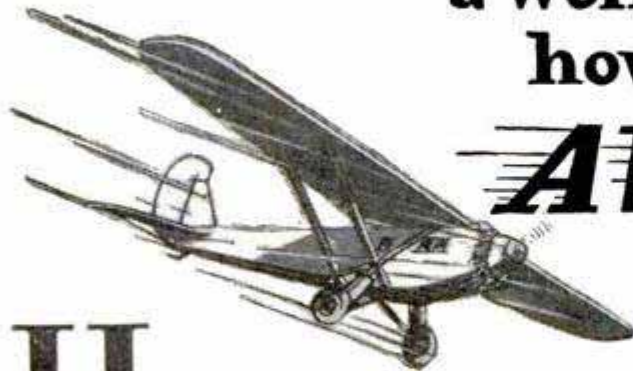

HERE is the book that tells you straight from the shoulder what Aviation offers YOU. You've been wondering how to break into the field—wanting all the facts, all the information. Here it is! A story more exciting, more thrilling, more inspiring than fiction—yet a man-to-man message of FACTS from cover to cover. Walter Hinton—hero of history-making flights—gives you the brass tacks of Aviation Today. He shows you exactly *where* your opportunities lie—exactly *what* to do to make the most of them—exactly *how* to fit yourself for them. Here is a book for men with too much backbone to stay chained to a small-pay job—too much adventure in their blood for a humdrum grind—too much good sound business sense in their heads to let this opportunity of a lifetime outgrow them!

The Richest Fastest Growing Industry the World Has Ever Known

You haven't heard anything about this being a "bad year" for Aviation! Men like Ford, DuPont—millionaires—are investing fortunes in the field. Cities everywhere are building more airports; 24-hour shifts are racing construction on new plane and equipment plants. Air lines, air service of every kind is doubling and redoubling itself almost while you watch! There's no doubt about there being BIG PAY plus a real future for YOU in Aviation. Your one sure move is to get the right training—QUICK!

You Must Be 18 or Over

To take an active part in Aviation you must be at least 18 years of age. If you are under 18, please do not ask for Lieut. Hinton's Book because it will not interest you.

Aviation Is Ready, Hinton Is Ready—Now It's Up to YOU

Right at home in spare-time Hinton will teach you all the essential facts about plane construction, rigging, repairs, motors, instruments, theory of flight, navigation, commercial Aviation. Whether you plan to fly, or to cash-in on one of the more than forty Big-Pay ground jobs, you must have this ground-work to land the job you want at the pay you expect. Learn just where you stand and what first steps to take. This Free Book tells how. Clip the coupon and send it TODAY. Hinton will rush your book by return mail.

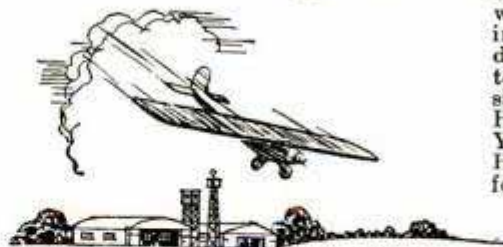
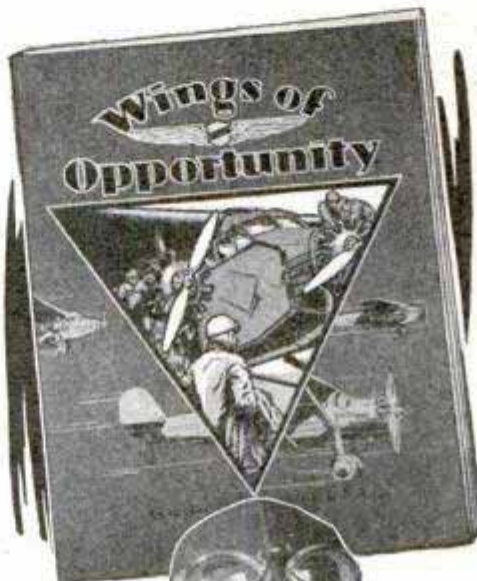

40

Jobs on the Ground for Each One in the Air

Fliers are in demand—certainly! But for every man in the air, trained men are needed in over 40 highly-paid jobs on the ground. Hinton's training gives you your ground-work to earn real money as one of these:

Engineers, Designers and Draughtsmen, Pilots, Engine and Plane Mechanics, Riggers, Electricians, Welders, Instrument Makers, Wood and Metal Workers, Plane and Motor Inspectors, Airport Operators, Radio Experts, Assemblymen, Aerial Surveyors and Photographers, Aerial Transport Managers, Salesmen.

Walter Hinton

Trail-blazer, pioneer, explorer, author, instructor, AVIATOR. The first man to pilot a plane across the Atlantic—the famous NC-4—and first to fly from North to South America. The man who was a crack flying instructor for the Navy during the War; who today is training farsighted men for Aviation. Hinton is ready to back YOU up to the limit. His Book is yours FREE for the coupon below.

Aviation Institute of U. S. A.

Walter Hinton, President

1115 Connecticut Ave., Washington, D. C.



Rush Back to Washington!

Walter Hinton, Pres.,
Aviation Institute of U. S. A.,
1115 Conn. Ave., Washington, D. C.

1-Z

Dear Lieut. Hinton: Send me your FREE Book telling how I can train under you right at home for Aviation.

Name.....

Street..... Age.....
(must be over 18)

City..... State.....



Isn't she worth fighting for?

SHE believes in you and trusts you and she's depending on you to fight some of her battles for her.

As wife or mother, she can't go out in the world and earn the money necessary to support a family in comfort. That is your job.

Are you fair to her when you let the days drift by without making a real effort to get ahead? Is it right to ask her to scrimp and save and deny herself when with just a little grit and effort you could provide her with the comforts and luxuries she would like to have?

Think this over—then act! Decide today that you are going to get the special training that is becoming more and more necessary in every line of business.

There is an easy, fascinating way to do it. Right at home, in the spare time that now goes to waste, the International Correspondence Schools will prepare you for advancement and more money.

At least find out how by marking and mailing the same salary-raising coupon that has meant so much to so many other men in just your circumstances.

It doesn't cost you a penny or obligate you in any way to do this, but it may be the means of changing your entire life. Do it now. Do it for HER.

Mail Coupon for Free Booklet

INTERNATIONAL CORRESPONDENCE SCHOOLS
Box 5644-F, Scranton, Penna.

Without cost or obligation, please send me a copy of your booklet, "Who Wins and Why," and full particulars about the course before which I have marked X in the list below:

TECHNICAL AND INDUSTRIAL COURSES

- | | |
|--------------------------------------------------|-----------------------------------------------------------------------------|
| <input type="checkbox"/> Architect | <input type="checkbox"/> Automobile Mechanic |
| <input type="checkbox"/> Architectural Draftsman | <input type="checkbox"/> Aviation Engines |
| <input type="checkbox"/> Building Foreman | <input type="checkbox"/> Plumber and Steam Fitter |
| <input type="checkbox"/> Concrete Builder | <input type="checkbox"/> Plumbing Inspector |
| <input type="checkbox"/> Contractor and Builder | <input type="checkbox"/> Foreman Plumber |
| <input type="checkbox"/> Structural Draftsman | <input type="checkbox"/> Heating and Ventilation |
| <input type="checkbox"/> Structural Engineer | <input type="checkbox"/> Sheet-Metal Worker |
| <input type="checkbox"/> Electrical Engineer | <input type="checkbox"/> Steam Engineer |
| <input type="checkbox"/> Electrical Contractor | <input type="checkbox"/> Marine Engineer |
| <input type="checkbox"/> Electric Wiring | <input type="checkbox"/> Refrigeration Engineer |
| <input type="checkbox"/> Electric Lighting | <input type="checkbox"/> R. R. Positions |
| <input type="checkbox"/> Reading Shop Blueprints | <input type="checkbox"/> Highway Engineer |
| <input type="checkbox"/> Telegraph Engineer | <input type="checkbox"/> Chemistry |
| <input type="checkbox"/> Telephone Work | <input type="checkbox"/> Pharmacy |
| <input type="checkbox"/> Mechanical Engineer | <input type="checkbox"/> Coal Mining Engineer |
| <input type="checkbox"/> Mechanical Draftsman | <input type="checkbox"/> Navigation <input type="checkbox"/> Assayer |
| <input type="checkbox"/> Machine Shop Practice | <input type="checkbox"/> Iron and Steel Worker |
| <input type="checkbox"/> Toolmaker | <input type="checkbox"/> Textile Overseer or Supt. |
| <input type="checkbox"/> Patternmaker | <input type="checkbox"/> Cotton Manufacturing |
| <input type="checkbox"/> Civil Engineer | <input type="checkbox"/> Woolen Manufacturing |
| <input type="checkbox"/> Surveying and Mapping | <input type="checkbox"/> Agriculture <input type="checkbox"/> Fruit Growing |
| <input type="checkbox"/> Bridge Engineer | <input type="checkbox"/> Poultry Farming |
| <input type="checkbox"/> Gas Engine Operating | <input type="checkbox"/> Mathematics <input type="checkbox"/> Radio |

BUSINESS TRAINING COURSES

- | | |
|------------------------------------------------------------------|-------------------------------------------------------|
| <input type="checkbox"/> Business Management | <input type="checkbox"/> Business Correspondence |
| <input type="checkbox"/> Industrial Management | <input type="checkbox"/> Show Card and Sign Lettering |
| <input type="checkbox"/> Personnel Management | <input type="checkbox"/> Stenography and Typing |
| <input type="checkbox"/> Traffic Management | <input type="checkbox"/> English |
| <input type="checkbox"/> Accounting and C. P. A. Coaching | <input type="checkbox"/> Civil Service |
| <input type="checkbox"/> Cost Accounting | <input type="checkbox"/> Railway Mail Clerk |
| <input type="checkbox"/> Bookkeeping | <input type="checkbox"/> Mail Carrier |
| <input type="checkbox"/> Secretarial Work | <input type="checkbox"/> Grade School Subjects |
| <input type="checkbox"/> Spanish <input type="checkbox"/> French | <input type="checkbox"/> High School Subjects |
| <input type="checkbox"/> Salesmanship | <input type="checkbox"/> Cartooning |
| <input type="checkbox"/> Advertising | <input type="checkbox"/> Illustrating |
| | <input type="checkbox"/> Lumber Dealer |

Name.....

Address.....

City..... State.....

Occupation.....

If you reside in Canada, send this coupon to the International Correspondence Schools Canadian, Limited, Montreal, Canada



"I earned \$75 last week, Flo—and my banjo did it!"

"ISN'T it just great to make so much money—especially when the work is so fascinating and easy! I could kick myself that I didn't learn to play the banjo years ago. Then it looked so difficult to learn—but gee, you know how easy it was for me once I started!"

Banjo is the easiest and most enjoyable instrument to play. Our home study course is so simple, so completely explained that you will be able to play the most difficult pieces in almost no time—classical, jazz, "hot numbers."

There is always plenty of work for the banjo player—no orchestra or jazz band is complete without one. And the beauty of it is, you get paid for having a good time! Let us tell you without cost or obligation how you can quickly learn to play the banjo and earn big money—or win quick popularity. Write TODAY for details.

TENOR BANJO STUDIOS

Dept. A-101, 9th Floor, Woolworth Bldg., New York City

DRAW CARTONS

Turn Your Talent Into Money

Cartoonists earn from \$50 to \$250.00 per week—some even more. Remarkable new Circle System of Drawing teaches you in half the usual time. Send for booklet and sample lesson plate explaining full details of the Course.

THE NATIONAL SCHOOL OF CARTOONING
623 Penton Building Cleveland, Ohio



LAW STUDY AT HOME

Become a lawyer. Legally trained men win high positions and big success in business and public life. Be independent. Greater opportunities now than ever before. Big corporations are headed by men with legal training. Earn \$5,000 to \$10,000 Annually

We guide you step by step. You can train at home during spare time. Degree of LL.B. conferred. LaSalle students found among practicing attorneys of every state. We furnish all text material, including fourteen-volume Law Library; Low cost, easy terms. Get our valuable 64-page "Law Guide" and "Evidence" books FREE. Send for them NOW.

LaSalle Extension University, Dept. 1064-L, Chicago.
The World's Largest Business Training Institution

Learn Watchwork, Jewelrywork and Engraving

A fine trade commanding a good salary, and your services always in demand. Address **Horological**, Dept. P, Bradley Institute, PEORIA, ILLINOIS, for our latest catalog.



ZIP-ZIP SHOOTER

THOUSANDS of boys are made happy with this wonderful Zip-Zip shooter, scientifically and practically made. If you like hunting and outdoor sports, get a Zip-Zip shooter with plenty of pep and force.

If your dealer happens not to have them, order from us. Zip-Zip shooter 35c or three for \$1.00; send stamps, coin or money order.

Automatic Rubber Co., Columbia, S. C.



Broadcasting Station WISN is operated from The School of Engineering; also Amateur Station W9SO.



Established 1903. Chartered by State of Wisconsin.

Oscar Werwath, E. E.

Director of the Extension Division, School of Engineering — Pioneer in electrical training for 25 years.

"NOW I will train YOU for BIG PAY in ELECTRICITY IN YOUR OWN HOME Just as I have trained 25,000 Graduates in my Great Electrical School"

NOW, through my Extension Division, I will train you for advancement and **MORE PAY** in Electricity without your leaving your home! You will get the same course, the same methods, the same faculty of skilled engineers that have made The School of Engineering internationally famous.

Behind your training will be an institution specializing in Electricity. Not a mere correspondence school but a fully established college, over 25 years old, recognized by the U. S. Gov't. Thousands of S. of E. graduates now employed in important positions with largest concerns in the country.

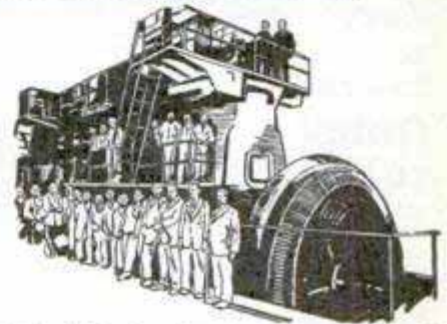

Diesel Engines for the Panama Canal, on which S. of E. Students assisted with acceptance tests at the request of U. S. Government.

ELECTRICALLY TRAINED MEN Earn \$3,000 to \$10,000 a Year

In Radio, Television, Aviation, Automotives, Refrigeration, Moving Pictures, Super-Power, Lighting—Electricity is the key. Big manufacturers are pleading for men trained in **Practical Electricity**. Salaries of **\$3,000 to \$10,000** a year now are common. Here is a vast field for you, with unlimited opportunities. **Now** is the time. Start on the road of Electrical Training that leads to bigger pay—bigger opportunities—and **SUCCESS!**

EARN AS YOU LEARN

Cash in on your Electrical Training while you're learning. Many students report increased earnings, advancement, even while studying. Train in your spare time at home. Employment Service renders **FREE** aid for life. Lifetime Consultation Service. Many exclusive features available nowhere else. Mail the coupon today for full particulars.

EXTENSION DIVISION

SCHOOL of ENGINEERING

Dept. 31, Milwaukee, Wisconsin

FREE!

Send Coupon **TODAY** for **FREE** illustrated Catalog — "Practical Electricity—the Key to Success"—and full details of Extension Division Training.

MAIL COUPON NOW!

Extension Division, Dept. 31
SCHOOL OF ENGINEERING
Milwaukee, Wisconsin

Please send me, without obligation, **FREE** illustrated catalog, "Practical Electricity—the Key to Success," and details of Extension Division training.

Name.....

Address.....

Home Shop-Laboratory Without Extra Cost!



A Full-sized Home Shop-Laboratory (not toys) that you can't duplicate for \$60, included with each course without extra charge.

Exclusive Patented Laboratory Equipment

that cannot be secured elsewhere. **Special Unit Board System** makes fascinating sport of laboratory experiments. Amazingly easy to use.



Learn By Doing



No mere book on theoretical study—but **PRAC-TICAL** training on full-sized motor, switchboard, circuits, and electrical equipment.

Satisfaction Guaranteed

You can take S. of E. Home Shop-Laboratory training without risking a penny. **Guarantee Bond** protects you.



BARBERING

Now One of the Highest Paid Professions! \$90 to \$150 Every Week!



Easy to Learn—Quick

to Earn! That's BARBERING for YOU! And the best part of it all is this—scientific barbering, as taught the modern MOLER way, makes YOU a Master Barber in a short course of intensive training, at small expense! You soon step out as your own Boss, if you wish, in your own Shop, which we will gladly help you equip.

MOLER Graduates are Always Busy! MOLER trained Men are always given the preference, for they alone possess the valuable, thorough MOLER training in the application of all the latest scientific Barbering methods, including the Electric hair cutter, the mechanical massage, and the latest vogues in ladies' hair bobbing. MOLER also gives special training in ladies' marcelling and an easy practical course in the treatment of skin diseases.

EARN WHILE LEARNING!

"Where there's a Will there's a Way" to earn BIG pay! Write to the nearest MOLER College, there is one near you, and learn how you can earn while you learn the barber trade. Ask for the new FREE MOLER Barbering Booklet B. Find out HOW MOLER helps you help yourself AFTER you graduate, as well as BEFORE! Find out why MOLER Men are making DOUBLE the money others made last year, before Ladies' Shingle Bobbing became so popular. You're NEXT in line for big pay—the MOLER way. Send Coupon TODAY!

Standardized Branches

Moler System of Colleges

139 E. 23rd St., New York City.	109 S. 15th St., Omaha, Nebr.
512 N. State St., Chicago, Ill.	501 E. Water St., Milwaukee, Wis.
810 N. 6th St., St. Louis, Mo.	81 Forsyth St., N.W., Atlanta, Ga.
801 Main St., Kansas City, Mo.	81 S. Second St., Memphis, Tenn.
206 E. 4th St., Cincinnati, Ohio.	912 Main St., Dallas, Texas.
215 Huron Road, Cleveland, Ohio.	
559 Michigan Ave., Detroit, Mich.	

Address Nearest Branch

Please send me without obligation on my part your Booklet B.

Name.....

Address.....

City.....State.....

New Course in OFFICE MANAGEMENT

GET into this profitable, uncrowded field. Training period is short, inexpensive, and does not interfere with your present work. Free 32-page book gives all the interesting facts. Send for it. No obligation.



International Accountants Society, Inc.
A Division of the
Alexander Hamilton Institute
Department 32, 3411 S. Michigan Avenue, Chicago, Ill.

BE A JAZZ MUSIC MASTER



Play Piano By Ear

Play popular song hits perfectly. Hum the tune, play it by ear. No teacher—self-instruction. No tedious ding-dong daily practice—just 20 brief, entertaining lessons, easily mastered.

At Home in Your Spare Time Send for FREE BOOK. Learn many styles of bass and syncopation—trick endings. If 10c (coin or stamps) is enclosed, you also receive wonderful booklet "How to Entertain at Piano"—and many new tricks, stunts, etc.

Niagara School of Music
Dept. 338, Niagara Falls, N. Y.

Send for this Free Book

LAW HIGH-GRADE INSTRUCTION BY CORRESPONDENCE

College, Post Grad. and Bar Ex. Rev. Courses. Law has attracted more keen, brainy men than any other calling. Send today for catalog. Low cost, easy terms. Standard texts. Degrees.

Chicago School of Law Dept. 801, Reaper Block CHICAGO, ILL.



easily, permanently corrected. Win happiness and success. Ask for full information and special phonograph record. Send dime for postage.

12972 Woodward Ave., LEWIS INSTITUTE, Detroit



\$1260 to \$3400 YEAR
MEN—BOYS—18 Up
STEADY WORK
Paid Vacations

Common education usually sufficient

Mail coupon today—SURE

FRANKLIN INSTITUTE
Dept. B196, Rochester, N. Y.

Gentlemen: Rush to me, FREE of charge, list of U. S. Government big pay positions now obtainable. Send me FREE 32-page book describing salaries, hours, work, vacation and giving full particulars on how to get a position.

Name.....

Address.....

Learn AVIATION at GREER COLLEGE

Come into Aviation

Man's Dream Is Answered—Aviation Is Here

Transport Flyers will train you

Greer Air Transport supervises all flying instruction. Greer pilots have had long experience in instruction and transport flying. You are safe and will learn quickly with their expert help.

C. L. Laird superintends ground training

C. L. Laird, with years of Aviation

experience as a designer and builder, supervises all ground training. He has been in Aviation and actual flying since 1911.

Earn Big Money in a 4 Hour Day

What are a Flyer's hours? **Four Hours**—not work—but fun—nevertheless those are usually the hours for him.

And the pay! Many make \$300 on a single Sunday. My Free Book gives astonishing details. Send for it now!

Adventure—Prestige—Thrills—BIG PAY—Easy, Fascinating work—that IS Aviation.

I'll allow you railroad fare from any point in the United States

Come to Chicago. I'll pay your fare when you enroll. Here is the **real** hub of the Aviation Industry. The World's finest and biggest Airport is here. Get my Free Book — tells all remarkable facts.

LEARN DAYS OR EVES A Job while Learning

You can attend the Great Shops of Greer College and learn Aviation either days or evens. We even help get you a job so you earn as you learn—in short—what does this wonderful training cost? Nothing!



Erwin Greer

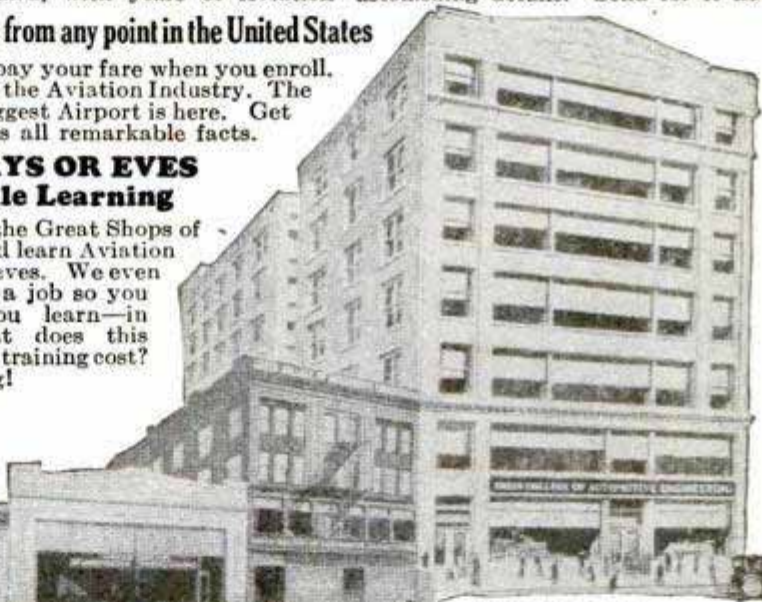

HOW!

I offer you a \$100 a week opportunity, perhaps more. But you must prepare. \$100 a week jobs mean nothing unless you can hold those jobs—so Prepare. I make it easy—26 years doing it—proves it, so when those jobs arrive—be ready—I'll help you get them—but be able to hold them.

TODAY Tomorrow is just a day—but think—is it to be a day **wasted** or a day **rushing** to success? Think of it. Tomorrow may be just the second day to your real triumph—but tomorrow can't possibly come before today. I ask you to do nothing but find out for yourself. My Book is Free. Look at it at least, it costs you nothing and it **will** help you if you enroll or don't.

Sincerely, **ERWIN GREER, Pres.**

GREER COLLEGE

Dept. 1001

2024 So. Wabash Ave.

CHICAGO



ERWIN GREER, President
Dept. 1001
2024 So. Wabash Avenue,
Chicago, Illinois

Send Free Book and details of Special offer, without obligation to me.

Name

Address Age

Genuine UNDERWOOD Below 1/2 Price



NOW ONLY **\$1** DOWN

Standard 4-Row Keyboard

Think of it! Only \$1.00 brings the World's most famous Underwood Typewriter for 10 days' free trial. Lowest price and easiest terms ever offered. Pay only 10c a day on easy monthly payment plan. This is the full size standard Underwood 4-row keyboard typewriter, manufactured to sell for \$100.00.

Do not confuse this 4-row standard office model Underwood with other frail machines originally costing only one-half as much.

Lowest Price — 10-Day Free Trial



FREE!!

Nothing Else to Buy

We teach you free. Complete Home Study Course of the famous Van Sant Speed Typewriting System, fully illustrated, easily learned, used in schools, business offices, everywhere.

This late model Underwood, specially priced at \$39.90 cash, is the lowest price ever quoted; has modern improvements including 4-row keyboard, two-color ribbon, back spacer, ribbon reverse, tabulator, release, shift lock and many other improvements. Beautifully refinished and renewed. Looks and operates like brand new

International Typewriter Exchange,
231 West Monroe Street, Chicago, Ill., Dept. 1094.

I enclose \$1 deposit. Send Underwood No. 4 at once for 10-day Free Trial. If I am not perfectly satisfied I can return it Express Collect and get my deposit back. If I keep it I will pay \$3 a month until I have paid \$44.90 (term price) in full.

Name..... Age.....

Address.....

Town..... State.....

Books on 65 Practical Subjects

Popular Mechanics Press specializes in supplying the outstanding best books on many subjects. As new books of merit appear, we will revise the list accordingly.

AIR NAVIGATION AND METEOROLOGY
Every flyer needs.... \$3.00

AIRCRAFT ENGINES
Dyke's New Instructor
Best Engine Book.... \$5.00

ARCHITECTURAL
Drawing and Lettering \$2.00

ARMATURE WINDING
Excellent new book... \$2.00

AUTO ENCYCLOPEDIA
Dyke's. (Covers New Model A Ford).... \$6.00

AVIGATION
By Dead Reckoning... \$2.00

BIRD HOUSES
How to Make..... \$1.00

BLUE PRINTS
How to Read..... \$2.00

BOAT BUILDING
35 Craft, Popular Outboard Engine Type..... \$3.00

BOY MECHANIC
Famous 4 Vol. Library, 4000 Things to Make. \$7.00

BUILT-IN FURNITURE
Complete Instructions. \$2.50

CARBURETORS
Excellent book on all makes..... \$2.00

CARPENTRY
Hand book of 336 Kinks. \$1.50

CHEMISTRY
For Old and Young Beginners..... \$2.50

CIVIL SERVICE
How to Prepare for... \$3.00

COLOR SIMPLIFIED
Practical new Book (for Color Users)..... \$3.50

CONCRETE
173 Ways of Using New Edition (Cloth) \$1.00

CONTRACTOR
Building Cost Estimator. \$2.00

DIESEL ENGINES
(New Work). Best Authority..... \$5.00

DOGS
Care and Raising..... \$2.00

ELECTRICIAN
214 Practical Kinks... \$1.50

ELECTROPLATING
Practical Results Easily Obtained..... \$1.00

ENGLISH
Self-Improvement in... \$2.50

ETIQUETTE
New 560-Page Book. Only..... \$1.00

FARMER'S BOOK
of 861 Kinks and Book for Farmers' Wives... \$1.00

FLIGHT TRAINING
Practical, new book, best on subject..... \$5.00

FORD (HENRY)
His Philosophy of Industry..... \$1.50

FORMULAS
10,000 Money Making. \$4.00

FURNITURE
Homemade (3 vols.)... \$3.00

HOME REPAIRS
Practical Book of..... \$2.50

INTERIOR DECORATING
Best book of new methods..... \$4.00

INVENTIONS (American)
Popular History of 2 vols. Reduced to... \$5.00

INVESTMENT
Policies that pay By Ray Vance..... \$4.00

JOINT WIPING
(New Edition)..... \$1.00

KITES THAT FLY
How to make..... \$1.25

LANDSCAPING
Practical..... \$2.50

LATHE WORK (METAL)
and Drilling and Thread Cutting..... \$1.00

LETTER WRITING
Social and Business Only..... \$1.00

MACHINIST
419 Kinks for..... \$1.50

MAGIC
200 New Tricks for Amateurs..... \$1.00

MAKING THINGS YOURSELF
900 Different Articles... \$3.00

MATHEMATICS
Made Easy for the Practical Man..... \$1.50

MECHANICAL DRAWING
Practical Course in... \$1.00

MODEL AIRCRAFT
Building and Flying... \$2.25

MOVIE MAKING
for Amateurs..... \$3.00

OUTDOOR OPPORTUNITIES
for Making a Living... \$2.00

OUTDOOR SPORTS
for All Year 'Round... \$1.50

PAINTING
House (Best Methods)... \$2.00

PETS
For Pleasure and Profit. \$2.00

PLUMBING
500 Plain Facts for Every Homeowner... \$1.50

POULTRY RAISING
for Profit..... \$2.00

POWER WIRING (D. C.)
Electrical (Just Out)... \$3.50

PUZZLES
Amusing Mathematical. \$1.50

RADIO
Trouble Shooting. Covers All-Electric Sets and Television..... \$3.00

ROPE SPINNING
Only Book on Subject... \$1.50

SHIP MODEL
Making..... \$2.50

SHOP NOTES
15 Vols. of 6000 Valuable Kinks..... \$4.50

STEEL SQUARE
Pocket Book, Practical. \$1.00

TAXIDERMY
Best Book of Methods... \$3.50

TENNIS
By Helen Wills..... \$2.00

TOY MAKING
Complete instructions... \$1.50

WELDING
ENCYCLOPEDIA All Methods..... \$5.00

WIRING
House (New Book)... \$2.50

WOOD TURNING (LATHE)
Practical Course in... \$1.50

WOODCRAFT
Famous 590 Page Book by Ernest Thompson Seton; Only..... \$1.00

Books sent C. O. D. anywhere in U.S.

Just check the books you want, write your name and address below, and mail the advertisement. It is your order blank. When postman hands you books, pay him the price and the postal charges. If outside the U. S. remit when ordering and include 10 cents per book extra for postage. We have many other books on these and 2,000 other subjects. Catalog free.

Name.....

City..... State.....

Address.....

Mail to Popular Mechanics Press,
Room P10—200 East Ontario St., Chicago, Ill.

We have placed machinists, carpenters, masons, plumbers, railroad men, office clerks, farmers and even laborers in fine Drafting Jobs under this plan. Mail coupon for details of our remarkable offer.

Men Who Work With Their Hands Make the Best DRAFTSMEN



and We'll Back Them With Tested Plan to Get Into DRAFTING



"Only one other man and I, of six taking California State Board examination for Architect passed. Then I realized the thorough and practical training given by American School. In 18 months I have gone from tracer to Chief Draftsman, in charge of all architectural and engineering work in one of the oldest offices here." R. L. WARREN, Los Angeles, Calif.

We are looking for more ambitious young fellows with factory, building-trade or any other kind of mechanical experience to prepare for and help place in well-paid Drafting positions. Such men, we find, are unusually successful as Draftsmen, because they know how things are done, and that's a priceless asset to the man who makes the blueprint plans. For there's a great deal more to Drafting than "mechanical drawing" and reading blueprints. The real jobs, those paying \$50 to \$100 a week, give you a chance to cash in on your entire past mechanical experience. Get in touch with me and I'll tell you how.

DRAFTING Is Logically YOUR NEXT MOVE!

Of course you realize the biggest handicap to mechanical work is that you're limited in earning capacity to the output of your two hands, as long as you live. Even the skilled mechanic earning \$50 to \$60 a week has reached his limit. He can never earn more and when he gets old he will earn less. So I don't blame any man for wanting to get away from his futureless outlook. For wanting to get into something where he can use his head as well as his hands—where he will be paid for what he **knows**, instead of only for what he **does** . . . You know enough about blueprints to understand that PLANS govern every move in factory and construction job. The Draftsman who makes them is several jumps ahead of the workman who follows them. And so I want you to know that DRAFTING is a logical, natural PROMOTION from mechanical and building work—better-paid, more interesting—just the kind of work you'd enjoy doing.

Get My NO-RISK PLAN

The way to a fine Drafting job for you—is easier than you think. It takes no "artistic talent" or advanced education. Thousands of men no smarter than you, with no more education or ability, have learned it quickly and you can, too. With the co-operation of some of the biggest employers and engineers in the U. S. we have worked out a plan to prepare you for Drafting work in your spare time at home—to help you get a fine position and to raise your pay. Backed by the contract shown above to refund the small cost, if we fail. Mail the coupon and I'll be glad to tell you all about this life-time chance to get into Drafting.

The American School

Dept. D-747A, Drexel Ave. and 58th St., Chicago, Ill.

American School

We will make this
Contract with you

1. We will prepare you for a fine simplified Drafting-room practice, at home, in spare time.
2. As soon as you are ready, we will help you get a good position, without cost to you or to employer—
3. At a substantial increase in salary—OR MONEY REFUNDED.



Mail Coupon for
Complete information.

3 Drafting Lessons Actually FREE

To Show You How Interesting
and Simple Drafting Is . . .

I wish I had the room here to tell you all about DRAFTING—how it has become the most important branch of every kind of manufacturing and construction work—how fascinating the work is—what a fine bunch of fellows Draftsmen are, the big salaries paid—how while Drafting is white-collar office work, it is closely hooked-up with big projects and big men. All that takes a 36-page book to tell and I'll be glad to send it to you free, and in addition I want to send you the first three lessons of our home-training so you can see how you'll like the work and how simple it is to learn. Coupon brings everything—mail it right away.

American School, Dept. D-747A,
Drexel Ave. & 58th St., Chicago, Ill.

Please send free and without the slightest obligation 3 Drafting lessons, 36-page book about the opportunities in Drafting and your plan to help get me a Drafting Job and a Raise.

Name.....
St. No.....
City.....State.....
Age.....Occupation.....



"I have obtained a position as a junior draftsman with the MuncieOilEngineCo., and so far I like the work real well and think it will continue so. I appreciate your aid in obtaining this position very much." MAURICE N. BAREHAM.



He Found the Key to \$10,000 a Year!

"Just a bookkeeper"—that's how J. A. Hogg, now Public Accountant at Logan, W. Va., would have classified himself six years ago when he first enrolled with LaSalle for home-study training in Higher Accountancy.

Little he dreamed that within two years—thanks to his specialized training—his yearly income would be \$5,000, and that two years later he would be making better than \$10,000 a year! But read what he writes, under recent date—

"It isn't often that an investment brings money profit of more than 7500 per cent in only six years, yet that's exactly what my enrollment in two LaSalle courses—Higher Accountancy and Law—has meant to me. I estimate it worth more than \$30,000 in cash returns, besides additional returns in personal and business prestige, in self-confidence and all-round larger success.

"Whereas when I first became a LaSalle member I was earning about \$100 a month, today I have my own successful public accounting firm, and have been mayor and police judge of my home town for the past five years, and LaSalle has made all this possible.

"I have enjoyed very much my LaSalle work. Your Problem Method has been a revelation—so much easier and more efficient than the classroom methods of my school days."

His Opportunity Is Yours— Send for Free Book

Are you ambitious to make a real success in business—to fit yourself for positions paying \$3,000, \$5,000, \$10,000 a year, and even better?

Here, then, is your chance—the same chance that faced J. A. Hogg when he clipped a LaSalle coupon.

Below is the coupon, and it will bring you—free—LaSalle's 64-page book, "Accountancy, the Profession that Pays." You will find it of the greatest help and inspiration.

If you mean what you say when you say that you want to get ahead—fill in, clip and mail the coupon NOW.

— Find Yourself Through LaSalle! —

LaSalle Extension University
The World's Largest Business
Training Institution

Dept. 1064-HR Chicago
I should be glad to have details of your salary-increasing plan as applied to my advancement in the business field checked below. Also a copy of "Ten Years' Promotion in One," all without obligation.



- Higher Accountancy
- Business Management
- Modern Salesmanship
- Traffic Management
- Railway Station Mgmt
- Railway Accounting
- Law—Degree of LL.B.
- Commercial Law
- Industrial Management
- Banking and Finance
- Personnel Management
- Credit and Collection Correspondence
- Modern Business Correspondence
- Modern Foremanship
- Expert Bookkeeping
- C. P. A. Coaching
- Business English
- Commercial Spanish
- Effective Speaking
- Stenotypy—Stenography
- Telegraphy

Name.....
Present Position.....
Address.....

Why Good Dancers Are Popular

Every one wants to dance with the person who knows the smart new steps!

Through my new method you can learn the latest, most popular steps in one evening—right in your own home, without music, partner, teacher. Simple as taking one step after another.

Thorough—takes you from the very beginning to this season's newest dances and all their variations.

Would cost you \$24.00 if taken at a Studio. Practice in your spare time—

surprise your friends—with your new-found popularity. **5 Day Trial—Free** 400,000 have already become accomplished, versatile dancers this easy way. Your success is guaranteed!

To prove it I will send you my dancing course without one penny in advance! Just send your name and address and when the package arrives give postman only \$1.98, plus delivery charges, and this famous course is yours. Try for 5 days—money back if not delighted! Don't delay—act now and be a good dancer soon.



ARTHUR MURRAY Studio 944, 7 East 43rd Street
NEW YORK, N. Y.

LEARN ELECTRICAL TRADES

Practical Training on Massive Lay-Out of Expensive Electrical Equipment. Armature Winding, House Wiring, Electric Welding, Electric Refrigeration, Power Plants, Switchboards, Transformers, Motors, Generators, Radio Batteries. Automobile Course included without extra cost. Write Today for Free Catalog.

COLEMAN ELECTRICAL SCHOOL, 1628 Main St., Kansas City, Missouri

MUSIC LESSONS IN YOUR HOME

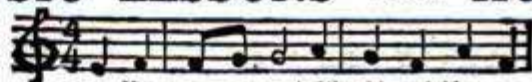

You can read music like this quickly

Write today for our **FREE BOOKLET**. It tells how to learn to play Piano, Organ, Violin, Mandolin, Guitar, Banjo, etc. Beginners or advanced players. You pay as you learn. Costs only a few cents a day. Thousands of satisfied students.

AMERICAN SCHOOL OF MUSIC, 51 Manhattan Bldg., CHICAGO

"The TRUTH about VOICE"

SENT FREE No Obligation to Buy

If you act quick!—we will send you postpaid—for 30 days free reading—new Voice Book disclosing startling **FACTS** that may save hundreds of dollars to every man or woman seeking a strong, rich voice for either singing or speaking. 30 days free reading—then send \$1. Otherwise, return it.



Prof. E. Feuchtinger, Dept. 13-57 Chicago, Ill.

SHORTHAND IN 30 DAYS

Boyd, the wonderful easy system, 150 words a minute guaranteed. Send today for Catalog and sample lesson.

CHICAGO HOME STUDY SCHOOLS
801 Reaper Block Chicago, Ill.

Learn How to WRESTLE



In Your Own Home
By Mail

Yes, learn to become an expert wrestler right in your own home, by mail, from the greatest wrestler the world has ever known. Be an athlete, be strong, be healthy. Learn how to throw and handle big men with ease. Learn to defend yourself. All taught in our course of lessons, and illustrated with hundreds of charts and actual photographs by

Farmer Burns and Frank Gotch

Farmer Burns, "the grand old man of the mat," taught Frank Gotch, the World's Champion, all he knew about wrestling, so Gotch said. He will now teach you Scientific Wrestling—Physical Culture—Jiu-Jitsu—Self Defense. Every man and boy in America, no difference what age, needs this wonderful course of lessons. Write today—your name, age and address on a postcard or letter brings you our fine book absolutely free, — no obligation of any kind. A splendid book on wrestling and physical culture. Write today stating your age.

Farmer Burns School of Wrestling 3377 Range Bldg., Omaha



Wanted... Men To Read Blue Prints *And Run Big Building Jobs!*

**Builders! Here's A Mes-
sage Of Vital Importance
To Every Ambitious Trades-
man In America! To Help You Win
Promotion In Building At Man Sized
Salaries, This Old Established School
For Builders Now Offers Quick, Easy,
Practical Training in Plan Reading. Cou-
pon Below Brings You Absolutely FREE A
Valuable Book, "How to Read Blue Prints";
Also A Set Of Real Building Blue Prints. Write
At Once!**

**SEE HOW QUICKLY YOU CAN BECOME A SUPERIN-
TENDENT OR BUILDING CONTRACTOR BY THIS NEW,
EASY BLUE PRINT WAY TO BIG PAY**

EVERY man in the Building Industry today knows that in order to win promotion and run big building jobs he must understand Blue Print Plans and Specifications from A to Z. With a trained mind it is easier to hold a big pay job in Building.

This announcement spells wonderful news for every man who is practical and ambitious. Here at last is an opportunity for you to take a quick, easy step that will bring you the success you have hoped for—if you are of this type and are willing to supply the honest effort necessary. Remember, your spare time is enough.

Practical Blue Print Training

You've needed it, you've prayed for it and now at last Chicago Tech brings it to you! For by a marvelous new practical blue print method, this old established and recognized School for Builders brings to you in an amazing short time everything you need to put you on the "headwork" side of the Building Industry. Prepares you for big pay and a real future right in your own home and in your spare time—right while you are on the job! It doesn't matter what your age is. You don't even have to have previous education. If you can read what is written here, you can grasp every money-making principle easily.

No Textbooks—Sim- ple as A B C

This astonishing blue print training is entirely different from ordinary schooling. No study grind. No text books to wade through. No useless theory. Practical from start to finish. Based on many sets of real blue prints which we give you to examine and keep. Twenty famous experts go over these actual working plans with you step by step and explain everything in plain, everyday language you can easily understand. Fascinating throughout and as easy to understand as your newspaper.

This is the kind of training that has enabled builders throughout the country—practical, ambitious men like yourself—to make the kind of money they wanted. Samuel Schrier, Pennsylvania, reports that he has been raised to foreman with an increase of \$72.70 per week. W. Fout, Virginia, was promoted from workman to superintendent as a result of his training. Percy F. Blair, Oklahoma, writes: "When I started your course, I received \$49.50 per week working with my tools. Now I am superintendent and make \$100 a week for the same concern."

Mail Coupon for FREE Facts

Investigate this short-cut to promotion at once! Don't send one penny. Simply fill in and mail the coupon. It brings you promptly a valuable free book, "How to Read Blue Prints," and actual working blue prints as well as convincing proof. No cost or obligation.

Write today—NOW!

If You Live Nearby

Visit our big Day and Evening School attended by over 1,000 builders. You can get the same training at home by mail—same lessons, same plans, same instructors—in your spare time.



FREE! BOOK and BLUE PRINTS To Carpenters and Builders

Without cost or obligation, every ambitious, practical man may now secure a copy of "How To Read Blue Prints" and a set of valuable working blue prints. Also, full facts and details about the new easy at-home training that has made possible promotions and bigger pay checks for scores of builders all over the country. Remember — there is absolutely no risk for you, so fill in and mail the coupon below!

Chicago Technical School For Builders,
Dept. N-142, Chicago Tech Building,
118 E. 26th Street, Chicago, Ill.

Send me at once your FREE BOOK and complete set of FREE BLUE PRINTS which I understand are mine to keep without obligation. It is understood that no salesman will call on me.

Name.....
Address.....
City..... State.....
Age..... Occupation.....

**Chicago Technical
SCHOOL for BUILDERS**

Dept. N-142, Chicago Tech Building, 118 E. 26th St., Chicago, Ill.

Earn \$75 to \$100 a Week as AUTO MECHANIC

In 8 Weeks You Can Have a Big-Pay Job as an Auto, Airplane or Tractor Mechanic

Eight short weeks of pleasant, fascinating, practical Auto, Airplane or Tractor work in my big shops—and then a real job paying \$75 to \$100 a week! You can step right out of low pay, long hours, and no future into the job of a high-salaried trained mechanic. Everywhere jobs are waiting for men trained as I train them. Change the whole course of your life in 8 weeks!

Learn on Real Machines—No Books

Come to my shops. I will make you a mechanic able to handle the hardest mechanic's job easily and quickly. I'll teach you to know Autos, Airplanes and Tractors inside out. You don't need education. You don't need previous experience. All you need is ambition. You learn by doing—by working on actual machines with real tools. This is not a correspondence course. (No facilities for colored students.)

Short Cut to Big Pay Learn how easy it is to get a steady, big pay job in the great Auto, Tractor and Aviation fields. Learn what other fellows like you have done with McSweeney training. Get special low tuition offer.

McSweeney Auto, Tractor and Aviation Schools, Dept. A-18-K, Chester at 30th St., Cleveland, O., or 263 Madison St., Memphis, Tenn.

Without cost or obligation, send me your big FREE Book on Autos, Tractors and Aviation, also full details of your special tuition offer.

Name.....

Street.....

Town.....State.....

Mail Coupon for Book

Money Back Guarantee

If, after completing my training, you are not satisfied, if you are not qualified to accept a big-pay job, your tuition will be refunded.

Special Aviation Course

AVIATION is paying tremendous incomes to trained men! Learn on real airplane engines under experienced instructors. Ask about special course in FLYING. Don't miss this remarkable opportunity.



McSWEENEY Auto, Tractor and Aviation SCHOOLS

Dept. A-18-K
 Chester at 30th St., Cleveland, O. or 263 Madison St., Memphis, Tenn.

NEW FREE BOOK

On How to Raise Poultry for Profit will be sent postpaid, on request to readers of Popular Mechanics. It tells how we help you start a highly profitable spare-time or full-time business of your own or get a good job at good pay. One of our students, J. L. Mosher, of Buffalo, N. Y., for example, started at \$35 a week after tenth Lesson.

Read of the International Poultry work done by Harry M. Lamon, whose methods of increasing egg production, culling out non-layers, saving on feed, raising fat broilers quick, etc., have doubled poultry profits—have raised salaries—have brought good jobs to men and women all over the country. You need this Book. It shows how you too can make poultry pay, make big money quick. Write for your FREE copy—today. Address, National Poultry Institute, Dept. 411-B, Washington, D. C.

TELEGRAPHY

(Morse and Wireless) and RAILWAY ACCOUNTING, taught thoroughly. Big salaries. Tremendous demand. Oldest, largest school. Endorsed by Telegraph, Railway, Radio, and Government officials. Expenses low—opportunities to earn large portion. Catalog free. DODGE INSTITUTE, Jones St., Valparaiso, Ind.



Many Other Government Jobs Obtainable
 Steady Work—No Layoffs—Paid Vacations
 Common Education Sufficient
MEN—BOYS 18 UP

LEARN WATCHMAKING AND ENGRAVING

BY OUR PROFIT-SHARING PLAN
OUR GRADUATES SUCCEED

One of our Iowa students started in a very small way—now doing over \$30,000 a year. Another in Wisconsin, over \$10,000 the first year. Day or night classes. Call or write for FREE BOOK.

Chicago School of Watchmaking, Dept. 5701, 549 W. Randolph St., CHICAGO

30 Days' Free Trial

New Models now ready for delivery direct from our factory. Astonishing low prices and terms. Do not buy until you get them.

RIDER AGENTS WANTED to ride and exhibit sample. Make big money. Many models \$21.50 up. Guaranteed \$1.50 each, wheels, lamps, horns, equipment at half usual prices. **Send No Money.** Write for our marvelous prices and terms on RANGER Bicycles.

Mead CYCLE CO. Dept. R109 CHICAGO

6 Ft. LONG GIVEN Boys! Here's the great navy model Airship. Large 6-foot air bag with inflators, parachute with automatic release and complete instructions for flying. Will fly for miles at height of 1000 feet. Great chance to study aerial navigation. Send name and we'll send 6 of our new art pictures to dispose of on special 25c offer. Send the \$1.50 you collect and as a reward for this service we will send this wonderful Airship with full instructions free.

C. M. THOMAS, 337 W. Madison St., 10-K-91 CHICAGO

Travel on "Uncle Sam's" Payroll \$158 TO \$225 MONTH

Mail Coupon Before You Lose It

FRANKLIN INSTITUTE, Dept. B197, Rochester, N.Y.

Sirs: Rush to me, without charge, (1) Full particulars, telling how to become a Railway Postal Clerk; (2) send copy of 32-page book, "How to Get U. S. Government Jobs," with list of many positions obtainable.

Name.....

Address.....

A Coupon That Has Meant Real Money To More Than 20,000 Ambitious Men!



\$6,000 A Year!

"From a life of want at \$600 a year to a life of plenty at \$6,000 a year, thanks to N. S. T. A. training." Chas. H. Barth.



N. S. T. A. Brought Him Wealth

M. V. Stephenson credits N. S. T. A. with his salesmanship earnings which have brought him his own home, a 70-acre farm, bank stock and a bank account.

National Salesmen's Training Ass'n, Dept. J-102,
N. S. T. A. Building, Chicago, Illinois.

Without cost or obligation, send me your free book, "The Secrets of Modern Dynamic Salesmanship." Also include full details of your training and your free employment service.

Name.....

Address.....

City..... State.....

Age..... Occupation.....



Ex-Clerk Earns 150% More Money

R. D. Baxter, former bookkeeper, is now head salesman of his division. In 3 years his salary increased 150%. "My success is due directly to N. S. T. A."

Who Else Wants to Raise Their Pay 700% or More?

Can It Be An Accident When Man After Man Raises His Pay—Each One Taking The Same Identical Steps? If You Are One Who Aspires To Earn REAL Money—If You Want To Get

Out Of A Monotonous, Low-Pay Job, Find Out About This Tested Plan For Increasing Incomes. It Has Raised More Salaries Than All The "Pull" And Luck In The World!

Get a Copy of This Amazing Book Free

Let's be practical. You want to make more money. . . A few years ago the three men pictured above were in the same situation. They had the urge to increase their pay—but didn't know how to do it.

Take J. H. Huppert, for instance. A plumber's apprentice at \$23 to \$25 a week. Naturally he was dissatisfied with such low pay. But like so many other men he was caught in a blind alley job—he could see no way out.

And then something happened! A certain book fell into his hands. Between its covers, he discovered certain facts and secrets he had never dreamed of. Within a period of three months he had earned more than his old job paid him in two years! One week's pay amounted to \$525!

Remarkable Salary Increases

A lucky accident? Not a bit of it! Other men, too, who raised their salaries after reading these vital facts are numbered by the thousands! After R. D. Baxter read them, his salary increased 150%. Charles B. Barth writes that he "went from a life of want at \$600 a year to a life of plenty at \$6,000 a year!"

The Secret of Big Pay

How did they do it? What did the book show them? Just this:—Every

one of these men realized that Salesmanship offers bigger rewards and delivers them QUICKER than any other line of work under the sun. This vital book, "The Secrets of Modern Dynamic Salesmanship," revealed to them the real TRUTH about the art of selling. It blasted dozens of old theories and told them exactly how the great sales records of nationally-known star salesmen have been achieved. And not only that, it outlined a simple plan that will enable almost any man to master scientific salesmanship without losing a day or dollar from his present position.

A Few Weeks—Then Bigger Pay

There was nothing "different" about these men when they started. Salesmanship is just like any other profession. It has certain fundamental rules and laws—that you can master just as easily as you learned the alphabet. And through the NATIONAL DEMONSTRATION METHOD—an exclusive feature of the N. S. T. A. system of SALESMANSHIP training—you can acquire the equivalent of actual experience while studying.

Free to Every Man

If we were asking several dollars a copy for "The Secrets of Modern Dynamic Salesmanship" you might hesitate. But it is now FREE. So you

get your copy now. Learn the real facts about the selling profession, and about the tremendous demand for trained salesmen in every line, to fill city and traveling positions paying up to \$5,000 and \$10,000 a year. (Last year this association received calls for over 50,000 N. S. T. A. members from Wholesalers, Manufacturers and Jobbers.) A copy is yours for the asking, and your request entails no obligation. Simply fill out and mail the coupon above. Do it now!

NATIONAL SALESMEN'S TRAINING ASSOCIATION

Dept. J-102, N. S. T. A. Bldg.
CHICAGO, ILL.



Now Free

MAIL COUPON ABOVE

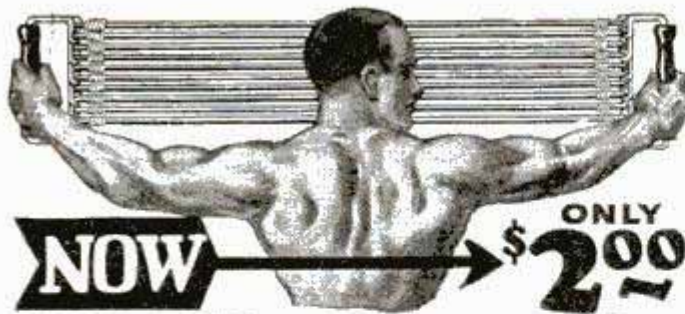

NOW → ONLY \$2.00
Giant Chest Expander

and Progressive Exerciser

Be a muscular marvel. Have the muscles of a superman. Become strong for your health's sake or to astound your friends with extraordinary feats which only men of giant strength can do. In a few short weeks you will easily do stunts which now seem difficult—then real muscles and strength will be yours—and yours to keep. If you want exercise to just keep in good shape you can reduce the strength of the Progressive Exerciser by eliminating as many cables as you wish. If you want great resistance so as to build up big solid muscles then use the full strength.

Send No Money Use This Money Saving Coupon

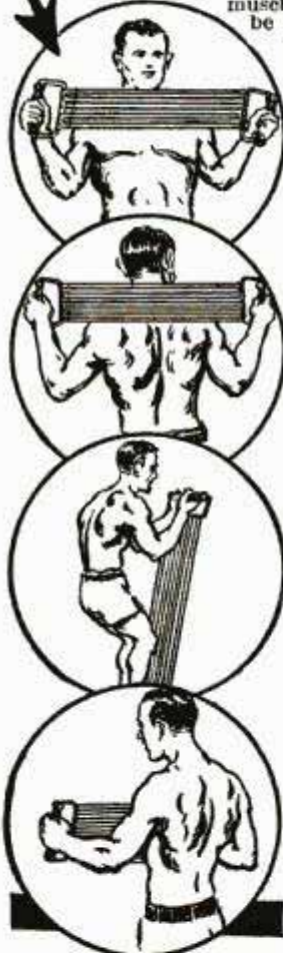

How the Giant Chest Expander and Progressive Exerciser is Made

The Giant Chest Expander and Progressive Exerciser is made with new live, springy rubber so as to give it long wearing and great resisting qualities. Do not pay more for an exerciser that has forty or less rubber strands to each cable. Get the best and most durable. The Giant Progressive Exerciser has 50 strands of the finest rubber procurable to each cable.

Free Instructions

We do not think it enough to send you an exerciser worth double what we ask, so for a limited time, we will also include instructions absolutely free. These instructions are interesting and simple to follow—they show you the short cut to health and strength. Order today before this wonderful offer is withdrawn.

Your Guarantee

The Giant Chest Expander is sold with a guarantee that you will say it is the finest you ever saw or your money back.

5 Cables or double 10 Cables for strength for \$2

The double strength exerciser has resistance of over 200 lbs. \$4

How to Order—Send No Money

Sign your name and address to coupon below and get your Giant Exerciser at the present low introductory price by return mail. The price is made low because we want everyone to enjoy muscles and strength at the lowest possible cost. Don't pay more—order from us—get the most for your money. Use coupon now.

PROGRESSIVE EXERCISER CO.,
 4010 Langdon Bldg.,
 Broadway and Duane Street, New York

Please send Your 10 cable Progressive.
 Your 5 cable Exerciser.

Check the Exerciser you want, and it will be sent you by return mail. Pay postman introductory price, plus few cents postage on arrival. It is understood that if you are not entirely satisfied with your exerciser you may return it within 5 days and get your money back.

Name.....
 Street.....
 City..... State.....

If you live outside the United States, send cash with order.

BE A RAILWAY TRAFFIC INSPECTOR



Earn up to \$250 per month SALARY plus expenses

Meant everything to Anthony Maine

Gentlemen:—I want to take this opportunity to express my appreciation for your course. It has meant everything to me. Before taking your course, I was working in a lens factory back home for \$20.00 per week; the work was a drudgery, and I did not always work steady. Some weeks I had to be satisfied with \$15.00 or less. Since completing your course a year ago last March, I have been averaging \$140 per month and expenses. At present time, I am getting \$155 a month and expenses. The work is simple and wonderful. I never thought it could be so attractive. My only regret is that I didn't take your course sooner than I did. (Signed) ANTHONY MAINE.

Many men are needed to fill existing vacancies in this fascinating railway work. Pays \$120 to \$135 monthly to start. Rapid advances to \$175, \$200, \$250. Travel, or remain near home. For eleven years this school has trained men for Traffic Inspection and assisted them to positions upon completion of training. Railways look to us for men. We'll train you in a few weeks' spare time home instruction, and upon completion assist you to a position at a definite salary or refund your tuition. You take no risk.

Send for free booklet

Learn complete details of this great uncrowded profession today. Our free booklet explains all about it—how we have obtained positions for our graduates, and what we can do for you. Write today.

Standard Business Training Inst. Div. 2 BUFFALO, NEW YORK

A NEW CAR in 30 MINUTES



Get the BEAUTY and LUSTRE of a NEW PAINT JOB at a small fraction of the cost. Do it Yourself with NUKAR, NOT a Wax. NOT a Paint-NOT a Polish. This New Chemical discovery instantly restores Original Color to dull faded cars, and gives a Beautiful, Brilliant, Mirror-Like Lustre that lasts for months. Does not hold Dirt or Dust. Actually makes old Shabby Cars look NEW. No rubbing—No hard work. Flows on like water from a sponge. No Waiting—No Delay—Drive a NEW CAR the same day. Results Guaranteed.

MEN! Amazing Cash Profits

Are being made by Agents, Distributors and Service Station operators. Get in on the biggest thing in the automobile business today. Earn up to \$50 a day. Full or part time. Millions of cars need NUKAR. Makes a Sensational sales compelling Demonstration. We back you to the limit with powerful Sales Co-operation and give you FREE—a Business Start that Money could not Buy. Let us send Prepaid and without charge a FREE SAMPLE and our Big Book in colors. Act NOW. Write TODAY. Atlas Solvent Co., 5647 Harper Ave., Dept. 170, Chicago, Ill.



B.S. Degree in 2 YEARS MECHANICAL Engineering

Today's big opportunities go to the Mechanical Engineer, the "Key" man in all manufacturing, machine design, etc. At TRI-STATE only 96 weeks thorough, technical work gives you a B. of Sc. degree (State-authorized)—in Mechanical, Civil, Electrical, Chemical, Aeronautical or Administrative Engineering. Our graduates get \$50 to \$150 a week. LOW TUITION and living expenses. Noted teachers. Write for free catalog, stating course wanted. TRI-STATE COLLEGE, Box M-7113, Angola, Ind.

Learn to PAINT SIGNS and SHOW CARDS

We quickly teach you by mail, or at school, in spare time. Enormous demand. Big future. Interesting work. Oldest and foremost school. **EARN \$50 TO \$200 WEEKLY**

Otto Wiegand, Md., home-study graduate, made \$12,000 from his business in one year. John Vascoe, N.Y., gets \$25 for a show card. Crawford, B. C., writes: "Earned \$200 while taking course." Write for complete information.

DETROIT SCHOOL OF LETTERING
 154 Stimson Ave. Est. 1899 Detroit, Mich.



I Will Allow Your Railroad Fare to Chicago Without Extra Cost

This funny juice~

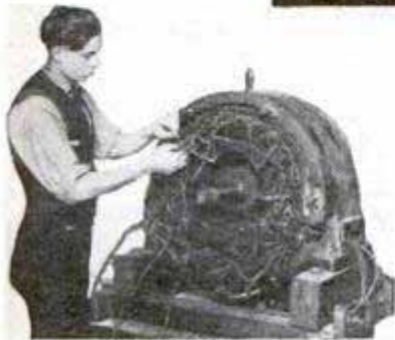
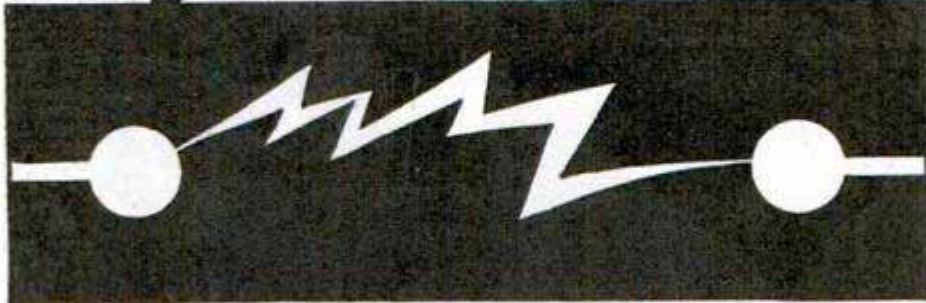

A 25 H. P. Motor for student practice

- helps to run automobiles
- makes radio possible
- makes your telephone work
- makes the wheels go round in thousands of factories
- illuminates homes, factories, office buildings and city streets
- toasts bread, percolates coffee and heats flat-irons
- runs street cars and fast trains

No one knows what it really is—it is called Electricity—but you can learn how to handle it.

—AND IT WILL PAY YOU

\$1⁰⁰ per Hour to \$5,000⁰⁰ per Year

IF you get a real "kick" out of this subject of Electricity you're *crazy* if you don't make it earn you real money. Pretty plain speaking—but I want to make you *think*. The world's greatest, most successful men were men who worked at things *they liked*. Work is fun if you like your job. If YOU like electricity, *make it pay you real money*.

Here's Your Chance

To get somewhere you've got to start, haven't you? It'll mean breaking away from home for about 12 weeks—but you and the family will be mighty glad you *started* and *finished* something. Especially something that pays so big.

We'll take mighty good care of you here in the big Greer Electrical Shops. You'll be in company with hundreds of men temporarily away from home, like yourself. And you'll learn Electricity—*oh man*—how you'll learn it! You'll marvel at the way a subject apparently so mysterious is made so easy to understand. Just wait till we turn you loose among our hundreds of motors, rotary converters, generators, telephone and radio equipments. Competent, friendly instructors will show you

how to take 'em apart and put 'em together till you can do it in your sleep.

How to Get This Training

The coupon at the bottom of this page is the open door to pleasant work and big money in the Electrical Profession. We can't tell the whole story here because it takes a Book to tell it. The book is free. Mail the coupon, and be thankful the rest of your life for doing it. Delayed action never put money in the bank. DO IT NOW.

What About Automobiles?

Maybe automobiles interest you as much as electricity—or more. There's a lot of money in fixing autos, too. The well trained auto man is never out of a job. He's ready to go in business for himself. Would you like that kind of work? \$6 a day to \$20,000 a year is what it pays you.

Then mark the coupon for the free book on our Automotive Course. We've helped make automobile experts out of thousands of men who didn't know a carburetor from a universal joint when they came to our big training shops. How much does it cost? You'll be surprised to learn *how easily you can afford it*. Mail the coupon NOW for complete information.

Greer College Dept. 1001.E
2024 S. Wabash Ave., Chicago

FREE

Employment Service

Our employment department is ready to help you—while in training and for life. Day and evening classes. Low cost. Easy terms.

ERWIN GREER, President, Greer College
Dept. 1001.E, 2024 S. Wabash Ave., CHICAGO.

Please send me your FREE BOOK and offer for Electrical course
Automotive course
It is understood I am not obligated in any way

Name

Address

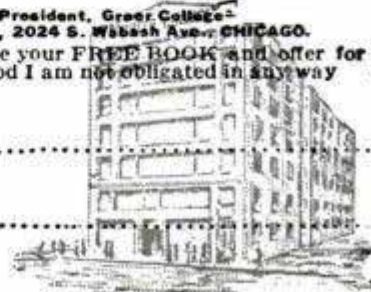

Using the "Wrecker Crane" in the Automobile repair department. Here you learn about all up-to-date auto equipment — by actually using it. Real experience on all makes of cars, under supervision of an expert.

VOICE

NOW! you can have the VOICE you want!



100% Improvement Guaranteed!

No matter how hopeless your case may seem—send for free Voice Book. New SILENT Method of Voice Training. Increases Range. Improves quality. Banish huskiness—hoarseness. 100 per cent improvement *guaranteed*—or money back. Mail coupon *at once* for free booklet—the greatest voice booklet ever written—sent FREE with no obligation!

Perfect Voice Institute, Dept. 13-57
1922 Sunnyside Ave., Chicago

Mail Coupon for Free Voice Book

Perfect Voice Institute, Dept. 13-57
1922 Sunnyside Ave., Chicago

Please send me FREE and without obligation, Prof. Feuchtinger's new book, "Physical Voice Culture." I have checked subject in which I am most interested.

Weak Voice Singing Stammering Speaking

Name

Address

City State

Play Piano BY EAR

—IN 90 DAYS!



Play anything—jazz to classical! Even if you know **nothing** about piano music—I'll have your fingers dancing over the keyboard with **confidence** in 90 days. If you can hum or whistle a tune **you can play it!** My students are broadcasting—making money. **MAKE ME PROVE IT!** Without puzzling notes! Without practicing tedious scales! I've found the way to bring out your musical instinct. New and original system does away with years of work. **YOU WANT THE PROOF!**

I'll send it. Write me now.
D. M. SUTTLE, Director
ILLINOIS SCHOOL OF MUSIC
1801 Byron, Dept. 1015, Chicago, Ill.

Send NOW for PROOF!

Learn Watchwork, Jewelrywork and Engraving A fine trade commanding a good salary, and your services always in demand. Address **Horological**, Dept. P, Bradley Institute, PEORIA, ILLINOIS, for our latest catalog.

LAW Free Book

Write today for FREE 64-page book, "THE LAW-TRAINED MAN", which shows how to learn law in spare time through the Blackstone home-study course prepared by 80 prominent legal authorities, including law school deans, and U. S. Supreme Court justices. Combination text and case method of instruction used. All material necessary furnished with the course, including elaborate 25-volume law library, delivered immediately upon enrollment. Many successful attorneys among our graduates. LL. B. degree conferred. Moderate tuition, low monthly terms. Money-Back Agreement.

Write for free book today.

BLACKSTONE INSTITUTE, 307 N. Michigan Ave., Dept. 67 Chicago



DRAFTING

BOOKS SENT FREE!

For Beginners

Written so you can understand every word, by 18 famous Engineers and Architects. Deluxe, flexible binding. 1750 pages, 1050 blue prints, charts and diagrams. Prepares you for a good Drafting job in mechanical or architectural lines. Sent for 15 days' free use, if you mail coupon immediately.

Only fifteen minutes a day with these WONDER BOOKS will prepare you for a good Drafting job in less than a year! Mechanical and Architectural Drafting from simple straight lines to important, complex plans, a step at a time! Built especially for beginners, for men with only grammar schooling. Drafting room practice *plus engineering* made easy and clear!

Big Field—Big Demand—Big Pay!

Competent Draftsmen are urgently needed right now in all building and manufacturing lines at \$50 to \$100 a week. That's just the beginning—for draftsmen have the best chances for advancement! Pleasant, fascinating work, easy to learn and do. Learn quick with these books—send coupon for a set FREE, and see for yourself!

A year's Consulting Membership in the American Technical Society now given free to all readers of this famous Cyclopaedia of Drafting. Many say that's worth more than cost of books.

American Technical Society
Dept. D719, 58th & Drexel Ave., Chicago

Modern American Homes FREE!

American Technical Society
Dept. D719, 58th & Drexel Ave., Chicago

Send for 15 days' free use 4-volume set of DRAFTING. In return for mailing this coupon promptly send absolutely FREE "Modern American Homes," 112 plates, exteriors, interiors and plans. I will pay the few cents delivery charge. If I wish I may return books in 15 days and owe you nothing. But if I prefer to keep them I will send \$1.50 after 15 days, then \$2.00 a month until \$14.50 (special reduced price) is paid.

Name

Address

Employed by

Address

A Fascinating New Way To Make Money Through The Arts!



free of extra cost

Our amazing new plan tells how you can get every one of the beautiful gift-wares illustrated here with all instructions for decorating. Mail coupon for Free Book and Offer.

Want Some Money? Here's a wonderful way to get it. Our beautifully illustrated book tells how. It tells all about our new methods of art decoration, art treatment, and how anybody can learn without previous experience. It tells how you can get the full assortment of gift-wares and objets d'art shown on this page without one cent of extra cost, how we start you with this assortment and set you up in business. Contains page after page of color illustrations of what you can make and sell. You can make good money and this book is—

FREE Our system is amazingly easy to learn and the profits are larger than in almost any other business. You can produce beautiful objects almost from the start. Best of all you don't have to know how to draw for we show you the famous "3-Step Method." Begin making money now! All supplies are sent by us with instructions and many have made from \$10 to \$25 a week. Many society women do this work for their own amusement. But either way—pleasure or profit—it's the most delightful home work you can imagine. Don't miss this opportunity to get all these gift-wares free of extra charge. Send now for your copy of this valuable book. It's FREE.

FIRESIDE INDUSTRIES

Dept. 66-P

ADRIAN, MICH.



Fireside Industries

Dept. 66-P
Adrian, Mich.

Gentlemen: Send me free book and complete plan for making money.

Name.....
Address.....
City.....State.....

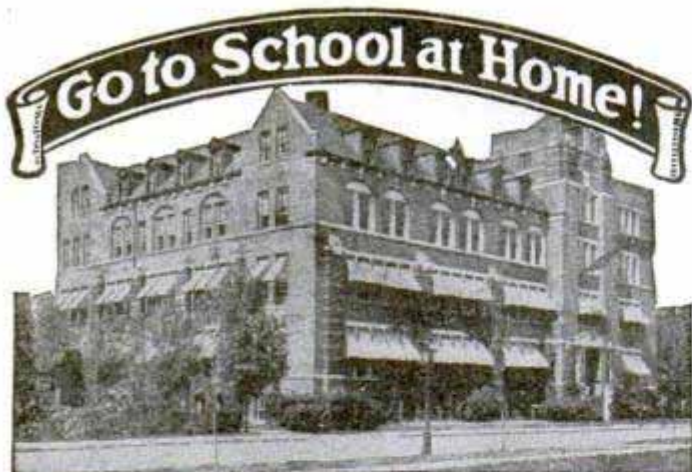

High School Course in Two Years!

You Want to Earn Big Money!

And you will not be satisfied unless you earn steady promotion. But are you prepared for the job ahead of you? Do you measure up to the standard that insures success? For a more responsible position a fairly good education is necessary. To write a sensible business letter, to prepare estimates, to figure cost and to compute interest, you must have a certain amount of preparation. All this you must be able to do before you will earn promotion. Many business houses hire no men whose general knowledge is not equal to a high school course. Why? Because big business refuses to burden itself with men who are barred from promotion by the lack of elementary education.

Can You Qualify for a Better Position

We have a plan whereby you can. We can give you a complete but simplified high school course in two years, giving you all the essentials that form the foundation of practical business. It will prepare you to hold your own where competition is keen and exacting. Do not doubt your ability, but make up your mind to it and you will soon have the requirements that will bring you success and big money. YOU CAN DO IT.

Let us show you how to get on the road to success. It will not cost you a single working hour. Write today. It costs you nothing but a stamp.

American School

Dept. H-747 Drexel Ave. and 58th St., Chicago

American School

Dept. H-747 Drexel Ave. and 58th St., Chicago

Send me full information on the subject checked and how you will help me win success.

- | | |
|-----------------------------|---------------------------|
|Architect |Business Law |
|Building Contractor |Lawyer |
|Automobile Engineer |Machine Shop Practice |
|Automobile Repairman |Mechanical Engineer |
|Civil Engineer |Shop Superintendent |
|Structural Engineer |Employment Manager |
|Business Manager |Steam Engineer |
|Cert. Public Accountant |Foremanship |
|Accountant and Auditor |Sanitary Engineer |
|Bookkeeper |Surveyor (& Mapping) |
|Draftsman and Designer |Telephone Engineer |
|Electrical Engineer |Telegraph Engineer |
|Electric Light & Power |High School Graduate |
|General Education |Wireless Radio |
|Vocational Guidance |Undecided |

Name

Address

\$2500 DRAWING \$298 COURSE for



Haven't you often wished that you could draw cartoons, illustrate some idea, sketch some pretty face, etc.? You can do all of these things. One of America's most famous Cartoonists and Illustrators has developed a great, simple system for success in all branches of Commercial Art. This system has revolutionized the entire theory of drawing. It means that drawing can be as easy for you as writing — much simpler than learning shorthand, bookkeeping or typewriting. We are now placing this original system for learning Drawing, Art and Cartooning, consisting of 34 lessons with over 500 illustrations, within reach of every one. If you will devote a few hours each week to the Course WE ABSOLUTELY GUARANTEE that you will learn to draw and draw well before you have half finished the Course. If we fail to make this claim good, we will refund every cent paid us. By eliminating a large office force for answering correspondence, expensive catalogs, etc., we are enabled to make a price of \$2.98, the cheapest price ever known for a high-grade, home study course. Many have sent us letters similar to that of Rob't P. Davis of Detroit, who wrote: "I can't see how you ask so little. It is more than I expected." Learn to draw. It is a big asset, no matter what field you are in.

Send No Money

Just order the course and **\$2.98** on arrival pay postman plus a few cents postage, payment in full for the entire Course and Drawing Outfit. If not entirely satisfied, return within five days and we will Refund Money. Address:

If you order the course at once, we will include a drawing outfit, consisting of artist's pencils, pens, paper, erasers, thumb tacks, etc., enabling you to go to work without any additional cost.

LEDERER SCHOOL of DRAWING, Dept. 962-U, Chattanooga, Tenn. Orders from outside the U. S. A. are payable \$3.28 cash with order.

NERVES?

Are You Always Excited? Fatigued? Worried? Gloomy? Pessimistic? Constipation, indigestion, cold sweats, dizzy spells and bashfulness are caused by NERVE EXHAUSTION. Drugs, tonics and medicines cannot help weak, sick, nerves! Learn how to regain Vigor, Calmness and Self Confidence. Send 25c for this amazing book. **RICHARD BLACKSTONE, N-4710 FLATIRON BUILDING, N. Y.**

BIG Demand for Skilled Mechanics!

The entire country is calling for skilled mechanics! Good pay—steady work—good opportunities for advancement! Master this fascinating trade with the aid of the

AMERICAN MACHINISTS' LIBRARY

6 volumes—2,000 pages—2,500 illustrations

(A combined home-study course and reference library)

This library of machine shop practice was written for practical men. It gives you the best methods for every kind of machine shop work. It explains machine tools and their operation, tool work, gears and grinding, jigs and fixtures, automatic screw machines, their tools, punches, dies, etc. Plainly written—completely illustrated—the best kind of help to the machine-shop man who wants to advance himself.

Free TRIAL

No money down—only 7c a day

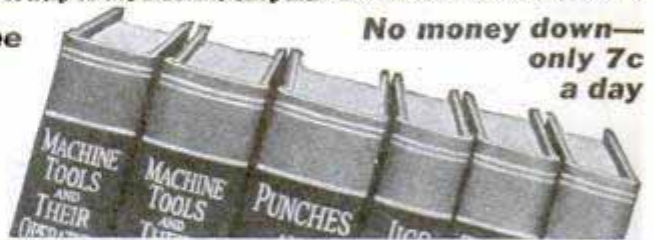

FREE EXAMINATION COUPON

McGRAW-HILL BOOK CO., Inc., 370 Seventh Ave., New York Send me for 10 days' free examination the AMERICAN MACHINISTS' LIBRARY. If satisfactory, I will send \$1.50 in 10 days and \$2 monthly until the special price of \$17.50 is paid. If not wanted, I will return the books at your expense.

Signed

Address

City and State

Position

Company

Read what BIG money these fellows have made in the RADIO BUSINESS

\$375 One Month Spare Time



"Recently I made \$375 in one month in my spare time installing, servicing, selling Radio sets. And, not so long ago, I earned enough in one week to pay for my course."
EARLE CUMMINGS,
 18 Webster St., Haverhill, Mass.

\$1597 in Five Months



"The N. R. I. is the best Radio school in the U. S. A. I have made \$1597 in five months. I shall always tell my friends that I owe my success to you."
HENRY J. NICKS, Jr.,
 302 Safford Ave.,
 Tarpon Springs, Fla.

\$1164 Spare Time Profits



"Look at what I have made since I enrolled, \$1,164—money I would not have had otherwise. I am certainly glad I took up Radio with N. R. I. I am more than satisfied."
HENRY R. HEIKKINEN,
 123 W. Erie St., Chicago, Ill.

Over \$1000 in Four Months



"My opinion of the N. R. I. course is that it is the best to be had at any price. When I enrolled I didn't know a condenser from a transformer, but from December to April I made well over \$1000 and I only worked in the mornings."
AL. JOHNSON,
 1409 Shelby St., Sandusky, Ohio.

I will show you too how to start a spare time or full time Radio Business of Your Own without capital



J.E. SMITH Pres.

Radio's amazing growth is making many big jobs. The world wide use of receiving sets and the lack of trained men to sell, install and service them has opened many splendid chances for spare time and full time businesses.

Ever so often a new business is started in this country. We have seen how the growth of the automobile industry, electricity and others made men rich. Now Radio is doing the same thing. Its growth has already made many men rich and will make more wealthy in the future. Surely you are not going to pass up this wonderful chance for success.

More Trained Radio Men Needed

A famous Radio expert says there are four good jobs for every man trained to hold them. Radio has grown so fast that it simply has not got the number of trained men it needs. Every year there are hundreds of fine jobs among its many branches such as broadcasting stations, Radio factories, jobbers, dealers, on board ship, commercial land stations, and many others. Many of the six to ten million receiving sets now in use are only 25% to 40% efficient. This has made your big chance for a spare time or full time business of your own selling, installing, repairing sets.

So Many Opportunities You Can Make Extra Money While Learning

Many of our students make \$10, \$20, \$30 a week extra while learning. I'll show you the plans and ideas that have proved successful for them—show you

how to begin making extra money shortly after you enroll. G. W. Page, 1807-21st Ave., S., Nashville, Tenn., made \$935 in his spare time while taking my course.

I Give You Practical Radio Experience With My Course

My course is not just theory. My method gives you practical Radio experience—you learn the "how" and "why" of practically every type of Radio set made. This gives you confidence to tackle any Radio problems and shows up in your pay envelope too.

You can build 100 circuits with the Six Big Outfits of Radio parts I give you. The pictures here show only three of them. My book explains my method of giving practical training at home. **Get your copy!**

I Will Train You At Home In Your Spare Time

I bring my training to you. Hold your job. Give me only part of your spare time. You don't have to be a college or high school graduate. Many of my graduates now making big money in Radio didn't even finish the grades. Boys 14, 15 years old and men up to 60 have finished my course successfully.

You Must Be Satisfied

I will give you a written agreement the day you enroll to refund your money if you are not satisfied with the lessons and instruction service when you complete the course. You are the only judge. The resources of the N. R. I. Pioneer and Largest Home-Study Radio school in the world stand back of this agreement.

Get My Book

Find out what Radio offers you. My 64-page book, "Rich Rewards in Radio" points out the money making opportunities the growth of Radio has made for you. Clip the coupon. Send it to me. You won't be obligated in the least.

Address

**J. E. Smith, Pres.
 Dept. 9XPP**

**National Radio Institute
 Washington, D. C.**

This Book points out what Radio offers you Get a copy!



This coupon is good for a FREE copy of my Valuable Book. Mail it NOW!

J. E. Smith,
 President,
 Dept. 9XPP
 National Radio Institute, Washington, D. C.

Dear Mr. Smith: Send me your book. I want to know more about the opportunities in Radio and your practical method of teaching at home in spare time. This request does not obligate me to enroll and I understand no agent will call on me.

Name.....Age.....
 Address.....
 City.....State.....

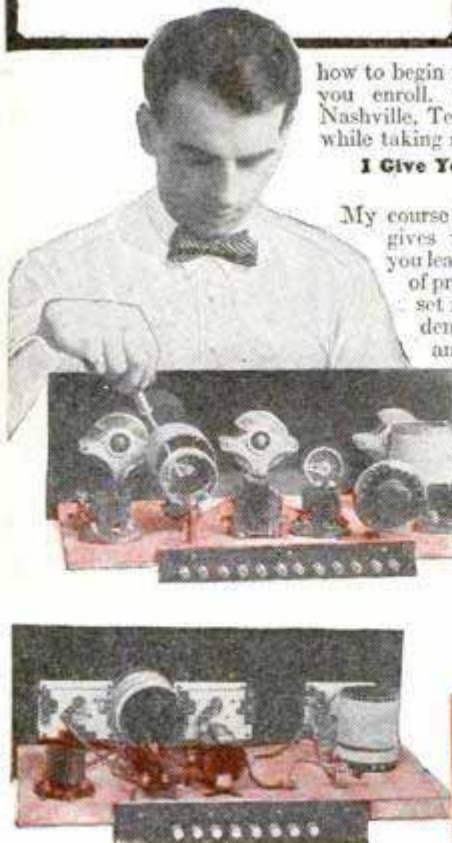

The real money is in these professional fields DRAFTING—ARCHITECTURE ENGINEERING—ELECTRICITY

A real salary—a steady five-figure income—a dignified out-of-the-trades-class position or a business of your own. That, briefly, is what Engineering, Architecture, Electricity or Drafting can mean to you. For in these fields, billions are spent annually. Millions go to those men specially trained to lay out and superintend construction work. Industry needs trained Draftsmen,

Engineers and Architects. Everywhere big salaries and bonuses are being paid. Men are at a premium. You're needed—and wanted if you're trained.

Chicago Tech Gives You That Training

For 26 years one institution—the Chicago Technical College—has been developing trained specialists in drafting and engineering. Its graduates are in great demand. Its courses represent the last word in tested and proved practical training for young men.

3 Easy Plans

You need not be without this training. 3 Plans make it easy for you no matter what your circumstances.

Come to Chicago if you can. Enter our resident school in either the 2 year Diploma or 3

year B. S. Degree Course. Either of these courses gives you the maximum in thorough, up-to-the-minute and practical training. Mark Plan No. 1 on the coupon if interested in these courses. It brings you our free 80 Page Blue Book and all the facts.

If your time is limited, consider our 4 months' course in Drafting—just mark Plan No. 2 on coupon.

And finally, if you can't come to Chicago, then study at home—earn while you learn—and mark Plan No. 3 on the coupon.

But get the coupon going now—for you can't afford to be without the facts that show you how to get into these 4 Big billion dollar fields.

Earn While Learning

Chicago offers opportunities for part time work to help defray expenses. The College assists students in making desirable employment connections.

Mail Free Book Coupon

Chicago Technical College, Dept. N-77, 118 E. 26th St., Chicago.

Please send me your Free Book and other information about plan of training marked below.

Name.....

Address.....

City.....State.....

Check plan in which you are interested.

- No. 1. Complete College Training (2 yr. Diploma —3 yr. Degree) Engineering or Architecture at the College in Chicago.
- No. 2. 4 months' Special Drafting Course at Chicago Tech. Earn while learning.
- No. 3. Home Study—College-Training-At-Home in Drafting. Your spare time is enough.

CHICAGO TECHNICAL COLLEGE

Dept. N-77, Chicago Tech. Bldg., 118 East 26th St., Chicago, Illinois



Complete Course in BOXING

Jiu-Jitsu & Wrestling

Complete Course

\$2.97

Plus Postage

Complete course in Boxing, for only \$2.97. Our scientific methods cut time of learning in half. Teaches the blows used by professionals—Dempsey's Triple, Fitzsimmons' Shift, etc. Every blow illustrated. Also Wrestling, Jiu-Jitsu and History of Boxers. Six big books—hundreds of pages. Send no money—see coupon.

Marshall Stillman Association, Dept. 10-M, 247 Park Avenue, New York. Send on 10 day approval complete Self-Defense course. I will deposit \$2.97 plus postage, with postman. I will return course in 10 days if not satisfactory and money will be refunded. (Outside U. S. A.—Cash with order.)

Name.....
Street and City.....

BART'S NEW CHALK TALK BOOK

"Their Best Stunts" from 25 chalk experienced talk artists. \$1.25 prepaid, 5-day trial. Also catalog "A," Art Supplies, or "S," Show Card Supplies.

BART SUPPLIES, 523 Eustis Bldg., Minneapolis, Minn.

LEARN WATCHMAKING

and become independent. We help you secure a position. Easy to learn. Send for FREE CATALOG.

ST. LOUIS WATCHMAKING SCHOOL Dept. 5, ST. LOUIS, MO.

LEARN TO PLAY

VIOLIN, TENOR BANJO, HAWAIIAN GUITAR, BANJO CORNET, UKULELE, BANJO UKULELE, GUITAR, BANJO MANDOLIN, BANJO GUITAR, MANDOLIN, SNARE DRUM, FIELD DRUM, PIANO OR ORGAN

at home, this new and "easy to learn" way. No teacher or talent required. Entirely different from any "chart" or "diagram" system. Lessons are so simplified and so easily mastered most pupils play by note after only 10 lessons. Thousands of men, women, boys and girls have learned to play quickly and proficiently by our Home Study method. Your opportunity to become popular and play for profit or pleasure. A few cents a day pays for lessons. Pay while you learn. Write to-day for full particulars and free trial. No obligation. Instruments except Piano and Organ furnished at cost if desired. CHICAGO CORRESPONDENCE SCHOOL OF MUSIC, INC. 1632 No. Halsted St., Dept. 13, Chicago, Ill.

DANDRUFF

Millions Use Lucky Tiger

for Hair and Scalp and Whyte-Fox (1 and 2) for skin ailments. Ask your barber for Whyte-Fox Medicated Massage. Valuable booklet free on request. Money-Back Guarantee. At Barbers, Druggists, Beauty Parlors.

Kansas Dept. City, Mo. A LUCKY TIGER REM. CO.

WANT A GOVERNMENT JOB?



RAILWAY POSTAL CLERKS

\$158 to \$225 Month

Mail Coupon Before You Lose It

City Carriers—Postoffice Clerks—General Clerks
Steady Work—No Layoffs—Paid Vacations

FRANKLIN INSTITUTE, Dept., B175, Rochester, N. Y.
Sirs: Rush to me without charge copy of 32-page book; "How to Get U. S. Government Jobs," list of positions open to men—boys, 18 to 50 and full particulars telling how to get them.

Name.....
Address.....

BRAND NEW



GENUINE Model 3 CORONA

LOWEST PRICE
EASIEST TERMS
EVER OFFERED



HERE'S your chance to own that *brand new* Genuine Model 3 Corona you've wanted—on the easiest terms ever offered—at **LOWEST PRICE** ever offered. Complete in every detail; back spacer, etc., *Manufacturer's Guarantee*. Recognized the world over as the finest, strongest, sturdiest portable built.

Yours for 10 DAYS FREE

**Send
No
Money**

Leatheroid carrying case, oiler, instructions free on this offer. Send no money—just the coupon. Without delay or red tape we will send you the Corona. Try it 10 days. If you decide to keep it, send us only \$2—then \$3 a month until our special price of \$39.90 is paid. Now is the time to buy. This offer may never be repeated. Mail coupon now.

Only a limited number of these splendid machines available. To get one, you must act now! Experience the joy this personal writing portable typewriter can give you! Use it ten days free! See how easy it is to run and the splendidly typed letters it turns out. Ideal for the office desk, home, traveling. Small, compact, light, convenient. Don't send out letters, manuscripts, reports, bills in poor handwriting when you can have this Corona at such a low price on such easy terms. Remember, these are *brand new* machines right out of the Corona factory.



Save Money Use this Coupon

Smith Typewriter Sales Corp., (Corona Division)
469 E. Ohio St., Chicago, Ill. Dept. A 3

Ship me the Corona, F. O. B. Chicago. On arrival I'll deposit \$2 with express agent. If I keep the machine, I'll send you \$3 a month until the \$37.90 balance of \$39.90 price is paid; the title to remain with you until then. I am to have 10 days to try the typewriter. If I decide not to keep it, I will repack and return to express agent, who will return my \$2. You are to give your standard guarantee.

Name _____

Address _____

Employed by _____



Electrical Engineering Learn at Home

ONE of the best ways to prepare for a good position in the Electrical field or to have a business of your own is through the home-study courses of the International Correspondence Schools.

Nearly \$200,000 has been spent in the preparation of these courses and they have been endorsed by Thomas A. Edison and Charles P. Steinmetz—the late “electrical wizard” of the General Electric Co.

Here are some of the men who have prepared these courses:
EDGAR KNOWLTON—Electrical Engineer, Alternating Current Engineering Department, General Electric Co.

J. LESTER WOODBRIDGE, E.D. and M.E.—Chief Engineer of the Electric Storage Battery Co.

S. A. FLETCHER—Electrical Engineer, Superintendent of Service, Alabama Power Co.

S. H. MORTENSON—Designer of Alternating Current Motors and Generators, Allis-Chalmers Manufacturing Co.

O. J. BUSHNELL—Supt. of the Meter Dept., Commonwealth Edison Co.

Mail Coupon for Free Booklet

INTERNATIONAL CORRESPONDENCE SCHOOLS
Box 5642-F, Scranton, Penna.

Without cost or obligation, please send me a copy of your booklet, “Who Wins and Why,” and full particulars about the course before which I have marked X in the list below:

- | | |
|--------------------------------------------------------------------------|-----------------------------------------------------------------------------|
| <input type="checkbox"/> Electrical Engineer | <input type="checkbox"/> Electric Draftsman |
| <input type="checkbox"/> Electrician | <input type="checkbox"/> Electric Car Running |
| <input type="checkbox"/> Electric Wiring | <input type="checkbox"/> Electric Machine Designer |
| <input type="checkbox"/> Electric Lighting | <input type="checkbox"/> Radio |
| <input type="checkbox"/> Architect | <input type="checkbox"/> Plumber and Steam Fitter |
| <input type="checkbox"/> Architectural Draftsman | <input type="checkbox"/> Plumbing Inspector |
| <input type="checkbox"/> Building Foreman | <input type="checkbox"/> Foreman Plumber |
| <input type="checkbox"/> Concrete Builder | <input type="checkbox"/> Heating and Ventilation |
| <input type="checkbox"/> Contractor and Builder | <input type="checkbox"/> Sheet-Metal Worker |
| <input type="checkbox"/> Structural Draftsman | <input type="checkbox"/> Steam Engineer |
| <input type="checkbox"/> Structural Engineer | <input type="checkbox"/> Marine Engineer |
| <input type="checkbox"/> Reading Shop Blueprints | <input type="checkbox"/> Refrigeration Engineer |
| <input type="checkbox"/> Telegraph Engineer | <input type="checkbox"/> R. R. Positions |
| <input type="checkbox"/> Telephone Work | <input type="checkbox"/> Highway Engineer |
| <input type="checkbox"/> Mechanical Engineer | <input type="checkbox"/> Chemistry <input type="checkbox"/> Pharmacy |
| <input type="checkbox"/> Mechanical Draftsman | <input type="checkbox"/> Coal Mining Engineer |
| <input type="checkbox"/> Machine Shop Practice | <input type="checkbox"/> Navigation <input type="checkbox"/> Assayer |
| <input type="checkbox"/> Toolmaker <input type="checkbox"/> Patternmaker | <input type="checkbox"/> Iron and Steel Worker |
| <input type="checkbox"/> Civil Engineer | <input type="checkbox"/> Textile Overseer or Supt. |
| <input type="checkbox"/> Surveying and Mapping | <input type="checkbox"/> Cotton Manufacturing |
| <input type="checkbox"/> Bridge Engineer | <input type="checkbox"/> Woolen Manufacturing |
| <input type="checkbox"/> Gas Engine Operating | <input type="checkbox"/> Agriculture <input type="checkbox"/> Fruit Growing |
| <input type="checkbox"/> Automobile Mechanic | <input type="checkbox"/> Poultry Farming |
| <input type="checkbox"/> Aviation Engines | <input type="checkbox"/> Mathematics |

BUSINESS TRAINING COURSES

- | | |
|------------------------------------------------------------------|-------------------------------------------------------|
| <input type="checkbox"/> Business Management | <input type="checkbox"/> Business Correspondence |
| <input type="checkbox"/> Industrial Management | <input type="checkbox"/> Show Card and Sign Lettering |
| <input type="checkbox"/> Personnel Management | <input type="checkbox"/> Stenography and Typing |
| <input type="checkbox"/> Traffic Management | <input type="checkbox"/> English |
| <input type="checkbox"/> Accounting and C. P. A. Coaching | <input type="checkbox"/> Civil Service |
| <input type="checkbox"/> Cost Accounting | <input type="checkbox"/> Railway Mail Clerk |
| <input type="checkbox"/> Bookkeeping | <input type="checkbox"/> Mail Carrier |
| <input type="checkbox"/> Secretarial Work | <input type="checkbox"/> Grade School Subjects |
| <input type="checkbox"/> Spanish <input type="checkbox"/> French | <input type="checkbox"/> High School Subjects |
| <input type="checkbox"/> Salesmanship | <input type="checkbox"/> Cartooning |
| <input type="checkbox"/> Advertising | <input type="checkbox"/> Illustrating |
| | <input type="checkbox"/> Lumber Dealer |

Name.....

Address.....

City..... State.....

Occupation.....

If you reside in Canada, send this coupon to the International Correspondence Schools Canadian, Limited, Montreal, Canada

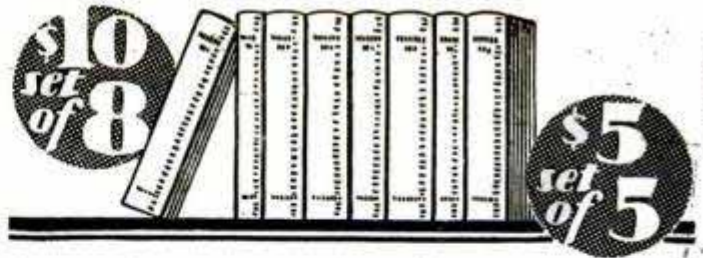

HOME SHOP LIBRARY

Practical Books On Making Things

Puzzles in Wood; Toys Every Child Can Make; Boy Bird House Architecture; Instructional Units in Wood Finishing; Projects in Furniture Making; The Set of Five Books—\$5.

Easy-to-Make Toys; Permanent Bird Houses; Model Boat Building; Puzzles in Wood; 100 Problems in Woodwork; Problems in Artistic Wood Turning; Problems in Furniture Design and Construction; Instructional Units in Wood Finishing; The Set of 8 Books—\$10.

A HAPPY, helpful library idea for every home—for youngsters and grown-ups as well. Interesting, entertaining, instructive. Beneficial play and pastime. Useful recreation and occupational development for boys. Full of ideas of what to make and how. Plainly descriptive; completely illustrated to scale. An ideal gift: the set of five—\$5; or the more complete set of eight—\$10—listed here. By mail prepaid—send money order. Returned if you are not satisfied.

The Bruce Publishing Company
P.M.-10 Milwaukee, Wis.

\$\$\$ BE A \$\$\$

MOVIE OPERATOR

Make big money in this easy and pleasant work. Big demand for trained operators. We help you earn while learning. Complete course in 5-10 weeks. Don't Wait. Write to-day.

MOVIE OPERATORS SCHOOL
61 Sprout St. Detroit, Mich.

10c NEW SCIENTIFIC WONDER

3 for 25c "X-RAY" CURIO

SILVER ONLY

BOYS You apparently see thru Clothes, Wood, Stone, any object. See Bones in Flesh. **FREE—PKG. RADIO BIG FUN**

PICTURE FILMS. Takes pictures without camera. "You'll like 'em." 1 pkg. with each 25c order.

MARVEL MFG. CO. Dept. 31 NEW HAVEN, CONN.

Frat Secrets

HOW TO GET INTO A COLLEGE FRATERNITY. That's the name of this amazing new book which tells you ALL about college fraternities and sororities. You learn what goes on in fraternities—all about secret initiations—how to act if you wish to be pledged to a frat—all about the mysteries of the rushing season. Here is a book everyone needs, **today as never before!** It not only gives you complete information on how to get into a college fraternity, but it also shows you how to be like a fraternity man, whether you are going to college or not. This regular \$2 book is offered now for \$1, as long as the present edition lasts. **And we pay the postage!** Take advantage of this great offer NOW! Write your name and address on the margin of this advertisement, attach \$1, and mail to

THE GREEK LETTER PUBLISHING CO., Dept. 4
Suite 728, 149 Broadway, NEW YORK, N. Y.

4 of the 40 Easy Ways to Make \$3⁰⁰ an Hour

THE four plans shown are but a sample of the many ways in which our members are making \$3.00 an hour upwards, spare time and full time, from the day they join the Association. If you want to get into Radio, have a business of your own, make \$50 to \$75 weekly in your spare time, investigate the opportunities offered the inexperienced, ambitious man by the Association.

Our Members Earning Thousands of Dollars Weekly

The Association was formed to help men cash in on Radio. It makes past experience unnecessary. As a member of the Association you are trained in a quick, easy, practical way to install, service, repair, build and rebuild sets—given sure-fire money-making plans developed by us—helped to secure a position by our Employment Department. You earn while you learn, while you prepare yourself for a big-pay Radioposition.

The Association will enable you to buy parts at wholesale, start in business without capital, help you get your share of the \$600,000,000 spent annually for Radio. As a result of the Association, men all over the country are opening stores, increasing their pay, passing licensed operator examinations, landing big-pay positions with Radio makers.



In Your Spare Time in RADIO

Below are a few reports from those cashing in on the "easy ways"

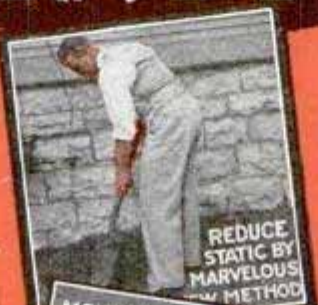

Clears \$3,000.00 Frank J. Deutch, Pa.—"Since joining the Association I have cleared nearly \$2,000.00. It is almost impossible for a young fellow to fail, no matter how little education he has, if he will follow your easy ways of making money."

\$1,100.00 in 6 Weeks J. R. Allen, Calif.—"Have done over \$1,100.00 worth of business in the last 6 weeks. Next month I am going to open up a store of my own. I never knew that money could come so fast and easy."

\$25.00 a Week Spare Time N. J. Friedrich, N. Y.—"I have averaged \$25.00 a week for the last 7 months even though I am not a graduate but just learning."

Training Lands Him Job R. C. Kirk, N. C.—"Your training has been very valuable to me. I landed a job with the big department store out here a few weeks ago because I had my membership card with me. There were a large bunch of applications ahead of me."

ACT NOW If You Wish NO-COST Membership

For a limited time we will give to the ambitious man a No-Cost Membership which need not—should not—cost you a cent. For the sake of making more money now, and having a better position in the future, mail coupon below *now*.

Mail Coupon for the FREE HANDBOOK

It is not only chock-full of absorbing information about Radio, but it shows you how easily you can increase your income in your spare time. Mailing the coupon can mean \$50 to \$75 a week more for you.

Radio Training Association of America

4513 Ravenswood Avenue Dept. PM-10 Chicago, Illinois

Radio Training Association of America
Dept. PM-10, 4513 Ravenswood Ave., Chicago
Gentlemen: Please send me by return mail full details of your Special No-Cost Membership Plan, and also a copy of your Radio Handbook.

Name _____

Address _____

City _____

State _____

Fix that Car! Learn How Easily



JIFFY INDEX in These Five New Big Auto Books Makes All Facts Instantly Available. Find Anything You Want to Know in a Moment in This Latest Edition

All Shipped **Free**
Don't miss a word of our free shipment offer. We ship without receiving one penny.

Repair any auto fault, learn how now. You can do it easily in this new simple way. These five big automobile books are the most interesting, the most practical books we have ever published on automobile construction, operation and repairs. Brimful of facts, photographs and explanations so easy to understand that anyone can learn how to repair auto faults in almost no time. Over 2,000 pages full of diagrams, data sheets and everything else needed to make anyone an authority on automobiles. Whether you want to qualify as garage owner, auto repair expert or merely wish to know how to keep your own car 100% efficient, you will recognize the amazing value of these five big books, especially on our

No Money Offer

A very liberal plan of distribution brings these books to you for examination without one cent of payment to us. We don't ask a cent of you, but ship the books free. Look them over, read them as much as you want to, note the splendid photographs and drawings, and then if you decide you want them, send only \$2.00 and then \$3.00 a month until only \$24.80 is paid. That is all. Nothing more to pay us. There is no further obligation.

American Technical Society Membership Free

Yes, we include a certificate of membership in the American Technical Society, which entitles you to free consultation for one year on any subject relating to automobile engineering. We have over a million dollars of resources enabling us to get co-operation of the largest automobile manufacturers and dealers who have furnished us plans and photographs. You can write or wire any time for special information. Answers will be sent promptly without cost.

Learn All About AUTOS

Get these five big books on this liberal offer and learn all the things you want to know about autos—carburetors, engines, springs and spring suspension, brakes, 4-wheel drive, lubricating system—all are fully covered. These complete and comprehensive books are yours if you want them on this easy plan. Send for a set now. Fill in the coupon.

FIND FACTS QUICKLY

One of the best things about these money making books is the Jiffy Index, which puts vital facts at your finger tips. You don't have to read the books through; you don't have to spend long hours over them. This Index enables you to put your finger on the information wanted in a jiffy.

DON'T HESITATE

There are no strings to this offer—it means just what it says. Send name and address on the coupon and all of the five big books will be sent you. Remember, one fact alone may save you an expensive repair or help you to a better job.

**American Technical Society, Dept. A719
Drexel Ave. at 58th St., Chicago, Ill.**

I would like to look at the five big auto books—send them on your free offer. I will pay the few cents delivery charges. If I like them I will send you \$2.00 when I have had the books fifteen days, and then \$3.00 a month until the special low price of only \$24.80 is paid. Otherwise I will return the books at your expense. You are to include, without charge, free consulting membership certificate in the American Technical Society.

Name

Address

Employer's Name

Employer's Address

FOR FREE OFFER USE COUPON

ACCOUNTING LESSON FREE

Don't wonder about Accounting Courses

Find out about this one by trying it free

Send for our 84-page book "How to Learn Accounting" and the first lesson free of charge.

INTERNATIONAL ACCOUNTANTS SOCIETY, INC.
A Division of the
ALEXANDER HAMILTON INSTITUTE
Dept. 84, 3411 So. Michigan Ave., Chicago

Learn to PAINT SIGNS and SHOW CARDS

We quickly teach you by mail, or at school, in spare time. Big demand. Big future. Interesting work. Oldest, foremost school.

EARN \$50 TO \$200 WEEKLY

Otto Wegand, Md., home-study graduate, made \$12,000 from his business in one year. John Vassos, N. Y., gets \$25 for a show card. Crawford, B. C., writes: "Earned \$200 while taking course." Write for complete information.

DETROIT SCHOOL OF LETTERING
150 Stimson Ave. Est. 1899 DETROIT, MICH.

STOPS ACHE—SUPPORTS BACK THE NATURAL BODY BRACE

Takes strain off the back, the abdomen; relieves nervousness, constipation. Gives wonderful sense of relief and well being. For men and women.

COSTS NOTHING TO TRY IT

Write for our 30 days free trial offer, free illustrated book, measurement blank, etc.

NATURAL BODY BRACE CO.
Howard C. Rash, Pt., 77 Rash Bldg., Salina, Kansas

BOW LEGS?

THIS GARTER (Pat'd) Makes Trousers Hang Straight If Legs Bend In or Out

Free Booklet—Plain Sealed Envelope

THE T. GARTER CO., Dept. E
South Bend, Ind.

BUCHSTEIN'S FIBRE LIMB

is soothing to your stump—strong, cool, neat, light. Easy payments. Braces for all deformities.

D. BUCHSTEIN CO.
610 3rd Ave., So. MINNEAPOLIS, MINN.

Send for Catalog Today

Stop Using a Truss

STUART'S ADHESIF PLAPAO-PADS are entirely different—being mechanico-chemico applicators—made self-adhesive purposely to keep the herbal muscle-tonic called "PLAPAO" continuously applied to the affected parts, and to minimize danger of slipping and painful friction. The adhesive fabric is soft as velvet, and clings to the body

without straps, buckles or springs.



Easy to apply—comfortable—inexpensive.

For almost a quarter century stacks of sworn testimonials from many different countries report success—without delay from work. The epidermatic absorption of Plapao and the utilization of "plaster therapy" tend toward a natural process of recovery, after which no further use for a truss. Test of factor "PLAPAO" sent you **FREE**

—Mail Coupon below TODAY—

Plapao Laboratories, Inc., 1307 Stuart Bldg., St. Louis, Mo.
Send me FREE Trial Plapao and 48-page book on Rupture. No charge for this now or later.

Name

Address

"The Von Hoffmann Graduate Qualifies"

Von Hoffmann Aircraft School

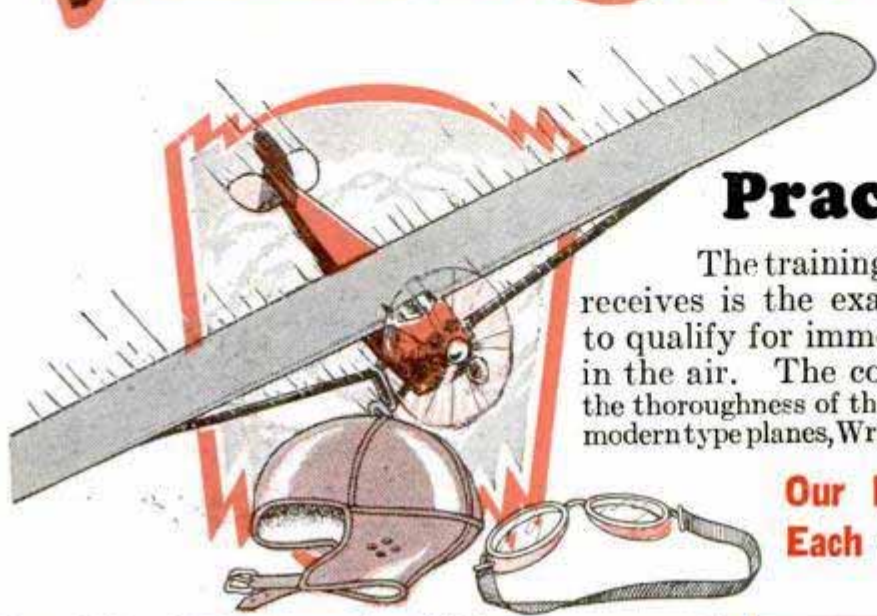

**Will Give You
a Thorough—
Practical Training**

The training which the Von Hoffmann student receives is the exact training which he must have to qualify for immediate positions on the ground or in the air. The cost is low considering daily flying, the thoroughness of theoretical and ground instruction on latest modern type planes, Wright Whirlwind and other standard motors.

**Our Instructors Are Ex-Army Pilots
Each with Over 3000 Hours of Flying**

Our School Registered, All Instructors and Airplanes Licensed by U. S. Government, Aeronautics Branch, Dept. of Commerce

All Airplanes used by us for both instruction and passenger service are planes licensed by the U. S. Government and our instructors are U. S. Licensed Transport Pilots and U. S. Licensed Mechanics. Our equipment is new and of modern design, subject to daily U. S. Government Inspection. (We have a resident U. S. Government Inspector on the field—think what this means to you.)

**A Record
to Be
Proud Of**

Our record to date shows that every Von Hoffmann graduate has received a U. S. Government License.

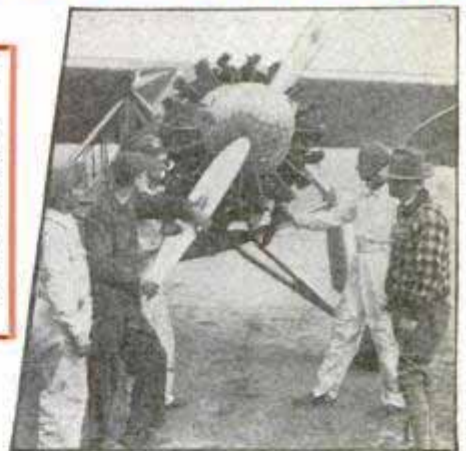

Ground Course



Easy Monthly Payments

It is easy to pay the Von Hoffmann way because small monthly payments are extended. Let us show you how you can start now and pay later, even after you have finished the course of training.

**Von Hoffmann
Aircraft School**

122 Lambert-St. Louis
Flying Field
(Lindbergh's Own Field)
St. Louis,
Mo.

Flying Course

We teach you by actual flying and practical instruction; no long course needed. No student bond required.

Start NOW!

Free Information Coupon—

Von Hoffmann Aircraft School,
122 Lambert-St. Louis Flying Field (Lindbergh's Own Field), St. Louis, Mo.
Please mail FREE information at once.

Name
Address
Town State Age



Are You Bashful?



???

**SHY?
NERVOUS?
EMBARRASSED?**

**DO YOU LACK
CONFIDENCE?**

* * *

**ARE YOU
SELF-CONSCIOUS?**



**NO WONDER YOU ARE A
"STAY-AT-HOME"**

DO YOU ever feel embarrassed in the presence of strangers? Are you always bashful and confused when you meet people for the first time or when you are in company of the opposite sex?

You Are Self-Conscious!

Shame on you! There is no need for you to be nervous and embarrassed. Stop being shy. You can learn how to conquer the terrible fear of your superiors.

DO NOT BE DISCOURAGED!

Every individual now suffering from *Bashfulness* (Self-Consciousness) will welcome this good news. My method used with great success by many people throughout the world. *Be cheerful and confident of your future!* If you're Bashful—don't wait another day—Send 25c for my fascinating, amazing book. Tells how to master and overcome Self-Consciousness. Write today.

R. BLACKSTONE

B-4710 Flatiron Bldg. New York, N. Y.

Richard Blackstone,
B-4710, Flatiron Building, New York City.

Please send me a copy of your book on Nervousness and Bashfulness. I am enclosing 25 cents in coin or stamps.

Name

Address

City..... State.....

You Can Learn **HYPNOTISM** ... or No Cost **Try FREE 5 Days!**

DON'T be unpopular, lonesome, or unhappy a minute longer. Now you can make your life what you want it to be—now you can win admiration, success and big money—through the strange power of hypnotism. I'll show you how to use this great force to help you master every situation or *The Five Day Trial is FREE!*

In just a few hours I'll teach you the hidden secrets of Hypnotism—the methods used by the great operators—the amazing things you can accomplish once you understand this mighty power. You can use it to overcome obstacles, achieve your fondest ambitions and become MASTER of yourself, friends and acquaintances—either sex. See for yourself how Hypnotism can banish fear, worry and opposition—improve your memory—increase your earnings—and force others to give you the good things in life you deserve!

In his startling NEW book, *The Science of Hypnotism*, the world famous hypnotist—Prof. L. E. Young—reveals the most carefully guarded secrets of this fascinating subject. He not only explains the methods of noted hypnotists, step by step—but tells clearly all about the nine stages of hypnotism, the Hypnotic Mirror, Mental Telepathy, how to select your subjects, magnetic healing, methods of hypnotizing, how to waken the subject, how to make money out of hypnotism!

**Try 5 Days FREE—
Send No Money**

So confident are we that Prof. Young and his great book will quickly teach you the science of hypnotism, that we will send you a copy without one cent in advance! Simply clip and mail the coupon below. When the book arrives pay the postman the special low price of \$2.50 plus few cents postage. Then test the power of Hypnotism 5 days! If not amazed and delighted return the book and money will be refunded at once! Mail the coupon now.

**FRANKLIN PUBLISHING CO.
Dept. M-70, 800 N. Clark St., Chicago**

Mysteries of Hypnotism Revealed

- How to Hypnotize at a Glance
- Susceptible Subjects
- How to Hypnotize by Telephone
- How to Give an Entertainment
- How to Make Others Obey You
- Overcoming Bad Habits
- How to do Dozens of Hypnotic Feats
- Use of Hypnotism in Operations

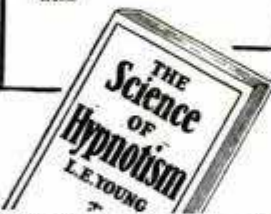

Franklin Publishing Co., Dept. M-70,
800 N. Clark St., Chicago

Please send me your amazing new book—*The Science of Hypnotism*—by Prof. Young. When the book arrives I'll pay the postman only \$2.50 plus postage. If I am not satisfied after 5 days' trial, I may return the book and you are to refund my money.

Name.....

Street and No.....

Town..... State.....

If you are likely to be out when postman calls, send \$2.50 with coupon and we'll pay delivery charges. Customers outside U. S. must send cash with order.

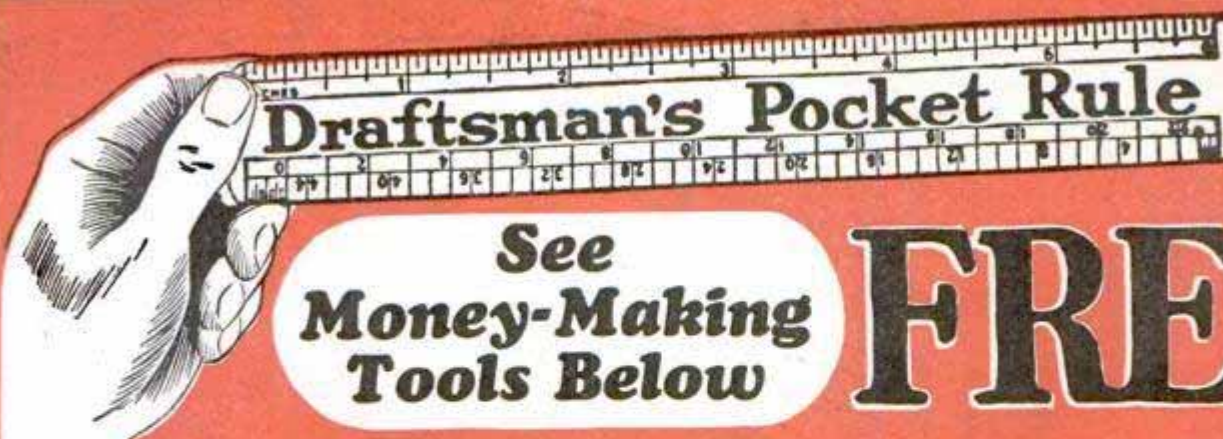

**GIVEN
TO
YOU**

**See
Money-Making
Tools Below**

FREE

If you are 16 or older and will copy jack shown at right and mail it to me I will send you a Draftsman's pocket rule, free.



Copy me and get Invoice Rule Free. — Jack

NEW
Just Copy This Jack Today!
Pay-Raising Plan



Write to me. I will send you this new book. Not a catalog. My Pay-Raising Plan and Money Making Advice. I can prove that John Savadge, trained by me, makes \$300 a month. Earl J. Dupree, trained by me, refused \$600 a month because he makes more in his own business. A. H. Bernier, trained by me, earns \$7000 to \$9000 a year. Arthur Dewalt, trained by me, makes more than \$400 a month. D. C. Stroop, trained by me, makes \$475 a month. L. V. Broughten, trained by me, makes \$300 a month.

Now is the time to learn to be a draftsman. Get Free, "My Pay-Raising Plan." Send for it at once.

Let me tell you how some Dobe Draftsmen make \$250.00 to \$750 a month. Read this advertisement clear through. See for yourself how you can make real money as a draftsman. Read how much work there is for them.

**Age or Lack of Education
No Drawback**

You do not need previous experience. You do not need to be a high school graduate. My practical, home study course gives you just the kind of training you need to become successful, during only your spare time.

I Train You at Home

My practical working method makes every step in learning drafting as clear as a moving picture. That's why I train you so fast to be a draftsman.

Money Back if Not Satisfied

I train you under a positive Money Back Agreement. If my training does not satisfy you after you have finished you get every penny back.

Earn While You Learn

You can start earning extra money a few weeks after beginning my training. I give you special work and tell you how to make money.



**Money-Making Tools
Furnished by Me**

You get these fine quality, genuine, imported draftsman's tools, just as soon as you become my student. No finer tools made for practical drafting work.

Employment Service

After training you I help you to get a job without charging you a cent for this service. Employers of draftsmen come to me for men because they know that men I train make good.

**Draftsmen
Needed In:
Auto Work**

The automobile industry is one of the greatest in America. Thousands of draftsmen needed. I'll train you for the work.

Electricity

Electricity is the coming motive force of the world. Draftsmen are needed in every department of this fascinating work. I'll train you at home. Get a job here.

Aviation

Aviation is just in its infancy. It is bound to expand to enormous proportions. Draftsmen are essential to it. I'll train you quick at home for drafting position.

Motor Bus Work

Motor bus building and motor bus transportation have become leading world industries. Hundreds of draftsmen engaged in this work. I'll show you the way.

Building Work

There will always be building. No structure can be erected without plans drawn by draftsmen. I'll make you an architectural draftsman at home.

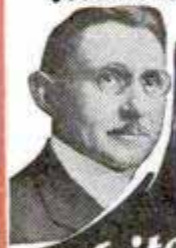

**"If You Earn Less
Than \$70 a Week
Write Me Today!
I Will Train You At Home"**
Engineer Dobe

ACT NOW Before You Put this Magazine Down, Let me send you my books "Successful Draftsmanship" and "My Pay Raising Plan". Remember Draftsmen are needed everywhere. That's the kind of profession to get into. Get started now. Get into a better position, paying a good straight salary the year around.
Engineer Dobe 1951 Lawrence Avenue Div. 13-57 Chicago, Ill.

Mail Sketch—Get Free Rule

ENGINEER DOBE

1951 Lawrence Ave., Div. 13-57 Chicago

Here's the sketch. Send me free rule; also send me free of all cost books "Successful Draftsmanship" and "My Pay-Raising Plan."—how to earn money while learning and proof of big money paying positions.

Name.....Age.....

Address.....

Post Office.....State.....



Tobacco Is Hurting You

Look the facts square in the face, Mr. Tobacco User. You may think tobacco is not hurting you.

That is because you haven't as yet, perhaps, felt the effects of the nicotine poison in YOUR system. For you know that nicotine, as absorbed into the system through smoking and chewing tobacco, is a slow working poison. Slow, yes—but sure.

Tobacco lowers efficiency. It slows a man down. Makes it harder to concentrate the mind on work. Tobacco users seldom have the amount of "pep" and energy of those who do not use the weed. There's many a man older than you in years who is younger in energy, simply because he lets tobacco alone.

Some day, probably, you will realize to what an alarming extent tobacco does undermine the system.

When your hands begin to tremble—
and your appetite begins to fail—
and your heart seems to "skip a beat" now and then—
and slight exertion makes you short of breath—
then you have a right to suspect that
TOBACCO is getting the upper hand.

Any well-informed doctor will tell you that these are only a few of many symptoms of tobacco poisoning.

And YOU know that the use of tobacco in any form is an expensive, utterly useless habit. You know you ought to quit.

Tobacco Habit Banished

Let Us Help You

It doesn't make a particle of difference whether tobacco has been used for a single month or fifty years, or how much, or in what form—whether cigars, cigarettes, pipe, plug, fine cut, or snuff. In most cases, Tobacco Redeemer removes all craving for tobacco in any form in a very few days. Not the slightest shock to the nervous system. The tobacco craving will usually begin to decrease after the very first dose—there is no long waiting for results.

Tobacco Redeemer contains no habit-forming drugs of any kind and is quick, safe, pleasant and thoroughly reliable.

It is in no sense a substitute for tobacco. After finishing the treatment, there is usually no desire to use tobacco again or to continue the use of the remedy. It helps to quiet the nerves and makes one feel better in every way.

Results Guaranteed A single trial will convince you. Our legal, binding, money-back guarantee goes with each full treatment. We will refund every cent you pay for the treatment if, after taking it according to the easy-to-follow directions, it should fail to banish the tobacco habit completely.

SEND Coupon for Free Proof Let us send you our free booklet on the injurious effects of tobacco, together with testimonial letters from men all over the country telling how they have been absolutely freed from the tobacco habit by this simple home treatment. You could not ask for stronger proof that Tobacco Redeemer does do the work than the evidence we will gladly send on request. Just mail the coupon—or a postal will do.

NEWELL PHARMACAL CO.
Dept. 300 Clayton Station St. Louis, Mo.



Free Book Coupon

NEWELL PHARMACAL CO.

Dept. 300 Clayton Station St. Louis, Mo.

Please send, without obligating me in any way, your free booklet regarding the tobacco habit and proof that Tobacco Redeemer does positively relieve the tobacco habit or money refunded.

Name.....

Street and No.

Town..... State.....



Bald Men! Free

One Full Ampoule of my amazing Hairerbs fluid which I discovered myself and which grew hair on my head.

This Ampoule is absolutely free. Don't send any money. There is no C.O.D. No charge whatsoever. All I want is an opportunity to show you the fluid with which I grew hair on my own and on other men's heads. Merely mail coupon below for Free Ampoule.

Here is How I Used to Look

I was just as bald as this picture. It is a true photograph without any tampering or retouching. It is exactly like I used to look. Then look at the full head of hair I have in the picture on the left! As I have stated so often, I don't know whether I am the first man who discovered this great secret, but I do know I have it, that I grew my own hair and that I am growing hair on the heads of other men.



Bald Men It's No Joke to Be Bald!

What I accomplished on my own head and on other heads I believe I can do for you, provided you are under 45 years of age and loss of hair was not brought about by burns, scars or any other causes leading to absolutely dead hair roots. Anyhow, I must succeed or your money is refunded in strict accordance with my guarantee. No apparatus. My home treatment is simple, and easily applied.

Mail This Free Coupon

Mail the coupon today—Right Now—I will send you, immediately, one full Ampoule of my marvelous Hairerbs fluid which I discovered, of which I hold the secret and which grew my own hair on my own bald head. Besides the Free Ampoule of Fluid, I will send photographs, names and addresses of men and women who successfully used my Hairerbs Fluid for dandruff, falling and loss of hair.

VREELAND

1357 Euclid-Windsor Building
Cleveland, Ohio



These are exact untouched photographs of Miss Augustine Raimondo, 2350 East 25th Street, Cleveland, who was almost entirely bald and who had to wear a net covering in the school room. She was a very unhappy young lady. Physicians, hospitals and clinics told her that she would be bald for life. She saw one of our advertisements, became interested and began taking treatments with Hairerbs. The growth of hair was surprisingly fast. A hairy fuzz began to appear after twelve treatments. More hair came steadily until today Miss Raimondo has a full head of hair which is daily becoming more luxuriant. This case is open to investigation by anyone.

FREE COUPON

VREELAND 1357 Euclid-Windsor Bldg.
CLEVELAND, O.

Please send me, entirely free, one full Ampoule of the same Wonderful Hairerbs Fluid which grew your hair.

My Name.....

My Address.....

State.....

BOYS GET THIS ELECTRIC MOTOR



ALMOST GIVEN AWAY!

Genuine ERECTOR Motor

Here's a genuine Erector Motor equipped with driving pulley. Runs all mechanical toys like Erector, Meccano, etc. Binding posts connect with dry battery or transformer. The name ERECTOR is your guarantee of quality. 100% satisfaction guaranteed. Just the motor you've been waiting for. Get yours at once.

32 Page Book of Experiments FREE

On this very special offer with every motor will be packed a 32 page book of interesting electrical stunts and experiments. Tells all about motors, take them apart and reassemble them. Mysterious tricks and optical illusions. Full of illustrations. Very valuable.

The Magazine of Thrills

The Open Road for Boys Magazine has 50 pages crammed with thrilling, breath-taking stories that will hold you spell-bound. Tense stories of high adventure on land, on sea and in the air. Deep mystery. Suspense. Most thrilling mystery serial smash in ten years now starting. Regular subscription price alone \$1.00 a year. We will send you the Open Road for Boys Magazine for a whole year and this wonderful electric motor and valuable experiment book all for \$1.25! Wow! what a bargain.



BOTH TOGETHER \$1.25

SEND IT NOW

Open Road for Boys Magazine,
Department 10PC
130 Newbury Street, Boston, Massachusetts.
Canadian Postage 25c Extra
Foreign 50c Extra

You bet I'll grab that bargain. Enclosed is \$1.25. Rush me the electric motor and 32 page experiment book and put me down for a year's subscription to the Open Road for Boys Magazine.

Name.....
Street.....
City or Town.....State.....

10 Days Trial and 10 Months to Pay on any Mead Instrument



Select your own payment terms. Make money playing in local orchestras. Be the "life" of the party wherever you go. Mead instruments are **easy to play** and a joy to learn. Free instruction book—new simple method. Send a postcard **TODAY** for free instrument catalog with marvelous offers and terms.

CYCLE CO.
Mead
DEPT 254 R CHICAGO



SQUAB BOOK FREE

Breed squabs and make money. Sold by millions for more than chickens. Write at once for free 48-page book beautifully printed in colors telling how to do it. *You will be surprised.*
PLYMOUTH ROCK SQUAB CO.
634 H Street Melrose Highlands, Mass.

FOY'S BIG PIGEON BOOK

in **NATURAL COLORS**, a complete guide to successful Squab and Poultry Raising. Tells how to feed, breed, grow and make money raising squabs. Quotes low prices. Write today. **FREE.**

F. FOY Box 18 CLINTON, IOWA

WAKE UP!

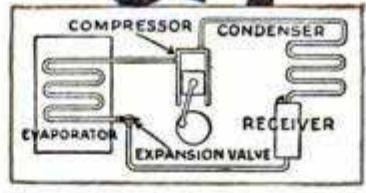

Amazing Opportunities in ELECTRIC REFRIGERATION

WHY look for big pay in crowded industries? Get into the newest and fastest growing industry in America—**Electric Refrigeration**. Millions of dollars being invested by Wall Street in factories and advertising. Urgent need for scientifically trained men in manufacture, installation, sales and service. Jobs pay \$200 to \$1,000 a month. And now a new easy method trains you at home to fill a big pay job. Learning Electric Refrigeration simplified amazingly. This course sponsored by Kelvinator, and praised by Servel and other leading manufacturers. Our Employment Dept. helps you find big jobs, **FREE.**

BIG BOOK FREE

Mail coupon now for big book free "The New Giant Industry—Electric Refrigeration." See how easy it is to quickly become a highly paid refrigeration expert. No obligation. **Utilities Engineering Institute, Dept. 1109, 4403 Sheridan Road, Chicago, Ill.**

"Your Institute should be of great interest to young men wishing to get into the service and sales end of this business. It will be a pleasure to co-operate with you."
Col. F. E. Smith,
President, Servel, Inc.

Utilities Engineering Institute,
Dept. 1109, 4403 Sheridan Road, Chicago, Ill.
Without obligating me, send free book "The New Giant Industry—Electric Refrigeration."
Name.....
Address.....
City.....State.....

**MICHIGAN STATE
AUTO SCHOOL
AND
GREER COLLEGE
AMERICA'S GREATEST
TRAINING SHOPS
NOW UNDER MANAGEMENT
OF
ERWIN GREER**



ERWIN GREER, President

**LET ME HELP You to the
Sunny Side of Life**

My Free Auto Book will tell you about these remarkable GREER COLLEGE FEATURES: *Railroad Fare included from any point of the United States—Easy Terms—Big Equipment—Help you get a Job while learning—Man's size income and YOUR FUTURE as a trained AUTO EXPERT.* I will and can solve your life's money-making problem. While your fine ambition is urging you on—**ACT—SEND FOR MY FREE AUTO BOOK.**

**ERWIN GREER, President
GREER COLLEGE**
Dept. 1001 A.T.
2024 Wabash Ave., Chicago, Illinois

LEARN AUTOS

Seven Billion Dollars are spent each year to repair Twenty-four Million Autos, Trucks and Tractors. Tinkering Mechanics are losing out. EXPERTS, trained on Big Equipment, by EXPERT TEACHERS are demanded at Big Pay. Thousands of Garage owners make up to \$15,000 a year.

New Purchase of Big School Gives Me Big Advantage

I recently bought the famous Michigan State Auto School, formerly of Detroit. NOWHERE ELSE I know of, is there NOW such Auto TRAINING SHOPS as GREER COLLEGE, where you get practical training on a world of equipment.

Up to \$15,000 a Year

Clip coupon below for Free Auto Book. Learn how I fit you for Big Jobs. I have trained thousands to earn over \$100 a week. Ninety Thousand men, in 26 years, have started their Auto careers at Greer College. Welding, Ignition, Starting, Lighting—EVERYTHING—I teach you. MY TRAINING IS COMPLETE—no dull books or deep theory.

A Job for You While Learning

My Free Book shows how you DON'T NEED a lot of MONEY or EDUCATION, and how I PAY YOUR FARE HERE—how I HELP GET YOU A JOB WHILE LEARNING, to help pay your living expenses and tuition—also another one at graduation. Send for this great book today.

Only 3 Months—Then Big Pay

It takes me ONLY THREE MONTHS to fit you for big pay. In this great seven story building (shown above) which is filled with machinery and training equipment, I fit you for every branch of the auto business. There are AMAZING OPPORTUNITIES for Foremen, Garage Owners, Auto Specialists the country over. Let my Free Book show you.

If unable to come to Chicago, now for resident courses, write for information about Home Study Course!

SCISSORS FOR SUCCESS BOOK

ERWIN GREER, Pres.
GREER COLLEGE,
2024 Wabash Avenue,
Dept. 1001 A.T.,
Chicago, Ill.

Dear Sir:
Send me your Big Auto Book—Free of Charge and without obligation to me.

Name.....

Street and No.....

City..... State.....

You Fellows Who Want **BIG PAY**

Get into

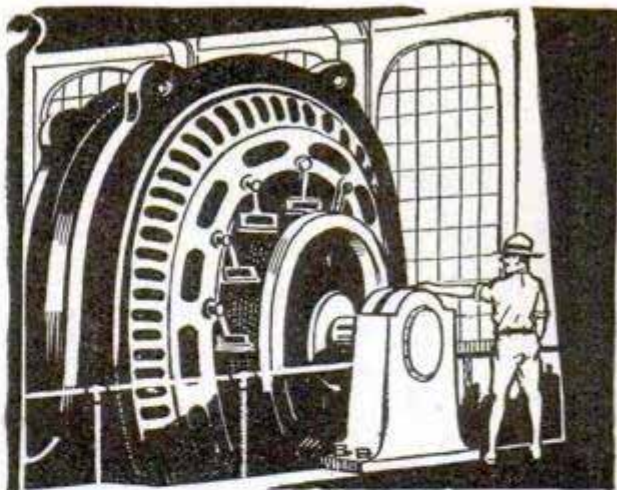

WHY earn \$15 or \$20 or \$30 a week, when in the same six days as an Electrical Expert, you can make \$60 to \$100 — and do it easier — not work half so hard. Why, then, remain in a small-pay, no-future job that offers no chance for big promotion — no chance for big income? Fit yourself for a real job. **Get into Electricity.** That's where the big money is being made, and always will be made.

Electricity — The Big Pay Field

Today even the ordinary Electrician — the "screw driver" kind — is making money — big money. But it's the trained man — the Electrical Expert, — who makes the really big money, — \$10 to \$20 a day — \$60 to \$100 a week. Be a Big-Pay man, yourself. Get in line, now, for one of these "Big-Pay" Jobs.

I'll Train You At Home

I'll train you at home, — in your spare time. You work just as you are working now — at your same job. My now famous "Work-Sheet and Job-Ticket" method, guarantees you simplified, practical training along work-shop lines. In a few short months you can step out of your old job into a new job — into electrical work where you can be a Big-Pay man in this Big-Pay field.

You Earn As You Learn

To learn Electricity my way you don't have to be a College man, or even a High School graduate. You can read. You can write. That's enough. With me, you get experience as you go along and make good money while learning. I'll show you how, — and I'll give you, without extra cost tools and apparatus to work with — 6 Big Outfits in all.

Money Back If Not Satisfied

That's what I agree to do. And back of me in this agreement stands a \$2,000,000 Illinois Corporation. There's nothing like "Cooke" Training, anywhere. It's the Training that big Electrical men are praising; it's the Training that employers recommend; it's the Training that one of our greatest Engineering societies has endorsed 100 percent. **It's the Training for you.**

If You're Earning Less Than \$70 A Week — Investigate

Don't wait a minute! Find out today why "The Cooke Trained man is the Big-Pay Man", everywhere! Find out how "Cooke" Training will help you boost your pay! Mail coupon right now for my Big FREE Book of Facts. See the Six Big Working-Outfits I give you without extra charge. See the hundreds of pictures, the proofs, the Big-Pay letters of other "Cooke" Trained Men. Get this great free Book. Send for it today. Clip, sign, and mail coupon **RIGHT NOW!**

L. L. COOKE, Chief Instruction Engineer

**L. L. COOKE SCHOOL
OF ELECTRICITY**

Dept. 17,
2150 Lawrence Ave.
Chicago, Illinois

ELECTRICITY

**Hundreds of Men
I have trained
are now earning**

**\$60 to \$100
A WEEK**

So Can You

**If you
earn less
than \$70
a week
INVESTIGATE
ACT
NOW**



I'll train you at home in a few short months.
L. L. COOKE

FREE BOOK COUPON

L. L. COOKE, Chief Instruction Engineer,
Dept. 17, 2150 Lawrence Ave., Chicago, Ill.

Send me **FREE** and prepaid, your Big Book "Secrets of Success in Electricity," with all details about your Home Study Course in Electricity.

Name _____
Address _____
City _____ State _____

Residents of Canada send coupon to: L. A. Farrow, Special Representative, 7 Meadbury Lane, East, Windsor, Ontario, Canada.



\$30 A DAY

Dear Mr. Cooke: I was making \$25 a week when I enrolled. Now with my own Electrical Shop I make as high as \$30 a day. A. J. Daigneault, 225 Worcester, Southbridge, Mass.



\$1.50 AN HOUR
Dear Mr. Cooke: I had to work like a slave for 45c an hour before I enrolled. Now, thanks to you, Mr. Cooke, I make \$1.50 an hour. G. W. Oprea, 4220 N. Meade Av. Chicago, Ill.

**6 BIG
OUTFITS
NO EXTRA
COST**

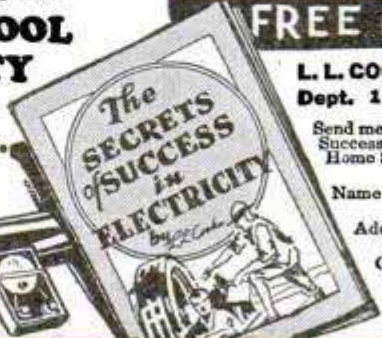

The "Cooke" Trained Man is the "Big Pay" Man

Classified Advertisements

WORLD'S BEST WANT AD MEDIUM

Advertisements in this section, 30 cents per word, each insertion, minimum 10 words, payable in advance.
Rate starting January, 1930, issue 35 cents per word
To be inserted under proper classification in November issue, copy should be in our office September 18th

ADVERTISING AGENCIES

ADVERTISERS. Our 32 years mail order experience at your disposal. 68 page self-help guide, with United States map in colors, giving complete information best paying daily, weekly and monthly publications sent free. Frank W. Lenhoff Advertising Agency, 66 East Lake St., Chicago.

ADVERTISE In 24 big Sunday newspapers, 24 words \$15.00. Excellent for securing agents, salesmen and business opportunities. Catalog listing 1,000 leading dailies, weeklies, mail-order magazines, everything. Free. Wade Agency, Great Northern Bldg., Chicago.

GET Into advertising. Learn quickly at home. Experience unnecessary. New easy plan. No text books used. Practical work. Old established school. Send name and address for interesting free booklet. Page-Davis School of Advertising, Dept. 3437, 3691 Michigan, Chicago.

ADVERTISING—Display or classified; placed anywhere; copy prepared; no additional charge. Newspaper, magazine, farm papers. List free. P. LeGrand Agency, 34 W. 33rd St., New York.

BEFORE Advertising get our catalog. No charge. 25 years in business. The largest classified agency in the world. Ankrum Advertising Agency, 100 No. LaSalle St., Chicago, Ill.

FREE—New 1929 Advertisers Rate Guide, 44 pages. Includes everything. Lowest rates. E. H. Brown Advertising Agency, 140 S. Dearborn, Chicago.

ADVERTISE In rural weeklies. Lists free. Meyer Agency, 4112 Hartford, St. Louis, Mo.

TIME Counts in applying for patents. See pages 136 and 137. Clarence A. O'Brien, Registered Patent Attorney, Washington, D. C.

FOR ADVERTISERS

"FINKEL Bull" sales letters and literature save you time, mistakes, money! Long, successful experience. Moderate charges. Investigate. Finkel Advertising, 131P Glenwood, Jersey City, N. J.

ADVERTISE To boys! Rates on request. Boys' Ideal Magazine, Monaco Place, Pittsburgh, Pa.

ADVERTISE, 24 Words, 50 monthlies, 100 weeklies, \$4.50. List free. Allen, 234, Bound Brook, N. J.

"THE Master Letter Writer," including 500 successful letters, by Ad-Man Davison, world-famous letter expert; 704 pages, \$3. Circular sent. Opportunity Press, Westport, Conn.

ADVERTISE 300 Country newspapers, 28 words, \$10. Business getter. Lists free. Keator, Hartford Bldg., Chicago.

SALES PROMOTION

\$50 TO \$50,000 Daily sales secured for our clients. Three months from the date we undertook to overhaul this manufacturer's selling program, his closures increased from 16% (a mighty good average in his field) to 35%. Sales long since extended beyond national boundaries. They now include a dozen foreign countries too. 35 years' salesmanship-in-print experience back of our campaigns. Submit sales problems for free diagnosis. 10 years' Sales Promotion Manager Larkin Co., James C. Johnson, 118A Woodbridge Ave., Buffalo.

QUALITY Mail order advertising for superior sales! Sales letters, followups, circulars, folders—our specialties. Mid American Advertising Company, Rowan, Iowa.

LETTERS That talk—If you need sales letters that really sell. Mailing lists; form letters; any direct-mail advertising service. Write Omaha List & Letter Co., Box 1172, South Omaha, Nebr.

LETTERS That sell—Banning Advertising Service, Times Building, Watertown, N. Y.

BRANCH OFFICE SERVICE

MONTREAL, 827 Davaar; Honesty, dependability, method. Reasonable rates. N. McGlashan.

CHICAGO—6 No. Michigan Ave. A real address. Write Russell Albin.

AGENCIES WANTED

WANTED Particulars, goods, sole indenting rights Australia. A. E. Harvey, Brookton, Western Australia.

MANUFACTURER! Agency open for unique household necessities, novelties, etc. Send catalog, samples, prices, to: Specialty Supply Co., Merewether, N. S. W., Australia.

MAILING LISTS

LATE Names, buyers, agents, opportunity seekers, single women. Guaranteed correct. Free price list. De Muth, 88-15 82nd Ave., Glendale, N. Y.

SEND \$1.00 For \$1,000 rural women buyers names. Sheasgreen, PM1427 North Penn, Minneapolis, Minn.

AUTOMOBILES

TIME Counts in applying for patents. See pages 136 and 137. Clarence A. O'Brien, Registered Patent Attorney, Washington, D. C.

AUTO SUPPLIES

WHIRLGAS Carburetor attachment. Scientific construction. No moving parts. No air vents. Greatly increases automobile power, speed, mileage. No carbon. No motor knock. Immediate start cold weather. Applied with wrench in few minutes. Sample mailed \$1.25. Whirlgas, 816 Ford Bldg., Detroit.

SURPRISING Results obtained from use of newly invented vapor air filter on automobile and tractor engines. The Vapor Air Filter Co., Mitchell, S. Dak.

AMAZING New hub-cap wrench. \$50,000 Chevrolet-Six owners. Agents wanted. Box 311, Apponaug, R. I. Price \$1.25.

VALVE Troubles positively eliminated. Stop grinding valves for life of your engine by installing Trembley valve rotators. Prevent burned, stuck, pitted, warped valves. Trembley Products, 1423 So. Hill St., Los Angeles, Calif.

USED Air compressor, fully automatic, upright space saving type, beltless. Reconditioned and guaranteed like new. Shipped on trial and easy terms. Also a few test stands, car washers, battery chargers and paint sprays. E. M. Connor, Box M1094, Troy, Ohio.

YOU Are wanted to resilver mirrors at home. Immense profits plating autoparts, tableware, etc. Write for information. Sprinkle, Plater, 77, Marion, Ind.

GARAGE. Set of easily read blueprints and full instructions for building a substantial garage cheaply. Price two dollars. Healey Engineering, 119 Rosslyn Ave. North, Hamilton, Ontario.

RADIATORS At wholesale prices. All standard makes. Satisfaction guaranteed. Send for prices, stating make and model. Independent Radiator Co., 1119 S. Wabash Ave., Chicago.

OPEN Car owners. Don't "give" your car away. Equip it with Badger Enclosures and enjoy it for several more years. Car owners, dealers and agents write for catalog and special prices. Badger Auto Enclosure Co., 5501 Broadway, Chicago.

AUTO Parts new and used. Lowest prices. Bankrupt supplies, motors, wheels, radiators, transmissions, generators, gears, carburetors, touring tops complete \$15. Brakelining 50% off. Brightman, 2065 Main St., Hartford, Conn.

DYKE'S Famous Automobile Encyclopedia—Latest edition, the 15th. Fully revised to cover all latest facts regarding newest developments in automobile field, including new Model A Ford. Information given on repairing and adjusting every part of all motor cars. How to find trouble and fix it. 1,250 pages. 4,200 illus. Price, cloth, \$6. Flexible Morocco \$7.50. Pay postman price and postage when he delivers book. Popular Mechanics Press, Room 808, 200 E. Ontario St., Chicago.

AUTO SERVICE EQUIPMENT

BIG Opportunity in 8-hour battery charging. Let me tell you how you can install equipment with practically no investment. Earn \$150 to \$300 monthly from it. Bargains in used outfits. Write today. Also have a few reconditioned car washers, paint sprays, automatic air compressors. I. C. Helmick, Box M1096, Troy, Ohio.

BATTERY Chargers for service stations. Several makes. New and used bargains. Get price sheet. Adams-Barr, Columbus, Ohio.

SAVE Money—Garage equipment reconditioned and guaranteed like new. Unusual bargains in test stands, car washers, battery chargers, air compressors, etc. Shipped on trial, easy terms. What do you need to complete your equipment? E. C. Galbreath, Box M1095, Troy, Ohio.

RUBBER Top dressing made from old inner tubes, makes old tops new. Send \$1.00 for formula and instructions. Glover Rubber Co., Rome, Ga.

FOR FORD OWNERS

AURORA Underslung parts and 3.1 racing gears. Speedster bodies, headlights, hi compression head. See Sport Factories ad page 155.

MOTORCYCLES, BICYCLES AND SUPPLIES

MOTORCYCLES \$25 To \$50. Easy terms. Tires \$2.50, frames \$3, forks \$3, tanks \$5, wheels \$4, chains \$2, saddles \$5, handle bars \$5, engines \$15, side cars \$25, transmissions \$12, belts \$6, airplane engines \$15, airplane wheels \$5, bicycle tires \$1.25, velocipedes \$7.50, bicycles \$9.50, new auto tires \$3, used auto tires \$2.50. Send 50c for catalogs. Price Cutter Deninger, Rochester, N. Y.

MOTORCYCLE Bargains, lowest prices, bargain sheets for stamp, special aviators supplies, motorcycle accessories largest line in America, lowest prices. Largest motorcycle mail order house in the United States. Rochester Harley Davidson Corporation, 129 West Main St., Rochester, N. Y.

HARLEY-DAVIDSON Bargains at a tremendous sacrifice. All models and prices. Guaranteed. Send for our catalog, "Money Saving Motorcycle Bargains." Knuth's Harley-Davidson Agency, 2525 Fond du Lac Ave., Milwaukee, Wis.

MOTORCYCLES, Outboard motors. New. Used. Bargains. Easy terms. Catalog free. Clymer, Denver, Colo.

BARGAINS Used motorcycle parts for all makes. Goodyear balloon tires, \$8.25. J. B. Dahl, 3661-63 Archer Ave., Chicago, Ill.

MOTORCYCLES—Largest stock used motorcycles and parts in middle west. Indian scouts \$35 up. Send 15c for latest motorcycle catalog. Indian Motorcycle Sales, Kansas City, Mo.

MOTORCYCLE Parts, new and used. Lists free. Tower Cycle Co., Pine Lawn, Mo.

AVIATION

HEATH-HENDERSON Aircraft motors are the ideal light plane motor. Weighing only 115 lbs., they are suitable for airplanes, sleds, boats. Remanufactured motors as low \$190 or \$325 brand new and complete with propeller. 10c in stamps or coin brings our large illustrated booklet describing the changes that must be made in the Henderson motor for aircraft purposes. Heath Airplane Company, Chicago, Ill.

BUILD Speedy ice sled for coming winter. Blue print \$2.00. Twin and four cylinder converted engines, Henderson conversion parts, propellers, hubs, etc. Send dime for new catalog. The Sensenich Brothers, Lititz, Pa.

ZEPPELINS! Boys! They're easy to build with our plans. Blue prints 3-foot models Los Angeles, Graf, Italia 50c a-piece. List free. Southern Aero Model Co., 1421 No. Washington Ave., Dallas, Tex.

TIME Counts in applying for patents. See pages 136 and 137. Clarence A. O'Brien, Registered Patent Attorney, Washington, D. C.

BLUEPRINTS Of Curtiss Hawk, 50c; Junkers monoplane, 50c; K. G. Twin-speedster (out-door record holder for speed) 50c; flying seaplane and mystery R.O.G., 25c; Bellanca scale model, 50c; Junkers "Bremen" flying kit special complete, \$3.50. Send 2c postage stamp for complete price list. A. A. C. Model Aircrafts, Dept. PL, 340 East 188th St., New York.

WRITE For new free book, "Aviation." Tells you quickest way to get into aviation, money earned, etc. Also describes new method of home-study training that is preparing hundreds of men for big pay jobs. Address National Aviation Training, Dept. 116, 1031 South Broadway, Los Angeles.

OX-5 MOTORS For sale. Some need overhauling and some liknu, cheap, also parts. New aircooled 165hp. Gnome never out of crate \$60. Quitting business. Pennsylvania Aero Service, 155½ Dennick, Youngstown, Ohio.

WE Build everything for the airplane. Send us your requirements, we will do the rest. Revelation Aircraft Co., 225 West 57th St., New York.

HEATH Propellers represent the most efficient aerial drive, each propeller is designed to fit the particular requirements of the customer. Made to measure they give results that are phenomenal. 4c in stamps brings our propeller catalog. Heath Airplane Co., Chicago, Ill.

KITS—Byrd's Antarctic, Lockheed Transcontinental, army pursuit, or navy seaplane scale models, quarter each, postpaid. Casson-Craft, Canton, Mass.

TEN Cents brings our new bargain list of light planes, motors, propellers, hubs and blueprints. Storms Aviation Co., Spartanburg, S. C.

\$175 WILL Build our beautiful steel fuselage, one place monoplane. Plans \$1. Literature 10c. Barney Snyder, E. San Diego, Calif.

TELESCOPIC Sights 26" long for airplane machine gun sacrifice at \$4.50. Air Transport Co., Garden City, N. Y.

SIMPLEX Air Model Co., Auburn, Mass. Send five cents for supply booklet.

THE American School of Aviation announces a new correspondence course in mechanics of aviation. A thorough training in practical aeronautics. American School of Aviation, Dept. 1872, 3601 Michigan Ave., Chicago, Ill.

THE Heath super parasol is America's most popular sport plane because it is the easiest to build and fly. Complete set of material \$199. All material for the fuselage at less than \$40. Modern steel tube construction but so easy to assemble. 10c stamps or coin brings our large illustrated booklet. \$5.00 for complete detailed shop prints. Heath Airplane Co., Chicago, Ill.

USE Your Ford or motorcycle motor to drive your ice-sled. Conversion parts for Ford \$10, Indian \$12, Harley \$15. Send 10c for list. Heine Motor Works, Orwigsburg, Pa.

MODEL Airplane builders. Send for free catalog. Baby R. O. G. Kit 60c. Model Airplane Supply, 29 North Ave., New Rochelle, N. Y.

PROPELLERS For model aeroplanes. Semi carved, 6", 8", 10", 12" 10c each. Any size. Aero Shop, 3050 Huribut Ave., Detroit, Mich.

PROPELLERS For airplanes, boats, hydroplanes, road speedsters, snow and ice sleds, canoes. Crawford Motor and Airplane Manufactory, Incorporated, Seal Beach, Calif.

LIGHT Plane ribs, cloth Y, 4½" sample 50c; twenty or more 35c. Wings, fuselages, wheels, etc. Price list 20c. Kamm Aircraft Co., 524 12th St., Oshkosh, Wis.

NEW Model airplanes, supplies of finest obtainable materials, perfectly made. Catalog 10c. Dealers list 35c. Cleveland models, 1866P West 57th St., Cleveland, Ohio.

OPTICAL Aeroplane machine gun sights. Air service surplus. New in original cases. 5 ground lenses. Rubber eyepiece. Size 2 by 24. Cost government over \$50, \$6 postpaid. Money order or cash. Western Salvage Co., 648 Market, San Diego, Calif.

"IF You want to fly" let Alexander Klein, brilliant engineer, teach you. With great skill whole course of training has been simplified and made crystal clear. Remarkable book teaches in most practical and easily understood fashion. Recommended by skilled flyers. Sent C.O.D. anywhere in U. S. Simply pay postman \$2.50 and postage when delivered. Sent postpaid to any address upon receipt of \$2.50. Popular Mechanics Press, Room 808, 200 E. Ontario St., Chicago.

NEW Burd piston rings for OX-5, 10c each. Brand new Hispano Stromberg carburetors, complete, \$55.00; new type extra strength ribbed wrist pins for OX-5, \$1.00; OX-5, \$1.00. Hispano, \$1.00; new Berling OX-5 magnetos, \$60.00. Gasoline level gauges, \$2.50, any depth. Dixie converted booster magnetos, \$7.50. Air Transport Equipment, Inc., Carle Place, N. Y.

BOYS—Model airplanes supplies 2ft. Curtiss Hawk Flying Model Construction Set containing all necessary parts, \$2.50. Baby R. O. G. Kit, 50c. Send 5c for booklet. Hawthorne Model Aero Co., Hawthorne, N. J.

AVIATION—Salary \$18 to \$35 a week while under instruction for U. S. government aviation license in our factory and on the airport. Write for information, without obligation. Aero Corporation of America, Department GL, 63 Second St., Milwaukee, Wis.

\$100 FLYING Course. Six hours, including solo. Only \$10 an hour for additional solo time. Allison Airplane Co., Lawrence, Kans.

SPORTPLANE—\$25 Payments. Buy the Alco Junior coupe monoplane. We deliver the knockdown parts to you express prepaid in eight convenient groups. Blueprints sold separately, \$2.50 per set of four big sheets. Allison Airplane Co., Lawrence, Kans.

MOTORCYCLE Engines for airplanes, motor boats, ice sleds; wheels, gasoline oil tanks, frames, less than half price. Send 50c for catalogs. Price Cutter Deninger, Rochester, N. Y.

GET The new 1929 sportplane Constructor-book containing 8 full page blueprints, drawings, photographs, etc. Answers hundreds of questions, sizes, weights, material, dimensions, methods, motors, flight instruction. All for \$1.00. Circular five stamps. Russell Aero, Box 455, Toledo, Ohio.

BIGGEST, Best catalog model airplanes; parts, supplies; 5c postpaid. Ideal Company, 19 West 18th St., New York.

VARIOUS Sizes wood, reeds, bamboo, rubber band, wheels, propeller, onion skin covering and other supplies. Big bundle for 25c, five for \$1.00. No stamps. Will also send circular on free three foot model. Aero Shop, 3050 Huribut Ave., Detroit, Mich.

"SKYWARD HO!" Wonder book on aviation—32 pages, 150 illustrations. Shows you complete training for flying career, fame, fortune! Sent free. Write today! Parks Air College, 213 Mo. Theatre Bldg., St. Louis, Mo.

PROPELLERS—4", \$8.75; 5", \$13.25; 6", \$16.50; Special Henderson propeller, \$15.00; Aerodrive boat or sled blueprints, 50c each. Helmets, \$3.00; goggles, \$3.00, both only \$5.00. Engines, fuselages. Ostergaard Aircraft, 4303 North Narragansett, Chicago.

BARGAINS In model airplanes and supplies. Catalog 5c. Marx Aircraft, 320 South 4th East, Salt Lake, Utah.

AIRPLANES Motors and propellers bargains. Smith, Box 1343, Houston, Tex.

BOYS: Get a pursuit tractor kit complete 35c. No stamps. Send 5c for price list. W. & J. Aeroplane Shop, 200 Maple St., Wyandotte, Mich.

BOOKS AND PERIODICALS

WE Guarantee to teach you how to read eyes instantly. As easy to understand as actual words when you know how. New method discovered and perfected by the world-famous Stage Prestidigitator Martine. Quickest, easiest, surest method. Learned in few minutes. Simply amazing—amazingly simple. Complete illustrated course \$1. Send stamps or money order or pay postman \$1.15 on delivery. Educator Press, 19 Park Row, New York. Dept. ER-24.

INDUSTRIAL Alcohol. Wright's book. Full directions for making, fully illustrated, \$2.50. Spon & Chamberlain, 120 P.M. Liberty Street, New York, N. Y.

HYPNOTISM Easily learned. Lessons guaranteed. Postpaid, \$1.10. Smith Pub. Co., Dept. 3, Springfield, Mass.

THE Cause of Hard Times, 25c. Modern Publishing Co., Station A, Box 162, San Diego, Calif.

FAMOUS Bailey Handbook—The book that prepares you to pass the examination for any grade of license for stationary, marine and Diesel engineers, firemen and boiler inspector in any state of the Union or any province of Canada. Flexible cover. Handy pocket size. Pay postman \$2.00 plus postage when he hands you the package. Popular Mechanics Press, Room 807, 200 E. Ontario St., Chicago, Ill.

PICTURES AND POSTCARDS

TEN Real photo post card views of Caracas—the Springtime Capital—sent anywhere postpaid for \$1. Newton Bernard, Aptdo 722, Caracas, Venezuela, South America.

PHOTOS, 20, \$1.00. Agents' samples. Cartoons, cuts. Art-Gpo, Bx471, New York.

FRENCH Lovers photos. Love scenes of French girls and fellows. Taken from live poses. Imported direct from France. 12 for \$1.00. All different poses. Carrano Novelty Co., Dept. PM-O, West Haven, Conn.

ART Pictures—220 all different. 160 samples \$1.00. Particulars 10c. Howard Sales Co., Dept. 15, Box 529, San Francisco, Calif.

NOVELTIES, CURIOS, ETC.

MEXICAN Jumping beans. World's greatest curiosity. Samples with Mexican game card 35c. Hundred with five cards, \$1.00. Stamps or cash. Midwest Novelty Company, 1508 Main St., Kansas City, Mo.

GET Descriptive list interesting woods novelties. C. Peltier, Ontonagon, Mich.

GAMES, ENTERTAINMENTS AND PLAYS

PLAYS, Musical comedies and revues, minstrels, comedy and talking songs, black-face skits, vaudeville acts, monologs, dialogues, recitations, entertainments juvenile plays and songs, musical readings, make-up goods. Catalog free. T. S. Denison & Co., 623 So. Wabash, Dept. 11, Chicago.

VENTRILOQUISM—Complete course, 50c Premier, 1980 Dorchester Ave., Dorchester, Mass.

VENTRILOQUISM By mail—small cost. 2c stamp brings particulars. Geo. W. Smith, Room S-371, 125 N. Jefferson St., Peoria, Ill.

MAGIC TRICKS, BOOKS AND JOKER NOVELTIES

RARE Offer! 10 amazing, closely guarded secrets of master magic men all for \$1.00, sent prepaid, with our complete illustrated catalog of magic and book on card tricks thrown in. Think of it! Less than 10c apiece for these spectacular mystifying illusions of the great: the cut cord restored, reading dates on unseen coins, picking weird objects from thin air, etc. Every purchaser will receive coupon entitling him to "Trix and Chatter," a large finely bound 286 page \$4.00 book of magic for only 75c. Biggest value ever! Only a few sets left. Mail in your dollar today. Palmer Magic Shop, 119 S. State St., Chicago.

"THE Book of 1,000 Wonders" explains many mystifying tricks with coins, cards, handkerchiefs, etc. Also, contains complete catalog of magic tricks, jokes, puzzles, books, escapes, mind-reading acts, spiritualistic effects, illusion plans, curios and imported novelties. Largest assortment, lowest prices. Amaze and mystify your friends! Send 10c today. Lyle Douglas, Station A-5, Dallas, Tex.

MAGIC—Tricks, Books and Supplies. For amateurs as well as the great professionals. Anyone can learn through our instructions. Feature Acts in Mind-Reading, Spiritualism, Rope Ties, etc. Large illustrated professional catalog, 20c. Chicago Magic Co., 140 So. Dearborn St., Dept. B, Chicago, Ill.

HINDU Rope trick 50c. Catalog free! Stringer, 3020 Sheffield, Chicago.

BOOK Of 153 magic tricks and big magic catalog, all for 20c stamps. Midwest Novelty Store, 1312 Main St., Kansas City, Mo.

READ Your friends' minds. A wonder mindreading stunt. Twenty cents. Popular Service, Box 122, Sayre, Penna.

SIX Tricks, 25c, including paraphernalia, magical catalog. Weber, 647-E2 62nd, Chicago.

MAGIC Tricks, books, etc. Catalog free. Geo. Fenner, Louisville, Ky.

MAGIC Catalog 20c. Lynn's, 105 Beach, Dept. 3, Jersey City, N. J.

VANISHING Coin trick—Mysterious, bewildering. Amaze your friends. 20c silver. Dana, 413-M Rose Place, Long Beach, Calif.

SEVEN Magical Delusions and catalogs—25c. Gilmagico, Morgan Park, Ill.

ELECTRIC Fun! Seventy stunts, 110 volts, \$1. Kutting Sons, Campbell, Calif.

ESCAPE From Sacks, Rope, Ties and Chains. Easy with these complete instructions. Give an evening's entertainment and mystify the "wise ones." Let them tie you hand and foot, place you in a bag and seal the bag. In a minute you are out. Complete instructions in "33 Rope Ties" and "Sack Escapes." Pay postman \$1.50 and postal charge for these two books when delivered. Popular Mechanics Press, Room 808, 200 E. Ontario St., Chicago, Ill.

STAMP COLLECTING

MYSTIC "Queer Country" Packet! Contains scarce stamps from the following strange lands: San Marino, Antioquia, Congo, Cyprus, Fiji Islands, Gwalior Hyderabad, Iceland, Jhond, Kenya, Uganda, Lebanon, Monaco, North Borneo, Nyassa, St. Thomas Prince, Eastern Roumelia, Siam, Sierra Leone, Tanganyika, Trinidad Tobago, Uban-gi, Upper Volta, Wallis Futuna, Alaouites. Get this wonderful packet of "freak countries" and make your friends envious! Price only 10c to approval applicants! Write today. Mystic Stamp Company (Dept. 8), Camden, N. Y.

500 DIFFERENT Stamps for 25c. Big collection from Bosnia, Crete, Epirus, Honduras, Iceland, Kenya, Liberia, Malta, Nyassa, Quelimane, Siam, Zambesia and other "hard" countries. Catalog value \$10. Price 25c to approval applicants! Bargains. 1,000 different 79c; 15 triangles 49c; 100 Africa 45c; 100 Asia 50c; 100 Balkans 35c; 100 British Colonies 30c; 100 French Colonies 35c; 100 Portuguese Colonies 50c. Eight packets for \$3.00! Illustrated lists free. Loma Stamp Co., 3926 32nd St., San Diego, Calif.

ANCHERS \$\$\$ Outfit—only 12c! Fine triangle stamp; set German stamps with (pre-war) value forty million dollars (interesting!); perforation gauge, mm scale; airmail set; scarce stamp from smallest republic on earth; newspaper set; packet good stamps and Travancore, Malay, Dutch Indies, etc. Entire outfit for 12c to approval applicants! (Nice pocket stock book, value 25c, with every order!) Ancher Stamp Co., Box 126, Rutherford, N. J.

A SNAP—300 Different foreign and 60 different U. S. stamps, including \$1 and \$2 revenues, all for only 25c. Free, with each order, our pamphlet which tells "How to Make a Stamp Collection Properly," together with our price lists of albums, supplies and hundreds of bargains in sets, packets, etc. Queen City Stamp & Coin Co., Room 36, 604 Race St., Cincinnati, Ohio.

ONLY 5c! 10 Airmail stamps, including scarce Latvian triangle stamp, Portuguese Red Cross set and 8 different Latvian Occupation stamps. Approvals and free lists with each order. Curhan Stamp Company, Gloucester, Mass.

SPECIAL Packet—United States, Congo, Liberia, Siam, Tunis, etc., for 10c to approval applicants. Paul Wilde, 4643 Carrie, St. Louis, Mo.

ILLUSTRATED, Descriptive U. S. list, 1929, price 50 cents; also second edition U. S. and B. N. A. list. Stanley Gibbons, Inc., 38P Park Row, New York City.

POPULAR Approvals, popular prices. Napp, 413 Oak Grove, Beloit, Wis.

\$1.00 YELLOW Canadian (cata. 25c), a stock slip with U. S. and N. Y. \$2.00 stamps and 100 all different foreign free to approval applicants who send 5c for packing, etc. Stamps on approvals 1/4, 1/2, 3/4, 1c, etc. Lowest prices and best quality. Kelgin Stamp Co., P. M., Fernandina, Fla.

STAMPS Sent on approval at 70% discount. Reference required. Emory Renoll, Hanover, Pa.

AFRICA, British colony set free with approvals. William Monjar, 1551 Knox St., Cincinnati, Ohio.

33 1-3% COMMISSION. Sell our stamps, sheet catalog value, \$4. Our price, \$2.00. Unsold stamps returnable. No investment required. References necessary. Lux Stamp Co., 805-C Fairmont Place, Bronx, New York.

COVERTCO Packet, 200 different stamps 10 cents, with 60% discount approvals. Covert Stamp, 39 State, Rochester, N. Y.

FREE Premium to approval applicants. Irwin Batson, 2919 St. Paul St., Baltimore, Md.

CHINA, 20 Varieties, C. V., at least 65c, including postage due and offices in Manchuria, free to approval applicants. Target Stamp Shop, 6 Holland St., Binghamton, N. Y.

ANNIVERSARY Offer! (15c) seven beautiful sets: "Airmail," "Commemorative," "Red Cross," "Occupation," "Charity," "Prisoners," "Pictorial," also three packets: (International) (Colonies) (Bulgaria). Approvals. G. W. Deering, 164 Albion, W. Somerville, Mass.

FREE—31 Different stamps to applicants for Royal approvals. 2c return postage. Royal Stamp Company, Bristol, Pa.

40 DIFFERENT United States with latest pricelist 12c. Approvals at 60% discount. Seidenberg, Baroda, Mich.

125 FOREIGN 10c. Johnson, 32 St. Marks Ave., Brooklyn, N. Y.

FREE! Largest stamp* in the world! Fine packet 65 different stamps from Cape Verde, Jamaica, Mozambique, Syria, etc., including dying soldier, beautiful women, ships, maps, savages, airplane, scenes, bird and animal stamps, for only 5c to approval applicants. Largest stamp in the world (Rare China Wild Goose Special Delivery) given absolutely free with each order. Supply limited! Send your 5c today. Western Philatelists, 6021 Harper Ave., M10, Chicago.

205 DIFFERENT, including triangle, birds, animals, Europe, Asia, Africa, 15c. Approvals when requested. Hollister, 3523 N. Secley Ave., Chicago, Ill.

UNITED States postage only, 100 varieties 75c; 50 varieties 25c. Page, 15 School St., Boston, Mass.

BULGARIA—25 For 10c to approval applicants. Cleveland Stamp Co., Caxton Bldg., Cleveland.

SPECIAL 500 Different from all parts of the world, 25c to approval applicants. Ohio Stamp Co., Box 249, Cleveland.

SPECIAL Thirty day offer. Portugal, 1926, 10 escudo, thousand hinges, pocket duplicate container, perforation gauge and millimeter scale, lists, sent to serious advanced approval applicants for only 25 cents. Dominion Stamp Company, Box 222, Toronto, Can.

SURPRISE Packet—Borneo, Congo, Malay, United States Commemoratives. Illustrated list, etc., to approval applicants 8c. Moseley, 4521 Parkview, St. Louis, Mo.

2,000 DIFFERENT Stamps \$2.65; 1,000, 80c; 500, 30c; 300, 20c. Maurice Michael, 942 So. 23rd, Bellwood, Ill.

RARE Congo airmail and 5 other airmails in our packet, 61 different, from Antioquia, Hyderabad, Morocco, Oceania, etc., 5c. Approvals and free lists. Monumental Company, Arlington Post, Baltimore, Md.

SCHLESWIG: 5 Varieties free to approval applicants. Allison, Angola, Ind.

DANDY Mint stamps 2c to those requesting approvals. Harvey Teeple, Decatur, Ind.

BIG Combination, including nice packet Liberia, scarce Turkestan, Sudan, Famine Stamp, Azerbaijan, packet others and fine pocket wallet. All for 10c to approval applicants. Rogers, 1136 Woodland Ave., Houston, Tex.

GREAT Britain No. 60, cat. \$1.00, net 35c. Lists free. Dutton, East 19th, Eugene, Oreg.

FREE Hawaiian stamp to approval applicants. Postage 2c. Eastern Stamp Co., 1809 Kilbourne Place, N. W., Washington, D. C.

"NEWFOUNDLAND" Means "Rev. Butler." Collectors need my catalog (free). Rev. Butler, St. Georges, Newfoundland.

UNITED States stamps on approval. Reference essential. Stamp House, 38 Torrey, Dorchester, Mass.

CONFEDERATE Essays (pair) free. 2c postage. Tatham Stamp Co., 49 Van Horn, West Springfield, Mass.

CINCINNATI Bank mixture 2 ozs. \$1.00 unpecked. Plenty good stamps, mostly new issues used. H. Hussey, Dury Ave., Cincinnati, Ohio.

DOUBLE-HEADER Packet and U. S. high values, 7c. Golden Rule Stamp Co., Box 1248, Chicago.

TWENTY French colonial 5c. Approvals. Norono Stamp Co., 4401 National Ave., Milwaukee.

GOOD Premium given to every serious general collector buying stamps from our 50% approval sheets. Please state preferences. Iron Spring Stamp Co., Iron Springs, Pa.

PREMIUM With best approvals. Alla Stamps, Box 311, Quebec, Canada.

AFRICA, 25 Different for 5 cents to approval applicants. Harry Brown Co., Elmsire, N. Y.

50 DIFFERENT Stamps from 50 countries, 10c with approvals. Precancel Stamp Co., 406 East 18th, Minneapolis, Minn.

ACME Price list free upon request. Acme service is the best. Acme approvals against references. Acme Stamp Company, 1480 B'Way, New York.

FREE, 6 Different Luxemburg to approval applicants. E. D. Stamp Co., 3905 Forest Park Ave., Baltimore, Md.

FREE! 15 French colonies. Postage 2c. R. F. Roberts, 901 Fourth, Bay City, Mich.

WHOLESALE: 100 British colonies 10c; 500 good foreign 20c; 100 airmail 20c. Alvin Johnson, Storm Lake, Iowa.

150 GOOD Mixed foreign stamps 3 cents. Stanton, Niantic, Conn.

FREE—\$1.00 U. S. postage old issue free. If you write for our 56 page price-list of U. S. and foreign stamps, 2,000 illustrations. Also fine but cheap stamps on approval. Hussman Stamp Co., 620-3 Olive St., St. Louis, Mo.

FREE Set to approval applicants. Koenig, 968 First Place, Woodcliff, N. J.

STAMPS Correctly listed on approval. Premium. G. Bloedel, Box 84, Hamlet, Ind.

80 DIFF. U. S. including \$1.00 denomination 50c—200 diff. foreign, 10c. Mountain City Stamp Co., P. O. Box 335, Man-nington, W. Va.

82 FAR OFF countries only 10c—Inhab- bane, Travancore, Kouang Tchou, Syria, Liban and 77 other countries—82 different stamps; 82 different countries, 10 cents; approvals and illustrated lists with each order. Reimers, 30 Flatiron Bldg., Fort Worth, Tex.

85 DIFFERENT Foreign stamps, from 20 countries (every continent), stamp hinges, perforation gauge, and illustrated album with places for hundreds of stamps for 10c (coin) and 2c stamp. 5 Liberia 10c; 2 Korea 10c; 3 Hawaii 15c; 1,000 diff., 90c; 1,000 mixed, 30c. Dept. 18, Argonaut Stamp Co., New Canaan, Conn.

70% APPROVALS, 3c. H. R. Stamp, 193 S. Ninth, Brooklyn, N. Y.

UNITED States, early issues, covers, high values. Catalog free. Nagy, 8P South 18th, Philadelphia.

AIRMAIL Stamps, 25 different 14c. Approvals. Victoria Stamp Shop, 1453 Victoria, Chicago, Ill.

SIX Turkestan (speculative); two Corea, 15c. Approvals. Simmons Stamp Company, Horton, Mich.

FREE—Canada (15 Var.) for new ap- plicant of my 1c, 2c and 3c approval, and also my 50% discount. Chas. W. Schmidt, P. O. Box No. 4832, Frankford Sta., Phila, Penna.

3/4c APPROVALS, including Liberia, Nyassa, etc. Also 14,000 averaging 1/2c. References. Philatelic Exch., Huntington, W. Va.

SIAM Airmail set of 4 weird stamps only 10c to applicants of our low-priced ap- provals. Lists free. E. P. Johnson, Box 692, San Jose, Calif.

DANZIG Stamps free—interesting packet from Danzig with big catalog free for 2c. Midland Stamp Company, Toronto, Can.

ONLY 25c For a five months' subscrip- tion to The Stamp Collector, America's finest stamp magazine. 100 all different stamps given free to each subscriber. Money re- funded if you are not more than pleased. The Stamp Collector, Dept. P. M., 515 Sedgwick Drive, Syracuse, N. Y.

100 DIFF. United States 25c, 1,000 mixed 25c. 70% approvals. Burton, Mad-ison, N. Y.

25 SCANDINAVIAN 10c. M. Gustafson, 766 East, New Britain, Conn.

105 CHINA, Etc., 2c. Album (500 illus- trations) 3c. Bullard, Sta. BB, Boston.

WHITE Russia, complete country for 8c. Approvals. Victoria Stamp Shop, 1453 Victoria, Chicago, Ill.

5c ONLY, 25 Different fine U. S. stamps; \$1.00 Canada postage; scarce Siam. Air mail with approvals. L. W. Hudson, Box 118, Plainfield, N. J.

ATTRACTIVE Approvals at 50% discount and 25% discount. Noemus Stamp Co., 312 East 23rd St., New York.

UNITED States \$2 present issue (cata- logs 50c) for ten cents to approval buyers. State size of collection. Ledue, Redlion, Penna.

PENNY Approvals that Satisfy. Neil Gronberg, Box 5441, Philadelphia, Pa.

FREE! 115 Different stamps to approval applicants, 2c postage. Paige Stamp Co., Oak Park, Ill.

110 DIFFERENT Stamps, many unused, high values, free to collectors requesting our net approvals. Postage 2 cents. Christen- sen, Milwaukee, Wis.

100 FOREIGN Stamps 3 cents. Lufbery Stamp Co., Branford, Conn.

COMPLETE Sets on approval. References necessary. Kenneth White, Rockville, Conn.

FREE! Triangles, airmail, Iceland and 50 others to approval applicants inclosing 3c postage. Hawkeye Stamp Co., Cedar Rapids, 39, Iowa.

UNITED States—Send on approval. Send me your want list. Ref. please. M. Hanna, New Kensington, Pa.

AIRMAILS—15 Different stamps, in- cluding 12 different airmails, 6c. Sent only with approvals and price list. Inland, 1021 Main St., Kansas City, Mo.

110 NEW Europe All Different, a wonderful collection cataloguing several dollars, free to collectors requesting our Net Approvals. Postage 2 cents. Badger Stamp Co., Milwaukee, Wis.

24 VARIETIES Cuban stamps, 10 cents. List of 6,000 low-priced stamps free. Address Chambers Stamp Co., 111P, Nassau St., New York City, N. Y.

FREE 50 British Colonials, if approvals requested. Postage 4c. Berkeley Stamp Co., South Berkeley, Calif.

200 DIFFERENT stamps 10c; 1,000 hinges 10c. R. H. Carlton, 380 W. So. Temple, Salt Lake, Utah.

STAMPS, 100 Varieties, Africa, Brazil, Peru, Cuba, Mexico, etc., 10c; 25 different U. S. 25c; 1,000 mixed, 40c; 1,000 hinges, 15c. List free. C. Stedman, 5941 Cote Brillante, St. Louis, Mo.

STAMPS, 100 all different. Postage 2c. Lists free. P. M. Quaker Stamp Co., Toledo, Ohio.

BEST One cent approvals in America. F. P. Hand, 1117 So. 60th St., Philadelphia, Pa.

101 STAMPS Free with approvals. Postage 2c. Johnson Stamp Co., (PM) Jamestown, N. Y.

REVENUES—Telegraphs—Every country. Pretty—Intriguing—Cheap. Mint \$5.00 revenue free to applicants with references. Vanderhoof, 1114 Logan, Denver, Colo.

FREE—20 Different African stamps. Atlantic Stamp Company, 68 Garden St., Springfield, Mass.

FIFTY French colonials 5c to approval applicants. Prall, Somerville, N. J.

111 DIFFERENT, Arabia, Azerbaijan, Zanzibar, etc., 10c to approval applicants. Floyd Marsh, 524 Hamilton Ave., Indianapolis, Ind.

BARREL Of foreign stamps while they last. 25c-1,000 or pound \$1.00 (over 4,000). Approvals sent. Hinges 3,000-25c. Elmer, 61 Court St., Boston.

FREE—20 Different Argentine. Approvals. List. Send 4c today for postage, etc. Reuter, Santa Ana, Calif.

STAMP Collectors, magazine. Finest monthly stamp paper. Write for free sample copy. Philatelic Publishing Co., Inc., 15 John St., New York, N. Y.

MAGNIFICENT Packet free—Beauties from distant lands, many richly colored, unusual designs. 2c postage. Empire Stamp Co., Toronto, Can.

RARE COINS

SPECIAL Prices on United States commemorative half dollars in uncirculated condition; Columbian 79c; Lincoln \$1.29; Pilgrim \$1.19; Maine \$1.39; Grant \$1.39; Monroe 99c; Lexington 99c; Huguenot \$1.59; Stone Mountain 99c; California \$1.69; Sesquicentennial \$1.19; Oregon \$1.20; Bennington \$1.29. Arcy, Box 483, Muskogee, Okla.

OLD Money wanted. Will pay \$100.00 for 1894 dime, S. Mint, \$50.00 for 1913 Liberty head nickel (not buffalo). Big premiums paid for all rare coins. Send 4c for large coin folder. May mean much profit to you. Numismatic Co., Dept. H, Ft. Worth, Tex.

CALIFORNIA Gold quarter 27c, half 52c, 1832 silver $\frac{3}{4}$ \$1; eagle cent, 20c; 1837 Jackson cent, 20c; \$100.00 confederate 20c. A. Wylie, 365, Wheaton, Ill.

COMMEMORATIVE Half dollars. Stone Mountain, 85 cents. Pilgrim, 90 cents. Vermont, \$1.00. Lafayette dollars, \$2.75. Trade dollars, \$1.05. G. T. Davis, Huntington, W. Va.

BARGAINS—20 2c Pieces, \$1.00, 25 large cents, \$1.00, 12 1922 cents, \$1.00, 100 different foreign coins, \$1.00 15 different, 25c. Romanocoinshop, Springfield, Mass.

\$2 TO \$500 Each paid for hundreds of old coins. Keep all old money, it may be very valuable. Send 10 cents for illustrated coin value book, 4x6. Prices guaranteed. Get posted. We buy and sell. Clarke's Coin Office, Box 5, Le Roy, N. Y.

40 OLD Coins all different \$1.00; 100 different coins, \$3.00; 100 mixed foreign coins, \$1.00; Pilgrim half-dollar unc., \$1.00; Monroe half-dollar unc., \$1.00. Claud Denney, Box 315, Dallas, Tex.

5 DIFFERENT Foreign coins 25c; 25 different \$1.00. Price list and coin 10c. Bob Cohen, Box 483, Muskogee, Okla.

RARE United States, foreign coins, war medals, Chinese coin and catalog 10c. Alexis Mengelle, Colorado Springs, Colo.

AMERICAN Coins, bought, sold. Coin value booklet, 12c. Frank Saco, 735 45th St., Brooklyn, N. Y.

GET Profit and Pleasure in collecting old coins. Send 10c for large illustrated coin catalog. You'll be delighted with it. Send for it right now. B. Max Mehl, Numismatist, Mehl Bldg., Dept. P, Fort Worth, Tex. Largest Rare Coin Firm in the U. S.

OLD Coins, large fall selling catalog of coins for sale free to collectors only. Catalog quoting prices paid for coins, ten cents. William Hesselin, 101A Tremont St., Boston, Mass.

3 DIFFERENT Fine bronze or nickel coin, 2 large crisp bank notes and catalog 10c. George Best, Cedar Rapids, Iowa.

CALIFORNIA Gold—Quarter size, 27c; $\frac{3}{4}$ size, 53c; 3c piece and catalog, 10c. Norman Shultz, Box 746, Salt Lake, Utah.

UNITED States. Large cent, two-cent bronze, three-cent nickel and bargain list, 25c. Thirteen dates large cents, \$1.00. George Coffin, Greenwood Mountain, Me.

FOR BOYS

EARN Christmas money. Order 50 sets Christmas seals. Sell for 10c set. When sold return \$3.00, you keeping \$2.00. No work—just fun. St. Nicholas Seal Co., Dept. 43PM, Brooklyn, N. Y.

CAMERAS AND PHOTO SUPPLIES

SEND For our free bargain book listing hundreds of slightly used still and motion picture cameras and supplies of every description for the amateur or professional photographer. Can save you from 25% to 60%. Everything guaranteed the same as new. Money back if not satisfied after ten days' trial. Central Camera Co., Dept. PM-10c, 230 So. Wabash Ave., Chicago, Ill.

EARN Big money with your camera in your spare time, using Hallidorsen Home Portrait Lamp. Write for booklet "Home Portrait Photography" and catalog—both free. The Hallidorsen Company, 4748 N. Western Ave., Chicago.

TIME Counts in applying for patents. See pages 136 and 137. Clarence A. O'Brien, Registered Patent Attorney, Washington, D. C.

KODAK Films developed—Six glossy prints, one beautifully hand colored, 25c. Careful work. Quick service. Falls Foto Finishers, Glens Falls, N. Y.

EXPO Watch camera. Twenty pictures in a watch and every tick a picture. Complete \$5—outfit post paid \$3.98. Send for our Diamond Jubilee sales list of thousands of cameras at less than wholesale to celebrate our 75 years in business. G. Gennert, Inc., 24 East 13th St., New York, N. Y.

MAKE Money in photography. Learn quickly at home. Spare or full time. New plan. Nothing like it. Experience unnecessary. American School of Photography, Dept. 3432, 3601 Michigan Ave., Chicago.

HAVE You a Camera? Write for Free sample of our big magazine, showing how to make better pictures and earn money. American Photography, 116 Camera House, Boston, 17, Mass.

FILMS Developed. Special Trial Offer. Any Size Kodak film developed 5c, prints 3c each. Trial 6x10 Enlargement in handsome folder 40c. Overnight Service. Roanoke Photo Finishing Co., 209 Bell Ave., Roanoke, Va.

SAMPLE Enlargement—dime, and negative (returned). Trial roll, glossy prints, 25c silver. Brown, Warsaw, N. C.

\$50.00 FOR Photographs—This price paid for photographs meeting our requirements. Perhaps one of yours will bring this amount. Full particulars free. Redkrafts, Denver, Colo.

GERMAN Cameras, Lenses, Birtiro, 129 W 3rd St., Los Angeles, Calif.

MOTION PICTURES

SOUND Motion Pictures! The great and only authoritative text book on this subject by James Cameron, world's foremost authority. 400 pages complete information on all systems—Vitaphone, Movietone, Photofone. Methods of recording, maintenance of equipment. Complete information for projectionists and all interested. Thousands sold. Send for your copy, \$5.00 postpaid. Bass Camera Company, Motion Picture Headquarters, 179 W. Madison St., Chicago, Ill.

\$1.250 FOR Original photoplay story. Our sales department sold unknown author's first story for above amount. We revise, copy-right and market stories for both silent and talking pictures. Located in the heart of motion-picture industry. We know the demand. Established 1917. Free booklet. Universal Scenario Company, 206 Western and Santa Monica Bldg., Hollywood, Calif.

MOVIE Films. Standard size, 250 feet Western or Comedy, \$1.00 postpaid. Home Movies, Box 744, Minneapolis, Minn.

THE Bass Bargaingram No. 198 hot off the press, culminating twenty years of success with a tremendous offering of bargains in rebuilt standard and amateur Motion Picture Cameras, Projectors, Accessories, Text Books. The great bargaingram will be sent to you for 4c in stamps. Send for your copy today. Bass Camera Company, Motion Picture Headquarters, 179 West Madison St., Chicago, Ill.

MAKE Money writing photoplays for silent and talking pictures and magazine stories. Send for writing analysis chart and test your ability. No cost or obligation. Hollywood Photoplay & Fiction Institute, 105 Western & Santa Monica Bldg., Hollywood, Calif.

GOOD Film—300 feet \$1.00. Reels \$2.45. Samples, lists, particulars for stamp. Eastin Feature Films, Galesburg, Ill.

BARGAINS Excellent films, talking equipment, projectors. Marshall Films, Rome, Ga.

MONEY Making photoplays for sale. Nick Carter thrillers, \$5.00; cartoons, \$5.00; complete features, \$15; thousands others. Lists. Remington, 461 E. Fifth St., Cincinnati, Ohio.

325 FEET \$1.10. Lists for stamp. Hoffman Films, 57 Broad, Albany, N. Y.

FILMS, 200 Feet \$1.00. Reels \$2.50. List. Edgeworth Sales, Box 155, Blue Island, Ill.

PERFECT Condition films. Searles, 136 Fisk St., Providence, R. I.

LOOK Boys, cartoon films 50 cents. Star Films, Allentown, Pa.

TIME Counts in applying for patents. See pages 136 and 137. Clarence A. O'Brien, Registered Patent Attorney, Washington, D. C.

FILMS, \$2.00 Reel; 5 reel features, \$10; 250 feet, \$1. Werner-Leslie, 4442 South Broadway, St. Louis, Mo.

BE A Movie exhibitor. Big opportunity. Only moderate capital required. Complete equipment at remarkably low prices. Write Atlas Moving Picture Co., 624 South Michigan Ave., Chicago, Ill.

NEW And rebuilt projectors for theaters, schools, churches, traveling shows. Supplies and complete theater equipments. Bargain prices. Free catalog. Monarch Theatre Supply Co., Memphis, Tenn.

MOVIE Films, 1,000 ft. reels, \$2.50 each; shipped anywhere on receipt of remittance. Particulars on request. Independent Films, 177 Golden Gate Ave., San Francisco, Calif.

SPRING Motor 35m movie camera \$25; movie projector, \$35. Negative stock 2 cents foot. Pathe camera and projector, \$33. Bargains in 16m cameras, kodaks, typewriters. Ray, 266 W. 46th St., New York.

LEARN—Modern theatre management. Big opportunities. Free particulars. Theatre Managers Institute, 307 Washington, Elmira, N. Y.

CHALK TALKS

LAUGH Producing program, \$1.00. Catalog free. Balda, The Cartoonist, Oshkosh, Wis.

RADIO SETS AND SUPPLIES

\$5 RADIOS All makes Atwater-Kent, Majestic, R. C. A., and others. Hundreds—world's best makes. Used, new and rebuilt. Going at \$5 to \$65. Many formerly priced at \$150 to \$300. Amazing bargains. Backed by responsible guarantee and 30 years' experience. Write for big free list today. Brown's Radio Exch., Dept. E, 3018 East 91st St., Chicago.

NEW 300-Mile "pocket" radio, \$3.50. Complete with special loud receiver. No tubes or batteries required. Order direct. Spencer Laboratories, 116 Atlas, Akron, Ohio.

RADIOS \$12.95 Up. Free list. Radio Bargain Co., 2040 Farnam, Omaha, Nebr.

TIME Counts in applying for patents. See pages 136 and 137. Clarence A. O'Brien, Registered Patent Attorney, Washington, D. C.

TRADE AND TECHNICAL SCHOOLS

BE A blue print reader. Write for facts. See how men in your trade got to the top. What's your trade? Carroll Ramsey, Drexel Bldg., Philadelphia.

DRAFTSMEN! Be an expert. By our method we train you quickly. Books and tools furnished. Write for illustrated catalog. Columbia School, 204P Drexel Bldg., Philadelphia.

LEARN Morse and wireless telegraphy. Big salaries. Tremendous demand. Expenses low, can earn part. Catalog free. Dodge's Institute, Fern St., Valparaiso, Ind.

OUR Commercial radio operating and junior engineering course pays our graduates \$150 to \$300 monthly from start. Rapid advancement. Fall term begins in September. Write for catalog of course including Extension Course. Loomis Radio College, Dept. 5-E, Washington, D. C.

HILES Watchmaking and engraving school. The largest and best equipped school in the west. 5330 Mission St., San Francisco, Calif.

BUSINESS OPPORTUNITIES

BUILD A Business of your own. Subscribe to The Income Increaser, the only magazine edited by Edward C. Barroll, the well known advertising man and mail order writer. This 40 page magazine filled with the latest ideas, plans, schemes, pointers and suggestions comes to you monthly for only one dollar per year. Sample copy 10c. Income Increaser, 88 Pearl St., Boston, Mass.

MAGIC SPRAY kills bedbugs, roaches, flies, fleas, moths, mosquitos, etc. Guaranteed formula. Instructions \$5.00. Wm. Ballantyne, Ware, Mass.

LOIDLAC. Chemist's amazing new discovery. Forever ending automobile polishing and repainting! Instantly restores all colors, producing hard, brilliant lustre-finish. Guaranteed water, sun and weather-proof. You make Loidlac from my guaranteed exclusive copyright-protected formula for \$1.40 gallon, sell at \$14.00 a gallon profit! Write for exceptional offer. Miller, Chemist, 707 Jetton, Tampa, Fla.

ARTIFICIAL Marble sanitary flooring instructions, covering wood or cement flooring 1/2 inch thick, fireproof, waterproof, all colors, low cost. Ornamental casting, concrete, plaster, papier-mache decorations, garden furniture, statuary, flexible molds. 18 years instructing the public; particulars and illustrations free. Chris. Mahler, Huntington, N. Y.

MAIL Order business your opportunity. Brenner's famous hand books by expert 28 years' experience show how to start selling articles you make or buy—all or part time—small capital. Fascinating, profitable. Set eleven books, \$3.25. Brenner Company, 1607 P. Sanson, Philadelphia. Sample book, 25c, pay \$3 for other ten if satisfied.

MIRRORS Resilvered at home. Costs near 5 cents per square foot; you charge 75 cents. Immense profit plating like new brass, worn-off autoparts, reflectors, tableware, stoves, etc. Outfits furnished. Details free. Sprinkle, Plater, 127, Marion, Ind.

"HOLD-TITE Rug Dressing" stops rugs from slipping. Something new. No competition. Big profits. Enormous demand. Sample 75c postpaid. Hold-Tite Products Co., 1847 Market St., San Francisco, Calif.

BUSINESS Opportunity. Are you tired of giving your profit away? Why not make it all! Be the manufacturer yourself. Make your own flavoring extracts. Earn tremendous profits from the start. Write me concerning my formulas. They explain the complete manufacturing process which you do at home without special equipment. H. C. Stearns, Chemist, 1189 Kossuth St., Bridgeport, Conn.

START Dry cleaning, dyeing and pressing business. Easily learned. Pays immense profits. Complete course \$1.00. R. H. Graeme, 107 North Harvie, Richmond, Va.

GIGANTIC Mail. Send me 25c (coin or stamps) for one pound of mail. Edward Armour, 136 East 28th St., New York.

\$100 STARTS Route automatic vending machines. Large steady profits. Write Chewit Corp., Dodworth St., Brooklyn, N. Y.

"ODD-THINGS"—Money making Ideal Schemes! Plans! Tips! Opportunities galore! New—different! Special three months' subscription, 10c postage. "Odd Things," 1516 Prospect, Cleveland.

START Collection company. Large profits—easy, dignified work. We show you how. Mid American Company, Rowan, Iowa.

YOUR Circulars mailed to the right prospects, entire satisfaction guaranteed. Write for our low rates and particulars. Leredu Company, Park Row Bldg., New York City.

AMAZING Screwdriving screw driver! Factories, garages, workers buy on sight! Profit 75c each. Exclusive territory. Free trial offer. Jiffy, 1202 Winthrop Bldg., Boston.

FOR Sale, copyrights for two books. Reasonable. Good mail order. Cost 15c. Sell for dollar. Strong appeal to homeowners. Opportunity for somebody. Write. George L. Brockman, Laporte, Ind.

BUSINESS Profession of your own and earn income in service fees. See Stephenson Laboratories, display ad page 144.

NICKEL-SILVER Plate auto parts, silverware, jewelry, lighting fixtures. Metal costs 50c will plate work worth \$9.00. Free laboratory baths. Big money evenings in basement or spare room. Send stamp for samples, data. Lincoln Engineering Company, 855-B South 37th, Lincoln, Nebr.

LEARN Marbleizing, and stone enameling concrete products, to resemble polished marble. How to veneer concrete slabs, tile, table tops, etc.; also to enamel wall boards or wood. How to make granite grave markers. How to make your own molds for all uses. Membership inexpensive. Send dime for samples and literature. The Cowell Institute, Grayling, Mich.

FLORAGRAPH Show cards, paintless, clean, paying, home business, mastered first day. No hand lettering. Learn today, earn tomorrow. Ideal for ladies. Two gorgeous, tubed samples, 50c deductible. Laird's Floragraphs, 5925m Eggleston, Chicago.

FREE Booklet describes 67 plans for making \$20-\$100 weekly in home or office business of your own. Elite Co., 84 Elizabeth St., N. Y.

TIME Counts in applying for patents. See pages 136 and 137. Clarence A. O'Brien, Registered Patent Attorney, Washington, D. C.

ASSOCIATED Chemists, Indianapolis, Ind. Write for formula lists latest household toilet, automobile and medical specialties. Long profits easily made. Analysis.

DRY Cleaning business of your own. Cleaning hats, clothing, dyeing, pressing. Particulars free. Dry Cleaner, 408 Grand St., Buffalo, N. Y.

RESPONSIBLE Manufacturer wants competent men open office, manage salesmen; \$200 to \$1,000 necessary. Will pay expenses to Baltimore if you qualify. Address Manager, 603 N. Eautaw St., Baltimore, Md.

CAPITAL—An experienced dependable broker will aid in financing projects of merit. Amster Leonard, East Orange, N. J.

THE Best anti-freeze 20c per gal. Get particulars at once. Fred Herrick, Wahoo, Nebr.

THAXLY Formulas produce perfect products. All lines. Catalog free. B. Thaxly Co., Washington, D. C.

UNPATENTED Ideas can be sold. I tell you how and help you make the sale. Free particulars (Copyrighted). Write W. T. Greene, 910 Barrister Bldg., Washington, D. C.

SIGNS And showcards easily painted. If you use Letter Patterns. Write for free samples. John Rahn, B2120 Neva Ave., Chicago.

SUCCEED With your own products. Make them yourself. Formulas, processes, trade secrets. All lines. Catalog, circulars free. B. Thaxly Co., Washington, D. C.

CHEMICAL Expert will furnish formulas and trade secrets. All lines. Lists free. W. L. Cummings, Ph. D., 228 Gordon Ave., Syracuse, N. Y.

SELL By mail! Books, novelties, bargains! Large profits! Particulars Free! B-Elfo, 525 South Dearborn, Chicago.

DO You want an independent business of your own, one you can start on small capital? Start a Free-Lance Advertising Bureau. Opportunities everywhere. Details. Carolina Business System, Box 511, Columbia, S. C.

AGENTS, Dealers, handle our line of Mexican curios, Indian novelties, jewelry, feather cards. Uncompeted field. Liberal discounts. Samples fifty cents. None free. G. Medina, 78-P La-Rosa St., Mexico City, Mex.

DELAWARE Charters; fees small; free forms. Chas. G. Guyer, Wilmington, Del.

SIXTY Meritorious big-profit mailorder products, trade secrets, sales plans. Success assured. K. Home, 3949 Metropolitan, Chicago.

GO Into Crispette business—Everybody likes Crispettes; make a lot of money. Geo. Alexander, Pennsylvania, reports "profits \$3,000 in four months." We start you. Write for facts. Long-Eakins, 1960 High, Springfield, Ohio.

MAKE Your own products. Employ agents yourself. Toilet articles, soap, extracts. We furnish everything. Valuable book free. National Scientific Laboratories, 1984W Broad, Richmond, Va.

MECHANICS, Painters, carpenters, start furniture refinishing, painting, handyman shop on nearly nothing; winning plan brings customers quickly. John Braceland, 1439 So. Ninth, Philadelphia, Pa.

WE Start you in business, furnishing everything Men and women, earn \$40 to \$100 weekly operating our original "New System Specialty Candy Factories." Begin home spare time. Unlimited opportunity. Valuable booklet free. W. Hillyer Ragsdale, Drawer 4, East Orange, N. J.

"SCHEMER" Subscribers surely succeed. One reports \$50,000 from one tip; another \$25,000 from three Schemes; another \$10,000 from one formula. Try your luck! Year, \$1.00; three months, 30c. Patterson, Publisher, Alliance, Ohio.

FREE Book. Start your own little business anywhere, selling novelties by mail. My beginner's outfit contains everything required, novelties, circulars, instructions, etc. Descriptive book free. Hadwil, 3A-74 Cortlandt St., New York.

LEARN The collection business. Good income, quick results. Interesting booklet, "Skillful Collecting" free. National Collectors Assn., Long St., Newark, Ohio.

A BUSINESS Of your own making—Sparkling Glass Name and Number plates, Checkerboards, signs. Big book and sample free. E. Palmer, 540, Wooster, Ohio.

CHARTERS Delaware; best, cheapest; free forms. Colonial Charter Co., Wilmington, Del.

COMPOSITION Floor making earns industrious men \$12 and more daily if used as trade. Or make business of it with profits up to \$10,000 yearly. Openings everywhere. Semi-Tile, Box 43, Hollis, N. Y.

MAN In each town to plate auto parts, reflectors, bathroom fixtures, refinish beds, mirrors, chandeliers; by new method. No capital or experience required. Simple plan of manufacturing at home starts you in big money-making business. Outfit furnished. Free particulars and proofs. Gun Metal Co., Ave. H, Decatur, Ill.

AGENTS, Opportunity seekers. Make amazing profits. Write, Empire, Shawano, Wis.

AN Honest circular mailer looking for business. Make up a package, key them, inclose what you think a fair price and I guarantee to mail every piece to live prospects. No nude pictures or etc. Edward Armour, 136 East 28th St., New York.

MANUFACTURING Concrete building blocks is your home town opportunity. Particulars free. Concrete Machine Co., 5 Main, St. Louis, Mo.

I MADE \$50 a week home. French bread-making. 15 years' experience; free booklet tells. Ashbrook 67, Marengo, Ohio.

AMATEUR Cartoonists: Sell your cartoons. New plan. Smith's Service, PA-1194, Wenatchee, Wash.

ENTIRELY New business: Baked ice cream pies, 10c seller. Big profits. Plans and samples \$1. Mele Co., Inc., Station A, New Haven, Conn.

TELEGRAPHY

LEARN Morse and wireless telegraphy. Big salaries. Tremendous demand. Expenses low, can earn part. Catalog free. Dodge's Institute, H St., Valparaiso, Ind.

CHEMISTRY

SUBSCRIBE To the new Popular Chemistry! A monthly magazine containing latest chemical news, experiments, recent advancements in medicine, new uses for X-rays, ultra-violet light, radium, etc. Three (back issues), 30 cents. \$1.50 year. Free book catalog to immediate yearly subscribers. Popular Chemistry, Dept. UP, Swedesboro, N. J.

YOUR Chemical problems solved and formula or process furnished for \$5.00. Write me. W. Stedman Richard, Industrial Chemist, Box 2402, Boston, Mass.

BOOKLET Of experiments and chemical catalog 15c. General Chemical Company, Box 397, Reading, Penna.

CHEMICAL Analysis, processes, technical information. Robert Henderson, Laboratory, Madison, Me.

FORMULAS AND TRADE SECRETS

FORMULAS, Processes; all lines. Moderate charge. Individual service. L. Clore, Industrial Chemist, Crawfordsville, Ind.

LEATHER Powder, wood fiber, chemicals, formulas, everything for the manufacturer, beginner and experimenter. Moscato, 757 East 107th St., Brooklyn, N. Y.

"PETRIFY Wood, small reptiles, etc. German secret." "Seven wonderful beauty," "17 auto specialties," "32 modern manufacturing," 30 more specialties. All \$1. Interesting circular free. Teycer, Chemist, Box 1275P, Chicago.

MOST Sensational formula bargain ever offered. Latest, best sellers. List free. Specialty Mfg. Service, 801 So. Farragut, Bay City, Mich.

EFFORTLESS, Instantaneous automobile refinisher, top dressing, Duco-luster polish, carbon eliminator, battery recharger, powdered polish, radiator stop-leak, puncture plugger, 50c each. All, \$3.50. Any formula, 50c. Catalog free. Bernerd Wells, Room 307, 852 George, Chicago.

BAKED Enamel remover 20c per car. E. M. Reighard, 4437 Finley Ave., Los Angeles, Calif.

3,000 FORMULAS \$1.00; 500, 25c. National Service, 3937 Marburg, Cincinnati, Ohio.

500 FORMULAS And big illustrated catalog 25c. Ideal Book Shop, Park Ridge, Ill.

TEN Handy guaranteed formulas, 25c. Neil Tasker, Shamokin, Pa.

NEWEST Tested formulas. Particulars, catalog free. Grinstead Laboratories, Oswego, Kans.

GUARANTEED Formulas, best science can produce for making popular, biggest-selling specialties all lines. Don't buy formulas till you've received valuable eye-opening literature. Miller, Chemist, 706-F Jetton, Tampa, Fla.

MAKE Your own products. Employ agents yourself. Toilet articles, soap, extracts. We furnish everything. Valuable book free. National Scientific Laboratories, 1984W Broad, Richmond, Va.

FORMULAS: Guaranteed, catalog free. Bestovall Laboratories, 6720 Oconto Ave., Chicago.

SUCCEED With your own products. Make them yourself. Formulas, processes, trade-secrets. All lines. Catalog, circulars free. B. Thaxly Co., Washington, D. C.

10,000 MONEY-MAKING Formulas. Tells you how to make and sell almost everything under the sun; cosmetics, mucilage, anti-freeze solutions, battery solutions, beverages, cheese, chewing gum, cleaning preparations, extracts, hair preparations, inks, bluing, leather polish, mirrors, perfumes, polishes, typewriter ribbons, carbon paper, washing powders, liquid soap, and hundreds of other profitable articles. Send No Money. Just write a postal for "Henley's 20th Century Book of Formulas." Pay postman postage and \$4. Popular Mechanics Press, 200 E. Ontario St., Room 808, Chicago, Ill.

AGENTS WANTED

WANTED At once: More good men to introduce and retail Rawleigh's Good Health Products. Town and country. Wonderful opportunity. Get into business with backing of largest manufacturer its kind. Capital over 15 million dollars. Quick freight, express, parcels post service from 10 great factories and branches—one near you. Nothing new—no experimenting. No experience required. You simply follow the same old time-tested Rawleigh Methods which secure the most business everywhere and have given consumers best values and satisfaction for 40 years. 170 necessities frequently needed every home. Enormous demand. Annual sales now over 35 million products. Big free trial inducements. Quick easy sales. Repeat every 30-60 days. Enormous profits—\$200-\$400 month and more clear profits. Steady year around; no lay-off. No boss—you become sole owner and manager. Practically no capital required. We supply everything—stocks, outfit, sales and service methods. Big pay every day. Profits increase every month. "First come first served." For full particulars write W. T. Rawleigh Co., Dept. A-10PPM, Freeport, Ill.

NEW Patented sideline sells on sight! 40% profit. Here's a knock-out: The "Rouge Ring"—a brand new sensation, started in Hollywood, now sweeping the country like wildfire. Everyone's "Going Hollywood" on this. It's a beautiful solid sterling silver finger ring with a secret compartment for holding rouge or lip stick, and a dainty French mirror. The set is Catalina sapphire-tinted moon-stone. It looks like \$25—but sells for only \$2.50—with \$1.00 profit to you—just 40%. Just show a sample to a few girls; they will mob you for 'em. Holds big buyers attention. Gets agents "inside the door" quicker than anything else. Hosiery, lingerie and brush salesmen—carry few in vest pocket and are making cleanup. Also sell druggists, gift shops, 1 dozen on beautiful display card. Sideline salesmen, agents, wagon men, get wise. Send \$1.50 today for regular \$2.50 ring and full information. Hollywood Rouge Ring Co., Dept. I, Drawer 1040, Hollywood, Calif.

GENUINE Gold Leaf Letters anyone can put on store windows. Guaranteed to never tarnish. Large profits. Enormous demand. Free samples. Write today. Metallic Letter Co., 438-D North Clark, Chicago.

A REAL Money-maker. Our Christmas box assortment makes real money for live men and women agents. 21 superb Christmas cards and folders. Biggest value ever offered. Ribbed, parchment folders, Florentine, water color, engraved, embossed designs. All in beautiful Christmas box. Actual value \$2.80. Sells for \$1.00. Costs you 50c. Get in on this quick—Today! Free samples and particulars. Waltham Art Publishers (established 30 years), Dept. SO, 7 Water St., Boston, Mass.

AGENTS \$6 Day made by our sales agents. Bonus besides. Sell finest line guaranteed hosiery, all styles, colors. Finest line silk hosiery you ever saw. Commission earned daily. Auto given to producers when earned. Earn fine silk hose for your own use through new plan. Write quick. Wilkint Hosiery Co., Dept. 7831, Greenfield, Ohio.

SELL Beautiful "Style Tailored" shirts, lumberjacks and neckties direct to wearer at factory prices. Many beginners earn \$50 first week in spare time. \$100 weekly full time easy. Selling outfit free. Howard Shirts, 1213 VanBuren, Factory 250, Chicago.

CAN You show us a successful record, as agent or distributor, for a high class mechanical device? New electric Snoko Ice Shaving Machine is sure fire among concessionaires and soft drink dispensaries. Exclusive territory. Write Sno-Ko, Inc., Hunter Dulin Bldg., San Francisco, Calif.

AGENTS Make big profits selling oil and gas wash furnaces. Profits each sale, \$1.50 to \$7.00. Every home a prospect. Your territory open. Write Adams Manufacturing Co., Dept. A, Commerce, Tex.

\$85 WEEKLY Selling nationally advertised dresses, lingerie, hosiery, amazing values. Complete equipment and earn your own clothing. Sure profit plans furnished. Shaughnessy Knitting Co., 349 Shaughnessy St., Watertown, N. Y.

AGENTS "Strike a gold mine" when selling Nulustre cloths at 25c; cleans, polishes all metals; free samples with every package boosts your sales. Write for agents' terms, sample. Shef Mfg. Co., 1 Shef Bldg., Weehawken, N. J.

AGENTS Buy direct. Hosiery, lingerie, neckwear at lowest mill prices. Men's finest silk and Rayon hose, dozen prs., \$2.25, \$3.50; ladies' fancy hose, dozen prs., \$1.45, \$2.25; finest silk ties, dozen, \$2.75, \$3.25; silk bows, dozen, \$1.50; ladies' silk hose, dozen, \$3.75, \$4.25, \$6.75. Plus postage. Guaranteed first quality. Satisfaction or money back. Act today. Superior Knitting Co., Dept. 31, New Haven, Conn.

EARN 40 To 50% commission. Box assortments and personal cards. Write today. Full or part time. Artistic Card Co., Dept. 12, Elmira, N. Y.

ENGRAVED Name plates, signs, numbers, desk plates, store window signs, etc.; profits large. Brett Bros., Winthrop, Mass.

BIG Money selling shirts and ties! Wonderful values. Finest line now ready. 54 latest New York styles. Big outfit and special samples. Everything free. Pioneer Mills, 1225 Broadway, Dept. C16, New York.

AGENTS—Make a dollar an hour. Sell new kind of sharpeners. Sharpens all knives and tools quickly. Demonstrating sample 10c. Premier Mfg. Co., Dept. 96, Detroit, Mich.

SNAPPY Shirt line ready! Season's best values. Agents cash in big. Nothing to invest. Get free outfit and handsome samples. Special features. Gracefit, Dept. 611, 504 Sixth Ave., New York.

BIG Ohio corporation wants county manager. Opportunity \$50 to \$75 weekly. Earnings start immediately. Good for \$5,000 yearly. We furnish everything, deliver and collect. Capital or experience unnecessary. Fyr-Fyter Co., 1907 Fyr-Fyter Bldg., Dayton, Ohio.

TIME Counts in applying for patents. See pages 136 and 137. Clarence A. O'Brien, Registered Patent Attorney, Washington, D. C.

CASH Paid for Butterflies, Insects. See Sinclair Display Advertisement on page 28.

SALESMEN—Earn \$100 weekly taking orders for Dazzler and Rainbow glow electric signs. Big commission. Exclusive territory. High grade proposition. Write Chicago Sign Sales Co., Dept. 81, Charlotte, N. C.

SELL Stores 5c candy specialties. 100% profit. Lorrac Products, Albany, N. Y.

AGENTS: Free catalog 200 household specialties, toilet preparations, food products, portraits, frames, photo pillows, medallions, religious goods, pictures. Credit. James C. Bailey Co., Station C-10, Chicago.

STRANGE New electric iron cord! Prevents scorching. Saves electricity. Cannot kink or snarl. Used on telephones also. \$25 daily. Samples free. Neverknot, Dept. 10-A, 4503 Ravenswood, Chicago.

MAKE \$85 Weekly. Amazing one-year guarantee sells Rosecliff shirts fast. 24 hour shipments. No substitutions. Big advance commissions. Customer gets free initials. Earn your own shirts. Get free outfit including ties. Write today. Dept. PM10, Rosecliff Shirts, 1237 Broadway, New York.

NEW Style needle books pay \$22.00 daily profit. Free clever threader invention creates eager buyers. Sweeping country. One billion Paty needles sold. Proof free. Four different samples 25c. Paty Needle Co., West Somerville, Mass.

FAMOUS "775" Everclean spark plugs. Old Fords \$1.00 set; new Fords \$1.50 set. Limited quantity. Postpaid. Guaranteed. American Equipment Company, 5958 Washington, Chicago.

EVERYBODY Buys Christmas cards! Tremendous demand. Our boxed assortments—sure money makers. Great values! Big profits! Write quickly. Patterson Co., 4111 University, Des Moines, Iowa.

SOMETHING Different! Fountain pen with check protecting device. Protects checks against check-raisers who steal thousands. Works like expensive checkwriters. Earn \$10 to \$30 daily. Free outfit offer. Securograph Pens, MC-55 Securograph Bldg., Oakland City, Ind.

SURPRISING Results obtained from use of newly invented Vapor Air Filter on automobile and tractor engines. Very easy sellers. Sales agents write The Vapor Air Filter Co., Mitchell, S. Dak.

MAKE Big money every day. Sell finest work pants and breeches. Every man buys 1 pair \$1.95, 3 pair for \$5.50, your commission \$1.00. Customer's satisfaction guaranteed. Largest, finest sales outfit free. Write today. Dept. LM10, Longwear, 489 Broome St., New York.

AGENTS Making \$40 week extra. Raincoats, \$2.45. All colors. Sample coat free and bonus to workers. Big outfit free. Bradley, 228 So. Wells, Dept. AB-10, Chicago.

AGENTS—The Gyro-Whirl Brush washes an automobile in fifteen minutes without splash or spray! Every owner and garage man a prospect; every user satisfied. Attaches to ordinary garden hose. Takes labor out of car washing. We help you sell and make money—\$15-\$30 daily. Write Gyro Brush Co., Dept. C, Ampere, N. J.

WELLS Cleared \$620.00 in one month with Business Guide and free legal service. Write for free outfit. Prof. Nichols, Dept. 59, Naperville, Ill.

MAKE \$20 Daily selling merchants' changeable letter show window signs. Experience unnecessary. Send for free sample offer. Maze Company, 542 W. Washington, Chicago.

SELL Rhinestone Initial Belt Buckles, etc. Big season on. Big commission daily. We deliver. Pocket outfit free. Chaton, 606 Blue Island, Chicago.

PORTRAIT Men: Why not Pasco portraits; we refund your money for all you cannot deliver. Frame catalog free. Portrait Agent's Supply Co., Dept. F, LaPorte, Ind.

WISE Agents. No canvassing. Pleasant work. No delivering. Big money. No investment. Appointing agents. Welcome Foods, Harvey, Ill.

"WHAT Shall I Sell?" Copyrighted booklet free. Leonard, Western Reserve Bldg., Cleveland.

"WHERE" To buy 500,000 articles at lowest wholesale prices." 1929 directory. Distributors wanted. Pruitt System, Brookfield, Ill.

GOOD Men always wanted! I can use more men to distribute Hoyt groceries, toilet goods, extracts, home remedies. Only one to a town. Big pay for hard workers. Spare time or full time. Free auto for own use if you succeed. Handsome sample case furnished. Get my free proposition at once. Dan Hoyt, Hoyt Brothers, Inc., Dept. B-27, Newark, N. J.

EARN \$75 Weekly selling guaranteed broad-cloth shirts at wholesale prices. Big commissions. Free outfits. Polo Shirts, 4015 Belvedere, Baltimore, Md.

BIGGEST Money maker tailoring line pays \$4.00 to \$7.00 order. Cash bonuses. Earn your own suits. All wool serges, cassimeres, top coats. Quality worsteds, heavy weight overcoats. Giant outfit, 1/4 yd. samples free. Dept. PM10, Olympic, 5th Ave., at 19th St., New York.

AGENTS: To sell electric water heater for \$2.75. New invention. Heats water almost instantly. A real money maker. Write Lux-Visel Company, Dept. D, Elkhart, Ind.

BECOME Your home town leading business man. Sell full line of groceries, motor oils, paints. Everybody a customer. No capital or experience necessary. Selling outfit free. Write Loverin & Browne, 1602K So. State, Chicago.

TECHNICAL Mop Wringers. Price \$2.20. Sample \$1.50. H. K. Christensen, Fort Atkinson, Wis.

JUST Out—New kind of electric lamp. 101 lamps in one. So beautiful women can't resist. So useful men buy instantly. Wonderful spare or full time proposition. Sell C. O. D. or deliver as you sell. Big profits daily. Write for money making plan. Falcon Mfg. Co., Dept. M-251, 2550 Sullivan, St. Louis, Mo.

AGENTS—You can earn \$12 daily wearing fine felt hats and show to friends. Smartest styles. Latest shades. \$2 to \$5 saving on every hat. Samples free. Taylor Hat and Cap Mfrs., Dept. PC-135, Cincinnati, Ohio.

MEN Wanted—to demonstrate and take orders direct from motorists. Amazing magnetic trouble light. Sticks on metallic surfaces. Our men earn as high as \$75.00 weekly. Write for demonstrator. Magno, Beacon Bldg., Dept. 167, Boston, Mass.

MAKE More money selling most complete line raincoats, sportcoats, sheeplined coats, leather jackets and tablecloths. Latest styles. Lowest prices. Biggest commissions. 7x5 Swatch line free. Jeffrey, 716 Madison, Chicago.

SELLING Like blazes! Beautiful toilet goods assortment at \$1.50, with 24-inch pearl necklace free to your customers. 100% profit. E. M. Davis, 234 North Ave., Dept. 530, Chicago.

AGENTS, Men, women, boys, girls. Propositions from firms who want agents. Send one dime and stamped addressed envelope. Byron Graybill, 419 Glenn, Springfield, Ohio.

AGENTS: Sell nursery stock. Free landscape service. Wonderful possibilities. Pay check weekly. Write for particulars. Perry Nurseries, R-10, Rochester, N. Y.

BE Independent; make, sell your own goods. Immense profits. Catalog dependable formulas, special selected agents' best sellers, free. R. Luro, 4211 Cottage Grove, Chicago.

AGENTS—Absolutely new! Our hand-colored popular-priced photo statuettes going big! Everyone wants them! Agents making \$10-\$25 daily! Samples furnished! Cruver Mfg. Co., KS2456 Jackson, Chicago.

NEW "Hire-Fire" two-in-one spark plug, just out—reversible—one end cleans other; fires 11,000 volts, for cars, trucks, tractors. Free sample offer. Write for open territory. Hire Mfg., Peoria, Ill.

AGENTS Give customer two pounds toilet soap free with \$1 bottle superior vanilla. 100% profit. Midwest Drug Company, Dept. O-1, Columbus, Ohio.

NEEDLE Mends runs in hosiery, sweaters, other knit wear, quickly, easily, perfectly; no thread; every woman a prospect; sells for 50c, cost \$1.50 dozen; \$12.00 gross working sample, 25c. National Needle, 2212-B No. Tripp Ave., Chicago.

AGENTS, Distributors; 2 sales a day; profit \$120 weekly; thousands in use; wanted by every home and building owner. National Engineering Company, Lancaster, Pa.

100% PROFIT. Titeline outdoor clothes-line reel strings and stretches line tight in two minutes. No more straining and stretching for women. Line always clean and free from kinks, no props needed. Hewes Co., 6952 N. Albany, Chicago.

AMAZING New kind of window washer paying agents \$75-\$100 weekly. Also need district sales managers. Experience unnecessary. Simple demonstration gets the orders. Write for sample. MacLeod Mfg. Co., Dept. P.M.-10, 2640 Greenview Ave., Chicago.

BIG Money weekly year round appointing agents. No canvassing, delivery or investment. Mother Hubbard Foods, 554U Congress, Chicago.

WANT Distributing agent for Hanslick, powdered handsoap; removes anything from the hands without injury to skin; everybody a customer; great opportunity for hustler to get in business; sample free. Solar Products Co., J2144 So. Troy, Chicago.

BIG New line ready. Everyone wears shirts, underwear, lingerie, hosiery, raincoats, sweaters, etc. Show samples, take orders. Outfit free. May Co., 103 S. Wells, Chicago.

FREE Booklet describes 67 plans for making \$20-\$100 weekly in home or office business of your own. Elite Co., 84 Elizabeth St., N. Y.

OVER 200 Reliable manufacturers need agents in every locality in the United States. Learn all about it in the current issue of Opportunity Magazine. Free sample copy sent on request. Opportunity Magazine, Dept. M310, 750 N. Michigan, Chicago.

BIG Money daily, selling shirts of all kinds, lumberjackets, underwear, hosiery, sweaters, playuits, overalls, pants, raincoats, leather coats! Outfit free! Experience unnecessary. Nimrod Co., Dept. 8, 4922-28 Lincoln Ave., Chicago.

MAKE Steady money. Amazing one-year guarantee sells Roseliff shirts fast. 24 hour shipments. No substitutions. Big advance commissions. Customer gets free initials. Earn your own shirts. Get free outfit including ties. Write today Dept. ME10, Roseliff Shirts, 1237 Broadway, New York.

JUST Out—New patented apron. No strings or straps—\$20.00 a day every day; over 100% profit; commissions daily. Write for free outfit. Sta-Put Co., Dept. 210, St. Louis, Mo.

MAKE Your own products. Employ agents yourself. Toilet articles, soap, extracts. We furnish everything. Valuable book free. National Scientific Laboratories, 1984W Broad, Richmond, Va.

AGENTS Can make \$7 day. Sell new line guaranteed hosiery. Can't be beat for beauty and quality. Fast sellers. Latest styles. Commission earned daily. Earn silk hose for your own use through my plan. Write today. Silkkit Hosiery Co., Dept. 1231, Dayton, Ohio.

BIG List of Christmas sellers! Greeting cards, combination toilet sets, perfumes. More than 400 items. Details free. Write! Togstad Co., 30 Punion St., Kokomo, Ind.

HOUSEHOLD Necessities for men and women. Fast sellers. Big profit. Kansas City Mail Order House, 515 Kemper Bldg., Kansas City, Mo.

SELL Complete line household brushes. Send for free catalog and sample case offer. National Brushes, St. Louis, Mo.

MAKE \$35 To \$75 a week selling home owners, shrubs and roses. Commissions paid weekly. No collecting. No delivering. Compact pocket outfit furnished. Our line sells everywhere. Purtell-Burke Nurseries, 448 Cutler Bldg., Rochester, N. Y.

AMBITIOUS Man—If \$15 profit a day interests you, I'll show you how to make it as my local representative. No experience, training or capital required. Business office not necessary. Immediate earnings. Albert Mills, 3944 Monmouth, Cincinnati, Ohio.

MIRRORS Resilvered at home. Costs near 5 cents per square foot; you charge 75 cents. Immense profits plating autotaps, reflectors, tableware, stoves, refinishing metalware, etc. Outfits furnished. Details free. Write Sprinkle, Plater, 128, Marion, Ind.

YOU Can make big money daily, selling Public Service ties and shirts styled on Fifth Ave. Largest assortment in the field. Splendid values, liberal commissions. Finest complete sales outfit free. Write today. Public Service Mills, 4941CF Hudson Boulevard, North Bergen, N. J.

AMERICA'S Greatest tailoring line—Free. 150 large samples. All wool—tailored to order—union made—sensational low price. Big commission paid daily. Cash bonus besides. Exclusive territory to producers. Hustlers making \$100 a week and up. Get outfit at once. Address Dept. 214, Goodwear, 814 Adams, Chicago.

PHOTO Medallion men and women, the largest line of photo novelties in the world. Lowest prices, quickest service. Send for catalog showing over 200 money makers. Photo medallions, photo medallion clocks, photo mirrors, photo fountain pens, photo powder compacts, photo jewelry and photo buttons. Gibson Photo Jewelry Co., 608-614 Gravesend Ave., Brooklyn, N. Y.

NEW Invention lights gas without sparks. Free sample. Other specialties. Maywood, P-925, Broadway, New York.

AGENTS—Mosco Corn and Callous Remover will build you a steady repeat business. Send today for pocket-size trial outfit. The Moss Company, 442 Searle Bldg., Rochester, N. Y.

DO You want to make money. Get our whirlwind seller, real agents only. Ask for territory. Sample 20c. Supreme Mfg. Co., 345 Battery St., San Francisco, Calif.

\$10-\$25 DAILY Simply showing new Polly wrench. 10 wrenches in one. Guaranteed seller. Sample free. Gellman Mfg. Co., Dept. 6J, Rock Island, Ill.

BIG Money applying gold initials on automobiles. Easiest thing today. No experience needed. \$1.45 profit every \$1.50 job. Free samples. "Ralco," X-1043 Washington, Boston, Mass.

SENSATIONAL Pencil, writes four different colors, instantly interchangeable. Wonderful item for agents, distributors or side line. Splendid profit. American Sales, Tribune Annex, Minneapolis, Minn.

BIGGEST Surprise offer ever made. Be sure to answer this ad. My line of soaps, coffee, tea, spices, toilet articles, household specialties, pays you bigger profits. M. G. Roth, President, 2716 Dodier, St. Louis, Mo.

SPARE Time enterprises. Free particulars. Maywood, PP-923 Broadway, New York.

REAL Opportunity for go-getters—be our sales representative. A-C Safety Razor with lifetime blade has no equal. Sells on sight. Big cash commission for you. Get details today. A-C Specialty Co., Cincinnati.

BEST 50% Seller in years! "Snap-On" phone list. Ready reference for telephone numbers most frequently used. Telephone owners buy on sight! 50 sales a day easy! Profit \$15.00. Sample 50c. W. J. Lynch, Drawer 718-P, Springfield, Ill.

AGENTS. Quick sales, big profits selling direct to housewives "Eresco" metal milk markers. Entirely new, entirely different kitchen necessity. Ideal gift or prize. Write today for details. Pope, International Bldg., Washington, D. C.

THE Best fifty cent bread knife. Never needs sharpening. Cuts meats, vegetables. Particulars free. Samples 50c. P. O. Box 687, Atlantic City, N. J.

MAKE Big money selling the bootlegger's map. Fast selling comic number. Send 10c for copy and prices. The Griswold Press, 854 Howard St., Detroit, Mich.

SELL The new crystal clear Eureka fabric paste for mending clothing and rubber. Sample dozen \$1.25. Eureka Cement Co., 128 So. Canal St., Chicago.

ANTI-STEAM (Keeps steam, rain, snow off windshield) is proposition we regret we can't begin to outline in an advertisement. Unprecedented possibilities. Request free sample and complete story. Walter S. Doe Co., Dept. A, Kent, Ohio.

NEW Selling sensation! Distributors for bulldog automatic garage door prop. Holds doors open in strongest wind. Sells for \$1 pair. 100% profit and bonus. Write quick for territory and free demonstrator offer. Tishken Products, 4744 12th St., Detroit, Mich.

AGENTS. Make 80% to 200% clear profit selling Zam. A new, wonderful household necessity that works like magic. Sells itself on demonstration. Write quick for complete demonstration outfit and sample. Address Dept. 49, Zam Mfg. Co., Wainwright Bldg., St. Louis, Mo.

BRANDNEW 50c Specialty, 150% profit. Quick demonstration sells every housewife. Pocket sample. Deliver on spot. Great side line. Agents, distributors cleaning up \$65 to \$124 weekly. Territory going fast. Write today sure. H. Harker Co., Battlecreek, Mich.

RUN Menders \$2.75 to \$10.00 per gross. 18 samples \$1.00. Run Mender Works, Box 382A, Waukesha, Wis.

15,000 FORMULAS in "Scientific American Cyclopaedia of Formulas." Includes following and many others: Accidents and emergencies, agriculture, alloys and amalgams, artist's materials, beverages, cements, glues, pastes, mucilages, bleaching, renovating, coloring metals, dyeing, glass, heat treatment of metals, household formulas, ice cream, confectionery, chewing gum, lapidary work, exterminating vermin, lubricants, paints, varnishes, photography, condiments, canning formulas, rubber, soap, candles, soldering, toilet preparations, perfumes, waterproofing, fireproofing, writing materials. Send no money. Just write a postal. When postman hands you book pay \$5.50 and postal charges. Popular Mechanics Press, Room 807, 200 E. Ontario St., Chicago, Ill.

WILL Finance married man 25-60, good appearance, fair education, in a paying business of his own. Profits to start will average only about \$30.00 weekly but will increase as you learn the business. Must furnish A-1 references and have car for delivery. Make application in own handwriting to McConnon & Company, Room B-6610, Winona, Minn.

BOWMAN'S Bread knife. Last indefinitely; never needs sharpening. Pays as much as 125%. Ideal Sales Co., Box 5129, Philadelphia, Pa.

DISTRICT Manager. Territorial men. \$5,000 to \$10,000 yearly. New, snappy electric advertising device. Big money; quick returns. Manager, 6137 S. Park Ave., Chicago.

\$20.00 DAILY. Latest trench coats \$2.98. All colors. Also DuPont's tablecloths \$1.30. 74 other big money makers. Samples free. American, 724LN Roosevelt, Chicago.

MAKE \$50 Weekly giving away free fountain pens and selling useful 25c article. National Co., 2309 Lawrence, Toledo, Ohio.

AGENTS, \$240 Month. Dri-Klean It makes any car look like new. Removes mud, grease, tar, road oil all in one operation. No soap or water used. Cleans any car for 10c. Exclusive territory. Make \$5,000 year. Write for free sample. American Accessories Co., Desk 5631, Cincinnati, Ohio.

Sell Christmas cards (Customer's name engraved free). Biggest commission. Samples free. Start now. Harold Smith Studio, Ellenville, N. Y.

SELL Ladies', children's underwear, bags, hosiery, house dresses; big commissions. Lippman, 37 East 28th St., New York.

CHRISTMAS Boxes—Greeting cards, 100% profit. 21 cards sell for \$1.00; 12 cards 50c. Complete samples both boxes, booklets 5 to 25c. Stamps-tags, \$1.00. Klees, 1110 Undercliff Ave., New York.

AGENTS—Golden Crown shampoo will build you a steady repeat business. Send today for pocket-size trial outfit. D'Oma Company, Box 786, Omaha, Nebr.

LATEST Craze! Show new kitchenware in 5 appealing colors to housewives. Kitchen necessities. Low factory prices. \$90 weekly easy. Big repeat sellers. No experience or cash needed. Beautiful colorful selling outfit free. Write for full particulars. Modern Kitchenware, Dept. 6-XPP, 176 W. Adams St., Chicago.

ARE You old at Forty? See our advertisement on page 169 of this issue. The Electro Thermal Company, 2122 Morris Ave., Steubenville, Ohio.

EMPLOY Agents yourself; make your own toilet articles, soaps, extracts. Particulars free. Benton Service, 417 Grant St., Buffalo, N. Y.

ADDING Pencil. Adds mechanically, almost human. Make big money daily. Get sample and territory now. Add-O-Graph Co., Dept. 25, Saitillo, Miss.

SELL The "Relief" electric magnetic blanket, made in Yankton, S. Dak. Write frankly. Opening for experienced representatives only. Relief Blanket Co.

\$5.00 HOURLY. Mercerized damask scalloped tablecloths. Size 58x58", 75c. Tremendous demand. Other bargains. Big sample line free. American Braiding, R-329 W. Monroe, Chicago.

WONDER Hotpad invention paying \$18.00 daily. Banishes water bottles and electric pads. Sales helps. Experience unnecessary. Free sample offer. Applicator Company, Armour Station, C. Chicago.

MEN, Women, make big money selling Amity greeting cards for Christmas and all occasions. Biggest deal on market. Write for catalogs 10 and 11 giving all particulars. Splendid opportunity for a business of your own. Amity Greeting Cards, 1104 So. Wash, Chicago.

\$20.00 \$20.00 DAILY In advance selling Lintex tablecloths. Washes like oilcloth. Experience unnecessary. Free sample. Lintex, 2035F Charleston, Chicago.

SELL "Prevents Runs." Guaranteed to prevent runs in silk hosiery. Large profits. Particulars. Specialty Mfg., 307A West First, Los Angeles, Calif.

AGENTS—100% Profit selling our low-priced, beautiful and attractive felt rugs. Perfect color combinations win instant admiration, insuring quick sales. Excellent opportunity to build substantial business. Eastern Mills, Everett, Mass.

FREE Booklet describes 67 plans for making \$20-\$100 weekly in home or office business of your own. Elite Co., 84 Elizabeth St., N. Y.

START An honest-to-goodness, successful-paying business that's yours. Making world's greatest sellers! Investment small. Profits great. Start anywhere. Get my valuable "eye-opening" literature about specialty manufacturing—How you can easily make guaranteed exclusive automobile specialties, including wonderful LoidLac, finest household cleaners, best soaps, high-grade toilet preparations, modern insecticides, delicious food and beverage lines fastest-selling carded specialties. 32 years unequaled reliable service. Miller, Chemist, 706-J Chemical Building, Tampa, Fla.

"HOW To Secure Agents," a specially prepared booklet, tells of one of the most inexpensive methods in which to secure good live producing agents. It is free; write for your copy today! M. L. Rund, Mgr. Classified Advertising, Popular Mechanics Magazine, 209 E. Ontario St., Chicago, Ill.

SELL Personal Christmas card, names embossed in gold. \$1 dozen up. 50% commission. Samples free. Also box assortments. Dunbar Corp., New Brunswick, N. J.

BIG Line Xmas card assortments, boxes, packs. Our 17th season. Liberal profits. Samples, three leading sellers \$1.00. Send quickly for free details, price list. Ufert, 100 W. 21st, New York.

\$60 PER Week. Get free sample Dupont launderless tablecloth. Looks, feels like linen. Guaranteed against all stains. Amazing low price. 7 colors. Premium with every order. Box 272-F, Oak Park, Ill.

32 CHRISTMAS Cards, one dollar, worth \$3.20. Best results selling our varieties. Talbert Novelty Company, 55 Hager St., Buffalo, N. Y.

START Your own business, making newest household specialties, toilet preparations, foods, remedies, motorists' necessities, etc. Our formulas and instructions teach you. Catalog, particulars free. Grinstead Laboratories, Oswego, Kans.

FREE Formula catalog, for agents.. Pitches. Western Chemical, Salem, Oreg.

MYSTERY Polishing cloth in tin cans sell like hot cakes. Write free sample. Mohler, Box 453GM, Chicago.

AGENTS—Make a dollar an hour. Sell Mendets, a patented patch for instantly mending leaks in all utensils. Sample package free. Collette Mfg. Co., Dept. 404, Amsterdam, N. Y.

AGENTS Wanted—Grady's Grease Getter. Hand cleaner for factories, households, etc. Good commission. 30c for 12 oz. can and particulars. Grady Bros. & Moran Mfg. Co., Horse Cave, Ky.

BIG Money selling new preparation that will prevent runs in silk hose. Agents everywhere report tremendous sales. Every woman a prospect. We furnish amazing new sales guide and charts. Don't delay, write today. Save-O-Silk Laboratories, Box M99, Troy, Ohio.

MAKE Your own products. Employ agents yourself. Toilet articles, soap, extracts. We furnish everything. Valuable book free. National Scientific Laboratories, 1984W Broad, Richmond, Va.

\$60-200 A WEEK. Genuine gold letters for store windows. Easily applied. Free samples. Liberal offer to general agents. Metallic Letter Co., 438-B North Clark, Chicago.

400% PROFIT Selling flower drops. One drop lasts a week. Melrose Works, Box 731, Chicago, Ill.

HOSIERY—Real money selling Montgomery hosiery. Great satisfaction in selling better quality for less. Catalog free. Montgomery Hosiery Co., Dept. 101, Trenton, N. J.

CHRISTMAS Cards. We have complete quality line. Popular prices make easy sales. Box assortments and personal. Big profits to workers. Grote, Box 277, New Brunswick, N. J.

FAST-SELLING Specialties—Make them yourself! Appoint agents. List free. Girard Research Laboratories, Wheeling, W. Va.

THAXLY Formulas produce perfect products. All lines. Catalog free. B. Thaxly Co., Washington, D. C.

HOME Economy oil gas burners for stove or furnace \$20.00. Agents wanted. M. E. Page Sales Co., Watkins Glen, N. Y.

POLMET Polishing Cloth removes tarnish from metals without the use of liquid, paste or powder. Our agents say it sells like "hot cakes." Retail 25c; sample free. Gale & Co., Inc., 15 Edinboro St., Boston, Mass.

AGENTS—Here's a new one. "Bestever Powdered Hand Soap." Sells like wildfire. Marvelous discovery. Removes grease, paint, ink, oil, in fact anything from hands. Cannot harm skin. 150% profit. Great repeater. Agents simply coining money. "Free Samples Get the Business." Write immediately. Bestever Products Co., 4315W Irving Park, Chicago.

YOU Can make big money in the food business. No capital or experience needed, credit given. Here is your chance to establish a permanent business of your own in exclusive territory. We furnish free sample case and free samples for customers. Repeat orders every week. Ask now! Federal Pure Food Co., A2307 Archer, Chicago.

SUCCEED With your own products. Make them yourself. Formulas, processes, trade-secrets. All lines. Catalog, circulars free. B. Thaxly Co., Washington, D. C.

GOLD-LEAF Sign Letters; copyrighted manufacturing instructions; profits 1,000%. Johnston Co., Quincy, Ill.

SELL Razor blades; large profits; samples 15c. Information for stamp. Kramer, 161 St. Paul's Ave., Jersey City, N. J.

\$75.00 WEEKLY Placing Genuine Gold Leaf Signs. Experience unnecessary. Demand unlimited. Best agency offer. Premier Company, 179 N. Wells, Chicago.

MANUFACTURE Auto Specialties; Radiator Seal, Hand Soap, Puncture Plugger, Silk Life, Glass Cleaner. Get my free list. John Mickman, Chemist, St. Paul, Minn.

SELL Men's neckwear—wonderful proposition. Astor-M. 39 East 28th, New York.

REMNANT Store, Bethel, Ohio. Greatest Dry Goods Bargains on Earth. Agents and Dealers.

MONOGRAM Automobiles. \$1.35 Profit ten minutes' work; every owner wants them; millions without; particulars free. Motorists Accessories Co., Mansfield, Ohio.

GOLD-LEAF Window letters and script signs; no experience; 500% profit; samples free. Consolidated, 69-T West Van Buren, Chicago.

GET Our free sample case—Toilet articles, flavoring and specialties. Wonderfully profitable. LaDerma Co., Dept. A, St. Louis, Mo.

AGENTS: Stamping names on pocket-key protectors. Sample check with your name and address, 25c. Stamping outfits. Emblem checks, check-fobs, name plates. Hart Mfg. Co., Desk 2, 303 Degraw St., Brooklyn, N. Y.

AGENTS. Our cigar lighters, musical novelties and salesboards sell quick. Large wholesale catalog free. Joseph Sales Company, 223 Madison St., Chicago.

\$200 MONTHLY Selling amazing new automobile trouble light. Sticks anywhere on car. Electro magnetic. It's also an everlasting flashlight. Send for demonstrator and prices. National Electric Corporation, 222 High St., Newark, N. J.

MAKE \$100 Week placing electric advertising cigar lighters and fans on dealer's counter. Flashing colored advertisements. Write Drake Mfg. Company, Dept. M, Milwaukee, Wis.

HOMEOPATHIC And Biochemic preparations sent postpaid to all parts of the world. Manual and booklet free. Halsey Bros. Co., 5547 Ravenswood Ave., Chicago, Ill. Established 1855. Agents wanted.

32 SECONDS Complete tire change by Detmer, Ohio, with Morey Quick Action Rim Tool. Sold singly, 49 three days cleared \$100. Anderson, Mont., sold 1,400 in 14 weeks. Get details for good territory. Harvest time now. M. Morey Rim Tool, Buffalo, N. Y.

MAKE Your own products. Employ agents yourself. Toilet articles, soap, extracts. We furnish everything. Valuable book free. National Scientific Laboratories, 1984W Broad, Richmond, Va.

NO Matter what you are selling postal addressed to Excello Sales Co., Shreveport, La., will bring best money making offer you ever received.

BIG Profits taking orders for ties and shirts. Latest styles. Made in our own big mills. Sell on sight at factory prices. Liberal commissions. Write for free selling outfit. Supra Value Shirt Co., 4925-M Hudson Blvd., No. Bergen, N. J.

AGENTS—New shirt proposition. No capital or experience needed. Commissions in advance. Samples free. Madison Company, 566 Broadway, New York.

RIM Tool—Complete tire change 24 seconds. Exclusive territory. Victory Tire Rim Tool Co., Santa Monica, Calif. 1516 Pico Blvd.

\$12.00 DAILY Showing new table cloth. Looks like linen. Wash like oilcloth. No laundering. You just take orders. We deliver. Pay daily. Sample free. Bestever, 152 Irving Park Station, Chicago.

\$75 WEEKLY Up placing Aspirin, Notar-tar, Lighter Filints, Silk-Tone and other self-selling counter display cards with merchants, soda fountains, cigar stores, etc. Over 100% profit. Steady repeats. Sterling Company, F. Baltimore, Md.

A BUSINESS OF your own—Making sparkling glass name and number plates, check-boards signs. Big book and sample free. E. Palmer, 512, Wooster, Ohio.

AGENTS Wanted—On a fast selling 25c item for the kitchen, costs you 8 1-3c. Sample sent parcel post prepaid for 10 cents. P. Seed Filter Mfg. Co., Inc., 353 Broadway, New York.

MEN With autos sell Koehler signs. 717 North Fourth, St. Louis, Mo.

AUTOMOBILE Specialties. Guaranteed formulas for all latest money makers. Lowest prices. Write for free lists. Murphy, Chemist, Tujunga, Calif.

FLAVORING Extracts—Bottle yourself! Concentrated. Free labels. 600% profits! Whirlwind moneymaking proposition! Write Thomas Manufacturing Company, Indianapolis, Ind.

100% CLEAR Profit! Men and women! Enormous profits can be made selling new \$2.00 patented Pinless Curtain Stretcher. Miniature demonstrator furnished. Article sells itself. Exclusive territories available to first applicants. Western Newell Mfg. Co., Freeport, Ill.

SHOE Creme, cleans, polishes all color shoes. Fred Heitmueller, 830-A Cherry, Jamestown, N. Y.

MAN in each town to plate auto parts, reflectors, bathroom fixtures, refinish beds, mirrors, chandeliers; by new method. No capital or experience required. Simple plan of manufacturing at home starts you in big money-making business. Outfit furnished. Free particulars and proofs. Gun Metal Co., Ave. H, Decatur, Ill.

REPLATE Brass worn-off automobile parts, reflectors, bath room fixtures, worn spoons, forks, etc., with pure silver. Looks like new. Use U-Kan-Plate Polish. Positively no mercury. \$1.00 half pints. Post paid. Satisfaction guaranteed. Agents wanted. Dept. A, U-Kan-Plate Co., Philadelphia.

MAKE Your own products. Employ agents yourself. Toilet articles, soap, extracts. We furnish everything. Valuable book free. National Scientific Laboratories, 1984W Broad, Richmond, Va.

AGENTS—Clever invention! Inkspoon makes every pen a fountain pen. Fast office seller; big profit, demand increasing everywhere. Exclusive territory offered. Sample free. H. Marul Company, Tribune Bldg., New York, N. Y.

TWO Money makers for agents. "Francia" Pocket Adding Machine retails \$4.85. To you \$1.00. "Excellograph" Rotary Stencil Duplicator \$37.50 retail. Write Typewriter Supply, 102 Hersch Bldg., Pittsburgh, Pa.

WE Start you without a dollar. Soaps, extracts, perfumes, toilet goods. Experience unnecessary. Carnation Co., 641, St. Louis, Mo.

BIG Profits! Fast sales! \$9.75 automatic washing machine. Guaranteed. Write Storm Royalty Co., 3601 Enright, St. Louis, Mo.

CALIFORNIA Perfumed beads selling like hot cakes. Agents coinng money. Big profits. Catalog free. Mission Factory P. 2328 W. Pico, Los Angeles, Calif.

SELL Supreme No-Cement tire and tube patches. 300% profit. Particulars. Supreme, 135 Winder, Detroit, Mich.

\$50,000 PICTURE Man Friedman made canvassing. Beginners can make \$100.00 weekly with my sales talk. Experienced men make more. Free book "Profits in Portraits" explains. Sample free. Picture Man Friedman, Dept. 8, 109 West Austin, Chicago.

BIG Money and Fast Sales. Every owner buys Gold Initials for his auto. You charge \$1.50; make \$1.34. Ten orders daily easy. Write for particulars and free samples. American Monogram Co., Dept. 40, East Orange, N. J.

WORKERS Buying and applying Axtell Metal Weather Strips to door bottoms make \$1.00 to \$3.00 hourly. Prices, territory, etc. E. L. Church Co., Whitman, Mass.

HIGH-GRADE SALESMEN WANTED

SALESMEN—Wonderful sideline. 40% commission paid daily. Sells all merchants. Pocket outfit free. Willens Co., Dept. 253, 2130 Gladys Ave., Chicago.

BIG Free printing line brings easy, quick profits. Bigger commissions—up to 55%! Experience unnecessary. Now write orders with America's most profitable printing stationery line. Union label. Over 2,000 free cuts. Over 150 standard items covering every business need; letterheads, note-heads, envelopes, billheads, business cards, statements, garage forms—shipping, battery, dry cleaning, tire, storage, parking and hat cleaning tags—repair forms—blotters—gummed shipping, drug, advertising stickers, etc. Lowest prices. Steady repeat orders. Ship everywhere. New free outfit just off press. Write quick. Dept. 146, Box 498, Cincinnati, Ohio.

OLD Established manufacturing firm, have openings in every state and in Canada, for live wire distributing salesmen to handle their line of Metz Automatic Garage Door Controls. Mechanically inclined men who have had some selling experience preferred. Will also consider applications from salesmen desiring a first-class side line. Protected territories available. This opportunity available for a short time only. Communicate at once if interested with the Metz Products Corp., 3051 Rosslyn St., Los Angeles, Calif.

LUSTROUS Aluminum stove pipe. Beautiful, durable, inexpensive. Displaces black pipe on gas stoves and heaters. Every housewife a prospect, hardware, furniture, stove dealers also, sold under money-back guarantee. McCarthy Mfg. Co., Pear Ave., Cleveland, Ohio.

AMAZING Screwholding screw driver! Factories, garages, workers buy on sight! Profit 75c each. Exclusive territory. Free trial offer. Jiffy, 1193 Winthrop Bldg., Boston.

100% PROFIT Selling wind-o-regulators. Eliminates cords and weights. Proved seller. Retain business from builders, contractors, dealers. Sample pair, 35c, postpaid. E. Lewis, 919 Board of Trade Bldg., Portland, Ore.

BIG Money daily, selling shirts of all kinds, lumberjackets, underwear, hosiery, sweaters, playsuits, overalls, pants, rain-coats, leather coats! Outfit free! Experience unnecessary. Nimrod Co., Dept. 65, 4922-28 Lincoln Ave., Chicago.

OVER 200 Reliable manufacturers need salesmen in every locality in the United States. Learn all about it in the current issue of Opportunity Magazine. Free sample copy sent on request. Opportunity Magazine, M410, 750 N. Michigan, Chicago.

PAYING Position open. I'll put you in the shoe and hosiery business. Permanent income, protected territory, full commission on repeats. Experience not necessary. Handsome sample outfit, literature—everything you need to become a successful shoe merchant. Send for free booklet "Getting Ahead." Wm. J. Mishel, Tanners Shoe Mfg. Co., M, 20010 C St., Boston, Mass.

\$18 To \$25 Daily; biggest selling line of 2-piece suits, \$9.95 and \$12.50; 3-piece wool suit, \$17.95 (regular \$28.00 value). All-wool overcoats \$18.50. Splendid rain-coats, slickers and boys' suits. Biggest commission. Free outfits. "Jim" Foster, Inc., Dept. 210, 2250 S. Spaulding Ave., Chicago, Ill.

\$78.00 MADE By Iowa salesman first day selling new electric hot dog machines. Sells \$18.50; commission \$8.50. Direct factory connections. Leonard E. Dickerson, Dept. E-17, Springfield, Mo.

100% PROFIT Demonstrating Motorists' Magnetic Emergency Light. Sells on sight. Sticks anywhere on car. Quick-Set Co., 3218 Avenue Eye, Dept. C10, Brooklyn, N. Y.

CHRISTMAS Cards—Engraved and process. \$2.00 hourly, spare time. Samples free. Windermere Press (Established 1900), 6702 Dorchester, Chicago.

COVERALL Salesmen—Make \$20 daily selling new \$3.50 improved coveralls also service coats with customer's name embroidered on back. Unusual construction. Commission 75%! Wonderful advertising value. Lowest priced; highest commission. Free outfit. Am. B. Co., H-329 W. Monroe, Chicago.

ADVERTISING Salesmen. Brand new winner! Pays over \$100.00 weekly. Simplest desk calendar ever put on market. No competition. Amazing commission. Credit on repeats. Wonderful outfit free. Write at once. Reinauer Manufacturing Co., 1001W Washington Blvd., Chicago.

AUTO Seat covers. Full or slip coverage all cars. Every autoist prospect. Selection and prices beat competition. \$3.00 commission advanced per set. Earn additional \$3.00 installation optional. Outfit free. Coverall, Inc., Lakewood, Ohio.

NEW Discovery astounds America. Salesmen cleaning up \$75 to \$125 weekly. "Elastishine" destined to revolutionize automobile painting. Flows on like magic over old paint. Brush marks disappear instantly. Guaranteed not to chip, peel or crack. Free starting offer. Southern Products Co., Dept. 51, Hopkinsville, Ky.

ZINGOIL, The new petroleum oil hand-cleaner, outsells two to one any other cleaner on the market; replacing ordinary hand soaps wherever shown; if you can't build up a business worth \$100 weekly with Zingoil, quit calling yourself a salesman. B. C. Carter Co., 6647 Foothill Blvd., Oakland, Calif.

STATE Mgr. Marvelous invention sells 3,000 envelopes hourly! Sells \$4.50 only; equals work expensive electric machines. Offices buy 1-100. Exclusive territory. Opportunity earn \$7,000 yearly. Free trial offer. Write quick! Rede, 36 Winthrop Bldg., Boston.

SALESMEN And state managers. Selling guaranteed line patented socket wrenches and other time-saving tools. Every mechanic a live prospect. Liberal offer. Steady income. Protected territory. York Mfg. Co., PM-210, 2640 Greenview Ave., Chicago.

ELECTRICAL Tool line selling to garages, mechanics and auto owners, wonderful demonstrators, big commissions. Salesmen, write Barker Specialties, Girard, Penna.

SPARE Time work for young men selling the super automatic oil heater (for residences) to the trade. Generous commissions on all wholesale sales. Write the Super Oil Heater Sales Company, 275 Connecticut Boulevard, Hartford, Conn.

MEN And women, profit a dollar every fifteen minutes demonstrating our one motion envelope sealer. Retail \$2.25. Seals fifty envelopes minute. Attractive trial offer. Kendall Sealer Company, C-14, East Jaffrey, N. H.

PUNCHBOARD Salesmen. \$10,000 yearly. New line. All fast sellers. Lowest prices. Full commission on repeat business. Catalog free. Hurry! Puritan Novelty Co., 1409 Jackson, Chicago.

EARN \$20 A Day. Establish income for life selling for \$1 a year, \$1,500 accident policy. Write W. C. Stone, 11 So. LaSalle, Chicago.

SELL Popcorn poppers. Low prices, big commissions. Northsides Co., 1306 5th, Des Moines, Iowa.

A SIDELINE That pays 40% advanced commissions. Biggest line illustrated printing for all businesses. No experience needed. Selling outfit free. Hillside, 1217 Van-Buren, Dept. 16, Chicago.

SALESMEN To sell sales builders. A time tested, result producing flexible plan of direct advertising for retailers. Big earnings for high grade men. Write A. D. Bradley, 500 South 4th St., Minneapolis, Minn.

\$40.00 SUITS For \$23.50! Union made to special order, of finest quality virgin wool. You don't have to know anything about selling clothing. We guarantee your success if you are honest and willing to work. Write at once. Goodwear, Inc., 844 West Adams, Dept. 213, Chicago.

SALESMEN—America's leading collection service wants you to help doctors, merchants collect their bad accounts. You list them; we collect. Hustlers actually make \$75-\$100 weekly. Pleasant work, increasing profits. Get the facts. Arrow Service, 29 Jay St., Schenectady, N. Y.

EARN \$300.00 Before Christmas, full or part time, selling an exclusive line of Christmas cards. Big cash commissions. Season just starting. Write at once for sample book. O. A. Koss Company, Inc., 531 W. Larned St., Detroit, Mich.

PUNCHBOARD Salesmen. New deal. \$25 daily profit. Great assortment. No selling. Repeats. Free outfit. Manager, Dept. A, 4332 Harrison, Chicago.

POOL Shooter, new, fascinating vending machine. Merchants everywhere buy! Splendid sideline. Big profit maker! Free outfit! Specialty Mfg. Co., W617 W. Division, Chicago.

PROFITABLE Side line; 10 cent counter card standard headache tablet for drug stores, soda fountains, cigar stands, hotels, gas stations, resorts, etc.; quick sales, good commission; good repeats. Write Prentiss Corporation, Utica, N. Y.

SALESMAN—New thing: "Little Saxo" hat and clothes hanger slips on window of auto. Regular wardrobe. Sample 15c. Frank Saxton Mfgs., Blissfield, Mich.

FEW \$1,000 Monthly earnings ads are truthful. Our men actually earn \$300 to \$500 regularly selling our lines. Adelite, the newcomer in electric window salesmen, is making a big hit. More for the money than anybody gives. Business posters for every line. Changeable letter system too. Permanent business for you working with us. Territory protected and repeats credited. Fat commissions. Full details will prove very interesting. Display Products, Ltd., 409-A East 31st St., Kansas City, Mo.

SALESMEN—Become independent. Own your business; experience unnecessary. Selling our \$10,000 Accidental Death; \$50 Accident; \$25 Sick Weekly Benefits—\$10.00 yearly. Other amounts proportionate. Guaranteed steady income from renewals. \$250,000 deposited Insurance Department, Universal Policy Dept. A, 40 Clinton St., Newark, N. J.

SALESMEN Don't look further! We have what you want. Best staple necessities to sell garages, oil stations, accessory stores. Just in season, liberal commission, protected territory. Our proposition will surprise you. Write today for particulars. Box 197, Spencer, Iowa.

SELL "Union Label" business stationery. Lowest prices. Prompt delivery. Big commissions advanced. Amazing bonus. Cuts furnished, every business. Experience unnecessary. Outfit free. Northwestern, 2002 Division, Chicago.

SELL Goodyear raincoats; \$2.95 up. Goodyear Rainwear, 682 Sixth Ave., New York.

A MONEY Making sideline. A new quick seller to merchants and banks everywhere. Sales outfit free. Comm. paid daily. Carroll Co., Carroll & Albany Aves., Dept. 206, Chicago.

RIGHT Now! Wonderful chance to represent big shirt manufacturer. Best season coming. Easy work. Commission in advance. Outfit given free. Write Gracefit Company, Dept. 611-A, 504 Sixth Ave., New York.

A SPLENDID Opportunity for specialty men to sell our patented auto products to dealers. No investment necessary. Write Inventor Milhander, 1424 East 38th St., Los Angeles, Calif.

SALES Crew managers to organize and sell "Kleen-Rite" window cleaners. The latest and most practical ever offered. Write for particulars of free sample offer. Industrial Tool Co., 5518 Euclid Ave., Cleveland, Ohio.

ADVERTISING Pencils cheaper than greeting cards. New Christmas designs appeal to all lines business. Fast sideline for hustlers. Cash in now. Northern Pencil Works, 126 S. Clinton, Chicago.

SALESMEN—Calling on banks; sell pass books, check covers, money bags, etc. A wonderful line. Commission basis. Write H. M. Lindstrom Co., Cicero, Ill.

SALESMEN—Let me tell you about "Readylite, the Emergency Friend." Sells everywhere to auto owners; pays you real profits. L. T. Kauffmann, Norfolk, Va.

AMAZING New invention protects milk from filth, thieves! Sensational demand every home! Positively no competition! \$12 daily easy! Get facts! San-Pro-Tex, Shelby, N. C.

BUSINESS Stationery. Largest line; highest quality; quickest delivery; biggest commissions; liberal bonuses; free copyrighted cuts every business; experience unnecessary. Instructions and outfit free. David Lionel Press, 312 S. Hamilton, Dept. 94, Chicago.

MAIN Or sideline. Sell auto tires and auto accessories to tire stores, garages, etc. Protected territory, liberal commission. Economy Rubber Products Co., 604 Burkhardt Ave., Dayton, Ohio.

EVERY Call a prospect. Every sale means big repeat business. Complete line—attractively packaged. Nationally used household chemical necessities, etc. Protected territory to producers. Big earnings. Opportunity to build up permanent business. The Holmerden Company, Stratford, Conn. Dept. P.

35% COMMISSION. Liberal repeats. New sales-producing service increases business 20% to 50%. Every retailer live prospect. Sales Stimulators, 339 W. Madison, Chicago.

SALESMEN! Sell Bostonian Shirts. Direct to wearer. Start in a money-making business of your own without a penny of capital. No experience necessary. Wonderful complete selling outfit free with everything you need to start collecting your profits at once. Write today, sure! Bostonian Mfg. Co., 106 Bleckford St., Boston, Mass. Est. 1863.

WANTED District managers—Capable men to represent us in prosperous territories with direct home office contract. Our organization is the oldest of its kind in the health and accident business and offer exceptionally remunerative compensation. Write today for information. Dept. 18, Inter-State Business Men's Accident Association, Brown Bldg., Des Moines, Iowa.

GOLD-LEAF Window letters and script signs; no experience; 500% profit; samples free. Consolidated, 69-V West Van Buren, Chicago.

EXTRA Money—Easy! Sell Christmas cards! Make 50c on each \$1 box of 24 finest assorted engraved designs. 40% on personal greetings. Deal direct with manufacturers! Write for samples and details. Thistle Engraving & Pub. Co., Dept. P, 20 Vesey St., New York.

PUNCHBOARD Salesmen make \$200.00 weekly selling punchboards and vending machines. Big repeat commissions. Beautiful 3-color catalog free. Best season now. Write today. Old reliable company, established 20 years. Lincoln Sales, 116 S. Wells, Chicago, Dept. D.

MAKE Your own products. Employ agents yourself. Toilet articles, soap, extracts. We furnish everything. Valuable book free. National Scientific Laboratories, 1984W Broad, Richmond, Va.

\$60-\$200 A WEEK. Genuine gold letters for store windows. Easily applied. Free samples. Liberal offer to general agents. Metallic Letter Co., 438-A North Clark, Chicago.

SUCCESS is no accident! You will fully understand this slogan when you examine our automatic credit and collection plan. Copyrighted, brand new, unusual. You make 250% on original sale. Half cash on repeats without call-backs. Commonwealth J. Publishing Company, 508 So. Dearborn St., Chicago, Ill.

SALESMEN—Four \$15.00 sales to merchants net you \$40.00 daily. Sayers Systems, 2813 Sheffield, Chicago, Ill.

TO Market 3A garage door holders, simple automatic action, quickly installed, instantly attracts garage owners, builders, dealers. Write for exclusive territory proposition. Knowlson-Stevenson Co., 1118 Packard, Ann Arbor, Mich.

NEW Invention—Sell every business. Four \$15 sales daily pay \$288 weekly. Walker made \$165 first day. Exclusive territory. Adjustment Service, Dept. PM, Mobile, Ala.

LADY Or gentleman—Sell sparkling glass name plates, house numbers, signs, 150% profit. Sample free. O. Vance, Wooster, Ohio.

HELP WANTED

WANTED: Women who need quick money. "New Idea" imported ladies' necessity sells on sight; everyone buys; representatives everywhere are cashing in big. Miss Ely has made \$1,900; Mrs. Hart \$2,200, without experience. New salesplan put you in business for yourself. Sample free. Write Mary P. Coleman, Meriden, Conn.

AMBITIOUS Women make big money selling Prisella dress fabrics, dry goods, hosiery, lingerie, specialties. Full or spare time. Pleasant work. Samples furnished. Write Fitzcharles Co., Dept. 46, Trenton, N. J.

ARE You old at forty? See our advertisement on page 169 of this issue. The Electro Thermal Company, 2122 Morris Ave., Steubenville, Ohio.

BOYS, Girls, make some extra spending money during your spare time. No experience necessary. Albert E. Pickett & Co., 3019 Diversey Ave., Chicago, Ill.

CASH Paid for Butterflies, Insects. See Sinclair Display Advertisement on page 28.

OBTAIN Employment desired, quickly, anywhere. Use "Ways That Win." Write Box 39-201, Station K, New York.

EDUCATIONAL AND INSTRUCTION

WANT A Government job? \$105.00 to \$280.00 month. Steady work. Short hours. Paid summer vacation. Common education sufficient. Experience usually unnecessary. 25 men-women, 18 to 50 coached free. We coach you without leaving home. 32 page book with full particulars free. Write immediately. Franklin Institute, Dept. B3, Rochester, N. Y.

TALKING Pictures need men. Learn how to build, operate and service theatre talking equipment. Write A. Des Biens, Talkie Engineer, 37 Winchester St., Boston, Mass.

LEARN Aircraft welding, auto mechanics, electricity, Magnetos, radio. Big pay. Big demand. Low rates. Free catalog. Stevinson School, 2008A Main, Kansas City, Mo.

RAILWAY Postal clerks. \$158.00-\$225.00 month. Steady. Examinations coming. Common education sufficient. Men 18-35. 25 coached free. Write immediately. Franklin Institute, Dept. B14, Rochester, N. Y.

START Mailing and addressing bureau. Opportunities everywhere for men and women. Good income, quick results. Complete instructions one dollar. Frank S. Perkins, Box 255, Fremont, Nebr.

WANTED Immediately, men-women, 18-55, qualify for permanent government positions, \$105-\$250 month; no gov't experience required; paid vacations; common education; many needed soon. Write Ozment Inst., 101, St. Louis, Mo.

STAMMERING, Stuttering, other speech troubles, corrected. Wilson Schools, Dayton, Ohio.

"THE Personal Liberty Course"—A clever combination of mirth, information and instruction for quickly overcoming fear, bashfulness and physical complexes in men. No drugs, no gymnastics. Full particulars free, sealed. Harry J. Gardener, P. O. Box 607, Station C, Los Angeles, Calif.

753 TIME, Labor and Money Saving Ideas for all who own, drive or repair autos. These practical hints are based upon the actual experiences of hundreds of owners and repairmen. Three books, Auto Owners', Auto Repairman's and Auto Tourists' Handbooks, regular \$1.50 value will be supplied at 98c plus the postage C. O. D. for a limited time only. Send your order today to Popular Mechanics Press, Room 810, 200 E. Ontario St., Chicago.

BECOME A landscape architect. Uncrowded profession; wonderful opportunity for money-making. Easily mastered by mail. Earn while you learn. Est. 1916. Write for details. American Landscape School, 29 Plymouth Bldg., Des Moines, Iowa.

U. S. GOVERNMENT Wants men, \$1,700-\$1,900 and up at start. Railway mail clerk examination coming. Let our expert (former government examiner) prepare you for this and also rural carrier, post office, customs, internal revenue, and other branches. Write today for free booklet. Dept. 8, Patterson School, Rochester, N. Y.

AMATEUR Cartoonists: Sell your cartoons. New market. Smith's Service, PR-1194, Wenatchee, Wash.

MEN, Women, everywhere. Manage your own business. Learn local advertising (distributing and supervising the distributing of free samples, folders, circulars, etc., and tacking-up signs). Unlimited opportunities. Complete instructions one dollar. John Wagner, Box 457, Palo Alto, Calif.

LEARN Linotype—Pays good salary; home or college course; small cost; free catalog. Linotype School, Maumee, Ohio.

STUDY A scientific profession. Microbiology, Bacteriology, Sanitation, Extension-residential course. Diplomas, degrees granted. Urinalysis outfit-prospectus free. College of Microbiology, 23 State, Hammond, Ind.

DOUBLE Entry bookkeeping 60 hours with 8 keys; guaranteed. (Diplomas.) International Bookkeeping Inst., 8 Springfield, Mo.

DON'T Prepare for any civil service examination without seeing our catalog. Free. Columbian Correspondence College, Washington, D. C.

BIG Demand for photoplay talking picture and magazine stories. We revise, develop and copyright. Sell on commission. Established 1917. Booklet free. Universal Scenario Company, 406 Western and Santa Monica Bldg., Hollywood, Calif.

AIR Navigation and meteorology—New, simple, nontechnical book needed by every flyer. Nothing else on the subject like it. Written by Captain Duncan who has over 3,000 hours of flying to his credit. 225 pages. Flexibly bound. 80 pictures, maps, etc. Pay postman \$3.00 when he delivers book. Popular Mechanics Press, Room 808, 200 E. Ontario St., Chicago, Ill.

INFORMATION

OUTDOOR Books—Send for large free list of the best books on all outdoor subjects for recreation, study and profit, etc. Popular Mechanics Press, 200 E. Ontario St., Chicago.

200 TRICKS You can do—Mystify your friends; have loads of fun. This collection of tricks has been selected by Thurston for the average person. Neither unusual skill nor elaborate apparatus are required. Send for this 200-page illustrated book. Pay postman \$1 plus postage when delivered. If outside U. S. remit when ordering. Popular Mechanics Press, Room 809, 200 E. Ontario St., Chicago.

TYPEWRITERS AND SUPPLIES

TYPEWRITERS—Factory rebuilt Royals, Remingtons, Underwoods, New Royal, Remington and Corona portables. New "Excelligraph" Rotary Stencil Duplicator \$37.50. Catalog free. Pittsburgh Typewriter Supply, Dept. 945, Pittsburgh, Penna.

TYPEWRITERS, All standard makes. \$10 up. Fully guaranteed. Free trial. Write for complete illustrated lists. Northwestern Typewriter Exchange, 121 N. Francisco Ave., Chicago.

TYPEWRITERS, Motorcycles, radios, \$4.99-\$24.99. Rent \$1.00 Knight, 1516 Locust, St. Louis, Mo.

TYPEWRITERS—All makes, \$6 to \$32. Fully guaranteed. Dee Typewriter Exchange, Ada, Okla.

ADDING MACHINES

NEW \$3.50 Automatic adding machine. Adds, subtracts, multiplies, absolutely accurate. Capacity \$999,999.99. Fully guaranteed. 75,000 pleased users. Makes adding easy, positive, quick. Eliminates mistakes. Saves time. Postpaid \$3.50. Bassett Co., 1458-D, Hollywood Ave., Chicago.

PRINTING, ENGRAVING AND MULTIGRAPHING

100 BUSINESS Size letterheads, 100 envelopes, \$1.50. Crane Printing, 1111 East 32rd, Kansas City, Mo.

QUICK Service. Ask us about your next printing job. No obligation. We print anything. Burket Printing Co., Roaring Spring, Pa.

1,000 Hammermill Letterheads or envelopes \$3.25. Cards, statements, billheads, 5½x8½ letterheads, \$2.50 cash delivered. The B. & M. Press, "Printers Extraordinary," Dawson, Okla.

PEPPY Stylish printing. Quality high—prices away down. Fast service. Battlefield Press, Gettysburg, Penna. Free souvenir.

1,000 LETTERHEADS, Envelopes, cards, circulars, \$2.75m. Morganrice Press, Springfield, Mass.

QUALITY Printing! For less money! Free samples. Knott Printing Co., 3231-B Park, Kansas City, Mo.

TRIAL 150 8½x11 Hammermill letterheads, envelopes, billheads or cards only \$1.00 postpaid. Race Printery, Hudson, N. Y.

LADIES, Gentlemen, 200 envelopes, 100 noteheads, \$1.00. Your printed name, address. American Press, Oshkosh, Wis.

1,000 BOND Letterheads, statements, etc., \$2.85. Price list. Specialty Printing Shoppe, Sumner, Ill.

PRINTING—Low prices, fine work. New price list and samples. Stationery, circulars, folders, booklets, catalogs, ruled forms. Sell direct, large or small orders. Large modern plant in small town, low operating cost. Shenandoah Publishing House, Inc., Box 1120, Strasburg, Virginia.

500 BUSINESS Cards \$1.25 post paid. Other printing reasonable. Samples free. Hanzer's, 1039 S. Cleveland, Phila, Pa.

150 LETTERHEADS, 8½x11, and 150 envelopes printed, \$1.25. Other printing priced right. Angel, Box 1002, Leavittsburg, Ohio.

1,000 BOND Letterheads, envelopes, billheads, statements, cards, \$3.45 each. Satisfaction, samples. H. Curtis, 811 Harrison, Kalamazoo, Mich.

"NEARGRAVURE"—If particular. Special 250 envelopes—500 8½x11 letterheads \$4.44 postpaid. Solidays, Knox, Ind.

1,000 BUSINESS Cards \$2.75 postpaid. Samples free. John Miller, Montgomery Ave., Narberth, Pa.

INTRODUCTORY Special! 50 cards, 50 letterheads and 50 envelopes, all for \$1.00. Quotations on various printing solicited. Congress Printing Company, 2402 West Division, Chicago.

MULTIGRAPHING Business correspondence two dollars thousand. Hammermill letterheads, four dollars; inexpensive quality, three dollars. Miscellaneous printing. Mayera Corporation, Monmouth, Ill.

ART Ad slips, 3½x5½, 200 words, attractive colors: 1,000, \$2.00; 5,000, \$5.00, prepaid. All printing low prices. Samples. Goodprint, Harrisonburg, Va.

QUALITY Printing! Reasonable Prices! Send for Free Standardized samples and prices. Folders, Circulars, Catalogs our specialty. Earnest Fantus, 525 South Dearborn, Chicago.

250 BOND Letterheads, Envelopes, Billheads, Cards, \$1.35 each. Economic Press, Leonia, N. J.

WE Print stationery, booklets, catalogs, circulars, Samples. Commercial Press, Batavia, Ohio.

200 LETTERHEADS And 100 envelopes \$1.00. 200 letterheads, 8½x11, 150 envelopes \$2.00. 250 cards \$1.00. Hoosier Print Shop, Portland, Ind.

SAMPLES Raised letter printing with special prices free. LaClyde Service, Westfield, Mass.

PRINTING OUTFITS AND SUPPLIES

COMPLETE Printing outfits, presses, type, ink, paper, supplies. Write for catalog. Kelsey Company, G-11, Meriden, Conn.

MAKE Your own printing device. It's practical—different. Particulars, specimens free. Grinstead Company, Oswego, Kans.

PREUSED Printing presses and supplies. Lists 2c stamp. Popular Bargains, Richland, Pa.

PRINTING Outfits—Presses, type supplies, type novelties. Send stamp for catalog. Model Press, York, Penna.

RUBBER STAMPS

RUBBER Stamps! Name, address, two lines 25c; three lines 35c. DeLux Stamp Works, B572M, Auburn, Nebr.

DUPLICATORS AND DEVICES

YOU Can make 50 to 100 copies of a letter, notice, etc., at a cost of three cents on a Heyer Quality Duplicator. Write for free trial offer. The Heyer Duplicator Co., 909 Jackson Blvd., Chicago, Ill.

"EXCELLOGRAPH" Portable rotary stencil printing duplicators \$39. Terms. Description, testimonials, printed samples, free. Pittsburgh Typewriter Supply Co., Dept. 531, Pittsburgh, Pa.

FOR THE HOME

GRANDFATHER'S Clock Works. \$5.00. Build your own case; instructions free; make good profits selling your friends. Clock works with chimes for old or new cases. Write for full particulars. Clock Co., Ruffner St., Philadelphia.

CEDAR Chests only \$11.65—"Red-i-Kut" complete with rich copper trim—you assemble and save half—send for pictures. Kuempel Furniture Company, Guttenberg, Iowa.

ALL-ELECTRIC Radio Sets—First book on subject—just out. Kenneth A. Hathaway, well known radio adviser of the Chicago Daily News has written this clear, interesting and non-technical book. It covers dynamic speakers also. 120 pages. Illustrated. Pay postman only \$1.50 plus postage upon delivery. Popular Mechanics Press, Room 808, 200 E. Ontario St., Chicago.

FOR MECHANICS

A BIG Opportunity in 8-hour battery charging or 20 minute car washing. Let me tell you how you can install equipment with practically no investment. Earn \$150 to \$300 monthly. Bargains in used outfits. Also a few reconditioned buffers, grinders, air compressors, paint sprays, arc welders. Write today. Ken Byrum, Box M1099, Troy, Ohio.

753 TIME, Labor and Money Saving Ideas for all who own, drive or repair autos. These practical kinks are based upon the actual experiences of hundreds of owners and repairmen. Three books, Auto Owners', Auto Repairman's and Auto Tourists' Handbooks, regular \$1.50 value will be supplied at 98c plus the postage C. O. D. for a limited time only. Send your order today to Popular Mechanics Press, Room 808, 200 E. Ontario St., Chicago.

FOR SMOKERS

TOBACCO: Virginia gold leaf. Smoking, chewing; mild, mellow. Like rare old wine. Four pounds \$1 postpaid. Belmont Farms, Box A, Chatham, Va.

RAZORS AND BLADES

GILLETTE Razor blades sharpened to perfection, 1c each. Petter Wetterquist, Rockford, Ill.

BOATS AND LAUNCHES

MAKE 16' Rowboat. Blueprint 30c. Weesho-Uco, 31st Office, Detroit, Mich.

BUILD Your own boat using our ready cut semi assembled materials. 55 designs. Outboard speedsters, cruisers, runabouts, launches, sail, row. Send 10c for catalog. Hurry for this season's use. Brooks Boat Co., Inc., Saginaw, Mich., Box NN.

HUBBELL Marine Coolers convert Ford engine into marine motors. Booklet free. Ford speedboat easily built, large blueprint and directions one dollar. C. C. Hubbell, Perry Ave., Norwalk, Conn.

MAKE Rowboats, houseboats, canoes. Interesting literature free. Weesho-Uco, 31st Office, Detroit, Mich.

TWENTY Mile outboard racer. Complete plans 25 cents. Free boatbuilding catalog. The Rudder, 15 Murray St., New York.

16' CANVAS Canoe. Easily made. Blueprint, 30c. Weesho-Uco, 31st Office, Detroit, Mich.

BUILD Your own boat—Complete directions make it comparatively easy. 14 different types for all purposes including row, motor, sail, canoe, out-board motor boats, etc. With this book is included "Outdoor Sports the Year 'Round'" on making all sorts of devices for outdoor recreation. Pay postman \$1.98 plus postage when delivered. Popular Mechanics Press, Room 808, 200 E. Ontario St., Chicago.

MAKE 12' Rowboat. Blueprint 30c. Weesho-Uco, 31st Office, Detroit, Mich.

GUNS, SPORTING GOODS AND FISHING TACKLE

HUNTERS, Trappers, fur farmers, fishermen, do you read Fur-Fish-Game magazine? Price \$2.00 year, 25c copy. Special 4 months 35c. Fur-Fish-Game, Guggle Bldg., Columbus, Ohio.

HUNTERS, Remington autoloading shot guns, \$47.00. Ithaca field grade, \$33.00; Fox Sterlingworth, \$33.00. Low prices on all shot guns and rifles. List free. Pulver Sporting Goods, Hudson, N. Y.

FIELD GLASSES, TELESCOPES AND MICROSCOPES

TELESCOPES—Field glasses: Rare bargains, 75c up. Stamp for list. United Shop, 1316 North American Bldg., Chicago, Ill.

C-FAR Field Glasses \$2. Consists of two rimmed lenses in neat leather case, slips into vest pocket, weighs only 1½ ounces. Gives 6 diameters magnification. Money back if not satisfied. Send \$2 today to Buffalo Optical Co., Dept. PM-1, 559 Main St., Buffalo, N. Y.

USED Fieldglasses: \$2 to \$75. J. Alden Loring, Dept. J, O-we-go, N. Y.

ANTIQUES, WAR RELICS AND INDIAN GOODS

SEND 5c for fine new list Indian relics, antique firearms. F. E. Ellis, Webster Groves, Mo.

NICELY Mounted deer heads, birds and animals for sale. 25 years' experience. D. H. Swinburn, Taxidermist, Littleton, N. H.

GENUINE Indian goods direct from an Indian trader. Navajo blankets, rugs, pottery, basket, silver work. Price list Southwest Indian Crafts, Box M-247, Gallup, N. Mex.

INDIAN Relics, Beadwork, Coins, Curios. Catalog free. Vernon Lemley, Osborne, Kans.

MINERALS, PRECIOUS AND SEMI-PRECIOUS STONES

WE Are dealers in rough and polished minerals and polished semi-precious gems for scientific, educational, cabinet display or jewelry craft purposes. List of gem minerals and their varieties, table of birthstones and pricelists free with an order for any of the following. PM Special—8½x assorted rough and polished minerals for \$1. Four genuine mined, fully polished gem stones \$1. Two interesting Montana mineral specimens 35c. Any of these postpaid, correctly labeled and with satisfaction guaranteed. The Gem Shop, Box 373, Wolf Creek, Mont.

SMOKY Topaz: buy them direct. I have a number of stones I will have cut for you. Be the first one to own one of these beautiful stones, just the thing to get for your holiday gifts. If you are not pleased with your stone when you get it return it in ten days and your money will be returned. (\$12.50) for one carat size (\$18.50) for two carat size. I have all sizes. Write your wants to R. A. Garner, Box 188, Lancaster, Pa.

PHONOGRAPHS AND RECORDS

MR. STOREKEEPER, Why pay \$1,000 or more for a coin-controlled Amplified Phonograph? We sell reprocessed phonographs at \$295.00 each. Photograph on request. Buckeye Music Co., 186 Ira Ave., Akron, Ohio.

BUILD Your own phonograph. Parts catalog and instructions to build new horn, mailed for 10c. American Phonograph Co., 4116 West 24th Place, Chicago.

MUSIC AND MUSICAL INSTRUMENTS

SONG Poem writers, "Real" proposition. Hibbler, DI, 2104 N. Keystone, Chicago.

SONGWRITERS: Submit your song-poem of complete song. Quick decision on availability for publication—unacceptable manuscript returned. Chester A. Escher, Music Publisher, 125 W. 45th St., New York City.

SONG Poems arranged for publication. Submit poems; prompt decision. Brennen, 11658 B'way, New York.

SONGWRITERS; Substantial advance royalties are paid on publisher's acceptance. Write for free booklet on developing ideas for song words or music required by talking pictures. Newcomer Associates, 1674 Broadway, New York.

TWO-BIT Sale "Great-Music Mender" Transparent-Tape, San Jose, Calif.

SOLO "Heaven Is My Home," beautiful lyrics and music stir imagination. 30c copy, \$1.00 five copies. Schmidt, 35 E. Wacker Drive, Room 986, Chicago, Ill.

SONGWRITERS: Have your song expertly harmonized and arranged before submitting to publisher. Legitimate proposition. "Songcraft," Easton, Penna.

COMPOSERS—Verse or music. Brilliant opportunity. Write Van Buren, 1885 McClurg Bldg., Chicago.

MUSIC Composed, arranged for piano, orchestra, music set to song poems, by eminent composer. Butler, 158 West 74th St., New York.

SONGWRITERS: Submit your song-poem or complete song. Will return it immediately if not accepted. Chester Escher, Music Publisher, 125 W. 45th St., New York City.

SONG Lovers—You should buy this beautiful number, "The Old Hawthorne Tree in the Garden" and an appealing waltz number "I Want My Daddy." Each 30c. Gertrude Lang, Waymart, Pa.

VIOLINS—Hand-made masterpieces. John Lehto, 953 14th San Pedro, Calif.

FREE! Song Writers Guide. Beaver, 1257 Elm, Green Bay, Wis.

MAKING Violins. Plans and instructions free. For particulars write Rodell Music House, New Bedford, Mass.

POEMS Wanted. Work guaranteed. We publish. Great Eastern Song Bureau, Dept. 27, Thomaston, Me.

SEND Song poems, 50-50 plan. Indiana Song Bureau, (Brookside), Salem, Ind.

SONG Poem writers. Write Sequola Songwriters' Service, Sherman Branch, Los Angeles, Calif.

VIOLINS, Deep, mellow, soulful—on credit. Easy terms for wonderful instrument. Get details today. Gustav F. Henning, 302 University Building, Seattle, Wash.

CORNETISTS—Trumpetists—Saxophonists—Clarinetists. Get "Free Pointers." Name instrument. Virtuosi School, Buffalo, N. Y.

PLAY Piano by ear. A sound system. Booklet free. Boucher's Harmony Studio, Ottawa, Can.

"MUSIC Composed" to words. Bauer Bros. (formerly of Sousa's Band), Oshkosh, Wis.

SONG Writers. Send for our "Publishing Agreement." McKinley Music Printers, 1501 E. 55th St., Chicago.

WRITE Songs. Big money and reputation. Write for information. J. Gordon Pub. Co., 201 N. Hoyne Ave., Chicago.

SONG Poems solicited. A different proposition. Richard Broughton, Sioux Falls, S. Dak.

PATENT ATTORNEYS

INVENTIONS Patented; inventions developed; correspondence invited; confidential advice; trademarks registered; copyrights. Edward Gottlieb, Patent Attorney, Engineer, 5 Beekman St., New York.

PATENTS Procured; trade marks registered—preliminary advice furnished without charge. Booklet and form for disclosing idea free. Irving L. McChrath, 704 International Building, Washington, D. C.

UNPATENTED Ideas can be sold. I tell you how and help you make the sale. Free particulars (Copyrighted). Write W. T. Greene, 906 Barrister Bldg., Washington, D. C.

SELL Your invention before patenting. Write for free particulars. W. T. Greene, 901 Barrister Bldg., Washington, D. C.

PATENTS, Trade-Marks, Designs. This firm has 27 years' experience and gives expert personal service at reasonable rates. We properly protect your invention. Write for free information and exact cost of procuring patent before proceeding. John B. Thomas & Co., 902 F St., N. W., Washington, D. C.

MONROE E. MILLER, Ouray Bldg., Washington, D. C., Patent Lawyer; Mechanical, Electrical Expert. Booklet and Priority Record blank gratis.

PATENTS Procured. Prompt, careful and efficient service. Highest references. Moderate fees. Send sketch or model for actual search and advice. George P. Kimmel, Master of Patent Law, 54-J Legal Bldg., Washington, D. C.

PATENTS Procured under my easy payment plan. See ad page 141. M. S. Cayne.

TIME Counts in applying for patents. See pages 136 and 137. Clarence A. O'Brien, Registered Patent Attorney, Washington, D. C.

PATENTS—Write for our free book, "How to Obtain a Patent" and Record of Invention Blank. Send model or sketch of invention for inspection and instructions free. Terms reasonable. See advertisements on pages 138 and 139. Victor J. Evans & Co., 934 Ninth, Washington, D. C.

LACEY'S Patent Sense. Valuable book free. See ad page 141.

INVENTORS: Send for booklet telling how to patent and sell your inventions at lowest cost. Ralph Burch, Patent Lawyer, 900 F St., Washington, D. C.

PATENT Information bureau. Free advice regarding procedure. Booklet upon request. Established for the convenience of inventors. Inventors' Service Bureau, Union Trust Bldg., Washington, D. C.

JOHN PATTEN DUFFIE, Registered patent attorney, Victor Bldg., Washington, D. C. Reasonable rates. Advice free. Booklet.

ESTABLISHED 1861. Milo B. Stevens Company. Free booklet. Patents. Trade marks. Copyrights. Offices, Monadnock Block, Chicago; Barrister Building, Washington, D. C.

INVENTORS—Write for our Guide Book, "How to Get Your Patent," and Evidence of Invention Blank. Send model or sketch of your invention for our prompt examination and instructions free. Randolph & Co., Dept. 430, Washington, D. C.

PATENTS. Prompt personal service. Write for information. Albert E. Dieterich, Registered Patent Lawyer, 621½ Ouray Bldg., Washington, D. C.

LANCASTER and Allwine, 221 Ouray Bldg., Washington, D. C. "Originators of the Form Evidence of Conception." Before disclosing your invention to anyone send for blank form to be signed and witnessed. Form and patent information bulletin free.

PATENTS. Send sketch or model for advice. Free book: "How to Obtain a Patent." Established thirty years. Highest references. Prompt service. Reasonable charges. Chandee & Chandee, 910 F St., Washington, D. C.

INVENTOR'S Adviser with mechanical movements sent free. Labiner, Three Park-row, New York.

PATENTS. Booklet free. Highest references. Best results. Promptness assured. Send model or drawing for preliminary examination. Watson E. Coleman, Patent Lawyer, 724 Ninth St., Washington, D. C.

PERCY S. WEBSTER, 203 Saving and Loan Building, Stockton, Calif. Patent booklet free.

"INVENTOR'S Guide," valuable information, free. Frank Ledermann, Registered Attorney-Engineer, 1712 Woolworth Bldg., New York.

PATENTS—Write for free instructions. Send drawing or model for examination. Carl Miller, Registered Patent Attorney (former Patent Office examiner), 259 McGill Bldg., Washington, D. C.

FOR INVENTORS

PATENTS. If you have an invention which you wish to patent you can write fully and freely to Munn & Co., for advice in regard to the best way of obtaining protection. Please send sketches, or a model of your invention and a description of the device, explaining its operation. All communications are strictly confidential. Our Hand-Book on Patents is sent free on request. This explains our methods, terms, etc., in regard to patents, trade marks, foreign patents, etc. "Scientific American" contains patent office notes, decisions of interest to inventors and particulars of recently patented inventions. Munn & Company, Solicitors of Patents, 524 Scientific American Bldg., Washington, D. C.; 1523 Scientific American Bldg., 24 W. 40th St., New York City; 1313 Tower Bldg., Chicago, Ill.; 666 Hobart Bldg., San Francisco, Calif.; 521 Van Nuys Bldg., Los Angeles, Calif.

UNPATENTED Ideas can be sold. I tell you how and help you make the sale. Free particulars. (Copyrighted). Write W. T. Greene, 907 Barrister Bldg., Washington, D. C.

INVENTIONS—Write for our free book "How to Obtain a Patent" and Record of Invention Blank. Send model or sketch of invention for inspection and instructions free. Terms reasonable. See advertisements on pages 138 and 139. Victor J. Evans & Co., 157 Ninth, Washington, D. C.

TIME Counts in applying for patents. See pages 136 and 137. Clarence A. O'Brien, Registered Patent Attorney, Washington, D. C.

LACEY'S Patent Sense. Valuable book free. See ad page 141.

INVENTORS, Manufacturers. If you have a specialty of real merit suitable for national distribution write The Plomo Specialty Mfg. Co., Cleveland, Ohio.

INVENTORS Opportunities, a bulletin of ideas revised quarterly by an experienced industrial engineer. 50 cents. Beandbe Engineering Co., Midland, Mich.

RELIABLE Corporation desires to manufacture and sell patented articles of merit. Write P. O. Box 1246, Fort Worth, Tex.

LET Us sell your invention. Holzinger, 341 S. Campbell, Chicago.

I MAKE Dies for blanking and forming parts from sheet metal. Write for free estimate on dies you want made. B. L. Northend, Mitchell, S. Dak.

IF You can't sell your patent, address W. T. Box 131, East Ave. Station, Rochester, N. Y.

INVENTIONS Wanted—Patented, unpatented. If you have an idea for sale, write Hartley, Box 928, Bangor, Me.

GET Your own patents. Legal blanks, complete instructions \$1. Cutting Sons, Campbell, Calif.

INVENTORS Universal - Educator - contains 900 mechanical movements; 50 perpetual motions. Tells how to obtain and sell patents. Suggests new ideas. Explains how to select your attorney and avoid patent sharks. Price (revised edition) \$1.00 post-paid. Albert E. Dieterich, 621 Ouray Bldg., Washington, D. C.

PATENTS, Patents pending sold to manufacturers. You pay for results only. W. Nestle, 852 Belmont Ave., Chicago.

INVENTORS—Ideas developed and working models built. Electrical problems solved. Lowest charges and confidential service. Industro Electric Tools Co., Petersburg, Va.

I SELL Patents. Established in 1900. A nationally-known service. Experienced, respected. Why take chances? Charles A. Scott, 773PM Garson Ave., Rochester, N. Y.

SELL Your invention before patenting. Write for free particulars. W. T. Greene, 902 Barrister Bldg., Washington, D. C.

INVENTORS—Cash in on your invention now! Don't delay the sale any longer! Send for a free copy of our specially prepared booklet, "Turn Your Patent Into Money," today! It contains helpful information for all inventors. M. L. Rund, Mgr. Classified Advertising, Popular Mechanics Magazine, 200 E. Ontario St., Chicago, Ill.

PATENTS FOR SALE

OUTRIGHT Or royalty. U. S. and Canadian patents. Something new in roller skate. An opportunity for manufacturers in this line. Henry Sahlmann, 5423 9th Ave., Brooklyn, N. Y.

OUTRIGHT Or royalty. Latest improvement safety mats for bath tubs. Patented 1929. Tony Scarpel, 3 City Hall Av., Room 307, San Francisco, Calif.

MILLIONS In doorlatches; made out of leftovers. U. S. and Canadian patents for sale and royalties. David Smith, Box 6, Howe, Nebr.

"FIVE-PIN" Bowling game; no pin setting. Also adapted for flat floors. Outright or royalty. B. A. Bristow, 96 Hiawatha, Toronto, Can.

FOR Sale—Patent on automatic labor-saving sprinkling systems. Lenora Spencer, 218 Oak St., Hot Springs, Ark.

ATTACHMENTS For musical instrument. Millions dollars. U. S. patent No. 1,19,832. Nothing like it on the market. For sale or royalty. 13433 Hazelridge Ave., Detroit, Mich.

FOR Sale—Patent on aeroplane passenger apparatus; outright or royalty. Full particulars on request. Valuable invention. Address Mary Rachbauer, Durham, Conn, Rt. 1.

SOMETHING Different wringer mop. Stamped, sheet metal; cheap to manufacture. Cash or royalty. Patent pending. G. C. Johnston, Box 548, Terro, N. Mex.

ATTENTION, Patent, buyers useful article for kitchen or restaurant. Address Box 172, Elizabeth, Pa.

AUTOMATIC Flushing valve just patented. Also have some airplane inventions to be patented. F. Benske, 1422 Stebbins Ave., New York.

ELECTRIC Face lifter. Gets results on muscles and skin; no vibrator. Mfg. cost 50c. Patent pending. Outright or royalty. Walter Moffitt, 3357 Kenwood, Indianapolis, Ind.

OUTRIGHT Or royalty, dispensing cap for collapsible tubes. Daniel W. Lee, 6256 S. Halsted St., Chicago, Ill.

HERE It is! Entirely new self-filling device for fountain pens. Outright or any reasonable proposition. Patent pending. Box 163, Fishers' Island, N. Y.

COIN Operated vending machine for newspapers, magazines, envelopes, stationery. Cash or royalty. W. T. Cole, 6307 Hancock Ave., St. Louis, Mo.

U. S. AND Canadian patents on new paring knife and machinery to manufacture. Advance cash as much as \$2,000.00 and royalty. W. D. Connelly, Dodge City, Kans.

AUTOMOBILE Inner-tube tester, test tubes under pressure. \$5,000.00 outright. Samples \$8.00. Geo. E. Mancos, Libbie and Monumental Aves., Richmond, Va.

POISON-BOTTLE Lock. Big opportunity. Moses, Box 2735, Cleveland, Ohio.

FOR Sale—New roroll window and door screen. Non-rust. Nothing like it. Lasts a life time. Patent pending. Best offer takes it. Jesse Howe, Box 98, Roscommon, Mich.

OUTRIGHT Or royalty. "Quick adjustable pipe wrench." William Parker, Jr., 7215 Perryville Ave., Ben Avon, Pa.

OUTRIGHT Or royalty. Brake testing machine. No. 1,702,817. R. F. Daniels, 1717 Versailles Ave., Alameda, Calif.

OUTRIGHT Or royalty basis newly patented neck band for collars. Simple device eliminates the ordinary collar button. Mike Vanson, 735 Washington Ave., Plymouth, Pa.

PATENTS For sale. Canada No. 216,023 and U. S. patent No. 1,397,670 on new and useful improvements on garment holders. D. W. York, 3 Temple St., N. Abington, Mass.

UNIQUE Shopping bag design, paper. Amazing. 2061 Monroe, Chicago.

TIME Counts in applying for patents. See pages 136 and 137. Clarence A. O'Brien, Registered Patent Attorney, Washington, D. C.

OUTRIGHT Or royalty. Glare shield, patent pending. Every Chevrolet, Pontiac, Oakland, Buick owner a prospect. Box K, Nora Springs, Iowa.

OUTRIGHT Or royalty—Spacing and marking machine for tailoring, dressmaking, underwear, sweaters marked correctly. Button-holes, buttons, hooks, eyes. E. T. Benson, 6445 N. Clarendon Ave., Chicago, Ill.

OUTRIGHT Or royalty. Simplest home permanent waving tested device, amazing results. Cost exceedingly low. I lack capital for international marketing. E. Lund, 1103 E. Mercer, Seattle.

BATHING Toy. Nothing like it. Wonderful possibilities as money maker. J. Montague, Olivet, Mich.

COMBINATION Motor truck, concrete and mortar mixer; establishing a new mixing principle and will prove a big money maker to manufacturer. Chas. Payne, 27 Fulton Ave., Waukegan, Ill., U. S. A.

OUTRIGHT Or royalty—Patented keyless automatic door lock. Jay Westcott, 103 Wilmore Pl., Syracuse, N. Y.

INVENTORS—Cash in on your invention now! Don't delay the sale any longer! Send for a free copy of our specially prepared booklet, "Turn Your Patent Into Money," today! It contains helpful information for all inventors. M. L. Rund, Mgr. Classified Advertising, Popular Mechanics Magazine, 200 E. Ontario St., Chicago, Ill.

ELECTRICAL

NEW Electrical Dictionary. Complete up-to-date electrical dictionary to which has been added a special dictionary of radio words and terms together with illustrations of electrical symbols, radio diagrams and other wiring diagrams. 191 Pages—Vest pocket size. Price only 35c postpaid. Popular Mechanics Co., Room 810, 200 East Ontario St., Chicago, Ill.

MODELS AND MODEL SUPPLIES

SHIP Model Fittings: Send Dime for booklet. A. J. Fisher, 1002 Etowah Ave., Royal Oak, Mich.

LET Our experience be your guide. Models that are models; tools and equipment for economic manfg. Patterns of all types; manufacturing in all branches. Satisfaction guaranteed. United Machinery Company, Cincinnati, U. S. A.

TIME Counts in applying for patents. See pages 136 and 137. Clarence A. O'Brien, Registered Patent Attorney, Washington, D. C.

MODELS. Experimental work. Equipped for complete machine construction any description. Hulit & Company, Machinists, 115 South Clinton, Chicago.

READ The Model Yacht! The only national magazine in America devoted to the interests of the model yacht sailor. Published monthly. \$1.50 the year, 15c the copy. Yachting, Inc., 215 East 42nd St., New York.

WORK With master machinist; 15 years experimental experience, well equipped shop. Albert Weiss, 161 W. 21st St., New York City.

THE Modelmaker, a magazine for all interested in making working models, boats, etc. Sample 10c. Modelmaker, 122 Liberty St., New York.

WE Make working models for inventors and do experimental work and carry a complete stock of brass gears and model supplies. Send for catalog. The Pierce Model Works, Tinley Park, Ill.

SPECIAL Machine builders, tool and die makers, inventors' models production work of all kinds. Dept. L. Quality Hardware & Machine Corporation, Ravenswood and Thorndale Aves., Chicago, Ill.

MODEL Steam engines and boilers for miniature power boats. Boat and boiler fittings. New catalog 15c. Model Machine Shop, 212 Price St., Rahway, N. J.

THREE Ship model plans for \$1. Catalog 6 cents. Richter's, 3217 Walnut St., Milwaukee, Wis.

MANUFACTURING

LARGE Factory exceptionally well equipped to manufacture your product complete, warehouse it and ship to your instructions. Dies, stampings, casting, screw machine, wire products, plating, enameling, assembling, cartons and printing. Quantity production. Estimates promptly furnished. A reliable and efficient organization. Malesic Products Mfg. Company, Box 877, Chicago.

MANUFACTURING Models, dies, stampings, brass work, one or thousands. Circular free. Baum's Metal Specialties, Kansas City, Mo.

SPECIAL Machinery or parts, dies, tools, metal specialties, models, special gears, stock gears and model supplies. Send for Catalogue. The Pierce Model Works, Tinley Park, Ill.

WIRE Goods made to order. Cooley Mfg. Co., 530 N. Western Ave., Chicago.

SPECIALTY Manufacturing. Stampings, wire products, patents developed and marketed. Safety Globe & Mfg. Co., Columbus, Ohio.

MANUFACTURING: Small machines, parts, dies, stampings. Write Birchall, Reading, Mass.

DIES, Stampings, machine work. B. L. Nortwed, Mitchell, S. Dak.

MACHINERY, TOOLS AND SUPPLIES

NO. 3 CINCINNATI Universal Milling Machine with dividing heads, \$550.00; 14 in. x 6 ft. Von Wyck lathe, \$140.00; No. 60 Head Grinder, \$275.00; 20 in. Hendy Shaper, \$225.00; 24 in. Steptoe Back Geared Crank Shaper \$550.00. 36 in. x 18 ft. Niles Lathe, \$775.00; 20 in. Barnes Drill Press, complete, \$65.00; Quincy Air Compressor with tank and hose, \$65.00; 10 in. Bench Drill Press, \$23.00. Terms to suit. Write for catalog. Cincinnati Machinery & Supply Co., 27 West Second St., Cincinnati, Ohio.

USED Arc welders, air compressors, buffers, grinders, reconditioned and guaranteed like new. Shipped on trial and easy terms. If you're in need of good guaranteed equipment, write today to Bob Jones, Box M1097, Troy, Ohio.

CRUSHERS, Hoists, conveyor loaders, compressors, boilers (new, used machinery). Ross Power Equip. Co., Indianapolis, Ind.

LATHES with motor, \$23.50. Hallin Machine Co., Parkers Prairie, Minn.

CONCRETE Building block machines and molds. Easy payments. Catalog free. Concrete Machine Co., 5 North Main St., St. Louis, Mo.

START Business of your own, small investment required, doing nickel, copper and silver plating. This work in big demand. Information free. Electro Platers Supply Co., 28 W. Second St., Cincinnati, Ohio.

ENGINES, MOTORS AND DYNAMOS

SPECIAL—Motors geared to 4 r.p.m. with 4 contacts for flashing, a.c. 110 volts, \$8.00, G.E. transformers, 110 volts to 15 volts, 21 watts for bell ringings, \$1.00. Atwater-Kent ignition coils, \$1.00. Magnet coils, 110 volts, \$1.00. Better prices in quantities. Air compressors for all purposes. Send for catalog "E." Pioneer Air Compressor Co., 243 Canal St., New York City.

FOR Sale—1-6- $\frac{1}{2}$ hp. motors, 60 cycle, alternating current, slightly used, first class condition; all motors tested before shipping \$4.50 and \$5.00 while they last. Cash with order. The Maytag-Chicago Co., 160 E. Illinois St., Chicago, Ill.

ELECTRIC Motors, reconditioned equal to new. A.c. or d.c. Single phase, two or three phase. $\frac{1}{2}$ h.p. \$16.00, $\frac{3}{4}$ h.p. \$18.50, 1 h.p. \$22.50. Others to ten h.p. Tell us your motor problems. Temps Bros. Motor Company, 123 Nostrand Ave., Brooklyn, N. Y.

SAVE Money—Automatic air compressors, constant potential battery chargers, reconditioned and guaranteed like new. Unusual value—shipped on trial and easy terms. If can use, better write today to D. W. Baker, Box M1098, Troy, Ohio.

TIME Counts in applying for patents. See pages 136 and 137. Clarence A. O'Brien, Registered Patent Attorney, Washington, D. C.

NEW 10v. 5 Ampere battery charging generators \$6.50. A.c. 110v. $\frac{1}{4}$ hp. motors, \$7.50, $\frac{1}{2}$ hp. \$16.50. 32v. motors, $\frac{1}{4}$ hp. \$19.50; 1-3 hp. \$12.50; $\frac{1}{2}$ hp. \$8.50. 32v. motors with emery, buffer, drill chuck \$8.00. 12" a.c. desk fans \$8.00. Large stock motors and generators. Queen City Electric, 1736 Grand Ave., Chicago.

NEW 1-3 Horse Westinghouse 110 volt alternating current motors, \$10.50. $\frac{1}{4}$ horse, \$7.00. 32 and 110 volt 500 watt generators, \$18.50. All with pulleys. Hundreds of other bargains. Electrical Surplus Company, Dept. 12, 1911 Chicago Ave., Chicago.

EDISON Phonograph motors with speed governor. Westinghouse dictaphone motors, both universal, \$5.00 plus express 10 lb. Geo. Schulz, Calumet, Mich.

STEAM Engines. 1 hp. \$18. $\frac{3}{8}$, \$12. James Chambliss, Bessemer, Ala.

COMPRESSORS. Twin cylinder, for small tire shops. Duco spraying. J. Trockman & Sons, Inc., 110-112 Lincoln Ave., Evansville, Ind.

WELDING AND SOLDERING

START In highly profitable arc welding business with practically no expense. Our constant arc welder starts you on road to success. Easy monthly terms, liberal trial on money back guarantee. Write today. Hobart Industries, Box M1009, Troy, Ohio.

BENDING MACHINES

THE Famous Hossfeld "Wrenchless" Universal Iron Bender is the last word in bending machines. Bends metal, cold or hot, into most any conceivable shape, including Eye Bolts and Automobile Spring Eyes. Bends up to 1" bars or $1\frac{1}{2}$ " pipe cold. Thousands in use by all classes of trade, from the smallest shops to the largest railway system. Write for circular and prices. Hossfeld Mfg. Co., Winona, Minn.

SURVEYING INSTRUMENTS

COMPLETE Farm level outfit \$25.00. Combination transit \$45.00. Sent pre-paid for cash. Money back guarantee. Wissler, 639 No. Broadway, St. Louis, Mo.

SUBSTANTIAL Savings on transits and levels. Rebuilt and guaranteed. All makes. Cash or terms. Write today for descriptive list M-310. Warren-Knight Company (Manufacturers of "Sterling" Transits and Levels), 136 N. 12th St., Philadelphia, Pa.

LUMBER

KNOW Your wood. 33 samples rare woods \$2.00, 20 cabinet and 20 inlay \$1.75, choice \$1.00. Sets postpaid and labeled. Send for catalog. Craftsman Wood Service, 715B East 62nd St., Chicago.

FARM LANDS

LAND Opening—The Great Northern Railway serves an agricultural empire in Minnesota, North Dakota, Montana, Idaho, Washington and Oregon. These states abound in opportunities for small farmers or large operators to rent or purchase a farm at lowest prices and best terms of many years. Every kind of farming, grain, livestock, dairying, fruit, poultry; large acreage or small suburban tracts, rich cutover or high producing irrigated land. Write for free Zone of Plenty book with detailed information. Low homeseekers' rates. E. C. Leedy, Dept. 457, St. Paul, Minn.

GOOD California home, 6 rooms, excellent location, corner city lot; furniture. You can't go wrong. \$4,600. Other good buys. Fleming, 27 Prospect Ave., San Francisco, Calif.

WANTED: Hear from owner having good farm for sale. Cash price, particulars. John J. Black, Chippewa Falls, Wis.

GET Quick cash sale for your property anywhere. Details free. Write Fisher Agency, Hannibal, Mo.

\$5.00 DOWN, \$3.00 Monthly, buys 2½ acres No. Michigan fruit or poultry farm. Camp Site or Summer Home, \$100.00. Burt Lake, Cheboygan county. Finest hunting, fishing, boating, swimming. Good auto roads. Get free booklet and map. O. Hermann, 3106 Indiana Ave., Chicago.

CALIFORNIA Small fruit and poultry farms near Los Angeles; 5 advisers; U. S. rabbit exp. station; co-operative marketing. Illus. booklets. Write owner, Fontana Farms Co., 631 (R) S. Spring, Los Angeles, Calif.

PECAN-Orange-Fig groves "On the Gulf." Monthly payments. Guaranteed care. Big, quick returns. Suburban Orchards, Dept. M., Biloxi, Miss.

SELL Your property quickly for cash, no matter where located. Don't pay big commission. Particulars free. Real Estate Salesmen Co., Desk B, Lincoln, Nebr.

MONEY Made in Mich. potatoes. \$10 down now and easy terms buys land near markets, lakes, streams. Write today, Swigart & Co., P-601, 32 N. State St. Bldg., Chicago, Ill.

EASTERN Pennsylvania farms near Philadelphia. Write for bulletin giving prices, sizes and descriptions. Wilson George, Quakertown, Pa.

CALIFORNIA Land Buyer and Home Seekers Guide sent to any address 25c. M. E. Biggs, 1706 Broadway, Oakland, Calif.

OZARKS. 40 Acres Missouri; \$5 month. Own a home. Jarrell, Mt. Vernon, Ill.

MICHIGAN'S Best, lowest-priced farms. Stocked, equipped. Free booklet. Paras, 432 Linden St., Hartford, Mich.

OZARKS—10 Acres near White river and zipped power dam, \$100, \$5 monthly. Alvin Zimmerman, 1802 N. 5th, Kansas City, Kan.

REDUCE Labor on your farm and increase income. One farmer writes he would not part with the information for \$100 if it could not be duplicated. Send today for our valuable "Farmers' Handbook" and get ready to put some of the 861 practical ideas into operation for your own benefit. Pay postman only 98 cents plus postage when delivered. Popular Mechanics Press, Room 808, 200 E. Ontario St., Chicago.

MUSKRATS

MUSKRATS From our pens and our advice assure success to amateur fur farmers. Young or proven breeders for immediate or fall shipment. Terms and particulars free. Peoria Breeding Co., Peoria, Ill.

TRAPPERS—"Eleven Box Traps," Complete blueprints, 30c. Weesho-Uco, 31st Office, Detroit, Mich.

MUSKRAT Farming—The greatest book on one of the greatest opportunities today. Tells of the opportunity in this business and how to do everything in connection with the raising and marketing of muskrats. Pay postman only \$2.25 and postage when delivered or, outside U. S., remit when ordering. Popular Mechanics Press, Room 809, 200 E. Ontario St., Chicago.

DOGS AND PETS

PRICES Reduced. Pedigreed police, collies, airedales, chows, Russian wolf hounds, wire hair pups. Maplewood Kennels Medway, Mass.

BLUE Merle collies—Most beautiful collie colors. Bred from imported and show winning stock. Beechwood Kennels, Rouses Point, N. Y.

SALE: Beautiful females, puppies, studs. White collies, German shepherd, Boston terrier, Springer Spaniels. Imported, prize-winning blood-lines. Lawnhaven Kennels, Frankfort, S. Dak.

ST. BERNARD Puppies! Registered thoroughbreds. Priced reasonable, duty free, photos submitted. Write Helvetia Kennels, Dept. P, Napierville, Que.

POLICE Dogs. Handsome, intelligent. Write for circular describing dogs and pups. Hillside Rabbitry, Route 5-K, Kewaunee, Wis.

FOR Sale. Minks, squirrels, raccoons, foxes, ferrets, muskrats, ginseng, rabbits, skunks, wolf pups, opossums. B. Tippman, Caledonia, Minn.

WHITE Collies and other colors. Beautiful and useful. Dept. P, Shomont Kennels, Monticello, Iowa.

POLICE Pups—Best imported bloodlines, \$8 upwards; registered. David Schmidt, Cologne, Minn.

HUNDRED Hunting hounds cheap; trial; literature free. Dixie, A14, Herrick, Ill.

ILLINOIS Hunting hounds. Dog remedies, feed, horns, supplies. Catalog. River-view, Ramsey, Ill.

DOG Fancliers—The Dog Encyclopedia by Will Judy is the only book that gives the photograph, description and standards of all breeds in addition to all other information such as breeding, grooming, kenneling, exhibiting, etc. Answers every dog question. 163 illustrations. Price only \$2. Pay postman when delivered or, if outside U. S., remit when ordering. Popular Mechanics Press, Room 809, 200 E. Ontario St., Chicago.

POULTRY

\$4,223.00 PROFIT From a town lot in one year. H. Cecil Sheppard tells you his disastrous and profitable experiences in raising chickens from the start until in the sixth year he took the above net profit. He would have gladly paid \$100 for this information during the first year. Send for his book. Price only \$1. Pay postman when delivered, or, if outside U. S., remit when ordering. Popular Mechanics Press, Room 809, 200 E. Ontario St., Chicago.

RABBITS

CHINCHILLA Fur rabbits for profits. Complete booklet information and instructions 10c. Parshalls Ranches, 11th and B, Lincoln, Nebr.

MAKE Big profits chinchilla rabbits. Guaranteed plan returns your investment. Real money makers. V. Mueller, U. S. National Bank Bldg., Denver, Colo.

BIG Money raising rabbits. Make \$1,000 to \$3,000 year in spare time. Former government expert teaches you how. Big book free. National Rabbit Institute, Dept. 11, 1709 West 8th St., Los Angeles, Calif.

WANTED—MISCELLANEOUS

USED Outboard motors wanted. All makes. State model, condition, size, lowest price. Floyd Clymer, Denver, Colo.

HUNDREDS Of people have sent their old gold, silver, platinum jewelry, dental work to me. Why not mail yours today? Highest prices paid. Satisfaction guaranteed or goods returned. F. Polcer, 2408 South Cicero Ave., Cicero, Ill.

MAIL Us your discarded jewelry, gold, crowns and bridges, watches, diamonds, silver, platinum. Money promptly mailed. Goods returned if offer refused. United States Smelting Works (The Old Reliable), Dept. 71, Chicago.

FOR SALE—MISCELLANEOUS

ADDRESSOGRAPHS, Letter folders, multigraphs, envelope sealers, duplicators, less than half price. Guaranteed. Pruitt Co., 117 No. Wacker Drive, Chicago.

WATCHMAKERS Lathe for sale at a bargain. R. Jaegermann, 5815 Easton Ave., St. Louis, Mo.

ROOTS AND HERBS

HERBS, Roots, barks, seeds. All kinds. 25c box. Lists free. Botanic, 145 West 112th St., Chicago.

PERSONAL

FOOL Your friends! Make them think you are in New York. Send 25c for 10 New York postcards. I will mail them to your friends from here. Or send any letter you want mailed from here, with 10c for service. Marvelous fun for practical jokers! A. Wilgreen, Box 59, Whitestone Station, New York. Dept. PM.

TOBACCO Or cigarette habit cured in seven days. Guaranteed. Costs two dollars. Marvin Helle, 4152 Gladwin, Detroit, Mich.

BUNIONS—Natural, painless, home correction information free. Eugene Eaton, D106, Bandon, Oreg.

TOBACCO Or snuff habit cured or no pay. \$1.50 if cured. Remedy sent on trial. Superba Co., N3, Baltimore, Md.

ADVICE, Information, any subject, 25c coin. References. Fred Klotz, Reading, Pa.

OXYGENATORS Improve breathing, health; free information. A. Factor, 135 Concord, Ottawa, Canada.

CHALK-TALK Your way to popularity. Audiences at your feet if you learn how to entertain with a few simple pictures. Little artistic ability needed. "How to Chalk Talk" tells what to say and what to draw. Profusely illustrated. Make \$1 and more a night. Just order on a postal. Pay postman \$1.00 and postage when delivered. Popular Mechanics Press, Room 808, 200 E. Ontario St., Chicago, Ill.

HYPNOTISM Easily learned, by the Cantor method. Instructions free. Zenda, Kankakee, Ill.

ANTISEPTIC, Medicated shaving cream. Handy jar, 350 shaves, \$1.00 prepaid. Zanco, 3344 Mosspratt, Chicago.

ARCHERY

ARCHERY—How to shoot accurately with the bow and arrow. Target shooting exclusively. New book "Modern Archery" by A. W. Lambert, champion shot, just what every enthusiast needs. Fully illustrated. Pay postman \$3 and postage when delivered, or if outside U. S., remit when ordering. Popular Mechanics Press, Room 809, 200 E. Ontario St., Chicago.

MISCELLANEOUS

MEXICAN Jumping beans, 3 for 25 cents. Valley Novelty Store, Box 1, Ottawa, Ill.

INDIAN Methods—World's greatest trapping secrets exposed for first time. Best "weatherproof" Fox—Coyote—Mink sets on earth. Methods \$1.00—worth hundreds. Cecil Atkinson, 446-T, Mandan, N. Dak.

NEW Self propelling floor machines \$100.00 each. 935 Broadway, Denver, Colo.

ARTISTS And art students are printing 250 signs or pictures an hour without machinery. Sample and particulars 10c. Straco, 1013 Mulberry, Springfield, Ohio.

TIME Counts in applying for patents. See pages 136 and 137. Clarence A. O'Brien, Registered Patent Attorney, Washington, D. C.

CASH Paid for Butterflies, Insects. See Sinclair Display Advertisement on page 28.

MIRRORS Resilvered at home. Costs near 5 cents per square foot; you charge 75 cents. Immense profits plating autoproducts, reflectors, tableware, stoves, refinishing metalware, etc. Outfits furnished. Details free. Write Sprinkle, Plater, 288, Marlon, Ind.

PAINT-Varnish remover. \$1.75 gallon. Refinishers Supply Company, Camden, Ohio.

CREOLE Pecan Praline. Delicious candy made of sugar and pecans, average weight, two ounces. Packed in boxes, Indian sweet grass baskets, cedar chests. Sample Praline and price list, 10c. Cape Cod Praline Company, South Yarmouth, Mass.

TATTOOING—Learn with my outfit. Descriptive circular sent anywhere. Sergt. Bonzey, 367 So. Main, Providence, R. I.

BUILD And fly model aircraft. Complete instructions cover all types including tournament prize winners. Lindbergh's famous "Spirit of St. Louis" and others. Great sport and very instructive. Official handbook approved by Lindbergh, Wright, Ford, Byrd, government officials and others. Sent C.O.D. anywhere in U. S. Simply pay postman \$2.25 and postage when delivered. Sent postpaid to any address upon receipt of \$2.25. Popular Mechanics Press, Room 808, 200 E. Ontario St., Chicago.

AMATEUR Cartoonists: Sell your cartoons. New market. Smith's Service, PN-1194, Wenatchee, Wash.

CUTS Anybody can make. Simple, cheap process, \$1.25. Specimens, particulars. 2c stamp. M. Day, Windfall, Ind.

CARTOONISTS. Sell your drawings. Proven plan. Castle Studios, Independence, Missouri.

I CATCH From 45 to 60 foxes in from 4 to 5 weeks' time. Can teach any reader of this publication how to get them. Write for particulars. W. A. Hadley, Stanstead, Que.

WEEDS—Cut them with cutter bar on Shaw Garden Tractor. Also plows, cultivates and runs belt machinery. Low prices. Immediate delivery. Shaw Manufacturing Company, Dept. C, Galesburg, Kans.

COMIC Art. Complete short course especially for high school and college students, by return mail \$5. 10c brings synopsis, comics. Greene Studio, 1753 W. 46th St., Los Angeles.

NEW Fad; collecting monograms; yours designed \$1.00. Cregier, 732 N. Main, Goshen, Ind.

ADVERTISING Illustrations, trade marks and designs, patent drawings. Grout, P. O. Box 162, Denver, Colo.

TATTOOING Outfits, supplies. Illustrated, list free. "Waters," 965 Putnam, Detroit.

TELL An army of 3,000,000 live readers all about your offer! If you have anything to sell, buy or exchange, or if you have any reasonable proposition, tell our readers all about it—they'll respond quickly. Our booklet "How to Create More Business" contains some very interesting, helpful facts. Write today for your copy—it's free. M. L. Rund, Manager Classified Advertising, Popular Mechanics Magazine, 200 E. Ontario St., Chicago, Ill.

If You Were Down and Out



AND I agreed to start you in a big, new, money-making business of your own—WITHOUT CAPITAL OR EXPERIENCE—a business in which I have helped other ambitious men and women double, triple and QUADRUPLE their earnings, would you jump at it? You BET YOU WOULD!

Well, you may not be down and out. But if you are earning A CENT LESS than \$100 a week—\$5,000 a year—here is your chance to break into real estate MY WAY—build a big profit business of your own—right at home—in your spare time—without capital or experience. My free book tells the whole story. Get it now!

From Failure to Success

I like to get hold of the down-hearted—the discouraged—the “has-beens” and the “also-rans.” It gives me a big “kick”—a real thrill—every time I help a man or woman who felt they were failures. It's easy enough to make successful men more successful. But give me the man who is struggling along—trying to make both ends meet—who has never had a real “look-in” on business success. The most fun I get out of life is turning such men into happy, contented, prosperous, independent business men. And I'm doing it right along! There's E. G. Baum, past 50, lost his job as bookkeeper, sick, discouraged, down-hearted. I got Baum started and he cleaned up \$8,000.00 his first year. And J. M. Patterson. He'd just landed in Texas with a baby, a sick wife and only \$10.20 in his pocket. He started to use my Successful Real Estate System, and writes me he will clean up \$20,000.00 in profits this year. Send for my free book. Learn how I am helping others—and how I can help you—win big business success.

New Lives for Old

I teach ambitious men and women my way of making big money in the Real Estate Business, without capital or previous experience. I give them new lives for old. I transform them from low-salaried employees to successful employers—in business for themselves—independent—prosperous—contented—men and women from 21 to 79—from all walks of life—former mill-hands, clerks, railroad men, barbers, hotel employees, grocers, salesmen, bookkeepers, teachers, ministers, printers, musicians, insurance solicitors, etc., etc. Take “Bill” Dakin for example. He worked for fifty years in Buffalo, N. Y., steel plant. Never had any schooling to speak of. Never had any real estate experience. Bill jumped at my offer. Writes me that last month he earned \$1,125.00 my way. Write for a free copy of my book today. Learn how wide-awake men and women are changing their jobs—trading old lives for new—with my System for Becoming a Real Estate Specialist. Address

Mail Coupon

for FREE BOOK

President, American Business Builders, Inc., Dept. K-44, 205 East 42 Street, New York.

Amazing Profits

\$17,000 IN ONE DEAL

Eugene Walrath, formerly in the clothing business. Got my scientific System for making money in real estate. Cleaned up \$17,000 in one deal. Free book tells how he did it.

\$5,500 IN 1 WEEK

Evalynn Balster, Illinois widow, school teacher, three children to support, got my system, made \$5,500 in one week on her first real estate deal. Free book tells how!

\$8,500 IN 17 WEEKS

That's the big money Chas. F. Worthen, Mass., made with my successful Real Estate System. Free book tells you how I helped him to do it!

\$14,400 IN 6 MONTHS

That's the fat profit H. G. Stewart, Maryland, made with my remarkable System for making big money in real estate. Stewart is a live wire. Are You? Get my free book and find out!

\$248 FIRST PROFIT

That's the first pin-money Mrs. J. H. Hastings, Mich., made with my System for Becoming a Real Estate Specialist. She has a fine business lined up. Free book tells how!

200% MORE MONEY

Alfred J. Bennett, Ford Salesman, was earning \$300 a month. Got my Real Estate System. Increased income 200%. Has well equipped office. Just bought new Chrysler Sedan. Free Book tells how!

FREE

“How To Become
A Real Estate
Specialist”



Pres.
American
Business
Builders, Inc.

(Established 1917—
Capital, \$500,000)

Dept. K-44,
205 E. 42 St., New York

Send me—without cost or obligation—your free illustrated book “How to Become a Real Estate Specialist.”

Name.....
(Please print or write plainly)

Address.....

City..... State.....

Learn AVIATION *The One and Only Right Way*

Your plane is Govt. licensed. Your instructor is a transport pilot.



Practical Experience Is All That Counts

To learn flying, you must actually fly. To learn aviation mechanics, you must actually work on planes and motors. In Universal Aviation Schools you get the practical training that counts as well as the theoretical instruction. Universal flight and ground courses are probably the strictest in the country. But they teach you what you need to know.

The Universal student gets practical work on modern type motors.



Universal Training Is Exceptionally Thorough

When you complete a Universal flying, mechanic's or welding course, you are immediately placed in a position to put yourself on a money-making basis. Universal graduates are making good on highly paid jobs all over the United States. Their thorough training prepared them to grasp big opportunities when offered.

The Universal graduate knows airplanes from "prop" to "tail skid."



Prepare Now for Next Spring's Opportunities

Year around training is available in Universal Aviation Schools. By starting your training at once you may become a full-fledged licensed pilot in the Spring. Or by beginning your ground school training now you may be ready to step into other branches of this fast growing industry early in the year. Take the first step toward getting into aviation by mailing the coupon below.



Universal Aviation Schools
1047-56 Boatmen's Bank Building, St. Louis, Mo.

Please send me at once your free book, "Aviation--What It Means To You." I am interested in: Flying Mechanic's Business Course

Name Age

Address

City.....State.....NR344

Get the Facts - Clip the Coupon

UNIVERSAL AVIATION SCHOOLS

- | | |
|--------------------------------------------------------|---------------------------------------------------------|
| Universal Flying School St. Louis, Mo. | Universal Flying School St. Paul, Minn. |
| Universal Flying School Minneapolis, Minn. | Universal Flying School Memphis, Tenn. |
| Universal Flying School Marion, Ill. | Universal Flying School Cleveland, Ohio |
| Universal Flying School Oklahoma City, Okla. | Universal Flying School Wichita, Kansas |
| Universal Flying School Rochester, Minn. | Porterfield Flying School Kansas City, Kansas |

Division Universal Aviation Corporation
Gov't rating applied for by all Universal Flying Schools

Be A Commercial Photographer

Earn \$2,000 to \$12,000 a Year!



THERE'S big money—fascinating work for YOU in commercial photography! Many photographers receive as much as \$100-\$250-\$500 and even more for only one photograph. Photography today is one of the nation's most profitable professions—one that offers unequalled opportunities to the man or woman looking for interesting work, big pay and unlimited future.

IT'S ALL IN KNOWING HOW!

Now, at last, you can quickly qualify yourself for this well-paid profession—in which you come in daily contact with society people, prominent business executives, theatrical stars and athletic luminaries. Be your own boss or secure a well-paid position. Many photographers have incomes ranging from \$2,000 to \$12,000 a year and more!

SUCCESS IS WITHIN YOUR GRASP!

Now it is up to you—if you want your share of this lucrative profession! In your spare time at home you can master our entire course in modern photography. Many of our students earn many times their tuition fees even while learning.

Thousands of men and women are winning quick success in commercial photography. One student, Michael Shuter of Brooklyn, N. Y., writes: "There is every indication that this time next year I shall reach the \$10,000 mark."

Commercial and News Photography; Portrait Photography; Lighting and Posing; Retouching; Enlarging; Finishing—these are but a few of the many fascinating branches of photography in which you are thoroughly trained by our simplified home study method.

FREE Book Gives Full Details!

Let us show you how in a few weeks you can qualify as an expert photographer and earn a large income. Send NOW for our BIG, FREE BOOK giving full details.



N. Y. Institute of Photography,
Dept. B-1414, 4 West 33rd St.,
New York, N. Y.

Please send me your FREE Book, "The Modern Art of Photography," and details as to how I can qualify as Commercial Photographer.

Name.....

Address.....

City.....State.....

YOUR SUCCESS COUPON

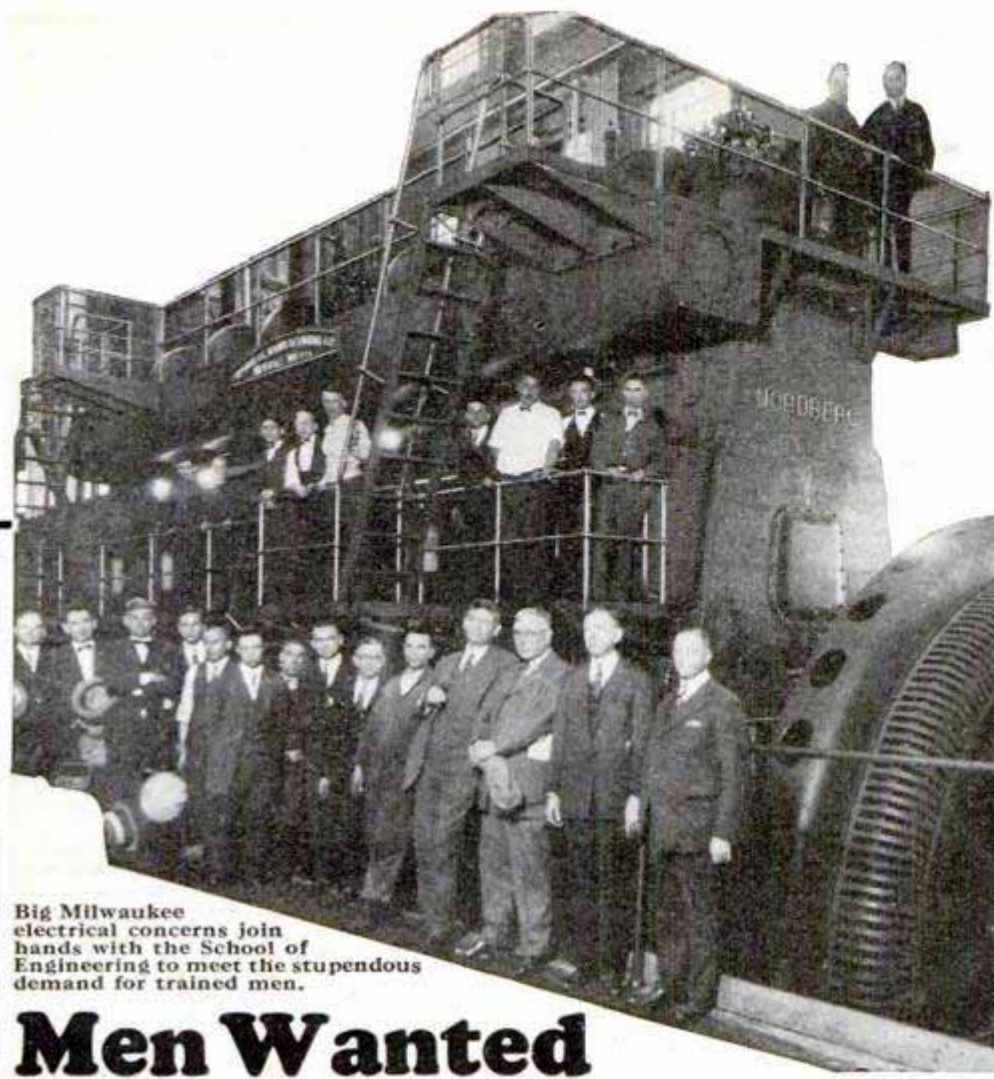

At the request of the United States Government, S. of E. Students Made the Acceptance Test of this Huge Electrical Generating Unit, consisting of 4000 H. P. Nordberg Diesel Engine direct connected to 3125 K. W., 2300 Volt Allis-Chalmers Generator built for the Panama Canal.



Electrical Engineering, B. S. Degree in 3 years.

Big Milwaukee electrical concerns join hands with the School of Engineering to meet the stupendous demand for trained men.

Men Wanted FOR Commercial Electrical Engineering

Takes you out of the class of the common laborer of which there is always an over plentiful supply at cheap rates of pay. Makes you a **Graduated Master Electrician in 6 months, or Commercial Electrical Engineer in 12 short months.** Puts you in line for a job where big manufacturers are actually pleading for trained men and glad to pay **Big Salaries** ranging from \$2,000 to \$10,000 a year. Not a dream — **A DEAD SURE FACT!** For 26 years we have trained men for the electrical profession and **Our Graduates Have Succeeded in All Parts of the World.** Our 12 months' intensive training is the boiled down essence of what **We Know** fits men for big paying positions. It is work you'll love. **No Limit** to advancement. **Practical engineers teach you.** They know **What** to teach and **How** to teach it, so you can **earn money with it.** Hundreds of thousands of dollars worth of actual commercial machinery to work on in this school.

Uncle Sam Asks S. of E. OK!

Think of the opportunity to test plants such as this. The Nordberg Manufacturing Company is only one of many large concerns that is co-operating with School of Engineering students. This type of practical work, while in school, insures your future when you graduate. That's why our men are always in demand and always command big salaries. You can be one of these men if you **ACT!**

Earn While You Learn

By our special system you may earn part of your way while learning. Our Employment Department will help secure you a position to which you may devote a part of each day, spending the remainder at the school. This plan both solves the students' financial problems and provides splendid experience at the same time. Low tuition fee. Board and room reasonable. Daily Broadcasting WISN. School Orchestra. Fraternities.

Write for FREE Catalog

Write today for our free, illustrated catalog. Read about this wonderful institution and the great opportunities that lie before you. Find out about our specialized method of training and the details of our "Earn While You Learn" plan.

SCHOOL of ENGINEERING of Milwaukee
 Founded 1903 Dept. P.M. 1029 Milwaukee, Wis.

Radio and Electrical Refrigeration



Learn in three months — just 90 days and you can be one of the new group of trained men who will guide and develop the newest and best paying of America's gigantic industries. Radio and Electric Refrigeration are tremendous money makers for the trained man who gets into the game early. Experts are needed for big, responsible, well-paying jobs. We train you quick and help place you in a good position. **ACT NOW!**

WINTER CLASSES ORGANIZE NOW

SCHOOL OF ENGINEERING OF MILWAUKEE

Dept. P. M. 1029. E. Wells and Jackson, Milwaukee, Wis.

Without obligating me in any way, please mail free illustrated book, "Rise to Success through Electricity," and particulars regarding the course I have marked with an X.

- RESIDENT COURSES:**
- Electrical Engineering, B. S. Degree. (3 years)
 - Commercial Electrical Engineering. (H. S. graduates 1 year—others 1½ years)
 - Armature Winding.
 - Light Motor Wiring and Testing.
 - Electrical Refrigeration.
 - Master Electrician.
 - Radio Sales Service and Broadcasting.
 - Home Laboratory Service. (Home Study Course).
 - I am interested in your "Earn While You Learn" plan.
 - Day.... Evening Classes.

Name.....Age.....
 Address.....
 City.....State.....
 Education.....

Would **YOU**
like to get into



Colonel ART GOEBEL
Winner of Dole Race (California to Hawaii) and
countless flying honors.

AVIATION

the FASTEST GROWING—MOST FASCINATING, and BEST PAYING industry of all time. Rapid extension of scheduled air lines, both mail and passenger, aerial taxi and privately owned planes creates demand for more PILOTS. Competent MECHANICS for engine and plane assembly, repair and maintenance in demand.

Learn at Home the fundamental principles of aviation, before learning to fly. The basic principles of Aerodynamics and Theory of Flight, Air Navigation, Meteorology, Airplane Engines and Airplane Design can be learned at home in spare time. Students who have mastered these subjects can become pilots or mechanics in half the time required by the average student.



Our HOME STUDY EXTENSION COURSE completely covers necessary subjects to enable student to pass all theoretical and written examinations required by Department of Commerce for rating as Pilot or Mechanic. Our graduates will easily find employment in factories, shops, and hangars of the airplane industry. Our Flying School will deduct full cost of Home Study Course any time you enroll for our flying course.

**Write for
Free Booklet**

Get Full Details—USE COUPON BELOW

The Home Study Preparatory Course

THE ART GOEBEL SCHOOL OF FLYING

103 W. 12th St., Dept. 100

Kansas City, Mo.



Extension Department
The Art Goebel School of Flying
103 West 12th St., Dept. 100, Kansas City, Mo.

Send me your Free Booklet about Opportunities in Aviation and "How to Attain Quick Success."

Name.....Age.....

Address.....

City.....State.....

It's a GUITAR!

BE popular with today's most favored instrument, the sweet-toned Gibson. You hear it everywhere, on the radio, records, in vaudeville and ballrooms. EASY to learn; you play tunes quickly. Play and sing together; just with "her," or with the crowd.

You'll have the spotlight!



Gibson

GUITARS - MANDOLINS
BANJOS and UKULELES

Carson Robison, pictured here, and many other famous radio and record stars use Gibsons, the "Music Pals of the Nation."

FREE Trial; Easy Payments. Send the coupon for complete information and copy of the Free Book "The Road to Happiness." Check the instrument which interests you.



GIBSON, INC., 1003 Parsons St., Kalamazoo, Mich.

Please send free book and details of trial offer on instrument checked.

Name.....

St. or R. F. D.....

City, State.....

GUITAR BANJO MANDOLIN UKULELE



FREE!
CATALOG
ON REQUEST

\$3.00

MARVELS of MODERN MECHANICS

Some day airplanes are going to stop in the sky to receive passengers hauled up from the earth. Some day man is going to ride on the sea-bottom in a sea-going motor. Some day the X-Ray is going to detect old buried cities.

These are but a few of the many fascinating adventures in science about which Harold T. Wilkins writes on the scientific achievements of the future in his thrilling, amazing book—"Marvels of Modern Mechanics"—the mastery of land, sea and air—price \$3.00. This book is but one of 383 fascinating books included in our

Sent Free—NEW CATALOG of Wonderful Books

This catalog tells you about such books as "Cork Ships Models And How to Make Them," by Peter Adams, \$1.25. "Shores of Adventure," by Everett McNeil, \$2.00. "Hunting Hidden Treasures," by Harold T. Wilkins, \$3.00. "Won by the Fleet," by Fitzhugh Green, \$2.00. Books by favorite authors. Books of every type. And recommended by more than 1000 critics.

If your bookstore can't supply you with "Marvels of Modern Mechanics" and the other books mentioned, order direct from us, enclosing check or money order. Books will be sent charges prepaid.

And send for the catalog today because it is free for a limited time only.

E. P. DUTTON & CO.
296 Fourth Ave. NEW YORK

Are You Interested in Flying?

No matter what you want to know about this subject, send for our free catalog of aviation books. It is the latest and most complete published. A post card brings it.

Popular Mechanics Press, 200 E. Ontario St.
Chicago

NEED A BETTER GRIP ON MATHEMATICS?



SEND for a copy of "Mathematics for the Practical Man," only \$1.50. By common sense methods it removes the mystery and difficulties so that algebra and even calculus are made simple.

Assuming your knowledge is limited to arithmetic you quickly and easily gain a working knowledge of Algebra, Geometry, Trigonometry and Calculus. Simply pay postman price of book plus the postage when he hands you the package.

Popular Mechanics Press
Room P10
200 E. Ontario Street, Chicago

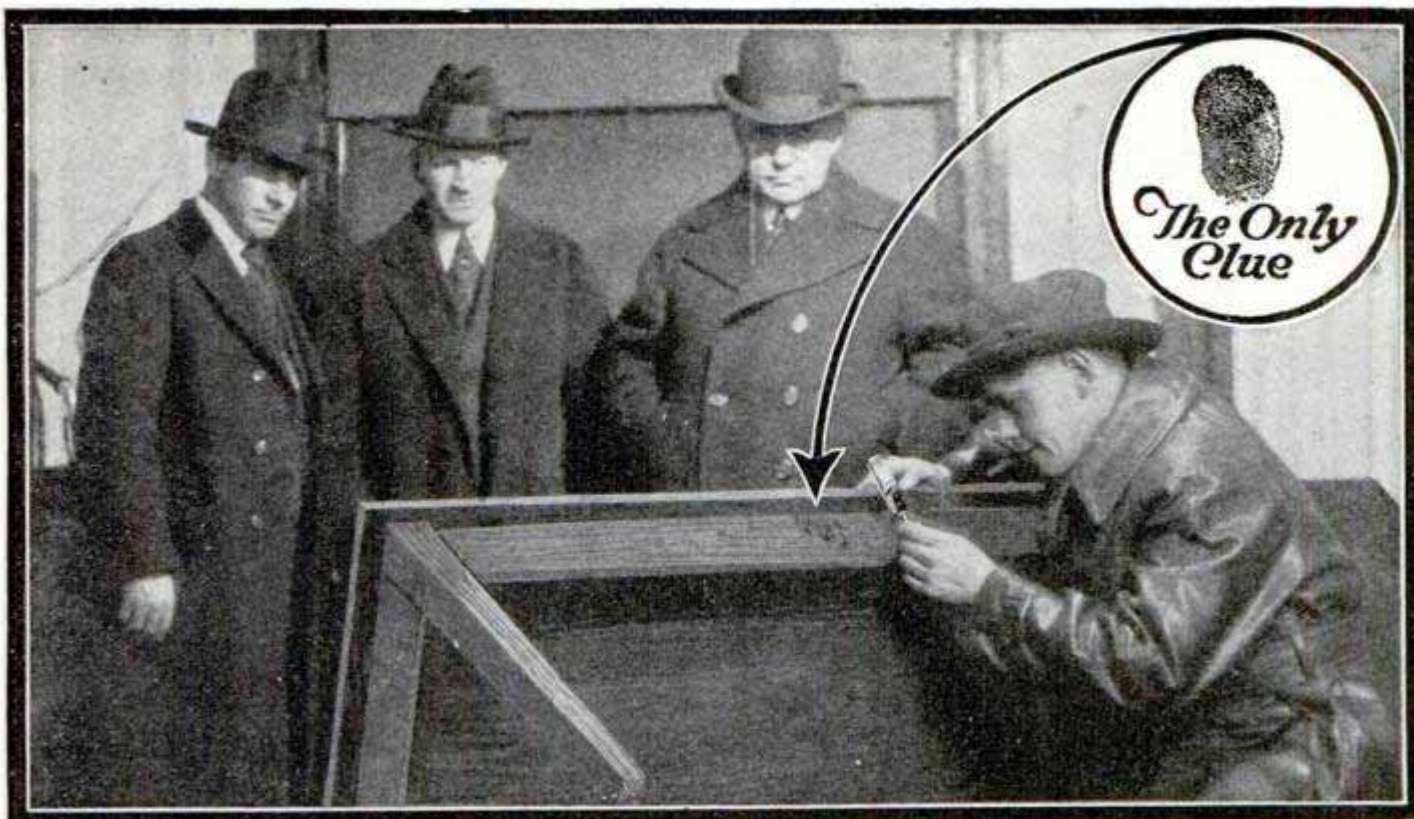

\$500 REWARD for TWO HOURS WORK

WARREN BIGELOW, the Finger Print Expert, was making his usual review in the morning newspapers. He had just finished reading the press reports of the daring robbery of the offices of the T-O-Company when the telephone on his desk rang. Central Office was calling, asking him to come immediately to the scene of the robbery. Although he drove his high powered roadster rapidly and arrived very shortly at his destination, he had plenty of time to consider the main features of the case as reported by the press. The job had undoubtedly been done by skilled cracksmen and robbers of uncommon nerve. Sixty-five hundred dollars in currency—the company pay-rol!—were gone. Not a single, apparent clew had been found by the police.

Finger Print Expert Solves Mystery
On his arrival, Bigelow was greeted by Nick Austin, Chief of Detectives, who had gone over the ground thoroughly.

"Hello, Warren. Here's a job that has us stumped. I hope you can unravel it for us."
By this time, the district officers and the operatives from Central Office had almost given up the investigation. After hours of fruitless efforts, their work was at a standstill. They were completely baffled.

With lively interest and a feeling of relief they stepped back to await the results of the Finger Print Expert's findings. They were plainly awed at his quiet, assured manner. The adroit old Chief himself was manifestly impressed at the quick, sure way in which Bigelow made his investigation.

Almost immediately Bigelow turned his attention to a heavy table which had been tipped up on its side. Examination of the glossy mahogany showed an excellent set of finger prints. The thief might just as well have left his calling card.

To make a long story short his prints were photographed and taken to Central Office, where they were matched with those of "Big Joe" Moran, a safe blower well known to the police. Moran was subsequently caught and convicted on Bigelow's testimony and finger-print proof. Most of the money was recovered. In the meantime the T-O-Company had offered a \$500.00 reward, which was given to Bigelow—his pay for two hours' work.

Learn at Home in Spare Time
Could you imagine more fascinating work than this? Often life and death depend upon decisions of finger-print evidence—and big rewards go to the **Expert**. Thousands of trained men are now needed in this great field. The finger print work of governments, corporations, police departments, detective agencies and individuals has created a new profession. Many experts regularly earn from \$3,000 to \$10,000 a year in this fascinating game. And now you can easily learn the secrets of this new Science in your spare time—at home. Any man with common school education and average ability can become a Finger Print Expert in a surprisingly short time.

FREE The Confidential Reports No. 38 Made to His Chief

If you write us at once, we'll send you free and postpaid the gripping confidential report Operator No. 38 made to his Chief. And the best part of it all is this. It may open your eyes to the great future for YOU as a highly paid Finger Print Expert. More men are needed right now. This school has taken men just like you and trained them for high official positions. This is the kind of work you would like. Days full of excitement. Big salaries. Rewards.

WRITE and I'll send the Free Reports—also a wonderful illustrated book telling of the future awaiting you as a FingerPrintExpert.

INSTITUTE OF APPLIED SCIENCE
Dept. 13-57, 1920 Sunnyside Avenue, Chicago, Illinois

INSTITUTE of APPLIED SCIENCE, Dept. 13-57, 1920 Sunnyside Ave., Chicago, Ill.
Gentlemen: Without any obligation whatever send me your new fully illustrated, FREE book on Finger Prints and the Confidential Report Operator No. 38 made to his Chief.

Name.....
Address.....
Present Occupation..... Age.....

*Why don't You be a
Finger Print Expert?*



FREE! Body Chart

If you will mail the coupon below, this Anatomical and Physiological Chart will be mailed to you without one cent of expense. It shows the location of the Organs, Bones of the Body, Muscles of the Body, Head and Vertebra Column and tells you how the nerves radiate from your spinal cord to all organs of the body. This chart should be in every home.

Where Is That PAIN?

It may be in the neck, back, hips, stomach, liver, legs or arms. Wherever it is, the chart will help to show you the location and cause of your ailment. For instance, this chart will help you locate vermiform appendix pains. Hundreds of lives might have been saved if people had known the location and character of the pain and had received proper attention.

Stop that Pain

By Relieving the Cause with

**Violet Ray - Vibration
Ozone - Medical Electricity**

The Four Greatest Curative Powers Generated by This
Great New Invention!

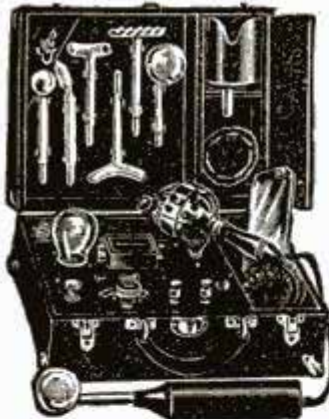

Elco Health Generators at last are ready for you! If you want more health—greater power to enjoy the pleasures and delights about you, or if more beauty is your desire—write! Ask for the book on these inventions which has just been prepared. It will be sent to you without cost. It tells you how Elco Health Generators aid you in leaving the lethargy and hopelessness of bad health and weakness behind forever. Re-vitalize yourself. Bring back energy. Be wholly alive. Write today!

Here's What Elco Users Say—

"Wouldn't take \$1000 for my Elco. Has done me more good in 2 weeks than doctors did in three years."



"Cured my Rheumatism." "My Eczema gone." "Cured my stomach trouble." "Cured my weakness." "Now I sleep soundly all night." "Thanks to Elco my strength and vigor are back." "No more pain." "Colds never bother me now." "Chronic Constipation banished." These great new inventions generate Violet Ray, Vibration, Electricity and Ozone—combined or separate. They operate on the electric light in your home or on their own motive power at less than 50 cents per year. Elco Health Generators are positively the only instruments which can give you in one outfit Electricity, Violet Ray—Vibration and Ozone—the four greatest curative agents. Send the coupon below. Get the Free Book NOW!

MAIL COUPON for FREE BOOK

Do not put this paper down without sending the coupon. Don't go on as you are with pains and with almost no life and energy. You owe it to yourself to be a better man or woman. You were put here to enjoy life—not just to drag through it. So do not rest another day until you have put your name on the coupon here. That will bring the whole story of these great new inventions. Do it today—now.



***** Lindstrom & Co. [Makers of Therapeutic Apparatus since 1892.] *****
 2322 Indiana Avenue Dept. 13-57 Chicago
 Please send me your free book, "Health—Power—Beauty" and full information of your 10-day Free Trial Offer.
 Name.....
 Address.....

Be An Aviator

—earn \$400 to \$500 per month. You can do it. Aviation is key to success. Build planes, repair engines, make real ribs and struts, under PERSONAL instructions of Lt. H. P. Whittle, U. S. Government licensed Aero-plane and Engine Mechanic, President of Aviation Mechanics Association. Learn to fly in latest model plane with U. S. Licensed Transport Pilots at U. S. Air Mail field. You study directly under Lt. Whittle. Only eight places left. LIMITED class. Write NOW for FREE booklet. Training Division, Weeks Aircraft Corp., 373 11th St., Milwaukee, Wis.

QUIT TOBACCO



No man or woman can escape the harmful effects of tobacco. Don't try to banish unaided the hold tobacco has upon you. Join the thousands of inveterate tobacco users that have found it easy to quit with the aid of the Keeley Treatment.

KEELEY Treatment For Tobacco Habit Successful For Over 50 Years

Quickly banishes all craving for tobacco. Write today for Free Book telling how to quickly Free yourself from the tobacco habit and our Money Back Guarantee.

THE KEELEY INSTITUTE, Dept. A-926, Dwight, Illinois

You Are Paying the Penalty For Your Weakness



You can't imagine the terrible price you pay for being a physical weakling. You are being robbed of most of the joys of life. You are despised, sneered at, avoided everywhere—a veritable outcast socially. Weaklings are not wanted where manhood is a first requirement—on football, basketball or hockey teams, or in a crew of oarsmen; they are not wanted on airship flights; they can't go with exploring parties; they can't qualify for military training camps, they can't get or hold the good jobs; the big things of life, the thrilling events are barred to the fellow without pep or stamina. You pay a rightful penalty for your physical failure.

STRONGFORTISM Restores Your Strength

Strongfortism gives you restful, peaceful sleep; eagerness for work; sustaining energy throughout the day; better earning power, desire for pleasure and athletics; a springy step; bright eyes; a hearty hand clasp; a more cheerful outlook on life; optimism; hopefulness; happiness. These come with health—all of them, just as sure as sunrise. If you have a healthy body—full powered, muscular, energetic, manly—you will make good throughout life, at work, in business, in society and in athletics.

Send for MY FREE BOOK "Life's Energy Through Strongfortism"—a revelation of inside facts about the human body.

STRONGFORT INSTITUTE

LIONEL STRONGFORT, DIRECTOR
 PHYSICAL AND HEALTH SPECIALIST
 DEPT. 955 NEWARK, NEW JERSEY, U.S.A.

—Send this Consultation Coupon—
 MR. LIONEL STRONGFORT, STRONGFORT INSTITUTE, Dept. 955, Newark, N. J.
 Please send me, without obligation, my copy of your book, "LIFE'S ENERGY THROUGH STRONGFORTISM." This does not place me under any obligation.
 Name.....
 Age..... Occupation.....
 Street.....
 City..... State.....



**NEW KIND OF
CAN OPENER
Works Like Magic!**

NO MORE DANGER!

Imagine Having a Little Machine to Open Cans! Why, to Women Everywhere, the Very Idea is Revolutionary! No More Fuss, Muss or Danger! No More Hacking With Old-Style Can Openers! To Housewives by the Millions This New Invention Is a Literal Godsend! Now You Can Test It Free Just by Mailing the Coupon Below at Once.



Everyone knows how dangerous the old-style can opener is. Women all hate to use it. They realize the danger of infection and blood poisoning that always follows a cut finger. Almost daily they read in the newspaper of amputations and even deaths that sometimes follow even the tiniest "can opener scratches." Now imagine their astonishment and delight to learn that all this is ended. An almost magical, yet amazingly simple little machine does it . . . opens cans automatically, at a mere twist of the wrist!

Approved By All Experts

This wonder-working little machine is so small that it can easily be slipped into a man's coat pocket. Yet note what it does. First it holds the can for you so you don't need to touch it. Then it spins the can quickly around. Next the lid pops up so you can grab it. The entire top is cut out slick, smooth and clean. No edges, no jagged corners, impossible to cut yourself! Opens every shape can, square, round or oval. Demonstrates itself to anyone in five seconds or less by the clock. Approved by practically all experts including Good Housekeeping Inst., Modern Priscilla, Youth's Companion Laboratory, etc. No wonder everyone buys! And no wonder so much money is being made by demonstrators, both full and spare time.

Offered By a 20-Year-Old Company

This little can opening machine for the home is called "Speedo." It is made of heavy, solid steel and is guaranteed by the manufacturer for five full years. A well-known, 20-year-old company is back of this revolutionary device. News of it is being spread rapidly through advertising and through the company's demonstrators. This offers men and women everywhere an unusual chance to make extra money. If your present income is less than \$75 a week, get full details at once. Learn how you may obtain your own Speedo FREE, also make big money either full or spare time. Mail the coupon while this advertising offer is open and full details of a liberal Free Test Offer will be sent you at once. Many good territories are offered on an exclusive profit basis so it will pay you doubly to mail the coupon right now.

**SMOOTH
SLICK
CLEAN**



AGENTS: \$6 to \$14 in an Hour

Here is really a new way to make money . . . you don't need to sell . . . merely demonstrate for us. O. H. Dickinson, Idaho, made a cool \$1,000 in just 27 1/2 selling days. E. T. Barclay, N. Y., cleaned up \$117 in 2 days. O. C. Gregg, Wyo., made \$20 in 3 hours' spare time. We furnish everything. Use the coupon quick.

**\$2,000.00
PRIZES
In Cash To Agents.
Write For Details.**



CENTRAL STATES MFG. CO.
Dept. M-2673 4500 Mary Ave.
St. Louis, Mo.

Central States Mfg. Co.
Dept. M-2673, 4500 Mary Ave.
St. Louis, Mo.

Rush your Free Test Offer and details of \$6 to \$14 an hour. I am not obligated.

Name

Address

City State

MOULDING A MIGHTY ARM



Get a 17 Inch Bicep Complete Course on Arm Building ONLY 25c

Get an arm of might with the power and grip to obey your physical desires. Within 30 days you can now build your arm from a scrawny piece of skin and bone to one of huge muscular size. I don't mean just a 17-inch bicep but a 15-inch forearm and an 8-inch wrist. This specially prepared course will build every muscle in the arm because it has been scientifically worked out for that purpose. You can develop a pair of triceps shaped like a horseshoe and just as strong, and a pair of biceps that will show their double head formation. The sinewy cables between the biceps and elbow will be deep and thick with wire cable ligaments. In that arm of yours, the forearm will belly with bulk, and the great supinator lifting muscle you can make into a column of power, while your wrist will grow alive and writhe with cordy sinew. All this you can get for 25 cents—send for this course today and within 30 days time you can have a he-man's arm built to be as beautiful, brawny and magnificent as the village blacksmith's.

You can't make a mistake. The guaranty of the strongest armed man in the world stands behind this course. I give you all the secrets of strength illustrated and explained as you like it. 30 days will give you an unbreakable grip of steel and a Herculean arm. Mail your order now while you can still get this course at my introductory price of only 25c.

RUSH THE COUPON TODAY

To each purchaser will be given a FREE COPY of *THE THRILL OF BEING STRONG*. It is a priceless book to the strength fan and muscle builder. Full of pictures of marvelous bodied men who tell you decisively how you can build symmetry and strength the equal of theirs.

REACH OUT--GRASP THIS SPECIAL OFFER

JOWETT INSTITUTE of PHYSICAL CULTURE
422 Poplar Street, Dept. 4X, Scranton, Penna.

Dear Mr. Jowett: I am enclosing 25c. Please send me the course "MOULDING A MIGHTY ARM" and a free copy of "THE THRILL OF BEING STRONG."

Name _____

Address _____

GET INTO AVIATION

BE A PILOT



Fly your own plane. Know engine and airplane mechanics. Study meteorology, air navigation. Our ground work and flying courses lead to adventure and success. This school endorsed by America's Ace, **Eddie Rickenbacker**, "**Eddie**" **Stinson** and other real flying experts. The old reliable Michigan State, at Detroit, the Aviation Center, is the logical place to study aviation. Practical experience guaranteed. **GARAGE MECHANICS**—can qualify quickly for new airfield jobs and bigger opportunities. 20 trained service men needed for every flyer. Learn at America's big school. 19 years' experience in training men. **WE WANT** only sincere, earnest men and women students. We are not looking for easy marks and do not "give" free railroad tickets or special discounts.

Send for Illustrated Catalog

MICHIGAN STATE AVIATION SCHOOL
4466 Woodward Ave. Detroit, Mich.

Don't Be Afraid To Tackle That Concrete Job!

With the instructions found in the new, revised edition of Popular Mechanics Concrete Handbook you can make any of the following useful articles:



Garden Seats—Fountain and Basin—Flower Boxes and Vases—Pedestals and Bird Baths—Ornamental Pools—Sanitary Drinking Fountain—Gateposts—Auto Driveway—Sidewalks—Boat Landings and Docks—Entrance and Garden Walks—Sidewalk Flagging—Narrow Curb Walks—Curbs and Gutters—Wall Coping—Steps—Garage Floor—Basement Floor—Fence Posts—Lawn Roller—Cistern—Chimney Cap—Refuse Burner—Culvert—Benches for Greenhouses—Tile—Retaining Walls—Foundation Supports—Engine Foundations—Septic Tank—Toy Blocks—Forge—Fireproof Safe—Ice House—Watering Troughs—Milk House—Smokehouse—Silo—Horse Stalls—Hitching Post—Rural Mail Box Post—Cyclone Cellar.

Build With Ease for Permanence and Beauty

This is a book of practical plans for using concrete about the home, farm or shop. For amateurs as well as contractors. In addition to making all the articles mentioned above the making of good concrete mixtures for various classes of construction is given; mechanical mixers and homemade tools are dealt with. All necessary form and mold making are covered as well as many other valuable pointers too numerous to mention here.

Simply write and ask us to send you this book. When postman hands you the package pay him \$1.00 plus the postage. If outside U. S. remit when ordering and include 15 cents extra for mailing.

POPULAR MECHANICS PRESS
Room P10 200 E. Ontario Street CHICAGO

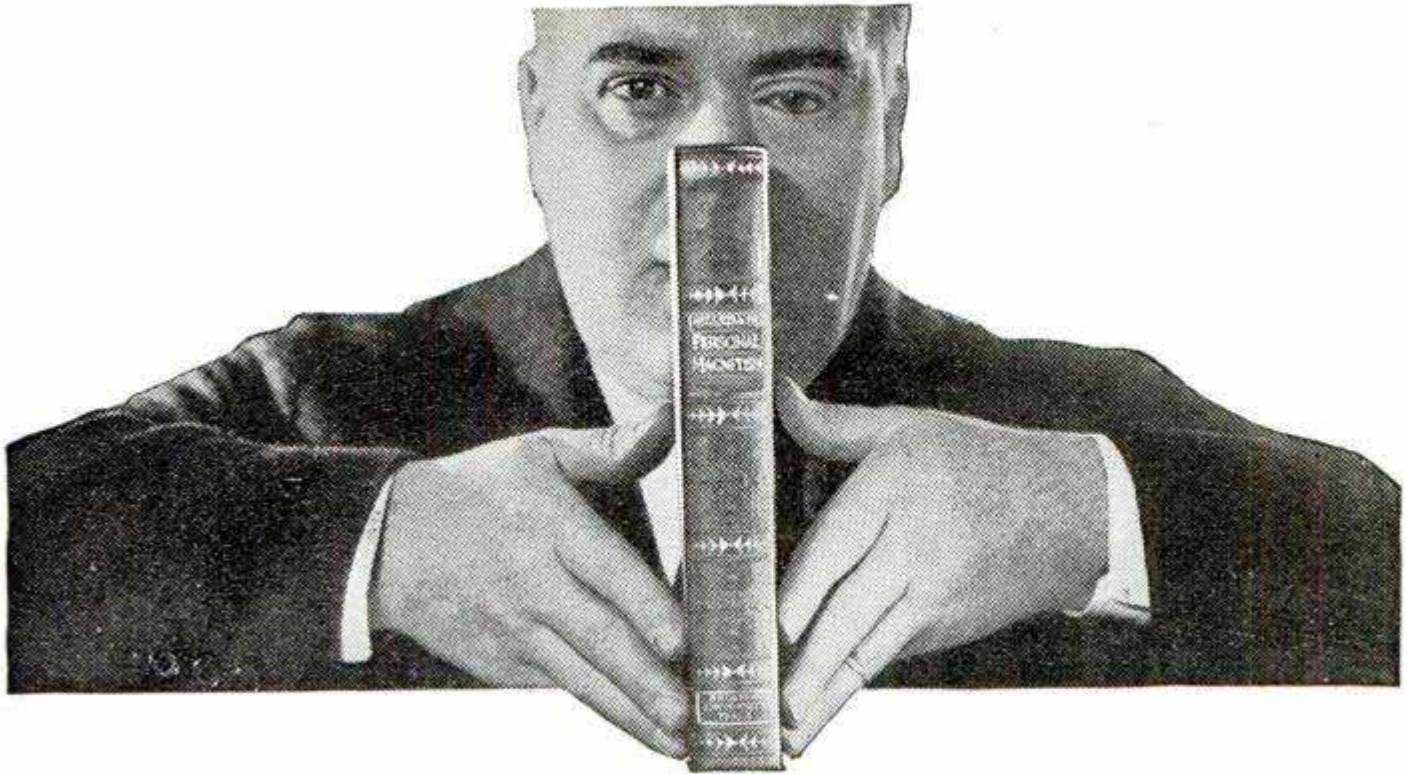

Utterly Amazing! The Way This Singular Book Can Give You **MAGNETIC POWER** IN 24 HOURS...OR NO COST!

IMAGINE a man struggling for years in obscurity—suddenly finding himself popular, dominating, successful! Imagine *yourself* suddenly discovering a strange, new power that enables you to attract new friends, new achievements! Picture everyone's amazement if you unexpectedly *changed your entire personality*, banished self-consciousness and became instead a vibrant, fascinating, *magnetic* person!

A thrilling experience! Yet it can be yours—and I'll prove it. No matter *who* you are—I'LL PROVE to you that **YOU CAN ACQUIRE THE SECRET OF MAGNETIC POWER**, as described above, **IN EXACTLY 24 HOURS** or no cost! And even more! I'll send you *all* details of Shaftesbury's famous method (nothing concealed) and let you examine them in your own home for **5 DAYS ABSOLUTELY FREE!** Then you can see with your own eyes exactly what I mean. Without risking one penny, you can judge for yourself what an entirely new world the mastery of Magnetic Power can open up to you!

Whence Come These Uncanny Discoveries?

Forty years ago, Edmund Shaftesbury, famous student of the human mind, set out to discover the secret of Magnetic Personality. He first applied his discoveries in his own circle of friends. Results were astonishing. His method seemed to have the curious power of giving people *new personalities!*

Quietly, almost secretly, Shaftesbury's fame spread. Great men came to him.

Examine These Secrets 5 Days FREE!

See how to develop a Magnetic Personality
Learn how to gain nerve control
Discover how to make your face appear years younger.
Find out how to read people's feelings by watching their mouths
How to be attractive to the opposite sex
Learn how to control others
and dozens of other vital topics.

His students and friends embraced such names as Cardinal Gibbons, Queen Victoria, Gladstone, Henry Ward Beecher and others of equal prominence.

Until recently, Shaftesbury's teachings have been available only to people who could pay as high as \$25 to \$50 each for instruction books. But now, through the efforts of a group of his students, some of his wonderful teachings have been collected into a single volume *within the reach of all!* And furthermore, in this new volume are revealed hundreds of Shaftesbury's important discoveries never before put into print—discoveries which you may now study in detail for **5 days free** under the terms of this special offer!

Almost before you finish reading this curious book, you will probably become aware of a subtle "something" you cannot describe. In the days that follow a change should come over you. People will seem to seek out your

society, eager to know you. Even your closest friends will be baffled by the obvious change.

Send No Money—Act At Once!

Enjoy the benefits of Shaftesbury's singular discoveries for 5 days absolutely FREE. Send no money—just mail the coupon below and we'll mail you a copy of this remarkable volume—extra large size, 400 pages—gold embossed and handsomely bound in rich burgundy cloth. When it arrives, delve into its illuminating pages. Then if you are not delighted at the end of 5 days, return it and pay nothing. Otherwise keep it as your own and remit the special price of only \$3 in full payment. You risk nothing. Mail the coupon now! **RALSTON UNIVERSITY PRESS, Dept. 13-S, Meriden, Conn.**

**Ralston University Press,
Dept. 13-S, Meriden, Conn.**

All right—I'll be the judge. You may send me the volume "Instantaneous Personal Magnetism" for 5 days' FREE EXAMINATION in my home. Within the 5 days, I will either remit the special low price of only \$3 in full payment, or return it without cost or obligation.

Name

Address

City.....State.....

Special cash price \$2.00 if payment accompanies coupon. This saves heavy book-keeping and clerical expense. Money refunded if dissatisfied and book is returned within 5 days.

We Will Train You in a Few Months



Day and Night Schools in Chicago, Detroit, Cleveland, Boston, Phila.

No Books—No Classes—

Wonderful Future in this Uncrowded Field

Experts Earn Up To \$125 A WEEK

as MECHANICAL DENTISTS

We teach you to make rubber plates, crowns, bridge work, metal base dentures, etc., for dentists. After graduating you are ready for a job or can open your own laboratory. We assist you.

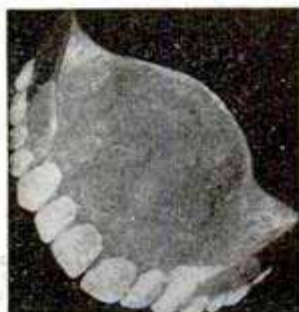

Big Demand for Men!

Mechanical Dentistry is the laboratory bench work which the dentist turns over to the laboratory worker. Master this profession and help meet the demand of 64,000 dentists for laboratory work. Every city and every town where dentists are located offers work to the mechanical dentist. We train you in a few months in day or night school for this uncrowded field—no classes—no books—no mechanical experience necessary. **No Educational Requirements.**

Work Your Way Thru School

We will help you find a job to meet your expenses while taking our training. And we will help you find satisfactory living quarters when you arrive.

Schools located in Chicago, Detroit, Cleveland, Boston, Philadelphia. Day and night schools.

INTERESTING FREE BOOK

Our illustrated free book on Mechanical Dentistry will acquaint you with some surprisingly interesting facts. It tells about the thriving profession of Mechanical Dentistry—the way to swift and certain success. And it tells about the progress of many of our graduates—men who have succeeded beyond their expectations, also full details of our liberal offers. Mail the coupon and find out more about this fascinating opportunity.

**McCarrie School of Mechanical Dentistry
1338 S. Michigan Ave., Dept. 347, Chicago, Ill.**

**McCARRIE SCHOOL OF MECHANICAL DENTISTRY
1338 S. Michigan Ave., Dept. 347, Chicago.**

Without cost or obligation, send me your illustrated book on Mechanical Dentistry, and complete information as to my opportunities in dental laboratory work.

Name.....

Address.....

MAKE \$40⁰⁰ A DAY!



Showing This Sensational Pocket Lighter Value

Agents, here is the greatest value and most sensational money maker you ever came across. The popular one hand Master Pocket Lighter—regular \$5.00 value—now sells for only \$1.00. Does everything \$10.00, \$20.00 and \$50.00 lighters do. Lights instantly, never misses—a masterpiece of mechanical perfection. Genuine leather covered with gold initial shield—fine gold working parts, extra sinter. The ideal all year round gift.

Sells for Only \$1.00—You Make Over 100%

Dealers and consumers everywhere buy on sight. Williams sold 48 in one day. Only one day's sales to dealers nets you \$40.00 profit. No experience necessary. Spare time workers make \$8.00 to \$12.00 an hour. Our sure fire selling plans show you many ways of making big money.

SAMPLE 50c TO AGENTS ONLY

This lighter in your pocket will pay you big profits daily. Just show it and make sales and profits on sight. Send 50c for sample and selling plans, or \$9.00 for a dozen. (Send \$1.00 deposit—will ship C. O. D. for balance.) The dozen comes packed in a colorful self-selling display box. You make \$6.00 profit selling to consumers, or use sample box to take orders from dealers. Your money refunded if you do not find them quick sellers. Send today!

Gordon Mfg. Co., Dept. PK-19, 110 E. 23rd St., New York, N.Y.

FREE BOOK CATALOG

Send today, without obligation, for our new 72 page catalog, describing books on more than one hundred and fifty practical and scientific subjects, including books on Aviation, Automobiles, Air Brakes, Alloys, Electricity, Horology, Heating, Hydraulics, Model Making, Metallurgy, Radio, Ship Models, Soaps, Perfumes, Recipes, Plumbing, Inventions, Tanning, Television, etc.

Norman V. Henley Publishing Co., 2 West 45th St., New York, N.Y.

Anyone CAN LEARN

No talent or experience necessary. Fascinating work. **Pays Big Money.** Complete instruction book tells about: Alphabets, Colors, How to Mix Paints, Show Cards, Window Board and Wall Signs. Ready made letters, Gildings, Tricks of the Trade, also gives 100 Alphabets and Designs. Book bound in flexible int. leather—gold edges, and four ball bearing Show Card Pens. Sent postpaid \$3.00. (C.O.D.) 10c ex. Quillie Pub. Co., 57 Ross St., Dept. 20, N.Y. City

EARN MONEY IMMEDIATELY—
WE FURNISH EQUIPMENT TO START!!

\$100 to \$500 A Week Is Earned By Cartoonists Today

DO YOU LIKE TO DRAW?
Billy Hon's Famous Cartoon Book Will Teach You

Develop your talent, learn this interesting and profitable profession. Billy Hon, the celebrated newspaper Cartoonist, has devised a simple, up-to-date course in Cartooning consisting of 30 lessons with over 300 original drawings, which you can easily learn in your spare time. Sent postpaid for \$1.00, outside of U.S.—\$1.25. Satisfaction guaranteed or money refunded.

Wesley Publishing Co., 210-P W. 14th St., Los Angeles, Cal.

LEARN CODE Morse or Radio NAT HOME WIT Omnigraph

Leads quickly to big money jobs in an interesting profession. The Automatic Omnigraph teaches you easily and cheaply to read **Telegraph and Short Wave Codes.** The World's Hobby—Catalog. Omnigraph Mfg. Co., PZ, 810 E. 39th St., Brooklyn, N.Y.

SCIENTIFIC APPARATUS OF EVERY DESCRIPTION PROCURED. WRITE YOUR REQUIREMENTS.

YOU CAN OIL PAINT

Amazing new method teaches men or women to earn after first lesson. OIL PAINT photos—portraits, landscapes or art subjects. Earn \$18 to \$50 and more a week. OIL PAINT OUT-PUT GIVEN. Send now for free illustrated book. PICTORIAL ART STUDIOS Inc. Dept. MP. 2926 Broadway, Chicago, Ill.

The man who studies gets ahead. Popular Mechanics Press will advise you what books to read to advance in your trade. 200 East Ontario Street, Chicago, Illinois.

Motion Pictures Train You **QUICKER**



THE NEW WAY



For a **BIG-PAY JOB** in **ELECTRICITY**



The NEW WAY Is the BEST WAY

Just as the electric locomotives of today are superior to the old steam engines. As the aeroplane is a swifter than the Pony Express. So is our new **MOTION PICTURE** training quicker, better and easier than the old methods. E. A. B., Brooklyn, N. Y., says "I finished Reel Lesson No. 3 today and certainly can understand now why you claim your course is so easy to learn. The films make it easy to grasp any point."

NOW—it's easy to get a *better* job with *bigger* pay—to get ahead—to save money—to become independent. Everybody agrees that the field of **ELECTRICITY** is where the **REAL OPPORTUNITIES** are today and will be *for years to come*. And here is an amazing new way to *sure* success in **ELECTRICITY**. It will startle you with its improvement over old methods.

Motion Picture Machine Furnished

Now you learn from **MOTION PICTURES** right in your own home. You get a \$75.00 motion picture machine *without extra cost*. You are furnished thousands of feet of film. You watch the motion pictures. You see giant dynamos in operation, moving diagrams, trained men at *actual electrical work*. It's so plain and *easy* anyone can understand. What your eye sees your mind remembers. It's just as easy as it sounds. Students everywhere are enthusiastic. You will be too. So lose no time in finding out all about this newest, *quickest, EASIEST* way to train for a *big-money* job.

Make \$60.00 to \$150.00 a Week

Thousands of trained men are needed in the electrical field. *Demand exceeds supply*. \$60.00 to \$150.00 or more per week is common. **YOU** can get in on this *big money*. You take no risk. We pledge in writing to give you the training and employment service necessary to get a better job at bigger pay or *you need not pay a cent*.

Write Now for Big FREE Book

It costs you nothing to get all the facts on this remarkable new **MOTION PICTURE** method. Our big **FREE** Book, *The Film Way to Bigger Pay*, tells you just how we train you for a bigger job. Send for it today. Find out how easy it now is to qualify for the big money. *Mail coupon and get all the facts.*

The NATIONAL SCHOOL of VISUAL EDUCATION
 "The Film Way to Bigger Pay"
 537 S. Dearborn Street, Chicago, U. S. A. Dept. 10-HA
 Send book, "The Film Way to Bigger Pay," with facts about this new, easier way to master electricity.

Name.....
 St. or R.F.D.....
 City.....
 State.....
 Age.....

Mail this Coupon

TAKE THE FILM WAY TO BIGGER PAY

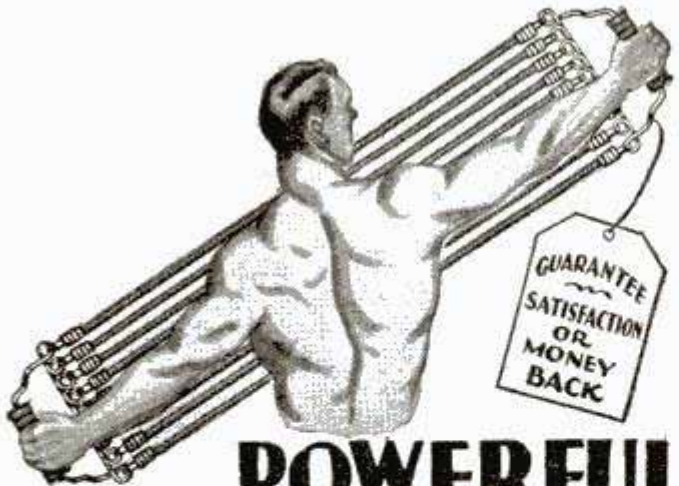

POWERFUL CHEST DEVELOPER and Body Builder Course \$1.95

Seek no longer if you want the muscles of Hercules. Here's your opportunity to realize your muscle dreams. This powerful chest developer is specially made, inasmuch as it has double strength cables which are adjustable up to 200 lbs. resistance. Each cable is guaranteed to have at least fifty strands of the freshest and finest rubber procurable. This means extra strength and extra wear. With the course of instructions which we furnish without extra cost you are easily shown with pictures how to develop your chest, arms, legs and your entire body. Act at once and we will ship everything to you for the special price of \$1.95.

HAND GRIP FREE

The above offer is for our five-cable chest developer only. If you order our ten-cable exerciser, we will not only include our body building course, but we will also present you free with a pair of patented hand grips for developing powerful grip and forearms. You get all this at the special price of only \$3.95.



Send No Money

Mark "X" in coupon showing which offer you want. Sign your name and address and rush coupon to us. We will ship to you by return mail. Pay postman price plus postage on arrival. Money back if not entirely satisfied.



Crusader Apparatus Co., Dept. 110, 44 Parker Ave., Maplewood, N. J.

I have checked below the offer that I accept. Send this by return mail. I will pay postman your special price plus few cents postage on arrival. It is understood my money back if I am not entirely satisfied.

- Offer No. 1.—Five-cable chest expander and body builder, course, \$1.95 plus postage.
- Offer No. 2.—Ten-cable chest expander, body builder, course and a pair of hand grips, \$3.95 plus postage.

NOTE—No C.O.D. orders shipped to foreign countries or Canada.

Name.....
 Street.....
 City..... State.....

MEN for RAILROADS

Nearest their homes—everywhere—to train for firemen, brakemen; Average wages \$150-\$200 monthly. Promoted to Conductor or Engineer—highest wages on railroads. Also clerks.

RAILWAY EDUCATIONAL ASSOCIATION, Dept. D-1, Brooklyn, N. Y.



SENT ON REQUEST

Helpful discussion of this important problem and of fastest growing of Mechanical Trades—Mechanical Dentistry. Of interest to men of all ages. Send for Bulletin 2.

BODEE INSTITUTE

1755 Broadway, New York
 1305 N. Broad St., Philadelphia
 85 Court St., Brooklyn

LEARN TO FLY~



WHERE LINDBERGH LEARNED!

GET the same complete, thorough, foundational training that Lindbergh received. Get it now—under greatly improved facilities—at the Lincoln Airplane School. Much better than when Lindbergh learned here. Get the best training now available. Here competent, experienced instructors teach you practical Flying and Ground Work. You go right up into the sky in our famous Lincoln Page Government Licensed Planes—with transport pilots. Learn on actual planes and motors supplied by the Lincoln Aircraft Factory. Write for full information today!

LINCOLN AIRPLANE SCHOOL
 203 Aircraft Bldg., LINCOLN, NEBR.

Does YOUR Job Pay \$50 Every Week?

As a Railway Postal Clerk you can average \$53 a week the year 'round. I help you get the job if you are a citizen—18 to 50. Steady work, pleasant travel, vacation and sick leave with pay, regular advancement.

Send for My FREE BOOK

Tells how I help you get this and other Civil Service jobs: Post Office, Custom House, Internal Revenue, or Panama Canal Clerk; City or Rural Carrier; etc. For years I was Secretary-Examiner of Civil Service Commission; have helped thousands. SEND TODAY for my FREE 32-page book.

ARTHUR R. PATTERSON, Civil Service Expert
 Patterson School
 810 Wisner Bldg., Rochester, N. Y.



FREE VOCATIONAL TEST

Tells What Kind Of Work You're Best Fitted For
DISCOVERS UNSUSPECTED TALENTS

NOW science will help you find the RIGHT JOB! Every man is good in some things, poor in others. Test yourself right at home, by this tried scientific method, to learn what your own strongest abilities are and what occupation you ought to be following. Guessing doesn't pay—thousands of men who guessed today are square pegs in round holes, side-tracked away from success. Any man (or woman) with grade school education can take this test. Not at all like a school examination. Sent to you absolutely free. A small fee will be charged only if, after examining test, you wish to retain our helpful professional services. Otherwise no cost to you. To receive test and explanatory booklet, free and without obligation on your part, clip coupon below.

New York Vocational Institute,
 Dept. D-27, 215 East 73rd Street, New York City.

Gentlemen: Kindly send me your Free Vocational Test for examination. I understand that I am not obligated either to return the test to you, or in any other way.

Name.....
 Address.....

This New VIX will SAVE 1/4 to 1/2 your GAS

WILL YOUR CAR DO IT ?



New Moisture Humidifier & Carbon Eliminator

for all Makes of Cars, Trucks, Tractors and Engines

Big Profits

to Man with Car Spare or Full Time

\$350 to \$1500 a month

1 man \$4,939.66 in 3 1/2 months
Another \$1,656.60 in 58 days
\$5,150.00 in 5 months to another. **BIG MONEY** can be—**IS** being made

Fitting Motors With Vix
One man sold 8 first morning
Another sells all 3 men can install

Another's profits as high as \$100.00 a day

VIX sells itself by 8 **STARTLING** demonstrations—**BIG, STUNNING, ASTOUNDING** DEMONSTRATIONS. Successful VIX men make **MORE MONEY** than they ever made before.

An amazing NEW Scientific Vapor Humidifier and GAS SAVER has been patented throughout the World that beats anything ever gotten out before. It makes engines run ALL THE TIME with the same wonderful efficiency they do on a cool moist night. It gives MORE pep and power—HIGHER topspeed—automatically ELIMINATES hard carbon from engine—and causes engine to give AMAZING MILEAGE RECORDS NEVER EQUALLED BEFORE.

ENTIRELY UNLIKE ANY OTHER DEVICE. This startling invention is radically different from every other kind. It uses MOISTURE from the radiator and makes the car run like on a damp cool night. It is GUARANTEED to save from 1/4 to 1/2 the gas and oil, stops boiling and steaming, makes engine start easier in all kinds of weather, and completely de-carbonizes the engine as you run.

This new principle device has been extensively tested out by Technical Engineers and Experts and found to give vastly more mileage, with largely increased power and pep from the engine. With it the engine used approximately 90% air, 6% moisture and ONLY 4% of gas.

Free Trial TRY This New Principle Gas Saver AT MY RISK

Try this wonderful VIX Moisture Humidifier and Carbon Eliminator AT MY RISK on YOUR OWN CAR to prove that VAPOR MOISTURE (drawn from Radiator to Engine) gives you that wonderful night driving effect ALL THE TIME with MORE mileage from gas and oil—eliminates hard carbon accumulation—gives MORE power, a SNAPPIER, PEPPIER motor, FASTER acceleration, a SMOOTHER, QUIETER running engine and HIGHER top speed.

VIX will PROVE ITS MONEY SAVING MERIT on your own car by 8 DEMONSTRATIONS—conducted by yourself AT MY RISK—the most SENSATIONAL, most ASTOUNDING, most CONVINCING DEMONSTRATIONS you ever saw. If you don't find from your tests that it does MORE than I claim: return it and it COSTS YOU NOTHING. I want wide-awake hustling, County, State, Province and National Agencies everywhere, part or full time, to make \$350 to \$1500 per month filling the great DEMAND for this wonderful invention wherever introduced. Write for my FREE TRIAL and MONEY MAKING OFFER. Use coupon below.

WALTER CRITCHLOW

Inventor and Manufacturer, 805-T. 7 Street, WHEATON, ILL., U. S. A.

FREE VIX offer Mail Now

WALTER CRITCHLOW, INVENTOR and MANUFACTURER, 805-T. 7 Street, Wheaton, Ill., U. S. A.

Please send me without obligation or charge your FREE TRIAL and MONEY MAKING VIX OFFER.

Name.....

Address.....

Town.....State.....

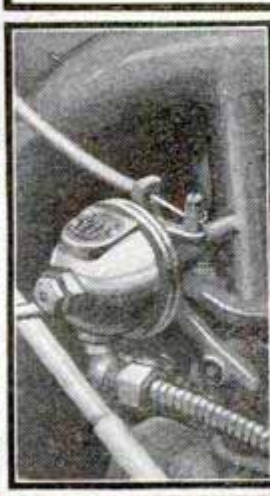

Pictures here and at top show Model "B" VIX attached to my own New Model A. Ford. This car is wonderfully improved in performance with the VIX Moisture Humidifier. So is every Auto, Truck, Tractor, Taxi, Bus, Marine, Stationary and Aircraft Engine, both American and all Foreign makes.

GUARANTEED TO SAVE { 1/4 to 1/2 Gas
Carbon Cleaning
Engine Repairs
or Costs You Nothing

Big Money for You as an Automobile Mechanic

These four practical books, written by five well known teachers of automobile practice, will teach you right in your own home during your leisure time just what you need to know about automobile troubles and repair. They will teach you automobile construction, maintenance and repair as practiced by experts and will help you to earn an expert's pay.

Practical Automobile Library: Four Books—\$1.50 in 10 days and \$2 monthly for 6 months—only \$13.50 in all!

Hundreds of question-answering diagrams—hundreds of clearly-marked illustrations—make the books plain and readily understandable. All the explanations and descriptions are clear, simple, direct. Every chapter is packed with definite, step-by-step, how-to-do-it information. Here is your opportunity to enter a big-pay field.

FREE TRIAL

**Send No Money
Mail the Coupon**



FREE EXAMINATION COUPON
McGraw-Hill Book Co., 370 Seventh Ave., New York
 Send me for 10 days' free examination the New Practical Automobile Library. If satisfactory, I will send you \$1.50 in 10 days and \$2.00 monthly until the special price of \$13.50 is paid. If not wanted, I will return the books at your expense.
 Signed.....
 Address.....
 City and State.....
 Position.....
 Employer..... PM-10-29

Air-Minded Men!

Heed the Call to...

Aviation.

Quickly Train at Home for BIG PAY

Aviation is calling for men—trained men—within the next few months. Mechanics, Pilots, Designers, Assemblers, Riggers, Motor Experts, Airport Managers, Traffic Managers, Salesmen are needed.

A New FREE Book, "Aviation" tells you how to get started; the money you can make; how to quickly prepare for one of the Big Pay Jobs. Also tells you about a remarkable new method of Home Study Training—at LOW COST—that trains you until you get the job you want. Free Employment Service.

Prepare yourself now, while the Big Pay Jobs are looking for you. Mail coupon NOW for this free book. It outlines a plan that has helped many ambitious men get started towards success in the Aviation Industry. Coupon below brings you FREE copy if mailed at once.



FREE Book Coupon
 National Aviation Training,
 Dept. 117, 1031 So. Broadway, Los Angeles, Calif.
 Send me, without obligation, the Free Book "Aviation."
 Name..... Age.....
 Address.....
 City..... State.....

Build a BOAT

How to Make 14 Kinds

If you want a boat, you can save several dollars by making it yourself. Or you can pick up money on the side making boats for your friends. Besides you'll have barrels of fun. Everything is made so simple and easy in Popular Mechanics Boat Book. Complete and simple directions and necessary illustrations for building these boats and canoes:

Rowboat suitable for outboard motor, Canoe, Whiz (14-ft. step hydroplane), Portable Canvas Boat, Fast 19-ft. Runabout Motorboat, Cabin Scow driven by auto engine, Long Island Scooter with aero-propeller, Portable Folding Boat, Convertible House Boat and Camp, Sea-Gull (sailing boat), Pile-Driven Punt, Inexpensive Motor Boat, Power-Driven Catamaran, Fishing Sleigh and Boat. In addition there are valuable instructions for caulking, repairing, painting and making boats watertight, also articles on picking your canoe, handling and fitting outboard motors, laying up for winter and making a boat trailer and boathouse for small canoe club.

This book, together with its companion, Outdoor Sports (containing hundreds of practical plans and ideas on sports, games, tours and camping), will be sent to you C. O. D. if you live anywhere in the U. S.

Just send a note saying you want the Boat Book and Outdoor Sports. When they arrive, pay postman \$1.98 and the postage. If outside the U. S. remit when ordering and include 15 cents extra for postage.

POPULAR MECHANICS PRESS

Room P10, 200 E. Ontario Street, CHICAGO, ILL.

**Build
Your
Own
Boat**



**Be a
Civil
Engineer!**

**Learn
at
Home!**



**Cyclopedia of
Civil
Engineering**

9 great volumes.
 4000 pages.
 3000 illustrations.
 New edition just off the press, by twelve of America's greatest engineers. Includes: Surveying, bridges, railroads, steel structures, municipal engineering, water supply, road building, etc.

**Earn
\$5000**

a Year—and Up!

"CIVIL ENGINEERING"—in plain English written so you can understand it, even if you have only a limited education. Prepares you for a well paid railroad structural or public works position. Covers every branch of Civil Engineering practice. At once a reading course for the ambitious student and an authoritative reference work for the experienced engineer. Borrow a set—free. Look over the test questions which help you master each subject quickly. Mail the coupon without obligation today!

**American Technical Society,
Dept. C-719 Chicago**

**Loaned
Free!**

To prove you can learn Civil Engineering at home in your spare time. And because no description here could do it justice, to let you see for yourself the scope and simplicity, the authority and quality of this great home reading course. Cost and terms are within your reach. Send no money—just mail the coupon.

**American Technical Society,
Dept. C-719, Chicago**

I want to BORROW the CIVIL ENGINEERING Cyclopedia for 15 days FREE. I will gladly pay the few cents extra, but I am to pay nothing for the loan of the 9 big volumes if I return them within 15 days. If I wish to keep them I will send you \$2 after the 15 days, then \$3 a month until special advertising price, \$34.80, is paid.

Name.....

Address.....

(Attach letter stating age, occupation, employer's and references' names and addresses.)

I GUARANTEE YOU MUSCLES-or No Cost

COME ON, FRIEND, GET A LOAD OF MUSCLE. I GUARANTEE TO MAKE YOU STRONG. I GUARANTEE TO ADD LAYERS OF SOLID MUSCLE TO YOUR BODY. I GUARANTEE TO DEVELOP YOUR ARMS, YOUR BACK, YOUR CHEST, YOUR LEGS. AND BOY, - BUY A SIZE LARGER COLLAR FOR THAT MUSCULAR NECK I'M GOING TO GIVE YOU - AND TAKE IN YOUR BELT A NOTCH OR TWO ON THE TRIM, ATHLETIC WAIST-LINE YOU'RE GOING TO HAVE.

THAT'S THE TICKET I'M WRITING FOR YOU, FRIEND AND I DON'T PROMISE ANYTHING - I GUARANTEE RESULTS -



WEAR THIS MEDAL



Strong men all over the world wear it. Made of solid statuary bronze and given to you free. Mail coupon for full details.

Get Strong—QUICKLY!

Why be the goat of your crowd? Why let the wise-cracker pick on you? There's always one of those smart guys around. But did you ever notice that it's the little fellow he picks on—the chap who doesn't dare put up his dukes? But YOU don't have to be IT.

Say good-bye to that miserable, half-dead carcass you've been dragging around. I'm going to build you a NEW BODY. I'm going to give you the prettiest development that ever stepped out in a bathing suit. And I'll not only make you over

outside, but inside, too. Give me just a few minutes a day in your own home, and watch those muscles GROW!

I'm going to broaden your shoulders and fill out your chest. I'm going to cover your body with massive layers of powerful muscles. Not beef, not lumps of lead—but beautiful, long, rippling muscles that are ALIVE with speed and strength. That's the kind of a MAN I'm going to make YOU. You're NEXT! So send for my FREE BOOK right now and get the PROOF. See what I've done for thousands of others—and what I can do for YOU.



WHICH IS YOU?

Look at those two pictures! Which is YOU? A puny run-down weakling, scorned by your fellow-teen, avoided by the fair sex, ashamed to show yourself in a bathing suit? Snap out of it, friend! Take a look at that big boy at the right and cheer up. That's the way TITUS builds men.



YOUNG ATLAS

who claims the title of the world's strongest man, is internationally known for his amazing feats of strength, such as pulling a trolley car, with 40 passengers, by his teeth. He is here using the Titus Apparatus in the "baseball pose," one of the many ways in which this famous exerciser can be used to develop every muscle in the body.

MIRACLES IN MUSCLE IS FREE!

Is your body worth a 2c stamp? Then tear off that coupon and shoot it in the mail TODAY. By return mail you'll get my big, illustrated book—one of the most inspiring, most amazing books you've read. Chock-full of muscle-building facts, packed with pictures of men rebuilt. Read how, in just a few minutes a day at home, YOU can develop MIGHTY MUSCLES OF STEEL. No cost, no obligation, no salesman will call. RUSH the coupon.



Mail the Coupon

TITUS, DEPT. M-143
55 East 11th St., New York, N. Y.

Dear Titus: Okay, send that wonderful, big illustrated book of yours, "MIRACLES IN MUSCLE." Get it to me by return mail, without the slightest cost or obligation on my part.

TITUS
55 East 11th St.
NEW YORK CITY

Name.....

Address.....

Town..... State.....

You Can Learn ELECTRIC REFRIGERATION

*in 3
Months*

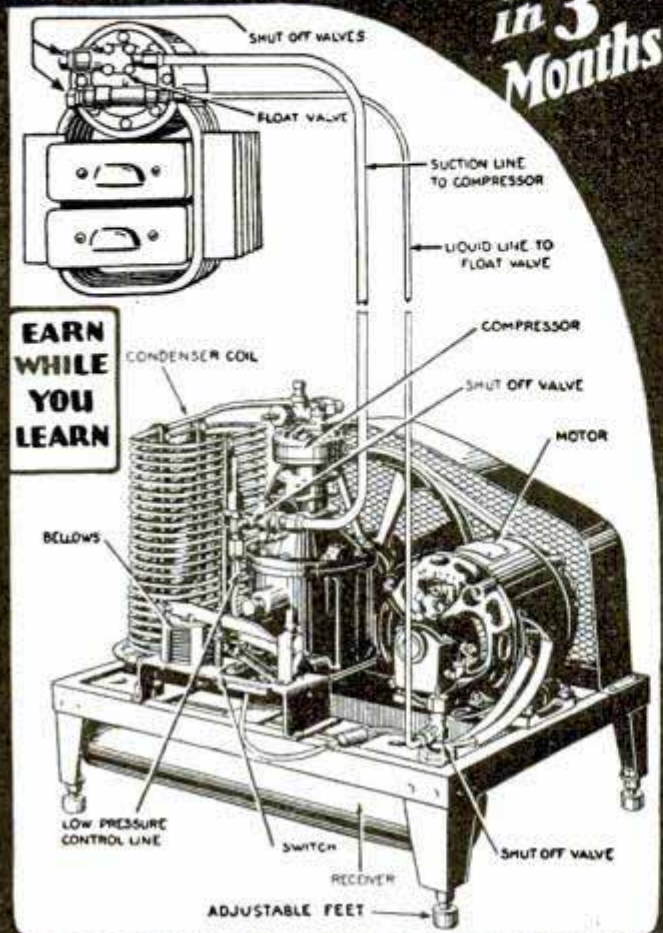

**EARN
WHILE
YOU
LEARN**

Men in Big Demand!

Rapidly growing industry. Regular mechanics cannot service the new machines. Trained experts who know the scientific principles of refrigeration and are familiar with construction and repair of every part of the refrigeration units earn big pay. To meet the great demand the School of Engineering of Milwaukee (America's greatest electrical school) offers a thorough course in Electric Refrigeration.

COMPLETE PRACTICAL COURSE

In three months includes Electric Refrigeration, Applied Electricity, Merchandising, and Practical Mathematics. Some of the topics are: Physics and Chemistry of Refrigeration, Heat and Heat Transfer, General Theory of Refrigeration, Systems of Refrigeration, Household Compression Systems, Refrigerants, Household Absorption Machines, Refrigeration Cabinets, Installation and Repair, Maintenance, Troubles and Their Cures, Sales and Merchandising. All instruction is thoroughly practical. Splendid equipment and laboratories. Expert instructors.

WRITE FOR FREE BOOK

entitled "YOUR FUTURE IN ELECTRIC REFRIGERATION," giving complete description of the Electric Refrigeration Course, details on the "Earn While You Learn Plan" and the after-graduation Employment Service. Big opportunities await you in this new profession. Write today!

New Class Organizing NOW Act at Once!



Founded 1905

163 East Wells Street MILWAUKEE, WIS.

School of Engineering of Milwaukee,
P. M. 1029B, 163 East Wells St., Milwaukee, Wisconsin.

Send me FREE, with no obligations, a copy of "YOUR FUTURE IN ELECTRIC REFRIGERATION."

Name.....Age.....
Address.....
City.....State.....
Education.....

Books on 32 Subjects

Popular Mechanics Press specializes in supplying books on any subject. Look over this list. Check the books you want, and mail this advertisement as your order blank. Catalog with lists on 2,000 subjects free.

- | | |
|---------------------------------------------------------------|-------------------------------------------------------------------|
| AIRCRAFT (Modern)
Complete. Up-to-date...\$5.00 | FURNITURE REPAIRING
Finishing and Decoration.....\$5.00 |
| ARTIST (Commercial)
Money-Making Art....\$5.00 | HYPNOTISM
A Reliable Treatise...\$2.00 |
| ATLAS (of World)
Modern. New Boundaries...\$3.00 | INVENTIONS
How to Make Pay....\$2.50 |
| AUTOMOBILE (Modern)
Gasoline. New Edition...\$5.00 | MAGIC
World's Best Book of...\$2.00 |
| BOOKKEEPING
Practical Handbook...\$1.00 | MIRRORS
Silvering.....\$1.00 |
| BRICKLAYING
Plain and Fancy.....\$1.50 | MODEL ENGINEERING
Very Interesting.....\$4.00 |
| CARBURETORS (All Makes)
Only Book Covering...\$2.00 | PLASTERING
Best Instruction Manual.....\$1.25 |
| CHALK TALK
and Crayon Presentation.....\$1.25 | RADIO ENCYCLOPEDIA
Very Complete.....\$6.00 |
| DRAWING
Freehand and Perspective.....\$1.50 | REAL ESTATE
Educator.....\$2.00 |
| DRY CLEANING (Practical)
and Dyer.....\$3.00 | SHOW CARDS
Artistic.....\$3.50 |
| ELECTRICAL SYSTEMS
Automobile.....\$3.50 | SIGNS (Artistic)
How to Make.....\$3.50 |
| FLOWER RAISING
1001 Questions Answered.....\$2.00 | Steam Engineer's License
How to Obtain.....\$2.00 |
| FLYING
A B C of.....\$1.50 | STEEL SQUARE
How to Use.....\$1.00 |
| FUNNY PICTURES
How to Draw (by Zim).....\$3.00 | TELESCOPE (Amateur's)
How to Make.....\$3.00 |
| FUR RAISING
For Profit.....\$4.00 | TOOLS (Using)
Tinkering with Tools...\$2.00 |
| | TRICKS (200)
For the Amateur.....\$1.00 |
| | WOOD FINISHING
Plain and Decorative...\$2.00 |

-----SEND NO MONEY-----

Just check the books you want, and mail the whole advertisement. It is your order blank. When postman hands you books, pay him the price and the postal charges. If outside the U. S. remit when ordering and include 10 cents per book extra for postage. **POPULAR MECHANICS PRESS, Room P10, 200 East Ontario St., Chicago, Ill.**

AUTO REPAIRMEN EARN GREATER PROFITS

Get your share of the big money being spent on automobile upkeep.

Put improved time, labor and money-saving ideas to work in your shop to-day. Take advantage of our special bargain offer and secure 3 valuable kink books at a reduced price.

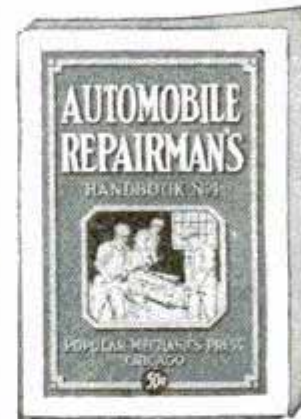

1. 334 Valuable Discoveries made by auto mechanics in our **Automobile Repairman's Handbook**. 337 Illustrations.

2. 301 Ways to use drills, drill presses, taps and dies more effectively in our **Drilling and Thread Cutting Handbook**. 298 Illustrations.



3. 259 Kinks furnished by the most expert Lathe Operators in our **Lathe Handbook**. 212 Illustrations.

Special Offer—These 3 books (regular price 50 cents each, \$1.50 value) are offered for a limited time for only 98 cents plus postage. Pay postman C. O. D. when he delivers or if outside U.S. send 98 cents and 15 cents extra for postage.

POPULAR MECHANICS PRESS
Room P 10
200 E. Ontario St. CHICAGO

If (Annoyed Irritated Handicapped Depressed with a) Rupture

Let Me Make You A "Millionair"

For Now, After Testing and Trying, Studying and Making More Than One Hundred Thousand (100,000) Rupture Supports, We Offer "Millionair" Comfort, Coolness, Security, Lightness and Washability With a New Kind of Positive Anchorage.

The little coupon in the corner below will bring a free sample of the newest Airtex material of which the "Finger Tip" or "Millionair" rupture support is made. With it will come, likely, the most interesting, plain, helpful information you have ever read regarding rupture help. The new "Millionair" is so light that (for single rupture) it weighs only four ounces. Its garment-like girdle is called "Airlastic," it has the needed firmness and ventilation, and yet sufficient elastic. Every part of "Millionair" can be washed in hot soapsuds quickly. The girdle has no rubber in it to rot. In the new "Millionair" is embodied the idea that a finger tip can hold a reducible rupture, if the finger tip is held in the one right place. The "Three Point" anchorage of the new light, cool "Millionair" uses a thin pad that imitates a finger

tip, and is anchored by our own tiny but exclusively patented invention. It has no leg straps and of course no body springs. Its bulk is so small (four ounces for single rupture) that it does not show embarrassing outlines through clothing.

50,000 Samples Free

Rupture to be healed must be held. Every time your rupture comes out you are really re-ruptured. Nature heals broken bones, help her heal rupture. The comfortable anchorage of "Millionair" is a modern invention and accounts for much of the lightness, coolness and security of it.

We are distributing 50,000 samples as mentioned above. Get yours before they are gone. No obligation but a surprise and education. Use the coupon.



More Freedom of motion. Does not bulk or show outline through clothing to embarrass you.

Newest "Finger Tip" Rupture Comfort
 With "3-Point" Anchorage

Most ruptured persons know that a finger tip rightly placed will hold most reducible ruptures. "Millionair" imitates this method with a four-ounce support. Clean, cool, washable, secure. Made only by New Science Institute, Steubenville, Ohio.

NEW SCIENCE INSTITUTE
 2165 Clay Street Steubenville, Ohio

Worth Money to Ruptured

NEW SCIENCE INSTITUTE,
 2165 Clay St., Steubenville, Ohio.

Send me my free sample, also full information about "Millionair." No obligation now or later.

Name.....

Address.....

City.....State.....

Please write plainly and save disappointment.

Learn to Mount Specimens like These

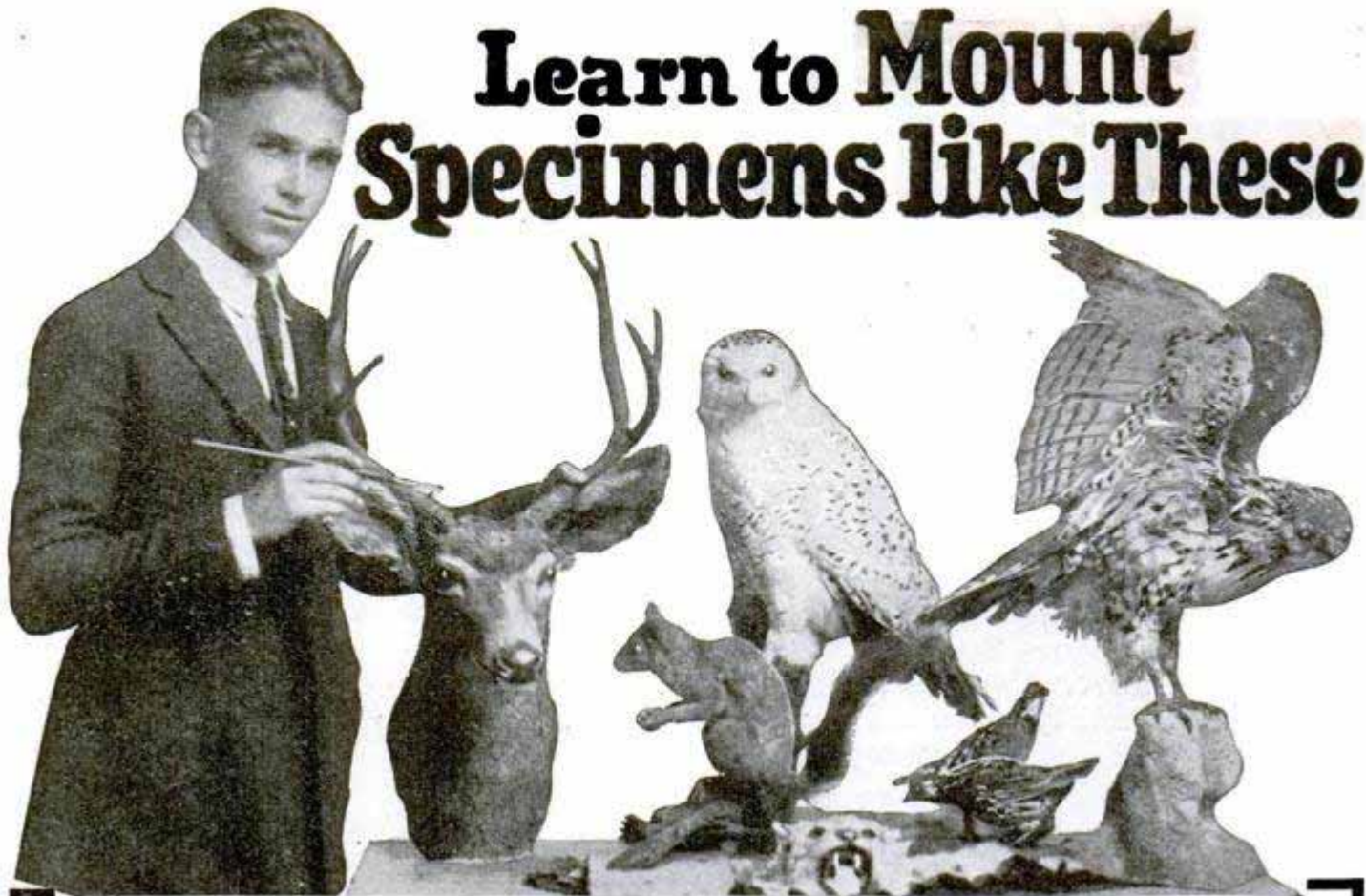

Make Big Money —

Taxidermy is the most profitable OF ALL spare time work. Sell your mounted specimens. Mount trophies for your friends, hunters, trappers and fishermen. Have a side business of your own. Be independent. Have plenty of spending money—for athletic goods, radio, books, traps, and for vacations. Here is your opportunity. Don't delay. Send the coupon right NOW.

Free Book Coupon

Northwestern School of Taxidermy
3377 Elwood Bldg., Omaha, Nebr.

Send me, absolutely free, your illustrated book, "How to Mount Game." Also tell me how I may learn to be an expert taxidermist easily and quickly by mail. No obligation.



Name _____

Address _____

LEARN to mount and stuff all kinds of game, animals, birds, fish—tan furs and skins, make beautiful rugs, robes, etc. You can learn *easily and quickly* during your spare time by mail. *Great sport and lots of fun.* Lessons are easy and intensely interesting. Latest museum methods. This school is 20 years old, high class and reliable, and has 75,000 graduates. *Success guaranteed.* Don't delay, but start to learn this extremely fascinating art NOW.

FREE

Beautifully illustrated book, "How to Mount Game." Explains the secrets of taxidermy. Dozens of photos of mounted specimens. Tells how you can learn this great art, no longer a secret, right in your own home during *spare time*. Tells how to

become a taxidermy artist, how to save your own splendid trophies, how to beautify and decorate your room and home with nature's choicest art.

Tells how young men and boys can make the **BIGGEST MONEY** from their spare time. Don't delay. Clip coupon now. Send **TODAY** for this Free Book.



FLYING SIMPLIFIED

Just Published — Non-Technical

Up-to-the Minute training on Aviation. Shortens student training period; gives added dexterity at controls. All flying facts in simple language. With this book *you can thoroughly understand flying.* Learn flying. Get started at once. Order today.

Send Only \$1.00. Your book will be sent prepaid.

FLYING SIMPLIFIED, DEPT. 3138 Southport Ave., Chicago, Ill.

Put a Million Dollar High School in Your Home

only \$19.85
easy terms

Fifteen expert instructors teach you by fascinating question and answer method. Certificate awarded. Write for free booklet "New Way to Get Your High School Education at Home."
High School Home Study Bureau, 31 Union Sq., Dept. K-32, New York

HEALTH BEAUTY VIGOR quickly won by using violet rays. No medicine. Very simple and easy to use. Give quick relief from pain and disease. VIOLETTA is endorsed and used by thousands of hospitals, sanitariums and physicians. Send for free book telling of the magical curative power of this marvelous discovery by Nikola Tesla, great electrical wizard. Testimonials by satisfied users. Write for it now. **VI-REX COMPANY, Dept. 1031, 2304 Warren Ave., Chicago.**

LEARN CARTOONING

AT HOME DURING SPARE TIME

with the course that has trained HUNDREDS of beginners successfully. The Landon Picture Chart Method of teaching ORIGINAL drawing by mail makes cartooning easy to learn. This school is a Member of The National Home Study Council. Write today for sample picture chart to **TEST YOUR ABILITY** and examples of the work of successful students now earning from \$50 to \$200 and more per week. Enclose 6c in stamps and **STATE YOUR AGE.**

THE LANDON SCHOOL, 2838 National Bldg., Cleveland, Ohio



OIL HEAT

Now at a FRACTION of PRESENT COSTS!

Now—the remarkable invention of a foremost American engineer solves the oil burner industry's greatest problem—to produce a burner every home can easily afford,—which SAVES MONEY on the fuel bill—and eliminates dirt, soot and grease!

WONDERFUL INVENTION BURNS OIL! NEW WAY!

Other power burners, by means of air pressure, convert the liquid oil into a spray and burn oil in spray form. The surplus air pressure thus required blows a large part of the spray upwards, out of the smoke-stack, wasting heat, increasing fuel expense. Contrast this with the LACO, which by means of the indestructible MINERAL WICK, converts the oil into hydrocarbon GAS, the most perfect medium for creating heat known to man—because ALL of it burns and WASTE IS ELIMINATED! A given amount of oil, burned in the LACO, lasts longer and saves you money!



FITS ANY STOVE OR FURNACE

In one minute, the Laco turns your hot-air furnace, hot-water or steam heat plant, parlor stove, or kitchen range, etc., into an up-to-date heating system!



MINERAL WICK Smashes Fuel Costs Eliminates Smoke, Soot, Grease

The spray form method of burning oil means waste oil and that means smoke, soot, grease. The LACO does away with all this! The LACO, by burning ALL of the oil in GAS form eliminates waste, thus providing CLEAN HEAT, free from dirt or grease. This is an exclusive feature of the LACO—fully covered by U. S. patents—the LACO is the ONLY burner so equipped and the ONLY burner of its kind on the market!

The SMALLEST Home Can Afford a LACO!

Oil heat is no longer a luxury for the rich! The LACO, the Ford of the oil burner industry, is the cost so low that EVERYONE may now enjoy the convenience of oil heat.

Sold on EASY TERMS

Our EASY PURCHASE PLAN enables you to enjoy oil heat this very year! Now, resolve to end your slavery to King Coal—carrying dirty, heavy coal and ashes, chopping, shoveling, smoke, odor. No more getting up early on cold mornings to start stubborn fires—install a LACO and forget about your furnace!

MAIL COUPON for Information and Introductory Low Price Offer

Tell type of heating system you now have. Special offer if you mail the convenient coupon NOW!

LACO OIL BURNER CO.
124 Union St., Griswold, Iowa

DEALERS Wanted Quick!

Laco sales have leaped from 68th to 9th place practically overnight! The opportunity is now being offered for you to go into one of the country's best paying businesses. We want rated men preferably—but also the man who will invest a small amount in demonstrators—then get out and SELL. If this description fits you, we will offer you an opportunity big enough for any man!

Fully Automatic

Thermostat control—as much heat as you want, WHEN you want it. Operates quietly. Nothing to adjust. Designed to last a lifetime. Guaranteed. Complies with all ordinances. Actually SAFER than the ordinary kitchen gas range!

Laco Oil Burner Co.,
124 Union St.,
Griswold, Iowa

Send facts about your burner, the New Mineral Wick, and Special Low-Price Offer.

Name.....

St. or Rt.

Town.....tate.....

Kind of heating system I now have.....





The Boss—Could You Handle his Job?

SUPPOSE the Boss should leave tomorrow—who would they put in his place? Could you handle his job?

It's worth thinking about because such things happen—every day. Would you have the background—the technical knowledge to carry on his work?

In an hour a day of your spare time, right in your own home, the International Correspondence Schools can give you exactly the training you need. And when you are ready, the opportunity will surely come.

Choose now the job that you would like to hold a year—two years—five years from now. Then prepare yourself for that job through I. C. S. study. Thousands of men—starting where you are today—have advanced to better positions and bigger pay in just this way.

You can do it too. There is no cost or obligation in finding out how. Just mark and mail the coupon and we will gladly send you full details at once.

INTERNATIONAL CORRESPONDENCE SCHOOLS
Box 5640-F, Scranton, Penna.

Without cost or obligation, please send me a copy of your booklet, "Who Wins and Why," and full particulars about the course before which I have marked X in the list below:

TECHNICAL AND INDUSTRIAL COURSES

- | | |
|--------------------------------------------------|-----------------------------------------------------------------------------|
| <input type="checkbox"/> Architect | <input type="checkbox"/> Automobile Mechanic |
| <input type="checkbox"/> Architectural Draftsman | <input type="checkbox"/> Aviation Engines |
| <input type="checkbox"/> Building Foreman | <input type="checkbox"/> Plumber and Steam Fitter |
| <input type="checkbox"/> Concrete Builder | <input type="checkbox"/> Plumbing Inspector |
| <input type="checkbox"/> Contractor and Builder | <input type="checkbox"/> Foreman Plumber |
| <input type="checkbox"/> Structural Draftsman | <input type="checkbox"/> Heating and Ventilation |
| <input type="checkbox"/> Structural Engineer | <input type="checkbox"/> Sheet-Metal Worker |
| <input type="checkbox"/> Electrical Engineer | <input type="checkbox"/> Steam Engineer |
| <input type="checkbox"/> Electrical Contractor | <input type="checkbox"/> Marine Engineer |
| <input type="checkbox"/> Electric Wiring | <input type="checkbox"/> Refrigeration Engineer |
| <input type="checkbox"/> Electric Lighting | <input type="checkbox"/> R. R. Positions |
| <input type="checkbox"/> Reading Shop Blueprints | <input type="checkbox"/> Highway Engineer |
| <input type="checkbox"/> Telegraph Engineer | <input type="checkbox"/> Chemistry |
| <input type="checkbox"/> Telephone Work | <input type="checkbox"/> Pharmacy |
| <input type="checkbox"/> Mechanical Engineer | <input type="checkbox"/> Coal Mining Engineer |
| <input type="checkbox"/> Mechanical Draftsman | <input type="checkbox"/> Navigation <input type="checkbox"/> Assayer |
| <input type="checkbox"/> Machine Shop Practice | <input type="checkbox"/> Iron and Steel Worker |
| <input type="checkbox"/> Toolmaker | <input type="checkbox"/> Textile Overseer or Supt. |
| <input type="checkbox"/> Patternmaker | <input type="checkbox"/> Cotton Manufacturing |
| <input type="checkbox"/> Civil Engineer | <input type="checkbox"/> Woolen Manufacturing |
| <input type="checkbox"/> Surveying and Mapping | <input type="checkbox"/> Agriculture <input type="checkbox"/> Fruit Growing |
| <input type="checkbox"/> Bridge Engineer | <input type="checkbox"/> Poultry Farming |
| <input type="checkbox"/> Gas Engine Operating | <input type="checkbox"/> Mathematics <input type="checkbox"/> Radio |

BUSINESS TRAINING COURSES

- | | |
|------------------------------------------------------------------|-------------------------------------------------------|
| <input type="checkbox"/> Business Management | <input type="checkbox"/> Business Correspondence |
| <input type="checkbox"/> Industrial Management | <input type="checkbox"/> Show Card and Sign Lettering |
| <input type="checkbox"/> Personnel Management | <input type="checkbox"/> Stenography and Typing |
| <input type="checkbox"/> Traffic Management | <input type="checkbox"/> English |
| <input type="checkbox"/> Accounting and C. P. A. Coaching | <input type="checkbox"/> Civil Service |
| <input type="checkbox"/> Cost Accounting | <input type="checkbox"/> Railway Mail Clerk |
| <input type="checkbox"/> Bookkeeping | <input type="checkbox"/> Mail Carrier |
| <input type="checkbox"/> Secretarial Work | <input type="checkbox"/> Grade School Subjects |
| <input type="checkbox"/> Spanish <input type="checkbox"/> French | <input type="checkbox"/> High School Subjects |
| <input type="checkbox"/> Salesmanship | <input type="checkbox"/> Cartooning |
| <input type="checkbox"/> Advertising | <input type="checkbox"/> Illustrating |
| | <input type="checkbox"/> Lumber Dealer |

Name.....
Address.....
City..... State.....
Occupation.....

If you reside in Canada, send this coupon to the International Correspondence Schools Canadian, Limited, Montreal, Canada

Add 5 Inches To Your Chest!

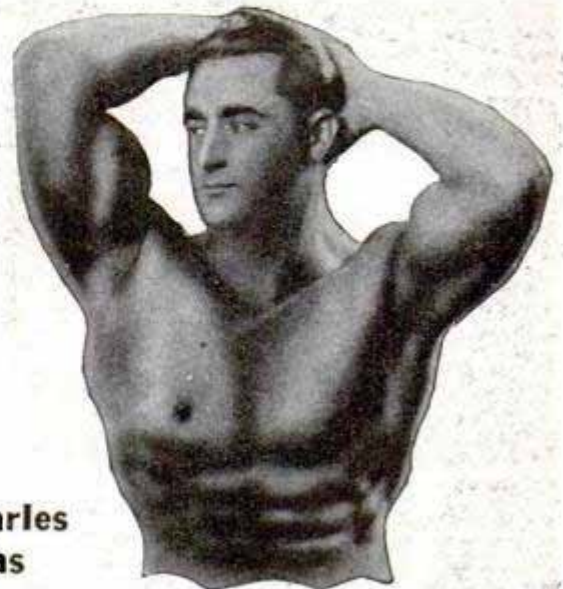

Charles Atlas

Holder of the title, "The World's Most Perfectly Developed Man." No other living man can claim this title.

Old or Young—Thin or Fat—I'll Make You a Muscular Giant in 90 Days

Yes, in less than three short months you can add layers of solid muscle, add five inches to your chest; a couple or more inches to your biceps; have a tremendous broad back; massive, powerful shoulders; wrists and fingers with a grip like steel and remarkable energy by my wonderful New System. You can attain the same wonderful results that I have by following the methods which enabled me to change from a weakling.

LOOK AT THESE PUPILS!



Anthony Sansone



Clelio Massimo

Here's convincing proof my pupils become tremendous, Herculean Giants. Regardless of your age or physical condition I GUARANTEE to give you the same marvelous quick-fighting muscles in record-smashing time, and develop your nerve, courage, confidence, and everlasting strength.

FREE! "Everlasting Health and Strength"

My new book is packed with pictures of men, whom I've taught. Nothing else compares with it. It will positively thrill and inspire you. It's the one Master Book of Health and Strength. Send for it today—NOW while this is before you.

FREE! I am giving every pupil a valuable Trophy—a beautiful Diploma and Medal.

CHARLES ATLAS

"The World's Most Perfectly Developed Man"

Dept. 810

171 Madison Ave. New York City

MAIL THIS NOW!

CHARLES ATLAS, 171 Madison Ave., Dept. 810, New York City
Dear Sir: Please send me your new big free book: "EVERLASTING HEALTH AND STRENGTH." This places me under no obligation.

Name.....
Address.....
City..... State.....
(Please print or write PLAINLY)

FREE!

MEN! Here's the dope you've been looking for

HOW TO GET INTO THE RADIO BUSINESS~

J.E.S.

Many Earn \$50 to \$250 a Week in Work That is Almost Romance

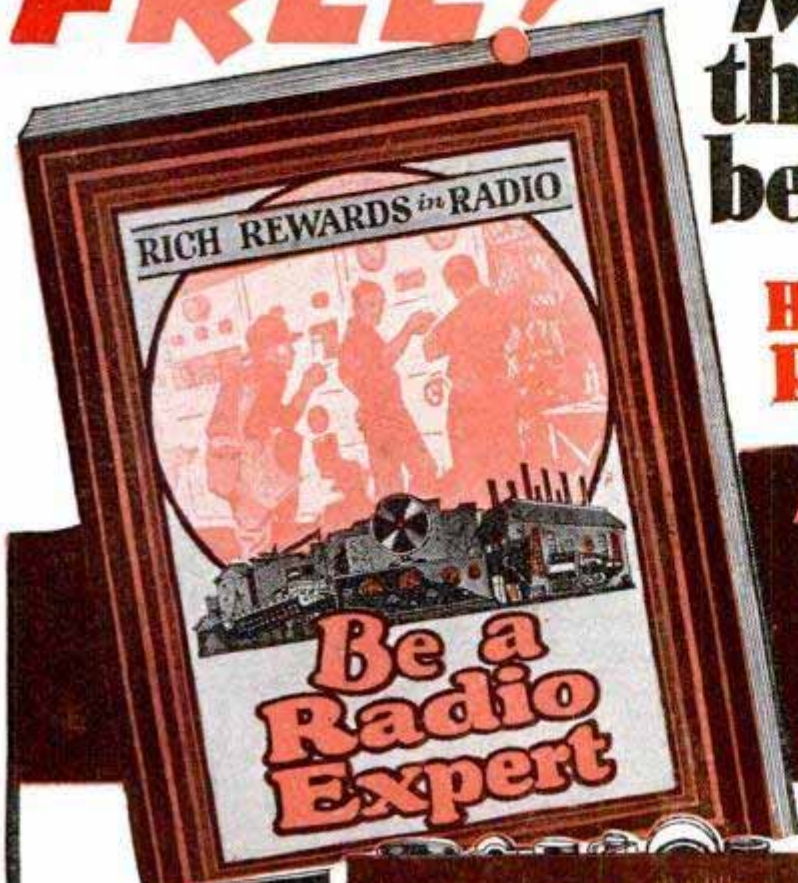

If you're earning a penny less than \$50 a week, clip coupon now for FREE BOOK! New 64-page book pictures and tells all about the Radio business; hundreds of opportunities—in work that is almost romance! YOU can learn quickly and easily at home, through my tested, proved methods to take advantage of these great opportunities! Why go along at \$25, \$35, or \$45 a week when you can pleasantly and in a short time learn how to hold the big-pay jobs?

Clip Coupon for Free Book

Don't envy the other fellow who's pulling down the big cash! My proven home-study training methods make it possible for you, too, to get ready for better jobs, to earn enough money so you can enjoy the good things of life. One of the most valuable books ever written on Radio tells how—interesting facts about this great field, and how I can prepare you in your spare time at home, to step into a big-pay Radio job. **GET THIS BOOK. SEND COUPON TODAY.**



J. E. SMITH, Pres.
National Radio Institute
Dept. 9XP, Washington, D. C.



I Give You 6 Big Outfits of Radio Parts

With them you can build 100 different circuits—learn the "how" and "why" of practically every type of Radio set. This kind of training fits you to step into the good jobs—sends you out an experienced Radio expert. When you complete, my Employment Department will help you get a big Radio job like Graduate Edward Stanko, Chief Operator of Station WGR, or Frank M. Jones, 922 Guadalupe St., San Angelo, Tex., builder and operator of Station KGFI and Manager of the best equipped Radio shop in the Southwest, or help you start a Radio business of your own like Richard Butler, 1419 No. 17th St., Phila., Pa., who made around \$500 a month compared with a job as motorman when he enrolled.

The Famous "Course That Pays for Itself"

Spare time earnings are easy in Radio almost from the time you enroll. G. W. Page, 1807 21st Ave., S. Nashville, Tenn., made \$935 in his spare time while taking this course. Al Johnson, 1409 Shelby St., Sandusky, O., \$1,000 in four months, and he didn't know the difference between a condenser and a transformer when he enrolled. I'll give you a contract, backed by N. R. I., pioneer and largest home-study Radio school in the world, to refund every penny of your money if you are not satisfied, upon completing, with the lessons and instructions received. Find out what Radio offers you. Mail coupon.

I Have Trained Hundreds of Men at Home for Big Radio Jobs. My Book Proves I Can Do the Same for You.



J. E. SMITH
President
NATIONAL RADIO INSTITUTE
Dept. 9XP
WASHINGTON, D. C.

Dear Mr. Smith: Without obligating me in any way, send me your big FREE BOOK, "Rich Rewards in Radio," and all information about your practical home-study Radio Course.

Name..... Age.....
Address.....
Town..... State.....

ACT NOW~COUPON BRINGS MY

FREE BOOK

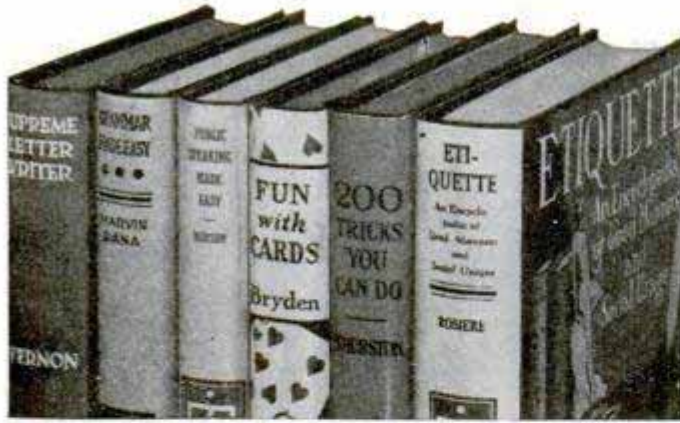

76 Books

Full-Sized, Cloth Bound

Only \$1.00 Each

HERE is a real bargain—regular \$2.00 and \$3.00 books—on many subjects—now only \$1.00 each. Don't confuse these books with small paper bound pamphlets. These books are full library size—averaging 300 pages each—beautifully bound in cloth—large clear type—high-grade book paper. Sensational value for \$1.00; 3 books, \$2.85; 5 books, \$4.75; 10 books, \$9.50. Order now! Money refunded if not delighted.

Take Your Pick—\$1 Each

- 200 Tricks You Can Do
- Legless Lady Trick
- 200 More Tricks You Can Do
- Tricks and Magic Made Easy
- Supreme Letter Writing
- Social Letters Made Easy
- Better Business Letters
- Public Speaking Made Easy
- How to Develop Your Speaking Voice
- Toasts and Anecdotes
- Speeches and Recitations
- The Art of Speech Making
- Speech — How to Use It Effectively
- Entertaining Made Easy
- Telling Fortunes by Cards
- Fortune Telling and Character Reading
- Deck of Gypsy Witch Fortune Telling Cards
- Riddles and Conundrums
- Telling Fortunes by Tea Leaves
- Palmistry for Pleasure
- Fun with Cards
- Fortunes and Dreams
- Hoyle's Games
- Your Face is Your Fortune
- Stories and Toasts for After Dinner
- Cohen on the Telephone
- It is to Laugh
- Jokes for all Occasions
- A Laugh a Day Keeps the Doctor Away
- Spelling Made Easy
- Drawing Made Easy
- Penmanship Made Easy
- How to Develop Your Will Power
- How to Develop Your Personality
- Shorthand Made Easy
- Arithmetic Made Easy
- Grammar Made Easy
- Training for Power and Leadership
- Bookkeeping Made Easy
- 1000 Literary Questions & Answers

- The Handbook of Quotations
- Electrical Engineer's Handbook
- Mechanic's Handbook
- Machine Shop Handbook
- Radio Handbook
- Automobile Handbook
- Psycho-analysis — Kinks in the Mind
- Law at a Glance
- Short Cut in Figures
- Ropp's Commercial Calculator
- Cushing's Manual of Parliamentary Practice
- Standard Webster Pocket Dictionary
- The Science of Numerology
- The Key to Hypnotism
- How to Get a Position and How to Keep It
- The First Principles of Astrology
- Astronomy for Everybody
- A Perfect Memory—How to Have and Keep It
- Personality—How to Build It
- Wilde's Primer of Astrology
- Poise—How to Attain It
- Opportunities — How to Make the Most of Them
- Character—How to Develop It
- Practicality—How to Acquire It
- Influence—How to Exert It
- Timidity—How to Overcome It
- Laws of Financial Success
- Handbook of Freemasonry
- Nerve Control
- The Encyclopedia of Etiquette
- Better Business English
- Better Advertising
- Home Furniture Making
- Studies in Murder
- Trader Horn
- Revolt in the Desert

Use This Handy Coupon

Franklin Publishing Company,
800 North Clark Street, Dept. 9421, Chicago.

Enclosed is \$..... (Add 10c extra for postage) for which send me books checked above:

Name.....

Street and No.....

City and State.....

FREE! Big Bargain Book Catalog with Each Order

BIG PAY! Cash Bonuses Liberal Commissions



Get in line for big money quickly. Learn profitable **MEAT CUTTING**. Possibilities unlimited. **Good Pay. Cash bonuses. Liberal Commissions. Manage stores. Run your own business.** All these possible through our home instruction course. **Ends job and pay day worries forever.** You make money long as people eat meat. No invention or machine can ever displace meat cutters. With this profession you are set for life. Jobs everywhere. No matter where you go—cities, towns, villages, summer resorts, north, east, south or west; you'll find jobs waiting. Get more details of this fascinating profession. Write for big **FREE** book "Big Pay the National Way." Send postal now and you'll have whole proposition within 72 hours. Address: **NATIONAL SCHOOL OF MEAT CUTTING, Inc.** Dept. 10-A Toledo, Ohio

SONG WRITERS!



SUBSTANTIAL ADVANCE ROYALTIES are paid on work found acceptable for publication. Anyone wishing to write either the words or music for songs may submit work for free examination and advice. Past experience unnecessary. New demand created by "Talking Pictures" fully described in our free book. Write for it Today. **NEWCOMER ASSOCIATES**
759 Earle Building, New York, N. Y.

NOW YOU CAN EASILY

Educate Yourself

—And Soon Make Big Money



AT last it is possible for you to complete your education at home in a new, simple and inexpensive way.

☐ **THE OUTLINE OF MAN'S KNOWLEDGE**, by Clement Wood, is a complete outline of all branches of education. The man or woman who reads this remarkable book will be better educated than 99 out of 100 college graduates.

☐ It is what you know that really determines your own future. An educated man has the best opportunity for advancement—

socially and financially. Now, by simply reading this one fascinating book you will easily and quickly absorb all that men and women must know in order to succeed and forge ahead.

Read It FREE

Mail the coupon for a copy of **THE OUTLINE OF MAN'S KNOWLEDGE**.

Read it for a week at our expense. Thrill to the story of all that man has done and learned from prehistoric times to radio and television. Then, at the end of the week, either return the book or send us only \$1.50 first payment and two dollars a month for two months thereafter. Fill in the coupon and put it in the mails at once.

LEWIS COPELAND COMPANY, 119 West 57th St., Dept. 554, New York

LEWIS COPELAND COMPANY,

119 West 57th St., Dept. 554, New York, N. Y.

Kindly send me **THE OUTLINE OF MAN'S KNOWLEDGE**, illustrated, handsomely bound. Within 7 days I will either return the book or remit \$1.50 as first payment, and then \$2.00 per month for two months, a total of \$5.50. (Ten percent discount for cash with order. Same return privilege.)

Name.....

Address.....

City..... State.....

If outside continental U. S. send \$5.00 with order

Learn AUTOS

I Train You
At HOME

up to **EARN \$5000 A YEAR**



Start to Make Money Quick Like Morrision

M. J. Morrision, Parkersburg, W. Va. (photo at right), never had a day's experience on cars before starting my training. Read what he says when less than half-way through his "JOB-WAY" course. "What I have already learned is worth over \$500 to me. I have gone into business and I'm making over \$50 a week clear, with wonderful prospects." And what Mr. Morrision and hundreds of others have done I will help you to do!



M. J. MORRISTON, Parkersburg, W. Va.

Clip this Coupon Now for my Big **FREE AUTO BOOK**

3 repair & testing OUTFITS INCLUDED

The World's biggest, most fascinating business needs you!

You needn't slave away at small wages another minute—mail coupon and I'll tell you how I train you at home in your spare time for positions paying up to \$150 a week. Unlimited opportunities for trained Electrical and Mechanical Auto Experts. Let me show you how my "JOB-WAY" training has prepared hundreds of men just like yourself for a quick, brilliant success in the Auto business.

Earn Up to \$150 a Week!

Don't sell your time for low pay! You don't need to when you have my "JOB-WAY" training. As Directing Engineer of this Institution I know what training you need to succeed. AND I GIVE YOU THAT TRAINING right in your own home. MASTER every branch of Auto, Truck and Tractor work. I train you with JOBS—not books. I bring the original "JOB-WAY" training TO YOUR HOME!

No Other "JOB-WAY" Training!

My training includes ALL Electrical work—Ignition, Starting, Lighting—ALL Mechanical end, Welding, Brazing, Vulcanizing—also Business Course—also Monthly Magazine, also 3 Testing and Repair Outfits. Nowhere else I know of, can you get ALL this.

Six Billion dollars spent each year to repair 18 Million Autos, Trucks, Tractors—It's the world's biggest business. Amazing money opportunities everywhere for trained men. My Employment Service helps you to big jobs, and I help you to get into business for yourself.

AVIATION Training FREE of extra cost

Coupon brings full details of complete Aviation Training. I am offering FREE of extra charge. Send it now.

Read My Agreement!

Ten agreements in my big free Auto Book. No. 1 is "I will refund every cent of your money if after receiving my training you are not absolutely satisfied." This and nine other wonderful agreements make my "JOB-WAY" course the training for you! Be sure to get my book and read all ten agreements.

Experience, Education Not Needed!

I don't care how little schooling you have. I will train you to become an Auto Mechanic or refund your money! Boys and men of all ages have become Garage owners and managers, Superintendents, Foremen, Auto Experts, BIG PAY executives, after completing Cooke "JOB-WAY" training. I prove to you that I will prepare you to take advantage of the many wonderful opportunities of the great auto business!

Get My Big Book Quick!

I will send it to you without one penny of cost. Read all the facts, find out about the demand for trained Auto Experts. Let me tell you how easily and quickly you, too, may become an Auto Expert. Splendid offer right now to ambitious men. Coupon brings complete information. Mail it today!

Address Me Personally **B. W. COOKE** DIRECTING ENGINEER
MOTOR INSTITUTE OF AMERICA

Formerly Chicago Motor Training Corporation

Motor Institute Bldg., Dept. 9167, Evanston, Ill.

MAIL THIS COUPON NOW!

Free Auto Book

B. W. COOKE, Directing Engineer, Motor Institute of America Formerly Chicago Motor Training Corporation Motor Institute Bldg., Dept. 9167, Evanston, Ill. Send me FREE your Big Auto Book "Auto Facts" and proof that you will train me in spare time at home. Also reserve Complete Aviation Course and 3 Testing and Repair Outfits without obligating me.

Name.....
Address.....
City..... State.....
Age..... Occupation.....

Become a Trained Radio-Technician



in
**90
DAYS**

RADIO INDUSTRY

Pleads For "Registered" Radio Experts



MICHAEL ERT, President, Michael Ert, Inc., and Past Pres. Wis. Radio Trade Assn. and Pres. Federated Radio Trade Assn.

Opportunity beckons as never before in the Radio Industry. Good paying positions, interesting work, a chance to become independent—radio offers all this and more to ambitious men who seize the opportunity NOW!

Radio Trade Association Approves S. of E. Radio Graduates

The Wisconsin Radio Trades Ass'n now compels every radio service man to pass severe examinations and become registered. Dealers are tired of untrained, incompetent help. Radio trade associations the country over are planning to follow Wisconsin's example. *The School of Engineering is the only institution in the country whose course is approved by a radio trade association.* Graduates of the S. of E. are "registered" without examination—14 S. of E. men successfully employed by R. C. A. Photophone, Inc.

Most Thorough Practical Radio Course in America

Here in this big splendidly equipped electrical school (from which Station WISN is operated) you can secure in three months the most thorough, the most compact and practical radio training offered anywhere. Covers entire field of radio! Complete course includes Radio Laboratory Practice, Radio Telephony Theory, Radio Transmission, Code Instruction, Electrical Mathematics, Service and Installation, Radio Sales and Merchandising. Daily broadcasting from WISN. All training is 100% practical. You learn everything in three short months!



TELEVISION INCLUDED

Complete Radio Course also includes study of fundamentals of Television and latest developments in that gigantic new field. Enables anyone to keep up with progress of this new industry.

EARN WHILE YOU LEARN

Not only do we help place our men after graduation, but we can help arrange for part-time employment for ambitious men who can finance their tuition. This will cover part if not all of your living expenses while you are taking the Radio Course at the School of Engineering.

SEND FOR FREE BOOK

Send today without obligation, for FREE catalog describing the wonderful opportunities in radio, the three month Radio Course, and details of our Earn While You Learn Plan.

SCHOOL of ENGINEERING
of Milwaukee

School of Engineering
Milwaukee, Wis.

Dept. P. M. 1029A

Without obligation, please send me FREE Book describing your 3 months Radio-technician course and full details of your "Earn While You Learn Plan."

Name.....Age.....

Address.....

City.....State.....



BOYS

It's Fun to Make Things

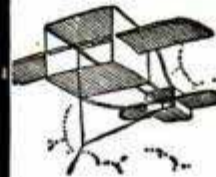

Let the other boys wonder how you can make so many interesting things. Make your own automobile. Make your own radio. Make your own kites and gliders. You can learn how to make almost anything that any boy could want by following the pictures and the simple directions in

The Boy Mechanic Library

And just think of it, there are nearly 4,000 separate articles in the four beautiful volumes! Some of the most fascinating subjects are listed below:

How to Make Things

- | | |
|-------------------|-----------------------|
| Boats | China painting |
| Winter sports | Decorative metal work |
| Camping | Furniture making |
| Ice boats | Farming |
| Water sports | Poultry |
| Toboggans | Models |
| Tents | Laboratory helps |
| Skis | Household helps |
| Indian snowshoes | Wood working |
| Skating | Electrical devices |
| Gymnasium | Photography |
| Wind wagons | Music |
| Motor sleds | Outdoor games |
| Radio | Stoves |
| Magie | Furnaces |
| Trapping | Wireless |
| Pets | Tricks |
| Leather work | Puzzles |
| Carpentry | Bicycle |
| Painting | Flowers |
| Toys | Hunting |
| Fishing | Kites |
| Fruit growing | Metal working tools |
| Entertainments | Secret locks |
| Automobile | Swings |
| House decorations | Sleds |
| Drafting | Power devices |

Buy the complete library, including Book 1, Book 2, Book 3 and Book 4, for \$7, thus saving \$1 as single volumes are \$2. If you want individual books at \$2 each order by number 1, 2, 3 or 4.

When the postman delivers the books to your door, pay him the price of the books and the postage. That is all. If outside U. S. remit when ordering and include 28 cents per volume extra for postage.

POPULAR MECHANICS PRESS
200 E. Ontario St.
Room 710 CHICAGO, ILL.



2½ Tons Heats 6 Rooms!

"With our Bulldog Furnace we use about 2½ tons of coal a winter on the average, and it is cozy all the time. We have only a 6-room house so we just use a third of the grate. Three cheers for the 'Bulldog!'"
Frank H. Taylor, Dunning, Nebr.

Fuel Saved Pays for Furnace

"This is the second winter I have used the Bulldog and the savings in my coal bills have paid for my furnace!"—Milton E. Spain, Casey, Ia.

After 6 Years—"Heats as Good as Ever"

"Our furnace has been in use 6 years and heats as good as ever."—Arthur Cloepfl, R. F. D. No. 1, Rock Port, Mo.

Does the Work of 3 Stoves

"This is my third winter with the Bulldog. It does the work of 3 coal stoves, which only warmed up part of the house and not very well at that. My Bulldog not only does that, but also 3 rooms upstairs, with great satisfaction. My house is located in a very cold place, with no protection at all."—Edwin C. Diplock, 106 Elm Street, Camden, Maine.

No Money Down!

Small Monthly Payments—Installed Almost as Easily as a Cook Stove!

The Bulldog is sent to you for *free inspection*. Then, if satisfied, you make only small monthly payments at our remarkably low price. Write today! *Don't miss this chance to cut down your fuel bills! Install a Bulldog Furnace!* It comes to you completely erected—goes through any door—fits any height of basement—and you install it yourself in less than two hours! In fact, you can install the Bulldog just about

as easily as a kitchen cook stove. *Don't put up with the old fashioned stove heat or some outworn furnace—when you can so easily get the greatest advance in scientific heating at an astonishingly low price.* The Bulldog burns almost any kind of fuel, from hard coal to cheap screenings. Keeps a wood fire over night. We have factory connections in both east and west and ship from the nearest point.

Send for Free Book!

Learn how to have all the heat you want—where you want it—and save money! Remember the Bulldog is *different—and better!* Complete combustion of gases save 25% of your fuel bill. Exclusive Gable-Top Radiator receives *all* the direct rays of the fire. Exclusive oblong fire-pot is not only ideal for coal, but enables you to keep a wood fire over night. Remember—the Bulldog is sent for *free inspection*—then small monthly payments at an amazingly low price!—Send for Free Book TODAY!

Bulldog Furnace Co., 19th and California Avenue, Dept. 13-57 Chicago, Ill.

Bulldog Furnace Co.,
19th and California Ave., Dept. 13-57, Chicago

Without obligating me, please send me your free catalog and special offer on the Bulldog Furnace.

Have you a basement? Yes No

Name.....

Street Address.....

Town.....

County..... State.....

3321

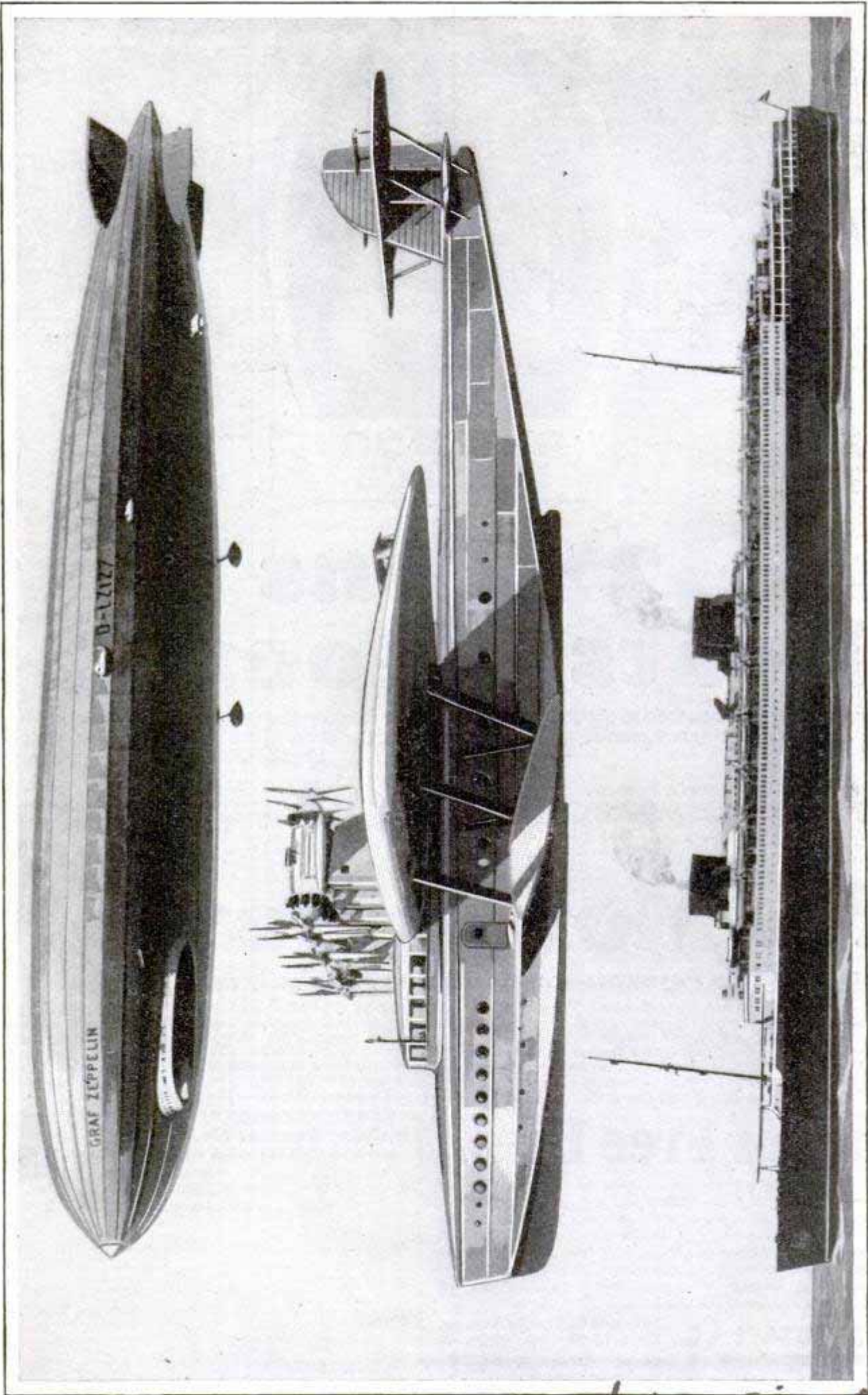

Germany's Peace-Time Triumphs of the Air and Sea; the "Graf Zeppelin," the Big 100-Passenger Dornier Seaplane, Propelled by Twelve Motors, and the Steamship "Bremen," Breaker of Ocean Speed Records; These Three Huge Units Promise a Complete Change in the Picture of International Transportation

International

Popular Mechanics Magazine

REGISTERED IN U. S. PATENT OFFICE

WRITTEN SO YOU CAN UNDERSTAND IT

Vol. 52

OCTOBER, 1929

No. 4

3268

Planes Aid Fire Fighters

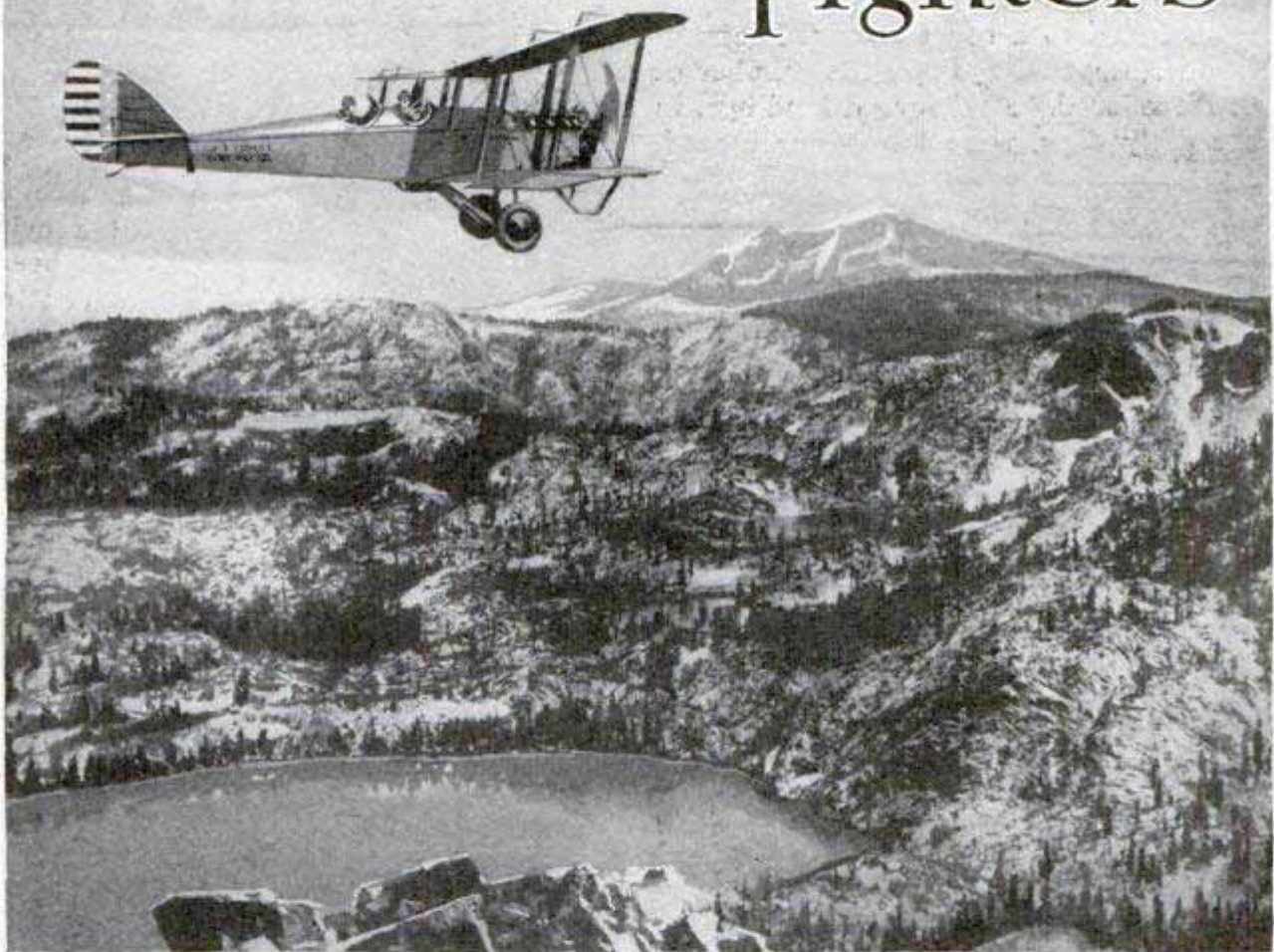

By K. M. PAINTER,

*28 Bull St.
Newport, R.I.*

A VOICE thundering advertisements from the skies suggested the possibility of using a loud speaker in fire-patrol planes to direct the ground forces in their war on forest fires.

When the great fire swept over the Sierra Madre mountains a few years ago, fire fighting was directed from the city hall, and many hours elapsed before an

order could be taken to the men at the front.

Now, by using an airplane equipped with a loud speaker, an order can be given directly to the fire fighters. With such an airplane to patrol the fire front, the men can be kept working at greater advantage and out of zones of danger.

At the close of the World War, the

army co-operated with the forestry service and established an aerial patrol system. During the first four years of patrol work, definite routes were followed, varying from 200 to 500 miles in length. Each plane was equipped with a radio sending set. The ground stations were so located that when a plane passed from the receiving range of one station, it went within the radius of another. By this means all new fires discovered, and the status of old fires, could be reported immediately.

A pilot and observer were in every plane. The pilot attended exclusively to the flying duties, while the observer confined his attention to finding and reporting fires. To adequately cover the territory assigned to a route required four to six hours, depending upon the number of fires discovered. And forced landings, in those early days, were hazardous indeed, but more and more fields are being cleared to reduce the risk involved in "lighting in the trees."

In 1928, the forest service stopped the use of army planes and contracted with commercial companies for its aerial patrol work. These contracts were made with flying companies operating in Oregon, Washington, northern Idaho, western

Montana and California. Bases were maintained at Tacoma and Spokane, Wash.; Portland, Oreg., and Oakland and Los Angeles, Calif.

Thus, today, the airplane works in co-operation with the forest ranger or "lookout." When the lookout sights smoke, he must locate the spot of conflagration on his regional map. Then, by telegraph, he communicates with the fire-suppression headquarters of the district, and men, picturesquely called "smoke chasers" are dispatched to put out the blaze. But after severe "dry" lightning storms, when as many as 300 fires are burning in one district, it is impossible for the lookout to spot them all. Here the air patrol helps out.

When C. W. Meredith, assistant fire warden of the Los Angeles county forestry department, made his first patrol flight, he was detailed to observe the Ridge Route fire of 1928, and make a survey of its extreme western boundaries.

"We climbed aboard, taxied out, headed into the wind and were off at 5:15 p. m.," relates Mr Meredith. "While I was arranging my maps and getting ready for a hurried survey of the fire line, we were gaining altitude. We found that the ceil-

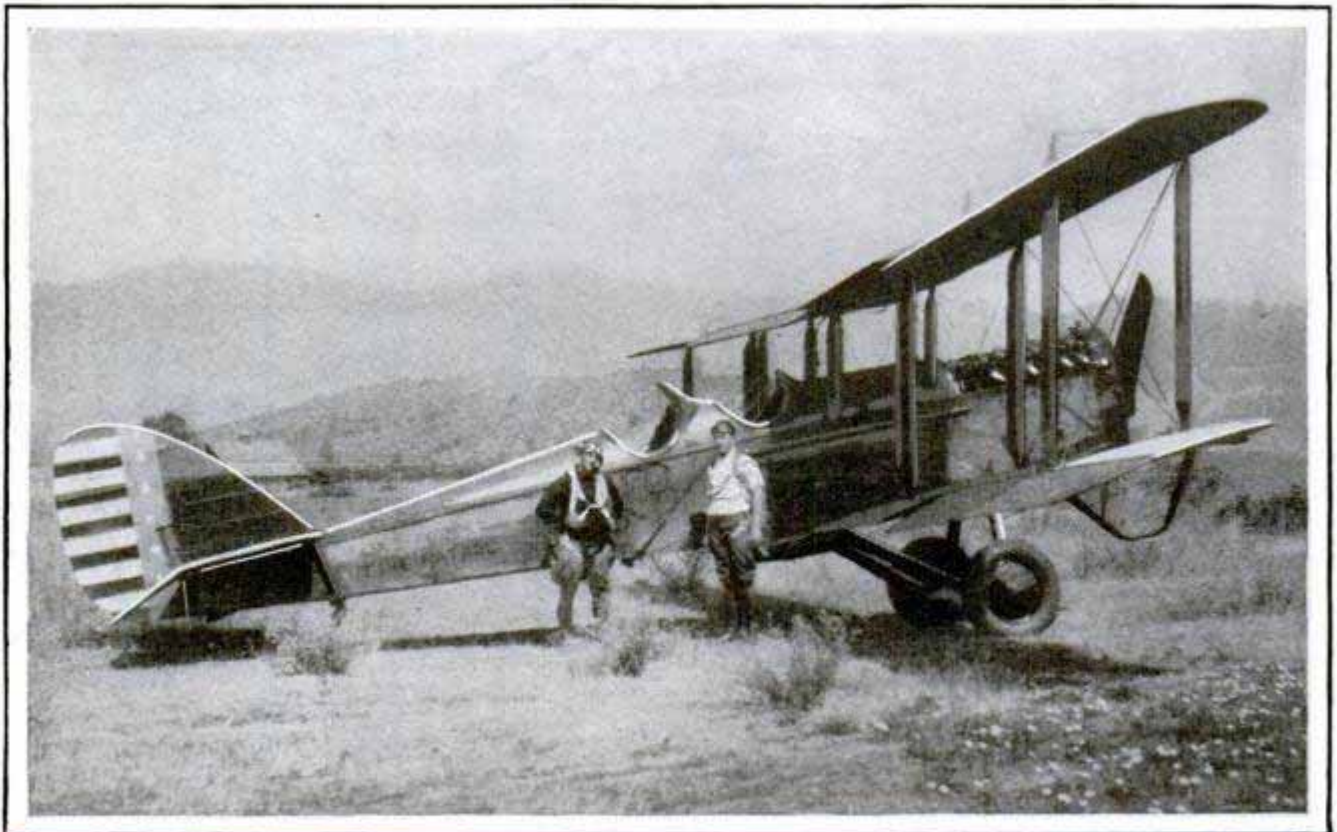

One of the Forest-Service Patrol Planes Used to Spot Fires over Klamath National Forest in California; Each Plane Carries Its Two-Man Crew of Pilot and Observer

ing was very low, and off to the west the fog was rolling in thicker than the well-known peasoup. A pall of smoke lay over the rest of the surrounding country, and my fears grew to grave concern that our mission would spell failure. It was of vital importance that the men on the ground should know the direction of the fire and at what points it was making the most headway.

"It was our duty to get the information to the fire fighters that evening, for on a going fire we have a decided advantage in our favor at night; that is, providing there is not a high wind blowing. At night the humidity rises and the temperature drops, consequently fires are reduced to a lower burning point.

"When we were over the portions of the fire that had been brought under control, I slipped out of my safety belt and grabbed my map and pencils. Being in the forward cockpit, I did not have the vision that I would have had were I in the rear. I tried standing up, but my chute inconvenienced me and the air currents over the fire made the going bumpy. My pilot took a hand, and by banking the ship to the right or left at an angle that would give better visibility, made my work much easier.

"It was close to being dark when we turned south for home, and at 6:40 p. m., we were once again at the Saugus field. I telephoned the results of the survey and reports were rushed to the camps on the fire lines. The information was obtained in one hour and fifteen minutes."



This Two-Story House Was Built Years Ago by a Prospector in the Stump of a California Redwood 3,000 Years Old

BUNGALOW ERECTED IN STUMP OF CALIFORNIA REDWOOD

In the stump of a California redwood, estimated to be 3,000 years old, a mining prospector years ago built himself a two-story dwelling which is still intact in what is now General Grant National Park. He kept his horse downstairs and lived in a room on the second floor.

BURGLAR-PROOF STRONG BOX HANDCUFFED TO CARRIER 287

Intended to thwart thieves when valuables are being carried through the streets, a woman detective has invented a strong box which is handcuffed to the carrier and also equipped with a burglar alarm. The wrist is thrust inside the cover and chained to a handle there. Pressure of the messenger's fingers sets the alarm sounding if an attempt is made to kidnap him.



To Thwart Thieves, the Messenger's Hand Is Chained to the Handle of This Strong Box

Mrs. Louella Hayes
1610 Amsterdam Ave

532
3276



© P. & A.

In Circle, German Glider Which Set Record, and, Above, Transporting It by One-Horse Power

GLIDER MAKES WORLD RECORD IN GERMAN CONTEST

Robert Kronfeld, German aviator, and his glider "Vienna," established a world record for motorless planes in the tenth annual international glider contests recently held in Germany. The "Vienna" and its pilot flew 150 kilometers (about ninety-three miles) and reached a height of 2,000 meters (4,400 feet).

tourists and sportsmen and aiding agriculture and commerce, Alaskans claim the project would also help the proposed air route to Asia by way of Alaska.

WHITE-HOUSE PHONE SYSTEM GREATLY EXPANDED

Included in President Hoover's plans for efficient administration of government business are additional telephone facilities, and a switchboard, equipped for eighty telephone lines and forty trunk and tie lines, has been ordered. Telephone service in the White House first was installed during the administration of President Hayes, but the first switchboard serving the executive offices was not in operation until 1901. The service was expanded during the war. President Hayes and President Cleveland rarely used the telephone and even President McKinley transacted little government business by phone, because the system was not extensive enough. President Roosevelt likewise did not use the telephone much, but President Taft employed it extensively and President Harding transacted daily routine business by phone. President Wilson, however, was not a telephone user, but President Coolidge found it helpful in his daily work.

AUTO HIGHWAY TO ALASKA

Alaskans are planning an automobile highway connecting that country with the United States by way of Canada, with Seattle as one terminus and Fairbanks as the other. Of the 2,000 miles necessary, 1,250 miles of road already is constructed. Aside from opening up the country to

Cont. Kenneth S. Corlies, Fairbanks, Alaska

International Highway and Airways

Western Electric Co.

EIGHTY-THREE INSTRUMENTS GUIDE AIR LINERS

3296

Flying a big tri-motored transport plane requires watching eighty-three different controls and instruments, including the separate devices showing the functioning of each of the engines. Preparatory to landing, it is necessary that pilot and copilot check the position of ten controls, and, at night, this number is increased to twelve when landing lights must also be adjusted. In one of the Boeing transport planes, there are twenty-seven electric lights, eighteen of them with individual switches. In addition to the routine operations of flying, the pilots, in landing, must adjust the horizontal stabilizer, switch on the generator cut-out, put on the reserve tank, switch on both wing tanks, put altitude adjustment to "rich" on left, central and right motors, and adjust the throttle of left, center and right wing landing lights in position.

3290

BABY HUMMING BIRD IS NURSED WITH MEDICINE DROPPER

When a California man found a baby humming bird, he took it home, but did not know what to feed it. After diligent search of bird literature, he learned that honey and sugar were humming-bird delicacies, and fashioned a nursing bottle out of a medicine dropper from which the waif learned to take its meals and soon was hopping about the house.

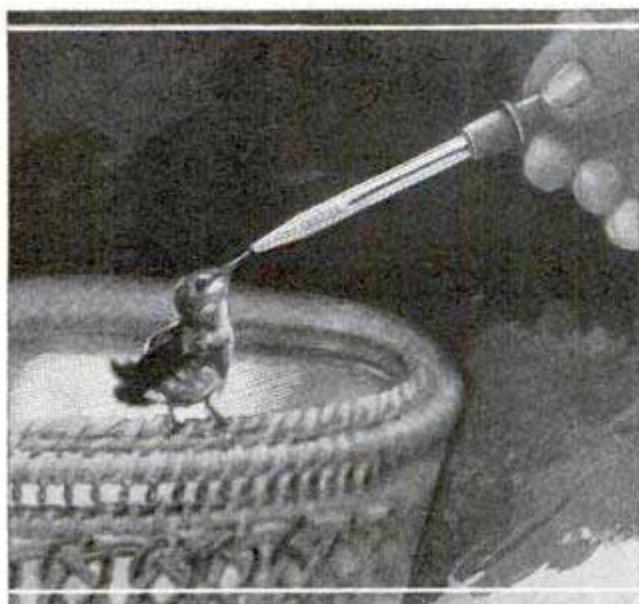

A Medicine Dropper Serves as Nursing Bottle for "Eleanor," a Baby Humming Bird

Thomas Breeze,
Hillsborough Calif



The Instrument on the Girl's Arm Measures the Effects of Violet Rays on the Skin

TIME NEEDED TO ACQUIRE TAN MEASURED BY MACHINE

Effects of ultraviolet rays on the skin are determined by an instrument used by the Chicago health department. In measuring the time required for tanning by sunshine, the minimum has been shown to be about thirty minutes. The test consists in making a series of exposures of the skin to sunlight through the apparatus, which is a metal plate containing a dozen holes with shutters. The appliance, with shutters open, is placed on the arm, and one shutter after another is closed at five-minute intervals for an hour.

NOISES FOR DRAMA OVER RADIO RECORDED ON PHONOGRAPH

3280

"Crowd noises" and background sound accompaniment of dramatic productions broadcast over the radio, including gunfire, train sounds, opening and closing of gates and doors, and cheering and hissing, are being recorded on phonograph records for permanent use by a British broadcasting company. As required, the company sends out its men to make records of noises of trains and elevators or of water lapping along a beach, as the play may specify. The method is costlier than the older one, but more realistic.

Carl Wilson

London, England

Quartz cell. Hammaria Chemical Co, Newark, N.J. Other apparatus assembled by the Journal of Preventive Medicine.

WORLD'S FIRST ALL-METAL DIRIGIBLE BUILT

crasse de nuit

3286

see March 1929 - 447

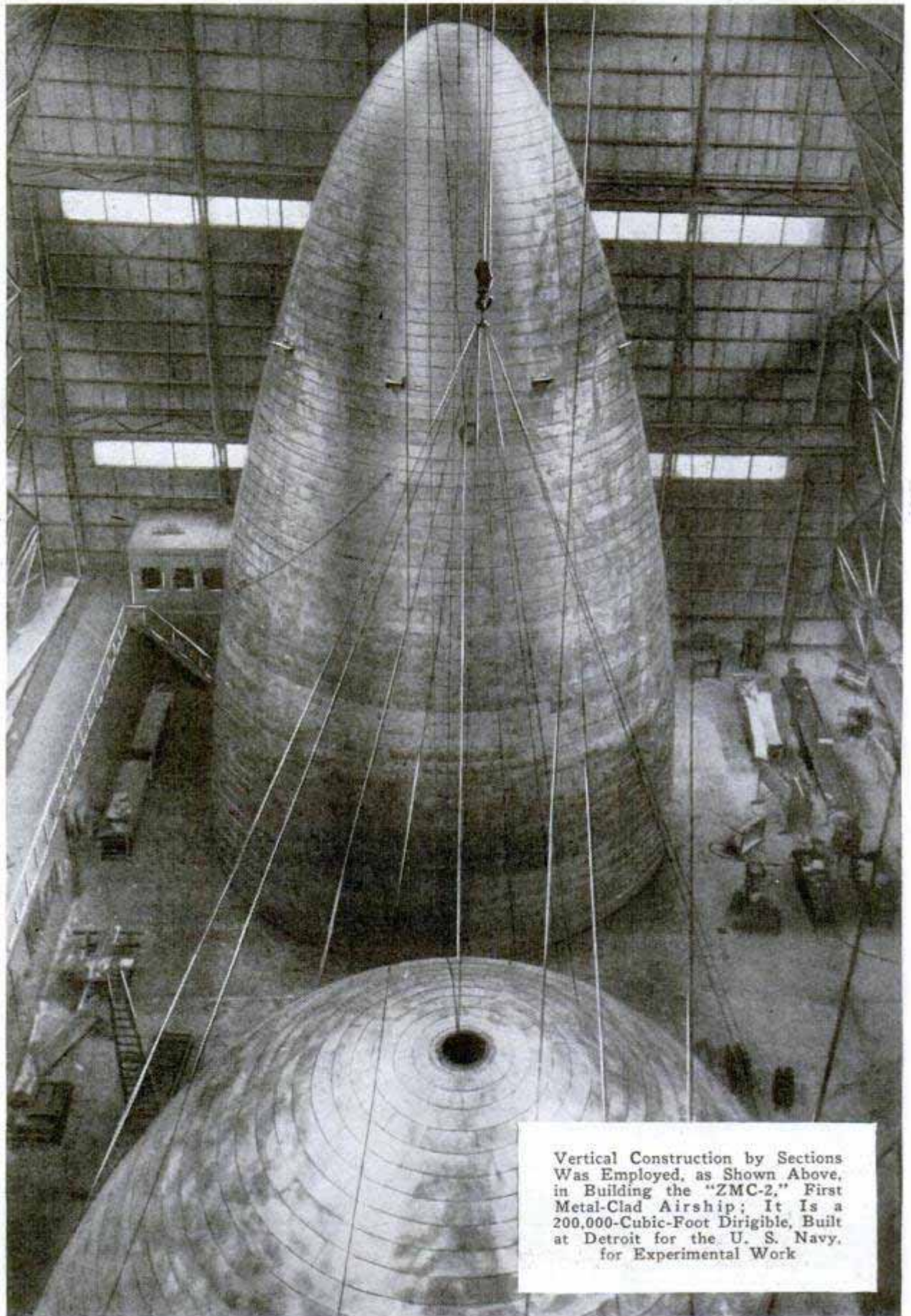

Vertical Construction by Sections Was Employed, as Shown Above, in Building the "ZMC-2," First Metal-Clad Airship; It Is a 200,000-Cubic-Foot Dirigible, Built at Detroit for the U. S. Navy, for Experimental Work

FOR THE NAVY HAS A LONG FLYING RADIUS

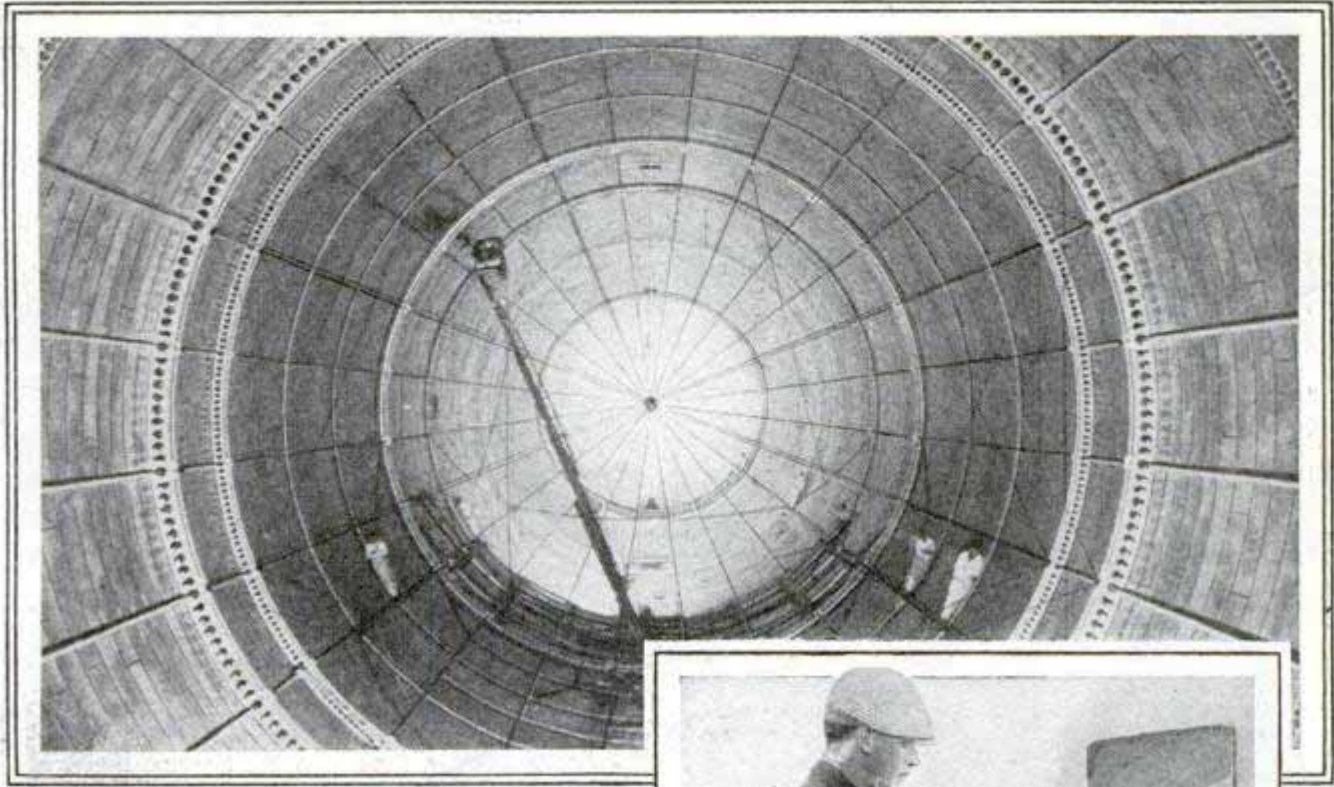

Above, Unusual Interior View of the Metal-Covered "ZMC-2," Which, Engineers Say, Is the Forerunner of Super Metal Airships to Be Used in Transoceanic Flight; at Right, Automatic Riveting Machine Used to Build the "ZMC-2," Which "Sews" 5,000 Rivets an Hour and Does the Work of 120 Men; in the Metal Ship There Are 17,596 Feet of Riveted Seams, or About 3,000,000 Rivets; Below, Front View of the All-Metal Control Cabin and Some of the Motors, Developing 440 Horsepower

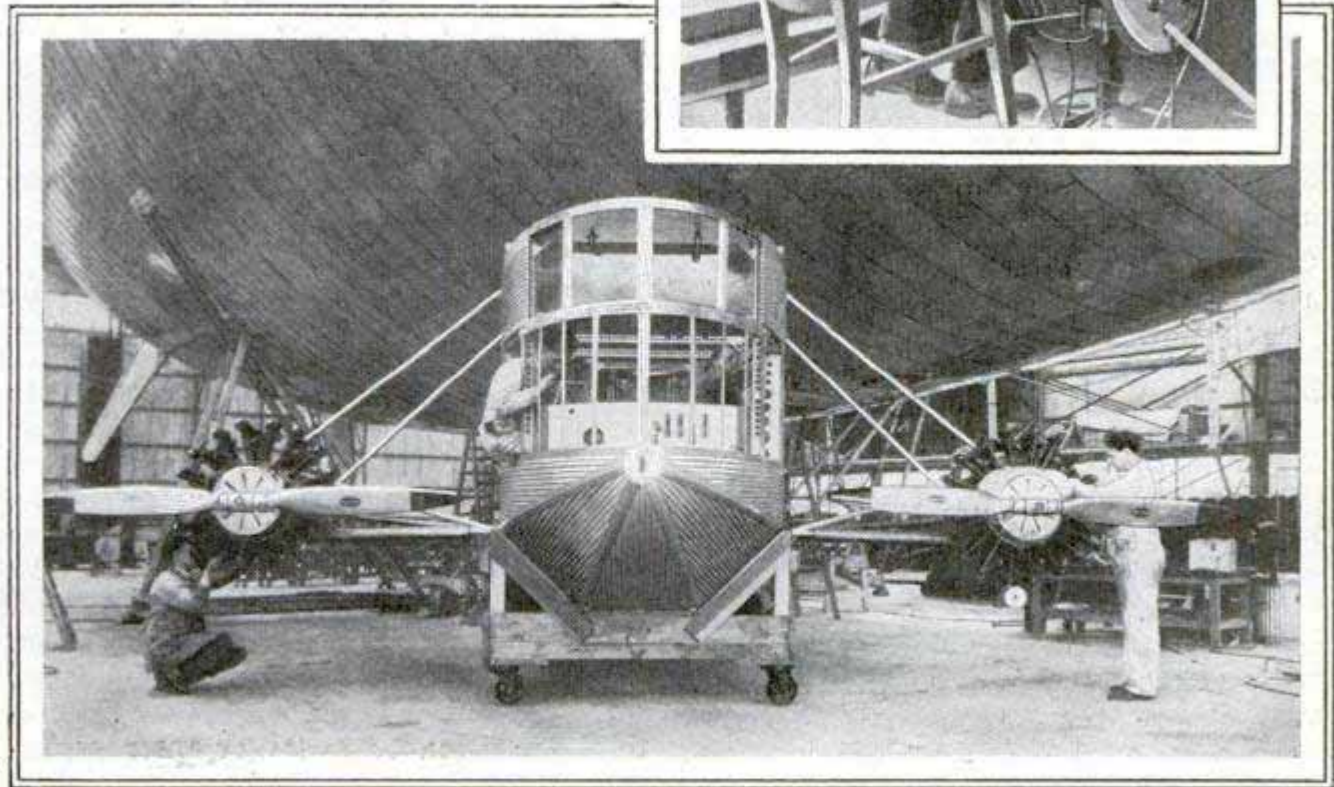
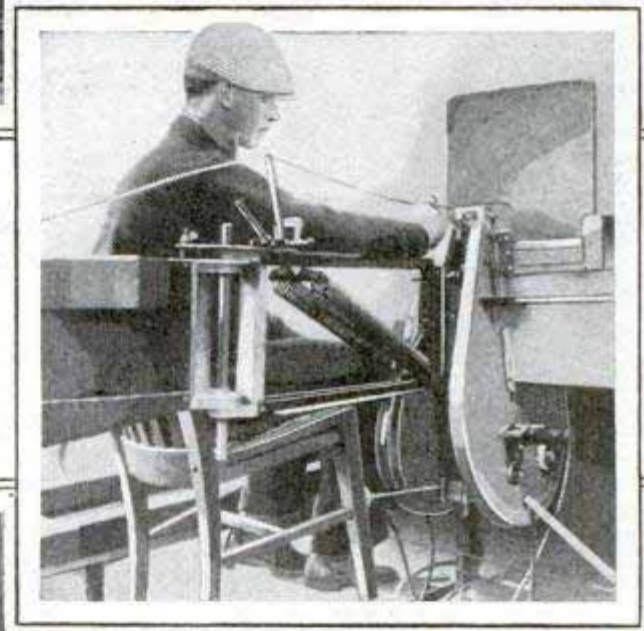

for Michigan California Lumber Co
near Camino Calif

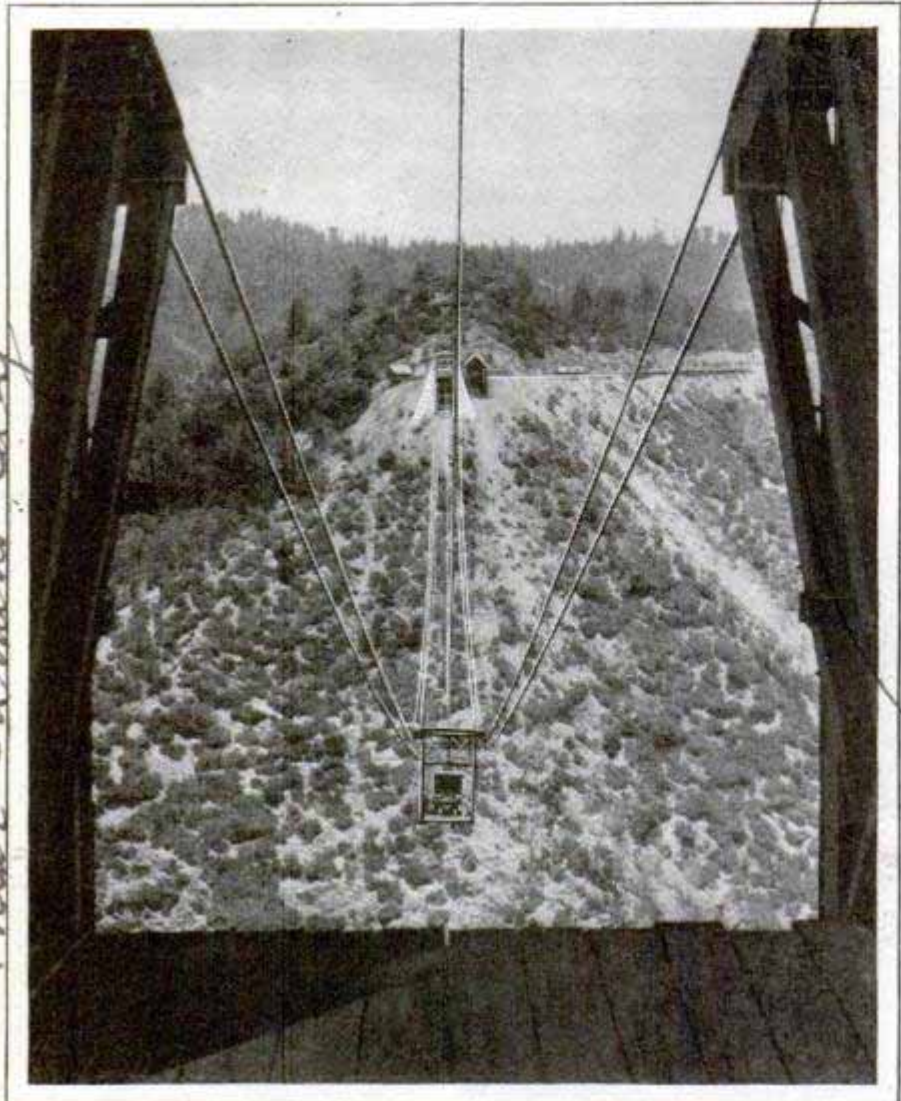

Courtesy General Electric Co.
An Electric Cableway Which in Six Minutes Transports 24,000 Pounds of Lumber a Half Mile over a 1,200-Foot Canyon

ELECTRIC TRAM HAULS LUMBER OVER HALF-MILE CANYON

Spanning a canyon a half mile wide, the largest electric cableway in the world transports lumber from a loading point on one side to the mill on the other, near Camino, Calif. The tram carrier hauls 24,000 pounds of sawed lumber between the two terminals, 2,700 feet apart, making a round trip over the 1,200-foot canyon at a maximum speed of 1,800 feet a minute. The round trip takes a little over six minutes, including loading and unloading. Four steel cables, each two inches in diameter, support the carrier, which runs on thirty-two wheels, while the one-inch traction rope is endless. The electric equipment includes two 225-horsepower hoist motors, operating in parallel. A single manually operated master con-

troller governs both motors, geared to two large sheaves which engage the traction rope. Stopping the carrier normally is accomplished automatically, in four graded steps, and "spotting" the car at terminals for loading or unloading is accomplished by the use of a push button. Magnetic brakes will stop the carrier when descending if the power fails.

MIRRORS AND LOUD SPEAKERS DIRECT COAL-YARD GANG

Executives of a Toledo, Ohio, coal company issue their orders to yard employes through a public-address system and see that their instructions are being obeyed. The system involves the use of a reflector combining the properties of mirror and field glasses along with the voice-amplification unit. A man receiving a message through the loud speakers raises his arm to indicate that he has heard it, and this movement registers on the operator's mirror.

SUN'S ACTIVITY HELPS RADIO RECEPTION IN DAYTIME

Better daylight radio reception in 1929 has been attributed by the bureau of standards to solar activity. A study has revealed that daylight reception this year has been at a maximum and static at a minimum as compared with recent years, and solar activity also has been at or near its maximum in its eleven-year cycle. In 1923 and 1924 reception was weak, and static was high, but since 1927 has been falling off. When solar activity increases, something resembling ultraviolet radiations are given off in larger amounts, affecting the earth's electrical atmosphere.

Early news 8/7/29

3265

W. C. ... Co. 193

The Facts About Hail



Courtesy Dr. Clyde Fisher

Hail Fell to a Depth of Three Feet on the Level during This Remarkable Storm in New Mexico; Note the "Natural Bridge" Formed by Stream under Hailstones

By CALVIN FRAZER,

*Pactogran Co
Box 8040
Washington
D.C.*

THOUGH hail is familiar to everybody, the majority of human beings go through life without witnessing a really destructive hailstorm. Many such storms occur every year, but each is limited to a relatively small portion of the earth's surface.

Although, geographically speaking, the severe hailstorm, like the tornado, is always a small affair, it represents such a concentration of nature's destructive fury that, in the aggregate, hailstorms levy a heavy toll on property. The average annual damage done by them in the United States is three or four times that done by tornadoes. According to a recent estimate, the hail losses on ten leading agricultural crops of the country amount to \$47,500,000 in the average year. The losses on these crops in the year 1915 totaled \$69,000,000. Last year there were two hailstorms in the state of Kansas, each of which cost the farmers \$3,000,000.

The loss sustained by agriculture is only part of the annual hail bill. In the old world some of the heaviest losses occur in vineyards, and on both sides of the ocean, greenhouse glass comes in for an immense share of damage. Ordinary windows are sometimes broken on a large scale. A remarkable case of this kind occurred in Vienna, Austria, when an early-morning hailstorm smashed more than a million window panes in the course of a few minutes. Another possibility in the line of hailstorm losses was illustrated at Dallas, Tex., in 1926, when big hailstones riddled the tops of thousands of automobiles, shattered many windshields and wrought damage totaling about \$100,000 to these vehicles. This hailstorm was the most destructive that has ever occurred in an American city. Tons of ice fell on streets and buildings during a period of fifteen minutes, and in the business center of the city the stones attained

3194
the size of baseballs. Not only were thousands of windows and skylights broken, but a great many tile, slate and shingle roofs were wrecked, street lights and electric signs were shattered, and there was the usual damage to greenhouses. The losses in the city and its vicinity were estimated at \$2,000,000.

According to an official publication of the weather bureau, an unusually severe hailstorm swept a path five miles wide across the southern part of Gove county and the northern edge of Lane county, Kansas, on the night of June 4, 1927. The report says: "Fields in the path were left as bare as a highway. Trees were stripped of branches and leaves, and horses, cattle, hogs, sheep, rabbits, chickens and wild birds were killed. Hailstones piled into drifts eight to fifteen feet deep, and many of these drifts remained for three days after the storm."

There is a proverb in eastern Europe to the effect that "hail brings not hunger"; referring to the fact that, because of its local character, a hailstorm cannot cause a general famine. There was, however, a case in which a hailstorm caused such widespread distress that it helped bring about a great social upheaval—the French revolution. Beginning in the center of France in the early morning of July 13, 1788, this storm passed northward in two parallel bands about twelve miles apart,

crossed Belgium, and finally died out in Holland in the afternoon. One band was ten miles wide and 420 miles long, the other five miles wide and 500 miles long; making the total area over which hail fell vastly greater than in the average hailstorm. No less than 1,309 communes in France suffered from this visitation, and the total losses were estimated at \$5,000,000—an immense sum at that period. This disaster undoubtedly hastened the coming of the revolution.

In comparison with the enormous damage done to property of various kinds by icy missiles from the sky, the number of human beings killed or seriously injured by hail is insignificant. Why this should be so is a mystery. Leaving exceptionally large hailstones out of consideration, it is not at all uncommon for hailstones weighing from one to several ounces to fall by the thousands or tens of thousands on inhabited areas. The speed with which they fall, in many cases, is indicated by the fact that they smash skylights of heavy wire glass, pierce window panes with a clean round hole, like a bullet, and bury themselves a foot deep or more in soft earth. Why do not these missiles slay scores or hundreds of people every year? No satisfactory answer to this question has yet been offered.

The most fatal hailstorm of which we have an authentic record was one that

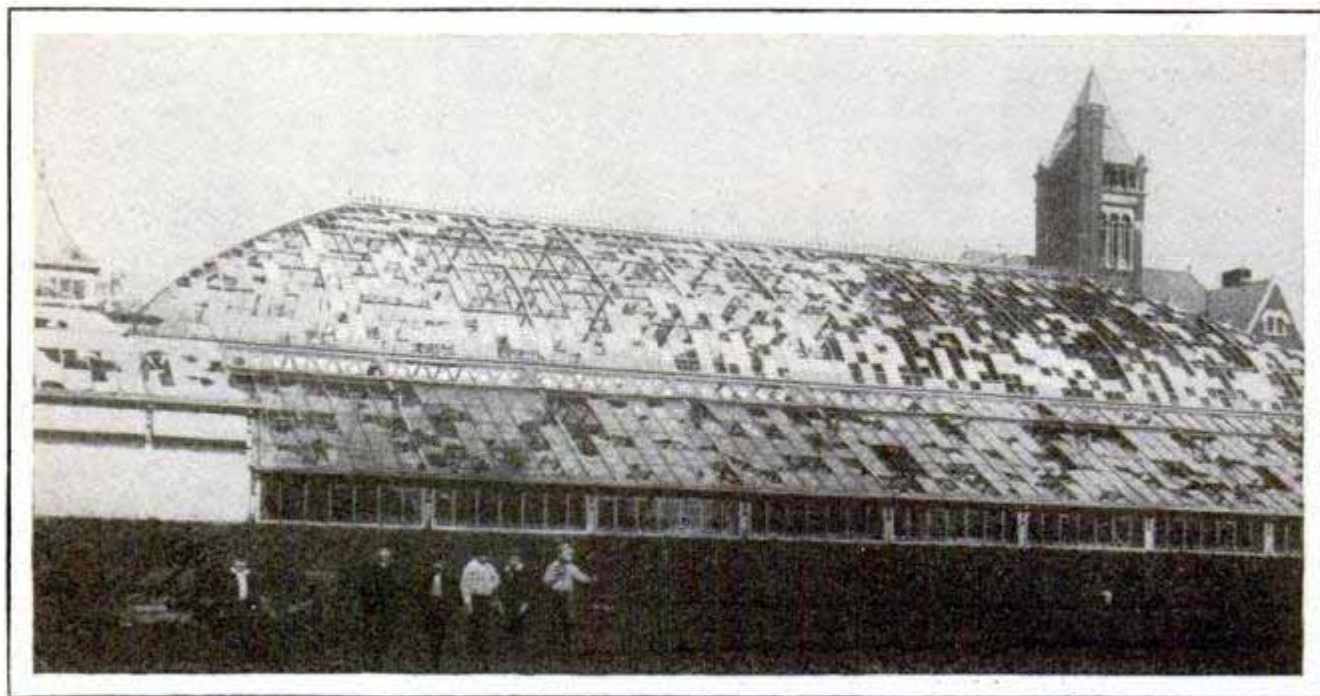

All That Was Left of the Glass in a Pennsylvania Greenhouse after a Severe Hailstorm; This Shows Why Hail Insurance Is Popular in Many Localities

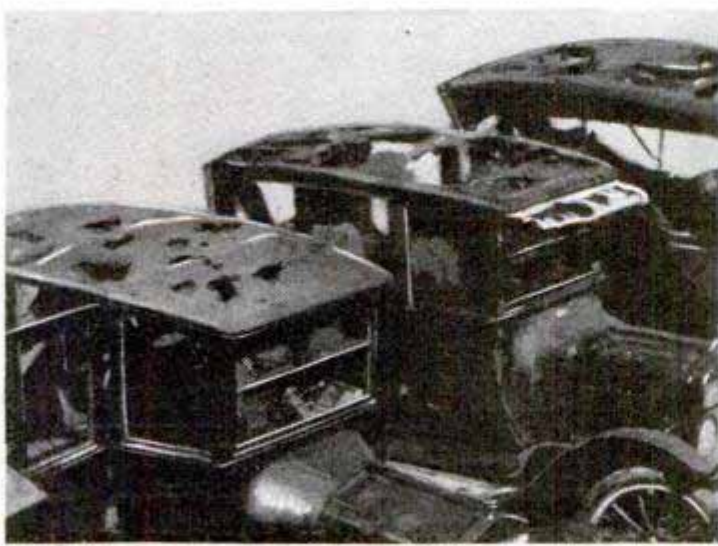

After a Hailstorm in Montpellier, France, Plaster Models of Large Stones and Auto Tops Riddled by Hail

occurred at Moradabad, India, May 1, 1888, which cost about 250 lives. According to one English writer who witnessed the effects of this storm, a majority of the victims were actually pounded to death by hailstones, but according to other reports most of them were knocked down by hail and wind, buried under the drifts, and died of cold and exposure. There have, however, been several cases reported from India in recent years in which hailstones killed from one to a dozen or more people by the direct action of the hailstones. Big hail seems to be more prevalent in India than in any other country. Writing of the furious hailstorms of eastern Bengal, Mr. W. R. Haughton says, in a recent article:

"Hailstones of over three inches in diameter are not unusual. I have seen two hundred cattle killed by hail in a single storm. These large hailstones may be sometimes seen falling few and far apart, when they look like small birds swooping down."

At the village of Klausenburg, Roumania, on May 1, 1928, six children were killed and ten

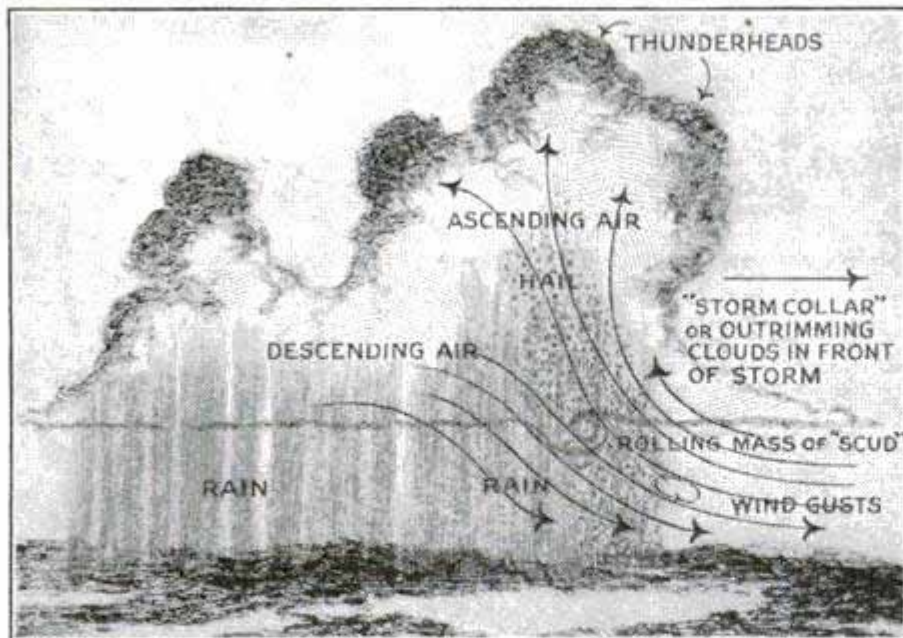

Cross Section of a Typical Thunderstorm, According to Dr. W. J. Humphreys of the Weather Bureau, Showing Ice or Hail "Factory" in Clouds

packed closely on the ground readily freeze together to form huge masses of ice is at the bottom of all the most remarkable hailstone stories not made out of "whole cloth."

Not all particles of ice that fall from the sky are hail. Little pellets like miniature snowballs, about the size of coarse shot, falling in cold weather, are known to science as "graupel," while the bits of clear ice, like frozen dewdrops, that also fall during the cold season are called

adults were badly injured by hail during the celebration of the May-day festival. On July 4 of the present year two men and one woman were killed and several persons were injured by hail in the suburbs of Nuremberg, Bavaria. These events were quite exceptional, however, for in most years there are no deaths from hail in Europe, and apparently not more than two or three have been recorded in the whole history of the United States; the only case of recent date was on May 21, 1928, when a fourteen-year-old boy was killed by hail while working in a field near Laredo, Tex.

The maximum size attained by hailstones is a matter of great uncertainty. A new record of size for the United States is said to have been established by the storm that occurred at Potter, Nebr., on July 6, 1928, when among numerous hailstones "as large as grapefruit" one was found to be seventeen inches in circumference and to weigh one and a half pounds. This huge stone, with several others, was measured, weighed and photographed. At Cazorla, Spain, on June 15, 1829, houses were crushed under blocks of ice some of which are said to have weighed four and a half pounds. In the summer of 1902, hailstones weighing ten pounds were reported by an English missionary to have fallen at Yuwu, Shansi province, China. The missionary undoubtedly found such stones, but did they fall? The fact that hailstones lying

"sleet." True hail occurs almost exclusively in connection with thunderstorms. It is usually of brief duration, though it has been known to fall steadily in one place for more than an hour.

A distinguishing feature of true hail is that it consists partly of ice and partly of snow. Large hailstones frequently show several alternate layers of these substances. Most hailstones are approximately spherical or somewhat conical, but other and very striking shapes are sometimes found. The peculiar structure of hailstones is explained by the fact that hail is formed in the turbulent region at the front of a thunderstorm, where it makes several journeys up and down between relatively cold and warm regions of the atmosphere before finally falling to earth. At high levels the incipient hailstone is coated with snow and at lower levels with rain, which changes to ice as the stone is again carried aloft.

Red hail is a reality, though very rare. As in the case of red rain and some red snow, the color is due to fine dust in the atmosphere.

EARTH AS GREATEST DYNAMO YIELDS MUCH ENERGY

Generating enough current to supply light, heat and other electrical needs for the ten largest cities in the United States for 1,000,000 years, the earth is a huge dynamo and one of the greatest electrical

3309

Science Service Bulletin
437 C, 8/7/29

wonders of the universe. Dr. Ross Gunn of the naval research laboratories, estimates currents generated inside the earth at more than 200,000,000 amperes, although this energy, like atomic energy, is unavailable for use by man, being kept in nature's storehouse for the benefit of generations perhaps a million years hence. He attributes the electrical currents inside the earth to the motions of tiny electrical charges known as electrons, the motions being caused by the high temperatures existing inside the earth.

the Hans bench 3113

REMOVES POISON FROM DRUGS

Drugs such as those contained in morphine, coffee or tobacco may be made innocuous while preserving full medicinal qualities, a German scientist declares, by adding small quantities of lipoid, a neutralizing wax or fat-containing matter which is present in many animal and vegetable bodies. With coffee, for instance, the scientist says, the addition of a few drops of lipoid entirely obliterates the noxious effects, while preserving the nutritive and momentarily sustaining effects.

Hamburg Huesch

ELECTRIC TOASTER FOR BUNS MAKES HOT SANDWICHES

Bun sandwiches may be served hot and toasted by using an electric oven intended primarily for buns, but which may be used for bread also. It takes from five to ten buns, or eight slices of bread, at a time and requires less than a minute for toasting. The device adjusts itself automatically to various sizes of buns.

Int. a. Ben

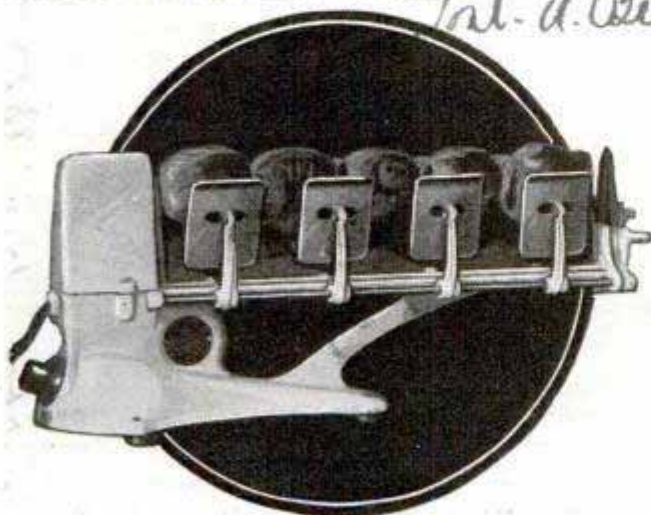

An Electric Toaster for the Quick-Lunch Counter Provides Customers with Hot Bun Sandwiches

*National Appliance Co
205 W. Wacker Drive*

RAISED BENCH FOR SHOE STORE MAKES FITTING EASIER

3253



Fitting Shoes Is Made Easier for Salesman and Customer by Using This Raised Bench

Paul

Greater comfort for customer and salesman alike is provided by a raised bench for the purchaser of shoes which brings him up to a height where the clerk may fit shoes without stooping. Wide steps are provided for the bench, and to the salesman's right is a cabinet where shoe accessories may be kept.

TALKIES FOR THE DEAF

3264

Talking pictures are proving a source of amusement for the hard of hearing in Brooklyn, where a section of a theater has been fitted with acoustic equipment for the use of persons whose hearing is impaired. Each seat of the section has a receiver and headpiece and a potentiometer, shaped like a fountain pen. A control button on this instrument regulates the volume of sound to the hearers' needs. According to government statistics, there are 15,000,000 deaf persons in the United States, and many of them viewed the talkies with alarm because they feared they would be unable to follow the picture without the usual titles.

Paramount

*June 6/20/29 = Ch. Obster in
Ermer & Arnold*

3216

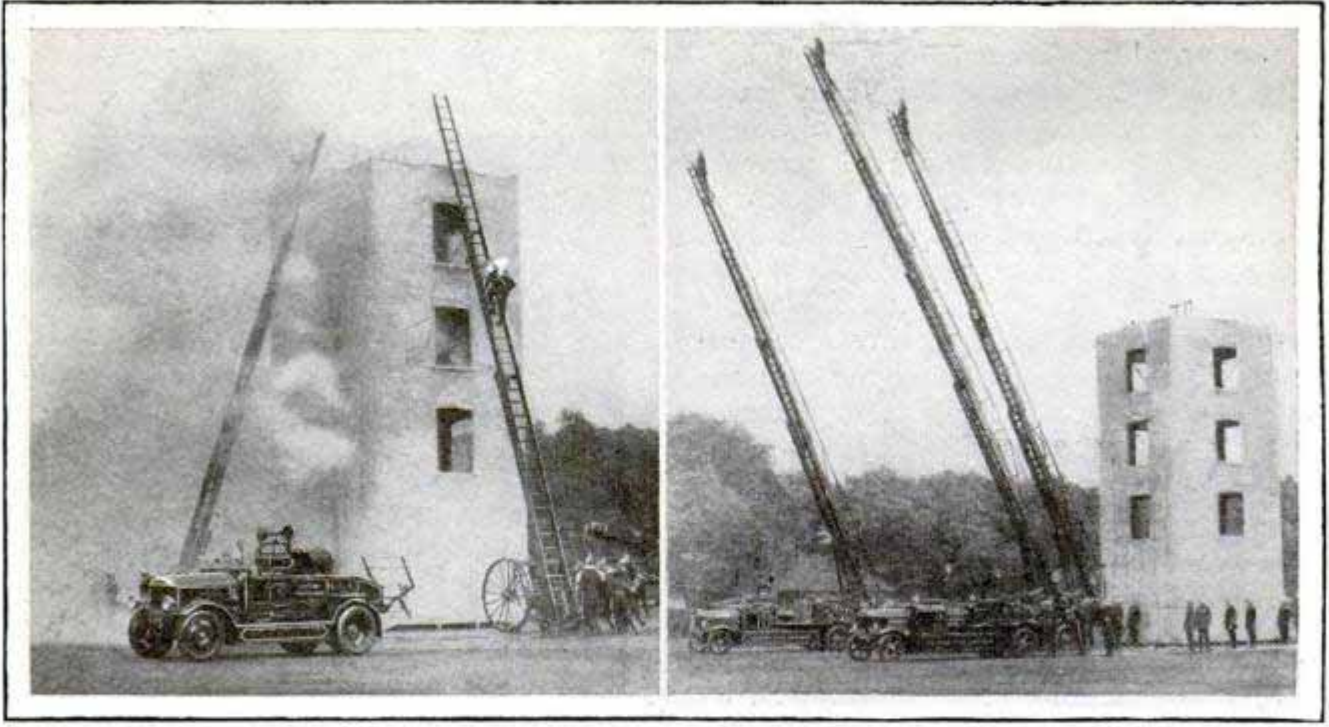

© P. & A.

The Prince of Wales Witnessed a Display by the London Fire Brigade, Including Thrilling Rescues from a Burning Building and Daring Feats on Extension Ladders, Such as Pictured Above

LONDON'S FIREMEN DO STUNTS FOR PRINCE OF WALES

London fire fighters performed stunts for the Prince of Wales at the annual display of the fire brigade recently. Among the feats witnessed by royalty was a rescue from a burning building and daring tricks executed from the top of lofty extension ladders.

time on all surfaces except concrete. The tire resembles a huge doughnut and is streamlined so its wide cross section offers minimum wind resistance.

PARACHUTE OPENED BY WATCH LOWERS MAIL FROM PLANE

Delivery of small packages of mail from an airplane while it is in flight is accomplished by an apparatus attached to the mail bag which opens a parachute after the pouch is dropped. An aluminum shell is equipped with a precision watch and is

AIRPLANE TIRE ACTS AS WHEEL AND SHOCK ABSORBER

Requiring no wheel, but fitting directly onto the hub, an airplane tire of great thickness has been successfully tested as landing gear. The cushioning effect of the tire under low air pressure causes it to act as a shock absorber as well. Brakes can be fitted to the hub, if desired, and experiments have shown that the tire reduces take-off

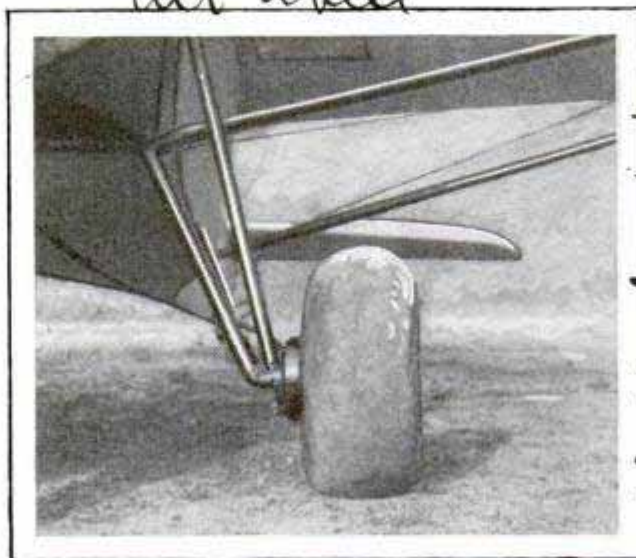

This Airplane Tire Fits Directly onto the Hub, Acting as Wheel and Shock Absorber

Air Wheel

U.S. Daily 8/5/27
Reported from Commerce office

Goodyear Tire + Rubber Co. Akron Ohio

d.w. Swiss engineer

Handwritten notes on the right margin, including the word 'copy'.

Belgian
Pittsfield Mass
other form a parachute is attached to a skyrocket which lights at the moment contact with the earth is made.

TALKING PICTURES SHOWN IN SLOT MACHINE 327

Slot machines now dispense talking motion pictures. A Massachusetts man has invented an apparatus designed to project talking and singing films when a dime is dropped in a slot. The films may be shown in daylight in a boxlike structure, five minutes being required for one picture. The coin is dispensed with in machines intended for the home, the apparatus then being controlled by a switch. When a coin is inserted, red and blue "footlights" flash on, a curtain rises displaying a screen twenty-four inches wide and twenty inches high, after which the lights are dimmed and the picture begins. The inventor calls his appliance an "acrophone."

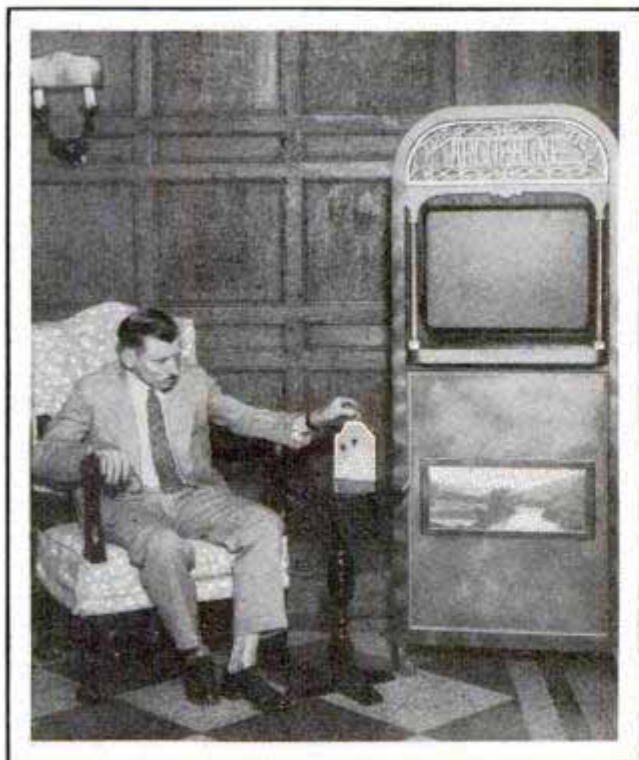

Talking Moving Pictures Are Shown by This Machine When a Dime Is Dropped in a Slot.

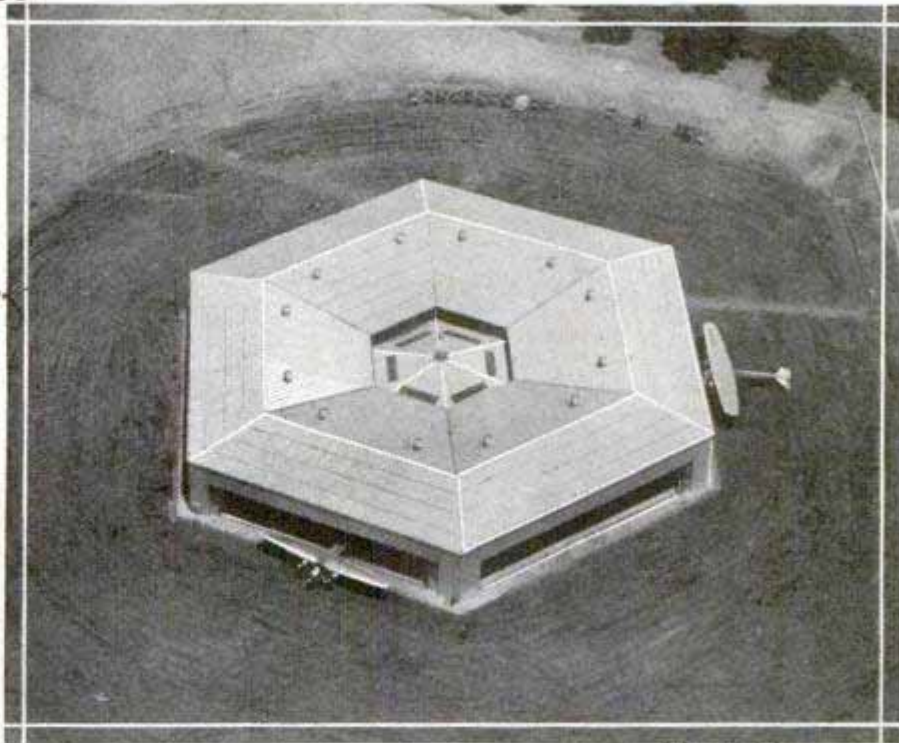

Emptying This Huge Hexagonal Airplane Hangar, with 54,000 Square Feet of Floor Space, Requires Only Thirty Seconds

HEXAGONAL AIRPLANE HANGAR MAY BE EMPTIED QUICKLY

Requiring but one minute to remove all the airplanes from its 54,000 square feet of floor space, a hexagonal hangar, believed to be the largest in the world, has been constructed at Los Angeles for the Western Air Express. Each of the six sides has a self-opening steel door 126 feet wide, and all the doors may be opened in thirty seconds. Emptying the hangar is simplified by sloping floors, enabling one man to handle a big tri-motor plane with ease.

OIL-WELL VALVE CUPS CHANGED HALF MILE UNDER GROUND 3271

Removing the valve from a deep oil well to change cups and leathers, heretofore a tedious and expensive process, is unnecessary with a valve which allows cups and leathers to be changed automatically 3,000 feet under ground. The first operation is to drop a cartridge down the rods, which releases the valve case and brings it to the surface. Then, another case, equipped with fresh leathers, is lowered and the cartridge fastens it to the core. The whole takes about half an hour, while previously several men and a tractor were required for a day or more.

Unit Charles W. Herrin
4503 Bellevue Ave

*Designed by Bell Telephone Lab 3245
Manufactured by Western Electric Co.*

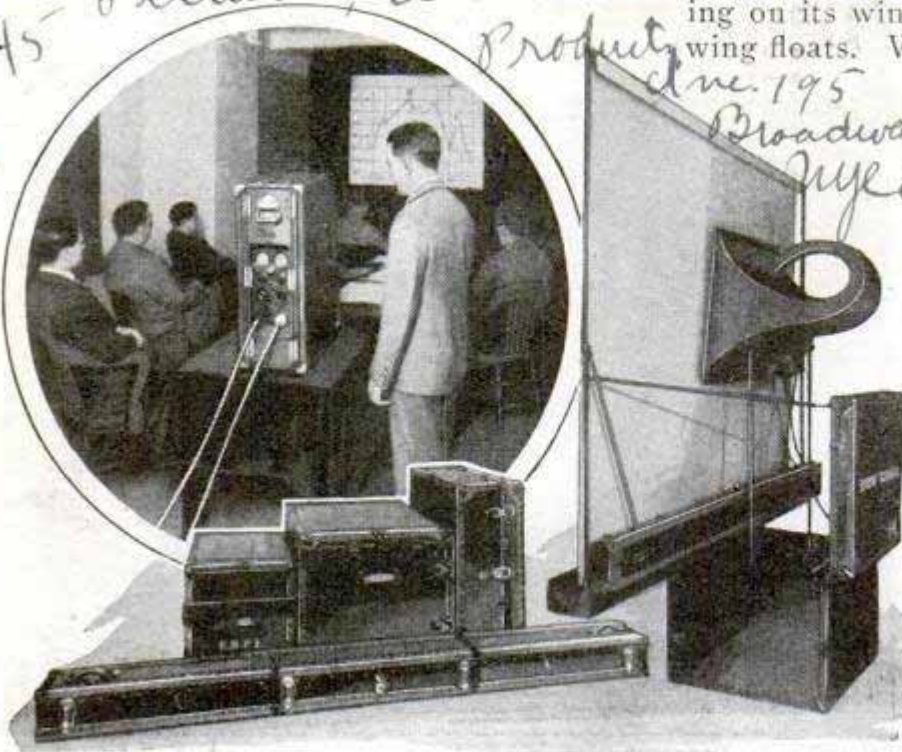

Four Trunks, Such as Shown Above, Contain an Entire Portable Talking-Picture Apparatus for Use in Schools and Salesrooms

PORTABLE TALKIES FOR SALES AND SCHOOL WORK

For use in education and industry, a portable talking-picture machine has been designed, employing the sound-on-film method of reproduction and operating from the ordinary alternating-current electric-light supply. The entire equipment is contained in four trunks and can be set up in a few hours. The apparatus weighs 800 pounds and the amplifier is of sufficient power to supply sound volume for an audience of 800 persons. Screen and horn are supported on the two trunks in which they are placed for shipment, supports to wall or ceiling being unnecessary, the screen rolling on a curtain roller which fits in the screen trunk. The machine has been used successfully in churches, classrooms, salesrooms, auditoriums and offices.

A SINGLE-WHEELED SEAPLANE

214 Performing perfectly in its first trials on land, a single-wheeled seaplane was demonstrated recently in New York. The wheel is fitted in the middle of the center pontoon with the hole covered by a trapdoor, so that a landing may be made in water. The ship is prevented from bump-

Productive
Line 195
Broadway
N.Y.C.
ing on its wings by skids fastened to the wing floats. When alighting on or taking off from land, the weight is borne by the single wheel, with the skids supporting the wings if the amphibian tips to either side. The device, it is hoped, will solve the problem of landing gear for light seaplanes.

AIRPLANE STARTED BY SHOTGUN SHELLS

32 75
Half-length twelve-gauge shotgun shells supply the initial force for a self-starter for airplanes sponsored by Charles A. Levine, transatlantic flyer. The starter, weighing four pounds, is

screwed into the aperture of a cylinder from which the spark plug has been removed. The plug then is placed in the starter in such a manner that it continues to operate after the motor has started. A shell inserted in the starter is held in place by a military-type gunlock equipped with a safety device to prevent premature firing. There is no noise, and smokeless powder is used.



Here Is a Self-Starter for an Airplane, Using a Shotgun Shell to Supply the Force

Dr. Erwin C. Loening
Loening Aeronautical Corp.

**ALUMINUM COVERS FOR BOOKS
 RESIST TROPICAL HEAT**

Because in some parts of Africa the air is so dry that the covers of books are turned back by the heat and lack of moisture, an aluminum binding has been made for volumes subject to such conditions. The aluminum cover is of about the thickness of an ordinary tin can, is light in weight, insect-proof, and washable. The metal is chemically treated to take ordinary printing ink as well as enamel or paint. The paper as well as the cover is made insect-proof, the paper being treated with a carbonate-of-soda solution.

322 4

IMPORTED PEAS IMPROVE SOIL

Three peas, imported accidentally when a veterinarian ordered two quarts of Swedish vetch for his farm, may contribute much to the wealth of American farmers. The three peas, now increased to nine bushels, have a vigorous root system, knotted with nitrogen-bearing nodules, and the vines are prolific, often extending from six to twelve feet in length. Indications are that the peas will yield about thirty bushels of seed to the acre, and a marked improvement in productivity of the soil has been noted wherever they have been planted.

3058

**TAR SHAVED FROM PAVEMENT
 BY TRACTOR RAKE**

Confronted with the problem of removing the slippery and dangerous tar which oozed out of the cracks in the pavement during hot weather, the employes of the Delaware River bridge made a steel-claw rake and attached it to the rear of a tractor used to push a sweeper. The weight of a man on a seat over the rake forces it down into the tar, the apparatus dislodging lumps of tar, which are then gathered with the sweeper.



Scraping Excess Tar from Pavements Is Accomplished with This Tractor and Steel-Claw Rake

Conl. Newman H. Hartman
 1049 Edgemoor Road



This 7,000-Pound Sea Elephant, a Circus Attraction, Eats 450 Pounds of Fish Daily

**FOUR HUNDRED POUNDS OF FISH
 IS DAILY MEAL**

Weighing 7,000 pounds and making a daily meal of 450 pounds of fish, "Goliath," a sea elephant owned by a circus, attracts crowds wherever the show goes. He was captured in the Lost Sea near the south pole, and weighed one ton then, but has gained 1,000 pounds a year ever since and is not yet fully grown. He is known as a sea elephant for want of a better name and is said to be the only specimen of his kind to survive captivity for any time. On the circus lot "Goliath" has a special tank holding 6,500 gallons of water and when he travels he goes on a 100-foot flat car equipped with a 10,000 gallon tank and a sand beach. He eats only fish which he swallows whole and has learned to answer his trainer's call.

Seventy years ago it took mail twenty-four days to go from coast to coast.

Experiment at U. S. Dept. of Agr. with Holder.

Cont. Mr. J. Wilson 435 3rd N. Ashland. Am. Chicago

28/4

Am. M. A. ...
3728 1/2 Park Blvd
San Diego, Calif

Oakland Calif



Gliding

few feet as they pick up speed. A dozen paces, and the pilot calls, "Turn loose!"

The man at the wing tip has already lost contact, and the pair in the rear, at the word "loose" drop their rope, which falls free from the ship. As the back pressure relaxes, the glider catapults upward and forward like a stone fired from a sling shot. The pulling rope, caught in its middle in an open hook, point downward, drops free, and the pilot and glider are off to soar among the birds.

That's motorless flight, as it has been introduced into America from Germany.

The ship described, with its sketchy form of fuselage and the pilot sitting out in the open in front of the wing, is a primary-training glider. For more advanced work, and particularly

"READY! Walk!" shouts the pilot, seated on a little board, with his back against an upright post, which forms one member of a rather sketchy airplane fuselage.

At his signal a half dozen men, three to the left and three to the right, walk away with the ends of a rubberized cable that leads back, in a "V," to a hook in the nose of the ship. At the tip of one wing another man trots along to hold the wings level, and behind the craft another pair pull back slightly on a tail rope.

Ten steps and the pilot shouts, "Run!"

The glider, which has been skidding along the ground on a keel skid, rises a



Miss Maxine Dunlap, Successful Glider Pilot, and, Below, Launching a Popular Type of Glider

on the Wings *of the* Wind



Miss Dunlap in the Air during Her First Successful Glider Flight; in This Type of Machine, the Pilot Sits Out in Front of the Landing Skid

for real soaring flights, gliders are built with comfortably inclosed cockpits, a windshield to protect the pilot, and many even have an instrument board, featuring an altimeter and a clock, to tell both height and duration of the flight.

Since gliding grew up and came of age in Germany—one of the unforeseen results of the peace treaty of Versailles, which put obstacles in the way of motorized flying beyond the Rhine—the sport has been classified into two distinct types: First there is gliding, a term which the initiate use only to describe short flights down a wind hill, sliding down an air current just as a sled slides down a snow-hill. And then there is soaring, which is something for the adept to do, and covers any flight in which the glider pilot takes advantage of rising currents of air to ascend to a greater height than that from which he started.

Given the proper sort of terrain below, which means the right kind of air currents above, and there is almost no limit to what a good soaring pilot can do. German glider experts have stayed in the air more than fifteen hours, climbed to heights of

more than 2,000 feet above the point from which they started, flown as far as 200 miles, and more than forty miles in a point-to-point race. An expert in soaring can take off, climb hundreds of feet in the air, circle, cut figure eights, and eventually come back to the starting point as easily as though he had a motor to pull him wherever he wanted to go.

The pilots who have done that, describe soaring flight as life's greatest thrill. They go up and play among the birds as equals; in fact, last summer when Peter Hesselbach, the German pilot, visited this country and made a ten-hour flight at Cape Cod, a flock of seagulls came in from the ocean, fell into line and flew alongside in formation while they studied this strange, new, noiseless bird plane.

It takes from thirty to sixty days in a glider school for a graduate of primary-training gliders to master the secrets of the more responsive soaring ship. It not only is necessary to know how to fly it, but the flyer who hopes to go after duration records in the motorless-flight field must be an accomplished student of meteorology, for his success depends largely

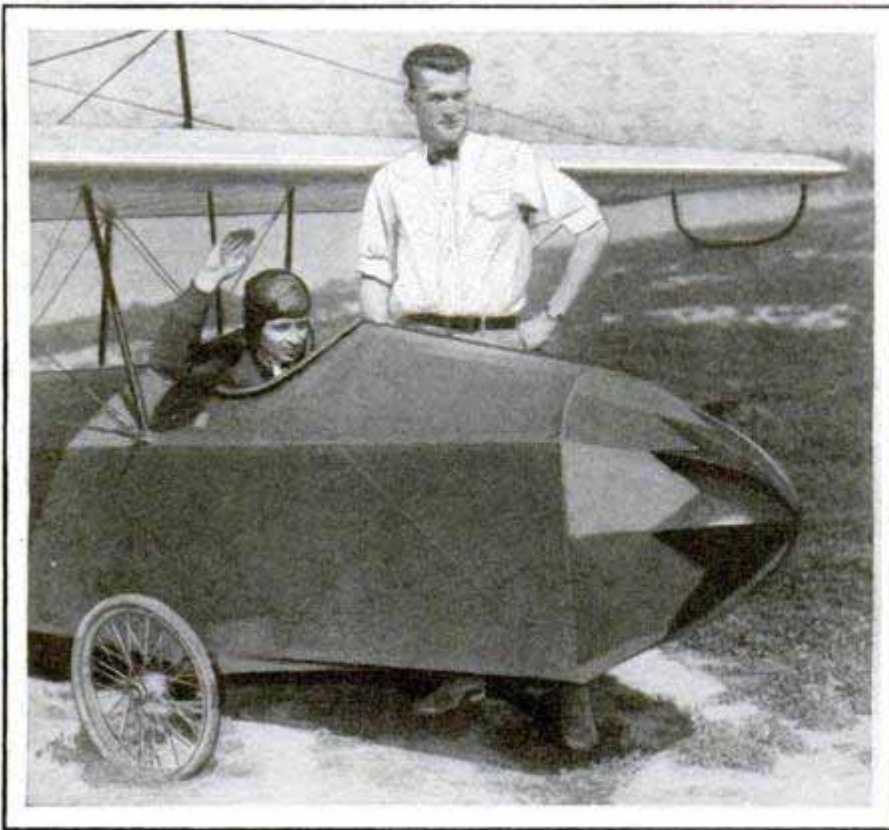

Dale L. Drake in Glider and Lloyd O'Donnell, Pilot of Plane That Towed Glider in Long Demonstration Flight

on his ability to guess, from the terrain below, the kind of air currents that are flowing about him, and so twist and turn as to take advantage of every upward thrust.

It is because of his dependence on air currents that hilly country or duneland near a large body of water make the best gliding land, for there are always upward air currents among hills, when the breezes rise from the valleys, and there is usually a rising current at the edge of any large body of water.

The National Glider association, which has been organized to popularize the sport in America and attempt to capture the duration and distance records from Germany, already has established glider clubs in many cities. The gliding enthusiasts are organized in San Francisco, San Diego, Portland and Seattle, on the west coast; in Denver, Kansas City, Cleveland, Akron, Cincinnati, Indianapolis and Detroit, in the central section, and at New York, on the Atlantic, as well as in many smaller towns and cities. All of the clubs, and many individual members, are building ships, either primary or soaring types, and one or two factories are turning out the former at prices as low as \$500 to \$600.

The glider association has issued a very explicit warning about the type of gliders that are safe to fly. They turn thumbs down on the light and cheaply constructed outfits in which the pilot's body is suspended from the framework, while he tries to get control by swaying his weight from side to side. It was a machine of this type that killed Lilienthal, the great German experimenter, whose work, with that of Chanute, contributed to the Wright brothers' success.

Instead of this type of craft, the association recommends that both primary and advanced training ships should be operated from the pilot's

seat with controls exactly similar to those used in a motorized airplane. In other words, a pair of pedals work the rudder and a control stick manipulates the ailerons at the wing tips and the elevators at the tail. Experience has shown that the movements required to operate either a motorized airplane or a glider with these controls are the most natural and therefore reduce danger to the minimum.

To build a glider of the type recommended requires a rather thorough knowledge of aerodynamics and aircraft construction. In fact it may take more skill to build a good glider than it does to build a good airplane.

Why this is so can be easily understood by examining the construction details of the soaring glider being flown at San Diego by William H. Bowlus, who has been building gliders of various types since 1912. His craft is a high-wing full-cantilever monoplane, with tapered wing. In other words, the wing is above the pilot's head and has no external bracing, while it is narrower at the tips than in the center. The fuselage is built up with four square longerons, running the full length of the plane. They are only three-quarters of an inch square at their thick-



Drake

Drake in Glider Which Was Towed by Plane 200 Miles during Recent Exhibition by the Long Beach Glider Club; at Right, Glider, Designed by Hawley Bowlus of San Diego, in the Air; It Has a Wing Spread of Forty-Six Feet and Has Been Built to Enable the Pilot to Take Quick Advantage of Favorable Currents, Which Often Rise Several Times Higher than the Take-Off Hill

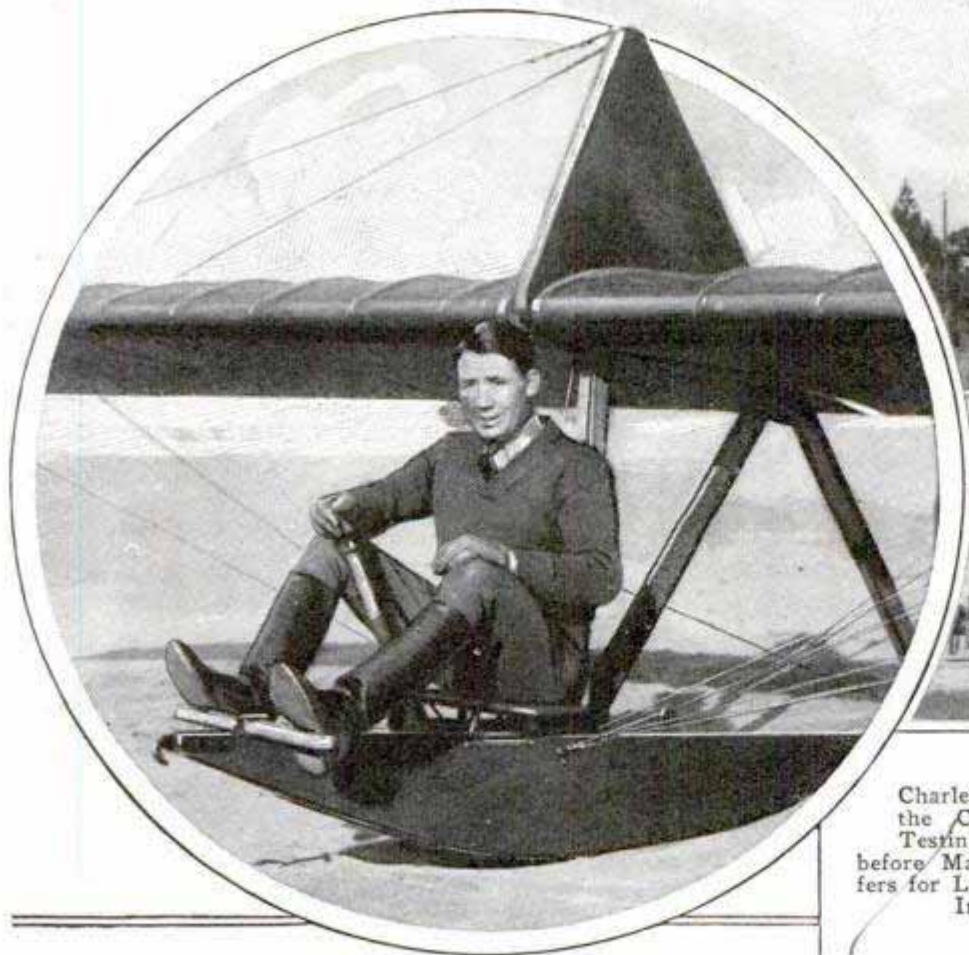

Charles Ferguson, President of the California Glider Club, Testing Out Controls of Glider before Making a Flight; Prize Offers for Long Hops Are Stimulating Interest in Gliding

Flitted during flight. about. Dec. 9th. 1929

San Francisco. 2195-22nd St.



Vance Breese, San Francisco Aviator, at the Controls of a Ferguson Glider Which Is Being Launched by Men with Aid of Tow Rope, Dropped Free as Glider Rises

est point, beside the pilot's seat, and taper to one-quarter inch square in front and three-eighths inch square at the tail. The four form a rectangle, nineteen inches wide and twenty-four inches deep, where the pilot sits. In front, the thin ends are brought together to form a horizontal wedge, like a chisel point, and at the tail they form a rectangle, ten inches high and six inches wide. The struts that brace them also are of spruce, with a square area equal to that of the longerons at the point where they are applied. The whole structure is braced with thin diagonal strips of spruce, only an inch wide and a sixteenth of an inch thick. They are wetted before being glued in place, and when they dry and shrink, they exert sufficient tension to make a rigid body, capable of carrying a 500-pound load.

Two bulkheads of plywood in front and behind the pilot's seat afford him some protection and likewise transmit his weight to the wing when in flight, and onto the skid when the craft is on the ground.

The wing itself is built in three parts, so it can be taken apart when the glider is

towed to or from the field. The center section, measuring six feet, is built in as a part of the fuselage structure, and two tips, each nineteen feet long, are bolted to it to prepare the ship for flight. The ribs of the wing, and the ribs in the tail surfaces are made of "kraft" paper, with spruce strips, only an eighth by a sixteenth of an inch, glued to either side. It is almost unbelievable that such a paper web would have sufficient strength for the purpose, but tests in many flights have shown that it is actually stronger than necessary for the load it carries.

The whole craft weighs but 160 pounds, and two men can hold it up by the wing tips without any appreciable bending of the structure. The weight includes the landing skid normally used for soaring flights. In addition, Bowlus has built a light-wheeled landing gear which is used both for towing on the highway and in experimental flights, and adds but twenty pounds to the weight of the craft.

Such a machine is only for the adept to fly, but anyone with normal faculties can, under a competent instructor, make safe flights of a few hundred feet in one

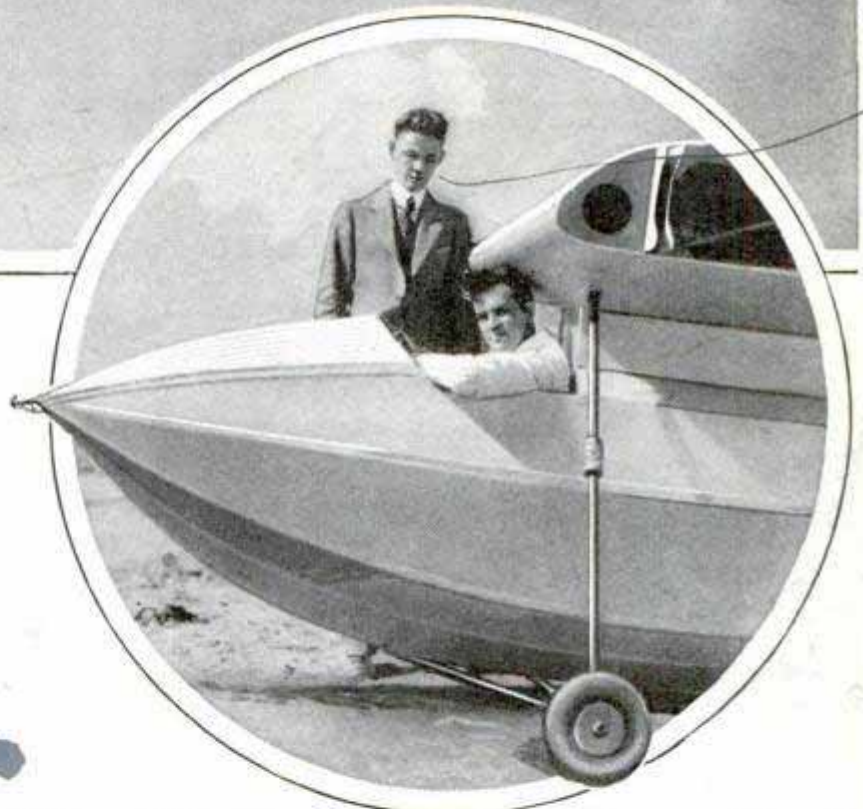
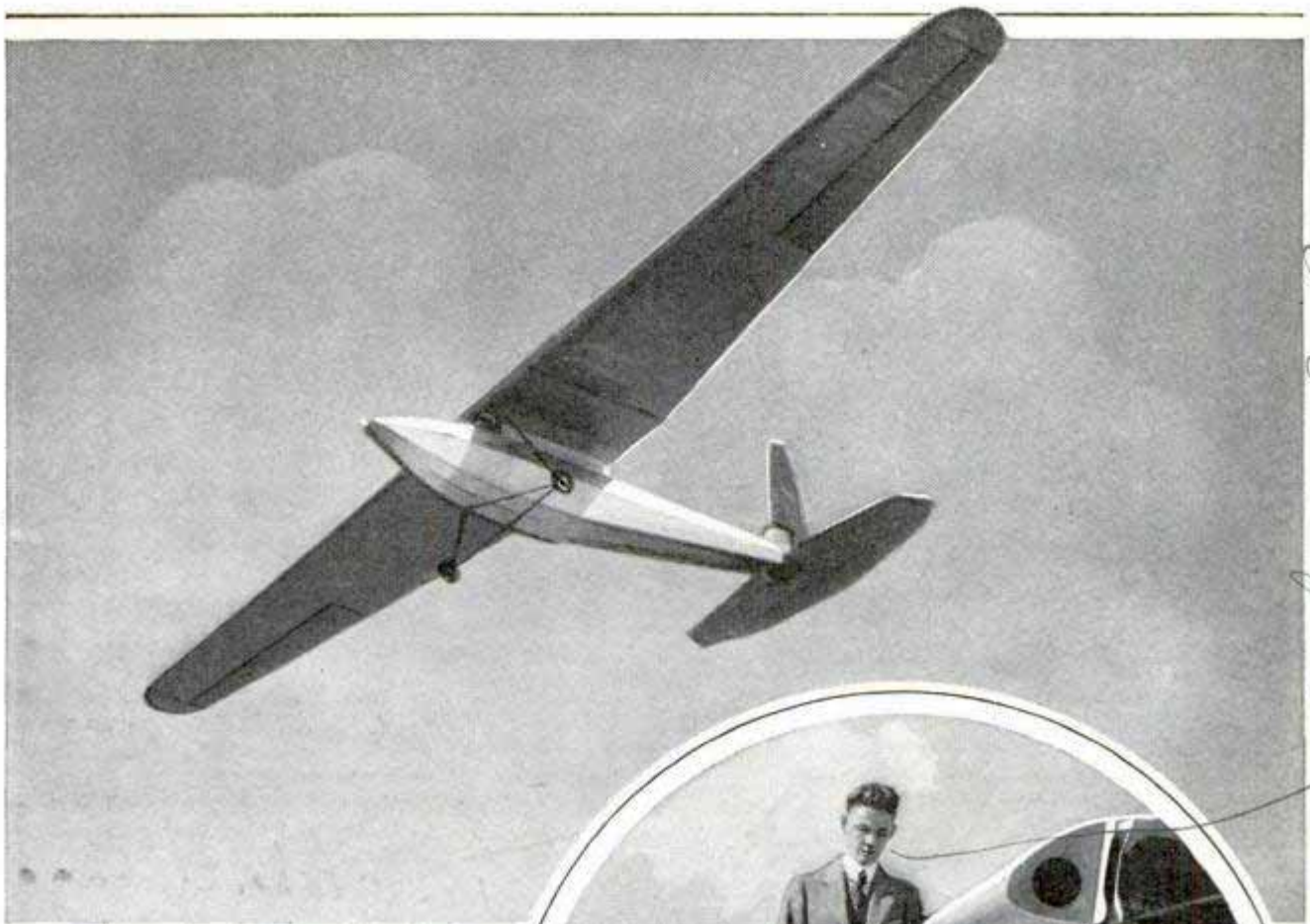

of the primary training planes. For instruction purposes, the clubs seek a hillside of fairly gentle slope, clear of obstructions for at least 200 yards, and place the plane not too far up from the bottom.

The student is strapped in with a safety belt, the ground crew take positions, and the instructor calls the signals. As the ship leaves the ground, it rises a few feet and glides down the wind until it comes to rest, the length of the glide depending not only on the speed of the upward current, but the skill of the student at the controls.

At most, he cannot fall more than a few feet, and the worst damage that can be done to the ship, as a rule, is to break a few wing ribs; in fact, a certain amount of rib breakage is counted on as the ship settles down and topples over on a wing tip, since its single central skid affords no lateral stability.

A well-built glider of this type is so fool-proof that, if in doubt what to do,

Climbing: Skilled Glider Pilots Learn to Take Advantage of Favorable Air Currents and Have Reached Altitudes of 2,000 Feet; Below, William H. Bowlus in Cockpit of His Glider

the student has only to return his control stick to neutral, in other words hold it vertically between his knees, and the glider will settle gently to earth of its own accord.

¶The Popular Mechanics' Bureau of Information offers its free service to all readers of this magazine. Names and addresses of manufacturers and dealers in articles described, and any other details in our possession, will be promptly furnished.

*F. H. Lawson, Jr. Pres
San Diego Air Service, Inc. Higher Flight
a letter
Practical
San Diego*



Courtesy Holmberg Air Mapping Co.
 An Aerial View of an Automobile Roller Coaster Where Motorists May Speed Up and Down over the Half-Mile Track and Enjoy All the Thrills of the Old-Time Amusement

AUTOMOBILE ROLLER COASTER GIVES MOTORISTS THRILL

Thrills for the motorist are provided by automobile roller coasters along some of the widely traveled highways. Near Chicago a farmer has set aside a field beside an arterial road for construction of a U-shaped track where, for a dime a passenger, an automobile party may shoot the chutes and enjoy all the ups and downs of the old-time roller coaster without leaving their car. After reaching the top of the first incline, the car is virtually carried over the track by the momentum gained on the declines, and at times travels at high speed. Cars are dispatched one at a time by a starter, and motorists often wait in line for an opportunity to experience the novel trip.

VAST GLACIAL TRACT IN ALASKA REMAINS UNEXPLORED

Areas of many thousands of square miles of unexplored territory still remain under the American flag. In Alaska is a great tract of land that has never been visited by white men, and even the natives have not penetrated some of it. One of the largest of the unexplored regions

132 W. Lake, Chicago
 lies between the Skwentna river on the north and Lake Clark on the south, and between the west front of the Alaska range and Cook inlet. This area, in the south central portion of the territory above the Alaska Peninsula, is entirely occupied by rugged glacial mountains except for a narrow strip of low marshy land between Cook inlet and the mountains. A portion of this territory was invaded by geologists and topographic engineers of the geological survey under considerable difficulties, and an area of about 1,200 miles was mapped. In this new unknown country, where streams are too swift for ordinary boating and the only trails are those made by the native animals, the map makers used the primitive methods of transportation, including the pack horse and the boat dragged by hand through swift currents. In one locality, no human being was seen for more than two months, and even signs of native camps indicated that they were from twenty to thirty years old. The animal life remains virtually undisturbed, black and grizzly bears, caribou, moose and mountain sheep being found in abundance. Fish, however, are scarce in most of the streams because of the large amount of glacial silt in the waters.

do not allow photos taken

3261

Science News Bulletin

PULSATING EARTH MAY CHANGE QUAKES

3260

Pulsation of the earth, causing it to expand a little, then to contract slightly, may be responsible for the shift of the centers of earthquakes away from the equator during the twentieth century in the opinion of Prof. T. Terada and Dr. S. Miyabe, of Tokio Imperial University. Successive earthquakes in Japan recently have shown a tendency to appear farther and farther north, and the investigators, in trying to find the cause for the slow change in the latitude of the quakes, searched records to find if there had been similar occurrences. They learned that during the sixteenth century earthquakes in Japan and Eurasia moved south while those in South America moved northward, all approaching the equator. About 1600, however, the tendency was reversed and they moved away from the equator, only to move toward it again about 1700 with a reverse tendency noted about 1800. Approaching 1900, the Eurasian quakes again moved south and the South American ones north, but as the century opened, they went in the opposite direction. Earthquakes in North America also moved approximately in the same way as others of the northern hemisphere. Two Dutch astronomers have studied the unexpected shifts of the moon from predicted positions on a theory that this might affect the locality of earthquakes, and the Japanese scientists compared these findings with the curves representing the quakes' movements. Although there is a rough agreement, they think it more likely that the earth itself pulsates over a long period and that these pulsations govern the quakes.

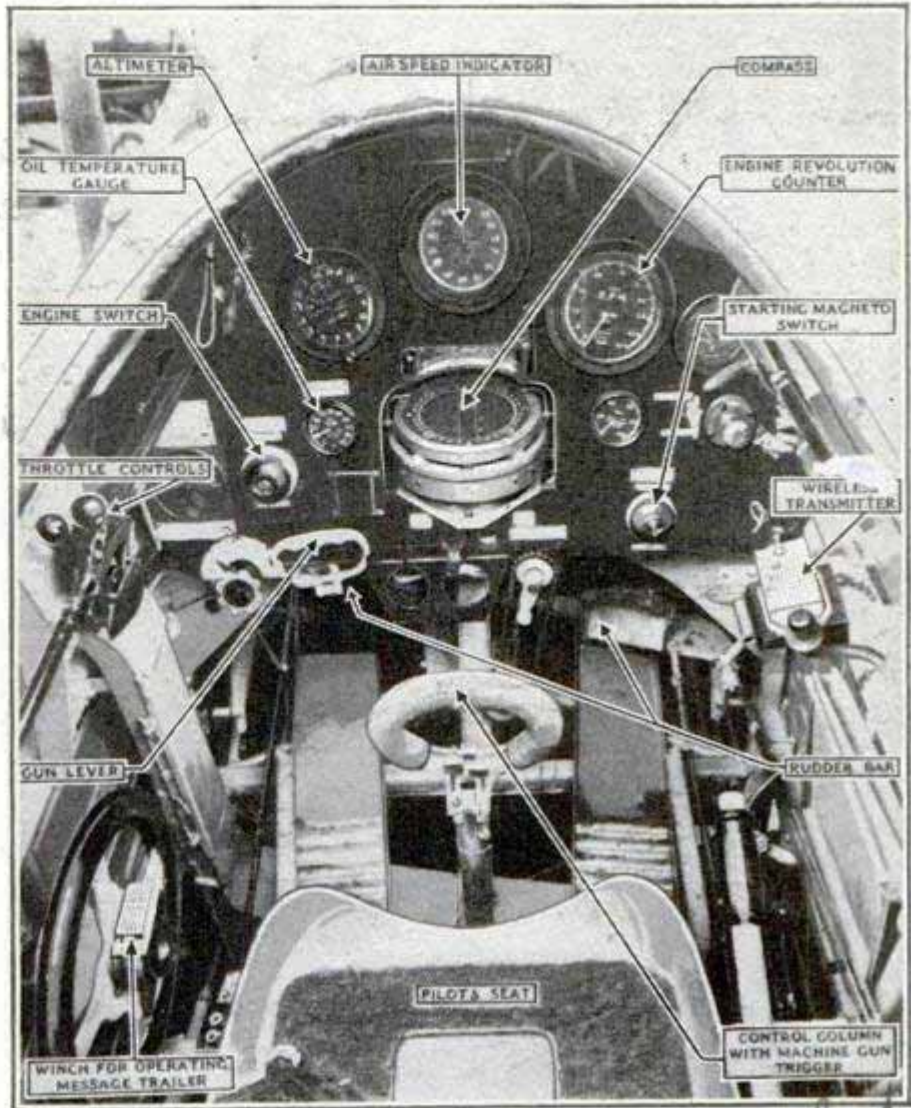

Pilots of the Australian Air Force Face This Maze of Controls When They Fly One of the Combat Planes Recently Purchased

MAZE OF CONTROLS IN COCKPIT OF AUSTRALIAN PLANE

Pilots of the royal Australian air force face a maze of controls when they enter the cockpits of the planes recently constructed for use there. Besides all the instruments necessary to operate the ship, there are many others, including a device for operating a message trailer and a machine gun. Had such machines been available earlier, pilots say, they might have been able to save the two flyers who perished in central Australia while seeking the airplane "Southern Cross."

WORLD'S FASTEST WAR SHIP 3232

Remarkable achievements in French naval construction were demonstrated recently when the "Valmy," latest war ship constructed under the post-war plans, attained an average speed of 39.85 knots.

marine engineer
Arthur's magazine

Colomberie 9 Regent Road, Desley Heath,
 Mr. London, England

Chasing Chinese

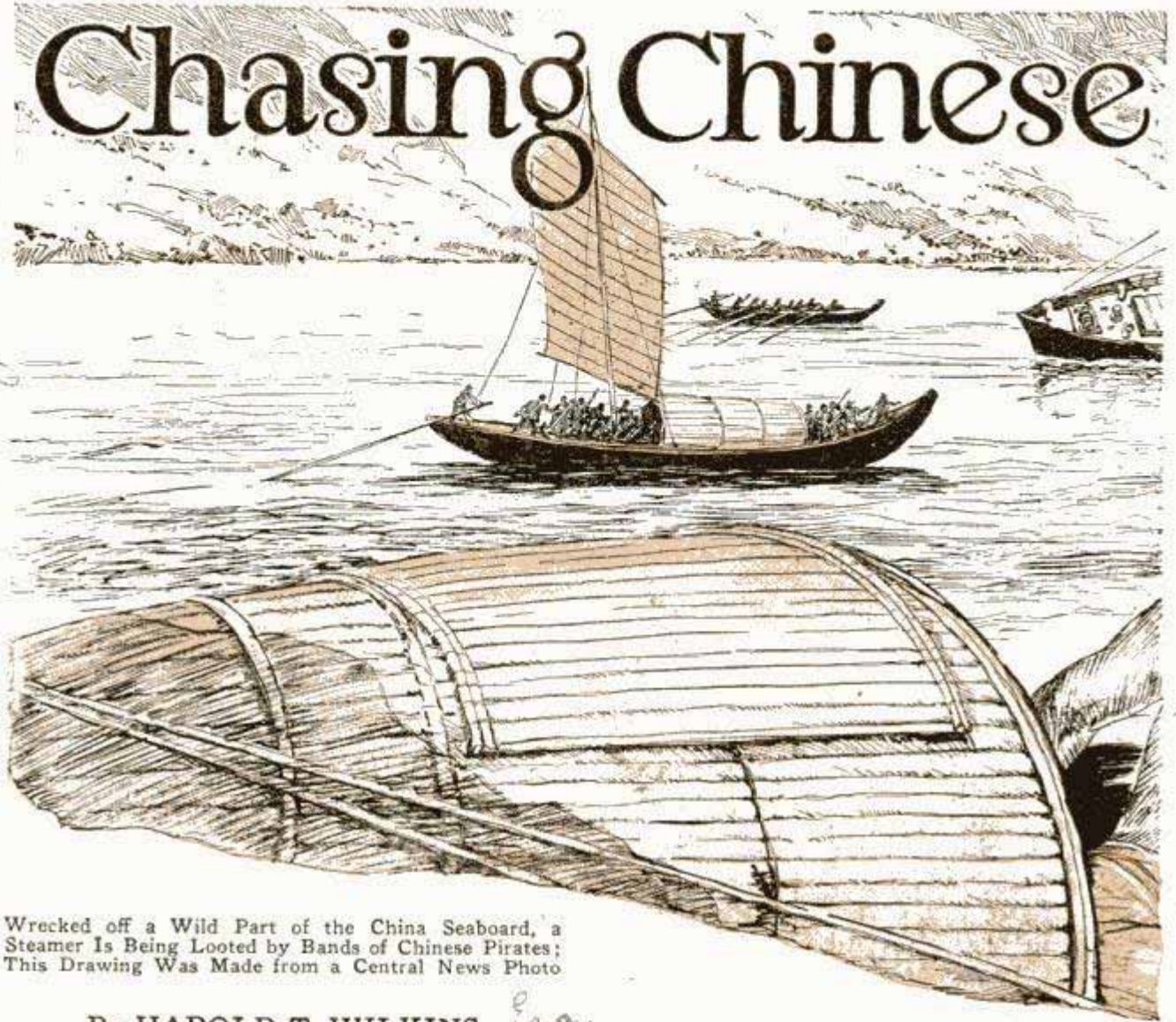

Wrecked off a Wild Part of the China Seaboard, a Steamer Is Being Looted by Bands of Chinese Pirates; This Drawing Was Made from a Central News Photo

By HAROLD T. WILKINS, Esq.

THE old-time pirate, with a slash across his face, picturesque gold earrings, and a brace of Spanish pistols, could be recognized easily even without the "Jolly Roger" flying at the masthead. But the modern pirate of the China seas—his equal in ferocity and daring—depends for his success on the fact that his blue dungaree trousers and coat are exactly the same in appearance as those worn by millions of honest Chinese workers.

He comes as an ordinary coolie aboard a steamer plying between the ports on the China seaboard. To the eye of the officer who scans him shuffling up the gangplank, carrying his food and pots and pans, he seems what he says he is—a poor coolie on the way to seek work in another port. He joins the hundreds of other coolies on the open deck and makes himself as comfortable as the hard planks allow. To the shipowner he is a profitable

item of cargo and it is not until some months later, when the relative of a wealthy Chinese passenger, captured on that steamer, receives a severed ear or thumb—a hint to forward a remittance promptly or something worse may happen—that it becomes evident the innocent coolie and his equally innocent-appearing brothers were neither profitable nor harmless.

The British government recently has become seriously alarmed at the growing frequency and daring of the buccaneers of the north and south Chinese seas and rivers. A few months ago, a member of parliament proposed that seaplanes should be used to chase pirates in the Chinese waters and deltas, just as the British admiralty's anti-slavery patrol in the Persian gulf, today carries a flying boat armed with bow chaser guns to war on the Arab slave dhows which at night frequently run cargoes of slaves from the Abyssinian

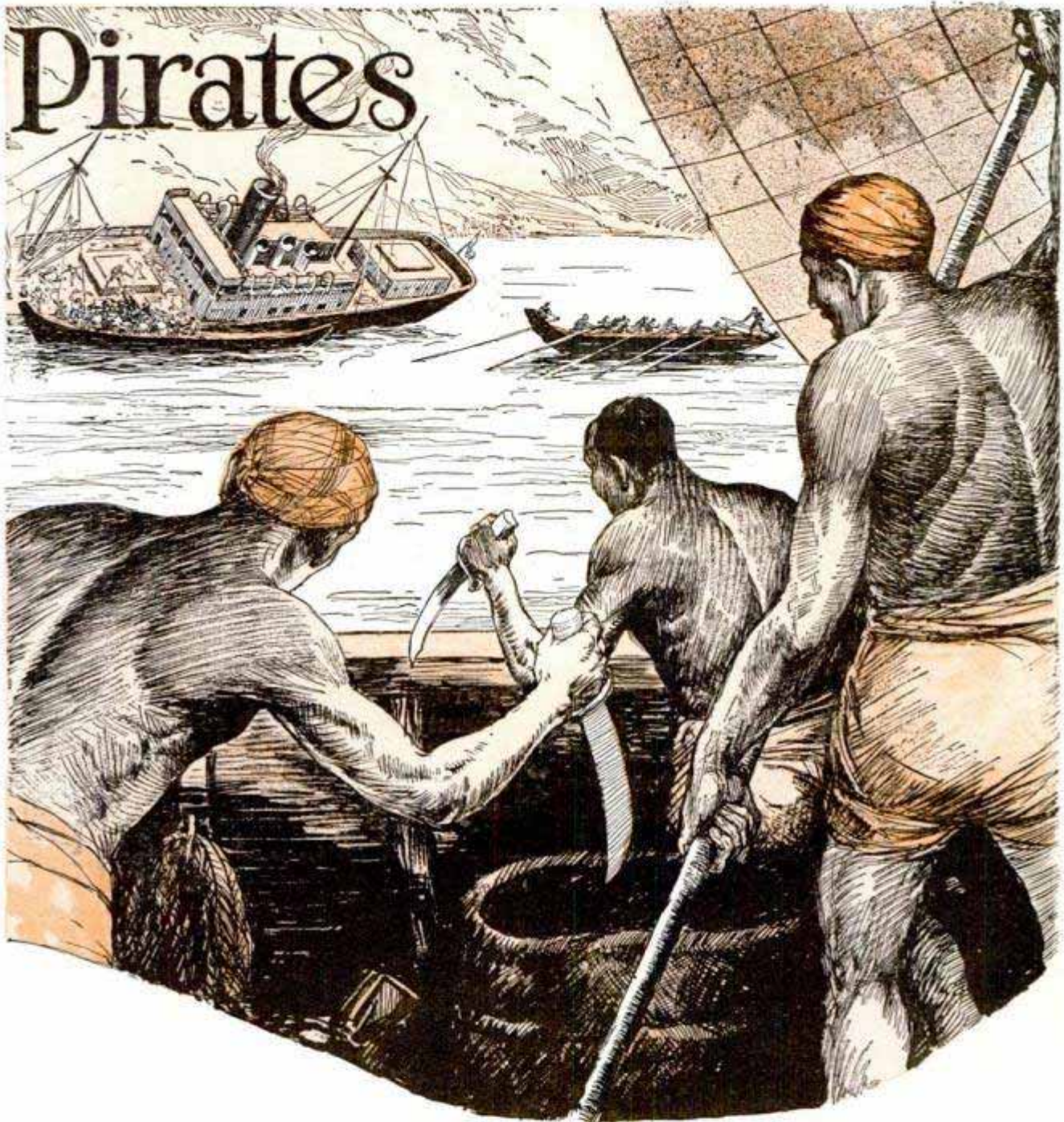

coast of the Red Sea across to the "bad spots" of Arabia. The Chinese government of Canton has now joined Uncle Sam and John Bull in the war against river and sea pirates in the notorious Canton delta.

Recently, an adventure recalling the Middle Ages at their worst, happened in one of these pirate campaigns. After a fierce night attack on a pirate castle in Fu-kien, south of Shanghai, in which the pirates put up a desperate resistance, Chinese marines and a brigade of mixed troops stormed a high wall and entered the castle, which has 130 rooms. They found a ghastly torture chamber of huge

dimensions, in which forty captives were hanging in chains or bound on tables. The stone pillars and walls were stained with blood. A terrifying assortment of medieval instruments of torture were found. Many hundreds of victims, captured from looted steamers, had been held for ransom in this den, and been killed or maimed. The stronghold was in the middle of a dense forest on an island in Hingwa bay, and the pirates had carried on their operations for years past.

The steamer "Irene," flying the Chinese flag, was steaming off the Chinese coast recently, bound for Amoy, her captain, J. H. Jansen, a Norwegian, and his second

officer and engineer at breakfast in the cabin, when a pirate appeared and shot the Chinese steward. Other pirates overpowered the officers, robbed the passengers, and made for the bullion room. They collected their loot, and ordered the ship to steam slowly so as to reach Bias bay about dark. A few pirates kept guard, while the rest gambled and gorged below. The "Irene" was creeping into Bias bay, when the pirates got a shock. Anchored under the lee of the land for the night was the British submarine "L-4," and her captain, seeing a steamer with no lights, suspected something was wrong. He flashed out the signal, "Stop at once!" No answer came. The submarine switched on her searchlight, and fired a blank shot. Still no answer. Then the pirates fired on the submarine, which retaliated by firing two live shells across the bow of the steamer. All this time, the "Irene's" captain was on the bridge, under the guns of the watching pirates, but he rang for the engines to stop. Down below in the engine room, pirates, at the muzzle of the pistol, forced the engineer to keep the engines running.

Then a shell burst in the engine room, putting the engines out of action, and dis-

abling a pirate who was about to shoot the chief engineer. The submarine's captain saw men leap off the deck of the "Irene," so he took the sub alongside and picked up the strugglers in the water. Among the first rescued were six of the European officers. A heavy swell was on the sea, and the "Irene" was now ablaze from stem to stern. The submarine rescued all the passengers, many of them leaping into the water wearing lifebelts. A radio message brought up the warship "Delhi," which picked up twelve survivors and stood by to put out the fire on the blazing steamer, while the submarine, packed with 222 survivors, left for Hongkong. Twelve pirates were made prisoners.

"SOS. This is the steamer 'Hsin Chi' in distress. We are beached on Tae island, Foochow. Hundreds pirates round waiting loot ship. Hurry. Can't hold them off much longer!"

The wireless operator on the British destroyer "Serapis" read off this message recently, and rushed it to the captain. A Chinese gunboat, which had also picked up the message, was first on the scene, but stood helplessly by while a hurricane raged

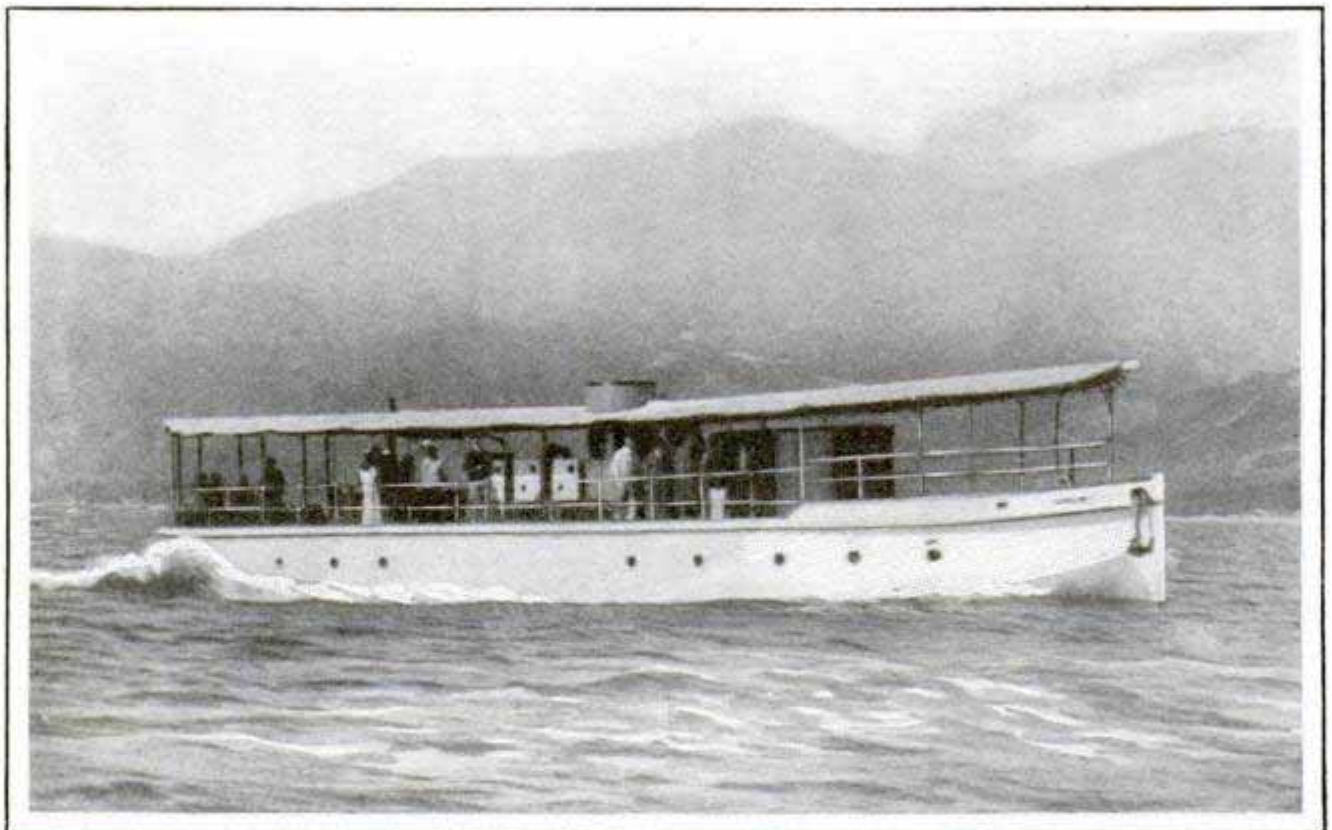

Courtesy C. B. D. Lauchan
Cruising South China Waters Where Piracy Is Rife Today, an Armed Motor Launch Keeps Vigil over Vessels That Might Fall Prey to Bands of Marauders

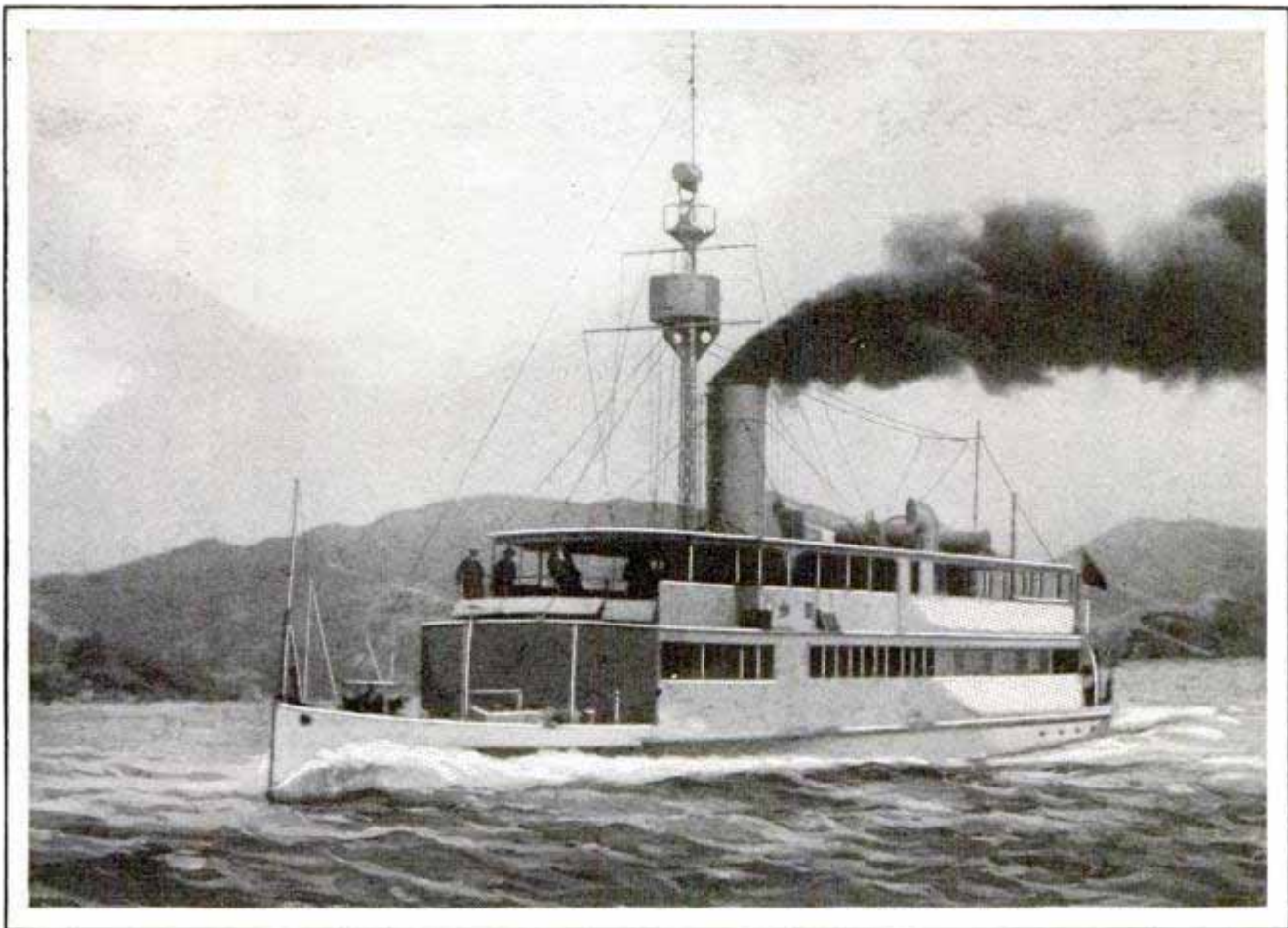

Courtesy C. B. D. Lauchan

Special Gunboat Built for Rapid Travel in Shallow Waters, Where Pirates Frequently Are Found; the Vessel Is Equipped with Radio and Powerful Searchlights

and the pirates looted the helpless steamer. Finally, they set fire to her and fled.

Another radio to Hongkong naval depot told of the capture of the British 2,200-ton steamer "Tean," on the way to that port and boarded off the island of Hainan, in south China waters. She had been taken to the notorious Bias bay, where the disguised pirates landed with seven passengers. The British destroyer "Somme" gave chase, causing the pirates to abandon their loot and prisoners, one pirate being killed.

The next and latest affair happened in north China waters where the steamer "Shasi" was bound for Shanghai from Hankow. She had left the latter port when thirty-two young Chinese refused to pay the fares which the ship's compradores were collecting. Some of these Chinese rushed the wheelhouse, overpowered the captain—an Englishman—the chief officer, the Chinese pilot, and the Chinese quartermaster. The pirates locked the captain in the cabin with his wife and two children, while the ship was left to drift

helplessly. Later, the pirates unlocked the captain's prison and ordered him to let go his anchor. They then rushed the cabins of four first-class passengers.

Off Seven Miles creek, a launch came alongside, and the pirates, loaded with loot, consisting of the plundered cargo, the passengers' money and jewelry, went on board, complaining bitterly that their booty was worth only \$10,000 or so. No sooner had the pirates left, than the captain of the plundered steamer returned to Hankow. A fortnight later, the Chinese authorities executed sixteen of the pirates who took part in the looting of the "Shasi."

3138' ——— DEEPEST FRESH-WATER LAKE

Lake Tanganyika in central Africa, believed formed in the craters of an extinct volcanic range, claims the distinction of being the deepest fresh-water lake. Depths of 4,190 feet have been located in various parts of the lake, which is 200 miles long and forty miles broad.

*Cmt. Chas. L. Stewart,
Cape Argus, St. Georges*

WHY THE DREADED TAILSPIN IS SO OFTEN FATAL

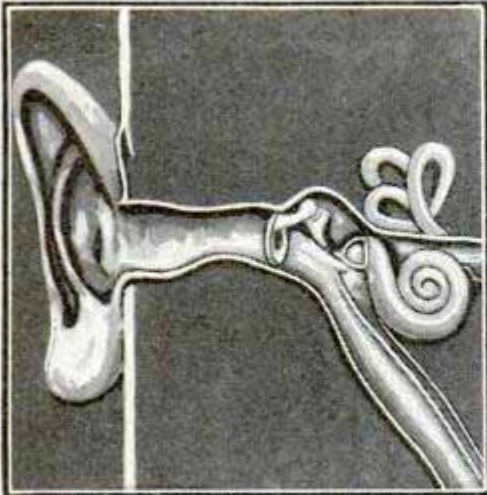
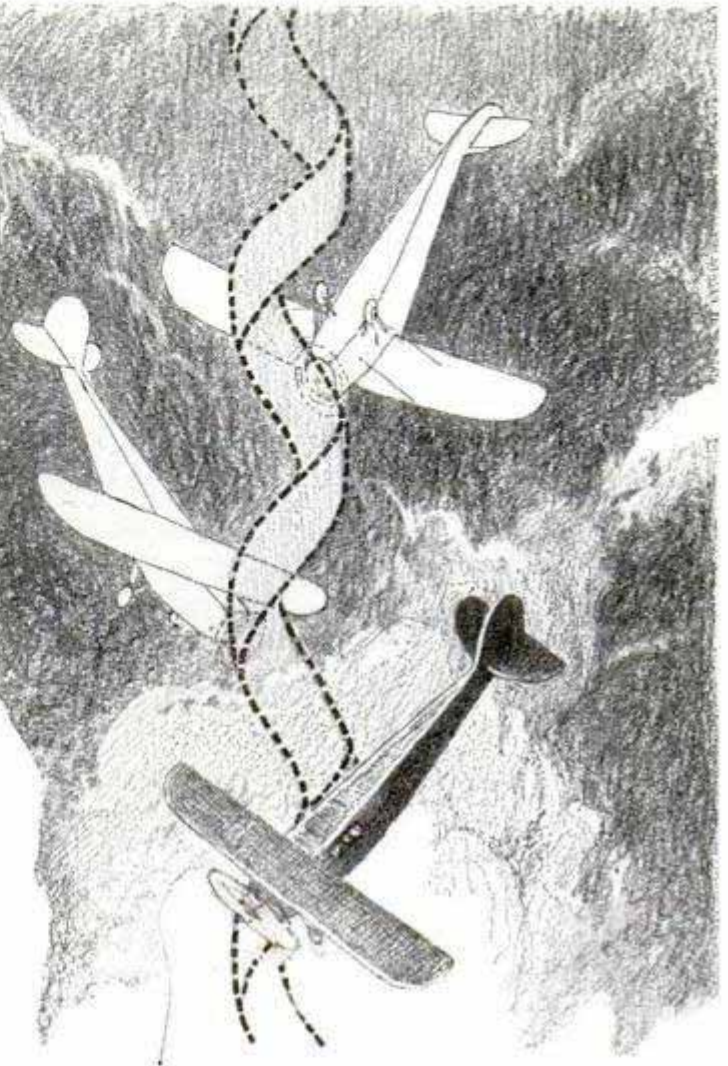

Diagram of Human Ear and Drawing Illustrating Nature of Tailspin

"WE WENT INTO A TAILSPIN—SOS—WE CAME OUT OF IT, BUT WERE SURE SCARED. IT WAS A CLOSE CALL. WE THOUGHT IT WAS ALL OFF, BUT WE CAME OUT OF IT. THE LIGHTS ON THE INSTRUMENT BOARD WENT OUT, AND IT WAS SO DARK THAT BILL COULDN'T SEE THE... WE ARE IN ANOTHER—SOS—"

In the middle of the sentence the wireless transmitter was stilled and two more ocean flyers, Erwin and Eichwaldt of the "Dallas Spirit," had plunged into the Pacific while bound for Hawaii seeking traces of two lost planes. For the first time the occurrence of a dreaded tailspin had been actually reported at the moment it happened. That was in 1927, and the same year forty per cent of all the fatal accidents to army planes were due to spins. In the last five years forty-five per cent of navy airplane accidents have been due to the same cause. The figures were compiled by Lieut. Carl Brown Harper, U. S. N., who has been making a study of spins, their causes, and means of preventing them. Why a spin is so dangerous is easily told. The inner ear is affected, the waterlike liquid which it contains, is set in motion, nerve impulses are transmitted to the brain, and from there down to the eyes, and the eyes begin to oscillate from side to side. The pilot, realizing he is in a spin when the stick tries to force its way back into his chest, shoves it forward and applies oppo-



site rudder to bring his ship out, but having done so his eyes continue to oscillate, until they make him believe he is still in the spin, with the result that he keeps on holding the stick forward and the rudder over until the plane goes into a second and opposite spin. But, more dangerous still, the pilot, even when provided with a parachute, cannot leave his ship during the spin, because centrifugal forces during the gyrotory movement have multiplied his weight by four. The only way he could escape from his craft would be through a trapdoor in the floor, and the navy is now studying that problem. An airplane in a tailspin describes an unusual course. Imagine a giant screw, with threads of enormously long pitch and small radius. Hold the airplane with nose down, the propeller against the screw, and the tail sticking upward at an angle of sixty or seventy degrees. Now revolve it around the screw. It describes small circles, because of the small radius, but de-

scends rapidly, because of the great pitch of the threads. That is exactly the course of an airplane in a spin. Spins usually result from trying to climb too fast, with the result that the engine is unable to pull the weight up the steep aerial hill; the speed falls to the stalling point, and, lacking sufficient forward speed to give control, the craft falls off on one wing. Wing slots, small movable flaps curved to fit the leading edge of the wing, can prevent a spin by flapping open and increasing the lift on the lower wing. The American rights to the slots have been purchased by the government, and experiments are being carried on by the navy to improve their design. One problem has been the necessity of providing some means of locking the slots so the military pilot can render them ineffective when he wants to deliberately spin his ship in fighting maneuvers.

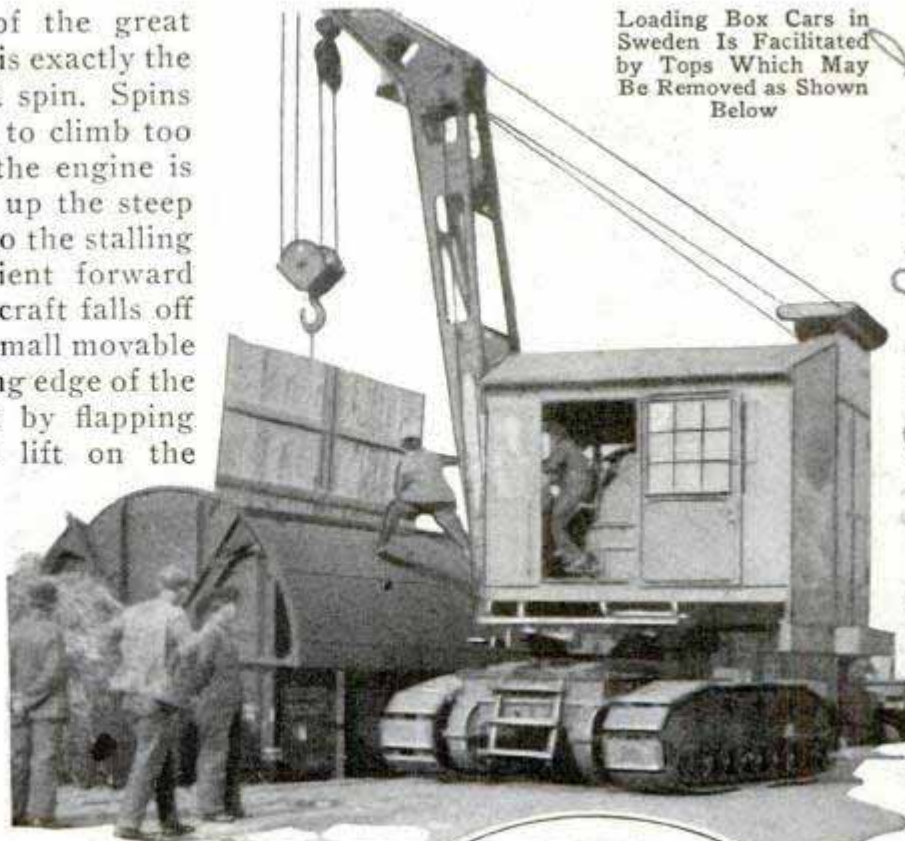

Loading Box Cars in Sweden Is Facilitated by Tops Which May Be Removed as Shown Below

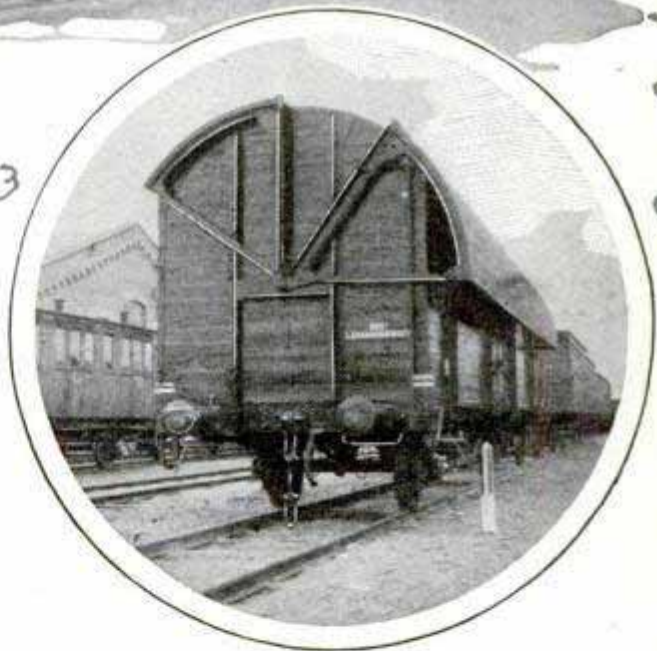

3223
THREE TESTS FOR OLD RUGS

Rug collectors hunting old and valuable pieces are given three simple tests by an English expert, to determine rug quality. A wet handkerchief rubbed over the rug will determine if the colors are fast. If the color rubs off on the handkerchief the design may be spoiled. Examining the inner strands determines if they are of the same color as the outer ones and if the design extends through the thickness of the rug, and a marked sheen or dull polish to the fiber usually indicates that the rug is more than fifty years old and so of good value. Lastly, the rug should be examined for moths, cuts, or worn places.

3213
BOX CAR WITH REMOVABLE TOP ENABLES EASY LOADING

Top-loading freight cars with removable roofs are being used by a railway in Sweden, it having been found that when package-loaded by derricks, they can be filled much more rapidly and easily than the side-loading type. The cars also retain the side doors for service when equip-

ment is not available for lowering freight from above into the car. The roof is divided lengthwise in two quadrant-shaped segments which can be let down, one on each side. A shaft along the top of each car side with pinions at the ends works on a gear rack under the segment and is connected through a bevel gear to a vertical shaft which has at the bottom a worm gear with a crank that is easily reached from the ground.

☐ Coal can now be rendered dustless by the use of certain chemicals sprayed on it.

Emb. George H. Holden

Cont. Mel Wharton, 709 Union League Bldg. 200 Angels Calif.

Swedish State Railway

Patent handled by - H. J. Atwater
at Pioneer Island & Harland &
Harrison St. Seattle Wash.

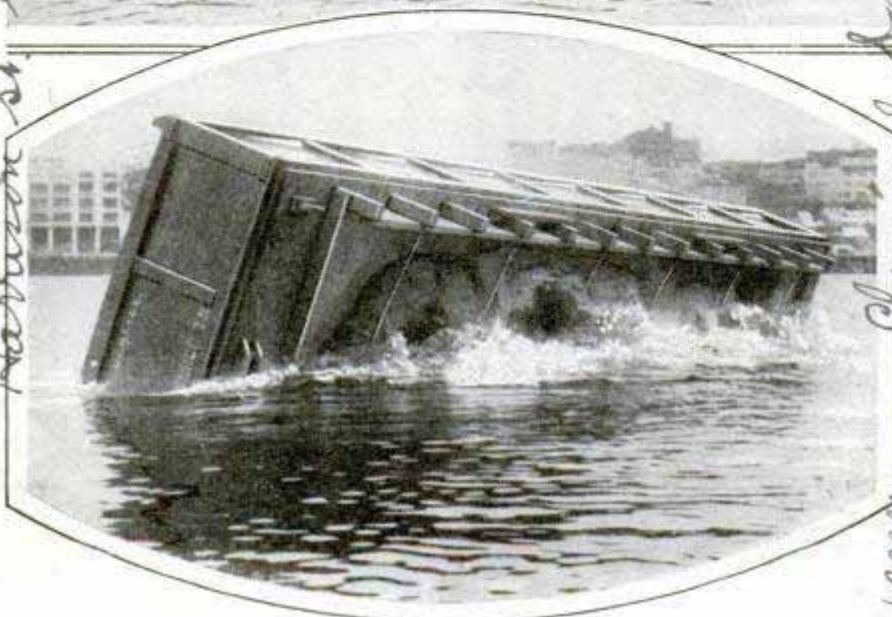

Two Views of a Self-Dumping Scow Operated by Flooding Air Chambers, Whereupon the Bottom Becomes the Top for the Next Load

plished in less than four minutes, the tug continuing on its course as the scow is overturned.

BLACK FENCE POST TURNS WHITE EVERY NIGHT

A man's puzzlement over a fence post, which he had painted black but which turned white every night, was the starting point of a program of research which has culminated in the discovery of a number of chemicals having this remarkable chameleonlike property, scientifically termed phototropy. The famous fence post was painted with a "pigment having a zinc basis." It would turn black soon after sunrise each morning, only to turn white again when darkness came. Many explanations have been given for the phenomenon but scientists

unpleasant chemical beauty U.C.
262
the new Washington B.C.

SELF-DUMPING SCOW CAPSIZES AND BOTTOM MAKES DECK

Scows of 800 tons' capacity which unload automatically by overturning, whereupon the bottom of the loaded barge becomes the deck for the next load, are being used successfully in excavating operations in Seattle. The top and bottom of the self-dumping barges are identical and the sides are built up for holding the dirt, while inner wooden tanks on either side serve the purpose of flooding. The load forces the air-tight chambers beneath the water line. A one-man tug tows the scow to deep water, the tug operator pulling open the valves on one side with a line. This shifts the center of gravity as the water rushes into the opened chamber, and the scow overturns. Dumping of the load raises the air chamber above the water line and the water runs out. With the valves closed, the scow is ready for the next load. Unloading is accom-

are not yet agreed as to the cause of it. They have, however, found several other substances besides the zinc sulfide, which was in the paint on the post, that will also change color with the light. Most of the known phototropic liquids are solutions of colorless derivatives of certain dyes.

BRAND CATTLE WITH SQUEEZER

Operating like the old-fashioned V-shaped lemon squeezer, a cattle squeezer is being used to expedite stock branding in Nevada. Animals to be branded are driven into the open end of the V-shaped contrivance one by one, after which a lever closes the sides until the imprisoned animal is unable to move and scarcely a minute is required for the branding operation. For dehorning, a headpiece is provided also and is adjusted after the animal no longer is able to struggle. Cattlemen say the "squeezer" more than doubles the daily output of a branding gang.

Concl. R. Terrell
Ludlow, Nev.

PORTABLE STAGE ON WHEELS MOVES ON RAILS

Built on wheels fitted to steel rails, a portable stage and canopy has

and the canopy is covered with material which adds to the acoustic quali-

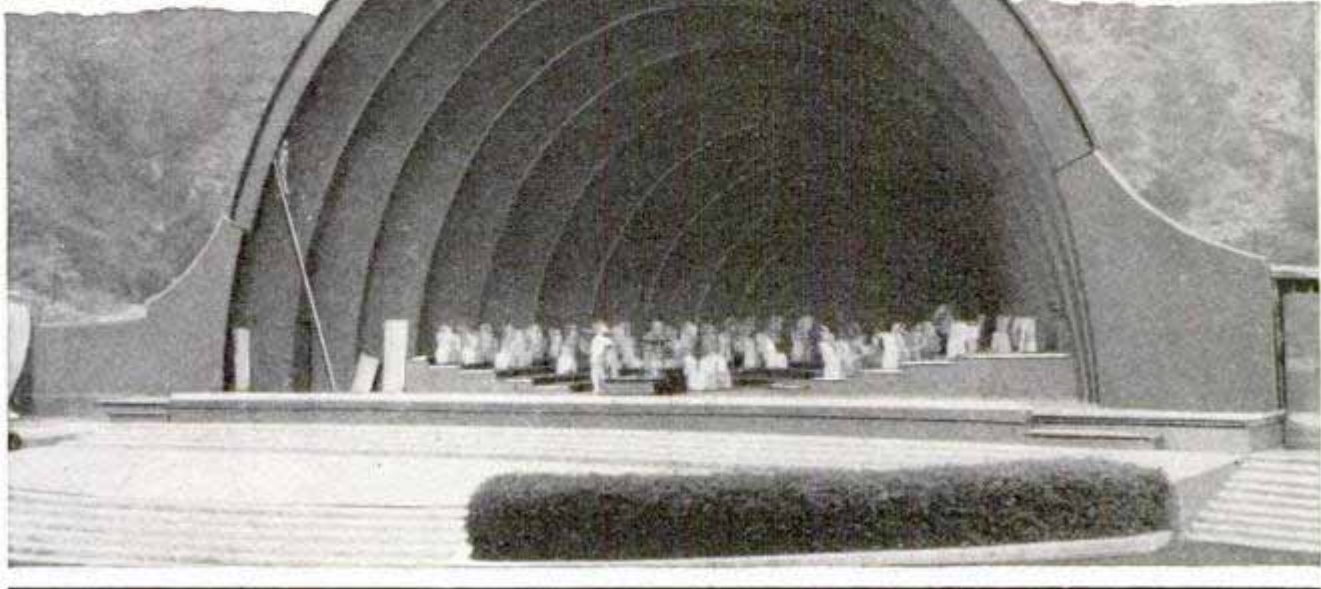

Placed on Wheels Which Move along Steel Rails, This Portable Stage for the Hollywood Bowl, with Its Ten Arches Decreasing in Size, Has the Appearance of a Huge Bonnet

been constructed for use in the Hollywood Bowl. The movable stage makes possible a canopy-covered platform for orchestra work and an open stage with natural sylvan background for drama and dancing. The shell consists of a series of ten arches decreasing in size, giving the proscenium somewhat the appearance of a gigantic bonnet. Dressing rooms are provided on each side so that the width of the movable unit is about 120 feet and the depth sixty feet. The framework is steel,

while lights are set in the flanges separating each of the series of arches. The structure is supported by wooden girders to which are attached flanged wheels which in turn are supported by steel rails. By means of a small engine, the proscenium unit may be pulled up into a canyon wholly out of view. The only connection between the structure and the ground is the wiring and the plumbing and these may be disconnected with little trouble. A fanlike curtain is used for the canopy.

AIRPLANES REPLACING BURROS IN LATIN AMERICA

Airplanes are replacing burros and other crude forms of travel as a means of transportation in Mexico and other parts of Latin America. Here today the airplane is being used where before primitive forms of travel prevailed. Air lines extend from the Texas border to the oil fields of Tampico, Tuxpan and Mexico City, while from Vera Cruz one may go to the Isthmus of Tehuantepec or to Tapachula on the Guatemalan border, or to Yucatan by way of the almost unknown coast of Tabasco and Campeche.

A branch line is planned from Merida across Yucatan to Cozumel over territory inhabited entirely by hostile Indians, and the Guatemalan government has a line from Guatemala City to Flores. Mexican air lines from Tapachula, in the south, soon will be extended to Guatemala City and mail will go from Texas to Guatemala in twelve hours. From there, the Republic of Salvador and the Pacific side of Nicaragua are to be linked by air with the Atlantic side. At present one may fly from Florida to Santiago, Chile, and before the year is ended, the journey may be continued across the Andes to Buenos Ayres, Argentina.

Scene News Bulletin 436 B Sheet!

7/2/10

3205

Record Breakers

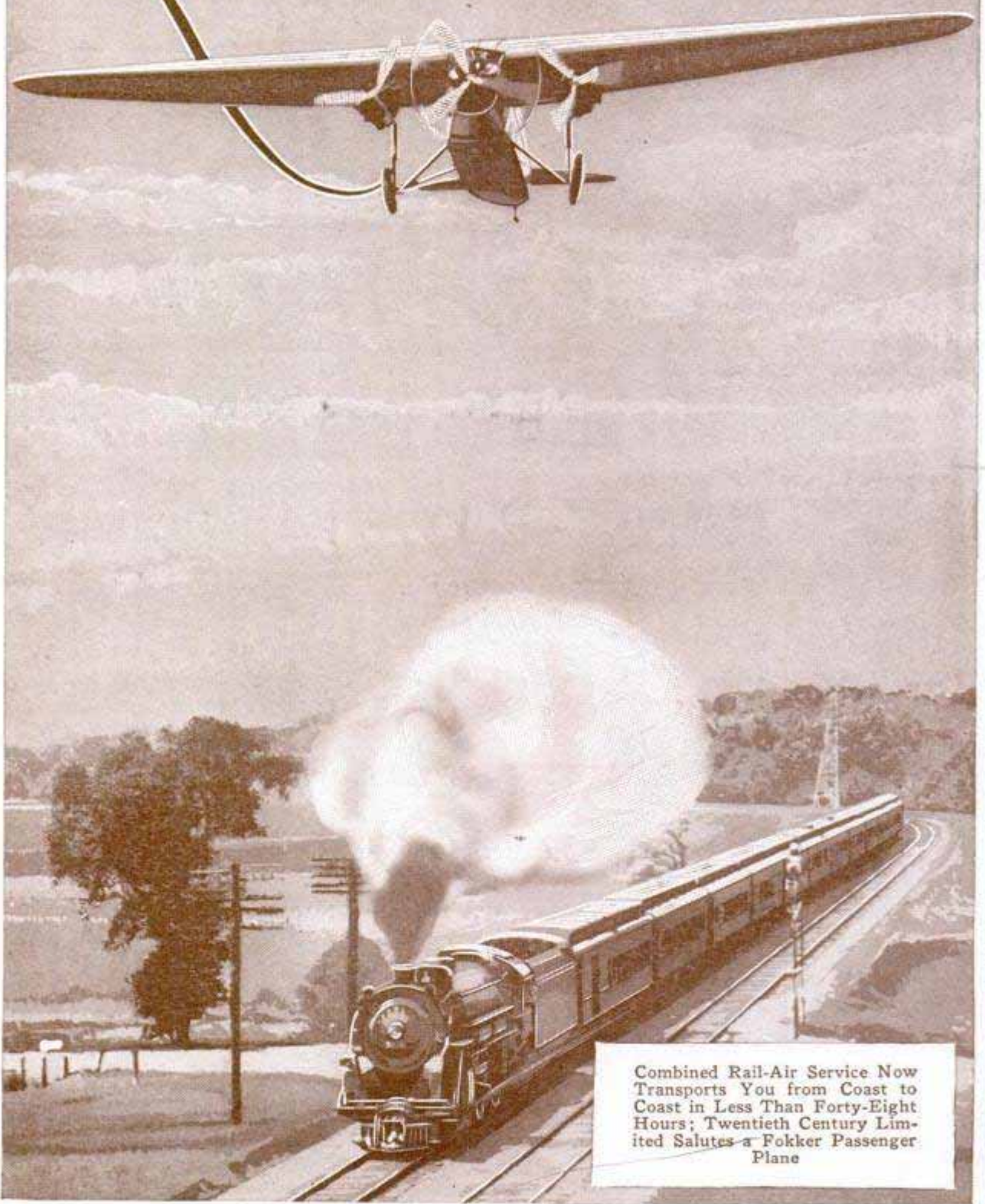

Combined Rail-Air Service Now
 Transports You from Coast to
 Coast in Less Than Forty-Eight
 Hours; Twentieth Century Lim-
 ited Salutes a Fokker Passenge
 Plane

Fokker Aircraft Corp. Copyright, Ralph Rugh
 1128 112

3205

of the Air Age

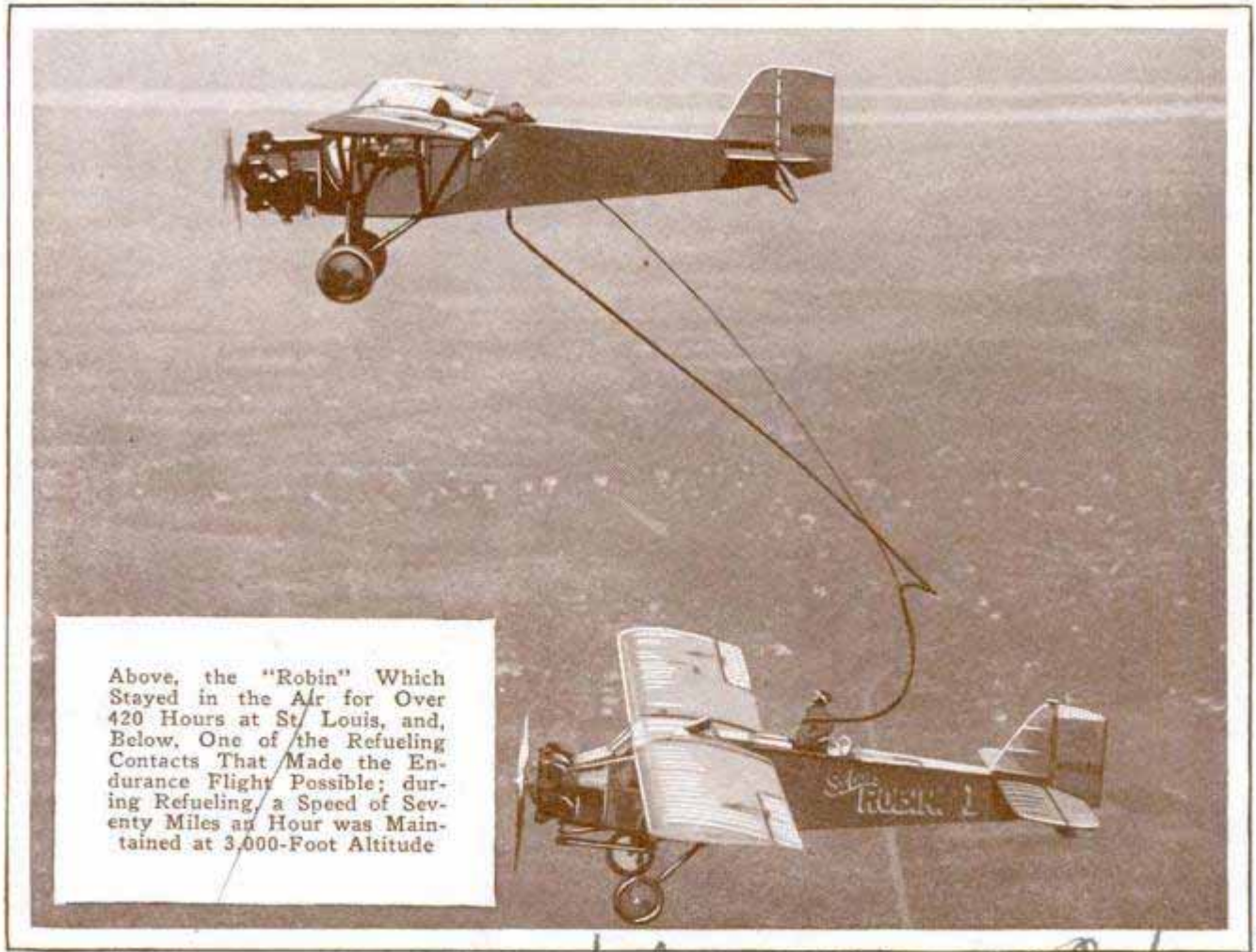

Above, the "Robin" Which Stayed in the Air for Over 420 Hours at St. Louis, and, Below, One of the Refueling Contacts That Made the Endurance Flight Possible; during Refueling a Speed of Seventy Miles an Hour was Maintained at 3,000-Foot Altitude

Long Island NY

Curtis Aeroplane & Motor Corp. 563

3205
564

Bernard ...
Bernard ...
at La Courneuve Paris, France

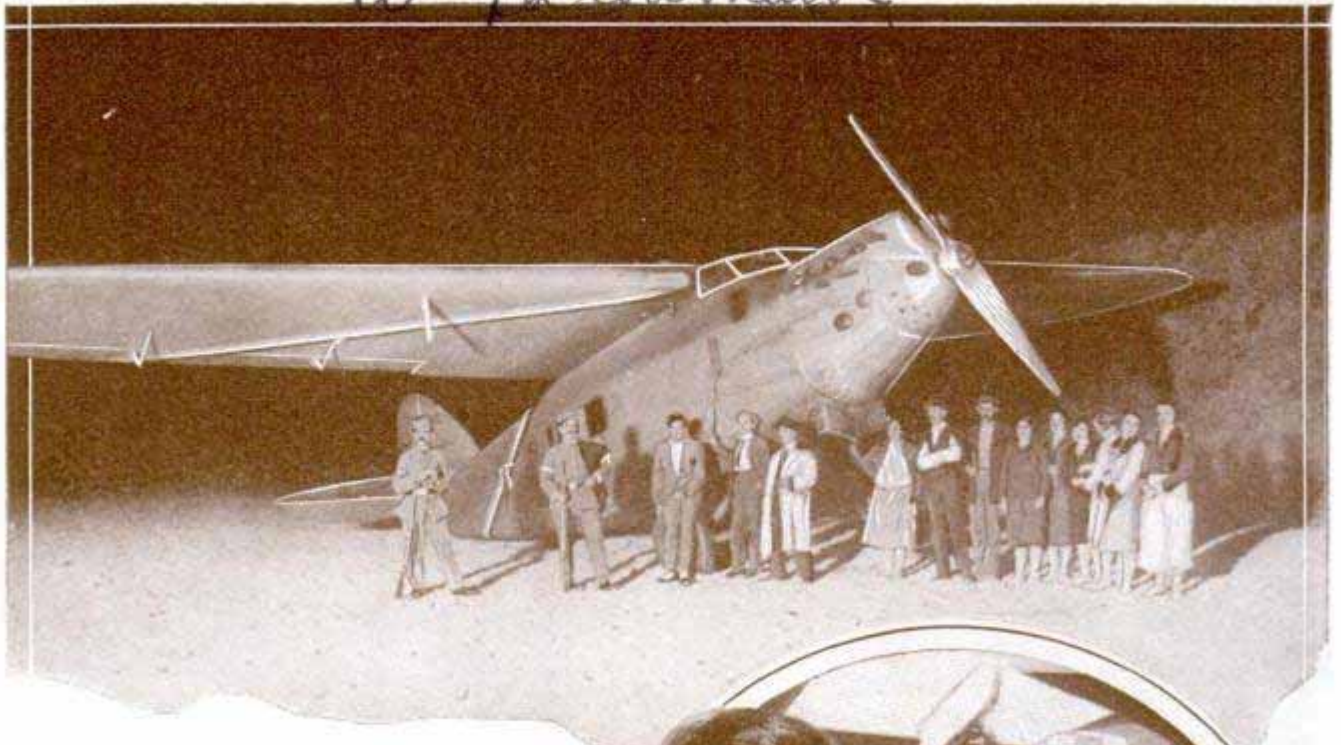

Above, the Monoplane "Yellow Bird" on the Beach at Comillas, near the French Border, Where It Was Landed after a Flight across the Ocean from Old Orchard, Maine; at Right, Leo Nomis Testing a High-Pressure Grease Gun Used on His Endurance Flight with Maurice Morrison, Which Ended after Forty-Two Hours When the Ship Crashed

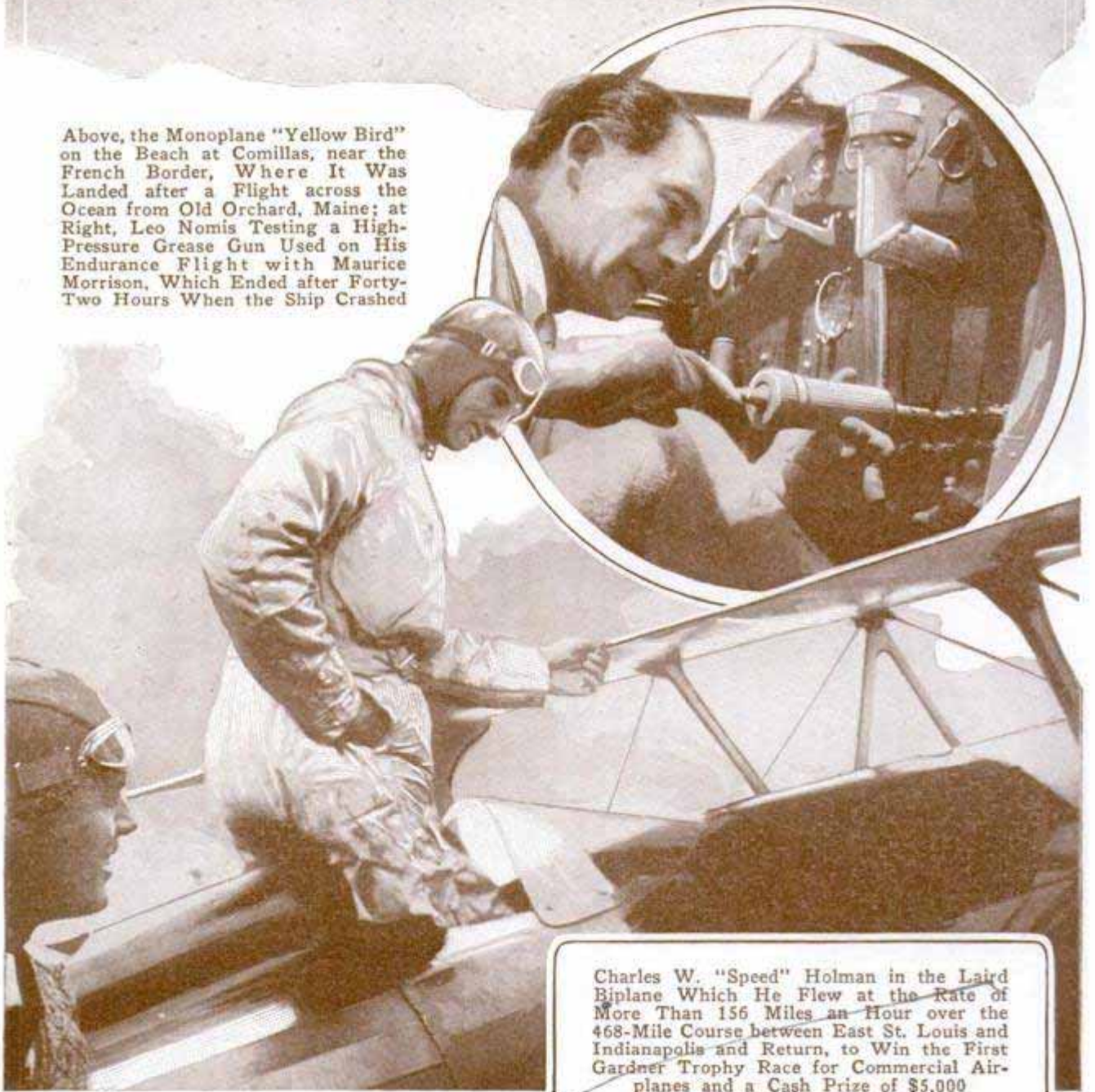

Charles W. "Speed" Holman in the Laird Biplane Which He Flew at the Rate of More Than 156 Miles an Hour over the 468-Mile Course between East St. Louis and Indianapolis and Return, to Win the First Gardner Trophy Race for Commercial Airplanes and a Cash Prize of \$5,000

21 M. Laird Airplane
4500 111 83 1st



Gasoline, Food and Water Are Necessities for the Successful Endurance Flight and the Refueling Ship and Its Crew Play an Important Part in Keeping the Plane in the Air; Upper Right Shows a Refueling Plane Making Contact over Los Angeles with the Endurance Ship "Angeleno" (Lower Left); in Oval, Capt. Frank Hawks, Who Smashed Records by a Round-Trip Flight from New York to Los Angeles and Return with One Stop for Fuel

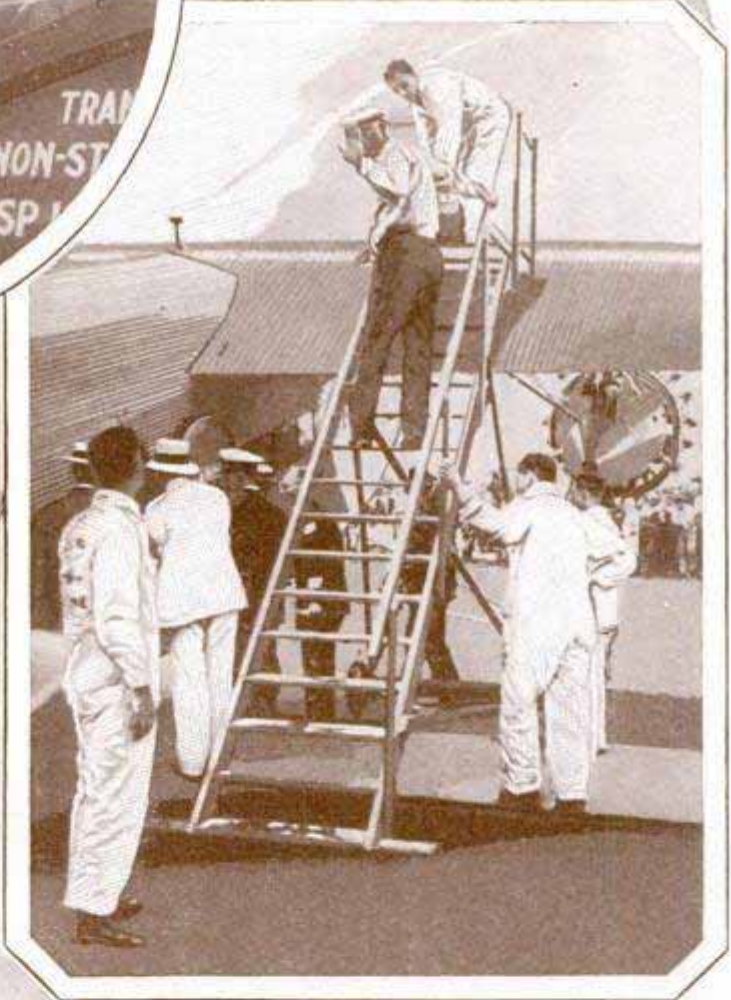

Space Is Ever at a Premium in Passenger-Carrying Ships, Particularly When It Comes to Baggage; the Transcontinental Air Transport Planes, Carrying Passengers on the Coast-to-Coast Rail-Air Route, Solved the Baggage Problem by Providing Space for It in the Wings; Above, Transport Employees Are Loading Bags into the Wing of the "City of Columbus" before the Initial Rail-Air Trip

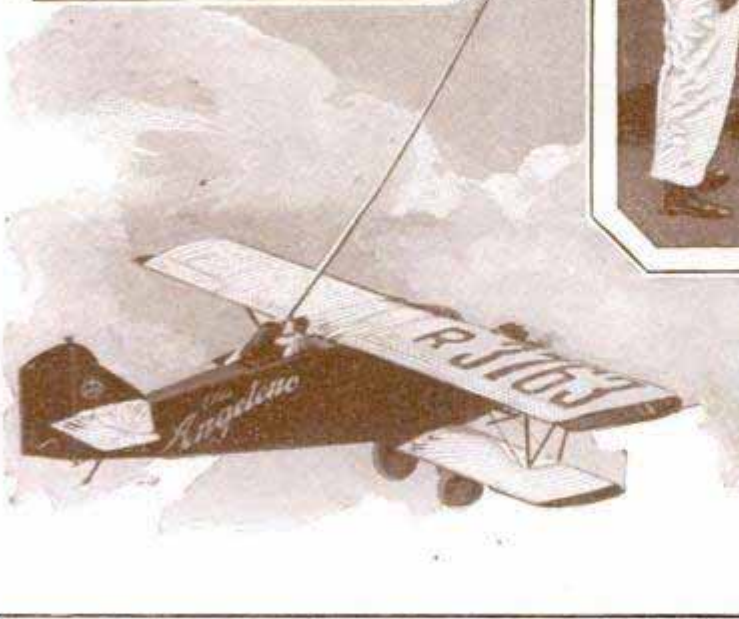



Women Are Manifesting an Enthusiastic Interest in Aviation, as Is Evidenced by Their Use Daily of Air-Travel Facilities, and the Fact That They Have Gone In for Not Only Transatlantic Flights but for Endurance and Altitude Records as Well; Above Is Shown Mrs. Louis Thadden, a California Woman, Who Stayed in the Air over the Oakland Airport for More Than Twenty-Two Hours to Establish an Endurance Record for Her Sex, While at the Left Is Pictured Miss Marvel Crosson, Another California Girl Pilot, Who Took a Cabin Monoplane to an Altitude of 24,000 Feet in an Effort to Set a Record for Height for Other Women Flyers to Emulate

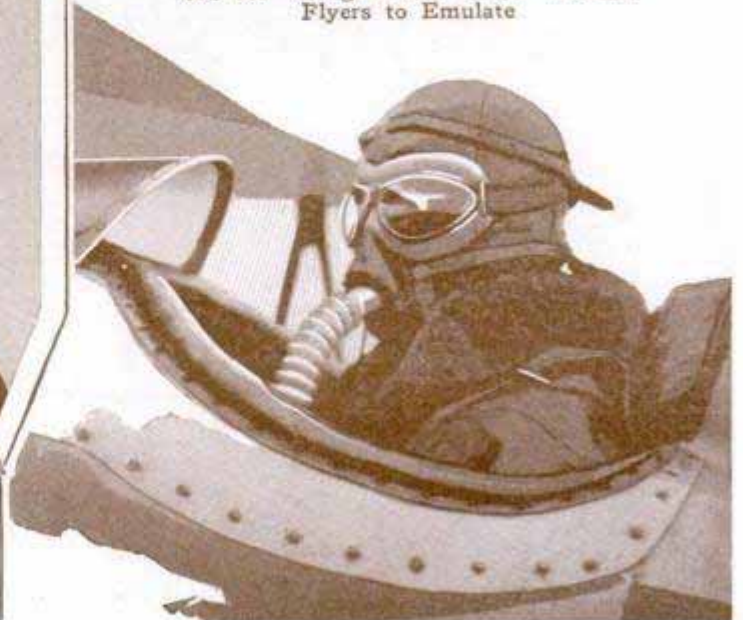

Altitude Flyers Must Carry Their Air Supply Along; Right, Lieut. Apollo Soucek with the Apparatus He Used in His Recent Record Flight

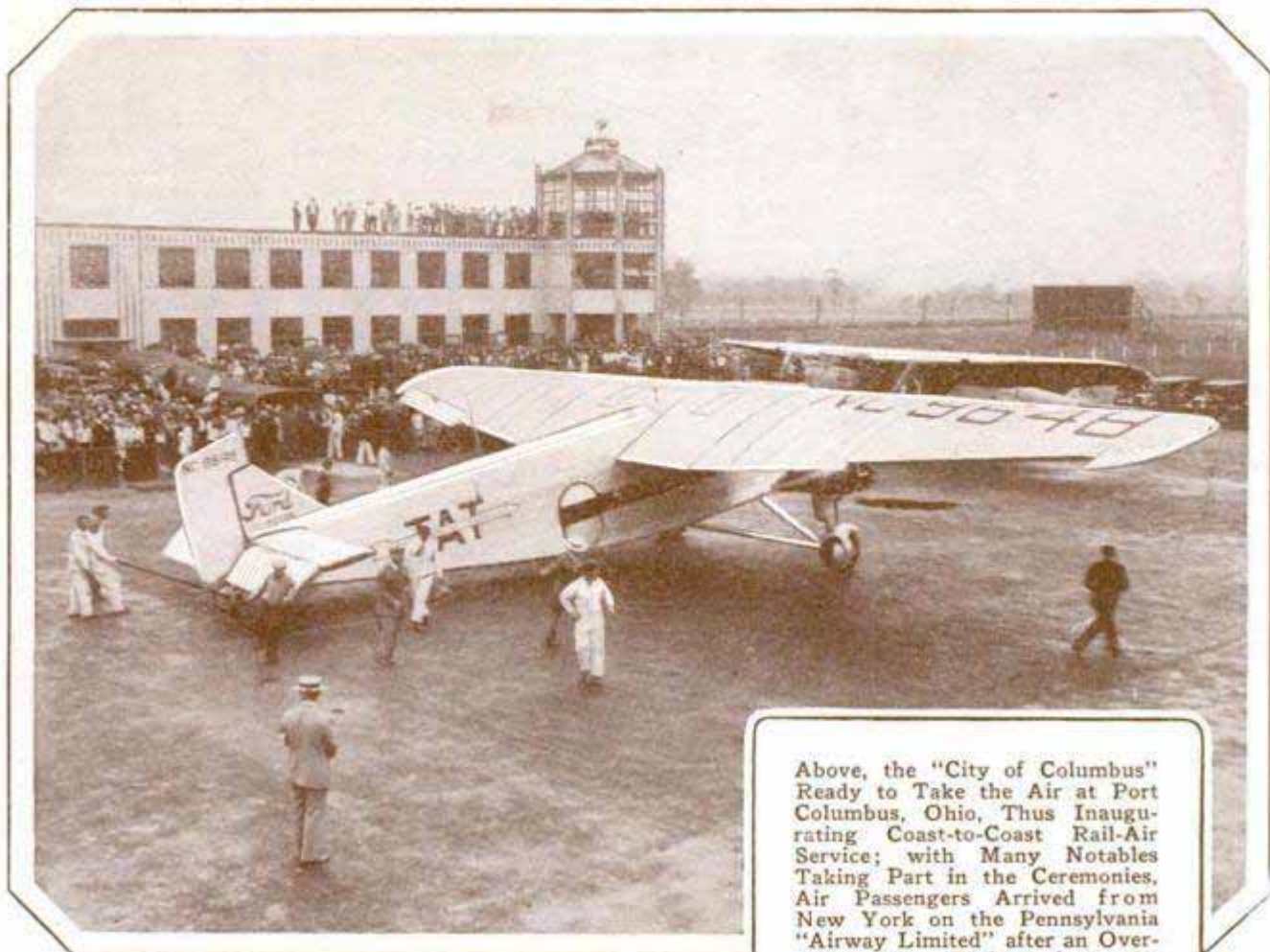

Above, the "City of Columbus" Ready to Take the Air at Port Columbus, Ohio, Thus Inaugurating Coast-to-Coast Rail-Air Service; with Many Notables Taking Part in the Ceremonies. Air Passengers Arrived from New York on the Pennsylvania "Airway Limited" after an Overnight Ride, Walked from the Station under a Canopy to the Hangar of the Transcontinental Air Transport, Where a Plane Was Waiting, and after Flying throughout the Day, Resumed Their Journey Westward by Train in the Evening; Below, One of the T. A. T. Planes Flying over Los Angeles



3205
568

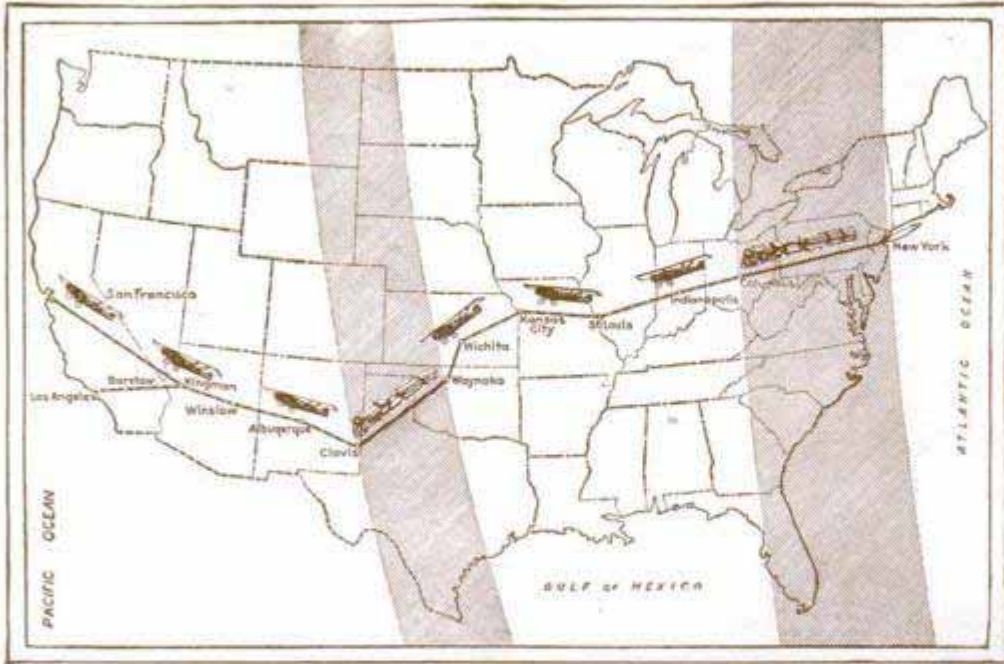

The Map Shows the Coast-to-Coast Rail-Air Route with Shaded Portions Indicating Night Travel by Train and Light Parts the Distances Covered by Air during Two Days; Passengers Leave New York in the Evening. Take Planes from Columbus, Ohio, the Next Morning. Resume Train Travel the Second Night, and Transfer to Airplanes for the Pacific Coast at Clovis, N. M., the Second Day

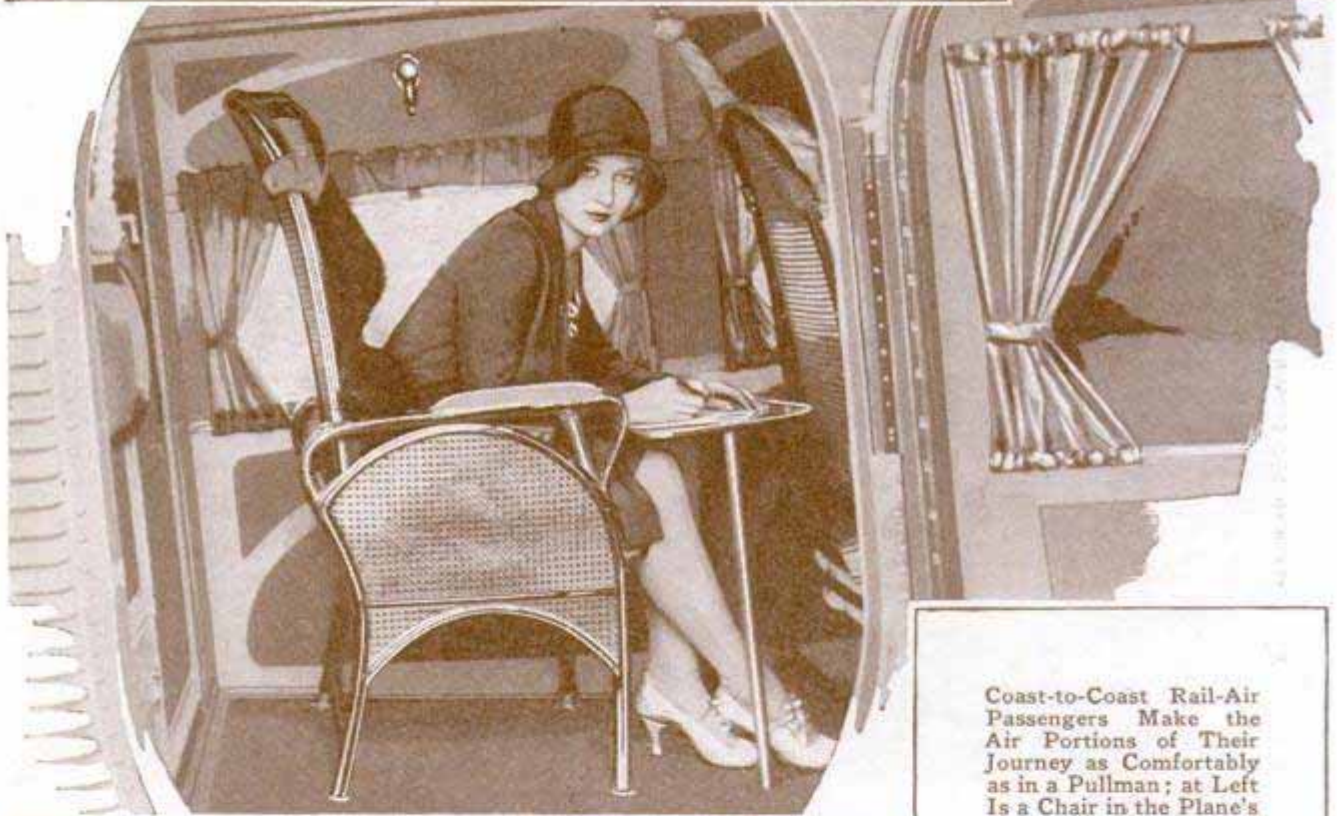

Coast-to-Coast Rail-Air Passengers Make the Air Portions of Their Journey as Comfortably as in a Pullman; at Left Is a Chair in the Plane's Passenger Compartment

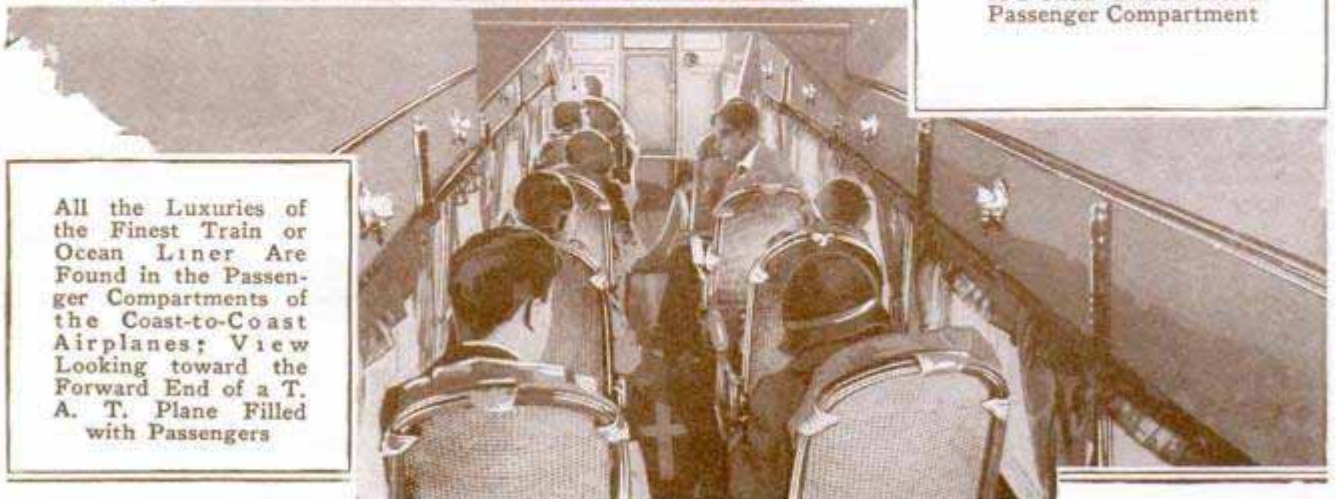

All the Luxuries of the Finest Train or Ocean Liner Are Found in the Passenger Compartments of the Coast-to-Coast Airplanes; View Looking toward the Forward End of a T. A. T. Plane Filled with Passengers

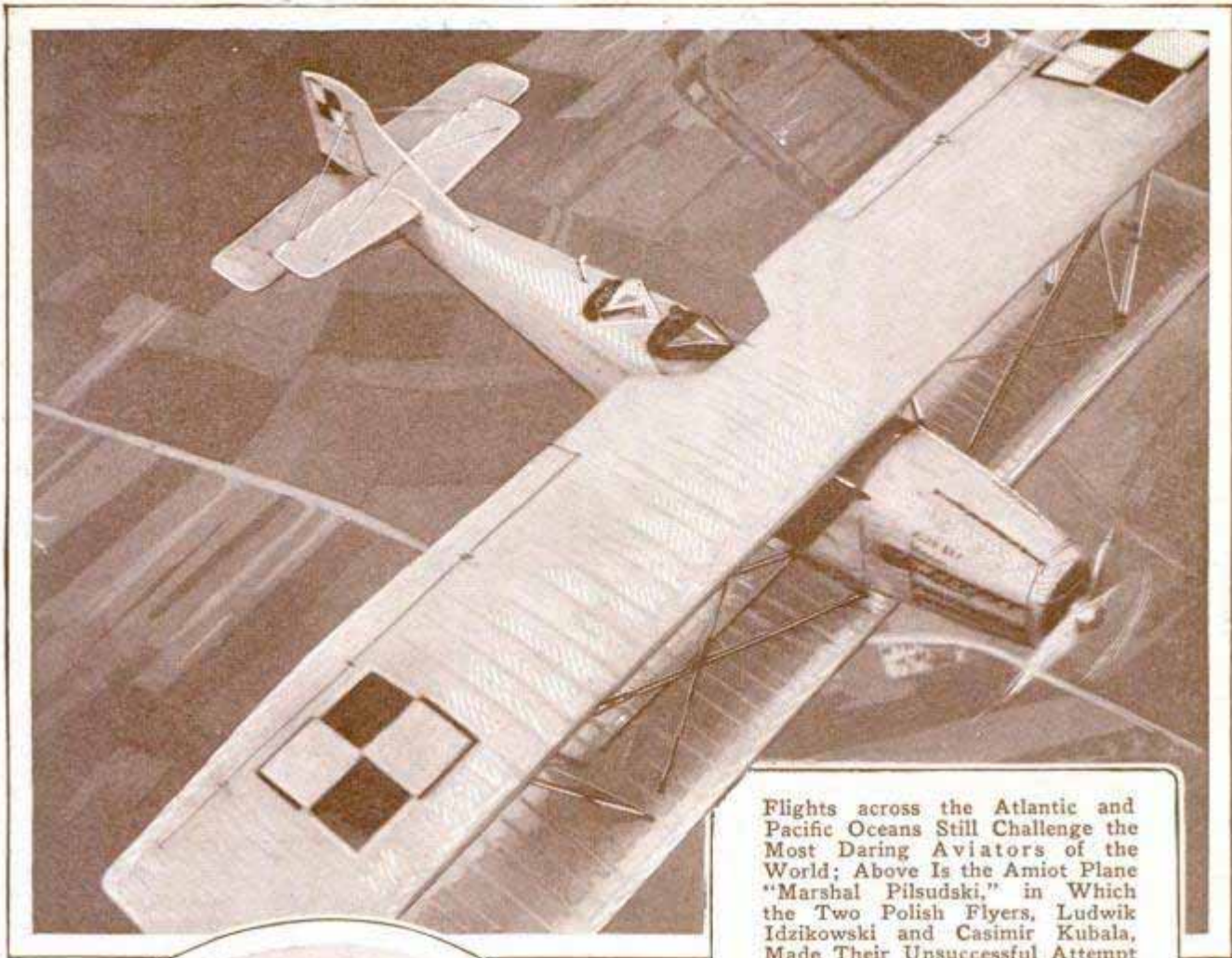

Flights across the Atlantic and Pacific Oceans Still Challenge the Most Daring Aviators of the World; Above Is the Amiot Plane "Marshal Pilsudski," in Which the Two Polish Flyers, Ludwik Idzikowski and Casimir Kubala, Made Their Unsuccessful Attempt to Fly from Europe to the United States without a Stop

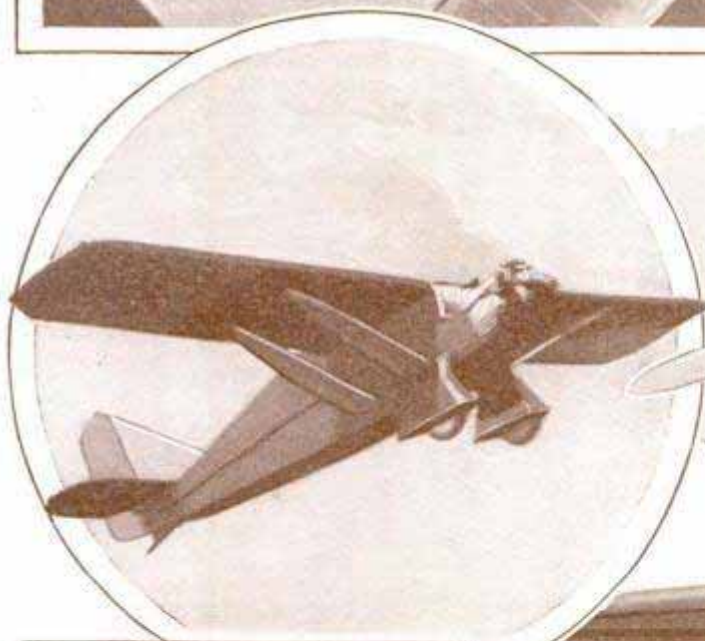

Above Is the Bellanca Monoplane "Pathfinder," in Which Roger Q. Williams and A. Yancey Flew to Rome after Failing with the "Green Flash"; Right, Mechanic Is Weighing the Lockheed Monoplane in Which Lieut. Harold Bromley Crashed at the Start of a Non-Stop Flight to Japan, the Weighing Being Done to Insure Accurate Balance

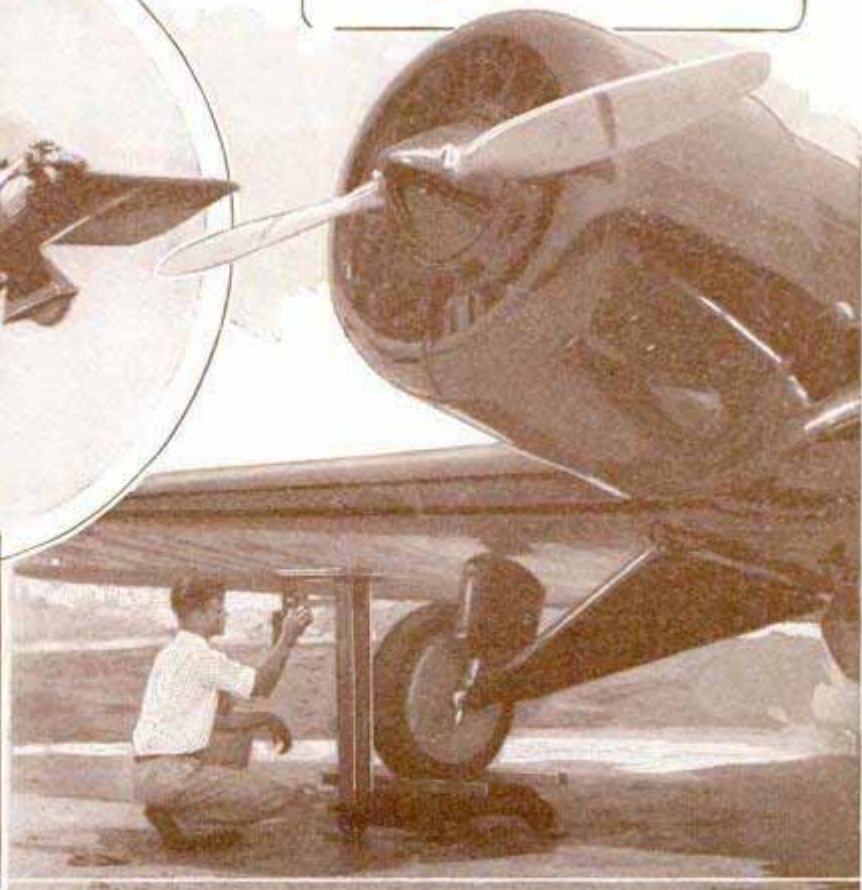

Wright Aircraft Corp. New Castle, Del

3205
570

Societe Anonyme
POPULAR MECHANICS
La Courneuve near Paris, France

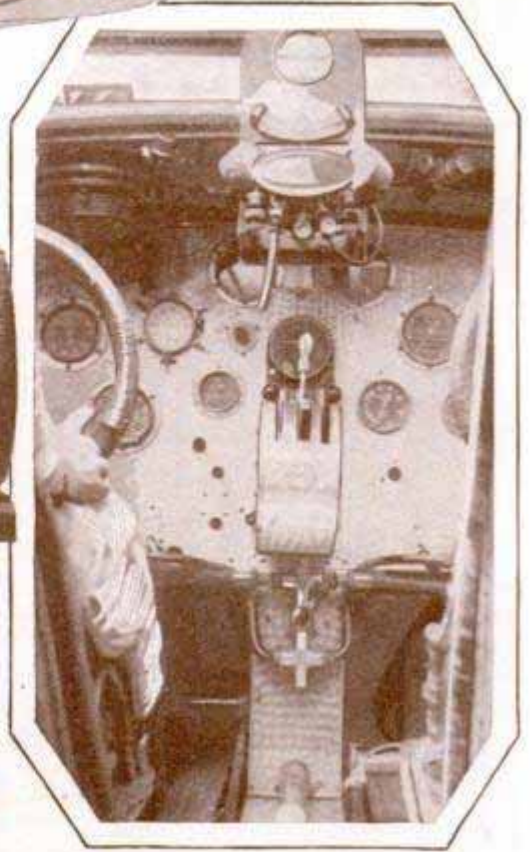
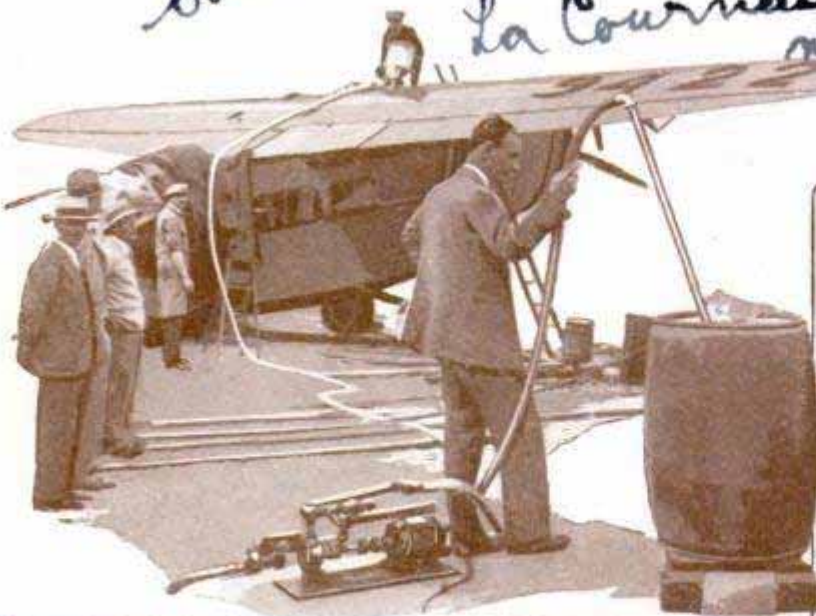

Above, the French Plane "Yellow Bird," at Old Orchard, Maine, Taking on Gasoline Before It Hopped Off on the Flight Which Eventually Brought It to Paris with the Three French Airmen and an American Stowaway



Above, the Instrument Board of the Single-Motored "Yellow Bird" on Which the French Aviators, Jean Assolant, Rene Lefevre and Armeno Lotti, Jr., Relied for Their Successful Transatlantic Flight; Left, Mechanics Repairing a Dump Valve Which Was Damaged during the First Attempt of the Frenchmen to Get Away, Necessitating a Return for a Second Start

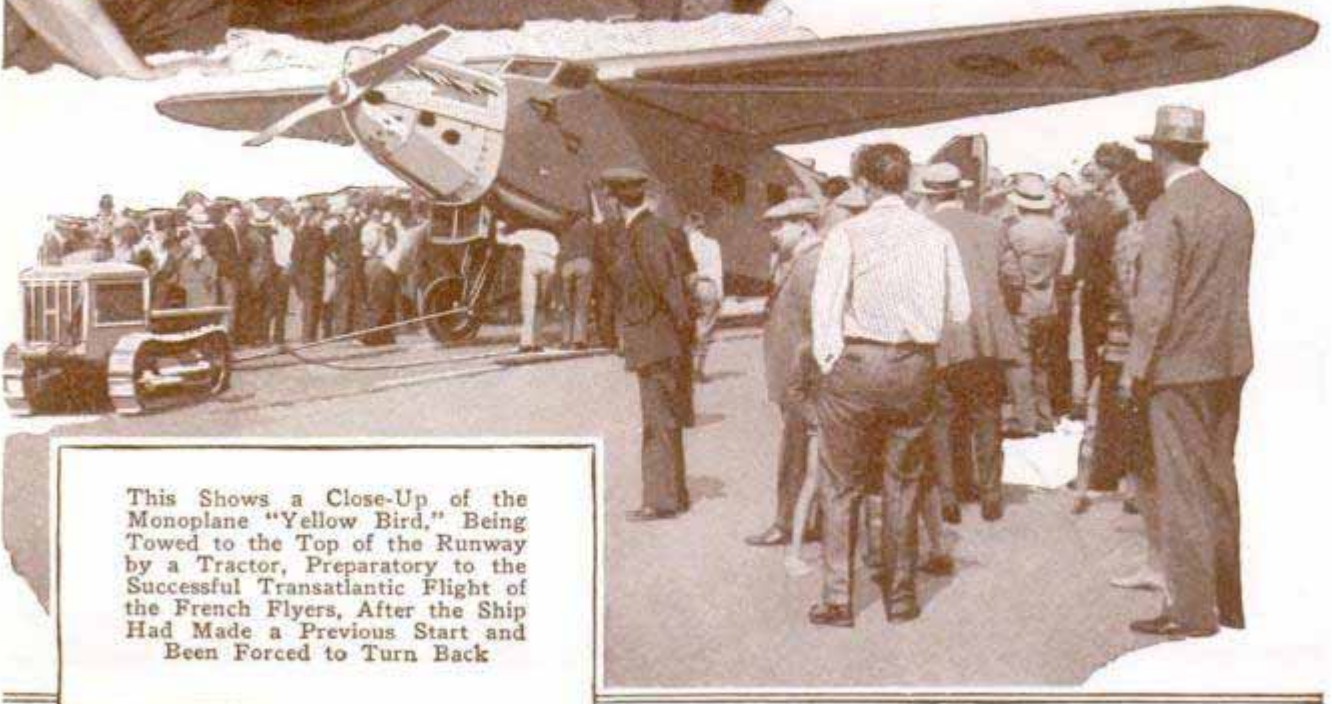

This Shows a Close-Up of the Monoplane "Yellow Bird," Being Towed to the Top of the Runway by a Tractor, Preparatory to the Successful Transatlantic Flight of the French Flyers, After the Ship Had Made a Previous Start and Been Forced to Turn Back

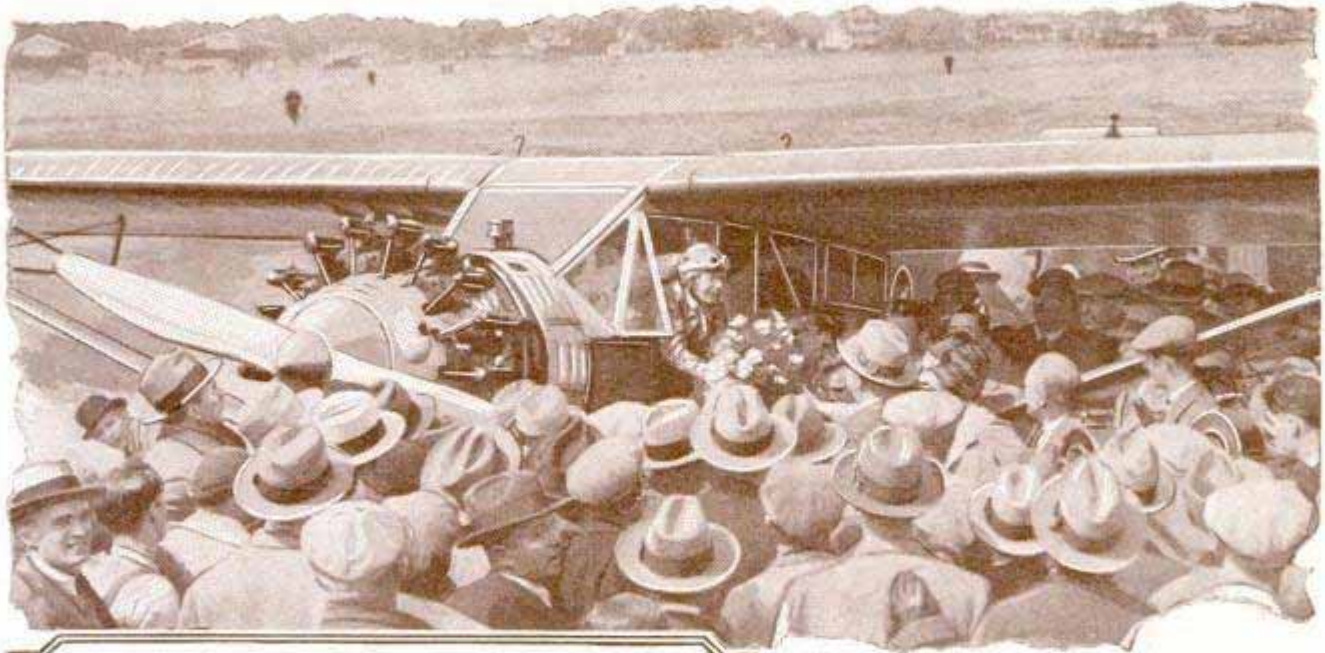

Above Is Shown the Crowd Welcoming Miss Eleanor Smith, Nineteen-Year-Old Girl Aviator, Seen Leaving Her Plane at Roosevelt Field, Long Island, After Making a Solo Endurance Flight of Twenty-Six Hours and Twenty-One Minutes to Better a Mark Set by a California Woman



Right, a Smiling Close-Up of Miss Smith Before She Started on Her Solo Endurance Flight, While Above Are Shown Two Other Endurance Flyers, Pete Reinhart and Loren Mendell, Who Flew over Los Angeles in the "Angeleno" to Make One of the Several Endurance Records Established in the Last Few Months, Only to See Their Mark Shattered a Few Weeks Later



3205

*Stamms Metallbauwerk
Friedrichshafen
Gesellschaft*

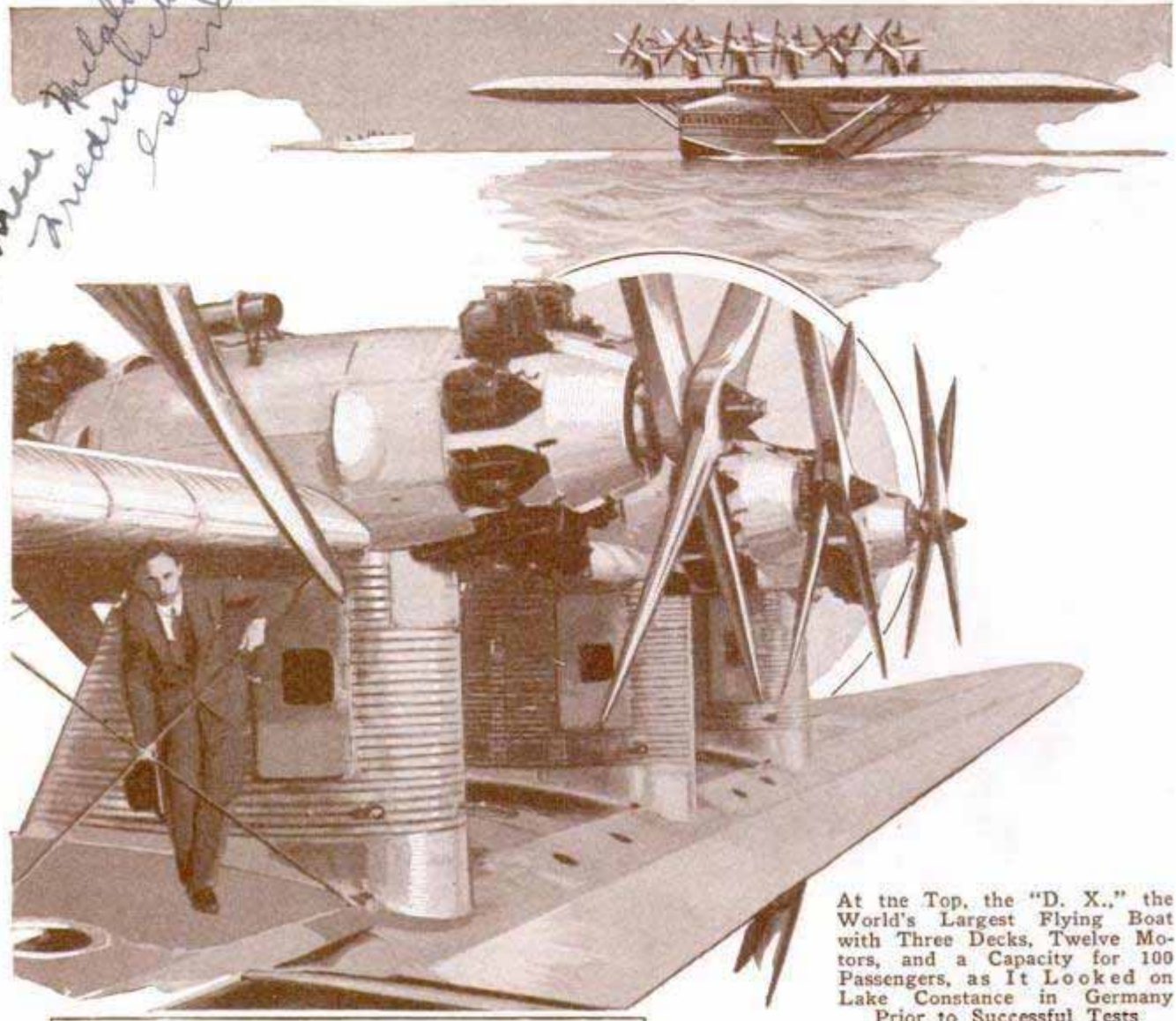

At the Top, the "D. X.," the World's Largest Flying Boat with Three Decks, Twelve Motors, and a Capacity for 100 Passengers, as It Looked on Lake Constance in Germany Prior to Successful Tests

Above, Three of the Twelve Motors of the "D. X." Which Lifted the Plane off the Water in a Trial Flight in Twenty-Eight Seconds, and, Below, the Mechanism Which Operates the Motors

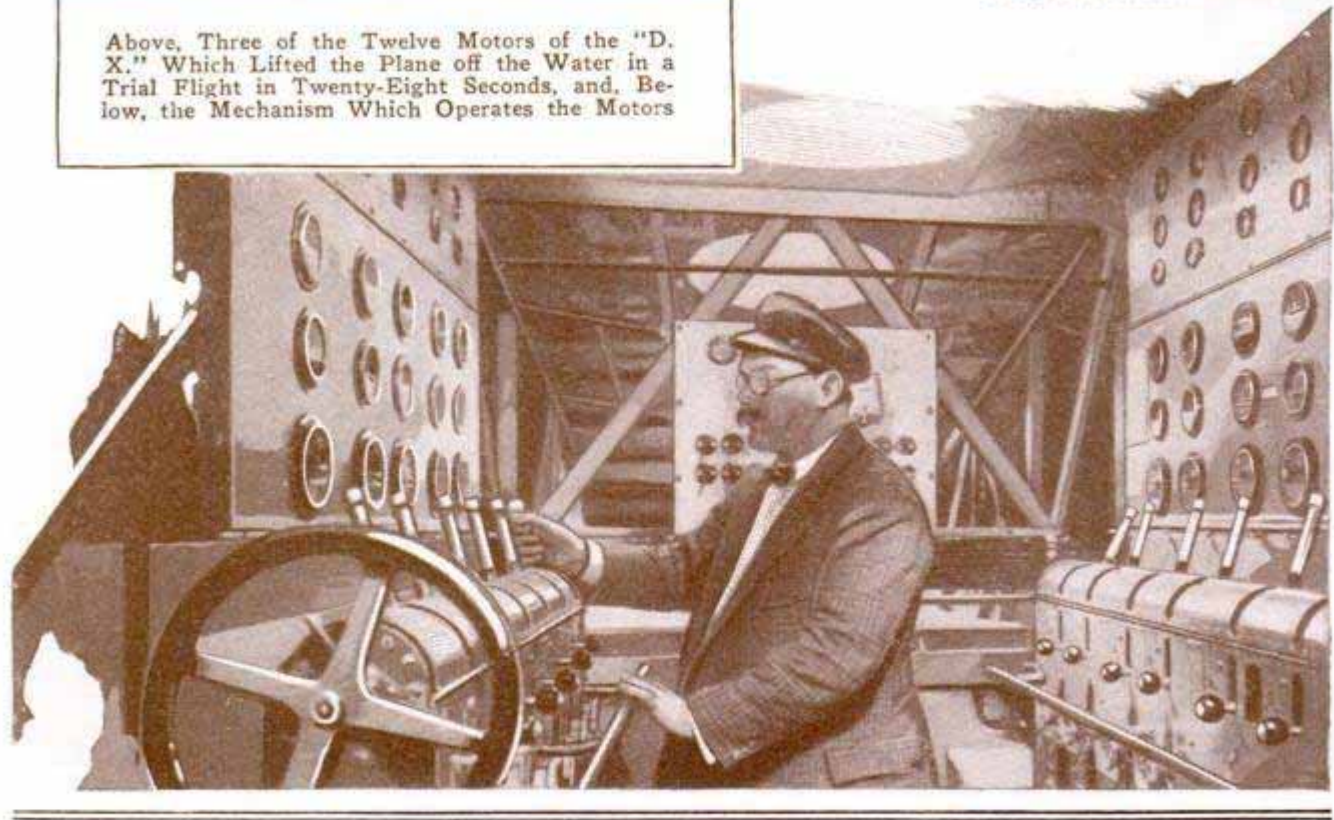

rev. 1930-782

see

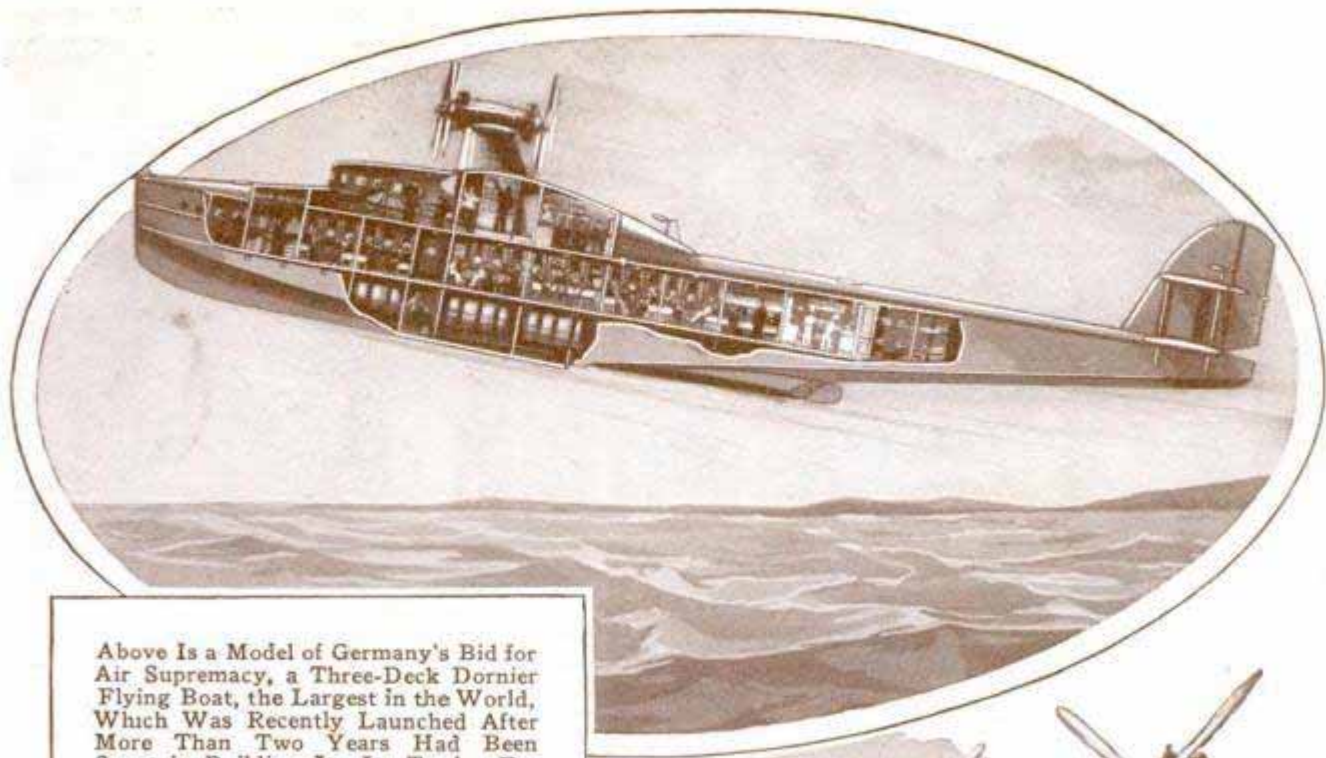

Above Is a Model of Germany's Bid for Air Supremacy, a Three-Deck Dornier Flying Boat, the Largest in the World, Which Was Recently Launched After More Than Two Years Had Been Spent in Building It; Its Twelve Engines Develop 3,000 Horsepower

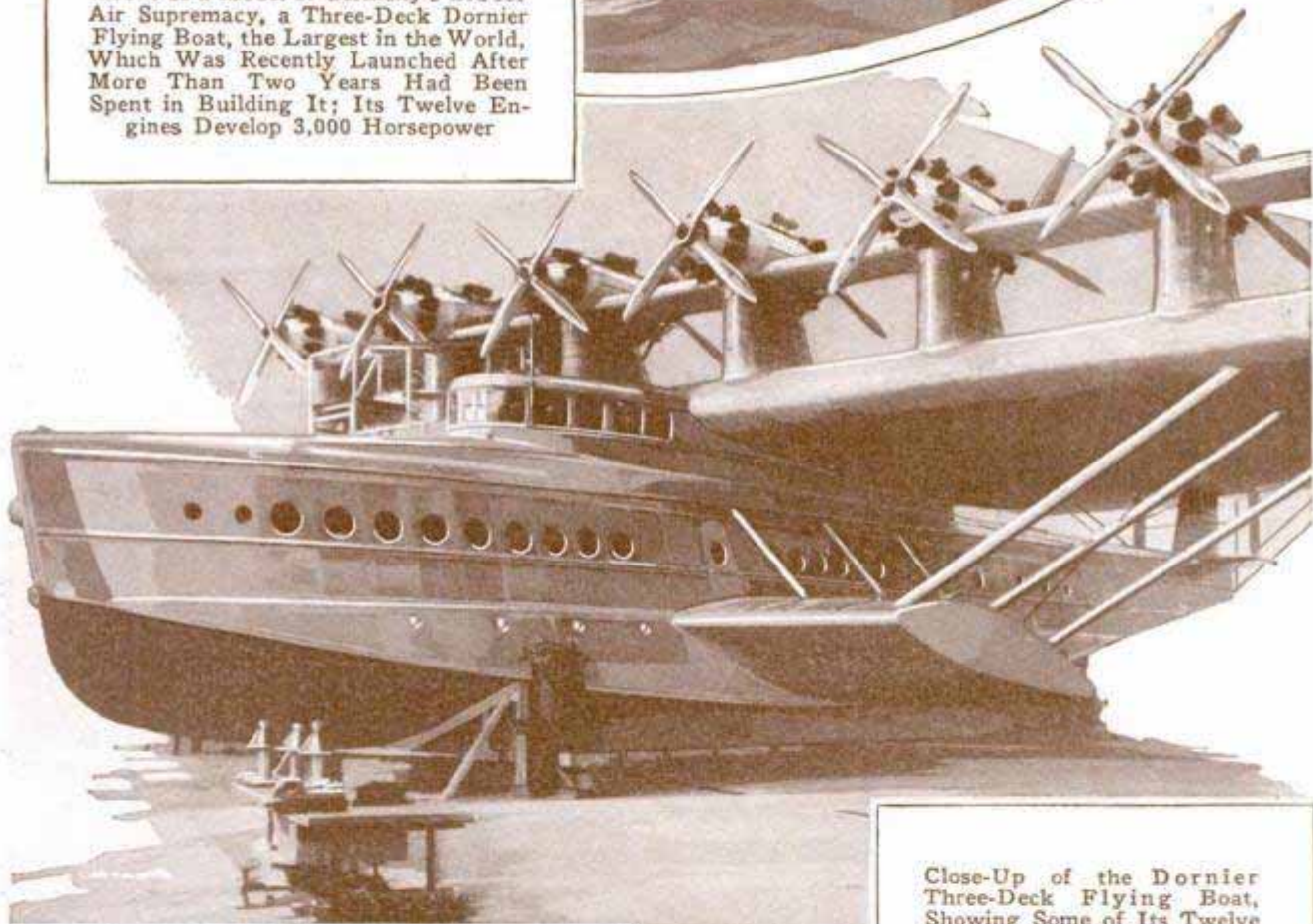

Close-Up of the Dornier Three-Deck Flying Boat, Showing Some of Its Twelve Engines, Which Propel the 137-Foot Craft with Its Wing Spread of 157 Feet at a Rate of 155 Miles an Hour; the Craft Can Carry 100 Persons and Has Salons and Luxurious Sleeping Accommodations for Sixty

Below, Model Showing the Proportions of the Dornier Craft; the Gigantic Air Liner Is the First of Several Huge Craft Which Are Being Planned with a View to Establishing Speedy Mail and Passenger Service between Hamburg and the United States





The Map Above Indicates the Distance the Los Angeles Endurance Flyers, Mendell and Reinhart, Would Have Traveled around the World in Their Plane, the "Angeleno." If They Had Flown Straight East Instead of Hovering over the City; Following the Los Angeles Parallel They Would Have Crossed the United States, the Atlantic Ocean, All of Europe and Part of the Pacific Ocean, or Nearly 18,000 Miles; at the Left Are Some of the Empty Gasoline Cans Used by the Ship

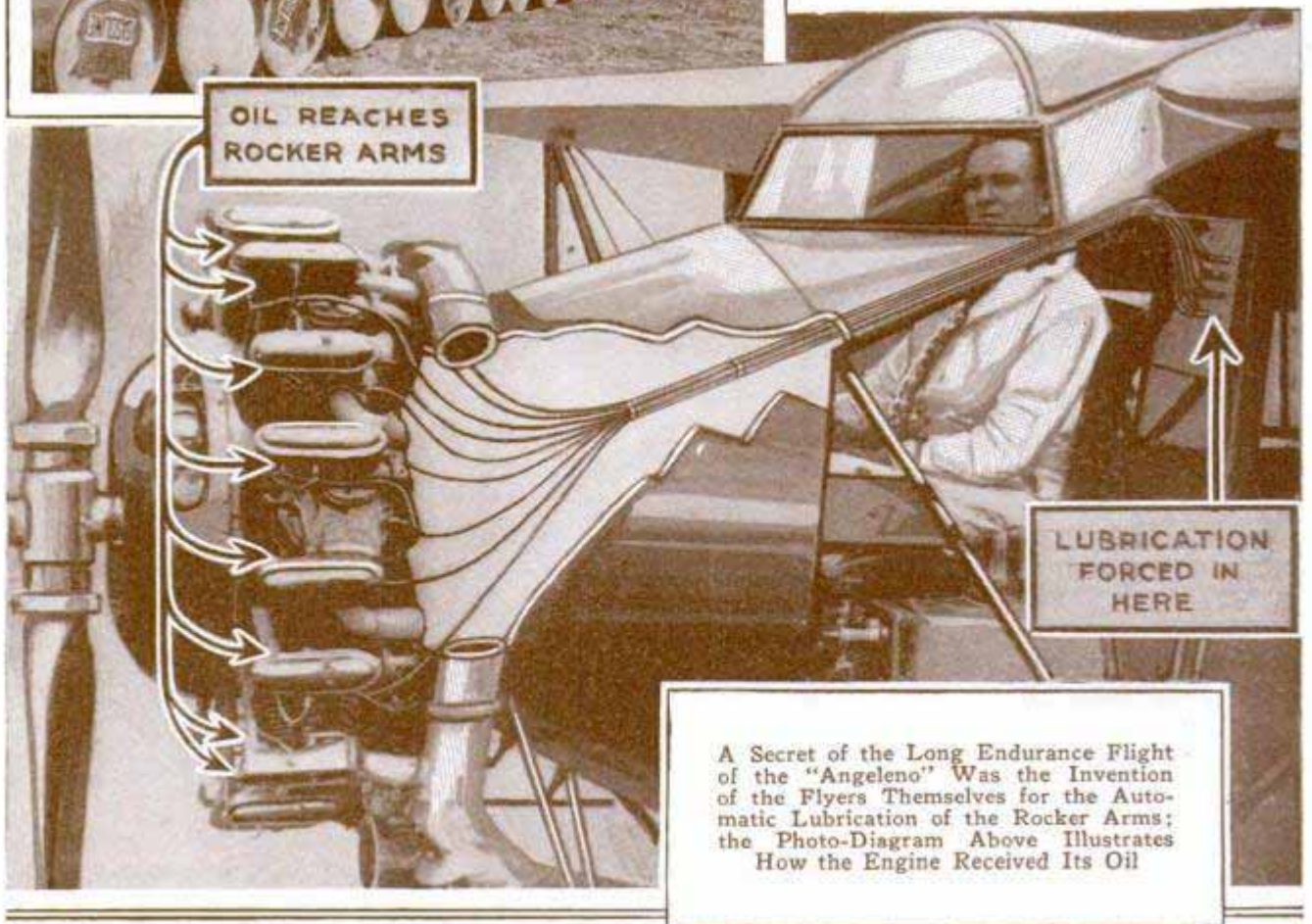

A Secret of the Long Endurance Flight of the "Angeleno" Was the Invention of the Flyers Themselves for the Automatic Lubrication of the Rocker Arms; the Photo-Diagram Above Illustrates How the Engine Received Its Oil

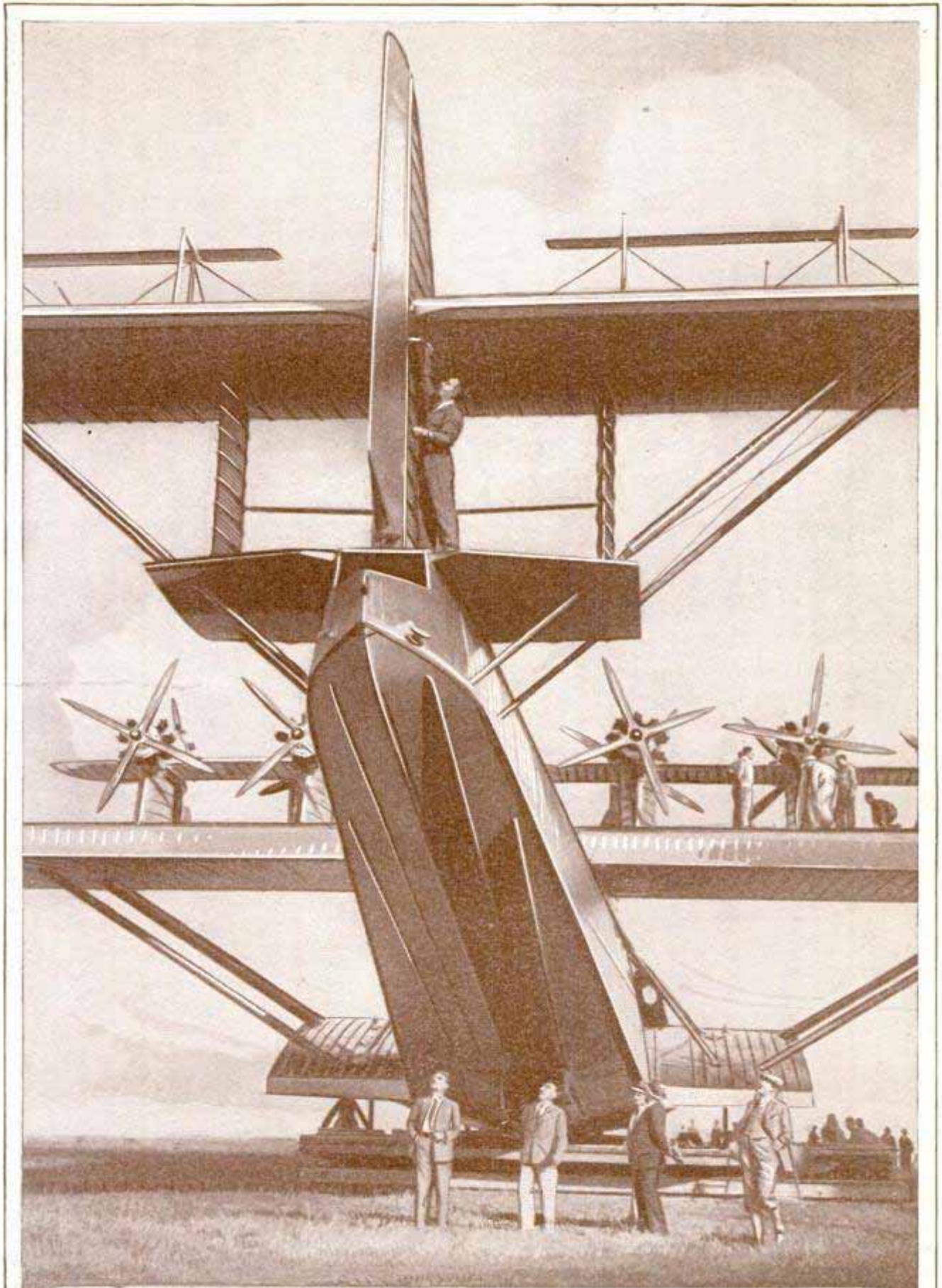

This Picture, Taken at Its Christening, Shows the Mighty Steering Fin of the Giant Dornier Plane Built in Germany, the World's Largest; Its Size May Be Estimated by Comparing It with the Persons on the Ground; Its Twelve Motors Will Carry a Load of 100 Passengers, and It May Be Used as an Air Liner between Germany and America

3254

Racine Wis

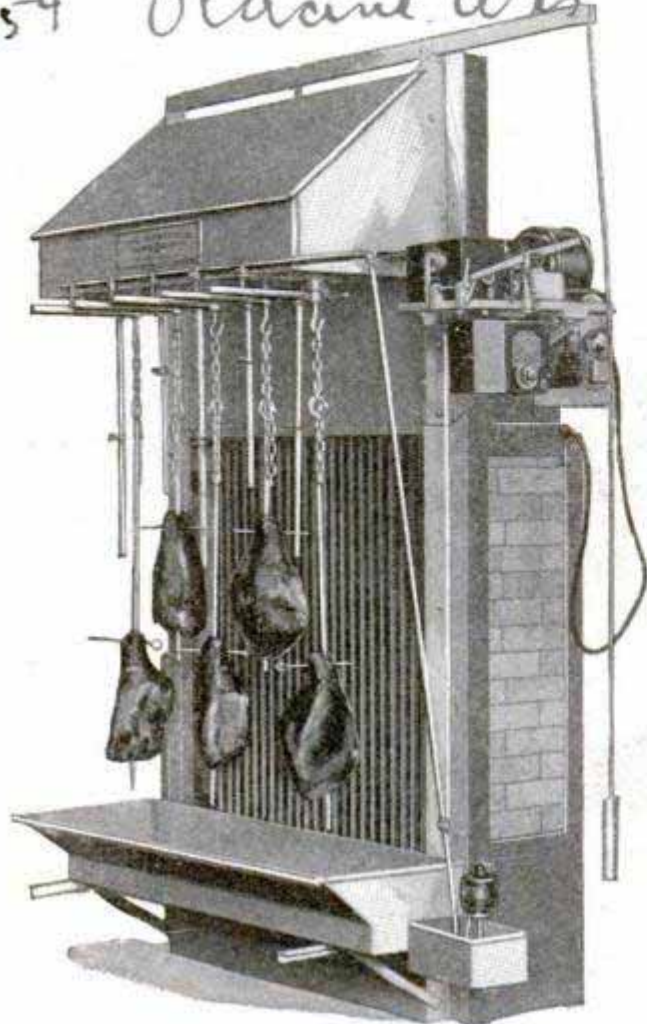

A Barbecue Roaster Which Turns the Meat Automatically, Saving Labor and Meat Shrinkage

AUTOMATIC BARBECUE ROASTER SAVES MEAT AND LABOR

Operated automatically, a barbecue roaster for the roadside stand cooks and bastes meat, leaving the owner free to wait on customers. The roaster is contained in an all-metal house, and the roasts are hung on spits which revolve in a vertical plane in front of an open coke fire, an electrically operated mechanism keeping the meat turning at regular intervals. The basting reduces the shrinkage, which, in ordinary methods of roasting, sometimes runs as high as fifty per cent. A time clock attached to the electric motor rings when the roast is finished, and a

safety curtain suspended before the fire descends if the roasts quit revolving or the mechanism stops functioning, thus preventing burning or spoiling the meat. Twenty chickens or 150 pounds of meat may be prepared at one time.

INFLATING BIG BRITISH AIRSHIP REQUIRES SIX WEEKS

3219

Inflating the gas bags of Great Britain's latest airship, the mammoth "R-101," under construction at the Cardington Royal Airship works, lasted more than six weeks. The big bags above the passengers' quarters were first filled and more than two months' production of the works' gas plant was required.

ELEVENTH FINGER FOR ORGAN GIVES ADDED TONE EFFECT

3239

Deciding that the ten fingers of the hands and all the stops on the modern pipe organ did not suffice to produce the blend of sound of which the instrument is capable, a New York organist uses an eleventh finger manipulated by moving his head. This mechanical digit consists of a band fitting snugly about the head, to which is attached a rod curved downward at the end and long enough to reach the third or fourth manual. The organist uses the eleventh finger to sustain or play a melody on one of the upper manuals, and his hands for variations and second-touch effects.

Curved Rod Fastened to Headpiece Provides Eleventh Finger for the Organist



Wm. William Hoffmann
Louis State Theatre

3/92 A. W. O. Sea King London Eng.

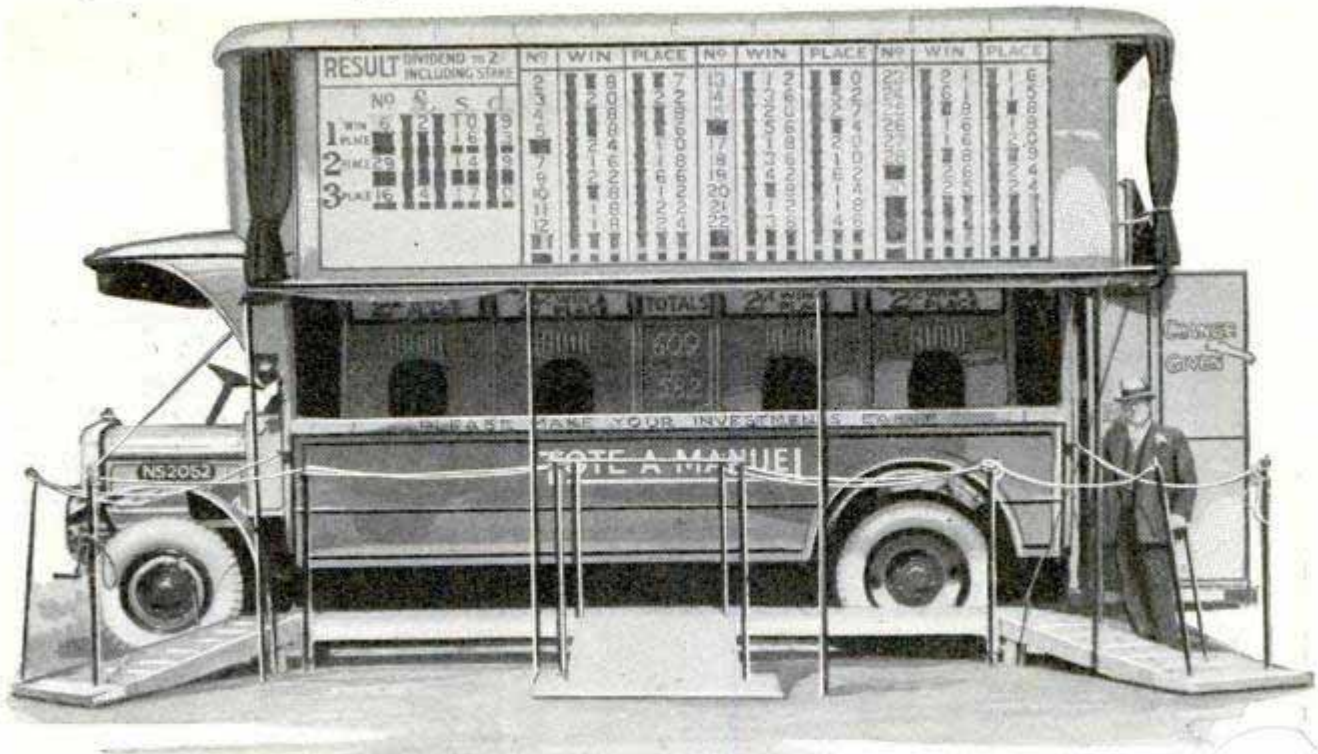

The Lower Part of This Betting Machine on Wheels Is Composed of Booths Where Wagers May Be Placed, While on the Roof Is a Quick-Totaling "Pari-Mutuel" Machine

BETTING MACHINE ON WHEELS PLEASES RACE FANS

English racing fans are hailing a portable quick-totaling "pari-mutuel" machine carried on the top of a truck, the lower section of which is given over to the wagering. Tickets on horses are issued and from each side of the car the turf enthusiasts immediately see the totals on the big adding machine, which the inventor calls a totalisator.

less than that of the recently developed Diesel engine for aviation. The weight of the fuel required to make steam would be greater than in internal combustion engines, but the cost would be less as lower grades of crude oil would be used. The steam would be condensed and returned to the reservoirs.

SHAPER FOR THE SMALL SHOP IS EASILY CARRIED

Intended for the small cabinet or carpenter shop, and for schools, a portable electric wood shaper has been placed on the market. It is upright, direct motor-driven, beltless and ball bearing, and so designed that lubricants cannot reach the motor.



The table is mounted on a screw on which it raises and lowers, and the spindle has a capacity of two and one-half inches between two steel shaper collars, or three and one-quarter inches, using solid cutters. A combination guard and fence is part of the equipment.

STEAM TURBINE FOR AIRPLANE TO REDUCE COST

Steam may enter the air as the source of power for extra-large airplanes, as plans have been prepared for a steam turbine for aviation by Swedish engineers at the request of an American manufacturer. By using a high-pressure boiler fired with crude oil and a high-speed turbine, the Swedish engineers expect to develop from 2,000 to 10,000 horsepower, a single boiler supplying steam for two turbine units geared to as many propellers, or two boilers for four propellers. Already the weight of these turbines has been reduced to less than two pounds per horsepower, which is about the same as the weight of gasoline engines now used on planes, and

Herald-Tribune 6/30/29

*Designer - Ljungstrom J. H. Wallace & Co
Steam Turbine Co
134 S. California Ave*

1st and 2nd and 3rd and 4th and 5th and 6th and 7th and 8th and 9th and 10th and 11th and 12th and 13th and 14th and 15th and 16th and 17th and 18th and 19th and 20th and 21st and 22nd and 23rd and 24th and 25th and 26th and 27th and 28th and 29th and 30th and 31st and 32nd and 33rd and 34th and 35th and 36th and 37th and 38th and 39th and 40th and 41st and 42nd and 43rd and 44th and 45th and 46th and 47th and 48th and 49th and 50th and 51st and 52nd and 53rd and 54th and 55th and 56th and 57th and 58th and 59th and 60th and 61st and 62nd and 63rd and 64th and 65th and 66th and 67th and 68th and 69th and 70th and 71st and 72nd and 73rd and 74th and 75th and 76th and 77th and 78th and 79th and 80th and 81st and 82nd and 83rd and 84th and 85th and 86th and 87th and 88th and 89th and 90th and 91st and 92nd and 93rd and 94th and 95th and 96th and 97th and 98th and 99th and 100th

3166

Cessna Wichita Kansas Model A-W

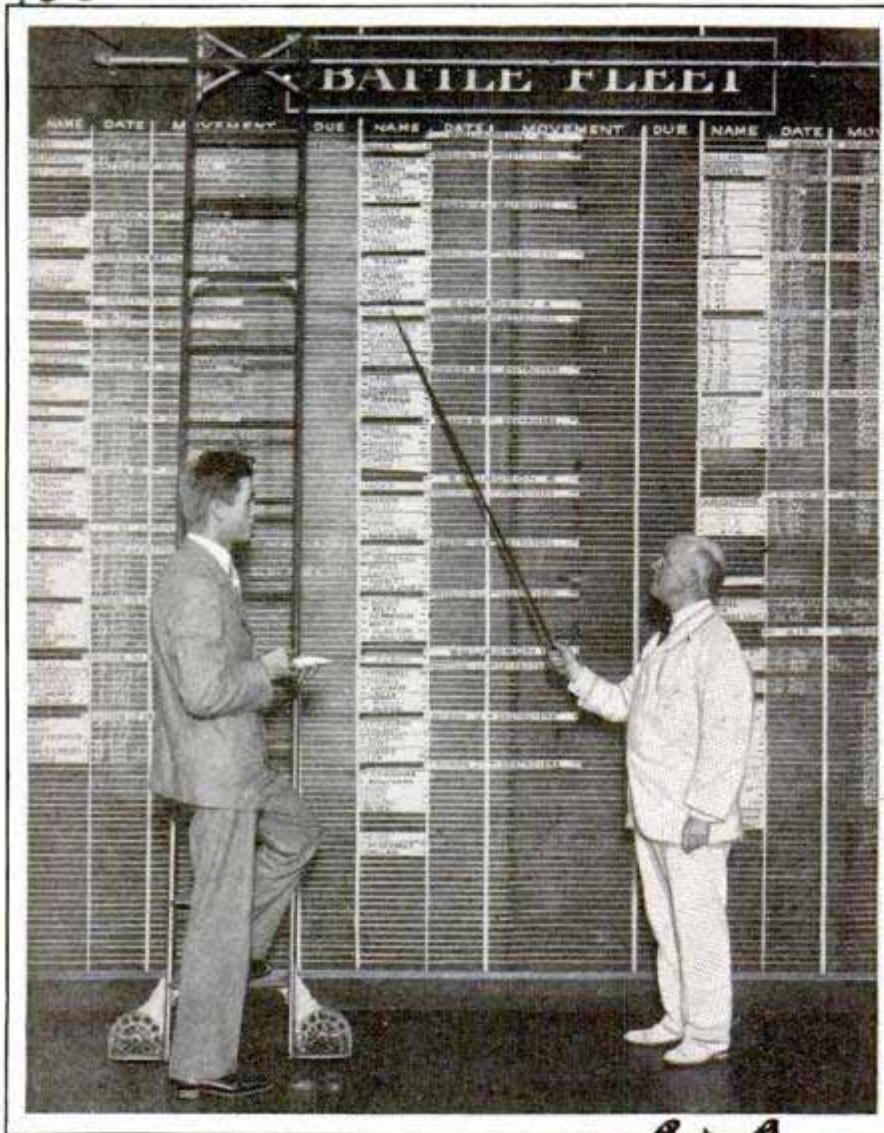

Uncle Sam Keeps Daily Tab on the Location of Each of His Fighting Vessels by Means of This Ship Chart

monoplane in which expenses were less than three cents a mile. The flyer covered 17,124 miles and visited fifty cities. During the trip the ship was flown in 330 demonstrations by 108 pilots who covered 9,278 miles, while cross-country flights accounted for the rest of the distance, the ship landing and taking off 410 times and carrying 656 passengers. Gasoline, oil, storage, service repairs and all incidentals totaled \$456.61. The flying time was 174 hours and thirty-six minutes, the cost per hour being \$2.61. The average speed was about ninety-eight miles an hour.

CASEMENT LOCK IS BURGLAR-PROOF

3172 Depending on gravity and an eccentric pin for security, a casement lock has been made that cannot be opened from the outside while the same principle is applied to

SHIP CHART SHOWS POSITION OF NAVAL VESSELS

Uncle Sam keeps daily tab on the exact location of every ship in the fighting fleet by means of a huge blackboard in the naval-operations office at the navy department in Washington. The ship chart, or location board, shows the daily battle-fleet maneuvers so that, at any given time, the department knows where each one of its fighting vessels may be found.

make the casement itself water-tight. The window, when closed, is made water-tight by a rabbeted stool and tongue-and-groove machining for the meeting sides. An eccentric pin in the operating handle, placed below the window sill, raises the casement out of the lower groove so that the window may be opened fully inward. A slotted guide in the handle allows for both horizontal and vertical motion of the casement. When closed, the casement drops into the bottom groove as the eccentric pin releases it when the handle is turned.

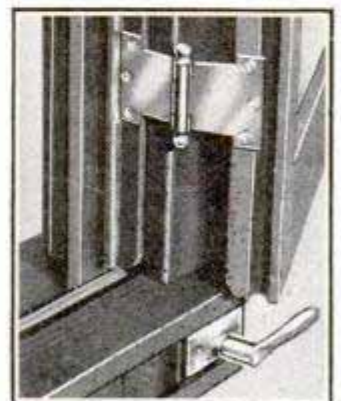

UPKEEP OF A SMALL AIRPLANE SAME AS THAT OF AUTO

3200 Upkeep of a small airplane compares favorably with the operating cost of an automobile, on the basis of distance covered, an official of a flying service has decided after a demonstration trip in a

*A. J. Pryor, Curtis
Flynn Service*

*Pacific Coast Wash
Co. 6600 Washington*

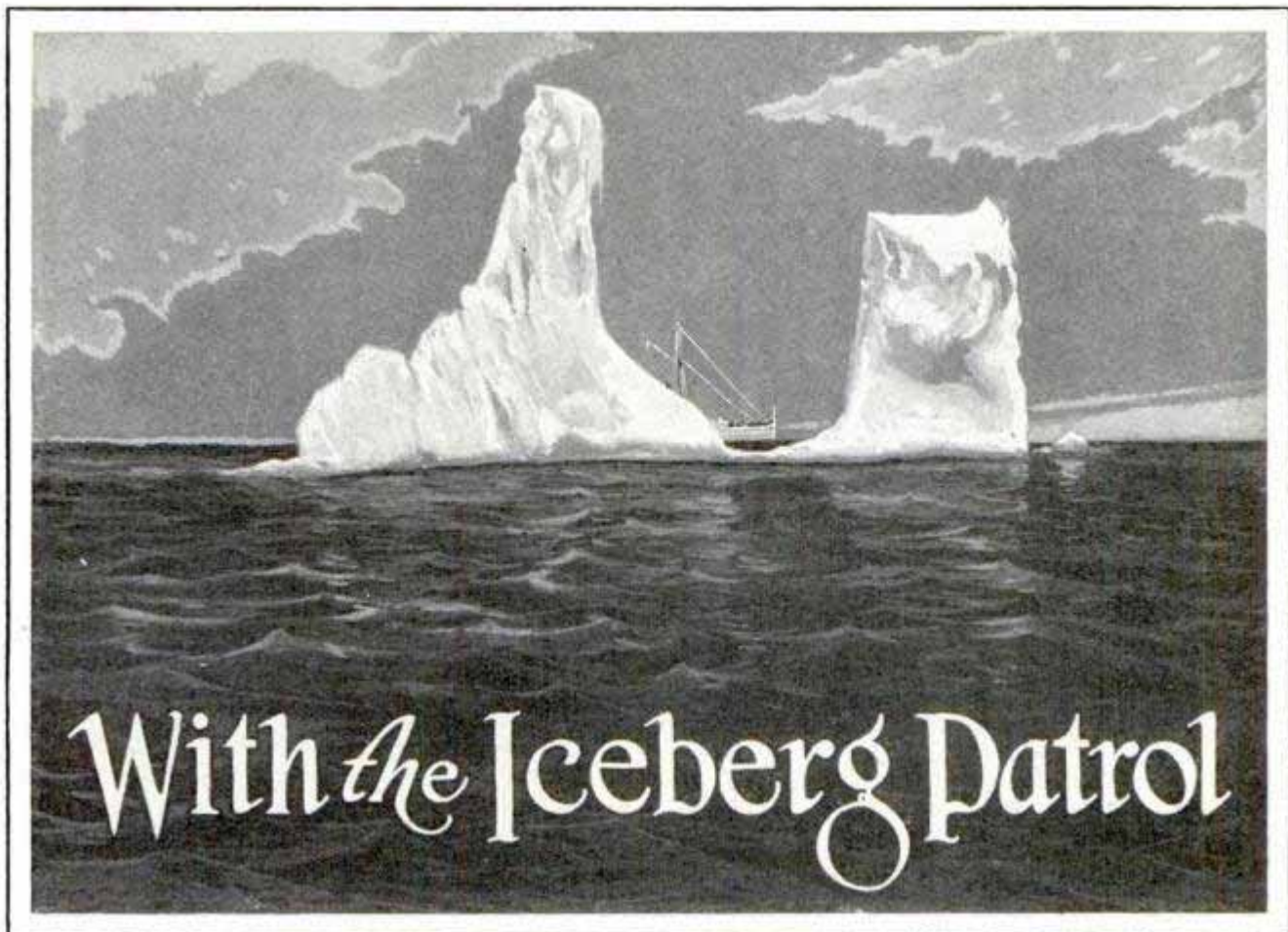

By EARL CHAPIN MAY, *Sharon, Conn*

ONE night in April, 1912, the palatial "Titanic" on its maiden voyage struck an iceberg near the Grand Banks of Newfoundland. More than 1,500 human beings lost their lives in the greatest maritime disaster of the century.

Since that tragedy no transatlantic liner has collided with an iceberg. Complete avoidance of collision between fast-steaming ships and wandering remnants of Greenland's glaciers is due to the efficiency of the International Ice Patrol for which the United States coast guard is responsible.

From the first of each April to the last of June, the offsprings of the Greenland ice cap slide into Davis strait and Baffin bay, float southward with the Labrador current and, between Newfoundland and the neighboring Gulf Stream, become menaces to shipping. To avoid this danger, ships between Europe and America have been run in "traffic lanes." They began doing it when 300 people lost their lives by the collision of two ships off Cape Race in the early seventies. Since then, east-bound liners are allowed to cruise only in

a lane sixty miles wide from north to south; westbound liners keep in their own lane just north of this.

Since the "Titanic" disaster, United States coast guard cutters, have often shifted these travel lanes to keep liners away from drifting icebergs. The cutters direct shipmasters by radio. If captains ignore warnings, they are disciplined by ship owners. The ice patrol knows its business because it makes a scientific study of icebergs.

Ice patrolling is a risky business. It offers plenty of variety. For example, the number of menacing bergs varies in size and number annually. About 350 of them get south of Newfoundland each spring—on the average. Yet, in the year of the "Titanic" disaster, 1,200 were identified in shipping lanes. Some have been seen as far south as the Azores, but they seldom last more than three days when they get into the warm Gulf Stream.

Once spotted, as it rounds the southeast corner of Newfoundland, a berg, no matter how formidable, is shadowed by a coast-guard cutter. This is relatively

easy in fair weather. When a fog shuts down, human eyes are valueless in iceberg hunting. I've known a patrol boat to sight a block of ice 1,700 feet long and, though only sixty-five feet high above the water, weighing some 36,000,000 tons. Just as the cutter approached to make more detailed examinations, a fog has shut down and the 1,700 tons of ship has had to feel its way about. Testing temperature of air and water does not give sufficient warning of a berg's location. On one occasion the "Mojave" found the water registering sixty degrees from a distance of two miles to within one hundred feet of a berg.

Each year the coast-guard cutters study and plot berg-carrying currents over an area equal to that of Pennsylvania. Current plotting is done by comparing sub-surface temperatures. When a coast-guard vessel is "dead" in the water, the crew lowers a fine wire into the ocean. At intervals, marking water levels, a bottle is attached. There are usually seven bottles between the surface and the greatest depth, 750 meters. After this length of line is payed out a weight, called a "messenger," is dropped down and successively trips each water bottle, causing it to fill, while a thermometer records the

water's temperature. The wire and bottles are then hauled on board, the bottled water siphoned into an electric salinometer and the saline contents or solid salts measured accurately. Temperature and salinity are then converted into terms of specific gravity, and the currents are calculated from the latter. Having determined the drift of current and made due allowance for wind drift, the ice-patrol ship commander can come pretty close to telling where a berg will be twelve hours hence. He can also tell by observation and experience how much the berg will lose from erosion by waves and from melting.

Many attempts have been made to aid nature in disintegrating dangerous icebergs. Coast-guard cutters are well armed. Five-inch guns are carried by most of them. These five-inchers have bombarded icebergs without any effect on the mass of ice. Fifty-pound guncotton mines were equally ineffective. Only currents, wave erosion and warm water can put the floating islands out of business.

The protection given shipping by patrol ships is 100 per cent valuable partly because of radio. Hundreds of weather reports are sent and received. If any vessel wants special information, the cutter promptly radios it. Each spring about

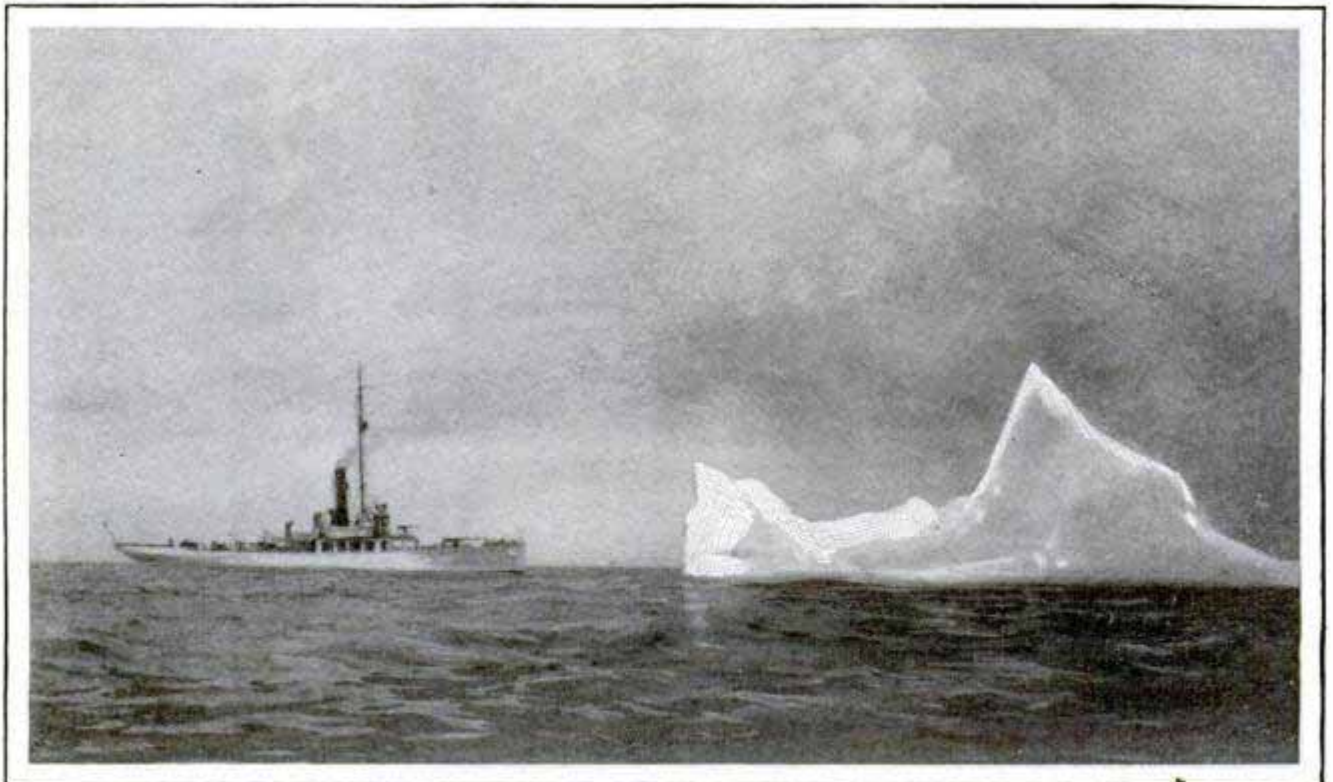

The U. S. S. "Mojave," Having Located an Iceberg, Proceeds to Take Measurements as to Its Speed of Drift, Determined by the Ocean Current and, to a Degree, by the Wind



Plunging through a Heavy Sea on an Iceberg Hunt; the "Mojave" Forges Ahead in All Sorts of Weather, to Guard Other Vessels against the Iceberg Menace

300,000 words are thus handled. Ship masters have learned to respect these warnings. In summer time, New York-Europe liners, cruise over what are known as courses A and B. From September to February 1, they cruise on courses C and D. During the normal ice season, from March until June, they may be shifted, upon recommendation of the ice patrol, from track B to track A, if the drift of ice is extra southerly.

One night last May, the "Aquitania" was running at a speed of twenty-two and a half knots across the Grand Banks. Her course, as given to the coast-guard cutter, indicated that she was headed toward the position which would soon be taken by the southernmost berg. She was also headed into a fog. The cutter gave her a special warning, then broadcast information about the drifting berg. The liner promptly altered her course—and proceeded safely. The thousands on board the "Aquitania" knew nothing about the cutter's work.

By ceaseless vigilance and daring in fog, wind and cold; by weeks of cruising in dense fog; by long days and nights on the bridge with the fog whistle blowing double blasts at two-minute intervals so that liners may keep clear of them, the patrol boats keep safe the great transatlantic lanes of travel.

GOLF-BAG CONTAINER FOR CAR HELD ON RUNNING BOARD

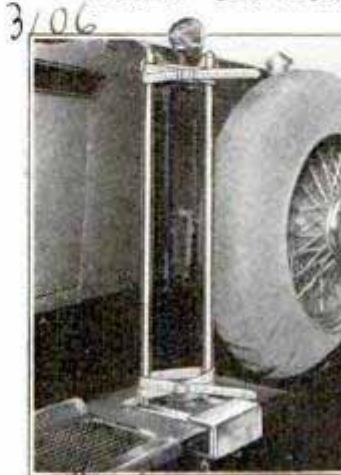

Stowing golf bags in an automobile is simplified by a holder which is attached to the running board. The outfit has a capacity of four bags, is chromium-plated and can be detached easily when it is not wanted.

Jonnieau Shield Co, Inc.
518 W. 57th St. New York

*Chicago. Immovite Carriage
Mfg. Co. 3515 S. Michigan*

RUDDER SHAPE SECRET OF GREAT LINER'S SPEED

One of the secrets of the 28.5-knot speed attained by the German ship, "Bremen," the largest motor-driven liner afloat, has been disclosed by pictures taken while she was in drydock which show that the vessel has a rudder shaped

Dr. Max Oertz, German hydroplane maker, who was associated with the late Count Zeppelin, airship designer. The airplane wing-type of rudder has been tried previously in single-screw freight steamships, where it was found to increase

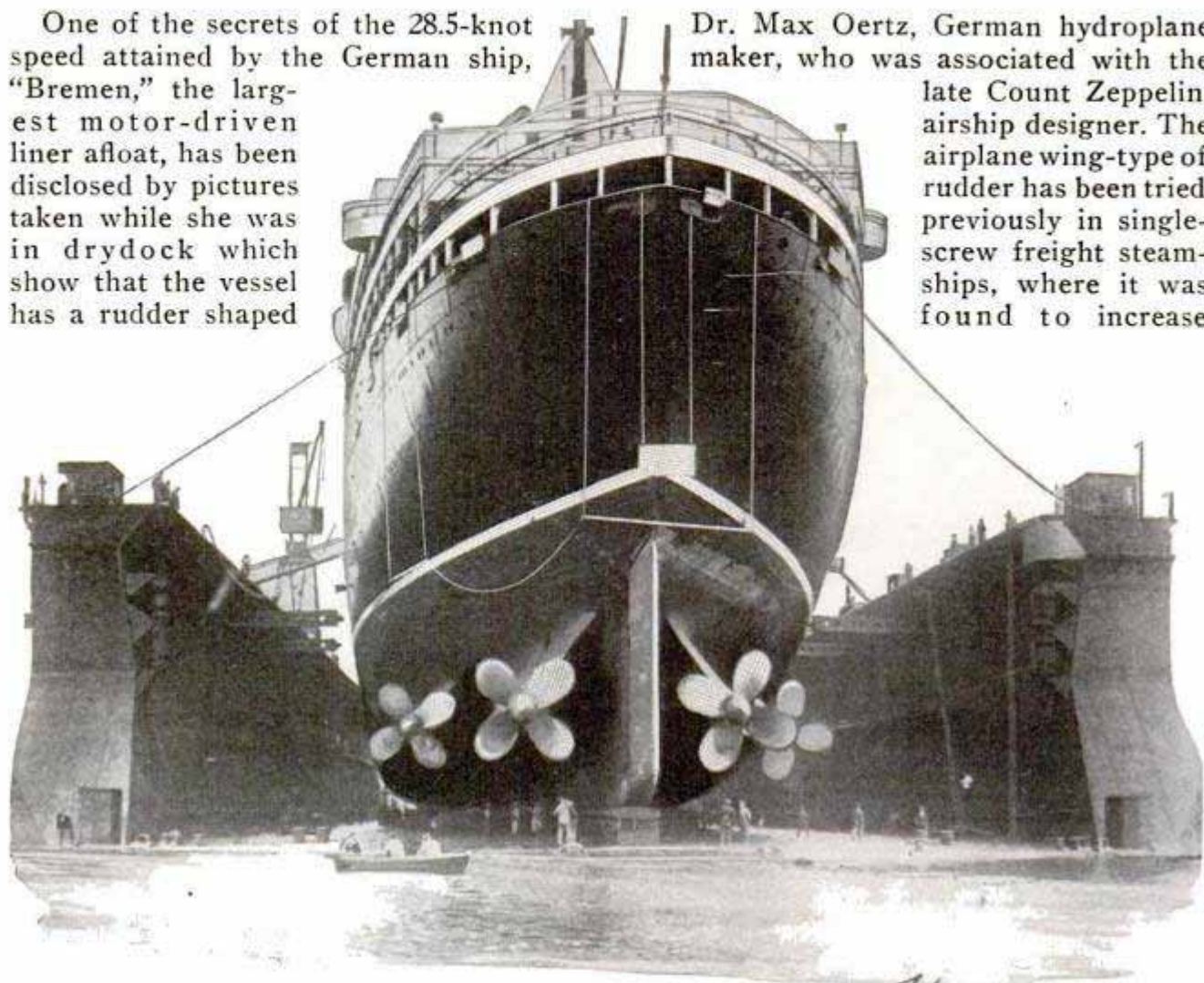

Here is the German Liner, "Bremen," Fastest Steamer Afloat, in Drydock Before Her Record-Breaking Trip to America; Note the Propellers, and the Rudder Shaped Like an Airplane Wing

like the wing of an airplane, on the streamline principle. The streamline rudder of the fast 50,000-ton ship, navigators explain, increases effectiveness in steering, and reduces eddies and currents which interfere with the propellers, thus minimizing resistance to the speed of the boat. The rudder was designed by

speed from four to eight per cent and to save ten to fifteen per cent in fuel. The "Bremen," however, is the first passenger ship to be so equipped, and if the airplane rudder continues successful on this vessel, it may be adopted by other ships which deem speed and fuel-saving essential to successful operation.

ARE YOU RIGHT OR LEFT-EYED SHOWN BY TESTS

Are you right-eyed or left-eyed? This question is settled by a vision test through which an experimenter may determine whether an individual looks with the right or left eye. The test is so simple that it can be tried on children, and groups can be tested at one time. In sixty-five per cent of persons the right eye is dominant,

thirty per cent are left-eyed, and five per cent have mixed vision. About fifty per cent of left-handed persons have been found to be left-eyed, and the relation between eyes and hands is considered significant, but still obscure. Double vision, the inevitable outcome of having two eyes, is overcome by ocular dominance in which the right of way is given to the image of the dominant eye, that of the other eye tending to be suppressed.

*Suence Service Bulletin
431-B, 6/25/29*

*Prof. Walter Miles
Standard PC*

3174

Carl W. Marguerite
Jacob, 224 N. Ludlow St. Dayton, Ohio

NON-LIQUID STORAGE BATTERY REDUCES MOTOR TROUBLES

2284

Filled with a solidified sulphuric-acid solution, instead of liquid, a storage battery now on the market requires distilled water but once every three months. It prevents the formation of injurious substances, eliminating the likelihood of burned plates, and the battery cannot freeze under any conditions. Taxicab companies claim it reduces their battery costs nearly fifty per cent a year.

Electric Power

AERIAL CAMERA SHOWS DETAILS OF GROUND FROM ALOFT

3231

Successful tests recently were made at Dayton, Ohio, with the world's largest aerial camera which weighs 130 pounds. The film is 150 feet long and nine and one-half inches wide. An instrument times the interval at which the photographs are to be taken and trips the camera shutter. The film is wound automatically and a registering apparatus notes the altitude of the plane, the time of day, the date and the number of the negative. The camera is electrically heated so it will function in low temperatures. The first photograph taken was from an elevation of 18,300 feet. The possibility of obtaining colored motion pictures from the air also was demonstrated with another camera. The value of the color pictures from a military standpoint thus far has been limited because of their small size, but experiments are being made with a view to producing larger pictures.

World's Largest
Aerial Camera
Which Gives
Ground Details at
20,000 Feet



maker unknown

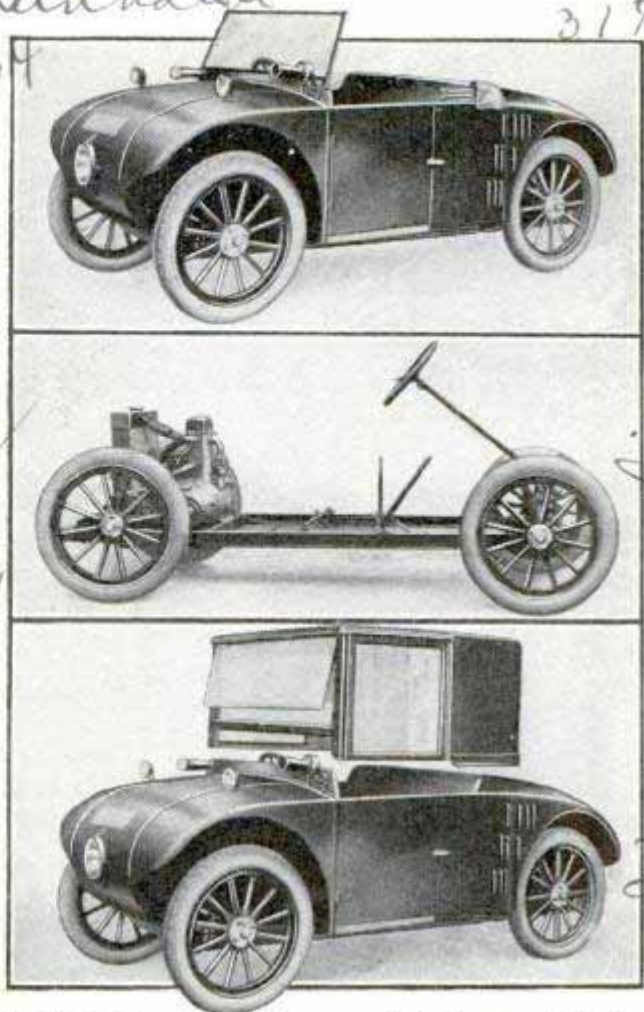

A Light German Car Constructed with a One-Cylinder Engine, and the Motor in the Rear

SINGLE-CYLINDER AUTOMOBILE HAS MOTOR IN REAR

Built with a one-cylinder engine and the motor in the rear, a light and compact automobile turned out by a German manufacturer presents a strange contrast in appearance to the American car. Aside from the reverse position of the engine, the body itself is original in design. A coupe has a removable top, and a single-seated car designed for a cab has the passenger's seat beside the driver with a glass panel separating them. A single light is built into the middle of the hood, and the body itself is contoured so as to form the fenders.

3209

PLANE SMOKERS START FIRES

Lighted cigar and cigaret stubs thrown from airplanes may start forest fires, forest rangers have determined after a series of tests. As a result, forestry officials have issued warnings to pilots and air passengers against throwing any sort of burning material from the ships.

*Conducted by Jack York and
Lieut. A. H. Lyon*

*Hannover, Linden
no longer made Germany to U.S. agent
12/17/29 New 4-cylinder car. 1/11/30*

Washington

3018
584

Architect. *Cletcher & ...*
835 *Range Road*
POPULAR MECHANICS
Los Angeles, Calif.

DRIVE-IN MARKETS HELP SOLVE TRAFFIC PROBLEM



Drive-In Markets to Accommodate the Motorist; This One Is Built in Spanish Style to Harmonize with Surrounding Residential Section and Helps to Solve the Parking Problem



Showing How Easily Cars Leave the Highway to Reach the Market and, Below, Drive-In Store of Chinese Architecture

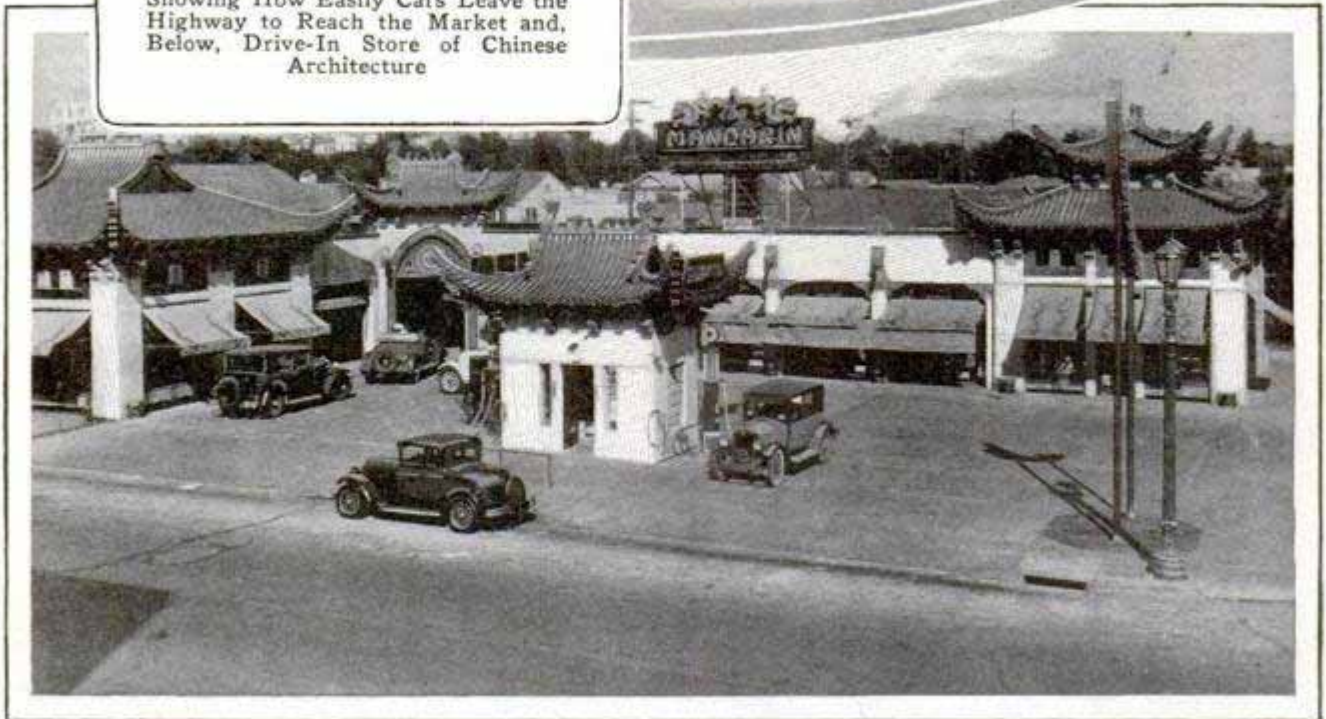

City of Los Angeles, Department of Public Works, Division of Traffic Engineering

Corbett, J.
48 W. 75 St.
New York

3199

**FORGED STATUARY
IS DETECTED BY
VIOLET RAY** 320

Ultraviolet rays are being tried out by the Metropolitan museum of art to supplement the connoisseur's "sixth sense" in detecting fake marble antiques. In the past, X-rays have been tested with some success. Museum officials who are using the ultraviolet ray on marble said it has possibilities which are not limited to this field alone. The use of the rays is made possible because objects exposed to this light tend in varying degrees to reflect the purple rays. Experiments have shown that the color of old marble under the rays was different from that of freshly cut marble, as its luminescence was of a different color.

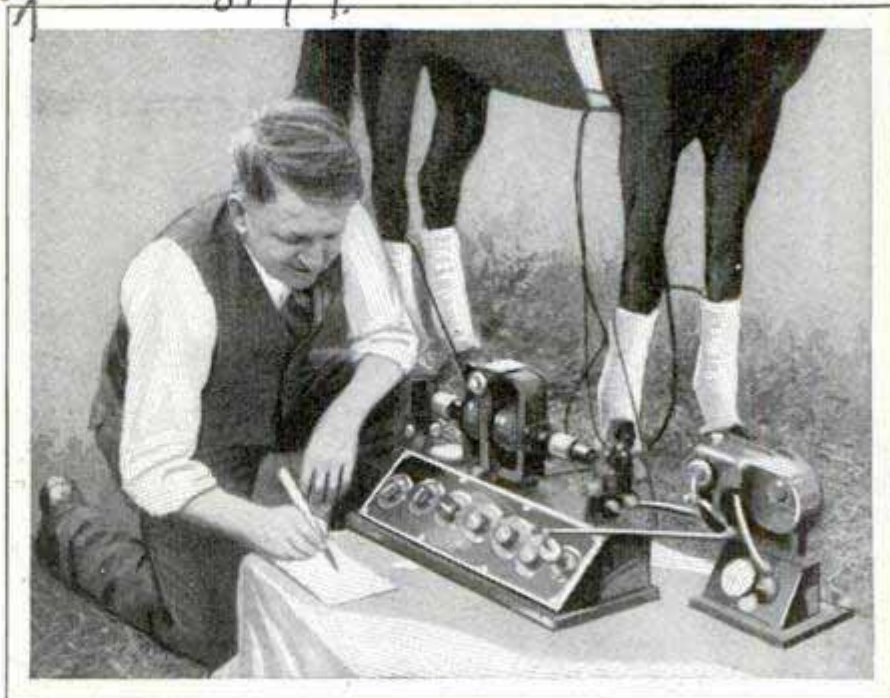

Race Horses Must Have Sound Hearts, and the Machine Pictured Utilizes Light Rays to Test the Thoroughbreds

**HEART OF RACE HORSE TESTED
BY LIGHT-RAY MACHINE**

Race horses, like boxers, must undergo a physical examination to determine their fitness for competition, including for yearlings, a heart test for congenital abnormalities or other disorders. An official of the thoroughbred institute has made a device which utilizes light rays to determine the racer's soundness of heart. The machine somewhat resembles a radio set.

"DRY ICE" CAUSE OF INJURIES 3201

One of the latest hazards in connection with the development of new industrial processes is that arising from the use of "dry ice," says the department of labor. Dry ice is used by ice-cream plants and dairy companies to pack their products, having an estimated temperature of 110 degrees below zero and being capable of producing a serious injury if carelessly handled. The ice, made from carbon dioxide, is delivered as cubes which are shaved into small pieces to suit the users. Handling the ice with bare hands, despite warnings, has resulted in the injuries.

ROUND SAW TO CUT PLASTER

Intended particularly for cutting plaster or artificial stone, a round saw blade has barbs cut about its circumference and is used in an ordinary hacksaw handle. It cuts rapidly and may be used for circular or irregular designs where it does not fracture the work. It is useful in making ornamental articles from plaster.

**TENNIS BALL SEALED FROM AIR
UNTIL READY TO USE** 3228

Tennis balls are kept fresh and preserved from deadening by a viscose cover that is shrunk onto the ball, contracting it and removing the inflation pressure from the walls. The cover also seals the ball, preventing air and moisture from oxidizing it. The seal is removed by running a cutter under the seam, and, when bounced, the ball resumes normal shape and size.



Viscose Cover Shrunk on Tennis Ball Removes Inflation Pressure until It Is to Be Used

Chicago 211 S. State Sold by J. & Silverman, 1033 Chestnut, Phila.

A. S. Spalding & Bros. Statistics Dept. of Labor, July issue

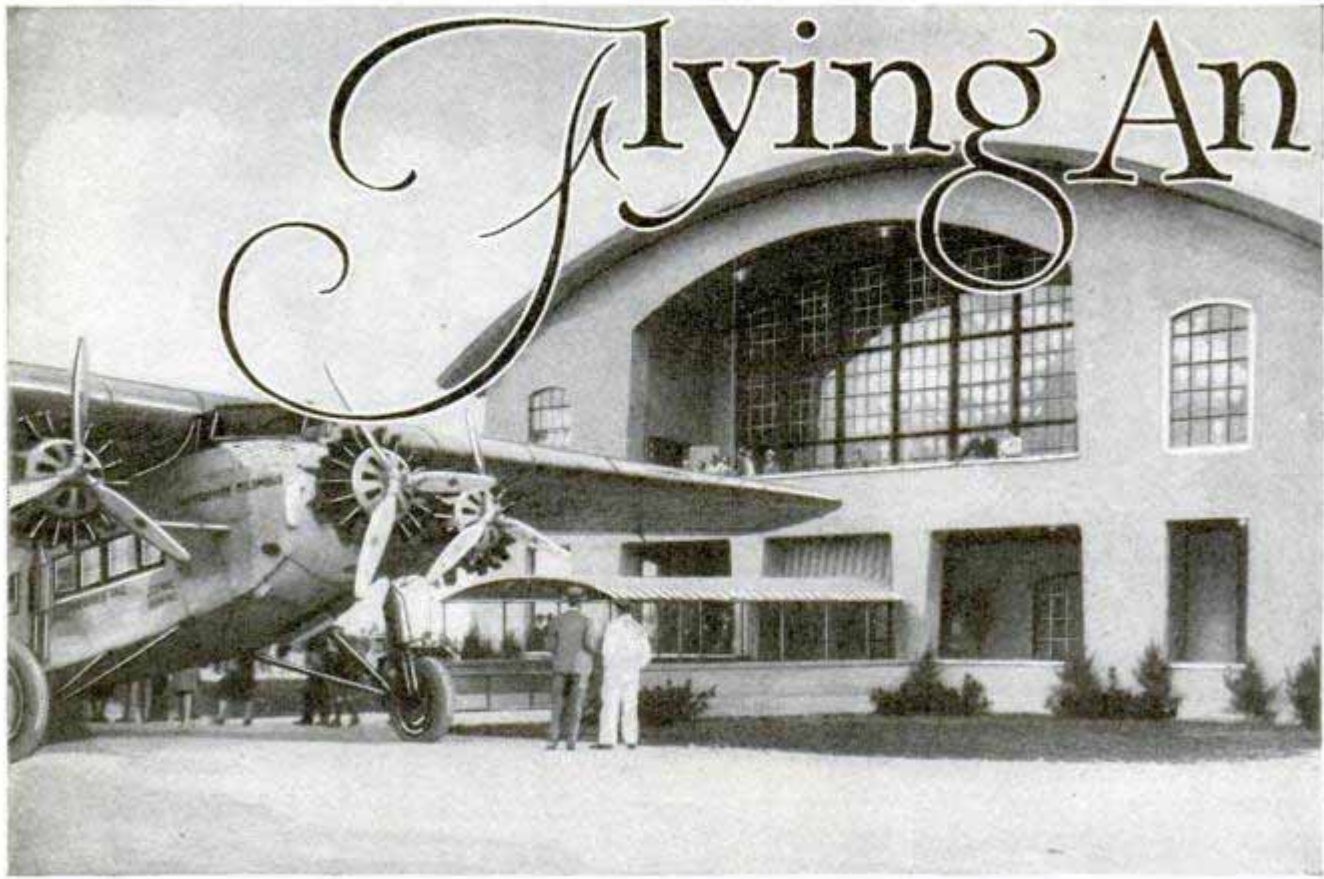

Pan-American Airport Station and Typical Tri-Motor Ship with Its Three-Bladed Propellers; Note the Covered Passenger Lane and the Roomy Observation Platform

By J. EARLE MILLER

PART II

"WHEN it's rough aloft," says a recent advertisement, "or the report says dirt above the Alleghenies... or ice and fog over the Hump... then only master pilots should take to the skyways."

How to become a master pilot is a problem that is engaging the attention of a large part of the youth of America.

One of the largest factories has its own system, which consists of taking men with hundreds of hours of solo experience, starting them in the factory bucking rivets, and putting them through every branch of the work of building an air liner, with a finishing course of flying the ship. Five hundred hours as a pilot is the minimum requirement for entering the school. How to get that 500 hours, or how to work up the hours required for any of the better-paying pilots' posts, is the problem.

Training pilots has undergone a remarkable change in the last year. Government regulations are getting more stringent all

the time, and the men behind the air lines and behind the companies that manufacture planes recognize the importance of creating competent flyers. A plane can be built in a few days, even the big tri-motored air liners are turned out daily, but it takes not only months but years to make a finished pilot.

The Ford-Stout company has made a rule that it will not sell a plane for use to anyone except a pilot it has approved, or one that has graduated from its school. An accident involving the lives of twelve or fourteen passengers, a pilot and mechanic, as well as some \$70,000 worth of airplane, is too serious a matter not to warrant every possible measure to avoid it, and insistence on the adequate training of pilots is the one way the manufacturer has of protecting the reputation of his aircraft.

There are more planes flying every day, however, that do not require the skill and training of an air-line pilot, and it is

Air Liner



through them the young flyer has a chance to work up to the more important jobs. It is like training as fireman and then engineer on a freight train, then engineer on the local as preparation for pulling the throttle on the Century or the Broadway Limited.

The planes which take the place of the railroad freight and local are the private ships owned by business men and manufacturers, and flown, either to carry important executives about the country or for delivering express and freight, and advertising the company's product. Most of them are cabin ships, ranging from the pilot and two-passenger craft of the Curtiss "Robin" class, up through the four, five, six, seven and eight-passenger—the Alexander "Bullets," Stinson "Juniors" and "Detroiters," Ryan "Broughams," Fokker "Universals" and "Super-Universals," and like craft.

The ships in this class are

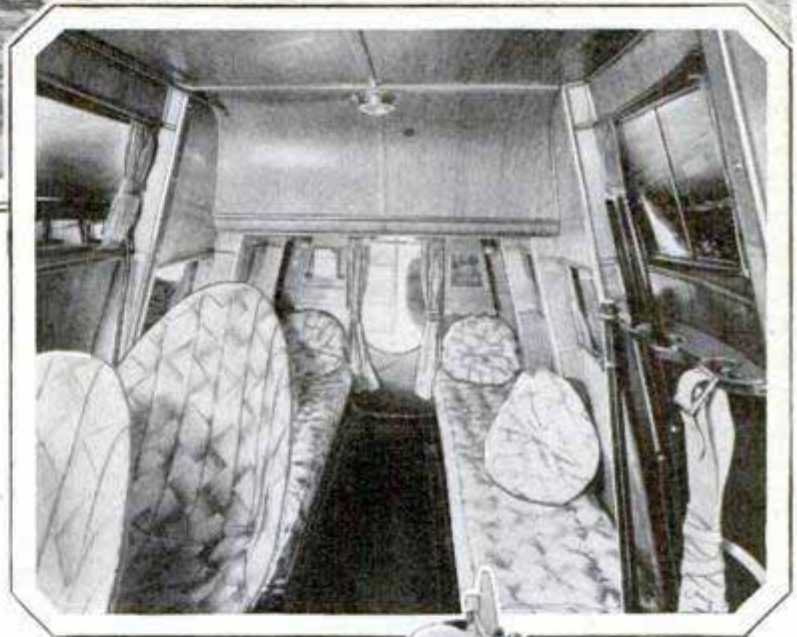

Fokker Flying Yacht with Dual Hull, Interior of the Craft's Luxurious Cabin and, Below, Anthony Fokker Leaving the Ship

1727 Sedgwick
Chicago

mainly powered with air-cooled radials, ranging from the light engines of the "Velie" type up through the Wrights and the Pratt and Whitney "Wasps" and "Hornets." Speed and excess power are common in the more expensive jobs, such as the Lockheed "Vega" and "Air Express," which hold the transcontinental speed records.

It is possible to get all the training needed to fly one of these planes, at least to meet the license requirements, without leaving the flying school to get a job. A two-hundred-hour transport license course, including ground school, primary training, solo, and the 200 hours of solo flying, can be had for around \$4,000. One school has been experimenting with a 200-hour course in which the student is given a new plane, all for \$4,970. In this course the young pilot, after graduation from ground and primary school, gets his first ten hours in a school ship, to qualify for a private owner's license. As soon as he passes the necessary tests for that the school delivers his own ship, and he can proceed to work up the other 190 hours as fast as he wants to. He pays for gasoline and oil and a nominal hangar fee, and the school supervises the condition of the ship and any overhaul and repairs he makes, and provides instructors for check hops at regular intervals, to determine

what he is learning and check any tendency to fall into sloppy ways of piloting.

Another school, operated by a manufacturer of light planes, has an even more novel arrangement. Any student who has graduated from the primary school, or has twenty hours in another school, or boasts a private pilot's license, can rent a ship by the month and work up his flying time as fast as he wants to. The school claims it is possible by this system to get in 200 hours of solo flying for about ten per cent of what it has cost in the past. The charge is \$90 for the first month, \$80 for the second, \$70 for the third, and, if the flyer wishes to use a ship thereafter it costs him only \$60 a month. The student furnishes the gasoline and pays the insurance premium on the ship, while the school provides the oil. Those prices are basic figures, applying during the month of April. Owing to variations in the amount of good flying weather in the latitude where the school is located, the figures are cut as much as forty per cent in January, thirty-five in February and December, twenty per cent in November and March, and raised from twenty to thirty per cent in the summer months.

Under the new regulations which the



Courtesy Mahoney-Ryan

Man Power Is Still Popular in China, although Airplanes Are Appearing in Various Parts of This Ancient Country; Hauling a Plane to Be Used in Transport Service on Coast

*Sikorsky Amphibian
College Blvd
L.I. N.Y.* 13132



Sikorsky Amphibian Transport Ship Used by Pan-American Airways between Florida and West Indies; the Same Sort of Plane Flies between Catalina Island and the Coast of California over Western Air Express

department of commerce is expected to issue in the fall it is thought that student instruction and commercial flying from the same field will be prohibited, not only because of the danger to the air liners from the presence of inexperienced students, but because the air-line operations delay student instruction.

In expectation of this order the larger schools are already taking steps to separate their work from commercial fields. Several of the bigger organizations, with manufacturing, operation and school departments, are acquiring double fields. Several of the schools are emphasizing the necessity of every flying student receiving instruction in both open and cabin planes. Heretofore all pilots were trained in the open-cockpit craft, and picked up their closed ship flying ability after leaving school.

Flying an aerial sedan instead of an open roadster doesn't require anything radically new in education. The pilot must accustom himself to the more limited range of vision, and, as a great portion of the cabin ships are monoplanes, he must learn, if he learned to fly in a biplane, that the monoplanes are, as a rule,

more sensitive or "tricky" and require a longer glide to land.

The smaller air sedans have standard stick controls, so there is nothing new to learn in handling them. Every ship feels different in the air, and this may be true of two exactly similar ships of the same make and model. An accomplished pilot can disregard this, for they all take off much alike, and once in the air he can study the response to the controls, the flying and stalling speed and the gliding angle, and then bring the craft in and make a good landing.

The "floating" habit of most monoplanes is the most disconcerting thing about them to the student who graduates from the low-powered, big-winged training biplane. Most of the primary training ships land at anywhere from thirty-two to forty miles an hour, more of them at the slower than at the higher figure. Compared to that even the little Curtiss "Robin" has a landing speed of about fifty miles an hour, with a correspondingly longer roll after the wheels touch the ground.

Landing and stalling speed are the two most important things in a flyer's life.

Harder City, L.I. N.Y.

Curtiss Motor Aeroplane

32
590

400
Cabinet are
Harford
Conn

Boeing Airplane Co.
See getax to what health work

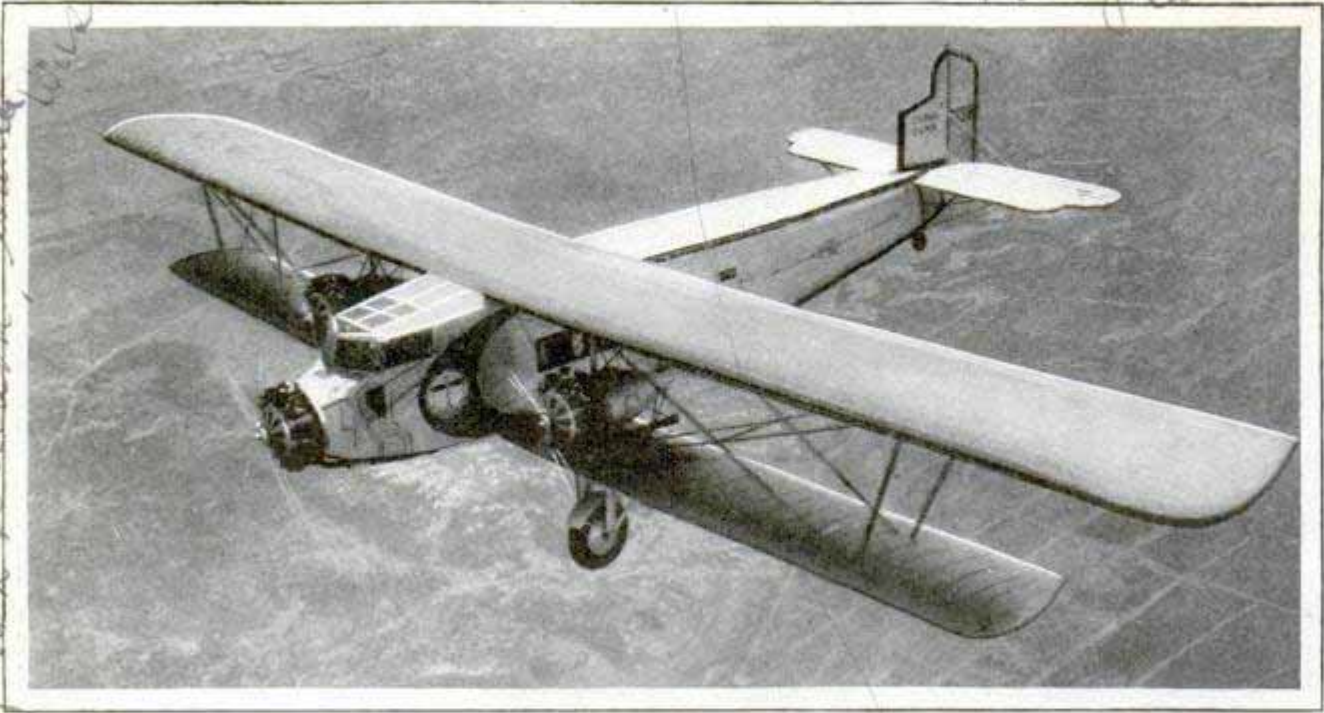

Specially Designed for High Altitudes Encountered on the Transcontinental Run between Chicago and San Francisco, a Boeing Transport, Powered with Three "Wasp" Engines

They are virtually the same, for a ship stalls at the point where speed falls so low it no longer responds to the controls, and a ship lands within a mile or so of this same speed. Increase the landing speed, and the speed which must be maintained in the air also increases. Many of the training biplanes can be cruised at sixty miles an hour or even less in perfect safety. Raise the landing speed to fifty miles an hour and the safe cruising speed goes up to sixty-five or seventy; raise it to sixty and cruising speed should not be permitted to fall below eighty.

Students usually learn to fly with the minimum of instruments, sometimes nothing but tachometer, oil gauge and temperature indicator. After they have mastered the trick of judging flying speed and flying position by the feel of the ship and the whistle of the wind through the flying wires, graduation to a better-equipped ship comes as a pleasant relief. Given an air-speed indicator to check flying speed, turn and bank indicators to check flying position, and, possibly, a rate-of-climb indicator as a check on climb and gliding angles, there is small chance of a wide-awake pilot getting into an involuntary spin or even stalling the ship.

Every plane is rated by the manufacturer to climb so many hundreds of feet per minute in air of sea-level density.

With lighter air at a higher altitude, the climbing rate becomes less, so the climb indicator, which shows the rate not as an angle but in feet per minute, cannot always be relied on. But a check-of-climb indicator against the air-speed dial determines whether the plane is maintaining a safe climbing speed, so one instrument is an aid to the other.

Instrument flying is becoming increasingly important, as air lines must maintain schedules in all kinds of weather, and blind flying through fog and storm is only possible for the pilot who is skilled in the use of his instruments. Because a flying education sufficient to fit a man to pilot one of the big air liners costs considerably more than a college education, and takes as long or longer to acquire, there probably will be a shortage for some years to come of men for the air-line posts.

3154
LUMINOUS CLOTH LURES COONS

Raccoons are curious animals, easily attracted by bright objects, and an inventor has utilized this fact to aid trappers. Bright objects, such as colored bits of cloth, often are placed near the traps, but these are useless at night. Then a double-faced adhesive tape with a luminous coating may be used, which glows so that it may be observed for some distance.

Chas. Harris & Talbot
Attawa, Ill.

INTER-CAR TELEPHONE SYSTEM SAVES STEPS ON TRAIN 320

Long trips through a train to find if there is a seat in the diner or if the barber is busy, now are unnecessary for passengers on the Cascade limited between San Francisco and Portland. This train has installed an inter-car telephone system, each car being equipped with a telephone instrument with which passengers may communicate with any other car. The telephones may be used to order a meal, call a maid, summon train attendants or obtain any other service. A combination dial and push button, of the one-piece continental type, is used.

ELECTRIC SUNBATHS FOR FRUIT 3155

Demands that the natural "bloom" be on fruit when it is purchased has resulted in the use of artificial sunbaths to restore the tints of the skins and give them the appearance of having been freshly gathered. The fruit first is wiped free of dust and moisture, polished by leathers arranged for rapid handling, then placed under the rays of the apparatus for from one to five minutes. English

BAIT BUCKET WITH SPRING TOP HOLDS MINNOWS SECURELY 3227

Minnows, frogs and other live bait are kept securely in a bucket that is equipped with coil springs which form the top. A perforated container fits inside the bait bucket, allowing water to circulate freely when it is carried, or the container may hang over the side of the boat in the water. When removing bait, the hand is inserted between the coil springs which snap back into position when the hand is removed.



*Holden, Highgate, England
Chesterfield.
Newington, New York
Davenport, Iowa
George & Leverage
Inquiries & Leverage
Newington, New York*

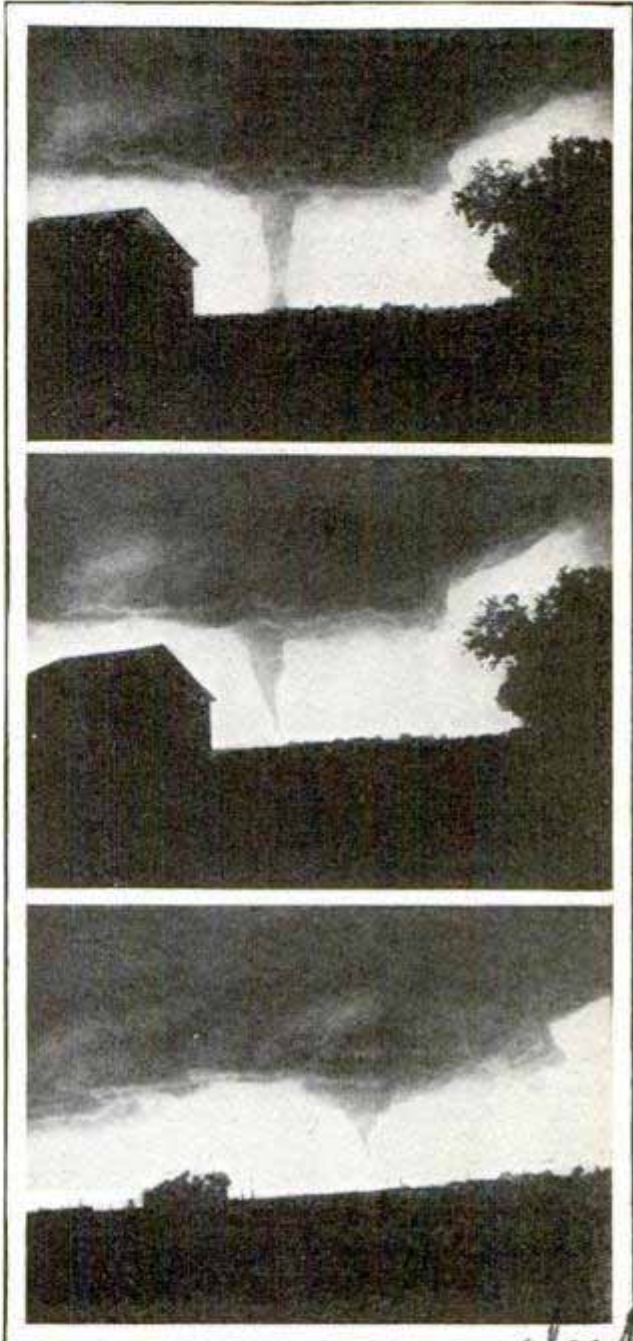

A Photographer Risked His Life to Snap These Pictures of a Kansas Twister in Action

TORNADO IN ACTION PICTURED BY DARING PHOTOGRAPHER

Pictures of a Kansas twister in action were obtained by a daring photographer who risked his life to snap the tornado in various poses as it approached. The series of pictures the cameraman obtained included views of the tornado at a considerable distance, a nearer view with the black clouds throwing dark shadows on the ground and a close-up with the spout of the twister less than a mile away.

Twenty-nine states now levy a tax of four cents or more on gasoline.

*Burt, Bergren Inc
307...*

3104

PLANE GLIDES UP CANVAS RUNWAY ONTO STEAMER

Using a special runway covered with canvas or sail padding, a seaplane was successfully landed aboard a ship in recent tests. The runway was towed behind

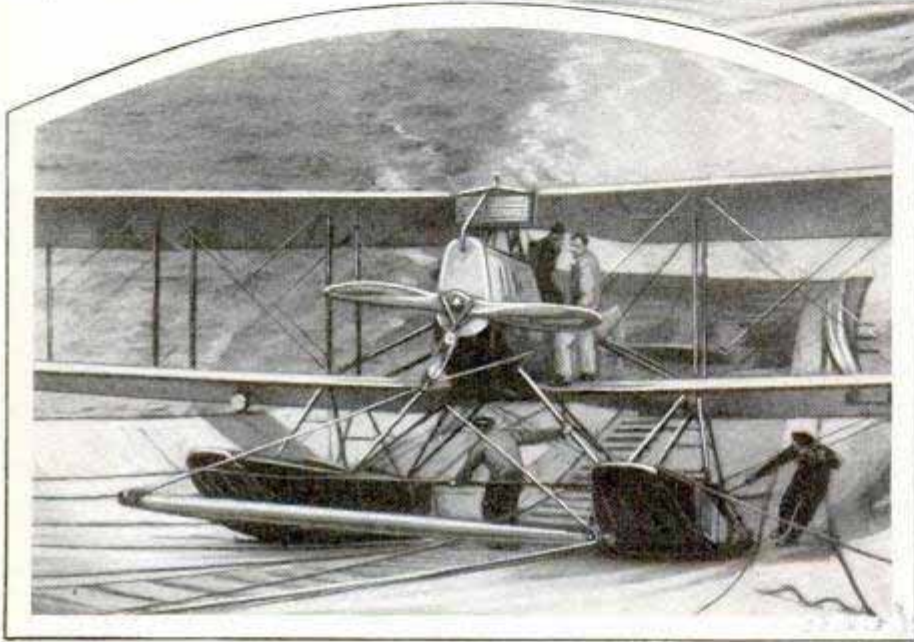
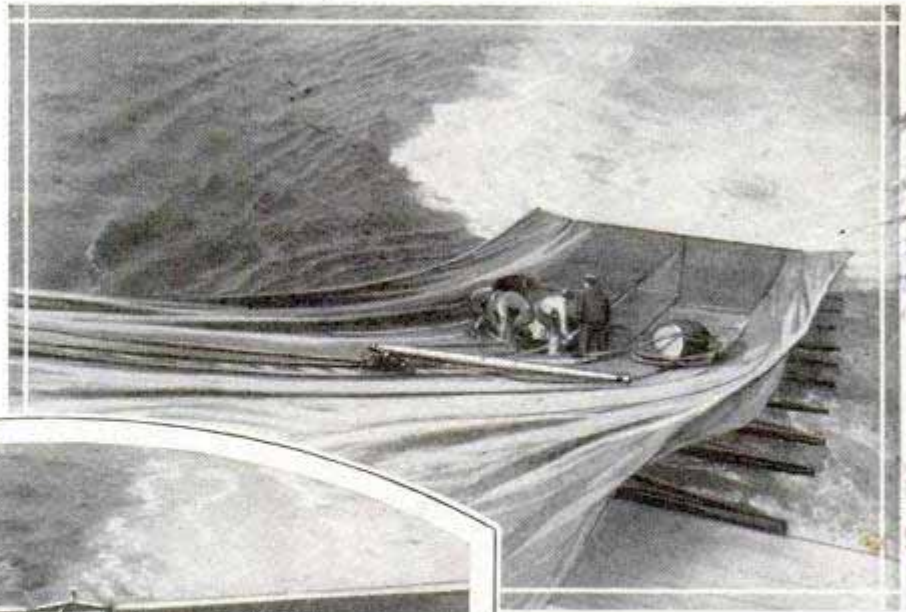

Towed behind a Ship, the Canvas Runway, Above, Was Used to Land a Seaplane; Below, the Plane Being Towed up the Runway

the North German Lloyd steamer "Luetzow," and the plane alighted on it and was pulled on board the vessel.

DYED GOOSE FEATHERS PUZZLE CUSTOM CHEMISTS

3141

While tariff has always occupied a vital place in politics, the average person's knowledge of the vast organization required to carry it into effect ends with the custom inspector he meets upon his return from abroad. It does not include the hundreds of workers whose business it is to appraise the value of millions of dollars worth of goods brought into the United States yearly. That is the business of the chemists of the custom appraisers. Their subjects, the materials that come under the microscope or go through retorts and tubes, range from Chinese hair nets to toy Christmas trees and Scotch home-spuns, sugar and manganese ore. For instance, a firm imported some toy Christ-

mas trees from Germany and a sample was brought to the laboratory to have its value fixed. There was a little paper-bound pot and from it rose the tree with lovely green needles and tiny candles. The needles puzzled the chemists, and one was soaked in water. It swelled a little and ultimately opened

and revealed itself as half a goose feather which had been dyed. Motion-picture films are brought to the laboratories and weighed, examined and appraised. Coal-tar products, liquor and various synthetic fluids are distilled and their parts made known. Another example of the work of the custom chemists was shown at the time of the Philadelphia exposition. Some of the exhibitors brought in fabrics, scarfs and small carpets, which were said to be so old that exemption was claimed on the grounds that they were antiques. The tariff law lists as antiques articles over 100 years old which have an artistic value. The fabrics in question were examined. They certainly looked old enough, but the tests showed they contained coal-tar dyes and as those dyes were not discovered until 1857, they could not have been as old as it was claimed. The exhibitors protested, but the goods were taxed. The work of the custom chemists is constantly full of surprises.

Cont. James W. Booth
Chilton Station

Vertical text on the right margin, possibly a page number or reference: 3104

For example, one day some hair nets were brought to the laboratory. Human hair carries a duty of forty-five per cent while all other kinds are taxable at ninety per cent. In hair nets, yak hair is sometimes used. The chemists knew that but they were unfamiliar with yak hair and this hair might be merely coarse human. So they sent to the zoo for yak hair and the microscope told them the rest.

ANGLERS SEE BENEATH WAVES WITH A WATER SCOPE *3170*

Peering into twenty-five or fifty feet of water to discern objects clearly is made possible with an instrument known as a water scope which fishermen are using to advantage. The scope is two feet long with a nine-inch lens cemented in place to make it water-tight. The lens is submerged in the water and the operator peers through a visor, obtaining vision thirteen feet in diameter in twenty-five feet of water. Besides being used by anglers, the instrument also is employed in locating articles lost in water, and has even been used to find the body of a drowning person and thus save his life. In the average fresh-water lake, distinct vision is possible at twenty-five feet.

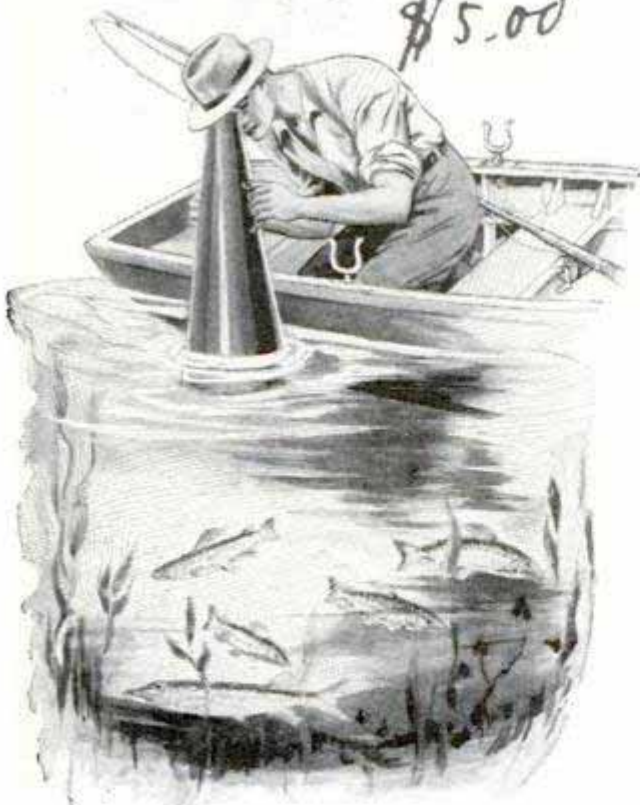

Angler Peering beneath the Surface with a Water Scope Which Penetrates Twenty-Five Feet

*Indestructible Mfg. Co.
278 Boston Bldg.*

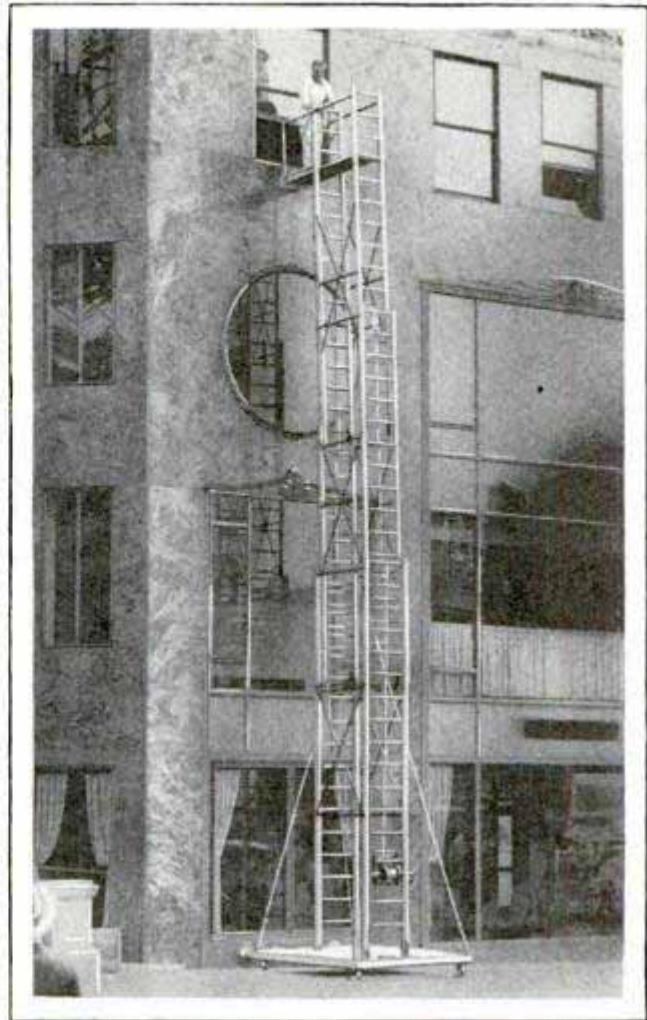

Extension Platform, Like an Extension Ladder, Used to Wash the Surfaces of Tall Buildings *W.C.*

WASHING FACES OF BUILDINGS IS MADE EASY

Even buildings must have a bath at intervals, and a lofty extension platform, which extends to the fourth story, has been made to allow workmen to clean the polished stones of a tall Chicago structure. Parallel extension ladders form the legs of the elongated platform resting on a base to which rollers are attached, so it may be wheeled easily along the wall. *333 7 inches gap.*

Keeps it
KEEPING FOODS DRY *3071*

Foods that are likely to absorb moisture, such as dry cereals and crackers, may be kept in a palatable condition in a cabinet constructed to prevent moisture. The container holds an odorless material that has a great affinity for moisture and absorbs dampness from the air or food. Besides being used to keep foods crisp and fresh, the cabinet also may be utilized to store metals that rust or any articles harmed by moisture.

*American Business Builders, Inc.
18 & 18th St.*

2967



On the Trail of

the shoestrings! A similar oversight led to the conviction of another man who had forgotten to wash his shoes. Incriminating blood stains were found on the leather.

"Chemists have positive means of identifying human blood from that of animals, although it is not possible to identify the blood

By **PAUL D. PADDOCK**

POISONS and mysterious deaths have been linked in the public mind since the dawn of history but modern chemical science has done much to rob such cases of their baffling aspects. Along with the scientific detective, the chemist is winning increased recognition in the war against crime. Police departments are installing laboratories where such apparently trivial things as spots on clothing, weapons or money frequently provide the final evidence that may free or convict the accused.

"Mysteries? Yes, there are plenty of them in the chemical realm of police investigations," says Dr. W. D. McNally, former coroner's chemist of Cook county, Illinois, and one of the best known experts on poisons in the country. "But the problem of finding the poison and identifying it is a relatively simple process in chemistry. Witnesses may disagree but test tubes, in the hands of efficient men, generally tell the same story. That's just one reason why the chemical evidence in a case is regarded as so important.

"Not long ago, a suspect in a murder case was about to be freed when a tiny spot was discovered on one of his shoestrings. Analysis showed that the spot was human blood. He had carefully washed all his clothing but had forgotten



Portable Chemical Laboratory Los Angeles Police Use in Solving Crimes, and Guard with Machine Gun

of a specific person. In the same way, human hairs can be distinguished from those of animals, but cannot always be identified as coming from a particular person.

"Recognizing that soils have different chemical and physical properties, detectives sought for incriminating evidence in a recent murder by closely examining an

Poison Mysteries

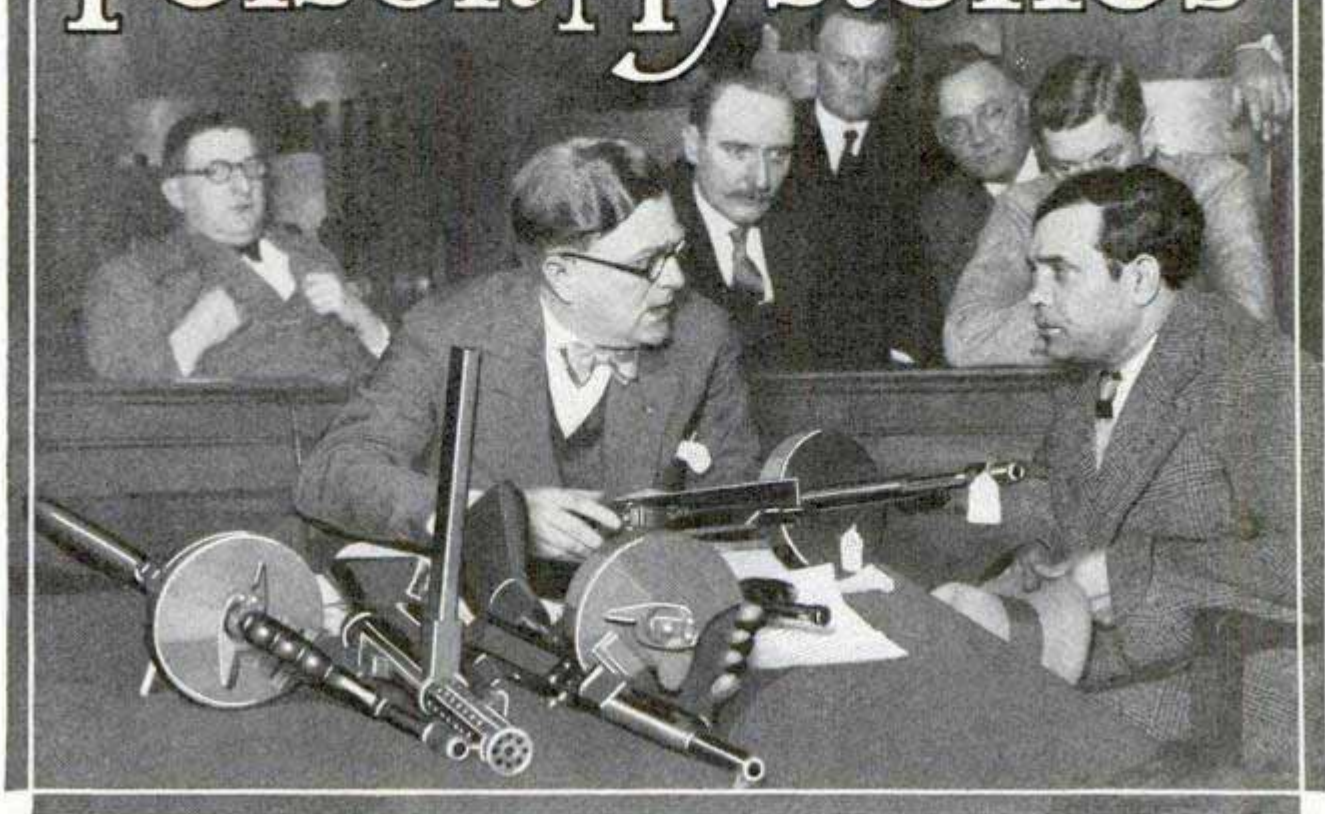

Coroner Herman N. Bundesen Questioning a Witness during a Gang-Slaying Inquest; the Gun Was Linked to the Murders through Marks on the Bullets in the Victims' Bodies

automobile for traces of swamp mud like that in which the victim was found.

"Chemical science has developed interesting facts concerning weapons. For instance, analysis of the contents of a gun barrel will tell whether the weapon has been fired recently, although it is not possible to determine this factor exactly in terms of hours. There is an interesting field of research here, and possibly chemists will be able to fix the time accurately on the basis of chemical investigation of the powder marks.

"Important court cases have been decided on the basis of the kind of powder found in shells, weapons or upon the body of the victim. It is well known that suicide or murder is often established by the presence or absence of powder marks upon the body. A trained investigator can tell almost to the inch how far a weapon was held from the person killed, by careful inspection of these marks.

"In a court case, a suspect was alleged to have been in a pool room at the time

a crime was committed. He denied being there, but dust found in his pockets, on chemical analysis, proved to be chalk such as is used on billiard cues. Like many other players, he was in the habit of putting his hands in his coat pocket after using the chalk and the dust proved a clue against him. Chemical and microscopic examination of the dust found on clothing, on automobile tires or other objects frequently reveals important evidence. The physical size of an article is not of great moment to the chemist to whom tiny spots and flecks of dust are sometimes monumental in their significance.

"In the field of poisons, the chemist has developed tests that reliably identify the 100 or more kinds commonly used. Poison is a hazardous tool for the slayer. Today, with proper investigation, it is practically impossible to 'cover up' a death by poison. It leaves an unmistakable trail that frequently can be followed as plainly as though it were written in stone,



Coroner's Chemist Ralph W. Webster Examining Blood Stains on Handles of a Wheelbarrow That Figured in a Murder Case

although the unfortunate victim may have been buried for months."

During his seventeen years' experience as coroner's chemist, Doctor McNally investigated and helped solve some 15,000 poison and other cases in which chemistry produced deciding evidence. He planned the present Cook county chemical laboratory, one of the most completely equipped in the country. Here, almost daily, important evidence relating to deaths under mysterious circumstances, is discovered by chemical methods. In one corner of a room where special tests are made, is a tragic collection of objects, each one of which might tell a dramatic story. A stained dagger, an old wheelbarrow, a flatiron, clothing with spots, all awaiting the searching eye of science.

"I was a university student when I first became interested in poisons," Doctor McNally said. "There had been a suicide. The late Prof. Albert Prescott was called and, after a brief examination, he named the drug that had been used. Its characteristic odor had made identification relatively simple, he explained. I decided that I would like to be able to clear up such cases in as efficient a manner, so I

began to study. I have encountered many poison cases since that time. In one, a woman had used a drug to kill several husbands. She and her cousin had disposed of thirteen men in this manner. Their victims were supposed to have died from natural causes. But I happened to be called to attend one of them. I detected a peculiar odor on the dying man's breath. The Prescott instance came back to me and the crime was revealed.

"A chemist-detective, however, must never jump at the conclusion that the drug he finds has caused the death, and he must apply wide knowledge to the facts in each particular case.

It's one thing to find poison in a body; it's an entirely different thing to prove that the poison caused the death or that it was administered by a certain person for a specific motive. Take the case of a supposed murder. Now, murder is committed for three chief reasons: first, love; second, financial gain; third, hatred. The chemical evidence discovered must be alined with all the other facts in the case and with such motives as were supposed to have prompted the crime. Frequently it happens that the chemist's findings are of supreme importance.

"Such was the fact in a recent case in which an unfortunate error on the part of a chemist almost led to the conviction of a young man for murder. The trial was one of the most sensational in recent years and developed, among other mystifying factors, the presence of three spots on the coat of the young victim. These proved a riddle until it was shown, with little likelihood of error, that they had been placed on the coat after the death.

"The testimony was that the young man had access to large quantities of a chemical substance said to be the same as that which caused the young woman's

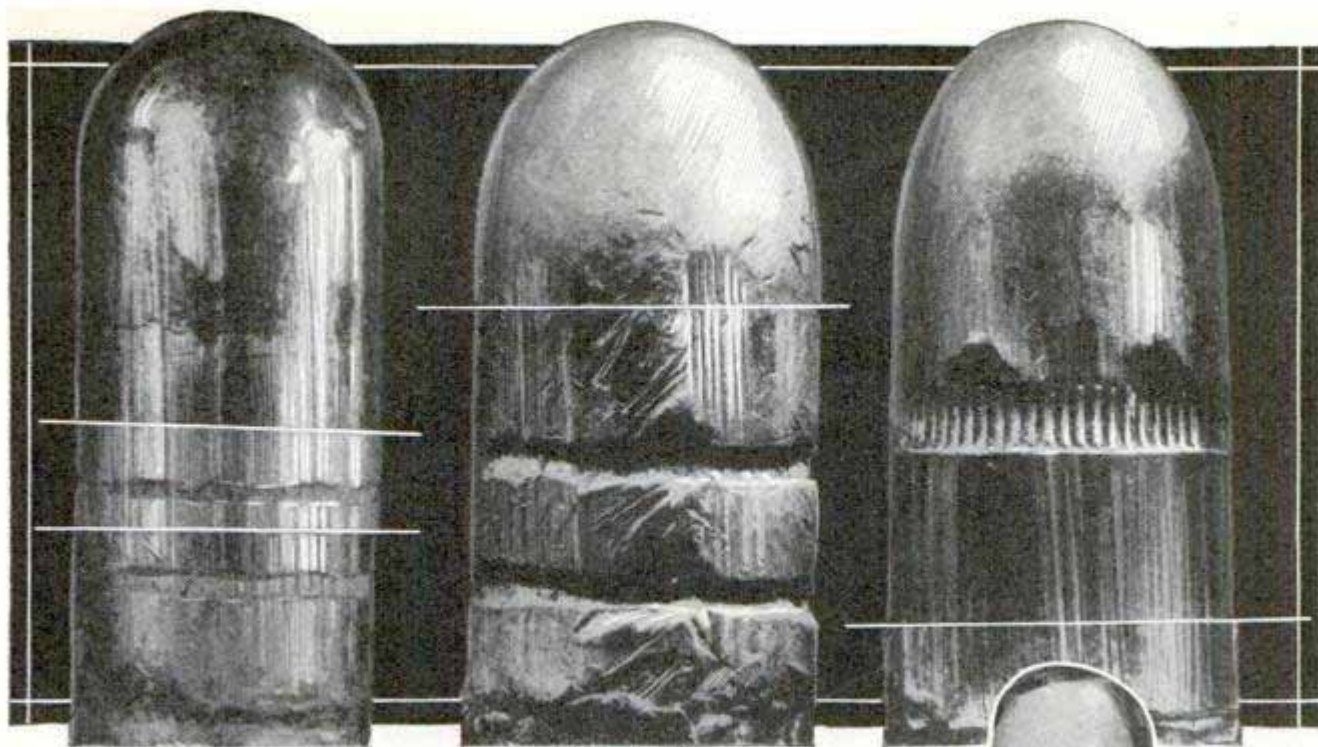

death. The stuff had been thrown on a greenhouse refuse heap. Naturally, this point was incriminating, and had it not been destroyed by later evidence, there is little question but that the defendant, who finally was acquitted, would have been convicted. But a chemist had made a mistake in his analysis. The substance on the refuse heap, although like that which had caused the death, was not exactly the same, hence could not have been used in the crime.

"The three spots were especially interesting. Witnesses testified that no such marks had been seen on the young woman's coat when her body was found. But they were clear enough weeks later, about fifteen inches from the coat collar and four inches from the buttonhole. The fact that they were in an absolutely straight line was important. Only a miracle could have arranged them in that order had they been caused by drops falling from a bottle of liquid poison. Obviously, the spots were meant to indicate that the young woman had taken the poison voluntarily, a supposition that was strengthened by the fact that when she was found, her right hand was bare and her left hand gloved.

"The spots gave off the odor of the fatal drug. But my tests plainly showed that the substance would not retain its odor over so long a period as had elapsed since the young woman died. In the examina-

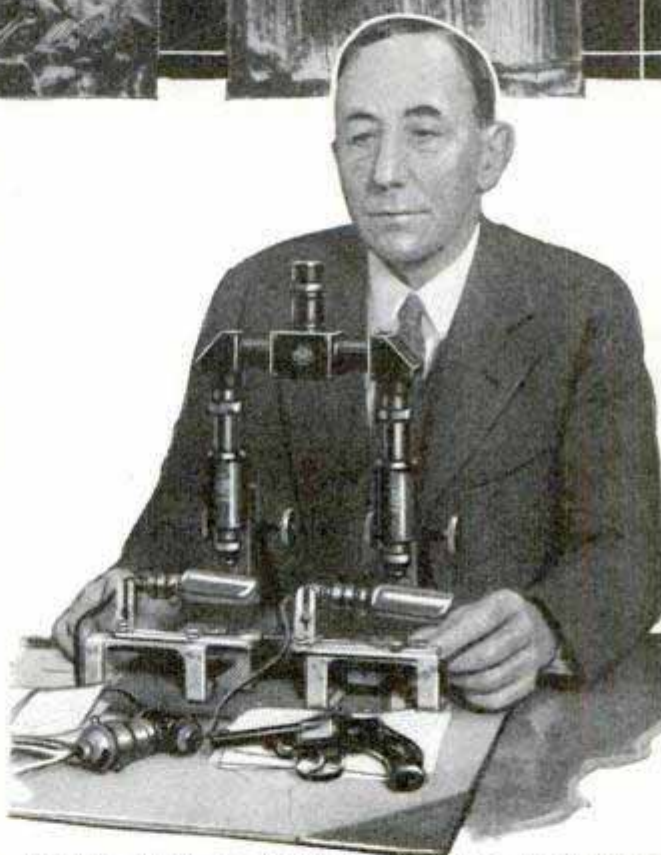

Telltale Marks on Bullets from a Suspect's Revolver, and Capt. William A. Jones at "Bullet-Fingerprinting" Microscope

tion of hundreds of blood stains and other spots found on clothing, I had never observed a parallel case in which spots were found in a straight line. Other tests showed that the chemical, when dropped upon coarse woolen material, like that of the coat, rolled off like so much mercury. How the spots got there, when they were made and by whom are still unsolved mysteries.

"We live in a world of chemistry and are surrounded by poisons in our daily

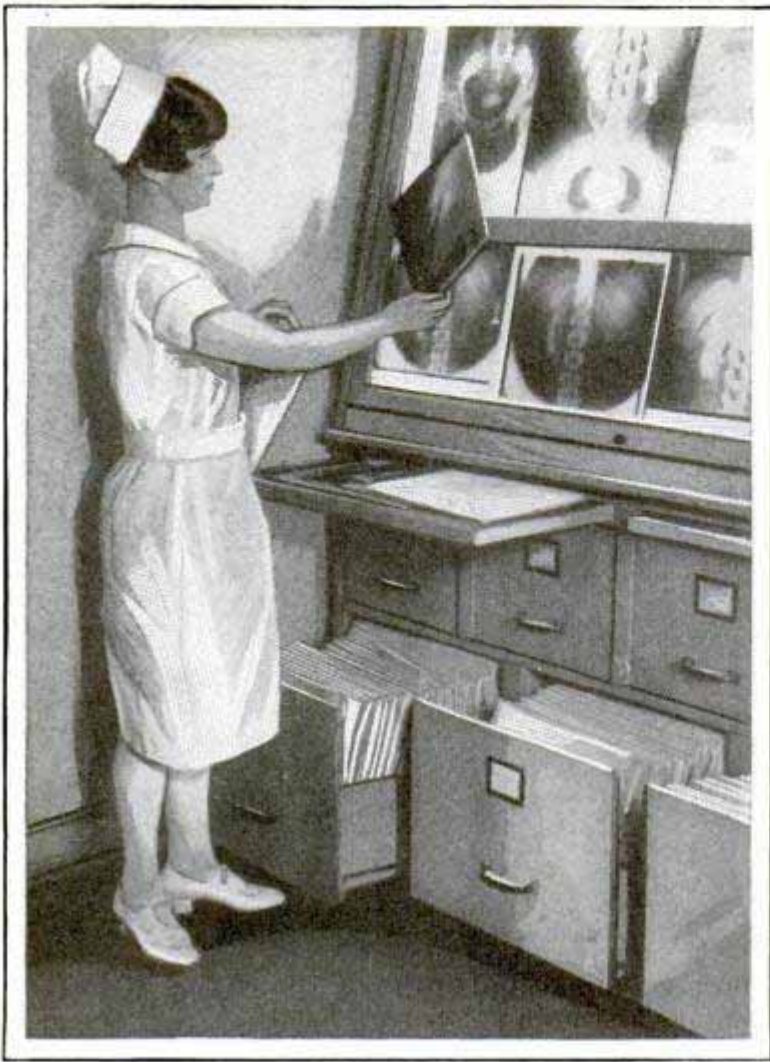

X-Ray Films That Will Not Burn, to Prevent Poison Fumes in Case a Hospital Fire Threatens the Storage Vaults

toil, but that need give no cause for alarm. Science has found reliable antidotes for various harmful substances and has developed safeguards where danger lies. Most of the superstitions about various drugs and foods have been abandoned. We know that tomatoes are not poisonous, for instance, although not many years ago they were considered inedible. Until recently, there has been a lot of useless worry about poison in foods. Some persons still believe that fatal poison will rapidly develop if food is left in tin cans. Well, it is not a good practice to leave foods so exposed and juices in time will react upon the solder in the can if that material is there and is in contact with the food, but most containers are much safer than is popularly supposed. Illness is frequently caused by eating spoiled or partly decayed food, but it is a mistake to think that every such case is one of 'ptomaine poisoning.'

ture him. He will be a combination of the detective and the true scientist, and will have at his command increasingly reliable instruments to help him in the warfare against crime."

AUTOMATIC ELECTRIC KETTLE
3084 **WILL NOT BOIL DRY**

Like toasters, coffee pots and waffle irons, the tea kettle now is moving to the dining room. An electric kettle may be used with safety on the dining table because it is self-regulating, cutting off the current before it boils dry, automatically reducing the heat before boiling over, and maintaining any predetermined temperature.



Metro. Vict. Supplies
155 Charing Cross
London W.C. 2 Eng

MODEL PLANE HAS PARACHUTE AND CLOTHESPIN JUMPERS *3083*

Clothespins serve as the heroes of leaps from a model airplane equipped with parachutes, in an ingenious toy made by a Los Angeles school boy. The twenty-seven-inch parachutes with their dare-devil wooden-headed passengers are packed on

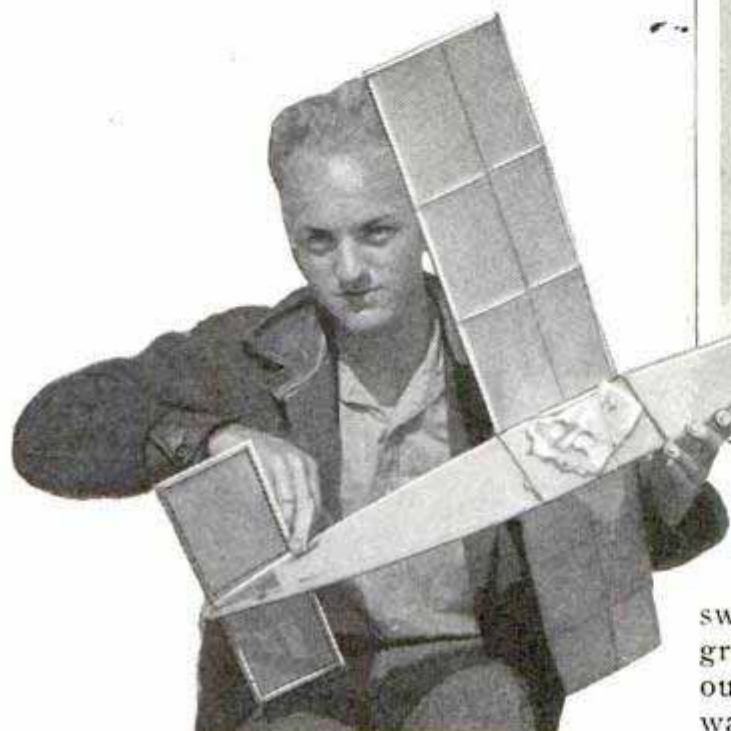

Model Plane Equipped with Parachutes for Clothespin Passengers; at Right, a Parachute Descent

each side of the fuselage underneath the wings. They are held in place by a triangular flap, one point of which is fastened by a pin thrust through eyelets. When the plane reaches an altitude of 100 feet, the pins are pulled out automatically and the parachutes, with their clothespins dangling safely at the end, come floating to earth.

SWEETS HELP WORKING GIRLS RESIST FATIGUE *3203*

Feeding candy or other highly concentrated, energizing food to working girls speeds up their production, particularly during the late afternoon slump, Dr. Thaddeus L. Bolton, head of the department of psychology of Temple university, has decided after a series of tests on twenty stenographers. Fatigue, diet and working capacity were found to be closely related. One group of girls each afternoon received candy, cake and sweetened

Phnia

orangeade, two other groups received sweets on part of the days and the fourth group went through the afternoon without any refreshments. Working capacity was comparatively low at the beginning of the day, increased after a "warming up" until about 2:30 p. m., then fell except that there was a spurt at the end. The groups taking the nourishment, even only part of the days, showed a higher working rate than the no-food group.

TIDE EMPLOYED TO SAVE PILING FROM MARINE BORERS *3065*

Marine borers, the foes of wood, metal and concrete piling, are being fought by harnessing the tide to combat them on the west coast. Heretofore it had been customary to inject preservatives in the piling material to prolong life. The latest appliance consists of blocks of wood tied to a metallic ring about a pile. The free-floating blocks shift up and down the piling and by their friction knock off incrustations, preventing new growths from taking hold. The average life of untreated wooden piling in this region ranges from eight months to two years and those equipped with the blocks last many times that long, marine engineers say.

*Ans. Alva L. Reynolds
Long Beach, Calif.*

*cont. Mel Wharlick
Union League Bldg.
Los Angeles 709*

600
 Isasserstrasse 20
 Berlin, Friedenau, Germany
POPULAR MECHANICS
 Parma Chrome Process Corp

3217
 3274
 Stille, 93 Victoriastrasse 3274
 Berlin, W. 10, Germany
 Dr. C. W. Dr.

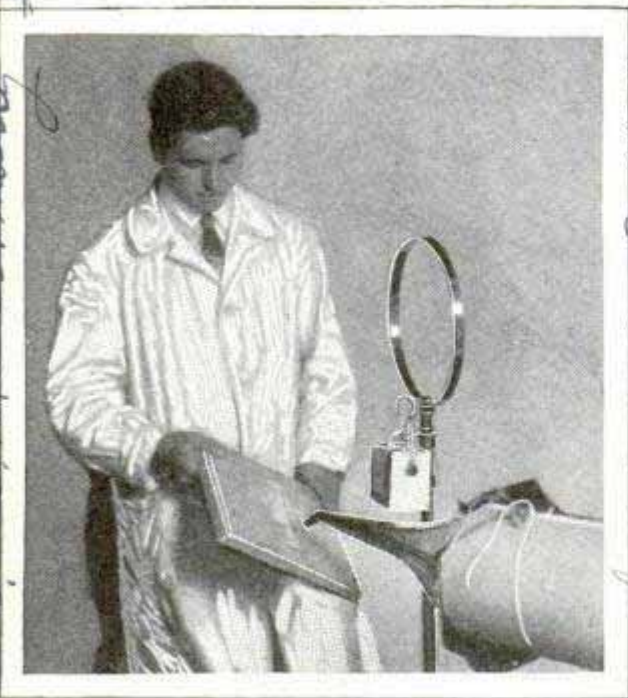

Testing the Acoustic Properties of the Wall Board with the Help of Radio

Acoustic properties of wall linings are tested by radio at the Berlin Academy of Music. A tube containing a miniature loud speaker producing a standard-tone effect terminates at one end in a funnel from which the sound strikes the material to be tested. The reflected sound waves are picked up by a microphone communicating with a loud speaker in another room where comparative tests are made with the original tone. Another device, the steel-wire voice recorder, enables a student to study his own voice. It is based on the variable magnetization of a steel wire passing in front of the poles of an electromagnet activated by microphone current. By reversing this process, causing the magnetized wire to pass in front of a similar electromagnet, currents corresponding to the original microphone currents are induced, resulting in a remarkably faithful reproduction of the singer's voice in a loud speaker.

HARDENED ALUMINUM WILL NOT STAIN OR TARNISH

Durability of aluminum is increased by a treating process recently developed which not only hardens the metal but also eliminates the tendency of the sur-

Chromium Plating Co
 Cedar & Ashland

face to smudge, tarnish or scratch, and enables it to resist the effects of salt water and various acids and corrosive agencies. The process provides a protective finish which will take many delicate color effects. The advantages of the treated metal extend into every field where aluminum products are used. The treatment in effect is comparable to the cyanide process of hardening steel. Every item treated is completely submerged and the inherent advantages of ductility and flexibility in forming are preserved. Laboratory tests showed an increase in hardness of more than 100 per cent. Cooking utensils so treated are left free from tarnish and preserve a bright polish. Airplane manufacturers and the automobile industry see possibilities in the treated metal for uses where it could not be employed previously because it lacked hardness.

See Dec 1928

SAND TESTER SHOWS QUALITY OF CONCRETE MIXTURE

Determining the quality of sand being used in concrete work without sending samples to a laboratory is possible with a sand tester that is simple in operation. The tester grades the sand and gives an indication of its cleanness. It consists of a water-tight frame into which are fitted a graded series of fine-mesh screens and a series of glass vials connecting with each of the screen sections. A small metal measure of sand is poured into an opening in one end of the casing, to which water is added, the mixture being gently shaken to cause separation. The instrument is turned vial side down, the various screenings falling into the several vials, giving the percentage of each grade of sand either passing or retained.

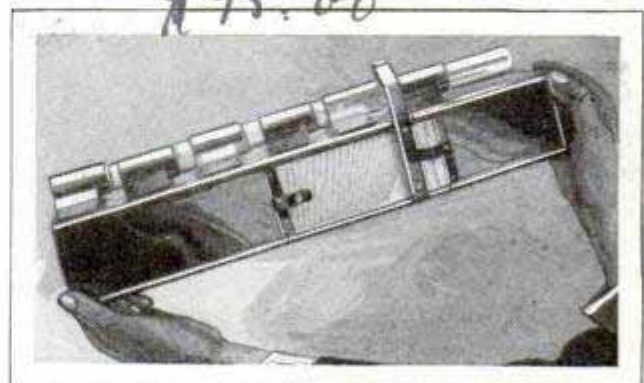

Sand Passes Successively Through a Graded Series of Screens in This Simple Sand Tester

Kolesch & Co.
 138 Fulton St

A Thunderbolt Factory

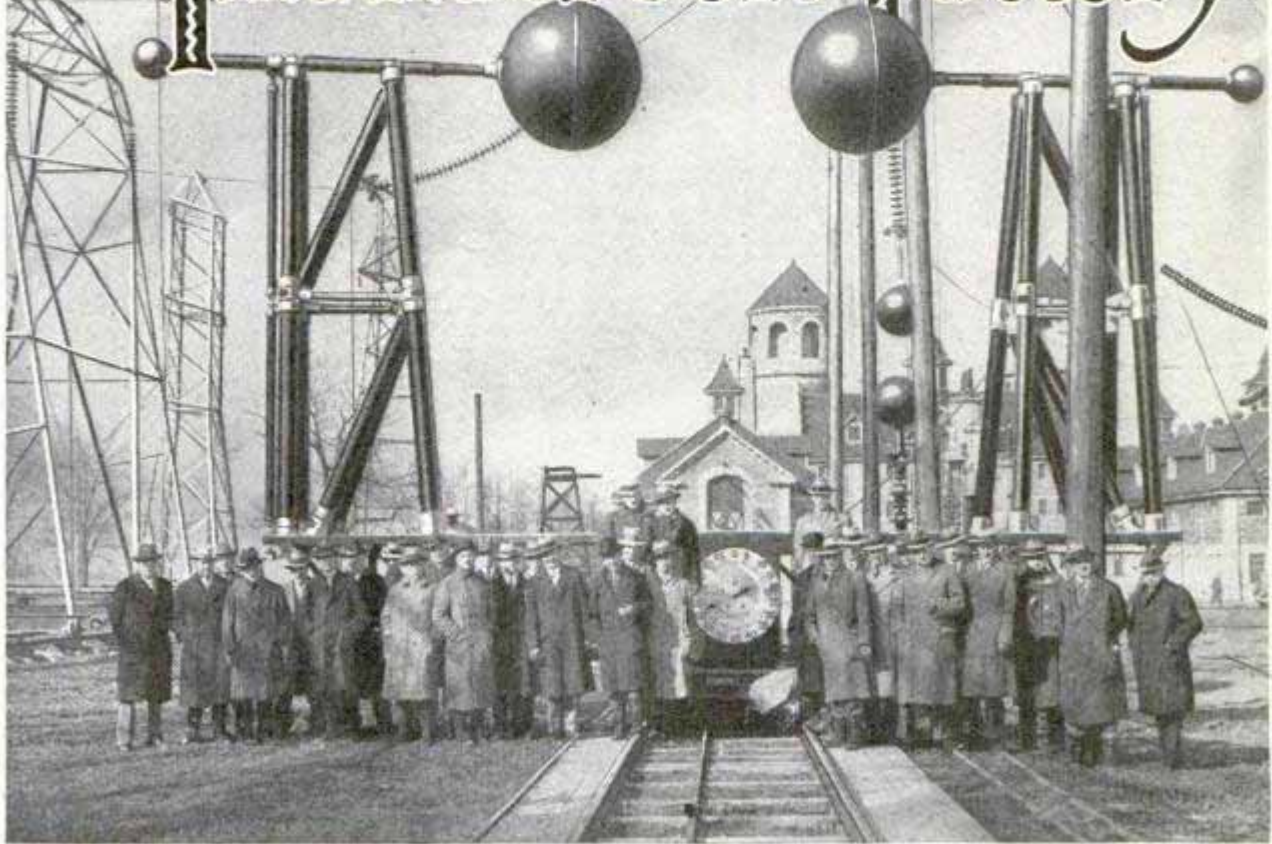

Sphere Gap Used for Controlling and Measuring Artificial Lightning at the Outdoor Laboratory; the Upright Supports Are Special Insulators and the Dial Records Distance between the Spheres

IN THE MIDST of a strange forest of poles and towers of various shapes, a seven-foot balloon, filled with hydrogen gas, sways at the end of an anchor rope. About thirty feet above the sphere is a huge cage aerial, of the type used in radio and supported by long strings of heavy insulators. A small metal ball hangs down a short distance below the cage, just above the balloon. At respectable distances, several men are standing, evidently waiting for something to happen.

One gives a signal, and another presses a button that projects from the side of a small box. At once the spectator experiences a strange sensation. He knows that something is taking place about him, yet he cannot tell what. He feels that a strange tension is in the air. Then a rustling sound greets his ears, coming from the general direction of the cage-aerial arrangement.

Something is happening around the

small sphere hanging from the cage. Streamers almost invisible, like heat waves above a railroad track on a summer day, are darting down from it. Then suddenly a blue-white flame of great brilliancy darts from the sphere to the balloon, zips over the surface to the anchor rope, and is gone. There is a report like the firing of a three-inch gun. The balloon seems to shudder as the man-made lightning strikes it, and then continues to wave in the breeze.

Such a demonstration which, to the visitor, seems like an event that takes place in the setting for a highly imaginative scientific novel, is an almost daily occurrence at the huge outdoor high-voltage laboratory of the Ohio Insulator company at Barberton. The hydrogen-filled balloon was being subjected to artificial lightning flashes of more than 3,000,000 volts in an attempt to develop a method of protecting racing balloons from natural

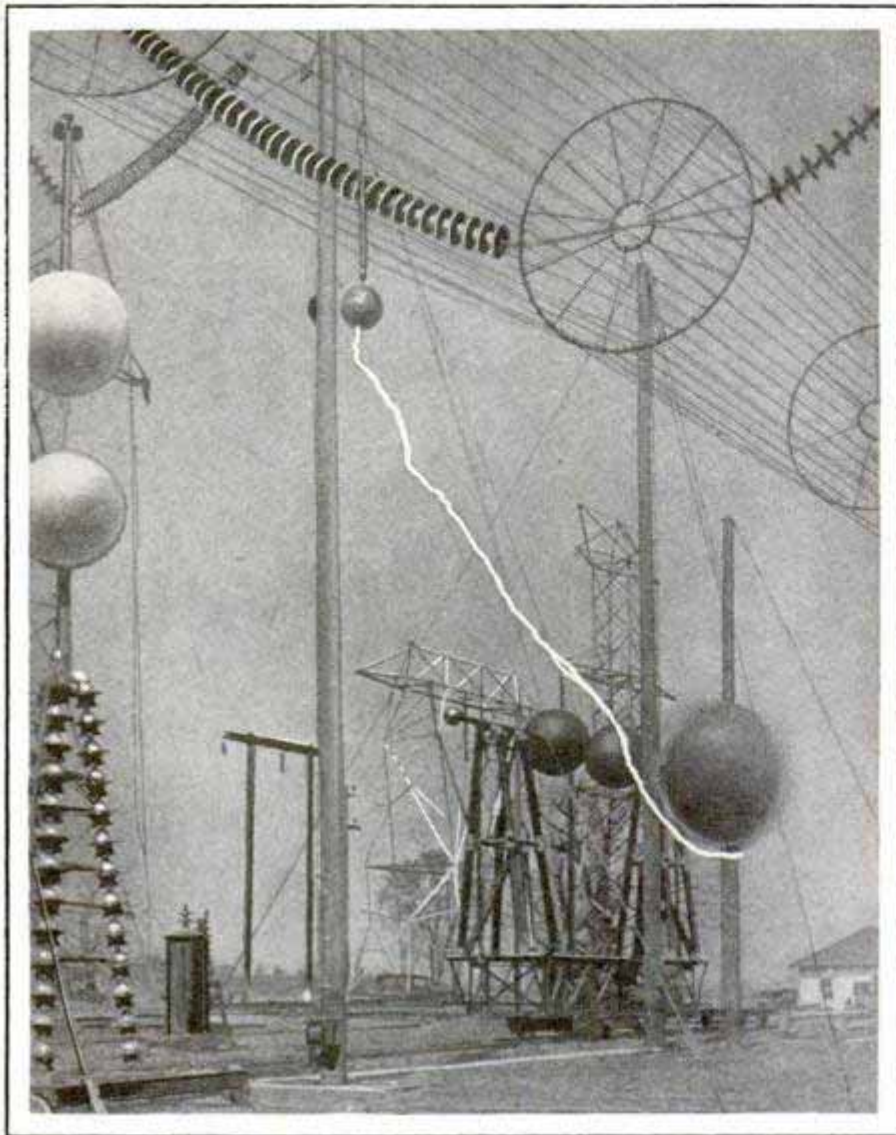

Testing a Hydrogen-Filled Balloon with a 3,000,000-Volt Spark; the Flash Suggests the High Voltage in Lightning

lightning. Incidentally, following the experiments described, a satisfactory protective device, consisting of a wire screen about the gas bag and balloon basket, was designed.

But the developing of a balloon protector was but one of the many things that are done at this unusual "lightning factory." Arthur O. Austin, chief engineer, is the modern Thor who can manufacture thunderbolts at will. With his associates, he built the high-tension laboratory on what was formerly a model farm. At various places in the maze of apparatus that fills the field in front of a chateau-barn, are pairs of huge copper spheres, four in all. By increasing or decreasing the distance between the spheres of a gap, the operators can control and measure the voltage of the arc during a test. Each of the spheres is of heavy copper, and weighs nearly one-half ton.

The laboratory field is covered by a network of railroad tracks upon which a strange game of chess is frequently played. The chessmen are steel and wood transmission towers of all types, oscillators, sphere gaps, and the like. The process of weeding out a particular tower from the forest of several dozen, and placing it in position for a test is as intricate a task as winning a closely contested chess or checker match. Each of the towers, as well as other portable apparatus, is mounted upon a small car to permit easy moving.

Engineers using the laboratory often have the job of "shooting trouble" for a power company in some remote corner of the world in an effort to learn why an apparently perfect transmission line failed to do its job of carrying power to some center of population.

Instead of going to the scene of the trouble, they can bring the problem to their laboratory and reproduce the conditions which caused the failure.

The lightning manufactured at the experimental station can produce many of the results of that made in nature's laboratory. If a man should get in the way of a 3,000,000-volt spark, he would immediately become a task for an undertaker. But it is surprising that a wide-open wire screen can provide complete protection from twenty-seven-foot lightning flashes. At the indoor laboratory, the spectators' balcony is equipped with such shielding. It is a strange experience to stand behind this screen and watch streamers of fire leap out and strike a foot from your nose.

It is by playing with lightning that scientists hope to develop methods of transmitting electrical power at practically no loss, so that you can make toast,

6/16/29

Co Hartford 603

Conn

heat your home in winter and cool it in summer, and do a hundred other jobs electrically, at a fraction of the cost today. Who knows but that an accidental discovery will be made in such a laboratory which will give the world practical radio power transmission, or some other equally revolutionary development?

THE PAY OF AIR PILOTS 3064

Pay of the pilot on a regularly scheduled American air-transport line is estimated at \$5,556 a year by the aeronautics branch of the department of commerce, which adds that he averages less than two and one-half hours a day in the air. As he flies slightly more than 40,000 miles a year, his daily mean is about 110 miles. The records were compiled from reports on 275 pilots employed by twenty-five air-transport organizations. During the latter half of 1928 the operating revenue of the air companies was slightly under \$5,500,000, of which about four-fifths was from air-mail contracts.

3136

LIFE-SAVING RIFLE AND ROCKET SHOOT LINE TO SWIMMERS

Capable of throwing a float attached to a lifeline 250 yards, an ordinary rifle fitted with a rocket attachment recently was demonstrated in South Africa. The rifle has a container for a roll of cord and is capable of throwing the float 150 yards, but as it is falling a rocket explodes and carries it 100 yards farther. Six swim-

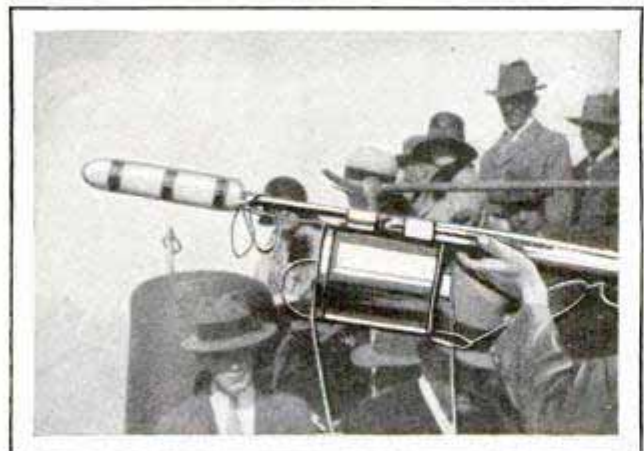

Life-Saving Rifle, Fitted with Rocket Which Throws Line and Float for 250 Yards

mers were hauled ashore at one time during tests with the thin line.

Capt. Chas. D. Stewart
Cape Argus, St. Georges
Island, St. Helena

BANK USES VENDING MACHINE TO ATTRACT SAVERS



This Vending Machine Encourages Thrift by Dispensing Small Savings Banks for Coins

Automatic devices for vending "book banks" have been placed in operation outside the doors of a New York bank. A quarter dropped into the machine brings forth a metal container shaped like a bank book, one end of which is slotted to receive coins up to a quarter. When the container is filled, the owner brings it to the bank, where his quarter is refunded, the contents of the savings box removed and deposited in a savings account and the container returned to the owner. Boys and girls have been the best customers.

3057

PHEASANTS KILL CROP PESTS

In response to a complaint by Nebraska farmers that pheasants were destroying planted cornfields, a game warden killed thirty-six of them for tests. Corn was found in only one crop, but in another were found sixty-one cutworms, a third had eight June bugs, still another contained forty-two black beetles, and in all the others were found bugs, worms and seed pods from poison ivy and weeds. Some of the corn taken from one crop appeared to be poisoned corn that had been spread about to kill ground squirrels. The poison does not affect the pheasants.

Capt. James A. Swell,
292 N. 11th St.
Lincoln, Neb

Inv. Mr. Eisenmann, 40 Myrcer, Borch + Hickson, Ship Chandler
Level Road Cape Argus, St. Georges

Kansas City
7/18/29

Walsh Co. 1652 Builders Bldg
221 N. La Salle, Chicago

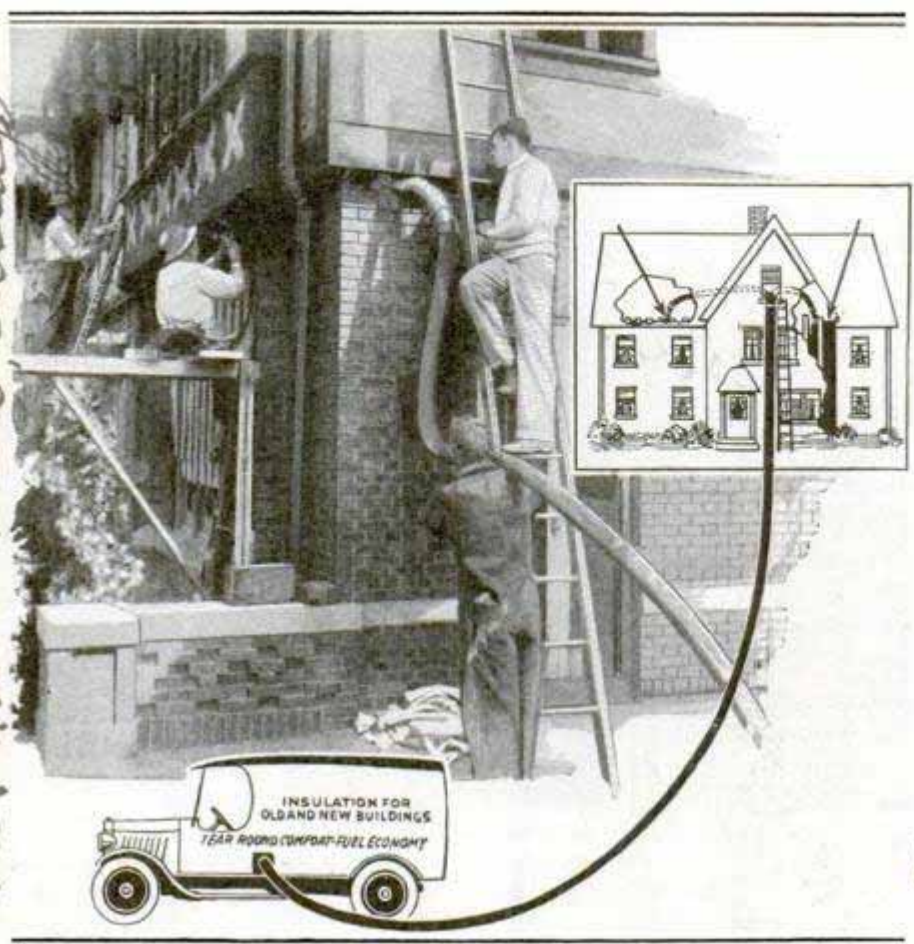

Photograph of a Typical Filling and Insulating Job and, Drawing to Show How Material Is Pumped between the Walls of a House

INVISIBLE WALLS SHIELD HOME FROM HEAT AND COLD

Effective insulation for residences and other buildings is furnished by a wool-like substance prepared from stone and blown over ceilings and into hollow wall spaces by special pneumatic apparatus. The result is that the interior is protected by a blanket of the wool, four inches thick or more, virtually a house within the outer walls, to keep out the cold, prevent heat losses and to help keep the home comfortably cool in summer. The insulation also acts as a sound deadener. It is fireproof, does not settle, is dust free and will not harbor vermin. Old homes, as well as new ones, of frame construction, brick veneer or stucco, may be treated. The material is blown through a hose from a trailer truck, and the work is done from the attic or the outside of the house.

Johns manville

COLLEGE TRAVELS ON WHEELS

3142 In order to study geology, geography, history and other subjects at first hand, a motor college is traveling from Massachusetts to California and back. The students, carried in motor coaches from place to place, make stops to study soil, mines, forests, fauna and flora, deserts and mountains besides visiting historical points and making trips through the Grand Canyon, Yosemite and Yellowstone.

PUNCHING BAG FOR AUTOISTS

3187 Striking with a stick at a captive balloon while driving an automobile, fifty miles an hour is a stunt that is proving popular among Berlin motorists. It was started simply as a form of practice for auto polo, but was found to be a good way to prevent auto accidents on the roads, as it forced drivers to develop steady nerves.



This Girl Driver Is Developing Steady Nerves by Striking at Captive Balloons with a Stick While Speeding

Salvage from the Sea

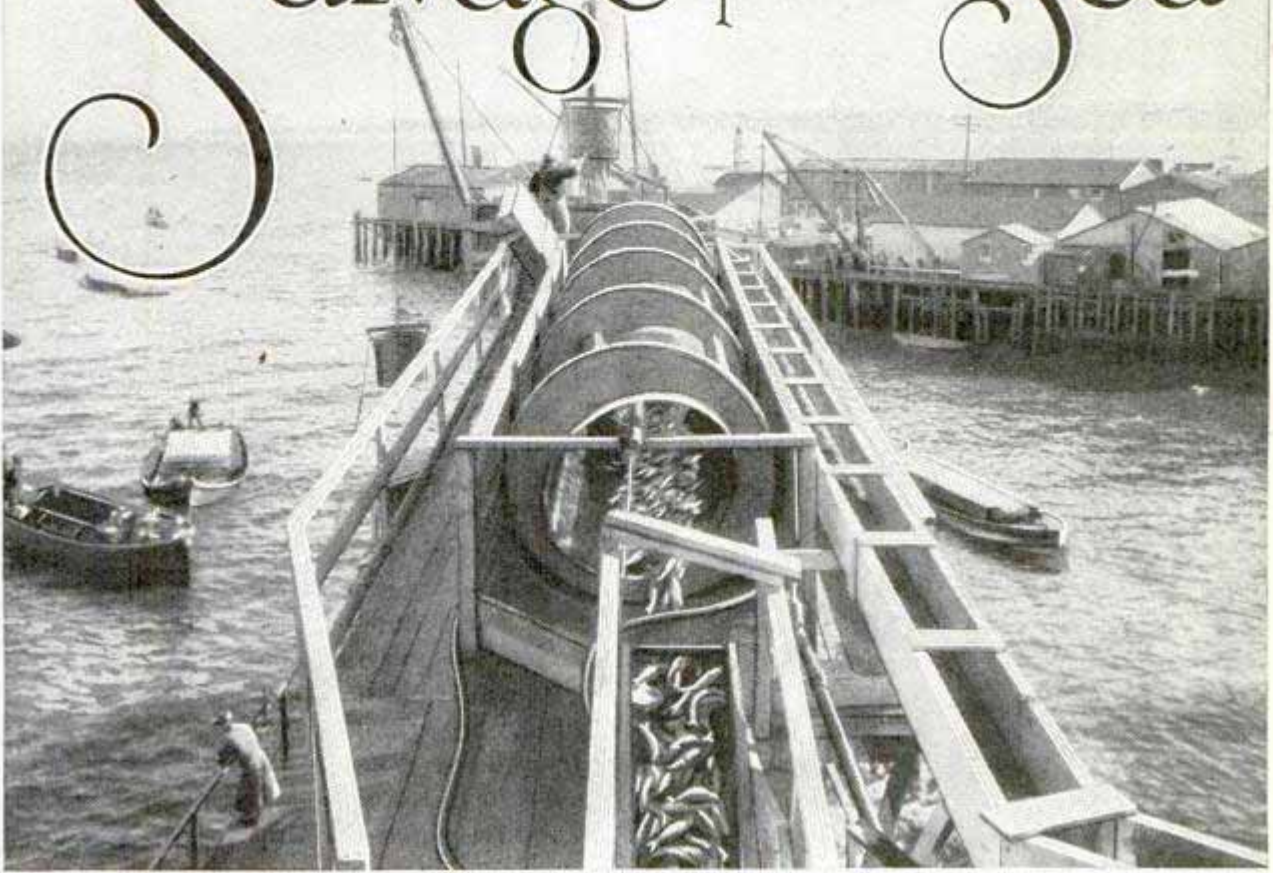

Scaling Fish at a Large Commercial Plant; the Scales Are Used in the Manufacture of Pearl Essence and Other Lustrous Materials

A FIFTEEN-million-dollar business in the utilization of waste and the development of by-products of the fisheries industry has been established in the United States during the last three years, and new sources of revenue are being sought, from methods of utilizing fish scrap as feed for dairy and barnyard animals to the deodorizing of fish oil for use in soaps, cosmetics and cooking substances.

Hunting sharks for their fins and hide for use in the manufacture of a large variety of articles ranging from women's handbags to sword hilts and nose grips for eyeglasses is a growing and thriving industry. The skins of many aquatic animals, including those of sturgeon, garfish, wolf fish, cod, cusk, watersnakes and frogs, are being used for leather or novelty purposes. Eel skins are tanned for bookbinding, in making whips, suspenders and other articles, or dried and oiled for use as a substitute for window glass. Bags made of alligator hides are in much

demand. Hides of seal, sea lion and walrus are also tanned into leather of especial value to silversmiths, gun manufacturers, and the like, for removing mars and scratches and for polishing fine metal surfaces. Fish skins, such as cod and haddock, are used in the manufacture of fish glue, and fish sounds or air bladders are extensively used in the manufacture of isinglass, for clarifying beverages, in adhesives and in sizings to impart a luster and stiffness to linens and silks.

The "Christiania," modern floating oil factory, was cruising lazily over the whaling grounds. A bull sperm appeared suddenly to starboard and the gun crew sprang into action. A bomb-laden harpoon shot out over the water and sank with deadly explosion into the whale directly back of its head. Late that afternoon not a trace of whale in its original form was to be found anywhere on the ship. The fat had been made into oil, the whalebone was stored in the hold, and

3-1-23
Bluffas Pearl Essence
By Chemical of Bluffas
East Sun
Pedro
Calif
Paripare Product, 65 Nassau New York

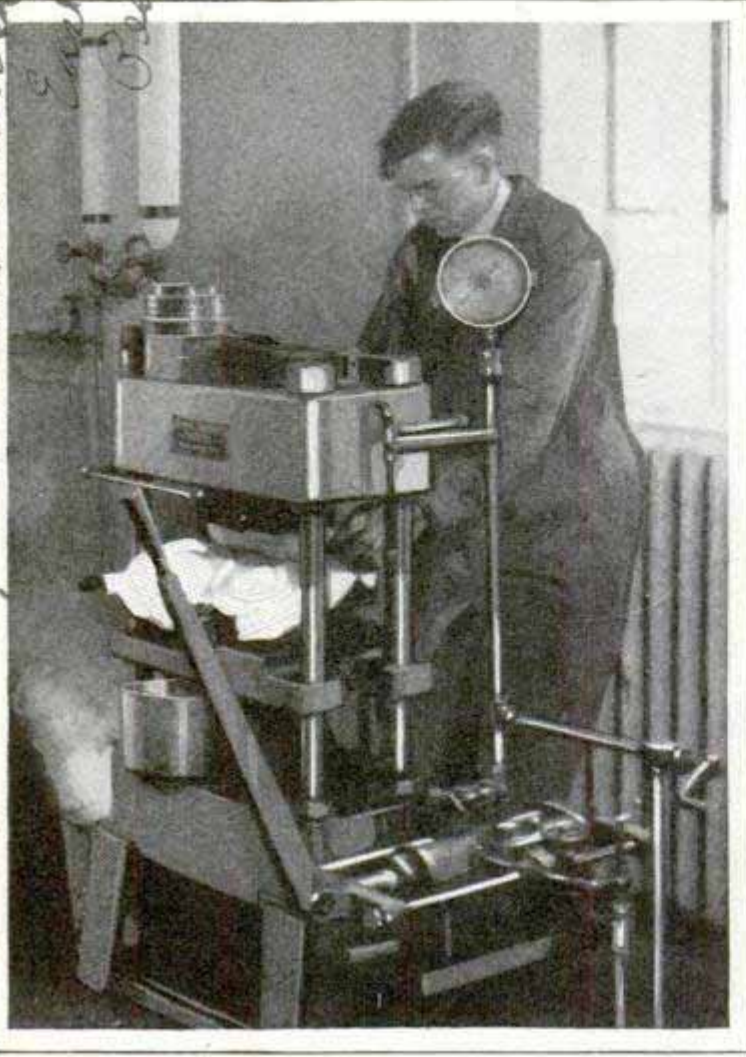

Bureau of Fisheries Experimental Plant for Extraction of Fish Oil Used in Making Soaps and Cosmetics

the scrap made into meal. Thus has modern science improved upon former wasteful methods of capturing whales and of transporting the fat to land stations. The floating factories are provided with equipment at bow, stern or sides for hauling the huge mammals aboard for cutting up and reduction. But by very reason of the efficiency with which these mammals are being hunted in order to furnish milady with scented soaps, coldcreams, and other cosmetics, the whaling industry is threatened with extinction, and extensive research is now being made in developing other fish oils.

Milady will not be pleased, perhaps, to learn that her vanishing cream, beauty cream, toothpaste and perfumed soap may have been made in part from a fish; but these articles may contain glycerin, and glycerin is a by-product of the soap industry and derived from fats and oils such as fish and whale oil. The more than 10,000,000 gallons of these oils produced

annually is valued at \$5,000,000.

The total annual catch of hard crabs in the United States and Alaska is approximately 39,000,000 pounds. Inasmuch as approximately eighty-five per cent of the crab is non-edible, the annual waste is around 33,000,000 pounds. Nearly 20,000,000 pounds of this green waste should produce, upon reduction, about 8,000,000 pounds of dried crab scrap suitable for poultry feeding.

In a recent experiment, the bureau of fisheries used crab scrap to supplement the poultry diet. A flock of birds was divided into two pens of twenty-five each. From December to March the birds that received crab scrap laid 938 eggs as compared with 479 eggs laid by the birds which were fed a standard ration.

The huge beds of oyster shells of ancient civilizations are now proving a bonanza in the manufacture of poultry grit and lime, and no oyster packer any longer has difficulty disposing of this former waste. The demand for oyster shells is larger than the fishery can supply and exploration parties are continually searching for beds of other ages.

The annual production of poultry grit and lime from oyster shells is now approximately 300,000 tons, and is valued at \$2,600,000.

During the war, the European supply of pearl essence or fish-scale essence was cut off and research had to be conducted looking toward the development of new sources of supply in this country. The scales of the sea herring of New England were found to contain the necessary element, and, at the present time 2,000,000 pounds of fish scales are used annually in the manufacture of imitation pearls and imitation mother-of-pearl celluloid products for use on the backs of hairbrushes, hand mirrors and other toilet articles, umbrella handles, buttons, and other commodities. The domestic production of pearl essence has become so large as to attract foreign buyers and the manufactured products are to be found in every five and ten-cent store in the land.

ARMCHAIR AND BED IN ONE
SAVE ROOM SPACE



An Armchair That Is Transformed into a Comfortable Bed at Night by Turning a Lever

Simply by raising a small lever at the back, a comfortable armchair, now on the market, is quickly converted into a single bed. The two arms descend and the back section swings around to make a head support. The bed pad may be attached permanently and is completely hidden when the chair is folded up again. The conversion into a bed is accomplished by a single motion as there are no extra parts to insert or adjust. Folding or unfolding the chair takes but a few seconds and its double purpose is not apparent when used as a chair.

MEADOW MICE DESTROY CROPS

One meadow mouse eats more than an ounce of green food a day or twenty-three pounds a year, government experiments to determine the destructiveness of these rodents have shown. One hundred mice to an acre, which is not a large number, in a year destroy more than a ton of green grass and even as few as ten to the acre on one hundred acres of meadow consume eleven tons of grass. This number, on the 65,000,000 acres of hay raised, represents a loss of more than 3,000,000 tons a year, or about \$30,000,000 in hay alone.

Vernon Bailey,
U. S. Biological Survey.

Discussing the marked growth of the fisheries by-products industry in recent years, and the possibilities for further expansion, Deputy Commissioner Radcliffe, of the bureau of fisheries, declared that "the number of fishery products catering to our needs and vanity today are greater than at any time in the history of the world. Figuratively speaking, the modern woman might dive into the sea and emerge completely clothed and adorned.

"She will be wearing a dress of artificial silk made from the shells of crabs, lobsters, or other crustaceans; a fur coat of otter, sealskin or beaver, with mink or muskrat trimmings; shoes of shark skin and mussel-shell buckles adorn her feet; and the buttons on her dress are of pearl derived from fresh-water mussels.

"Coral earrings and a tortoise-shell comb complete her outfit. In her alligator-leather handbag, she carries a cake of soap made from fish oil; coldcream from whale oil; a sponge; a bottle of perfume with ambergris as the fixative, a hand lotion made from seamoss, and gloves of cod skin. On her way home, she views a photogravure which was covered with fish glue before etching, and purchases a beaver hat adorned with an aigrette made from whalebone; a toilet set trimmed with artificial pearl made from fish-scale essence; an amber pipe for her husband; a bottle of cod-liver oil, agar-agar for gelatin, and cuttlefish bone for the canary."

BATTERY INDICATOR FOR AUTO
CHECKS POWER AND WATER



is indicated at all times, both being shown by the same needle.

3189

3150

Ward Battery Indicator
211 W. Elm
St. Comfort, Calif.

Cont. Henry Hodges
2404 S. Tenth St

Scene Service Bulletin
431 - J. 6/29/29

Chicago
3302 Ohio

3159 *Mc Clintic Marshall Corp.*
 STEEL HOUSE FRAME GIVES SKYSCRAPER STRENGTH

Oliver Oldy Pittsburgh Pa.

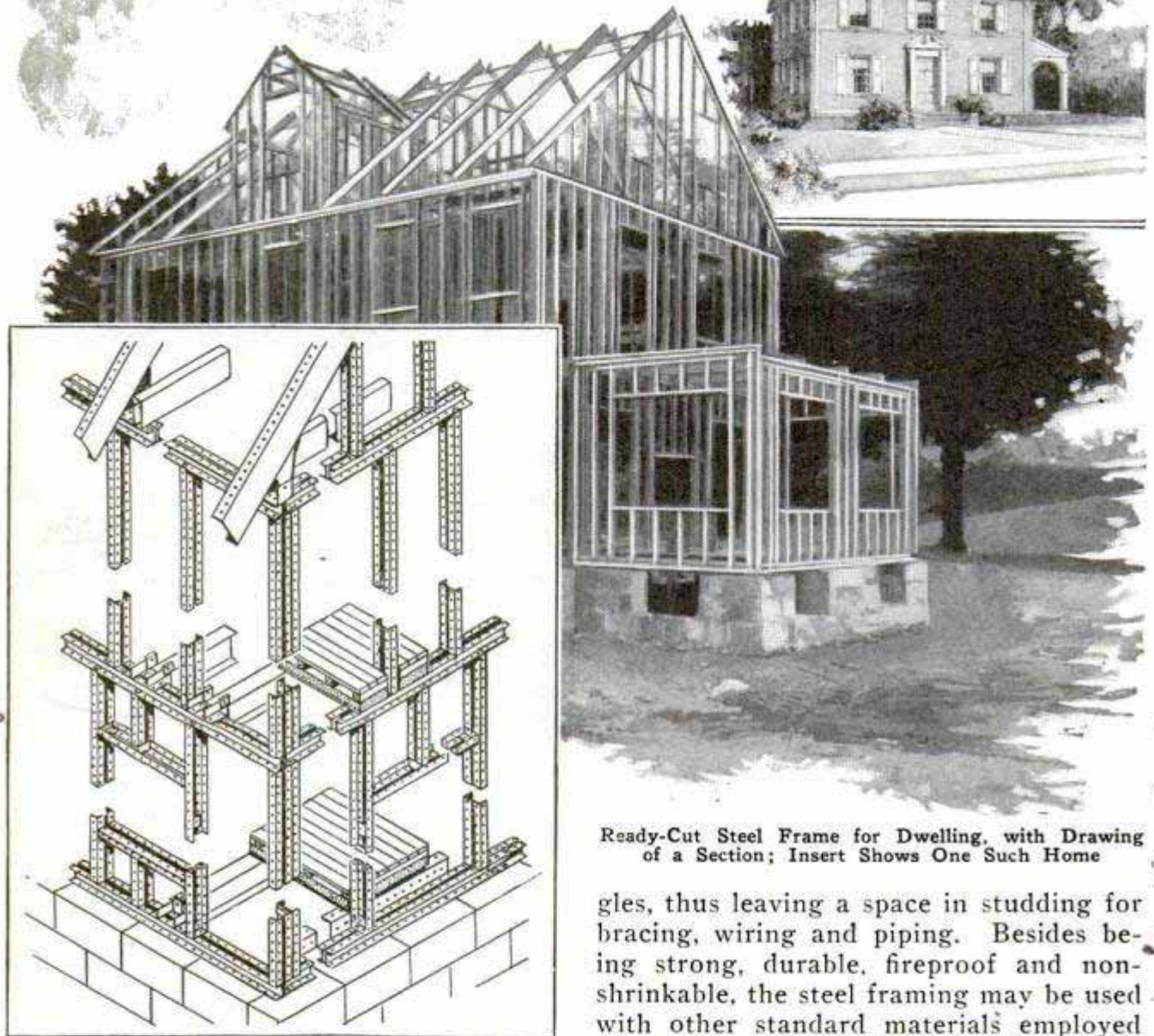

Ready-Cut Steel Frame for Dwelling, with Drawing of a Section; Insert Shows One Such Home

Steel framework, long used for the skyscraper and office building, is now utilized for the modern dwelling along the same lines as wood framing. The steel is delivered ready for assembly without cutting or fitting. Ease in assembling is afforded by perforations of all pieces except floor joists each two inches, the system being so flexible that a house may be planned without the restriction in arrangement and style which heretofore has prevented the economic use of steel for small homes. The metal is used for sills, girts, plates, studs, joists and rafters, with light angles for studs and corner posts, and separation plates to join an-

gles, thus leaving a space in studding for bracing, wiring and piping. Besides being strong, durable, fireproof and non-shrinkable, the steel framing may be used with other standard materials employed in fireproof construction with no more trouble than when such materials are employed with solid masonry walls or wood framing. Standard clips and plates for connecting various parts make the assembly of such a structure resemble the piecing together of a child's erector set. The framing also is being used successfully in the construction of garages, small apartments, school houses and farm buildings, and for partition work in hotels, apartments and office buildings. While the first cost of steel framing is higher than wood, this, the makers say, is offset by the saving in labor. Little skill, aside from the ordinary supervision over construction work, is required in assembling

Chicago. 38 S. Dearborn

of arts.

the framing, and mechanics wholly unfamiliar with the system have been able to complete the frame quickly after a demonstration of the method, because it is so similar to the assembly of the ready-cut wood framing.

AUTO SIDE SWAY REMEDIED BY CONTROL 3234

Consisting of only two parts, a cylinder and piston, a shock absorber has been made to control starting jerks, sudden stops and side sway as well as the ups and downs of automobiling. The six-way shock control, aside from simplification of the hydraulic principle, also involves angular, instead of vertical, installation, the rear absorbers being inclined forward, and the front axle units inward, connections in each instance being with the chassis and the axle, giving direct action. Angular instead of vertical installation results in controlling side sway and starting and braking jerks, while the direct-action installation gives a quicker response. The absorbers also check the tendency of the car to skid or overturn, stopping the twisting torque caused by uneven braking, and extending

to keep the wheels fixed to the ground around turns. It has only one moving part cushioned in a fluid impervious to temperature changes, contains no complicated parts, levers, wheels or springs and is intended to last as long as the car without attention. "Shimmying" is eliminated and "bottoming" the springs is prevented.



Hydraulic

Superior Equipment
Cork Wheel

Robert Mason, New York

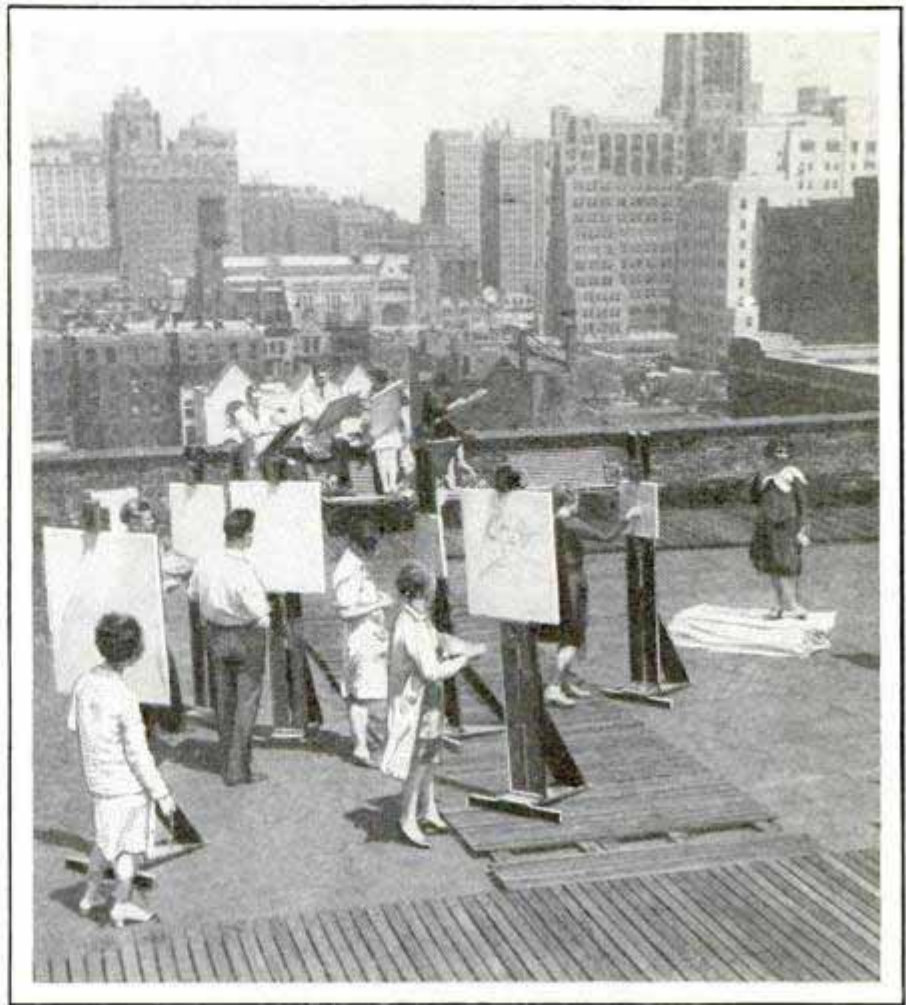

This Roof-Top Studio for Pupils of a Chicago Art School Provides Both Natural Lighting and a Skyline for a Model

ART STUDENTS HAVE CLASSES ON SKYSCRAPER ROOF

Chicago's skyline forms an excellent model for pupils of an art school who hold classes on the roof of a tall building. The location, it was found, provided both the natural lighting and the natural scenery for the students' work.

FINDS SYMBOL FOR WORD "THE" 3107

After spending thirty years checking up on Hebrew, Anglo-Saxon and other languages, a scholar has formulated a symbol for the word "the," which is used more often than any other—once in every fifteen words on an average. The symbol he hopes to have adopted generally looks like a merger of the letters "p" and "b" in lower case, while the capital resembles the capital "E" married to the second half of the parenthesis sign. The symbol is an adaptation of the Anglo-Saxon character designating the "th" sound.

making made by...

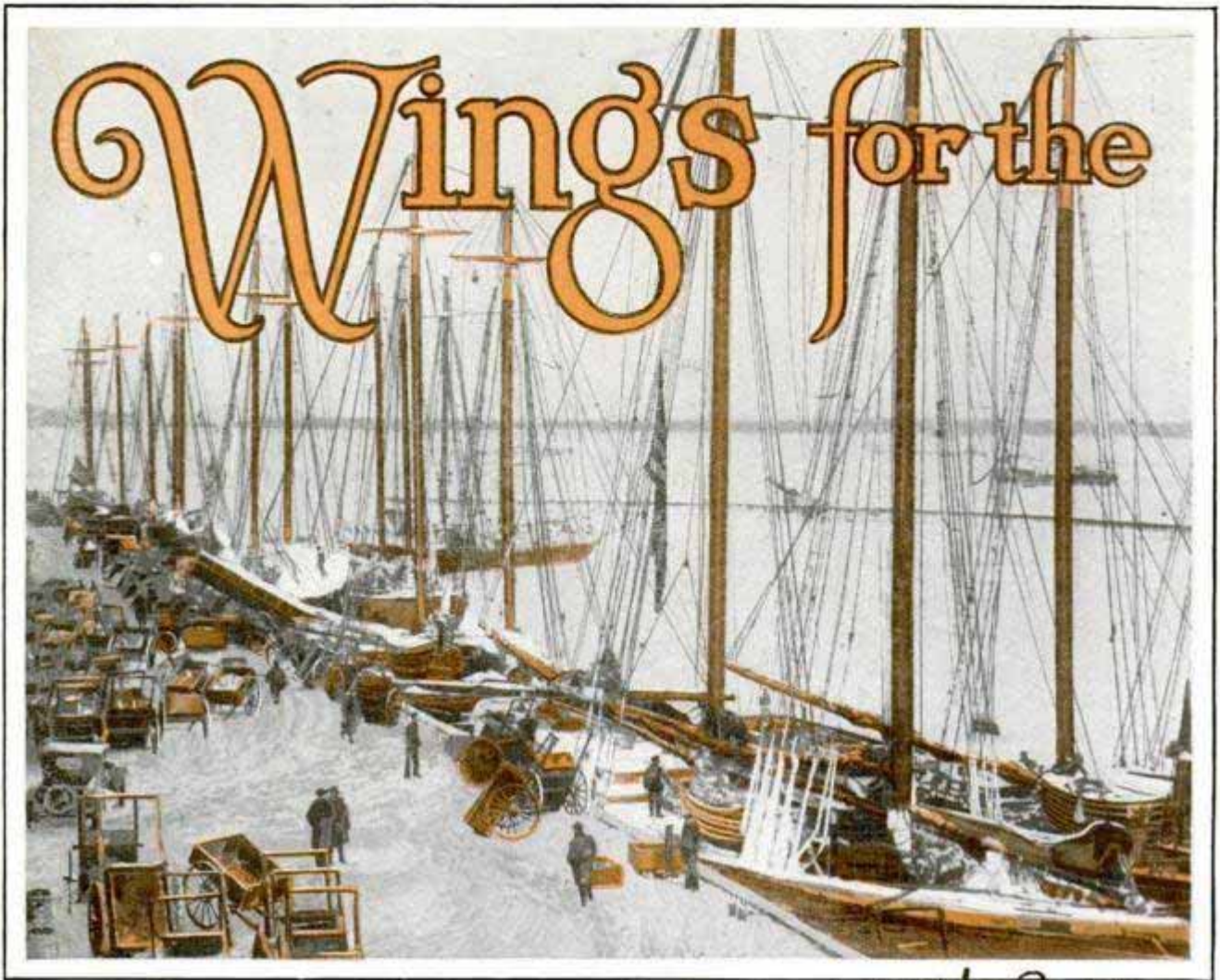

By EDMUND GILLIGAN, *c/o The Boston Post Boston, Mass*

THE SEAPLANE, the radio and the homing pigeon are bringing a new era to Gloucester fishermen.

For generations the city of Gloucester, Mass., lying in the wide embrace of Cape Ann, has been the home of the harvesters of the sea. These fishermen have always been willing to gamble with the elements. They have matched their seamanship against the tricks of the northeaster. They have been ready to chance life and ships and strength for their one prize: a holdful of mackerel.

But even bravery and stout seamanship could not win the prize if the mackerel could not be found. Days and nights of searching off Stellwagen banks and in the other shoal waters often ended in disappointment. Money for outfitting and for wages was wasted. Often the great fleets came slowly home without a single fish aboard.

Now all that is changed through the

radio and the airplane. The coast-guard pilot, soaring high in the clear morning sky from Gloucester harbor, roars far above the Atlantic area that stretches between the curling tip of Cape Cod and the brown rocks of Thatcher's island. Straight into the rays of the dawn, the big ship climbs until the proper altitude is reached and it stands out to sea. To the east and to the south, where the keen eyes of the bareheaded pilot gaze steadfastly, the ocean lies calm and blue, save where the crests of the waves break in tiny silver falls and splashing fountains.

The sea and the land, visible from the cockpit for miles, reveal the world awakening. Swift minutes pass as the pilot drives onward into the sun. Suddenly, upon the rim of the ocean, where the sea breaks somewhat whiter on Cashes ledge, he spies a group of schooners. Four in number, they ride together on the waves—painted ships upon a painted ocean. A

Fishing Fleet

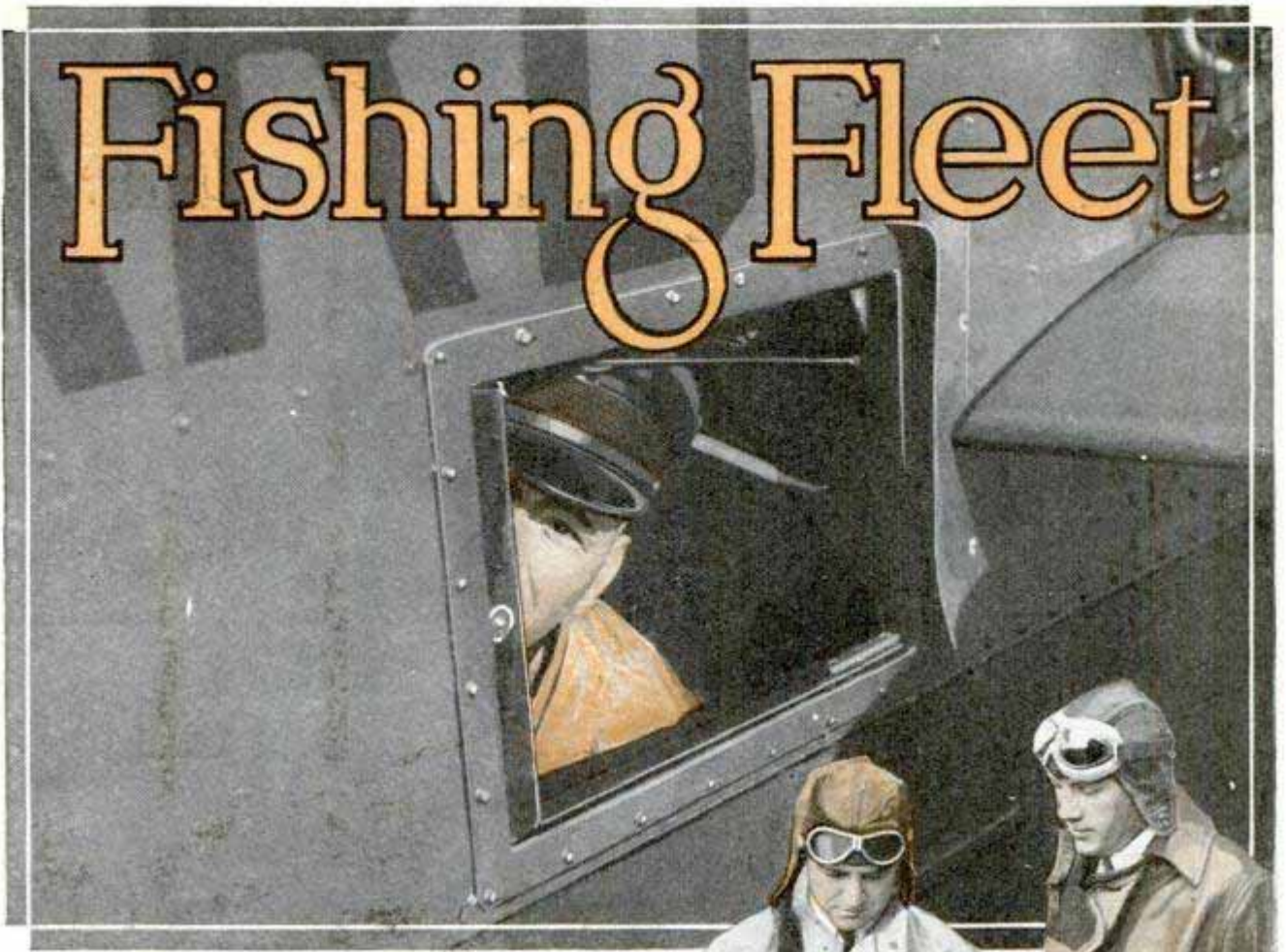

minute later, as the plane roars steadily toward the fleet, another group of schooners, idle also, come into view. Five hulls this time, black-timbered, businesslike, waiting for action. The seines are ready under the beam.

Now the plane drops slowly down. The pilot shuts off the motor and the organ-like strumming ceases. There is silence, save for the whine of wind in the struts and against the broad wings. Springing to their feet, the fishermen wave their hats as the airman swoops nearer. He salutes them. But his face is serious. He scans the empty decks. No sign of rich sea harvest there. He sees the wheeling gulls, hungry voyagers that follow the fishermen, flying aimlessly around, crying plaintively. The birds have not had breakfast yet. Nor have the men gone to work.

Three days now the ships have beaten up and down the coast from Cashes ledge to Platts bank and thence to Stellwagen bank, patiently on the lookout, hoping for the sign of the great schools of fish. Empty holds wait for the welcome cry of



Glimpse of Radio Compartment in Plane, and Receiving Reports at Gloucester Coast-Guard Station

discovery. The men listen to the radio program from the station at Gloucester, which

sends out the reports of fish prices, tells of the fish splitters waiting for work at the wharves, and gives the small receipts at Boston that mean higher prices.

Now the motor of the plane catches hold once more and away it soars, turning high circles, reaching for the fleck of cloud that has been driven down from the blue. The pilot smiles to himself as he gazes first from one side of the cockpit and then from the other. He leaves the fleet miles behind. He scribbles a note to his observer, who sits below him with the radio operator. "Keep a sharp lookout for mackerel." "O. K." comes the answer.

The radio operator sits in front of his transmitter. They are in the compartment below and to the rear of the pilot's cockpit. At the right hand of the observer is a rack containing binoculars and writing pads. Near it is the speaking tube to the cockpit which is used, of course, only when the motors are silent. At his left hand is a small cage, made of wire and

wood, where sits a silver-necked homing pigeon, much at its ease.

Now the ship's blunt nose strikes against the breeze above Stellwagen bank. In the east the fleets fade away. The pilot can see far down into the clear water. A school of tumbling porpoises comes rioting from the west, bound eastward on some silly business of blindman's buff. More majestically sails a huge blackfish, as big as the plane itself, sliding through the waves, blowing lustily with a dash of spray as his curved back glistens in the sunlight.

At this turn, the pilot discovers a new color in the blue water. It is a patch of darker shade and extends from west to east for a quarter of a mile. Down goes the nose of the plane. Swiftly it circles nearer to the ocean. The wind screams in the struts. The patch of dark color takes on a phosphorescent glow. Its shade becomes bluish-black. Leaning far over the side of the cockpit, the pilot gazes down. A broad smile comes upon



A Stormy Day for Flyers, but Lieutenant Melka, Right, and Commander Paulsen, Left, Get Ready for a Flight When the Radio Warns of a Ship in Distress

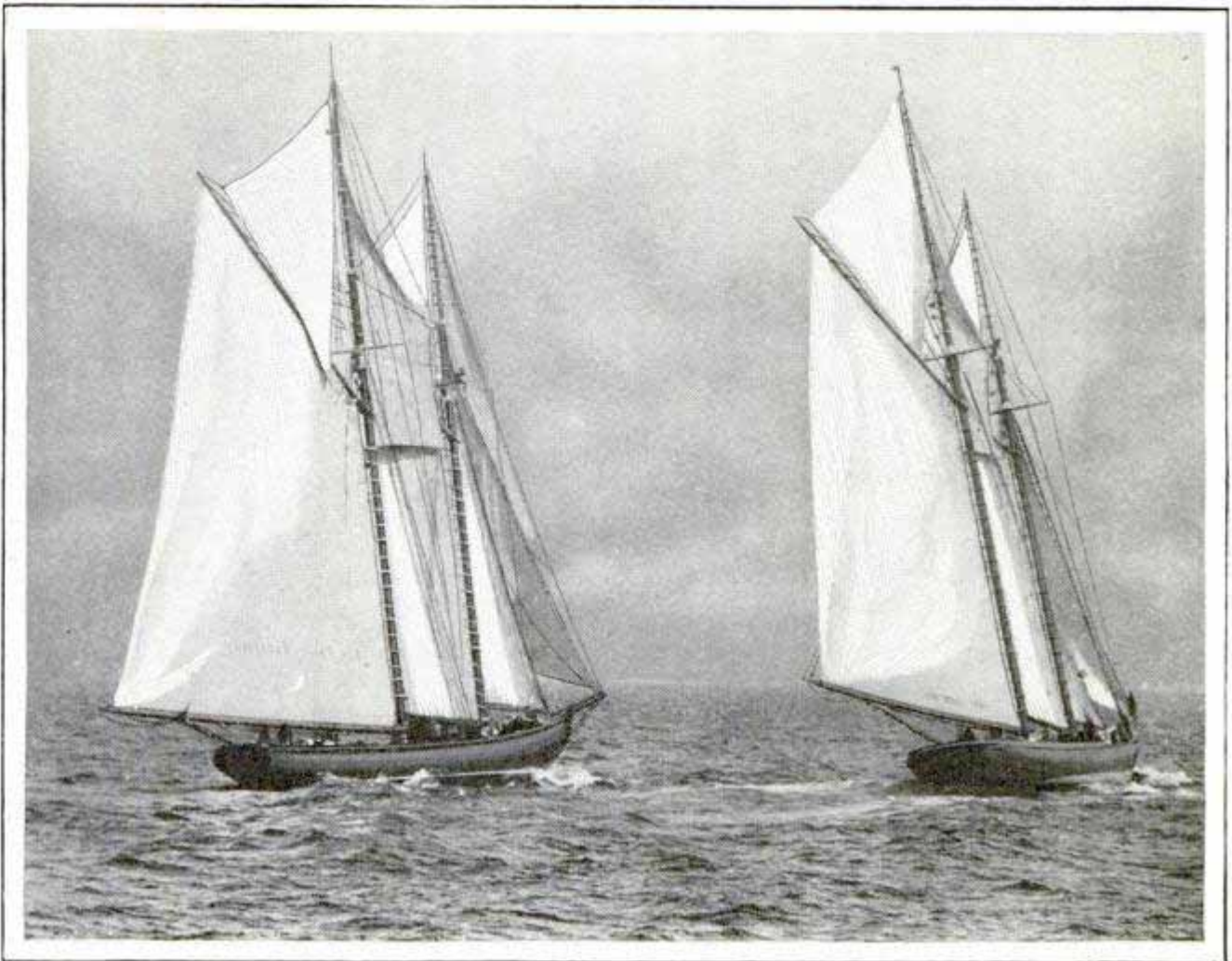

Beating Up and Down the Coast, Sometimes for Days, the Fishing Boats, When the Radio Tells the Location of a School of Mackerel, Make Haste to the Spot

his tanned face. He is almost sure. A moment more of swooping descent—and he is sure! He sees a mass of black objects moving forward. A foam bubbles and creeps and spreads around it in the advance. Mackerel!

Millions of fish are gathered in the wide turmoil. Now and then a big mackerel throws itself over the backs of its myriad fellows. And as the plane comes nearer, again with motors silent, the pilot sees that the school is a monster of its kind. Thousands of dollars swarm there. The treasure of the sea waits to be taken. Far off the fishermen lie idle.

Another note is passed to the radio operator: "Report to base the presence of large mackerel school four miles west of Stellwagen banks." While the operator is speaking into his transmitter, the observer has written the report on a tiny square of fine paper which he has thrust into the little tube that the pigeon carries attached to its leg. He then leans out of

the opening in the side of the ship and skillfully "tosses" the bird.

With wings folded tight, the homer dives straight down to the sea, almost within reach of the spray of the waves. He circles three or four times and then darts toward the pigeoncote on Ten Pound island, at Gloucester.

The message into the transmitter continues: "Base No. 7. A-25 calling. A-25 calling. Base No. 7, come in. Base No. 7, come in, please."

Now he stops and listens. No answering voice comes. Again he renews his signal. Then from his earphones a voice calls clearly: "A-25. A-25. A-25. Base No. 7 calling. Base No. 7 calling. Come in. Come in. Come in."

They begin to talk: "A-25 on patrol wishes to report to the base the presence of a large mackerel school four miles west of Stellwagen bank."

Base No. 7 repeats the message. A word or two of other matters are passed



Returning to Hangar after a Successful Search for the Mackerel Schools

between the radio man in the plane and the operator on Ten Pound island.

The plane soars back to height again. Lieutenant Melka gazes back at the fishing fleets, almost hull-down but plainer to the eye of the pilot as he gains altitude. The plane's radio operator listens to the broadcast of the Gloucester station: "The Master Mariners association of Gloucester has requested this station to broadcast to the fishing fleet a report from air patrol from coast-guard Base No. 7, Gloucester, that a large school of mackerel is moving in the vicinity of four miles west of Stellwagen bank."

The speed of radio is instantaneous. It will be an hour, perhaps, before the pigeon flutters down into the coast-guard pigeoncote and waits for the removal of its message tube. But already the fleet has sprung into life. The auxiliary motors sputter. Far up in the air, the pilot gazes down and sees the blue smoke from the exhausts puff out over the white wakes as the ships glide forward. Cheerily the men shout to one another as the schooners get under way. They have the word. Mackerel!

Between the two converging fleets of fishermen the patrol plane now comes. Wild cheers greet it from the tipping decks of the schooners. Shouts and queries are sent up from mighty lungs.

But the coast guardsmen are at work again. A wave of the hand that signifies, "Glad to help," and off goes the great plane on the wide sweep of patrol.

AIRPLANE SIREN WARNS PILOT 3090 OF STALLING DANGER

Warning that an airplane's speed has dropped to a point where there is danger of stalling is given by an automatic siren which sounds only when the air speed drops below a certain rate. The screech of the siren can be heard above the noise of the engine and the instrument is adjustable to any plane.

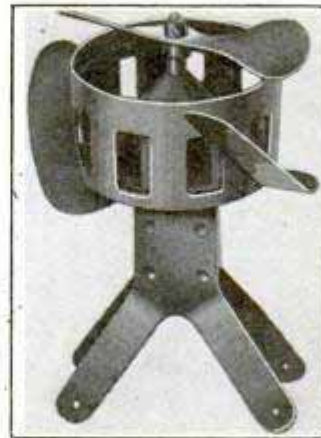

The apparatus consists of two concentrically mounted cages, one moving clockwise and the other counterclockwise. The inner cage is mounted against a spring and above stalling speed is forced back by the air-flow against a cork friction ring, but when the speed is decreased the spring forces the inner cage forward until it is rotated and the noise starts.

The Aeroplane 6/29/29
 Chas. E. S. Wynn (Eng.)
 36 Hartung St.

**LOWEST PLACE IS THE SAFEST
IN A THUNDERSTORM** 3202

Safety from lightning in a thunderstorm will be found in the lowest possible place, says an official of the weather bureau. He advises the person caught in an electrical storm to seek a low place and sit down, or even lie down. Nothing, particularly not an umbrella, should be held above the head. If the person is soaked to the skin, he may find relief in knowing that the wetting is a further protection, because wet clothes are good conductors.

**CYLINDER LIKE AN AUTO MOTOR
ACTS AS HAMMER** 3236

Tamping down paving stones without lifting, and dropping a heavy weight, is accomplished in Berlin with a ramming machine weighing about 200 pounds, which operates automatically. The heavy rammer has in its middle a single cylinder, like that of a motor car, and gasoline tank, and the worker carries batteries in a case on his back, operating the ignition by pressing a lever with his thumb. The piston throws an iron bolt at the bottom of the rammer against the ground and the whole apparatus jumps upward about eighteen inches from the impact, then tamps the paving blocks as it descends.

(Pflastermaschine)



Machine for Tamping Paving Blocks Contains a Cylinder Like an Auto Motor, to Operate It

Del. mag. C. S. ...
... ..

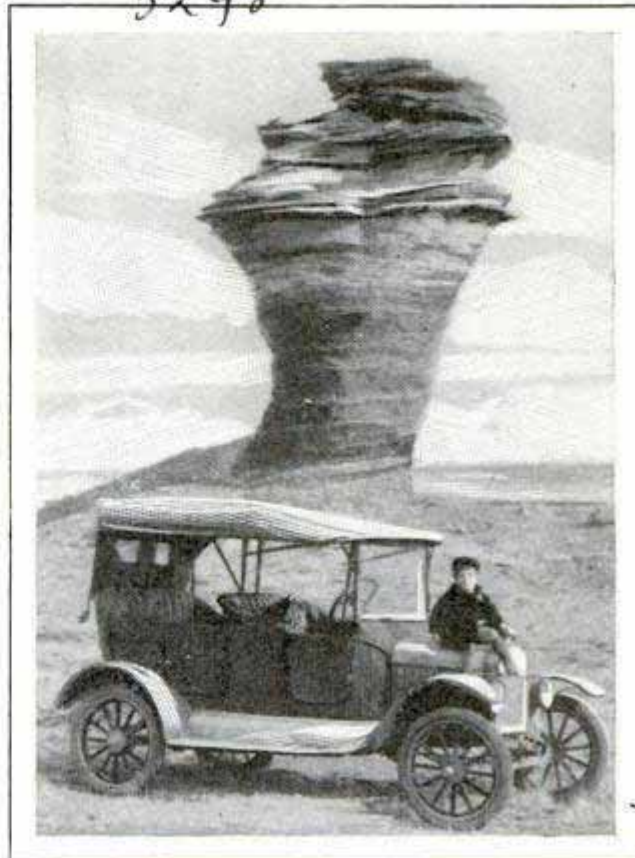

A National Highway Was Rerouted to Preserve This Balanced Rock as a New Mexico Landmark

**BALANCED ROCK IS PRESERVED
BY REROUTING HIGHWAY**

Monument rock, a natural pillar of shale and sandrock, near San Jon, N. M., has been saved as a landmark even though it was necessary to reroute a United States highway to do it. Engineers found that a logical tangent for a road would necessitate destroying the balanced rock and put two curves into the road to preserve the stone, which to the casual observer appears about to fall at any minute. Careful measurements, compared with measurements taken years ago, show that the rock is likely to stand for a long time to come

3248
Cmt. Edgar Sherman, Tucuman, N. M.

PRICKLY PEARS AS STOCK FEED 3137

After South African farmers had spent years in vain endeavors to clear their lands of a species of cactus, known as the spineless prickly pear, it is now being cultivated for use as both food and water for cattle during prolonged drouths. It contains a large percentage of water and mineral salts, and has been the means of saving the lives of hundreds of cattle during dry periods, which sometimes extend for as long as two years.

Cmt. Chas. L. Stewart,
Cape Argus, St. Georges St.

Williamsburgh Savings Bank Bldg

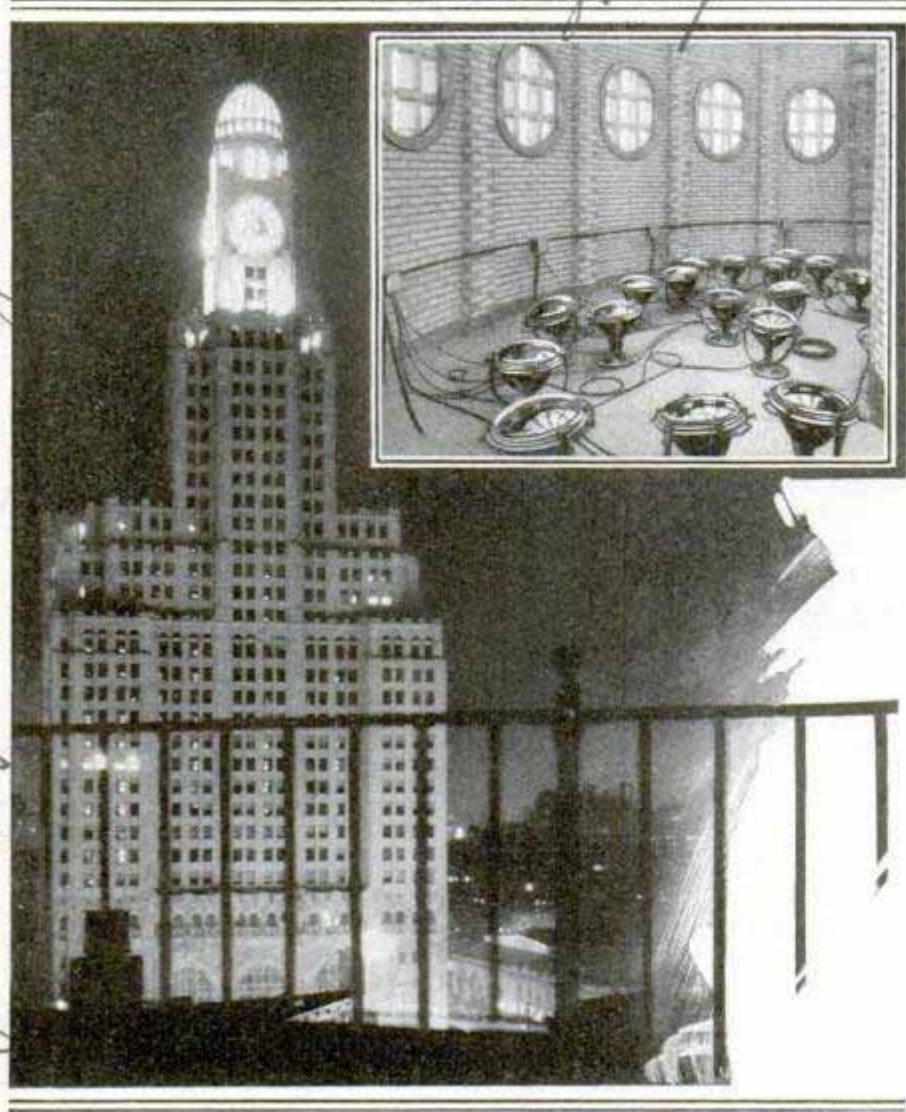

Courtesy General Electric Co.

Lights Illuminating This Tower Are Inside the Dome, Which Is of a Shutter-like Framework through Which the Light Passes

DOMES' OUTSIDE ILLUMINATED BY INSIDE FLOODLIGHTS

Internal floodlighting has been used to illuminate the outside of the dome of a Brooklyn bank building. The dome is not of glass, but its curved surfaces are built up of horizontal louvers, or sloping overlapping sections of metal. Viewed by an observer from any point below the level of the dome, these louvers overlap and their gilded surfaces appear to the eye as a solid gilded dome. The surfaces of the louvers are lighted by lamps placed on the floor within the dome, and colored lights, through a cycle of automatic changes, give a variety of effects.

no card

Wire automobile wheels are being made from a high nickel, chromium, steel alloy that neither stains nor rusts.

Endura Inrosta Ka2 Steel

Central Alloy Steel Corp

Cunard line is planning one or more ships even larger, to be propelled by steam turbines developing 160,000 horsepower, or twice as much as the "Mauretania." The race among shipbuilders to reduce the time of passage across the 3,000-mile expanse of ocean recalls that the first steamship to cross the Atlantic took twenty-six days. Columbus made the passage in a little more than two months and until scarcely a century ago many sailing vessels consumed almost as much time, although clipper ships often made better speed than the early steamers, one of them making the trip in thirteen and one-half days. The American-built "Savannah," only 100 feet long, was the first steamer to cross, but she used sails to assist her paddle wheels in rough weather. The little boat "Sirius" was the first real liner, and in 1838 reached New

York from Queenstown in eighteen and one-half days, but the "Great Western" came into port a few hours later with a record of thirteen and one-half days from Bristol. In 1864 the time was cut to less than nine days, and in 1872 it was further reduced by the White Star line to a trifle under eight days. The "Oregon" made the Queenstown-New York run in 1884 in six days, nine hours and forty-eight minutes, and five years later the record was set at under six days by the "City of Paris." The rivalry finally resulted in the building of the "Mauretania" and "Lusitania," and now liners are planned to materially reduce all records.

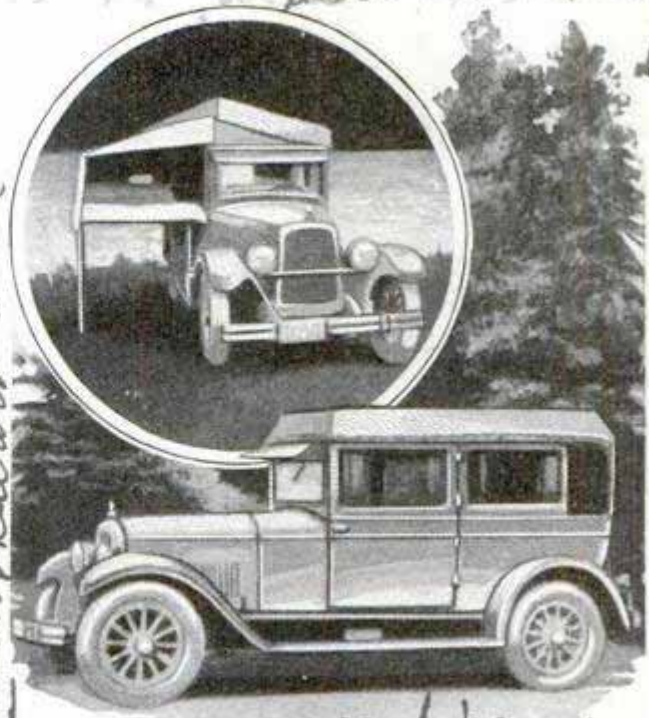

A Camper's Bed Which Is Stored on Top of the Automobile When It Is Not in Use

PLANE BEATS HOMING PIGEONS

Man scored another victory over nature recently when an airplane won in a race from Chicago to Detroit with four homing pigeons. The birds, long considered faster than planes, were released by the pilot as he stepped into his cockpit, but the first one did not reach Detroit until an hour and nineteen minutes after the plane arrived. This bird previously flew from Fort Worth, Tex., to Detroit in four days and eleven hours.

STEEL MESH WITH FIBER COAT MAKES PLASTER BASE

Steel mesh coated with bands of pressed fiber is being used by contractors as a plaster base to provide fire resistance, sound deadening and rat-proofing of walls.

The rigid steel mesh is supplied in sheets of two square yards, and makers claim the base not only affords more substantial construction, but results in plaster economy in addition to other advantages. The mesh is not subject to weather changes and neither shrinks nor swells, while overlapping at joints eliminates joint cracks. The fiber-coated back of the mesh base prevents plaster from penetrating or falling.

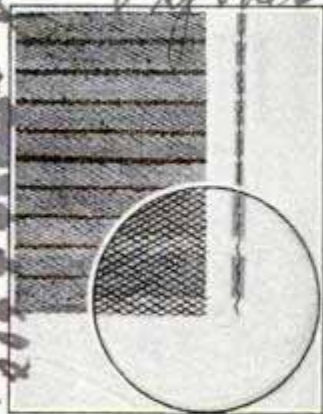

CAMPERS' BED ON TOP OF AUTO GIVES MORE SPACE IN CAR

Prepared for occupancy in a few seconds, a comfortable bed for campers is carried on the top of the automobile, leaving all space in the car available in the daytime. The bed, equipped with spring and mattress, rides in a hangar placed on wooden slides to which clamps are attached to hold it rigid. When the bed is set up, one side rests on supports on the car just above the fenders. A waterproof tent with netting windows also fits over the bed and is attached to the car, this being carried in the hangar in the daytime or used as a fly tent. The roof that covers the bed is of regular auto-top material and is supported by a light wooden frame.

A CLOTHESLINE WITHOUT PINS

Clothespins are unnecessary with a clothesline made of two strands of wire twisted together. Between the wires runs a brass separator consisting of two small wheels on an axle, the clothes being placed between the wires as the separator is pushed along the line, while the latter closes to hold the wash as the separator is moved. The separator also cleans the line as it is moved along the wires.

308
D. A. ...
4719
John D. Pawlowsky
3168
205 E 40th St
Chicago
Pena Metal Co
Pembroke Mass

La Compagnie de Lignes
5145
montreal, can
Quebec

101. "Colombere" Barchurst Road,
Derby Heath, nr Ludlow Eng

The Mystery of

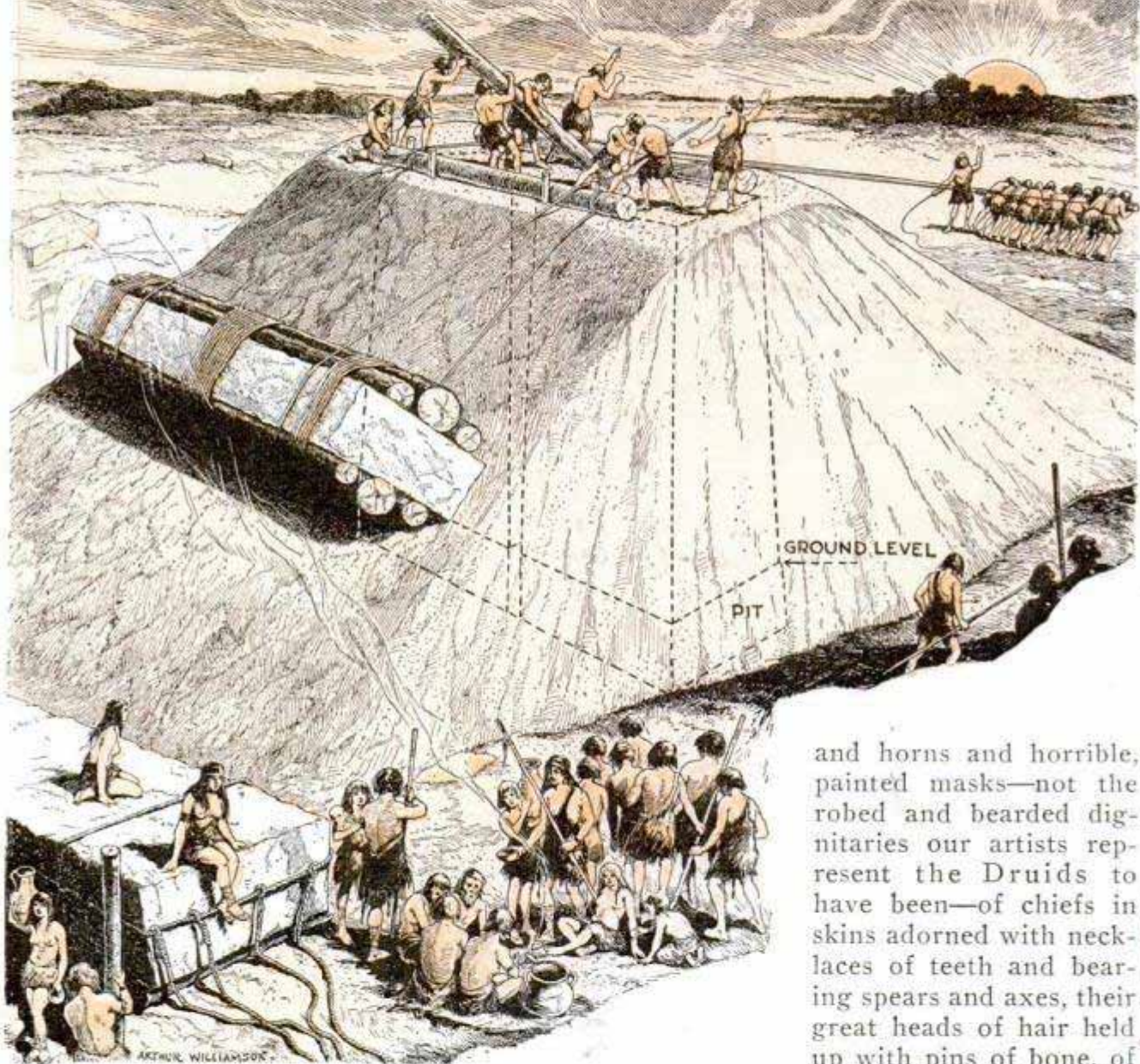

and horns and horrible, painted masks—not the robed and bearded dignitaries our artists represent the Druids to have been—of chiefs in skins adorned with necklaces of teeth and bearing spears and axes, their great heads of hair held up with pins of bone, of women in skins or flaxen

“AWAY beyond the dawn of history, 3,000 or 4,000 years ago, one thinks of the Wiltshire uplands in the twilight of a midsummer day’s morning. The torches pale in the growing light. One has a dim apprehension of a procession through the avenue of stone, of priests, perhaps fantastically dressed with skins

robes, of a great peering crowd of shock-headed men and naked children. They have assembled from many distant places; the ground between the avenues and Silbury Hill is dotted with their encampments. A certain festive cheerfulness prevails. And amidst the throng march the appointed human victims, sub-

Stonehenge

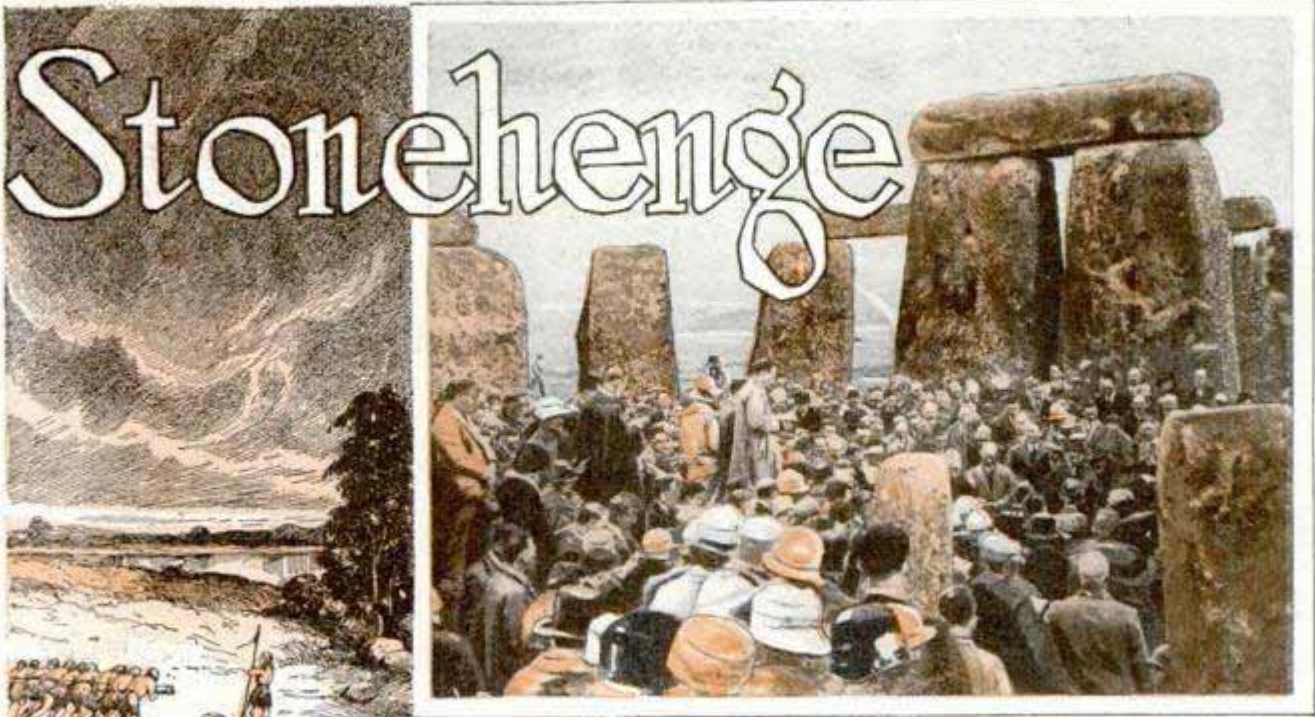

Copyright Speedpoints

How the Big Stones May Have Been Set Erect by Dragging Them up Earthen Ramps, and Stonehenge as It Is Today; a Modern Druid Meeting in Progress

missive and helpless, staring toward the distant smoking altar at which they are to die—that the harvests may be good and the tribe increase. To that had life progressed 3,000 or 4,000 years ago from its starting place in the slime of the tidal beaches.”

So wrote H. G. Wells, the famous novelist and historian, and that is one theory—a very probable one—of the mysterious origin of Stonehenge, the strange stone circle in Wiltshire, England.

Another theory is that the Druids, or wise men of the ancient Britons, described by Julius Cæsar as living in dens and woods and caves, built Stonehenge as an astronomical observatory or temple.

As a matter of fact, Inigo Jones, architect of King James I of England, who investigated this strange circle, knocked the Druid theory of the origin of Stonehenge on the head, showing that it was built hundreds of years before the rise of the Druids, who, however, may have used it.

Some 12,000 to 20,000 years ago, a new Stone-Age people, who made polished stone implements and began to domesticate animals, arose either in the now

submerged Mediterranean basin, or in western Asia, or north Africa, and gradually spread eastward over Europe, which was recovering from the last great Ice Age. They began to sow and harvest grain, and by some strange process of reasoning conceived that the sacrifice of a chosen human being would conduce to a successful harvest. These people developed what Prof. Eliot Smith calls a “Sun-Stone” culture, and wherever they migrated, set up vast pyramids and mounds, and circles of big stones, perhaps to aid the astronomical observations of their priests or wise men.

They were a dark curly-haired folk with round heads and skulls broader than long. Preceding them in Britain, an earlier race of long-skulled men with fair hair, who tended flocks, had built a vast circle of stones on Salisbury plain, not far from Stonehenge. Today, only about twenty out of the original 600 enormous stones remain at the original site. Circles of such stones also are found in Cornwall and Wales. They were objects of worship and were believed to possess magical or medicinal properties.

The fame of the stone circles spread all over Britain and reached the ears of the men on Stonehenge Down. The Bronze Age was just beginning, when, it is surmised, the folk of Stonehenge—then a center of manufacture of stone tools, axes, and weapons—made a raid on such a cir-

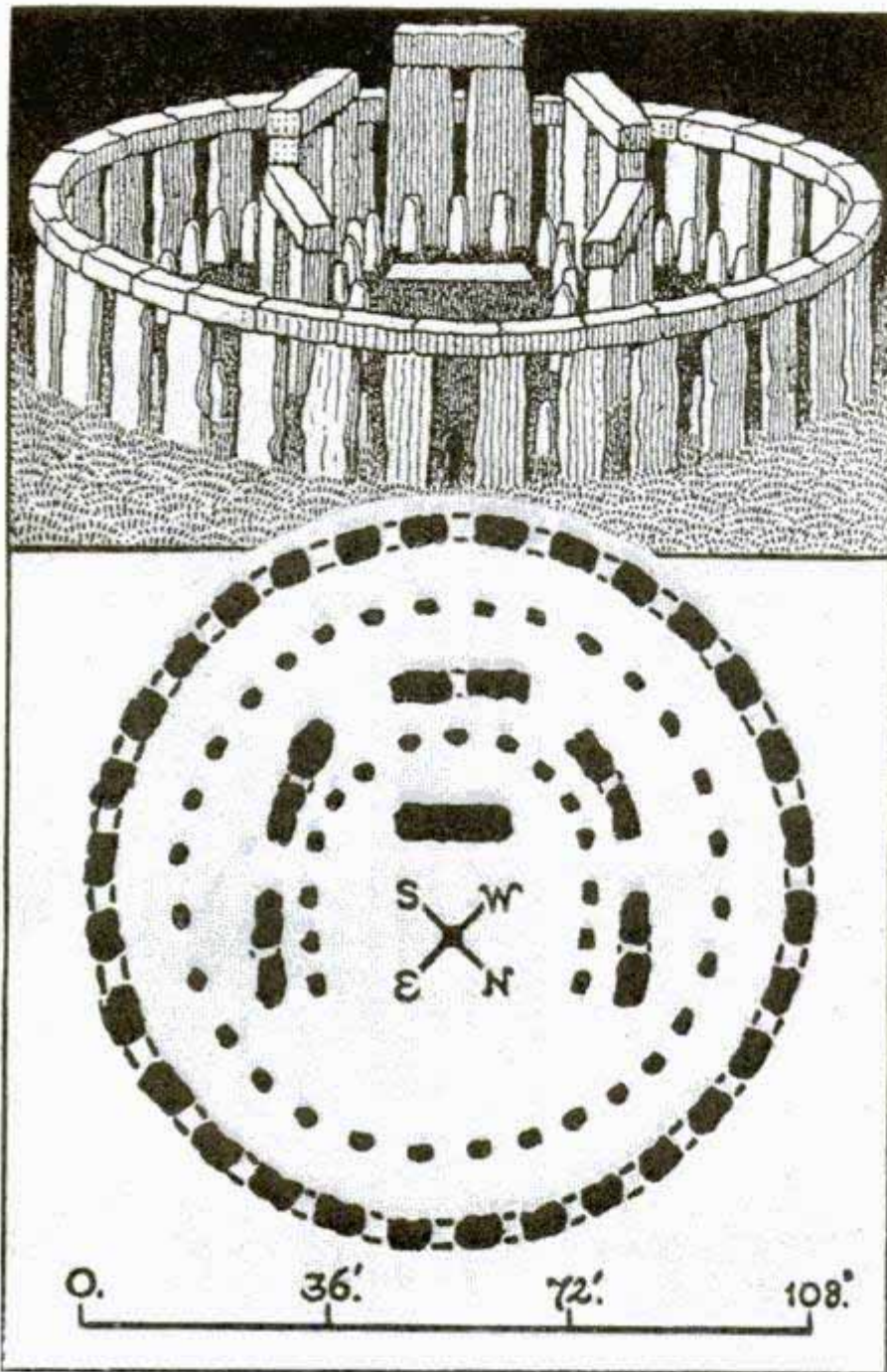

Stonehenge as It Probably Was Some 4,000 Years Ago, and Plan of Original Structure with Scale

cle of blue stones in the Prescelly mountains of Pembrokeshire, South Wales, 170 miles overland from the Wiltshire plain.

A fierce battle was fought between the fair-haired long-heads and the dark men of the round-headed invading race, and 115 of these blue stones were taken by sea from the coast of Wales around the shores of the English Channel to the mouth of the river Avon, in Hampshire. Up this little river, the foreign blue stones were sent on rafts to West Amesbury in Wiltshire.

Recently, a British government airplane, surveying and mapping the North

Wiltshire country, took photographs which revealed hidden lines indicating the old trackway over which the stones were dragged on rollers by Stonehenge men pulling on ropes of hide. Excavators have confirmed this fact.

Today, Stonehenge is bounded by an earthwork, 300 feet wide and approached from the northeast by a banked avenue of great width. At first sight, a chaos of fallen and upright stones meets the eye. The approaching visitor sees a large, unworked stone called the "Hele stone" or "Friar's heel." Hele is an Anglo-Saxon word suggestive of the Greek word Helios, or sun. The Hele stone, over which the sun appears to rise at midsummer-day dawn, is some yards outside the earthwork.

Passing inside the earthwork, the visitor sees on his left a great block, called the "Slaughter stone" and thought to have been used as a place of execution. This stone is one of the mysteries of Stonehenge. Excavations

under the Slaughter stone have shown that the ancient builders intended to bury it in a hole roughly dug in the chalk, and just deep enough for the soil to cover the stone at ground level. But the builders made the hole too short, and so the stone rests on the sloping chalk at either end.

On the outside of the circle, and within the 300-foot-wide circular earthwork, are two rough, unworked stones, one of which appears to mark the rising of the sun on the winter solstice, and the other its setting on the summer solstice. Then comes a ring of unhewn stones, about twenty-one feet high, standing upright,

with lintels mortised to their tops. The diameter of the circle is 108 feet.

Next comes a ring of hewn stones brought by sea from Wales, of which seven are still standing, and nine prostrate, out of the thirty or forty original stones. Behind these, in the next circle, once stood five great trilithons in horseshoe formation, opening to the northeast. Inside the site of these trilithons, of which only one still stands, is a ring of smaller upright stones, also in horseshoe formation.

Then the eye falls on a singular, flat block, called the "Altar stone," almost buried beneath the remains of a fallen trilithon. It is possible that this stone may have been a roster or platform. There is no proof that it ever was upright. Looking northeast from this slab, through the arches of the outer circle, one can see the Hele stone, or Friar's heel, some way distant on the plain. On the longest day of the year—midsummer dawn of the summer solstice—the sun appears to rise over the top of this monolith as one looks from the center on the Altar stone. All round

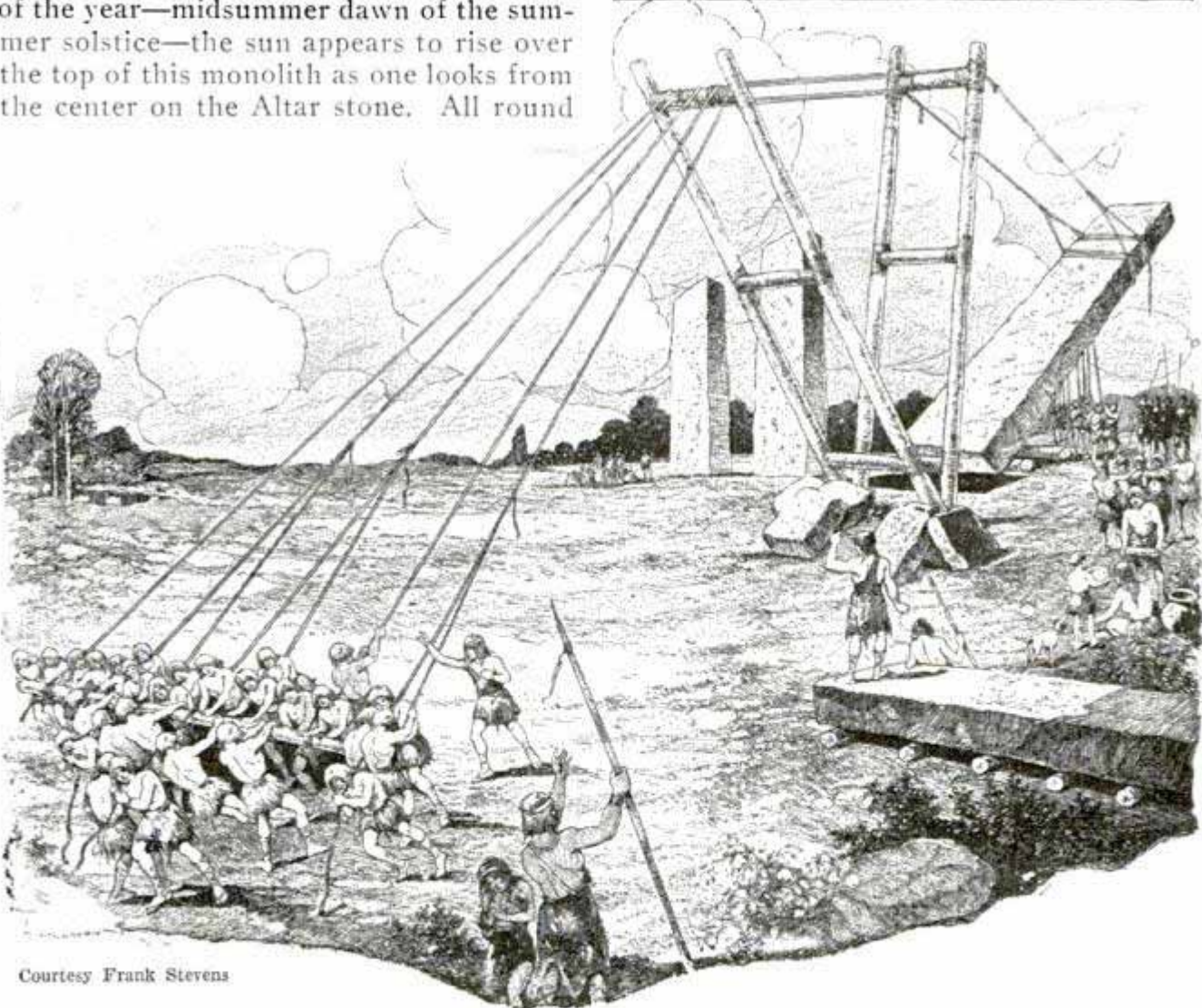
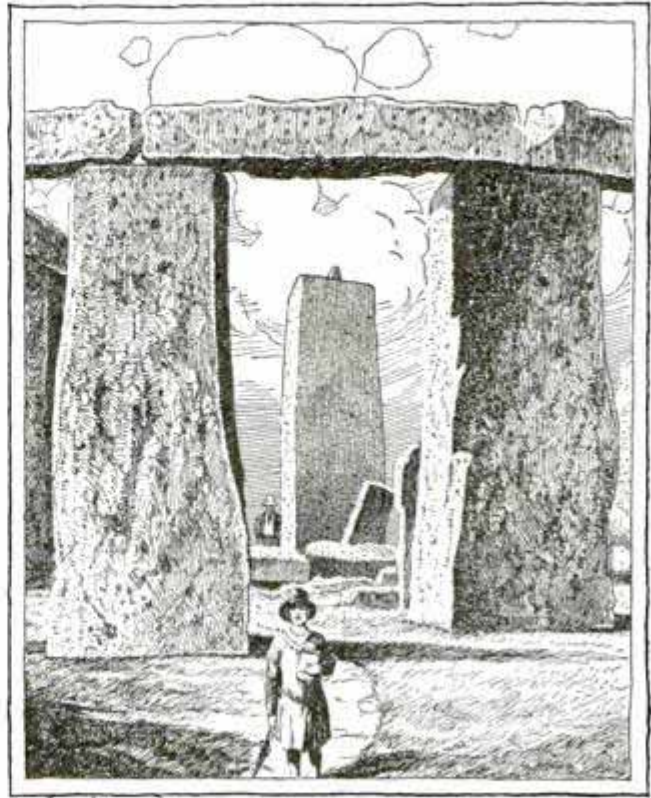

Courtesy Frank Stevens

Sketch of the Huge Blocks as They Appear Today, and Another Solution of the Construction Problem, Tipping the Stones into a Pit with the Aid of Tackle

on the plain are great numbers of prehistoric burial mounds, or barrows, which may house the long-dead builders of Stonehenge, or may be the graves of the famous and forgotten chieftains of the new Stone Age.

The engineering of Stonehenge is remarkable. How were the great trilithons raised when men had none of the derricks, slings and electric hoists of our modern days? The only tools used were crude hammer stones or mauls of flint. E. H. Stone, an English engineer, suggests that a man of extraordinary ability designed and supervised the erection of the stone circles. Foremen or overseers measured the sites for the foundation pits of the great monoliths and trilithons, while other men dressed the great stones, shaped and repaired the stone and flint tools, dug the foundations, and lugged the stones into place. No articles of metal have been found near the site of Stonehenge, showing that no Bronze-Age men using metal tools were employed.

The stones probably were split in a way similar to that still practiced in parts of modern India. Men stood in a line across the stone. Each one held a stone maul above his head, gripping the tool with

both hands, and at a signal from the overseer each man simultaneously dashed his maul on the slab, and so split it across. Quartz mauls have been found at Stonehenge, showing signs of this terrific battering. Then, the stones, resting on timber rollers, were tugged across country by men pulling on ropes of hide.

The difficulty of the job can be judged from the fact that each of the trilithon uprights weighs forty tons, and each block and lintel weighs twenty-six tons. Seventy-five blocks were needed, so that the total weight of these alone was 1,950 tons. The master engineer probably laid out the design of Stonehenge by marking the circles with a rope staked to a center on the ground of the site. The great circle was divided into thirty equal parts and the space for the stones marked out on the ground. His first problem was how to erect the forty-ton uprights.

These great stones were of different heights, but it was arranged that the tops of the stones forming the seatings for the lintels should, after erection, be as nearly as possible at a uniform level. To do this, the foundation pits had to be dug at varying depths, according to the lengths of the stone uprights. The bottom of the pits

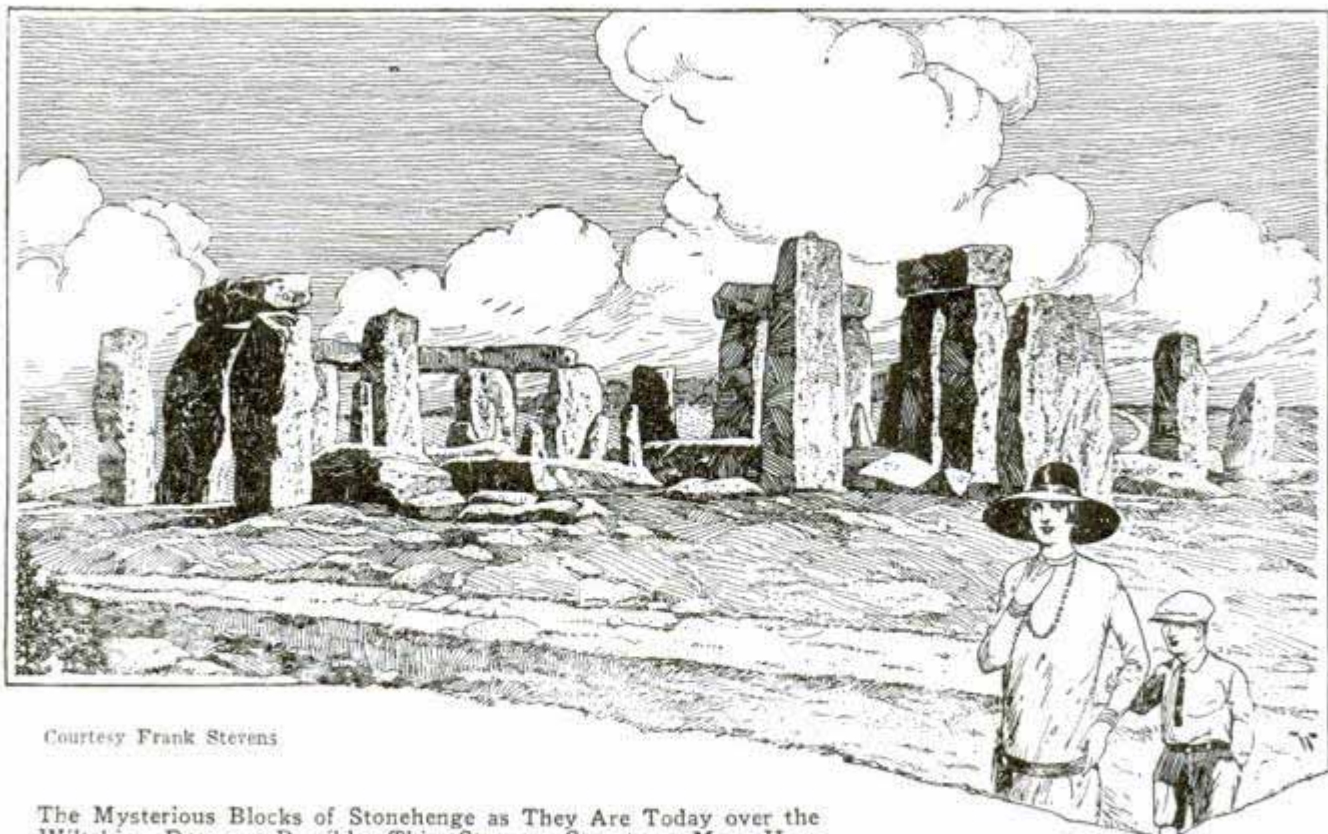

Courtesy Frank Stevens

The Mysterious Blocks of Stonehenge as They Are Today over the Wiltshire Downs; Possibly This Strange Structure May Have Served as a Place of Sacrifice of Human Victims on Each Midsummer Day When the Sun Rose over the Plains; the Upright Megaliths Are Over Twenty-Two Feet High and Several of the Lintels Are Still in Place

31 21
 2061 Southport
 Chicago 623

was carefully excavated to correspond with the shape of the bottom of the stone, so as to secure a firm foundation. Round the pits, the ground was rammed hard as a platform for the stone. Then, the great stones, on rollers and with the flat-dressed face uppermost, were rolled over the floor, each stone end on, and so balanced as to tip itself into the pit. Mr. Stone suggests that a rough derrick, made of a pair of timber sheer legs, was used to raise the stone erect.

There is no direct evidence to show how these Stone-Age men got the lintels on top of the uprights, twenty-two and a half feet high. Mr. Stone believes a bank of earth was thrown up around each pair of upright stones. The top of the earth was rammed flat to make a working stage, above which the tops of the big uprights projected a few inches. The bank so ringed in the uprights as to exert equal pressure on all sides, and hence not shift the upright on its foundation. Then the lintel was pulled up the sloping side of the bank and set on top of the upright.

The visitor sees, just inside the earth-work circle of Stonehenge, a puzzling series of twenty-three holes in the chalk. Most of these contain cremated human remains, and in three the signs are that the cremation was done on the spot.

The mauls used in dressing the great stones weighed from thirty-six to sixty-four pounds and were wielded by two to three men. Picks of deer horn may have been used to cut the holes for the foundations of the uprights, since splinters of horn have been found in these pits.

Even today, after years of patient research, scientists do not really know the exact purpose for which Stonehenge was built, nearly 4,000 years ago. Was it intended for a court of justice, a hall for ceremonial meetings of chiefs and kings, a sun temple for sacrifice of human victims, or a hall for the rites of the dead? No one is sure.

RADIO WIRES KEPT OFF FLOOR WITH BASEBOARD CLIPS

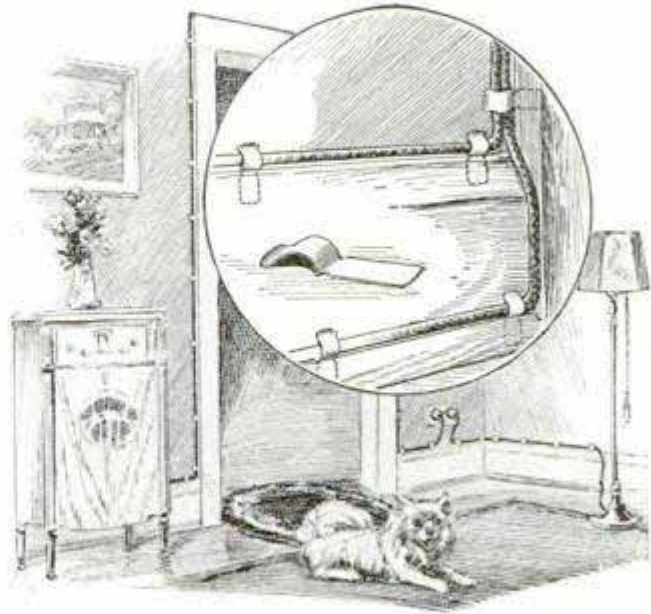

Metal Clips Inserted in Baseboards Keep Radio and Telephone Wires off the Floor

Clips that may be inserted in baseboards, door frames and moldings serve to keep lamp, radio and telephone wires off the floor. The metal fasteners are slipped into the space between the trim and the wall, the top being bent to receive the electric-light cord.

TALKS TO LONDON FROM PLANE FLYING OVER NEW JERSEY

5126

Talking with persons in London while soaring in an airplane 2,000 feet over Hadley field, N. J., was accomplished recently by a hookup of radio and long-distance telephone wires. The London call from the man in the plane was sent to the

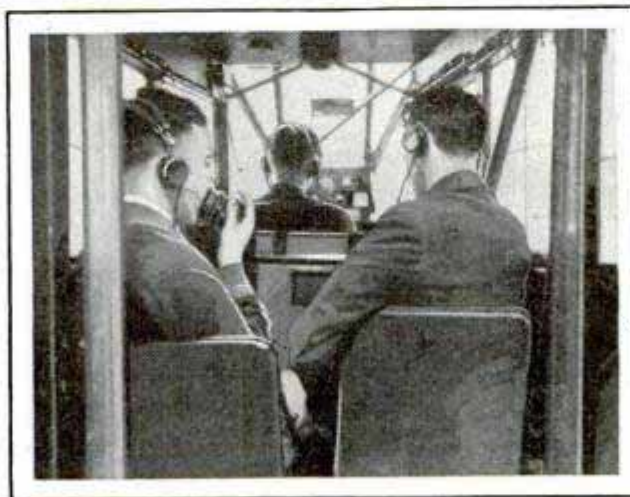

Airplane Passengers Talking with London by Telephone and Radio While Flying over New Jersey

Bell laboratories' ground station at Whippany, N. J., by radio and there picked up and relayed over transatlantic wires. The call was completed in a few seconds, but the first conversation was hampered by considerable interference, although the voice from London was distinct.

International

7/25/29

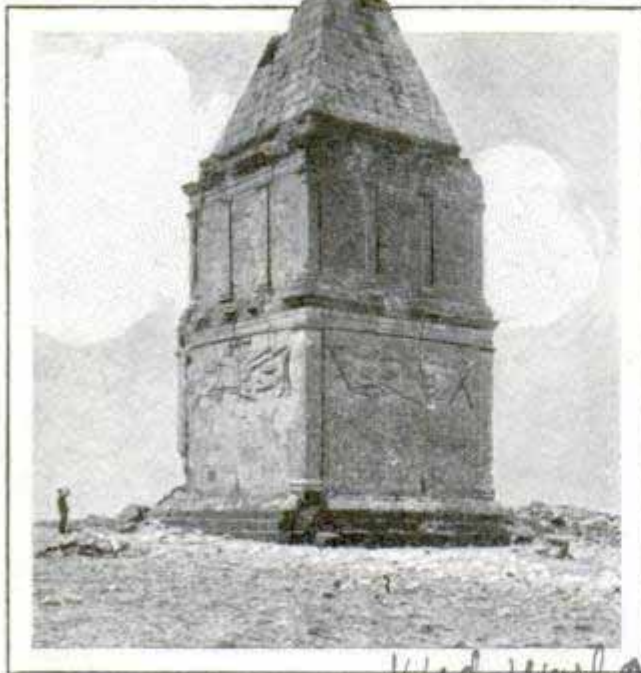

Memorial of Some Long-Forgotten Event, This Sixty-Foot Monument Stands in the Holy Land

FORGOTTEN STORY OF ANCIENTS TOLD BY MONUMENT

Built to commemorate a forgotten event, an ancient monument stands near the ruined city of Baalbeck, Syria. It is sixty feet high and on its sides are sculptured hunting scenes and hunting regalia, but of its origin, age or its builders, nothing is known.

MOISTENER SEALS ENVELOPES AND CLOSES FLAPS

Sealing envelopes in the busy office is accomplished quickly with an automatic moistener which not only moistens the flap but closes it securely so that a slight pressure on a pile of finished letters is all that is required, thus keeping the envelopes clean as well as eliminating sealing by mouth. The sealer consists of a

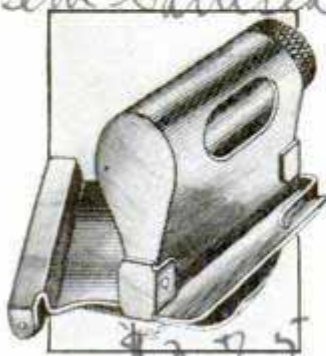

metal container in which a supply of water is kept, the moistener responding to a pressure of the thumb when more water is wanted on the felt pad used for sealing. The moistener is mounted above a frame shaped like a lip through which the flap passes to be sealed.

SUBMARINE BLOWN TO SURFACE WITH CREW IN TESTS

3246

America's largest undersea fighting craft, "V-4," was rescued from the deep by being blown to the surface with her crew of eighty-seven officers and men in tests off San Diego, Calif., hailed by naval authorities as marking another step to make these craft safer. Fresh air was supplied to the submarine's compartments, the old air was exhausted, and finally the sub and its crew were brought to the surface by compressed air lines from the rescue vessel which blew the ballast tanks of the boat eighty-six feet beneath the surface. Thirty-nine minutes after the submarine settled to the bottom a diver from the rescue boat was on its deck and had connected an air hose to its salvage valves. Fresh air was sent into one compartment and then another, and finally the air was pumped from one compartment into another and completely through the vessel. Air pressure then was applied to the main ballast tank, and twenty-three minutes later there was a rush of foam and the submerged boat was afloat without any action on the part of its crew.

WAR ON DREADED FRUIT FLY WAGED IN FLORIDA

3243

Described as the "gaudiest lady and the most damaging pest of Bugville," the Mediterranean fruit fly is being attacked in Florida by an army of 5,000 scientists and

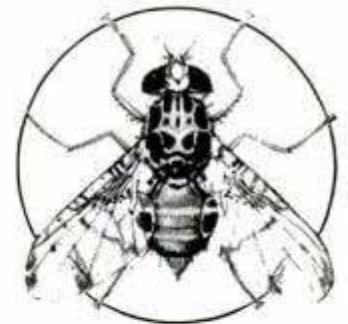

workers equipped with chemicals, sprayers and other impediments of war. The dreaded fly succeeded in almost ruining the citrus crop before the counteroffensive was started, state and nation having placed a fund of more than \$5,000,000 at the disposal of the attacking army. It is the female that does the damage, laying eggs in seventy-two kinds of fruit, including the orange, lemon, grapefruit, pear, plum and apple. Strict quarantine was one of the measures taken, with the state militia seeing that it was maintained.

International

seem Envelope Sealer Co. Chicago
 612 N. Michigan Ave.

Wed World

OLD WARSHIP IS TURNED INTO FLOATING CLUB



The U. S. Monitor, Which Guarded New York Harbor during the World War, Has Been Transformed into a Floating Country Club and Serves as a Summer Resort for Long Island Society

Transformed into a floating country club, the former U. S. monitor, which guarded New York harbor from submarines during the World War, is now utilized as a summer resort for the social elite of Long Island.

value, could be destroyed after being filmed. The photographic system would first be used for books seldom called for and a special film-reading room would be established for the celluloid library. A small projection machine beneath each table would throw the pages on individual screens so students would be able to read while seated comfortably in armchairs, the book film operating like a movie film.

PLAN FILMS OF LIBRARY BOOKS TO CONSERVE SPACE 3/10

Confronted with the prospect of "drowning in books," librarians of the Berlin state library have advanced a plan for photographing the books and storing the celluloid film to save space. Books photographed page by page on a celluloid film, it was found, could be stored in less than one-fortieth of the space needed for the printed volumes. Old and precious examples of the bookmakers' art, when photographed, would need no longer be exposed to the wear and tear of usage, and new books, having no particular intrinsic

FRAME FOR TRACING STENCILS MAKES DUPLICATING EASY 3/95

Tracing drawings, art work and maps on stencils is simplified with a tracing frame, adjustable in six positions, in which the stencil is locked by two clamps. It may be used for any type of rotary duplicating machine, the equipment including a glass with a ground surface to insure sharper lines, a transparent celluloid tracing sheet and celluloid triangle for ruling.

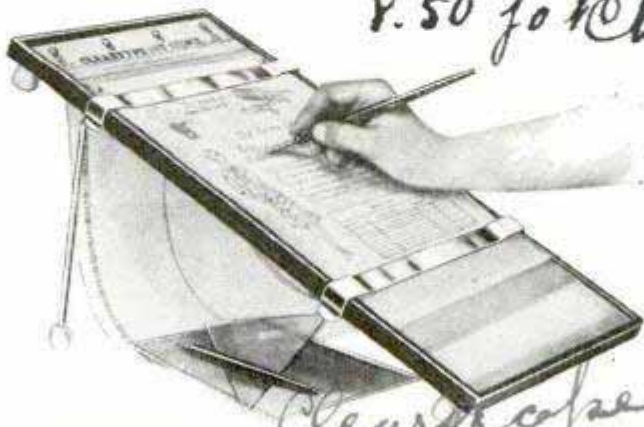

Tracing Drawings and Art Work on Wax Stencils Is Made Easy with This Tracing Frame

ny James 9/23/29

*clear case
Hoyer Duplicator Co.
801 W. Jackson*

Byrd Chicago

Hoyer Duplicator Co. 901 W. Jackson

3034

4480-49th, San Diego, Calif

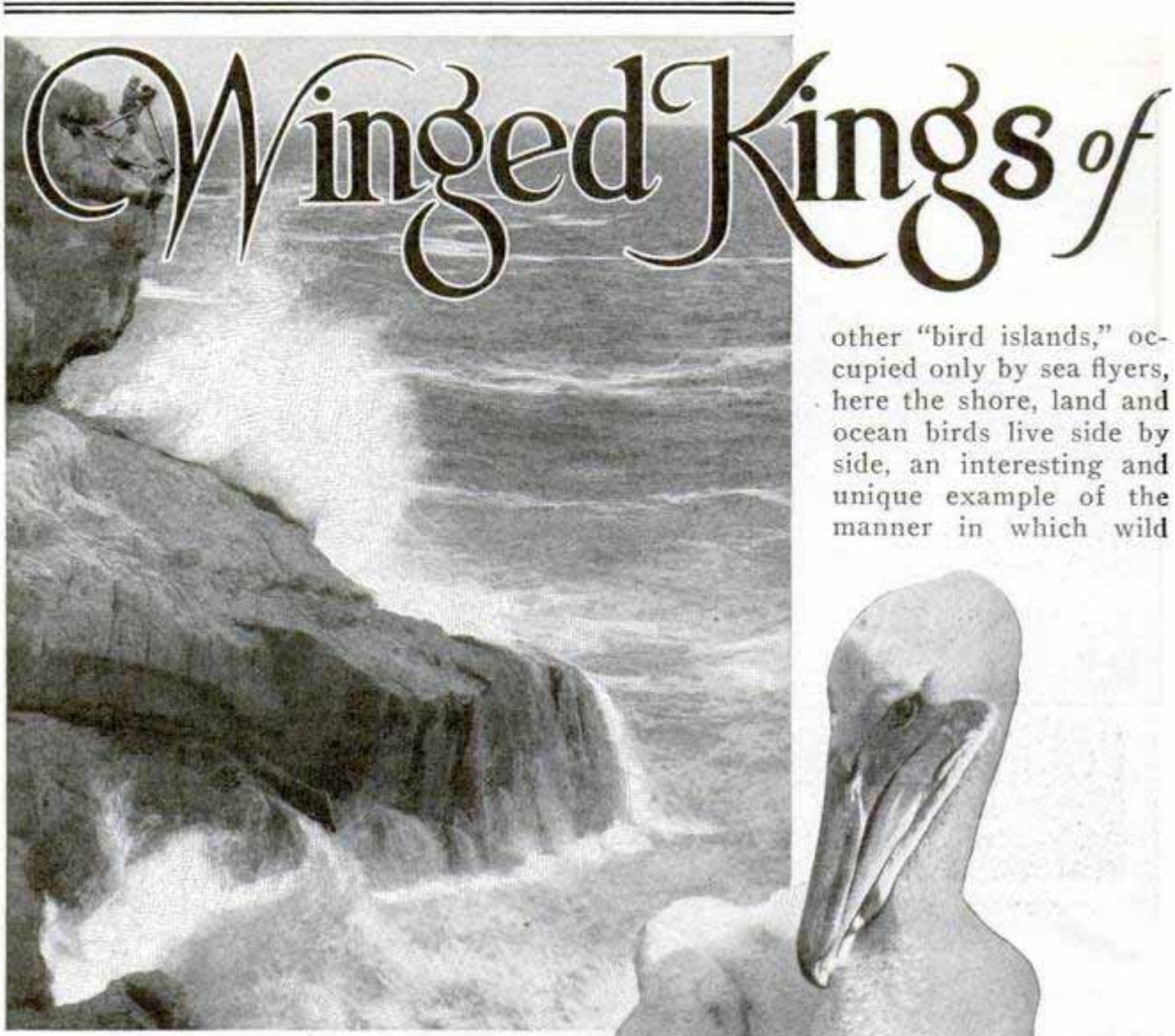

other "bird islands," occupied only by sea flyers, here the shore, land and ocean birds live side by side, an interesting and unique example of the manner in which wild

Young California Brown Pelican, and a Rugged Bit of the Coast along the Bird Retreat

By H. H. DUNN, *3728 1/2 Park Blvd San Diego Calif*

Photography by Lee Passmore and the Author *Calif*

RULED by several pairs of bald eagles, whose ministers of war are ospreys, five small islets, ten miles off the western coast of Mexico and twice as far south of San Diego, form the most complete bird empire in the world. Into this harshly dominated kingdom, mammals, even man, have not entered, with the exception of one small variety of field mouse, and several herds of sea lions.

Protected by the government of Mexico, and watched over by that of the United States because of their inviting possibilities as centers of smuggling operations, these five Coronado islands are so surrounded by red tape that few, save scientific expeditions, ever visit them. Unlike

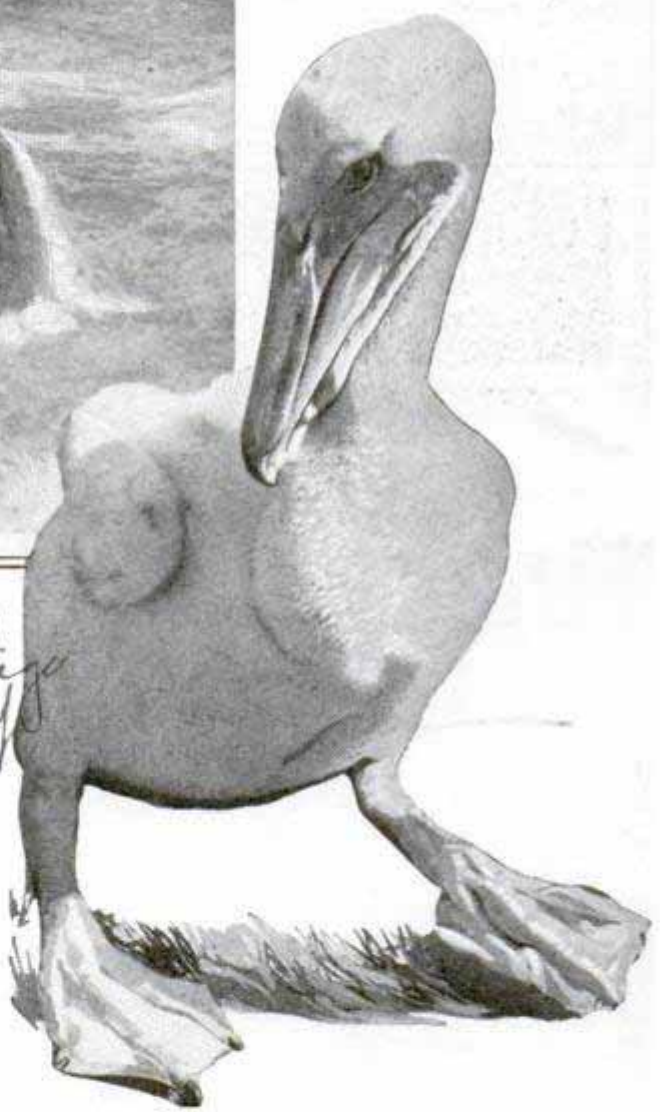

life rules itself when completely free from man's influence.

Rising straight from the sea, composed of granite—the "backbone of the Earth"—covered with a scant layer of soil, in which grows low brush, the Coronados offer few landing places, there being only

a Bird Empire

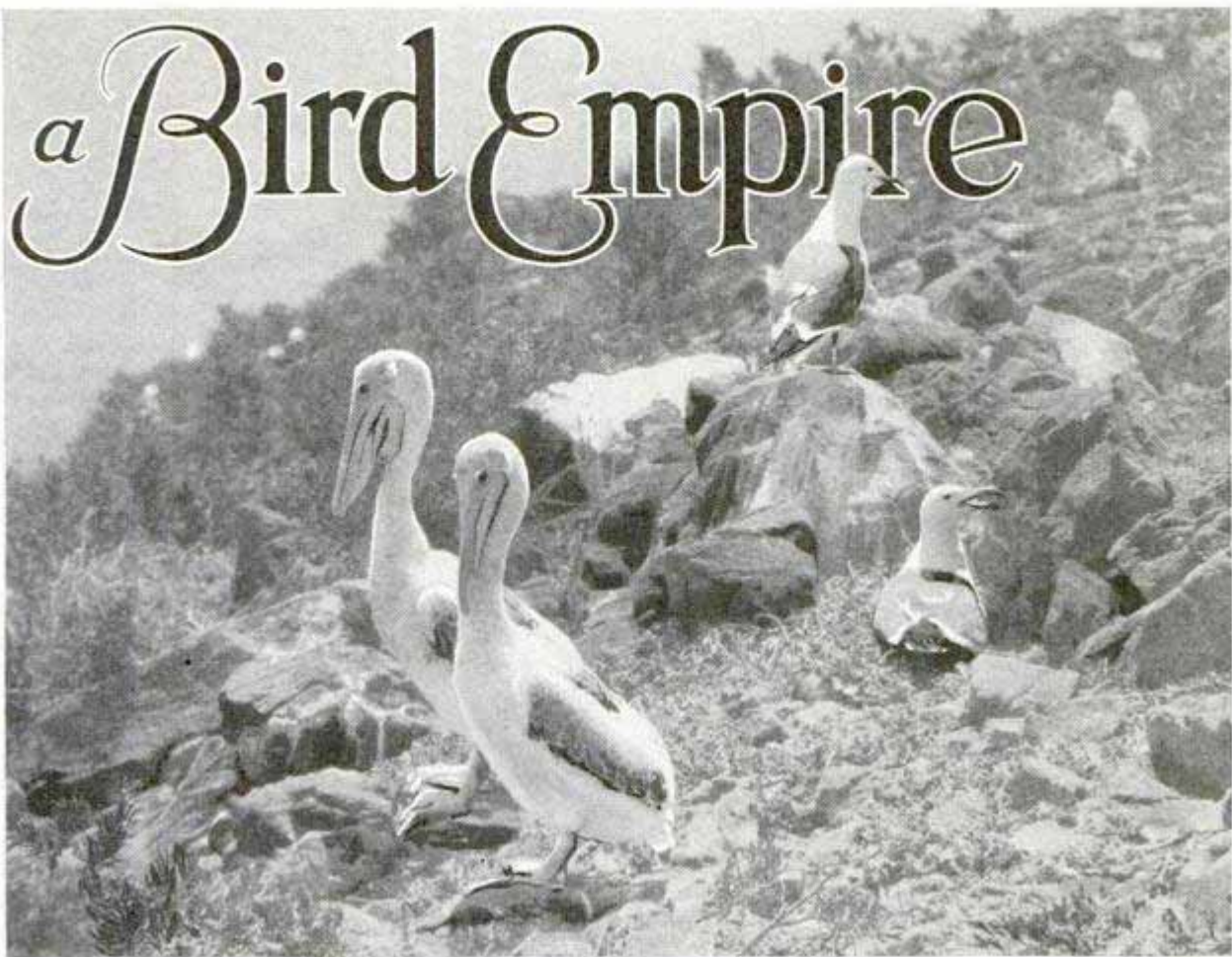

Pelicans and Gulls, the Nesting One "Talking" to the Photographer; Pelicans Attain Nearly Full Size Before They Discard the Down of Babyhood or Are Able to Fly

one on North Island, the largest of the group, and one on South Island, next in size. At the former, an expedition from the San Diego Museum of Natural History landed recently. A few of the results, some of them the first photographs of their kind ever made, are shown herewith.

An estimate, made by trained observers, places the winged residents of the Coronados at 100,000. One of the mysteries of the islands is the presence of several flocks of California valley quail. If they arrived there in recent years, they must have flown at least ten miles from the mainland; if they were there when the islands were separated from the continent, as the floor of the sea sank, they are indeed old-timers, for this parting occurred, according to the geologists, not less than 10,000 years ago.

On this same island, too, are the smallest birds in the world—humming-birds. They are not so mysterious, for they fly annually hundreds of miles in

their migrations, but the quail are not migrants.

This avian empire is divided into distinct states, territories, zones, or whatever one wishes to call them, each inhabited by one variety of bird—with the exception of the gulls, which, preying on all their neighbors, nest where they please, rob whom they please, and generally lead the lives of winged "racketeers." First and closest to the shore come the Brandt cormorants, flyers, underwater swimmers, divers and the best fishers of all birds.

In years past, these cormorants nested by thousands on the flat shelves of the Coronados; today there are only a few hundred, due to the depredations of the great black-and-white western gulls. Here, at the very boundary of the Bird Empire, we began to see the workings of its government. As we stood photographing and counting the cormorant nests, one of the birds appeared, loaded with a fish, driving at top speed from the sea toward her home. Before she reached the land,

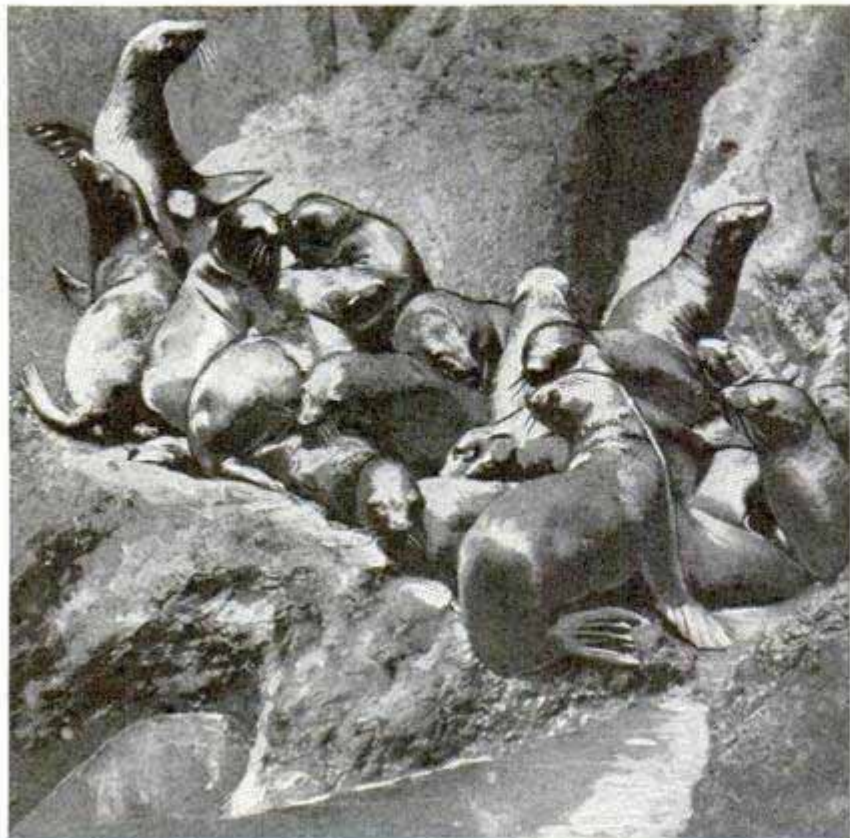

Playful Sea-Lion Pups Parked in a Stone-Walled Refuge of the Bird Empire While Their Mothers Go Fishing

a gull fell upon her, and as the cormorant released the fish, the gull dropped to the water, seized the booty and rose in the air. There was a scream from above, and an osprey, watching from the cliff four hundred feet higher, struck at the gull. In and out and round about they went, cutting circles, loops and spirals in the air until the gull, turned from her own nesting place, put out to sea.

The osprey followed, flying beneath the gull and driving her ever upward, until at last the first robber dropped the fish, while the pursuer, folding his wings, fell faster than the falling mackerel, took it in midair, and rose on a long slant toward the cliff. But he was not to enjoy his loot. From far aloft there came, in total silence, but with the speed of a ten-inch shell, the body of a bald eagle, folded compactly into a living spearhead, with a snow-white point. Passing within what seemed to be inches of the osprey, the eagle found wing, turned upward, and struck at the fish in the hawk's beak.

The osprey dived, swerved, lifted, at a speed which would have taken the swiftest duck, but the eagle was always with

him, always screaming, always striking, until he also dropped the thrice-looted dinner. Then the eagle, again folded into the spearhead, fell, seized the fish before it struck the water, and zoomed in a thousand-foot rising slant, to scream in triumph as he sloped down again to his mate and nestlings on the lofty ledge. So life goes in the Bird Empire: rob or be robbed; kill or be killed; survive by wit or wings, or both, or perish as unfit.

Rather sharply cone-shaped, the eggs of the gulls offer an interesting phase of nature's protection for bird life. Being of this contour, if one or all start rolling, they wing in circles, on the smaller end as a center,

coming back to their original position. Thus, on bare ledges, or in scanty nests, or when disturbed by the sudden rising of the parent bird, the eggs do not roll away. More than this, their tendency being to roll together, they remain in the center of the warm area of the mother's body, thus aiding incubation.

Sea-lion puppies, one-third grown, snapped at us when we undertook to play with them, some fifteen being parked in a small stone gully, while the mothers went fishing out at sea. A huge brown pelican waddled along beside us, as if familiar with man. Suddenly there was a whimpering in the air, and from the earth-covered slopes above, little murrelets and Cassin auklets by thousands began to pour from their burrows for their flights. Night had come to the Empire of the Birds.

Popular Mechanics Magazine does not publish the name of the maker or seller of any device described in its pages, but this information is kept on file and will be furnished free upon application to our Bureau of Information.

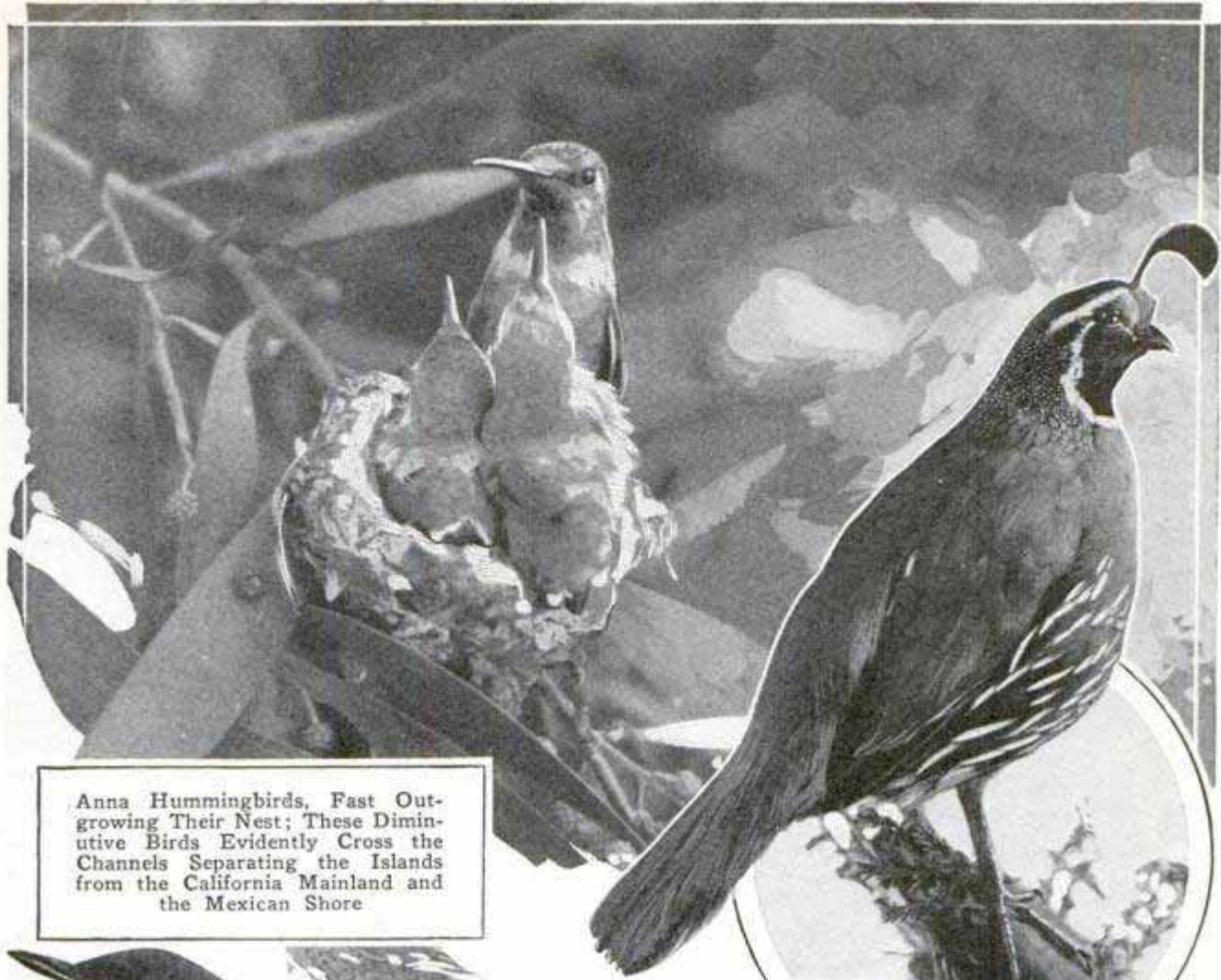

Anna Hummingbirds, Fast Outgrowing Their Nest; These Diminutive Birds Evidently Cross the Channels Separating the Islands from the California Mainland and the Mexican Shore



California Valley Quail Play Tamey around the Photographer on South Coronado Island; Here Is One of the Cocks of the Flock Which Does Not Migrate, Although the Minimum Flight from the Mainland Would Be About Ten Miles; Below, at Left, a Murrelet, Pulled from Its Nest in a Hole in the Rocks



Four Hours of Patient Stalking, Most of the Time Prone on the Ground, Were Required to Obtain This Photograph of the Western Gull with Her Nest and Eggs

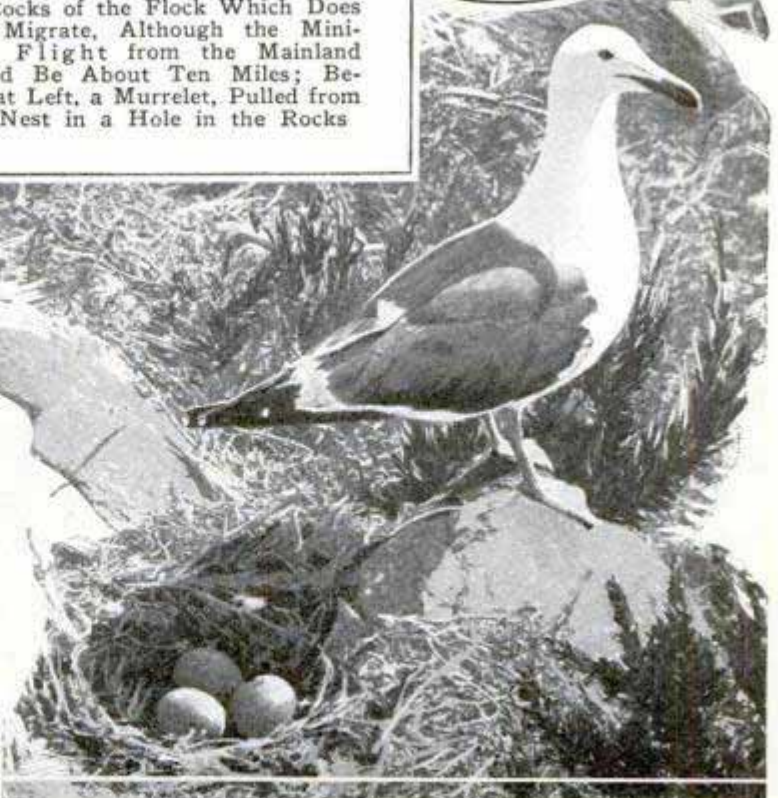

ALL-METAL AMPHIBIAN TO CRUISE LONG DISTANCES

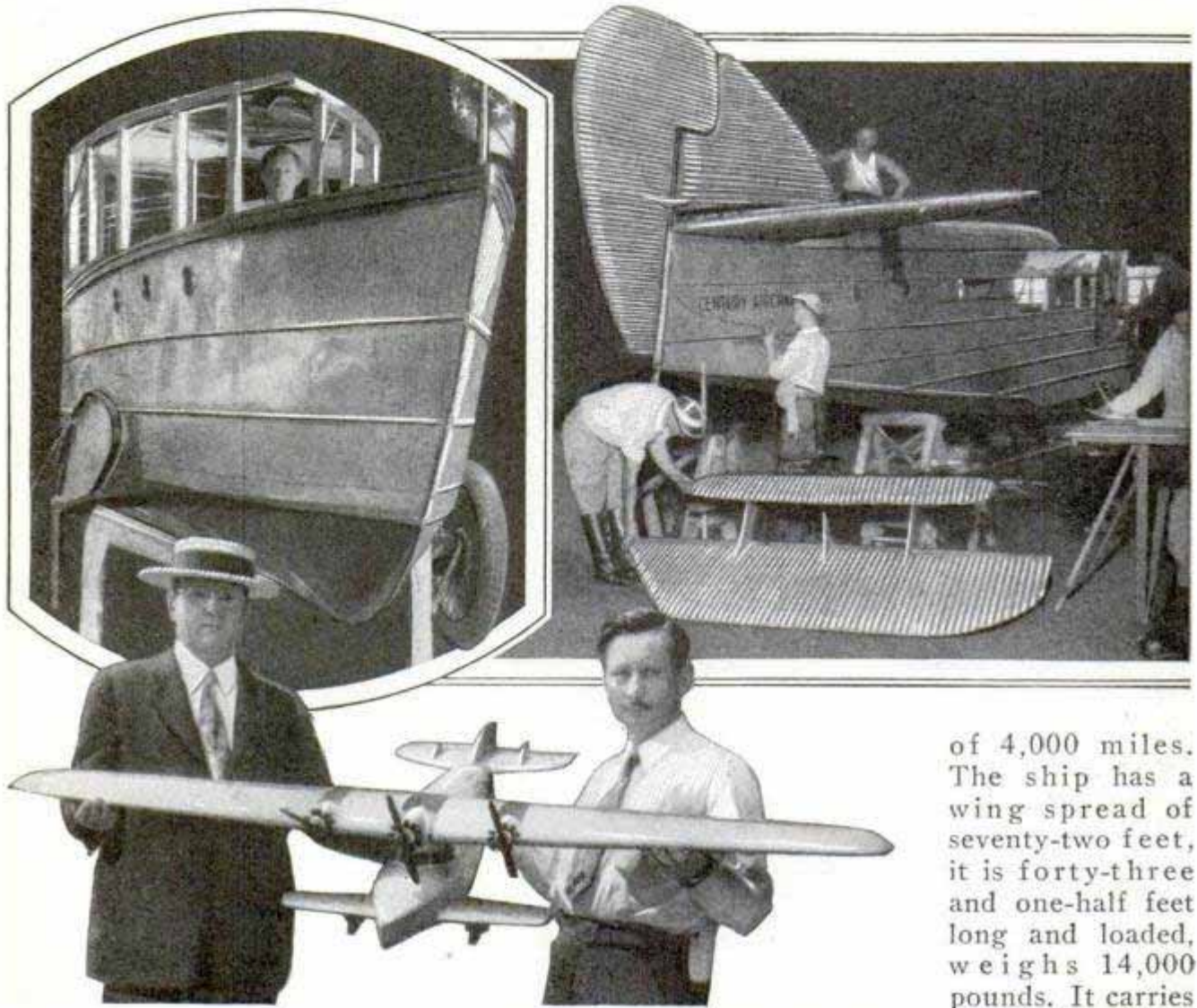

Views of the Amphibian under Construction and, Below, Erwin Greer, at Left, and J. H. Wendt, Designer of the Craft, Holding a Small Model

Flights over the oceans will be most successful with amphibian planes, in the opinion of many aeronautical engineers, and to further demonstrate the efficiency of these craft, a novel amphibian has been built in the shops of Greer college at Chicago. Outstanding features are its all-metal construction, the elimination of pontoons and the use of two smaller auxiliary motors besides the three 300-horsepower engines in the main power plant. These smaller motors, according to J. H. Wendt, the designer of the ship, will be employed to keep the craft flying once it has attained speed and altitude, so that all the big engines will not have to be run continuously. By this arrangement, a saving in fuel will be effected, giving the amphibian an estimated cruising range

of 4,000 miles. The ship has a wing spread of seventy-two feet, it is forty-three and one-half feet long and loaded, weighs 14,000 pounds. It carries twelve passengers and two pilots and is equipped with cabin conveniences of the most luxurious air liners, including radio-receiving and transmitting apparatus.

CITY NOISES TIRE STRANGERS

Visitors in a large city burn up body energy one-fifth more rapidly than average residents because of the effects of city noises upon the nervous system, according to experiments conducted by a neurologist in New York. The city dweller, he found, became immune somewhat to city noises through adaptation, but the stranger responds to the unusual clamor with a reaction which increases or decreases the respiration rate, tends to create abnormal muscle tension and sometimes causes heart changes.

Cont. C. W. Senger, Union League Club, San Francisco, Cal.

PHONE WIRE ON GROUND HELPS GUARD FORESTS

A forest-fire patrol observation post in the far west is connected with the outside world by a single iron wire lying on the rock and snow of the mountain. Members of the hiking parties that often climb this mountain, observing this wire, are usually unable to understand how a single-wire grounded circuit can operate under such circumstances. The explanation is that very low-resistance iron wire is used and that snow and rock have little conductive ability, hence do not ground the wire. As it is not possible to secure good ground on the top of the mountain, a wire leads from the observation cabin to Crater Rock, 800 feet below, where excellent contact is made in the place where the steam issues from the ground.

3097

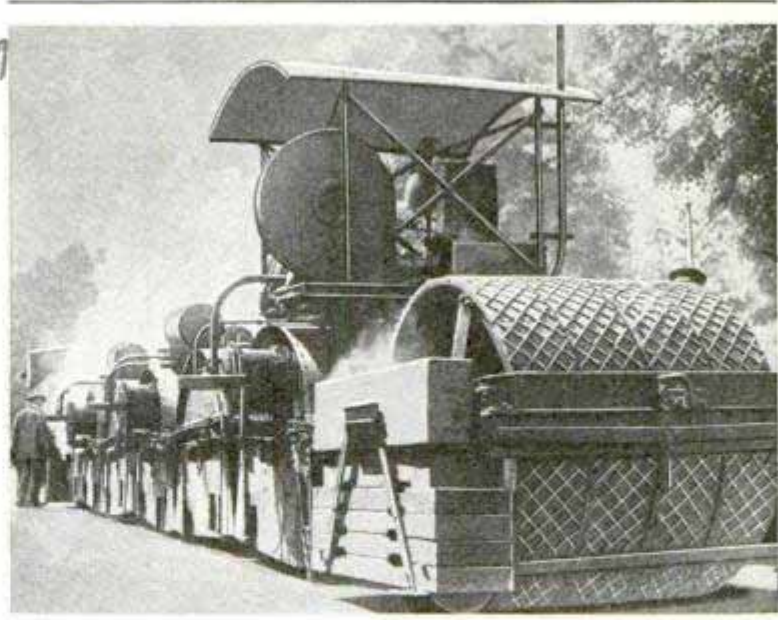

This Machine, Resembling a Steam Roller, Marks Crisscross Designs in Asphalt to Keep Vehicles from Skidding

PREVENT SKIDDING IN STREET BY DESIGNS IN PAVEMENT

Streets in Berlin, Germany are being made skid-proof by a huge machine which stamps into the asphalt pavement a deep crisscross design, the lines of which prevent slipping. The engraving is somewhat similar to the designs on the treads of some automobile tires which are intended for the same purpose. The machine that does the stamping resembles a gigantic steam roller.

Reuser, Bohmenschonhause in near Berlin

VANISHING TOP CHANGES TRUCK FROM CLOSED TO OPEN VAN

Converting a closed truck into an open van is made possible by a disappearing top and collapsible sides, all of which are shoved away out of sight. The roof over the driver's cab is divided into two parts, and it is between these that the truck top disappears. The upper part of the casing over the cab is hinged and may be lifted up. The rubber van top slides on metal crosspieces which are bent around metal rods along the top of each side of the van. Over the topping and crossbars are metal plates, to force the top to fold as it slides back and to prevent the fastenings from working loose. The top also may be entirely removed. The sides are formed of hardwood panels and slide in grooves in the standards to open or close any section. The panels are held in place by setscrews and rubber plates, making each panel section adjustable.

3179

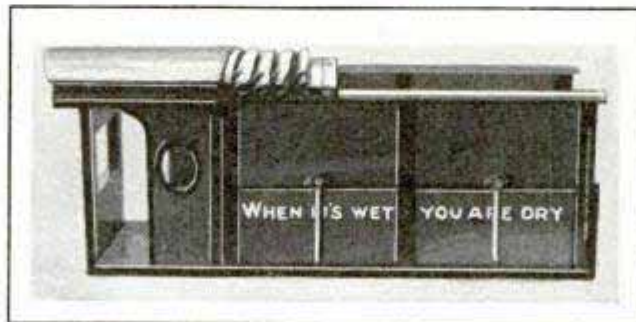

Vanishing Truck Top Which Slides into Roof of Cab to Convert It into an Open Van

QUAIL CHECK POTATO BEETLE

Reluctant small boys who spend many back-aching hours over beetle-infested rows of potatoes soon may relinquish this unpleasant task to the quail or bobwhite. Experiments have shown this attractive game bird has a decided taste for the potato beetles, and if given a chance, will clean them out completely. Where bob-

whites are protected by a closed season and increase greatly in numbers, potato beetles have been found to diminish to such a degree that it is no longer necessary to spray vines with poison.

3102 Prof. G. S. Moseley, Normal College, Ohio State, studying forest, Ohio

Chas. Arthur, Esq. Schlicher, 1418 Turner St.

San Diego, Calif

3181



Contrasting in Appearance with the Ordinary Plane is This 'Ship' with a Flanged Cylinder for a Propeller

PROPELLER LIKE HUGE BARREL TESTED FOR AIRPLANE

Resembling a huge barrel with the ends knocked out, a cylindrical propeller has been tested for an airplane whose construction is in odd contrast to the ordinary plane. Projections inside and outside the cylinder give it the appearance of a turbine flange, and when the cylinder is whirling the flanges operate in a manner similar to a screw propeller. While differing radically from usual methods of construction, the craft underwent successful ground tests recently.

*Tested by Byrd, Admiral
at Loch Long, Scotland*

ESCAPE FROM SUBMARINE AIDED BY BREATHING APPARATUS

Successful tests of a breathing apparatus enabling trapped submarine crews to escape from deep water have been made by the British admiralty. Sunk to a depth of 126 feet, those making the tests reached the surface safely in a minute and a quarter. The apparatus, weighing less than five pounds, is attached to the chest and has a flexible breathing tube through which exhaled air is regenerated by absorption of carbon dioxide and res-

3095

toration of oxygen. At the same time tests were made of a diving apparatus which is said to permit divers to descend 300 feet. The previous record was 204 feet. This appliance reduces to one-third the time of decompression and freedom from the effects of nitrogen. As soon as the diver is ready to come up to the point where decompression must begin, a cylinder with an attendant inside is lowered and this man helps the diver into the cylinder for the decompression period. Its advantage is that it does away with much armor.

LAWN MOWER RUN BY CURRENT FROM LIGHT SOCKET

3123

Lawn mowing is made easier and quicker with an electric mower that is designed like the small hand machine, except that it has a motor that is attached. The mower cuts around shrubbery and hedges better than the hand mower because the blades revolve whether the wheels turn or not. It is light in weight and equipped with rubber tires to avoid noise.



A Hand Lawn Mower with Electric Motor Eliminates Some of the Work of Cutting the Grass

*Siehe Isornan Co. Ltd.
187, Westminster Bridge*

*Whalley Machine
Co. Jeffersonville*

Colombene, 23 Dean Road, Bessley
Walthamstow, London, Eng.



COMBINATION of television with "noctovision"—seeing things at night by invisible light—is to be used by the British government to guard England against aerial attack. Searchlights which cast no visible rays will sweep the skies above the Channel coast at night in wartime, pick up invading aircraft with their unseen light beams, and furnish the illumination to transmit the picture of the invader to the anti-aircraft batteries on the ground, to the airdromes of defending pursuit squadrons, and to the war office in London.

Two devices invented by John L. Baird, the English television expert, are to be combined. Secret tests have already been made before Lord Allenby, the conqueror of the Turks in Palestine; Lord Arnold, Admiral Sir Mark Kerr, Sir Thomas Inskip, Sir Herbert Samuel and others, representing the army, navy and air force. Experiments in long-distance transmission of night scenes are about to be inaugurated between London and New York.

The Baird noctovisor utilizes the invisible infra-red rays—the band of vibra-

tions below the visible red of the spectrum, rays of a wavelength so long the eye cannot see them. They have sixteen times the fog-penetrating power of visible light, which makes them particularly useful in a climate such as England has.

In operation, the searchlight, fitted with carbons which produce large quantities of red light and little of the shorter wavelengths, is covered with a black screen, usually Corning glass, which prevents the escape of any of the visible light. As it sweeps the sky, nothing can be seen, and from above it cannot be detected, save for a tingling sensation in the eyes, if one looks directly into the beam. The sensation is somewhat like the feel of looking into an intense light, though the eye sees nothing.

A photo-electric cell on the ground, however, picks up the image of the plane overhead as easily as though it was bathed in visible light. From that stage on, ordinary television processes complete the transmission of the picture.

The Baird apparatus is still in the experimental stage, but the army, navy and

x 2.2 Level St. London, W. 1. Eng. 633

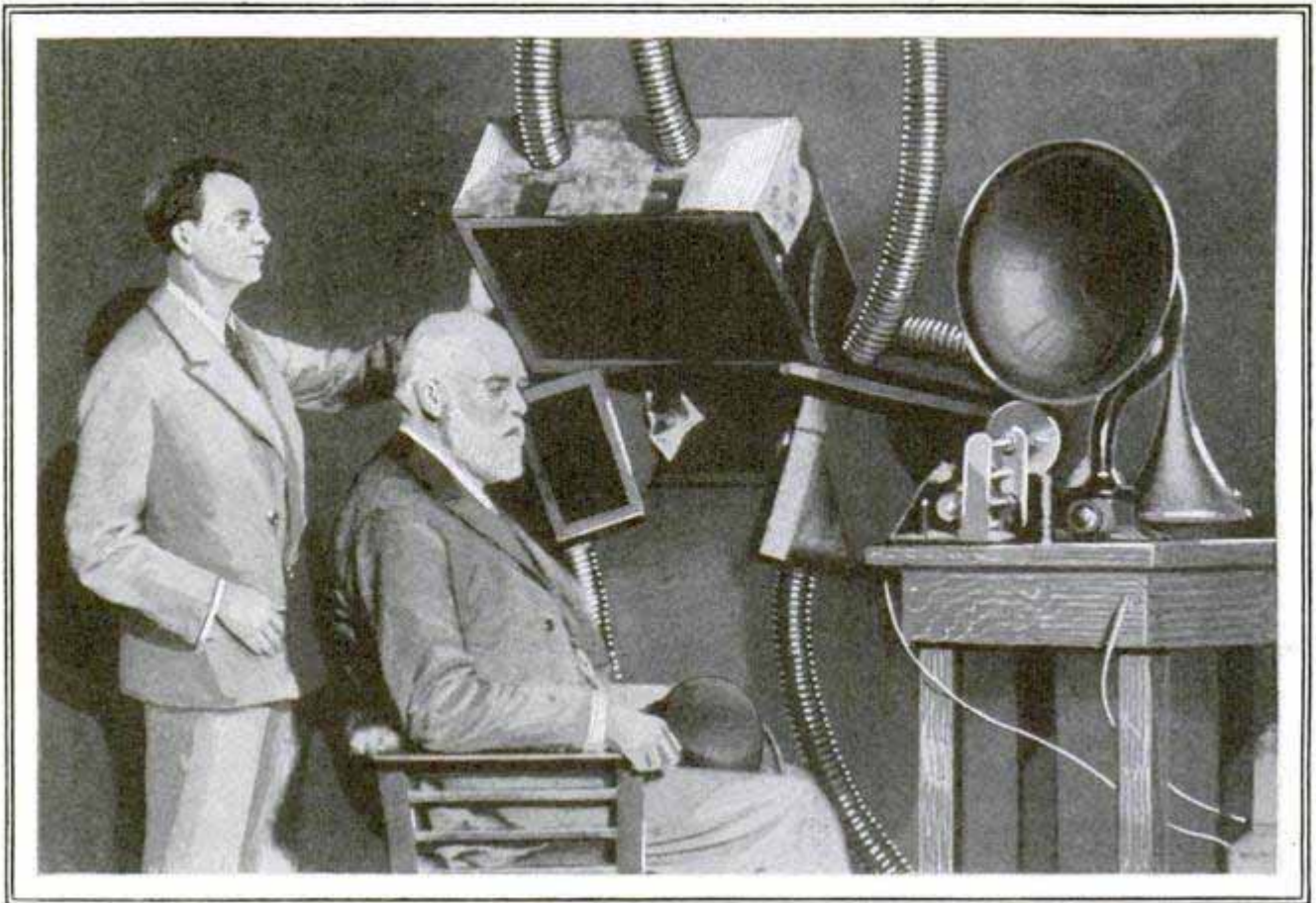

Sir Oliver Lodge and J. L. Baird Examining Experimental Apparatus by Which Images of Aircraft or Other Objects Are Transmitted on Beams of Invisible Light at Night and Seen on Small Screen

air-force officials who viewed the tests were all enthusiastic about its possibilities in the defense of London from enemy air raids. The air-raid problem has been given intensive consideration since maneuvers last autumn showed that squadrons of planes could penetrate all existing aerial defenses and reach the heart of the metropolitan district with ease.

Navy officers were particularly interested in the possibility of applying the noctovisor to warships. They pointed out that in a battle between two fleets, fought at night, the one equipped with invisible light as eyes would have all the advantage. The ability of the infra-red rays to penetrate fog and smoke screens also would be of great importance.

The use of invisible light rays at sea is not a new thing, for it was first developed during the war by the American navy as a means of keeping convoy ships in line without showing navigation lights. Instead of infra-red, ultraviolet lights were used. On the stern of each ship in line, an arc lamp producing high ultraviolet values was placed, covered with a Corning glass screen, a sheet of black glass which

no visible light can penetrate. The watch officers on the bridge of the next ship were equipped with a fluoroscope, such as is used in X-ray work, and with this they could see the signal light plainly, while it remained invisible to the enemy.

Neither noctovision nor television can see farther than the human eye, but the ability of the former to penetrate atmospheric conditions which balk the eye, gives it its value. In experiments in California, photographs have been taken, through fog and clouds, of sequoia forests more than 200 miles away, and infra-red pictures of Pasadena, taken through the fog from the observatory on a near-by mountain top, are regularly used to check similar infra-red pictures taken of Mars.

OLD THEATERS TRANSFORMED 3094 INTO SWIMMING POOLS

Old theaters, usually difficult to dispose of, are being remodeled into swimming pools in New York. The sloping floors make conversion into pools easy, and the balconies provide space for spectators. Four vacant theaters will be so used.

Ny Service
6/20/29

HAY DRIER REMOVES MOISTURE IN FORTY SECONDS

Acting somewhat on the principle of a corn popper, a giant hay drier shreds and removes the moisture from hay in forty seconds, during which the grass travels through 1,500 feet of pipe and is delivered in bags ready to be hauled to storage. Green hay is fed into the machine, cut into inch lengths and then blown through a series of insulated pipes where it is subjected to a temperature of 700 degrees. The exhaust from two gasoline engines used as power first strikes the hay as it passes through the pipes, after which the curing is completed by steam and various gases of combustion. The hay does not burn or bake because it passes through rapidly, and at the time the highest temperature is reached, there is no oxygen in the chamber to support combustion. In the early stages, the principle of the corn popper is used, for, as the heat increases, a small volume of steam is created in each tiny stem, causing a mild explosion which blows the piece open. Hay comes from the drier somewhat shredded and pulverized, but retains a green color and typical odor. An automatic stoker assures a fairly smokeless exhaust, keeping the hay from becoming sooty.

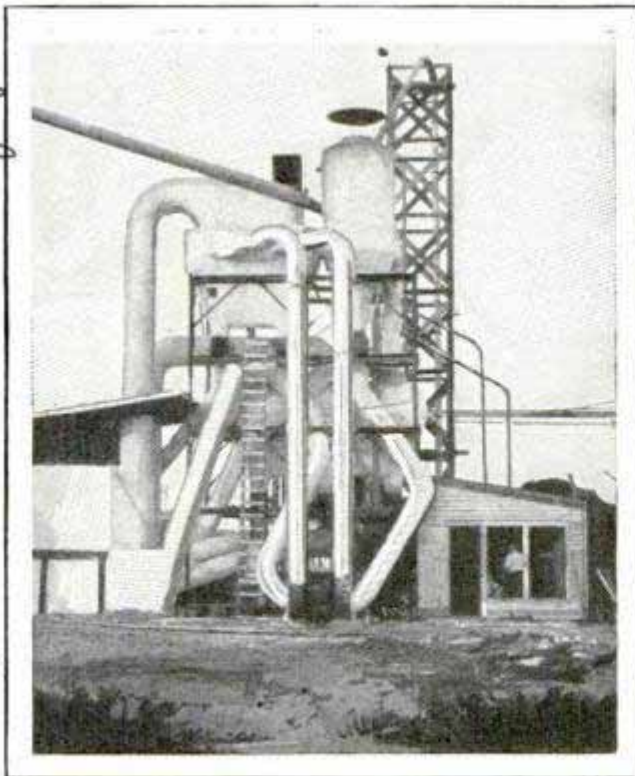

Hay Drier Works Like a Corn Popper to Remove Moisture from Grass in Forty Seconds

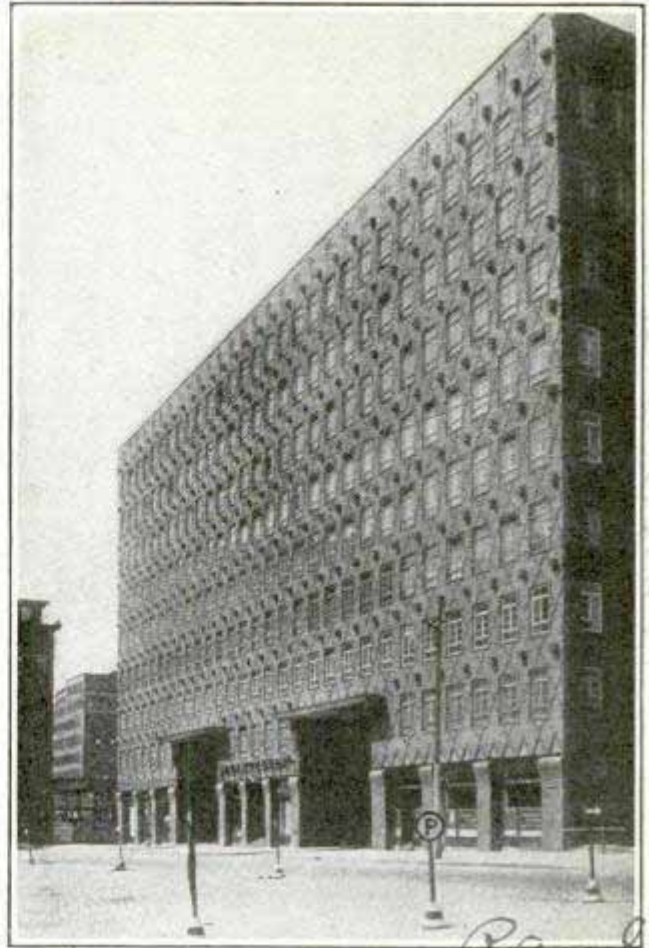

Diagonal Lines and Headlike Designs Give a Facade Effect to This German Business Block

CROSSLINES ON BUILDING GIVE UNIQUE EFFECT

Diagonal lines which form a crisscross design have been used to produce a remarkable appearance by the architects of a mercantile building in Hamburg, Germany. Combined with these lines are projecting headlike designs which give a facade effect rarely carried out in a tall business block.

\$ 1.00 for 12.

INDELIBLE COLORED PENCILS LIKE WATER COLORS

Colored indelible pencils now are being produced with a thin lead that will take a sharp point like an ordinary pencil for fine work. The leads, in twelve colors, are stronger and more durable than those in the ordinary colored pencil, and the makers say they will last about three times as long. By going over the fine markings with a moistened brush, wash effects are obtained, the shades blending like water colors. The pencils are used for sketching diagrams, maps and charts. They may also be used to supplement colored inks.

Eberhard Faber Pencil Co. 37 Greenpoint Ave

Made by National Blowpipe & Mfg Co., 724 Magazine St. New Orleans

3169

Chicago. 209 8th Ave

Director, Bureau of Engraving and Printing

WIND DIRECTION IS INDICATED BY LANDING FIELD LIGHTS

308

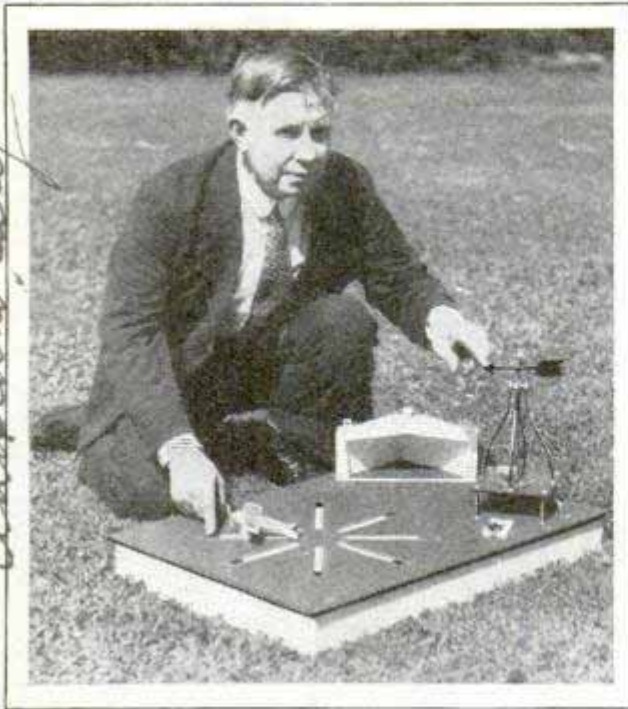

Model of a System of Sunken Ground Lights for Airports Which Also Shows Wind Direction

Ground lights on airplane-landing fields may serve the double purpose of indicating the exact center of the field and showing the prevailing wind direction. The arrangement includes a series of eight glass-covered trenches shaped like the spokes of a wheel in the center of the field, which light automatically to show wind direction. They are faced with heavy plate glass capable of sustaining the weight of a plane and are wired separately to a rotary switch driven by a wind vane, the vane switching light to the trench which lies toward the wind. A white and red glass combination on the trench makes it easily seen from the air.

REDUCED SIZE OF BANK NOTES CUTS PRINTING BILL

316

Uncle Sam expects to save about \$1,600,000 a year by using the smaller-size currency which was placed in circulation recently. The new bills will result in a saving of 550 tons of paper, worth \$500,000, and 500 tons of ink, valued at \$100,000, while reduced labor will save \$1,000,000. Plates used for long-run engraving now are made by the electrolytic process, which multiplies the number of plates that can be made from the original

engraving, thus lengthening the life of an original plate. The change in size of the money meant only slight changes in the mechanical equipment of the bureau of engraving and printing. Machines for trimming sheets to size were rebuilt, and those used for the final operation of numbering, sealing and separating were replaced with typographic presses which take sheets of twelve subjects each, print two serial numbers and a seal on each note, cut the sheet in half, separate each half into six notes, collate the notes in numerical sequence, and deliver them in units of 150 each. Twelve notes now are cut from one sheet of paper where only eight were obtained before. A new-type press produces 336,000 notes a day.

SELF-LOADING TRUCK HANDLES TEN TONS OF STEEL

3129

Ten tons of sheet steel are handled at a time by a self-loading truck with tilting platform on which the bundle of sheets is pulled by a looped cable attached to a motor-driven drum at the front of the truck which is operated by storage batteries. At the lower end, the platform tapers down to the thickness of steel plate, this end resting on the floor when the platform is tilted down for loading. When the bundle is in position, it rests on the center of gravity so the platform can be tilted up by hand, being held in position by a locking mechanism. Rollers on the upper part of the platform facilitate unloading. The truck has ten wheels and is driven by two large wheels through spur gears. It has a short turning radius to permit operation into and out of box cars.

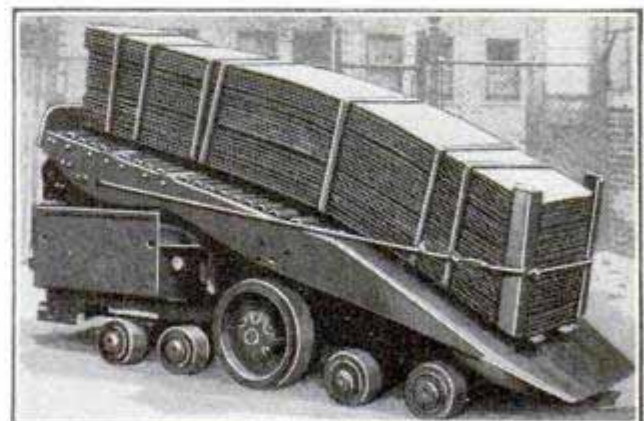

Self-Loading Truck with Tilting Platform Which Handles Ten Tons of Steel at a Time

*Atlas Car Mfg Co
1100 Franklin Road*

*Mr R. Clay Jackson
Oakland Calif*

"WALL OF DEATH" LATEST MOTORCYCLE THRILLER

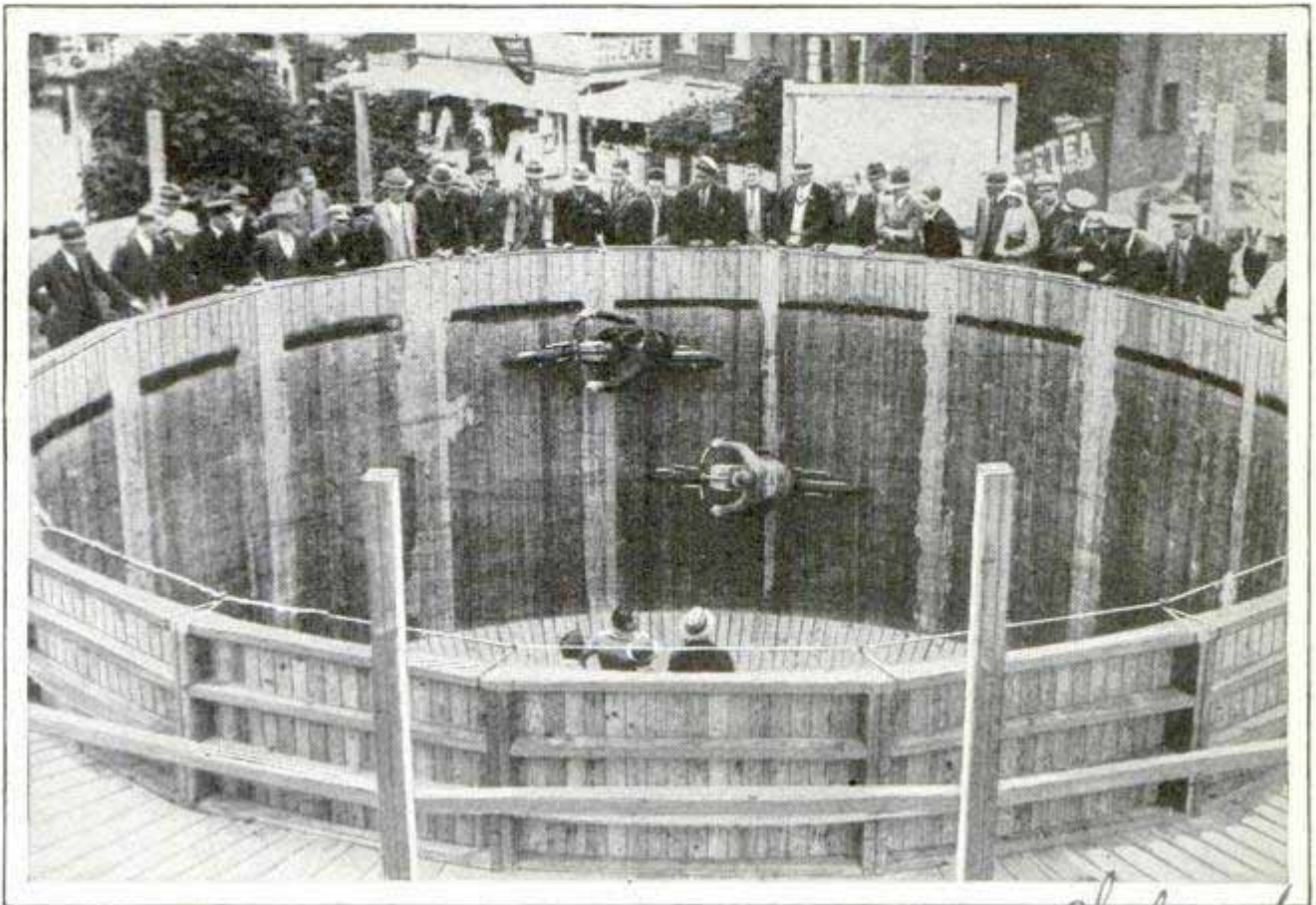

Motorcycle Riders Assume Almost Horizontal Positions as They Speed around the Vertical Sides of This London Bowl, Which Has Come to Be Known as the "Wall of Death"

Daring motorcycle riders who use the almost vertical sides of a large bowl as a racing track are affording thrills to London's seekers after diversion. The riders are in almost horizontal position as they speed around the perpendicular track, which has come to be known as the "wall of death," because of the danger involved.

birds sleep standing up on the ice-covered concrete. Native shrubs and greens surround the house and outside is a lake where the birds disport themselves.

CIGAR EXTINGUISHER COMBINED WITH ASH RECEIVER 3176

For the careful smoker, who avoids fire hazards, a combined cigar extinguisher and ash receiver is on the market. The extinguisher unit is operated by pressure of the finger which brings water into a recess at the top, the heat from cigar, cigaret or pipe drawing the water to the glowing ash. After extinguishing the fire, the water flows back into the container, which will not leak even if held upside down. The ash receiver is carried on a tray as a separate unit. The appliance is made for attachment to automobiles and can also be fastened to the clothing of hikers.



ZOO PENGUINS LIVE IN ICE BOX

When eight penguins, accustomed to the antarctic regions, arrived recently at the Philadelphia zoo, officials faced the problem of keeping them cool, because the expensive birds were unable to withstand the temperate climate. The zoological society met the issue by building an ice box for them. The floor of the shelter is a shallow concrete basin on which was erected a house made of heavy planks with a roof of heat-resisting tar paper. A door in the front and a window at the rear for the ice completed the abode. Each day 500 pounds of ice, cut in layers, is spread on the floor and the

3171
cost. under 50 dollars
 Carl Newton H. Hartman
 1049 Edgemore Road

3176
Ante person \$1.00
 De Luxe
 Windshield Co
 Franklin

2919

New Conveniences



With These Rubber Protectors, the Wearer Can Place Arms in Water Almost Up to Elbows without Wetting the Sleeves; They Are Decorated to Match Apron and Have Tight-Fitting Wristbands

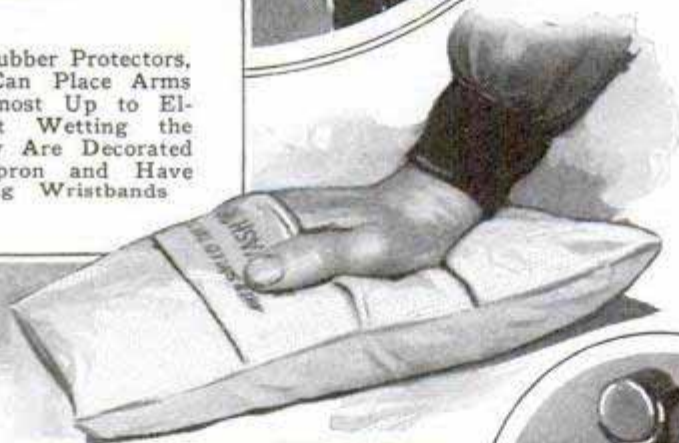

Polishing Pad, Used like a Mitten, Has a Washable Cover Easily Removed or Readjusted; Hand Is Afforded Strong Grip



Gripper Serves as Extra Fingers; It Does Scores of Tasks Such as Reaching inside Bottles, Taking Things from Fire and Dusting Difficult Places

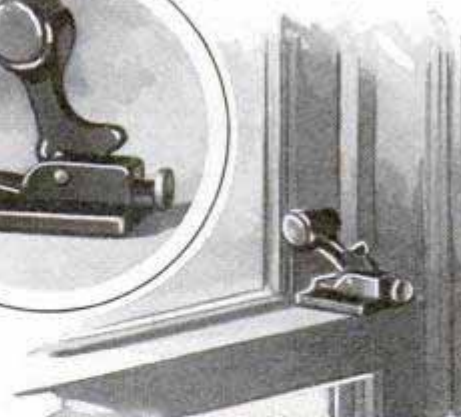

Above Is an Easily Attached Window Lock That Firmly Secures Both Sashes and May Be Employed to Hold Doors Open or to Lock Them; at Left, a Built-In Dust Bin That Takes the Sweepings for Later Removal or Deposits Them through a Chute into the Basement; It Is Furnished in Nickel or Colors to Match the Woodwork

for Your Home

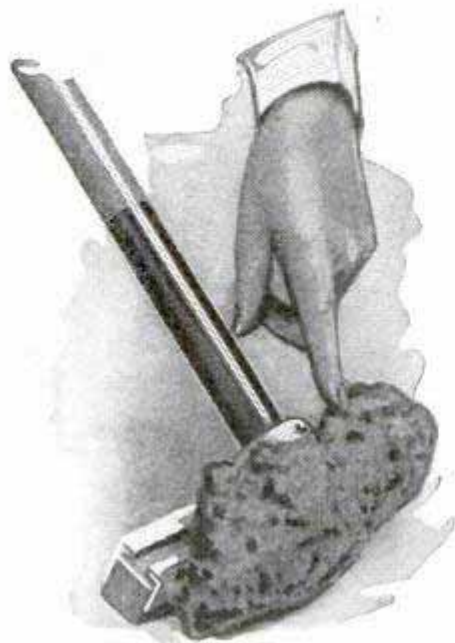

Double-Sponge Scrub Brush Saves Handling Dirty Water; the One on Base Does the Drying and the Bulky One Absorbs the Water; It Is Cleaned by Holding It under Faucet

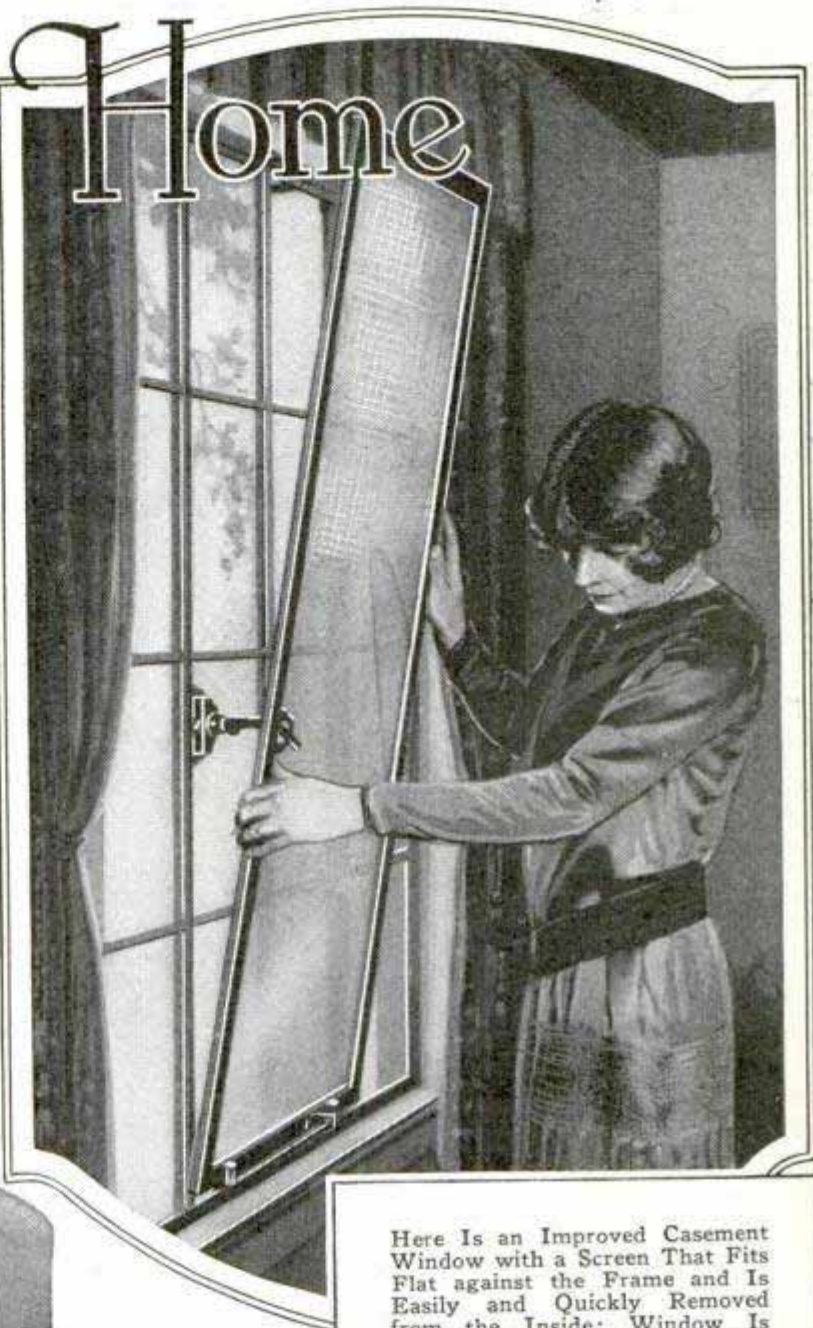

Here Is an Improved Casement Window with a Screen That Fits Flat against the Frame and Is Easily and Quickly Removed from the Inside; Window Is Readily Opened by Handle That Extends through the Screen

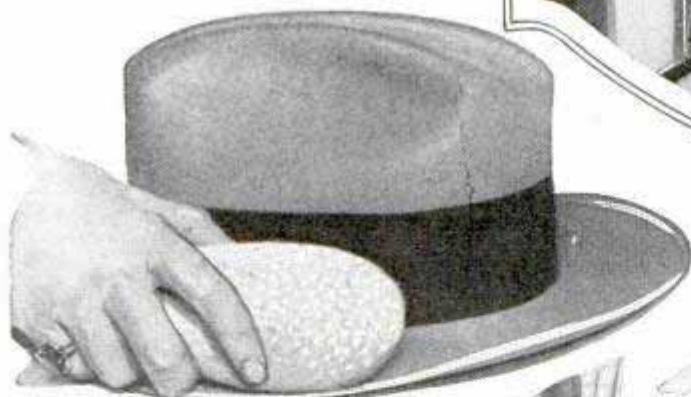

Chemically Treated Rubber Sponge Keeps the Hat Clean and Is Also Useful in Removing Spots from Lamp Shades and Fabrics; It Is Washed with Soap and Water

Sanitary and Well-Ventilated Cooling Cabinet for Food Fits on Window Ledge to Save Space; Shutter Vents Close When Door Is Opened, to Keep Cold Out of Room

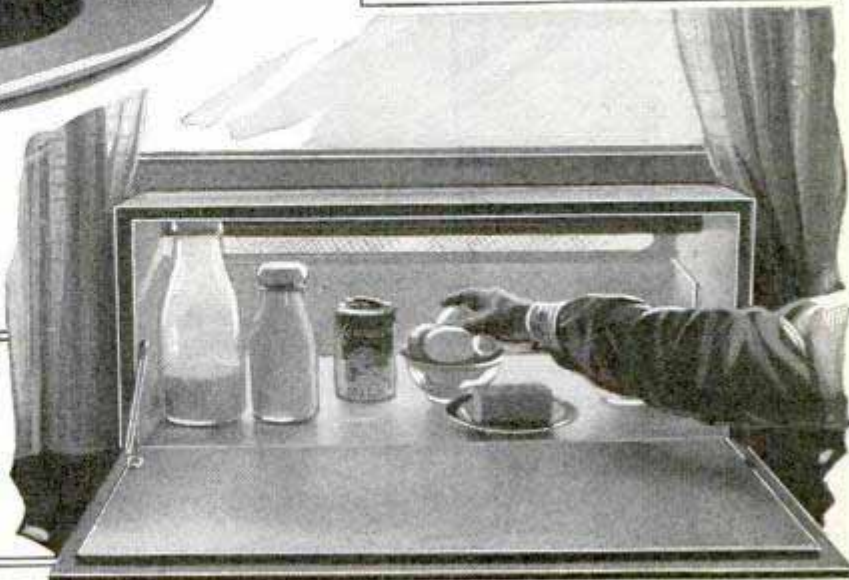

Jack Brown, Fox studio

Emb. Helen Burns 1905 h. Highland in Hollywood Calif.



Modeling Tiny Heads in Colored Clay to Demonstrate Character Make-Up in Movie Studios

MOVIE MAKE-UP IS TRIED OUT ON MODELED FACES

Tiny heads modeled in colored clay are used in the moving-picture studios to work out and demonstrate character make-up. Three or four-inch heads are made of Indian chiefs, prize fighters or Arabian sheiks and submitted to the director who suggests any changes desired, after which every detail of make-up is worked out on the models. The actor then is made up to resemble the clay image and a screen test is made. The method gives a view of the head from all angles, enabling visualization of the actor in make-up, thus saving time and money.

GAS IS STUBBORN PRISONER ABOARD AIRSHIPS

3140

Roast beef is a close relative of the largest airships in use today, the "Los Angeles," "Graf Zeppelin" and the new British air liners. Hydrogen or helium gas that provides lifting power for the air giants is contained, not in a single compartment within the rigid hull, but in a series of gas cells. These drum-shaped

containers have nothing to do but retain the precious lifting gas. The job of warding off rain, hail, sunlight and wind is left to the outer covering of aluminum-coated balloon cloth. Lives of airship builders have been made less tranquil by the fact that hydrogen and helium gases are more difficult to keep in captivity than the most ferocious circus animals. No matter what kind of material is used for the gas cells, there always is a constant oozing of the contents into the outer air. One of the most satisfactory materials for keeping the gas captive is goldbeater's skin. This extremely tough substance forms the outer covering of a portion of a steer's intestinal system. Hence the close relation of roast beef and airships. Goldbeater's skin, as the name implies, is used in beating gold—hammering it into sheets so thin that light will pass through. With its toughness is combined the ability to retain gas better than almost any other material. As it comes from the packing company, a barrel of salted skins contains 2,500 pieces. Gas cells are manufactured from the skins cemented to a cloth base. One method makes use of glue to hold the pieces in place. An improved system consists of laying the skins on rubberized balloon cloth coated with rubber cement, the pieces overlapping about one and a half inches. An idea of the number of steers represented in a dirigible is given by an order for the ill-fated "Sherandoah," totaling 1,500,000 skins.

HUB PLATES FOR AUTOMOBILE 3180 ADD TO ITS BEAUTY

Hub plates for Ford cars now are on the market as an accessory to add to the car's appearance. The plates are chromium-plated, fitting around the original hub cap which does not need to be removed to install them. Once in place, they do not jar loose or interfere with removal of the wheel.

Monogram



4-1-50 - \$3.00 - 4/50

Lead year Zeppelin Co Akron Ohio

Kingsley Miller Co 625 W. Jackson Blvd Chicago

MOVIE WIND MACHINE SNUFFS OUT OIL FIRES

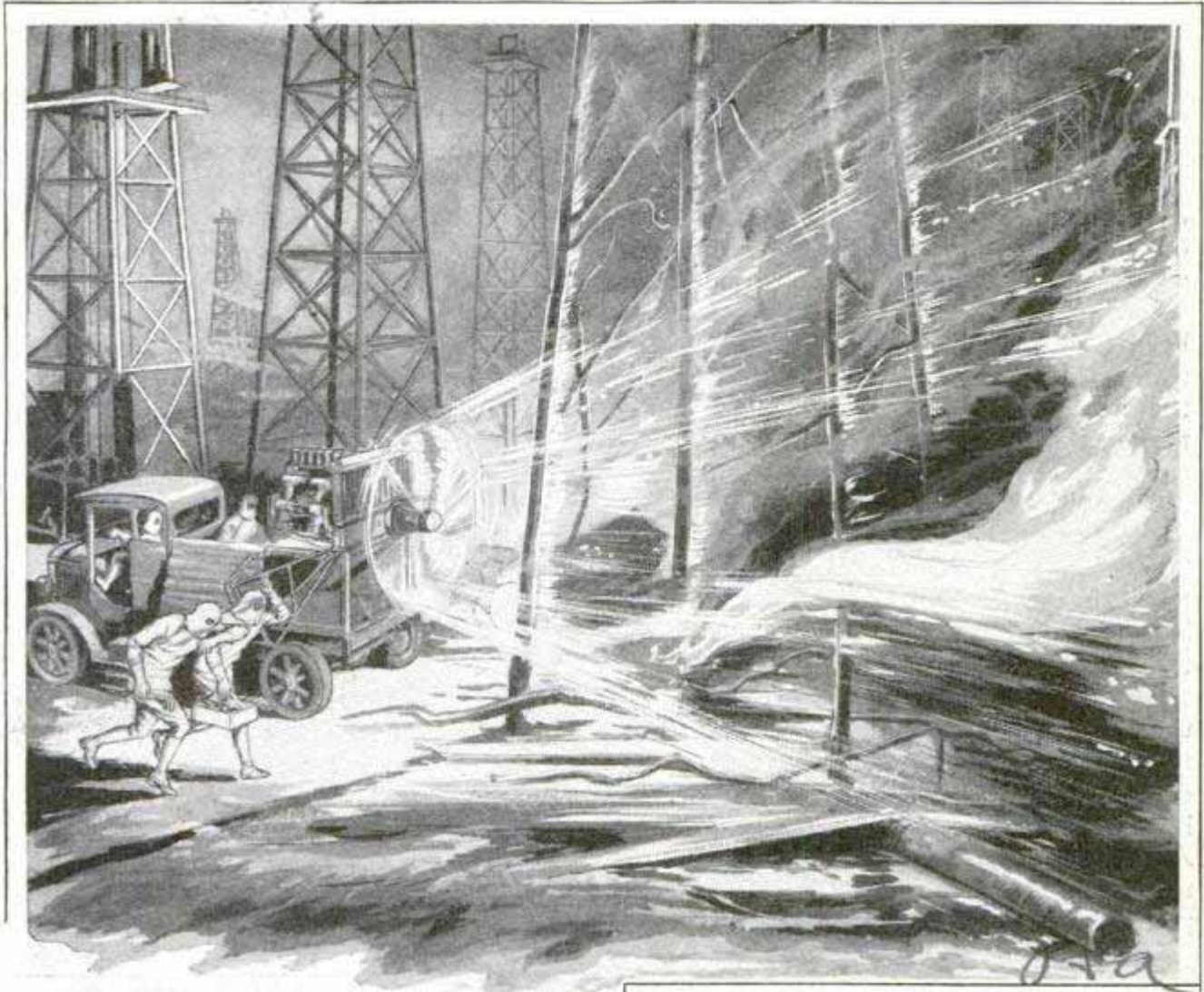

Above, Wind Machine Extinguishing Oil-Well Fire, and, at Right, Aerial View of the Blaze

Hollywood's movie industry contributed the latest development for the conquering of burning producing wells, when a wind machine, such as used in moving pictures to create windstorm effects, extinguished a burning gasser in the Santa Fe Springs field. Two wells broke out as uncontrollable producers and a day later developed into that terror of town-lot fields—burning gushers. With blazing oil spouting 200 feet into the air, neighboring wells, tanks, sump holes, warehouses and offices soon fell a prey to the flames, and before the spreading fire was even partly controlled, a damage of approximately \$4,000,000 had been caused. The original two wells burned as flaming torches for more than a week. The usual methods employed to "kill" the flames failed and, as a last desperate method, a committee of



operators decided to borrow a wind machine from one of the motion-picture companies, in an effort to enable their men to approach closer to the well to make necessary observations. When the machine arrived at the field, a test revealed its wind-producing strength to be so powerful that it was decided to attempt to blow out the well with it as a man blows out a candle with his breath. A crew of eighty workers was selected to make the experiment. They were garbed in asbestos coats and trousers, and carried shields before them as protection against the heat. Then the wind machine was turned on, full blast, toward the burning geyser. To the joy of the oil operators, the machine blew the column of fire to one side sufficiently to enable the crew to "hook" a flow line to one pipe of the well. With the flow of the well diminished by half, the machine was next directed at the twelve-inch casing from which the fire and oil roared forth. At the third attempt, when the machine was turned on full force, the blaze suddenly died out. The wind machine is a truck-like affair, carried on rubber-tired wheels. A housing contains a powerful electric motor which operates a series of four airplane propellers which produce the wind.

1122 d 7th
Louisville, Ky
**WASTE FROM AUTOS FILTERED
FOR OIL BURNER**

315-8 \$25.00
Oil burners have been designed to use waste oil from the drainage of cars. The equipment includes a filter to strain dirt and water from the waste, and the burners are used in both heating and cooking stoves. The heater is intended particularly for economical use in garages and workshops where such fuel is plentiful, but heavy oils, such as those remaining after the extraction of gasoline or kerosene, also may be used in homes. A settle filter is operated on the principle that the oil rises to the top while water and sediment sink, the oil being drawn off through gauze. A small air pump is used to clean the gauze at intervals.

**GLIDER FITTED WITH PONTOONS
TO LAND ON WATER**

3118
German gliders long have flown successfully over land, but have been at a disadvantage when air currents forced them over open water and then made a landing necessary. Now, one of the wind craft has been fitted with pontoons resembling those attached to amphibian planes, making a water landing easy.

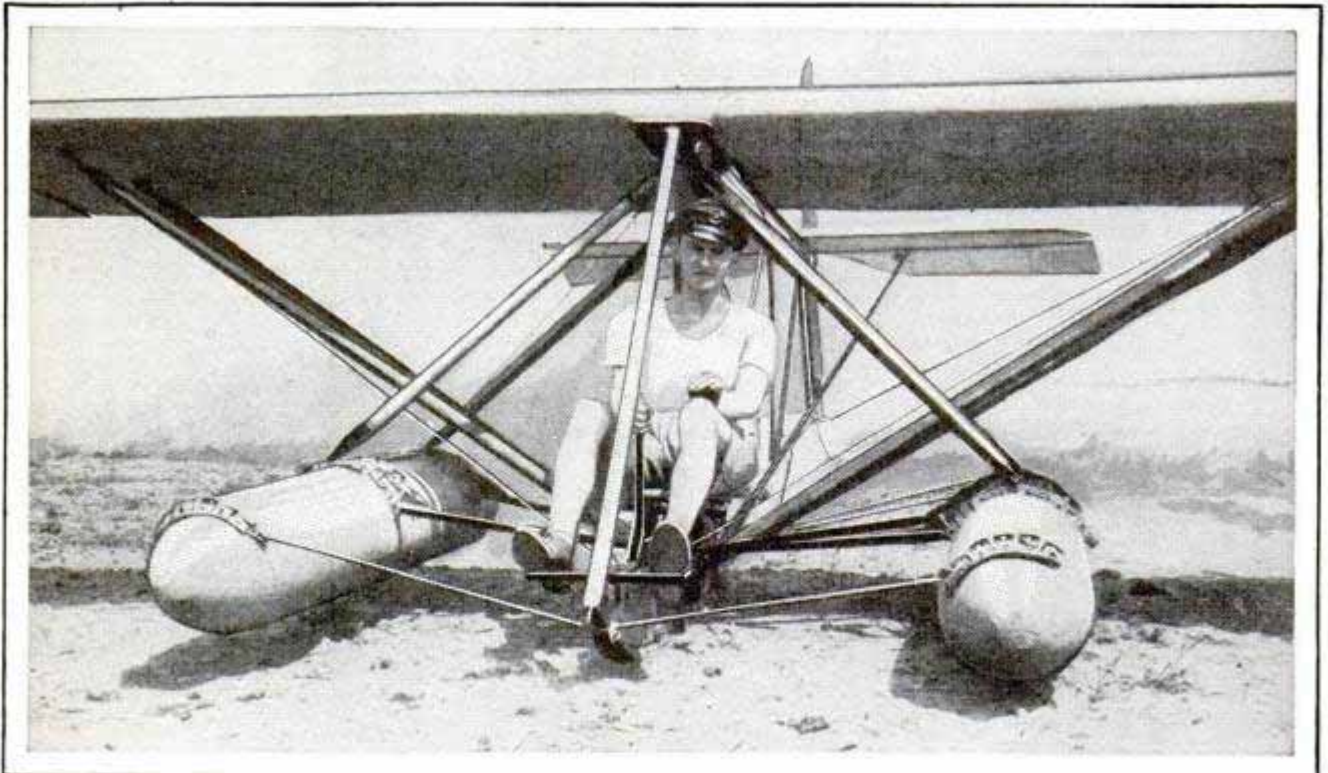

Here Is a German Glider Fitted with Pontoons, Like an Amphibian Plane, So It Can Make a Successful Water Landing When Air Currents Carry the Craft to Sea

Curt Barnemann
Glider meet at Isator

3020

Hollywood Calif.

Making Crown Jewels for the Movies

IN THE last five years the motion pictures have used more than half a billion dollars' worth of crown jewels, famous gem sets and historic ornaments worn by their stars, stolen by their crooks, and missed in their mystery plays. This year approximately \$200,000,000 worth will appear on the screen. That is to say, they would be worth that if they were real.

Yet they are such perfect imitations that, under the glowing lights of the studios, worn by a daughter of Pharaoh, a queen of Babylon, a Czarina, an empress of India, or a modern social leader, all show, in the film, exactly the design, size, color and appearance of the jewels of the women they represent at the period presented in the play.

Up to five years ago, the motion pictures used whatever jewelry the costumer could supply. Then the public and the critics arose, demanding accuracy in gems as well as in costumes and customs. They never hoped to see the Kohinoor, the Orloff diamonds, Persia's royal sapphires, Hyderabad's pigeon-blood rubies, Naishapur's emeralds, or the priceless pearls of the crown of Holland, but they did want to see them reproduced accurately whenever called for in the film scenes.

Simultaneously with this demand, there appeared in Hollywood a slender Dane, who had walked through all the capitals

Willy
Petersen-Fagerstam with Completed Replicas of Crown Jewels of the Russian Czars; He Is Holding the Czarina's Tiara, and, at the Extreme Right, Is a Bracelet of Sapphires from Persian Crown Jewels

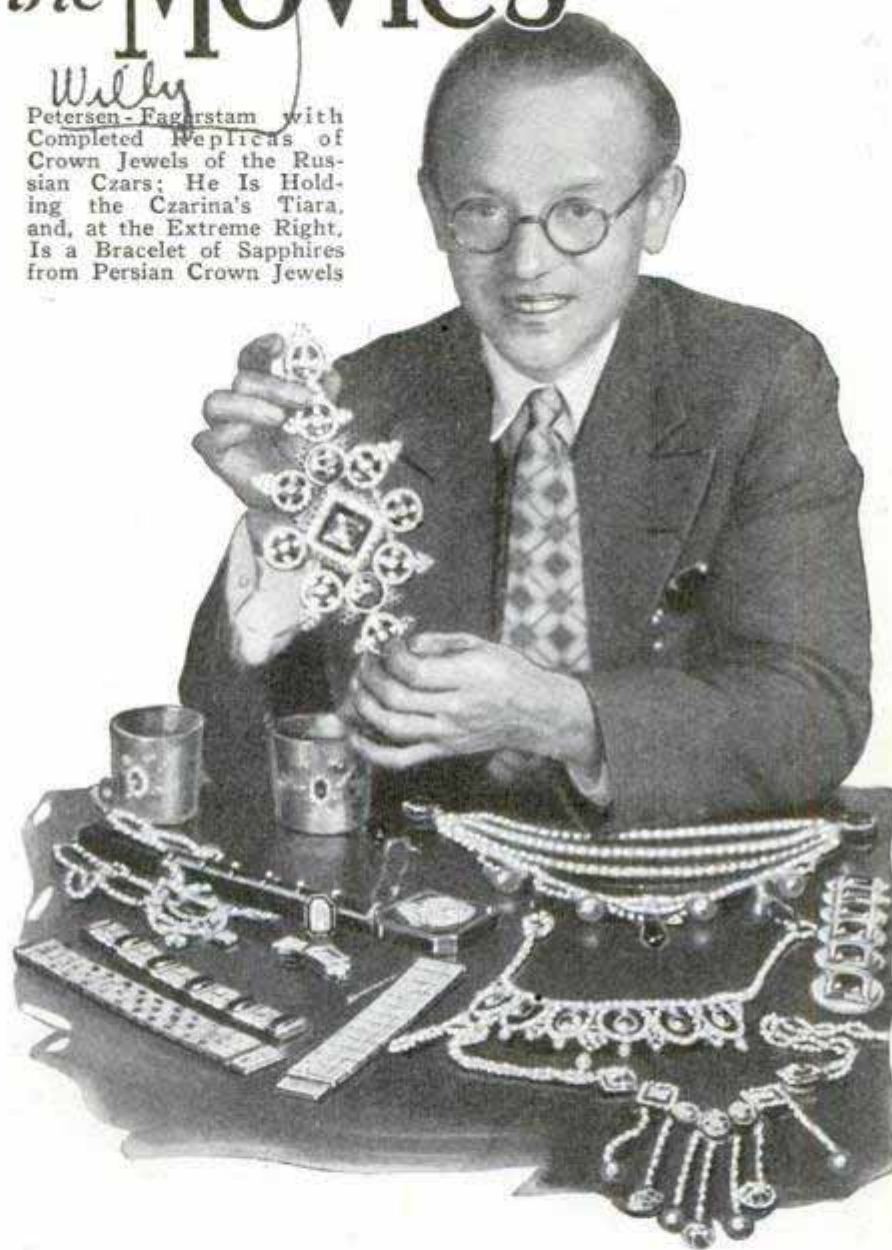

of Europe, studying the designing of jewelry, viewing the world's famous gems, and learning to make what we now know as "period jewelry." His name is Willy Petersen-Fagerstam, and he is descended from generations of jewelers in the Danish capital. From white and colored glass he fashions gems of all kinds; from copper, pewter, German silver and brass, he works the platinum, gold and silver mountings, and from glass, blown thin as a sheet of goldleaf, he forms pearls, covered with fishscale composition of all the shades of the sea treasures of Ceylon and

the South Seas. In the last year these replicas of famous stones and their settings cost the motion-picture companies more than \$20,000. This year, the total invested will be nearly twice as much. What time Petersen is not making gems and jewel settings, he is studying designs and imitations preserved in libraries and museums. In this work, he cannot originate; he must imitate. From the necklace of sabertooth-tiger teeth for the Stone-Age medicine man down to the Hope diamond or other famous stones and their settings of today, Petersen makes them all exact replicas of the individual productions of ancient and modern jewelers, and gold and silversmiths.

He uses glass, and glass only, to produce replicas of the famous, and common, jewels of the world. Virtually all of it, cast and ground with the proper "faceting," comes from Czechoslovakia, Prague being the largest source. These countries produce a cast glass, uniform in coloring, with a very high factor of reflection, such as can be had nowhere else in the world. This cast glass is used for diamonds, except when wanted in

composition stone is ever used. These "casts" are made in duplication of the originals, from exact measurements and color photographs. They mimic not only the size, shape and color of the famous gems of the world, but reproduce every flaw possessed by the originals—and no great gem exists without faults of some kind. Once cast, the imitation gems are ground by hand. There is no wholesale production of these stones. Almost as much attention is given to each as the cutters of Amsterdam give to the genuine stones.

Pearls for the motion pictures—from the great pear-shaped pink pendants in the crown jewels of Holland, England and some of the Indian states, to the smaller but more uniform treasures of modern necklaces—are blown in the thinnest of glass by the workers of central Europe. Every famous and valuable pearl in the world has been so imitated as to size, shape and color, in blown glass. When the "pearl" has cooled, it is covered with several coats of a varnish made from fishscales, and colored to the exact tint of the original. Laid side by side, except for weight, it would be extremely difficult



Replica of Pearl and Diamond Necklace of Italian Court Jewels

large quantities, as for the covering of slippers, sandals or gowns, when rhinestones are called in; for emeralds, rubies, sapphires, topazes, amethysts, lapis-lazuli, zircons, Alexandrites, indeed for every "solid" stone. No paste or other

Replica Tiara from Austrian Jewels Above and Pearl Necklace from Holland

Copy of Valuable Indian Necklace of Sapphires and Diamonds

to distinguish the original from the imitation.

At first Petersen attempted to use synthetic and culture pearls, but these did not photograph so well, cost more, and, once broken, could not be replaced immediately. Moreover,

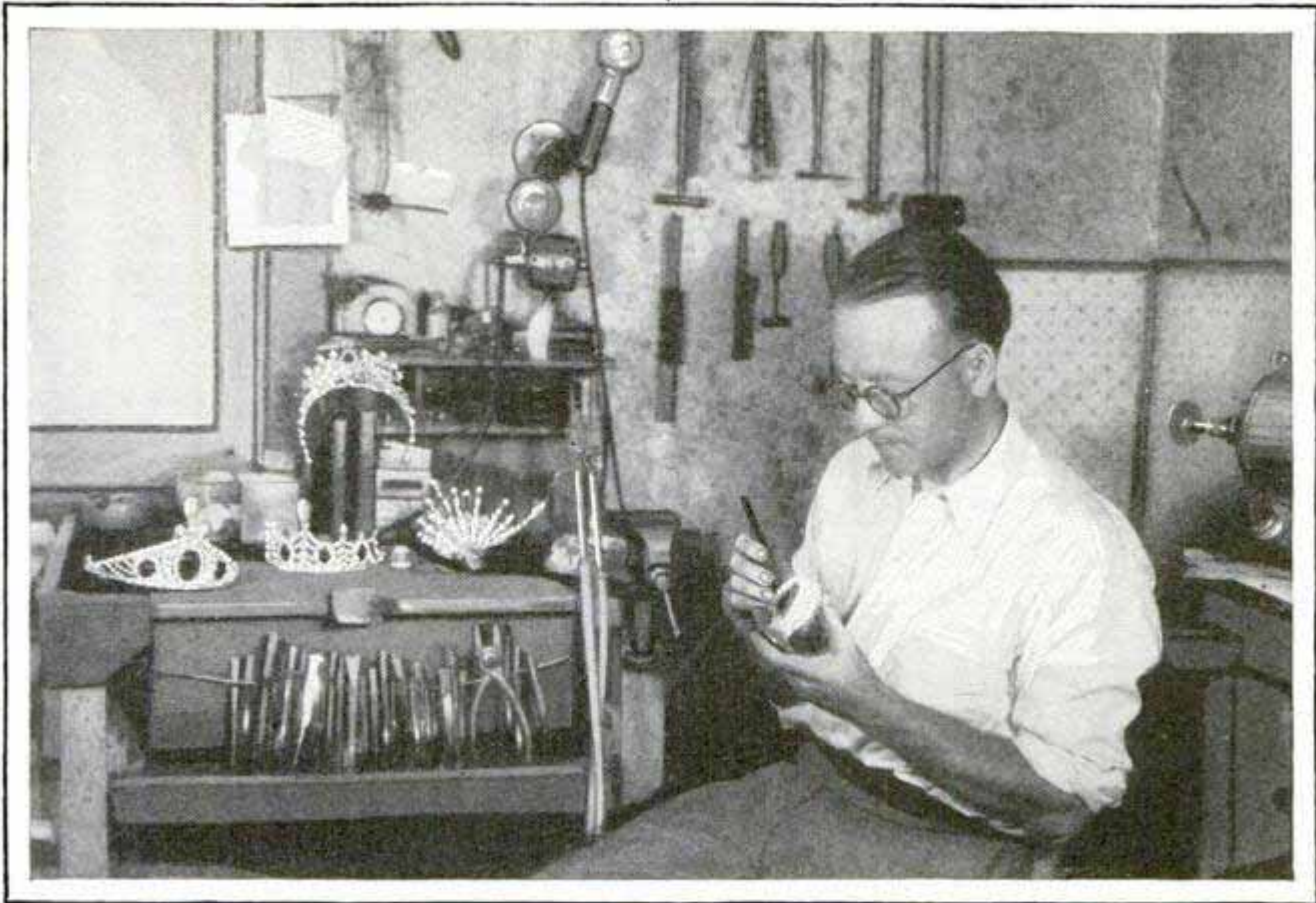

Photos Courtesy Paramount Pictures

Making a Jeweled Slipper for Period Costume of the Time of Louis XIV; on the Bench Are Exact Imitations of Royal Russian and Austrian Headdresses

they could not be obtained in the shapes, sizes and colors to duplicate the originals. In these pearls, liquid glass of a shade of pink, gray, cream, ivory or black, exactly the same as that of the particular gem to be imitated, is used in the blowing. Then the fishscale composition is tinted to the same degree and applied. The result, to one who is not an expert on these treasures of the sea, is the same as the original.

In plain, unlocked wooden drawers Petersen keeps thousands of these imitation jewels. There one sees the Orloff diamonds, the Kohinoor of Shah Jehan, the great sapphires of Persia's royal regalia, the empress of India "set" of diamonds, replicas of the world's most notorious necklace, that of the diamonds which involved Louis XVI, Marie Antoinette, Cardinal Rohan and other dignitaries of France in a historic fraud. There are reproductions of the Great Mogul, the Regent, the Nizam of Hyderabad, the particular yellow Orloff, said to have been the looted eye of an East Indian idol; the Great Table of Persia, once the property of Genghis Kahn, one of the few rectangular diamonds, the Duke of West-

minster's Nassak; the famous bearer of bad luck, the blue-tinted forty-five-carat Hope diamond, probably part of a mysteriously missing 112-carat colored stone, brought to Europe by Tavernier and later stolen from the French crown jewels.

The large stones, like the Cullinan, Tiffany, De Beers and others, though never worn, must be on hand for museum scenes, jewel-robbery stories, and royal scenes in which such huge gems might be on display. Similarly, Petersen keeps in his workshop a collection of artificially made matrix containing excellent imitations of the various precious stones, for use in pictures whose scenes are laid in the remote parts of Africa, India, or other gem-producing countries.

Petersen's tools are of the simplest, and any maker of real crown jewels would laugh at his little workbench and its equipment. Several pliers, with round, square and flat noses, and four or five hammers of varying weights and faces, will make any kind of jewelry of any period, when they are helped out by a small vise with corduroy pads on the jaws and some colorless cement.

130 Beverly Place
Wayton, Ohio

317

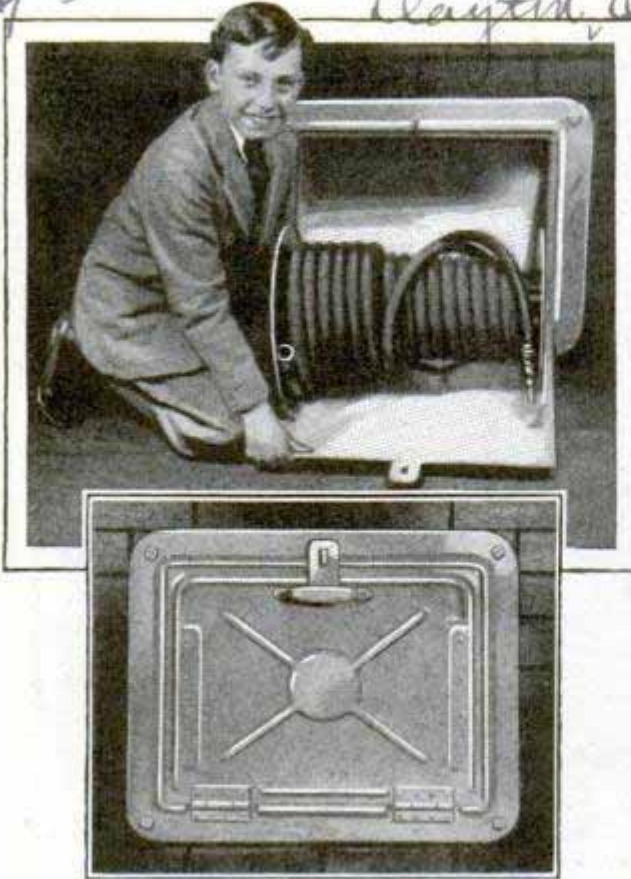

Above, Disappearing Hose Reel Which Fits in Coal-Chute Door; Below, the Door When Closed

DISAPPEARING HOSE REEL FITS ON COAL-CHUTE DOOR

Caring for the garden hose has been simplified by combining a hose reel and coal-chute door, the reel being mounted on the door, which opens at the top, allowing it to rest on the ground. The reel is made of heavy steel and operates on ball bearings, while the frame is formed by the flange of the coal chute. When the winding reel is removed the chute is unobstructed. The end of the hose connecting with the faucet is fastened to a projecting pin so it may be hooked up without unwinding the length of hose, or a connection from inside the basement may be made. The hose also may be used in the basement for washing the floor or for wetting down the coal pile.

COTTON SEED "FUZZ" VALUABLE

316 Cotton manufacturers are finding a valuable by-product in the heretofore useless "fuzz" that remains on the cotton seed after the fiber has been removed. Chemists have found that this fuzz can be made into a fabric resembling silk and now the seed is shaved very close to ob-

Cont. Allen Bronson
c/o Brauerstein

tain the product, which is used for making automobile tops, as a leather substitute, and for combs, brushes, mirrors, films, sausage casings, paper and collodion.

DETACHABLE AIRPLANE CABIN FOR SAFETY AND PRIVACY

318 Models of a detachable cabin for airplanes have been made by an inventor to add to the safety, privacy and comfort of future air travel. The detachable compartment has a parachute on top so that in case of danger, the pilot may release the compartment containing his passengers, the cabin dropping through the fuselage and floating to earth beneath the parachute. The cabins have wheels like auto trailers, and a person traveling much by air might own such a cabin, keeping it in his garage. When going on a trip the cabin would be hauled to the airport as a trailer, there attached to the airplane, and, if necessary, detached and fastened to another airplane at a transfer point, then hauled to the passenger's hotel door at his destination. The cabins also might be used in handling mail and freight without packing and unpacking.

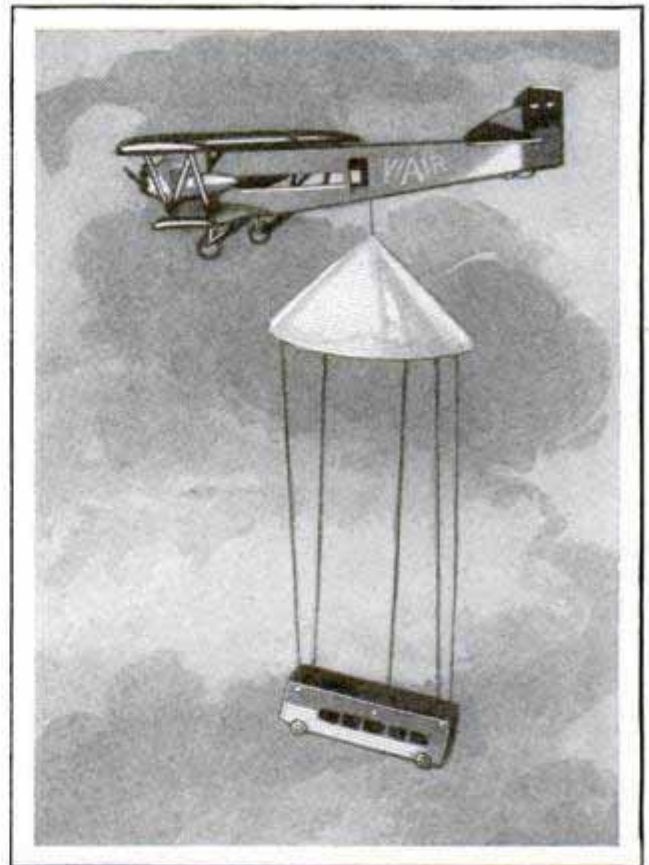

Detachable Airplane Cabin Which Floats to Earth by a Parachute When Loosed from Plane

Chas. Robert M.
Thompson 79
Bldg

MODEL LOCOMOTIVE HAULS SIXTEEN PERSONS

*5349 Worcester Ave
Chicago*

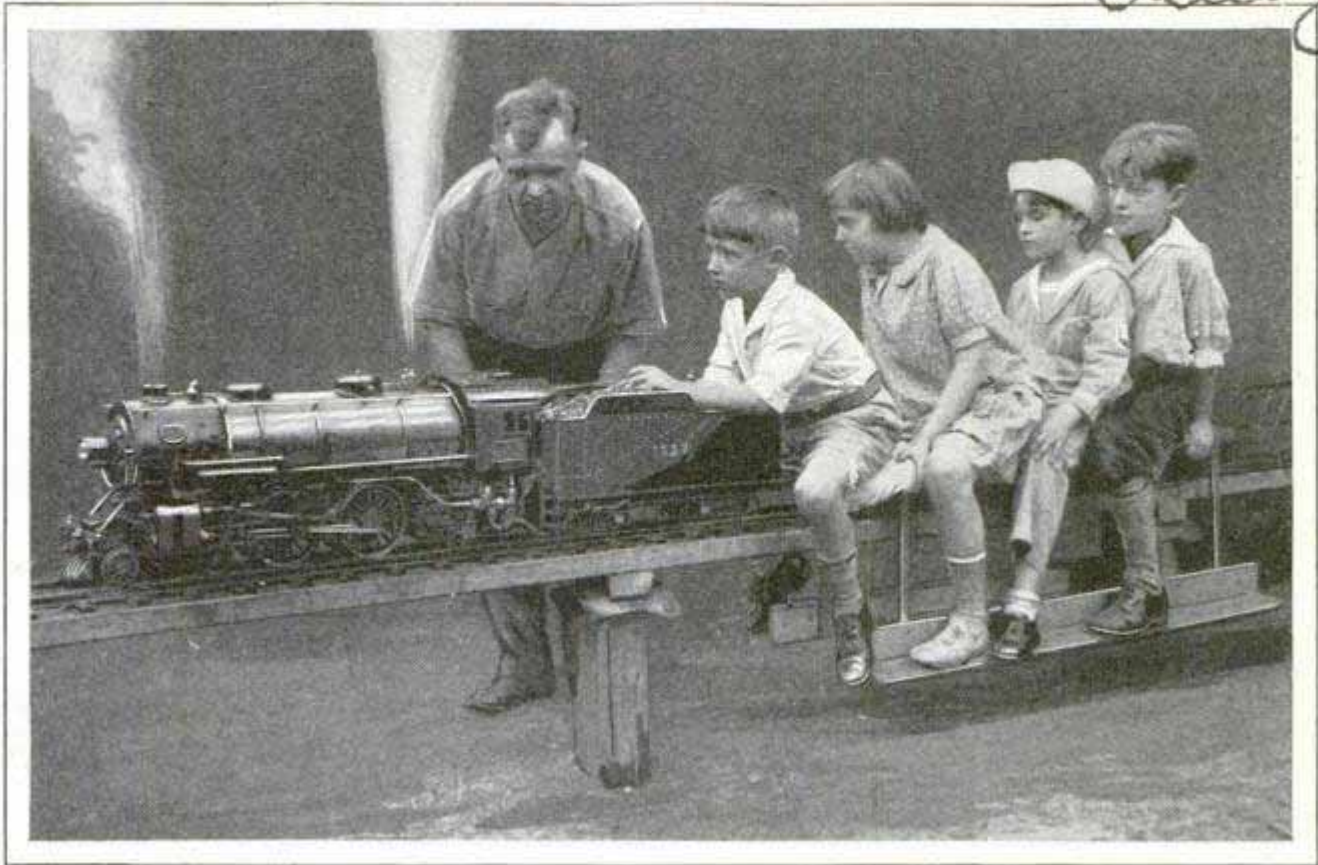

A Model Locomotive, Built on a Scale of Three-Fourths of an Inch to a Foot, Pulls Sixteen Persons on a Real Railroad Track, and Has Made a Continuous Run of Nine Hours

Built on a scale of three-fourths of an inch to one foot, a one-sixteenth-size model of an Atlantic-type locomotive has been made by a mechanic as a toy for his children. The locomotive, complete in every detail and operating on a real railroad track, has pulled sixteen persons in addition to the engineer and has made a continuous run of nine hours. It won a medal, a cup and a diploma of merit at a British model-engineering exhibition. Leisure time of two years was spent by the maker in its construction.

weather conditions and forecasts, adding to this local observations including wind conditions. Charting this information, the observer makes a forecast for the fire area which is rushed to the fire fighters, who are thus enabled to concentrate their efforts at strategic points of the fire zone.

WEATHER BUREAU ON WHEELS BATTLES FOREST FIRES

305 2.

California forest fires are being fought by a portable weather bureau mounted on an automobile truck. The weather bureau on wheels is equipped with a radio-receiving set, apparatus for establishing three emergency weather stations, and complete charting equipment, a radio operator and weather observer composing the crew. The outfit is rushed to the scene of a forest fire, where the radio picks up

BLIND TAUGHT MATHEMATICS BY TOUCH SYSTEM

309 3

In a further effort to help overcome the handicap suffered by the blind, the American Braille Press



has evolved a system of teaching sightless persons simple mathematics by the touch system. Heretofore efforts had been centered mainly on improved methods

of dot printing, read with the finger tips. The mathematics system substitutes raised figures and symbols for the dots.

Designed by E. L. Esray, official in

Paris France

Self-Contained Volume



THIS completely shielded a.c. screen-grid receiver employs a band-pass filter in a highly efficient three-tube circuit. Designed and built in Popular Mechanics radio laboratory and thoroughly tested in a locality where selectivity is an absolute necessity, this receiver easily separated strong locals. The volume and tone are remarkably good; in fact, the volume is equal to that of a six-tube receiver employing standard type 201-A tubes. This is, of course, due to the greater amplification and careful handling of the a.c. screen-grid tube.

Selectivity is possible only through the use of the band-pass filter and careful shielding, and is practically that obtained by the use of three r.f. stages employing the usual tuned r.f. circuit.

The all-metal cabinet for the set and power supply is the one described in detail in the September issue of Popular Mechanics, and the only alteration necessary is to provide a slightly deeper compartment to the right of the dial for the band-pass filter. The layout diagram shows the shielding and location of all the instruments with the exception of the three

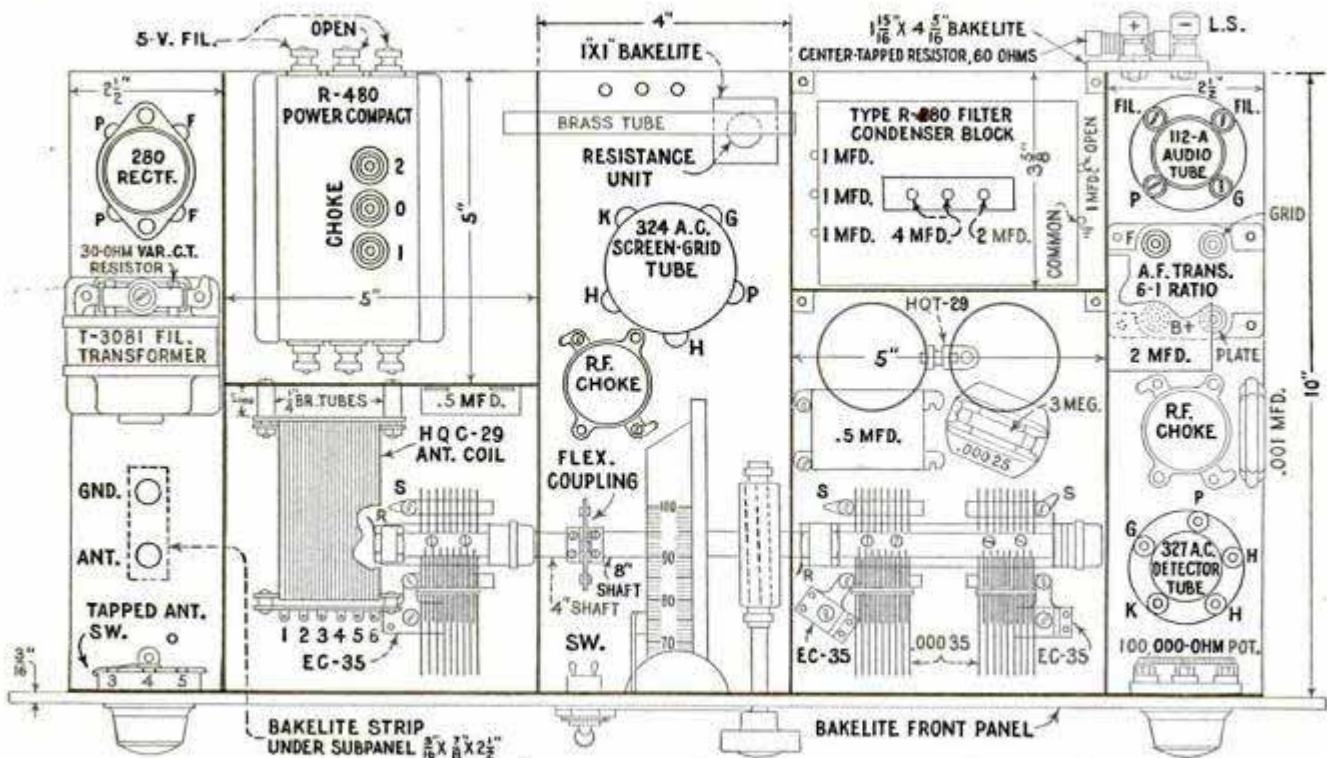

A-C-Three has and Tone

by

Frank L. Brittin

biasing resistors and two by-pass condensers, located for convenience below the metal subpanel. These instruments are shown in dotted lines in the wiring diagram on page 650. The resistors and by-pass condensers could just as well be placed above the subpanel, which would avoid the necessity of raising the $\frac{1}{2}$ -in. subpanel to $\frac{3}{4}$ in. to accommodate them. Therefore, the front-panel template is laid out for a $\frac{1}{2}$ -in. subpanel; a bakelite panel, $\frac{3}{16}$ by 7 by 21 in., will fit nicely in a standard 21-in. wood cabinet, which must be 12 in. deep, to house the entire receiver. If a $\frac{3}{4}$ -in. subpanel is used, either cut $\frac{1}{4}$ in. off the partitions at the top or use a bakelite front panel, $7\frac{1}{4}$ in. wide instead of 7 in., and leave the partitions as they are. It will, of course, be necessary also to raise the holes in the panel $\frac{1}{4}$ in. higher than shown on the template.

Mount the instruments as shown in the layout diagram, and use soldering lugs for all possible connections. Keep the coils at least $\frac{1}{2}$ in. from the metal partitions. The holes for the antenna and ground posts are drilled large enough to drop the two Eby binding posts through the subpanel, where they are mounted on the bakelite strip and held to the underside of the subpanel with short machine screws. The large fixed-resistance unit is mounted upright on a small piece of bakelite at the rear, by means of a rod threaded at each end for 6-32 nuts.

The rotors of the variable condensers

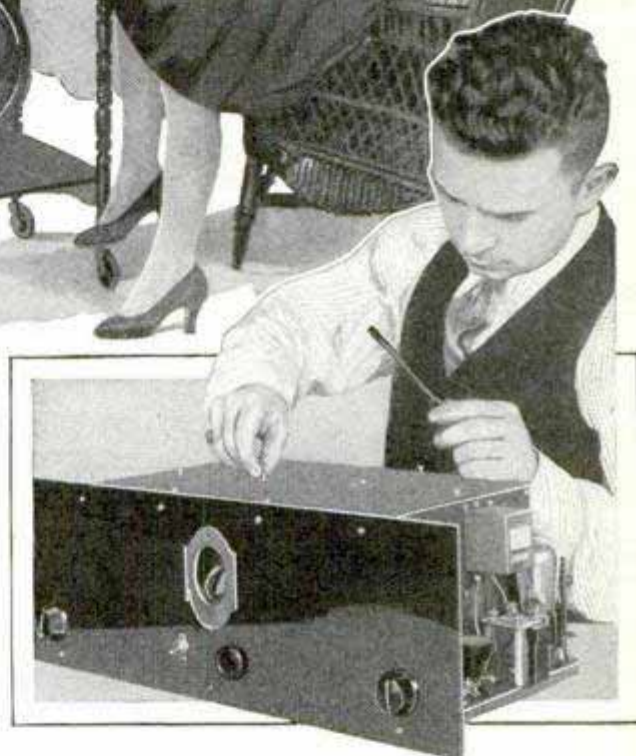

are all grounded to the metal subpanel through the condenser frames. The holes in the center partitions for the shaft should be drilled no larger than necessary to clear. The balancing condensers, E-C-35, are mounted before the condensers are in position and should be accessible for adjustment.

The original metal-cabinet front panel is drilled by using the bakelite panel as a template. An opening is cut in the metal panel for the rear of the escutcheon plate and lamp bracket, and for the antenna switch, a.c. line switch and potentiometer. The indicator-drum bracket is mounted directly on the metal panel and held in position with two screws through both panels.

Bolt the front panels together temporarily and mount the instruments. Line



screws on the subpanel in order to line up the condensers correctly. When in position, loosen all setscrews and remove the condenser shafts and front panels. It is best to wire as much of the set as possible with the end partitions and front panels off.

Use nothing but well-insulated standard hookup wire designed for a.c. receivers; the leads from the power compact should have $\frac{1}{2}$ -in. rubber insulation, especially where they run through the metal tubing from the compact to the filter-condenser block and to the resistance unit at the rear. The same kind of wire is used for the lead to the switch on the front panel, and a smaller a.c. twisted-type for the $2\frac{1}{2}$

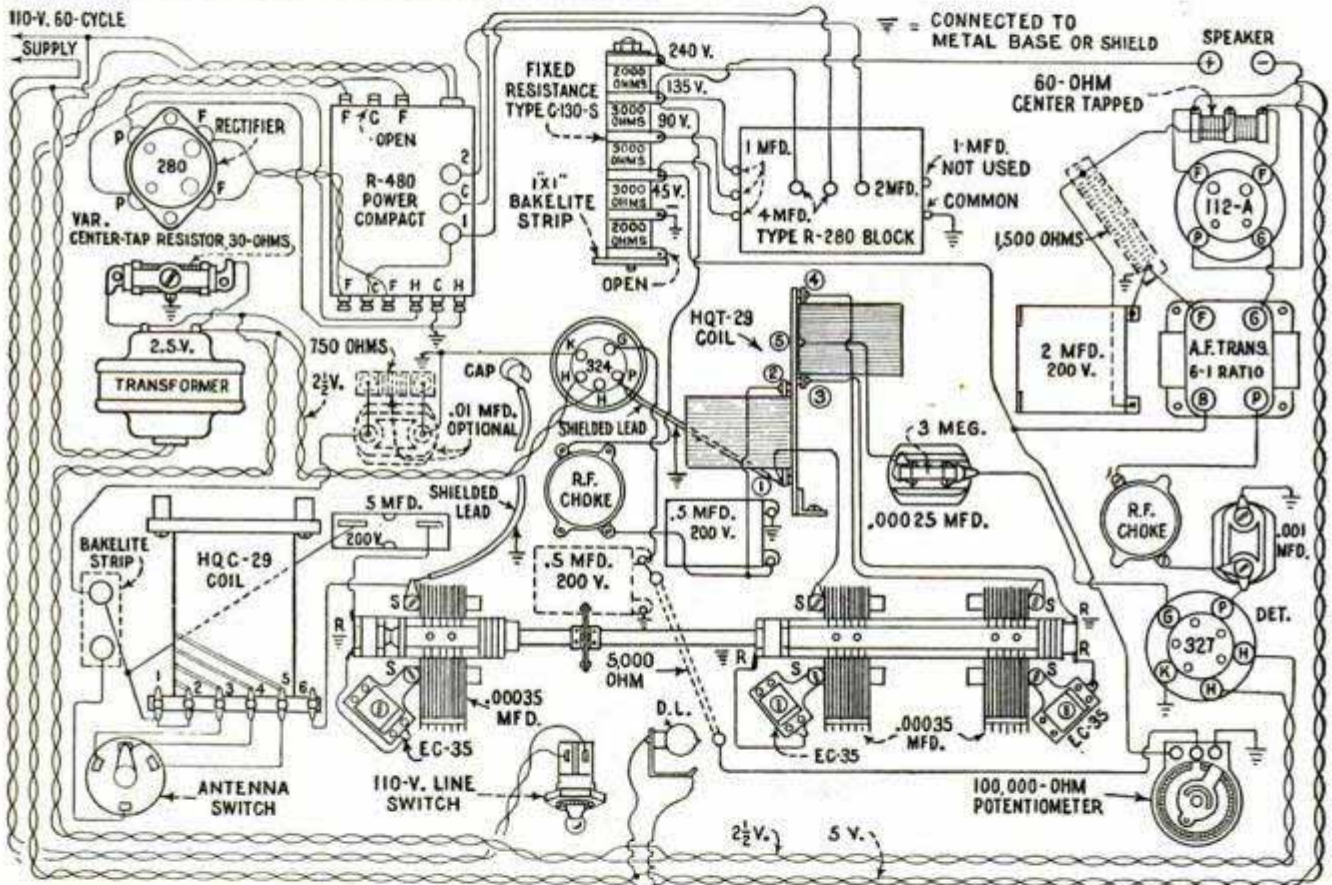

Upper Left, Underside View of the Completed Receiver Showing the Location of the Biasing Resistors and By-Pass Condensers; Below, Simplified Wiring Diagram Showing the Various Instruments in Approximately the Same Positions They Occupy in the Assembled Set

up the variable condensers, shafts and dial through the indicator drum. To insert the shafts, remove the two end partitions. Mount the flexible coupling as shown and tighten the setscrews in the coupling, condensers and indicator drum. The knob on the indicator drum should now turn all the condensers freely. It may be necessary to loosen and slightly shift some of the condenser-mounting

and 5-volt filament leads. The metal base and shielded compartments form a common ground, eliminating long leads. Note that the control-grid lead and plate lead from the screen-grid tube are shielded by means of insulated wire covered with a woven-metal sheath. These shields are grounded where they come in contact with the metal cabinet. Care should be taken that the metal sheath does not touch

the terminals at either end. The filament transformer has a 2½-volt secondary winding for the screen-grid tube and detector.

The variable center-tapped resistor across the 2½-volt secondary is mounted with stiff busbar wire, above the transformer, in an easily accessible position for adjustment to prevent hum. The center lug is connected to a short lead and

metal. The 2-mfd. by-pass condenser across this resistor is mounted on the partition above the a.f. transformer. The .01-mfd. fixed condenser and 750-ohm resistor, indicated with dotted lines under the subpanel and marked optional, is really necessary for the correct operation of the set. The leads 3, 4 and 5, from the antenna coil, run through holes drilled in

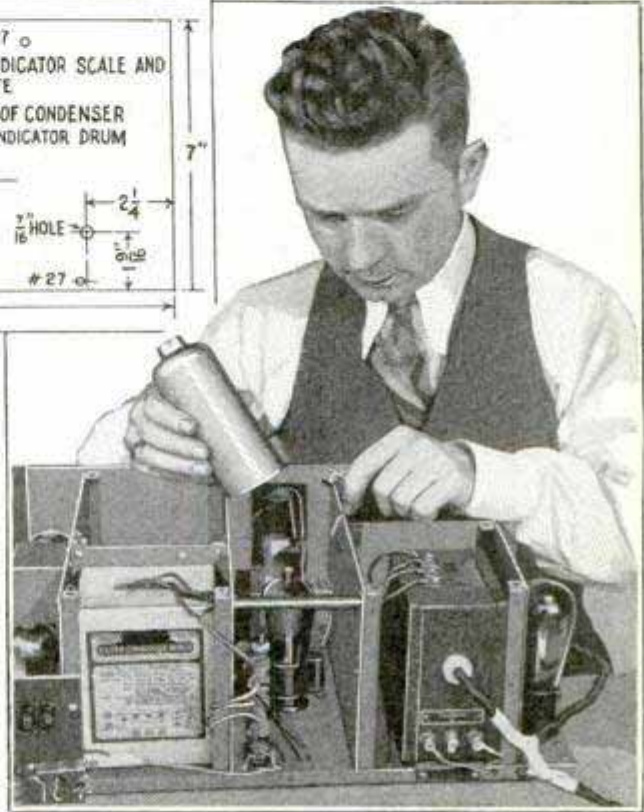
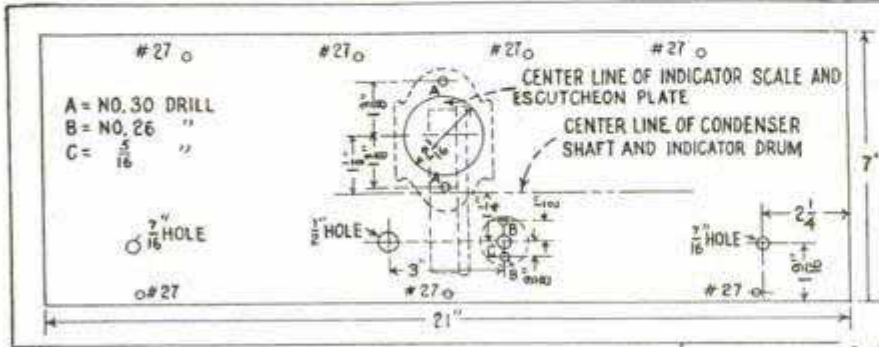

grounded on the metal partition. The other center-tapped resistor across the 5-volt filament line, near the audio tube, is mounted on a small bakelite panel which also carries the speaker posts. The center post of this resistor is taken to the 1,500-ohm resistor under the subpanel, and the other end of the 1,500-ohm resistor is screwed directly to the metal subpanel. The opposite end must not touch the

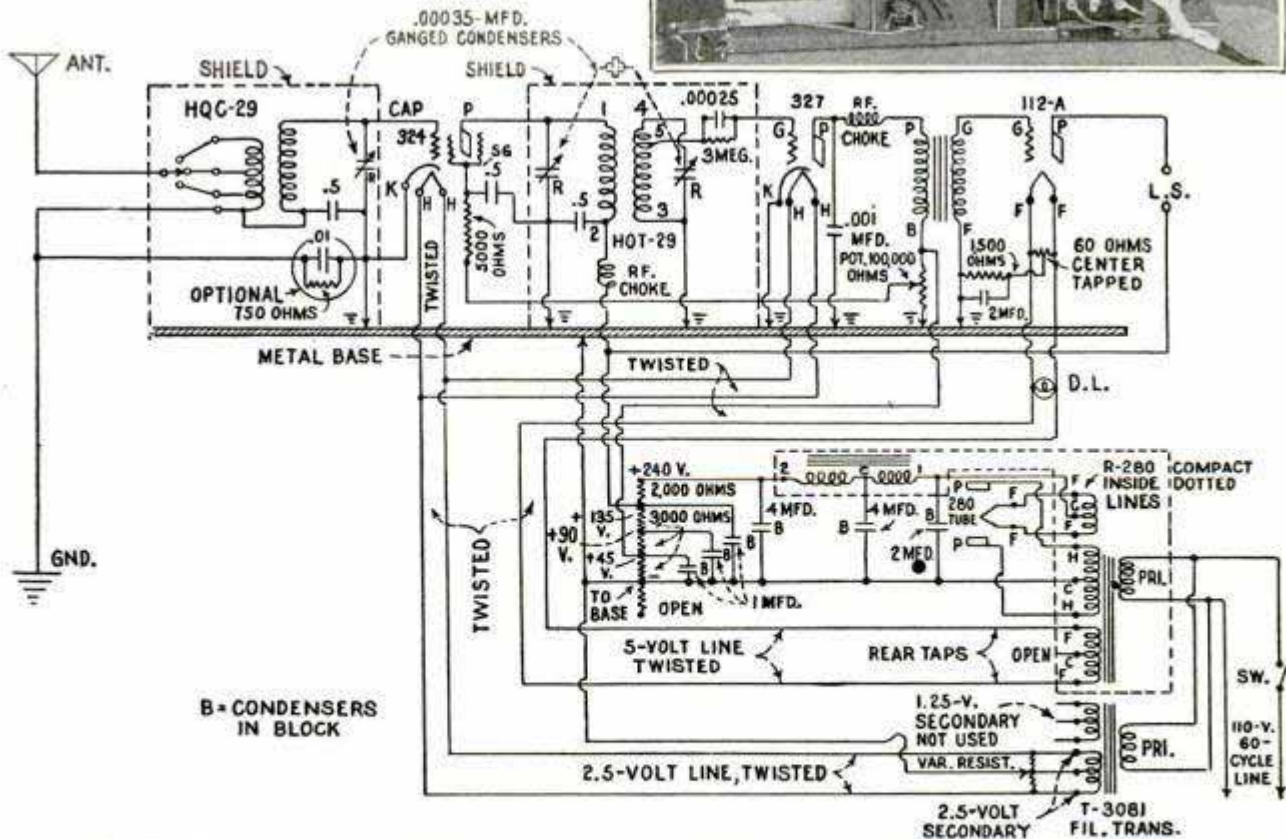

Upper Left, Panel Template for One-Half-Inch Subpanel; Right, Placing Shield over Screen-Grid Tube; Below, Schematic Diagram of Three-Tube A.C. Screen-Grid Receiver and Power Supply

the end partition and go to the taps on the antenna switch.

With the end partitions removed and the front panels in position, insert the

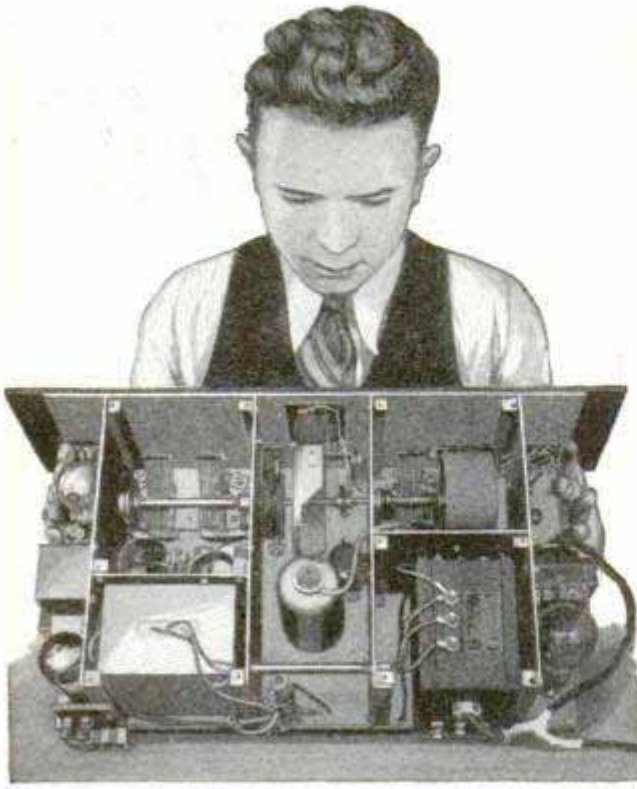

Above, the Completed A.C. Screen-Grid Receiver Ready for Testing

shafts in the variable condensers, and replace the coupling. See that the rotors of the three condensers are "all in," and then tighten the two setscrews on the shaft in each rotor unit. The rotors are now all in one unit on the shaft and turning freely through the indicator drum. Lift the rotors to the "all-out" position, turn the knob on the indicator drum to the left as far as it will go and then tighten the setscrews which hold it to the shaft. Now turn the dial on the shaft until zero shows at front and tighten the setscrew which holds it to the shaft. The knob of the indicator drum will now control all three condensers and drum dial. Complete the wiring to the front panel, replace the end partitions, and the set is ready for testing.

Go over the wiring carefully and check each connection. See that every lead that goes through a hole in the metal subpanel or partition, with the exception of the shielded leads previously mentioned, is carefully insulated. The holes should be large enough to pass all insu-

lated leads without touching, if possible. Insert the tubes, connect the antenna, ground and speaker, and plug the supply lead to the transformers into a convenient 110-volt, 60-cycle lighting socket. A single wire, 100 ft. long, will provide a very efficient antenna. Turn on the a.c. switch on the front panel and check the various B-voltages on the upright resistance unit with a B-eliminator voltmeter.

If the voltages are approximately as specified and there is no evidence of a short circuit, slowly turn the knob of the indicator drum until a station is tuned in about the middle of the dial. Now set the antenna switch at the point of loudest reception. Adjust the balancing condenser across the antenna-tuning condenser for the loudest and clearest signal with the volume control at the right full on. This is done with a wooden stick shaped like a screwdriver. Never use a metal tool in the set while the current is on. After adjusting the first balancing condenser, move to the next and balance it also for best possible signal, then serve the last one in the same manner. Once balanced, there is no further need to touch these condensers. A slight adjustment of the potentiometer volume control and the antenna switch may be needed in tuning in some stations to best advantage.

The compact, self-contained construction of this a.c. receiver makes it available for use in a variety of console installations as well as the two suggested methods shown in the photos at the head of this article. However, when the metal chassis is placed in a wooden cabinet, ventilating holes should be drilled in the rear of the cabinet. Do not close the back of the rear metal compartments.

The cost of the parts, including the tubes and metal cabinet, at net list prices will be approximately \$65.00. If there are any points that do not seem clear or if additional information is desired, address your letters to Popular Mechanics radio department, 200 E. Ontario St., Chicago.

Blueprint No. 144, describing in greater detail the construction of this unusual three-tube a.c. receiver, is now available. It may be obtained for 25 cents, together with a complete list of the parts used. The list of parts will be mailed free to readers who do not desire the blueprint.

Improving the Audio Amplifier

Many experimenters have failed to find any improvement when substituting the new large-type a.f. transformers for the small types in common use. This, however, is not the fault of the new transformers, as they require the use of by-pass condensers and resistors in the circuit to take full advantage of their high-impedance winding and large core. One of the most common difficulties is feedback from the power tube into the grid circuit of the first audio stage. This may be prevented by connecting a resistor varying from 8,000 to 60,000 ohms between the F terminal of the transformer and the C-negative line. For the first audio stage 60,000 ohms is best, and in the power stage employing either the 112-A or 171-A tubes, 25,000 ohms are used. For the type-210 tube, use 15,000 ohms and for the type-245 tube, 10,000 ohms. The type-250 tube works very satisfactorily with 7,500 ohms. A by-pass condenser of 1-mfd. capacity should then be connected from F on the transformer to one side of the filament in all cases.—D. A. Brown, Marion, Ohio.

Station Selector Replaces Tuning Knob

A station finder that takes the guesswork out of tuning does not require any changes in the tuning of the radio set nor does it interfere in any way with its regular operation. It is fastened to the front of the set by means of a setscrew on the shaft of the drum dial, or regular tuning dial. Supporting arms fit on the rheostat

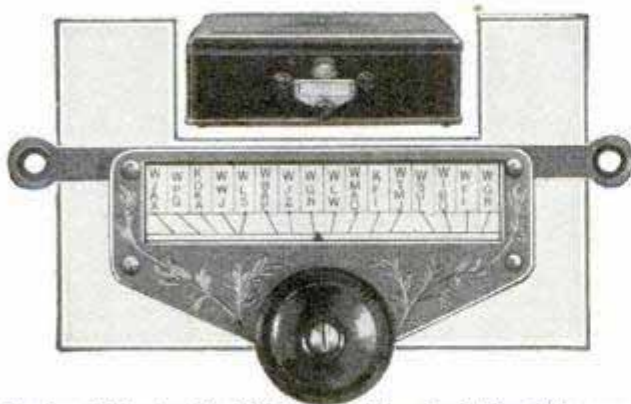

Tuning Selector Installed on a Standard Panel Assembly; and Close-Up Showing Call Letters

or other control shafts behind the knobs. A celluloid chart for writing in the call letters of from 16 to 20 stations is located directly above the control knob.

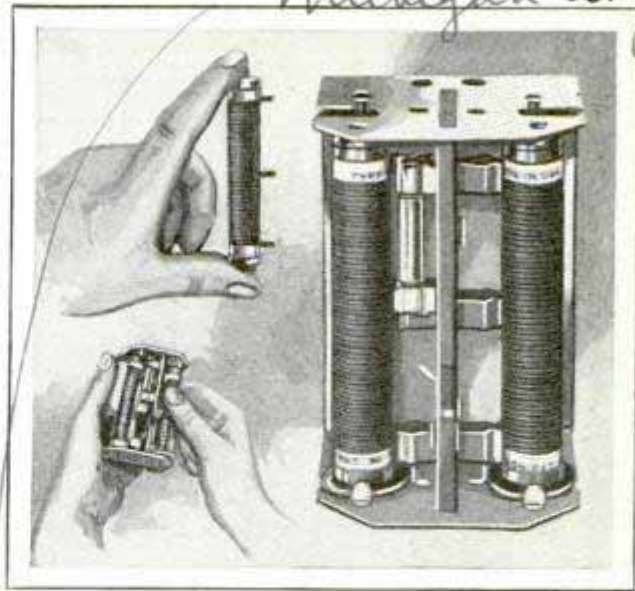

Rectifying Unit Being Placed in the Double Mount; and Complete Rectifier Ready for Installation

New Rectifier for Dynamic Speakers

Operating direct from the a.c. line, a new rectifier for dynamic speakers eliminates the usual power transformer, reducing the cost of assembly. Two units are required for each installation and are supplied either separately or mounted ready to install. The units may be replaced when necessary as easily as a tube is changed in a socket.

Salvaging Charger Bulbs

The writer has found that quite a few charger bulbs are discarded because they are thought to be burned out when such is not the case. Frequently, the base of the tube makes an imperfect contact in the socket and this causes arcking, with the result that in a short while the bulb ceases to function and goes out. The remedy is to scrape the inside of the socket and base of the bulb and sand the prongs bright to insure a good contact, and the bulb will be restored to useful service.—Glenn F. Stillwell, Collinsville, Ill.

Cost of Operating A.C. Sets

The average a.c. receiver operates at a current cost of but one cent for every three hours of actual use. This is much less than the cost of operating many of the electrical household appliances in common use. The manufacturers of some electric irons estimate the cost of the current consumed to be 3½ cents per hour.

Michigan Ave. Chicago Ill. dney. 2029 E. Washington

2349 *OK*

Disk Coils for the Experimenter

By EDWARD A. McMURTRY

PART II

*9133
Kenmore Ave
Chicago*

DISK coils of the neutralized-field type, equivalent to the binocular or dough-

nut varieties, are very efficient.

The construction, as shown in Figs. 5, 6 and 7, is quite clear, and the method of winding is very simple. Fig. 5 of the first part of this article, which appeared in the September issue, gives the disk layout for coils of this type. Three disks, 2 in. in diameter, and a fourth piece of cardboard stock, cut on the dotted lines to form the main or center card, are required. The disks are then bolted to the main card with $\frac{1}{16}$ -in. spacer washers, to provide the winding spaces as in Fig. 6. Note that there are two winding spaces on one side of the main card and one on the other. The two lower spaces are to be occupied by the divided secondary winding, and the separate primary coil is wound

in the upper space with the large washer. The primary coil contains 10 ft. of wire, with the start and finish ends brought out above. From 20 to 25 ft. of wire is wound on each secondary coil, the two coils being connected in series. The coil at the left, Fig. 7, is wound clockwise and the one at the right counterclockwise. These coils are easily mounted on a strip of bakelite and a small metal bracket may be employed to hold them upright on the baseboard in any position required for circuit and space demands. The wire used should not be of the enameled variety, silk or cotton-covered wire being best for disk coils. If No. 26 wire is used, the coil disks will be somewhat larger than would be required for No. 28 or No. 30 wire. If wire as small as No. 30 is used, cut the wire the proper length and solder special flexible stranded lead wires to each end before winding. Start the winding with the soldered joint just inside the coil form, so that the lead wire only

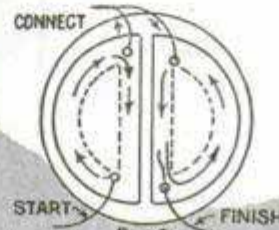
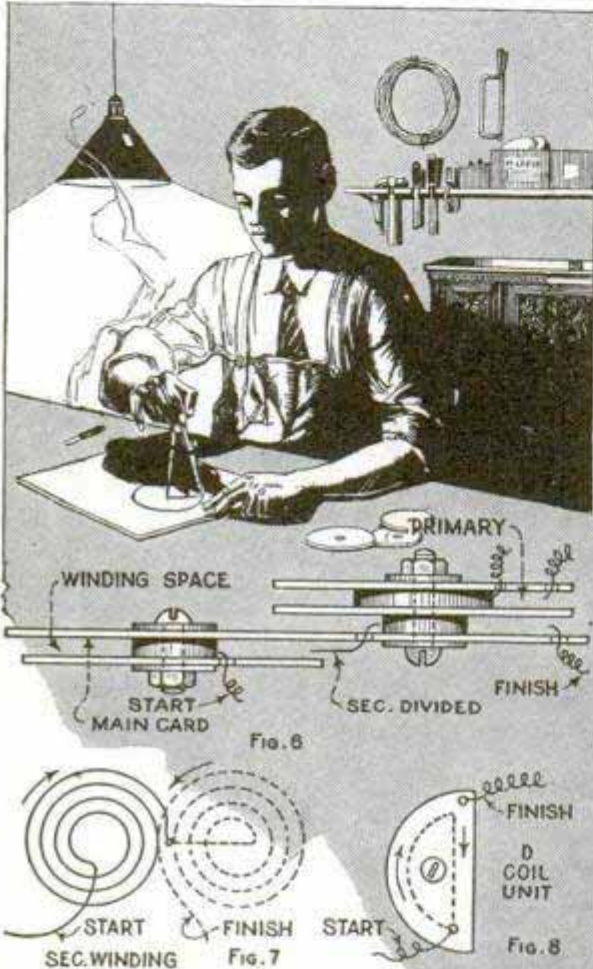

Fig. 9
DIAGRAM FOR WIRING AND
CONNECTING "D" COIL UNIT

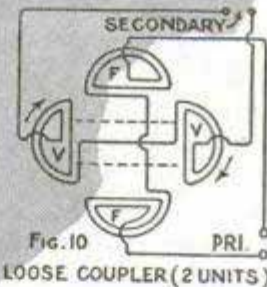

Fig. 10
LOOSE COUPLER (2 UNITS)

shows on the outside and finish in the same manner. By employing this method the fine wire is protected, as the flexible leads take up the strain and wear. Coils of the D-type may be closely followed in the modified disk form as shown in Figs. 8, 9 and 10, and very interesting adaptations for variometer and loose-coupler devices are available with the coils rotating in a flat plane. The winding form is shown in Fig. 8 and consists of a disk, 3 in. in diameter, cut in two to provide the sides for the winding form. A smaller piece of cardboard is cut for the winding-core piece, as indicated by the dotted lines. It should be just large enough to provide a $\frac{1}{2}$ -in. winding space all around. Glue the core piece in posi-

shows on the outside and finish in the same manner. By employing this method the fine wire is protected, as the flexible leads take up the strain and wear.

Coils of the D-type may be closely followed in the modified disk form as shown in Figs. 8, 9 and 10, and very interesting adaptations for variometer and loose-coupler devices are available with the coils rotating in a flat plane. The winding form is shown in Fig. 8 and consists of a disk, 3 in. in diameter, cut in two to provide the sides for the winding form. A smaller piece of cardboard is cut for the winding-core piece, as indicated by the dotted lines. It should be just large enough to provide a $\frac{1}{2}$ -in. winding space all around. Glue the core piece in posi-

tion and bolt all three pieces together at the center. This is one-half of the complete unit which is composed of two such coils wound in opposite directions and connected in series.

The single-coil units are then mounted flat on a slightly larger cardboard disk. When two such complete units are put together, the result is a loose coupler or variometer, depending on the manner in which they are connected.

Fig. 10 shows the connections for a loose coupler; if a variometer is desired, the coils should be connected in series, and there will be but two leads instead of four. One set of coils is stationary and the other set forms the rotor. Mount the units facing each other on bakelite strips, one unit stationary and the other so that it may be rotated.

The correct length of wire to be used on a disk-coil unit, the secondary of which is to be tuned with a variable condenser of a given number of plates, such as the unit shown in Fig. 4, in September issue, is best found in the following manner: Wind about 50 ft. of No. 30 wire on the secondary and about 8 ft. on the primary; place the coil in the set and tune in a station operating on the longest available broadcast wave. The station should come in well on the high end of the dial; if this is not the case and the station comes in about the center of the dial, take turns off the secondary and make tests until the station comes in at the high-wavelength end of the dial.

Electrolytic Rectifier Replaces Tube

This simple rectifier differs from the ordinary electrolytic cell in that it employs two aluminum electrodes instead of one. It will replace any rectifying tube or other rectifying element used in conjunction with a mid-tapped transformer secondary. The glass container may be a ½-pt. fruit or salad jar and should be examined carefully to make sure that it is free from cracks. A hole, about 1¾ in. in diameter, is cut in the metal cap, leaving a narrow retainer rim as shown. A hard-rubber or bakelite disk is then cut to fit snugly inside the metal cap, where it is held by the retaining rim. Four holes are drilled in the disk, three for the electrode binding

posts and one for a vent. Ordinary wire solder may be used for the lead electrode; the aluminum electrodes are ½ in. wide and 3½ in. long, holes for the binding posts being drilled in one end and these ends bent over ¼ in., to form electrodes 3¼ in. long; the lead electrode is the same length. The electrolyte may be the familiar borax solution made by dissolving as much borax as ½ pt. of distilled water will take up, or a solution of 1 oz. monobasic ammonium phosphate in ½ pt. distilled water. The aluminum electrodes must be carefully sanded and absolutely free from grease or dirt before they are placed in the solution. The connections

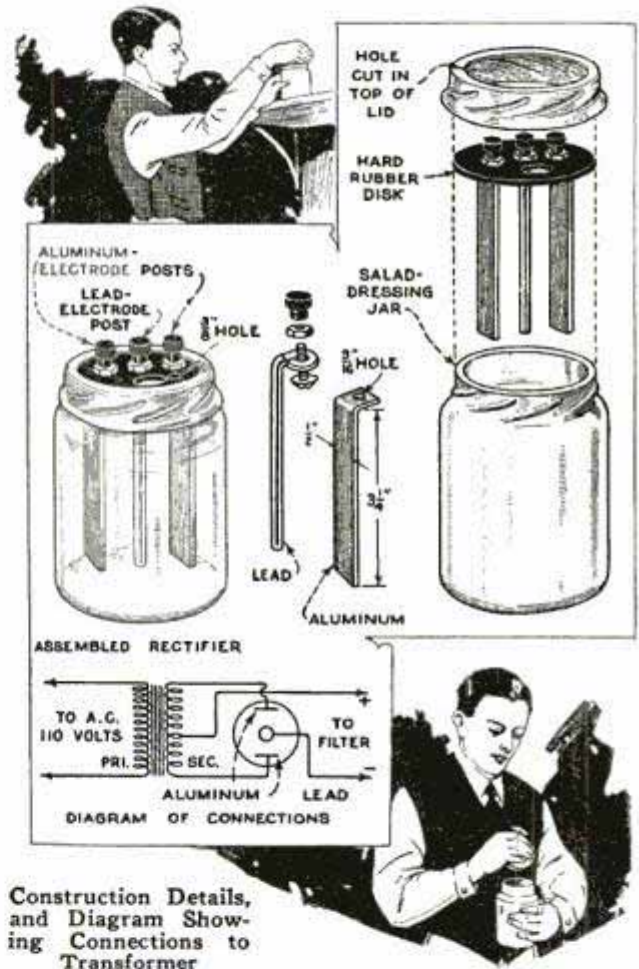

Construction Details, and Diagram Showing Connections to Transformer

are plainly shown and must be closely followed. The advantage this type of rectifier has over the tube or cartridge is its low cost; the lead electrode will last indefinitely and the aluminum electrodes are easily replaced when exhausted.—W. G. Fisher, New Haven, Conn.

☐ A small wire brush is useful for the purpose of cleaning the tip of a soldering iron before it is tinned.

A De-Luxe Receiver of Unit Design

Probably one of the most elaborate assemblies for home use in the way of a radio receiver is shown in the photo. Seven aluminum cabinet units contain the various components of the set proper. These units, together with a power pack, power amplifier, dynamic speaker and an

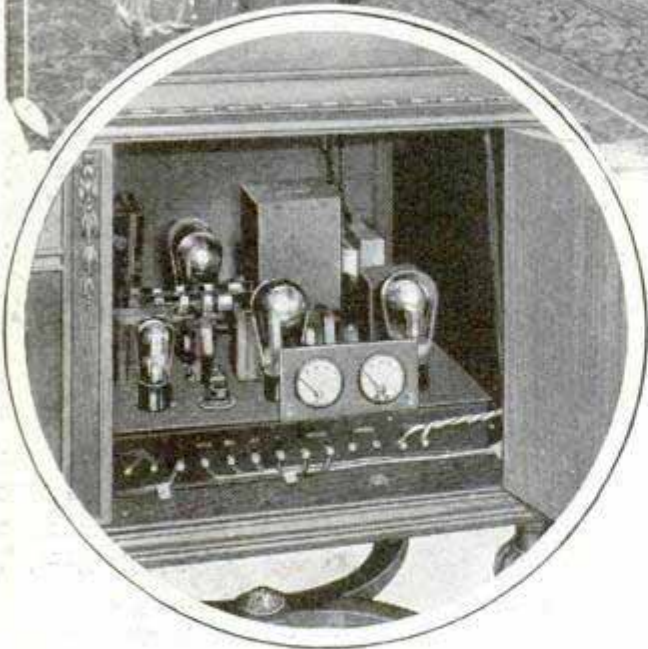
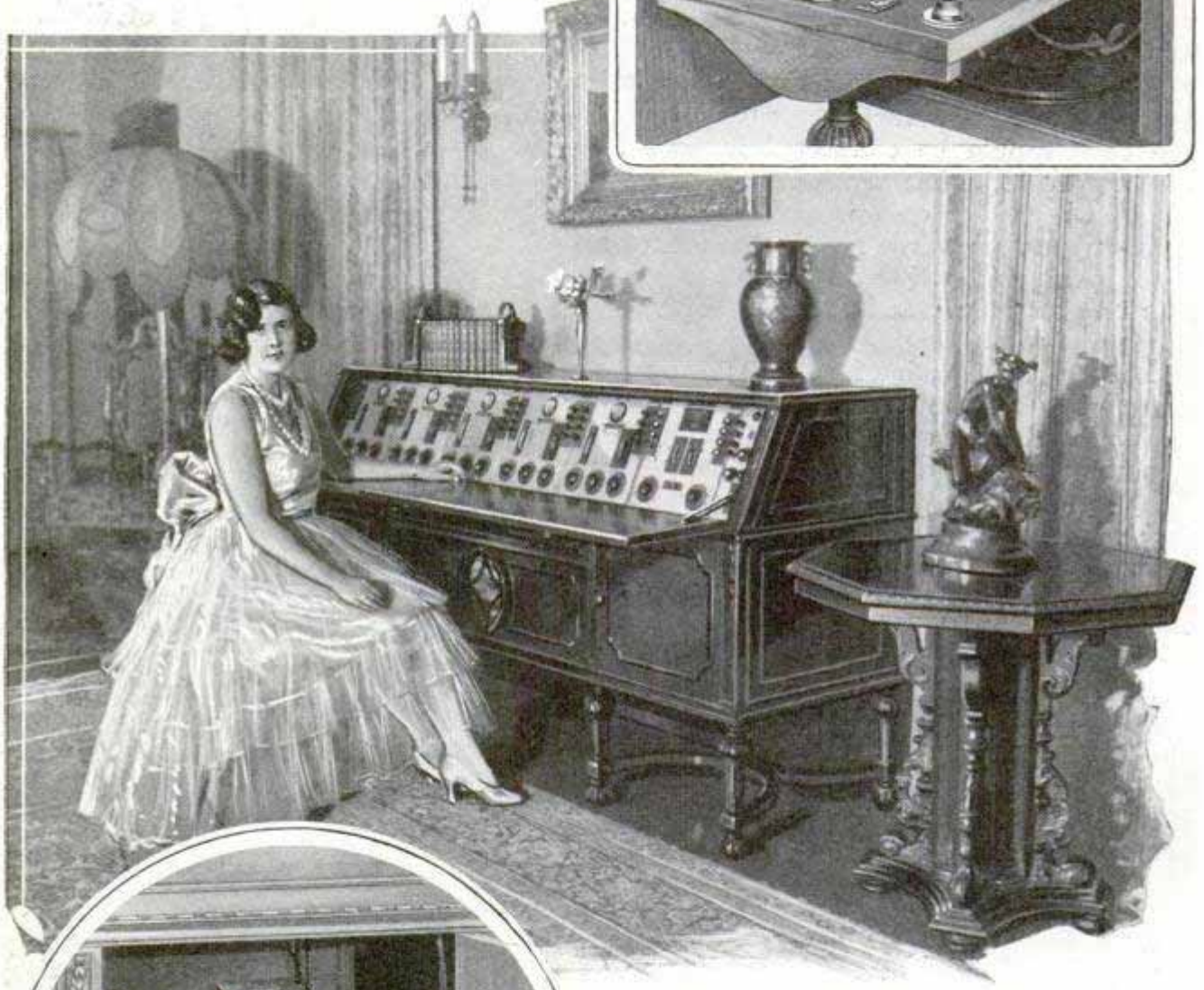
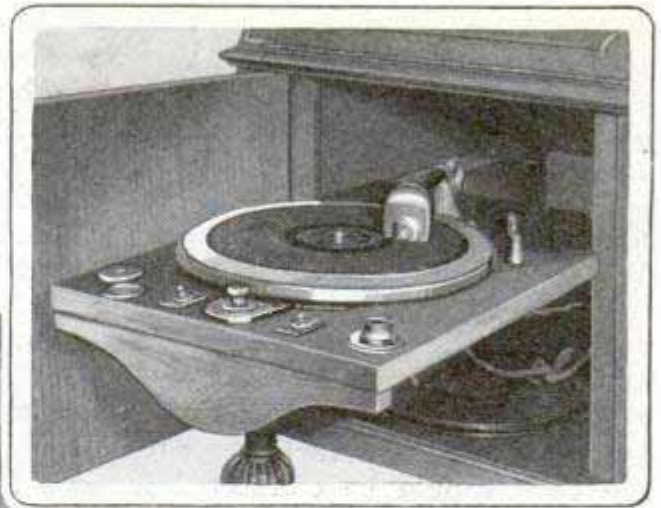

Top, Phonograph Turntable Located in Lower Compartment; Center, Complete Installation; Left, Power Pack and Amplifier

electric-phonograph turntable, have recently been installed in this specially designed console. The circuit employs four

stages of tuned screen-grid amplification, detector, two stages of resistance-coupled audio amplification and type-250 power tubes in push-pull. The four screen-grid tubes, the 200-A detector and the two type-240 resistance-coupled tubes are operated on rectified a.c. current, supplied by a 3-amp. 6-volt power plant. The B and C-supply is obtained by means of two type-281 tubes arranged for full-wave rectification. Plug-in coils for the tuning units cover a wavelength range from 200 to 3,000 meters, including the higher

W. Monroe
 2366 R
 New Device Eliminates Antenna
 Chicago

waves employed by European stations as well as those of American and Canadian broadcasting stations. The receiver is not difficult to tune, although each tuning unit is provided with its drum control, and the various units may be coupled together so as to be operated as a single group, thus simplifying tuning. The inclusion of the phonograph feature makes it possible to reproduce records taking full advantage of the audio system.

Simple Grid and Filament Control by Fixed Resistors

Inexpensive fixed resistors may be used for grid and filament controls with the standard vacuum tubes in common use. If a fairly steady source of filament current is available, the filament of the tube may be protected by a resistor of suitable resistance for the tube, used as shown in Fig. 1. As a means of stabilizing an r.f. tube with the least trouble and expense, the grid suppressor method in Fig. 2 leaves little to be desired. An inexpensive strip resistor, having a value of from 300 to 800 ohms, may be used for this purpose, as the exact value is not critical. Grid-biasing the heater-type a.c. tube is easily done by inserting a strip resistor in the negative-B lead as in Fig. 3. This method depends on the voltage drop across the resistor for the biasing effect and a bypass condenser of either .5 or 1 mfd. is employed as shown

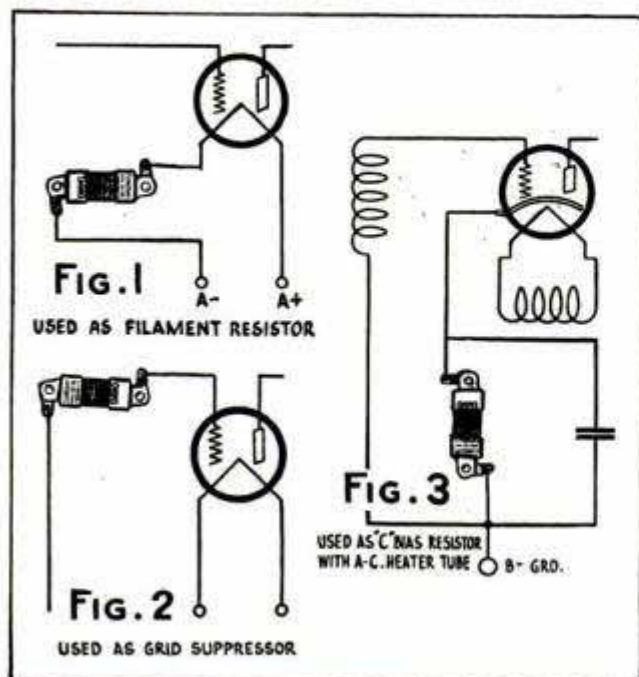

The device shown in the photo is said to give results equal or superior to those obtainable from a good outdoor antenna

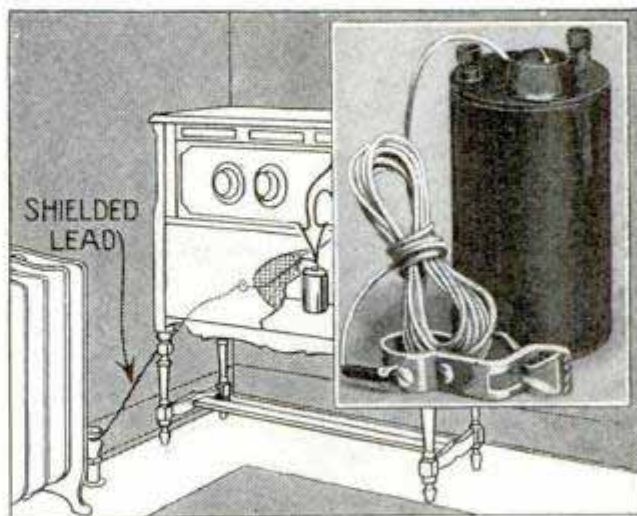

Antenna Eliminator, Showing Shielded Ground Lead and Clamp; Left, Sketch Showing Installation

through the employment of a new pick-up principle. It consists of an insulated cylindrical shell, 3 in. in diameter and 5 in. high, containing an inductance and capacity unit. This unit consists of a single-element shielded vacuum tube, arranged in electromagnetic relation to a solenoid coil, the inductance of which is variable in order to adapt it to any receiver, for better selectivity and reduced local interference. It is claimed that the r.f. signal delivered to the receiver from the vacuum tube is both filtered and amplified by its action. The device is self-contained and may be installed in the back of the radio cabinet or console. Antenna and ground binding posts are provided and these are connected to the corresponding binding posts on the receiver. A shielded ground lead is provided with a clamp which is connected to a radiator, water-pipe or other ground. When installation is made, a station is tuned in at the set and the knob on the unit is turned until maximum volume is obtained, after which no further adjustment or attention is required.

Popular Mechanics' radio department offers its information service free to all readers of our magazine. We will be glad to help you with your radio problems and will promptly answer all inquiries.

Helpful Radio

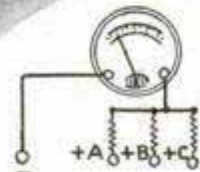
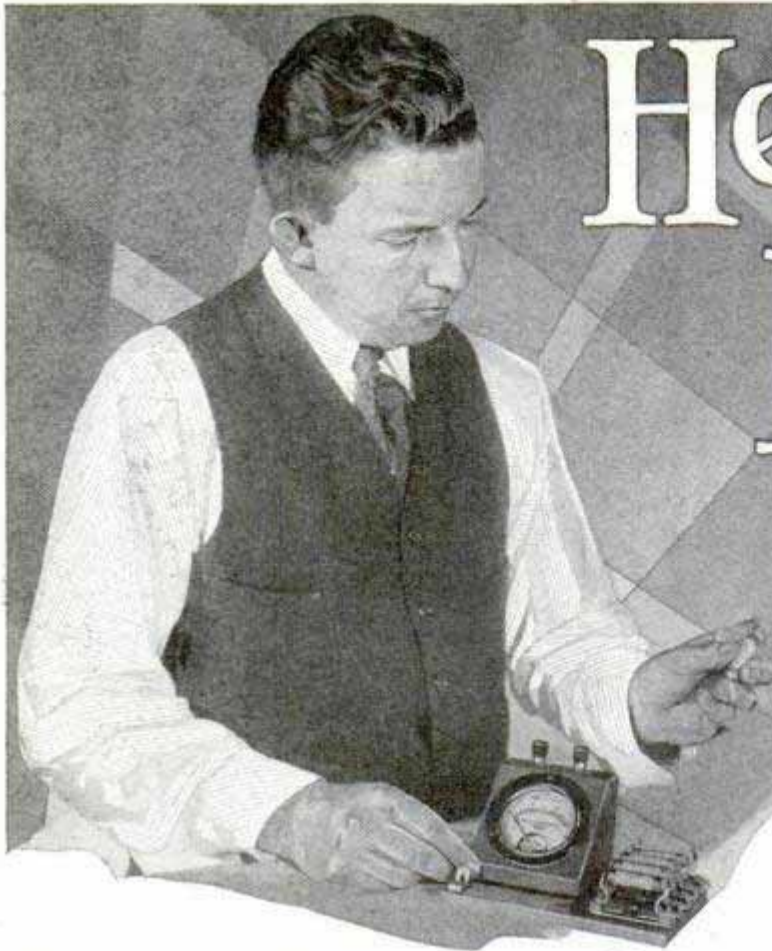

FULL SCALE DEFLECTION OF METER	A 1,000 OHMS	B 10,000 OHMS	C 100,000 OHMS
1. MA.	1. V.	10 V.	100 V.
1.5.	1.5	15	150
2.	2.	20	200
3.	3.	30	300
5.	5.	50	500
8.	8.	80	
10.	10.	100	

Right, a Simple Trouble Shooter for Multitube Receivers; Start at Antenna-Stage Socket in Set and Transfer Tube to Tester, Insert Plug and Tune Set for Signals; If Signals Are Heard in the Phones, Move Tester to Succeeding Stages Until Dead Stage Is Located; When Plugged into Audio Stage, Shunt Out Grid Condenser; Jumper Is Removed for Ammeter to Read Filament Current of Tube

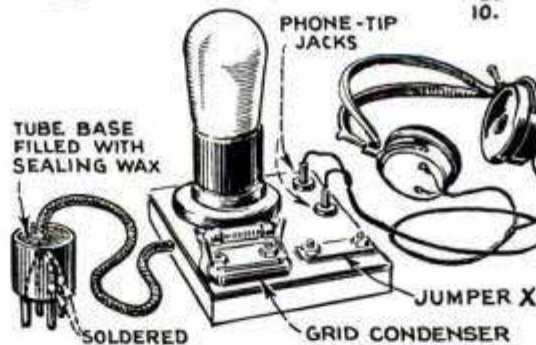

Above, Diagram and Chart for Using a Milliammeter as a Voltmeter by Means of Suitable Resistors in Series; a Milliammeter with Full-Scale Deflection Is Best for Testing B-Power Voltages, as the Resistance Is 1,000 Ohms per Volt; Others May Be Used for General Voltage Testing; Left, Above, Meter and Resistance Units Arranged on a Small Wooden Base

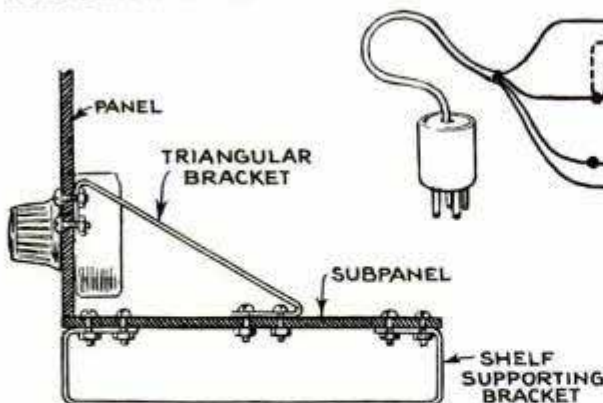

Easily Made Angles and Brackets for the Homemade Receiver; Brass Strip 1-16 by 1/2 In., Is Suitable for the Triangular Brackets, and 1/8 by 1/2-In. Strip Is Best for Shelf-Supporting Brackets, Which Must Carry More or Less Weight; Right, Bending the Brass Strip around Large Nails Clamped in a Vise Insures Angles of the Same Height

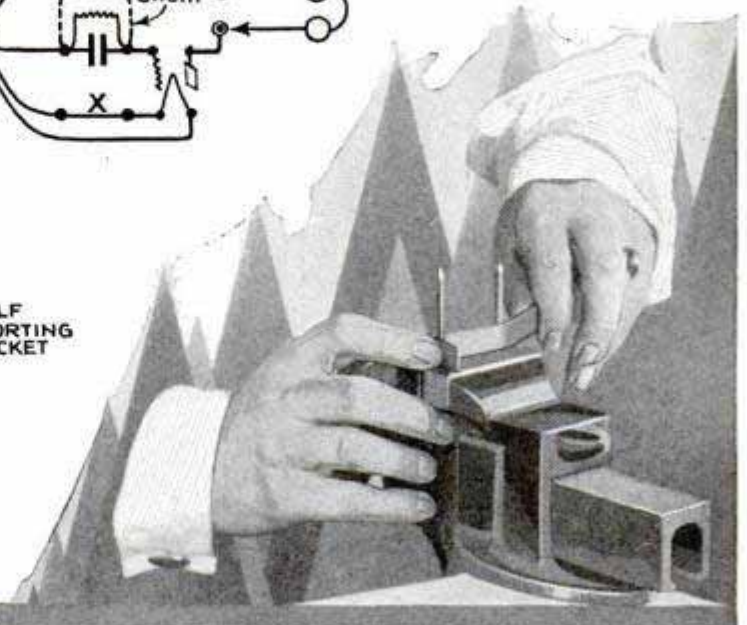

Hints from the Lab.

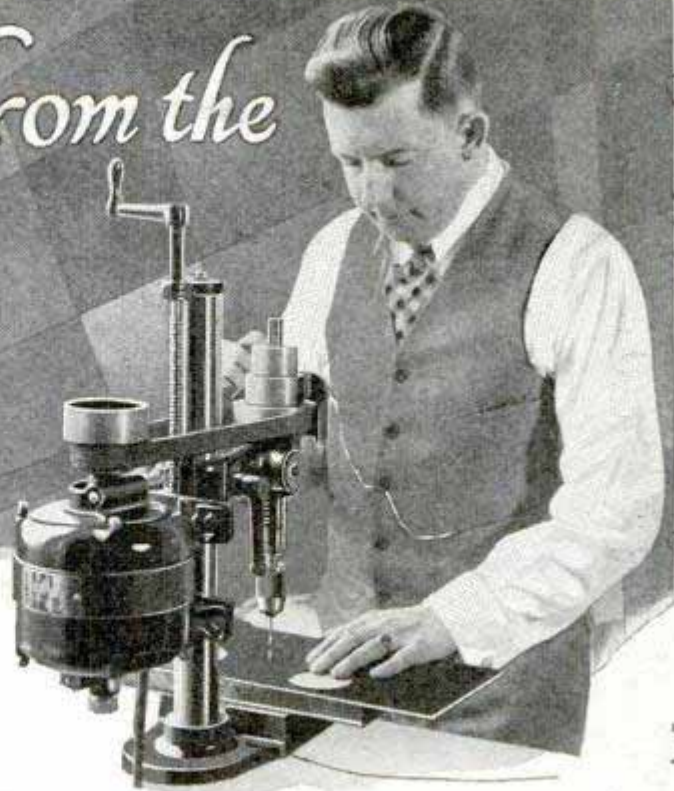

Drill. Cassidy. Otto Co. Chicago Heights, Ill.

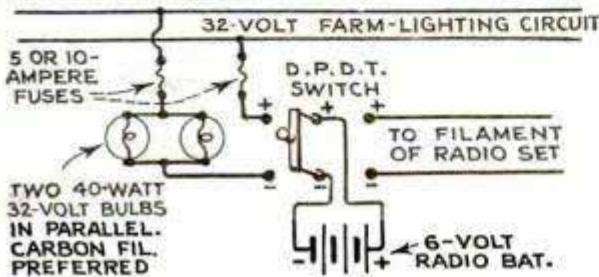

Above, a Simple Method of Charging Radio Battery from Farm-Lighting Circuit; the Fuses Protect the Main-Line Fuses; for a Light Charge Remove One 40-Watt Lamp; Right, Additional R.F. Amplification for a Superheterodyne from a Tuned R.F. Receiver Connected to Antenna and Ground; a 60-Turn Coil, Connected to the Loop Posts, is Inductively Coupled to the Detector-Stage Coil

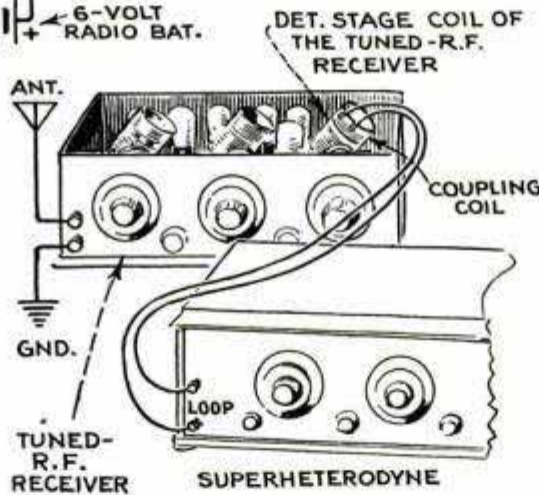

Above, When Drilling Radio Panels, Place a Piece of Soft Wood of the Same Width under the Panel, and Always Drill Panels from Front to Back to Insure a Clean-Cut Hole at the Front

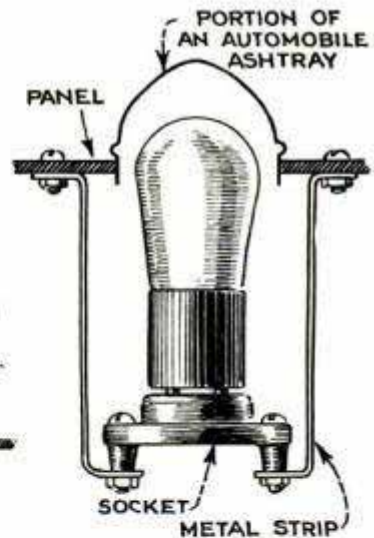

Upper Left, a Single-Throw Relay Switch Made by Changing the Terminals and Lengthening the Blades of an Ordinary Double-Pole Double-Throw Knife Switch; Above, Tube Mounted in a Portable Instrument So That It May Be Removed Easily from Above; the Metal Cover Was Obtained from the Junk Box; the Tube Socket Is Supported by Two 1-16 by 1/2-In. Brass Strips; Left, Soldering a Tap on an Inductance Coil is an Easy Matter, If the Wire on the Coil Is Raised with a Toothpick

Combination Hookup for the Experimenter

By D. A. BROWN

RADIO programs, phonograph music or two-way conversation is possible with

receiver, and at the extension end there is a relay panel consisting of a push button and a small 4½-volt battery mounted as shown below.

The switchboard should be located in some convenient position near the receiver. Mount the switches just as shown in the insert photo and wiring diagram below, so as to avoid confusion when following the directions to be given.

The audio section of the set should fol-

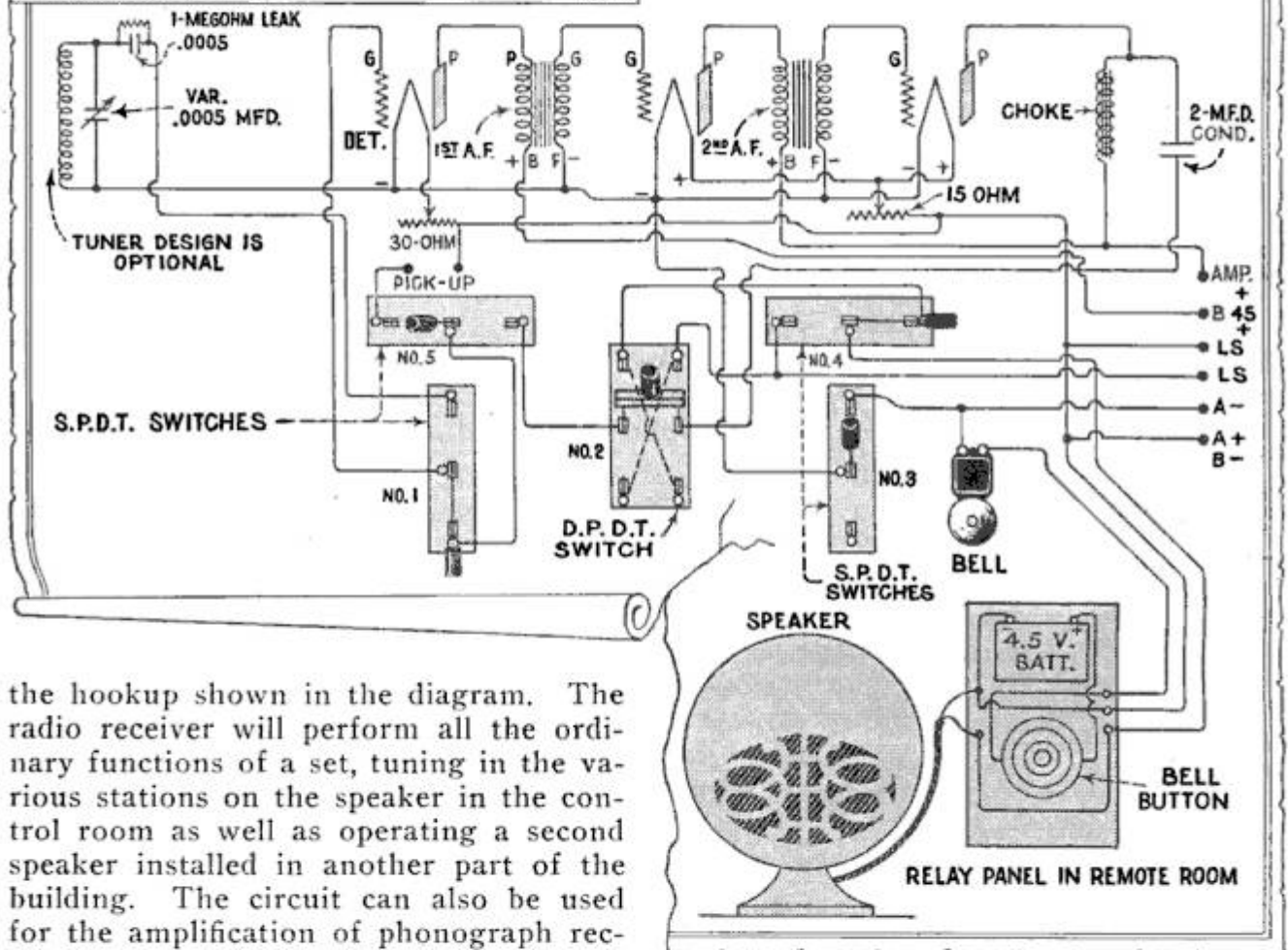
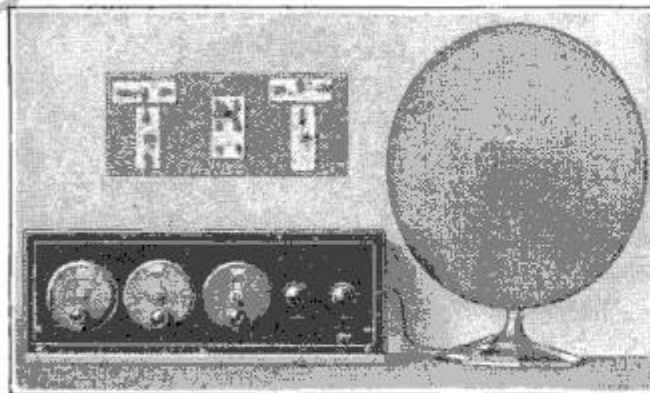

the hookup shown in the diagram. The radio receiver will perform all the ordinary functions of a set, tuning in the various stations on the speaker in the control room as well as operating a second speaker installed in another part of the building. The circuit can also be used for the amplification of phonograph records which may be heard in either or both rooms as desired.

The switches are arranged so that a person in the control room may speak to another in the room where the remote speaker is located and vice versa, to carry on a conversation both ways. Ordinary loud speakers are used for all three operations. The equipment for this domestic telephone exchange costs very little. An electric bell is installed near the radio

low the diagram closely, but the tuner may be of any type desired and is not shown in the circuit diagram. When the set is completed and the extension wires laid to the other room, the batteries and speakers are connected. Now, to tune in a station on the receiver and operate the set speaker only, place switch No. 1 up, switch No. 2 up, switch No. 3 up and throw switch No. 4 to the right. Switch

61 Sherman
Malden Mas
664

No. 5 is left out for broadcast signals. Switch No. 3 is merely a line switch in negative-A and is left closed in the up position for all operations.

To operate the extension only, on broadcast signals, place switch No. 1 up, No. 2 down and throw No. 4 to the right. Now, if the operator wishes to have the broadcast signals on both speakers, place switch No. 1 up, No. 2 up and throw No. 4 to the left. This places the loud speakers in parallel.

To use the audio amplifier for phonograph records, a standard pick-up device is connected to the terminals marked "pick-up" above switch No. 5. Place switch No. 1 down and throw No. 5 to the left. Switches No. 2 and No. 4 will now throw the speakers in and out as desired.

For two-way telephone communication, with the set speaker acting as the microphone, turn switch No. 1 down, No. 2 down, No. 4 left and No. 5 right. The operator may now speak softly into the speaker, and the person at the other speaker will hear his voice at loud-speaker volume. To listen to the reply from the other room, the operator throws switch No. 2 to the up-position. When the person at the remote speaker wishes to call the operator, he simply presses the push button to ring the bell and the operator throws the switch to listen.

FOR THE RADIO BUILDER

The blueprints below include the best of Popular Mechanics tested circuits. When ordering, simply quote numbers of blueprints desired and inclose proper amount addressed to Popular Mechanics Magazine, Radio Dept., 200 E. Ontario St., Chicago, Ill. Magazines containing full descriptions of the circuits can be obtained. Send 25 cents for each magazine desired, giving date of publication.

- No. 111, Homemade Tube Tester July 1926 . 25c
- No. 115, 15 to 550-Meter Three-Tube Receiver Nov. 1926 . 25c
- No. 116, Three-Tube Loop Set Dec. 1926 . 25c
- No. 123, Economy-Nine Super-heterodyne Nov. 1927 . 50c
- No. 130, One-Tube Short-Wave Adapter Mar. 1928 . 25c
- No. 134, Edison Type B-Battery July 1928 . 25c
- No. 138, Screen-Grid Perfect-Tone Six Receiver Nov. 1928 . 25c
- No. 139, Simple Television Receiver Dec. 1928 . 25c
- No. 140, Power Amplifier and B-supply for Television Jan. 1929 . 25c
- No. 142, Two-Tube Screen-Grid Short-Wave Adapter Mar. 1929 . 25c
- No. 143, Four-Tube Screen-Grid Receiver May 1929 . 25c
- No. 144, Three-Tube Self-Contained A.C. Receiver Oct. 1929 . 25c

Tuner Employs Four Screen-Grid Tubes

Five tubes, four of which are of the screen-grid type, make this new tuner especially interesting to the DX fan. The

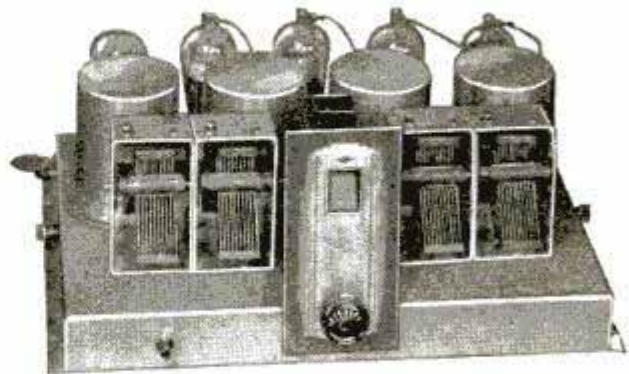

Completely Assembled Tuner Unit Showing the Screen-Grid Tubes in Position

parts are available in kit form for home assembly, and the completed unit is suitable for mounting in a console. The a.c. screen-grid tubes are used with a new type of completely shielded r.f. transformer, and a type-227 tube is used for the detector. A feature of the tuner is the new color dial, whereby, as the knob is turned, the scale is projected in various colors on a ground-glass screen. Any good power supply and audio amplifier may be used with the tuner, but a specially designed power unit, consisting of a type-280 tube for a rectifier, one stage of transformer audio with a type-227 tube and a stage of push-pull amplification with two of the new type-245 power tubes is sold completely wired by the manufacturer of the above kit.

Locating Defective Condensers in Power Units

In most cases trouble in power units is located in defective condensers. A simple and effective method of locating condenser trouble is to connect the eliminator to the light line in series with a 100-watt lamp. With the rectifying tube in the eliminator, the 100-watt lamp will glow if the condensers are shorted. It is then an easy matter to unsolder the connections on the condenser bank until the lamp goes out, and then check up on the condenser unit that caused the lamp to go out. If there are no shorted condensers and no load on the eliminator, the lamp should be out.

Chas. Brown and Miller

Jobe. Deutchman Co. Canton, Mass.

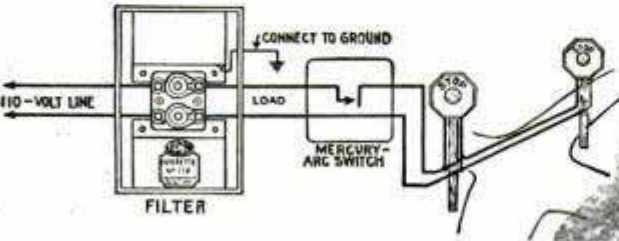
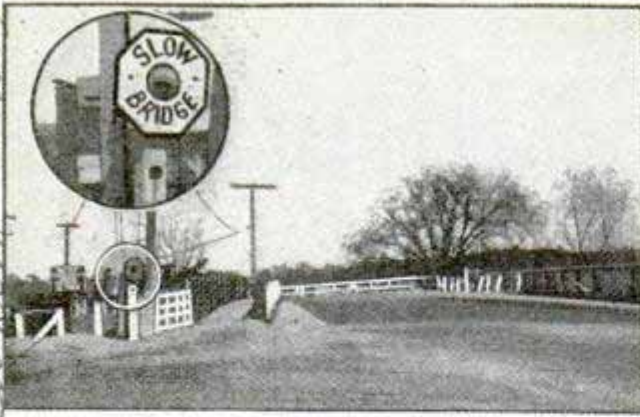

Upper Left, Bridge Approach Showing Location of Flasher Signal; Below, Diagram of Filter Installation; Right, Signal at Through Street

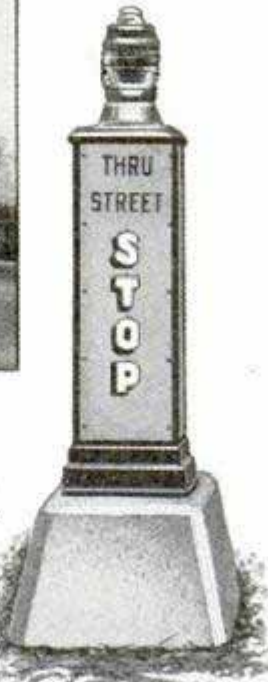

transformer. If this does not produce results, group them in series and parallel across the secondary, until the desired low tone is obtained. When these condensers are connected in parallel, the capacities are added; if connected in series the effective capacity is less than that of the smallest unit in the series.

card list

Radio Switch Clock Is Designed for Fruit Growers

A radio switch clock that automatically turns the radio set on or off at any desired time has been especially designed for the citrus growers of southern California.

Interference from Flashers under Control

In many suburban districts, through streets are protected by flashing signals. The interference from such an installation is usually in the form of a periodic clicking which may be picked up by radio receivers located anywhere within a one-mile radius of the flasher. Similar flashing signals are used at rural crossings and bridge approaches. The installation shown in the upper photo is located near Walpole, Mass., and consists of two 25-watt lamps on opposite sides of the road, about 25 ft. apart. It caused set owners in the vicinity to look about for a remedy. A special filter designed for this form of interference completely eliminated the trouble. The local service man investigating receiving conditions in the vicinity of such flashing signals can co-operate with the local highway department in eliminating interference from this source, as these filters are now available.

The temperature readings for each district are announced by radio at frequent intervals throughout the night, and if frost is likely to appear, the grower must be wide awake and on the job. With the automatic switch, he notes the time announced for the next report, sets the dial for that time and returns to bed, knowing that he will be awakened by the radio announcer when his set is turned on at the expected time. The switch is mounted in a neat metal base upon which the clock is supported by two standards.

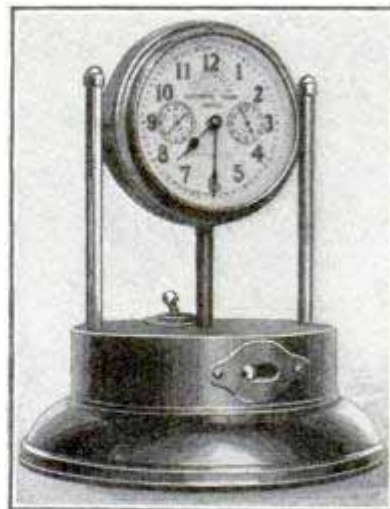

There are two dials, one for setting the turning-on time, and the other for setting the turning-off time. The switch is connected between the battery or light socket and the set, in series with the filament.

Deeper Tones from the Speaker

If the depth of tone is not satisfactory, the following method will often secure the desired result: Provide three fixed condensers of .00025, .0005 and .002-mfd. capacity, and connect them, one at a time, across the secondary of the first audio

It is designed for operation with sets employing either 6-volt batteries, eliminators, trickle chargers or with a.c. sets.

Pacific Apparatus Co. Venice, Calif.



Old Favorites in New Forms

EVERY boy at some time or other makes a windmill, and for years these devices have been merrily whirling on the barn, garage or backyard fence. Of late, however, it has become quite a fad to make animated windmills of all sorts, two types of which are described in this article. The first drawing shows a dancing ducky, and is the work of I. M. Monteny, of Castle Rock, Wash., while the galloping horse on the following page was designed and made by Owen Stevens, of Chico, Calif.

Four-bladed propellers are best to use for this purpose as they catch more air and consequently transmit more energy

to the mechanism. To make a suitable propeller to operate the dancing ducky, take two 12-in. lengths of 1 by 2-in. stock, such as poplar, which is easy to cut to shape. The detail at the upper right-hand corner shows how the block is cut diagonally to form a blade at each end. Remember that opposite blades must be inclined in opposite directions when viewing them from end to end, this being clearly indicated by the diagonal lines in the detail. The two pieces are mortised and nailed together in the exact center, after which the blades may be trimmed down separately to balance the whole propeller. A 6-in. shaft, cut from $\frac{1}{2}$ -in.

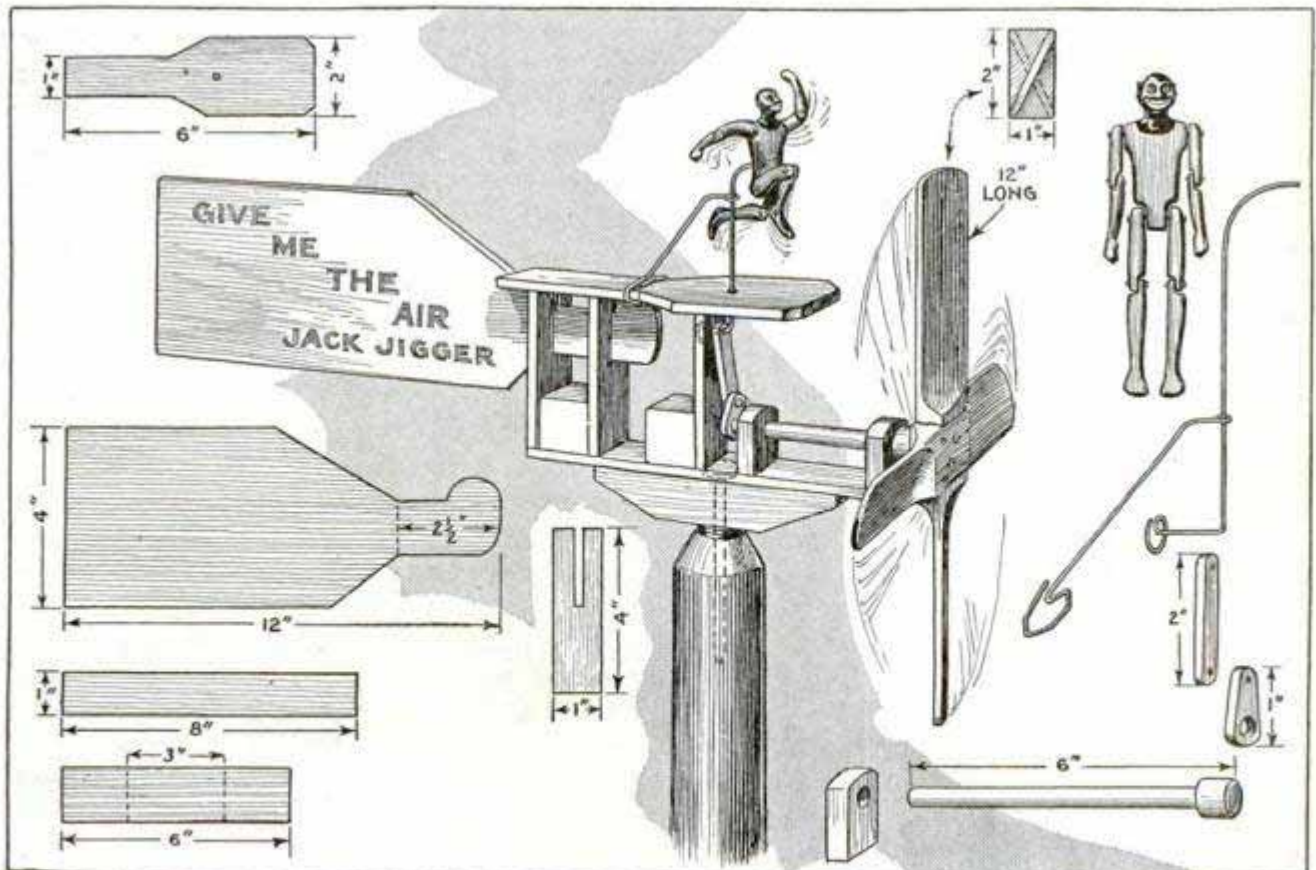

Animated Windmills Are Now the Fad; This Dancing Ducky Is Always Full of Pep When the Wind Blows

dowel stock, is set firmly in the propeller hub and two hardwood blocks, drilled to receive the shaft, form the bearings. A collar on the shaft next to the hub, keeps the hub from rubbing against the bearing and thus eliminates excessive friction. The 1-in. crank arm, which is attached to the end of the shaft, is shown just above the detail of the shaft, together with a 2-in. connecting rod. A length of wire, to which

Although the Horse Keeps on Galloping without Fatigue, the Huge Fish Wiggles Its Tail and Always Keeps the Same Distance behind Him

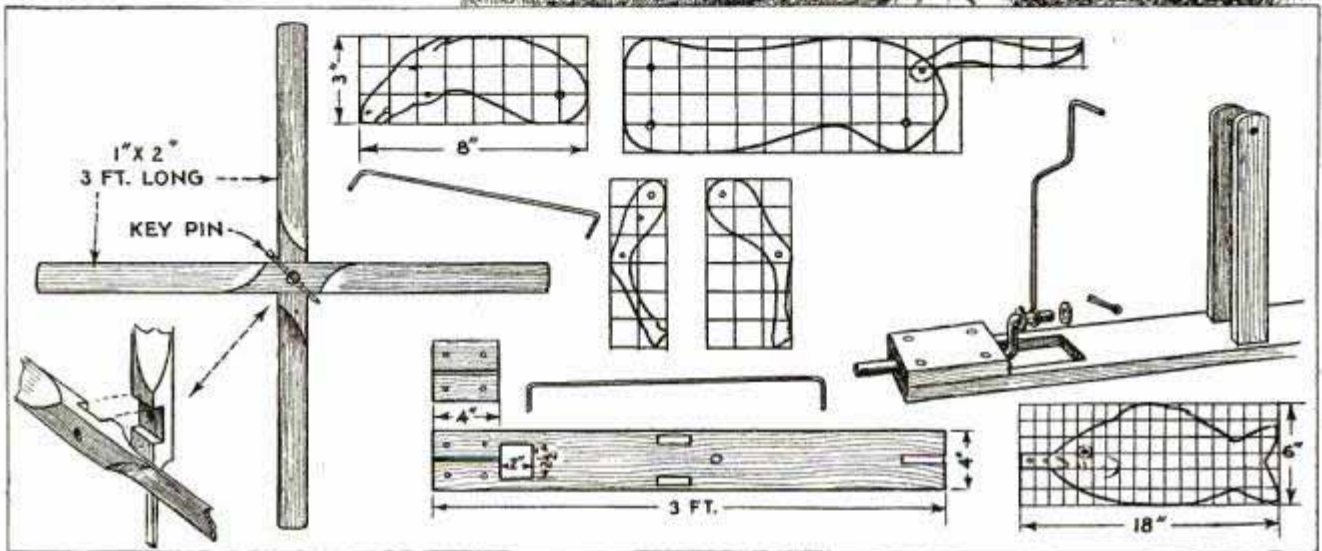
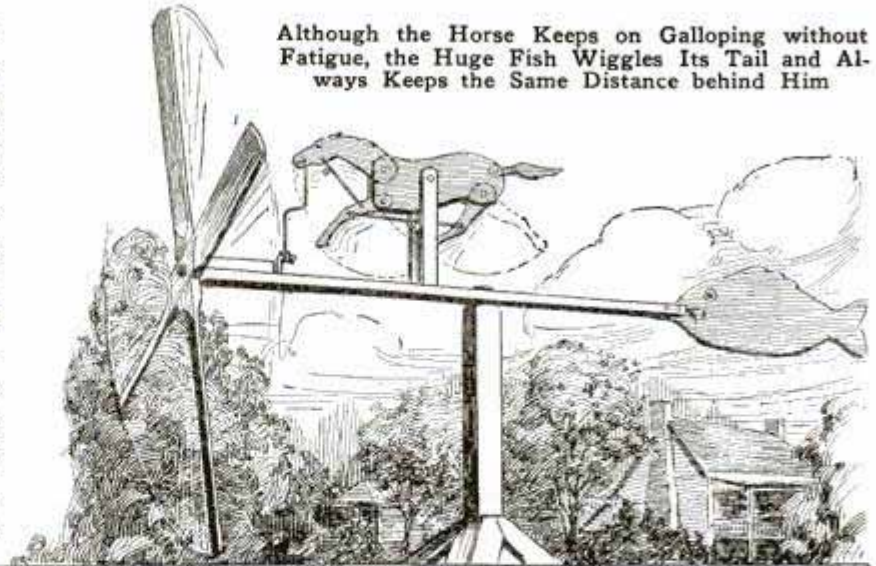

the figure of the darky is attached, is bent at the lower end to pivot on the end of the connecting rod and is supported in two bearings so that it stands vertically. The first of these bearings is formed by a hole drilled through a wooden platform, representing the floor on which the darky does his dance, while the second bearing is made by forming an eye in a length of wire, which is attached to the platform as indicated. The figure must be carefully made, the arms and legs being loosely pivoted so that they will move freely when the figure reciprocates up and down. The remaining parts of the device, including the framework, the weather vane and the base, which is fitted with a pin at the point of balance, are all clearly shown, and no difficulty will be experienced in making and assembling the device. Bright colors add considerably to the attractiveness of the windmill, and paint also preserves the wood. Take care, however, not to get any thick paint be-

tween the bearing surfaces, or on the joints of the figure. Oil applied to these points will reduce friction and also keep moisture from penetrating the wood.

Besides its obvious usefulness as a weather vane, the galloping horse, which is much larger than the dancing darky, makes a suitable adornment for the barn. The propeller is 3 ft. across and the blades are made of 1 by 2-in. wood. The drive pin, consisting of a length of light metal rod or heavy galvanized-iron wire, is securely anchored to the hub of the propeller and the other end is bent to form a crank. The crank moves a connecting rod attached to the horse's head, which is pivoted to allow a vertical movement. The legs are also pivoted and a positive movement is imparted to them by wire connecting rods, one of which is attached to the head. Thus the head and both pairs of legs move in unison, as indicated by the dotted lines. The horse can be made of either wood or sheet metal, and the vane, attached to the

rear part of the frame, is cut from sheet metal to resemble a huge fish. The impression one gets is that the horse is trying to outdistance the fish, which wiggles its tail—if this is made of thin shim brass—and swims after the horse.

An Electric Radiator Heater

In an unheated garage it is rather difficult to keep the engine reasonably warm, to permit easy starting. If desired, however, a simple electric heater can be made to fit against the radiator. Get a shallow pan large enough to fit the front of the radiator and obtain a heating coil about 6 or 8 in. long, which is designed for use on 110-volt current, and draws from 400 to 600 watts. If such a coil is not readily available an ordinary radiant electric-heater element, which can be obtained at any hardware store, will do. In the case of the coil first mentioned, it is mounted on the inside of the pan with suitable brackets, care being taken to keep it well insulated, and two lengths of asbestos-covered cord are connected to it as shown. If a heater coil is used, merely screw a cleat receptacle to the inside of the pan on a right-angle bracket so that when the element is screwed into the receptacle it will be parallel to the bottom of the pan. A bail is provided so that the pan can be hung over the radiator filling spout.

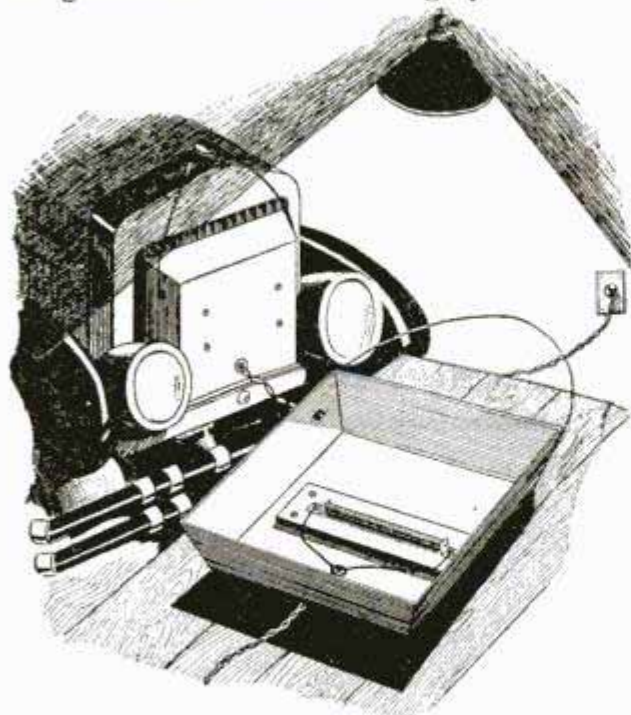

Electric Radiator Heater for the Auto Is Easy to Make and Costs Little

Holder for the Baby's Bottle

There is no necessity for holding the baby's bottle by hand, as a simple bottle



Wire Holder for the Baby's Bottle That Will Save Mother Much Time

holder, of the kind shown in the drawing, can readily be made. It consists of a length of wire bent to clamp on the bottle. Rubber tubing is slipped over this end to insure a good grip. The wire fits into a length of tubing which is drilled and tapped for a thumbscrew to permit adjustment for height. The tubing is split at the lower end and bent out so that it can be attached to a square frame by means of screws, the bent ends of the tubing being drilled to accommodate them. The frame fits under the pad of the cot, and is held firm by the baby's weight. If desired, the tubing can be attached directly to the side of the cradle instead of the square base, but this arrangement limits its use to the cradle only.—Mrs. Ruth E. Shaw, Kansas City, Mo.

Peeling Onions

When peeling onions just hold the onion in the left hand with the root end uppermost, and peel downward toward the stem end. By doing this you will find that "there is not a tear in a peck."—Mrs. J. E. Bourne, East Providence, R. I.



Simple Device for Gassing Rodents in Their Burrows Has Been Found Effective

Gassing Rodents

In cases where it is not advisable to lay poison to destroy rats and other rodents, try gassing them by the method shown in the drawing. Take an old paint drum about 12 in. long and 8 in. in diameter, and fasten the lid to the side by means of a link hinge. Punch a hole in the lid to admit the point of a pair of bellows. In the base of the drum punch a 2-in. hole, and solder a short length of sheet-metal tubing around the hole as shown. Rivet or solder a strip of sheet metal about $2\frac{1}{2}$ in. wide to the inside of the drum to prevent cotton waste and sulphur, which is later put into the drum, from clogging the pipe. In use, the drum is opened and some old, oily cotton waste is placed inside and ignited. If necessary, the lid may be closed and the cotton waste fanned with the bellows to get a good glow. Usually, however, the waste will burn readily if the lid is

removed. While smoking well, place the pipe in the mouth of the burrow, preferably to the windward side of the other holes. All holes from which smoke issues should be plugged up tightly. Then the drum is opened and some sulphur is sprinkled on the cotton waste, after which the cover is replaced and the bellows operated to force the fumes into the burrow. Sulphur dioxide is generated and this will kill the rats if they cannot get out.—George H. Holden, Chesterfield, Eng.

Glass-Cutting Kink

Glass cutting without special tools is usually unsatisfactory and sometimes wasteful. The ruler or yardstick commonly used, often slips when the cutter is pressed against it, and the whole piece of glass may be ruined. To avoid this trouble, cut a strip of rubber from an inner tube, about the width and length of the ruler or stick. Lay the strip under the ruler, and no slipping will occur.—F. W. Bentley, Jr., Missouri Valley, Ia.

Repairing Lawnmower

Many lawnmowers are constructed with a pawl and a ratchet wheel, as shown in Fig. 1 of the accompanying illustration. They are quickly worn so that the ratchet does not hold at all times, particularly when the cutter stops with the pawl in a

horizontal position. However, the machine can be made as good as new by filing or grinding the pawl as shown in Fig. 2, grinding a twist drill to a sharper angle than usual and cutting out the ratchets as shown in Fig. 4. By using the adjacent ratchet as a fulcrum for the drill, it can be worked across the face of the ratchet, and a perfectly square face readily cut on it in a few turns.

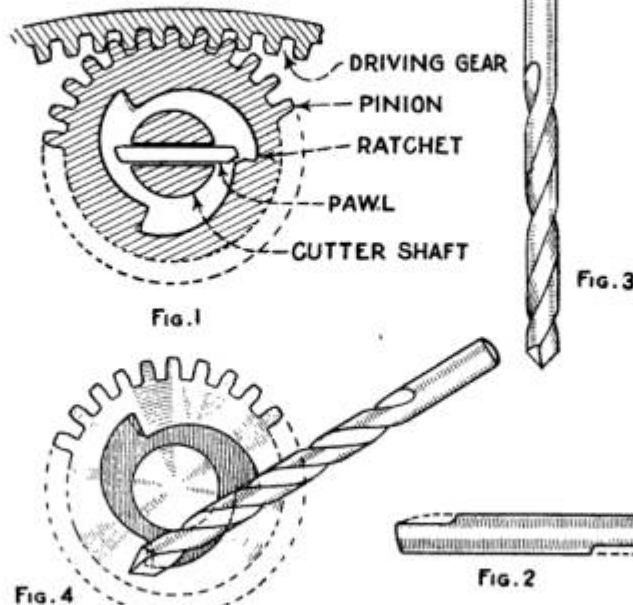

Fig. 1, the Ratchet Mechanism, Showing Wear; Figs. 2 to 4, How the Parts Are Repaired

Repair for the Timer Roller of Old-Model Ford

While making a long drive, the owner of an old-model Ford had the misfortune to break a timer-roller spring and was unable to proceed. As there was no service station or telephone handy, he was at a loss what to do until he thought of taking a rubber band, which he had in his pocket, and wrapping it around the roller arm to take the place of the spring. The result was entirely satisfactory and he was able to drive to the next service station without any trouble.—Glen F. Stillwell, Collinsville, Ill.

Inexpensive Electric Vaporizer

When you wish to warm or vaporize a small quantity of liquid, or melt a solid, such as paraffin or wax, which does not require an intense heat, try the method shown in the drawing, which makes use of a 16-cp. lamp of the carbon type as a heating unit. Screw a cleat receptacle to a small piece of wood, which is used as a base. Connect a length of lampcord to the receptacle for plugging into a convenient outlet. Take a clean tin can and remove the ends so that the resulting cylinder will be about 2 in. longer than the combined height of the lamp and socket. In cutting one end leave two small lugs. These are bent over to form feet which are tacked to the base.

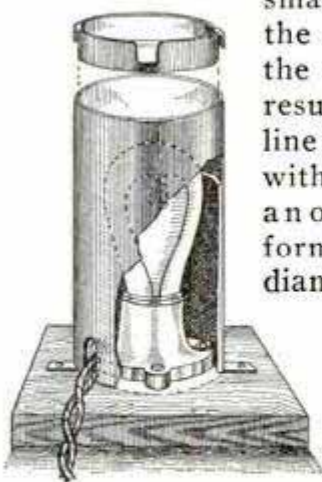

A small notch is also cut in the bottom to receive the lampcord. For best results, it is advisable to line the inside of the can with asbestos paper. Cut another can down to form a shallow dish of a diameter a trifle smaller than that of the first. Also leave four lugs which, when bent over, form hooks for supporting it on the top of the tall can. The heat generated by the carbon lamp is sufficient to melt or vaporize the contents of the shallow dish in a few moments.—L. B. Robbins, Harwich, Mass.



Pair of Andirons for the Fireplace Made from Iron Ship Anchors

Andirons Made from Old Anchors

For the cottage or lodge fireplace, a novel pair of andirons can be made from old anchors, preferably those of the "kedge" type with a fixed crossbar. The length of the shank should not be over 20 in. to fit in the average fireplace. Plain black iron makes the most rustic appearance. Saw off one fluke about halfway between the tip and the shank and saw off each end of the crossbar near the ball and the crook as shown. Heat the ends of the bar and bend them down at right angles to form legs parallel to the remaining fluke. The height of the legs should be the same as that of the portion from which the fluke was removed. Place the andirons thus made side by side in the fireplace as shown, and you will find them quite nautical in appearance and able to support a heavy load of logs.

☞ To make your shoe soles last longer, warm them and then apply two or three coats of hot copal varnish; this treatment makes the soles waterproof.

Stunts for Your

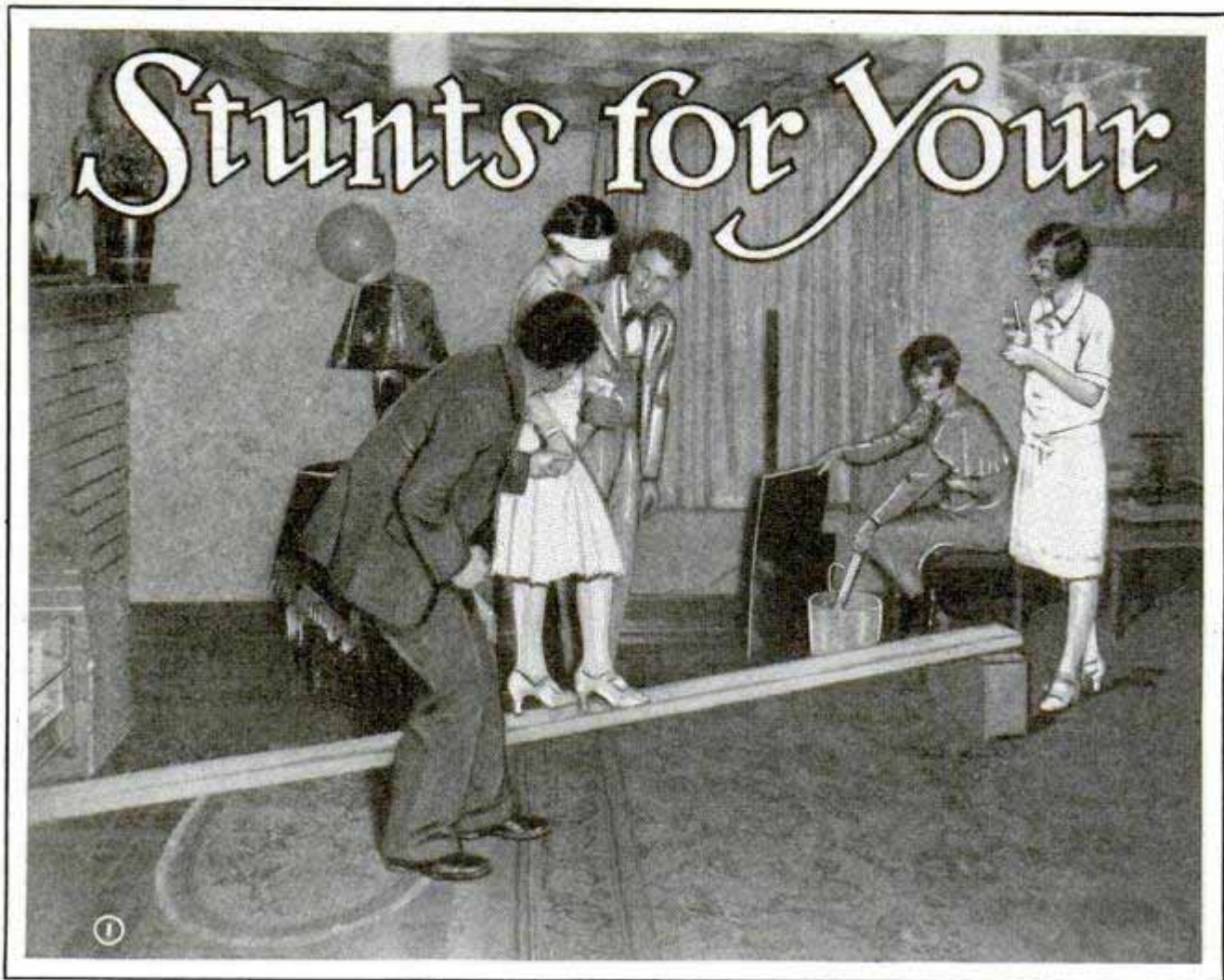

OCTOBER 31—Hallowe'en—that's the night the "ghost walks," and, believe it or not, if you can cause delicious shivers to run up and down the respective spines of your various party guests, you'll get three cheers and a tiger from everyone concerned.

Did you ever "walk the plank?" Off into the briny deep, I mean, with salt water and everything! You will need a plank, of course, and one end of this should be supported on a low box. Also, you should have on hand an ordinary sprayer filled with salt water. Your victim is blindfolded, and a guide on either side take his hands and lead him up the plank, as shown in Fig. 1. As he progresses, the guides should stoop lower and lower in order to give the plank-walker the impression that he is going up a considerable height. At the end of the plank, the victim is told to halt. The guides step away. You can give a short farewell address: "The howling sea that is upon us tonight!" At this part of the speech, someone takes the sprayer and sprays

salt water in the victim's face, while another member of the "plank-walking brigade" runs a wooden paddle around in a pail of water. A sheet of tin can be shaken to get the windstorm effect. The victim is then prodded gently from behind and commanded to "yump." From all past observations, he should experience a considerable thrill in jumping down through space those few short inches.

Here's something else. No Hallowe'en party is complete without the traditional "ghost story." An excellent manner in which to put this across is to seat your guests in a circle on the floor, see Fig. 2. In the center of the circle place three or four lighted candles. As the telling of the story proceeds, the candles magically go out, one by one, until at the climax, the "Now I've got you!" stuff, the last candle goes out, leaving the room in total darkness.

The "nigger in the woodpile" isn't much. It is merely a matter of cutting the candles, taking out a small piece of

Hallowe'en Party

by Sam Brown



the wick, as shown in Fig. 3, and then putting the candles together again by slightly heating both of the cut ends. Of course, when the candle burns down to the break in the wick it will go out. Give the idea a little experimenting beforehand, so that the various candles will be properly timed.

Try this stunt: You are seated at a table. Around the table are other spectators, all holding hands, making a complete chain. The room is dark. Now, slowly and with a soft glowing intensity, a small light appears in the center of the group. It grows in intensity and form until you are horrified—or should be—to see a death head floating above the center of the table, bathed in a halo of saffron fire. The illusion lasts for a full breathtaking ten seconds, and then the head slowly fades from view. Lights! Everybody's hands clasped! Nothing on the table!

The manner of effecting this spooky illusion is quite simple. Get a hollow tube of tin or cardboard, about $\frac{1}{2}$ in. in



diameter and 5 in. long. Paint the outside of this tube black. Now, glue a large dark balloon to one end of this tube, as shown in Fig. 4. After the glue has set, inflate the balloon to its full dimensions, and on it, with luminous paint, paint the figure of a grinning skull, as shown in Fig. 5. Mark the tube at the free end in some manner so that you can tell, with your lips alone, whether the skull head is upside down or not. Stuff the balloon up into the tube.

And now for the stunt. You are seated at the table. Your hands are held. The prepared tube, looking for all the world like a fountain pen, is in your upper coat



pocket, or if you happen to be a "leddy," under the top of your dress. The lights are out. Now, do you see how the trick is accomplished? A simple matter to duck your head, as shown in Fig. 6, get the end of the tube, and, oh, well, the rest is just a lot of "hot air!"

How's this? The host (that's you) brings forward to the center of the room a sheeted, ghost-like figure, which, up until then, had occupied an unobtrusive place in one corner. This ghostlike figure is introduced as the Talking Fool, Ghostland's only interpreter. This figure, as explained further, not only talks, but will answer any questions which may be asked of it. And it does—a deep sonorous voice that answers all and sundry interrogations with varying degrees of truthfulness.

No, there's no small boy concealed beneath the sheet. In fact, there is nothing at all under the sheet except a wooden pole to hold the figure upright.

Well, then, how is it done? Like this:

Get a small wooden barrel hoop. Get two lengths of 1½-in. half-round lumber about 4 ft. long, and two short lengths of wood, 4 in. wide by ¾ in. thick. Get a speaker unit of the type used in the average radio set and some wire. With these various things in readiness, you can very easily duplicate the figure shown in Fig. 7. The barrel hoop is nailed to the top of the two pieces of half-round molding. The speaker unit is fitted into a hole drilled through the hoop, as shown in Fig. 8, and the wires from this unit are inclosed between the two pieces of half-round. The two pieces of 4-in. wide-wood stock are used to fashion a base for the

upright pole, and the wires from the speaker are fastened in place at either end of one of these crosspieces to two nails, the ends of which project about ¼ in. below the under surface of the wooden support, as shown in the diagram, Fig. 11. The idea of these nails is to allow an elec-



trical connection between the speaker unit and two pieces of tin which should

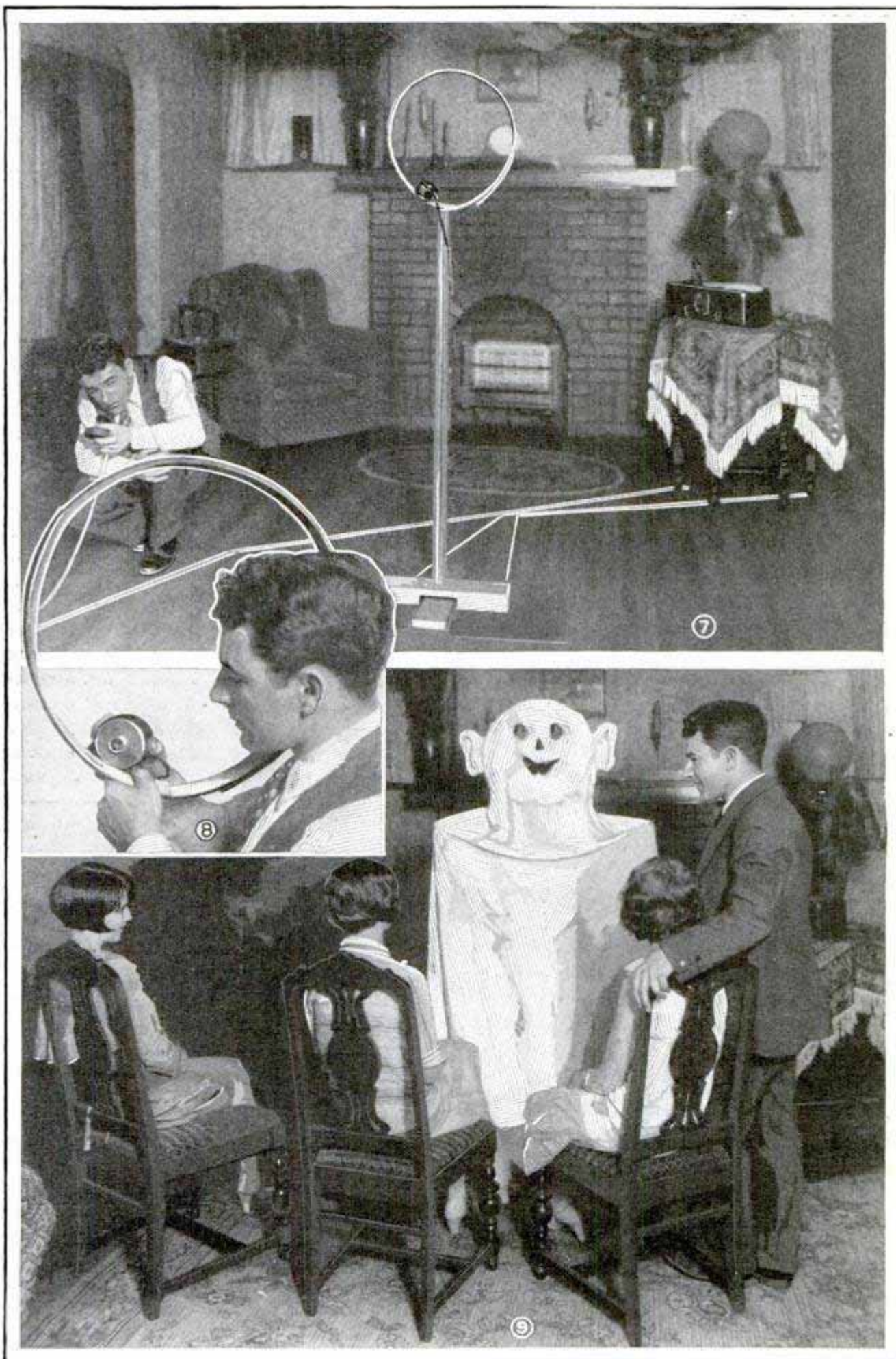

be placed on the floor, as may be seen in Fig. 7.

Are things getting any clearer? Well, two wires are bolted or soldered to the tin sections, and these wires, fastened to the floor by means of thumbtacks, lead

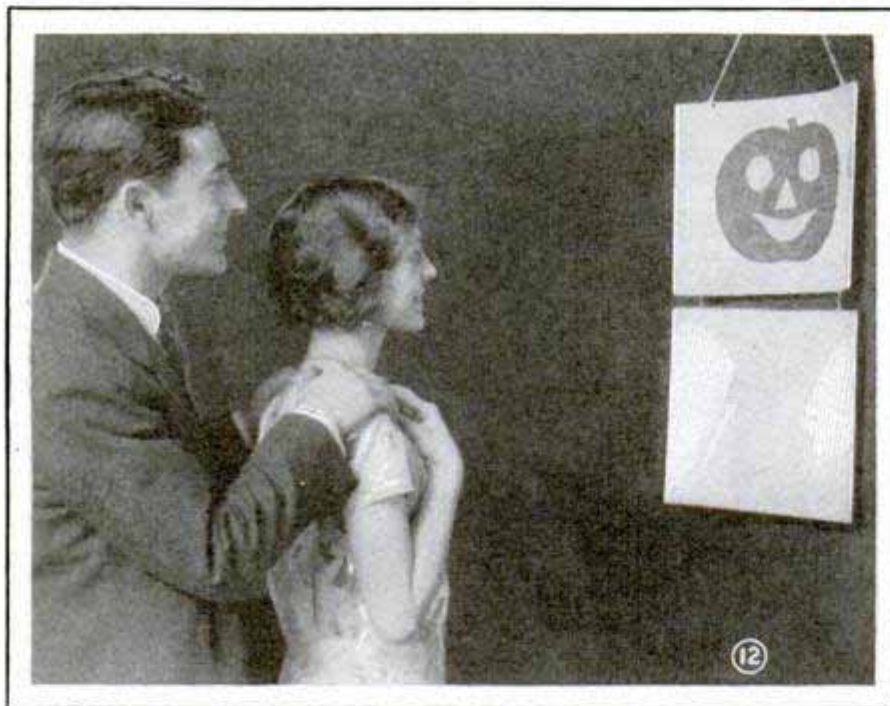
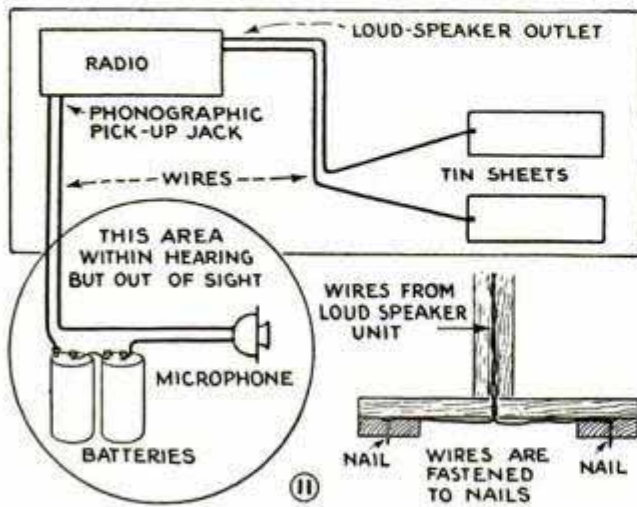

into the loud-speaker outlet of your radio set. Now, from the phonographic pick-up jack of your set, run two wires, over the floor again, to a convenient closet or down to the basement via the hot-air shaft—anywhere that is within hearing yet out of sight. Two batteries are hooked onto this line, and a microphone ends the whole thing.

Maybe it sounds rather complicated, but the diagram shown in Fig. 11 should make the whole thing clear: A speaker unit at one end, a connection made by nail ends projecting through the rug

onto tin plates, a line to the radio and out to a microphone—that's the whole outfit.

And now for the performance. You bring the outfit to the center of the floor. An old sheet has been fastened in place over the bare framework, with features painted on, as shown in Fig. 9. You take care that the figure is placed just so, in order that the nails in the crosspiece will make contact through the rug with the tin sheets. And there you are! The man at the end of the microphone should be close enough to the party group to hear the various questions. His answer is whispered softly into the microphone, it goes through an amplifying stage by radio, and comes out like the proverbial "ton of bricks" from the ghost's mouth. The assistant's voice, however close, cannot be detected because it is perfectly synchronized with the "ghostly chatter."

Try it! You will find that with a little care in the concealment of the wires, everybody will be very much mystified.

Of course, there are hundreds of other spooky stunts which you can effect at Hallowe'en. You can use flasher buttons in order to make a ghost or a black cat with orange or red blinking eyes. How about painting skull heads on balloons with luminous paint so that they will glow weirdly in the dark? Painting a white skeleton on a black bag, touching it up with luminous

paint, and having it shoot along a long wire from the top of the house to the garage? A wet glove, with thin sticks glued inside each finger to imitate the real bony handclasp of some departed spirit, gives a real thrill in the dark. How about writing fortunes with a solution of baking soda and water, and then revealing the fortunes by holding a lighted candle under them, causing the writing to turn brown?

But try this one: On a white sheet of cardboard, paste a large orange pumpkin cut-out, with eyes, nose and mouth of blue

paper pasted on, as shown in Fig. 12. Hang this pumpkin face on the wall and below it arrange a second sheet of plain white cardboard, as shown in Fig. 13. If you will look the jack-o'-lantern square in the mouth as you count twenty without blinking, and then stare at the plain sheet of cardboard, you will soon see the filmy, ghostly spirit of Mr. Jack-o'-lantern—a blue face with orange features—mysteriously appear on the blank cardboard and then as mysteriously pass through the solid wall. No, Amos, there's no trick about it. It's merely a matter of retention of vision—whatever that is—and you need but try it to be convinced.

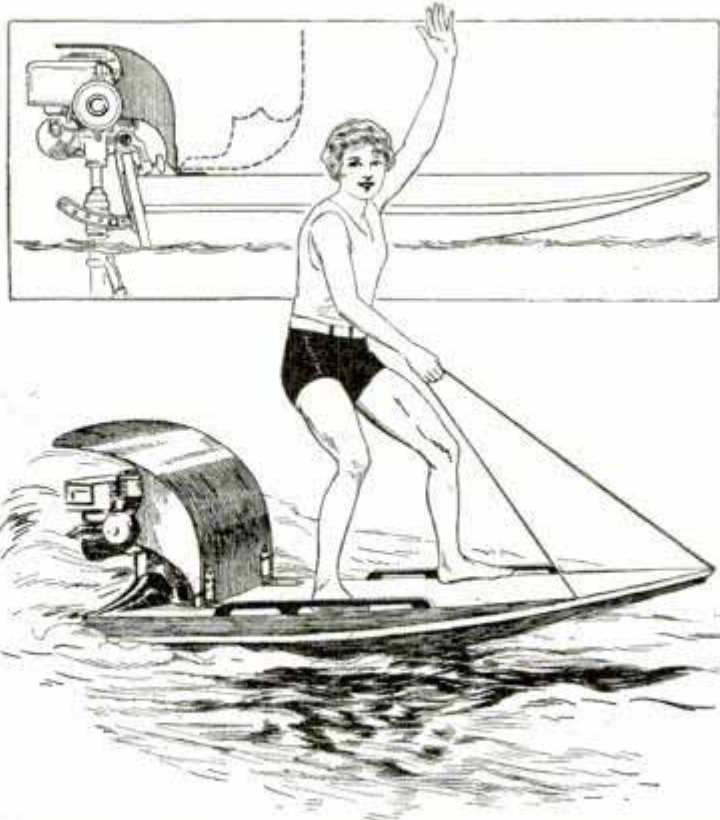

Sheet-Metal Hood for the Motor That Protects the Outboard Aquaplaner from Injury

Preserving Fishing-Rod Grips

Often the cork grip of a fishing rod chips or peels off after several seasons' use. This is caused by perspiration absorbed from the palm by the cork. The trouble can be prevented as follows: Before storing the rod away wash the cork with lukewarm water and soap, scrubbing it lightly with a soft brush. It should then be rinsed and wiped, and hung in a shady well-ventilated place until thoroughly dry.

Stove-Pipe Cleaner

Everyone who has taken down stove-pipes for cleaning knows how messy the job is. The writer has found it much better to disconnect the pipes and scrape the soot out as shown, which eliminates the trouble of taking them down. The scraper used for this purpose has a sheet-metal blade cut to the shape shown and having a curved edge to fit the contour of the pipe.—A. C. Schofield, Craven, Canada.

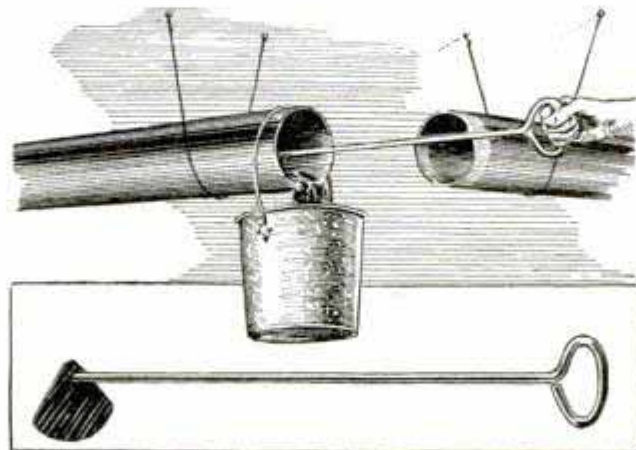

With This Scraper It Is Not Necessary to Take Stove-pipes Down for Cleaning

Safeguard for the Outboard Aquaplaner

Although outboard aquaplaning is a comparatively safe sport, there is always some danger that the operator may overbalance and fall back against the motor with painful if not serious consequences. To avoid this trouble make a sheet-metal hood, preferably of heavy aluminum, and hinge it to the deck just ahead of the motor as shown in the illustration. When starting the motor, the hood can be pushed forward so that it will not be in the way, and when running, it completely covers all the projecting parts of the motor. Sharp edges and corners must, of course, be avoided or the hood would defeat its own purpose.—D. Rockwell, Hollywood, Calif.

☛An emergency corkscrew, which will prove efficient, can be made in a few moments by straightening a safety pin to its full length and coiling it around a nail.

*The Skiboard Corp
72 Hubbard St
Brooklyn, N.Y.*



Cornstalk Fuselage for Model Airplane Is Strong and Durable

Cornstalk Makes Airplane Fuselage

A piece of cornstalk makes an ideal model-airplane fuselage, according to Myron Alber of Beatrice, Nebr. A section of stalk, about 20 in. long, is carefully hollowed out. This can be done by means of a length of wire, one end of which is flattened and bent over at right angles to form a scraper. The shell of the cornstalk is very strong, stands considerable twisting, and completely incloses the rubber band used as motor. A balsa-wood plug is fitted into the front end of the stalk. The rear part is reduced in size by cutting out triangular sections, about 5 in. long and $\frac{1}{4}$ in. wide at the base. After these sections have been removed, the end of the stalk can be brought together and glued, leaving a hole about $\frac{3}{8}$ in. in diameter at the end. This hole is also plugged with balsa wood in which a hook is fastened for the attachment of the rubber bands.—Dale R. Van Horn, Lincoln, Nebr.

Tinning Soldering Bits

A soldering bit may be tinned without any trouble by using the following method: Get a coarse brick, a fire brick being preferable, although an ordinary red brick will do. Cut some grooves in the upper surface to receive the bits, the grooves being made a little deeper at one

end than at the other. The brick is warmed enough to melt some rosin which is put in the grooves. The bit is filed bright, heated and placed in one of the grooves. A stick of solder is held against it and the bit rubbed back and forth in the groove. It may be necessary to add a little more rosin. The bit should be dipped in zinc chloride both before and after it is heated. A short rubbing in the puddle of solder will tin the bit quickly. If a file for brightening the bit is not available, rub the bit against the brick, which will serve the same purpose.

Watch Holder for the Auto

All that is necessary to make the dashboard watch holder shown in the photo, are a few inches of heavy copper wire, rubber tubing of the same length as the wire and of sufficient diameter to permit it to be slipped over the wire, and a 4-in. piece of soft iron, about $\frac{1}{16}$ in. thick and $\frac{1}{2}$ in. wide. After the tubing is slipped over the wire, the latter is bent to the shape shown, to grip the watch securely, and mounted on the iron strip by means of a short screw, the wire being bent to form an eye for the screw, and the iron strip drilled and tapped to receive it. A second hole is drilled through one end of the strip so that it can be fastened to the instrument board as indicated. The purpose of the rubber tubing is to hold the watch securely without marring its surface, and to avoid rattling.—Walter E. Burton, Akron, Ohio.

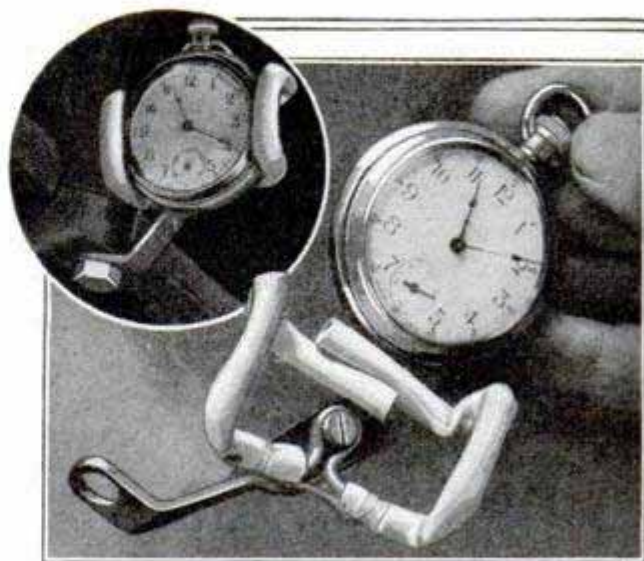

Dashboard Watch Holder Made from a Length of Heavy Wire and a Strip of Sheet Metal

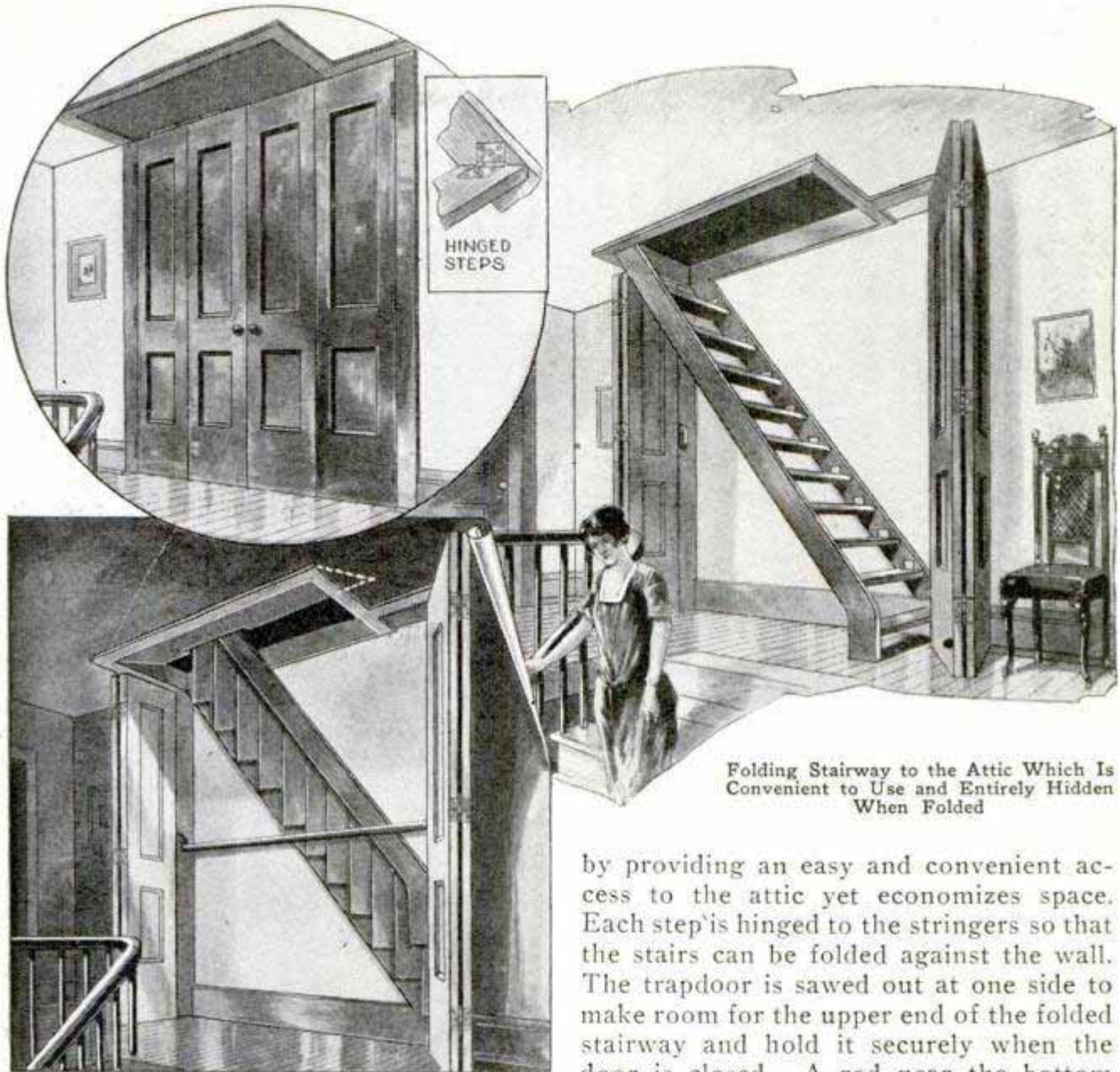

Folding Stairway to the Attic Which Is Convenient to Use and Entirely Hidden When Folded

Convenient Folding Stairway to the Attic

In many a small home or summer cottage, the attic can be reached only through a trapdoor in the ceiling, which is troublesome, especially when it is necessary to lift boxes for storage. In one of the suburban homes of Boston, there is a hidden stairway which solves the problem

by providing an easy and convenient access to the attic yet economizes space. Each step is hinged to the stringers so that the stairs can be folded against the wall. The trapdoor is sawed out at one side to make room for the upper end of the folded stairway and hold it securely when the door is closed. A rod near the bottom supports the folded stairs, the ends of the rod fitting in slots cut in a specially built door casing. Four doors, which completely hide the stairway when it is not in use, are hung from the casing. The drawings show the construction of the installation with sufficient clearness to enable anyone to duplicate it, if desired.—Mrs. Lillian S. Loveland, Wellesley, Mass.

Sealing-Wax Lacquer

Sealing wax, which consists mostly of rosin and shellac, is soluble in denatured alcohol and dries with a high gloss, making the solution desirable as a lacquer for decorative purposes. The sticks of wax should be broken into very small pieces and enough alcohol added to dissolve

them. Unglazed pottery can be decorated with this lacquer as follows: Cut the design from a piece of printed crepe paper and glue it to the surface of the work. Both the paper and the exposed surface of the pottery are given an application of the lacquer. After this has hardened, the paper is removed and the background can be treated in another color.

613 2' Remond Are
South Pasadena Calif



Takie Tabata with His Prize-Winning Model Plane; Note the Position of the Wing

This Plane

fields before coming to earth again. Had it not been for the timer's error this would have set a world's record.

Of course Takie had made other model planes; many of them, and he "knew his stuff." The features which enabled the record-breaker to ride on the breeze and cover over 2 mi. are, in his opinion, the exceptionally wide wing span of 48 in. and the reverse camber of the stabilizer which tends to hold the tail down when losing speed, and preventing a nose dive. By no means did the propeller pull continuously for 41 min.; on the contrary, tests demonstrated that when wound to the safe limit of 200 turns with a 4-to-1 mechanical winder, the prop revolves only $2\frac{1}{2}$ min. But in that comparatively brief space enough altitude is gained to permit duration and distance before yielding to gravity. It is estimated that this plane attained from 800 to 1,000 ft. altitude on its record flight.

Young Tabata says there are no tricks in building a duplicate of his prize winner,

TAKIE Tabata, a 14-year-old boy scout of Pasadena, spent three painstaking days constructing this trim monoplane. It looked pretty good to Takie, but this modest little craftsman was in no way prepared for the sensation his ship made by remaining in the air 41 consecutive

STRAIGHT-GRAINED PIECE OF HARD BALSA $\frac{3}{8}$ " X $1\frac{1}{8}$ " X 16 " USED IN MAKING PROPELLER

$\frac{1}{2}$ " WIDE

SHAFT HOLE MADE WITH PIN DRILL

CARVED FLAT BLADES ABOUT $\frac{3}{16}$ " THICK

BLADE HOLLOWED OUT WITH SANDPAPER

minutes at the Star-News—Pitzer and Warwick model-airplane meet at Ross field, Arcadia, Calif., on June 1st.

The judges were amazed at the swift climb of this 2-oz. tractor, and when it passed out of sight beyond a tall eucalyptus tree, the timer assumed it had come to earth and stopped his watch at 10 min. 46:5 sec. Even that seemed a long flight to the timer, but the adventurous little monoplane had only begun to warm up; for 30 more minutes it soared above the

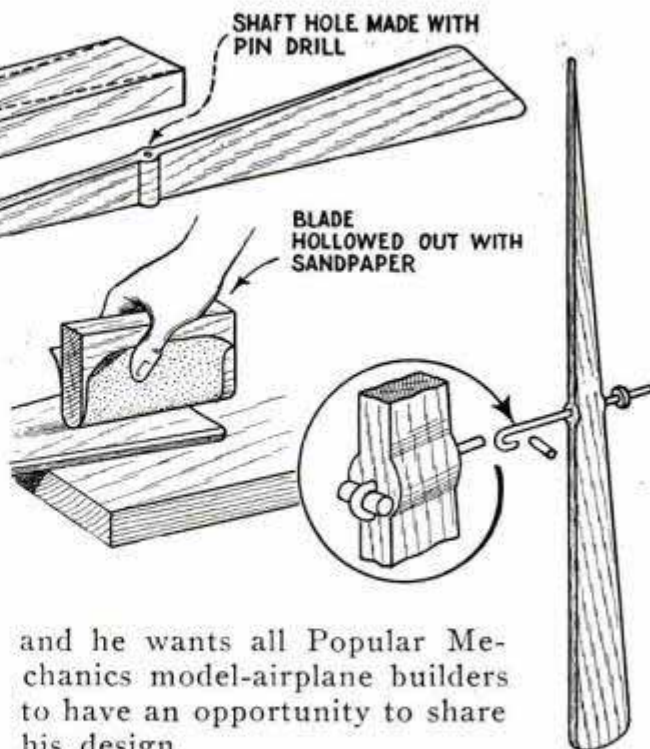

and he wants all Popular Mechanics model-airplane builders to have an opportunity to share his design.

With the exception of bam-

FIG. 1

Flew Forty-One Minutes

by Hi Sibley

*1954 Bridget
Blod
Pasadena, Calif*

boo "wishbone" ribs in the fuselage and such music wire and washers as are required, the plane has an all-balsa framework throughout.

Begin with the two top longerons, Fig. 2, tying them together with cross-

frames of the sizes shown, all of $\frac{1}{8}$ -in. square so-called "hard" balsa, which is

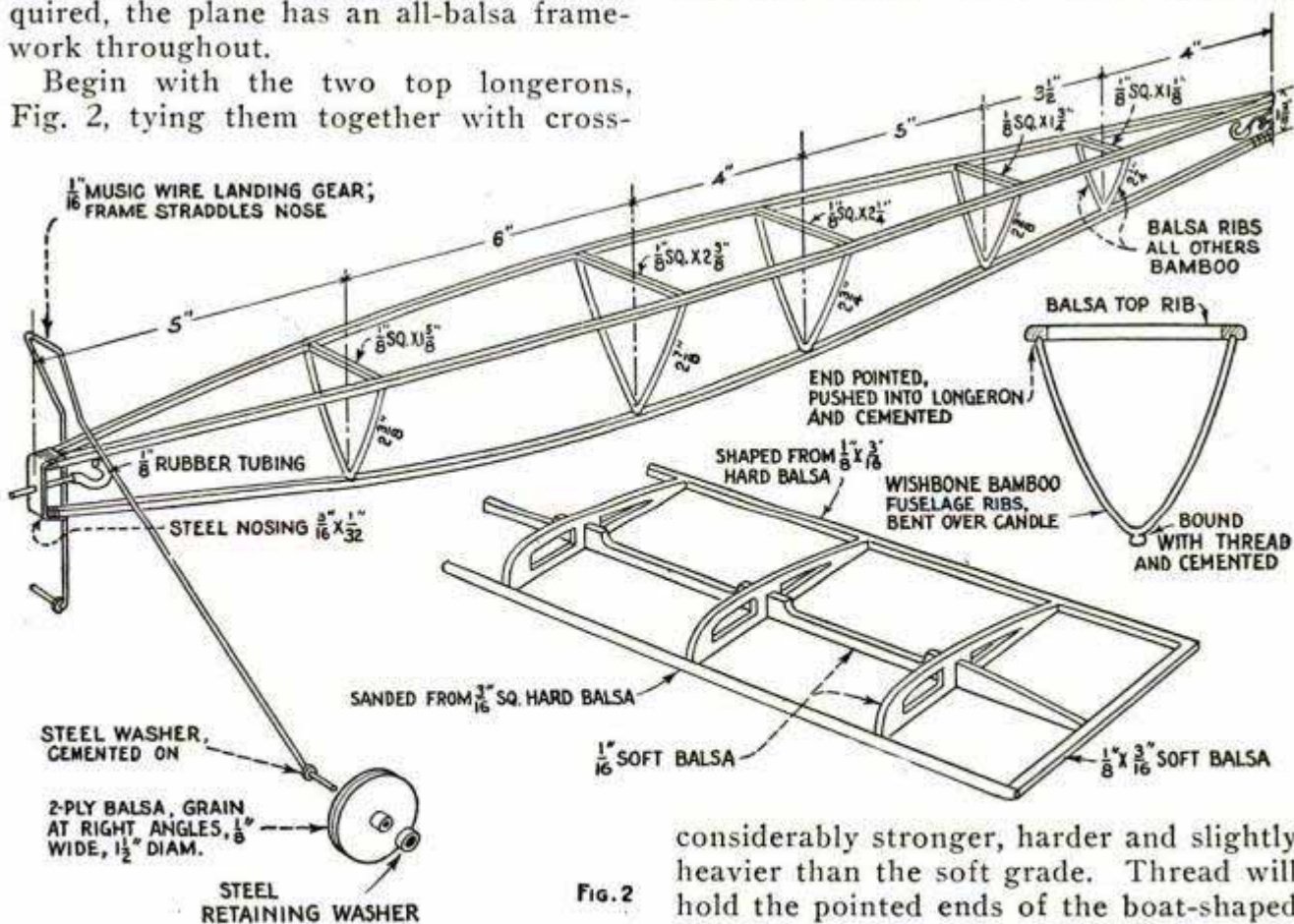
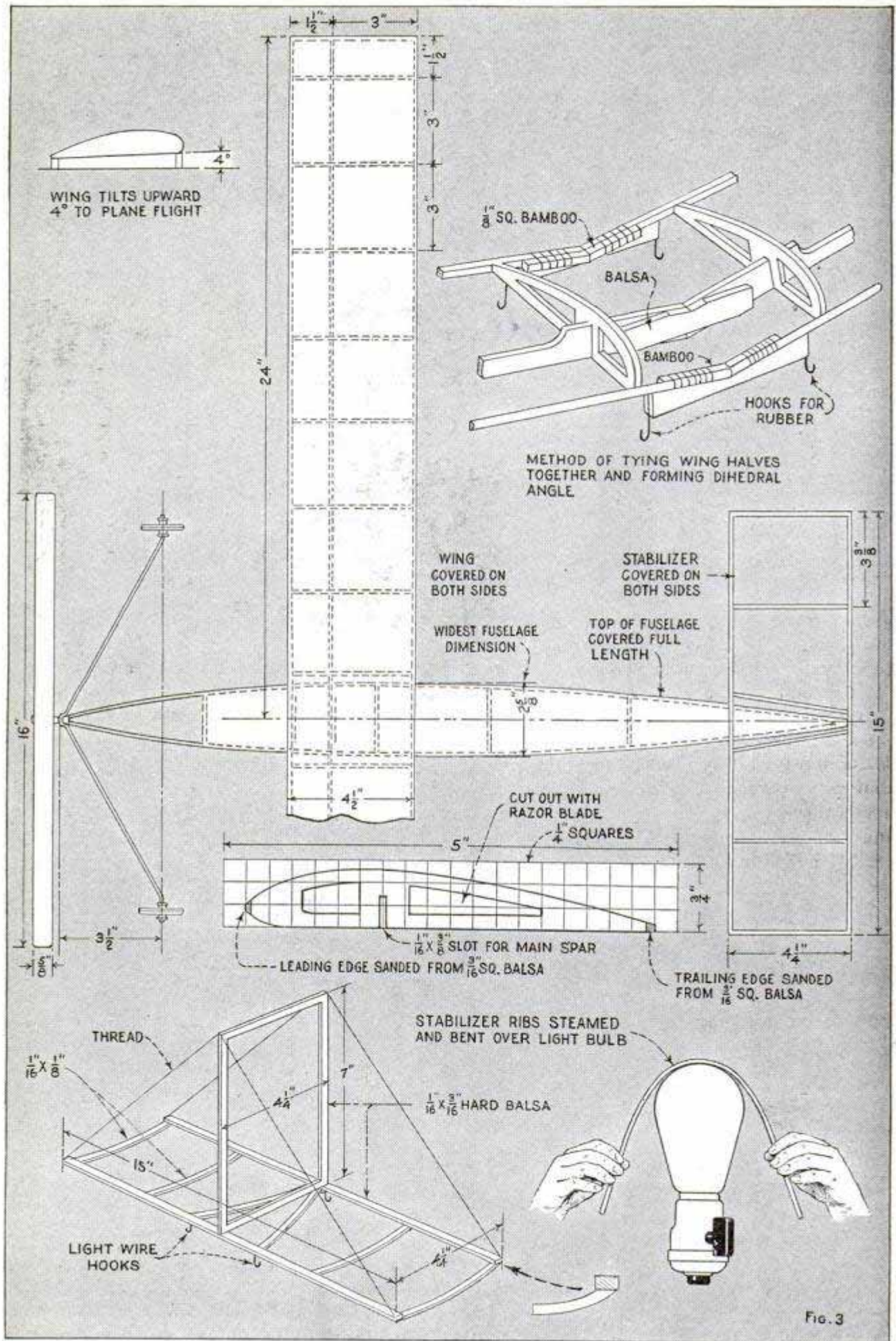

FIG. 2

considerably stronger, harder and slightly heavier than the soft grade. Thread will hold the pointed ends of the boat-shaped



frame together until the ambroid hardens at the joints of the cross-pieces. Next bend four bamboo wishbones at a sharp angle over a candle flame. The bamboo pieces should be about $\frac{1}{16}$ -in. square section, and bending should be done slowly and gently, with the glossy side of the bamboo about an inch above the flame. The ends of the bamboo are pointed and pressed a little way into the top longerons, just enough to keep them from springing out while the ambroid is hardening. When all are set, install the bottom longeron, binding it to the apexes of the wishbones with thread and ambroid.

The nosing, which serves also as a prop-shaft bearing, is of steel, $\frac{3}{16}$ in. wide and about $\frac{1}{32}$ in. thick, or less. Neither aluminum nor brass will carry the load properly. The rear ends are tied together with a piece of $\frac{1}{32}$ -in. music wire having a "U" bent in the center to carry the S-hook.

For such a long and thin propeller as this 16-in. job, a select piece of straight-grained hard balsa should be used. The diagrams (Fig. 1) illustrate the method of shaping the blades, substantially the same as on the prop of the Hixon-Wheaton tractor described in the September issue. The thinness of the blades is limited only by the builder's skill, but should not be over $\frac{1}{16}$ in. at the tips. The hole in the hub for the shaft should be absolutely square with the blades and can be drilled with a tool made by flattening the end of a short section of music wire, grinding the edge sharp and chucking in a hand drill. This tool also is handy for drilling the hole in the nosing, although a fine twist drill is even better. A small steel washer is ambroided to the back of the hub, and a loose brass nut runs on the shaft behind it. All steel washers can be cut from the same size sheet steel as the nosing.

Make the wheels of 2-ply balsa by ambroiding two pieces of $\frac{1}{16}$ -in. stuff to-

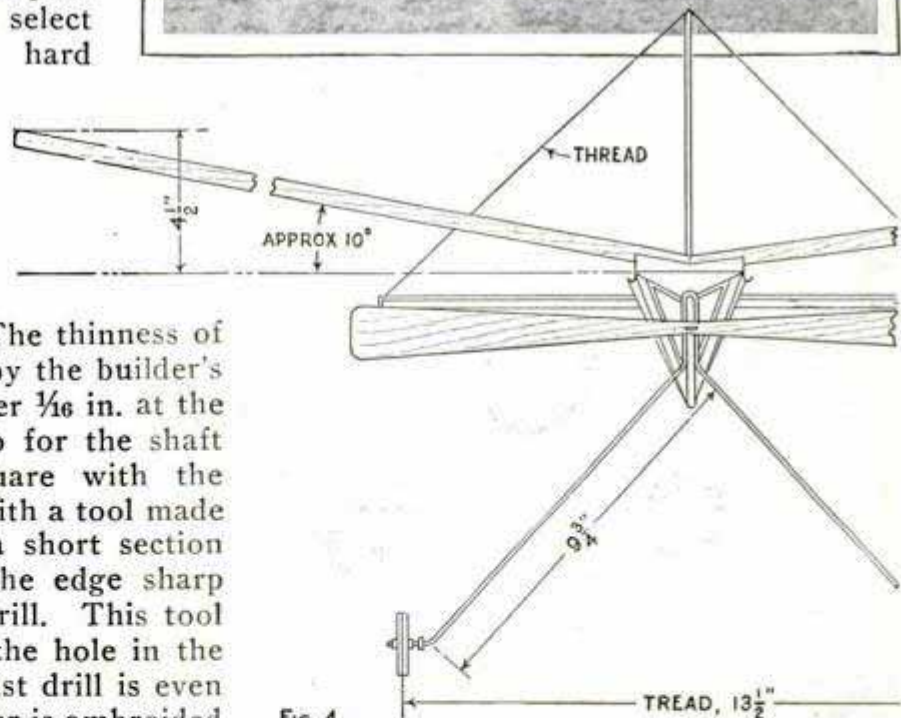
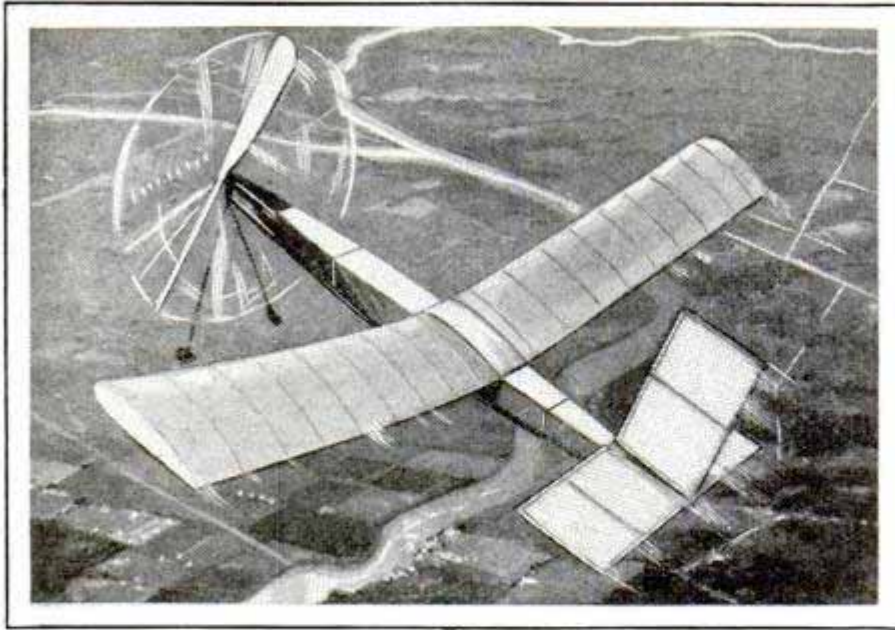

FIG. 4
Tabata Launching His Plane for Its Astonishing Flight at the Arcadia Meet, Where It Created a Sensation

gether with the grain at right angles. A short piece of brass tubing serves as the hub. Washers ambroided to the axles keep the wheel in place.



When the glue holding the paper fabric is thoroughly dry, apply wing dope with a soft brush. Best results are secured with a half-and-half mixture of the dope and lacquer thinner. But do not use any dope on stabilizer or fin, as it will warp the delicate frames.

The three sides of the fuselage are covered one at a time with separate pieces of rice paper. As

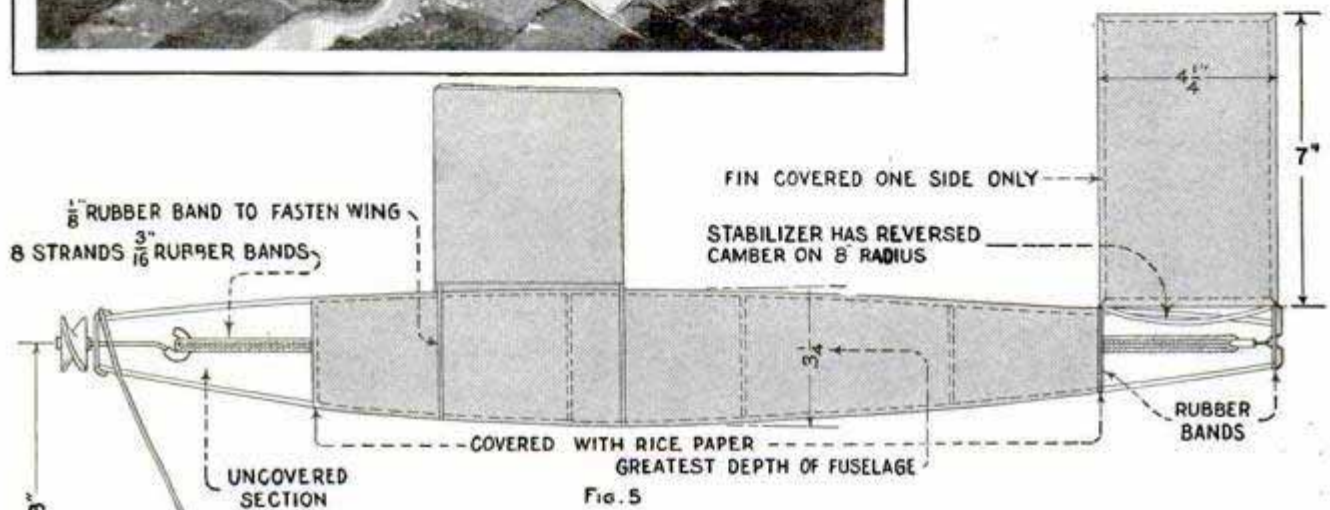

The wing, Fig. 3, is an all-balsa job, with hard balsa for the outer spars and soft for the central

spar and ribs. The diagram illustrates the exact size and shape of the Clark-Y airfoil used in this wing. Young Tabata used a surgeon's scalpel for cutting out the ribs and central spar. A razor blade will do. Before tying together, the two wing halves are covered with rice paper. This material is extremely fine-textured and tough, and better for the purpose than the coarser bamboo paper. Glue is applied on the outer edges of the leading and trailing spars and end ribs. Use the finger tip in applying glue; it spreads more thinly than a brush. The lightest application is sufficient. Hold the paper taut from end to end over the glued end ribs and press down with a dry finger. Then pull it taut from front to back and press down on the glued spars. Do not put glue on the intermediate ribs,

in the case of the wing, do not apply glue to the ribs.

When the glue is dry on the wing halves, tie them together at the dihedral angle (see Fig. 4) by means of short pieces of bamboo bent over a candle. The central spar is tied with a short and stout piece of balsa. All joints are ambroided and bound with thread.

In making the stabilizer frame, Fig. 3, take care that all ribs are bent on the same curve, that is, with an 8-in. radius. This can be done by steaming and bending over a lighted electric bulb, or over a wooden form. They should be thoroughly dry, however, before ambroiding to the framework. Paper is used only on the bottom of the stabilizer, and on one side of the fin, or rudder. The frame of the latter is simplicity itself, being merely a rectangle of $\frac{1}{16}$ -in. by $\frac{3}{16}$ -in. hard-balsa strips mitered at the corners. It is braced by threads to the corners of the stabilizer. A small block of balsa is ambroided to the rear center of the stabilizer to make

it level with the direction of flight, or parallel with the strands of the motor.

Balsa blocks are also ambroided to the underside of the wing at the center in order to tilt the front edge upward at approximately 4°. The most efficient angle will be determined by experiment.

Now adjust eight strands of $\frac{3}{16}$ -in. flat-rubber band so there is a little slack when unwound. By all means provide yourself with a mechanical winder, or make one from an egg beater. It is indispensable for this type of ship, since the rubbers can be wound four times as much by stretching them out. At first do not go over about 75 turns with a 4-to-1 winder. Tabata says that 200 turns with the winder is a safe limit; he has gone as high as 250, but does not recommend it.

You will get best results at first by launching in the air by hand. Give it a gentle thrust—and always into the breeze, not with it. The breeze will help it gain altitude, though in the meantime it will swing about and follow the direction of the wind.

It is of utmost importance to have all surfaces in their proper alinement. A slight variation one way or another will ruin its performance. And note from the photo how far back Tabata sets his wing—well back of the center of the fuselage. But this is precisely the position in which it made the record flight for him.

Make this wonderful little monoplane according to these plans and you will have a ship you've always hoped to own—one that flies and flies—and how!

Wax Covers Barb on Fishing Hook

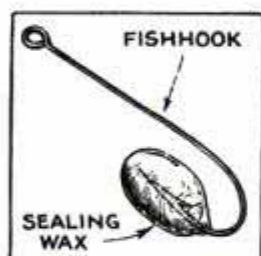

To prevent the barb of fishing hooks from catching on the inside of the fishing-tackle kit, cover the barb with a wad of paraffin or wax as shown. When the hook is to

be used it is an easy matter to break off the wax. The writer found that hooks with barbs protected in this way could be carried in the pocket when it was not desired to carry along any unnecessary equipment.—George Woodwin, Ramea Island, Newfoundland.

Concrete Lawn Seat and Tree Guard

Besides serving as a lawn seat, a circular slab of concrete with a suitable open-

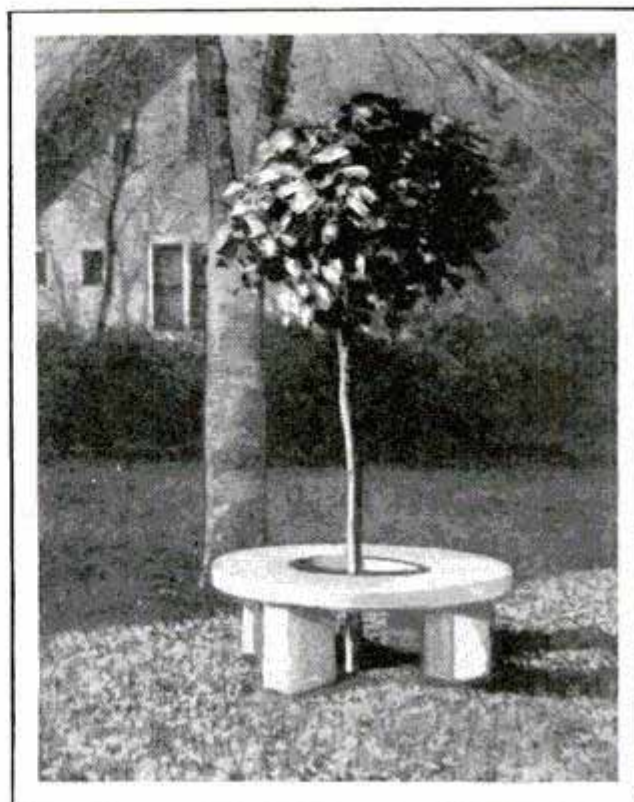

Neat Lawn Seat and Tree Guard Made of Concrete Slab and Blocks

ing in the center, as shown in the photo, makes a good guard for a small tree. It is set on three concrete blocks, although tile can be used if desired. The slab was cast on a smooth surface with two strips of tin or galvanized sheet iron on edge serving as a form. The ends of the strips were soldered together previous to pouring the concrete, the outer one measuring 48 in. and the inner one 20 in. in diameter. The inside form was laid down first and filled with sand to prevent crumpling. Then the larger form was laid about it so that both were concentric, giving a uniform spacing of 14 in. between the two all the way around. Concrete made in the proportions of 1 part of cement to 3 parts of sand, with just enough water to make a quaky mixture, was used. The supporting blocks were made by pouring concrete into small nail kegs. After the concrete was thoroughly dry (it was allowed to stand for five days) the seat was assembled and given a coating of white cement wash.—Dale R. Van Horn, Lincoln, Nebr.

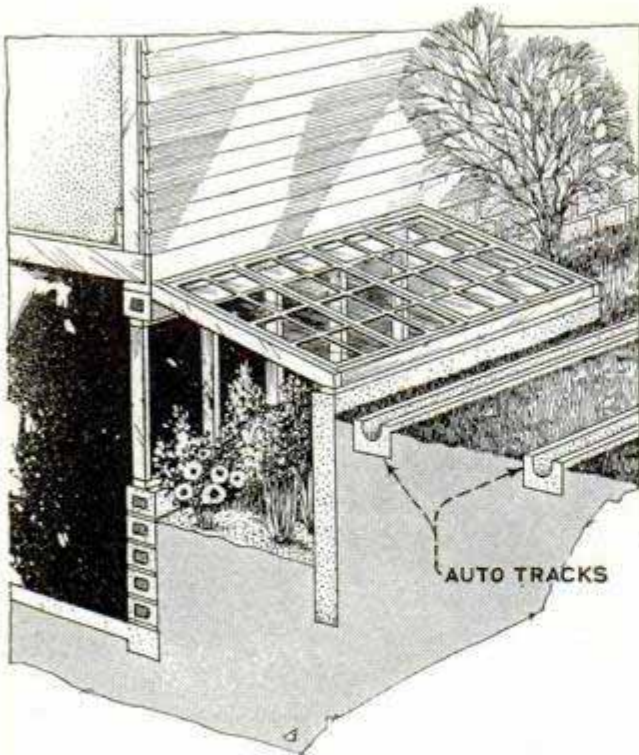

Hotbed Which Is Accessible from the Basement Keeps the Flowers Blooming during Winter

Basement Hotbed

A hotbed accessible from the basement, as shown in the illustration, has been in use for several years by a Nebraska resident. A suitable opening in the basement wall was made and finished off by fitting a 2 by 6-in. frame snugly in it. A number of studs were set at $2\frac{1}{2}$ -ft. intervals to accommodate sash, which could be closed when desired in order to keep out furnace fumes, although these fumes were not found detrimental to plant life in the hotbed. The earth was, of course, excavated on the outside before the opening in the wall was made. The wall was made 5 in. thick and was built all around the edge as indicated. The level of the hotbed should be about 3 ft. below the lawn and the wall should project about 6 in. above it. A frame of 2 by 4-in. material was built over the hotbed, sloping from the house, and fitted with sash. One-fourth-inch wire mesh was tacked over the outside of the sash to prevent the glass from being broken by negligence or accident. Although a southern exposure of the bed is preferable, this one was built on the east side of the house and was found entirely satisfactory. As the auto drive ran right past the hotbed, the owner thought it advisable to provide concrete tracks as shown in the drawing. These were made in 6-ft. lengths, 10 in. high and

12 in. wide, with a groove of sufficient width to accommodate the auto wheel. It is almost impossible to get out of these tracks, and this eliminates the possibility of skidding over against the bed, which is likely to occur during the winter.—Dale R. Van Horn, Lincoln, Nebr.

Drying Negatives Quickly

When it is necessary to dry negatives quickly, make a saturated solution of carbonate of potash, which has the property of absorbing water from gelatine. An immersion of five minutes in this solution will be sufficient, after which the surplus water must be soaked up with a blotter and the negative rubbed dry with a soft cloth. If there is not enough time to wash the negatives thoroughly after fixing, this can be postponed until after they have been used for printing. A peculiarity of this process is that the film may be stripped from its backing by cutting all around the margin, after which it may be transferred to another and used in reverse.—George Parke, Chicago.

Film-Spool Ends Make Good Grommets

Small chains used in a drilling outfit passed through some canvas covering in several places, and it was found necessary to provide grommets, but these could not be procured at once, so they were improvised from a number of old film-spool ends as shown in the photo. The raised portion of one ferrule was cut off and enlarged a trifle to go over the other ferrule when the latter was pushed through the hole in the canvas. The pen of a hammer was held over it and the hammer struck with a block of wood, beading the ferrule over and compressing the disks firmly on the canvas.

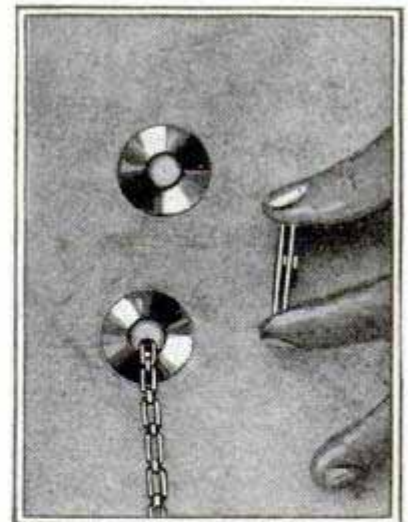

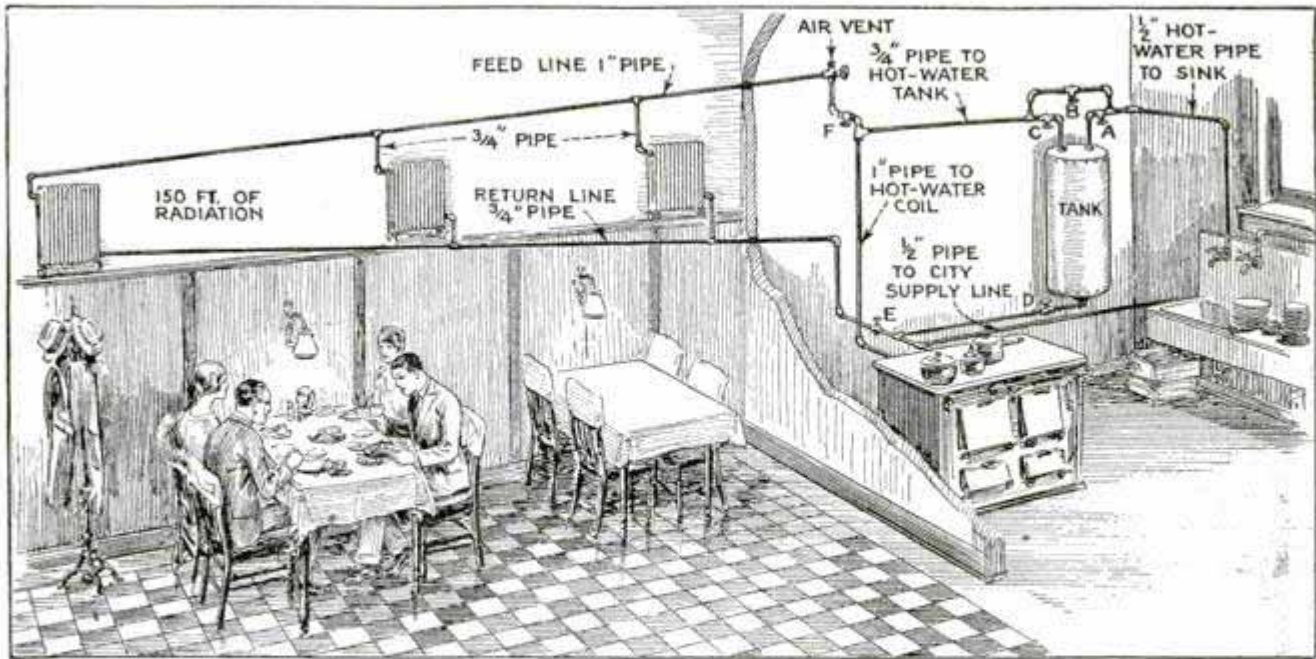

Small Cafe, Formerly Using Stove Heat, Made More Modern by the Installation of Hot-Water System Using the Excess Heat from the Kitchen Range

Heat Cafe with Excess Heat from Range

When the proprietor of a small cafe found that his range heated the water in the range tank to the boiling point much faster than he could use it, he asked a steam fitter if this waste heat could not be used to heat the dining room, where stoves were more or less unsatisfactory. The steam fitter made the installation shown in the drawing, and it has given good service for over two years. The hot water rises out of the tank into the top pipe, which runs down at a slight angle to the farthest radiator. Two other radiators are also connected as indicated. After the water has passed through them, it is cooled considerably and flows back to the heating coil in the range through a return pipe installed so that it slants toward the stove. An air vent is placed at the high point of the feed line.

Keeping Auto Free from Rust

The owner of a new car usually takes pride in the appearance of the nicked parts of his car. If the car is purchased during the winter months, some of these parts may become partly rusted before warm weather arrives. When I buy a new car I give them several coats of light oil applied with a rag. This protects the finish by covering the nickel, and the oil can easily be removed when the weather

moderates. Certain parts of the chassis and engine of a new car may show signs of rusting, but this can be prevented by giving them a coat of old crankcase oil with a brush. Keep a small fruit jar of such oil on hand in the garage for this purpose. Surplus oil may be removed with a rag. Many mechanics clean greasy parts of the motor with gasoline. This is effective, but highly inflammable. It is much better to use carbon tetrachloride and gasoline mixed in equal parts.—Ross J. Plaisted, Cleveland, Ohio.

Emergency Knife Sharpener

A knife sharpener that takes very little room, costs practically nothing and has been found highly efficient, can be made from any old metal twist drill, $\frac{1}{8}$ in. in diameter or less. The bit is merely fastened to a table top, shelf or a piece of wood by means of two staples. Pulling the knife blade across the drill, as indicated, will produce a clean, sharp



edge, equal to one made by using an expensive sharpening device.



Cart Equipped with Old Auto Wheels and Casings Provides Comfort for the Driver

Cart Equipped with Old Auto Tires

Old auto casings give many miles of comfort to the driver of the two-wheeled cart shown in the photo. In a small Kansas town two carts thus equipped are in use, and the owners claim that the extra comfort is worth the cost of the wheels and tires. An additional advantage is that they are practically noiseless on paved streets.—Frank Sargent, Holten, Kans.

“Strait-Jacket” for Drills Prevents Breakage in Sheet Metal

When drilling holes in sheet metal with an ordinary hand drill, one is likely to bend and break the drill. A wooden jacket, as shown in the drawing, will eliminate this trouble. Such a jacket can be made in a moment. Rip out a strip approximately $\frac{1}{4}$ in. square, a piece of tonguing from an old board being about the right size. Cut it a little shorter than the drill and then run the drill through it lengthwise, as indicated. Give the drill just a



few extra turns so that the chuck jaws will seat firmly against the top of the strip. This gives valuable support where it is most needed because the wood, especially hardwood, will bind on the drill and will hold tightly against the chuck jaws.—W. J. Lennox, Wiarton, Ontario, Can.

Make This Speedy Skimmer

Although the little paper craft shown on the opposite page may seem too frail to last long, it is waterproof and, with care in handling, will have surprisingly long life. It draws scarcely $\frac{1}{8}$ in. of

water and the slightest puff of wind will send it skimming across the pond like the proverbial “scared cat.” Cut some strips for the lengthwise parts of the frame from three-ply bristol board. The crossmembers are made from the lightest cigar-box lids you can obtain. Get one of cedar if possible. This wood is strong enough for the purpose, very light and easy to whittle. Cut the triangular stem from white pine. To assemble the frame, tack the crossmembers upside down in their relative position on a board. Let the nails project on the underside so that they can be withdrawn easily. Thin, short brads are best for the purpose. Now lay a keel of very thin wood, gluing it in place with shellac. Gunwales are next and then the long strips. The latter are first fastened to the two central crossmembers with waterproof glue or shellac and, when dry, are similarly glued to the bow and stern pieces. The “planking” thus provided should be bound to the crossmembers securely with strips of light paper, also glued or shellacked on. Ordinary wrapping paper is now cut to cover the hull, coated with spar varnish, and applied before the varnish dries. For a rudder, attach a piece of tin, cut and bent to the shape shown, and tack it to the stern. The mast and spars are made of light bamboo splints and the sail of waxed sandwich paper. If you find that your particular model requires ballast to prevent it from capsizing, simply put a nut or washer on the floor just back of the middle crossmember. This boat has been found to outrun any model boat with sails.

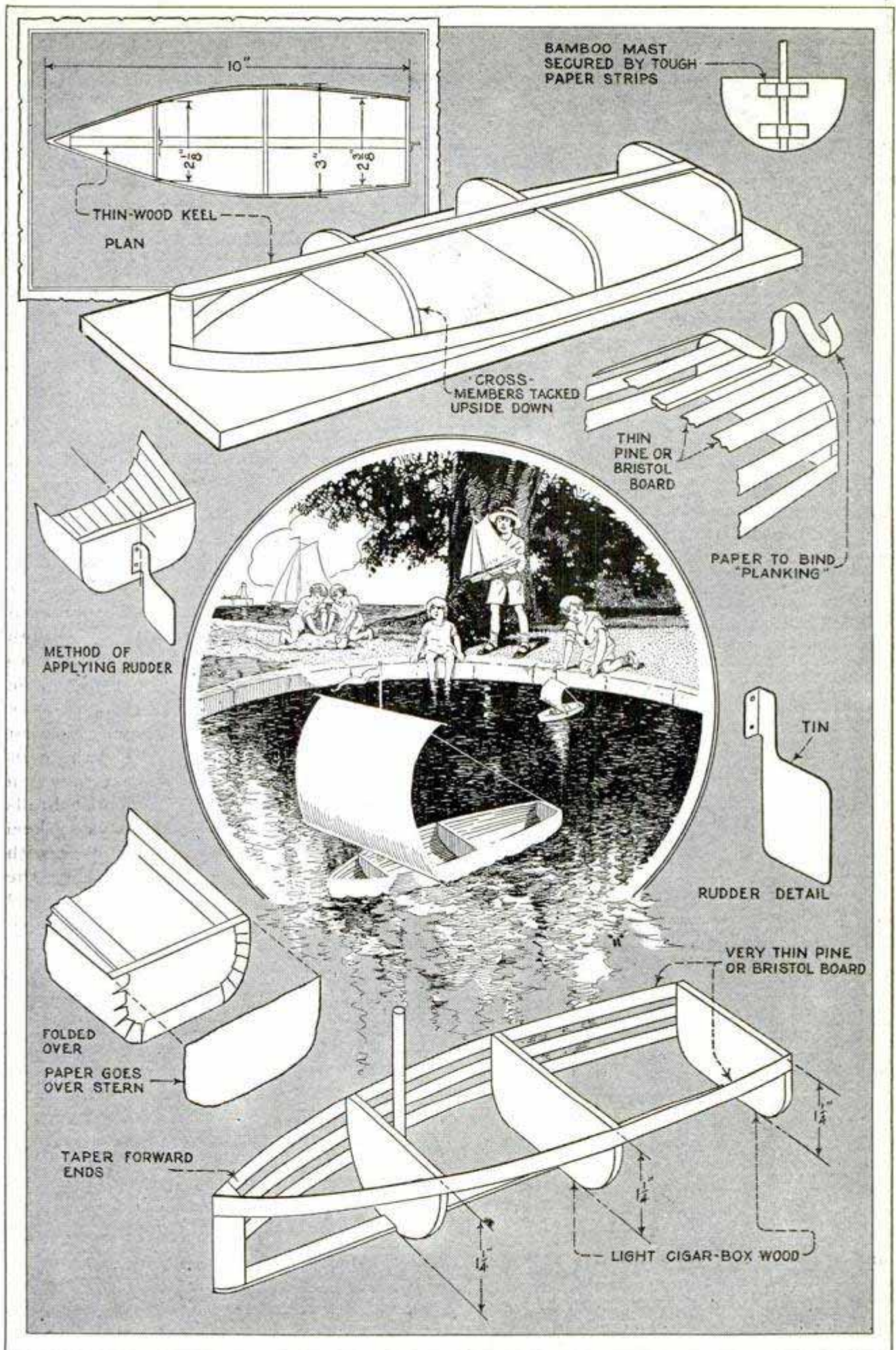

This Ten-Inch Paper Boat Is So Light That It Draws Only One-Eighth Inch of Water and Develops a Surprising Speed

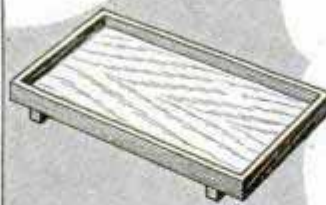

TRAY FITS OVER
CHAIR ARM

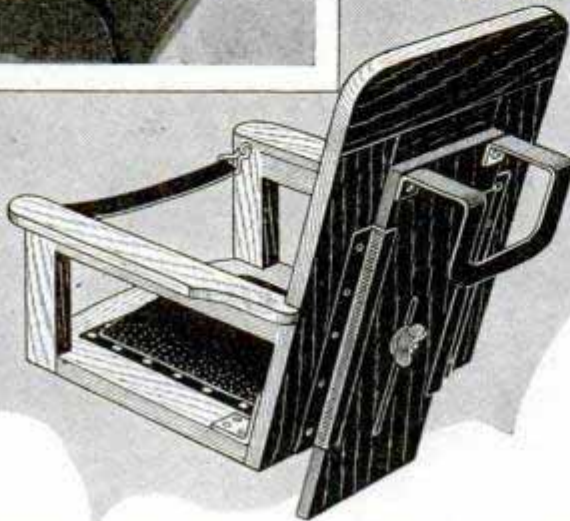

Small Adjustable Baby Seat Hooks over the Front Seat of Any
Make of Car

Comfortable Auto Seat for Baby

The seat shown in the drawing is home-made and can be hooked onto the front seat of any make of car. It can be made from new material or the top part of any small child's chair may be altered to suit, if one is available. A couple of slides are fastened to the back to accommodate a board by which adjustment for height is made possible. In the center of the board a slot is cut as indicated, and a hole is drilled through the back of the seat in line with the slot to receive a bolt and wingnut with which the board can be securely tightened in any desired position. A U-shaped bracket of flat iron is attached to the top part of the board and hooks over the seat. It will be found that a tray made to be clamped over the chair arms provides additional convenience. When the tray is not used a strap across the arms keeps the baby from falling forward. Besides being handy in the auto, such a seat can be hooked over the back of an ordinary chair to make a high chair. —Wayne M. Judy, Clear Lake, Iowa.

Saving Time When Repairing Inner Tubes

After finding the leak in an inner tube, which has been previously inflated, insert a pointed cotter pin in the hole. This spreads the rubber and lets the air out quickly, in fact much faster than it takes to remove the valve core for the same purpose. The cotter pin is ground to a point and then spread apart so that every time it is used it must first be squeezed together. The spout of an old oilcan will serve the same purpose.

Old Coffee Bottles Decorated in Modern Style

You can revamp your old coffee bottles in keeping with the latest style and will then find them especially popular for use on bridge tables. Get some silk cord, or any other colored cord to your taste, and wrap it around the neck of the bottles tightly. Shellac the cord after it is wrapped. Procure some carved wooden figures of suitable size to be fastened to the corks of the bottles. Use waterproof glue to do this and be sure to scrape all traces of paint and varnish from the two surfaces that are to be glued. Wooden beads can be attached to the neck with thread slipped and tied between the cord wrapping. In case you have no coffee bottles, get some similar bottles used for chemical tests. They are made of specially annealed glass, which, although very thin, will with-



stand considerable heat, and hot coffee can be poured into them without breaking them. The cost of these bottles is about 50 cents and the decorative material should not exceed the same amount.

—Frank H. Williams, Santa Ana, Calif.

SHOP NOTES

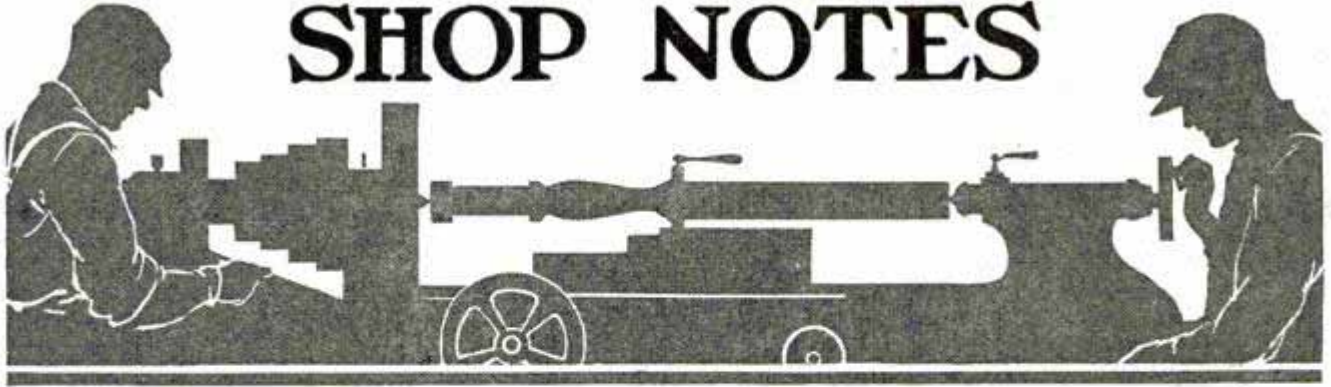

All Shop Notes published in 1928, in book form—Fifty Cents—from our Book Department

How to Apply the "Sugi" Finish

By HAROLD JACKSON

SOME of the finer arts come to us from the orient. The Japanese, especially, are very artistic people and we have learned many things from them, among which is the beautiful treatment of wood known as the "sugi" finish. Many generations ago the Japanese gathered driftwood and fashioned beautiful articles from it without artificial treatment of any kind. After continued pounding of the waves and the chemical action of the salty

caused a beautiful embossed finish which rendered every delicate curve and irregularity of the grain in a particularly striking manner.

On account of the irregular shape and the limited amount of driftwood, the use of this naturally embossed wood was very restricted. But the Japanese craftsman was not content to sit down at the beach and wait for inferior pieces of driftwood to blow in. Besides, the chemical action

of the sea is very slow. The Japanese then turned to another element of nature that is more rapid in its action. They used fire. They made artificial driftwood that is far superior to that made by nature in the sea.

Craftsmen found that, by scorching the surface of the wood and brushing out the charred parts, a perfect driftwood finish re-

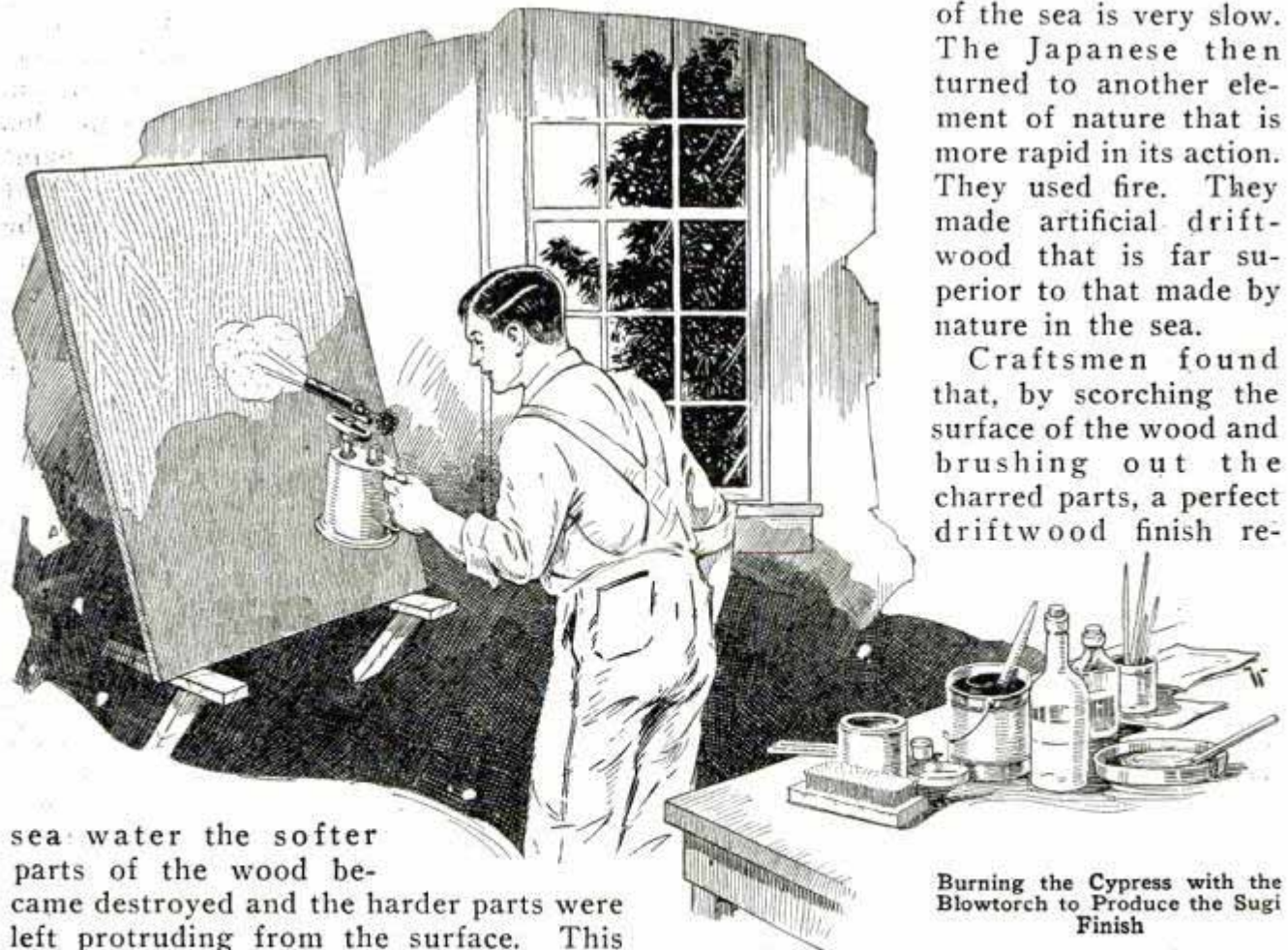

sea water the softer parts of the wood became destroyed and the harder parts were left protruding from the surface. This

Burning the Cypress with the Blowtorch to Produce the Sugi Finish



Scrubbing Out the Charred Portions with a Wire Brush

sulted, and they gave the world something entirely new and different in the way of wood treatment.

Sugi is a wood the Japanese have found to be especially adapted to this finish. Sugi and cypress are very much alike in their characteristics and the latter takes the finish just as well as sugi itself. Of the American woods, cypress is the only one that takes the sugi finish perfectly. Fir does fairly well, but a wood that has considerable difference between the hard and the soft parts, that has an elaborate and showy grain, and that is free from resin, is essential.

The process of applying the sugi finish is more simple than the reading of the instructions. Anyone can do it. A gasoline blowtorch and a wire brush are the required tools. Nothing else is needed. The entire surface of the wood is charred with the torch until it is totally black all over. Burn the surface as evenly as possible. When burnt, set the wood away for 48 hours before doing anything more to it. At the end of that time the finish is completed by brushing the charred surface with a rather stiff wire brush. Brush with the grain. This completely removes all of the charred portions and leaves the wood a rich brown color which is very pleasing to the most critical eye.

No varnish should ever be used on this

finish. To do so will spoil the whole job. If a little gloss is desired wax only should be used. Rags or waste should be used to polish the surface whether wax is used or not.

The parts must be finished before they are installed. During the burning the board will warp on account of the moisture being forced to the back of the board by the application of the intense heat of the torch. This should cause no alarm, and the difficulty can be remedied by allowing time for the moisture to again adjust itself within the board. It takes about 48 hours to do this. This adjustment can be hastened by placing the board in the sun, burnt-side down.

In applying the sugi finish there are only four rules that require special attention. They are, use dry cypress, do not overburn, do not rub for 48 hours after burning, and use care in rubbing so as to get an even tone. The more you rub, the lighter the color becomes. The shade depends upon the rubbing, not the burning.

Artists' Brush Holder

Two rubber bands attached to a tumbler, as shown in the drawing, make an excellent brush holder for artists.

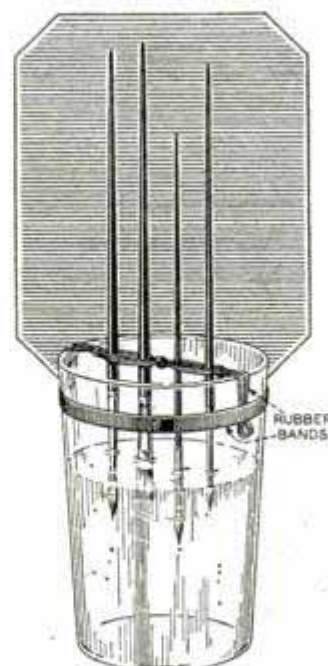

bottom of the glass, which allows them to retain their shape.

Three knots are tied in one of the bands at equal intervals. This band is stretched over the top of the glass and another band is snapped around the glass to hold the first one. The brushes are slipped between the knots so that the bristles dip in the water without touching the sides or

Removing Tar and Asphalt Spots

Do not use soap on tar or asphalt spots on cloth, as this will set it in a way to make the cleaning almost impossible. Rub the spots with soft grease, and set aside until the grease penetrates the tar. Remove the tar and grease with gasoline, or by washing in hot suds. Asphalt should be wetted with kerosene and left to stand, then washed in turpentine or alcohol.

Double Parting Tool

The time required to part off work in a lathe can often be reduced by one-half if the arrangement shown in the drawing is used. In the case illustrated a piece of tubing is being parted to make collars. Ordinarily a parting tool will cut freely until it gets into the cut a short distance and then it is likely to clog because the cuttings do not clear themselves. By using two parting tools as shown, neither tool cuts into the work enough to permit clogging. Both tools are offset and are mounted one over the other in the tool-holder. However, as it takes more time to set two tools than a single one, this arrangement is not suggested as a time-saver for cutting a single collar.

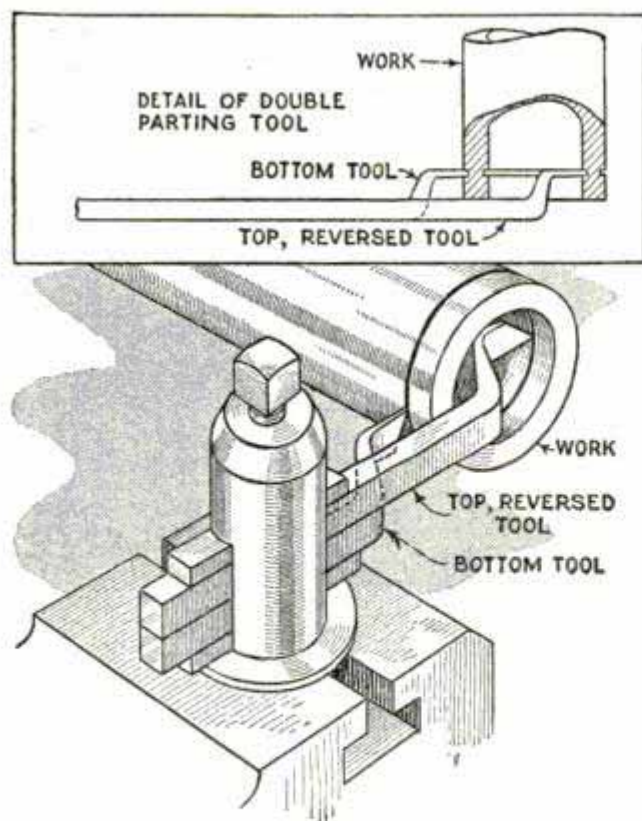

Two Offset Parting Tools Cut Collars from Both Sides of the Tubing

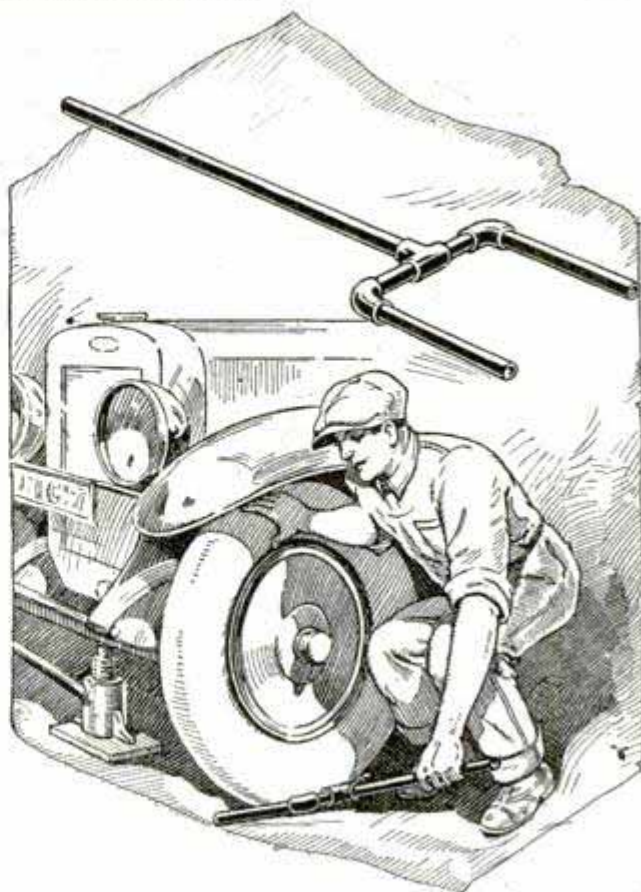

Forked Tool Made from Pipe and Fittings Helps Remove and Replace Heavy Disk Wheels

Forked Tool Helps Mount Disk Wheels

Heavy disk wheels of the demountable type can be put on the hub with little exertion if the illustrated tool is used. It consists of pipe and fittings and has a forked end which is slipped under the wheel while the other end serves as a handle. The method of using it is clearly shown. Anyone who has changed disk wheels will appreciate this helpful tool.—G. A. Luers, Washington, D. C.

Weight on Mower Lightens Tongue

The weight of a mower tongue together with the vibration of the machine, will usually cause sore necks on a team of horses after a day or so of steady work. One farmer suspends a cement block from the seat by means of a strong strap, which counterbalances the tongue and also absorbs some of the vibration.—J. R. Gentry, Lincoln, Nebr.

☛ In the absence of a brace to hold your wood auger, get an ordinary faucet handle and slip it over the square tapered end of the auger so that it can be turned by hand.



Developing Sodas Can Be Dissolved Quickly by Dusting Them in the Water and Rocking the Tray

Quick Method of Making Photo Solutions

Ordinarily, when making developers, the sodas, stirred into a tray of water, set in chunks as hard as rock before they can be scattered sufficiently, and many minutes are lost before they are all dissolved. The drawing shows a method which greatly reduces the time needed to dissolve them. First, be sure that the sodas are thoroughly powdered. Put the water for the solution in a large tray so that it will not be too deep. Lift one end of the tray and rock it steadily without allowing it to slop over the ends. Sprinkle the soda powder evenly in the water, in the middle of the tray where the washing action is strongest. With a little practice, this can be done so that no lumps will be formed, the swishing of the water keeping each tiny grain in suspension and almost instantly dissolving it. In a timed test, 1 oz. of carbonate of soda was dissolved in 10 oz. of water, by stirring and crushing the lumps after they were formed, in 12½ minutes at 65°, for perfect solution. When the same quantity was dissolved by sprinkling it in as the tray was rocked, complete solution was accomplished in 3 minutes. In dissolving larger quantities, the use of

a salt shaker makes it impossible to drop too much soda into the water accidentally. This method holds good only with powdered sodas, but as they are the kinds almost universally used, the busy photographer can save many valuable minutes. When the sodas are mixed separately, the sulphite will give little trouble, but most ready-mixed developers for amateurs will have them combined, and the carbonate will control both.—C. K. Van Druff, McLouth, Kans.

How to Prevent "Offset" in Printing

On a rush job where printing was necessary on both sides of the paper, and there was not enough time to permit the first run to dry properly before backing up, the makeshift method of preventing offset described below was used with success. Sufficient packing was removed from under the draw sheet of the jobpress platen to allow for a sheet of ordinary print paper. This sheet was pasted along the top of the platen and extended to the guide pins to which the work was fed. After 50 to 100 impressions had been made, the sheet was replaced with a clean one. This method saves time and gives permissible results where speed is essential on an ordinary run.—Edgar Sherman, Tucumcari, N. M.

Measuring Diameter of Flanged Holes

By equipping a pair of inside firm-joint calipers with toolmakers' buttons as shown, one can take accurate measurements in flanged holes. When a calipering job is to be done, "mike" the buttons with the caliper points set inside of the flange. Remove the calipers and reset them to the same distance between the buttons, and you will have the exact diameter of the hole inside the flange at the caliper points.

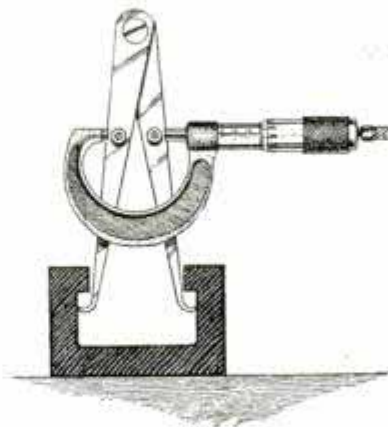

Can for Local Hardening

It is often necessary to harden both ends of a piece of work and leave the middle section soft. When the piece is short, as in the case of link pins, it is a rather difficult job to do this. If one end is hardened at a time the heat is likely to travel along the pin and soften the end previously hardened. As it is out of the question to heat the ends at the same time and leave the center cold, the next best thing is to heat the whole surface of the pin and keep the central portion away from the water when the ends are quenched. The photo shows a simple method of doing this. Obtain a tin can and drill a hole through the sides, about 1 in. below the top, making the holes a trifle larger than the pins, so that these can be inserted and removed easily. For convenience a stiff handle may be affixed to the can. In use, a pin is heated to the right temperature, pushed through the holes in the can and the whole dipped into the water until the pin is submerged, but not the top of the can. Of course, some water leaks through

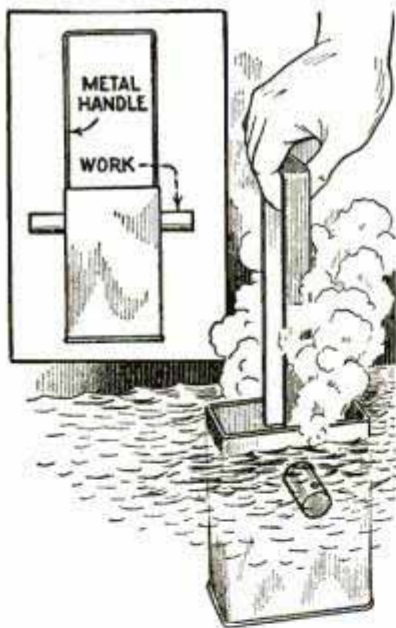

the holes but the ends of the pin are thoroughly cold before much water gets into the can, and the center section is too cold to be affected by the water, so that consequently it remains soft.—Harry Moore, Hamilton, Canada.

Cutting Threads without a Die

After bolts had been set in the concrete foundation for an engine, it was found that the threads were not cut far enough down to allow the nuts to be tightened on the engine bed. Not having a threading die, the makeshift method shown in the drawing was used with good results. A nut fitting the thread was attached to a

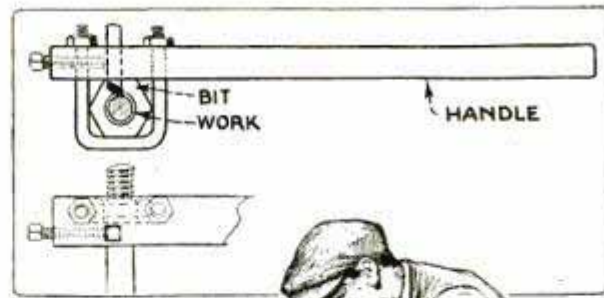

Improved Method of Threading Bolts Set in Concrete Foundation

steel bar near one edge by means of a U-bolt. A threading tool was put through the bar near the other edge and was held in place by a long setscrew. By rotating the nut with the bar and feeding the tool lightly with a hammer for each cut, the threading was accomplished in a short time, and the job was found entirely satisfactory.—August Jeffers, Bedford, Ind.

Simple Method of Slinging a Barrel

A simple method of slinging a barrel, which is open at the top, is to put the barrel on the sling so that the latter comes in the middle of the bottom. Then take one side of the sling and put a half hitch around the barrel near the top, but not too close to the edge. Take the other side of the sling and put another half hitch around the barrel just above the first. The barrel can now be safely hoisted.—C. Newkirk, Chicago.

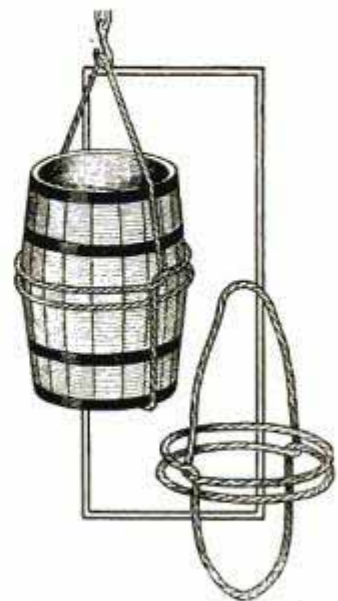

Restoring Damaged

By BERTON ELLIOT

BY FAR the greater part of the furniture in use today is stain-finished walnut, mahogany or oak. As some pieces of furniture receive harder wear than others, and as frequently one piece of a suite meets with an accident, some practical information on the restoration of such pieces should be of general interest in every home. Of course, the processes described are only those that can be attempted by the amateur, as the skillful professional worker uses many methods that cannot be followed by the unskilled layman. Before attempting any work of this kind get a bottle of good furniture polish, a small bottle of sewing-machine oil and 10 cents' worth of powdered rottenstone. One of the high-grade furniture pol-

ishes, sold by paint-supply stores to furniture repair men, is best, if procurable.

Light damages to the finish of a piece of furniture, which have not dug down into or through the stain in the wood can be inspected by wetting the finger and rubbing over the bruise. If the bruise is not through the color it will be practically unnoticeable when wet and will show the same effect as you will get when varnish is applied. Practically all varnish-finished surfaces in which there are light damages can be greatly improved in appearance with furniture polish, rottenstone and sewing-machine oil, and plenty of "elbow grease"; in fact, most of them can be restored nearly to their original state. You may be surprised to find that a table top that you thought was practically ruined beyond repair can be made a thing of beauty again in about 20 minutes.

Marks caused by hot dishes are treated as follows: First try to polish out the marks with furniture polish, rubbing them vigorously with a soft cloth and using just as much pressure as possible. As there is no abrasive in liquid furniture polish the surface will stand a good deal of rubbing without injury. Give the surface a final rubbing off with a dry, clean cloth to remove all the surplus polish. If there are any marks or spots that show dull, polish them up with the rottenstone as follows: Place some of the rottenstone in a saucer and pour out some of the sewing-machine oil into another shallow receptacle. Dip a pad of soft cloth into the oil first and then into the rottenstone, and rub briskly, but with not too much pressure, over the dull spots on the finish. This will not put a polish where there is no finish,

Light Damages to Furniture Surfaces Can Often Be Removed by a Brisk Rubbing with Rottenstone and Oil

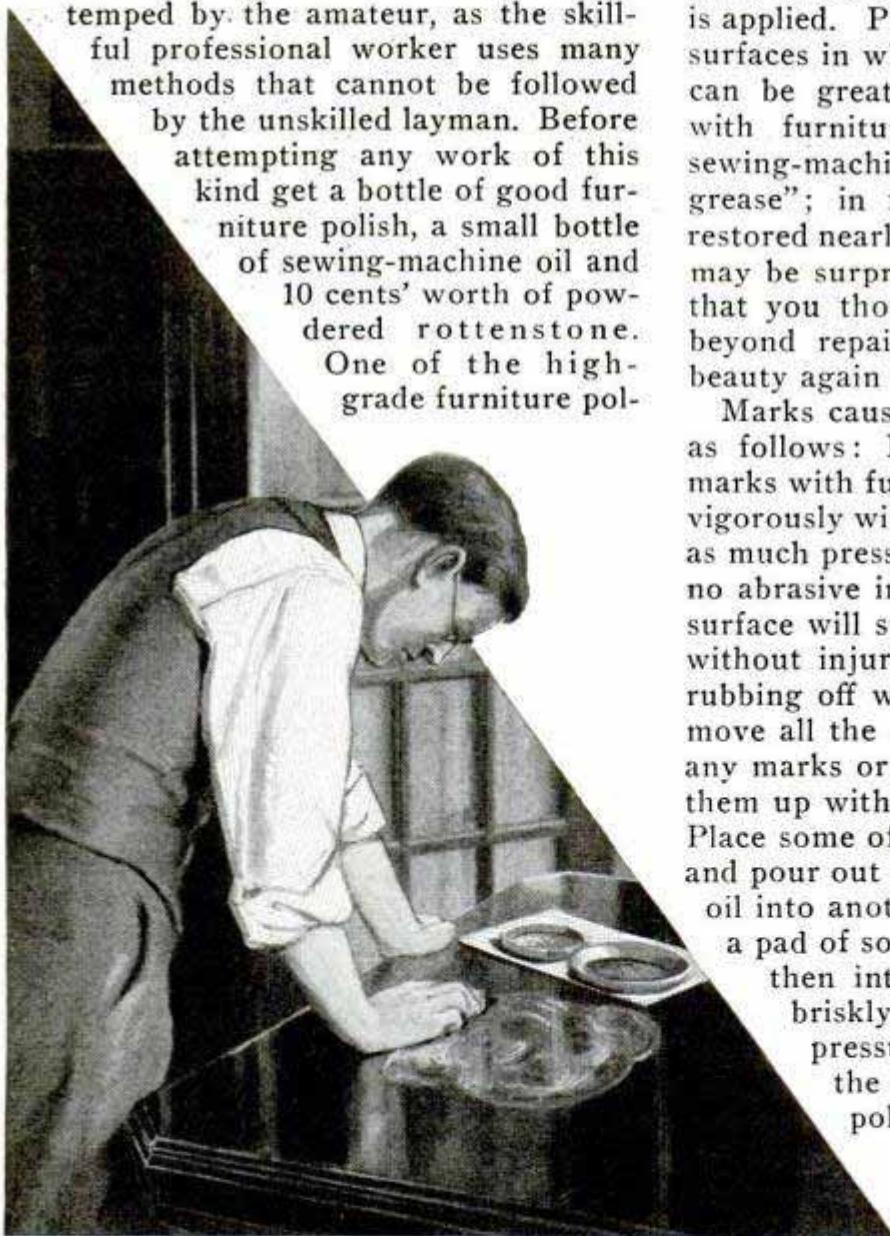

Furniture

as a foundation is a necessity, but if there is any finish at all it will be improved. Give the entire surface a rubbing off with a clean cloth to remove the sludgy mixture and polish again with furniture polish.

By working on a table, buffet or dresser top with the furniture polish and rottenstone alternately for 20 to 30 minutes, it can be brought up to a fine finish, with all light blemishes rendered practically, if not entirely, unnoticeable.

A dresser on which perfume has been spilled, the luster spoiled and the finish roughened, can be restored so that the blemish is hardly noticeable. The remedy depends on how bad the blemish is. If the perfume was wiped up immediately after spilling, a vigorous rubbing with furniture polish or rottenstone and oil may bring up the finish so that it will be quite satisfactory. If the pieces are too badly roughened to be finished in this way, the best thing to do is to give the top a finishing coat of varnish, unless the piece is an expensive one and requires the services of an expert craftsman for refinishing. The ordinary piece of furniture, however, especially golden oak and other furniture in gloss-varnish finish, can be satisfactorily refinished by the home worker in the following way: Sandpaper the place where the perfume was spilled until perfectly smooth, and also sand the rest of the top lightly, using sandpaper not coarser than No. 00, No. 0000 being preferable. Dust the surface carefully and then apply a coat of high-grade interior finishing varnish over the



The Top Which Looked Beyond Repair Is Polished to Look Like New with Little Effort

entire surface. If the finish was in extremely bad condition from the perfume, it may be necessary to apply two coats of varnish, in which case the first coat should be sanded lightly or rubbed over with fine steel wool, after drying for at least 48 hours. The final varnish coat may be left in full gloss or rubbed to a semi-dull finish after drying 48 hours, by using steel wool of a very fine grade, dipped in linseed oil, or by using pumice stone and oil. Some prefer to give a piece a finishing coat of flat-drying varnish, following the gloss-varnish coat, instead of rubbing, which produces a very beautiful semi-dull finish, although not having quite the richness of a hand-rubbed job.

If some of the varnish finish has been chipped off, but the color still remains in the wood, clean the disfigured part thoroughly with soap and water. Rinse off with clear water and allow to stand until

absolutely dry. Sandpaper the entire surface lightly, feathering the edges around the chipped place so that they taper down gradually instead of forming a sharp indentation. When this has been done, apply a coat of varnish over the entire surface. In case this does not produce a perfectly smooth finish, without showing any trace of the chipped place, sandpaper lightly again, and flow on another coat of varnish, after the first coat has been allowed to dry for 48 hours. This can, of course, be rubbed or given a finishing coat of flat-drying varnish, as previously mentioned.

Deep bruises that go down into or through the stain in the wood will show up distinctly even when rubbed with a moistened finger. Such damages are more difficult to repair than light ones, especially for the amateur who has not the equipment and cannot well attempt the more intricate processes open to the professional finisher. With injuries of this kind the color is more or less gone and must be supplied in some way. The method usually employed by skilled furniture patchers is to fill the dig or abrasion with a material known as "stick shellac" or "furniture finishers' stick cement," which is melted into the abrasion and smoothed with a hot knife. This material comes in colors to match the popular hardwood finishes, and is of a transparent nature so that the grain of the wood shows through. After the stick shellac has been melted in or "burned in," the entire surface is polished off, which the professional finisher usually does by a process known as French polishing. This is the only method that will permit good matching of deep damages. However, unless one is skilled in the work, he is likely to make a

mess of it, so that the finish will look worse than before.

For less conspicuous surfaces and articles where a flawless repair is not necessary, the following method may be used satisfactorily. Work a little stain into the bruise so that it colors the exposed wood to about the same shade as the finish. A "penetrating" stain is best for this purpose and may be obtained in all of the popular hardwood effects. It should be worked into the abrasion with a small camel's-hair penciling brush, and the surplus stain wiped off quickly with a cloth, to prevent coloring the wood too dark. If the effect is found to be too light, work in a little more stain and wipe off again, repeating the process several times if necessary, until the color matches the rest of the surface. When the stain is thoroughly dry carefully flow the scratch full of varnish with a small camel's-hair brush. When the varnish has dried thoroughly

for at least 48 hours, go over it a few times with a dry cloth and then rub the entire surface with furniture polish. It may also be necessary to use rottenstone and oil as previously described. If trouble is experienced in dulling down the gloss of the varnish patch to match the rest of the surface, rub over the glossy place lightly and carefully with a small piece of fine steel wool, then polish up the surface again. This should produce a

uniform effect. In case it is found that the stain applied to the abrasion did not darken the bruise sufficiently to match the rest of the surface, a touch of stain may be applied over the filled abrasion with a small brush.

Water marks in furniture greatly detract from its appearance. Some kinds of varnish will not stand water without be-

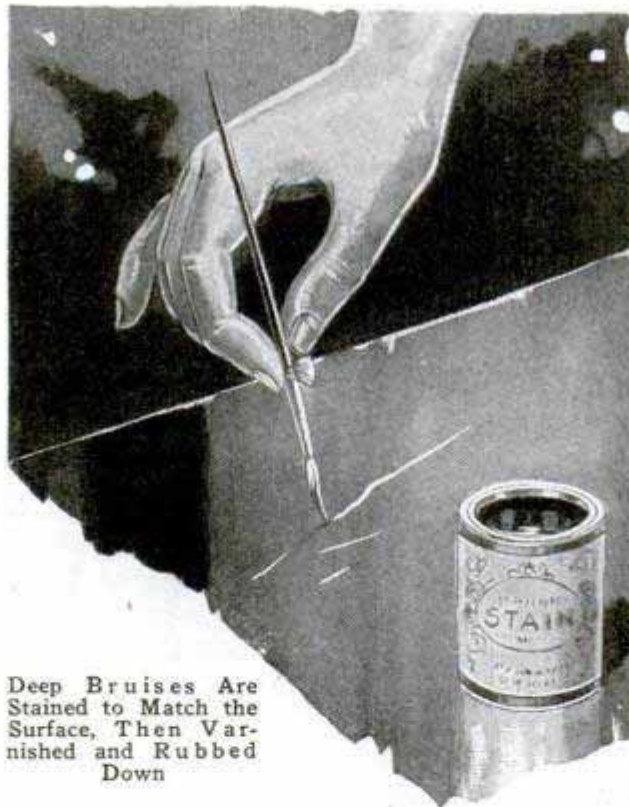

Deep Bruises Are Stained to Match the Surface, Then Varnished and Rubbed Down

coming white. If, for example, a wet bathing suit or towel is left on a chair for any length of time, it may be found that the surface has turned to a very pronounced grayish color wherever the wet article has touched it. While this disfigures the piece seemingly beyond repair, all that is necessary is to sandpaper the surface with very fine sandpaper and apply a coat of varnish. The cloudy effect entirely disappears with this revarnishing. The new finish may be left in full gloss or the glare may be softened to a semi-dull luster by rubbing down as described.

Clear lacquer has recently come into extensive use for the finishing coats on stain-finished furniture, instead of varnish. For the finest possible patching of lacquer-finished pieces somewhat different methods than those described are employed in the professional shop. However, for the home worker, the methods described in this article may be used, the slight differences in luster between the varnish patch and the lacquer being taken care of by polishing or rubbing the patch after the retouching has been finished.

Brace Keeps Door from Sagging

When a heavy door begins to sag it is often quite a task to remove it to plane off the edge. Sometimes a door will keep on sagging and if constantly planed it will be out of square to a noticeable extent. In places where appearance is not of utmost importance the diagonal brace shown in the photo will keep the door

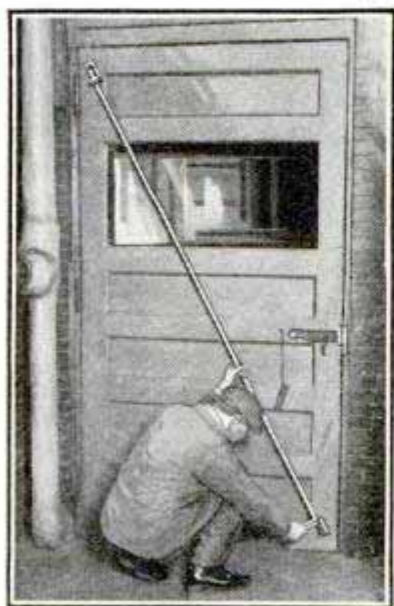

from sagging. It is simply a rod or length of pipe that is threaded at both ends and slipped through two brackets fastened to the door. Tightening a nut on each end pulls the door back in proper alignment.—A. Mathieu, Chicago, Ill.

Handle for the Bench Screw

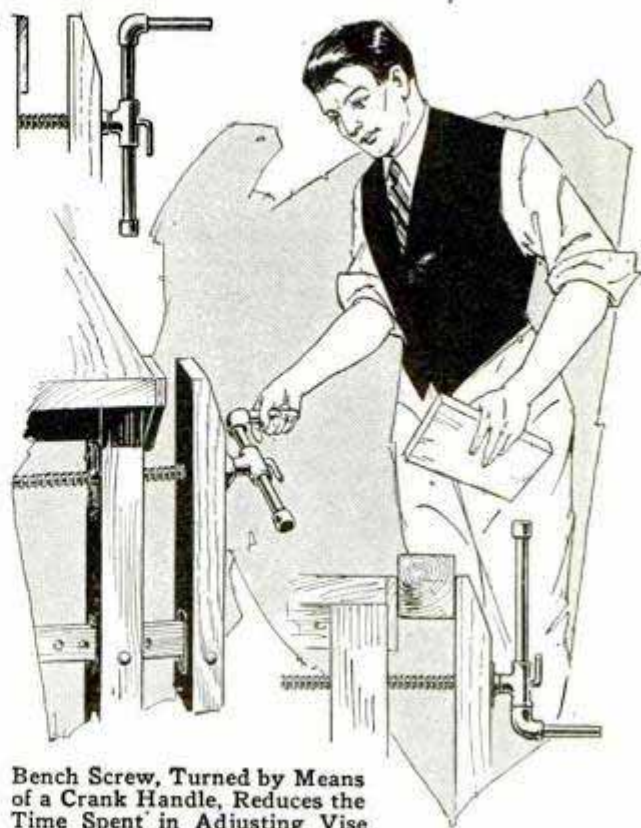

Bench Screw, Turned by Means of a Crank Handle, Reduces the Time Spent in Adjusting Vise

While using a bench screw, a home-workshop owner devised a simple crank handle which enabled him to turn the screw in and out much faster than was possible with a handle of the usual type. It was made of pipe and fittings, as indicated in the drawing. The tee which accommodates the handle is drilled and tapped to receive an L-bolt, which, when tightened, holds the handle securely.

Bands for Bandsaw Wheels

We were in need of bands for our bandsaw wheels and did not have time to wait for new ones. It was therefore necessary to improvise some bands, which we did in the following way: We purchased a quantity of adhesive tape of the same width as the width of the bandsaw wheels. This was wrapped on the wheels and found entirely satisfactory.—F. L. Jester, Bainbridge, Ga.

☞ An easy method of repairing a leaky bucket or a tin gutter so that it will last a year or more is as follows: Paint the metal inside and out, then paint one side of a strip of cloth and apply it to the inside painted surface of the metal.



Footboard or Treadle with Pivoted Hook Holds Work Firmly in Sawbuck

Holding the Work in the Sawbuck

When sawing wood on a buck, it will be found best to hold the work firmly, which can be done by means of the foot clamp shown in the drawing. It consists of a 3 or 4-ft. piece of 2-in. stock, to one end of which a $\frac{1}{2}$ -in. iron rod is pivoted, the rod being shaped to form a hook at one end and an eyelet at the other, where it pivots in the footboard or treadle. The hook is ground to a point so that it will grip the work securely. Pressure of one foot on the treadle suffices to keep the log from turning while being sawed.—Leslie H. Phinney, Orange, Mass.

Template for Drawing Angles of Machine-Screw Heads

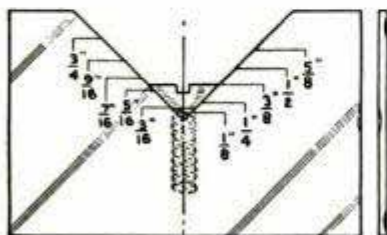

In our plant flat-head machine screws are made, ranging from $\frac{1}{8}$ to $\frac{3}{8}$ in. in diameter, and the included angle of the heads is 70° . The time required to lay out the angles on the drafting board has been greatly reduced by the

use of the illustrated template, made of celluloid. It is placed against the T-square with its center line coinciding with that of the screw. The horizontal lines on the template give the exact position for the top of screws of various sizes. The angle of the head is first drawn, leaving the lines for the top and the slot to be filled in later with the use of the T-square and triangle. Cuts on the underside of the template, near the top, provide ready means for lifting it up from the drawing.—August Jeffers, Bedford, Ind.

Feeding Paper on Job Press

On many job-printing presses, especially where a solid foundation is lacking, the feeder is continually annoyed and frequently some valuable paper stock is ruined, because the vibration makes it work off the feed board. The trouble can be remedied by cutting two wide bands from an old inner tube and slipping them over the feed board crosswise of the way the stock is fed into the press.—Edgar Sherman, Tucumcari, N. Mex.

Two Screwdriver Kinks Worth Knowing

A small metal pipe cap fitted on the end of a screwdriver will protect the handle against damage when used for tapping. Also the handle can be given a blow with a hammer without the risk of splintering the wood. Drill a hole in the handle under the cap and fill the hole with a mixture of white lead and tallow, which when applied to the threads of screws, will make it easy to drive them into hardwood, or in the case of machine screws, will facilitate driving them down if the tapped hole is rusted.



Cement-Floor Covering to Prevent Dust

If it is desired to make a concrete floor in a factory or mill that will not sand off or make dust, a coating for the purpose can be prepared when making the floor. This coating consists of one part of cement to two parts of crushed rock or hard

gravel, which will pass through a $\frac{1}{2}$ -in. sieve, and from which the fine dust has been removed. This is thoroughly mixed in a mixing box, or by a machine mixer, with a sufficient amount of water to produce a plastic but not sloppy consistency, and spread on the under concrete before either the finish or the under concrete has had time to set. It is floated with a wood float to a true level, and then slightly troweled with a steel trowel, to bring it to a proper level and to smooth the top slightly. This will give a finish which is pebbly, and not dead smooth or slick like a sand finish. After the finish has been troweled, and has set sufficiently so that the covering will not mar the surface, it should be covered with sawdust, sand, cloths, or any other material which will hold water continuously. The finish should be kept soaking wet for at least a week, or, better, for ten days.

Half of Large Tank Used for Truck Body

For hauling odd-shaped pieces of iron, such as castings or steel forgings, which cannot be neatly piled on an ordinary truck, a body made from half of a large, discarded tank, has been found highly satisfactory. The cutting of the tank was done with an acetylene torch. Simple blocking keeps the body securely on the chassis and prevents it from rolling.



Useful Truck Body for Odd-Shaped Iron Pieces Can Be Made from Half of Discarded Tank



Tool Made of Steel-Bar Stock

Tool for Removing Terminals from Storage Batteries

For removing terminals from storage batteries quickly and without injury to the battery, the illustrated tool was devised by an attendant in a service station, and was found entirely practical and time-saving. It consists of two hooks and a

thrust end for the battery post, the latter being formed on the end of one of the handles, which are made from steel-bar stock, found around the shop. The hooks are pivoted to the handles as indicated in the upper detail which shows all the parts of the tool. In use, the hooks engage on opposite sides of a terminal, while the thrust end bears against the top. Manipulation of the handles forces the hooks up against the terminal, first on one side and then on the other, prying it off slowly.—Geo. A. Luers, Washington, D. C.



Two Harrow Disks on a Wooden Handle Make a Good Tool for Covering Freshly Seeded Rows

Covering Rows of Seed with Dirt

Rows of seeds can be quickly covered with the illustrated tool which was made and used by a Nebraska truck farmer. It consists of a handle cut from a 1 by 6-in. board, 4 ft. long, the corners on the wide end being cut off at an angle, as indicated, and two harrow disks attached by means of suitable screws. Holes should be drilled in the handle to receive the screws, to prevent splitting the wood. Washers are provided on each side of the disks to reduce friction and prevent excessive wear on the wood by the rotating disks. In use, the tool is pulled along over the row so that the disks push the dirt up between them, which leaves a small ridge completely covering the seed.—Dale R. Van Horn, Lincoln, Nebr.

How to Set and Level a Door Jamb

For a 2-ft. 8 in. by 6-ft. 8-in door, make a mark at a point 6 ft. 9 $\frac{3}{8}$ in. above the rough floor and then with a level transfer this point to the other side of the opening. In the same way locate this point on both sides of each door opening to be cased up, using a hand level, straightedge or some other leveling instrument. Then

cut the side jambs 6 ft. 8 $\frac{3}{8}$ in. long and case up the sides of the opening, using straight casings. When the side casings are on, set the frame into the opening, holding the top of the casing to the 6-ft. 9 $\frac{3}{8}$ -in. mark. This distance will allow $\frac{1}{4}$ in. for margin, 6 ft. 8 in. for the door, $\frac{3}{8}$ in. for clearance, and $\frac{3}{4}$ in. for finish floor. Nail the casings at the top first, being careful to keep them to the mark. Then, using the casing for a straight-edge, plumb the side jambs and finish nailing the casings. The other side casings can now be put on and the work on the opening completed. Before leaving the opening, nail the jamb to the rough work with 10-penny finishing nails, driving them at an angle of about 60°. This slant prevents the jamb from being pulled out of place.—H. H. Siegele, Emporia, Kans.

Hydrometer Syringe Used to Test Auto Oil Line

To locate trouble in the oil-circulating system of an auto often is a puzzling job. Air leaks on the suction side of the oil pump will stop the supply of oil. To avoid the trouble of taking down the oil pan, use a hydrometer syringe as shown in the illustration. If the rubber nozzle is too small to fit tightly, it may be wound with tape to make it air-tight. If the line leaks inside of the crankcase, the rubber bulb will expand freely, and if the line is clogged, the bulb will not expand at all.

In case everything is in good condition, the bulb will expand slowly and oil will gradually come up inside the glass. The same method may be used to test gas lines, but the capacity

of the syringe must be equal to the volume of the parts being tested.—R. Hadley, Fairfield, Conn.

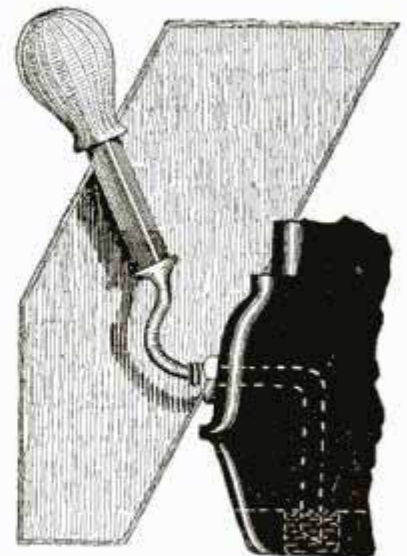

Sliding Toolrest for Emery Wheel

By W. CLYDE LAMMEY

FOR best results, chisels, plane irons and similar tools must be ground to a

to the base, which permits grinding the edge of the tool to any desired angle.

To make a rest of this kind for a hand-operated, 7-in. emery wheel, first remove the iron rest with which the wheel is already equipped. Rip from $\frac{7}{8}$ -in. hard-maple stock a piece 3 in. wide and 8 in. long. For wheels of other sizes the dimensions may, of course, be changed. Plow or dado a $\frac{1}{2}$ by $\frac{1}{2}$ -in. groove in the rest as indicated, and plane one edge off at a 30° angle. Drill the iron rest for screws to fasten the wood rest to it securely, with the beveled edge next to the

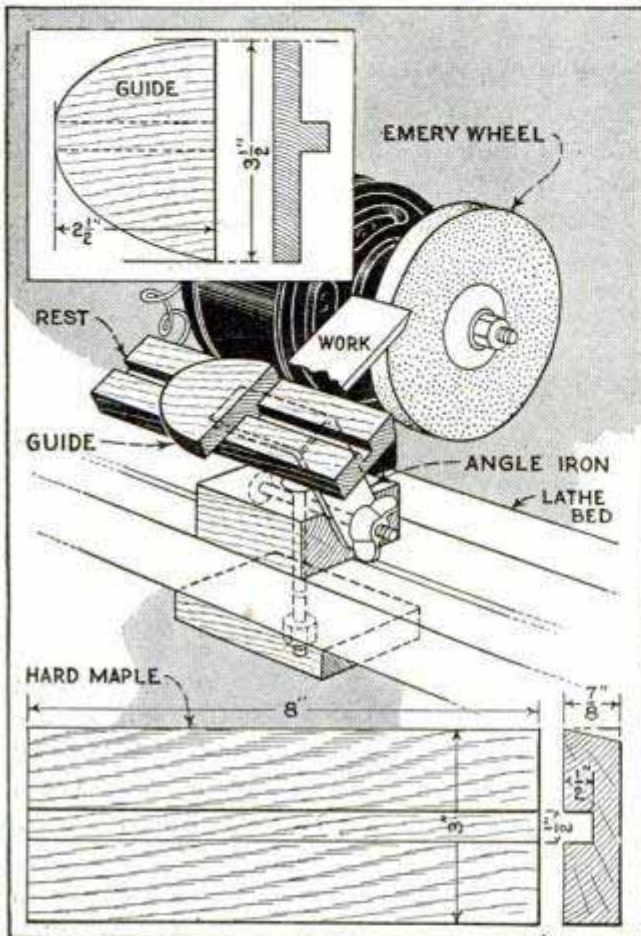

Easily Made Toolrest for Grinding Plane Irons and Chisels Accurately and at Any Desired Bevel



certain bevel, and the edge must be perfectly square with the tool. The average home mechanic and small-shop owner, who grind these tools on an ordinary hand-operated emery wheel, know how difficult it is to get the edge ground accurately, and will therefore appreciate the sliding toolrest shown in the drawing. With its use the work can be ground to any bevel desired without depending on the accuracy of the eye and the steadiness of the hand. The illustration shows two applications of the tool, one, a lathe-bed attachment and the other an attachment for a hand-operated grinder fastened to a workbench. Essentially the device consists of a wooden toolrest and a small guide sliding in a groove cut across the top of the rest. The adjustable feature of the tool makes it especially valuable, the rest being pivoted

wheel. A guide made of a $\frac{1}{2}$ by $\frac{1}{2}$ -in. strip with a $\frac{7}{8}$ -in. block nailed or screwed to the end is then made. The edge of the block must be perfectly straight and must be set at right angles to the guide strip or tongue, which must be a close fit in the groove. Use a small square to check for accuracy. Rub paraffin or soap in the groove and over the guide strip in order to prevent binding. In the case of a toolrest designed to fit a lathe bed, the rest is screwed to a flat-iron support, which is bent at right angles as indicated, and is drilled to receive screws, two of which hold it to the rest securely, another one serving as a pivot. Two blocks fitting on and under the lathe bed serve as the base to which the rest is at-

tached, as is clearly shown in the upper detail. A bolt and wingnut are used to clamp these pieces to the lathe bed. In use the rest is first set to the correct angle for grinding the work, which is held firmly on the rest with the thumb and first finger of the left hand, while the other fingers go over the guide. Both the guide and work are slid back and forth as a small cut is taken off along the edge of the tool. The emery wheel is turned with the right hand at a fairly good speed.

Device to Pick Up Articles Saves Back

Stooping over constantly to pick things off the ground is rather hard on the back



Hinged Sticks Make Handy Device for Picking Objects off the Ground

and therefore the device shown in the photo will be appreciated. It consists of two sticks hinged together near one end, and a spring near the hinge to hold the sticks together. Squeezing the handle opens the sticks so that they can be set over the object to be picked up. Releasing the handle allows the sticks to grip the object securely. It was found advisable to provide the ends of the sticks with sheet-metal tips.

How to Eliminate Static Electricity from Moving Belts

Static can best be eliminated from a moving belt by applying to its surface some material which is a good conductor of electricity. Although the theory is not new, it is a question what kind of material to use for this purpose. Rapidly moving metal parts, such as metal disks, never are subject to static troubles because the disks themselves are excellent conductors. For the same reason, metal bandsaws, which run at velocities of thousands of feet per minute, never give static troubles. Therefore, if a belt is made conductive it will not collect static, but the substance applied must not decrease the coefficient of friction between the belt and the pulleys, must not injure the belt in any way, and must wear well. Experiments with a number of materials for use on rubber belts showed that a good grade of spar varnish was a very satisfactory vehicle. Powdered aluminum, bronze, copper, graphite and lampblack have also been tried, various proportions of each being mixed with the varnish. The most satisfactory results for rubber belts were obtained by using a mixture of lampblack, 18 parts, and spar varnish, 82 parts. For a good non-inflammable thinner, equal parts of carbon tetrachloride and painters' naphtha are recommended. This dressing was carefully tested on belts in actual installations on an air compressor and on a rubber conveyor belt. It was also tried on rubber belts in flourmills and on threshing machines. When it was applied to the entire surface and allowed to dry, static did not develop. The belt should, of course, not be used until the dressing is entirely dry. For leather belts the following formula has been found satisfactory: liquid fish glue, 100 cu. centimeters; glycerin, 88 cu. cm.; sulphonated castor oil, 100 cu. cm.; water, 170 cu. cm.; lampblack, 82 grams, and 2-per-cent ammonium hydroxide, 20 cu. cm. In some instances, it is well to increase the amount of glycerin and fish glue. The material for leather belting may be applied while the belt is moving, but the dressing for the rubber belting must be allowed to dry before the belt can be used.—W. F. Schaphorst, Newark, N. J.

Tapping Soft Materials

Experimental model work frequently calls for tapped holes in soft materials, such as hard rubber, fiber, wood, and the like. In connection with such work, one may make use of what may be called a "lead" plate. By its use, remarkably clean and accurate threads can be cut with an ordinary tap, even in such material as pine wood. The lead plate is nothing more than a small piece of metal, such as brass or steel, in which a hole of the desired size has been tapped. It should be of sufficient thickness to accommodate about three or four threads. In operation, the lead plate is laid over the hole to be tapped and is held in place with the fingers while the tap is revolved through it into the soft material below. Inasmuch as the feed is thus automatically assured, the threads will come out clean and true. When one has occasion to thread very small holes, the tap can be dispensed with and the screw itself can be made to cut its own thread by screwing it through the lead plate in the same manner as is done with the tap.—August Jeffers, Bedford, Ind.

Roller Helps Load Lumber in Box Cars

Loading box cars with lumber can be done easily and quickly by using the pivoted roller shown in the photo. A piece of heavy flat steel is bent at right angles to form a wide "U," and the ends are drilled to serve as bearings for the roller shaft. A hole is also drilled through the center part of the roller support, which is pivoted by means of a bolt to a 4 by 4-in. beam as indicated, a jack screw on the end of the beam permitting it to be wedged securely in the doorway.—C. Groat, Portland, Oreg.

☐ To stop a dripping faucet until a plumber can be called, get a rubber band, at least 1 in. wide, and stretch it over the spout and handle.

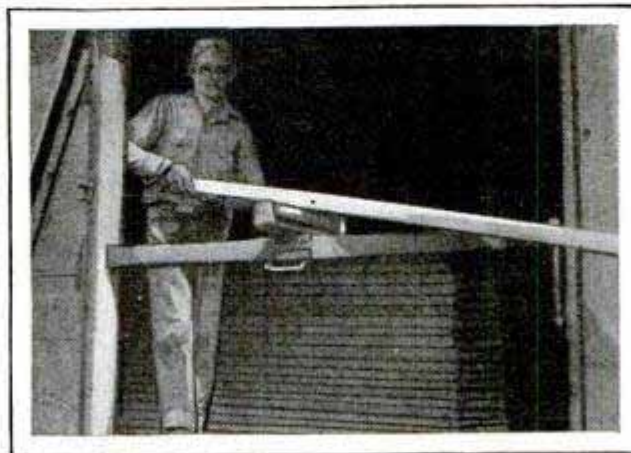

This Pivoted Roller Lightens the Task of Loading Lumber into Box Cars

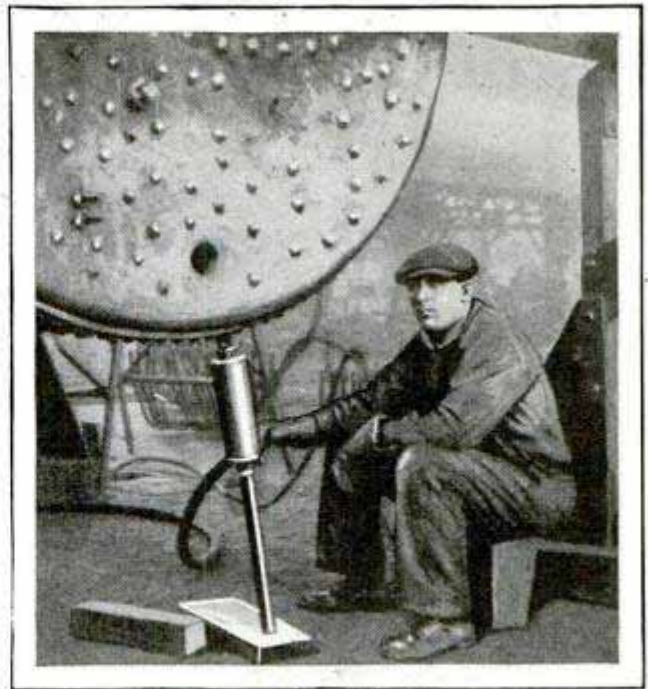

Air Bucker Used in Riveting Can Be Suitably Adjusted under Heavy Tank with Wood Blocks

Adjusting the Air Bucker-Up

When riveting heavy material, where bucking-up must be done from below, an air bucker, with a piston range of 7 or 8 in., will be found a great help. By using several lengths of metal pipe to slip over the bar of the bucker, setting the lower end of the pipe on a wood block, its elevation may be regulated to suit the height of any rivet, on oval surfaces like that of a boiler.—Jos. C. Coyle, Denver, Colo.

Saving Electric Light in the Stock Room

A toggle switch, arranged so that the opening and closing of a stock-cabinet door would turn the light on and off, resulted in a considerable saving of current. The arrangement was found successful in a printing shop, where the stock cutter, with both hands full of paper, rarely, if ever, stopped to turn the snap switch, but always pushed the cabinet door closed with his foot, switching off the light that formerly burned unnecessarily.—E. Sherman, Tucumcari, N. M.

Testing Metal Cans for Leaks

In a Denver establishment, where metal cans are manufactured, tests for leakage

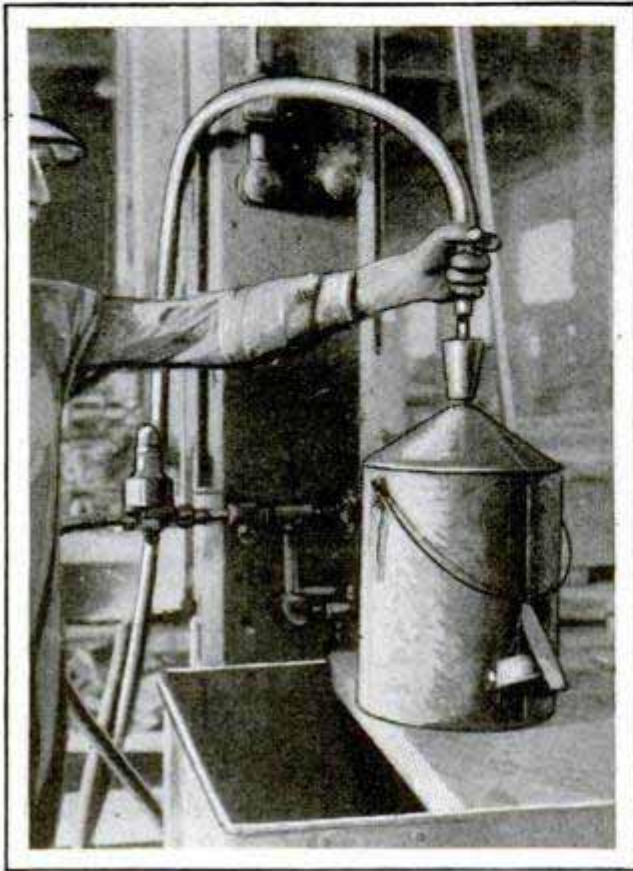

Tapered Rubber Nozzle Admits Air to Cans When Testing Them for Leaks

are made by filling the cans with compressed air and then submerging them under water. The air is admitted to the can by means of a cone-shaped rubber nozzle, 3 in. long, 2 in. in diameter at one end and $\frac{7}{8}$ in. at the other. A $\frac{3}{8}$ -in. nipple is passed through the center of the nozzle to allow easy attachment of the air hose. Owing to its taper, the nozzle can be quickly fitted into any circular opening from $\frac{7}{8}$ to 2 in. in diameter.—J. C. Coyle, Denver, Colo.

Expansion and Contraction of Wood

One of the most serious drawbacks to the use of wood for accurate work is its susceptibility to moisture. The sap cells absorb moisture in damp weather and the wood swells, while in dry weather the moisture is drawn out and the wood contracts. This expansion and contraction is practically all

in the direction running crosswise to the grain. Woods ordinarily swell ten times as much crosswise as lengthwise. Knowing this, the user should arrange his structure so that changes come in the least important sections. Pacific coast redwood is an exception to the above rule. It expands just about as much lengthwise as the other way and for that reason it is undesirable for most uses.—Donald A. Hampson, Middletown, N. Y.

Efficient Guard for a Saw Trimmer

An ordinary shower-bath curtain was made into a satisfactory inclosure for the saw trimmer, to prevent metal chips from flying about the shop, in a western printing plant. A large ring of heavy iron rod was hung from the ceiling, high enough to allow plenty of room for the worker using the saw to stand under it. From this ring the curtain was suspended by means of the ordinary brass rings, so that it extended about 18 in. below the level of the saw mandrel. A quick jerk on the curtain closes it around both the saw and the worker. When not in use, the curtain is pushed to the rear or one side of the saw.—Edgar Sherman, Tucumcari, N. M.

Canvas Top for the Tractor

Driving a tractor in the rain is not a pleasant task, but the situation can be improved by providing a canvas top like the one shown in the photo. The frame is made of pipe and fittings or iron rod, and the canvas is cut and sewed together to fit over it snugly. Celluloid windows sewed into the canvas give sufficient vision.—Carlton Groat, Portland, Oreg.

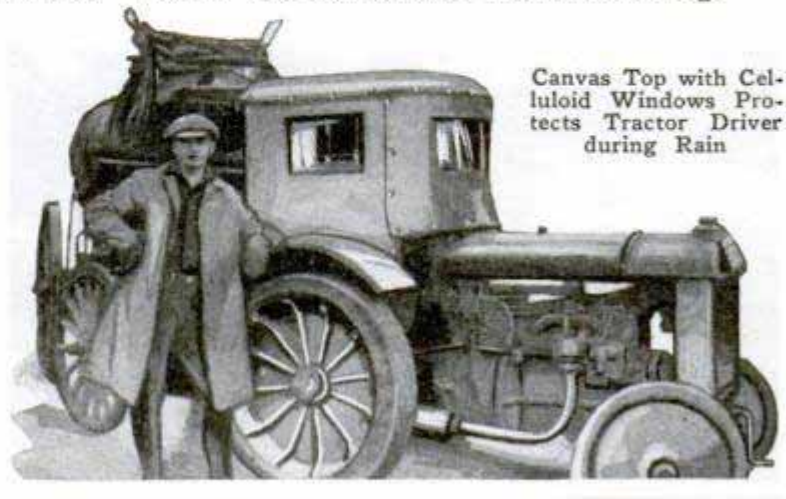

Canvas Top with Celluloid Windows Protects Tractor Driver during Rain

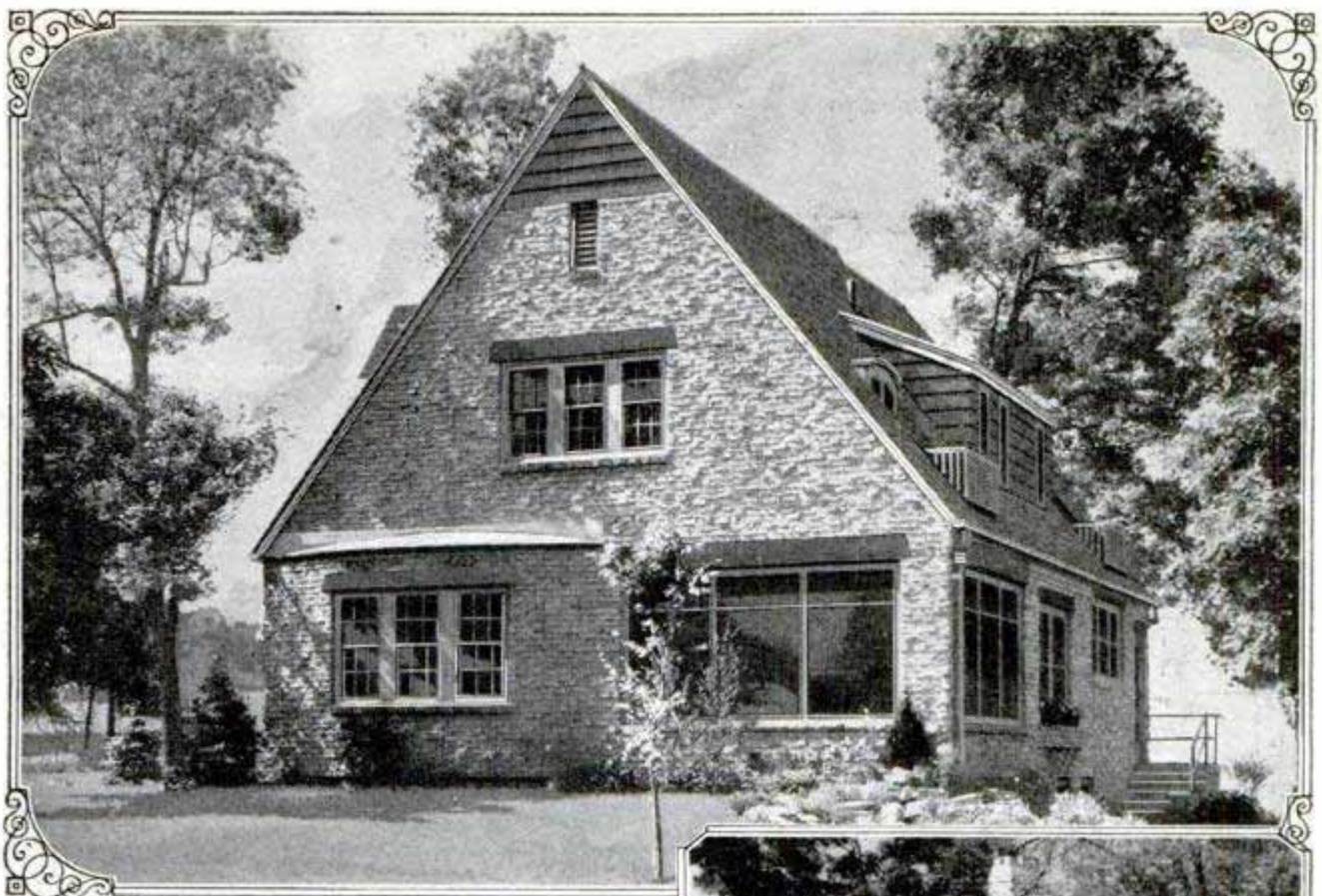

COPYRIGHT POPULAR MECHANICS

PLAN NO. 5-B-13

They Said It Couldn't Be Done

WHEN Chicago architects, several years ago, asked Chicago brick layers to build walls of common brick skintled-fashion, many refused because they said it was not brickwork. It was at variance with habits of years of bricklaying.

But the architects were insistent. And today both Chicago architects and bricklayers can claim a large measure of credit for developing a new idea—skintled brickwork—out of an old material. At the same time they have made an aristocrat out of a product which for many years had been used for the more common everyday structural purposes, such as rear and sidewalls.

Common brick now face the street in fine residence jobs. The endless skintle variations produce a charm of wall texture and

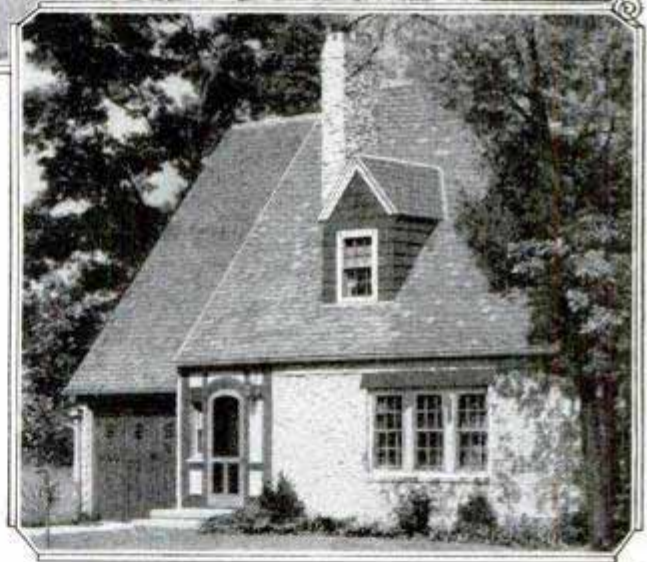

newness of style quite different from anything we have had before. Furthermore, such walls are relatively inexpensive. So much so that this new treatment is becoming very popular in small houses.

HOW TO GET A BLUEPRINT

To help our readers get started on one of life's most glorious experiences—building and owning a home—Popular Mechanics Magazine will supply readers a one-sheet blueprint of any house appearing in the magazine for \$1. This blueprint does away with the necessity of first purchasing a complete set of plans to find out whether you can afford to build. It contains floor plans, elevations, a section detail, size of joists, studs, etc., and also a brief specification. Submit it to tradesmen and dealers for building estimates.

There are no definite rules for laying skintled brickwork. The idea is to produce an irregular surface or facing in which the brick, unevenly laid in the wall, sometimes project at one end as much as an inch. No

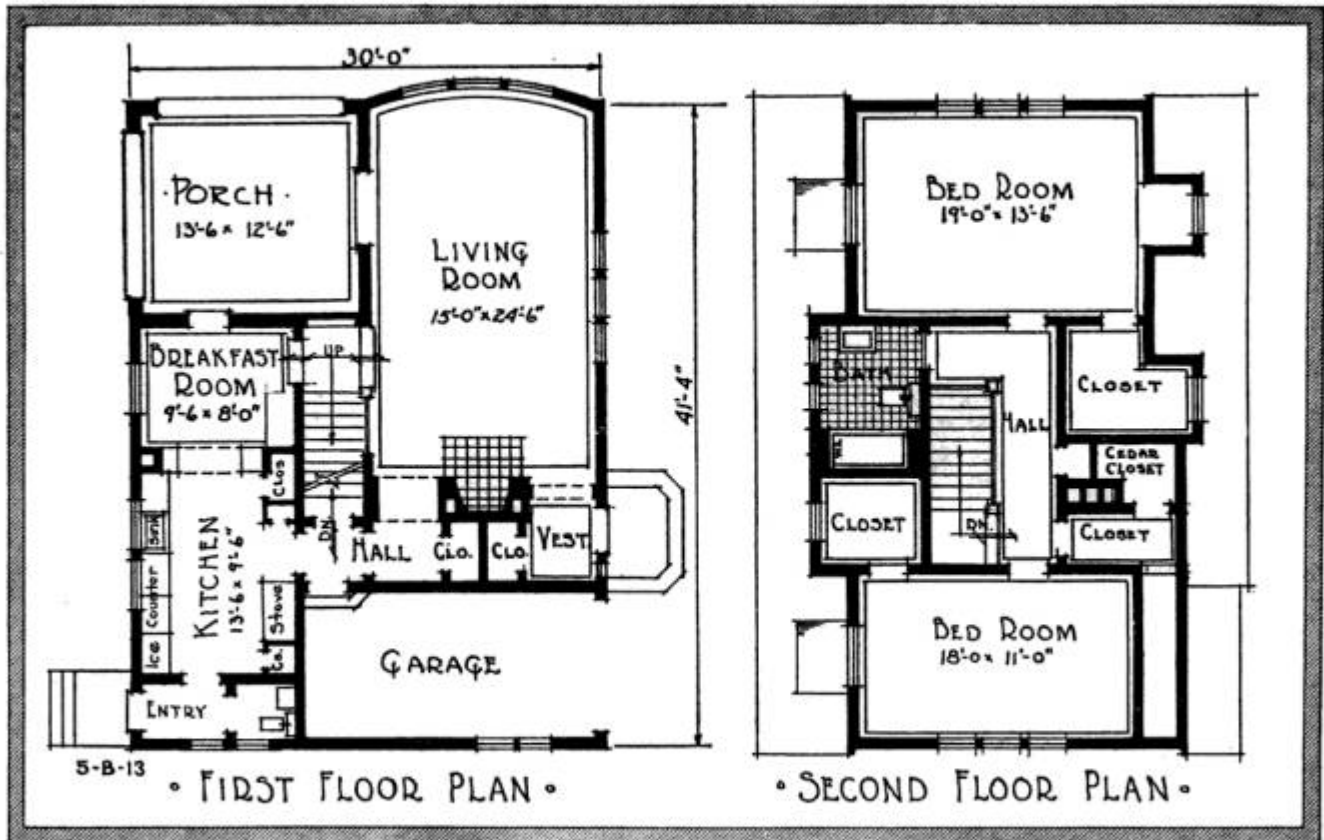

definite pattern is followed, save perhaps some particular bond such as Flemish, English or Dutch. The only idea is to obtain a sense of extreme irregularity or texture, which in itself becomes tremendously appealing. The projections of the brick cast shadows on the wall surface. These shadows give what architects call a play of light and shade or decorative effect.

Aside from common brick, laid skintle-fashion, you find salvage brick used in the same manner. What is meant by salvage brick? Brick selected from old buildings, being torn down. Many are weatherworn but still in excellent condition, and when used in a skintled wall, produce original and colorful effects.

What about the cost of a brick house? Manufacturers say that costs have been brought down until today. In various types of wall construction, the brick house will not cost over six per cent more than a frame house. They also add that the moderately increased first cost for brick is soon offset through savings made in annual upkeep, such as painting, insurance, etc.

A word of advice about selecting brick for your house. Don't try to judge a finished wall by a few loose bricks. Remember that the mortar joints are almost

as important as the brick itself. So, if possible, select your brick from a group of wall panels. These are on display in most dealers' offices. Try to picture your completed house done in brick and appropriate mortar joints before you place your order.

The house illustrated this month is a common-brick skintled job done uncommonly well. The owner says the final cost was not more than \$400 over and above frame construction.

In this house a built-in garage opens onto a rear hall. The hall is a pivot around which radiate the service and living quarters of the house. A large living room is a feature. The adjoining sunporch adds more room to the living area. On the second floor there are two good-sized bedrooms and an abundance of closet space. You have here a small house of reasonable cost that departs sufficiently from standards to make it individual and of excellent resale value.

PLAN BOOK FOR READERS

A NEW BUNGALOW BOOK: Sixteen selected low-cost bungalows in popular styles, at prices ranging from \$5,000 down to \$2,000. Each house fully described and illustrated. Send ten cents in stamps to cover mailing.

“.. when accuracy is at stake”

ONLY a “Yankee” Ratchet Drill is good enough — when accuracy is at stake!

A “Yankee” Ratchet Drill gives you the “feel” of the work—

It gives you control of drilling, every instant and down to the smallest fraction of a revolution.

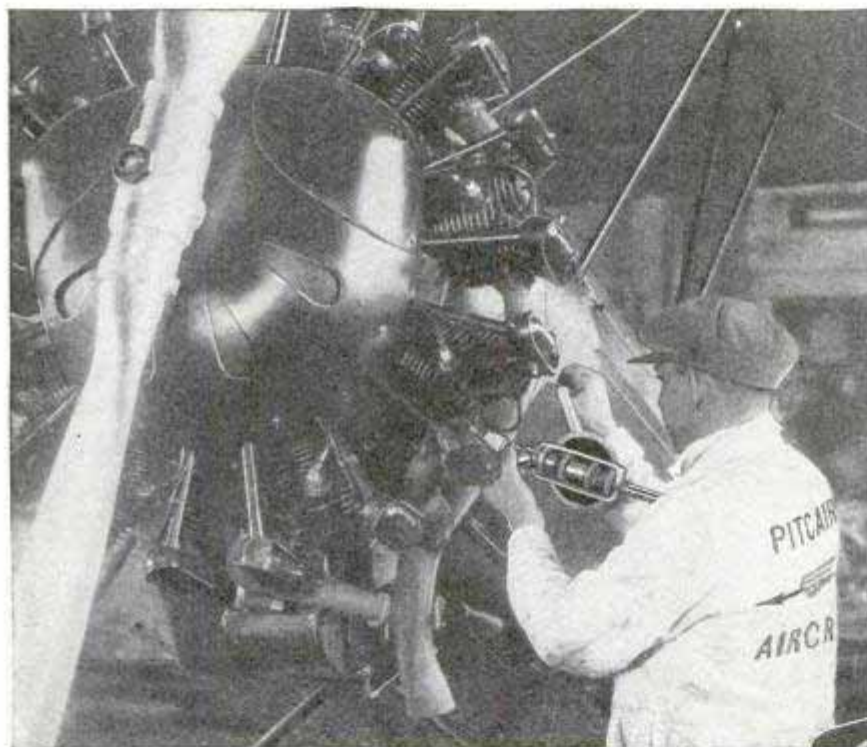

Photograph by permission Pitcairn Aircraft Inc. “Yankee” Ratchet Drill in use, on Pitcairn Super-Mailing, by John Van Winkle, who says, “I have used ‘Yankee’ Drills and Screw-drivers for eight years in Aircraft Work and found them very satisfactory; and convenient in close quarters.”

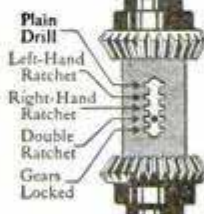

No. 1555 (illustrated). Length, 17 in. 3-jaw; 1/2-in. Double speed. Also, 2-jaw. Price, \$11.00.

No. 1545 — H a n d Drill. Length, 16 in. 3-jaw; 3/8-in. Double speed. Also, 2-jaw. Price, \$10.00.

No. 1530 — H a n d Drill. Length, only 10 1/2 in. but has same ratchet adjustments as large drills. 3-jaw; 1/4-in. Single speed. Price, \$5.25.

Eighteen styles of “Yankee” Breast and Hand Drills, at prices from \$3.00 up. Ask dealer for “Yankee.”

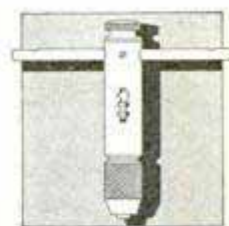

Tap hole with “Yankee” Tap Wrench No. 250. Ratchet adjustments and sliding cross-bar make awkward jobs easy. Price, \$1.85.

“YANKEE”

With a “Yankee,” you drill fast or slow at will. Change gears, high power or low, or change ratchet adjustments, at a finger-touch; and without removing drill from work. In tight places, “Yankee” Double Ratchet brings work out into the open and speeds it up; any slight motion of crank, forward and back, drives drill continuously.



TOOLS

MAKE BETTER MECHANICS
WRITE for “Yankee” Tool Book, Free. Shows how work is made easier with “Yankee” Tools! Spiral Screw-drivers. Automatic Push Drills. Ratchet Bit Braces. Ratchet Breast and Chain Drills. Bench Drills. Vises, etc.

NORTH BROS. MFG. CO., Philadelphia, U. S. A.
You may send me your “Yankee” Tool Book.

Name.....

Address.....(pm)

This FREE BOOK answers questions —

this famous **PLEDGE**
removes risk *in*
buying a used car!

At last, a real guide, to help you save money in buying a used car—and yours for the asking! "How to Judge a Used Car" has been written out of the experience of men who buy thousands of used cars for resale—in 32 interesting pages and 19 pictures these experts show you step by step how to pick a *good* used car at lower cost! Send the coupon now for your *free* copy.

This valuable free book explains in a simple, graphic way how to judge a used car's actual condition, how to learn the year model, how to set a fair price on a car offered you by a friend, what speedometer figures show, how to avoid "orphans," what code prices mean—why you get five days' driving trial on a used car backed by the famous Studebaker Pledge. Much of this trade information has never before been made public at any price—

Mail This Coupon Today!

THE STUDEBAKER CORP. OF AMERICA

Dept. 1510, South Bend, Ind.

Please send me my copy of your valuable free booklet, "How to Judge a Used Car."

Name.....

Street.....

City.....State.....

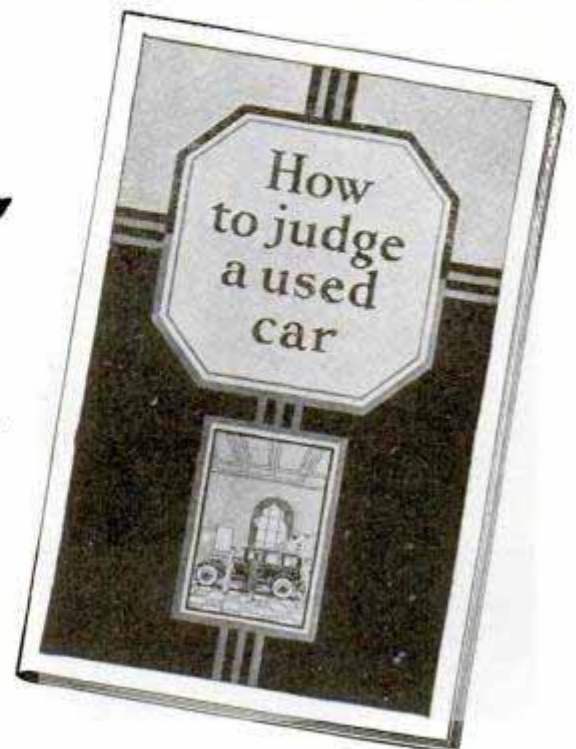

now the coupon below will bring all of this expert counsel to you without cost.

Before you buy or trade a used car it will pay you to read this free book, "How to Judge a Used Car"—use the coupon below *now!*

Pledge to the Public on Used Car Sales

- 1 Every used car is conspicuously marked with its lowest price in plain figures, and that price, just as the price of our new cars, is rigidly maintained.
- 2 All Studebaker automobiles which are sold as CERTIFIED CARS have been properly reconditioned, and carry a 30-day guarantee for replacement of defective parts and free service on adjustments.
- 3 Every purchaser of a used car may drive it for five days, and then, if not satisfied for any reason, turn it back and apply the money paid as a credit on the purchase of any other car in stock—new or used. (It is assumed that the car has not been damaged in the meantime.)

© 1928 The Studebaker Corporation of America

STUDEBAKER

Builder of Champions

How to Choose and Use Files

Told by the World-Famous Makers of Disston Files

IN the Disston Saw Works, more than 35,000 dozen files are used every year. They are Disston Files, made of Disston Steel, cut and hardened with Disston skill. This daily use of Disston Files, by Disston saw-makers, guards the quality of all Disston Files.

For Disston Steel puts longer life—and faster, easier cutting—into files as well as saws. It is

the world's great cutting steel, with toughness and temper unequalled. You will find a Disston File still cutting true, long after another file would be useless. Far longer service, mechanics say, and better service *always*. There is no substitute for genuine Disston Files.

Ask for Disston! Hand Saws, of course; but also Disston Files—every style, for every purpose.



Files for the Wood Worker

Disston Cabinet Files (fine teeth) for smoothing and finishing wood surfaces, easing tight doors and drawers, etc. Disston Wood Rasps (coarse teeth) for rough and fast cutting, enlarging holes, etc. Half-round 8" Cabinet File, 65c. Flat 8" Wood Rasp, 50c.

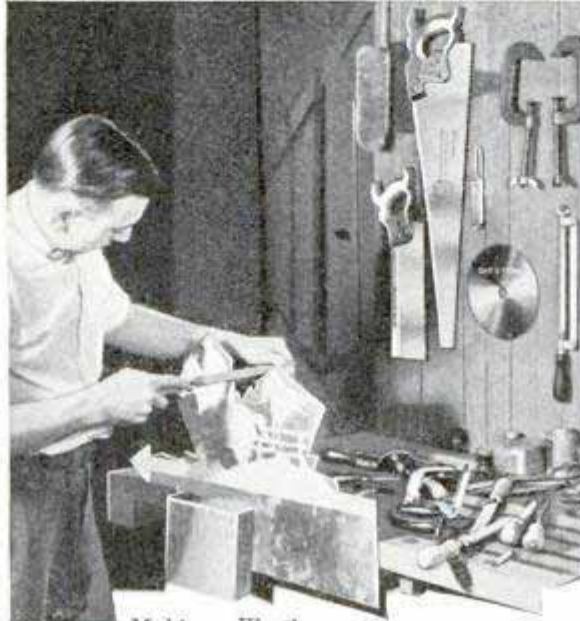

Making a Weathervane

HOLD file firmly against metal to be cut. Allow file to slip dulls it quickly. Proper position is with left hand at point, thumb on top of file, with right hand holding handle. For fast cutting, rest ball of left hand on file. Cut on forward stroke, use full-length of file and cut with a straight, regular motion. In draw-filing, or making a finish cut for flatness, take position shown at right.



Always keep file free from chips and filings, by using a file card and brush. Oil file before putting it away. Don't dull teeth by careless handling.

Single-cut files have one course of teeth diagonally across them, as in a taper saw file. Double-cut files have two courses of teeth, as illustrated below, with spacings of teeth differing as shown.



Bastard double-cut hand, flat and half-round files are widely used for fast cutting, with single-cut mill and taper files for a fine finish.

All good hardware merchants can supply Disston Files for every purpose, as well as Disston Saws and Tools.



"The Saw Most Carpenters Use"

The two handiest saws for the home workshop are the 26-inch 8-point for cross-cutting, and the 26-inch 5 1/4-point for ripping. You will need these on almost every job. The popular "D-S" Lightweight costs \$3.45. Many other styles and sizes to choose from.



Handiest of Pocket Levels

For truing up construction work, levelling shelves, etc., use a Disston Featherweight Pocket Level. It is the lightest and handiest level made. Length, 9"; weight, 2 oz. Aeroplane aluminum. Three proved glasses. \$1.25.



Band Saws for Better Work

Disston "Thin Gauge" Narrow Band Saws are 2 to 3 gauges thinner. They run better on machines with wheels up to 26" diameter. Saw 9' 8" long, 1/2" wide, 25-gauge, brazed, \$2.03. Other sizes in proportion.

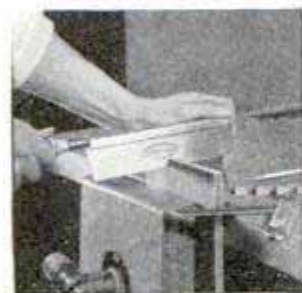

For Cutting Dovetails, etc.

Wherever the finest possible joint is needed, and for dovetailing, pattern making, etc., use a Disston No. 68 Dovetail Saw. Blade extra thin, with fine teeth. The 8" blade, 17 points to inch, is most popular. \$1.60.

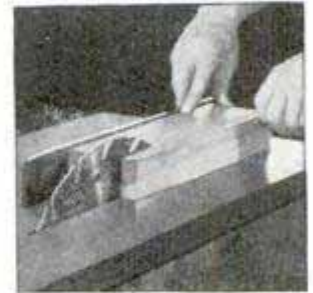

For Your Power Saw Outfit

Disston Saws insure better work. Cut easier, stay sharp longer. Disston Circular Saws—cross-cut, rip or combination—are made to fit any make of machine. If your dealer cannot supply you, write to us for prices.

DISSTON

Makers of "THE SAW MOST CARPENTERS USE"



Every saw user will enjoy reading "The Disston Saw, Tool and File Book," an illustrated manual on the selection, care, and use of tools. It tells how to file and set saws, etc., and contains helpful information on the correct use of files. Use coupon, or write.



Henry Disston & Sons, Inc., Philadelphia, U. S. A.
(In Canada, Henry Disston & Sons, Ltd., Toronto, Ont.)

Please send me "The Disston Saw, Tool and File Book."

Name and Address.....

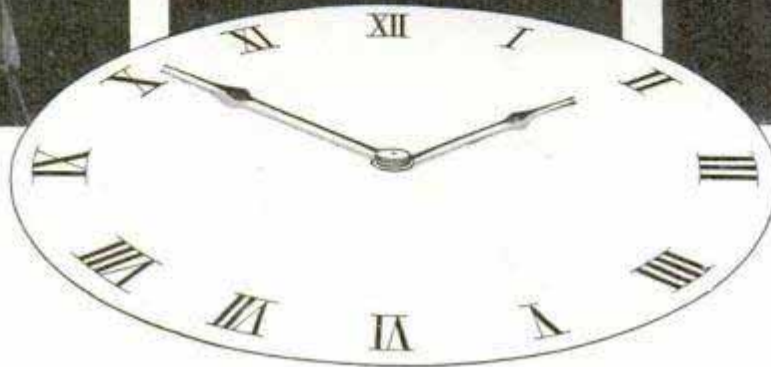

Rob yourself of sleep . . . *but you can't rob the Gillette Blade of its sure, smooth shave*

AFACE drawn and tight from lack of sleep, a slapdash lather and a hurry-up shave—it can't ruin the even temper of a Gillette Blade, even though it may wreck your own.

On such mornings lather extra thoroughly and treat yourself to a fresh Gillette Blade. You're sure then of the smooth, even, comfortable shave which has been honed and stropped into every Gillette Blade by machines adjusted to one ten-thousandth of an inch.

Every Gillette Blade *must* be even and sure. To guarantee that,

four out of every nine of our blade department employees are inspectors and are paid a bonus for detecting every blade that won't do a superb job of shaving.

No two men have identically the same kind of beard. No man

King C. Gillette



THE only individual in history, ancient or modern, whose picture and signature are found in every city and town, in every country in the world, is King C. Gillette. This picture and signature are universal sign-language for a perfect shave.

gives his Gillette the same kind of job to do every morning. A dozen varying conditions affect the comfort of your shave. The Gillette Blade alone remains constant.

Eight out of ten American men count on the Gillette Blade to do its job *well* every morning. It does. Witness the smooth faces of American men today. Gillette Safety Razor Co., Boston, U.S.A.



★ **Gillette** ★



*for Economical Transportation***CHEVROLET**

Using
RADIO
 to test

the quietness of the Chevrolet Six

The engineers of the General Motors Research Laboratories have found a new use for radio—testing Chevrolet gears for noise.

This fascinating scientific process is illustrated in the photograph above. A pair of gears is set in motion at high speed. The slight "hum" is picked up by the microphone and amplified by a high quality vacuum tube amplifier similar to those used in the better radio sets.

A recording apparatus makes it possible to check one set of gears

against others and thus to determine which design will give the most satisfactory results under actual operating conditions.

This special testing device is only one of thousands used in the General Motors Research Laboratories to take the guesswork out of designing and building better automobiles—

—one of the many reasons why Chevrolet combines marvelous six-cylinder power, speed, acceleration and smoothness with such remarkably quiet operation.

The Roadster, \$525; The Phaeton, \$525; The Coach, \$595; The Coupe, \$595; The Sport Coupe, \$645; The Sedan, \$675; The Imperial Sedan, \$695. All prices f. o. b. factory, Flint, Michigan

CHEVROLET MOTOR CO., DETROIT, MICHIGAN
Division of General Motors Corporation

A SIX IN THE PRICE RANGE OF THE FOUR

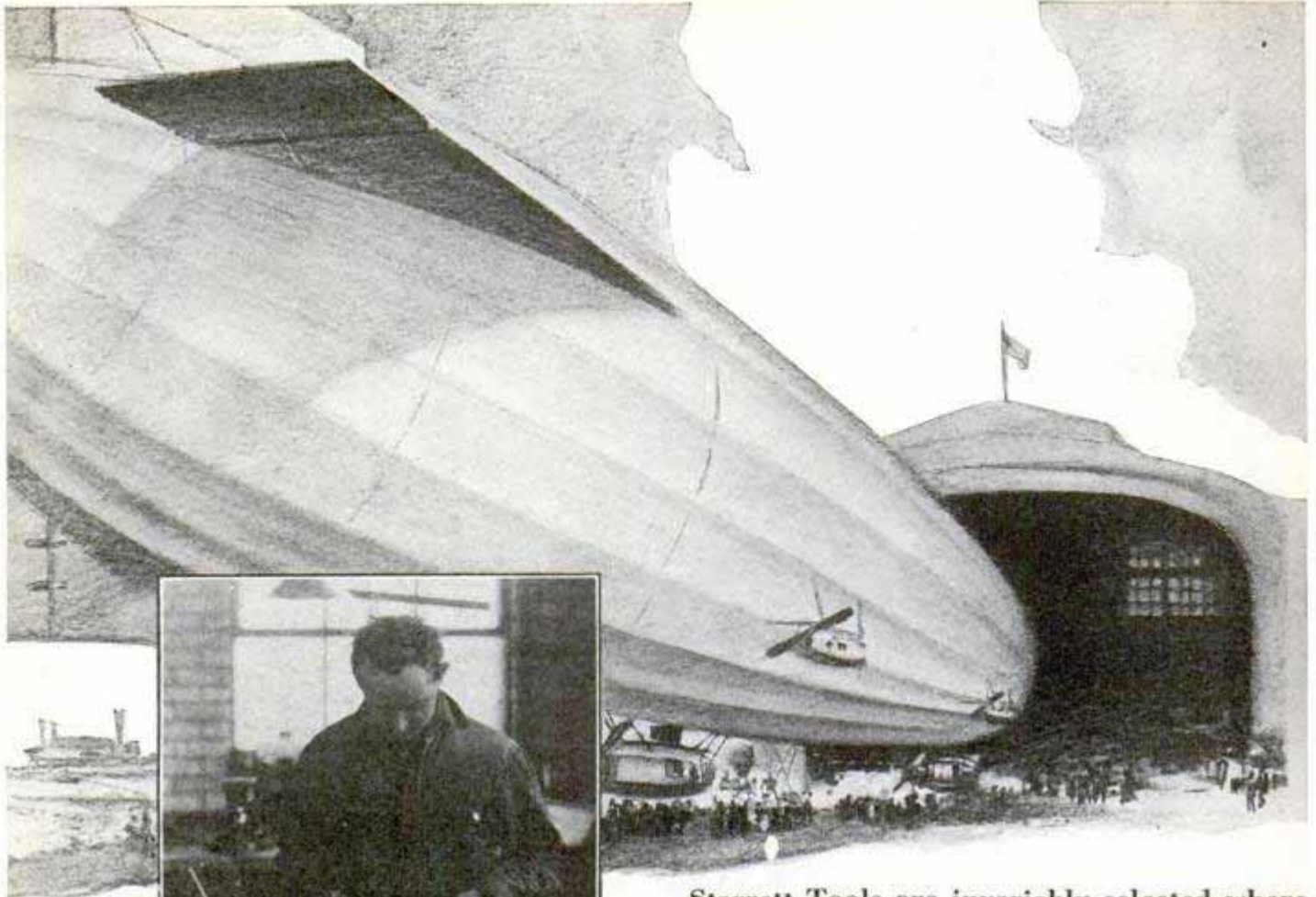

Starrett Tools are invariably selected where accuracy and dependability count most. They offer you equal satisfaction and service whether you use them for work or for fun.

Your dealer has the genuine. Ask him for Starretts.

Send today for the free catalog No. 24 "AP"

THE L. S. STARRETT CO.
World's Greatest Toolmakers
 Manufacturers of Hacksaes Unexcelled
 Steel Tapes—Standard for Accuracy
 ATHOL, MASS., U. S. A.

Over 2500 Starrett Tools described and illustrated in the Starrett Catalog



Starrett Combination Square No. 94



Starrett Micrometer No. 230



Starrett Thickness Gages No. 172



Starrett Pocket Slide Calipers No. 425



Use Starrett Tools

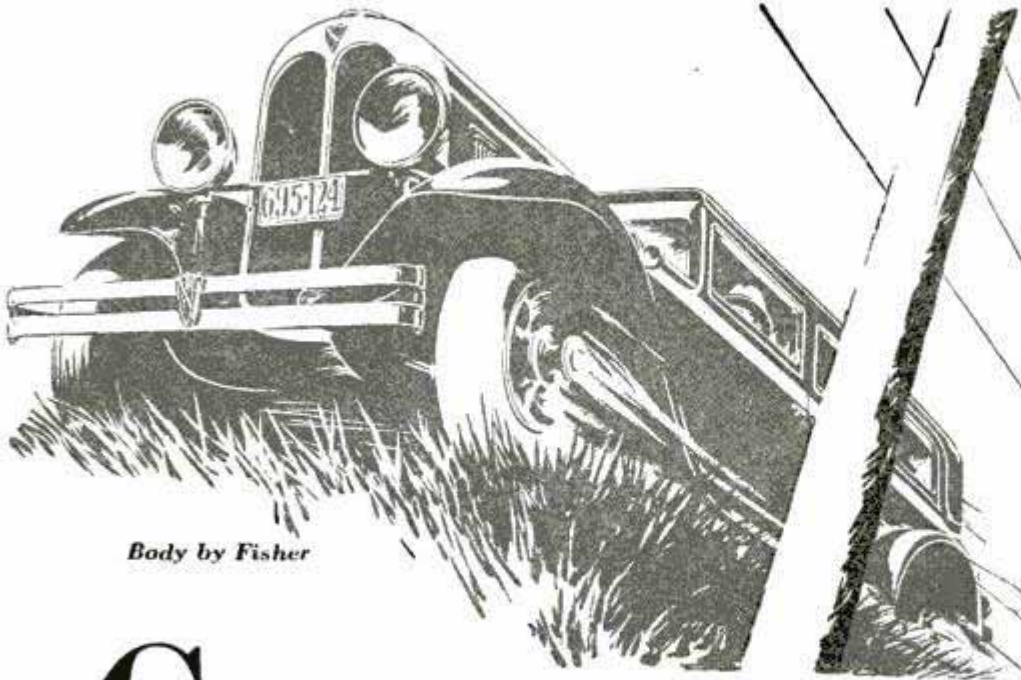

Body by Fisher

Compare mechanical
features and you will find this car
America's finest
medium-priced automobile

TO ANYONE interested in the mechanical construction of motor cars, the superiority of today's Oakland All-American Six can be quickly proved. The All-American Six has been compared with twenty other medium-priced cars. 878 individual comparisons of features have been made. In these comparisons, Oakland proves to be definitely superior on 451 items or 51.37 per cent. The twenty other cars combined are at best equal to Oakland on 382 or 43.50 per cent. And 13 of the 20 are higher priced than Oakland.

Such facts as these are revealed by the comparison: Only Oakland in the entire field employs the rubber "biscuit" mountings which are such important

factors in giving the All-American Six its matchless smoothness and silence. Only Oakland, in the entire field, uses the cross-flow radiator, one of the greatest engineering advancements since the advent of four-wheel brakes.

Any Oakland-Pontiac dealer will gladly show you complete returns from this analysis. You will be amazed at the clear-cut manner in which Oakland supremacy is disclosed. And you will find upon comparing mechanical features that today's All-American Six is *America's finest medium-priced automobile.*

Prices, \$1145 to \$1375, f. o. b. Pontiac, Michigan, plus delivery charges.

Oakland Motor Car Co., Pontiac, Michigan

OAKLAND
ALL-AMERICAN SIX
PRODUCT OF GENERAL MOTORS

Tools of Dependable Accuracy

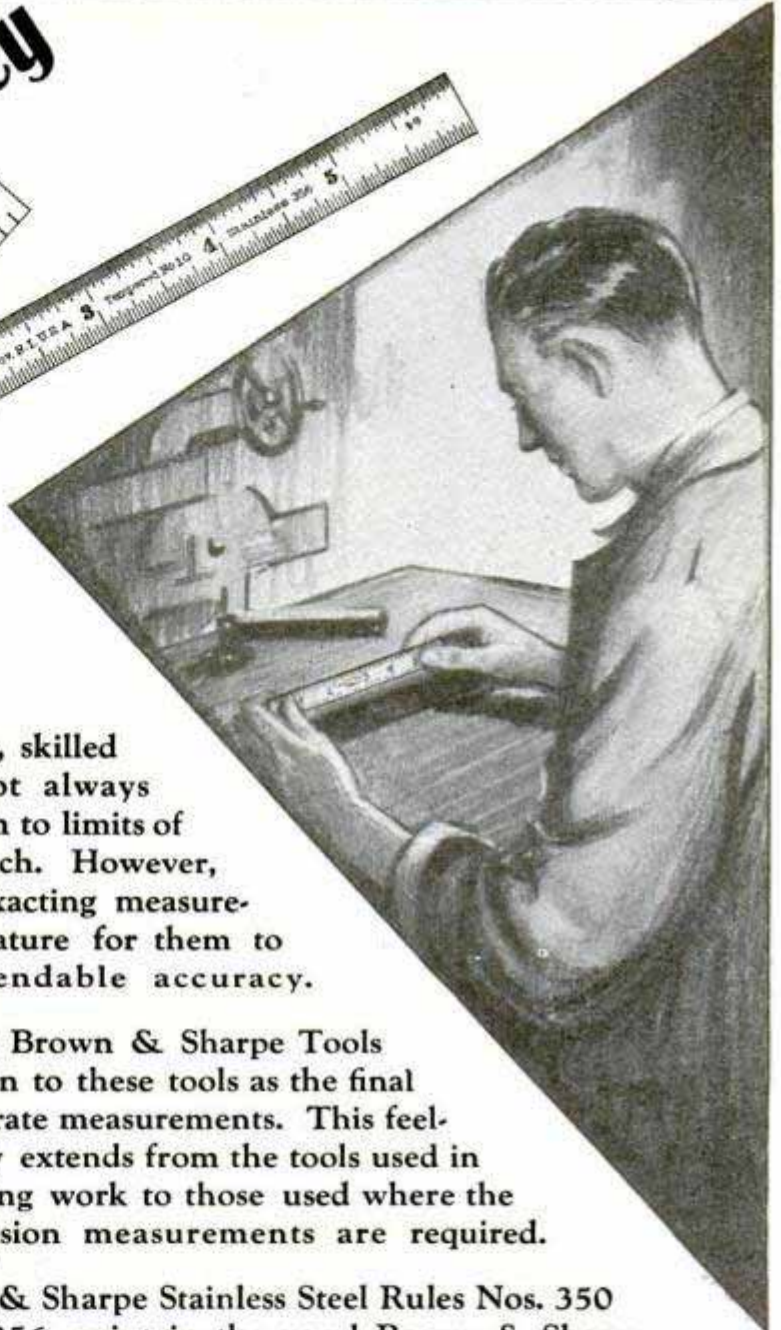
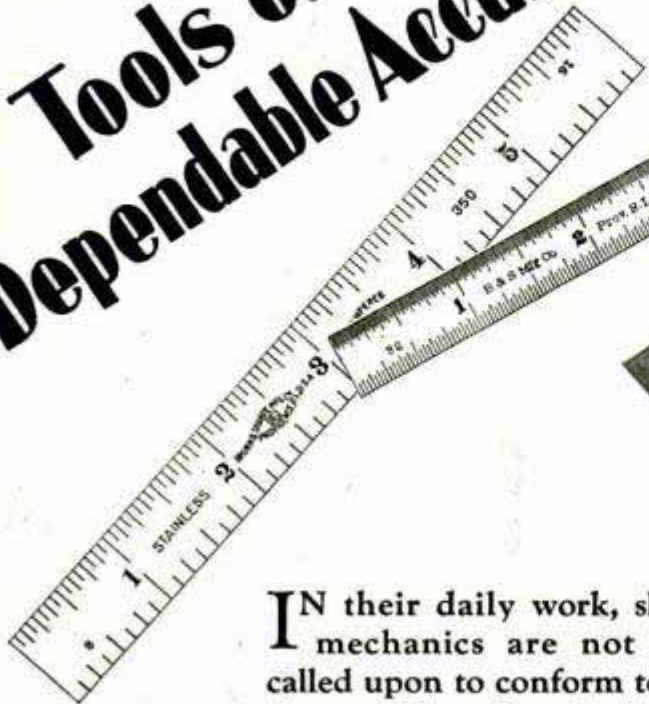

IN their daily work, skilled mechanics are not always called upon to conform to limits of thousandths of an inch. However, even for their less exacting measurements, it is second nature for them to want tools of dependable accuracy.

Their experience with Brown & Sharpe Tools has led them to turn to these tools as the final authority for accurate measurements. This feeling of reliability extends from the tools used in the less exacting work to those used where the finest precision measurements are required.

Brown & Sharpe Stainless Steel Rules Nos. 350 and 356 maintain the usual Brown & Sharpe standard of accuracy. They are rustproof and will not stain or discolor. Full descriptions of these rules, as well as over 2300 other tools, are contained in our new Small Tool Catalog No. 31. Ask your hardware dealer for a copy or write direct to us for one. Dept. P.M., Brown & Sharpe Mfg. Co., Providence, R.I., U.S.A.



Micrometer Caliper
No. 11 RS



Combination Square
No. 401



Spring Dividers
No. 810



Surface Gauge
No. 621



Twist Drill and Machine Screw Tap Gauge
No. 707



"WORLD'S STANDARD OF ACCURACY"

BROWN & SHARPE TOOLS

WURLITZER
TRADE MARK REGISTERED
 THE WORLD'S LARGEST MUSIC HOUSE



Try Any Wurlitzer Instrument in Your Own Home

EXAMINE IT. show it to your friends, play it as much as you wish. An ample free trial—no obligation to buy. We make this liberal offer because we want you to see for yourself this superior quality of Wurlitzer instruments, the result of 200 years' experience. Noted musicians praise them for unusual tone quality, artistic workmanship and ease of playing. They are used in the finest bands and orchestras throughout the country.

Easy Payments

If you decide to buy, payments are arranged in small monthly sums. A few cents a day pays for your instrument. Special offers on complete musical outfits.

SEND FOR New Catalog

The greatest musical catalog ever published! Over 3,000 articles—every known instrument described and illustrated; many of them shown in full colors. Gives you lowest prices and all details of Free Trial, Easy Payment plan. All sent FREE—no obligation. Send coupon below.

Clip and Mail

THE RUDOLPH WURLITZER CO., Dept. 1777
 117 E. 4th St., Cincinnati

Send me, absolutely free, new illustrated catalog, with prices and details of Free Trial Easy Payment plan. No obligation.

Name _____

Address _____

City _____ State _____

Instrument _____

(State Instrument in which you are interested)

New England Mills Bargain Radio Catalog is Ready!



NEW England Mills offers everything in radio at wholesale prices that spell real savings! That's what you will find in this great catalog just off the press, featuring Radio's newest creations in sets, kits, parts and supplies. Everything in our catalog is backed by the guarantee of this old, stable concern and its vast resources, accumulated through 17 years of faithful service to its customers.

WHY OUR PRICES ARE LOW

We are one of the largest outlets by mail to the trade. Our arrangement with many of America's leading factories enables us to buy on our own terms. Our cash resources makes it possible to command the very lowest prices from manufacturers—in most cases merely a small margin above the actual manufacturing cost—and frequently at lower than cost. This in turn is reflected in the net wholesale prices we show in our catalog. We give our customers the benefit of our vast purchasing power.

ALL RADIO DEALERS SAVE MONEY

by trading with New England Mills. This saving applies to complete radio sets of every description, dynamic and magnetic speakers, A. C. and all other types of tubes, eliminators, batteries, radio cabinets—in fact, everything required by dealers for resale or servicing. Every dealer knows that by buying right he is in position to sell at prices that meet all kinds of competition, thereby increasing his profits and good-will.

SET BUILDERS AND REPAIR MEN!

A tremendous amount of business will be done this season in rebuilding sets which users want to keep, and by modernizing old models. Our catalog contains everything required for this work. Besides, we have a supply of the latest models of nationally renowned kits—either knocked down or completely assembled chassis ready to install in table or console cabinets, all at wholesale prices that permit of excellent profits to you.

**Catalog also contains complete lines of electrical goods, tires, tubes, and auto supplies
All kinds of sporting goods and hundreds of other items at wholesale prices**



free
send
for it
TODAY

for
**RADIO
DEALERS
SET BUILDERS
AGENTS
& SERVICE
MEN**

A. C. Electric Radios

Our new catalog contains a large selection of the finest A. C. Electric, 6, 7, 8 and 9 tube chassis and complete sets

obtainable at the amazingly low prices we quote. Every modern radio improvement is embodied in these marvelous electric radios. All are sold by us with the guarantee of satisfaction backed by this 17 year old institution.

BATTERY SETS FOR UNWIRED HOMES

The vast number of rural communities with homes that are not wired for electric radios offer a tremendous market for battery sets, repairs and replacements. We have not overlooked this important field, as evidenced by the large stock of batteries, eliminators, speakers, tubes, transformers, coils, and all kinds of accessories needed for battery sets. These supplies include some of the best known nationally advertised goods, such as Cunningham, Sonatron and Arcturus tubes, Burgess batteries, Jewel instruments, Belden Products, Utah, Temple, Farrand and other popular dynamic and magnetic speakers.

Send for Free Book—NOW!

Radio dealers, agents, set builders, service men, etc., cannot afford to be without the New England Mills catalog. It contains everything you need for a more profitable radio business. We maintain a complete radio service department, supervised by expert radio engineers who will help you with all your radio problems. All goods catalogued are stocked for immediate shipment. Write for this book today. It's FREE! Send request on your business stationery.

NEW ENGLAND MILLS COMPANY 851 WASHINGTON BLVD.
DEPT. 30 CHICAGO, ILL.

New Model SOUTH BEND LATHES

BACK GEARED SCREW CUTTING LATHES

15,000 Lathes in Use in U. S. and 78 Foreign Countries

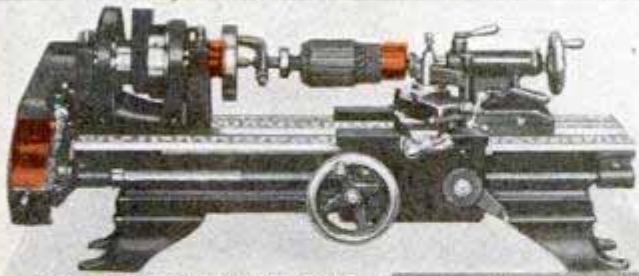

9' x 3' New Model South Bend Jr. Back Geared Screw Cutting Lathe
(Weight 375 lbs.) Complete with Countershaft and \$169
Equipment shown only

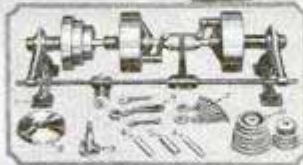

FOR THE

Manufacturing Plant	Service Station Maintenance
Tool Room	Airport
General Repair Shop	Electrical Shop
Machine Shop	Engineering Shop and Laboratory

USED BY MANUFACTURERS OF

Automobiles	and
Electrical Parts	Government Departments
Machinery	National and State
Aircraft	
Textile Machines	

Prices of 9-in. Junior Bench Lathes Including Lathe Equipment

Size of Lathe	Shipping Weight	Countershaft Drive	Horizontal Motor Drive
9' x 2 1/4'	350 lbs.	\$163.00	\$248.00
9' x 3'	375 lbs.	169.00	254.00
9' x 3 1/2'	400 lbs.	175.00	260.00
9' x 4'	425 lbs.	182.00	267.00

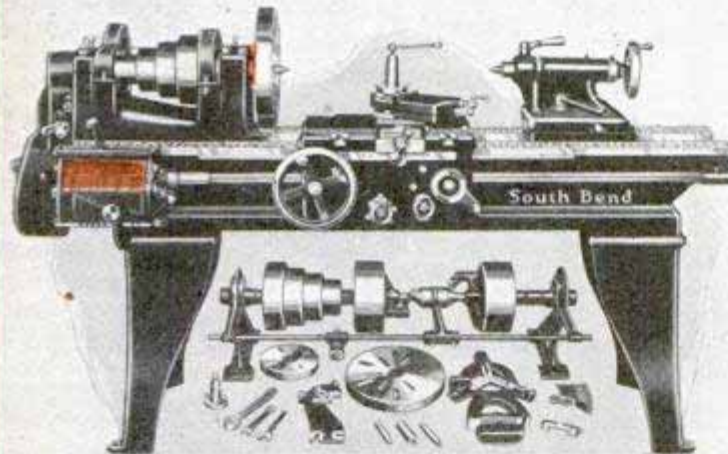

16' x 6' Quick Change Gear New Model South Bend Lathe - - - \$598

Prices of Popular Sizes of Quick Change Gear Lathes with Lathe Equipment

Size of Lathe	Shipping Weight	Countershaft Drive	Silent Chain Motor Drive
9' x 3'	490 lbs.	\$294.00	\$398.00
11' x 4'	725 lbs.	359.00	498.00
13' x 5'	1110 lbs.	443.00	602.00
15' x 6'	1550 lbs.	543.00	720.00
16' x 8'	2035 lbs.	638.00	817.00

Easy Payments

We ship any South Bend Lathe immediately upon receipt of only 20 percent of Catalog Price. Balance in 12 equal monthly payments. Write for Time Payment Catalog.

New FREE Catalog
Shows 96 Sizes from 9-in. to 18-in.
Write or send coupon today for the New South Bend Lathe Catalog. This complete book illustrates and describes 96 sizes and types of Countershaft Driven Lathes, Motor Driven Lathes, Quick Change Gear Lathes, Standard Change Gear Lathes, Tool Room Lathes, Gap Bed Lathes, Brake Drum Lathes and Bench Lathes. Investigate the New Model Lathe as it has all the latest improvements.

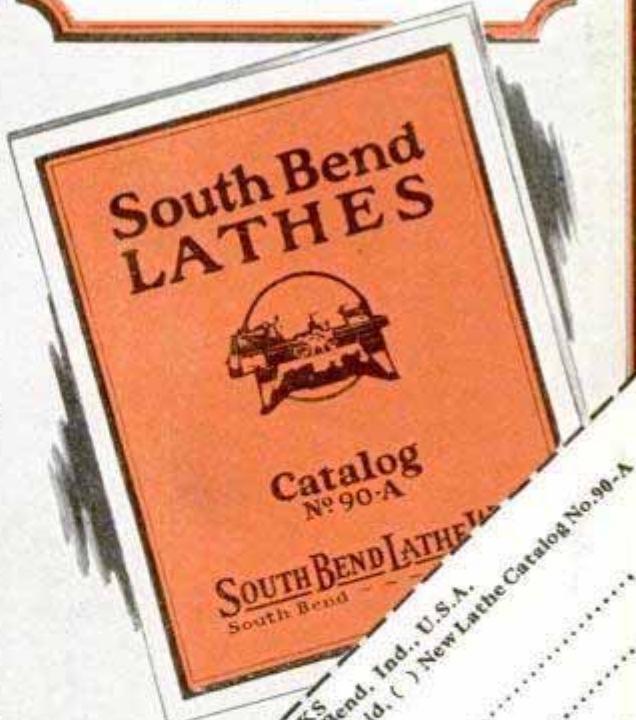

SOUTH BEND LATHE WORKS

610 E. Madison St., South Bend, Ind., U.S.A.

Lathe Builders for 23 Years

SOUTH BEND LATHE WORKS
610 E. Madison St., South Bend, Ind., U.S.A.
() Time Payment Catalog, () New Lathe Catalog No. 90-A

Name.....
Address.....
City.....
State.....

Stanley Electric Tools

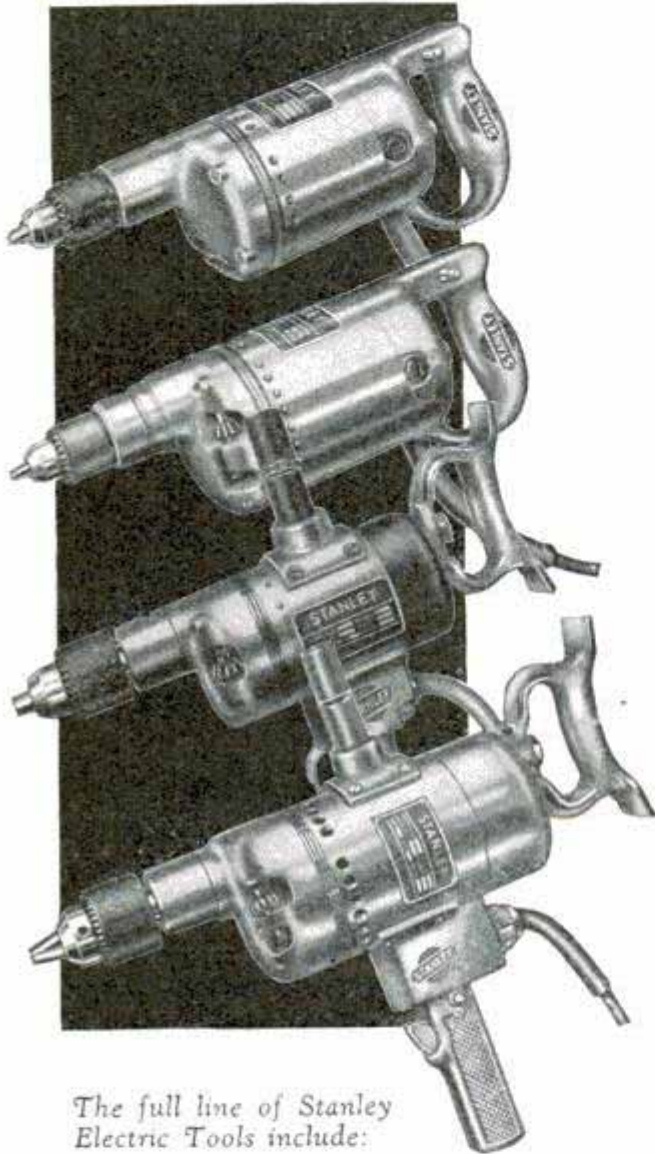

The full line of Stanley Electric Tools include:

DRILLS

No. 141—	1/4"	Standard Duty	\$30.00
No. 142—	1/4"	Heavy Duty	40.00
No. 562—	3/8"	Heavy Duty	44.00
No. 382—	3/8"	Heavy Duty	52.00
No. 121—	1/2"	Standard Duty	54.00
No. 122—	1/2"	Heavy Duty	60.00
No. 582—	5/8"	Heavy Duty	68.00
No. 341—	3/4"	Standard Duty	70.00
No. 342—	3/4"	Heavy Duty	78.00
No. 781—	7/8"	Standard Duty	85.00

GRINDER—No. 556 Bench Grinder
AC Current, \$46.00 DC, \$48.50
Drill Stands, Attachments, etc.



Five Important Points of Superiority of Stanley Electric Drills are

POWER—Motors of the highest quality are used. Plenty of reserve power.

LIGHT WEIGHT—Specially designed aluminum alloy housing combines strength and rigidity with light weight.

COOL RUNNING—A scientifically built ventilating system keeps the drill cool even under continuous operation.

SMOOTH DESIGN—No bumps and hollows to collect dirt and grease. Straight line construction permits their use in corners and other places having minimum clearance.

CHUCK—Furnished with three jaw type chuck. Note the convenient key holder in housing.

Backed by the reputation of the company that has been supplying you with the best tools for over 75 years.

Catalog S59 upon request

THE STANLEY RULE & LEVEL PLANT
New Britain, Conn.

STANLEY TOOLS

The Choice of Most Mechanics

TRY IT 30 DAYS FREE BEFORE YOU BUY

FACTORY TO YOU - SAVE 50%
Choice of beautiful **DYNAMIC** Consoles

1 Year Guarantee

9 tube-perfected
SCREEN GRID, PUSH-PULL

MIRACO
TRADE MARK REGISTERED

CATHEDRAL TONED, SUPER SELECTIVE, POWERFUL DISTANCE GETTER

only \$49.88
COMPLETELY ASSEMBLED

Compare with costliest sets before you buy!

You needn't send us a cent! America's big, old, reliable Radio Factory springs its 10th Anniversary Surprise in high-grade full-year guaranteed sets at history's lowest prices! With its latest perfected Screen-Grid, push-pull, super-powered and hum-free AC electric Miraco's—you are guaranteed satisfaction, values and savings unsurpassed.

At our risk compare a Miraco with highest priced radios, for 30 days in your home. Surprise and entertain your friends—get their opinions. Unless 100% delighted, **don't buy!** Your decision is final—no argument!

Only marvelously fine radios, of latest perfected type, at rock-bottom prices, can back up such a guarantee. Send postal or coupon for *Amazing Special Factory Offer!*

Don't Confuse with Cheap Radios

With Miraco's rich, clear cathedral tone, quiet operation, razor-sharp separation

of nearby stations, tremendous "kick" on distant stations and latest improvements—you'll be the envy of many who pay 2 or 3 times as much!

Send for proof that delighted thousands of Miraco users cut through locals, get coast to coast, with tone and power of costly sets. Miraco's are custom-built of finest parts—product of 10 years' successful experience. Approved by Radio's highest authorities.

DEAL DIRECT WITH BIG FACTORY

Miraco outfits reach you splendidly packed, rigidly tested with everything in place ready to plug in! No assembling! Entertain yourself 30 days—then decide. Liberal year's guarantee on each set. Play safe, save lots of money, insure satisfaction—deal direct with Radio's old, reliable builders of fine sets—10th successful year. **SEND POSTAL OR COUPON NOW!**

MIDWEST RADIO CORP., 407-EO Miraco Bldg., Cincinnati, O.
Get our Send No Money 10th Anniversary Offer

Dealers Write! - mail coupon right Now!



BEAUTIFULLY ILLUSTRATED LITERATURE

Free!

Amazing Special Factory Offer

All the proof you want—of our honesty, fairness, size, financial integrity, radio experience and the performance of our sets—including Amazing Factory Offer—sent without obligation!

User Agents Wanted! Exclusive Territory

DEMONSTRATOR SENT GET OUR PROPOSITION

Excels \$425 Outfit
My 30 days trial on my Miraco AC-9 is up and if you would offer me \$200 extra for it back, I would tell you nothing doing. We had some very expensive sets in our home, one a \$425 9-tube AC set. Thanks to you I have a set that gets any and all stations. I have got stations in 45 states, also Cuba and Canada. It is beyond words to tell you what we think of our wonderful bargain. I will always praise Miraco's to everyone. J. W. LAUDERBACK, Barborton, Ohio.
Coupon brings proof like this from people in YOUR locality, too.

SPECIAL ELECTRIC AC-7 \$39.85

BATTERY SET \$29.50

THIS COUPON IS NOT AN ORDER

MIDWEST RADIO CORPORATION
10th Successful Year
407-EO Miraco Bldg., Cincinnati, Ohio
WITHOUT OBLIGATION send latest literature, **AMAZING SPECIAL FREE TRIAL OFFER**, testimony of nearby users, etc.

User Agent Dealer
 Check here if interested in an **EXCLUSIVE TERRITORY PROPOSITION.**

Name.....
Address.....

« « PREPARE YOUR CAR FOR WINTER DRIVING

AN OUNCE OF PREVENTION NOW, WILL PREVENT
A POUND OF TROUBLE WHEN WINTER COMES

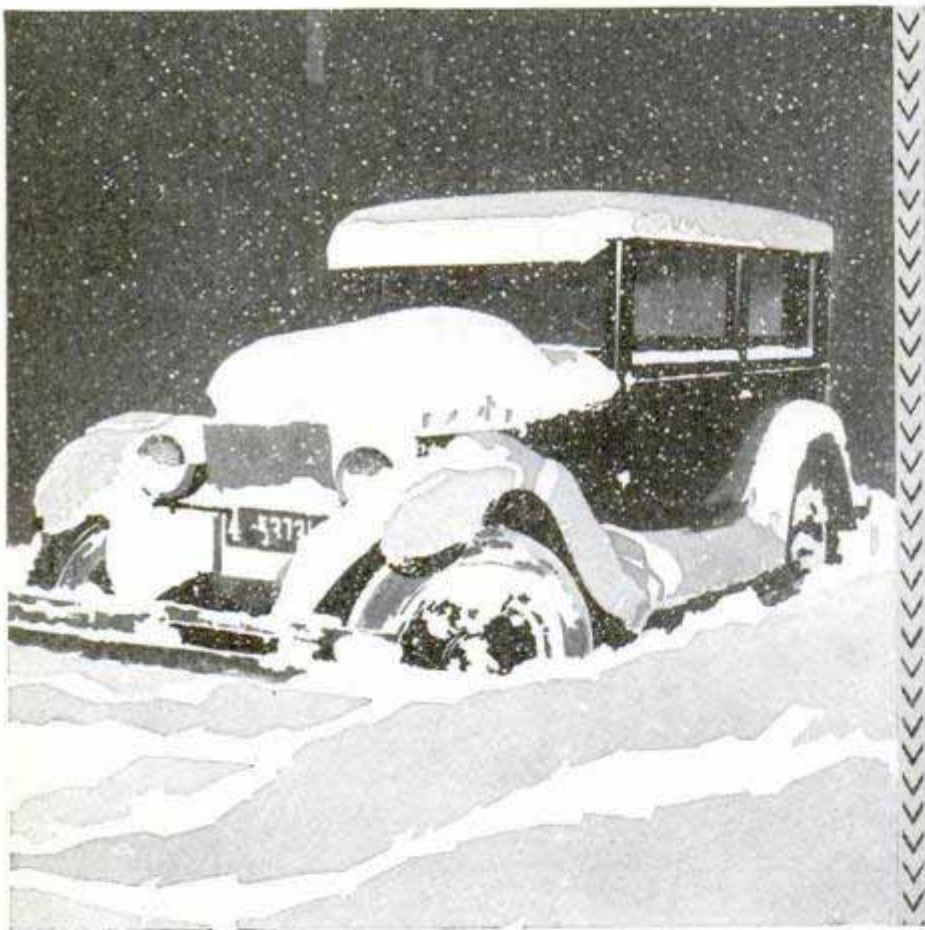

AFTER a summer's use every car should have some simple, inexpensive service to get it ready for cold weather.

There should be a fresh supply of winter-grade oil in the crankcase, transmission and differential. Spark plugs, ignition cables and battery should be at their best. See that the *cooling system* is *clean* and *tight*, then give your car the perfect protection of Eveready Prestone. One supply protects the car all winter.

Any garage will flush out the cooling system, examine it for leaks, tighten up hose connections or pump glands—look over the complete system for a small fee.

Eveready Prestone is approved by automobile manufacturers and possesses *all* the properties which the National Bureau of Standards has declared essential for an anti-freeze.

It contains absolutely no alcohol and no glycerine—and

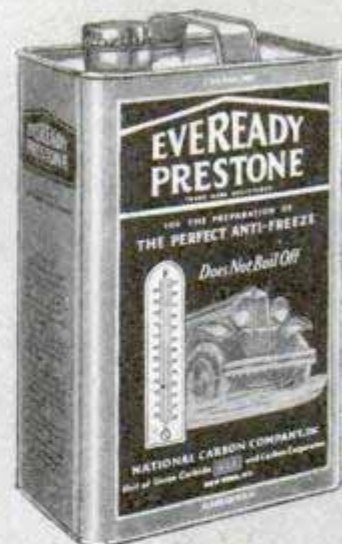

Eveready Prestone does not contain any alcohol or glycerine.

9 POINTS OF SUPERIORITY

1. Gives complete protection.
2. Does not boil off.
3. Positively will not damage cooling system.
4. Will not heat up a motor.
5. Circulates freely at the lowest operating temperatures.
6. Will not affect paint, varnish or lacquer finishes.
7. Non-inflammable.
8. Odorless.
9. Economical—one filling lasts all winter.

EVEREADY PRESTONE

TRADE MARK REG. U.S.

FOR PREPARATION OF THE
PERFECT ANTI-FREEZE

Thoroughly tested and 100% approved by the American Automobile Association.



is a pure, undiluted product.

Be ready before cold weather can harm your car. Have the cooling system of your car serviced and get a supply of Eveready Prestone today.

NATIONAL CARBON CO., Inc.
General Offices
New York, N. Y.

Unit of  and Carbon Corporation

THE INCOMPARABLE *Red Jacket* ELECTRIC HANDY-SHOP, 1930 Model

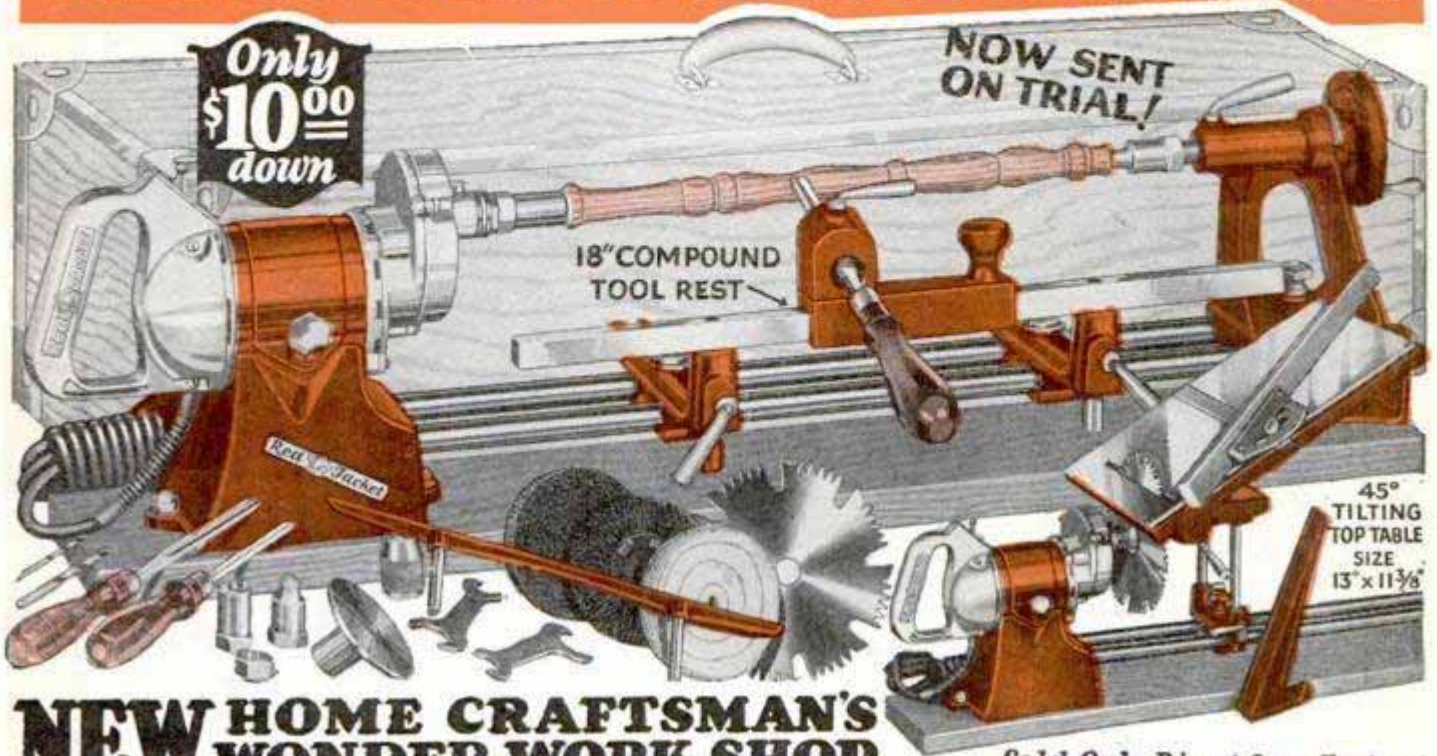

NEW HOME CRAFTSMAN'S WONDER WORK SHOP

Sold Only Direct from Factory

4 years of testing, experimenting and improvement is wrapped up in each new Red Jacket Home Work Shop. The finest tools and accessories that can be made go with each assembly order. Red Jacket equipment is designed, tested, approved and guaranteed by Wm. L. Aylward, a nationally known craftsman and manufacturer, who has developed his hobby into a co-operative association of thousands of craftsmen.

Portable — Interchangeable — Complete RED JACKET Home Work Shop

The new Red Jacket Combination of Electric tools brings you a Red Jacket Band Saw and in addition the powerful Red Jacket Master Drill Motor with direct drive to the Waco Craftsman's wood turning lathe (capacity 9"x36", also compound and 18" rests, a tilting top mitre saw with both depth and side gauges, scroll and jig saw, and all accessories for both portable and stationary power drilling, buffing, grinding and cleaning. Attaches to light socket and converts your work bench into a complete private tool and machine shop. It is a complete chest full of electrically driven tools designed for the private use of tool lovers and men who create, repair and appreciate handy tools at home.

Make It Yourself!

Exclusive Features with WACO—

- All Aluminum Master Drill Motor
- Perfect Tilting Saw Table 13 x 11 1/2 in.
- Patented Compound Tool Rests
- Finest Quality Hand Tools
- Unconditional Guarantee
- Unlimited Service
- Read Our Code of Business Ethics—
- Ask 7000 Happy Waco Owners



45° Tilt Top Table

Mail Coupon for Interesting FREE Literature

Send coupon at once for information valuable to those interested in beautiful handiwork. It is FREE. It tells you how easy it is to operate a Red Jacket set of tools and lists the advantages and privileges that are free to member craftsmen. Don't miss knowing all about Waco. You are invited. **Look out for imitations.** There is only one Red Jacket—one Waco—you will not find WACO TOOLS sold by retailers. All sales made direct from factory.

The WACO Guarantee
If it is not what you want when you get it—send it back.

SPECIAL CRAFTS COURSE FREE

SPECIAL CRAFTS COURSE and blueprint service is free to Red Jacket Shop owners—all there is to know about handicraft methods, raw materials, woods, carving, sawing, turning, designing, carpentering, decorating, is taught by special correspondence.

BUY ON YOUR OWN TERMS Only \$10.00 down. Liberal discount for cash. Easy monthly payment plans. It is no hardship to own a Red Jacket.

SEND THE COUPON—Interesting Literature Free You will be surprised with all it contains. Beautiful, Instructive, Fascinating, Interesting. Fill in and MAIL TODAY.



Loring Cup Won by Waco Grand Prize of American Master Craftsmen's Assn.



The most elaborate and unusual drill motor ever designed for driving power.

free BLUE PRINTS



This Headstock furnished where no electricity is available.



WACO TOOL WORKS, Inc.,
5216 W. Kinzie St., Chicago

Manager, Dept. 110. Please send me all free information and literature on Red Jacket Assemblies and FREE Services.

Name.....

Address.....

Longer-Lasting Shave Spares Embarrassment

Here's a new way to shave closer—
to get a shave that lasts longer.



IT'S a satisfaction . . . to realize in the evening that your morning shave has lasted. How to get a close shave has been solved for you by Colgate chemists with small-bubble lather, the kind that can get down to the roots of the beard . . . and moisten it properly for a close shave. So why run any risk of an unshaven appearance?

Compare with ordinary lather

The minute you lather up with Colgate's, two things happen: 1. The soap in the lather breaks up the oil film that covers each hair. 2. Billions of tiny, moisture-laden bubbles seep down through your beard . . . crowd around each whisker . . . soak it soft with water.

Instantly your beard gets moist . . . easier to cut and pliable . . . scientifically softened right down at the base . . . then your razor can do its best work.

Better grooming—the utmost in shaving comfort. A world of critical men, after various experiments with big-bubble lathers, have found that Colgate's is supreme. You, too, will agree. Let us help you in deciding—note our offer below.



COLGATE, Dept. B-1782,
P. O. Box 375, Grand Central Post Office, New York.
Please send me, FREE, the seven-day trial tube of Colgate's Rapid Shave Cream; also a sample bottle of "After-Shave."

Name.....
Address.....

140-Page Book of record-keeping forms, filled in to show you their uses. It answers problems of accounting for office, factory and professions. This Free Book describes and illustrates Moore's Security 4-Post Binders, the simplest, easiest handled on the market. To insert or remove sheets takes but a moment. Low in cost—long in life. Moore's Binders are Different.

Write on your business stationery for this Free Book on up-to-date Loose-Leaf equipment

Free

A great help toward simple and accurate record-keeping

Write for it today!

JOHN C. MOORE CORP. Est. 1839
6031 STONE STREET ROCHESTER, N. Y.

MAKE YOUR FORD Into The "ACE"

\$5.99 Red-i-Kut life size patterns Class—Snap

38-inch Easy Riding Seat

Famous sure-fit RED-I-KUT life-size patterns and picture instructions show how you can easily convert your Ford into this Fast, Saucy, Sport-Car as thousands have done with easily obtained materials. No need to lay up the car. Makes wonderful 4-passenger car. Send 10c coin for actual photo of sport car and new manual of distinctive sport car patterns from \$5.50 up—'RKO' Steel "Spring-Lo" irons, Tops, Windshields and many speed necessities. ORDER RIGHT NOW and get a real thrill.

KUEMPEL COMPANY, 113 Kuempel Bldg., GUTTENBERG, IOWA

MOTORCYCLES



Price \$10 and up purchased through our Co-Operative Plan for as low as \$1.00 down and \$1.00 per week Indians Harley-Davidsons Ace Henderson and Clevelands

Send ten cents for Bulletin A. Motorcycles shipped to all parts of the world

WALKER-INDIAN CO., 78 Brookline Ave., BOSTON

Super Elto Quad

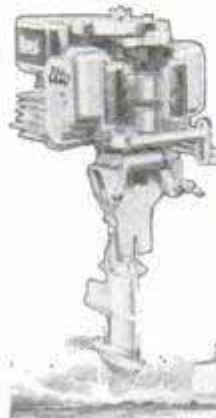

World's finest outboard motor. Four cylinders. Powerful, vibrationless, easy starting. The motor for fastest racers, luxurious runabouts, comfortable cruisers. Send for Catalog. ELTO DIVISION, Outboard Motors Corporation, Mason Street, Dept. AA, Milwaukee.



NEW THRILLS

Every Mile

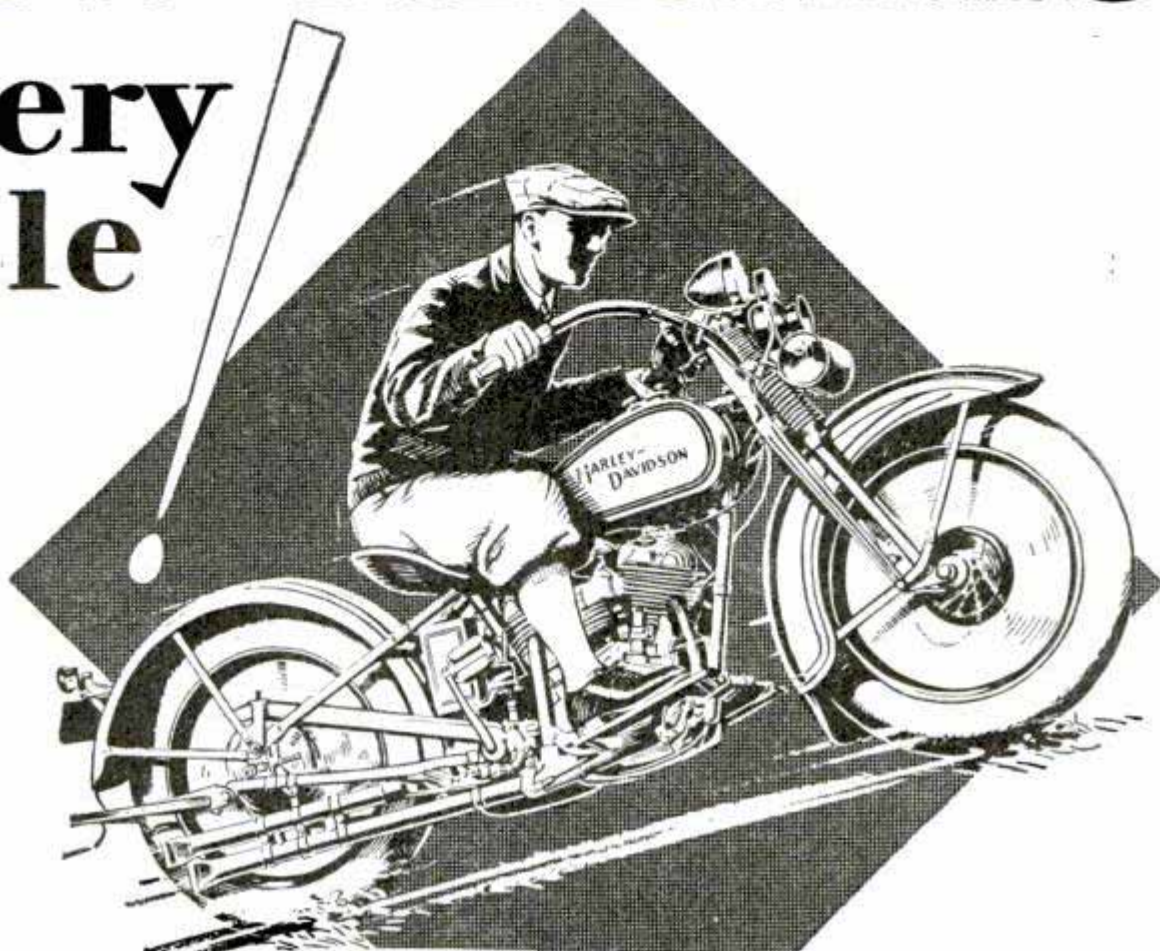

H EAD your new Harley-Davidson "45" Twin up the longest hill you know—feel the thrill of surging power that whisks you up and over.

Swing out on the straightaway—feel the thrill of the lightning getaway and quiet speed that answer the throttle so eagerly.

Speed over a rough stretch — feel the thrill of the cradle-like springing and big 4-inch balloon tires that smooth all roads out for you.

Hurry down to the nearest Harley-Davidson Dealer — look over the 1930 model "45" Twin — then ride out and feel these thrills, and more! Ask about his Pay-As-You-Ride Plan.

Mail the Coupon for Illustrated Literature.

HARLEY- DAVIDSON *Motorcycles*

HARLEY-DAVIDSON MOTOR CO.
Dept. P., Milwaukee, Wis.

Interested in your motorcycles. Send literature.

Name.....

Address.....

My age is 12-15 years 16-19 years
 20-30 years 31 years and up.
Check your age group.

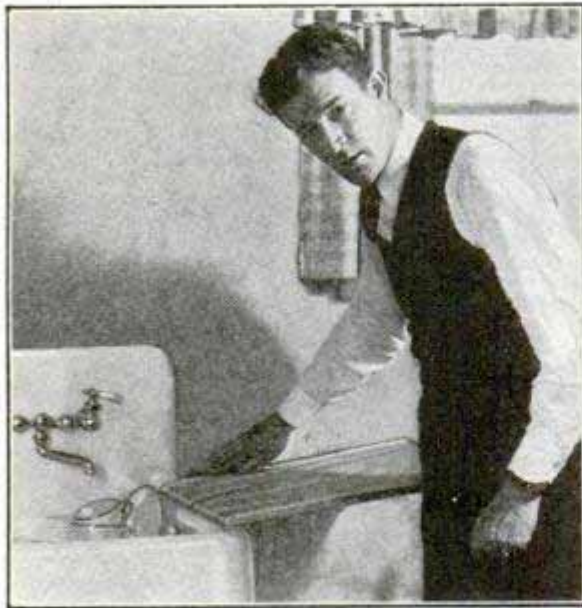

Where's the can of PLASTIC WOOD?

(Reg. U. S. Pat. Off.)

Don't wait for your wife to complain when the drainboard cracks or opens up along the wall. You know the greasy water settles there. Fix it up with Plastic Wood, which handles like putty and hardens into wood.

Let the drainboard dry. Scrape out all dirt, rot and grease. Then fill the cracks with Plastic Wood and let it harden. The repair will be waterproof and greaseproof, and the drainboard as clean and sanitary as new.

Plastic Wood Solvent

For thinning or softening Plastic Wood, and for cleaning hands and tools when it sticks, use Plastic Wood Solvent. At your dealer's in 25c and 50c cans.

Handles
Like
Putty



Hardens
Into
Wood

1 lb. can \$1.00

1/4 lb. can 35 cts.

At Hardware and Paint Stores

ADDISON-LESLIE CO., 420 Bolivar St., Canton, Mass.



THIS MODERN
6 ROOM HOME
NOW \$1024
ONLY \$1024

PAY ONLY
\$15.65
Per Month

Why not live in a modern new home of your own instead of in an old and shabby rented house that is costing you a fortune every year? You can build a new home on the STERLING PLAN and pay for it with your rent-money—as low as \$8.10 per month for a 6-room house. We even advance cash to help you build, if you own a well located city lot.

Build Now and Save Money!

We ship you any home you select, ready to erect—lumber cut to fit, FREIGHT PAID TO YOUR STATION. No high interest or financing charges. Lowest prices in the history of our company. Big discounts for cash. Send 25c in coin today for beautiful Color Book of Sterling Home Plans and select the home that you want us to ship you.



International Mill & Timber Co.
9104 S. Wenona Ave., Bay City, Mich.

FLY THIS ARMY PURSUIT SHIP!

Light and fast, this one-foot model is a realistic copy of a single-seater military pursuit plane. Will rise from ground by own power and fly 60 ft. Can be used indoors or out. Has air service insignia on wings, in colors. Construction set includes ready-made aluminum propeller, shaft, rubber band motor, stream-line wood wheels, pre-cut balsa wing ribs and all other parts, with clear directions. Can be assembled in 3 hours by average 14-year old boy, without tools. Complete set, packed in unbreakable mailing tube, only 75c, postpaid in U. S. Send check or money order today (no stamps). Print address plainly. Satisfaction or money refunded.



LOGAN TOY WORKS, 35 E. Gay St., COLUMBUS, O.
(We cannot make C. O. D. shipments. No retail catalogue issued)

\$1 Brings this BULOVA Watch



10 Months to Pay
No. 26 - This new Bulova guaranteed 15 Jewels, radium dial, leather strap; will come for 15 day trial. Pin \$1.00 to this ad and state: Age, How long at address, Employer; Nature of work. Everything confidential. Satisfaction or money refunded. \$2.88 a month.
Jewelry Book sent FREE to any Adult.

L.W. SWEET Inc.
DEPT. 69-R 1660 BROADWAY NEW YORK



LePage's Third Home Work Shop Book, only 10 Cents, Shows How to Make These 20 Projects

Cape Cod Chest of Drawers, Alexandria Nest of Tables, Old Salem Ship's Cupboard, Plymouth Built-In China Closet, Lady Washington Sewing Cabinet, Set-Back Book Shelves, Modernistic Desk, Modernistic Table, Modernistic Folding Screen, Modernistic Fire Screen, Chess and Checkers Table, Smoking Table, Caned Side Chair, China or Book Cabinet, Book Trough and Magazine Stand, Magazine Carrier, Vanity Case, Book Stand, Fernery Stand and Folding Sewing Screen.

Job Plans 10 cents each. Order by number as indicated in Coupon.

- 16 Sheraton Writing Desk
- 17 Sheraton Desk Chair
- 18 Colonial Hanging Book Shelves
- 19 Smoking and Reading Cabinet
- 20 Colonial Mirror
- 21 Tea Wagon
- 22 Telephone Cabinet
- 23 Stool for Telephone Cabinet
- 24 Manual Training Work Bench
- 25 Home Worker's Tool Cabinet
- 26 Spanish Galleon
- 27 Vanity Table

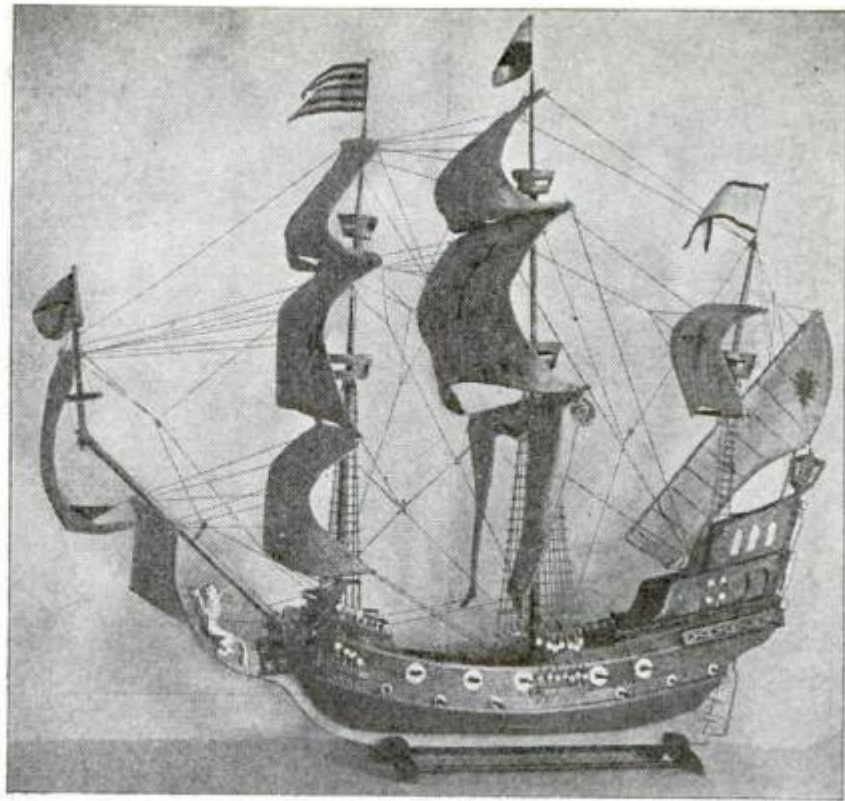

You Can Easily Make This Spanish Galleon

LePage's Complete Plans and Instructions Show You How

Any man handy with tools can easily make this ornamental Galleon with the help of LePage's step-by-step printed directions and full size patterns for every part. And just as easily make any of the attractive, useful projects found in LePage's Third Home Work Shop Book or in LePage's Job Plans.

Expert Instruction

You have expert instruction to guide you. The designs, dimension drawings, photographs, step-by-step directions and the actual furniture itself were made by William W. Klenke, Instructor in Woodworking, Central Commercial and Manual Training High School, Newark, New Jersey. His experience as an expert gives assurance that each project and the directions for making it are thoroughly practical.

To make the Spanish Galleon as shown in the illustration (over-all length of hull 26 inches) order LePage's Job Plan No. 26 at 10 cents. Look over the contents of LePage's book and the Job Plans available as shown in the column at the left. The price of the book is 10 cents. The Job Plans are 10 cents each and are for projects requiring more elaborate instructions than those shown in the Book. In all cases the instruction consists in printed step-by-step directions, dimension drawings or full-size patterns, and a photograph of the finished article.

Send 10 Cents for LePage's Third Home Work Shop Book

Simply use the coupon below, sending it to us with 10 cents in coin or stamps, and we will at once send you a copy of this latest LePage's Book, postage paid.

**LE PAGE'S
GLUE**

HANDIEST TOOL IN YOUR WORK SHOP

**Mail
This
Coupon**

LEPAGE'S CRAFT LEAGUE
722 Essex Ave., Gloucester, Mass.

Gentlemen: Enclosed please find 10 cents (coin or stamps) in payment for LePage's New Third Home Work Shop Book. Please send a copy of this book to:

Name.....

Street.....

City.....State.....

Please also send the following Job Plans (indicate by number those you want. See column at left), for each of which I enclose an additional 10 cents.



Remington
Knife R 1823
PRICE \$1.00

As the Chips Fall

THE chips made by a knife blade tell the story of its quality better than the knife itself.

Smooth and clean chips mean true temper and keen edge, while rough and ragged chips indicate an entirely different condition.

When you take a Remington Knife in your hand, we don't ask you to judge it by its good looks (of which it has full measure), but we do ask you to put it to the "chip" test. Get a piece of pine or oak, soft wood or hard and whittle away. It won't take you long to find out that each blade lives up to the smooth, clean-cutting job its appearance indicates.

The R1823 Remington Pocket Knife is moderately priced, but it will turn out the cleanest and smoothest sort of a cutting job, that will convince you of its quality. It has the usual Remington finish—none better. It's a dandy in every way.

See R1823 at your dealer's, or if he hasn't it in stock, send his name with \$1.00 and it will be forwarded promptly.

REMINGTON ARMS COMPANY, Inc.
Originators of Kleanbore Ammunition
25 Broadway New York City

Remington

Cut the Family Barber Bills

Belle City Home Electric Hair Clipper

Anyone can trim or bob hair, shorten bangs, clip neck or underarms in a shape almost impossible with hand clippers or shears. Operates on direct and alternating current. Will not clog or cut the skin, and cuts as cleanly as a razor. Thousands in use. Rigidly guaranteed.

Fits Any Light Socket

TEN DAYS' FREE TRIAL

If your hardware or electrical dealer can't supply you, write for interesting booklet, or order from this ad. Send no money—pay postman \$8.75. Return it in ten days if not satisfactory. State whether 110, 220 or 32 volt current is used.

Dealers and Representatives Wanted
Belle City Appliance Co., 1022 12th St., Racine, Wis.

INKOGRAPH PENCIL POINTED PEN

\$1.50 **FREE 10 DAYS TRIAL**

Writes with ink smooth as a lead pencil on cheapest or finest paper, without miss, skip or blur. Won't blot, scratch or leak.

Makes 3 carbon copies at one time with original in ink. Anyone can use your Inkograph—hard pressure cannot spread or injure its 14 Kt. gold point. Patent automatic feed prevents point from clogging. No complicated mechanism. Best material and workmanship. Fully Guaranteed.

Send No Money. Pay postman \$1.50 plus postage. Sent prepaid if remittance accompanies order. Money back if not satisfied within 10 days.

INKOGRAPH CO. 161-75 Centre St., NEW YORK

AGENTS Send for Inkograph or FREE sales plan booklet. Sells on sight, no investment, immediate commissions.

only \$1.00 DOWN

10 Day FREE Trial

You can have a genuine L. C. Smith (the world's only ball bearing typewriter) for \$1 down. Lowest price ever offered! Easiest terms. All the 1928 operating attachments. Re-newed, GUARANTEED FOR FIVE YEARS. \$1 down and we ship. No delay. No red tape. 10 day Free Trial. Free Typewriter Course, Tools, Waterproof Cover if you act now. Write for \$1 down offer and free manual.

Smith Typewriter Sales Corp., 11A-469 E. Ohio St., Chicago, Ill.

Build a CLOCK for Pleasure or Profit!

FREE BOOK shows how YOU can Make Fine Clocks Right at Home

Check full of Clock-Making and Money-Making ideas. Gives full details, descriptions, prices of movements and parts. Write NOW for your copy.

THOUSANDS of men have built our Clocks. For their own use—or to sell at money-making prices. It's easy, fascinating. Only ordinary tools needed. We furnish plans, instructions, parts. Works all assembled, ready to install, as low as \$1.65; others with chimes at all prices. You make the case, or simply assemble knock-down parts. Cash-in on the demand for craftsmen-built Mantel Clocks, Banjo Clocks, Grandfather's Clocks. Here's a hobby that PAYS—in pleasure, in ownership and in spare-time or full-time PROFITS!

Write for FREE Catalog and Special Blue Print Offer

American Chime Clock Company
1670-K Ruffner St., Philadelphia, Pa.

SPIRIT OF TIME
BANJO CLOCK

Test This Amazing Money Making Invention **FREE**



Men, here's the most remarkable money maker of the age! A little automatic machine that makes old-style can openers obsolete! Now, just a twist of the wrist makes the dollars hum for you! So mail the coupon today for liberal **FREE TEST OFFER**.

\$7 to \$10 In An Hour Just Showing This \$1,000,000 Can Opening Machine

NO more awkward stabbing and hacking with old-style can openers! No more danger of blood poisoning from gashed and lacerated fingers! For now a remarkable new invention banishes every old-style can opener to the scrap heap. Now a simple twist of the wrist opens any can in a couple of seconds. No wonder they all simply go wild over it! No wonder salesmen often sell to every house in the block and make from \$7 to \$10 in an hour!

Works Like a Charm

This queer little device doesn't just chop a ragged hole in the top of the can. It cuts the entire top completely out, clean as a whistle! The machine takes hold of the can—opens it—flips up the lid so you can grab it—and gives it back without any sharp edges to snag your fingers. You just put the can in the machine—turn the handle—and almost instantly the job is done!

Sells Itself in 10 Seconds

Everyone knows how women detest the dangerous old style can opener. Imagine, then, how they welcome this startling new method—this *automatic* way of doing their most distasteful kitchen task. Men, honestly, I'm not exaggerating one bit when I tell you that not ten words are necessary to sell any of them! All you do is hand your demonstrator to your prospect and let her try it. She sells herself in ten seconds by the clock—and you pocket a nice, fat profit! Yes, really, it's just that simple and easy! That's why \$75 to \$150 a week is easy anywhere.



Opens Any Can in a Jiffy

You just fasten the can in the holder and turn the handle. Nothing complicated, nothing to get out of order. Opens any can, square, round or oval, in a few seconds. And, men, IT'S PATENTED, so there is no competition.

Act Quick for Free Trial Offer

I don't care whether you're an "old-timer" or just breaking in—the quickest, easiest money of your life is waiting for you now, right here! That's a mighty strong statement. But all I ask is a chance to prove it at my risk. I know this proposition will coin money for you so fast that it will make your head swim! Territories are closing fast. The Free Test costs you nothing. Just mail me the coupon and I'll shoot you the most sensational dollar making plan you ever heard of. Mail it today! Right now!

OH BOY!

How the Dollars Roll In
FULL TIME
\$265 In A Week



"Here is my record for first 30 days with Speedo: — June 13, 60 Speedos; June 20, 84 Speedos; June 30, 192 Speedos; July 6, 288 Speedos. Speedo sells to 9 out of 10 prospects."

M. Orloff, Va.
SPARE TIME—\$9 First Half Day

"The first afternoon I received my Speedo outfit I made \$9."

Mrs. R. Spain, Kansas.
PART TIME—\$20 in 3 Hours

"I worked about three hours and took 25 orders. This is certainly a money-maker."

O. C. Gregg, Wyo.



Revolutionary New Sharpener

Works like magic. Puts a razor edge on any knife or tool in a few seconds. Anyone can use it. Sharpens scissors too. The coupon brings full details.

\$2,000.00 PRIZES

Now Being Given in Cash to Agents. Write for Details.

Central States Mfg. Co.
Dept. M-703, 4500 Mary Ave. St. Louis, Mo.

Central States Manufacturing Co.,
Dept. M-703, 4500 Mary Ave.,
St. Louis, Mo.

Rush me facts and details of your Free Test offer.

Name.....

Address.....

Town..... State.....

() Check here if interested only in one for your own home.

Hotter than Coal and no dirt



A New Invention

Do away forever with the drudgery of wood or coal. The most simple and economical invention on the market is now giving perfect satisfaction to enthusiastic users everywhere.

Burns 96% Air—4% Cheap Oil

The International Oil Burner fits in the fire box of your furnace or stove. Installed in a few minutes. No noisy motors or complicated parts.

Costs only a Few Dollars

Heats any stove or furnace just as well as a \$400 or \$500 oil burner without electricity or gas. Simply turn one valve and have all the heat you want. Cleaner and better for heating and cooking. Approved by engineers everywhere. Over 100,000 in use.

30 Days FREE Trial Offer

Try this wonderful International Oil Burner right in your own home at our risk. Act quickly and get our special low introductory price. Sold under absolute money-back guarantee. Write at once for our free booklet on home heating and free burner offer.

AGENTS—Our men are making big money

introducing International Oil Burners. The demand is enormous. We want spare or full time workers immediately. If \$500 a month and more interests you, write or wire us for our protected territory offer.

----- Clip This Coupon -----

INTERNATIONAL HEATING CO.

Spring and Park Ave., St. Louis, Mo., Dept. O-4

Send your free booklet and free details on home heating for stove furnace . Also free burner offer.

Name.....

Address.....

Check if interested in making money as an International representative with protected territory.

\$100 a Week Showing Merchants It Pays to Advertise
R. O. Gosden made \$321 in 9 days—sold 5 machines in 2 1/4 hours.

THE EUREKA ADVERTISER (Automatic Wrapping Paper Printer)

Automatically prints the merchant's "ADS" on his wrapping paper in one or two colors. Costs only what it costs to have "AD" printed on twenty rolls of paper. Flint of New York sold four machines in two hours. You collect and keep your commission. We deliver. Every merchant a prospect. Many buy five or more machines—one for each paper rack they use.

SALESMANAGER, Dept. A-10, 1201 Cortland Street, Chicago, Illinois



250 POWER MICROSCOPE \$16⁵⁰
MADE IN U.S.A.

Educational, entertaining, this fine microscope helps all to know life that can't be seen with unaided eye. Tiny insects look like monsters. Plant and mineral life reveal new wonders in form and color. Used by students, dentists, physicians, scientists—in home, office, school and laboratory. Precise optical qualities. Magnifies 100 to 250 times. Tilting stand, fine finish, nickel trim, push-lined case, prepared slide, instructions. At your dealer or direct postpaid. Money back guarantee. Other models \$2.50 to \$8.50.

Catalog Free

Wollensak Optical Company
869 Hudson Ave. Rochester, N. Y.



FREE New Book FACTORY PRICES

Save 1/3 to 1/2

New FREE book quotes **Reduced Factory Prices. Lower terms—year to pay.** Choice of 5 colors in New Porcelain Enamel Ranges. New Circulating Heaters—



\$34.75 up. 200 styles and sizes. Cash or easy terms. 24-hour shipments. 30-day FREE trial. 360-day test. Satisfaction guaranteed. 29 years in business. 750,000 customers. Write today for FREE book.

Furnaces \$59⁰⁰ up



Ranges \$37⁷⁵ up

KALAMAZOO STOVE CO.
391 Rochester Ave. Kalamazoo, Mich.

"A Kalamazoo Direct to You"
Trade Mark Registered

Beautiful HOUSES \$900 and BUNGALOWS

CAN BE BUILT FOR AND UP

This and many others in my new book, Building Plans for Modern Homes, will save you hundreds of dollars. One of the most complete and comprehensive books of plans ever published by any architect. New edition just off the press. Nearly 600 floor plans and photographs of Colonial houses, bungalows, etc., costing from \$200 up; gives sizes and cost to build. Sent postpaid for \$3.00.



FREDERICK H. GOWING ARCHITECT
101 Tremont St., BOSTON, MASS.

JENKINS Watch-Lighter \$4⁹⁷



Guaranteed 6 Jewel watch and new design elegant quality lighter in one. Watch is of excellent Swiss make, tested and adjusted. Two years' written guarantee. Radium dial—tells time in dark. Lighter is of sturdy construction and can be opened with one hand. Gives instant flame. Large fluid capacity. Easily replaceable flints. Elegant leather covered case. **SEND NO MONEY.** Pay on delivery \$4.97 plus postage. Satisfaction guaranteed. **JENKINS, 683 Broadway, New York, Dept. 10-A-23.**

Andy Sannella Talks to Reed Players. Get this Free Book!



On the air tonight, and every night, Andy Sannella is earning a **fabulous salary** with his Selmer Sax. In his book of "Advice to Saxophone Players" he gives **more valuable information** than in ten private lessons. This book is free to all reed players. Send a postal today for your copy. No obligation. If you will mention the instrument you play, we will send also, free sample of our **Alexandre Reeds. They Play!**

Selmer
58 SELMER BUILDING, ELKHART, INDIANA
In Canada: 516 Yonge St., Toronto

SHOOT THE REAL THING!

Here is that famous genuine pump boys everywhere are turning to. Single stroke outshoots all others. Two to three strokes now give full shooting force. New rear peep sight, leak-proof valves, fully enclosed action. A beauty. Amazing accuracy. Full factory guarantee for one year. Uses regular air rifle lead shot. Photo shows flattening power at 30 ft. on steel target. The biggest money's worth in genuine air rifles ever offered.

"The Shooter's Art" FREE
Tells how to hold, aim and handle rifles; helps you guide others in correct knowledge of guns. Gives facts that make crack shots. Contains safety and common sense instructions every parent and boy should have. Helps to make boys leaders. Your copy free. Write at once.



\$5 at your dealer's or sent postpaid
NEW MODEL "G"
BENJAMIN
Genuine Pump Air Rifle
BENJAMIN AIR RIFLE & MFG. CO., 645N. Broadway, St. Louis, Mo.

Men's Strap Watch
LATEST MODEL
SAVE 50%
\$3.69
A fully GUARANTEED accurate timekeeper—tested and adjusted jewelled Swiss movement—artistically engraved case as illustrated—radium dial—genuine leather strap. Order This Bargain Today. Pay on delivery only \$3.69. We pay postage.
"VEDCO", U. S. Swiss Agents,
561 Broadway, New York, N.Y., Dept. D-1013.

AGENTS AND SIGN MEN
Now Making \$50.00 to \$100.00 and Up Per Week Selling Our **GOLD LEAF SIGN LETTERS**
R For store and office windows, board signs, trucks and glass signs. We also make to order script signs and business emblems singly or by the thousands. A permanent business. No capital or experience required. Big demand in every city. Samples and Literature Free.
CONSOLIDATED SIGN LETTER CO. 71-X W. Van Buren CHICAGO, ILL.

AGENTS: \$14 a Day
Our wonderful new plan will put you in the big money class. 350 High Quality Products at low prices. Everyone a household necessity. All fast sellers. Big orders in every home. Repeat business. Steady income.
New Plan—Big Profits
We show you new way to build permanent business. Big profits from the start. Spare or full time. No capital or experience required. Ford Tudor Sedan free of cost as extra reward. Write now.
AMERICAN PRODUCTS CO.,
2390 Monmouth Ave., Cincinnati, Ohio



WET CELLARS MADE DRY from the Inside!

DAMP musty cellars are unsanitary, a danger to health and a poor place to store valuable material.

Where water or moisture seep in through cracks or porous spots in the floor or walls, you can make and keep your cellar dry and sweet—a fit place to work, free from odor, mold and rust—by filling the cracks and coating the moist surface with Smooth-On No. 7.

This is the one practical waterproofing that you can apply yourself, easily, from the inside, to wet or dry surface and with every assurance of thorough watertightness, even in the wettest seasons.

Excellent also for patching concrete floors, waterproofing garage, stable and washroom floors, brick walls, cisterns, septic tanks, water troughs, fountains, fish ponds, swimming pools, manure pits, etc.



Write for **FREE BOOK**

About 25 pounds of Smooth-On No. 7 are required for each 100 square feet of surface covered, and no experience is necessary. Complete instructions on the package.

Sold in 5-pound cans and 25 and 100-pound kegs.



Do it with SMOOTH-ON No. 7

Name

Address

Return this coupon for FREE copy of Booklet

PATENT

Protect Your Ideas

Take the First Step Today

If you have a useful, practical, novel idea for any new article or for an improvement on an old one, you should communicate with a competent Registered Patent Attorney AT ONCE. Every year thousands of applications for patents are filed in the U. S. Patent Office. Frequently two or more applications are made for the same or substantially the same idea (even though the inventors may live in different sections of the country and be entirely unknown to one another). In such a case, the burden of proof rests upon the last application filed. Delays of even a few days in filing the application sometimes mean the loss of a patent. So lose no time. Get in touch with me at once by mailing the coupon on the opposite page.

Prompt, Careful, Efficient Service

This large, experienced organization devotes its entire time and attention to patent and trade mark cases. Our offices are directly across the street from the U. S. Patent Office. We understand the technicalities of patent law. We know the rules and requirements of the Patent Office. We can proceed in the quickest, safest and best ways in preparing an application for a patent covering your idea. Our success has been built on the strength of careful, efficient, satisfactory service to inventors and trademark owners located in every state in the Union.

NO CHARGE for Information On How to Proceed

The booklet shown here contains valuable information relating to patent procedure that every inventor should have. And with it I will also send you my "Record of Invention" form on which you can sketch your idea and establish its date before a witness. Such evidence may later prove valuable to you. Simply mail the coupon and I will send you the booklet, and the "Record of Invention" form, together with detailed information on how to proceed and the costs involved. Do this NOW. No need to lose a minute's time. The coupon will bring you complete information entirely without charge or obligation.

My Patent Law Offices
Just Across
Street From
U.S. Pat. Office



Above is a view of my drafting and specification offices where a large staff of experienced experts are in my constant employ. All drawings and specifications are prepared under my personal supervision.

NEWS

*Inventors
Write for these*

**Free
Books**

Strict Secrecy Preserved

All communications, sketches, drawings, etc., are held in strictest confidence in strong, steel, fireproof files, which are accessible only to authorized members of my staff. Feel free to write me fully and frankly. It is probable that I can help you. Highest references. But **FIRST**—clip the coupon and get my free book. Do **THAT** right now.

Clarence A. O'Brien

*Registered Patent Attorney
& Attorney-at-Law*

Member of Bar of: Supreme Court of the United States; Court of Appeals, District of Columbia; Supreme Court, District of Columbia; United States Court of Claims. Practice confined exclusively to Patents, Trademarks and Copyrights

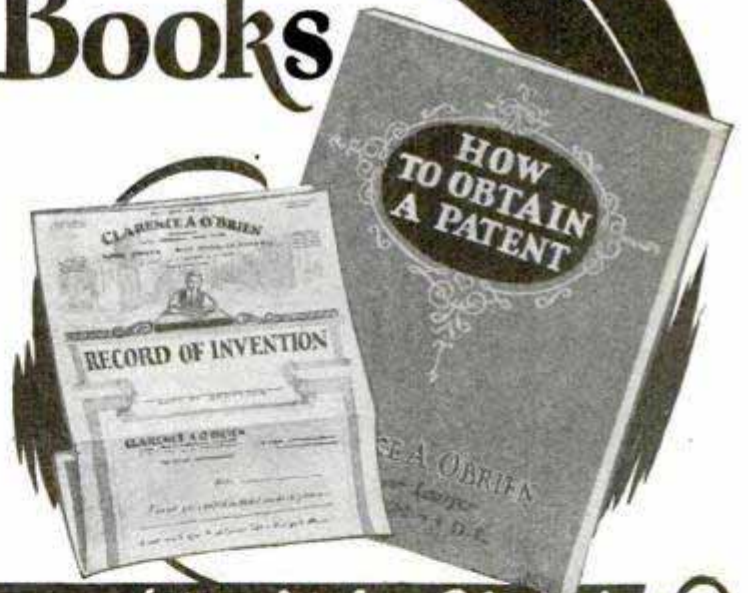

Clip this Coupon and Mail it Now!

CLARENCE A. O'BRIEN, *Registered Patent Attorney & Attorney-at-Law*

70-W Security Savings and
Commercial Bank Bldg.,
Washington, D. C.

OR

Suite 1106 Woolworth Bldg.,
New York City

Please send me your free book, "How to Obtain a Patent," and your "Record of Invention" form without any cost or obligation on my part.

Name.....

Address.....

(Important—Write plainly and address office nearest you)

PATENTS TRADE MARKS COPYRIGHTS

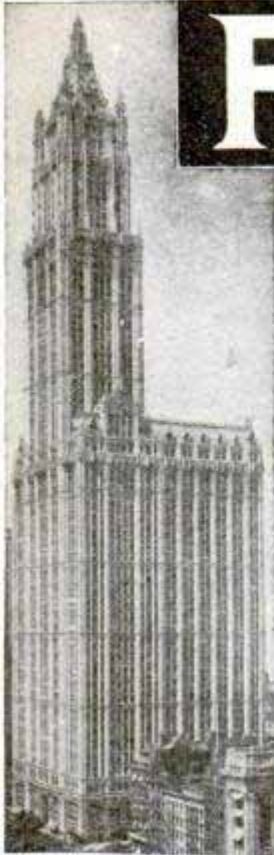

Our New York Office
Suite 1007 Woolworth Bldg.



Our Philadelphia Office
828 Fidelity Phila. Trust Bldg.



VICTOR BUILDING
Our New Building Nearly Opposite U. S. Patent
Office Specially Erected by Us for Our Own Use



Have You An Idea?

Our Offer: FOR THE PROTECTION
OF YOUR INVENTION

YOUR FIRST STEP

The inventor should write for our blank
form

"RECORD of INVENTION"

This should be signed and witnessed and
returned to us together with model or
sketch and description of the invention for
INSPECTION AND ADVICE
No Charge for the Above Information

Our Five Books Mailed Free to Inventors

Our Illustrated Guide BOOK

How to Obtain a Patent

Contains full instructions regarding U. S. Patents.
Our Methods, Terms, and 100 Mechanical Move-
ments illustrated and described.

Our Trade Mark Book

Shows value and necessity of Trade Mark Protec-
tion. Information regarding *Trade Marks and un-
fair competition in trade.*

Our Foreign Book

We have Direct Agencies in Foreign Countries, and se-
cure Foreign Patents in shortest time and lowest cost.

Progress of Invention

Description of World's Most Pressing Prob-
lems by Leading Scientists and Inventors.

Payment of Fees in Installments

It is not necessary that the total cost for the preparation and
prosecution of a patent be paid in one payment. Our custom
is to permit our clients to pay for their applications in three
installments as the preparation of the application progresses in
our office. This plan makes the payments easy for the inventor.

We Regard a Satisfied Client as our best advertise-
ment, and furnish anyone, upon request, lists of clients
in any state for whom we have secured patents.

**Highest References—Prompt Service
—Reasonable Terms**

VICTOR J. EVANS & CO.

Patent Attorneys, Established in 1898

Main Offices: 789 9th St., N. W., Washington, D. C.

Nearly Opposite U. S. Patent Office

DELAYS ARE DANGEROUS IN PATENT MATTERS

IMPORTANT! To Avoid Delay!

YOU SHOULD HAVE YOUR CASE MADE SPECIAL IN OUR OFFICE to save correspondence, secure protection and early filing date in the Patent Office. To secure **special preparation** of your case send \$25.00 on account with model or sketch and description of invention.

ACT NOW—Often two or more inventors file applications for practically the same idea. In such cases the burden of proof rests upon the last application filed. Therefore, delays often cause the loss of a patent.

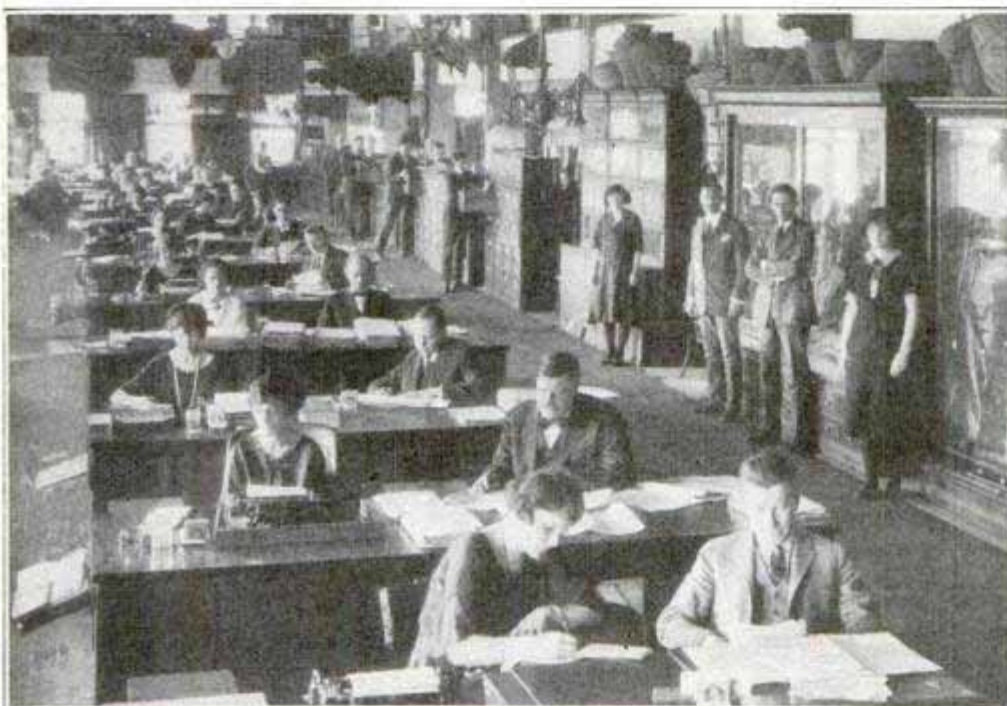

MAIN OFFICE, VICTOR J. EVANS & CO.—VICTOR BUILDING, WASHINGTON, D. C.

Our Large, Comprehensive Organization has been established for 30 years and offers Prompt, Efficient and **Personal Service** by experienced Patent Lawyers and Draftsmen. Every case is in charge of a Specialist who has been selected for his knowledge and experience in certain lines of invention. Our Lawyers practice in all U. S. Courts and defend clients in suits involving Patents, Trademarks and Copyrights. **All Communications and Data** strictly Secret and Confidential. We shall be glad to have you consult us or to answer any questions in regard to Patents, Trademarks or Copyrights without charge or obligation.



Our Chicago Office
Suite 1640-42 Conway Bldg.



Our Pittsburgh Office
Suite 514 Empire Building



Our San Francisco Office
Suite 1010 Hobart Building

**FREE
COUPON**

VICTOR J. EVANS & CO.
PATENT ATTORNEYS *Established
in 1898*

NEW YORK OFFICES
1007 Woolworth Bldg.

CHICAGO OFFICES
Suite 1640-42 Conway Bldg.

PHILADELPHIA OFFICES
828 Fidelity Phila. Trust Bldg.

PITTSBURGH OFFICES
514 Empire Bldg.

SAN FRANCISCO OFFICES
1010 Hobart Bldg.

MAIN OFFICES: 789-9th Street, N. W., WASHINGTON, D. C.

Gentlemen: Please send me *Free of Charge* your books as described on preceding page.

Name

Address

PATENTS

Booklet Free Highest References
Promptness Assured Best Results

Send drawing or model for preliminary examination and advice.

ALL BUSINESS GIVEN PROMPT AND PROPER ATTENTION

Listed Patent Lawyer in the latest editions of the Rand-McNally Directory of Bankers and Bonded Attorneys, published by Rand-McNally & Co., Chicago, Ill.; The Baggott & Ryall Directory of Guaranteed Attorneys, published by the Ryall Legal Directory Company, New York City; Flugel's List, published by the Legal Directory Publishing Co. of St. Louis, Mo.; the American Lawyers Annual, published in Cleveland, Ohio; Eyre's Law List, Bush Terminal Building, New York City.

WATSON E. COLEMAN,
REGISTERED PATENT LAWYER

Victor Building, 724 Ninth Street, N. W.
WASHINGTON, D. C.

PATENTS

To the Man with an Idea

PATENTS Procured. Trade Marks Registered. —A comprehensive, experienced, prompt service for the protection and development of your ideas. Preliminary advice gladly furnished without charge. Booklet of information and form for disclosing idea free on request.

IRVING L. McCATHRAN, Patent Lawyer
Formerly with and successor to RICHARD B. OWEN
704 International Bldg., Washington, D. C.
41-E Park Row, New York City

TRADE-MARKS
REGISTERED

Let us recommend the best books to study on any subject. Popular Mechanics Press, Chicago, Illinois

PATENTS

Trade Marks, Copyrights, Patent Litigation Handbook with illustrations, 100 mechanical movements. Sent free on request.

ALBERT E. DIETERICH
formerly member Examining Corps U. S. Patent Office
REGISTERED
PATENT LAWYER and SOLICITOR
621-A, Ouray Bldg.
30 Years' Experience Washington, D. C.

PATENTS

PROTECT YOUR IDEAS

Write today for FREE INSTRUCTIONS—or send Drawing or Model of your Invention for Examination.

Promptness Assured with Best Results

CARL MILLER
REGISTERED PATENT ATTORNEY

Former Member Examining Corps U. S. Patent Office
255 McGill Building Washington, D. C.



PATENTS

TRADE-MARKS

**Don't Lose Your Rights
To Patent Protection**

Before disclosing your invention to anyone send for blank form "EVIDENCE OF CONCEPTION" to be signed and witnessed.

LANCASTER & ALLWINE
480 Ouray Bldg. WASHINGTON, D. C.
Originators of forms "Evidence of Conception."

INVENTORS PROTECT YOUR IDEAS

Send for our Guide Book, **HOW TO GET A PATENT**, and Evidence of Invention Blank, sent Free on request. Tells our terms, methods, etc. Send model or sketch and description of your invention for INSTRUCTIONS. No charge for the above information.

RANDOLPH & CO.
301 Victor Bldg., WASHINGTON, D. C.

NAME.....

STREET.....

CITY..... STATE.....

PATENTS

TRADE-MARKS • DESIGNS
FOREIGN PATENTS

MUNN & CO.
PATENT ATTORNEYS

Associated since 1846 with the Scientific American

SCIENTIFIC AMERICAN BUILDING
625 F Street, Washington, D. C.

1303 TOWER BUILDING
Corner of Michigan Blvd. and Madison St.
Chicago, Ill.

1551 SCIENTIFIC AMERICAN BUILDING
24 West 40th Street, New York City

HOBART BUILDING
582 Market Street
San Francisco, Calif.

511 VAN NUYS BUILDING
Spring and Seventh Streets, Los Angeles, Calif.



Books and Information on Patents and Trade-Marks by Request.
Associates in All Foreign Countries.

PATENTS

As one of the oldest patent firms in America we give inventors at lowest consistent charge, a service noted for results, evidenced by many well-known Patents of extraordinary value. Book, Patent-Sense, free.

Lacey & Lacey, 646 F St., Washington, D. C. Estab. 1869

**\$10.00 PER MONTH BUYS
Fibre-Life Limbs**



NEXT TO NATURE. BRACES MADE TO ORDER. AGENTS WANTED. FREE FIBRE SAMPLE
WORMAN CO. 252-P HENNEPIN AVE. MINNEAPOLIS, MINN.

NO JOKE TO BE DEAF

—EVERY DEAF PERSON KNOWS THAT



I make myself hear, after being deaf for 25 years, with these Artificial Ear Drums. I wear them day and night. They stop head noises and ringing ears. They are perfectly comfortable. No one sees them. Write me and I will tell you a true story, how I got deaf and how I make you hear. Address



Medicated Ear Drum

GEO. P. WAY, Artificial Ear Drum Co. (Inc.)
80 Hoffman Bldg., Detroit, Mich.

**Agents!-Here's
Something New**



Make \$50 to \$90 A Week
Amazing new fast-selling invention—Crystal Home Filter for fruit juices and beverages. Patented. Nothing like it. Removes all sediment, pulp, fibres. Filters a gallon every 4 minutes. Perfect results guaranteed. Simple. Practical. Low priced. Every home a prospect. Big profits. Quick, easy sales.

Write Today for FREE Sample Offer
500 more agents needed NOW. Make money fast. No experience needed. Write **quick** for Free Demonstrator and territory Offer. Send NOW.
Home Filter Co., 430 Central Ave., Bay City, Mich.



\$300,000
For This Invention

That's what Eastman Kodak paid for the Autographic idea. Thousands of other inventions are needed and offer enormous opportunities for earning fortunes. If you are of an inventive turn of mind, why not concentrate on things that are really NEEDED?

Get Raymond Yates's new book

"1000 NEEDED INVENTIONS"

Costs only \$1.50 and may start you thinking along the right lines. You'll get nowhere just fussing around. Concentrate on what the industries need, and on what the public wants. Mr. Yates's book tells you what these things are. Send no money. Just write postal. Pay mail man \$1.50 plus postage when book arrives. Your money back if you want it. This offer limited. Write now and get on the right track. (Outside U. S. \$1.70, cash with order.)

BUREAU OF INVENTIVE SCIENCE
Dept. 310, Wisner Building, Rochester, N. Y.

PATENTS
ON
EASY PAYMENTS

Don't let lack of ready money keep you from protecting the idea which may prove the turning point in your life.

**FORMER ASSISTANT EXAMINER
OF U. S. PATENT OFFICE**

will now handle your patent matters on easy payments. Write today for free information and particulars.

M. S. CAYNE

(Registered Patent Attorney)

Main Offices

BANKERS BLDG., 105 W. Adams St., CHICAGO

(With Offices in Washington, D. C.)

LUMINOUS PAINT

Make Your Watches, Clocks, Etc., Visible by Night

The very latest discovery in the scientific world. Hitherto, practically unobtainable except at an exorbitant price, we have at last succeeded in producing this remarkable LUMINOUS PAINT, which, applied to the surface of any article, emits rays of white light, rendering it perfectly visible in the dark. THE DARKER THE NIGHT, THE MORE BRILLIANT IT SHINES. Quite simple to use. Anyone you can do it. A little applied to the dial of your watch or clock will enable you to tell the time by night. You can coat the push buttons or switch plates of your electric lights, match boxes, and innumerable other articles; make your own Luminous Crucifixes, Luminous Rosaries, etc. Small bottle, price 25c. Larger size, 50c and \$1 postpaid. JOHNSON SMITH & CO. Dept. 843 RACINE, WIS.



CIGARETTE MAKER

Roll your own and save money. Better and quicker; saves more than half. Use your favorite brand of tobacco. Neat, useful, handy. Pocket size, weighs 1/2 oz. Made entirely of metal, nickel plated, 25c, 3 for 65c postpaid anywhere.



GOOD LUCK RING

Very striking, quaint and uncommon. Silver finish; skull and crossbones design, two brilliant, flashing gems sparkle out of the eyes. Said to bring good luck. Only 25c ppd.



Exploding Cigarettes

JUST LIKE ORDINARY CIGARETTES. BUT SUCH REAL STARTLERS! The box contains ten genuine cigarettes of excellent quality. They appear so real, but when each cigarette is about one-third smoked, the victim gets a very great surprise as it goes off with a loud BANG! A great mirth provoker yet entirely harmless. Price 25c box.

NOVELTY BADGES



Kissing Permit 10c. Garter Inspector 10c. Two very novel metal badges, nickel plated, that you can wear, giving you fun out of all proportion to their trifling cost. 10c, each badge, 3 for 25c, or 75c per doz. postpaid anywhere.

MIDGET BIBLE

GREAT CURIOSITY Smallest Bible in the World. Size of a postage stamp. 200 Pages. Said to bring good luck to the owner. A genuine work of art. Must be seen to be appreciated. Make good money selling them to friends, church acquaintances, etc. PRICE 15c each, 3 for 40c, 12 for \$1.35, 100 for \$7.50. Also obtainable in Leather Binding, with gold edges. Price 50c each, 3 for \$1.25, \$4.50 per doz. Magnifying Glass for use with Midget Bible 15c.

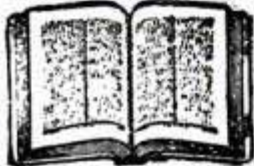

STAGE MONEY

With a bunch of these bills, it is easy for each person of limited means to appear prosperous by flashing a roll of these bills at the proper time and peeling off a genuine bill or two from the outside of the roll, the effect created will be found to be all that can be desired. Prices, postpaid: 40 Bills 20c, 120 for 50c, or \$3.50 thousand postpaid.

MAGIC NOSE FLUTE

The Magic Nose Flute, or Humanstone, is a unique and novel musical instrument that is played with nose and mouth combined. There is just a little knack in playing it which, when once acquired after a little practice, will enable you to produce very sweet music that somewhat resembles a flute. There is no fingering, and once you have mastered it you can play all kinds of music with facility and ease. When played as an accompaniment to a piano or any other musical instrument, the effect is as charming as it is surprising.

JOHNSON SMITH & CO.

Dept. 843 RACINE, WIS. A De Luxe Edition of our new 1929 CATALOG mailed on receipt of 25c. Handsome binding. Bigger and better than ever. Only book of its kind in existence. Nearly 600 pages of all the latest tricks in magic, the newest novelties, puzzles, games, sporting goods, rubber stamps, unusual and interesting books, curiosities in seeds and plants, etc., unobtainable elsewhere. Remit by Coin, Money Order, Check or unused U. S., Canadian and Foreign Stamps for all articles listed above.

BLANK CARTRIDGE PISTOL

Protection against Burglars, Tramps, & Dogs Special Offer

1 Blank Cartridge Pistol
100 Blank Cartridges
1 550-page Novelty Catalog
ONLY \$1.50
The Lot Shipped by Express Only With Order Only

Well made and effective, modified on latest type of Revolver; appearance alone is enough to scare a burglar. When loaded it may be as effective as a real revolver without danger to life. It takes standard .22 Cal. Blank Cartridge - obtainable everywhere. Special cash with order offer: 1 Superior quality Blank Cartridge Pistol, 100 Blank Cartridges, and our new 550 page De Luxe Catalog of latest novelties; all for ONLY \$1.50. Shipped by Express only. Cannot go by parcel post. Extra Blank Cartridges 50c per 100. Special Holster (Cowboy Type) for pistol 50c. No C. O. D. shipments.

LOOK 35c LOOK Wonderful Instrument.

Greatest thing yet. Nine separate articles in one. Everybody delighted with it. Odd, Curious and interesting. Lots of pleasure as well as very useful. It is a double Microscope for examining the wonders of nature. It is also an Opera Glass, a Stereoscope, a Burning Lens, a Reading Glass, a Telescope, a Compass, a pocket Mirror, and a Laryngoscope - for examining eye, ear, nose and throat. It is worth all the cost to locate even one painful cinder in the eye. Folds flat and fits the pocket. Something great - you need one. Don't miss it. Sent by mail. Only 35c or 3 for \$1.00.

INVISIBLE INK Rubber Chewing Gum

The most confidential messages can be written with this ink, for the writing makes no mark. Cannot be seen unless you know the secret. Invaluable for many reasons. Keep your postals and other private memoranda away from prying eyes. Great fun for playing practical jokes. Only 15c a Bottle; 3 for 40c.

It is just like a regular package of chewing gum and looks so real that it fools everybody. Of course no one suspects it is not genuine until they start to chew it. There's a world of fun in this rubber chewing gum - 5 sticks to the package. Price, 10c Pkg.; 3 for 25c; 12 for 75c postpaid. Johnson Smith & Co., Dept. 843, Racine, Wis.

Watch Charm Pistol \$1.75

Exact reproduction of a real pistol; actually fires REAL BLANK CARTRIDGES of miniature size. Illustration is a natural size. 1 1/4 inches long, with ring at end for attaching to watch chain. Pistol is break open type; illustration shows position for loading. Made entirely of high grade steel, nickel plated, octagon barrel, handomely engraved handles, complete in box with cleaning rod. PRICE \$1.75. Also furnished with pearl handles, \$2.50. BLANK CARTRIDGES, 50c per box of 25. JOHNSON SMITH & CO., Dept. 843, RACINE, WIS.

MICROPHONE TRANSMITTER BUTTON

You can easily make a highly sensitive telephone by using this Transmitter Button to collect the sound waves. You can build your own outfit without buying expensive equipment. It is simple and inexpensive. You can install an outfit in your home and hear conversations being held all over the house. You can connect up different rooms of a hotel. This outfit was used by secret service operatives during the war. It is being used on the stage. It is ultra-sensitive and is the greatest invention in microphones. You can mount the button almost anywhere - card board boxes, stove pipes, stiff calendars, on the wall behind a picture frame, etc. Button is so light and small it cannot be detected. Persons can be overheard without suspecting it. You can listen in on conversations in another room. A deaf person in the audience can hear the speaker. Connected to phonograph, piano or other musical instrument, music can be heard hundreds of feet away. Button may be used to renew telephone transmitters; often makes an old line "talk up" when nothing else will. The ideal microphone for radio use; carries heavy current and is extremely sensitive. Amplifies radio signals. Countless other similar uses will suggest themselves. Experimenters find the button useful for hundreds of experiments along the lines of telephones, amplifiers, loud speakers, etc. Many fascinating stunts may be devised, such as holding the button against the throat or chest to reproduce speech without sound waves. PRICE \$1.00. JOHNSON SMITH & CO., DEPT. 843, RACINE, WIS.

SURPRISE MATCHES

More fun than fighting with your wife. Look just like ordinary matches. Put up in boxes just like regular Safety Matches. As the victim tries to light one he gets quite a surprise. Price 10c per box, 3 boxes for 25c, 12 for 75c cents.

STAR TOY MAKER

Greatest boys' book written. Tells how to make a Pinhole Camera, a Canoe, model Railroad, a Telephone, Boomerang, Telegraph Instrument, Box Kite, Talking Machine, Microscope, Electric Motor, Electric Door Bell, Water Wheel, Paddle Raft, a pair of Skis, a Dog Sled, Bird House, Rabbit Yard, etc. 64 pages, 150 illustrations. PRICE 10c postpaid.

Wonderful X-Ray Tube

A wonderful little instrument producing optical illusions both surprising and startling. With it you can see what is apparently the bones of your fingers, the lead in a lead pencil, the interior opening in a pipe stem, and many other similar illusions. A mystery that no one has been able to satisfactorily explain. Price 10c, 3 for 25c, 1 dozen 75c. Johnson Smith & Co.

NOSE BLOWER

When some men blow their noses it sounds like a trombone. Now the NOSE BLOWER has come to torment us. It is ingeniously concealed in the handkerchief. Proceed to blow your nose and your friends will think they heard a steam engine or something. You can blame the hideous noise to your having a very bad cold and keep up the fun as long as you like. PRICE 10c, 3 for 25c, or 75c doz. postpaid.

Serpent's Eggs

Box contains 12 eggs. When lit with a match, each one gradually hatches itself into a snake several feet long, which curls and twists about in a most life-like manner. Price per box, 10c postpaid, 3 for 25c.



BOYS! BOYS! BOYS! Throw Your Voice

Into a trunk, under the bed, under a table, back of the door, into a desk at school, or anywhere. You get lots of fun fooling the teacher, policemen, peddlers, and surprise and fool all your friends besides.

THE VENTRILO

is a little instrument that fits in the mouth out of sight. Cannot be detected. It is used in connection with the above, and with the aid of this wonderful DOUBLE

THROAT, or VENTRILO, you can imitate many kinds of birds, animals, etc. Remember you get everything for **ONLY TEN CENTS**—a booklet giving you full instructions how to become a ventriloquist and throw your voice, the Double Throat, or Ventrilo, and our big 600 page catalog of novelties, tricks, puzzles, masks, books, etc., **10 cents**
ALL SENT POSTPAID TO ANY ADDRESS FOR ONLY **10 cents**



MEXICAN JUMPING BEANS



Scientists are unable to give a reasonable explanation for what purpose nature created these curious **Jumping Beans**. They are found growing on small trees in the high mountainous regions of Mexico. The Beans **Wiggle, Move, Jump, Flop Over, Etc.** It is amazing to see them keep up this endless activity. Send for a few of these great curiosities. **Three Sample Beans sent for 25c, 12 for 75c, or One Gross (144) for \$7.50 Postpaid.**

JOHNSON SMITH & CO., Dept. 843, RACINE, WIS.

U. S. BABY TANK

25 Cents



It goes with real Yankee Pep—by its own power

Most remarkable toy ever invented. By drawing the Tank backward, either with the hand or over the floor or table and then placing it down, it will crawl along, overcoming all obstacles, in the same life-like manner as the larger Tank that proved so deadly in the great war. What makes it go is somewhat of a mystery, for there is no mechanism to wind up as is usually understood with mechanical toys, yet this tank will keep plodding along ten times longer than the ordinary run of toys. It will perform dozens of the most wonderful stunts. 2 1/2 inches long. Price only 25c prepaid. Stamps accepted.

JOHNSON SMITH & CO.

KEYLESS COMBINATION LOCK



These clever Locks cannot be opened unless you know the combination. Each Lock has a different combination, the secret of which we send with the Lock. No key is necessary, simply arrange the tumblers in the proper order and the Lock opens. For your locker, bicycle, tool chest, mail box, thousands of uses. A good, strong lock, weighing about 4 ounces, that will baffle the attempts of all unacquainted with the secret combination to open it. Price, with secret and full instructions **Only 50c postpd.**

JOHNSON SMITH & CO., Dept. 843, RACINE, WIS.

Great Fire Eater



A great trick by which you can apparently breathe fire from mouth, to the horror and consternation of all. Quite harmless. All apparatus necessary sent complete in box for **ONLY 30c. p. pd.** **JOHNSON SMITH**

SQUIRT ROSE

25c



A REAL STARTLER. This is the most popular of all squirt tricks. The flower in your coat looks so fresh and sweet that everyone is tempted to inhale the delightful perfume. Then is the moment to press the bulb. Geewhilkens. Don't they nupt? There is a very long rubber tube that easily reaches to the pocket of your coat or trousers, and the bulb is large enough to make a dozen shots with one loading. **PRICE 25c each, or 3 for 65c postpaid.**

SEEBACKROSCOPE

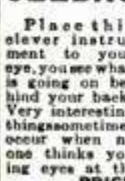

Place this clever instrument to your eye, you see what is going on behind your back. Very interesting thing sometimes occur when no one thinks you are looking. Just like having eyes at the back of your head. **PRICE 25c POSTPAID**

Send remittance (Postage Stamps accepted) for all articles listed above also in our other ad on previous page

MAGICIAN'S BOX OF TRICKS

Apparatus and Directions for a Number of Mysterious Tricks, Enough for an Entire Evening's Entertainment..... \$1.00

ANYONE CAN DO THEM

It is great fun mystifying your friends. Get this Conjuror's Cabinet, and you will be the cleverest fellow in your district. It contains the apparatus for ten first-class tricks, including **THE MAGIC BALL AND VASE TRICK** (a wooden ball is placed inside, and upon replacing the lid has disappeared and is found in someone else's pocket); **THE HINDOO TRICK CARDS** (can be made to change completely no less than five times); **DISAPPEARING COIN BOX** (a coin, placed in the wooden box, vanishes entirely or changes into a coin of another denomination); **THE GLASS GOBLET TRICK** (a coin is dropped into a glass of water and when the water is poured out the coin has vanished and is found somewhere else); **THE RIBBON FACTORY FROM THE MOUTH TRICK** (a seemingly endless supply of colored paper ribbons comes out of your mouth); **THE DISAPPEARING HANDKERCHIEF** (a handkerchief held in the hand mysteriously vanishes); **THE WIZARD'S RING COIN TRICK**; **THE EXCHANGING COIN TRICK** (no one but yourself is able to make it lay down); **THE GREAT HAT AND DICE TRICK** (a large die is placed on top of a hat, disappears, and is found underneath yet no one has touched the hat), and last, but not least, **THE GREAT PHANTOM CARD TRICK**, or two from five leaves nothing. Full instructions are sent for performing each trick. In addition to the above, a number of other feats and illusions are fully explained for which you can easily make or procure the necessary apparatus. **Price complete \$1.00 postpaid. JOHNSON SMITH & CO.**



RESURRECTION PLANT



Great curiosity. Place in water, plant opens up and starts to grow in few minutes. Taken out it dries up and goes to sleep until put in water again. **PRICE 10c, 3 for 25c, 75c dozen, postpaid.**



DISSOLVING VIEWS



You may have a lot of fun with this little peep-show. A regular startler. Made entirely of metal, having a microscopic lens fitted into one end. While the victim is absorbed in admiration of the pretty picture, and turns the button in the confident expectation of seeing something interesting, a spring syringe is brought into action, and the observer experiences a very great surprise. **50c. pd. JOHNSON SMITH & CO., Dept. 843, Racine, Wis.**



Comical Motto Rings

Lots of harmless fun and amusement wearing these rings. Made in platinum finish (to resemble platinum), with wording on enameloid, as illustrated. **Price only 25c Postpaid.**

The "Little Giant" Typewriter

A First Class Writing Machine For \$1.50

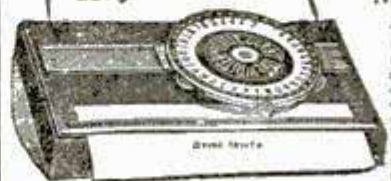

A perfect little typewriter for \$1.50. There are thousands of persons who would like to use a typewriter but whose needs and business do not warrant the expense attached to the purchase and use of a fifty or seventy-five dollar machine. To such persons we constantly recommend our Little Giant. It is strongly made, but simple in construction, so that anyone can quickly learn to operate it, and write as rapidly as they would with pen and ink. The letters of the alphabet most frequently used are so grouped as to enable one to write rapidly, the numerals 1 to 10, and the punctuation marks being together. With this machine you can send your best girl typewritten love letters, address envelopes, make out bills, and do almost any kind of work not requiring a large, expensive machine. With each typewriter we send a tube of ink and full printed instructions for using the machine. **Price complete \$1.50 by mail postpaid to any address in the world.**

JOHNSON SMITH & CO. Dept. 843 Racine, Wis.



**ARTISTIC
PORTRAIT
ENLARGEMENTS**
only **98¢** each
FROM ANY PHOTO
or **SNAP-SHOT**
SIZE 16 x 20 INCH

(or smaller if desired)
The usual price of this work is \$5.00 but by taking advantage of this **Special** beautiful life-like enlargement of that favorite picture of mother, dad, sweetheart, baby or any friend for only **98 cents**.

SEND NO MONEY—Just mail us the photo—any size (Full figure, bust or group) and in about a week you will have your enlargement guaranteed never to fade. It comes to you C.O.D. On arrival pay postman 98c plus a few cents postage, or send one dollar cash with order and we pay postage. Money back if not delighted. You can send us your most treasured photograph, it will be returned to you unharmed.

FREE In order to advertise this remarkable offer we send free with every enlargement ordered, a **Highly-Glazed Hand Painted** miniature reproduction of the photo sent. These miniatures alone are worth the whole price charged for the enlargement. Take advantage of this really **Amazing Offer** and send your order today. **DO IT NOW.**

ALTON ART STUDIO, Dept. 46	
5654 West Lake St., Chicago, Ill.	
Please enlarge artistically the enclosed photo. Return enlargement and FREE Hand Painted miniature, C.O.D. 98c plus postage. (If \$1.00 is enclosed you are to send postage paid.)	
Name _____	Check Size Wanted
Address _____	<input type="checkbox"/> 16 x 20 in.
Town _____ State _____	<input type="checkbox"/> 10 x 16 in.
	<input type="checkbox"/> 11 x 14 in.
	<input type="checkbox"/> 8 x 10 in.

DO YOU

WANT a new business profession of your own, with all the trade you can attend to? Then become a foot correctionist, and in a few weeks earn big income in service fees,—not medical nor chiropody—easy terms for home training, no further capital needed, no goods to buy, no agency. Address

Stephenson Laboratory, 1 Back Bay, Boston, Mass.

Keds

At \$1.00, \$1.25, \$1.50, \$1.75 and up to \$4.00. 
United States Rubber Company

**NEW VEST POCKET
ADDING MACHINE**



ADDS, SUBTRACTS, MULTIPLIES, DIVIDES
Does work of \$300 machine. Guaranteed 5 years. NOT A TOY.
Made of steel and indestructible. Million dollar capacity. Fits in pocket. Will not make mistakes. So simple child can operate it. Instructions furnished. Everybody should carry one for figuring.

FREE TRIAL \$2.50 Total Cost

SEND NO MONEY—Just name and address. We will ship Calculator immediately. On delivery pay postman \$2.50 (Plus few cents Postage). (If outside U. S. send cash.) 10¢ additional in Leatherette Case. If not satisfied after 10 day trial you get your money back. **THOUSANDS OF SATISFIED USERS.**

Guaranteed This is lowest priced practical calculator made. "Why pay more for inferior imitations?" Order from this ad.

Mail Coupon Today

BABY CALCULATOR MACHINE CO., (MANUFACTURERS)
Dept. 41, P. O. Box 1118, CHICAGO, ILL., U. S. A.
 I am enclosing \$2.50—send adding machine prepaid.
 Send Adding Machine C. O. D. \$2.50 plus 18c postage. (10c additional in Leatherette Case)

Name _____
Address _____
City _____ State _____

AGENTS Write for big commission and territory proposition.

\$50 and up Weekly



Making Amazing Demonstration

Commission checks mailed every Saturday to our men. Work full or spare time making amazing demonstration that will save prospects thousands of dollars.

Demonstrator Furnished

IN ONE MINUTE
We will furnish outfit for sensational demonstration. No investment for stock—no deliveries or collections. Every one a prospect. Show in homes, stores, garages, schools, offices, and to farmers, etc. Many of our men now making \$300 to \$600 a month. Write at once to **FYR-FYTER COMPANY**
90-X Fyr-Fyter Bldg., Dayton, Ohio

BIG MONEY FOR YOU

AGENTS—You'll find big profits falling in your lap—letting your friends see this **Marvelous Sunshine Radiant Heater**. Every home a hot prospect. Gives clean, live gas heat no matter where you live for 1 1/2 an hour. No servicing; no installation—no investment nor stock. You collect profits in advance. Thousands in use!



SUNSHINE RADIANT HEATER

Makes and Burns Its Own Gas.

FREE Most Startling Offer Ever Made! Try one in your own home 15 days. Write quick for full details and make territory reservations. **SUNSHINE SAFETY LAMP CO.**
336 Factory Building, Kansas City, Missouri 3

EASY \$100 a Week FUGO FIRE EXTINGUISHER



Unusual opening for live agents in every locality. Make \$5000 or more a year—easily. Fugo—the instantaneous automatic fire extinguisher—is needed and wanted in every home, store, theatre, garage, shop, school, automobile, etc. Cheapest fire protection available today. Within reach of all.

1 Qt. Size \$5.00 2 Qt. Size \$7.50

Recharged in a *flurry*
Amazing 30-second demonstration clinches sale—each one sold sells others. Territory going fast. Write at once for wonderful proposition that will make you big money.

THE NATIONAL FORMETAL CO.
6535 Metta Ave., N. E. Cleveland, Ohio

DOUBLE ACTION AUTOMATIC
Patented **\$1.79**
Pull the Trigger—Out Pops a Cigarette



Protect yourself against hold-up, rowdies, etc. with this clever cigarette case of light weight metal. Looks like genuine automatic! Pull the trigger and out shoots a cigarette through the muzzle. Holds nearly a full pack of cigarettes. Handsome gun metal finish. **Double action.** Lots of fun scaring friends and a great protection. Order one to-day. When your friends ask for a cigarette, shoot one to them and enjoy a big laugh. Either enclose money order for \$1.79 or pay postman \$1.79, plus postage on arrival. **Money back if not satisfied.**

PATHFINDER CO., Dept. 810, 200 Hudson St. New York

AGENTS Make big earnings, taking orders for made-to-individual measure suits at less than ready-to-wear prices. Giant Chicago wholesale house makes world's greatest values at \$23.50 and \$29.50. Your profit \$4 and \$5 per sale in advance—we deliver and collect. No experience needed, work full or part time. **FREE OUTFIT** Send no deposit. Write for details of our unique money-making plan. Nothing like it ever before offered. Act at once.
GENERAL TAILORING CO., DEPT. 529 South Franklin St., Chicago

You Need This— COMPLETE HOME GYMNASIUM

It gives you facilities at home for playful, health-building exercise—to strengthen weak muscles—to reduce flesh—to keep vigorous and physically contented while indoors. Fits in 3 1/4 x 4 1/2 ft. floor space—it is so compact.

Is of durable tubular metal construction, attractively finished. Hundreds have been purchased and set up in dens, bedrooms, basements, sleeping porches, attics, garages, play-rooms, etc.

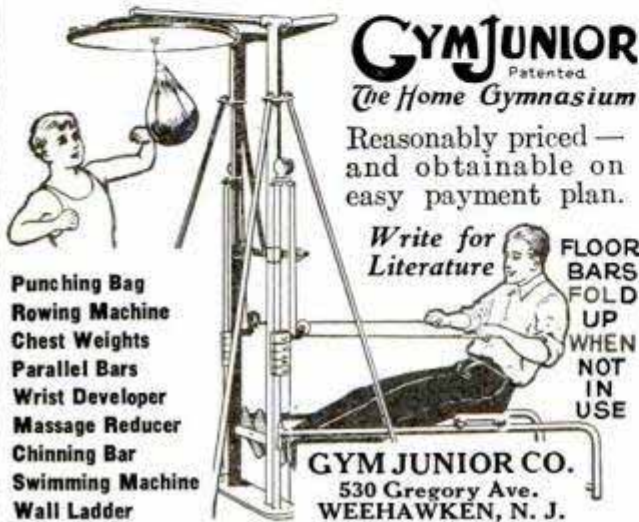

GYM JUNIOR
Patented
The Home Gymnasium

Reasonably priced — and obtainable on easy payment plan.

Write for Literature

FLOOR BARS FOLD UP WHEN NOT IN USE

GYM JUNIOR CO.
530 Gregory Ave.
WEEHAWKEN, N. J.

- Punching Bag
- Rowing Machine
- Chest Weights
- Parallel Bars
- Wrist Developer
- Massage Reducer
- Chinning Bar
- Swimming Machine
- Wall Ladder

You'll Turn Out Beautiful Work with Your H&A BAND SAW

Work you'll be proud of—because it's the saw that thousands of skilled workers choose—smooth, speedy, accurate. A heavy-duty outfit, but reasonably priced. Portable, electric. Write for catalog and prices.

HESTON & ANDERSON
610 Market St. Fairfield, Iowa



BIG MONEY MAKER

Selling Kit Furnished

"A great idea!"

Something different—an original idea—never before seen on the market. Every man and boy a prospect.

Hook-Fast Belt and Buckle made to individual order—no two alike. Every buckle with personal initials and emblems—according to individual taste. Splendid profits made easily—**HANDSOME SELLING OUTFIT FURNISHED**—contains actual samples.

Become the official representative of Hook-Fast Belt and Buckle in your locality—Make big money—Sells itself.

Belt made of genuine English cowhide—never wears out—Buckle made of attractive plati-croyd—lasts a life time, bright and untarnished—Specially patented Hook-Fast catch never slips.

Red-Hot selling proposition. Get in on it now! Write for Full Particulars.

NATIONAL CRAFTS COMPANY
20 West 27th Street, Dept. B-106 New York City



Buy a Watch
the Modern Way

**This 21 Jewel—
Santa Fe Special**

Sent You On-Approval
Wear 30 days Free!

Thank you for making it possible for me to own a 21-jewel Santa Fe Special, writes thousands of our customers.

Buy Direct
Our catalogue is our showroom. Any watch will be sent for you to see without one penny down. No obligation to buy.

Save 1/3 to 1/2

at the price you pay for a similar watch made by other Manufacturers. Most liberal offer. Our "Direct to You" offer and Extra Special Distribution Plan is fully explained in the New Santa Fe Special Booklet just off the press. The "Santa Fe Special" Plan means a big saving of money to you and you get the best watch value on the market today. Watch sent for you to see without one penny down.

**Railroad Accuracy
Beauty Unsurpassed
Life-long Dependability**

—all are combined in the highest degree in the famous "Santa Fe Special" Watch.

These watches are now in service on practically every railroad in the United States and in every branch of the Army and Naval service. Thousands of them are distributed around the world. You will never miss the few cents a day that will make you own one of these watches.

Just Out! Send coupon for our New Watch Book—just off the press. All the newest watch case designs in white or green gold, fancy shapes and thin models are shown. Read our easy payment offer. Wear the watch 30 days FREE.

SANTA FE WATCH CO.

Dept. A-6 Thomas Bldg. Topeka, Kans.

SANTA FE WATCH CO., Dept. A-6, Thomas Bldg., Topeka, Kansas.

Please send me your New Watch Book with the understanding that this request does not obligate me in any way.

Name.....

Address..... State.....



BE PREPARED -take along Absorbine, Jr.

OFF for an outing—miles from home—suddenly a fall bringing painful sprains and bruises—the day is spoiled! No, it need not be if you use Absorbine, Jr. Rub it on full strength at once. It will reduce swelling; draw out inflammation. Absorbine, Jr. is antiseptic. When used full strength it eliminates the danger of infection in cuts, skin bruises, wounds and abrasions. Keep a bottle in the car. It is a reliable first aid—easy to use, and does not stain the skin.

At All Druggists, \$1.25. Send for Free Trial Bottle
W. F. YOUNG, INC., Springfield, Mass.



For First Aid



To Relieve Sore Muscles



Absorbine Jr.



R.O.G.

GIANT CHIC-A-DEE

Record Flight 7 Minutes

This new BROADFIELD model plane, of bird-like beauty, gives amazing performance! Sweep back main wing provides marvelous stability. Features all the latest improvements in perfect model plane construction. Complete Construction Kit includes all parts and supplies for quickly and perfectly assembled plane. Flies indoors and outdoors!

Complete Construction Kit..... \$1.00
Built Up ("Ready to Fly Away")..... 3.00

NEW BROADFIELD CATALOGUE

Here's the perfect guide in better model plane building! Broadfield parts and supplies "from plans to dope" assure more expert model plane construction. Catalogue sent FREE with Giant Chic-A-Dee, or separately, for 10c in stamps.

BROADFIELD AEROPLANE CO.
 Hempstead Dept. 510 L. I., N. Y.

BOYS! Make Big Money

BUILD BIRD HOUSES



Boys! Here's a real money maker. With my simple instructions any boy can build and erect Grandpa Bird Houses. They sell at \$2 to \$30 each. \$2,000 worth sold in Oak Park, Ill., in one year. Send \$1 for 16 Blue Print Drawings showing correct building plans so you can build my famous bird houses. Valuable book on song birds with tips and advice on making sales included free. Get busy—act Now—Today.

GEO. J. BREIDERT, 1040 N. Elmwood Ave., Oak Park, Ill.

MOVIES AT HOME



Many models of genuine MOVIE MACHINES, some as low as \$3.75, all using standard size big theatre films. Our stock of films is the most complete and lowest in price—with an exchange service. Films of leading stars and religious subjects are available. **DON'T DELAY. WRITE FOR FREE INTERESTING CATALOGUE NOW!**

PARAMOUNT MFG. CO.
 Dept. G-20 BOSTON, MASS.

Sousa



GREATEST of all Band leaders says: "Complete Equipment of Conn Instruments enhances musical value of any band at least 50%." More than 50 years of experience, and exclusive patented processes make Conn instruments superior. Easiest blowing. Most flexible mechanical action. Most perfect tone. Yet they cost no more. Any instrument sent on free trial. Easy payments if desired. Write for literature. Mention instrument

C. G. CONN, Ltd.
 1031 Conn. Bldg., Elkhart, Indiana



CONN

WORLD'S LARGEST MANUFACTURERS OF BAND INSTRUMENTS

PROFIT WHILE YOU PLAY! BECOME A M.C.H.C. OWNER-DEALER!

BUY FOR $\frac{1}{3}$ REGULAR RETAIL PRICES

Featuring
1930 **SCREEN GRID**

LATEST ALL-ELECTRIC A.C. RADIOS

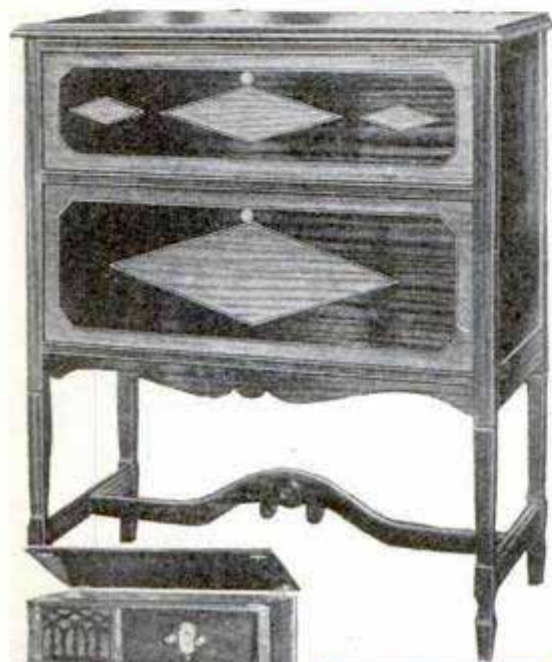

ROYALE—
Model 638
All-Electric Console

Regular Retail Price.....\$130.00
Special Sale Price.....\$ 60.00
Owner-Dealer Price \$39.50
Complete with Tubes



With a Marvelous 7-Tube, Completely Shielded, 1-Dial Illuminated Chassis Built by One of Radio's Outstanding Manufacturers.

ALL CONSOLES EQUIPPED WITH RENOWNED, POWERFUL

UTAH SPEAKERS

FREE Send for Amazing Offer Giving Full Details and Specifications NOW!

A M. C. H. C. OWNER-DEALER Can Also Sell for $\frac{1}{2}$ Regular Retail Prices and Make 50% Profit Without Any Investment Except for Own Set. We Equip You to Make **FREE! Sales. Any Owner Can Qualify!**

A SENSATIONAL OPPORTUNITY!

The last word in Radio enjoyment can be yours at the lowest cost. Well-known, high-grade All-Electric A. C. Radios, including the newest type SCREEN GRID, made by prominent manufacturers, with world-renowned, powerful Utah Speakers, in magnificent quality genuine Walnut and Mahogany Consoles—sets with a guarantee of complete satisfaction behind them that you can always be proud of as well as enjoy.

These sets and cabinets are big surplus stocks of latest approved models which we have bought at tremendous discounts—so low we can give them to you at less than original factory prices.

All up-to-the-minute improvements are embodied in them. They include the finest Screen Grids. All are All-Electric A. C. Operation, with Illuminated One-Dial Control, Seven Tubes, Completely Shielded in All-Metal Chassis, giving razor-edged selectivity with velvet-toned reproduction—true tone qualities without hum, interference or distortion.

The models equipped with Screen Grid Chassis have the only totally enclosed all-metal screen grid chassis on the market today.

Famous Makes—Highest Grade

They are not cheap except in price—no seconds or defectives—all A 1 firsts, worth retail at least three times our Owner-Dealer prices. We have merely removed the maker's name plates and substituted our own. Many thousands of the same identical sets have been bought by satisfied individuals at the higher prices.

Under our liberal plan merely to own one of these Radios qualifies you to act as an Owner-Dealer. You can buy your own set at the Owner-Dealer price. Enjoy it in your own home! Show it to your friends with our advertising quoting Special Sale Prices one-half original! Take their orders or let them send direct and make big profits for yourself! Act at once! Fill out and mail the coupon. Stocks and territories are, of course, limited. Full details of our offer and complete specifications of sets and cabinets will be sent you.

Merchandise Clearing House Corporation

Dept. 507,
1737 So. Michigan Ave.,
Chicago,
U. S. A.

LESS THAN FACTORY PRICES

Roosevelt—Model 20

Improved Screen-Grid, totally enclosed, 7-tube all-electric including Rectifier; Utah Dynamic Speaker in handsome Walnut Console. Owner-Dealers' Price (Without Tubes)

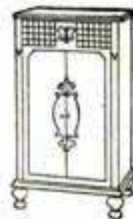

\$64.50

Royale—Model 6

De Luxe Walnut Console of striking design—with 7-tube all-electric shielded chassis; Utah Speaker. Owner-Dealers' Price. Complete with Tubes.



\$49.50

WE GUARANTEE Complete Satisfaction

CLIP, FILL OUT, MAIL NOW FOR OWNER-DEALER OFFER
Merchandise Clearing House Corporation, Chicago, U. S. A.
WITHOUT OBLIGATION, send me your FREE catalog and Special Owner-Dealer Offer.

Name

Street

City

State

Date

Now! Do Your Own Electric Nickel Plating

Introductory Offer

ONLY \$6.50 Plus Postage



For Plating Nickel, Brass, Copper, Silver, Gold, etc.

Make \$150 to \$500 a Week

NO EXPERIENCE REQUIRED. DO YOUR OWN Electro-Plating in Your Home, Garage, Office or Place of Business. Electrically Deposit Metal—Nickel, Brass, Copper, Silver, or Gold. You can Successfully do all the plating on your Automobile, Electric Fixtures, Faucets, Spoons, Forks, Chandeliers, Tools, Coffee Urns, Surgical and Dental Instruments, Utensils, large or small, Iron Stoves, Music Instruments; recondition worn plating or plate New Work; do it Instantly without interrupting the Service or without removing the parts to be plated with the

ALADDIN PORTABLE ELECTRO-PLATER

Simple and Economical to operate. Not a toy, but a practical Plating Outfit with which Perfect and Durable Work can be done. Positively Guaranteed to do as we claim. BE YOUR OWN BOSS! Build up a Profitable Aladdin Electro-Plating Business of your Own. This offers wonderful ECONOMY to users and BIG MONEY-MAKING possibilities to AGENTS. Thousands in Service since 1924. Write for FREE Booklet and Testimonials and 30 Day Trial Offer Today.

P. J. F. BATENBURG, Dept. 113, RACINE, WISCONSIN

AGENTS WANTED EVERYWHERE

Write Today for details

Establish a Good Future

ONLY \$50.00

DOWN AND \$4.00 Weekly Starts a business of your own—No experience necessary. Instructions furnished. The only key machine that cuts ALL types of keys. No hand-filing. Make first keys by number of lock without taking lock apart.

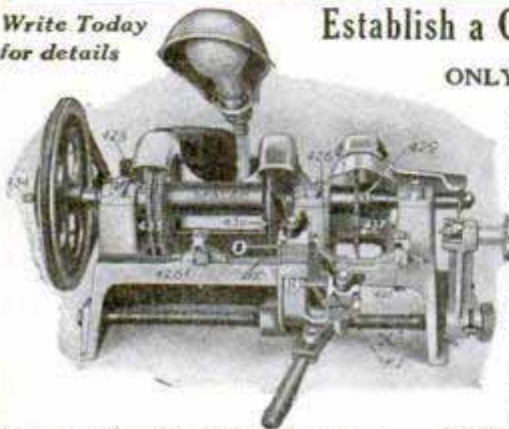

Beisser Key Machine Company 407 Fort St. East Detroit, Mich., U. S. A.

SAVE 1/2 ON PLUMBING HEATING

Cut-to-fit Heating System
New Easy method enables any man to install his own PLUMBING and HEATING. Lowest wholesale prices on Highest Quality Grade A goods.

WE SHOW YOU HOW
Send for our new free catalog telling how you save waste material and high labor costs by being your own plumber. This book has saved money for builders, home-owners, farmers and mechanics for over 50 years. Send for your copy today.



MILLION DOLLAR BONDED GUARANTEE PROTECTS YOU

OVER 50 YEARS **HARDIN-LAVIN Co.** EST 1876
122-32A West Pershing Road, Chicago, Ill.



Boys 50 Prizes!

awarded every month in the BULLS EYE Air Rifle Shooting Contest. No entry fee. For best scores, use Bulls Eye Steel BB shot—smooth, polished, shoot straighter, will not jam in rifle, do not flatten out, can be used over and over.



Get Free Targets, Rules of Contest and list of Prizes from your hardware dealer, or write us.

BULLS EYE 3106 Snelling Ave. MINNEAPOLIS MINN.

Learn the Code with Teleplex!

Be an expert Morse or Continental code operator! **BIG PAY—TRAVEL—FUN—ADVENTURE.** After a few short weeks of practical study with Teleplex you will be an expert operator. This amazing instrument teaches you right in your own home. Works like a phonograph. No knowledge needed—beginners learn at once! **Not a school. Free 10 days' trial. Write for free booklet E-10.** TELEPLEX COMPANY, 72 CORTLANDT ST., NEW YORK CITY



The Musical Sensation **ACCORDEON** Played by Music Rolls

Without any knowledge of Music or Notes, you play in a few minutes, as perfect as an Artist, latest hits, songs and dances. Every instrument guaranteed. Circular No. C and roll list mailed free.

TREASURE SALES CO. 1690 Boston Road New York

DIAMONDS

(Sent Free Examination)
here 60% of Market Prices



10 large loan firms combined (world's oldest, largest association of its kind—rate over \$1,000,000.00), loans money on diamonds. A few such loans not repaid. Diamonds originally sold by outstanding jewelers. Of course we can loan but a fraction of real values. You get the advantage in Unpaid Loans at cash prices you can try to match at full 60% more. Every liberal privilege.—Examination free—No obligation to buy.

Free List of Unpaid Loan Diamond Bargains Every diamond accurately described. Radically low prices for any quality, any size. Written guaranteed amounts you can borrow (like Insurance Policy loan guarantee). Get full details of free examination offers. You don't risk a penny. 1/2 century old house (references: Bank of Pgh., Union Trust Co., 3rd Nat'l Bank). Lists limited—Send now. For **FREE LIST** write today to **Jos. DeRoy & Sons, Opp. P. O. 1985 DeRoy Bldg., Pittsburgh, Pa.**

Unpaid Loans Low as \$60 per Carat

WITTE ENGINES

The famous line of WITTE Engines are now sold by established dealers throughout the country. 300,000 already in use the world over. 2 to 30 H. P. Wico Magneto equipped. A lifetime guarantee with every engine. Ideal for the home, farm, shop or mill. The cheapest reliable power available. Catalog Free, on request. If your dealer cannot supply you, write us.

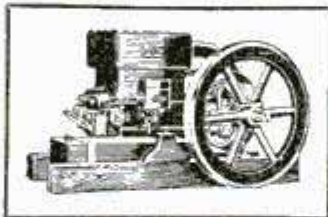

WITTE ENGINE WORKS
KANSAS CITY, MO.
ENGINE BUILDERS SINCE 1870

ATKINS SILVER STEEL SAWS

for YOUR HOME WORKSHOP



C. E. Palmer, Wilmette, Ill., won July prize of \$10 with this photo of his home workshop.

Start a Home Workshop!

SAWS to cut wood or metal are the most important tools in your home workshop. So buy the best. Your hardware dealer can show you a full line of ATKINS Silver Steel Saws, to cut faster, easier and last longer than any other saws you've owned.



ATKINS "400" and "401" are finest hand saws made. Silver Steel blades, mirror polish; Perfection handles—no rick strain. Many other ATKINS hand cross-cut and rip saws.



Circular Rip, Cross-cut, or Mitre Saws, in size to fit all power saw outfits. Also Dado Heads to cut grooves from 1/4" to 4" in width.



Has rigid blade with fine keen-edged teeth to do quick, accurate work in cutting mitres, grooves, frames, etc. 8 to 18" blade lengths.



Nickel steel frame extends 8 to 12 inches. Pistol grip handle. Non-Breakable or Silver Steel Blue-End Blades that cut twice as fast, last six times longer.

Also, Narrow Band Saws, Cabinet Scrapers, Files, Saw Sets, etc. Write us for the four helpful booklets shown below. Send coupon.

4 Saw Booklets Sent FREE



E. C. ATKINS & CO.
Est. 1857 426 S. Illinois St.
Indianapolis, Ind.

Send "Saws in the Home," "Circular Saws," "Dado Heads," and "Saw Sense"; also information on your offer to pay \$10 for best home workshop photo.

Name

Address

My Dealer is

WIN
\$10
for Best Photo of a Home Workshop!

BIG MONEY

easily made by floor surfacing contractors who average \$40 per day. The New "American High Production" Machine does the work—makes you the money and builds you a business of your own. No dull seasons—no large capital nor experience required. Complete information free without obligation—write today.

THE AMERICAN FLOOR SURFACING MACHINE COMPANY
523 So. St. Clair St. TOLEDO, OHIO

CRESCENT

20" Band Saw

A high grade, mod-erately priced band saw for light work; affords all the accuracy, convenience and efficiency of large band saws. Ball bearing. Self contained motor operates from light socket; or may be driven from line shaft. Machine finished table, with graduated scale, tilts any angle to 45 degrees. Quick locking device. Saw, with spring tension, is fully guarded. We make wide line of light machines for cabinet makers, schools, and amateurs, also heavy machines for factories.

THE CRESCENT MACHINE CO.
93 Columbia St. Leetonia, Ohio

Send for FREE BULLETINS

MARVELOUS NEW PATENTED SCREW-HOLDING SCREW DRIVER

Non-magnetic. Holds screws any material tight! Removes and inserts them INSTANTLY from inaccessible places. Factories, garages, radio, electricians, machinists, auto owners, etc. Buy on sight! Indispensable for all wherever you work. Price \$1.50 only. (Send postpaid receipt money order.)

DISTRIBUTORS: Genuine opportunity, enter big industry. Exclusive territory, closing fast. Write or wire quick for full details.

JEFFY-TITE MFG. CO., 1203 Water St. Boston, Mass.

Chesterfield

The MILD cigarette that SATISFIES

VICAM STANDARD MOVIE CAMERA

Make your own action movies of events, trips, parades, etc. Takes 25 feet of standard film. Equipped with F.5 universal lens. Loads in daylight. Films developed free. Film can be projected from any standard projector. Order today C. O. D. or send 10c in stamps for illustrated booklet.

\$18.50 F.O.B. Phila.

VICAM PHOTO CO. 1224 No. 44th Street PHILA., PA.

NOW —
GET MY
GREATEST
Log Saw
Offer



Fastest Cutting

Saws 15 Cords a Day

ONLY \$39

Used by The United States Government

It's easier, now, than ever before to own this fastest-cutting, easiest-moved, most powerful Log Saw. Now you can make big money sawing firewood, stove-bolts, ice, shingle timber, etc. **WRITE TODAY FOR FULL DETAILS.**

Try 30 Days **OTTAWA**

— ONE WHOLE MONTH to use the OTTAWA at your own sawing. Every saw shipped on trial—

Backed by 10-Year Guarantee

FREE Send me your name and address on a postcard today for my wonderful new edition of the "Wood Sawing Encyclopedia."

Make Big Money— Wood selling at \$3 a cord brings owner \$45.00 a day. Go into the wood business. Don't let the lack of ready money stop you. Remember, we sell on very easy terms.

To Save You Freight— and get your machine to you a few days after your order, I ship from factory or nearest to you of **FOUR BRANCH HOUSES.**

Put the OTTAWA Working For You!

350 Cuts a Minute!

Take any size log — in a few seconds it's all sawed up — without any hard work!

FREE Wood Sawing Encyclopedia

OTTAWA MFG. COMPANY
1745-L Wood St., Ottawa, Kans.

\$15
Electric Drill



1/2 in. Steel Chuck, key operated, Universal Motor. A sturdy tool for wood or metal. Fully guaranteed. Postage paid.

GEO. M. STUDEBAKER, Jr., B, South Bend, Ind.
512 Citizens Bank Building

AGENTS WANTED \$50 TO \$100 WEEKLY!
Take orders from Motorists for Electro Magnetic Trouble Light! Sticks to any part of car. Both Hands Free to Work. Amazing demonstration. Send for demonstrator and particulars, **WONDERLITE**, Industrial Trust Bldg. Dept. PM, Providence, R. I.

CORNWELL
QUALITY TOOLS
in Convenient Kits



A KIT of "CORNWELL" tools is a prized possession of the expert mechanic. Valued not alone for their high quality but because they do better work in less time than any other tools. 65 different tools for almost every purpose. Their remarkable performance in difficult work is simply amazing.

There is No Substitute for CORNWELL QUALITY

Every CORNWELL tool is hand made under our exclusive CORNWELL processes from Swedish or Chrome Molybdenum steels.

Tools of Amazing Strength

No other tools are like them. They withstand the most severe tests to which any tools can be put. Try them at our risk.

Let Us Demonstrate

Ask for salesman to call and show you many startling demonstrations of CORNWELL QUALITY TOOLS. Or send for free catalog, order tools, and make these tests yourself.

COUPON BRINGS CATALOG—FREE

The Cornwell Quality Tools Co., Dept. O, Mogadore, Ohio. (Suburb of Akron)

Send me new illustrated catalog with prices on full line of CORNWELL Hand-made Tools.

..... Where Employed
Name.....
Address.....
City..... State.....

A Genuine Robbins & Myers
1/4 H. P. Electric Motor
for 110 V., 60 Cycle light circuit at the low cost of \$10.70 net. A tool that will lighten your chore, connected to your lathe, grinder, pump, washer, etc. Always ready for service.

ROBBINS & MYERS, Inc.
Department A, Springfield, Ohio



Systematic and Orderly Arrangement of Tools
assured by GERSTNER Tool Chests for Machinists and Toolmakers. No more worry about loss or damage when you use one of these fine chests.

Free Catalog

Gerstner Sons
470 Columbia Street, Dayton, Ohio



Makes Old Ford a Tractor

Now you can convert that old Ford car into a useful farm tractor without altering any Ford parts. We furnish the traction wheels, drive gears and auxiliary axle and mountings, ready to clamp on to the Ford frame. Pulls 16' plow.

We supply a Belt Pulley also

Write for Free Particulars.
Shaw Mfg. Co., Dept. PM10, Galesburg, Kan.



PARKS
WOODWORKING MACHINES
Cabinet Shop
Special No. 10
\$290
With Motor

You ought to have this handy Parks in your shop. Compact, complete machine designed like a big production outfit at 1/2 the cost. Floor space required only 42x72 in. Does any kind of cabinet and joinery work. **Write for circular.**

The Parks Woodworking Machine Co.
Builders of quality woodworking machines since 1887
1500-40 Knowlton St. Cincinnati, Ohio
Canadian Factory: 338 Notre Dame East, Montreal



TWO HANDY TOOLS

for the
Outdoorsman's
Kit

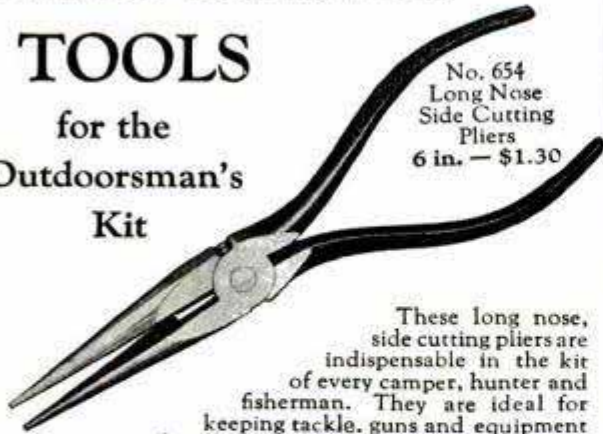

No. 654
Long Nose
Side Cutting
Pliers
6 in. — \$1.30

These long nose, side cutting pliers are indispensable in the kit of every camper, hunter and fisherman. They are ideal for keeping tackle, guns and equipment ship-shape. Drop-forged of special analysis steel, fully polished and absolutely guaranteed.

This cabinet screw driver with its forged alloy steel shank riveted thru the hardwood handle is another useful tool in the outdoor kit as well as home shop.

See them at your hardware dealers.

CRESCENT TOOL COMPANY
210 Harrison Street
Jamestown, N. Y.



No. 1315
Screwdriver
20c. to 80c.

CRESCENT and Smith & Hemenway TOOLS

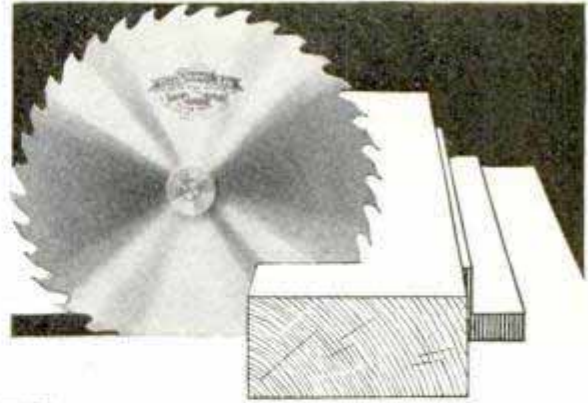

For every sawing job in the home workshop!

HALF the satisfaction in operating a portable rig comes from using saws that hold sharp cutting edges — Simonds Circular Saws, for instance!

Exactly the same steel that's used in Simonds Saws made for the large industrial plants, is used in Simonds Small Circular Saws for all portable types of electric sawing outfits. That's the big reason why these saws cut faster and stay sharp longer.

If your dealer can't supply you, we will gladly forward you any of the Circular Saws listed below upon receipt of listed price.

When ordering state size of arbor hole.

- | | |
|---------------|----------------|
| 6 inch \$3.30 | 10 inch \$5.60 |
| 8 inch 4.40 | 12 inch 7.00 |

SIMONDS SAW AND STEEL CO.
FITCHBURG, MASS.

"The Saw Makers" Established 1832
Branch Offices and Service Shops in Principal Cities

SIMONDS

SAWS FILES KNIVES STEEL

The Handy Outfit—Torit No. "23"

Uses acetylene only from a Presto auto tank. Finest thing you ever saw for Radiator and Battery Repairing, Soldering, Light Brazing, Heating, etc. Complete with 4 tips, soldering copper, hose, connections. **PRICE (except tank) \$7.50**
ST. PAUL WELDING & MFG. CO.
177 W. THIRD ST. ST. PAUL, MINN., U. S. A.



BURN YOUR NAME ON TOOLS WITH THE ARKOGRAF

PROTECT YOUR TOOLS FROM THEFT
Write with electricity any name or design on the hardest and finest tools and instruments, or any metal, like writing on paper with pen or pencil. **Complete Outfit \$3.50**—Prepaid Anywhere Interesting illustrated circular free. Write today. Agents wanted.
ARKOGRAF PEN CO., 1171 E. Stark St., Portland, Oregon



SALESMEN WANTED!

SELL COX HOLDFAST SCREW DRIVERS

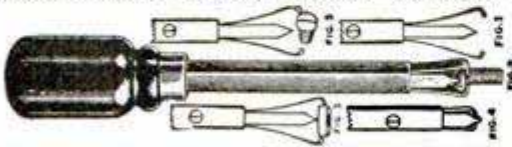

Sells on sight to mechanics for Auto, Radio and Electrical Work. Self Holding, Self Releasing.

Send 50c for sample and ask how to get Salesman's Outfit Free.
S. J. COX Dent. F. FRANKLIN, PA.

ELECTRIC LIGHTS ANYWHERE

Also runs Household Electrical Appliances. Install it yourself. Write for circular.

D. W. ONAN & SONS **\$147.50**
24 Royalston Ave.
Minneapolis, Minnesota.



110 Volt—complete plant with all Wiring, Fixtures and Lamps for 7 rooms \$147.50, Direct-To-You.

Ideal for Farms, Camps, Summer Homes.



I'll hand it to you!

I'll hand it to you for doing your darnedest to get your hands clean with ordinary soap. But, man, you can't do it with ordinary soap. I've tried, and I know. The only soap I've found which can do it is Lava Soap. Ask Jim, or Ed or Bill—fellows who have work like yours—they know Lava, too. They'll tell you it's the best hand-friend they've got. It gets the grime and grease, but leaves the skin behind. Gets work-stained hands clean in 58 seconds, because it's made from pure vegetable oils and pulverized Italian pumice that's almost as fine as flour. Makes a rich, creamy lather in the hardest water.

George, the Lava Soap Man

Lava costs a dime (or 6c for the medium size cake) at any drug or grocery store. But if you want to try it at our expense, mail this coupon.
Procter & Gamble, Dept. W-1029
Cincinnati, Ohio

George: I want a free sample cake of your Lava Soap.
Name.....
Street.....
City..... State.....



Do Your PRINTING

Cards, stationery, circulars, tags, labels, advertising, etc. Save money. Print for Others, Big Profits. Junior Press, \$5.90. Job Presses \$11 up, Rotary \$149. Will do popular Raised Printing like Engraving. Easy rules sent. Send for catalog outfits. THE KELSEY CO., S-37, Meriden, Conn.

STRANGE NEW IRONING CORD

NEW FIELD FOR AGENTS

MAKE \$90 A WEEK

Can't Kink or Snarl—Prevents Scorching—Saves Electricity!

THIS CORD SET FREE

Every Neverknot Salesman is given FREE the complete Neverknot Cord Set pictured. This new type Cord Set automatically coils itself out of the way yet every inch is available. A new kind of plug prevents scorching and saves electric bills. It is a "gold mine" for house-to-house workers.

Big Companies Equip Phones

This unique patented invention sells readily to phone users as it abolishes kinks, snarls and disconnects. Now used on phone cords of Fed. Res. Bk., Gen. Elec. Co., Mellon Nat. Bk., The Tex. Co., and many others.

There is only one Neverknot. It is protected by U. S. Patent. Get territory with free cord set NOW!

NEVERKNOT COMPANY
Dept. 10-V, 4503 Ravenswood, Chicago

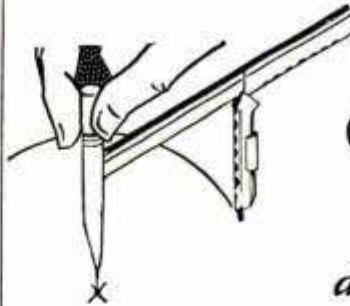

NEW COMPASS

makes accurate drafting work easy!

THERE are dozens of jobs on which you need a good compass—radio hook-up diagrams, lighting outlets—no end to its workroom uses!

Now you can have an accurate compass without buying a set of cumbersome, expensive drafting instruments! This **ESTERBROOK COMPASS** is so small that it seems like a toy. It is very inexpensive, yet amazingly precise.

It works on an ingenious

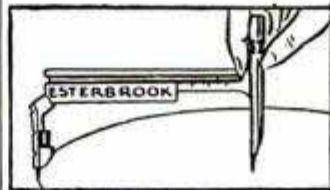

Above: Slide adjusted for long radius.

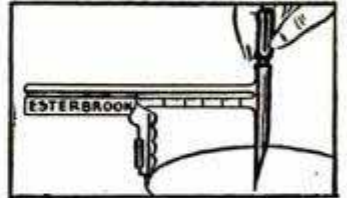

Above: Slide at the short radius.

new principle which prevents wobbling or slipping. Center-pin and pencil-lead are always parallel and vertical. Radius shown clearly and correctly on the beam, in inches or centimeters. Makes true circles from 1/8" to 8" diameters. With slide reversed radius is exactly 2" greater than scale reading.

50¢ at all stationers—or send direct to Esterbrook Pen Co., Camden, N. J. We mail postpaid.

12-INCH SCALE MODEL

of Lindbergh's Spirit of St. Louis. Scientifically designed and very realistic. Rises from ground by own power and flies 40 ft. or more. Only \$10.00 scale model sold at this price. Easily built in 2 or 3 hours. No tools needed. Construction set, with all parts and full directions, postpaid in U. S. and Canada, only 50c (no stamps). Satisfaction or money back. Send today and print your address plainly.

MANN & BENTON
Box D, Chillicothe, Ohio

Cal. 30-40 Six Shot

KRAG CARBINE

All the qualities of a high price rifle. In fine used condition, all working parts guaranteed for one year. Send today for our Free 50-page illustrated catalog of money saving values; Guns, Ammunition, Cutlery, Sports and Gov't goods. Terms Cash. No C. O. D.

Price \$9.75

W. Stokes Kirk, Dept. P. M. 10, 1627 N. 10th St., Philadelphia, Pa.

Part-Time Men Get This Suit OFFER

Make \$45 a Week and up

Cash profits paid daily. No question about it, any man can easily earn \$45 a week and up, just showing our wonderful outfit and taking orders for our high-grade tailoring. Never before such low prices and beautiful styles.

New Style Outfit FREE

To introduce our unbeatable values, classy styles and perfect tailoring, we make this introductory free suit offer—something different, better, bigger, more liberal than any offer ever made.

New Style Outfit of large real cloth samples—everything furnished FREE. Write today for free suit offer and big money-making plans.

PROGRESS TAILORING CO. Dept. K-216 CHICAGO

... a New IDEAL Model Airplane



The
"American Eagle"

Wing Span: 26 in. Weight: 5 1/2 oz.

Distinctive in design . . . new in construction . . . a light, durable, fast-flying model with IDEAL'S twenty years' experience behind it, and months of dependable performance before it! Wonderful stability in the air, and GUARANTEED to FLY when hand or ground launched. Constructed largely of Balsa wood, with many new features; motor can be wound with winder without removing from fuselage; indestructible landing gear; new type propeller. Construction is easy. Also sold completely built.

Construction Set—\$2.50 Assembled Model—\$5.00

Ford Tri-motor Monoplane 3-ft. Model. Construction Outfit, \$8.50

Sold by Toy, Sporting Goods and Department Stores. Ask for IDEAL Model Airplanes. If unobtainable, order direct. West of Denver, prices are 50c higher.

Catalog of Models, Parts and Supplies for builders — 5c

IDEAL AEROPLANE & SUPPLY CO., Inc.
26 WEST 19th ST. NEW YORK CITY

BIG MONEY for YOU!

Free!

The Big Book of Big Profits is ready for you—the finest produced in 25 years of our business history—showing a Complete Line of guaranteed Shoes and Leather Goods for the Entire Family at Lower Prices—direct from factory to you!



THE MASON FACTORY

It's Easy to Earn \$15 to \$25 Every Day

Our new, big FREE CATALOG—SALES MANUAL and COMPLETE SELLING OUTFIT—will help you earn Big Money regularly—

MASON Men will tell you so! Write us NOW!
MASON SHOE MFG. CO., Dept. I-18, Chippewa Falls, Wis.

WANTED! Man with Car

To Run Store On Wheels

Sell the largest, finest quality line of daily necessities from your car. No experience necessary. Hundreds now making

\$200 TO \$500 A MONTH

Our proposition is entirely different from all others. Our advertising half sells the goods for you. Premiums, samples and gifts all make business come your way. Business is permanent, pleasant and profitable.

BE A DOUBLE MONEY MAKER

Two entirely different lines, 241 items, a sale at every home. Two lines mean two profits. We will give you liberal credit. Write for details about our new proposition.
FURST-McNESS CO., Dept. 449 Freeport, Ill.



\$2 to \$4 an hour for Spare Time

-A NEW Business

Here's a BIG OPPORTUNITY for men who want to get ahead in a PERMANENT, WELL PAYING BUSINESS for themselves. Hundreds of men all over the country are making BIG MONEY sharpening saws on the Foley AUTOMATIC Saw Filer. Nothing else like the Foley—it files saws automatically better than the most expert hand filer, and faster too!

No Competition with the FOLEY AUTO-SAW FILER

Start in your spare time and work up a full-time business. You can get all kinds of saws to file—from carpenters, contractors, factories, schools, hardware stores, saw mills, woodworking plants and every kind of business that uses saws, because the Foley files them AUTOMATICALLY with such mechanical accuracy that they cut faster, cleaner and truer. When your customers see what good work you do for them on your Foley, they will give you all the business you can handle.

Chas. E. Fuller Made \$3.00 in 40 Minutes

Most Foley users get 50c for each saw filed and average —5 to 8 hand saws an hour easy.

Harry O'Brien says, "I had 7 saws waiting before I got my machine. Have already made \$130." *** From Nels Emstad, "Have filed 225 saws, and it works absolutely perfect. Not bad for a side line."

"I am a carpenter working every day and file about 100 saws a month." says Oscar Porr. *** "I have sharpened over 2000 saws with the filer—it's a wonder," says L. J. Frederick.

Money-Making Plan Free

No experience needed to operate the Foley. Our Free Plan has started hundreds on the road to success. Don't delay—get it now! OTHERS MAKE BIG MONEY—why don't you? Send the coupon today for complete information.



MAIL THIS COUPON TODAY

Foley Mfg. Co., 244 Foley Bldg., 11 Main St. N. E., Minneapolis, Minn.

Gentlemen: Please send me Free Plan to build a business filing saws on the Foley.

Name.....

Street.....

City.....State.....

DOES \$35.00 per day interest YOU?



That's what you can earn as a DENNIS Weather Strip Contractor

No experience necessary. No special tools. Quick cash profits on strips and labor. We furnish free working models and teach you how to get contracts. Patented "S" shape provides snug weatherproof seal that is self-adjusting and SAVES 1/2 FUEL. Quick application and low price enables you to double volume of contracts. No grooving or removing of sash or doors—saves labor, time and expense.

Comes in convenient Window and Door sets, and bulk.

Easily Installed in New or Old Buildings
Every property owner can be sold DENNIS metal strip at wood strip prices. A proven success endorsed by Contractors, Builders, Architects and Owners. Write now for details.

Mail Coupon Today

DENNIS

ONE PIECE - DOUBLE CUSHION
BRONZE WEATHERSTRIP

W. J. Dennis & Co., 2110 W. Lake St., Chicago, Ill.

- Send Money-Making Plan for Contractors
 - Send.....Sample Window Sets at \$1.75 each postpaid
 - Send.....Sample Door Sets at \$2.00 each, postpaid
- Name.....
Street.....
City..... State.....

One Year

To Pay



No Red Tape

10 Days Trial

SEND NO MONEY When you get the ring, pay only \$2.00 to the postman. If you keep it, pay only \$1.25 a week for one whole year. All credit dealings kept strictly confidential—No orders accepted from persons under 20 years of age.

We are an old **Money Back** firm of diamond importers. **GUARANTEE** You take no risk. If you are not satisfied that the ring is the biggest bargain you ever got, return it and we will refund every cent that you paid.

PRICE CUT TO \$62.00—WORTH \$100.00
You can now buy this gorgeous ring at the wholesale price. Compare it with similar rings at \$100. We guarantee it to stand any test or comparison. Greatest bargain offered by any Diamond Importer. We allow 8% annual increase in exchange for a larger diamond ring. **Write for FREE Illustrated Catalog**

It brings our large Jewelry Store right into your home. Gives weights, grades and complete description so you can buy diamonds like an expert. Gives you information other jewelers dare not tell.
Genuine Blue-White Diamonds as low as \$197.00 a Carat.
AGENTS WANTED—EARN \$100 WEEK. Write for details.

STERLING DIAMOND & WATCH CO. INC.
DIAMOND IMPORTERS—\$1,000,000 STOCK—ESTABLISHED 1879
1540 BROADWAY DEPT. 2640 NEW YORK

CAMPBELL'S

INFRA-RED RAY LAMP



STOPS PAIN QUICKLY
Have You Some Troublesome Ailment?

I want to send you one of my INFRA-RED Lamps to use for 30 days without obligation to purchase—so you see for yourself how quickly you will be relieved. Infra-red (invisible) rays penetrate deeply into the tissues. This creates an active circulation in the congested parts, stopping pain almost instantly. Nature herself does the healing by stimulating the normal circulation of blood.

Sent on 30 days' trial

May be used safely by anyone. Just plug into any light socket, and concentrate the Infra-red beam on the affected part. A blessing in the home both for children and adults. Physicians say most ailments are due to congestion—relieve the congestion with Infra-red rays and you relieve the ailment.

Now—low factory price and easy terms

Write today for free book quoting medical authorities and hundreds of users. For a limited time low introductory price and small monthly payments.

WM. CAMPBELL CO., Dept. 1040, ALLIANCE, O.

- Sinus Trouble**
Sore Throat
Lumbago
Bronchitis
Neuralgia
Rheumatism
Neuritis
Tonsillitis
Catarrh
Ear Trouble
Hemorrhoids
Backache
Asthma
Gall Bladder
Try my Infra-red Lamp at my risk for these and other ailments.

Free Book Tell us your trouble, and we'll send free valuable suggestions for Infra-red treatment during 30-day trial period.

NEW No. 10 FOUNTAIN PEN-PENCIL

With compass. Guaranteed 2 years. Money back if not pleased. Sells for \$1.25.

SEND ONLY

39c



WRITE for FREE Wholesale catalog showing over 400 fast sellers.
F. SPORS & CO.
829 Main St., Lesueur Center, Minn.

AGENTS 500% PROFIT

GENUINE GOLD LEAF LETTERS

S guaranteed to never tarnish. Anyone can put them on stores and office windows. Enormous demand, large profits. Paul Clark says: Smallest day \$28.70. R. L. Reel made \$920 in two months. Write today for free sample and liberal offer to general agents.
METALLIC LETTER CO. 433-B N. Clark St., CHICAGO

Chemical Tricks for Boys



Surprise and puzzle your friends with magic chemical tricks; make ink, dye cloth, test water and soil; write secret letters with invisible ink; pour blue, brown and black liquid from a pitcher of water. All these and many more chemical stunts are easy with Chem-Craft Junior. It's the best box of fun you ever had! Get yours now.

ONLY 25c POSTPAID

FREE Magazine

of the Chem-Craft Club to every boy who writes for it now. Full of new ideas and chemical stunts. Ask for yours!

The Porter Chemical Co.
54 East Washington St. HAGERSTOWN, MD.

Pay as You Please



Select your own payment terms for a Mead instrument. Make money playing in local orchestras. Be the "life" of the party wherever you go. 10 DAYS FREE TRIAL—no obligation to buy and no cost to you. Mead instruments are easy to play and a joy to learn. If you can hum a tune, you can play. Free instruction book—new simple method. Send a postcard today for free instrument catalog with marvelous offers and terms.

CYCLE CO.
Mead
DEPT 254P CHICAGO

MOTORCYCLES

WE WILL TRUST YOU
Pay As Low As \$2.00 per Week
Hendersons, Harley-Davidsons, Indians
Slightly used and rebuilt. Hundreds to select from.
Send 10c for list today.

MYEROW BROS. CO., 15 Berkeley St., Boston, Mass., U. S. A.
RACING AND SPORT EQUIPMENT
Direct from Manufacturers

Bodies for Ford and Chevrolet
\$18.75 and up
Hi-Compression Heads, underslung Parts, Racing Gears, Cowl Lamps, Roadlites, Seat covers. Also Boats, Canoes, Portable Radio, Bicycles, and Camping Outfits. Send 10c for Catalog showing bodies of rare beauty and complete equipment.



Build a Real Auto from Used Chassis
Dept. K-2 AURORA, ILL.

MOTORCYCLES

Direct to you at wholesale prices. Send 10c today for the latest Illustrated Bulletin and Confidential Price List of Guaranteed Indians Harleys Hendersons SuperX etc. (Sold on easy terms if desired)

CRANDALL CYCLE CO., 826-28 State St. Springfield, Mass. Shipments to all parts of the world
Motorcycles Since 1905

Catch Fish!

Eels, Mink, Muskrats with our new folding galvanized STEEL WIRE TRAP. Write for our FREE TRAP OFFER and Bargain Catalog. \$1 Box of our famous FISH BAIT FREE to introduce our traps. WALTON SUPPLY CO., 3502 JUNIATA AVE., ST. LOUIS, MO.

CLASS PINS 35¢
FREE CATALOG SHOWING 200 DESIGNS
EITHER DESIGN SHOWN, SILVER PLATE 35¢ EA.; 12 OR MORE, \$3.50 DOZ.; STERLING SILVER OR GOLD PLATE, 50¢ EA.; 12 OR MORE, \$5.00 DOZ.; 1 OR 2 COLORS ENAMEL, ANY 3 LETTERS AND DATE.
BASTIAN BROS. CO., 925 BASTIAN BLDG. ROCHESTER, N. Y.

Champion Spark Plugs —Maximum Performance and Dependability



THE importance of spark plugs in modern engines cannot be over-emphasized. It is the spark plugs which give the engine life. On them the latent forces of power, speed and acceleration ultimately depend.

Champion Spark Plugs have always been the unqualified choice of the great majority throughout the world. And Champion is universally recognized as the better spark plug by reason of perfectly obvious superiorities.

The exclusive Champion Sillimanite insulator is recognized by ceramic science as the finest known. Special analysis electrodes with positive parallel sparking surfaces insure a spark of uniform intensity for all engine speeds. The solid copper gasket seal retains all the advantages of Champion's two-piece construction and is permanently gas tight.

With these exclusive features, Champion excels and outsells throughout the world and assures maximum performance and dependability.

CHAMPION Spark Plugs

Toledo, Ohio

Windsor, Ontario

This Specially Priced

REFLEX BATTERY CHARGER

Shipped to You on EASY TERMS

SEND for free illustrated literature describing amazing features of the specially priced Reflex Charger for starting a battery service in your own shop. Small down payment puts it right to work. Balance on very easy terms.



1 to 15 Battery Capacity Complete ONLY \$58.00

BATTERY CHARGING PAYS BIG PROFITS

Battery charging is the most profitable service you can add to your shop. One corner is sufficient room. Requires no watching. A Reflex charges in 24 hours without attention. No upkeep except current. Attracts customers. Big profits immediately. Small investment. Mail coupon and see how quickly and easily a Reflex Charger will increase your volume of business.

Low Operating Costs—Requires No Attention

Charges batteries in series for less than 6¢ apiece. Operates on regular light current. Literature shows sizes and diagrams for use in your shop.

Money-Back Guarantee

Guaranteed against defect for one year. No wear out to it. Cannot overcharge or discharge. Runs quiet. Built for years of service. Satisfaction guaranteed or money returned.

Mail this Coupon for Complete Details

Get detailed information today on this amazing Reflex Battery Charger specially priced to you. Quickly pays for itself. Can be put in your shop right now on our easy term plan. MAIL THIS COUPON BELOW!

REFLEX SPARK PLUG CO.

10807 Berea Road, Cleveland, Ohio

Gentlemen: Without obligation, send me complete details on the specially priced Reflex Battery Charger, explaining how I can operate a battery charging service on a big, profit paying basis.

Name.....

Address.....

SALESMEN WANTED

For new invention. Sells every business and professional man. Used by Bell Telephone Co., Armour & Co., etc. Four \$15 sales daily pay \$288 weekly. Walker made \$165 first day. Write at once.

F. E. Armstrong, Dept. PM, Mobile, Ala.

A BIG MACHINE at a LOW PRICE!

DOES 20 DISTINCT WOODWORKING OPERATIONS

TURN YOUR HOBBY INTO INCOME!

No trick at all with this amazingly low price Woodworker, which you may try, and pay for, on terms, to turn idle hours into profit. Does 20 wood-working operations. Ideal size, capacity for shop, home or the job. Economical to operate. The best buy in the market!

Just **25% OFF** BRINGS IT TO YOU **FREE TRIAL**



COMES COMPLETELY EQUIPPED!

Comes complete with 8-in. Cross Cut, 8-in. Rip Saw; 12 in. Band Saw; Jointer, Lathe, Borer, Sander, Guides, Electric Motor. Investigate it!

FREE Working Drawings of Items You Can Make **with Saw**

SEND FOR FULL DETAILS!

A. S. ALOE CO.
1831 Olive St.,
St. Louis, Mo.

Without obligation, send me details on the Woodworker, and the Free Trial and Easy Terms Plan.

NAME.....

ADDRESS.....

PAINT with ELECTRICITY

the New and EASY WAY



THE Paint-O-Mister
THE EVEN PRESSURE SPRAYING MACHINE

The latest development in an electric cup gun spraying machine —The Paint-O-Mister Made by the makers of the Atomister A larger, more powerful, more durable machine. Maintains an air pressure of 25 to 30 pounds.

Sprays paint, lacquer, varnish, disinfectants, insecticides. For use in the home, factory, garage, dairy, farm, sign shop, boat yard, greenhouse, etc

\$39.50 complete

Write for Booklet At your dealer's—or from us,

THE ATOMISTER CORPORATION
32 Hamilton St., Rahway, N. J.



DISTRIBUTING AGENTS MAKE \$100 A WEEK



Finest steel tow-cable, retails \$1.50 to \$2.00. Agents make 85¢ up. Clear \$100 next week easy.

No bunk, big value, Car owners buy at sight. Send only 65¢ for sample (complete, full length cable). Wolverine Cable Mills, Detroit, Mich.

6 Shot 22 Cal. BLANK-Automatic



A REAL HOME PROTECTOR Shoots six loud-powerful shots—like expensive automatic in appearance. Construction, finish, durability—use for fun or self defense. Frightens thieves, traps, dogs—fool your friends. Guaranteed absolutely safe. Automatically loads magazine and ejects cartridges. SEND NO MONEY—Pay postmaster \$4.85 on delivery, we pay the postage. 100 CARTRIDGES GIVEN FREE FEDERAL 561 Broadway, New York City, Dept. A-1013.

NO PERMIT or LICENSE REQUIRED



MOULDS For Making Toy Soldiers, Indians, Cowboys, Animals, etc.

With one Mould you can make many HUNDREDS OF CASTINGS, whole Armies. Outfits, including material for casting, enamel paints and everything complete, \$4.50. Easy enough for any boy to make and great fun for grown-ups. Sport for the whole family. Write for illustrations of dozens of patterns you can make.

MAKE-A-TOY COMPANY, Dept. E, 1696 Boston Road, N. Y. CITY

Choice of 1200 Newest RADIO VALUES



SEND for our 1930 catalog. Filled with amazing values in screen grid radios, push pull audio, consoles, kits, parts. All standard makes and guaranteed merchandise.

FREE

WESTERN RADIO MFG. CO.
128 W. LAKE ST. CHICAGO ILL.



This 260 Page
Wholesale Radio Catalog
A Liberal Radio-Education Within Itself!

FREE

Containing 75 radio hook-ups, 1,000 illustrations, 6,000 articles.

Build your own with Rasco parts.
Positively lowest prices in the country.

Radio Specialty Company

98E Park Place NEW YORK, N.Y.

RADIO CATALOG FREE!

WHOLESALE PRICES on standard radio equipment! Also special proposition on Lafayette Receivers. Get this latest 62 page book - a valuable radio guide - Absolutely Free! Nothing to compare with it. Confidential price list for dealers, agents and fans. All merchandise fully guaranteed. Write to-day for your free catalog. **WHOLESALE RADIO SERVICE CO.** 26 Vesey St., Dept. A-11, New York City



CHI-RAD'S NEW 1930 RADIO CATALOG SENT FREE

Now ready—Chi-Rad's latest money-saving catalog. All the latest parts, accessories, kits and sets such as:—New Super Wasp Shield-grid Short Wave Receiver, kit \$29.50 or completely constructed \$42.50; New National Shield-grid Short Wave Receiver, kit \$33.00 or completely constructed \$39.00; 3000 volt New type R3 Rectobulbs \$10.00.

Send today for your free copy
Mail to **CHICAGO RADIO APPARATUS CO.**
415 S. Dearborn St., Dept. PM, Chicago, Ill.

30 Days' Free Trial

New Models now ready for delivery direct from our factory. Astonishing low prices and terms. Do not buy until you get them.

RIDER AGENTS WANTED to ride and exhibit tires. Make big money. Many models \$21.50 up. Guaranteed \$1.50 each, wheels, lamps, horns, equipment at half usual prices. Send No Money. Write for our marvelous prices and terms on RANGER Bicycles.

Mead CYCLE CO. Dept. R109 CHICAGO



RADIO TONIC

When it comes to making sick radios well, good radios better, or an excellent radio the very best, just remember—

CLAROSTAT

The name of a line of products dedicated to better radio results. Ask your dealer or write us for data.

CLAROSTAT MFG. CO., Inc.

286 N. 6th St. Brooklyn, N. Y.

The Perfect RADIO VOLUME CONTROL

ELECTRAD Super-TONATROL



U. S. Pats.
1034103-04
& Pats.
Pend.

A volume control designed especially for use with the high voltages of modern receivers. Its principle is entirely new and superior. The resistance element is fused to the surface of an enameled metal plate, over which floats a pure silver contact with marvelously smooth action. Made in seven types for all practical uses, including control of volume from phonograph pick-up. \$2.40 to \$3.50.

When you buy a quality-built resistance or voltage control, you buy quality performance. You cannot get more service out of a resistance than there is quality built into it. The ELECTRAD policy is to make the best—and put the price on afterwards. Yet mass production of a full line of resistances for every radio and power-supply need, including Television, enables ELECTRAD to sell the BEST at popular prices.



ADJUSTABLE
SLIDING
CLIP

TRUVOLT All-Wire RESISTANCES

U.S. Pat.
1676869
& Pats.
Pend.

Heavier-than-usual Nichrome resistance wire. Air-cooled—perfectly insulated—accurate values—long life. Exclusive sliding clip for quick adjustments.

Best for Your
Eliminator

ELECTRAD, INC., Dept. PM10, 175 Varick St., New York, N. Y.
Please send TRUVOLT data.
Name
Address

ELECTRAD INC.



FREE RADIO CATALOG

The New SCREEN GRID models

Write for latest catalog just off the press — 148-page book offering hundreds of radio bargains — New Humless Screen

Grid, A. C., all-electric and battery operated sets—beautiful consoles, accessories, parts and kits —all at wholesale prices. **\$15⁹⁵** Complete sets as low as

Chicago Salvage Stock Store
509 So. State St., Dept. 110, Chicago



PANTS MATCHED!

Why Throw Away That Coat and Vest? Save \$25 or more! Let us match your coat and vest with new trousers and save the price of a new suit. Each pair tailored to your measure. (Average price \$8.50). Over 100,000 patterns. Mail sample of suit, or your vest which will be returned together with

FREE Sample for your approval.
MATCH PANTS CO., Dept. 81, CHICAGO
20 W. Jackson Blvd.

Sell Nothing

EARN \$170^a week!

Sounds amazing! Wait! It IS amazing, this new sales plan this old reliable company now offers you. Man, think! When you can walk into thousands of places, leave something absolutely without collecting one cent, place it on the Merchant's counter to be paid for after it's sold—unsaleable merchandise returnable—YOU'RE NOT SELLING! You carry no sample case. You don't invest one penny. You're earning anywhere from \$60 to \$170 every week.

K. & S. Salesboard Assortments Wonderful Sideline

K. & S. Salesboard Assortments actually pay merchants 40 per cent profit. Your commission 15 per cent and full commission on every repeat order! If you can't interest 99 out of 100 with this amazing liberal plan you're in the wrong business. Your prospect invests nothing—we even pay shipping charges. Any wonder K. & S. men laugh at \$6,000 and \$7,000 selling jobs? If you are not earning at least \$8,000, grab this! There isn't a man on earth who can't make amazing big money! Don't wait!

K. & S. SALES COMPANY
4335 Ravenswood Ave. CHICAGO

It's a BULOVA—sent with a Mesh Band! For \$1⁰⁰ TAKE 12 MONTHS TO PAY

Send \$1.00 with order and tell us a little about yourself: (A) How long at present address, (B) Age, (C) Married or Single, (D) Name of Employer, (E) Position, (F) How long employed. All information held strictly confidential. We make no direct inquiries of anyone—not even from your employer.

10 Days Free Trial—Satisfaction Guaranteed
This genuine Bulova watch comes to you postage paid—no C.O.D. to pay on arrival. You take no risk—satisfaction guaranteed or money back.

Estab. 1895



\$29⁷⁵

DG5-
15 jewel BULOVA gent's wrist watch. White Gold filled case; "dust-tite" protector; radium dial and hands; latest woven mesh wristband. Guaranteed. \$1 now \$2.39 a mo. *Nationally advertised cash price, no extra charge for credit.*



Catalog FREE New catalog of genuine diamonds, standard nationally advertised watches, fine to Adults jewelry. Write for it now.

ROYAL DIAMOND & WATCH CO.

ADDRESS DEPT. 11 X 170 BROADWAY, N.Y.



\$10⁰⁰ DOWN

Lathes \$6.00 to \$75.00. Largest line of small lathes in America. Send six cents for 32 page catalog of lathes, drill presses, bench saws, jig saws, band saws, etc.

Brings this Lathe to You

SYFHER MANUFACTURING COMPANY
Toledo, Ohio
Dept. D10

3 SHIRTS \$4⁹⁵ GENUINE BROADCLOTH

\$1.50 profit to salesman paid in advance. Monogram initial free. Hundreds of similar values in our big line of shirts, underwear, hosiery, neckwear. \$20 a day easy. All or part time. **Big outfit free.** Write at once. Chicago Shirt Corp., 227 W. Van Buren St., Dept. 21, Chicago.

\$125.00 Four Hours

That's what F. C. Benjamin made selling world's finest driving light for autos. 67,000 beam candle-power—NO GLARE. Low price, big profit. Just awarded Grand Prize, two gold medals, Paris exposition. We want you to sell this light. Write for amazing proposition TO-DAY.
AERIAL ELECTRIC COMPANY 342 W. Ohio Street CHICAGO, ILL.

I Want a Man!

A real live he-man, full of the Dynamite of Determination—to make real money and lots of it—right in his home town—among neighbors, friends, strangers! Sound, substantial business—large profits—from \$25 to \$250 for him on each sale—every home needs it—no dinkey specialty line, but a cashab'e man's-sized proposition that will **LAST!** We back you up!

Just address Opportunity Division
PYRAMID METALS CO.,
2014 Wabansia Ave. Chicago

Big Pay for Your Spare Time!

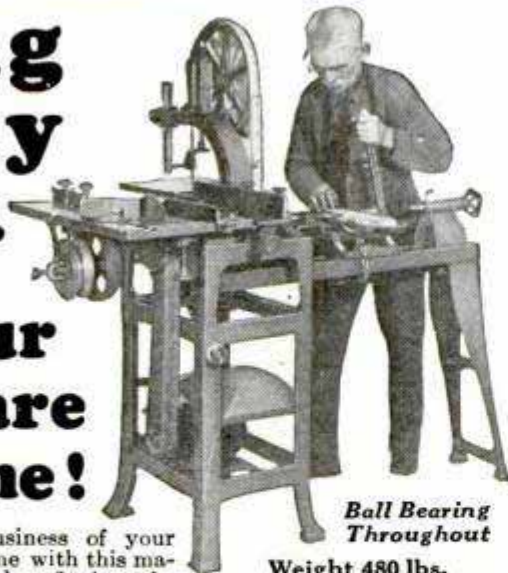

Ball Bearing Throughout

Weight 480 lbs.

\$35

Build a business of your own at home with this machine. Good profits in making screens, storm-sash, garden furniture, toys, novelties, etc. Saws 3 1/4" thick. Lathe swings 10". Rugged iron frame; no warping, twisting or vibration.

THE ELECTRIC CARPENTER deposit brings it to you for **Free Trial.** **6 Months to Pay!**

Does 35 Woodworking Operations. Runs from any light socket.

7 MACHINES IN ONE 8" Circular Saw, 14" Band Saw, 36" Lathe with 10" Swing, 4" Jointer, Reversible Shaper, 1/2" Hollow Chisel Mortiser, Sander.

Write Today for New Illustrated Folder

THE WOODWORKING MACHINERY CO., INC.
Eleventh and Vine Sts., Philadelphia, Pa.

Let us recommend the best books to study on any subject. Popular Mechanics Press, Chicago, Illinois

Play Tunes The Very First Day!



Be the Life of the Party

with this remarkable new Instrument—the OCTOPHONE. Many play tunes in few minutes! No knowledge of music required. No long, tiresome practice. No expensive lessons. Play tunes right from the start—and learn music automatically as you play.

8 INSTRUMENTS IN ONE!

"Octophone" is complete orchestra in one instrument—Ukulele, Tenor Banjo, Mandolin, Tenor Guitar, Mandola, Tiple, Taro-Patch, and Mando-Cello. Produces rich harmony, syncopated jazz. Astonish your friends. Loads of fun. Money-making chances in orchestras, radio and stage.

7-DAY TRIAL

In your own home. No risk. No obligation. Over 50,000 have learned to play this amazingly easy way. Easy Payments. Write today.



FREE!

Write for FREE particulars about Octophone and full details of 7-Day Trial Offer and Easy Payment Plan.

FERRY & CO. 1750 N. Damen, Dept. 178, Chicago, U. S. A.



Here's an Amazing New Business THAT PAYS UP TO \$1,000 A MONTH

MEN, here is a real, red hot money-making opportunity! It's a chance to jump into business for yourself and make more money every week than the average man makes in a month.

Surprising as it may sound, we actually put you in a business, with the first day's profits often running from \$18 to \$55. \$350 to \$600 the first month is not unusual for ambitious men.

Cut in on the Big Money

All you need is the ambition to make real money. We supply you with complete equipment to make and sell that famous new food specialty—Brown Bobby—a greaseless doughnut baked by electricity!

It's a crispy, flaky, delicious new kind of doughnut cooked without one drop of oil or grease. Easily digested by everyone. More appetizing than old-style doughnuts ever were. Costs less to make. Sells four times as fast. No baker's skill required. Just add water to our prepared "Mix."

You can open a shop; rent cheap floor space in a grocery, delicatessen, lunch-counter, drug store, etc. Or start at home—and make up to \$250 your very first week.



"I made \$3,000 in 3 months from my greaseless doughnut business!" — T. Chas. Minch, Fla.

Start at Once ANYWHERE!

Men and women everywhere are starting in this business daily! YOU cannot afford to delay! Details will gladly be sent without obligations of any sort. Such an amazing money maker may never come your way again. So fill in and send the coupon at once! TODAY—

MAIL COUPON NOW!

Food Display Machine Corp.,
Dept. 3-P, 500-510 N. Dearborn St., Chicago, Ill.

Gentlemen: Please send me the plan by which I can cash in on Brown Bobby, the Greaseless doughnut. It is understood that this obligates me in no way whatever.

Name.....

Address.....

City..... State.....

Play Your Way to BIGGER PAY!



and Popularity with a **Buescher**

The Saxophone has brought big money to many stars. As Orchestra features — as Orchestra leaders — as stage soloists—as recording artists and in other ways—hundreds of musicians have played their way to big pay and stardom on the



True Tone Saxophones

Only a Buescher Gives You All These:

Patented Snap-on Pads—greatest improvement for beauty of tone; easy to replace—no more cementing.

Patented Automatic Octave Key—always positive.

Hands never moved from one playing position.

6 Days' Trial in Your Home

on any Buescher Saxophone, Cornet, Trumpet, Trombone or other instrument. Try the fingering arrangement—play it; hear its true, rich, clear tones, without obligation to buy.

Easy to Play—Easy to Pay

Besides being easy to play we make it easy to pay. A small down payment and a little each month. Write today for full information on our liberal offer. Give name of instrument in which you are interested.

Buescher Band Instrument Co.
2888 Buescher Block Elkhart, Indiana

Buescher Band Instrument Co., (518)
2888 Buescher Block, Elkhart, Ind.

Gentlemen: Without obligating me in any way please send me your free literature.
I am interested in the following instrument.....

Name.....

Street Address.....

City..... State.....

factory prices!

on Nationally Popular 21-JEWEL—Thin Model

STUDEBAKER

The Insured Watch

The only high-grade watch sold direct from factory!

Imagine being able to purchase these magnificent thin model watches at lowest factory prices on easy payments out of your income, or for cash! Let us send you one of these marvelous watches—you are under no obligation to keep it. You'll agree it is the world's greatest watch value. Write for free 6-color book and learn the true facts!



FREE 6-Color Book

If you write at once we will send beautiful style book, showing lowest factory prices on these lifetime insured watches. Thousands save money this way. Write today!

WRITE!

Luxurious strap and bracelet watches at remarkably low prices! Write for free style book TODAY!

STUDEBAKER WATCH COMPANY
Directed by the Studebaker Family—known for Three-quarters of a century of fair dealing
Dept. NU103 South Bend, Indiana
Canadian Address: Windsor, Ont.



A WONDERFUL BUY—A \$25 VALUE for \$12.50 delivered. Money back guarantee. Violin genuine Ebony trimmed, fine bow, full lined case and Violin Method for self instruction. Stock limited, so send order now. H. ELLERSIECK, 633 Loew's State Bldg., 707 So. Broadway, Los Angeles, Calif.

DENINGER WILL TRUST YOU

SEND 50c INSTAMPS FOR CATALOGUES
BIG MONEY SAVING FOR YOU

Used and rebuilt motorcycles \$25 to \$100, used bicycles \$9.50, tandems \$20. All machines fully guaranteed. New bicycles and motorcycles at factory prices, save dealers' profits. Motorcycle and automobile tires \$3. Complete tire frames, engines, accessories.

DENINGER PRICE CUTTER, ROCHESTER, N. Y.

PAY AS YOU RIDE

8" COMBINATION SAW OUTFIT \$35 F.O.B. Phila.

ABSOLUTELY the best Saw Outfit Buy on the market. We invite you to make thorough comparisons before you place your order, particularly check on these specifications:

Our outfit includes 1/2rd H.P. Double Extension Shaft Motor; table tilts to 45 degree angle, and may be raised or lowered to cut any depth from 0" to 2 3/4". We also include necessary attachments to Rip, Crosscut, Bevel, Grind, Mitre, Groove, Sand, Mortise, Tenon and Polish.

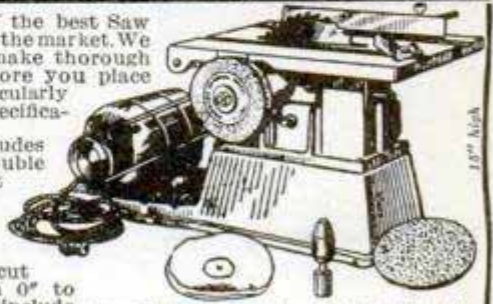

Everything is complete, ready to plug in any light socket. Note base which holds Saw and Motor. It is Portable. Same specifications, but with Ball Bearings, and 12" by 18" table top—\$45.00. Catalog Free in which this Saw Outfit is more clearly pictured. It also contains Bench Lathes, 12" Band Saw, Complete Work Shop and Hardware Specialties.

WILBAR CO., INC., 2020 E. Arizona St., PHILA., PA.

At last! A NEW AND HANDY WAY TO PAINT A Spray Painting Outfit At a Price Everyone Can Afford

This amazing new AIR-O PAINT SPRAYING OUTFIT NOW BRINGS AIR BRUSH PAINTING WITHIN THE REACH OF ALL. It's truly a revelation in modern painting. Makes work into play. Notwithstanding its low price, it is reliable, practical; a real spraying machine, not a toy.

IT WORKS FROM AUTOMOTIVE POWER

Most astounding of all, the AIR-O Spray machine operates on an entirely new principle for its power. No cumbersome electric motor or complicated machinery to get out of order or to lug around. Nearly everyone has automotive power available—an auto, a truck or tractor. Just remove one Spark Plug and screw in its place the AIR-O Compressor Unit.

Fill the jar with paint, lacquer or whatever material is to be sprayed and you're "all set" for that "brightening up" job, making the old like new and putting a finish on your automobile, woodwork, furniture, garage, spraying your automobile springs with oil (it penetrates), spray disinfectants or insecticides. With the tire inflating attachment you can pump up your tires and with the fan type spray nozzle you can tackle a big building.

HANDY—PORTABLE—FOOL PROOF

The AIR-O Spray outfit weighs only six lbs., complete with 18 ft. of hose. It is fool proof and so simply constructed that even an inexperienced person can do as fine work as an expert. The connections are standard and permit attaching your own garden hose, any length, for distant work. The specially constructed Compressor valve does not permit gas or oil to enter into the air line. This outfit will do the work of many high priced sprayers. Its performance will surprise you; it has no equal at several times the price.

SEND FOR YOUR AIR-O SPRAY TODAY!

You owe it to yourself to own one of these marvelous spraying machines, to enjoy doing the task that you're now putting off or paying others to do for you.

Remember the price is only \$11.50 and you are positively taking no chance as we guarantee absolute satisfaction or **Money Refunded**. Just fill in the coupon and mail at once.

The AIR-O SPRAY EQUIPMENT CO.
60 S. SAN PEDRO ST. SAN JOSE, CALIF.

SPRAY PAINTING OUTFIT COMPLETE \$11.50



The AIR-O SPRAY

Read This from a Paint Man Who Knows

"Your spraying outfit was quite a revelation to me. Surely no outfit, regardless of its highest cost, could perform its work more satisfactorily than the Air-O Spray did."

W. D. Legg, Mgr., The Adams Paint Co., Cleveland, O.



Air-O Spray Equipment Co.
Dept. D, 60 So. San Pedro St., San Jose, Cal.

Please send me an AIR-O Spray outfit at once, you to guarantee delivery.

I enclose one dollar and will pay the postman \$10.50 plus P. P. charges.

I enclose \$11.50 as full payment. I understand that if cash in full is included you will send shipment fully postpaid. (For fan type attachment add \$2.00. For tire inflating attachment add 75 cents.)

Please send me descriptive literature.

Name.....
Address.....
City..... State.....

(Check in Square Desired)

Build a Ship Model at Home

For Pastime and Pleasure



It is a wonderful fascination and a beautiful decoration for your mantel, radio cabinet or it may be used in any part of the home.

- Santa Maria—Size—25' high, 10' wide, 27' long.....\$4.98
- La Pinta—Size—26' high, 11' wide, 27' long.....\$4.98
- Mayflower—Size—26' high, 10' wide, 30' long.....\$4.98
- Constitution—Size—25' high, 8' wide, 29' long.....\$6.98
- Flying Cloud—Size—27' high, 9' wide, 36' long.....\$6.98

These prices are f.o.b. Philadelphia, plus a few cents postage. These models are sold in knock-down form. All parts are cut to fit and ready to assemble. They will be sent anywhere in United States C.O.D.

Money order or check must accompany all foreign orders.

Write for free illustrated catalog

MINIATURE SHIP MODELS, Inc.

3216 BARING STREET PHILADELPHIA, PA.

BARGAIN! ONLY 39¢ GUARANTEED RADIO TUBES



Get guaranteed 201A type Barawik tubes for only 39¢ each. Send check or money order. These and thousands of other bargains are shown in Barawik's Big Radio Guide. Newest radio sets, speakers, parts, short wave and television supplies, etc.—all at lowest prices. Send for free copy today—NOW!

BARAWIK CO., 109-A Canal Sta., Chicago, U. S. A.
Mail This Coupon Now for Free Radio Guide

Name.....
Address.....

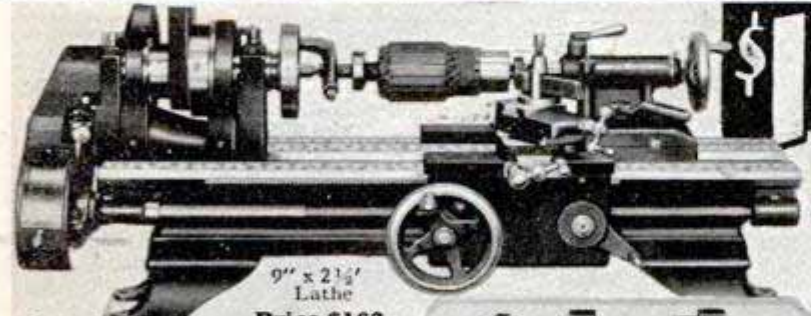

9" x 2 1/2' Lathe Price \$163

\$4 A MONTH for 9" x 2 1/2" LATHE

Use this famous New Model South Bend Jr. Lathe while you pay. It's a Back Geared, Screw Cutting Precision Tool. Same high quality throughout as our 45,000 other Lathes used by Studebaker, General Motors, Ford, General Electric, Radio Corporation, Westinghouse, and others in the United States and 78 Foreign Countries. Lathe comes complete with Countershaft and Equipment. Weight, 350 lbs. Easy payments of only \$11.41 a month for 12 months.

WRITE FOR FREE CATALOG No. 23-P

Illustrates and describes all sizes of the South Bend Jr. Lathe. Shows Bench and Floor types, with Countershaft and Motor Drive. Also easy payment terms on each size. If interested in a larger lathe, ask for Catalog No. 90.

SOUTH BEND LATHE WORKS
613 E. MADISON ST., SOUTH BEND, IND., U.S.A.

- Work this Lathe Will Do**
- Machine armatures — Make bushings
 - Reface valves — Machine pistons
 - Undercut Mica — Cut threads
 - Bore, file, drill, turn, face, grind, polish and hundreds of other jobs.

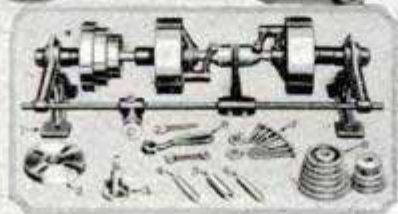



The Real Sport of Out-board Motor Boating Is to Build Your Own Boat **\$98⁰⁰** F. O. B. Factory

The famous Bossert Pirate Kid may be bought unassembled and built by any amateur—any boy with only ordinary knowledge of every-day tools can build one.

This is the boat that is breaking all records with B, C, and D motors.

World's Champions such as Malcolm Pope, Jack Kerr and many others are now driving Bossert Pirate Kids in all their stunts and races. They know good boats when they see them.

Walter Peterssen built his own boat and has won many 1 1/2 g races as well as broken records in time trials in the boat he built himself.

Ask Pop to let you build your own—a lot of fun and you surely will like it much better than if you bought your boat all completed.

Many boys have already built their own Bossert Pirate Kid—A wonderful model.

The price is \$98.00 F.O.B. factory and the freight will average less than \$5.00 most any place in the U. S. Send in your order now.

You can also earn one of these boats for nothing for after you purchase your boat you are listed with us as an agent and then from every order you get for us you receive a bonus of 10% so you see if you are able to induce only 10 other boys to join you you get your own boat free.

Write now for order blank and further particulars.

LOUIS BOSSERT & SONS, INC.

1301 Grand Street

BROOKLYN, N. Y.

"Jewel" Electric Fountain

A delightful home beautifier. Motor and pump built inside of fountain make water connection unnecessary. Connect to any light socket. Humidifies and cools atmosphere. New lily pond fountain changes color by spectroscopic beams. Patented prismatic geyser searchlight fountain is a marvel. World's largest electric fountain makers. Make your own fountain from our standard fountain parts. Send for our large free catalog.



"Jewel" Oil Burner Sells fast everywhere. For 7-room home, complete with 250-gal. tank, only \$150. Blue print and instructions. Any practical man can install. 4000 in use in Cook County, Ill. Send for FREE catalog of original "JEWEL" Electric Specialties for the Home. Install a burner in your own home as a sample. Reliable agents and dealers wanted.



JEWEL ELECTRIC & MFG. CO.

Dept. 547

4505 Ravenswood Ave.

Chicago, Ill.

Electric Radio \$24⁰⁰
6 TUBE - A.C.

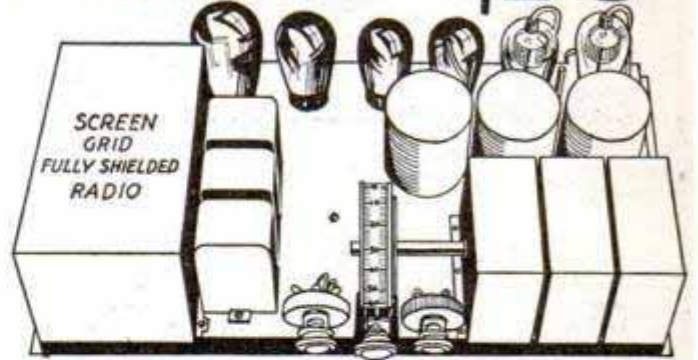

At last, a long distance electric radio at a price all can pay. Just plug in your electric light socket. Every owner of a battery operated radio will want one.

AGENTS WANTED Keep your present job but add \$50 a week to your income. A demonstration means a quick sale—big profit. Sell in spare time—evenings. You'll equal the results of highest priced radio and yet sell for far less. Exclusive rights to good men.

Write for FREE illustrated literature today—don't delay, better still, telegraph.

ELGIN RADIO CO., 4947 North Crawford Ave., Chicago, Ill.

GET INTO BIG PROFIT WORK



Garages, filling stations, auto mechanics can easily get into profitable arc welding business with equipment that's sure to earn tremendous profits—with lower current costs. HB Constant Arc Welder starts you on the road to success with practically no experience on your part.

COSTS ONLY \$30 MONTHLY

Liberal trial on money back guarantee to prove its worth. Write today to **HOBART BROTHERS, Box M 1093, TROY, OHIO**



SPEED LATHE \$10.50

complete as shown. 7 in. swing, 24 in. metal bed, 3 speed cone pulley. Longer bed, \$1.00 per additional foot.

GOODWIN MFG. CO.

435 Keota St. Ottumwa, Iowa

The man who studies gets ahead. Popular Mechanics Press will advise you what books to read to advance in your trade. 200 East Ontario Street, Chicago, Illinois.



Attractive New Binders

For Popular Mechanics Magazine

Your choice of colors; blue, green, brown, red or black in these beautiful and durable art binders. Ideal for the home or for libraries, schools, reading rooms, etc. **Price \$1.25 each, postpaid.** Your name in gold on front cover for **25 cents extra.** Address **POPULAR MECHANICS COMPANY 200 E. Ontario Street, CHICAGO, ILL.**



Agents Cleaning Up... just showing KITCHENWARE in Brilliant COLOR!

\$30,000 Coffee Pot Just One Item of Wonderful New Line of Modern Kitchenware bringing profits of \$10, \$20, and even \$50 a day!

Quick! Rush name for details of century's most amazing opportunity for agents. Every woman wants popular new Kitchenware in Color. Show samples—write orders! First time offered direct. No competition. No experience needed. Spare time workers accepted. Write for Big Selling Outfit—FREE!

Latest Craze Pays Big Money

Kitchenware in color is the latest fad, the best of them all. Imagine showing housewives pots, pans, kettles, mixing bowls, and many other kitchen necessities in sparkling Woodland Green, Romance Blue, Modern White, Sunbright Orange, American Red. So low priced, every woman can buy! Over 20 items. Big profit for you in advance on every order.

BIG SELLING OUTFIT FREE—No charge—No deposit

Get big FREE selling outfit in original colors. See for yourself why 4 out of 5 order. Rush coupon for Free Outfit, agents' prices, new home selling plan. Fortunes waiting for those who act quick.

Modern Kitchenware, Dept. 6-P, 176 W. Adams, Chicago



Your BRAINS and this machine can make anything

Why waste your time and money on toy machines when you can get this real rig at such a low price?

RIPS...MITERS...
CROSS-CUTS...
BEVELS...DADOES...
PLOUGHS...
GROOVES...
RABBETS...
SANDS...
BORES...
GRINDS...
POLISHES...ETC.

The SAFETY-SAW MODEL N

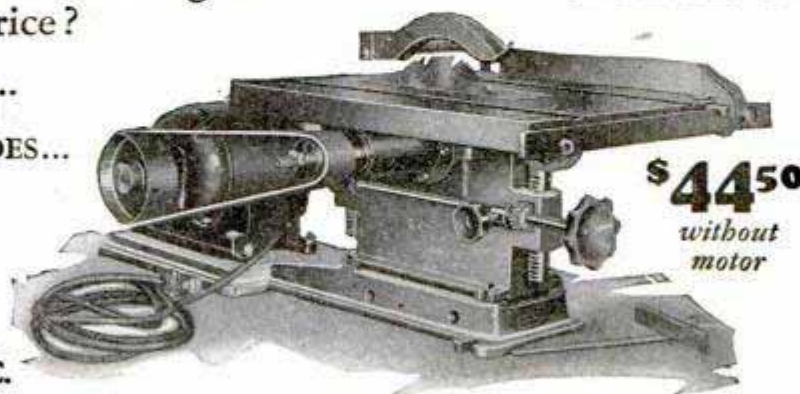

\$44.50
without
motor

Easy to operate
Easy to own
BALL BEARING
Table Top 18" x 14"
Raises and lowers
on a level.
Saw Arbor 3/4" Dia.
Cuts 2 1/2" Thick
Rips 12" Wide
Cross-cuts any width
Bevel Rips to 45°

Send Coupon
Now for Details,
Illustrations and
EASY TERMS

TRY THIS Safety-Saw AT OUR EXPENSE

Put this machine on your work bench . . . give it a thorough test . . . compare it with others . . . and then if you're not more than satisfied with it in every way . . . send it back and we'll return every cent of your down payment and pay the transportation charges both ways. You can't lose a nickel, but you can gain a lot. Don't buy any machine until you've read our FREE descriptive folder . . . It shows Bench Saws . . . Band Saws . . . Lathes . . . Jointers . . . and all equipment.

SAFE TOOL MFG. CO. • BRIDGEPORT, PA.

SAFE TOOL MFG. CO., Bridgeport, Pa.

Please send me full information about your woodworking machines.

Name.....

Address.....

Auto Seat Covers \$2.95
Special Price Offer

AGENTS Make \$20 a Day

Write orders fast for this excellent Quality line Auto Seat Covers. Amazing values—quick sales. Cash daily. We deliver. Write for handsome Free Leatherette Sample Outfit. **Quality Sales, 515 S. Dearborn St., Dept. 1016, Chicago**

WRITE NOW!

A red handle with a gold stripe marks the most popular blow-torches in the world. They are Clayton & Lambert blow-torches.

**CLAYTON & LAMBERT MFG. CO.,
DETROIT, MICH.**

BLUEPRINT READING For the Building Trades

Every man who is ambitious to learn the last detail of blueprint reading will want this new book which is thorough, complete and up-to-the-minute. Written in a clear, non-technical manner. An ideal working tool for apprentices, teachers, students, carpenters, bricklayers, etc.

Over 100 pages—50 plans and illustrations.

Cloth—Price \$1.25 postpaid

**Popular Mechanics Press
Room P 8
200 E. Ontario St. Chicago**



Special Sale of ALADDIN HOUSES at Astonishing Low Prices

Never before have you had the opportunity to secure such savings! A complete, high quality Aladdin "Economy-Construction" House at actual mill cost price is Aladdin's offer to you for a limited time only!



Cozy 5 Room Aladdin "Economy-Construction" House **\$410**

PAY CASH

Save 20% to 40% CASH saves you the heavy financing charge. Aladdin's famous Read-Cut System saves labor costs,



Beautiful 6 Room Aladdin "Economy-Construction" House **\$448**

lumber waste, and middlemen's profits. Aladdin "Economy Construction" Houses are backed by a money-back guarantee. All lumber cut to fit at mill, on mass production machines.

FREIGHT PAID Your Aladdin House comes to you complete in one car, freight paid to your R. R. station. All plans for quick, easy erection. Choice of many designs and floor plans.

WRITE FOR FREE CATALOG

Send quick to nearest mill for Special Sale Catalog No. 961 before sale prices are withdrawn. Write TODAY.

THE ALADDIN COMPANY

Bay City, Mich. Wilmington, N. C. Portland, Ore.

7 Shaves for a Postage Stamp

That is all it costs you to try this unique new shaving method — we stake everything on this free trial

GENTLEMEN:

The postman is our best salesman. For he brings the test that wins men to our new product. The product actually sells itself daily in the greatest laboratory of the world—America's bathroom.

Each morning hundreds of new users try Palmolive Shaving Cream at our expense. And 86% of them, we find, discard their former methods for it. Thus, our problem is to get men to take our test. To sign and mail the coupon.

If we can win so many millions in so short a time, surely you want to try this remarkable cream yourself. We do not want to sell you sight unseen. First let us prove our case—then you will want to buy.

Mail coupon—learn its 5 points

You risk nothing. We undertake, in 7 shaves, to win you. It's an open-and-shut proposition, and you are the judge. So won't you mail the coupon?

PALMOLIVE RADIO HOUR—Broadcast every Wednesday night—8:30 to 9:30 p. m., E.T.; 7:30 to 8:30 p. m., C.T.; 6:30 to 7:30 p. m., mountain time; 5:30 to 6:30 p. m., Pacific time—over station WEAJ and 39 stations associated with The National Broadcasting Company.

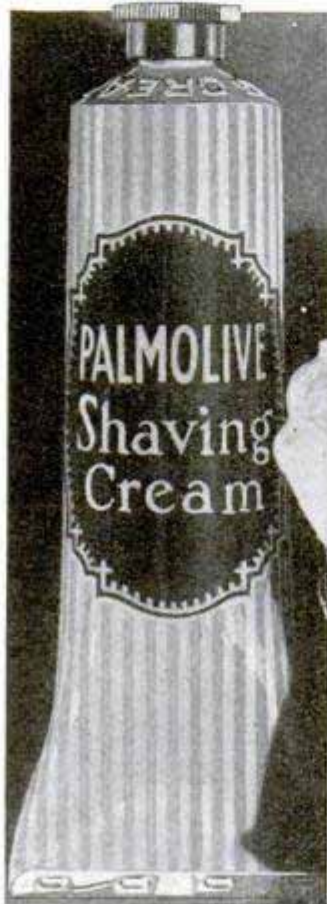

Popular Mechanics Handbooks

If you would thumb through these books, you would want them all. They are literally jammed with practical ideas. Each one is written so clearly that a boy can understand the directions. Each contains the experiences of practical men and women. Most articles are illustrated with photographs or drawings. The practical nature of the subjects has made a wide sale for them. Here are the titles of those now available:

Popular Mechanics Lathe Handbook No. 1	Any 2 for \$1	Popular Mechanics Boat Book
Home Mechanics Handbook No. 1		Automobile Owner's Handbook
Handbook for Women		Auto Tourist's Handbook
Popular Mechanics Shop Notes for 1929		Auto Repairman's Handbook No. 1
		Drilling and Thread Cutting

Order Several at One Time

So low is the price that it is certainly wise to order as many of these at one time as you can use. You may have any two for \$1. These books make good presents. They are splendid for boys taking manual training courses.

POPULAR MECHANICS PRESS

Popular Mechanics Bldg., Room 710, Chicago, Ill.

BUILT-IN FURNITURE

Adds Beauty and Convenience to Your Home



With the plans and directions given in this new book by Edwin M. Love any handy man will be able to build the various pieces of popular space-saving furniture.

These useful and ornamental cabinets are easily added to an old house and many are designed to be built into odd nooks and recesses.

The construction is very simple as the walls offer support and no structural alteration of either floors or walls is necessary.

Stock sizes of material are specified in each instance. The home owner will be able to alter designs if necessary to suit available space.

That practically every adaptation of built-in furniture is covered by this book is shown by the following list of contents.

General Details of Construction—Portable Buffet—Recess Buffet—Corner China Closets—Clothes Closet Linen Cabinet—Furnishing a Clothes Closet—Bathroom Cabinet—Linen Closet—Mantel Shelves—Bookcases—Writing Desk—Seats—Indirect Lighting Fixtures—Sewing Cabinet—Corner Kitchen Cupboards—Breakfast Nook—Bathtubs—Laundry Porch Furnishings—Dining Table—Dressing Table—Radio Set—Phonograph—Safe—Shaving Cabinet—Cupboard and Drainboard Cabinet—Clothes Chute—Wood Box—Work Bench and Tool Cabinet—Mortise and Tenon and Dado Joints—Wood Dowels—Bending Small Moldings—Driving Nails and Screws—Care of Tools.

198 pages. Size 7x10 In. Fully illustrated. Price \$2.50 postpaid.

Popular Mechanics Press

Room P-102

200 E. Ontario St.

Chicago, Ill.

7 SHAVES FREE

and a can of Palmolive After Shaving Talc

Simply insert your name and address and mail to PALMOLIVE, Dept. B-3044, P. O. Box 375, Grand Central Post Office, New York City

.....

Please print your name and address

4723



The Face

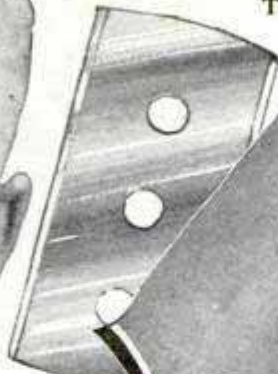

The Blade

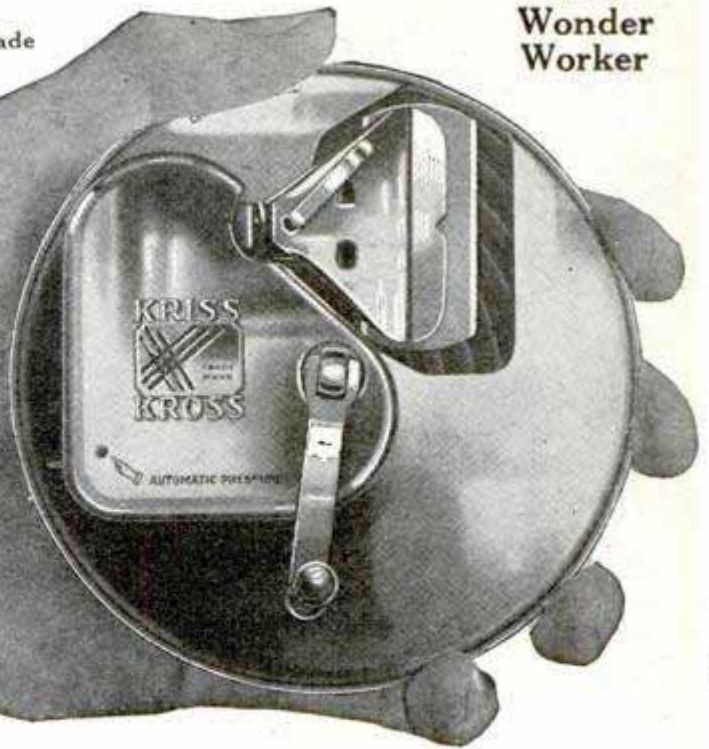

The Wonder Worker

365 Shaves With the Same Blade! —and Still Going Strong

THINK of it! 365 keen, cool shaves a year—and not one penny for blades during the whole time! That's what an amazing new shaving invention did for J. W. Starksbury of Oklahoma! And W. D. Carroll of Pennsylvania got *two* solid years of slick shaves out of an old blade that was just about worn out to begin with! No wonder experts everywhere are simply astonished!

KRISS-KROSS—the remarkable invention that makes such long-distance shave records possible—deserves to be called much more than a stropper. Rather it is a *super-stropper* or blade *rejuvenator*. Almost literally, it makes a new blade out of an old one every day—makes hundreds of keen, quick shaves blossom where only one grew before. Until you've seen KRISS-KROSS and tested its uncanny ingenuity, you'll never know how really sensational it is!

MAGIC DIAGONAL STROKE

KRISS-KROSS employs the diagonal stroke, same as a barber uses. Never before has anyone captured the secret of reproducing this stroke automatically. Eight "lucky leather grooves" do the trick in 11 seconds with a precision it takes a master barber years to attain.

But that's not all. KRISS-KROSS embodies still another feature that has hitherto baffled mechanical reproduction. It stropps from *heavy* to *light*. It's absolutely uncanny the way the strokes grow lighter and lighter until an adjustable, automatic jig flies up and notifies you that your blade is ready—*ready with the keenest cutting edge that steel can take!*

NEW-TYPE RAZOR BLADE FREE!

To introduce KRISS-KROSS stropper, we are including this month free samples of a revolution in razor blade construction. Made to fit your present razor. Guaranteed to last longer and

Rhodes **KRISS KROSS**

KRISS-KROSS CORP.

Dept. P-3714, 1418 Pendleton Ave., St. Louis, Mo.

shave better than any other. Expect a new shaving sensation—KRISS-KROSS blades are made of a unique steel, made a new and better way.

GET FREE OFFER!

Send for full information on these surprising new inventions today. KRISS-KROSS products are never sold in stores. You deal direct with me or my authorized representative. Write for illustrated description and full details of free razor blade offer. It's even more remarkable than I can tell you in this short space. Clip the coupon now. Mail it today.

MAKES \$66 IN ONE DAY

Make big money with KRISS-KROSS. Giving away FREE razor blade boosts your profits amazingly. H. King made \$66 in one day. N. C. Paige made \$104 in 3 days. Others average \$350 and up to \$750 a month! SPARE-TIME workers, OFFICE and FACTORY men make \$6-\$12 extra a day showing KRISS-KROSS to friends and fellow employees. Get details at once. Check bottom of coupon and mail it tonight!

KRISS-KROSS CORPORATION,
Dept. P-3714, 1418 Pendleton Ave., St. Louis, Mo.

Send me details of KRISS-KROSS Stropper. Also send free sample of your new type razor blade for Razor. (Fill in your make of razor.)

Name

Address

City State

() Check here for agents' money-making plan, full time or spare hours.

Signals Auto Driver When Tire Needs Air



SAVES TIRES & TUBES
Prevents Accidents

SALESMEN and DISTRIBUTORS

can make \$350 to \$1000 per month. Write for FREE SAMPLE and Big Money Making Offer.

Name

Address

Size of Tire

Simpson Manufacturing Co.

Dept. D. 307 West Douglas, Wichita, Kan.



RAISE CHINCHILLA

AND NEW ZEALAND WHITE
FUR RABBITS **Make Big Money**

We Supply Stock and pay you following prices for all you raise: Chinchillas average \$3 each—New Zealand Whites \$2 each. 32-page illustrated book, catalog and contract, also copy of *Fur Farming* magazine, tells how to raise rabbits for big profits, all for 10c. Address **OUTDOOR ENTERPRISE CO., Box 1021 Holmes Park, Missouri**

WAISTLINE Too Big?

A new belt called Director gets at the cause of excess fat and quickly corrects the condition. With every movement of the body, during every working hour, Director acts as a massage on the abdomen and actually dissolves excess fat away. F. P. Cowan of Pinehurst, N. C., says, "Director is the finest thing I ever wore. I want another, but not so large, as I am 5 inches smaller around the waist now." Doctors endorse Director as the natural way to accomplish a permanent reduction.

SENT ON TRIAL

Let us prove our claims. We'll send a Director to you for free trial. If you don't get results you owe us nothing. You don't risk a penny. Write now for free trial offer, doctors' endorsements and letters from users. No obligation. Mail coupon.



Langon & Warner, Dept. B-44, 332 S. La Salle St., Chicago, Ill.

Langon & Warner, Dept. B-44, 332 S. LaSalle, Chicago.

Tell me how I can reduce my waistline 4 to 6 inches with Director Belt. Send details of your trial offer. This places me under no obligation.

Name

Address

RADIO FREE CATALOG

NEW SCREEN GRID SETS Wholesale Prices

Everything in radio at wholesale prices—New, Screen Grid, A. C. Humless All-Electric Sets—Standard A. C. Sets—battery operated sets—

Priced as Low as **\$15.95**

Also an attractive array of beautiful consoles—accessories, parts, kits.

Most complete catalog in radio—196 pages of unusual price values. Write for it today!

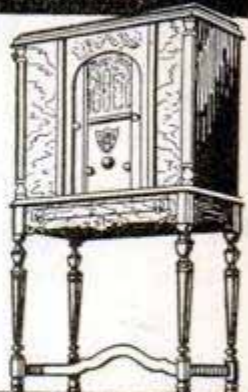

ALLIED RADIO CORPORATION

711 W. LAKE ST. DEPT. 66 CHICAGO

HB PAINT SPRAY

"DOES THE WORK OF FIVE MEN"



EASY TERMS
30 DAYS TRIAL
QUICKLY PAYS FOR ITSELF

QUICK, EASY PROFITS!

Practically no investment. Small space required. Steady demand and BIG PROFITS refinishing autos, furniture—painting houses and barns with HB quick spray method. One man does the work of five with brush.

Pays for itself on easy monthly payments. 30 DAYS TRIAL. Write today for details.

HOBART BROS. CO.
Box M-1091, Troy, Ohio



THREAD CUTTING LATHE

A REAL Lathe. 9" swing; 30" between centers. Speedy and accurate. Special attachments and tools available. Write today for Circular and

12" Band Saw Powerful, practical. Not a toy. Prices on these and other machines.

Has tilting table. Price **\$30**. Bronze bearings. **only \$30**.
Rossbacher Machine Co., 1516 Farwood Ave. TOLEDO, OHIO

Boils 50 Gallons In Less Than Hour

No Other Compares With This

Improved Oil Burner

Use Ordinary Kerosene or Coal Oil

[Burns Outdoors as Well as Indoors]

THE most remarkable Kerosene Burner ever built. Boils down apple cider, maple syrup, molasses, etc., in half the ordinary time. Ideal burner for dairies, butchers, indispensable on the farm.

PRODUCES TERRIFIC HEAT WITH SILENT BLUE FLAME

**NO NOISE
SMELL
SMOKE
SOOT**

So efficient it produces twice the amount of heat of City gas at half the cost. So simple anyone can install and operate. Double generator assures continuous operation without shut-downs. Nothing to wear out, starts in a jiffy, will last a life time. Every burner guaranteed fully. Write for special introductory price and free catalog of outdoor utility and kitchen stove oil burners.



HOME MFG. CO., Dept. 3613, 20 E. Kinzie St., CHICAGO

Win \$1000.00 CASH

This Offer Is Open to Every Reader of This Announcement

It makes no difference who you are or where you live we want you to send us a name for our toothpaste. Whoever sends the most suitable name will win—nothing more is necessary to gain this cash prize of \$1000.00.

Nothing to Buy—Nothing to Sell

You can use a coined word or a word made by combining two or more words, such as "Snow-White," "Gum-Strength," etc., or any other name you might think would fit the high quality of this dental cream. There is nothing to buy or sell—simply the person sending the best and neatest suggestion for a name will receive \$1000 cash prize, or, if prompt, \$1100 in all.

ANY NAME MAY WIN

No matter how simple you think your suggestion is you cannot afford to neglect sending it at once. Any name may win.



\$100 EXTRA for PROMPTNESS

To get quick action I am going to pay the winner an extra \$100 for promptness, or \$1100 in all—so send your suggestion AT ONCE!

CONTEST RULES

This contest is open to everyone except members of this firm, its employees and relatives.

Each contestant may send only one name. Sending two or more names will cause all names submitted by that person to be thrown out.

Contest closes November 30, 1929. Duplicate prizes will be given in case of ties.

To win the promptness prize of \$100 extra, the winning name suggested must be mailed within three days after our announcement is read.

Win this \$1000 cash prize by a few moments' thought. How can you earn this amount of money easier or more quickly? Remember, there is no obligation! The person submitting the winning name will have nothing else to do to win the \$1000 and the extra \$100, if prompt. In choosing a name bear in mind this dental cream is marvelous for teeth and gums. It is designed to sweeten the breath, beautify the teeth, cleanse cavities and promote teeth and gum health. The only thing necessary to win is to send the name we choose as the neatest and best suited for this dental cream. Only one name will be accepted from each contestant. This unusual offer is only one of a number of offers embraced in our novel distribution plan, whereby those taking part may win any one of twenty-odd prizes, the highest of which is \$3500 cash. By participating in our distribution plan the winner of the \$1100 cash prize may win an additional \$3500, making a total of \$4600. Everyone sending a name, regardless of whether it wins or not, will be given the same opportunity to win the \$3500 or one of the other cash prizes. Get busy with your suggestion at once—do not delay! Neglect may cost you thousands of dollars.

MR. H. E. RAY, *Contest Manager*
717 McCune Bldg., Des Moines, Iowa

Enclosed with this coupon on separate sheet is my suggestion for a name.

Date this announcement was read.....

Date my suggestion is mailed.....

Name.....

Address.....

Note: Being prompt qualifies you for the extra \$100.00 as outlined in this announcement.

Earn \$150 to \$300 MONTHLY

COSTS ONLY \$16 MONTHLY

30 DAY TRIAL

Mechanics, filling stations, tire stores and garages are increasing profits, without expense to themselves, through use of HB service equipment. Start for yourself in this profitable work with HB 8-Hour Battery Service—Starting, Lighting, Ignition Service—Car Washing—Spray Painting. HB guarantees bigger profits, lets you do better work, at less expense to you.

ONLY \$16 MONTHLY
—a small part of your increased profits.

- 8-Hour Battery Service** Gives you edge on competitors. Saves 30 to 50% on electric bills over rectifiers—eliminates bulb cost and turns out work in 1/2 time. Recommended by leading car and battery makers. Tests starting, lighting, ignition systems. Brings you this work from other shops. Does more than outfits priced \$100 to \$150 higher.
- Test Bench** Easily washes complete car in 20 minutes. Eliminates all drudgery. Doubles your business. Users report \$100 weekly profits. Liberal trial, easy terms. Savings in labor and materials will easily pay for it. One man and an HB can earn five men's wages painting cars, houses, furniture. Paint Spray contractors earn big profits yet charge less than brush painters. Gas engine for country, electric for town. Liberal trial and easy terms.
- Car Washer** Only \$10 monthly lets you have this business pulling air service. Its automatic, ball bearing, two cylinder, compact spiral drive eliminates breaking belts. It's the best buy on the market. Liberal trial and easy terms.
- Paint Spray**
- Free Air**

30-Day Trial
—at our risk

Hobart Brothers
Successful Manufacturers since 1893

Box M 109 Troy, Ohio

TEAR HERE - MAIL TODAY

Hobart Brothers, Box M 109, Troy, Ohio.

Without obligation send me complete information on the items I've checked together with your 30-day trial offer and liberal terms. Tell me how I will increase my earnings, without expense to me.

8-Hour Battery Service HB Electrical Service
 HB Car Washer H3 Paint Spray
 HB Air Service

Name.....
 Address.....

World's Wonder Wrench
Banishes Old Style Wrenches!

Pays Agents \$100 a Week

It's new! Different! Never before a nut wrench like "SPEEDNUT." A whole kit of wrenches in one. Adjusts itself automatically. Permits a tighter grip the harder it's pulled. Can't slip. Won't round corners. Ratchets. Works in closer quarters by 1-12 turn grip. Also grips rounded nuts. Sells at low price with big profit.

FREE Demonstrator Offer

"Flash" demonstration Plan guarantees your sales and gives you a FREE demonstrator. Make \$100 a week—and more, part time, full time, side line—just writing orders from tool users, car owners. No stock investment necessary. We deliver. Factories, shops, garages order in quantity. Write quick for territory. Grab this live seller quick!

SPEEDNUT WRENCH CORP.
190 N. State Street, Dept. 58, CHICAGO

Chicago Auto Show Sensation!

VACUUM CLEANER MEN

Your selection of 30 leading makes, rightly rebuilt vacuum cleaners. From \$5.00 up. All fully guaranteed. Perfect in action and appearance. Any quantity desired. Biggest vac bargain ever offered. Here's real money for you. ATTACHMENTS, bags, belts, brushes, all other parts, and new specialties. Highest quality. Lowest prices. World's Largest Factory Rebuilders.

UNITED ENTERPRISES, Inc.
13024 Athens Ave. CLEVELAND, U. S. A.
COMPLETE FREE CATALOGS

DEAF? READ THIS

Vibraphones Reduce Head Noises

A new and scientific discovery stimulates the hearing processes by utilizing sound waves through small silver devices that fit the ears perfectly. The vibrators are built inside the sound chambers. The instruments are so small that your friends will seldom know you are wearing them. Comfortable, easily put in the ears or removed. No wires. No batteries. No head bands. Nothing like them. This new and scientific triumph produces marvelous results. Head noises are reduced. And hearing gradually improves. Don't be handicapped or embarrassed another day by deafness. Write for complete details.

VIBRAPHONE CO., Inc., Station 701
Central National Bank Bldg. St. Louis, Mo.

MODERN AIRCRAFT

By V. W. Page, just published, is a most complete and informative treatise on every phase of modern aeronautical science and aviation.

Written in simple language for the practical man by an experienced instructor, this book covers types of craft, construction, principles of operation and commercial applications. How any plane flies and is controlled. Parts, their functions and how repaired. Latest engines, instruments and accessories. Deals with all types of planes, engines, etc., used in recent epoch making flights.

A special chapter on aerial navigation. The equipment of airports, airways and landing fields is considered. Dictionary of terms prepared with the help of Army and Navy authorities and civilian airplane constructors.

The completeness of the book may be judged by its 855 pages and 400 illustrations.

Price \$5.00

Will be sent C. O. D. in U. S. Pay postman price and postage.

Popular Mechanics Press
Room P-10
200 E. Ontario St. CHICAGO

This Discovery for Men

**Brings New Meaning
to the Years that Follow 40!**

***NOW . . . In Your Own Home You
Can Use This Great Natural
Drugless Gland Stimulant***

THE long sought method of drugless gland stimulation has been found. Already it is used by more than 50,000 men—victims of prostate gland disorder—men past 40, men who have found themselves suddenly on the down grade. Quietly, without the noisy publicity which has attended the work of certain European gland surgeons this great discovery has almost over night spread from coast to coast, from nation to nation. Absolutely harmless, including nothing of medicine, drugs, violet ray or quackery, this type of treatment has been accepted by many physicians and specialists.

America's foremost sanitarium has advised this great discovery for home treatment.

This "treatment-discovery" is the work of a pioneer scientist in the field that has recently made discoveries recognized as the most momentous by medical science the world over. It can be used by any man in the privacy of his own home. Men 90 years old have used it successfully.

Are you aging too soon—getting up 5 to 10 times at night? Is vitality ebbing . . . are you half-living . . . blue, depressed, subject to chronic fatigue, constipation, backache, foot and leg pains? Then you should know at once about the vital prostate gland, how it sends its warning to every part of the body, slowing up mental as well as physical functions. Do not make the mistake of confusing your trouble with bladder or kidney ailments as so many thousands of men do.

Users are telling how this method worked when all others had failed. Many say they were on the verge of a painful gland operation when relief was found at last. Others tell of beneficial results which seem almost miraculous. Thousands say they felt years younger.

So wonderful are the marvelous results this treatment often brings that it is sent to your home with the understanding that unless its benefits are positive and immediate—within 6 days—it costs you nothing.

Mail the coupon below for full details. An interesting illustrated book will be sent you free, in plain wrapper. No obligation. But act now. It may mean the saving of years from a painful and torturous condition.

W. J. Kirk, President, 2122 Morris Ave., Steubenville, Ohio

If you live West of the Rockies, address The Electro Thermal Co., 303 Van Nuys Building, Dept. 21-Y, Los Angeles, Calif. In Canada address the Electro Thermal Co., Desk 21-Y, 53 Yonge St., Toronto, Can.

W. J. Kirk, President

2122 Morris Ave., Steubenville, Ohio.

Please mail at once a FREE copy of the booklet, "Why Many Men Are Old at 40," and all details about the new treatment. I'm not obligated in any way.

Name.....

Address.....

City..... State.....

In Canada address: The Electro Thermal Co., Desk 21-Y,
53 Yonge St., Toronto, Ontario, Can.

Build It with a Boice Workshop!

No matter what you want to build of wood, Boice-Crane can help you. He'll send you this heavy-duty Saw-Jointer-and-Lathe motorized workshop on easy monthly payments with an ironclad guarantee of satisfaction or money back.

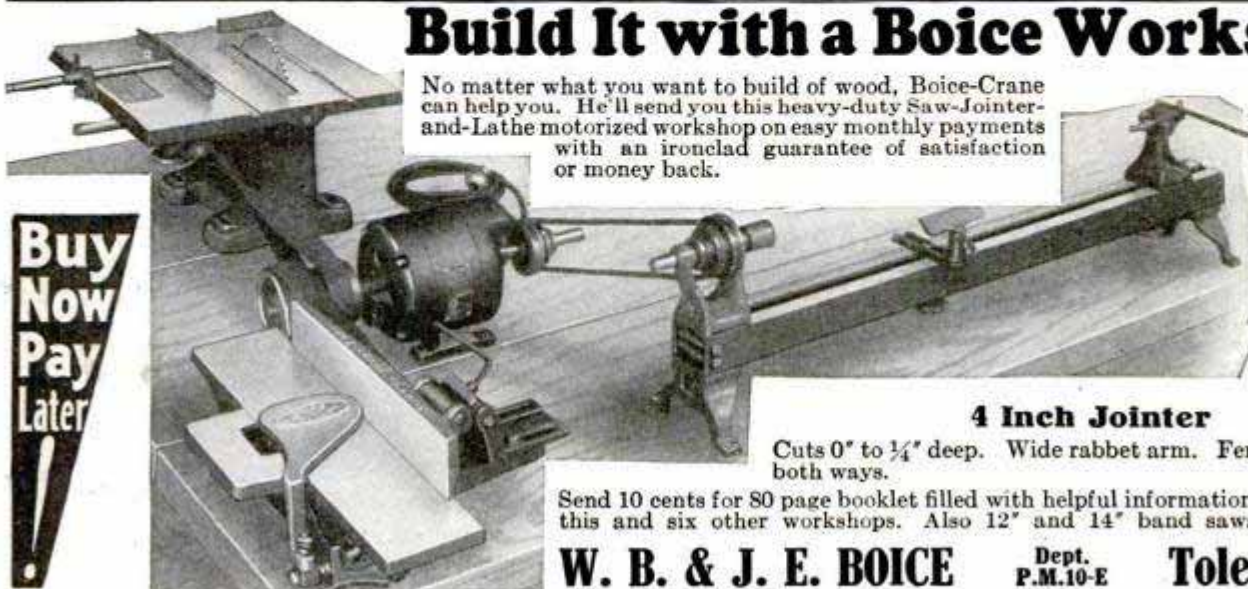

**Universal
Handisaw**

15"x17" tilting table.
9" saw cuts
2½" stock.

**7 Inch
Lathe**

Rigid bed, 3
speeds. 40"
C. to C.

4 Inch Jointer

Cuts 0" to ¼" deep. Wide rabbet arm. Fence tilts 45 deg. both ways.

Send 10 cents for 80 page booklet filled with helpful information and describing this and six other workshops. Also 12" and 14" band saws and jig saws.

W. B. & J. E. BOICE

Dept.
P.M.10-E

Toledo, Ohio

**Buy
Now
Pay
Later**

COMPLETE PLANS
AND INSTRUCTIONS **FREE**



Build these of metal yourself!

Be up-to-date! The latest airplanes, trucks, etc., are of ALL-METAL construction. Build your models that same way! Working with metal is fascinating fun. It's easy to make an all-metal monoplane model like the "Spirit of St. Louis" or an all-metal model army truck with the complete Plans and Instructions we give you FREE.

All the materials you need are tin, wire and solder. You can get these anywhere and soldering is made simple with Kester Metal Mender—the genuine wire solder with the flux right inside. We send you a FREE sample to use.

There's a new thrill for you in building things of metal. Win a Metalcraft Merit Medal! Be the first in your neighborhood! Just write today for FREE Plans and Instructions and we'll mail you full particulars about the Medal Awards with them. Be sure to state your age and address.

KESTER SOLDER COMPANY
Formerly Chicago Solder Company
4206-04 Wrightwood Ave., Chicago
Makers of Kester Metal Mender Established 1899

The man who studies gets ahead. Popular Mechanics Press will advise you what books to read to advance in your trade. 200 East Ontario Street, Chicago, Illinois.

GASOLINE AT HALF COST? AGENTS WANTED

Big money demonstrating, and selling Aerostat, first real improvement in carburetion in 20 years. Absolutely new! Patented! Positively gives 25% to 50% more mileage! Saves car owners hundreds of gallons of gas! Entirely new principle, tested and approved by automotive engineers. AN AMAZING SELLER! Guaranteed. Fits all cars! EXCLUSIVE TERRITORY GIVEN! Get in on the BIG MONEY NOW! FREE TRIAL! Test Aerostat at our risk! Send no money! Simply send name and address for FREE OFFER!

AEROSTAT MFG. CO., Dept. H-21
3601 Vliet Street MILWAUKEE, WIS.



**WRITE!
TODAY!**

LOST!
AUTO LICENSE
PLATE. FINDER
PLEASE RETURN

This Never Happens
IF
You Use the
E-Z ON-OFF
LICENSE CLAMPS

Made of high-tension spring steel. Vise-like grip. Easy to put on (snaps into place in a second). Easy to take off when changing plates. Replaces bent, rusty nuts, bolts and hand screws. Can't rust tight or rattle loose. Holds plates securely. Heavy nickel plate finish. Outlasts life of car. Send 25c for set of 4. (2 for each license plate.)

The DILCAP CORPORATION
Comstock Bldg. Port Chester, N. Y.

Write for special agent's proposition—big profits! Every car owner and dealer your prospect. Millions of cars on the road today need the E-Z ON-OFF Clamps.

Lighter and Pencil Combined
PENCILITE GETS BIG PROFITS QUICK!
"It Lights and It Writes"

Uses any lighter fluid. Does work of \$5 lighter or pencil. Sells on sight! Write for special offer!

It's irresistible! No. 5 Bullet Style PENCILITE—a serviceable pencil and sure-fire cigar lighter. Sells on attractive display cards to all stores, soda fountains, cigar stands, etc. Extra big profits to salesmen. Big repeater. Get sample! Protect territory now!

Sample 25c Prepaid
THE LYCO COMPANY
701 E. 40th St., Dept. 805-N, Chicago, Ill.



No. 882
\$100
\$2.50
a week

No. 27
\$50
\$1.25
a week

No. 924—Woman's Elgin Bracelet Watch, \$29.50; \$2.95 down; \$2.95 a mo.
FIERY BLUE WHITE DIAMONDS

LOFTIS
BROS. & CO. F&S'S
DIAMONDS WATCHES
CASH or CREDIT

Send for FREE Catalog!

Write for big Christmas Catalog, showing quality gifts at reasonable prices, 2000 illustrations and descriptions of Diamond Rings in Platinum and Solid Gold, Dinner Rings, Pins, Brooches, All Standard Makes of Pocket Watches, Pearls, Dresser Sets, Silverware, Clocks, Kodaks, Leather Goods.

Satisfaction guaranteed or money back. Goods sent for your free examination on request. CREDIT TERMS: Pay one-tenth down; balance weekly, semi-monthly or monthly at your convenience. Goods delivered on first payment.

Dept. F-894 108 North State Street, Chicago, Illinois

Stores in Leading Cities



No. 925
\$50
\$1.25
a week

No. 918
\$37.50
\$1.00
a week

No. 927—Elgin "Legionnaire" for Men, \$19; \$1.90 down; \$1.90 a month.

SOLID 18-K WHITE GOLD RINGS

Boys / Don't wish Earn these Prizes for yourself

Boys, have you been wishing or dreaming for a football, baseball glove, bicycle or anything else that would make your day a happy one? Perhaps you have been dreaming about how wonderful it would be to have your own money to buy ice cream sodas and go to the movies.

If you have, your worries are now at an end. Here's your chance to become a Crowell Junior and easily earn for yourself both money and prizes. Hundreds of boys are happily earning such prizes, as shown on this page, selected from our Big Book of over 300 prizes. This opportunity is open to you. Send the coupon today. **NOW!**



As a Crowell Junior you will have a regular paying business of your own. You deliver The American Magazine, Woman's Home Companion and Collier's, The National Weekly, to regular customers. You need no experience and it will not interfere with your school work or fun. Hurry and mail the coupon before some other boy in your neighborhood gets the money and prizes that should be yours.

*Don't
Wish or Dream -
Mail this
Coupon Now*

Mr. Jim Thayer, Dept. 121,
The Crowell Publishing Co.,
Springfield, Ohio.

Dear Jim: I want to earn woney and win prizes. Please start me off as a salesman.

My Name

Address

Town State

ELECTRIC MOTOR BARGAINS

Heavy starting duty, 110 Volts, 60 Cycle, 1725 Speed—General Electric Repulsion Induction MOTORS in original cartons

1/6 H. P.

\$12⁵⁰

1/4 H. P.

\$13⁵⁰

1/3 H. P.

\$15⁰⁰

These motors were built by the G. E. Co. for a concern that failed before delivery could be made. We purchased 1500 of them at a very low price. You can buy one or more at prices quoted above until stock is exhausted. Furnished with feet or rubber cushion base. Shaft diameter 5/8 inch. Pulleys 75c extra.

OTHER MOTOR BARGAINS

We have a large stock of new and rebuilt motors. Write us your requirements. We can save you money on any type and size motor.

NORTHWESTERN ELECTRIC CO.

410 So. Hoyne Ave.

CHICAGO, ILL.

Go INTO BUSINESS AT HOME FOR YOURSELF!

"BE YOUR OWN BOSS"

We Set You Up in Business

Don't waste your time working for others. Get into a profitable business for yourself. You can earn good money making and selling toilet articles, perfumes, soaps, flavoring extracts, household specialties, etc. No experience necessary. We furnish everything and show you how. Wonderful opportunity for both men and women to make money at once!

Send for Free Booklet Today

Write immediately for free booklet explaining our proposition. This is your opportunity to become independent and have a profitable business absolutely your own. Don't delay. There is no obligation, so write for booklet NOW.

National Scientific Labs. 1927W W. Broad St. Richmond, Va.



SENSATIONAL!

IT "TAXIES"—"TAKES OFF"—FLIES!

Under its own power

The thrill of a lifetime and fun galore are yours with the new Kingsbury "Silver Arrow" Flying Plane. It's the most sensational model plane in years. Launches by hand and also "taxies" over the ground, "takes off" and flies—under its own power. Just wind up the propeller and let 'er go! She's off like a flash—faster and faster—climbing, climbing—'way over the housetops, diving and dipping and banking on a long continuous flight—then gliding down to a perfect landing. Not a construction toy but a fully built plane. A few moments to assemble and it's ready to fly. Designed by Charles H. Grant, pioneer model airplane designer. Wings and body of light Balsa wood reinforced with aluminum braces; aluminum propeller; strong elastic motor. Four models: No. 1, Racing Type, wing spread 18 in. \$1.00; No. 2, Racing Type, wing spread 24 in. \$2.00; No. 21, Cabin Type, wing spread 22 in. \$2.50; No. 22, Cabin Type, wing spread 26 in. \$3.50. (West of Miss. \$1.10, \$2.20, \$2.75, \$3.85.) Be first in your neighborhood to own a "Silver Arrow." If your dealer hasn't this Kingsbury thriller, order direct. Kingsbury Mfg. Co., 83K Myrtle St., Keene, N. H.

KINGSBURY MOTOR DRIVEN TOYS

SEND 10c for this Eraser! A steel disc wheel from a Kingsbury Toy with a "balloon"



tire of solid eraser rubber. Set of four, 35c.

Toy Catalog Free

\$100 WEEKLY WASHING CARS

20 minute car washing is highly profitable with the new HB Double Action Car Washer. Quickly builds a paying business for you in garage, filling station or parking space—saves enormously on labor, material, time. Throws more water per minute at high pressure than others using quicker washing.

Only \$20 Monthly

Easily paid out of profits. Many users report profits of \$100 and over weekly. You try it 30 days at our risk on money back guarantee. Write today for details. Hobart Brothers, Box M1092, Troy, Ohio.



RADIO BARGAINS!

Used 5-tube sets \$14.90; Guaranteed Transformers 75c; Condensers 50c; Rheostats 25c; Crosley cone units \$2.00; 1-tube sets \$1.95; A. C. Filament Transformers \$1.90; A & B Transformer for A. C. sets with chokes \$4.25; Used Experimental 5-tube sets in cabinets \$6.90. Complete list upon request.

CHAS. HOODWIN COMPANY
2420 Lincoln Ave., Dept. 1023, Chicago, Ill.
Dealers in Bankrupt Radio Stocks



Engines & Motors Big Catalog No. 30



Illustrating Electrical, Mechanical and Model Maker's Supplies, Small Steam & Gasoline Engines, Motors, Generators, Lathes, Drill Presses, Bench and Band Saws, etc., 16-32 & 64 Watt Dyna-Motors, School Projects, Engine Castings, Motor Parts, etc., Books, Blue Prints, Brass and Steel Tubing, Gears, Pulleys, Hangers, Experimental Material. Send for Copy. Mailed anywhere for 20 cents, 25 cents Canada, refunded first order. LUMIS ELECTRIC & MFG. CO., 2822 N. CALIFORNIA AVE., CHICAGO, ILL.



SPRAYIT

ELECTRICALLY
New Agitator Type

Revolutionizes paint spraying performance and results. Constant fluid agitation, instantaneous control of spray, many other new features. Hold 1-lb. gun only—put rotary compressor unit on floor or ladder. Price, \$39.50. Write for complete details.

THE ELECTRIC SPRAYIT CO. Inc.
210 East Colfax Avenue
South Bend, Ind.

BE INDEPENDENT! Sell Standard Printing, supply all quality. A Successful Combination that will build a permanent business for you. Send for Sample Outfit. Also good as side line. No experience needed.

ALL-TRADES PRINTING SERVICE, 132 North Second St., Rockford, Ill.

HOMES!
15 Years
to Pay

Buy Direct from Mill!

Get FREE Book 100 HOME PLANS MATERIAL PLAN-CUT. EASY TO BUILD!
GORDON-VAN TINE, 1400 Case St. Davenport, Ia.



WADE AMATEUR MECHANICS, REPAIR SHOPS, INVENTORS, STUDENTS

BENCH LATHE

A real machine tool for the home work bench—capacity 4" dia. x 12' length. For Metal—Wood—Composition materials. Turning—Facing—Boring—Drilling—Winding—Thread Cutting. Accurate—Strong—Quiet—Compact. Slide-rest has travel entire length of bed. Leadscrew inside bed. No. 1 Lathe, plain headstock, \$40.00. No. 2 Lathe, back-gear headstock, \$68.00. Extra for lathes with 18 inches between centers, \$7.00. Complete line of accessories at equally low prices. Write for free catalog.

THE GEROLD CO.

Dept. P-56

120 Liberty St.

New York

SAVE ONE-HALF YOUR GASOLINE

Thousands of auto owners everywhere are enthusiastic in their praise of a remarkable new device. They report gasoline savings that seem almost unbelievable. They also report that their motors run much smoother, carbon formation seems to disappear and quicker starting and pick-up is noticed. This amazing device, called the Whirlwind, uses a simple principle of mixing gas and air so as to actually make an auto run on over 93% air. It is estimated that if every car were equipped with this invention, millions of dollars would be saved yearly by the American motorists.

FITS ALL CARS

In just a few minutes the Whirlwind can be installed on any make of car, truck, or tractor. It's actually less work than changing your oil, or putting water in the battery. No drilling, tapping or changes of any kind necessary. It is guaranteed to work perfectly on any make of car, truck or tractor, large or small, new model or old model. The more you drive the more you will save.

**Salesmen and
Distributors Wanted
FREE SAMPLE
and \$100 a Week Offer**

Whirlwind men are making big profits supplying this fast-selling device that car owners cannot afford to be

without. Good territory is still open. Free sample offer and full particulars sent on request. Just check the coupon.

WHIRLWIND MFG. CO.

999—96-E Third St. Milwaukee, Wis.

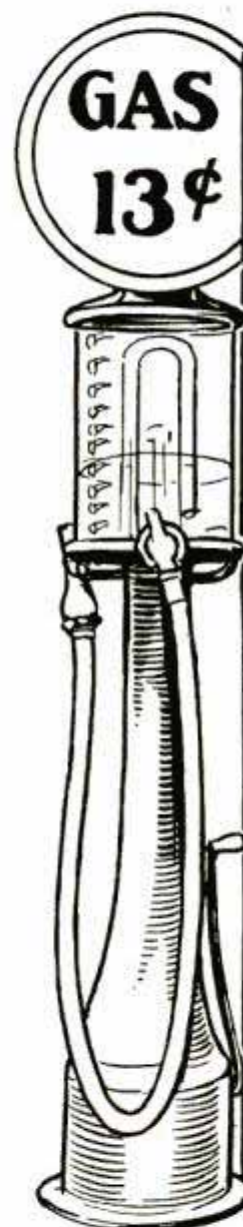

GUARANTEE

No matter what kind of a car you have—no matter how big a gas eater it is—the Whirlwind will save you money. We absolutely guarantee that the Whirlwind will more than save its cost in gasoline alone within thirty days, or the trial will cost you nothing. We invite you to test it at our risk and expense. You are to be the sole judge.

FREE TRIAL COUPON

Whirlwind Mfg. Co.,
999—96-E Third St., Milwaukee.

Gentlemen: You may send me full particulars of your Whirlwind Carbureting device and free trial offer. This does not obligate me in any way whatever.

NAME..... ADDRESS

CITY.....

COUNTY..... STATE.....

Check here if you are interested in full or part time salesman position.

Stage Money**New Bills To Conform With Small Size Currency**

With these bills it is easy for a person of limited means to appear prosperous by flashing a roll of them at the proper time. By peeling off a genuine bill or two from the outside of the roll, the effect created will be all that can be desired. Prices, postpaid: 40 bills 20c, 120 for 50c, or \$3.50 thousand postpaid.

Serpent's Eggs

When lit with a match each egg hatches itself into a snake several feet long, curling and twisting in life-like manner. Box of 12, 10c postpaid, 3 for 25c.

**Black Art**

This book tells of the sciences of Magic, Witchcraft, Alchemy, Necromancy, Mesmerism, etc. It tells how to make persons think of you, how to charm those you love, etc. The book contains 122 pages. Price 30c prepaid.

**Real X-Ray**

A wonderful instrument producing optical illusions. With it you see what is apparently the bones of your fingers, the lead in a pencil and other such illusions. A mystery not as yet explained. Price 10c, 3 for 25c, 1 doz. 75c.

Fire-Eater

A great trick by which you appear to breathe fire from mouth. Quite harmless. All necessary apparatus sent complete for only 30c, postpaid.

**Revolving Pictures**

This consists of nicely ornamented tube. The victim is told to hold the tube close to his eye and revolve tube until pictures appear in the center. In trying to locate the picture he will receive the prettiest black eye. The victim is not aware of it and does not know why everyone is laughing at him. Perfectly harmless. Price 25c.

Nose Blower

It is concealed in the handkerchief. Proceed to blow your nose and your friends will think they heard a steam engine or something. You can blame the noise on a very bad cold and keep up the fun as long as you like. Price 10c, 3 for 25c, or 75c doz. postpaid.

**Buddha's Money Mystery**

With this contrivance it is apparently possible to change a blank piece of paper into a bill of any denomination. Can be performed by anyone. Price 25c.

**Seebackroscope**

With this instrument to your eye you can see what is going on behind your back. Many times things occur when no one thinks you are looking. Just like having eyes at the back of your head. Price 25c postpaid.

**Magic Nose Flute**

Is a unique and novel musical instrument played with nose and mouth combined. Just a little knack required to enable you to produce sweet music that resembles a flute. No fingering. Effect is charming when played as an accompaniment to piano or other musical instrument. Price 10c postpaid.

Send 20c in stamps or coin and our 1929 catalogue, DeLuxe Edition, containing 202 pages of all the latest tricks and novelties, will be sent to you. We are the largest dealers in tricks of all kinds in the world. Order from this advertisement or send for our catalogue today. FREE—Our large die box trick when you have sent in orders amounting to \$25 within one year.

OAKS MAGICAL COMPANY

Dept. 800

Oshkosh, Wisconsin



Gasoline Engines, Steam Engines, Motors, Dyna-Motors, Lathes, Drills, Gears, Books, Blueprints, Pulleys, Hangers, Bench Saws, Display Tables, Model Makers' Materials and Supplies.

Catalog sent postpaid 20c, refunded first order

HOWARD ENGINE & MFG. CO.

2417 N. Ashland Ave. CHICAGO, ILL.

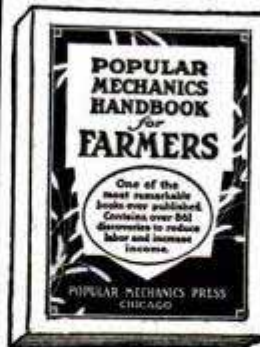
861 PRACTICAL IDEAS for REDUCING FARM LABOR and INCREASING INCOME

One farmer writes: "I would not take \$100 for my copy if I could not secure another."

The Handbook for Farmers contains: 138 ideas for the farm shop, 35 on fencing, 98 on auto, truck and tractor, 61 on farm buildings, 36 on field machines, 48 on concrete work, 22 on orchard work, 23 on painting, 15 on live stock, 34 on poultry, 54 on garden work, 25 on electrical work, 22 on farm tools, 16 on hunting, fishing and trapping, 140 household helps.

394 HELPFUL KINKS to LIGHTEN the LABOR of the FARMER'S WIFE

The Handbook for Women contains: 83 kitchen and dining room helps, 17 on garden and flowers, 19 on sewing and mending, 37 on furniture, pictures and fixtures, 38 on laundry and cleaning, 32 on house cleaning, 12 on music, 14 on sleeping rooms, 11 on care of children, 16 on lights, 9 on photography, 14 on clothing and shoes, 23 on house temperatures, 12 on water and drains, 10 on insect pests, and 47 miscellaneous.

SPECIAL OFFER BOTH for \$1

(Regular \$1.50 Value)

For a limited time you are offered both books for \$1 plus the postage. Pay postman when he delivers package. If outside U. S. send remittance and include 15 cents extra for postage.

POPULAR MECHANICS PRESS
Room 710, 200 E. Ontario St., Chicago

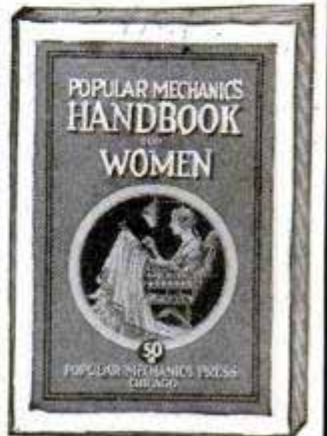
**A POPULAR AVIATION GUIDE at a Popular Price**

Prepared to meet the demand for a simplified book on Aviation suitable for young people, beginners, and all persons desiring general information.

Everybody's Aviation Guide by V. W. Page, just published. 256 pages, 140 Illustrations, tells all about flying in simple, easily understood language.

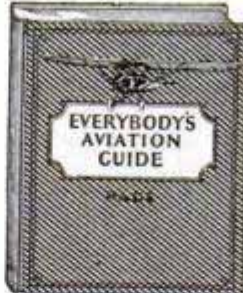

Aviation terms, operating principles, elementary rules, forms of air craft, functions of parts, types of power plants, machines, control systems and methods of flying. Learn now and prepare for the future. Price \$2

Will be sent C. O. D. in U. S. Pay postman price and postage.

POPULAR MECHANICS PRESS
Room P10, 200 E. Ontario St., Chicago

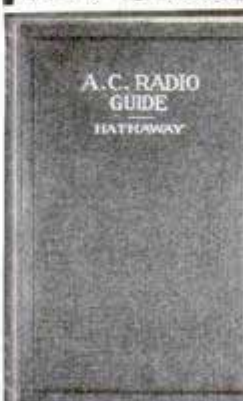
ENTIRELY NEW**A. C. RADIO GUIDE**

KENNETH A. HATHAWAY, Radio Technical Advisor of the Chicago Daily News, has written this new book dealing exclusively with all-electric sets in a clear, interesting and non-technical manner.

A thorough explanation of the new dynamic speakers is also given. Adapted to the needs of manufacturers, dealers, repairmen, students and amateurs.

120 Pages. Cloth. Illustrated.

Price \$1.50 postpaid.

Popular Mechanics Press

Room P 10

200 E. Ontario St., Chicago

"Delta" Electric Handi-Shop

Patented Jan. 1, 1929

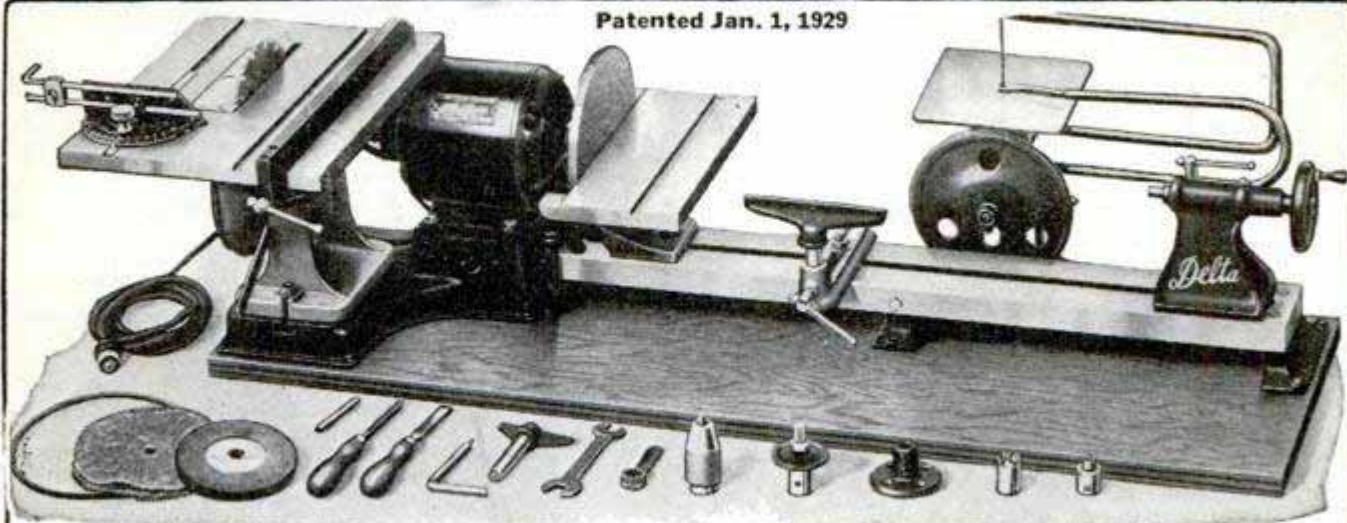

Make the Things You Have Always Wanted To Make Quickly and Easily

with this complete, sturdy, efficient, man-sized motorized workshop. Takes all the drudgery out of wood craftsmanship. Enables you to save money on repair work—earn money in spare time. Includes all necessary equipment for Circular Sawing, Wood-turning, Jig Sawing, Sanding, Drilling, Grinding and Buffing.

Blue Prints Included



Many Basic Advantages

are found in the "Delta" Handi-Shop such as the powerful, constant-speed two-shaft motor and the heavy U-shaped Lathe Bed, the improved Circular Saw, Jig Saw and Sanding Disc—each with special improved Tilting Table, and automatically-oiled bronze bearings. The new 1929 model has in addition a score of important improvements.

10 DAY TRIAL

Without obligation, you can see how this big, practical workshop stands up under actual working conditions.

Easy Terms

Mail coupon now for FREE, beautifully illustrated literature giving complete description of New 1929 Model Delta Handi-Shop, and pictures of its many features. Also full details of 10-Day Trial Offer and your choice of three convenient methods of payment.
Dept. A. 109



The TWO-SHAFT motor is the practical motor for the workshop. Permits you to carry on two or three important operations at one time without continually dismantling set-up.



Heavy Triple Foundation U-shaped Lathe Bed (not rods or rails) is guaranteed not to spring or chatter.

Delta Specialty Company, Dept. A. 109, 1661-67 Holton St., Milwaukee, Wis.

Please send FREE illustrated literature on new Delta Handi-Shop. Also full details of 10-Day Trial Offer and Easy Payment Plans.

Name.....

Address.....

DELTA SPECIALTY CO.
1661-67 HOLTON ST. MILWAUKEE, WIS.

MAIL THIS COUPON NOW!



NEW IMPROVED PAYNTGUN LACQUERS CARS AND FURNITURE

Skillful painting easy for anyone this new simplified way. Exclusive Payntgun features cut painting time in half. Sturdy. Compact. Powerful spray. Complete Outfit \$9.65

FREE Attractive folder on Perfect Painting ready for you. Write for it NOW!

HAYWOOD EQUIPMENT CO.

2345-P Ogden Ave., CHICAGO, ILL.

AGENTS WANTED

Photos ENLARGED

Size 16x20 inches Same price for full length or bust form groups, landscapes, or pet animals, etc., enlargements of any part of group picture. Safe return of your own original photo guaranteed. **98c** Just mail photo or snapshot (any size) and within a week you will receive your beautiful life-like enlargement size 16x20 in. guaranteed fadeless. Pay postman 98c plus postage or send \$1.00 with order and we pay postage. **SPECIAL FREE OFFER** With each enlargement we will send FREE a hand-tinted miniature reproduction of photo sent. Take advantage now of this amazing offer -- send your photo today! **UNITED PORTRAIT COMPANY**
1652 Ogden Ave. Dept. M-369 Chicago, Ill.



Easy to Make
\$25.00
a Day

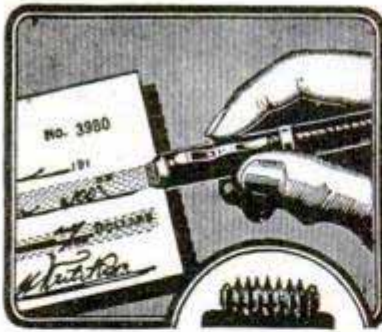

Sell Security Pens

Agents make three out of five sales on the spot! Hundreds making over \$600 a month! Others pocket \$5 an hour spare time. You, too, can make big money with this "wonder" 2 in 1 Security Pen—the most amazing pen on the market. Every man and woman with a checking account buys.

Why They Sell

Show men and women both ends of your Security Pen, demonstrate the sturdy, perfect writing, fountain pen, guaranteed for five years. Then show the other end—the patented CHECK PROTECTOR which protects checks from crooks, who, every year, steal over \$250,000.-000 raising checks. No other pen has this wonderful feature. No competition. A five-minute demonstration closes sale, pays you almost 100% clear profit at once. No experience necessary. Make big money.

Amazing New Plan

Entirely new selling plan to introduce this sensational novelty. Write now for details and while exclusive territories are open. No obligation.

DISTRICT MANAGERS:—If you have an organization or can form one we can make you an attractive offer.

SECUROGRAPH PEN CO.

M-55 Securograph Bldg. **STRAIGHT LINE** Oakland City, Ind.

Sample Offer!

Learn how you can get a Security Pen sample outfit. **ABSOLUTELY FREE.** Or, quicker, enclose \$1.00 for Securograph sample (without the pen).

SILVER ACE FLYING

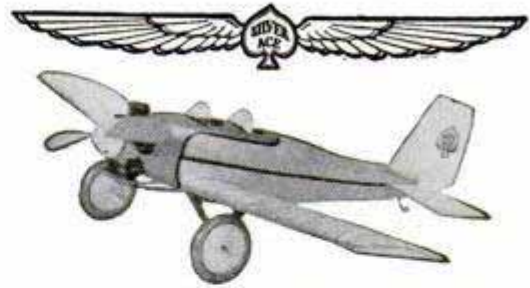

F-21 LOW WING MODEL.

Wing Span 25 inches

Weight 3 oz.

Price, Ready to Fly, \$7.00

The entire fuselage of this fascinating new flying model is made of strong celluloid, beautiful in detail and color. Like all Deluxe Silver Ace ships, it has a semiflexible, detachable propeller, shock absorbing landing gear, and silk covered demountable wings. In design and performance it will thrill you.

Send 10 cents for illustrated catalogue of 18 Silver Ace models and construction sets. The most life like, longest flying, and most economical models produced by modern engineers. Light enough to save you disappointment in the air. Strength to give by far the lowest average cost per flight of any models you can buy or build. All first class dealers can supply you. If not, remit to us, adding 50 cents for packing and shipping.

THE AERO MODEL CO.

Dept. M-10
111 North Wacker Drive
CHICAGO



AUTOMATIC WINDOW WASHER
Price \$1.95



Washes, Cleans, Dries Polishes in One Quick Operation

Amazing new invention. **CARRIES OWN WATER SUPPLY!** Eliminates all drudgery and splashing! 5 times as fast as old methods. Patented features: **No pail. No brush. No sponge. No chamois.** Can be used with or without a pole. **\$90-\$150 weekly easy for agents.** Sells on sight. Sensational demonstration! Every housewife, autoist, store-owner a prospect. Write for our **Free Sample Offer** and big money-making proposition. Be first.

NATIONAL INDUSTRIES, 67 E. Lake St., Dept. 1510, Chicago

BEAUTIFUL PORTRAIT Enlargements

From Any **SNAPSHOT** or **PHOTO YOU HAVE**

Now is your chance to get a life-like Bromide photo enlargement at an unusual bargain. Reproduced from any clear photograph, tintype, snapshot or group picture you send.

ONLY **49¢** EACH



Size 11 x 14 inches

No photo too large; none too small. We guarantee safe return of your original photo. Send as many photos as you wish at the bargain price of 49 cents each.

SEND NO MONEY Simply mail photo, name and address. In a few days you will receive a beautiful enlargement that will never fade. With the enlargement comes an illustrated circular describing our most popular frames. From this circular you can choose the frame which we are giving **FREE** with every enlargement ordered in colors. On arrival of enlargement, pay postman only 49c plus a few pennies postage or send 50c with order and we will prepay postage.

Free Beautifully Carved Frame—As a special inducement to acquaint you with the high quality of our work, we will frame every enlargement done in Pastel Water Colors **Absolutely Free.** Don't put it off. Mail your photo now.

NEW ERA PORTRAIT COMPANY
10 E. Erie St. Dept. 301 Chicago, Ill.

SOLDERALL

METAL IN PASTE FORM



The only convenient metal solder

Every Electrical Connection needs Solderall for perfect reception

25¢

The **SOLDERALL CO., NEWARK, N.J.**

MASTER INTERLOX SLIDE RULE

For Any **INSIDE** or **OUTSIDE** MEASURE

Every inside measurement at a glance. Just slide out the Master till it reaches from stop to stop. (Runs outlike tape—does not fold.) Exact measure figured for you. No guessing. Quick results. Other side for outside measure. Looks rigid in use.

Ask Dealer, or send 20c each lineal foot.

MASTER RULE MFG. CO., INC. 821 East 136th St., N.Y. C.
DEALERS AND AGENTS WANTED

AGENTS



New Type Flour Sifter Sells on Sight

No more pouring and re-pouring of flour through sifter! Now flour can be sifted and mixed without removing from sifter. Saves time and work, ends mess and waste flour, assures light, fluffy cakes and biscuits. No wonder 350,000 women have bought on sight. Montgomery made \$54 in six hours. **FREE.** Write for \$20 a day plan for demonstrators, full time or spare hours. Also get liberal sample offer.

KWIK FACTORIES
715 Kolmar Ave., Dept. M-130, Chicago, Illinois

Let Me Start *you* in this ~ Amazing new Business of your Own ~ Now!

**YOUR CHANCE TO MAKE
\$5,000 to \$10,000 A YEAR, in
Your Own Home, Basement, or Garage
Charging and Repairing Batteries**

**Miranda Makes
\$125 A Week!**
He writes "I
am making more
money in one day
charging batteries,
compared to the
money I used to
make a week as
an electrician.
My wages are
now \$125.00 a
week."
Ralph Baron
Miranda.



**\$150 a Week
for Proesel**
"My chargers
are loaded to capacity
day and night. Started in
a small way but
now I have all the
business I can
handle."

Here's your great opportunity to get into a Big Pay field that's growing by leaps and bounds—charging and repairing batteries. We furnish all the tools and equipment to get started in a real business of your own that brings you large earnings right from the start. Clip coupon below and get complete facts.

**Pocket 90c Clear Profit
On Every Battery**

I have invented a new Service Station Charger which saves 40% to 60% in electric current, yet handles 50% to 70% more batteries than similar outfits. Millions and millions of batteries in daily use by auto owners everywhere. Amazing new principle of my Service Station Charger simply scoops up all the business in town for you. My Free Book tells you how to get started.

**No Experience or Education
Required**

Why go along at \$25 or \$30 a week when the battery field holds out an opportunity for you to make upwards of \$5,000 a year? Easy to get started with my charger. When the outfit

arrives, you're all ready to begin business. Charger is automatic and requires no attention during operation. Profits go into your pocket without effort on your part. Free Book tells how.

**FREE Book Tells How To
Start!**

Clip coupon and get your Free copy of my book "Big Profits." Read how hundreds of other fellows like yourself have established themselves in their own business. See the description of my amazing Service Station Charger. Find out about my plan for establishing you in this Big Pay field. Along with the charger goes my complete outfit of tools, supplies, testers, advertising—in fact everything that you need to do business—you can take in \$20 a day or more right from the start. Get your copy of this book quick.



I help you make big money quick. C. F. H.



**\$85 a Week for
McDermott**

"You are the best company I ever dealt with. My own station is now bringing me in plenty of money with practically no effort."

Free Advertising, Tools, and Working Outfits

As an owner of my charger you get the benefit of my advertising. When you open up, business comes right to your door. No soliciting—no plugging for business. Customers are glad to give you their trade.

Operate in Full or Spare Time

At first you can still work on your regular job. Go to your job in the morning and your batteries will be fully charged when you come home. You can make more money in this way during your spare time than at your job. Free book explains just how to do it.

Get Your Copy of "Big Profits"—Over 100 Illustrations

Find out the facts for yourself without one cent of expense. Read what the other fellows are doing. Let me show you how easy it is to get started—and how quickly you can build up your own business netting you \$5,000 to \$10,000 a year. Clip and mail coupon now.

Address Me Personally
C. F. HOLMES, Chief Eng.
Independent Electric Works, Dept. A
5116 Ravenswood Ave., Chicago, Ill.

**7 BIG FREE
OUTFITS
for
Quick
Action**

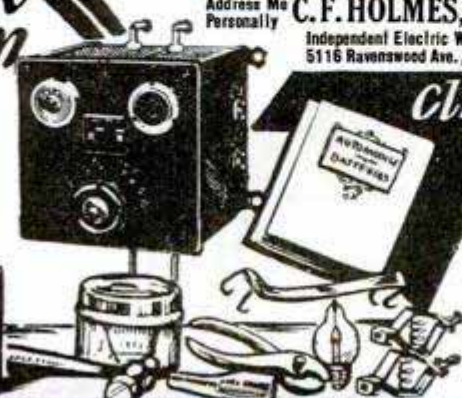

Clip Coupon Quick ~ ~

C. F. Holmes,
5116 Ravenswood Ave., Dept. A,
Chicago, Ill.

Rush me by return mail a copy of your Free Book "Big Profits."

Name.....

Address.....

Town..... State.....

If you are earning less than \$90.00 a week mail Coupon!

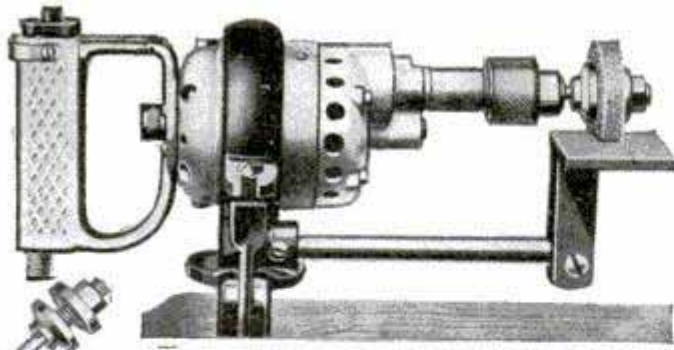

A Complete Machine Shop for \$25!

The most complete outfit ever offered at this price. Here's what you get:

1. Jones Portable Electric Drill. Universal Motor, 110, 220, or 32 volts. Jacobs Chuck. Bore up to 1/4". Guaranteed one year.\$18.75
2. Bench Clamp. (as illustrated)..... 5.00
3. Steel Arbor to fit Jacobs Chuck.... 2.00
4. Cloth Buffer, 4" dia..... .30
5. Wire Cleaning Brush, 4" dia..... 2.00
6. Circular Saw, 2 1/2" dia..... 1.00
7. Carborundum Grinding Wheel, 2" dia..... 1.00

Regular Price \$30.05

Order Now—Save \$6.05

For a limited time only you can get this complete outfit for \$25.00—a saving of \$6.05—each part of the best materials and workmanship obtainable. If you already have the Jones Drill you can get the attachments separately. Send check or money order now. If not satisfied return in 5 days and money will be refunded.

JONES-MOTROLA SALES CO.

Dept. 8, 370 Gerard Avenue, New York



write for complete catalog

New Kind of Phonograph Has Amazing "Dynamic" Tone



"Bluebird" Portable has new scientific tone system. Reproduces electrical records with astonishing naturalness. Has deep, rich tone, thrillingly life-like, and tremendous volume. Sold direct from manufacturer at

Startling Low Price

never before equalled. Beautiful in appearance. Fully guaranteed. Ideal for homes, outings and radio amplification.

AGENTS

"Bluebirds" sell on sight. Agents make big money—even on part time. Write for sample offer and quick money making proposition.

SAUL DISTRIBUTORS
430 S. Wabash Ave.
Room 1510 Chicago, Ill.

\$9.95

Retail Price

Plays All Standard Records

New Complete "Wonder" Workshop

Outfit saves you \$15.00



A COMPLETE LINE

- Bench Saw
- Band Saw
- Scroll Saw
- Bench Drill
- Jointer
- 3-Speed Lathe
- Motor-Driven Lathe
- Grinder

Now you can have this new, amazing 8-in. Combination Saw (18 tools in one) shipped on 15 days' approval, at manufacturer's risk. A complete ideal machine shop for factory, workshop or home; will rip, cross cut, bevel, miter, mortise, drill groove, tenon, grind, rabbet, buff and polish. 113 H. P.-A. C. motor included with all attachments.

Dealers Wanted

Write quick for special 10 day offer.

Scott-Bansbach Co., 142-J So. Clinton St., Chicago

PRINT YOUR OWN

Bulletins, Circulars, Programs, Letters, etc.—with this Amazing New "EXCELLOGRAPH"



Simple and easy. Prints anything written with pencil or typewriter. Just make stencil and print 1,000 copies per hour. Wonderful for illustrations drawn or traced. All supplies and instructions furnished. Guaranteed 10 years. Prints any size from postcards to sheets 9x14. Does beautiful work.

SAVE MONEY—MAKE MONEY

Saves and makes money for Merchants, Ministers, Teachers, Offices, etc. Use it to build your business. Do work for others at big profits.

Write for Free Book — Today

Shipped at our risk. Positive money-back guarantee. Amazing value. Thousands in use. Get free book describing all details and easy payment plan.

Only \$39.00 Easy Terms

PITTSBURGH TYPEWRITER & SUPPLY COMPANY

Dept. M—339 Fifth Avenue

Pittsburgh, Pa.

MODEL SHIPS



We can supply construction sets and all sorts of parts such as semi-finished hulls, blocks, dead-eyes, special flags, anchors, steering wheels, capstans, figureheads, blue prints, books, etc., for building a Flying Cloud, Constitution, Spanish Galleon, Mississippi River Steamboat, Sovereign of the Seas, Mayflower and many others. Also special construction sets for racing sail boats, power boats, model steam engines, propellers, etc., and fine tools for the model maker. Our large 48-page photographically illustrated booklet contains valuable information and hints for building ship models in addition to prices and full description of the above articles. Many people only slightly interested in models have become greatly enthused upon receiving this booklet. A copy will be sent postpaid upon receipt of 15 cts. (coin preferred).

Model Ship Supply Co., Dept. G, Mineola, N. Y.



Why Not Start Welding Shop Of Your Own?

- Welding Outfits.....\$25.00 Up
- Lead Burning Outfits..... 18.00 Up
- Soldering Outfits..... 8.00
- Paint Sprayers..... 14.00 Up
- Regulators and Gauges... 9.50 Up
- Lead Burning Torches... 6.00 Up
- Welding Torches..... 10.50 Up
- Cutting Torches..... 30.00 Up

Write for catalog—also our payment plan.

SUPERIOR OXY-ACETYLENE MACH. CO., P. O. Box 255, Hamilton, Ohio

Save Your Feet



When all else fails end your suffering with the flexible "no metal"

Heefner ARCH SUPPORT

WRITE FOR FREE BOOKLET

HEEFNER ARCH SUPPORT CO., 671 M. E. TAYLOR BUILDING, LOUISVILLE, KY.

WOOD

Samples of 33 rare woods \$2.00.
20 cabinet and 20 inlay \$1.75,
choice \$1.00

Sets labeled and postpaid. Send for catalog

CRAFTSMAN WOOD SERVICE, 717 E. 62nd St., Chicago, Ill.



ALL GIVEN

10 year guar. Watch with chain and ring, large Eastman Roll Film Camera or 22 cal. Hamilton Rifle, yours for introducing finest assorted liquid perfume at 15c a bottle. Send for 20 bottles and choose gift as per offer in our catalog. We trust you—just write to

BELL PERFUME CO., Dep. 7153, Chicago, Ill.

22 CAL. RIFLE



Amazing New Window Washer

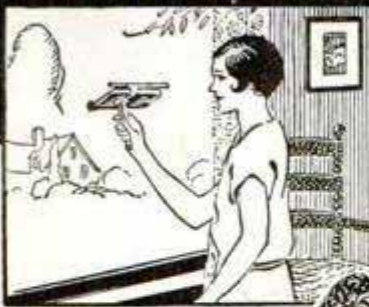

**For homes,
autos, offices,
stores, factories**
—wherever there
is glass to clean
Sells for \$2.25



**CARTER
WINDOW WASHER**



Make \$25 to \$35

a Day—A Marvelous Opportunity That Leads the Way to Your Financial Independence

HERE it is at last!—An amazing invention that cleans windows in a jiffy, does away with water pails or sponges, prevents hands from getting wet or cold and absolutely eliminates all drudgery. Works like a charm. Operates three times as fast as any other method. Makes an instant appeal to every housewife and car owner as well as stores, factories, offices, etc. The Carter Window Washer sells like wild fire. The money-making opportunity for agents is simply amazing. \$25 to \$35 a day is easy. Hundreds of men and women are becoming financially independent by selling this marvelous device. You can do that, too. With our plan, you start as small as you like and quickly work up into the big money class.

Quick Demonstration—Sell on Sight

Carter Window Washers are easy to use. No parts can rust or get out of order. No instructions necessary. Quickly demonstrated right on the glass door of any home or nearby window. Any housewife understands its use and advantages in a few seconds. A thorough demonstration is completed in a minute's time and everybody wants one. No clever salesmanship required—just a courteous approach and a simple, quick demonstration.

Sell Every Home - - Every Auto

There is an astounding market in every city, town or village for the Carter Window Washer. Every home needs one; every auto driver should have one in his car; stores need them for show-cases. Wherever there is glass to clean there is an opportunity to sell a Carter Window Washer.

Get Free Trial Offer

Just mail coupon or write or wire. You will get the biggest, quickest, easiest money-making plan you ever heard of. Our Free Trial Offer proves everything to you absolutely at our risk. Act now—without a minute's delay!

CARTER PRODUCTS CORPORATION
Dept. A2 — 983 Front Ave., Cleveland, Ohio

Sales come quick and fast. You find business wherever you go. Simply show this great invention to every home in your town and write up the orders.

Tremendous Margin of Profit

We give our agents an extraordinary margin of profit so that every sale at \$2.25 means a lot of money in your pocket. Here is the biggest money-making opportunity you ever had. Get in on it right away.

We are fast building up a large organization of money-makers throughout the country. New agents in every section are wanted. Get our complete proposition—make big profits—be independent and run your own business.

ESTABLISHED SALES FORCES Can Triple Profits

One salesman can make \$100 a week and more by his own efforts but managers of crews can multiply this income many times according to the size of their sales forces. Tell us what territory you cover thoroughly and we will explain sales quota required.

MAIL THIS COUPON NOW

Carter Products Corporation,
Dept. A-2, 983 Front Ave.,
Cleveland, Ohio.

I want you to show me how to make \$25 to \$35 a day. Send me full particulars and Free Trial Offer.

Name.....

Address.....

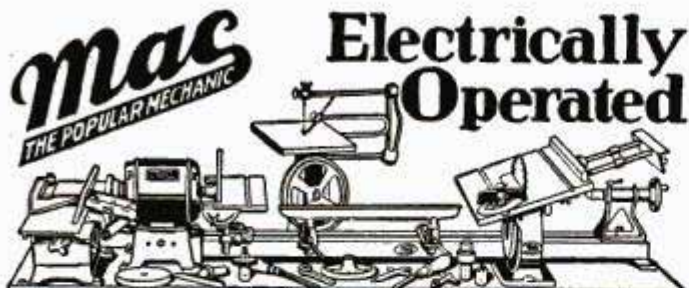

mac
THE POPULAR MECHANIC

Electrically Operated

MAKE IT YOURSELF!

Home Mechanics, Inventors, Model Makers, Craftsmen! Here is a strong, sturdy, practical workshop designed to perform the most intricate feats of woodcraft. With MAC you can produce the most difficult woodworking jobs—and you can do it easily—with little effort. You will be surprised, and your friends amazed when they see the beautiful things you have developed with your own hands—in your own shop.

Now Sent on 10 Days' Free Trial

We will gladly send you this superb craftsman's shop on approval for 10 DAYS' FREE TRIAL. It embraces everything necessary for a complete motorized workshop. 1-3 H. P. Motor; 8 in. Circular Saw, 36 in. Lathe, 4 in. Jointer; sturdy Jig Saw and complete accessories for doing all kinds of wood operations. We guarantee MAC to give the highest degree of service and will take back any equipment if it is not satisfactory. Never before has machinery of this character and quality been sold at the amazingly low prices we quote. **PRICES FROM \$65 UP.**

Small Monthly Payments We will ship this outfit on approval for 10 days' free trial. You can pay for it in small convenient terms as low as \$5.94 per month. The things that you make will be worth many times the small amount you pay.

PLANS AND INSTRUCTIONS FREE

A complete service, including instructions and plans, is furnished free. It is simple to master the art of wood turning. In a very short time under our guidance you will become an expert cabinet maker. We'll help you to develop your mechanical talents.

WRITE TO-DAY FOR COMPLETE DETAILS

Just send us your name and address and we will mail without obligation literature illustrating and describing MAC—The POPULAR MECHANIC Workshop and details of our liberal monthly terms. **WRITE TODAY—DO NOT DELAY.**

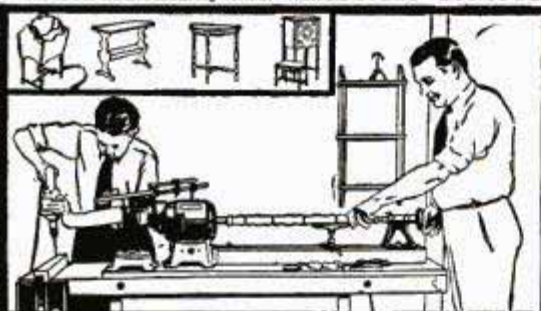

MIDLAND APPLIANCE CORP.

Dept. 1010 225 N. Michigan Ave. CHICAGO



Ford Owner Stop that ruinous chatter on your car. **MAKE THIS TEST**—take out your floor boards, pull your emergency brake back and forth. If you notice play at the ball joint, you need Bredar's Ball Shim. Price \$1.50. Ask your Dealer or order direct. Demand Bredar's Shim.
NIC BREDAR'S SON MFG. CO., Rock Island, Ill.

ELECTRIFY YOUR RADIO FOR ONLY \$6.85 COMPLETE

Why discard your present good set when you can electrify it for only \$6.85, and banish the annoyance and expense of buying new "B" batteries?

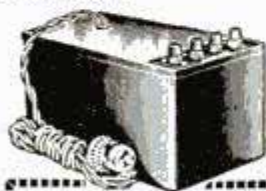

Over 100,000 Townsend "B" Power Units in Use

Hooked up in a few minutes. Use same tubes—no changes. You'll be amazed at the improvement in reception and distance getting. Send name and address today for full details, proof and Free Trial Offer.

TOWNSEND LABORATORIES
715 Townsend St., Chicago, Ill.

Please send me full information on the Townsend "B" Power and Free Trial Offer.

Name.....
Address.....
City.....State.....

See Miles Away

Big 3 1/2 Ft. Telescope

Lend wings to your eyes! People and objects miles away seem close. Wonder telescope brings new pleasures to home, farm, camp, travel, sport. Study the mysterious Sun spots; see Moon and Stars as never before. See people on the beach, on the mountains, etc.

FREE Yes, absolutely free! A handsome leatherette Carrying case and Shoulder Strap. Also Solar Eye Piece to view the sun—a special feature, found only on expensive instruments.



SEND NO MONEY

On delivery of Telescope, free Case, Strap and Eye Piece pay Postman only \$1.85, plus postage (2 complete outfits \$3.50), or send price with order and we'll pay postage. Satisfaction guaranteed or money refunded. Send today, entertain your friends! Be first.

FERRY & CO., Dept. 179, Chicago, U. S. A.

5 Sections
8 Power Lenses
Brass bound; measures 12 in. closed; powerful achromatic lenses protected by dust caps.
Thousands Pleased
Thousands who have ordered this big telescope have written us how delighted they are—how much fun they have had. Satisfaction guaranteed.

5 DAY TRIAL

Beach Views

Build and Fly America's Popular Sport Plane



\$199 brings complete kit to construct the Heath Super Parasol. Fly it from our Airport for \$975. Complete detailed shop prints at \$5 per set. 10c brings large illus. booklet.

Heath Airplane Company 1721-29 Sedgwick Street, Dept. P-10, CHICAGO, ILL.

AMAZING NEW TABLECLOTH



LOOKS LIKE LINEN WASHES LIKE OILCLOTH

New material rivals Irish linen in appearance—washes without laundering. Stainproof. Does not crack, peel. Saves time, laundry bills. A five piece set given to all agents.

AGENTS
\$15 daily easy! Write for Free Sample Offer and full details.

National Industries, 67 E. Lake, Dept. 15-J, Chicago

Green Top Gas Saver, Lubricator and Carbon Remover, complete, including one quart of oil and installation fittings \$3.45



GREEN TOP has only one simple adjustment controlling oil and carbon-removing solution. Adaptable to any gasoline engine. Can be regulated to use the amount of oil required by different types of motors. Attaches to dash, where most convenient to intake manifold. Easily attached in a few minutes by anyone. Saves gasoline, increases power, speed and pick-up. Prolongs life of motor. **GREEN TOP SUPER OIL** is a perfect lubricant. Will not cause excessive smoke or foul spark plugs. Can be purchased from us at 80c per quart. Order your **GREEN TOP** today. Agents Wanted.

GREEN TOP PRODUCTS CO.
Dept. P. M., 1706 S. State St., Chicago



HUNDRED HUNTING HOUNDS

Cheap. Fur Finders. Money Makers. Dog Feed. Remedies. Collars. Hunting, Fishing, Camping Equipment. Agents Wanted. *Catalog.*

KASKASKIA, M-144, Herrick, Ill.



BUILD "FLYING CLOUD"

Send for quality parts and clear blueprints of 20" model. Readily made in spare hours as hull fully shaped and sanded. Set includes anchor, bell, capstan, dead eyes, wheel, rigging line, etc. Complete for \$11. Postage 5 lbs. White metal figure-head 50c. Send 10c today for catalog and folder on clipper ships.

R. E. HANCOCK
323 Douglas Ave. Portsmouth, Va.

"I was in a rut, Ed --but I've got going in big pay work now"



ARE you earning \$25 to \$75 a day, month in and month out? Or are you still sweating in the wage struggle—with future advancement blocked by other men?

This ad tells about a *new profession*—Clarke FlorKraftsmanship. In it over 1600 Popular Mechanics readers now earn big, steady, year round incomes. You can become a FlorKraftsman without buying any course of study or set of books. This tells how.

There's not a bit of magic about FlorKraftsmanship. It's simply the plain honest job of surfacing floors in new buildings (or resurfacing those in old) to velvet smoothness.

A machine—one of the most amazing pieces of wood surfacing machinery ever built—does the work. You get the profits. And these are \$25 to \$75 (sometimes considerably more) per day.

What It Pays

You come onto the job with your 31-pound Clarke Vacuum Portable Sander, hook it into a light socket and start over the floors just as though you were running a vacuum cleaner—and almost as easily. The Clarke surfaces 800 to 2,000 square feet a day (experienced men do far more). Contractors pay 3 to 5 cents per square foot for floor surfacing. Right at the start that's \$25 to \$50 a day you earn. And as you get faster with experience *your pay goes up to \$75 a day or even more!* That's why so many Popular Mechanics readers who became FlorKraftsmen after reading ads just like this, now write Clarke

such wonderful letters about their earnings. That's why there's such an opportunity in FlorKraftsmanship for you.

Start Toward Financial Independence

Do you want the things money buys? A shining new auto—perhaps a home of your own some day—and money in the bank? Then why not take the first step toward financial independence? These other Popular Mechanics readers did just that. They mailed a coupon like the one printed below direct to Clarke, the pioneer maker of Electric Portable Sanders. About \$100 is all you need to get going in this profitable business. You will find the Clarke quickly pays for itself.

No cost or obligation to you in sending this coupon today. It will bring you the full valuable information about what FlorKraftsmanship is and what it pays.

What Users Say:

I bought a Clarke Sander some two weeks ago. Like it fine. Have done over \$200.00 worth of work with it already.

—J. M. Frazier,
Alturas, Calif.

I have tried my little "Gem" Sander out and I certainly think it is a dandy. I have tried it on most all kinds of floors and it is a go-getter.

—J. G. Jones,
Jackson, Tenn.

The machine I bought from you is a wonder, and am getting more work than I can do.

—Louis Glommen,
Suttons Bay, Mich.



Clarke Sanding Machine Co.

Dept. T-210, 3831 Cortland St., Chicago, Ill.

Originators and, for over 12 years,
Manufacturers of Portable Sanding Machines.

USE THIS COUPON

Clarke Sanding Machine Co.,
Dept. T-210, 3831 Cortland St., Chicago, Ill.
Gentlemen: Please send me your free booklet
"Pointing The Way"; with full details of the
Clarke Sander and the money-making possibilities
of FlorKraftsmanship; without obligation
to me.

Name.....

Address.....

City.....State.....

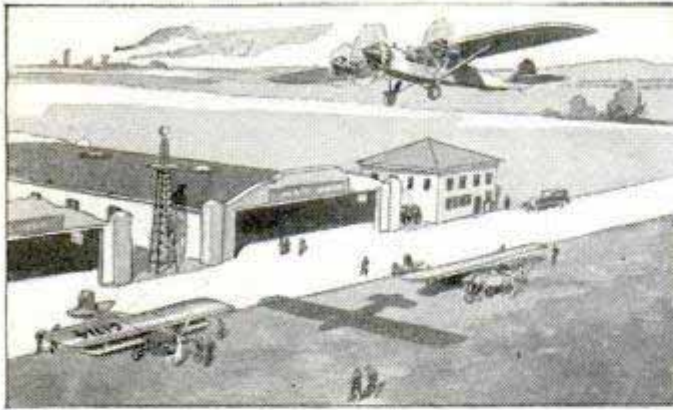

Get into the Air from the Ground!

AVIATION holds the greatest future of any vocation a young man can choose today. Get into it *now*, by the shortest, most practical route—from the ground, as a mechanic.

With the new course in Aviation Engines offered by the International Correspondence Schools, you can quickly gain the knowledge that will qualify you as an expert aviation mechanic. The lessons were written by such experts as Lieut. Commander D. M. Carpenter, U.S.N., formerly in charge of ground training at the Pensacola Naval Air Station.

The course includes a study of the necessary Mathematics, Mechanical Principles, Heat and Its Effects, Combustion and Fuels, Principles of Gas Engines, including the newer Diesel-type engines, Construction of all present-day Aviation Motors, Carburetion, Ignition, Lubrication and Cooling, Pumps, Propellers and other accessories, Aviation Engine Management, Repair and Maintenance.

You can start at *once*. No need to give up your present job. You can study at *home* in spare time.

It costs nothing to find out all about this splendid new course in Aviation Engines, or any other I. C. S. course that interests you. Mark and mail the coupon *today!*

INTERNATIONAL CORRESPONDENCE SCHOOLS

"The Universal University"

Box 5641-F, Scranton, Penna.

Without cost or obligation on my part, tell me how I can qualify for the position or in the subject *before* which I have marked an X.

AVIATION ENGINES

- | | |
|-------------------------------------------------------------------------|----------------------------------------------------------------------|
| <input type="checkbox"/> Complete Automobile Course | <input type="checkbox"/> Gas Engine Operating |
| <input type="checkbox"/> Automobile Electric Equipment | <input type="checkbox"/> Complete Gas Engine Course |
| <input type="checkbox"/> Electrical Engineering | <input type="checkbox"/> Architect |
| <input type="checkbox"/> Electric Lighting | <input type="checkbox"/> Architects' Blueprints |
| <input type="checkbox"/> Mechanical Engineer | <input type="checkbox"/> Contractor and Builder |
| <input type="checkbox"/> Mechanical Draftsman | <input type="checkbox"/> Architectural Draftsman |
| <input type="checkbox"/> Machine Shop Practice | <input type="checkbox"/> Concrete Builder |
| <input type="checkbox"/> Railroad Positions | <input type="checkbox"/> Structural Engineer |
| <input type="checkbox"/> Civil Engineer <input type="checkbox"/> Mining | <input type="checkbox"/> Chemistry <input type="checkbox"/> Pharmacy |
| <input type="checkbox"/> Surveying and Mapping | <input type="checkbox"/> Agriculture |
| <input type="checkbox"/> Plumbing and Heating | <input type="checkbox"/> Navigation |
| <input type="checkbox"/> Steam Engineering | <input type="checkbox"/> Mathematics <input type="checkbox"/> Radio |

BUSINESS TRAINING COURSES

- | | |
|------------------------------------------------|-------------------------------------------------------------------------|
| <input type="checkbox"/> Business Management | <input type="checkbox"/> Salesmanship |
| <input type="checkbox"/> Industrial Management | <input type="checkbox"/> Advertising |
| <input type="checkbox"/> Personnel Management | <input type="checkbox"/> Business Correspondence |
| <input type="checkbox"/> Traffic Management | <input type="checkbox"/> Show Card and Sign Lettering |
| <input type="checkbox"/> Accounting and C.P.A. | <input type="checkbox"/> Stenography and Typing |
| Coaching | <input type="checkbox"/> English <input type="checkbox"/> Civil Service |
| <input type="checkbox"/> Cost Accounting | <input type="checkbox"/> Railway Mail Clerk |
| <input type="checkbox"/> Bookkeeping | <input type="checkbox"/> Common School Subjects |
| <input type="checkbox"/> Secretarial Work | <input type="checkbox"/> High School Subjects |
| <input type="checkbox"/> Spanish | <input type="checkbox"/> Illustrating |
| <input type="checkbox"/> French | <input type="checkbox"/> Cartooning |

Name.....

Street Address.....

City..... State.....

Occupation.....

If you reside in Canada, send this coupon to the International Correspondence Schools Canadian, Limited, Montreal,

The Model A Ford Car

is treated in a special supplement to the latest edition, the 15th, of

Dyke's Auto Encyclopedia

For 15 years "Dyke's" has been the one recognized and undisputed authority on the Automobile. Each succeeding edition has surpassed the last one. Now comes the greatest book of all—the wonderful 15th Edition—A. L. Dyke's crowning triumph—the super auto book of all times.

Some "High Spots" of the New Book!

- 1,249 pages covering every known auto fact.
- 4,200 Pictures, Plans, Diagrams and Charts.
- 15,000 lines of Index by which you can instantly locate any subject you want.
- A new section of "Trouble Shooting" Charts in Colors to enable you to quickly locate any major or minor trouble on any car.
- Special instructions on testing and adjusting every part of the automobile.
- Specifications of Gasoline Passenger Cars, Trucks and Tractors.

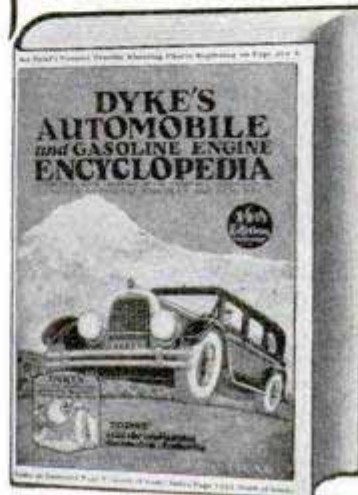

Specifications for Replacements, Accessories, Interchangeable Parts and Equipment.

Large colored Combination Chart which shows the working principles of the Automobile.

Large Charts showing the working principles of Trucks and Tractors.

Cloth \$6.00; Limp American Morocco \$7.50

Sent postpaid upon receipt of price.

Will be sent C. O. D. if preferred to any address in the U. S.

POPULAR MECHANICS PRESS
Room P-10
200 E. Ontario St.,
Chicago



ATTRACTIVE NEW BINDERS

For Popular Mechanics Magazine
In your choice of colors; blue, green, brown, red or black. We recommend these beautiful and durable art binders to libraries, schools, reading rooms and our readers generally.

An Ornament To Any Reading Table

Price \$1.25 Each
Postpaid

Your name in gold on the front cover for 25 cents additional.

Address.....

You will be delighted with the artistic waterproof covers in colors and other improved features. ■

Popular Mechanics Company, 200 E. Ontario St., Chicago

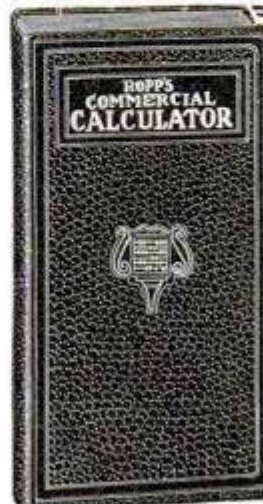

Mathematics Made Easy by ROPP'S CALCULATOR AND SHORT-CUT ARITHMETIC

Shows the Answer as Quickly as a Watch shows the Time to all Problems likely to occur in the Office, Store, Shop, Bank, Farm, or Factory.

Over 2,000,000 Sold
Explains and simplifies every principle in Arithmetic, Mechanics, and Mensuration.

PRICES POSTPAID
Desk Size, Flexible Keratol Binding..... \$2.00
Pocket Size, Art Leather Binding..... \$1.00
Pocket Size, Cloth Binding, \$0.50

POPULAR MECHANICS PRESS
Room P-10 200 E. Ontario St. Chicago

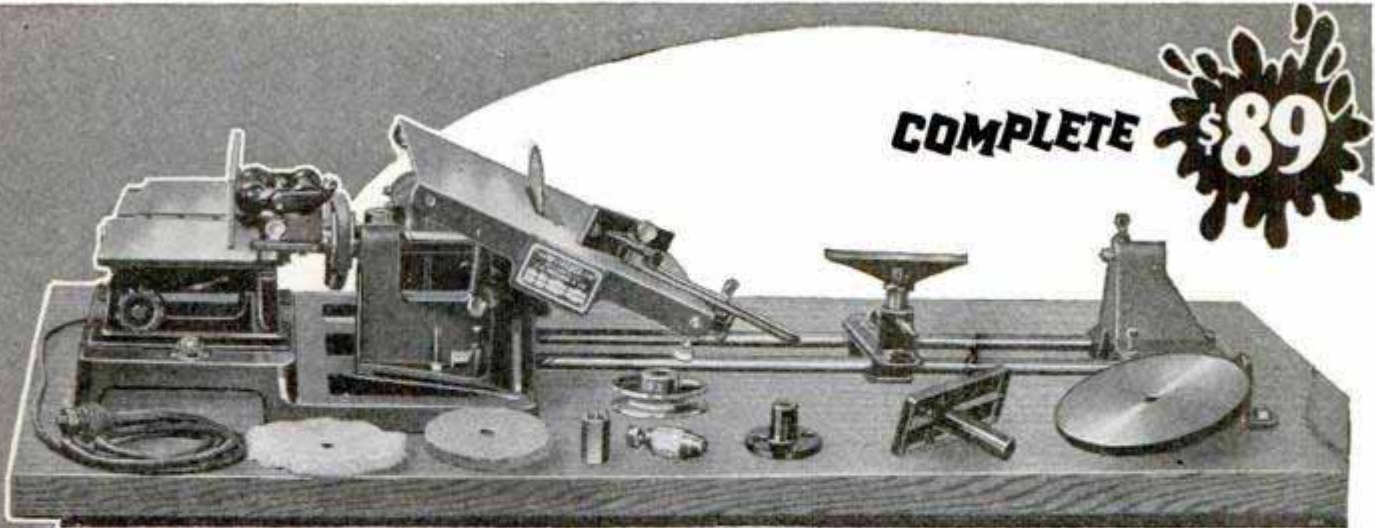

WORKACE Electric WOODWORKER

Recognized everywhere as the standard outfit for home and commercial use!



Jig Saw Attachment for the Workace Electric Woodworker..... **\$10**

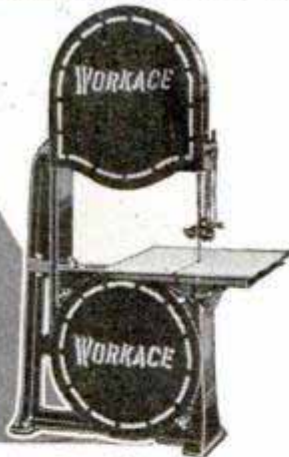

14" Workace Band Saw, fast accurate, economical..... **\$75**

The most complete all-electric wood-working shop made. It's guaranteed for one year against defective parts and you can have it for only \$9 down. The Workace is fast, accurate, powerful and easy to work with; can be made to pay for itself either as a hobby or as commercial woodworking equipment. Nothing like it sold or advertised. Send for complete illustrated description of the Woodworker and other portable machines.

J. D. WALLACE & COMPANY
 ADAMS STREET AT CALIFORNIA AVENUE
 45 WEST 45th STREET, NEW YORK CITY
 268 MARKET STREET, SAN FRANCISCO

Consult telephone directory for branch addresses in other cities

Low Price

includes all this:

- 4" Planer
- 8" Circular Saw
- 6"x36" Lathe
- 8" Disc Sander
- 6" Buffing Wheel
- 5" Emery Grinder
- 1/4" Drill Chuck
- 1/4 H. P. G. E. Motor, 110-Volt, A.C., 60 Cycle.

Endless V-Belt, two 4" and one 2 1/4" V-Belt Pulleys, Cast Iron Sub Base and 10 ft. Cable with separable Plug. The Planer and Circular Saws are each complete units and may be purchased separately at the correspondingly low price of \$25.00 each.

EASY TERMS

\$9 down

\$9 per month

MAIL THIS COUPON



Workace high speed, direct drive, portable Electric Shaper **\$95**



Workace Radial Saw quickly set at any angle..... **\$140**



Workace Portable 4" Planer..... **\$25**

J. D. WALLACE & COMPANY,
 Adams St. at California Avenue,
 Chicago, Illinois

I want to know all about the Workace Electric Woodworker. Also interested in (Jig Saw) (Band Saw) (Radial Saw) (Shaper) (Planer)

Name.....

Address.....

PILOT presents PILOTRONS



"BUILT FOR PROFESSIONALS"

PILOTRONS are made especially to meet the exacting requirements and super-critical judgment of professional radio engineers, custom set-builders and advanced radio experimenters. Moreover, newly developed Pilotrons are available long before similar-type tubes can be obtained from the usual sources. This enables you to use new-type tubes many months before they appear in manufactured receivers. Pilot's self-contained manufacturing policy provides definitely superior tubes at less than usual prices!

Explore the Short Waves

Would you know the thrill of roaming the world with a Super-Wasp? Of bringing in nightly international programs from the far corners of the earth? For a few dollars and a few hours "work" using only screw driver and pliers, you can assemble the Pilot Double Duty Super-Wasp, a combination short-wave and broadcast receiver utilizing the super-sensitive screen grid! Covers all wave bands from 14 to 500 meters. Hear this dissolver of distance at nearest Pilot Authorized Agency!



Custom Set-Builder's
Price

\$29⁵⁰

Slightly Higher West
of the Rockies

TRADE MARK



REGISTERED

Qualified Dealer's Opportunity!

The custom-set builder and radio construction fan prefers the Pilot Authorized Agent because of his technical knowledge and stability. Technically qualified and financially responsible dealers write for full details of Pilot's Agency Plan.

Radio's Biggest 50c Value

For 50c you receive 4 issues of Radio Design, Quarterly Magazine and one year's membership in Radio International Guild—a world-wide organization offering many advantages to radio enthusiasts. Send 50c to Radio Design, Dept. F, 103 Broadway, Brooklyn, N. Y.

PILOT RADIO & TUBE CORP.

WORLD'S LARGEST RADIO PARTS PLANT

323 BERRY STREET
BROOKLYN NEW YORK
U. S. A.

Start to Play Very First Day

This Year Give Yourself
Lifelong Fun
Profit and
Popularity



PARENTS!

What greater gift can you confer on your children this year than lifelong fun and entertainment?

Love of music means love of home, an appreciation of the finer things in life. Here is a chance to give your boy or girl that love without the tedious practice that most instruments require. The Xylorimba is easy to play. No teacher is needed. Practice is actually a joy.

Remember, the Xylorimba is the guaranteed product of a company established nearly half a century ago—a company that stands back of every promise it makes.

THINK of the best gift you have ever received. Multiply the pleasure it gave you by ten, and still you have only an idea of the joy you can give yourself right now if you act at once!

Start to Play the Very First Day!

Haven't you, like millions of others, envied the fellows who "bring down the house" with snappy xylophone or xylorimba numbers? Haven't you longed to create your own music, to be looked up to wherever you go, to be able to make real money in spare time? If you have, this ad spells O-p-p-o-r-t-u-n-i-t-y. The xylorimba—wonderful for home, in demand at dances and gatherings—is nevertheless the *easiest of all instruments to play*. In fact, on the very day you get yours you play simple melodies, even if you can't read a note of music right now. In a few weeks you astonish your friends and family. *All your life* you have the joy that comes to those who can entertain.

Plays 20 Minutes; Gets \$20!

Ralph Smith, Chicago, played twenty minutes at wedding; his "pay" was \$20. Altho only 12, Turk McBee, Jr., plays big-time vaudeville exclusively. Harry Breuer, New York, has

made thousands of friends thru his xylophone selections on the radio. L. E. Hallman, Reading, Pa., writes: "Made \$300 in 5 weeks—spare time."

And now J. C. Deagan, Inc., (world's largest manufacturer of xylophonic instruments) has made it so easy to own a xylorimba that nothing stands in your way. Sizes and styles to fit every age and pocketbook. A five-day free trial that eliminates risk. Free, easy lessons that make teacher unnecessary—and, best of all, such easy payments that they are hardly noticed.

Will You Investigate?

Everyone wants to be popular. Everyone wants to make extra money. Everyone wants to be *center of attraction* at gatherings. But these advantages don't come by themselves. Opportunities must be seized. This is *your* opportunity—will you pass it up without investigation? The accompanying coupon will bring our big FREE book to your door. It tells all about the Deagan line, the free trial, the easy payments. Remember, no cost or obligation! Simply fill in and mail the coupon—but do it before it slips your mind. Today is as good a day as any. Do it NOW!

YOUR
MAGIC
KEY

to Popularity

Mail
Now!

Send for
BIG FREE
Book!

Please send me full details on the Free Trial offer and easy payment plan of the Deagan Xylorimba.

J. C. DEAGAN, Inc.
Dept. 1457, 1770 Berteau Avenue, Chicago

Name _____
Address _____
City _____
State _____

Good taste
will always
discover

Camels

