

POPULAR MECHANICS

MAGAZINE

WRITTEN SO YOU CAN UNDERSTAND IT

REG'D TRADE MARK GREAT BRITAIN NO. 410420

REG. U.S. PAT. OFF.



SEE PAGE 811

WACH

Suppose somebody said—

“I can add 10% to 30% more power to your engine.
I can preserve its first-year feel for 30,000 miles.”

You'd want to know **how** and **why**.
The **“how”** is the New Mobiloil.
The **“why”** is told below.

IN spite of our scientific prejudice against superlative language, we are prepared to make some very strong statements about the *New Mobiloil*.

For example: We are willing to say that use of the New Mobiloil will help your engine develop 10% to 30% more power than other oils generally sold for the same motor. Our road and laboratory tests have bettered the higher figure.

Our assurance that the New Mobiloil will stand up better and consume more slowly under high speed is a conservative reflection of the speed-test records made in thousands of miles of running at the Atlantic City Speedway. And it is an established engineering fact that the oil which lasts longest and stands up best at high speed lubricates best at any speed.

We believe that, with regular draining and refilling, and with reasonable care of your car, the New Mobiloil will keep the first-year feel in your new engine for at least 30,000 miles. Actually, Mobiloil has preserved the first-year feel in many engines for more than twice this distance.

VACUUM OIL COMPANY
Makers of high quality lubricants for all types of machinery

the New  **Mobiloil**

Make this chart your guide

It shows the correct grade of Gargoyle Mobiloil for certain prominent cars. If your car is not listed below, see complete Mobiloil Chart at your Mobiloil dealer's.

NAMES OF PASSENGER CARS	1929		1928		1927		1926	
	Engine		Engine		Engine		Engine	
	Summer	Winter	Summer	Winter	Summer	Winter	Summer	Winter
Auburn, 6-66.....	BB	Arc.	BB	Arc.	BB	Arc.	A	A
" 8-cyl.....	BB	Arc.	BB	Arc.	BB	Arc.	A	A
" other models	A	Arc.	A	Arc.	A	Arc.	A	A
Buick.....	BB	Arc.	BB	Arc.	BB	Arc.	A	Arc.
Cadillac.....	BB	Arc.	BB	Arc.	BB	Arc.	BB	Arc.
Chandler Special Six			A	Arc.	A	A		
" other models	A	Arc.	A	Arc.	A	Arc.	A	Arc.
Chevrolet.....	A	Arc.	A	Arc.	A	Arc.	A	Arc.
Chrysler, 4-cyl.....			A	Arc.	A	Arc.	A	Arc.
" Imperial...	BB	Arc.	BB	Arc.	A	A	A	A
" other models	A	Arc.	A	Arc.	A	A	A	A
De Soto.....	A	Arc.						
Dodge Brothers.....	A	Arc.	A	Arc.	A	Arc.	A	Arc.
Durant.....	A	Arc.	A	Arc.			A	Arc.
Erskine.....	A	Arc.	A	Arc.	A	Arc.		
Essex.....	A	Arc.	A	Arc.	A	Arc.	A	Arc.
Ford, Model A.....	A	Arc.	A	Arc.				
" Model T.....					E	E	E	E
Franklin.....	BB	Arc.	BB	Arc.	BB	BB	BB	BB
Gardner, 8-cyl.....	BB	Arc.	BB	Arc.	BB	Arc.	A	Arc.
" other models							A	A
Graham-Paige.....	BB	Arc.	BB	Arc.				
Hudson.....	A	Arc.	A	Arc.	A	Arc.	A	Arc.
Hupmobile.....	BB	Arc.	BB	Arc.	A	Arc.	A	Arc.
La Salle.....	BB	Arc.	BB	Arc.	BB	Arc.		
Marmon, 8-cyl.....	A	Arc.	A	Arc.	A	Arc.		
" other models			BB	A	A	A	A	A
Moon.....	A	Arc.	A	Arc.	A	Arc.	A	Arc.
Nash, Adv. & Sp. 6.	BB	Arc.	BB	Arc.	BB	Arc.	A	Arc.
" other models	A	Arc.	A	Arc.	A	Arc.	A	Arc.
Oakland.....	A	Arc.	A	Arc.	A	Arc.	A	Arc.
Packard.....	A	Arc.	A	Arc.	A	Arc.	A	Arc.
Peerless, 72, 90, 91...	BB	A	BB	A	BB	A	BB	A
" other models	A	Arc.	A	Arc.	A	Arc.	A	Arc.
Plymouth.....	A	Arc.						
Pontiac.....	A	Arc.	A	Arc.	A	Arc.	A	Arc.
Reo.....	A	Arc.	A	Arc.	A	Arc.	A	Arc.
Stearns Knight, 6-80.	BB	Arc.	BB	Arc.				
" other models	BB	A	BB	A	BB	A	BB	A
Studebaker.....	A	Arc.	A	Arc.	A	Arc.	A	Arc.
Velie, 8-cyl.....	BB	Arc.	BB	Arc.				
" 6-cyl.....	A	Arc.	A	Arc.	A	Arc.	A	Arc.

CASH
 When YOU need
 it most
A \$10 Bill
 Protects YOU and
 Your FAMILY against
SICKNESS
 and
ACCIDENTS
 FOR A WHOLE
 YEAR

**WHEN
 You Are
 SICK
 or
 HURT**

SUPPOSE you meet with an accident or sickness tonight—will your income continue?

Remember, few escape without accident—and none of us can tell what tomorrow holds for us. While you are reading this warning, somewhere some ghastly tragedy, flood or fire, some automobile or train disaster is taking its toll of human life or limb. **NOW IS THE TIME TO PROTECT YOURSELF.**

If you suddenly become ill—would your income stop? What if you suffered from lobar pneumonia, an appendicitis operation, or any of the many common ills, which are covered in this unusual policy; wouldn't you rest easier and convalesce more quickly if you knew that our company stood ready to help lift from your shoulders, the distressing financial burdens in case of a personal tragedy? **PROTECT YOURSELF NOW!**

Largest and Oldest Exclusive Health and Accident Insurance Company in America.

Under Direct Supervision of 48 State Insurance Departments

ESTABLISHED OVER 42 YEARS

MAIL COUPON TODAY

North American Accident Insurance Co. [of Chicago]
 298 Bonnell Building, Newark, New Jersey.

GENTLEMEN: At no cost to me send details of New \$10,000 Premium \$10 Policy.

Name.....

Address.....

City.....

Mail the Coupon Today!

Mail the Coupon before it's too late to protect yourself against the chances of fate picking you out as its next victim.

**Don't
 Wait For
 Misfortune
 To Overtake
 You**

NO MEDICAL EXAMINATION
\$10 A Year Entire Cost.
 No Dues. No Assessments.
MEN AND WOMEN
 16 to 70 Years Accepted
\$10,000
 Principal Sum.
\$10,000
 Loss of hands, feet or eyesight.
\$25 Weekly Benefits
 for stated Accidents or Sicknesses

Doctor's Bills, Hospital Benefit, Emergency Benefit and other liberal features to help in time of need—all clearly shown in policy.

This is a simple and understandable policy—without complicated or misleading clauses. You know exactly what every word means—and every word means exactly what it says.

AGENTS wanted for New Territory.



Planning high-speed business

*An Advertisement of the
American Telephone and Telegraph Company*

MORE than 95% of the telephone calls from one town to another in the Bell System are now on a high-speed basis. This holds whether the call is from New Orleans to Boston or from New York to Oyster Bay.

Even if it is a long call, the operator in many cases now asks you to hold the telephone while the call is put through.

Calls from one town to another used to be handled by one operator taking your order and giving it to another group of operators to put through. You now give your call direct to the operators who put it through—and put it through fast



while you are on the line. The average time for handling all toll and long distance calls in the Bell System was further materially reduced in 1928.

A high-speed service to all parts of the country—calls from one town to another as swift, clear and easy as local calls—that is the aim of the Bell System.

This is one of the many improvements in methods and appliances which are constantly being introduced to give high-speed telephone service. Better and better telephone service at the lowest cost is ever the goal of the Bell System.

“THE TELEPHONE BOOKS ARE THE DIRECTORY OF THE NATION”

Popular Mechanics Magazine

200 E. Ontario Street, Chicago, U. S. A.

H. H. WINDSOR, Founder

H. H. WINDSOR, Jr., Editor and Publisher

London: Hachette & Cie.,
16-17 King William Street, Charing Cross, W. C. 2

Paris: Hachette & Cie.,
111 Rue Reaumur

Melbourne: Gordon & Gotch
509-513 Little Collins St.

ISSUED MONTHLY

SUBSCRIPTION:

SINGLE COPY, 25 CENTS

In United States and its possessions, also Canada, Cuba, and Mexico, per year, postpaid - \$2.50

To all other countries in the Postal Union - - - - - 3.00

All subscriptions are discontinued at expiration. Please examine the date printed on your wrapper.

Entered as Second Class Matter Sept. 15, 1903, at the Post Office at Chicago, Illinois, under Act of March 3rd, 1879.

Entered as Second Class Matter at the Post Office Department, Canada.

Published monthly by POPULAR MECHANICS CO.

Copyright, 1929, by Popular Mechanics Co.

Copyright in Australia. Copyright in France

Vol. 51

Contents for May, 1929
Special Features

No. 5

ello Below	723
e Gold Rush in Cannibal Land	732
3 New Navies	738
ring through Your Fingers	755
oked Holes	760
cks of the Auto Thief	770
hting Mysterious Diseases	778
on Men of the Lighthouse Service	786
Secrets of the Polar Sea	794
Lifting a River Out of Its Bed	802
Static Speaker—New Radio Marvel	818
Agriculture—berries ripen in forty days with electric lamps	800
Airplanes	
equipped with three-wire radio aerial	721
pigeons carried in, to rescue flyers	817
to make malaria fight in Nicaragua	784
Animals—four little-known subjects of Uncle Sam	783
Automobiles	
drivers test speedometers on mile-long stretch	754
seek new speedmark with streamline car	752
Automobiles—Accessories	
foot scraper on running board	749
gas-filled stoplight	816
jack cranked at side simplifies raising car	737
suction-grip cigar lighter	757
vacuum cup fastens watch to dash	753
Automobiles—Cleaning—auto runs washer pump	766
Automobiles—Driving—signal arm for closed car	809
Automobiles—Fuel—synthetic benzine process to aid Germany	791
Automobiles—Tires	
air from spare inflates flat	801
shock absorbers add life to	758
Automobiles—Touring—roller maps for autoists	813
Automobiles—Truck—extra wheels on Ford "AA" doubles its capacity	785
Aviation	
"beehive" airport and hotel to hold many planes	816
face mask permits free breathing	798
gas tank directs aviators to landing field	757
heavier fuel to aid	793
mirage seven miles in air described by flyers	766
safer, cuts insurance cost	737
seaplanes speed up mining in Canadian fields	765
Bank—coin sorter and counter saves time	823
Bees—have poor eyesight, tests show	823
Bicycle—snap spring luggage carrier	753
Birds—mystery, land on ship at sea	793
Boats and Boating—speed boat in somersaults	808
Bricks	
blade removes mortar and pries apart	800
see hundred-story building as result of new	736
Bridges	
arch, in Australia to have record span	759
painters risk life on St. Lawrence river	817
Buildings—of non-rust steel has novel lighting	769
Cable—joining ocean, calls for special hands	799
Chandelier—weighs over ton	799
Clothing—paper, is washable	816
Crime—steel armor in folding kit protects policeman	785
Electricity	
circuit breaker stops flash	813
in small towns shows industry's growth	809
Electric Wire—oiled cover on simplifies installation	728
Electric Wiring—steel tube to hold	754
Erosion—soil, stopping is urgent need	749
Fire Hose—holder for nozzle	808
Fires—electric "eye" sees smoke and puts out	793
Rish and Fishing—worms given special diet make better bait	801
Floors—steel armor for concrete	793
Garage—twenty-four story, holds thousand cars	810
Glass—tinted for greenhouse	799
Golf	
"gun" holds balls on outside of bag	728
tee is set at angle for longer drives	768
wire net on club head helps recover balls	799
Homes—models of aid builder and buyer	823
Household Devices	814
House Plan	879
Ice—colored cubes	822
Ice Pick—with spring handle	808

[Continued on Page 4]

Cooling cabinet P/3

Cigaret lighter
in pencil 731

Inventions—how some of the world's familiar looked at birth	750
Knapsack—for hunters holds ammunition and food	753
Lake—vast salt lake is planned to water the Sahara	753
Life Saving	
buoy to carry life line	777
latest invention for saving lives at sea	811
Lighting—masterpiece in, seen in store's exterior	731
Magazine—rack for holds many back numbers	775
Mines and Mining—refrigeration to aid workers	777
Moving Pictures	
editing of home movies	792
electric shocks direct actor in talking films	721
film shutter stops flicker	801
home-movie title writer	736
in three dimensions by new screen	798
of beating heart to aid doctors	752
of city under the sea	785
Nicaragua Canal—to save time in shipping	798
Paints and Painting—automatic painter for wall	766
Pencil—on extension cord	764
Photography	
home-movie film enlarger	731
travel of flame from explosive snapped by camera	752
Plants—germ spray routs pests	808
Postcard—made from fir tree	753
Radiator—table on top of helps protect walls	810
Radio	
latest from the radio shops	824
mystery of echoes perplexes engineers	800
new parts for screen-grid circuits	833
new unit of many uses	828
tips from the laboratory	836
using lamps as resistance units	827
Radio—Application—radio helps to repair ship at sea	816
Radio—Coils—variable resistance replaces filter	834
Radio—Eliminators—A-unit employs three-ampere bulb	833
Radio—Loud Speaker	
battery of horns for sound effect	827
built of concrete	835
compact power amplifier for dynamic	835
Radio—Receivers	
four-tube set operates dynamic speaker	829
operating a.c. apparatus on d.c. supply	827
Radio—Reception	
double impedance amplifier unit	838
filter prevents power line noises	838
wiring suggestion for apartment building	834
Radio—Television	
photo-electric cells of new design	838
red-head actors found best for	754
Radio—Tube	
grid bias for heater type a.c. tube	838
two new	835
Railroads	
robot rides trains to test engines	769
school on wheels reduces accidents	784
Refrigeration—automatic air-cooler cabinet for home	813
Ring—vanity case in	776
Rock—New England picture mystery solved	810
Rubber	
from oil shale to cut cost	730
to make plants pay is real problem	776
Safety Devices and Measures—too-late sign for pedestrians	735
Scooter—skates for child's	776
Sewer—cutter removes tree roots which clog	759
Sewing Machine—small-size carried with one hand	728
Shade Cords—ornaments for	812
Shaving Accessories—mirror set on safety razor	758
Ships and Shipping	
art treasure ship guarded by destroyer escort	764
giant liner to be driven by electric motors	728
land ship aids training of students	757
tug launched by crane	737
Smokers' Accessories—combination cigaret lighter and pencil	730
Snow—boiling water clears street of	731
Sports Track—starting frame for racers	782
Streets—names on curbstones easily read	791
Trapping—trap catches animals alive in wire bag	735
Trapshooting—night is turned into day for shooters	812
Trees	
giant timbers are shipped on special cars	775
immune to disease yields edible nut	736
Tunnel	
electric "eye" to count autos using	730
new plan for English Channel	767
Tweezers—pull with spring to reduce pain	775
Ventilation—fan hidden in chandelier improves	721

Warfare—war tank is run by radio from moving plane	792
Warfare, Aerial	
heat bombs for air raids	785
invisible walls hung in sky to foil planes	749
Water Pipe—guard for house prevents freezing	758
Whales—storm "shipwrecks" on Africa coast	809
Windmill—with six sails to generate power	730

AMATEUR MECHANICS

Automobiles—Accessories—ash receiver is emptied through chute	849
Automobiles—Repairing	
fishing rod aids in removing broken parts of axle	841
how to silence Ford valves	849
repair spacer for door-catch bolt	842
Automobiles—Lubrication—oiling lock wheel on Ford	847
Automobiles—Trailer—simple attachment for	860
Boats and Boating—"pepping up" old outboard motors	839
Camping—spare auto tire supplies compressed air for campers	857
Clothesline—simple tightener for	856
Clothes Press—improvised	860
Drain—under outside door	856
Eardrums—homemade	846
Fence Posts—auto jack for removing	857
Files—hand holder for	847
Fish and Fishing—old bottle caps help catch fish	856
Fruit—preventing quick decay of	849
Furniture—tape used for decorating	847
Glue—electric drill used for mixing	840
Golf—tee tip for golfers	857
Joints, Wood—for the amateur	858
Lamps—water tumbler substitute for night	856
Liquid—saving when pouring	848
Musical Instruments—improving tone of stringed	841
Pans—cleaning burnt	860
Photography	
removing single sheets of photographic paper from box	855
use of slow paper when enlarging photos	847
Pipe, Water—repair for leaky	848
Plants—transplanting tomato	846
Prints—guide helps trim curled	848
Roof—easy method of patching shingle	849
Saws and Sawing—sewing machine head and small motor used to make circular	840
Sodding—a hint on	846
Soldering—vacuum cleaner supplies air for torch	842
Sprinkler—homemade lawn	841
Toys—the fighting saurians	843
Tricks—you can learn to juggle	850
Walnuts—auto used for hulling	855
Wire—straightening fine	857

SHOP NOTES

Bees—earn income by pollenizing fruit blossoms	877
Concrete	
diaphragm protects canal bank from gophers	877
miniature dikes keep moist	867
Dirt Hopper—fitted with wheels	877
Drafting—how to lay out an ellipse	866
Floors—handy chip and dirt blower for repairman	872
Gardening—the latest magic for your garden	868
Lathe—sand disk for small	875
Oats—efficient oat sprouter	873
Photography—use of bakelite in	866
Piano—gluing ivories on keys	872
Pistons—rebuilding old with bronze	878
Porch Columns—method of alining caps and base blocks in setting	864
Roof—device for straightening roof boards	866
Rubber Stamp—guide for on tracing cloth	876
Rule—hammer serves as	873
Sheet Metal—small motor-driven shuttle shear	865
Signs—novel swinging	878
Steam Table—and coffee urn single burner for	874
Stumps—cheap puller for	873
Tools	
for transferring hole locations	878
thread tool forms straightedge	874
two useful tools for home mechanics	861
Tractor—stationary engine starts	867
Trapping—care of animal traps	876
Towing—tow bar steers towed car	874
Vise—pins hold circular parts on	876
Wax—melting rods for, heated with curling iron	873

Enlarger 731

Salto, Rochelle 701

DRAKE'S PRACTICAL MECHANICAL BOOKS

THEY WILL RAISE YOUR PAY—

ORDER ON 5-DAY TRIAL

The books listed below will perfect you in your chosen trade—pave the way to the big positions. Written in non-technical language—easy to read and understand. Every book covers its subject completely. An entire course of instruction condensed into one volume. Your choice sent postpaid—you benefit 5 days—money refunded in full if not entirely satisfactory. Order direct from this page.

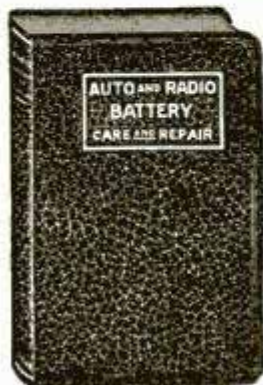

Automobile Books

- Automobile Starting, Lighting and Ignition, by Manly... 700 pp. \$3.00
- Brookes' Automobile Handbook... \$2.00
- Ford Motor Car, Truck and Tractor, by Manly... Cloth \$1.50
- Auto and Radio Battery, Care and Repair, by Manly... Leatherette \$2.00
- Motorecycle Handbook, by Manly... \$1.50



Shop Practice Books

- Practical Heating Systems, Trouble Jobs and Ventilation... \$4.00
- Sheet Metal Workers' Manual... \$2.00
- Oxy-Acetylene Welding and Cutting... Cloth \$1.25
- Slide Rule and Logarithmic Tables... \$2.00
- Handbook for Millwrights... Cloth \$2.00
- Machine Shop Practice... Cloth \$2.00
- Mechanical Drawing and Machine Design... Cloth \$2.00

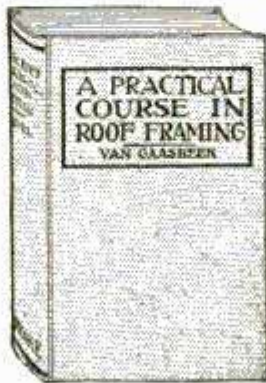

Carpentry Books

- Cloth Binding
- Modern Carpentry, 2 vols... \$3.00
 - The Steel Square, 2 vols... \$3.00
 - Modern Estimator... \$1.50
 - Timber Framing... \$2.00
 - Builders' Architectural Drawing... \$2.00
 - Concretes... \$1.50
 - Practical Bungalows... \$1.00
 - Roof Framing, by Van Gaaasbeek... \$1.50

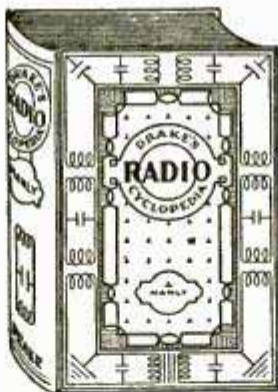

Drake's Radio Cyclopaedia

June, 1928 Edition
By H. P. Manly
920 Pages, 1025 Illustrations, 1700 Subjects, arranged alphabetically. For Service and Repair Men, Dealers, Salesmen, Experimenters and Designers. Bound in Art Buckram. Price... \$6.00



Painting and Decorating

- The Lacquer System of Sign Painting... Cloth \$3.00
- Practical Estimating for Painters and Decorators... Cloth \$2.00
- How to Draw Funny Pictures—a Complete Course in Cartooning... Cloth \$3.00
- Layouts for Advertising... Lea. \$3.00
- Furniture, Furniture Finishing, Decoration and Patching... \$5.00
- Ross Crane Book of Home Furnishing and Decoration... Cloth \$3.00
- House Painting Methods... Cloth \$2.00
- Interior Wall Decoration, by Vanderwalker... Leatherette \$4.00
- The Mixing of Colors and Paints, by Vanderwalker... Cloth \$2.00
- Studio Handbook—Letter and Design... \$3.00
- A Show at Sho' Cards... Cloth \$4.00
- Sign Painting, by Atkinson... Cloth \$4.00
- Strong's Book of Designs, Leatherette \$4.00
- Modern Painters' Cyclopaedia... Cloth \$2.00
- Automobile Painting... Cloth \$1.50
- Wood Finishing, Plain and Decorative... Cloth \$2.00

Steam Engineering

- Swingle's Handbook for Steam Engineers and Electricians... Leatherette \$4.00
- Examination Questions and Answers for Marine and Stationary Engineers... Leatherette \$2.00
- Steam Boilers... Leatherette \$2.00
- Swingle's Catechism of Steam, Gas and Electrical Engineering... Leatherette \$1.50

Modern Languages

- By Prof. P. S. Allen, U. of Chicago
- French without a Teacher... Cloth \$1.25
- Spanish without a Teacher... Cloth \$1.25
- German without a Teacher... Cloth \$1.25
- Everyday French... \$1.25
- Everyday Spanish... \$1.25

ORDER DIRECT FROM THIS PAGE—ON OUR MONEY-BACK PLAN

The books listed above are only a few of the many in our catalogue, which you will receive promptly after filling out and mailing us the attached coupon. For quick action order direct from this page—cross name of each book wanted and send in with price quoted. We prepay postage and send the books on our money-back plan.

FREDERICK J. DRAKE & CO.

Publishers

R508—179 No. Michigan Ave. CHICAGO

Drake Books Are For Sale at All Book Stores

Mail Coupon For Free Catalogue
Your Guide to Home Study

FREDERICK J. DRAKE & CO.
R508—179 No. Michigan Avenue
Chicago, Ill.

GENTLEMEN:—Please send me free, postage paid, your illustrated catalogue which lists and describes 200 Practical Mechanical Books for Home Study.

My name

This one

and my a



R3YQ-87F-8DHC

Higher Accountancy— What does it offer you?

What 15 LaSalle-Trained Accountants Reported During a Single Week!

"I have enjoyed every minute of the work. It has been a wonderful education for me, and will mean the making of a great success."

Glen Black (Ontario, Canada)

"I want to thank LaSalle for the excellent knowledge and coaching received throughout the entire course. You have given me one big thing in life, and that is a desire to promote myself in business."

Jack Cohen (Shanghai, China)

"I was successful in passing the Spring examinations in this state."

Charles Pichetti (Missouri)

"I was successful in passing the C. P. A. examination, and have received my certificate."

F. H. Chant (Massachusetts)

"I not only passed the examination but have been notified that I am to receive the silver medal awarded by the Illinois Society of Certified Public Accountants for passing with honors."

Benton W. Powell (Illinois)

"Passed the California C. P. A. examination held last November."

T. H. Mugford (California)

"Your course was a great help to me in preparing for the C. P. A. examination." Charles Silep (Indiana)

"Not only was I successful in passing the last Manitoba intermediate examination in Accountancy but also had the honor of receiving the W. A. Henderson silver medal, a local award for the best all-around paper turned in on the examination in question."

W. M. MacDonald (Manitoba, Can.)

"I have written nearly 100 applications to prospective employers lately. It may interest you to know that I received about 65 replies, many of them favorable. I have finally accepted a position with a large foundry in Pittsburgh, at an increase in salary, and unlimited future possibilities."

Fred W. Hill (Pennsylvania)

"My salary is greater than before taking this course. I am now Auditor of the company."

R. H. Bennett (Ohio)

"After finishing your course in Higher Accountancy my salary increased 100 per cent. I should like to apply for membership in your 100% Club."

Arthur E. Newell (Virginia)

"As one result, my husband is now Secretary and Treasurer of Warwick Laundries, Inc. We both wish to thank you for the greater prosperity which has come to us as a result of his training by your school."

Mrs. Herbert Hulse (New York)

"My present position, as Assistant Comptroller of the Ranier National Park Company, has been made possible largely through the knowledge and ability gained through LaSalle training."

D. F. Crammond (Washington)

"I owe my present position, which incidentally gave me a salary increase of over 50 per cent, to my knowledge gained from the course."

Lester G. Page (New York)

"Today my salary has increased 350 per cent as a result of taking your course—thanks to LaSalle and the untiring efforts of its associates."

Marshall R. Burson (Texas)

"Of course those cases are exceptional!"

We can almost hear you say it, when we tell you about a clerk who enrolled for LaSalle home-study training in Higher Accountancy and increased his income more than 250 per cent—or about an assistant bookkeeper who within seven years increased his yearly income more than 700 per cent, meantime qualifying for the position of Comptroller.

But again we say, they're not exceptional—just to give you an accurate picture of what we mean when we speak, for example, of "thousands of success-reports in the files of LaSalle Extension University," we are summarizing here fifteen reports from *Higher Accountancy members only, received during a recent single week.*

Note the enthusiasm which these men express for LaSalle training. "I have enjoyed every minute of the work," writes Glen Black. "You have given me one big thing in life . . . a desire to promote myself in business," writes Jack Cohen, out in Shanghai, China.

Note that four of the fifteen report passing the C. P. A. examinations, in as many different states—and that two others report successful progress toward that goal.

Note that six report definite promotions, one of them giving credit to LaSalle for a 350 per cent increase in salary!

Send for Salary-Increasing Plan

Do you appreciate what accountancy means in the business world? Do you realize that it is a necessary factor for the success of every business undertaking? Do you know that the expert accountant commands \$3,000, \$5,000, \$10,000 a year and has a favored route to general executive positions?

Why let the other fellow walk away with these better jobs, when right in your own home you can equip yourself for a splendid future in this profitable profession?

Under the LaSalle Problem Method you can acquire a thorough understanding of Higher Accountancy, master its fundamental principles, become expert in the practical application of those principles—this without losing an hour from work or a dollar of pay.

Your training will be under the direct supervision of William B. Castenholtz, A. M., C. P. A., former comptroller and instructor, University of Illinois, member of American Institute of Accountants, and a director of the National Association of Cost Accountants. He is assisted by a staff of legal, organization and management specialists, business efficiency engineers and Certified Public Accountants.

Preliminary knowledge of bookkeeping is unnecessary. Our free book on accountancy fully explains how we train you from the ground up, according to your individual needs. Low cost; easy terms.

If you are dissatisfied with your present equipment, the coupon just below this text will bring you an inspiring story—"Ten Years' Promotion in One"—of how one man, through study at home, cleared the path to success; also the true facts about present-day opportunities in Accounting, all without obligation. The man in earnest to get ahead will find in this coupon a most profitable aid to progress.

Find Yourself Through La Salle

LaSalle Extension University

The World's Largest Business Training Institution

DEPT. 564-HR

CHICAGO

Opportunities in Accountancy—Check below and we will send you copy of "Accountancy, the Profession that Pays," also copy of "Ten Years' Promotion in One," all without obligation.

Higher Accountancy:

Other LaSalle Opportunities: If more interested in one of the other fields of business indicated below, check here:

- | | | |
|---|--|--|
| <input type="checkbox"/> Business Management | <input type="checkbox"/> Industrial Management | <input type="checkbox"/> Expert Bookkeeping |
| <input type="checkbox"/> Modern Salesmanship | <input type="checkbox"/> Business Correspondence | <input type="checkbox"/> C. P. A. Coaching |
| <input type="checkbox"/> Traffic Management | <input type="checkbox"/> Credit and Collection | <input type="checkbox"/> Business English |
| <input type="checkbox"/> Railway Station Management | <input type="checkbox"/> Correspondence | <input type="checkbox"/> Commercial Spanish |
| <input type="checkbox"/> Law: Degree of LL. B. | <input type="checkbox"/> Banking and Finance | <input type="checkbox"/> Effective Speaking |
| <input type="checkbox"/> Commercial Law | <input type="checkbox"/> Modern Foremanship | <input type="checkbox"/> Telegraphy |
| | <input type="checkbox"/> Personnel Management | <input type="checkbox"/> Stenotypy—Stenography |

Name

Present Position

Address



POCKET EDUCATORS

For all BUILDERS AND MECHANICS



Read Audels Pocket Educators for advancement and profit in your work. Every mechanic in the building trades should have this inside trade information at his fingers' ends. Learn the scope and possibilities of your profession. Any job can be done better if you are well informed. To earn more, learn more.



AUDELS CARPENTERS AND BUILDERS GUIDES—4 VOLS. \$6



Inside Information for Carpenters, Builders, Joiners, Building Mechanics—all Woodworkers. **1600 pages; 3700 diagrams; flexible; pocket size.** Short-cut instructions, new methods, ideas, solutions, plans, systems—money saving suggestions. An easy progressive course for the apprentice. A practical daily helper and Quick Reference for the master worker. A Helping Hand to Easier and Better Work and Better Pay. To get this aid for yourself, simply fill in and mail the FREE COUPON below.

INSIDE TRADE INFORMATION ON:
 How to use steel square; How to file and set saws; How to build furniture; How to use mitre box; How to use chalk line; How to use rules; How to make joints; Carpenters' arithmetic; Mensuration problems; Estimating strength of timbers; How to set girders and sills; How to frame houses and roofs; How to estimate costs; How to build houses, barns, garages, bungalows, etc.; How to read and draw plans; Drawing up specifications; How to excavate; How to use settings 12, 13 and 17 on the steel square; How to build hoists and scaffolds—skylights; How to build stairs; How to put on interior trim; How to hang doors; How to lay floors; How to paint.

"Audels Guides worth four times their price—handy too, as I carry them in pocket for reference." **W. J. Bates, Knoxville, Pa.**



A new set—just out! A practical, illustrated, Reference Library and Study-Course for Master Plumbers, Journeymen and Apprentice Steamfitters, Gas Fitters and Helpers, Sheet Metal Workers, Draughtsmen, Master Builders, Engineers and all Building Trade Students. **1670 pages; 3642 diagrams; flexible; pocket size.** Guides explain all the principles, advances and short cuts of the Plumbing and Heating trade. Contains instructions on how to figure and estimate jobs. Use FREE COUPON below to examine, without obligation, this valuable work.

INSIDE TRADE INFORMATION ON:
 Soldering, tinning. Joint wiping, bending, beating. Pipe—iron—steel, threading. Mathematics, tables, physics. Materials—iron, steel, copper, brass, lead, tin, antimony. Sheet metal—galvanized—plate. Sanitation, syphonage, tanks. Drainage, sewage, purification. Fixtures—bath—kitchen. Pipe fittings, soil pipe, tools. Laying out work. Roughing. Screwed fittings, flanges, joints. Pipe bending, examples. Elbows. Heating, ventilation, refrigeration. Water supply, mains, wells, tanks. Gas-fittings. Underwriters. Sheet metal work, problems, methods, brazing, heating, lead burning. Welding, various welds, methods. Blacksmithing, forges, tools.

"Audels Guides are practical, easy to understand, reliable. Cover the field in plain language." **W. F. Arringer, Annapolis, Md.**

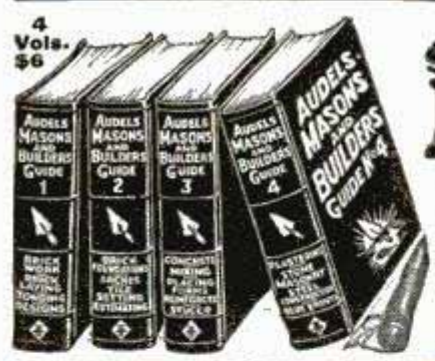

A new, complete, illustrated trade reference library, for Bricklayers, Cement Workers, Plasterers, Tile Setters and Stone Masons, including a practical outline of Steel Construction. **1100 pages; 2067 diagrams; flexible; pocket size.** A practical Trade Assistant explaining modern methods of masonry construction. Easy to understand and apply. A reliable and authentic reference work and study-course for Master Journeyman and Young Mechanic. Use FREE COUPON below and find out for yourself, without obligation, whether this set will benefit you.

INSIDE TRADE INFORMATION ON:
 Bricklaying, tools, materials; Brick designs, patterns, bonds; Setting frames and foundations; Mortars, scaffolds, estimating; Mortars and mortar mixing; Tile setting, mosaic, hollow tile; Straight edge test, troweling; How to figure brick work; Safe loads, piers, chimneys; Boiler settings, anchors, fire stops; Labor tables; Concrete, forms; How to figure concrete work; Stucco—on old and new buildings; Plastering—wood lath—metal; Plasterers agreement; Plastering on various surfaces; Stone masonry; Cutting, finishing, estimating stone; Derricks, rigging; Steel construction; Fire proof; How to read blue prints.

"Audels Masons Guides are the best books on the subject. Have laid brick 12 years and am able to judge." **H. A. Sonnett, Cortice, Pa.**

PRACTICAL ELECTRICITY — 1 VOL. \$4

Audels Handy Book of Practical Electricity is a simplified Ready Reference and Study Course in one pocket size, leather bound volume—for Engineers, Professional Electricians and Students. **1040 pages; 2600 diagrams; flexible red leather bound.** A reliable authority and handy helper for every electrical worker. Contains important and valuable wiring diagrams, calculations, machine sketches, helps on maintenance and repair. Use this FREE COUPON today and find out, without obligation, how this handy book will help you in your daily work.

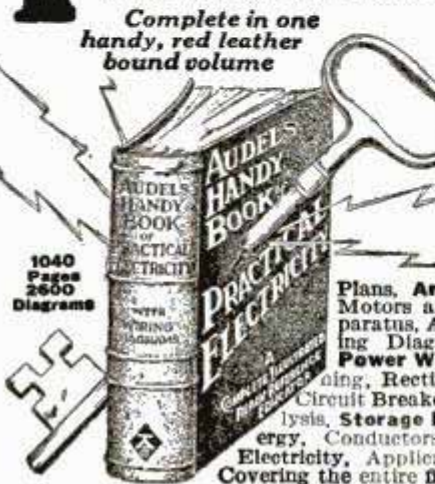

INSIDE TRADE INFORMATION ON:
 Electro-Therapeutics, X-Rays, Shocks, Welding, Brazing, Radio Hook-ups, Motion Pictures, Telephone, Telegraph, Cranes, Bells, Elevators, Pumps, Tools, Ship Drive, Railways, Vehicles, Automobile Electric Systems, Ignition, Generation, Lighting, Plant Management, Power Plans, Armature Winding, Repairing, A. C. Motors and Apparatus, D. C. Motors and Apparatus, Alternator Construction, Dynamos, Wiring Diagrams, Sign Flashers, Cable Splicing, Power Wiring, Outside Wiring, Switches, Lighting, Rectifiers, Converters, Transformers, Fuses, Circuit Breakers, Rheostats, Electro Plating, Electrolysis, Storage Batteries, Magnetism, Electrical Energy, Conductors, Insulators, Static, Dynamic, Radio Electricity, Applications, Ready Reference and Index Covering the entire field of Modern Electricity.

Learn More and You Will Earn More!

Know your job and you'll never be without one. The skilled man is always in demand. Knowledge is power. Learn your trade thoroughly by easy reading. This coupon is your opportunity for advancement and better pay. You risk nothing in sending for Audels Guides for free examination. Send it NOW!

FREE EXAMINATION COUPON

THEO. AUDEL & CO.,
 65 W. 23 ST., NEW YORK CITY

Please mail me for free examination the books marked (x) below. If I find them satisfactory, I agree to mail \$1 in 7 days, on each set ordered, and to further mail \$1 monthly on each set until I have paid the purchase price.

4 CARPENTERS GUIDES \$6 4 PLUMBERS GUIDES \$6

4 MASONS GUIDES \$6 1 ELECTRICIANS HANDY BOOK \$4

NAME

ADDRESS

OCCUPATION

EMPLOYED BY.....5T30

Famous Racers Say: Learn Autos

the B.W. Cooke
"JOB-WAY"

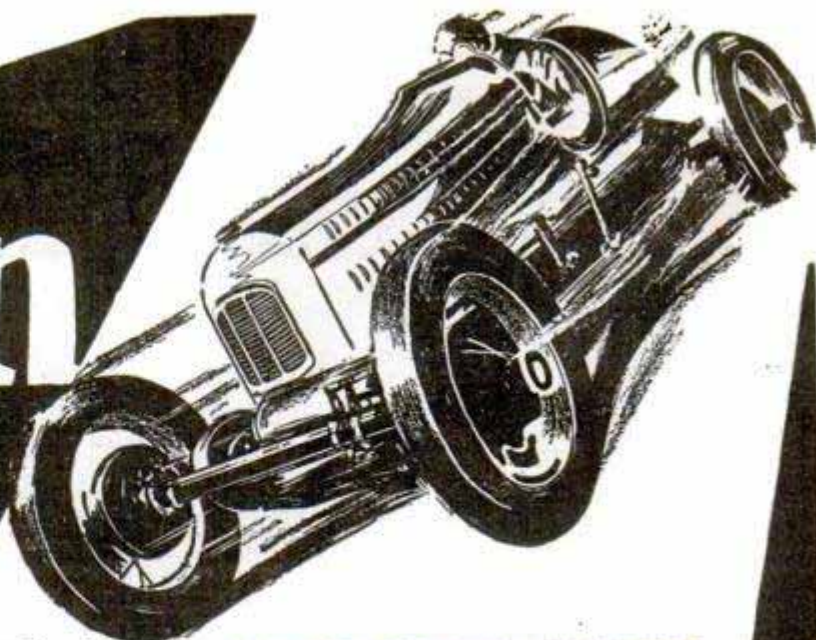

AT HOME

Race Drivers know autos. They have to. For they hold their lives in their hands every minute they are on the track. And, they tear down and rebuild their cars after every big race. Knowing autos and auto work as they do, where could you find better judges of Auto Training than these authorities? Champions like Lockhart, Souders, Cooper, De Paola, Woodbury, Duray and other famous racers enthusiastically endorse and recommend "Job-Way" Auto Training—a reliable, dependable, authoritative stamp of approval.

Earn up to \$100 a Week!

There's BIG MONEY in this fascinating auto business. Not just in racing, for that's too risky for most folks, but in service and repair work. Why look here—Cliff Woodbury, the dirt track champion, does a \$50,000 a year repair business. Get into this big money game. Get my FREE Auto Book. See how easily and quickly I train you at home—prepare you for a good job paying up to \$50, \$75 and even \$100 a week.

Common Schooling All You Need

If you can read and understand plain English you can take my "Job-Way" Training. You don't need previous experience. You don't need to quit your job or leave home. Just give me a little of your spare time and I'll show you how to start making big, extra, spare time money—QUICK—within a few short weeks. My FREE Auto Book gives all the facts about the World's Biggest Business and "Job-Way" Training. Send the coupon today.

Clip Coupon for FREE Auto Book

See how my Employment Department will help you get a good job. Learn about the three working and testing outfits I give my students. Read my money-back agreement and the many other features you get in "Job-Way" Training. Clip that coupon, NOW!

B. W. COOKE,
Directing Engineer,
CHICAGO MOTOR
TRAINING CORP'N,
1916 Sunnyside Ave.,
Dept. 1165, Chicago



"B. W. Cooke, one of the greatest authorities of today."—DE PAOLA.



"Easiest way I know is Cooke 'Job-Way', says LEON DURAY.



"I do not hesitate to recommend 'Job-Way' to any one."—Geo. SOUDERS.

**B. W. Cooke, Directing Engineer,
Chicago Motor Training Corporation,
1916 Sunnyside Ave., Dept. 1165, Chicago.**

Send me your FREE Auto Book. Show me how I can train at home for a BIG PAY Auto Job. Also details of your Employment Service, and other features of "Job-Way" Training. No obligation to me.

Name.....

Address.....

Town..... State.....

Age..... Occupation.....





“Last Night I Came Home With *Great News*”

“I'D TELEPHONED Nora that I had a surprise for her and she could hardly wait for me to get home. You should have seen her face when I told her the Boss had called me in and given me a \$25 increase in salary.

“‘It's wonderful,’ she said, ‘just wonderful. Now we can pay those bills that have been worrying us and even put a little in the bank.

“‘Remember the night we saw that coupon in a magazine and you decided to take up an I. C. S. course? It made a new man of you, Bob, and I knew it wouldn't be long before the firm would notice the difference in your work.

“‘We certainly owe a lot to the Interna-

tional Correspondence Schools. You would never have received this increase if you hadn't studied at home and prepared yourself.’”

How about *you*? Are you always going to work for a small salary? Are you going to waste your natural ability all your life? Or are you going to get ahead in a big way? It all depends on what you do with your spare time.

Don't let another precious hour pass before you find out what the I. C. S. can do for you. It doesn't cost you a penny or obligate you in any way to ask for full particulars, but that one simple little act may be the means of changing your entire life. *Do it now!*

INTERNATIONAL CORRESPONDENCE SCHOOLS, Box 5614-F, Scranton, Penna. “The Universal University”

Without cost or obligation on my part, please send me a copy of your 48-page booklet, “Who Wins and Why,” and tell me how I can qualify for the position, or in the subject, before which I have marked an X:

BUSINESS TRAINING COURSES

- | | | | |
|---|--|--|---|
| <input type="checkbox"/> Business Management | <input type="checkbox"/> Cost Accounting | <input type="checkbox"/> Business Correspondence | <input type="checkbox"/> Railway Mail Clerk |
| <input type="checkbox"/> Industrial Management | <input type="checkbox"/> Bookkeeping | <input type="checkbox"/> Show Card and Sign | <input type="checkbox"/> Mail Carrier |
| <input type="checkbox"/> Personnel Management | <input type="checkbox"/> Secretarial Work | <input type="checkbox"/> Lettering | <input type="checkbox"/> Common School Subjects |
| <input type="checkbox"/> Traffic Management | <input type="checkbox"/> Spanish <input type="checkbox"/> French | <input type="checkbox"/> Stenography and Typing | <input type="checkbox"/> High School Subjects |
| <input type="checkbox"/> Accounting and C. P. A. Coaching | <input type="checkbox"/> Salesmanship | <input type="checkbox"/> English | <input type="checkbox"/> Illustrating <input type="checkbox"/> Cartooning |
| | <input type="checkbox"/> Advertising | <input type="checkbox"/> Civil Service | <input type="checkbox"/> Lumber Dealer |

TECHNICAL AND INDUSTRIAL COURSES

- | | | | |
|--|--|---|--|
| <input type="checkbox"/> Architect | <input type="checkbox"/> Telegraph Engineer | <input type="checkbox"/> Airplane Engines | <input type="checkbox"/> Pharmacy |
| <input type="checkbox"/> Architectural Draftsman | <input type="checkbox"/> Telephone Work | <input type="checkbox"/> Plumber and Steam Fitter | <input type="checkbox"/> Mining Engineer |
| <input type="checkbox"/> Building Foreman | <input type="checkbox"/> Mechanical Engineer | <input type="checkbox"/> Plumbing Inspector | <input type="checkbox"/> Navigation <input type="checkbox"/> Assayer |
| <input type="checkbox"/> Concrete Builder | <input type="checkbox"/> Mechanical Draftsman | <input type="checkbox"/> Foreman Plumber | <input type="checkbox"/> Iron and Steel Worker |
| <input type="checkbox"/> Contractor and Builder | <input type="checkbox"/> Machine Shop Practice | <input type="checkbox"/> Heating and Ventilation | <input type="checkbox"/> Textile Overseer or Supt. |
| <input type="checkbox"/> Structural Draftsman | <input type="checkbox"/> Toolmaker | <input type="checkbox"/> Sheet-Metal Worker | <input type="checkbox"/> Cotton Manufacturing |
| <input type="checkbox"/> Structural Engineer | <input type="checkbox"/> Patternmaker | <input type="checkbox"/> Steam Engineer | <input type="checkbox"/> Woolen Manufacturing |
| <input type="checkbox"/> Electrical Engineer | <input type="checkbox"/> Civil Engineer | <input type="checkbox"/> Marine Engineer | <input type="checkbox"/> Agriculture |
| <input type="checkbox"/> Electrical Contractor | <input type="checkbox"/> Surveying and Mapping | <input type="checkbox"/> Refrigeration Engineer | <input type="checkbox"/> Fruit Growing |
| <input type="checkbox"/> Electric Wiring | <input type="checkbox"/> Bridge Engineer | <input type="checkbox"/> R. R. Positions | <input type="checkbox"/> Poultry Farming |
| <input type="checkbox"/> Electric Lighting | <input type="checkbox"/> Gas Engine Operating | <input type="checkbox"/> Highway Engineer | <input type="checkbox"/> Mathematics |
| <input type="checkbox"/> Electric Car Running | <input type="checkbox"/> Automobile Work | <input type="checkbox"/> Chemistry | <input type="checkbox"/> Radio |

Name..... Street Address.....

City..... State..... Occupation.....

If you reside in Canada, send this coupon to the International Correspondence Schools Canadian, Limited, Montreal, Canada

TO ALL YOU FELLOWS
WHO WANT TO GET
AHEAD - READ THIS MESSAGE.

I've got a sure
quick easy way
to get into a real
live money making
game. I'll take you
here in my school
for 90 days and train you
for big pay jobs in the
world's most interesting and
big future field ELECTRICITY.
I'll train you not by books
or mail but right here in
my big shops on real live
Electrical machinery. I won't
make any difference to me if
you haven't had a high school



PAGE - 2

education or a single day of electrical experience. My most successful graduates haven't had either.

Then when you graduate from my school I'll give you Free employment service for life and while you're attending school I will help you get a part time job so you can EARN WHILE LEARNING

I've got a big book that tells you the whole story and it's ABSOLUTELY FREE. Right now I'm including at no extra cost my AVIATION, RADIO, and AUTOMOBILE electrical courses. MAIL THE COUPON below for this BIG FREE BOOK. It tells you an amazingly easy way to get into a big pay field.

Sincerely H. C. Lewis

MR. H. C. LEWIS - PRES.
COYNE ELECTRICAL SCHOOL
500 - SOUTH PAULINA ST.
CHICAGO ILLINOIS

DEPT. 59-72

Dear Sir. I want to get ahead send that Free book.

NAME _____

ADDRESS _____

TOWN _____

STATE _____

WIN A PRIZE



By copying this picture

HAVE you a liking for drawing? Then copy this picture and send us your drawing before May 5, 1929. You may win one of the sixty-five prizes.

1st Prize.....	\$100.00	4th Prize.....	\$15.00
2nd Prize.....	50.00	5th Prize.....	10.00
3rd Prize.....	25.00	6th Prize.....	Each 5.00

To the Next 50 Best Drawings
a Beautiful Fountain Pen

FREE DRAWING TEST. In addition to these prizes, everyone submitting a drawing in this contest may have his art ability tested free. When your Contest Drawing is received, we will mail you our Vocational Art Test. Fill this in, return it, and our staff of Art Instructors will send you a frank personal estimate of your drawing ability. This is free and places you under no obligation whatever. The purpose of this contest is to discover talent and show you how to develop it.

Artists were never in greater demand than today. Prices for illustrations and commercial art work have greatly increased in the last ten years. Many Federal School graduates who started by answering just such an advertisement as this are now earning \$3,000.00 to \$6,000.00 and more yearly.

Find out if you, too, possess the talent to fit yourself for this highly paid, enjoyable work. Begin your drawing now.

FEDERAL SCHOOL OF ILLUSTRATING

5139 Federal School Building, Minneapolis, Minn.

RULES OF CONTEST

1. Contest is open to amateurs over 17 years of age only. Professional artists and Federal School students or graduates are not eligible. Judges of the Contest will be the Faculty of the Federal School of Illustrating. Draw only the girl—no lettering.
2. Send one drawing only, making it exactly 5 inches high on paper about 7 inches square.
3. Use only pencil or pen and ink.
4. No drawing will be returned.
5. Write your name, address, age and occupation on back of drawing.
6. Drawings must reach Minneapolis by Noon, May 5, 1929. Prizes will be awarded for drawings best in proportion and neatness, as your ability to copy accurately indicates your capacity to observe—the first requisite of an artist. All contestants will be notified of the prize winners. Make your drawing now.

**The Foundation
of an institution
or a man
Is Character**

Charter

The School was chartered in 1897 as an educational institution.

Not for Profit

Being conducted as an educational institution, not for profit, it is exempt from all income taxes.

Entrance Requirements

The School does not accept boys and girls under 16 as students except for High School work, and then only when they have completed the elementary (or grammar) grades.

Satisfaction Guaranteed

The School guarantees every graduate satisfactory instruction or his money back.

Home-Study Council

The American School, like the home-study departments of colleges and universities, is not a member of the National Home - Study Council.

Quality of Instruction

Our instruction material was prepared specially for our use by experts holding prominent positions in such well-known industrial and educational organizations as:

- Geo. A. Fuller Const. Co.
- Holabird & Roche
- Stone & Webster Eng. Corp.
- Condron & Post Co.
- Solvay Process Co.
- Standard Oil Co.
- General Electric Co.
- Commonwealth Edison Co.
- Cutler-Hammer Mfg. Co.
- Western Electric Co.
- Continental Motors Corp.
- Westinghouse Mfg. Co.
- Univ. of Pennsylvania
- Mass. Inst. of Technology
- University of Wisconsin
- New York University
- University of Illinois
- Harvard University
- Columbia University
- Purdue University
- University of Chicago
- Lehigh University
- Queen's University
- Ohio State University

American School
Drexel Ave. at 58th St.
Chicago, U. S. A.

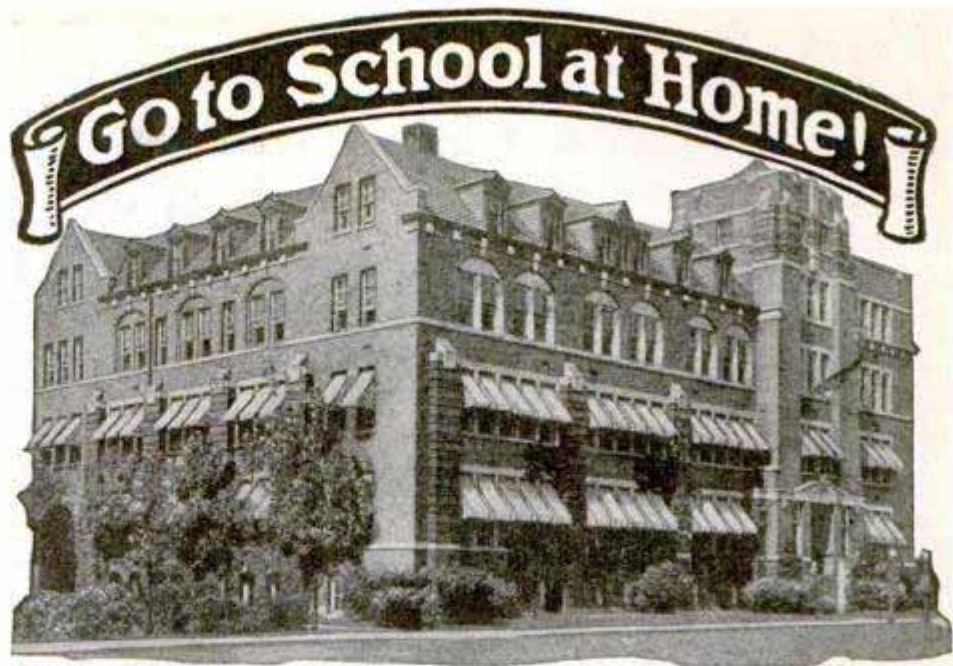

**Quality Training Fits You
for the Better Position**

Today everybody agrees that a man's position in business or industry—and especially his fitness for the better position—is decided by the quality of his training. It is a fact that you can buy the tools for almost any trade or profession—but do you know how to make proper use of them? That knowledge—which is the result of training—decides whether you get the better job.

Get Ready for the Better Position

You want to earn big money—steady promotion. Are you prepared for the position ahead of you? To write a sensible business letter, to prepare estimates, to figure costs, and to prepare reports, you must have a certain amount of training. Many concerns will not hire men who are barred from promotion by the lack of elementary education.

If You Have Not Completed High School

and are under thirty, we urge you to do so at once. If you can't go back to your local high school, take our simplified High School Course. We use the same standard textbooks as your local high school and will give you equivalent training. Get at once the foundation training required for success and big money. **YOU CAN DO IT.**

If You Have Completed High School

you are ready to specialize in some well-paid trade or profession: Architecture — Drafting — Electrical — Mechanical — Business — Automotive Engineering, etc. A knowledge of higher-grade work brings promotion. The work you are doing today fits you to continue doing it. Promotion doesn't mean longer hours—but shorter hours and more pleasant work. It is the reward of the man who has fitted himself for the more important positions.

Test Our Instruction Methods

Let us send you samples of our special lesson papers. We guarantee you **satisfactory instruction or your money back** on graduation. Write today. It costs you nothing but a stamp.

American School, Dept. H-574, Drexel Ave. at 58th St., Chicago

American School, Dept. H-574, Drexel Ave. at 58th St., Chicago

Send me full information and sample instruction material on the subject checked and tell me how you will help me win success.

- ... Electrical Eng.
- ... Drafting & Design
- ... Business
- ... Architecture & Building
- ... Shop Practice
- ... Mechanical Eng.
- ... Civil Eng.
- ... Automotive Engineering
- ... High School in 2 years (College entrance or business)

Name..... Age.....
Street and Number.....
Town..... State.....

Want More Fun?



DO YOU want more good times—more invitations? Would you like to be right "in the spotlight," entertaining the others and having a lion's share of the fun at all the parties? Would you? If your answer is "Yes"—then you can't afford to say anything but "Yes" to the offer I'm going to make you—right on this very page!

—I asked Basil Glaze, of Germantown, Md. He answered "Yes!" and a few months later wrote me: "Though I started with no knowledge of music, your Course certainly taught me quickly. My playing has opened the doors to a new world of fun for me."

Want More Friends?

More Invitations - Good Times?

DO YOU want more real pals to fill your spare hours with enjoyment? Do you? Then I'll show you how to make them—more than you've ever dreamed of having. How? Easy! By teaching you to play an instrument that everyone loves—the Hawaiian Guitar! Even if you think you have no "talent"—don't worry. You don't need any talent or previous experience whatsoever, to learn at home by this simple method!

—I asked Pauline Hamrick, of Matthews, N. C. She, too, answered "Yes!" and soon wrote: "The very day I received my Guitar and first Lessons I began to have fun. Now my lonesome days are over. I make new friends almost every day—everywhere I go, with my playing."

Want More Money?

Extra Dollars Easily Earned

—I asked Ralph Prutzman of Lehighton, Pa. He also said "YES"—and I showed him the quickest, easiest way to make it. Now he writes: "I'm getting along fine. The Lessons are easy and interesting. Made \$16 the very first night I played professionally and I'm not even through the Course yet! I see lots of good money-making opportunities ahead and I'm making more friends and having a better time than ever before."

Big Hawaiian Guitar and Outfit Come with Very First Lesson! We send you this fine, full-size Hawaiian Guitar, Phonograph Records of 55 selections and Complete Outfit. These are yours to keep. The Free Book explains everything. Get it NOW.

Learn the Hawaiian Guitar at Home—By Quick Easy Method.

Ralph Prutzman didn't believe we could teach him—but he let us PROVE that we could! Never mind if you've never played a note in your life, either, this easy, simple method will teach you quick, just as it taught Ralph Prutzman, Basil Glaze, Pauline Hamrick and a thousand others. The Coupon below brings your copy of my big Free Book. It tells all about the Course and famous method. It tells, too, how I send you everything you need to learn. Get it quick! Clip and mail the Coupon today—right now—and I'll get your copy to you by return mail!



This Brings FREE Book

A. F. BLOCH, President, Hawaiian Studios 52059 of New York Academy of Music, 100 Fifth Avenue, New York City.

Send me the book that tells more about getting more FUN—more FRIENDS—More MONEY. No obligation to me, of course.

Name.....
 Address.....
 City..... State.....

8 weeks then BIG WAGES

In eight short weeks I train you for one of the 70,000 jobs open everywhere. Why work for boy's wages? No schooling required; no book study. No unions to join; no apprenticeship. Get this amazing offer. Become an expert.

AUTO Tractor and AVIATION

Real Wages

Large firms want McSweeney trained men. Our graduates are earning up to \$6,000 a year and more. Learn with real tools on real equipment.

BIG FREE BOOK

Save One-Third NOW on our Special Reduced Tuition Offer. Write today for particulars and big FREE book. (No facilities for colored men.)

McSWEENEY

AUTO, TRACTOR and AVIATION SCHOOLS

Dept. 11-A Cleveland, Ohio

"BECOME A LIGHTNING TRICK CARTOONIST"

Send \$1.00 for Laugh Producing Program of 29 Trick Drawings with Instructions. Catalog of Chalk Talk Supplies Free. BALDA ART SERVICE, Dept. 1, Oshkosh, Wis.



WANT A STEADY GOVERNMENT JOB?

\$1260 to \$3400 YEAR
 MEN—BOYS—18 Up
 STEADY WORK
 Paid Vacations

FRANKLIN INSTITUTE
 Dept. R175, Rochester, N. Y.

Gentlemen: Rush to me, FREE of charge, list of U. S. Government big pay positions now obtainable. Send me FREE 32-page book describing salaries, hours, work, vacation and giving full particulars on how to get a position.

Common education usually sufficient

Mail coupon today—SURE

COUPON

Name.....
 Address.....

NEW BODIES *in 24 hours*

HAVE you ever watched a magician pick wriggling rabbits out of a high hat? A wonderful trick, you say. Well, I'm a magician of a different sort—a magician that builds health and strength into your body in just 24 hours. And it is no trick. It took me 19 years of tireless planning and experimenting to be able to do it.

People call me the Muscle-Builder, because I take weak, run-down bodies and transform them into strong, virile, handsome bodies in double-quick time. *And I actually do it in 24 hours.*

In the Privacy of Your Own Room

By this I do not mean that you must exercise 24 hours continuously. My scientific short-cut to healthy, handsome, broad-shouldered bodies must be taken in short 15 minute doses. Because, if you exercise more than that in my high-pressure, quick development way, you would tear down more than I can build up. So all I ask of you is 15 minutes of your spare time each day for 90 days (actually only 22½ hours time) doing simple, easy exercises under my guidance. You can do them in the privacy of your room, if you wish, but you must do them every day to get the best results.

And What Results!

In the first 30 days I guarantee to add one whole inch of real, live muscle on each of your arms, and two whole inches of the same revitalizing strength across your chest. I'll take the kinks out of your back, strengthen and broaden your shoulders, give you a wrist of steel, and a fighting, peppy personality that just yells youth, vigor and vitality all over.

I Work Inside As Well As Out

Your heart, your liver, your kidneys, your lungs—all your internal organs get the jolt of their young lives when I start to work on them. And they settle down to an orderly, well-mannered existence that means a new kind of happiness for you—the joy of living that only a healthy, virile body can give you. And the headaches, constipation troubles, aches and pains that are always caused by weakened, flabby bodies somehow miraculously disappear.

You'll See It in Her Eyes

And will your friends notice the difference! Just watch that girl you love so dearly open her eyes, and *fight* to hold your attention! And the men in your crowd—they'll look up to you as a real leader. Instinctively they worship strength and leadership that must go with it. But let me tell you all about it. All you have to do is

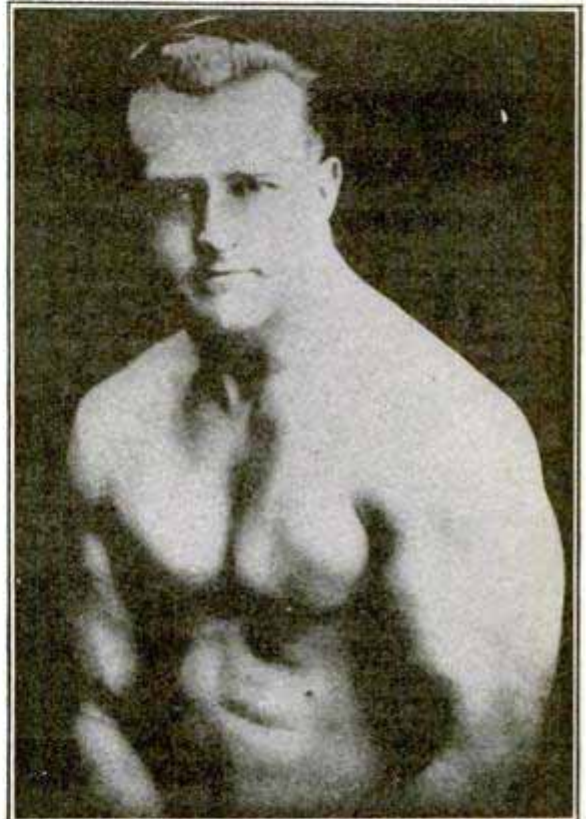

EARLE LIEDERMAN—*The Muscle-Builder*,
Author of "Muscle Building," "Science of Wrestling,"
"Secrets of Strength," "Here's Health," "Endurance," etc.

Send For My New
64 Page Book
"Muscular Development"

IT IS FREE

The Earle Liederman System of Physical Education has been approved as a Correspondence School under the laws of the State of New York.

What do you think of that? I don't ask one cent. And it's the peppiest piece of reading you ever laid your eyes on. I swear you'll never blink an eyelash till you've turned the last cover. And there's 48 full-page photos of myself and some of my prize-winning pupils. This is the finest art gallery of strong men ever assembled. And every last one of them is shouting my praises. Look them over. If you don't get a kick out of this book, you had better roll over—you're dead. Come on, then. Take out the old pen or pencil and sign your name and address to the coupon. If you haven't a stamp, a postal will do. But snap into it. Do it *now*. Tomorrow you may forget. Remember, it's something for nothing and no strings attached, no obligation. *Grab it!*

EARLE LIEDERMAN

Dept. 2005, 305 Broadway, New York City

**It
Is
F
R
E
E**

EARLE LIEDERMAN

Dept. 2005, 305 Broadway, New York City

Dear Sir: Please send me, absolutely FREE and without any obligation on my part whatever, a copy of your latest book, "Muscular Development."

Name..... Age.....

Street.....

City..... State.....

(Please write or print plainly)

Learn Electricity IN LOS ANGELES

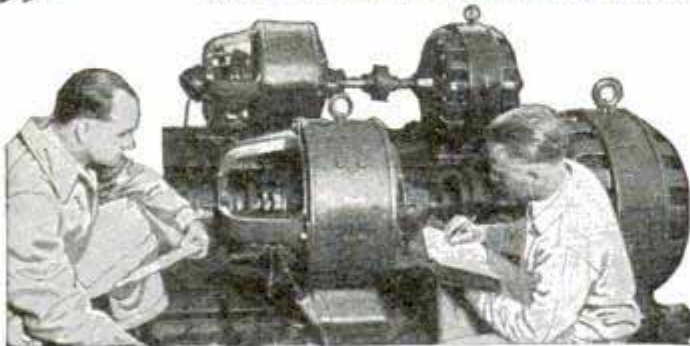

—and learn IT RIGHT!

1. What Kind of School is National?

A practical-technical school, established in 1905—24 years ago—recognized throughout the electrical industry as one of America's foremost trade schools. National offers intensive courses in all electrical branches. Thorough training of the highest quality in fundamentals of electricity, mathematics, physics, and other essentials. Extremely practical electrical experience in completely equipped, modern work departments assure you success in the profitable electrical trades.

2. How Long to Learn Electricity?

A LIFETIME—and then you'll never know it all! BUT—to become properly qualified in the shortest practical time, without sacrifice of quality in instruction or endangering your chances for securing satisfactory employment in electricity, National's condensed course of nine months fully trains you as a Practical Electrician.

3. What Employment Service does National Guarantee?

National GUARANTEES to qualify you as a Practical, Competent Electrician and to render an unlimited Employment Service to students wishing to earn living expenses while learning and graduates ready to enter the electrical field, which is the most any school can be expected to do.

4. What Inducements Does National Offer?

National offers YOU the very best technical - practical training that money can buy at a cost within every man's reach. It does not offer to pay your railroad fare, room and board or other personal expenses, preferring to limit its activities to the PROPER TRAINING OF MEN FOR SUCCESS. Los Angeles is in the heart of rapid electrical development—an ideal city in which to study and prepare for success in Electricity.

Write at Once for FREE Illustrated Catalog "ELECTRICITY—Your Life Vocation"



National Electrical School

Dept. 531, 4006 Figueroa St., Los Angeles, California.

Send me your big free illustrated catalog of Electrical Opportunities.

Name.....

Address.....

Age..... City..... State.....

\$2500 DRAWING COURSE for \$298

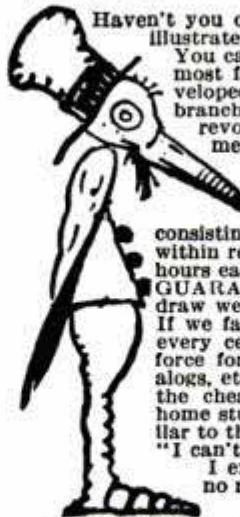

Haven't you often wished that you could draw cartoons, illustrate some idea, sketch some pretty face, etc.? You can do all of these things. One of America's most famous Cartoonists and illustrators has developed a great, simple system for success in all branches of Commercial Art. This system has revolutionized the entire theory of drawing. It means that drawing can be as easy for you as writing—much simpler than learning shorthand, bookkeeping or typewriting. We are now placing this original system for learning Drawing, Art and Cartooning, consisting of 34 lessons with over 500 illustrations, within reach of every one. If you will devote a few hours each week to the Course WE ABSOLUTELY GUARANTEE that you will learn to draw and draw well before you have half finished the Course. If we fail to make this claim good, we will refund every cent paid us. By eliminating a large office force for answering correspondence, expensive catalogs, etc., we are enabled to make a price of \$2.98, the cheapest price ever known for a high-grade, home study course. Many have sent us letters similar to that of Rob't P. Davis of Detroit, who wrote: "I can't see how you ask so little. It is more than I expected." Learn to draw. It is a big asset, no matter what field you are in.

Send No Money

Just order the course and \$2.98 on arrival pay postman plus a few cents postage, payment in full for the entire Course and Drawing Outfit. If not entirely satisfied, return within five days and we will Refund Money. Address:

If you order the course at once, we will include a drawing outfit, consisting of artist's pencils, pens, paper, erasers, thumb tacks, etc., enabling you to go to work without any additional cost.

LEDERER SCHOOL of DRAWING, Dept. 712-U, Chattanooga, Tenn. Orders from outside the U. S. A. are payable \$3.28 cash with order.

DEVELOP POWER

AT HOME

to initiate, persevere, achieve; carry on through life your education; earn credit toward a Bachelor degree, by using the 450 courses

The University of Chicago Gives by Correspondence

Inquire, or check the advertisement to show desire and mail to 327 Ellis Hall, University of Chicago, Chicago, Illinois.

IF YOU STAMMER

Write for my free book "Millard's Advanced Natural Corrective Course" and a free copy of my speech magazine. 10,000 cases successfully treated. Est. 24 years. Largest school for stammerers in world. Millard Inst. of Normal Speech, 2317 Millard Bldg., Milwaukee, Wis.

Learn Advertising at HOME

Send your name and address for free booklet giving interesting information and vital facts about Advertising. Find out how we prepare you at home, in your spare time, for the opportunities open in this fascinating business. Practical work. No text books. Old established school. Successful graduates everywhere. Just the plan you have always wanted. Write today. No obligation.

PAGE-DAVIS SCHOOL OF ADVERTISING
Dept. 1355 3601 Michigan Ave. Chicago, U. S. A.

GOV'T. POSITIONS \$35 TO \$75 WEEKLY

- | | | | |
|-------------|----------------------------------|-------------------------|--------------|
| MEN - WOMEN | () Ry. Mail Clerk | () Steno-Typist | AGE 18 to 55 |
| | () Prohibition Inv. | () Immigrant Inspector | |
| | () R. F. D. Carrier | () Seamstress | |
| | () Special Agent (Investigator) | () Auditor | |
| | () City Mail Carrier | () Steno-Secretary | |
| | () Meat Inspector | () U. S. Border Patrol | |
| | () P. O. Clerk | () Chauffeur-Carrier | |
| | () File Clerk | () Watchman | |
| | () General Clerk | () Skilled Laborer | |
| | () Matron | () Postmaster | |
| | | () Typist | |

OZMENT INSTRUCTION BUREAU, 111 Arcade Bldg., St. Louis, Mo. Send me FREE particulars How To Qualify for positions marked "X". Salaries, locations, opportunities, etc. ALL SENT FREE.

NAME.....

ADDRESS.....

A Coupon That Has Meant Real Money To More Than 20,000 Ambitious Men!



\$7,200 a Year
 "I feel that my increase from \$1,800 to over \$7,200 per year is mostly due to your excellent training." L. D. Mather, E. Cleveland, Ohio.



Over \$10,000 a Year
 "When I started the N. S. T. A. course, I was making \$100 a month. To-day my salary runs into 5 figures." R. B. Hansen, Akron, O.



National Salesmen's Training Ass'n., Dept. E-101, N. S. T. A. Building, Chicago, Illinois.
 Without cost or obligation, send me your free book, "The Secrets of Modern Dynamic Salesmanship." Also include full details of your training, your free employment service, and your additional guarantee.

Name.....
 Address.....
 City..... State.....
 Age..... Occupation.....



\$1,000 a Week
 "Before taking the N. S. T. A. course, I was making \$200 a month, but could see no future. Last week my earnings amounted to over \$1,000." O. D. Oliver, Norman, Okla.

Who Else Wants to Raise Their Pay 700% or More?

Can It Be An Accident When Man After Man Raises His Pay—Each One Taking The Same Identical Steps? If You Are One Who Aspires To Earn REAL Money—"Pull" And Luck In The World!

If You Want To Get Out Of A Monotonous, Low-Pay Job, Find Out About This Tested Plan For Increasing Incomes. It Has Raised More Salaries Than All The

Get a Copy of This Amazing Book Free

LET'S be practical. You want to make more money. . . A few years ago the three men pictured above were in the same situation. They had the urge to increase their pay—but didn't know how to do it.

Take Mark Barichievich of San Francisco, as a typical example. Not long ago he was working in a restaurant, struggling along on a salary that was actually as low as \$8 a week! Naturally he was keenly dissatisfied—but like so many other men caught in blind-alley jobs, he could see no way out.

And then something happened! A certain book fell into his hands. Between its covers he discovered certain facts and secrets he had never dreamed of! Within a short time his pay jumped to \$50 a week. And to-day he makes as high as \$125!

YOUR INCOME MULTIPLIED OR YOU PAY NOTHING

N. S. T. A. is now offering to every man who wants to increase his income, an amazing Double Money-Back bond that assures you a definite stipulated addition to your income, within three months after your training is completed—or the course costs you nothing. This daring offer is possible only because of the success of thousands of members. Send coupon immediately for full details.

The Secret of Big Pay
 How did they do it? What did the book show them? Just this:—Every one of these men realized that Salesmanship offers BIGGER rewards and delivers them QUICKER than any other line of work under the sun. This vital book, "The Secrets of Modern Dynamic Salesmanship," revealed to them the real TRUTH about the art of selling. It blasted dozens of old theories and told them exactly how the great sales records of nationally-known star salesmen have been achieved. And not only that, it outlined a simple plan that will enable almost any man to master scientific salesmanship without losing a day or dollar from his present position.

FREE TO EVERY MAN
 If we were asking several dollars a copy for "The Secrets of Modern Dynamic Salesmanship" you might hesitate. But it is now FREE. So get your copy now. Learn the real facts about the selling profession, and about the tremendous demand for trained salesmen in every line, to fill city and traveling positions paying up to \$5,000 and \$10,000 a year. (Last year this association received calls for over 50,000 N. S. T. A. members from Wholesalers, Manufacturers and Jobbers.) A copy is yours for the asking, and your request entails no obligation. Simply fill out and mail the coupon above. Do it now!

NATIONAL SALESMEN'S TRAINING ASSOCIATION
 Dept. E-101, N. S. T. A. Bldg. CHICAGO - ILLINOIS

Remarkable Salary Increase
 A lucky accident? Not a bit of it! OTHER men who have increased their salaries after reading these vital facts are numbered in the thousands! For example, C. W. Birmingham of Ohio, read it and his salary raised from \$15 a week to \$7,500 a year. . . Wm. Shore of California made \$3,000 his first 5 months. . . and J. V. Champion of Illinois, became president of his company at over \$10,000 a year!

A Few Weeks—Then Bigger Pay
 There was nothing "different" about these men when they started. Salesmanship is just like any other profession. It has certain fundamental rules and laws—that you can master just as easily as you learned the alphabet. And through the NATIONAL DEMONSTRATION METHOD—an exclusive feature of the N. S. T. A. system of SALESMANSHIP training—you can acquire the equivalent of actual experience, while studying.



Now Free MAIL COUPON ABOVE

\$85

**a Week for
McCarty**

Kenneth McCartney, South Haven, Mich. — former \$18 week clerk — now orchestra Tenor Banjoist earning \$85 weekly.



\$278

**Extra for
McGriff**

J. P. McGriff, Hawkinsville, Ga., playing for dances and movies, has already earned \$278 in spare-time.



\$100

**a month extra
for Abbott**

L. G. Abbott, Williston, N. D., "happiest fellow in town," cashing-in BIG every month.



YOU Can Make Real Cash Quick this Easy Fascinating Way

TENOR BANJO Pays Big!

McCarty, McGriff and Abbott are only three out of thousands of my students who have made more money and friends through my amazingly simple, rapid method of learning to play the Tenor Banjo. Most of them had never read a note or touched a string—but my clear, interesting instruction has made them top-notchers socially and financially. Now I'm ready to do the same thing for YOU!

Have Friends, Fun and EXTRA MONEY—Learn at Home in 1 to 3 Mos.

The Tenor Banjoist has all the friends, all the invitations, all the good times he wants. And he makes **BIG MONEY**—spare-time or full-time. Parties, dances, entertainments, orchestras—all of them want the melodious, snappy music of this favorite instrument. YOU can cash-in on such popularity; make yourself the most popular one in town; put plenty of good round dollars into your pocket too! And you can do it in 1 to 3 months' spare-time study at home—actually be playing your first tune within the first half hour!

Get this Big FREE Book Now—Tells How

"The Play-Way to Popularity and Big Pay" is the book that has started thousands toward popular, prosperous Success! It brings all the proof and facts about my astounding course—describes the wonderful Tenor Banjo and Outfit I send you—shows how you too can have more friends, fun and EXTRA CASH this easy way. Get this big book quick; no obligation. Don't put it off, don't delay. Mail the coupon at once!



This \$20 TENOR BANJO

Complete Outfit and Phonograph Records Come with 1st Lesson

The same day I receive your "O. K."—telling me that you want to get in line quick for good times and good pay—I'll send you at no extra cost this splendid, professional size, full-tone Tenor Banjo worth \$20; Complete Outfit of pick, tuner, strings; Gain-time Chart; rapid progress lessons and instructions—and *Demonstration Phonograph Records* of every selection in the course, showing you exactly how to play each note, each tune. No long, tedious practicing or "scales." Instead, real fun—easy, fascinating! Get the FREE Book first—get the facts! Send coupon now!

Clip-Sign-Send!

**A. F. Bloch, President
NEW YORK ACADEMY OF MUSIC
Studio 1059, 100 Fifth Avenue,
New York City.**

Please send me FREE Book on Tenor Banjo Success—"The Play-Way to Popularity and Big Pay."

Name.....
Address.....



**THE CHICAGO DAILY NEWS
School and College Bureau**

**Offers You Its Specialized
Services in Choosing a School**

Last year the School and College Bureau of The Chicago Daily News saved many busy parents and questioning boys and girls both time and worry by sending them prompt, reliable information about just the kind of school they wanted—personal requirements as to location and tuition charges being considered in each individual case.

Again this year many young people will be perplexed by the problem of finding the right school. Why not let us help you?

The Chicago Daily News maintains this service absolutely free of charge to you. No need to hurriedly select a school on mere hearsay when expert advice can be obtained by telephoning Dearborn 1111, writing or calling for a personal interview at

**THE CHICAGO DAILY NEWS
School and College Bureau
Dept. K, 15 N. Wells St., Chicago, Illinois**

Electrical Engineering

Course for men of ambition and limited time. Over 5000 men trained. Condensed course in Theoretical and Practical Electrical Engineering including the closely related subjects of Mathematics and Mechanical Drawing.



Students construct motors, install wiring, test electrical machinery. Course designed to be completed in one college year. Prepare for your profession in the most interesting city in the world. Est. 1893. Catalog on request.

Bliss Electrical School
115 Takoma Ave., Washington, D. C.

**"STAMMERING
Its Cause and Cure"**

You can be quickly cured if you stammer. Send 10 cents coin, or stamps, for 288 page cloth bound book on Stammering and Stuttering. It tells how I cured myself after Stammering and Stuttering for 20 years. **BENJAMIN N. BOGUE**
11117 Bogue Building, 1147 N. Ill. St. Indianapolis



WHY NOT spend Spring, Summer and Fall gathering butterflies, insects? I buy hundreds of kinds for collections. Some worth \$1 to \$7 each. Simple outdoor work with my instructions, pictures, price-list. Send 10 cents (not stamps) for my illustrated Prospectus before sending butterflies.
MR. SINCLAIR, DEALER IN INSECTS,
Dept. 6, Box 1424. San Diego, Calif.

**Learn to PAINT
SIGNS and SHOW CARDS**
We quickly teach you by mail, or at school, in spare time. Enormous demand. Big future. Interesting work. Oldest, foremost school.
EARN \$50 TO \$200 WEEKLY
John Vassos, N. Y., gets \$25 for single show card. Crawford, H. C., says: "Earned \$200 while taking course." Send today for free information samples and guarantee.
DETROIT SCHOOL OF LETTERING
154 Stimson Ave. Est. 1899 Detroit, Mich.



"How can I get into Aviation?"

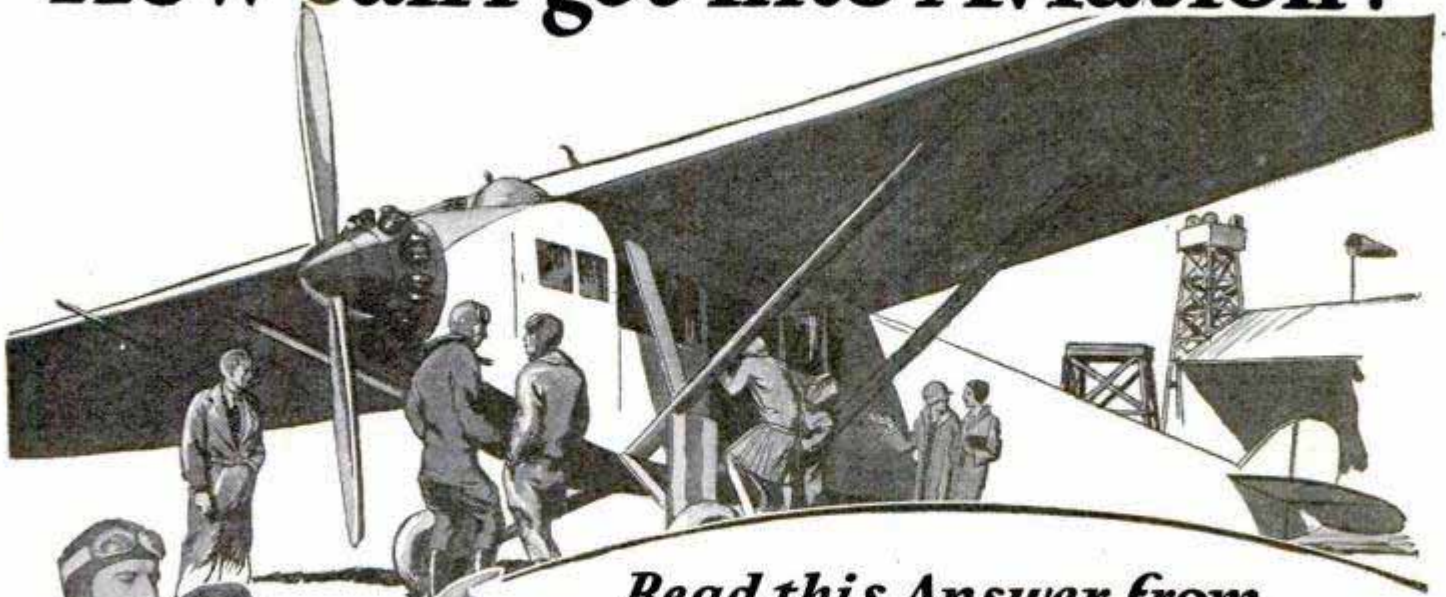

Read this Answer from

A World Famous Trans-Atlantic Pilot

AVIATION is waiting for no one! Too many millions of capital are already invested—the demand for air service of *every* kind is increasing too fast. Aviation demands men who KNOW. Men who can DO. Men who can step into the real jobs and command the real salaries. Landing fields, municipal airports, plane and equipment factories, air mail and passenger lines, service and sales organizations—all are leaping ahead in the fastest, most amazing development that any industry has ever known. In such racing, feverish activity, *where* is there any room for a man who has nothing to offer? An empty pocketbook is no drawback—but Aviation has no place, no patience, no *time* for empty hands or empty heads! Aviation is taking off for the greatest non-stop flight in history—and the men who will go along and climb to the top are the men with a foundation of FACTS under them.

Walter Hinton

Walter Hinton was pilot of the famous NC-4, first plane to fly the Atlantic; he piloted the first plane from North to South America; he was first to fly to the headwaters of the Amazon. During the War he was a crack flying instructor for the Navy. Today—with a course that experts agree is the most complete and practical ever produced—Hinton is training keen-sighted men for the Big Pay jobs in Aviation.

Get his FREE Book

You Must be 16

To take an active part in Aviation you must be at least 16 years of age. If you are under 16, please do not ask for Lieut. Hinton's Book.

You Don't Have to Fly; 40 Different Jobs on the Ground PAY BIG TOO!

To succeed in Aviation—make BIG MONEY—you need not necessarily be a pilot. There must be many thousands of pilots, certainly. But for every plane that flies there's an immediate need for trained men in more than forty different important jobs on the ground. Construction, motor and instrument experts—airport managers, service foremen, salesmen—all make *real* money. But every last one of them must have the FACTS. Today's problem—YOUR problem—is to LEARN Aviation *quick*. And right there is where Walter Hinton is achieving the biggest success of his career.

Get Your Ground Work NOW Right at Home—Hinton Is Ready to Train You

YOU can train at home in spare-time for the best paid jobs in the Industry. Hinton's proved course starts you at the beginning, trains you fast. You get *all* the facts about construction, rigging, motors, repairs, instruments, theory of flight, navigation, commercial Aviation—facts that *every* man must have to intelligently and profitably fill ANY job in the Industry. With this Institute's training you'll have your foundation, your *start*, for real accomplishment. Serious-minded — *air-minded* — men are reading and *acting* on the Free Book shown below. YOU should have a copy too. Send the coupon NOW.

Aviation Institute of U. S. A.
Walter Hinton, President
1115 Connecticut Ave., Washington, D. C.

Rush back to Washington Quick!

Walter Hinton, Pres.
Aviation Institute of U. S. A.
1115 Connecticut Ave., Washington, D. C.

I-T

Please send me at once your FREE Book "Wings of Opportunity" showing how I can get into this tremendous field.

Name.....

Street..... Age.....

(Must be over 16)

City..... State.....

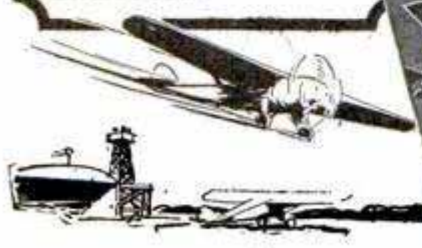

DRAFTING



Learn at Home

DRAFTING is one of the best professions a young man can choose because it pays good salaries and it is the stepping stone to even better positions. Many leading architects, mechanical engineers and electrical engineers got their start at the drafting board.

There is no easier way to learn Drafting than through the home-study courses of the International Correspondence Schools. The practical value of these courses is shown by the success of I. C. S. students and also by the fact that employers are constantly writing us for trained men. We receive more calls for I. C. S. draftsmen than for graduates of any other course.

F. E. King was "a poorly paid clerk" when he enrolled for the I. C. S. Drafting Course. By study, industry, and perseverance he became Chief Draftsman of the U. S. Steel Furniture Company, of Syracuse. He is now earning more in a day than he used to earn in a week.

A. J. Hutchins became Chief Draftsman for the American Strawboard Company and increased his salary 300 per cent—also as a result of I. C. S. Training.

There is no doubt that Drafting offers a real opportunity to ambitious men and it will pay you to investigate it. Just mark and mail the coupon and we'll gladly send you a booklet telling all about the I. C. S. courses in Drafting or other subject in which you are interested.

INTERNATIONAL CORRESPONDENCE SCHOOLS Box 5615-F, Scranton, Penna.

Without cost or obligation on my part, please send me one of your booklets and tell me how I can qualify for the position or in the subject before which I have marked an X:

- | | |
|---|--|
| <input type="checkbox"/> Mechanical Drawing | <input type="checkbox"/> Sheet Metal Worker's Course |
| <input type="checkbox"/> Draftsman's Course | <input type="checkbox"/> Sheet Metal Pattern Drafting |
| <input type="checkbox"/> Boilermaker's Course | <input type="checkbox"/> Boilermaker's Laying Out |
| <input type="checkbox"/> Structural Drafting | <input type="checkbox"/> Ship Drafting |
| <input type="checkbox"/> Architectural Drawing | <input type="checkbox"/> Illustrating and Designing |
| <input type="checkbox"/> Mechanical Engineer | <input type="checkbox"/> Machinist |
| <input type="checkbox"/> Electrical Engineer | <input type="checkbox"/> Toolmaker |
| <input type="checkbox"/> Civil Engineer | <input type="checkbox"/> Iron and Steel Worker |
| <input type="checkbox"/> Steam Engineer | <input type="checkbox"/> Patternmaker |
| <input type="checkbox"/> Structural Engineer | <input type="checkbox"/> Foundryman |
| <input type="checkbox"/> Architectural Engineer | <input type="checkbox"/> Automobile Mechanic |
| <input type="checkbox"/> Surveyor | <input type="checkbox"/> Architect's Blueprint Reading |
| <input type="checkbox"/> Concrete Builder | <input type="checkbox"/> Electrician |
| <input type="checkbox"/> Contractor and Builder | <input type="checkbox"/> Apprentice Trades |
| <input type="checkbox"/> Business Management | <input type="checkbox"/> Salesmanship |
| <input type="checkbox"/> Traffic Management | <input type="checkbox"/> Advertising |
| <input type="checkbox"/> Bookkeeping | <input type="checkbox"/> Business English |
| <input type="checkbox"/> Secretarial Work | <input type="checkbox"/> Civil Service |
| <input type="checkbox"/> Spanish and French | <input type="checkbox"/> Common School Subjects |
| <input type="checkbox"/> Mathematics | <input type="checkbox"/> High School Subjects |

Name.....

Address.....

Make Yourself a Popular Favorite with the TENOR BANJO

Easy to Play—Learn at Home in Spare Time

\$18 TENOR BANJO GIVEN with case When You Enroll

Play for Fun or Money
Don't be a wallflower. Entertain your friends. Be popular. Play at dances, parties, etc. Form an orchestra. Earn extra money. Our 52-lesson course will soon make you a real Tenor-Banjo player. Everything explained clearly.

Our Simple Method Makes It Easy
Even if you don't know the first thing about music, even if you can't read a single note, you are sure to learn by our simple, easy method of teaching. In 30 minutes you play a complete piece! You study in spare time—your lessons always before you. 61,000 successful students.

Pay as You Play
We make it easy for you to obtain the many advantages of this Conservatory. Our course is low in cost—only a few cents a day. No class to wait for. Start any time with a small first payment—then pay while learning.

Write for Special Offer
Sweet toned professional style TENOR BANJO, in genuine Seal Grain Fabrikoid Case, valued at \$18 to \$20 given when you enroll. Write for full information and special offer. A postal will do. **ACT!**
FIRST HAWAIIAN CONSERVATORY OF MUSIC, Inc.
9th Floor, Woolworth Building, Dept. 22 New York, N. Y.
Approved as a Correspondence School Under the Laws of the State of New York—Member National Home Study Council

LEARN ELECTRICAL TRADES

Practical Training on Massive Lay-Out of Expensive Electrical Equipment. Armature Winding, House Wiring, Electric Welding, Electric Refrigeration, Power Plants, Switchboards, Transformers, Motors, Generators, Radio Batteries. Automobile Course included without extra cost. Write Today for Free Catalog.

COLEMAN ELECTRICAL SCHOOL, 1628 Main St., Kansas City, Missouri

LEARN WATCHMAKING AND ENGRAVING

BY OUR PROFIT-SHARING PLAN
OUR GRADUATES SUCCEED

One of our Iowa students started in a very small way—now doing over \$30,000 a year. Another in Wisconsin, over \$10,000 the first year. Day or night classes. Call or write for FREE BOOK.

Chicago School of Watchmaking, Dept. 5201, 549 W. Randolph St., CHICAGO

Want a Government Job?

New Bandit Proof Railway Mail Car

\$1260 TO \$3400 YEAR

Men—Boys, 18 Up

Steady Work
Paid Vacations
Common Education
Usually Sufficient
Mail Coupon
—Today
SURE

FRANKLIN INSTITUTE
Dept. R173, Rochester, N. Y.

Gentlemen: Rush to me without charge 32-page book with list of U. S. Government big paid positions obtainable. Advise me regarding the salaries, hours, duties, vacations and full particulars.

COUPON

Name.....

Address.....

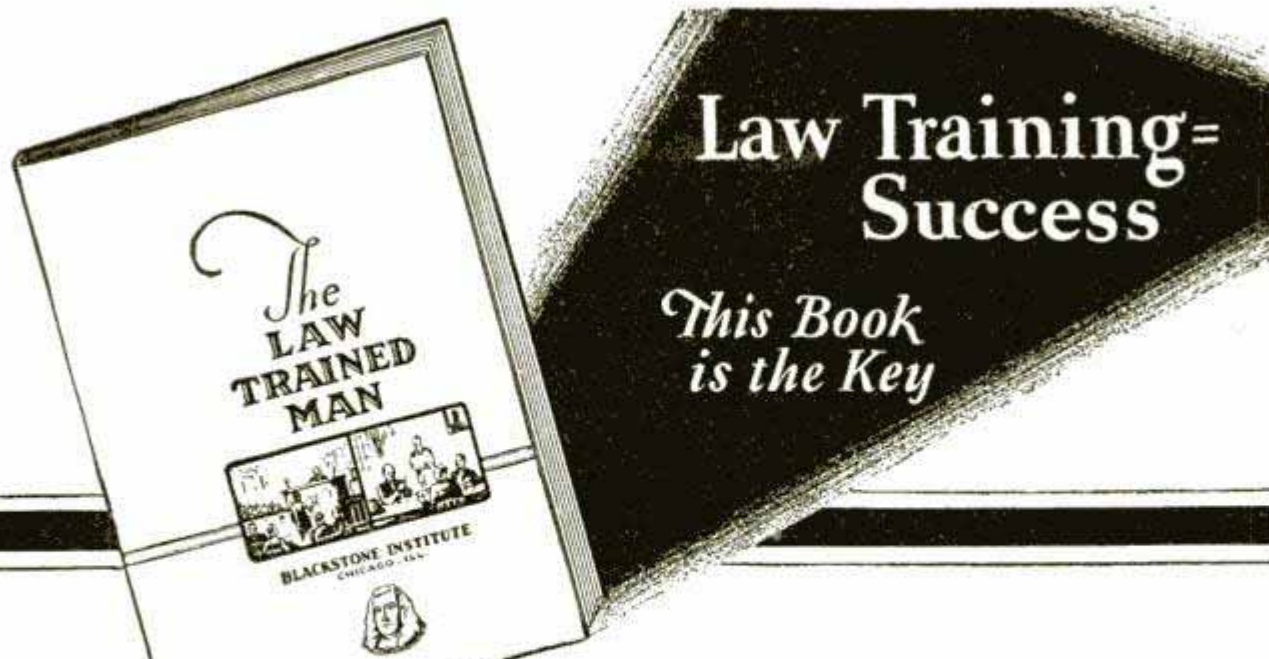

Send for this FREE book

THE LAW-TRAINED MAN—that is the name of an attractive book the Blackstone Institute has just published for complimentary distribution among those to whom a knowledge of law would be a business asset. YOU may have a copy if you desire, FREE, upon request.

All the questions you ever asked yourself about the money-making opportunities for the man trained in law are answered in this authoritative book. The partial list of chapter headings which follows gives some idea of the scope and value of the contents:

Law and American Business—The Blackstone Method—Increasing Business Profits—Famous Law Authorities—Training Worth \$150,000—Success at the Bar—Advantages of Home Study—Now Is the Time

Frankly, we published *The Law-Trained Man* for the sole purpose of creating an interest in the Institute's internationally famous home-study law course. One section of the book, therefore, deals with a detailed description of the course—its authoritative text and case books (delivered complete at the time of enrollment) and its fascinating lesson material and effective instruction service.

Another section deals with the successes of the Institute's 50,000 students, many of whom have gone on record in the book so that you might read and profit by their experiences. Hundreds of these have elected to enter the practice of law. Thousands of others have secured substantial business benefits. Graduates are awarded the LL.B. degree.

Money-Making Ideas

Blackstone Law training offers immediate money-making possibilities to business men by showing how to cut costs, facilitate sales and collections, reduce taxes, collect damages, protect against unfair competi-

tion, safeguard contracts, and 2083 other practical money-saving ideas.

The application of one idea alone will more than cover the modest monthly fee the Institute asks for its services.

The Nation's Best Legal Talent

The business-building ideas incorporated into the Blackstone Law Course were developed by a group of 80 of the most prominent law authorities in the country. Among them are two justices of the United States Supreme Court, and the deans of eight leading resident law schools.

These men know law and they present their ideas to you through the Blackstone Course in understandable and workable form. A small amount of your spare time for a few months will enable you to master these methods.

3 STRONG REASONS

1. The Blackstone Institute conducts only one course—LAW. The training plan now in use is based upon 38 years of experience in non-resident educational work.
2. Instruction is given through a combination of text reading and study of leading illustrative cases—a method recognized as the best and most thorough plan yet devised.
3. The Course is arranged to bring out the money-making possibilities of applying the principles of law to the operation of businesses of all kinds.

Investigation Costs Nothing

Law training equals success. The book, *The Law-Trained Man*, illustrated in miniature above, is the key. This book is not for boys or mere curiosity seekers, but there is a copy available for every man and woman of serious purpose.

Send for your copy at once while the present edition is available for complimentary distribution. Write a letter or use the convenient coupon below. Mail your request today. It may prove to be the shrewdest business move you have ever made. Address Blackstone Institute, Department 55, 307 N. Michigan Ave., Chicago, Ill.

BLACKSTONE INSTITUTE

Dept. 55, 307 N. Michigan Ave., Chicago, Ill.

Please send me a free copy of the revised edition of *The Law-Trained Man* and details of your law course.

Name.....

Business Position.....

Business Address.....

City..... State.....

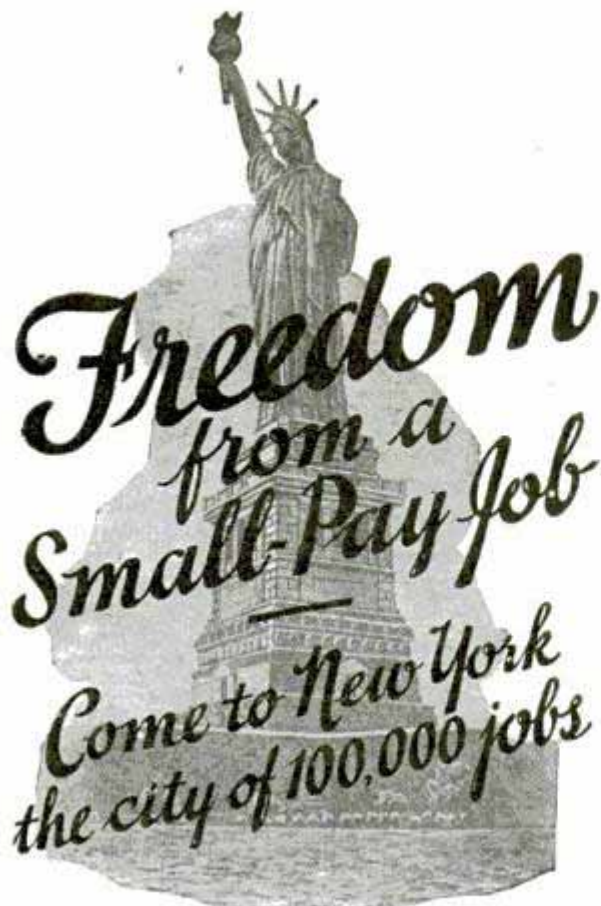

ANY MAN who can read and write and use a pair of pliers can become an electrical expert and free himself forever from the long hours and drudgery of a small pay job.

And you can learn the BIG PAY profession of electricity right in New York City—the heart of the electrical world—the city of 100,000 jobs. At the same time you are learning the BIG PAY profession you can be enjoying the sights and wonders of New York, the modern Bagdad.

Be An Electrical Expert

Graduates of the NEW YORK ELECTRICAL SCHOOL are in demand by all the big electrical companies. Or, if you prefer the independence of a business of your own, there are thousands of opportunities for efficient, dependable men to become electrical contractors. When you are your own boss the money you can make is limited only by your own energy and ability.

Personal Instruction

The NEW YORK ELECTRICAL SCHOOL is not a correspondence school. You learn by doing—by personal instruction on full size standard electrical equipment under the personal supervision of trained instructors.

At N. Y. E. S. you train your hands and mind at the same time. You learn the theories of electricity—and then you are shown how to put the theories into actual practice by solving the problems with your own hands.

The man who has learned electricity by actually doing electrical work under intelligent personal instructors can go to any part of the world and be sure of a good living. There are N. Y. E. S. graduates in all the countries of the world.

Write today for the 48-page booklet giving full information about the N. Y. E. S. Course and showing pictures of the equipment available for your personal use in our two seven-story buildings. Mail coupon now! The New York Electrical School, 44 W. 17th Street, New York.

The New York Electrical School,
44 W. 17th Street, New York.

Please send me FREE your 48-page booklet. It is understood that this request puts me under no obligation.

Name.....

Address.....

Increase Your Earning Power

Apply time and labor-saving kinks to your work. Your efficiency will soon be recognized and you will be in line for advancement.

If you do machine shop work of any kind, sheet-metal work, painting, carpentry, auto repairing, farming, concrete work, plumbing, electrical work, welding, building, glass work, general repairing, tool-making, poultry raising, masonry or home repair work, get this

**LIBRARY OF 6000
TIME AND LABOR SAVING
IDEAS FOR SHOPMEN
AND HANDYMEN**

JUST PUBLISHED

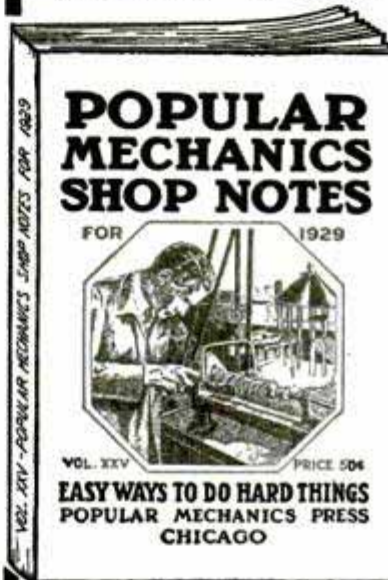

**SHOP
NOTES
for
1929**

347 Articles
400 Illustrations

**PRICE
50 CENTS**

See list of
partial contents
below

Including the new 1929 issue illustrated above, there are now 16 volumes in the Shop Notes Library of 6,000 easily understood short cuts to every-day jobs. Here are just a few of the subjects taken from the 347 articles in the latest issue.

Aluminum Mending	Drilling Kinks	Plant
Artistic Doorplates	Dumb Waiter	Practical Mimeograph
Artistic Plaques	Electric Crucible	Reamer Holder
Attractive Lampshades	Furniture Designing	Removing Roller Bearings
Bird Bath in Concrete	Handy Workshop	Renewing Old Pumps
Blowtorch Making	Homemade Jack	Renovating Gaskets
Brass Pipe Handling	Homemade Silt	Repairing Laundry Tubs
Build Your Own Garage	Insulating Hot Water	Rush or Fibre Seats
Burning Coke	Tank	Safe Folding Ladder
Burning Out Carbon	Lathe Kinks	Six-Inch Bench Shaper
Camera Exposure Meter	Long Narrow Photo-	Softening Leather Belt-
Candlestick Making	graphs for Making	Tables in Art Moderne
Chute for Parcels	Machine for Making	Tin Can Mechanics
Colonial Spinning Wheel	Rope	Tractor for Light Work
Crane for Small Garage	Paint Removing	
Double Vise Press	Piston Ring Compressor	
Draft Regulator	Pneumatic Soldering	

Each volume contains approximately 500 articles and 400 illustrations and has 224 Pages. At the regular price of 50 cents per single volume this library costs \$8.00, but for a limited period we will supply the 16 vols. when ordered at one time at the special reduced price of only \$5.00.

SPECIAL OFFER COUPON

POPULAR MECHANICS PRESS,
200 E. Ontario St., Room P5, Chicago, Ill.

Send me, as per your special offer the following books. I will pay for books C. O. D. when they arrive. My money will be refunded if I am not satisfied. (Check what you want.)

1929 Shop Notes and Drilling and Thread Cutting Handbook, 98c.
 Complete Shop Notes Library (16 vols.) \$5.00.

Name.....

Street and No.....

City..... State.....

"Watch him make a fool of himself" - *I heard someone whisper*



-then I started to play!

IT was the first big party of the season and the fun was at its height. The room fairly rocked with laughter as Jim finished his side-splitting imitation of a ballet dancer.

Tom, who was giving the party, turned to me and said, "And now our young friend here will give us his well-known imitation of Paderewski!"

Instantly all attention centered upon me. Feigning reluctance, I made as if to beg off, but was forthwith dragged to the piano. Admonitions of "Come on, old timer, do your stuff!"—"Don't be bashful!"—came from all sides.

They expected me to do my usual clowning—but I had a surprise up my sleeve for them. Just as I was about to begin, I heard someone whisper, "Watch him make a fool of himself—why, he can't play a note!"

I Surprised My Friends

They thought I was going to give them my one-finger rendition of chop-sticks. But instead I swung into the opening bars of "The Road to Mandalay"—that rollicking soldier song of Kipling's. You should have seen the look of amazement that spread over their faces. This was not the clowning they had expected! Then Tom began to sing. One by one they joined in, until soon they were all crowding around the piano, singing away at the top of their lungs.

It was almost an hour before they let me get up from the piano. Then a deluge of questions: "How in the world did you ever do it?"—"Where did you study?"—"When did you learn to play?"—"Who was your teacher?"—"How long have you studied?"

"One at a time, please," I begged. "I'll tell you all about it. To begin with, *I didn't have any teacher.*"

"What! Say you don't expect us to believe that, do you?"

"Sure thing. But I don't blame you for not believing it. I wouldn't have myself. As you know, I've never been able to play. But I always liked music, and many a time when I was pepping up a party with my clowning I would have given anything in the world to be able to sit down at the piano and *really* play.

"But it never occurred to me to take lessons. I thought I was too old—and besides, I couldn't see my way clear towards paying an expensive teacher—to say nothing of the long hours I'd have to put in practicing.

How I Learned to Play

"But one day I noticed an advertisement for the U. S. School of Music. This school offered to teach music by a new and wonderfully simplified method which *didn't* require a teacher, and which cost only a few cents a lesson.

"Well, boys, that certainly sounded good to me, so I filled out the coupon and sent for the Free Demonstration Lesson. When it arrived I found that it seemed even easier than I had hoped.

"I made up my mind to take the course. And believe me that was the luckiest decision of my life! Why, almost before I knew it, I was playing simple tunes! And I studied just whenever I pleased, a few minutes a day in my spare time. Now I can play anything I like—ballads, classical numbers, jazz. Listen to this!"

With that I snapped right into a tantalizing jazz number. All evening I was the center of a laughing, singing, hilarious group. And it's been that way at every party I've attended since. * * * * *

This story is typical. Over half a million men and women have already learned to play musical instruments through the U. S. School of Music system.

First you are told what to do—then a picture shows you what to do—then you do it yourself and hear it. No private teacher could make it clearer.

One of the reasons for the quick results is, that learning music this way is such fun. Instead of waiting a year before playing tunes—you learn by playing tunes. You play simple familiar melodies by note right from the start. You learn twice as fast—three times as fast—as those who study by old-time plodding methods.

Free Book and Demonstration Lesson

Our wonderful illustrated free book and our free demonstration lesson explain all about this remarkable method. They prove just how anyone can learn to play his favorite instrument by note in almost no time and for just a fraction of what old slow methods cost.

If you really want to learn to play—if new friends, good times, social popularity and increased income appeal to you—take this opportunity to make your dreams come true. Sign the coupon and send it before it's too late. Instruments supplied when needed, cash or credit. U. S. School of Music, 75 Brunswick Building, New York City.

U. S. SCHOOL OF MUSIC,
75 Brunswick Building, New York City

Please send me your free book, "Music Lessons in Your Own Home," with introduction by Dr. Frank Crane, Free Demonstration Lesson and particulars of your easy payment plan. I am interested in the following course:

Have You
.....Instr.?.....

Name.....

Address.....

City.....State.....

Pick Your Course

- | | | |
|--------------------|---------------|-------|
| Piano | Cornet | Cello |
| Organ | Sight Singing | |
| Violin | Ukulele | |
| Drums | Guitar | |
| and Traps | Hawaiian | |
| Mandolin | Steel Guitar | |
| Clarinet | Harp | |
| Flute | Piccolo | |
| Saxophone | Trombone | |
| Voice and Speech | Culture | |
| Automatic Finger | Control | |
| Piano Accordion | | |
| Banjo (Plectrum, | | |
| 5-String or Tenor) | | |



Come into DRAFTING

Good positions at \$50 to \$100 a week waiting for trained men



"Only one other man and I, of 12 taking California State Board examination for Architect, passed. Then I realized the thorough and practical training given by American School. In 18 months I have gone from tracer to Chief Draftsman, in charge of all architectural and engineering work in one of the oldest offices here."
R. L. Warren
Los Angeles, California.

Drawing plans and reading blueprints is the first step in all manufacturing and building construction. The work is interesting and well-paid, with good chances for advancement. Many of our leading Architects, Contractors and Engineers started as Draftsmen. Many mechanics, men engaged in building-trades work and office men handicapped with lack of early education have found in Drafting a chance to get ahead rapidly. No artistic talent is needed, and the Drafting room offers a short cut to promotion for men facing a futureless outlook in underpaid, routine tasks.

During the past 12 months over 70,000 Drafting positions were advertised, and the demand is increasing. So this is a good time to learn Drafting. Why not mail the coupon and get three free lessons and see how you like the work, and how easy it is to learn? There is no cost or obligation, and you may find just the chance you have been looking for.

Chief Draftsman,
THE AMERICAN SCHOOL
Dept. D-574, Drexel Ave. & 58th St., Chicago

3 DRAFTING LESSONS FREE

The American School,
Dept. D-574, Drexel Ave. & 58th St.
Chicago, Ill.

Without cost or obligation send three Drafting lessons and tell me how I can get a good Drafting position.

Name.....
Address.....
Age..... Occupation.....



Poor English!

How much is it costing you in wasted opportunity?

Every day your associates are judging you — by what you say and how you say it! Hazy ideas, ill-chosen words, halting sentences, crude, slovenly speech—these mark a man as loose in thinking. Thoughts clear-cut, words that give true shape and color, sentences aflame with power and originality—these are the things that proclaim ability, that win for their users swift advancement. Stop apologizing for poor English—it's inexcusable! In the quiet of your home—with LaSalle's help—you can learn to speak and write with real distinction, learn to make the words you utter and the letters you compose stamp you as educated, cultured, a power to reckon with in the business world. Complete details in an attractive 32-page book, "Effective Business English," sent you free upon request. Ask for it TODAY, LaSalle Extension University, Dept. 564-BE, Chicago

BEDFORD YMCA TRADE SCHOOL

Auto Mechanic
Aviation Mechanic
Starting, Lighting, Ignition
Electric Welding
Oxy-Acetylene Welding
Machine Shop. Battery Repair
Electrical Course. Radio Mechanic
Plumbing, Brick-laying
Plastering, Tile Setting
Mechanical, Architectural Drawing
Blue Print Reading
Building Estimating
Show Card Writing
Window Dressing. Sign Painting
Commercial Art. Fine Art
Write for Catalog 50
Brooklyn Engineering Institute
(Operated by Bedford Y. M. C. A.)
1125 Bedford Avenue, Brooklyn
New York City



I Teach by Mail

Begin Today—Write for My FREE Book, I can make a good penman of you at home during spare time. Write for my FREE BOOK, "How to Become a good Penman." It contains specimens and tells how of best mastered penmanship by the Tamblin System. Your name will be elegantly written on a card if you enclose stamp to pay postage. Write today for book. F.W.Tamblin, 418 Ridge Bldg., Kansas City, U.S.A.



MUSIC LESSONS IN YOUR HOME



Write today for our FREE booklet. It tells how to learn to play Piano, Organ, Violin, Mandolin, Guitar, Banjo, etc. Beginners or advanced players. Your only expense about 3c per day for music and postage used. American School of Music, 51 Manhattan Bldg., Chicago.

Learn Watchwork, Jewelrywork and Engraving A fine trade commanding a good salary, and your services always in demand. Address **Horological**, Dept. P, Bradley Institute. PEORIA, ILLINOIS, for our latest catalog.

AVIATION Information FREE

Send us your name and address for full information regarding the Aviation and Airplane business. Find out about the many great opportunities now open and how we prepare you at home, during spare time, to qualify. Our new book *Opportunities in the Airplane Industry* also sent free if you answer at once.
AMERICAN SCHOOL OF AVIATION, Dept. 1355, 3601 Michigan Ave., CHICAGO

5 Dancing Lessons FREE

*—if you can
do this step*

NO matter how poorly you dance now—even if you've never been on a dance floor in your life—if you can do the simple step pictured at the right, I'll give you five of my famous dancing lessons *absolutely free*.

Think what that means! My new method of teaching dancing is so simple and easy to understand that *you can master any of the latest steps in one evening*—without music, partner, or teacher!

For I have discovered that all modern dancing is based upon *five fundamental movements*. The step pictured here is one of these basic movements. *The other four are just as simple*. Once you have mastered these key steps you can learn to do *any* dance—no matter how complicated it may appear—in almost no time.

There's no excuse now for playing wallflower—no excuse now for passing up good times because you can't dance! As soon as you receive the lessons you can learn the fundamental steps—in just a few hours. Then the very next time dancing starts you can surprise your friends by stepping right on the floor with the best dancers in your set—and with as much ease and assurance as if you had been dancing for years!

How to Be Popular

You'll never regret being an accomplished dancer! Think what it means to be popular, sought after, sure of a good time wherever you go!

And dancing is great fun—wonderful exercise. It takes your mind off your worries and cares. Keeps you happy and healthy—always on your toes and full of pep. Develops poise and self-confidence—enables you to make friends easily—and often opens the door to important business and social contacts.

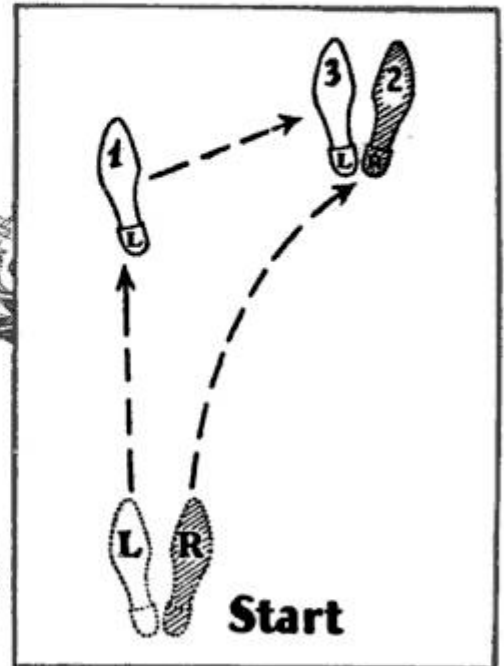

And it's so easy now to be a *good* dancer, able to do all the newest, smartest steps.

My new method makes learning to dance just as simple as taking one step after another. Nothing is omitted—nothing taken for granted. You start right at the beginning, and go through the entire field of social dancing. You learn to master every step from the simple waltz to the newest, smartest dances and all their variations.

Five Lessons FREE

I have already taught over 400,000 men and women how to dance at home without music, partner, or teacher. And I'm so sure that you, too, can become a good dancer and get your full share of fun and popularity through my amazingly easy method that I'm willing to send you five lessons from my remarkable course, **without charge**.

Simply send the coupon, with 25c, to cover cost of printing and mailing, and these valuable lessons will be forwarded at once. Also a free copy of my new booklet, "The Short Cut to Popularity." Don't wait—you owe it to yourself to clip and mail the coupon NOW. ARTHUR MURRAY, Studio 915, 7 East 43rd St., New York City.

ARTHUR MURRAY,
Studio 915, 7 East 43rd Street, New York City

To prove that I can learn to dance at home you may send the FIVE FREE LESSONS. I enclose 25c (stamps or coin) to pay for postage, printing, etc. You are to include free "The Short Cut to Popularity."

Name.....

Address.....

City..... State.....

The Truth about Voice

New Voice Book Discloses Startling Voice Facts

Sent Post-Paid for 30 Days FREE Reading No Money Down



KNOW *The TRUTH about* **YOUR VOICE**



Eugene Feuchtinger
A. M.
Master of Voice
European Maestro

Send today—for 30 days free reading—for the most remarkable voice book ever written. This book has startled the whole voice world. Written by a man recognized the world over as a voice authority—a man with the courage to tell the TRUTH about voice, about the vocal organ and the real basic, fundamental truths about voice training. Advances astounding new method. Discloses startling facts that may save hundreds of dollars to every

man and woman seeking a strong, rich, compelling singing or speaking voice. Send for this most remarkable voice book today.

FREE 30 Days Reading

Certainly I could not afford to make you this liberal 30 days free reading offer if I did not KNOW what "The Truth About Voice" will do for YOU. Send for this book today. KNOW the truth about YOUR voice—a truth just as SIMPLE as it is astounding! Know WHY I actually guarantee to improve every man or woman's voice at least 100%. 30 days free reading to prove this! Then, if convinced, send only \$1.00—although you'll gladly admit that the book may be worth thousands to you. If not—return it—that's all! Mail coupon NOW—before the demand exceeds the supply!

Prof. Eugene Feuchtinger, Studio 13-55
Suite 29, 1810 Wilson Ave., Chicago, Ill.

Send me at once—for 30 days free reading—with no obligation to buy, your "The Truth About Voice" Book. If after the free reading period I desire to keep the book I am to send you \$1.00. Otherwise, I have the liberty to return it with no further obligation.

Name _____
Address _____

attractive professions ART and ADVERTISING

Meyer Both Company, a dominant factor for 28 years in art and advertising service, with over 5,000 clients thruout the English speaking world, offers practical instruction in these two fascinating fields open to both men and women. This instruction—based upon so wide an experience—translates the maze of vague theory into demonstrated fact. Individualized home study instruction. If interested in a career in either of these well paid professions send for free book on (1) Art (...) or (2) Advertising (...).

MEYER BOTH COMPANY
MICHIGAN BLVD. AT 20TH ST. Dept. 16, CHICAGO

BIG PAY

CAMERA MEN- PHOTOGRAPHERS

BE A MOVIE OPERATOR
Projector Given
Learn at Home. Big Demand by Movie and Vaudeville Theatres.

You can soon qualify for the wonderful opportunities in this big pay profession. **FREE BOOK** explains opportunities as Motion Picture Camera Man, Portrait, Commercial or News Photographer or in your own business. Learn at Home or in our great New York Studios. Write for Free Book and Job Chart.

N. Y. INSTITUTE OF PHOTOGRAPHY
10 West 33rd St., N. Y. Dept. 49

WORLD PLUMBERS NEEDS PLUMBERS

Old style plumbers are fading like the horse and buggy. The world demands modern Plumbing and Skilled Trained Mechanics to do it. Unlimited, swift growing field. Make \$50 to \$100 a week or start own shop. We train you quick. Learn in 8 to 12 WEEKS to do any job with skill and science. Need no previous experience. Strictly tool using system. Opportunity knocks. Investigate today—amazing offer—low tuition. World's greatest school.

Write—
UNIVERSAL PLUMBING SCHOOL
2130 Troost Ave. Kansas City, Mo.

LEARN WATCH REPAIRING

You can learn by our modern and original system of instruction every part of the Watch Repairing Trade at home as good or better than at a shop. You can earn money while learning and secure a well paying position or start in business after completing our course of instruction. Good watch repairers are always in demand and earn from \$50 to \$75 per week. For particulars apply to the Wisconsin School of Watch Repairing 166 Mason St., MILWAUKEE, WIS.

ALWAYS Ask For DENISON'S—53 Years of Hits

Comedy-Dramas, Farces, Musical Comedies, Revues, Musical Readings, Blackface Skits, Make-up Goods.

PLAYS

Vaudeville Acts, Monologs, Dialogs, Entertainments, Comedy Songs, Chalk Talk Books, Minstrels.

T. S. DENISON & CO., 623 S. Wabash. Dept. 9, CHICAGO

Write Like This

Wonderful, new device, guides your hand; correct your writing in few days. Big improvement in three hours. No failures. Complete outline FREE. Perfect Penmanship Inst. D-34, St. Louis, Mo.

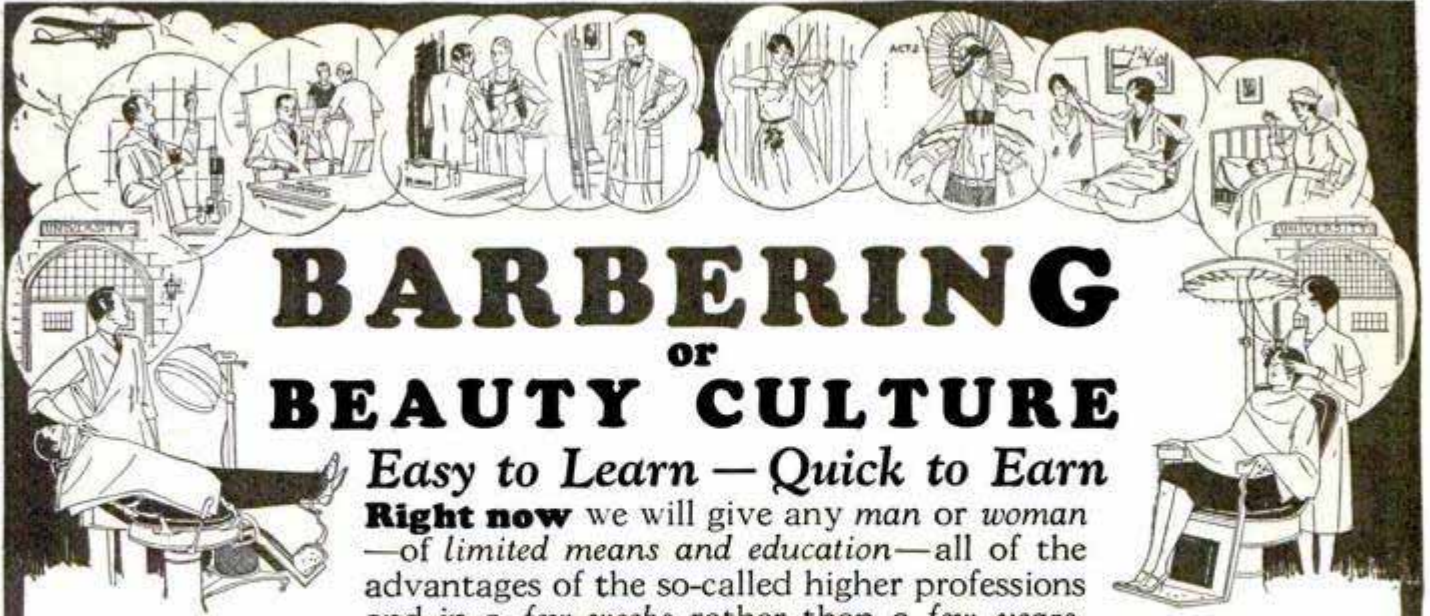

BARBERING or BEAUTY CULTURE

Easy to Learn — Quick to Earn

Right now we will give any man or woman —of limited means and education— all of the advantages of the so-called higher professions and in a few weeks rather than a few years.

State Laws make it More Difficult—You Must Act at Once

Soon every State in the Union will have Laws making it impossible to learn this work without a high school education—health certificate—longer period of training—greater expense, etc.

CLEAN INSIDE WORK—

The glowing warmth of a clean, interesting, inside position with every Saturday night your Pay check—twice the size of your present salary, or your own business in any city or hamlet, or travel and see the world, all yours if you register now, while you can qualify.



William McClintock, former President Master Barbers' Ass'n and proprietor of the highest priced rented shop in the world, says, "My son, who learned at Moler's, is top man in my shop every week. I gladly recommend the Moler System as the proper place for men to become successful barbers."
—WM. McCLINTOCK.

IF YOU HAVE IN MIND—

Aviation, Nursing, Drafting, Electricity, Dramatics, Music or any other Profession, Saturday work alone in barbering or beauty culture will earn a scholarship and a living during the years necessary to acquire it and I can give it to you in a few weeks.

SEE how the drift for better personal appearances throughout the world has made barbering and beauty culture a **BILLION DOLLAR BUSINESS.**

See how bad weather lay offs, strikes, crop failures, shut downs, lock-outs, etc., are absent from barbering and beauty culture. I can put you into one of my colleges established convenient to you no matter where you may now be located.

The call is constant and under state restrictions becoming more urgent but for you the opportunity without capital or education is right now. Opportunity doesn't wait.

Miss Mae Greene—
Beauty Contest Winner Says:

I am now armed with the Diploma of the Moler College—an accredited school—that gives me access into the best shops of the world and I have a great many offers from which to choose.



Mae L. Greene

MOLER SYSTEM

The Standardized Branches

- | | | |
|------------------|-----------------|--------------------|
| New York, N. Y. | Cleveland, Ohio | New Orleans, La. |
| Chicago, Ill. | Detroit, Mich. | Atlanta, Ga. |
| St. Louis, Mo. | Denver, Colo. | Memphis, Tenn. |
| Kansas City, Mo. | Omaha, Nebr. | Dallas, Tex. |
| Cincinnati, Ohio | Milwaukee, Wis. | Minneapolis, Minn. |

CUT THE COUPON →

MOLER SYSTEM OF COLLEGES

Address Nearest Branch
(Street Address NOT Needed)

Please tell me how I may register before State Laws make it more difficult. I want as a future life work Barbering Beauty Culture
 I want the above checked item to help me acquire another vocation. Also send me booklet B.

Name.....

Address.....

City..... State.....

**DRAFTING
ARCHITECTURE
ENGINEERING
ELECTRICITY**

FREE BOOK COUPON

Chicago Technical College
Dept. E-77, 118 E. 26th St., Chicago
Please send me without obligation, your
Free Book and other information about
plan of training marked below.

Name.....

Address.....

City..... State.....

Check One of these Plans

- 1—Complete College Training (2 year Diploma—3 yr. Degree) Engineering or Architecture at the College in Chicago.
- 2—4 months' Special Drafting Course at Chicago Tech. Earn while you learn.
- 3—Home Study—College training at home in Drafting. Your spare time is enough.

**Check one of these
3 Plans
Then Mail Coupon**

It Starts you on your way to Big Pay in These Billion Dollar Fields

The Coupon brings all the facts about 4 fields where billions are spent annually. Millions go to men trained to lay out and superintend construction work. Industry needs trained Draftsmen, Engineers and Architects. Huge salaries are paid. Bonuses offered—for men are at a premium in Drafting, Architecture, Engineering and Electricity. All you need is training. The coupon starts you to a real position or a business of your own. Send it now.

TRAIN

THE CHICAGO TECH WAY

Here at this school you get the specialized training you need to become a Drafting or Engineering expert. For 26 years we have been training men for big-pay.

3 PLANS—TAKE YOUR PICK
No need to be without this training.

No matter what your circumstances these 3 plans make it easy for you.

1. Come to Chicago if you can. Enter our resident school in either the 2-year Diploma or 3-year B. S. Degree Course. Thorough, up-to-the-minute, practical training. Opportunities for self-support while studying. Mark **Plan 1** on the coupon. It brings you our free 80 page "Blue Book".

2. If your time is limited, take our 4-months' course in Drafting. Mark **Plan 2** on the coupon.

3. Finally, if you can't come to Chicago, then study at home. Mark **Plan No. 3** on the coupon.

One of these plans holds the key to your future success. Fill in and mail the coupon—find out what Chicago Tech training can mean to you.

CHICAGO TECHNICAL COLLEGE

Dept. E-77 Chicago Tech Bldg. 118 East 26th St., Chicago, Illinois

PATENTS

**Booklet Free Highest References
Promptness Assured Best Results**

Send drawing or model for preliminary examination and advice.

ALL BUSINESS GIVEN PROMPT AND PROPER ATTENTION

Listed Patent Lawyer in the latest editions of the Rand-McNally Directory of Bankers and Bonded Attorneys, published by Rand-McNally & Co., Chicago, Ill.; The Baggott & Ryall Directory of Guaranteed Attorneys, published by the Ryall Legal Directory Company, New York City; Flugel's List, published by the Legal Directory Publishing Co. of St. Louis, Mo.; the American Lawyers Annual, published in Cleveland, Ohio; Eyre's Law List, Bush Terminal Building, New York City.

WATSON E. COLEMAN,
REGISTERED PATENT LAWYER

Victor Building, 724 Ninth Street, N. W.
WASHINGTON, D. C.

TRAVEL - for 'UNCLE SAM'

RAILWAY POSTAL CLERKS

**MAIL CARRIERS—POSTOFFICE CLERKS
PROHIBITION AGENT—INVESTIGATOR**

\$1700 to \$3400 a Year for Life

No "lay-offs" because of strikes, poor business, etc.—sure pay—rapid advancement. Many other U. S. Government Jobs. City and country residents stand same chance. Common sense education usually sufficient.

STEADY WORK

Cut coupon and mail it before turning the page.

**MEN—BOYS
18 to 45**

Use Coupon Before You Lose It

COUPON

FRANKLIN INSTITUTE, Dept. R 177, Rochester, N. Y.

Rush to me, free of charge, (1) A full description of the position checked below; (2) 32-page book, with list of positions obtainable; (3) Tell me how to get the position checked.

- Railway Postal Clerk (\$1900 to \$2700) General Clerk (\$1260 to \$2100)
- Postoffice Clerk (\$1700 to \$2300) Prohibition Agent (\$2300 to \$2800)
- City Mail Carrier (\$1700 to \$2100) Rural Mail Carrier (\$2100 to \$3300)

Name

Address.....



Learn AVIATION at GREER COLLEGE

Come into Aviation

Man's Dream Is Answered—Aviation Is Here

Transport Flyers will train you

Greer Air Transport supervises all flying instruction. Greer pilots have had long experience in instruction and transport flying. You are safe and will learn quickly with their expert help.

Capt. Bryan superintends ground training

Captain Bryan—with years of Army

and Civilian Aviation Experience—supervises all ground schooling. He has been in Aviation and actual Flying for over twelve years.

Earn Big Money in a 4 Hour Day

What are a Flyer's hours? **Four Hours**—not work—but fun—nevertheless those are usually the hours for him.

And the pay! Many make \$300 on a single Sunday. My Free Book gives astonishing details. Send for it now!

Adventure—
Prestige—
Thrills—**BIG PAY**—Easy, Fascinating work that **IS Aviation.**

I'll pay your fare to Chicago

Come to Chicago. I'll pay your fare when you enroll. Here is the **real** hub of the Aviation Industry. The World's finest and biggest Airport is here. Get my Free Book — tells all remarkable facts.

LEARN DAYS OR EVES A Job while Learning

You can attend the Great Shops of Greer College and learn Aviation either days or eves. We even help get you a job so you earn as you learn—in short—what does this wonderful training cost? Nothing!



Erwin Greer



HOW!

I offer you a \$100 a week opportunity, perhaps more. But you must prepare. \$100 a week jobs mean nothing unless you can hold those jobs—so Prepare. I make it easy—26 years doing it—proves it, so when those jobs arrive—be ready—I'll help you get them—but be able to hold them.

TODAY

Tomorrow is just a day—but think—is it to be a day **wasted** or a day **rushing** to

success? Think of it. Tomorrow, may be just the second day to your real triumph—but tomorrow can't possibly come before today. I ask you to do nothing but find out for yourself. My Book is Free. Look at it at least, it costs you nothing and it **will** help you if you enroll or don't.

Sincerely, **ERWIN GREER, Pres.**

GREER COLLEGE

Dept. 501

2024 So. Wabash Ave.

CHICAGO



ERWIN GREER, President

Dept. 501
2024 So. Wabash Avenue,
Chicago, Illinois

Send Free Book and details of Special offer, without obligation to me.

Name.....

Address.....Age.....

You can play the HAWAIIAN GUITAR just like the Hawaiians!

Play all the latest hits just as the Hawaiians do. Be the most popular member of your set, a happy crowd always around you, everybody enjoying and admiring your playing. Get in on all the good times. Entertain your friends—or play professionally. We will help you.



Native Hawaiian expert directs you

You get expert instruction, directed by a world-famous player and teacher, Prof. Walter Kolomoiku. He quickly reveals to you the secrets of this fascinating instrument.

Complete Conservatory Course

You get 52 complete printed lessons. Nothing is omitted. Pictures explain every move. And no matter how little you know about music when you begin, no matter if you have never touched a musical instrument, you can positively learn to play by our plain, easy picture method. You are sure to learn! What we can do for others we can do for you. 51,000 successful students. This record assures your success.

Learn at home in spare time

Study in spare time—in absolute privacy—when you like—as long as you like. Even if you don't know one note from another, our method is so simple you begin a piece your first lesson. In half an hour you can play it!

Only 4 motions to learn

Then you can play any music—popular songs, classical, old-time melodies, native Hawaiian airs—or real jazz—separately or with accompaniment. You'll never be lonesome after you learn to play on this beautiful Hawaiian Guitar.

GIVEN when you enroll—
\$18 to \$20
Hawaiian Guitar

With Genuine Seal Grain Fabrikoid Cover and Complete Playing Outfit

Reliable retailers ask \$19 to \$20 for a similar instrument and outfit without the fine Fabrikoid Case, which alone is valued at \$3.50. Yet you receive this sweet-toned splendidly built Hawaiian Guitar, case and entire playing outfit, including picks, steel playing bar, tuning pipe, etc., without one penny of expense, as soon as you enroll.

Pay as you play

We make it easy for you. Start any time with a small first payment—then pay while learning. It comes to only a few cents per lesson. And bear in mind: Your only investment is the cost of the course—we furnish everything else.

No waiting—begin now

No waiting for a class to form—begin at once. The sooner you do, the sooner you will realize your ambition to become a real Hawaiian Guitarist. ACT!

OTHER COURSES: Tenor Banjo, Violin, Tiple, Tenor Guitar, Ukulele, Banjo, Ukulele—well-known instructors.

FIRST HAWAIIAN CONSERVATORY OF MUSIC, Inc.

9th Floor Woolworth Bldg. Dept. 648 New York, N. Y. Approved as a Correspondence School Under the Laws of the State of New York.

Member of National Home Study Council.



Send This Coupon for Liberal Offer!

FIRST HAWAIIAN CONSERVATORY OF MUSIC, Inc.
9th Fl., Woolworth Bldg., Dept. 648, New York, N. Y.

Please send full information about your 52-lesson Hawaiian Guitar Course. I am not obligated to enroll unless I want to.

Name _____

Address _____

City _____ State _____

Books on 65 Practical Subjects

Popular Mechanics Press specializes in supplying the outstanding best books on many subjects. As new books of merit appear, we will revise the list accordingly.

- AIR NAVIGATION AND METEOROLOGY** (Just Out)..... \$3.00
- AIRCRAFT ENGINES** Dyke's New Instructor Latest Types..... \$5.00
- ARCHITECTURAL** Drawing and Lettering \$2.00
- ARMATURE WINDING** and Motor Repairs... \$3.00
- AUTO ENCYCLOPEDIA** Dyke's. (Covers New Model A Ford)..... \$6.00
- AVIATION** Everybody's Guide... \$2.00
- BIRD HOUSES** How to Make..... \$1.00
- BLUE PRINTS** How to Read..... \$2.00
- BOAT BUILDING** Outboard Motor Type 30 Designs..... \$3.00
- BOY MECHANIC** 4 Vol. Library, Covers 4000 Things to Make \$7.00
- BUILT-IN FURNITURE** How to Make..... \$2.50
- CARPENTRY** Handbook of Kinks... \$1.50
- CIVIL SERVICE** How to Prepare for... \$3.00
- COLOR SIMPLIFIED** Practical (for Color Users)..... \$3.50
- CONCRETE** 173 Ways of Using New Edition (Cloth) \$1.00
- CONTRACTOR** Building Cost Estimator \$2.00
- DICTIONARY (ENGLISH)** New, Simplified. 1500 Pages. 3000 Illus... \$5.00
- DIESEL ENGINES** (New Work). Best Authority..... \$5.00
- DOGS** Care and Raising..... \$2.00
- ELECTRIC LIGHTING** 25% More Light at No Increase in Cost..... \$1.00
- ELECTRICIAN** 214 Practical Kinks... \$1.50
- ELECTROPLATING** Practical Results Easily Obtained..... \$1.00
- ENAMELING** and Japanning (Baked Finishing)..... \$3.50
- ENGLISH** Self-Improvement in... \$2.50
- ETIQUETTE** New 560-Page Book. Only..... \$1.00
- FARMER'S BOOK** of 861 Kinks and Book for Farmers' Wives... \$1.00
- FLY (HOW TO)** Written So a Boy Can Understand It..... \$2.50
- FORMULAS** 10,000 Money Making \$4.00
- FURNITURE** Homemade (3 vols.)... \$3.00
- GARAGE** Money Making Methods in Management.... \$3.00
- HEATING** Systems (Practical) and Ventilation..... \$4.00
- HOME REPAIRS** Practical Book of..... \$2.50
- INVENTIONS** How to Make Pay..... \$2.50
- INVESTMENT** Policies that pay By Ray Vance..... \$4.00
- JOINT WIPING** (New Edition)..... \$1.00
- LACQUERING** (Practical). Valuable New Book for Metal Working Industry... \$3.50
- LANDSCAPING** Practical..... \$2.50
- LATHE WORK (METAL)** and Drilling and Thread Cutting..... \$1.00
- LEATHER WORKING** Making Artistic Articles..... \$1.00
- LETTER WRITING** Social and Business Only..... \$1.00
- MACHINIST** 419 Kinks for..... \$1.50
- MAGIC** 200 New Tricks for Amateurs..... \$1.00
- MAKING THINGS YOURSELF** 900 Different Articles... \$3.00
- MATHEMATICS** Made Easy for the Practical Man..... \$1.50
- MECHANICAL DRAWING** Practical Course in... \$1.00
- MODEL AIRCRAFT** Building and Flying for Boys..... \$2.25
- MOVIE MAKING** for Amateurs..... \$3.00
- OUTDOOR OPPORTUNITIES** for Making a Living... \$2.00
- OUTDOOR SPORTS** for All Year 'Round... \$1.50
- PAINTING** House (Best Methods)... \$2.00
- PLUMBING** Repair Your Own.... \$1.50
- POULTRY RAISING** for Profit..... \$2.00
- POWER WIRING (D. C.)** Electrical (Just Out)... \$3.50
- PUZZLES** Amusing Mathematical \$1.50
- RADIO** Trouble Shooting..... \$3.00
- ROPE SPINNING** Only Book on Subject... \$1.50
- SHIP MODEL** Making..... \$2.50
- SHOP NOTES** 16 Vols. of 6000 Valuable Kinks..... \$5.00
- STEEL SQUARE** Pocket Book, Practical \$1.00
- TAXIDERMY** Best Book of Methods... \$3.50
- TOY MAKING** Speed (for Boys)..... \$1.25
- WELDING** Encyclopedia All Methods..... \$5.00
- WIRING** House (New Book).... \$2.50
- WOOD TURNING (LATHE)** Practical Course in... \$1.50
- WOODCRAFT** Famous 590 Page Book by Ernest Thompson Seton; Only..... \$1.00

Books sent C. O. D. anywhere in U.S.

Just clip the ones you want, write your name and address below, and mail with coupon. It is your order blank. When postman hands you books, pay him the price and the postal charges. If outside the U. S. remit when ordering and include 10 cents per book extra for postage. We have many other books on these and 2,000 other subjects. Catalog free.

Name.....

City..... State.....

Address.....

Mail to **Popular Mechanics Press,**
Room P5—200 East Ontario St., Chicago, Ill.

Strongfort Gives You Vigor, Health and Strength



STRONGFORT

Dr. Sargent, of Harvard University, U. S. A., declared Lionel Strongfort to be unquestionably the finest specimen of physical development he had ever seen.

YOU can't get by any more without being physically fit. The world of industry, the world of business, the world of finance—all demand that you have abundant health and manly strength. Everywhere comes the demand for fellows who are full of pep, "up on their toes," "go-getters," real men of speed and stamina. You must be fit—and how are you going to be fit?—how are you going to pull yourself out of the languid, lazy, dragging habits that have made you a second-rater, a shambling, aimless, timid individual?

You Can't Hide Weakness

You weaklings—you grown-up physical babes—may masquerade in men's clothes—you may devour cigarettes and poisonous booze and make a pretense at manliness, but you can't hide your weakness nor lack of real manhood. Men know you—you can't fool them. Women quickly size you up for what you are. Nobody cares a rap for you. You can't get or hold good jobs. You can't get into sports. You can't qualify for military training camps. You are just so much deadwood in the scheme of life. Rubbish! Misfits! Rejects!

What are you weaklings going to do about it?

Let *Lionel Strongfort* point the way. Let him take hold of you and make a he-man of you by his original, muscle-making methods. Let him, through **STRONGFORTISM**, banish vitality-sapping weaknesses, constipation, catarrh, indigestion, sleeplessness, nervousness, stomach troubles, rupture, rheumatism and other afflictions.

Strongfortism Dominates

There isn't any question about **STRONGFORTISM** dominating in the field of physical culture. It is the supreme method of attaining health and strength. It towers above all fads, fakes, and frills; all "cures," all drugs and dope and stimulants. It has proved its merit throughout years of performance and has outlived hundreds of pretenders.

Send this Coupon

Free Confidential Consultation

Mr. Lionel Strongfort, Strongfort Institute, Dept. 906, Newark, N. J.—Please send me absolutely free my copy of your book, "LIFE'S ENERGY THROUGH STRONGFORTISM" printed in..... English..... German..... Spanish. This does not place me under any obligation and no salesman is to call on me. I have marked (x) before the subjects in which I am most interested.

- | | | |
|-------------|-----------------|----------------------|
| .. Catarrh | .. Constipation | .. Lung Troubles |
| .. Colds | .. Rheumatism | .. Round Shoulders |
| .. Asthma | .. Nervousness | .. Stomach Disorders |
| .. Headache | .. Overweight | .. Increased Height |
| .. Rupture | .. Weak Back | .. Muscular |
| .. Thinness | .. Weak Eyes | .. Development |
| .. Pimples | .. Short Breath | .. Great Strength |
| .. Insomnia | .. Weak Heart | |

Other Ailments.....

Name.....

Age..... Occupation.....

Street.....

City..... State.....

Send For My FREE BOOK

A revelation of inside facts about the human body that makes it priceless to men seeking to banish vitality-sapping ailments, weakness unfitting them for business and the joys of life. This book points the way to a newer, better, joyous life. I will be glad to send it to you Free. **WRITE TODAY** for your copy.

STRONGFORT INSTITUTE

LIONEL STRONGFORT, DIRECTOR.

Physical and Health Specialist for Over 30 Years

Dept. 906, NEWARK, NEW JERSEY, U. S. A.



"AVIATION" GUIDE FREE With Auto Books!

For a limited time only we will give absolutely free Major PAGE'S sensational "best seller" among aviation books, 256 pages crammed full of the latest dope on modern aircraft, airplane motors, control systems, lessons on flying, etc. Written in simple, non-technical language, especially for beginners planning to go into aviation. Mail coupon, send no money.

AUTO BOOKS SENT FREE!



Can You FIX IT?

Can you take the "play" out of differentials? Can you kill the SHIMMY in steering? Can you reset TIMING? Can you put your finger on engine-trouble without guessing or tinkering? Can you pull the STARTER off and fix it? Can you adjust and repair transmission, rear-axles, engines and electrical systems?

These Books Tell HOW!



Whether you are a mechanic or helper, expert or student, auto owner or driver, by all means take advantage of this opportunity to see and use the latest and most complete library on AUTOS every published! Built by eighteen of America's greatest automotive engineers. Simple enough for men with little schooling to understand, yet in daily use by thousands of engineers, service station superintendents and foremen. Tells you how to do any auto job RIGHT the first time.

5 BIG VOLUMES

2400 pages, over 2000 illustrations, wiring diagrams, equipment charts, etc. DeLuxe edition with gold-stamped flexible binding. Sent FREE for 15 days' use. If not wanted return express collect. If kept, send only \$2. after 15 days, then \$3. a month until special advertising price, \$24.80 is paid.

Don't "Study"—LOOK IT UP!

The ten-billion dollar auto industry offers rich prizes to men with gumption enough to really learn all branches of automotive mechanics. A better job—bigger pay—the chance to go into business for yourself and get a share of the huge profits are waiting for any man who even half tries to improve his ability to deliver service. And here's the quickest, easiest way—no tedious memorizing or lessons. JUST LOOK UP the facts you seek. You'll find the answer to any auto problem literally at your finger-tips in the famous JIFFY INDEX.

American Technical Society
Dept. A-519 Drexel Ave. & 58th St., Chicago, Ill.

DON'T SEND A PENNY!

American Technical Society
Dept. A-519 Drexel Ave. & 58th St., Chicago, Ill.

I would like to see the new 5-volume edition of your AUTO BOOKS, but without obligating me to buy them. I will pay the few cents delivery charges only, and if I choose to, I will return them express collect. If after 15 days' use I prefer to keep them I will send you \$2 and pay the balance at the rate of only \$3 a month, until \$24.80 is paid. Please include a year's consulting membership free, and send "AVIATION GUIDE" without cost after I notify you I will keep the books.

Name.....
Address.....
Employer's Name.....
Employer's Address.....

AVIATION BOOK FREE

FOR YOUR FUTURE



INVESTIGATE THIS VOCATIONAL TRADE OPEN TO ALL WHETHER 18 OR 50

The opportunity of a lifetime to become financially independent. Earn up to \$5,000 a year. Great demand and always will be because it is a human necessity. Easily learned in three to six months by actual practice with the regular tools of the trade. No previous training required. Business of your own if desired. Oldest establishment in this field is now ready to train an additional number of men for this work. Remarkably low cost—starting fees as low as \$15. R. R. Fare to nearest school included. Earn while you learn if necessary—regular arrangement for part time positions. Investigate this opportunity. The facts are convincing. Write today for Bulletin No. 2 which gives complete information.

BODEE INSTITUTE

New York 1756 Broadway Philadelphia 1305 North Broad Street Brooklyn 85 Court Street

LEARN TO PLAY

VIOLIN, TENOR BANJO HAWAIIAN GUITAR, BANJO, CORNET, UKULELE, BANJO UKULELE, GUITAR OR MANDOLIN



Instrument Furnished. No Extra Charge

We will furnish you without extra charge when you enroll any instrument you select and teach you to play it by our NEW copyrighted easy to learn home-study course. Thousands of men, women, boys and girls have learned to play by our simplified method. Cost is only a few cents a day. You pay while you learn. Instrument and first lesson sent on FREE trial. Write today.

CHICAGO CORRESPONDENCE SCHOOL OF MUSIC, INC.
1632 No. Halsted St., Dept. 778 Chicago, Ill.

Learn Photography at HOME

Make money taking pictures. Prepare quickly during spare time. Also earn while you learn. No experience necessary. New easy method. Nothing else like it. Send at once for free book, OPPORTUNITIES IN MODERN PHOTOGRAPHY and full particulars

AMERICAN SCHOOL OF PHOTOGRAPHY
Dept. 1355 3601 Michigan Ave. Chicago, U. S. A.

Make Much Money

Making and Selling Your Own Goods. Formulas by experts. Manufacturing Processes. Trade-Secrets. All Kinds. All Lines. Send for interesting catalog, special circulars, free.
W. THAXLY CO., Washington, D. C.



6 Ft. LONG GIVEN Royal Here's the great navy model Airship. Large 6-foot air bag with inflators, parachute with automatic release and complete instructions for flying. Will fly for miles at height of 1000 feet. Great chance to study aerial navigation. Send name and we'll send 6 of our new art pictures to dispose of on special 25c offer. Send the \$1.50 you collect and as a reward for this service we will send this wonderful Airship with full instructions free.
C. M. THOMAS, 337 W. Madison St., 5-K-91, CHICAGO

MINSTRELS Musical Comedies and Revues. Unique Minstrel First - Parts for complete show with special songs, opening choruses, etc. Full line of plays, stage songs, crossfire, monologues, afterpieces, vaudeville acts and make-up. CATALOGUE FREE.
T.S. DENISON & CO., 623 So. Wabash, Dept. 18, Chicago

Anyone CAN LEARN

No talent or experience necessary. Fascinating work. Pays Big Money. Complete instruction book tells about: Alphabets, Colors, How to Mix Paints, Show Cards, Window Board and Wall Signs, Ready made letters, Gilding, Tricks of the Trade, also gives 100 Alphabets and Designs. Book bound in flexible inst. leather-gold edges, and four ball bearing Show Card Pens. Sent postpaid \$3.00. (C.O.D.) 10c ex. Ogilvie Pub. Co., 57 Rose St., Dept. 20, N.Y. City

EARN MONEY IMMEDIATELY— WE FURNISH EQUIPMENT TO START !!

BIG PAY in ELECTRICITY

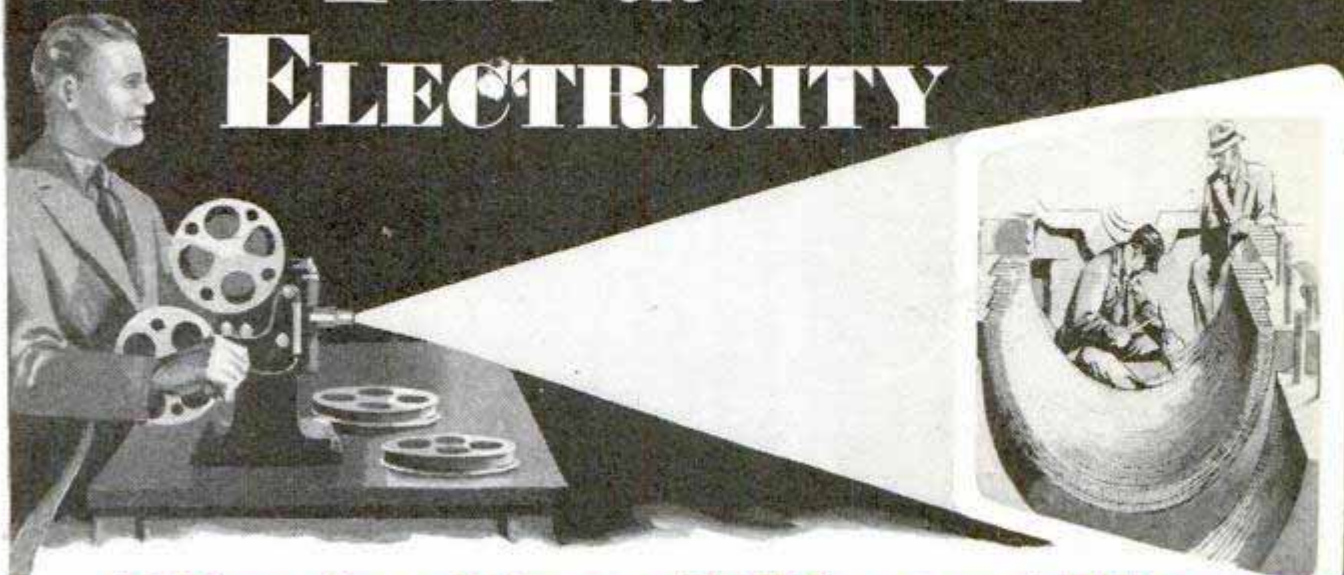

Movies Teach You at Home

THIS new, *easier* way shows you just how electricity acts and how to control it. Trains you quickly for a big pay job, \$60 to \$150 and more per week, in this rapidly growing field.

Right in your own home, in *actual moving pictures*, you see electrical machinery of all kinds, in operation. You see moving diagrams which make every point clear.

Nowhere Else Can You Get This Training

Well known electrical engineers have examined this new method of teaching and say it is clearer and *easier to understand* than any other way of learning electricity. This new method shows how electricity operates, better than can be done even in the laboratory and shop. It prepares you thoroughly for a big pay job. And nowhere else can you get this kind of training with *actual moving pictures*.

\$75.00 Projector Given

Every student gets a \$75 DeVry Motion Picture Projector to keep, at no extra cost. So simple anyone can operate it. Thousands of feet of film furnished. *Complete Drafting Outfit* of professional quality also given, without extra cost.

We Help You Get the Job

We pledge in writing on your enrollment, to give you the training and employment service necessary to get a better job and raise in pay, or you *need not pay a cent*. If you want more money, send the coupon now for details of this great opportunity.

FREE Our new book, "*The Film Way to Bigger Pay*," tells how we use movies to train you in spare time at home for a better job. Get your copy now. Mail the coupon today. No obligation to you, of course.

Mail This Coupon

**The NATIONAL SCHOOL of
VISUAL EDUCATION**

"The Film Way to Bigger Pay"
537 S. Dearborn Street, Chicago, U. S. A. Dept. 5H
Send your book "*The Film Way to Bigger Pay*," with all
facts about this new, easier way to learn electricity.

Name.....
St. or R.F.D.....
City.....
State.....
Age.....

Take the Film Way to Bigger Pay

\$30 a WEEK



\$60 a WEEK

They Might Look Alike

You can't always tell the \$60 man from the \$30 one, just by LOOKS. When two men start EQUAL, with about the same schooling and brains—and a couple of years later one is making TWICE as much as the other—it's interesting to find out WHY.

The \$30 man did the work laid out before him, and *nothing more*. He "stayed put." He was not curious about what was going on around him. He was *waiting* for promotion, but doing nothing to *merit* it.

The other man did his \$30-a-week work well, too. But he *wanted more money* and a BETTER JOB. He realized that the only way to get these things was to learn the company's business, and *the work in the job ahead*.

So he took a course of training that brought him the practical experience of successful men in his line, right in his own home, in spare time. And when he was able to tackle the \$60 job, he automatically got the \$60 pay.

Why don't YOU find out what home-training will do for you? Even an hour a day devoted to self improvement has made a big increase in the earning capacity of the thousands of men who have come to us in the past 33 years. If you'll mark on the coupon the kind of work you'd like to be doing, we'll be glad to tell you how easily you can get ready for it.

American School

Dept. G-574, Drexel Av. & 58th St., Chicago

American School, Dept. G-574,
Drexel Av. & 58th St., Chicago

Without obligation or cost, please tell me how I can get position marked X below:

- | | |
|---|---|
| <input type="checkbox"/> Architecture | <input type="checkbox"/> Drafting and Design |
| <input type="checkbox"/> Building Construction | <input type="checkbox"/> Business Management |
| <input type="checkbox"/> Automotive Engineering | <input type="checkbox"/> Mechanical Engineering |
| <input type="checkbox"/> Electrical Engineering | <input type="checkbox"/> High School in 2 years |

Name.....

Address.....

Age..... Occupation.....

Become a Trained Radio-Technician in 90 Days

Thousands of trained men are needed for Radio Service, Radio Engineering, Broadcasting, Television, Station-operation and Radio Merchandising. Get into this wonderful, fast-growing field NOW! Good pay, big opportunities. Become trained Radio-Technician in 3 months at this splendidly equipped school (which Station WISN operates). Complete practical course covers Radio Broadcasting, Merchandising and Television. The only radio course in the country approved by a radio trade association. Graduates receive "Class B" license without examination. Moderate tuition fee. Our illustrated free catalog gives details of how to become a trained radio technician in 90 days. Send for it today. No obligation.



FREE BOOK

SCHOOL of ENGINEERING of Milwaukee

Founded 1905 Dept. P. M. 529 Milwaukee, Wis.

HOT PIANO Ultra-modern Piano



Jazz taught by mail. Note or ear. Easy rapid lessons for adult beginners. Also Self-instruction system for advanced pianists. Learn 358 Bass Styles, 976 Jazz Breaks, hundreds of Trick Endings, Hot Rhythms, Sock, Stomp and Dirt Effects; Symphonic and Wicked Harmony in latest Radio and Record Style. Write for Free Booklet.

WATERMAN PIANO SCHOOL, 1826 W. Adams St., Los Angeles, Calif.

BIG Demand for Skilled Mechanics!

The entire country is calling for skilled mechanics! Good pay—steady work—good opportunities for advancement! Master this fascinating trade with the aid of the

AMERICAN MACHINISTS' LIBRARY

6 volumes—2,000 pages—2,500 illustrations

(A combined home-study course and reference library)

This library of machine shop practice was written for practical men. It gives you the best methods for every kind of machine shop work. It explains machine tools and their operation, tool work, gears and grinding, jigs and fixtures, automatic screw machines, their tools, punches, dies, etc. Plainly written—completely illustrated—the best kind of help to the machine-shop man who wants to advance himself.

Free TRIAL

No money down—only 7c a day

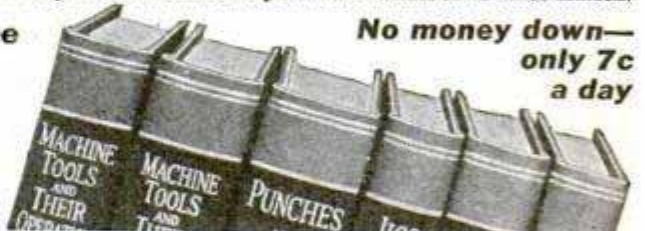

FREE EXAMINATION COUPON

McGraw-Hill Book Co., Inc., 370 Seventh Ave., New York

Send me for 10 days' free examination the AMERICAN MACHINISTS' LIBRARY. If satisfactory, I will send \$1.50 in 10 days and \$2 monthly until the special price of \$17.50 is paid. If not wanted, I will return the books at your expense.

Signed.....

Address.....

City and State.....

Position.....

Company..... P. M. 5-29

GENUINE MODEL 3

CORONA

LOWEST PRICE EVER OFFERED

HERE'S your chance to own that genuine Model 3 Corona you've wanted—on the easiest terms ever offered—at **LOWEST PRICE** ever offered! Complete in every detail; back spacer, etc., **NEW MACHINE GUARANTEE**. Recognized the world over as the finest, strongest, sturdiest, portable built.

\$2⁰⁰
DOWN
BALANCE
EASY TERMS

Yours for 10 Days FREE
Send No Money

Only a limited number of these splendid machines available. To get one, you must act now! Experience the joy this personal writing portable typewriter can give you! Use it 10 days free! See how easy it is to run and the splendidly typed letters it turns out. Ideal for the office desk, home, traveling. Small, compact, light, convenient. Don't send out letters, manuscripts, reports, bills in poor handwriting when you can have this Corona at such a low price or on such easy terms.

**Carrying
CASE**

Included—If You Act Now

Leatheroid carrying case, oiler, instructions free on this offer. Send no money—just the coupon. Without delay or red tape we will send you the Corona. Try it 10 days. If you decide to keep it, send us only \$2—then \$3 a month until our special price of \$39.90 is paid. Now is the time to buy. This offer may never be repeated. Mail coupon now.

Smith Typewriter Sales Corp.

Corona Division

Dept. 35, 469 E. Ohio St.

Chicago, Ill.

**MONEY SAVED
BY USING THIS COUPON**

Smith Typewriter Sales Corp.
[Corona Division]
469 E. Ohio St., Chicago, Dept. 35

Ship me the Corona, F. O. B. Chicago. On arrival I'll deposit \$2 with express agent. If I keep machine, I'll send you \$3 a month until the \$37.90 balance of \$39.90 price is paid; the title to remain with you until then. I am to have 10 days to try the typewriter. If I decide not to keep it, I will repack and return to express agent, who will return my \$2. You are to give your standard guarantee.

Name.....

Address.....

Employed by.....

I'll Refund your R.R. Fare to Chicago

Learn Electricity

Men Wanted

I can help place 20 TO 40 men a day, in JOBS, while learning and after. Never before such unusual opportunities. Get my free book now. Learn about the big pay in ELECTRICITY—the Big Pay BUSINESS of today. That's why GREER College selected this Great Field. Coupon brings you amazing facts.



A Great Profession

ELECTRICITY now pays hundreds of Greer trained men up to \$200 A WEEK. Here

Earn up to \$150.00 a week

is a most wonderful business. One hundred million is spent annually to keep it going. Get your share—clip the coupon.

Greer trained men are NEEDED. I HAVE MADE hundreds of \$10,000 A YEAR MEN. 90,000 in the last 26 years have come to Greer.

Only 3 Months

Learn in ONLY 3 MONTHS in GREAT GREER SHOPS on large live equipment. I'LL PAY YOUR FARE HERE Free of extra cost, then help you to a job while learning. Then I not only FIT YOU to GET the big pay job, but I'll help YOU HOLD IT. Young and Old, Educated and Uneducated, Inexperienced and Unexperienced have found GREER SHOPS training easy, fascinating and valuable.

COUPON BELOW BRINGS YOU BIG FREE BOOK

Don't let money hold you back. Get my Free Book. Find out NOW how I PAY YOUR FARE HERE, let YOU ATTEND either days or evenings and help you find DAY OR EVENING WORK to PAY YOUR EXPENSES while learning. Then when trained we help you find the real big pay job. Learn about amazing opportunities in Electricity, and GREER COLLEGE. Right now, if you act quick, I can make you a most unusual short time offer. Address me personally

Erwin Greer, President, GREER COLLEGE
Dept. 501E, 2024 So. Wabash Av., Chicago.

FREE BOOK

Erwin Greer, President
Dept. 501E, 2024 So. Wabash Avenue, Chicago, Illinois

Send Free Electrical Book and details of Special offer without obligation to me.

Name.....

Address.....Age.....

SUCCESS THROUGH LAW

"I find that nearly all positions commanding a salary of \$10,000.00 a year or more are filled by men who have studied law," writes a prominent Eastern manufacturer. Whether you ever intend to practice law or not, spend your spare time at home training your mind to deal with problems from the sound, practical standpoint of the trained attorney. The lawyer is a leader of men—in and out of business. Standard Oil of Indiana, U. S. Steel Corp., Packard Motor Car Co., hundreds of corporations are headed by legally trained men. Law is the basis of all business—large or small. A full law course leading to the degree of LL. B. or shorter business law course under LaSalle guidance is available for your home study. Full and up-to-date texts and modern law library. Cost low—terms easy. Write today for our free but valuable books "Law Guide" and "Evidence." Act Now.

LaSalle Extension University, Dept. 564-L Chicago, Ill.

FOREMEN!

Every foreman, factory worker, manager and ambitious mechanic will find a gold mine of inside information in "The Modern Foreman," by Robt. Grimshaw. The 28 chapters of this great work, are a complete \$25 lecture course pointing the way to success, efficiency, better pay and the job higher up. A complete study course in leadership; a handy, daily reference and guide.

"The Modern Foreman" has 297 pages, quick reference index, many tables, diagrams, illustrations and forms; big type, easy to read and understand; rich binding, gold stamped. Size 6 x 9 x 1 1/4. Reg. price \$2.50. Our special sale price \$1.98. Send no money. Mail name and address only. Pay postman \$1.98 plus postage on arrival. Satisfaction guaranteed.

GREGG PUB. CO., Dept. A, 20 W. 47 St., New York, N. Y.

BE AN ARTIST

WE CAN TEACH YOU DRAWING in your own home during your spare time. Twenty-five years of successful teaching proves our ability. Artists receive large salaries. Write Today for Art Year Book



SCHOOL OF APPLIED ART
ROOM NO. 2 BATTLE CREEK MICH.

STAMMERING

easily, permanently corrected. Win happiness and success. Ask for full information and special phonograph record. Send dime for postage

12972 Woodward Ave., LEWIS INSTITUTE, Detroit

BASHFUL?

"Shame on you!" Are you nervous, embarrassed in company of the other sex? Stop being shy of strangers. Conquer the terrible fear of your superiors. Be cheerful and confident of your future! Your faults easily overcome so you can enjoy life to the fullest. Send 25c for this amazing book.

RICHARD BLACKSTONE, 88-475, FLATIRON BLDG., NEW YORK

Earn money AT HOME

Men or women earn \$25 to \$50 a week at home. All or part time. Fascinating work. Nothing to sell. We teach you at home. Furnish all tools and materials. ARTCRAFT STUDIOS, Dept. 50, 427 Diversey Parkway, Chicago.

AUTOMATIC WASHING MACHINE

Price \$1.95

Washes, Cleans, Dries Polishes in One Quick Operation

Amazing new invention. CARRIES OWN WATER SUPPLY! Eliminates all drudgery and splashing! 5 times as fast as old methods. Patented features: No pail. No brush. No sponge. No chamois. Can be used with or without a pole. \$90-\$150 weekly easy for agents. Sells on sight. Sensational demonstration! Every housewife, autoist, store-owner a prospect. Write for our Free Sample Offer and big money-making proposition. Be first.

NATIONAL INDUSTRIES, 67 E. Lake St., Dept. 975, Chicago



FREE
Radio
Handbook



IMPROVE TONE AND VOLUME OF OLD SETS



MODERNIZE OLD SETS WITH ONE DIAL CONTROL



REDUCE STATIC BY MARVELOUS NEW METHOD



RADIO-FY & ELECTRIFY PHONOGRAPHS

5 Easy Ways to Make \$3.00 an hour in Your Spare Time in RADIO

Each of these plans, developed by the Radio Association of America, is a big money-maker. Set owners everywhere want to get rid of static, to have their sets operate from the electric light socket, the tone improved, and the volume increased, and transformed into single-dial controls. Phonograph owners want their machines electrified and radiofied. If you learn to render these services, you can easily make \$3.00 an hour for your spare time, to say nothing of the money you can make installing, servicing, repairing, building radio sets, and selling supplies.

Over \$600,000,000 is being spent yearly for sets, supplies, service. You can get your share of this business and, at the same time, fit yourself for the big-pay opportunities in Radio by joining the Association.

Join the Radio Association of America

A membership in the Association offers you the easiest way into Radio. It will enable you to earn \$3.00 an hour upwards in your spare time—train you to install, repair and build all kinds of sets—start you in business without capital or finance an invention—train you for the \$3,000 to \$10,000 big-pay radio positions—help secure a better position at bigger pay for you. A membership need not cost you a cent.

The Association will give you a comprehensive, practical, and theoretical training and the benefit of its Employment Service. You earn while you learn. Our cooperative plan will make it possible for you to establish a radio store. You have the privilege of buying radio supplies at wholesale from the very first.

Earned \$2,000 In Spare Time

Frank J. Deutsch, Penn.: "I have made over \$2,000 out of Radio in my spare time."

Radio Engineer In One Year

Claude DeGrave, Canada: "I knew nothing about Radio when I joined a year ago. I am now a member of a very exclusive organization of Radio Engineers, and my income is 225% greater than it was."

Doubles Income In 6 Months

W. E. Thon, Chicago: "Six months after I enrolled I secured the managership of large Radio store and doubled my income."

ACT NOW—If You Wish the No-Cost Membership Plan

To a limited number of ambitious men, we will give Special Memberships that may not—need not—cost you a cent. To secure one, write today. We will send you details and also our handbook filled with dollars-and-cents radio ideas. It will open your eyes to the money-making possibilities of radio.

Radio Association of America, Inc.
4513 Ravenswood Ave., Dept. PM-5, Chicago, Ill.

Radio Association of America, Inc.

Dept. PM-5, 4513 Ravenswood Ave., Chicago

Gentlemen: Please send me by return mail full details of your Special Membership Plan, and also copy of your Radio Handbook.

Name.....

Address.....

City..... State.....

LEARN AUTOS IN LOS ANGELES

Jobs Open Now—\$40 to \$100 a Week

You are urgently needed to help repair the one and a half million autos in California. Trained auto repair men are also needed badly in every other state. The rapidly increasing number of cars means prosperity and big pay for auto men—more garages, tire shops, battery stations are needed. You can be one of the highly paid men in this fastest growing industry—if you get the right training.

YOU CAN BE An Auto Expert!

National Automotive special, practical Shop Training makes it easy for you to become an Auto Expert. In a quarter century this great institution has trained

20,000 men for bigger pay. It will help YOU make more money by giving you individual instruction on repairing Packards, Buicks, Cadillacs, Fords, etc., all types of electrical equipment, machine shop equipment, etc. You learn everything RIGHT at National.

Paul Briggs Earns \$4000 a Year

"I want to thank you for the big part National has played in helping me to success in auto work. I am now assistant sales manager and made \$4,000 this year—which is more than I would have made in three years at my former work."—Paul Briggs, Portland, Ore.

Money-Making Book—FREE



Earn While You Learn

Free employment service. Spare time jobs help pay expenses while training. All tools included. No extras. Send for big free illustrated catalog explaining how National trains you for bigger pay. Learn the opportunities for you in California. Mail coupon now.

Million Dollar Training Headquarters for Auto Experts



NATIONAL AUTOMOTIVE, Dept. 722, 4006 Figueroa St., Los Angeles, Calif.

Send me, absolutely free, your big illustrated catalog of Automotive Opportunities showing how I can train for a Big-Pay Auto Job.

Name.....
Address.....
Age..... City..... State.....



Stop Making Mistakes in English

Wonderful new way to improve your English. No rules to learn. No hard study. Grammar, spelling, punctuation, and expression, taught in 15 minutes a day—at home. Self-correcting feature makes it fascinating as a game. Write today for free book "How to Speak and Write Masterly English." Address:



SHERWIN CODY SCHOOL OF ENGLISH, 55 Searle Building, Rochester, N. Y.

Learn to PAINT SIGNS and SHOW CARDS

We quickly teach you by mail, or at school, in spare time. Big demand. Big future. Interesting work. Oldest, foremost school. **EARN \$50 TO \$200 WEEKLY**
Otto Wiegand, Md., home-study graduate, made \$12,000 from his business in one year. John Vassos, N. Y., gets \$25 for a show card. Crawford, B. C., writes: "Earned \$200 while taking course." Write for complete information.



DETROIT SCHOOL OF LETTERING, 150 Stimson Ave., Est. 1899, DETROIT, MICH.

DRAW CARTOONS TURN YOUR TALENT INTO MONEY

Cartoonists earn from \$50 to \$250 per week—some even more. Remarkable *Circle System of Drawing* teaches you in half the usual time. Students from all parts of the world are enrolling for this exceptional instruction. *Personal* criticism service and up-to-the-minute instruction make it easy for National students to attain success. Send for interesting **BOOKLET** and **SAMPLE LESSON PLATE** explaining full details of the Course and what National students are accomplishing. No salesman will call.

The National School of Cartooning, 623 Penton Bldg., Cleveland, Ohio



Men! Extra Money Quick

Here's An Easy Way!

—to bring you a fine cash income! Without taking any time away from your job. Pleasant easy work at home. Decorate beautiful giftwares the Fireside way. You can do it—in spare moments. No previous training required. No special ability needed. No tedious study. No memorizing. With the Three Simple Steps sent you by Monsieur Petit the great artist—Director of Fireside Industries, it is just fun! We want men in every community. Be the first!

Fireside Industries, Dept. 66-E, Adrian, Mich.

Begin Right Now!

Thousands are making Fireside decorations—making from hundreds to thousands of dollars and doing their own work besides. We supply you with everything you need. Big Generous Complete Kit WITHOUT EXTRA COST. It's a cinch! We absolutely guarantee your success.

FREE!

Fill out and mail coupon at once. Without any obligation it brings you wonderful Fireside Book in colors. Explains everything. **Act now!**



Fireside Industries, Dept. 66-E, Adrian, Mich.

Send me your wonderful Free Book in colors. This does not put me under any obligation.

Name.....
Address.....



IF YOU WANT

BIG PAY

The Easy Way to Big Pay



FOLLOW THE PICTURES TO SUCCESS—ENTIRELY NEW METHOD

At last—a quick, complete, fascinating way to learn Drafting, and learn it right! Experts acknowledge my new, simple, easy "Picture Method" to be the first new idea in teaching Drafting in 30 years. It's the most easily-grasped, sound and sensible plan ever devised for Home Study instruction—so clear, so interesting, so practical that almost before you know it, you're through—have finished—and are ready to go to work on a Big Pay Job.

Learn to Earn—\$60 to \$100 a Week

That's what drafting positions lead to. And the draftsman's never out of work the year 'round—for he's the King-Pin of Industry—the man they've got to have. Not a wheel can turn, not a brick can be laid, not a wire can be strung, until the job has first been planned and drawn on paper by a draftsman. Why don't you get into work like that? Why don't you be a man they can't get along without—a Big Pay Man with a year 'round Big Pay Job? You can—it's easy—I'll show you how!

I'll Quickly Prepare You for Drafting

With my new method, I'll help you get ready for a Big Pay job so quickly you will be astonished. Spare time only needed. With my method—you see how it's done, and you do it yourself almost automatically. It's amazingly simple—yet so thorough and complete you learn Drafting from A to Z—learn it so you can sit in with the best of them on the Jobs that pay Big Money.

Investigate Promotion Plan Now

Don't sign up for any training until you've investigated my amazing new method. Mail coupon for Big FREE Book. See my great Earn-while-Learning Plan—see the big Professional Drafting Outfit you get at no extra cost—learn about my Nation-wide Job Service—my positive Money Back Agreement. Mail coupon NOW!

This Professional Outfit and Job Service Is Included—NO Extra Charge

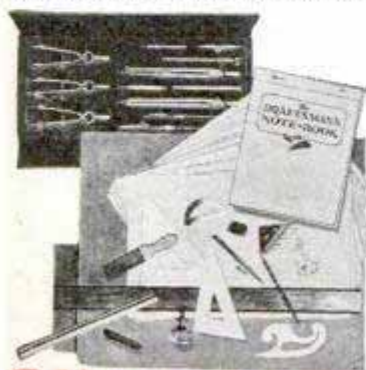

GET INTO ENGINEERING DRAFTING

With My Amazingly Easy Picture Method

IF YOU EARN LESS THAN \$60 A WEEK MAIL THE COUPON FOR BIG

FREE BOOK

THOUSANDS OF MEN NOW EARNING

\$60 to \$100

A WEEK



FREE BOOK COUPON

**K. M. Boyd, Chief Drafting Engineer
L. L. COOKE SCHOOL OF DRAFTING
Dept. 15, 2132-2158 Lawrence Ave.
Chicago, Ill.**

Send me your book "Draw Big Pay in Drafting" and tell me more about your "Picture Method." This does not obligate me in any way.

Name.....

Address.....

City..... State.....

This is a Machine Age—and all Machinery Starts with DRAFTING

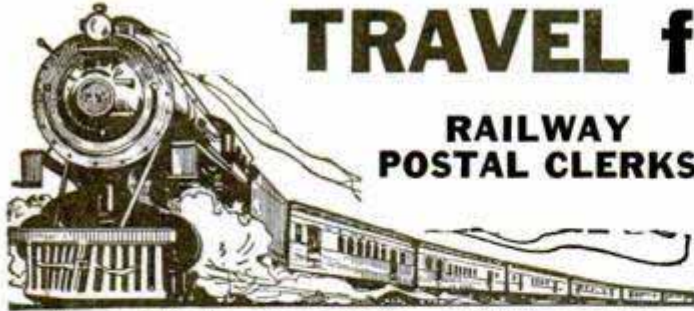

TRAVEL for "UNCLE SAM"

**RAILWAY
POSTAL CLERKS**

\$158 to \$225 Month

Mail Coupon Before You Lose It

FRANKLIN INSTITUTE, Dept. R174, ROCHESTER, N.Y.

Sirs: Rush to me without charge copy of 32-page book, "How to get U. S. Government Jobs," list of positions obtainable and full particulars telling how to get them.

Name

Address

Steady Work—No Layoffs—Paid Vacations
See Your Country
Common Education Usually Sufficient

LEARN CARTOONING

AT HOME DURING SPARE TIME

with the course that has trained HUNDREDS of beginners successfully. The Landon Picture Chart Method of teaching ORIGINAL drawing by mail makes cartooning easy to learn. This school is a Member of The National Home Study Council. Write today for sample picture chart to TEST YOUR ABILITY and examples of the work of successful students now earning from \$50 to \$200 and more per week. Enclose 6c in stamps and STATE YOUR AGE.



THE LANDON SCHOOL, 2838 National Bldg., Cleveland, Ohio

FREE BOOK ON MIND TRAINING

An instructive book which explains an amazing system of mind training already used by more than 650,000 people.

Let us send you a free copy of "Scientific Mind Training." It will show you how and why Peimanism is the *only* system of teaching for developing *all* the mental powers at the same time. Endorsed by such distinguished men as Judge Ben B. Lindsey, Sir Harry Lauder, Jerome K. Jerome, Prince Charles of Sweder, and hundreds of others. Write TODAY to

THE PELMAN INSTITUTE OF AMERICA

71 WEST 45th STREET DEPT. 65 N. Y. C.

TELEGRAPHY

(Morse and Wireless) and RAILWAY ACCOUNTING, taught thoroughly. Big salaries; great opportunities. Oldest, largest school. Endorsed by Telegraph, Railway, Radio, and Government officials. Expenses low—opportunities to earn large portion. Catalog free. **DODGE INSTITUTE, Jones St., Valparaiso, Ind.**

Rider Agents Wanted

Select from 44 Styles, colors and sizes of Mead Bicycles. Ride and exhibit sample RANGER and make money.

Factory to Rider: We ship on approval for 30 Days' Free Trial, direct from FACTORY. Get our marvelous offers before buying.

Tires Lamps, horns, wheels, parts, equipment, and repairs at half usual price.

Mead Cycle Company Write us today for free catalog
Dept. H-109 Chicago



Learn Watchwork, Jewelrywork and Engraving

A fine trade commanding a good salary, and your services always in demand. Address **Horological, Dept. P, Bradley Institute, PEORIA, ILLINOIS**, for our latest catalog.

Win A Well-Paid HOTEL POSITION

PROOF!

B. R. Casaday—"I have been in charge of one of the finest resorts in the country, since last March. I owe a great deal to Lewis Training."

Mrs. L. G. Thurman—"I begin on the 8th as Hostess of a new hotel. I am going to put every ounce of 'pep' and do my best to make good."

Henry A. Leisenring—"I am employed as Steward here and yesterday was given a substantial increase, which I attribute directly to your valuable instructions."

Della M. Field—"I am nicely situated as Assistant Manager."



Thousands Earn \$2,500 to \$10,000 a Year—YOU CAN DO AS WELL!

WITHOUT cost let us show you how big pay, fascinating work, quick advancement can be yours in the great hotel and institutional field. Today, more than ever before, there are opportunities in this uncrowded industry that YOU cannot afford to miss.

We Train You in Your Spare Time

Thousands of positions open all the time in America's 3rd Largest Industry. Hotels, clubs, restaurants, schools, colleges, hospitals and institutions everywhere are daily calling for Lewis Trained Men and Women. \$1,750,000,000 building program this year means almost 200,000 positions open—positions paying \$2,500 to \$10,000 a year, with meals and apartment frequently included, FREE!

Previous Experience Unnecessary

We train you right at home and put you in touch with well-paid positions. Thousands of Lewis Students winning quick success. Totally unacquainted with hotel work before taking the Lewis Course, Miss Ella Bearden is now Manager of a beautiful resort hotel in Jocassee, S. C.—B. G. Trumbower is Assistant Manager of a Country Club in Easton, Pa. Free Book, "YOUR BIG OPPORTUNITY," tells how YOU can do as well. Send for it today—NOW!

LEWIS HOTEL TRAINING SCHOOLS
Room BL-304—WASHINGTON, D. C.

Charter Member National Home Study Council. The Original and Only School of its Kind in the World.

Be a Hotel Manager

Hotels, clubs, restaurants everywhere look for Trained Managers. YOU can qualify!



Lewis Hotel Training Schools, Room BL-304, Washington, D. C. Send me, without obligation, the Free Book, "YOUR BIG OPPORTUNITY."

Name

Address

City.....State.....

OPPORTUNITY COUPON

Read what BIG money these fellows have made in the RADIO BUSINESS

\$375 One Month Spare Time



"Recently I made \$375 in one month in my spare time installing, servicing, selling Radio sets. And, not so long ago, I earned enough in one week to pay for my course."
EARLE CUMMINGS,
 18 Webster St., Haverhill, Mass.

\$1597 in Five Months



"The N. R. I. is the best Radio school in the U. S. A. I have made \$1597 in five months. I shall always tell my friends that I owe my success to you."
HENRY J. NICKS, JR.,
 302 Safford Ave.,
 Tarpon Springs, Fla.

\$1164 Spare Time Profits



"Look at what I have made since I enrolled, \$1,164—money I would not have had otherwise. I am certainly glad I took up Radio with N. R. I. I am more than satisfied."
HENRY R. HEIKKINEN,
 123 W. Erie St., Chicago, Ill.

Over \$1000 in Four Months



"My opinion of the N. R. I. course is that it is the best to be had at any price. When I enrolled I didn't know a condenser from a transformer, but from December to April I made well over \$1000 and I only worked in the mornings."
AL JOHNSON,
 1409 Shelby St., Sandusky, Ohio.

I will show you too how to start a spare time or full time Radio Business of Your Own without capital



J.E. SMITH Pres.

Radio's amazing growth is making many big jobs. The world-wide use of receiving sets and the lack of trained men to sell, install and service them has opened many splendid chances for spare time and full time businesses.

Ever so often a new business is started in this country. We have seen how the growth of the automobile industry, electricity and others made men rich. Now Radio is doing the same thing. Its growth has already made many men rich and will make more wealthy in the future. Surely you are not going to pass up this wonderful chance for success.

More Trained Radio Men Needed

A famous Radio expert says there are four good jobs for every man trained to hold them. Radio has grown so fast that it simply has not got the number of trained men it needs. Every year there are hundreds of fine jobs among its many branches such as broadcasting stations, Radio factories, jobbers, dealers, on board ship, commercial land stations, and many others. Many of the six to ten million receiving sets now in use are only 25% to 40% efficient. This has made your big chance for a spare time or full time business of your own selling, installing, repairing sets.

So Many Opportunities You Can Make Extra Money While Learning

Many of our students make \$10, \$20, \$30 a week extra while learning. I'll show you the

I Will Train You At Home In Your Spare Time

I bring my training to you. Hold your job. Give me only part of your spare time. You don't have to be a college or high school graduate. Many of my graduates now making big money in Radio didn't even finish the grades. Boys 14, 15 years old and men up to 60 have finished my course successfully.

You Must Be Satisfied

I will give you a written agreement the day you enroll to refund your money if you are not satisfied with the lessons and instruction service when you complete the course. You are the only judge. The resources of the N. R. I. Pioneer and Largest Home-Study Radio school in the world stand back of this agreement.

Get My Book

Find out what Radio offers you. My 64-page book, "Rich Rewards in Radio" points out the money making opportunities the growth of Radio has made for you. Clip the coupon. Send it to me. You won't be obligated in the least.

This Book points out what Radio offers You Get a copy!



Address

J. E. Smith, Pres.

Dept. 9RP

National Radio Institute

Washington, D. C.

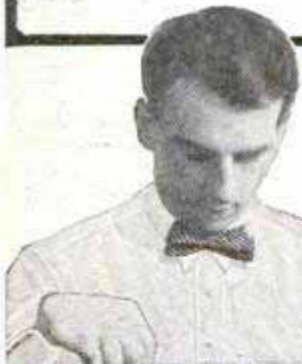

how to begin making extra money shortly after you enroll. G. W. Page, 1807-21st Ave., S., Nashville, Tenn., made \$935 in his spare time while taking my course.

I Give You Practical Radio Experience With My Course

My course is not just theory. My method gives you practical Radio experience—you learn the "how" and "why" of practically every type of Radio set made. This gives you confidence to tackle any Radio problems and shows up in your pay envelope too.



You can build 100 circuits with the Six Big Outfits of Radio parts I give you. The pictures here show only three of them. My book explains my method of giving practical training at home. Get your copy!



This coupon is good for a FREE copy of my Valuable Book. Mail it NOW!

J. E. Smith, President, Dept., 9RP National Radio Institute, Washington, D. C.

Dear Mr. Smith: Send me your book. I want to know more about the opportunities in Radio and your practical method of teaching at-home in spare time. This request does not obligate me to enroll and I understand no agent will call on me.

Name.....Age.....
 Address.....
 City.....State.....



—“and now he’s in the firm”

“I REMEMBER when he first came here. The Boss put him to work helping Charley Moore.

“He didn’t know much about the business then, but I noticed that he was quick to learn and that he was always studying those I. C. S. textbooks in his spare moments. The fellows laughed at him and said he was wasting his time. But he smiled that quiet smile of his and kept right on.

“Pretty soon we saw that the Boss was taking an interest in his work, and the next thing we knew he was made foreman—then assistant superintendent—then superintendent—then general manager—and now he’s a member of the firm.

“It goes to show what spare-time study will do for a man. I might have his job today if I had only studied with the I. C. S. when he did.”

If you want to make more money, show your employer you’re trying to be worth more money. If you want a bigger job, show him you’re willing to prepare for it.

There’s a simple way to do it. For 34 years the International Correspondence Schools have been training men and women right in their own homes.

Can you afford to let another priceless hour pass without finding out what the I. C. S. can do for you? Here is all we ask—without cost, without obligation, mark and mail this coupon.

INTERNATIONAL CORRESPONDENCE SCHOOLS Box 5616-F, Scranton, Penna.

Without cost or obligation, please send me a copy of your booklet, “Who Wins and Why,” and full particulars about the course before which I have marked X in the list below:

TECHNICAL AND INDUSTRIAL COURSES

- | | |
|--|---|
| <input type="checkbox"/> Architect | <input type="checkbox"/> Automobile Mechanic |
| <input type="checkbox"/> Architectural Draftsman | <input type="checkbox"/> Aviation Engines |
| <input type="checkbox"/> Building Foreman | <input type="checkbox"/> Plumber and Steam Fitter |
| <input type="checkbox"/> Concrete Builder | <input type="checkbox"/> Plumbing Inspector |
| <input type="checkbox"/> Contractor and Builder | <input type="checkbox"/> Foreman Plumber |
| <input type="checkbox"/> Structural Draftsman | <input type="checkbox"/> Heating and Ventilation |
| <input type="checkbox"/> Structural Engineer | <input type="checkbox"/> Sheet-Metal Worker |
| <input type="checkbox"/> Electrical Engineer | <input type="checkbox"/> Steam Engineer |
| <input type="checkbox"/> Electrical Contractor | <input type="checkbox"/> Marine Engineer |
| <input type="checkbox"/> Electric Wiring | <input type="checkbox"/> Refrigeration Engineer |
| <input type="checkbox"/> Electric Lighting | <input type="checkbox"/> R. R. Positions |
| <input type="checkbox"/> Reading Shop Blueprints | <input type="checkbox"/> Highway Engineer |
| <input type="checkbox"/> Telegraph Engineer | <input type="checkbox"/> Chemistry |
| <input type="checkbox"/> Telephone Work | <input type="checkbox"/> Pharmacy |
| <input type="checkbox"/> Mechanical Engineer | <input type="checkbox"/> Coal Mining Engineer |
| <input type="checkbox"/> Mechanical Draftsman | <input type="checkbox"/> Navigation <input type="checkbox"/> Assayer |
| <input type="checkbox"/> Machine Shop Practice | <input type="checkbox"/> Iron and Steel Worker |
| <input type="checkbox"/> Toolmaker | <input type="checkbox"/> Textile Overseer or Supt. |
| <input type="checkbox"/> Patternmaker | <input type="checkbox"/> Cotton Manufacturing |
| <input type="checkbox"/> Civil Engineer | <input type="checkbox"/> Woolen Manufacturing |
| <input type="checkbox"/> Surveying and Mapping | <input type="checkbox"/> Agriculture <input type="checkbox"/> Fruit Growing |
| <input type="checkbox"/> Bridge Engineer | <input type="checkbox"/> Poultry Farming |
| <input type="checkbox"/> Gas Engine Operating | <input type="checkbox"/> Mathematics <input type="checkbox"/> Radio |

BUSINESS TRAINING COURSES

- | | |
|--|---|
| <input type="checkbox"/> Business Management | <input type="checkbox"/> Business Correspondence |
| <input type="checkbox"/> Industrial Management | <input type="checkbox"/> Show Card and Sign Lettering |
| <input type="checkbox"/> Personnel Management | <input type="checkbox"/> Stenography and Typing |
| <input type="checkbox"/> Traffic Management | <input type="checkbox"/> English |
| <input type="checkbox"/> Accounting and C. P. A. Coaching | <input type="checkbox"/> Civil Service |
| <input type="checkbox"/> Cost Accounting | <input type="checkbox"/> Railway Mail Clerk |
| <input type="checkbox"/> Bookkeeping | <input type="checkbox"/> Mail Carrier |
| <input type="checkbox"/> Secretarial Work | <input type="checkbox"/> Grade School Subjects |
| <input type="checkbox"/> Spanish <input type="checkbox"/> French | <input type="checkbox"/> High School Subjects |
| <input type="checkbox"/> Salesmanship | <input type="checkbox"/> Cartooning |
| <input type="checkbox"/> Advertising | <input type="checkbox"/> Illustrating |
| | <input type="checkbox"/> Lumber Dealer |

Name.....
 Address.....
 City..... State.....
 Occupation.....

If you reside in Canada, send this coupon to the International Correspondence Schools Canadian, Limited, Montreal, Canada

NEW INDUSTRY NEEDS MEN

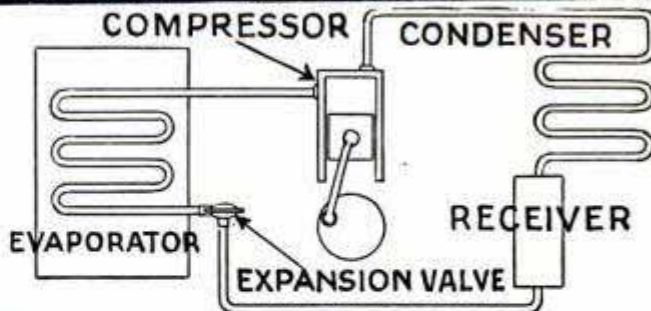

ELECTRIC REFRIGERATION Calls You!

Newest American industry needs men for \$200 to \$1,000 a month jobs in production, service, installation and sales. Fastest growing money-making field—backed by General Motors, General Electric, etc. New easy home training qualifies you for big pay job. This training is endorsed by Servel, Kelvinator and other large manufacturers.

FREE BOOK

“Opportunities in Electric Refrigeration” reveals amazing plan to ambitious men. Sent free. No obligation. Be the first in your neighborhood to get into this new magic industry. Write today.

Utilities Engineering Institute

Dept. 15, 3120 N. Clark St., Chicago, Ill.



EARS should HEAR

IF THEY DON'T—MAKE THEM
 No operation. No inconvenience. No harmful drugs or tedious treatments. Comfortable, safe and entirely invisible. Stop head noises and ringing ears. A letter or postal will bring you my true story, how I became deaf and how I restored my hearing. Also booklet on deafness. They are free. Send name and address today.
 GEORGE P. WAY, ARTIFICIAL EAR DRUM CO.,
 46 Hoffman Bldg. Detroit, Michigan



DRAFTING

BOOKS SENT FREE!

For Beginners

Written so you can understand every word, by 18 famous Engineers and Architects. Deluxe, flexible binding. 1750 pages, 1050 blue prints, charts and diagrams. Prepares you for a good Drafting job in mechanical or architectural lines. Sent for 15 days' free use, if you mail coupon immediately.

Only fifteen minutes a day with these WONDER BOOKS will prepare you for a good Drafting job in less than a year! Mechanical and Architectural Drafting from simple straight lines to important, complex plans, a step at a time! Built especially for beginners, for men with only grammar schooling. Drafting room practice plus engineering made easy and clear!

Big Field—Big Demand—Big Pay!

Competent Draftsmen are urgently needed right now in all building and manufacturing lines at \$50 to \$100 a week. That's just the beginning—for draftsmen have the best chances for advancement! Pleasant, fascinating work, easy to learn and do. Learn quick with these books—send coupon for a set FREE, and see for yourself!

A year's Consulting Membership in the American Technical Society now given free to all readers of this famous Cyclopedia of Drafting. Many say that's worth more than cost of books.



Modern American Homes FREE!

American Technical Society
 Dept. D-519, 58th & Drexel Ave., Chicago

Send for 15 days' free use 4-volume set of DRAFTING. In return for mailing this coupon promptly send absolutely FREE “Modern American Homes,” 112 plates, exteriors, interiors and plans. I will pay the few cents delivery charges. If I wish I may return books in 15 days and owe you nothing. But if I prefer to keep them I will send \$1.80 after 15 days, then \$2.00 a month until \$14.80 (special reduced price) is paid.

Name.....
 Address.....
 Employed by.....
 Address.....

BAKELITE Automobile CIGAR LIGHTER

**Sensational
New**

"Pull-a-Lite"

**With ONE HAND
WHILE
DRIVING**

**New Patented
Suction Grip
Holds Like
Iron**



**Attached in a Second
to Windshield,
Wall, Dashboard
or Inside the Car**

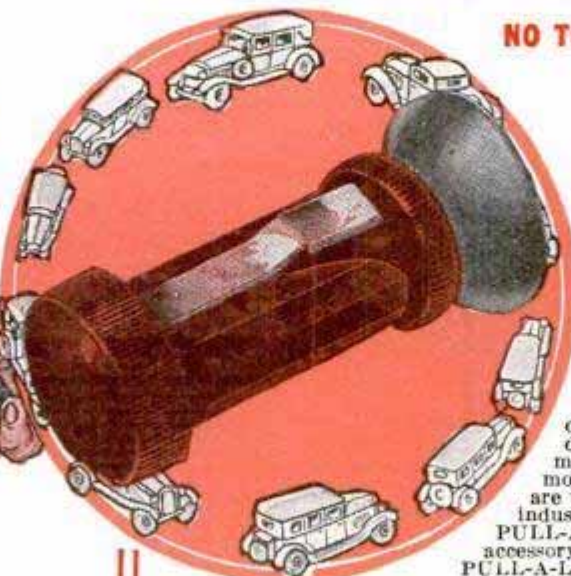

NO TOOLS—NO WIRES—NO BATTERIES

**JUST PULL
FOR A SURE LIGHT**

**25 MILLION
CAR OWNERS**

AWAIT THIS NEW INVENTION

Motorists have long felt the need for a popular priced and dependable cigar lighter that works without clumsy wires or batteries. The amazing new PULL-A-LITE now fills that need. It sells to every car owner, in every home and office, and every dealer on a flash demonstration. The automobile accessory field is the Best Paying and most profitable industry in the country. If you are to reap the benefits of the prosperity in this industry, now is the time to get into it with PULL-A-LITE Cigar Lighter. No other automobile accessory will sell so largely and so profitably as the PULL-A-LITE Cigar Lighter.

\$72.00 PROFIT A DAY!
ON ONLY TWELVE EASY SALES TO DEALERS

**PULL-A-LITE
Pulls Dollars
Like Magnet**

The biggest market in the world is your field and the margin of profit is greater than on any product ever offered.

**Exclusive Territory
to Producers**

Our policy in selling the New PULL-A-LITE Cigar Lighter will be to appoint limited distributors in exclusive territory. We want livewire men who can appreciate a good proposition and act upon it. PULL-A-LITE Cigar Lighter is new and exclusive—has no competition. If interested, you must lose no time. Reserve your territory now.

If you have the foresight to recognize a new money-making opportunity you will quickly take hold of this new, sensational Bakelite Cigar Lighter and cash in big. Even cars that are now equipped with expensive electric lighters find it more economical and convenient to use the PULL-A-LITE Cigar Lighter. It requires no connection to batteries or wires of any kind. PULL-A-LITE lights instantly by a single pull of a fine gold file on a special oversized flint and burns ordinary pocket lighter fluid. No mechanical parts—nothing to get out of order. The light can be passed around to the other occupants of the car as there are no wire connections. PULL-A-LITE is attached permanently in a second to dashboard, windshield or wall by new patented suction grip. PULL-A-LITE is made of Bakelite in a variety of lustrous colors and makes a beautiful addition to every car. It is not only useful in automobiles, but can be attached in a convenient place in the home or on the desk in the office. And get this: This handy, sure-fire lighter retails at the popular price of only \$1.50, the lowest price of any automobile lighter on the market today. Can you picture the enormous market for the PULL-A-LITE Cigar Lighter?

**Start a Wholesale Business of Your Own
Make \$72.00 a Day Selling to Dealers**

Figure it out for yourself. This new sensational PULL-A-LITE Cigar Lighter retails for only \$1.50. This brings in \$18.00 for a dozen and leaves the dealer a net profit of \$6.00, as your price to him is \$12.00 per dozen. In five gross lots our price to you is \$6.00 per dozen and you MAKE A PROFIT OF 100% or \$6.00 on every dozen you sell to the dealer. Any experienced salesman knows that it is easy to make 12 sales a day to dealers with a popular priced specialty that sells as readily as PULL-A-LITE. You can see at a glance your profit margin is so large that you can even hire salesmen and pay them a handsome commission to sell for you. Nearly every dealer along the street is a prospect—garages, accessory stores, stationery stores, hardware stores, novelty shops, drug stores, cigar stores, etc. Every dozen PULL-A-LITE lighters is packed assorted colors in magnificent multi-colored display carton illustrated here. This self-selling display carton placed on any dealer's counter will sell the lighters with hardly any attention from the clerk. Keen merchants realize this at a glance and stock the item with no urging from you.

**Our 5 Tested Selling Plans
Start You Making Big
Money at Once**

\$10.50 an hour is guaranteed to anyone following any one of the other five plans. You make \$10.50 clear profit by selling only one box of lighters to motorists and it will take you less than an hour to do it. If

you buy in quantities you make 200% PROFIT SELLING DIRECT TO CONSUMER. All you do is walk up to an automobile, stick the lighter on the dashboard, pull with one hand and then let the prospect select a lighter of any color he may choose from your box. Another plan is to get orders by mail. We have originated a new mail order circular which will bring you orders and money by mail without selling. Anyone can operate this plan from his own home either in full or spare time. Full details of this plan and a copy of the circular will be submitted to you with your order for a single sample or a dozen box. Another plan given in detail in the assignment plan. This plan holds unlimited possibilities. Our Initial and Emblem Plan is a winner. You sell every prospect a PULL-A-LITE Cigar Lighter with their own individual initial or emblem on the lighter. It will clinch the sale for you without fail and greatly add to your day's profits.



**For Automobile,
Table or Desk**

**Send for Dozen or Sample Now! A Dozen Easily
Sold in an Hour Nets You \$10.50 Clear Profit**

If you are the right man to take on an agency, we want you to write us immediately. At the same time, we recommend that you order a dozen PULL-A-LITES at our regular dozen price of \$7.50, packed in our self-selling multi-colored display carton. You can quickly and easily sell them out to consumers in an hour and cash in \$10.50 clear profit on the dozen. Or you can start right out with the sample dozen taking orders from your nearby dealers to test out the great selling power of this article. Send \$7.50 with the coupon or attach \$1.00 bill and we will ship a dozen promptly C. O. D. for the balance. If you want a sample only—send \$1.00. Full details of all our selling plans will be sent you with your order for single sample or dozen. If interested, you must lose no time. Territories are going fast. Reserve yours today. Quick action is necessary. You take no risk ordering a dozen. OUR MONEY BACK GUARANTEE PROTECTS YOU. We guarantee you will make sales or refund your money absolutely. FILL IN AND MAIL COUPON NOW.

GORDON MANUFACTURING CO.
(Dept. LE-19) 110 E. 23rd St., NEW YORK CITY

Gordon Mfg. Co. (Dept. LE-19), 110 E. 23rd St., New York City.

I enclose \$..... for which please send me order checked below:

- One dozen Pull-a-Lite Cigar Lighters, in self-selling counter display carton. Price \$7.50. (If \$1.00 is enclosed, send one dozen for the balance C. O. D.)
- One Sample Pull-a-Lite Cigar Lighter. Price \$1.00. Please send full details of all your sure-fire selling plans which guarantee that I will make sales.

Name.....

Address.....

City..... State.....



I'll Refund Your R.R. Fare to Chicago

Auto Experts

Get

BIG PAY!

Men Wanted

I can help place 20 TO 40 men a day, in JOBS, while learning and after. Never before such unusual opportunities. **Get my free book now.** Learn about the big pay. AUTOS lead WORLD'S BUSINESS. That's why GREER College selected this Field. Coupon brings you amazing facts.



Be Your Own BOSS

Earn up to \$150.00 a week

AUTOS now pay hundreds of Greer trained men up to \$200 A WEEK. Here is a most wonderful business. BILLIONS—not millions, but BILLIONS of dollars are spent in it every year.

Greer trained men are NEEDED. I HAVE MADE hundreds of \$10,000 A YEAR MEN. 90,000 in the last 26 years have come to Greer.



Learn to Boss the Job

Only 3 Months

Learn in ONLY 3 MONTHS! in GREAT GREER SHOPS on large *live equipment*. I'LL PAY YOUR FARE HERE Free of extra cost, then help you to a job while learning. Then I not only FIT YOU to GET the big pay job, but I'll help YOU HOLD IT. Young and Old, Educated and Uneducated, Inexperienced and Experienced have found GREER SHOPS training easy, fascinating and valuable.

COUPON BELOW BRINGS YOU BIG FREE BOOK

Don't let money hold you back. Get my Free Book. Find out NOW how I PAY YOUR FARE HERE, let YOU ATTEND either days or evenings and help you find DAY OR EVENING WORK to PAY YOUR EXPENSES while learning. Then when trained we help you find the real big pay job. Learn about amazing Auto opportunities and GREER COLLEGE. Right now, if you act quick, I can make you a most unusual short time offer. Address me personally

Erwin Greer, President, GREER COLLEGE
Dept. 501 AT, 2024 So. Wabash Ave., Chicago

FREE BOOK

Erwin Greer, President
Dept. 501 AT, 2024 So. Wabash Avenue, Chicago, Illinois.

Send Free Auto Book and details of Special offer without obligation to me.

Name.....

Address..... Age.....

ACCOUNTING

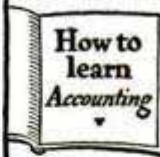

THOUSANDS of ambitious men are earning more money today because they know Accounting. Send for our 80-page book, "How to Learn Accounting," and the first lesson. Both will be sent free.

International Accountants Society, Inc.

A Division of the
ALEXANDER HAMILTON INSTITUTE

Dept. 30 3411 So. Michigan Ave., Chicago, Ill.

Learn to Dance

This New Easy Way

You can learn all the modern dances—Charleston, Black Bottom, Valencia, Canter, French Tango, St. Louis Hop, Latest Waltzes, Fox Trot, etc., at home easily and quickly. New chart method makes dancing as simple as A-B-C. No music or partner required. Learn anywhere, anytime. Win new popularity. Be in demand at parties. Same course of lessons would cost \$20 if taken privately.

Send No Money

Just send your name and address. We'll ship the complete course—323 pages, 49 illustrations—with-out one cent in advance. When package arrives, hand postman only \$1.98, plus delivery charges, and this wonderful course is yours. Try for 5 days. Money back if not delighted. Send your name NOW.

FRANKLIN PUB. CO., 800 N. Clark St., Dept. 9422, CHICAGO



LEARN TO Mount Birds

Learn at home by mail to mount Birds, Animals, Heads, Tax Furs and Make Rugs. Be a taxidermy artist. Easily, quickly learned by men, women and boys. Interesting and fascinating. Decorate home and den. **Make Big Profits from Spare Time.** Free Book Yes absolutely FREE—beautiful book telling all about how to learn taxidermy. Send Today for this wonderful new book. Don't delay! N. W. School of Taxidermy, 3375 Elwood Bldg., Omaha, Neb.

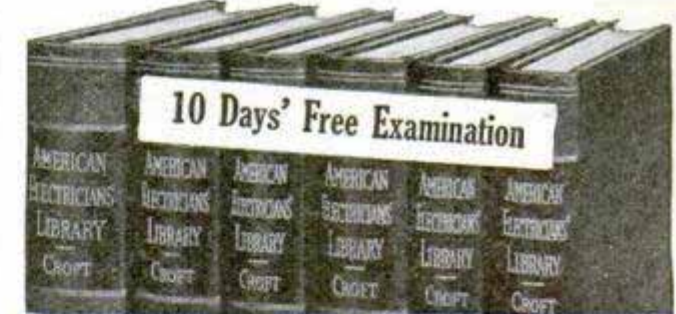

10 Days' Free Examination

Get into the electric wiring field—big demand—big money!

THE whole wiring field covered. Kinks; helps; short cuts; practical, on-the-job electrical data, written particularly to help wiremen, trouble shooters, maintenance men, armature winders, electrical contractors and students.

American Electricians' Library
6 volumes, 2000 pages, illustrated, \$17.50 payable \$1.50 in ten days and \$2.00 a month

The books tell you all you must know about conduit wiring, armature winding, wiring for lighting circuits and switches, wiring for machinery, circuit troubles, circuit testing, or electrical machinery erection. Through a study of this great set you can push yourself into a big-pay job for life.

See it FREE—Send no money—ACT

FREE EXAMINATION COUPON

McGRAW-HILL BOOK CO., Inc.
370 Seventh Avenue, New York

Send me the American Electricians' Library for 10 days' free examination. If satisfactory, I will send you \$1.50 in 10 days and \$2 monthly until the full price, \$17.50, is paid. If not wanted, I will return the books at your expense.

Name.....

Address.....

City and State.....

Position.....

Company..... P. M.-5-29

Raise Your Pay

with these
Tools ↓



These drawing instruments and 14 other Tools furnished with my Course.

Make these tools help you to land a job leading to salaries of from

\$70.00 to \$175.00 a week

and with this
FREE
Pay Raising Plan ↓

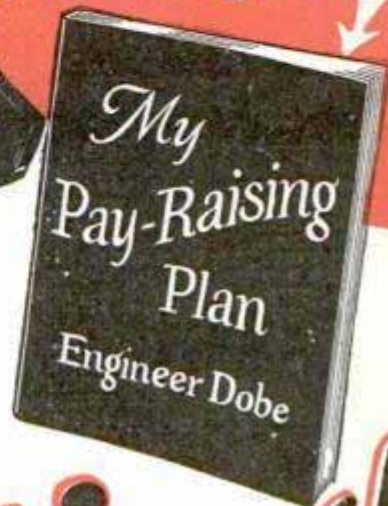

Jobs Waiting!

For Men Who Can Use These Tools In—

Aviation Building Construction Bus Building
Electricity Automobile Manufacturing Road Construction

There are jobs for Draftsmen in all of the above industries. Those industries are growing bigger every year.

Industry cannot continue without draftsmen. All construction, all new machinery, all automobile and motor bus manufacturing, all electrical machinery building depend upon draftsmen.

I train you in drafting at home by mail. You keep your job while learning. I even show you how to earn extra money. I train you entirely in your spare time. No previous experience is necessary. You do not need to be a college man or high school graduate to learn by my quick, easy method.

After you have taken my training, I help you get a job without charging you a cent for this service. Employers of draftsmen come to me for men because they know they are not taking any chances on men trained by me.



"I train you at home!"—
Engineer Dobe

Men I have trained are making from \$3500 to \$9000 a year. They lifted themselves from poor paying jobs to positions paying a good, straight salary, the year around, with comfortable surroundings and inside work.

IF YOU EARN LESS THAN \$70.00 A WEEK, you should write to me for my Free "Pay-Raising Plan."

Mail this coupon now. It points the way to success and opens up a road to salaries leading to from \$70.00 to \$175.00 a week. You owe it to yourself to send for this Pay-Raising Plan. Find out how I help you locate good paying opportunities in practically all the big industries. The book will come to you postpaid and free.

MAIL THE COUPON FOR IT TODAY

Engineer Dobe, Div. 13-55, 1951 Lawrence Ave., Chicago

Free "Pay-Raising Plan"

ENGINEER DOBE, Div. 13-55
1951 Lawrence Ave., Chicago

Send me Free of all cost, "My Pay-Raising Plan". Also plan to earn money while learning to be a draftsman and proof of big money paying positions in great industries.

Name Age

Address

Post Office

State

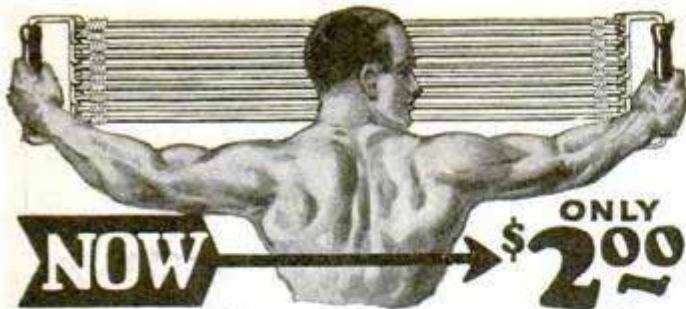

NOW → **ONLY \$2.00**

Giant Chest Expander and Progressive Exerciser

Be a muscular marvel. Have the muscles of a superman. Become strong for your health's sake or to astound your friends with extraordinary feats which only men of giant strength can do. In a few short weeks you will easily do stunts which now seem difficult—then real

Send No Money Use This Money Saving Coupon

muscles and strength will be yours—and yours to keep. If you want exercise to just keep in good shape you can reduce the strength of the Progressive Exerciser by eliminating as many cables as you wish. If you want great resistance so as to build up big solid muscles then use the full strength.

How the Giant Chest Expander and Progressive Exerciser is Made

The Giant Chest Expander and Progressive Exerciser is made with new live, springy rubber so as to give it long wearing and great resisting qualities. Do not pay more for an exerciser that has forty or less rubber strands to each cable. Get the best and most durable. The Giant Progressive Exerciser has 50 strands of the finest rubber procurable to each cable.

Free Instructions

We do not think it enough to send you an exerciser worth double what we ask, so for a limited time, we will also include instructions absolutely free. These instructions are interesting and simple to follow—they show you the short cut to health and strength. Order today before this wonderful offer is withdrawn.

Your Guarantee

The Giant Chest Expander is sold with a guarantee that you will say it is the finest you ever saw or your money back.

5 Cables or double 10 Cables for strength for

\$2 The double strength exerciser has resistance of over 200 lbs. **\$4**

How to Order—Send No Money

Sign your name and address to coupon below and get your Giant Exerciser at the present low introductory price by return mail. The price is made low because we want everyone to enjoy muscles and strength at the lowest possible cost. Don't pay more—order from us—get the most for your money. Use coupon now.

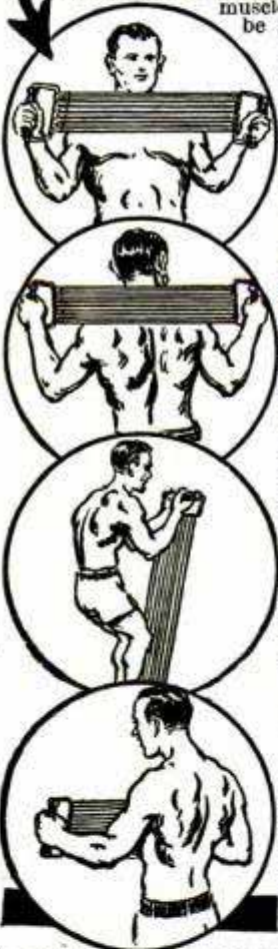

PROGRESSIVE EXERCISER CO.,
4005 Langdon Bldg.,
Broadway and Duane Street, New York

Please send Your 10 cable Progressive.
 Your 5 cable Exerciser.

Check the Exerciser you want, and it will be sent you by return mail. Pay postman introductory price, plus few cents postage on arrival. It is understood that if you are not entirely satisfied with your exerciser you may return it within 5 days and get your money back.

Name.....
Street.....
City..... State.....

If you live outside the United States, send cash with order.

BE A RAILWAY TRAFFIC INSPECTOR



Earn up to \$250 per month SALARY

NO HUNTING for a Position After Completing Your Training

plus expenses

Read what Dan'l M. Mack says:

Our students never worry about a position as they are assisted to one within a few days after completing the Traffic Inspection course. You get at least \$120 per month plus expenses to start and advance rapidly to \$185, \$250. Our contract shows why you take no risk.

"I received my certificate on April 15, was on my way to take a position on the evening of April 16, and started to work on April 17. If this is not quick work, I don't know what it is. I found the school very thorough."

As a Railway Traffic Inspector, you are practically your own boss, see new faces and places each minute, report only to high officials, are rapidly advanced. It's healthful outdoor work with regular hours.

Hundreds of Satisfied Graduates

Write today for free booklet giving full details and contract agreeing to assist you to a position, or refund your tuition.

Standard Business Training Inst. Div. 2 BUFFALO, NEW YORK



There's Quicker, Bigger MONEY for YOU—in POULTRY

No Matter Where You Live—You Can Make \$1000 to \$5000 a Year—EXTRA!



A Big money-making opportunity is waiting for YOU right NOW—in your own back yard! Thousands of my students are cashing in BIG, the way you can—in part or full time. Start with a small flock—small investment, and make a good profit. Eggs and poultry meat are in big demand at high prices. I'll PROVE that I can put YOU among the big money-makers QUICK!

Spare Time or Full Time YOU Can Cash-in BIG

No matter where you live—city, town or country—or what you do now, my proved methods will assure your success right from the start. I give you all the "secrets"—all the "short cuts." You'll be your own boss and I'll show you how to make from \$1000 to \$5000 a year—and UPI—and how to make your tiny investment multiply itself automatically. What I've done for thousands of others—I can do for you.

FREE Book Shows Way to Success and BIG Profits

Mail coupon below TODAY—for my Big NEW FREE Book, "How to Raise Poultry for Profit." My forty years of experience are yours. The Poultry Industry needs YOU. You need my book. Get it—and get in line for the BIG Money that's waiting for you in POULTRY.

Mail NOW for FREE Book

NATIONAL POULTRY INSTITUTE, Dept. 411-J
Washington, D. C., Attn: Harry M. Lamon, Pres.

Dear Mr. Lamon: Send me your FREE Book, "How to Raise Poultry for Profit." I want to know more about my opportunity to make \$1000 to \$5000 a year, spare or full time.

Name.....
Address.....

Look! Bald Men

One Full Ampoule of my amazing hair fluid which I discovered myself and which grew hair on my head.



FREE

This Ampoule is absolutely free. Don't send any money. There is no C. O. D. No charge whatsoever. All I want is an opportunity to show you how easily I grew hair on my own and hundreds of other men's heads. Merely mail the coupon below for free Ampoule.

Here Is How I Used to Look

I was just as bald as this picture. It is a true photograph without any tampering or retouching. It is exactly as I used to look. Then look at the full head of hair I have in the picture on the left.

As I have stated so often, I don't know whether I am the first man who discovered this great secret, but I do know I have it, that I grew my own hair and that I am growing hair on the heads of other men all the time.



Bald Men Grow Hair Quick!

What I accomplished on my own head and on other heads I can do for you, provided you are under 45 years of age and loss of hair was not caused by burns or scars. Anyhow, I must succeed or you pay nothing. No apparatus. My home treatment is simple, quick, inexpensive.

Mail This Free Coupon!

Mail the coupon today — Right Now — I will send you, immediately, one full Ampoule of my marvelous fluid which I discovered, of which I hold the secret and which grew my own hair on my bald head. Besides the Free Ampoule of Fluid, I will send photographs, names and addresses of men and women who successfully used my Wonder Fluid for Dandruff, Falling Hair and Baldness.

Vreeland

1355 Euclid-Windsor Bldg., Cleveland, O.



Here is
← **Brennan**
Brennan while he was bald.

And Brennan after Vreeland grew his hair. Write and I will tell you Brennan's story and give you his address.



Here is
→ **Wiseman**
Wiseman was bald.

But Wiseman grew his head of hair with my wonderful hair growing fluid. All about Wiseman and how he did it, if you write. You will get his address, too.



FREE COUPON

Vreeland 1355 Euclid-Windsor Bldg.
CLEVELAND, OHIO

Please send me, entirely free, one full Ampoule of the same Wonderful Hair Fluid which grew your hair.

My Name _____

My Address _____

State _____

Electrical Experts are in Big Demand!



It's a shame for you to earn \$15 or \$20 or \$30 a week, when in the same six days as an Electrical Expert you could make \$60 to \$100—and do it easier—not work half so hard. Why then remain in the small-pay game, in a line of work that offers no chance, no big promotion, no big income? Fit yourself for a real job in the great electrical industry. I'll show you how.

Be an Electrical Expert Learn to Earn \$3,000 to \$5,000 a Year

Today even the ordinary Electrician—the “screw driver” kind—is making money—big money. But it's the trained man—the man who knows the whys and wherefores of Electricity—the Electrical Expert—who is picked out to “boss” the ordinary Electricians—to boss the big jobs—the jobs that pay \$3,000 to \$5,000 a year. Get in line for one of these “Big Jobs.” Start by enrolling now for my easily learned, quickly grasped, right-up-to-the-minute, Spare-Time Home-Study Course in Practical Electricity.

Age or Lack of Experience No Drawback

You don't have to be a College Man; you don't have to be a High School Graduate. I know exactly the kind of training you need, and I will give you that training. My Course in Electricity is simple, thorough and complete and offers every man, regardless of age, education, or previous experience, the chance to become, in a short time, an electrically trained man, able to make from \$60 to \$100 a week.

Satisfaction or Money Back

So sure am I that you can learn Electricity—so sure am I that after studying with me, you, too, can get into the “big money” class in electrical work, that I will agree in writing to return every single penny paid me in tuition, if, when you have finished my Course you are not satisfied it is the best investment you ever made. And back of me stands a two million dollar institution, thus assuring to every student enrolled, a wonderful training in Electricity.

FREE Book on Electricity

I want you to read my Electrical Book and other material, all Free. These cost you nothing and you'll enjoy them. Make the start today for a bright future in Electricity. Send in Coupon—Now!

L. L. COOKE,
Chief Instruction Engineer

**L. L. Cooke School of
Electricity**

**2150 Lawrence Ave.
Dept. 15 Chicago**



**GET
MY
FREE
BOOK!**

L. L. COOKE, Chief Instruction Engineer
Dept. 15, 2150 Lawrence Ave., Chicago, Ill.

Send me at once without obligation your big illustrated book and complete details of your Home Study Course in Electricity, including your outfit and employment service offers.

Name.....
Address.....
Occupation.....



**I Will
Train You at
Home for a
Big Pay Job**
L.L.C.

5 Big Fine Outfits to work with No Extra Charge

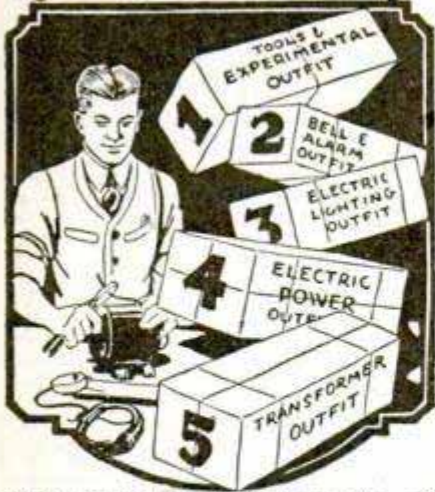

With me, you do practical work—at home. You start right in after your first few lessons to work at your profession in the regular way and make extra money in your spare time. For this you need tools, and I give them to you—5 big complete working outfits, with tools, measuring instruments, and a real electric motor—5 outfits in all.

The Cooke Trained Man is the "Big Pay" Man



\$20 a Day for Schreck

“The biggest thing I ever did was answer your advertisement. I am averaging \$600 a month from my own business now. I used to make \$15 a week.”

A. SCHRECK, Phoenix, Ariz.



\$700 in 24 Days

“Thanks to your Course, I made \$700 in 24 days in Radio. I run from \$10 to \$40 clear profit every day.”

FRED G. McNABB
7 W. 16th St.,
Atlanta, Ga.

Classified Advertisements

WORLD'S BEST WANT AD MEDIUM

Advertisements in this section, 30 cents per word, each insertion, minimum 10 words, payable in advance. To be inserted under proper classification in June issue, copy should be in our office April 18th

ADVERTISING AGENCIES

ADVERTISERS—Send immediately for our new 1929 68-page improved rate book with United States map in colors, just off the press. Gives complete information best paying daily, weekly and monthly newspapers and magazines. Our copy department has seasoned advice to give on advertising and selling. No obligation. Frank W. Lenhoff Advertising Agency, 66 East Lake St., Chicago. (Established 1897.)

ADVERTISE in 24 Big Sunday Newspapers, 24 words \$15.00. Excellent for securing agents, salesmen and business opportunities. Catalog listing 1,000 leading dailies, weeklies, mail order magazines. Everything. Free. Wade Advertising, Baltimore Bldg., Chicago.

BEFORE Advertising get our catalog. No charge. 25 years in business. The largest classified agency in the world. Ankrum Advertising Agency, 100 No. LaSalle St., Chicago, Ill.

GET into advertising. Learn quickly at home. Experience unnecessary. New easy plan. No text books used. Practical work. Old established school. Send name and address for interesting free booklet. Page-Davis School of Advertising, Dept. 3431, 3601 Michigan, Chicago.

FREE—New 1929 Advertisers Rate Guide, 44 pages. Includes everything. Lowest rates. E. H. Brown Advertising Agency, 140 S. Dearborn, Chicago.

ADVERTISE 50 Magazines 5c word; \$4.00 inch; 5,000 country weeklies 1c line, per paper; lists free. Evans King Co., 672P, Wilmington, Del.

TIME Counts in applying for patents. See pages 140 and 141. Clarence A. O'Brien, Registered Patent Attorney, Washington, D. C.

ADVERTISING: 24 Words 8 newspapers \$5; ten farm papers \$15. List free. LeGrand Agency, 150 Nassau St., New York.

ADVERTISING: 24 Words 8 newspapers \$5; ten farm papers \$15. List free. M. LeGrand Agency, 150 Nassau St., New York.

INCH Display 50 Monthlies Thrice \$8.00. Meyer Agency, 4112M Hartford, St. Louis, Mo.

FOR ADVERTISERS

ADVERTISE 300 Country newspapers, 28 words, \$10. Business getter. Lists free. Keator, Hartford Bldg., Chicago.

40 WORDS Insert 50 magazines \$2.00. Empire Agency, Shawano, Wis.

SALES PROMOTION

\$50 TO \$50,000 Daily sales secured for our clients. Three months from the date we undertook to overhaul this manufacturer's selling program, his closures increased from 16% (a mighty good average in his field) to 35%. Sales long since extended beyond national boundaries. They now include a dozen foreign countries too. 35 years' salesmanship-in-print experience back of our campaigns. Submit sales problems for free diagnosis. 10 years' Sales Promotion Manager Larkin Co. James C. Johnson, 118A Woodbridge Ave., Buffalo.

LETTERS That talk—If you need sales letters that really sell. Mailing lists; form letters; any direct-mail advertising service. Write Omaha List & Letter Co., Box 1172, South Omaha, Nebr.

"THE Master Letter Writer," including 500 successful letters, by Ad-Man Davison, world-famous letter expert; 704 pages, \$3. Circular sent. Opportunity Press, Westport, Conn.

BUSINESS ADDRESSES

CHICAGO—6 No. Michigan Ave. A real address. Write Russell Albin.

TYPING SERVICE

I DO Expert typing; duplicate manuscripts 50c 1,000 words. 335 Rockwall, Tex.

AUTOMOBILE SUPPLIES

AUTOMOBILE Formulas save you big money; easily compounded yourself, trifling cost. Reduce gas consumption, radiator leak stop, windshield anti-rain solution, body polish, metal polish, glass polish. Also valuable to start business for yourself. These six big money savers, only \$1.00, sealed. Order today. Dugdale Laboratories, Kearny, N. J.

USED Air compressor, fully automatic, upright space saving type, beltless, fully automatic. Reconditioned and guaranteed like new. Shipped on trial and easy terms. Also a few test stands, car washers, battery chargers and paint sprays. E. M. Connor, Box M593, Troy, Ohio.

MILLIONS—Mechanics, motorists, farmers waiting to buy the universal self adjustable rapid-wrench. First 500 samples 75c only. Schultes & Co., West New York, N. J.

MECHANICS Get out of the grease, travel, and make real money selling our electrical tools to garages and mechanics, easy sales, very liberal commission. Barker Specialty Co., Girard, Pa.

RECLAIM Motor oil, 5c gallon. Formula \$2. Sheeley, Smithsburg, Md.

MECHANICS Get out of the grease, travel, and make real money selling our electrical tools to garages and mechanics, easy sales, very liberal commissions. Barker Specialty Co., Girard, Pa.

BRAKE Lining at lowest prices. Satisfaction or money back. Price 80% off list. 2x3-16" at 20c per foot. F. C. Bentley, Box 1392, Charlotte, N. C.

AUTO Parts new and used. Lowest prices. Bankrupt supplies, motors, wheels, radiators, transmissions, generators, gears, carburetors, touring tops complete \$15. Brakelining 50% off. Brightman, 2065 Main St., Hartford, Conn.

RADIATORS At wholesale prices. All standard makes. Satisfaction guaranteed. Send for prices, stating make and model. Independent Radiator Co., 1119 S. Wabash Ave., Chicago.

KOO KOO, Newest sound device for all cars, independent, \$2.50. Koo Koo Mfg. Co., Box 323, Hollywood, Calif.

BARKING Dog horn. Newest horn for your car. Barks like real dog. \$2.50. John Samon, Yorkville, N. Y.

AUTOMOBILES

DON'T Buy a new radiator—Use plumbers' secret. Also saves hot-water systems. Dime and your address brings everything. Mechanics' Service Bureau, Marina Station, Mayaguez, Porto Rico.

TIME Counts in applying for patents. See pages 140 and 141. Clarence A. O'Brien, Registered Patent Attorney, Washington, D. C.

AUTOMOBILE—Make your own motor car, toy size, operated with motorcycle engine. Any boy can make it. Costs little aside from engine. Full directions with drawings and dimensions in *The Boy Mechanic*, Book 2. Send No Money. Pay postman postage and \$2. Popular Mechanics Press, Room 805, 200 E. Ontario St., Chicago, Ill.

AUTO SERVICE EQUIPMENT

SAVE Money—Garage equipment reconditioned and guaranteed like new. Unusual bargains in test stands, car washers, battery chargers, air compressors, etc. Shipped on trial, easy terms. What do you need to complete your equipment? E. C. Galbreath, Box M594, Troy, Ohio.

BIG Opportunity in 8-hour battery charging. Let me tell you how you can install equipment with practically no investment. Earn \$150 to \$300 monthly from it. Bargains in used outfits. Write today. Also have a few reconditioned car washers, paint sprays, automatic air compressors. I. C. Helmick, Box M595, Troy, Ohio.

YOU Are wanted to resilver mirrors at home. Immense profits plating autoparts, tableware, etc. Write for information. Sprinkle, Plater, 77, Marion, Ind.

BATTERIES AND BATTERY SUPPLIES

BATTERIES—How to make and repair radio and auto. Formula and complete instructions \$1.00. Arthur Clarke, Paris, Tex.

SAVE One-third cost new batteries. Write for method. Georgia Battery Company, Atlanta, Ga.

FOR FORD OWNERS

AURORA Underslung parts and 3.1 racing gears, speedster bodies, headlights, hi compression head. See Sport Factories ad, page 150.

FORD A or T high speed oversize carburetor with special manifold \$17.50 racing cars, racing boats, racing motors, speed specialties. Catalog 10c. Green Motor Co., Dayton, Ohio.

MOTORCYCLES, BICYCLES AND SUPPLIES

MOTORCYCLES \$25 To \$50. Easy terms. Tires \$2.50, frames \$3, forks \$3, tanks \$5, wheels \$4, chains \$2, saddles \$5, handle bars \$5, engines \$15, side cars \$25, transmissions \$12, belts \$6, airplane engines \$15, airplane wheels \$5, bicycle tires \$1.25, velocipedes \$7.50, bicycles \$9.50, new auto tires \$3, used auto tires \$2.50. Send 50c for catalogs. Price Cutter Deninger, Rochester, N. Y.

SPECIALIZED Harley-Davidson service depot. Harley-Davidson parts, accessories, oil. Send us your motors and parts and we will rebuild them like new. Let us overhaul your motorcycle. All work guaranteed. Send 25c in stamps for our flat rate repair costs and parts and accessories book. Knuth's Harley-Davidson Agency, 2525 Fond Du Lac Ave., Milwaukee, Wis.

PRICES Slashed! Send for catalog showing bargains in rebuilt genuine Harley-Davidson motorcycles. Some as low as \$50.00. Fully guaranteed to look, act and last like new. Special easy-payment plan. These bargains won't last long. Write today. Heinz Motor Company, 607 West North Ave., Baltimore, Md. (Authorized Harley-Davidson Distributors).

FINE Harley-Davidson bargains, \$50.00 and up. Order your motorcycle now for spring delivery. Send for our new catalog, "Money-Saving Motorcycle Bargains." Knuth's Harley-Davidson Agency, 2525 Fond Du Lac Ave., Milwaukee, Wis.

USED Motorcycles, all makes, lowest prices; price list free; used parts half price and less. Rochester Harley Davidson Corp., 129 West Main St., Rochester, N. Y.

BARGAINS in used motorcycle parts for all makes. No Catalogs. J. B. Dahl, 3661 Archer Ave., Chicago, Ill.

CLOSING Out bicycles, reducing and exercising machines, tricycle delivery, tandems, racing tandems, tandem frames, parts. McDougald, 175 W. Lake, Chicago.

MOTORCYCLE Parts, new and used. Lists free. Tower Cycle Co., Pine Lawn, Mo.

AVIATION

ACE Universal kit, builds 6 baby r.o.g. or 3 large models, commercial monoplane, or any indoor machine, 36" strips balsa 1-32, 1-16, 1/8, 3-16, 1/4" thick, propeller blocks, dope, glue, piano wire, tissue, bamboo strips, wheels, bearings, \$1.00. Postage 10c. Super universal kit, builds Morris racer, Elliot, Lefker, 40", strips balsa, 5 sizes, dope, ambroid (balsa veneer 1-16x 5") super jap tissue. \$2.00 postage 15c. Stinson-Detroit kit as built as in March American Boy, finished ribs, balsa disc wheels, wire, glue, tissue and everything to build this machine \$1.25. Postage 10c. Catalog for 5c. Ace Aeroplane & Model Supply, 131 Prospect St., Jersey City, N. J.

A REAL Flyer model; wind it; watch it fly. 50c, 3 for \$1. Vano Company, 318 Washington St., Brooklyn, N. Y.

HEATH Super parasol is America's most popular sport plane, because it is backed by 21 years' experience; is the only after solo sport plane produced. The only factory producing an airplane of which blue prints and material can be purchased. Send 10c for large descriptive booklet. Heath Airplane Company, Chicago, Ill.

FOR Sale: Brand new 80 LeRhone nine-cylinder air-cooled motor, with cloth-tipped propeller, magneto, carburetor and cowling; crated free, \$150.00. Towee Hoyde, Tyler, Minn.

BUILD A Ford-motored "Flying Flyover." Blue prints \$5. Circulars 10c. Storms Aviation Co., Spartanburg, S. C.

HEATH Converted Henderson with prop. One hundred dollars. Glenn Kneeland, Chapin, Ill.

LE RHONE Motor \$85; Gnome \$120; Clerget \$150. Avro airplane new complete fly away \$975; or partner interest for car. Latslaw, Clarion, Mich.

AVIATORS' Goggles, helmets! Jackets, coats, flying suits, lowest prices. Catalogs free. Rochester Harley-Davidson Corp., 129 Main St., West Rochester, N. Y.

BIGGEST. Best catalog model airplanes; parts, supplies; 5c postpaid. Ideal Company, 19 West 18th St., New York.

NEW Book. Five hundred aviation questions correctly answered. Postpaid \$1.00. G. Tuck, 73 S. Shirley Ave., Pontiac, Mich.

PARACHUTES For airplanes. Specify weight. Thompson Bros. Balloon Co., Aurora, Ill.

SPECIAL—Pure live rubber for airplane motors. $\frac{1}{4}$ " flat, $\frac{1}{2}$ c per foot; 3-16" flat, 1c per foot. Postage 5 cents. No stamps. Speedo Mfg. Co., Dept. M, 200 Albany Ave., Brooklyn, N. Y.

DON'T Attempt to build a sportplane until you learn how. Get the true facts, figures, data, dimensions from my latest book with drawings, answers hundreds of questions, problems, etc. Postpaid one dollar; may save you hundreds more. Circular five stamps. Russell Aero, Box 455, Toledo, Ohio.

CONVERSION Parts for motorcycle engines. Send 10c for list. George K. Heine, Orwigsburg, Pa.

PURSUIT Monoplane model. Fourteen inch wingspan, dummy whirlwind engine, pilot and machine gunner. Will stunt. Send half dollar for complete construction outfit. Hodgdon, 324 Bay, Springfield, Mass.

AVIATION'S Greatest safety invention. Send ten cents for booklet. Big business opportunity for student flyers. Gyropter, Blueash, Ohio.

PARTS For parasol monoplane, less wheels, dope, \$125. Time payments. Complete blueprints \$1.50. Circular and parts list 20c. John Kamm, 45 Mt. Vernon St., Oshkosh, Wis.

SIMPLEX Air Model Co., Auburn, Mass. Send five cents for supply booklet.

THE American School of Aviation announces a new correspondence course in Mechanics of Aviation. A thorough training in practical aeronautics. American School of Aviation, Dept. 1872, 3601 Michigan Ave., Chicago, Ill.

"WE." By Colonel Charles Lindbergh. New 75c edition. Clafred's, 162 Utica Ave., Brooklyn, N. Y.

NEW Book. Five hundred aviation questions correctly answered. Postpaid \$1.00. G. Tuck, 73 S. Shirley Ave., Pontiac, Mich.

VIKING Galley construction outfit 50c postpaid. Casson-Craft, Canton, Mass.

BYRD'S Antarctic plane scale model construction outfit, quarter, postpaid. World record type indoor tractor monoplane construction outfit, 50c postpaid. Casson-Craft, Canton, Mass.

CONDENSED Lectures on light aircraft construction 75c. Hawley Aircraft, Box 121, Sta. C, San Diego, Calif.

PROPELLERS, For snow and ice sleds. Small airplanes and boats. Blueprints for ice sleds, one dollar. Crawford Airport, Seal Beach, Calif.

ACTUAL Photographs of Famous Flying Fleet, 20 sparkling photos of 20 famous planes, only \$1 for 20 photos. Illinois Aerial Photo Co., 226 E. Superior St., Chicago, Ill.

AIRPLANE Models, supplies. Baby R. O. G. kit, 45c complete. Send 5c for booklet. Money refunded on first order. Hawthorne Model Aero Co., Hawthorne, N. J.

AVIATION Position with an assured future for inexperienced young men who have determination and can be trusted. Write in confidence giving references. To show sincerity of application enclose one dollar to partially defray cost of investigation. R. & R. Aeroplanes, 130 N. Wells, Chicago.

EAGLE Model airplanes. Ready-to-fly. Knocked down. Best models obtainable. Real low prices. Catalogs 5c coin. Eagle Model Airplane Co., Box 152, North Haven, Conn.

JOIN A flying organization. Send \$2.00 for silver wings and membership card. Associated Aviation Clubs of America, 315 East Kingsbridge, New York City.

CLINTON Airplanes—The best performing and most true to life models obtainable. All types; send dime for catalog of ready-to-fly models and construction outfits. The Clinton Toy Corp., North Haven, Conn.

VARIOUS Sizes wood, reeds, bamboo, rubber band, wheels, propeller, onion skin covering and other supplies. Big bundle for 25c, five for \$1.00. No stamps. Will also send circular on free three foot model. Aero Shop, 3050 Hurbit Ave., Detroit, Mich.

"SKYWARD Ho!" Wonder book on aviation—32 pages, 150 illustrations. Shows you complete training for flying career, fame, fortune! Sent free. Write today! Parks Air College, 213 Mo. Theatre Bldg., St. Louis, Mo.

MODEL Airplane supply. August Schaefer, 29 North Ave., New Rochelle, N. Y. Send for free catalog.

BUILD Our wonderful one-place monoplane adapted to motorcycle or other small aircooled motors. Detailed blueprints \$2.00. Literature dime. Hawley Aircraft, Box 121, Sta. C, San Diego, Calif.

HENDERSON Engines—for light aircraft use. Folder 10c. Ballak & Co., 100 N. 12th St. Louis, Mo.

PROPELLERS For model aeroplanes. Semi-carved 6" 35c; 8" 40c; 10" 45c; 12" 50c. Postpaid. Aero Shop, 3050 Hurbit Ave., Detroit, Mich.

MOTORCYCLE Engines for airplanes, motor boats, ice sleds, wheels, tires, chains, gasoline tanks. Send 50c for catalogs. Price Cutter Denlinger, Rochester, N. Y.

TIME Counts in applying for patents. See pages 140 and 141. Clarence A. O'Brien, Registered Patent Attorney, Washington, D. C.

PROPELLERS—4", \$8.75; 5", \$13.25; 6", \$16.50; Special Henderson propeller, \$15.00; Aerodrive boat or sled blueprints, 50c each. Helmets, \$3.00; goggles, \$3.00, both only \$5.00. Engines, fuselages, Ostergaard Aircraft, 4303 North Narragansett, Chicago.

MODEL Airplanes, supplies. Guaranteed perfect stock. Unusual! List 10c (coin). Cleveland Model, 1866P West 57th, Cleveland, Ohio.

THE Age of the Air Is Here. For reliable information on both airplane building and flying we recommend "Aeroplane Construction and Operation," by Rathbun, a book used in government schools. All features of construction treated. Send no money. Pay postman \$2.50 and postage. Popular Mechanics Press, Room 805, 200 E. Ontario St., Chicago, Ill.

BOOKS AND PERIODICALS

4TH EDITION, revised "Radio Theory and Operating," by Mary Texanna Loomis. The standard radio text and reference book of America. 992 pages, 800 illustrations, flexible binding. Price \$3.50 postage paid. For sale by hundreds of book dealers throughout America and many foreign countries. Or may be purchased direct from the publishers. Send check or money order to Loomis Publishing Company, Dept. 18, Washington, D. C.

"CARTOONING For Profit." Illustrated, contains selling plans, cartoon pointers, shortcuts, syndicate work, commercial cartooning, getting the professional touch, best markets, syndicates, cartoon contests, etc. \$1. postpaid. Smith's Service, PK1194, Wenatchee, Wash.

BOOKS, 6th and 7th Book of Moses, 75c; Albertus Magnus, 75c; Pow-Wow, 60c; Silent Friend, \$1.00; Book of Luck, 25c. The F. & R. Co., 87 Fourth Ave., Dept. "L," New York.

KNOW The Stars. Instructive chart of the heavens, 30x44, with 8,000 word course \$1 postpaid. Cosmic Bureau, Miami, Fla.

WONDERFUL Book; Also catalog 15c postpaid. Warren Novelty Shop, Warren, Ohio.

\$5.00 BOOK Of 200 different collection letters for \$2.95. Cash only. A necessity for anybody who sells. Business Press, Box 519, La Crosse, Wis.

INDUSTRIAL Alconol. Wright's book. Full directions for making, fully illustrated. \$2.50. Spon & Chamberlain, 120 P.M. Liberty Street, New York, N. Y.

CURIOUS Books, unique novelties, stunning pictures. Samples, 10 cents prepaid. Linds, 214 W. 34th St., New York.

BOOKS—Electrical, mechanical, etc., discount prices. Catalog, Manhattan Co., 333d W. Manhattan Blvd., Toledo, Ohio.

15,000 FORMULAS in "Scientific American Cyclopedia of Formulas." Includes following and many others: Accidents and emergencies, agriculture, alloys and amalgams, artist's materials, beverages, cements, glues, pastes, mucilages, bleaching, renovating, coloring metals, dyeing, glass, heat treatment of metals, household formulas, ice cream, confectionery, chewing gum, lapidary work, exterminating vermin, lubricants, paints, varnishes, photography, condiments, canning formulas, rubber, soap, candles, soldering, toilet preparations, perfumes, waterproofing, fireproofing, writing materials. Send no money. Just write a postal. When postman hands you book pay \$5.50 and postal charges. Popular Mechanics Press, Room 805, 200 E. Ontario St., Chicago, Ill.

PICTURES AND POSTCARDS

FREE Book—"What men know about women?" Humorous and interesting. Kind men like. 10 snappy cards. Red hot pocket novelty. Copy America's greatest illustrated cartoon book. All for 25c. White Mule, Beaver Dam, Wis.

ART Pictures—220 all different. 160 samples \$1.00. Particulars 10c. Howard Sales Co., Dept. 15, Box 529, San Francisco, Calif.

NOVELTIES, CURIOS, ETC.

CONCERTINA Plays by rolls, talking cards. Pittle, New Bedford, Mass.

GAMES, ENTERTAINMENTS AND PLAYS

PLAYS, Musical comedies and revues, minstrels, comedy and talking songs, black-face skits, vaudeville acts monologs, dialogs, recitations, entertainments, juvenile plays and songs, musical readings, make-up goods. Catalog free. T. S. Denison & Co., 623 So. Wabash, Dept. 11, Chicago.

LEARN Ventriloquism by mail—small cost, 2c stamp brings particulars. Geo. W. Smith, Room 8-344, 125 N. Jefferson St., Peoria, Ill.

MAGIC TRICKS, BOOKS AND JOKER NOVELTIES

"THE Book of 1,000 Wonders" will be sent postpaid for 10c. Explains many mystifying tricks with coins, cards, handkerchiefs, etc., you can do. Also, contains complete catalog of magic tricks, jokes, puzzles, books, escapes, mindreading acts, spiritualistic effects, illusion plans, curios and imported novelties from many foreign lands. Large assortment, lowest prices. You will amaze and mystify your friends! Send 10c today. Lyle Douglas, Station A-5, Dallas, Tex.

SIX Wonderful magic tricks, with apparatus, directions, professional magicians' catalog. Complete 25c. Weber, 647-K3, East 62nd, Chicago.

MAGIC And novelties. Free catalog. Alex Bucnis, 1527 South 48 Court, Cicero, Ill.

MAGIC Tricks. Card tricks, Coin tricks, Hypnotism, Ventriloquism. Popular 64 page books, 10c each. All five 40c. Geo. Fenner, 2401 Jefferson, Louisville, Ky.

MAGIC Tricks and novelties. Send 15c for illustrated catalog. E. Kay Magic Shop, 8832 Commercial Ave., Chicago, Ill.

MARVELOUS Stunts in electricity, magnetism, chemistry & illustrated instructions. The Home Laboratory Institute, Brockton, Mass, Dept. A, Box 192.

ORIGINAL Trick—Drop a coin through a table into a tin pail with little practice, or money back. Send \$1.00. Henderson, Maple St., 105, Stanley, Wis.

VENTRILQUIST, Punch and Judy figures. Illustrated booklet 10c. Frank Marshall, 5518 So. Loomis, Chicago.

ELECTRIC Fun! Seventy stunts, 110 volts. \$1. Cooper Sons, Campbell, Calif.

SEVEN Magical Deceptions and catalogs—25c. Gilmagic, Morgan Park, Ill.

FREE With \$25 order die box. Send 20c for our large catalog of tricks, wigs, sensational escapes. Oaks Magical Co., Dept. 548, Oshkosh, Wis.

MAGIC—Tricks, Books and Supplies. For amateurs as well as the great professionals. Anyone can learn through our instructions. Feature Acts in Mind-Reading, Spiritualism, Rope Ties, etc. Large illustrated professional catalog, 20c. Chicago Magic Co., 140 So. Dearborn St., Dept. B, Chicago, Ill.

LATEST French model pocket mirror and set of transparent art cards all for \$1.00. World Service Co., 336 Marcy Ave., Brooklyn, N. Y.

TRICKS, Puzzles, novelties, catalog free. B. Z. Puzzles, Fairview, Mass.

CHALK TALKS

LAUGH Producing program, \$1.00. Catalog free. Balda, The Cartoonist, Oshkosh, Wis.

BECOME Chalk talk wizard in one evening. Make crayon, clay, sand and smoke pictures. New method. No talent needed. G. E. Hendrickson, Argyle, Wis.

STAMP COLLECTING

SAMPLE Copy free. In order to introduce the readers of this magazine to Scott's Monthly Journal, philately's liveliest magazine, we will send a copy free to all who write us and ask for it. Scott's Monthly Journal is not only a very interesting and up-to-date philatelic journal, but it is also a monthly supplement to the Standard and the specialized U. S. catalogs, listing new issues, price changes, etc. Approvals. The world-wide connections of this company have made it possible for us to build up, and keep on hand, one of the finest assortments of fine approvals in the world. Write us for approval circular. Scott Stamp and Coin Co., 1 West 47th St., New York, N. Y.

MYSTIC "Queer Country" Packet! Contains scarce stamps from the following strange lands: San Marino, Antioquia, Congo, Cyprus, Fiji Islands, Gwalior Hyderabad, Iceland, Jhind, Kenya, Uganda, Lebanon, Monaco, North Borneo, Nyassa, St. Thomas Prince, Eastern Roumelia, Siam, Sierra Leone, Tanganyika, Trinidad Tobago, Ubangi, Upper Volta, Wallis Futuna, Alaouites. Get this wonderful packet of "freak countries" and make your friends envious! Price only 10c to approval applicants! Write today. Mystic Stamp Company (Dept. 8), Camden, N. Y.

500 DIFFERENT Stamps for 25c. Big collection from Bosnia, Crete, Epirus, Honduras, Iceland, Kenya, Liberia, Malta, Nyassa, Quellimane, Siam, Zambesia and other "hard" countries. Catalog value \$10. Price 25c to approval applicants! Bargains, 1,000 different 79c; 15 triangles 49c; 100 Africa 45c; 100 Asia 50c; 100 Balkans 35c; 100 British Colonies 30c; 100 French Colonies 35c; 100 Portuguese Colonies 50c. Eight packets for \$3.00! Illustrated lists free. Loma Stamp Co., 3926 32nd St., San Diego, Calif.

\$1.00 FREE. Black U. S. postage, given away with each order. Pioneer Stamp Album with 500 illustrations, 150 different stamps from 40 countries, Syria, Lebanon, Hejaz, Liberia, New French Colonies, British, Portuguese Colonies, South Africa, Australia, 500 hinges, 36 page illustrated catalog. All for 15c. Big commission to agents for the best approval sheets of stamps ever offered. Write for sample outfit. Hussman Stamp Co., Dept. M, 620 Olive St., St. Louis, Mo.

(1) **FANTASTIC** Liberia set! (2) Airmail set. (3) Triangle stamp. (4) Strikingly beautiful Azores 1928 Independence commemorative set of 5 stamps. (5) 50 different stamps from 50 different far off countries. All 5 groups of stamps above, containing birds, beasts, boats, buildings, battles, circus, savages, scenery, airplanes, maps, portraits, and many other showy picture stamps for only 10c to approval applicants. Western Philatelists, 6021 Harper Ave., M5, Chicago.

"GOLIATH'S Bazaar!" \$10.00 black U. S., 5 Irish Free State 'billion-dollar' packet (prewar value \$1,000,504,786.25), hideous Slam airmail, forbidden set of Bulgaria (the stamps that nearly started a war), scarce "Charity" set, packet rare Triangles (Nyassa, Liberia, etc.), unique new Europe package (no trash), packet hinges, nice swap book. This entire bazaar to approval applicants for only 15c. Get it now! Goliath Stamp Co., 205 South Second St., Chambersburg, Pa.

NEWFOUNDLAND Catalog free. Illustrated and written up. Prices net. Rev. Butler, St. Georges, Newfoundland.

ANCHERS \$\$\$ Outfit—only 12c! Fine triangle stamp; set German stamps with (pre-war) value forty million dollars (interesting!); perforation gauge, mm scale; airmail set; scarce stamp from smallest republic on earth; newspaper set; packet good stamps and Travancore, Malay, Dutch Indies, etc. Entire outfit for 12c to approval applicants! (Nice pocket stock book, value 25c, with every order!) Ancher Stamp Co., Box 126, Rutherford, N. J.

100 DIFFERENT Foreign stamps from 100 different foreign countries, including Africa, Asia, Australia, Europe, West Indies, etc., for only 20c. Free with each order, our pamphlet which tells "How to Make a Stamp Collection Properly," together with our price lists of albums, supplies, and hundreds of bargains in sets, packets, etc. Queen City Stamp & Coin Co., Room 36, 604 Race St., Cincinnati, Ohio.

15 AIR Mail free, if you send 10c for 111 different stamps from hard countries, as Kauang-Teheou, Sudan, etc., including animals, savages, also full particulars how to secure many more packets and sets free. Glendale Stamp Co., 1341 Linden, Glendale, Calif.

200-200-200-2000—ALL Different stamps; 200 hinges; approval sheet to hold 200 stamps; perforation gauge, millimeter scale and ruler; duplicate stamp container—all for only 15c to approval applicants. Edgewood Stamp Company, Milford, Conn.

ONLY 25c For a five months' subscription to The Stamp Collector, America's finest stamp magazine, 100 all different stamps given free to each subscriber. Money refunded if you are not more than pleased. The Stamp Collector, Dept. P. M., 515 Sedgwick Drive, Syracuse, N. Y.

82 FAR Off countries only 10c—Quellimane, Inhambane, Travancore, Kouang Teheou, Syria, Martinique, Liban, Pierre, Peru, South Africa and 72 other countries—82 different stamps from 82 different countries for only 10 cents. Big lists and approvals with each order. Reimers, 8 Flatiron Bldg., Fort Worth, Tex.

CANADIAN Confederation special packet 25 diff. Canada, 5 diff. Nfld., and our new large illustrated lists for only 10c to approval applicants. We list 282 countries in our dime packets. Specials: 500 diff. 25c, 1,000 diff. 75c, 2,000 diff. \$2.50. Victoria Stamp Co., Dept. 4, London, Ont., Can.

FREE—Beautiful complete mint set 18 stamps and two stamps, catalog \$1.15 to approval applicants. Postage 4c. Iron Spring Stamp Co., Iron Springs, Pa.

ANNIVERSARY Offer! 15c six beautiful sets: "Occupation," "Commemorative," "Airmail," "Charity," "Pictorial," "War." Also three packets: (International), (British, French, Portuguese Colonies), (Bulgaria). Approvals, lists, discounts. Deering, Fairmount, Marlborough, Mass.

SPOT Cash paid for stamp collections. Kelgwin, B192, Middletown, N. Y.

IRAQ, U. S., Albania, Kenya, Ubangi. 60 diff. stamps only 8c to approval applicants. J. Dennie, 7763 Logan, Detroit, Mich.

DANDY Mint stamps 2c to those requesting approvals. Harvey Teeple, Decatur, Ind.

STAMP Album free; spaces for 1,200 stamps, with purchase of 100 different unused stamps for 25c. B. Nagle, 1101 Marion, Reading, Pa.

TEN Different United States commemorative stamps 12c. Frederick Lawrence, No. 9 Third Ave., San Francisco.

FREE—Our 2,000 pkt. is three dollars. Add fifteen cents for insurance and receive 500 different free. Rev. G. Welsh, Spring Grove, Penna.

ILLUSTRATED Descriptive U. S. list, 1929, price 50 cents; also second edition U. S. and B. N. A. list free; old stamps bought Stanley Gibbons, Inc., 38P Park Row, New York City.

WONDERFUL Bargains, sets, packets; illustrated catalog free. University Stamp Co., Box 31E, Washington Bridge Sta., New York.

PHILLIPS' Monthly Bulletin (illustrated) offers over 2,000 special bargains, sets, new issues, packets, etc., each issue. Free. Phillips, Box 1012, Hartford, Conn.

SPECIAL! 25 Different airmail 10c. List 5 and 10c packets free. Stamp Shop, 15 Pershing Ave., Elizabeth, N. J.

UNITED States, four different airmail stamps 12c. Frederick Lawrence, 9 Third Ave., San Francisco.

75 DIFFERENT Foreign stamps, from 20 countries (every continent), stamp hinges, perforation gauge and illustrated album with places for hundreds of stamps for 10c (coin) and 2c stamp, 1,000 all different 90c, 1,000 mixed 30c. Dept. 38, Argonaut Stamp Co., New Canaan, Conn.

ST. LUCIA; 3 free to approval applicants. Allison, Angola, Ind.

THREE Musketeers combination 7c. Price lists. Lowest prices. Golden Rule Stamp Co., Box 1248, Chicago.

100 DIFF. United States stamps 38c to approval applicants. Rotnem Co., McKnight Bldg., Minneapolis, Minn.

100 BAVARIA, 30 Brazil, 100 Danzig, 50 Luxemburg, 25 Guatemala 25c each packet, all different. Schoemann, Box 726, Chicago, Ill.

52 DIFF. U. S. (no current) 50c. Mountain City Stamp Co., Box 335, Mannington, W. Va.

105 CHINA, Etc., 2c. Album (500 illustrations) 3c. Bullard, Sta. BB, Boston.

FREE! 15 French Colonies. Postage 2c. R. F. Roberts, 901 Fourth, Bay City, Mich.

101 STAMPS Free with approvals. Postage 2c. Johnson Stamp Co., (PM) Jamestown, N. Y.

DON'T Miss this! Prewar foreign stamps on approval. Breaking collection at half catalog. J. Sainsbury, 35 Thomas, St. Catharines, Can.

FREE—150 Different. Approvals. Applebaum, 1258 Brook Ave., New York.

MAGNIFICARCIUS Packet free—Beauties from distant lands, many richly colored, unusual designs. 2c postage. Empire Stamp Co., Toronto, Can.

CONFEDERATE Assay, 5c to approval applicants. Patapasco Stamp Co., 3110 Ferndale Ave., Baltimore, Md.

TRIANGLE, Old U. S. stamp, 2 sets war tax 4c. With approvals. Murray, 1202, 705 Olive, St. Louis, Mo.

FREE, 12 Diff. British colonies for a request for my popular approvals of large showy picture stamps, at 50% disc't. Postage 2c. Chas. Bushnell, 4728 Princeton Ave., Tacony, Phila., Pa.

CLEARANCE! Every stamp different! 550, 30c; 1,050, 80c; 2,000, \$2.50; 4 triangle, 14c; 5 triangle and 20 air mail, 28c; 45 air mail, 57c. Hotchkiss, 7742 South Shore Drive, Chicago.

CANADIAN And American commemoratives, five cents to approval applicants only. The Stamp Chest, 84 Jane St., Toronto, 9, Can.

9 NYASSA Triangles (beauties) and 6 Malay tigers for only 25c. Weber's Stamp Shoppe, Plainfield, N. J.

UNITED States, 24 varieties 1/2 to \$2 current, catalog \$1.25 for 25c. Leduc, Red Lion, Penna.

1,000 MIXED U. S., old and new, 25c. Weatherby, Box 1987-A, Cleveland, Ohio.

FREE! Scarce set Azerbaijan, special 24 page illustrated bargain list. Premiums cataloging \$13 for liberal buyers, 2c postage. Penna Stamp Co., Greensburg, Penna.

BARREL Of foreign stamps while they last, 25c-1,000 or pound \$1.00 (over 4,000). Approvals sent. Hinges 3,000-25c. Elmer, 61 Court St., Boston.

200 STAMPS And year's subscription 50c. Popular Monthly, 204 Sprenger, Buffalo, N. Y.

LIBERIA Snake Triangle and two other triangles in our packet of 53 genuine foreign stamps for five cents. Crowder Company, Waverly, Baltimore, Md.

STAMPS Sent on approval. Discount 70%. Minimum deposit 60c. E. G. Peters, Peters-Woolworth Bldg., Rome, Ga.

33-1-3% COMMISSION. Sell our stamps, sheet catalog value, \$4. Our price, \$2.00. Unsold stamps returnable. No investment required. References necessary. Lux Stamp Co., 805-C Fairmont Place, Bronx, New York.

FREE—20 Different Argentine. Approvals. List. Send 4c today for postage, etc. Reuter, Santa Ana, Calif.

COVERTCO Packet, 50 Soviet Russia 15 cents, with 60% discount approvals. Covert Stamp, 39 State, Rochester, N. Y.

DIME Packets, 25 Africa, 12 Cape Verde, 25 Asia, 12 Mozambique, 7 Nyassa, 10 Togo, only 10c each, three for 25c. Skillman, Titusville, N. J.

CONGO. Free five fine to approval applicants. Bernard Karch, Bengies, Md.

TREASURES—135 Different semi-rare stamps 25c. Including Bermuda, Jamaica, Nicaragua, Africa, Asia, etc. (No Europe). Stamp Mart, St. Paul, Minn.

TWO First flight airmail covers, 25c. Chanin, 3684 Concord, Detroit.

100 FOREIGN Stamps 3 cents. Lufbery Stamp Co., Branford, Conn.

MAGNIFICENT! Nine Nyassa triangles and 15 airmails 25c. Free 50 foreign, 50% approvals. Webster Stamp, Box 11, Tremont Sta., New York.

24 VARIETIES Cuban stamps, 10 cents. List of 6,000 low-priced stamps free. Address Chambers Stamp Co., 111P, Nassau St., New York City, N. Y.

200 DIFFERENT stamps 10c; 1,000 Hinges 10c. R. H. Carlton, 380 W. So. Temple, Salt Lake, Utah.

300 DIFFERENT, 20c; 600, 50c; 1,100, \$1 2,000, \$3.50. Fred Onken, 630 79th St., Brooklyn.

STAMPS sent on approval at 70% discount. Reference required. Emory Renoll, Hanover, Pa.

FREE Germany air mail (5 var.) for new applicant of my 1, 2c and 3c approvals and also my 50% discount. Chas. W. Schmidt, P. O. Box 4832, Frankford Sta., Philadelphia, Pa.

FREE! 115 Different stamps to approval applicants, 2c postage. Paige Stamp Co., Oak Park, Ill.

FREE! Triangles, airmail, Iceland and 50 others to approval applicants inclosing 3c postage. Hawkeye Stamp Co., Cedar Rapids, 39, Iowa.

FREE—31 Different stamps to applicants for Royal approvals, 2c return postage. Royal Stamp Company, 1728 S. 58th St., Philadelphia, Pa.

111 DIFFERENT, Arabia, Azerbaijan, Zanzibar, etc., 10c to approval applicants. Floyd Marsh, 524 Hamilton Ave., Indianapolis, Ind.

FREE, 12 DIT, large, showy picture stamps for a request for my popular approvals. Postage 2c. Premiums with every purchase. A. Bauer, Palmyra, N. J.

110 DIFFERENT Stamps, many unused, high values, free to collectors requesting our net approvals. Postage 2 cents. Christensen, Milwaukee, Wis.

STAMPS, 100 Varieties, Africa, Brazil, Peru, Cuba, Mexico, etc., 10c; 25 different U. S. 25c; 1,000 mixed, 40c; 1,000 hinges, 15c. List free. C. Stegman, 5941 Cote Brillante, St. Louis, Mo.

FREE Souvenir and packet to approval applicants 4c postage. Huffman, 405 Pennsylvania Ave., Brooklyn, N. Y.

ONLY 5c! 10 Airmail stamps, including scarce Esthonian triangular stamp; Portuguese Red Cross set and 10 different Central Lithuanian stamps. Approvals and free lists with each order. Curhan Stamp Company, Gloucester, Mass.

APPROVAL Stamp packet sent on request. Paul Cornish, Schenectady, N. Y.

STAMPS, 100 all different. Postage 2c. Lists free. P. M. Quaker Stamp Co., Toledo, Ohio.

REVENUES—Telegraphs—Every country. Pretty—Intriguing—Cheap. Mint \$5.00 revenue free to applicants with references. Vanderhoof, 1114 Logan, Denver, Colo.

FREE 50 British Colonials, if approvals requested. Postage 4c. Berkeley Stamp Co., South Berkeley, Calif.

110 NEW Europe All Different, a wonderful collection cataloging several dollars, free to collectors requesting our Net Approvals. Postage 2 cents. Badger Stamp Co., Milwaukee, Wis.

100 DIFFERENT 3c if approvals are requested. Glenn R. Knight, Box 3, Sausalito, Calif.

101 DIFFERENT Free with 50% Approvals, 2c postage. Noemus Stamp Co., 312 East 23rd St., New York.

PENNY Approvals that Satisfy. Neil Gronberg, Box 5441, Philadelphia, Pa.

150 GOOD Mixed foreign stamps 3 cents. Stanton, Niantic, Conn.

40 DIFFERENT United States 10c. 60% approvals. Seldenberg, Baroda, Mich.

250 DIFFERENT Foreign postage stamps only 10c. Skillman, Titusville, N. J.

FREE, 20 Different United States and 100 foreign with approvals. L. W. Hudson, 1439 East 7th St., Plainfield, N. J.

UNITED STATES—Send on approval. Send me your want list. Ref. please. M. Hanna, New Kensington, Pa.

OLD Money wanted—Will pay fifty dollars for nickel of 1913 with Liberty head (no buffalo). We pay cash premiums for all rare coins. Send 4c for large coin folder. May mean much profit to you. Numismatic Co., Dept. H, Ft. Worth, Tex.

1,100 UNUSED Stamps, cataloging nearly \$25.00. Only 95c. Forty page illustrated price list free. West Coast Stamp Company, Alhambra, Calif.

BEAUTIFUL New set 2c with approvals. Send reference. Edgewater Stamp Co., Box 2731, Cleveland, Ohio.

FRENCH Colonies free—Jungles, Tigers, Native Chiefs, 2c postage. Empire Stamp Co., Toronto, Can.

RARE COINS

\$2 TO \$500 Each paid for hundreds of old coins. Keep all old money, it may be very valuable. Send 10 cents for illustrated coin value book, 4x6. Prices guaranteed. Get posted. We buy and sell. Clarke's Coin Office, Box 5, Le Roy, N. Y.

OLD Coins, large spring selling catalog of coins for sale free to collectors only. Catalog quoting prices paid for coins, ten cents. William Hesslein, 101A Tremont St., Boston, Mass.

3 DIFFERENT Fine bronze and nickel coin, 2 large crisp bank notes and catalog 10c. George Best, Cedar Rapids, Iowa.

AMERICAN Coins. Relics bought. Coin value booklet, 12c. Frank Saco, 735 45th St., Brooklyn, N. Y.

10,000,000 MARK And Hist, 3c. Greenclay, Box 2551, Denver, Colo.

ICELAND—Scarce nickel only 10c. Leo D. Phaneuf, Numismatist, Box 677, Marquette, Mich.

GET Profit and pleasure in collecting old coins. Send 10c for large illustrated coin catalog. You'll be delighted with it. Send for it right now. B. Max Mehl, Numismatist, Mehl Bldg., Dept. P, Fort Worth, Tex. Largest Rare Coin Firm in the U. S.

UNITED States, Large cent, two-cent bronze, three-cent nickel and bargain list, 25c. Thirteen dates large cents, \$1.00. George Coffin, Greenwood Mountain, Me.

CALIFORNIA Gold—Quarter size, 27c; $\frac{1}{2}$ size, 53c; 3c piece and catalog, 10c. Norman Shultz, Box 746, Salt Lake, Utah.

RARE United States and foreign coins, war medals and decorations. Chinese coin and catalog 10c. Alexis Mengelle, Colorado Springs, Colo.

40 OLD Coins all different \$1.00; 100 different coins, \$3.00; 200 different coins, \$6.75; 100 mixed foreign coins, \$1.00; 40 different silver coins, \$4.00. Claud Denney, Box 315, Dallas, Tex.

50 DIFFERENT Coins \$1.00. 12 different 25c. Oddehon, Box 681, Kansas City, Mo.

CAMERAS AND PHOTO SUPPLIES

FREE, Bargain book listing hundreds of slightly used cameras, kodaks, lenses and photographic supplies at great savings. Some sample bargains $2\frac{1}{2} \times 4\frac{1}{4}$ folding pocket kodak \$10.50, Ansoo memo camera, f:6.3 Anastigmat lens, \$14.50, 4x5 auto Graflex camera with series II f:4.5 Velostigmat lens, \$49.75. Send for your copy at once; it will pay you, as our prices are extremely low. Everything guaranteed fully. Central Camera Co., 112 So. Wabash Ave., Dept. PM-5c, Chicago, Ill.

COLORED Photos: Anyone who can take a picture can color it—by the Marshall method. No brushes necessary—colors self-blending. John G. Marshall, 1752 Atlantic Ave., Brooklyn, N. Y.

TRIAL Offer: 11x14 inch photo enlargements; black and white 35c; hand colored in oil, 65c. Send negative or print. Williams, 827 East Newall, Flint, Mich.

SELL Photographs to the magazines! Send stamped envelope for instructions. Braden, Gray, Me.

NEGATIVE For memos, repts, kumaras, cheap. Hollywood Still-Film Studio.

GERMAN Cameras, lenses, Barttro, 6436 La Brea Way, Los Angeles, Calif.

MAKE Money in photography. Learn quickly at home. Spare or full time. New plan. Nothing like it. Experience unnecessary. American School of Photography, Dept. 3432, 3601 Michigan Ave., Chicago.

SAMPLE Enlargement—dime, and negative (returned). Trial roll, glossy prints, 25c silver. Brown, Warsaw, N. C.

TIME Counts in applying for patents. See pages 140 and 141. Clarence A. O'Brien, Registered Patent Attorney, Washington, D. C.

\$50.00 FOR Photographs—This price paid for photographs meeting our requirements. Perhaps one of yours will bring this amount. Full particulars free. Redkrafts, Denver, Colo.

ENLARGEMENTS, Best ever, 8x10 50c. Send film or negative. Price list other sizes. Jengar Photographic Laboratory, 478-79 Simon Long Bldg., Wilkes-Barre, Penna.

BIG Money in photography, motion picture projection. Catalog 49A free. New York Institute of Photography, 10 W. 33d St., New York.

HAVE You a Camera? Write for Free sample of our big magazine, showing how to make better pictures and earn money. American Photography, 116 Camera House, Boston, 17, Mass.

FILMS Developed. Special Trial Offer. Any Size Kodak film developed 5c, prints 3c each. Trial 6x10 Enlargement in handsome folder 40c. Overnight Service. Roanoke Photo Finishing Co., 209 Bell Ave., Roanoke, Va.

EARN Big money with your camera in your spare time, using Halldorson Home Portrait Lamp. Write for booklet "Home Portrait Photography" and catalog—both free. The Halldorson Company, 4746 N. Western Ave., Chicago.

MOTION PICTURES

\$1,250 FOR Original photoplay story. Our sales department sold unknown author's first story for above amount. We revise, copy-right and market stories for both silent and talking pictures. Located in the heart of motion-picture industry. We know the demand. Established 1917. Free booklet. Universal Scenario Company, 206 Western and Santa Monica Bldg., Hollywood, Calif.

OUT And ready for you! The great spring number, Bass Bargaingram No. 196. A mighty array of bargains in motion picture cameras, projectors for amateur and professional, text books and accessories. You can make big money by becoming a camera man. This great bargaingram will be sent to you on receipt of 4c in stamps. Send for it today. Bass Camera Company, 179 West Madison St., Chicago, Ill.

BARGAINS, Meyer Kino-Plasmat f:1.5 lens, 1" focus, will fit Film No. 70 camera, \$37.50; 16mm., Bell and Howell projector, \$132.50; 35mm., N. Y. Institute motion picture camera with f:5 lens, \$69.75. These are just a few of the types of bargains you will find listed in our new bargain book issued free. Send for your copy now. Central Camera Co., 112 S. Wabash Ave., Dept. PM5c, Chicago, Ill.

STARTLING Bargains in motion-picture cameras, projectors, apparatus. Send stamp for the 192nd issue of the Bass Bargaingram. Never in history has such startling bargains been offered in guaranteed apparatus. Write for your copy now. Remarkable motion-picture exposure meter, \$2.00. Sixty-six page catalog. Send stamp. Bass Camera Company, 179 W. Madison St., Chicago, Ill.

FILMS—250 Feet \$1.00. Particulars, Samples free. Eastin Feature Films, Galesburg, Ill.

MOVIE Films for sale cheap. List free. Michael Passaro, 126 Fourth Ave., Paterson, N. J.

MOVING Picture film. Features, westerns and others \$10.00 to \$15.00 for complete feature. Progressive Pictures, 3329 Lindell Blvd., St. Louis, Mo.

300 FEET Film \$1.10. Lists stamps. Hoffman Film Service, 57 Broad St., Albany, N. Y.

COMPLETE News reels \$2.50. Clifford Hoffman, 25 Hamilton, Albany, N. Y.

SPECIAL—25 California scenes, 25c (standard) for home, school, toy projectors. Catalog. Hollywood Still-Film Studio, Box 1410, Hollywood, Calif.

\$150 SPRING Motor camera \$27.50. Negative film $2\frac{1}{2}$ cents foot. Projector \$30. 16M camera \$15. 16M projector \$25. 100 feet 16M negative \$4.50. Ray, 296 5th Ave., New York.

EXCELLENT Westerns, features, \$2.50 per reel. Stewart Marshall, Rome, Ga.

BE A movie exhibitor—Big opportunity—Only moderate capital required—Complete equipment at remarkably low prices. Write. Atlas Moving Picture Co., 624 South Michigan Ave., Chicago, Ill.

MOVIE Films, 1,000 ft. reels, \$2.50 each; shipped anywhere on receipt of remittance. Particulars on request. Independent Films, 177 Golden Gate Ave., San Francisco, Calif.

MOVIE Films 1c foot, 200 feet \$1.00. Reels \$2.75 up. Stamp brings sample and list. X Sales Co., Box 1506, New Haven, Conn.

NEW And rebuilt projectors for theaters, schools, churches, traveling shows. Supplies and complete theater equipments. Bargain prices. Free catalog. Monarch Theatre Supply Co., Memphis, Tenn.

FILMS: 200 Feet \$1.00. Reels \$2.50. List. Edgeworth Sales. Box 155, Blue Island, Ill.

BIG Money in photography, motion picture projection. Catalog 49A free. New York Institute of Photography, 10 W. 33d St., New York.

FILMS—250 Feet 80c., westerns, etc. A. Savarese, 149 Pallsade Ave., Union City, N. J.

TIME Counts in applying for patents. See pages 140 and 141. Clarence A. O'Brien, Registered Patent Attorney, Washington, D. C.

SCENERY TO RENT

WORLD'S Most Beautiful Settings for operas, plays, minstrels. Amelia Grain, Philadelphia.

RADIO SETS AND SUPPLIES

WIRELESS—We have a few new 75 watt portable spark transmitters, complete cost \$60.00 each while they last \$15.00 each. Guaranteed. Lamar Radio Shop, Lamar, S. C.

RELAYS—Automatically connects eliminator to set, remote control for amateurs, telegraph work, etc. Operates off storage battery or dry cell. Will break plenty of volts. Only \$2.00 each. Also UX 210 7½ watt tubes, nationally known make, special at \$3.95. Prepaid. Mitchell Radio Company, 635 Waveland Ave., Chicago, Ill.

CONE Speakers—\$10.00 value \$3.65. Beautiful 18" cone. Full tone and volume. Satisfaction guaranteed. Welch Radio Products Co., Independence, Mo.

LOUDSPEAKERS, Headphones; repaired, rebuilt. Melodian Laboratories, Independence, Mo.

MODEL 35 Atwater Kent all electric console with R. C. A. tubes \$75.00. Genuine R. C. A. tubes 226, \$2.00; 227, \$3.00; 280, \$3.50; 171A, \$2.50; 201A, \$1.40. Send for list of renewed battery models. French Sales Co., Melrose, Mass.

BUILD A Pilot Wasp 3-tube short-long wave set. Complete kit of parts only \$25.00. F. O. B. New York. Will ship C. O. D. Write R. L. Deverall, 136 Liberty St., New York.

NEW 300-Mile "pocket" radio, \$2.00. No tubes or batteries required. Over 50,000 users. Order direct. Spencer Laboratories, 116 Atlas, Akron, Ohio.

RADIO Set builders—We sell parts, kits, sets, at Chicago prices F. O. B., Seattle, Wash. Wedel Company.

TIME Counts in applying for patents. See pages 140 and 141. Clarence A. O'Brien, Registered Patent Attorney, Washington, D. C.

WANTED: Men to work with National Radio Service organization. No selling scheme. Radio Doctors, Inc., Dept. M, Essex St., Salem, Mass.

BEST Radio Book—New Revised Edition. Radio Theory and Operating by M. T. Loomis of the Loomis Radio College is America's Standard Radio Text-Book. Used by the various gov't departments, and schools and leading radio schools. 900 pages, 700 illus., flexible krafty leather binding. Sent C. O. D. Pay postman \$3.50 and the postage when package is delivered. Popular Mechanics Press, Room 805, 200 E. Ontario St., Chicago.

TRADE AND TECHNICAL SCHOOLS

BE A blue print reader. Write for facts. See how men in your trade got to the top. What's your trade? Carroll Ramsey, Drexel Bldg., Philadelphia.

TELEGRAPHY—Both Morse and wireless—taught thoroughly. Big salaries. Wonderful opportunities. Expenses low; chance to earn part. School established fifty-four years. Catalog free. Dodge's Institute, Fern St., Valparaiso, Ind.

OUR Commercial radio operating and junior engineering course pays our graduates \$150 to \$300 monthly from start. Rapid advancement. Winter term begins in January. Write for catalog of course including Extension Course. Loomis Radio College, Dept. 5-E, Washington, D. C.

DRAFTSMEN! Be an expert. By our method we train you quickly. Books and tools furnished. Write for illustrated catalog. Columbia School, 204P Drexel Bldg., Philadelphia.

BECOME Watchmaker, diamond setter, own your business. Paying job. Standard Watchmaker's Institute, 111 West 111th, New York.

BUSINESS OPPORTUNITIES

LOCAL Managers wanted for Phelps power and light plants. A great industry is developing. The potential market in some counties is estimated in the neighborhood of 1,000. One county would make a good business and a permanent income. Experience is necessary. Only men who know how to sell electrical goods and install them are wanted. If you want to get into a permanent business this is your opportunity. Particulars free. Phelps Power and Light Corp., Rock Island, Ill.

MANUFACTURE Newest, fast-selling novelties, toys, wooden and molded goods, foods, beverages, preparations. Free list of reliable plans, patterns, processes. Manufacturer's Bureau, 3937R, Tracy, Kansas City, Mo.

READ The Mail Order News—America's pioneer mail trade journal. Quarter century old. Approximately 600 pages yearly of valuable information for beginners and established mail-order houses. Analyzes mail-order business, its opportunities. Practical mail-order ideas, legitimate money-making schemes, instructive articles. Tells how to start, what to sell. Published monthly. Subscription \$3.00 yearly. Send 25c for sample copy. None free. Mail Order News, 500 Fifth Ave., New York.

MAN In each town to plate auto parts, reflectors, bathroom fixtures, refinish beds, mirrors, chandeliers; by new method. No capital or experience required. Simple plan of manufacturing at home starts you in big money-making business. Outfit furnished. Free particulars and proofs. Gun Metal Co., Ave. H, Decatur, Ill.

LEARN Marbelizing! Cowell's Vitreous cement process. Makes garden furniture, anything concrete, resemble polished marble. Also how to make molds for all uses cheaply. Plaster cast. Wonderful business. Dime brings folders and samples. John Cowell, Grayling, Mich.

MAIL Order business your opportunity. Brenner's famous hand books by expert 28 years' experience show how to start selling articles you make or buy—all or part time—small capital. Fascinating, profitable. Set eleven books, \$3.25. Brenner Company, 1607 P. Sansom, Philadelphia. Sample book, 25c, pay \$3 for other ten if satisfied.

"WEATHER-LOX"—10,000 Carpenters and handy men. We start you in an entirely new business of your own. Furnishing everything. A surprise! No more laying offs. Send 25c for sample and descriptive matter. Hickman-Bryant Corporation, Inc., 2228 Pennsylvania Ave., S. E., Washington, D. C.

IT'S Easy to make \$30 weekly, spare time, collecting names! Complete guaranteed plan 25c. Send for yours! Sowin Co., 245 Sheridan Ave., Albany, N. Y.

"BARRELS Of mail free!" Magazines, samples, propositions, etc. 2,000 pieces guaranteed if you join our Big-Mail club. Membership fee 10c (coin). National Big-Mail Club, 205 South Second St., Chambersburg, Pa.

GIGANTIC Mail, unlimited opportunities. 1 month 25c; 3 months 50c. Henry Weiss, 824 Park Ave., Weehawken, N. J.

MAKE Your own products. Employ agents yourself. Toilet articles, soap, extracts. We furnish everything. Valuable book free. National Scientific Laboratories, 1984W Broad, Richmond, Va.

WILL Sell valuable patent your terms. Elizabeth Smith, 3634 Suitland Road, Washington, D. C.

SELL Books by mail. Sample circulars. Wholesale prices 10c. Green, 15788 Parkside, Detroit, Mich.

SIXTY Successful mailorder products, sales plans. K. Home, 3949 Metropolitan, Chicago.

MIRRORS Resilvered at home. Cost near 5 cents per square foot; you charge 75 cents. Immense profits plating like new, brassy, worn-off autoparts, reflectors, tableware, stores, etc. Outfits furnished. Details free. Sprinkle, Plater, 127, Marion, Ind.

SPLENDID Opportunity. Business man, philanthropist, offers free interest in patented product with volume demand. Enjoy steady income from manufacturer on royalty basis. Two years Authority papers, including pattern 25 cents. Bakers, 168 Main St., Oneonta, N. Y.

"THE Lucky Seven." Guaranteed money-making ideas for 25c. Rey-Lan, Sampsonia, Pittsburgh (12), Pa.

FREE Booklet describes 67 plans for making \$20-\$100 weekly; home, office. Your own business. Elite Co., 84 Elizabeth St., New York.

501 WAYS To make money. Particulars free. Arthur A. Terry, 1964 West 7th St., Brooklyn, N. Y.

MANY Opportunities. Part or whole time work. Full particulars for stamp. Metzgars, Box 167, Seattle, Wash.

\$30-\$150 EXTRA Monthly, spare time. Interesting. Small capital. Sample dime. Interstate, 268-pm., Battle Creek, Mich.

LEARN Telephone advertising. New profession. Good income quick. Man or woman. Capital and experience unnecessary. Booklet free. Teleplan, Brown Bldg., Wichita, Kans.

GO Into Crispette business—Everybody likes Crispettes; make a lot of money. Geo. Alexander, Pennsylvania, reports "profits \$3,000 in four months." We start you. Write for facts. Long-Eakins, 1960 High, Springfield, Ohio.

\$100 STARTS Route automatic vending machines. Large steady profits. Write Chewit Corp., Dodworth St., Brooklyn, N. Y.

GOING Into the mail order business? Information free. Demuth Company, 88-15 82nd Ave., Glendale, N. Y.

SUPPLIES For making chipped glass house numbers and signs. Tinfoils, glass and frames. Osborne Sins, 13580 Tuller, Detroit, Mich.

GO Into business for yourself; make \$30.00 daily, becoming a photographer. Previous experience unnecessary. Catalogs free. Benson Camera Company, 168 Bowery, New York.

SUCCEED Real mail order business, valuable booklet tells 25c. Write Nygoon Co., Akron, Ohio.

CAPITAL—For copy of the "Promoter's Hand Book," a leaflet on financing, an eye opener for capital seekers, send \$1.00 to Amster Leonard, East Orange, N. J.

BUSINESS Profession of your own and earn income in service fees. See Stephenson Laboratories, display ad page 136.

PENN Realty School trains men and women at home, by mail, prepares them for starting business or assuming well paid executive positions. Booklet free. 1131 S. 19th St., Phila., Penna.

KING System mail order business, co-operation idea. It's new! Honest! Different! Big profits! Details free. Evans P. King Company, Wilmington, Del.

MANUFACTURE For dealers. No canvassing. H. Wooding (Laboratory), North Hollywood, Calif.

UNPATENTED Ideas can be sold. I tell you how and help you make the sale. Free particulars (Copyrighted). Write W. T. Greene, 910 Barrister Bldg., Washington, D. C.

SELL Your own goods. Fast sellers, labels, formulas. Service Guide shows how. 10c. Box 184-P, McCleary, Wash.

ARTIFICIAL Marble sanitary flooring instructions, covering wood or cement flooring ½ inch thick, fireproof, waterproof, all colors, low cost. Ornamental casting, concrete, plaster, papier-mache decorations, garden furniture, statuary, flexible molds, 18 years instructing the public; particulars and illustrations free. Chris. Mahler, Huntington, N. Y.

MECHANICS, Painters, carpenters, start furniture refinishing, painting, handyman shop on nearly nothing; winning plan brings customers quickly. John Braceland, 1439 So. Ninth, Philadelphia, Pa.

FREE Book. Start your own little business anywhere, selling novelties by mail. My beginner's outfit contains everything required, novelties, circulars, instructions, etc. Descriptive book free. Hadwil, 3A-74 Cortlandt St., New York.

PICTURED Sign Cards. 400% Profit. Samples 10c. Breneman, Lima, Ohio.

LOIDLAC Wonderful, new, amazing discovery ends polishing and repainting. Restores colors—makes the old car look like new in 30 minutes! Not a polish, paint, cleaner or wax. Make it yourself, have hundreds selling it. \$14.00 gallon profit. Write for exclusive manufacturing rights. Miller, Chemist, 706 Jetton, Tampa, Fla.

CHEMICAL Expert furnishes manufacturing directions. Reliable individual service only. No lists. Charges reasonable. Correspondence invited. Dr. Arthur Vaning formulas and processes with complete Heeden, 2410 Congress, Chicago.

TIME Counts in applying for patents. See pages 140 and 141. Clarence A. O'Brien, Registered Patent Attorney, Washington, D. C.

SELL Latest imported novelties. French model pocket mirror and transparent art cards. Samples of all postpaid \$1.00. World Service Co., 336 Marcy Ave., Brooklyn, N. Y.

LEARN the collection business. Good income, quick results. Interesting booklet, "Skillful Collecting" free. National Collectors Assn., Long St., Newark, Ohio.

GIGANTIC Mail: Over 100 pieces guaranteed if you list your name in my directory; one month 10c, 3 months 25c. Edward Armour, 136 East 28th St., New York.

KEY to Real Estate Success. The Real Estate Educator, new edition. Most valuable work on real estate selling, buying, advertising, appraising, investigating, leasing, sub-letting, transferring, insuring, mortgaging, etc., in simple, practical, usable form. Based on the experience of leading realtors. Pay postman \$2 and postage when he delivers the book. Popular Mechanics Press, Room 805, 200 E. Ontario St., Chicago.

A BUSINESS of your own making—Sparkling Glass Name and Number plates. Checkerboards, signs. Big book and sample free. E. Palmer, 540, Wooster, Ohio.

MAKE Big profits with a fur farm in your backyard. Chinchilla rabbits, muskrat, mink. Write for facts, 252 Conrad's Ranch, Denver, Colo.

SUCCEED With your own products. Make them yourself. Formulas, processes, trade-secrets. All lines. Catalog, circulars free. B. Thaxly Co., Washington, D. C.

\$200 WILL Start your own business; chance to enlarge; unlimited money-making possibilities; you manage, distribute and collect; experience unnecessary. For particulars, address Manager, 603 N. Eutaw St., Baltimore, Md.

WE Start you in business, furnishing everything Men and women, earn \$40 to \$100 weekly operating our original "New System Specialty Candy Factories." Begin home spare time. Unlimited opportunity. Valuable booklet free. W. Hillyer Ragsdale, Drawer 4, East Orange, N. J.

"SCHEMER" Subscribers surely succeed. One reports \$50,000 from one tip; another \$25,000 from three Schemes; another \$10,000 from one formula. Try your luck! Year, \$1.00; three months, 30c. Patterson, Publisher, Alliance, Ohio.

CHEMICAL Expert will furnish formulas and trade secrets. All lines. Lists free. W. L. Cummings, Ph. D., 228 Gordon Ave., Syracuse, N. Y.

CHARTERS: Delaware; best, cheapest; free forms. Colonial Charter Co., Wilmington, Del.

SELL by Mail! Books, novelties, bargains! Large profits! Particulars Free! B-Elfre, 525 South Dearborn, Chicago.

PROFIT! Read "Advertising and Selling Ideas." Illustrated monthly magazine, crammed full latest business ideas. Over 973 usable ideas printed last year—just what you need. One year, \$1; sample copy 10c. Ideas, 504B, 52nd St., Milwaukee, Wis.

"WHY Not a business of your own?" Cleaning hats, clothes, dyeing and pressing. Particulars free. Scientific American Cleaner, 482 Tenth St., New Kensington, Pa.

START A candy kitchen. We will furnish you a \$15 course in candy making for \$2. You may earn \$100 or more a week. Lewis & Co., Box 92-M, Gloucester Point, Va.

I MADE \$30 a Week Home. French Breadmaking. 15 years' experience; Free Booklet tells. Ashbrook 67, Marengo, Ohio.

AMATEUR Cartoonists: Sell your cartoons. New plan. Smith's Service, PA-1194, Wenatchee, Wash.

TELEGRAPHY

TELEGRAPHY—Both Morse and wireless—taught thoroughly. Big salaries. Wonderful opportunities. Expenses low; chance to earn part. School established fifty-four years. Catalog free. Dodge's Institute, H St., Valparaiso, Ind.

CHEMISTRY

1929 **BOOKLET** Of chemical experiments. Illustrated, 15c. General Chemical Company, Box 397, Reading, Penna.

CHEMICAL Analysis. Processes, technical information. Robert Henderson, Laboratory, Madison, Me.

YOUR Chemical problems solved and formula or process furnished for \$5.00. Write me. W. Stedman Richard, Industrial Chemist, Box 2402, Boston, Mass.

FORMULAS AND TRADE SECRETS

10,000 **FORMULAS**, Trade secrets, recipes and money-making ideas. Big 807-page Reference Book—just out. Tells how to make and sell cosmetics, muckage, anti-freeze solutions, battery solutions, beverages, cheese, chewing gum, cleaning preparations, extracts, hair preparations, inks, bluing, leather polish, mirrors, perfumes, polishes, typewriter ribbons, carbon paper, washing powders, liquid soap and thousands of other profitable articles. Send no money. Just send name and address. Pay postman only \$4, plus delivery charges upon arrival. Satisfaction guaranteed. Franklin Publishing Company, 800 North Clark St., Dept. 206-A, Chicago.

WONDER Egg producer and clear view cloth keeps windshields clear in any rain. Two formulas \$1.00. DeGroot & Badeau, 1427 E. Mason, Green Bay, Wis.

12 **VALUABLE** Formulas. Free wonderful information. Dr. Mundell, 5851 Wentworth Ave., Chicago.

MAKE Money by working this product in full time, or very good extra side money from shops you are working in, sell your fellowmen a good hand paste soap, which is very cheap to make in your spare time at home. Everyone who has soiled hands needs it; at least they like to have clean hands when they leave the shops. Send \$3.50 and my formula—literature will follow by return mail. A. Koch, 1025 Scott St., San Francisco, Calif.

WHAT is it? Not paint, polish or wax. "Flexon" Auto Refinish. Transparent for colors. Black for fenders. Applied with cloth. Restores color luster in 30 minutes. Lasts months. Costs \$1.50 gallon to make. Sells \$1.50 pint. Formula \$3.00. G. W. Donahoe, 2621 Jackson, Wilmar, Calif.

500 **SUCCESSFUL** Money making formulas and trade secrets \$1.00. C. Shafer, 518 E. Charles St., Muncie, Ind.

\$1.00 **BUYS** 3,000 Formulas. National Service, 3937 Marburg Cincinnati, Ohio.

MAKE Your own products. Employ agents yourself. Toilet articles, soap, extracts. We furnish everything. Valuable book free. National Scientific Laboratories, 1984W Broad, Richmond, Va.

INDUSTRIAL Chemist furnishes and develops formulas, processes; all lines. Moderate charges. Individual service. All inquiries answered personally. L. Clore, Industrial Chemist, Crawfordsville, Ind.

NOT Wax, polish or paint. "Rejuvo," marvelous. Effortless automobile instantaneous refinisher formula, 50c. Any formula 50c. Bernard Wells, 852 George, Chicago.

TESTED Formulas. Catalog free. Special—Five regular \$5.00 formulas and six sample products 10c. Grinstead Company, Oswego, Kans.

6 **GUARANTEED** Formulas 20c stamps. Carl-Abbott Company, Oswego, Kans.

SANITARY Flooring \$1.00. Other useful formulas. Universal Supply Co., 777 Boulevard, Bayonne, N. J.

SHAVING Cream made at home. Dime's worth lasts months. Nothing better. Guaranteed. Simple directions 50c. Sterling, 255 W. 60th St., Chicago.

SOFT Drink powders. All flavors. Best made. Formulas with material for 2 gals. \$1. J. Wright, Box 674, San Diego, Calif.

RHEUMATISM—Formula \$1.00 bill Yram, 8713 W. Muskegon Ave., Chicago, Ill.

ASSOCIATED Chemists, Indianapolis, Ind. Analysis and chemical consultation. Manufacturing ideas developed. Money-making formulas. Charges moderate. Write.

INDUSTRIAL Chemist furnishes formulas, plans, trade secrets. All lines. Work guaranteed. Lists free. J. F. Mazur, 941 20th, Lorain, Ohio.

GUARANTEED Formulas, best science can produce for making popular, biggest-selling specialties all lines. Don't buy formulas till you've received valuable eye-opening literature. Miller, Chemist, 706-F Jetton, Tampa, Fla.

FORMULAS—170 Money makers and big illustrated catalog 20c. Ideal Book Shop, (K) Park Ridge, Ill.

SUCCEED With your own products. Make them yourself. Formulas, processes, trade-secrets. All lines. Catalog, circulars free. B. Thaxly Co., Washington, D. C.

FORMULAS: Guaranteed, catalog free. Bestovall Laboratories, 6720 Oconto, Ave., Chicago.

10,000 **FORMULAS**. A real Gold Mine of money-making ideas. Tells how to make almost everything under the sun. You can make and sell cosmetics, muckage, anti-freeze solutions, battery solutions, beverages, cheese, chewing gum, cleaning preparations, extracts, hair preparations, inks, bluing, leather polish, mirrors, perfumes, polishes, typewriter ribbons, carbon paper, washing powders, liquid soap, and hundreds of other profitable articles. Send No Money. Just write a postal for "Henley's 20th Century Book of Formulas." Pay postman postage and \$4. Popular Mechanics Press, 200 E. Ontario St., Room 805, Chicago, Ill.

AGENTS WANTED

NO Dull times in the food business. Selling Federal Pure Food Products is the greatest, surest and safest business in the world today, and here is your opportunity to get into it. You can make \$3,000, \$5,000, \$10,000 or more per year—the only limit is your ability to take care of the business. You will need no experience or money to get into this business. We teach you everything you need to know. We furnish you with license. No dull times, for the people must eat, and our food products are the fastest selling, surest and quickest repeat order goods in the world. Sell on sight in every home where food is used—repeat orders immediately and every week thereafter. A real big business all your own. Every new customer adds a great deal to your weekly income. Your business once established, has a market value just like a store and can be easily sold. The greatest money-making opportunity of your lifetime because you risk absolutely nothing. Remember! Guaranteed! Best products, biggest sellers, surest repeat orders. No capital or experience is required. We furnish capital and everything necessary for you to become a Federal distributor. Exclusive territory will be given honest men or women who write at once. Federal Pure Food Company, A2307 Archer Ave., Chicago, Ill. Largest packers of pure food specialties in the world. Reference, any bank, Dun or Bradstreet Rating Agency, Express or Railway Company in America.

DISTRICT Managers! Crew managers! General agents! Wanted: Men and women to appoint saleswomen to sell "New Idea" imported sanitary necessity. New feature never before used, sell on sight. Every woman buys and repeats. Without capital, new salesplan nets you big commission on sub-agents' sales. Exclusive territory to producers. Write Box J-708, Meriden, Conn.

AGENTS—I want a good, honest man or woman, all or part time, to look after my established business in your locality; take a few orders; distribute teas, coffees, extracts, spices, things people eat and use every day. I furnish everything, make you my partner; you keep half of what we take in; pay starts as soon as case arrives. Get my amazing offer. Curtis W. Van De Mark, 103-E Health-O Bldg., Cincinnati, Ohio.

AGENTS—Right now, canvas the country for Sodisil, the latest egg preserver; endorsed by the United States department of agriculture. Write for interesting details. St. Clair Sales Bureau, Tolland, Colo.

AGENT Wanted—One in each city. All-steel wire brush for factories, shops and garages. C. S. Brush Works, 18 E. 16th St., Chicago.

MAKE \$100.00 Weekly placing amazing new tooth whitener in stores. Unique sales plan assures you steady business, and big profits. Write quick for wonderful free offer. Tyrrell Products Company, 458 First, Martins Ferry, Ohio.

\$75 TO \$150 Easy with wonderful new 5 second sharpener. Greatest dollar seller in history. Makes dull blades new. Men buy on sight. Stanford Mfg. Co., Dept. D, Baltimore, Md.

WANTED: Women who need quick money. "New Idea" imported ladies' necessities; sells on sight; everyone buys; representatives everywhere are cashing in big. Miss Ely has made \$1,900. Mrs. Hart \$2,200. New sales-plan puts you in business without capital or experience. Sample free. Write Mary P. Coleman, Meriden, Conn.

\$75-\$150 WEEKLY. Glo-Bac amazing new necessity for every car owner, garage. Easy sales. \$2.00 saves \$75.00. Big profit. Marvel-Glo Company, Dept. B-2, Columbus, Ohio.

AGENTS: You'll never have a dull day when you begin offering my vanilla to your knowing neighbors. The refined aroma sells it the moment the cork is drawn. Sample bottle 50c (coin). Write today. J. H. Conlin, 78 Broadway, East Somerville, Mass.

AGENTS: Make 500% selling guaranteed flavoring extracts, furniture polish and toilet preparations; particulars free. Address, Chemist, Box 346, Roanoke, Va.

INTRODUCE Automatic window washer to homes, stores, autoists, factories. Amazing invention. Write for free sample offer. National Industries, 67 East Lake St., Dept. 155-C, Chicago.

IT Rings the bell for salesmen who must have big money. Krystal Kleen actually sells 100% on calls. Its demonstration is irresistible, its field is three-fold. Fifty-fifty deal. Write today. Fenton Chemical Company, Jackson Heights, New York.

\$\$ MONEY! Big money! \$\$ Carter window washer. Exclusive territory. Cleans, dries and polishes—one operation. Carries its own water. Big profits. Carter Products, 987 Front Ave., Cleveland, Ohio.

SELL Hanslick, powdered soap. On market 8 years. Easy seller, everybody customer. Fine repeater. Big profits. Sample free. Solar Products, 52144 S. Troy, Chicago.

GENUINE Gold Leaf Letters anyone can put on store windows. Guaranteed to never tarnish. Large profits. Enormous demand. Free samples. Write today. Metallic Letter Co., 438-D North Clark, Chicago.

EASY As pie. To make big money with Christy's Polishing Cloth. Works like magic. Sells like wildfire. Big profits. Write for free sample. Christy, Inc., 6467 Canal, Newark, N. Y.

AGENTS: \$240 Month. Bonus besides. Introduce finest line silk hosiery. Guaranteed 7 months. Auto given when earned. We give you fine silk hosiery for your own use. New plan gets business fast. Samples furnished. Write quick. Betterknit Hosiery Co., Silk 4231, Greenfield, Ohio.

MAKE Your own products. Employ agents yourself. Toilet articles, soap, extracts. We furnish everything. Valuable book free. National Scientific Laboratories, 1984W Broad, Richmond, Va.

\$13.00 DAILY Installing nifty stair corners. Particulars free. M. Ruth Co., Wheelersburg, Ohio.

\$15 DAILY Selling custom quality shirts and ties. Largest cash commissions, extra bonuses. Outfits free. District managers wanted. Parmode, 21 Lesser Bldg., St. Louis.

AGENTS: Our gold-eyed needle cases are wonderful sellers; immense profits; \$50 to \$300 weekly; proof free; sample outfits 10c; factory prices. Paty Needle Co., West Somerville, Mass.

IMPORT Your own goods. German export magazine published in English, offers numerous bargains latest novelties; opportunity for obtaining profitable agencies. Copy 60c. Square Deal Supply, P-246 Fifth Ave., New York.

AGENTS: \$250 Month. Sell new line guaranteed hosiery. Latest styles. Big sellers. Extra commission. Samples furnished. Silk hose for your own use. Write quick. State size hose worn. Silkknit Hosiery Co., Dept. 231, Dayton, Ohio.

MAKE \$65 And more every week distributing our new, pure quality household products. We train you to increase earnings. Attractive premium deals. Protected territory. Dignified, growing repeat business. 150-200% profit. Dept. B-5, Midwest Drug Co., Columbus, Ohio.

SELL Men's neckwear; wonderful proposition. M-Astor, 39 East 28th, New York.

OPPORTUNITY—Men-women. Make \$50 weekly. Dupont's Fairy Damask flannel-back, hemstitched tablecloths, bridge sets, etc. Looks and wears like linen. No laundering. Pastel colors. Free outfit. Sheldon Co., Gallon, Ohio.

SPLENDID Income for crew managers. Extra heavy demand in spring and summer for Duo Wonder Cleanser, Gloss Oil, other specialties. Large all-year line household necessities. Prices right. Big discounts on large orders. Beautiful premiums for customers. A-1 service. Write today. Duo-form Co., M-1, Attica, N. Y.

FREE Booklet describes 67 plans for making \$20-\$100 weekly; home, office. Your own business. Elite Co., 84 Elizabeth St., New York.

AGENTS Big profit. No investment. Electric belts for aches, pains, bladder, kidney, stomach troubles, rheumatism, weak organs. Alexander, Box 96K College Station, New York.

AGENTS—No selling. Place Mystery Floss in stores. Easy winner. Counter display. Mohler, Box 453CC, Chicago.

AGENTS Wanted to sell the best fiber house broom made. Write Kendallville Brush & Broom Co., Dept. P, Kendallville, Ind.

AGENTS Wanted: Make \$15.00 a day selling the original patented phone memo recorder. Sells itself. No competition. Golden opportunity. Write for territories. Rudley Mfg. Co., 52 S. 60th, Philadelphia, Pa.

AGENTS—100% Profit selling our low-priced, beautiful and attractive felt rugs. Perfect color combinations win instant admiration, insuring quick sales. Excellent opportunity to build substantial business. Eastern Mills, Everett, Mass.

AGENTS—Summer months mean big money selling Vano Kills Moths. Sample 10c. Vano Company, 316 Washington St., Brooklyn, N. Y.

CLEVER invention. Milbender Pneumatic Door Cushion stops rattles, squeaks, slam on auto, house, hotel doors. Retails 25c. 400% profit. Territory protected. Sample 25c. Inventor Milbender, 1424 East 38th St., Los Angeles, Calif.

AGENTS—Make hot pads, fairy damask table covers, sponge rubber mats and 50 other fast sellers. Write B & G Rubber Company, Dept. 410, Pittsburgh, Pa.

BUY Direct: Hosiery, lingerie, neckwear, at lowest mill prices. Defy competition. Write today. Superior Knitting Company, Dept. 17, New Haven, Conn.

HINGE Clevis every farmer must have. Sells on sight. Send 50c for sample and proposition. Hinge Clevis Co., Canistota, S. Dak.

\$20.00 PER 100 Stamping keytags. Sample and instructions 25c. M. Ruth Co., Wheelersburg, Ohio.

MIRRORS Resilvered at home. Costs near 5 cents per square foot; you charge 75 cents. Immense profits plating autoparts, reflectors, tableware, stoves, refinishing metalware, etc. Outfits furnished. Details free. Write Sprinkle, Plater, 128, Marion, Ind.

OVER 125 Reliable manufacturers need representatives in every locality in the United States. For complete list of firms and full particulars write Opportunity News, Dept. K, 750 No. Michigan, Chicago, Ill.

AGENTS Wanted to introduce marvelous new free-lathering soap and distribute samples to consumers. \$1.25 an hour easy. Particulars free. Albert Mills, 3774 Monmouth, Cincinnati, Ohio.

AGENTS: \$16 Day and earn new Bulk auto. Sell groceries. Over 400 items used daily every home. Steady all-year job. Your own groceries about half price. Send for samples. Harley Company, Dept. E-2015, Dayton, Ohio.

"WHERE To buy 500,000 articles at lowest wholesale prices." 1929 directory. Distributors wanted. Pruitt System, Brookfield, Ill.

MYSTERIOUS Fluid mends hosiery and fabrics instantly. Make \$100 weekly introducing it. Free outfit to workers. New Way Laboratories, Dept. 146, Mt. Healthy, Ohio.

\$100 WEEKLY—Appointing agents Mother Hubbard Foods. No canvassing, delivering or investment. Mother Hubbard Products, 554U Congress, Chicago.

MEN: Make money selling specialized shirt and tie line. Fine tailored broadcloths, 3 for \$6.95, you make \$1.50. Rayon lined ties, latest patterns, 3 for \$2.85. Quick sellers, steady repeats. Outfit free. Dept. PM5, Big Bob, 489 Broome St., New York.

CASH Paid for Butterflies, Inserts. See Sinclair Display Advertisement on page 18.

WE Offer the selling agency for the world's largest, most complete direct to wearer men's wear line; consists of 135 large cloth samples, shirts, neckties, underwear, pajamas, waterproof trench coats and lumberjacks; spare or full time; experience unnecessary; outfit free. Howard, 1213 Van Buren, Factory 237, Chicago.

PORTRAIT Men: Why not Pasco portraits? We refund your money for all you cannot deliver. Frame catalog free. Portrait Agent's Supply Co., Dept. F, LaPorte, Ind.

OH Hello! Why didn't I see this before? Christy's iron rust and stain remover sells like blazes. Write for free sample. Christy, Inc., 5067 Canal, Newark, N. Y.

\$15 DAILY—Genuine DuPont hemstitched tablecloths, luncheon sets, table runners; wash like oilcloth; look like linen. Six colors, outfit free. Doll-ETTE, 1018 Wabash, Chicago.

FREE Booklet describes 67 plans for making \$20-\$100 weekly; home, office. Your own business. Elite Co., 84 Elizabeth St., New York.

\$25 DAILY Selling—newest damask tablecloths, no laundering, ironing. Complete line, raincoats, trenchcoats, umbrellas and rubber specialties. Free outfit. American G724 Roosevelt, Chicago.

MAKE Your own products. Employ agents yourself. Toilet articles, soap, extracts. We furnish everything. Valuable book free. National Scientific Laboratories, 1984W Broad, Richmond, Va.

SELL Famous fashions from Fifth Avenue. \$95 weekly. 100% virgin wool suits, ram-head wool, camel's hair topcoats, \$19.75. \$4 commission; special numbers \$13.75; commission \$3.50. Free outfit. Dept. PM-5, Avenue Tailors, 140 Fifth Ave., New York.

\$85 WEEKLY Selling nationally advertised dresses, lingerie, hosiery, amazing value. Complete equipment and your own clothing free. Sure profit plans furnished. Shaughnessy Knitting Co., 344-C Shaughnessy St., Watertown, N. Y.

AGENTS Free sample fast selling mail-order and agency specialty. Repeater. Big profits. Going strong. Fllnner, 5003 Y, Gateway, Kansas City, Mo.

\$75 WEEKLY. Man or woman wanted with ambition and industry, to distribute Rawleigh's Household Products to steady users. Fine openings near you. We train and help you so you can make up to \$100 a week or more. No experience necessary. Pleasant, profitable, dignified work. Write today. W. T. Rawleigh Co., Dept. E-53 ITM, Freeport, Ill.

AGENTS—Make a dollar an hour. Sell new kind of sharpeners. Sharpens all knives and tools quickly. Demonstrating sample 10c. Premier Mfg. Co., Dept. 91, Detroit, Mich.

JUST Out—New patented apron. No strings or straps—\$20.00 a day every day; over 100% profit; commissions daily. Write for free outfit. Sta-Put Co., Dept. 205, St. Louis, Mo.

AGENTS: Free catalog 200 household specialties, toilet preparations, food products, portraits, frames, pillow tops, medallions, religious goods, pictures. Credit. James C. Bailey Co., Station C-5, Chicago.

HOME Aprons and caps; every home a prospect. Write for price list and free sample offer. The Chandler Factories, 3443 Ogden Ave., Chicago, Ill.

\$75,000 WEEKLY Demonstrating and distributing soft drink powders, homes and stores. Powell sells 30,000 monthly. Sol E. Rich Co., 622 So. Sangamon, Chicago.

INSTANT Weld welds rubber instantly. Steck's profit one day \$72.25. Enormous demand. Exclusive territory. Free sample. Tourists Pride Mfg. Co., Desk E, Minneapolis, Minn.

BECOME Your home town leading business man. Sell full line of groceries, motor oils, paints. Everybody a customer. No capital or experience necessary. Selling outfit free. Write Loverin & Browne, 1602 E. So. State, Chicago.

HOME Sewing sets find sales in every home. Set contains 142 articles; retails 50c; sample 25c. Putnam-Lee, 128 East 23rd St., New York.

BRANDNEW 50c Specialty, 150% profit. Quick demonstration sells every housewife. Pocket sample. Deliver on spot. Fine side line. Agents, distributors cleaning up \$60 to \$110 weekly. Territory going fast. Write today. Harker Products, Dept. 34, Battle-creek, Mich.

SOMETHING Different—new patented home filter for fruit juices, beverages. Perfect results guaranteed. Low priced. Sells like blazes! Make \$87.50 weekly. Write quick for free demonstrator and territory offer. Home Filter Co., 3025 Central Ave., Bay City, Mich.

WELLS Cleared \$620.00 in one month with amazing book "Business Guide" and free legal service. Outfit free! Prof. Nichols, Dept. 114, Naperville, Ill.

AGENTS—Absolutely new! Our hand colored popular priced photo statuettes going big! Everyone wants them! Agents making \$10-\$25 daily! Samples furnished! Craver Mfg. Co., D2456 Jackson, Chicago.

\$60-\$200 A WEEK Genuine gold letters for store windows. Easily applied. Free samples. Liberal offer to general agents. Metallic Letter Co., 438-B North Clark Chicago.

MAKE \$20 Daily selling merchant's changeable letter show window signs. Experience unnecessary. Send for free sample offer. Maze Company, 542 W. Washington St., Chicago.

ARE You old at forty? See our advertisement on page 75 of this issue. The Electro Thermal Company, 2117 Morris Ave., Steubenville, Ohio.

AGENTS For "aladdin" polishing cloths; big demand wherever shown, 200 per cent profit; sample free. L. Dougherty, 518 West 39th St., New York.

FREE Copy of People's Review, 2519 So. Crawford Ave., Chicago, Ill., describing good opportunities in new chemical specialties.

AGENTS—Magic counter cards of Glt-snifes; pays agents \$20 day; our amazing plan guarantees sales. Write Gits Co., W-5419 Chicago Ave., Chicago, Ill.

AGENTS. A real gold mine! See Dome Specialties display ad page 130.

ARVEO Polishing Cloths offer big profits to salesmen. Sample and particulars free. Arveo Industries, Box F 147, Gross Ile, Mich.

BIG Money manufacturing vanilla flavor in your own home. Sell to housewives, stores, bakeries, hotels. Guaranteed formula, instruction \$5.00. Sample bottle \$1.00. Stark, 1216E College, Bowling Green, Ky.

FAST Seller. 140% profit. Exclusive territory. Sample free. Amazing new moth proof garment banger. Austin Company, 2642 Shields Ave., Chicago.

\$10-\$25 DAILY Simply showing new Polly wrench. 10 wrenches in one. Guaranteed seller. Sample free. Gellman Mfg. Co., Dept. 6E, Rock Island, Ill.

MAKE \$500. Show tablecloths. Save laundry bills. Women scramble for them. Free sample. Mohler, Box 453BE, Chicago.

AGENTS: High class house to house representatives wanted all localities. New product, needed in every home; easy seller at one dollar; steady repeater, good profit. Complete information free. No samples, trial package mailed on receipt of one dollar. Kyolac Corporation, 100 Fifth Ave., New York City.

FREE Sample—Fumigated nest egg. Carl-Abbott Co., Oswego, Kans.

ARCH-AIDS Give instant relief to foot sufferers. Agents wanted. Outfit free. Peterson, 1906 San Pablo, Oakland, Calif.

AGENTS—Make big money! New inventions sells on sight to mechanics, motorists, surgeons, plumbers, railroad employes and scores of other trades and professions! Write today for complete information and our proposition. Address Sales Manager, 409 Z, Amarillo Bldg., Amarillo, Tex.

MAKE \$20 To \$35 a day selling Imprint Book Matches, spare or full time. Big repeat business—no investment—every merchant a prospect. Write Imprint Book Match, Dept. 115, 877 Meigs St., Rochester, N. Y.

WE Will manufacture your own formula into a finished product, in small quantities. Either as completed packages or bulk; at reasonable prices. Correspondence invited. Barth, Aiton, Ill. Box 68. (Unusual processes, formulas; supplied or developed).

AGENTS: Sell changeable letter signs. Season just starting. Good steady business. 300% profit. Two samples, postpaid, \$1.00. Particulars free. Popular Signmakers, 379 Logan St., Brooklyn, N. Y.

YOU Can start a paint business. Expense small. Profit large. Free particulars. Emmelmann Bros. Mfg. Co., Dept. 2, Indianapolis, Ind.

WANT A bigger income? Write now for the fastest-selling line in America. Get my free outfit, latest shirt fabrics. Full year guarantee with every shirt. Free initials 48-hour delivery. Biggest commissions in advance. Leonard Gould, Dept. PM-5, 1237 Broadway, New York.

BIG Pay every day taking orders for dress shirts, work shirts, pants, overalls, sweaters, underwear, hosiery, pajamas, play-suits! Experience unnecessary. Outfit free! Nimrod Co., Dept. 8, 4922-28 Lincoln Ave., Chicago.

OIL Paint photos, enlargements; talent unnecessary, all profit. Particulars free. Hughes, Box 1264, Los Angeles, Calif.

SELLING Like blazes! Beautiful toilet goods assortment at \$1.50 with 24 inch pearl necklace free to your customers. 100% profit. E. M. Davis, 234 W. North Ave., Dept. 530, Chicago.

"MAGNARLOTH" Taking people by storm, one rub, absorbs dust from car or furniture, quick sales, big profits. National Service Co., B, Pierre, S. Dak.

AGENTS Become a regular established McConnon dealer! Buy on credit; sell for cash or credit. 228 absolute household necessities; all repeaters. Enjoy a sure income 52 weeks per year, year after year. City or country trade. Capital, experience unnecessary. McConnon & Co., Dept. M905, Winona, Minn.

MAKE Your own products. Employ agents yourself. Toilet articles, soap, extracts. We furnish everything. Valuable book free. National Scientific Laboratories, 1984W Broad, Richmond, Va.

GENTINE Goodyear raincoats, rubber mats with names, aprons, specialties, etc. Deal direct—distributors make big profits. Goodyear Sundries, 116 Chambers St., New York City.

AGENTS Wanted—City or country. Double your present income; sell cutlery specialties; 85% to 100% profit. Write American Knife Ass'n, Little Valley, N. Y.

CAN You sell a guaranteed corn and bunion remover? One live agent wanted every town. Greatest 25¢ repeater made. For particulars write Liberty Chemical Co., 729 Race St., Philadelphia, Pa.

NEW Washing machine. Sells for \$9.50. Entirely automatic. No strong soaps or lye. Slips into ordinary boiler. Sterilizes and cleans entire washing in twenty minutes. Agents "Cleaning up." Write for protected territory. Preston Mfg. Co., Dept. 529, St. Louis, Mo.

MEN With cars to demonstrate and sell the best auto polish on the market. Big money. Write Vocco Chemical Co., 3342 N. Whipple, Chicago.

AGENTS—Distributors \$12 to \$15 daily. Something new. Fast seller. Cee-Dar kills moths, chases insects. New form hangs on hook. Repeater. Women buy one to six. Free particulars. Cee-Dar, H77 W. Washington, Chicago.

STRANGE New electric iron cord! Prevents scorching. Saves electricity. Cannot kink or snarl. Used on telephones also. \$25 daily. Samples free. Neverknot, Dept. 5-A, 4503 Ravenswood, Chicago.

\$25 DAILY. Raincoats, all colors, \$2.45. Trancheats, alligators, leatherettes. Free coat and outfit. Bradley, Dept. AB-5, 230 So. Wells, Chicago.

RE Independent. Make, sell your own goods. Immense profits. Catalog dependable formulas, special selected agents best sellers. Free. T. Lusto, 626 Reaper Block, Chicago.

PATENTED Invention cuts gas bills 25%. Housewives delighted. My positive guarantee sells them. No competition. Starting stock free if you're a hustler. Box 18C, East San Diego, Calif.

GOLD-LEAF Window letters and script signs; no experience; 500% profit; samples free. Consolidated, 69-T West Van Buren, Chicago.

\$50 WEEKLY. Men wanted to demonstrate and take 10 orders daily direct from motorists. Amazing magnetic trouble light. Striks anywhere! More orders, bigger pay. Write for demonstrator and particulars. Magno, Beacon Bldg., Dept. 165, Boston, Mass.

\$2.95 AUTOSEAT Covers—Cash daily—Amazing. All America. Postcard brings leatherette sales outfit. "Quality," JJ513 So. Dearborn, Chicago.

SELL "Salesavers." 200% profit. Roman Arndt, Box 1401, Detroit, Mich.

START The new year right! Manufacturing these popular specialties yourself. Have salesmen everywhere. Investment small. Profits great! Get my eye-opening literature explaining all. Mystery Polishing Floss, Loidiac, guaranteed automobile refinish; Thermaxx Eveready Anti-Freeze; twenty-six new unusual carded specialties, many other wonderful necessities. Here's an exceptional opportunity. Miller, Chemist, 706-B Chemical Building, Tampa, Fla.

FASTEST \$1.00 Seller ever produced. Housewives buy on sight. Approved by Good Housekeeping. Patented duplex sifter sifts and re-sifts without removing flour. Saves time and labor. Magnus sold 120 first 24 hours. Profit \$54.40. Protected territory. Sample sales outfit 60c stamps. Uneek, 4515 Lexington, Chicago.

A GOLD Mine—New liquid discovery mends fabrics, hosiery. Stops runs, 400% profit! Every woman buys. 100 other fast sellers. Johnson Co., Dept. 477, 6129 Wentworth, Chicago.

MONOGRAM Automobiles, \$1.35 Profit ten minutes' work; every owner wants them; millions without; particulars free. Motorists Accessories Co., Mansfield, Ohio.

AGENTS Wanted high class germ proof pressure water filter. Brownlow Mfg., 1152 West 31st, Los Angeles, Calif.

100% PROFIT. Amazing paste quickly removes rain spots, polishes nickel on automobiles, etc. Complete line home necessities. Williams Corp., 305 Williams Bldg., Montclair, N. J.

SELL Ties—Make big profits. Get big sample selling outfit absolutely free. Wonderful patterns. Splendid value. Liberal commissions. Write today to Public Mills, 4931-CF Hudson Boulevard, North Bergen, N. J.

ENGRAVED Nameplates, signs, numbers, initial, desk, city nameplates. Big profits. Hilton Specialty, 90 Stewart, Providence, R. I.

AGENTS—Fastest selling household necessities for men and women. Big profit. Ideal Utensil Company, Otis Bldg., Chicago.

FREE—Complete selling outfit free. We furnish honest and industrious men and women complete selling outfits free. Start a toilet and household specialty business of your own. Exclusive territory. Write today. W. C. Johnson Co., Dept. 22, Atlantic Highlands, N. J.

REMNANT Store, Bethel, Ohio. Greatest Dry Goods Bargains on Earth. Agents and Dealers.

AGENTS: Stamping names on pocket-key protectors. Sample check with your name and address, 25c. Stamping outfits, Emblem checks, check-fobs, name plates. Hart Mfg. Co., Desk 2, 303 Degraw St., Brooklyn, N. Y.

AGENTS—\$50 Weekly selling shirts. No capital or experience needed. Commissions in advance. Samples free. Madison Company, 566 Broadway, New York.

\$3.90 PER Hour selling a service to keep stairways clean. Every housewife interested. Write today. Ideal Stairway Equipment Co., Dept. PM, Canton, Ohio.

BIG Money and Fast Sales. Every owner buys Gold Initials for his auto. You charge \$1.50; make \$1.35. Ten orders a day easy. Write for particulars and free samples. American Monogram Co., Dept. 40, East Orange, N. J.

PHOTO Medalion Men and Women, the largest line of Photo Novelties in the world. Lowest prices, quickest service. Send for catalogue showing over 200 money makers. Photo medallions, photo medallion clocks, photo mirrors, photo fountain pens, photo powder compacts, photo jewelry and photo buttons. Gibson Photo Jewelry Co., 608-614 Gravesend Ave., Brooklyn, N. Y.

SELL "Prevents Runs." Guaranteed to prevent runs in silk hosiery. Large profits. Particulars, Specialty Mfg., 307 West First, Los Angeles, Calif.

SPONGE Nozzle auto washer. Agents making big money. Retail \$2.00. Liberal discounts. Write the company. 3780 Clairmount Ave., Detroit, Mich.

AGENTS Wanted on a fast selling 25c item for the kitchen; costs you 8 1-3c. Sample free. Send 2c stamp to cover postage. P. Seed Filter Mfg. Co., Ind., 353 Broadway, New York.

THE Christensen Mop Wringer. It rubs the mop and scrubs it clean. H. K. Christensen, Fort Atkinson, Wis.

SELL Handy tool to garages, large and small shops of every kind. Sell several each day with profit to you of \$2.50 each sale. Well advertised article. St. Paul Welding & Mfg. Co., 177 W. 3rd St., St. Paul, Minn.

\$48 WEEKLY Selling automobile trouble lights. No capital or expense required. Commissions in advance. Sticks anywhere on car—electro magnetic. It's also an everlasting flashlight. Sell itself on sight. Write for demonstrator and particulars. National Electric Corporation, 223 High St., Newark, N. J.

AGENTS—Mosco Corn and Callous Remover will build you a steady repeat business. Send today for pocket-size trial outfit. The Moss Company, 429 Searle Bldg., Rochester, N. Y.

MAN In each town to plate auto parts, reflectors, bathroom fixtures, refinish beds, mirrors, chandeliers; by new method. No capital or experience required. Simple plan of manufacturing at home starts you in big money-making business. Outfit furnished. Free particulars and proofs. Gun Metal Co., Ave. H, Decatur, Ill.

BROUGHT From Holy Land. Fascinating, inspiring religious novelty. Christians buy on sight. Big commissions. Write Jadet, 1472 Broadway, New York.

FLAVORING Extracts—Bottle yourself! Concentrated, add water. Free labels, 600% profits! Whirlwind moneymaking opportunity! Hurry! Thomas Manufacturing Company, Indianapolis, Ind.

AGENTS. Send for free sample. "Fretnot" washes clothes snow white without rubbing. \$5.00 daily and more easily made. Credit given. Empire, 1549 N. Wells, Dept. 201, Chicago.

AGENTS: Get vanilla extract at one cent a bottle. Also new black walnut flavor. Welcome Foods, Harvey, Ill.

AGENTS—Clean-Rite window cloths, washes windows without soap, water or powders, enormous demand, tremendous profits. Write quick. Gordon Dustin, 73 Bridge St., Watertown, Mass.

FROM The Argentine. Imported from Buenos Aires, latest novelty, never before on American market, tremendous possibilities. Write: don Francis X. Cassera, Dept. PM, 23 Washington St., New York.

SELL Stores carded 5c Breathlets. Cost you 1c per package, 150% profit. S. H. Carroll Co., Albany, N. Y.

BRAND New auto accessory. Can't run out of gas. Dozen in coat pocket to wholesale or retail. Big profits. Fine side line. Sample 25c. Lupton, Hill & Lupton, Dayton, Ohio.

MAKE Your own products. Employ agents yourself. Toilet articles, soap, extracts. We furnish everything. Valuable book free. National Scientific Laboratories, 1984W Broad, Richmond, Va.

HANDYMAN Shop; painting, fixing; start yours on nearly nothing. Braceland, 1457 So. Ninth, Philadelphia, Pa.

NEW Patented necessity; pocket carries dozens; \$7.99 dozen; sells \$1.00 Sample 65c. Write Rex Sales, 1235 Lexington Ave., New York City.

\$50,000 PICTURE Man Friedman made canvassing. Beginners can make \$100.00 weekly with my sales talk. Experienced men make more. Free book "Profits in Portraits" explains. Sample free. Picture Man Friedman, Dept. 8, 109 West Austin, Chicago.

SALESMAN Wanted to represent half million dollar manufacturer. No cash required. Big sample outfit free. Sell paints, varnishes and roofing with money-back guarantee, direct from factory to user. We give exclusive territories in which our men can earn \$4,000 to \$10,000 a year. Permanent position. Manufacturer, Box 797, Dept. 32, Kansas City, Mo.

TIME Counts in applying for patents. See pages 140 and 141. Clarence A. O'Brien, Registered Patent Attorney, Washington, D. C.

MAGIC Polishing cloth. Great seller. Big profit. Try this cloth. It's a money maker. Samples free. Get this proposition. Newton Co., 25 Main St., Newark, N. Y.

START A business of your own selling fifty different kinds of household brushes. Send for catalog and free sample case offer. National Brushes, St. Louis, Mo.

WRITE Atlas Sign Works for free working equipment. Beautiful gold window sign letters. Penny each! Any size. Wonderful offer to general agents. K1032 E. 55th St., Chicago, Ill.

EARN \$10 To \$15 daily, \$5 evenings, showing startling new trouble light. Sticks anywhere on car by electro-magnetism. Just demonstrate, motorists grab it. Big cash commission and extra bonus. Best season just starting. Write quick. Lea Sales Co., 426 Shell Bldg., St. Louis, Mo.

WE Have the finest needle case, self threading needles, needle threaders. \$50.00 to \$200.00 weekly. Samples 25c; particulars free. Empire, 1549 N. Wells, Dept. 201, Chicago.

40 CENTS Profit on every \$1.00 sale. Our article is a repeater. Excello Sales Co., Shreveport, La.

MAKE Big money. Be the sign man in your town. New process. Beats them all. Particulars free. Swanson's, Inc., Mankato, Minn.

WE Start you without a dollar. Soaps, extracts, perfumes, toilet goods. Experience unnecessary. Carnation Co., 641, St. Louis, Mo.

BIG Profits! Fast sales! \$9.75 automatic washing machine. Guaranteed. Write Storm Royalty Co., 3601 Enright, St. Louis, Mo.

ELECTRIC Cigar lighters. Make \$100 week. Brilliant flashing advertisements. Three beautiful models. Used by dealers everywhere. Write Drake Mfg. Company, Dept. M, Milwaukee, Wis.

AGENTS—Clever Invention! Inkspoon makes every pen a fountain pen. Fast office seller; big profit, demand increasing everywhere. Exclusive territory offered. Sample free. H. Marui Company, Tribune Bldg., New York, N. Y.

MAKE And sell your own goods. No machinery. Guaranteed formulas. Catalog free. Clover Laboratories, (E) Park Ridge, Ill.

A BUSINESS of your own—Making sparkling glass name and number plates, check-boards signs. Big book and sample free. E. Palmer, 512, Wooster, Ohio.

AGENTS—Engraved name plates, signs, numbers, etc., easily sold, profits large. Brett Bros., Roxbury Crossing, Boston, Mass.

CALIFORNIA Perfumed beads selling like hot cakes. Agents coining money. Big profits. Catalog free. Mission Factory P, 2228 W. Pico, Los Angeles, Calif.

"HOW to Secure Agents," a specially prepared booklet, tells of one of the most inexpensive methods in which to secure good live producing agents. It is free; write for your copy today! M. L. Rund, Mgr. Classified Advertising, Popular Mechanics Magazine, 200 E. Ontario St., Chicago, Ill.

32 SECONDS Complete tire change by Detmer, Ohio, with Morey Quick Action Rim Tool. Sold, singly, 49 three days, cleared \$100. Anderson, Mont., sold 1,400 in 14 weeks. Get details for good territory. Harvest time now. M. Morey Rim Tool, Buffalo, N. Y.

\$12.00 DAILY Showing new table cloth. Looks like linen. Wash like oilcloth. No laundering. You just take orders. We deliver. Pay daily. Sample free. Bestever, 152 Irving Park Station, Chicago.

PORTRAIT Agents make more money than any other class of agents. Write for our new catalog—Portrait enlargements, medallions, etc. Adam J. Krull & Co., 2543 South State St., Chicago, Ill.

SOMETHING New! Every motorist buys our Electro Magnetic Emergency Wonderlamp. One minute's demonstration makes a sale. Experience unnecessary. \$5 an hour easily made. Full time or evenings. Write for sample. Wonderlamp Co., Fisk Bldg., Dept. 10A, New York.

AUTOMOBILE Specialties. Guaranteed formulas for all latest money makers. Lowest prices. Write for free lists. Murphy, Chemist, Tujunga, Calif.

AGENTS, Our cigar lighters and sales-boards sell quick. Large wholesale catalog free. Joseph Sales Company, 223 Madison St., Chicago.

GOLD-LEAF Sign letters; copyrighted manufacturing instructions; profits 1,000%. Johnston Co., Quincy, Ill.

\$1,000.00 REWARD If this is not the greatest money-making house to house proposition ever known. N. R. G. tablets wash clothes in 10 minutes without rubbing. Free samples. N. R. G. Co., H 500 W. Division, Chicago.

TWO Money makers for agents. "Francis" Pocket Adding Machine retails \$4.85. To you \$1.00. "Excelligraph" Rotary Stencil Duplicator \$37.50 retail. Write Typewriter Supply, 102 Hersch Bldg., Pittsburgh, Pa.

POLMET Polishing Cloth removes tarnish from metals without the use of liquid, paste or powder. Our agents say it sells like "hot cakes." Retails 25c; sample free. Gale & Co., Inc., 15 Edinboro St., Boston, Mass.

OUR Luminous Crucifix Shines in the Dark. Every one amazed at the wonderful effect. Easily demonstrated—easily sold. W. G. Hannan Co., 2543 So. State St., Chicago.

SUCCEED With your own products. Make them yourself. Formulas, processes, trade-secrets. All lines. Catalog, circulars free. B. Thaxly Co., Washington, D. C.

\$50.00 WEEKLY Easy, applying gold initials on automobiles. No experience needed, \$1.45 profit every \$1.50 job. Free samples. "Ralco Monograms," X1043 Washington, Boston, Mass.

REPLATE Brassy worn-off automobile parts, reflectors, bath room fixtures, worn spoons, forks, etc., with pure silver. Looks like new. Use U-Kan-Plate Polish. Positively no mercury. \$1.00 half pints. Post paid. Satisfaction guaranteed. Agents wanted. Dept. A, U-Kan-Plate Co., Philadelphia.

GET Our free sample case—Toilet articles, flavorings and specialties. Wonderfully profitable. LaDerma Co., Dept. A, St. Louis, Mo.

HIGH-GRADE SALESMEN WANTED

FEW \$1,000 Monthly earnings ads are truthful. Our men actually earn \$300 to \$500 regularly selling our lines. Adelle, the newswoman in electric window salesmen, is making a big hit. More for the money than anybody gives. Business posters for every line. Changeable letter system too. Permanent business for you working with us. Territory protected and repeats credited. Fat commissions. Full details will prove very interesting. Display Products, Ltd., 409-A East 31st St., Kansas City, Mo.

TO Market 3A garage door holders, simple automatic action, quickly installed, instantly attracts garage owners, builders, dealers. Write for exclusive territory proposition. Knowlson-Stevenson Co., 1118 Packard, Ann Arbor, Mich.

SALESMAN, Clean-cut, Seeking permanency. Guaranteed line for industries. Marketed successfully for 20 years. Highly endorsed. Repeater. Large earnings. No limit to opportunity for man of clean character and ability. Ensign Co., 10703 Quebec Ave., Cleveland, Ohio.

SELL Printing—40% commission daily; lowest prices; with or without deposit. Copyright cuts free. Inquiry brings pocket outfit. Merchants Assn., Insurance Center Bldg., Chicago.

BIG Pay every day taking orders for dress shirts, work shirts, pants, overalls, sweaters, underwear, hosiery, pajamas, playsuits! Experience unnecessary. Outfit free! Nimrod Co., Dept. 65, 4922-28 Lincoln Ave., Chicago.

\$282.80 COMMISSION On a \$21.50 original sale. Every merchant a prospect. Absolutely new and different. Exclusive territory. Ben Braude, 337 W. Madison, Chicago.

SALESMEN—Become independent. Own your business; experience unnecessary. Selling our \$10,000 Accidental Death; \$50 Accident; \$25 Sick Weekly Benefits—\$10.00 yearly. Other amounts proportionate. Guaranteed steady income from renewals. \$250,000 deposited Insurance Department. Universal Policy, Dept. A, 10 Clinton St., Newark, N. J.

ESTABLISHED Cosmetic manufacturer wants aggressive men for exclusive territory, selling to beauty parlors, barber shops, or through crews. Combine your knowledge of salesmanship with our proven sales plans and watch the business grow. Sell yourself in first letter. Secretary, 578 Maccabee Bldg., Detroit.

40% PROFIT Selling complete printing line. 49 attractive products. Experience unnecessary. Lowest prices. Startling selling features! Ship everywhere. Outfit free! Dept. 122, Kaeser-Blair, Cincinnati, Ohio.

SALESMEN And jobbers for auto specialties. Sell direct or to the trade. Liberal commission. Write now for available territory. Davis Specialties Company, Box 131, Station A, Worcester, Mass.

SALESMEN—You make \$130.00 monthly selling only one \$10.00 accident-sickness policy a day. Policy pays \$10,000. Death, \$25.00 weekly benefit. Full or spare time. Tremendous demand. \$100,000 guarantee with state. Leads furnished from our direct newspaper advertising campaign. Write quick for territory and special contract. Underwriters, 1002 Bonnell Bldg., Newark, N. J.

\$18 TO \$25 Daily; biggest selling line of 2-piece suits, \$9.95 and \$12.50; 3-piece wool suit, \$17.95 (regular \$28.00 value). All-wool overcoats \$18.50. Splendid raincoats, slickers and boys' suits. Biggest commission. Free outfits. "Jim" Foster, Inc., Dept. 25, 2250 S. Spaulding Ave., Chicago, Ill.

ALL Year round profitable business. Earn extra money spare time selling wonderful new water softener and cleanser. Cleans like magic, grease, ink and dirt from everything. Every home and business place a live prospect. 100% profit. Big repeat orders. Agents protected. Trial case \$4.00 delivered U. S. A. Seacoast Laboratories, Inc., Sea Bright, N. J.

MAKE Your own products. Employ agents yourself. Toilet articles, soap, extracts. We furnish everything. Valuable book free. National Scientific Laboratories, 1984W Broad, Richmond, Va.

SELL Printing. Commission in advance with or without deposit; 48-hour service. Write for outfit. E. Willis Printing Co., 5939 Wentworth, Chicago.

ADVERTISING Pencils. Quick-action sideline money-maker. Free samples for real salesmen. Northern Pencil Works, 126 So. Clinton, Chicago.

SALESMEN: You can sell our complete vending machine line. Make \$12.50 on \$32.50 sale. Pay daily. Leads furnished. Postal Confection Company, 2033 Charleston, Chicago.

SPECIALTY Salesman calling on retail trade; sell proved advertising business builders to all your present prospects and customers. Add \$100.00 to \$300.00 weekly to your earnings. The country's most remarkable selling success. Commissions averaging from \$7.00 to \$300.00 each sale—advanced. Outfit free. Gold Seal Mfrs. Co., Inc., 71 West 23rd St., New York City.

OH! What a sideline. Gigantic money-getter. \$4.00 commission every \$5.00 sale. Collects accounts so fast—storekeepers, doctors get dizzy. Brooks, Texas, sold (20) first day—commission \$80.00. We deliver and collect. Full commissions all reorders. Sample free. Federal Association, Hartford, Conn.

PRINTING Salesman wanted; salesbooks, manifold printing, stationery, restaurant checks, register printing fanfold, tags; full or part time; splendid opportunity. Shelby Salesbook Co., Shelby, Ohio.

SALESMEN—\$4 in your pocket every half hour. Write orders for Hollywood News. New idea advertising service for store windows. No competition; every store prospect. Permanent repeat business. Free sales outfit. Retail Stores Service Corp., 1165 Broadway, Dept. J-3, New York.

WOW Of a sideline! Make \$200 monthly extra. Show new, exclusive line coveralls and shop coats. Advertising embroidered on back. Every business prospect. Outfit free. Master Co., 4734 Dorchester, Dept. A-5, Chicago.

STATE Manager wanted—Eastern manufacturer of marvelous auto safety signal, wishes to correspond with man or firm financially responsible to develop your state worth seventy five hundred dollars per year and up. Write National Distributors, 501 Colorado Bldg., Denver, Colo.

EARN \$20 A day. Establish income for life selling for \$1 a year \$1,500 accident policy. Write W. C. Stone, 11 So. LaSalle, Chicago.

COVERALL Salesmen—Make \$20 daily selling new \$3.50 improved coverall, also service coats with customers name embroidered on back. Unusual construction. Commission 75c! Wonderful advertising value. Lowest priced; highest commission. Free outfit. Am. B. Co., H-329 W. Monroe, Chicago.

40% PROFIT Selling complete printing line. 49 attractive products. Experience unnecessary. Lowest prices. Startling selling features! Ship everywhere. Outfit free! Dept. 122, Kaeser-Blair, Cincinnati, Ohio.

STATE Mgr. Marvelous invention seals 3,000 envelopes hourly! Sells \$4.50 only; equals work expensive electric machines. Offices buy 1-100. Exclusive territory. Opportunity earn \$7,000 yearly. Free trial offer. Write quick! Rede, 31 Winthrop Bldg., Boston.

SALESMAN: Sparkling chipped glass, name plates, house numbers, signs. Request particulars. Roscoe Lynch, Bausman, Penna.

REPRESENT Auto seat cover manufacturer. Direct to automobile owners. High quality, low prices. Make \$125 weekly. Elaborate samples free. Marvelo, 2392 Wabansia, Chicago.

A PAYING Position open to representative of character. Take orders shoes-hosiery direct to wearer. Good income, Permanent. Write now for free book "Getting Ahead." Tanners Shoe Mfg. Co., 2005 C St., Boston, Mass.

SELL Printing: experience unnecessary; main or sideline. 40% commission advanced; copyright cuts and elaborate outfit free; beats all competition. Meyerson, G1132 So. Racine, Chicago.

EARN \$90.00 Weekly selling world's greatest \$23.50 value; all wool tailored-to-measure suits. Big commissions; liberal bonus. Outfit free. Style-Center, Dept. 9, Cincinnati.

SALESMEN For carbon solvent. No more spark-plug trouble; valve grinding; motor overhauling and excessive cylinder oil. Write for details. St. Clair Sales Bureau, Box 26, Tolland, Colo.

FREE—1,000 Money-making opportunities from reliable firms. Sample copy free. Specialty Salesman Magazine, 4220 Mather Tower, Chicago.

BUSINESS Stationery. Largest line. Highest quality. Quickest delivery. Biggest commissions. Liberal bonuses. Free copyrighted cuts every business. Experience unnecessary. Instructions and outfit free. Willens Co., Dept. 212, 941 Van Buren, Chicago.

GOLD-LEAF Window letters and script signs; no experience; 500% profit; samples free. Consolidated, 69-V West Van Buren, Chicago.

SELL Union label printing. Lowest prices. 72 hour delivery. Big commissions advanced. Amazing bonus. Cuts for every business furnished. Experience unnecessary. Outfit free. Northwestern, 2002 Division, Chicago.

POOL Shooter, new, fascinating vending machine. Merchants everywhere buy! Sideline men make \$200 weekly! Free pocket outfit! Specialty Mfg. Co., Dept. 1, 617 W. Division, Chicago.

\$78.00 MADE By Iowa salesman first day selling new hot dog machine at \$18.50, commission \$8.50; direct factory connections. Leonard E. Dickerson, Dept. E-12 Springfield, Mo.

WONDERFUL Invention. Seals fifty envelopes minute. Sells on sight at \$3.50. Attractive proposition. Square deal. Bank references. Kendall Sealer Co., C-11 East Jaffrey, N. H.

EVERY Home a prospect. Make big money. Take orders free, shrubbery. Experience unnecessary. No dull season. Commissions paid weekly. We deliver, collect. Write Perry Nurseries, Dept. R-5, Rochester, N. Y.

MONEY Every day selling service. 1113 Title Guaranty, St. Louis, Mo.

SALESMEN. Wonderful sideline. 40% commission paid daily. Sells all merchants. Pocket outfit free. David Lionel Press, 406 So. Sangamon, Dept. 44, Chicago.

EVERY Car-owner and garage a prospect. New \$2.00 puncture finder; beats tub, no leak too small; a few ounces, lasts a lifetime. Sample \$1.00. P. J. O'Sullivan, 546 8th St., Brooklyn, N. Y.

JUST OUT! Amazing new vending machine! Pays merchant 1,600% profit! Sensation wherever introduced. \$50.00 daily! Dept. 9, Acme, 4554 Broadway, Chicago.

SALESMEN—Earn \$100 weekly taking orders for Dazzler and Rainbow glow electric signs. Big commission. Exclusive territory. High grade proposition. Write Chicago Sign Sales Co., Dept. 71, Charlotte, N. C.

CANVASSERS: Stop! Look! Listen! Mexican curios, den fixtures, Indian rugs, feather work. Fastest selling goods. Full particulars, samples fifty cents. G. Medina, 78-P LaRosa St., Mexico City, Mexico. Highest references.

PUNCHBOARD Men! Sideline salesmen! Sensational merchandise catalog just added to famous "Lincoln Line"! No more closed territory! \$200 weekly. Easy repeat commissions paid daily. Smashing color catalog free. Samples unnecessary. Best season now. Get busy! Lincoln Sales, 116 So. Wells, Chicago, Dept. D.

SUCCESS is no accident! You will fully understand this slogan when you examine our automatic credit and collection plan. Copyrighted, brand new, unusual. You make 250% on original sale. Half cash on repeats without call-backs. Commonwealth J. Publishing Company, 593 So. Dearborn St., Chicago, Ill.

PUNCHBOARD Salesmen. \$200 weekly. Liberal plan assures sales. Latest assortments. Nothing to carry. Full commissions on repeats. M&L Sales Co., 301 W. Adams, Chicago.

SALESMEN—Four \$15.00 sales to merchants net you \$40.00 daily. Sayers Systems, 2813 Sheffield, Chicago, Ill.

NEWEST, Finest and most complete line of novelties and pencils for 1929. State experience. Advertising Novelty Company, Newton, Iowa.

SALESMEN—Make big money handling our advertising "Twin Pencil"—unique novelty; just out. Large commissions to experienced men. Multipoint, Corona, N. Y.

SALES Workers—With mechanical inclination, to place Air-Lee Door Operators; should have car; a short training and demonstration will be given you in your territory; good commissions begin immediately. Write Schoelkopf Mfg. Co., Madison, Wis.

SALESMEN: Manufacturer and distributor one of country's leading lines automotive shop equipment and hand tools offers exclusive territory. Proposition assures good income; advance against commission basis. Applicants must be financially responsible, have some knowledge of tools and must own car. Write for proposition to Mr. Merrell, Woods Organization, Inc., 37 W. 20th St., New York, N. Y.

SIDELINE—New! Quick seller to merchants, banks, manufacturers. Full commissions daily. Pocket sample free. Carroll Co., 319 N. Albany, Dept. 346, Chicago.

THE Health sponge, new patented article just out. Making big hit. Sells for 50c. Sample 35c. Details free. B. C. Meister, Methuen, Mass.

FURNACE Coal saver. Reduces smoke and soot and coal bill. Easily sold and installed. Big money for hustlers. The Campbell-Hausfeld Company, Box 9, Harrison, Ohio.

PUNCHBOARD Salesmen. \$10,000 yearly. New line. All fast sellers. Lowest prices. Full commission on repeat business. Catalog free. Hurry! Puritan Novelty Co., 1409 Jackson, Chicago.

PICK A winner! \$200 every week. "Seven-Eleven" dealers wild about it. Every cigar counter waiting. 31 other sellers. Rudy, 339 Madison, Chicago.

IT'S Legal. New and aplenty different! "Gypsy." It's whirling wheels fascinate everybody. Merchants buy eagerly. Clean up \$100-\$150 weekly. Dept. 18, Cigar Stores, Peoria, Ill.

SELL Nothing! \$170 weekly empty handed. Punchboard headquarters announce amazing new plan. No investment. We even pay express. K&S Sales Co., 4378 Ravenswood, Chicago.

\$60-\$200 A WEEK. Genuine gold letters for store windows. Easily applied. Free samples. Liberal offer to general agents. Metalle Letter Co., 438-A North Clark, Chicago.

HELP WANTED

YOU Are wanted to resilver mirrors at home. Immense profits plating autoparts, tableware, etc. Write for information. Sprinkle, Plater, 287, Marion, Ind.

MEN—Big money. Free samples. Pop-Gpo, Box 471, New York.

ARE You old at forty? See our advertisement on page 75 of this issue. The Electro Thermal Company, 2117 Morris Ave., Steubenville, Ohio.

OBTAIN Employment! Get best positions quickly anywhere. Learn how. Request free offer. Write Box 39-101, Station K, New York.

THE Boulder dam. Eight year's work. Latest information regarding conditions, employment, concessions, etc., sent by return mail for \$1.00. Money back if dissatisfied. M. Roberts Service Bureau, Box 1051, Denver, Colo.

2,000 PIANISTS. Make \$2.00 hour. Details and three latest novelty-comedy songs, \$1.00. Al McDermott, Pound, Wis.

BIG Wages paid in Canada for construction work, etc. Write for list of positions. Stamp appreciated. A. Allard, 4724 Des Erables, Montreal, Can.

SILVERING Mirrors. French plate, patented process, easily learned. Immense profits. Plans free. Wear, Excelsior Springs, Mo.

CASH Paid for Butterflies, Insects. See Sinclair Display Advertisement on page 18.

EDUCATIONAL AND INSTRUCTION

U. S. GOVERNMENT Jobs. Become railway postal clerks. (\$158-\$225 month), city carriers, postoffice clerks. (\$142-\$192) Prohibition agents (\$191-\$283 month). Men 18 up. Steady work. Life positions. Paid vacation. Common education sufficient. Experience unnecessary. Sample coaching and full particulars free. Write to day sure, Franklin Institute, Dept. R3, Rochester, N. Y.

MANUSCRIPTS Wanted. Stories, articles, poems. Write for particulars. Sachs, 2533 Park Ave., Cincinnati, Ohio.

BIG Money in real estate business. Complete guaranteed twenty lesson course that gets the business, only \$2. P.O. Box No. 1, Everett, Wash.

BIG Demand for photoplay talking picture and magazine stories. We revise, develop and copyright. Sell on commission. Established 1917. Booklet free. Universal Scenario Company, 406 Western and Santa Monica Bldg., Hollywood, Calif.

FIREMEN, Brakemen, baggagemen (white or colored), sleeping car, train porters (colored), \$150-\$250 monthly. Experience unnecessary. 810 Railway Bureau, East St. Louis, Ill.

U. S. GOVERNMENT Jobs. \$1,250-\$3,400 year. Men-boys, 18-50. Steady jobs. No "layoffs." Pleasant work. Vacation. Short hours. Experience usually unnecessary. Thousands 1929 appointments. Full particulars with sample coaching free. Write today sure. Franklin Institute, Dept. R-14, Rochester, N. Y.

FIFTEEN Dollars a day jobs and how to get them. No selling, no canvassing. Complete book, numerous opportunities. Sent postpaid 25c. No stamps. Tranole, 715 E. 4th St., Brooklyn, N. Y.

SNAPPY Instructive sales stories. Quarter. Stamps. Kent Ruggles, Cuyahoga Falls, Ohio.

OUTDOOR Opportunities. Instructions for raising and selling rabbits, guinea pigs, milk goats, silver foxes, ferrets, white rats, white mice, dogs, cats, pigeons, pheasants, bantams, canaries, bees, frogs, mushrooms, ginseng and golden seal all profitably on town lot. Just write for "Outdoor Opportunities." Pay Postman \$2 and postage. Popular Mechanics Press, Room 805, 200 E. Ontario St., Chicago, Ill.

"MAKE 'Em Laugh!" A course of lessons for public speakers, writers, salesmen, students. Will make you witty, clever, popular. Nothing like it ever before offered. Sample lesson and "part-ticklers" 25c. National, 205 South Second St., Chambersburg, Pa.

INVESTIGATING And tracing. Work home or travel. Experience unnecessary. Write American System, 2188 Broadway, New York.

YOUNG Men: with some high school education to work and learn radio, television business. Write Mgr., Box 331, Milwaukee, Wis.

WANTED—Boys-men. Become automobile mechanics. \$1,800 year. Sample training free. Franklin Institute, Dept. R-400, Rochester, N. Y.

RETAIL Shoe selling easily learned at home in 3 weeks. Positions waiting. First salary pays course. Write Shoecraft Institute, 36 Lefferts Place, Brooklyn, N. Y.

STORY Writers—Send stamp. Christensen, 308 W. 70th Pl., Chicago.

BECOME A landscape architect. Uncrowded profession; wonderful opportunity for money-making. Easily mastered by mail. Earn while you learn. Est. 1916. Write for details. American Landscape School, 29 Plymouth Bldg., Des Moines, Iowa.

WANTED Immediately, men-women, 18-55 qualify for government position, \$125-\$250 month. No experience required. Steady work. Vacations with full pay. Write, Ozment Inst., 101, St. Louis, Mo.

U. S. GOVERNMENT wants men, \$1,700-\$1,900 and up at start. Railway mail clerk examination coming. Let our expert (former government examiner) prepare you for this and also rural carrier, post office, customs, internal revenue, and other branches. Write today for free booklet. Dept. 8, Patterson School, Rochester, N. Y.

BIG Money in photography, motion picture projection. Catalog 49A free. New York Institute of Photography, 10 W. 33d St., New York.

LINOTYPE Operating easily learned; home or college; small cost; big wages. Free catalog. Linotype Institute, Maumee, Ohio.

STUDY A scientific profession. Microbiology. Bacteriology. Sanitation. Extension-residential course. Diplomas degrees granted. Urinalysis outfit-prosperus free. College of Microbiology, 722 Calumet, Hammond, Ind.

MANUFACTURE Novelties, patterns; instructions, including scroll saw, \$1.00. Borgen, 2264 Herman Ave., New York.

DOUBLE Entry bookkeeping 60 hours with 8 keys; guaranteed. (Diplomas.) International Bookkeeping Inst., 8 Springfield, Mo.

DO you like to make things? If so, you should have a copy of Popular Mechanics new book entitled "Make It Yourself." A large book of 480-pages describing how to make 900 different articles. 823 illustrations. Price \$3 postpaid. A full description will be sent upon request. Popular Mechanics Press, Room 805, 200 E. Ontario St., Chicago, Ill.

INFORMATION, SERVICE, COUNSEL

W. SCOTT WILKERSON, 901 Nat. Press Bldg., Washington, D. C.

INFORMATION \$1.00. Commercial, real estate, insurance, financial, scientific, names, importers, publishers, producers, manufacturers, investigations, exposures, etc. Satisfaction or money back. F. Pavlik, Kenilworth, Ill.

TRACING. Make secret investigations. Work home or travel. Experience unnecessary. Write American System, 2188 Broadway, New York.

TYPEWRITERS AND SUPPLIES

TYPEWRITERS—Factory rebuilt Royals, Remingtons, Underwoods, New Royal, Remington and Corona portables. New "Excellograph" Rotary Stencil Duplicator \$37.50. Catalog free. Pittsburgh Typewriter Supply, Dept. 945, Pittsburgh, Pa.

TYPEWRITERS—All makes, \$8 to \$20. Fully guaranteed. Typewriter Exchange, Three Lakes, Wis.

TYPEWRITERS, all standard makes, \$10 up. Fully guaranteed. Free trial. Write for complete illustrated lists. Northwestern Typewriter Exchange, 121 N. Francisco Ave., Chicago.

ADDING MACHINES

NEW \$3.50 Automatic adding machine. Adds, subtracts, multiplies, absolutely accurate. Capacity 9999,999.99. Fully guaranteed. 75,000 pleased users. Makes adding easy, positive, quick. Eliminates mistakes. Saves time. Postpaid \$3.50. Bassett Co., 1458-A, Hollywood Ave., Chicago.

PRINTING, ENGRAVING AND MULTIGRAPHING

5,000 ELEGANT Enamel folders \$13.75; 5,000, 5 1/2 x 8 1/2 circulars, \$10.00; envelope slips, \$5.00. Samples. Goodprint, Harrisonburg, Va.

FREE Envelopes, request details. Printed stationery—anything, \$2.80 thousand. Samples? Interprint, 268-pm, Battle Creek, Mich.

FINE Printing—Low prices. Large modern plant (thirty employees) in small town, low operation cost. Special prices on stationery, circulars, pamphlets, ruled forms, catalogs, large or small orders. Write for samples and prices. Shenandoah Publishing House, Inc., Box 1070, Strasburg, Va.

100 LETTERHEADS, 100 Envelopes neatly printed, postpaid, \$1.00. James Pierce, 6138 Iroquois, Detroit, Mich.

500 BUSINESS Cards 98c. Other printing reasonable. Samples free. Hanzer's, 1039 S. Cleveland, Philadelphia, Pa.

1,000 LETTERHEADS Or envelopes \$2.50 cash. Patton Co., 534 Patton Bldg., Omaha, Nebr.

"NEARGRAVURE"—"Neargravuremboso" processes. Special—Neargravure, 250 envelopes, 500 8 1/2 x 7 1/4 letterheads \$3.33—8 1/2 x 11" \$4.44, postpaid. Solldays, Knox, Ind.

BUSINESS Stationery. High quality. Low cost. Write for samples and prices. Commercial Printing Company, Allendale, S. C.

QUICK Printing and form letter service. Samples and money-saving prices furnished. Artercraft, Chillicothe, Mo.

BARGAINS' Every kind printing. Samples. Battlefield Press, Gettysburg, Penna. Free battlefield souvenir.

1,000 LETTERHEADS Or envelopes, 20 lb. bond paper, \$2.95 postpaid. 125 of each \$1 postpaid. Ace Letter Shop, Dept. P-1, Moline, Ill.

PRINTING. Properly produced, promptly, reasonably. Samples, price list free. Moulton Press, 1410 East 8th, Kansas City, Mo.

LABELS, Circulars, rubber stamps. Profit features. McPherson Printing Works, Middletown, Conn.

\$3.00, 500 LETTERHEADS 8 1/2 x 11, 250 Envelopes, 1,000 letterheads \$3.95; envelopes \$2.95. Catalog free. National Printing, Goshen, Ind.

FINEST Bond letterheads 8 1/2 x 11, \$3.95m. Envelopes, \$2.95. Oberman Company, Box 1042, Chicago.

MULTIGRAPHING—Expert work. Get prices, samples. Box 1071, Knoxville, Tenn.

FREE—Samples of our printing and price-list. Letter Service, 4019 East 15th, Kansas City, Mo.

SAMPLES Raised letter printing with special prices free. LaClyde Service, Westfield, Mass.

200 LETTERHEADS And 100 envelopes \$1.00. 200 letterheads, 8 1/2 x 11, 150 envelopes \$2.00. 250 cards \$1.00. Hoosier Print Shop, Portland, Ind.

QUALITY Printing! Reasonable Prices! Send for Free Standardized samples and prices. Folders. Circulars. Catalogs our specialty. Earnest Fantus, 525 South Dearborn, Chicago.

MULTIGRAPHING Business correspondence two dollars thousand. Hammermill letterheads, four dollars; inexpensive quality, three dollars. Miscellaneous printing. Mayera Corporation, Menmouth, Ill.

250 BOND Letterheads, Envelopes, Billheads, Cards, \$1.35 each. Economic Press, Leonia, N. J.

WE Print stationery, booklets, catalogs, circulars. Samples. Commercial Press, Batavia, Ohio.

QUALITY Stationery—500 8 1/2 x 11 bond letterheads, 250 No. 6 1/2 envelopes, \$3.25. Samples. H. Curtis, 811 Harrigan, Kalamazoo, Mich.

PRINTING OUTFITS AND SUPPLIES

PRINT Your own cards, stationery, circulars, advertising, etc. Complete outfits, \$8.85; job presses, \$11, \$29; rotary, \$149. Print for others; big profit. Easy rules furnished. Write for catalog presses, type, paper, etc. Kelsey Company, J-11, Meriden, Conn.

MAKE Your own printing device. It's practical—It's different! Particulars, printed specimens free. Grinstead Company, Oswego, Kans.

USED Presses, type, supplies. C. L. Whitfield, Ballentine, Norfolk, Va.

PREUSED Printing presses and supplies. Lists 2c stamp. Popular Bargains, Richland, Pa.

PRINTING Outfits—Presses, type supplies, type novelties. Send stamp for catalog. Model Press, York, Penna.

DUPLICATORS AND DEVICES

STENCIL Duplicator—Anyone can make. Particulars, specimens, free. Grinstead Company, Oswego, Kans.

YOU can make 50 to 100 copies of a letter, notice, etc., at a cost of three cents on a Hoyer Quality Duplicator. Write for free trial offer. The Hoyer Duplicator Co., 909 Jackson Blvd., Chicago, Ill.

"EXCELLOGRAPH" Portable rotary stencil printing duplicators \$39. Terms. Description, testimonials, printed samples, free. Pittsburgh Typewriter Supply Co., Dept. 531, Pittsburgh, Pa.

MAILING LISTS

LATE Names; all kinds. Guaranteed correct, priced right. DeMuth Company, 88-15 82nd Ave., Glendale, N. Y.

1,000 1928 RURAL Women names, \$1.00. Sheasgreen, PM1427 North Penn. Minneapolis, Minn.

RUBBER STAMPS

RUBBER Stamps—Name, address, 35c. Pad 12c. Agents wanted. Newman & Son, Auburn, Nebr.

FOR THE HOME

GRANDFATHER'S Clock Works. \$5.00. Build your own case; instructions free; make good profits selling your friends. Clock works with chimes for old or new cases. Write for full particulars. Clock Co., Ruffner St., Philadelphia.

CEDAR chests only \$11.65—"Red-I-Kut" complete with rich copper trim—you assemble and save half—send for pictures. Kuempel Furniture Company, Guttenberg, Iowa.

BUY Direct from manufacturer. Mexican curios, den fixtures, Indian sarapes, rugs, novelties, cushion covers. Bed-rock prices. Samples fifty cents. G. Medina, 78-P La-Rosa St., Mexico City, Mexico. References furnished.

REFRIGERATING Machine, homemade. Operates successfully. Gives better service than ice. This and 328 other practical articles in our book "Home Mechanics." Just ask for this and "Handbook for Women," containing 394 valuable household helps and pay postman 98 cents and postage for the two books. Popular Mechanics Press, Room 805, 200 E. Ontario St., Chicago, Ill.

FOR MECHANICS

ATTENTION—Home mechanics: We sell unusual cabinet hardware, chest trimmings, tea wagon wheels and casters, big line small hinges, locks, etc. Upholstering supplies electrical hardware, knocked down cedar chests, etc. Send ten cents stamps for catalog. Thurston Manual Training Supply Company, Jobbers and Manufacturers, Anoka, Minn.

FAMOUS Bailey Handbook—The book that prepares you to pass the examination for any grade of license for Stationary, Marine and Diesel Engineers, Firemen and Boiler Inspector in any state of the Union or any province of Canada. Flexible cover. Handy Pocket Size. Pay Postman \$2.00 plus postage when he hands you the package. Popular Mechanics Press, Room 805, 200 E. Ontario St., Chicago, Ill.

FOR SMOKERS

SEND 10c Silver or stamps, for sample package 20 finest quality cigarettes. Large tin special smoking tobacco sent for 10c. Direct-to-smoker. French Tobacco Company, Dept. 69, Statesville, N. C.

GUARANTEED. Postpaid. Good red leaf juicy chewing. Five pounds \$1.50, 10 pounds \$2.75. Smoking, 20c. Homer Prince, Agent, Sharon, Tenn.

HOMESPUN Tobacco—Guaranteed. Chewing, 5 lbs., \$1.25; 10, \$2.00. Smoking, 5 lbs., \$1.00; 10, \$1.50. Pay when received. Farmers Union, Mayfield, Ky.

CIGARETTE Machine rolls, glues 50 for 10 cents. Ask illustrated folder. Postpaid \$2.50. Automatic Cigarette Machine Works, 6247 Broadway, Chicago.

CIGARS—Box of 50 \$1.25. Good mild quality. Send to E-S Co., 1647 W. Locust St., Davenport, Iowa. Postage 10c extra.

RAZORS AND BLADES

BUILD A business for yourself. Sharpen razor blades. Make a dollar per hour with our machines. Ideal proposition for elderly men. Easy light work. Opportunities everywhere. Direct factory price \$175.00. No agents, no commissions. Velvet Edger Mfg. Co., 725 West 59th Place, Los Angeles, Calif.

ALL Makes razor blades sharpened, 1c each. Satisfaction guaranteed. Petter Wetterquist, Rockford, Ill.

GUNS, FISHING TACKLE AND SPORTING GOODS

SUCCESSFUL Fishermen's recipe for favorite fish bait. Easily prepared 25c. Henry Bergman, Box 5, Springfield, Mo.

LEARN Trick shooting. Copy of "Secrets of Trick Shooting," \$1.00. Vincent MacLean, 97 Parkview, Bangor, Me.

WINCHESTER Rifles, field glasses, poker racks; sporting goods. Catalog free. Hudson Sporting Co., W52 Warren St., New York.

ARCHERY

BOYS! Get ready! Best bows and arrows. See our new stock—prices. Practical, 510 Van Buren St., Chicago.

BOATS AND LAUNCHES

PROPELLERS, Pumps, stuffing boxes, bearings, rebuilt reverse gears. Wm. H. Baker, Pond St., Quincy, Mass.

OUTBOARD Racer and family runabout. Blueprint and directions \$1.00. Stanley Wien, 4th St., East Norwalk, Conn.

HUBBELL Marine Coolers convert Ford engine into marine motors. Booklet free. Ford speedboat easily built, large blueprint and directions one dollar. C. C. Hubbell, Perry Ave., Norwalk, Conn.

NEW Boat Book telling how to make 21 kinds of boats. Also many other helpful ideas on boating. Profusely illustrated. With this we include the big book, "Outdoor Sports the Year Round." Directions for making all sorts of devices for outdoor recreation. Send no money. Simply pay the postman \$1.98, plus postage when books are delivered. Popular Mechanics Press, Room 805, 200 E. Ontario St., Chicago, Ill.

FIELD GLASSES, TELESCOPES AND MICROSCOPES

USED Fieldglasses; \$2 to \$75. J. Aiden Loring, Dept. J, O-we-go, N. Y.

WATCH REPAIRING

EXPERT Watch repairing. Twenty-five years' experience repairing Swiss watches. Average cost \$2.50, never over \$3.50. All watches repaired like new. References furnished. Sandoz Watch Repair Shop, 67 So. California St., Ventura, Calif.

ANTIQUES, WAR RELICS AND INDIAN GOODS

ANTIQUE Firearms: Lists to buyers. Dexter, 910 Jefferson, Topeka, Kans.

ANTIQUES, Firearms, daggers, swords, Indian relics, curios. Nagy, O-8 South 18th, Philadelphia.

GENUINE Sioux Indian costumes and beadwork. Buying direct from Indian. Prices reasonable. Free price list. Lyon Curio Store, Clinton, Nebr.

SEND 5c For fine new list Indian relics, antique firearms. F. E. Ellis, Webster Groves, Mo.

FOR Dens. Relics and medals from Europe's battlefields. Illustrated catalog, 25c. International, 885 Flatbush Ave., Brooklyn, N. Y.

PHONOGRAPHS AND RECORDS

BUILD Your own Phonograph. Parts catalog and instructions to build new horn, mailed for 10c. American Phonograph Co., 4116 West 24th Place, Chicago.

MUSIC AND MUSICAL INSTRUMENTS

SPARE-TIME Work. Eight million pianos in U. S. need tuning right now. Ninety minutes to tune average piano; pay ranges around \$5. Player work pays big too. We train you thoroughly at home at small cost. Capital, experience unnecessary; two diplomas. Get our free booklet "Piano Tuning as a Business." Mack Institute, Crafton Station, PM-2, Pittsburg, Pa.

PIPE Organs, residence; assemble yourself. We furnish pipes, console, instructions, etc. Dundee Electric, Dundee, Ohio.

COMPOSERS—Verse or music. Brilliant opportunity. Write VanBuren, 1835 McClurg Bldg., Chicago.

SONGWRITERS: Substantial advance royalties are paid on publisher's acceptance. Write for free booklet on developing ideas for song words or music required by talking pictures. Newcomer Associates, 1674 Broadway, New York.

I WROTE the song hits "Dreamy Carolina Moon," "Twilight," "Somebody Lied," "Little Gray Mother O' Mine," 100 others. I will personally write melody to your song poems. Investigate before investing. Evans Lloyd, 8 So. Dearborn, Chicago.

ATTRACTIVE Music to your words. Dr. Wooler, Composer, Buffalo, N. Y.

SONG Poems arranged for publication. Submit poems. Brennen, Song Specialist, L1652 Broadway, New York.

SONG Poem writers—"Real" proposition. Hibbeler, D1, 2104 N. Keystone, Chicago.

"BANJOS" Should interest all musicians on account of the popularity of the Banjo, as it easily increases a Player's income. Illus. Catalog of 48 pages free. The Bacon Banjo Co., Inc., Groton, Conn., U. S. A.

"MUSIC Composed" to words. Bauer Bros. (formerly of Sousa's Band), Oshkosh, Wis.

WRITE Songs. Big money and reputation. Write for information. J. Gordon Pub. Co., 201 N. Hoyne Ave., Chicago.

SONGWRITERS: Submit your song-poem or complete song. Will return it immediately if not accepted. Chester Escher, Music Publisher, 125 W. 45th St., New York City.

FREE—"Song Writers Guide." Beaver, 1257 Elm, Green Bay, Wis.

VIOLINS, Deep, mellow, soulful—on credit. Easy terms for wonderful instrument. Get details today. Gustav F. Henning, 302 University Building, Seattle, Wash.

POEMS Wanted, 50-50 plan. Great Eastern Song Bureau, Dept. 27, Thomaston, Me.

SONG Poems solicited. A different proposition. Richard Broughton, Sioux Falls, S. Dak.

SONG-POEM Writers: Address Monarch, 236 W. 55th, Dept. 304, New York.

CORNETISTS—Trombonists—Saxophonists—Clarinetists. Get "Free Pointers." Name instrument. Virtuosi School, Buffalo, N. Y.

PLAY Piano by Ear. A Sound System. Booklet free. Boucher's Harmony Studio, Ottawa, Can.

SONG Poem Writers. Write Sequoia Songwriters' Service, Sherman Branch, Los Angeles, Calif.

PATENT ATTORNEYS

PATENTS Procured, prompt service, personal, careful and efficient service. Highest references. Moderate fees. Send sketch or model for actual search and advice. George P. Kimmel, Master of Patent Law, 54-E Legal Bldg., Washington, D. C.

SELL Your invention before patenting. Write for free particulars. W. T. Greene, 902 Barrister Bldg., Washington, D. C.

UNPATENTED Ideas can be sold. I tell you how and help make the sale. Free particulars (Copyrighted). Write W. T. Greene, 907 Barrister Bldg., Washington, D. C.

PATENTS Procured under my easy payment plan. See ad page 145. M. S. Cayne.

PATENTS Procured; low rates; easy terms; established 25 years. H. Sanders, 7 Rand McNally Bldg., Chicago, Ill.

LACEY'S Patent Sense. Valuable book free. See ad page 145.

PATENTS—Write for our free book, "How to Obtain a Patent" and Record of Invention Blank. Send model or sketch of invention for inspection and instructions free. Terms reasonable. See advertisements on pages 142 and 143. Victor J. Evans & Co., 934 Ninth, Washington, D. C.

TIME Counts in applying for patents. See pages 140 and 141. Clarence A. O'Brien, Registered Patent Attorney, Washington, D. C.

PATENTS. Send sketch or model for advice. Free book: "How to Obtain a Patent." Established thirty years. Highest references. Prompt service. Reasonable charges. Chandler & Chandler, 910 F St., Washington, D. C.

MONROE E. MILLER, Ouray Bldg., Washington, D. C., Patent Lawyer; Mechanical, Electrical Expert. Booklet and Priority Record blank gratis.

ESTABLISHED 1864. Milo D. Stevens Company. Free Booklet. Patents, Trade-Marks, Copyrights. Offices, Monadnock Block, Chicago; Barrister Building, Washington, D. C.

INVENTORS—Write for our Guide Book, "How to Get Your Patent," and Evidence of Invention Blank. Send model or sketch of your invention for our prompt examination and instructions free. Randolph & Co., Dept. 430, Washington, D. C.

PATENTS. Prompt personal service. Write for information. Albert E. Dieterich, Registered Patent Lawyer, 621½ Ouray Bldg., Washington, D. C.

LANCASTER and Allwine, 221 Ouray Bldg., Washington, D. C. "Originators of the Form Evidence of Conception." Before disclosing your invention to anyone send for blank form to be signed and witnessed. Form and patent information bulletin free.

PATENTS, Trade-Marks, Designs. This firm has 27 years' experience and gives expert personal service at reasonable rates. We properly protect your invention. Write for free information and exact cost of procuring patent before proceeding. John B. Thomas & Co., 902 F St., N. W., Washington, D. C.

PATENTS. Booklet free. Highest references. Best results. Promptness assured. Send model or drawing for preliminary examination. Watson E. Coleman, Patent Lawyer, 724 Ninth St., Washington, D. C.

PATENTS Procured: Trade marks registered—A comprehensive, experienced, prompt service for the protection and development of your ideas. Preliminary advice gladly furnished without charge. Booklet of information and form for disclosing idea free on request. Irving L. McCathran, 704 International Bldg., Washington, D. C., or 41-R Park Row, New York.

PATENTS, Trade-marks, Copyrights. Reliable services by an experienced practitioner devoting personal attention to each case. Inquiries invited. References furnished. B. P. Fishburne, Patent Lawyer, 525-A McGill Bldg., Washington, D. C.

INVENTOR'S Advisor with mechanical movements sent free. Labiner, Three Park-row, New York.

"INVENTOR'S Guide," valuable information, free. Frank Ledermann, Registered Attorney-Engineer, 1712 Woolworth Bldg., New York.

PATENTS—Write for free instructions. Send drawing or model for examination. Carl Miller, Registered Patent Attorney (former Patent Office examiner), 259 McGill Bldg., Washington, D. C.

PATENTS—Free instructions. Former patent office examiner. Moderate terms. Booklet. Albert Jacobs, 727 Barrister Bldg., Washington, D. C.

PERCY S. WEBSTER, 203 Saving and Loan Building, Stockton, Calif. Patent booklet free.

INVENTORS: Send for booklet telling how to patent and sell your inventions at lowest cost. Ralph Burch, Patent Lawyer, 900 F St., Washington, D. C.

FOR INVENTORS

PATENTS. If you have an invention which you wish to patent you can write fully and freely to Munn & Co., for advice in regard to the best way of obtaining protection. Please send sketches, or a model of your invention and a description of the device, explaining its operation. All communications are strictly confidential. Our Hand-Book on Patents is sent free on request. This explains our methods, terms, etc., in regard to patents, trade marks, foreign patents, etc. "Scientific American" contains patent office notes, decisions of interest to inventors and particulars of recently patented inventions. Munn & Company, Solicitors of Patents, 1523 Scientific American Building, 24 W. 40th St., New York City; 524 Scientific American Bldg., Washington, D. C.; 1313 Tower Bldg., Chicago, Ill.; 666 Hobart Bldg., San Francisco, Calif.; 521 Van Nuys Bldg., Los Angeles, Calif.

INVENTORS Universal - Educator—contains 900 mechanical movements; 50 perpetual motions. Tells how to obtain and sell patents. Suggests new ideas. Explains how to select your attorney and avoid patent sharks. Price (revised edition) \$1.00 post-paid. Albert E. Dieterich, 621 Ouray Bldg., Washington, D. C.

GET your own patents. Legal blanks, complete instructions \$1. Cutting Sons, Cambell, Calif.

SELL Your invention before patenting. Write for free particulars. W. T. Greene, 901 Barrister Bldg., Washington, D. C.

UNPATENTED Ideas can be sold. I tell you how and help you make the sale. Free particulars (Copyrighted). Write W. T. Greene, 906 Barrister Bldg., Washington, D. C.

MANUFACTURER Wants practical patents. Will buy outright or manufacture on royalty. Prefer articles for hardware, house-furnishing or office supply trade. Address Eroom Room 113, Care of Popular Mechanics, Chicago, Ill.

PATENTS. Patents pending sold to manufacturers. You pay for results only. W. Nestle, 852 Belmont Ave., Chicago.

NOVELTY Wanted—Inventors, manufacturers who have new article that can be sold through agents write Lea Sales Co., Shell Bldg., St. Louis, Mo.

INVENTIONS—Write for our free book "How to Obtain a Patent" and Record of Invention Blank. Send model of sketch of invention for inspection and instructions free. Terms reasonable. See advertisements on pages 142 and 143. Victor J. Evans & Co., 157 Ninth, Washington, D. C.

"FACULTY Of Inventing," Price \$1.00. Elmer Raymond Carlson, Galva, Ill.

INVENTORS—Ideas developed and working models built. Electrical problems solved. Lowest charges and confidential service. Industro Electric Tools Co., Petersburg, Va.

WANTED—Patented medical or health device to manufacture on royalty basis. Cincinnati Automatic Machine Co., Cincinnati, Ohio.

I SELL patents. A service for the man with a valuable patent to sell. Charles A. Scott, 773PM Garson Ave., Rochester, N. Y.

INVENTORS. Try Samuel Smith Machine Company, Lawrence, Mass., for jigs, dies, fixtures, general machine work, stampings. Wide experience. Reasonable prices.

TIME Counts in applying for patents. See pages 140 and 141. Clarence A. O'Brien, Registered Patent Attorney, Washington, D. C.

LACEY'S Patent Sense. Valuable book free. See ad page 145.

JOIN The American Inventors Association, Cedar Rapids, Iowa. Protection, consultation, capitalization.

PATENTS—Write to B. P. Fishburne (a South Carolinian), Registered Patent Lawyer, 525-E McGill Bldg., Washington, D. C.

INVENTIONS Wanted—Patented, unpatented. If you have an idea for sale, write Hartley, Box 928, Bangor, Me.

INVENTORS—Cash in on your invention now! Don't delay the sale any longer! Send for a free copy of our specially prepared booklet, "Turn Your Patent Into Money," today! It contains helpful information for all inventors. M. L. Rund, Mgr. Classified Advertising, Popular Mechanics Magazine, 200 E. Ontario St., Chicago, Ill.

PATENTS FOR SALE

SHIPS—Equipped with safety devices for all classes of vessels purpose if it sinks to be raised without service of a diver and where the diver can't go when the water is too deep. Jerome Parini, 94 Baxter St., New York.

OUTRIGHT Or royalty: Recently patented, electric socket; also time switch and sign flasher; two devices; more efficient, less expensive than any known, thoroughly practical, absolutely safe, proven successful. L. E. Chance, 4230 Ellenwood Ave., St. Louis, Mo.

NEW Improved door catch. Very simple. Best offer takes it. Harold W. Bergmann, 3658 South Western Ave., Chicago, Ill.

MANUFACTURER Wanted for new type engine. W. M. Culver, Inventor, 1010 N. Wood St., Chicago, Ill.

OUTRIGHT Or royalty—Window locking and adjusting device. Key locks window when closed or open. J. Hochberger, 7643 S. Marshfield Ave., Chicago.

OUTRIGHT Or royalty—Fountain shaving brush. Clyde Ormond, Rigby, Idaho.

OUTRIGHT Or royalty newly patented closure lock for pencil boxes. Milton H. Borzin, 1800 So. Fisk, Chicago.

AUTOMATIC Electric advertising machine and street annunciator for street cars. R. O. Fortune, 569 Margaret St., Los Angeles, Calif.

OUTRIGHT Or royalty—New type demountable rim. Will revolutionize wheel industry. Simplifies tire changing. Involves little manufacturing cost. Ivan Hancock, Route 39, Zionsville, Ind.

DISHWASHING Machine, simplest. William Stokes, 6919 Hawthorne Ave., Hollywood, Calif.

PATENTED Game, and city residential mail box, patent pending. Royalty. Linnie D. Nix, 1509 Wood St., Dallas, Tex.

FOR Sale—Patented mosquito bars for cot. Rees Pritchard, 313 W. 8th St., Chester, Pa.

OUTRIGHT Or royalty. Sheet-metal paper bag holder for kitchen garbage disposal. Replaces all existing garbage cans. Patent applied for. W. R. King, 521 Mercantile Bank Bldg., Dallas, Tex.

PATENT Pending. Dustproof sandblast helmet; outright or royalty; greatly needed, stamping job. Friedrich Dumin, 630 Superior Ave., Sheboygan, Wis.

1929 PATENT For sale—Emergency waterproof paper umbrella. Universal appeal. Big repeater. Everybody buys. Perpetual resale. Enormous production. Manufacturing cost 3c. Retail big. Profit 15c. Responsible parties only. 419 Third Ave. South, Clinton, Iowa.

ELECTRIC Thermostat snap, make and break, alternating or direct current, for irons, percolators, etc. Mfg. Cost 25c. For information write Arley Hook, Upper Sandusky, Ohio.

OUTRIGHT Or royalty, atomizer for internal combustion engines; attach to intake valves. Sale on sight attachment. E. Heaton, 859 6th, Bremerton, Wash.

FOR Sale—Patent on "I Love You" spinning charm. The greatest novelty yet patented. Jens Tonnefoss, Klamath Falls, Oreg.

FOR Sale: Valve grinder; invented by college professor. Frederick Booth, Room 1411, 631 St. Clair St., Chicago, Ill.

SMOKER'S Receptacle; combined ash-tray, cigarette dispenser, match and cigarette holders. Stamping job. Sells on sight. Cash and royalty. William Goscener, 483 Jersey Ave., Jersey City, N. J.

FOR Sale—Automatic spark control for Model A Ford. Cost 50c to manufacture. H. S. Wilburn, 16 Fredonia Ave., Lynchburg, Va.

COMBINATION Motor truck, concrete and mortar mixer; establishing a new mixing principle and will prove a big money maker to manufacturer. Chas. Payne, 27 Fulton Ave., Waukegan, Ill., U. S. A.

TIME Counts in applying for patents. See pages 140 and 141. Clarence A. O'Brien, Registered Patent Attorney, Washington, D. C.

YOUR Idle patent can be turned into ready cash, quickly! One inventor sold his patent at a cost of only \$3.50. Send today for a free copy of our booklet, "Turn Your Patent Into Money." M. L. Rund, Mgr. Classified Advertising, Popular Mechanics Magazine, 200 E. Ontario St., Chicago, Ill.

MODELS AND MODEL SUPPLIES

MODEL Ship—Unusually pretty 16" Santa Maria, electric light in hollow of composition hull. Nothing to do but paint and rope. Pictured directions for roping. Kit \$7.50; without light, \$6.50; completely finished \$15.00. Dr. Irl J. Neal, Mattoon, Ill.

EXPERIMENTAL Work, designing and working models. Specialty automobile, marine, airplane motors and accessories. 25 years' experience. Green Engineering Co., Dayton, Ohio.

MODELS, Tools, machinery or parts made to order. Arthur Schmidt, 61 Park Place, New York, N. Y.

WORK With master machinist; 15 years experimental experience, well equipped shop. Albert Weiss, 161 W. 21st St., New York City.

MODEL Steam engines and boilers for miniature power boats. Boat and boiler fittings. New catalog 15c. Model Machine Shop, 213 Price St., Rahway, N. J.

MODELS. Experimental work. Equipped for complete machine construction any description. Hult & Company, Machinists, 115 South Clinton, Chicago.

THE Modelmaker, a magazine for all interested in making working models, boats, etc. Sample 10c. Modelmaker, 122 Liberty St., New York.

MODEL and experimental work at lowest cost. Wagor Model & Machine Works, 115 So. Clinton St., Chicago.

SPECIAL Machine builders, tool and die makers, inventors' models production work of all kinds. Dept. L, Quality Hardware & Machine Corporation, Ravenswood and Thorndale Aves., Chicago, Ill.

SHIP Model Fittings: Send Dime for booklet. A. J. Fisher, 1002 Etowah Ave., Royal Oak, Mich.

WE Make working models for inventors and do experimental work and carry a complete stock of brass gears and model supplies. Send for catalog. The Pierce Model Works, Tinley Park, Ill.

TIME Counts in applying for patents. See pages 140 and 141. Clarence A. O'Brien, Registered Patent Attorney, Washington, D. C.

MANUFACTURING

SPECIALTY Manufacturing. Models, dies, stampings, casting, screw machine, wire products, plating, enameling and assembling very reasonable. Quantity production. Estimates promptly furnished. Satisfaction guaranteed. Majestic Products Mfg. Company, Box 877, Chicago.

MACHINE Work, special machines, models, electric welding. T. A. Oberhellmann, 1025 N. 6th St., St. Louis, Mo.

MANUFACTURING Models, dies, stampings, brass work, one or thousands. Circular free. Baum's Metal Specialties, Kansas City, Mo.

WE Will manufacture and market your ideas. Write us. Ezy-Set Wall Tie Co., Dayton, Ohio.

SPECIAL Machinery or parts, dies, tools, metal specialties, models, special gears, stock gears and model supplies. Send for Catalogue. The Pierce Model Works, Tinley Park, Ill.

WIRE goods made to order. Cooley Mfg. Co., 530 N. Western Ave., Chicago.

MACHINERY, TOOLS AND SUPPLIES

NO. 14 1/2 Becker universal milling machine, with dividing head, complete, \$450.00; 16"x8" Prentice engine lathe, \$175.00; No. 69 Heald grinder, \$275.00; 20" Hendy shaper, \$225.00; 24" Barker back geared crank shaper, \$400.00; 20"x8" Bradford engine lathe, complete, \$275.00; 20" Barnes drill press, complete, \$65.00; Quincy air compressor with tank and hose, \$65.00; 19" bench drill press, \$19.00. Terms to suit. Write for catalog. Cincinnati Machinery & Supply Co., 27 West Second St., Cincinnati, Ohio.

CONCRETE Building block machines and molds. Easy payments. Catalog free. Concrete Machine Co., 5 North Main St., St. Louis, Mo.

START business of your own, small investment required, doing nickel, copper and silver plating. This work in big demand. Information free. Electro Platers Supply Co., 547 Considine Ave., Cincinnati, Ohio.

SMALL Power bench type punch presses, \$75.00. Circular. Allen Industries, Independence, Mo.

ENGINES, MOTORS AND DYNAMOS

NEW With pulleys, 1/4 horse, 110-volt, alternating motors, cord and plug, \$7.00. 32 and 110-volt General Electric, 500-watt, 1,750 speed generators, \$18.50. 1-3 horse, 110-220 volt, 1,750 speed, repulsion-induction, alternating, heavy-duty motors, \$12.00. Write for quantity discounts or quotations on others. Electrical Surplus Company, Dept. 12, 1911 Chicago Ave., Chicago.

BARGAINS—Elec. drills \$11.95; bench saw outfit \$7.35; elec. bench grinders, \$13.20; combination lathe, \$8.15; scroll saw, \$5.60; motors, generators, farm plant equipment; flexible shafts; 100 other bargains. Send for special bargain bulletin. Acme Tool Co., 627 W. Washington, Chicago.

EDISON Phonograph motors with speed governor, Westinghouse dictaphone motors, both universal motors, \$5.00 plus express 10 lb. Geo. Schulz, Calumet, Mich.

BRAND New a.c. motors 1/4 horse \$7.00; 1/2 horse \$16.00. 32v. motors 1/4 horse \$8.50; 1-6 horse \$6.50; 32v. motors with emery buffer, drill chuck \$6.50. 750 watt 32v. ball-bearing generators \$24.50. Converters 32v. d.c. to 110v. a.c. \$35.00. Large stock motors and generators. Queen City Electric, 1736 Grand Ave., Chicago.

ELECTRIC Motors—Yours for rewinding or make your own quarter, half and one horse-power electric motors. A.c. induction motor winding models show winding connections plain sight. Learn quick, easy way. Gaines Bros., Box 481, Gainesville, Tex.

ELECTRIC Motors, reconditioned equal to new. A.c. or d.c. 1/4 hp. \$3.50; 1/2 hp. \$16.00. 3/4 hp. \$18.50, 1 hp. \$24.00. Others to 10 hp. Also motors rebuilt, repaired, armature winding. Tell us your motor problems. Temps Brothers Motor Company, One Martin Ave., Glendale, Long Island, New York.

NAVY Surplus 800 new radio generators, d.c. and 500 cycle. Unusual prices. Literature. Henry Klengle, 501 East 84th St., New York.

STEAM Engines—One H. P. \$18.00; 1/2, \$12.00. James Chambliss, Bessemer, Ala.

ONE Horsepower, four cycle, air-cooled engines, complete, \$35 each. Warren Onan, 43 Royalston Ave., Minneapolis, Minn.

AUTO Engines make excellent power plants in the shop, mine, mill or farm, but they need governing. We make the governors for \$10 up. Fit any make of engine. See advertisement below.

GOVERNORS For auto engine when used for power plants. Circulars. Candee-Smith Governor Co., 215 W. Manchester Ave., Los Angeles, Springfield, N. Y., or St. Catharines, Ont.

TIME Counts in applying for patents. See pages 140 and 141. Clarence A. O'Brien, Registered Patent Attorney, Washington, D. C.

MOTORS: New General Electric 1/4 hp., \$8.95; 1/2 hp., \$24.85; 1 hp., \$31.50. Mail \$3. Will ship C. O. D. anywhere. Motor Specialties Co., Crafton, Penna.

BENDING MACHINES

THE Famous Hossfeld "Wrenchless" Universal Iron Bender is the last word in bending machines. Bends metal, cold or hot, into most any conceivable shape, including Eye Bolts and Automobile Spring Eyes. Bends up to 1" bars or 1 1/2" pipe cold. Thousands in use by all classes of trade, from the smallest shops to the largest railway systems. Write for circular and prices. Hossfeld Mfg. Co., Winona, Minn.

SURVEYING INSTRUMENTS

LARGEST Stock of new and used surveying instruments in the country direct from factory. Satisfaction guaranteed or money refunded. Also farm levels. Wissler, 619 N. Broadway, St. Louis, Mo.

BARGAINS. Rebuilt transits and levels. Guaranteed. All makes. Cash or terms. Write for descriptive list M-35. Warren, Knight Co. (Manufacturers of "Sterling" Transits and Levels), 136 N. 12th St., Philadelphia, Pa.

LUMBER

CABINET Woods, 20 samples; walnut, mahog., chestnut, etc. Fancy inlay woods, 20 samples; tigerwood, ebony, satinwood, vermillion, etc. Either set one dollar, post-paid. Kiln-dried wood, cut to size. Send for list. Craftsman Wood Service, 715A E. 62nd St., Chicago.

FARMS AND FARM LANDS

FARMS—Cut-over and timber lands cheap. 40 acre farm 400 dollars. Good unimproved lands \$10.00 per acre. Terms six per cent. J. D. Smith, Marianna, Fla.

FARMS—40 acres Missouri \$5 month; own a home. Jarrell, Mount Vernon, Ill.

WANT To hear from owner having farm for sale; give particulars and lowest price. John J. Black, Box 52, Chippewa Falls, Wis.

FREE Books, descriptive of the opportunities offered homeseekers and investors in Minnesota, North Dakota, Montana, Washington and Oregon. Low round-trip homeseekers' tickets every Tuesday. E. C. Leedy, Dept. 157, Great Northern Railway, St. Paul, Minn.

CALIFORNIA—Small fruit and poultry farms in community of 6,000 near Los Angeles; 5 advisers. U. S. rabbit exp. station; co-operative buying and marketing. Free illustrated booklets. Write owner, Fontana Farms Co., 631 (R) S. Spring, Los Angeles, Calif.

MONEY made in Mich. potatoes. \$10 down now and easy terms buys land near markets, lakes, streams. Write today. Swigart & Co., P-1276, 1st Nat'l Bank Bldg., Chicago.

PECAN—Orange-fig groves "On the Gulf" Monthly payments. Guaranteed care. Big, quick returns. Suburban Orchards, Dept. M, Ocean Springs, Miss.

OZARKS—10 acres near White river and proposed power dam, \$100, \$5 monthly. Alvin Zimmerman, 1802 N. 5th, Kansas City, Kans.

GET Quick cash sale for your property anywhere. Details free. Write Fisher Agency, Hannibal, Mo.

SELL your property quickly for cash, no matter where located. Don't pay big commission. Particulars free. Real Estate Salesmen Co., Desk B, Lincoln, Nebr.

CALIFORNIA Fruit and poultry farms on hard surfaced streets with gas, electricity, water and all city conveniences at Muscoy adjoining city limits of San Bernardino, population 43,000, east of Los Angeles. Send for 36 page book free. J. B. Roof, Inc., Owners, 708 Quinby Bldg., Los Angeles, Calif.

ROOTS AND HERBS

HERB Doctor book—10 cents, 250 recipes for making herb medicines. Hazzard Company, Box 1, Vanderveer Park, Brooklyn, N. Y.

MUSKRATS

MUSKRATS—Make big money dry farming muskrats in your back yard. Complete course of instructions sent for a dollar bill. Insures success. Dolson Fur Farm, 320 Capitol Bldg., Cedar Rapids, Iowa.

MAKE Money From Muskrat Fur—Raise Muskrats in dry land pens or hutches. Get the facts. 652, Conrad's Ranch, Denver, Colo.

RABBITS

MAKE Big profits with Chinchilla rabbits. Real money-makers. Write for facts. Fox Farms, Inglewood, Calif.

MAKE big profits with Chinchilla Rabbits. Real Money-makers. Write for facts. 852 Conrad's Ranch, Denver, Colo.

POULTRY, EGGS AND GAME

RINGNECK Pheasant eggs, 35c each; mallard duck eggs, 25c each. Free catalog on wild game and muskrats. Wagner Game Farm B, 105 W. Adams, Chicago.

DOGS AND PETS

BEAUTIFUL Shepherds (police dogs), all ages, reasonably priced. H. Mount, Adena, Ohio.

WHITE Collies and other colors. Beautiful and useful. Dept. P, Shomont Kennels, Monticello, Iowa.

NEWFOUNDLANDS? Puppies? Pedigreed, registered. No duty, photos sent. Brockington Kennels, 181-P McKenna, Montreal, Que.

FLYING Squirrels—For pets or show. Stamp for booklet. Wildwoods Fur Farm, Woodville, Tex.

DOGDOM—America's greatest dog magazine. Established 1900. Monthly. Fully illustrated. Single copies 20 cents; \$2.00 a year; Canada, \$2.25; foreign, \$2.50. Dogdom, 612 City Bank Bldg., Battle Creek, Mich.

SEIFERT Roller canaries. Free booklet and prices on raising canaries. Canary Breeder's Co., Not Inc., LaGrange, Ill.

HUNTING Hounds cheap; trial. Literature free. A7, Dixie Kennels, Herrick, Ill.

RAISE Guinea pigs; easy to raise; little space required; very profitable. Particulars and booklet how to raise free. Cavies Distributing Co., 3102 C. C. Station, Kansas City, Mo.

ST. BERNARD Puppies! Registered thoroughbreds, priced reasonable, duty free. Photos submitted. Write Helvetia Kennels, Dept. P, Napierville, Que.

WANTED—MISCELLANEOUS

HUNDREDS Of people have sent their old gold, silver, platinum jewelry, dental work to me. Why not mail yours today? Highest prices paid. Satisfaction guaranteed or goods returned. F. Polcer, 2408 South Cicero Ave., Cicero, Ill.

CONCERN Wishes novelties, small articles, tricks, games, etc., suitable for mail order. Send samples and prices. J. Kelly, 1116 Carroll St., Brooklyn, N. Y.

MAIL Us your discarded jewelry, gold, crowns and bridges, watches, diamonds, silver, platinum. Money promptly mailed. Goods returned if offer refused. United States Smelting Works (The Old Reliable), Dept. 71, Chicago.

FOR SALE—MISCELLANEOUS

ADDRESSOGRAPHS, Letter folders, multigraphs, envelope sealers, duplicators, less than half price. Guaranteed. Pruitt Co., 117 No. Wacker Drive, Chicago.

FAMOUS Dyke's Automobile Encyclopedia—Latest 15th edition. Fully revised to cover all latest facts regarding newest developments, including new Model A Ford. Information given on repairing and adjusting every part of all motor cars. How to find trouble and fix it. 1,250 Pages, 4,200 Illus. Price, cloth, \$6. Flexible Morocco \$7.50. Will be sent C. O. D. anywhere in U. S. Pay postman price and postage when he delivers book. Popular Mechanics Press, Room 805, 200 E. Ontario St., Chicago.

HEALTH

SAFEST. Cheapest, surest cure known. Dime brings "Nature's Way." Health Bureau, Wood Bldg., Glenside, Pa.

PERSONAL

TOBACCO Or snuff habit cured or no pay. \$1.50 if cured. Remedy sent on trial. Superba Co., N3, Baltimore, Md.

ADVICE. Information, any subject, 25c coin. References. Fred Klotz, Reading, Pa.

FURNITURE—Make furniture at home. Popular Mechanics books tell how to make all pieces. "Mission Furniture and How to Make It." Book 1, Book 2, Book 3. Send no money. Just write a postal. Pay postman postage and \$3. Popular Mechanics Press, Room 810, 200 E. Ontario St., Chicago, Ill.

THE "Sanatory Physician," an 80-page book teaching natural laws of health, also suggests reliable self-treatment of disease. Appreciated by every reader. Mrs. S., Denver, Colo., says: "I owe my regained health to that dear little book." Postpaid 20c. Address Author, 320 James St., Seattle, Wash.

ARE You old at forty? See our advertisement on page 75 of this issue. The Electro Thermal Company, 2117 Morris Ave., Steubenville, Ohio.

PEN Picture of yourself by cartoonist 8x10. Send photo and 50c coin. E. Hildreth, 2136 Clinton Ave., New York City.

TOBACCO Or snuff habit cured or no pay! \$1.50 if cured. Sent on trial! Frances Willard, 5724 1/2 Lemon Grove, Hollywood, Calif.

MEDICINAL Herbs, roots, barks, flowers, etc., for many ills. Over 1,000 varieties. Write for catalog. Botanicals Co., 145 W. 112th St., Chicago.

RUDDY Cheeks without cosmetics, and how to keep the teeth sound, 10 cents. A. Wildman, Deerbrook, Wis.

INGROWING Nails or bunions, painless correction by removing the cause then aiding nature, full information free. Write Eugene Eaton, D106 Randon, Ore.

ELECTRICAL Kinks on all phases of practical electricity. 47 ideas on wiring, 45 on making electrical devices, 19 on lighting, 5 on transformers, 5 on motors, 8 on generators, 11 on switches, 22 on testing, 12 on repairing, 11 on battery manufacture and repair, 3 on telephones, and 9 on electricians' tools. 214 articles, 162 pictures. Send no money. Just write postal for "Electrical Kinks." Pay postman postage. 895, 290 E. Ontario St., Chicago, Ill.

MISCELLANEOUS

MIRRORS Resilvered at home. Costs near 5 cents per square foot; you charge 75 cents. Immense profit plating autotarts, reflectors, tableware, stoves, refinishing metalware, etc. Outfits furnished. Details free. Write Sprinkle, Plater, 288, Marion, Ind.

"EVER Sharp" lawn mower is a blessing. We have it. 25c coin brings it. Shaw Mfg. Co., 316 Randolph, Maywood, Ill.

KILL Rats and mice. Destroy roaches. We manufacture and sell guaranteed products. Medium size, 50c each. Large 1-lb. container, \$1.00. 5 lbs. and upwards, 80c a pound. Henry Weiss & Co., 824 Park Ave., Weehawken, N. J. (a)

JEFFY Stripper, speedy and sure; used by striping artists and painters of Flint, Mich. Send for sample striping. Complete set \$10.00, check or C. O. D. E. M. Reeves Co., Flint, Mich.

TATTOOING Outfits, supplies. Illustrated list free. "Waters," 965 Putnam, Detroit.

TIME Counts in applying for patents. See pages 140 and 141. Clarence A. O'Brien, Registered Patent Attorney, Washington, D. C.

ARTISTS And art students are printing 250 signs or pictures an hour without machinery. Sample and particulars 10c. Straco, 1013 Mulberry, Springfield, Ohio.

25 COPIES Your photograph \$1.00. Sample 6c. Stanley, 13 Kirkland St., Boston, Mass.

WONDER Polish for polishing out scratches, pressed nicks, stains, etc., on automobiles, furniture and manuring nails, 25c postpaid, 344 84th St., Brooklyn, N. Y.

CARTOONS, Illustrations, sample only 50c. Smith Cartoon Service, Calhoun, Tenn.

FREE Prize, Steady income, taking orders. Attractive folio. Bon Delaine Stationers, 35 West Park Station, Cleveland, Ohio.

SHOP Notes for 1929. Get your copy now. Only a limited edition. Contains all the articles published in the Shop Notes department of Popular Mechanics Magazine during 1928. Send 50 cents. If you want the entire set of Shop Notes books consisting of 16 volumes including the 1929 number and 15 others issued previously we will send them C. O. D. at a special reduced price of \$5. Popular Mechanics Press, Room 895, 200 E. Ontario St., Chicago, Ill.

SAVE \$ Leggett's vanilla—The flavor supreme. Universal favorite since 1895. Delicious. Vanilla process, Pint \$1.00 postpaid. Satisfaction guaranteed. Leggett's Flavors, Princeton, N. J.

WEEDS—Cut them with cutter bar on Shaw Garden Tractor. Also plows, cultivates and runs belt machinery. Low prices. Immediate delivery. Shaw Manufacturing Company, Dept. C, Galesburg, Kans.

CASH Paid for Butterflies, Insects. See Sinclair Display Advertisement on page 18.

HOMEOPATHIC And Biochemic preparations sent postpaid to all parts of the world. Manual and booklet free. Halsey Bros. Co., 5547 Ravenswood Ave., Chicago, Ill. Established 1855.

THAT Concrete Job. Don't be afraid to tackle it. With the instructions found in Popular Mechanics Concrete Handbook you can make 173 articles of utility and beauty ranging from ordinary steps to garden furniture. This book will be sent for only 98c plus postage C. O. D. Send your order today to Popular Mechanics Press, Room 895, 200 E. Ontario St., Chicago, Ill.

AMATEUR Cartoonists: Sell your cartoons. New market. Smith's Service, PN-1194, Wenatchee, Wash.

GOLD Finishing. Composition, molds; \$1.00. Hardacker, Box 717, East San Diego, Calif.

CUTS Anybody can make. Simple, cheap process, \$1. Specimens, particulars. 2c stamp. M. Day, Windfall, Ind.

HYPNOTISM Taught in all its branches. First lesson \$1. Dr. Mundell, 5851 Wentworth Ave., Chicago.

MEXICAN Made holsters, lariats, horse-hair articles; rattlesnake belts. Send four cents for illustrated list. Tex-Mex Leather Co., 309 Esperson Bldg., Houston, Tex.

TELL An army of 3,000,000 live readers all about your offer! If you have anything to sell, buy or exchange, or if you have any reasonable proposition, tell our readers all about it—they'll respond quickly. Our booklet "How to Create More Business" contains some very interesting, helpful facts. Write today for your copy—it's free. M. L. Rund, Manager Classified Advertising, Popular Mechanics Magazine, 200 E. Ontario St., Chicago, Ill.



Pick the Radio Job You Want... and fill it...in 9 months!

Free!

Mail the Coupon now
... for this free book.



cause they are posted right up to the minute in everything in radio. Radio's progress each year is measured by the accomplishment of the great engineers at work in the research laboratories of the Radio Corporation of America. This world-wide organization sets the standard for the industry... and stands back of every lesson in the course! A signed agreement by the president of the school assures you of complete satisfaction upon completion of the training—or your money will be promptly refunded.

RADIO INSTITUTE OF AMERICA
326 Broadway, N. Y.
Dept. PM-5

RADIO INSTITUTE OF AMERICA, Dept. PM-5
326 Broadway, New York, N. Y.

Gentlemen: Please send me your big FREE 50-page book which tells about the brilliant opportunities in Radio and about your famous laboratory-method of guaranteed radio instruction at home.

Name

Address

Learn to Fly



with Air Mail Pilots

Private School of NATION'S LARGEST AIR LINE OPERATOR

TODAY more properly trained men are needed to take the controls of and maintain T-A-T Air Mail and Passenger planes. Routes of the FIVE T-A-T Companies, including Air Mail Routes CAM 21-22-23 and 29,

require 10,000 miles daily flying. Such activity demands a large active and reserve personnel. Scarcity of properly trained men made it necessary to establish our own school.

Air Mail Pilots and Licensed Mechanics Instruct: Classes are purposely kept small, allowing close personal supervision of each student's work. Instructors are all veteran Air Mail Pilots and licensed mechanics, picked because of their special ability to give to others their knowledge of aviation.

NEW, Safe Training Planes—Many types: From the smaller dual control Travel Air and Curtiss Robin planes used in primary flying, students progress to many other makes and types of large transport and fast pursuit planes.

Ground School and Mechanical Courses: Practical shop work in the same completely equipped shops where T-A-T planes are maintained gives students first hand actual experience. All subjects necessary for a transport license are thoroughly taught, lectures are given and text books studied.

Six Courses Are Offered: Time required ranges from thirty days to six months. Prices, from \$75 to \$2,000. Write today for illustrated booklet, "Flying the Golden Trail," giving full details about the T-A-T Flying School.

FLYING SCHOOL

Incorporated

Fort Worth
Dallas

San Antonio
Houston

**611 FT. WORTH NATIONAL BANK BLDG.
Ft. Worth, Texas**

Send me your fully illustrated FREE Booklet.

Name.....
Address.....
City..... State.....
Age..... Occupation.....

A guaranteed 10-Cable CHEST PULL (the most powerful one ever manufactured), adjustable up to 200 lbs., that will quickly develop muscles of shoulders, arms, abdomen and back—

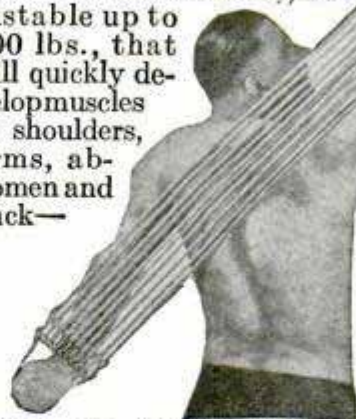

both only \$3.95



and a pair of patented HAND GRIPS for developing powerful grip and forearms . . . all for only \$3.95. Free illustrated Course of Instruction also included.

5-Cable Chest Pull and pair of Hand Grips for only \$1.95. ORDER TODAY!

Fred A. E. Korth, 1139 Tiffany St., New York City

SHOWCARD CARTOONIST

A New Book just chock full of ideas, better methods, short cuts,—shows you how to make cartoons and comics that give show cards and posters a real selling punch. You'll use it.—write now for Show Card Cartoonist, \$1.25 postpaid. Another good one!—"Their Best Stunts," by 25 successful chalk talkers, \$1.25 postpaid. Two new catalogs: A—Art Supplies, S—Show Card Supplies.



BART SUPPLIES, 518 EUSTIS BLDG., MINNEAPOLIS, MINN.

QUIT TOBACCO



No man or woman can escape the harmful effects of tobacco. Don't try to banish unaided the hold tobacco has upon you. Join the thousands of inveterate tobacco users that have found it easy to quit with the aid of the Keeley Treatment.

KEELEY TREATMENT STOPS Tobacco Habit

Quickly banishes all craving for tobacco. Write today for Free Book telling how to quickly Free yourself from the tobacco habit and our Money Back Guarantee.

**THE KEELEY INSTITUTE
Dept. A-921 Dwight, Illinois**

Eight Instruments in One—that's the OCTOFONE

IF YOU play the "uke," tenor guitar, tenor banjo, mandolin, mandola, mando-cello, tiple or taropatch—then you can play the OCTOFONE. It tunes and plays like any one of these instruments, but has a wonderful, mellow tone of its own. The OCTOFONE is great for solo or ensemble playing and for voice accompaniment. Adds new tone qualities to any dance orchestra.



Easy for Beginners—Free Instruction Book shows you!

OCTOFONE FREE INSTRUCTION BOOK!

\$15.00

No obligation. Mail coupon to:
Regal Musical Instrument Co.
3207 W. Grand Ave., Dept. 1001E, Chicago

He Clipped This Coupon



Charles F. Worthen

American Business Builders, Inc.,
 Authorized Capital \$500,000
 Dept. 4-AA, 18 East 18 St., New York.

Send me—without cost or obligation—your free illustrated book, "How to Become a Real Estate Specialist."

Name *Charles F. Worthen*

Address *242 Third St.
 Fall River Mass.*



and Made \$8,500 in 17 Weeks!

C. F. Worthen deserves success.

When he read my ad in the *American Magazine*, he was wise enough to answer it.

He clipped the coupon. He got my free book. He enrolled for my course. He followed my instructions. Now he is out of the rut of routine work and poor pay. Now he has a splendid business of his own. Now he is making more money than he ever thought possible.

If you want to do what Worthen did, send for this remarkable book of business opportunity. Learn the secret of his success. Use my money-making system. Begin at home. In your spare time. No capital—no experience—no special ability needed. Start now. Free book tells how.

Success Without Capital, Experience or Education

C. F. Worthen is not the only one I have put on the high road to real estate success.

Hundreds of ambitious men and women—young and old—have followed my instructions and are now reaping rich rewards—in business for themselves—independent—prosperous—happy.

Mrs. Evalynn Balster, a widowed Illinois school teacher, with three children to support, made \$5,500 her first deal, using my amazingly successful real estate sales system.

"Bill" Dakin, of New York, worked in a steel mill before he got his copy of this free book. Now he is a successful Real



Own a new business of your own. Be a Real Estate Specialist. Begin now in your spare time. My new book, giving full information and positive proof of amazing success, mailed free.

Estate Specialist. Owns his own business. Has a new automobile. Making more money than he ever dreamed he could.

E. G. Baum, ill and discouraged, past 50, lost his job as a bookkeeper. Sent for my free book. Made \$8,000 his first year in real estate.

H. D. Van Houten, New Jersey, formerly a grocery clerk, got my free book, followed my advice, and did a gross business of over \$100,000 his first year in real estate.

But I have no more room here to tell you about the many remarkable stories of amazing business success

that are coming to me from readers of my free book. So, send for a copy of it today. Don't be skeptical. Don't say, "It's too good to be true." Don't cheat yourself. It costs nothing to learn the truth. So mail the coupon now!

My Book Costs You Nothing

If you had to pay \$10 for this book, and take a whole day off to read it, it would pay you to do so. But you don't have to do that. You get the book for nothing if you mail the coupon promptly. And you can read it in thirty minutes. And I guarantee that you will find it the most fascinating book of business opportunity and business success you ever read.

Get this book at once. Learn what it has done for others. Learn what it can do for you in the way of business success—independence—big earnings—cash profits.

Others who have sent for this book have revolutionized their business lives—climbed out of the rut of obscurity—built substantial businesses of their own—made more money in a week or a month than they formerly made in a whole year of hard work.

Perhaps this book will do as much for you.

It costs you nothing to find out! Address me personally, President, AMERICAN BUSINESS BUILDERS, INC., Dept. E-44, 18 East 18 St., New York.

\$1,000 Reward

Here's the proof that this is the biggest money-making opportunity of all: one thousand dollars in gold will be paid to anyone who shows us any other business course of any kind that has helped as many men and women make as much money in as short a time as our remarkably successful Real Estate Course.

American Business Builders, Inc.



Mail This for Free Book!

President, American Business Builders, Inc.
 (Authorized Capital \$500,000.00.)
 Dept. E-44, 18 East 18 St., New York.

Please send me—without cost or obligation—a copy of your book which shows me how to get into real estate, without capital or experience, and make more money than I ever made before.

Name.....
 Please print or write plainly.

Address.....

(Get This Free Book! Blame Yourself if You Don't!)

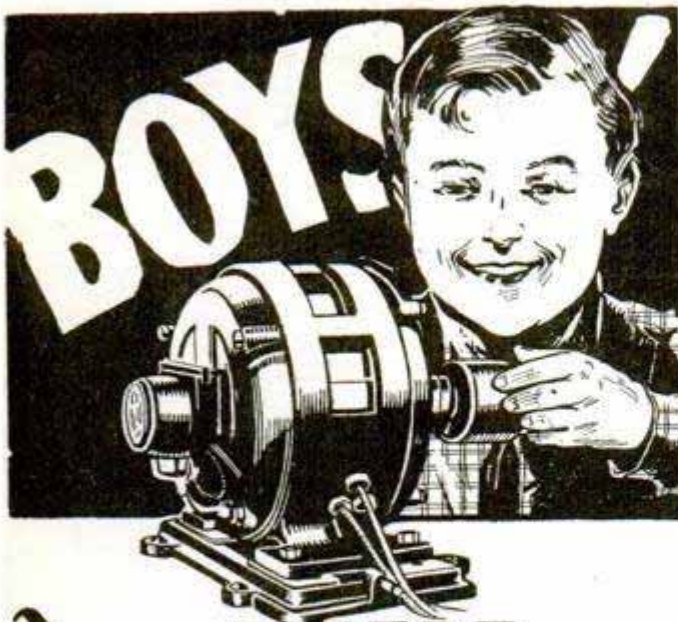

Here's FUN and SPENDING MONEY

How'd you like to have a pocketful of spending money all the time—\$5 or \$10 or even \$15 every week—all your own—and a lot of real fun at the same time! It would be great, wouldn't it? Well, you can have it! Hundreds of boys still in school are getting it! And they're no different from you except that they are "Cooke" Trained—they know how to do little electrical jobs in their spare time, after school hours, for which they get real money. I showed them how. And I'll show you, too, just as easily!

I Will Train You at Home

With my easily learned, fascinating Electrical Course, I'll train you at home like I've trained hundreds of other boys who are now successful men with jobs paying \$60 to \$100 a week! It's all done after school hours, without interfering with your school work or with your regular job if you're working. And it's more like play than study. But it's practical. It's sound. It's up-to-the-minute. It fits you thoroughly to land a Big-Pay job when school days are over. And it pays for itself as you learn and gives you plenty spending money besides, through the spare-time work I tell you how to get, how to do and what to charge for.

Tools—Apparatus and Radio Course—Given Without Extra Charge

You'll need tools to do Electrical work with, so I give them to you—six big outfits of instruments and apparatus, and a real electric motor—a dandy layout that you can do any kind of spare-time work with—and it's all yours for "keeps." And not only that, but I also give you a brand new Course in Radio! All without extra cost!

Makes \$200 a Month

"Dear Mr. Cooke: When I began with you I was a sophomore in High School. Was making \$40 a month as grocery clerk. Now I am a \$200 a month electrician. Not so bad for a 17 year old boy, eh?"
Oliver P. Cooper
1131 Middle St.
Ashland, Pa.

Mail Coupon Now!

You want lots of spending money! You want a Big-Pay job when you're through school! Sure, you do! Then don't wait a minute—don't hesitate a second—act right this instant to get into this Big-Pay field where you can make \$2 or \$3 or more spare-time money every day while learning. Mail coupon at once and I'll send you my big 72-page book and a sample lesson, too—All FREE. See for yourself how easy it is. Fill in and mail coupon this minute!

6 BIG WORKING OUTFITS
NO EXTRA CHARGE

Use this FREE BOOK COUPON

L. L. COOKE, Chief Instruction Engineer.
L. L. COOKE School of Electricity,
Dept. O15, 2150 Lawrence Ave., Chicago, Ill.

Send me your big Electrical Book, Sample Lesson and particulars about your Electrical Course and extra Radio Course. This does not obligate me in any way.

Name.....

Address.....

(This Coupon only for boys 15 years old or more)

WANTED!

Auto Paint Shop Managers

Any honest, ambitious man with good reputation can
EARN \$90 A WEEK

as manager of one of our auto paint shops. Nation-wide chain of shops now being organized. Prefer men without painting or executive experience. We train you—and the men who work for you. Only your spare time required for instruction. Get details now—be the first in your community. Write G. Klig Franklin, Supt.,

AMERICAN AUTO PAINT SHOPS,
Dept. 2601, 427 S. Ashland Ave., Chicago, Ill.



2-YEAR-TO-ENGINEERING DEGREE!

Be a Civil, Electrical, Mechanical Administrative or Chemical **ENGINEER** in 96 weeks. No entrance examinations or high school diploma required. Low tuition expense. Degrees conferred by State authority. Catalog FREE.

TRI-STATE COLLEGE Box E-5113, Angola, Ind.

STOPS FALLING HAIR

Lucky Tiger Knocks Dandruff and Scalp Irritations like Whyte-Fox (1 and 2) Medicated Massage heals skin eruptions, and No. 2 Whyte-Fox knocks piles in 2 to 3 weeks. Used and endorsed by millions. Money-Back Guarantee. Write for free booklet. At Barbers, Druggists, Beauty Parlors.



Kansas Dept. City, Mo. **LUCKY TIGER REM. CO.**



STOPS ACHE—SUPPORTS BACK THE NATURAL BODY BRACE

Takes strain off the back, the abdomen; relieves nervousness, constipation. Gives wonderful sense of relief and well being. For men and women.

COSTS NOTHING TO TRY IT

Write for our 30 days free trial offer, free illustrated book, measurement blank, etc.

NATURAL BODY BRACE CO.

Howard C. Rash, Pt., 77 Rash Bldg., Salina, Kansas

Skin Troubles

Cleared Up—often in 24 hours. Pimples, Blackheads, Acne Eruptions on the Face or Body, Barbers Itch, Eczema, Enlarged Pores, Oily or Shiny Skin. "CLEAR-TONE" has been tried and tested in over 300,000 cases. Used like toilet water. Is simply magical in prompt results. At All Druggists—with Proven Directions. You can rely on "CLEAR-TONE" for Skin and Complexion. Manufactured by GIVENS CHEMICAL CO., Kansas City, Mo.



CORRECT Your NOSE

to perfect shape while you sleep. Anita Nose Adjuster guarantees SAFE, rapid, permanent results. Age doesn't matter. Painless. 68,000 doctors and users praise it. Gold Medal Winner. Write for FREE Booklet and 30-Day Trial Offer. **ANITA INSTITUTE**

E-12 Anita Bldg. Newark, N. J.

Earn \$5,000 a year in photography and photo-engraving

"After 6 months in your school I was employed in a studio; I am now owner."—A. Z. P. Our 6 to 8 months course prepares men and women for fascinating big-pay work in photography or photo-engraving. Thorough, practical training, moderate cost. Graduates in demand. 35th year.

Illinois College of Photography, Box 459, Effingham, Ill. Please send me free catalog with stories of graduates' success.

Name.....

City..... State.....

INVENTORS

FOLLOW THIS STRAIGHT ROAD TO WEALTH FROM

PATENTS

**INVENTIONS
AND
PATENTS
—
WRIGHT**



Every inventor and mechanic—professional or amateur—should have this book. Here you find out just how to turn new ideas into money—how to protect yourself—how to get a patent—what to invent. Billions of dollars in royalties have been paid—*billions more* will be paid to professional and amateur inventors who know how to go about patenting their ideas in the right way.

There is no need for you to pay big fees that you can't afford just to be "shown the ropes." Here in one handy book you have the best advice obtainable—written by an editor of the Scientific American and member of the New York Bar—published by the outstanding technical publisher of the U. S. A.

How To Make Patents PAY

Here is a partial list of the money-making information fully covered in "Inventions and Patents" by Milton Wright:—

- How to Make Patents Pay
- Questions and Answers for Inventors
- Twenty "Don'ts" for Inventors
- Easy Ways of Preventing Infringement
- Inventing as a Profession
- How to Raise Capital
- How to Advertise
- How to Sell a Patent
- How to Choose a Patent Attorney
- What to Do When Inventions Conflict
- "Patent Pending"
- Inventor and Employer
- Traps Set for Patentees
- What Is a Patent Worth

How to Find a Buyer
When to Sell a Patent Outright
Territorial Rights—Shop Rights
Patenting Abroad

Complete with all necessary legal forms and quick reference index for inventors.

HIGHLY ENDORSED

Journal of the Patent Office Society:—"This valuable guide should be in every inventor's hands." Beulah Henry (famous New York inventor):—"Have read 'Inventions and Patents' three times. It has shown me how to make bigger royalties."

Henry L. Dubiner (Indianapolis, Ind.):—"If I only had had your book 20 years ago I would have been a millionaire today."

**2/3 ACTUAL
/3 SIZE**

"Inventions and Patents," by Milton Wright, LL.B., is here shown $\frac{2}{3}$ actual size. It is a beautiful, well-made special edition McGraw-Hill volume—maroon cloth bound, gold stamped; 255 pages. Our usual price is \$2.50—now reduced to \$1.98 in order to give this valuable and useful information the widest possible circulation.

Special Edition
Order Now While Supply Lasts

McGraw-Hill

Mail Today!

Tells You All You Need Know to Make Money and Protect Yourself

Don't take chances! Don't fail to collect royalties that are rightly yours. Let this valuable book be your guide and friend. Although a standard \$2.50 McGraw-Hill book, price is now reduced on this special edition to give "Inventions and Patents" the widest possible circulation.

SEND NO MONEY—Send only this convenient coupon. Money refunded if not entirely satisfied.

1.98
SPECIAL BARGAIN PRICE

McGraw-Hill Book Co.,
370 Seventh Ave., New York, N. Y.

You may send me "Inventions and Patents" by Milton Wright. I will pay postman \$1.98 plus postage on arrival. My money to be refunded if I am not satisfied.

Name.....

Address.....

P.M. 5-29

(If you prefer to send cash with order, enclose \$2.00 with this coupon.)

if-

you pledge

**yourself to secrecy we will
teach you the secrets of**

Real Professional

Magic



Dr. Harlan Tarbell, internationally known magician and teacher of some of the world's greatest magicians.

Be a Magician!

Earn \$250 to \$1000 a Month

For the first time in the history of Magic the age-old, sacredly guarded secrets of Mystic Art are being revealed. Now at last you can learn to be a Real Professional Magician. Yes, and you can learn this wonderful art *easily and quickly* AT HOME. You are taught the mysterious *Principles* by which the Professional Magician works. But before you can study, you must sign the Magician's Solemn Pledge of Secrecy. This means you are getting the *guarded secrets* of the Magic Profession.

Mail Coupon Below Now!

**Tarbell System, Inc., Studio 13-55
1926 Sunnyside Avenue Chicago, Illinois**

**Tarbell System, Inc., Studio 13-55
1926 Sunnyside Avenue, Chicago, Ill.**

Gentlemen: Without any obligation send me your free literature and information all about your wonderful "Tarbell Course in Magic." Also tell me about your Low Price Offer and Easy Payment Plan.

Name

Address

Age

Well Fixed for Life!

\$100 a Week

Steady Earnings

A Fine Pleasure

Car

A Beautiful

New Home

An Interesting

Business

**What More Could
You Want?**



**BERT FUNK
OF ILLINOIS
\$100 a Week**

A little over a year ago he married and took his bride to a beautiful new home he had built for her out of his Watkins profits. He is "well fixed for life" and says: "I would rather distribute Watkins Products than eat."

IS THERE any red-blooded man who doesn't want to be his own boss—keep all of his own profits?

BUT, lack of business experience, lack of capital or some other obstacle has always stood in the way.

With this mighty Company there is nothing to

hold you back. *You don't need capital or experience.* You simply supply such daily necessities as food products, soaps, cleansers, toilet articles and home remedies, etc., to long-established customers who welcome you. Orders are big, quick and easy.

Find out how you can become as well fixed as Bert Funk, with all the good things of life and big money right from the start. Do as Bert Funk did.

**If you want to make big money in this business
like Bert Funk—write today!**

**THE J. R. WATKINS CO.
Dept. CS45 WINONA, MINN.**

Stop Using a Truss

STUART'S ADHESIF PLAPAO-PADS are entirely different from trusses—being automatically continuous mechanico-chemico applicators of the herbal muscle-tonic "PLAPAO" to the affected parts. Made self-adhesive purposely to minimize painful chafing and dangerous slipping and to eliminate harmful pressure.

Comfortable when—
no straps,
buckles
or springs
attached.



Fabric
soft as
velvet—
easy
to apply.

For almost a quarter of a century satisfied thousands report success without delay from work. Stacks of sworn statements on file. Process of recovery natural, so no subsequent use for a truss. Awarded Gold Medal, Rome, Grand Prix, Paris, etc. Test of factor "PLAPAO" sent you **FREE** Mail Coupon below **TODAY.**

Plapao Co., 1307 Stuart Bldg., St. Louis, Mo.

Name

Address

Return mail will bring Free Trial "PLAPAO"

EARN UP TO
\$125
a Week
!



WE WILL TRAIN YOU IN A FEW MONTHS

Enter this uncrowded field of limitless possibilities—big demand for trained mechanical dentists—we teach you in a few months of personal instruction without books, how to make crowns, plates, bridge-work, etc., for dentists. Day or night laboratory schools in Chicago, Detroit, Cleveland, Philadelphia and Boston.

BIG DEMAND for MECHANICAL DENTISTS

Mechanical Dentistry is the laboratory bench work which the dentist turns over to the laboratory worker. Master this profession and help meet the demand of dentists for laboratory work.



Rubber Plates

Learn to make partial upper or lower plates with soldered, cast or wire clasps, with palatal bars; with lingual bars, etc.

Crowns

Here's only a small part of your practical training in Crown-work: Two-piece, seamless, open-face, Richmond, cast-base porcelain, Carmichael, split-pin, carved (swaged) cusp, cast cusp, etc.

Bridge Work

Complete training in both fixed and removable bridgework.

Metal Base Dentures

Cast bases of Aluminum, Watt's metal, etc., are included in your training. Both centrifugal and air pressure casting machines are used. Free Book contains complete list of subjects in course.

Send for Interesting Book

Read absorbing facts about mechanical dentistry—the laboratory benchwork that the dentist turns over to the laboratory worker, the making of plates, crowns, bridge work, etc.—why 64,000 dentists need laboratory work—how we train you in a few months, day or night for this growing, money-making field! Mail coupon today and get free copy of this handsomely illustrated interesting book giving complete details on Mechanical Dentistry—our low rates and easy terms.

McCarrie School of Mechanical Dentistry
1338 S. Michigan Ave., Dept. 277, Chicago, Illinois

One graduate writes that he earns **\$400 monthly profit**. Another that he makes as high as **\$45 a day**. A former bookkeeper after receiving our training **earned \$150 a week** in his own laboratory. You can enter this fascinating profession. We have hundreds of success letters from students telling how they made money after graduating from our schools.

64,000 Dentists Need Laboratory Work!

Only a few hundred Laboratories in all the U. S.—most of them in the larger cities. Dentists can't afford to do their own mechanical jobs. They can secure the services of a Laboratory Expert for about \$3.00 an hour and receive for their own time \$6 to \$15 an hour. Dentists will encourage you to learn mechanical Dentistry, start a "Lab" of your own, give them quicker service than sending their work to other cities. Dentists can't wait and keep their patients waiting.

Work Your Way Thru School

Some of our students work during the day and attend school at night. Others attend day school and secure spare time employment in the evening. There is always a way for the ambitious man and we assist you to secure employment that will help you to pay your way thru school. No matter what your occupation may be, this opportunity is open to you. Mechanical Dentistry paves the way to a successful career. Your name and address on the coupon is your next step.

McCARRIE SCHOOL of MECHANICAL DENTISTRY
1338 S. Michigan Ave., Dept. 277, Chicago.

Without cost or obligation, send me your illustrated book on Mechanical Dentistry, and complete information as to my opportunities in dental laboratory work.

Name.....

Address.....

SCHOOLS
IN
Chicago
Cleveland
Detroit
Boston
&
Phila.
MAIL
THIS
COUPON

Build a Glider and WIN a FREE COURSE in AVIATION!

**Everybody
Can Enter!**



FLYING ACES, the most popular aviation story magazine ever published, is conducting a nation-wide Glider Contest among boys and young men. Everyone can enter. Great sport building a glider in which you can actually fly! Send coupon and 25c for 64-page Book which tells you how to build and fly a winner.

Read Full Details in
FLYING ACES
The Magazine of Thrilling Aviation Stories

Buy a copy of **FLYING ACES** at any newsstand. Read all about this great contest. First Prize is a FREE course in aviation. Other prizes call for free flights with America's leading flying aces. Send for Free Entry Blank today.

Editor—**FLYING ACES**—Dept. 12, 120 W. 42nd St., N. Y. C.
 Please send me FREE Entry Blank for your Glider Contest
 Enclosed find 25c for which please send me 64-page Book on "How to Build and Fly a Glider."

Name _____
Address _____

It's a GUITAR!

BE popular with today's most favored instrument, the sweet-toned Gibson. You hear it everywhere, on the radio, records, in vaudeville and ballrooms. EASY to learn; you play tunes quickly. Play and sing together; just with "her," or with the crowd.

You'll have the spotlight!



Gibson

GUITARS - MANDOLINS
BANJOS and UKULELES

Carson Robison, pictured here, and many other famous radio and record stars use Gibsons, the "Music Pals of the Nation."

FREE Trial; Easy Payments. Send the coupon for complete information and copy of the Free Book "The Road to Happiness." Check the instrument which interests you.



GIBSON, INC., 503 Parsons St., Kalamazoo, Mich.

Please send free book and details of trial offer on instrument checked.

Name _____

St. or R. F. D. _____

City, State _____

GUITAR BANJO MANDOLIN UKULELE

Choose as Your Profession ELECTRICAL ENGINEERING



America's best equipped electrical school, 25 years old, offers complete, practical 1 year course in Commercial Electrical Engineering and 3 year course in Electrical Engineering—B. S. Degree. Lacking high school credits made up. 3 months courses in Armature



Winding, Light, Heat and Power, Radio Broadcasting and Electrical Refrigeration. Faculty of recognized experts. Splendid laboratory facilities. Low tuition. Board and room reasonable. Daily broadcasting WISN (formerly WSOE). Amateur Station W9SO. Orchestra, Fraternities.

FREE Catalog Write today for our FREE, illustrated catalog. Find out about our specialized method of training. Mention age, education and course interested in.

SCHOOL of ENGINEERING of Milwaukee
Dept. P.M. 529 A Milwaukee, Wis.

\$10.00 A DAY AND MORE
with manufacturing rights of National Seat Cover sensation. Instructions and material Furnished. Easily and quickly learned. Large field, excellent profits—let us tell you more. National Trimmers, 462 W. 37th St., Los Angeles, California

Big Profits Charging Batteries
\$5 DOWN Starts You. Let me show you how to make big money in the battery charging business. I've prepared a free book explaining all details. My charger is years ahead of ordinary chargers—will handle 50 per cent more batteries. Get into a business of your own with a very small investment. Write for my book today.
C. F. Holmes, Chief Engineer
INDEPENDENT ELECTRIC WORKS
Dept. P. M., 5116 Ravenswood Ave., Chicago
Write for FREE BOOK

Learn Watchwork, Jewelrywork and Engraving A fine trade commanding a good salary, and your services always in demand. Address **Horological**, Dept. P, Bradley Institute, PEORIA, ILLINOIS, for our latest catalog.

BE A RAPID-FIRE TRICK CARTOONIST
\$2 BUYS COMPLETE COURSE, including 40 Clever Cartoon Stunts, "How to Give a Performance;" "How to Originate Ideas;" Fun—Profit—Popularity! Send \$2 or pay C. O. D. Educator Press, 19 Park Row, New York, Dept. 0-24.

BOW LEGS?
THIS GARTER (Pat'd) Makes Trousers Hang Straight If Legs Bend In or Out
Free Booklet—Plain Sealed Envelope
THE T. GARTER CO., Dept. E
South Bend, Ind.

MAKE MONEY AT HOME!
Painting photos and miniatures. No talent required. Fascinating work. **Make \$35-\$100 a week.** Earn while learning. We teach you at home. Professional artist's outfit, employment service, given. Write for FREE book TODAY.
NATIONAL ART STUDIOS, 1008 N. Dearborn, Dept. 24-5, Chicago.

RAILWAY POSTAL CLERK
\$1900 to \$2700 a year

Long vacations with pay. Work easy. Travel on fast trains with all expenses paid, including hotel. No worries about the future.

MY FREE BOOK TELLS HOW
you can get a job as Railway Postal Clerk, Post Office Clerk, City Mail Carrier, R. F. D. Mail Carrier, Postmaster, Forest Ranger, Internal Revenue and numerous other fine paying Government positions. If you are a citizen, between 18 and 65 years, you can get a Government Civil Service Position. I'll show you how. Get the facts in my 48-page booklet. It is absolutely free. Write today.

PATTERSON SCHOOL, A. R. Patterson, Civil Service Expert,
85 Wisner Building, Rochester, N. Y.

How to get a better position

- You tried answering advertisements.
- You advertised for yourself and got many useless answers.
- You were trading in the left-over market for workers.
- You read signs at employment agencies.
- You registered at the white-collar exchanges.
- Were you able to identify yourself with any promising opening?
- Then you know the second-hand market for salaried men.



A HIGH CLASS COMMODITY like yourself has to be sold. You have to call on the buyer personally. A famous press agent, who people always imagined had enviable positions thrown at him, says he never got a position without going and asking for it.

As a salesman you cannot call, saying, "Mr. Prospect, I want to sell you some goods." He might ask, "What kind of goods?" Will you say, "Oh, any kind of goods. What do you prefer?" No, you must make the proposal. You must have the thing to sell.

The most pathetic thing in the business world is the "Situations Wanted" column of advertisements by men with no training—whereas the "Help Wanted" columns teem with advertisements for specialists to serve in important capacities!

Accounting The key to profit

How can you get an executive position? Because of changing business conditions (chain stores, long distance trucking, hand-to-mouth buying, etc.), there is now an extraordinary demand for the architects of finance, executive accountants. This generation will not produce enough accountants.

Why should that interest you? Because Account-

ancy is one of the highest paid professions in the world. Because the demand exceeds the supply. And because Accountancy offers a quick and sure road to a better position—and a better income.

Forget the money side for a minute. Accountancy is fascinating. It leads you into the vital problems of business management. Profits and losses depend on your decisions. Your opinions are sought because you are the man who measures profits—the man whose decisions are vital to the company's success. You are no longer an *observer*, you have become a *decider*. And your future is unlimited.

Now you can learn Accountancy easily and quickly without interfering with your present work. The International Accountants Society has made this possible. Through its Course thousands of ambitious men and women have risen to positions of greater responsibility and larger opportunity. The same opportunity which has enabled them to double or triple their incomes is open to you. You at least owe it to yourself to investigate this thoroughly!

To the man who wants to insure himself against the "Situations Wanted" columns, who wants to have a definite commodity to sell at a high market price, we offer an interesting booklet, "How to Learn Accounting." It explains everything in a clear and helpful way. It tells how Accounting will help you in your present work, and enable you to get a better position. Write your name and address below. Tear off the coupon. Mail it—today!

INTERNATIONAL ACCOUNTANTS SOCIETY, INC.

A Division of the
ALEXANDER HAMILTON INSTITUTE

INTERNATIONAL ACCOUNTANTS SOCIETY, INC., 3411 South Michigan Avenue, Chicago, Illinois.
Send me, free, "HOW TO LEARN ACCOUNTING," and tell me how I can increase my income as your other students have done.

Name Business Position.....
(Please write plainly)

Street City State

The MOCAR MODEL AIRPLANES THAT FLY



SET NO. 1

\$1.50

COMPLETE POSTPAID

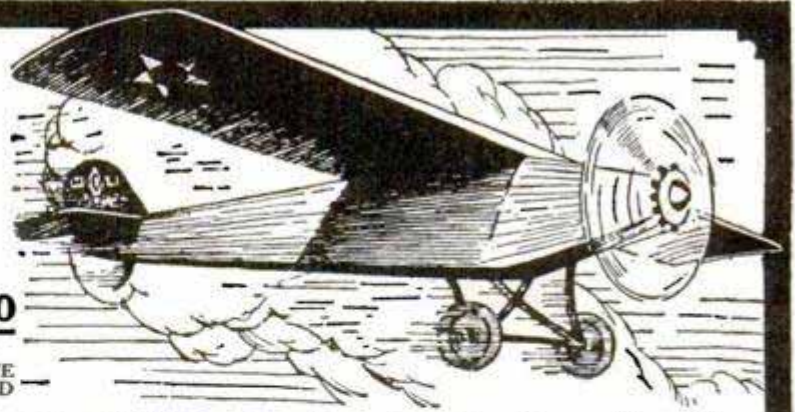

From Hawaii

Mt. Carmel Mfg. Co.
Dear Sirs:

Yesterday was Aviation Club Day. We received our Construction Outfit (Set No. 1). In about an hour and a half I riveted the parts and covered the outside and everything. I took it out and flew it. It flew gracefully! I have already made many planes and racers, but never in my life have I gotten a plane that you could make so easily, so quickly and fly well. Think of it, an hour and a half since I started making it, it flew, and well too!

It is just the kind of plane that the airplane builders like, especially the "Green-Horns."

Yours very truly, KIGOSHI UZAWA

Schofield, Oahu, T. H.

**and from
the Schools**

Sanborn, Iowa
Mt. Carmel Mfg. Co.
Dear Sirs:

Received the Mocar model airplane which I ordered from you some time ago. I find it highly satisfactory for classroom use.

Please send me nine more Mocar model airplanes for one of my classes.

JOE E. CUFFEL
Instr. Manual Arts
Sanborn, Iowa



BOYS Don't miss the fun of making and flying a "MOCAR"

HERE IS THE GREATEST VALUE YOU'VE EVER SEEN — A GENUINE ALUMINUM MODEL AIRPLANE THAT REALLY FLIES, AT A SMALL PRICE

The "Mocar" monoplane—Set No. 1—is a copy of Lindbergh's famous Spirit of St. Louis. Wing spread 18 inches, fuselage 12 inches, powerful motor, special propeller, rubber tired disc wheels. Weight complete only about 2½ oz. This is a practical, simple, real model plane that gives you a whole lot of fun at a very moderate cost.

The all metal construction makes a sturdy plane that will stand a whole lot of abuse. The outfit is mounted on cardboard with all parts plainly marked and full instructions for assembly. Pliers only tool necessary.

Construction Set No. 1. Complete with rivets, bolts, wheels, wing and fuselage covering material, only \$1.50 postpaid (3 for \$4.00). Model L made up ready to fly \$2.25 (3 for \$6.00) postpaid.

Order now—or see your dealer

THE MOUNT CARMEL MFG. CO.
Dept. M NEW HAVEN, CONN.

GREAT FUN, LEARN HOW TO MAKE AND FLY AIRPLANES

Big Money for You as an Automobile Mechanic

These four practical books, written by five well known teachers of automobile practice, will teach you right in your own home during your leisure time just what you need to know about automobile troubles and repair. They will teach you automobile construction, maintenance and repair as practiced by experts and will help you to earn an expert's pay.

Practical Automobile Library: Four Books — \$1.50 in 10 days and \$2 monthly for 6 months—only \$13.50 in all!

Hundreds of question-answering diagrams—hundreds of clearly-marked illustrations—make the books plain and readily understandable. All the explanations and descriptions are clear, simple, direct. Every chapter is packed with definite, step-by-step, how-to-do-it information. Here is your opportunity to enter a big-pay field.

Send No Money
Mail the Coupon

FREE TRIAL



FREE EXAMINATION COUPON

McGraw-Hill Book Co., 370 Seventh Ave., New York

Send me for 10 days' free examination the New Practical Automobile Library. If satisfactory, I will send you \$1.50 in 10 days and \$2 monthly until the special price of \$13.50 is paid. If not wanted, I will return the books at your expense.

Signed.....
Address.....
City and State.....
Position.....
Employer..... P. M.—5-29



Be a drummer!

Trap Drumming made easy in a short time. Our free instruction course furnished with genuine Ludwig Trap-Drum Outfit. Develop your natural sense of rhythm. Go to your nearest dealer or write for full details.

LUDWIG & LUDWIG, 1611 North Lincoln Street, Chicago

ELECTRICITY

Graduates in Constant Demand at Big Salaries

Intensive, practical training. **Low Tuition Rates.** Diploma in 1 year. Engineering degree in 2 years. Special 12 weeks' courses. Also Aviation Electricity. No time wasted. Expert instructors. Extensive modern equipment. Free employment service for graduates. Part-time work secured during training. 28th year. **Write Today for Free Illustrated Catalog.**
FINLAY ENGINEERING COLLEGE, 1001-B Indiana Ave., Kansas City, Mo.



Travel for "UNCLE SAM"

**\$1900 to \$2700
YEAR**
Railway Postal Clerks
Many U. S. Government
Jobs open to men and
boys, 18 up.

MAIL COUPON
Today Sure!

FRANKLIN INSTITUTE
Dept. R171, Rochester, N. Y.
Rush to me, free information, telling how I can get a U. S. Government job. Send 32-page book describing positions now obtainable.

COUPON
Name.....

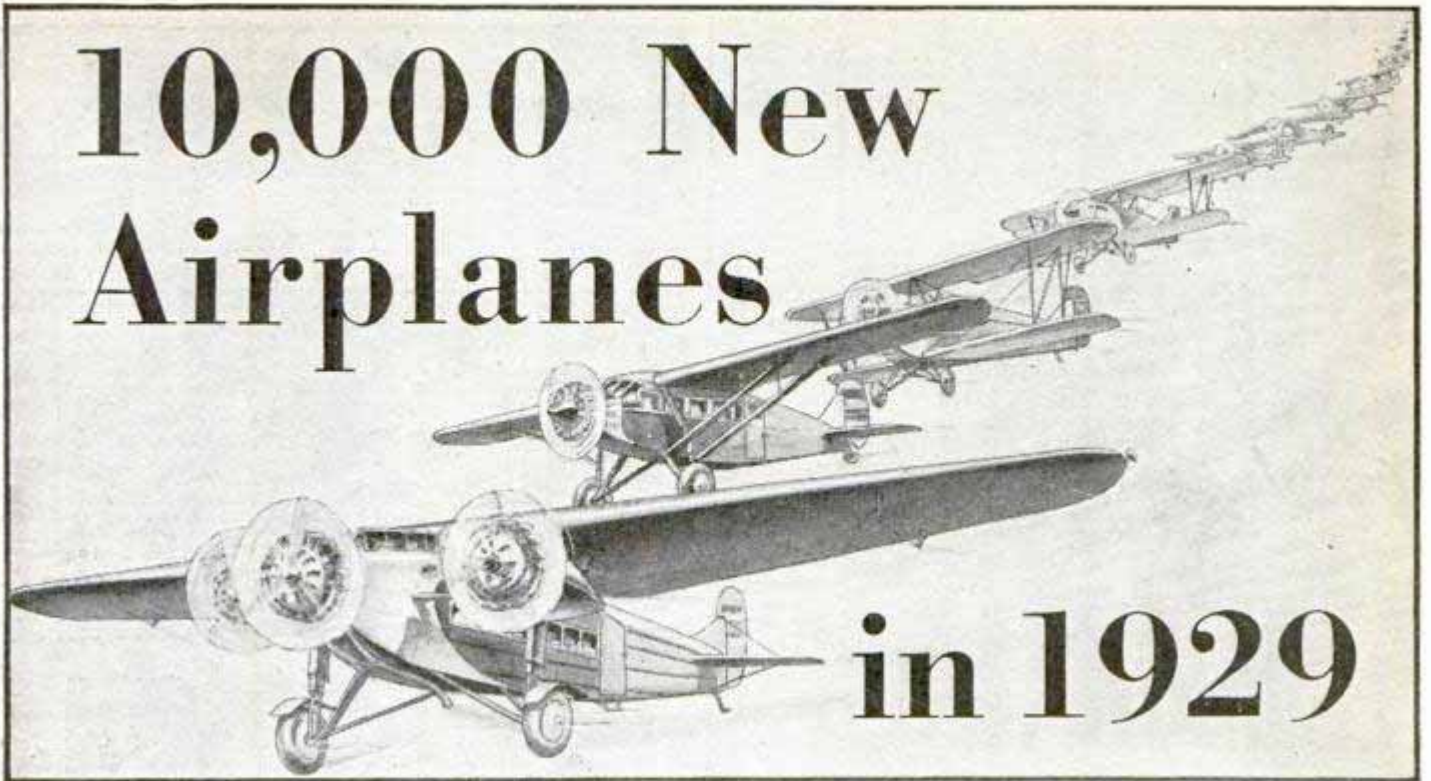

10,000 New Airplanes

in 1929

Who will fly them? Keep them in repair? Young man, that's your job

There were only 6,077 pilots and 4,873 airplane mechanics licensed or pending the first of this year. Who then will fly the airplanes that were produced in 1928 as well as the 10,000 new planes which authorities conservatively estimate will be produced in 1929? Who will service these planes? This shortage of

trained men, it is widely said, is the only factor that can interfere with aviation's development. Aviation needs trained men. Aviation needs you, young man.



Aviation Offers These Opportunities

When you have graduated from any of the Universal Aviation Schools, you know your subject from a practical as

well as a theoretical point of view. Universal training is thorough. A pilot's course prepares you for the government examination in whichever grade you have qualified. The mechanic's course qualifies you for examination as airplane apprentice mechanic and immediately puts you on a money making basis. The Aviation Business Course gives you a thorough ground work in avia-

tion which you may use in advancing yourself in any of the many diversified fields which aviation touches upon. At this date you may practically pick the field in which you wish to specialize, get your training through any one of the Universal Aviation Schools and be assured there is a place for you in the industry.

Facts About Universal Aviation Schools

To supply the present as well as the future need for thoroughly trained men, the Universal Aviation Corporation, a \$10,000,000.00 concern operating over 5,000 miles of airways a day, has established a number of aviation schools at various airports out of which they operate. These schools have been given the finest, most modern aeronautical equipment available and have been placed in charge of the most competent instructors in the country. All instruction meets with the requirements of the Aeronautical Branch of the U.S. Department of Commerce. If you are ambitious, anxious to really get somewhere in aviation and are willing to buckle down to what is perhaps the stiffest aeronautical course in the country, enroll in a Universal Aviation School.



25c Brings This Book

"Aviation—What It Means To You" answers all your questions. It gives you information you should have before you ever decide to study aviation. In a frank, clear manner, without exaggeration, it gives you a true picture of the aviation industry today. Send 25c for your copy. Mail with the coupon, today.

Universal Aviation Schools

A Division of the
Universal Aviation Corporation



The Universal Aviation Corporation operates air lines between Minneapolis-St. Paul, Chicago, St. Louis, Kansas City, Omaha, Cleveland, Cincinnati and Louisville, carrying air mail and passengers. New Air Lines are being extended into other large cities as rapidly as conditions permit.



UNIVERSAL AVIATION SCHOOLS
Suite 1047-56, Boatmen's Bk. Bldg., St. Louis, Mo.

Enclosed find 25c. Send me your book, "Aviation

—What It Means to You." Also complete information on
 Flying Mechanics Business Course.

Name..... Age.....

Address.....

City..... State..... NR 521

Universal Aviation Schools are Members of the U. S. Aeronautical Chamber of Commerce



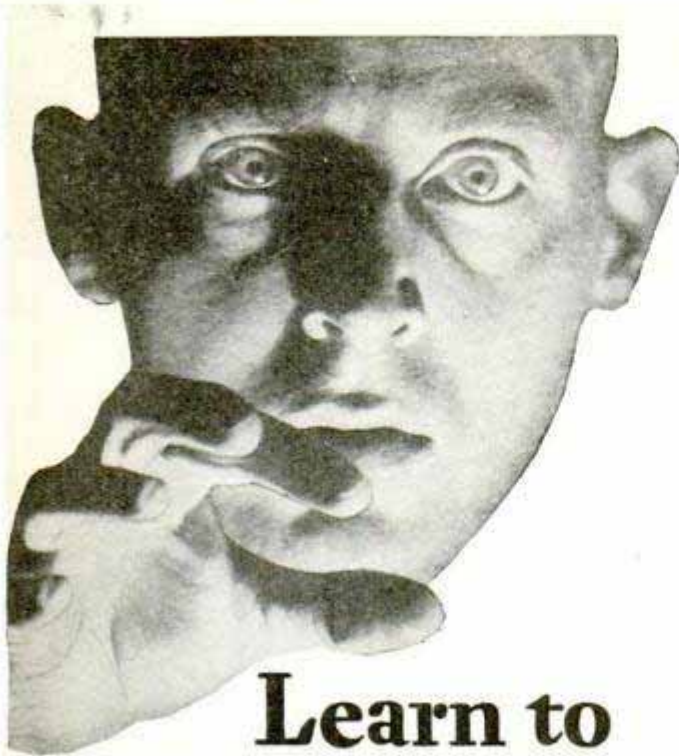

Learn to HYPNOTIZE

**5 DAY TRIAL - NO COST
IF NOT SATISFIED**

Gain New Power!

QUIT being just one of the crowd! Stand out—dominate—make others admire and obey you! Learn how to bend people to your will; how to develop a winning, magnetic personality; how to gain popularity, success, big money—by the USE OF HYPNOTISM.

In just a few hours, I'll show you the inner secrets of this mysterious force or the Five Days' TRIAL IS FREE! I'll show you how to develop the hidden germ of this magic power within yourself. Once you know how, you can use it in overcoming obstacles, achieving your fondest ambitions and becoming MASTER of yourself, friends and acquaintances—either sex. See for yourself how Hypnotism can banish fear, worry and opposition—improve your memory—Increase your earnings—and force others to give you the good things in life that you desire!

In his startling NEW book "The Science of Hypnotism," the world famous hypnotist—Prof. L. E. Young—reveals the most carefully guarded secrets of this fascinating subject and TELLS ALL! He not only explains the methods of noted hypnotists, step by step—but tells clearly all about the nine stages of hypnotism. The Hypnotic Mirror, Mental Telepathy, how to select your subjects, magnet in healing, methods of hypnotizing, how to waken subject, how to make money out of hypnotism!

Try 5 Days Free—Send No Money

So confident are we that Prof. Young and his great book will quickly teach you the science of hypnotism, that we will send you a copy without one cent in advance! Simply clip and mail the coupon below. When the book arrives, pay the postman the special low price of \$2.50 plus few cents postage. Then test the powers of Hypnotism 5 days! If not amazed and delighted, return the book and money will be refunded at once! Mail the coupon now.

Franklin Pub. Co., Dept. E-70

800 N. Clark St., Chicago, Ill.

SEE

- How to Hypnotize at a Glance
- How to Hypnotize By Telephone
- How To Give An Entertainment
- How To Make Others Obey You
- How To Do Dozens of Hypnotic Feats



Franklin Pub. Co., Dept. E-70

800 N. Clark St., Chicago, Ill.

Please send me your amazing new book—"The Science of Hypnotism"—by Prof. Young. When the book arrives, I'll pay the postman only \$2.50 plus postage. If I am not satisfied after 5 days' trial, I may return the book and you are to refund my money.

Name.....

Street and No.....

Town..... State.....

If you are likely to be out when postman calls, send \$2.50 with coupon and we'll pay delivery charges. Customers outside U. S. must send cash with order.

LEARN MECHANICAL DENTISTRY

SEND FOR FREE BOOK

Your Success

Earn up to \$5,000 a year

You can EARN WHILE LEARNING this modern money making business and become *Your Own Boss*. Big demand. Age no barrier and no previous experience required. You learn by doing actual work in rubber and gold. Easy terms. Individual instruction. Day and night school. Write NOW for Catalog P. Railroad fare allowed—no extra charge.

NEW YORK SCHOOL OF MECHANICAL DENTISTRY
147 W. 33rd Street NEW YORK

DEPENDABLE ECONOMICAL HEAT at LOWER COST

The Proved! **LACO**

Own your own business and be the leading Oil Burner man. Sell the LACO, very reliable, low in price. You can't beat it as a money-maker for the live dealer. Only a small amount of capital required. Write to

LACO OIL BURNER CO.
119 U St., Griswold, Ia., U.S.A.

Makes Every Heating Plant Burner Free From Accidents

Violet Ray

New Health
Beauty
Vigor

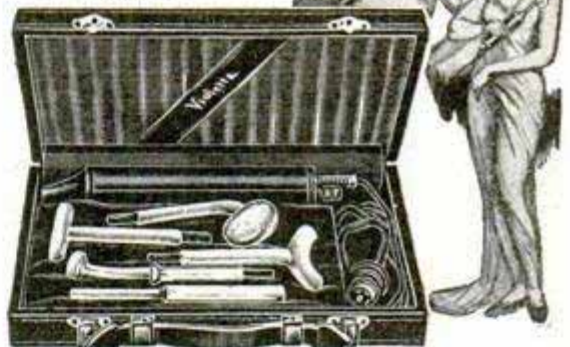

Let us tell you how thousands of men and women suffering from rheumatism, paralysis, neuritis, nervousness, skin diseases, headaches, constipation, sprains, prostate trouble, goitre and many other ailments, even hay fever and asthma, have found quick relief, new health and vitality with this marvelous, scientific invention. Pains vanish almost instantly.

Violetta 10 Days FREE TRIAL

Endorsed and used by hospitals, sanitariums and physicians. Every home should have one. Saves hours, days, months of suffering. No medicine. Painless, pleasant treatment. Only the violet ray can penetrate to every nerve affected. Simple, safe, painless—anyone can use VIOLETTA. Don't suffer pain and poor health when you can try VIOLETTA 10 days FREE.

This Book Free

Tells all about violet rays—how this marvelous discovery by Nikola Tesla, the electrical wizard, now brings this mysterious curative power to all. Contains many astounding testimonials from our hundreds of satisfied users. Send for all the facts and our liberal trial offer. Mail the coupon now.



**VI-REX CO., Dept 531
2304 Warren Av., Chicago**

Vi-Rex Co., 2304 Warren Ave., Dept. 531, Chicago

Please send me your free book on Violet Rays and details of your 10-day free trial offer.

Name.....

Address.....

City..... State.....

Ailment.....

Seven Age Pains Caused By Tiny Gland Say Physicians

Foot and Leg Pains
Many users of this new drugless treatment say relief from distressing leg and foot pains is swift and lasting.



Sleepless Nights
Many men who have been forced to get up 2 to 10 times at night report amazing new freedom and sound sleep every night with this new method.



Mental Fatigue
Reports from men who suffered this distressing symptom show new mental power, ability and cheerfulness.



Backache
Some users say they enjoyed noticeable relief overnight and that relief is complete and lasting.



Thousands of men past 40 suffer loss of strength and the other ailments shown here and often blame approaching old age. Many medical men claim that 65% of men past a certain middle age are victims of a grave ailment, called prostate gland decline.

Now an amazing drugless treatment has been perfected that directly reaches this gland. So startling has been its results that a large business institute with offices in America and England has arranged to distribute it to every sufferer. Already over 50,000 men have tested and proved it. Some even 60 and 70 report quick relief and return to normal activity. Some say they felt 10 years younger in 6 days. This amazing treatment has proven such a success that it is endorsed and used by many physicians, hospitals, sanitariums and specialists. It is not a medicine, drug, massage, exercise, diet or violet ray. It is as safe and easy to use as combing your hair. So many thousands of letters are pouring in from users who tell of a new joy of living that it has been decided to send it on a guarantee that if it does not make you feel 10 years younger in 6 days you pay nothing.

DARING BOOK FREE

The prostate gland is such a vital factor to the happiness and health of middle age men that a daring book of startling facts has been prepared at great expense. It is called "Why Many Men Are Old At 40" and contains intimate information that may mean new health and joy to you. Just mail the coupon for a Free Copy and details of trial offer. Address

W. J. KIRK, President,
2117 Morris Ave. Steubenville, Ohio

No Pep
Many users write of a new joy of living—new pep, new vim, new physical power since using this amazing gland treatment.



Headaches
Men who suffered for years and tried glasses and other treatments report complete freedom from severe headaches now.



Nervousness
This affliction, too, can be expected to vanish quickly after the prostate gland starts again to function properly.



If you live West of the Rockies, mail your inquiry to The Electro Thermal Co., Dept. 21-T, 303 Van Nuys Building, LOS ANGELES, CALIFORNIA.

Desk 21-T, 44 Yonge St., TORONTO, ONT., CAN.

W. J. KIRK, PRESIDENT,
2117 Morris Ave., Steubenville, Ohio.

Send Free Copy of your daring book: "Why Many Men Are Old At 40" and facts about your trial offer. No obligation to me.

Name.....
Address.....
City..... State.....

Cash for Old Gold
WE PAY CASH
for OLD GOLD, SILVER, PLATINUM, JEWELRY, Dental work. Write for information today!
L. Pelcer, 2408 So. Cicero Ave., Cicero, Ill.

**MEN TO LEARN
MOTION PICTURE PROJECTION**
A BIG-MONEY PROFESSION—\$2,000 to \$4,000.
We Assist Students to Earn While Learning
MOVIE OPERATORS SCHOOL
61 Sproat Street Dep't 23 DETROIT, MICHIGAN

NO SELLING

Pays \$350 to \$400 a Month

Men, here's real news: No more house-to-house selling, canvassing, or soliciting. No more long-winded sales talks, yet you can earn \$350.00 a month and more. Sounds too good to be true — but you have only to write us—today—and judge for yourself.

A Unique Plan!

When you can walk into a store—make 35% extra profit for the merchant, without asking him to buy anything, and make big money for yourself—you'll agree our plan is unique. More than this, it's new—different—and requires no selling experience whatever. Don't let this chance slip. Send your name and address now!

NEVERUN CORPORATION Dept. 940, 185 N. Wabash Avenue **CHICAGO, ILLINOIS**

MOULDING A MIGHTY CHEST



Get a 46 Inch Chest
Complete Course on Chest Building
ONLY 25c

Learn the real secret of powerful chest building. Know all about the muscles that lift, widen and deepen the chest and broaden the shoulders. Practice the specialized exercises which will make YOUR chest massive and powerful. The greatest analysis of vital, vigorous chest development ever written. Learn the Hindoo religious system of exercises that makes their wrestlers and strong men invincible. A Hindoo strong man and wrestler threw Zybyso in two seconds. Many other methods unknown to the American body builder, are explained. Complete with anatomic illustrations on which are indicated the little known vital spots in creating vital internal strength. You can build for yourself a Herculean chest. The author, George F. Jowett, built his chest from 32 inches of weakness to 48 inches of colossal muscular strength. Develop your chest with straps of big steel muscle. Fill it full of unresisting vital strength energy.

WORTH ITS WEIGHT IN GOLD—GET IT TODAY

To each purchaser will be given a FREE COPY of *THE THRILL OF BEING STRONG*. It is a priceless book to the strength fan and muscle builder. Full of pictures of marvelous bodied men who tell you decisively how you can build symmetry and strength the equal of theirs.

REACH OUT—GRASP THIS SPECIAL OFFER

JOWETT INSTITUTE of PHYSICAL CULTURE

422 Poplar Street, Dept. 4S, Scranton, Penna.

Dear Mr. Jowett: I am enclosing 25c. Please send me the course "MOULDING A MIGHTY CHEST" and a free copy of "THE THRILL OF BEING STRONG."

Name _____

Address _____

Claims 300 Miles In One Gallon of Gas ... He Guarantees 30!



J. A. Stransky

The American Research Foundation is quoted as announcing that only 5% of the pent-up power in gasoline is transformed into actual momentum in an automobile. And if all the force could be harnessed a single gallon would drive a car 300 miles.

A western inventor has taken the first great step in this direction. He has patented a tiny device that fits any car in five minutes and gets amazing mileage out of gasoline. The inventor actually guarantees a big saving on any make or model car.

The inventor is now ready to distribute 5000 samples all over the country for trial at his risk. To get his sample offer address him at Pukwana, So. Dakota, J. A. Stransky, E-10 Stransky Block. He also wants 1000 men to help him introduce his device to car owners. Write him today.



PAINT SHOW CARDS

and SIGNS. LEARN AT HOME IN SPARE TIME. WE TEACH YOU QUICKLY FASCINATING WORK. \$75 WEEKLY. SEND 6c IN STAMPS FOR INTERESTING BOOK, Universal School of Lettering NEW HAVEN, CONN.

ATTENTION: Become a Finger Print Expert, good pay, steady work. Up-to-date Instructions, compiled by Experts, fully Illustrated, easy to learn. Sent Complete \$5.00. Why pay more? We coach you for one year without extra charge.

AMERICAN FINGER PRINT INSTITUTE

Box 2398

Los Angeles, Calif.

\$2500 TO \$10,000 A YEAR
AS A BUSINESS
OR PROFESSION
WRITE FOR CATALOG M
MOVING PICTURE THEATRE MANAGERS INSTITUTE
ELMIRA, N.Y.



ZIP-ZIP SHOOTER

BOYS; join a Zip-Zip Shooter's club, everywhere boys are forming these clubs, fine sport using this shooter which is scientifically and practically made. Zip-Zip Shooter is the best buy we know of for 35c or 3 for \$1. We will ship to you if your dealer can't supply you. Automatic Rubber Co., Columbia, S. C.

NERVE EXHAUSTION!

Are You Always Excited? Fatigued? Worried? Gloomy? Pessimistic? Constipation, indigestion, cold sweats, dizzy spells and bashfulness are caused by NERVE EXHAUSTION. Drugs, tonics and medicines cannot help weak, sick nerves! Learn how to regain Vigor, Calmness and Self Confidence. Send 25 cents for this amazing book. RICHARD BLACKSTONE, N-475 Flatiron Bldg., N. Y.

10c NEW SCIENTIFIC WONDER

3 for 25c "X-RAY" CURIO

SILVER ONLY
BOYS You appear-ently see thru Clothes, Wood, Stone any object. See Bones in Flesh. FREE—PKG. RADIO BIG FUN PICTURE FILMS. Takes pictures without camera. "You'll like 'em." 1 pkg. with each 25c order.

MARVEL MFG. CO. Dept. 31 NEW HAVEN, CONN.

This New, Easy Blue Print Way Prepares You for These 9 Big Pay Jobs!



Make
\$4,800 To \$12,000 A Year!

HAVE you ever stopped to consider what stands between you and a big-pay job? Simply a lack of training on the "Headwork" side of Building and Contracting—that's all! The men who command the high-salaried positions know how to read blue prints—how to lay out and run jobs.

There is no reason why you, too, can't bridge this narrow gap between you and the jobs that pay up to \$12,000 a year. You need only to equip yourself with this essential knowledge to win a better position or a business of your own. With the Building Trades calling frantically for practical men who can read blue prints—with this training so easily available to you the Chicago Tech "Blue Print Way"—the opportunity is yours to take NOW!

Get This Big-Pay Training

The day when a tradesman could get practical "headwork" training only on the job is gone forever. The records of thousands of Chicago Tech graduates have proved that the idea is no longer true. That it's easy to learn how to read blue prints by the Builders' Course, the "Blue Print Way To Big Pay." This practical method is quick, easy and it's certain. You learn right at home in your spare time with real blue prints and les-

sons as simple and easy to understand as a story book. Everything is explained in every day language and worked out by practical, experienced building experts. No text books. No grinding study. Simple as A. B. C.

Mastered In A Few Weeks

And the beauty of this wonderful course is that it teaches you plan reading in amazing short time. Yet this valuable knowledge is just what you need to equip yourself for one of the big indoor or outdoor jobs that yield \$4,800 to \$12,000 annually!

Take this positive, easy way to make your ambitions materialize. Simply mail the coupon at once. It brings a complete set of actual working blue prints and a valuable, instructive book, "How to Read Blue Prints" free, *absolutely FREE!* Get these true facts before you as soon as possible. See what fun it will be to learn the fascinating "Blue Print Way." Know what wonderful opportunities await you in the seven billion dollar building field! Don't delay!

If You Live Nearby

Visit our big day or evening school attended by over 1,000 builders. You get this training at home by mail—same plans, lessons and instructions.

FREE

BLUE PRINTS AND BOOK!

We will send you absolutely FREE a full set of practical working Blue Prints, also valuable book, "How to Read Blue Prints." We want you to see for yourself how easily and quickly you can now master blue print plan reading—the "Blue Print Way." Mail the coupon NOW—don't delay!



Chicago Technical School for Builders, Dept. E-142, Chicago Tech Bldg., 118 E. 26th St., Chicago, Ill.

Please send your Free Books and Blue Prints which I understand are mine to keep without obligation. It is also understood that no salesman will call on me.

Name.....
Address.....
City.....State.....

Chicago Technical
SCHOOL for BUILDERS

Dept. E-142, 118 E. 26th St., Chicago, Ill.



Swear Off Tobacco



Tobacco Tells on Nervous System



Tobacco Ruins Digestion



Tobacco Stunts Boy's Growth

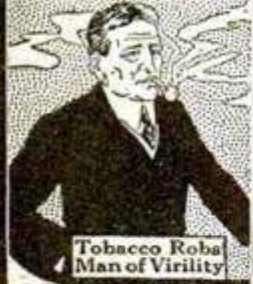

Tobacco Robs Man of Virility



Tobacco Steals from You the Pleasures, Comforts, Luxuries of Life

Tobacco Habit Banished Let Us Help You

Quick Results

Trying to quit the tobacco habit unaided is often a losing fight against heavy odds, and may mean a serious shock to your nervous system. So don't try it! Make the tobacco habit quit you. It will quit you if you will just take **Tobacco Redeemer** according to directions.

It doesn't make a particle of difference whether you've been a user of tobacco for a single month or 50 years, or how much you use, or in what form you use it. Whether you smoke cigars, cigarettes, pipe, chew plug or fine cut or use snuff—**Tobacco Redeemer** will positively remove all craving for tobacco in any form in a few days. Your tobacco craving will usually begin to decrease after the very first dose—there's no long waiting for results.

Tobacco Redeemer contains no habit-forming drugs of any kind and is marvelously quick, scientific and thoroughly reliable.

Not a Substitute

Tobacco Redeemer is in no sense a substitute for tobacco, but is a radical, efficient treatment. After finishing the treatment you have absolutely no desire to use tobacco again or to continue the use of the remedy. It helps to quiet the nerves, and will make you feel better in every way. If you really want to quit the tobacco habit—get rid of it so completely that when you see others using it, it will not awaken the slightest desire in you—you should at once begin a course of **Tobacco Redeemer** treatment for the habit.

Results Absolutely Guaranteed

A single trial will convince the most skeptical. Our legal, binding, money-back guarantee goes with each full treatment. If **Tobacco Redeemer** fails to banish the tobacco habit when taken according to the plain and easy directions, your money will be cheerfully refunded upon demand.

Let Us Send You Convincing Proof

If you are a slave of the tobacco habit and want to find a sure, quick way of quitting "for keeps" you owe it to yourself and to your family to mail the coupon below or send your name and address on a postal and receive our free booklet on the deadly effect of tobacco on the human system, and positive proof that **Tobacco Redeemer** will quickly free you from the habit.

Newell Pharmacal Company
Dept. 300, Clayton Station, St. Louis, Mo.



Free Book Coupon

NEWELL PHARMACAL CO.,

Dept. 300, Clayton Station, St. Louis, Mo.

Please send, without obligating me in any way, your free booklet regarding the tobacco habit and proof that **Tobacco Redeemer** will positively free me from the tobacco habit or my money will be refunded.

Name.....

Street and No.....

Town..... State.....

Tear Out My Face!

RHODES KRISS-KROSS Corporation

Dept. E-3713 1418 Pendleton Ave., St. Louis, Mo.

Without obligation, send me full description of KRISS-KROSS, and your new type razor free. Include your offer that permits me to test it at home without obligation to buy.

Name.....

Address.....

City..... State.....

Check here if interested in making money as KRISS-KROSS representative.

I'll Send You a Machine that Gives You Keen Razor Blades FREE!

LET me put in your hands an uncanny machine that practically ends your expense of buying new razor blades! More than that, it provides a new shaving comfort that you've always sought but never hoped to find!

These are bold statements. But these are the days when surprising new inventions are supplanting old-fashioned methods. And already a million users will agree that my invention keeps them in keen razor blades free, a saving of \$3 to \$15 a year. Gives them a man's size shave—keen and close yet comfortable and long-lasting. And cuts shaving time in half.

J. T. Main reports he has used only one blade for five years. Another, E. L. Vinal, has had 500 slick shaves from one old Gillette blade. Thousands write letters like this. And if you'll use the coupon above, I'll let this amazing device prove it on your face—at my risk.

How It Works

My invention is called KRISS-KROSS, a device that makes ordinary blade-sharpening twenty years behind the times. For the first time, blade-sharpening doesn't depend on the accuracy of the human eye or such amateur tests as "hair-splitting." Now you can sharpen blades without fear of under-stropping or over-stropping.

For KRISS-KROSS introduces a new principle in blade sharpening—*automatic graduated pressure*. This amazing feature of KRISS-KROSS makes a 100% perfect edge an automatic certainty. No other blade-sharpener

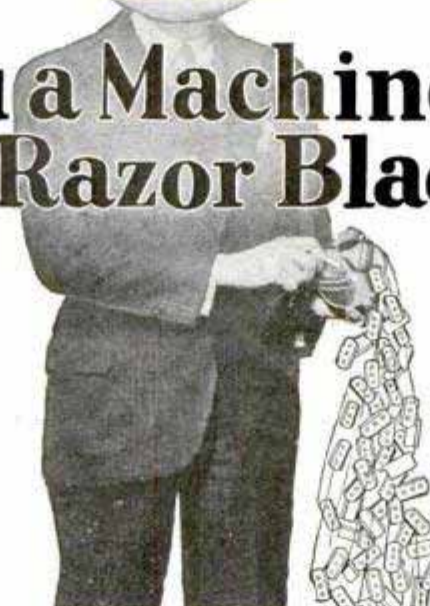

has this patented KRISS-KROSS feature.

Fits All Blades

KRISS-KROSS fits all blades (except Durham Duplex). It does all the stropping (reversing the blade, bringing it to the surface) with a turn of the crank. It uses the barber's stroke—the diagonal. And the whole operation takes only eleven seconds. Men are amazed at its uncanny automatic accuracy. Men who formerly threw away a blade after one or two shaves now use the one old blade for weeks—months—yes, even years! It is giving new faces for old—clean cut, close shaved, comfortable faces instead of raw, stinging and half shaved jaws!

I Do the Gambling

See for yourself if I haven't settled your shaving problems for life—and practically ended the expense and bother of buying new razor blades. Test this amazing device in your own home without obligation to buy. If it doesn't do all I say and more—I lose. If it does, it has cost you less than what you pay for a few months' supply of razor blades. All I ask now is that you mail the coupon above for full description (including my free razor offer). Men in every station of life have mailed it. Among them a prominent radio manufacturer, a breakfast food king and a famous Wall Street financier. Before you forget—tear it out now. And settle the shaving question for life.



and Pays Men \$30 to \$40 a DAY Ending Razor Blade Expense for Shavers

\$30 to \$40 a day are unusual earnings. But this is a decidedly unusual proposition. Men walk into one office, start turning the KRISS-KROSS crank—and walk out with ten, twenty or thirty sales! No wonder, then, that King made \$66 in one day, Kellogg \$200 in seven days, Laughren \$5300 in one year. You need no previous selling experience—this is order-taking, not selling. And our plan shows you how to make big money right from the first day. Even carrying a KRISS-KROSS in your pocket and showing to men in spare hours will earn you a handsome extra income—to pay for your car, your clothes or a vacation trip. Check the bottom line in coupon above and mail today—without obligation.

Rhodes

KROSS-KRISS Stroppler

Rhodes KRISS-KROSS Corp., M. H. Rhodes, President

Dept. E-3713, 1418 Pendleton Ave.
St. Louis, Mo.

Canadian Address:

CANADIAN KRISS-KROSS CO.

World's largest mfrs. of mechanical stropplers

39 Wellington Street East, Toronto 2, Canada



FREE!

Body Chart

If you will mail the coupon below, this Anatomical and Physiological Chart will be mailed to you without one cent of expense. It shows the location of the Organs, Bones of the Body, Muscles of the Body, Head and Vertebra Column and tells you how the nerves radiate from your spinal cord to all organs of the body. This chart should be in every home.

Where Is That PAIN?

It may be in the neck, back, hips, stomach, liver, legs or arms. Wherever it is, the chart will help to show you the location and cause of your ailment. For instance, this chart will help you locate vermiform appendix pains. Hundreds of lives might have been saved if people had known the location and character of the pain and had received proper attention.

Stop that Pain

By Relieving the Cause with

**Violet Ray - Vibration
Ozone - Medical Electricity**

The Four Greatest Curative Powers Generated by This
Great New Invention!

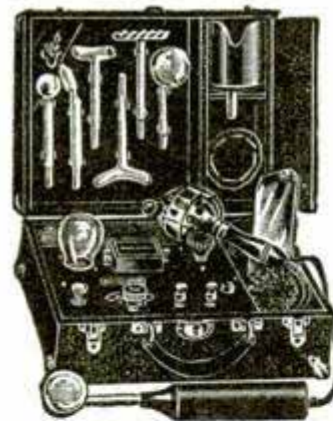

Elco Health Generators at last are ready for you! If you want more health—greater power to enjoy the pleasures and delights about you, or if more beauty is your desire—write! Ask for the book on these inventions which has just been prepared. It will be sent to you without cost. It tells you how Elco Health Generators aid you in leaving the lethargy and hopelessness of bad health and weakness behind forever. Re-vitalize yourself. Bring back energy. Be wholly alive. Write today!

Here's What Elco Users Say—

"Wouldn't take \$1000 for my Elco."
"Has done me more good in 2 weeks than doctors did in three years."



"Cured my Rheumatism." "My Eczema gone." "Cured my stomach trouble." "Cured my weakness." "Now I sleep soundly all night." "Thanks to Elco my strength and vigor are back." "No more pain." "Colds never bother me now." "Chronic Constipation banished."
These great new inventions generate Violet Ray, Vibration, Electricity and Ozone—combined or separate. They operate on the electric light in your home or on their own motive power at less than 50 cents per year. Elco Health Generators are positively the only instruments which can give you in one outfit Electricity, Violet Ray—Vibration and Ozone—the four greatest curative agents. Send the coupon below. Get the Free Book NOW!

MAIL COUPON for FREE BOOK

Do not put this paper down without sending the coupon. Don't go on as you are with pains and with almost no life and energy. You owe it to yourself to be a better man or woman. You were put here to enjoy life—not just to drag through it. So do not rest another day until you have put your name on the coupon here. That will bring the whole story of these great new inventions. Do it today—now.



Lindstrom & Co. [Makers of Therapeutic Apparatus since 1892.]
2322 Indiana Avenue Dept. 13-55 Chicago
Please send me your free book, "Health—Power—Beauty" and full information of your 10-day Free Trial Offer.
Name.....
Address.....

Study Flying NOW!

ABC of AVIATION

Gives complete flying foundation in simple language. By Major V. W. Pagé, America's leading instructor and engineer, 160 pages. Illus. Sent C. O. D., if desired. Only \$1.00.

3 new BOOKS

MODERN AIRCRAFT

Veritable encyclopedia of well-written explanation of everything in connection with planes and flying. Used in schools everywhere. Also by Major Pagé, 855 pages, 500 costly illustrations. Sent C. O. D., if desired. Only \$5.00.

The One Authority

EVERYBODY'S AVIATION GUIDE

Major Pagé, famous instructor, asks and answers 600 questions. Covers everything you should know about planes and flying. 256 pages. Illustrated. Sent C. O. D., if desired. Only \$2.00.

CATALOG Free!

Get our FREE catalog covering all Henley books on more than fifty different practical and scientific subjects. Books shipped to any U. S. address C. O. D. plus postage, or postpaid if you enclose remittance. Order now.

Norman V. Henley Co., Dept. 10
2 West 45th St. New York, N. Y.

ELECTRICAL ENGINEERING

Eight Flexible Maroon Volumes

4300 pages, 3200 illustrations, deluxe gold stamped binding. Index in each book, general index in Vol. 8. Covers every subject in Electricity.—Light, Power, Transmission, Generators, Motors, Switchboards, Radio, Telephone, House Wiring, Railways, etc.

BOOKS SENT FREE!

Complete Course in Book Form

We want to place this set for 15 days in your home, to use as your own, in order to show you how easily you can prepare yourself for a good job in the world's biggest, fastest-growing, best-paying industry. Written by America's greatest Electrical Engineers in simple, non-technical language, for the beginner, the Electrical worker and Engineer.

New Edition with 100 pages on

A. C. Radio

"Alternating Current Radio" only one feature in this new, up-to-the-minute edition, just off the press. All the new things in Electricity included. The equivalent of a complete trade course at less than one-fifth the usual cost.

Learn Electricity in your spare time and go after office—factory—drafting—building construction—sales—radio—telephone—power plant—telegraph and railway jobs. Take your choice of thousands of opportunities now open to men who know Electricity.

LOOK IT UP! The Jiffy Index makes this set the best of Electrical reference works. Find the answers to 20,000 questions instantly at your very finger tips.

AMERICAN TECHNICAL SOCIETY
Dept. E-519, Drexel Ave. & 58th St., Chicago

American Technical Society
Dept. E-519—Drexel Ave. & 58th St., Chicago.

Please send for 15 days' free trial 8-volume set of Electrical Engineering just off the press subject to return if I wish to. (I pay the few cents express charges on receipt of books you pay express if returned.) If I decide to keep them, I will pay \$2 after 15 days' trial then \$3.00 a month until \$34.80, special advertising price, is paid, after which books become my property. Year's Consulting Membership to be included free.

Name.....
Address.....
Employed by.....
Employer's Address.....



LEARN AVIATION WICHITA THE AIR CAPITAL

Where **25%**

of the commercial airplanes produced in the United States the past year were made — where this production record will be more than doubled in 1929 — where eight airplane factories are now established and others are being organized — where you can get daily contact with big men of the industry and literally hobnob with opportunities.

Braley trained pilots, mechanics, and aeronauts are qualified to make good in aviation. Braley courses are designed to meet individual requirements and the regulations of the U. S. Department of Commerce. If you get the BRALEY OK you are ready to fly out into the world — anywhere — with confidence, to take the pick of good jobs on the nation's flyways or in leading factories. The heights you achieve are only up to you; once you have been properly prepared by Braley training, success is awaiting your call. Many opportunities await Braley trained experts, from pilots to field managers and executives.

Learn to fly at one of the finest exclusive school airports in America!

Board and lodging at only \$7 a week in our two-story dormitory.

IT'S UP TO YOU—ACT NOW!!

The **BRALEY SCHOOL OF FLYING** Inc.

Send for the new booklet, "Learn Aviation In the Air Capital"



The Braley School of Flying, 501 Temple Building, Wichita, Kans. Please send me the booklet, "Learn Aviation In the Air Capital."

Name.....
Address.....
Post Office..... State.....

FREE—"MIRACLES IN MUSCLE"



Which Looks Most Like You?

Note the amazing difference. Which are you? Have you the puny, undeveloped body of the man at the left—a body you're ashamed of? Let me make you over into a powerful, big-muscled MAN.

Do YOU Want a New Body?

SEND for my wonderful Free Book. Read the amazing story of MIRACLES IN MUSCLE. See how EASILY you can have a superb physical development. No matter how weak or run down you may be now, I GUARANTEE to cover your body with big, brawny layers of LIVE muscle—to broaden your shoulders—to fill out your chest—to put new strength and vitality into every organ of your body.

Amazing Results in 30 Days

A few minutes a day will work wonders! In a week you'll feel and look like a new man! In 30 days you'll be PROUD of your magnificent build; your strength will amaze you. Get the facts about this wonderful method of body-building that has changed thousands of men from sickly weaklings into big, strapping HE-MEN.

Send Name and Address NOW

Whether you're weak or strong, young or old, you NEED this great book on body-building. It shows the way to new HEALTH, STRENGTH, SUCCESS, POPULARITY. Add INCHES to your muscles. Be the MAN you want to be. Write your name and address on the margin NOW—or send a letter. Do it TODAY.

Address, Dept. M138

The One and Only **TITUS** 105 E. 13th St. New York City



Commercial Cartooning NEW INSTRUCTION

Owing to the increased demand by business firms for cartoons for advertising, sales promotion letters, house-organs, bulletins, etc., we have added new special instruction in commercial cartooning to Cartoonist W. L. Evans' regular course.

If you like to draw send 6c in stamps for portfolio of cartoons and full information. You can earn while you learn.

THE W. L. EVANS SCHOOL OF CARTOONING

521 Leader Bldg. Cleveland, Ohio

MEN WANTED for RAILROADS

Nearest their homes, everywhere, to train for Firemen, Brakemen, beginners \$150 to \$250 monthly. Promoted to Conductor or Engineer—\$300 to \$400 monthly. Highest wages on railroads. Also clerks.

RAILWAY EDUCATIONAL ASSOCIATION DEPT. D 1 BROOKLYN, N.Y.

Photos ENLARGED

Size 16x20 inches
Same price for full figure or bust, groups, landscapes, or pet animals etc., enlargements of any part of group picture. Safe return of your own original photo guaranteed.

98c

SEND NO MONEY Just mail photo or snapshot (any size) and within a week you will receive your beautiful life-like enlargement size 16x20 in. guaranteed fadeless. Pay postman 98c plus postage or send \$1.00 with order and we pay postage. **SPECIAL** With each enlargement we will send FREE a hand-tinted miniature reproduction of photo sent. Take advantage now of this amazing offer—send your photo today. **UNITED PORTRAIT COMPANY** 1652 Ogden Ave. Dept. E-369 Chicago, Ill.



Used RADIOS AS LOW AS \$9.90

5 tube

UNHEARD OF VALUES!

Take your choice. All in beautiful table model cabinets. Lot No. 1 Can hardly be told from new. Guaranteed \$14.90 Lot No. 2 Perfect working order. Guaranteed.... 12.90 Lot No. 3 Requires slight adjustment. Sold as is... 9.90 Mail your order today or send for circular. We ship promptly. Upon arrival pay price of set ordered plus a small delivery charge. Foreign countries send money order with order.) CHAS. HOODWIN CO., 4240 Lincoln Ave., Dept 510 Chicago Dealers in Bankrupt Radio Stocks

Up-to-Date Home Craftsman Shop For the man or boy who enjoys working with well-equipped electrically driven wood working machinery. Complete in every detail. Every purchaser given FREE OF CHARGE 12-months' course in Wood Craftsmanship and 27 blue-prints of various pieces of furniture, toys, models. Full details and illustrations sent without obligation. 10-day FREE trial. Can be purchased on monthly payment plan. Write today.

Up-to-Date Machine Works, Dept. 34, 2915 S. Wabash Ave., Chicago, Ill.

Play Tune in 10 Minutes ON THESE New Amazing INSTRUMENTS

New Kind of E-Z Playing Tenor Banjo, Ukulele, Mandolin and Guitar

equipped with exclusive patented invention that enables you to play tunes in a few minutes. Simple as A. B. C. Press keys and play tunes at once. No knowledge of music required. No long months of tiresome practice. No expensive lessons. Play by numbers at first—learn to play by note automatically while playing tunes.

Popularity! Big Money

Astonish your friends. Be center of attraction at all parties. Produce rich harmony, syncopated jazz. Loads of fun! Money-making chances.

10 DAY TRIAL—EASY TERMS Choose favorite instrument

on Special 10-Day Free Trial Offer. Play tunes at once. Trial costs you nothing. If satisfied, pay at rate of few cents a day. Send for Free Catalog of E-Z Playing Instruments. Contains big money-saving values. (If you have instrument, you can secure E-Z Playing Method separately.) You risk nothing. No obligation. Send today!

FERRY & CO., Dept. 1775 Chicago, U. S. A.



10 DAY TRIAL

A New and Timely Book for You Dyke's AIRCRAFT ENGINE INSTRUCTOR



Order NOW on Approval

Air travel has arrived. Thousands of planes carrying precious human lives are propelled by complicated engines that require constant care and attention. The industry needs men who know engines, accessories and instruments to keep these planes going.

That is why the manufacturers assisted A. L. Dyke, eminent gasoline engine expert and author, of Dyke's Auto and Gasoline Engine Encyclopedia in the preparation of the first real, up-to-date book dealing exclusively with modern aircraft engines.

The builders of the famous "Whirlwind" engine, say "... better than our own instruction book for laymen." 400 Pictures and Master Charts in colors make engines simple as A. B. C. Special Sections on detecting and repairing worn parts. Shows where troubles develop and how to correct or prevent them. Includes also full information on carburetors, starters, magnetos, controls, etc. The entire book is simplified and practical from cover to cover.

400 pages, 400 illus. Flexible binding. Price \$5 postpaid. Money back if not satisfactory.

Popular Mechanics Press
Room P 5, 200 E. Ontario St., Chicago

The Book of the Hour—the most popular of all Airplane Books



Ain't Life Wonderful!

By Mason

 <p>NO HE CAN'T PLAY GOLF WITH US, HE'S RUPTURED POOR FELLOW</p>	 <p>YOU'RE SO GROUCHY SINCE YOU'VE BEEN WEARING THAT TRUSS - WHY DON'T YOU TRY SOMETHING THAT WILL RELIEVE YOU?</p>	 <p>POOR OLD JOE IS LOSING HIS GRIP SINCE HE'S BEEN RUPTURED</p>
<p>WHEN YOUR BARRED FROM AN ACTIVE LIFE BECAUSE YOU'RE STRAPPED DOWN WITH A TRUSS</p>	<p>- AND CONSTANT DISCOMFORT SOURS YOUR DISPOSITION</p>	<p>- AND YOUR AILMENT BEGINS TO AFFECT YOUR WORK AND BUSINESS SUCCESS</p>
 <p>JOE - HERE'S WHAT YOU OUGHT TO GET</p>	 <p>OH BOY! NO MORE TRUSSES FOR ME</p>	 <p>IS THIS A MIRACLE? MY RUPTURE HAS DISAPPEARED GOOD-BYE TRUSS TORTURE</p>
<p>THEN - SOME KIND FRIEND TIPS YOU OFF ABOUT MAGIC DOT</p>	<p>- AND YOU'RE AMAZED TO FIND IT SUPPORTS RUPTURE WITHOUT STEEL SPRINGS, LEG STRAPS OR HARD, GOUGING CUSHIONS</p>	<p>- AND TWO MONTHS LATER YOU FEEL TWENTY YEARS YOUNGER - AIN'T LIFE WONDERFUL!</p>

Button Rupture Newest Way (Without Pressure!)



SCIENCE now advises discarding cruel steel springs, barbarous leg straps, and other harness that press against the rupture and thus prevent nature from healing it. A new sensible method has been perfected, after experience of more than 40,000 cases, called Magic Dot—entirely different from any other way. Instead of "pressing" it "seals" rupture, and, of course, allows users to run, jump, bend and cough in safety.

Rupture Help Breathes Air

With this 1/25th oz. device is a new kind of pad, air-porous and washable. It actually "breathes" air and cannot slip off the rupture—a feature you'll frankly admit that is lacking in your present appliance. In fact, it is so superior and different that it is praised by physicians as "an entirely new departure." Users report they have

forgotten they are wearing it. But don't buy it yet.

Ruptured? See It First!

By a special arrangement you can now have it sent to your home. Don't send a penny or order it now. Just mail the coupon for full description of "Magic Dot" and details of this unusual offer. Act now for quick relief. Write your name and address on the coupon and mail it today!

FREE SAMPLE

NEW SCIENCE INSTITUTE
2160 Clay St., Steubenville, Ohio

NEW SCIENCE INSTITUTE, 2160 Clay St., Steubenville, O.

Please send me free your illustrated book, sample of Airtex material that "breathes" and full details of the amazing new way to button rupture. Include also your offer which permits me to see the New Science System without cost or obligation.

Name.....

Address.....

City.....State.....

(Be sure to write or print very plainly.)



GET POPULAR!

Play the Piano Accordion

Learn by playing real music —instead of tiresome "exercises." Learn at home in your spare time.

SUDDENLY the Piano Accordion has become the most popular instrument of the day. It is an entire orchestra in itself. Piano Accordion players are in great demand for solo and specialty work in the modern orchestra and make a "big hit" at any party.

Yet now, even if you have no knowledge of music or notes, you can learn to play this, or any other instrument that you choose, right at home in a few short months—and learn without a teacher at an average cost of only a few cents a day. Already over a half-million people have become popular musicians this quick easy way.

Select your favorite instrument today. Then write for *Free Book and Demonstration Lesson* which gives you the whole story of this remarkable home study method. No obligation. Mail card NOW. U. S. School of Music, 75A Brunswick Bldg., New York City.

LEARN TO PLAY ANY INSTRUMENT

- | | |
|-------------------------------------|----------|
| Piano | Violin |
| Organ | Clarinet |
| Ukulele | Flute |
| Cornet | Harp |
| Trombone | Cello |
| Saxophone | Piccolo |
| Mandolin | Guitar |
| Sight Singing | |
| Piano Accordion | |
| Drums and Traps | |
| Automatic Finger Control | |
| Banjo (Plectrum, 5-String or Tenor) | |

U. S. SCHOOL OF MUSIC, 75A Brunswick Bldg., New York City

Send me your free book, "Music Lessons in Your Own Home," with introduction by Dr. Frank Crane. Also Free DEMONSTRATION LESSON. This does not put me under any obligation.

Name.....

Address.....

City..... State.....



BE AN OFFICER in the U. S. Coast Guard \$1700 Up to \$7,500 Yearly

\$780 yearly at the U. S. Academy while training. You rank Ensign to Captain in service. Age requirements 18 to 22. Write Dept. KP for information.

COAST GUARD PREPARATORY SCHOOL
4000 Ga. Ave., N. W. Washington, D. C.

LEARN CODE TELEGRAPH OR RADIO



AT HOME with the Omnigraph AUTOMATIC TRANSMITTER

The best, easiest, quickest way known for over 20 years. Gov't schools and scientific institutions use it. Short wave code at all times. Interesting. Develops mind. Start now. Catalog 5c. Omnigraph Mfg. Co., 810 E. 39th St., P. M., Brooklyn, N.Y.

LEARN WATCHMAKING

and become independent. We help you secure a position.

Easy to learn. Send for FREE CATALOG.

ST. LOUIS WATCHMAKING SCHOOL Dept. 5, ST. LOUIS, MO.

WANTED

Boys—Men, 17 to 50. Prepare yourself for U. S. GOVERNMENT STEADY JOBS. \$1700 to \$2700 year. Write today sure for FREE list of positions, sample coaching and full particulars.

FRANKLIN INSTITUTE, Dept. R200, Rochester, N.Y.

Camp ELECTRIC Light Plant

110 Volt—Complete with all wiring, fixtures and lamps for seven rooms.....\$147.50

for Farms, Camps and Summer Homes

Install it yourself. Write for direct to you prices. Immediate delivery

D. W. ONAN & SONS
8 Royalton Ave., Minneapolis, Minn.



BOYS who's next



Hundreds of boys are receiving such prizes as a football, skates, radio, bicycle, watch, and baseball equipment. They do this by being Crowell Juniors.

Crowell Junior Salesmen are a group of ambitious boys who deliver, in their spare time, The American Magazine, Woman's Home Companion, and Collier's, The National Weekly.

You need no experience to start. We will tell you how to locate readers of these well known magazines.

Mail the coupon as your first step toward money and prizes.

Boys mail this NOW

Mr. JIM THAYER, Dept. 93
THE CROWELL PUBLISHING CO.
Springfield, Ohio

Dear Jim: I want to earn money and prizes. Please start me off as a salesman.

My Name.....

Address.....

Town..... State.....

Learn AVIATION

GET THOROUGH TRAINING NOW!

from A Practical School with Modern Equipment



Our School Registered, All Instructors and Airplanes Licensed by U. S. Government

All Airplanes used by us for both instruction and passenger service are planes licensed by the U. S. Government and our instructors are U. S. Licensed Transport Pilots and U. S. Licensed Mechanics. Our Chief Instructor is Lieutenant Murel R. Bouse, former instructor at the U. S. Air-Service Technical School of Chanute Field, and each and every one of our pilots has more than 1500 hours in the air to his credit.

We Guarantee to Qualify Our Students for Immediate Positions

There is money for you in Aviation, if—you get thorough training NOW! Our courses will give you this training—they cover everything about planes, motors, their operation, maintenance and construction. Everything a pilot or mechanic must know to secure a good-paying position. We guarantee that upon completion of a course at our school you will have all the knowledge necessary to qualify you for an immediate position in the particular branch of Aviation for which you have trained, whether on the ground or in the air. Our equipment is new and of modern design, subject to daily U. S. Government Inspection. (Most schools do not have a resident U. S. Government Inspector on the field—think what this means to you.)

HERE IS PROOF

Three Lakes, Wis.
June 19, 1928.

VON HOFFMANN AIRCRAFT SCHOOL,
ST. LOUIS, MISSOURI.

Gentlemen:

I feel that I certainly owe you people a letter of recommendation.

When I decided to take a course in Aviation I corresponded with a number of schools, before I left home, and when I did start out I took my car and drove to a number of cities, so consequently visited a number of schools. I was well satisfied, when I enrolled in your school, that it was by far the best school I had visited, and I still feel the same way about it. The courses you have are complete; the instructors surely know how to handle the students, as well as planes; and the equipment is of the very best. Two things I wish to emphasize are the facts that I found everything at your school as you advertised it, and that my first solo flight was with a new Eaglerock plane, used less than thirty hours, which surely shows that you have confidence in your students.

The Eaglerock plane I got from you is doing fine. Just got back from a 500-mile trip through southern Wisconsin, advertising the summer resorts of this district.

Thanking you for the many things you have done for me, I am

Cordially yours,

(Signed) HAROLD L. GRANDY.

This is just one of the many letters we have received from former students. We will be pleased to send copies of them upon request.

ON THE GROUND

To make our ground course thorough, intensive and complete it has been patterned strictly after the course of ground instruction given by the U. S. Government. It covers complete theoretical instruction and practical shop training in Airplane Structure and Repair of various type planes, Aircraft Welding, Wing and Fuselage Covering and Doping, Motor Construction, Adjustment and Repair (Water and Air-Cooled Motors), Motor Testing and Trouble Shooting, Airplane Instruments, Aerial Navigation, etc. Instruction is given on every type of motor—the OX-5—to the larger types such as the Wright Whirlwind.



"Trouble Shooting on the Flying Line"

This is a vital and essential part of the Von Hoffmann training on all types of planes. It is additional training of this kind which secures and holds positions in Aviation for Von Hoffmann Graduates.

IN THE AIR

We guarantee sufficient hours in the air to make each student master of his ship; pilot it safely and efficiently by himself. Instruction is given by U. S. Licensed Transport Pilots on four different types of approved modern aircraft—Eaglerock Biplane with OX-5 Motor, Eaglerock with Siemens-Halske Radial Type Motor, Ryan open cockpit Monoplane powered with Hispano-Suiza (Hisso) Motor and Ryan four passenger closed Cabin Monoplane powered with Wright Whirlwind Motor.

Trained Men Are Needed

The training which the Von Hoffmann student receives is the exact training which he must have to qualify for immediate positions on the ground or in the air. Our courses have been laid out with a single object in view—to give thorough training in all branches of Aviation. Commercial Aviation needs men and there is an ever increasing demand, ONLY for those who have been properly trained—Von Hoffmann gives you this training.

THOROUGH INSTRUCTION AT LOW COST

We teach you by actual flying and practical instruction; no long course needed. No student bond required. Our ground course gives thorough instruction in ground and qualifies you for a position as motor and plane mechanic, rigger, electrician, welder, or any other ground position, or you can take the course combining ground instruction and flying which will qualify you for an industrial, limited commercial or transport pilot. The cost is low considering daily flying, the thoroughness of theoretical and ground instruction on latest modern type planes, Wright Whirlwind and other standard motors. Our big new book "AVIATION and YOU" tells all the facts—write for it TODAY!

MAIL COUPON NOW!

If you are interested in Aviation, you should know the necessary physical qualifications and what is required by the Government for a mechanic's or pilot's license. Our big, new book, "AVIATION and YOU," tells all the facts. It is FREE. Fill out the coupon and mail it at once—no obligations. DO IT NOW!



Von Hoffmann Aircraft School
Distributors for Eaglerock Planes
117 Lambert-Saint Louis Flying Field,
ANGLUM, MISSOURI

Von Hoffmann Aircraft School,
117 Lambert-Saint Louis Flying Field,
(Lindbergh's Own Field), Anglum, Missouri.

Send me your big, new book "AVIATION and YOU," giving all the facts about your ground and flying courses. I assume no obligation;

CHECK I am interested in GROUND COURSE
HERE I am interested in FLYING COURSES

I expect to start about.....19.....
Month

Name.....

Address..... Age.....

TOWN.....State.....

NOTE: Be Sure To Answer All Questions.



PAINT with ELECTRICITY
The New and Easy Way

The ATOMISTER
 THE EVEN PRESSURE SPRAYING MACHINE

Model "B"
 Air Compressor and Spray Gun complete **\$39.50**

Cut your painting time in half—do a better job—with this handy, convenient spraying machine. Sprays paint, lacquer, enamel, bronze, varnish, stain, shellac, whitewash, insecticides, disinfectants. For use in the home, factory, garage, dairy farm, sign shop, boat yard, truck fleet, gas station, greenhouse, etc. Plugs into any light socket. Weighs 6½ lbs. Air pressure 25-30 lbs. Material container 1 qt.

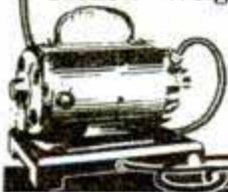

At your dealer's—or from us **\$39.50**. Write for booklet.

The Atomister Corporation
 32 Hamilton Street, Rahway, N. J.

Join an ASPA FLYING CLUB

Airplane FREE!

By enrolling as a member of The American Society for Promotion of Aviation, you can help us—with the aid of the country's most prominent "air-minded" individuals—to influence Congress to follow the lead of Canada by appropriating \$40,000,000 to supply *grants* airplanes to every Flying Club of fifty members. We have already organized over 500 Flying Clubs. Will you help us organize one in your community? All ASPA members receive special courtesies at Airfields and Factories and secure practically 25% discount on all aeronautical books and equipment purchased through National Headquarters.

ASPA Home Study Course Complete for \$1.00

This Course is endorsed and recommended by America's leading armen and leading students of aviation, as the most complete, the soundest, clearest and most informative of any Course ever prepared. It teaches you the fundamentals of aviation and materially cuts down the number of hours necessary before qualifying as a flier. Membership in the ASPA, including Silver Wings (pictured below) is but \$1.00. The Complete Home Study Course, including Blue Print of a Model Airplane, is also \$1.00. Show your spirit and patriotism by lending support to this national determination to "Make America Supreme in the Air." Use Coupon below—TODAY!

SECRETARY, ASPA,
 Dept. PM-5, 522 Fifth Ave., New York.

- [] I enclose \$1 for Membership in ASPA, including Silver Wings, Membership Card and literature of the Society.
- [] I enclose \$1 for ASPA Complete Home Study Course in Aviation, including Blue Print of Model Airplane.
- [] I enclose \$2 for both Membership and Course.

Name.....

Address.....

City.....State.....



An Actual \$14 Value

FOR ONLY \$5.00



BIGGEST BARGAIN OFFER EVER MADE

The finest, strongest 10-Cable Chest Pull (*guaranteed in every particular*), a pair of powerful Hand Grips, a complete Illustrated Physical Culture Course of Instruction and a Manual of Physical Education by Dr. William Gilbert Anderson, famous Professor and Director of the Yale University Gymnasium—all for only \$5.00 postpaid—if ordered NOW!

The Chest Pull quickly develops muscles of arms, shoulders, back and abdomen; the Hand Grips give you a powerful grip and a strong forearm. These appliances used with the Illustrated Course and Dr. Anderson's Manual rapidly build up your **MUSCLE, STRENGTH and HEALTH!** This amazing bargain is truly the greatest value ever offered by any manufacturer. **SEND IN YOUR ORDER TODAY!**

MOOSEHEAD-WHITELY EXERCISER CO.
 1139 Tiffany St., New York City

YOU CAN OIL PAINT

Amazing new method teaches men or women to earn after first lesson. OIL PAINT photos—portraits, landscapes or art subjects. Earn \$18 to \$50 and more a week. OIL PAINT OUT-FIT GIVEN. Send now for free illustrated book. PICTORIAL ART STUDIOS Inc., Dept. MP, 2926 Broadway, Chicago, Ill.

THE RED ACE A Supreme COMBAT PURSUIT PLANE Achievement



Boys Get This Plane FREE with The Open Road for Boys Magazine.

The development of the Red Ace Combat Pursuit Ship will be nothing short of sensational in the world of model planes. Here's one plane that will not disappoint you—one plane that will perform like a real ship. Has wing spread 16" with main fuselage 14"; reinforced main wing; perfectly balanced tail wing and adjustable rudder. Main wing can be shaped to suit conditions; front landing gear and rear skid. Perfectly carved, 7" wood propeller, propeller bearing. 6 ply motor of newly developed extra strong rubber. Not a construction set but a completely assembled plane. Simply fasten wings and launch.

The Red Ace will rise from ground under its own power; climb easily to 60 feet. Soar over roof-tops and buildings. Glides perfectly to earth. Guaranteed to fly. Don't let a day slip by until you order this plane.

Magazine. Has 50 pages every month crammed with just the stories you want, thrilling, breath-taking tales. Marvelous departments, fastest-growing boys' magazine. Has the punch! Regular subscription price \$1 a year. Rush us your subscription to-day on coupon below, and we will give you free the Red Ace Combat Pursuit Ship. But you must act at once.

Both for \$1 Canada 50c extra Foreign \$1 extra

This Is a Great Bargain!

PILOT KNIGHT, Open Road for Boys Magazine, 130 Newbury Street, Boston, Mass.

Friends: Bet your life! I will grab the big offer. Here's my dollar. Put me down for a year's subscription to The Open Road for Boys, and rush me the Red Ace Combat Pursuit Ship.

Name.....

Street.....

Town or City.....State.....



A Liberal Education in Only ONE Book!

EVERYONE MUST FACE THESE FACTS FRANKLY: The world today admires and rewards only the educated and cultured men and women. It rejects and ridicules the Babbitts, Lowbrows and Dumbbells. So he or she who wants to enjoy power and leadership, social standing and financial success must immediately acquire all-around and up-to-date knowledge and culture. Fortunately, such training and education are now easily available to every ambitious man or woman.

"The ONE book to read and know."
—Philadelphia Public Ledger.

Educate Yourself

—And Soon Hold Down a Real Job and Make Big Money

AT LAST it is possible for you to complete your education at home in a new, simple and inexpensive way—and thus realize your dreams and ambitions. Here are all the 31 steps to knowledge and learning—not sold as a costly course—but bound together in a single volume so that it is within the reach of everyone. Now any man with spunk and red blood can climb to fame and fortune.

THE OUTLINE OF MAN'S KNOWLEDGE, by Clement Wood, in its 700 pages is a complete outline of all branches of education, so clearly and interestingly written that anyone can understand, enjoy and appreciate it. The man or woman who reads this remarkable book will be better educated than 99 out of 100 college graduates. This great work has been endorsed and praised by the foremost educators and newspapers.

Education is Necessary to Financial and Social Success

It is what you know that really determines your own future. An educated man has the best opportunity for advancement—socially and financially. Now, by simply reading this one fascinating book you will easily and quickly absorb all that men and women must know in order to succeed and forge ahead.

Clip and mail the convenient coupon and it will bring you, prepaid, a copy of THE OUTLINE OF MAN'S KNOWLEDGE. Examine it. See for yourself how fascinating is the story of knowledge. Read it freely for a week. See how much you have

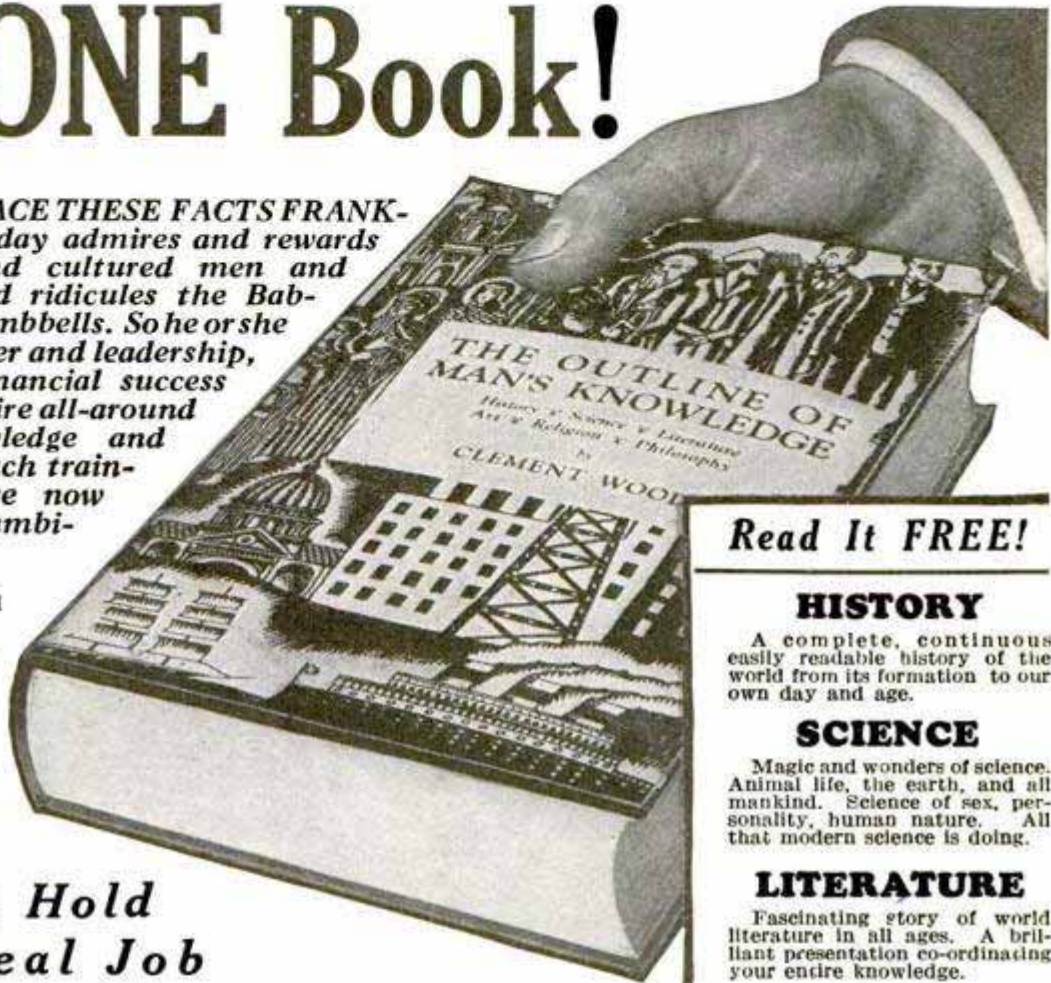

Read It FREE!

HISTORY

A complete, continuous easily readable history of the world from its formation to our own day and age.

SCIENCE

Magic and wonders of science. Animal life, the earth, and all mankind. Science of sex, personality, human nature. All that modern science is doing.

LITERATURE

Fascinating story of world literature in all ages. A brilliant presentation co-ordinating your entire knowledge.

ART

Entire story of the Arts: Painting; Sculpture; Architecture, Music, Dancing. Brings you a new appreciation of art.

RELIGION

Man's first spiritual aspirations. Mysteries of religious beginnings up to the story of all modern sects and beliefs.

PHILOSOPHY

The story of Philosophy and Philosophers. The wisdom of the ages.

ALL in THE OUTLINE OF MAN'S KNOWLEDGE. Send this coupon and examine it Free.

missed in the realm of things you OUGHT TO KNOW. If you are not completely satisfied send the book back within seven days. Otherwise, keep it as your very own and remit the astoundingly low price of only \$1.50 and two dollars a month for two months.

Send No Money—BORROW It at Our Expense

But don't decide now. See this all-absorbing work first. You can do that at our expense. Send no money. Just clip and mail the coupon. Lewis Copeland Company, Dept. 520, 119 West 57th St., New York, N. Y.

Tear Off Along This Line and Mail Today

Lewis Copeland Company, Dept. 520,
119 West 57th St., New York City.

Kindly send me THE OUTLINE OF MAN'S KNOWLEDGE by Clement Wood, 700 pages, illustrated, handsomely bound. Within 7 days I will either return the book or remit \$1.50 as first payment, and then \$2.00 per month for two months, a total of \$5.50. (Ten per cent discount for cash with order. Same return privilege.)

Name.....

Address.....

City.....State.....

If outside limits of Continental U. S., enclose \$5.00 with order.

2018

Ship

FITTING A NEW RUDDER TO AN OCEAN GIANT

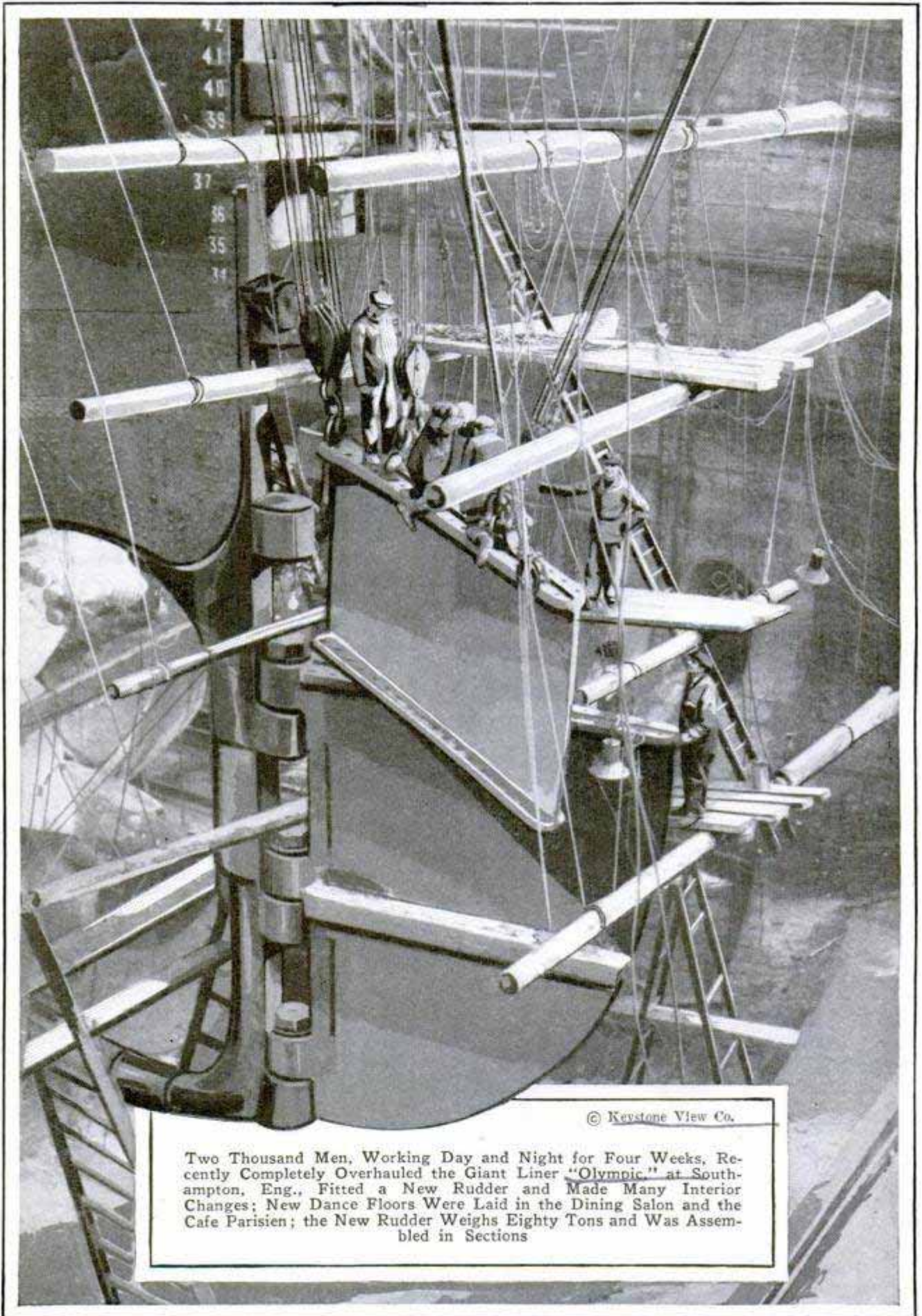

© Keystone View Co.

Two Thousand Men, Working Day and Night for Four Weeks, Recently Completely Overhauled the Giant Liner "Olympic" at Southampton, Eng., Fitted a New Rudder and Made Many Interior Changes; New Dance Floors Were Laid in the Dining Salon and the Cafe Parisien; the New Rudder Weighs Eighty Tons and Was Assembled in Sections

Popular Mechanics Magazine

REGISTERED IN U. S. PATENT OFFICE

WRITTEN SO YOU CAN UNDERSTAND IT

Vol. 51

2448

MAY, 1929

No. 5

Hanging 600 Pounds from a Flame

SIX hundred pounds, hanging in mid-air supported only by the energy created by a small gas flame, is the latest spectacular stunt of science. The heat of the flame warms one end of a copper bar, while the other is immersed in cold water, and the result is an electric current so powerful that six boys can stage a tug of war with the magnet and armature without pulling them apart.

Dr. Paul E. Klopsteg is responsible for the most powerful thermomagnet ever built. That temperature changes can produce electrical energy in metal is not new, for that is the theory on which thermocouples—the electric thermometers used in so many industries—are based. But the energy produced is only a minute fraction of a volt and a minute part of an ampere. In Doctor



Doctor Klopsteg and an Assistant. Total Weight 370 Pounds, Held Up by a Heat Magnet Getting Its Energy from a Small Gas Burner

Klopsteg's new apparatus, with a current pressure of about one fourteen-thousandth of a volt, a current of approximately 150 amperes has been measured.

The apparatus consists of a circular magnet of soft iron and an armature of the same shape, each fitted with a strong steel hook. A groove is cut in the face of the magnet to take a loop of copper bar about half an inch square, the ends of the bar projecting through slots in the side. The result is an electromagnet with a single turn, the copper bar. To the ends of the bar, larger copper plates are soldered, one to be heated by the burner and the other immersed in water, and between the ends is a bar of copper-nickel alloy.

Several German scientists in the past have produced somewhat sim-

Development Laboratory

Central Scientific Co. Park Blvd Chicago
1700 Alving
Chicago



Crystals That Talk and Also Give Electrical Shocks; the Small Device in the Lower-Left Corner Is a Demonstration Unit, Ready to Be Attached to a Cone; It Produces Excellent Volume and Tone

ilar arrangements, but never succeeded in obtaining a lifting pull of more than a few pounds. Discovering that the effect depended as much on the shape of the parts as on the difference in temperature between the ends, Doctor Klopsteg experimented until he evolved a design that would support hundreds of pounds. In testing apparatus, weights up to 600 pounds have been piled on before the armature pulled free from the magnet.

To check the actual current produced against theoretical calculations, which had showed a force of 135 amperes in supporting more than 450 pounds' weight, he designed a small wire coil of 100 turns, to fit into the magnet in place of the copper bar, and, with it connected to a single volt and a half dry cell, was able to support correspondingly heavy loads. As many as three 160-pound men can hang from the armature at one time.

Whether the heat magnet eventually will find some practical application, or whether it will remain a scientific curiosity, the future only can reveal. German experimenters with thermopiles have demonstrated it is possible to charge a storage battery with the current generated by heat.

Another scientific curiosity, which may shortly make its appearance in the radio field, is being prepared for school demonstrations. It is the Rochelle salt crystal—a substance even more responsive to radio waves than the quartz crystals used to keep broadcasting stations on the correct wave. Two thin bars of the crystal make

an effective loud-speaker unit, which has no coils, wires or moving parts, except for the atoms of the crystals when a current is applied.

The salt crystals are so re-



Measuring a Radio Wave Produced by a Small Oscillator; the Signal Lights the Lamp, at Right, at One-Half the Wavelength

sponsive to electric current that, by reversing the process and, instead of having the current vibrate the crystals, vibrating them mechanically, an electric current can be produced. Two small crystals mounted for a loud-speaker unit can be made to light a neon test lamp, or produce a strong electric shock merely by tapping them lightly with a lead pencil. By applying the two wires of the lighting circuit to opposite sides of a larger crystal, lying on a table, it is possible to make it vibrate so violently that it sounds like a buzzer.

The crystals are produced by a secret process in a chemical bath. A seed crystal is used as a starter, and more salt is deposited on it through electrochemical action. The finished crystal is nearly as clear as the finest window glass. One of its peculiarities is that it always grows in the shape of a prism, due to the arrangement of the molecules as they are deposited, and another is that the greatest mechanical and electrical effect is across the diagonal of the crystal. For use in loud-speaker units, they are cut on that line. The Rochelle crystals can be manufactured at comparatively low cost.

Doctor Klopsteg's laboratory also has produced a small oscillator for school use to give visible demonstrations of radio waves. One of the uses to which it can be put is the measurement of the length of the radio wave. The oscillator, employing a pair of power tubes and operated off the lighting current, produces a wave of about three and a half meters' length. With a pair of wires stretched across the room from its output terminals, and a small flashlight globe as a test lamp, it is possible to light the lamp at the points of maximum signal intensity, which come at one-half the wavelength, and again at the full wave, wave and a half, and so on.

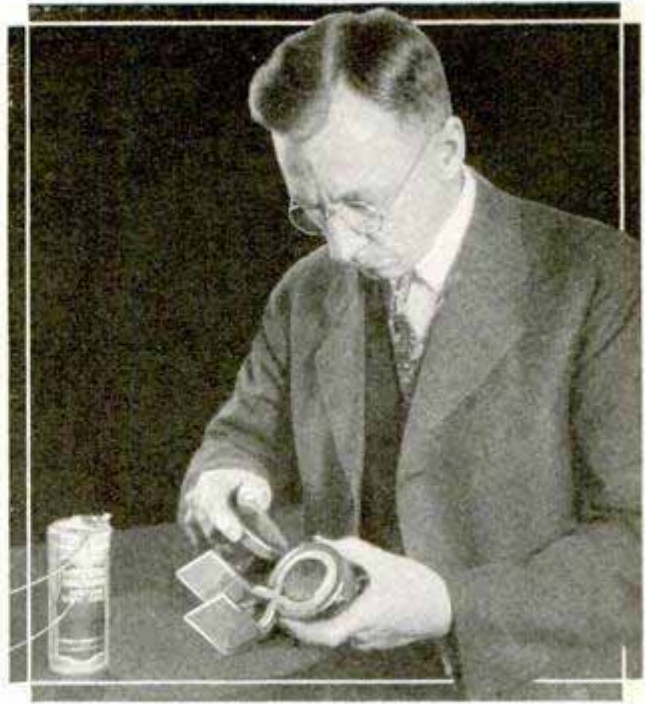

Doctor Klopsteg with His Heat Magnet, Showing the Copper Single-Turn Coil in the Soft-Iron Housing, and the Two Copper Plates, One of Which Is Immersed in Water and the Other Heated, to Produce Electricity

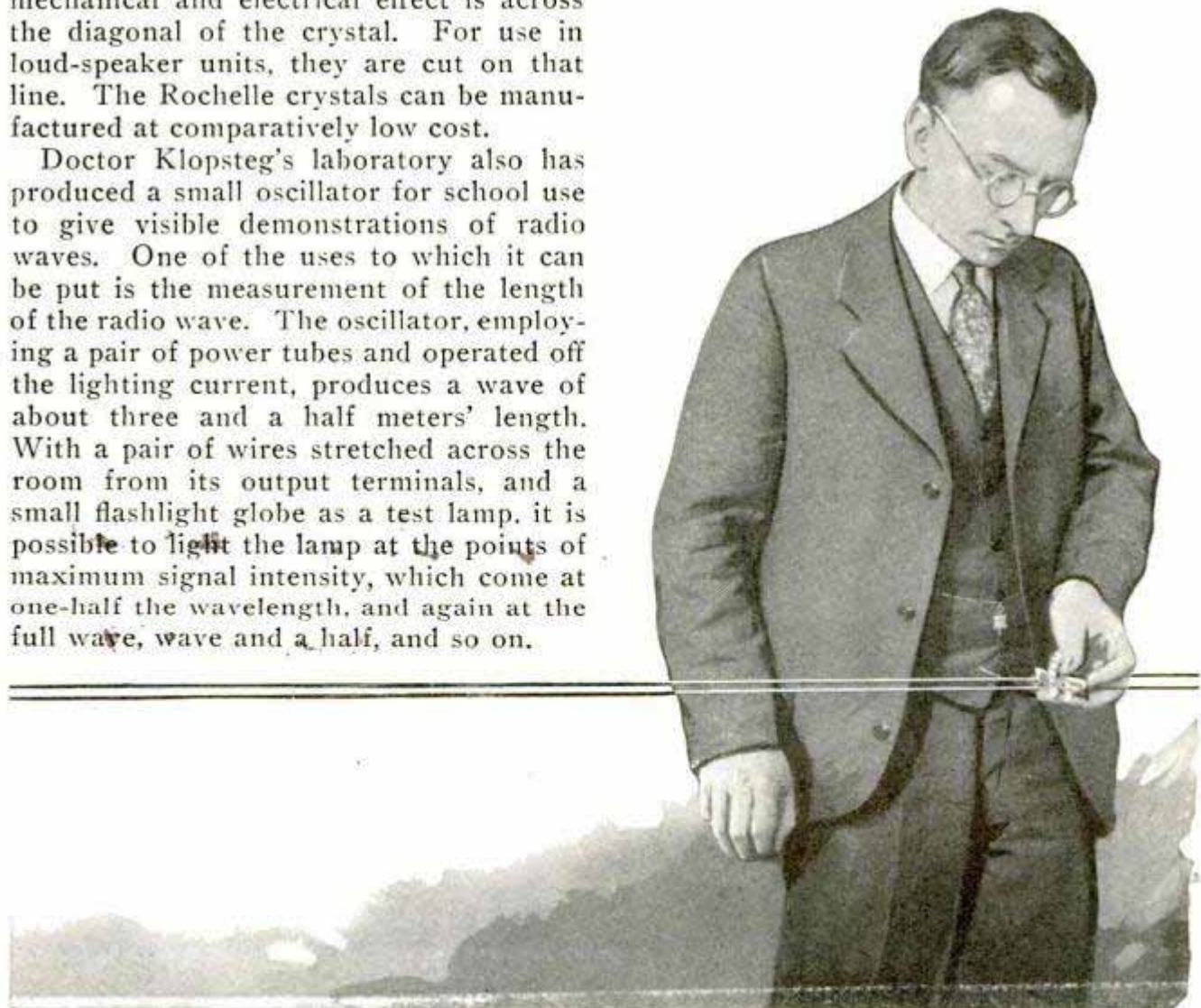

813 S. Van Ness Ave.

Santa Ana Calif.



Two Notable Examples of Floodlighting, a Motion-Picture Theater and the Los Angeles City Hall; the Latter Is One of the Largest Buildings So Treated

FLOODLIGHTING OF MOVIE THEATER DRAWS CROWDS

Effective use of floodlights on the exterior of a motion-picture theater in a California city has helped increase attendance at the night performances, the management reports. The lamps are directed in such a way that the special features of the building, including its tower, are made prominent. Another recent example of attractive floodlighting is that installed at the Los Angeles city hall, which can be seen for miles around at night time, bathed in the soft glow from scores of floodlights.

IMPROVED STEEL HAS SKIN FOR LONGER WEAR

Production of an improved steel that has a skin to protect it against rust and wear was announced recently. The coat-

ing is produced by placing the steel in a gas bath at a temperature of 1,000 degrees. This results in the formation of a tough film that is extremely hard and is impervious to rust. It has been asserted that bearings made of this steel seem never to show signs of wear and that they may be run safely though they become red-hot. A number of electric motors, using bushings of the new steel, were tested recently. They were started and stopped by an automatic mechanism and, after



22,000,000 operations, everything but the special steel units had worn out.

PULVERIZED COAL TO RUN SHIPS

2416 RIVALS OIL AS FUEL

That pulverized coal is a satisfactory fuel under marine boilers has been demonstrated with the United States shipping board's steamer "Mercer," a vessel of 9,500 tons. On the first trip, the efficiency was ninety-five per cent of that obtained from her best voyage with an oil burner, and the installation cost less.

Corn is believed to have first been grown in middle America.

Mechanics Steel Corp. N.Y.
W. D. Navy, Phila.
2/25/29
414-A
A mel (oil) sea tank

2418

Westinghouse Electric

3/2/29
**RECORD DISTANCE BIRD FLIGHT
MADE BY ARCTIC TERN**

The longest flight by a banded bird ever reported to the biological survey was made recently by an arctic tern only three months old. It was banded at Turnevick bay, Labrador, and was found dead on the beach at Margate, Natal, South Africa, less than four months later. The terns are among the greatest bird travelers, for they nest as far north as land has been discovered, arriving in the arctic regions about the middle of June, each year, and leaving about August 15. Several months after their northern visits, the birds are found near the antarctic continent, 11,000 miles distant from the starting point. Experts estimate that the terns cover at least 150 miles a day in their migration flights, although the exact routes are not known. Spending its life at opposite ends of the globe, the arctic tern has more hours of daylight and sunlight than any other animal in the world. In the north, the sun never sets during its entire stay and in the antarctic regions, broad daylight continues throughout its sojourn there.

**FADE-OUTS IN AMATEUR MOVIES
EASILY MADE WITH DISK**

Fade-ins, fade-outs, dissolve and double-exposure effects are easily attained in the amateur motion-picture film with the aid of an automatic disk arrangement, which is said to give results that will compare favorably with those achieved in the professional films. The disk is operated by a clockwork and is simply clamped over the lens. In using it, the time indicator is set, the camera focused as usual, and the fade-in button is pressed simultaneously with the camera button. The disk button is pressed again for the fade-out and the camera button released.

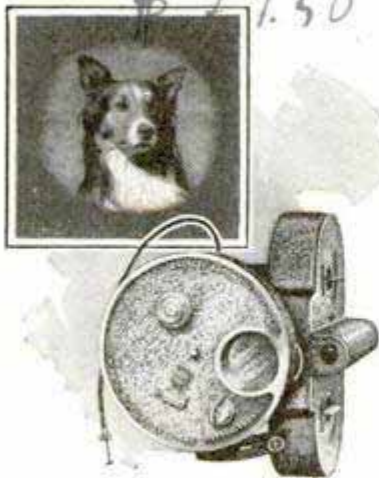

2345
compare favorably with those achieved in the professional films. The disk is operated by a clockwork and is simply clamped over the lens. In using it, the time indicator is set, the camera focused as usual, and the fade-in

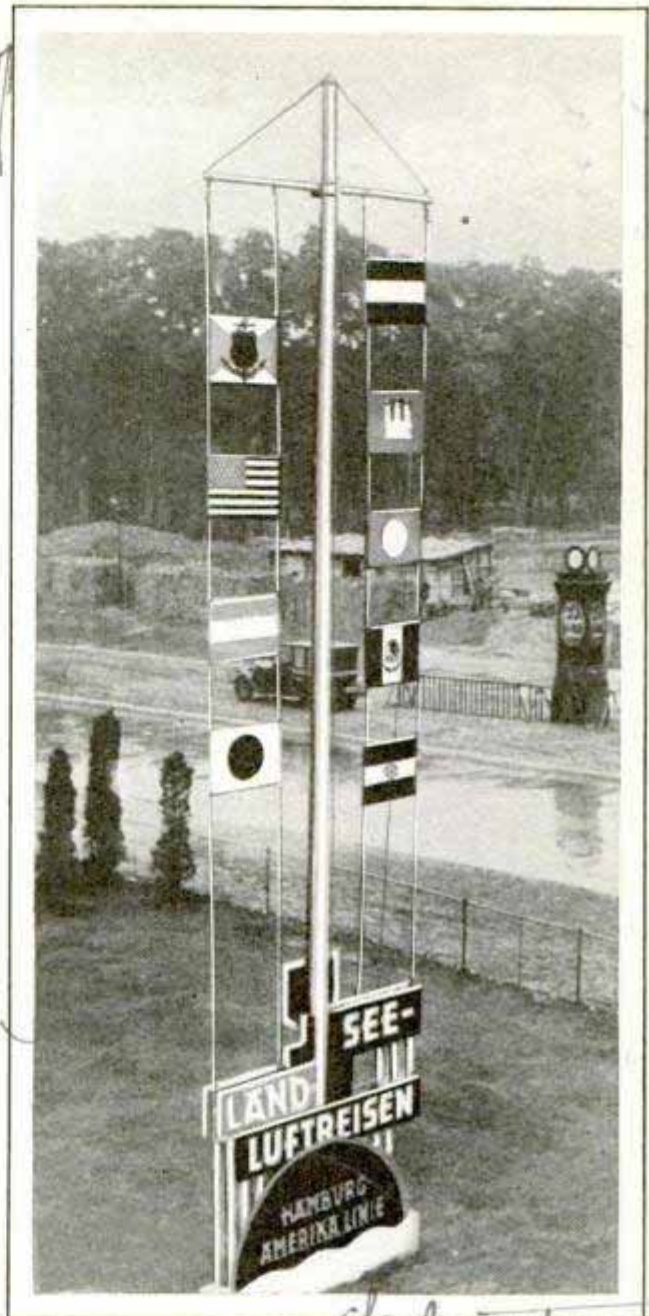

Flags at Flying Field Show How Many Parts of the Globe May Now Be Seen from the Air

**FLAGS DIRECT AIR TRAVELERS
TO FOREIGN PORTS**

How extensively travel by air has developed in Europe is seen at the Templehof landing field, at Berlin, where the flags of different countries to which air lines extend, are hung on a special mast for the guidance of tourists. Several nations are represented, and fast airplanes serve each one. Ticket offices, where transportation by air may be purchased to various parts of the world, are being established abroad and in this country as well.

Some of the cables under the Pacific ocean lie six miles beneath the surface.

Baso Camera Co.
179 W. Washington Madison

*U.S. Patent - 53 Moorhouse Ave
J.A. Schenck Hazel Park Mich*

*U.S. Pat. 2,405,129
3/1/29*

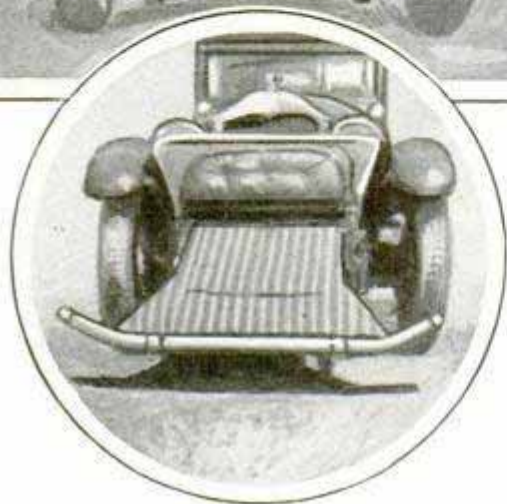
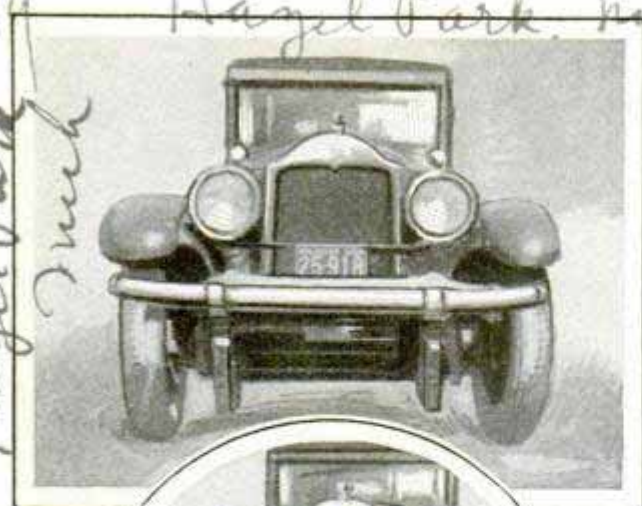

Bumper Protector Lowered and Raised; the Apron and Pad Shield Pedestrians from Injuries

SAFETY BUMPER FOR AUTOS SERVES ON STREET CARS

To prevent serious accidents to pedestrians, a safety bumper for the automobile and street car has been designed. As applied to the auto, it consists of a drop-apron unit, padded with cushions and operated from the driver's seat. It is lowered in less than a second, regardless of the speed of the car, and is intended to catch the victim in the soft canopy where he is little likely to suffer serious hurt. When folded up, the cushions and apron are out of sight. The device is also closed from the driver's seat, and the bumper unit is made adjustable to different makes of autos, trucks and street cars.

FLOATING FLOORS IN BUILDINGS HELP REDUCE NOISE

By constructing walls in layers, "floating" floors and suspended ceilings, engineers have succeeded in eliminating many bothersome noises in buildings. Tests made by the bureau of standards show that such types of construction prevent the transmission of impact sounds to a

marked degree. The experiments were made particularly with regard to the noises produced in walking across floors, and by the vibration of machinery. Introduction of air spaces was effective in curbing the sounds.

OYSTER-BREEDING IN TANKS TO INCREASE SUPPLY

Successful experiments are being made by British government research workers in breeding oysters in large tanks. Several years of disease have depleted the natural beds and have produced a scarcity of English oysters. One oyster, at the age of six years, can incubate about 1,000,000 young.

ROCKER BECOMES WHEEL CHAIR WITH FOLDING TRUCK

Rocking-chairs are quickly converted into wheel units, for service in hospitals and other places, with the aid of a folding roller truck. It is easily adjusted to the rockers, being adaptable to different widths and requiring no tools, and, when not in use, can be folded into small space and carried in the hand baggage. The wheels are rubber-tired, and there is also an adjustable footrest.

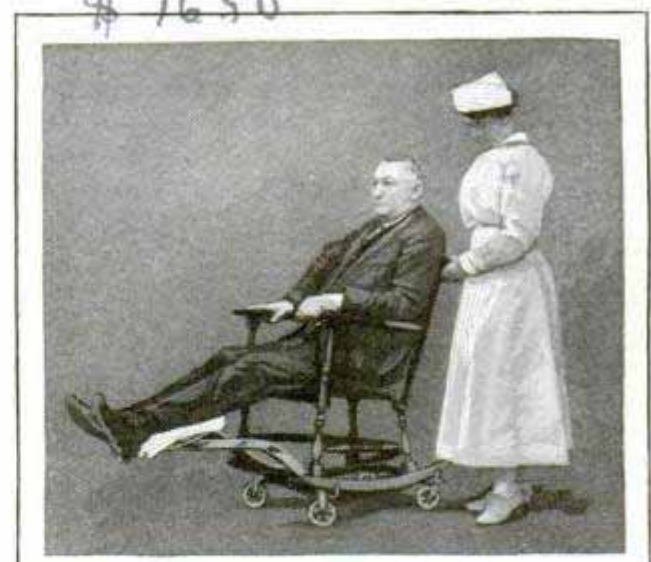

Close View of the Wheel Truck, and Photograph of It in Use with Ordinary Rocking-Chair

*at Conway, W. Va
2389
Capt. Williams*

*2336
\$ 16.50*

*Nurse Aid Co
Dickinson, N.D.*

29 21



International

Framed in a Natural Setting That Suggests the Severity of the Recent Winter in Europe; One of the Planes Sent to the Relief of the Lighthouse Crew by the German Government

PLANE RESCUES LIGHT KEEPERS MAROONED BY ICE

Rescuing keepers of lighthouses by air is an uncommon occurrence. Such a rescue was effected last winter. Due to the ice blockade, keepers of the light at Warnemunde on Mecklenburg bay, Germany, were marooned and unable to obtain supplies. The government sent an airplane to their relief with food and other materials which were dropped where the lighthouse tenders could get them.

DIAMOND MINES IN ARKANSAS PRODUCE RARE GEMS

24 42

Although most of the diamonds found in the Arkansas mines are small, many of them are of unusual beauty and brilliance, and, occasionally, stones of considerable size are discovered. In 1917, a canary-colored diamond, weighing eighteen carats was found. The Arkansas fields, opened in 1906, cover about sixty acres. Diamonds are found in the mountain ranges of northern California and southern Oregon, but not in quantities to justify commercial

New York Sun

development. Some years ago, a diamond weighing more than twenty-three carats was found in Virginia and a large black crystal, unearthed in North Carolina and broken by an inexperienced mineralogist, proved to be a black diamond.

SALT ON WINDSHIELD WIPER HELPS CLEAR GLASS

and

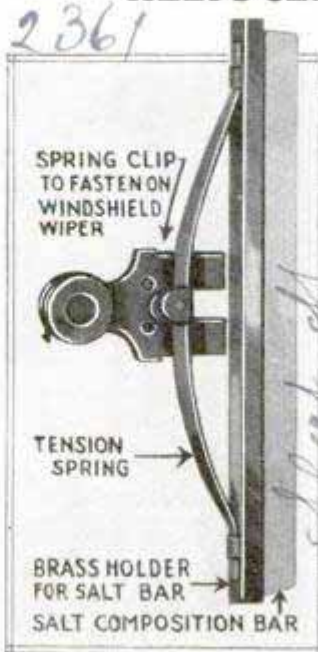

Inclosed in a brass holder on the windshield wiper is a bar of material, chiefly salt, which helps melt ice and frost that form on the glass. The bar will last for about six hours of wiping and, when not in use, is carried in the tool kit. New salt bars are easily inserted in the brass holder when needed.

William Lorenz Co., 211 - First Ave., North

2392

Paddock

The INVISIBLE

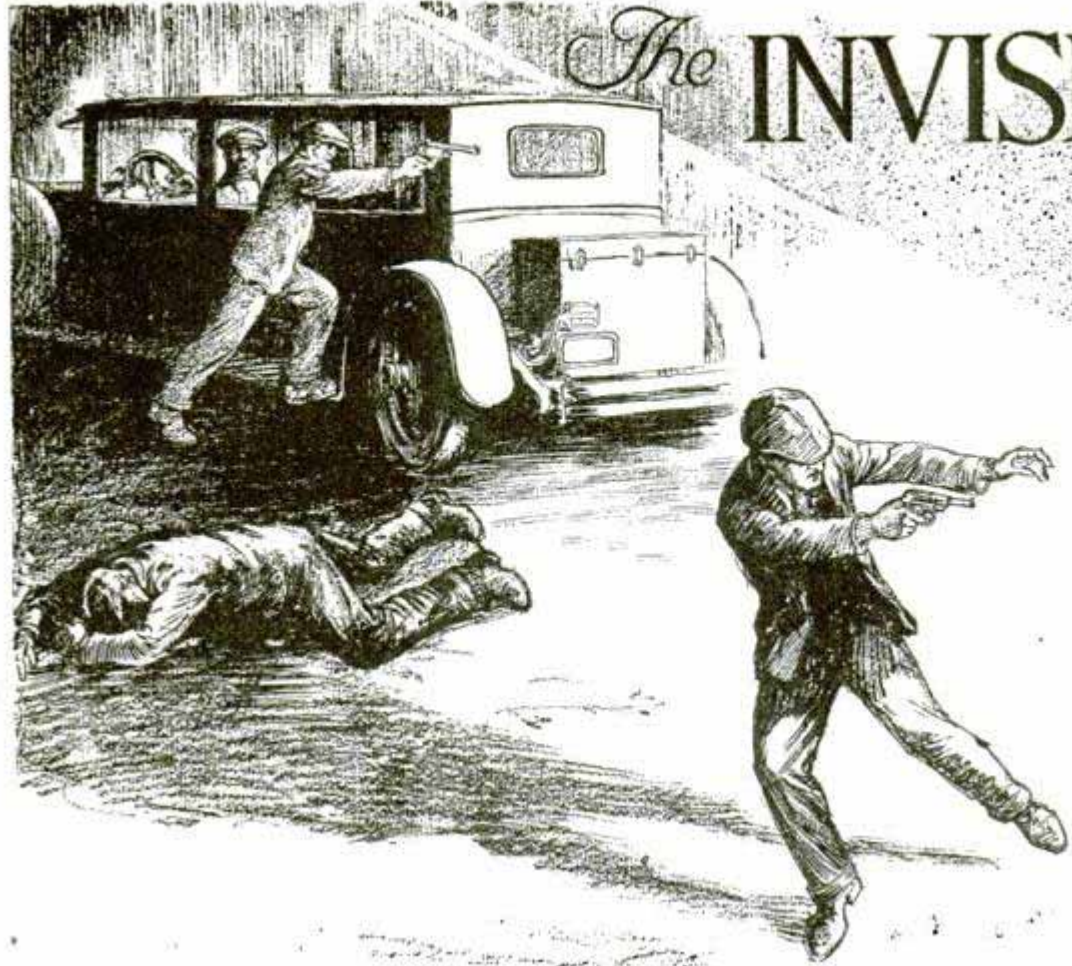

"NUMBER 7 cruiser. Number 7 cruiser. 3327 Gratiot avenue. A haberdashery holdup. 3327 Gratiot avenue."

The voice, coming from a little black horn behind the front seat, sent the big police car roaring through the night. Down startled streets, the car crunched to a stop in front of the store. A police sergeant and two men leaped out. The amazed proprietor and a customer, victims of the holdup, had hardly recovered from the shock of the gunman's visit. The cash-register till was open and empty, just as the bandit left it. He had won his escape by the narrow margin of seconds!

You are on a night tour with "Cruiser No. 7," one of the fleet of nine radio-equipped cars that the city of Detroit is sending against the criminal. In the first 227 days of its operation, this remarkable fleet effected 551 arrests for major crimes, recovered thousands of dollars' worth of stolen property, caught criminals literally red-handed in the act of committing crimes, or endeavoring to conceal them, and spent, on the average, just seventy seconds in reaching the scene of the crime

after receiving the first report by radio.

Not long ago, a burglar alarm sounded from one of the city's largest office buildings. Elevators were stopped and doors were closed. Three minutes after that, the building was surrounded by policemen. Five of the radio cruisers had picked the alarm out of the air as it was relayed from the broadcasting station W8FS on Belle Isle, miles away. In all, seventy-one policemen responded in a matter of a few minutes.

Quick work by a boy and the radio resulted in the rout of a bandit crew just the other day. One of the alleged robbers was shot and killed in the fight with the police. The boy saw the holdup in a

MAN HUNTER

store. He called the police, then watched the bandits who entered a cab. He saw the number on the license plate and telephoned that information to headquarters.

A cruiser squad, receiving by radio news of the robbery, encountered the cab a few blocks from the scene and another creditable entry for quick response and arrest was written, in red ink, in the big logbook that records performances of the cruisers.

These instances are picked at random from the logbook entries that tell a graphic story of how wireless is being harnessed

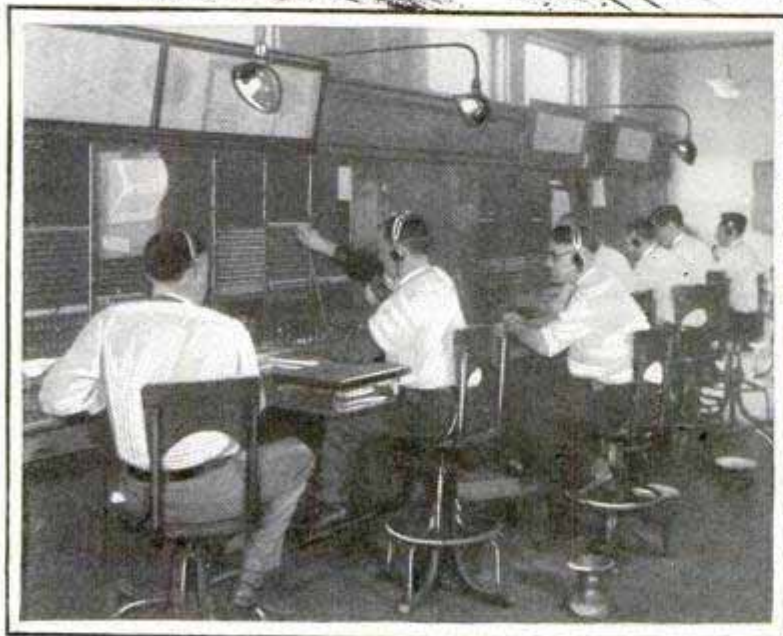
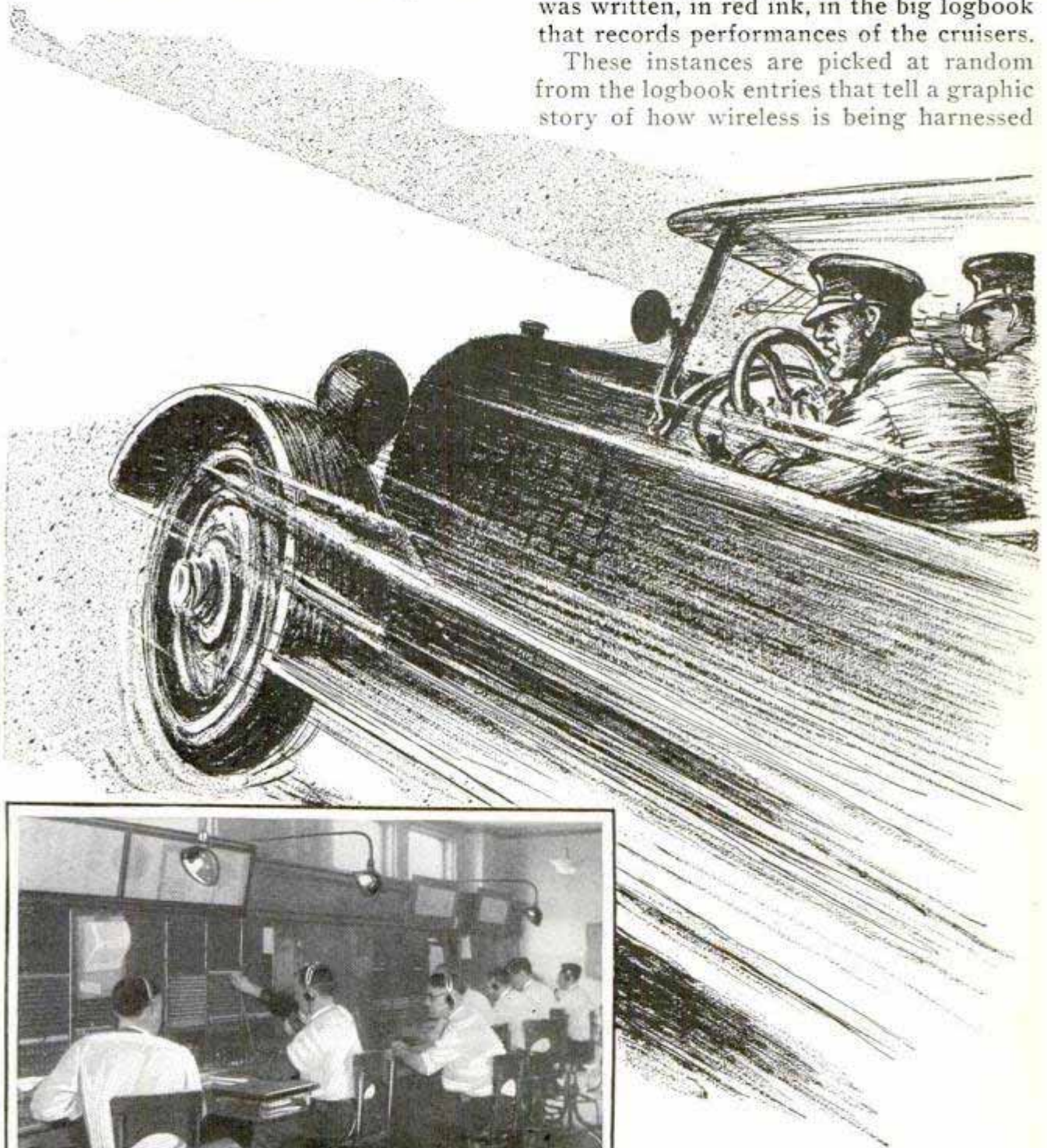

Where Police Alarms Are Received and Relayed; View of the Main Board in the Detroit Police Headquarters; the Man Second from the Left Is the Chief Dispatcher Who Relays Proper Calls Directly to the Broadcasting Station



Sgt. Kenneth R. Cox, Chief of Detroit's Radio Police Broadcasting Station, Working on One of the Portable Receivers

to aid in the fight against crime, and how it is putting speed into the arm of the law. The radio announces the misdeeds of the criminal to the whole world. The voice of W8FS has been heard abroad. A station in Germany picked up a crime report at the same moment the local crews were speeding to the scene. However, this was unusual, for the station broadcasts on a low wavelength that is calculated not to disturb other stations.

Here is what happens when a crime "breaks." The alarm or telephoned report reaches an operator at the main board in headquarters and is instantly relayed through a loud-speaker telephone to the radio station at Belle Isle, where one of the operators throws a switch that puts the set on the air. The word to the cruiser squad thus goes out without repetition, directly from headquarters. Arrived at the scene, the cruiser men make an immediate report back to the inspector at headquarters and their radio station. A shorthand reporter jots down the conversation and condenses it into a bulletin which is then typed on a marvelous machine, the teletype. It operates somewhat

like a stockbroker's ticker. As the message is written, the words are duplicated on receiving machines in each of the city's precinct stations, signal, traffic and motorcycle bureaus and at the radio station also. The radio operator there then broadcasts the teletype message so that all the cruiser squads will have the latest developments of the crime.

In case of a general alarm, word is relayed to suburban police stations. Four bells sound in each of the offices, and the operator at headquarters in Detroit reads off the teletype message. At the same time, the police operator at each of the precinct stations presses a switch that lights the patrol boxes in his territory.

When the green light flashes on the box, the patrolman on duty near by is required to open the box and listen to the operator's message. The lights remain on until patrolmen on every beat have been reached. They check in by giving their badge number as they receive the word.

By this system, a net can be flung over a radius of 100 miles or more within a few seconds after a crime has been committed. Plans are now under discussion whereby intercity communication can be carried on so that cruiser squads in other cities or radio-equipped machines operated by state police departments, for instance, would have immediate word of the crime and be on the lookout for fugitives.

Radio in police work is not new, but until recently, it has been chiefly experimental and in some cities a failure. Results were disappointing in Detroit up to April 7, 1928. But that date marked a new day in the city's radio department and brought to light an interesting story. Radio fans in the police department had watched the unsuccessful operation of the system with concern and disappointment. When it was suspended and the station,

2392

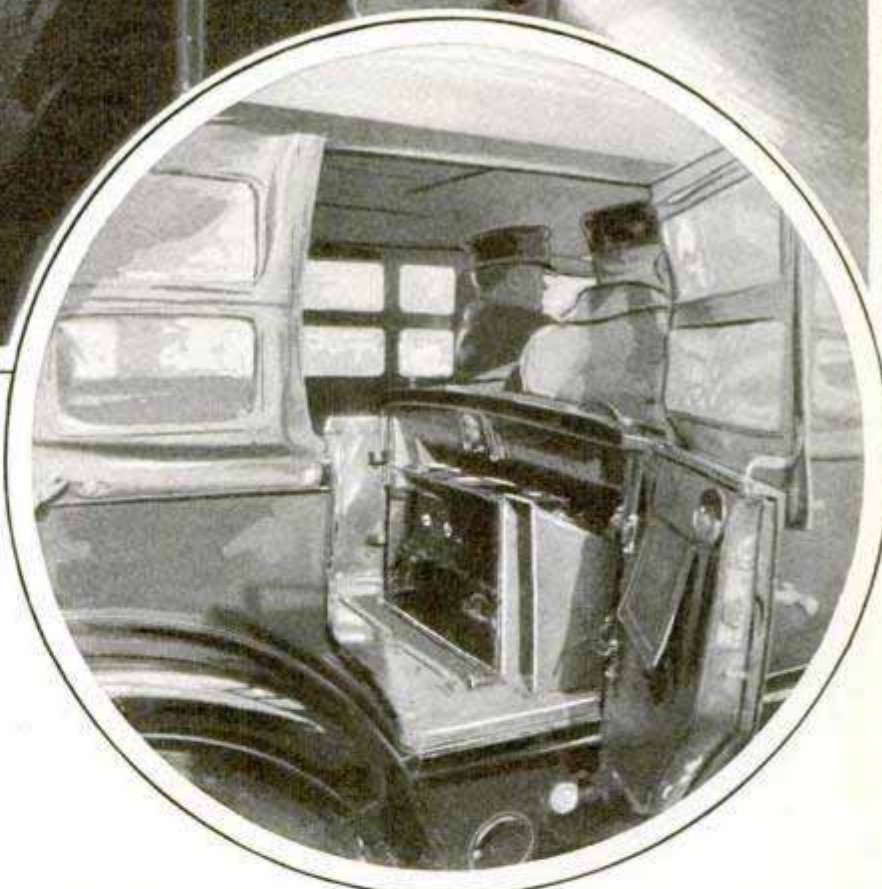
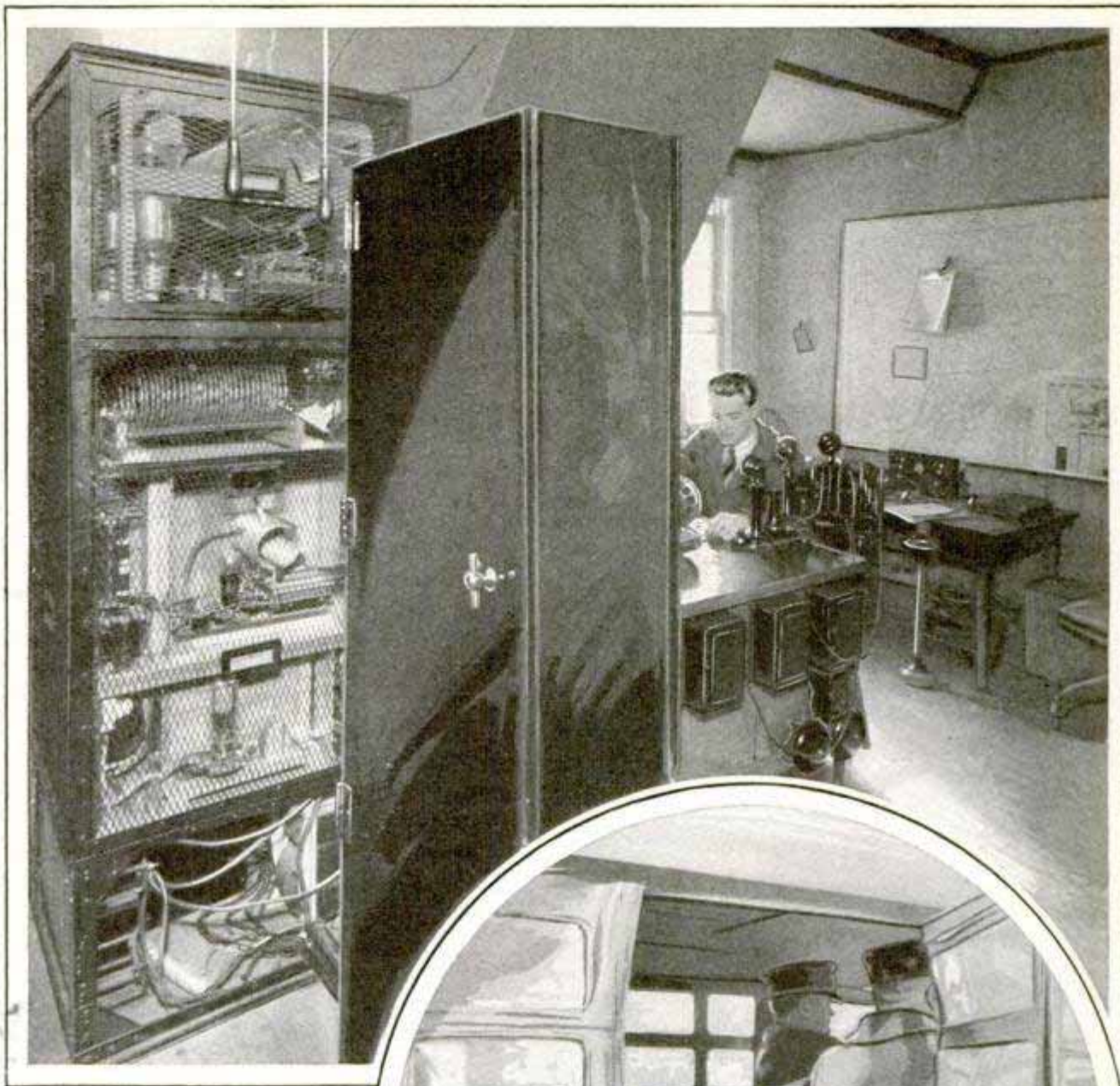

Interior View of Broadcasting Studio of Station W8FS and Glimpse Inside of One of the Cruisers, Showing the Set

then KOP, closed in 1927, their regret was keen. Patrolman Kenneth R. Cox, one of the wireless experts, went to Commissioner William P. Rutledge with an explanation as to why he believed the radio apparatus had failed. Cox and two other young radio fans, Policemen Bernard Fitzgerald and Walter H. Vogler, were commissioned to remedy the situation. They decided that the chief trouble lay in the transmitter. It was down town on the police headquarters building where it was hedged in with steel skyscrapers. So the set was

completely rebuilt, adjusted to work on a wavelength of approximately 150 meters instead of 200 and moved to Belle Isle. The old receiving sets were abandoned

The set was completely rebuilt, adjusted to work on a wavelength of approximately 150 meters instead of 200 and moved to Belle Isle. The old receiving sets were abandoned.

716

Identifying Eng

Daytona Beach & Palm Beach, Fla.

for new ones that the station staff designed. They were built into steel cabinets designed to fit back of the front seats of the police cars. The receiving sets work only on the wavelength of the police broadcasting station so that they cannot be used for other purposes. So successful has been the performance of the entire system, the direct result of a hobby on the part of Sergeant Cox and his associates, that radio-equipped cruisers are contemplated for every precinct in the city and sets are planned for smaller "scout" cars as well.

Back and forth through the silent streets, the cruiser car and its alert crew keep constant watch over the district until two o'clock in the morning, when the shift is over and the broadcasting station is silenced for the day. Normally, each car will travel from sixty to ninety miles during a single shift. Every half hour, the operator at the station sends out a test announcement to determine if all the receiving sets are working. If the men in the cruisers do not hear the test call at the scheduled time, they immediately notify the station so that repairs can be made. Up to the middle of February, before the system had been in operation

a year, there had been but three failures of the receivers. During that time, the station sent out more than 20,000 calls.

SEAWEED PADDING IN AIRPLANE DECREASES NOISE

By packing walls and ceilings of cabin airplanes with a special variety of seaweed, an effective way has been found to reduce the sound of the propellers and the motors. The weed is also being employed successfully in the insulation of homes.

FAVORITE STEAMER-DECK GAME NOW PLAYED ON LAND

Shuffleboard, one of the most popular of the games played by ocean travelers, is now enjoyed on land at a Florida resort. A smooth concrete court, properly marked, has been provided and many players can be accommodated at once. The game, now essentially the same as it was when it was played in England in the fifteenth century, consists in shooting wooden disks upon a scoring diagram with a cue and, at the same time, of course endeavoring to prevent the opponent from winning a tally.

St. Petersburg



Accommodations in groups and complete courts

Playing an Ancient Ship-Deck Game on Dry Land; Shuffleboard Court in Use at a Florida Resort; Many Players Can Be Accommodated at One Time; the Surface Is Smooth Concrete

Capt. B. A. Eschhart, manager, General Education Bureau, Portland Cement Assn.

W. A. Skellett, Germany.



© P. & A.

Rocket Sled at Full Speed, and a Close View, to Show the Arrangement of the Ski-Shaped Runners; Sixty Miles an Hour Was the Rate during a Test

**ROCKET-DRIVEN SLED
 MAKES HIGH SPEED**

Speed of more than sixty miles an hour was developed by a rocket sled, tested on a lake in the Bavarian Alps last winter. The manner of propulsion is essentially the same as that of the wheeled vehicles which have been run by harnessing the force of exploding powder. To show how simple the powder vehicles are to operate, a woman piloted the sled during one test run.



**RADIO HELPS TO FIND MOTOR
 THAT SUNK IN LAKE** *2430*

Already used with considerable success in prospecting for oils and metals and seeking buried treasure, radio has scored another triumph in finding lost articles. Not long ago, a friend of Prof. A. M. Skellett, of the University of Florida, had the misfortune to lose an outboard motor in Orange lake, near Gainesville. Professor

Skellett, who is also electrical engineer for radio station WRUF, rigged a "treasure hunter" somewhat like a small transmitting set and, with his friend, rowed to the approximate location where the motor had dropped. The apparatus was lowered into the lake and the current turned on. As the set was towed along, the hunters kept careful watch of a meter attached to it. Presently they noticed a marked decrease in the strength of the current, indicating approach to a body of metal. A brief further search, and the engine was found. The motor was raised and soon put in running condition again.

*Letter recd. 9/16/29
 locate*

Cont. Mill. Rec. 20
Camp, Kalamazoo, Mich

235² SUMMER HOMES IN NATIONAL FORESTS FOR ALL

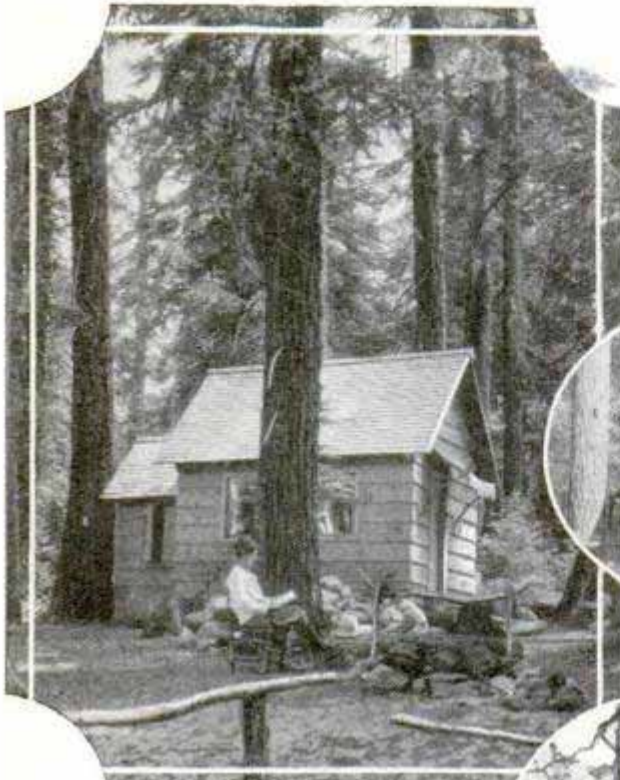

for leases is made to the forest supervisor in the district in which the site is selected. Detailed information about the national forests and all regulations may be obtained from the forest service of the department of agriculture at Washington,

Courtesy U. S. Forest Service

Typical Homes Built by Vacationists Who Have Leased Land from the Government on National Forest Preserves; Uncle Sam Encourages This Practice and Has Room for Many Tenants

The delights of a summer home among forest surroundings may be enjoyed by thousands as a result of the government's plan for renting sites in the national forests at small cost. The rental ranges from five to twenty-five dollars per year, depending upon the location, and the leases run from one to fifteen years, when a renewal is necessary. Improvements may be built as desired, but plans for houses and other buildings must first be approved by the forest officer; the strict regulations against fire must always be observed, and certain rules of sanitation must also be obeyed. Sites are available in all of the national forests with the exception of the White Mountain forest in New Hampshire and Maine and the Wichita in Oklahoma. They include many hundreds of thousands of acres. In some areas, logs for building, fencing and firewood are furnished free. Application



D. C. The plan applies also to the national forests in Alaska and Porto Rico.

CHEMICAL PROCESS KEEPS FISH FRESH FOR ONE MONTH

2424. Fish are reported to be kept fresh for a month and at low cost by a chemical process developed in Norway. The method requires a boiler, a pump and a tank. The tank is filled with water, either fresh or salt, which is heated with steam to a certain temperature, when various chemicals are added. The solution is then allowed to cool and the fish are soaked in it for one or two hours.

U. S. Weekly 2/27/29

Information from N. Lund
attached at Oslo, Norway

2900
Laboratory at Montainville

2393

ANTS FIGHT FIRES TO SAVE THEIR NESTS

Further demonstrations of the remarkable abilities of ants have been observed in a series of experiments performed in France. The tests disclosed that the ants, of the common red variety, become accomplished firemen when necessity demands. The discoveries were made as the result of an accident. A laboratory worker was in the habit of tossing lighted cigaret stubs into an ant-hill which had been partly demolished. He noticed that the stubs went out more quickly on the hill than when thrown on the ground near by. Investigation showed that the ants were extinguishing the stubs. They crowded about the glowing cigaret and ejected an acid fluid of some sort until the embers were entirely extinguished. A lighted candle was placed under the hill. Great numbers of ants immediately swarmed about it, formed into squads and finally scaled the candle. Then, at the risk of their lives, they proceeded to put out the flame by ejecting the fluid. Several ants were fatally burned in the operation. Observers witnessed attempts on the part of the ants to rescue one another, some appearing to prevent others from taking part in the fire fighting. The first candle was snuffed out in three minutes, but as the ants became more experienced, they learned to extinguish the flame in ten to thirty seconds. When the test was applied to ants in other hills, where the occupants had had no experience in handling fires, confusion and evident panic resulted.

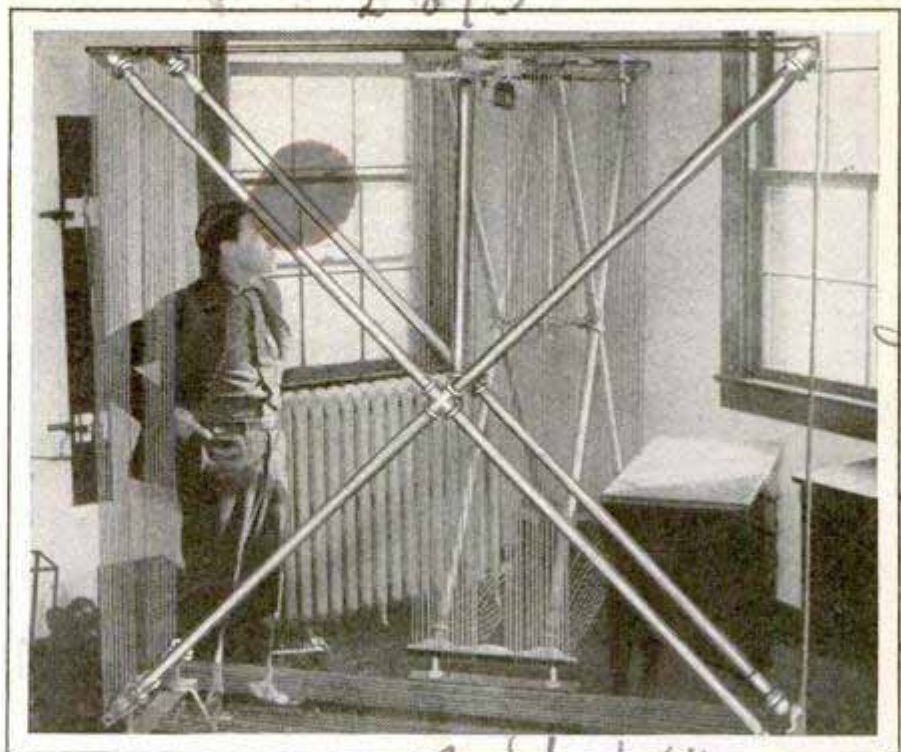

Courtesy Harris & Ewing
View of the Static Apparatus Which Gives Weather Experts Indication of the Approach of Storms

STATIC HARNESS TO AID IN WEATHER FORECASTS

Static electricity has been harnessed by the navy department in making weather forecasts for the benefit of aviators. The apparatus used consists of two six-foot radio loops which pick up static signals in such a way that the experts can derive from them the approach of storms.

BLACKSMITH SHOP ON WHEELS SAVES FARMERS' TIME

Farmers near Eugene, Oreg. do not have to drive their horses to town when the animals need shoeing, for a traveling blacksmith shop serves the community. The outfit is carried in a trailer behind an automobile and includes a portable forge, anvil and other necessary equipment. The work can be done in the fields, at the farm yard or in any other convenient place.

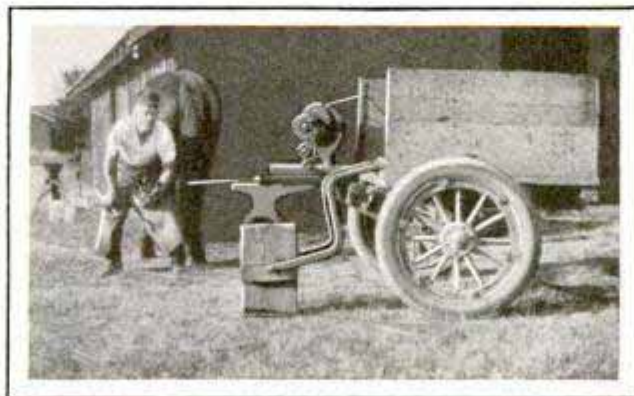

"The Village Smithy" Now Rolls on Wheels: View of the Traveling Shop and Owner at Work

Aerological Section Bureau of Aeronautics

Washington, D.C.

*Com. Div. C. U. & ...
Crown & ... Eugene, Oreg.*

New York Times 2/24/29

New York Times operated by ...

2391

Cont. In White Box 44
Alameda Calif

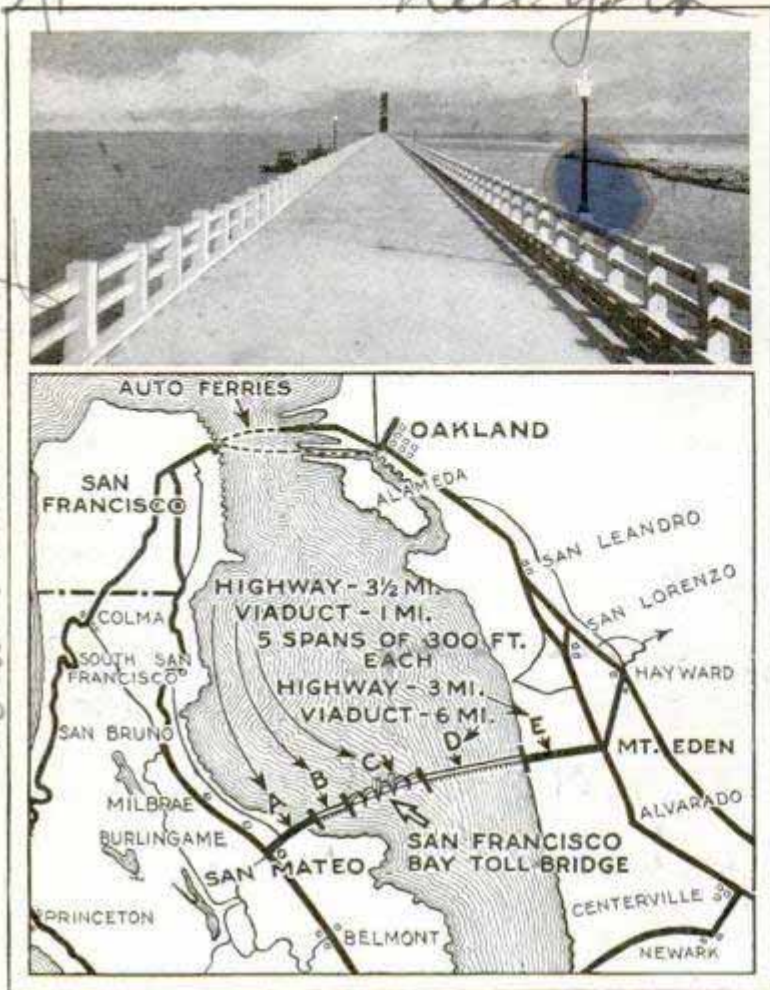

View of the Partly Completed Viaduct, and Map to Show Its Location across the Bay

SEVEN-MILE BRIDGE OVER BAY REDUCES TRAVEL TIME

Cities in northern and central California have been moved nearer to San Francisco by approximately twenty minutes as a result of the seven-mile bridge spanning the bay from Mt. Eden to San Mateo. The viaduct has space for three lines of traffic and has one lift span to permit the passage of ocean-going vessels through the ship canal. Oyster shells, dredged from the bay within a mile of the bridge site, were used in making the concrete, and the work was expedited by precasting the units for the bridge and then fitting them in place.

MOST ACCIDENTS IN FLYING LAID TO PILOTS

Of the 1,062 airplane accidents during 1928, in which 368 persons were killed and 322 severely injured, more than half were due to personnel, according to data collected by the aeronautic branch of the department of commerce. Poor technique,

errors of judgment, disobedience of orders, carelessness and negligence were accountable for most of the mishaps in which the operators of the planes were directly involved, it was found. Less than twenty-two per cent of all the accidents were laid to material failures. A total of 349 accidents occurred to airplanes driven by unlicensed pilots, and, of all the accidents recorded, only eighty-five occurred to planes flying regular schedules from airway to airway.

RADIO FACSIMILES SPEED NEWS REPORTS

Successful transmission of the front page of a newspaper by radio was made in London recently during a test. The whole page was flashed through the air from New York city to a London office. The entire operation took but twenty minutes. By this system, it is now possible to send pictures and messages at the rate of 1,400 words a minute.



Facsimile Sent by Radio from New York to England on Special Low-Wavelength Transmitter

2425

7-1 Starty 2/27/29

Marcconi Facsimile

Raymond Concrete Sales Co.,
26 B'way
Marconi International Marine Communication



Radio Antenna Installed on Plane of London Air Line; the Three Wires Are Permanently Attached and Do Not Have to Be Reeled Up When a Landing Is Made

World War I

THREE-WIRE AIRPLANE AERIAL ELIMINATES WINDING

Imperial Airways

Airplanes on an English line are being equipped with permanent radio aerials, stretched between the wings and the tail. This arrangement is reported to have given satisfactory service in all kinds of weather and also eliminates the task of having to wind the wires up before a landing, a necessary precaution with aerials that are simply suspended from the ship.

sensitive receiving apparatus. The idea was inspired by an old trick of the mind reader who sent messages to his confederate by shocks in code.

FAN HIDDEN IN CHANDELIER IMPROVES VENTILATION

Concealed at the base of the electric chandelier, a fan is said to give better ventilation and more effective circulation of



the air at less cost than the usual unit. The blades are specially designed to provide a cooling breeze of ample volume and direct the air at a wide angle so that it will not annoy persons below or disturb papers on a desk.

Ed Lewis, Inc

ELECTRIC SHOCKS DIRECT ACTOR IN TALKING FILMS

Actors are literally shocked into good performances for the talking films, through an arrangement that has been developed at a western studio. Impulses are silently transmitted from a battery under the carpet, so that signals can be sent without the need of spoken directions or other sounds that would spoil the record on the

Standard news 2/15/19

Metro-Goldwyn

Ed Lewis & Co

22 76

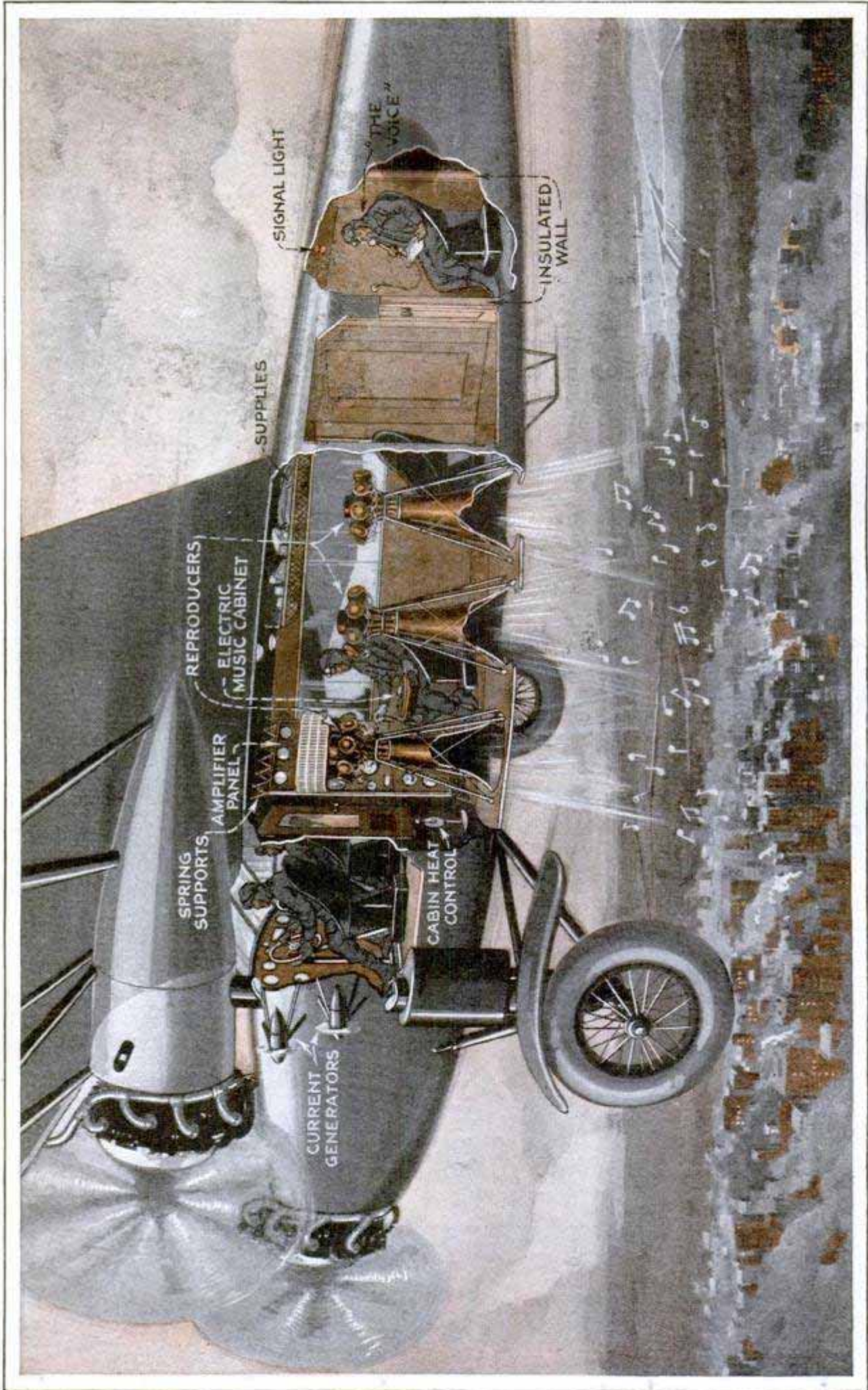

Photo Diagram of the "Voice of the Sky," a Powerful Tri-Motored Airplane Equipped with Giant Speakers That Can Make Its Announcer Heard on the Ground Far Below; a Portable Talking Machine Held in the Operator's Lap Provides Music



With an Enormously Extended Lower Wing, This Big Ship Has Carried a Neon Sign over Several Cities; Note the Cluster of Inspection Mirrors Projecting beneath the Fuselage

Flying Electric Billboards and Talking Airplanes Introduce Novelty in Outdoor Advertising

By PAUL D. PADDOCK

IT WAS two degrees below zero and he was in the middle of the street, but the man stopped to listen to a voice that seemed to be coming from the sky.

"Don't let your car freeze," it said cheerily.

The voice was coming from the sky! From a height of 3,000 feet, it was booming down, echoing in the streets, entering homes and closed cars, warning the motorist to repel the cold. The town crier of the twentieth century, the "Voice of the Sky" was aloft.

This marvelous five-mile voice—it actually has been heard that far and farther—is already familiar to millions but few know how a man can speak so clearly and so loudly from a roaring, tri-motored airplane, half a mile in the air and speeding along faster than the fastest train. Take the extra seat in the cabin and watch what goes on.

You are in a combination studio, laboratory, generating and broadcasting station, but the voice is not sent by radio. The startled citizens of the city below you, are hearing sound waves directly from the human throat except that the tones have been tremendously amplified. The seats on the left side of the cabin have been removed and, in their place, are three huge horns. Their bulging mouths open out on the underside of the fuselage. On top of each of these horns, are nine of the most powerful sound-reproducing units in the world, making twenty-seven in all. Each is pouring out the voice from the amplifying set, which is at the right of the door that leads to the pilot's compartment. Cooped up in a tiny booth, thickly insulated against the roar of the motors, is the actual source of the mighty voice, a young man, calmly speaking into a microphone. His words travel along

Wgr - Entirely covered by patents.

Wid. World

Attn. Mr. H. Muller, Sales, Lexington Ave

Voice of the Sky, Inc. 643 Broadway, New York, N.Y. 177



McCauley, crew chief and inventor of some of the plane's interesting equipment, who was seated before the control panel of the amplifying set. The panel is swung from special spring supports to deaden the shocks and vibrations. Electric current is generated by four little snub-bladed propellers, two tiny blurs on either side of the plane. These units are among the most amazing parts of the entire ship. They are driven by the wind and are so regulated that they spin at exactly so

many revolutions per minute, no matter how fast the wind may be blowing or how rapidly the plane may be traveling after it has gained the speed that gives the propellers their proper momentum. The secret of their remarkable performance is an arrangement of weights and balances that give the propellers a slight twist if the speed should increase, regulating the pitch of the blades so that they cannot turn too fast.

the little wire from the "mike," pass down through the amplifying set, into the reproducers and emerge from the big horns. By the time they leave, they have been magnified in the ratio of 1,600,000 to one. That is another way of saying that the voice of the one man has become greater than the combined shout of a huge army. The single speaker could drown out a stadiumful of college rooters. These sound vibrations are so powerful that, in ground tests, butterflies and other insects flying close to the horns were killed, small birds became stupefied and human beings became nauseated after a short exposure at close range. Such effects, of course, could not be produced from a moving airplane or at the lofty altitude at which you are riding.

Pilot Lew Gower eased the three whirring motors and the majestic Fokker with its six-ton load of gasoline, men and machinery, dipped from a graceful left bank and leveled off. He signaled "ready" by a downward jerk of his right arm to G. W.



Close-Up of the Inspection Mirrors; the Control Cabin of the Neon-Light Plane, and the Light Tubes on the Lower Wing

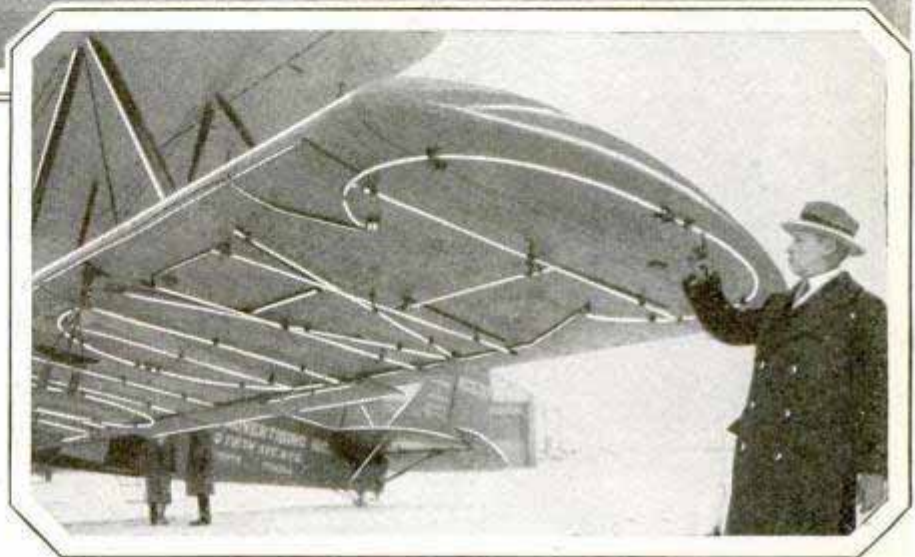
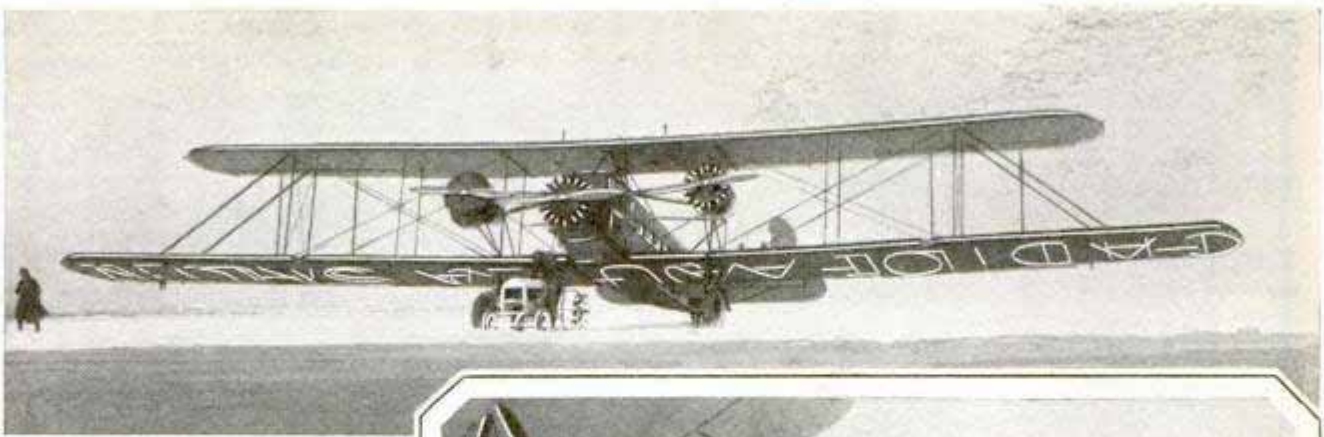

The Tri-Motored Bomber Rebuilt with an Enormous Lower Wing, to Carry the Neon Sign, and a Close-Up of the Glass Tubes

McCauley lifts a portable electric cabinet upon his knees, adjusts an electric record and sets the needle, which is held in a patented clasp that keeps it in the record grooves no matter at what angle the ship may sway and regardless of any bumps or vibrations. If necessary, this strange music box could be placed upside down on the ceiling and played without allowing the needle to fall from its path. The unit is plugged into the amplifier panel and the sprightly strains of a jazz orchestra go ringing down through the frosty air. Next, a short, sharp bugle call from a record. Then McCauley pulls out the music-box plug, tickles a small switch, and a little light flashes in the "padded cell" at the rear of the cabin, where Bert McGrath, who provides the actual voice and who probably has talked directly to more persons than any other living man, is seated at the microphone. "Hello," his voice booms out. "This is the 'Voice of the Sky.'" The tones fill the cabin, rivaling the drone from the three busy motors, although only a tiny fraction of the sounds' volume reaches the interior. The deeper notes cause the floor of the fuselage to vibrate. The effect is as though the plane were sliding over rough ground.

The voice continues for fifty seconds, when Gower gives another signal. The plane has sped from one end of a city suburb to the other. Now it is to turn

back, just as a farmer turns his plow, for another "furrow" of sound. McCauley touches the switch to signal McGrath to stop talking, for the voice is not broadcast on the turns, the chief reason being that, when the ship banks, the horns are at an angle that would send the sound out into space instead of down upon the ground where it is wanted. The earth below seems to dip and wheel slowly about as the plane sends one wing deep down over the city, the other high into the blue of the open sky, seems to hesitate for an instant, and then settles down for another even flight over the wondering land below.

Again the signal from Gower that he is above "location" and has slackened speed slightly for a rate of sixty miles or so, as this pace is required in order that the messages may be heard more clearly. In twelve minutes, every section of the suburb has been covered. McCauley gives another signal, and now McGrath steps out of the broadcasting room to get a breath of fresh air and to stir about a bit during the cross-country dash for the next



Another Kind of Aerial Advertising: Painting a Word across the Sky in a Trail of Chemical Smoke

town. While shut in the booth, he cannot see out, for the compartment is tightly closed to exclude every sound but his voice from the sensitive microphone.

For twenty-two minutes, the plane soars over another city while the mysterious voice continues. Skaters halt on the ponds and stare up to listen, their faces tiny blurs against the ice. People come running out of their houses. Another dash across silent farm lands and the golden glaze of sun upon icy snow, and the voice is over a village. Like a huge, persistent bee, the big plane buzzes back and forth. Then away again for a dash at ninety miles an hour to the next audience. McCauley has made a minor repair of the microphone and has relieved Gower at the controls for a few moments while the set was not working. This is a versatile crew. All its members are flyers, inventors and skilled trouble shooters as well.

As the sun slips into a cloud bank and the night lights begin to wink among the cluttered skyscrapers of the big city, the voice is silenced for the day and the Fokker snorts home to the warm and welcome hangar. At 5:15, exactly four hours and sixteen minutes since the ship hopped off, the big propellers stop on the landing-field runway. In those few hours, the voice has spoken to at least 1,000,000 persons, the plane has winged through 300 miles of zero air, and ten cities have been visited. Not a bad afternoon's work, although covering as many as thirty towns in a single day is not uncommon for this electric-lunged crier of the skies.

The plane, now in the hands of Mechanic H. E. Wendt, who usually accompanies the ship but remained at the hangar this time to make cowl-

ing for the motors, is one of three equipped to sing, play and speak from the skies. Years of research and a fortune are back of the apparatus that has made the sky voice possible. There was the problem of amplification. How to adjust the big air-cooled tubes and other delicate parts of the set. How to rig the generating system that supplies 2,500 watts of current at the necessary voltage and amperage to give the required results. How to build those small miracles, the generating propellers, so that they would keep a constant speed, regardless of wind conditions. Before the wind-power apparatus was used, an air-cooled engine was employed inside the cabin with a big scoop at the side to permit an inrush of fresh air. But the motor was a risk, it produced unpleasant fumes and did not perform as dependably as the tiny propellers.

The future possibilities of this idea are

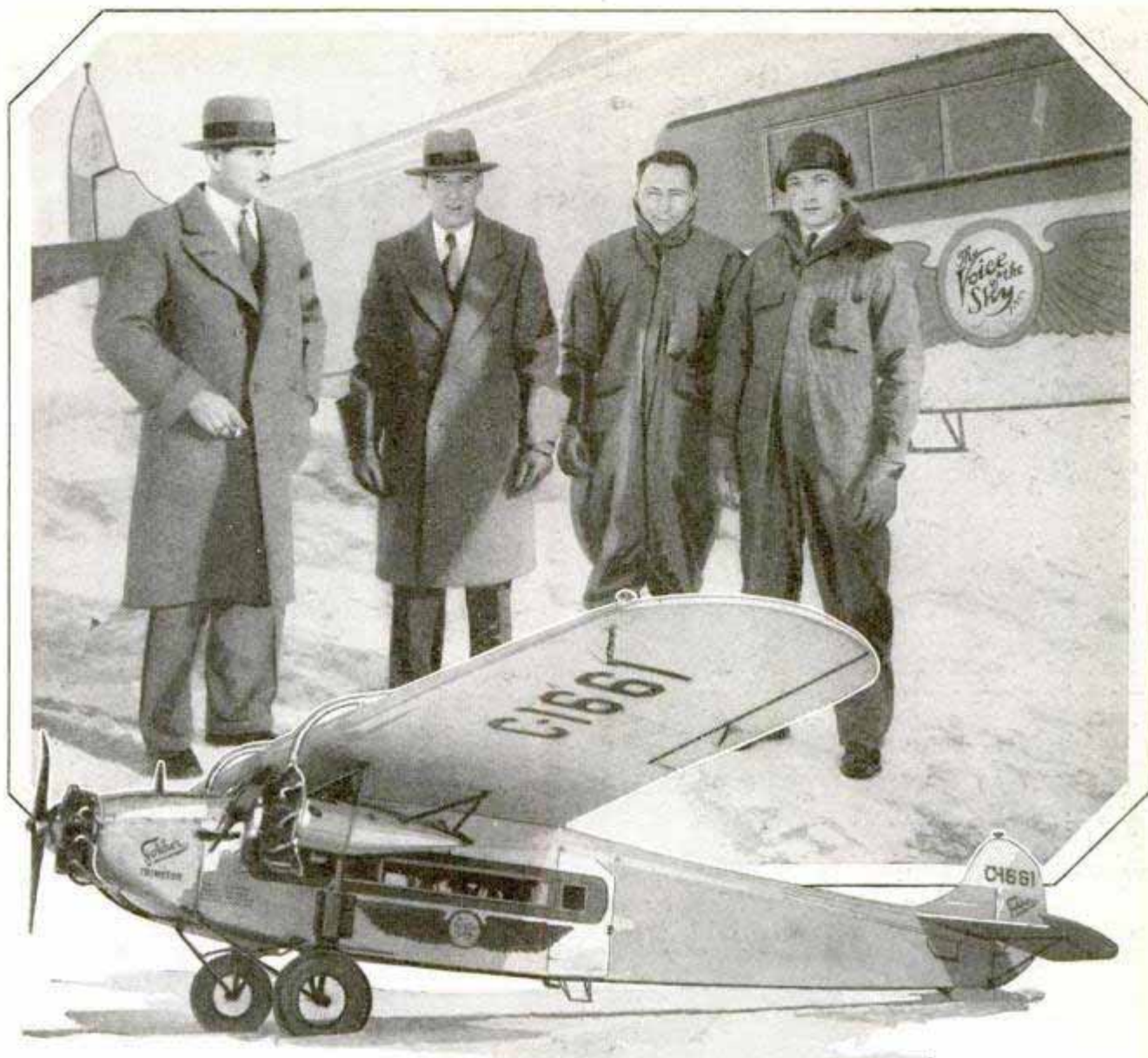

The Operating Crew of the "Voice of the Sky" Standing beside Their Ship, and, Inset, the Three-Motored Fokker; the Loud Speakers Project through a Hole in the Cabin Floor

just beginning to be seen. In time of flood or fire, it could be utilized for warning whole communities. An entire army could be directed from the sky. Commanding officers could speak in code that the enemy would not understand.

The "Voice" was hauled into the hangar just as the three big motors of its friendly competitor in this new age of advertising from the skies, a huge biplane, equipped with neon gas tubes that automatically flash three different legends in glowing color from the underside of its lower ninety-four foot wing, were being warmed up for its brilliant journey over Chicago by night. This ship, although voiceless, is an interesting complement to the town crier that cruises the sky by day. The idea of using neon gas lighting from an

airplane for advertising purposes, has been developed by Roland Rholf who pilots the huge ship, a remodeled army bomber. Wind-driven propellers generate 8,000 volts of alternating current to operate the tubes which are protected with specially devised shock absorbers to prevent breakage at landings. The plane is equipped with a system of special lights and flares to be used in emergency descents or should the landing field lights fail. It had 450 feet of glass tubing that spelled three different signs to herald the name of two well-known makes of automobiles. According to Albert H. Miller, who watches results after a trip of the "Voice," sales of a popular brand of cigarets increased nearly fifty per cent everywhere in territory recently covered.

2295



Ball Container for Golfer's Bag; Pressure on a Spring Trigger Releases One Ball at a Time

GOLF-BALL TRIP GUN ON BAG SAVES PLAYERS' TIME

Attached to the outside of the golf bag, a "gun" that holds twelve new balls and releases them one at a time as they are needed, by pressing the thumb on a spring device, saves the player time in looking for new balls. It protects the spheres from damage and loss, is always in position for use and does not interfere with handling the bag in the usual way. Old balls are kept in a container on the inside so that they do not become mixed with the new ones.

OILED COVER ON ELECTRIC WIRE SIMPLIFIES INSTALLATION

Electric wiring, covered with an oiled rubber preparation in colors, is now on the market, to simplify the task of installation and alteration of home and building circuits. The lubricated feature enables two men to pull a line through a building as easily as four men could with the ordinary wire. By the colors the electrician easily picks out the line on which he is working. This principle has been used for some time in telephone and motor construction, and has just recently been adopted in the building field.

GIANT LINER TO BE DRIVEN BY ELECTRIC MOTORS

When the White Star line puts its first big post-war liner into service, it will be not only the biggest ship ever built—1,050 feet in length and displacing 60,000 tons—but also the biggest electric-driven ship. This type of drive, pioneered by the American navy in battleships some years ago, has been applied to the 17,000-ton liner "California" and the "Virginia," now building, both under the American flag, and in the new 19,000-ton P. & O. liner "Viceroy of India," recently launched in England. The White Star ship, on which work has been started at Belfast, will have four boiler rooms, the aftermost of which is shown in the foreground of the artist's drawing. Oil fuel, with automatic firing, will be used. High-pressure water-tube boilers will be fitted with forced draft of preheated combustion air. In the main engine room, seen beyond the boiler room, the steam will drive turbo-generators at about 3,000 revolutions per minute to generate the electricity for the driving motors, directly connected to the propeller shafts and revolving at about 100 revolutions per minute. The electric drive has many advantages, including ease in maneuvering, quickness of reversing power, and the fact that the propellers cannot race when thrown clear in heavy seas.

SMALL-SIZE SEWING MACHINE CARRIED WITH ONE HAND



Operated by current from a lighting socket, a sewing machine can be carried with one hand and may be used on a card table or other small area. It weighs less than twelve pounds, including the motor, is simple to use and does practically everything that the larger machines will do. The motor is built into the base of the machine.

Scientists believe that ancestors of the whale lived on dry land.

Chicago
 428 W. Washington
 2299

United States Rubber Co. Standard Sewing Machine

ELECTRIC DRIVE FOR LARGEST VESSEL EVER BUILT

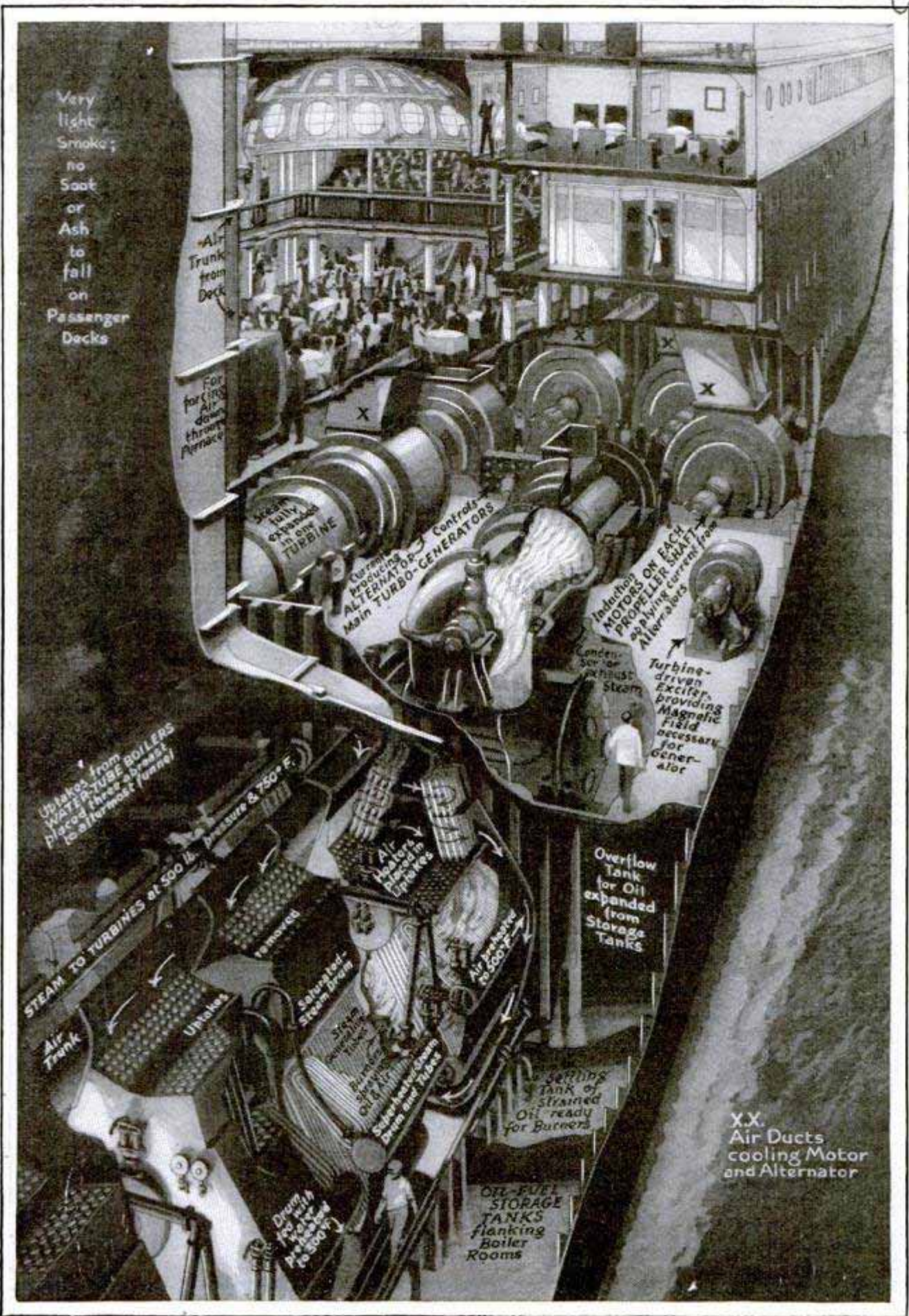

Very light smoke; no soot or ash to fall on Passenger Decks

Air Trunk from Deck
For forcing Air down through Furnace

Steam fully expanded in one TURBINE

Current producing ALTERNATOR MAIN TURBO-GENERATORS

Indicators ON EACH PROPELLER SHAFT as playing current from Alternator

Turbine-driven Exciter, providing Magnetic Field necessary for generator

Overflow Tank for Oil expanded from Storage Tanks

XX. Air Ducts cooling Motor and Alternator

Uptakes from WATER-TUBE BOILERS placed three abreast to aftermost funnel

STEAM TO TURBINES at 500 lb. Pressure & 750° F.

Saturated Steam Drum

Air Motors placed in Uptakes

Air heated to 200° F.

OIL-FUEL STORAGE TANKS flanking Boiler Rooms

Settling Tank of Strained Oil ready for Bucoers

Drum for Air to be heated to 200° F.

HOME-MOVIE FILM ENLARGER NEEDS NO DARKROOM

Enlargements may be made from home-movie films without the use of a darkroom by employing a unit just introduced. It consists of a tapered box, at the small end of which is an enlarging lens, mounted in fixed focus. The lens on the projector is removed and the enlarger slipped on. A shaft on the enlarger automatically focuses the latter. A film-pack adapter, supplied with the enlarger, is loaded with film and slipped into place at the large end of the box. The hinged cover is then raised so that the film may be viewed as it is projected upon the surface of the adapter slide. When a scene from which an enlargement is desired appears upon the screen, the projector clutch is disengaged, the enlarger shutter closed, the pack-adapter slide removed, and the picture is projected just as one would project a single frame upon a screen.

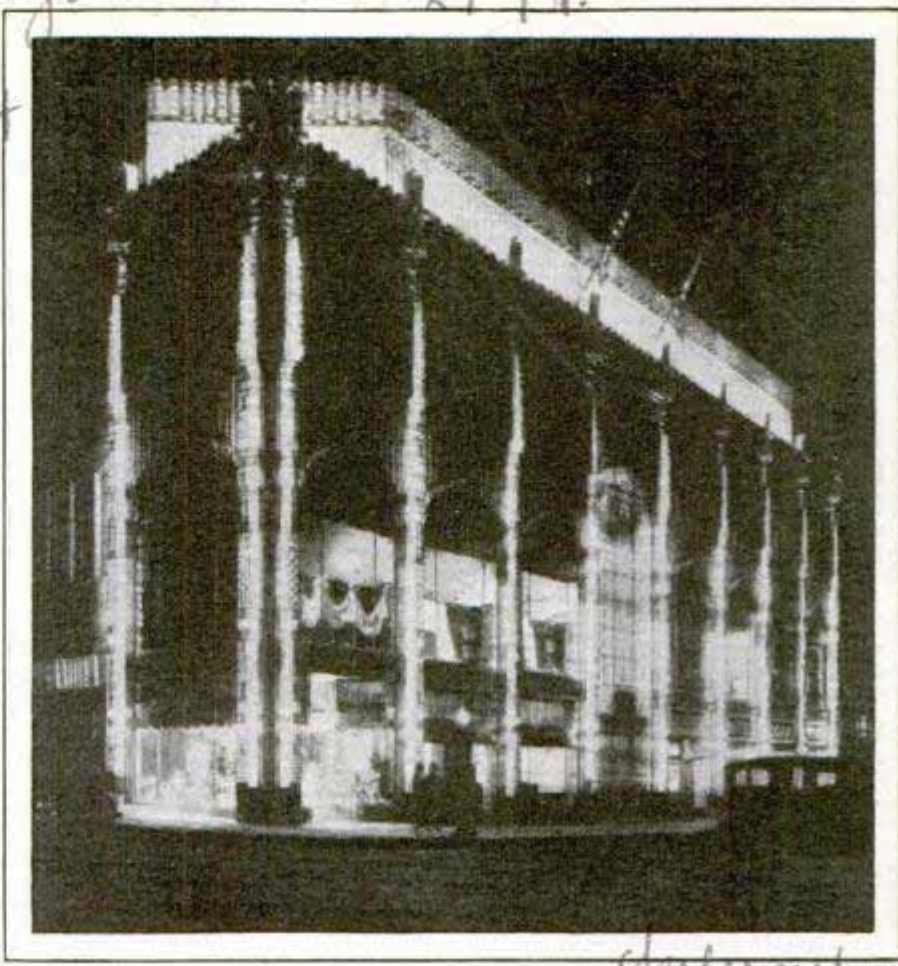

How the John H. McClatchey Building in Philadelphia Appears at Night with Its Special Lighting System

MASTERPIECE IN LIGHTING SEEN IN STORE'S EXTERIOR

Illuminating engineers have pronounced the John H. McClatchey building, in Philadelphia, the most beautifully lighted structure in the United States. It has sixteen terra-cotta-faced columns which are set off by art-glass panels lighted from within, while diffused light, in different colors, bathes the face of the building in many hues. Above the main entrance is a stained-glass window with deep sea-blue, orchid and lavender tones predominating.

BOILING WATER CLEARS STREET AS SUBSTITUTE FOR PLOW

Tank loads of boiling water were used in Seattle to clear away piles of snow and ice, that accumulated during a cold period last winter. Regular street-flushing tanks were employed and were filled at the city light company's steam plant. Columns of the hot water were forced into the snow piles, quickly melting and softening them so that the material ran down the drains.

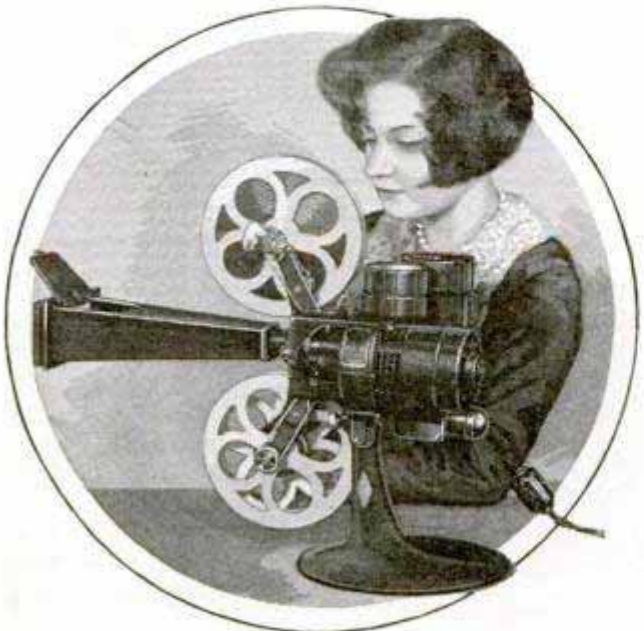

Enlarging Outfit for the Home-Movie Film in Operation; It Can Be Used without a Darkroom

Carl E. von Hamn
No. 1

2210

A. C. Wilkins vs. Cambridge
Dean Road, Box by Heath
near London, England

The Gold Rush

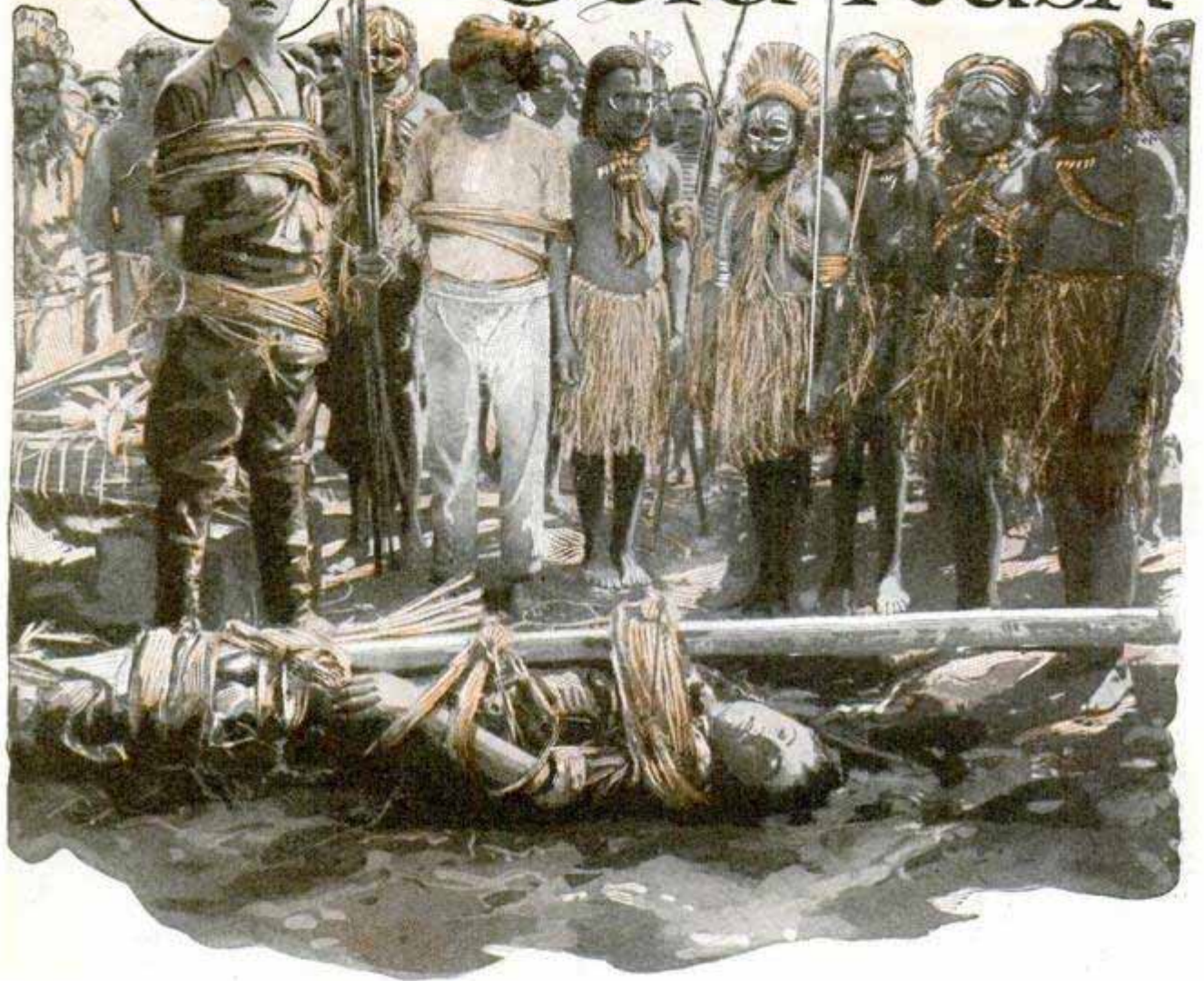

Courtesy Sir Oswald Stoll

Staging a Cannibal Scene in the Jungle; a Pair of Gold Hunters and Their Native Servant Bound by the New Guinea Savages as a Preliminary to a Cooking-Pot Scene

By HAROLD T. WILKINS

A CREW of Papuans, some of them blood relations of the tribes of cannibals and head-hunters in the gold mountains back of the Razorback range of the far interior of New Guinea, have recently taken on a new job.

When the steamer from Sydney, Australia, carrying the newest thing in airplanes for the New Guinea airways, berths in the palm-fringed coast port of Papua, the natives, uttering fearful shouts, rush down the coral beaches to haul on the ropes of a derrick, one leg of which has a fulcrum in the shape of a coconut palm. The hook of the derrick is hitched in the fuselage of the new Junkers monoplane with Bristol "Jupiter" engines, on the

deck of the steamer, and with a real blood-curdling chorus of war cries, the natives strain on the ropes of the derrick.

The airplane rises slowly into the air, and is deposited on the coral beach, where another crew acts as a handling party, pushing the plane into the hangar whence it will be piloted by an ex-British royal air force airman taking gold prospectors over leagues of deadly steaming forests, infested with tree leeches, to the far-away gold fields, and bringing back the bulging pokes of the gold seekers who have "struck lucky." The airplane shortens to hours what, till a few months back, was a very dangerous trip of months through dense woods and mountainous country, peopled

in Cannibal Land

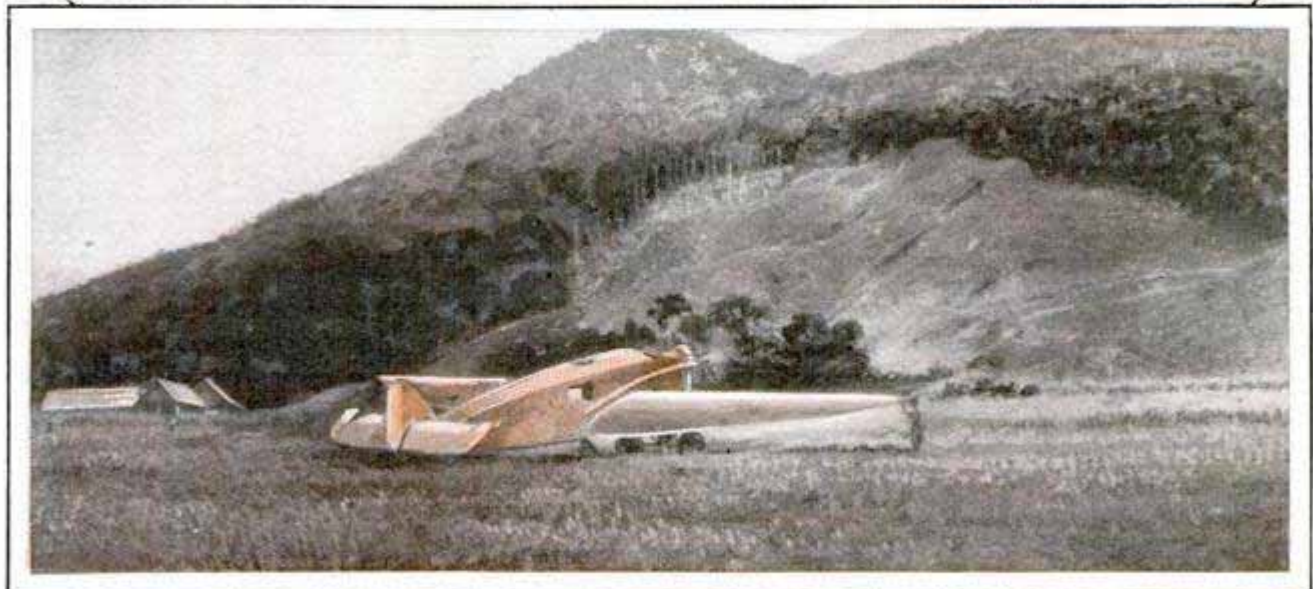
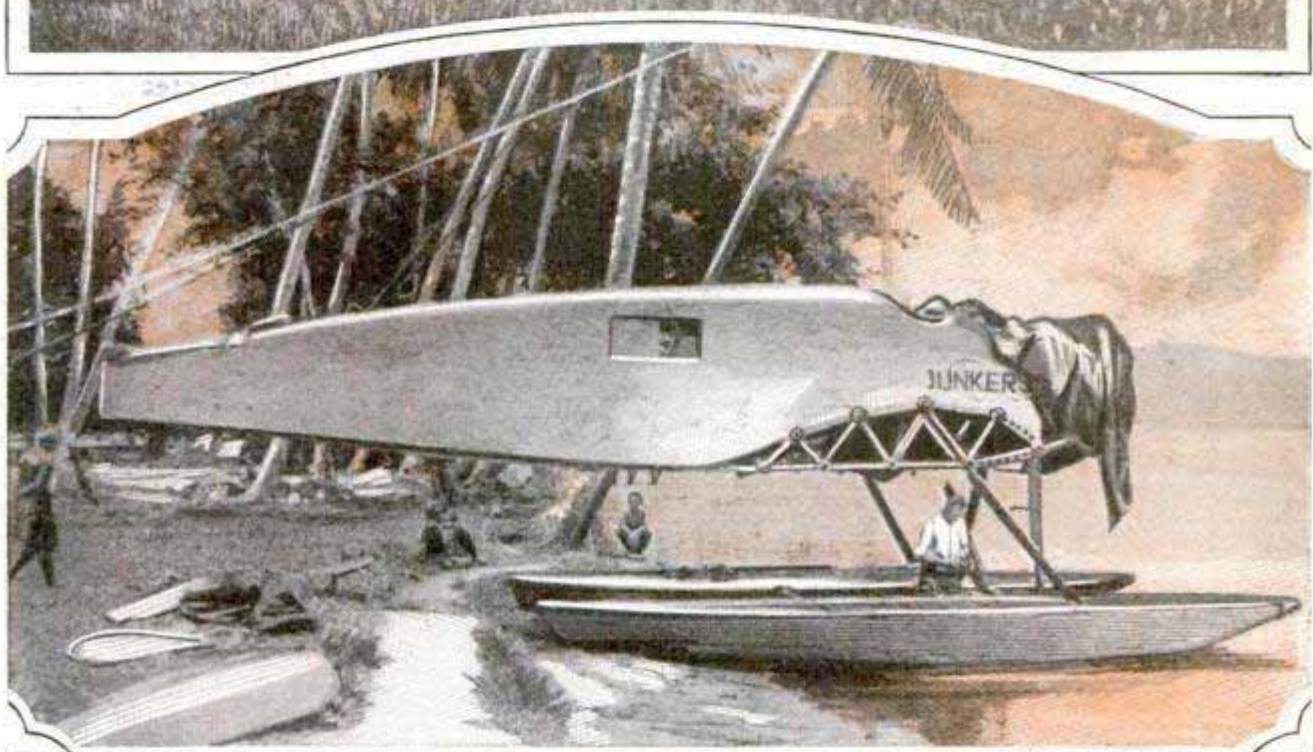

The Latest in Gold Prospecting, a Junkers "Jupiter" on Wheels and Floats; Top, Taking Off for the New Papuan Fields; Center, on a Palm-Fringed Lake; Bottom, the New Guinea Airport

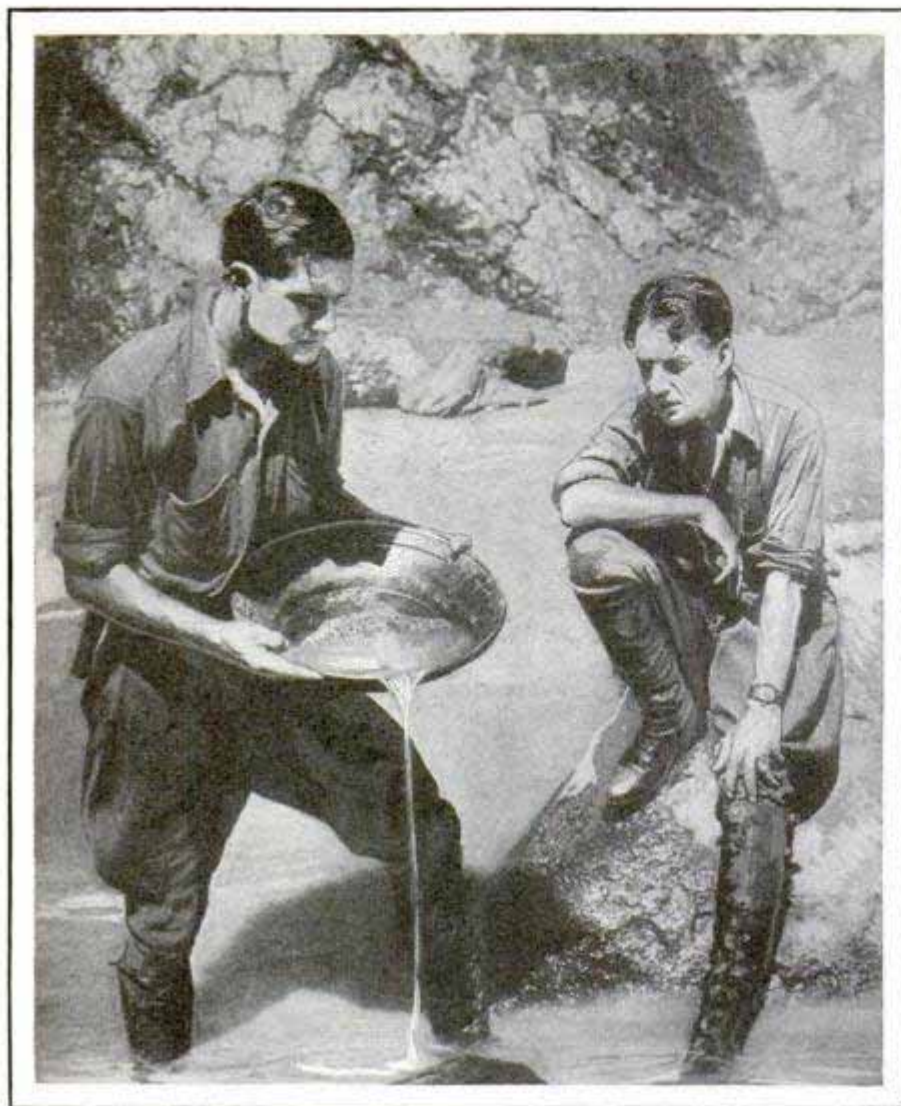

Courtesy Sir Oswald Stoll

Gold Diggers Washing River Sand on a Creek Bank in the Razorback Range of Interior New Guinea

by warlike head-hunters of ferocious fame.

Much of the gold is washed down the watershed parting Papua from what used to be German New Guinea. Years ago, British prospectors knew of the existence of the gold, but the Germans lost the territory before they could find the deposits. Gold worth \$5,000 was recently found in one day in the sands of a river on the "mandate" side of the mountain range of central Papua. But when, some months ago, a party of five Australian gold prospectors were eating dinner in a lonely valley of the range, hundreds of fierce Papuan warriors fired clouds of arrows out of ambush and killed three of the men. The survivors managed to reach a white outpost, after dreadful sufferings, when the government sent a punitive expedition to track down the murdering Papuans. The expedition advanced along a narrow path by a steep precipice, against a hos-

tile village, whose natives swarmed out armed, until the party advanced farther, firing over the natives' heads to cover the movement. The village was taken, and in four days six other deserted villages were occupied. The expedition had orders only to fire in self-defense and not to use machine guns. Then the natives turned out in hundreds, and the government expedition had to beat a retreat until the arrival of a steamer with reinforcements.

The natives have a system of taboos, or forbidden things, and it is the infringement of these taboos by white prospectors which leads to massacres. Though the tribes are cannibals, they are said to be particular about the men they eat.

"The victim at our cannibal feasts is a guest of honor. He is delighted to come. We pay him high tribute," so said the

New Guinea cannibals to a London university professor exploring the unknown hinterland, in the summer of 1928.

The coming of the airplane will revolutionize conditions of transport to and from the gold fields. Without the aid of aircraft, the prospector has to grope his way through the woods wherein tropical rains drip incessantly, and the atmosphere is humid and fever-laden at a nearly perpetual temperature of 100 degrees Fahrenheit in the shade. Leeches of abnormal size and ferocity hang on the branches of the trees and fasten themselves on the perspiring skins of living things until they drop off gorged with blood. Stores cannot be floated down rivers, but have to be carried on the shoulders of human beings over a range of wild mountains, sometimes 12,000 feet in height.

The nearest port to the new gold fields is the ex-German radio station at Mo-

2312 309 Ballard St
Ypsilanti, Mich

robe, which is fifty miles distant, while Rabaul, the one-time German capital of Papua, is nearly 100 miles from the gold fields, with a range of practically unknown and unexplored mountains in between the sands of the gold-bearing rivers and the nearest outpost of civilization.

The digger has a difficult problem to solve, if he carries away his load himself on foot. Coast natives are afraid of the upcountry natives, who are cannibals and head-hunters, while bushrangers of the type who infested the Australian gold fields of the 1840's, lie in wait nearer the coast to shoot and plunder the unsuspecting digger. The gold is not of the richest quality, since it is found with quartz. It is worth around \$3 an ounce, and no white man can carry a great load through pathless forests and over inhospitable ranges. Here is just where the Junkers monoplane, with its Jupiter Bristol engines, laughs at the thieves and head-hunters lying in wait in the ranges or ambushed in the depths of the leech-infested forests.

TRAP CATCHES ANIMALS ALIVE IN WIRE BAG 2314

For catching animals alive, a humane and efficient trap now on the market, has spring jaws to which is connected a net bag made of chain wire. It is also fitted with a lifting device which raises the trap as much as fifteen inches after it has been sprung. This is an advantage in catching mink, muskrats and similar animals, as they are automatically lifted out of the water after capture. The jaws of the trap fly up over the animal, drawing the net bag around it and, at the same time, the lifting device is released.

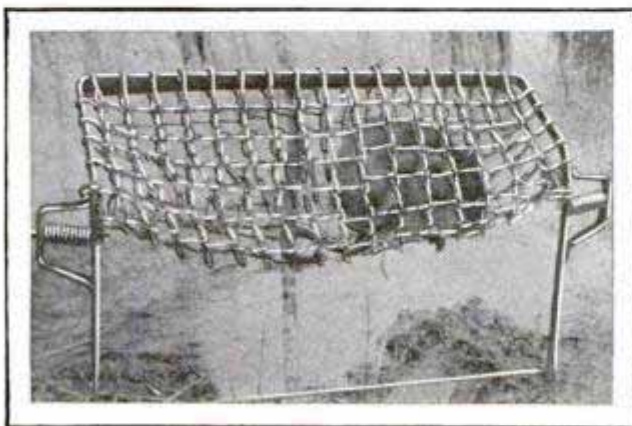

Trapped Alive and without Injury; the Wire-Net Snare Sprung and Ready for Opening



Sign at Detroit Street Crossing, Warning Pedestrians That It Is Too Late to Cross Before Lights Change

TOO-LATE SIGN FOR PEDESTRIAN HELPS REDUCE ACCIDENTS

To protect pedestrians by reducing the chances of their being caught in the center of a street intersection when the traffic-control lights change from green to red, a series of electrically operated warning signs have been installed by the Detroit police department on a busy downtown corner. The markers are so arranged that a pedestrian faces one of them, no matter in which direction he may be walking on any of the four crosswalks at the intersection. The signs are about two feet in diameter, drum-shaped and are suspended on brackets attached to the signal-light poles. At a carefully determined interval, the warning, "Pedestrians Stop, Too Late to Start," is flashed so that the person on foot will remain on the sidewalk instead of attempting to cross.

Those wishing further information on anything described in the editorial pages can obtain it by addressing Bureau of Information, Popular Mechanics Magazine.

W.A. Roberts + Son
Ypsilanti, Mich

*Inventor Edward C. Kerch
Secy. Hollow Building Tile Assn.
R. 1400, 205 W. 205 W.*



Testing a Sample of the New Brick, Which Is Light and Strong and Holds Nails Firmly

SEE HUNDRED-STORY BUILDINGS AS RESULT OF NEW BRICK

One-hundred-story skyscrapers will be as common in the city of the future as the twenty-story building is today, according to Dr. George A. Bole, of Ohio State University. His prophecy is based partly on the development of a new kind of brick. It weighs only one-sixth as much as the usual varieties, but is said to have greater strength and fire-resisting qualities. Ordinary brick weighs 120 pounds to the cubic foot. The improved form weighs but twenty. The new tile will defy a temperature of 3,250 degrees for fifteen hours, according to reports. Because of its lightness and strength, this material will permit higher buildings with more pyramiding, thinner walls and therefore less bulk so that space will be saved for practical uses.

TREE IMMUNE TO DISEASE YIELDS EDIBLE NUT

So far as can be learned, the Japanese ginkgo tree is the only species of plant life growing in this country today that does not have some sort of an enemy, an insect, fungus or other pest trying to take its life, according to Dr. William A. Tay-

lor, of the bureau of plant industry. A driveway leading to the department of agriculture buildings is lined on both sides with these trees. In the fall, their leaves turn a brilliant yellow of striking appearance. The ginkgo produces a nut which the oriental people relish but which is abominable to the white man, the chief reason being that, although the kernel is of a pleasant taste, it is surrounded by a pulp of a disagreeable odor.

HOME-MOVIE TITLE WRITER HELPS IMPROVE FILMS

Preparation of titles, special diagrams and other inserts for the motion-picture film taken at home, is made simple with a compact outfit recently introduced. It consists of a mount for the camera, a card holder, two specially designed electric lights, operated by current from a house socket, and an automatic focusing prism. The title is written in white ink on a black card which remains in its holder in correct position for photographing. If desired, the camera may be operated while the writing is in progress, showing the hand in motion. The outfit may be used for making movie cartoons, for taking reproductions of miniature scenes and special backgrounds, and for other "trick" shots that add variety and interest to the finished reel.

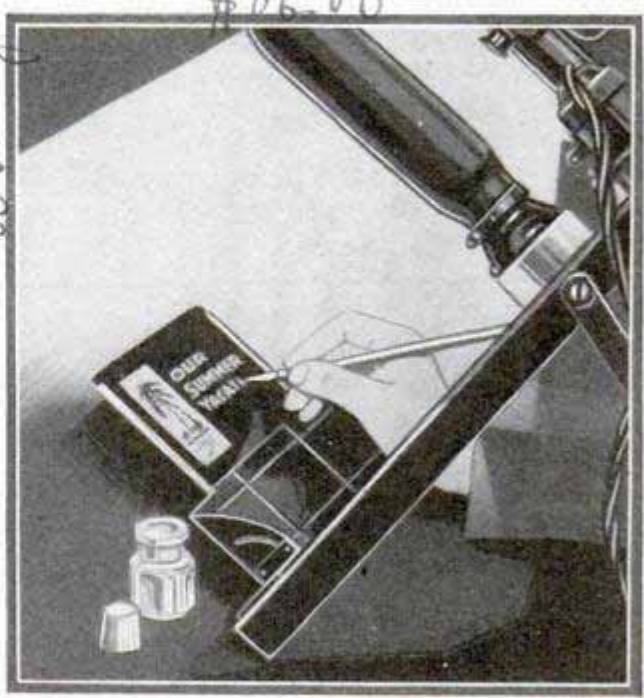

Drawing of the Title Writer for Amateur Motion-Picture Photographer; Note Special Lights at Sides

Developed at Roswell Experiment Station, Engineering Experiment Station, Ohio State Univ.

Structural Work polished by

Sent to Roswell Co. 1901

2/26/29

SAFER FLYING CUTS INSURANCE COSTS

Reductions of as much as forty per cent on premiums of aviation-insurance policies have been ordered since 1922 as a result of the constantly improving safety factor in flying, according to a copyrighted dispatch in the Daily News of New York. Many companies are omitting the clauses in life-insurance policies that make the policy void in case of an aviation accident, and are substituting specific provisions that cover such accidents. According to an official of a company specializing in this kind of insurance, the amount of aviation insurance written has increased more than 400 per cent during the last year. Men experienced in aviation, many of them pilots or ex-pilots, are handling the business for the companies. The American Air Transport association recently announced that passenger lines in the United States are operating on forty-two daily schedules which require more than 33,000 miles of flying every twenty-four hours with stops at 102 cities. At the time this statement was made, eight new lines were scheduled to start, adding about 8,000 flying miles to the daily total.

AUTO JACK CRANKED AT SIDE SIMPLIFIES RAISING CAR

By turning a crank at the side of the running board, the automobile is quickly and easily raised at the front or rear or at both ends together. This is made possible by a three-unit jack, one under the front axle and two at the rear. The jack fits any make of car.



Jacking Up the Car by Turning Crank at Side of Running Board; Front and Rear Are Raised

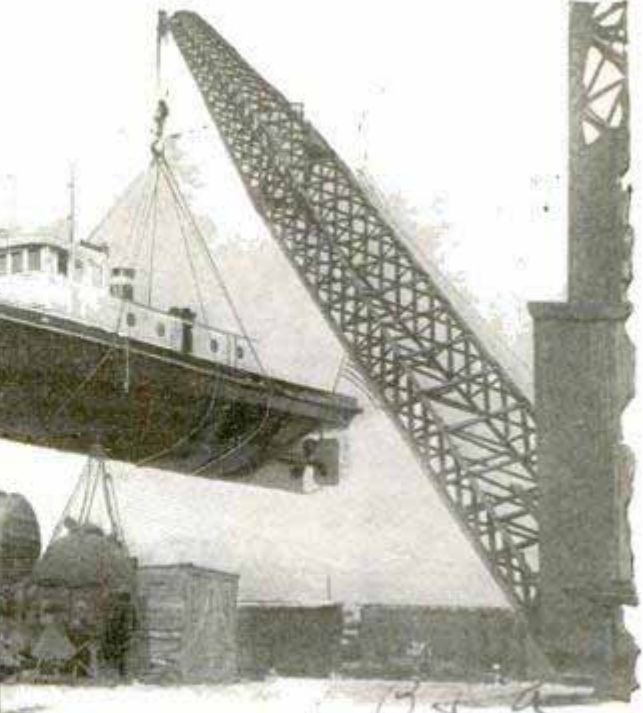

Swinging Steel Tugboat into the River with Huge Crane, the Method Saved the Building of Ways

STEEL TUG LAUNCHED BY CRANE FOR RIVER SERVICE

Instead of constructing ways for launching a steel tug, the craft was picked up by a huge crane and swung from the yard into the Willamette river, at Portland, Oreg. The boat is equipped with 250-horsepower motors and is sixty-five feet long over all.

PURIFYING WATER WITH SILVER REDUCES TREATMENT COSTS

By introducing a small quantity of a specially prepared silver compound, a German chemist is reported to have developed a method for purifying large amounts of water at a relatively low cost. He simply injects the compound into the water, one and one-half grams of the chemical being sufficient to disinfect about 2,500,000 gallons of water, it is said. Scientists who have investigated, declare that the effects also are lasting.

Certified by Prof. Rudolf Steiner at C. S. Straßwald, Straßwald, Germany

John L. Ekstrom Mr. George Krause

2158

3459 Piedmont Ave
Oakland, Calif

The New

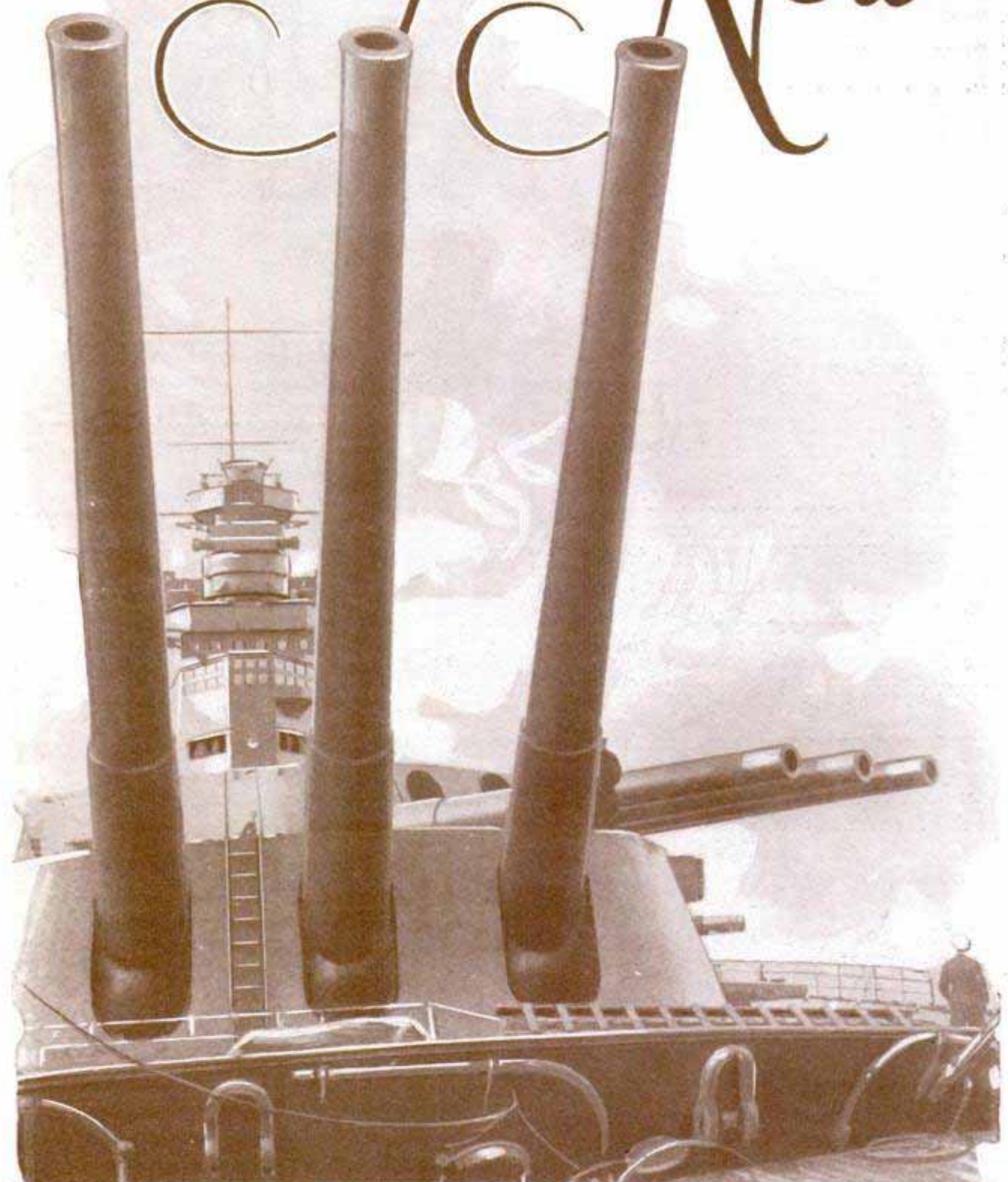

WITH the recent launch of the "Salt Lake City," first 10,000-ton American "treaty cruiser," built under the terms of the Washington disarmament conference, and the signing by President Coolidge of the new navy bill, calling for the building of fifteen similar cruisers and another aircraft carrier within the next three years, interest in the world's new navies has revived. While no capital ships have been built since the Washington treaty, several American battleships have been remodeled and their guns changed to equal the high-angle fire of the British big

Navies



ships, such as the guns of the "Rodney," on the opposite page. One of the important changes made in the American ships has been the replacement of basket-type masts with tripods, carrying extensive fire-control and searchlight platforms. The alteration in appearance is shown in the photo of the battleship "Texas," above, taken as she approached the Brooklyn bridge. Other changes include more deck armor to resist aerial bombs, bigger and better anti-aircraft batteries, and underwater protection against torpedoes. While the allies in the late war have been concentrating on treaty cruisers, the Germans stole a march by producing a new type of battleship, within the 10,000-ton limit set on German

2158
740

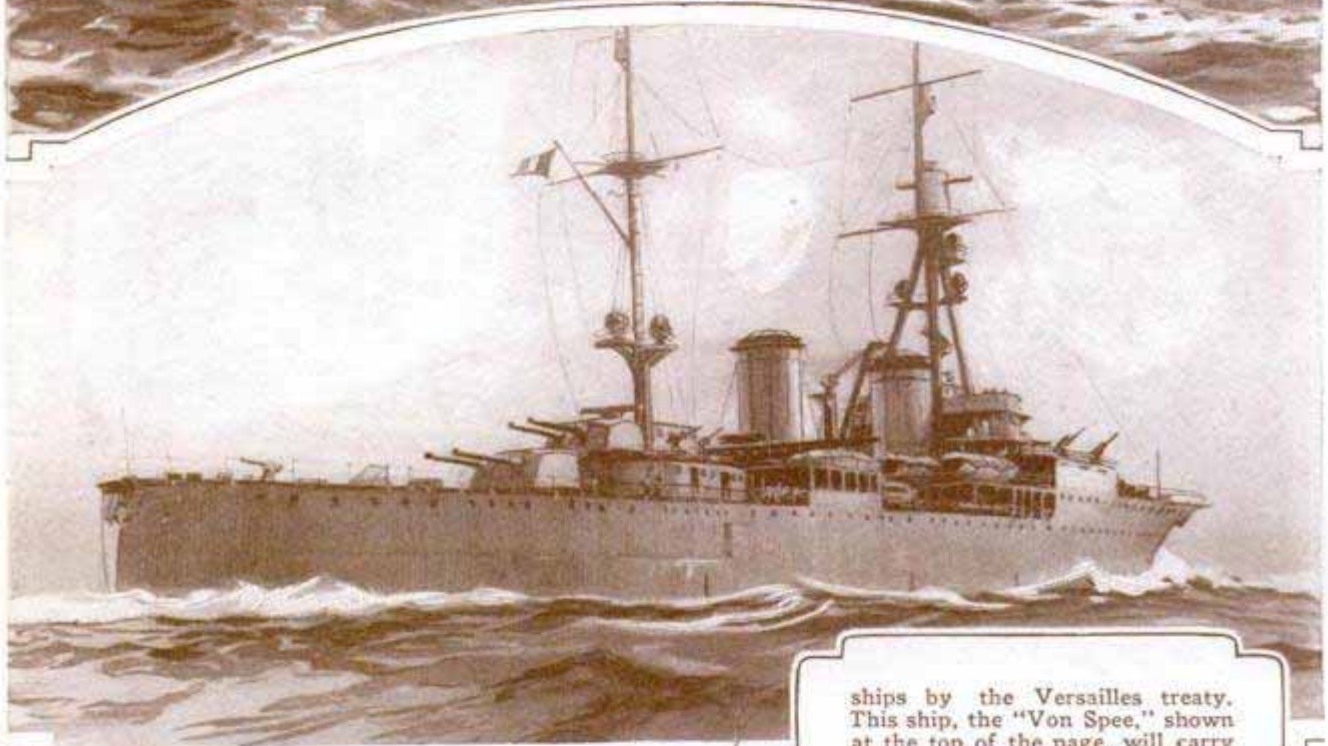
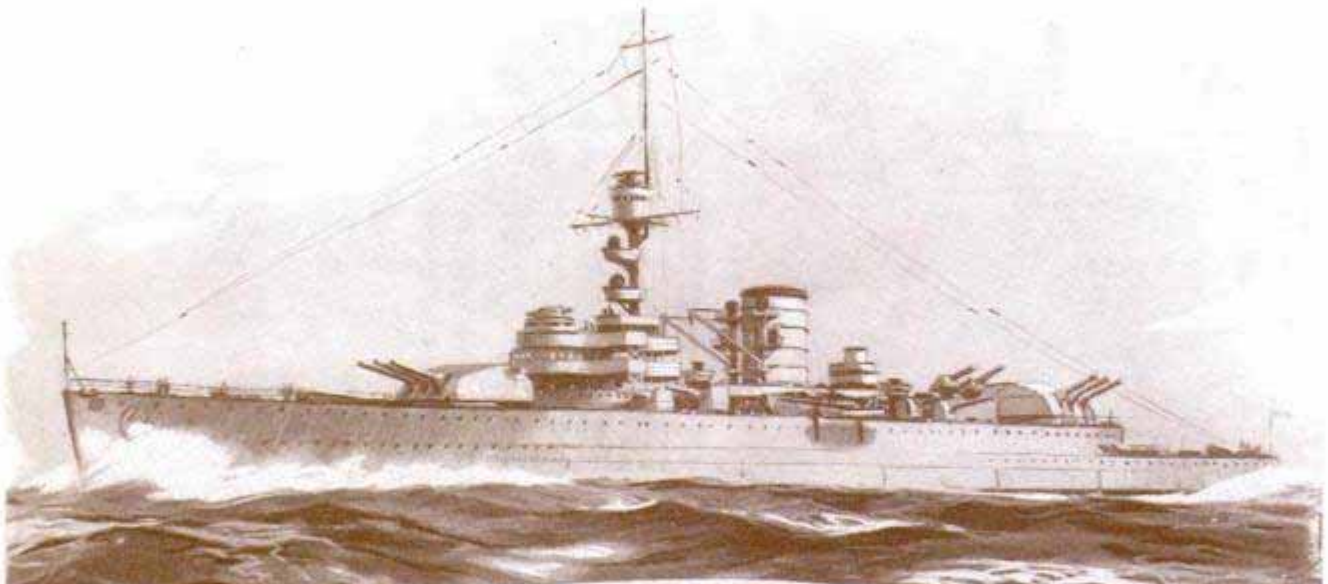

ships by the Versailles treaty. This ship, the "Von Spee," shown at the top of the page, will carry six eleven-inch guns, compared with eight-inch guns on the allied cruisers, and is the world's first Diesel-motor driven warship. By using welded plates, instead of riveting, and special light-weight alloys, the German designers saved 1,000 tons of normal hull and engine weight, and devoted it to heavier armor and guns. Below the new German

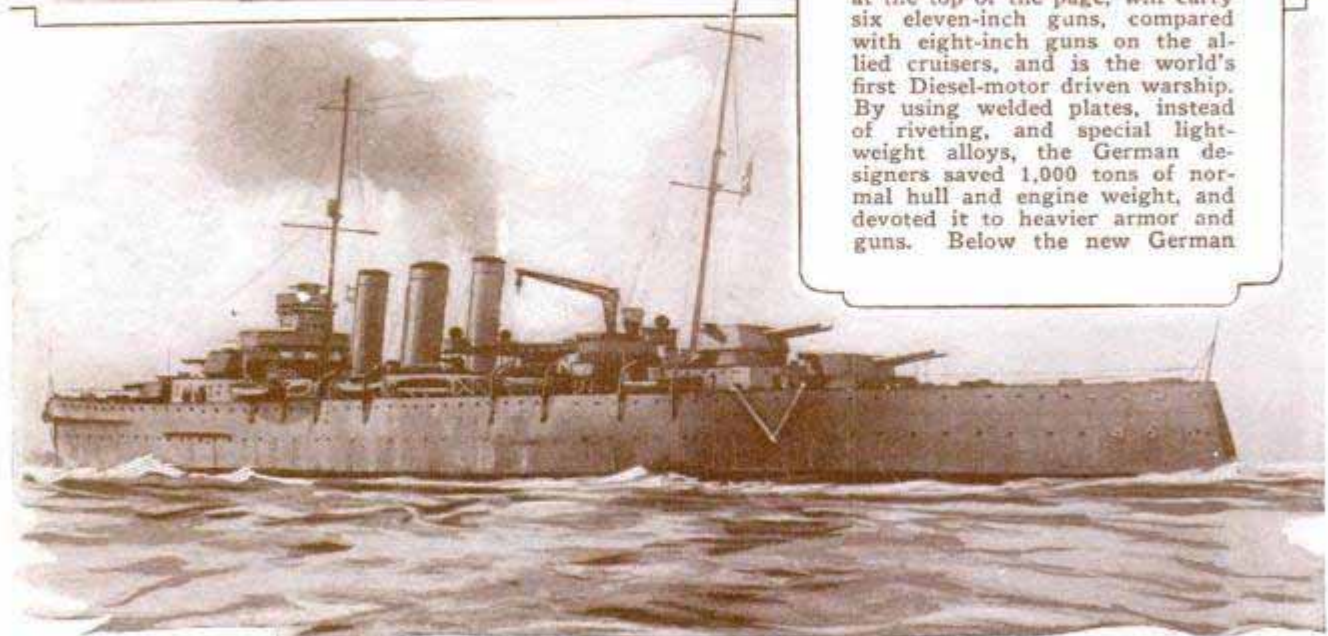

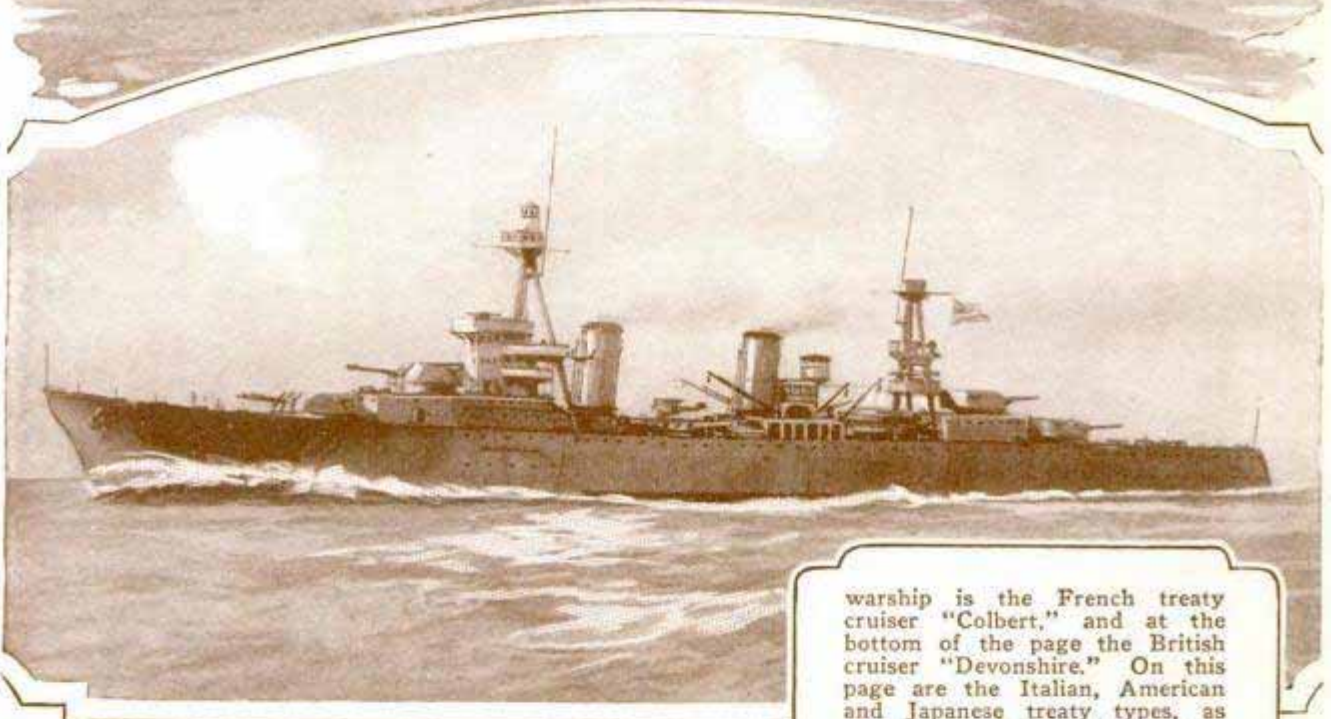

warship is the French treaty cruiser "Colbert," and at the bottom of the page the British cruiser "Devonshire." On this page are the Italian, American and Japanese treaty types, as represented by the "Trieste," "Salt Lake City" and "Nachi." The Japanese ship, below, is particularly interesting because of its curious trunk funnel, the "rake" of the funnels aft and the undulating deck line. The Italian ship also has an unusual uptake for the forward funnel and a particularly compact fire-control arrangement, as well as an airplane catapult on the forward deck,



2158

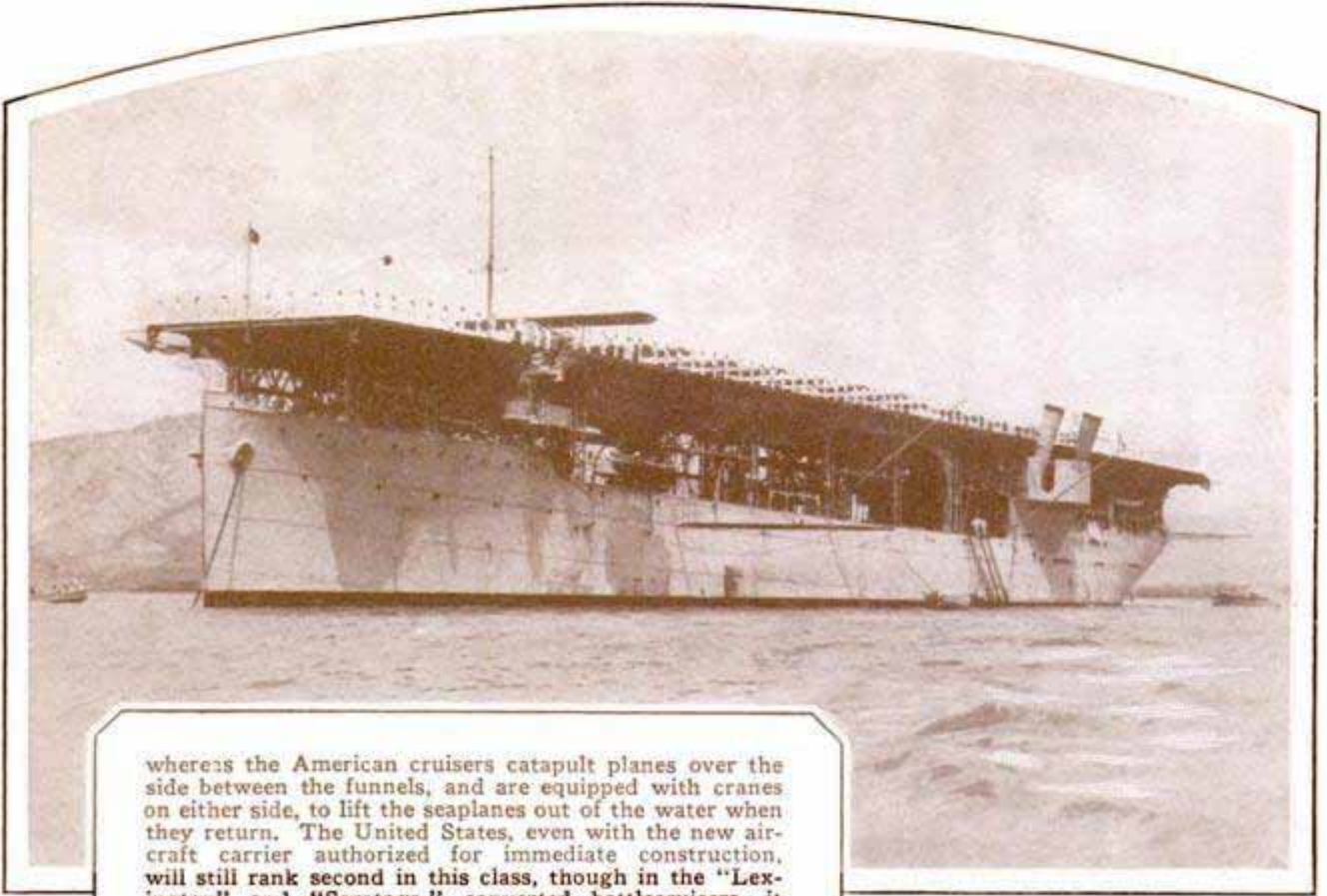

whereas the American cruisers catapult planes over the side between the funnels, and are equipped with cranes on either side, to lift the seaplanes out of the water when they return. The United States, even with the new aircraft carrier authorized for immediate construction, will still rank second in this class, though in the "Lexington" and "Saratoga," converted battlecruisers, it has the two largest airplane carriers afloat. At present, one other carrier is in service, the "Langley," above, which was converted from a collier. Some idea of the spaciousness of an aircraft carrier's flying deck can be gleaned from the picture below, showing the football team of the "Saratoga" practicing on the flying



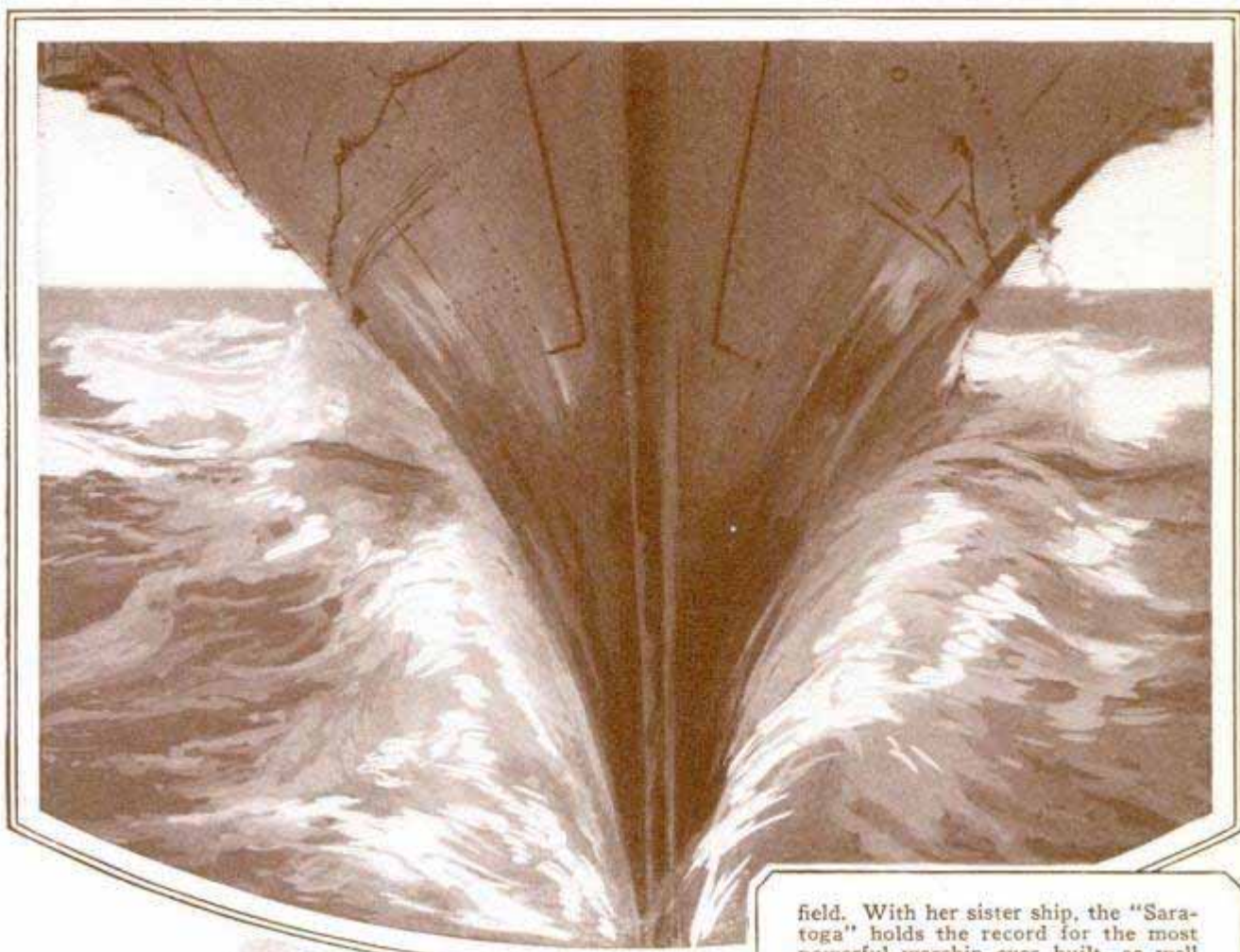

field. With her sister ship, the "Saratoga" holds the record for the most powerful warship ever built, as well as the fastest big ship in the navy. The photograph above shows the bow of the "Lexington" when she was making thirty-seven miles an hour in the Pacific, and illustrates the clean hull lines and enormous overhang of the flying deck above. The picture below shows the "Saratoga's" forward anti-aircraft battery of three guns, and above and behind them the two forward eight-inch-gun turrets, each with two guns. The anti-aircraft guns, of a new model, have a straight-up range of more

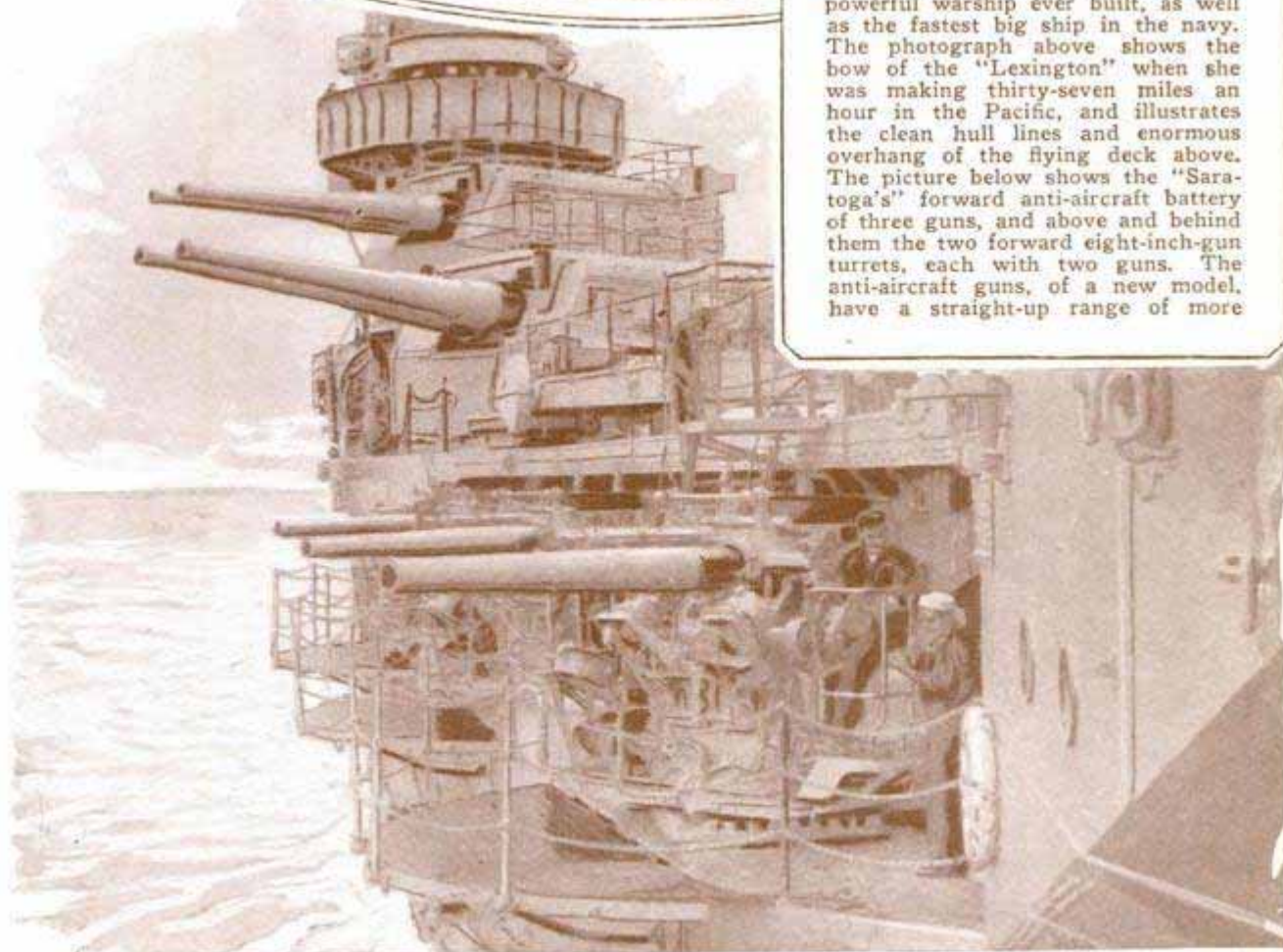

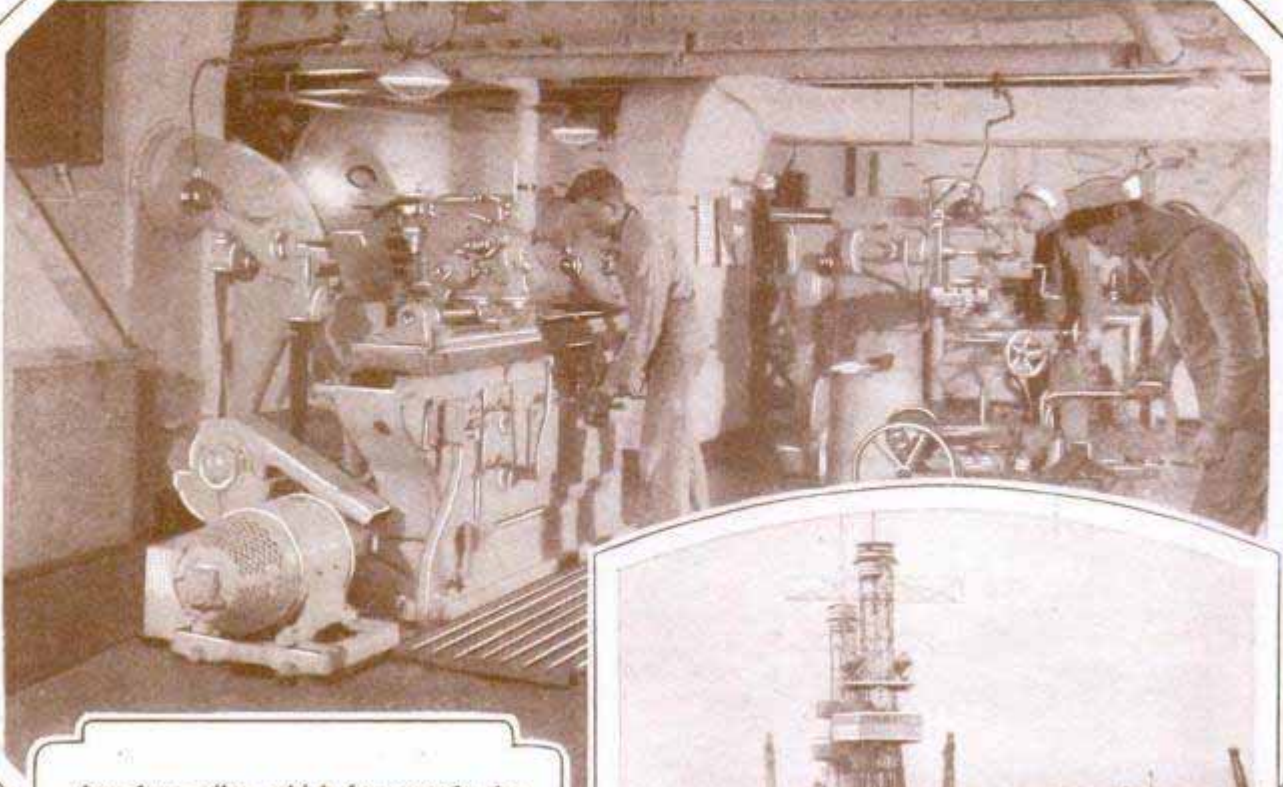

than four miles, which far exceeds the height at which a bomb-dropping plane can fly and still hope to make a hit on such a relatively small target. Above is the machine shop, which is fitted on each ship to repair engines and planes, while at the bottom of the page the great hull of the "Lexington" is in drydock at Seattle before starting south on the recent winter cruise of the battle fleet. At the right the "New Mexico" is being locked through the Panama canal en route to the Atlantic Ocean. The two big aircraft carriers tried

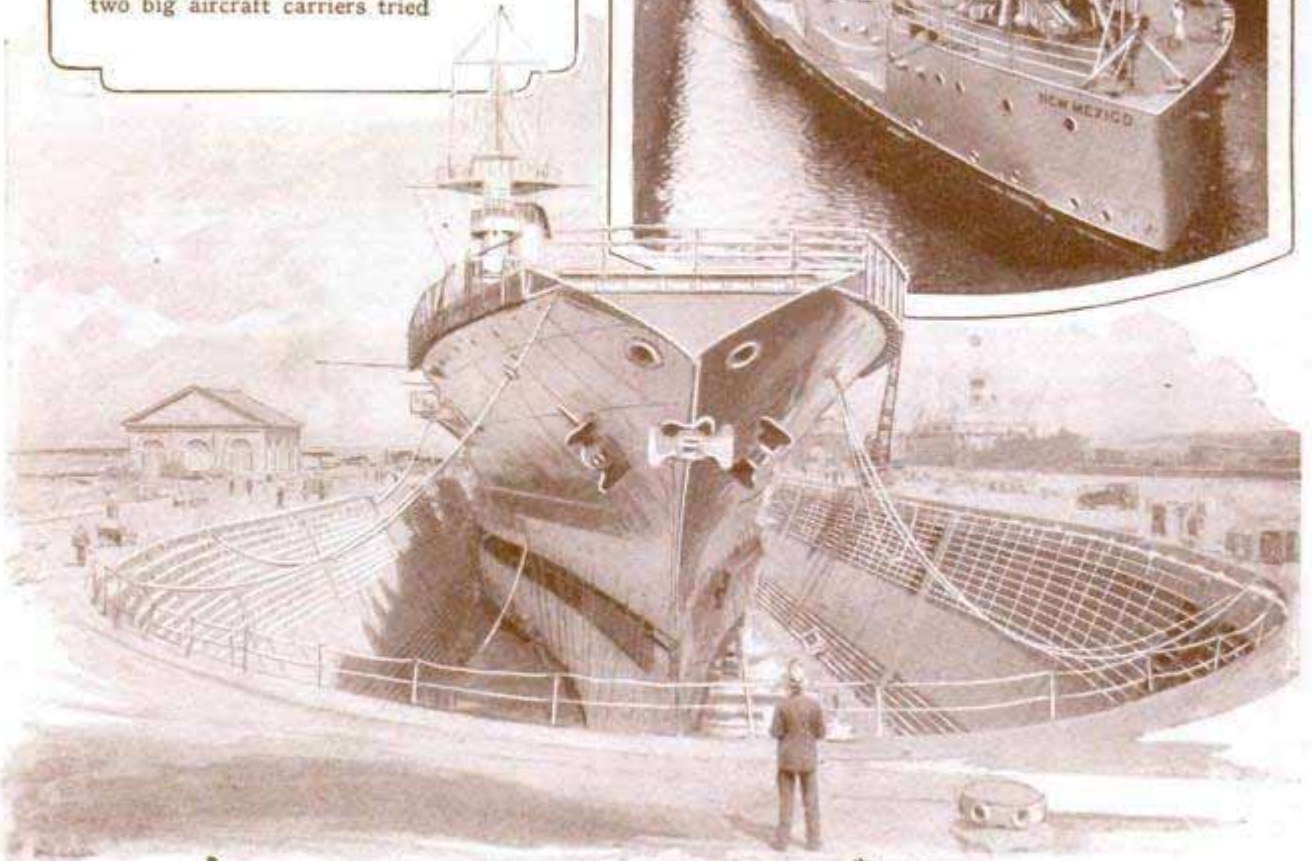

COMPARATIVE SIZE OF WORLD'S FIVE LEADING NAVIES

BATTLESHIPS



U.S.-18 SHIPS-625,850 TONS



ENGLAND-16 SHIPS-433,850 TONS



FRANCE-9 SHIPS-194,556 TONS



JAPAN-6-191,320 TONS



ITALY-5-109,220 TONS

BATTLE CRUISERS

THE UNITED STATES, FRANCE AND ITALY HAVE NO BATTLE CRUISERS BUILT OR BUILDING



ENGLAND-4 SHIPS-122,700 TONS



JAPAN-4 SHIPS-110,000 TONS

FIRST LINE CRUISERS UNDER 20 YEARS OLD



ENGLAND-62 SHIPS-379,540 TONS



JAPAN-32 SHIPS-203,955 TONS



U.S.-18 SHIPS-155,000 TONS



FRANCE-15 SHIPS-132,883 TONS



ITALY-18 SHIPS-107,370 TONS

FIRST LINE DESTROYERS UNDER 16 YEARS OLD



U.S.-262 SHIPS-312,479 TONS



ENGLAND-175 SHIPS-215,770 TONS



JAPAN-102 SHIPS-113,360 TONS



ITALY-85 SHIPS-110,490 TONS



FRANCE-78 SHIPS-110,490 TONS

FIRST LINE SUBMARINES UNDER 13 YEARS OLD



U.S.-114 SHIPS-88,527 TONS



FRANCE-84 SHIPS-80,987 TONS



JAPAN-71 SHIPS-73,087 TONS



ENGLAND-58 SHIPS-66,185 TONS



ITALY-56 SHIPS-82,243 TONS

AIRCRAFT CARRIERS



ENGLAND-6 SHIPS-106,950 TONS



U.S.-3 SHIPS-78,700 TONS



JAPAN-3 SHIPS-63,300 TONS



FRANCE-1 SHIP-21,653 TONS

ITALY HAS NO AIRCRAFT CARRIERS BUILT OR BUILDING

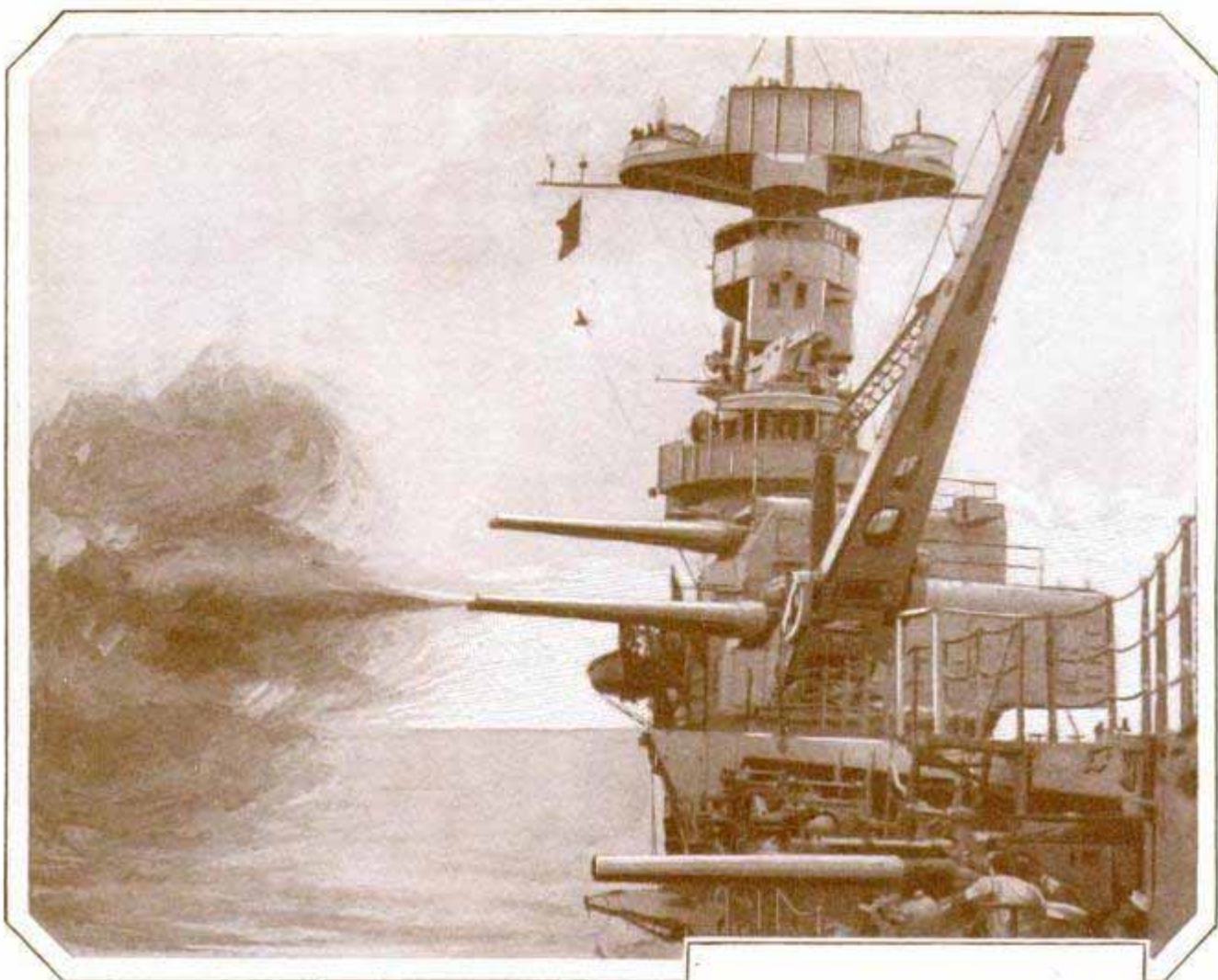

out their batteries in target drill recently. In photo above, the guns of the No. 1 turret of the "Lexington" are firing a broadside. Swung out at an angle, the turrets look very much like the control cabins of giant steam shovels. The red powder flag flying from the yardarm is a signal to other vessels that the magazines are open and ammunition on deck. The crane in the foreground is used to hoist seaplanes back to the deck. Land planes start from and land on the flying deck, while seaplanes must be picked up from the water. Below, the "Langley," with a flight of planes on deck, is following in the wake of a battleship division.

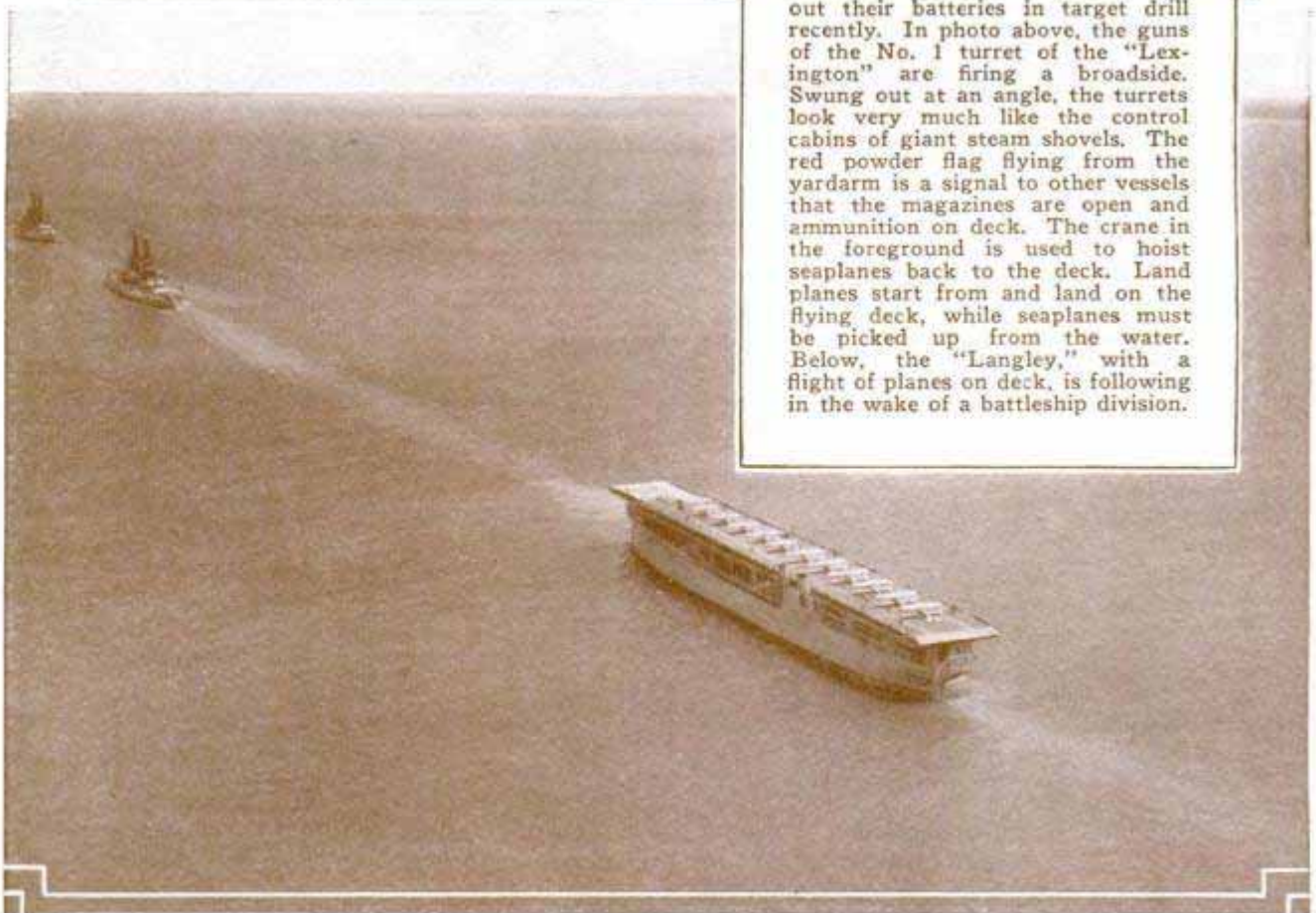

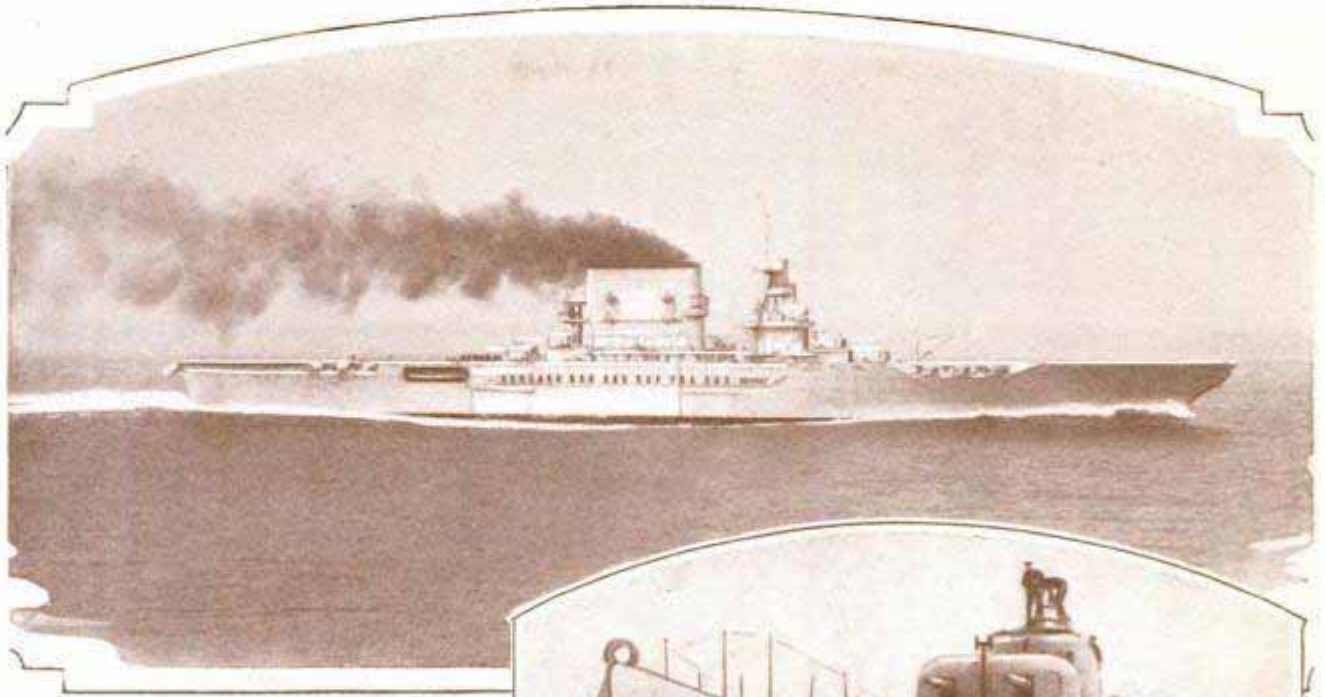

The picture above shows the "Saratoga" during her full-power trials, and at the right is England's most powerful submarine, a giant cruiser equipped with two long-range guns in an armorplated turret, making her as effective as a monitor in a surface battle. Below, the sailors of the "Lexington" are hook-

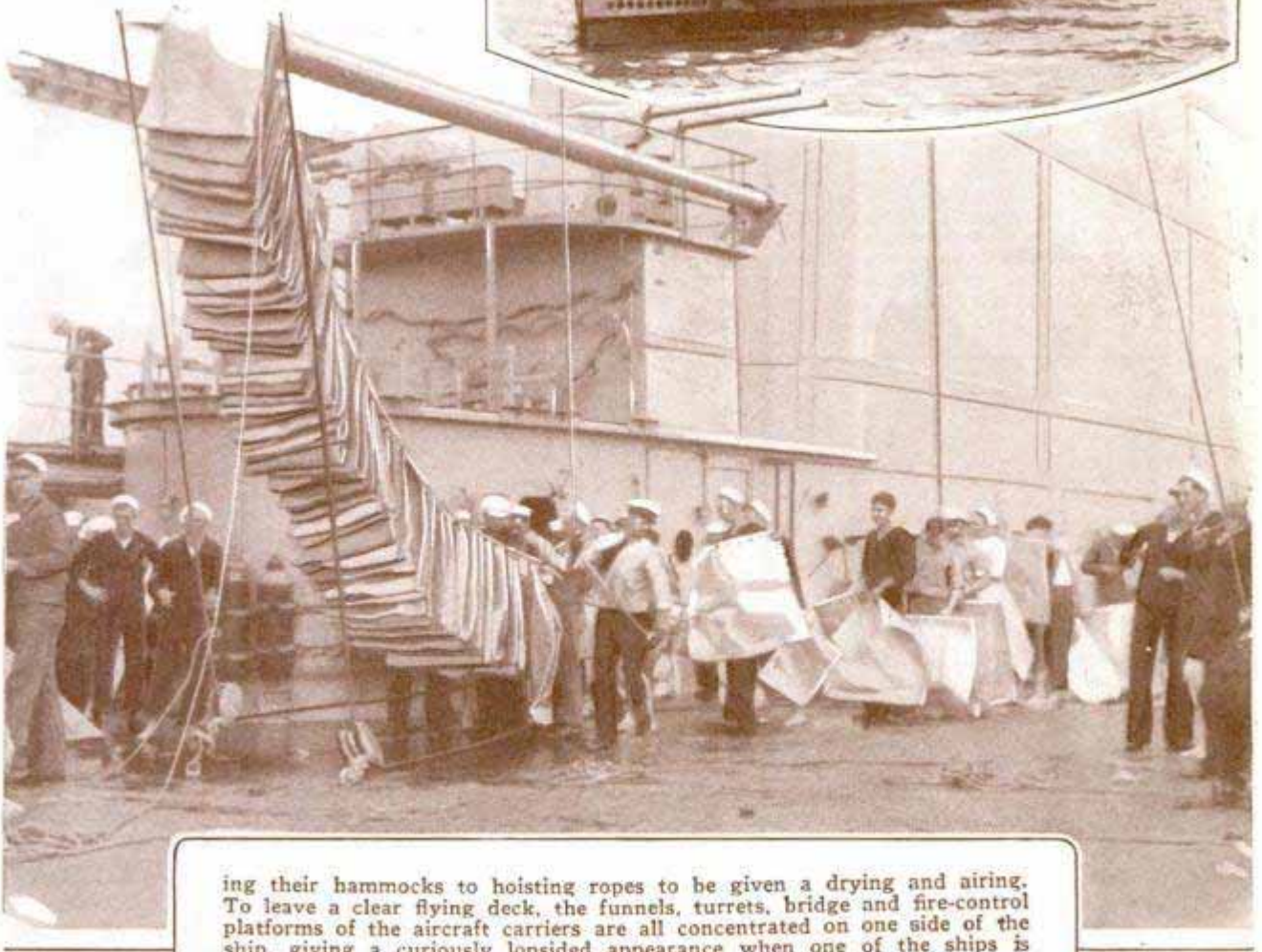
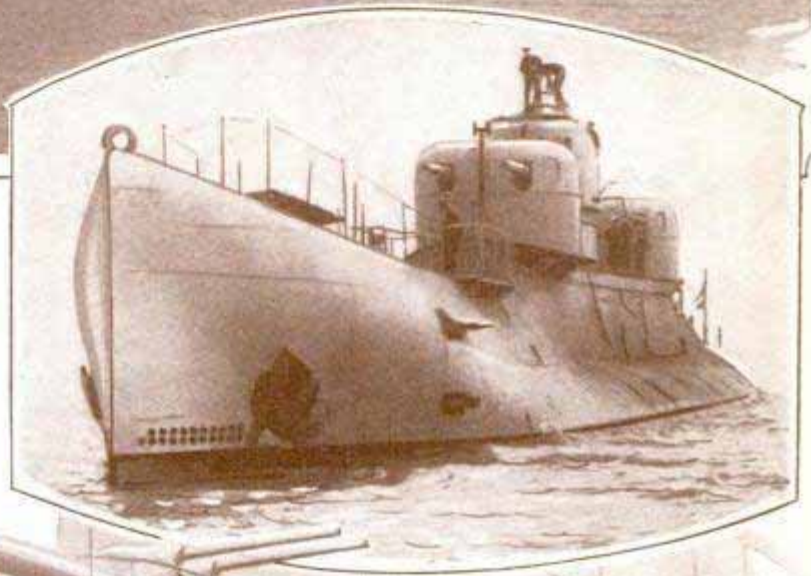

ing their hammocks to hoisting ropes to be given a drying and airing. To leave a clear flying deck, the funnels, turrets, bridge and fire-control platforms of the aircraft carriers are all concentrated on one side of the ship, giving a curiously lopsided appearance when one of the ships is

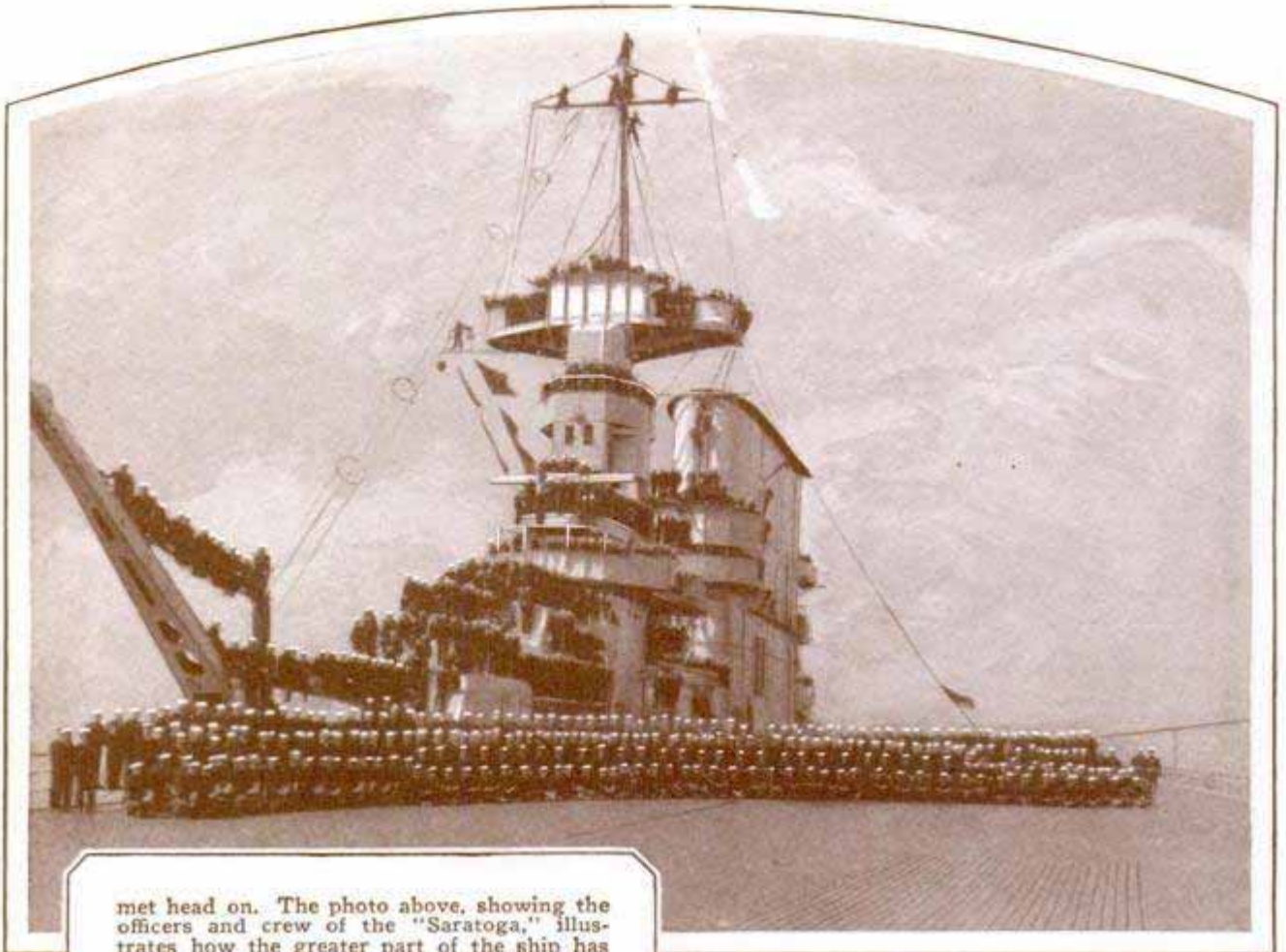

met head on. The photo above, showing the officers and crew of the "Saratoga," illustrates how the greater part of the ship has been left clear for airplanes. Elevators shaped like the letter "T" form a part of the deck, and are used to raise and lower the planes, which are stored and assembled below. The elevators are big enough for the crossarm of the "T" to accommodate the largest wings used on ship-board craft, while the base carries the tail. How a new 10,000-ton treaty cruiser looks from the air is shown below in a picture of the "Salt Lake City" just after she slid down the launching ways. Funnels and superstructure remain to be added before she is ready to fight.

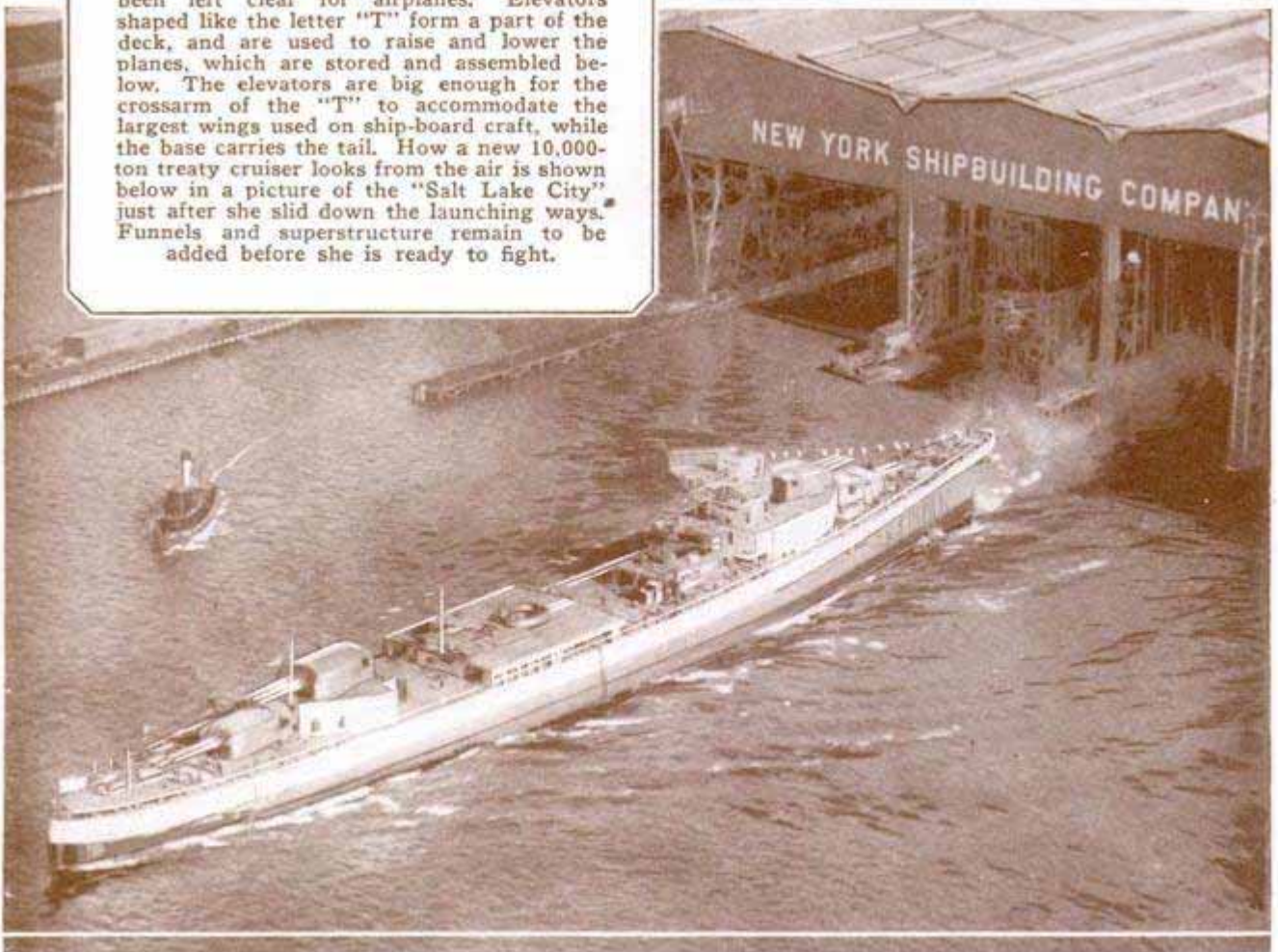

STOPPING WASTE OF SOIL EROSION IS URGENT NEED

More extensive and more effective measures to prevent erosion of the soil by rivers are urgently needed, department of agriculture investigators report, to reduce the annual destruction to fertile farms and valleys. More than 513,000,000 tons of soil are being washed out to the seas every year, they declare. The Mississippi river system alone is responsible for some 428,000,000 tons of this loss. Terracing fields, contour plowing and cultivating, wise forestry management and the further conservation of forests, are partial remedies, and the most complete co-operation on the part of farmers and engineers is all-important. It is estimated that with the soil washed away goes not less than 126,000,000,000 pounds of plant food, about twenty-one times the quantity that is naturally taken out of the fields by the annual crops harvested. If purchased at market prices, the phosphorus, potassium and nitrogen lost would cost over \$2,000,000,000.

RUNNING-BOARD FOOT SCRAPER HELPS KEEP AUTO CLEAN



It can be attached quickly, and is securely anchored so that it will not rattle.

To remove mud and dirt from the shoes before entering the car, a scraper adjusted to the running board and pushed underneath when it is not in use, has been introduced.

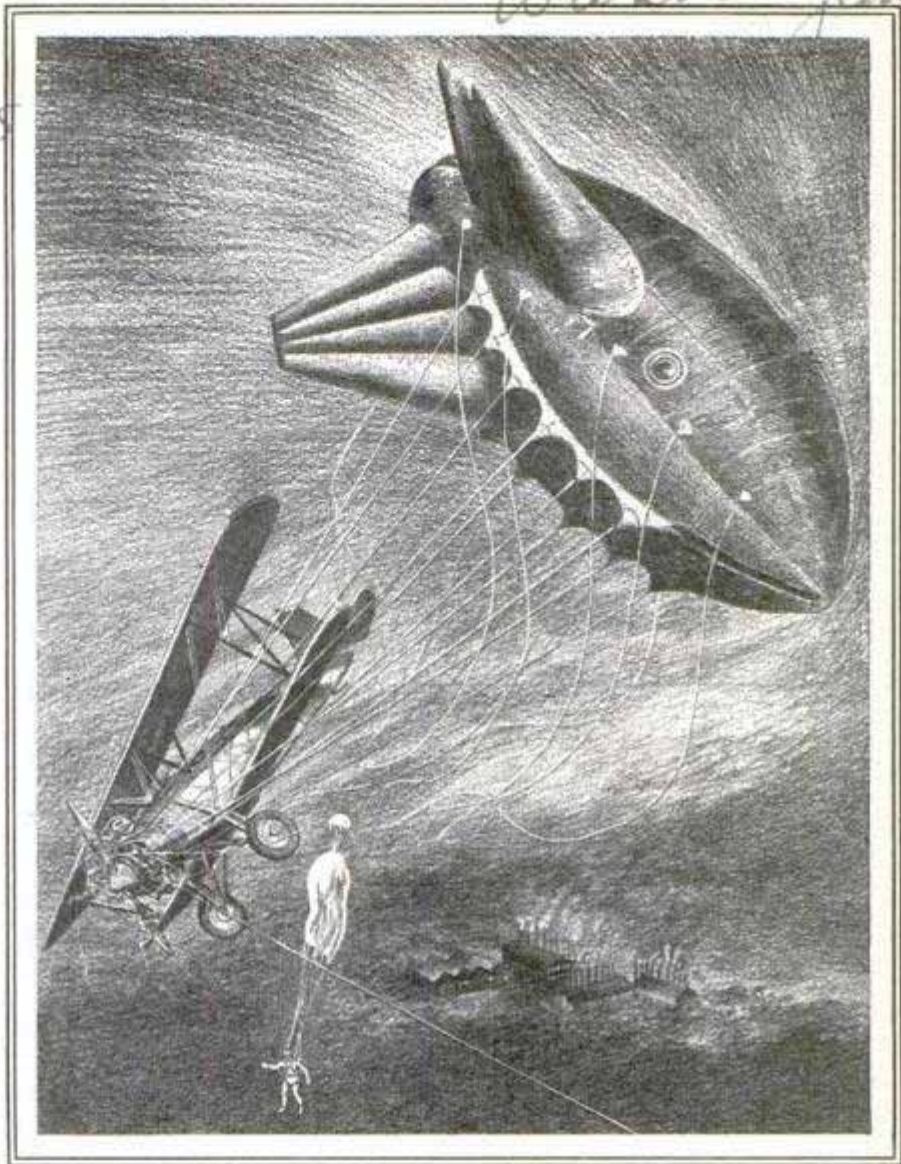

Drawing to Show the Operation of the Airplane Trap, a Captive Balloon Draped with Piano Wires as a Snare

INVISIBLE WALLS HUNG IN SKY TO FOIL AIRPLANES

Captive balloons, bearing nets of piano wire that hang down as invisible barriers for night-traveling airplanes, have been proposed as a means of curbing bomb attacks under darkness. Afloat at an altitude of 1,000 feet or so, a number of these trap-bearing balloons would form a serious obstacle to the bombing planes, which must fly comparatively low and are operated chiefly on very dark nights when they are not so likely to be seen. Big fins, holding gas, keep the balloons afloat, and what appears to be a huge eye in each bag, is the valve for the gas.

Whenever you find that you wish to know more about any article in this magazine, write our Bureau of Information.

Ben Smith
1822 E St
Washington DC
291
U.S. Navy
col, stan
le
U.S. Navy

1765
750

THIS IS HOW SOME OF THE WORLD'S FAMILIAR

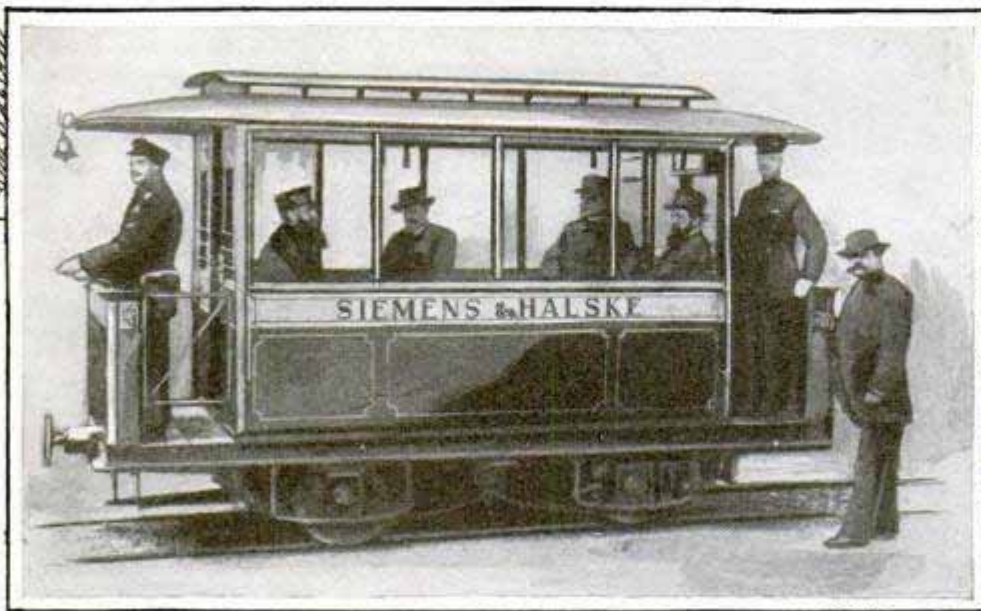

Here Is the World's First Electric Street Car, Built by Werner von Siemens at Gross-Lichterfelde, Germany, in the Year 1881



The Wrights Fathered the Airplane, But Otto Lilienthal, with His Successful Gliders, May Be Rated as Its Grandfather, for He Inspired Them

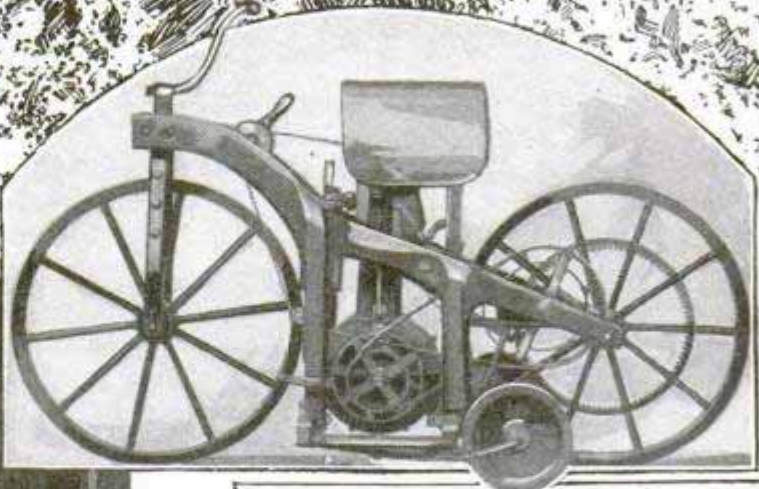

Daguerre, Who Gave His Name to a Process of Photography, Fathered That Art, and Here, at the Left, Is One of His First Cameras; Above Is Germany's First Motorcycle, a Bicycle with a Daimler Engine; the Combination Belt-and-Gear Drive Reduced Speed

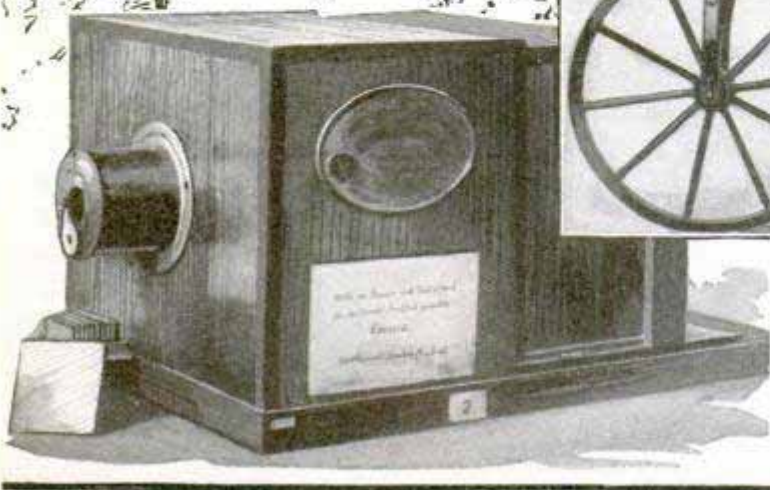

INVENTIONS LOOKED AT THE TIME OF BIRTH



Europe's First Typewriter, Designed by Peter Mitterhofer, and Now in the Technical Museum of Vienna, Wasn't Designed for Speed



Quart-Size Pockets Were Popular Long Ago When Peter Henlein Built His First Watch, Known as the "Nurnberger Egg"

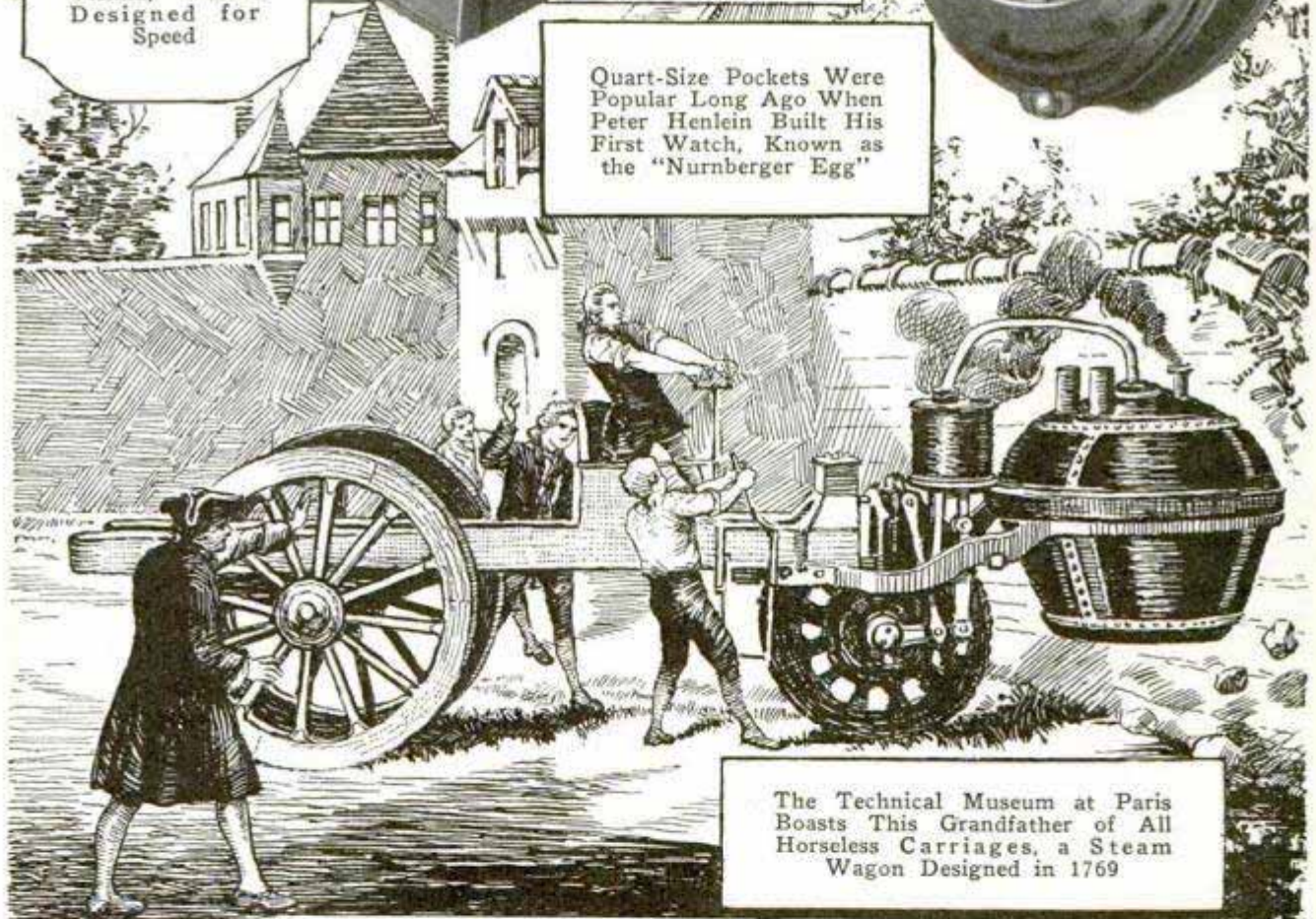

The Technical Museum at Paris Boasts This Grandfather of All Horseless Carriages, a Steam Wagon Designed in 1769

Early Attempts to Improve Bell's Telephone Provoked This Model Ear and Pair of Receivers with Pig-Bladder Diaphragms

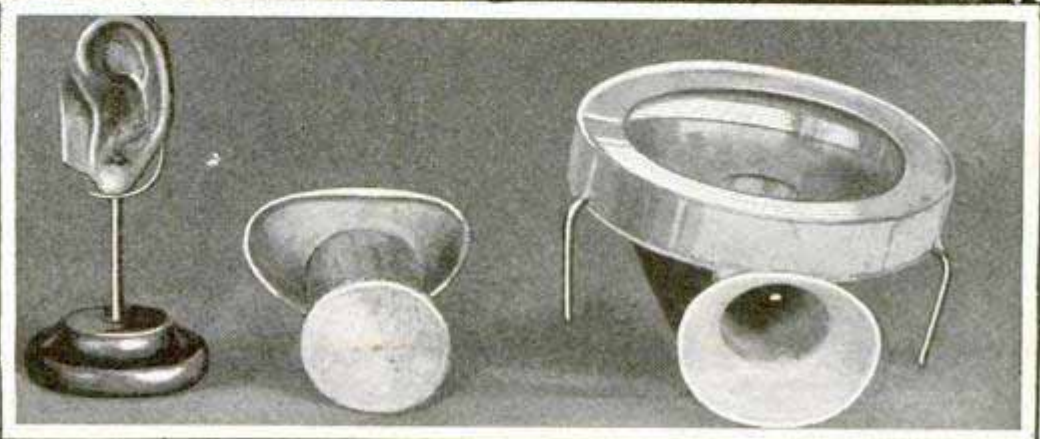

2189

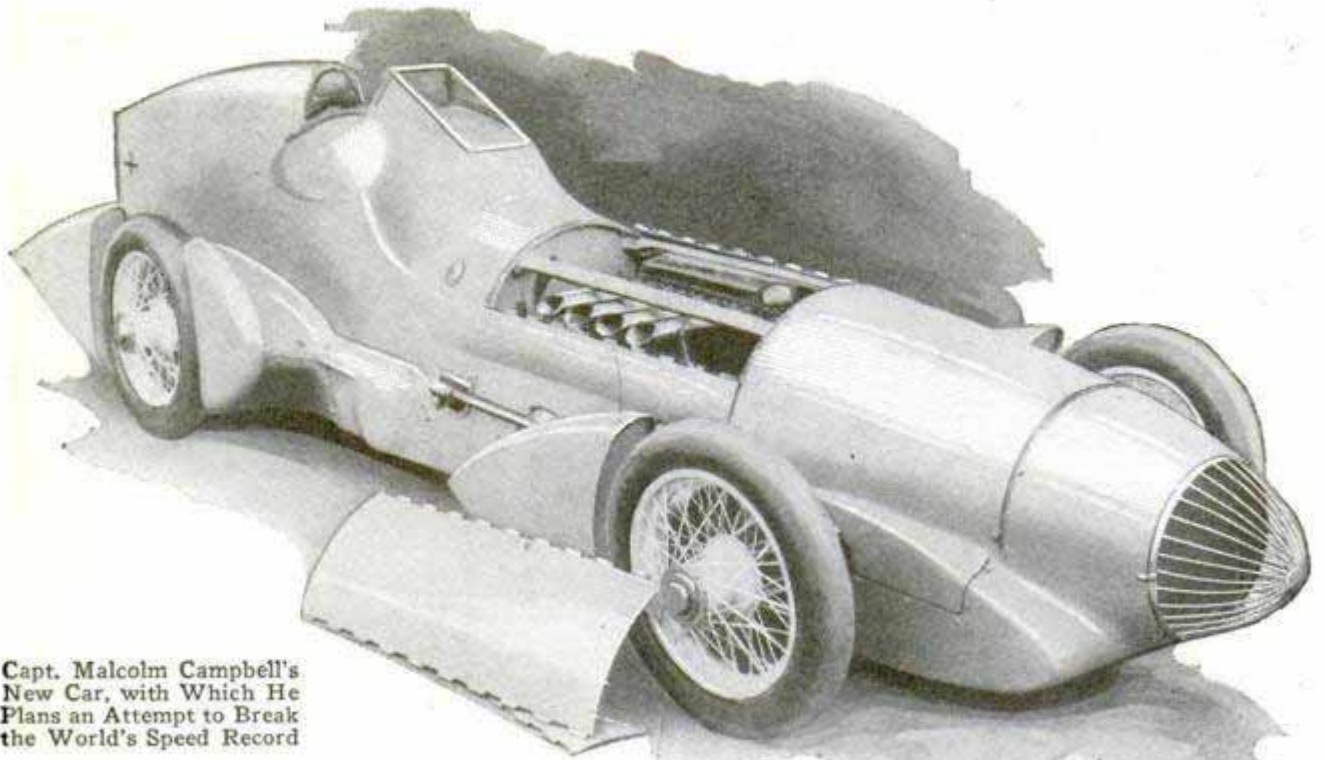

Capt. Malcolm Campbell's New Car, with Which He Plans an Attempt to Break the World's Speed Record

W. W. W. W.

SEEK NEW AUTO SPEED MARKS WITH STREAMLINE CAR

What engineers pronounce as the "last word" in streamlining is seen in Capt. Malcolm Campbell's new car, the "Bluebird," with which he hopes to achieve faster speed marks in tests in South Africa. The car was finished recently in England.

MOVIES OF BEATING HEARTS TO AID DOCTORS

Now the heart itself enters the movies. Electrical experts have developed an apparatus that films the organ in action, showing any change in its rate of pulsation or other features. The pictures are



Machine Which Films the Beating of a Heart for the Movies as an Aid to Doctors Studying the Organ

reproduced on the screen, and physicians are thus able to make more thorough studies in case of disease.

PHOTO OF FLAME IS SNAPPED BY HIGH-SPEED CAMERA

A camera, costing \$2,500 and taking accurate photos of a flame traveling at 21,000 miles an hour, recently has been tested in England. The camera, which works in conjunction with a dynamo and transformer, with an output of 20,000 volts, is the invention of R. A. Fraser, who has spent seven years investigating the problem of "flame rate," or the speed of an explosive flame. It has been used to photograph the explosion of enough nitroglycerine and dynamite to wreck a ten-roomed house. The photographer and an assistant were separated by five walls, each with an observation window, behind which the explosive was detonated in a large steel cylinder. An endless strip of film, traveling on a drum, at 400 miles an hour, is whirled past a system of lenses, and so well balanced is the drum, that having been once rotated at its maximum speed of 18,000 revolutions a second, it takes more than a quarter of an hour to come to rest. Photographs are taken at the rate of 200 a second, and though the flame

Carl H. J. ...

*Dr. Edward Henry Hanger
1551 S. ...
Los Angeles, Calif.*

of the explosion travels at from four inches to two miles a second, it appears stationary in the pictures. The experimenters hope to gain data which will help to prevent the present waste of about two-thirds of the power inside the cylinders of gasoline engines.

VAST SALT LAKE IS PLANNED TO WATER THE SAHARA

Creation of a vast lake of salt water to change the face of the Sahara desert and a sandy waste into a productive plain has been proposed to the French government by Dwight Braman, of New York, with plans designed by John F. Stevens, who was engineer of the Panama canal. The idea is to dig a canal from the Mediterranean, connecting a series of small lakes which dry up every summer, and admit enough salt water from the sea to keep the lakes filled the year around. An area, 265 miles wide, would be flooded. The presence of so big a body of water would modify the climate to such an extent, it is claimed, that 210,000 square miles could be reclaimed for farming.

SNAP-SPRING CYCLE CARRIER ELIMINATES STRAPS



Bundles are held in a bicycle luggage carrier by means of snap springs instead of with straps. This saves considerable time in loading and unloading, and also guards against loss, it is claimed.

POSTAL MADE FROM FIR TREE

A postcard, eight feet long and four feet high, carrying \$16 worth of stamps, recently was delivered to President Hoover, bearing greetings from the Hoover-Curtis club of Washington University, at Seattle. The giant card was in reality a thin board, cut from a Washington fir tree. More than 2,000 members of the club signed the message.

229 Phil B. Bekeart Co. 717 Market St. San Francisco Calif.



Hunter's Knapsack with Space for Ammunition, Food, Clothing, and a Design Built to Fit the Back

KNAPSACK FOR HUNTERS HOLDS AMMUNITION AND FOOD

Designed especially for duck hunters, but equally serviceable to hikers, trappers and campers, a waterproof knapsack now on the market has four compartments and is shaped to fit the back with comfort. The lower section holds six boxes of shotgun shells, while the upper divisions may be used for food, clothing and other articles. A cover keeps out rain.

VACUUM CUP FASTENS WATCH ON AUTO DASH

Attached to the automobile dash in a few seconds without boring holes, a watch held by a vacuum rubber cup is quickly squeezed into place. Besides keeping the time-piece where it can easily be seen, the cup, by its resiliency, shields the watch from much of the vibration in driving.

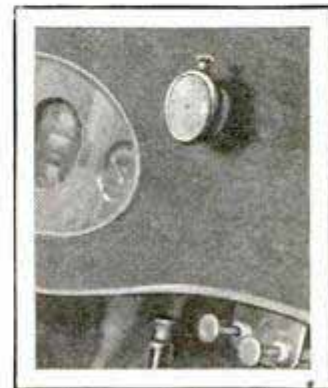

La Montagne, 369 Pine St. San Francisco, Calif.

The Caskey Metal Products, d. no. 660 Grand St. Buffalo, N.Y.

Contributed by W. B. Bekeart Co. 717 Market St. San Francisco

vacuum cup to watch

2328 131.21 26

70 Cleveland Ohio

secondary. Refusable from
and steel &



Bending Welded-Steel Conduit for Electric Wiring, Which Eliminates Threading and Corner Boxes

STEEL TUBE TO HOLD WIRING REQUIRES NO THREADING

Steel tubing for electrical conduits, formed with an electrically welded joint, simplifies work considerably, as it is equipped with patent couplings which eliminate threading, and can be bent to go around corners, instead of being threaded and screwed into special corner boxes. The tubing also weighs less than half as much as the old-style conduit.

RED-HEAD ACTORS FOUND BEST FOR TELEVISION

Red-headed people are the best subjects for television, while blondes, in general, are the poorest. This curious fact was brought out by V. A. Schoenberger, radio engineer, in addressing the federal radio commission, during the hearing on the advisability of allowing television transmission by stations in the broadcast band. Dr. Lee De Forest, radio pioneer, said that after the war-time restrictions on radio were removed in 1919, he began sound broadcasting on a small scale. He subsequently moved his station, and one of the government radio inspectors took advantage of a technicality and suspended

his license. To Doctor De Forest's protests he replied that "entertainment by radio had no place on the ether." "The radio commission should not repeat this early policy of discouragement, but should give television all the encouragement possible," Dr. De Forest said. Similar views were expressed by C. Francis Jenkins, Washington inventor, who urged that radiovision should be allowed on broadcasting wavelengths. The importance of broadcasting on a frequency between 1.500 and 550 kilocycles, that of the broadcast stations, comes from the fact that millions of people are equipped with radio sets capable of tuning in these waves.

DRIVERS TEST SPEEDOMETERS ON MILE-LONG STRETCH

Motorists are afforded an opportunity to test their own speedometers on a mile-long stretch of road which the state of Pennsylvania has provided at a point on the Delaware Water Gap main highway. Signs, 1,000 feet from the beginning of the test mile at each end, announce the trial stretch. The course is not a level straight-away, but has curves and grades and thus pictures true driving conditions rather than the ideal. This assures a more accurate testing of the speedometer both for mileage recorded and speed registered.



Measured Mile on a Pennsylvania Road Laid Out by the Highway Commission for Speedometer Testing

235t

concrete & steel

Harrison St. Hanford

2211

HEARING through your FINGERS

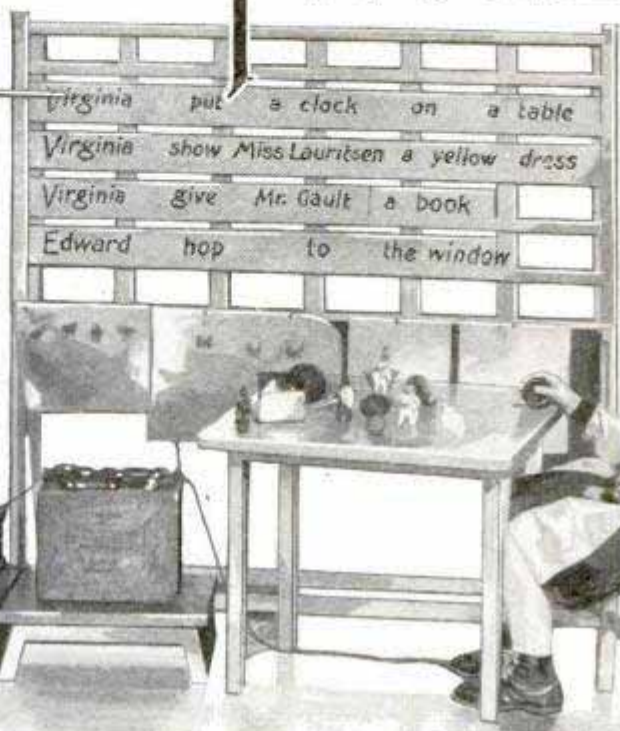

Designed by Bell Telephone Laboratories
195 B roadway. N.Y.C.

not on market as yet.

Six-Year-Old Deaf Child Studying the Printed Word, Lip Reading and the "Feel" of the Same Word through the "Teletactor." All at One Time; the New Device Speeds Education

NATURE is a great compensator. Rob us of our arms and we use our toes to write with. The loss of the right hand is soon compensated by new abilities developed by the left. The loss of the feet gives amazing versatility to the arms. Now our scientists tell us that we have only begun to scratch the surface of the possibilities that lie in utilizing nature's ability to increase the skill of another sense when one is lost.

Of all the five senses, touch is the most adaptable to increased uses. The trained sense of touch helps greatly to compensate for the loss of sight. Now it has been discovered that the sense of touch will also compensate for the loss or even the absence of hearing.

Dr. Robert H. Gault, of Northwestern University, became interested in exploring the limits of this amazing sense of touch.

He discovered that the sensitivity of the skin could compensate for lack of the ability to hear.

A little more than five years ago, Doctor Gault extended a speaking tube between two walls and the intervening room in his laboratory. This was his only apparatus, excepting a double-walled well-packed box into which one end of the tube projected. The whole was soundproof. One of his students crawled into the soundproof box and poked his arm through the hole, placing the palm of his hand tightly over the end of the long tube. By his sense of touch he could then feel the experimenter's voice at the other end of the tube and was soon able to distinguish thirty-eight words.

Here was an amazing fact. It was proved possible to distinguish words by the sense of feeling. Hearing by touch was thus

Urbns. Tactile Laboratory and Institute, Evanston, Ill.

Evanston, Ill. Research 755
for National

demonstrated. That was the simple beginning.

In order to perfect such a device, Doctor Gault next linked a suitable electrical apparatus to the system for conveying the vibrations from the voice. He believed that speech could thus be communicated to the skin. The skin could be made to hear.

He utilized the earpiece of the telephone for further experiments. The wire connecting the transmitter and the earpiece of the device was spliced so that he could take up his position at the transmitter end. Then, while he was talking in one building, and the listener in another, holding the receiver end in his fingers, sounds could be felt. Naturally, the meaning of the sounds at first could not be understood by way of this sense of touch, but some distinctions could be easily made between sets of vibrations, and ultimately these could be correctly translated. At this juncture, the Bell Telephone laboratories extended their aid in perfecting the device, and the vibrator which was held in the hand and extended the sound to the skin by means of vibrations, was invented.

Here, then, was a simple device that opened a whole new world to those who were deaf or hard of hearing. The world of sound could be reached through the gates of touch. The sensitive fingertips would answer the purpose of the ears.

Doctor Gault, in making practical application of his experiments, immediately thought of the valuable aid such a method would be to those who were wholly or partly deaf. Since there are about 100,000 persons in the United States who are totally deaf, and a far greater number partly so, and millions whose hearing is impaired, there seemed a real chance to make a useful application.

Deaf children and deaf adults who were introduced to the "teletactor" quickly learned to distinguish the pattern of the sounds they felt. By understanding the pattern of speech they easily learned the words and were able to "hear" themselves speak. Then, by a comparison between the feeling of their own words and the feeling of the words of one who spoke correctly, they could discover the difference and learn to speak as they should.

Some deaf people obtained a real thrill

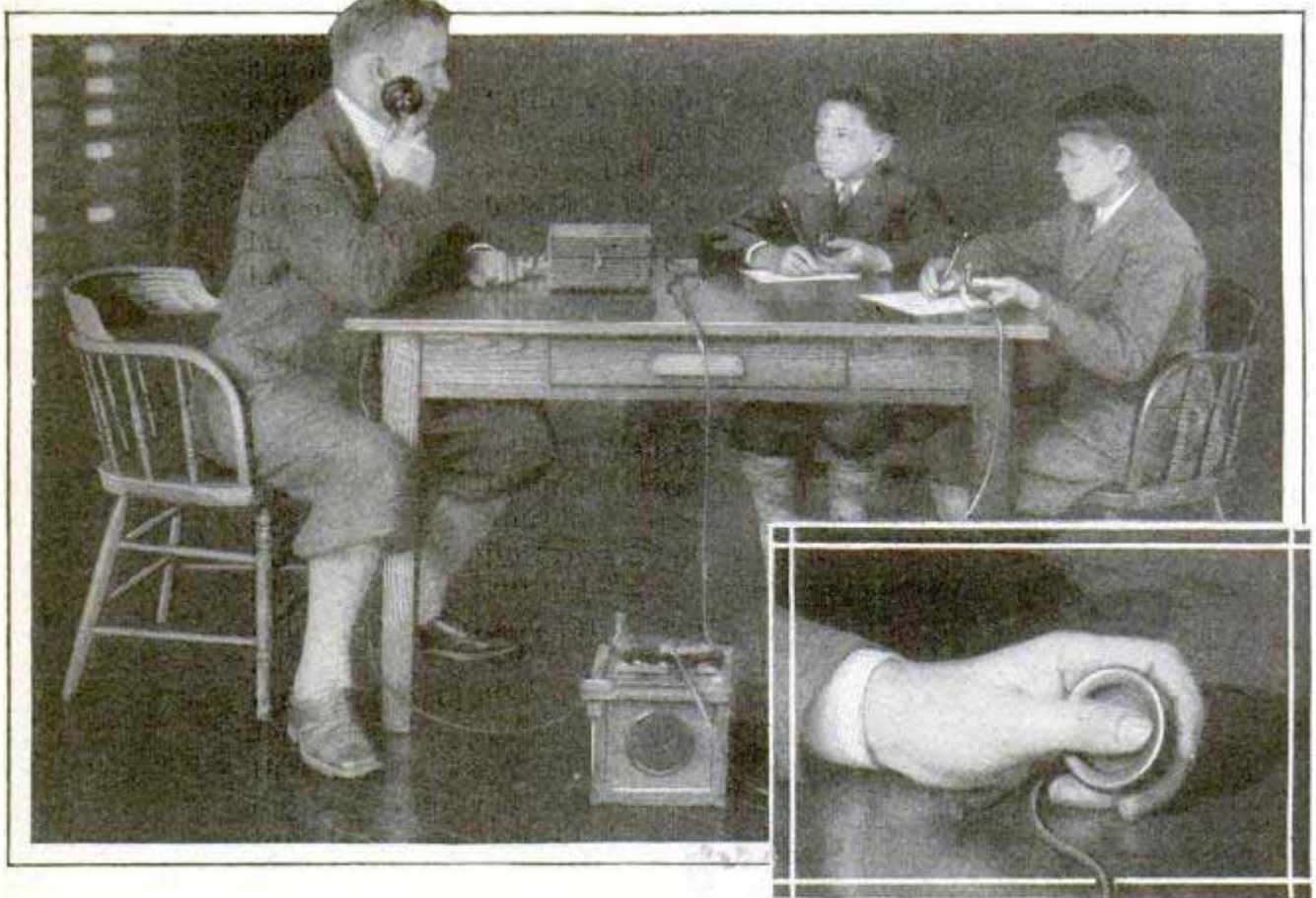

Boy Students Feeling Words While Watching the Instructor's Lips Form Them, and, Inset, the Sensitive Diaphragm Which Communicates Sound Vibrations through the Thumb

from the feel of their own voices. Certain vowel sounds gave them distinct pleasure. Some voices were found to be more pleasant than others. They showed that they enjoyed the feel of some sentences and some writers more than others. Out of ten varieties of verse, the biggest thrill for the totally deaf was the following:

"How does the water
Come down at Lodore
From its sources that well
In the tarn by the fell?"

This is fundamental. It is due to the fact that there is a predominating vowel quality: long and broad. Such sounds offered as distinct a pleasure to the one who had never heard with his ears but now heard through the sense of touch, as the normal individual would derive from any music.

The uses to which the simple little "teletactile auditors" will be put are easily imagined, and the ultimate possibilities too numerous to comprehend when applied to the sciences of human behavior, to business and to pleasure. There are immediately offered the pleasures of the radio, that thus will reach an audience of millions formerly beyond its reach.

2272

**SUCTION-GRIP CIGAR LIGHTER
LATEST MOTOR LUXURY**

Attached to the dash or any other convenient place in the car by a rubber suction cup, a cigar lighter ignites when the cap is pulled off. To install the device, it is not necessary to bore holes or insert screws. The vacuum cup holds the lighter firmly in position but may be removed and placed elsewhere quite as easily as it is affixed.

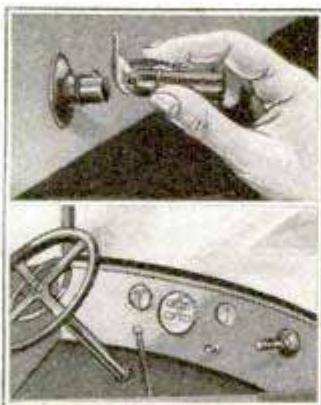

*Isordson, Inc. Co.,
110 E. 23rd St. / by request of*

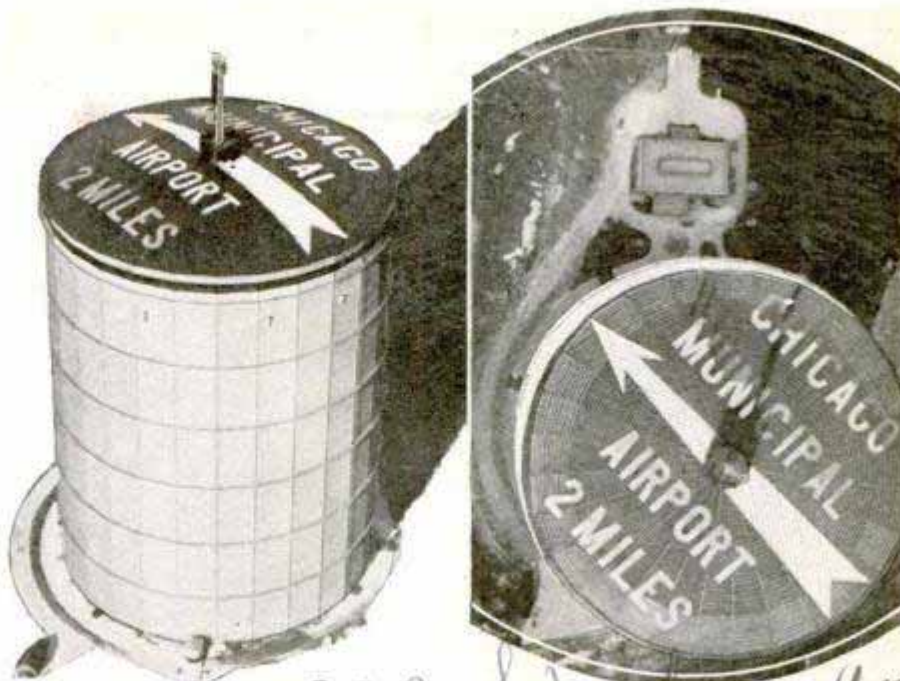

© Chicago Aerial Survey, 332 Michigan Ave.
Converted into an Aircraft Beacon, a Huge Gas Holder in Chicago Now Guides Flyers to the Airport

**GAS TANK DIRECTS AVIATORS
TO LANDING FIELD**

When a huge gas tank was erected on the outskirts of Chicago, fear was expressed that the dull-gray structure might prove a menace to airplanes, flying for the landing field not far away. Instead of being an obstacle, the tank has been made a guide to the flyers by painting a huge sign on top of it and installing lights on its sides and at the peak in the form of a flashing beacon. The letters in the sign are each thirty feet high and the top itself represents an area of an acre and a quarter, so that the directing arrow and sign can be seen from a great altitude. The lights are also visible at a long distance.

**LAND SHIP AIDS TRAINING
OF NAVAL STUDENTS 232**

A steel platform shaped like the bridge and bow of a ship has been designed at Mare Island navy yard, on the Pacific coast, for the training of R. O. T. C. students at the University of California, Berkeley. The bow revolves on a circular track, being controlled by a steering wheel on the bridge. The usual bridge instruments, including a compass, are mounted before the wheel, and the student learns certain aspects of navigation without leaving the campus.

Cont K. E. Chute, Box 407, Route 1, Fairward, Calif.

MIRROR SET ON SAFETY RAZOR
LATEST TRAVEL AID

2303 \$1.50

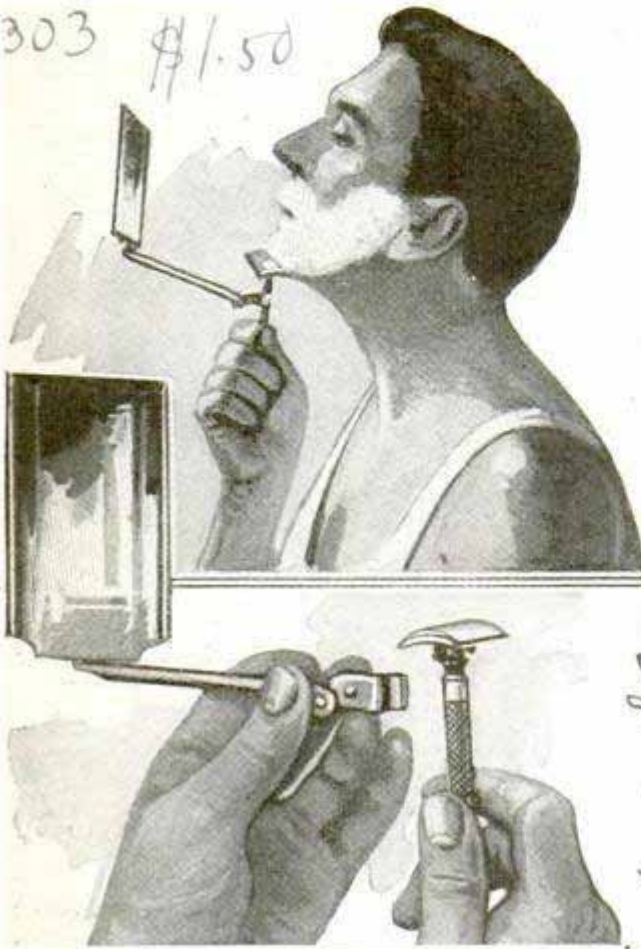

Shaving Mirror Attached to the Razor Handle Solves the Problem of Seeing the Blade at Work

Quickly attached to the handle of the safety razor, an adjustable mirror has been introduced for the convenience of campers, travelers, and others. It is fixed on a telescoping rod so that the distance between it and the eye may easily be regulated, and has a screw clamp that fits any make of razor. The attachment weighs but two ounces and folds into small space.

SHOCK ABSORBERS ADD TO LIFE
OF AUTOMOBILE TIRES

Exploding the theory that shock absorbers aggravate tire wear, experiments made by the engineering experiment station of the State College of Washington show that tire wear is reduced when shock absorbers or snubbers are used. "Excessive wear on corrugated roads is due to tires leaving the surface of the road, speeding up while in the air and being checked again when striking the road surface," Dean H. V. Carpenter explained.

"Some students of the problem have believed that, since absorbers tend to pull down the car body when the springs try to throw it high in the air, this same pull would lift the axle and tire off the road and so aggravate tire wear. Our studies show that the principal tendency to vibrate when driving over washboard highways is found in the axles themselves, and the application of shock absorbers tends to limit actual vibration. This is especially true when the disturbance comes from equally spaced corrugations, which tend to build up a resonant vibration of extreme magnitude in the axle, thus causing it to leave the road. It is this slowly built-up vibration of large amplitude that modern shock absorbers are so effective in preventing. It is a well-known fact that shock absorbers will reduce spring breakage. This can be explained in the same way. Most important of all, shock absorbers prevent, to a large extent, the tendency of the car to cut more and deeper corrugations in the road surface."

GUARD FOR HOUSE WATER PIPES
PREVENTS FREEZING

To keep the house water pipes from freezing, a protective device has been introduced in the form of a trap arrangement installed in the system at the point where the supply pipe enters the dwelling. The unit thins the stream into a wedge formation, thus permitting it to freeze at a higher point than would be required to freeze the main pipes. When the trap freezes, a spring release automatically drains the pipes in the house. When the trap thaws, the action is reversed and water again flows back into the house system.

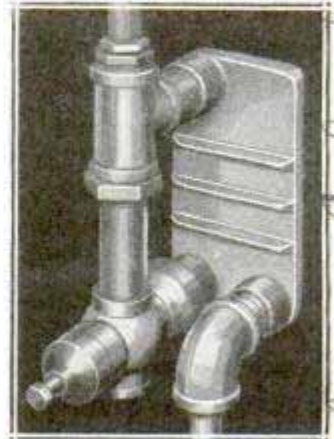

Write our Bureau of Information, if you wish to know who makes or sells any article described in this magazine. Send no postage; the service is free.

Science Service News
411 E. 7th St.

Congelator Co
349 E. Main St.

2208
D. J. Hartenberg, S.C.
Main St.

Advertisement
Congelator Co
349 E. Main St.

ARCH BRIDGE IN AUSTRALIA TO HAVE RECORD SPAN

St. Pakhertua, New Zealand

Building the Approaches for the New Harbor Bridge at Sydney, Australia; It Is to Have One 1,600-Foot Span

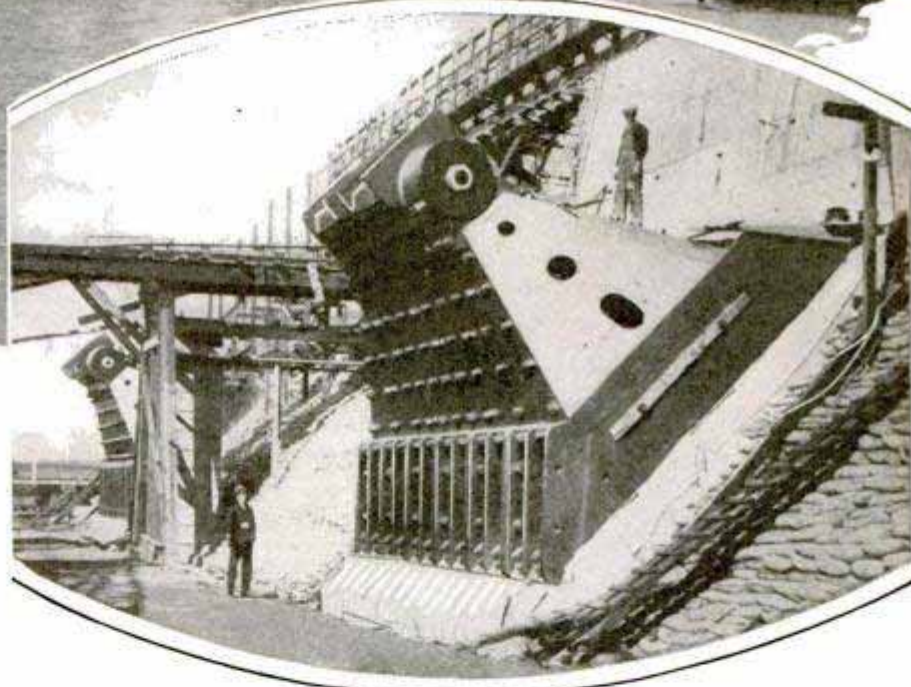
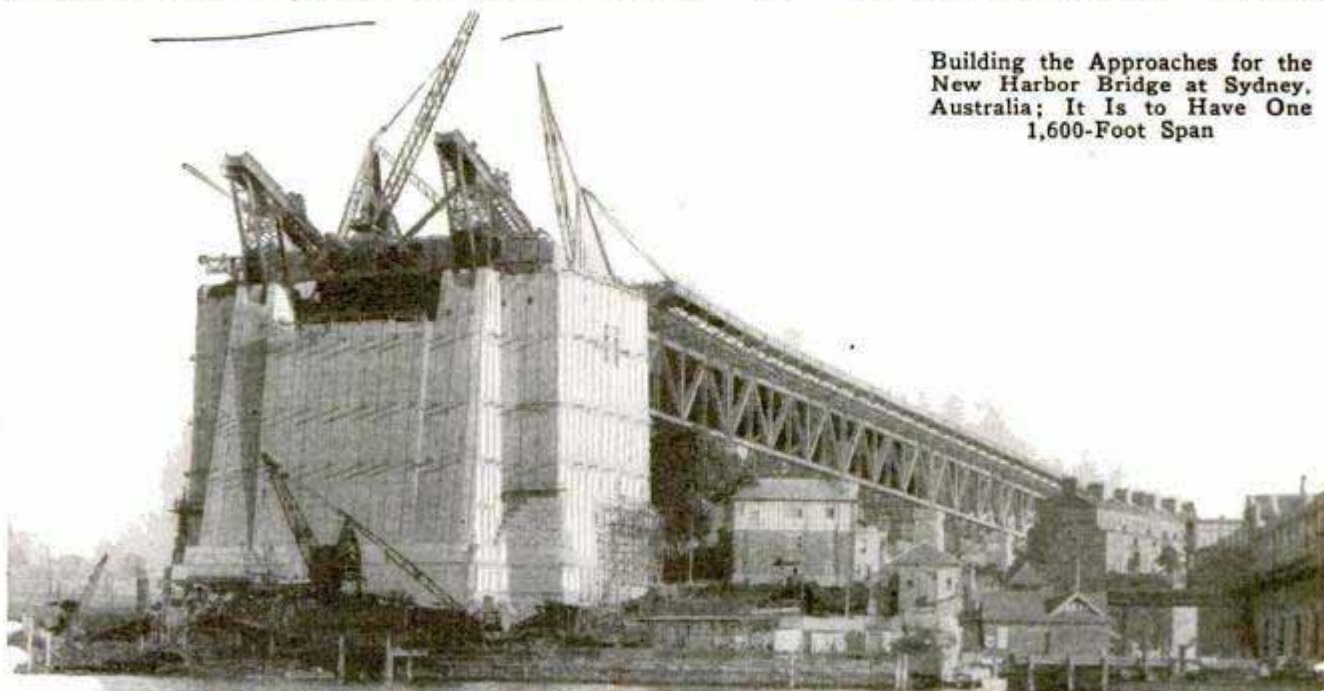

One of the greatest engineering tasks of its kind is under way in the harbor at Sydney, Australia, where a huge arch bridge is under construction. It will be 3,770 feet long and will have a center span of 1,600 feet, with a clearance of 170 feet above the water at mean high tide. More than 56,000 tons of steel will be used. The bridge will be 150 feet wide, providing passage for four railway tracks, a road, fifty-seven feet wide, and two footpaths, each ten feet wide. It will be completed in 1931.

CUTTER REMOVES TREE ROOTS WHICH CLOG SEWER 351

A cutter that can be drawn through a sewer to sever tree roots which threaten to clog the drain has been invented by a city councilman of Nappanee, Ind. The

cutter, which works on the same principle as a folding luggage rack, can be expanded or contracted from ten inches to twenty-nine inches, to fit any drain within those limits. It is fitted with five sets of double knives, and when drawn back and forth between two manholes by a windlass stationed at each end, the roots are severed by the knives, which operate in V-shape formation, like the blades of a pair of scissors. In their search for water, trees send fine tendrils between the joints in sewer pipes and the resulting matted growth often completely clogs the drain. The cutter has been tested with success.

Chas. A & Wright 108 E.

2145

Carl H. Hall

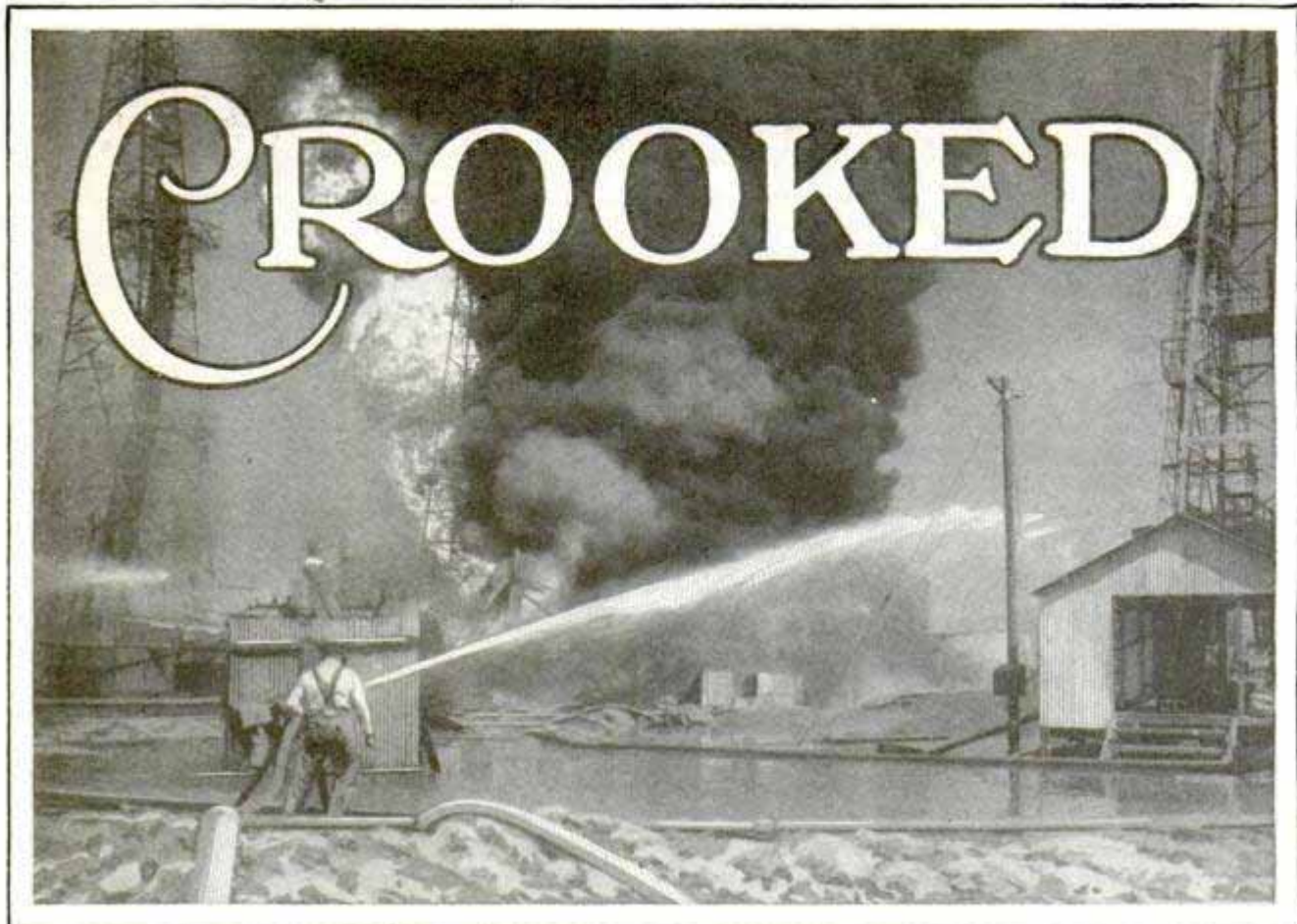

When the Getty Number 1 Well, at Santa Fe Springs, Caught Fire, Ten Thousand Barrels of Oil and Forty Million Cubic Feet of Gas Were Burned Each Day

By THOS. M. NELSON

*520 W. 13th Bldg
Houston, Texas*

STANDING three hundred feet apart, two gaunt steel oil derricks reared their structures high into the air. One belonged to the Texas Moon, the other to the Hardrock corporation, and each was bending every effort to beat the other down to the pay sand. The Texas Moon log showed a depth of 3,107 feet; that of the Hardrock corporation read 3,098. It was a close race.

Both derricks had been the scenes of intense activity, with mud pumps clanking and throbbing in rapid cadence, but now both were inactive, and the men sat about with expressions of bewilderment. Bob Rankin, driller for the Texas Moon, was talking to Red Malone, the Hardrock driller.

"Somethin's wrong," Rankin was saying. "Never before did I see a rotary drill act like mine was doin'—jumpin' around until I thought the blamed derrick would shake t' pieces. I sure..."

"Yeah," interrupted Malone. "My rig's gone crazy, too. Seems there's some-

thin' way down deep in that hole grabbin' and poundin' at the bit."

For a minute both men were silent as they mulled the matter over in their minds.

"Say," exclaimed Malone, "I'll bet these two oil wells have run together down there somewhere—that's what makes our rigs act so queer."

"We can soon tell," snapped Rankin. "You start your mud pump to workin'; I'm goin' back over to my rig and pump a lot o' red paint down our well. If you pump some red out of yours, that'll show the holes have run together."

Rankin hurried back to the Texas Moon derrick. Malone started his pumps, and the thin mud began to boil out of the top of the hole. Five minutes passed, and nothing happened. Then ten, and the mud took on a pinkish cast; the two wells had met far down under the surface of the earth.

The two shafts were being dug with rotary drills. These are exactly what the name implies. A bit shaped much like

HOLE'S

the tail of a fish, is screwed to the end of a joint of heavy steel pipe, and the pipe is rotated, the bit cutting its way into the rock just as a carpenter's bit cuts through a tough plank. As the hole increases in depth, joint after joint of pipe is added. Down through the drilling pipe, thin mud is pumped to serve the double purpose of a lubricant to reduce the heat caused by the friction of the bit against the rock, and to wash the rock cuttings and debris out of the hole.

When a bit becomes dull, or some other reason necessitates a withdrawal, the entire length of drilling pipe must be pulled out of the hole. When the shaft is several hundred feet deep, this is an arduous task, taking several hours' time. To save time in "coming out of the hole" and "going back in the hole," or as the drillers say, "making a round trip," it is customary to break the pipe every three or four joints, stacking these pieces in a corner of the derrick.

Bruce Pilley, drilling superintendent of the Texas Moon, and George Sloan, who held a similar position with the Hard-rock, both arrived at the scene of the crooked holes at about the same time. They were friends, though business rivals.

"What's the idea of letting your well wander over on our side of the line?" the Texas Moon drilling boss asked the Hard-rock chief.

"Our drill on your property? Why, it's the other way around; your tools came right over and invaded our hole."

"Well, we won't argue about it. Seriously, what do you think we ought to do about it? Seems a shame to abandon two perfectly good holes because we don't know which side of the line the bottom is on."

"Suppose we determine which well is

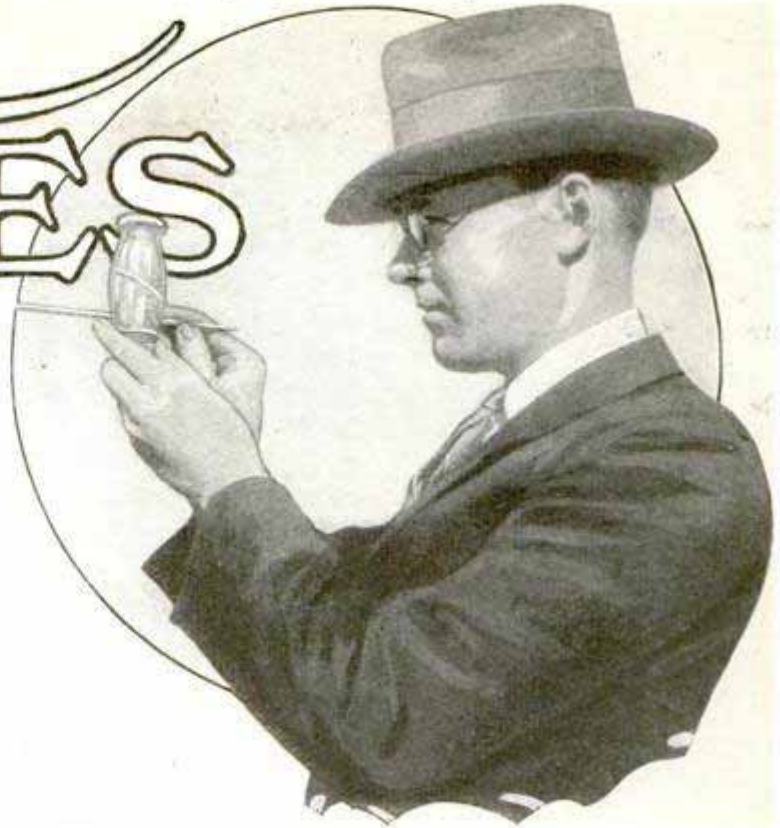

The Test of a Crooked Hole, a Bottle Etched by Acid to Show the Angle of Inclination

off center, then we can let the guilty party sidetrack his well," suggested Sloan.

"Okay with me," replied Pilley. "The sooner the better. The drilling crews can be getting the rigs ready for the test while we drive into the city for the necessary material."

In the case of wells made with rotary drills, there are two common methods of determining the amount and direction of deviation of the hole from true vertical, which has been known to be as much as 900 feet. The first, and the least satisfactory, employs gelatine and a magnetic compass. Into a small vacuum bottle, which fits snugly into the inside of the drilling pipe, cooked gelatine is poured. On the fluid gelatine is placed a floating magnetic needle. The bottle is then tightly sealed, placed in the drilling pipe, which is lowered into the hole. One of the bottles is placed every 200 or 300 feet in the drilling pipe, and after the entire length of pipe is lowered, it is allowed to stand for several hours. The theory is this: The vacuum bottle should hold the heat of the cooked gelatine for some time, keeping it in a fluid state until the entire length of pipe is in the hole. As the heat gradually radiates away, the gelatine will slowly congeal, and the angle the sur-

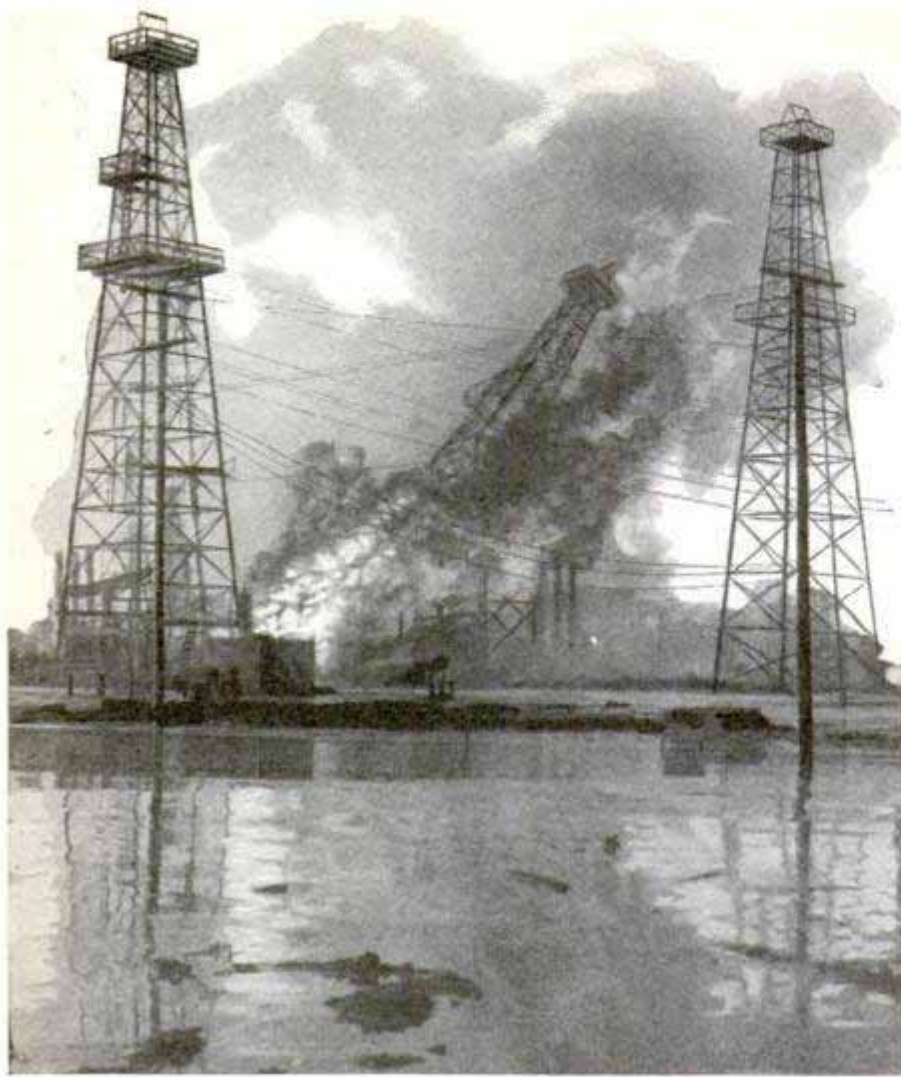

Getty Number 2, at Santa Fe Springs, Also Burned; This Photo Was Snapped Just as the Steel Derrick Melted and Crashed

face of the gelatine in the bottle forms with the perpendicular will give the amount, in degrees, that the hole varies from plumb. The magnetic needle which will become fixed in the congealed gelatine, will give an accurate check of the direction the hole is dipping.

In practice, this method is frequently a total failure. In some cases the heat encountered at increasing depths is sufficiently great to keep the gelatine in a fluid state, and in cases where the gelatine does congeal, the magnetic needle is in error, due to the attraction of the steel drilling pipe, or of certain minerals.

The second, and more successful, method of determining the deviations of oil wells, employs wide-mouthed glass bottles containing a solution of hydrofluoric acid. As in the case in which gelatine is used, the bottles are placed about every 300 feet in the pipe. After the entire length of pipe has been run into the hole, it is allowed

to stand for two hours. The acid has the property of corroding, or eating, glass, thereby etching in the glass bottle the exact angle at which the pipe in the hole is resting, thus giving the course the wandering oil-well drill may have taken.

Pilley and Sloan used the acid method to determine which well had so far wandered from its intended course as to infringe upon the property of the other.

Two hours passed, and the crew started to raise the pipe from the well, carefully labeling each bottle as it was removed. Finally, the engineers who were working on the figures pushed aside their scratch pads, indicating that they had finished.

"Who won?" shouted Pilley and Sloan as one man.

"You both lose," replied the engineer laconically. "The two wells

came together exactly on the dividing line of the properties."

Another problem in the oil fields is fire. After a two months' battle with a flaming oil well had been successfully terminated, engineers of a California oil company were confronted with the much more serious problem of extinguishing a three-million-foot gas-well blaze. Getty well No. 1, after causing a damage of nearly \$1,000,000, had hardly grown cold when the new outlaw well was brought in a few hundred yards away at Santa Fe Springs, Calif. The new well, known as Getty No. 2, came in with a terrific rush of gas, sending a geyser of mud and stones high into the air. A stone striking some of the metal work provided the spark that turned the well into a roaring inferno. The steel derrick melted and collapsed like spiderweb in the blaze. As there was little or no oil mixed with the gas, it burned with a brilliant white light that

could be seen at night from a distance of fifty miles.

The first fire had been snuffed out with a huge metal cap swung from a derrick on wheels, but in this case the heat was so intense and the pressure so great that some new method of fire-fighting had to be devised. A pipe line was laid to the well, and columns of mud and steam were forced upward into the flames, but this had little effect. Finally, a pit was dug 300 feet distant, and a tunnel was begun that would reach the casing at a point fifty feet below the surface of the ground. When the tunnel was completed, a large sleeve and valve were placed around the casing, and a hole was cut in the pipe. An

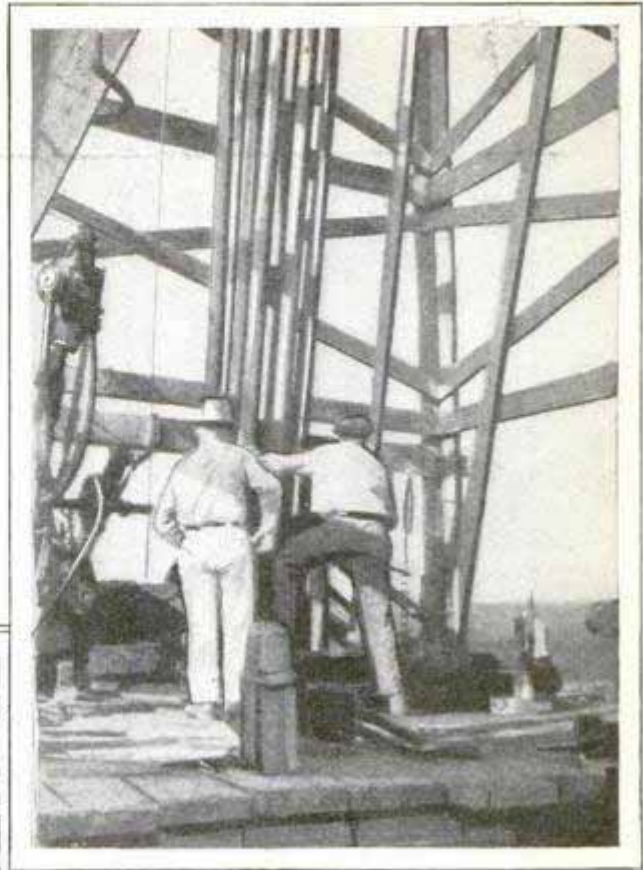

Lowering Sections of Drilling Pipe into a Well, Top, and, Bottom, a Close View of a Rotary Rig, Showing Stacked Pipe and the Mud Pumps

aluminum ball, slightly smaller than the diameter of the casing, was forced into the gas stream by means of the valve. As the hollow rotary drill was still hanging at the top of the hole, it was hoped that the ball would wedge itself into and around this smaller opening and effectu-

ally check the flow. Some idea of the great pressure may be obtained by the outcome of this attempt. The ball struck the end of the drill as expected, and it not only wedged itself in, but went on through the drill and out like a shell from a gun. Next a large inverted funnel of steel was dragged at the end of cables and placed over the mouth of the well. This increased the pressure at the outlet and lifted the flames higher above the ground, but did not sufficiently diminish the heat to enable workers to approach.

Finally, returning to their tunnel, the engineers laid an eight-inch pipe line to the casing and installed a large compressor and motor at the valve which they had previously placed. The motor was started, and the compressor, working at top speed, began drawing off a considerable portion of the gas and forc-

2145

Chas. A. J. Williams

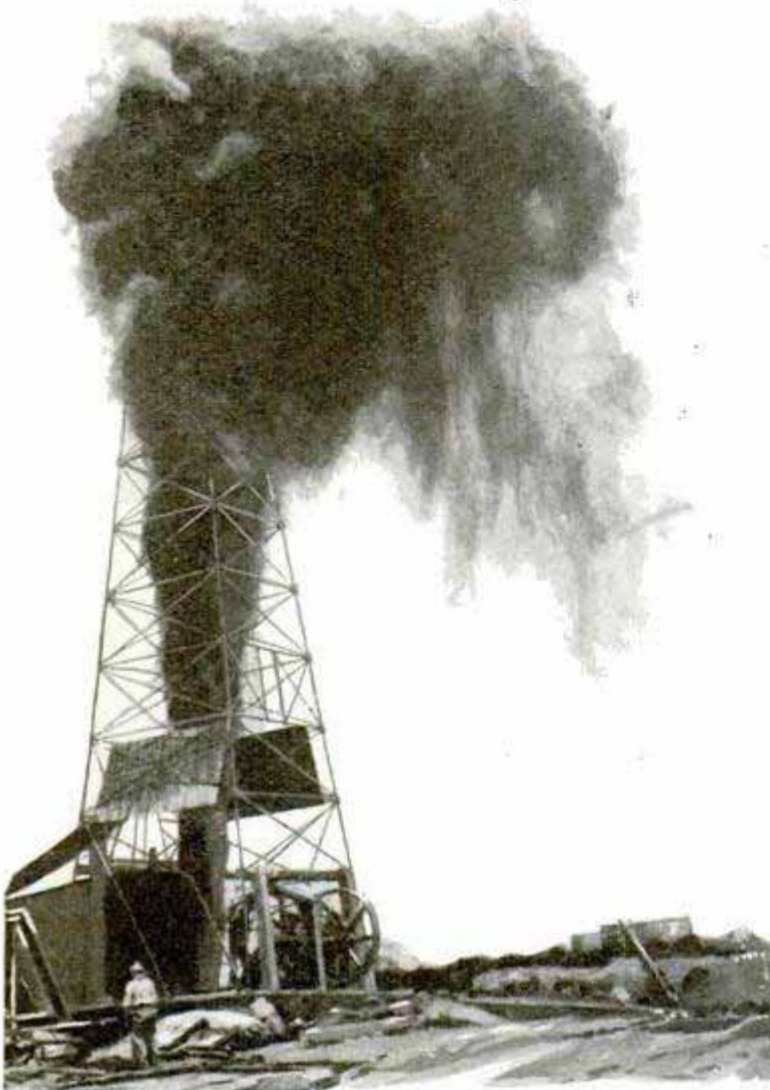

Not a Fire but an Oil Gusher, with Twelve Hundred Barrels an Hour Shooting High in the Air

ing it out into the company's lines. This plan eventually solved the problem.

The inverted funnel had lifted the flames to a height of twenty-six feet, and with the reduced pressure in the casing, the heat materially subsided. Three men in asbestos suits, protected from the blazing torch by streams of water and artificial wind from blowers, crawled to the control valve at the top of the casing and pried it loose. Companions, on the end of a thirty-foot bar, then were able to pinch off the fire as they drew the valve tight.

ART TREASURE SHIP GUARDED BY DESTROYER ESCORT

The very unusual sight of a destroyer escorting a ship, containing \$25,000,000 worth of art treasures and old Dutch

masters, was recently seen by watchers on the Tongue lightship in the estuary of the Thames, England. The ship—a Dutch Batavier liner—had loaded crates containing rare paintings and works of art into her hold, while two Dutch warships stood guard over the operations and lit up the Rotterdam quays with brilliant searchlights. One of the warships convoyed the ship as far as the mouth of the Thames, where she was handed over to the care of the British authorities. On the way, armed guards stood over the sealed hatches to prevent the operations of international thieves, who were suspected of having chartered a pirate steamer to make an attack on the liner, on the crossing of the North sea. The London custom officials waived the usual search on the quayside and accompanied the padded motor van, equipped with balloon tires and low wheels to resist vibration, to the exposition salon at Burlington House, Piccadilly. The motor was driven at a speed of only twenty miles an hour, straight out of the liner onto the wharves of the London docks, whence, with mounted police on either side and sharpshooters inside the van, it reached

the West End headquarters of the British Royal Academy, where the seals were removed from the crates. One of the Dutch paintings, Vermeer's "Head of a Child," is valued at \$500,000.

PENCIL ON EXTENSION CORD AIDS PHONE USER

2230

Attached to a wire cord that un-reels and winds up again, a pencil set has been introduced for the desk worker, phone user, and others. The pencil is kept from getting lost, is always in a convenient position, and the set occupies little space.



2063

Shake & Import Co
31 Union Square

**SEAPLANES SPEED UP MINING
IN CANADIAN FIELDS**

Canadian prospectors are taking to the air. Big planes, fitted with pontoons so that they can land on water, are carrying men, machinery and supplies far into the northern parts of the mining fields, traversing, in a few hours, areas that require two weeks or more by ordinary means of travel. In cold weather, the pontoons are replaced with skis so that the ships



Keeping the Airplane's Engine Warm in Winter; the Top Picture Shows a Simple Canvas Covering Serving as a Flue for a Heater; the Bottom, a Portable Workshop for the Mechanic

can land on ice and snow. Eighteen companies with more than sixty planes, are now serving the more recently developed mining districts in Canada. Flights have been made as far north as Fort Churchill on Hudson bay. One contract involved the transportation by air of thirty-five tons of supplies, diamond drills and other equipment with forty men. The air routes

save delays and the labor of portages and also have another advantage, greatly appreciated by persons who know the north. Soaring at rapid rate high in the air, the traveler is out of reach of the bothersome blackfly and mosquito, two insect pests that make life miserable in the north. Heated shelters are provided for the mechanics who look after the motors.

**SLEEPING IN THE UPPER BERTH
MEANS LONGER RIDE**

A traveler between Chicago and Billings, Mont., travels sixteen inches farther if he sleeps in an upper berth throughout the journey, than if he takes a lower, according to figures presented to the Pullman company by a Montana ranchman with a leaning for mathematics. The computation is based on the fact that an arc

of a circle with a radius equal to the distance of a Pullman lower from the center of the earth is somewhat shorter than an arc with a radius four feet greater. Actually, the ranchman went on to explain, the traveler in an upper does not gain the entire sixteen inches, as he does not spend all his time in his berth on a journey of that length. He estimated the added travel in nine hours in the upper berth at 7.6 inches.

*Emh. George J. Paul,
R.R. 537, Dearborn, Chicago*

RR

2343

*Christian Science Monitor
2/13/29*

2273
AUTOMATIC PAINTER FOR WALL SAVES DECORATORS' TIME
Hannover Germany

Home Crated in New York



Automatic Decorating Tool, Working Like a Grainer, Which Paints Designs Rapidly on the Walls

Artistic designs are quickly and accurately made on walls with the aid of an automatic painting device a German inventor has developed. It resembles somewhat the tool used to imitate the grain of woods and is easily operated. According to reports, it will do, in two hours, what would ordinarily take two days.

2342
MIRAGE SEVEN MILES IN AIR DESCRIBED BY FLYERS

Kansas City & Co

Ice caves, apparently hanging in festoons in the air, and decked in all the colors of the rainbow as the tiny ice particles broke up the sunlight, presented an awe-inspiring sight to two army flyers recently, when they rode a plane to an unofficial record height of 39,000 feet. Because they landed miles away from their starting point, Wilbur Wright field, at Dayton, Ohio, they cannot claim a record under the international rules which require altitude flights to end at the field from which they started. The flyers, Lieut. Harry Johnson, pilot, and Capt. Albert W. Stevens, the army's most famous flying photographer, blamed their failure to come down again within striking distance of their home field, when their gas supply ran low, to another phenomenon, exces-

sive visibility. Under ordinary flying conditions, the apparent horizon is 7,000 or 8,000 feet away, but in the upper air, after they had passed through the snow and ice clouds, visibility was so good they could see a distance estimated at 50,000 feet, and could not keep track of where they were. At the pinnacle of their flight, the temperature registered seventy-six degrees below zero. When the brilliantly colored ice clouds were sighted below, Johnson dived the plane into them several times, and to make sure of their formation, removed a glove and stuck his hand out of the fuselage, with the result that it was stung in hundreds of places by the tiny ice particles. Stevens also exposed one side of his face to the blast and acquired a bad ice blister. The plane used for the flight was an old army craft which has been the vehicle used in altitude-record flights for several years.

2020
AUTO RUNS WASHER PUMP FOR CAR CLEANING

Easily attached to the automobile motor and operated by it, a washing pump for cleaning the car has been introduced. It furnishes a strong jet of water, sufficient to remove mud and other dirt, saves time and work, and has few parts to get out of order.

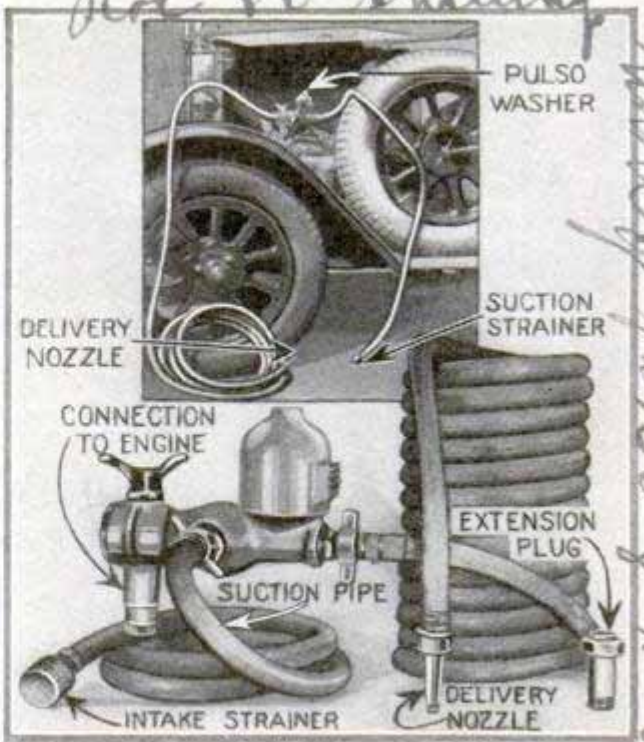

Attached in Place of One Spark Plug, This Water Cleaner Gets Pressure from Suction in the Cylinder

Head and Campbell Ltd. 75 Victoria St. N.B.

england
ready made 11/1/21

NEW PLAN FOR Channel Tunnel

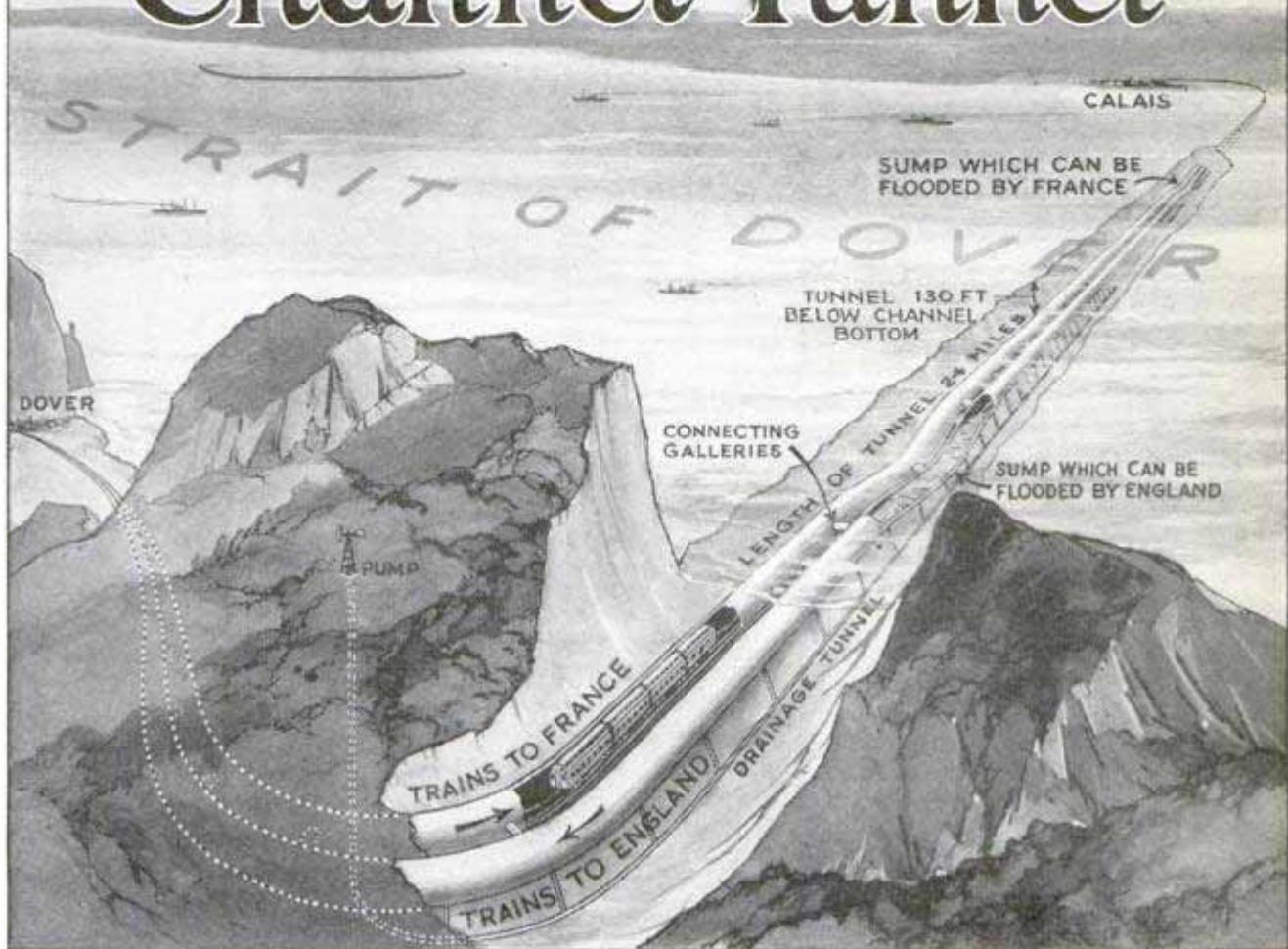

Artist's Diagram of the Proposed English Channel Tunnel, with Sumps near Either Shore to Permit Flooding against an Invasion, if France and England Should Ever Fight

PLANS which have been considered for more than half a century for a railroad tunnel under the English Channel, connecting France and the British Isles, were revived recently in the parliament, with a strong demand that the government authorize the work. A tunnel company has been in existence for many years, and construction of approaches was actually begun at one time, but stopped when the British army general staff objected.

The army leaders voiced the same objections again this time, claiming railroad connection with the mainland would imperil England in time of war and require a huge standing army to guard against a surprise attack by train, in event of war with France.

In answer, the tunnel proponents pointed out that the plans provide for a sump near either shore, so that either

England or France could flood a section of the tunnel at will, and prevent the other from using it, and that so far as danger to England went, a battery of long-range guns stationed along the French coast near Calais could bombard London as easily as the Germans bombarded Paris in 1918.

The plans being considered call for two parallel tubes, one for traffic in either direction, with connecting cross galleries at intervals for use in emergency. Smaller drainage tunnels would be sunk at a lower level, connecting with powerful pumps on shore. The length of the big bores would be approximately twenty-four miles, and the estimated cost of the project is in the neighborhood of \$150,000,000.

The main shafts would be 130 feet below the deepest part of the channel, and the bore would be through a layer of chalk

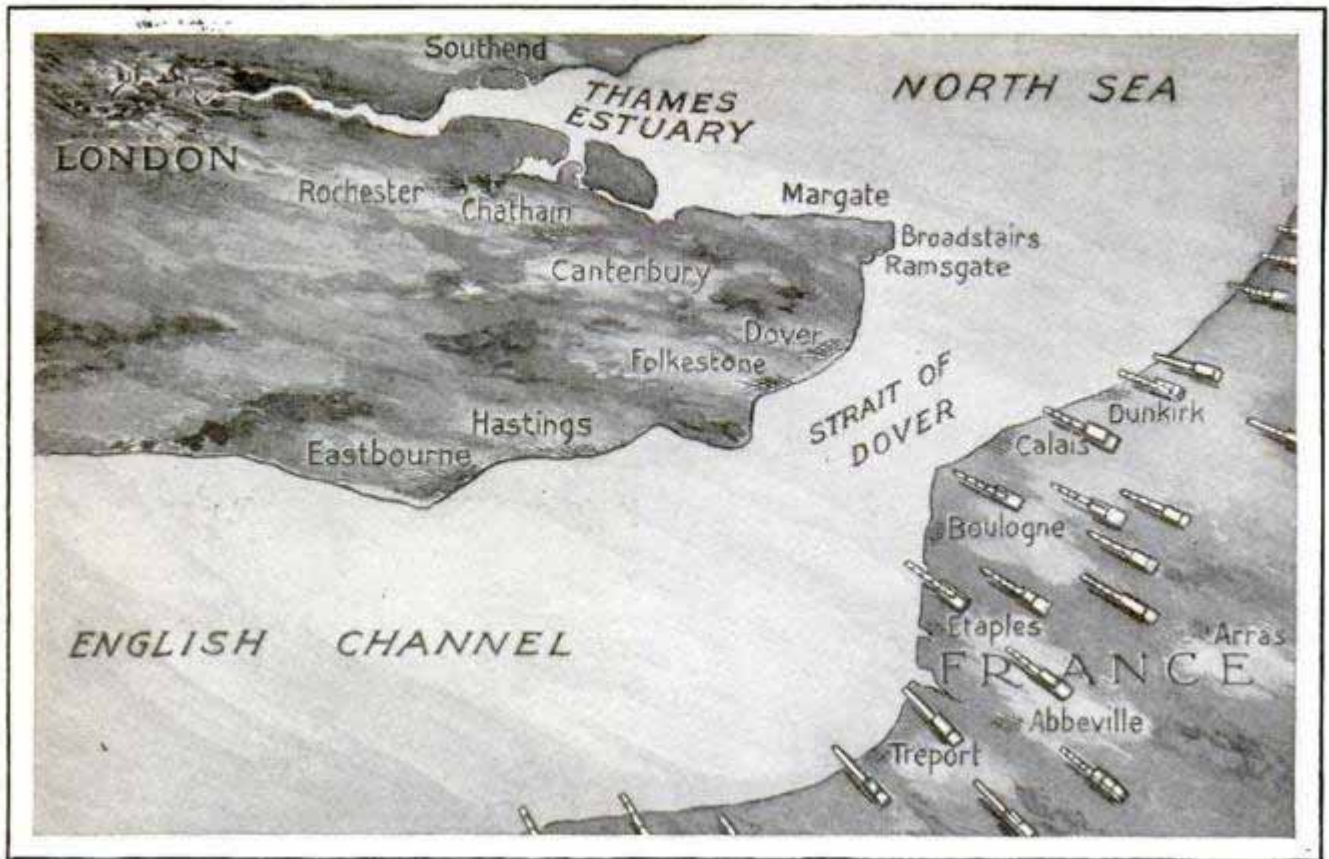

The Answer to the General-Staff Objections Is That Batteries of Long-Range Guns on the Calais Coast Could Shell London without Sending an Army across the Channel

marl that is almost impervious to water. Although about three times as long as the longest existing railroad tunnel, the project does not present any serious engineering difficulties.

Proponents of the scheme point out that it would eliminate the rough channel crossing, especially bad in winter; relieve the railroad companies of the expense of building and maintaining a fleet of fast channel steamers; cut an hour and a half to two hours from the journey between London and Paris, and provide an uninterrupted means of transporting troops to the continent and getting food into England in event of another war, as neither surface ships nor submarines could interfere with the tunnel trains.

Not all of the objections raised against the plan come from the general staff. The doctrine of England's "splendid isolation" was cited in some quarters, and the fear expressed that quick and comfortable train journeys would make England a holiday resort for hordes of more or less undesirable people, who would introduce foreign customs, deface the countryside and otherwise interrupt English habits of living.

Against this view, the friends of the project pointed out that the expenditure on the tunnel would do much toward relieving unemployment, particularly among miners, who could be used in the construction work.

GOLF TEE IS SET AT ANGLE FOR LONGER DRIVES

Inserted in the turf at an angle and so curved that it allows the ball to leave with less resistance, a golf tee now on the market is said to give longer drives.

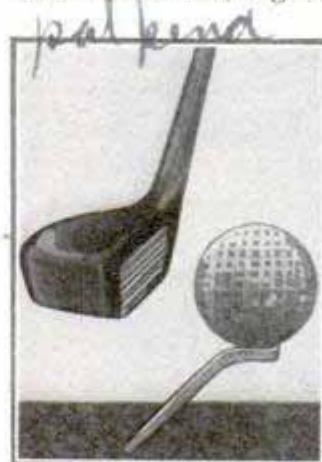

The club head strikes the arm of the tee, causing it to drop, leaving the ball suspended in mid-air where it receives the full benefit of the force of the swing. After the stroke, the tee is usually at its original position, since there is nothing for the club to catch upon.

*The Angle Tee Co
Cleveland*

TONS OF DRIED GRASSHOPPERS
FED TO ZOO ANIMALS

Two tons of dried grasshoppers were ordered from South Africa recently for animals at the National Zoological Park, at Washington. They were for the diet of some of the rare African birds and also for mixing with the food of some of the mammals, according to zoo director, Dr. William M. Mann. Valuable elements are combined in the proper amounts in the insects, experts have found, and few satisfactory substitutes for them have been discovered.

ROBOT RIDES RAILROAD TRAINS
TO TEST ENGINES

Housed in the cupola of a specially constructed steel coach, a mechanical man is riding trains of the Northern Pacific railway to show how locomotives behave while on duty. The apparatus checks and records, on each of its twenty-two fingers, an engine's reaction when under performance in drawing trains, and has been devised to save money for the railroad and, at the same time, increase the power of steam locomotives. The car is so equipped with delicate instruments that it will register the steam pressure, speed, air pressure and many other features which enable engineers to compute the actual pulling power of the locomotive. The "man" is at the head of the car, and as the train proceeds, a series of pens record on a roll of continuously moving paper, such data as drawbar pull, shock, speed, train-line air pressure, steam pressure, distance marks, stations, mileposts and other facts, so that a written picture of the engine's performance is obtained for analysis in combination with track conditions over the particular line and section where the test was made.

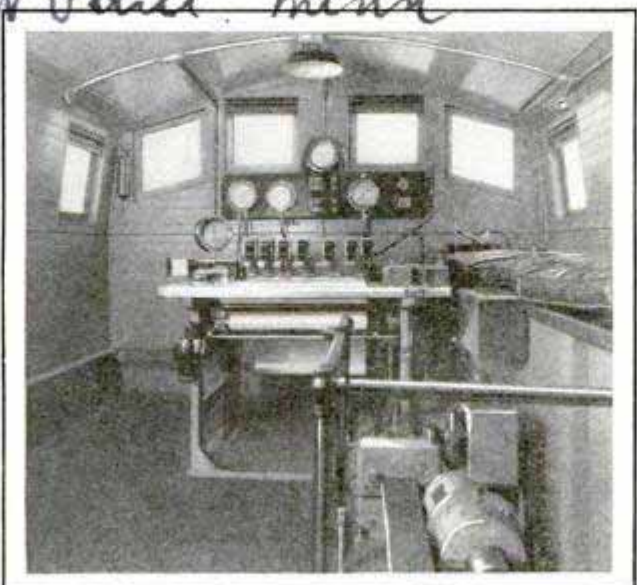

Interior of the Engine-Testing Railroad Car, Showing Chief Parts of the "Mechanical Man"



Front View of the All-Steel Building Erected in Essen, Germany; Note the "Groove" for Exterior Lighting

BUILDING OF NON-RUST STEEL
HAS NOVEL LIGHTING

At a street intersection in Essen, Germany, stands an interesting building that gives a hint of what the future city may adopt in place of masonry. It is constructed almost entirely of non-rusting steel, a material that has been used for some time in household utensils and surgeons' instruments but now is adapted to the building trade. An unusual feature of the structure is the vertical lighting arrangement on the front, whereby illumination is thrown up the grooved supports. Door and window frames, latches, etc., are also of the special steel.

*Steel Friedrich
Krupp, Essen, Germany
Turota*

*939 National Bldg
Washington, D.C.
2296*

2367

2371

St Paul mine

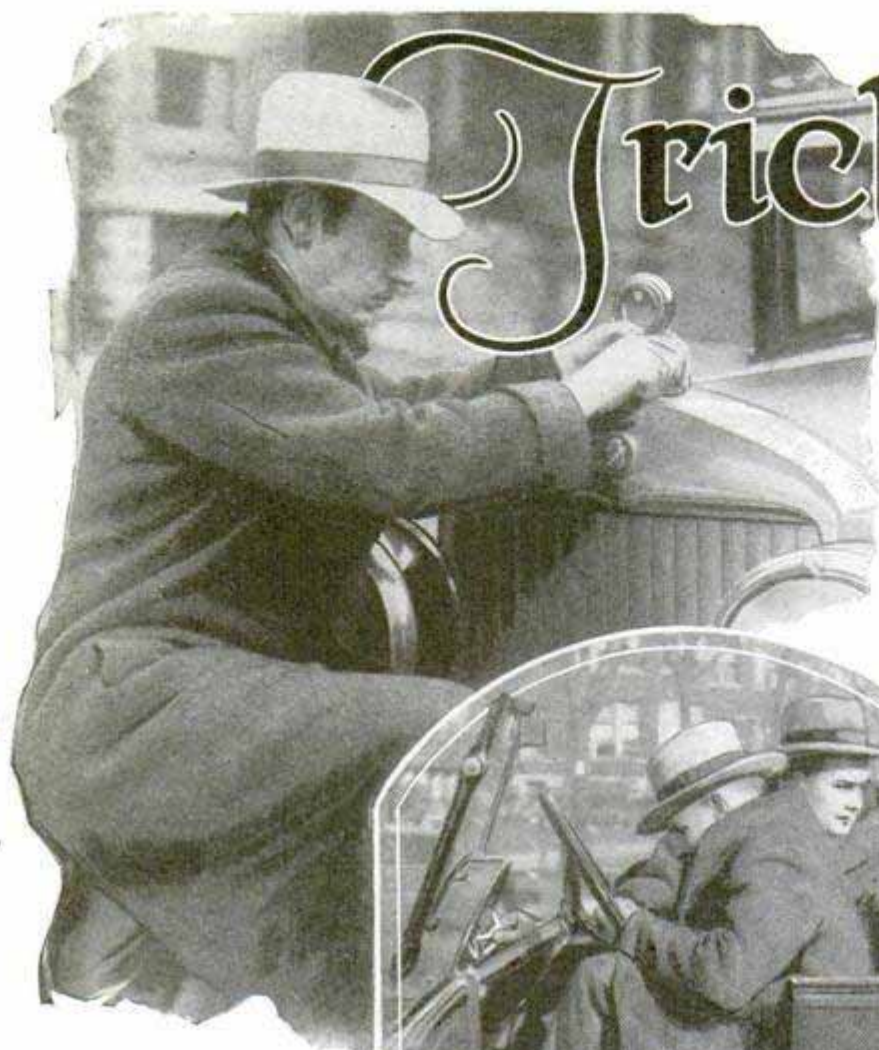

HE WAS proud of his automobile. It was one of the latest models and he had paid only about one-fifth the usual price for it. He enjoyed it for just three days, then a policeman called. "I'm sorry, Mr. Blank," he said, "that's a stolen car. We've found the owner."

This happened to a business man the other day, a man known for his shrewdness and for his absolute honesty. In an unguarded moment, he had neglected to "look his gift car under the hood." If he had, he might have discovered that the serial number had been altered. The digit 3 had been changed into an 8. But he had not suspected that anything was wrong, and the bargain had been too good to overlook. So he lost the car and what he had paid for it.

Carelessness on the part of buyers of secondhand cars, in the opinion of Lieut.

John J. Farrell, head of Chicago's stolen-automobile section of the detective bureau, is one of the chief reasons why automobile thieves prosper as they do. Some 200,000 cars are officially reported stolen each year. Possibly eighty per cent of them are recovered. But insurance companies have found that the average loss on a car, "just taken for a joy ride" and then returned, is about \$150. Conservative estimates place the yearly net loss through automobile thefts, simply on cars



Thefts of Accessories Cost Motorists a Fortune Yearly; Center, Unlocking Car with Duplicate Ignition Key

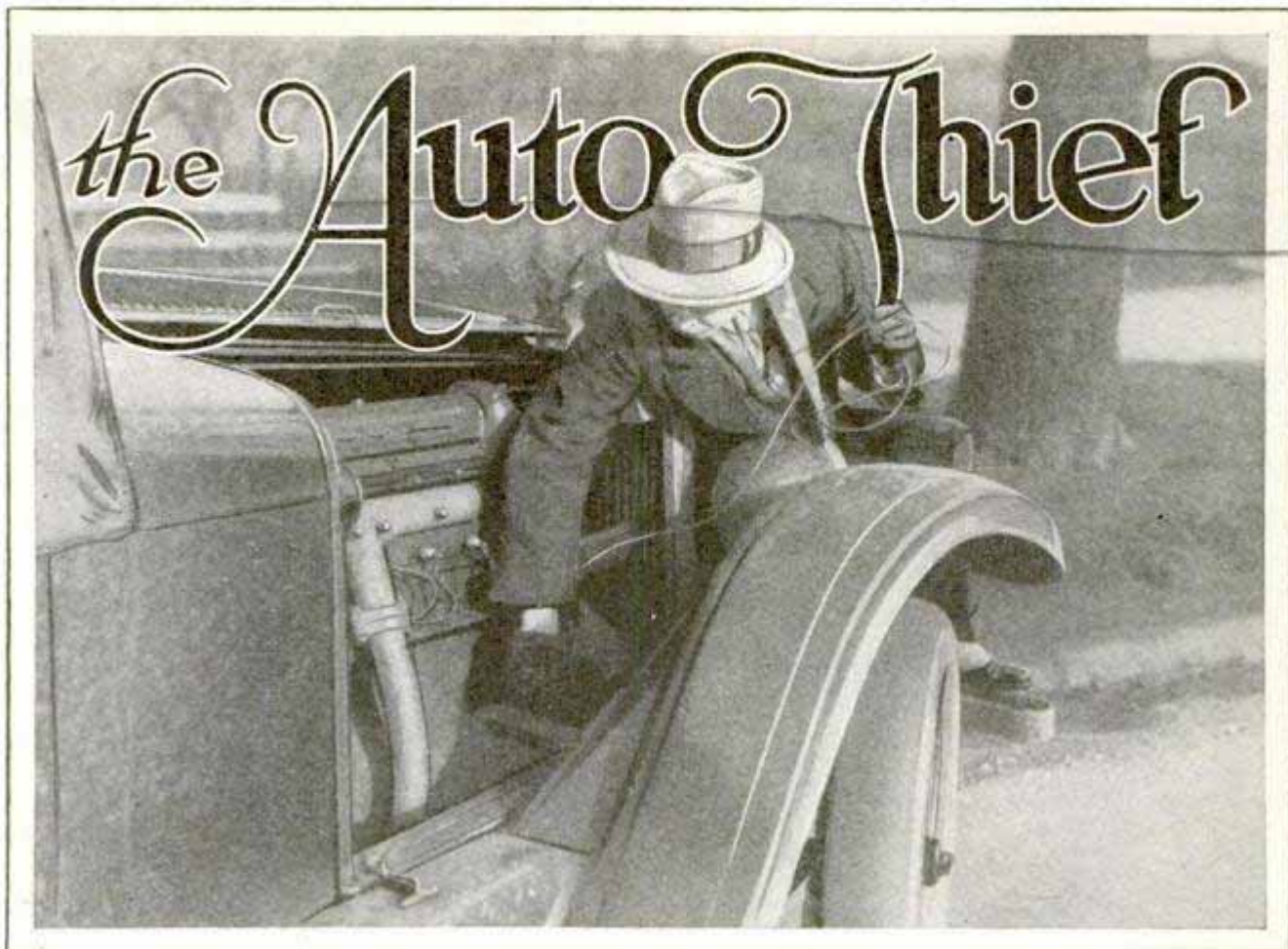

Another Way of Doing It; "Jumping the Ignition" by Placing a Wire across Ignition to Spark Plugs and Operating Car without Resort to Ignition Key

reported, at more than \$50,000,000. Add the estimated number of stolen cars not reported, and the grand total doubtless is well in excess of \$100,000,000. And this in a country where, but a few years ago, it was common to lynch horse thieves!

"It is curious," said Lieutenant Farrell, "but a man will cheerfully pay as much as \$1,500 or more for a used car, if he thinks he is getting it at a bargain, without satisfying himself whether it is stolen. But in the case of a building lot, for instance—something that cannot be driven away or lost—he will go to elaborate trouble to investigate the title, even if the land costs but a few hundred dollars. If the second-hand automobile buyer would beware, thieves would find their business cut in half. They steal to sell and they can sell, because, as in the case cited, the buyer rarely makes a thorough investigation as to the title of his purchase.

"Of course, the greatest vigilance will not detect every stolen car. But anyone can exercise a few simple precautions. Try to know something about the dealer.

Find out how long he has had the car. Don't be too eager to purchase one that has just been driven in. Ask for the bill of sale the dealer received when he bought the car. If you doubt any of the numbers, have them examined by an expert. Some of my men are so efficient in this that they can detect a forgery simply by running their fingers over the figures.

"Call your police department and ask if they have any report on the car. If you care to go to further pains, ask the same of one of the automobile-theft bureaus. There are five big ones that cover the entire country. They have records of every car reported stolen by their clients. If you still have doubts, write the manufacturers, giving the engine and other numbers that you find. They will compare these with their records and, if any discrepancy is found, an investigation will be in order, for all car numbers, including the so-called 'secret numbers' on obscure parts, and in other places where the average layman or mechanic never sees them, are issued in a prearranged system, that

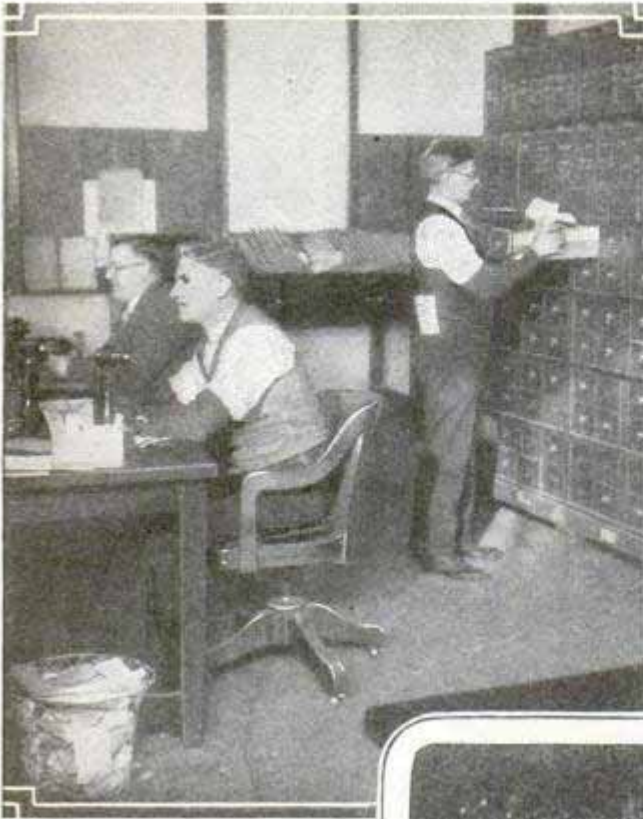

is, a certain serial number will accompany a certain engine number, carburetor number, and so on. Any change, therefore, is easy to detect. Every number should agree with the original sequence unless there have been alterations.

"There is no such thing as a thief-proof car. If they want your automobile badly enough, the thieves may break open your garage and truck it away or adopt the same method if it is on the street. Thieves sometimes have service trucks and pose as legitimate repair men. If they take your car and are detected, they plead a mistake, or say that they were ordered to get the car but confused it with another one of the same make and model that may or may not have been standing close by. If the steer-

ing wheel is not locked, one crook may break open the door, get in, and steer while a confederate, in another car behind, will push your car down the street, into an alley and, perhaps, into a garage where it is dismantled or disguised for sale. This method is called 'kissing them away,' and it is worked almost every day. It pays to have a good locking system, however. A lock that secures both the steering gear and the ignition is one of the most effective.

"A favorite scheme of the thieves is to operate in a party of four, two men and two women. They go to a fairly large-sized city, register at a good hotel and, the next day, the men appear at an automobile dealer's where the make of car in which they are interested is sold. Re-

member, practically all the thief rings specialize in certain makes of automobiles and rarely will bother with others. The reason is that they are especially equipped to disguise just those and no other kind, and they also find quicker sales for certain makes, especially new cars.

"The men explain to the dealer that they are driving to the coast

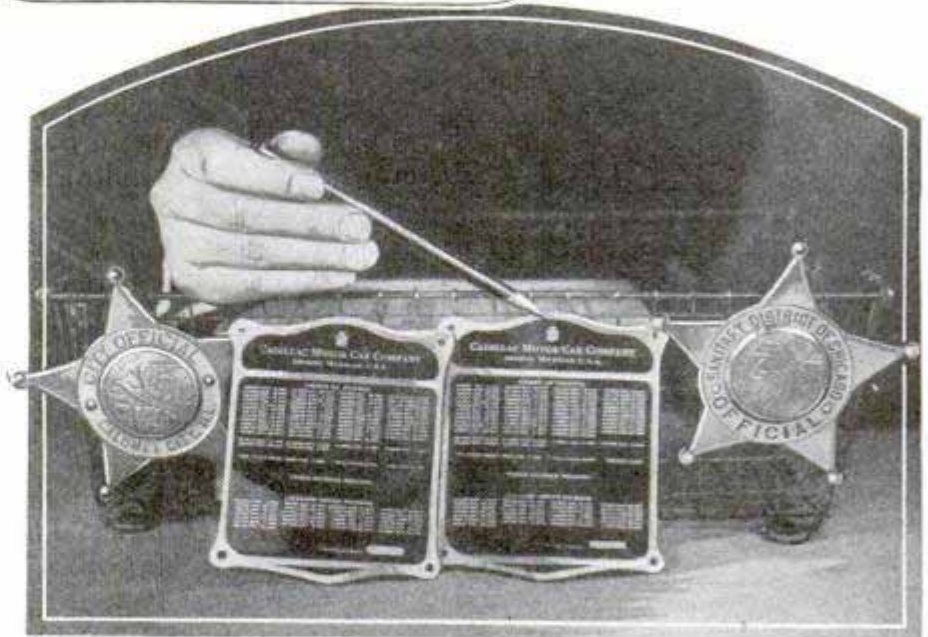

Interior of Stolen-Auto Division, Chicago Detective Bureau; Motor-Block Numbers Restored by Heating, and, Bottom, Trappings from Stolen Cars; Pencil Points to Counterfeit Plate; Thieves Sought Immunity with Stars

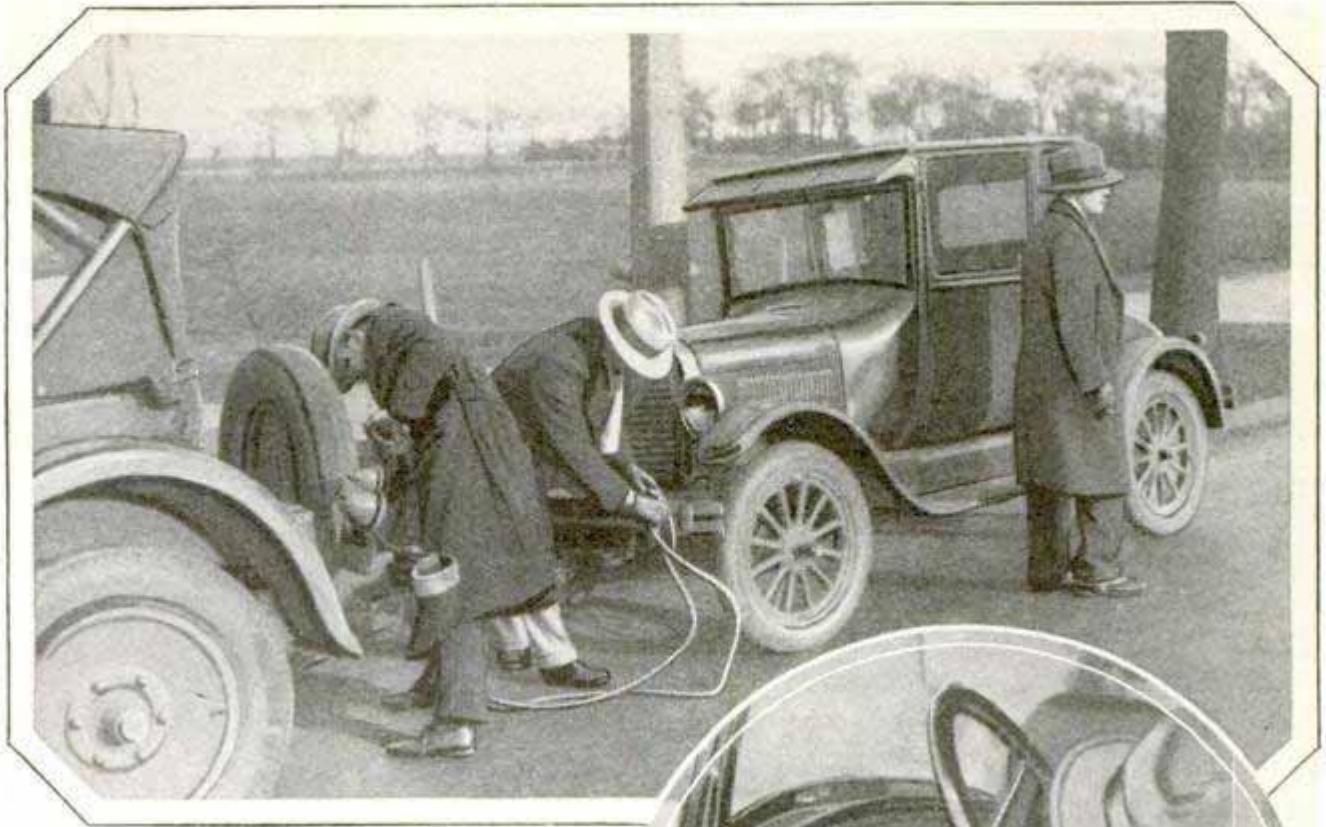

Thieves Towing Away a Parked Car and, at Right, Breaking a Gear-Shift Lock

from New York. Their own car broke down, and since it will take considerable time to repair it, they have concluded to purchase a new car and continue their journey without delay, they say. The salesman shows them a late model and is doubly pleased when his customers agree to pay cash in full. They give their hotel as their address, explaining that they do not expect to return to their New York homes for some time. Just after the bill of sale is made out, No. 2 of the duet, who, up to this time, has let No. 1 do most of the talking, goes into action. 'Say, Jack,' he exclaims, 'hadn't we better telephone the womenfolks and let them know we've bought the car and arrange to meet them somewhere?' 'Good idea,' No. 1 replies. 'May we use your telephone, Mr. Salesman?' The request is naturally granted, and as No. 2 takes his seat at the desk, No. 1 steers the salesman to the rear of the store. No. 2 watches his chance and, as he telephones, stuffs a number of the company's bills of sale into his pocket. Then he joins the others, and soon the men drive away with their car.

"But they do not go to the hotel. They already have chosen a garage somewhere

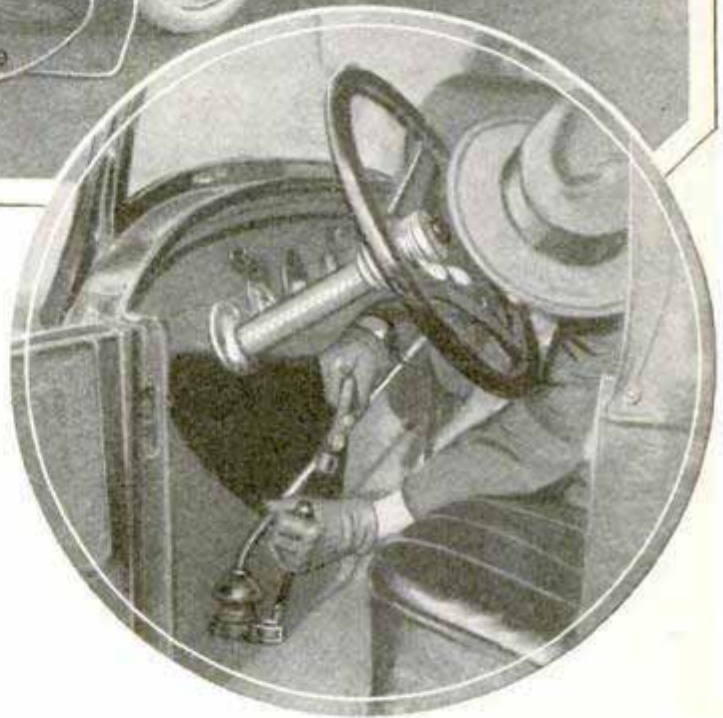

for their headquarters, a private one for which they have the only keys and on which they have paid a month's rent. The new car is stored there and, perhaps that night, the enterprising crooks go out and steal a car, as new as possible and of the same make and model as the one they purchased. Engine number plates and other parts are taken from their car and placed on the stolen one. In a day or so, they have an alluring bargain for some unsuspecting purchaser. If he asks verification of ownership, he is shown the bill of sale and cheerfully referred to the dealer. 'Why, yes,' the merchant says, 'those gentlemen were in here a few days ago. I sold them that car, gave them the bill of sale and everything is all right.'

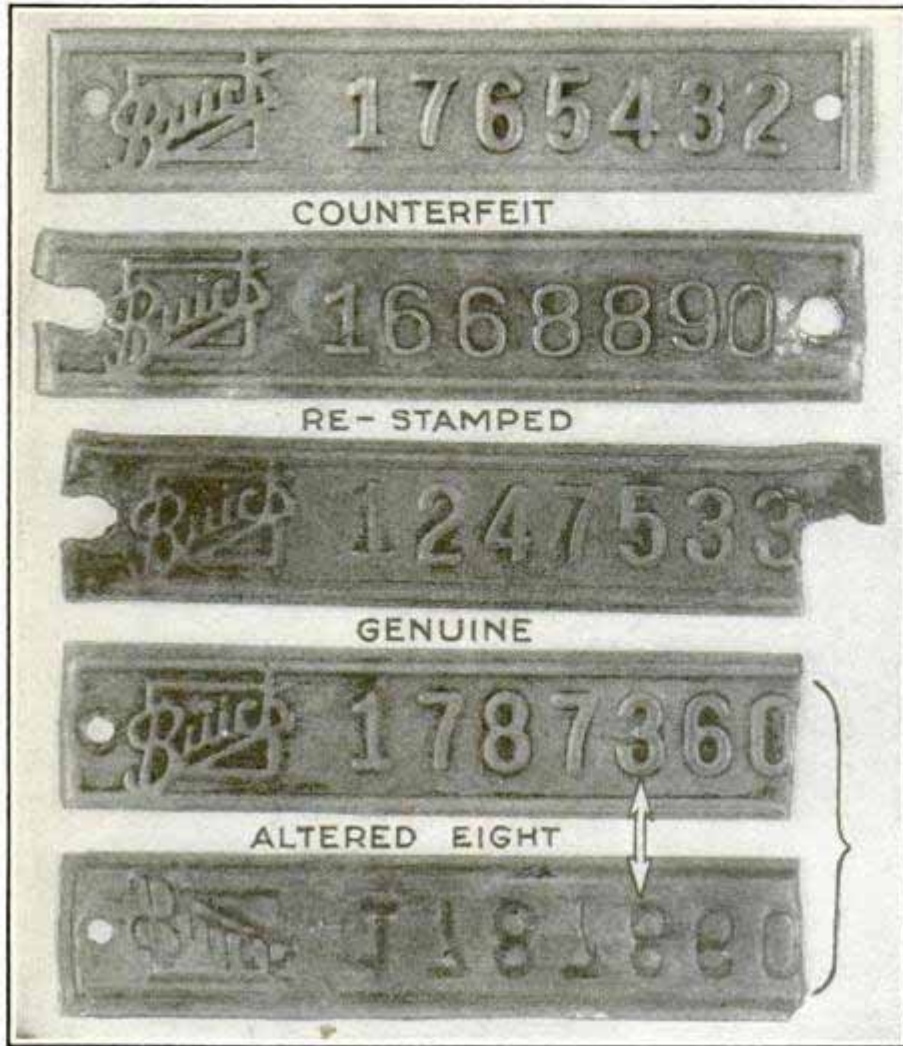

Sample Numbers Showing Counterfeiters' Skill; the Altered Figure Eight at Bottom Was Not Discovered Until Tag Was Removed

"A sharper will purchase a car from a dealer, make the first payment and then let the next lapse. The finance company advises him that the car will have to be taken back unless the account is brought up to date. The crook steals a car of the same make and model, and as nearly the same age as the one he bought, switches numbers, leaves the stolen car in front of his house and hides the one he bought in a garage. The next morning, the stolen car is hauled away and a week or so later, the crook appears in the first car. He may drive it for several weeks before the fraud is discovered.

"More careful investigation of secondhand cars before purchasing, always locking both steering gear and ignition, prompt reporting of the fact when the car is

The scheme rarely fails at this stage, for the bargain is too tempting and, so far, the purchaser has no reason to suspect fraud. Possibly the stunt will work four or five times in the same city before the thieves decide to go on to other fields. Counterfeit numbers are placed on each stolen car to agree with the original numbers on the bills of sale.

"Some thieves make a specialty of buying wrecked or burned cars as junk. They receive a bill of sale, salvage parts which they place on stolen cars, and so disguise the finished automobile as a legitimate car for which they have the bill of sale. Occasionally thieves visit a railroad yard where a shipment of automobiles is being unloaded. They drop a battery and an emergency tank of gasoline into one of them and drive it away. Sometimes the car is sold before the dealer realizes that it is missing from his lot, and he is naturally incredulous when the police tell him that the car has been stolen.

stolen, and more vigorous prosecution of automobile thieves when they are caught; these and other methods will help to cure the stolen-car evil. The situation today is bad, but there is room for hope. For instance, eleven of the largest middle-west cities reported 32,291 cars stolen during the first nine months of 1928. That was a large number, but still it was 4,259 less than during the same period of 1927, in spite of the great increase in the total number of automobiles in use. Several cities made a creditable showing. In Chicago, 1,308 fewer cars were stolen and the recoveries mounted to ninety per cent. In Detroit, there was a decrease of 5,940 in the number of auto thefts. This means that cities are learning the ways of the automobile thief, fewer thefts will result in cheaper insurance rates and eventually there will be a decrease in crime of all kinds as a result of the curbing of the auto thief, for in most of the major offenses, such as murders and big holdups,

the stolen car is an important factor." E. L. Rickards, secretary and manager of the Automobile Protective and Information bureau in Chicago, one of the five big divisions under the National Automobile Theft bureau, sees a cure for the situation in better state laws that will demand certificate of ownership and proper registration of titles, together with complete record of serial and motor numbers of all cars registered, properly recorded and indexed, and an interchange of information on stolen cars by the various state departments.

"A man or woman who leaves his car unlocked and unattended, is committing an offense against society," said Mr. Rickards.

RACK FOR MAGAZINES HOLDS MANY BACK NUMBERS

2250

Several advantages are claimed for a magazine-filing cabinet that keeps the latest issue in plain sight, and where it easily can be grasped, besides providing space for back numbers. It consists of a series of drawers, one for each magazine. The late copy is supported on the outside and the others are obtained simply by pulling out the drawer which is open at the top and one side. The file is made in three sizes.

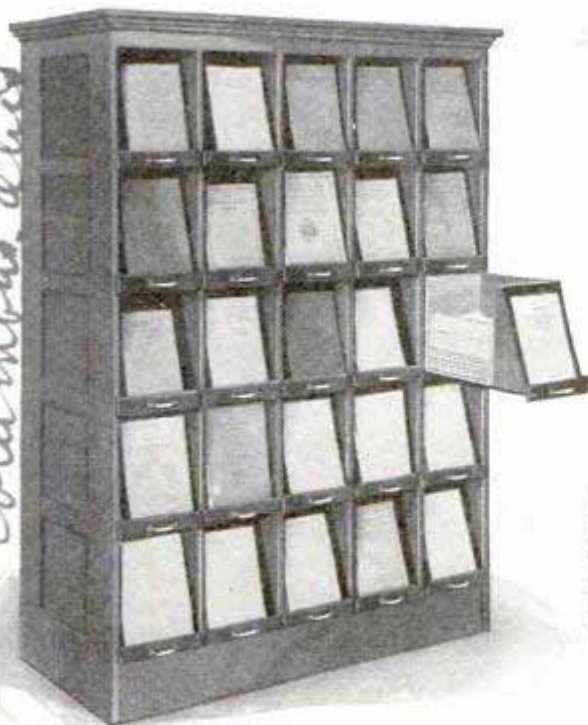

Novel Magazine Rack Displaying Current Numbers in Front, While Back Copies Are in Drawers

*Ohio State University
Columbus, Ohio*

*Dr. Lee Henderson,
Dept. of Psychology*

*2264 W. 4th St. Chicago
744 B. Over Ave
Chicago
Rochester, N.Y.*



Painless Eyebrow Plucking with Spring Tweezer Which Gives a Sharp Jerk When Button Is Pressed

TWEEZERS PULL WITH SPRING TO REDUCE PAIN

Spring tweezers that give a short, sharp jerk when a little button is pressed, have been introduced as an improvement over the usual type. They make extraction of hairs practically painless, as the spring pulls faster than is usually possible by hand methods. After the spring has once been released, it is quickly set again, and the entire operation can be executed with one hand.

GIANT TIMBERS ARE SHIPPED ON SPECIAL CARS

232

Shipping thirteen giant timbers for a new dredge being built at Parkersburg, W. Va., required special preparation by the railroads handling them recently. Each of the timbers, cut from 200-foot fir trees, was 102 feet in length and eighteen inches square. To handle them, three flat cars were used, and the timbers were supported on cradles pivoted on the two end cars, without touching the center one. In this way the timbers were free to move so that the cars could take curves without difficulty or danger.

*Truman Lumber Co
Chicago
332 S. Michigan*

Kanawha Sand Co

Hollywood change... Station, La Angeles, Calif



Vanity Case in a Ring: the Set Tips Back to Reveal a Mirror and a Small Amount of Rouge

RING THAT HOLDS ROUGE STICK ALSO HAS MIRROR

Underneath the setting of a ring now on the market, is a small compartment for lip or face rouge. The setting tips back as a lid, and the underside of it is fitted with a mirror, so that the ring serves as a small make-up outfit.

TO MAKE RUBBER PLANTS PAY IS REAL PROBLEM

There are easily 1,200 species of plants in the world that have rubber in their veins, as Thomas Edison said in his recent birthday message. There are probably nearer 12,000 such species, if we take into consideration all that have even a little rubber. The problem is to make any of them pay, and especially to make any of those that are hardy in temperate climates into paying sources of the gum that bounces. If Edison's hopes of establishing rubber plantations in the United States are to be realized, either hardy forms of the present rubber-yielding plants of the tropics will have to be evolved, or certain rubber-yielding plants native to the tem-

perate zones will have to be bred up to a point where their rubber content will pay for its own extraction. All the present rubber trees and vines are warm-climate plants. The Para rubber tree, Hevea, which now produces by far the larger part of the world's crop on the East Indian plantations, is decidedly a tropical form. It will just consent to grow in southern Florida, but will not grow for money unless it is permitted to hug the equator. It is out of the question for the United States proper, though it would thrive in the Canal zone and the Philippines. In our own semiarid southwest, and more extensively in the adjacent states of Mexico, there is a native bush, the guayule, which contains rubber in paying quantities, but even this native rubber plant requires the desert heat for profitable growth and holds out little hope of becoming adapted to the colder north. There remain native plants like the milkweeds and dogbanes, which yield a milky juice containing a little rubberlike material. These are hardy enough for the north, but their content of resilient gums is so low that it would be a bold undertaking to try to make them into commercial sources of rubber, even with the best methods now at the disposal of the plant breeder.

SKATES FOR CHILD'S SCOOTER AID WINTER SPORT

In a few moments, the child's scooter may be converted into a vehicle for winter sport by the addition of special skates now on the market. They are said to operate effectively on either ice or snow, permit quick turns in safety, and allow considerable speed.



Adding a Pair of Special Skates to a Scooter, in Place of the Wheels, Turns It into a Sled

Science Service Bulletin 412. B3

Merchant Service

Grand Pacific Hotel Long Beach Calif

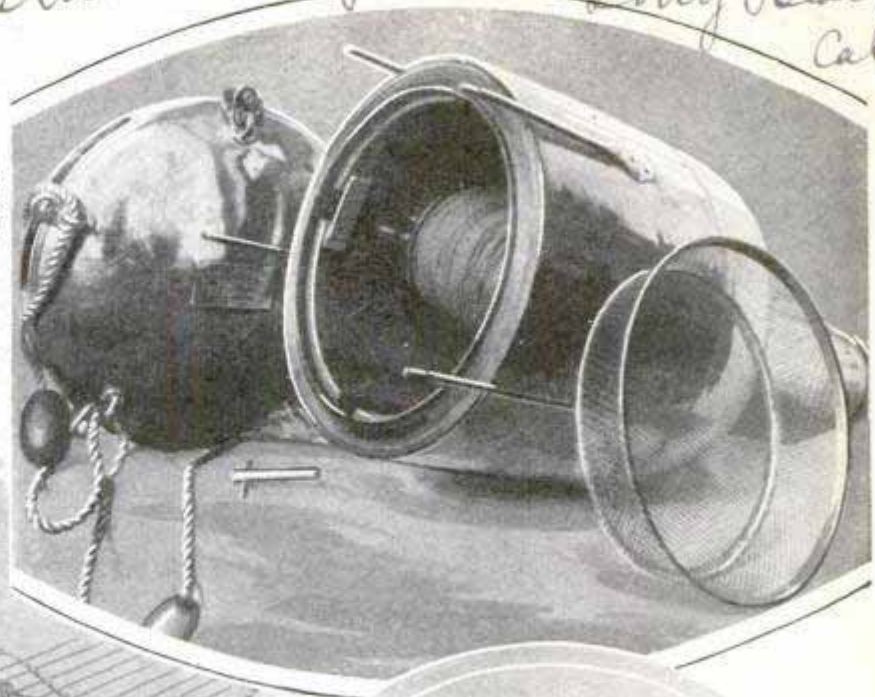

Close View of the Rescue Buoy; Cover Removed to Show the Reel for the Life Line and Space for Other Articles; Right, a Launching

BUOY TO CARRY LIFE LINE AIDS IN RESCUES

One of the most difficult tasks in effecting rescues at sea—getting a line to the distressed steamer—is simplified by a special buoy that is put overboard from the rescuing boat and is allowed to be driven by the wind and currents to the wreck. Besides the line, contained in a chamber inside, the float has a calcium light for night work, a container for the ship's log and other valuable papers, and is so constructed that it will anchor itself in sand or among rocks. The line is played out from a reel within the buoy itself.

REFRIGERATION IN DEEP MINES TO AID WORKERS 23 70

Artificial refrigeration, which is bringing greater comfort to thousands of persons in homes and public buildings each year, is to be extended for the benefit of the workers in deep mines, it was announced recently. Ventilating engineers point out that the present depth limit for successful operations in metal mines is

approximately 8,000 feet, as proper atmospheric conditions cannot be maintained at greater depths. Air, circulated from the surface to the deep workings, is heated by compression and by the heat of the rocks which is given off in increasing quantity as the depth increases. By placing specially designed refrigerating and air-treating units underground, near the workings, to cool the air and rob it of dampness, mining can be carried on at greater depths, it is predicted. Interesting tests have shown that when the temperature is over ninety-four degrees Fahrenheit, the wearing of clothing is beneficial, as it promotes cooling through greater evaporation, and is therefore recommended to workers in deep mines.

A. W. Waterfall, Newark, N. J.
before American Institute of Mining

2190 Ave James N. Miller
1906. H St. NW, Washington
DC



The Quarantine Officer Boarding a Ship Via a Rope Ladder to Inspect Passengers and Crew

Fighting Mysterious

tists of the service; Malta fever, which is spread by human contact with infected goat's milk, a disease which Dr. Charles Nicolle, recipient of the 1928 Nobel prize for medicine, says is the malady of the future; tularæmia, rare and serious ailment passed on to man by wild rabbits, flies and ticks; loathsome leprosy, age-old scourge of mankind, and our familiar "flu."

Not all these diseases are strikingly fatal, at least in an immediate sense, yet each one possesses characteristics so mysterious as to puzzle the best-trained minds of the medical fraternity. Considering the wealth of Doctor Goldberger's experience, which brought him into intimate contact with other dangerous maladies, such as yellow fever, typhus, and the peculiar, bone-breaking dengue fever, the wonder is that he was able to survive so long as he did. Indeed, long before his recent fatal attack, which certain experts believe may have been an ailment akin to pellagra, Doctor Goldberger three times fell a victim to diseases upon which he was conducting experiments.

JUST a short time ago, an ailment which science is unable to classify snuffed out the life of Dr. Joseph Goldberger, of the public health service, whose army of research workers aims to control the rise and spread of harmful diseases.

Those high up in the medical world are saying today that Doctor Goldberger's career represented in the very highest sense the adventure and extreme danger that is typical of the everyday existence of his colleagues. Continually they are called upon to handle germs of strange maladies that threaten the lives of men—maladies such as pellagra, a nutritional disease that wiped out hundreds of thousands in America before Doctor Goldberger found the remedy; Rocky Mountain spotted fever, which has killed seven scien-

Probably the most mysterious thing about pellagra, an ailment upon which Doctor Goldberger worked fourteen years, is the fact that, although it evinces certain prominent characteristics of anæmia, or a distinctly undernourished condition of the body, it has been hard to diagnose. Pellagra has been known for almost 200 years, notably in Spain, northern Italy, Egypt and the Balkans, but it was not discovered in America until 1908. Immediately the American health experts set out to find a possible cure, working on the already established premise that some sort of faulty diet mixture was the cause. But it was not until a few years ago that Doctor Goldberger met with success. Having been assigned to study pellagra in the south, he managed to gain permission to use human subjects for his tests. This done, he put the subjects, a group of Mis-

Diseases

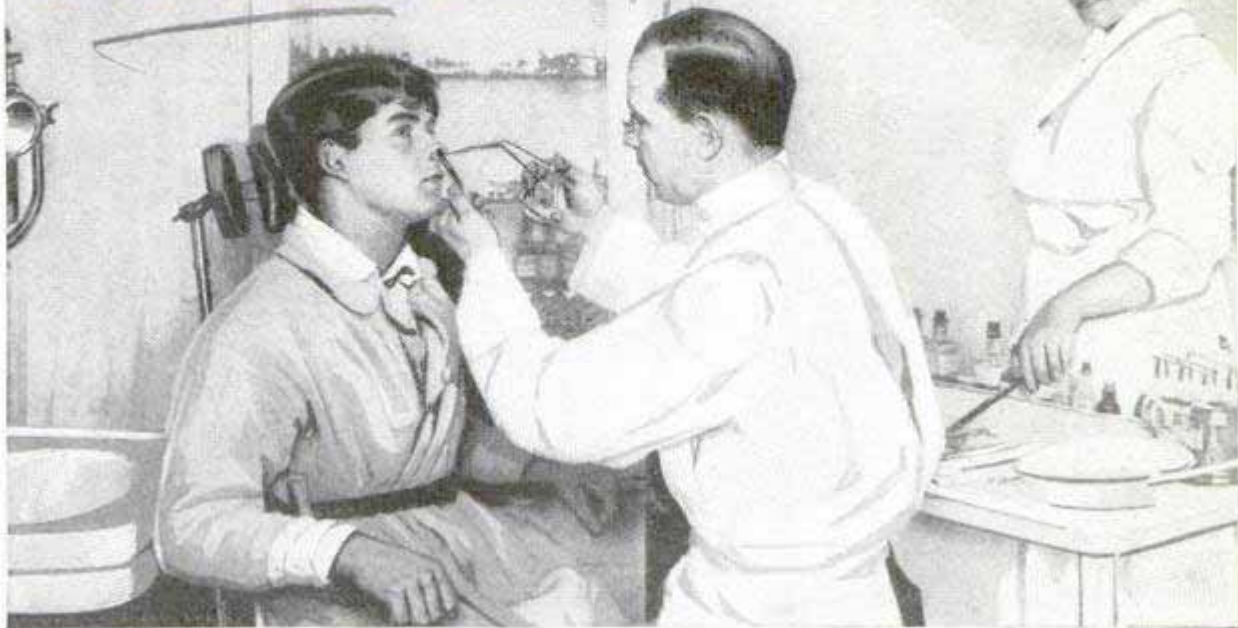

Treating a Patient at the United States Marine Hospital, at Stapleton, N. Y.; Marine Hospitals for the Care of Sailors Are Operated at Many Points on the Coast and Great Lakes

Mississippi convicts, on a special diet of corn-bread and bacon, designed to produce the disease. Successful here, not long afterward Doctor Goldberger discovered his world-famous cure in the form of the vitamin PP, or pellagra preventive, a substance obtainable in ordinary dried yeast.

Rocky Mountain spotted fever is far more fatal than pellagra. In fact, the patient hasn't a chance to survive unless he is so fortunate as to rally after surviving seven days' exposure to the disease. So we are told by Dr. R. R. Spencer of the service, and he should know since he is regarded generally as having done more important research in the disease than probably any person now alive.

Strange to say, the virulence of this ailment varies sharply according to the locality. In certain sections of Montana, for instance, the mortality has been eighty to ninety per cent, while in a near-by state the death rate is considerably less. As to how the disease manifests itself upon the human body, even those of us who have had smallpox may well afford to smile with relief rather than gamble with the grim reaper by risking getting an infection accompanied by severe chills and fever and characterized by a disagreeable,

turkey-red rash that covers the victim from head to foot.

It was Doctor Spencer who helped develop a preventive for this terrible malady a few years ago, and to say that he has risked his life in this connection is by no means overstating the facts. Even today there is no remedy for spotted fever, so if a man contracts it he goes to bed and prays that in seven days' time he'll still be alive.

In explaining how he was able to devise his preventive, now widely used as a vaccine, Doctor Spencer tells an absorbing story. Working with R. R. Parker, special entomological (bug) expert of the service, he paid particular attention to the behavior of the malady on small rodents to whom it is spread by ticks which likewise bite men. Since one attack of the disease apparently develops immunity, the possibility of a vaccine suggested itself. However, right here a difficulty presented itself, for it was found that the virus could not be cultivated in a test tube.

Therefore the scientists, noticing that the virus was developed and kept alive in the bodies of the ticks that transmit the disease, decided to make artificial test tubes of the wee crawlers and prepare the

specialist in malaria

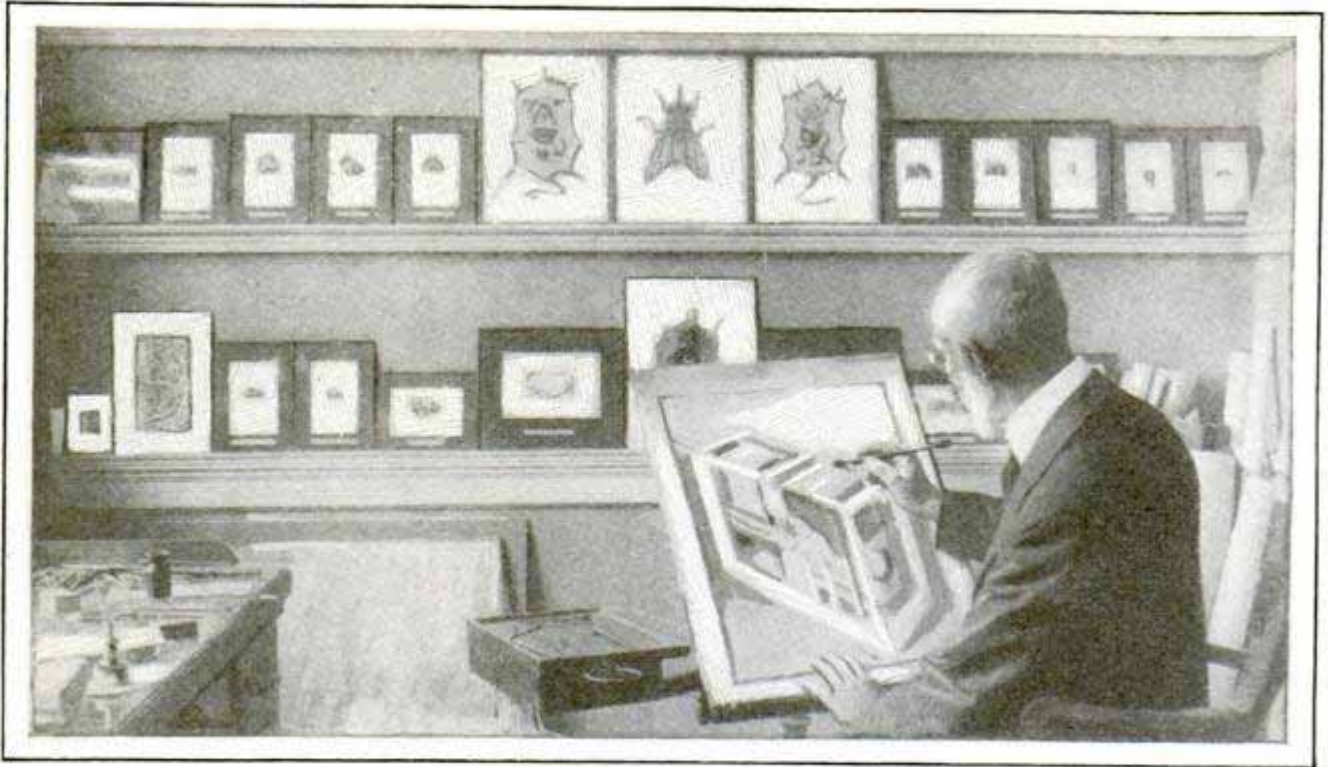

The Artist's Room at the Hygienic Laboratory; Uncle Sam's Doctors Not Only Treat the Sick but Contribute Largely to the Advancement of Surgical and Medical Knowledge

vaccine from them. The best procedure was to let the ticks feed upon infected guinea pigs until they had become thoroughly infected themselves. Whereupon, when tests showed the virus to be in highly concentrated form, the crawlers were ground up, and an emulsion prepared that would serve as a vaccine.

Tests on animals indicated that the vaccine might work, and now came the most important question of all, how would it affect human beings? Certainly the investigators were not going to risk the lives of outsiders, so Doctor Spencer, without the slightest hesitation, first of all tried out the new preventive on himself. Fortunately, he suffered no ill effects, and six months later his colleagues followed suit.

Since Doctor Spencer's gamble with death, there have been some highly interesting developments. Within the past few years, nearly 4,500 people in the Rocky Mountain district, mostly shepherders, who are exposed to the disease very frequently, have been vaccinated. Moreover, eight cases have appeared in the laboratories of the health service among scientists that were vaccinated, and only one died. And there is furthermore the fact that in a certain area in western Montana, there were recently, during a like period,

twelve cases among vaccinated persons that resulted in but one fatality.

The four experts of the service who lately have been suffering from Malta, or undulant, fever, are Miss Alice C. Evans, Dr. G. C. Lake, B. S. Stockrider and Dr. Edward Francis. Not one of them has the slightest idea as to just how or when the ailment first overtook them. Miss Evans is one of the best-known bacteriologists in the country, mainly through her pioneer work in connection with the puzzling disease. Ever since 1922, she has suffered off and on from its ravages, which sometimes resemble typhoid fever and, upon other occasions, rheumatism.

It was Miss Evans who, in 1918, made the important discovery that there is a very close relationship between the organism that causes Malta fever and that which causes a serious and contagious cattle disease. This finding paved the way for another notable discovery, made in 1922, to the effect that people drinking milk from infected cows might contract the ailment, which fact no doubt prompted the statement by Doctor Nicolle, recent Nobel prize winner, who says that it is high time modern scientists began to concentrate on the malady to the end of preventing it from becoming a serious menace.

Statistics sound dryly technical to most

of us. But the way they are used by government experts is a matter of utmost importance. When a country-wide epidemic study is planned, it requires the services of an efficient staff of statisticians, clerks and operatives whose job it is to analyze and draw conclusions from a great mass of information gathered each year. Facts must be marshaled with utmost care so that the country's health may be preserved in the best manner possible.

The service utilizes many unique instruments. One of the latest is the daylight recorder, designed to measure the exact extent of a building's contamination by city smoke, particularly that coming from the chimneys of private houses and industrial plants. Recently James E. Ives, government physicist, made tests with the instrument in New York City. It may be described as consisting of a photoelectric cell and what is known as a recording potentiometer. One such cell was stationed on the roof of a hospital in lower Manhattan, where the air is usually very dense,

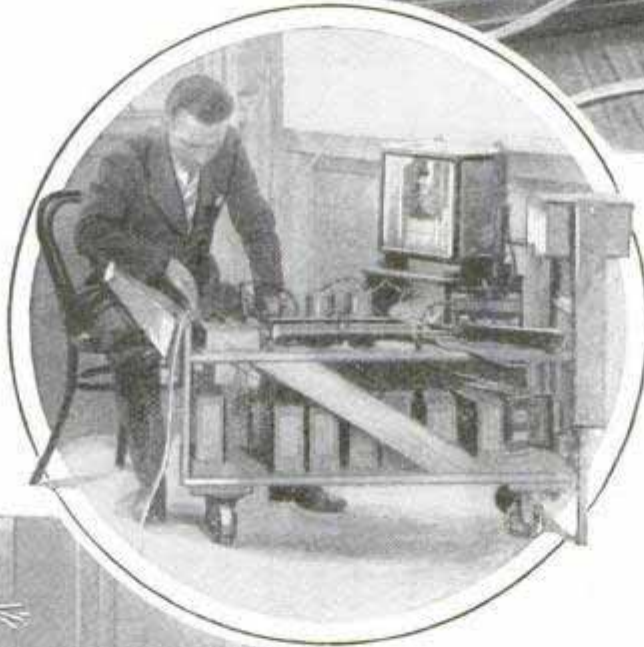
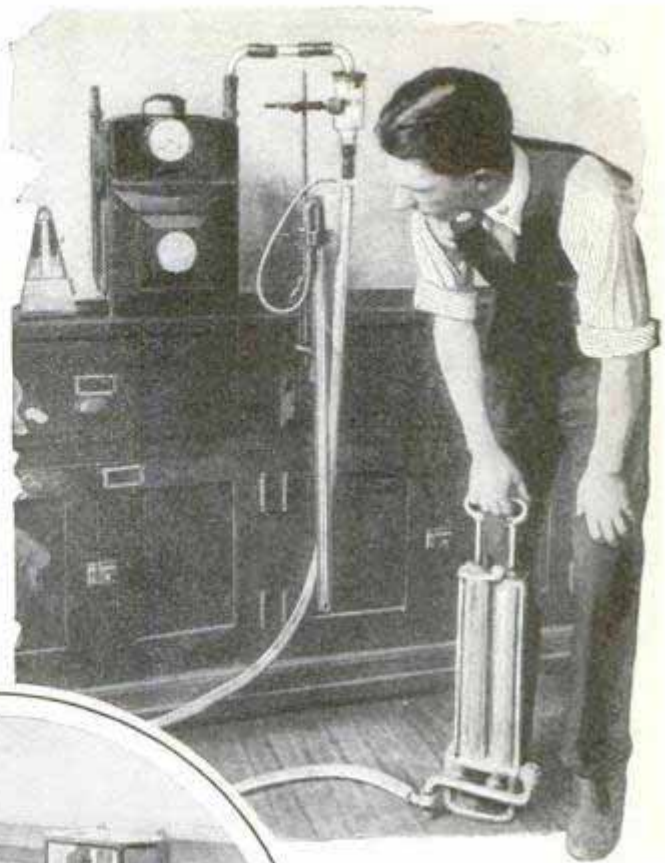

while the potentiometer was placed at a convenient point within the building. Another complete apparatus was installed in lower New York bay, where the air is ordinarily clear.

Both cells were installed on platforms so located

that no shadows were cast upon them at any time of the day. When light falls upon the cell, electrons, or negative charges of electricity, are discharged, the number of electrons thus projected increasing in proportion to the cell's total illumination. The potentiometer is the record-making part of the device. It is box-shaped and automatically makes a graph on paper. In the above test, the fact was disclosed that there is no definite relation between inside and total outside illumination, and, furthermore, that it is the ultraviolet component in sunshine which is responsible for the beneficial effects of the sun on man.



Dust-Counting Apparatus, Top; Daylight Recorder, Center, and a Bacteriological Laboratory in One of the U. S. Hospitals

Another novel device tested by the service is the dust recorder, used to help gain

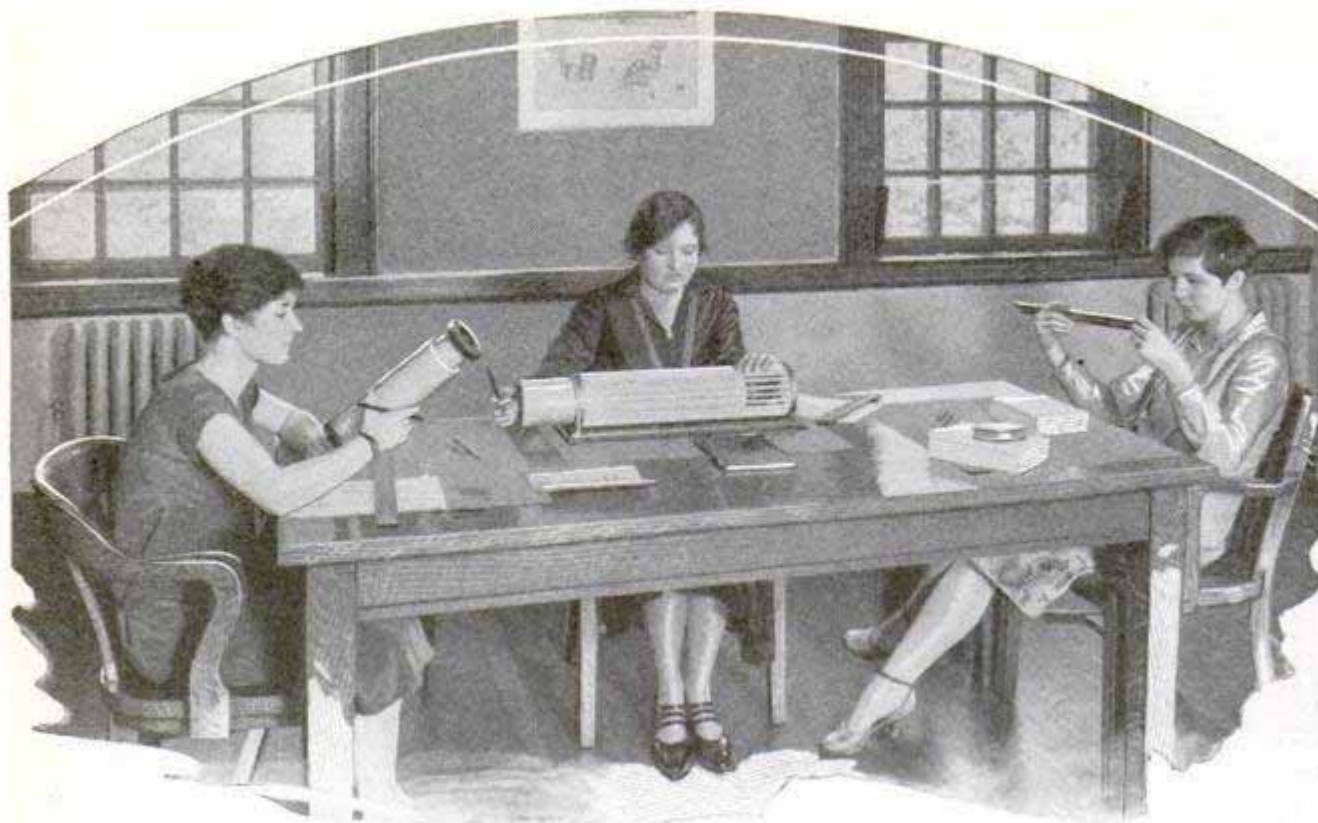

Photos Courtesy U. S. Public Health Service

Statistics on Perplexing Diseases Are Tabulated in This Department as Part of the Government's Efforts to Locate Affected Areas and Conquer New Ailments as They Appear

evidence of the pernicious effects of certain kinds of dusts upon the health of persons employed in certain industries. The dust counter consists of a glass tube, a non-collapsible rubber tube and a foot pump, besides a fine screen that prevents the dust from entering the pump, thus setting the dust apart for the critical examination of the expert. The dust samples may be preserved indefinitely before analysis.

All modern nations recognize the need of national quarantine regulations. The health service administers the quarantine at all ports of the United States by exercising two major functions, prevention of the entrance of diseases from foreign countries and medical inspection of aliens applying for admission. The service has jurisdiction over all ships and persons coming into our ports from abroad.

STARTING FRAME FOR RACERS
2316 SAVES DIGGING HOLES

To save digging holes in the track for bracing the toes of sprinters, a starting frame, consisting of a small metal pipe with two adjustable wooden pedals for

the racers' spiked shoes, has been introduced. The frame is set simply by stepping on it, and the starter is suitable for use on any track.

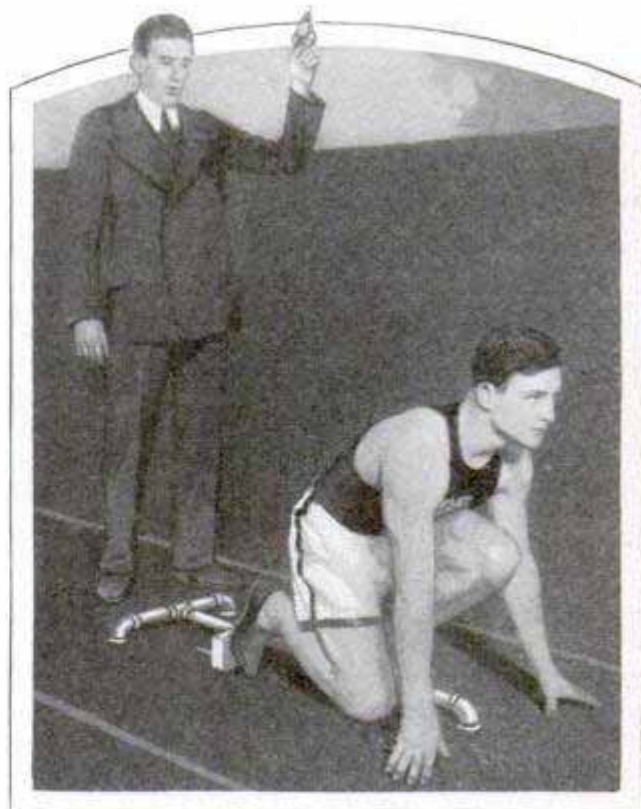

Starting Frame in Use; It Is Set by Stepping on Bracket at the Rear, and Toe Plate Is Adjustable

2316

*Chas. W. Nicholson, Track Coach
 Notre Dame University*

FOUR LITTLE-KNOWN SUBJECTS OF UNCLE SAM



Derby's Wabby Opossum Uses His Own Tail for a Ladder and Hangs by It in His Sleep

On Barro-Colorado, in Gatun Lake, Canal Zone, the U. S. Has a Strange Jungle Wild-Life Preserve; Above Is a Two-Toed Sloth Hanging, as Is Its Custom, Upside Down



The Digging of the Canal and Flooding of the Gatun Basin Cut Off All Hill Tops from the Mainland, and, as a Result, Jungle Types Are Preserved in the Unique Condition Found by the Crane-Field Museum Expedition When These Pictures Were Taken; at the Left, Karl P. Schmidt Is Holding a Live Iguana, a Lizard That Runs Mostly to Tail, and, Above, an Ant Eater Has Curled Up in the Fork of a Tree to Sleep Off a Full Meal; Precautions Are Being Taken to Protect the Wild Life on the Islands of the Artificial Lake



Railroad Employees at a Session of the Traveling School, and Close Views of Groups in Special Instruction

its kind in the world. The floor is inclined as in a stationary theater, the projection booth is at the rear and music is furnished by radio. In the two cars equipped with the mechanical displays, working models of various railroad appliances are employed to show those who have to operate the real equipment how the machines work. Classes are instructed in fuel conservation and care of accessories. The board of examiners is made up of seasoned employes from the groups which are required to take the tests to determine if the workers have the knowledge they should possess for their tasks, and if they are always mentally alert and "on their toes."

AIRCRAFT TO MAKE MALARIA FIGHT IN NICARAGUA

2326

Airplanes will be enlisted in the health service, if plans for combating malaria by killing mosquitoes with poisons sprayed from the air, materialize. A mixture of

paris green, capable of penetrating the densest vegetation and reaching the breeding places of the insect carriers of the disease is to be used, it was announced. Planes operated by the United States marine corps have already performed this work successfully in and around Managua, Nicaragua. There was a marked decrease in the number of new cases of malaria after the planes had made a few spraying trips. The mixture was released from a height of 100 feet through a special apparatus. Three dustings were found sufficient to clear an area, and additional visits were made at two-week intervals.

RAILROAD SCHOOL ON WHEELS REDUCES ACCIDENTS

Those of the Great Northern railroad's 30,000 employes who have anything to do with the operation of trains or maintenance of equipment and tracks, attend school in a rolling college, five steel cars equipped with classrooms, a laboratory and a motion-picture theater. A staff of instructors and an examining board have living quarters on the train. Particular emphasis is placed on safety-first lessons. The movies are used for this, and the theater car is said to be the only one of

*H. M. Davis, Executive Assistant
St. Paul, Minn.*

Cont. Mrs. J. S. Coleman 331.5 Mont.

**HEAT BOMBS FOR AIR RAIDS
TO MELT CITIES**

239 4

Experts who have declared that adequate defense from air raids will be impossible in the next war, receive support in the announcement of a powerful heat bomb which can destroy, not only metal, but even cement and granite. It is of an "electron incendiary" type and is said to develop 3,000 degrees of heat. Each bomb weighs only a little more than two pounds so that a large plane could carry 1,000 of them. A fleet of 100 planes, so equipped, could sow destruction over a city in a few moments, spreading flames that would entirely destroy it, experts believe.

Berlin despatch

**EXTRA WHEELS ON FORD TRUCK
DOUBLE ITS CAPACITY**

236 2

The carrying capacity of the Ford "AA" truck is said to be doubled by adding two wheels which run on the outside and closely behind the originals, to which they are connected by a flexible unit that is said to equalize the road pressure on all wheels under any road and load conditions. Steering is made easy and the turning radius of the truck is not increased. One user of the wheels applied them to a trailer on which he is able to haul three automobiles at one time.

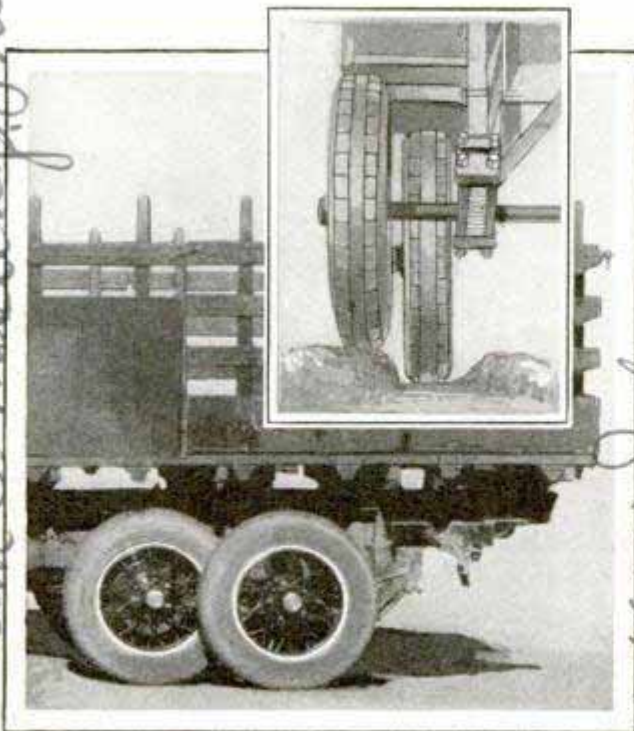

Photograph of the Wheels as Installed, and Drawing to Show How They Function



2355

French Policeman with His Armor Equipment; It Is Carried in a Folding Kit When Not in Use

**STEEL ARMOR IN FOLDING KIT
PROTECTS POLICEMEN**

Plain-clothes policemen in Paris are being equipped with a kit of folding armor for protection against bandits. The outfit consists of a steel headgear and a sheet of steel that serves as a shield in case of a battle. In addition, they wear bullet-proof vests.

**MOVIES OF CITY UNDER THE SEA
TO AID HISTORIANS**

2389

Motion-picture cameramen, working under the sea, recently have made valuable historical films of the submerged city of Jamestown, once the chief settlement on the island of St. Nevis, in the West Indies. The remains of the old city are to be seen under the water near the shore. On April 30, 1680, the town was destroyed by an earthquake and slipped into the ocean, carrying with it most of the inhabitants.

Cont H. J. Wilbur

Chicago Feb. 2/26/29

Am. J. Hastings Pres

44610 Jefferson

Turner - City & Co.

2133

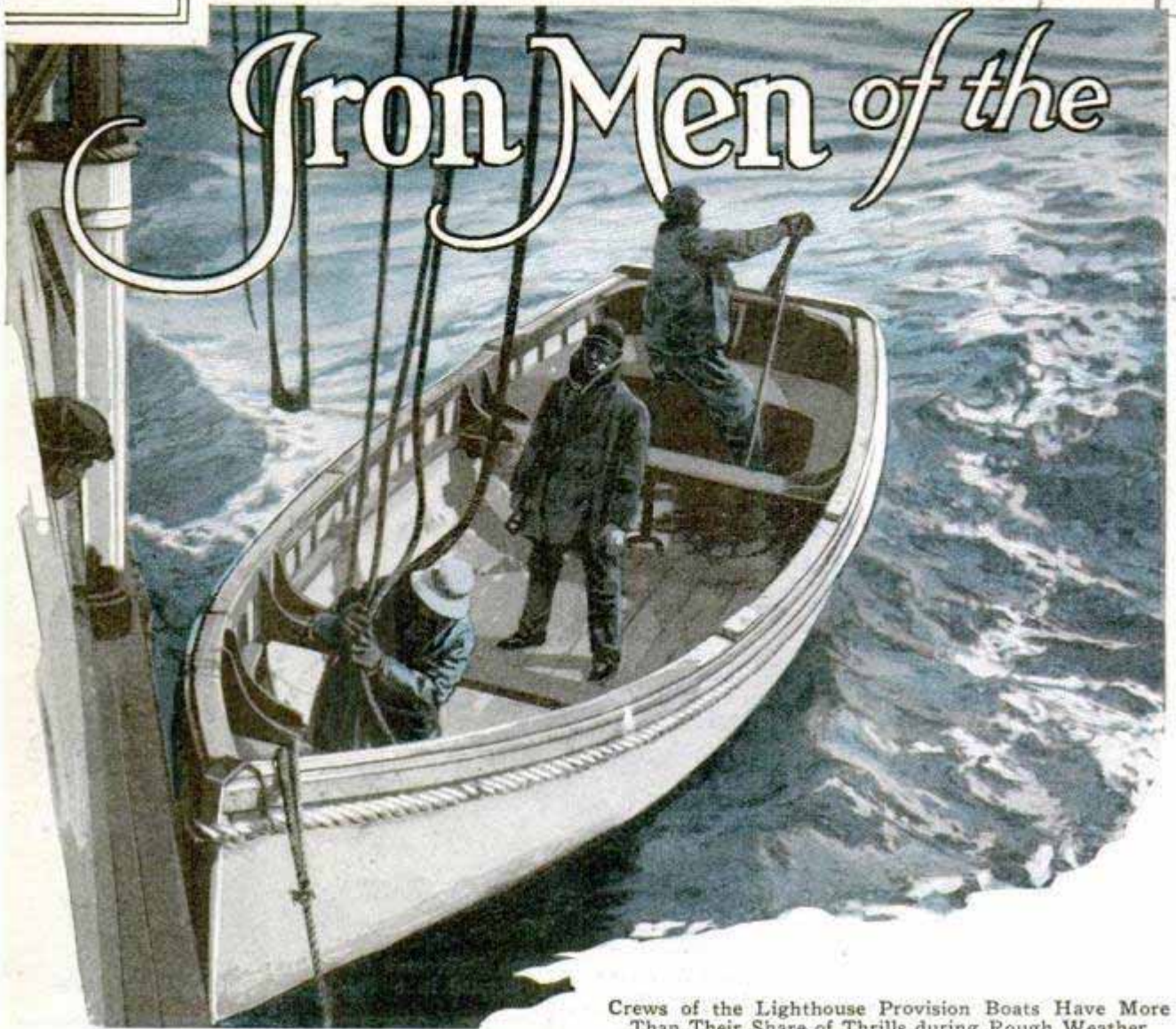

Crews of the Lighthouse Provision Boats Have More Than Their Share of Thrills during Rough Weather

HOW would you like to be a lighthouse keeper in a remote spot during a terrific hurricane? When the wind is raging furiously at a velocity of over 150 miles an hour, while the roof of your only dwelling place is being blown away, and all electric wires and poles in your immediate vicinity are being forced down and broken?

Such notations appear frequently upon the records of the United States lighthouse service, whereas there is oftentimes the added news: "The near-by radio station is out of commission due to lack of power and there are no telegraph communications."

One might well suppose that, during such periods, Uncle Sam's guardians of our coasts would be justified in seeking safety for themselves, but there seems to be no instance of such action. On the

contrary, the "Iron Men of the Lighthouse Service," as they are known, have established an enviable record of remaining on the job at all times.

Particularly striking instances of this sort took place during the great hurricane of last September, which on the thirteenth of the month struck Porto Rico and the Virgin islands, causing great property damage and loss of life. At San Juan, Porto Rico, the hurricane smashed and battered away until it had blown off the roof of the lighthouse quarters, extinguished countless lights and damaged a great portion of the electrical apparatus, causing a total loss of about \$63,000. Yet J. R. Monteiro, the superintendent, stayed at his post with six helpers until the fury of the storm had passed, as did also the men in charge at Key West and Jupiter Inlet stations, Florida, where the damage

Lighthouse Service

in each instance approximated \$25,000.

Time and again upon occasions of national disasters, the men of the lighthouse service have been on hand to aid materially in rescue operations. During the Mississippi flood of 1927, these tireless fellows worked night and day under the personal direction of Herbert Hoover, then secretary of commerce. The lightkeepers made a notable record by maintaining the regular aids to navigation under the greatest of difficulties and by checking up on the anticipated flood heights.

The same kind of unselfish aid was given when the great St. Francis dam in California broke a year ago. A notable instance took place on the evening of March 12, 1928, when Francis A.

O'Leary, inspector of airways construction in the region, happened to be driving his car in the vicinity. All at once he saw what seemed at first glance to be a heavy valley fog in the Santa Paula river bed. Investigating, he soon noticed a raging torrent which appeared like a wave twelve feet high crossing a highway at right angles to him. Above the deafening noise of the waters he heard a voice crying for help, and when he headed in the direction he found a man and woman struggling for a foothold. They had escaped the first great rush of water but now were caught in the overflow. O'Leary somehow contrived to help the couple to dry land, then

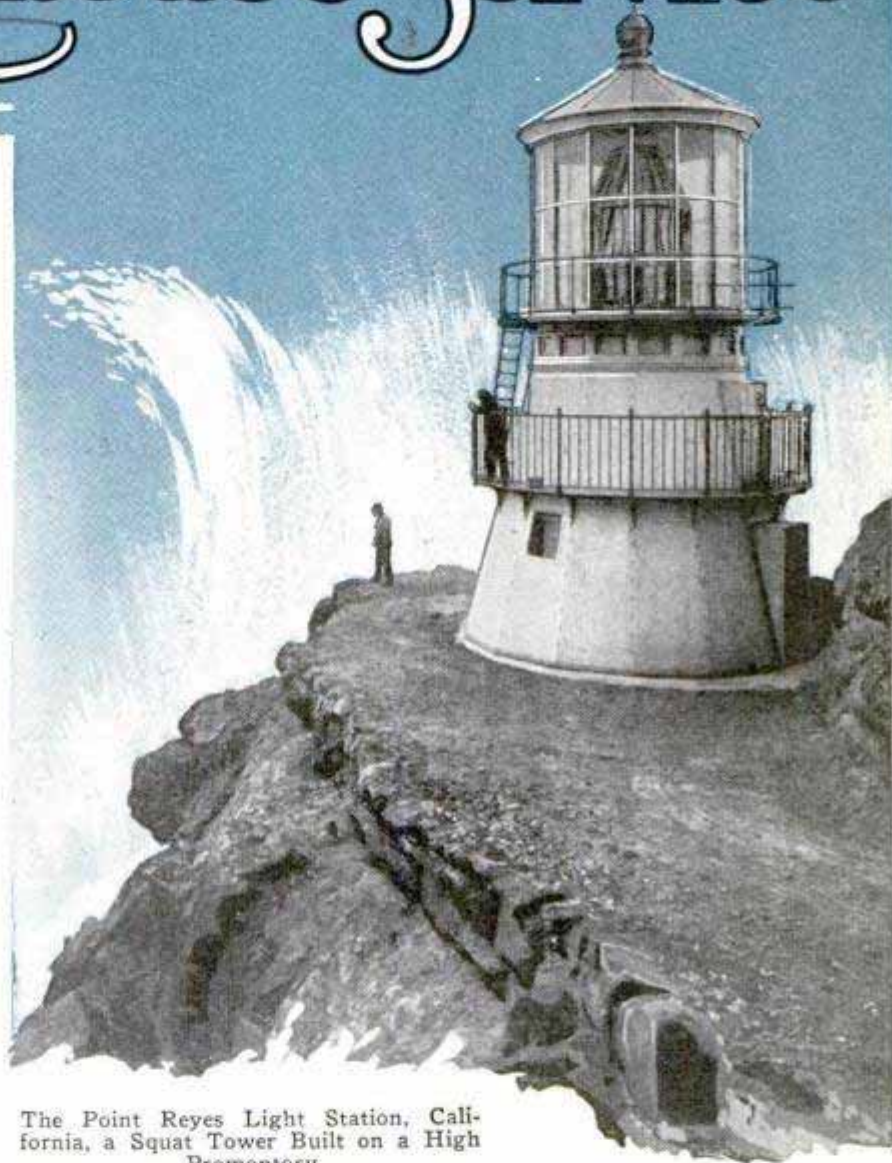

The Point Reyes Light Station, California, a Squat Tower Built on a High Promontory

into his auto, and carry them to safety.

Aside from unusual natural disasters, the lighthouse men are called upon continually, during their daily work, to cope with the severest kind of weather conditions. Particularly is this true in winter time at stations along the Great Lakes where ice mountains arise almost overnight. Not so long ago at the Ashtabula lighthouse, on Lake Erie, located on a breakwater pierhead in an extremely exposed position about a half mile off shore, a gale from the westward suddenly arose and lasted three days with the result that, due to the open water and the force of the wind, the sea and spray froze to the light-

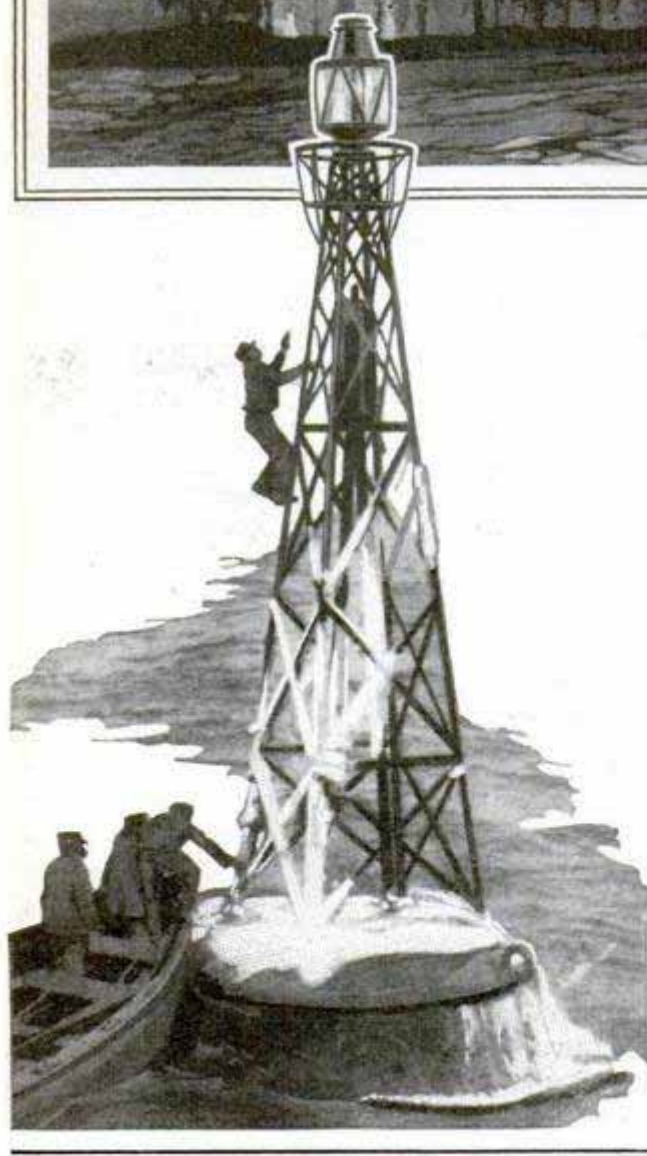
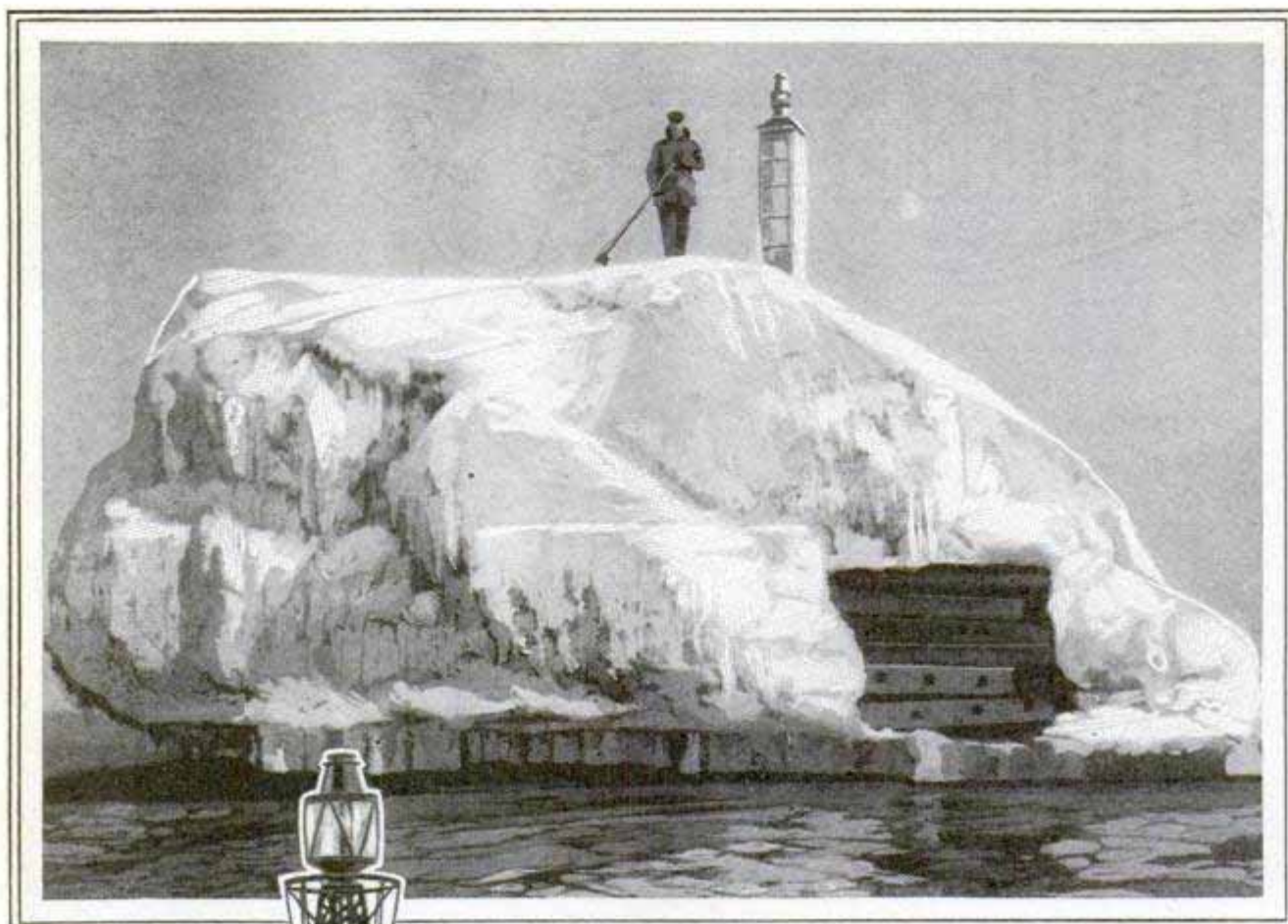

In Northern Waters, Lighthouse Keepers Must Fight Ice; Bottom, Examining a Gas and Whistling Buoy in New York Bay in Winter

house crib and buildings, completely incasing the structure in heavy ice.

Now the two keepers were storm-bound, unable to reach shore. However, at the end of the gale, the other two keepers, located ashore, went to their aid, though to do so they had to travel more than two miles along a treacherous course. Upon arriving at the station, they hardly could recognize it with its thick ice coating. In order to establish communication with the outside world, it was found necessary to thaw open the entrance door on the east side and literally dig through the ice with pick and crowbar for a distance of forty feet before a ladder could be placed on the breakwater.

Some of the more recent rescues effected by the Iron Men are classic examples of heroism. On a certain cold winter evening a young man fell over a cliff above Sea Lion Cave, two miles from Heceta Head light station in Oregon, eighty feet to the rocks below, and was believed to be seriously injured, if not dead. At six o'clock the lighthouse officials were notified. Their only means of illumination were a lantern, two flashlights and one tiny carbide light. Yet, for well

over an hour, the lighthouse keeper, his assistant and two other men risked their lives by traversing the side of a cliff for about 1,500 feet on a narrow trail, between eight and twelve inches wide. And all the while their distance from the treacherous surf and rocks below was close to 300 feet.

Nevertheless the men somehow managed to keep their balance and when they had reached a point just above the injured man, they lowered a rope. First of all, one of the lighthouse officials went down, and shortly thereafter the other rescuers followed. It did not take them long to discover that the victim was seriously injured, having a compound fracture of the leg. Since there was no doctor anywhere near the immediate vicinity, one of the men set the boy's leg. Whereupon the youth was lashed to a board and taken up the cliff, a feat that required two hours.

Countless other instances, both in the regular line of duty and outside it, might be cited. Many are the occasions when young boys, intent on swimming or fishing, venture far out into a bay and are rescued only by reason of the vigilance of

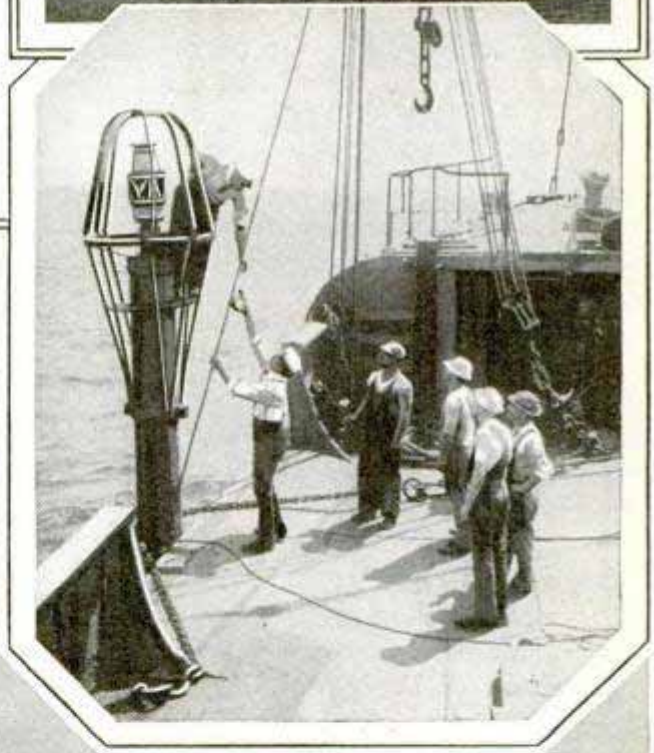
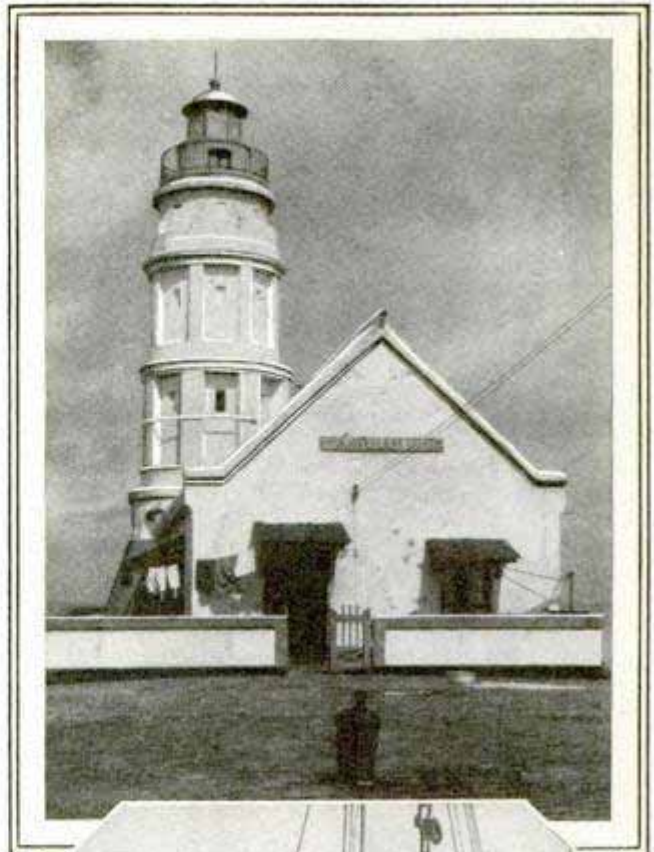

The Farola, Manila Harbor, Built in 1846, Is the Oldest Lighthouse in the Philippines; Bottom, Breaking Waves Dashing against Minots Ledge Lighthouse; Inset, a Gas Buoy

2133
790

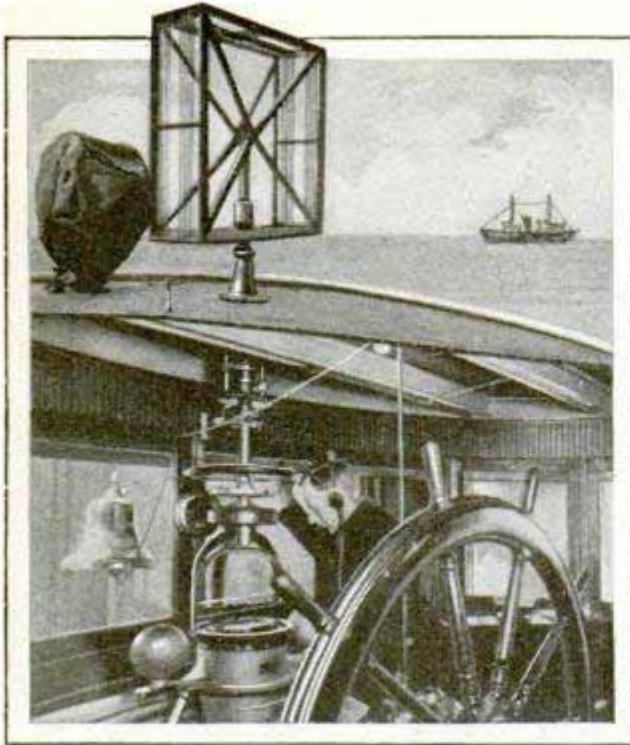

Using the Radio Compass to Obtain a Ship's Bearings from Signals Sent from Shore

a lighthouse keeper. Or perhaps a shipwrecked tug will sink in the midst of a storm, an automobile driver, temporarily blinded by extreme fog or darkness, will plunge into the water; and in these days, when forced landings in amphibian planes occur, there are frequent occasions when an officer of a lighthouse vessel gives assistance to the flyers.

Record-breaking airplane flights have been aided materially by the towering guardian lights of our shores. Fresh in memory is the first flight by plane between San Francisco and Hawaii, accomplished not so long ago by Lieutenants Maitland and Hegenberger. At dead of night, the two army flyers might easily have passed the Hawaiian islands entirely, had they not seen from their lofty heights the welcome flashes of Kilauea point light. But under the actual circumstances, airmen were able to pick up the light from a distance of about ninety miles, soon recognizing its source as one of Uncle Sam's lighthouses.

May be it's not quite fair to mention the almost breath-taking accomplishments of a single individual in the service, since there have been so many instances of heroic deeds. However, it is highly interesting to note that this particular individual has the following seven outstanding rescues to his credit: Back in 1914,

he ran a line through the surf to a drifting lightship; two years later, he rescued a man from drowning; three years after that, he towed a disabled steamer to safe anchorage; a year more, and he helped float a grounded transport; three more years, and he helped tow a disabled tugboat and dredge from a highly dangerous harbor position; a year later he rescued, at dead of night in rough sea, two fishermen who were physically exhausted and without provisions; and a few years ago rescued the entire crew of a coast-guard patrol boat.

But, of course, hazardous rescue work is only one phase of the everyday routine of the lighthouse men. A search for a buoy that simply won't stay put sometimes contains all the essential characteristics of the game known as "Hare and Hounds," except, of course, that there's a bit more territory to be examined on the surface of the oceans. Lighthouse construction of today is, in general, far different in principle from what it was in the not so remote past. Rarely, these days, do we see the towering structure that was so common yesterday. Which is partly because the earlier lighthouses were usually erected to mark prominent headlands or landfall points where range of visibility was the fundamental feature and the height of the tower increased its visibility range. Then again, the lighthouse of the earlier days was also used as a day mark, a fact toward which its height contributed.

At the present time, most prominent headlands have been marked for many a day, so modern-day lighthouse engineering is devoted in a large measure to marking out with greater preciseness the specific dangers and the courses of channels. For these purposes small structures of lesser visibility range are suitable. The increased power of illuminants as used today is another very good reason why structures of less height may ordinarily be used to great advantage. However, in some localities the conditions of former days still prevail and a skyscraping type of lighthouse building is occasionally built. In this connection an outstanding example is the lofty one on Navassa island in the West Indies. Built in 1917, it measures 162 feet in height.

Still another marked departure from the

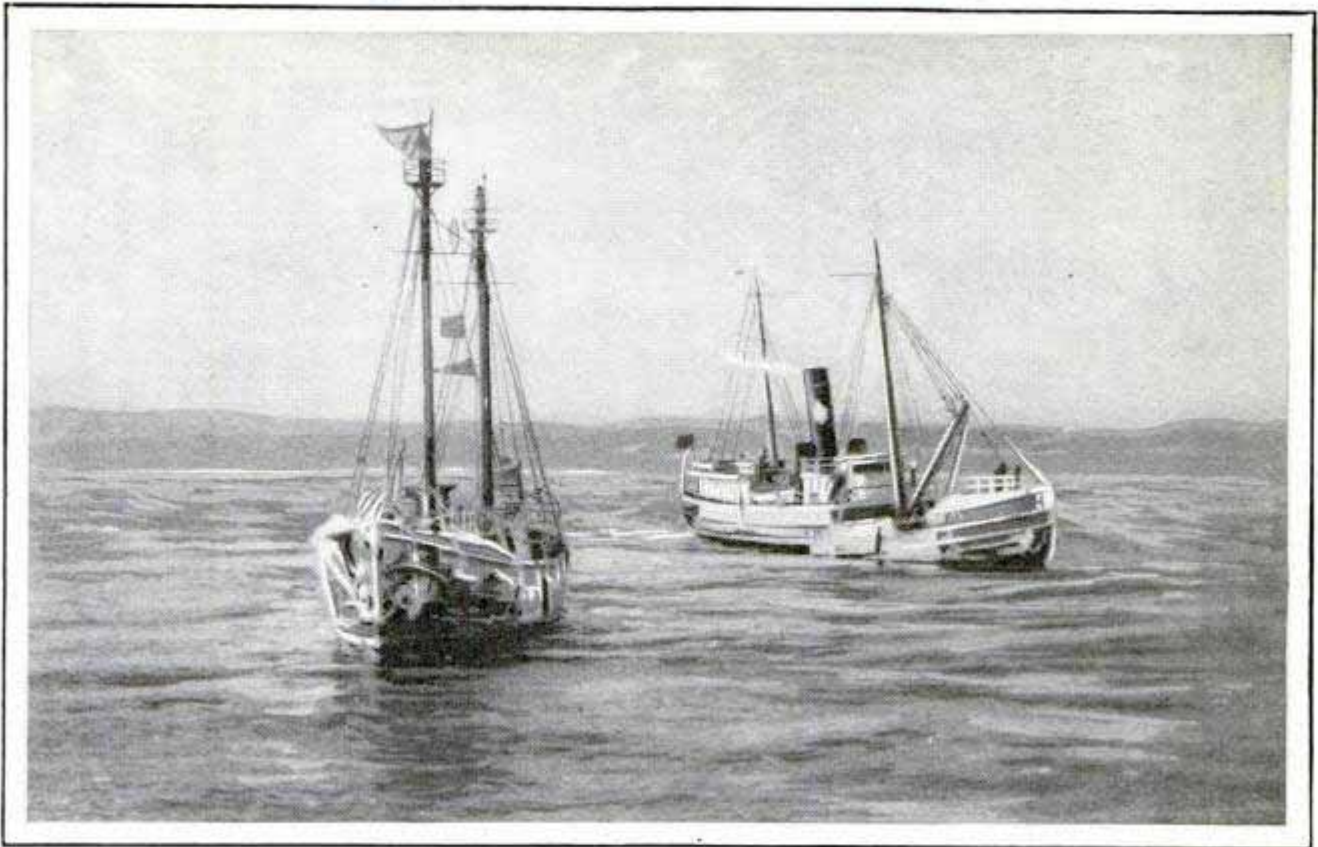

Photos Courtesy U. S. Lighthouse Service

The Lightship "Scotland," One of the Most Famous in the Atlantic, with the Lighthouse Service Tender "Tulip" alongside, to Deliver the Regular Quota of Supplies

old-time lighthouse system is the emphasis today on what is known as a "light vessel." All in all there are about sixty in commission and they are employed usually for marking danger zones at sea: entrances to harbors; important points in the course of vessels; in short, where a lighthouse would not be feasible or economical.

These ships are distinguishable in the daytime by their unusual shape and rig, including usually some form of gallery at the mastheads, and by their characteristic painting and lettering. The hull often is painted red or straw color, but other colors or combinations are also employed.

SYNTHETIC BENZINE PROCESS TO AID GERMANY 2378

German chemists are reported to have developed a process for making synthetic benzine to meet the great demand for motor fuel and the limited supplies of natural oil. Tests have shown that the synthetic product can be made at this plant in quantities up to 250,000 tons a year or approximately one-fourth of the entire consumption in Germany. There are now more than 1,000,000 automobiles in Germany

and the fuel question is one to which the chemists are directing much attention.

STREET NAMES ON CURBSTONE MORE EASILY SEEN 2317

Street names, painted on the curbstone, appeared in Washington, D. C., recently. The characters are easily renewed when they become dull, and the plan eliminates the need of posts or tags.



© U. & U.

Street Name Painted on Curbstone Where It Can Be Renewed Easily and Seen at a Distance

*Cmd. Clarence L. Hall,
2342-15 St. St. ...*

2315
792

Electrical National
Bank Bldg Washington DC

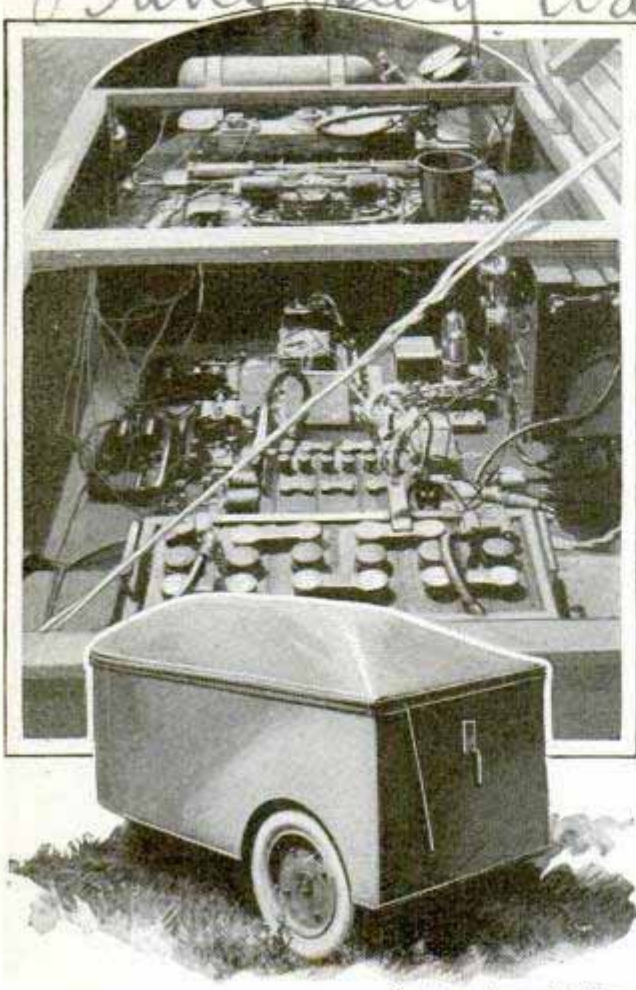

Courtesy Army Air Corps
Close View of the Radio-Controlled Tank and of Its Interior Equipment

WAR TANK IS RUN BY RADIO FROM MOVING PLANE

Flying at an altitude of 2,000 feet, an airplane operated the controls of a tank or miniature automobile on the ground—started, directed and stopped it—during an interesting test at Wright field, Dayton, Ohio, recently. The tank, without any other means of guidance, responded to radio impulses transmitted from the plane. Guns were fired and horns were blown by the same impulses, all radiated from a height of 2,000 feet. The car was shrouded in white to make it more clearly visible to the pilot. Aerial torpedoes and armored tanks may be guided by such means in the war of the future, the experiment suggests, and battleships, so controlled, could enter a naval engagement with heavy charges of explosives without a crew. Such vessels, loaded with dynamite, could be sent into enemy waters and exploded by radio. The United States navy and other naval forces have operated ships without a person aboard, the con-

trols being actuated by radio from another ship. The radio-controlled torpedo boat, developed by John Hays Hammond, Jr., is also familiar to those who have followed this phase of the growth of radio. A railroad company has experimentally operated a train with the hands of the engineer off the throttle, the engine obeying the unseen commands of a distant radio set. Miniature trains have also been run by this method.

EDITING OF HOME MOVIES EASY WITH SIMPLE SET

Added enjoyment in taking your own motion pictures is afforded by a simple outfit for editing the films. It permits inserting titles, "trick shots," corrections and other "extras" that feature the usual commercial film. It also simplifies the task of arranging the pictures in their proper order. The set consists of a viewer unit, simply a magnifying eyepiece set at a convenient level, a splicer block for cutting and splicing the film, and a rewinding reel, geared for rapid work. To edit a film, it is threaded through a channel on the underside of the eyepiece and attached to an empty reel. An extension cord is plugged into a socket to furnish light for the viewer. The magnifying glass enlarges the image to nine times its actual area and a prism causes the picture to appear right side up. When a section is to be cut out, the film is drawn from the



Using the Editing Outfit for Movies Taken at Home; the Magnifier Enlarges the Image Nine Times

2309

9/40.00

Beck & Howell Co Chicago

2306 Westinghouse Electric
2371
2360
2386

meanings before a mixture American metallog

channel upon the splicer block, the cutting is done, and the film is spliced again with cement that is kept in a bottle firmly held in a socket.

HEAVIER FUEL TO AID AVIATION

Use of heavier fuels in increasing quantities for automobiles and airplanes was forecast recently by a well-known petroleum engineer. He pointed out that an oil-burning Diesel engine for aircraft, which weighs but three pounds per horsepower, already has been developed, and that first tests with it indicate it will prove a success. He asserted that more fuel oil is being used every day, despite the popular idea that gasoline is the principal product from the distillation of petroleum. This development in fuels will be followed by changes in the design of internal-combustion engines, he predicted, and declared that one of the needs of today is more research in fuels to realize greater motor efficiency.

STEEL ARMOR FOR CONCRETE HELPS IMPROVE FLOORS

To strengthen concrete floors and simplify their construction, a reinforcing material in the form of a steel matting has been introduced.



It consists of a number of steel strips which, when placed together, form a series of separate rectangles of proper size to meet the conditions under which the floor must be used. The strips are set on edge and are connected by means of tie-rods. This steel matting, filled with concrete, prevents the formation of cracks and other irregularities, and distributes stresses more evenly.

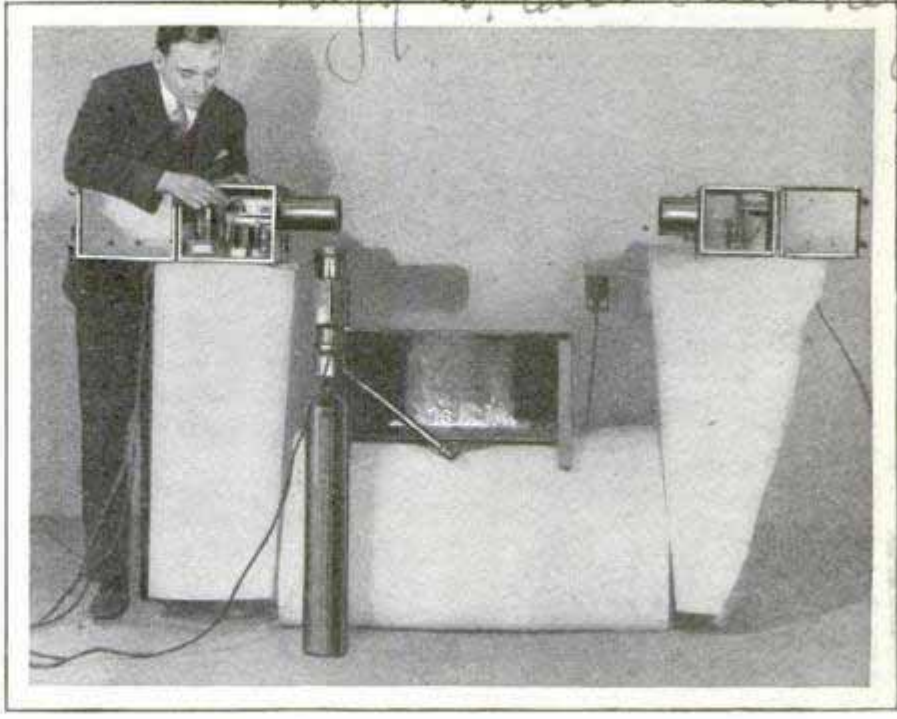

Testing Outfit Used to Demonstrate How Photo-Electric Cell Was Used to Extinguish a Fire; Smoke Caused It to Function

ELECTRIC "EYE" SEES SMOKE AND PUTS OUT FIRE

Further possibilities of the photo-electric cell, the magic "eye" that has been used to sort cigars, match colors, count automobiles and perform other tasks, were demonstrated in New York recently. A lighted match was tossed into a pan containing gasoline. The puff of smoke, drifting in front of the photo-electric cell, which is extremely sensitive to changes in the intensity of light, caused it to set up an electric impulse. This, in turn, released carbon dioxide from a container and the gas quickly smothered the fire. At the same demonstration, the eye counted the guests as they passed through a slender beam of light.

MYSTERY BIRDS LAND ON SHIP MANY MILES AT SEA

British naturalists have been faced with a problem in attempting to identify three birds which alighted on the rigging of a steamer 500 miles off the American coast, were captured, and are now on display at the Crystal Palace in London. They are about the same size as parrots, grayish-blue in color and white-breasted. At last reports, no one had been able to identify them positively.

Blaw-Knox Co

Com. H. J. Wilkins

22/2

William Fox Studios

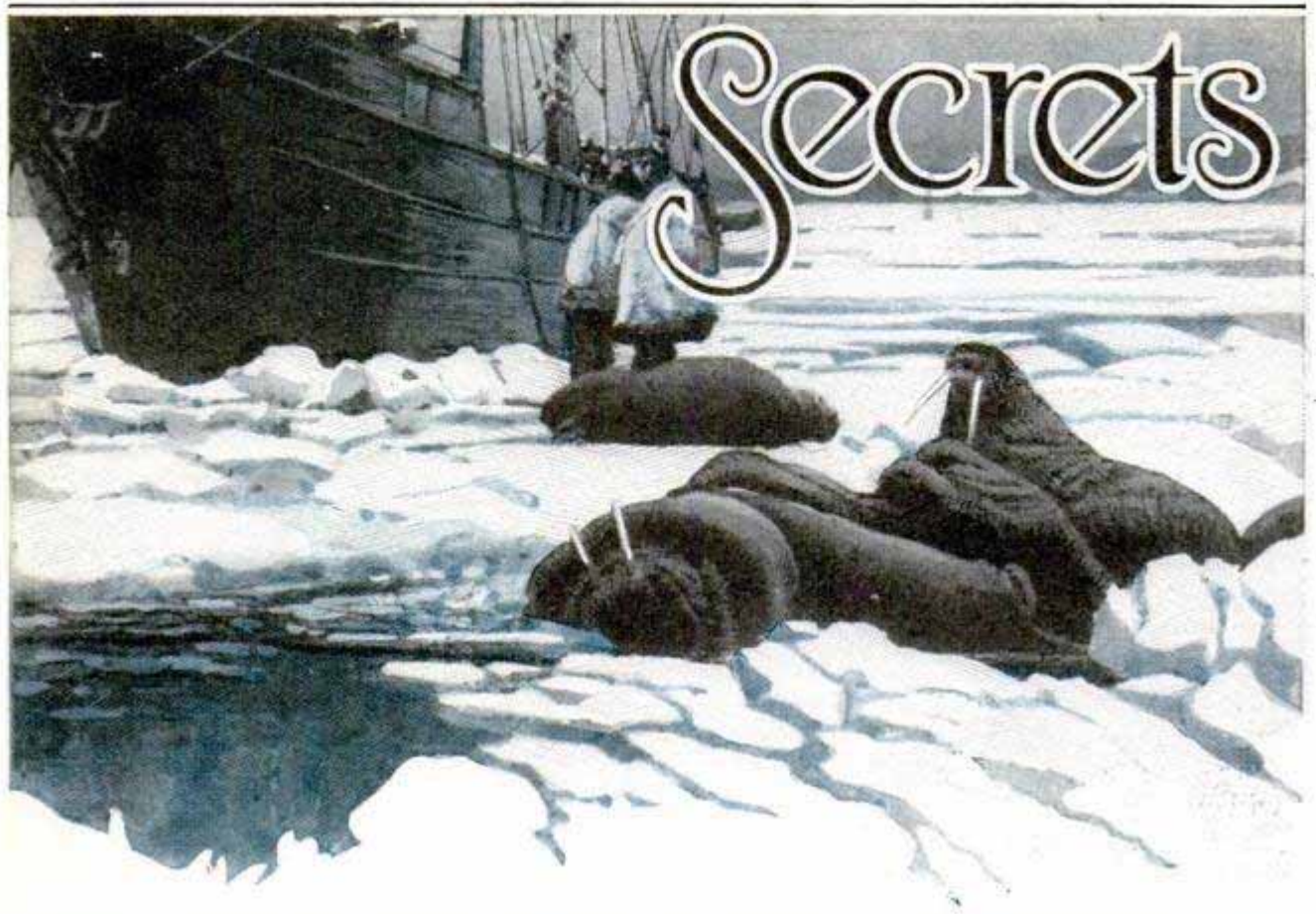

Hunters of the H. A. and Sidney Snow Arctic Expedition with Walrus Shot in Bering Sea, alongside Their Schooner "Herman"; the Snows Solved the Herald Island Mystery

By ALFRED ALBELLI

WHEN Dr. Fridtjof Nansen, the arctic explorer, who is now sixty-seven years old, returns to the north-polar haunts of his youth next year, he is going to explore the mysteries of a sea which science still knows little about.

In April, 1930, Doctor Nansen will be passing over the north-polar sea in the "Graf Zeppelin," the dirigible which Hugo Eckener brought to America in a transatlantic flight. Eckener will again be in command of the "Graf Zeppelin" as she sets out on the polar flight.

There are secrets locked in the depths, and the surface also, of the north-polar sea which Doctor Nansen wants to learn. He is confident that in the region still set down by science as "the Unknown" there are islands to be discovered.

As he passes through that unknown sector, Doctor Nansen expects to make a thorough study of the body of water there as well as of the islands themselves. He will seek to know what nature of life exists on those hitherto virgin islands.

But Doctor Nansen's expedition pri-

marily is a mission of science, not one of discovery. The latter will be subordinate to the amassing of scientific data in the north-polar area.

The veteran arctic explorer—he has led five scientific expeditions through the white wilderness—is returning to the land of the midnight sun after a varied career in international diplomacy. He was Norway's first minister to England and represented his country at the League of Nations. His first journey into the polar periphery was at the age of twenty as one of the crew of a sealing vessel.

Doctor Nansen's "Graf Zeppelin" expedition will be to determine various scientific issues which indirectly will have immense commercial value in the future, affecting navigation rather than fisheries.

"We are going to attempt to unravel the problem of the depth of the north-polar sea," he said. "We want to discover the fitness of the topography on the surface of the water, and beneath it, so to speak.

"By acquainting ourselves with the re-

of the Polar Sea

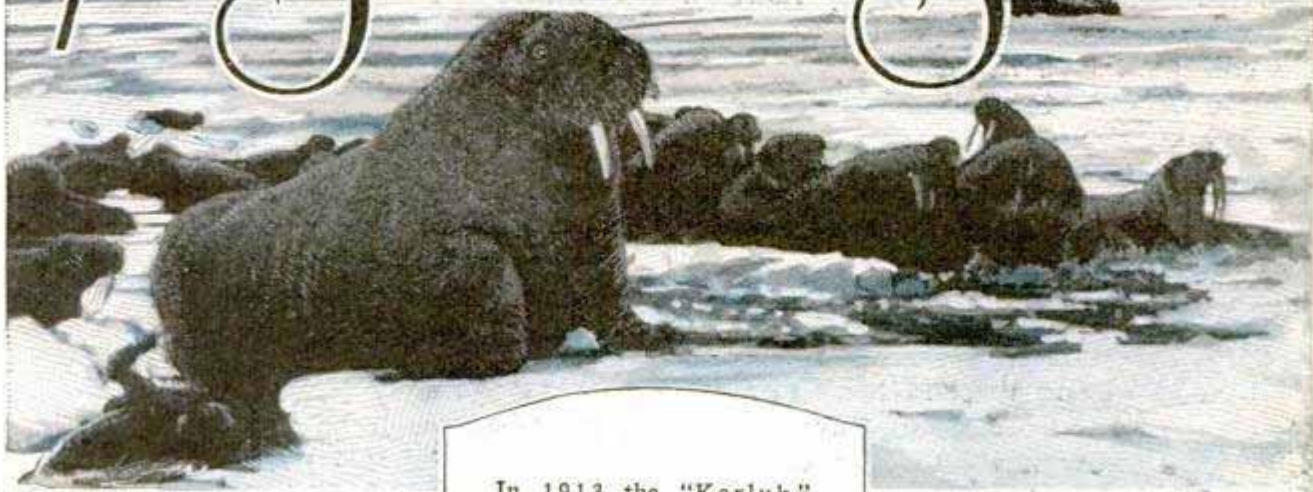

In 1913 the "Karluk," One of Vilhjalmur Stefansson's Polar Ships, Was Crushed in the Ice; Four Men Reached Herald Island and Perished There; Their Fate Remained a Mystery Until the Snow Brothers Three Years Ago Reached the Camp and Found the Bodies; Top, a Herd of Walrus on the Ice, with the "Herman" in the Distance; Left, a Dead Polar Bear on Deck, and, Right, One That Was Lassoed and Caught Alive; Below, the Herald Island Mystery Solved

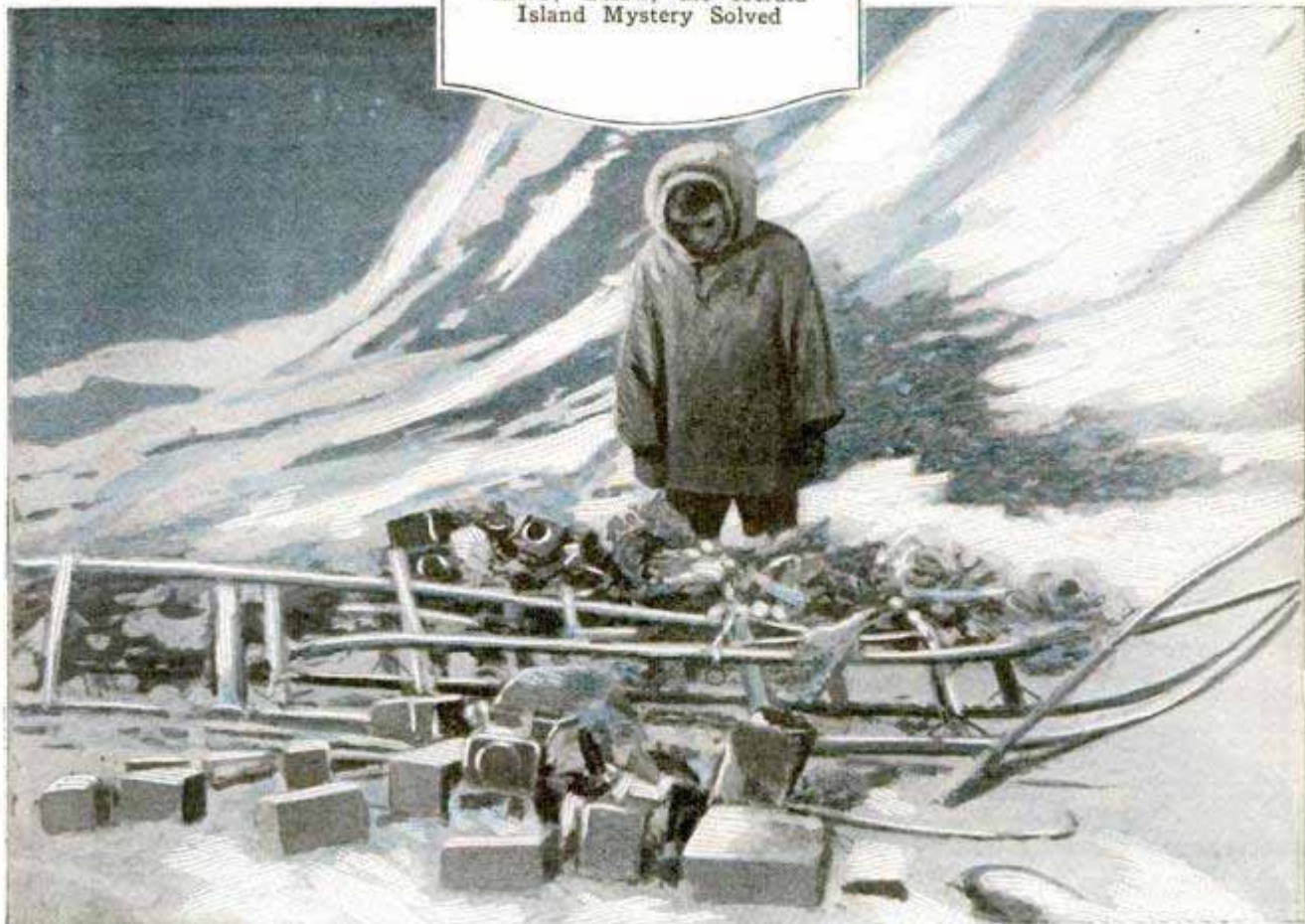

2212

lief conditions of the surface of the water," he continued, "we can establish a basis for future operations. We want to decide the boundaries of that deep ocean, where the converging continents of Asia, North America and Europe are really marked. We want to record the precise extent of the continental shelf.

"Also we want to get records of atmospheric conditions, the temperature under water, samples of that water in various regions and the ice movements. I am of the opinion that the climatic conditions of the universe are deep-rooted in the weather situation prevailing in the polar realm. The commercial value of our expedition will be realized in the end from deductions possible from our figures which will allow navigators to calculate the state of the atmosphere for sea and air travel at all times.

"We are going to spend exactly three months in this polar flight. The greater part of our work will be in connection with the soundings.

"Sounding is probably one of the most fascinating endeavors of the polar explorer. The computations may be made either by using an explosive or a metal plate, usually a gong.

"On the first sounding, which means either the explosion or the clanging of a gong, you can get a figure within a few feet of the actual depth. A second sounding will practically give you an accurate figure. Strong wind currents are apt to interfere with the sounding work. A special gong, called an echo lead, has been worked out by a German inventor for our journey, to cope with any interferences from the elements.

"In gathering sounding computations, one must reckon with the temperature, the salinity and speed. Those are the salient points. As for salinity and temperature in the particular regions we are heading for, I did a great deal of the work in 1912 on my expedition with my yacht 'Veslemoey.' We explored the water and the currents from the Atlantic ocean, and the drift of the ice. But, of course, there is still the unknown region to be taken in.

"My sounding experiences in the arctic go back to 1893-96, when I went there with the 'Fram.' It was then that I actually established the fact for the first time in history that the north-polar sea existed as one large body of water. I allowed my ship to become icebound; then, when the drift began, we sailed right along with it. Of course we never knew when we would be dropped off into eternity. We averaged one mile in twenty-four hours on this journey.

"But now on my return, I expect to do more in three months with the 'Graf Zeppelin' than I accomplished in three years with the 'Fram.' I will have with me not only all the data I gathered in former years, but also many new instruments to make my work more efficient. Many of the instruments I have invented myself.

"We are not blind to the fact that air travel over the pole is a hazardous undertaking. There will be about forty persons on the journey, twelve of them scientists.

"There will be special sledge equipment on the airship with abundant provisions as a safeguard in the event of some accident. Should the necessity to come down arise, we are not going to have to worry. The distance to the nearest known coast,



Eskimo Hunters from the "Herman" Chasing a Polar Bear to Head Him Off Until the Ship Can Come Up Close Enough for a Lasso to Be Dropped over His Neck

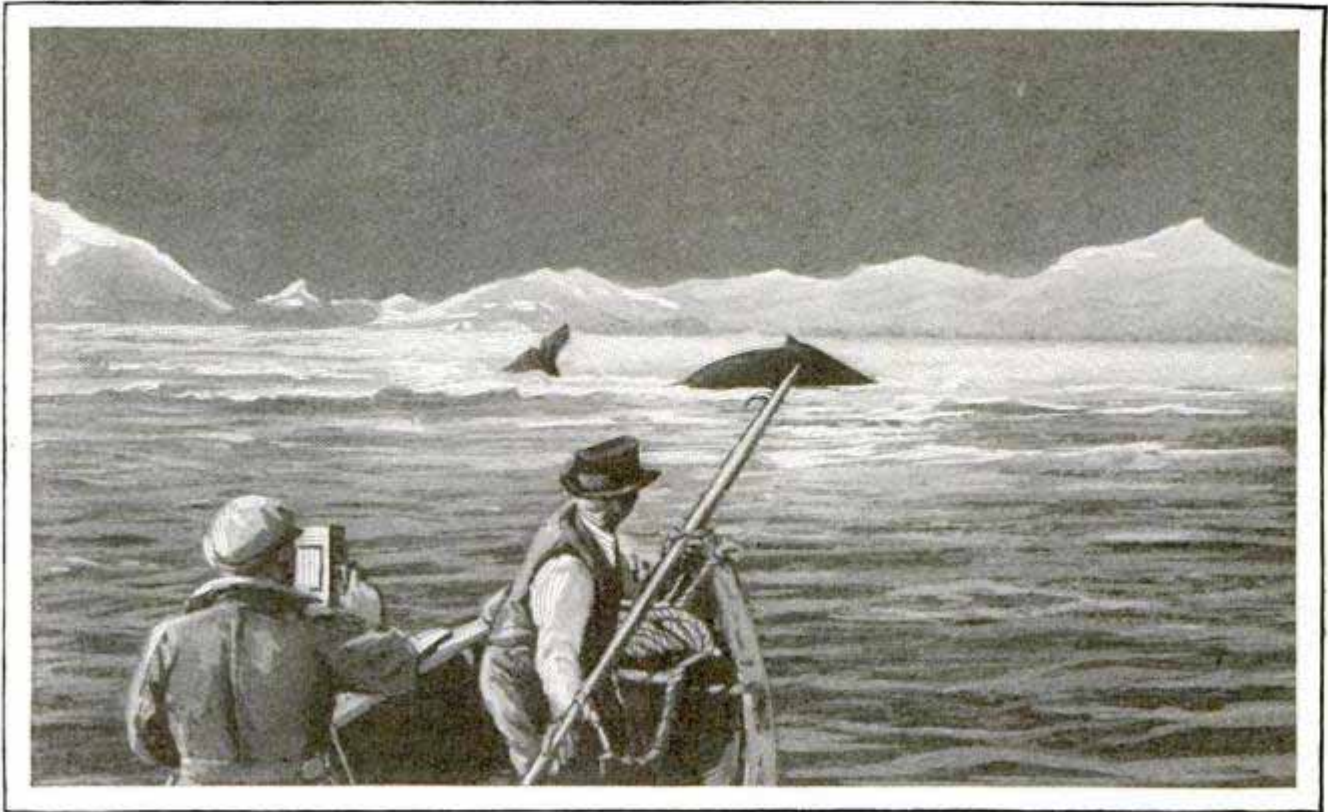

Photos Courtesy Fox Films

Whale Hunting off the Alaskan Peninsula; One of the Adventures of the "Herman" Was an Old-Time Whaling Expedition, with Hand Harpoons Instead of the Modern Harpoon Gun

from wherever we happen to be in the unknown region will never be so great that the 'Zeppelin' could not get near it in a few hours before the mobility of the ship would be completely spent.

"The bases for our expedition will be in Nome and Leningrad. We will travel from the Murman coast, over Franz Joseph Land, through the region about the north pole, on through the regions north of the North American archipelago toward Alaska, and thence to Nome in Alaska. From Nome the return trip will be nearer the Siberian side of the unknown region.

"Over this route we do not have hopes of discovering much of marine life. There is scarcely any extant. However, we are going to penetrate the secret of this barrenness too. Since the region is mostly covered with ice, the chemical properties of light are absorbed before they can reach the water. And where there is no light there can be no life of either the plant or animal variety.

"In case we do discover land or islands on our course, it is going to be simple for us to make an accurate photographic survey while flying over the section. The dirigible is ideal for surveying purposes.

Underneath, fore and aft, will be suspended two cameras in horizontal positions. Photographs will be taken simultaneously by these cameras wherever we choose to go. We have high expectations of solving the north-polar sea riddle."

2369
**FUTURE SUPPLY OF METALS
 PERILED BY BIG DEMAND**

Nature's mineral cupboards are running low in some sections of the world, and experts are wondering if our present efficient applications of science and technology can keep pace with the demands of coming generations. In America, according to D. F. Hewett, of the United States geological survey, vast resources of iron, copper, lead, zinc, silver and gold have been attacked so vigorously that many districts are approaching exhaustion, and production is being kept alive only by the application of refining methods to low-grade ores. The digging of deeper shafts is another indication of the tremendous drains that are being made on the supply of metals. In Europe, there is a trend toward agreements to control such metals as iron and steel, mercury, aluminum, lead and copper.

*Before American
 Institute Mining, Eng.*

*Bill Telephone Laboratory
195 Broadway, New York*

*2313
Lieut Frank H. Barber
Oakland*



Aviator's Face Mask with Its Stiff Nosepiece, Which Allows Free Breathing Regardless of Wind Pressure

AVIATOR'S FACE MASK PERMITS FREE BREATHING

Fastened to the helmet by snaps, an aviator's cold-weather face mask, devised by a California air-mail pilot, has a stiff leather nosepiece. This retains its shape in all wind pressures and hence does not obstruct the breathing.

NICARAGUA CANAL TO SAVE TIME IN SHIPPING

Interest in a proposed canal across Nicaragua has been revived with a suggestion that surveys be made as soon as practical to more definitely determine what the costs would be and what results would

accrue. The channel would materially reduce the shipping time between Atlantic and Pacific ports in this country.

MOVIES IN THREE DIMENSIONS BY NEW SCREEN

2383 Motion pictures that seem to possess depth from any position, a true stereoscopic effect, and that do not require the use of special viewing apparatus, are now possible.

The method is essentially that followed in producing still pictures of stereoscopic nature. The screen is of translucent material and just in front and behind it are vertical gratings with wide opaque strips separated by much narrower transparent areas. A large number of motion-picture machines project upon the screen from a number of films that were made with many cameras placed on all sides of the subject. The result is that, no matter where the spectator sits so long as he is in front of the screen, he sees the picture in relief. Because of the gratings, one eye sees a picture made with one camera and the other the next, made with another camera. This produces the stereoscopic effect.

not made by Kullie

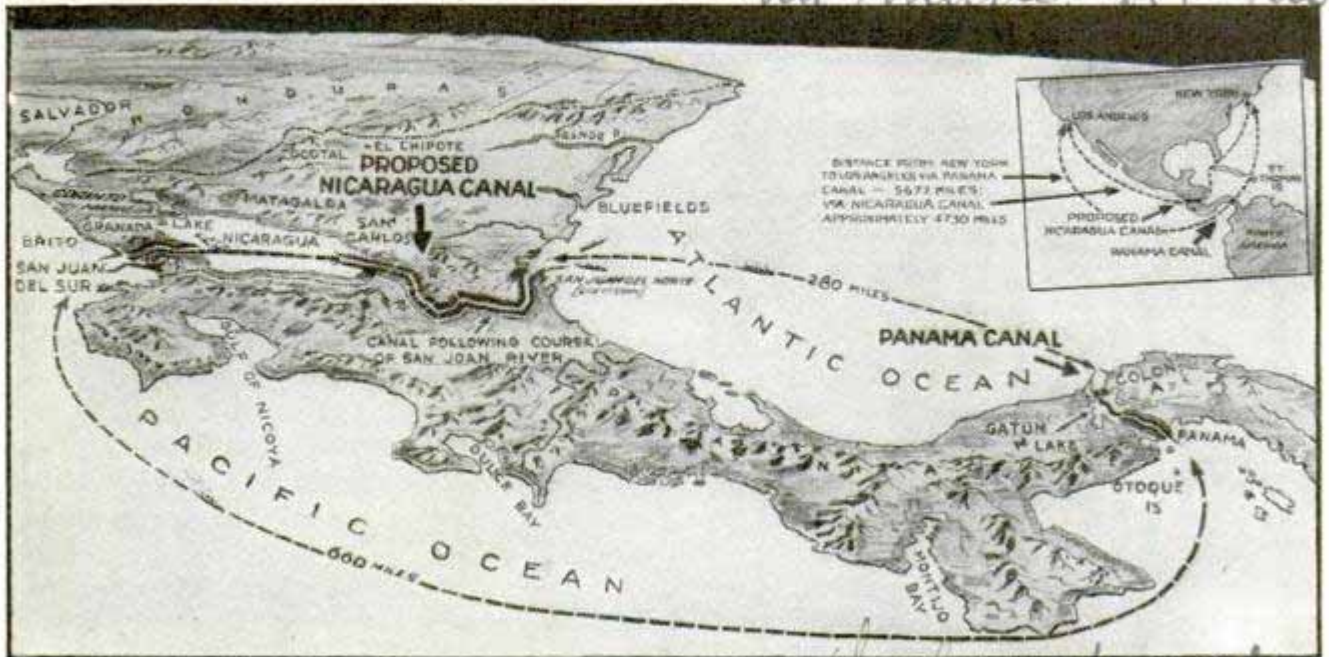

Diagram of the Proposed Nicaragua Canal Showing Routes and Distances as Compared with Those That Now Have to Be Traveled When Using the Panama Canal

International

JOINING OCEAN CABLES CALLS FOR SPECIAL HANDS *2401*

Of the many odd jobs in modern industry, few demand the skill of the cable joiner's, the master electrician who connects the ends of ocean telegraph cables. His task is all the more difficult because it involves physical requirements that bar many workers. In making a joint at sea, the electrician first exposes the copper core of the cable for several inches back from the two ends and then makes a mechanical "weld." Next begins the difficult part. He softens the gutta-percha on each side of the weld and manipulates it gently with his fingers from both sides of the gap in the insulation toward the completed weld and gradually builds up the section until it is the same size as the rest of the cable and absolutely air and water-tight. Many workers who know the tricks of making the joints are barred, however, for if their hands are inclined to give off an appreciable amount of alkali, they cannot make an air-tight joint. Every joiner is tested in the cable factory before he is permitted to attempt the work at sea. The importance of tight joints is easily appreciated. The last transatlantic cable cost \$1,800,000 and has five joints. A break in any one would result in costly delays and great repair expense.

WIRE NET ON GOLF-CLUB HEAD HELPS RECOVER BALLS *2365*

To help retrieve golf balls from water hazards, or other difficult places, a chain dip net has been put on the market which is attached to the steel head of the club with a clamp, as shown in the photo. It is quickly adjusted or removed, weighs only a trifle and occupies but little space in the caddy bag.



More than half of the coffee grown in Brazil is imported into the United States.

Wm. Fred J. Foster

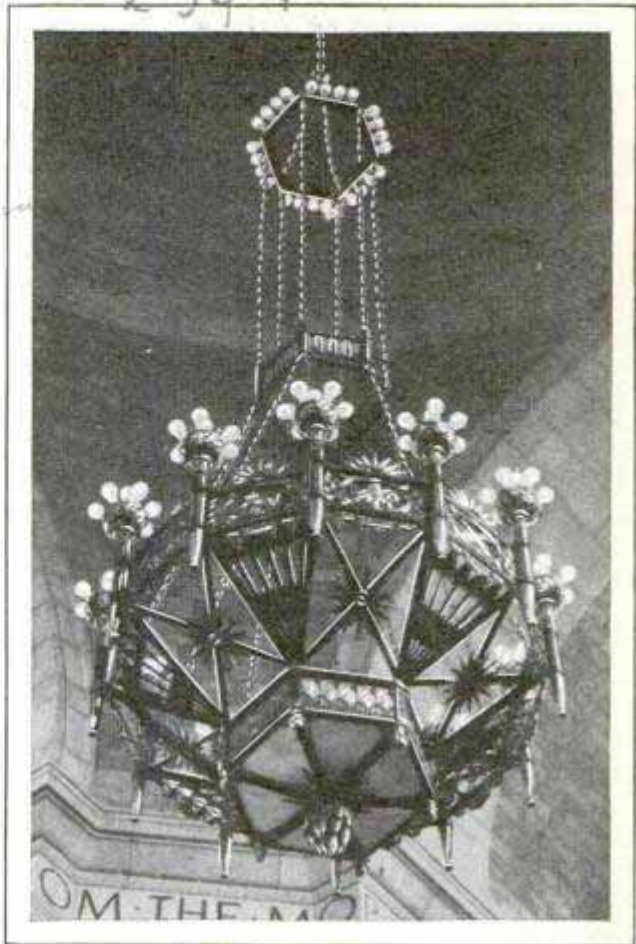

Huge Chandelier Installed under the Dome of the Nebraska State Capitol at Lincoln

CHANDELIER OF MANY LIGHTS WEIGHS OVER TON

One of the largest single pieces of lighting equipment ever made is the bronze and glass chandelier recently suspended from the top of the inner dome of the Nebraska capitol building at Lincoln. It weighs 3,500 pounds, aside from the huge chain that supports it, and holds 136 light bulbs which are specially adjusted to illuminate the huge area.

TINTED GLASS FOR GREENHOUSE HELPS PLANTS GROW *2396*

Glass of a greenish-yellow tint as a substitute for the clear variety, is being used successfully for greenhouses and sun boxes in Germany. It is said to give a light much more restful to the workers' eyes and also aids in the germination of seeds. In one test, sixty per cent of the seeds planted sprouted under the colored glass, as against twelve per cent under plain glass. Plants raised under the new glass also remained green longer.

*Chlorophyll 1918
Fighting 1918
D. C. 1919*

230
All mounted in lecture before
French Academy of Sciences

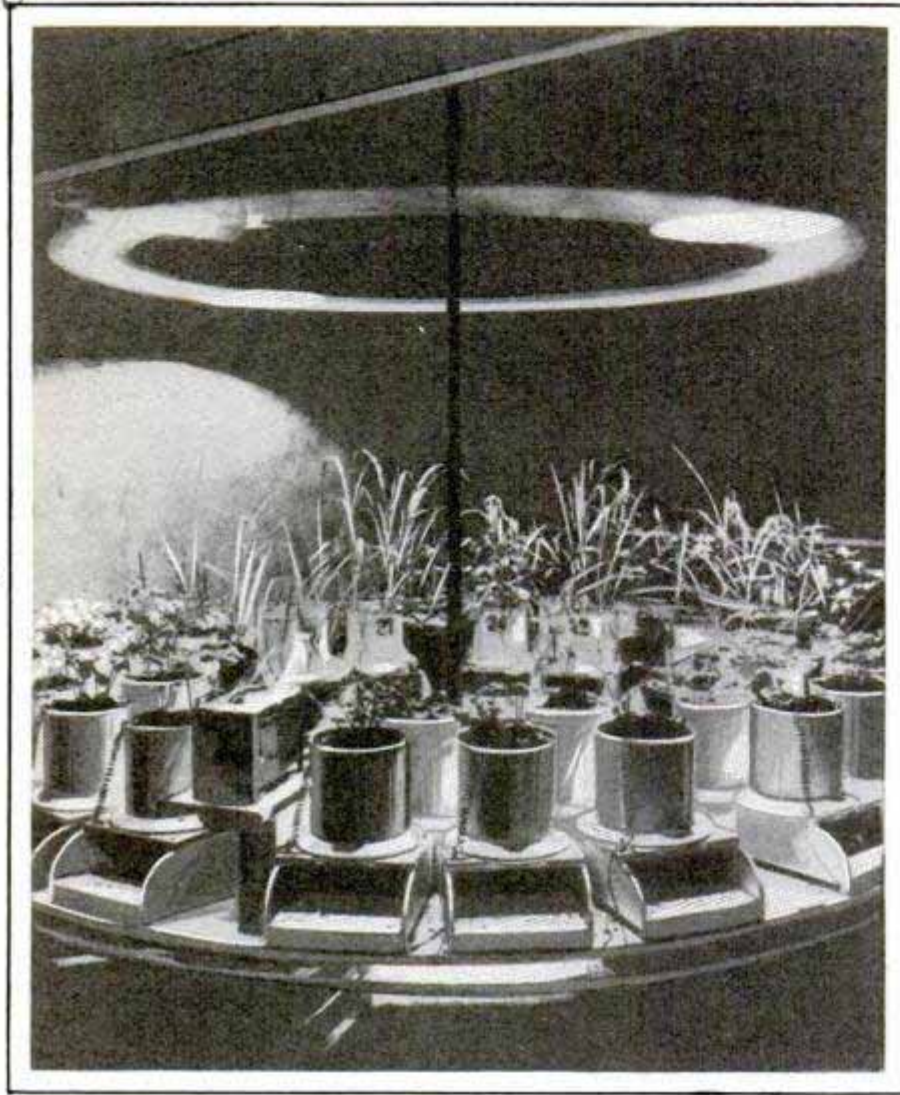

Growing Strawberry Plants under Electric Lights; Development of the Berries Was Rapid, but the Method Is Costly

BERRIES RIPEN IN FORTY DAYS WITH ELECTRIC LAMPS

Strawberries were grown and ripened in forty days, as against the eighty that nature requires, in an experiment conducted by Georges Truffaut and Mr. Thurneyssen, Paris scientists. As a substitute for the sun, they used two 1,200-watt electric lamps set four feet above the plants. While their method was interesting, it holds little commercial possibilities under present conditions, as each berry, so grown, cost about \$5.

MYSTERY OF RADIO ECHOES PERPLEXES ENGINEERS

Radio stations in Holland, co-operating with the Norwegian telegraph department, are trying to solve the mystery of short-wave wireless echoes, noticed a few weeks ago when one of the stations broadcast

signals on a special wavelength. Repetitions or echoes of the impulses were heard at Oslo at intervals of three to fifteen seconds after the signals left the transmitter. Since the waves travel around the earth in one-seventh of a second, it seemed clear that the delayed signals must have been reflected from space millions of miles beyond the earth and the Heaviside-Keneally layer, which many experts have thought impenetrable to the waves. There is no known body in space at the necessary distance from the earth to reflect the waves at the intervals that were recorded. Professor Stormer, of Oslo, believes that the phenomenon may have been due to the formation of "reflecting surfaces or areas" in space, caused by the position of the sun in reference to the earth at the time the ex-

periments were made. The delayed echoes were not registered at other times of the year. The echo phenomenon was noticed in the months of February, March and October.

BLADE REMOVES MORTAR AND PRIES BRICKS APART

235 5



To save time in cleaning used brick, a chipping tool devised by a western man is said to be an improvement over the ordinary hatchet, as it has a more slender blade. It can also

be used to pry bricks apart, and is not so liable to break them either when knocking off the mortar or removing them.

and H. J. Jenkins

Chas. Walter, Ore

**WORMS GIVEN SPECIAL DIET
MAKE BETTER BAIT** 2302

Worms kept on a special diet before being used as bait, are more tempting to fish than those that have been just taken out of the ground, the department of agriculture reports. According to W. R. Walton, the worms should be placed in a container partly filled with moistened moss for three or four days before they are used. A special variety, sphagnum moss, found in the damp north woods, is preferable, but other kinds will do. If the worms are kept longer, the diet should be varied with sweet milk every week, and the moss should be washed every ten days. At the end of a few days, the worms become pink in color, which hue is evenly distributed, and, in the water, the contents of the stomach can be seen through the skin. The diet is especially valuable in preparing worms for game fish, such as trout, Mr. Walton found. It makes the worms more lively, tougher and easier to handle and for some unknown reason makes the fish bite much quicker.

Handled by and hand...

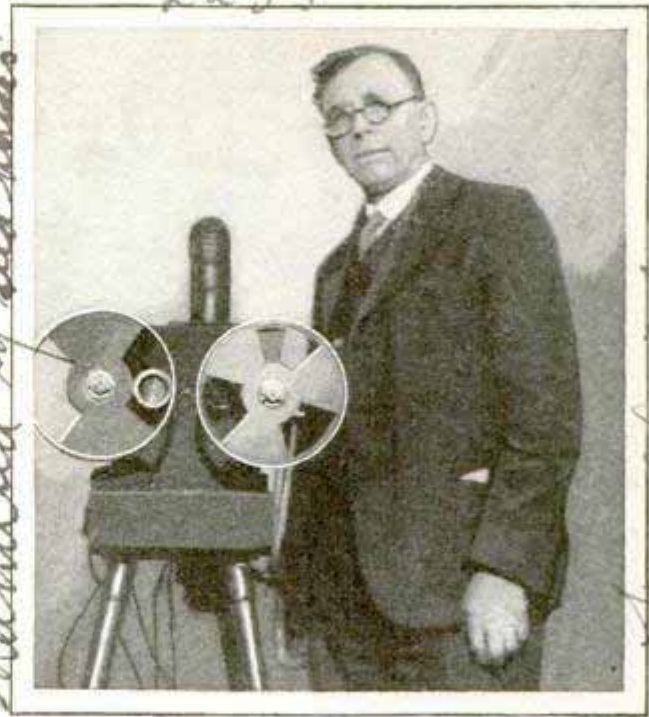

Moving-Picture Projector with New Shutter That Overcomes Flicker in Image

**FILM SHUTTER STOPS FLICKER
AND SAVES NEGATIVE**

Flickerless motion pictures can be made on two-thirds the quantity of negative now required, it is asserted, with the aid of a special projector shutter which a southern inventor has introduced. An important part of the unit is a small auxiliary shutter which runs reverse to the main one and is said to affect the light in such a way that the projecting machine can be run at almost half the rate of the ordinary apparatus and still produce clear, steady pictures. Cameramen will be able to take the films on shorter lengths, thus effecting marked saving on originals and copies, it is suggested.

*Mr. C. D. Allenby
4106 S. and St. Louisville*

Ann.

**TAKE AIR FROM SPARE TIRE
TO INFLATE FLAT ONE** 2261

Flat tires can be inflated with air from the spare tire through an emergency connection lately introduced for the convenience of the motorist to save using the hand pump. It is applied in a few seconds and may also be used in obtaining equal pressure in all the tires by allowing air

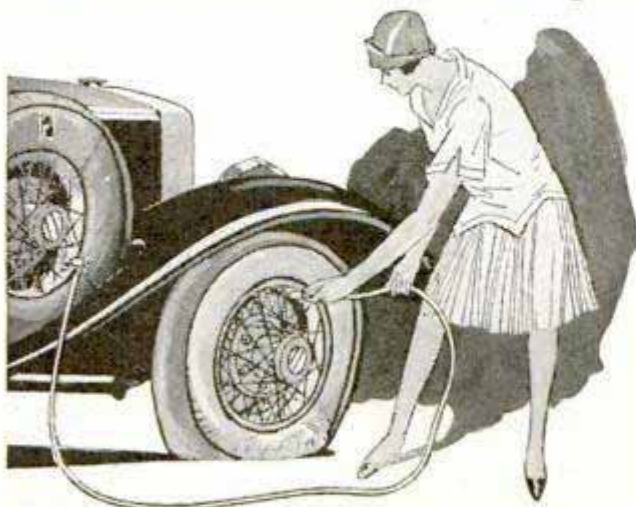

Spare Tire Serves as Air Tank for Emergency Filling of Tire in Use

**COIN NEW WORD TO DESCRIBE
TELEPHONE'S EFFICIENCY** 2301

Progress in science and industry is constantly demanding new terms and one of the latest of these is the word "decibel," coined by telephone engineers to describe the efficiency of telephone circuits. It is a substitute for the phrase "transmission unit." The actual unit decided upon was first called "bel," after the inventor of the telephone. The bel, however, is larger than is needed in practice, and, therefore, a unit one-tenth as large was adopted by engineers and named the decibel.

to pass between them until the pressure is equalized.

The Camp Mfg Co

*June Service
News Bulletin N.C. 2/6/29*

2089 Chicago Aerial Survey Co
332 S. Michigan St.
Chicago, Ill. Chicago

Lifting A River



Copyright, Chicago Aerial Survey

Chicago Is Taking a Bend Out of Its River to Uncork a Bottleneck South of the Loop District; the White Shows the New Channel Already Dug, and Dotted Lines the Work Remaining

PASSENGERS on incoming trains at Chicago a few months ago were surprised to see the giant steel leaves of a big bascule bridge rising into the air above a busy street, where there was nothing for it to span. While workmen placed the steel, two lines of street cars and all the traffic of a busy thoroughfare poured through the base of the bridge.

Weeks later, with the bridge complete, a portion of the street was removed, the leaves dropped into place, and then a dredge came along and dug a river beneath it. Chicago was off on an ambitious plan to turn a backyard river into a civic asset, flanked with broad double-decked boulevards and lined with mammoth skyscrapers.

As the first step in the new development, the Chicago river—the stream that has run backward since the drainage canal was completed years ago—was unknicked to open a bottleneck that has checked traffic to the south of the so-called “loop”

or downtown district of the city, so that three new main traffic arteries could be cut through. To prepare for the digging of the new channel, which removes a big eastward bend of the stream, the city's engineers built the new bridge and had it ready before the channel was dug.

The moving of the river involved a readjustment of property valued at millions. Seven railroads, as well as the city, were affected. Railroad yards on one side of the river had to be sold to rival railroads on the other side, as they changed locations when the stream was moved. The readjustment also took a kink out of all the railroads entering two big terminals, the LaSalle and Grand Central depots. After the tracks are straightened out, following the completion of the new channel and the filling of the old this spring, LaSalle, Sherman and Wells streets will be continued through, to relieve the burden now concentrated on four through streets to the east.

Out Of Its Bed

The development of the river front as a civic asset really started in 1920, when it was bridged at Michigan avenue with a double-deck structure, the top level for pleasure vehicles and the lower for the freight traffic to the near-by piers and warehouses. Encouraged by that success, the next step was the condemnation and wrecking of the South Water street produce market—several blocks of old three, four and five-story warehouses that backed up to the river—and their replacement by a broad two and three-level street, enabling traffic bound from either the north or west sides of the city to reach the other without passing through the congested loop district. One

section of Wacker Drive, the new river boulevard, has three levels, a top one for automobiles, a second one for trucks and drays, and a third street at the dock level.

Architects began to turn to the river front and utilize it in developing new buildings. Two, the new home of the Chicago Daily News and the new Chicago Civic Opera House, each occupying a block of river frontage, face each other across the stream, while the monumental development is carried on westward by the vast concourse and central office building of the new Union station. The opera house, which, in addition to the main theater, seating 3,400, includes a smaller theater for more intimate performances and an enormous office building, is to be opened next fall. The News building will be occupied this spring. The newspaper office structure is built over the railroad tracks adjoining the Union station, the

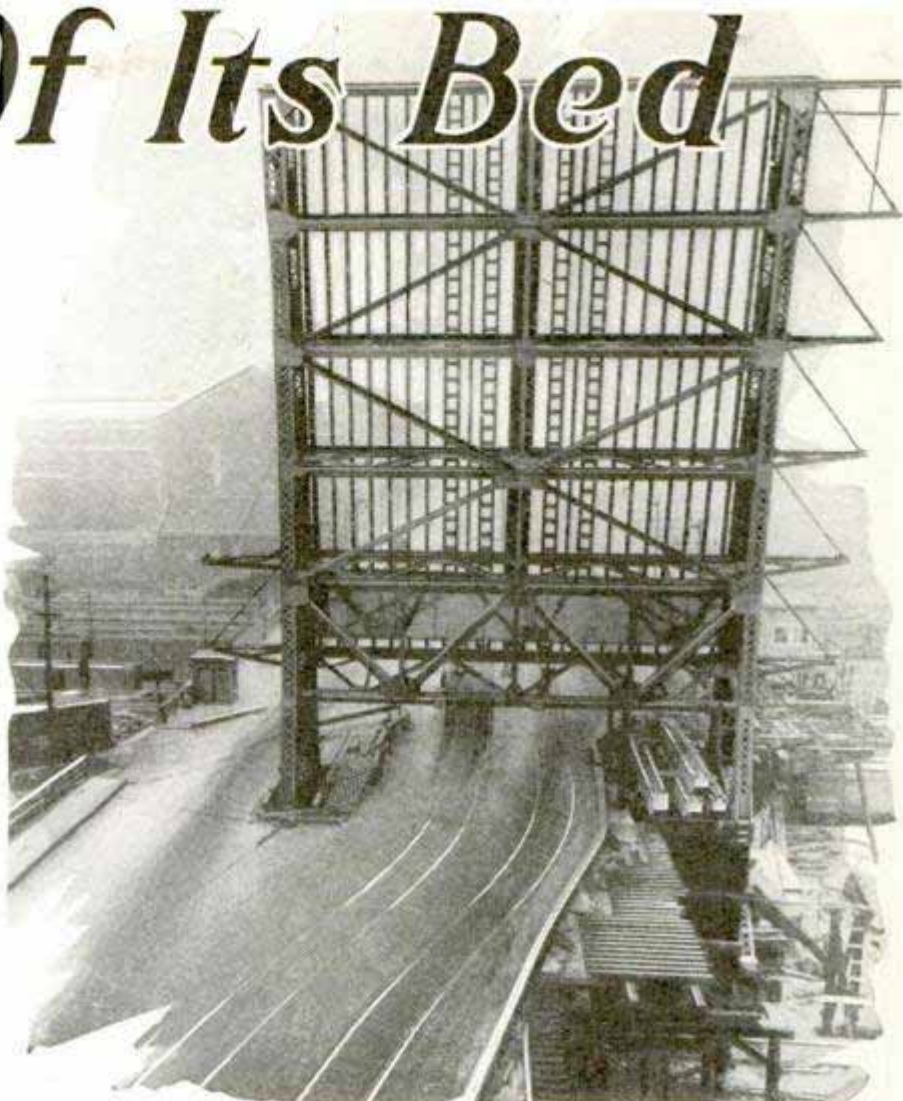

This Bascule-Bridge Leaf and Its Mate Were Built over a Busy Street; Then a River Was Dug beneath Them

first Chicago building to utilize leased railroad air rights.

Another air-right building is nearing completion, the eighteen-story Merchandise Mart, with three and a half million square feet of floor space, and plans have been completed for a third, to be the tallest building in the world. To be called the Apparel Mart, it will house, in its seventy-five story, 880-foot main structure and tower, an office building, hotel, garage, convention halls, restaurants, two clubs with swimming pools and all facilities of club life, and thousands of feet of display space for wearing-apparel manufacturers.

Fronting two blocks on the river boulevard, with a cross street running through the center of the building, the main entrance will be on the upper street level, with a "mezzanine basement" below and a railroad yard below that, so that Pullman cars carrying parties to conventions

2089
804

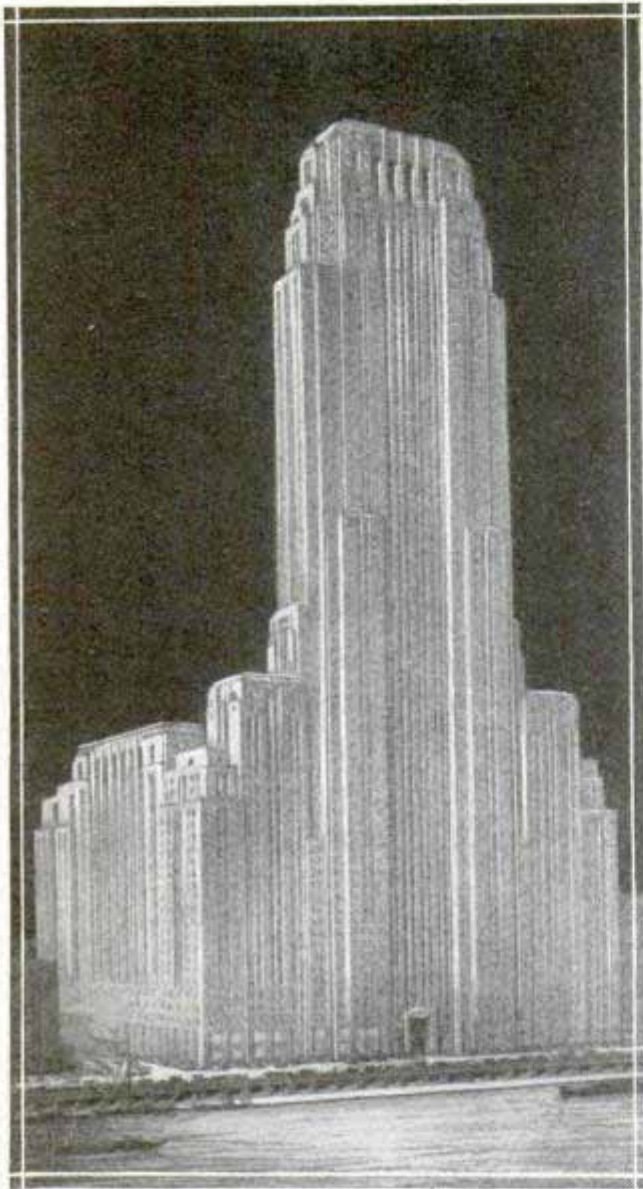

Courtesy Walter Ahlschlager

in the building can deliver their occupants to the elevator doors, to be carried up to the hotel section. Beneath the railroad yards, five subbasements will house the mechanical equipment of the structure, a complete city within itself.

The Apparel Mart is the first unit in a plan for development of sixteen city blocks of railroad-yard air rights, with Grant park on one side, the river boulevard on a second, and Lake Michigan on the third. As the first step in that development, the city has ob-

tained authority from the war department to bridge the river again, this time almost at its mouth, with a new boulevard, linking the Grant park and southern park system with the Lincoln park and north-parks boulevards. Miles of islands are being built in the lake along the city's water front, connected with each other and with the mainland by bridges, so that eventually it will be possible to drive from one end of the city to the other without ever passing through city streets, or being held up by cross traffic.

Describing the plan commission's ideas in river development, Graham, Anderson, Probst & White, architects of the Opera House and Marshall Field company's Merchandise Mart, explain:

"The men whose vision has seen Chicago in its future magnificence, have thought of the grand possibilities of this river, as contrasted with its present un-



Courtesy Graham, Anderson, Probst & White

The Apparel Mart, Top, Will Be the World's Tallest Building, While the Merchandise Mart, Below, Will Have over Seventy Acres of Floors

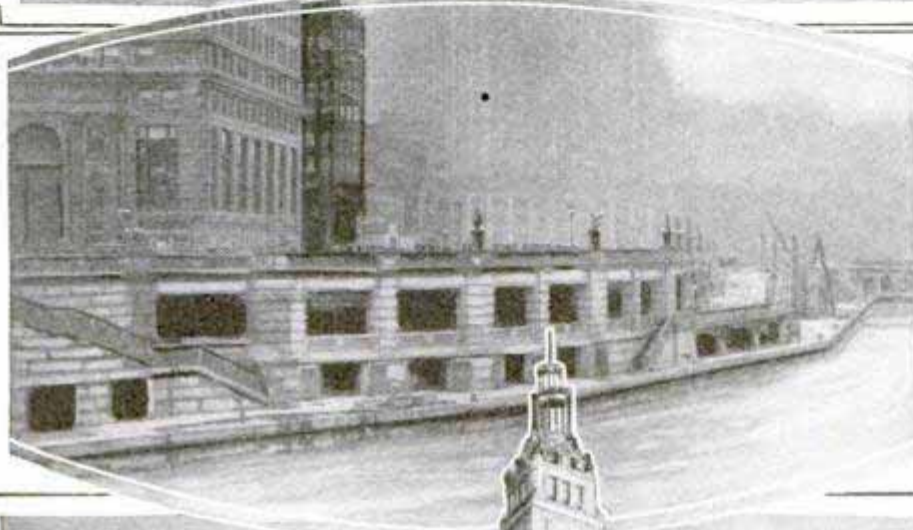
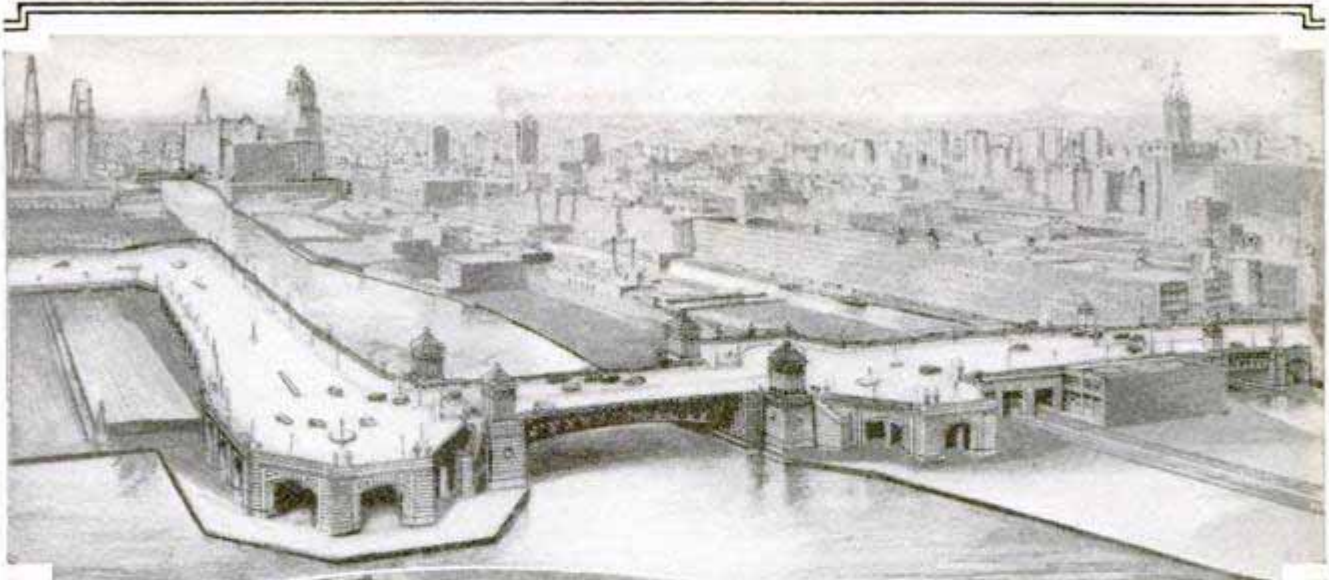

As Part of a Vast Boulevard-Drive System, Running the Length of the City on Island Parks, Chicago Is Preparing to Build This Bridge across the River Mouth, While a Second Lift Bridge, at the Extreme Right, Will Span a Warehouse Slip; at the Left, a Section of Three-Level Street in the Wacker-Drive Development; the Top for Pleasure Cars, the Second for Trucks, and the Lowest Serving Steamer Docks

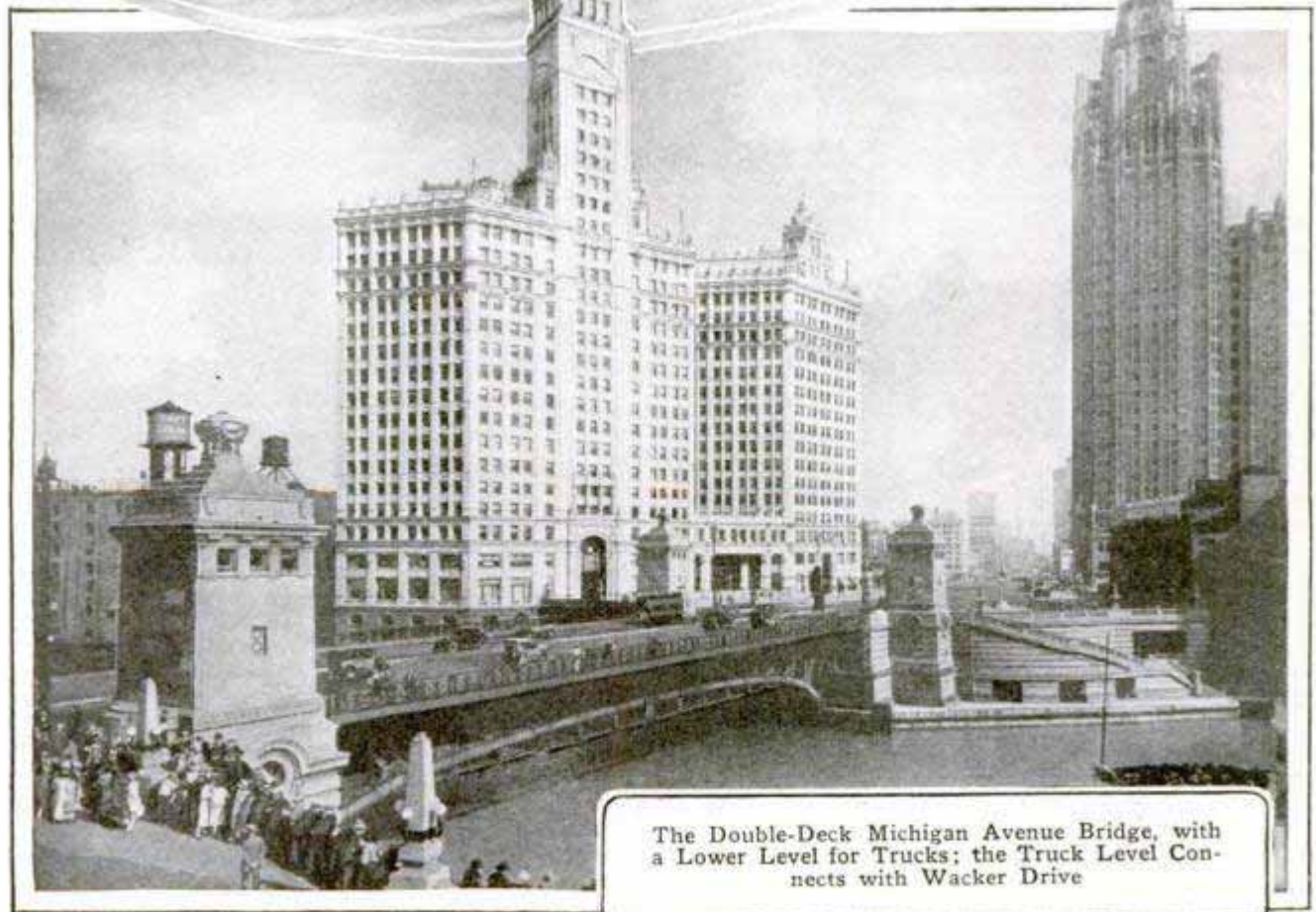

The Double-Deck Michigan Avenue Bridge, with a Lower Level for Trucks; the Truck Level Connects with Wacker Drive

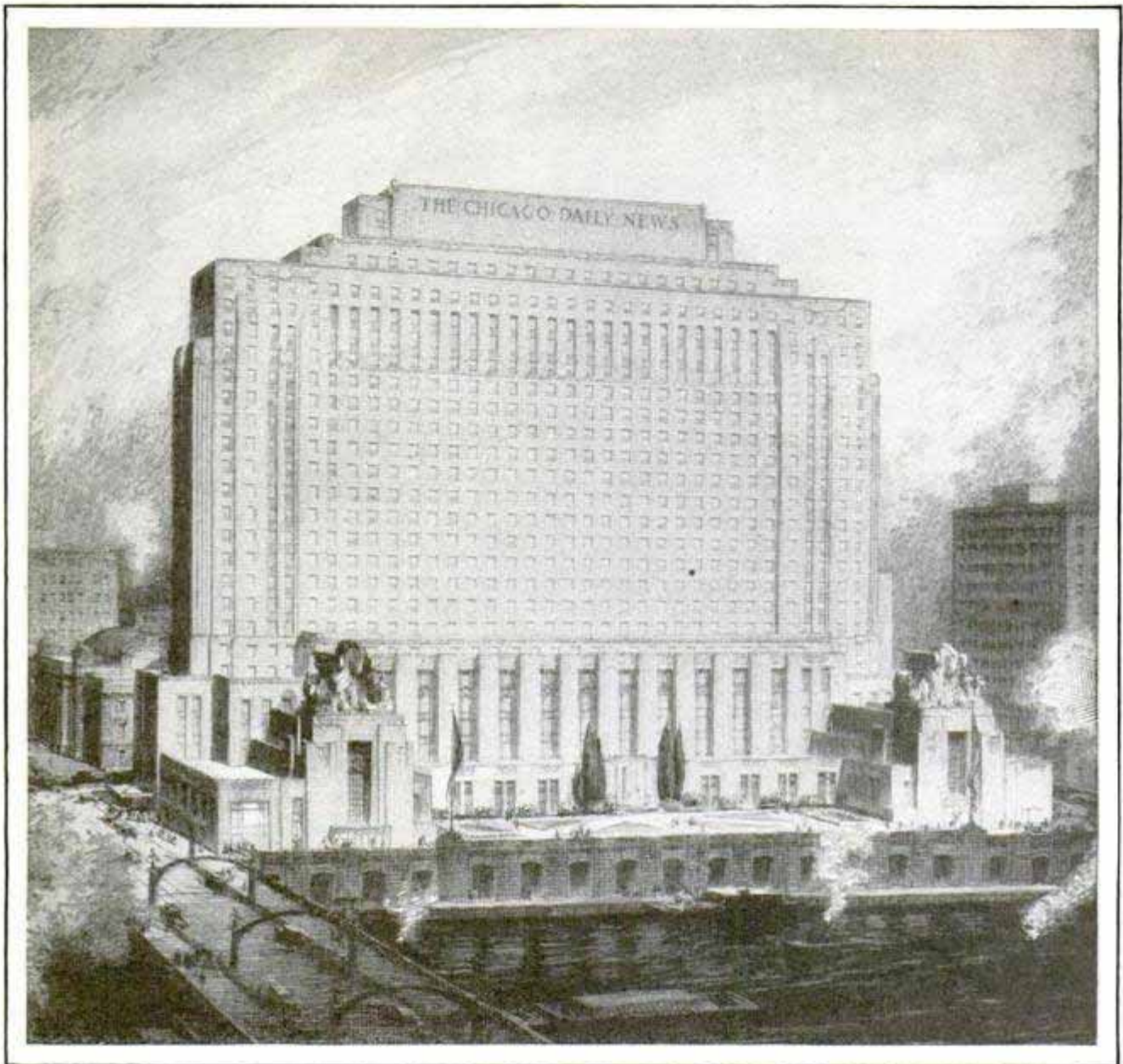

Courtesy Chicago Daily News

Facing Each Other across the Chicago River, the New Daily News Building, Recently Opened, and the Opera House, on the Opposite Page, Are Typical of the New River Skyline

kempt and neglected banks. Great cities of ancient and modern civilization have had similar opportunities. In Rome, the Tiber presented to the builders of the capital of the empire a problem which they handled in their own grandiose manner. The banks of the Tiber, the bridges across it and the islands in the stream were considered as opportunities for embellishment rather than difficulties which could not be handled. The Thames, in London, the embankment and bridges spanning it are as dear to the Londoner's heart as they are admired by the millions of visitors who go to the city. The architects of the bridges and the grand character of the buildings on the banks are reasons why the Thames is thought of as a civic asset

to the city. The bridges of Paris and the banks of the Seine have been brought to their present romantic and magnificent aspect by the courage and imagination of the citizens and builders of Paris from centuries ago to the present day. The banks of the Seine and the boulevards at the side are a very fair parallel to our Chicago river possibilities. In Florence, the streets which run alongside of the Arno show what city planners can do by putting the river in front of the city plan instead of back of the buildings along its banks, and the result, while not so pretentious as in Paris, is an extremely delightful one."

In planning the Merchandise Mart, the Marshall Field company voluntarily placed

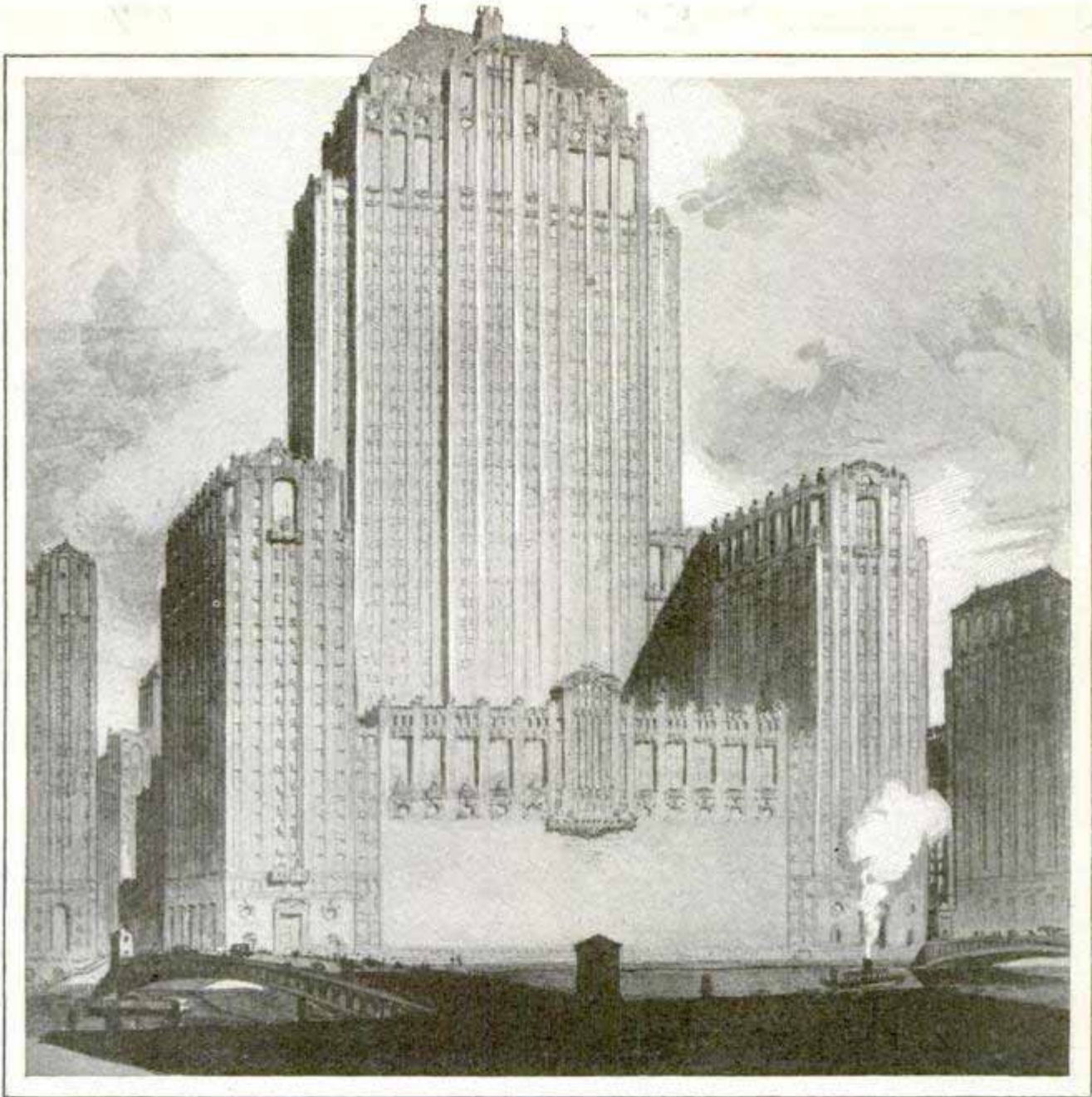

Courtesy Graham, Anderson, Probst & White.

This Vast Office Building and Theater Combined Will Open in the Fall as the Home of the Chicago Civic Opera; the Office Rents Are Expected to Pay the Opera Losses

its river side sixty feet back from the river, sacrificing that much of their land for a double-deck boulevard, which eventually will be a part of a north-bank system rivaling Wacker Drive, on the opposite shore.

Plans for the Chicago of the future were laid many years ago largely through the efforts of the late Daniel Burnham, an architect whose name was closely associated with the development of the skyscraper. As a result of his efforts the Chicago Plan Commission, a private civic organization, has for years prepared plans for boulevard, park, lake-front and river developments under a unified scheme. The various governing bodies accept the plan

commission's recommendations, and bond issues supported by the commission usually pass the voters.

One of the projects for which money is to be asked soon is a seven-mile elevated highway, running in a straight line from the turn of Wacker Drive at the bend of the river to the northwest side of the city, to furnish high-speed automobile connections with the northern suburbs, Milwaukee and other Illinois and Wisconsin cities.

Write our Bureau of Information, if you wish to know who makes or sells any article described in this magazine. Send no postage; the service is free.

Winter Haven Florida

news & opinion 4/11/24 2/7/29



Not an Accident, but a Normal Performance; Outboard Motorboat, after Somersault at Full Speed; Occupant Is Safe Inside

SPEED BOAT IN SOMERSAULTS GIVES WATER THRILLS

Something different in speed craft appeared recently at a Florida resort in an outboard motorboat that rolled over in somersaults at full speed without injury to the pilot. In that respect, the boat is somewhat similar to those used by the Eskimos who can turn completely over in their frail shells and bob out of the water again. The boat is so built that the interior is dry and the occupant is securely kept from falling out.

HOLDER FOR FIRE-HOSE NOZZLE DOES WORK OF SIX MEN

To hold and direct the powerful stream of water from a fire hose at full pressure, usually requires several men, but a unit that is said to do the work of six, thereby freeing them for other duties, has been devised in Scotland. It is simply a tripod



arrangement on a substantial wooden base upon which the nozzle can be firmly held and directed at almost any angle by means of levers and a brake, operated by a thumb-screw. Connection is quickly made with a hose.

GERM SPRAY ROUTS PLANT PESTS

Visions of the possible war of the future are seen in attacks scientists are now making against various insects that devour crops and orchards. The pests are being sprayed with a material that is loaded with the spores of a parasitic fungus which kills the insects. A Porto Rico expert recently waged a successful attack against lice that feed on egg plants, peppers and other

vegetables. The practical extension of this method depends largely on obtaining a sufficient and cheap supply of the fungus. At present, farmers cannot raise their own because it requires a greater technical equipment than the average farmer commands. Commercial insecticide manufacturers can hardly undertake to raise the fungi because their copper and lime dusts are poisonous to it.

ICE PICK WITH SPRING HANDLE PREVENTS CHIPPING

Operated on a "breach loading" principle, an ice pick now on the market is said to simplify the task of breaking up ice, reduce waste and save time. The point of the pick is placed and kept against the ice while force is applied with the handle that moves up and down as a plunger. A spring inside instantly raises the handle for another tap.

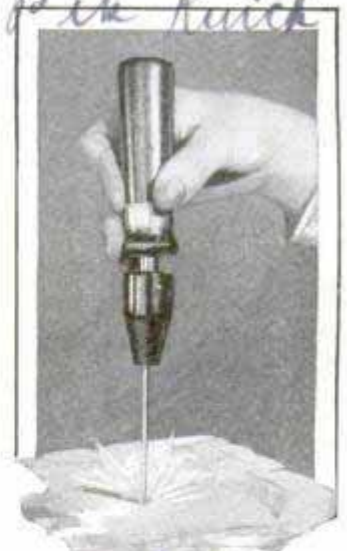

25 Cent.

Whenever you find that you wish to know more about any article in this magazine write our Bureau of Information.

W. L. Lane 53-55 Beach St. New York

Unusual Wreckage; School of Whales, Stranded on South African Shore, Being Removed with Teams for Disposal Before Decay Set In



STORM "SHIPWRECKS" WHALES ON AFRICA COAST

During a severe storm off the coast of South Africa, a large number of whales were washed into shallow water and died before they could swim back from the shoals. Emergency workers were recruited to dispose of the carcasses.

ELECTRICITY IN SMALL TOWNS SHOWS INDUSTRY'S GROWTH

One of the most interesting indications of the rapid development of applied electricity in this country is the spread of transmission lines to hundreds of small towns and villages that now enjoy the same twenty-four-hour service afforded the large cities. Since 1923, more than 4,000 such rural centers have been supplied with electricity for the first time. Light and power are now available to every city and town in the United States with a population of 5,000 or more; ninety-seven per cent of the communities with populations of 1,000 to 5,000 are supplied, and twenty-five per cent of all hamlets with less than 250 population are reached by wires that furnish light and power. Much of this development has been made possible

through improved methods of interconnecting lines. During the past fifteen years, the amount of electricity generated in this country has grown 626 per cent.

SIGNAL ARM FOR CLOSED CARS AIDS SAFER DRIVING

Quickly installed and easily operated, an arrow-shaped semaphore to signal a left turn without lowering the window or opening the door of a closed car, has been placed on the market. It is held in place by clips that fit over the glass when it is raised and is extended simply by pulling a cord. When the string is released, the arrow automatically returns.



Left-Turn Signal Operated by String from Inside

See next Edition Review Feb 1929

2233

\$1.95

National Elec. 290

The Universal Auto Signal Co. Minneapolis

209 E 43rd St New York

2138

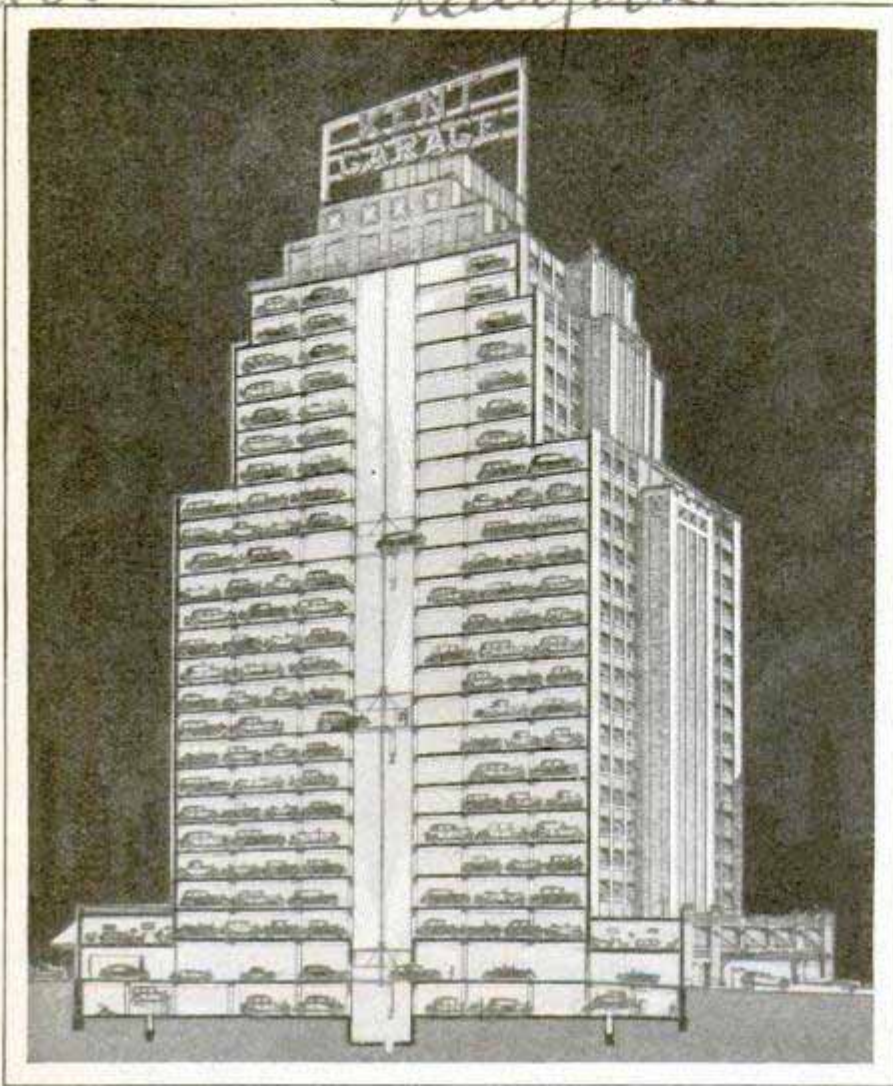

One-Thousand-Car Hotel for Automobiles. Built in New York in Effort to Solve Parking Problem

TWENTY-FOUR-STORY GARAGE HOLDS THOUSAND CARS

A hotel for autos exclusively has been built in New York city to help relieve the parking problem. It is twenty-four stories high and has a capacity of 1,000 cars. They are taken to the different floors, parked in selected spaces and returned again to the delivery room, all by electric control, so that no human hand touches them after they are once placed on the elevators.

NEW ENGLAND PICTURE ROCK MYSTERY SOLVED

2341

Dighton rock, which has been one of the pet mysteries from prehistoric America, has been explained by Dr. Edmund B. Delabarre, of Brown University. The pictures carved on the surface of this gray boulder, gained fame when the Rev. Cot-

ton Mather included the rock in his book on the wonderful works of God. Since then, the rock has done multiple duty bolstering up theories that the eastern coast of America was visited by the Phoenicians, the lost tribes of Israel, the Chinese, the Druids, and the inhabitants of the traditional lost continent of Atlantis. Doctor Delabarre explains that, in photographing the rock by flashlight, he revealed, beneath the childish pictures and signs, traces of the name Miguel Cortereal and the date 1511. Miguel Cortereal was one of two Portuguese brothers who sailed to Labrador in 1501. Later, the other brother sailed back home, and Miguel, who expected to follow, was never heard of again. If Doctor Delabarre's interpretation of the badly worn Roman lettering is correct, Miguel reached

New England and lived there for at least ten years. It also means that the scrawly picture writing on the rock was cut in later and probably is Indian in origin. One difficulty encountered by those who would study Dighton rock is that it stands at the edge of a river, and is exposed by the tides for only brief periods.

TABLE ON TOP OF RADIATOR HELPS PROTECT WALL

2229



A radiator top that may be used for a table in winter or summer, helps keep discolorations from the wall and also directs the heat side-

wise rather than upward into the room. It is easy to adjust and remove for cleaning.

Kay Products Co.

no data

P. 537
811

THE LATEST INVENTION FOR SAVING LIVES AT SEA

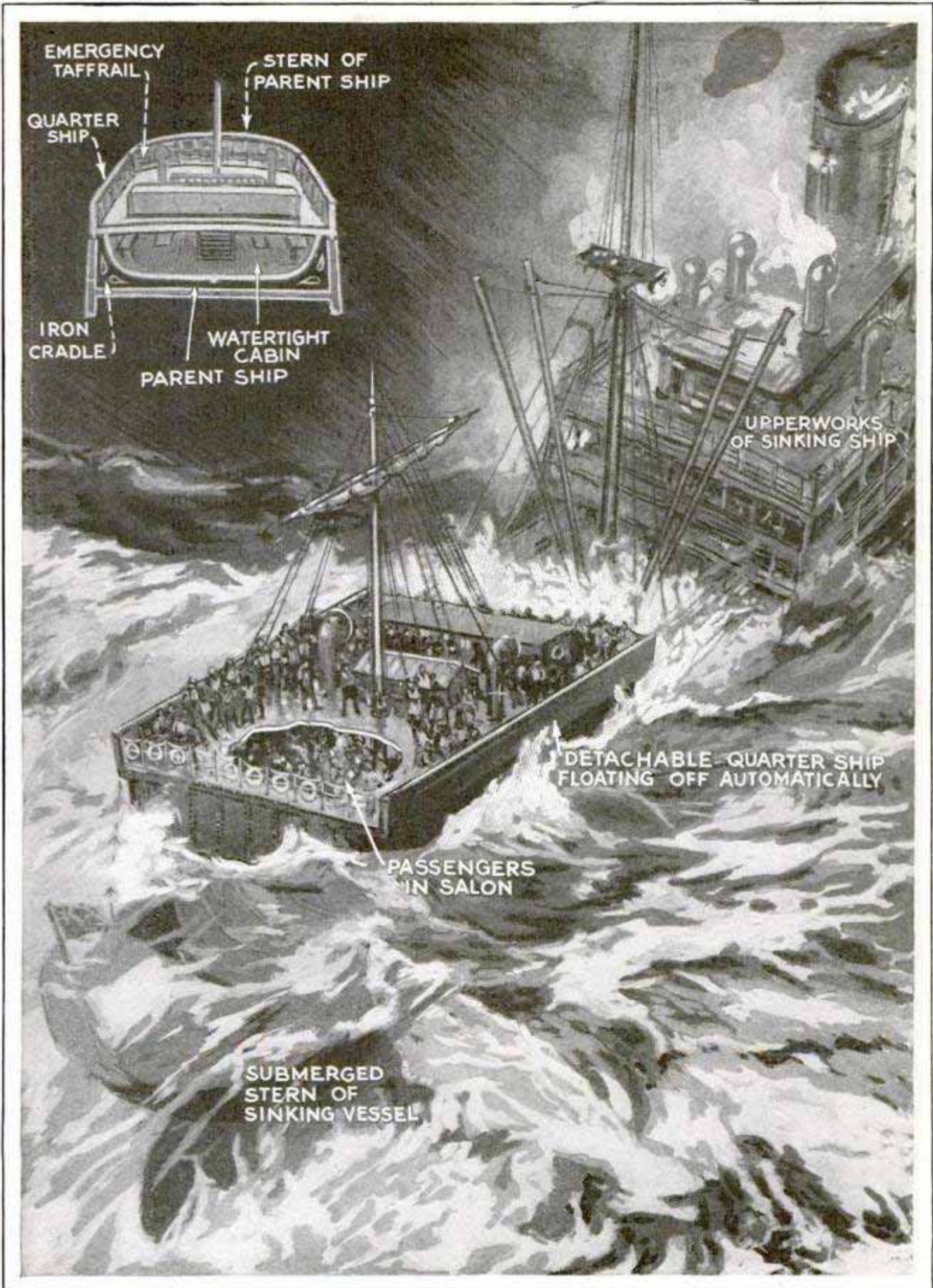

Copyright, D. MacPherson

Duncan Campbell, an English Designer, Has Proposed a Detachable Quarterdeck, Complete with Cabins, Food Supplies and Wireless, to Save Lives at Sea; Ordinarily It Would Rest within the Ship's Hull, but Would Float Free If the Vessel Sank

NIGHT IS TURNED INTO DAY FOR TRAPSHOOTERS



Trapshooting by Night, with a Battery of Floodlights to Illuminate the Clay Pigeons; the Shooters Themselves Stand in Darkness behind the Bank of Lights

This is an age of light and it is not surprising that the trapshooting world should feel its influence. Floodlights totaling 2,000,000 candlepower have proved sufficient for lighting up trapshooting fields for night tourneys. F. W. Ralston, lighting engineer of the General Electric company, who was the first to conceive the idea of floodlighting baseball diamonds for night playing and has been instrumental in lighting soccer fields and golf links, is the man who has made practical the shooting of clay pigeons after sundown. Lights had to be so placed that the beams did not shine into the eyes of the gunners and yet furnished sufficient illumination to sight over the barrels and follow the birds in their flight thirty feet into the air and sixty feet away from the trap house. Because the pigeons were, as a rule, black, yellow rings painted on their backs enabled the gunners to get a clear vision of them as they passed through the beam of light. Lighting the gunners' platform without detracting from the light on the field was accomplished by suspending four deep steel reflectors above the heads of the shooters and two projectors behind them. These were placed fifteen feet apart on

top of posts eighteen to twenty feet high. Mr. Ralston stated that the earliest form of trapshooting at night was done by Buffalo Bill and Anne Oakley with glass balls lighted by means of arc lights suspended in the air. Anne Oakley also did some shooting at targets on the ground. This was about 1894.

227 ORNAMENTS FOR SHADE CORDS
ADD BEAUTY TO HOME

Ornaments of non-shatterable glass, decorated with colored designs and figures that will not fade or disappear in washing, have been introduced for shade cords and light "pulls." They are easily attached, help form a grip on the cords, present an attractive appearance, both in artificial and natural light, and are furnished in many different designs.



Chicago - Miss Anna
A. Rich 236 N.

Hamilton Eye and Ind. Co.

Chicago - 151 N. Michigan

Original copy 2259

Rayton Bliss

AIR-COOLER CABINET FOR HOME TO ROUT SUMMER HEAT

Automatic refrigeration has been developed in a room-cooling cabinet for greater comfort in summer. It is compactly built and contains a cooling coil over which the air is drawn and then directed back into the room at a temperature that soon cools the entire room. In tests, the cabinet lowered the temperature of the average-size room as much as ten degrees in thirty minutes. The outfit is so constructed that the fan it contains may be used alone, without the cooling apparatus, and the moist coils also serve to wash out impurities in the air.

Chicago - 6349 72. Clark

ROLLER MAPS FOR AUTOISTS LATEST AID ON TOURS

At the turn of a knob, information is furnished the traveling motorist from maps, neatly and securely held in a small roller cabinet. The outfit does away with clumsy folders, torn pages and other inconveniences, is about the size of the average book, and holds three rolls that unreel like camera film. Rolls not in use are stored in the container. The special maps pre-

Podagraf



Roller Map for Autoist, with Roll Arrangement That Keeps It in Compact and Handy Form

pared for this holder are said to contain important information for tourists, which is not generally included in the ordinary guide maps.

Mail Steel Products Co

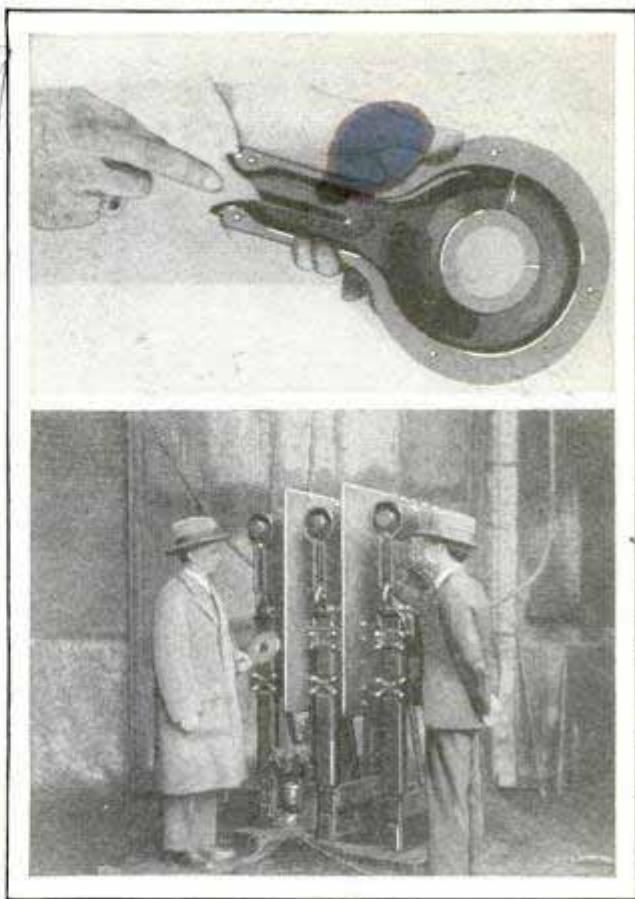

Circuit Breaker Which Stops Flash and Saves the Electric Fuses by Absorbing the Heat

CIRCUIT BREAKER STOPS FLASH AND SAVES FUSE PLUGS

Instead of having to replace plugs when they blow out, it is necessary only to push a small rod, somewhat like an ordinary light switch, when the house circuit is interrupted. This is possible with a device made available through the development of a new type of circuit breaker for high-power commercial circuits. It consists chiefly of two copper plates that perform two "important tricks with the current," eliminating the flash that usually occurs when a circuit is broken. The plates split the current into many smaller circuits and, second, they affect it in such a way that the heat ordinarily produced is reduced to such a degree that it will not even scorch a cotton thread held in the path of the current. The secret of the process is that the copper plates are made to accomplish the practical reverse of what usually happens, that is, instead of creating heat, the current is absorbed.

Our Bureau of Information will answer all questions regarding articles appearing in this magazine.

Chicago - 151 N. Michigan
Joseph Stepanik
Westinghouse Electric & Mfg Co.
Research staff
Earl Puttosh, Pa

Easier Ways

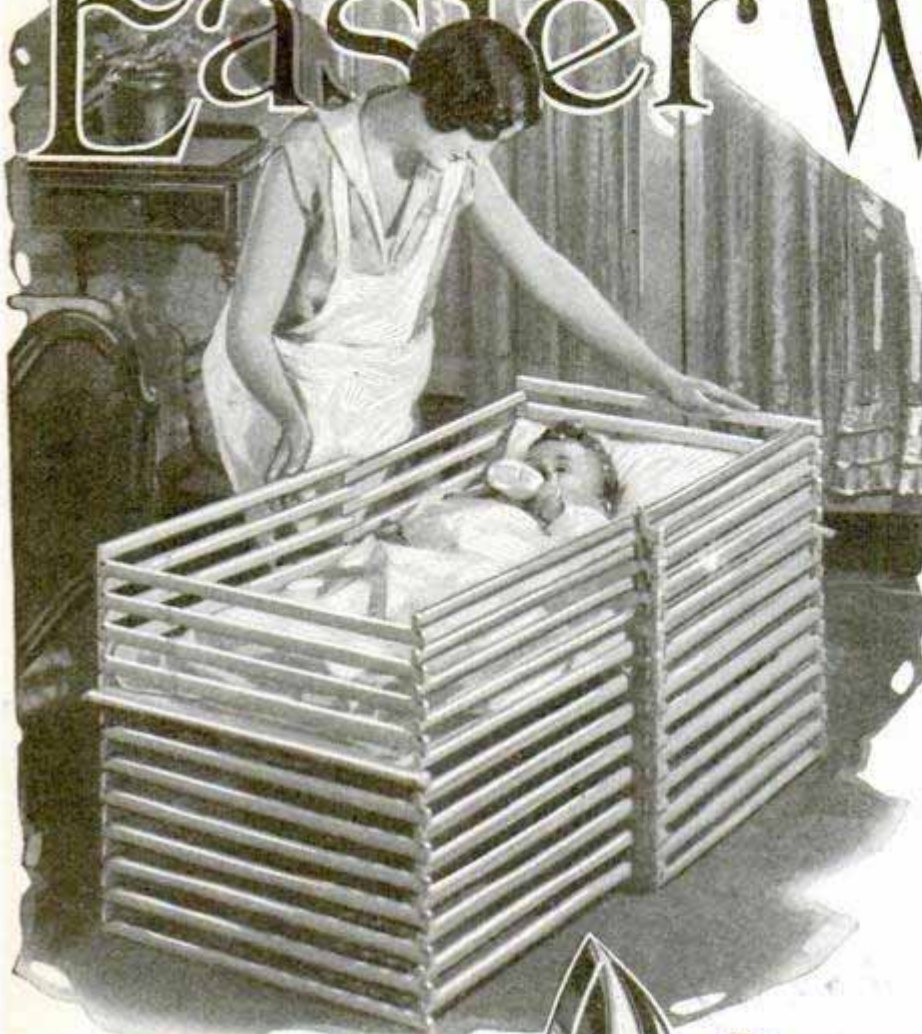

Collapsible Crib for Baby Is Easily Set Up or Taken Down and Fits into Small Space When It Is Folded Up; the Bed Itself May Be Adjusted to Different Heights



Stool and Ladder Are Combined in This Useful Article for Kitchen and Other Service; the Top Locks Open for Support

This Electric Iron Has a Ventilated Handle of Bakelite in Different Colors and a Control Switch Operated by the Thumb

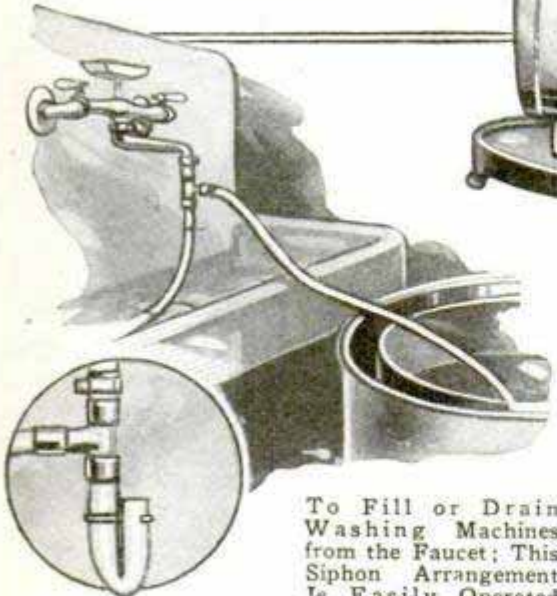
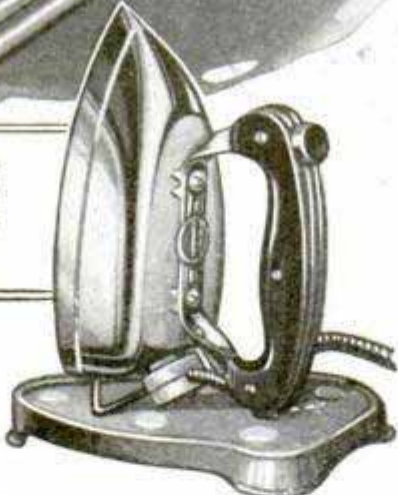

To Fill or Drain Washing Machines from the Faucet; This Siphon Arrangement Is Easily Operated and Quickly Attached



of Doing It

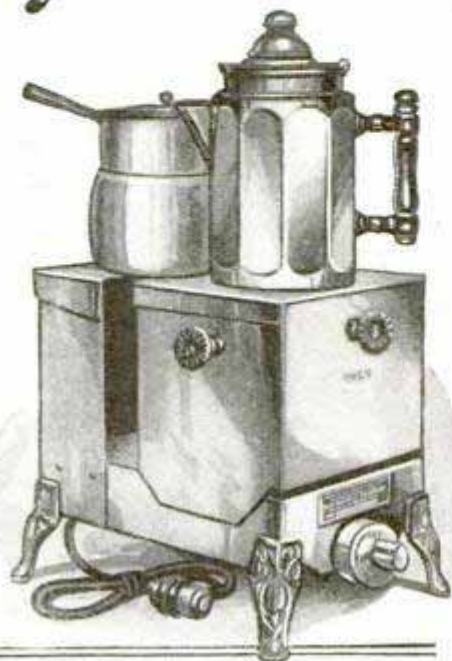

Electric Stove for Use on Table Has Burner Plate and Oven; It Will Cook, Bake or Roast and Keeps Foods Hot; Operated from 110-Volt Direct or Alternating-Current Socket



Electric Floor Buffer Gives a High Polish with Little Labor After Wax Is Applied; It Reaches Difficult Places and Weighs But Fourteen Pounds



Detachable Chair Pad, Below, Is Furnished in Different Colors and Designs and Is Washable in Certain Materials; a Heavy Felt Foundation Promotes Comfort; Loops at Rear Hold Pad in Place

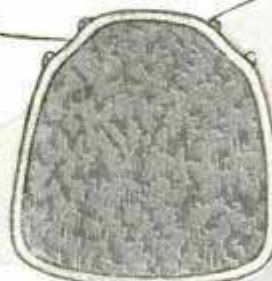

At Left, Attractive Holders for Serving Dishes Add Beauty to the Table and Protect Cloth; They Are Made in Sixteen Sizes



2274 *New York City*
**"BEEHIVE" AIRPORT AND HOTEL
 TO HOLD MANY PLANES**

at Aviation Show at Grand Central Palace

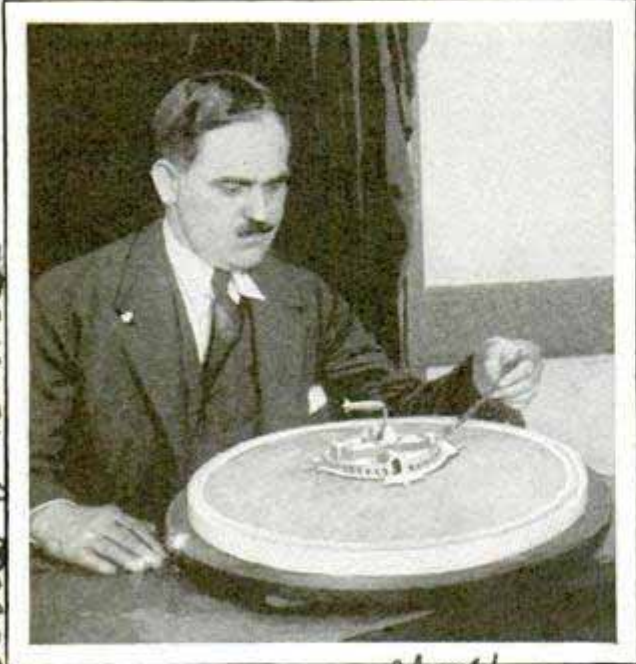

Model of "Beehive" Airport to Accommodate Forty Planes; Central Structure Is a Hotel

More than forty planes will be able to land and take off simultaneously from a proposed "beehive" airport, a model of which was displayed recently. The field is circular and is dominated at the center by a dome-shaped hotel, 850 feet high. At the top of the structure is a mooring mast for dirigibles. Tunnels provide passages, to and from the hotel and landing stations, to automobiles and transportation lines outside the field.

**RADIO HELPS TO REPAIR SHIP
 DAMAGED AT SEA**

How radio helped in repairing an ocean liner, crippled by a damaged rudder, 700 miles from New York, is one of the latest triumphs of wireless. The cargo carrier "Silver Maple" had encountered a severe storm. Her rudder and rudder stock were damaged. United States revenue cutters set out from Boston, 500 miles away, to lend assistance and plans were made for repairing the rudder. But no detailed drawings of the ship were available at the New York offices. A radiogram was dispatched to England by the steamship officials, asking that sketches be prepared from the original plans and sent back at once. The drawings were ready in a few hours and were then shot through space

My Times 2/6/29

by radio photography. The following day, less than forty-eight hours after the first message had been sent to London, the plans were on their way to a shipbuilding plant at Chester, Pa., and work was at once begun on the new rudder stock. Meanwhile, the steamer proceeded under her own power to Bermuda. The new rudder stock was sent there and installed. Officials estimate that radio was instrumental in saving at least \$7,000 and more than a week's time.

**PAPER CLOTHING IS WASHABLE
 AND KEEPS ITS SHAPE**

2305 *Carnegie*
 German manufacturers are reported to have introduced paper clothing that can be washed, does not crease and is quickly restored to its proper shape by shaking. It is waterproof, affords ample circulation of air and is considerably lighter than cloth. A winter overcoat that would weigh about six pounds if ordinary material were used, would weigh only about half a pound in the paper.

**GAS-FILLED AUTO STOPLIGHT
 MORE EASILY SEEN**

2225
 Installed on the inner side of the rear window of the car, where it can be seen more easily, a stoplight now on the market uses the glowing color of an illuminated gas instead of the usual filament bulb. The tubing is filled with a mixture of gases that produce the familiar penetrating hue now commonly seen in electric signs. Current is supplied from a specially designed spark coil, inclosed in a splash-proof casing and placed any-

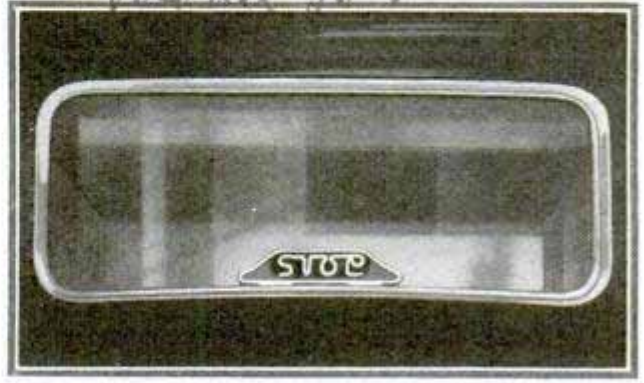

Stoplight of Neon-Tube Type Installed on Rear Window of Motor Car

where in the car. The light is easily removed for cleaning the rear window.

Stewart Warner

Stewart Warner

*2256 Mrs. C. W. ...
Ashville, N.Y.*

**PAINTERS RISK LIFE
ON BRIDGE JOB**

Perched at a perilous height, a workman pumps a fine spray of bright green paint upon the upper steel work of the huge cantilever bridge that spans the St. Lawrence river at Quebec. To fall would mean a drop of 300 feet. Naturally, the worker must stick to his job! The man is one of a small army of painters who are performing one of the largest jobs in the world. Before they have completed the task of applying a single coat, they will have pumped 30,000 quarts of paint upon the bridge, which is 2,830 feet long. Its center span is 1,800 feet in length. The work requires the united efforts of thirty-five men, working continuously from June 15 to September 15 each summer, over a three-year period. While they are engaged, a gang of mechanics is carefully inspecting every movable part and applying grease and oil. Apart from the 7,500 gallons used to give the bridge one coat, it requires seventy gallons to cover each one of the main posts, or 280 gallons for the four. The task involves several problems. The bridge is exposed to temperatures ranging from ninety degrees above to thirty-one degrees below zero. The surrounding atmosphere is frequently moist and foggy, and dew often coats the entire structure until eleven o'clock in the morning, meaning that the work must be arranged accordingly. Strong winds sometimes carry the paint away from the nozzles of the spray guns even when they are held within a few inches of the steel. The gang includes a blacksmith and a boatman. The

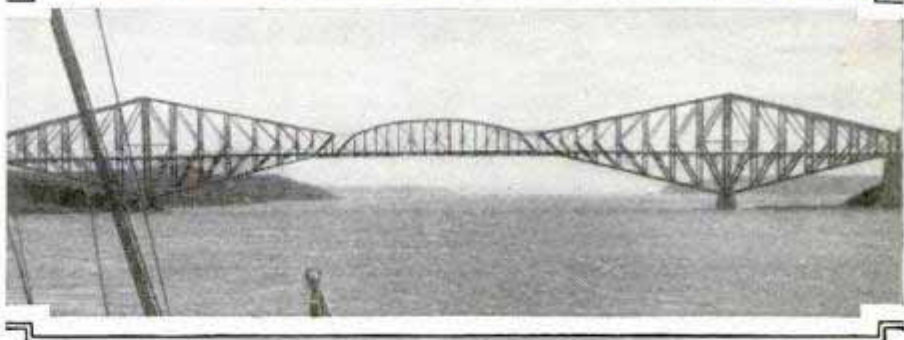
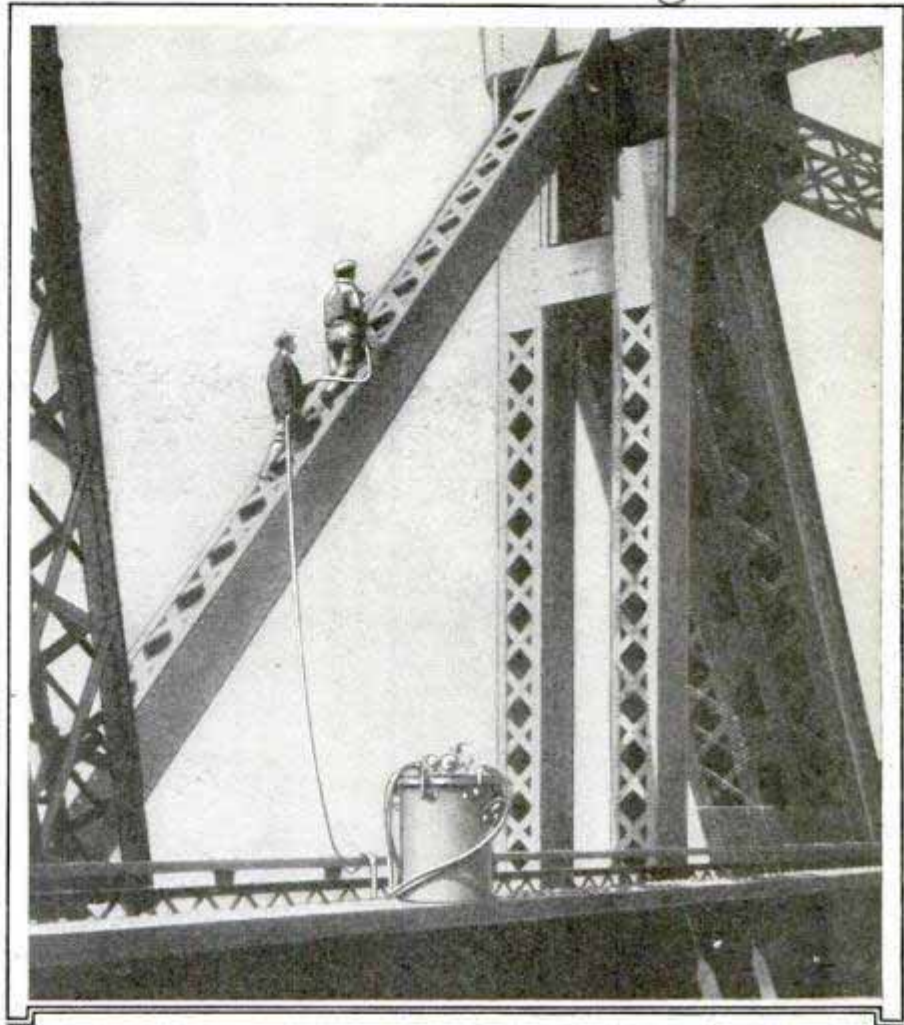

Painters at Work with Sprayer on the St. Lawrence River Bridge at Quebec; Below, View of the Whole Span

smith makes scaffold hooks and other units needed while the boatman is posted to rescue anyone who falls into the river.

**PIGEONS CARRIED IN AIRPLANE
TO RESCUE FLYERS**

Carrier pigeons are taken on some of the airplanes operating in Alaska. Should the planes be forced down, the birds would be released and would fly back to a base with a message for aid. The plan was adopted after several near-tragedies in which pilots were compelled to make forced landings in remote districts.

2094

*St. Joseph News Press
12/10/18*

Static Speaker-



Colin Kyle, with His Electrostatic Speaker, Less Than an Inch Thick, Built into a Fire-Screen

AN ELECTROSTATIC speaker—the most direct method ever evolved for converting electricity into sound waves—is to go on the market in a few weeks.

It has no coils or magnets and no moving parts. Essentially it is nothing but a condenser, two flat plates separated by a thin sheet of insulation. In the form in which it is being produced, it consists of an aluminum stamping about nine by twelve inches, with edges turned back three-quarters of an inch. The face of the plate is punched to form approximately 700 small slits, an eighth of an inch by about five-eighths. Over the face, a sheet of insulation, only one five-hundredth of an inch in thickness, is placed, and a thin coat of metal sprayed over the surface, or, in lieu of the spray method, a sheet of foil glued down.

A single plate can be used as a speaker, or any number of them may be bolted together through holes drilled in the turned back flanges. One speaker, built to go behind the screen in Roxy's Theater, New

York, is eight feet square. The average household size probably will have four or six units. In operation, one side of the radio receiver output goes to the metallic plate and the other to the metal or foil coating which forms the diaphragm. In addition, a positive bias of 450 volts of direct current is applied to the aluminum plate. The result is that the portion of the diaphragm in front of the slits in the plate vibrates—690 separate vibrating units in a single plate, or 4,140 in a six-plate speaker, all of them working in unison.

A single plate produces considerable volume, a speaker with six plates bolted together has a volume equal to the best of the dynamic types. The reproduction of voice and music is clear and exceptionally true. There is none of the overemphasis of the bass which mars the output of most dynamic types, no alternating-current hum, no noticeable muffling or mushiness in the voice, and the range, from the lowest note to the highest, is well covered. The only noticeable extraneous sound is a low murmur like that of a distant blower fan when the speaker is operated with considerable volume. As the output is tuned down, this sound of moving air decreases and fades out.

Because of its shape, it can be built up in cabinets no more than an inch thick. It can be hung or mounted flat against the wall, built into ornamental screens, or into a table-type cabinet, as a part either of the front panel or of the lid. In addition to several types for separate use, eight manufacturers have been licensed

Hans Vogt, Berlin W. 35,
Senthinerstrasse 14,
Germany

New Radio Marvel

to use the electrostatic reproducer in manufactured sets.

The principle of an electrostatic speaker is not new, but until recently no one had discovered a practical way of making one. Two appeared in Germany some time ago, one made by Hans Vogt and the other by Eugene Reisz. They did not attain any great popularity abroad, and only a few were imported in this country.

Essentially both inventors used the same method, stretching a diaphragm between two metallic plates, the latter being separated from the diaphragm by a dielectric. In the Vogt speaker, a bias of as high as 850 volts is used on one of the plates, and to protect users from this high potential, this plate is hidden within the speaker cabinet. Both speakers had the drawback of being difficult to make and expensive, and both had a tendency to develop faults in operation, notably that dust particles would get in and cause a short circuit between membrane and plate until the discharge of the current burned the dust away, and incidentally punctured a hole in the membrane.

A thirty-four-year-old school-teacher, who had taught in desert schools in California and Arizona, solved the principal problem. He is Colin Kyle, and the new speaker, which is shortly to make its appearance in this country, is his invention. His chief work consisted in the development of a dielectric which pro-



The Speaker Itself; in His Hands, Kyle Has the Thin Aluminum Plate; the Other One Is Completed with Foil Covering

vided sufficient insulation in sheets only one five-hundredth of an inch thick, and a construction plan that is simple, practical and cheap.

In tests at the Wallace Sabine laboratory of acoustics, at Riverbank, Ill., Prof. Paul Sabine found the Kyle speaker to be more nearly perfect than anything that has been produced up to this time.

Why and how the Kyle speaker works may be explained, in non-technical terms, as follows: The portions of the membrane over the slits in the plate are free to move slightly, and may be drawn into mechanical vibration in response to alternating-current oscillations within the limits of auditory vibration. It is necessary, however, to subject the plate to a constant voltage that is higher than the greatest voltage to which the membrane will be subjected by the radio-receiver output. The reason for the necessity of this positive potential, from a direct-current source, on the plate is interesting. Without it, the membrane would respond twice to each



fluctuation of the alternating-current output of the receiver, instead of once, and the result would be a note just one octave higher than it should be.

One of the defects of the original German speakers was that the membrane was stretched under considerable tension, and a mechanically strained membrane can never vibrate in its true "sine-wave" manner. Instead, its movement is uneven and produces tones two, three or more octaves higher than the fundamental. In the Kyle receiver, the method of applying the membrane does away with all stretching.

The static speaker rounds out the field of radio sound producers. First there were magnetic speakers, both air-column and cone types, following closely the idea of the telephone receiver. Then came the dynamic types, and now the static. How far the new speaker may go toward re-

placing the others is problematical, for, as Professor Sabine recently pointed out, the test of a good speaker is not so much its technical perfection as its effect on the listener's ear, and not all ears are alike. A speaker will be loudly praised by some listeners and as loudly condemned by others, merely as it happens to please or displease the listener's ear.

One drawback which air-column speakers have faced is that any device which was theoretically perfect, from the standpoint of the propagation of sound waves, would not be a loud speaker, as it would have no power to amplify the sounds put into the horn by the diaphragm of the speaker unit. Amplification of sound in a horn is the result of resonance, which in turn is the result of theoretical imperfections in the shape of the air-column chamber.

The exponential horn was the nearest development to a theoretically perfect air column. A sound wave, started down a tube, literally explodes when it reaches the end. The theory of the exponential horn is that the shape of the chamber is so

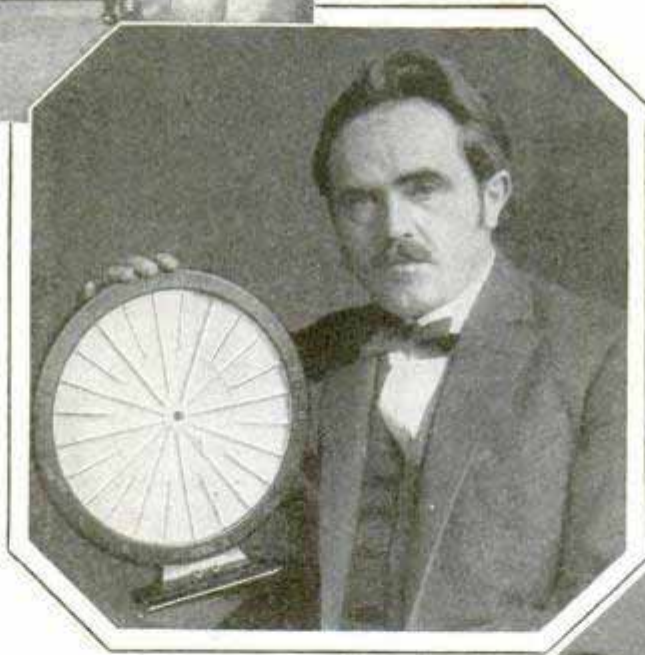

A Radio and Speaker Console Combination; Vogt and One of His Speakers, and the Back of a Kyle Model, Showing the D.C. Potential Unit

perfectly graduated that the expanding sound wave literally "doesn't know when it reaches the end," as Doctor Sabine puts it.

If that were actually true, and the horn itself were not resonant, the sound emitted at the end of the horn would be no louder than that produced by the speaker unit alone.

The exponential horn, and air-column speakers in general, had another serious drawback—the great length of air column needed to get a full range of tones, including the bass. It is possible to build such a horn that will reproduce as low notes as a good dynamic cone, for example, but it would have to be at least sixteen feet long. An eight-foot exponential air column has a natural period of vibration at sixty-four cycles, while a sixteen-foot column has a natural period at thirty-two, and with a still longer air column or horn the low note, which occurs at the first natural period of vibration, would be correspondingly lower. Another fact that should be noted in this connection is that lengthening of the horn brings closer together the recurring natural periods, which, in a

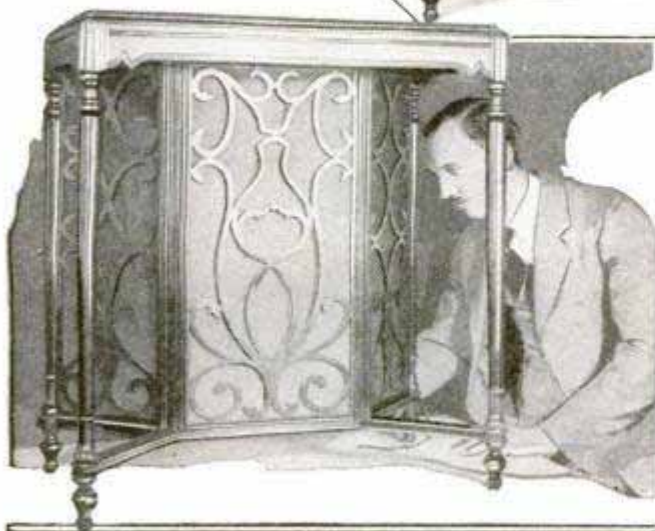
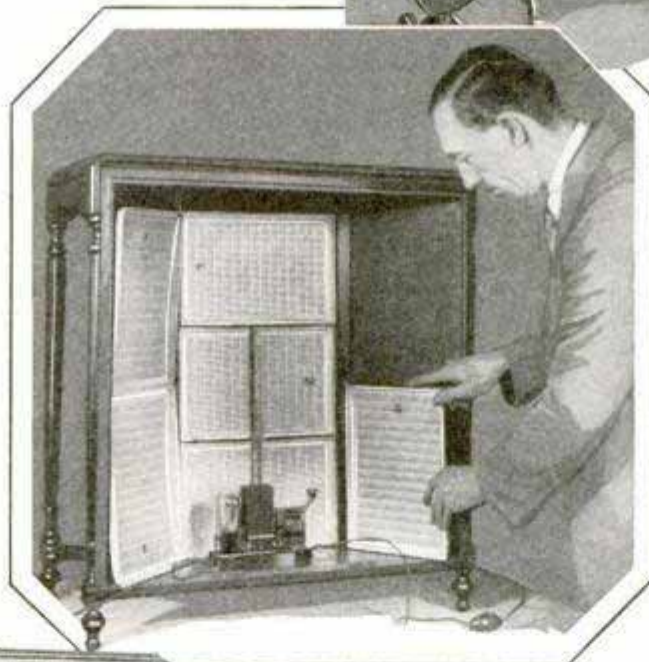

The Condenser Speaker Made Up into a Screen, and, Center and Bottom, the Back and the Front of a Console Model

sixteen-foot horn, would be multiples of thirty-two, instead of the multiples of sixty-four, as in an eight-foot speaker.

Besides the fact that the imperfections of the horn produce the amplification of sound, it is to be noted that the imperfections in the natural periods of the diaphragm of the speaker unit

produce modifications in the original source of the sound. Therefore, a unit which may be good on one maker's speaker, because its imperfections and the imperfections of the air-column chamber co-operate in such a way as to more or less neutralize each other, may be a decided failure on another shape and size of horn.

While the length of the horn fixes the lowest note which an air-column speaker can reproduce, the size of the baffleboard is the controlling factor in cones of both the magnetic and dynamic types. A baffleboard four feet square is roughly equal



Jess Hawley, Famous Football Star, Now a Speaker Manufacturer, with a Radio Set and Speaker Combination, and, Right, a Separate Kyle Speaker

to an eight-foot horn, in other words, it will reproduce sixty-four-cycle notes. It takes a baffle eight feet square to equal a sixteen-foot horn and get down to thirty-two cycles.

Two problems of interest to radio users, one of which is of special interest also to the public in general, have been studied in the Sabine laboratory. One is the question of proper acoustics to get good reproduction, and the other the problem of soundproofing walls to prevent transmission of sounds to adjoining rooms or apartments.

As it happens, the ordinary living room, with its curtains, drapes, rugs and furniture, is just about as satisfactory a setting for music reproduction as can be found, according to Professor Sabine. The reason is that people are accustomed to the acoustic properties of the ordinary home, and therefore music reproduced in such a room sounds right. In his laboratory Professor Sabine has a sound-absorbing room, with walls, ceiling and floor

covered with a thick blanket of soft absorbent felt and wool to kill the resonance of the walls. Trying to talk in such a room has a peculiar effect. The elimination of the usual echoes gives a sensation of heavy air pressure on the ears, as though one were incased in a high-pressure air lock, such as are used in tunnel digging. A room of this type was built in a New York bank for the adding-machine department, and after six months' trial the girl machine operators unanimately agreed they did not like it.

The other problem, sound deadening, which has become an important one in apartment houses since radio, talking machines and similar musical instruments have become so common, depends, according to Doc-

tor Sabine, entirely on the weight of the material in the walls. Sound-absorbing materials, which are soft and porous, are ineffective. Instead, the walls must be built of material so heavy that their ability to vibrate, and therefore transmit sounds to the other side, is minimized if not entirely eliminated. A wall of heavy bricks, plaster, tile or other material can be made an even more effective sound deadener by dividing it into two sections with an air space between them. The inner wall will transmit a certain part of sound vibration to the air space, but this reduced sound will have a correspondingly lessened ability to vibrate the outer wall.

COLORED ICE CUBES

By placing vegetable coloring matter in the water in the compartments of the refrigerator cube-freezing pans, blocks of different hues are obtained. These add an interesting color note and permit unusual effects in table decorations.

Pub. Service Bulletin
 Wash. D. C. U. S. G. P. Office
 11-10-36

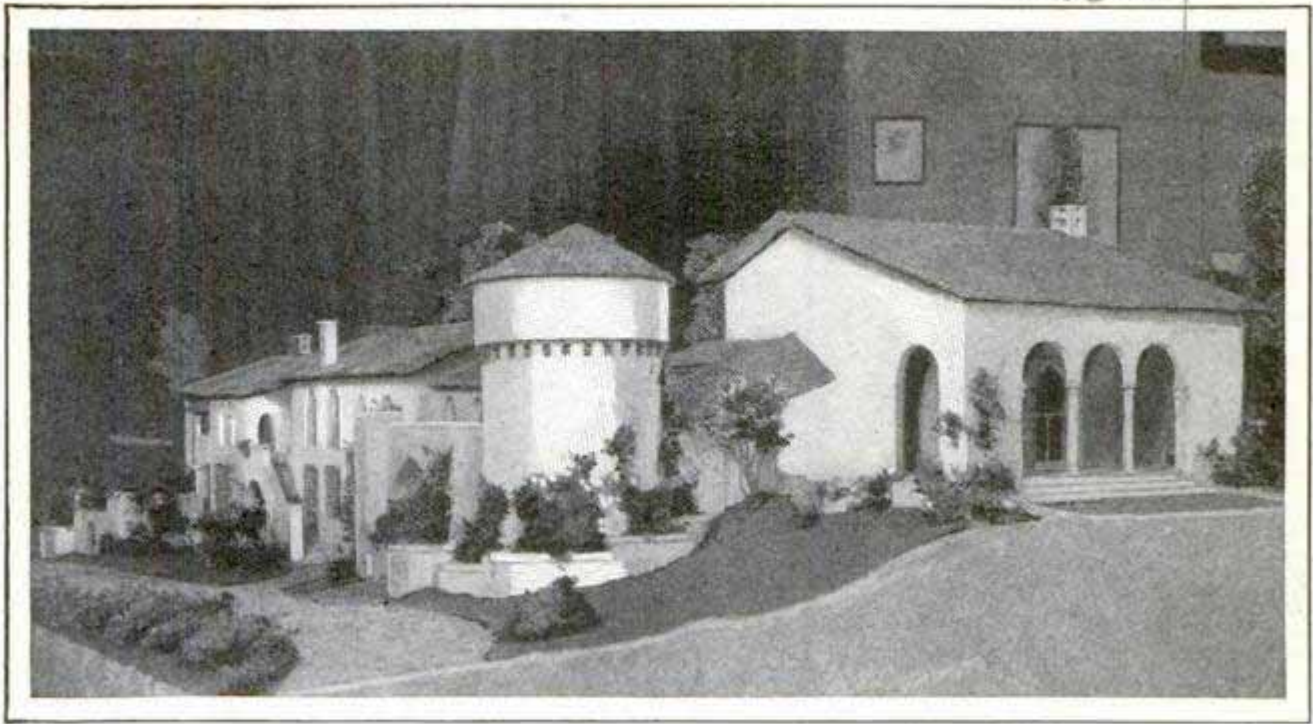

Realistic Model of Home Used by Architects in Explaining Details to Clients; the Roof and Floor Are Removable So That the Interior of the Replica May Be Studied

MODELS OF HOME AID BUILDER AND PROSPECTIVE BUYER

California architects are building scale models of residences to aid their clients in forming a more accurate idea of their future homes. The roofs and floors of the replicas are removable so that the interiors, with plumbing and other features revealed, may be carefully examined.

BEE HAS POOR EYESIGHT TESTS WITH LIGHT BAND SHOW

A bee's eyes are only about one per cent as efficient as those of a human being, recent tests have shown. Scientists allowed bees to walk up a sloping glass plate beneath which was a moving slide with alternating dark and bright bands, giving a sort of picket-fence effect. The bee would change the direction of its march when it saw the bright bands moving, and it paid no attention to bands that were too narrow for it to see. By using a number of slides with varying widths of bands, it was possible to find the narrowest object which a bee can perceive. This was found to be 100 times as wide as the narrowest object which a human being can observe at the same angular distance. Bee and human eyes were found to be alike in that both see poorly in a

dim light and better in a bright one. At certain degrees of brightness, however, no improvement in sharpness of vision could be discovered.

COIN SORTER AND COUNTER SAVES BANK TIME

Coins are counted and sorted in one operation with a simple device lately demonstrated in England. The pieces fall from a hopper upon moving screens which



Coin Counter and Sorter Which Replaces Hand Labor in Banks and Large Commercial Houses

separate the coins according to size. The outfit is intended especially for banks.

before American Play Guild Society
 and the Play Guild Society

*Deane Service
 Bulletin #13-B 2/19/29*

Business Efficiency Exhibition

*Prof. King, Keat
 and his first visit.
 make unknown.*

Latest from the



Compact Filter Unit, Designed for Use with Small Motors, Eliminates Troublesome Interference from Household Appliances; It Is Plugged into the Line as Shown in the Sketch

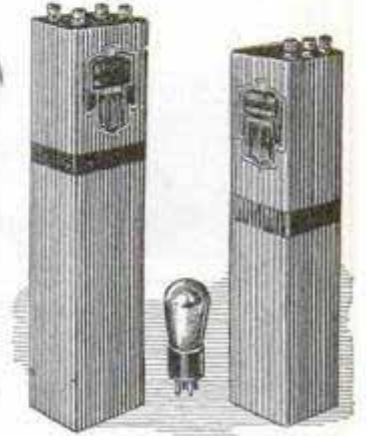

Above, New High-Voltage B-Batteries Designed for Use in Television and Radio-Equipped Airplanes

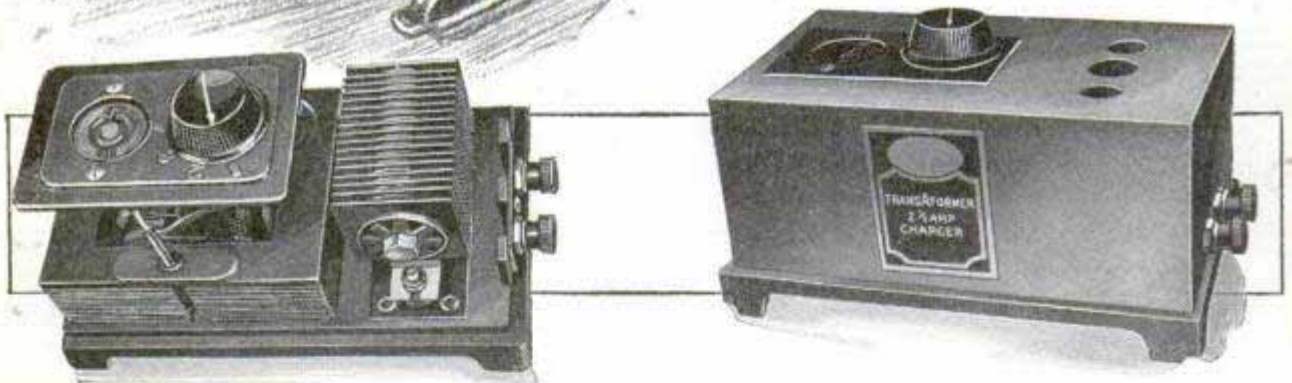

Above, a Complete Rectifying Unit Assembled in One Case Includes a Tapped Step-Down Transformer and Rectifying Device with a 3-Amp. Capacity; It Is Designed for Use with a Standard A-Filter for Assembling an Efficient A-Battery Eliminator; an Outlet Is Also Provided for the B-Eliminator

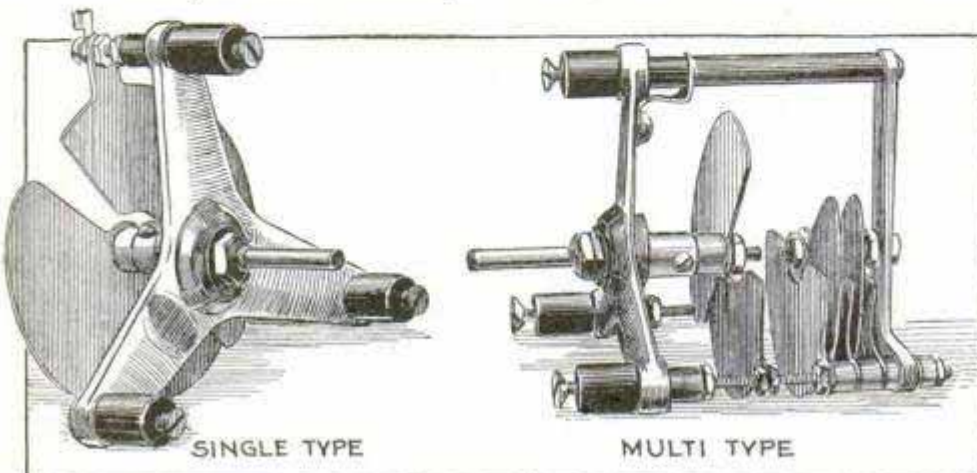

Left, Two New Condensers Especially Designed for Short-Wave Circuits; the Single Type Is a Two-Plate Variable, So Arranged That the Stator Plate May Be Moved for Maximum Capacity; the Multi-Type Is a Combination Semi-Fixed Tank and Variable Vernier Condenser and Is Designed for Low-Power Transmitters, Complying with the New Government Regulations in the Narrow Bands Allotted to Amateur Operators

Radio Shops

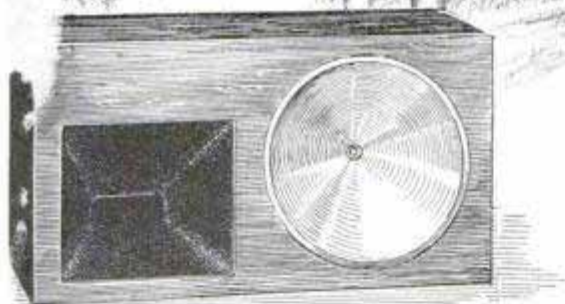
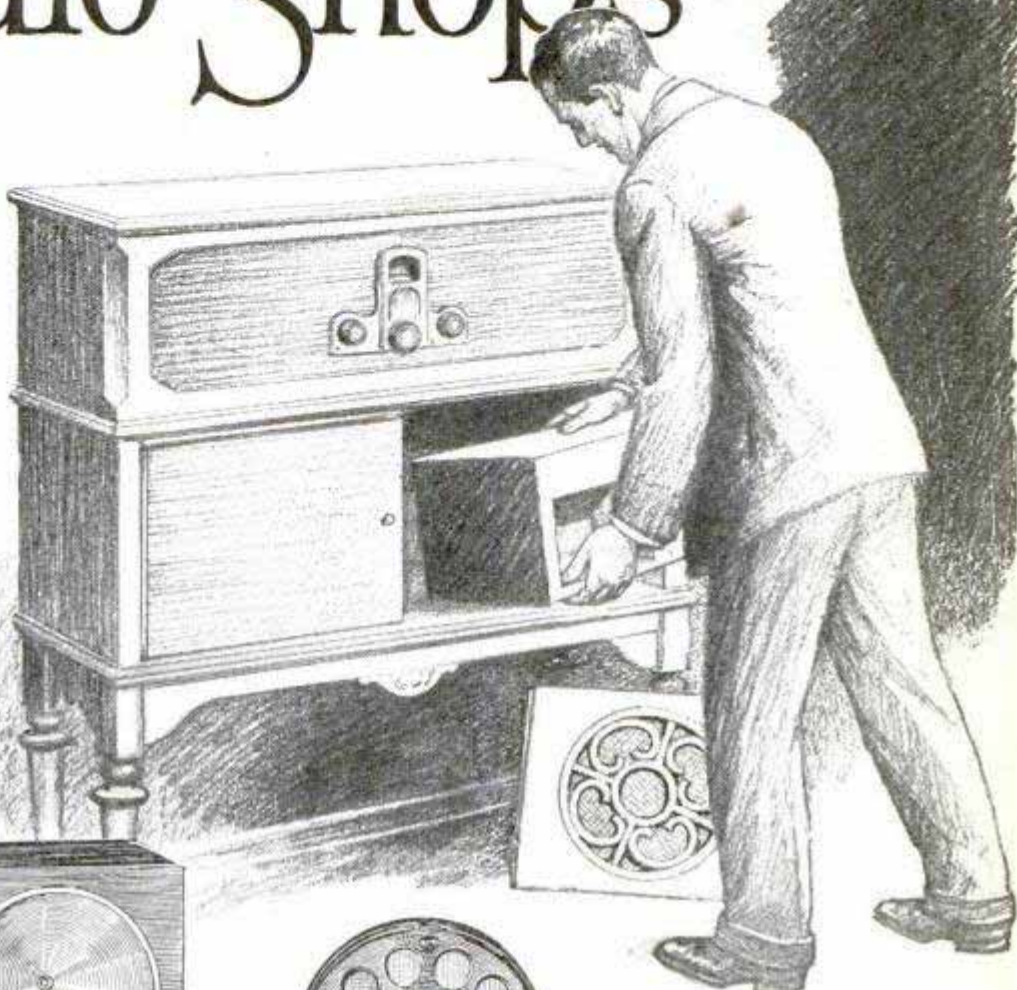

Left, an Efficient Indoor Antenna and an Attractive Lamp for the Radio Cabinet Are Combined in This Unit, Built to Represent a Broadcasting Microphone; the Necessary Fixed Condensers, Switch and Lamp Socket Are Inclosed within the Neat Metal Shell

Above, Cone and Exponential Horn, Combined in One Unit, for Installation in Consoles; the Unit is Designed So That Either or Both May Be Employed

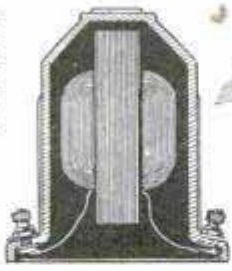

Left, a Demonstration to Prove the Moisture-Proof Qualities of a New A.F. Transformer; It Was Suspended in a Beaker of Water for One Week, after Which It Worked as Well as Ever; Section Diagram Shows Core and Coil Sealed in Bakelite Case



Right, Six-Tube A.C. Screen-Grid Receiver Has Automatic Control; Automatic Tuning Is Made Possible by a Mechanical Device Arranged So That the Dial Condensers Are Automatically Removed Whenever a Selection Is Made on the Automatic Finder

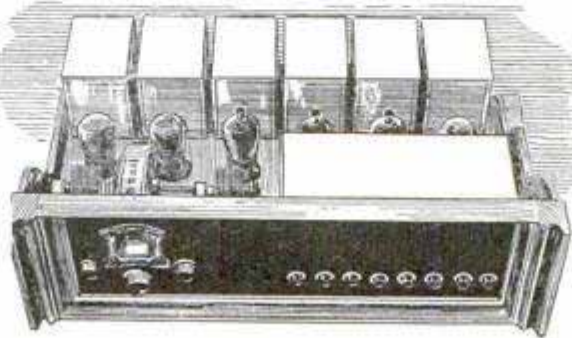

Above, the Owl Conceals an Automatic Cut-Off Switch Which May Be Set to Operate at Any Time the Set Owner Desires

Using Lamps as Resistance Units

THE USE of ordinary incandescent lamps as resistances in experimental radio work is common practice with a large number of fans with limited pocket-books. Anyone can take advantage of these cheap resistance units, and many broadcast listeners and set builders are beginning to find out for themselves that the incandescent lamp is really nothing but a resistance which passes a predetermined amount of current. Its only disadvantage is the bright light, but bulbs may be painted or shaded so that this will not be objectionable.

The lamps are mounted in ordinary porcelain sockets and arranged in any convenient manner for the nature of the work to be done. Fig. 1 shows how a series of lamps are employed as a voltage divider for a homemade B-eliminator of the type having a total output of 180 volts. The usual voltage divider for an eliminator of this type has a total resistance of about 10,000 ohms obtained by a combination of variable and fixed wire-wound resistors. A 10-watt lamp has a resistance

of about 1,000 ohms so ten of them in series, as shown, will provide an equivalent resistance. If the filter output is 180 volts, there will be a drop of 18 volts across each of the lamps in series. Begin at the negative end and count up two tubes and you have approximately 36 volts for the detector plate, or three tubes up gives a voltage of about 54 volts, this procedure being followed to obtain the other voltages desired. Of course, the space occupied by the lamps is much greater than with resistors of modern type but the saving of several dollars makes it worth while where space is not a consideration.

Another interesting use for an incandescent lamp is shown in Fig. 2, where it is placed in series with the primary of the power transformer for the purpose of reducing the output of the B-eliminator when the latter is in excess of the voltage required to operate the set properly. Lamps of various wattage should be tried,

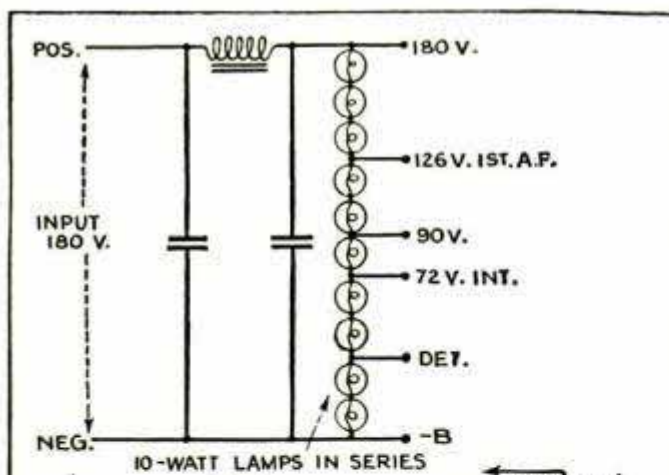

FIG. 1

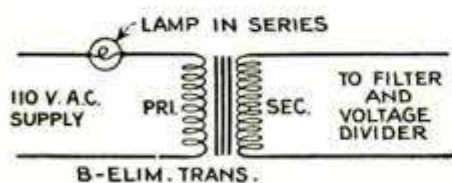

FIG. 2

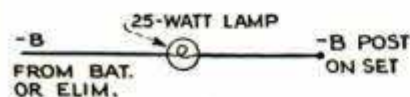

FIG. 3

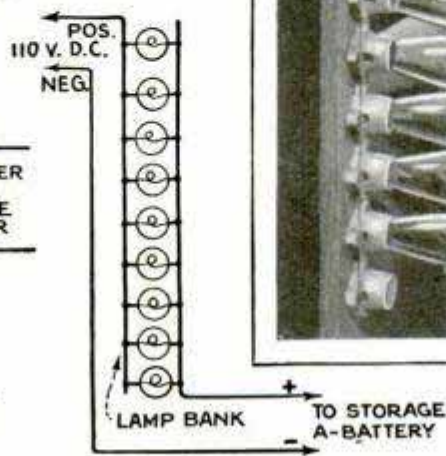
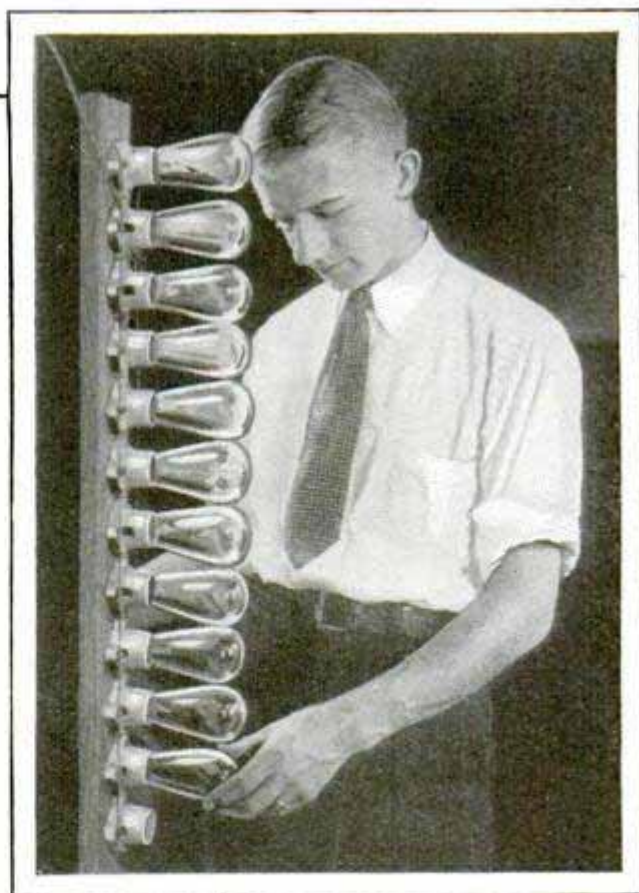

FIG. 4



Bank of Lamps and Various Ways of Using It in Connection with Radio Receiver or for Charging Batteries

and the total output in each case should be measured with a B-eliminator voltmeter until the lamp of the correct size for the job is found.

As a safety device, a lamp may be connected in series with the plate supply to protect the tubes, as shown in Fig. 3, and one of the 25-watt type will protect the tubes as well as the standard fuses employed for this purpose. It need not always be renewed, as in the case of a fuse, for it will not burn out unless the short is caused by a voltage higher than 90. An additional advantage the lamp has over the fuse is that it will light up as a warning signal. The resistance in the circuit is too slight to interfere with the operation of the set, and the idea can be applied to any type of receiver.

The most common use of lamps in d.c. districts is shown in Fig. 4 for charging storage batteries directly from the lighting line. The bank is arranged as shown in the photo and diagram. The battery is connected across the lighting line with as many lamps as are necessary to obtain the proper charging rate, the bank of lamps being connected in series with one side of the line to cut down the current. A 100-watt lamp, or its equivalent in smaller lamps, will permit about 1 amp. of current to pass to the battery. In this way the charging rate may be made any value the builder desires. The arrangement is sometimes used as a trickle charger and left on continuously. To obtain the necessary $\frac{1}{4}$ -amp. rate for this purpose, a 25-watt lamp should be used, and for a $\frac{1}{2}$ -amp. rate, a 50-watt type. This idea is, of course, limited to d.c. districts, and the builder must determine the polarity of the d.c. line before connecting the output terminals to the storage battery. This is a simple matter, and may be done by placing the terminals in a glass of water in which a pinch of salt has been dissolved, keeping the terminals about 1 in. apart. Bubbles will appear at both terminals, but the discharge will be greater at the negative wire.

It is a good plan to mark the wall supply plug in addition to marking the wire, if the plug is of the plug-in type, so that it will not be reversed if the lamp bank is disconnected from the house supply at any time.

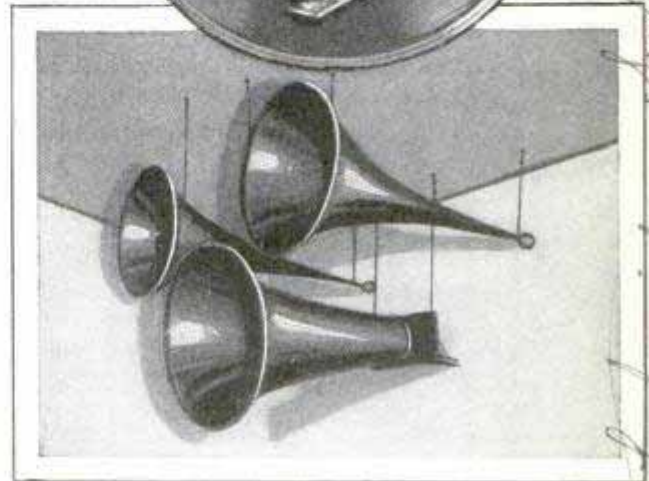

Battery of Horn and Trumpets for Large Volume; Above, Close-Up of Horn, Giving Idea of Size

Battery of Horns for Sound Effects

The battery of exponential horns shown is for use in motion-picture theaters and other public places where great volume is necessary. The large bell-type horn measures 9 in. at the small end, 32 in. at the large end and is 52 in. long. The two trumpets above it measure $\frac{7}{8}$ in. at the small ends, 24 in. at the large ends and are 60 in. long.

Operating A.C. Apparatus on D.C. Supply

The motor generator shown in the illustration is specially designed for operating 60-cycle a.c. radio receivers, loud



speakers and phonographs singly or in combination from d.c. lighting sockets without objectionable noises of any kind. The instrument is equipped with filters and is said to give better results than are obtained from the ordinary 60-cycle lighting supply.

Lakeside Supply Co.
 73 W. Van Buren, Chicago
 Electric Specialty Co. Stamford Conn.
 211 South St.

Lakeside Supply Co.
 73 W. Van Buren

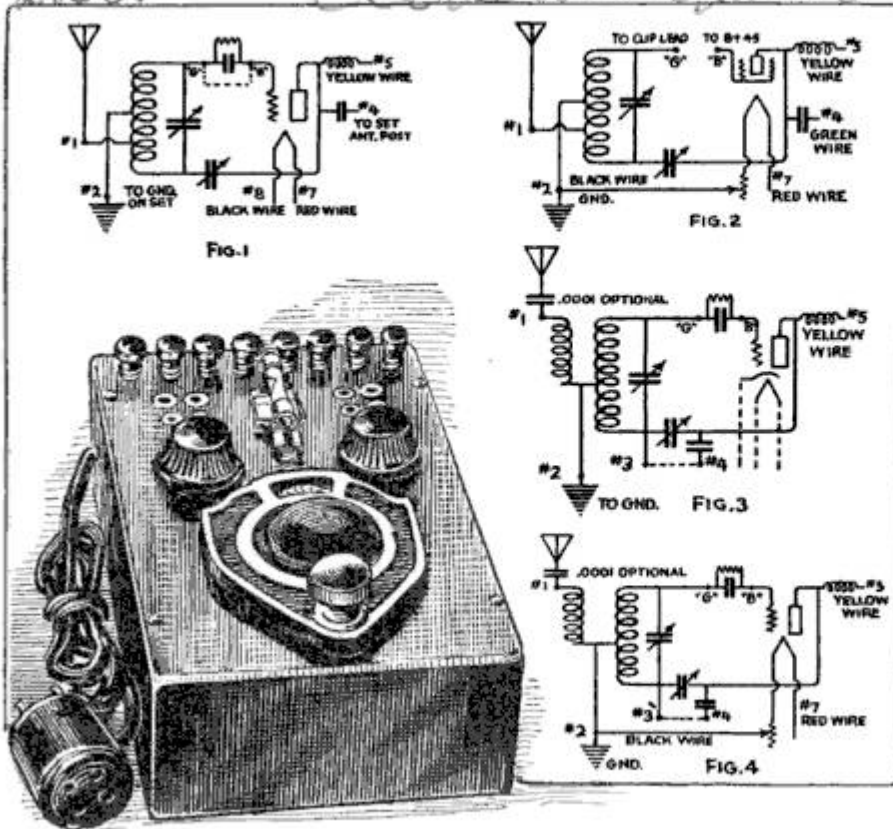

Lower Left, Unit of Many Uses, Showing the Arrangement of the Controls and the Adapter Plug for Connecting It to the Receiver

New Radio Unit of Many Uses

The new radio unit shown in the illustration not only tunes out troublesome stations but will serve as a short-wave receiver, short-wave adapter, regular broadcast receiver, screen-grid preamplifier, remote-control adapter, extra stage of tuned r.f. amplification, r.f. booster, single-dial converter, audio oscillator, wave trap and wave meter. Yet it is small and the binding posts are conveniently arranged at one end for easy connections to any part of the radio receiver. The plug-in coils supplied with the unit cover a short-wave range of from 20 to 80 meters. The adapter plug provides a quick connection to the sockets in the receiver, and the unit is designed to work separately or in connection with either an a.c. or d.c. set. The binding posts are numbered and the wires from the plug are of different colors to avoid confusion and to simplify the various hookups.

Practically any of the standard types of tube may be employed, one of the principal features being the use of a screen-grid tube as an r.f. amplifier, which provides great volume. Fig. 1 shows the unit employed as an r.f. booster in connection

with an a.c. receiver employing type-226 tubes. Fig. 2 shows its use as a screen-grid preamplifier in connection with a d.c. receiver employing type-222 tubes. It is employed as a 20 to 80-meter short-wave converter in Fig. 3, with an a.c. receiver operated with type-227 tubes. Fig. 4 shows the hookup as a short-wave adapter to convert a d.c. receiver using 199, 201-A or 112-A tubes for short waves. The increased sensitivity of the receiver is claimed to permit the use of a short indoor or light-socket antenna. This unit, together with a scanning disk, motor and neon tube in connection with the audio amplifier, makes

of practically any standard set a suitable television receiver for the various programs now on the air.

FOR THE RADIO BUILDER

The simplified blueprints listed below include the best of Popular Mechanics tested circuits. When ordering, simply quote the numbers of the blueprints desired and inclose the proper amount in an envelope addressed to Popular Mechanics Magazine, Radio Dept., 200 E. Ontario St., Chicago, Ill. Back magazines containing full descriptions of the circuits can also be obtained. Inclose an additional 25 cents for each magazine desired, giving date of publication.

No. 111, Homemade Tube Tester	July 1926	25c
No. 115, 15 to 550-Meter Three-Tube Receiver	Nov. 1926	25c
No. 116, Three-Tube Loop Set	Dec. 1926	25c
No. 117, Simple Electrolytic B-Eliminator	Feb. 1927	25c
No. 123, Economy-Nine Superheterodyne	Nov. 1927	50c
No. 126, Homemade B-Battery and Charger	Jan. 1928	25c
No. 130, One-Tube Short-Wave Adapter	Mar. 1928	25c
No. 131, Five-Tube All-Electric Receiver	Apr. 1928	25c
No. 134, Edison Type B-Battery	July 1928	25c
No. 135, Screen-Grid Browning-Drake Receiver	Sept. 1928	25c
No. 138, Screen-Grid Perfect-Tone Six Receiver	Nov. 1928	25c
No. 139, Simple Television Receiver	Dec. 1928	25c
No. 140, Power Amplifier and B-Supply for Television	Jan. 1929	25c
No. 141, Hammarlund-Roberts Hi-Q 29 Junior A.C. Receiver	Feb. 1929	25c
No. 142, Two-Tube Screen-Grid Short-Wave Adapter	Mar. 1929	25c

FOUR-TUBE SET OPERATES DYNAMIC SPEAKER

By F. L. BRITTIN



HERE'S a four-tube set that gives six-tube results; without a doubt the most powerful little receiver we have ever met, capable of operating any dynamic speaker on locals, including even a giant theater type, without the aid of additional equipment.

It combines volume, tone and selectivity with simplicity and low cost, making it an ideal set for the average builder. The short test log, obtained through strong local interference, shows that this receiver has the necessary sensitivity to step out for DX-reception, the distant stations coming in with good volume on a standard dynamic speaker.

This unusual efficiency is, of course, easily accounted for, as the circuit employs the well-known r.f.-amplifying characteristics of the screen-grid tube, and has a 340 hi-mu detector tube with regeneration in addition to the usual two stages of resistance-coupled a.f. amplification.

If volume sufficient for the average magnetic cone or exponential horn is desired, for locals only, this can be obtained with but one stage of a.f., and it is, of course, a simple matter to omit the last stage, if the builder prefers a three-tube set.

The assembly is very simple. The parts needed are few, but these have been carefully selected and are especially adapted to the circuit. The antenna-coupler coil is of the two-winding type, with extra primary taps which may be shorted to ground for the purpose

of obtaining a suitable input for individual antenna and location conditions. The

two outside lugs include the entire primary winding. The large coil is the secondary, one terminal of which is located on the strip at the top of the coil and the other on the center lug below. The screen-grid r.f. coil is a special type, consisting of a high-impedance primary and exceptionally low-loss secondary. The large winding of this coil, instead of being the secondary, as in the usual case, is the primary, and is tuned with a .0005-mfd. condenser.

The 50-mmfd. midget condenser across the .0005-mfd. antenna-tuning condenser is employed as a trimmer; the other 50-mmfd. midget condenser (the stator plates of which are connected directly to the plate of the detector tube and one terminal

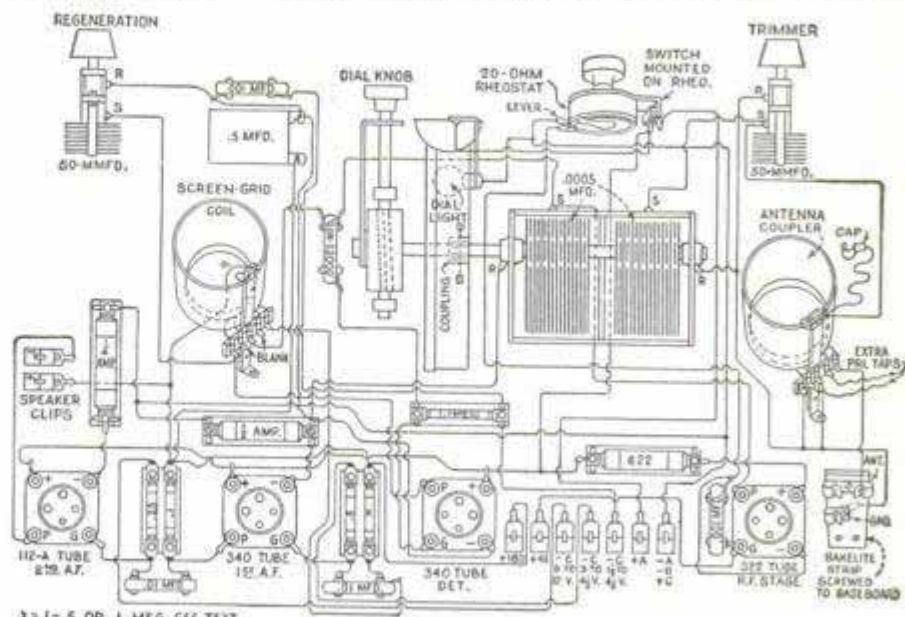

R-1-5 OR 1. MEG. SEE TEXT
R- ROTOR
S- STATOR

Simplified Wiring Diagram Showing the Various Instruments in Their Relative Positions



Top, Sawing Off Unused Length of Shaft at Rear of Ganged Condenser Unit; Above, Mounting Flexible Coupling for Shaft Extension

of the small winding) is used as a "snubber" for controlling regeneration. In a way, it also acts as a trimmer, making possible a very delicate balance without

loss of volume or selectivity. These coils are connected in the circuit in a manner which enables one to aid the other; in order to do this, run the B-positive lead up through the large coil and connect it at the top, while the other end of the large coil is run from the center lug below to one side of the .00025-mfd. condenser, as shown in the simplified wiring diagram.

The baseboard may be of poplar, or similar wood, and is $\frac{1}{2}$ by 7 by 17 in., and the front panel, $\frac{3}{16}$ by 7 by 18 in., of bakelite or similar material. A drilling template for mounting the drum dial and its escutcheon plate comes packed with the dial and is designed to accommodate baseboards of various thicknesses. The mid-geet condensers are mounted at each end of the panel, and the rheostat, with its accessory filament-switch assembly, in the position shown. Mount the escutcheon plate on the panel, then screw on the tun-

ing unit with the two flat-head screws provided. Now place the front panel in position against the baseboard and fasten it temporarily to the metal brackets. The two .0005-mfd. condensers, which are ganged together in what is known as "battleship" fashion, are permanently aligned, with a free-moving rotor. This condenser unit is now mounted on the baseboard with the short end of plates at the front, and must be carefully lined up so that the shaft is in line with the hole in the tuning-unit drum. Place the unit so that the other end is $2\frac{1}{8}$ in. from the right end of the baseboard, viewing the assembly from the rear. With a pencil, carefully trace a line on the baseboard around the mounting posts located under the unit. Complete circles are not necessary, as the center points, for drilling the holes for

mounting screws, may be located in half circles. The holes are now drilled in the baseboard to pass three 10-32 machine screws; these screws are 1 in. long and, if a baseboard thicker than $\frac{1}{2}$ in. is used, it will be necessary to countersink the

holes from the bottom. Three brass bushings are supplied with the drum dial;

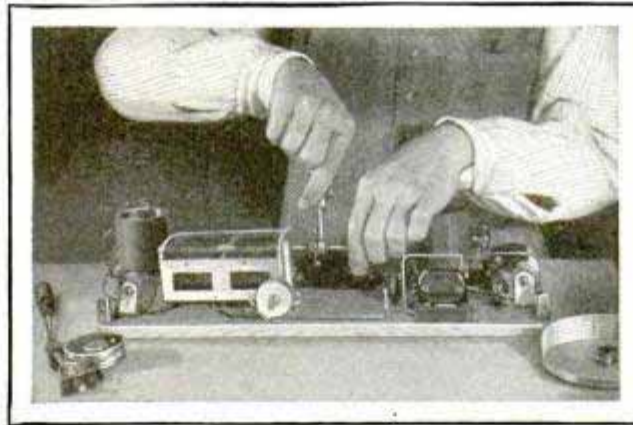

ABSTRACT OF TEST LOG

January 8, 1929; time 9:30 p. m.; testing time three hours. Equipment used: B-eliminator, A-eliminator, dynamic speaker (four-standard types), light-socket antenna.

All local stations, good volume, tone and selectivity

WJSK, Gary, Ind.	40 Miles
WGHP, Fraser, Mich.	236 "
WAPI, Auburn, Ala.	575 "
KMOX, St. Louis, Mo.	259 "
WTMJ, Milwaukee, Wis.	90 "

Jan. 9; two-hour evening test, same equipment

KDKA, Pittsburgh, Pa.	411 Miles
KMA, Shenandoah, Iowa	380 "
WPG, Atlantic City, N. J.	715 "
WOWO, Ft. Wayne, Ind.	170 "
KMOX, St. Louis, Mo.	259 "

Comment: Very little overlapping of locals and none which could not be completely separated by adjusting the trimmer-condenser. Set very quiet, no squeals unless regeneration is forced; volume on locals at resonance terrific but easily controlled. All distant stations received with good volume on dynamic speakers.

these are necessary to raise the condenser unit to the desired height. The bushings are drilled to pass No. 6 machine screws, so they must be drilled again to pass the No. 10 screws. This may be done by placing the bushings in a vise and employing a hand drill. An alternative would be to cut bushings of exactly the same height from brass tubing or build them up from small brass washers. Saw off the unused length of the shaft at the other end of the unit, as shown in the top photo on page 830, and be sure that you do not saw off the wrong end. The bushings are now placed under the condensers, the screws passed up through the baseboard, and tightly screwed into the condenser unit mounting posts.

A piece of 1/4-in. round brass rod, 2 1/8 in. long, is now mounted on the end of the shaft by means of a flexible coupling, which is held in position by

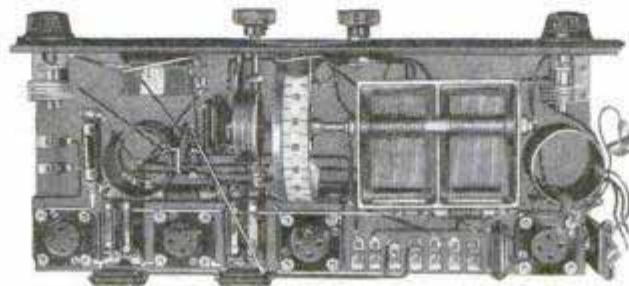

flexible leads are required. Make all leads as short as possible, wiring in "beeline" manner. This may not look as good as square turns and grouped wiring, but is far

better than parallel and long roundabout leads. Mount soldering lugs on the condenser frame, by means of short 6-32 machine screws, in the holes provided under the shaft at each end of the condenser gang, these lugs providing the rotor connections as the rotors are grounded to the frame. When as much as possible of the wiring on the baseboard is completed, mount the front panel on the brackets. The builder will find it advisable to use a wood screw at the lower center of the panel, to make a rigid assembly. Insert the condenser-shaft extension through the dial and tuning-dial drum; now, with the knob mounted on the shaft extending through the front panel, rotate this drum as far as it will go to the left, and, with the condenser plates "all in" or fully meshed, tighten the two screws through the holes in the drum. Rotate the knob at the front until the condenser plates are entirely out of mesh, adjust the dial on the condenser shaft until the zero mark is lined up properly in the front window of the escutcheon plate, and lock the dial in position with the setscrew provided. To obtain room behind the panel and use

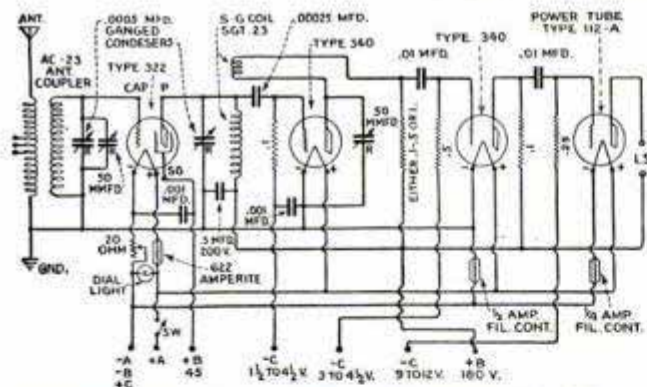

Top, Completed Set in Cabinet Placed on Table-Type Dynamic Speaker; Center, Looking Down on Completely Wired Receiver; Bottom, Wiring Diagram

four small setscrews, as shown in the center photo on the same page. This extension is necessary to provide room on the shaft for the dial and extends through the tuning-unit drum, where it is held tightly with two machine screws. The completed assembly is clearly shown on this page.

Remove the front panel and complete the baseboard assembly, arranging the parts exactly as laid out in the simplified wiring diagram. Complete as much of the baseboard wiring as possible, with the front panel removed, using "celatsite" wire and flexible rubber-covered hookup wire where

the drum dial, the battleship-type ganged condensers are reversed, and this necessitates the use of a reverse-scale dial, that is, one reading from 100 to 0 instead of from 0 to 100. The manufacturer makes both types. Those who wish to gang their own condensers instead of using the battleship type may do so and, in this case, the 0 to 100 scale should be used.

Clips for the battery and speaker terminals were used in order to keep the cost at a minimum, but the builder can arrange a binding-post strip if desired. The antenna and ground clips are mounted on a small bakelite strip, which is screwed to the end of the base-board for convenience. The extra primary leads on the antenna-coupling coil are just long enough to short any lead to the ground clip as desired. For those who wish to go to the expense of a tapped primary switch, the bakelite strip may be enlarged to accommodate it.

Go over the wiring carefully to be sure that it corresponds to the wiring diagram in every detail as far as point-to-point connections are concerned.

The B-supply may consist of four 45-volt B-blocks, or any standard B-eliminator which will provide the necessary 180 volts for the plates and 45 volts for the screen-grid terminal. The C-batteries consist of three $4\frac{1}{2}$ -volt tapped units in series; note that the detector tube is a 340 hi- μ type, and that the grid return is to C-negative, varying from $1\frac{1}{2}$ to $4\frac{1}{2}$ volts according to the tube and condition of the B-supply. This bias value also depends on condenser balance, which is obtained by use of the trimmer condenser. Unless the set is balanced carefully and the proper negative bias used on this detector-tube, regeneration cannot be obtained. That is, the midget condenser used to control re-

generation will have no value; so move this negative C-tap from $1\frac{1}{2}$ to $4\frac{1}{2}$ volts on the C-battery until the condenser functions. It may be necessary to try all three resistor values indicated at X for the detector-plate resistor, as one of the three will usually be found to work best. The

C-bias for the 340-tube in the first a.f. stage may vary slightly from the values given, as in the laboratory model $1\frac{1}{2}$ volts provided sufficient bias. The C-negative bias for the 112-A power tube in the last stage should not be less than 12 volts for correct operation. The 20-ohm rheostat in the negative filament lead of the screen-grid tube acts as a volume control, and the necessary 3.3 volts for the filament of

this tube is provided by means of the type-622 amperite in the positive filament lead. The A-supply may be either a 6-volt storage battery or one of the new A-eliminators.

There are great possibilities in this little set for the builder, but to obtain maximum results, he must learn to tune and balance it so as to maintain regeneration. The antenna may consist of a light-socket plug, short inside antenna, or a short and long outside installation, as desired. In crowded localities, where sharp tuning is essential, the short indoor type will give the best results. If there are any points that do not seem clear to the reader or if additional information is desired, address your letters to Popular Mechanics radio department, 200 E. Ontario St., Chicago.

Blueprint No. 143, describing in greater detail the construction of this unusual four-tube receiver, is now available. It may be obtained for 25 cents together with a complete list of the parts used. The list of parts will be mailed free to readers who do not desire the blueprint.



Rear View of Completed Receiver, Showing Tubes in Position

2189-C
New Parts for Screen-Grid Circuits

The new screen-grid tube, known as the UX-222 or CX-322, requires coils of special design if full advantage of its exceptional properties is to be secured. A screen-grid r.f. transformer of this type is shown in the illustration, the coils being of the low-resistance, space-wound, self-supporting type, 2 in. in diameter. The high-impedance primary of this r.f. transformer has three taps, so that the required selectivity may be balanced against maximum usable amplification. The tap leads are conveniently located on the bakelite terminal strip. A special antenna-coupler coil is also available which has three taps for varying degrees of selectivity and pick-up with any type of receiver. These taps also permit its use as an efficient interstage transformer in standard-tube circuits of the straight and neutralized mid-tap primary types. The variable condenser suits any modern layout. The plates are shaped to avoid crowding of stations on either the upper or lower bands and to retain normal separation in the middle of the scale. Adjustable ball and cone bearings, floating rotor shaft and excellent low-loss design, make this an ideal tuning unit for modern circuits. The rotor shaft may be entirely removed and a larger one inserted for coupling other condensers in tandem.

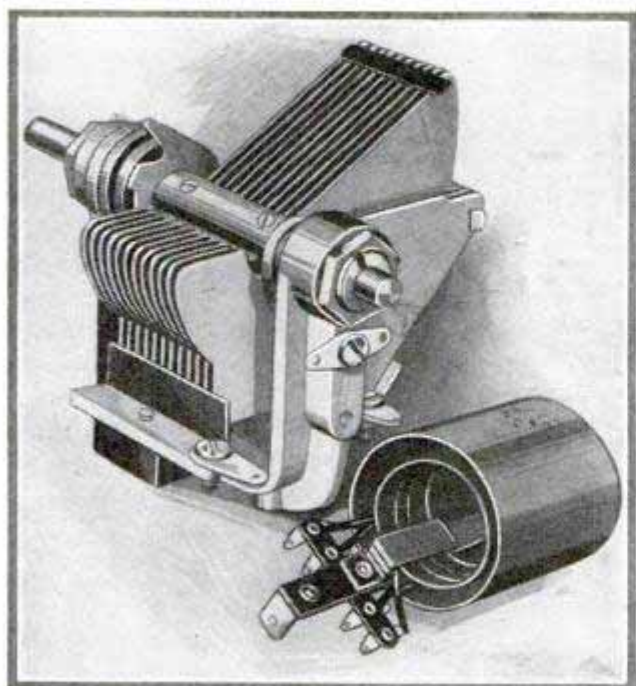

Above, Variable Condenser with Removable Shaft for Tandem Coupling; Below, Specially Designed R.F. Coil

2186 R
A-Unit Employs Three-Ampere Bulb

An A-power unit of excellent design is shown in the accompanying photo. It is of the dry type and employs a 3-amp. full-wave tungar

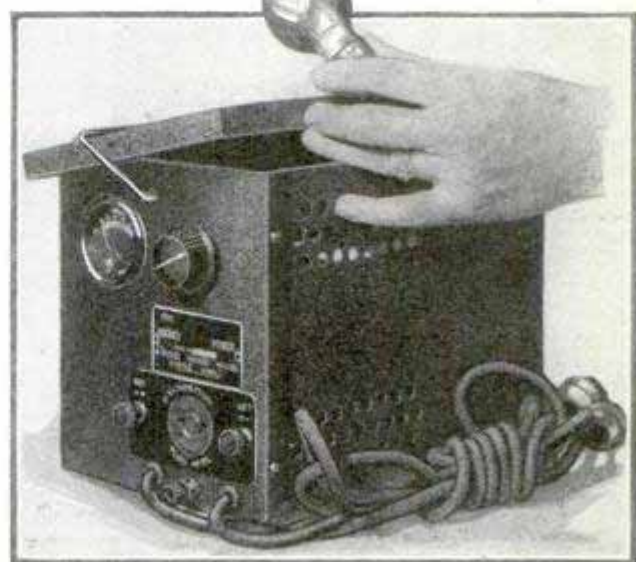

Dry A-Power Unit Showing Three-Ampere Full-Wave Tungar Bulb

bulb. It may be employed with sets using from 5 to 10 tubes, including the 112 or 171 power tubes, and is provided with a meter for exact voltage control. A single switch may be used to control A and B-power and set operation. The voltage as shown on the meter is adjusted by the rheostat; a special electrostatic condenser, combined with oversized chokes, produces a filter circuit capable of filtering 4 amp. This is considerably greater than the load of a 10-tube set. The tungar rectifier bulb is claimed to give the smoothest possible filament supply with a minimum of hum. A-power units of this type are gaining in popularity, as they not only eliminate the messy and troublesome storage battery but make possible all-electric operation of sets employing d.c. tubes.

When a set using a B-eliminator suddenly goes dead though the eliminator seems to be still delivering the full output voltage, the trouble is usually found to be a break-down in the variable resistor which controls the detector-plate voltage; this may be quickly remedied by replacing the defective resistor with a variable resistance, such as a clarostat of the universal-range variety, and adjusting it until the signals are satisfactory.

2186 R
Stirling Mfg. Co. 2831 Prospect - Cleveland, Ohio

Radio-Wiring Suggestion for Apartment Building

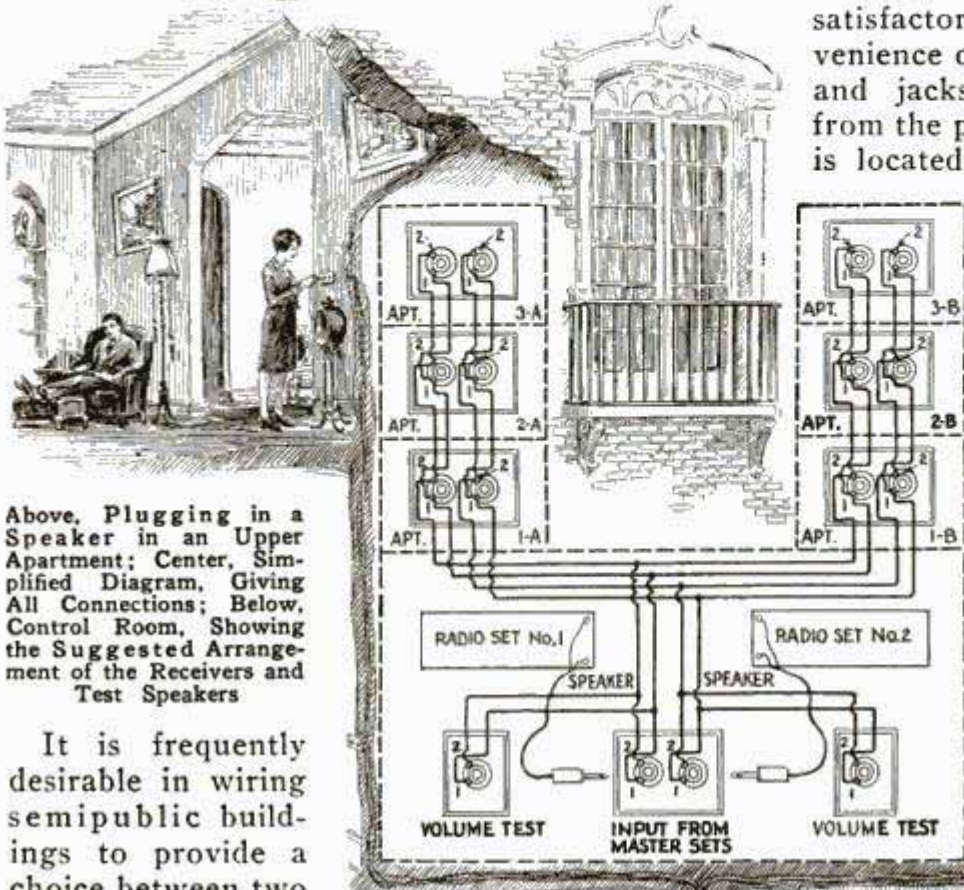

Above, Plugging in a Speaker in an Upper Apartment; Center, Simplified Diagram, Giving All Connections; Below, Control Room, Showing the Suggested Arrangement of the Receivers and Test Speakers

It is frequently desirable in wiring semipublic buildings to provide a choice between two programs. In this way, the listener-in may at his option select either of the two. The wiring diagram outlined in the sketch is easily followed. Two receiving sets, which may be of any modern type, are installed in the office or any other convenient room for centralized operation. Space limits the number of outlets shown in the diagram, but the loud-speaker connections may be extended as desired. The outlet plates now available fit any standard switch box. In some cases, the switch boxes may not be required, but they will make a more

satisfactory job. Each radio convenience outlet consists of a plate and jacks which are insulated from the plate. A two-gang plate is located convenient to the receiving sets, and additional outlets are connected in multiple to the input plate as desired. The two-gang plates in the apartments are fitted with impedance coils so as to give the same volume at each outlet, no matter whether one or more loud speakers are used on the same circuit at the same time. The two single-gang plates,



located in the control room convenient to each set, enable the operator to test for volume and proper tuning.

Variable Resistance Replaces Filter Choke

The use of an output transformer, or a choke and condenser combination, is common practice in coupling the output of the power tube with the input of the loud speaker. Several radio experimenters have lately substituted a suitable variable resistance for the choke coil in combination with the condenser, eliminating distortion frequently caused by core saturation in the choke coil. The resistance must be accurately set for the conditions

as well as for the loud-speaker volume desired, and takes the place of the usual choke coil. If a 171-A or 112-A power tube is used in the output, a standard clarostat will serve as the adjustable resistance, while, for the 210 or 250 power tube, whether alone or in push-pull amplification, the power type of clarostat is suitable. With this resistance, core saturation is avoided as well as burn-outs and open circuits, and, in addition, an excellent volume control for the loud speaker is provided.

Two New Tubes

A screen-grid tube adapted to a.c. use is now available. It has five prongs for the Y-type socket and the usual cap at the top for the control-grid lead. The maximum plate voltage is 180 volts with 75 volts at the screen-grid terminal; the plate current drain is 4 milliamp. and the heater requires 2.5 volts at 1.75 amp. The usual control-grid negative bias is 1.5 volts, and to reduce the hum in some circuits, it will be necessary to employ 9-volt bias in the heater lead. It is claimed the tube will deliver a signal twenty to forty times greater than that obtained with the standard 201-A tube. Special circuits and careful shielding are necessary to obtain maximum results with the tube, and filters and special shielding in all leads entering the stage shields are important. The tube may be used as a detector, either with gridleak or grid bias, with from 25 to 45 volts on the screen-grid terminal. Another new tube is a medium-power output type, an improvement over the 171-A. It is said to have an undistorted power unit of 1.6 watts, as compared with .7 watt for the 171-A and 1.7 watts for the 210 tube. The filament is of the rugged raw a.c. type, and draws 1.5 amp. at 2.5 volts.

Speaker Is Built of Concrete

This novel loud speaker stands in the yard of a home in Williamsburg, Ind., and is built of reinforced concrete. It is 8 ft. 8 in. high and weighs 600 pounds; the bell is 34 in. in diameter, and the air column tapers down to 3/4 in. at the base.

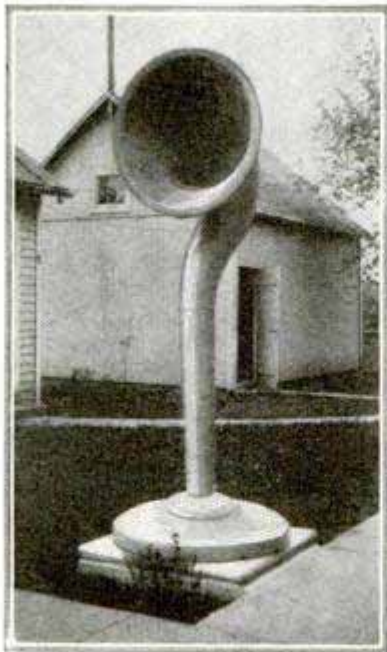

When the owner plugs his radio amplifier into this horn, the entire village can listen in on the program.

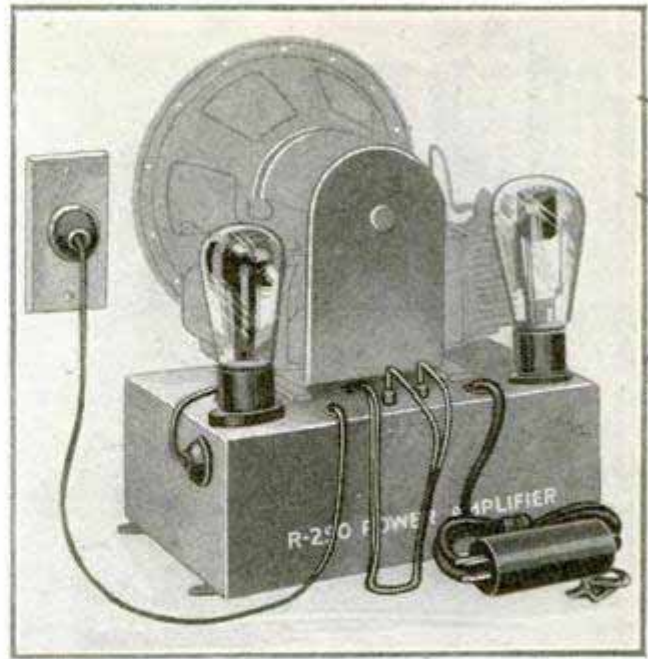

Power Amplifier, Showing Dynamic Speaker in Position for Compact Installation

Compact Power Amplifier for Dynamic Speaker

A new power amplifier which also serves as a base for the dynamic speaker makes a very compact unit for installation in radio consoles. The power amplifier may be used as a separate instrument where it is not practical to use it as a base. It is plugged into the last audio socket of any type of battery or electric radio set, thus supplying a stage of amplification employing one of the new super-power tubes. The power unit is plugged into the light socket and the dynamic speaker obtains its a.c. power from a receptacle on the amplifier. A 280 rectifier tube and either a 210 or 250 power tube are employed.

Output Filter Is Important

The use of an output filter is important in order to prevent damage to the speaker when the high voltage necessary for power tubes is employed. There is another reason for its employment, however, that is of equal importance. Due to the resistance of the speaker windings, when power tubes are employed, there may be a drop in voltage across the speaker amounting to as much as 30 volts. This means that another 45-volt B-block must be employed in order to make up for the loss, in a battery-operated set. When the output filter is employed this additional block is unnecessary, and such losses are avoided.

275
Starling Mfg Co 2831 Prospect Cleveland O. Ohio 2/19/30.

Tips from the

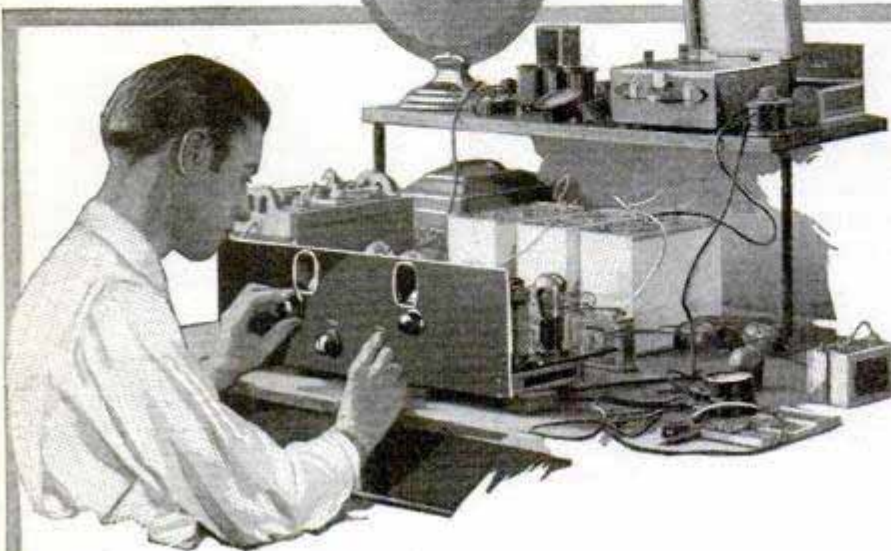

IF MORE THAN ONE TURN MUST BE REMOVED, DO SO AT THIS END

BARED END THROUGH HOLE IN LUG

Matching Homemade Coils with Condensers for One-Dial Operation; When Wired for Test, Slowly Pull Bared End through Lug, and When Coils Match, Solder Wire to Lug

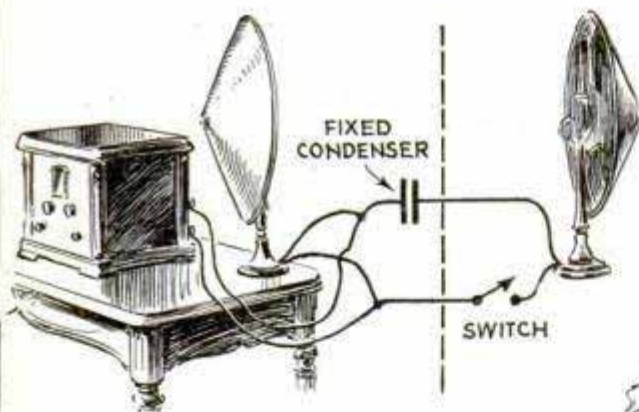

Simple Method of Connecting an Additional Loud Speaker to a Set without Impairing the Efficiency of the Regular Speaker; the Capacity of the Fixed Condenser Used May Be .5 Mfd.

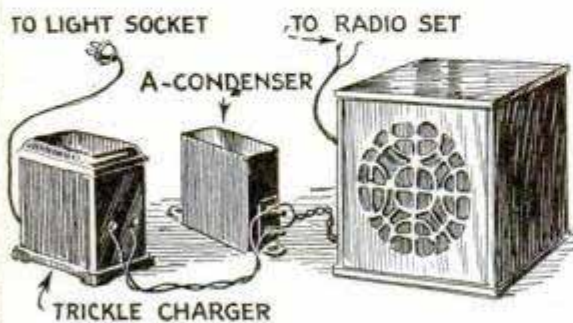

Energizing a Dynamic Speaker of the 6-Volt Battery-Operated Type from the 110-Volt A.C. 60-Cycle Line by Means of a 3-Amp. Trickle Charger and a Standard A-Type Condenser Unit

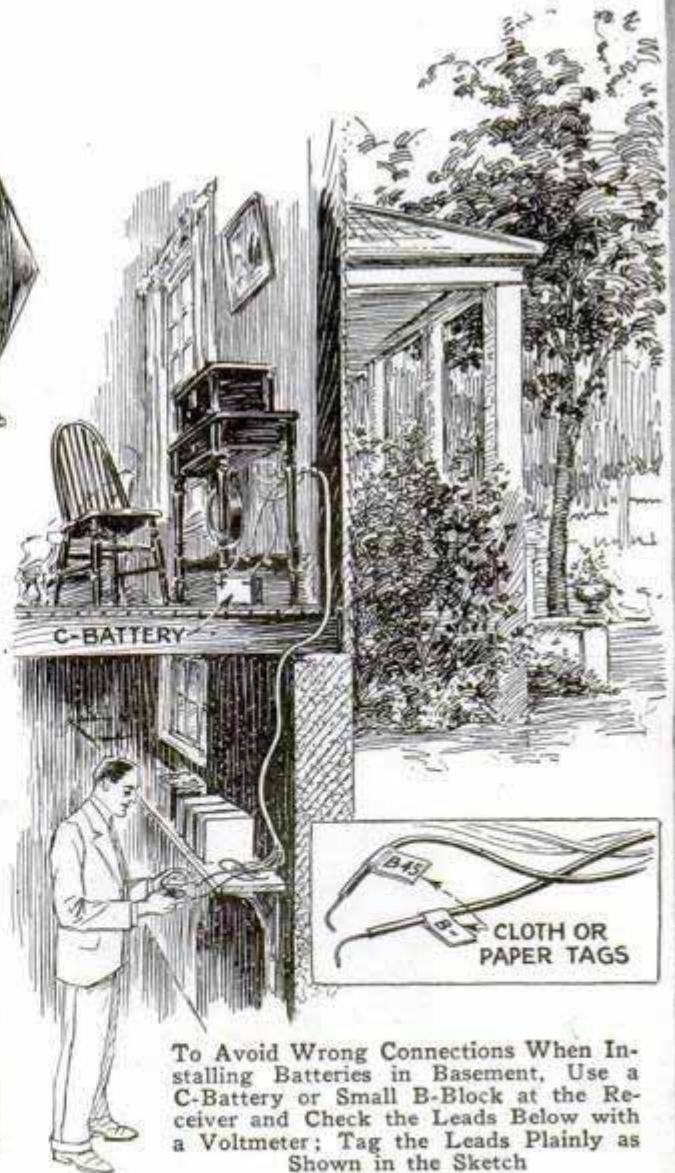

To Avoid Wrong Connections When Installing Batteries in Basement, Use a C-Battery or Small B-Block at the Receiver and Check the Leads Below with a Voltmeter; Tag the Leads Plainly as Shown in the Sketch

2102

Radio Lab.

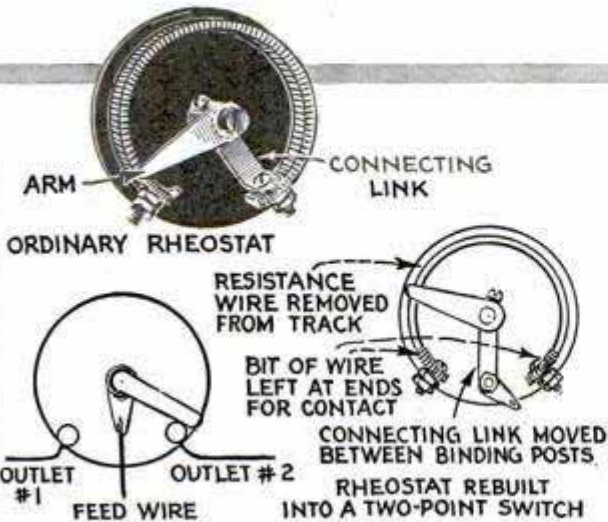

Double-Throw Switch Made from Old Rheostat; Remove Arm and Remount Connecting Link on Machine Screw between the Posts, Mount in Usual Manner and Connect as Shown

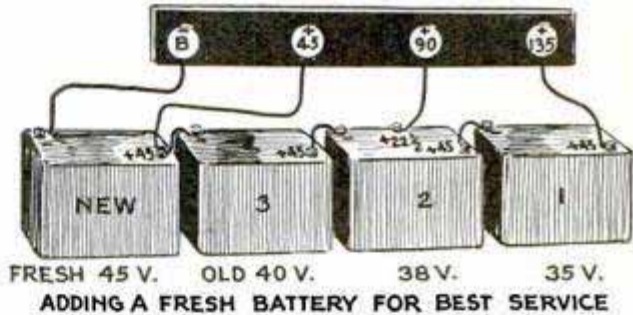
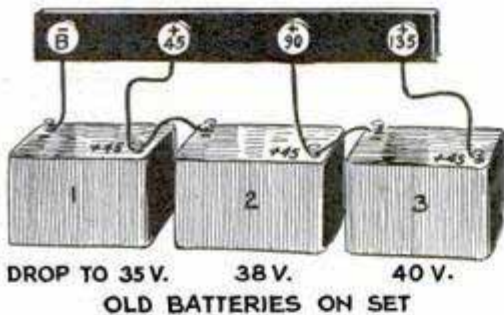

Additional Service from Old B-Batteries May Be Obtained if They Are Rearranged According to Their Value as Shown at the Right; the Fresh Battery Is Used for the Detector

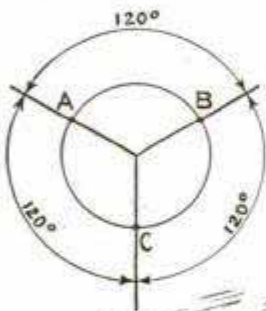

Locating the Position of Holes around the Circumference of a Tube for Mounting Brackets or Contact Lugs; Points A, B and C Are Obtained with a Protractor



REMOVING INSULATION WITHOUT DAMAGING WIRE

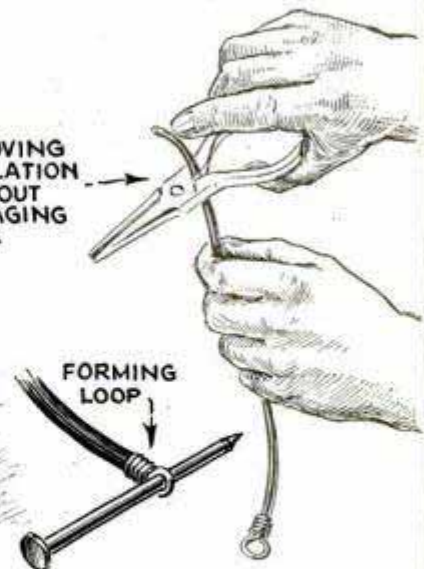

A Nail Provides a Means of Forming a Neat Terminal Loop; the End of the Wire Is Then Wound over the Insulation to Cover Frayed Ends

2168
838

Cambridge, Mass

Photo-Electric Cells of New Design

For television and other applications new photo-electric or light-sensitive cells

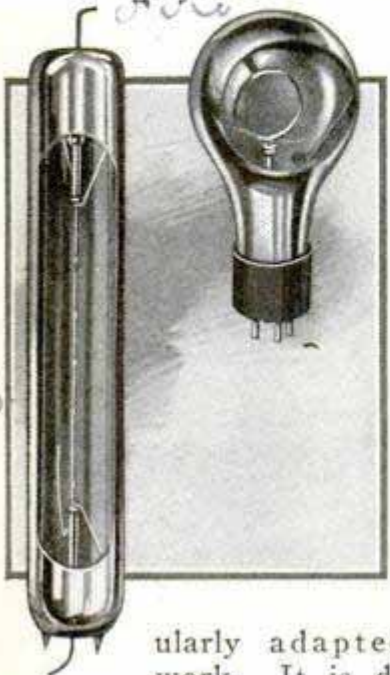

have lately made their appearance on the market. These cells are made in the hard vacuum and gas-filled types, as well as in bulb and tubular shapes. The spherical cell at the right is designed to fit a standard X-type socket and is particularly adapted to television work. It is designed for use where the so-called direct illumination system is employed, that is, when the object is floodlighted and the photo-electric cell is scanned with a rotating perforated disk. It is also used for picking up varying light through film as used in the broadcasting of radio movies and may be employed as an input to an amplifier for sound-recording films. The tubular type is for television broadcasting by scanning the object with a spot of light.

Double-Impedance Amplifier Unit

The compact amplifier unit shown is available for set owners and builders who wish to improve the volume and tone quality of their receivers. It employs three tubes, one of which is a standard power tube; the circuit is the tuned, double-impedance type and is said to give undistorted reception at greatly increased volume. The amplifier is ready to install and with it is included a built-in output filter, inserts for loud-speaker cord and plainly marked battery



built-in output filter, inserts for loud-speaker cord and plainly marked battery

cable. Its length is 10 in., width 6 1/2 in. and the height is 2 1/2 in. The double-impedance unit is hermetically sealed in a compound which protects the windings from electrolysis, a frequent source of trouble in transformers.

Grid Bias for Heater-Type A.C. Tube

Because the cathode element of the type-327 a.c. tube is entirely apart from the heating filament, supplying a grid bias for these tubes is a very simple matter. All that is necessary is to connect the grid return of the transformer of the stage in which the tube is connected, to the B-negative lead of the power pack, and then connect the proper value of grid-bias resistor between the grid-return terminal of the transformer and the cathode K-terminal of the tube socket. The grid-bias resistor should be shunted by a bypass condenser of at least 1 mfd. When several of these tubes are operated from the same filament winding, but the grid voltages required differ on the various tubes because of the stages in which they are used, merely connect separate grid-bias resistors in each stage, in the same manner.

Filter Prevents Power-Line Noises

An interference filter, to be connected between line and set and designed to prevent noises from the power line from affecting the operation of electric receivers or power-supply devices, is now available. The device is also useful to prevent radiation and interference from electric motors, electric refrigerators and sewing machines, oil burners and similar electrical appliances. It can be connected quickly by a novice.



Popular Mechanics' radio department offers its information service free to all readers of our magazine. We will be glad to help you with your problems, and will promptly answer all inquiries.

Paragon Electric Corp Upper Montclair, N.J.

70 U.S. Patent Office, New Haven, Conn.

AMATEUR MECHANICS



“Pepping Up” Old Outboard Motors

By DICK COLE

WHEN an automobile motor becomes sluggish and ignition and carburetor adjustments will not better the condition, the owner concludes that the valves require grinding and is usually correct in this conclusion. However, when a similar condition arises in an outboard motor, one must look for the cause of the trouble elsewhere, as these motors are of the two-cycle type and have no valves. Sluggishness, in this case, can almost invariably be traced to loss of compression in the crankcase.

In the two-cycle motor, the mixture from the carburetor is first drawn into the crankcase, compressed on the downward stroke of the piston or pistons, and is then injected through a port into the cylinder, displacing the previous charge. If the crankcase is not gas-tight, considerable power loss will be evident. A simple method of checking up the compression

and to locate the points of leakage is shown in the drawings.

An old auto oil-pressure gauge, Fig. 1, obtained from a junk yard, has been found useful to test a one-cylinder motor. Two such gauges may be used in case of two-cylinder motors, although only one is necessary. Whether or not these gauges register accurately, the pound pressure per square inch is immaterial so long as they are capable of indicating a pressure of 50 to 60 lb. At some convenient and accessible point in the crankcase,

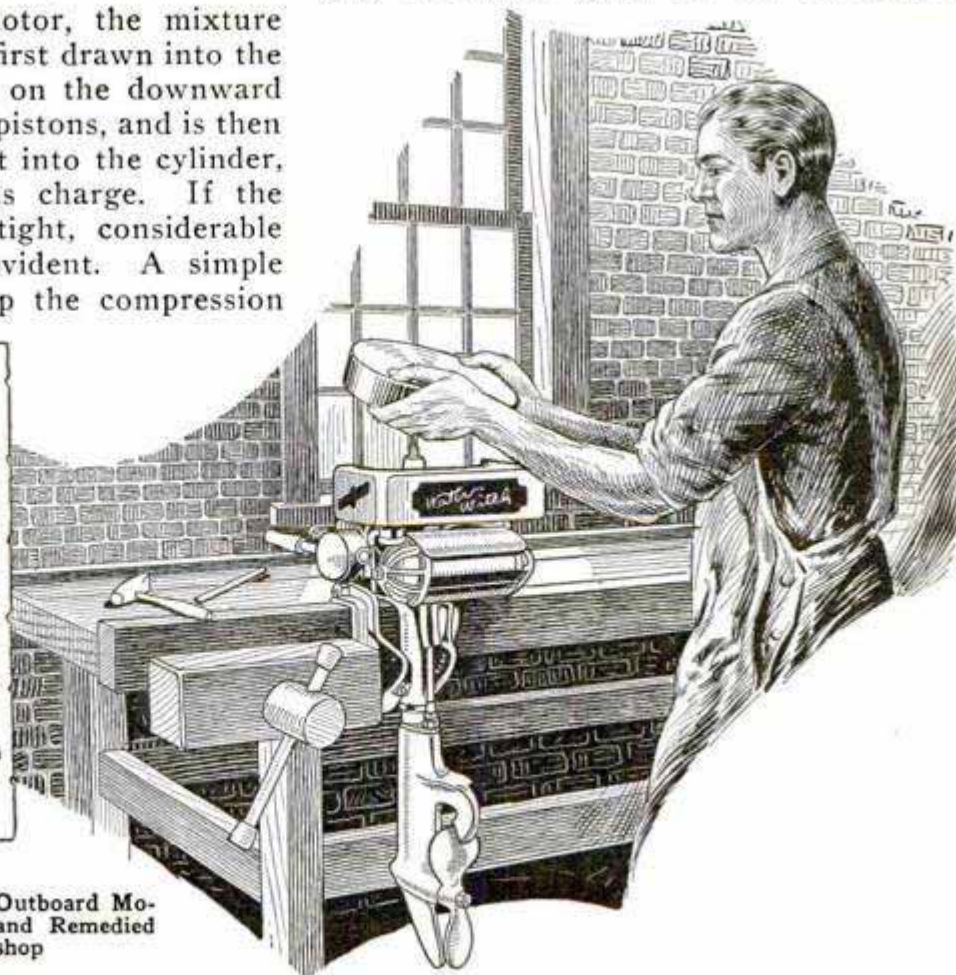
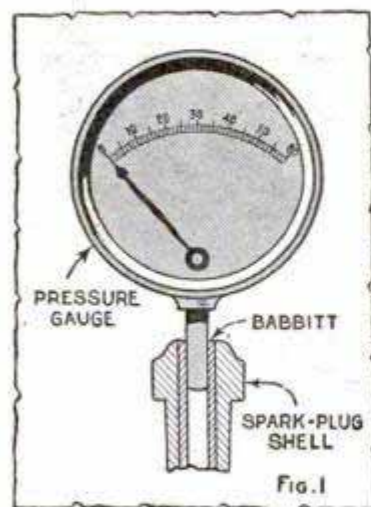

Cause of Sluggishness of Old Outboard Motors Can Readily Be Found and Remedied in the Home Workshop

drill a hole and tap it for a $\frac{1}{8}$ -in. pipe fitting. (See Fig. 2.) A short piece of $\frac{1}{4}$ -in. copper tubing and standard fittings are used to connect the pressure gauge with

cylinders, the motor should be run and oil squirted around the cylinder gasket. Bubbles will show a bad gasket. If there is no leakage at this point, it is obvious

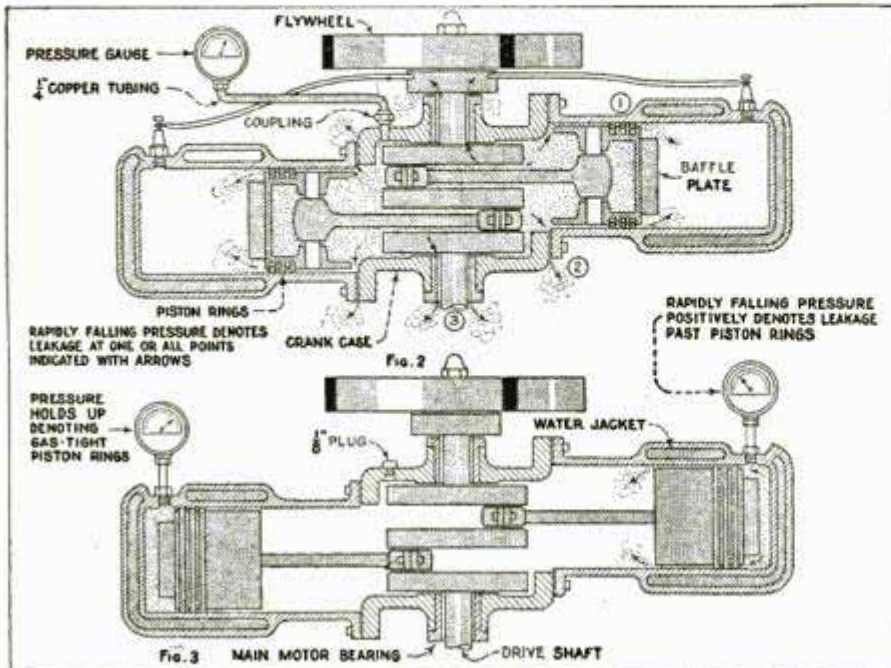

Old Auto Oil-Pressure Gauges Used for Checking Compression of Cylinder and Crankcase

the crankcase as indicated. The flywheel is turned to bring the pistons against the crankcase compression, and the gauge reading is observed. If the pressure drops quickly—in two or three seconds—then the point of leakage must be located and remedied. The points where leakage can occur are at the piston rings, through a faulty cylinder-base gasket, and between the crankshaft and main motor bearings. To check up the possible loss at the piston rings, the body of an old spark plug is bushed to receive the pressure gauge, as shown in Fig. 1.

In the case of a two-cylinder motor it is best to use two gauges, as indicated in Fig. 3, although the cylinders can be checked one at a time. The flywheel is turned to bring the pistons against the cylinder compression and the gauge readings noted. Rapidly falling pressure positively denotes leakage at the rings, as there is no other outlet for the gas, except on very rare occasions when a sand-hole may be found in the piston casting. If a cylinder does not hold compression, it should be removed, carefully checked for scoring and "out-of-roundness," and new pistons substituted. If there is no appreciable loss of compression in the

that the crankcase compression is lost between the crankshaft and the bearing. The remedy for this depends entirely on the design of the motor. If the crankcase and bearings are split along the center line of the crankshaft, the bearing shells can be shimmed and new bearing surfaces scraped. If the motor is equipped with roller bearings, there is always a gland which can be adjusted or packed with new packing.

Every outboard-motor owner should check up on the crankcase compression occasionally, and, if faulty, the cause should be located and remedied immediately, as loss of crankcase compression results in considerable fuel and power loss, and also contributes to difficult starting.

Electric Drill Used for Mixing Glue

For mixing large quantities of waterproof glue, an electric hand drill has been found useful. The stirring device, which is gripped in the chuck of the drill, con-

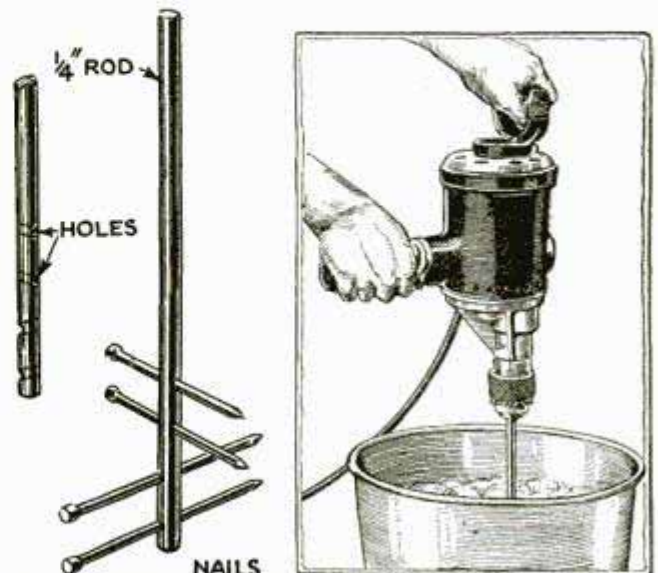

Large Quantities of Glue Can Be Quickly Mixed with the Aid of an Electric Hand Drill

sists of a short piece of $\frac{1}{4}$ -in. iron rod or steel. Two sets of slanting holes are drilled through the rod near one end, one pair being at right angles to the other, as shown in the drawing. The holes are spaced about $\frac{3}{8}$ in. apart and should be of such size as to allow a snug fit for four small finishing nails, which are driven halfway through.—E. F. Kierman, Pasadena, Calif.

Improving Tone of Stringed Instruments

A felt pick will wear out, one of celluloid will break, but a leather pick will do neither. While giving a loud tone, it will not "clang" or "slap" like a celluloid pick. Cut it out of a pliable piece of boot leather with a pair of shears. Such a pick will last indefinitely. The tone quality of a tenor guitar or tenor banjo can be greatly enhanced by doubling each string as on a mandolin. To do this, it is necessary to drill four extra holes in the head and insert pegs. Effective melody and harmony may then be executed on the two double strings only, making the playing much easier. By inserting an ordinary door key under the strings near the nut of a tenor guitar or ukulele having steel strings, it can be played like a Hawaiian guitar. The back of a knife blade makes a good steel. A tenor banjo or a banjo uke may be played this way also. I have tried out all of these ideas and found them entirely satisfactory.—Kenneth R. Dear-dorf, Bemidji, Minn.

Fishing Rod Aids in Removing Broken Parts of Axle

On three occasions I have used a telescoping fishing rod and a small soft-iron wire, looped as shown, to remove inner portions of broken axles without removing the opposite axle to punch the broken piece out. The illustration clearly shows how it is done, and the kink is quite a timesaver.—S. O. Stanfield, Maymont, Can.

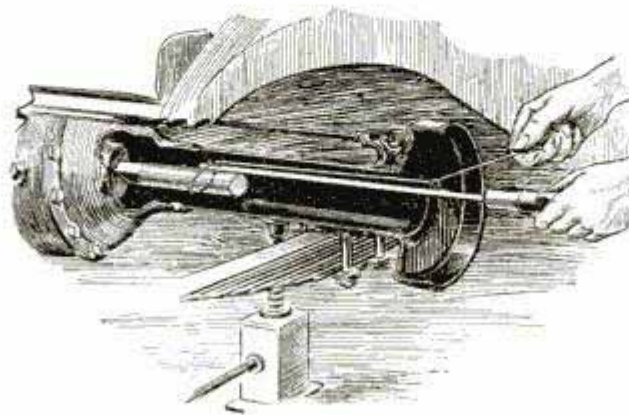

Fishing Rod and Wire Loop Enable Auto Mechanic to Remove Part of Broken Axle

Homemade Lawn Sprinkler

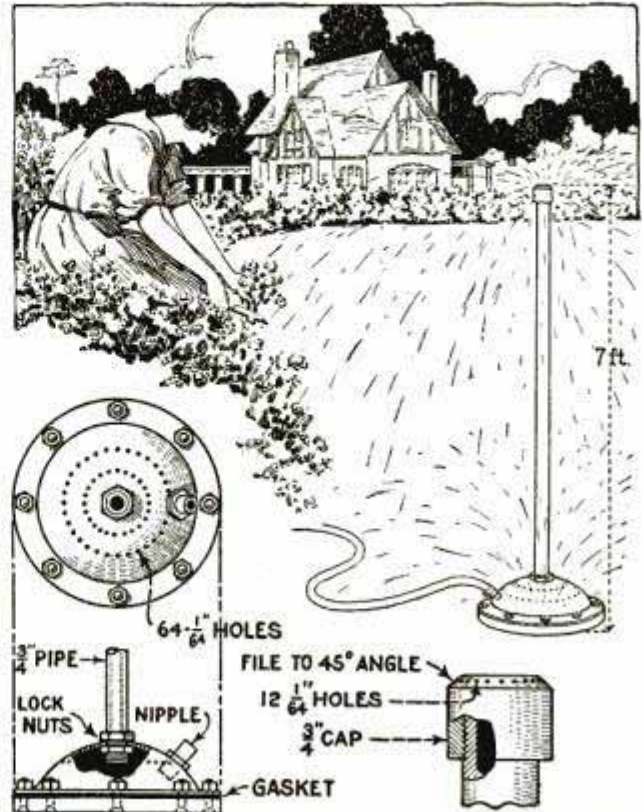

Simple Lawn Sprinkler Which Can Be Made from Pipe and Fittings

A differential-housing cover plate from a junked automobile makes a suitable base for a lawn sprinkler, as shown in the illustration. A hole is drilled in the center of the case for a 7-ft. length of $\frac{3}{4}$ -in. pipe, which is inserted in it and held in place with two $\frac{3}{4}$ -in. pipe nuts. A round base of wood is bolted to the flange of the case, and a $\frac{3}{4}$ -in. cap, with the edge turned to a 45° angle, is fitted to the top of the vertical length of pipe. A number of $\frac{1}{64}$ -in. holes are drilled in the cap and in the base as shown. A suitable nipple, to accommodate a hose, is fitted to the filler hole in the case, and for this purpose a reducing bushing may be found necessary.

The sprinkler is shown in its simplest form, but the design can, of course, be varied to suit the user. A horizontal arm can be screwed onto the vertical length and drilled with $\frac{1}{64}$ -in. holes or a whirling sprinkler can be provided at the top, if desired.

Vacuum Cleaner Supplies Air for Soldering Torch

An efficient soldering torch, using ordinary gas, acetylene gas or vaporized gaso-

Gas Soldering Torch, Supplied with Air from Old Vacuum Cleaner, Produces Intense Heat

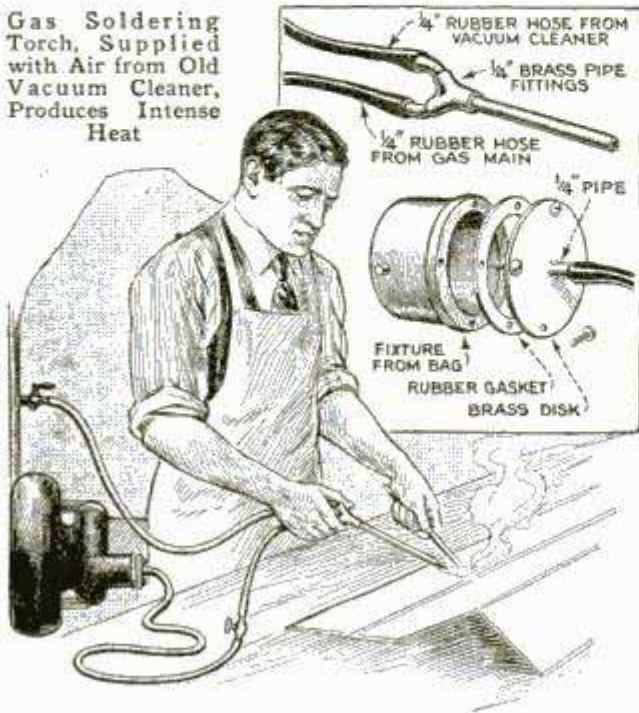

line, can be made by the amateur mechanic at a very small cost. It can be used for doing almost any job of soldering or brazing. A vacuum cleaner is rigged to supply air. The torch consists of a 3-in. length of $\frac{1}{4}$ -in. brass tubing. Thread one end and screw it into the single end of a Y-fitting. The two Y-openings are fitted with $\frac{1}{4}$ -in. brass 45° elbows, adjusted so that their ends are parallel. Apply red lead to the joints and turn them up tight. Lengths of tight-fitting heavy-duty rubber tubing are slipped over short nipples screwed into the elbows. One tube is connected to a $\frac{1}{4}$ -in. shut-off cock in the gas line, and the other to a similar cock in the air line. Remove the bayonet fixture that holds the bag to the housing of the vacuum cleaner, and make a similar fixture of heavy sheet metal. It must be a snug fit so that no air will escape between it and the socket. To the front of this, braze or solder a steel plate. If the fixture has a thick rim, the plate can be fastened to it by small machine screws, the rim being drilled and tapped for this purpose. Drill a hole in the center of the plate and braze in a 6-in. length of $\frac{1}{4}$ -in. pipe. This is attached to the air-line valve by means of a suitable length of rubber

tubing. Wire-clad tubing is the best for the pressure line, as it will not break under excessive strain. To use the torch, turn on the gas slowly and light it at the nozzle. Then turn on the air pressure, also slowly, until the flame is almost invisible. This is the hottest flame that can be obtained. The size and intensity of the flame can be regulated by adjusting the nozzles. The air pressure depends on the capacity of the vacuum cleaner. Place the cleaner where it will rest solidly while running, and in such a position that the switch can readily be reached. Do not start until ready for air, and turn it off just as soon as the flame is turned off.—L. B. Robbins, Harwich, Mass.

Repair Spacer for Door-Catch Bolt

Closed Ford cars, before the last two models, are equipped with a sliding catch bolt which moves in and out like the bolts on ordinary doors in buildings. The sliding bolt presses against the outer side of the opening in the door catch when the door is being closed, and wears the opening larger. The door must then be pulled much farther in to catch it, which necessitates hard slamming. A repair spacer can be made from a Ford upper coil point to take up the wear and hold the bolt farther in.

The coil point is cut and bent as shown, and is attached to the edge of the door with a small wood screw, with one side of the angle fitting into the lock opening alongside the catch bolt. A few of the cars using the sliding door bolt may have had steel-frame doors, in which the wood screw could not be used, and a hole would have to be drilled and tapped for a small machine screw or stovebolt to hold the spacer in place.

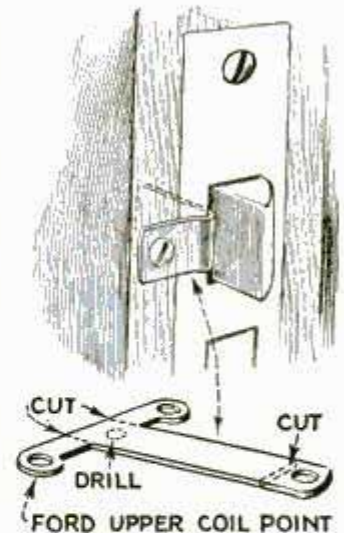

☞ To make brilliantine, mix castor oil, one part, olive oil, two parts, and eau de Cologne, four parts.

H.C. McKay, 2101 Myra Court
Brooklyn, N.Y.

The Fighting Saurians

by H.C. McKay

THESE fighting saurians will appeal to the youngster who is just learning of the monsters of the Jurassic age. The eccentric motions and bright colors, together with the strange form, all go to make up a toy designed to appeal to children of all ages.

The entire toy is made of thin wood, $\frac{3}{8}$ in. three-ply paneling being very good, as it does not warp or split easily. The wheels and crankshaft bolsters, or bearings, may be made of the same material, although, if a lathe is at hand, turned wheels may operate more smoothly. If the paneling is used for the bolsters, two thicknesses should be used, giving each bolster a $\frac{3}{4}$ -in. bearing surface.

The first step is to fretsaw the two saurians No. 1 and No. 2. It will be noticed that these outlined figures are not separated into individual members, but the whole is given in one figure. By the use of the guide lines, however, the legs may be drawn separately, while the figures give a good idea of the assembly. In both cases, one body and two pairs of legs will be needed.

As the most important point is to have all joints work smoothly, the decorating is best done before assembly. For this purpose, either

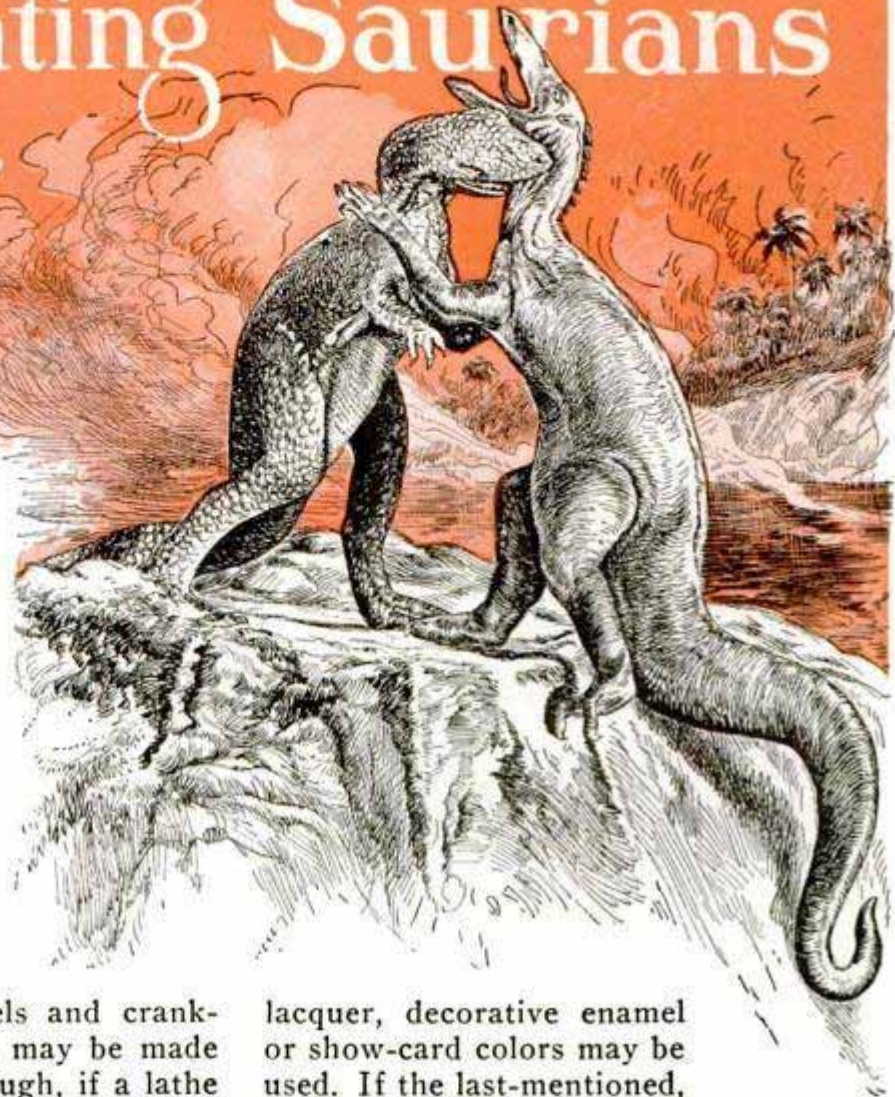

lacquer, decorative enamel or show-card colors may be used. If the last-mentioned, a coat of clear varnish should be applied later as these colors are not waterproof and are inclined to rub off when dry.

The exact coloration is left to individual fancy, as we have no means of knowing what colors these reptiles actually were. With our present knowledge of protective coloration and of the blotchy patterns of many present-day reptiles, we may assume that the abdomen was a yellowish-green,

or greenish-yellow, with a varicolored and blotched pattern on the back and sides. The drawings indicate the colors given the original models.

The next step is to make the carriage. The bed meas-

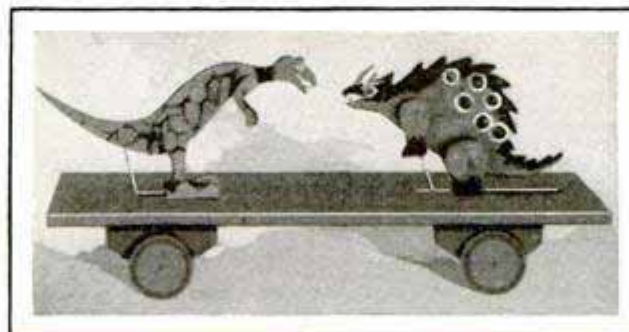

ures 5 by 18 in. and is cut out as shown. The opening between the feet of No. 1

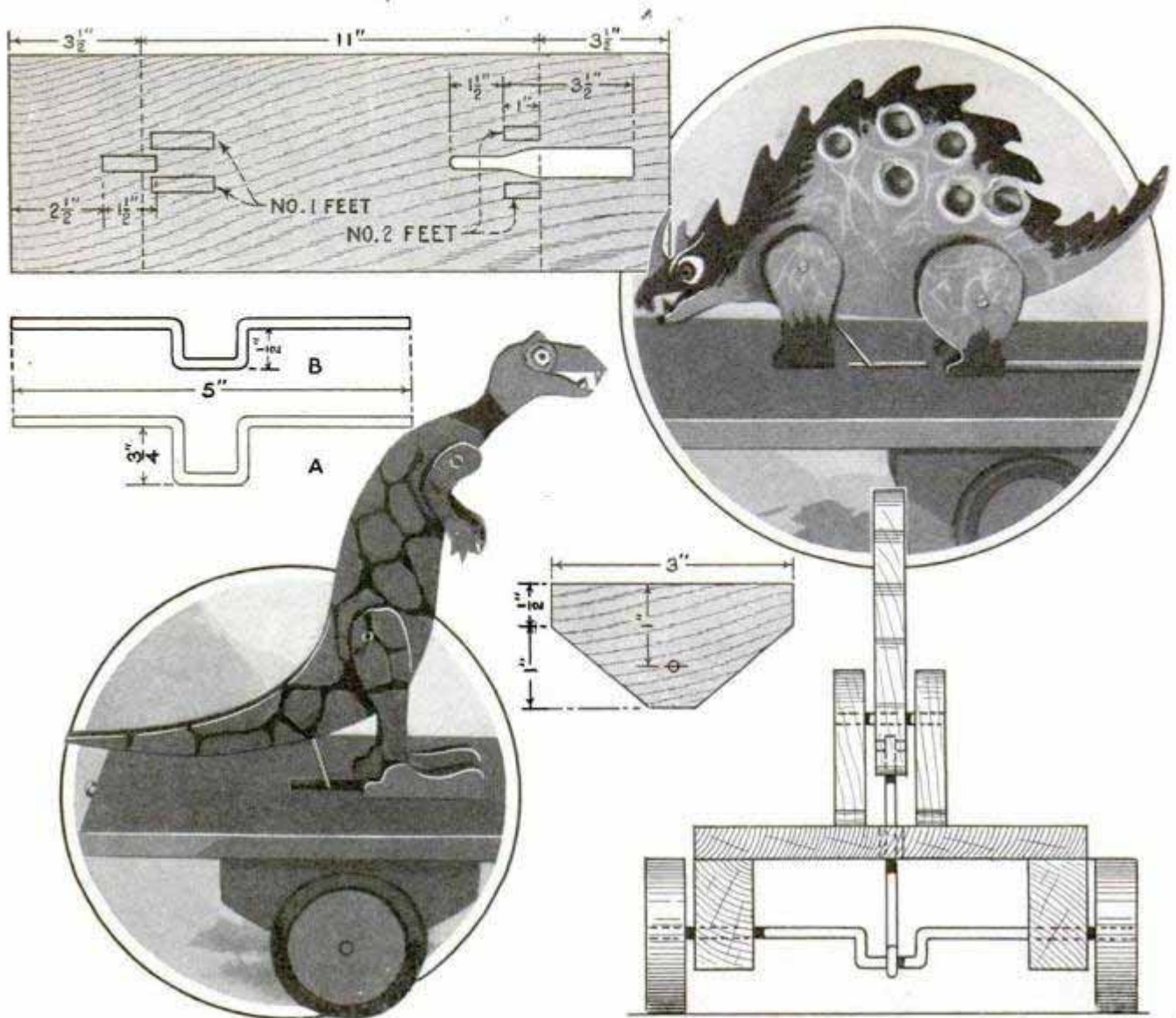

(the taller figure) measures about $\frac{3}{16}$ in. wide, but as this opening is for the wire drive rod to pass through, the width need not be exact. The opening for No. 2 is quite different. The larger end of the opening allows the tail to drop below the level of the bed when the animal rises. This opening is $\frac{1}{2}$ in. wide. The narrow end is for the No. 2 drive rod and is about $\frac{3}{16}$ in. wide. If the figures are drawn exactly as shown and placed upon the bed as indicated, they will work, but before fastening them, it would be well to make a trial to see that all action is smooth.

The bolsters, four in number, are made as shown in the detail; of the two cranks, made of stiff wire, A is for No. 1 drive and B for No. 2. Note that these cranks are made for use with 2-in. wheels. Mount the bolsters on the sides of the carriage with a 2-in. space between the end of the bolster and the end of the carriage. This places the axle (crank) line $3\frac{1}{2}$ in. from the end. The holes through the bolsters

should be from $\frac{1}{64}$ to $\frac{1}{32}$ in. larger than the diameter of the crank wire. The holes in the wheels are about $\frac{1}{64}$ in. smaller than the crank wire, requiring a drive fit. This gives the propelling traction.

The legs are assembled with the bodies by means of small wooden dowels. For this purpose, the small wooden sticks upon which lollypops are mounted will serve excellently. The holes drilled through the bodies are a trifle larger than the sticks, while the holes in the legs and arms are drilled so as to be a drive fit. This gives a firm support, while permitting free movement. The two arms of No. 1 may be glued solidly to the body if the maker prefers, but the movement is more natural if they are permitted to swing free. When attaching the legs to the body, it is an improvement to slip a small washer over the dowel, on each side, before driving on the leg or arm, although this is not essential. If washers are not used, be careful not to drive the limbs so

tightly up to the body that they will bind.

The connecting rods that actuate the bodies are merely lengths of stiff wire with loops formed at both ends. One loop of each is made to fit the crank of the axle fairly closely, while the loop at the other end is made to fit a small wooden dowel, similar to those used for the leg mounting. This dowel is driven through a hole drilled in the body at the spot marked "pivot." In order to allow clearance for the loops on the ends of the wires, and to permit entirely free movement, the center ply of the paneling is cut out with a chisel, as indicated by the dotted lines in the figure layouts. The connecting rods must be assembled on the axles first, and passed up through the slots in the base; then the figures are set in place and the pivot dowels driven through the holes in the bodies and the upper loop in the rods. All painting should be done before assembly, the ends of the dowels being covered with a spot of enamel or lacquer after being driven into place.

When the toy has been assembled and is pulled along the floor, the "reptiles" will rear and plunge to-

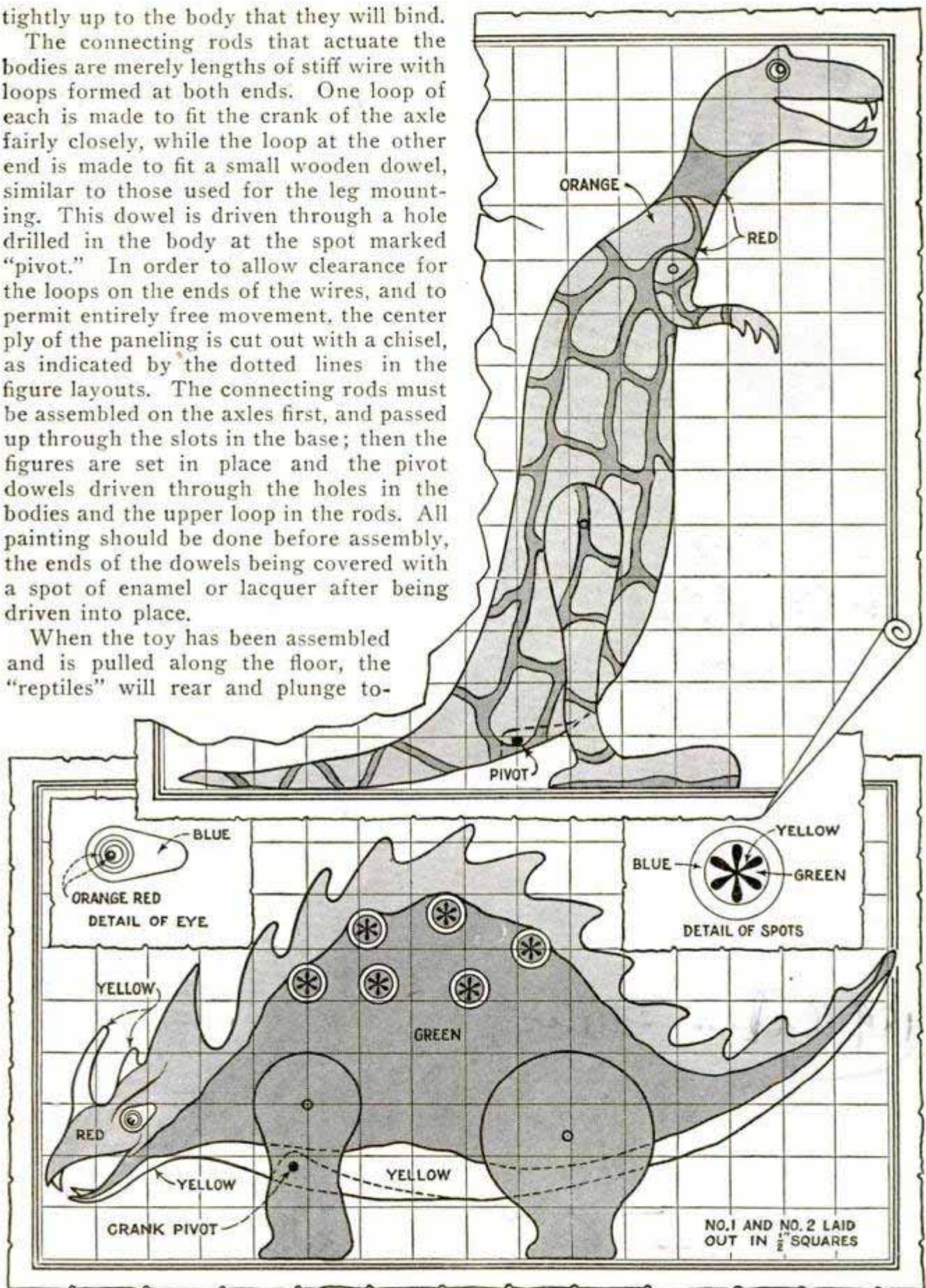

ward each other with a swinging motion. The weight and method of pivoting No. 2 will cause a certain amount of slip which

gives it an awkward, shambling, irregular motion that is much more realistic than would be a uniform up-and-down motion.

3rd floor.

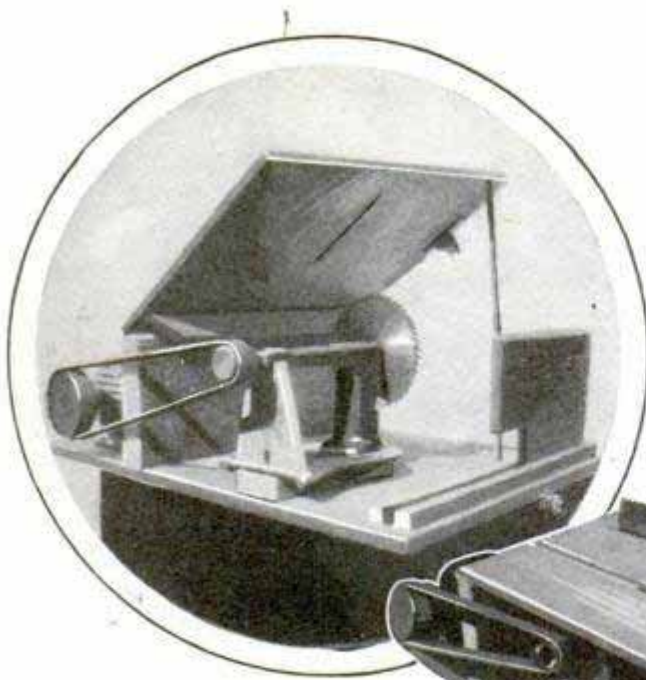

An Old Sewing-Machine Head and a 1/4-Hp. Electric Motor Were Used to Make This Handy Circular Saw



Sewing-Machine Head and Small Motor Used to Make Circular Saw

Capable of cutting 2-in. stock, the circular saw shown in the photos can be made by anyone, and will be found very useful in the home workshop. An old sewing-machine head is used, a 6 or 8-in. saw being attached to one end of the shaft and a pulley of suitable size to the other. The table top is made of 1-in. wood, pivoted at one end, and the ripping fence and crosscut guide from scrap material. A 1/4-hp. motor is used to supply power. This outfit cost the builder less than \$8.50 and answers the purpose excellently.—R. E. Hill, Pasadena, Calif.

buy store from whom he purchased drums out of stock in this design.

189 Claxton Arc Homemade Eardrums

I am rather hard of hearing and after carefully examining some small eardrums on the market, decided to make some myself. For 15 cents I purchased two rubber ear plugs used by swimmers. These were hollow and cone-shaped, as shown in the drawing. I drilled a small hole straight through the apex of each, as indicated, which made them ready for use. I found

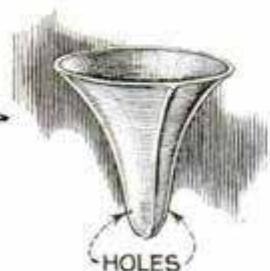

cannot locate maker

them highly satisfactory, as they did assist me in hearing much better.—James E. Noble, Toronto, Can.

Box 147, Lakeview Ont A Hint on Sodding Canada

In building a terrace at the front of his lawn, a Wisconsin home owner obtained quantities of sod from various places and thus completed the job in a much shorter time than would have been possible had he grown the grass from seeding. However, in the course of a few weeks, the terrace presented a rather mottled appearance; some of the patches of sod were fresh and green while others were brown and apparently dead. As the same care had been given all the sod in the laying, the owner was at a loss to understand the reason until a

landscape gardener explained to him that the sod containing the thriving grass had been taken from ground long exposed to the direct rays of the sun, while the remainder had been removed from shaded places. The change from shelter was more than the tender grass could stand.

Transplanting Tomato Plants

For transplanting tomato seedlings, the illustrated container will be found convenient. It consists of a wooden frame

just large enough to accommodate a paper egg-crate filler. The bottom

should not be nailed to the sides, as this would prevent the easy removal of the sides when the plants are to be taken out. Good, rich dirt is first put into the compartments formed by the paper filler, and the seed is planted. When the plants are large enough to be transferred to the ground, the sides of the box are slipped off, and the plants can then be removed one by one.—W. O. Hendrickson, Argyle, Wis.

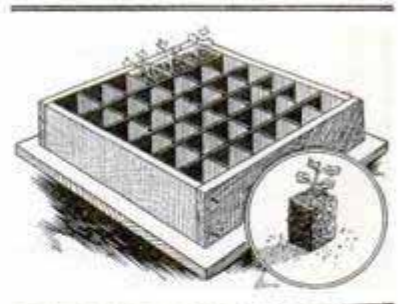

Use of Slow Paper When Enlarging Photos

Amateur photographers who do their enlarging at home may find it possible to use slower paper than the regular kind offered for the purpose by increasing the intensity of the light used. This can be done by "overrunning" the electric lamp for a short period of time, that is, forcing through it a slightly higher voltage than that for which it is rated. A 250-watt lamp designed for a 110-volt circuit can be used on a 220-volt circuit if a suitable resistance is connected in series with it. Then by short-circuiting the resistance for a few seconds an enormous brilliancy is obtained. Of course, some lamps will burn out when subjected to a voltage twice their normal rating, but generally the lamp will last through the ordeal, although its life will be shortened. By this method the average exposure of an enlargement is reduced to almost one-thirtieth of the time previously consumed.

Handy File Holder

One of the most used and abused tools is a file, and it is often found without a handle. The holder shown in the illustration will not come off and is much handier to use than the usual type. It consists of a length of flat iron, bent at one end to form a hook which is caught over the end of the file, and the other end of the iron strip is welded to a tapered piece of steel, as indicated. The latter is tapped lengthwise for a screw, which is anchored in a small wooden knob, and a hole is drilled in the other end of the screw to accommodate the pointed tang of the file. In use, the file is slipped into the holder, and the wooden knob is turned until the file is held securely.

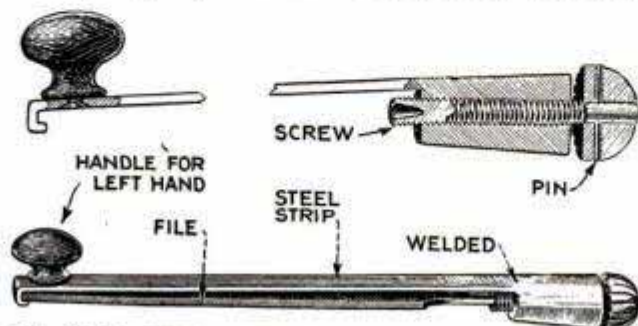

File Holder Which Will Not Come Off and Is Handy to Use



Strips of Ordinary Adhesive Tape Used as Stencil When Painting Furniture

Tape Used for Decorating Furniture

Many home owners purchase unpainted furniture because they wish to paint and decorate it themselves to match the color and carry out the design details of the room decoration. Adhesive tape has been found very useful as a stencil for blocking out parts not to be painted. Care must, of course, be taken to press the edge of the tape securely on the surface to be blocked out, in order to prevent paint from running under it. Quick-drying lacquer is most convenient for this work.

Oiling Lock Wheel on Ford

When a lock wheel is installed on a Ford, and is locked in place, the gears, shaft and bushing on the inside of the steering-gear case often run dry of grease. A squeak will result. If a small hole is drilled in the case, to admit an oilcan spout, this trouble is easily overcome.

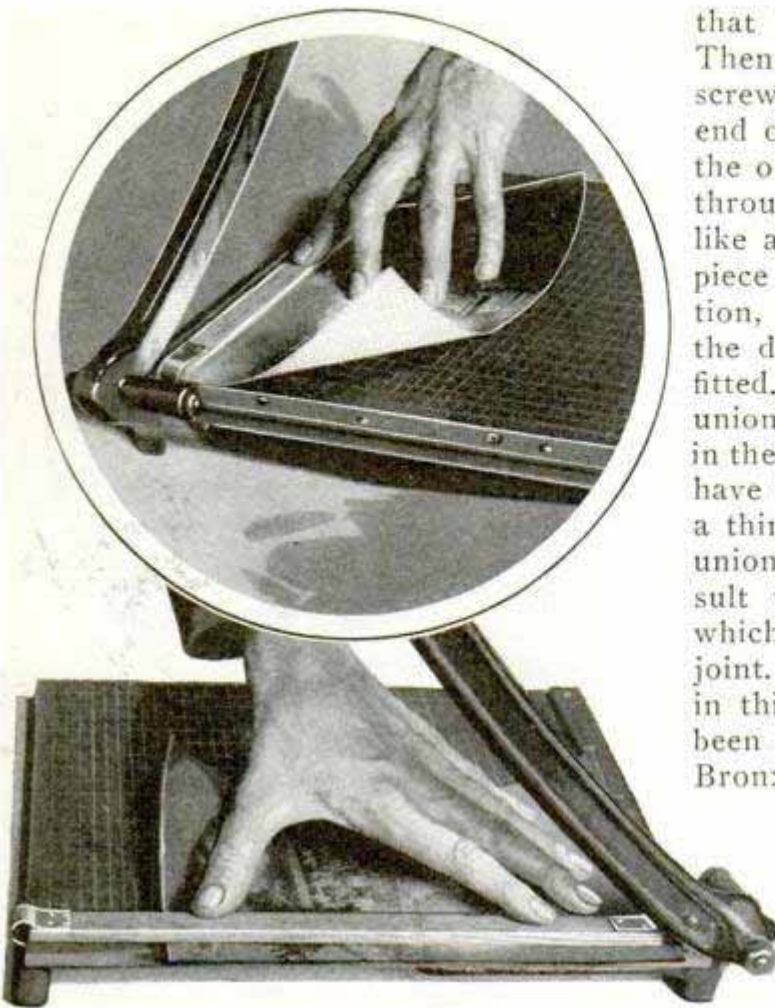

Simple Guide Strip Holds Prints Flat While They Are Being Trimmed

Guide Helps Trim Curled Prints

Curled prints are hard to trim unless held down flat with a ruler or otherwise. To do away with this difficulty, I devised the guide shown in the photo. It consists of a strip of wood, $\frac{3}{4}$ in. wide and $\frac{1}{4}$ in. thick, which is fastened to the ends of the trimming board with thin brass springs, so made that the guide is automatically raised about $\frac{1}{8}$ in. when released. The clips are tacked to the guide on the top, the ends below being free. The inside of the guide is beveled to facilitate the introduction of the prints under it. The slightest pressure on the guide will flatten the print and the guide does not interfere with the trimmer.—J. G. Pratt, Washington, D. C.

Repair for Leaky Water Pipe

Here is an easy and cheap method of repairing a leaky lead water pipe: Get two galvanized unions, file off the washer flanges and ream out the holes inside so

that they can be forced over the pipe. Then saw out the bad part of the pipe and screw one-half of the first union onto one end of the pipe, and the other half onto the other end, letting the lead pipe come through about $\frac{1}{4}$ in., which can be flanged like a washer and filed smooth. Take a piece of old lead pipe, still in good condition, and cut it about 1 in. longer than the distance between the unions already fitted. Screw the two parts of the second union onto this piece and flange both ends in the same way as before, being careful to have the flanges fit nicely together. Place a thin pasteboard washer in both of the unions, and screw them up tight. The result will be a rustless water-tight job, which will be much stronger than a wiped joint. I have made a number of repairs in this way, and every one of them has been found satisfactory.—John Kuhhorn, Bronx, N. Y.

Saving Liquid When Pouring

Spilling liquid when pouring it can be prevented by holding the can as shown in the drawing, and providing a suitable funnel. Instead of holding the can with the opening on the lower side, which seems to be the most natural way of doing it, turn it so that the opening is at the top. Set the ridge around the opening over the edge of the funnel, and proceed to pour out the liquid slowly. This method admits air through the opening to replace the liquid removed, and permits a steady

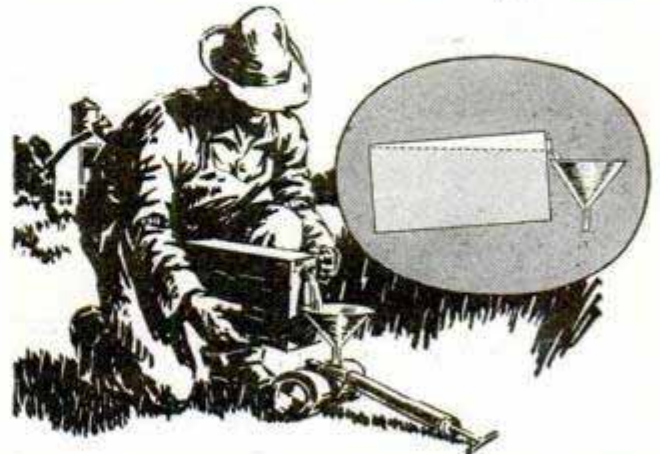

Pouring Liquid from a Can So That It Flows Evenly and Will Not Spill

flow without spilling.—Luther Strosnider, Onaga, Kans.

Preventing Quick Decay of Fruit

Ripe fruit, which spoils quickly during the hot months if not kept in a refrigerator, can be kept fresh for several weeks without the use of any ice whatsoever, by storing it inside of a cleaned-out squash, pumpkin, watermelon or similar large fruit. The top of the squash is cut off, the insides thoroughly cleaned out and the fruit is placed inside, care being taken to prevent bruising the fruit. Replace the top and set away in the cellar. Fruit so stored will be fit to eat after several weeks, whereas it would have spoiled in a few days if left in the open.—James E. Noble, Toronto, Can.

How to Silence Ford Valves

As no provision is made for adjusting the valves of a Ford motor, they usually become quite noisy. By taking the small brass ferrule off the top of the carbon of a discarded flashlight battery of standard size, it will be found that this fits nicely on the end of the valve stem. Stick one

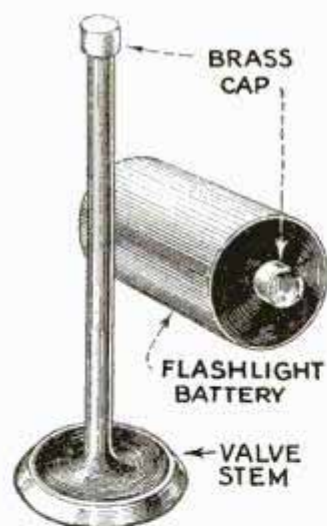

on each valve stem and tap it down gently with a hammer. If the ferrules do not take up enough of the play, build up the thickness of the end by inserting small disks of shim brass inside of the ferrules. The disks can be punched out with a piece of tubing ground to a sharp

edge. The ferrules will not only stop the noise, as the brass is soft and serves as a cushion, but oil runs into them, providing additional cushioning.—C. M. Mahood, Warren, Pa.

Ash Receiver for the Auto Driver Is Emptied through Chute

Many autoists will find the illustrated ash chute, which empties outside of the car, a real improvement over the ordinary ash receiver which is mounted on the dash or in any other position near the driver.

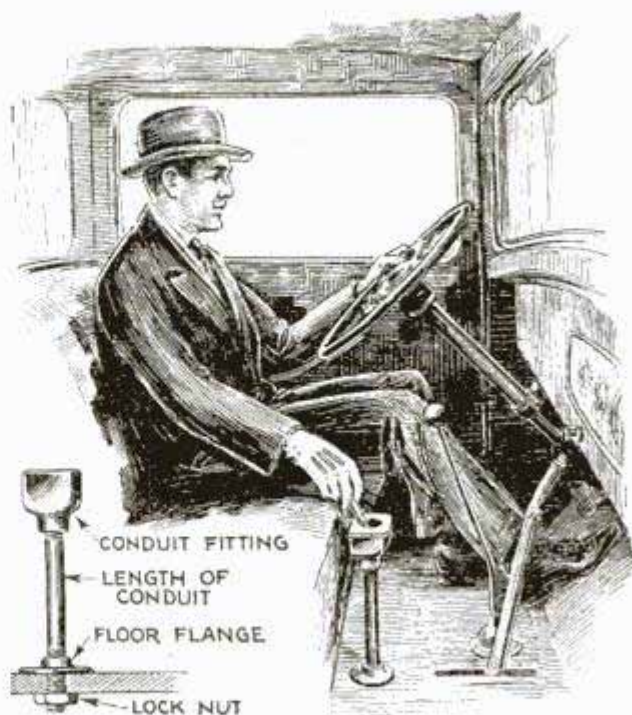

Length of Conduit and Fittings Make Handy Ash Chute for the Auto

It consists of a length of conduit, about 15 in. long, and a fitting of the type indicated. A hole, large enough to receive the conduit, is drilled in the floorboard just behind the position of the shifting lever, and the conduit is then fastened by means of a floor flange and a locknut. The installation of such a chute will take only a few minutes' time and anyone can easily do it.

Easy Method of Patching Shingle Roof

While looking after some electric wiring in my attic, I noticed a small hole in the roof where the water was leaking through. The roof was high and steep, so I devised a simple method of repairing the leak from the inside. I cut a piece of galvanized sheet iron, about 4 by 6 in. in dimensions, and bent one edge at right angles as indicated. It was an easy matter to work this piece between the shingles to cover the leak, and tack the bent edge to the roof board above the leak.—S. E. Schofield, Indianapolis, Indiana.

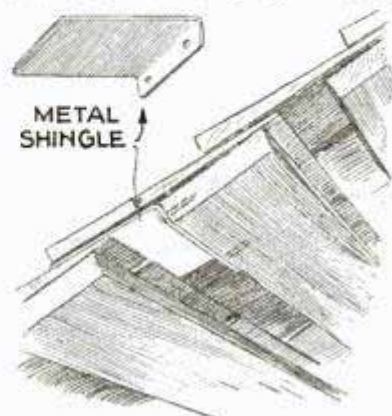

You Can Learn

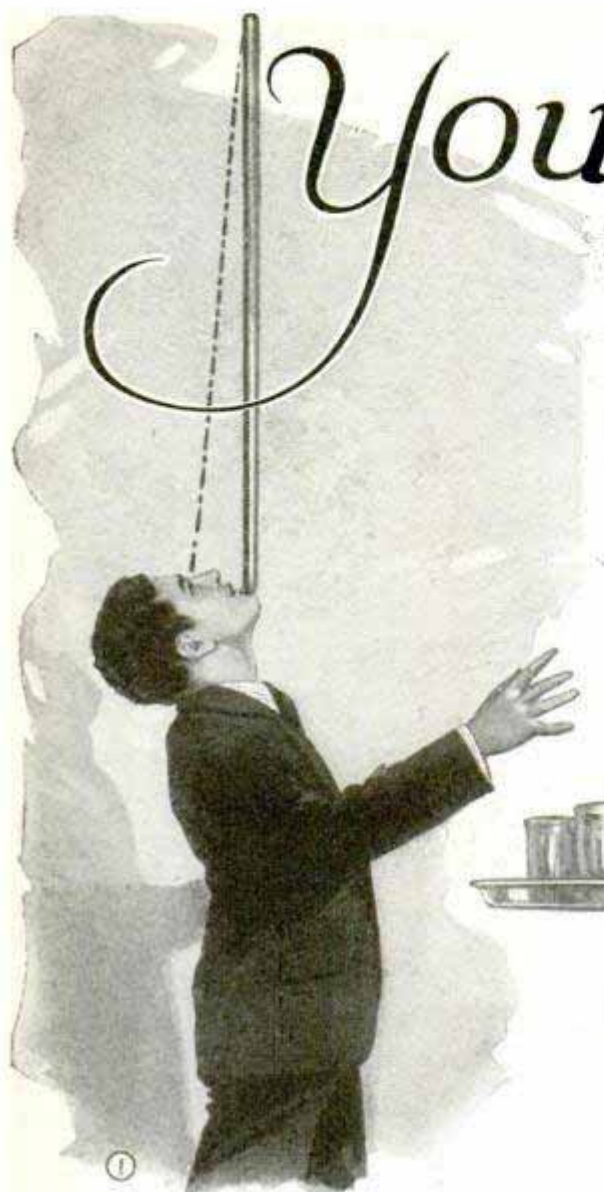

line, so that you can immediately detect any tendency to fall and correct it at once.

Once some degree of skill is acquired, you can go on to more showy effects in this branch of juggling. One of the best of these is the bottles-plate-glasses balance in Fig. 2. In performing this effect, the first bottle is balanced on the forehead or the chin. Then an assistant hands you the plate, which is set on top of the bottle. The second bottle is then set in place, followed by the four glasses, set equidistantly around the uppermost bottle. The lower bottle should be fitted with a cork, cut off flush with the glass, so that it will get a firmer grip on the flesh, and a round piece of cloth should be pasted to both the top and the bottom center of the plate in order to keep the bottles from slipping.

Other excellent effects, such as the balancing of a burning cone of tissue paper, as shown in Fig. 3, and the umbrella-

JUGGLING, whether it be the manipulation of balls, the spinning of plates, or the balancing of billiard cues, is one of the most healthful pastime-sports in the world, training the eyes and developing the muscles to a degree of co-ordination almost impossible to attain in any other art.

The beginner in juggling invariably starts with balancing effects, as these are the easiest to acquire. For the first lesson, nothing is better than a common broom handle, about 4 ft. long. Practice with this until you can balance it on the back of either hand with scarcely any visible motion, and then try a similar balance on the forehead, the nose and the chin, as shown in Fig. 1. Keep your eyes on the top of the pole, as indicated by the dotted



hat balance shown in Fig. 4 can be easily mastered once you have developed the

Sam Brown, 151 Corhardt
Marion Ohio

to Juggle

by K.H. Ward

initial technique with the broom handle. The tissue paper is pulled out stiff, before balancing; the hat is easiest balanced just where the nose meets the forehead.

Ball juggling is equally popular. There is something strangely fascinating in juggling three balls, then four, five, six, seven—where does it all end? For a beginning, however, two are sufficient. These can be of almost any variety—tennis balls or small rubber balls do very nicely. Hold both balls in the right hand. Toss one of these into the air about 5 ft., and, when it is just about to descend, shoot the other ball up after it. When the first ball comes down it is immediately sent up in the air again. Practice the same manipulation with the left hand until it becomes almost mechanical.

Next comes the three-ball juggles. There are many ways in which three balls can be ma-

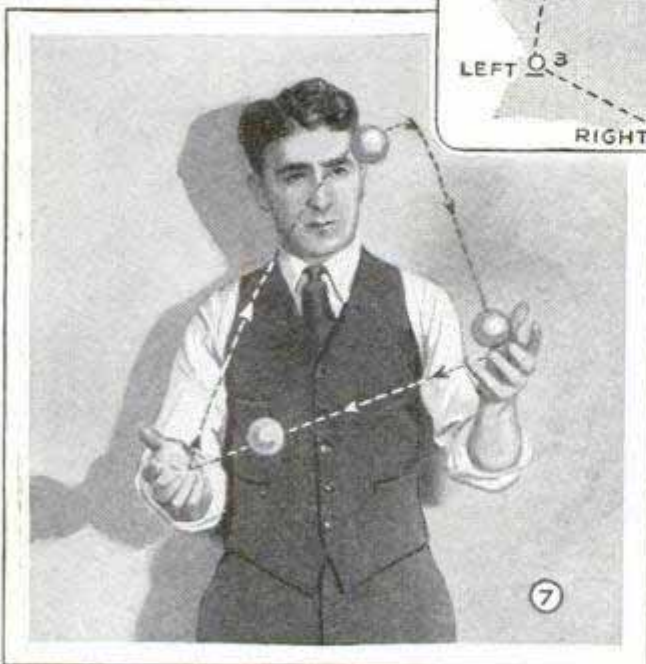

nipulated, but the "cascade" and the "shower" are the two forms most suited

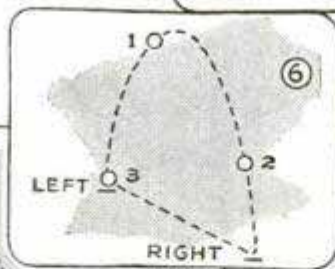
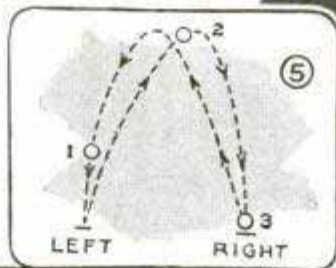

to the beginner. First try the cascade, which is shown in the diagram, Fig. 5. To commence, take two balls

in your right hand and one in your left. Toss ball No. 1 upward from the right hand, with a slight inward motion. As ball No. 1 is about to descend, ball No. 2 (left hand) is thrown into the air. As ball No. 1 comes down in the left hand, ball No. 3 (right hand) should just be starting its upward flight. Do not throw the balls too high, 5 or 6 ft. is the limit. If you count each ball as you throw it into the air, you will find the going much easier.

"Showering" three balls is a little more difficult. Start with two balls in the right hand and one in the left. The left hand should be held a bit higher than the right, as shown in Figs. 6 and 7. Start by throwing ball No. 1 from the right hand. This first ball should be thrown slightly higher than the rest in order to get the movement under way. Immediately the first ball is in the air, ball No. 2 (right



hand) is thrown up after it. Ball No. 3 (left hand) is then shot down to the empty right hand. As ball No. 1 is caught in the left hand, ball No. 3 should be leaving the right. Stick to the three-ball juggling until you can do it almost without thinking. To juggle four balls, you merely juggle two in each hand. Cascading five balls, as shown in Fig. 8, comes quite easily after you can do the three-ball juggles to perfection.

Another fascinating branch of juggling is plate spinning. For this you will need a number of metal plates, bowls or pie pans, as well as two or three spinning sticks cut from round wood stock and tapered to a round smooth point. To commence, you hold the stick and the plate in your right hand, as shown in Fig. 9.

Then the arm is raised quickly to throw the plate into the air and a rapid, right-hand twist, imparted by thrusting the thumb away from the body, is given to the plate, as shown in Fig. 10. The stick is lifted to catch the plate in its descent, as shown in Fig. 11. Simultaneously with the fall of the plate, the point of the stick is rotated or given a circular motion in the same direction as the plate is spinning, the stick being moved more and more



Above, Juggling with Five Balls; Below, the Three Steps in Plate Spinning; the First Position; Imparting the Spin to the Plate, and the Plate Being Kept in Motion by Rotating the Stick

rapidly so that the plate will pick up speed. Very skilled jugglers perform these spinning effects with flat-bottomed bowls or pans, but in your case it will be advisable to procure enameled metal plates and indent the bottom of these slightly with a punch, as shown in Fig. 12, so that the stick will have a recess in which to lodge itself. With a plate or bowl thus prepared, the trick becomes merely a matter of giving the plate a good spinning twist as it leaves your hand.

Advanced plate-spinning effects, like the one shown in Fig. 13, will come with practice. In this number, the first plate is set spinning with the right hand in the manner described. It is then transferred to the left hand. An assistant hands you a second plate and stick which you likewise spin and transfer to your left hand. A third plate can then be spun with the right hand or two or three balls may be juggled in that hand, if desired—after you have practiced enough.

An excellent bit of comedy in connection with plate juggling is to apparently drop the plate, as shown in Figs. 14, 15 and 16, and then recover it just

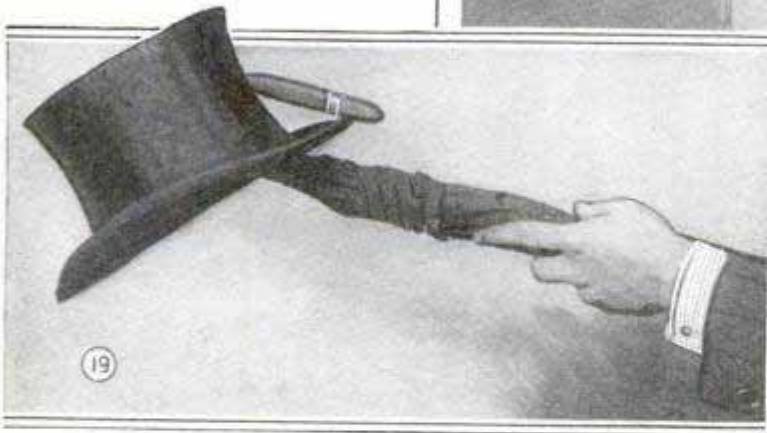
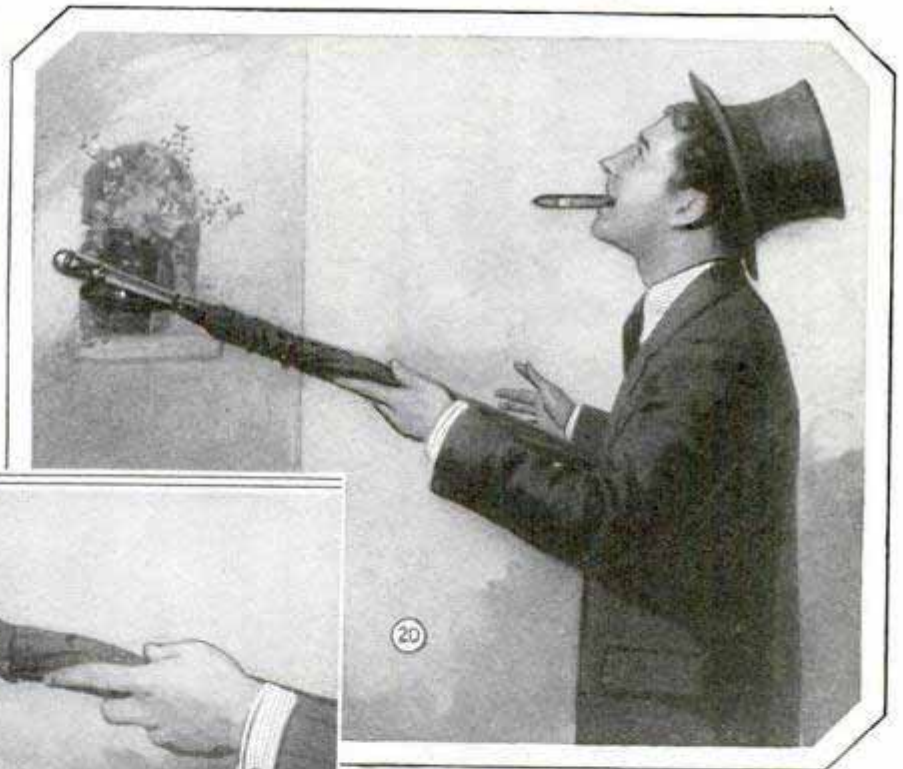
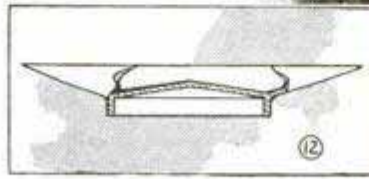
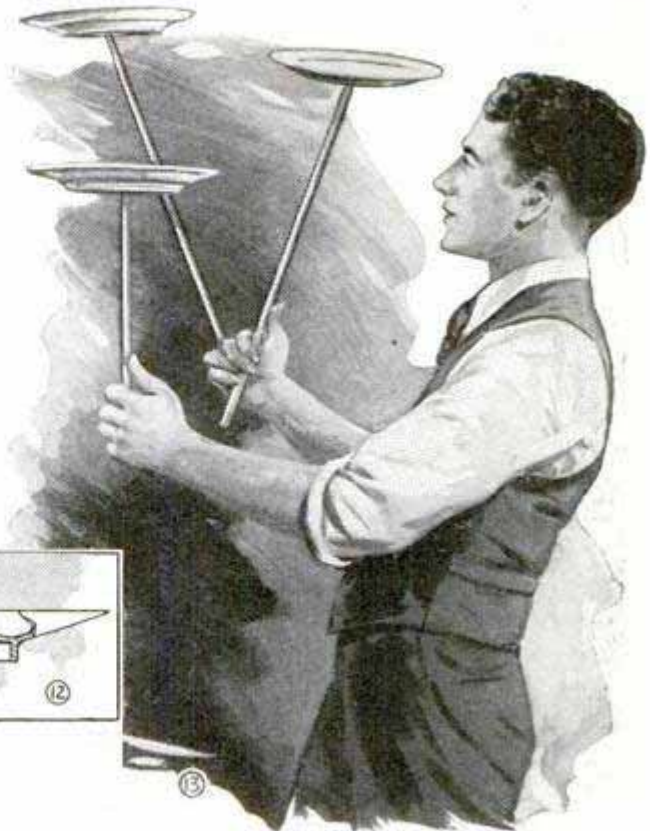

before it reaches the floor. The trick is a "catchy" little thing, but not at all difficult. You should bend your right arm, holding it close to your body, and rest the plate on the arm, as shown. Now, by extending the arm, the plate will fall, but the right hand will be exactly behind it. The right

hand continues to stay behind the plate for its entire journey, so that when the plate has almost reached the floor you need only lift the hand slightly to be in a position to catch the plate. To the audience it appears as if the juggler stooped down at exactly the critical moment; another second, apparently, and he would have been too late. Better use metal plates for this trick.

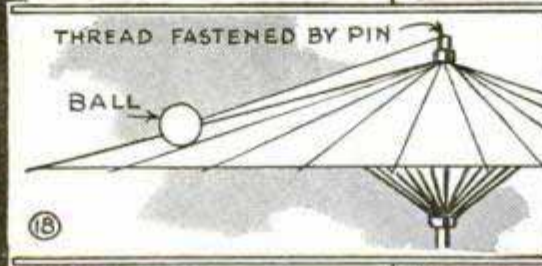

Above, Making a Ball Run around the Edge of a Parasol Is Easy When You Know the Trick; Figs. 14 to 16, a Tragedy Averted, or, the Dropped-Plate Trick, an Effective Comedy Interlude; There Is No Danger to the Plate, Once the Trick Is Mastered, but It Is Well to Use an Enameled Metal Plate at First



An easy bit of jugglery, and one used by many performers, consists in lighting a match on a matchbox which has been thrown into the air. It is performed simply by covering the matchbox entirely with coarse sandpaper, so that, no matter which side the match strikes, it will light. The box, of course, is colored to resemble an ordinary box of matches. Use a full box of matches, as the additional weight makes for easier lighting.

Another simple juggle is to make a light ball run around the edge of an opened parasol, as shown in Fig. 17. It is performed by attaching a thread between the ball and a pin which slips into the end of the parasol, as shown in Fig. 18.

But, to get back to legitimate juggling, how about the "Hat and Cigar" trick? Every juggler must be able to do that. It is accomplished by placing a silk hat on the end of an umbrella, and a cigar on the hat, as shown in Fig. 19. The stick is then lifted upward so that the hat and cigar are catapulted into the air. The hat is then caught on the head and the cigar in the mouth, as shown in Fig. 20.

The properties for the effect are, of course, the hat and the umbrella, together with a cigar, about 5 in. long, turned from soft wood and circled with a regulation band. The hat, by the way, can be a derby or a good felt hat instead of the "topper," if desired.

In the performance of the effect, the umbrella should be held at about the middle, and the hat and cigar thrown off the end with an easy upward movement. Both the hat and the cigar make but one complete revolution. It is best to practice catching the cigar in the mouth first, as this is the most difficult part of the trick. When the cigar can be caught fairly often, then practice catching the hat at the same time. It is easier to catch the hat on the back of the head, as there will be a fraction of a second longer between the two parts which compose the trick.

Auto Used for Hulling Walnuts

The photo shows how a Missouri farmer hulls walnuts with the aid of his car. A



Missouri Farmer Showing How Walnuts Are Hulled with the Aid of a Car

wooden trough, slightly wider than the tire, is provided under the rear wheel. The trough is open at both ends and the bottom board is long enough to extend under the front wheel, which holds the trough in place and prevents it from being dislodged. The rear wheel is raised a little by jacking up the axle, and after the engine is started the car is put in gear. The walnuts are fed under the front side of the wheel and as they are caught by the tire and are pushed out at the rear, the green hulls are entirely removed.—Uriel B. Stokes, Denver, Colo.

Removing Single Sheets of Photographic Paper from Box

Photographers who handle a large quantity of paper often have difficulty in removing single sheets from the box. A simple method of overcoming this trouble is shown in the photo. A strip of strong paper is fastened to one end of the box, and run along the bottom loosely, the free end being allowed to project. By pulling this end, the paper is lifted so that single sheets can be handled easily.

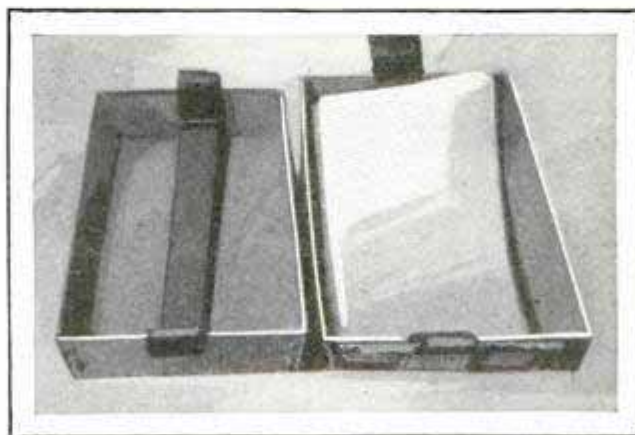

Strip of Strong Paper Helps Photographers to Get at Single Sheets

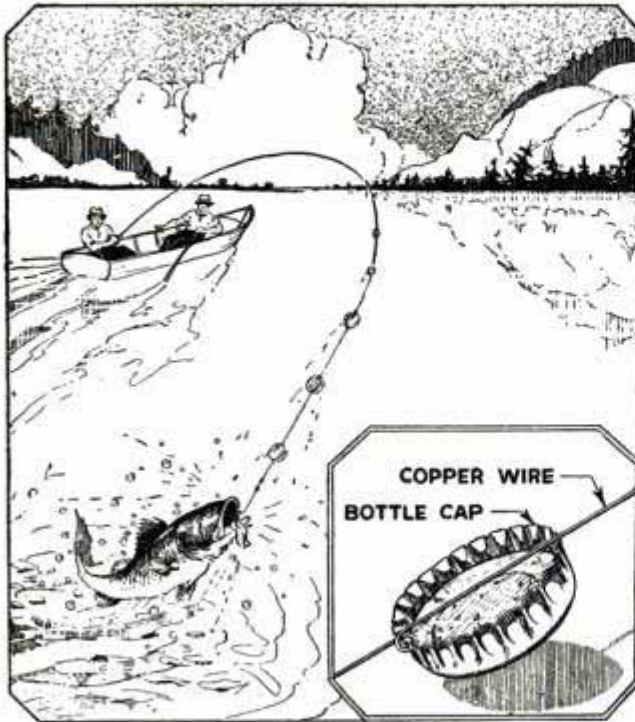

Trolling Lure Made from Old Bottle Caps Proves Effective for Catching Lake Trout

Old Bottle Caps Help Catch Fish

Some time ago the writer, equipped with flies for brook-trout fishing only, camped on the shore of an isolated lake that promised excellent fishing for lake trout. Not having suitable trolling tackle, a gear was made from old bottle caps, discarded by previous campers. The caps were polished in sand and were then attached to a length of copper wire, as shown in the detail. This gear did not rotate and therefore a swivel joint was not needed. The caps had a rapid fluttering movement when drawn through the water. This simple outfit was an effective fish catcher, equal in results to expensive lure.—Dick Cole, Los Angeles, Calif.

Drain under Outside Door

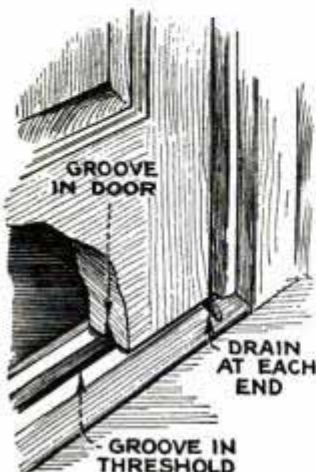

Water driven by a strong wind often enters the house under an outside door. This can be prevented by cutting a $\frac{1}{4}$ -in. groove in the threshold, lengthwise, as shown in the drawing. Two notches, at right angles to the grooves, allow

any water accumulated in it to run off on the outside. The groove should be V-shaped so that it can be kept clean by merely sweeping it with a broom. A similar groove is cut in the underside of the door, directly opposite that in the threshold to lead water running down the outside of the door into the groove. If this is not done, the water will creep along the underside of the door and will drop off on the inside.—Adolph Rieter, Marinette, Wisconsin.

Substitute for Night Lamp Made from Water Tumbler

When a candle or a night lamp is needed but is unavailable, a satisfactory substitute can readily be made by nearly filling an ordinary tumbler with water and adding a couple of tablespoonfuls of salad oil, which will float on the water. Take some cotton batting and form a small flat wad with a wicklike projection in the center. Lay this carefully on the surface of the liquid and, as soon as the oil has been drawn into it, light it, and you will find that it gives a small flame, which will last for several hours.

Simple Clothesline Tightener

Endless clotheslines of the kind running on pulleys have the tendency to become slack so that the clothes hang low and drag on the ground. A pole is sometimes used to prevent this, but is not always satisfactory. The simple device shown in the drawing will be found much better. It consists of a length of heavy galvanized-iron wire, bent to the shape shown and hooked over both lines, making it impossible for the wind to separate them. The handle may be made of any desired length so that it will be handy for the user. Placed in the center of the line, this device will keep the clothes above the ground.—John L. Love, Toronto, Can.

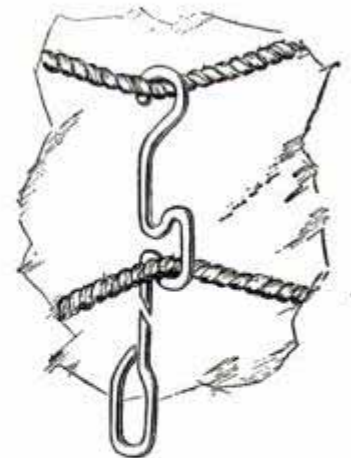

Spare Automobile Tire Supplies Compressed Air for Campers

Increasing use of air mattresses, pontoon-type boats, and other rubber goods that have to be filled with compressed air, makes an available supply of compressed air highly desirable to the camper to eliminate the need of a pump. The spare tire can be overinflated from 50 to 100 per cent without injury when it is not in use, and the extra air can be applied to inflating the mattresses, etc. If the tire is needed, the pressure can readily be reduced by letting out some of the air. It will be found convenient to use a piece of rubber tubing, one end being fitted with a connection which is adaptable to the tire-valve stem—the kind that depresses the valve when pushed or screwed on. The connection on the other end of the hose should be adaptable to the valve of the article to be inflated, and the operation takes only a few seconds in this way. Obviously, it is much easier to get your supply of compressed air from this source than to use a hand pump. When the camper "hits the road" again, he refills the spare tire.

Straightening Fine Wire

When it is necessary to straighten fine wire, a practical method, which is applicable in most cases, is shown in the photo. Tap the head of a fine-threaded stovebolt down halfway into a block of soft wood. Lay the wire on the wood under the bolt as shown, and press down firmly on the screw with the whole ball of the thumb. The bolt will not move as the other hand draws the wire through the vee of one of the threads. The thread provides a groove for the wire, straightening it with little or no jerk.—Frank W. Bentley, Jr., Missouri Valley, Iowa.

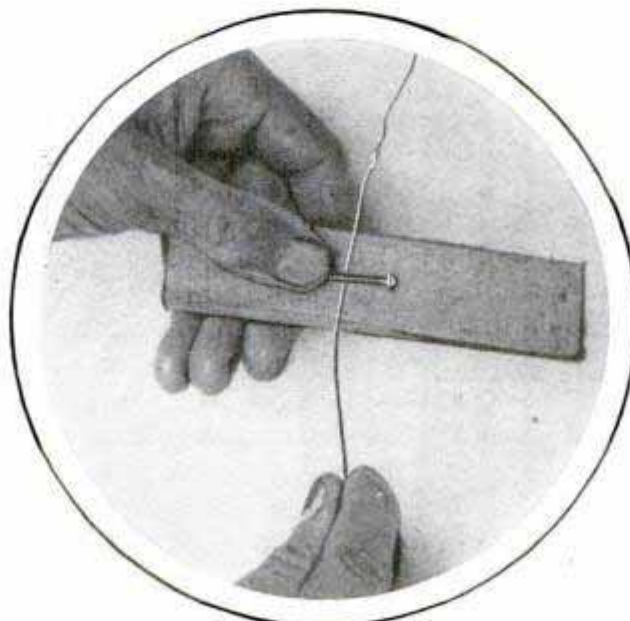

Using a Stovebolt and a Piece of Wood for Straightening Fine Wire

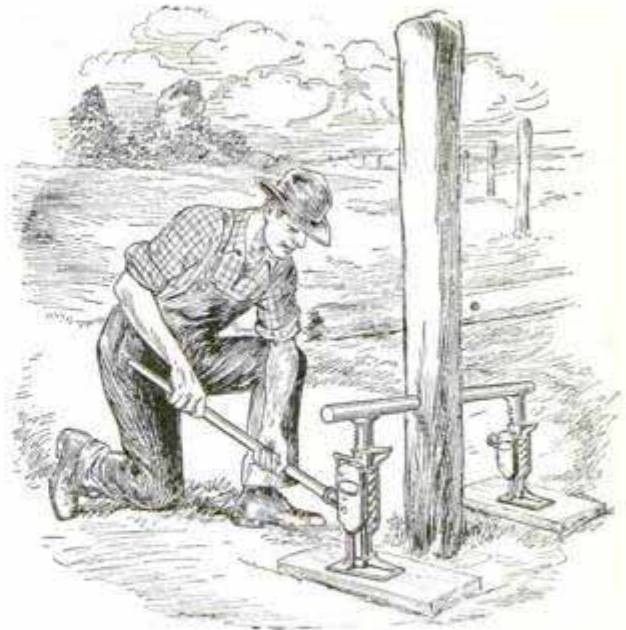

Simple Method of Using Auto Jacks for Raising Fence Posts Out of the Ground

Auto Jacks for Removing Fence Posts

Old fence posts can easily be removed without digging by using auto jacks as shown. A 2½-in. hole is bored through the center of the post about 1 ft. above the surface of the ground. An iron rod or length of heavy pipe is slipped through the hole, and the two jacks are set up under the ends of the rod. The post can be raised out of the soil by merely operating the jacks.

Tee Tip for Golfers

Tie a number of different-size tees at regular intervals along a piece of strong twine. This will do away with the need of hunting through your pockets for the tee you wish to use, and it is only necessary to pull the string out, select the tee, and proceed with the drive. An additional advantage is that the weight of the extra tees prevents the tee in use from being driven more than a few feet; consequently it is easily found.

Wood Joints for the Amateur

THE MORTISE and tenon joint probably is the most important one in woodworking, and no craftsman's education is complete until he has learned to make it well. The name mortise-and-tenon joint is applied to the method of joining two pieces of wood by forming a solid rectangular projection on one piece, and a corresponding cavity in the adjoining piece adapted to receive this projection. In other words, a rectangular end on one piece fits into a rectangular hole in the other, the projection being the tenon and the hole the mortise.

Before dealing with the way in which the parts of the joint are cut and fitted, it is well to know something of the various forms that the joint may assume. There are all kinds of mortise-and-tenon joints, each adapted to some particular purpose in construction. The simplest is the so-called barefaced tenon shown in Fig. 13. This has a single shoulder, and is usually employed only for framing on the interior of work. It will be noticed that the piece that carries the tenon is not so thick as the piece in which the mortise is cut, and that consequently the joint is flush on one side only. If used on a cabinet that is to be covered on the back with paneling, the flush side is made toward the interior of the cabinet, and the panel, as may

be seen in Fig. 14, fills up the space left between the plain side of the rail and the leg. It is obvious that the thickness of leg and rail may be proportioned so that the panel may either be flush with the leg or slightly sunk below it. If paneling is to be used on both sides and back, and if barefaced tenons are used on the side rails as well as the back, the mortises are not carried completely through the leg, and the ends of the tenons are cut off at 45°, as shown in Fig. 15. This form of tenon, which does not go through the leg, is a "stub" tenon, as distinguished from a "through" tenon, which does go

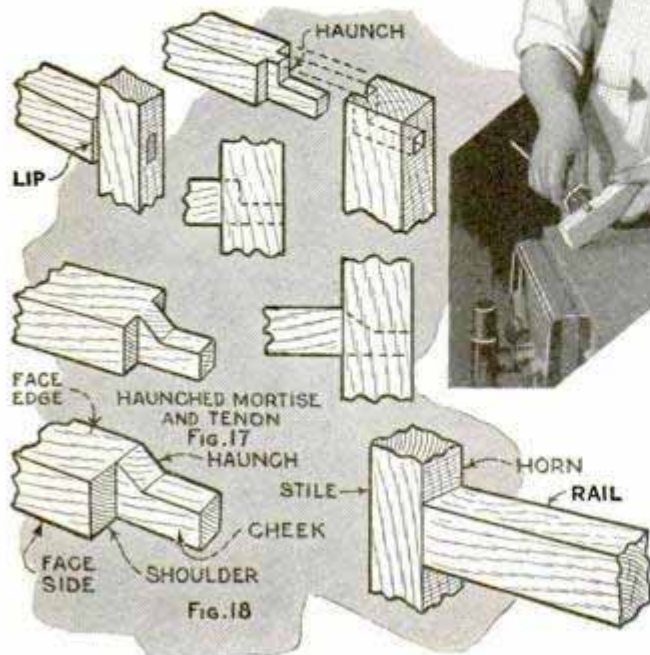
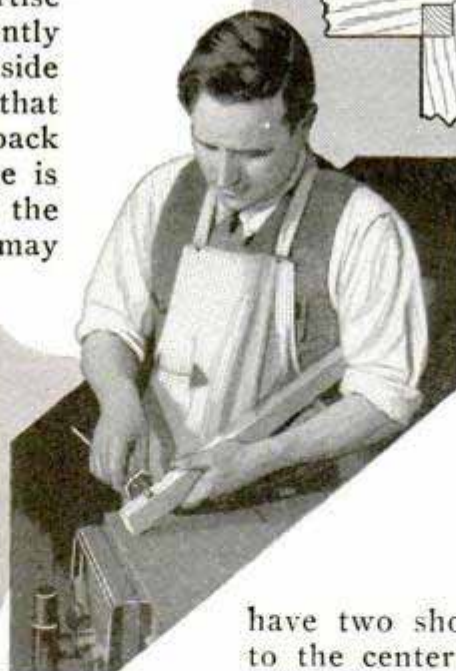
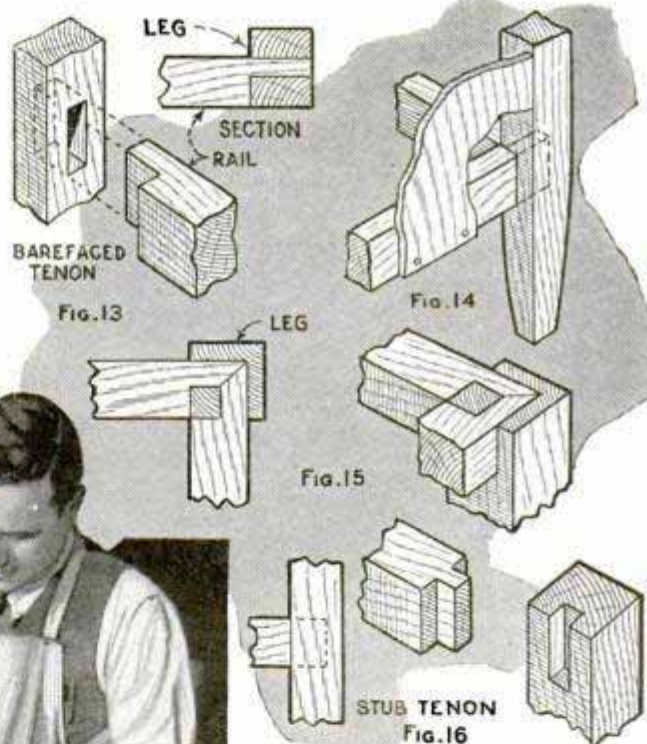

through the leg or other member of the frame.

The stub tenon, of course, is not necessarily of the barefaced type; as shown in Fig. 16, it may have two shoulders, bringing the tenon to the center of the stock, or shoulders may be cut on the edges also, thus reducing the size of the tenon. The advantage of the stub tenon is that, as it does not go through the leg, the outer surface of the latter is not marred by showing the end grain of a tenon.

The haunched tenon, Fig. 17, is very often used at the end of a door frame.

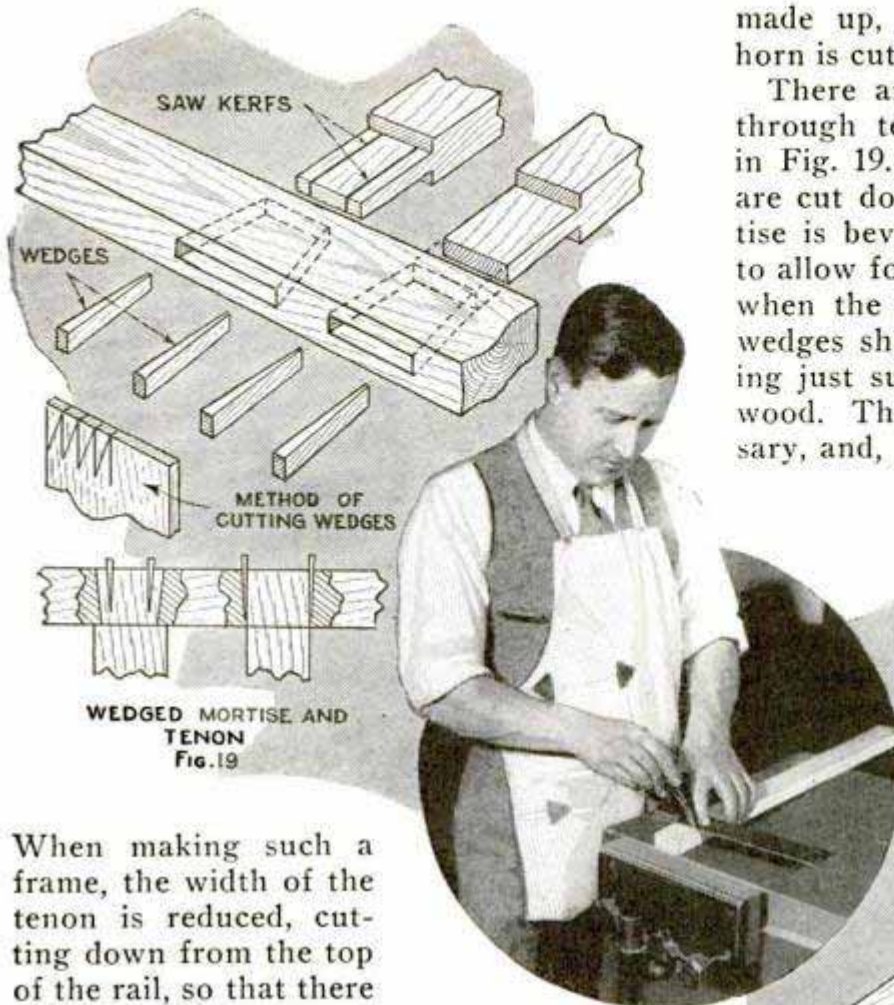

WEDGED MORTISE AND TENON
Fig. 19

When making such a frame, the width of the tenon is reduced, cutting down from the top of the rail, so that there will be sufficient wood above the mortise in the stile to resist the pressure of the tenon when the joint is put together. If a plain tenon were used, however, the faces of the pieces would have a tendency to lip, or become uneven, as indicated in the left-hand sketch, Fig. 17. It is to prevent this lipping that the haunch is employed. The cavity into which the haunch fits is called the haunching, and, in the case of paneled doors or cabinet sides, the haunching is formed by the grooves plowed for the panels. The haunched tenon shown in the lower sketch is sometimes called a secret haunch, because, as the haunch is beveled off and fits into a corresponding cavity in the stile, no sign of the haunching is visible on the outside. Fig. 18 gives the names of tenon parts. The right-hand drawing shows a good practice for the amateur when making up mortise-and-tenon joints at the end of a frame. The stile is left a couple of inches longer than the finished length, to avoid any danger of breaking out the wood beyond the mortise, either when cutting the latter or when assembling the joint. When the joint is

made up, and the glue has set, the horn is cut off and dressed flush.

There are two methods of wedging through tenons, and both are shown in Fig. 19. In the first, two saw kerfs are cut down the tenon, and the mortise is beveled toward the outer edge, to allow for the spreading of the tenon when the wedges are driven in. The wedges should be thin, and the beveling just sufficient to accommodate the wood. They are cut longer than necessary, and, when the glue is set, cut off

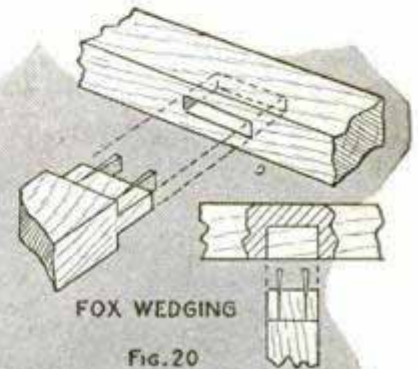
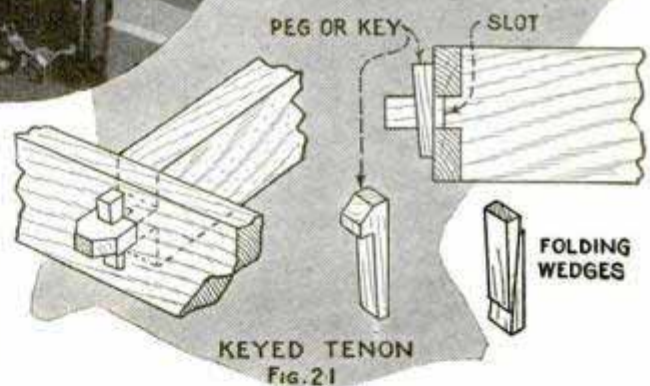

Fig. 20



KEYED TENON
Fig. 21

and dressed down. In the second method, no saw kerfs are used, and the wedges are driven in on the outer edges of the tenon, the mortise being beveled, as before, toward the outside. The method of cutting the wedges, to avoid waste of stock, is also shown in Fig. 19, the angle of the wedges being greatly exaggerated.

The method of wedging a stub tenon is shown in Fig. 20, and is called fox-wedging. The joint must be carefully made and fitted before the wedges are set in position for making up the joint, and the worker must be sure that the wedges are of the proper thickness and not too long, for, if the tenon is driven home and everything is not just right, he may find, when too late, that the joint is a very "foxy" one indeed, and that it is impossible to pull it

apart in order to fix things properly. In all these joints, the mortises and tenons, as well as the wedges, are coated with glue, although, for outside work such as doors, many old-time carpenters coat the joint surfaces liberally with white-lead paint instead of glue, dipping the wedges in the paint also.

The mortise and tenon shown in Fig. 21 is generally employed for "knock-down" construction, although, with a headed key, it was a favorite joint for some types of Mission furniture. It will

be observed, from the section, that the slot cut for the key, or peg, should be long enough to prevent the key from striking the bottom of the slot before the joint is drawn up tight; in other words, $\frac{3}{16}$ in., or so, of the slot should still be left inside the mortise when the key is driven down tight. Three forms of key are shown, the plain one and the folding wedges being used for such articles as knock-down garden or similar furniture, and for rough construction, and the one with the head for Mission furniture, etc.

Improved Clothes Press



In a bedroom which had no clothes closet, a resourceful housewife provided a satisfactory clothes press on the back of the door as shown in the photo. It was made of lightweight green canvas, although cretonne would serve just as well. The material is attached to the door in practically

the same way as a door curtain, excepting that it is not drawn taut but left loose to provide sufficient space for the clothes. In this case, the material was doubled and the clothes put between, but one thickness is all that is required. The clothes are supported on a screwhook driven into the door.—W. W. Snypp, Lakewood, Ohio.

Cleaning Burnt Pans

Boiling soda water in burnt pans is often advocated but, although this method seems successful in removing the burnt food, it makes the pans apt to burn again. A better method is to fill the pans with a saturated solution of salt and water, letting the solution stand overnight. Then put the pan on the flame and bring the

water to a boil, which will cause the burnt particles to loosen so that they can be removed without any trouble.

Renewing Silk

To restore the luster of silk, pare and grate a few potatoes in cold water, two medium-sized tubers to each quart. Mix well and then let the solution stand for a couple of hours. The clear solution is poured off into another container, and the silk is rinsed in it. Hang the silk up to dry without wringing and, while it is still slightly damp, iron it on the right side first. This will produce a gloss.

Simple Trailer Attachment

To eliminate the jar and noise caused by a trailer, an auto owner devised the simple arrangement shown in the photo. It consists of an old Ford spring leaf attached to the rear bumpers as indicated, a bolt being passed through the eyes on both spring leaf and bumper. The resili-



ency of the spring leaf and bumper supports absorbs the sudden jars caused by starting and stopping when the trailer is attached. A hole is drilled in the center

of the spring leaf and an eyebolt is inserted when the trailer is attached.—Howard Fowler, Rogers, Ark.

SHOP NOTES



Two Useful Tools for Home Mechanics

By EDWIN M. LOVE

THIS machine age has freed the crafts from slavish drudgery, and has multiplied the output manifold. Likewise, it has specialized the mechanic, removing the need of versatile skill. In the wood-working line, lumber is delivered to the carpenter's hand ready squared, dressed and sanded. Flooring boards are tongued and grooved; rounds and moldings are "stuck" by machine, and the cabinetmaker can purchase made-up inlay bands and carvings to be glued to any backing.

But the home mechanic, of necessity, follows the customs of the old-time craftsman. Quantity production and duplication are far from his mind, for every piece he builds differs from the others. True, he can, and does use mill-sized lumber,

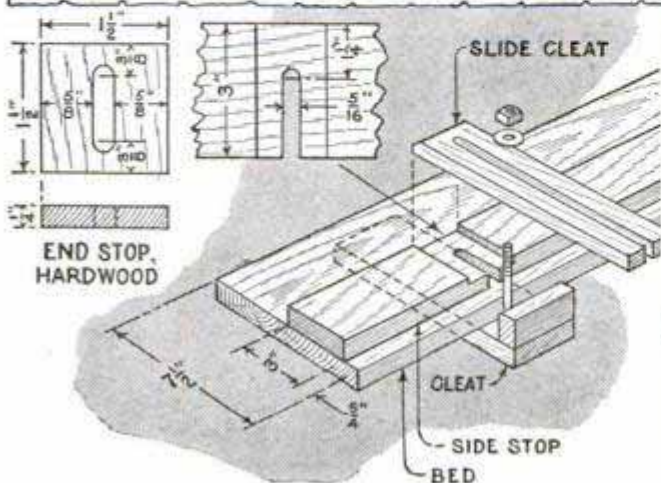
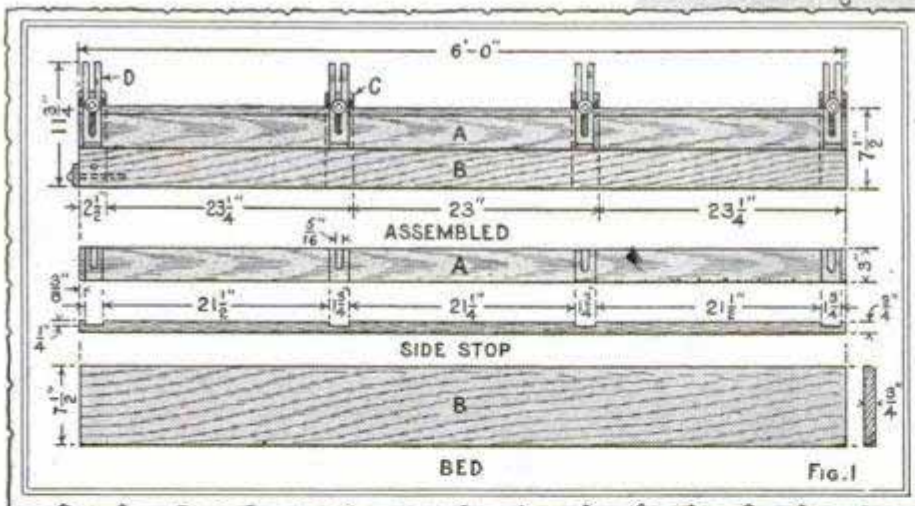
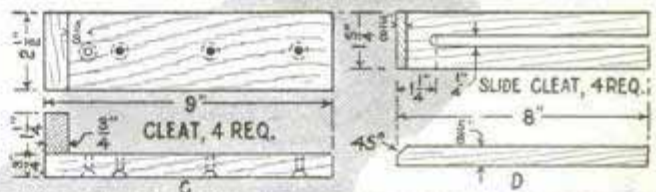

Fig. 1, Details of the Construction of the Molding Board; Fig. 2, Working a Rabbet on the Edge of a Piece Held in the Molding Board

and many a handy man lightens his tasks with woodworking machines, but, for the most part, he must make his dadoes and rabbets by hand, as well as small box parts, specially designed moldings, and the like. This means that he really should have a wider assortment of hand tools than is needed by his journeyman brother—and he generally has a limited number. But, with the expenditure of a little money and a few hours of time, he can build excellent jigs to facilitate his work.

Two such jigs are illustrated herewith: a molding board, and an adjustable shooting board. While definite dimensions are given, they may be varied to suit the needs

with which to attach them beneath the bed. Space them so that one end of each cleat will be flush with the jointed edge of the bed board. To the other end, on top, glue and nail a $\frac{3}{4}$ by $1\frac{1}{4}$ by $2\frac{1}{2}$ in. block. Put one cleat at each end of the board, and the other two dividing the board evenly. Drill lead holes for the screws, so that there will be no possibility of splitting the bed.

A piece, $\frac{3}{4}$ by 3 in. by 6 ft., is next straightened, to serve as the adjustable side stop. Four dadoes, centering on the bed cleats when the stop is rested on the bed with ends flush, are cut full width of the stop, $\frac{1}{4}$ in. deep and $1\frac{3}{4}$ in. wide. Mark the dado sides with a sharp knife, and cut with the saw kerf in the waste wood. Make four hardwood cleats, $\frac{5}{8}$ by $1\frac{3}{4}$ in. by 8 in. Bore a $\frac{1}{4}$ -in. hole $1\frac{1}{4}$ in. from the end of each, centering on the

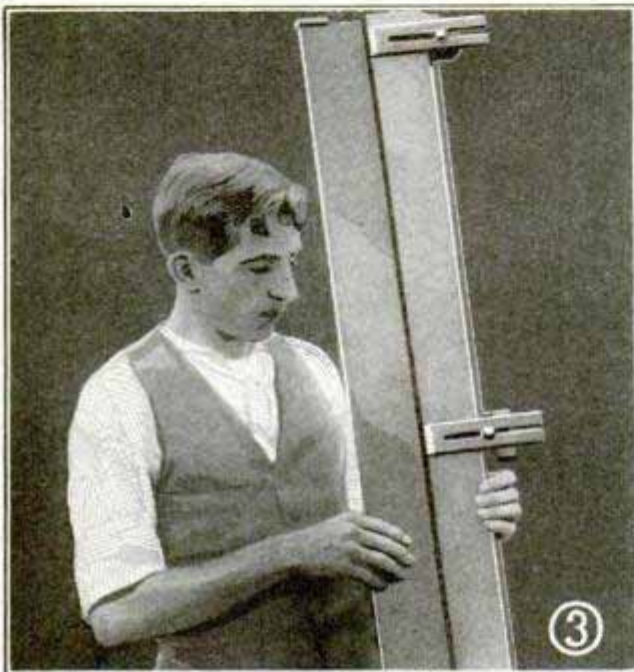

Fig. 3, the Completed Molding Board; Figs. 4 and 5, Details of the Shooting Board

of the individual. Most home mechanics will find enough scrap material for both tools. Hardwood is preferable, but for large parts pine may be used with the assurance that it will be serviceable for a long while.

Fig. 1 details the molding board. It may be reduced in length by 3 ft., if desired. Select for the bed a flat, straight 1 by 8-in. board, preferably vertical-grained, and joint one edge straight and square. Make four cleats, $\frac{3}{4}$ by $2\frac{1}{2}$ in. by 9 in., drilling them, and countersinking, on the underside, for three flat-head wood screws,

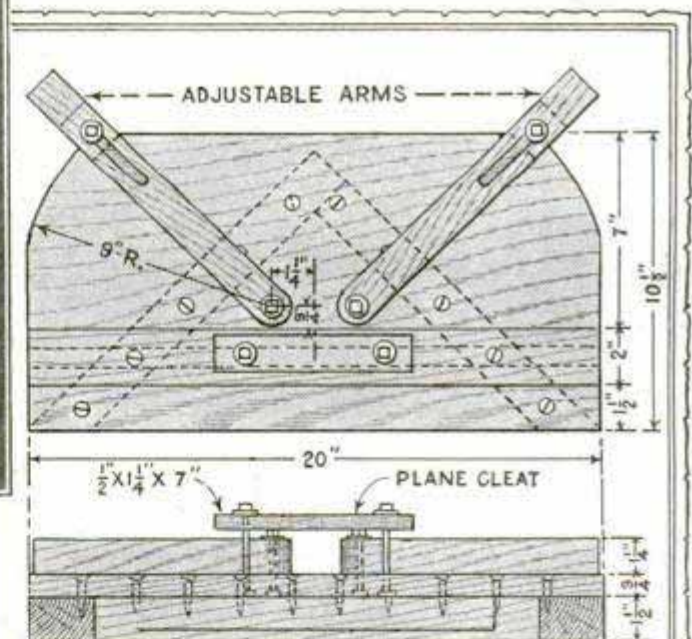

Fig. 4 PLAN AND ELEVATION OF SHOOTING BOARD

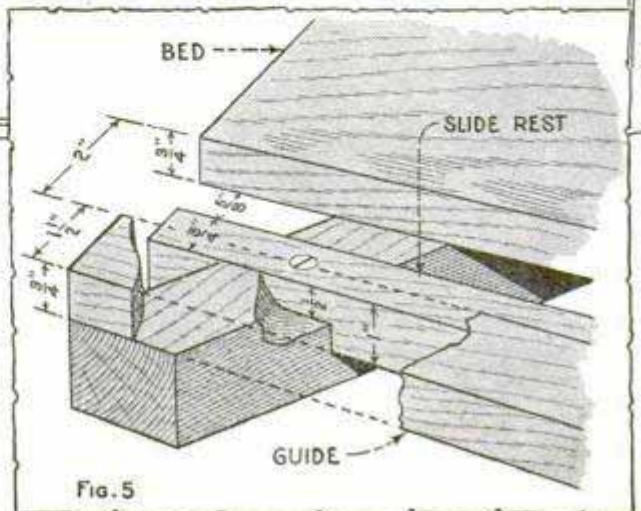
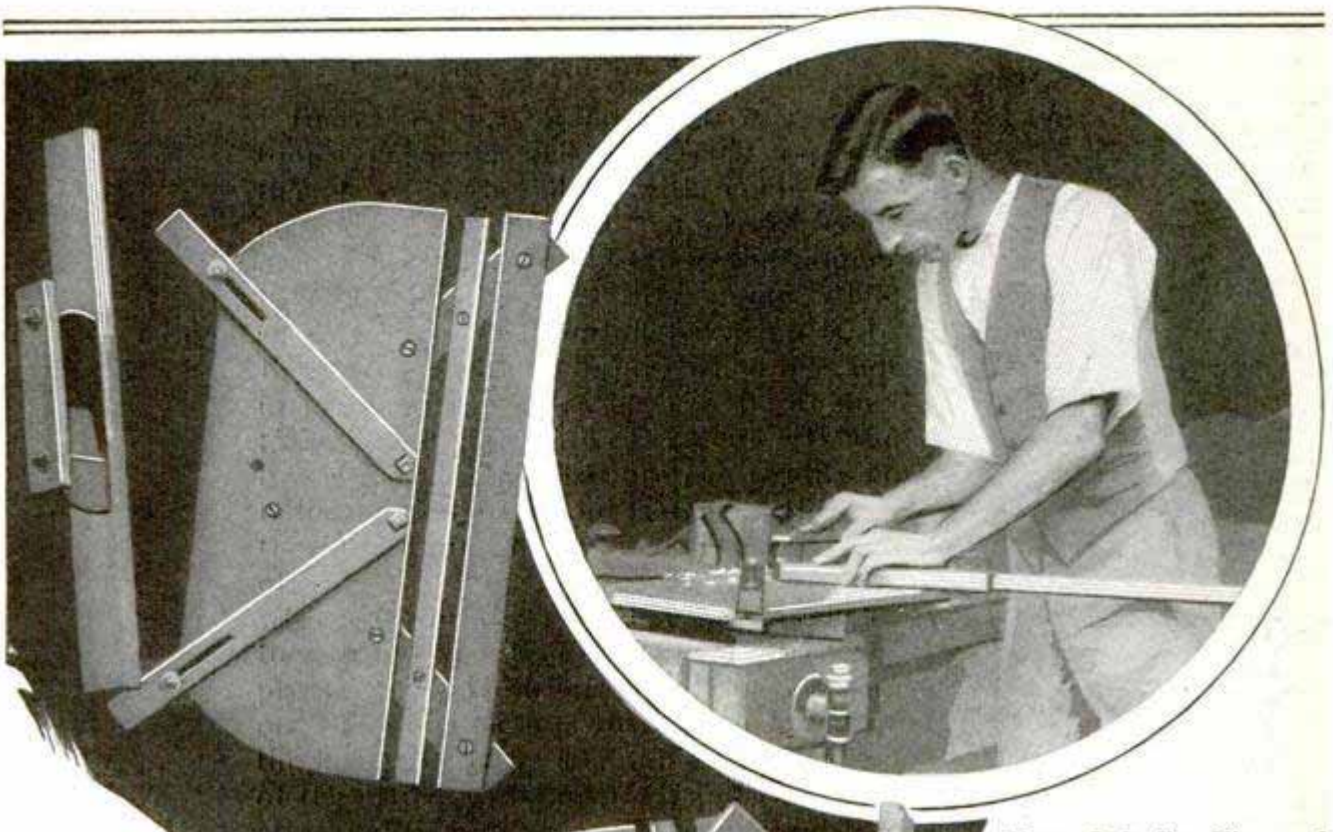

Fig. 5



Upper Left, Top View, and Below, Bottom View of the Shooting Board; Note the Plane Clamped to the Side

width; gauge lines to it from the far end, and rip out the slot indicated. Glue and nail these cleats into the dadoes of the stop, with the solid ends to the front. Saw the slots to the bottom, through the stop, when the glue is set. Lay the stop on the bed, ends flush, and bore $\frac{1}{4}$ -in. bolt holes through the bed cleats, guiding the bit through the stop slots and against the back edge of the bed, and counterbore for the bolt heads. Pass $\frac{1}{4}$ by 3-in. bolts through the cleats and stop cleats, and chamfer the front ends of the cleats $\frac{3}{8}$ by $\frac{3}{8}$ in.

The end stop is a $\frac{1}{4}$ by $1\frac{1}{2}$ -in. hardwood block slotted to allow a long $\frac{1}{4}$ -in. round-head wood screw to pass through with a vertical adjustment for projection above the bed. For a right-handed workman, screw this stop to the left end of the bed, flush with the front edge; for a left-handed mechanic, put it on the right end. Oil the molding board when completed.

To use this device, rest it on a bench,

with the end against the bench stop. Adjust the margin between the front edge of the bed and the side stop to a little less than the width of the molding to be made or the strip to be rabbeted, and screw the bolt nuts down firmly. Adjust the end stop so high that it will clear the plane and yet hold the work.

The shooting board is dimensioned in Figs. 4 and 5. It consists of a pair of adjustable angular arms, clamped to a bed, and a slide or carriage to which a plane is rigidly clamped. The ordinary shooting boards usually have the arms fixed at an angle of 45° with the front of the board, and the latter alone acting as a plane guide. The advantages of adjustable arms are obvious, while the mounting of the plane on a slide prevents the blade from cutting into the guide and destroying its usefulness.

For the bed board, square up a rectan-

gle of wood, $\frac{3}{4}$ by 7 by 20 in. Five-ply stock is excellent for this, as it will neither shrink nor warp. Square a center line across the width. Locate points, $1\frac{1}{4}$ in. to the right and left of the center, $\frac{3}{4}$ in. from the front edge, and with these as centers, using a radius of 9 in., strike arcs through the opposite corners. Saw to these lines, and smooth the curves. To the underside screw two pieces of $1\frac{1}{2}$ by $1\frac{1}{2}$ -in. net stock, forming a right angle centered on the bed, with the point $\frac{1}{2}$ in. from the back edge. The ends should project $3\frac{1}{2}$ in. beyond the front edge. The screws, of course, must be countersunk below the surface, so that they will not prevent the moldings to be "shot" from lying flat on the board.

Make a $\frac{3}{4}$ by 2 by 20-in. strip for a slide, being especially careful to preserve exactness in the width. The guide is $1\frac{1}{2}$ in. wide, and the same length as the slide. Lay the slide in place on the cleats, clamp the guide against it and screw the guide to the cleats. Remove the slide, wax the edges and replace. If it does not slide easily, take a shaving off the width, but make it fit as closely as possible.

As a bottom for the slide ways, sink a $\frac{3}{4}$ by 1-in. strip into the cleats until it is flush with the top. Lay it in the center of the slide opening and mark its position on the tops of the cleats. Likewise scribe the cleats on the underside of the strip. Notch it $\frac{1}{2}$ in. deep, and the cleats $\frac{1}{2}$ in. deep. Secure with countersunk screws, but do not glue. It can be replaced easily when worn.

The arms are $1\frac{1}{4}$ by $1\frac{1}{4}$ by 12 in., rounded at one end and pierced with a $\frac{1}{4}$ -in. hole centering on the curve. A slot, centering on the width, $2\frac{3}{4}$ in. long, and $2\frac{1}{2}$ in. from the square end, is made by boring with a $\frac{1}{4}$ -in. bit and trimming the sides with a chisel. Attach these arms to the

bed with bolts through the two front holes, and pass $2\frac{1}{2}$ -in. bolts through the slots. Washers, either wood or iron, under the heads allow the free ends of the arms to be clamped solidly in any position. Two bolts through a $\frac{1}{2}$ by $1\frac{1}{4}$ -in. hardwood strip straddle the plane to be used on the slide. A block plane is best, and the heads of the bolts must be sunk into the lower surface of the slide, so as not to interfere with its motion.

To use the shooting board, remove the slide and lay it on edge on a flat surface. Stand the plane beside it and clamp with the bolts. Set the arms for the desired angle, replace the plane-and-slide assembly and hold the cut molding against an arm. To insure that the planing will be done the full width of the plane, the molding must be rested on a strip of $\frac{1}{4}$ -in. stuff, to bring its entire width to the blade. The plane iron should be keen and set very fine. This board can also be used for planing the ends of boards square.

Method of Alining Caps and Base Blocks in Setting Porch Columns

Usually porch columns are set in place before any of the framework above is put together, which is considered the most economical method. However, this makes it more or less difficult to get the caps in alinement with the sides of the base block, unless care is taken and accurate measurements are made.

Fig. 1 of the drawing shows a column cut to the right length with the cap nailed on. It is laid on a level surface and a perpendicular line is drawn through the center of the base with the aid of a square, as indicated. A witness mark is then made at each end of this line as shown at A in the upper detail. The base blocks are set in line, on a level, and a chalk mark is

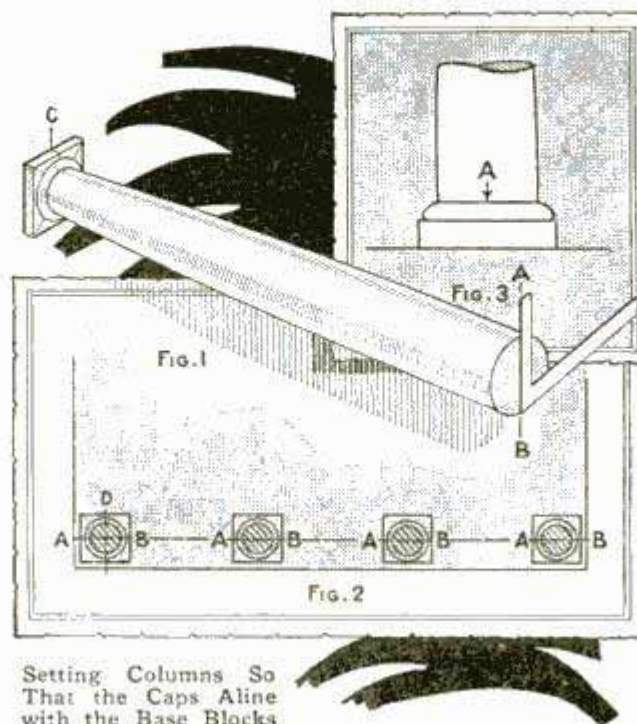

drawn through the center of the base blocks as indicated by the dotted line in the lower detail. Set the columns so that the witness marks are directly over the chalk line. If the work is done carefully, the sides of the caps will be in alignment with the base blocks.

Repair for Windshield-Wiper Arm

The following temporary repair has been found practical on an auto windshield wiper from which the rubber had come off: The wiper arm is removed, and cotton cord is wrapped around it and tied securely at both ends. If the wiper is automatic, it may be necessary to spring the arm out slightly to compensate for the added thickness of the cord. If a hand wiper is used, a light coat of glycerin on the cord will make it work better, preventing the rain from blurring the vision.—L. C. Ferguson, Manteca, Calif.

Increasing Utility of Small Tool Box

Electricians, plumbers and other workmen who use small tool boxes of the kind that have lids hinged to the sides, can greatly increase their usefulness by attaching two lengths of chain to the edges of

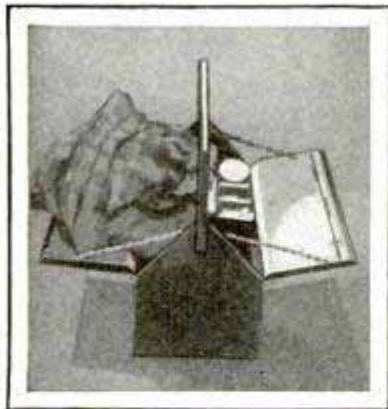

the lids so that the latter can be held in a horizontal position when opened, as shown. In this way small shelves or counters are provided for holding tools and other material. If desired, a shallow tray can be attached to the inside of one or both covers to hold small parts.

SHOP NOTES IN BOOK FORM

For the convenience of readers who desire a permanent collection of these notes indexed for quick reference, we publish in book form all the articles that have appeared in these pages during the year. Send 50 cents to our Book Department for latest issue; information regarding earlier issues available gladly sent upon request.

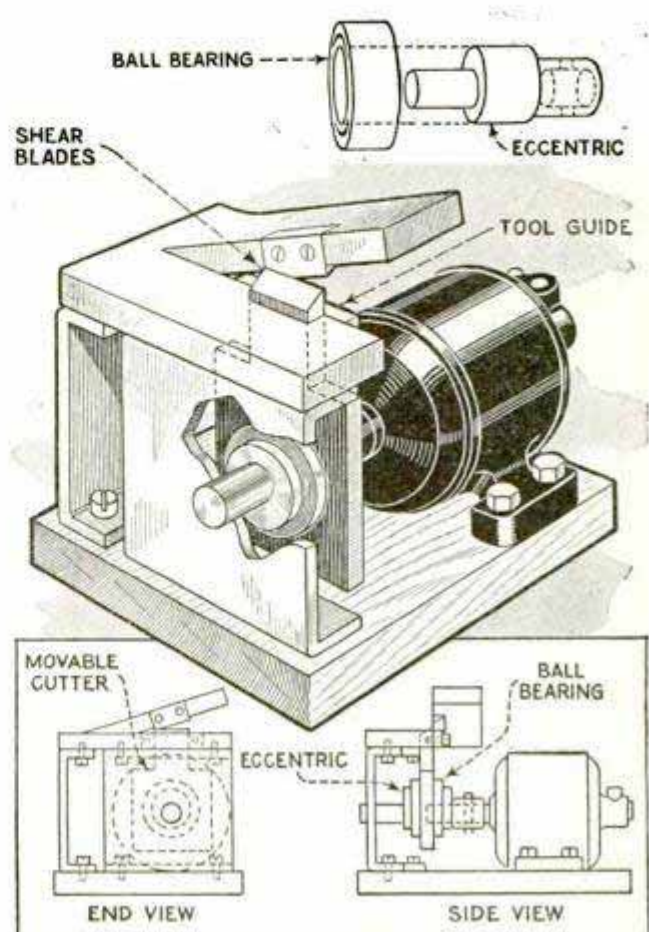

Small Electrically Operated Bench Shear for Cutting Light Sheet Metal

Small Motor-Driven Shuttle Shear

One workshop uses a novel motor-driven shuttle shear for cutting light sheet metal. Its usefulness will appeal to most small shops. It consists of a heavy steel frame, cut and bent as indicated in the drawing. The frame is mounted on a wooden base, to which a motor is also attached to operate a small cutting blade actuated by an eccentric. The bent section of the frame holds the upper cutter in a position where the lower cutter will move past it with a shearing action. The angle of the former causes shearing instead of a punching, which would be the case if it were parallel to the lower cutter. An extension to the motor shaft runs in a bearing drilled in the frame. The moving blade operates like a shuttle, passing through a free guide in the horizontal section. A hole is drilled in the lower end of the moving cutter to accommodate a ball-bearing race as indicated, which in turn fits on the eccentric of the extension shaft. An eccentricity of $\frac{1}{16}$ in. has been found sufficient. A short stroke is delivered but there is powerful cutting action.



Warped Roofing Boards Can Readily Be Straightened by Means of This Device

Device for Straightening Roof Boards

While working on a roof, I made a simple device for closing the cracks between warped roof boards before they were nailed to the rafters. The device consists of a length of a 2 by 4-in. wood, with a block nailed at one end and a lever pivoted to the other, as shown in the illustration. Another small block pivoted on the lever is pressed against the warped board, the long end of the lever being used as a handle. It is not necessary to use the lower block at the end as the 2 by 4-in. board can be nailed to the roof, if desired. This procedure is necessary when the width of the roof boards exceeds the distance from the lower block to the lever. To make the device more convenient, a series of holes may be drilled through the 2 by 4-in. board and a similar hole through the lever so that the two can be held together by means of a carriage bolt.—Kenneth R. Deardorf, Bemidji, Minn.

Use of Bakelite in Photography

Glossing amateur photographic prints, by squeegeeing them to ferrotype plates or glass, is rendered difficult to the beginner because the gelatin must be hardened or the glossy surface covered with some preparation before the prints are applied. This difficulty completely disappears if bakelite is used to hold the pictures while

drying. Wet prints can be applied to the smooth surface of the bakelite without any previous hardening or other preparation to avoid sticking. Although bakelite does not possess the intense gloss of glass or ferrotype plates, it has a distinct sheen which will impart a very attractive gloss to the dry print, and the material will last almost indefinitely.

How to Lay Out an Ellipse

Usually the drawing of ellipses is considered a somewhat difficult task, with the result that the draftsman spends either too little or too much time on it. The method described in this article has been used by the writer for many years with excellent results, particularly in designing power-plant piping, where an accurate projection is often needed to check clearances. The basis of the method is an old theorem in geometry. First draw lines representing the major axis AB and the minor axis CD . Then lay off on a small piece of pa-

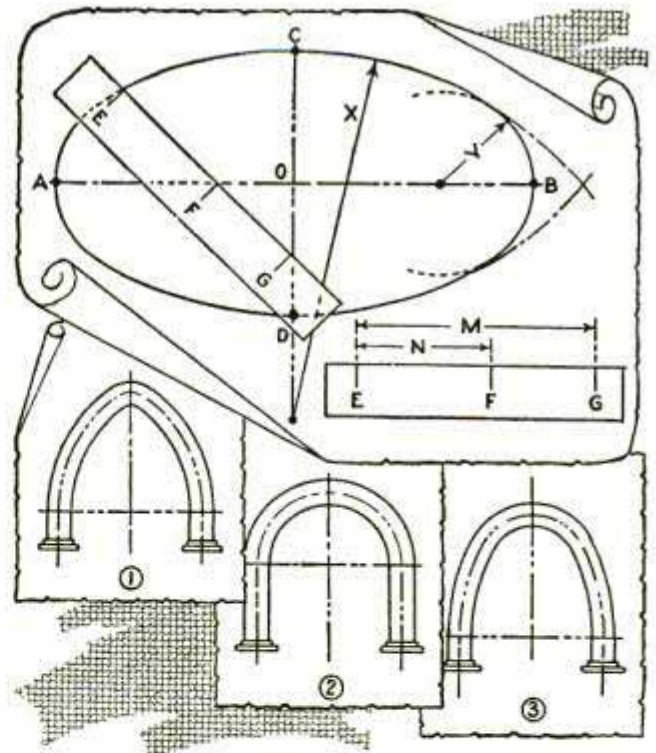

Method of Laying Out Ellipses; Applied with Care, It Produces an Accurate Curve

per the distances M and N , starting both from point E . M must be equal to one-half of the major axis and N equal to one-half of the minor axis. Point F is placed on the line AB , so that E coincides with A and G with O . By turning the strip clockwise with F sliding toward

the right, on the line AO and G downward on line OD, the point E will describe an elliptical curve from A to C. Make a number of dots as you proceed, to be connected later, and form one quadrant of the ellipse. If a compass is used for the purpose, the curve will in most cases be inaccurate. Fig. 1 shows an ellipse which is too pointed; Fig. 2 one which has a semicircular end, and Fig. 4 an ellipse made with the use of a French curve, the joining of the curves showing plainly.—W. E. Patrick, Jr., Salt Lake City, Utah.

Miniature Dikes Keep Concrete Moist

In order to keep new concrete paving moist for several days after it is laid, a western contractor uses the novel method indicated in the photo. When the leveled concrete is still quite "green," it is covered with dirt to a depth of several inches. Part of the dirt is hoed into small dikes, inclosing sections about 4 by 5 ft. square, while leaving a few inches of dirt covering the concrete. The squares are then filled with water nearly to the top. The water prevents the concrete from drying out too rapidly in hot weather. Of course, the water evaporates, but it is easy to replace it when needful.



Concrete Pavement Kept from Drying Too Quickly by Small Water-Retaining Dikes

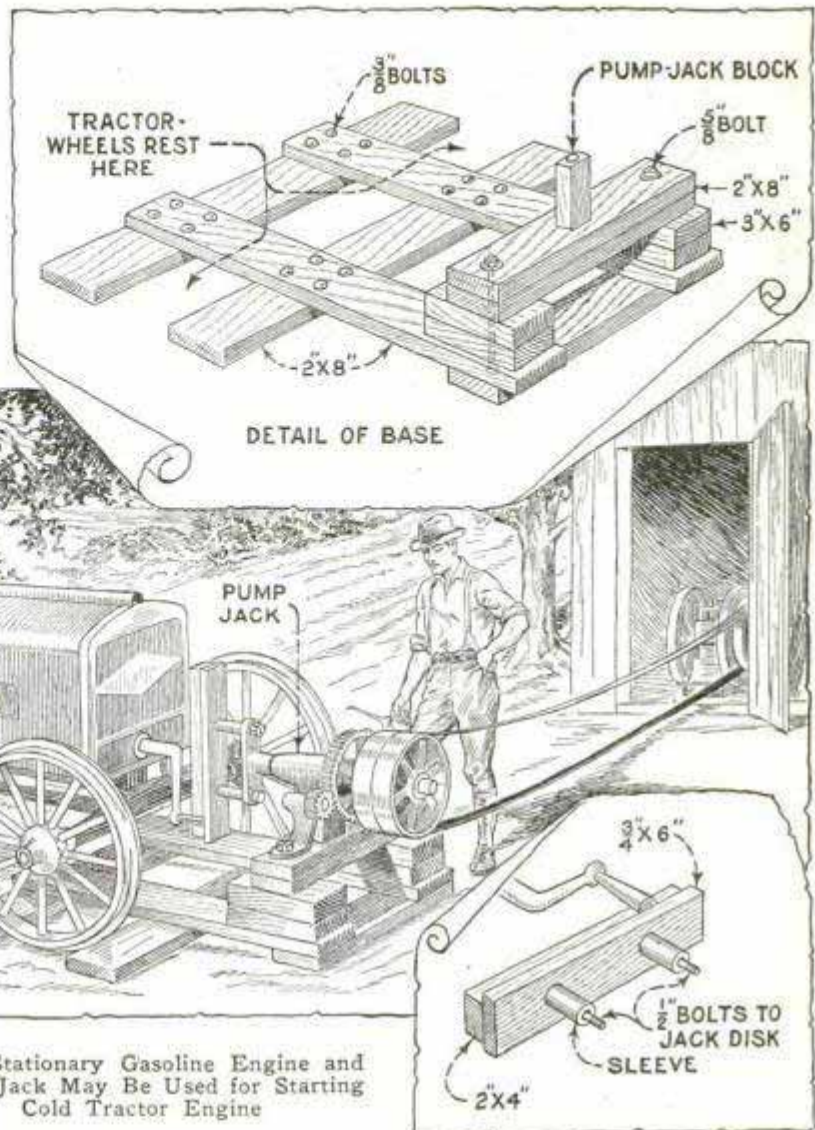

How Stationary Gasoline Engine and Pump Jack May Be Used for Starting Cold Tractor Engine

Stationary Engine Starts Tractor

To start his tractor on cold mornings when the crank can hardly be turned over, one farmer uses an old pump jack and a small stationary gasoline engine, and has found this method highly satisfactory. A suitable frame or cradle is made to hold the pump jack. Two cross planks of the frame are arranged so that they can be slipped under the front wheels of the tractor, in order that the wheels may hold the frame securely during the cranking. A wooden arm, made of 2 by 4-in. and $\frac{3}{4}$ by 6-in. stuff, is made, as indicated, to take the crank handle of the tractor. Then the engine is belted to the jack and no difficulty will be met in starting it.—H. H. Parker, Los Gatos, Calif.

Sections of old leather belts, placed on the floor of the garage, will protect the tires from changes in temperature due to frost on the concrete, and also from oil.

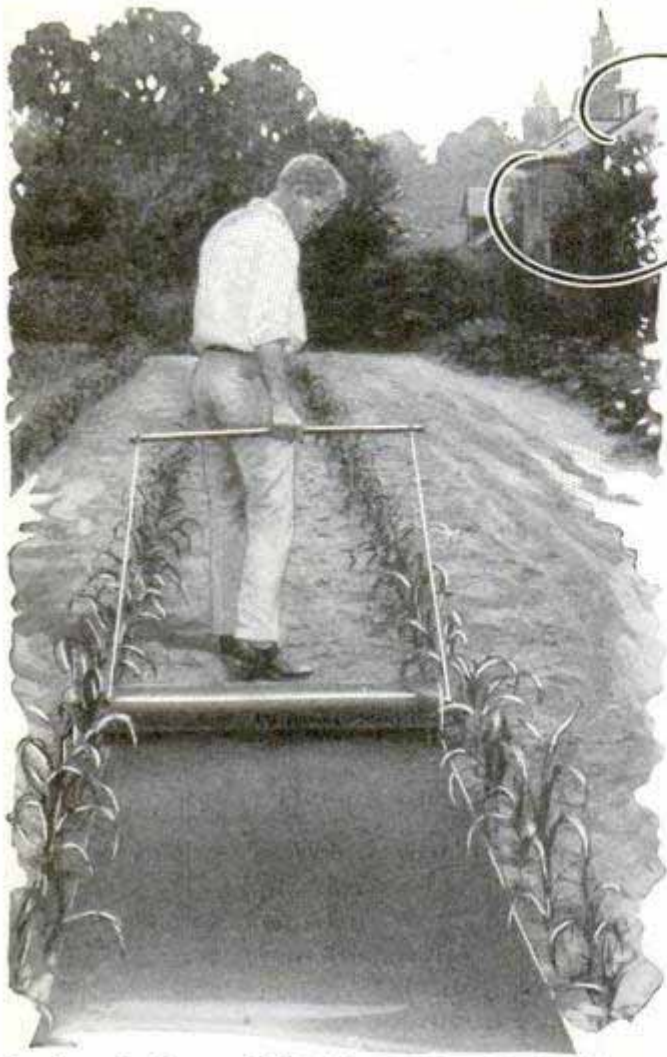

Laying the Paper Mulch Is an Easy Task with a Roller Made of a Couple of Broomsticks

NOW YOU can garden without infringing upon your limited time for golf, gunning, fishing, saddling, motoring or other outdoor pastimes which tempt you from the sunrise of spring until the advent of late autumn.

The suburbanite, townsman, villager or farmer all have available a new system of green-vegetable production which controls weeds, minimizes cultivation, guarantees good germination even during unfavorable seasons, doubles or even quadruples yield, engenders earlier maturity and affords the amateur or professional gardener plenty of time for other diversions.

When Charles F. Eckart, manager of a large sugar plantation in Hawaii, hit upon the scheme of using asphalt paper as a mulch to prevent weeds and conserve moisture, he originated a practice which potentially will prove a

The Latest

boon to gardeners around the world. Paper farming has rescued pineapple growing from the doldrums of despair and has introduced that branch of agriculture to permanent prosperity. Nine-tenths of the successful pineapple plantations now use heavy asphalt paper as a crop mulch. One application in the tropics lasts for three to five years and eliminates all cultivation of the fields during that period. Hawaiian growers alone expended more than \$500,000 for this protective paper with which they covered their pineapple fields last year. A very good investment, incidentally, as the average yield was increased from 30 to 50 per cent in this way.

Your home garden makes grateful responses to similar treatment in increased production and improved quality of produce. The efficacy of the system is greatest during the most unfavorable seasons, but it is a profitable practice every year, irrespective of weather conditions. Paper farming concentrates your work of gardening into a couple of days in the spring, when you apply the paper mulch and plant the seed. About all you have to do, subsequently, is to watch your garden's miraculous growth and harvest it.



In the Patented Eckart System, the Seeds Are Planted through Holes Cut in the Paper Mulch

Is H. Macy, 1216 Aquila Ave
Coral Gables, Fla.

Magic for your Garden

by G. H. Dacy



An Amateur's Garden Protected by Asphalt Paper; the Paper Is Held Down Simply by Shoveling Dirt over the Mulch after It Has Been Laid

There are two systems of applying the impervious paper. The easier method, and the one most suitable for the backyard gardener, is to paper the rows after the seed has been planted, leaving a 2 or 3-in. space of uncovered soil in each row through which the seeds may sprout and greet the stimulation of sunshine. The other system is one originated and patented by Mr. Eckart and consists in cutting holes through the paper and planting the seed or setting plants from the nursery or greenhouse in the soil through such apertures. This latter method is much more laborious, although it affords the most complete protection for the garden.

Varieties of wood-pulp paper treated with asphalt whose wearing qualities are remarkable are now available in two popular widths, 18 and 36 in. This paper comes in rolls of 150 yd. each and sells for from \$4 to \$6 a roll. The initial cost is high, but considering the durability of the paper in warm climates, it is an excellent investment.

The writer, and several other amateur gardeners who have experimented with the paper mulch, have ascertained that ordinary black asphalt building paper, costing \$1.50 for a roll which will cover 500 sq. ft., is well adapted to their requirements. Under the most favorable conditions, one application of this paper will last for two years and will eliminate the plowing and cultural practices necessary in preparing the seedbed the second year. Strips of the paper which have become seriously weathered or are damaged with holes and cracks will, of course, have to be replaced as needed.

You can make a roller from a couple of discarded broom handles which will simplify the task of papering your garden. Each handle should be 37 in. long with a screw-eye sunk in each end. Two lengths of No. 10 galvanized wire, each 4 ft. long, are hooked so that they will snap readily into the screw-eyes. One broomstick is inserted through the center of the roll of 36-in. paper and is then fastened to its



Corn without Paper, Six Weeks after Planting, 11 Inches High

mate, which serves as the handle of the homespun rolling device for applying the paper. The same outfit can be used for 18-in. paper rolls by boring two holes, 19 in. apart, at the central portion of the roller and inserting wooden or metal pins to hold the roll in proper position as it is applied to the garden.

If you experience difficulty in obtaining 18-in. rolls of cheap paper, the best method of cutting the 36-in. roll is to unroll it on the ground and cut it by hand with a sharp knife. It is not necessary to mark the paper. The average person with a good eye can split the roll evenly enough for gardening purposes. Of course the seed should be planted in rows just a trifle farther apart than the width of the paper.

The paper, after application, is held in place by the use of large staples made of No. 10 wire or by wooden strips, rocks or loose soil. The staples should be made a little wider than the roll, with 10-in. points, so that they can be anchored securely in the ground with their heads holding the mulch material in position.

The writer has used loose dirt successfully as paper weights, placing it along each edge of the paper or shoveling soil crosswise of the mulch at 3-ft. intervals along the row. It is advisable to stagger smaller vegetables, such as beets, carrots, radishes and onions, among the larger, such as corn, peas and pole beans, in order that the latter may serve as windbreaks and aid in protecting the paper from the violence of summer storms.

The paper mulch smothers out weeds, conserves soil moisture and provides an extraordinarily effective irrigation. Many summer rains are so light that the precipitation does not accomplish much good when distributed uniformly over the garden rows. The paper mulch concentrates this rainfall directly around the plant roots where it accomplishes maximum benefit. If you sprinkle your garden during drouthy weather, the paper mulch reduces the amount of water necessary for a good drenching by draining all that falls in the inter-row spaces directly into the rows of growing vegetables. Where an abundance of moisture is husbanded in the soil during the growing season, larger supplies of plant food are made available for crop use. Plenty of moisture and equable soil temperatures increase the activity of the soil bacteria which serve as "chefs" for the maturing vegetables by providing them with plenty to eat. The paper mulch also acts as an ideal insulator

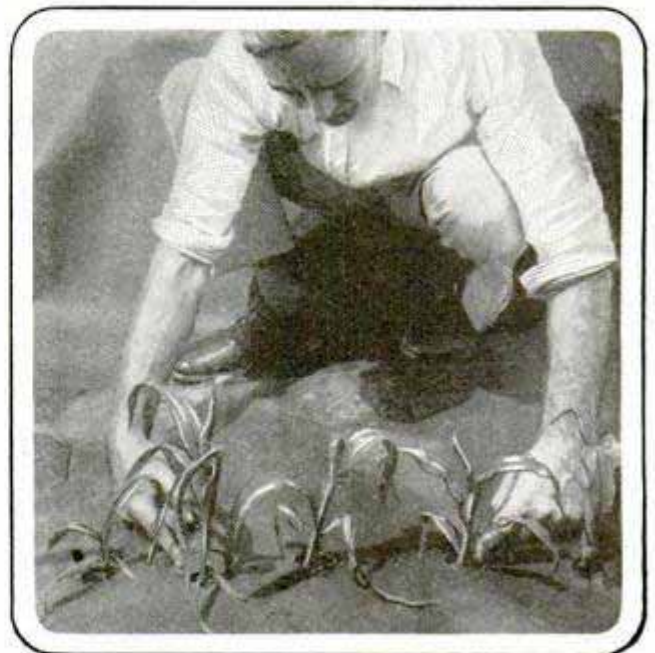

How the Young Corn Sprouts through the Holes in the Paper Mulch

for the ordinary garden, as it keeps in the heat and shuts out the cold. The soil temperature is increased from 5 to 10° where the paper mulch is used. Seeds thus germinate more uniformly and rapidly than usual, while the tender seedlings grow under adverse weather conditions when neighboring gardens, not papered, are practically dormant, with seed rotting in the ground. Crops mature from two to four weeks earlier as a result of the protective blanket of paper. This means that you are able to enjoy green peas, spinach, beets and carrots fresh from your garden while your neighbor who scoffs at paper farming is still dreaming about the future when his garden will come into bearing. In certain localities, the use of the paper mulch makes it possible to raise two crops of the same vegetable in one season because it measurably reduces the maturity period. Sweet potatoes under paper can now be raised as far north as Vermont—a hitherto undreamed of gardening feat.

“Plant one seed for the sparrow, one for the crow, one for the cutworm and two to grow,” is the venerable slogan of the corn farmer. The papered garden eliminates seed losses due to crows, pigeons and other winged plunderers. The paper acts as an effective scarecrow. The birds are suspicious and evidently believe that the black paper is some sort of a snare. They fly shy of the paper-mulch garden, much to the satisfaction of the gardener.

Inter-row crops, such as spinach, beets, carrots, lettuce and radishes, can be raised successfully between rows of corn under the paper-mulch system. Where land is extremely high-priced or where the gardening tract is small, this practice is ad-

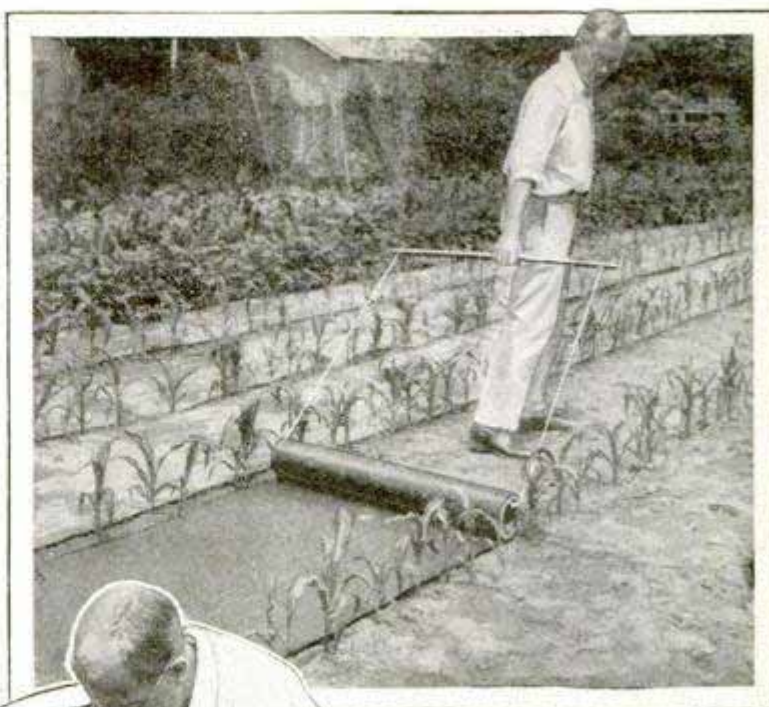

Above, Laying the Mulch; Below, Six-Week Corn Protected by Paper, 22 Inches High

vantageous. The inter-row crop can be planted in mid-summer, if desired, as the corn plants at that time will shade the tender seedlings from the hot sun and will facilitate their speedy development. Strips, 1 to 2 in. wide, can be cut the length of the paper so that the inter-row crop can be planted.

The paper mulch holds moisture in the surface 4 in. of soil even two weeks after the last rainfall. Tests made at the Arlington farm, Va., the national proving ground of scientific agriculture operated by the government, show that the moisture content of the surface soil two days after a rain is one-sixth greater under the paper than at an unprotected point, 18 in. from the border of the paper mulch. Two weeks after a rain, the moisture of the soil under the paper was one-fourth greater than at a similar depth in the same garden where the paper mulch was not used. Cleaner vegetables of better market quality result where the paper-mulch method is practiced. This is particularly true of vegetables like tomatoes,

which are apt to come in contact with the soil unless well trellised.

During wet weather, it is practically impossible to enter the ordinary garden in order to pick its "fruits" for the dinner table. The paper mulch favors harvest at any time, even during a rainstorm, as the housewife can walk carefully on the wet paper without tearing it and without risk of getting mired. You can walk at will over the papered garden during dry weather without packing the soil at the eventual expense of curtailed yield.

The paper mulch stimulates plant growth in some baffling manner which at present mystifies science. The department of agriculture has begun comprehensive experiments to ascertain how this gardening miracle is wrought. Scientists were at first skeptical about the long-term benefits of paper farming. They feared that the extended use of the paper "top-coat" would result in soil oxygen starvation, decreased yields and inferior crop quality. Practical tests, however, have demonstrated this theory as incorrect.

The writer has found that the paper mulch is admirably adapted for use in the home vineyard, in the rose garden and for the protection of seedling trees which are being grown in nursery rows until large enough to be transplanted as ornamental shade trees here and there about the lawn. It is a little more trouble to cut out and fit the paper in the vineyard, but the work pays big dividends in an increased harvest.

Rose bushes are protected against drouth where the paper mulch is employed, and a dozen or more hand hoeings each year are eliminated. Regular applications of fertilizer can be made to the seedling trees protected by paper mulch by lifting the paper temporarily and replacing it after the job is finished. This serves as a satisfactory substitute for the

forest blanket of leaves, pine needles and other decaying vegetation which in nature facilitates tree growth. The paper mulch simplifies strawberry, cantaloupe and watermelon production and insures fruits free from soil contamination.

Gluing Ivories on Piano Keys

A simple method of gluing ivories on piano keys is to get a little oxide of zinc (white) and mix it with ordinary glue. File or sand both the surface of the key and that of the ivory. Apply the glue to the key, and let it stand for 5 or 10 minutes before placing the ivory on it. Press the ivory in place and then wrap ordinary twine around both key and ivory. In three or four hours the glue will have set sufficiently to permit filing or sanding the dry glue off the sides. Do not apply water to it unless waterproof glue has been used. I have used this method successfully for many years in repairing pianos.—W. F. Caldwell, Portland, Oreg.

Handy Chip and Dirt Blower for the Floor Repairman

In patching an old floor, some trouble was experienced in fitting the butts and edges together properly, owing to dirt getting into the grooves and under the tongues. Sweeping did not remove it, so the simple blower shown in the drawing was improvised. It consists of an old

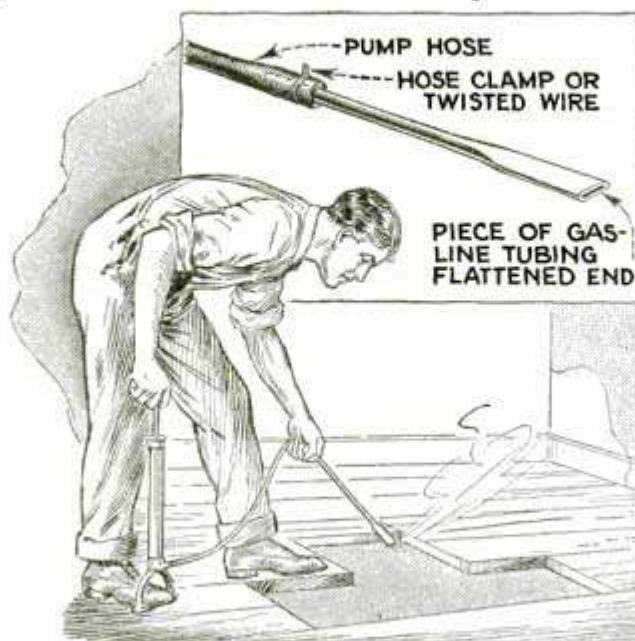

Auto-Tire Pump, Hose and Nozzle Make a Good Chip and Dirt Remover

auto-tire pump, a length of rubber tubing and a nozzle made by flattening the end of a short piece of copper tubing of the kind used in gasoline lines of autos. A hose clamp or a length of wire holds the nozzle securely. A few strokes blows all the dust and dirt out of the grooves and corners, so that the floor boards can be fitted accurately.

Cheap Stump Puller

In the Pacific northwest, where there are far more fields of stumps than there are fields under cultivation, you see all sorts of devices for pulling stumps. One of the cheapest and most successful I have observed was constructed as follows: A discarded Ford auto, with the wheels removed and the chassis mounted on a sled, was used to provide power. To each rear axle was fitted a pinion gear. The pinions drove a single shaft, with a gear on each end, and another pinion gear, which in turn drove a small cable drum. The rear axles, the bearings for the shaft and the drum were set on a piece of mild-steel bar to keep the gears in mesh. Both bearings and bar were securely bolted to the sled. The gear reduction obtained was $3\frac{1}{2}$ to 1 for the car rear end, 2 to 1 for the rear axles to the drum pinion shaft, and 3 to 1 for the final drive, making a total of 21 turns of the motor to one turn of the drum. In this way plenty of power was obtained in high gear and almost unlimited power in low.—K. E. Corliss, Langley, Washington.

Hammer Serves as Rule

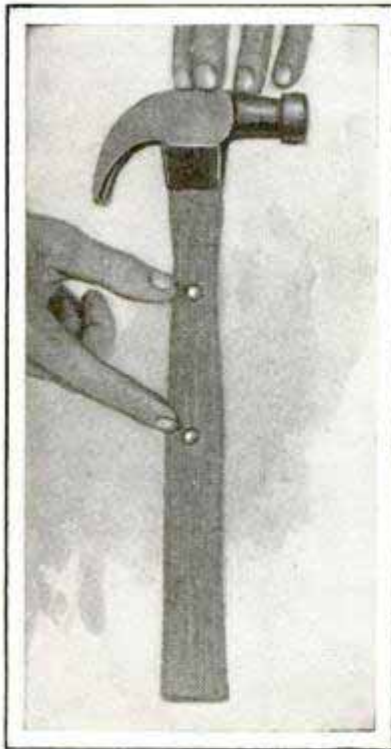

be done if you graduate it. To do this, take two small brass-headed tacks and drive them into the hammer handle, 6 and 9 in. from the end, as indicated.

We often neglect taking a rule along for small jobs, but before we get very far, it may be necessary to use one, or else resort to some "rule-o'-thumb" method, which is rather inaccurate. It is a good idea to make your hammer serve as a rule in such cases, and that can



Homemade Oat Sprouter Which Is Cheap and Has Been Found Entirely Satisfactory.

Efficient Oat Sprouter

The oat sprouter shown in the photo was made 5 ft. high and $2\frac{1}{2}$ ft. square. A full-length door was provided on one side, and six strips of wood were arranged along two sides so that trays in which the oats were sprouted could be easily slid in and out. The top of the sprouter was covered with sacking material for ventilation, and the rest was covered with tin on the outside, to prevent the entrance of rodents. The trays were about 3 in. deep, tin or heavy wood being used for the bottom. Each tray was half filled with earth and oats or wheat, and the earth was then saturated with water. A small oil stove or lamp was placed in the bottom and burned just enough to keep the sprouter warm. By using a knife, the oats can be cut out in pieces, the sand and all being placed in the chick pens.—David J. Morris, Weir, Tex.

Melting Rods for Wax Heated with Curling Iron

The task of heating melting rods for flowing wax into wood pattern fillets has usually been more or less troublesome. We have found, however, that an ordinary curling iron is an ideal tool for the purpose. The spring member is removed, and it is an easy matter to attach tips for the various-size fillets.—C. H. Benedict, Greenfield, Mass.

Rosehill Farm

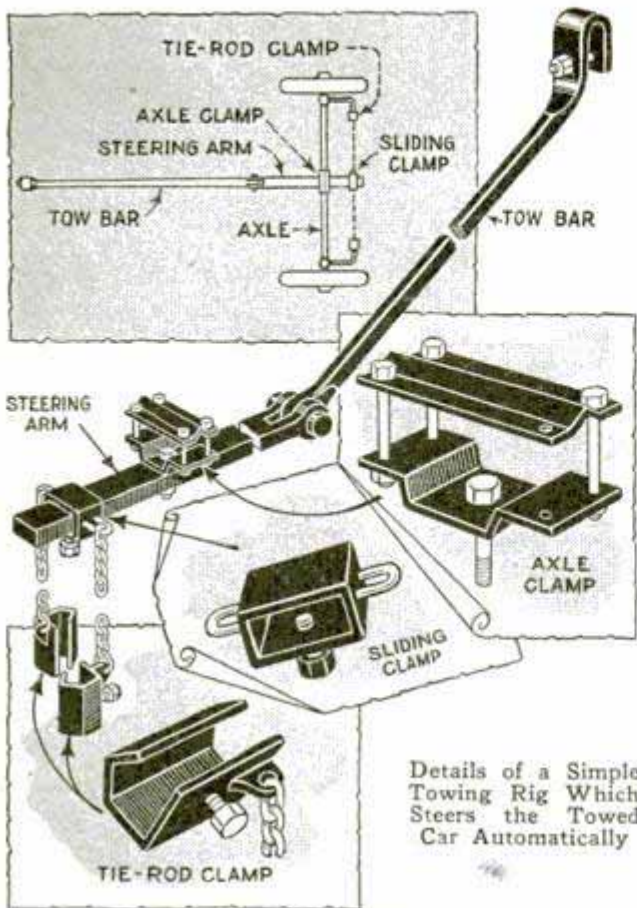

Tow Bar Steers Towed Car

When a garage attendant has to tow a car single-handed, it is almost necessary to raise the front end with a tow-truck crane. In the absence of a crane, a single-handed towing job is almost impossible unless a tow bar of the kind shown in the illustration is used. It consists of two sections, pivoted horizontally to allow for road inequalities. These sections are made from round and flat iron, as indicated, the rod part being the longer of the two and having a U-shaped clamp at one end to permit attachment to the towing truck. An axle clamp, shown in the detail, is bolted to the flat section, and is used for attaching the tow bar to the front axle of the car being towed. It is necessary that the axle clamp be pivoted to the flat section so that the latter can swing to the right and left, this movement being used to steer the towed car. Two lengths of chain are fastened by means of suitable clamps to the tie-rods and to the tow bar, or rather to the steering-arm section of the tow bar, as shown by the dotted lines in the upper detail. The clamp on the steering arm is a sliding arrangement equipped with a setscrew so that it can be securely fastened at any

point. The tie-rod clamps also have setscrews to keep them in place securely.—C. B. Evans, Ottawa, Can.

Thread Tool Forms Straightedge

Owners of Pratt and Whitney type of thread-cutting tools are able to use the fine pitch points as a straightedge for tool work. On a 40-pitch thread, for example, the width of the flat at the top and bottom of the thread is only .003125 in., and, as this flat is lapped on the tool, it forms practically a knife-edge, which is quite true and forms a perfect straightedge.—James McIntyre, Hartford, Conn.

Single Burner for Steam Table and Coffee Urn

We had been running a steam table and coffee urn with two separate gasoline burners, and the one under the urn could not be turned down low without going out all the time. I tried electric burners but their use was too expensive, so I devised the method shown in the drawing and found it entirely satisfactory. Only one burner is used for both the steam table and the coffee urn. Lengths of $\frac{3}{4}$ -in. pipe are used to extend from the urn to the burner under the steam table, two rubber-tube connections being provided in the pipes just below the urn so that the

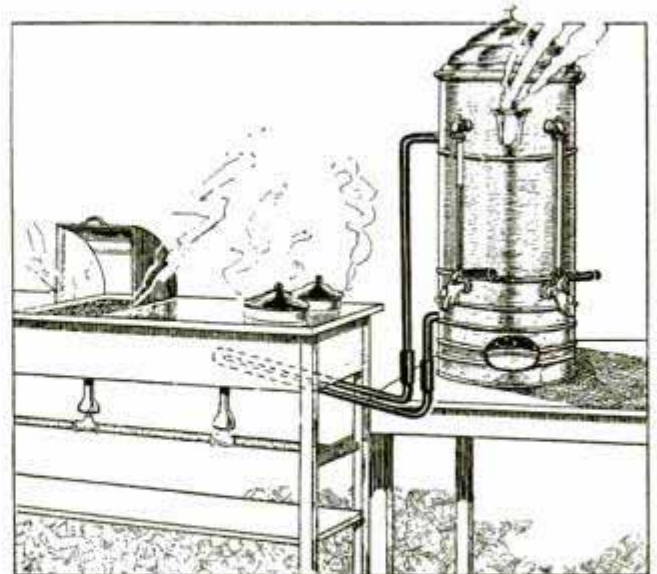

Reducing the Cost of Heating Steam Table and Coffee Urn by Using One Burner

pipes can be pushed to one side in case the water boils in the urn.—E. V. Pierce, Morris, Ill.

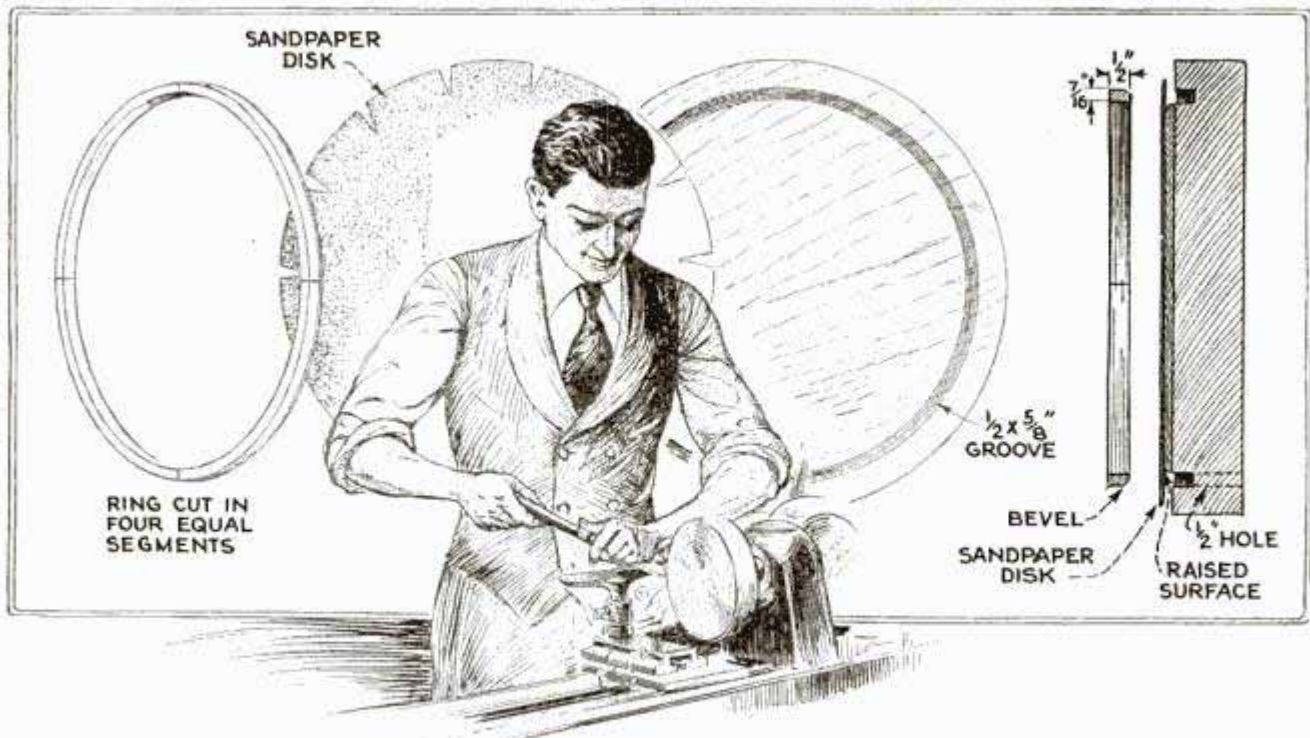

Sand Disk for Small Lathe

By W. CLYDE LAMMEY

A SAND disk for the workshop lathe is an extremely handy accessory, and where the price of the commercial disk is prohibitive, a very good one may be made to do the same work at a cost next to nothing, save the time spent. In size, the disk must be adapted to the swing of the lathe. For instance, if the lathe has a 9-in. swing, the disk may be $8\frac{1}{2}$ in. diameter. Select a piece of birch or gum stock and saw out a disk to the required diameter, then true and face it off in the lathe. The disk should be made of $\frac{1}{8}$ -in. stock. Turn a rabbet on the rim, $\frac{1}{8}$ in. deep and $1\frac{1}{2}$ in. wide. Round the shoulder of the rabbet slightly, and, using the shoulder as a guide, sink a groove, $\frac{1}{2}$ in. wide and $\frac{5}{8}$ in. deep. Centering in the groove, bore four $\frac{1}{2}$ -in. holes, equally spaced, through the disk.

Saw out another disk from $\frac{1}{2}$ -in. stock, of the same diameter as the circle formed by the outer edge of the groove in the first. Bevel this disk slightly in the lathe as indicated, making the bevel run from face to back. Strike a line with a sharp-pointed pencil just $\frac{7}{16}$ in. from the face edge and, holding the chisel to this line, cut off the ring. Cut the groove larger than the width of the chisel to prevent

binding. Then cut the ring into four equal segments.

Using an old pair of shears, cut a disk from an ordinary sheet of sandpaper of the required grade and large enough diameter to extend $\frac{1}{8}$ in. beyond the outer edge of the groove all around the sand disk. Cut a number of V-notches about the edge of the paper as shown, and, laying this over the raised portion of the disk, drive the ring segments tightly into the groove, thus binding the paper in place. When it is necessary to change the paper drive out the ring segments with dowels set in the holes on the back of the disk.

It will be seen that only the surface of the paper is presented to the work, as the ring segments are below the edge in the rabbet, and do not interfere with the sanding in any way. Be particular to get the disk centered on the lathe faceplate so that it runs without vibration. For sanding end grain and a variety of small work, a disk is practically indispensable as it cuts very fast and leaves the work smooth.

☛ A long nail in the end of a broomstick is convenient for picking up leaves that have blown on a raked lawn; a few notches should be filed in the nail.

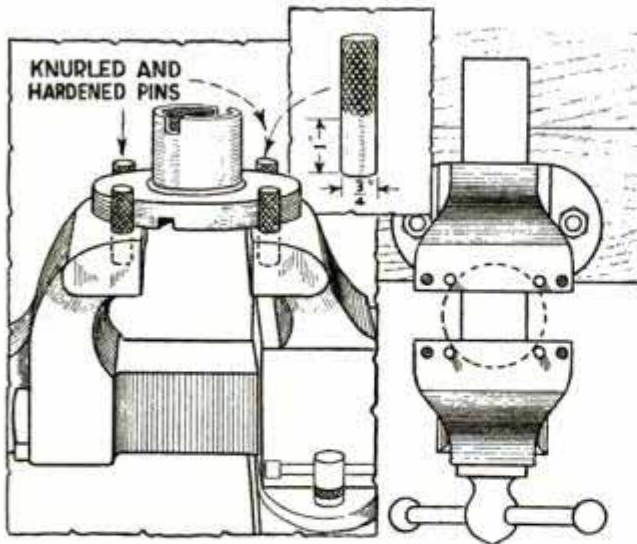

Knurled and Hardened Pins, Set in Holes in Vise Jaws, Hold Disk-Shaped Parts Securely

Pins Hold Circular Parts on Vise

Limitations of the jaw opening and the impracticability of holding disk-shaped parts in the usual bench vise can be overcome by the use of pins or studs set into the upper faces of the jaws. Four holes are drilled into the soft section of the jaws, and steel pins are inserted into the holes. Extra holes may be drilled to hold disks of various sizes, and, if desired, the upper ends of the pins may be knurled and hardened to obtain a firmer grip.

Guide for Stamp on Tracing Cloth

Although the use of rubber stamps for printing titles, lists of material, etc., on tracings has been found a timesaver, it is often difficult to place the imprint squarely on the tracing. To facilitate this, one engineering office uses a simple frame to guide the stamp, which can be knocked together from strips of wood in a few moments. The illustration shows a frame which is used for four stamps. The frame is laid on the tracing, and held securely with one hand, while the proper stamp is put

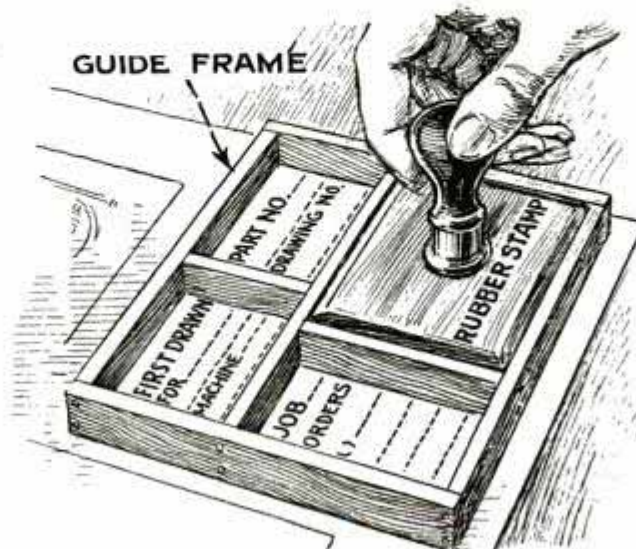

Wooden Frame Serves as Guide for Rubber Stamps to Get Impression Squarely on Tracing

in one of the divisions and the imprint made on the tracing. The result is that all the lettering will be in alinement.

Care of Animal Traps

Success in trapping fur-bearing animals, whether done for profit or as a hobby or pastime, depends on the fitness of the equipment used. No work can be done well unless the tools used are properly adjusted and handled. Traps are your tools in this instance and need good care. Oiling of traps is not especially recommended, but in some cases fish oil is used, or lard may be applied, the trap being heated just enough to melt the lard so that it covers the metal. The pungent odor of most oils is likely to keep the game away. Some old trappers bury their traps in old leaves under still water where the pile will lie undisturbed. When needed, they are taken out, blackened but practically free from rust. These traps are not easily detected by the game. A good method of blackening new traps is to boil them for an hour in water to which $\frac{1}{2}$ bu. of walnut hulls has been added. Then transfer the trap to fresh water, boil for another hour, and hang up to dry near heat without wiping. When cleaning rusty traps, never use kerosene. Rub the traps with fine sandpaper and a file, then boil them in a solution of walnut, maple or oak bark, after which they are hung up near a fire to dry. A light coating of rust is harmless. For snow trapping, it is desirable to make the traps white. This can be done by putting

them in a kettle of water and adding $\frac{1}{2}$ pt. of unslaked lime. Bring this to a boil and keep the traps in the boiling water for about ten minutes. They will come out white and absolutely odorless. Hang them up to dry. You can etch your name on the traps if you want to prove ownership in case of theft. Warm a trap and rub candle grease or par-

affin over the spot to be marked. Then write your name in the grease with a sharp-pointed steel instrument, clear through to the steel. Pour a few drops of a mixture consisting of muriatic acid, 4 parts, and nitric acid, 1 part, into the scratched marks, taking care not to get any acid on your hands or clothes, as it causes severe burns. In a few minutes, the acid can be washed off and the wax melted. The name will be indelibly etched in the steel. It is also a good idea to carry a camera with you on the trap line. It will give you authentic proof of the animal you caught, its size, markings, etc., and will prove valuable and trustworthy in later arguments with friends. Use a small compact outfit with a fast lens and speedy shutter. A film camera will be the best to carry.

Dirt Hopper Fitted with Wheels

The dirt hopper shown in the photo is filled with a steam shovel in the usual way and then a truck goes under it and takes the load. Instead of hauling the hopper from one job to another on a truck, a contractor provided it with wheels as shown. This enabled him to fasten it to the back end of a truck in the same way as a trailer and tow it, which required much less time than loading it on a truck. The hopper is tipped over onto the wheels, and the legs on the wheel side raised to the back of the truck. —Carlton Groat, Portland, Oreg.

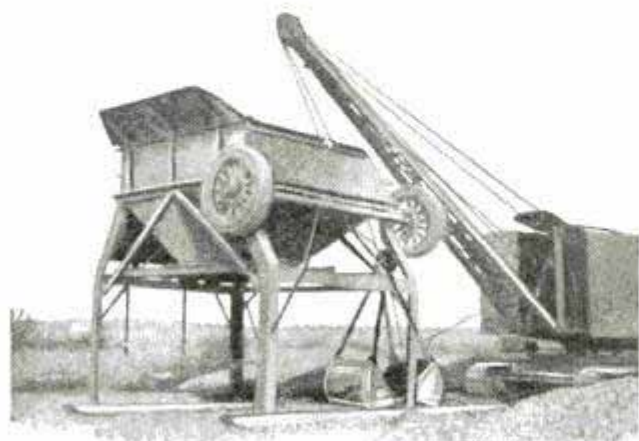

Dirt Holder Provided with Wheels to Facilitate Its Transportation

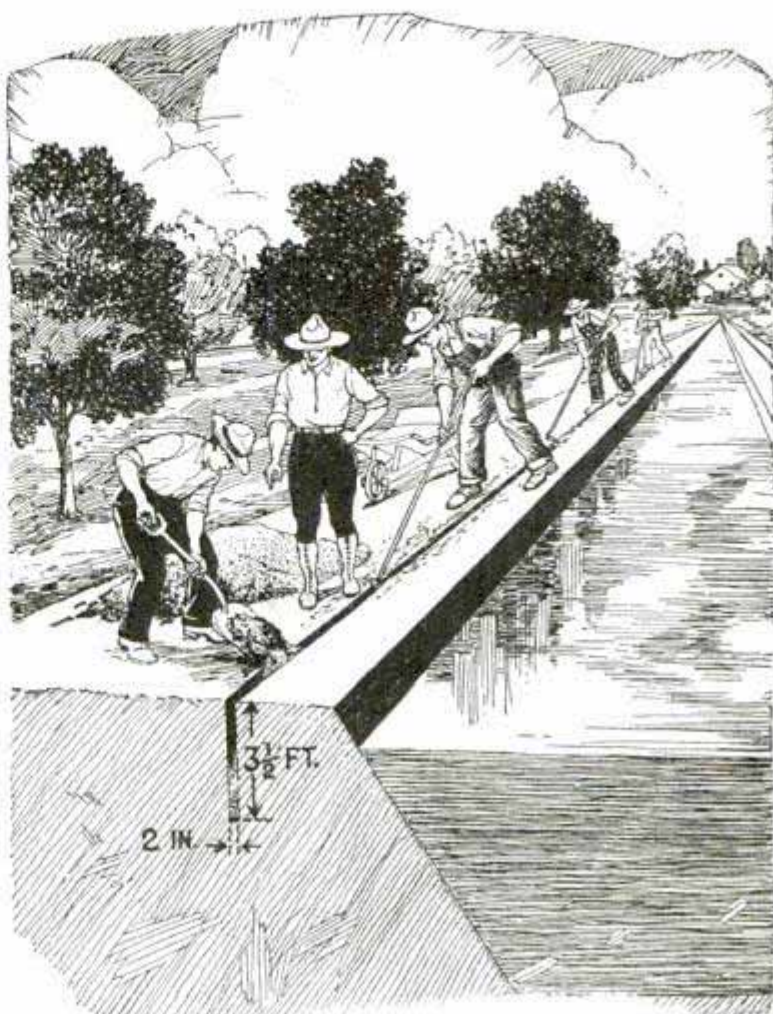

Narrow Concrete Diaphragm, About 3 Ft. Deep, Prevents Breaks Caused by Gophers in Irrigation-Canal Banks

Concrete Diaphragm Protects Canal Bank from Gophers

Concrete poured in a trench dug in irrigation-canal banks near the water's edge, as shown in the illustration, affords protection against breaks caused by gophers and other burrowing animals during the summer and fall months. The trench should be about 2 in. wide and about 3 ft. deep, and can be dug by means of specially made, hook-shaped hoes with long handles. Six workmen can dig a 100-ft. trench and fill it in an eight-hour day.

Bees Earn Income by Pollenizing Fruit Blossoms

One bee keeper derives additional profit from his bees by renting them to neighboring farmers to pollenize fruit blossoms. The bees are rented for about ten days, and when the blossoms have fallen, are returned to their owner who gets \$3 per hive for their service.

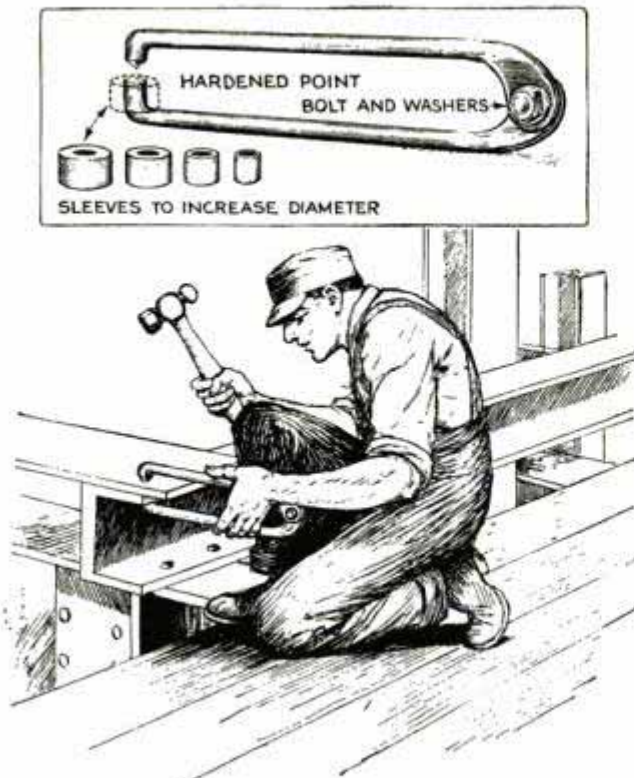

Tool Which Facilitates Transferring Hole Locations from Channels and I-Beams

Tool for Transferring Hole Locations

In structural iron work, there are many occasions to transfer holes from I-beams, channels or built-up girders, to plates or adjacent material so that it may be drilled with coincident holes. The restricted space on the I-beams, etc., which does not allow for the use of a drill to locate the holes by drilling through, is the obvious reason for transferring them to the top of the plate. An excellent tool for this use was developed by a worker and is shown in the illustration. It is made up as a caliper, consisting of two hinged legs, which work on an accurately fitted pivot. One leg terminates in a hardened-steel point that is used as a center punch. The other leg is made up as a plug to engage the hole in the work to be transferred. Steel thimbles are used to increase the diameter of the plug to correspond to the work. In accuracy, the tool will be found entirely satisfactory and it will save considerable time.

Rebuilding Old Pistons with Bronze

A western machine-shop owner has found that he can build up old pistons on "orphan" cars with welding bronze and has proved it to be a very satisfactory method

of getting an oversize piston. The method used is to clean the piston carefully with a file or a grinding wheel, as any scale or dirt will prevent the bronze from adhering properly and will result in a poor job. It is then heated to a cherry red, to burn out all the oil that might remain in the pores of the iron, as any oil remaining will cause bubbles in the bronze, which is then applied until it is thick enough to permit turning the piston down to a smooth job. This process does not pay in the smaller sizes of pistons that can be obtained at a moderate price, but is used in cases where pistons are expensive and hard to get. Another feature of these rebuilt pistons is that they do not score the cylinder walls when the engine becomes overheated. This was discovered when an air-cooled engine became overheated, due to improper functioning of the cooling system, and the piston froze. An investigation showed that the piston and cylinder wall were not damaged in the least, and after a few minor repairs to other parts of the engine, it worked as well as ever. Valve ports can also be built up with bronze in this way.—L. A. Krider, Coeur D'Alene, Idaho.

Novel Swinging Sign

Swinging signs of the kind shown in the drawing have their advantages in that their movement attracts attention, and they offer less resistance to a high wind than stationary signs, for which reason they are not wrecked as easily as the latter.



Movement of Swinging Signs Draws Attention of Passing Motorists

The sign itself is pivoted to the top of two stout poles or posts.—Leon I. Thomas, Oak Park, Ill.

2285

Our Second Most Popular Plan Now Developed for Log Cabin

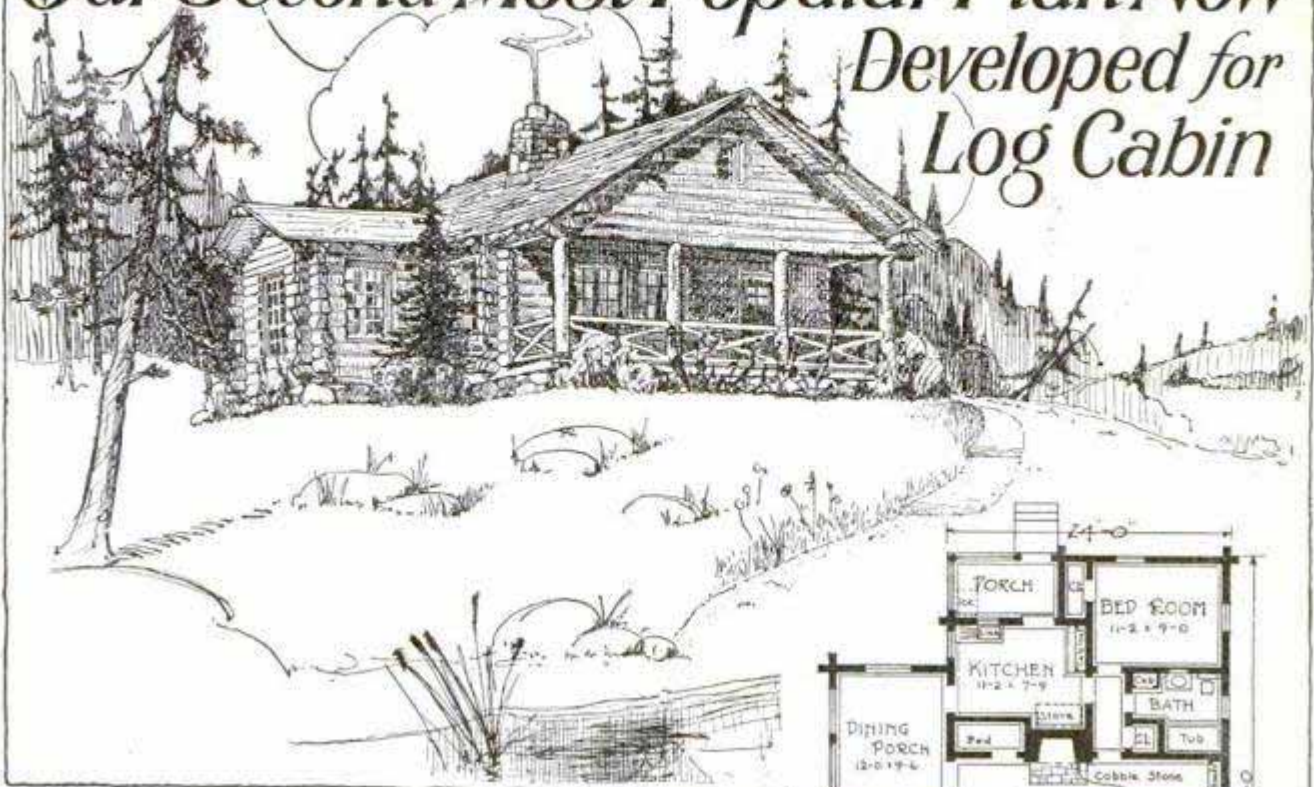

Copyright, Popular Mechanics

Plan 61-L-C



NOW that good roads and high-speed automobiles make woods and lakes accessible in a few hours from so many big cities, summer cottages and log cabins are not only growing a lot more popular but are used for longer periods each season. Furthermore, many a summer-cottage or cabin plan can, without much expense, be converted into a mighty comfortable, good-looking permanent small home for town, city or countryside.

That's exactly what happened in this case. This plan, originally designed for a summer-cottage, was finished as a year-around house. The owner built it on the shore of a lake not far from a big city, and liked it so well he has lived in it ever since, enjoyed lower taxes, better health, and it cost only \$2,500 complete.

With the exception of one other plan, this design (61-L-F) has been the most popular with Popular Mechanics readers the past year. And so we thought, at this time of the year when many people are planning sum-



Plan 61-L-F

HOW TO GET THE PLANS

One-sheet blueprints for this house in log-cabin style or as a permanent house for town or city, may be had for \$1.00 each. This blueprint does away with the necessity of first buying a complete set of plans to find out whether you can afford to build. It contains floor plans, elevations, a section, detail, size of joists, studs, etc. Submit them to local dealers and builders for cost information. Specify whether 61-L-C (the log cabin), 61-L-F (the original floor plan) or 61-L-F-B (the alternate plan) is desired.

mer cottages and cabins, you would be glad to see it in real log-cabin style. It may be the ideal plan for your summer camp.

Generally speaking, a log cabin or summer cottage

no longer furnished

need not be large, but it should be roomy. By adopting a dual-purpose plan, you can quickly convert living space into sleeping quarters. You also need reasonable comfort and convenience, and protection against tolerably cold weather. Then there is the appearance and style which many folks are now giving a lot of attention. Few are content these days with what was once called a summer shack.

There are, of course, various ways to build a log cabin. Real logs are picturesque and romantic. Unless you live in a timber country, they mean a long haul and considerable expense. However, you can get a satisfactory log effect by using the new forms of wide siding, sawed in quarter and half-round to look like logs. Another rustic and satisfactory exterior finish is rough siding stained brown. Shakes and large shingles used as outside finish produce that semi-crude, but sturdy quality most people prefer in cabins.

Let's look into the construction of this log cabin and the equipment. A fifty-foot frontage is required. Footings are concrete. Logs are six and seven-inch tops, calked with oakum. The base course is of cobblestones. Omitting this will save money. The roof is of log rafters with four-and-one-half-inch tops, overlaid with surfaced pine boards and then covered with wood or composition shingles. Log joists for the floors have eight-inch tops, on which is laid the subfloor and then felt or fiber insulation, and finally a finished floor of pine.

Interior partition walls are pine boards on two by four-inch studs. Casings for doors are half logs. Doors throughout are matched plank of one-and-three-fourths-inch pine with half-log battens. The fireplace is made of cobblestones with flagstone hearth. Floors throughout are pine, except the kitchen which is covered with linoleum.

Now about equipment and dual-purpose

space. A closet next to the fireplace may contain a roller-type bed. The front porch may be used for sleeping purposes by one or more people. In an emergency, the dining alcove or sun room can be converted into sleeping quarters. A bathroom is shown in the plan. If the cabin is only a skeleton and temporary in service, the space occupied by the bathroom can be made into a bunk room for boys.

At small expense, you can convert this house into a permanent town or city home. A partial-basement excavation with small heater will be satisfactory. Insulation for the walls, roof and floors will be necessary. Inside finish may be wall-board or lath and plaster.

An alternate plan shows how a second bedroom may be had, and if the family is small and a bedroom is rented, the occupant may enter his room through a door from the porch.

This house may be finished in logs, stucco, shingles or siding, or it can be built of brick. As a log-cabin plan or permanent home, you will look a long time to find a more flexible, roomy, convenient arrangement in so small space and at so reasonable a price.

One reason for the popularity of this house is the ease with which the interior can be altered to suit any taste and needs. The alternate plan on this page is only one of many arrangements that are easily made. A contractor can take the exterior and work out for the prospective builder any desired combination of rooms. Because of its simple roof lines, the house also is easily changed in size.





FIRST FLOOR PLAN
ALTERNATE "B"

A NEW BUNGALOW BOOK

Sixteen Bungalows. A new plan book just off the press. Selected low-cost bungalows in popular styles. Latest ideas on space, labor and money saving. \$5,000 homes and less. Some as low as \$2,000. Twenty Low-Cost Popular Homes and Ten Commandments for Home Builders. Selected homes actually lived in. Variety of types and sizes, all planned to fit average pocketbooks. \$5,000 and less. Send 10 cents in stamps for each, to cover postage. Address Building Editor.

To and Fro

{ Turn right  then left  }

drives the screw

ADD this pair of "Yankee" Ratchet Screw-drivers to your kit. Ingenious tools . . . efficient . . . interesting to use!

You grasp handle just once and simply turn it to and fro.



Tiny screw started by turning blade with thumb and forefinger.

The "Yankee" Ratchet drives the screw. Saves your strength and time. Smooth as stem-wind on your watch.

No. 15.— Takes care of pesky little screws. "Thumb-turn" on blade starts the wobbly screw. Ratchet movement drives it home. Blade, $\frac{3}{16}$ " diameter. Six lengths: 2", 70c; 3", 75c; 4", 80c; 5", 85c; 6", 90c; 8", 95c.



No. 10.— For husky screws. Eight blade lengths: 2", 65c; 3", 80c; 4", 85c; 5", 95c; 6", \$1.05; 8", \$1.20; 10", \$1.45; 12", \$1.60. Ratchet Shifter moves lengthwise.

No. 11.— Same as No. 10, except Ratchet Shifter moves across tool. All have right and left ratchet and rigid adjustments.

It is a relief in many places to be able to ratchet the screw home with one hand.

Remember, it is a "Yankee" Ratchet only when the name is on the tool. "YANKEE" on the tool you buy means utmost in quality, efficiency and durability.

Some Other "Yankee" Tools

Ratchet and Spiral Screw-drivers. Automatic Push Drills. Ratchet Hand, Breast and Chain Drills. Automatic Bench Drills. Ratchet Braces. Bit Extensions. Push Braces. Ratchet Tap Wrenches. Removable - base Vises. Etc.

NORTH BROS. MFG. CO., Philadelphia, U.S.A.

"YANKEE" TOOLS

Make Better Mechanics



Mail This Tool-Book Coupon NOW!

North Bros. Mfg. Co., Lehigh Ave., Philadelphia.
 Yes, I want to make my work easier: send tool book showing the new tools for saving time and labor, mentioned in Popular Mechanics.
 Name
 Address
 City
 State

"2¢ spent~
\$200 saved!"

Because I
sent for
this free
book..."



"A 2¢ stamp saved me \$200 on the used car I bought" — thousands of people will tell you that! Because thousands of people, before buying a used car last year, spent 2¢ to get this booklet "How to judge a used car".

They found out what to look for and what to

avoid in used cars. They got the benefit of years of experience spent in used car buying by acknowledged experts—men who helped to write this free book. They spent 2¢ for insurance against \$200 mistakes!

In 32 interesting pages you will learn the answer to these, and many more, used car questions: How can you tell the model of a used car? What do speedometers tell? How do you avoid "orphans"? How do you set a fair price on a used car offered by a friend? What do code prices mean? Why does the Studebaker Pledge give you five days' driving trial?

Isn't it worth a 2¢ stamp to know how to wisely invest your used car money? Then fill in and mail the coupon for *your* copy of "How to judge a used car"—*now!*

Pledge to the Public on Used Car Sales

- 1 Every used car is conspicuously marked with its lowest price in plain figures, and that price, just as the price of our new cars, is rigidly maintained.
- 2 All Studebaker automobiles which are sold as CERTIFIED CARS have been properly reconditioned, and carry a 30-day guarantee for replacement of defective parts and free service on adjustments.
- 3 Every purchaser of a used car may drive it for five days, and then, if not satisfied for any reason, turn it back and apply the money paid as a credit on the purchase of any other car in stock—new or used. (It is assumed that the car has not been damaged in the meantime.)

© 1928 The Studebaker Corporation of America.

THE STUDEBAKER CORPORATION OF AMERICA
Dept. 155, South Bend, Indiana
Please send me copy of "How to Judge a Used Car"

Name

Street

City..... State.....

STUDEBAKER

Builder of Champions

How to File Your Hand Saws

Told by Saw Makers Who Are the World's Largest Users of Files

DISSTON files were made first for Disston saw makers. These men must have files that cut fast, cut true, save time and stand up to the job. Files that are sharp! . . . accurate! . . . dependable! . . . lasting! These are the qualities that Disston Steel makes possible in a file and in all cutting tools.

Now, for the benefit of all who work with tools, Disston Files—for every purpose—all made from Disston Steel, may be had at good hardware stores.

Ask for "Disston"! Saws, of course; but also Disston Files.



Files for the Metal Worker

Every kind, size and style. Use a Disston 8-inch Mill File, bastard cut, for sharpening axes, lawn mowers, garden tools, and general work in the home and shop. Excellent for finishing metal surfaces. 25 cents each.



Hints on Using a Hack Saw

For cutting pipes, bolts, nails, curtain rods, etc. Strain blade tight. Cut on forward stroke. Disston No. 36 1/2 Hack Saw Frame takes 8" to 12" blades. Frame, \$2.10. Blades, 8", 55c doz.; 10", 65c doz.; 12", 75c doz.



For Finishing Wood Surfaces

For giving a fine finish to your work, removing paint, etc., use a Disston Acme Cabinet Scraper, made of Disston Saw Steel. Made in all needed sizes, 2 1/2" and 2 7/8" wide and 5" and 6" long being standard. 25c and up.



THE Disston Saw, Tool and File Book shows you how to sharpen your hand saws. It answers such questions as:

What tools do I need for filing a hand saw?

A saw file, with handle. The Disston Special Extra-Slim Blunt Saw File is easiest to use. A saw clamp is necessary. The Disston D-3 Filing Guide and Clamp will greatly assist you in filing your saws. If the teeth require setting, use a Disston Triumph Saw Set.

What is meant by "jointing" a saw?

Jointing is leveling the tops of the teeth before filing. Necessary only when teeth are uneven or out of shape, when they should be evened up on top with a Disston mill file or a Disston Hand Saw Jointer, before setting or filing.

How are the teeth to be filed?

Look at a new saw, or at perfect, sharp teeth at wide end of your saw, if it has never been sharpened. Follow these perfect teeth for shape and bevel. On cross-cut saws, start at small end of blade and work toward handle. File every other tooth, then reverse saw and file remaining teeth. Hold file level, at 45° angle to blade. On rip saws, file teeth straight across.

All your saw filing questions are answered in "The Disston Saw, Tool and File Book." Write to us for it.

DISSTON

Makers of "THE SAW MOST CARPENTERS USE"



"The Saw Most Carpenters Use"

The two handiest saws for the home work-shop are the 26-inch 8-point for cross-cutting, and the 26-inch 5 1/4-point for ripping. You will need these on almost every job. The popular "D-8" Light-weights cost \$3.45.



Handiest of All Small Saws

The Back Saw, with fine teeth and stiff back, enables you to do smooth, accurate cutting of mitres, grooves, etc., for making furniture, picture frames, etc. Disston No. 4, 12" size, 3" under back, 14-point, costs \$3.00.

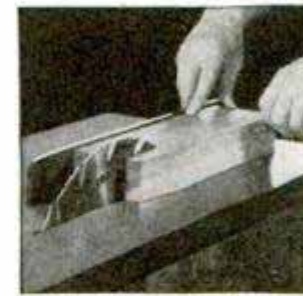

On Your Power Saw Outfit

With a Disston Circular Saw you can do better work. Disston Steel and Temper make a saw cut easier and stay sharp longer. There is a Disston Saw—cross-cut, rip or combination—for your outfit. Made in all sizes.



Every saw user will enjoy reading "The Disston Saw, Tool and File Book," an illustrated manual on the selection, care, and use of tools. It tells how to file and set saws and contains much other helpful information. Sent free. Use the coupon, or write for it.



Henry Disston & Sons, Inc., Philadelphia, U.S.A.
(In Canada, Henry Disston & Sons, Ltd., Toronto)

Please send me "The Disston Saw, Tool and File Book."

Name and Address.....

Never the same job twice

YES, it's the same man shaving on ten different mornings; ten different conditions of water, temperature, and nerves; ten different methods of lathering and stroking.

*But his Gillette Blade
meets all these chang-
ing conditions with
the same even temper.*

So much dependable shaving comfort has been honed and stropped into this blade that eight out of ten American men have learned to expect—and get—a comfortable shave even under the worst possible conditions.

To meet that expectation Gillette has developed and perfected some \$12,000,000 worth of new machines during the past ten years. They condition the Gillette blade far more delicately and precisely than even the most skilful artisan could sharpen a shaving edge.

Conditions vary. But the Gillette Blade is the one *constant* factor in your daily shave. Gillette Safety Razor Co., Boston, U. S. A.



THE NEW FIFTY-BOX—Fifty fresh double-edged Gillette Blades (10 packets of fives) in a colorful, useful gift chest. Five dollars at your dealer's.

★ **Gillette** ★

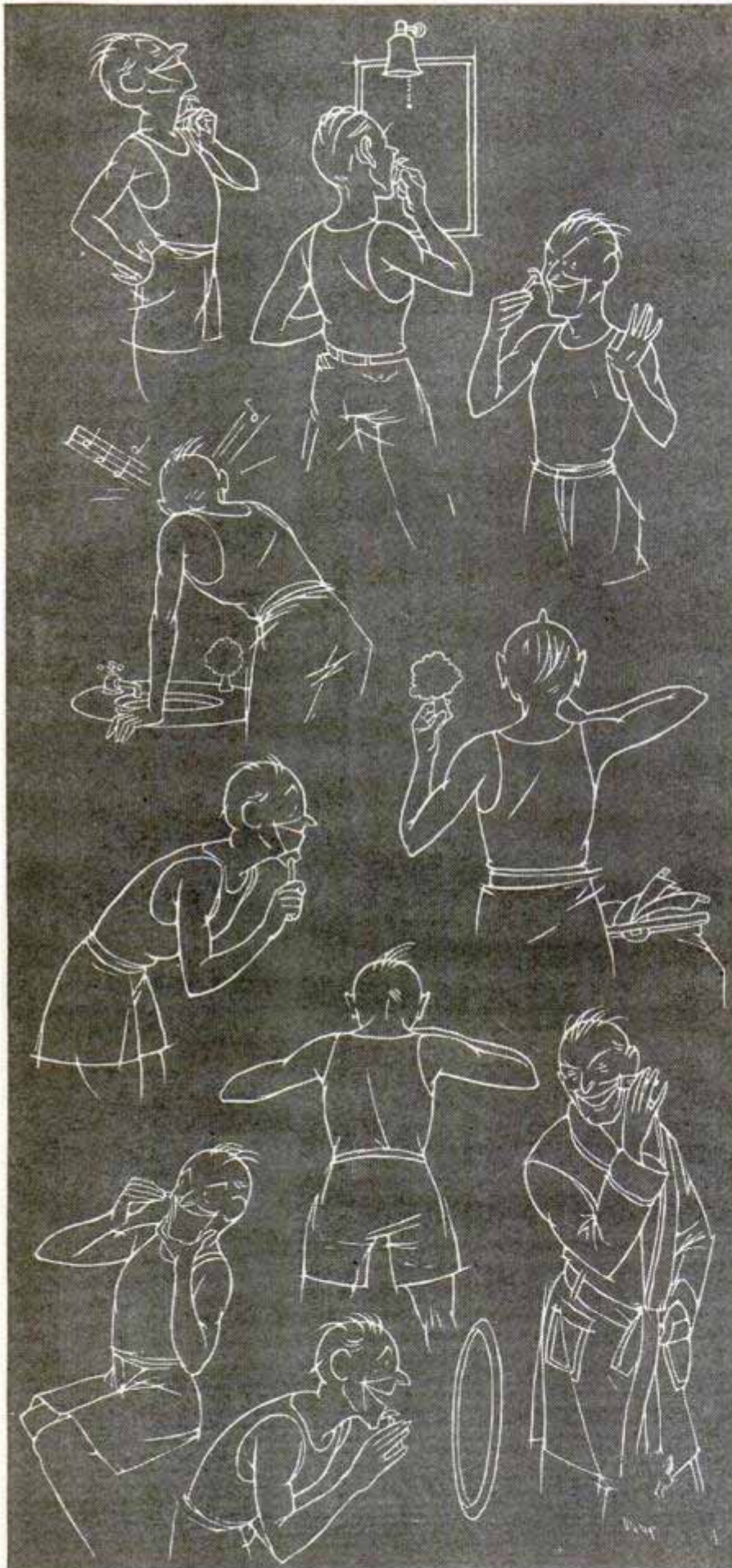

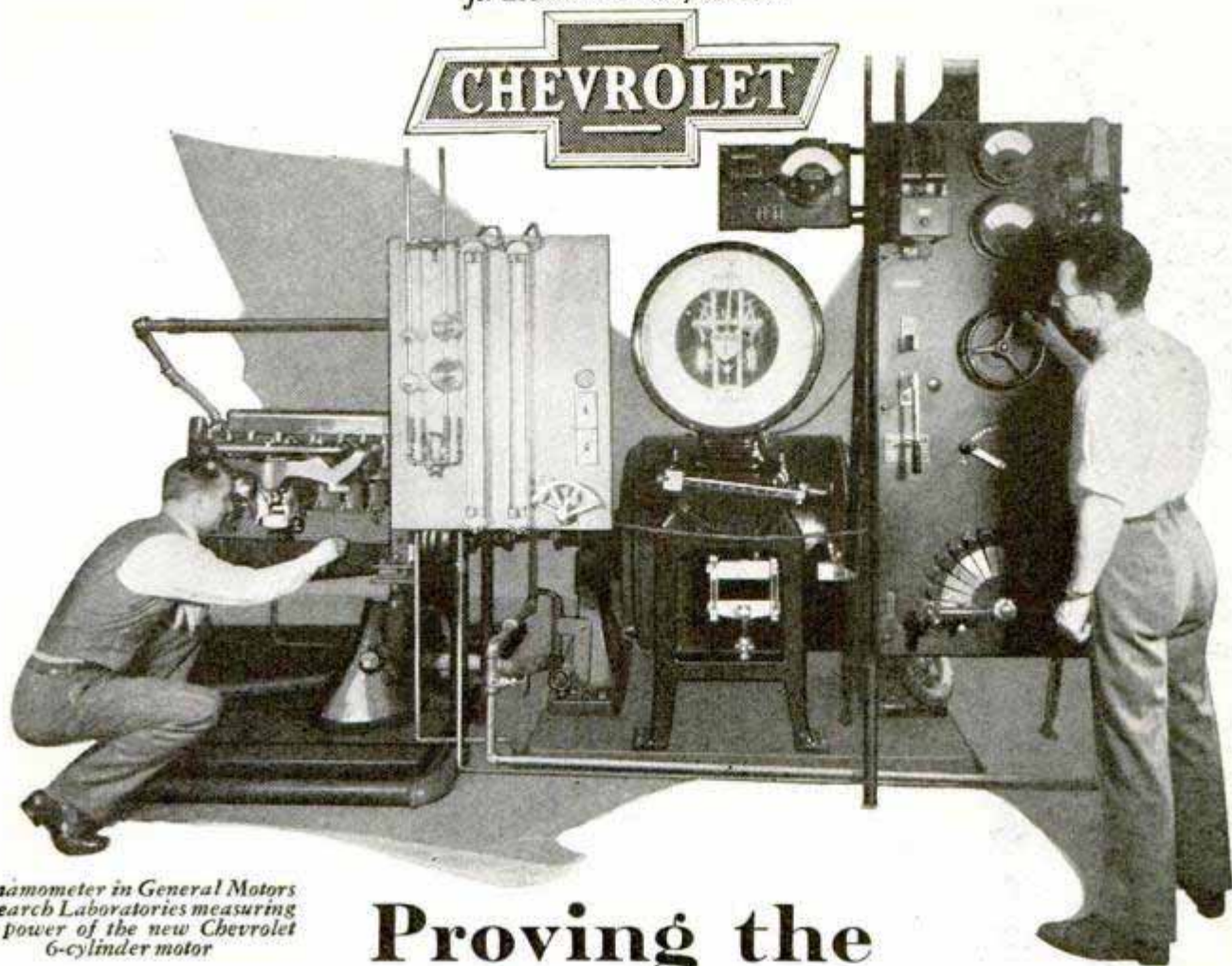
*for Economical Transportation***CHEVROLET**

Dynamometer in General Motors Research Laboratories measuring the power of the new Chevrolet 6-cylinder motor

Proving the

Abundant Power of the New Chevrolet Six-Cylinder Engine

Long before the new Chevrolet was announced, the abundant power of its new six-cylinder engine had been proved hundreds of times in the Chevrolet and General Motors Research laboratories.

In making these power tests, Chevrolet engineers used complicated and marvelously accurate dynamometers that for several years recorded the exact power output of the scores of six-cylinder motors that they designed.

As a result of these tests, combined with many others made in the laboratories and at the General Motors Proving Ground, the present Chevrolet six-cylinder engine was perfected and adopted.

Its abundant reserve power, its smooth operation and its flashing pick-up provide a type of all-round performance that was never before thought possible in a low-priced automobile.

The Roadster, \$525; The Phaeton, \$525; The Coach, \$595; The Coupe, \$595; The Sedan, \$675; The Sport Cabriolet, \$695; The Convertible Landau, \$725; Sedan Delivery, \$595; Light Delivery Chassis, \$400; 1½ Ton Chassis, \$545; 1½ Ton Chassis with Cab, \$650. All prices f. o. b. factory, Flint, Mich.

CHEVROLET MOTOR COMPANY, DETROIT, MICHIGAN
Division of General Motors Corporation

A SIX IN THE PRICE RANGE OF THE FOUR



Where Only the Best Tools Can Stand the Pace

The manufacturer, the foreman and the machinist are the ones who justify the extreme care taken in making Brown & Sharpe Tools.

They know that modern methods of manufacturing lay so much stress upon speed and accuracy that only tools of the high quality which Brown & Sharpe products are known to possess can stand the pace.

Visit your hardware dealer or send us a postcard and get a free copy of our Small Tool Catalog describing over 2300 tools (including Surface Gauge No. 621 illustrated above.)

Address Dept.P.M., Brown & Sharpe Mfg. Co., Providence, R. I., U. S. A.

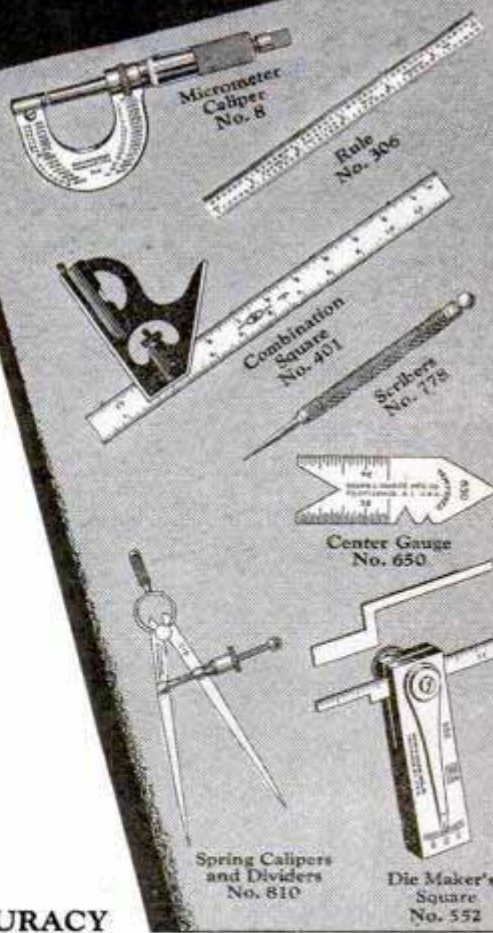
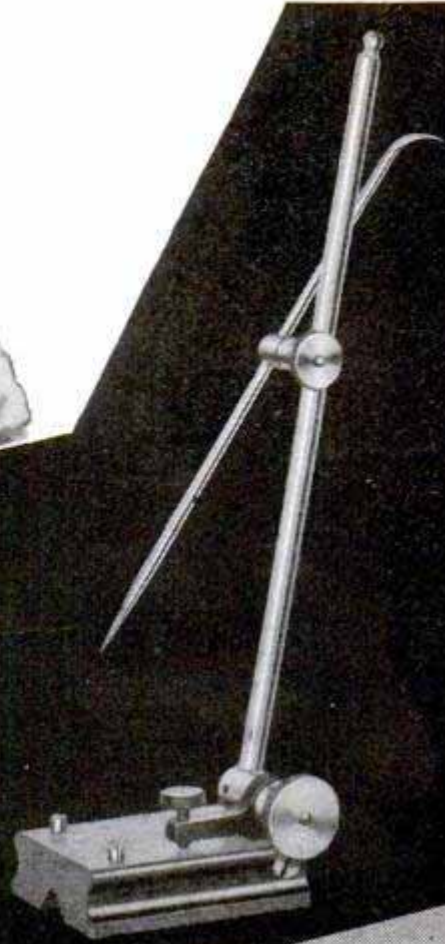

Micrometer Caliper No. 8
 Rule No. 306
 Combination Square No. 401
 Scribes No. 778
 Center Gauge No. 650
 Spring Calipers and Dividers No. 810
 Die Maker's Square No. 552

WORLD'S STANDARD OF ACCURACY

BROWN & SHARPE TOOLS

A row of "Knock-Fighters"

The little bottle on the extreme right contains less than a teaspoonful of Ethyl fluid, the active ingredient of Ethyl Gasoline. Yet this small amount is as effective as the much larger quantities of the other chemicals.

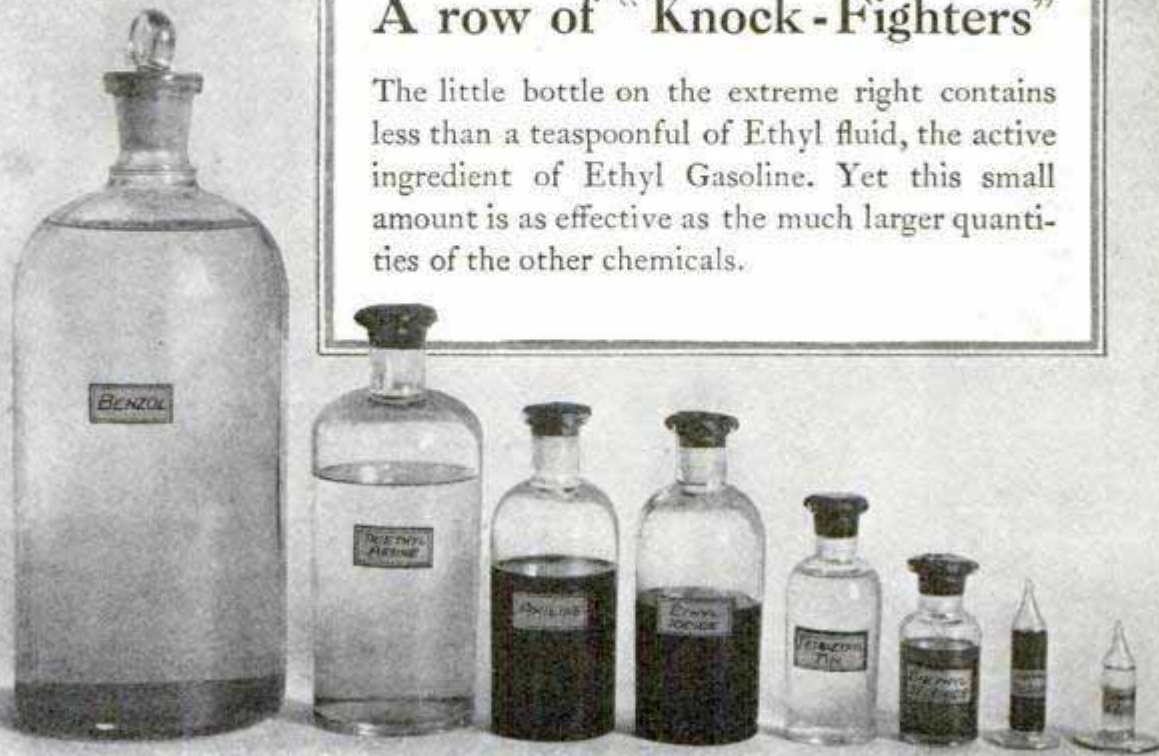

The Steps to High Compression Performance

THOUSANDS of chemical combinations were tested in the General Motors Research Laboratories to see whether they would eliminate the fuel "knock" in gasoline engines which was retarding the advancement of high compression engines. In the picture above are a few of the compounds that had anti-knock value. They illustrate the gradual

progress toward more and more effective elimination of the "knock."

The little bottle on the right contains Ethyl fluid, which is the active ingredient in Ethyl Gasoline. It is the most effective of them all. The amount in the little bottle is equivalent in anti-knock value to the amount of other chemicals contained in the larger bottles.

It is so effective that even a teaspoonful added to a gallon of gasoline makes Ethyl Gasoline—the standard high compression fuel which has made possible the new high compression cars. And it also brings out the maximum performance of which cars of average compression are capable.

Ride with Ethyl today.

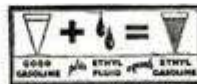

Knocks out that "knock"

ETHYL GASOLINE CORPORATION
25 Broadway, New York City
56 Church Street, Toronto, Canada
36 Queen Anne's Gate, London, England



ETHYL GASOLINE

© E G C 1929

"How we Blackfeet were saved

*in the year of the
Big Snow"*



"ONE winter we came near starvation. Our braves hunted over the plains for the frozen heads of buffalo they had killed early in the fall. They chopped the skin from the tops of the heads and our mothers cooked it for food. We were saved by finding a herd of mountain sheep which had been driven down into the foothills by the big snow. We slew the entire herd and ate them on the spot. On many occasions like this, our lives depended on the endurance of our

*Told by
Buffalo Child Long Lance:*

Blackfoot Indian Chief. Trick rider with Buffalo Bill. Tackle, Carlisle football team. Captain, World War (wounded, decorated for bravery). Author of "Long Lance."



legs and feet in hunting game for food.

"In our primitive life nothing was more important than our feet. I wonder if the white race would not be sturdier if they took better care of their feet in childhood—by wearing shoes that allow free exercise of the foot and leg muscles.

"As for myself I always wear rubber-soled canvas shoes on the stiffest climbing and the longest hiking I do, whenever the weather permits. They are most like moccasins in strength-building of any modern shoe."

By Lance

Modern Goodrich Sport Shoes are scientifically made to protect the foot against injury without stopping muscular development.

The moccasin-grip instep prevents flat feet. The hard-gripping soles and heels prevent slipping and body jarring on hard ground. Goodrich Sport Shoes come in 20 snappy models to suit particular men, boys and girls. Demand them by name—be sure of getting the best that Indian lore and modern science offer you. The B. F. Goodrich Rubber Co., Akron, Ohio; Pacific Goodrich Rubber Co., Los Angeles, Cal. In Canada: Canadian Goodrich Co., Kitchener, Ont.

The Pontiac. Stylish light grey with snappy-looking dark grey "saddle."

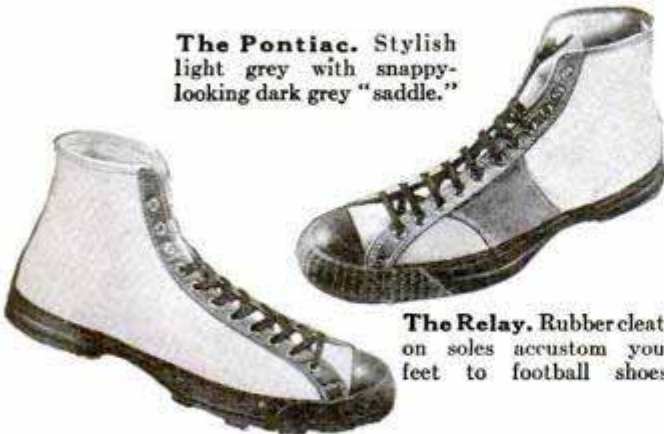

The Relay. Rubber cleats on soles accustom your feet to football shoes.

Goodrich *Sport Shoes*

The New Pontiac Big Six is a big car *mechanically*

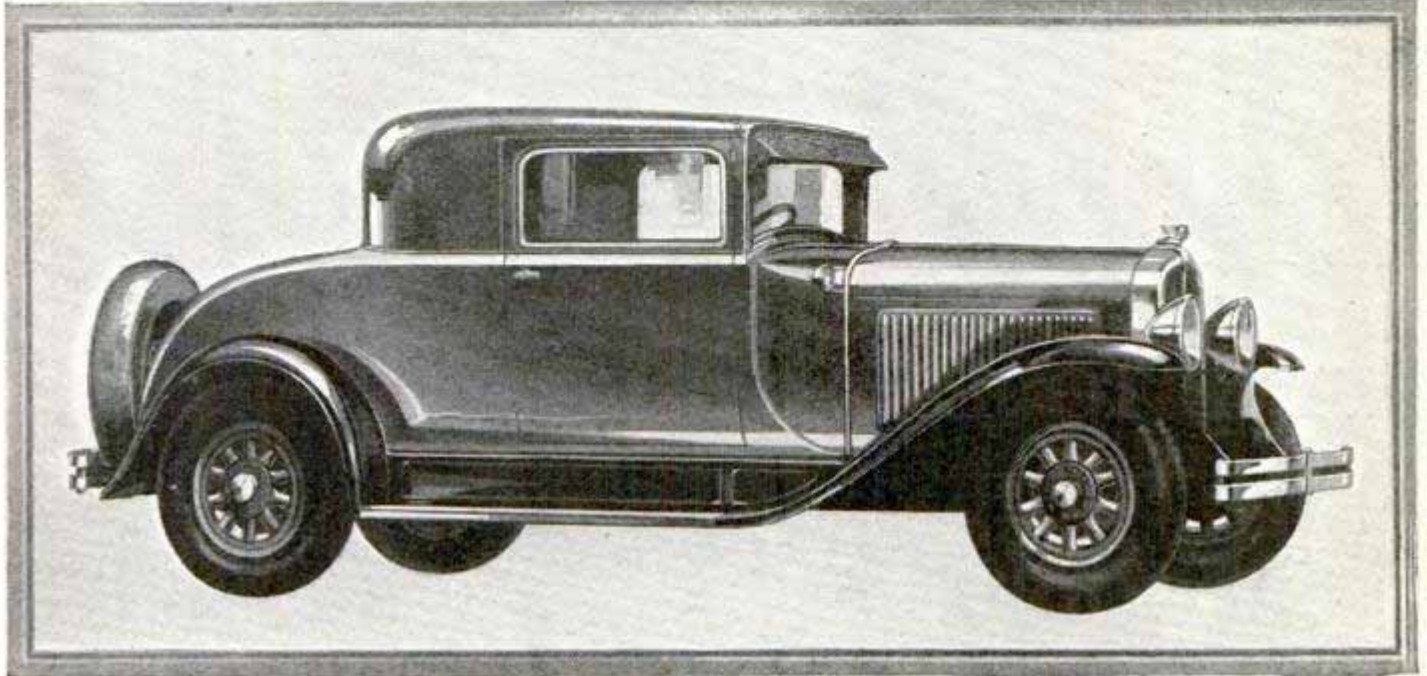

The Coupe + Body by Fisher

Give an automobile an engine, carburetion, ignition, transmission, axles and wheels and it will run. But not with big car smoothness, silence and speed. The New Pontiac Big Six offers big car performance because it is a big car *mechanically*.

Take its engine, for example. It is a big, simply-constructed L-head engine. But the noises of combustion are practically eliminated by means of the G-M-R cylinder head which minimizes knocks and thump even when ordinary gasoline is used. Torsional vibration in the crankshaft is counteracted by the Harmonic Balancer. Additional smoothness is attained by the accurate balance of all rotating parts. Big car power, speed and pick-up are achieved with the aid of a 1¼-inch carburetor, perfected to include such advancements as an accelerating pump for added snap on the getaway.

A thorough examination will show you that the New Pontiac Big Six is a big car in every desirable respect. That's why it enables you to *step up* the quality of your automobile without leaving the low-priced field.

Pontiac Big Six, \$745 to \$895, f. o. b. Pontiac, Michigan, plus delivery charges. Bumpers, spring covers and Lovejoy shock absorbers regular equipment at slight extra cost.

OAKLAND MOTOR CAR COMPANY, PONTIAC, MICHIGAN



Consider the Delivered Price as well as the List Price when Comparing Automobile Values. Oakland - Pontiac delivered prices include only reasonable charges for delivery and financing.

The New PONTIAC BIG SIX

PRODUCT OF

\$745
CASH PRICE

GENERAL MOTORS

C & L 32

This is one of the most popular blow-torches we have ever made. It is more expensive than the 158 because it is made for much harder use. It is designed for the man who uses a blow-torch in his daily business and demands not only excellent performance but rugged ability to stand rough handling. 32 contains the most advanced, patented C & L blow-torch improvements. It also has a gold-banded red handle. Sure sign of satisfaction.

IS THE FEELING FOR FINE TOOLS IN YOUR BLOOD?



Do YOU get a real kick when you pick up a good tool? One that makes working a real pleasure? That makes you want to stick at the job? Well, be set to feel that way when you take up a Clayton & Lambert blow-torch.



In a Clayton & Lambert you buy all the exactness and pride that can be put into a blow-torch. You get materials that have proved their value by use. You obtain the result of 40 years' experiment and invention—exclusive Clayton & Lambert improvements. In construction and mechanism, Clayton & Lamberts are made with an eye for long, efficient service.

For instance—the vaporizing chamber has an exclusive vein system for quicker, hotter heat. That

makes the torch function better and saves money on your fuel bills. All fittings are built into the tank by a patented method that prevents their falling in or coming out. There's *absolutely no danger* of an explosion with a Clayton & Lambert torch. Even the most delicate part—the gas orifice—is fool-proof. In the No. 158 the orifice has a guard. The slightly higher priced No. 32 has a patented control valve so that you'll never ruin the torch by a careless twist of your wrist. And when you close the valve you automatically clean out the carbon.

The next time you're in a hardware or electrical store look for the blow-torch with a gold-banded, red handle. Be sure of the handle—it marks a Clayton & Lambert. But look for the trade-mark too. Then you know you're getting the largest selling torch in the world.



C & L 158

This is especially made for the man who likes to do odd jobs around the house, or to tinker with mechanical things. It will last a lifetime if it is not abused. The price is about five dollars.

CLAYTON & LAMBERT

MANUFACTURING COMPANY
Detroit, Mich.

New Model SOUTH BEND LATHES

BACK GEARED SCREW CUTTING LATHES

LATHE BUILDERS FOR 22 YEARS — 43,000 LATHES IN USE



Weight 375 lbs.

9" x 3' Junior Back Geared Screw Cutting Bench Lathe with Countershaft and Equipment **\$155**



Prices of 9-inch Junior Bench Lathes

Size of Lathe	Including Shipping Weight	Lathe Equipment Counter-Shaft Drive	Horizontal Motor Drive
9" x 3'	375 lbs.	\$155.00	\$226.00
9" x 3 1/2'	400 lbs.	160.00	231.00
9" x 4'	425 lbs.	165.00	236.00

EASY PAYMENTS
as Low as \$12.40 a Month

Our Easy Payment Plan allows you to install a South Bend Lathe in your shop, by making one payment with the order; the balance to be paid month by month, the amount depending upon the size of lathe.

Write today for Catalog No. 89-P which describes Easy Payment Plan. Mention size of lathe desired.

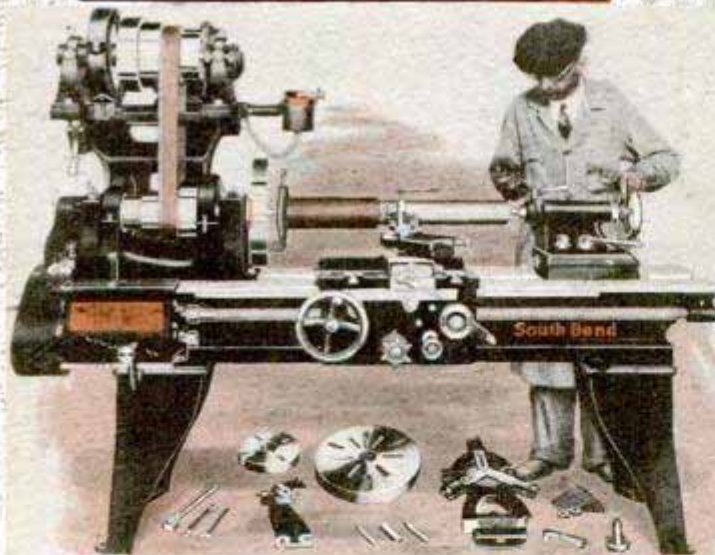

18" x 8' Quick Change Gear Silent Chain Motor Driven Lathe.....\$908.00

Prices of Popular Sizes of Quick Change Gear Lathes with Equipment

Size of Lathe	Shipping Weight	Counter-shaft Drive	Silent Chain Motor Drive
9" x 3'	490 lbs.	\$270.00	\$371.00
11" x 4'	725 lbs.	335.00	455.00
13" x 5'	1110 lbs.	402.00	537.00
15" x 6'	1550 lbs.	490.00	643.00
16" x 8'	2035 lbs.	570.00	725.00

For the
Manufacturing Plant
Tool Room
General Repair Shop
Machine Shop
Service Station
Electrical Shop
Engineering Shop and Laboratory

Used by Manufacturers of
Automobiles
Electrical Parts Machinery
Aircraft
Textile Machines and Government Departments
National and State

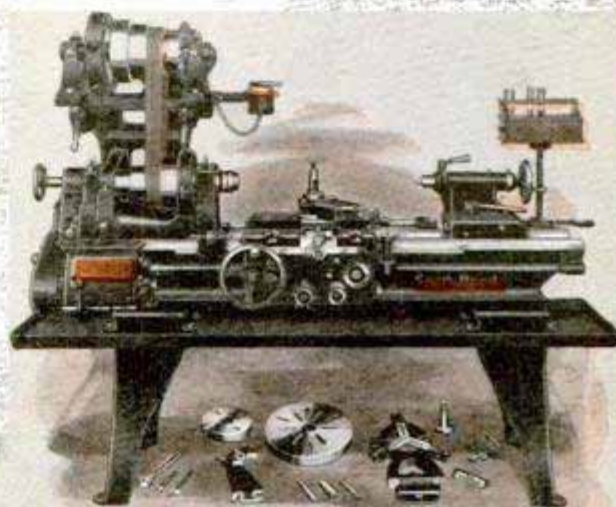

16" x 6' New Model South Bend Silent Chain Motor Driven Tool Room Lathe.....\$695.00

96 Sizes and Types
 Countershaft Driven Lathes, Motor Driven Lathes, Quick Change Gear Lathes, Standard Change Gear Lathes, Tool Room Lathes, Gap Bed Lathes, Brake Drum Lathes and Bench Lathes.

New Free Catalog No. 89-A
 Illustrates and describes the New Model South Bend Lathes in various Types and Drives. A copy will be mailed free on request. Write for it.

South Bend LATHES

Catalog No. 89-A

SOUTH BEND LATHE WORKS

605 E. Madison Street, South Bend, Ind., U. S. A.

Gentlemen: I would like your net factory price on a Screw Cutting Lathe, Size _____ for (check kind of work)

Manufacturing Machine Shop Garage

Electrical Work Catalog No. 89-A Catalog No. 89-P

Name.....

Address.....

City.....

State.....

Send free

South Bend Lathe Works

605 E. Madison St., South Bend, Ind., U. S. A.
 New York, J. E. Beggs Co., 183 Center St. Chicago, C. B. Burns Mach. Co.

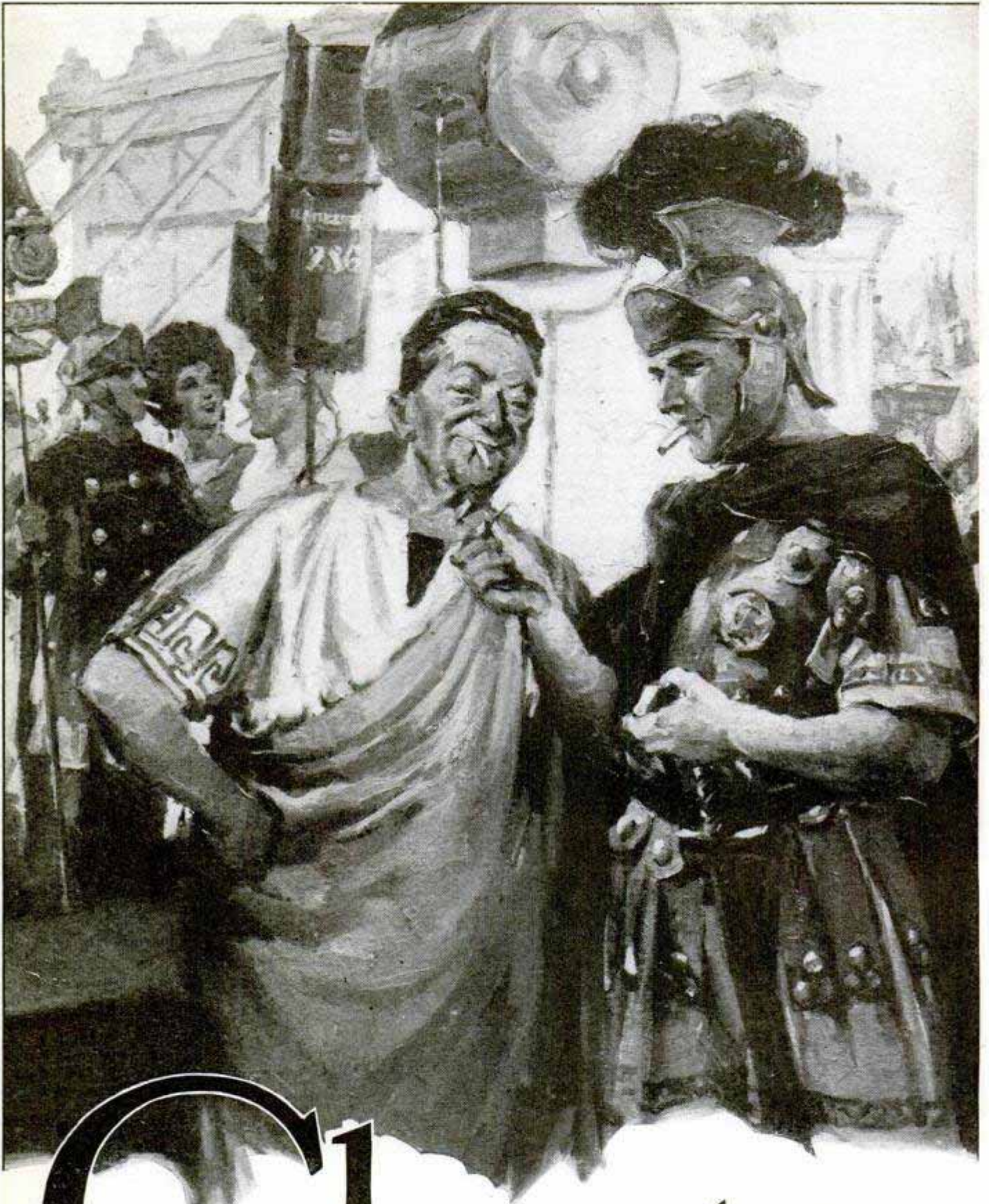

Chester

MILD enough for anybody

What a cigarette meant there

The actors play their part— and history moves thrillingly across the silver screen. But on the movie lot, how tense the days of strain! And how gratefully welcomed those hard-won moments that mean rest, relaxation... and a cigarette!

What a cigarette means here

They play their part, too— these buyers of Chesterfield tobacco.

Thousands of pounds auctioned each day; distinct types of leaf—twenty grades of "bright" tobacco alone, important distinctions of curing; differences in texture, color, size, in the natural sugar which means natural sweetness — and Chesterfield quality to be maintained.

Our buyers do their part. In New York or Manila, Paris or Alaska, our billions of Chesterfields taste the same. The same wholesome fragrance, the same natural mildness, the same satisfying "body," because our buyers know exactly what they want—and whatever it may cost, they get it!

Liggett & Myers Tobacco Co.



field

.... and yet **THEY SATISFY**

Typical scene in tobacco auction warehouse, where the farmer's work ends and the manufacturer's begins.

Pipe jurors Attention!

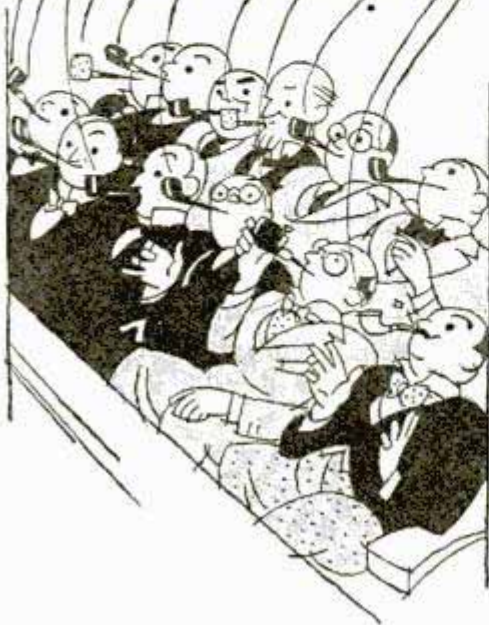

IF you want to give your favorite pipes a fair trial, start them all at scratch with Sir Walter Raleigh's favorite smoking mixture. It's milder than most, it's rich and mellow, and its fragrance is kept fresh by the heavy gold foil that lines the tin. Let Sir Walter show you how good *your* pipe can be.

LIMITED OFFER (for the United States only)
If your favorite tobacconist does not carry Sir Walter Raleigh, send us his name and address. In return for this courtesy, we'll be delighted to send you without charge a full-size tin of this *milder* pipe mixture.
Dept. 178, Brown and Williamson Tobacco Corporation, Louisville, Kentucky



SIR WALTER RALEIGH

Who discovered how good a pipe can be

It's



milder

Thompson
BEATS
the World
on BOATS

THOMPSON
BOATS

CATALOG
FREE!



OUTBOARD MOTOR BOATS—A complete line of strictly up-to-date racing models. Also some entirely new models for general pleasure use with speed of a racer. Built strong, staunch and durable, and absolutely safe.

Rowboats
\$44.00
and up—



The most complete line ever offered, at real money-saving prices.

Canoes
\$48.00
and up—



Some all wood, others canvas covered. Light, swift, safe, strong and durable. Choice of many distinctive color combinations.

Motor Boats



With or without Engine. Fast, handsome craft at money-saving prices.

CATALOG FREE — SAVE MONEY — ORDER BY MAIL
Please state the kind of boat you are interested in (30)

→ TWO LARGE FACTORIES ←
THOMPSON BROS. BOAT MFG. CO.

213 Ann St.
PESHIGO
WISCONSIN

(Write to
Either Place)

113 Elm St.
CORTLAND
NEW YORK

ELECTRIC
LIGHTS
ANYWHERE

Also runs Household Electrical Appliances. Install it yourself. Write for circular.
D. W. ONAN & SONS \$14750
6 Royalston Ave.
Minneapolis, Minnesota.

110 Volt—complete plant with all Wiring, Fixtures and Lamps for 7 rooms \$147.50, Direct-To-You.

Ideal for Farms, Camps, Summer Homes.



New Food Idea Pays Big Profits!

Men! Women! Investigate the wonderful NEW Brown Bobby GREASELESS Doughnut. Sells like wildfire! You can easily make \$50 week spare time; \$5000 to \$8000 year full time. Investment small! No experience needed. Write today for big special offer.
Food Display Machine Corp., Dept. 1355, 500-510 N. Dearborn St., Chicago

8" **SAW OUTFIT** \$35
COMBINATION F.O.B. Phila.

OUTFIT includes necessary attachments to rip, cross-cut bevel, grind, mitre, groove, sand, mortise, tenon, and polish. Table tilts to 45° angle. Base for saw and motor makes it portable.

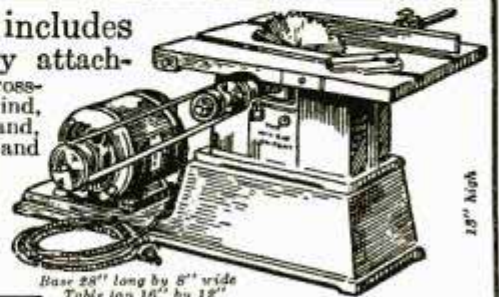

Base 28" long by 8" wide
Table top 16" by 12"

Send 10c in stamps for Catalog giving details of Saw, Bench Lathes, Complete Workshop and other Hardware Specialties. With it you'll receive a credit slip of \$1.00 toward purchase of Saw.

Makes 2 1/4" cut. 1/2 H. P. double extension shaft motor. Complete ready to plug into any light socket.

THE WILBAR CO., Inc.
2020 E. Arizona St., Phila., Pa.

Thrills of a Dozen Sports in One!

MOTORCYCLING—sport of sports! Zoom of airplane, soaring flight of skis, glorious freedom of sailing, thrill of racing speed—they are all yours to enjoy when you are astride a Harley-Davidson.

Whether you ride the "45" Twin shown in the picture, or a champion Big Twin, or a thrifty Single—all the multi-thrills of motorcycling are yours, at a cost so low it will never worry you.

Let your Harley-Davidson Dealer show you the 1929 Models, and explain his Pay-As-You-Ride Plan. Get our free illustrated literature — Mail the Coupon.

This model is our "45" Twin, a wonderful performer that sells at only \$290 f. o. b. factory.

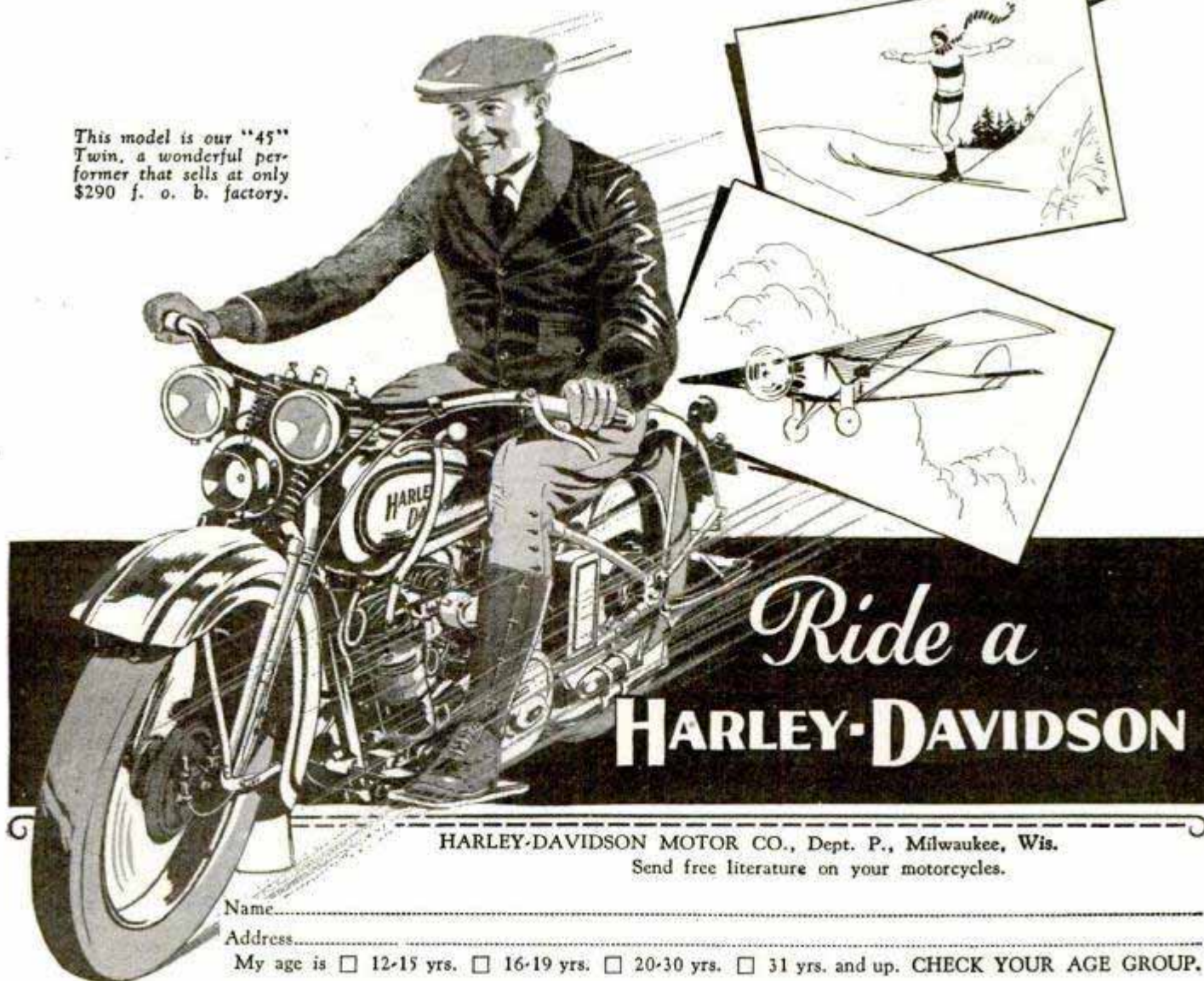

Ride a
HARLEY-DAVIDSON

HARLEY-DAVIDSON MOTOR CO., Dept. P., Milwaukee, Wis.
Send free literature on your motorcycles.

Name.....

Address.....

My age is 12-15 yrs. 16-19 yrs. 20-30 yrs. 31 yrs. and up. CHECK YOUR AGE GROUP.



Ownership

You're proud to possess PEXTO tools. Built by a manufacturer with 110 years' experience . . . who knows how! They'll be just as good tomorrow and for years as they are today. That's why it "Pays to Say Pexto."

It's a complete line, too . . . just about everything that you'll ever need. We'd like to send you booklet "M", and then the next time that you're in a hardware store, ask the man at the tool counter to show you PEXTO. You'll find worth while

- | | | |
|----------|---------------|----------------|
| HAMMERS | SCREW DRIVERS | SQUARES |
| WRENCHES | PLIERS | BRACES |
| CHISELS | SNIPS | PRUNING SHEARS |

"IT PAYS TO SAY PEXTO"

The Peck, Stow & Wilcox Co.

Southington, Conn., U. S. A.

A REAL Machine

Latest design on market

NOT A TOY

Weight 480 lbs.



Ball Bearing Throughout

The Electric Carpenter Runs from any Light Socket

New and better! For the Home Craftsman who wants to do accurate work . . . for the man who wants to get into business for himself making screens, cabinet work, mill work, etc. Saws 3 1/4" thick. Rips 12" wide. Lathe swings 10". Rugged cast-iron frame; no warping, twisting, or vibration.

- | | | |
|--------------------------|-----------------|--------------------|
| 7 Machines in One | 8" Circular Saw | Reversible Shaper |
| | 14" Band Saw | 1/2" Hollow Chisel |
| | 36" Lathe | Mortiser |
| | 10" Swing | Sander |
| | 4" Jointer | |

Does 35 Woodworking Operations

Write today for New Folder P-59

We also build a complete line of single-purpose machines

THE WOODWORKING MACHINERY CO., INC.
Eleventh and Vine Sts., Philadelphia, Pa.

CLASS PINS 35¢
FREE CATALOG SHOWING 200 DESIGNS
EITHER DESIGN SHOWN. SILVER PLATE 35¢ EA.; 12 OR MORE, \$3.50 DOZ.; STERLING SILVER OR GOLD PLATE, 50¢ EA.; 12 OR MORE, \$5.00 DOZ.; 1 OR 2 COLORS ENAMEL, ANY 3 LETTERS AND DATE.
BASTIAN BROS. CO., 893 BASTIAN BLDG., ROCHESTER, N. Y.

\$21¹⁵ A WONDER!

10" swing, 25", 35" and 45" centers. Weight 60 lbs. Biggest lathe value yet. Send 6c for 32 page catalog on lathes, saws, etc. Largest line of small lathes in America.
SYPHER MFG. CO. Dept. D TOLEDO, OHIO

MAKES A COMPLETE MACHINE SHOP
The New Improved EVERY-USE Electric Motor Attachment
\$1⁷⁵

Fastens directly on motor shaft, no pulleys or belts necessary. Holds grindstones, buffs, saws, wire scratch brushes, drills, etc. Serves as pulley. Made to fit 3-8, 1-2 and 5-8 inch shafts.

Without Chuck, \$2²⁵
With Chuck

State size. Postage prepaid if remittance accompanies order.
United Electric Motor Co.
178 Centre St., Dept. C-5, New York

They need Starrett ACCURACY and DEPENDABILITY too



The same quality of materials and workmanship that has made Starrett Tools the universal choice of expert machinists and carpenters has made Starrett Tapes and Transits and Levels equally popular favorites.

Your tool dealer has a Starrett Tape, Transit or Level that meets your exact requirements. Ask to see them. Let us send you a free copy of Starrett Catalog No. 24 "AP."

THE L. S. STARRETT CO.

*World's Greatest Toolmakers
Manufacturers of Hacksaws Unexcelled
Steel Tapes—Standard for Accuracy
ATHOL, MASS., U.S.A.*



The Starrett No. 530 Steel Tape in handsome black imitation leather case. Well made, strong, surprisingly low in price.



Wood leveling rod and target.



This chap is using a Starrett No. 99F Transit, an exceedingly simple, practical transit anyone can use at a very moderate price.



Starrett No. 132 Bench Level with Double Plumbs.



Use Starrett Tools



**“Lava-clean”
hands
are
clean!**



Men—you who love to tinker—here's just the soap you need. Cleans quickly and thoroughly the toughest-looking pair of hands that ever fussed around a work bench. Makes more lather in 15 seconds than ordinary soap in 60, and even hard or cold water won't discourage it. Millions use it. “Good old Lava,” they call it. Gets hands *clean!* Not just “surface clean,” but clean 'way down deep. As easy on your hands as fur-lined gloves—because it's made from the finest of vegetable oils. All grocers sell it.

Full size cake of Lava Soap FREE!

Mail this coupon

Procter & Gamble (Dept. W-529)
Cincinnati, Ohio

Please send me, FREE, a full size cake of LAVA, the hand soap that removes *all* the dirt and grease.

Name.....
Street.....
City.....
State.....

“OUT-OF-WAY” Iron Cord Holder

Illinois woman invents useful household utility to keep cord out of way while ironing. So simple and convenient all of her neighbors wanted one. Patent pending and now available to everyone. A real “Gold Mine” and big money maker for agents. Pays \$30 to \$50 daily. No real competition. Write for sample and agency proposition today. Exclusive Territory.



HOME SPECIALTIES
Dept. C-1 Aurora, Illinois



BOYS!—now you can own a real 100 POWER MICROSCOPE

Study wonders of insect, plant and other unseen worlds! Invaluable to amateur scientists, students of physics, botany, chemistry, etc. A real, professional microscope with imported lens and mirror, complete with case. Save money... buy direct—money back if not absolutely satisfied after 30 day trial. Send check, money order or cash. Catalog free.

for only **\$5.50**

Apparatus Engineering Co.

Dept. D

2006 Chestnut St. Philadelphia, Pa.



It's Easy

YOU PLAY tunes the first day with an easy-playing Conn instrument and the fascinating new instruction methods. No long drudging over scales. Conn gives you the exclusive features found in no others. Choice of famous artists. **FREE TRIAL, Easy Payments.** Write now for literature; mention instrument. **C. G. CONN, Ltd.,** 531 Conn Bldg. Elkhart, Ind.



AGENTS 500% PROFIT
GENUINE GOLD LEAF LETTERS

S guaranteed to never tarnish. Anyone can put them on stores and office windows. Enormous demand, large profits. Paul Clark says: Smallest day \$28.70. R. L. Reel made \$920 in two months. Write today for free sample and liberal offer to general agents. **METALLIC LETTER CO. 433-B N. Clark St., CHICAGO**

PANTS MATCHED

TO ANY SUIT—FREE SAMPLE

DON'T DISCARD YOUR OLD SUIT. Wear the coat and vest another year by getting new trousers to match. Tailored to your measure. With over 100,000 patterns to select from we can match almost any pattern. Send vest or sample of cloth today, and we will submit FREE best match obtainable.

AMERICAN MATCH PANTS CO.
Dept. F. N. 6 W. Randolph St., Chicago, Ill.



Complete Outfit \$9.65

PAINT WITH AIR
New Simplified Easy Way!

with improved Payntgun! Quickest, easiest way to paint ever discovered. Anyone can put perfect smooth brilliant surface on car, furniture, woodwork, etc., with lacquer, varnish, paint or enamel. No experience needed—years of painting skill built into the Payntgun. New exclusive features cut painting time in half. Sturdily built—compact—convenient. Powerful spray specially designed for easy sure control. Turns painting jobs into play. Fully guaranteed.

FREE Folder on Skillful Home Painting—Write for yours today!

HAYWOOD EQUIPMENT COMPANY
2345-G Ogden Avenue, CHICAGO, ILL.



AGENTS WANTED

PARKS

WOODWORKING MACHINES

Cabinet Shop
Special No. 10

\$290

With Motor

You ought to have this handy Parks in your shop. Compact, complete machine designed like a big production outfit at 1/2 the cost. Floor space required only 42x72 in. Does any kind of cabinet and joinery work. Write for circular.

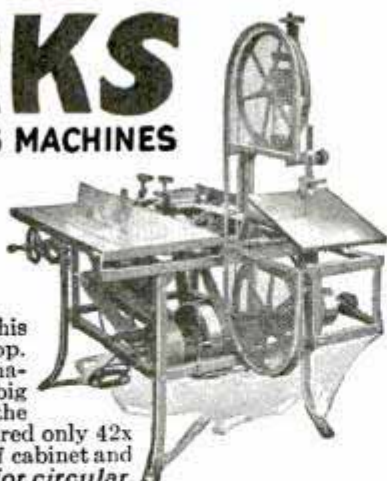

The Parks Woodworking Machine Co.

1500-40 Knowlton St. Cincinnati, Ohio

Canadian Factory: 338 Notre Dame East, Montreal



FREE CATALOG!
GERSTNER Better Made
TOOL CHESTS
are the Choice of Toolmakers and
Machinists.

Write to-day for catalog.

Gerstner & Sons

465 Columbia St., Dayton, Ohio

SALESMEN WANTED!

SELL COX HOLDFAST SCREW DRIVERS

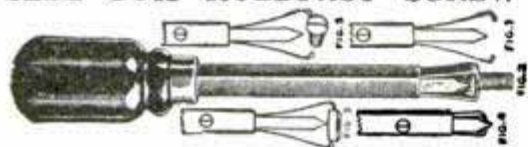

Sells on sight to mechanics for Auto, Radio and Electrical Work. Self Holding, Self Releasing.

Send 50c for sample and ask how to get Salesman's Outfit Free.
S. J. COX Dept. F, FRANKLIN, PA.

Engines & Motors Big Catalog No. 30

Illustrating Electrical, Mechanical and Model Maker's Supplies, Small Steam & Gasoline Engines, Motors, Generators, Lathes, Drill Presses, Bench and Band Saws, etc., 16-32 & 64 Watt Dyna-Motors, School Projects, Engine Castings, Motor Parts, etc., Books, Blue Prints, Brass and Steel Tubing, Gears, Pulleys, Hangers, Experimental Material.

Send for Copy, Mailed anywhere for 10 cents, refunded first order.
LOOMIS ELECTRIC & MFG. CO., 2822 N. CALIFORNIA AVE., CHICAGO, ILL.

The Handy Tool - Torit Torch "23"

Uses acetylene only from a Presto auto tank. Finest thing you ever saw for Radiator and Battery Repairing, Soldering, Light Brazing, Heating, etc. Complete with 4 tips, soldering copper, hose, connections. PRICE (except tank) **\$7.50**

ST. PAUL WELDING & MFG. CO.
177 W. THIRD ST. ST. PAUL, MINN., U. S. A.



Makes Old Ford a Tractor

Now you can convert that old Ford car into a useful farm tractor without altering any Ford parts. We furnish the traction wheels, drive gears and auxiliary axle and mountings, ready to clamp on to the Ford frame. Pulls 16" plow.

Write for Free Particulars.
Shaw Mfg. Co., Dept. PM5, Galesburg, Kan.



ATKINS SILVER STEEL SAWS

for Your Workshop

It will pay you to select ATKINS Saws when you start a home-workshop or need new tools. Only in ATKINS Saws do you get the world-famous "Silver Steel" which takes a sharper cutting edge and holds it longer. Ask your Hardware Store, or write us about these ATKINS Saws for home workshops. Three booklets sent free.

Finest saw made. Silver Steel. Ship Point blade. Perfection handle; no wrist strain.

ATKINS
No. 400 HAND SAW
SHIP POINT



ATKINS
JUNIOR MECHANIC
HAND SAW



Handy, high-grade saw for boys or men. 30-inch polished blade. Straight or skew back.

This Back Saw has Right Silver Steel blade, Apple-wood handle. 8 to 18 inch.

ATKINS
No. 2 BACK SAW



ATKINS MACHINE KNIVES



Knives for small workshop machines, up to the largest machine knife cutting job.

Nickel steel adjustable frame. Non-Breakable or Silver Steel Blue-End Blades.

ATKINS
No. 10 HACK SAW



ATKINS
No. 0 SCRAPER



"Silver Steel." Makes the best Scraper you ever used. Holds its edge. All sizes.

Silver Steel Narrow Band Saws for small machines. All lengths and widths.

ATKINS
BAND SAWS



ATKINS
CIRCULAR SAWS



Circular Rip Saws for fast, accurate work on any machine. Made of "Silver Steel."

A perfect file for every purpose. Silver Steel does your filing jobs faster and easier.

ATKINS
SILVER STEEL FILES



ATKINS
GROOVER OR DADO HEADS



The simple, easy way to cut grooves from 1/8" to 4" width. Does even, accurate work.

This specially designed saw is ideal for smooth cutting, with or across the grain.

ATKINS
M-KAM TOOTH CIRCULAR SAW



ATKINS
CIRCULAR MITRE SAWS



This Mitre Saw is for fine, smooth cabinet work. It planes as it saws. Silver Steel.

Circular Saws in many sizes for metal cutting machines. Insure fast, clean work.

ATKINS
SAWS FOR METAL CUTTING



E. C. ATKINS & CO., Est. 1857

426 S. Illinois St., Indianapolis, Ind.

Please send me "Saws in the Home," "Mill Saws" and "Saw Sense," free; also information on your
.....Saws.

Name.....

Address.....

My Dealer is.....

Stanley Hammer Lifts 2 Ton! Automobile!

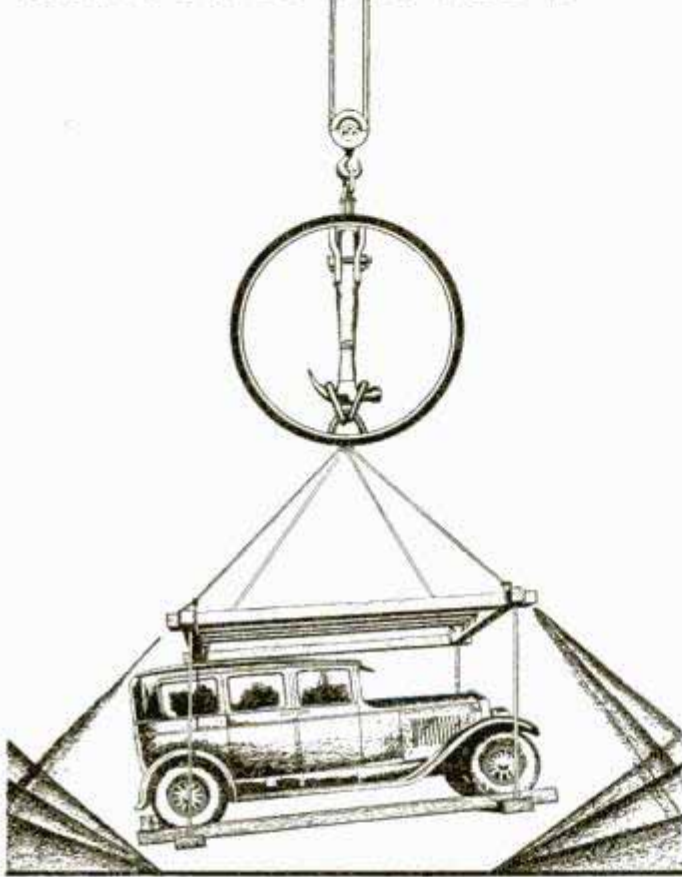

IN a spectacular and convincing test, a Stanley Nail Hammer has proved the fact that its steel head will not come off.

By means of the apparatus shown in the illustration, the Hammer lifted a seven passenger sedan, weighing two tons, from the ground.

A terrific strain! But this hammer is made to stand strain. Its thoroughly seasoned handle of sound young hickory is driven forcibly into the head and fastened with two special wedges. The end of the handle is treated to exclude all moisture, preventing swelling and shrinking.

Your hardware dealer can point out a number of other superior features of Stanley Nail Hammers. Buy one from him. Use it hard and often. You will find it an outstanding tool. The Stanley Rule & Level Plant, New Britain, Connecticut.

STANLEY TOOLS

The Choice of Most Carpenters



FOR SPRING REPAIRING



You have a dozen or more jobs to do about the house and car this spring. Why not equip yourself with *good tools* that will do these jobs quicker and better?

Crescent-Smith and Hemenway tools represent the highest quality in workmanship and design. Every tool is sold with a guarantee of absolute satisfaction or your money back. You are the judge. Ask your hardware dealer for them by name.

CRESCENT TOOL COMPANY

210 Harrison Street, Jamestown, N. Y.

Wrenches
Pliers
Screw Drivers

Chisels
Punches
Auger Bits

Snips
Hack saws
Nippers



CRESCENT and Smith & Hemenway TOOLS

Made under the supervision of and guaranteed by the originators of the Crescent Wrench



Start a Welding and Battery Shop

Outfits sold on the payment plan.

Write for particulars.

Soldering Outfits..... \$8.00
Lead Burning Outfits \$18.00 to \$25.00
Welding Outfits..... \$25.00 to \$69.20
Paint Sprayers..... \$14.00

Welding Supplies of every description

THE SUPERIOR
OXY-ACETYLENE MACHINE CO.
Box 285, Hamilton, Ohio

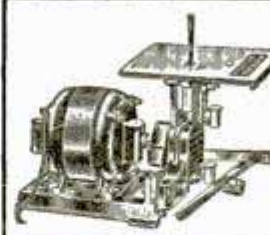

The International Motor Saw

does every sawing job from straight cutting to intricate scroll and design work; crosscuts, rips, miters, bevels, inside and outside jig sawing and scroll cutting. One saw instead of several.

Write for full description. Dept. S,
The International Stamping Co.,
400 N. Leavitt St., Chicago, Ill.

ASBESTOS

All grades of Crudes and Fibres
in large or small quantities

Sold by

KEASBEY & MATTISON COMPANY

Ambler, Pennsylvania

Branches in Principal Cities

AIR-CON UTILITool

THE KING OF THEM ALL

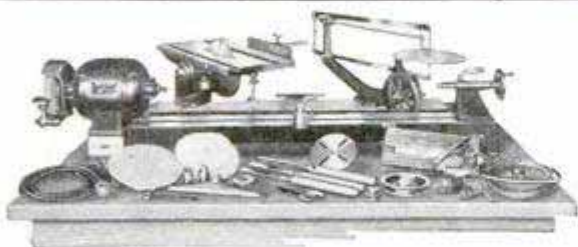

Versatility PLUS

Not only a complete work-shop, but a sturdy, powerful, precision-built work-shop, is the Ar-Con Utilitool.

The heavy, reinforced cast-iron-bed lathe is 31 in. between centers, and is powered by a 1/2 HP, ball-bearing motor of the super-efficient repulsion-induction type. Comes with grinding and buffing wheels and full lathe equipment, including wood-turning tools.

Lathe also serves as foundation unit and motor drive for circular-saw table, jig and scroll saw, and sanding disc and table—all of equally efficient design and sturdy, accurate construction.

You can buy the complete outfit, or any of the units separately, on very easy terms. To obtain complete information merely write your name and address in margin, tear out and mail to

THE AR-CON TOOL COMPANY
500 Fassett Street - - - Toledo, Ohio

OTTAWA LOG SAW



only \$39

GREATEST OFFER
EVER MADE

PUTS THIS
OTTAWA
TO WORK FOR YOU

Make Money! Wood is valuable. Saw 15 to 20 cords a day. Does more than 10 men. Ottawa easily operated by man or boy. Falls trees—saws limbs. Use 4-hp. engine for other work. **30 DAYS TRIAL.** Write today for FREE book. Shipped from factory or nearest of 10 branch houses.

OTTAWA MFG. CO., 1741 -W Wood Street, Ottawa, Kansas



DIE CUT OVAL PRINTS

Something new for kodakers. Send negative with dime for sample and catalog of specialties for kodakers.

FRANK SCOBIE, 43-0, Sleepy Eye, Minn.

BURN YOUR NAME ON TOOLS

WITH THE ARKOGRAF

PROTECT YOUR TOOLS FROM THEFT

Write with electricity any name or design on the hardest and finest tools and instruments, or any metal, like writing on paper with pen or pencil. Complete Outfit \$3.50—Prepaid Anywhere. Interesting illustrated circular free. Write today. Agents wanted.

ARKOGRAF PEN CO., 1171 E. Stark St., Portland, Oregon



SOLDERALL

METAL IN PASTE FORM

The only convenient metal solder



Every Electrical Connection needs Solderall for perfect reception
25¢
The SOLDERALL CO., NEWARK, N.J.

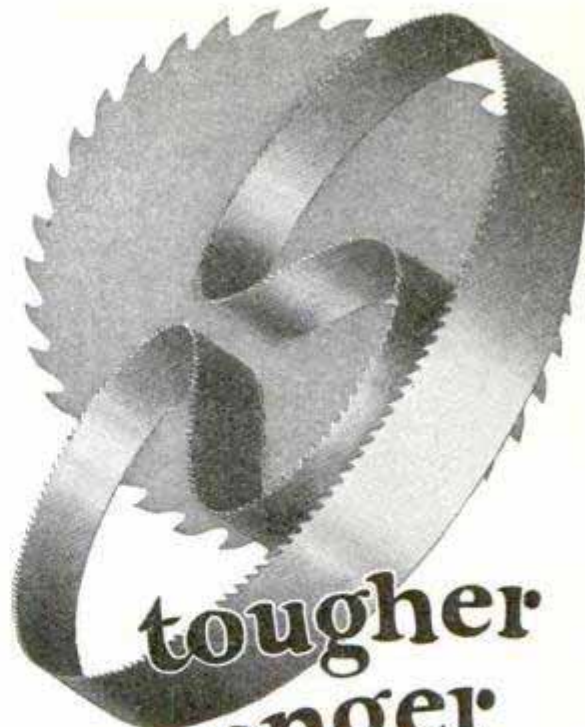

tougher
stronger
steel

makes Simonds Band Saws last longer

ALL over the country industrial plants use Simonds Band Saws because the steel from which these saws are made has unusual strength, toughness and flexibility. The same heat-treated alloy steel—made in Simonds own steel mills—is used in making Simonds Band Saws for home workshop outfits.

Simonds Band Saws are made with the skill and precision associated only with the highest grade cutting tools. The joint is carefully welded—not brazed—and is equally as strong as any other part of the blade. Free booklet on woodcutting saws sent on request. Write for it.

SIMONDS SAW AND STEEL COMPANY

"The Saw Makers" Established 1832
Fitchburg, Mass.

BRANCH OFFICES AND SERVICE
SHOPS IN PRINCIPAL CITIES

SIMONDS
SAWS FILES
KNIVES
STEEL

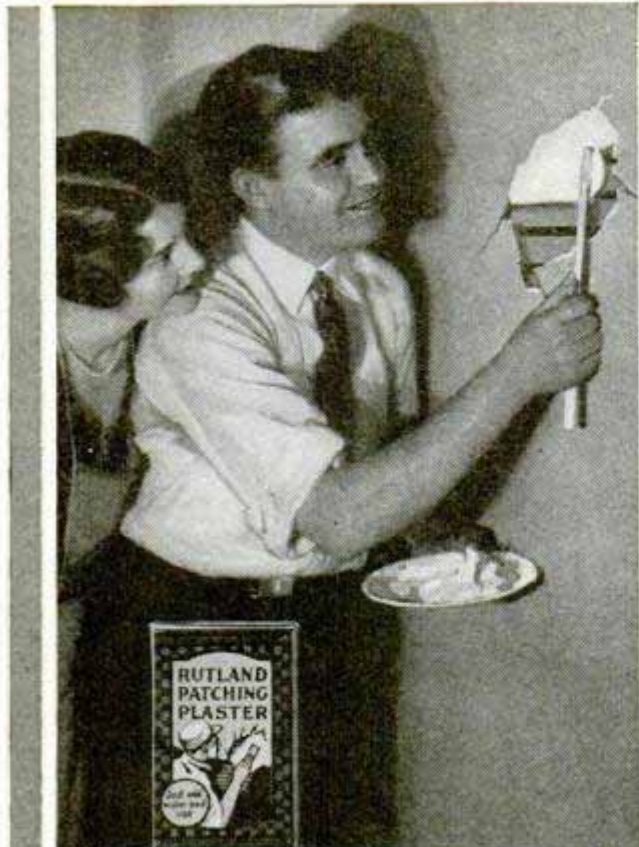

Good as New are cracked walls and ceilings when mended with Rutland Patching Plaster. You can easily do it yourself in a few minutes. Just mix with water, then fill the crack or hole. Makes a *perfect* patch that is as permanent as the wall itself. At all paint, wall-paper and hardware stores. Rutland Fire Clay Company, Rutland, Vermont.

Rutland Patching Plaster

MOVIES AT HOME



Many models of genuine MOVIE MACHINES, some as low as \$3.75, all using standard size big theatre films. Our stock of films is the most complete and lowest in price—with an exchange service. Films of leading stars and religious subjects are available. **DON'T DELAY. WRITE FOR FREE INTERESTING CATALOGUE NOW!**

PARAMOUNT MFG. CO.
Dept. G-15 BOSTON, MASS.



WADE AMATEUR MECHANICS, REPAIR SHOPS, INVENTORS, STUDENTS
BENCH LATHE
A real machine tool for the home work bench—capacity 4" dia. x 12" length. For Metal-Wood-Composition materials. Turning—Facing—Boring—Drilling—Winding—Thread Cutting. Accurate Strong—Quiet—Compact. Slide-rest has travel entire length of bed. Leadscrew inside bed. No. 1 Lathe, plain headstock, \$28.00. No. 2 Lathe, back-gear headstock, \$58.00. Extra for lathes with 18 inches between centers, \$7.00. Complete line of accessories at equally low prices. Write for free catalog.
THE GEROLD CO. Dept. P-52 120 Liberty St. New York

WITTE ENGINES

POWER SAWS AND PUMPER

300,000 In Use All Over the World

LIFETIME GUARANTEE

2-30 H.P.

Engine Builders Since 1870

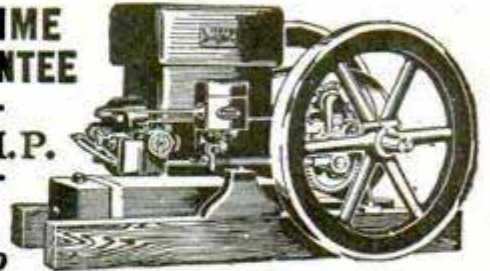

WILL DO ANYTHING A STEAM ENGINE WILL DO —AND AT FAR LESS EXPENSE.

Easy Terms—No Interest—Quick Delivery

WITTE ENGINE WORKS

1745 Oakland Avenue, KANSAS CITY, MO.

MASONS



Latest style genuine selected leather, gold trimmings; 5 window card case, Masonic emblem stamped in heavy gold.

Who would be without for only

\$1



Sent for \$2 to help cover cost, just to get our catalogue in the hands of Masons. The case is a beauty. Your name or other stamping 35c a line extra. Pin a dollar to this. Money back if not entirely satisfied. Larger and better cases from \$1, up to \$5. Masonic Books, Monitors, Jewelry and Lodge Supplies for over 69 yrs.

REDDING MASONIC SUPPLY CO. INC.
200 Fifth Ave. Dept. P.M., New York

MAKE YOUR FORD Into The "LARK"

\$5.00 Red-I-Kut life size patterns Class—Snap



38-inch Easy Riding Seat
Famous sure-fit RED-I-KUT life-size patterns and picture instructions show how you can easily convert your Ford into this Fast, Saucy, Sport-Car as thousands have done with easily obtained materials. No need to lay up the car. Rear seat folds, making 4-passenger car. Send 10c coin for actual body photo and new manual of other distinctive sport body patterns from \$3.80 up—"RKO" Steel "Swing-Lo" seats, Tops and Windshields. **ORDER RIGHT NOW**
KUEMPEL COMPANY, 108 Kuempel Bldg., GUTTENBERG, IOWA



The Musical Sensation
ACCORDEON
Played by Music Rolls

Without any knowledge of Music or Notes you play in a few minutes, perfect like an artist, latest hits, songs and dances. No study or practice. Nobody can see the arrangement. Musical Entertainers wanted everywhere, making easy money. Three models. Every instrument guaranteed. Interesting circular No. 1 and roll list mailed free.
TREASURE SALES COMPANY, 1690 Boston Road, New York

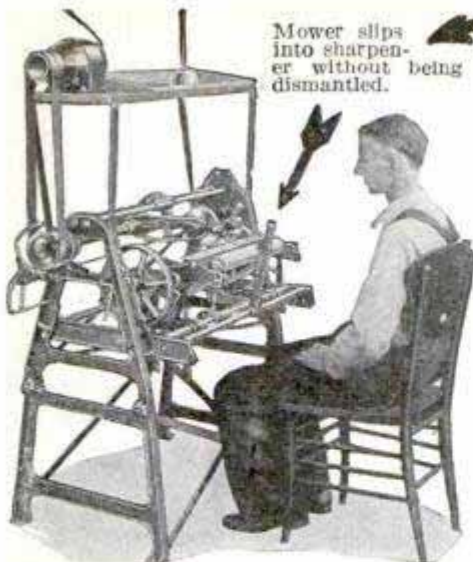

THIS MAN IS MAKING \$4.00 to \$6.00 an hour!

SHARPENING LAWNMOWERS in Spare Time With the "IDEAL" LAWNMOWER SHARPENER Man, Why Don't You Do That?

You've got the chance—the same chance as W. T. Moore, Twin Falls, Idaho, who made \$1200 net profits in 90 days—the same chance as Walter Wever, Middletown, N.Y., who made \$1000 in 4 months—the same chance as hundreds of others who have reaped rich rewards with this amazingly efficient lawnmower sharpener.

Use Your Spare Time. If you work at a trade, put an Ideal in your basement and earn \$4 to \$6 an hour evenings and Saturday afternoons. E. W. McCormick, Saginaw, Mich., writes: "Five years ago I bought an Ideal Sharpener on which I have ground over 5,000 lawnmowers. In the last few weeks I worked at my trade, machinist, full time 9 hours a day. I also ground 97 mowers which netted me \$114.10 clear gain."

Pays for itself and makes big profits: C. S. Coburn, Little Rock, Ark., writes that his "Ideal" Sharpener earned enough in 18 months to pay for itself and \$1857.00 worth of additional machinery.

Our Free Book Tells You How— these men and many others have made themselves independent—built substantial, permanent, BIG PAYING businesses with this Ideal Sharpener. Send for this book today—It's Free.

SIGN THIS AND MAIL TODAY

FREE BOOK TELLS HOW OTHERS DO IT!

THE "IDEAL" LAWNMOWER SHARPENER is a wonderfully simple machine that sharpens all makes of mowers perfectly, scientifically, without taking the mowers apart. Just pick up the mower, set it in the "Ideal," make a few simple adjustments and proceed to sharpen. In 15 minutes the mower is ready for the lawn, and you have made \$1.50 to \$2.00—depending upon the charge you fix. No training required, and machine set up in a few minutes. Plug into light socket and start to sharpen. Hundreds of dull mowers in your locality are waiting to be sharpened. Owners are looking for a place to get them sharpened. Sharpens skates—all kinds—perfectly.



THE FATE-ROOT-HEATH CO.
918-944 Bell St., Plymouth, Ohio.

Send me the book that tells me how I can make my spare time worth \$4 to \$6.00 per hour.

Name.....

Address.....

Save 1/2 **PLUMBING-HEATING**
Install Your Own
"New Easy Method"
Buy Now Pay Later

Lowest wholesale prices on Highest Quality, Grade A Goods. Any Handy Man can install his own Plumbing and Heating BY OUR NEW EASY METHOD. Get the best and pay only a little each month.

"We Show You How" BOOK
New bargain catalog just FREE issued. With our cut-to-fit systems you save waste material and high labor cost. 50 years of economical service to builders, home owners, farmers, and mechanics. FREE book gives you the whole story. Write for your copy today
Million Dollar Bonded Guarantee Protects You

HARDIN-LAVIN CO. EST. 1876
122-32B West Pershing Road, Chicago, Ill.

This CORNWELL Expert Mechanics KIT

Only \$8.60

Amazing Tests Prove Quality

Catalog describes remarkable tests by which the phenomenal strength and guaranteed quality of CORNWELL tools may be tested. Your money back for any tool that fails to do what we claim.

There Is No Substitute for Cornwell Quality

Mechanics are proud of their CORNWELL tools because they know there are none other like them. They meet the most exacting requirements for hard usage. They withstand the most severe tests to which any tools can be put.

Money Back Guarantee

You are fully protected by our guarantee that covers every CORNWELL tool. You take no risk. If tools are not all we claim for them send them back and your money will be immediately refunded.

OXO-GAS Oil Burners

Will Heat Stoves, Ranges, Coffee Urns, Steam Tables, Tanks, Boilers, Vulcanizers, Water Coils, Rendering Kettles, Bake Ovens, Griddles, Lead Pots, Pressing Machines, etc.

No Noise—No Smoke—No Soot—No Ashes
Require No Mechanical Skill to Operate
Can be Installed in 30 Minutes
Last a Lifetime

Responsible Distributors Wanted
Write for illustrated catalog.

DORAN OIL BURNER CO.
111-5 No. May St. CHICAGO, ILL.

This Catalog—FREE

The Cornwell Quality Tools Co.
Dept. J, Mogadore, Ohio.
(Formerly at Cuyahoga Falls, Ohio.)

Send me new illustrated catalog with prices on full line of Cornwell Hand-Made Tools.

.....Where employed
Name.....
Address.....
City.....State.....

LOFTIS

BROS. & CO. EST'D 1858

DIAMONDS WATCHES

CASH or CREDIT



No. 903
Fine blue white Diamond. Solid 18-k white gold. \$37.50.
\$100
a week



No. 849—
Brilliant blue white Diamond. Solid 18-k white gold. \$100.
\$250
a week



No. 906
Dazzling blue white Diamond. Solid 18-k white gold. \$75.
\$175
a week

GENUINE DIAMONDS GUARANTEED

We import Diamonds direct from Europe and sell to you direct by mail. Lowest prices.

SEND FOR CATALOG!

Write for big free book of 2000 illustrations and descriptions of Diamond Rings, Dinner Rings, Pins, Brooches, Watches, Pearls, Dresser Sets, Silverware, Clocks.

WEDDING RINGS

No. 824 \$800
"Elite", solid 18-k white gold. Set with 3 Diamonds, \$22.50; 5 Diamonds, \$32.50; 7 Diamonds, \$42.50; 9 Diamonds, \$52.50; 12 Diamonds, \$67.50. All platinum, \$25. With 3 Diamonds, \$72.50; 5 Diamonds, \$82.50; 7 Diamonds, \$92.50; 9 Diamonds, \$82.50; circled by Diamonds, \$200.

Satisfaction guaranteed or money back. Goods sent for your free examination on request. Credit terms: Pay one-tenth down; balance weekly, semi-monthly, or monthly at your convenience. Goods delivered on first payment.

No. 861—Ladies' Wrist Watch

Solid 14-k white-gold case. 15 jewels, \$25. \$2.50 Down and \$2.50 a month.

Railroad Watches—

GUARANTEED TO PASS INSPECTION

HAMILTON No. 992, 21 Jewels. Adjusted to 5 Positions. Gold filled 25-Year Quality Case	\$55
ELGIN'S LATEST RAYMOND, 21 Jewels, 8 adjustments. Runs 40 hours one winding. Gold filled 25-Year Quality Case	\$55
ILLINOIS "BUNN SPECIAL," 21 Jewels. Adjusted to 6 Positions. Gold filled 25-Year Quality Case. 60 hours one winding	\$50

CREDIT AT CASH PRICES • MEN'S STRAP WATCHES \$7.50 AND UP

Order direct from this ad or write for Free Catalog

The Old Reliable Credit Jewelers

LOFTIS

BROS. & CO. EST'D 1858

Dept. N-894
108 N. State St.
Chicago
Illinois

STRANGE INVENTION!

PAYS YOU \$90 A WEEK

NEW FIELD for AGENTS



Sell only device in the world that prevents kinking, snarling and tangling of telephone and electric iron cords. Housewives and business men buy 1 to 50.

NEW KIND OF CORD SET FREE

Every Neverknot Salesman is given a complete Neverknot Switch Plug Cord Set FREE. This new kind of ironing cord automatically coils itself out of the way and a new kind of switch plug prevents scorching and saves electric bills. This set is a "gold mine" for home-to-home workers. It's different and it's yours free if you work for us. Don't delay! Send now for free offer.



NEVERKNOT CO., Dept. 5-V, 4503 Ravenswood, Chicago

Part-Time Men Get This Suit FREE

Make \$45 a Week and up

Cash profits paid daily

No question about it, any man can easily earn \$45 a week and up, just showing our wonderful outfit and taking orders for our high-grade tailoring. Never before such low prices and beautiful styles.

Your Own Clothes FREE

To introduce our unbeatable values, classy styles and perfect tailoring, we make this introductory free suit offer—something different, better, bigger, more liberal than any offer ever made.

New Style Outfit of large real cloth samples—everything furnished FREE. Write today for free suit offer and big money-making plans.

PROGRESS TAILORING CO. Dept. E-216 CHICAGO



Beautiful HOUSES \$900 and BUNGALOWS

CAN BE BUILT FOR AND UP

This and many others in my new book, Building Plans for Modern Homes, will save you hundreds of dollars. One of the most complete and comprehensive books of plans ever published by any architect. New edition just off the press. Nearly 600 floor plans and photographs of Colonial houses, bungalows, etc., costing from \$200 up; gives sizes and cost to build. Sent postpaid for \$3.00.



FREDE RICK H. GOWING
ARCHITECT
101 Tremont St., BOSTON, MASS.

NEW VEST POCKET ADDING MACHINE

ADDS, SUBTRACTS, MULTIPLIES, DIVIDES

Does work of \$300 machine. Guaranteed 5 years. NOT A TOY. Made of steel and indestructible. Million dollar capacity. Fits in pocket. Will not make mistakes. So simple child can operate it. Instructions furnished. Everybody should carry one for figuring.

FREE TRIAL \$2.50 Total Cost

SEND NO MONEY—Just name and address. We will ship Calculator immediately. On delivery pay postman \$2.50 (Plus few cents Postage). (If outside U. S. send cash.) 10c additional in Leatherette Case. If not satisfied after 10 days trial you get your money back. **THOUSANDS OF SATISFIED USERS.** This is lowest priced practical calculator made. "Why pay more for inferior imitations?" Order from this ad.

Mail Coupon Today

BABY CALCULATOR SALES CO., (MANUFACTURERS)
Dept. 41, P. O. Box 1118, CHICAGO, ILL., U. S. A.

I am enclosing \$2.50—send adding machine prepaid.

Send Adding Machine C. O. D. \$2.50 plus postage. (10c additional in Leatherette Case)

Name.....
Address.....
City..... State.....

AGENTS Write for big commission and territory proposition.

LE PAGE'S GLUE

HOW TO MAKE YOUR OWN ATTRACTIVE FURNITURE

Send 10 cents for LePage's New Third Home Work Shop Book, containing complete directions for making 20 different projects. LePage's Craft League, 622 Essex Ave., Gloucester, Mass.

DO YOU WANT a new business profession of your own, with all the trade you can attend to? Then become a foot correctionist, and in a few weeks earn big income in service fees,—not medical nor chiropody—easy terms for home training, no further capital needed, no goods to buy, no agency. Address Stephenson Laboratory, 1 Back Bay, Boston, Mass.

FUGO FIRE EXTINGUISHER

EASY \$100 a Week



Unusual opening for live agents in every locality. Make \$5000 or more a year—easily. Fugo—the instantaneous automatic fire extinguisher—is needed and wanted in every home, store, theatre, garage, shop, school, automobile, etc. Cheapest fire protection available today. Within reach of all.

1 Qt. Size \$5.00 2 Qt. Size \$7.50

Recharged in a jiffy

Amazing 30-second demonstration clinches sale—each one sold sells others. Territory going fast. Write at once for wonderful proposition that will make you big money.

THE NATIONAL FORMAL CO.
6535 Metta Ave., N. E. Cleveland, Ohio

250 POWER MICROSCOPE \$16⁵⁰
MADE IN U.S.A.

Educational, entertaining, this fine microscope helps all to know life that can't be seen with unaided eye. Tiny insects look like monsters. Plant and mineral life reveal new wonders in form and color. Used by students, dentists, physicians, scientists—in home, office, school and laboratory. Precise optical qualities. Magnifies 100 to 250 times. Tilting stand, fine finish, nickel trim, plush-lined case, prepared slide, instructions. At your dealer or direct postpaid. Money back guarantee. Other models \$2.50 to \$8.50.



Catalog Free

Wollensak Optical Company

867 Hudson Ave.

Rochester, N. Y.

AGENTS AND SIGN MEN

New Making \$60.00 to \$100.00 and Up Per Week Selling Our GOLD LEAF SIGN LETTERS

R For store and office windows, board signs, trucks and glass signs. We also make to order script signs and business emblems singly or by the thousands. A permanent business. No capital or experience required. Big demand in every city. Samples and Literature Free.
CONSOLIDATED SIGN LETTER CO. 71-X W. Van Buren CHICAGO, ILL.

\$4.99 22cal. 81ank Automatic

WITH 100 CARTRIDGES FREE! You need no license or permit to own this 6-shot Automatic. Use for fun or self-defense. Keeps away tramps. Frightens thieves, scares away dogs—a real home protector. Fool your friends. Same as an expensive automatic in construction, finish, appearance, durability; automatic magazine loading and ejection of cartridges, instant and powerful report. Guaranteed absolutely safe. Send no money. Pay expressman \$4.99 and small shipping charge for automatic with 100 cartridges. JENKINS, 621 Broadway, New York, Dept. 5-J-23



DEAFNESS IS MISERY

Multitudes of persons with defective hearing and Head Noises enjoy conversation, go to Theatre and Church because they use Leonard Invisible Antiseptic Ear Drums. Tiny Megaphones fitting in the Ear entirely out of sight. No wires, batteries or head piece. They are Unseen Comforts and inexpensive. Write for booklet and sworn statement of the inventor who was himself deaf.

A. O. LEONARD, Inc., Suite 699, 70 5th Ave., New York

Do your own Printing!

Cards, stationery, circulars, tags, labels, advertising, book, menus, etc. Save money and time, cut cost in half. Easy rules furnished with every outfit.
Print for Others BIG PROFITS
A big opportunity to turn your spare time into cash, or develop a full time business of your own at small cost. New and popular Raised Printing like Engraving done with any of our presses. Complete Outfits \$8.85 up; Job presses \$11.29.; Rotary \$149.
Write for catalog No. 537 of presses, type, cards, paper, supplies and full information.
The Kelsey Co., Meriden, Conn.

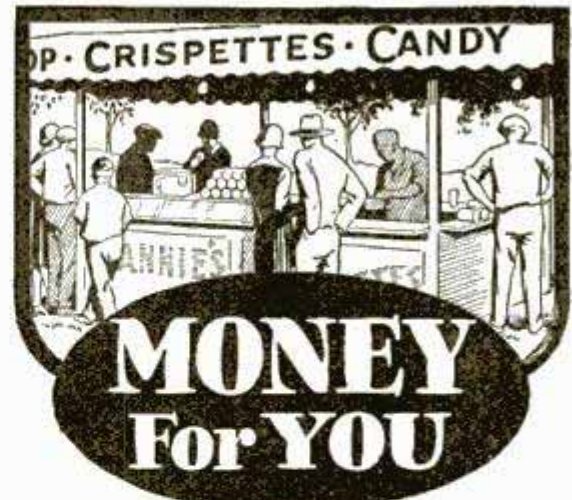

\$1000 Month Easily Possible

Letter from Calif. reports \$11,275 sales in 3 months; New Jersey \$4000 profits in 2 months; Pa. \$3000 profits in 4 months. Bram bought one outfit April 5 and 7 more by August. Iwata bought 1 outfit and 10 more within year. J. R. Bert says "only thing I ever bought that equalled advertisement." John Culp says: "Everything going lovely. Crispette wrappers all over town. It's good old world after all." Kellogg, \$700 ahead end of second week.

We Start You In Business

Furnish secret formulas, raw material and equipment. Little capital required; no experience needed. Big profits wholesale or retail. No town too small. Business is pleasant, fascinating and dignified. You manufacture a food product. No limit to sale of Crispettes. Everybody likes them. Write for facts about a business that will make you independent. Start now, in your own town.

Send Coupon for Free Book

Mail coupon for illustrated book of facts. It contains enthusiastic letters from others—shows their places of business, tells how and when to start, and all information needed. Free. Clip coupon now.
EAKINS CO. 528 High Street Springfield, Ohio
Please send Book of Facts at once.

Name.....
Address.....

Catch Fish!

Eels, Mink, Muskrats with our new folding galvanized STEEL WIRE TRAP. Write for our FREE TRAP OFFER and Bargain Catalog. \$1 Box of our famous Fish Bait FREE to introduce our traps. WALTON SUPPLY CO., 3502 JUNIATA AVE., ST. LOUIS, MO.



The Waco Wonder Shop

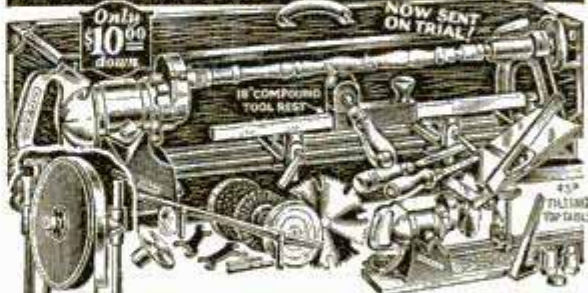

Make Things at Home
A set of Red Jacket Electric tools brings a powerful Master Drill Motor, Waco Craftsmen's wood turning lathe, compound and 15-tooth ream, tilting saw table, scroll, jig and bandsaw, and all accessories for drilling, boring, grinding and cleaning. Attaches to light socket and gives you private machine shop. ONLY \$10.00 DOWN.
Free Crafts Course and Blueprint Service
Send Coupon for Interesting Literature. You will be surprised, instructive, fascinating, beautiful.
WACO TOOL WORKS, Inc.
5216 W. Kinzie St., Chicago, Dept. 105.
Please send me all information FREE.

Name.....
Address.....

**FOR
MUSCULAR
ACHES**

**QUICK RELIEF,
COMFORT**

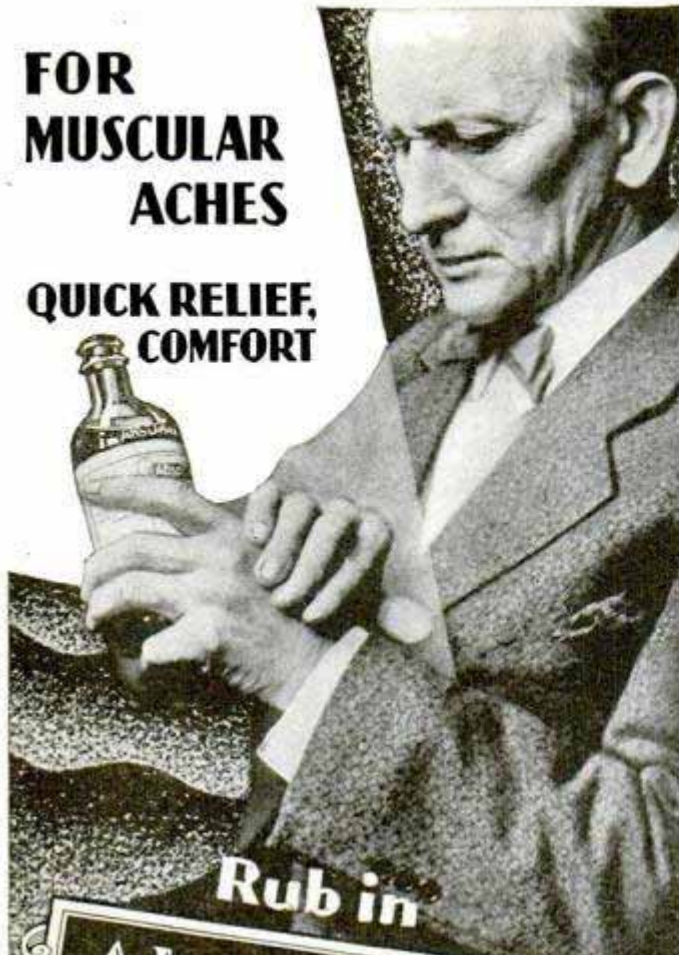

Rub in

Absorbine Jr.

WEATHER changes and sudden exposure bring aching muscles. Rub in Absorbine, Jr. at once. Almost instantly you will appreciate its soothing and comforting action. Stubborn attacks will respond to frequent applications of Absorbine, Jr. rubbed in vigorously. Absorbine, Jr. keeps the muscles in wonderful condition. It is pleasant to use—it is not greasy, and does not stain the skin. There are many other uses, for all the family. Read "Timely Suggestions."

AT ALL DRUGGISTS, \$1.25

Send for Free Trial Bottle

W. F. YOUNG, INC.
Springfield, Mass.



BERMUDA

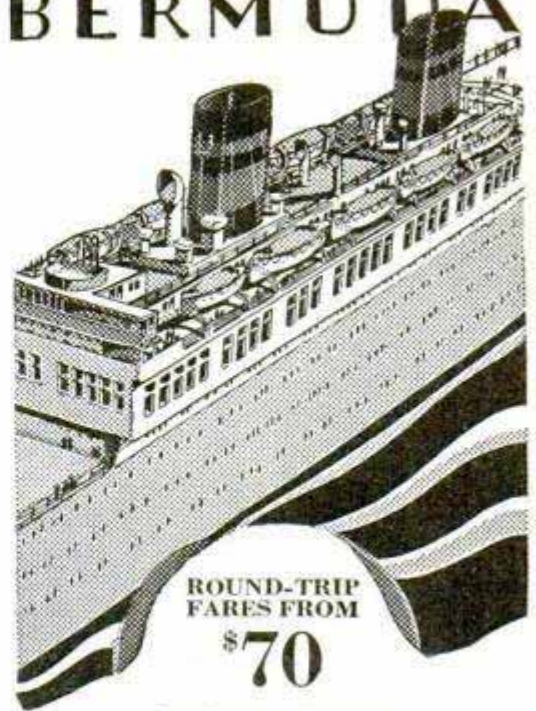

ROUND-TRIP
FARES FROM
\$70

*Inclusive Rates
on Application*

48 hours of Transatlantic luxury each way on the new 20,000-ton motorship "Bermuda" or the "Fort Victoria." Sailings twice weekly.

FURNESS
Bermuda Line

34 Whitehall St. . . . 565 Fifth Ave., New York



NO ONE CAN BEAT

the enjoyment of building your own substantial and safe 20-mile SPEED boat, requires but little spare time. We furnish the materials machined ready to fasten. **\$29.75** Also larger boats at corresponding attractive prices.
TRUSCOTT BOAT CO. - ST. JOSEPH, MICHIGAN

30 Days' Free Trial
on all **MEAD Bicycles**

New Models now ready for delivery direct from our factory. Astonishing new prices and terms. Do not buy until you get them.
RIDER AGENTS WANTED to ride and exhibit sample. Save big money. Many models, styles, wheels, lamps, horns, equipment at half usual prices. Send no money. Write for our marvelous prices and terms.



Mead CYCLE COMPANY
DEPT. H 109 CHICAGO

Write us today for free catalog

Catch Fish

Eel, Mink, Muskrats etc. with my New, Folding, Galvanized **STEEL-WIRE TRAP.**

It catches them like a fly-trap catches flies. Made in all sizes. Big money-makers for trappers and fishermen. **Get One Free to Introduce Our Goods.** Write today for price list, and my special free trap and bait offer.
J. F. GREGORY, Dept. 208, Lebanon, Mo.



MOTORCYCLES

WE WILL TRUST YOU
Pay As Low As \$2.00 per Week
Hendersons, Harley-Davidsons, Indians

Slightly used and rebuilt. Hundreds to select from.
Send 10c for list today.
MYEROW BROS. CO., 15 Berkeley St., Boston, Mass., U. S. A.



“Open up” and skip along

WINGS of spray and a frothy wake! There's a real thrill in this Old Town sea model. Properly designed to keep her nose level when you "open up" the outboard motor. You'll be proud of her clean aristocracy of line and graceful design—and she'll churn blue water into white at an astonishing clip.

Like all Old Town models, this craft is sturdily built, tough and durable, and remarkably easy to handle. There are Old Town boats and canoes for every use. Some priced as low as \$67. From dealer or factory.

Write today for free catalog. It shows and prices many light, water-tight models. Paddling, sailing and square-stern canoes, extra-safe Sponson models, dinghies and sturdy family boats. Also speedy craft for outboard motors—racing step planes and hydroplanes. Old Town Canoe Co., 1965 Middle Street, Old Town, Maine.

“Old Town Boats”

BUCHSTEIN'S FIBRE LIMB

is soothing to your stump—strong, cool, neat, light. Easy payments. Braces for all deformities. D. BUCHSTEIN CO. 610 3rd Ave., So. MINNEAPOLIS, MINN.

Send for Catalog Today

MOTORCYCLES

Direct to you at wholesale prices. Send 10c today for the latest Illustrated Bulletin and Confidential Price List of Guaranteed Indians Harleys Hendersons SuperX etc. (Sold on easy terms if desired)

CRANDALL CYCLE CO. 826-28 State St. Springfield, Mass. Shipments to all parts of the world

Motorcycles Since 1905

Stop that Gas Eater!

USE Electro GasSaver on your car and save half your gasoline. Aurora engineer invents new, dependable and electrically controlled accelerative gasoline saver which saves its cost many times over. An article of merit selling at \$12 and not to be confused with cheaper types with absurd claims. Nothing like it on the market. One model fits all cars. Works automatically. Combines vaporizing principle using generator as current for heating and controlling. Increases gasoline mileage $\frac{1}{4}$ to $\frac{1}{2}$ thru efficient combustion. Gives faster getaway. More power. Eliminates hard carbon. Lasts a lifetime. Installed in 15 minutes. Exclusive territory to agents. Big money maker. Write now for sample offer.

ELECTRO GASSAVER, Mfrs., Aurora, Ill.

Dept. A-40

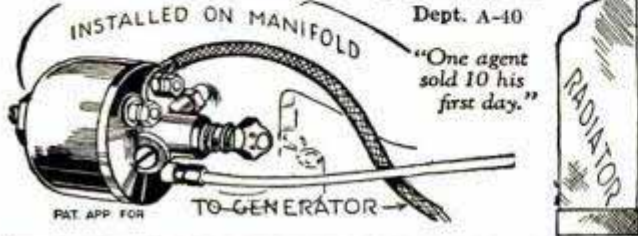

CHAMPION

*National
Change
Week...*

**May 5th
to 11th**

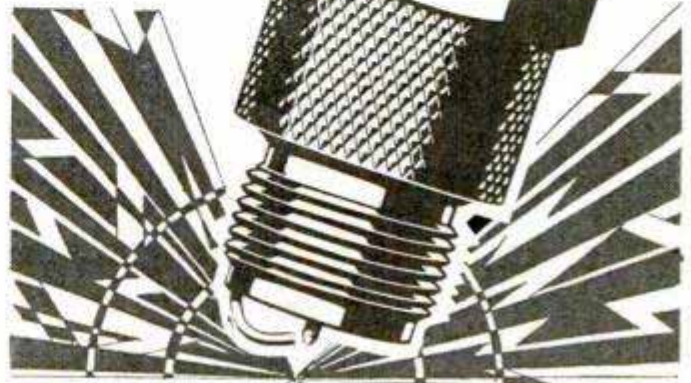

*Save the Price of
New Spark Plugs*

ONCE again Champion reminds you that to enjoy perfect engine performance during the next twelve months you should install a complete new set of spark plugs now.

You should renew even Champion Spark Plugs which give much better service for a much longer period than any other spark plug.

If you have used your spark plugs more than 10,000 miles, a new set of the new improved Champions will restore new car power and speed and save their cost many times over in less gas and oil used.

Make Champion National Change Week your yearly reminder to install a complete new set of Champions. It is a proved method of maintaining maximum engine efficiency and economy. Any one of more than 100,000 dealers will be glad to serve you.

**CHAMPION
SPARK PLUGS**

TOLEDO, OHIO

WINDSOR, ONTARIO

PATENT

Protect Your Ideas

Take the First Step Today

If you have a useful, practical, novel idea for any new article or for an improvement on an old one, you should communicate with a competent Registered Patent Attorney AT ONCE. Every year thousands of applications for patents are filed in the U. S. Patent Office. Frequently two or more applications are made for the same or substantially the same idea (even though the inventors may live in different sections of the country and be entirely unknown to one another). In such a case, the burden of proof rests upon the last application filed. Delays of even a few days in filing the application sometimes mean the loss of a patent. So lose no time. Get in touch with me at once by mailing the coupon on the opposite page.

Prompt, Careful, Efficient Service

This large, experienced organization devotes its entire time and attention to patent and trade mark cases. Our offices are directly across the street from the U. S. Patent Office. We understand the technicalities of patent law. We know the rules and requirements of the Patent Office. We can proceed in the quickest, safest and best ways in preparing an application for a patent covering your idea. Our success has been built on the strength of careful, efficient, satisfactory service to inventors and trademark owners located in every state in the Union.

NO CHARGE for Information On How to Proceed

The booklet shown here contains valuable information relating to patent procedure that every inventor should have. And with it I will also send you my "Record of Invention" form on which you can sketch your idea and establish its date before a witness. Such evidence may later prove valuable to you. Simply mail the coupon and I will send you the booklet, and the "Record of Invention" form, together with detailed information on how to proceed and the costs involved. Do this NOW. No need to lose a minute's time. The coupon will bring you complete information entirely without charge or obligation.

My Patent Law Offices
Just Across
Street From
U.S. Pat. Office



Above is a view of my drafting and specification offices where a large staff of experienced experts are in my constant employ. All drawings and specifications are prepared under my personal supervision.

NEWS

Inventors Write for these Free Books

Strict Secrecy Preserved

All communications, sketches, drawings, etc., are held in strictest confidence in strong, steel, fireproof files, which are accessible only to authorized members of my staff. Feel free to write me fully and frankly. It is probable that I can help you. Highest references. But **FIRST**—clip the coupon and get my free book. Do **THAT** right now.

Clarence A. O'Brien

Registered Patent Attorney

Member of Bar of: Supreme Court of the United States; Court of Appeals, District of Columbia; Supreme Court, District of Columbia; United States Court of Claims. Practice confined exclusively to Patents, Trade marks and Copyrights

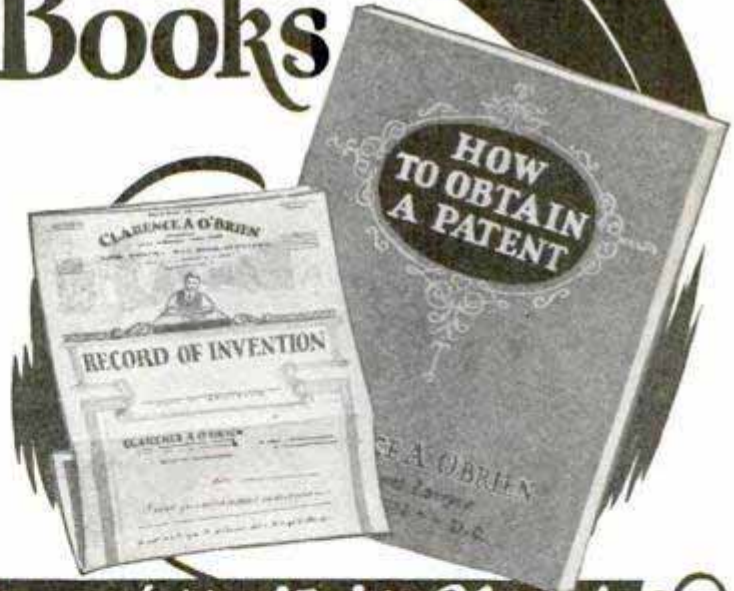

Clip this Coupon and Mail it Now!

CLARENCE A. O'BRIEN, Registered Patent Attorney

70-P Security Savings and
Commercial Bank Bldg.,
Washington, D. C.

OR

Suite 1106 Woolworth Bldg.,
New York City

Please send me your free book, "How to Obtain a Patent," and your "Record of Invention" form without any cost or obligation on my part.

Name.....

Address.....

(Important—Write plainly and address office nearest you)

PATENTS TRADE MARKS COPYRIGHTS



Our New York Office
Suite 1007 Woolworth Bldg.



Our Philadelphia Office
Suite 518-519 Liberty Bldg.



Our Washington Office, Victor Bldg.



Have You An Idea?

Our Offer: FOR THE PROTECTION OF YOUR INVENTION

YOUR FIRST STEP

The inventor should write for our blank form

"RECORD of INVENTION"

This should be signed and witnessed and returned to us together with model or sketch and description of the invention for **INSPECTION AND ADVICE**
No Charge for the Above Information

Our Five Books Mailed

Free to Inventors

Our Illustrated Guide BOOK

How to Obtain a Patent

Contains full instructions regarding U. S. Patents. Our Methods, Terms, and 100 Mechanical Movements illustrated and described.

Our Trade Mark Book

Shows value and necessity of Trade Mark Protection. Information regarding *Trade Marks and unfair competition in trade.*

Our Foreign Book

We have Direct Agencies in Foreign Countries, and secure Foreign Patents in shortest time and lowest cost.

Progress of Invention

Description of World's Most Pressing Problems by Leading Scientists and Inventors.

Payment of Fees in Installments

It is not necessary that the total cost for the preparation and prosecution of a patent be paid in one payment. Our custom is to permit our clients to pay for their applications in three installments as the preparation of the application progresses in our office. This plan makes the payments easy for the inventor.

We Regard a Satisfied Client as our best advertisement, and furnish anyone, upon request, lists of clients in any state for whom we have secured patents.

Highest References—Prompt Service

—Reasonable Terms

VICTOR J. EVANS & CO.

Patent Attorneys, Established in 1898

Main Offices: 789 9th St., N. W., Washington, D. C.

Nearly Opposite U. S. Patent Office

DELAYS ARE DANGEROUS IN PATENT MATTERS

IMPORTANT! To Avoid Delay!

YOU SHOULD HAVE YOUR CASE MADE SPECIAL IN OUR OFFICE to save correspondence, secure protection and early filing date in the Patent Office. To secure **special preparation** of your case send \$25.00 on account with model or sketch and description of invention.

ACT NOW—Often two or more inventors file applications for practically the same idea. In such cases the burden of proof rests upon the last application filed. Therefore, delays often cause the loss of a patent.

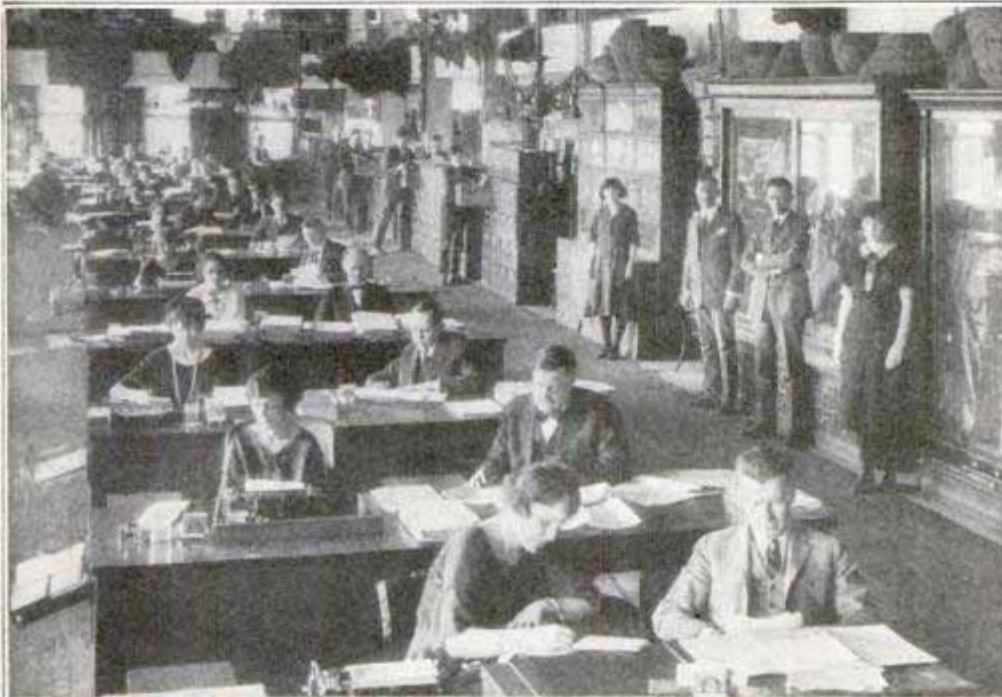

MAIN OFFICE, VICTOR J. EVANS & CO.—VICTOR BUILDING, WASHINGTON, D. C.

Our Large, Comprehensive Organization has been established for 30 years and offers Prompt, Efficient and **Personal Service** by experienced Patent Lawyers and Draftsmen. Every case is in charge of a Specialist who has been selected for his knowledge and experience in certain lines of invention. Our Lawyers practice in all U. S. Courts and defend clients in suits involving Patents, Trademarks and Copyrights. **All Communications and Data** strictly Secret and Confidential. We shall be glad to have you consult us or to answer any questions in regard to Patents, Trademarks or Copyrights without charge or obligation.



Our Chicago Office
Suite 1110 Tacoma Building



Our Pittsburgh Office
Suite 514 Empire Building



Our San Francisco Office
Suite 1010 Hobart Building

**FREE
COUPON**

VICTOR J. EVANS & CO.
PATENT ATTORNEYS *Established in 1898*

NEW YORK OFFICES
1007 Woolworth Bldg.

CHICAGO OFFICES
1110 Tacoma Bldg.

PHILADELPHIA OFFICES
518-519 Liberty Bldg.

PITTSBURGH OFFICES
514 Empire Bldg.

SAN FRANCISCO OFFICES
1010 Hobart Bldg.

MAIN OFFICES: 789-9th Street, N. W., WASHINGTON, D. C.

Gentlemen: Please send me *Free of Charge* your books as described on preceding page.

Name

Address

PATENTS

Booklet Free **Highest References**
Promptness Assured **Best Results**

Send drawing or model for preliminary examination and advice.

ALL BUSINESS GIVEN PROMPT AND PROPER ATTENTION

Listed Patent Lawyer in the latest editions of the Rand-McNally Directory of Bankers and Bonded Attorneys, published by Rand-McNally & Co., Chicago, Ill.; The Baggott & Ryall Directory of Guaranteed Attorneys, published by the Ryall Legal Directory Company, New York City; Flugel's List, published by the Legal Directory Publishing Co. of St. Louis, Mo.; the American Lawyers Annual, published in Cleveland, Ohio; Eyre's Law List, Bush Terminal Building, New York City.

WATSON E. COLEMAN,
REGISTERED PATENT LAWYER

Victor Building, 724 Ninth Street, N. W.
WASHINGTON, D. C.

PATENTS

To the Man with an Idea

PATENTS Procured. Trade Marks Registered. —A comprehensive, experienced, prompt service for the protection and development of your ideas. Preliminary advice gladly furnished without charge. Booklet of information and form for disclosing idea free on request.

IRVING L. McCATHRAN, Patent Lawyer
Formerly with and successor to RICHARD B. OWEN
704 International Bldg., Washington, D. C.
41-E Park Row, New York City

TRADE-MARKS
REGISTERED

The man who studies gets ahead. Popular Mechanics Press will advise you what books to read to advance in your trade. 200 East Ontario Street, Chicago, Illinois.

MASON, FENWICK & LAWRENCE PATENT LAWYERS

600 F St., N. W., Washington, D. C.

Estb. over sixty years. Send sketches.

Electrical and Chemical Inventions carefully handled. Practice before the U. S. Courts and the Patent Office. Prompt and careful service. WRITE US.

TRADE MARKS REGISTERED



PATENTS TRADE-MARKS

*Don't Lose Your Rights
To Patent Protection*

Before disclosing your invention to anyone send for blank form "EVIDENCE OF CONCEPTION" to be signed and witnessed.

LANCASTER & ALLWINE
480 Ouray Bldg. WASHINGTON, D. C.
Originators of forms "Evidence of Conception."

PATENTS

Trade Marks, Copyrights, Patent Litigation Handbook with illustrations, 100 mechanical movements. *Sent free on request.*

ALBERT E. DIETERICH
formerly member Examining Corps U. S. Patent Office

REGISTERED

PATENT LAWYER and SOLICITOR

621-A, Ouray Bldg.

30 Years' Experience Washington, D. C.



PATENTS

Send us sketch or model for advice and exact cost of patent. Our book "How to Obtain a Patent" sent free. It tells how to apply for Patents, Trade Marks, Foreign Patents, Copyrights, etc.; gives information on Patent Procedure; tells what every inventor should know. Thousands of inventors, who are our clients, are our reference.

CHANDLEE & CHANDLEE, 25 Years' Experience
910 F Street Washington, D. C.

INVENTORS PROTECT YOUR IDEAS

Send for our Guide Book, **HOW TO GET A PATENT**, and Evidence of Invention Blank, sent Free on request. Tells our terms, methods, etc. Send model or sketch and description of your invention for INSTRUCTIONS. No charge for the above information.

RANDOLPH & CO.
301 Victor Bldg., WASHINGTON, D. C.

NAME _____

STREET _____

CITY _____ STATE _____

PATENTS

TRADE-MARKS & DESIGNS
FOREIGN PATENTS

MUNN & CO.
PATENT ATTORNEYS

Associated since 1846 with the Scientific American

SCIENTIFIC AMERICAN BUILDING
24 W. 40th St., New York City

SCIENTIFIC AMERICAN BUILDING
Washington, D. C.

TOWER BUILDING
Chicago, Ill.

VAN NUYS BUILDING
Los Angeles, Cal.

HOBART BUILDING
San Francisco, Cal.



Books and Information on Patents and Trade-Marks by Request.
Associates in All Foreign Countries.

JOIN THE AMATEUR INVENTORS OF AMERICA

YOUR IDEAS through united effort bring SUCCESS. Given with membership TWO MAGAZINES, bought singly \$3.00. FOUR BOOKS: "Creating Ideas", \$1.00; "Patenting Ideas", \$1.00; "Developing Ideas", \$1.00; "Selling Ideas", \$1.00; combined into a ONE YEAR'S COURSE on spare time invention. Send \$2.00 for all above items and ONE YEAR'S MEMBERSHIP during this SPECIAL OFFER. AMATEUR INVENTORS OF AMERICA
294 No. Mason Ave., Chicago, Ill.

Books on all subjects are sold by Popular Mechanics Press, 200 East Ontario Street, Chicago, Illinois

New Model
Men's
Strap
Watch

\$3.85

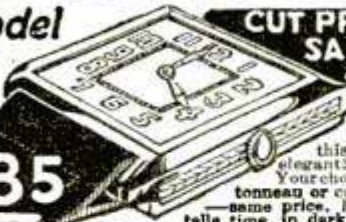

CUT PRICE
SALE

Two years written guarantee given with this full jeweled elegant Swiss watch. Your choice in square, tonneau or cushion shape—same price. Radium dial, tells time in dark. Accurate timekeeper, tested and adjusted. Rush your order. Quantity limited. Send no money, pay postman \$3.85. JENKINS, 621 Broadway, New York, Dept. 5-F-23



\$300,000
For This Invention

That's what Eastman Kodak paid for the Autographic idea. Thousands of other inventions are needed and offer enormous opportunities for earning fortunes. If you are of an inventive turn of mind, why not concentrate on things that are really NEEDED?

Get Raymond Yates's new book

"1000 NEEDED INVENTIONS"

Costs only \$1.25 and may start you thinking along the right lines. You'll get nowhere just fussing around. Concentrate on what the industries need, and on what the public wants. Mr. Yates's book tells you what these things are. Send no money. Just write postal. Pay mail man \$1.25 plus postage when book arrives. Your money back if you want it. This offer limited. Write now and get on the right track. (Outside U. S. \$1.45, cash with order.)

BUREAU OF INVENTIVE SCIENCE
Dept. 35, Wisner Building, Rochester, N. Y.

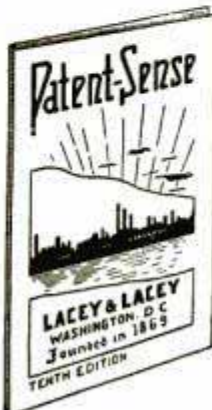

Patents

Inventors who derive largest deserved profits know and heed certain simple but vital facts BEFORE applying for patents. Our book PATENT-SENSE gives these facts. Sent FREE.

LACEY & LACEY
WASHINGTON, D. C.
ESTABLISHED 1869

Lacey & Lacey, 646 F St., N. W. Washington, D. C.
Please send me your FREE book PATENT-SENSE.
Name.....
Address.....
City.....
State.....

PAYS for ITSELF

**SAVES
TIME-TOOLS
TEMPER**



OPEN



CLOSED

TWO STYLES

Guaranteed to be as represented.

No. 616—6½ in. wide, 7 in. high, 16 in. long. Fitted with steel lock, brass plated. Two trays, as shown in the **\$6.50** above illustration

No. 316—6½ in. wide, 6½ in. high, 16 in. long, with only one tray. Finish and fittings as above **\$5.50**

HERE'S the kind of a tool box you can be proud of. Deep-drawn from a single sheet of specially processed lead-coated steel, it has no seams or joints to spread open. The box is absolutely water tight and unusually strong for its weight. Lid and trays so arranged that a single motion gives you access to the entire contents, and a single motion closes everything. The CHAMPION Cantilever Tool Box is finished inside and out with a heavy coat of baked enamel. If your dealer cannot supply you, send price direct to manufacturers, who will ship prepaid.

TAYLOR BROS. MFG. CORP.
569 E. Jackson St., Elkhart, Indiana

PATENTS ON EASY PAYMENTS

M. S. CAYNE

REGISTERED PATENT ATTY.

FORMER ASS'T EXAMINER
U. S. PATENT OFFICE

INFORMATION RELATING TO PATENTS AND MY EASY PAYMENT PLAN SENT ON REQUEST

MAIN OFFICE

BANKERS BLDG.—105 W. ADAMS ST.
CHICAGO, ILL.

Play for Money

PLAY in a dance orchestra! It's the most enjoyable way to make extra money—\$10 to \$50 weekly in spare time. Meet new people. Make new friends. Be the welcome guest at every party.

You can do it with the OCTOFONE—Eight Instruments in One. Can be tuned and played like a "uke", tenor banjo, tenor guitar, mandolin, mandola, mando-cello, tippie or taro-patch.

Easy for Beginners—Free Instruction Book shows you.

OCTOFONE

FREE INSTRUCTION BOOK!

No obligation. Mail coupon to:

Regal Musical Instrument Co.

3207 W. Grand Ave., Dept. 1002E, Chicago



\$15.00



WANTED!

500 Dissatisfied Farmers and Sons to Stop Renting

And begin retailing Rawleigh's Good Health Products to Consumers. Start your own business. Make from \$100 to \$400 a month or more clear profit. Be your own boss. No selling experience required. We supply everything—Products, Outfit, Sales and Service Methods. Profits increase every month. No lay off. Steady year-round. Lowest prices. Best values. Most complete Service. Rawleigh Methods get the most business everywhere. For particulars write

THE W. T. RAWLEIGH CO.
DEPT. E-18PPM FREEPORT, ILL.

WILL BUY

Products or Inventions

We will make liberal all cash or cash and royalty offer for complete rights on products or patented inventions. Household, automotive or other specialties with eye catching demonstration preferred. Prefer type of article not sold in stores, easy and economical to manufacture, sold at low price. Product must be completely protected with patents or be patentable, have real novelty and merit, and meet an existing or potential demand in big market. Give complete facts in letter, including product's selling history (if any). If interested, will close deal at once. Rhodes Kriss-Kross Corp., Dept. E-373, 1418 Pendleton Avenue, St. Louis, Mo.

LIGHTING FIXTURES

Ready to Hang

Direct from the manufacturer. Completely wired, including glassware. Send for new catalogue No. 29. Just Reduced Prices. Special Proposition to Dealers.

Erie Fixture Supply Company, Inc.
Station A ERIE, PA.



Puts New Soles On Shoes for 9c

A simple, amazing product has been invented by C. H. Geppert, Suite 1003-E, Second & Walnut Sts., Des Moines, Iowa, which makes new soles on shoes cost only 9c a shoe. Saves cost of new shoes. Reconditions old shoes. Spreads on with a knife like butter, wears like leather, and equally pliable, waterproof and can be applied by anyone instantly. Mr. Geppert wants agents and is willing to send a no-cost sample. Write him today.—©1929.

The same
Fast, Accurate

COMPLETE OUTFIT

for home use and profitable commercial work, including planer, saw, lathe and electric motor and many useful attachments

Every kind of woodworking operation

Make everything out of wood
with the famous

WORKACE Electric

WOODWORKER

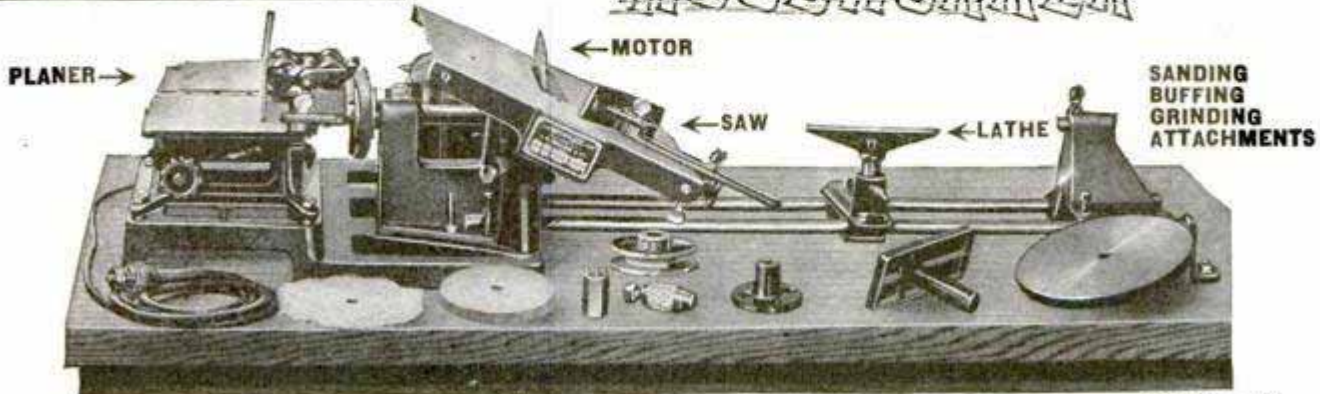

Amazing low price . . .

\$89

This complete all-electric shop costs less than most other outfits and gives you an excellent value! The Workace is fast, accurate and easy to work with. Planing, sawing, turning, drilling, grinding, sanding or buffing—you save time on every operation, do better, cleaner work, too!

It has ample power, strength and capacity to do any job quickly and economically . . . mitering, tapering, rabbeting, beveling, slotting, cross cutting, ripping—anything! Every unit works from the G. E. motor. The regular Wallace UNQUALIFIED GUARANTEE assures replacement of defective parts for one year. This is a simple straightforward offer—no exaggeration, no red tape—just plain facts that you yourself can

prove. If you want to make wood-working your real hobby—or a real source of income—send this coupon.

EASY TERMS

Small Down Payment—\$9 Per Month. Many pay for their Workace Shop out of the profits it makes. . . . A small down payment brings the Workace complete and ready to set up for immediate use. The monthly payment of \$9 is so small you'll scarcely miss the money. . . . Send the coupon now—today—and we'll see that you get full details and a complete description by return mail!

Includes all this:

- 4 in. Planer
 - 8 in. Circular Saw
 - 6 in. x 36 in. Lathe
 - 8 in. Disc Sander
 - 6 in. Buffering Wheel
 - 5 in. Emery Grinder
 - 1/4 in. Drill Chuck
 - 3/4 H. P. G. E. Motor, 110-Volt, A.C., 60 Cycle
 - Endless V-Belt, two 4 in. and one 2 1/4 in. V-Belt Pulleys Cast Iron Sub Base and 10 ft. Cable with separable Plug.
- The Planer and Circular Saws are each complete units and may be purchased separately at the correspondingly low price of \$25.00 each.



JIG SAW ATTACHMENT \$10

SEND TODAY GET OUTFIT RIGHT AWAY

J. D. Wallace & Company,
Adams St. and California Ave.,
Chicago, Illinois.

I want to know ALL about the Workace Electric Woodworker, including your easy terms.

Name
Kind of Business
Address
City State

HAVE YOU AN INVENTION?

A large American manufacturer, highest rating, equipped for producing small metal stampings, drawn articles, and screw machine products, desires new articles to manufacture. Preference will be given to products applicable to the automotive industry. Every idea submitted will be carefully considered, preference being given to patented articles. Will pay outright or pay royalty for acceptable ideas. Send complete information in first letter, and if possible a sketch or sample of your product.

Address ROOM 503, care of POPULAR MECHANICS MAGAZINE
200 E. ONTARIO STREET, CHICAGO, ILLINOIS

RUSH-ABSOLUTELY FREE!
THIS E-F ANGLE SCREWDRIVER—of tempered crucible Spring steel—has 7 powerful edges for large & small screws. Works under obstructions where others won't—101 other uses. Carries like pen-knife—often more valuable. Sent Free on Receipt of Coupon.

Name _____
 Route No., St. _____
 P. O. City, St't. _____

Interested in Factory Representative Proposition!
 In User Literature! **THE FLASH SALES CORP.**
 E P M - 4809 N. Ashland Ave., CHICAGO, ILL.

CLIP HERE - MAIL TO -

Also **FREE ON COUPON**—the "\$5,000" CIRCULAR giving amazing 125-Picture story of **The "Pocket Machine Shop!"**

with its **1-TON POWER-GEAR** It Outgrips a 40-Lb. Visel



The 'hand-grip' of a tiny Rubber band holds the Hardest-to-Hold thing known against a 300-Pound Pull!
 Its 10-to-1 ratio Power-Gear-Transmission gives YOUR hands the 1-TON GRIP of 20 Hands, yet -YOU CAN GRIP A HAIR.

An Automatic Lock-Grip Ratchet Wrench

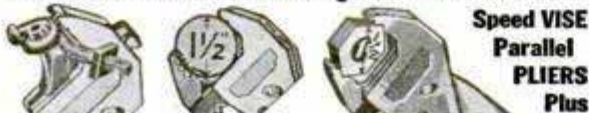

Speed VISE Parallel PLIERS Plus

No. 3—for all Wire, chain, spring-making, fence work, etc.
 No. 2—for all Pipe work, "chewed" nuts in tight places, etc.
 No. 1, Universal—for ALL Pliers, Nut Wrench, Vise and Clamp, Spring-making Work, etc.

EIFEL-FLASH PIERENCH KIT
 (Say "Eye-fel-Flash") "The T.N.T. of Tools"

You get the amazingly Quicker, Better, Easier, Universal Tool Service of Nos. 1, 2 & 3—Convertible in 1/5 second—in this new 24-Ounce Master Tool Kit—for the Price of One Good Tool; yet it does the Work of the best other tools Weighing 60 pounds and Costing \$50.00!

Hundreds of Thousands of Men and Women are using these wonder Kits to make Homes and Estates more comfortable—Farms, Shops, etc., more profitable; to get more and better service from Auto's and all mechanical devices with a huge saving in money, time and energy! Used by the U. S. Army and Navy. Just try a Plierench Kit Once, and you'd no more go back to other tools than to the ancient Ox-cart!

With each Kit a 64-page Manual of Mechanics
A GUARANTEED SUPER-QUALITY PRODUCT (©'29 J.E.)

Also Big Spring and Summer Money Maker for Plierench Factory Representatives—Full or Part Time. Amazing Demonstr'n sells at sight—makes \$75-\$200 weekly all year 'round. Seasonal Demand Doubles Profits. A Ga. Repr. made \$97 in 20-Min. Group Sale; a Mich. Repr. \$368 in 12 days; another \$379 in 5 days. Everybody wants the Kit!

Mail Valuable Coupon Above NOW!

BOYS! Make Big Money
BUILD BIRD HOUSES

Boys! Here a real money maker. With my simple instructions any boy can build and erect Grandpa Bird Houses. They sell at \$2 to \$30 each. \$2,000 worth sold in Oak Park, Ill., in one year. Send \$1 for 16 Blue Print Drawings showing correct building plans so you can build my famous bird houses. Valuable book on song birds with tips and advice on making sales included free.

GEO. J. BREIDERT, 1040 N. Elmwood Ave., Oak Park, Ill.

AIRPLANE

12-inch scale model of Lindbergh's Spirit of St. Louis. Scientifically designed and very realistic. Rises from ground by own power and flies 40 ft. or more. Stays in air 8 to 10 seconds. Easily built in 2 or 3 hours.

No tools needed. Construction set, with all parts and full directions, postpaid in U.S., only 50c. (no stamps). Satisfaction or money back. Send today and print your address plainly. **Mann & Benton, Box D, Chillicothe, O.**

Send for this Book of Model Homes just out!

ALADDIN Homes

Free!

Aladdin's latest Catalog is a revelation to prospective home builders! Shows many beautiful new model-home designs with prize-winning interiors and floor plans. Profusely illustrated in colors and overflowing with interest. Send for your **FREE** copy today!

Aladdin Read-Cut Construction Saves You \$200 to \$800

All lumber is cut-to-fit at Mill on huge labor-saving machines instead of on the job where labor and lumber waste costs dearly! You save the difference and get the finest home your money can buy.

Prices Include: All materials for a complete home, together with instructions and plans for erecting. Also Plumbing, Heating, Lighting Equipment, Built-in Kitchen Cabinet and other modernizing features. **We pay freight** and guarantee safe arrival of all materials.

Write TODAY
 Address nearest Aladdin Office today for your **FREE** Book of Model Homes, Summer Cottages and Garages. Ask for latest Catalog No. 761 No obligation. Send NOW!

The ALADDIN CO. Bay City, Michigan
 Wilmington, N.C. Portland, Ore.

HERE IS A GOLD MINE

FOR MEN AND WOMEN AGENTS
400% Profit—\$14 a Day Easy

Johnson's Liquid Quick Mend. For mending Fabrics and Hosiery without sewing. Stops runs in Silk Hosiery. Will stand repeated washings.

SELLS ON SIGHT—EVERY WOMAN BUYS.
 OVER 100 OTHER FAST SELLERS! No experience necessary. We furnish Sales Talk and unique Sales Plans that get the orders at every call.

J. E. JOHNSON & COMPANY, Dept. 577, 6129 Wentworth Ave., Chicago

NO JOKE TO BE DEAF
—EVERY DEAF PERSON KNOWS THAT

I make myself hear, after being deaf for 25 years, with these Artificial Ear Drums. I wear them day and night. They stop head noises and ringing ears. They are perfectly comfortable. No one sees them. Write me and I will tell you a true story, how I got deaf and how I make you hear. Address

GEO. P. WAY, Artificial Ear Drum Co. (Inc.)
 83 Hoffman Bldg., Detroit, Mich.

"BASHFUL"

"Shame on you!" Are you nervous, embarrassed or ill at ease? Stop being shy of strangers. Conquer the terrible fear of your superiors. Be cheerful and confident of your future! Your faults easily overcome so you can enjoy life to the fullest. Send 25 cents for this amazing book. **RICHARD BLACKSTONE, B-475 Flatiron Bldg., New York City**

MOTORCYCLES

Price \$10 and up purchased through our Co-Operative Plan for as low as \$1.00 down and \$1.00 per week

Indians Harley-Davidsons Ace Henderson and Clevelands
 Send ten cents for Bulletin A.
 Motorcycles shipped to all parts of the world

WALKER-INDIAN CO., 78 Brookline Ave., BOSTON

BE YOUR OWN BOSS

Make \$25 to \$40 a Day

Why be content to always work for the other fellow? Have your own business and make *big money* with the

American Universal FLOOR SURFACING MACHINE

Men in all sections of the country have built up a big paying floor surfacing business of their own through "The American

Universal Method." It is a year round business — no dull seasons—

no special training nor large capital necessary. This is the time of year when the demand is greatest.

Write *TODAY* for details.

The American Floor Surfacing Machine Co.
523 South St. Clair St., Toledo, Ohio



only **\$1.00**
DOWN
10 Day FREE Trial

You can have a genuine L. C. Smith (the world's only ball bearing typewriter) for \$1 down. Lowest price ever offered! Easiest terms. All the 1928 operating attachments. Re-noved. **GUARANTEED FOR FIVE YEARS.** \$1 down and we ship. No delay. No red tape. 10 day Free Trial. Free Typewriter Course, Tools, Waterproof Cover if you act now. Write for \$1 down offer and free manual.

Smith Typewriter Sales Corp., 115-469 E. Ohio St., Chicago, Ill.

Work Out Your Own Ideas With the H & A WOOD LATHE



For turning lamps, candlesticks and other useful articles. A sturdy, dependable machine for a reasonable price. Various attachments. Ask for complete information.

HESTON & ANDERSON
605 Market St., Fairfield, Iowa

AUTOMATIC WINDOW WASHER

Price \$1.95



Washes, Cleans, Dries Polishes in One Quick Operation

Amazing new invention. **CARRIES OWN WATER SUPPLY!** Eliminates all drudgery and splashing! 5 times as fast as old methods. Patented features: **No pail. No brush. No sponge. No chamois.** Can be used with or without a pole. **\$90-\$150 weekly easy for agents.** Sells on sight. Sensational demonstration! Every housewife, autotist, store-owner a prospect. Write for our **Free Sample Offer** and big money-making proposition. Be first.

NATIONAL INDUSTRIES, 67 E. Lake St., Dept. 155, Chicago

WURLITZER

Trade Mark Reg. THE WORLD'S LARGEST MUSIC HOUSE

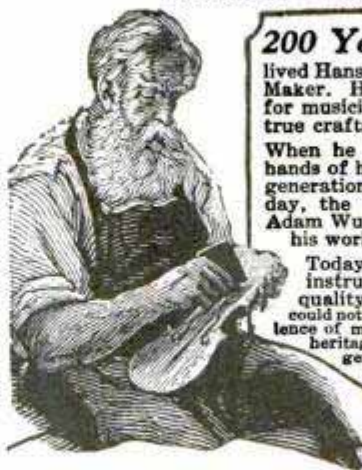

200 Years Ago in the little Saxon town of Shoeneck lived Hans Adam Wurlitzer, Master Violin Maker. His shop was a gathering place for musicians of the time, for he was a true craftsman.

When he died his shop passed into the hands of his eldest son, and for seven generations, down to the present day, the descendants of Hans Adam Wurlitzer have carried on his work.

Today in every Wurlitzer instrument you will find a quality, a character, that could not come from mere excellence of manufacture. It is the heritage of these seven generations of music craftsmanship.

Try any Wurlitzer Instrument in your Own Home

YOU may now have any Wurlitzer instrument for a generous free trial in your own home. Examine the instrument, show it to your friends, play it as much as you wish. No obligation to buy—no expense for the trial. We make this liberal offer because we want you to try for yourself these wonderful instruments, the result of 200 years' experience in musical instrument Building. Easy payments are arranged to suit your convenience. This is your opportunity to try a famous Wurlitzer instrument in your own home.



Send for New Catalog

The greatest musical catalog ever published. Over 3,000 articles—every known instrument described and illustrated; many of them shown in full colors. Gives you lowest prices and all details of Free Trial, Easy Payment plan. All sent **FREE**—no obligation.

Send this Coupon

THE RUDOLPH WURLITZER CO., Dept. 1775
117 E. 4th St., Cincinnati

Send me absolutely free, your new illustrated catalog, with prices and description of every known musical instrument. Also tell me how I may try any instrument in my own home and pay for it in small monthly sums. No obligation.

Name.....
Address.....
City.....State.....
Instrument.....
(State instrument in which you are interested)

Copyright, 1929, The Rudolph Wurlitzer Co.

Now! Do Your Own Electric Nickel Plating

Introductory Offer

ONLY \$6.50 Plus Postage



For Plating Nickel, Brass, Copper, Silver, Gold, etc.

Make \$150 to \$500 a Week

New Scientific Invention Enables Anyone to Nickel-Plate Anything, Anywhere

Do YOUR OWN Electro-Plating in Your Home, Garage, Office, or Place of Business. Electrically Deposit Metal—Nickel, Brass, Copper, Silver, or Gold. You can Successfully do all the plating on your Automobile, Electric Fixtures, Faucets, Spoons, Forks, Chandeliers, Tools, Coffee Urns, Surgical and Dental Instruments, Utensils large or small, Iron Stoves, Music Instruments; recondition worn plating or plate New Work; do it Instantly without interrupting the Service or without removing the parts to be plated with the

ALADDIN PORTABLE ELECTRO-PLATER

Simple and Economical to operate. Not a toy, but a practical Plating Outfit with which Perfect and Durable Work can be done. Positively Guaranteed to do as we claim. BE YOUR OWN BOSS! Build up a Profitable Aladdin Electro-Plating Business of your Own. This offers wonderful ECONOMY to users and BIG MONEY-MAKING possibilities to AGENTS. Thousands in Service since 1924. Write for FREE Booklet and Testimonials Today.

P. J. F. BATENBURG Dept. 69 RACINE, WISCONSIN

—AGENTS— WANTED EVERYWHERE

Do You Want—

a Cruiser



a Sail Boat



an Outboard



Speedster

Here's how you can have it and save $\frac{2}{3}$ your money.

That boat you have always wanted can now be yours at $\frac{1}{3}$ average cost. Choose the craft—we send you the parts, cut and numbered. You assemble them according to clear, simple instruction sheets—no complicated knowledge of carpentry needed—and there's your boat, true in design, perfect in finish—built as the architect planned it.

Act Now! Don't miss summer's sunny days. Send 10c for catalog and choose your boat.

BROOKS BOAT COMPANY, INC.

Dept. 4E,

Saginaw West Side,

Mich.

Actual Facts! \$85.00 to \$150.00 A WEEK EASY Selling "NEVER STUCK" TIRE LUGS Guaranteed to Work Where Chains Fail!



Salesmen in every State are making \$100.00 a week and more demonstrating and selling this amazing new tire lug. Nothing like it. The only practical lug that can be put on after you're stuck. NO JACK NECESSARY—Will outlast your car. Stop getting stuck in sand, mud or snow.

26 Million Autos Need "NEVER STUCK"

"Never Stuck" Tire Lugs Made of Steel.

Safety First! Save towing charges. The only lug that fits any tire from $3\frac{1}{2}$ to 6 inches, (without adjusting). Write today for our special offer to representatives.

HIRE MFG. COMPANY 3024 N. ADAMS STREET PEORIA, ILLINOIS

SPORT BODIES FOR FORDS

at FACTORY PRICES

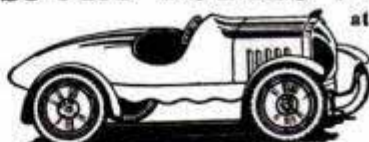

This Model in Grey Prime **\$38⁵⁰**

Hi-compression heads, underslung parts, 3:1 gears, headlights, cow/lamps for Ford & Chev. Seat Covers for all cars, Bicycles, SPORT FACTORIES, Dept. A-3, AURORA, ILL.

Send 10c for catalog showing all models of bodies for Fords and other equipment. Also radio, boats, tents and camping outfits.

All Separate Machines in Boice's Home Work-Shops

Here's one of Boice's seven new Workshops. Three individual machines—not mere attachments—each separate and complete in itself. Always ready to do three different jobs—sawing, jig sawing and lathe turning. Heavy duty motor gives plenty of power.

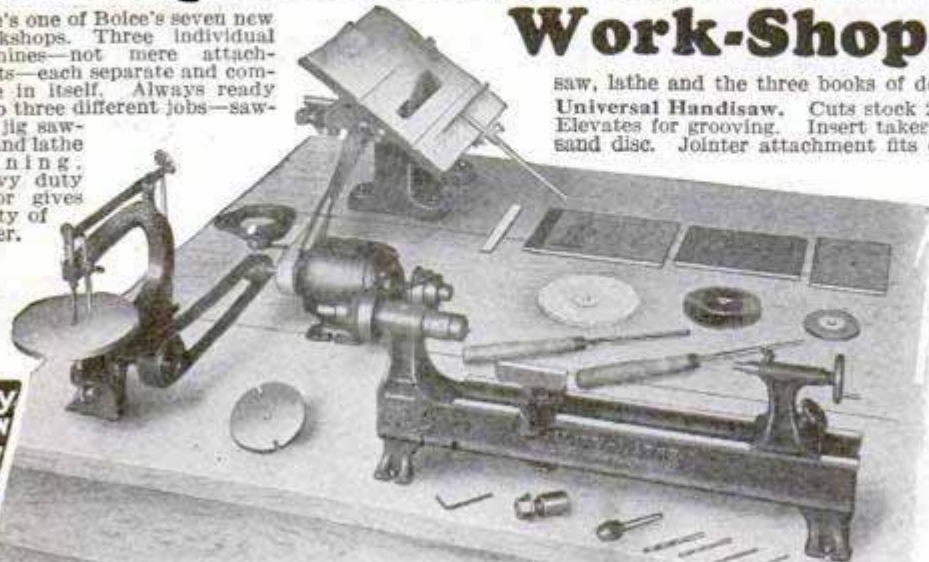

saw, lathe and the three books of designs it includes.

Universal Handisaw. Cuts stock $2\frac{1}{2}$ ". Elevates for grooving. Insert takes dado head $6 \times 1\frac{1}{2}$ " and also cope heads and sand disc. Jointer attachment fits on right of table. Guides always remain parallel to saw regardless of tilt or elevation of table. No other saw of equal cost has this feature.

New Jig Saw. Vertical stroke $1\frac{1}{2}$ ". Saw-to-frame 10". Table tilts 45° . Uses blades $\frac{1}{4}$ " to $\frac{3}{8}$ ". Bronze bearings.

Utility Lathe. 8" swing, 19" C. to C. or, Handilathe 7" swing, 40" C. to C. Each has 3 speeds.

Send 10c for new 1929 catalog of 80 pages. Describes complete line of 15 different Boice-Crane Machines and 7 different complete workshop installations that can't be beaten for practicality and low cost. We also make 12" and 14" Band Saws and 4" Jointer.

W. B. & J. E. Boice, Dept. P.M. 5-E, Toledo, Ohio

Buy Now Pay Later

SHOOT THE REAL THING!



Here is that famous genuine pump boys everywhere are turning to. Single stroke outshoots all others. Two to three strokes now give full shooting force. New rear peep sight, leak-proof valves, fully enclosed action. A beauty. Amazing accuracy. Full factory guarantee for one year. Uses regular air rifle lead shot. Photo shows flattening power at 80 ft. on steel target. The biggest money's worth in genuine air rifles ever offered.

"The Shooter's Art" FREE
Tells how to hold, aim and handle rifles; helps you guide others in correct knowledge of guns. Gives facts that make crack shots. Contains safety and common sense instructions every parent and boy should have. Helps to make boys leaders. Your copy free. Write at once.



NEW MODEL "G" \$5 at your dealer's or sent postpaid

BENJAMIN

Genuine Pump Air Rifle
BENJAMIN AIR RIFLE & MFG. CO., 645 N. Broadway, St. Louis, Mo.



Aching Burning FEET

Relieved in 3 seconds

JUST smooth this fragrant, ivory-white vanishing cream on your swollen, aching, burning feet—and all the fire and pain is drawn out in 3 seconds.

That's because Coolene, as it is called, contains a marvelous new combination of penetrating oils and healing unguents, in addition to frankincense and myrrh—two soothing ointments used by the ancients to relieve foot tortures caused by hot desert sands. These ingredients reach the cause of foot trouble—the inflamed, congested nerves and veins, bringing glorious foot comfort in 3 seconds—or no cost!

For real all day comfort get Coolene now. See how quickly it eases the pain from corns and bunions—how it reduces swelling—softens up the hardest callouses. Instant relief—or money back. Sold at all good drug and department stores.

COOLENE LABS., 27 W. 20th St., N. Y. C.

COOLENE



I Pay \$18 a Day

New proposition offers steady employment and chance to pocket \$18 cash every day. No experience needed. Simply demonstrate and take orders for new Comer Raincoats in your locality. You risk nothing. Keep present job and try in spare time. Smith, spare time worker, made \$14 in 2 hours. No investment. Sample outfit free. Write today. COMER MFG. CO., Dept. W-5142, Dayton, Ohio

AMAZING BURNER

Use

Ordinary Kerosene

The most startling heat producing burner ever made. Indispensable on the farm, in factory, for boiling, cooking, and heating. Ideal for butchers, dairies, repair shops, stoves, boilers, ovens, cooking equipment and numerous other uses. Will boil any quantity desired in half the usual time.

BOILS 50 GALLONS IN LESS THAN HOUR

TERRIFIC HEAT!

SILENT BLUE FLAME
NO NOISE
NO SMELL
NO SMOKE
NO SOOT



Think of it! Improved oil burner produces twice the heat of city gas at half the cost. Regulate to any degree desired. So simple. Easily installed and operated. Double generator assures continuous operation without shut-downs. Nothing to wear out. Starts in a jiffy. Will last allifetime. Every burner guaranteed fully to give complete satisfaction.

"I would not take \$500 for it if I could not get another," writes J. H. Cox, Mich. "It is worth its weight in gold and is the best on the market." J. B. Ashcraft, O. "Produces terrific heat and saves lots of kerosene." H. C. Kistler, Pa.

Also Burners for Cook Stoves and Heaters
Let us send you our catalog of Improved Therm-O-Gas Burners.
HOME MFG. CO., Dept. 3113, 20 E. Kinzie St., Chicago

A BIG MACHINE at LOW PRICE!

DOES 20 DISTINCT WOODWORKING OPERATIONS

TURN YOUR HOBBY INTO INCOME!

Just \$25.00 BRINGS IT TO YOU FREE TRIAL

No trick at all with this amazingly low price Woodworker, which you may try, and pay for, on terms, to turn idle hours into profit. Does 20 wood-working operations. Ideal size, capacity for shop, home or the job. Economical to operate. The best buy in the market!



COMES COMPLETELY EQUIPPED!

Comes complete with 8-in. Cross Cut, 8-in. Rip Saw; 12 in. Band Saw; Jointer, Lathe, Borer, Sander, Guides, Electric Motor. Investigate it!

FREE Working Drawings of Items You Can Make

SEND FOR FULL DETAILS!

A. S. ALOE CO.
1831 Olive St.,
St. Louis, Mo.

Without obligation, send me details on the Woodworker, and the Free Trial and Easy Terms Plan.

NAME

ADDRESS

Book of 100 Homes FREE!

"The Stratford"

5 Rooms, Bath; Monthly Payments



Buy Direct from Mill!

Easy Payments—Save up to \$2,000—Write!

We furnish lumber, millwork and other materials. Plan-Cut at mill, shipped to your station. Each piece sawed, cut and notched to fit—Save 30% labor cost and 18% lumber waste. Gives you stronger tighter home. Easy to build—many put up own homes. Architect's plans and full instructions furnished Free. One **guaranteed price** covers all materials. Send for Free Book of 100 Home Plans, 15-year payment plan, and lowest wholesale prices.



Gordon-Van Tine Company
1345 Case St., Davenport, Iowa

Please send free catalogs and monthly payment plan.

I expect to build.....

Name.....

Address.....



FIRIEIE!

Booklet of Advice on CLARINET and SAXOPHONE PLAYING, by Alexandre Selmer and Andy Sannella, world-known authorities. More authentic information than in ten private lessons. Mention instrument in which you are interested.

Selmer

58 Selmer Bldg., Elkhart, Ind.
In Canada: 516 Yonge St., Toronto



The Outboard Motor "That Folds Like a Jackknife"



Snap! When the Elto Lightweight is through for the day, you snap it "closed" — simple as shutting a pocket knife! Then it measures only 22" by 11" by 11"—easy to carry and stows anywhere.

The Super *Elto* Lightweight

It's the most compact outboard motor in the world, and the most practical for average needs. Catalog mailed on request. Write Elto Division, Outboard Motors Corporation, Mason St., Dept. AA, Milwaukee, Wisconsin.

The Lightweight weighs only 38 pounds, develops 3 horsepower. Drives average boats 7 to 10 miles an hour. Easy to start, extremely quiet.



DEALER and SET-BUILDER Bargains

Transformers, 75c. Condensers, 50c. 2 Mfd. Condensers, 65c. Rheostats, 25c. Potentiometer, 35c. 30 henry Chokes, 90c. Vogue Loop Antennas, without base, 95c. Tubes, 201A, 60c. UX171, \$1.50. UX226 A.C., \$1.00. UX280, \$1.75. UX227, \$1.75. Raytheon, B.H., \$2.85. Crosley Cone Unit, \$2.00. Dials, 4", 10c. Battery Cable, 25c. Aerial Kits, 75c. Send money order with order. Complete list upon request. CHAS. HOODWIN CO., 4240 Lincoln Ave., Dept 523 Chicago
Dealers in Bankrupt Radio Stocks

FLY THIS ARMY PURSUIT SHIP!

Light and fast, this one-foot model is a realistic copy of a single-seater military pursuit plane. Will rise from ground by own power and fly 60 ft. Can be used indoors or out. Has air service insignia on wings, incolors. Construction set includes ready-made aluminum propeller, shaft, rubber band motor, stream-line wood wheels, pre-cut balsa wing ribs and all other parts, with clear directions. Can be assembled in 3 hours by average 14-year old boy, without tools. Complete set, packed in unbreakable mailing tube, only 75c, postpaid in U. S. Send check or money order today (no stamps). Print address plainly. Satisfaction or money refunded.



LOGAN TOY WORKS, 35 E. Gay St., COLUMBUS, O.
(We cannot make C. O. D. shipments. No retail catalogue issued)

Buildin' Clippers!

is real sport—Hancock sends you all the parts you need from sanded hull to spars, anchor, bell, rigging line, blocks, deck houses, cabin, hatches, skylight.

Flying Cloud finishes 20" long. Sent for \$11 plus 5 lbs. postage. White metal figurehead 50c. Frigate Constitution, 55 guns and all parts, special at \$33, plus 7 lbs. postage. Booklet "She's a Clipper" sent with catalog.

ROY HANCOCK, 323 Douglas Ave., Portsmouth, Va.
... Rush Flying Cloud \$11 plus postage.
... Send illustrated catalog 10c enc.
... Send frigate Constitution for master set.

Name.....
Street.....
City..... State.....



L.L. Bean Manufacturer
Freeport, Maine



1929 Spring Catalog

FREE CATALOG

Just off the press. Shows 50 items of footwear, clothing, tents, etc., for the fisherman and motor camper.

L. L. BEAN

360 Main St., Freeport, Maine



Speeditwin—
20 H. P.,
6 to 45 M.P.H.

3 to 45 M.P.H.

More fun than flying!

FOR the whole family—“Evinruding!” For canoe, hunting skiff, rowboat, runabout, speed hull and small cruiser there’s an Evinrude for the job. Four “Twin” models—2½, 6, 14 and 20 horse power. More power, more speed, more features for 1929—underwater exhaust, water-proof ignition, easy starting made still easier, torpedo-streamline, pressure-vacuum cooling (no moving parts), self steering. Easy payments as low as \$31.10 down. Write for new free Evinrude Year Book.

EVINRUDE MOTOR COMPANY
2428 27th St., Milwaukee, Wis.

EVINRUDE

CRESCENT

\$65.00 buys a genuine 4' Crescent bench jointer, complete with powerful universal motor, ball bearings and guard. Ask for circular giving complete description.

Other Crescent machines that will help turn out your wood work to advantage are band saws, saw tables, self feed rip saw, shapers, jointers, variety wood worker, planers, planer and matcher, disk gripper, cut off table, swing cut off saws, borers, hollow chisel mortisers, tenoners, universal cut-off saw, universal wood workers.

THE CRESCENT MACHINE CO.
93 Columbia St. Leontia, Ohio

Send for **FREE BULLETINS**

Cal. 30-40 Six Shot



KRAG CARBINE

All the qualities of a high price rifle. In fine used condition, all working parts guaranteed for one year. Send today for our Free 50-page illustrated catalog of money saving values; Guns, Ammunition, Cutlery, Sports and Gov't goods. Terms Cash. No C. O. D.

W. Stokes Kirk, Dept. P. M. 5, 1627 No. 10th St., Philadelphia, Pa.

Price
\$9.75



**VICAM STANDARD
MOVIE CAMERA**

Make your own action movies of events, trips, parades, etc. Takes 25 feet of standard film. Equipped with F.5 universal lens. Loads in daylight. Films developed free.

\$13.50
F.O.B. Phila.

Film can be projected from any standard projector. Order today C. O. D. or send 10c in stamps for illustrated booklet.

VICAM PHOTO CO. 1224 Belmont Ave. PHILA., PA.



No. 414—Standard weighs 5½ lbs. Capacity ¼" in steel. Complete with 8' of best grade rubber-covered cord and plug. \$30.00



Drilling is only one thing this **POWER** tool does

Drilling metal or wood is only one of many jobs you can handle easily with this Millers Falls Standard Drill.

Buffing or polishing the nickel work of your car takes seconds instead of half an hour or more. A wire scratch brush slipped into the chuck will remove old paint quickly.

Instead of digging carbon out with the old putty knife, get a wire end brush busy at 1000 R. P. M. or better. You'll get a swift job and cleaner than you thought possible.

You can buy this drill separately—or as part of the Millers Falls Electric Toolshop. This Toolshop includes 21 separate attachments for drilling, cutting, sawing, sanding, polishing and grinding.

But—it's more interesting to TRY this good tool than just to read about it. Write us, and we'll tell you where you can handle it yourself.

The price? Much less than you thought for such quality—The Portable Drill, \$30.00—The Electric Toolshop, including the Drill, \$68.00. Saw Table, \$10.00 extra.

Millers Falls Co.  Millers Falls, Mass.

A Complete Line from ¼" Standard to ¾" Heavy Duty
**MILLERS FALLS
ELECTRIC DRILLS**



SAIL ON THE GREAT LAKES

The Detroit & Cleveland Navigation Company, operating lines between Detroit, Cleveland, Buffalo and Chicago, will be pleased to assist you in planning a vacation in the Great Lakes country.

Booklets containing pictures and descriptions of many delightful summer resorts including Niagara Falls, Mackinac Island, St. Ignace, Les Cheneaux Islands and Coryell Islands will be mailed you, without cost, upon request.

FOUR-DAY ALL-EXPENSE CRUISE, Detroit, Mich., to Chicago, Ill., and return, via Mackinac Island and St. Ignace. Hostess, music, dancing, bridge, teas, deck games; three hours at Mackinac Island. Round trip fares including meals and berth, between Detroit and Chicago, \$60; Mackinac Island and St. Ignace and Chicago or Detroit, \$30; Buffalo and Chicago, \$79; Cleveland and Chicago, \$71.50.

DETROIT AND CLEVELAND, overnight service, daily. Fare, \$3.00 One Way; \$5.50 R. T. **DAYLIGHT STEAMERS,** June 25 to Sept. 3, daily, except Sundays, July 4, and Labor Day. Fare, \$2.50 One Way.

DETROIT AND BUFFALO, overnight service, daily. Fare, \$5.00 One Way. Concerts by Finzel's orchestra, dancing, radio programs. Visit Niagara Falls and witness the wonderful illumination.

Autos carried on all steamers; wireless; meals and berth extra; no surcharge; unlimited stopovers. Fast Freight Service on all Divisions.

For information or reservations, address E. H. McCracken, G. P. A., 8 Wayne Street, Detroit, Mich.

**DETROIT & CLEVELAND
NAVIGATION CO.**



Into the woods with a reliable Taylor Compass in your pocket! No fear of lost trails or missing landmarks. The Leedawl or Ceebynite will guide you safely home. If you are a "hiker," canoeist or Boy Scout a Leedawl or Ceebynite should be included in your equipment.

Write for illustrated compass book. Better still, go to your sporting goods dealer and have him show you the compasses themselves.



**CEEBYNITE
COMPASS**

points the
way in the
dark.

ask your Dealer

Taylor Instrument Companies

ROCHESTER, N. Y.

Makers of Scientific Instruments of Superiority

An Airport

All your own!

WATCH the gleaming metal monoplane go taxiing out of its hangar—all three propellers spinning—then go "banking" round and round the field.

Just like life! Can you think of any toy an up-to-date boy or girl can have more fun with? Both

toys strongly built, all of steel. Plane has 15-in. wing spread. Long-running speed motor. Disc wheels, real rubber tires. Hangar 18 in. wide. Ask to see them at your toy dealer's. If he hasn't them in stock, order direct. We will ship parcel post paid, at above prices. Kingsbury Mfg. Co., 832 Myrtle St., Keene, N. H.

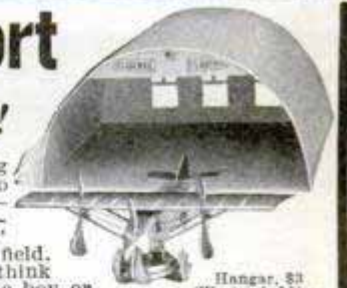

Hangar, \$3
(West of Miss. \$3.20)
Tri-Motor Plane \$2.00
(West of Miss. \$2.20)
Both Toys \$4.50
(West of Miss. \$4.95)

KINGSBURY Motor TOYS
Driven

SEND 10c for unique Eraser. A Kingsbury Monoplane wheel with tire of eraser rubber. Toy Catalog Free.

Build a CLOCK for Pleasure or PROFIT!

FREE BOOK shows how YOU can Make Fine Clocks Right at Home

Check full of Clock-Making and Money-Making ideas. Gives full details, descriptions, prices of movements and parts. Write NOW for your copy.

THOUSANDS of men have built our Clocks. For their own use—or to sell at money-making prices. It's easy, fascinating. Only ordinary tools needed. We furnish plans, instructions, parts. Works all assembled, ready to install, as low as \$1.65; others with chimes at all prices. You make the case, or simply assemble knock-down parts. Cash-in on the demand for craftsmen-built Mantel Clocks, Banjo Clocks, Grandfather's Clocks. Here's a hobby that PAYS—in pleasure, in ownership and in spare-time or full-time PROFITS!

Write for FREE Catalog and Special Blue Print Offer

American Chime Clock Company
1670-E Ruffner St., Philadelphia, Pa.

SPIRIT OF TIME
BANJO CLOCK



COMPLETE
PLANS and
INSTRUC-
TIONS—
FREE!

Build these of metal yourself!

Be up-to-date! The latest airplanes, trucks, etc., are of ALL-METAL construction. Build your models that same way! Working with metal is fascinating fun. It's easy to make an all-metal monoplane model like the "Spirit of St. Louis" or an all-metal model army truck with the complete Plans and Instructions we give you FREE.

All the materials you need are tin, wire and solder. You can get these anywhere and soldering is made simple with Kester Metal Mender—the genuine wire solder with the flux right inside. We send you a FREE sample to use.

There's a new thrill for you in building things of metal. Win a Metalcraft Merit Medal! Be the first in your neighborhood! Just write today for FREE Plans and Instructions and we'll mail you full particulars about the Medal Awards with them.

CHICAGO SOLDER COMPANY
4205-04 Wrightwood Ave. Chicago
Makers of Kester Metal Mender Established 1899

Own a CORONA

The Champion Portable Typewriter

Write for handsome descriptive booklet—free!



L.C. Smith & Corona Typewriters Inc., 51 Madison Ave., New York, N.Y.

42 Miles on 1 Gallon

Amazing New Vapor Gas Saver
For All Make Autos. Spare or full time Agencies Wanted. Big Profits.

1 SENT TO INTRODUCE

MOISTURE does it. Increase mileage 1/4 to 1/2. Faster getaway. More power. Higher top speed. Eliminates hard carbon from engine. CRITCHLOW, Inventor, RB-805, WHEATON, ILL., U.S.A.

DEAF

Hear After Using Radio

Many people heretofore deaf are hearing after using radio. Sympathetic sound vibration can cause locked parts to move again. The principle used has been embodied in a self-contained device, the SYNCRO-VIBRATOR, which has given wonderful results. Some helped immediately. No radio needed, nothing to wear, but just a simple home treatment. Full details on request. Address Yorke Burgess, Consulting Electrical Engineer, Crystal River, Florida. Dept. 6-B.

Christensen Wanted Money -

Now He Has a Business of His Own



Louis Christensen read an ad just like this, and decided that if so many other men were making money filing saws on the Foley Automatic Saw Filer, he could too. He sent in the coupon and soon started his business. Now he writes: "I am having a new shop built, and will have as good a saw filing shop as any. I have quite a lot of work to look after. People are coming from all directions to have their saws filed on my Foley Filer, and they pay me more than anyone else. I like the saw filing game very much."

FREE PLAN Helps You

Here is an opportunity for you to get into a FINE PAYING CASH BUSINESS of your own. Our FREE PLAN helps you get started in your spare time. Very little capital required—no stock to carry. Hundreds of men have started on the road to SUCCESS AND INDEPENDENT INCOMES. You can do it too if you send for our FREE PLAN.

No Experience Necessary

No special knowledge or past experience is necessary. You can file all kinds of saws perfectly by following the simple instructions. Micheal Brinza says, "I received the Foley Filer and learned to operate it in a few hours."

No Canvassing — There is a tremendous field from which you can get all the business you can handle because the Foley does such good work. Hardware stores, carpenters, contractors, farmers and hundreds of others will bring their saws to you to be filed. E. J. Hudson says, "People come from miles around because they like the way I file their saws on my Foley."

Start in Spare Time — You can make **GOOD MONEY** while you are starting, in your spare time. S. C. Moller, a carpenter, says, "I intended to keep my own saws sharp and do some filing on the side, but soon found that I would have to quit one or the other, so started filing. Now I have built up a nice business that is better than carpentering."

Send Coupon for FREE PLAN

Get started in your own CASH BUSINESS at once. Hundreds of men are making GOOD MONEY—so can you. Mail the coupon TODAY for FREE PLAN and complete information.

FOLEY SAW TOOL CO., Inc.
239 Foley Bldg., 11 Main St., N. E.
Minneapolis, Minn.

Please send me FREE PLAN telling me how I can start my own business in spare time and make GOOD MONEY with the Foley Automatic Saw Filer.

Name.....
Street.....
City..... State.....

REAL One-Dial Control



The sections of Hammarlund "Battleship" Condensers are matched to within 1/4 of one percent. Absolute precision can be obtained by attaching a Hammarlund Equalizing Condenser to each section. Recesses in the frame provide for this.

Made in 350 mmfd. and 500 mmfd. sizes in two, three and four gangs.

Hammarlund Radio Products are used in many of the best circuits featured by Popular Mechanics. Watch for them—it will pay you.

HAMMARLUND MANUFACTURING CO.
424-438 W. 33rd St., New York, N. Y.

For Better Radio Hammarlund PRECISION PRODUCTS



This 260 Page
Wholesale Radio Catalog
A Liberal Radio-Edu-
cation Within Itself!

FREE

Containing 75 radio
hook-ups, 1,000 illustra-
tions, 6,000 articles.

Build your own with Rasco parts.
Positively lowest prices in the country.

Radio Specialty Company
98E Park Place NEW YORK, N. Y.

DON'T PUT UP WITH A-C HUM!

Good radio means undistorted quality and an inconspicuous background. In A-C receivers, it is possible to reduce hum to a minimum with the *Hum-Dinger*—an improved center-tap resistor, instantly adjustable with ordinary screwdriver. Foolproof. Sturdy. Simple to install. Available in all necessary resistance ranges. Panel or baseboard mounting. And only 75 cents!

Ask your dealer to show you this new item as well as other Clarostat products. Or write us for details on how to improve your radio.

CLAROSTAT MFG. CO., Inc.
286 North 6th St. :: Brooklyn, N. Y.

CLAROSTAT

The Ounce of Prevention

AMPERITE automatically prevents "A" current fluctuations, lengthens tube life, improves set operation. Entirely unlike fixed resistors. A type for every tube—battery or A.C.

Radiall Company
50 FRANKLIN ST., NEW YORK



FREE New "Amperite Blue Book" gives latest construction data. Write Dept. PM5

AMPERITE

REG. U.S. PAT. OFF.

The "SELF-ADJUSTING" Rheostat



Shielded-Filtered

"Aero-Call" SHORT WAVE CONVERTER

Factory-Built, Ready to Plug Into Your Present Radio Set
The Aero 1929 Converter is a compact factory-built short-wave adapter equipped with special short-wave coils. It is designed for both A. C.

and D. C. sets. Operates perfectly without motorboating, by an auxiliary filter system control, an exclusive feature (patent applied for). It can be plugged into any regular radio set. This amazing radio instrument now makes it possible for you to reach 'round the world—England, Germany, Holland, Australia, Panama, Java and many foreign stations are some that are tuned in regularly on short wave. Permits you to enjoy international programs and many others from coast-to-coast that your regular receiver cannot get. What a thrill it is to plug this into a tube socket on your regular set and instantly be in another world! No change or wiring required. All complete, ready to operate, tubes and coils hidden, no apparatus in sight, except the neat, golden brown, compact metal cabinet in crackle finish. Size, 9x5 1/4 x 2 1/2 in. The only converter we know of that really works on all sets. Two models—A. C. and D. C. Write for Catalog and literature, or send \$25 and name of your dealer. Model A for A. C. sets; Model D for D.C. sets \$25.00, at leading dealers' and jobbers'

AERO PRODUCTS, Incorporated

4611 E. Ravenswood Ave., Dept. 459, CHICAGO, ILLINOIS

**ELECTRIC
OR
BATTERY**

See guarantee
AC-8
\$71.50

Ultra 8
\$49.88



Lighted
1 dial

**TRY IT
30 DAYS FREE
BEFORE YOU BUY**

Factory to you. Save 50% on latest AC Electric or Battery Radio. Free return privilege.

Big choice of cabinets

MIRACO

Radio's most amazing bargains direct from big, old, reliable maker. Don't buy unless 30 days you prove entire outfit unobtainable at 2 to 3 times the price, for tone, selectivity, distance, volume.

Free Catalog and BIG SPECIAL OFFER
9th Successful Year
407-UM Miraco Bldg., Cincinnati, O.



FREE RADIO CATALOG

Since the dawn of Radio, Barawik has been known the world over as headquarters for radio set builders and fans. Here, under one roof, is everything you need—sets, parts, supplies—thousands of products—ready to ship to you the same day your order arrives. Barawik prices save you money. Barawik service saves you time. Barawik merchandise always pleases. A quarter million satisfied customers say, "Barawik is Best." Let us send you the Big Barawik Book free and prove it to yourself.

BARAWIK CO., 105 Canal St., CHICAGO, U. S. A.



"You're there with a CROSLLEY"

Genuine neodymium battery type Handbox 855
AC Electric power speaker GEMBOX 865
THE CROSLLEY RADIO CORPORATION
Cincinnati, O. Powel Crosley, Jr., Pres.

Send for WESTERN RADIO New 1929 Catalog

LATEST and FINEST, nationally known A. C. sets, consoles, cabinets, speakers and accessories at LOWEST PRICES. Catalog sent FREE on request.

WESTERN RADIO MFG. CO.
128 W. Lake St. Dept. RPM-5 Chicago

PUT THIS WORKSHOP IN YOUR HOME

FREE For 10 Days—No Deposit!

A New and Improved Workshop

Here is a workshop built to a standard of perfection—accurate in operation—most durable in construction—easy to operate. It is absolutely dependable and will withstand severe constant service. Try it for ten days at our expense and you will be convinced of its superiority.

Suitable for Carpenters, Home Workers, Pattern Makers, Etc.

Furniture manufacturers use MAC—the Popular Mechanic Workshop—for making furniture models. Manual Art Schools use it for instruction. Home workers use it for pleasure and profit. Carpenters use it for making repair parts, spindles, chair legs, cabinets. It is ideal for making all kinds of furniture.

mac
THE POPULAR MECHANIC
TURNS, RIPS,
CROSSCUTS, DRILLS,
SURFACES, POLISHES,
GRINDS, CUTS SCROLLS.
A PERFECT
WORKSHOP

The Lowest Price for Such a Sturdy, Complete Workshop

MAC, THE POPULAR MECHANIC, represents the utmost in value and dependability. Now you can have an accurate, practical workshop at a big saving. Once you use MAC you will be convinced of its superior qualities. That's why we want you to try it for 10 days at our expense.

**NO
DEPOSIT**

**A YEAR
TO PAY**

**GET
DETAILS
QUICK**

MIDLAND APPLIANCE CORPORATION

Dept. 510, 219 N. Michigan Ave.
CHICAGO, ILL.

MODEL NUMBER 70

Wagner 1/2 H. P. Motor, 8 1/2 inch Sander Disc, Circular Saw, Jig Saw, 30 inch Lath with 9 inch swing, Black & Decker 1/2 inch Drill, Electric Glue Pot, Accessories include 5 inch Dia. Face Plate, Spur and Cup Type Wood turning Centers, 3/4 inch Three-jaw Geared Chuck, Arbor and Flange, 6-inch Cotton Buffs, 6 inch Wire Brushes, 5 inch Emery Wheel, Adjustable Tool Rest and Tool Supports with Eed Clamp, Two Turning Tools and Socket Wrenches.



Filters a Gallon Every 4 Minutes



Low Priced—Guaranteed
Amazing new invention—patented Home Filter for fruit juices and beverages. Nothing like it. Removes all sediment, pulp, fibres. Filters a gallon every 4 minutes. **Perfect results guaranteed.** No moving parts. Simple. Practical. Low priced. Lasts a lifetime. Thousands already in use.

FREE HOME TRIAL—Agents Wanted
Try free at our risk and return if not satisfied. Send name and address TODAY for full particulars of this liberal offer. Act NOW. AGENTS WANTED.
HOME FILTER CO., 425 CENTRAL AVE., BAY CITY, MICH.

Establish a Good Future

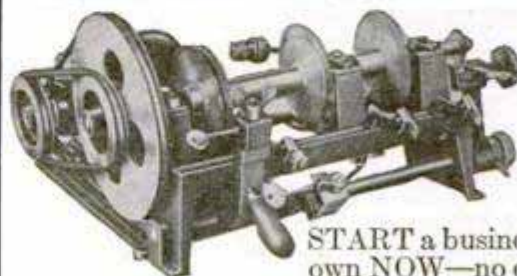

**DON'T
BE A
SHOP
WORKER**

START a business of your own NOW—no experience necessary. The only key machine that cuts ALL kinds of keys. No hand-filing. Make first keys by number without taking locks apart. Instructions furnished free.
WRITE TODAY.

BEISSER KEY MACHINE COMPANY

407 Fort St. East

Detroit, Mich., U. S. A.



BOYS! BOYS! BOYS! Throw Your Voice

Into a trunk, under the bed, under a table, back of the door, into a desk at school, or anywhere. You get lots of fun fooling the teacher, policemen, peddlers, and surprise and fool all your friends besides.

THE VENTRILO

is a little instrument that fits in the mouth out of sight. Cannot be detected. It is used in connection with the above, and with the aid of this wonderful **DOUBLE**

THROAT, or **VENTRILO**, you can imitate many kinds of birds, animals, etc. Remember you get everything for **ONLY TEN CENTS**—a booklet giving you full instructions how to become a ventriloquist and throw your voice, the **Double Throat**, or **Ventrilo**, and our big 600 page catalog of novelties, tricks, puzzles, masks, books, etc., **ALL SENT POSTPAID TO ANY ADDRESS FOR ONLY 10 cents**



LEARN TO PITCH

By the world's greatest pitchers. Prepares you mentally, morally and physically to become a great baseball player and a great athlete. Special course of lessons by **CHRISTY MATHEWSON**, who explains the secret of how to throw the great "FADEAWAY" ball, so much feared by the great batters; **ED WALSH**, and unhitable "SPIT BALL"; **JOE WOOD**, the "Smoke Ball" marvel, next to the speediest pitcher in the world; **WALTER JOHNSON**, the man who has struck out more league batters in a single season than any other pitcher known; **NAP RUCKER**, inventor of the "Knuckle Ball"; and **DOC WHITE**, who teaches you the art of **Shadow Pitching** by which you can develop control and speed necessary to become a star pitcher. Clearly described and illustrated by 56 pictures. Everything complete for **ONLY 25 cents** postpaid anywhere. Nothing more to buy.

the pitcher who discovered the secret of throwing that famous, mystifying, and unhitable "SPIT BALL"; **JOE WOOD**, the "Smoke Ball" marvel, next to the speediest pitcher in the world; **WALTER JOHNSON**, the man who has struck out more league batters in a single season than any other pitcher known; **NAP RUCKER**, inventor of the "Knuckle Ball"; and **DOC WHITE**, who teaches you the art of **Shadow Pitching** by which you can develop control and speed necessary to become a star pitcher. Clearly described and illustrated by 56 pictures. Everything complete for **ONLY 25 cents** postpaid anywhere. Nothing more to buy.

MAGICIAN'S BOX OF TRICKS

Apparatus and Directions for a Number of Mysterious Tricks, Enough for an Entire Evening's Entertainment..... \$1.00

ANYONE CAN DO THEM

It is great fun mystifying your friends. Get this Conjuror's Cabinet, and you will be the cleverest fellow in your district. It contains the apparatus for ten first-class tricks, including the **MAGIC BALL AND VASE TRICK** (a wooden ball is placed inside, and upon replacing the lid has disappeared and is found in someone else's pocket); the **HINDOO TRICK CARDS** (can be made to change completely no less than five times); **DISAPPEARING COIN BOX** (a coin, placed in the wooden box, vanishes entirely or changes into a coin of another denomination); the **GLASS GOBLET TRICK** (a coin is dropped into a glass of water and when the water is poured out the coin has vanished and is found somewhere else); the **RIBBON FACTORY FROM THE MOUTH TRICK** (a seemingly endless supply of colored paper ribbons comes out of your mouth); the **DISAPPEARING HANDKERCHIEF** (a handkerchief held in the hand mysteriously vanishes); the **WIZARD'S RING COIN TRICK**; the **ENCHANTED BOTTLE** (no one but yourself is able to make it lay down); the **GREAT HAT AND DICE TRICK** (a large hat is placed on top of a hat, disappears, and is found underneath yet no one has touched the hat), and last, but not least, the **GREAT PHANTOM CARD TRICK**, or two from five leaves nothing. Full instructions are sent for performing each trick. In addition to the above, a number of other feats and illusions are fully explained for which you can easily make or procure the necessary apparatus. **Price complete \$1.00 postpaid. JOHNSON SMITH & CO.**



U. S. BABY TANK

25 Cents



It goes with real Yankee Pep—by its own power

Most remarkable toy ever invented. By drawing the Tank backward, either with the hand or over the floor or table and then placing it down, it will crawl along, overcoming all obstacles, in the same life-like manner as the larger Tank that proved so deadly in the great war. What makes it go is somewhat of a mystery, for there is no mechanism to wind up, as is usually understood with mechanical toys, yet this tank will keep plodding along ten times longer than the ordinary run of toys. It will perform dozens of the most wonderful stunts: 2 1/2 inches long. **Price only 25c prepaid. Stamps accepted. JOHNSON SMITH & CO.**

toys, yet this tank will keep plodding along ten times longer than the ordinary run of toys. It will perform dozens of the most wonderful stunts: 2 1/2 inches long. **Price only 25c prepaid. Stamps accepted. JOHNSON SMITH & CO.**

15c POSTPAID Card Sailer Pistol



It shoots small squares of cardboard, sending them spinning and sailing through the air to great distances. Length 8 3/4 inches. Wood barrel, metal handle, heavy rubber band. Plenty of ammunition and extra rubber with each gun in neat box. More ammunition can be made as desired. Can use without the ammunition as a fly killer. **PRICE ONLY 15c each, 3 for 40c, or \$1.35 per doz. postpaid. Stamps accepted. JOHNSON SMITH & CO., Dept. 838, RACINE, WIS.**

them spinning and sailing through the air to great distances. Length 8 3/4 inches. Wood barrel, metal handle, heavy rubber band. Plenty of ammunition and extra rubber with each gun in neat box. More ammunition can be made as desired. Can use without the ammunition as a fly killer. **PRICE ONLY 15c each, 3 for 40c, or \$1.35 per doz. postpaid. Stamps accepted. JOHNSON SMITH & CO., Dept. 838, RACINE, WIS.**

Great Fire Eater

A great trick by which you can apparently breathe fire from mouth, to the horror and consternation of all. Quite harmless. All apparatus necessary sent complete in box for **ONLY 30c. p. pd. JOHNSON SMITH**

SQUIRT ROSE



25c

A REAL STARTLER. This is the most popular of all squirt tricks. The flower in your coat looks so fresh and sweet that everyone is tempted to inhale the delightful perfume. Then in the moment to press the bulb. Gee-hillikens. Don't they jump? There is a very long rubber tube that easily reaches to the pocket of your coat or trousers, and the bulb is large enough to make a dozen shots with one loading. **PRICE 25c each, or 3 for 65c postpaid.**

SEEBACKROSCOPE

Place this clever instrument to your eye, you see what is going on behind your back. Very interesting things sometimes occur when no one thinks you are looking. Just like having eyes at the back of your head. **PRICE 25c POSTPAID**



Send remittance (Postage Stamps accepted) for all articles listed above also in our other ad on previous page

RESURRECTION PLANT

Great curiosity. Place in water, plant opens up and starts to grow in few minutes. Taken out it dries up and goes to sleep until put in water again. **PRICE 10c, 3 for 25c, 75c dozen, postpaid.**



DISSOLVING VIEWS



50c
You may have a lot of fun with this little peep show. A regular startler. Made entirely of metal, having a microscope lens fitted into one end. While the victim is absorbed in admiration of the pretty picture, and turns the button in the confident expectation of seeing something interesting, a spring syringe is brought into action, and the observer experiences a very great surprise. **50c p. pd. Johnson Smith & Co., Dept. 838, Racine, Wis.**



Comical Motto Rings

Lots of harmless fun and amusement wearing these rings. Made in platinumoid finish (to resemble platinum), with wording on enameloid, as illustrated. **Price only 25c Postpaid.**

The "Little Giant" Typewriter



A First Class Writing Machine For \$1.50

A perfect little typewriter for \$1.50. There are thousands of persons who would like to use a typewriter but whose needs and business do not warrant the expense attached to the purchase and use of a fifty or seventy-five dollar machine. To such persons we confidently recommend our Little Giant. It is strongly made, but simple in construction, so that anyone can quickly learn to operate it, and write as rapidly as they would with pen and ink. The letters of the alphabet 1 to 10, and the punctuation marks being together. With this machine you can send your best girl typewritten love letters, address envelopes, make out bills, and do almost any kind of work not requiring a large, expensive machine. With each typewriter we send a tube of ink and full printed instructions for using the machine. **Price complete \$1.50 by mail postpaid to any address in the world.**

JOHNSON SMITH & CO. Dept. 838 Racine, Wis.



Where's the can of PLASTIC WOOD?

(Reg. U. S. Pat. Off.)

YOU don't like cracks and ants, dust and insects around your shelves any more than your wife does. But it's not a hard job to keep your kitchen insect-proof and sanitary. Cracks and holes in the shelving, around the baseboard, in cabinets, and behind the drainboard are so easily filled permanently with Plastic Wood! A small can goes a long way, and if desired, you can paint, varnish or lacquer it to make the job as ship-shape and snug as anyone could wish.

Freshen up the home for spring. There's no better time than now, and Plastic Wood will do much of the work. It handles like putty, and hardens into wood. It is waterproof and greaseproof, adheres firmly to wood, metal or other material, and will not crumble or disintegrate.

Plastic Wood Solvent

Plastic Wood can be thinned or softened with Plastic Wood Solvent. The Solvent will also clean hands or tools after using, and a few drops in the can keeps Plastic Wood soft. Plastic Wood Solvent comes in 25 and 50 cent cans.

Handles
Like
Putty



Hardens
Into
Wood

1 lb. can \$1.00 ¼ lb. can 35 cts.

At Hardware and Paint Stores

ADDISON-LESLIE CO., 415 Bolivar St., Canton, Mass.

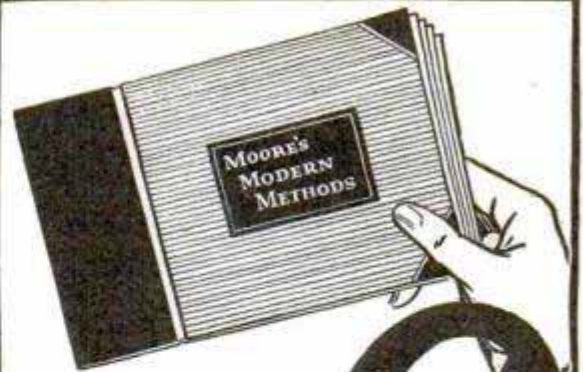

140-Page Book of record-keeping forms, filled in to show you their uses. It answers problems of accounting for office, factory and professions. This Free Book describes and illustrates Moore's Security 4-Post Binders, the simplest, easiest handled on the market. To insert or remove sheets takes but a moment. Low in cost—long in life. Moore's Binders are Different.

Write for this Free Book
on up-to-date
Loose-Leaf equipment

Free

A great help
toward simple
and accurate
record-keeping

Write for it
today!

JOHN C. MOORE CORP. Est. 1839
5088 STONE STREET ROCHESTER, N. Y.

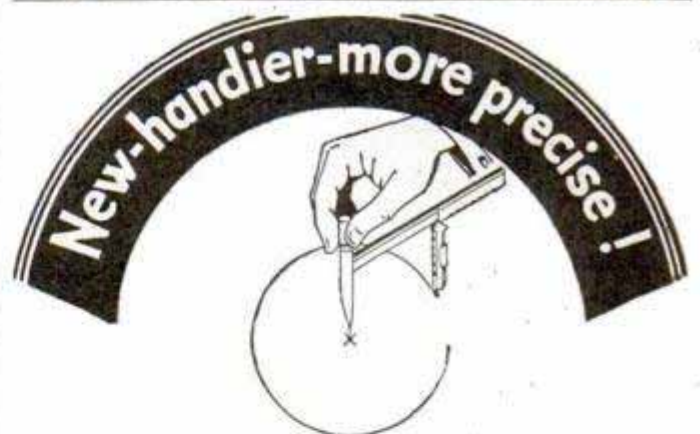

ON a new principle—keeps both needle and lead vertical—no digging in the paper. Accurate settings right on the beam. Makes circles up to eight inches across—yet fits easily in your vest pocket.

Only 50c—at your stationer's, or direct prepaid, from Esterbrook Pen Company, Camden, New Jersey.



Special! My 1929 Offer to You



**I Will Save
You Money**
Read my 1929 Offer to You

FREE

Your choice a gold watch chain or beautiful strand of pearls with every watch sold. Offer good for limited time only.

In addition to our New Low Price, I will send for your approval one of these Standard Watches, guaranteed for a lifetime of satisfactory service, not only by the Santa Fe Watch Company, but by the Great Illinois Watch Factory. They are found in the pockets of men in the service on every railroad in this country. Senators, Congressmen and Governors keep their official appointments by "Santa Fe Special" time. Army Officers and Privates carried them all through the Greatest War in history—thousands of these splendid watches are in use all over the World. If you want one on my liberal new **LOW PRICE PLAN**, you had better write for my Free Watch Book today and make your selection without delay. I will send the Watch for you to see **WITHOUT ONE PENNY DOWN**—I will even allow you to wear the Watch 30 days **FREE**—then sell it to you on a binding money-back guarantee.



**Save 1/3 to 1/2 of Your Money
Most Liberal Offer Ever Made**

Our "Direct-to-you" low wholesale terms and **EXTRA SPECIAL DISTRIBUTION PLAN** is fully explained in the New Santa Fe Special booklet just off the press. The "Santa Fe Special Plan" means a **BIG SAVING** of money and you get the **BEST** watch value on the market today. I want you to see all the newest designs in the new thin model Santa Fe Special in both white and green gold—the handsome sturdy case models



designed for our famous Santa Fe Mogul Watch—the very newest creations in Men's Strap Watches, sturdy in design and beautifully engraved in both white and green gold and the artistic Ladies' Bracelet Watch, in many shapes and designs in white gold, some with diamond and sapphire settings. No matter what your choice of a watch may be, there is a Santa Fe Watch for you.

Write for FREE Watch Book Today

shows newest watch case designs in 4 colors. **READ** the so-called **SECRETS** of watch making. **READ** how you can save from **ONE THIRD** to **ONE HALF** of your money—Buy "Direct." The wise man will act quickly if he wants a watch. **EASY PAYMENTS TO SUIT YOU**—Don't delay—Fill out and mail the coupon below for the **FREE** Watch Book.

SANTA FE WATCH COMPANY
56 THOMAS BUILDING TOPEKA, KANSAS



SANTA FE WATCH COMPANY,
56 Thomas Building, Topeka, Kansas.

Please send me the New Watch Book with the understanding that this request does not obligate me in any way.

Name.....

Address.....

City.....State.....



3 "Wonder" Outfits sent to you on 15 Days Approval *Money Back Guarantee*

FREE \$5.00 Book of Blue Prints, Showing 46 PRIZE PROJECTS with purchase

Price Includes 1/3 H. P. A. C. Motor

factory or the home; will rip, cross cut, bevel, miter, mortise, groove, drill, tenon, grind, rabbet, buff and polish. Motor is mounted on a base that is a part of the machine proper. Run from any light socket, also provides power for other purposes when the saw is not in use. Complete with attachments and price includes 1-3 H. P. Motor, 60-cycle, 110-Volt A. C. Price \$35.00 F. O. B. Chicago. Shipping Weight 100 lbs.

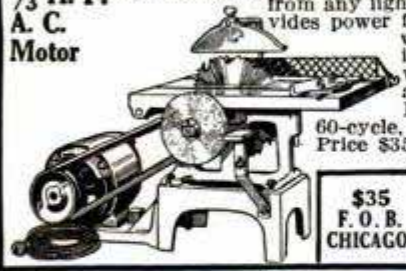

\$35 F. O. B. CHICAGO

Write for Complete Illustrated Folder—Dealers Wanted.

The S&B "Wonder" Lathe Outfit is the biggest value in lathes you can find. Heavy channel iron bed makes lathe rigid and prevents vibration. Head and tail stock in perfect alignment permits of fast and accurate work. This lathe is built for long service and hard use. Accessories to complete the S&B "Wonder" Lathe (as illustrated) \$16.60 extra.



\$35 F. O. B. Chicago

12" Band Saw—At this LOW PRICE you can NOW do the 1001 things you wanted quickly and easy. This 12" BAND SAW has a tilting table and sturdily built. Ideal for the shop or home. \$35 F. O. B. Chicago. Motor \$15 extra.



SCOTT-BANSBACH MACHINERY CO.
130 So. Clinton St., Dept. 114, CHICAGO, ILL.

Now You Can Own— Diamonds 60% of Market Prices



A 3/4 CENTURY HOUSE offers this 3/4 less 1/16 carat, snappy, solitaire just \$69.50. Try to match at \$115.00. A reason you rarely think of, makes possible RADICALLY LOW PRICES, even for FINEST QUALITY DIAMONDS. Offers backed by thoroughly responsible guarantees. Examination Free. Send now, use blank below.

Why Pay Full Prices?
World's oldest, largest diamond banking institution of 75 years, rated over \$1,000,000.00, must sell the DIAMONDS on WHICH MONEY was LOANED BUT NOT REPAID, Diamonds, too, from BIG CASH EUROPEAN DEALERS. Send NOW. Lists limited. Free—all details.—Exact descriptions.—Guaranteed amounts you can borrow. Examine Diamonds free, at our risk.

Unpaid Loans—Low as \$60 per Carat

Name.....
Address.....
For Free List clip this now, fill in and mail to—
Jos. DeRoy & Sons, Opp. F.O.1980 DeRoy Bldg., Pittsburgh Pa.

NOTE: These offers made by a 1/2 Century Old Firm. Bank References by permission.—Bank of Pittsburgh, Union Trust Co., 3rd Nat'l Bank; Any Mercantile Agency.

ELECTRIC SPRAY GUN



For applying Paint, Lacquer, Disinfectants or any liquid. Operates from light socket. An even pressure at all times insures perfect performance. The nozzle controls density of spray. Price complete, \$37.50.

Universal Motor.

Weil Lectrospray Co., 2648 E. Fort St., Detroit, Mich.

TYPEWRITERS ALL STANDARD 10 days FREE Trial at 1/2 PRICE

Underwood, Remington Royal, etc. ONLY 14¢ A DAY
All late models, completely refinished brand new. GUARANTEED for ten years. Send no money—big free catalog shows actual machines in full colors. Get our direct-to-you easy payment plan and 10 days' trial offer. International Typewriter Ex., 188 W. Lake St., Dept. 594, Chicago, Ill.



Ford Owner Stop that ruinous chatter on your car. MAKE THIS TEST—take out your floor boards, pull your emergency brake back and forth. If you notice play at the ball joint, you need Bredar's Ball Shim. Price \$3.50. Ask your Dealer or order direct. Demand Bredar's Shim.
NIC BREDAR'S SON MFG. CO., Rock Island, Ill.

District Sales Manager Wanted Who Can Make \$20,000 This Year

To handle our business on most phenomenal selling item on the market today. This is an electrical specialty selling direct and to trade. It is an easy seller if there ever was one, but we must have a man in each section to handle our orders. He must be thoroughly experienced and have a record of production. Apply at once by wire or letter, giving qualifications. G. Trippe, Pres., 319 West Ohio Street, Chicago.

Pin a Dollar to this Special Offer



\$1 Buys 5 Window Brown Tri-Tone Steerhide PASS CASE
ACTUAL \$2.50 VALUE
Genuine leather case made with turned-in sewed edges, gold filled corners—for lodge cards, auto license and other identifications.
3 WINDOW CASE \$1.50 13 WINDOW CASE \$2.00

FREE Your name stamped in 22K gold including any lodge or organization emblem—Masonic, Shrine, O. E. S., B. P. O. E., K. of P., I. O. O. F., etc.

N. J. MASONIC SUPPLY CO., Manufacturers
841 Broad St. Dept. M. M. NEWARK, N. J.

HOME CRAFTSMEN! Save Money!
Know Your Wood! Cabinet-Wood Samples (20 pieces), walnut, mahogany, rosewood, maple, etc. Fancy Inlay Wood Samples (20 pieces), oriental walnut, tigerwood, vermillion, ebony, etc. One Dollar brings either set postpaid. Five pieces basswood, 5 1/2 by 24 in., two pieces 3/4 in., three pieces 3/8 in., all five for one dollar postpaid. Clear kiln-dried wood, cut to size, write for price list. **CRAFTSMAN WOOD SERVICE, 715 E. 62nd St., Chicago.**

ANNOUNCING SPORS GUARANTEED NO. 1 PEN

SELLS FOR \$1.25
SEND ONLY
39¢ "Writes Like a \$7 Pen."
(Sent Post-paid)

Use 60 Days
Money Back If Not Pleased



WRITE FOR FREE WHOLESALE CATALOG SHOWING OVER 400 ARTICLES

F. SPORS & CO., 329 Main St., LESUEUR CENTER, MINN.

Hi-test footwear for high-powered feet

You pick a nice fast one! It comes clean over the heart of the plate! You swing! *Crack!* The ball zips like a scared jack-rabbit between second and short! Boy, *you run!* A single or a two-bagger? Come on feet—open up! . . . that's baseball!

Keds will give the motors in your legs full-throttle and flying speed, for Keds are light, tough, springy sports and play shoes.

Remember, Keds are much more than ordinary "sneakers." Made over special foot-health lasts, Keds have specially designed safety-soles which grip the smoothest surfaces, and absorb the roughest shocks. Keds have been endorsed for years by leading physicians and coaches.

With Keds on your feet, take turns just as fast as you please. You won't skid. You can lace Keds tight, too—so your feet can't slip or chafe. And Keds' strong-grip eyelets won't pull out.

Remember that Keds offer the most

complete assortment of styles and models for all indoor and outdoor sports activities. You'll find Keds in the best shoe stores in town—at all prices, too, from \$1.00, \$1.25, \$1.50, \$1.75 up to \$4.00.

Keds—Keds—Keds—Look for that name stamped on all genuine Keds.

Write for our new booklet containing all kinds of information on games, sports, camping, vacation suggestions and dozens of other interesting subjects. Dept. 2570, 1790 Broadway, New York City.

Keds

REG. U.S. PAT. OFF.

United States



Rubber Company

The more you pay, the more you get—
but full value whatever you spend.



Keds Gladiator

A medium price, sturdy shoe for all-round use. Patented "Feltex" insole keeps the foot cool and comfortable. Reinforced toe gives extra protection at point of hardest service. Special non-skid sole. Grins at punishment.



Keds Mercury

The winner in the popular-price field and a wonderful shoe for the money. Tough amber-colored sole. Black athletic trimmings and ankle patch. Nickel eyelets. "Feltex" insole. For an exceptional value ask your dealer for Mercury.



We'll pay for Your Test

Accept this 7-day trial tube at our expense. Prove these remarkable claims for this unique shaving cream. Mail the coupon

GENTLEMEN:

With a product such as ours the advertising problem is chiefly to get you to make this 7-day test. For results have proved that 86% of men adopt Palmolive Shaving Cream—once they try it.

A seven days' test on your own face beats all the laboratory tests that we can make.

Now, if you will return the coupon below, we will give you new ideas of shaving comfort. For we believe in proving our claims first—then asking you to buy.

Shaving preparations had not kept pace with shaving needs. We studied long, then asked 1000 men's advice. They told us others' shortcomings. And we set out to fulfill them. 129 formulas, tried and discarded, finally brought success. Five unique features were attained.

Suited or not, you owe it to yourself to try this remarkable shaving cream. So won't you mail the coupon now?

PALMOLIVE RADIO HOUR—Broadcast every Wednesday night—from 9:30 to 10:30 p. m., eastern time; 8:30 to 9:30 p. m., central time; 7:30 to 8:30 p. m., mountain time; 6:30 to 7:30 p. m., Pacific Coast time—over station WEAJ and 37 stations associated with The National Broadcasting Company. 4542

7 SHAVES FREE

and a can of Palmolive After Shaving Talc
Simply insert your name and address and mail to Palmolive, Dept. B-3063, 595 Fifth Ave., New York City.
In Canada, address Palmolive, Toronto, 8, Ont.

(Please print your name and address)

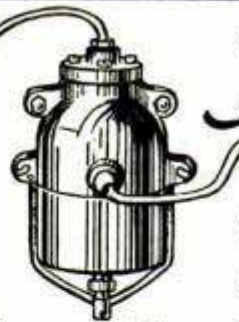

Fits Any Car
**Amazing
NEW
IDEA**

**- Saves Gas -
- More Power -
- More Miles -** **BANISHES
VALVE TROUBLES**

The Pierce Vapo Valve Oiler overcomes the present deficiencies in motor lubrication and avoids wear and damage to the valves. Makes any motor run better, smoother and quieter.

**Saves 95% of Your
Motor Troubles**

Eliminate your valve troubles—Get Better Compression. New and old cars alike need it. No more sticky valves. Perfect control under all speeds—Lubricates instantly.

**30 Days' FREE Trial
on Your Car**

MONEY BACK GUARANTEE

Try it on your car 30 days and if not delighted, your money will be refunded.

Dealers Wanted

THE W. C. PIERCE COMPANY
2431-C Prairie Avenue CHICAGO, ILL.

**THE BEST
THING
FOR
YOUR
CAR**
**PIERCE
MOTOR
VALVE
OILER**

**WRITE!
TODAY!**

Silver Ace Flying



"It's hot sport to see how good you are flying your Silver Ace." Says Air Mail Pilot

S. J. Samson, who flies the Air Mail between Chicago and New York says "Silver Ace Flying is great fun. The little ships are certainly well designed. Their maneuvers in the air are fascinating. It's hot sport to see how good you are in flying your Silver Ace."

Flying Enthusiasts the World Over

are always attracted by the beauty, scientific design and flying performance of Silver Ace models of the Ryan, Stinson, Fokker and Fairchild types.

Silver Ace models and quality supplies are sold, ready to fly or as construction sets, by the best dealers nearly everywhere. Send 10c for our new 32-page booklet in colors, "Silver Ace Flying."



AERO MODEL CO.
Dept. M5, 111 North Wacker Drive
Chicago, Illinois



Mammy Goes Home

by Radio



Steps right out thru powerful local Chicago stations, and finds Birmingham, Alabama

with **New Radio Invention**

"I Sho' was Happy!" says Mammy Jo

Mammy Jo was waiting up for us—her eyes rolling with excitement. She had been lonesome all day, she said. Even with the radio for company, she was blue—just pining for a voice from home. We knew she used to try often to pick up broadcasts from Southern Stations, but without any success. However, that was not surprising; strong local stations had always smothered out distant ones on my radio.

"I think that Radio's gone crazy," now cried Mammy joyfully. "I just thought I'd find me some peppiah music to cheah with the dials. Nex' thing I knows, the announcah man says I's listenin' to Station WAPI, at Bum-min'ham, Alabama—and thah I was, down in my Own Home Town! I listens to that station fo' a long time, and I sho was happy. Dey ain't got music like dat up heah. No, SUH! I sho' does think dat thing has gone crazy."

Ground Wave Reception

"No, it hasn't, Mammy," I laughed. "You've just been getting Ground Wave Reception with my new antenna, Subwave-Aerial. Until yesterday, I had my antenna up on the roof. That's why air noises and all the big powerful broadcasting stations we have around here in Chicago kept out-of-town stations away. Don't you remember, Mammy, you asked me yesterday why I was digging a hole in the ground under this window—and I told you I was digging up a new radio?"

Subwave - Aerial Recommended By Licensed Radio Operator

"After thoroughly testing your Underground Antenna I find that it gives entirely satisfactory results. I would recommend it in place of inside aerials, roof aerials or loop aerials, for reasons of clearer reception, reduced pick-up of outside interference and static, easy and convenient installation and it is non-directional."

Yours truly,
WM. STRINGFELLOW.

(Reprinted by permission of Mr. Stringfellow)



"Yes, Suh," grinned Mammy. "But does you-all mean to say dat aerial business got me my home town?"

"That's right, Mammy," I assured her. "You know it's the aerial that picks up radio waves and brings them to the set. When the aerial is in the ground, it's protected from a lot of interference. From now on you can probably go back to Alabama every night."

Reduces Static—Gets Clearer, Sweeter Tone

That was explanation enough for Mammy Jo. But when I told my friends how my new Subwave-Aerial reduces noise, gets clearer reception on both near and far stations, better selectivity, too, and much finer tone—and that it didn't cost me a cent more than an ordinary aerial—and is guaranteed for 25 years—every one of them wanted to know all about it and to try one.

YOU Can Test Subwave-Aerial FREE

When Subwave-Aerial can get results such as illustrated by the story above, why let noise and interference keep you from getting distance on your radio?

Now you can try out this wonderful new radio development without risking a cent. We feel confident that when you've heard the amazing difference in reception, and realize the great convenience of this modern combined antenna and ground, you'll wonder how you ever put up with the old, inefficient, dangerous method. Hurry and send for all the interesting details about Subwave-Aerial! Mail the coupon today!

UNDERGROUND AERIAL PRODUCTS

Suite 618, St. Clair Building, Dept. 805-G.W.
St. Clair and Erie Streets, Chicago, Ill.

UNDERGROUND AERIAL PRODUCTS,
Suite 618, St. Clair Bldg., Dept. 805-G.W.,
St. Clair and Erie Streets, Chicago, Ill.

—Rush illustrated literature on the new Subwave-Aerial and details of your Free Test Offer. No obligation to me.

Name.....

Address.....

City..... State.....



Remington
Knives R 4223
PRICE \$2.00

PUT THIS IN YOUR POCKET or TOOL KIT

RAZOR-SHARP, sturdily built, and bladed just right for the man or boy who makes things—Remington Knife R 4223.

Professional carpenters and mechanics take to this knife on sight. You'll find it in the pockets or tool kits of many skilled workers with tools. And it's the same with amateurs who make a hobby of carpentry.

There's a husky spear blade, a pen blade for fine work and a sheep-foot blade for marking. Finest high-carbon steel—hand-honed at the factory. Tough stag handle.

See this knife at your dealer's. If he hasn't it in stock, send his name with \$2.00 for R 4223. It will be mailed promptly, postpaid.

REMINGTON ARMS COMPANY, Inc.
113 Years of Quality
25 Broadway New York City

Remington



\$25 to \$30 A DAY In Your Own Business

That is what Woodmancy, of Minnesota, and many others have done during the season with the Foley Electrakeen Lawn Mower Sharpener. Start your own business in your garage, basement, attic, or any place. **THREE DAYS' PROFITS PAY FOR THE MACHINE!** You can make more money during the summer than many men make in a whole year. Others have done it, and YOU can too.

Foley Electrakeen Lawn Mower Sharpener

Don't let this **WONDERFUL OPPORTUNITY** go by! Don't hesitate for lack of money—**VERY LITTLE CAPITAL NEEDED.** Get started at once, early in the season and make **BIG MONEY** this summer.

Easy Work—Simple to Operate No Experience Necessary

This simple little machine sharpens all kinds of lawn mowers. Turns out a perfect job in a short time. You can learn to operate it quickly. Adjustments are few and simple. It will make **BIG MONEY** for you.

Get Started NOW! There are hundreds of lawn mowers right in your vicinity that will be sharpened this summer. **YOU** can do it, and **EARN A STEADY INCOME.** Write for complete information **QUICK—DON'T DELAY.** In two weeks you will be making a **FINE INCOME.** Get started in the **BIG MONEY** now—**W R I T E!**

Foley Saw Tool Co., Inc.

Mower Dept. A, 11 Main St., N. E., Minneapolis, Minn.



Beautifully Illustrated **Aviation and Marine Supply Catalog** Postpaid 25c

Features Aviation and Aviators' Supplies and Equipment, Marine Supplies, **MODEL AIRPLANE SUPPLIES** and **MODEL AIRPLANES** and **PARTS**, Seaplane-type Speedboats, Seaplane Floats, Ice Boats and Snowsleds, Outboard Motor Boats, **SKIBOARD**, the self-propelled aquaplane, German Air Gliders, Shop Tools and Equipment. Will save you hundreds of dollars. Gives you information unavailable elsewhere on how and where to obtain supplies and materials for constructing your own speed crafts. Send quarter for your copy of this Catalog **AT ONCE.**

INTERNATIONAL ENGINEERING CORP.
707-B, Westory Bldg., Washington, D. C.

The Delta Handi Electric Shop

Patented Jan. 2, 1929

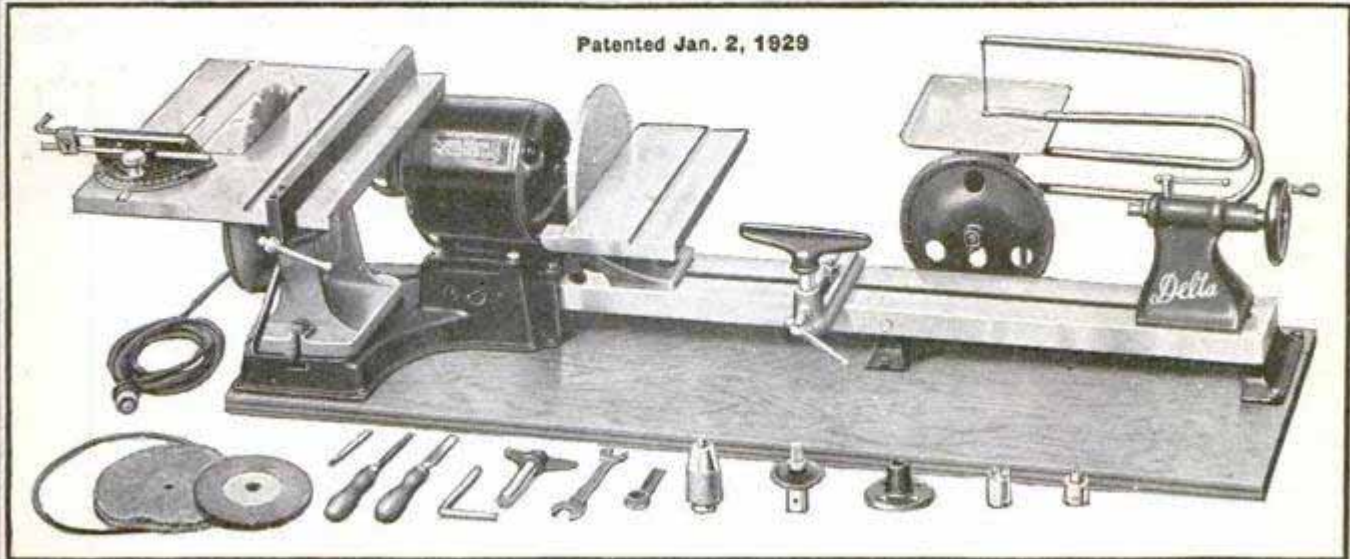

Designed for Efficiency in Operation

Practical craftsmen appreciate this man-sized, motorized workshop, with its carefully planned, efficient design. The "Delta" is equipped with a smooth-running, powerful, two-shaft motor. Permits carrying on two or three important operations at one time without continually dismantling set-up. Much-needed Circular Saw available 90% of the time! Also has heavy Triple Foundation Lathe Bed (no rods), guaranteed not to chatter; Improved Patented Tilting Tables on Circular Saw and Sanding Disc; Automatically Oiled Bronze Bearings. Comes completely assembled, thoroughly tested, on heavy veneered wooden base. Many new exclusive features in 1929 model—new low price.

Enjoy the thrill of Working with Quality Machinery

Make the things you have always wanted to make, with this sturdy, full-sized equipment. Save money on repair work—earn money in spare time. It is so easy—so quick, with the "Delta." Complete Handi-Shop includes all necessary equipment for Circular Sawing, Wood Turning, Scroll Sawing, Sanding, Drilling, Grinding and Buffing. Full instructions and complete set of working blue-prints furnished.

Sent on 10 Days Trial Easy Terms

Without obligation, you can test the Handi-Shop under actual working conditions for 10 days in your own home. Send at once for FREE illustrated literature, giving complete description of the new 1929 Model "Delta" Handi-Shop, and full details of 10-Day Trial Offer and Easy Payment Plans. Dept. A-59

Delta Specialty Co.
1661-1667 HOLTON STREET
MILWAUKEE, WISCONSIN



BLUE PRINTS INCLUDED
With each Handi-Shop, at no extra cost, is furnished a complete set of working drawings. Above are a few of the hundreds of useful articles you can make quickly and easily with this practical workshop.

Delta Specialty Company, Dept. A-59
1661-C7 Holton St., Milwaukee, Wis.
Please send me, FREE, illustrated literature describing 1929 model "Delta" Handi-Shop. Also details of 10 Day Trial Offer and Easy Payment Plans

Name.....
Address.....



SQUAB BOOK FREE

Breed squabs and make money. Sold by millions at higher prices than chickens. Write at once for free 48-page book beautifully printed in colors telling how to do it. You will be surprised.
PLYMOUTH ROCK SQUAB CO., 634 H Street, Melrose Highlands, Mass.



FOY'S BIG BOOK, in Colors

A complete guide to successful Poultry and Squab Raising. Low prices on CHICKS, Breeding Stock and PIGEONS.
Write Today! FREE!

FRANK FOY, Box 18, Clinton, Iowa



RAISE CHINCHILLA

AND NEW ZEALAND WHITE FUR RABBITS
Make Big Money We Supply Stock and pay you following prices for all you raise: Chinchillas average \$3 each—New Zealand Whites \$2 each. 32-page illustrated book, catalog and contract, also copy of *Far Farming* magazine, tells how to raise rabbits for big profits, all for 10c. Address: OUTDOOR ENTERPRISE CO., Box 1021 Holmes Park, Missouri

WRITERS VERSE OR MUSIC
Brilliant Opportunity
I have been associated with the large publishing companies all my life and I will help you get your songs before audiences and into music stores with beautiful title pages and fine orchestrations. Write
BURRELL VAN BUREN 1844 McClurg Bldg., Chicago

WET CELLARS MADE DRY from the Inside!

DAMP musty cellars are unsanitary, a danger to health and a poor place to store valuable material.

Where water or moisture seep in through cracks or porous spots in the floor or walls, you can make and keep your cellar dry and sweet—a fit place to work, free from odor, mold and rust—by filling the cracks and coating the moist surface with Smooth-On No. 7.

This is the one practical waterproofing that you can apply yourself, easily, from the inside, to wet or dry surface and with every assurance of thorough watertightness, even in the wettest seasons.

Excellent also for patching concrete floors, waterproofing garage, stable and washroom floors, brick walls, cisterns, septic tanks, water troughs, fountains, fish ponds, swimming pools, manure pits, etc.



Write for
FREE BOOK

About 25 pounds of Smooth-On No. 7 are required for each 100 square feet of surface covered, and no experience is necessary. Complete instructions on the package.

Sold in 5-pound cans and 25, 50 and 100-pound kegs.

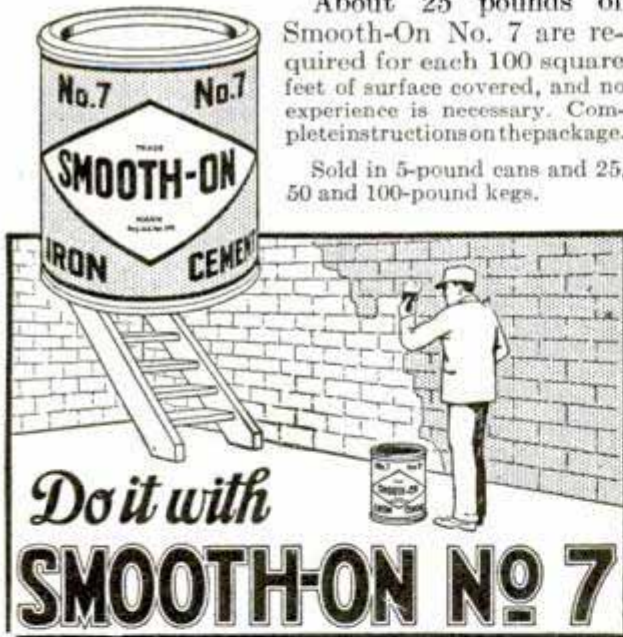

SMOOTH-ON MFG. CO., Dept. 37,
574 Communipaw Ave., Jersey City, N. J.
Please send the free Smooth-On Repair Book.

Name.....

Address.....

**Return this coupon for
FREE copy of Booklet**

One Year To Pay

No. A295 - \$59
\$5 Deposit - \$1 Weekly

You've never seen a more exquisite ring than this. The fine quality, full cut, genuine blue-white diamond is full of fiery brilliance. Two smaller, blue-white diamonds are set in the sides of this handsomely, hand engraved, 18 Kt. solid white gold, lady's mounting. Makes a wonderful engagement or friendship ring. Your friends are bound to admire this magnificent ring. Handsome gift case free.

10 Days Trial

No Red Tape

18 KT.

SEND NO MONEY When you get the ring, pay only \$5.00 to the postman. If you keep it, pay only \$1.00 a week for one whole year. All credit dealings kept strictly confidential—no unnecessary delay. **NO RED TAPE—10 DAYS TRIAL.**

We are an old **Money Back** firm of diamond importers. **GUARANTEE** You take no risk. If you are not satisfied that the ring is the biggest bargain you ever got, return it within 10 days and we will refund every cent you paid.

PRICE CUT TO \$59.00 - WORTH \$100.00

You can now buy this gorgeous ring at the wholesale price. Compare it with similar rings at \$100. We guarantee it to stand any test or comparison. Greatest bargain offered by any Diamond Importer. We allow 8% annual increase in exchange for a larger diamond ring.

Write for FREE Illustrated Catalog

It brings our large Jewelry Store right into your home. Gives weights, grades and complete description so you can buy diamonds like an expert. Gives information other jewelers dare not tell. Write today!

AGENTS WANTED—EARN \$200 WEEK. WRITE FOR DETAILS

STERLING DIAMOND & WATCH CO. INC.
DIAMOND IMPORTERS—\$1,000,000 STOCK—ESTABLISHED 1879
1540 BROADWAY DEPT. 2618 NEW YORK

When your eyes BURN!

Does exposure to sun, wind and dust make your eyes bloodshot and cause a burning sensation? Then you should use *Murine!* A few drops of this harmless lotion speedily ends the burning feeling and soon clears up the bloodshot condition.

Always apply *Murine* after motor-ing or outdoor sports to soothe and refresh your eyes. And also after reading or working to relieve eye strain. Write the *Murine* Co., 4 E. Ohio St., Chicago, for valuable free book on the care of the eyes.

MURINE
FOR YOUR
EYES

\$7000 a Year for YOU

New Profession CLARKE FLORKRAFTSMANSHIP Attracts over a thousand of Popular Mechanics Readers

If you want the kind of a job that pays \$5,000 to \$10,000 a year—a job you don't have to go to school or study in books to get—learn about Clarke FlorKraftsmanship.

1,300 Popular Mechanics readers are Clarke FlorKraftsmen now. They are their own bosses. They earn these big salaries. Many of them drive good-looking new automobiles they've bought and paid for as FlorKraftsmen. *And they got started by answering an ad like this.*

What FlorKraftsmanship Is

Making floors, new and old, velvet smooth and ready for the varnish or wax is the job of FlorKraftsmen. Once it was tedious, backbreaking work for a man with sandpaper. Now the Clarke Vacuum Portable Sanding Machine, weighing only 31 pounds, sands any floor velvet smooth almost as easy as a vacuum sweeper cleans a rug.

People have always paid big money for getting floors sanded. You are paid by the square foot. *The reason you make so much extra as a Clarke FlorKraftsman is that the Clarke sands faster and easier than any other method ever devised.*

\$25 to \$75 a Day

Get a pencil and figure this out! And remember all we say here about the work a Clarke Sander will do is guaranteed in writing—the only definite

\$25 to \$75 a Day
Get started toward one of these Big Pay Jobs. Full facts are Free. Mail Coupon.

Free Proof Tells Exactly
How Much Others
Earn and Why



READ what these POPULAR MECHANICS Readers Say

W. G. Roe, Clarke FlorKraftsman, Richmond Hill, L. I., N. Y.—"My Clarke is my 'Lindy'—he sure can fly over the work, in fact, I have made money; I have made from \$40.00 to \$45.00 per eight hours with it. I would never be without a Clarke, and with more work I will soon have two."

Roy P. Werntz, Barberton, Ohio: "I am doing very good with my Clarke. I have all I and my brother-in-law can handle with one machine and before long we will be wanting another."—Signed, Roy P. Werntz, a satisfied Clarke FlorKraftsman.

A. E. Sweeney, Alturas, Calif.—"I made \$76 the first week."

H. O. James, Mt. Sterling, Ky.—"I have already taken in \$348.00 for work and have 1,100 feet of old floors to do yet and some new ones too."

written guarantee of performance given by any sander. On new floors sanding prices range from 2 to 5 cents a square foot. The Clarke sands 800 to 2,000 sq. ft. a day. Suppose you do 1,200 square feet the first day and you're paid 3 cents a foot (a lower price than most Clarke men command), *you earn \$36 for 8 hours' work.*

In removing old varnish in houses you earn 7 to 15 cents a foot—and the Clarke sands 300 to 1,000 sq. ft. in 8 hours. That's an average of \$30 and up per day right from the start.

You Can Do It

What other Popular Mechanics readers are doing you can do. You need practically no capital. \$100 will start you as a FlorKraftsman. No office needed. No investment but your Clarke Vacuum Portable Sander and a few dollars' worth of sandpaper.

Get the facts. Don't delay longer if you sincerely want the luxuries and independence a bigger pay will bring you. Use the coupon placed here.

Be among the next 1,000 Popular Mechanics readers to win a worth while salary. *Act at once.*

MAIL THIS

CLARKE SANDING MACHINE CO.,
Dept. T-25, 3831 Cortland St., Chicago, Ill.

Gentlemen: Please tell me, without obligation, how I can make \$25 to \$75 a day as a FlorKraftsman.

Name.....

Address.....

City.....State.....



CLARKE SANDING MACHINE CO.
Dept. T-25, 3831 Cortland Street, Chicago, Illinois
Originators and, for 12 years, manufacturers of Portable Sanding Machines.



JAPANESE ROSE BUSHES

The Wonder of the World

Japanese Rose Bushes bloom all the year round. Just think of it. Six weeks after planting the seed, the plants will be in full bloom. It may not seem possible, but we positively guarantee it to be so. They will bloom every ten weeks, Summer or Winter, and when three years old the bush will be a mass of roses, bearing from five hundred to a thousand roses on each bush. The flowers are in three shades—white, pink, and crimson. The plants will do well both in and out doors. We guarantee at least three bushes to grow from each packet of seed. Price, 10c packet, 3 pkts. for 25c postpaid.

Chinese Fragrant Tree Fern

Just introduced; noted for its rapid growth. An exceptionally pretty ornamental plant. Foliage is rich dark green. Forms grand pyramidal bushes about 5 feet high. Branches very desirable for decorative purposes, wreaths, etc. Seeds 15c pkt., 3 for 40c.

Weather Plant

NATURE'S WEATHER PROPHECY
By mysterious changes that take place, this remarkable plant accurately forecasts the weather many hours in advance. Will grow anywhere all the year around. An interesting house plant. Bears large, fragrant, pink, butterfly shape flowers. Seeds, 15c packet, 3 for 40c, postpaid

GROUND ALMONDS

Amazingly Prolific—Easily Grown From Seed
The Ground Almond has a flavor that is MOST EXCELLENT, resembling the coconut. The meat is snow white, covered with a shell or skin of brown color. It grows close to the surface and anything from 200 to 300 Almonds may be expected from a single nut. There is no trouble whatever in growing anywhere and in any kind of soil. May be planted any time, and in eight or ten weeks from time of planting you will have an ENORMOUS CROP of the MOST DELICIOUS ALMONDS YOU EVER TASTED. Seeds 15c Pkt.



Perfume Plant

Blooms only at night, giving forth the most delightful scented fragrance for quite a distance. Causes much comment. For house or garden. Also valuable because of rare perfume made from it. SEEDS, 10c pkt., 3 for 25c.

SENSITIVE PLANT

Marvel of the Philippines. Leaves curl, fronds droop when touched. Apparently resents interference. A handsome shrub for house or garden; very curious and interesting. Seeds, 15c pkt., 3 for 40c.

Calabash or Pipe Gourds

A luxuriant and rapid growing climber; thrives anywhere. Produces the ornamental gourds from which the famous African calabash pipes are made. Grow this interesting vine and make your own. Seeds, with instructions, 15c pkt., 3 for 40c.

Japanese Nest Egg Gourds

Very curious. Produces fruit same size and shape and color of nest eggs. Matured fruit does not crack. Will serve for years as a nest egg, stocking darning, ornamental purposes, etc. Seeds 15c pkt., 3 pkts. for 40c, J.S. & CO.

Mammoth Peanuts

Peanuts can be easily cultivated. Their culture is very simple and exceedingly interesting. Mammoth Peanuts grow to an astonishing size. It is a good producer, very prolific, and the giant nuts have a thick, heavily ribbed protecting shell. The plant is very attractive, the leaves being of odd shape and a handsome green shade, tinted through the center with white. You will derive much pleasure cultivating this interesting species. Seeds 15c pkt., 3 pkts. for 40c.

Musk Plant

A universally admired favorite for house, flower garden or greenhouse. A very fine house plant. Lives for years. Is of the sweet scented variety, giving forth much fragrance. Also valuable on account of the perfume that can be made from it. Seeds 15c pkt., 3 for 40c.

Japanese Climbing Cucumber

Unusually strong and vigorous growing vine. Attains twice the size of ordinary varieties. Grows readily on fences, poles, trellises, etc. One hill will keep an entire family supplied all summer. Seeds 15c packet, 3 for 40c, postpaid.

GIGANTIC BUTTER BEANS

THE NEW EDIBLE VEGETABLE WONDER
Grows to an astonishing size, the Beans measuring from 3 to 6 feet long, and weighing anything from 10 to 16 lbs. and even more. One Bean is sufficient for a family for several meals. Very palatable and rich in nutritious materials. The delicate Buttery Flavor is much appreciated. The Vines are easily grown, very prolific, and a most welcome and valuable adjunct to your garden. Try them; you will find them the most delicious vegetable you have ever tasted. Imported direct. Unobtainable elsewhere. Sample package of seeds with full directions for cultivating and cooking. 25c, postpaid.

Kudzu Vine

Most rapid growing vine known. Will grow 20 feet in one week. Luxuriant foliage, lovely purple flowers, very fragrant. Nothing to equal it for shade purposes and quick growth. Seeds 15c packet, 3 for 40c.

Yard Long Bean

Produces enormous crop of long, slender, round pods, of excellent quality for snap beans. Pods grow from 2 to 5 feet in length. Very tender and fine flavor. The vines are rampant growers; an interesting, curiosity. Seeds, 15c pkt., 3 for 40c.

THE REMARKABLE FIREFLY PLANT

A Vine that Blooms at Night
Fills the Atmosphere with Fragrant Aroma
One of the most rapid growing vines known. Under favorable conditions this vine has been known to grow OVER 25 FEET IN A SINGLE WEEK. In a very short space of time indeed the Vine has climbed to a great height, and is covered with IMMENSE FLOWERS, from 5 to 7 inches in diameter. It is, indeed, a great novelty, for unlike other plants, the flowers OPEN IN THE EVENING, and remain open until about noon the following day. In dull weather they will remain open all day. It is a most INTERESTING SIGHT to watch the opening and closing of the flowers as the clouds appear and disperse. As the flowers open they give forth the most DELIGHTFUL AROMA and the whole atmosphere around is full of scented fragrance. It is always the object of favorable comment, and much curiosity is aroused by people passing at night time as to the cause of the charming aroma, frequently stopping in an endeavor to satisfy their curiosity. PRICE, 19 CENTS packet, two packets for 35 CENTS, POSTPAID. JOHNSON SMITH & CO.

The Great Wonderberry

A luscious berry that may be grown and ripened from seed in any soil or climate in 3 months. The flavor is fine and unsurpassed for eating raw, cooked, canned or preserved in any form. The fruit is blue-black in color, and tastes like a luscious, rich blueberry. One bush will produce an enormous amount of fruit, yielding great masses of rich fruit all Summer and Fall. Packet, 10c, 3 pkts. for 25c, postpaid.

Bush Musk Melon

A vineless Musk Melon, grows in bushes, and thus can be cultivated in the smallest garden. The fruit is of the popular "Jenny Lind" type, but larger, averaging 5 inches in diameter. The flesh is very deep, edible almost to the rind and is colored light green, flushed with salmon toward the center. The quality is superb, lusciously sweet and juicy. Packet of seeds, with full directions for culture, 15 cents, 3 packets for 40 cents, p.p.d.

The Great Umbrella Palm

A Graceful House or Japanese Conservatory Plant
Easily Grown From Seed Winter or Summer
The Japanese Umbrella Palm is a semi-aquatic plant. It is easily grown from seed either in a bowl of water or in very damp soil. Probably the most usual, as well as the most interesting method, is to cultivate the plant in a bowl or jardiniere filled with water, with two or three inches of good garden soil at the bottom. The seeds soon commence to germinate, and the plant shoots up stems two to three feet high and rapidly assumes a most pretty palm-like appearance, as shown in the engraving. The tops of the stems are surmounted by a whorl of umbrella-shaped leaves, of a waxy appearance. We will send a package of this seed, with full instructions for culture, for only 15c or three packets for 40c postpaid.

FAMOUS MEXICAN FIREFLY PLANT

Beautiful hedge plant, grows 2 to 2 1/2 feet high and resembling a closely clipped evergreen. The globe-shaped or pyramidal bushes are close and compact, and of a pleasing light green color. May be grown singly or in the form of a hedge or background. In early autumn the whole bush becomes carmine or blood red, hence the name of Mexican Fire Plant, or "Burning Bush," as it is sometimes called. Selected Seeds, 10c

Butterfly's Own Bush

This plant is a veritable refuge or haven for butterflies, and it attracts all the most beautiful types of butterflies to the neighborhood. Bees, too, are very fond of it. It is a pretty plant bearing perfectly double flowers, ranging from white to rich crimson, deep red and pink, lilac and other delicate shades. Packet 10 cents, 3 for 25 cents postpaid.

CROWN OF THORNS

A very curious clover-like plant, can be cultivated indoors or outdoors, the three red blotches on the leaves representing the three wounds of Christ. Has curious thorny seed ball; if loosened at tip the ball is found to consist of a long prickly-edged band wound spirally around the seed cluster, giving the plant its name. Seeds 15c packet, 3 for 40c.

"Wong-Bok" Chinese Cabbage

Novelty from China and should be grown in every garden. Seems to be a cross between Celery and Cos Lettuce. Flavor is more mild than any other cabbage. Can be served on the table and eaten raw or cooked like cabbage, spinach or lettuce or made into salad. Grows very rapidly, easy to cultivate. You can create quite a sensation by cultivating this remarkable novelty. Seeds, 15c packet, 3 pkts. for 40c.

Asparagus Sprengeri

The best plant for hanging baskets. Masses of rich, gleaming foliage droop in a very graceful manner. The foliage when cut for decorative purposes will last for weeks in water. The seed pods are very pretty red berries adding to its beauty. Packet, 25c, 3 pkts. for 65c postpaid

TREE OF HEAVEN

This splendid ornamental tree is a native of China, and is called the Tree of Heaven, on account of its great beauty. Very hardy, thrives in any soil, no matter how poor, and grows from 6 to 10 feet high from seed the first summer. The leaves are from 5 to 6 feet in any length, giving it a grand appearance. Nothing outside the tropics can rival it for lawn decoration. Large panicles of bloom, followed in season by great clusters of colored seed pods, make the tree a continual thing of beauty. Packet, 15c; 3 packets 40c

SURPRISE FLOWER GARDEN

Over Hundred Varieties of Mixed Flower Seeds
MANY RARE AND CURIOUS NOVELTIES
An Abundance of Flowers Assured Throughout the Season
A mixture of easily grown annuals that bloom very soon after sowing the seed; others vary in their time of blooming. Those who cannot give the constant care necessary for finely arranged flower beds will be delighted with the Surprise Wild Flower Garden. Will prove a continual surprise and pleasure, as new varieties and the old garden favorites flower successively throughout the season. There are over a hundred varieties of seeds. Many of the plants may be taken inside a house plants and will bloom during the winter. Fine for children, also teachers for school gardens. Packet, 15 cents, three packets for 40 cents, postpaid. J. S. & CO.



Bath Room Outfits \$55.75 COMPLETE UP.



Furnaces \$42.95 UP.

BIG BOOK FREE



Save 1/2 on Material
Save ALL Labor Cost

We Show How You Save Hundreds of Dollars Installing Your Own

PLUMBING and HEATING, FENCING, ROOFING and PAINTS

MAIL the coupon today and get this wonderful, Big FREE Book that lists 4000 great bargain offers and shows every little detail for installing your own plumbing and heating. Nothing like it ever printed before. Everything new, modern and up-to-date. Homes everywhere follow our instructions and save hundreds of dollars. You can do it too!

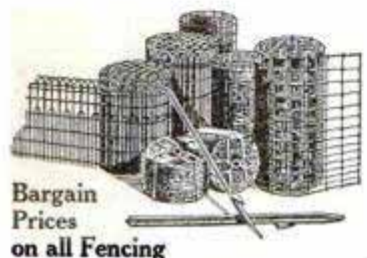

Bargain Prices on all Fencing

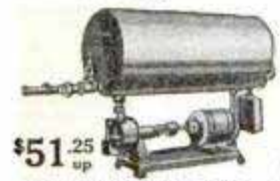

\$51.25 up Automatic Electric Water Systems

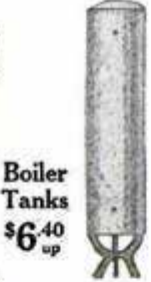

Boiler Tanks \$6.40 up



Lowest Prices on Paints, Enamels, Varnishes & Supplies



Pumps \$1.45 up

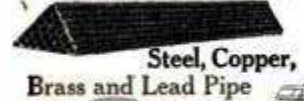

Steel, Copper, Brass and Lead Pipe



Roofing, Spouting and Fittings at Factory Prices

New, Low Factory Prices

You get the rock-bottom, wholesale, factory price on absolutely everything including fittings, accessories, supplies and tools. You make enormous savings here. No reliable firm ever undersells us. If our prices go down after you get catalog, we apply credit on your orders.

HIGHEST QUALITY GUARANTEED

Everything Sent On Approval

You never run the slightest risk buying from us. Not only do we guarantee highest quality and lowest prices but you are the sole judge. Your money always sent back at once if you are not completely satisfied.

Startling Plan Explains How You Can "Be Your Own Plumber"

If you can use a wrench you can be your own plumber. Our amazing, simple and easy plan explains everything. No experience necessary. We help you in every way possible. Thousands of our customers do their own plumbing and heating work.

Small, Easy Payments

Many offers in our Big Catalog sold on small, easy payments. Goods shipped in 24 hours. We carry largest stock and variety in U. S., covering two solid acres of floor and shelf space.

MAIL THIS COUPON - TODAY

Don't delay! Don't wait another minute to investigate the most successful home savings, plumbing and heating plan ever devised. Mail the coupon—now!

BURKE (4) BROS., 420 Liberty Ave., Pittsburgh, Pa.

Largest Stock of Accessories, Supplies and Fittings in the U. S. A.



GET FREE BOOK Now

UNUSUAL OFFER
Ends Midnight, May 15th, 1929

Sturdy, golden oak toilet seat with handsome nickel plated hinges, highest quality guaranteed. Complete \$2.18 only. Postpaid.

Immaculate, white celluloid toilet seat, never-split construction, nickel plated hinges, for best bathrooms. Complete \$5.00 only. Postpaid.

Add 20c to above prices west of Mississippi.

Send check or money order today! Your money returned if these are not the best seat values ever offered.

Will fit any closet bowl --Attached in 5 minutes.

Bathroom Outfits

Steam and Hot Water Heating Plants

Pipe & Pipeless Furnaces

Pumps and Septic Tanks

Plumbing Supplies

Burke (4) Bros., 420 Liberty Ave., Pittsburgh, Pa.

Send your Big FREE Catalog of 4000 Wholesale Bargains explaining how I can install my own plumbing and heating. (Check subjects in which you are specially interested).

Name.....

Address.....

City..... State.....

Start an HB Equipt Shop Earns \$150 to \$300 Monthly

Established Garages—Battery Stations and mechanics are adding substantial profits without expense to them. Start in business yourself with HB One Day Battery Service—Paint Spray—or Starting, Lighting, Ignition Service Equipment. HB guarantees bigger profits and enables you to do far better work than the other fellows with less expense to yourself.

Only \$16 Monthly Easily Paid By Increased Profits

One Day Battery Charging



Gives you the edge on competitors. Saves 30 to 50% on electric bills over rectifier and turns out work in one third the time. Recommended by leading car and battery manufacturers.

Free Air Service

With \$12 Monthly you can have constant Automatic Air Service to bring customers to your doors. Beltless, Silent, Ball Bearing. Quantity production makes possible the low price.



Paint Spray



Does work of five men with brushes. Paints cars, houses, furniture, barns, garages. You earn bigger profits yet charge less than any competition. Liberal trial and easy monthly terms.

Car Washer

Washes cars in twenty minutes, cleaner, better than hand methods. Puts real pep into car washing service. Eliminates all drudgery—makes washing a pleasure. Compact, free from trouble, economical. Liberal trial and easy terms. Will easily pay for itself.



Test Bench



The best paying work in the automotive field can be handled on this machine. Tests starting, lighting, ignition systems. Brings you business from other shops. Priced \$100 to \$150 lower than other similar outfits. Liberal trial and easy terms.

HOBART  BROTHERS
Successful manufacturers *~since 1893~*

Box M59

Troy, Ohio

Tear Off and Mail Today

Hobart Bros., Box M59, Troy, Ohio.

Send complete information on the items checked with your 30-Day Trial Offer and liberal terms. Tell me how HB equipment will increase my earnings. No obligation.

- HB Battery Charger
- HB Paint Spray
- HB Air Service
- HB Car Washer
- HB Test Bench

(Write your name and address in the margin and Mail Today. No obligation.)



Just the Lathe for *You* with its Universal Application~

TURRET ATTACHMENT



PROTRACTOR ATTACHMENT



Accurate, durable and strong. A real tool.

Attachments can be had for all manner of work—look them over.

We make 1499 other good tools.

SLIDE REST ATTACHMENT



FRET SAW ATTACHMENT



MILLING ATTACHMENT



SAWING ATTACHMENT



SEND FOR OUR TOOL HANDBOOK—IT'S FREE!

GOODELL-PRATT CO.
57 WELLS ST., GREENFIELD, MASS.



MAKE A MOTORCYCLE

OUT OF YOUR BICYCLE with a STEFFEY MOTOR ATTACHMENT. RELIABLE—ECONOMICAL—EFFICIENT. Easy to attach. Fits any wheel. Send 10 cents for circulars.

STEFFEY MFG. CO. Dept. P, 5040 Westfield Ave., Merchantville, N. J.

NEW DISCOVERY

Grows Hair Quickly!

Noted surgeon has discovered amazing way to grow hair called Dermo-Ray. Employs Infra-Red Rays. In thirty days **no more** dandruff. Scalp tissues given new life. Then within a few weeks luxuriant new hair! Two years ago the discoverer was himself bald. Today his hair is full and thick. Sent on Free Trial. Results or no pay. If you have electricity in your home write at once for Free, starting thirty-two page booklet. Address the **LARSON INSTITUTE** 216 North Wabash Ave. Dept. 441 Chicago, Ill.



Great Fun Assembling This Ship Model

Why pay a retail price for your Ship Model—when we will send you all necessary parts of a beautiful Santa Maria—which you can put together by following our simple instructions, in a few hours, and have lots of fun doing it.

Here's the **SANTA MARIA** One of our very popular models, 24" high, 12" wide, 27" long. Send off this coupon today to

Every part accurately made to fit perfectly. Sails, flags, etc. artistically printed. Packed complete in neatly arranged kit, for **\$5.48**

COLARK CO., Inc.,
2213 E. Susquehanna Ave., Phila., Pa.

Please send me a Santa Maria ready to assemble. I will pay postman \$5.48 plus a few cents postage.

Name

Street or R. F. D.

City..... State.....

Please print name, etc. plainly

Colark Co., Inc.
2213 E. Susquehanna Ave., Phila., Pa.

The New International TICKET SCALE

A Private personal weighing service.

Exclusive territorial franchises for the purchase and operation of chains of International Ticket Scales are now being negotiated. Your first opportunity to enter an outstandingly successful division of the Automatic Merchandising Field. . . .

Did you weigh yourself today? Perhaps you did not, but literally millions of people did. Tons of pennies are dropped into the familiar penny scales in drug and other stores each year.

Now comes a new and better scale that prints the weight and fortune on a ticket. It gives a private personal weighing service. It is the product of twenty years' experience in the manufacture and operation of penny-actuated scales.

Its slogan is "Nothing of its kind is so fine," and we might add, so profitable. In appearance the finest and most distinctive of scales. The scale and printing mechanisms are built on time tried and approved principles. Refined, perfected and simplified for faster, more positive operation and greater accuracy—and to stand up longer.

If you owned a chain of these scales, working for you day and night, you would have a steady sure source of income, unaffected by economic changes, by poor business, or by other unfavorable factors. You would have a business practically without overhead, with no credit problem, with no administration expense, and with the minimum of working personnel.

To Chain Store Executives: An International Ticket Printing Scale in each of your stores will add a substantial amount to your net profits. For full information, write the Chain Store Manager of the International Ticket Scale Corp., 17 E. 45th St., New York, N. Y.

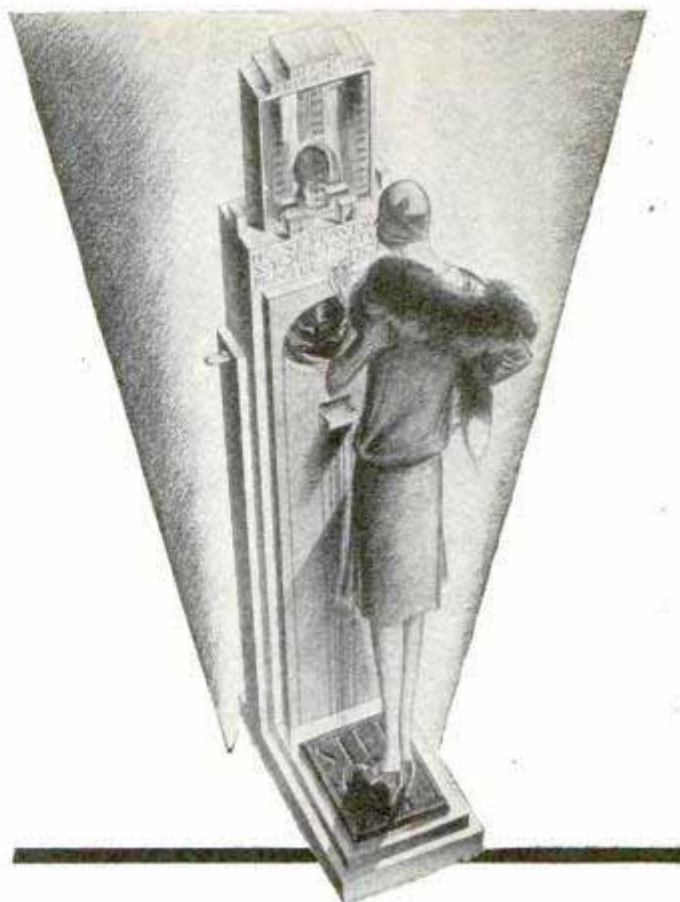

The first to place International Scales on location will reap an unusually rich harvest. Those now in a position financially to secure exclusive franchises for important cities, will look at the future with eyes that are unafraid. The earnings in this business, as high as 47% annually on the investment, will also attract those with a few thousand dollars, who desire the maximum return from their investment, and who are willing to devote a small amount of their own time to their care.

Full details concerning all phases of the operation of chains of International Ticket Scales, are given in a booklet which we will be glad to send on request to any financially responsible person. Simply write Dept. 111, International Ticket Scale Corp., 17 East 45th St., New York, N. Y.

International

TICKET SCALE CORP., Department 111,
17 East 45th Street, New York, N. Y.

Please send me your proposition.

Name _____

Address _____

**"Better
Than Your
Claims!"**

Say 9,400
Enthusiastic
USERS

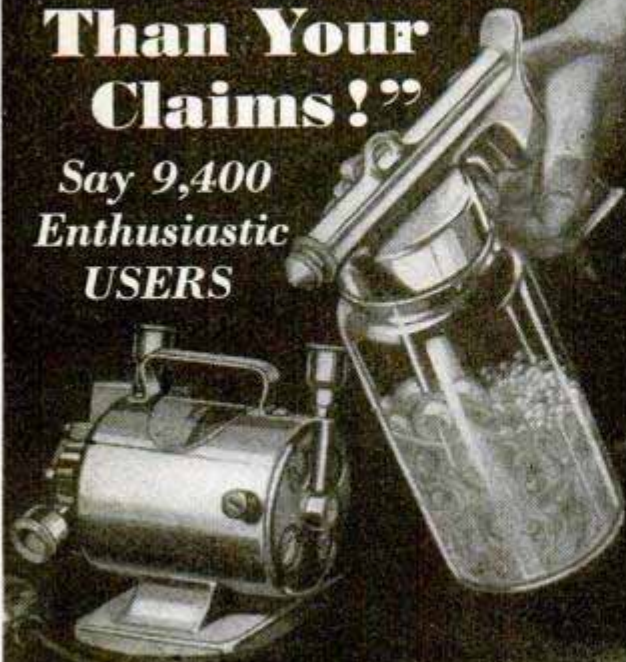

WITH THE *Agitator Type* ELECTRIC SPRAYIT, we promised a revolutionary development in paint spraying equipment. Thousands of *Agitator Type* owners say we have succeeded! Many have made their SPRAYIT pay for itself by doing better work, faster—hence cheaper.

Regardless of the nature of your utility or maintenance paint job—plug-in the new *Agitator Type* ELECTRIC SPRAYIT at the nearest light socket, grasp the pistol grip of the light-weight gun, and pull the trigger. Spray, either fan or round shape, starts or stops instantaneously. Trigger controls it, always at full pressure, in a flash. When not spraying, a stream of air is blown through the fluid, churning it so it is thoroughly mixed and broken up.

Sold by leading jobbers and dealers. If you prefer, use the coupon below. Complete, **\$39.50**

RENT A SPRAYIT For Home Use

For any paint job in your home, your dealer can now rent you an ELECTRIC SPRAYIT at a nominal daily charge. Check the coupon below for details of the new SPRAYIT Home Rental Plan.

SPRAYIT

Electrically

REG. U.S. PAT. OFF. 12-20-27

THE ELECTRIC SPRAYIT CO., Inc.
205 E. Colfax Ave., South Bend, Indiana

Send me the New *Agitator Type* ELECTRIC SPRAYIT at \$39.50 f. o. b.

Send details of New Sprayit Home Rental Plan. Send complete information only.

Principal use for ELECTRIC SPRAYIT

Write Complete Name and Address Below



Get the Applause and the Big Pay!

You've heard the applause given the saxophone soloist—you've seen how orchestras feature their saxophone players. The saxophone is today's most popular instrument and the big salaries are going to the good saxophone players.

BUESCHER True Tone
Saxophone

You don't need to be talented to play a Buescher. The Buescher Saxophone is the easiest of all instruments to learn and is the only saxophone that gives you all these features:

- Patented Snap-on Pads—greatest improvement for beauty of tone—easy to replace—no more cementing.
 - Patented Automatic Octave Key—always positive.
 - Perfect Scale Accuracy—every tone always true, clear and full.
- 6 Days' Trial on any Buescher Saxophone, Trumpet, Cornet, Trombone or other instrument. Write today for Free Literature and easy purchase plan. Mention instrument in which you are interested.

BUESCHER BAND INSTRUMENT CO., 2784 Buescher Block, Elkhart, Indiana ⁽⁵¹⁵⁾



AGENTS GIVE THEM SOMETHING FREE

and you're sure to get the money!

New, Different Advertising Plan
BRINGS \$15 A DAY
YOU

We are going to put Re-Ax Tooth-Paste in a million more homes this year, and we want 500 more men and women, all or spare time, to give away a \$1 patented de luxe Sanitary Dental Cabinet and a special Re-Ax Tooth Brush with every 50c introductory sale of this nationally known tooth paste.

YOU GET THE MONEY—We Get the Advertising

Everybody buys tooth paste frequently and they will buy from you to obtain the valuable FREE PREMIUMS. Get \$50 to \$100 next Saturday night and every Saturday thereafter. Write for full particulars or send 50c for complete sample outfit.

T. D. SHEA CO., 7035 E. Seven Mile Road, Detroit, Mich.



Mechanical Toys

Ship Models, Colonial Bric-a-Brac, Leather and Celluloid articles and hundreds of other useful things are described in our new book, Make It Yourself, 460 Pages, Illustrated. Price 53 Postpaid.

POPULAR MECHANICS PRESS, 200 E. Ontario St., Chicago

JUST OUT New Kind of Extension Light

Garages, stores, factories, homes, mechanics—buy on sight. Has everlasting Bakelite socket, wire guard and shade. Long extension cord and high-grade rubber handle. Sells for \$2.50. Year 'round money maker. \$90 to \$125 per week easy for agents. Sells on first call. Makes excellent demonstration, Easy to carry. Write for territory and unusual money-making plans. Just out. No competition.

FREE DEMONSTRATOR GIVEN: Get in on ground floor. Write for free sample offer today. You risk nothing.

ELECTRO UTILITIES, 29 No. Morgan St., Dept. 105, Chicago



NEW SIGNAL *to Auto Drivers* Automatically SAYS **STOP** *GIVE AIR TO YOUR TIRE!*

No more running on leaky tires without knowing it — no more broken down casings—no more rim cuts—banishes under-inflation — prevents accidents—

INCREASES TIRE MILEAGE

Proper air-pressure constantly maintained in tires gives maximum mileage—saves tire money. A simple new tire attachment just invented automatically signals the auto driver when a tire needs air — and as a result tires are easily kept up to standard pressure at all times and give increased mileage.

Now, no motorist need worry about broken down casing walls or rim cuts due to running on under-inflated tires without knowing it.

Anyone who wants to drive with that confident, safe feeling of knowing that his tires are properly inflated with air and desires to get the best possible mileage out of his tires and tubes, should try out a set of Simpson's remarkable "Need-air-signals," that make running on under-inflated tires unnecessary. Users report they would not be without them for twenty times their small cost.

Anyone can easily put a set on his own tires in a few minutes—no special tools required—insert between rim and casing—mount on side of tire next to body—practically out of sight. No mechanical features—nothing to get out of order—will not injure tires—no rattle—cannot become loose—absolutely rust proof.

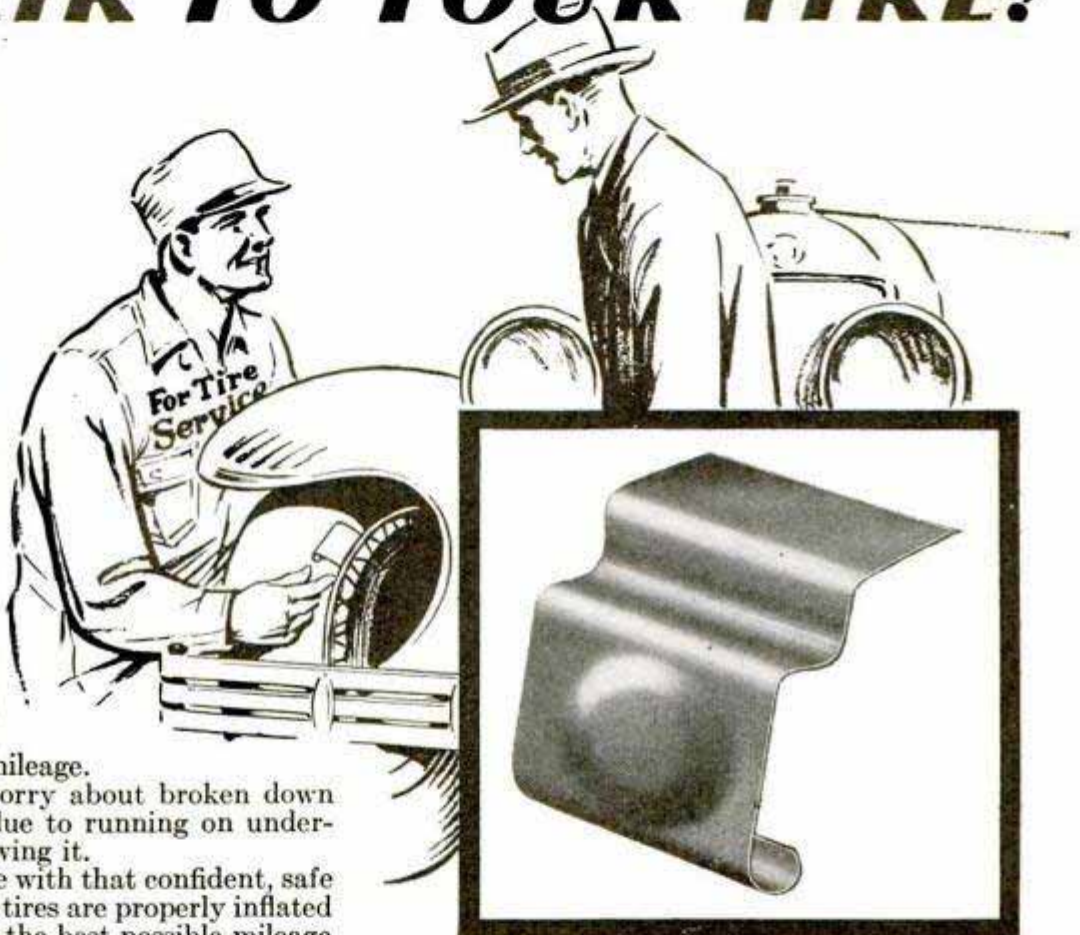

Test Them FREE

Test a set of Simpson's Need-Air-Signals on your own tires at our risk. See for yourself how silent they are when your tires have proper pressure and how automatically the "signal" works only when any tire needs air. See for yourself how it helps you to easily keep your tires properly inflated and saves your tires and tubes. You are guaranteed results or the test costs you nothing.

Get the full details of this wonderful invention, and FREE TEST OFFER. Mail coupon NOW.

SIMPSON MFG. CO.
3000A—307 W. Douglas St. Wichita, Kans.

MAIL this COUPON

Simpson Mfg. Co.
3000A—307 W. Douglas, Wichita, Kans.

Rush me full details about your NEW and SENSATIONAL SELLER, BIG MONEY MAKING AND FREE TEST OFFER.

Name.....

Address.....

\$400 to \$1500 Monthly
for Distributors,
Agents, Salesmen

A brand NEW, RAPID-FIRE SELLER. Going over BIG. Nothing ever like it. Strong demonstrative appeal coupled with tire saving and money saving for autoists. QUICK SALES—BIG PROFITS.

Mail coupon now—get full facts about this NEW and SENSATIONAL SELLER and FREE TEST OFFER. Act NOW.

NEW MODEL WALTHAM of ELGIN SENT FOR \$1.00



12 MONTHS TO PAY

Send \$1.00 with order and tell us a little about yourself: (A) How long at present address, (B) Age, (C) Married or Single, (D) Name of employer, (E) Position, (F) How long at that work. All information held **strictly confidential**. We make no direct inquiries of anyone—not even from your employer.

10 Days' Free Trial Satisfaction Guaranteed

Watch comes to you postage paid—no C. O. D. to pay on arrival. You take no risk—satisfaction guaranteed or money back.

Established 1895

ROYAL DIAMOND & WATCH CO.
ADDRESS DEPT. 11-S 170 BROADWAY, N.Y.

\$29.50

D C 15—A New Sport model. White or Green Gold filled case warranted 20 yrs.; guaranteed accurate Elgin or Waltham movement. Gold filled "Wristocrat" flat wrist band. \$1. down, \$2.97 a month.

Catalog FREE To Adults

New catalog of genuine diamonds, standard nationally advertised watches, fine jewelry. Write for it now.

Cut the Family Barber Bills



Belle City Home Electric Hair Clipper

Anyone can trim or bob hair, shorten bangs, clip neck or underarms in a shape almost impossible with hand clippers or shears. Operates on direct and alternating current. Will not clog or cut the skin, and cuts as cleanly as a razor. Thousands in use. Rigidly guaranteed.

Fits Any Light Socket

TEN DAYS' FREE TRIAL

If your hardware or electrical dealer can't supply you, write for interesting booklet, or order from this ad. Send no money—pay postman \$8.75. Return it in ten days if not satisfactory. State whether 110, 220 or 32 volt current is used.

Dealers and Representatives Wanted
Belle City Appliance Co., 1022 12th St., Racine, Wis.

PATENTS Write for FREE Instructions. Send Drawing or Model for Examination.
CARL MILLER, Patent Attorney
former member examining corps U. S. Patent Office
260 McGill Building Washington, D. C.

Build This Airplane Yourself



3-ft. model

JUNKER "Bremen" True scale, guaranteed to fly, all materials and instructions - - - \$8.50

Get Yours! Send for your copy of our 56 page booklet which contains the scientific knowledge we gained through 20 years' experience in model airplane construction. It illustrates and describes famous airplanes, also all parts required by model builders, experimenters and inventors. This booklet is mailed to you upon receipt of **10¢**

YOUR DEALER CAN SUPPLY YOU. IF NOT, WRITE US.

U. S. MODEL AIRCRAFT CORP.
397-399-F BRIDGE ST., BROOKLYN, N. Y.

KILLS GLARE FROM HEADLIGHTS OR SUN



The new Liberty Glare Shield actually protects your eyes from the glare of blinding sun or approaching headlights so perfectly that you can drive right into the face of any glare in absolute safety. Scientific in principle and design. Adjustable to all angles. A finger touch places it instantly wherever needed. Thousands have lost their lives in accidents due to glaring headlights. The Liberty Glare Shield banishes this danger. When not in use folds against roof of car. Approved by automotive engineers, safety commissioners and recommended by thousands of users.

A Money Maker for Agents

Here is an opportunity to build a dignified, legitimate business. Full time or part time workers will find this a substantial, continuous money maker. One demonstration makes a profitable sale. Every car owner is a prospect and users sell their friends.

Ask for full particulars about our sales plan, agents' wholesale prices and how to obtain free demonstrator. We give protection on territory. Some good territories are still open.

Liberty Mfg. Co.
Dept. 238 West Allis, Wis.

Retail Price \$ 2.50

Save time by sending money order or check for Liberty Glare Shield to try on your own car. Satisfaction guaranteed or money refunded.

BIG MONEY



\$5,000
\$7,500
\$10,000
PER YEAR

State Managers
County Agents—Car Owner Salesmen

Eastern Manufacturer of marvelous Auto Safety Signal wishes to correspond with man or firm financially responsible to develop your state. Also County Agents and Car-Owner-Salesmen. Proposition worth \$7,500 per year and up. Write for literature to National Distributors.

501 Colorado Building, Denver, Colorado

Enjoy Dependable Electrified Radio at Amazing, Low Cost!

Do you know that your present good set is capable of giving you quiet, dependable, more enjoyable reception direct from the light socket? Don't think of discarding it when you can electrify it for only \$6.85!

New Radio Thrills!

No need now to put up with the shrieks, howls and inconvenience of dying Batteries. You will see how easily you can electrify your set when you write us for proof and the truth about all electric radio. Get more volume without hum, sweeter tone, crystal clarity, surprising distance. New radio pleasure.

Over 100,000 Townsend "B" Power Units Now in Use

Hooked up in a few minutes—use same tubes—no changes. Over 100,000 Townsend "B" Power Units in use and giving satisfaction. Approved and passed by the rigid laboratory tests of Radio News, Popular Radio and other authorities.

TRY IT FREE! We are so sure the Townsend will do all we claim for it that we give you the privilege of testing it out for ten days at our risk. A new radio joy awaits you. Don't put up with second rate reception any longer. You don't have to—when you can have electric reception with a Townsend "B" Power Unit for the astounding low cost of \$6.85. Mail coupon for complete information TODAY!

Townsend Laboratories, 715 Townsend St., Chicago, Ill.

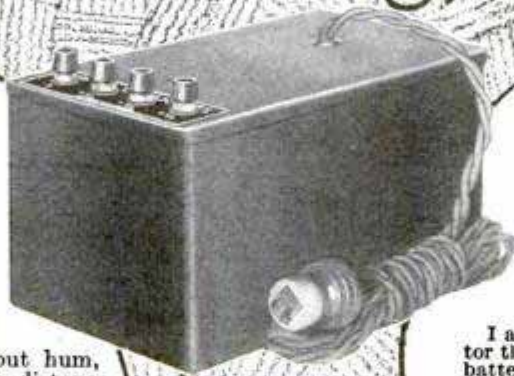

\$6 ONLY 85 COMPLETE

RESULTS

Have had good results with your Eliminator, in fact better than they have had from an all electric I recently heard in town.

V. C. KESSINGER, *Childress, Texas.*

I have had wonderful results since using your Eliminator on my 3-tube Harkness "Counterflex." I am able to get on the loud speaker with good volume such stations as Hollywood, Pittsburgh, Shreveport and dozens of others.

G. S. BAGOT, *Edmonton, Alta.*

I am receiving better results with your Eliminator than I ever received with THREE 45 volt "B" batteries. It is working fine on my Atwater Kent model 35.

CARL SPOROW, *Newberry, Pa.*

Please send us another Eliminator. We have one and find it very satisfactory and much to be preferred both in reception of programs and in cost.

NELSON VANHORN, *Milton, Wis.*

Your Eliminator has been in use for two years an average of six hours daily on my 5-tube Stewart-Warner and am well satisfied with it.

CLIFTON E. PALMER, *Highland Park, Mich.*

TOWNSEND LABORATORIES, 715 Townsend St., Chicago, Ill. 5/29

Please send me full information on the Townsend "B" Power and Free Trial Offer.

Name.....

Address.....

City..... State.....

PROFITS BUY \$9,000 HOME

"Your plant hasn't cost me a cent for repairs. Today I have a \$9,000 home, my own business property, well stocked and nothing to worry about." Arthur O. Wallace.



Be Your Own Boss

Over 100,000,000 tires now in use. Big opportunity for ambitious men. Small capital. Big earnings. We furnish everything—\$100 and up.

Easy Payments Free training. Write immediately for big free book. "Steps to Success." J. A. SCHREIBER, Pres.

Haywood Tire Equipment Co. 2330-G Ogden Ave., Chicago, Ill.



A NEW CAR in 30 minutes



Get the BEAUTY and LUSTRE of a NEW PAINT JOB at a small fraction of the cost. Do it Yourself with NUKAR. NOT a Wax. NOT a Paint. NOT a Polish. This New Chemical discovery instantly restores Original Color to dull faded cars, and gives a Beautiful, Brilliant, Mirror-Like Lustre that lasts for months. Does not hold Dirt or Dust. Actually makes old Shabby Cars look NEW. No rubbing—No hard work. Flows on like water from a sponge. No Waiting—No Delay—Drive a NEW CAR the same day. Results Guaranteed.

MEN! Amazing Cash Profits Are being made by Agents, Distributors and Service Station operators. Get in on the biggest thing in the automobile business today. Earn up to \$50 a day. Full or part time. Millions of cars need NUKAR. Makes a Sensational sales compelling Demonstration. We back you to the limit with powerful Sales Co-operation and give you FREE—a Business Start that Money could not Buy. Let us send Prepaid and without charge a FREE SAMPLE and our Big Book in colors. Act NOW. Write TODAY. Atlas Solvent Co., 5647 Harper Ave., Dept. 114, Chicago, Ill.



Information on any book free. Write Popular Mechanics Press, Chicago, Ill.

Fastest, Finest Outboard Motor for Runabouts, Cruisers, Racers



Hi-Speed Quad Price, \$325

Service Quad Price, \$295

ENJOY big-boat pleasures at a fraction of old-time costs. Snappy runabouts, roomy, seaworthy cabin cruisers give surpassing speed and dependability when equipped with the great 4-cylinder Super Elto Quad. The last word in outboard motor engineering. New 1929 model far faster, 60% more powerful than last year's model, official world champion. Send for complete catalog of Super Elto motors. Elto Division, Outboard Motors Corporation, Ole Evinrude, President, Mason Street, Department AA, Milwaukee, Wisconsin.

The Mighty 4-Cylinder Super Elto Quad



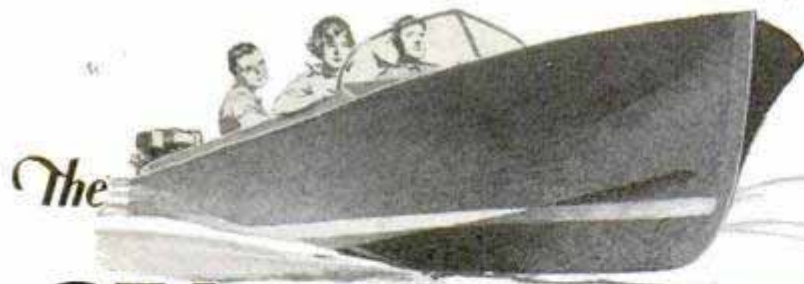

The SEA- HORSES

The Johnson Underwater Exhaust eliminates exhaust reports and gases from outboard motoring. It provides a quiet luxury you've never experienced in an outboard ride. Now you can talk and be heard while driving at full speed.

The Johnson Release Charger adds a hundredfold to outboard motoring enjoyment by insuring easy starting . . . positive starting . . . under all

conditions . . . even when the motor is stone cold or flooded with gas!

Write for catalog describing these and other revolutionary improvements that distinguish the new Johnson SEA-HORSES from all other outboard motors.

Six models, priced from \$115 to \$325, f. o. b. Waukegan. Sold on free trial and easy payment plan.

JOHNSON MOTOR COMPANY
2583 Pershing Road, Waukegan, Ill.

In Canada: Canadian Johnson Motor Co., Ltd.,
Peterborough, Ontario

Distributors for British Columbia
Hoffar's Ltd., Vancouver, B. C.

Johnson

Outboard Motors

WORLD'S LARGEST MANUFACTURER OF OUTBOARD MOTORS

Certainty
and Ease
of
Automobile
Starting

No
Exhaust
Noise
No Exhaust
Fumes



SEA-HORSE
32
Four
Cylinders

"Interlox" Speeds up all measuring.
Slides in and out—no folding.
Direct-reading for instant **inside** measurements, as well
as outside. Any length, 2 to
8 ft., 20c lineal ft. If not at dealers, sent postpaid.



MASTER RULE MFG. CO., 813 E. 136th Street, NEW YORK

Dealers and Agents: Write for attractive proposition.

Get this 500 lb. Capacity
Miniature
Simplex Screw Jack

for Home, Workshop, and
Manual Training

Dads and boys, you'll like this practical tool. It's mighty handy around the home, workshop, manual training and for jacking up mechanical toys. Will lift an end of piano or ice box.

"JACK-IN-THE-BOX"

Three inches high when closed. The illustration does not show the beauty or workmanship of this little jack which is sturdily built and beautifully finished in red, blue or green lacquer. Built by the world's largest manufacturers of screw and lever jacks. Permanently useful and unconditionally guaranteed. Send 35c for one "Jack-in-the-Box", or \$1.00 for three. Money refunded immediately if not satisfied.

Templeton, Kenly & Co., Ltd.
1020 S. Central Ave.,
Chicago, Ill.

Name _____
Address _____
City _____ State _____

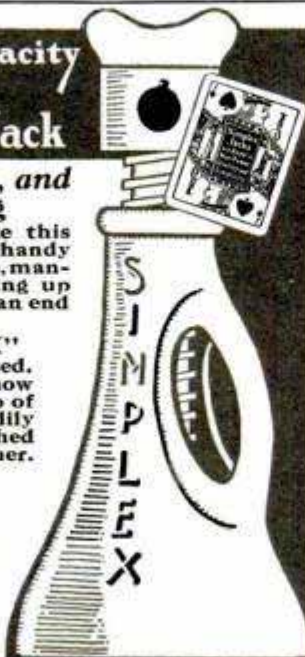

Oh, Boy!
Win \$50
Building
This Car
from our
PLANS!



40 Miles
per Hour

Any boy can build this car from our easy plans. Tread 36" wheel base 75". Send 50c today for detailed building plans, simplified so you can easily build this car. Also full information of prize contest. Five grand prizes. First prize \$50. Hurry. Write today.

SYCO SALES CO., 1524 Fernwood, Toledo, Ohio

Earn Five Men's Wages Every Day
Painting Cars, Houses, Furniture

HB portable paint spray lets one man without experience do the work of five and earn 5 men's wages every day—paints houses, barns, garages, cars, furniture, at lowest prices, with exceptionally large profits for you.

Easy Payment Terms
Easy payment terms lets it pay for itself out of profits—practically no expense to you. Tear out and mail for complete information without obligation. Also ask about money-making Battery Chargers, Test Benches, Air Compressors, Car Washers. Underline if interested and mail to

HOBART BROTHERS
Box M591 Troy, Ohio



New Easy Way To Surface Floors

will bring you a \$150 a week position

Read What Two National Electric Managers Say—

"While I am busy over capacity, and can secure all the business I want, I will appreciate any suggestions you may have to make. I started operations on October 15th, and with the single exception of Thanksgiving Day, we have been busy every day of those two months, the first four weeks with three men, ever since then, with five men. The sanders are all that is claimed, and I do not wish myself a better machine, nor do I know of any machine that will do more satisfactory work. Emil Szabo."

"It looks as though I will have all the work and rentals I can handle this winter. Prospects galore come in every day. Thanking you, and assuring you of my appreciation of your co-operation, I remain,

Yours very truly,
C. E. Van Horn."

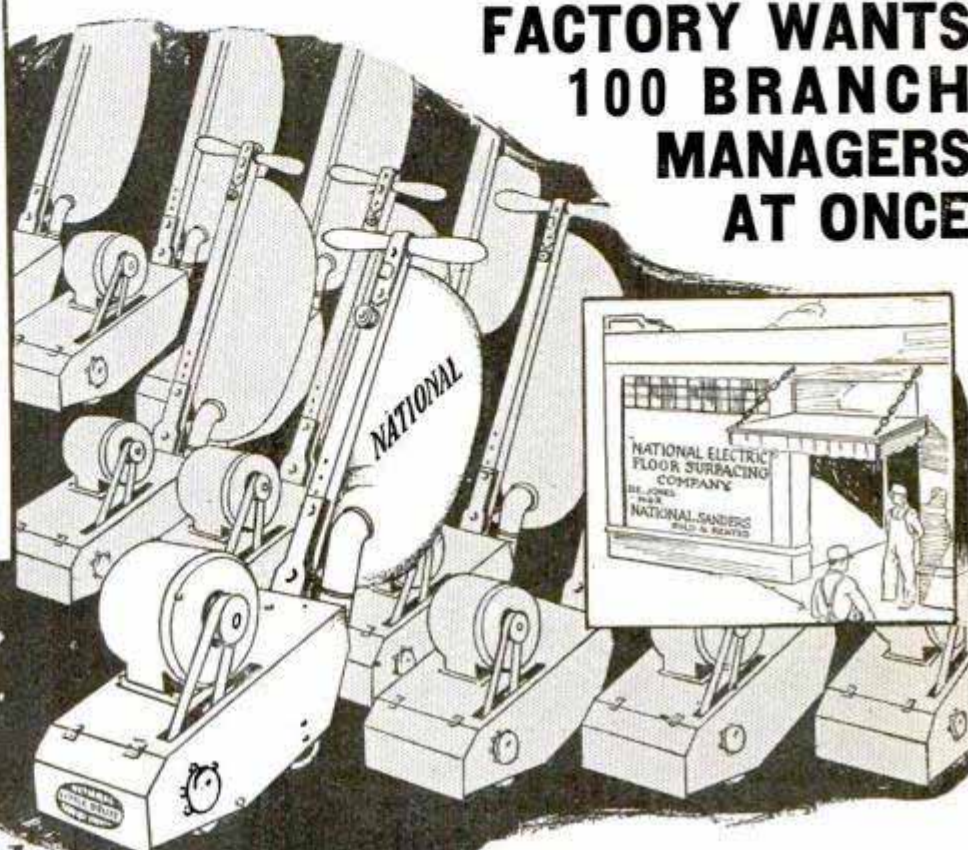

FACTORY WANTS 100 BRANCH MANAGERS AT ONCE

This Army of Little Brutes does all the work

NATIONAL ELECTRIC rental, sales and service stations are spread from coast to coast. "NATIONAL" has been the "making" of men from every walk of life. Our long experience, our thoroughly tested and proven plan is making undreamed of profits for "NATIONAL" branch managers.

In Chicago alone, we have five stations that are making money hand over fist by renting our machines to home owners, contractors, builders, carpenters, and a host of others. These Chicago stations alone have more than fifty "NATIONAL ELECTRICS" which are constantly kept busy making money for our branch managers. Why not let an army of "Little Brutes" put you on the road to success and independence?

FREE TRAINING

You need no experience whatever. We instruct you in every detail. We build your business up for you by our proven business plan which is given to all managers. Everything the plan requires is furnished by us. This includes, among other things necessary for your success, business cards, letter-heads, envelopes, statements, advertising blotters, all with your own name imprinted. Besides this proven business plan, a special "Consultation Department" is open to all "National" men at all times. We train you to become an expert National Electric floor engineer without any cost to you.

Fascinating— Amazingly Simple

NATIONAL ELECTRIC engineers are busy twelve months of the year. Moreover, it is inside work the year around, with no idle days because of bad weather. "Little Brutes" re-surface both new and old floors. Everywhere you look, you will find prospective customers. It is not uncommon to earn \$30.00, \$40.00, or \$50.00 a day. Four to seven rooms can be surfaced in one day. Four 10 x 12 rooms, at an average cost of 10c,

would bring \$48.00 for the day's work. It doesn't take an expert to figure out the huge money-making possibilities our station managers enjoy. Besides, the business is all cash. No months of waiting for your money. Have you ever had a greater opportunity to get ahead presented to you anywhere? All you need to have is ambition to get ahead. We will do the rest. Fill in the coupon below today and get further details of the position we are offering you.

National Sanding Machine Co

A national organization—"operating from coast to coast"

4553-55-57 Diversey Ave.

CHICAGO, ILLINOIS, U. S. A.



National Sanding Machine Company,
4553-55-57 Diversey Ave., Chicago, Illinois

Gentlemen: Please send to me at once, without obligations to me, full details of your managerial opening.

Name.....
Address.....
City.....



Why delay, men, getting acquainted

IT costs nothing to make this comparison. After a seven-day trial, we feel certain you'll thank Colgate chemists for their many years of research. They've proceeded along natural, common-sense lines, creating a moisture-laden lather utterly different from the ordinary air-filled lather. New friends are being won daily to Colgate's, not by lurid claims, but by vastly superior shaves—smoother shaves that last longer—keep you well-groomed from morning until midnight.

Compare with ordinary lather

We invite a critical comparison—your present lathering contrasted with the Colgate way.

The minute you lather up with Colgate's, two things happen: 1.—The soap in the lather breaks up the oil film that covers each hair. 2.—Billions of tiny, moisture-laden bubbles seep down through your beard . . . crowd around each whisker . . . soak it soft with water.

Instantly your beard gets moist and pliable . . . limp and lifeless . . . scientifically softened right down at the base . . . ready for your razor.

To prove its superiority, mail the coupon below and get a generous trial tube.



A Week's Shaves FREE

COLGATE, Dept. B 1777, 595 Fifth Avenue, New York

Please send me, FREE, the seven-day trial tube of Colgate's Rapid Shave Cream; also a sample bottle of "After-Shave."

Name

Address

Sparkling, Silvery Designs
in—
Brown
Green
Black
Blue
Red

A COMPLETE FLASHLIGHT
39¢
NOTHING ELSE TO BUY

FITS A MAN'S VEST
POCKET OR A
WOMAN'S
PURSE

**BURGESS
SNAP LITE
FLASHLIGHT**

BURGESS BATTERY COMPANY, CHICAGO
Mfrs. of Radio, Ignition and Flashlight Batteries.
Burgess Snap Lite Sold in These Stores—Hardware,
Drug, Electrical, Automotive, Department & Others

METAL TURNING LATHE \$35⁰⁰

Also 7 in. swing
3 speed cone pulley
Speed Lathes \$8.75

Goodwin Mfg. Co. 435 Koota St., OTTUMWA, IOWA

MODEL SHIPS

At last! A real model sail boat that is different from the type found in stores. Think of the joy of putting this 30-inch model together and taking her out to the lake and watch her go. Our special construction set contains all the necessary materials of the finest grades. All parts cut close to shape. Just put together, a little trimming here and there, and the job is done. Special blue print and full instructions. Everything but the paint. Price of set complete \$4.95 plus postage for 5 lbs. Put a dollar bill in an envelope and we will ship balance C. O. D.

We can supply construction sets and all sorts of parts such as semi-finished hulls, blocks, dead eyes, special flags, anchors, steering wheels, capstans, figureheads, blue prints, books, etc., for building a Flying Cloud, Constitution, Spanish Galleon, Mississippi River Steamboat, Sovereign of the Seas, Lightning and many others. Also special construction sets for model power boats, model steam engines, propellers, etc., and fine tools for the model maker. Our large 48-page photographically illustrated booklet contains valuable information and hints for building ship models in addition to prices and full description of the above articles. Many people only slightly interested in models have become greatly enthused upon receiving this booklet. A copy will be sent postpaid upon receipt of 15 cents (coin preferred).

AT LAST A real appropriate watch charm or coat lapel ensign for ship model makers or boat enthusiasts. This miniature steering wheel is made of heavily plated 14-Kt. gold spokes and hub. The rim is made from coco-bola (a Porto Rican hard red wood). Made in two styles. For the charm, one spoke has a small ring attached. The lapel style illustrated has a threaded hub and nut for fastening. Can also be worn on yachting caps. Packed in a handsome case. Price \$1.50 postpaid. Be sure to mention style when ordering.

Dept. L.
Model Ship Supply Co. Mineola, N. Y.

Over the Mountains from Los Angeles

559 Miles
on

11

Gallons of GAS

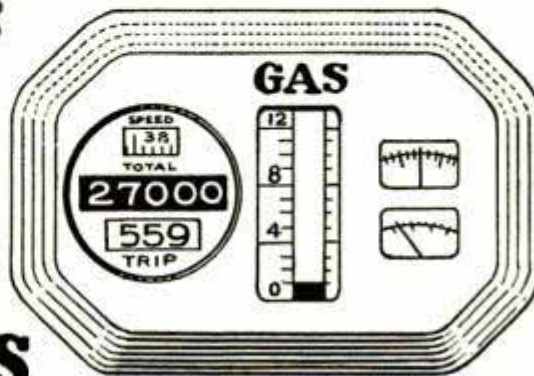
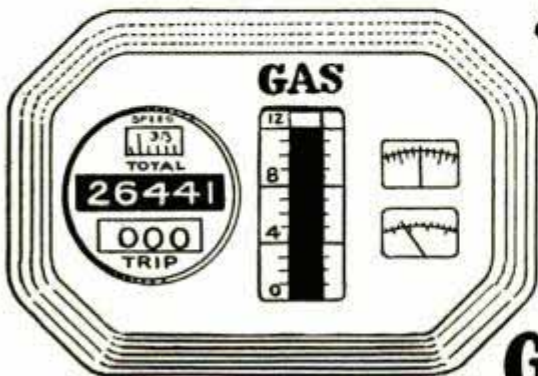

THINK OF IT! FIVE HUNDRED FIFTY-NINE MILES OVER ROUGH MOUNTAINOUS COUNTRY BURNING ONLY ELEVEN GALLONS OF GASOLINE. IMAGINE MORE THAN FIFTY MILES TO THE GALLON. THIS IS WHAT THE WHIRLWIND CARBURETING DEVICE DOES FOR D. R. GILBERT, ENOUGH OF A SAVING ON JUST ONE TRIP TO MORE THAN PAY THE COST OF THE WHIRLWIND.

THE WHIRLWIND SAVES MOTORISTS MILLIONS OF DOLLARS YEARLY

Whirlwind users, reporting the results of their tests, are amazed at the results they are getting. Letters keep streaming into the office telling of mileages all the way from 22 to 59 miles on a gallon, resulting in a saving of from 25% to 50% in gas bills alone.

Mark H. Estes writes: "I was making 17 miles to the gallon on my Pontiac Coupe. Today, with the Whirlwind, I am making 35 5/10 miles to the gallon. Am I glad I put it on? I'll say so!"

P. P. Goerzen writes: "I made an actual test both with and without a Whirlwind, getting 13 1/2 miles without and 34 6/10 miles with the Whirlwind, or a gain of 21 miles to the gallon. The longer the Whirlwind is in use on the machine the better the engine runs, has more pep and quicker starting. It makes a new engine out of an old one, and starts at the touch of the starter button."

R. J. Tulp: "The Whirlwind increased the mileage on our Ford truck from 12 to 26 miles to gallon and 25% in speed. We placed another on a Willys-Knight and increased from 12 to 17 miles per gallon."

Arthur Grant: "I have an Oakland touring car that has been giving me 15 miles to the gallon average, but I can see a great difference with the Whirlwind, as it climbs the big hills on high and gives me better than 23 miles to the gallon of gas, which is better than 50% saving in gas."

W. A. Scott: "I had my Whirlwind for three years. Winter and summer it gives the same perfect service, instant starting, smoother running, and what I have saved in gasoline these last few years has brought other luxuries which I could not have afforded previously."

Car owners all over the world are saving money every day with the Whirlwind, besides having better operating motors. Think what this means on your own car. Figure up your savings—enough for a radio—a bank account—added pleasures. Why let the Oil Companies profit by your waste? Find out about this amazing little device that will pay for itself every few weeks in gas-saving alone.

FITS ALL CARS

In just a few minutes the Whirlwind can be installed on any make of car, truck or tractor. It's actually less work than changing your oil, or putting water in the battery. No drilling, tapping or changes of any kind necessary. It is guaranteed to work perfectly on any make of car, truck or tractor, large or small, new model or old model. The more you drive the more you will save.

SALESMEN AND DISTRIBUTORS WANTED

Free Sample and \$100.00 a Week Offer

Whirlwind men are making big profits supplying this fast-selling device that car owners cannot afford to be without. Good territory is still open. Free sample offer and full particulars sent on request. Just check the coupon.

WHIRLWIND MANUFACTURING CO.
999-972 Third Street Milwaukee, Wis.

GUARANTEE

No matter what kind of a car you have—no matter how big a gas eater it is—the Whirlwind will save you money. We absolutely guarantee that the Whirlwind will more than save its cost in gasoline alone within thirty days, or the trial will cost you nothing. We invite you to test it at our risk and expense. You are to be the sole judge.

FREE TRIAL COUPON

WHIRLWIND MANUFACTURING CO.,
999-972 Third Street, Milwaukee, Wis.

Gentlemen: You may send me full particulars of your Whirlwind Carbureting device and free trial offer. This does not obligate me in any way whatever.

Name.....
Address.....
City.....
County..... State.....
 Check here if you are interested in full or part time salesmen position.



"I had to make more money—for her"

"THREE weeks after I met Ann we were engaged. It was when we began talking about rents and furniture and such things that I woke up.

"I'd been drifting along in a routine office job for years. I knew I didn't deserve a raise. And yet I had to make more money—a lot of it—and quick. It was Ann herself who suggested the International Correspondence Schools. She believed in me so thoroughly that she made me believe in myself, and I started studying the I. C. S. course in Accounting in my spare time.

"That was a year and a half ago. We've been married six months and I just got my third promotion. I'm head of the cost accounting department now. My I. C. S. course was the finest investment I ever made."

Are you one of the thousands of young men who need a bigger salary and a better job? In an hour a day of your spare time you can secure the training that will bring you advancement. Without cost, without obligation, find out what the I. C. S. can do for you. Mark and mail this coupon now!

INTERNATIONAL CORRESPONDENCE SCHOOLS

Box 5617-F, Scranton, Penna.

Without cost or obligation, please send me a copy of your booklet, "Who Wins and Why," and full particulars about the course before which I have marked X in the list below:

TECHNICAL AND INDUSTRIAL COURSES

- | | |
|--|---|
| <input type="checkbox"/> Architect | <input type="checkbox"/> Automobile Mechanic |
| <input type="checkbox"/> Architectural Draftsman | <input type="checkbox"/> Aviation Engines |
| <input type="checkbox"/> Building Foreman | <input type="checkbox"/> Plumber and Steam Fitter |
| <input type="checkbox"/> Concrete Builder | <input type="checkbox"/> Plumbing Inspector |
| <input type="checkbox"/> Contractor and Builder | <input type="checkbox"/> Foreman Plumber |
| <input type="checkbox"/> Structural Draftsman | <input type="checkbox"/> Heating and Ventilation |
| <input type="checkbox"/> Structural Engineer | <input type="checkbox"/> Sheet-Metal Worker |
| <input type="checkbox"/> Electrical Engineer | <input type="checkbox"/> Steam Engineer |
| <input type="checkbox"/> Electrical Contractor | <input type="checkbox"/> Marine Engineer |
| <input type="checkbox"/> Electric Wiring | <input type="checkbox"/> Refrigeration Engineer |
| <input type="checkbox"/> Electric Lighting | <input type="checkbox"/> R. R. Positions |
| <input type="checkbox"/> Reading Shop Blueprints | <input type="checkbox"/> Highway Engineer |
| <input type="checkbox"/> Telegraph Engineer | <input type="checkbox"/> Chemistry |
| <input type="checkbox"/> Telephone Work | <input type="checkbox"/> Pharmacy |
| <input type="checkbox"/> Mechanical Engineer | <input type="checkbox"/> Coal Mining Engineer |
| <input type="checkbox"/> Mechanical Draftsman | <input type="checkbox"/> Navigation <input type="checkbox"/> Assayer |
| <input type="checkbox"/> Machine Shop Practice | <input type="checkbox"/> Iron and Steel Worker |
| <input type="checkbox"/> Toolmaker | <input type="checkbox"/> Textile Overseer or Supt. |
| <input type="checkbox"/> Patternmaker | <input type="checkbox"/> Cotton Manufacturing |
| <input type="checkbox"/> Civil Engineer | <input type="checkbox"/> Woolen Manufacturing |
| <input type="checkbox"/> Surveying and Mapping | <input type="checkbox"/> Agriculture <input type="checkbox"/> Fruit Growing |
| <input type="checkbox"/> Bridge Engineer | <input type="checkbox"/> Poultry Farming |
| <input type="checkbox"/> Gas Engine Operating | <input type="checkbox"/> Mathematics <input type="checkbox"/> Radio |

BUSINESS TRAINING COURSES

- | | |
|--|---|
| <input type="checkbox"/> Business Management | <input type="checkbox"/> Business Correspondence |
| <input type="checkbox"/> Industrial Management | <input type="checkbox"/> Show Card and Sign Lettering |
| <input type="checkbox"/> Personnel Management | <input type="checkbox"/> Stenography and Typing |
| <input type="checkbox"/> Traffic Management | <input type="checkbox"/> English |
| <input type="checkbox"/> Accounting and C. P. A. Coaching | <input type="checkbox"/> Civil Service |
| <input type="checkbox"/> Cost Accounting | <input type="checkbox"/> Railway Mail Clerk |
| <input type="checkbox"/> Bookkeeping | <input type="checkbox"/> Mail Carrier |
| <input type="checkbox"/> Secretarial Work | <input type="checkbox"/> Grade School Subjects |
| <input type="checkbox"/> Spanish <input type="checkbox"/> French | <input type="checkbox"/> High School Subjects |
| <input type="checkbox"/> Salesmanship | <input type="checkbox"/> Cartooning |
| <input type="checkbox"/> Advertising | <input type="checkbox"/> Illustrating |
| | <input type="checkbox"/> Lumber Dealer |

Name.....

Address.....

City..... State.....

Occupation.....

If you reside in Canada, send this coupon to the International Correspondence Schools Canadian, Limited, Montreal, Canada



Build This IDEAL Flying Model of the

FORD MONOPLANE

A perfect 3-foot miniature of the "Floyd Bennett", the Tri-motor plane now in use by Commander Byrd at the South Pole. Anybody can build and fly it. The IDEAL Complete Construction Outfit contains everything needed; all parts, fittings and materials, full plans, diagrams and instructions. The Model is guaranteed to fly when correctly built. Complete Construction **\$8.50** Outfit

(West of Denver, Colo., and in Canada \$9.00)

Ask Your Dealer or Order Direct.

Plans for Model Airplanes

Complete, accurate, 1/4-size Plans with Building-Flying Instructions, for any one of the following: Ford, New York-Paris; FOKKER; Curtiss; DeHAVILLAND; NC-4 Seaplane; Blériot; Taube or Newport; Cecil Peeli—25c

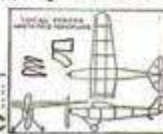

64-pg. Book for Model Builders

Contains plans for building Gliders and Racers, full information about Scale Models; and most complete catalog of Parts, Supplies, Materials and Fittings for all kinds of Models. **5c** Postpaid for

Ideal Aeroplane & Supply Co., Inc.

26 West 19th Street, New York City

The Holmes Twin-Shot DETONATOR

(An absolutely new departure in 100% dependable ignition)

Doubles Power of explosion, Does not Foul, Increases mileage, makes Snapper, Smoother Running Engine and Quicker Pick-up.

A Revolutionary Device and a Fast Seller—NO COMPETITION

Sells Instantly on demonstration:

Demonstration set of 6 for \$5.00, Four for \$3.50. Retail Price \$1.50 each. Replaces the ordinary spark plug without additional Fittings.

Opportunity Now Open for Aggressive Distributors

Money Refunded if Not Entirely Satisfactory as Represented

E. R. HOLMES

Littleton, Colorado (Denver Suburb)

Portable ELECTRIC Light Plant

110 Volt — Complete with all wiring, fixtures and lamps for seven rooms **\$147.50**

for Farms, Camps and Summer Homes

Install it yourself. Write for direct to you prices. Immediate delivery.

D. W. ONAN & SONS

7 Royalston Ave., Minneapolis, Minn.



Shoes Pay Him \$15 a Day!

Taking orders for Mason's Famous Shoes will pay you \$10 to \$20 a day. We need more representatives at once. You need no experience for we show you exactly what to do. No investment. Just take orders like many Mason salesmen who are earning \$75 to \$125 a week.



FREE OUTFIT will be furnished you. Show these wonderful shoes for men, women and children at amazing low prices. Everybody buys eagerly. Finest leather throughout at prices dollars less than stores. Latest styles by experts. You can build up a marvelous business of your own right in your own community. Write for your FREE outfit and step at once into real earnings. **MASON SHOE MFG. CO., Dept. 225, CHIPPEWA FALLS, WIS.**

START TO PLAY VERY FIRST DAY!

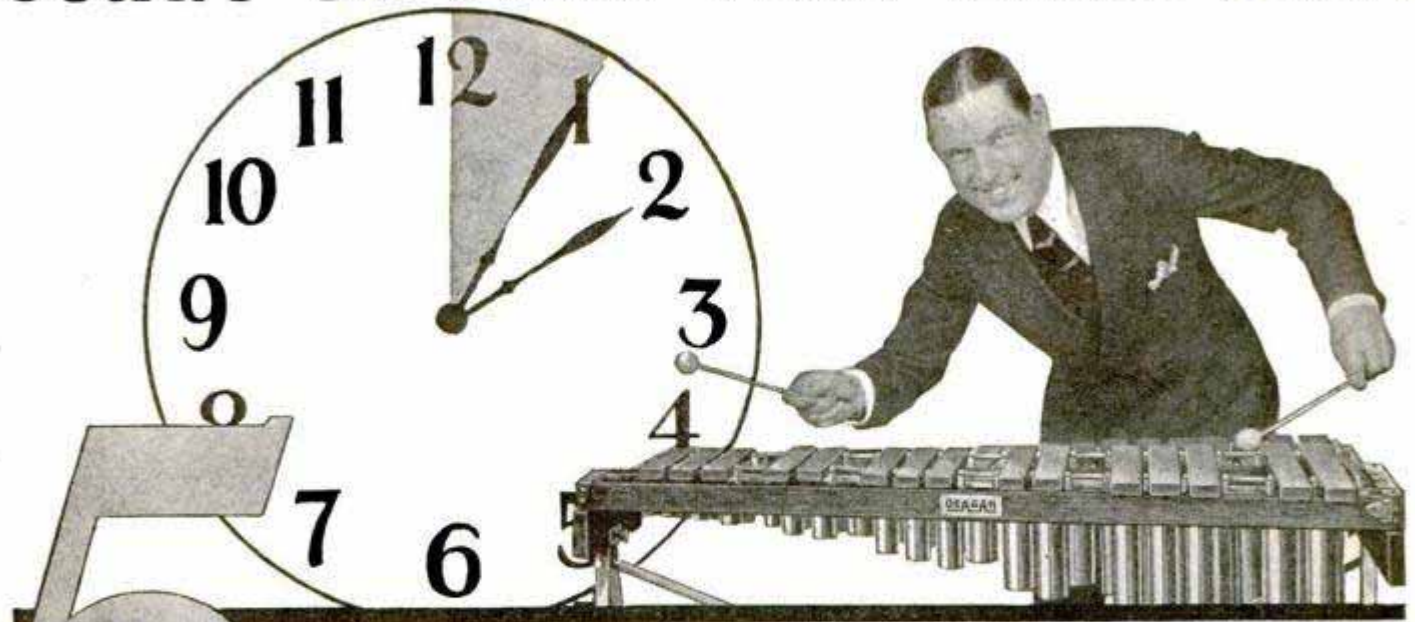

5 Minutes after I unpacked my Xylorimba I started playing!

FRANKLY, I was doubtful. I had always wanted to play some musical instrument. To be the *center of interest* at parties; to make \$5 to \$25 a night for work that is "play"; to know the joy of creating music—who isn't interested in these things?

But I had always dreaded the hours of exercise that most musical instruments require—"scale" practice in learning piano, finger exercises in learning violin, lip exercises in learning wind instruments. *It never occurred to me that the most spectacular of all instruments—the xylorimba—was also the EASIEST TO PLAY!*

First Step Toward Musical Happiness

Then one day I saw an ad like this one, wrote for the big FREE book, selected the instrument I liked best and ordered it on a strict 5-day trial basis—and on such easy terms that I hardly noticed the payments.

Five minutes after I unpacked my xylorimba, I was playing the notes of "Old Black Joe."

It was a simple melody, to be sure—but it proved that I would actually be playing *real music* from the very start, without the tiresome finger or lip exercises. How much more pleasant, under these conditions, to take up the wonderfully simple lessons, one by one, and gradually learn to play more intricate selections! How much more pleasant, too, to learn in the privacy of your own home without a teacher. Never have I had such fun—such cheery evenings—such a feeling of

progress. The whole family have become xylo-
rimba enthusiasts. Already, I am teaching my
sweetheart to play. What a happy pupil she is!

Friends Amazed!

Friends and relatives are amazed at my progress. To "dash off" a snappy fox-trot or dreamy waltz and then hear them shout for more, is a thrill that simply must be felt to be appreciated.

BIG BOOK FREE!

How would you like to play the xylo-
rimba—to have your presence
demanded at gatherings—to make
extra money playing at parties,
dances, radio studios and perhaps
even on the stage? Hundreds have

done it. You can, too, even if you can't read a note of music right now! On receipt of the coupon we will send our big FREE book telling all about the Deagan instruments—the easy payments—the delightfully simple free lessons. Five days' free trial in your own home—and a year to pay! No time like the present, no day like today, when fun and profit are involved. Send in the coupon NOW.

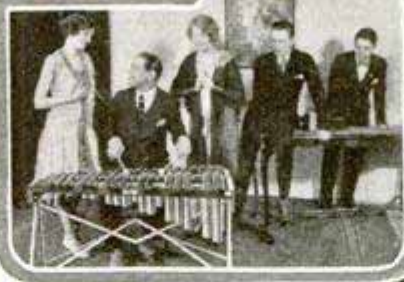

J. C. Deagan, Inc., Dept. 1455, 1770 Berteau Av., Chicago

Send me, without obligation, full details of Free Trial offer and easy-payment plan on the Deagan Xylorimba.

Name _____

Address _____



You Can Make

\$50 a day!

Without Selling!

Here's a new business plan for you—**AUTOMATIC MERCHANDISING!** Coins money for you while you take life easy. Simply place these machines in good locations and let them pyramid pennies for you. All you do is re-fill the machines when empty, and rake in your profits.

**Easy Work—
No Risk—
Read How**

**Wonderful
Automatic
Machines**

**Turn Pennies
Into DOLLARS For You**

Get Your Share of \$100,000,000 a Year

Yes, a Hundred Million Dollars spent in the United States EVERY YEAR for chewing gum! If you want a business that works seven days a week for you, where the profits pile up automatically, and where you can be an independent distributor, you want the Blue Ribbon Exclusive Franchise for your territory.

Amazing Premium Plan — We Pay All Costs

Not only is Blue Ribbon Gum the finest product of its kind on the market—made of the finest chicle and flavored with the juice of real mint leaves, but our Premium Plan is the cleverest and most successful thing you ever saw. Men, women and children save the gum wrappers to get the free premiums which we supply without cost to you! This premium plan explains why one Blue Ribbon Gum Sale ALWAYS means repeat orders. Arthur Wall started with ten Blue Ribbon machines—he has now contracted for TWO THOUSAND which he is placing as fast as he receives them. It's the business YOU have been looking for!

The Opportunity that Comes Once in a Lifetime



Just take the first Blue Ribbon Gum Vending Machine under your arm and place it in a good location—any place where people pass. You can expect the average sell-out to reach 600 sticks of gum per machine each week. You can easily afford to pay 25% of your take-in to the owner of the location. Establish a route of 50 to 100 machines and all you need to do is keep them filled—or hire a boy to do it for you.

Proof—

"Enclosed check \$147.50 for 5,000 sticks of gum and ten more machines"—Bollinger. "Rush 25 more machines and 25,000 sticks of gum. Then send 25,000 more sticks gum every three weeks"—Farr. "The first day the machine took in 73 pennies and the next 141. In five days it sold 400 sticks, and is selling faster as people start saving wrappers for premiums. Ordering 35 more machines"—Matzke.

Pays For Itself In 30 Days OR YOUR MONEY BACK

Cost of Blue Ribbon Automatic Machine	\$12.50
(400 sticks gum free with sample machine)	
Machine produces \$1.50 a day. In 30	
days	\$45.00
25% to storekeeper	\$11.25
Cost of gum 45c per 100	20.25
	31.50

Profit in 30 days.....\$13.50
Net Profit thereafter per month—\$13.50 per machine. Think what a chain of 100 machines will do—\$50 a day clear profit for you!

RESERVE YOUR EXCLUSIVE TERRITORY NOW!

**BLUE RIBBON
GUM CO., Inc.**

Dept. 24, 395 Broadway, New York City

Blue Ribbon Gum Co., Inc., Dept. 24, 395 Broadway, New York City.



Send me one BLUE RIBBON Automatic Dispensing Machine, 100 free sample advertising envelopes, each containing a full sized stick of gum with premium wrapper, advertising window strips, full instructions for selecting location and installing machine, and 400 sticks of BLUE RIBBON GUM. I am enclosing \$12.50 (your regular wholesale price for the machine alone).

I am to use the 400 sticks of gum and the 100 sample envelopes in testing the Blue Ribbon proposition. If I am not satisfied with the results I may return the machine in good condition at any time within 30 days and you will refund my money, making no charge for the advertising material and the 400 sticks of gum. If I like your proposition I expect you to make me your exclusive distributor in this territory.

My Name.....

Address.....

Town..... State.....

Housewives Wild with Joy Agents Making \$90 to \$200 a Week



An Amazing New Way to Open Cans Has Been Discovered!



CAN SPINS



LID FLIPS UP



**NO MORE CUT
FINGERS**

YES, it's here at last! The million-dollar discovery that inventors the world over have long dreamed about! Now, figuratively, in the flick of an eyelash the daily kitchen prayer of millions of women is answered! **Dangerous old-style can openers are banished to the scrap-heap instantly and forever!** No more stabbing and hacking! No cuts, no danger, no pain, no blood poison! Is it any wonder that the agents who are carrying this message to the women of America are being paid almost incredible sums of money? Daily, almost hourly, profit records are broken! In a single hour dozens of men have reported profits ranging from \$20 to \$30—all that for just 60 minutes work!

Magical—Yet Startlingly Simple

Call this invention amazing, astonishing, anything you like and still you have not adequately described it. For imagine, if you can, a little, pocket-size can opening machine that works exactly like magic. It holds the can for you—rapidly spins the can around—rips the top out as slick and clean as scissors snip through tissue paper—all in 5 seconds or less—opens every shape can, square, round or oval at a mere twist of the wrist!

Approved By All Experts

This newest and most remarkable can opening invention is called "Speedo." It has already been tested and approved by almost every known authority, including Good Housekeeping Inst., Modern Priscilla, Youth's Compan-

ion Lab., Household Searchlight Lab., etc. It has also now been tested and approved as a big money-maker by some of the smartest salesmen in America. When I say "big money," I'm thinking of men like D. C. Harris, Minn., who made \$41 a day; O. H. Dickinson, Idaho, made a cool \$1,000.00 in only 27½ selling days; O. C. Gregg, Wyo., made \$20 in 3 hours spare time; E. T. Barclay, N. Y., cleaned up \$117 in 2 days; and so it goes everywhere.

Accept This Free Test

Many Speedo exclusive territories are still open, some of them among the very best potential money makers. Today is none too soon to send for the famous Speedo Free Test Offer. Risk nothing. Easily gain an income running well over \$5,000 during the coming 12 months. Sell C. O. D. or collect and deliver. Even spare time will pay you \$5 to \$10 an hour at the start. Everything is furnished. You even get sales training entirely free. So if you really are in earnest about making big money mail the coupon below. Mail it today. Grab a pencil and send it right now!

**CENTRAL STATES MFG. CO., Dept. E-702
4500 Mary Ave., St. Louis, Mo.**

**Central States Mfg. Co., Dept. E-702,
4500 Mary Ave., St. Louis, Mo.**

I want to make a Free Test of this proposition that is driving housewives wild. Rush everything with full details of \$5 to \$10 an hour.

Name.....

Address.....

Town.....State.....

() Check here if interested only in one for your own home.

“Don't be
selfish”



CAMELS

Pleasure for all

